

Front Brake Pad

BRAKE

2. Front Brake Pad

A: REMOVAL

- 1) Lift up the vehicle, and remove the front wheels.
- 2) Remove the caliper bolt.

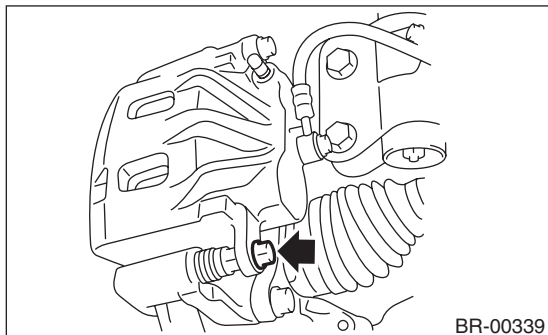

- 3) Raise the caliper body and support it.

NOTE:

Do not disconnect the brake hose from the caliper body.

- 4) Remove the pad.

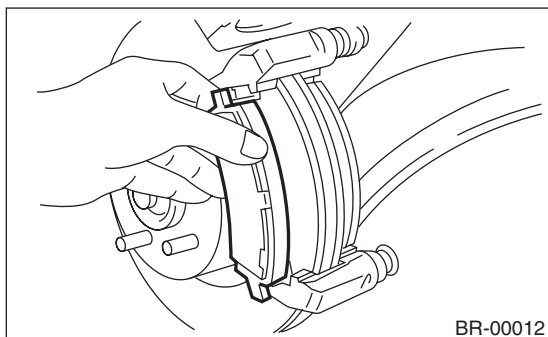

B: INSTALLATION

- 1) Apply a thin coat of grease contained in the pad kit or equivalent to the pad clip.

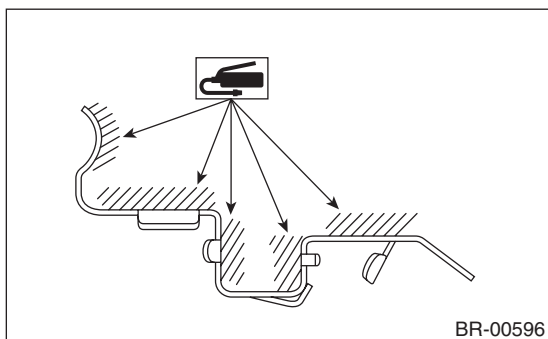

- 2) Apply a thin coat of Molykote AS880N (Part No. K0777YA010) or grease contained in the pad kit to both surfaces of the pad and inner shim.

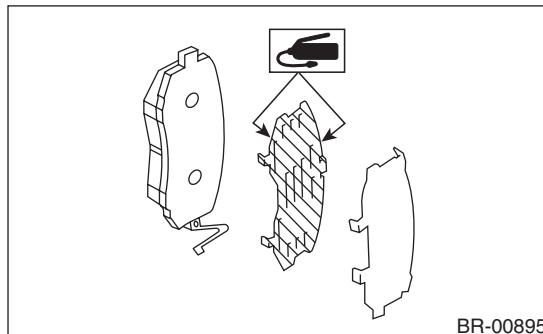

- 3) Install the pad to support.

NOTE:

Install the pad indicator in proper direction.

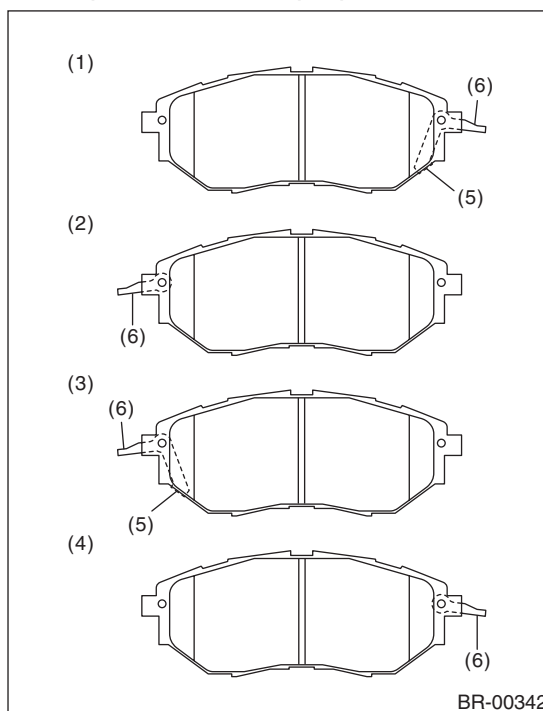

- (1) LH — IN
- (2) LH — OUT
- (3) RH — IN
- (4) RH — OUT
- (5) Pad indicator
- (6) Pad return spring

CAUTION:

- Be sure to install so that the pad return spring faces the input side of the direction of brake rotor rotation, as shown in the figure.
- Correctly install the pad return spring to the supporting surface of the pad clip as shown in the figure.
- If the pad return spring is deformed or damaged, replace the brake pad.

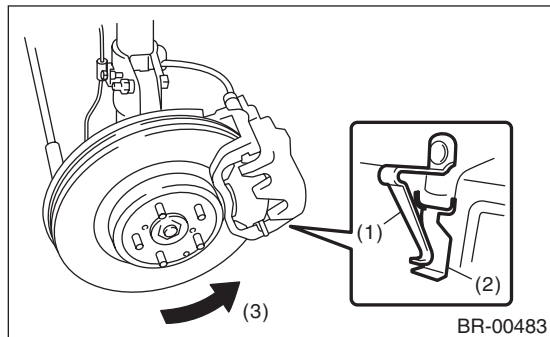

- (1) Pad return spring
- (2) Supporting surface of pad clip
- (3) Direction of brake rotor rotation

4) Install the caliper body to the support.

Tightening torque:

27 N·m (2.8 kgf·m, 19.9 ft·lb)

C: INSPECTION

Check the pad thickness A.

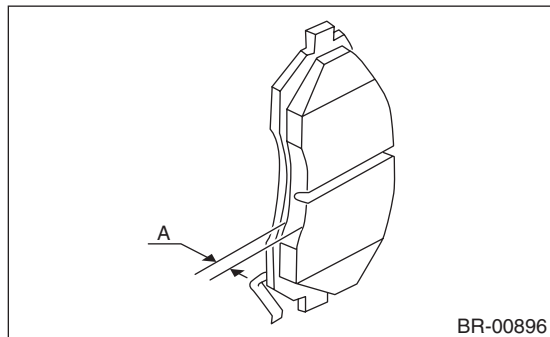

Pad thickness mm (in)	Standard	11 (0.433)
	Wear limit	1.5 (0.059)

NOTE:

- Always replace the pads of both wheels and both sides as a set.
- Replace pad clips if they are twisted or worn.
- A wear indicator is installed on the inner disc brake pad. If the pad is worn to the limit, the end of wear indicator contacts disc rotor, and a squeaking sound is heard as the wheel rotates. If the sound is heard, replace the pad.
- Replace the pad if there is oil or grease on it.