

### 9. Subaru Select Monitor

#### A: OPERATION

##### 1. HOW TO USE THE SUBARU SELECT MONITOR

1) Prepare the Subaru Select Monitor kit. <Ref. to EN(H6DO)(diag)-8, PREPARATION TOOL, General Description.>

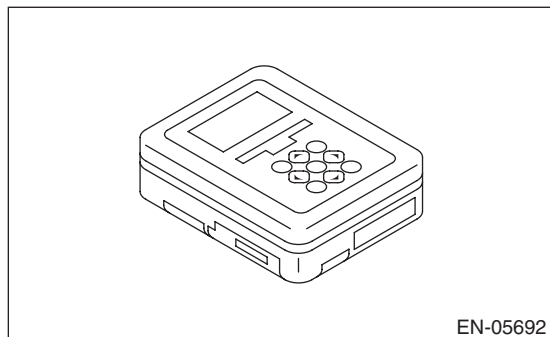

2) Prepare PC with Subaru Select Monitor installed.

3) Connect the USB cable to SDI (Subaru Diagnosis Interface) and USB port on the personal computer (dedicated port for the Subaru Select Monitor).

#### NOTE:

The dedicated port for the Subaru Select Monitor means the USB port which was used to install the Subaru Select Monitor.

4) Connect the diagnosis cable to SDI.

5) Connect SDI to data link connector located in the lower portion of the instrument panel (on the driver's side).

#### CAUTION:

**Do not connect any scan tools except Subaru Select Monitor or general scan tool.**

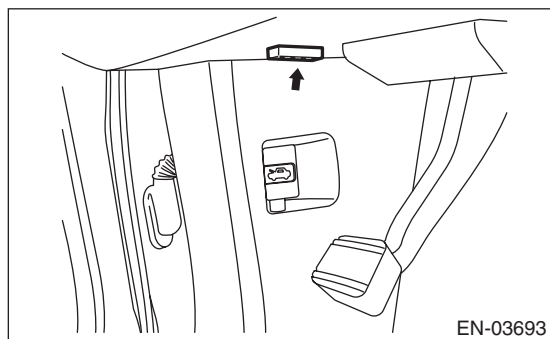

6) Start the PC.

7) Turn the ignition switch to ON (engine OFF) and run the "PC application for Subaru Select Monitor".

8) Call up DTC and data, then record them.

#### NOTE:

For detailed operation procedures, refer to "PC application help for Subaru Select Monitor".

## 2. READ CURRENT DATA FOR ENGINE (NORMAL MODE)

- 1) On «Main Menu» display, select {Each System Check}.
- 2) On «System Selection Menu» display, select {Engine Control System}.
- 3) Click the [OK] button after the information of engine type has been displayed.
- 4) On «Engine Diagnosis» display, select {Current Data Display & Save}.
- 5) On «Current Data Display & Save» display, select {Normal sampling}.
- 6) Using the scroll key, scroll the display screen up or down until the desired data is shown.

**NOTE:**

- For detailed operation procedures, refer to “PC application help for Subaru Select Monitor”.
- A list of the support data is shown in the following table.

Content	Display	Unit of measure	Note (at idling)
Engine load	Engine Load	%	2.4%
Engine coolant temperature signal	Coolant Temp.	°C or °F	≥ 85°C or 185°F (after warm-up)
A/F correction #1	A/F Correction #1	%	-10% — +10%
A/F learning #1	A/F Learning #1	%	-10% — +10%
A/F correction #2	A/F Correction #2	%	-10% — +10%
A/F learning #2	A/F Learning #2	%	-10% — +10%
Intake manifold absolute pressure	Mani. Absolute Pressure	mmHg, kPa, inHg or psig	210 mmHg, 28 kPa, 8.3 inHg or 4.1 psig
Engine speed signal	Engine Speed	rpm	600 — 800 rpm (after warm-up)
Meter vehicle speed signal	Vehicle Speed	km/h or MPH	0 km/h or 0 MPH
Ignition timing signal	Ignition Timing	deg	13 — 15 deg
Intake air temperature signal	Intake Air Temp.	°C or °F	(Ambient air temperature)
Intake air amount	Mass Air Flow	g/s or lb/m	2.5 g/s — 5.0 g/s or 0.31 lb/m — 0.71 lb/m
Throttle opening angle signal	Throttle Opening Angle	%	2%
Front oxygen sensor voltage value 1	Front O2 Sensor #1	V	0.900 V
Front oxygen sensor voltage value 2	Front O2 Sensor #2	V	0.900 V
Battery voltage	Battery Voltage	V	12 — 13 V
Mass air flow voltage	Air Flow Sensor Voltage	V	1.2 — 1.3 V
Injection 1 pulse width	Fuel Injection #1 Pulse	ms	2.5 ms — 3.5 ms
Injection 2 pulse width	Fuel Injection #2 Pulse	ms	2.5 ms — 3.5 ms
Atmospheric pressure signal	Atmosphere Pressure	mmHg, kPa, inHg or psig	(Atmospheric pressure)
Intake manifold relative pressure	Mani. Relative Pressure	mmHg, kPa, inHg or psig	(Air intake absolute pressure — Atmospheric pressure)
Learned ignition timing	Learned Ignition Timing	deg	+0.0 deg
Acceleration opening angle signal	Accel. Opening Angle	%	0%
Fuel temperature signal	Fuel Temp.	°C or °F	+28°C or +82°F
Radiator fan output	Radiator Fan Control	%	0% (Water temperature 90°C (194°F) when air conditioner is OFF)
Purge control solenoid valve duty ratio	CPC Valve Duty Ratio	%	18%
Number of EGR steps	No. of EGR steps	STEP	0 STEP
Fuel pump duty ratio	Fuel Pump Duty	%	33%
AVCS advance angle amount RH	VVT Adv. Ang. Amount R	deg	0 deg — +1 deg
AVCS advance angle amount LH	VVT Adv. Ang. Amount L	deg	0 deg — +1 deg
Oil flow control solenoid valve duty ratio RH	OCV Duty R	%	9.4%
Oil flow control solenoid valve duty ratio LH	OCV Duty L	%	9.4%
Oil flow control solenoid valve current RH	OCV Current R	mA	64 mA

# Subaru Select Monitor

## ENGINE (DIAGNOSTICS)

Content	Display	Unit of measure	Note (at idling)
Oil flow control solenoid valve current LH	OCV Current L	mA	64 mA
Front oxygen (A/F) sensor current value 1	A/F Sensor #1 Current	mA	0.0 mA
Front oxygen (A/F) sensor current value 2	A/F Sensor #2 Current	mA	0.0 mA
Front oxygen (A/F) sensor resistance value 1	A/F Sensor #1 Resistance	Ω	31 Ω
Front oxygen (A/F) sensor resistance value 2	A/F Sensor #2 Resistance	Ω	31 Ω
Front oxygen (A/F) sensor output lambda 1	A/F Sensor #1	—	1.01
Front oxygen (A/F) sensor output lambda 2	A/F Sensor #2	—	1.01
A/F correction #3	A/F Correction #3	%	0% — 1%
A/F learning #3	A/F Learning #3	%	0.0%
Throttle motor duty	Throttle Motor Duty	%	-20% — +20%
Throttle motor voltage	Throttle Motor Voltage	V	(Battery voltage)
Sub throttle sensor voltage	Sub-Throttle Sensor	V	1.4 V — 1.5 V
Main throttle sensor voltage	Main-Throttle Sensor	V	0.62 V — 0.70 V
Sub accelerator sensor voltage	Sub-Accelerator Sensor	V	1.0 V — 1.2 V
Main acceleration sensor voltage	Main-Accelerator Sensor	V	0.9 V — 1.1 V
Memory vehicle speed	Memorized Cruise Speed	km/h or MPH	0 km/h or 0 MPH
A/F correction #4	A/F Correction #4	%	-1% — 1%
A/F learning #4	A/F Learning #4	%	0.0%
Fuel level sensor resistance	Fuel level resistance	Ω	4 — 96 Ω
Engine oil temperature	Oil Temperature	°C or °F	≥ 85°C or 185°F (after warm-up)
Exhaust AVCS retard angle amount RH	Exh. VVT Retard Ang. R	deg	0 deg — +1 deg
Exhaust AVCS retard angle amount LH	Exh. VVT Retard Ang. L	deg	0 deg — +1 deg
Exhaust oil flow control solenoid valve duty ratio RH	Exh. OCV Duty R	%	9.4%
Exhaust oil flow control solenoid valve duty ratio LH	Exh. OCV Duty L	%	9.4%
Exhaust oil flow control solenoid valve current RH	Exh. OCV Current R	mA	64 mA
Exhaust oil flow control solenoid valve current LH	Exh. OCV Current L	mA	64 mA
#1 cylinder roughness monitor	Roughness Monitor #1	—	0
#2 cylinder roughness monitor	Roughness Monitor #2	—	0
#3 cylinder roughness monitor	Roughness Monitor #3	—	0
#4 cylinder roughness monitor	Roughness Monitor #4	—	0
#5 cylinder roughness monitor	Roughness Monitor #5	—	0
#6 cylinder roughness monitor	Roughness Monitor #6	—	0
Knock sensor correction	Knocking Correction	deg	0 deg
Fuel tank pressure signal	Fuel Tank Pressure	mmHg, kPa, inHg or psig	7.5 mmHg, 1 kPa, 0.3 inHg or 0.14 psi
AT/MT identification	AT Vehicle ID Signal	—	AT vehicle
D-check require Flag	D-check Require Flag	—	OFF
Delivery (test) mode terminal	Delivery Mode Connector (Test Mode Connector)	—	OFF
Neutral position switch signal	Neutral Position Switch	—	ON
Idle switch signal	Idle Switch Signal	—	ON
Ignition switch signal	Ignition Switch	—	ON
Power steering switch signal	P/S Switch	—	OFF (when OFF)
Air conditioning switch signal	A/C Switch	—	OFF (when OFF)
Starter switch signal	Starter Switch	—	OFF
Front oxygen monitor 1	Front O2 #1 Rich Signal	—	Rich, Lean
Front oxygen monitor 2	Front O2 #2 Rich Signal	—	Rich, Lean
Knocking signal	Knocking Signal	—	OFF

# Subaru Select Monitor

ENGINE (DIAGNOSTICS)

Content	Display	Unit of measure	Note (at idling)
Crankshaft position sensor signal	Crankshaft Position Sig.	—	ON
Camshaft position sensor signal	Camshaft Position Sig.	—	ON
Rear defogger switch signal	Rear Defogger SW	—	OFF (when OFF)
Blower fan switch signal	Blower Fan SW	—	OFF (when OFF)
Light switch signal	Light Switch	—	OFF (when OFF)
A/C middle pressure switch signal	A/C Mid Pressure Switch	—	OFF (when A/C OFF)
A/C compressor relay signal	A/C Compressor Signal	—	OFF (when A/C OFF)
Drain valve signal	Vent. Solenoid Valve	—	OFF (when OFF)
AT coordinate retard angle demand signal	Retard Signal from AT	—	OFF
AT coordinate fuel cut demand signal	Fuel Cut signal from AT	—	OFF
Vehicle dynamics control (VDC) torque down prohibition output	Ban of Torque Down	—	ON
Vehicle dynamics control (VDC) torque down demand	Request Torque Down VDC	—	OFF
AT coordinate permission signal	Torque permission signal	—	ON
Electronic throttle control motor relay signal	ETC Motor Relay	—	ON
Stop light switch signal	Stop Light Switch	—	OFF (when brake is OFF)
SET/COAST switch signal	SET/COAST Switch	—	OFF (when levers are not operated)
RESUME/ACCEL switch signal	RESUME/ACCEL Switch	—	OFF (when levers are not operated)
Brake switch signal	Brake Switch	—	OFF (when brake is OFF)
Main switch signal	Main Switch	—	OFF (when levers are not operated)
Cruise control cancel switch signal	CC Cancel SW	—	OFF (when levers are not operated)
Malfunction indicator light on flag	MIL On Flag	—	Light OFF

### 3. READ CURRENT DATA FOR ENGINE (OBD MODE)

- 1) On «Main Menu» display, select {Each System Check}.
- 2) On «System Selection Menu» display, select {Engine Control System}.
- 3) Click the [OK] button after the information of engine type has been displayed.
- 4) On «Engine Diagnosis» display, select {OBD System}.
- 5) On «OBD Menu» display, select {Current Data Display & Save}.
- 6) On «Current Data Display & Save» display, select {All data display}.
- 7) Using the scroll key, scroll the display screen up or down until the desired data is shown.

#### NOTE:

- For detailed operation procedures, refer to “PC application help for Subaru Select Monitor”.
- A list of the support data is shown in the following table.

Content	Display	Note (at idling)	Unit of measure
Number of diagnosis code	Number of Diag. Code:	0	—
Condition of malfunction indicator light	MI(MIL)	OFF	—
Monitoring test of misfire	Misfire monitoring (Supp)	YES	—
Monitoring test of misfire	Misfire monitoring (Rdy)	YES	—
Monitoring test of fuel system	Fuel system monitoring (Supp)	YES	—
Monitoring test of fuel system	Fuel system monitoring (Rdy)	YES	—
Monitoring test of comprehensive component	Component monitoring (Supp)	YES	—
Monitoring test of comprehensive component	Component monitoring (Rdy)	YES	—
Test of catalyst	Catalyst Diagnosis (Supp)	YES	—
Test of catalyst	Catalyst Diagnosis (Rdy)	NO	—

# Subaru Select Monitor

## ENGINE (DIAGNOSTICS)

Content	Display	Note (at idling)	Unit of measure
Test of heating-type catalyst	Heated catalyst (Supp)	NO	—
Test of heating-type catalyst	Heated catalyst (Rdy)	N/A	—
Test of evaporative emission purge control system	Evaporative purge system (Supp)	YES	—
Test of evaporative emission purge control system	Evaporative purge system (Rdy)	NO	—
Secondary air system test	Secondary air system (Supp)	NO	—
Secondary air system test	Secondary air system (Rdy)	N/A	—
Test of air conditioning system refrigerant	A/C system refrigerant (Supp)	NO	—
Test of air conditioning system refrigerant	A/C system refrigerant (Rdy)	N/A	—
Test of oxygen sensor	Oxygen sensor (Supp)	YES	—
Test of oxygen sensor	Oxygen sensor (Rdy)	NO	—
Test of oxygen sensor heater	O2 Heater Diagnosis (Supp)	YES	—
Test of oxygen sensor heater	O2 Heater Diagnosis (Rdy)	NO	—
Test of EGR system	EGR system (Supp)	YES	—
Test of EGR system	EGR system (Rdy)	NO	—
Air fuel ratio control system for bank 1	Fuel system for Bank 1	Cl_normal	—
Air fuel ratio control system for bank 2	Fuel system for Bank 2	Cl_normal	—
Engine load data	Calculated load value	21.0	%
Engine coolant temperature signal	Coolant Temp.	91	°C
Short term fuel trim by front oxygen (A/F) sensor (Bank 1)	Short term fuel trim B1	17.2	%
Long term fuel trim by front oxygen (A/F) sensor (Bank 1)	Long term fuel trim B1	5.5	%
Short term fuel trim by front oxygen (A/F) sensor (Bank 2)	Short term fuel trim B2	17.2	%
Long term fuel trim by front oxygen (A/F) sensor (Bank 2)	Long term fuel trim B2	5.5	%
Intake manifold absolute pressure signal	Mani. Absolute Pressure	233	mmHg
Engine speed signal	Engine Speed	700	rpm
Vehicle speed signal	Vehicle Speed	0	km/h
#1 Cylinder ignition timing	Ignition timing adv. #1	16.5	°
Intake air temperature signal	Intake Air Temp.	54	°C
Intake air amount	Mass Air Flow	2.8	g/s
Throttle position signal	Throttle Opening Angle	13	%
Oxygen sensor (Bank 1 Sensor 2)	Oxygen sensor #12	0.1 — 0.7	V
A/F correction (Bank 1 Sensor 2)	Short term fuel trim #12	0.0	%
Oxygen sensor (Bank 2 Sensor 2)	Oxygen sensor #22	0.1 — 0.7	V
A/F correction (Bank 2 Sensor 2)	Short term fuel trim #22	0.0	%
On-board diagnostic system	OBD System	OBD/OBD2	—
Front oxygen (A/F) sensor (Bank 1 Sensor 1)	Oxygen sensor #11	Supported	—
Oxygen sensor (Bank 1 Sensor 2)	Oxygen sensor #12	Supported	—
Front oxygen (A/F) sensor (Bank 2 Sensor 1)	Oxygen sensor #21	Supported	—
Oxygen sensor (Bank 2 Sensor 2)	Oxygen sensor #22	Supported	—
Elapsed time after engine start	Time Since Engine Start	—	sec
Travel distance after the malfunction indicator light illuminates	Lighted MI lamp history	—	km
A/F lambda signal (Bank 1 Sensor 1)	A/F Sensor #11	1.001	—
A/F sensor output signal (Bank 1 Sensor 1)	A/F Sensor #11	2.805	V
A/F lambda signal (Bank 2 Sensor 1)	A/F Sensor #21	1.001	—
A/F sensor output signal (Bank 2 Sensor 1)	A/F Sensor #21	2.805	V
Target EGR	Commanded EGR	0	%
EGR deviation	EGR Error	0.0	%

# Subaru Select Monitor

## ENGINE (DIAGNOSTICS)

Content	Display	Note (at idling)	Unit of measure
Evaporative purge	Commanded Evap Purge	0	%
Fuel level signal	Fuel Level	—	%
Number of warm ups after DTC clear	Number of warm-ups	—	—
Travel distance after DTC clear	Meter since DTC cleared	—	km
Fuel tank pressure signal	Fuel Tank Pressure	8.8	mmHg
Atmospheric pressure signal	Atmosphere Pressure	Atmospheric pressure	mmHg
A/F lambda signal (Bank 1 Sensor 1)	A/F Sensor #11	0.999	—
A/F sensor current (Bank 1 Sensor 1)	A/F Sensor #11	0.02	mA
A/F lambda signal (Bank 2 Sensor 1)	A/F Sensor #21	0.999	—
A/F sensor current (Bank 2 Sensor 1)	A/F Sensor #21	0.02	mA
Catalyst temperature #1	Catalyst Temperature #11	—	°C
Catalyst temperature #2	Catalyst Temperature #21	—	°C
Monitoring test of misfire	Misfire monitoring (Enable)	YES	—
Monitoring test of misfire	Misfire monitoring (Comp)	NO	—
Monitoring test of fuel system	Fuel system monitoring (Enable)	YES	—
Monitoring test of fuel system	Fuel system monitoring (Comp)	NO	—
Monitoring test of comprehensive component	Component monitoring (Enable)	YES	—
Monitoring test of comprehensive component	Component monitoring (Comp)	NO	—
Test of catalyst	Catalyst Diagnosis (Enable)	YES	—
Test of catalyst	Catalyst Diagnosis (Comp)	NO	—
Test of heating-type catalyst	Heated catalyst (Enable)	N/A	—
Test of heating-type catalyst	Heated catalyst (Comp)	N/A	—
Test of evaporative emission purge control system	Evaporative purge system (Enable)	YES	—
Test of evaporative emission purge control system	Evaporative purge system (Comp)	NO	—
Secondary air system test	Secondary air system (Enable)	N/A	—
Secondary air system test	Secondary air system (Comp)	N/A	—
Test of air conditioning system refrigerant	A/C system refrigerant (Enable)	N/A	—
Test of air conditioning system refrigerant	A/C system refrigerant (Comp)	N/A	—
Test of oxygen sensor	Oxygen sensor (Enable)	YES	—
Test of oxygen sensor	Oxygen sensor (Comp)	NO	—
Test of oxygen sensor heater	O2 Heater Diagnosis (Enable)	YES	—
Test of oxygen sensor heater	O2 Heater Diagnosis (Comp)	NO	—
Test of EGR system	EGR system (Enable)	YES	—
Test of EGR system	EGR system (Comp)	NO	—
ECM power supply voltage	Control module voltage	13.789	V
Absolute load	Absolute Load Value	22	%
A/F target lambda	Target Equivalence Ratio	0.976	—
Relative throttle opening angle	Relative Throttle Pos.	2	%
Ambient temperature	Ambient Temperature	Ambient air temperature	°C
Absolute throttle opening angle 2	Absolute Throttle Pos.#2	32	%
Absolute accelerator opening angle 1	Accelerator Pedal Pos.#1	13	%
Absolute accelerator opening angle 2	Accelerator Pedal Pos.#2	13	%
Target throttle opening angle	Target Throt. Act. Cont.	0	%

# Subaru Select Monitor

## ENGINE (DIAGNOSTICS)

Content	Display	Note (at idling)	Unit of measure
Engine operating time while malfunction indicator light lit	Time while MIL lighted	—	min
Elapsed time after DTC clear	Time since DTC cleared	—	min
Type of fuel	Type of fuel	GAS	—
Relative acceleration opening angle	Relative Accelera. Pos.	0	%
Neutral condition	AT drive status	NEUT	—

### 4. READ FREEZE FRAME DATA FOR ENGINE (OBD MODE)

- 1) On «Main Menu» display, select {Each System Check}.
- 2) On «System Selection Menu» display, select {Engine Control System}.
- 3) Click the [OK] button after the information of engine type has been displayed.
- 4) On «Engine Diagnosis» display, select {OBD System}.
- 5) On «OBD Menu» display, select {Freeze Frame Data Display}.

#### NOTE:

- For detailed operation procedures, refer to “PC application help for Subaru Select Monitor”.
- A list of the support data is shown in the following table.

Contents	Display	Unit of measure
DTC of freeze frame data	Freeze frame data	—
Air fuel ratio control system for bank 1	Fuel system for Bank 1	—
Air fuel ratio control system for bank 2	Fuel system for Bank 2	—
Engine load data	Calculated load value	%
Engine coolant temperature signal	Coolant Temp.	°C or °F
Short term fuel trim by front oxygen (A/F) sensor (Bank 1)	Short term fuel trim B1	%
Long term fuel trim by front oxygen (A/F) sensor (Bank 1)	Long term fuel trim B1	%
Short term fuel trim by front oxygen (A/F) sensor (Bank 2)	Short term fuel trim B2	%
Long term fuel trim by front oxygen (A/F) sensor (Bank 2)	Long term fuel trim B2	%
Intake manifold absolute pressure signal	Mani. Absolute Pressure	mmHg, kPa, inHg or psig
Engine speed signal	Engine Speed	rpm
Vehicle speed signal	Vehicle Speed	km/h or MPH
Ignition timing adv. #1	Ignition timing adv. #1	°
Intake air temperature	Intake Air Temp.	°C or °F
Amount of intake air	Mass Air Flow	g/s
Throttle valve angle	Throttle Opening Angle	%
Oxygen sensor #12	Oxygen sensor #12	V
A/F correction value #12	Short term fuel trim #12	%
Oxygen sensor #22	Oxygen sensor #22	V
A/F correction value #22	Short term fuel trim #22	%
On-board diagnostic system	OBD System	—
Oxygen sensor #11	Oxygen sensor #11	—
Oxygen sensor #12	Oxygen sensor #12	—
Oxygen sensor #21	Oxygen sensor #21	—
Oxygen sensor #22	Oxygen sensor #22	—
Elapsed time after engine start	Time Since Engine Start	sec
Target EGR	Commanded EGR	%
EGR deviation	EGR Error	%
Evaporative purge	Commanded Evap Purge	%
Fuel level signal	Fuel Level	%
Fuel tank pressure signal	Fuel Tank Pressure	mmHg, kPa, inHg or psig
Atmospheric pressure	Atmosphere Pressure	mmHg, kPa, inHg or psig
ECM power supply voltage	Control module voltage	V

# Subaru Select Monitor

ENGINE (DIAGNOSTICS)

Contents	Display	Unit of measure
Absolute load	Absolute Load Value	%
A/F target lambda	Target Equivalence Ratio	—
Relative throttle opening angle	Relative Throttle Pos.	%
Ambient temperature	Ambient Temperature	°C or °F
Absolute throttle opening angle 2	Absolute Throttle Pos.#2	%
Absolute accelerator opening angle 1	Accelerator Pedal Pos.#1	%
Absolute accelerator opening angle 2	Accelerator Pedal Pos.#2	%
Target throttle opening angle	Target Throt. Act. Cont.	%
Neutral condition	AT drive status	—

## 5. V.I.N. REGISTRATION

- 1) On «Main Menu» display, select {Each System Check}.
- 2) On «System Selection Menu» display, select {Engine Control System}.
- 3) Click the [OK] button after the information of engine type has been displayed.
- 4) On «Engine Diagnosis» display, select {Entry VIN}.
- 5) Perform the procedures shown on the display screen.