

## 3. Second Seat

### A: REMOVAL

#### CAUTION:

- Airbag system satellite safing sensor is located in the lower of the second-row seat center. Read the cautions and warnings indicated in the AB section before removing the second-row seat. <Ref. to AB-4, CAUTION, General Description.>
- The airbag system is fitted with a backup power supply. After disconnecting the battery ground cable, the airbag may deploy if you do not wait for 60 seconds before starting the service of airbag system.

#### 1. LH&CTR SEAT

- 1) Tilt the backrest forward, and move the seat forward.
- 2) Remove the slide rail cover at the seat rear side, and remove the two bolts.
- 3) Move the seat to the rear end.
- 4) Remove the slide rail cover at the seat front side, and remove the two bolts.

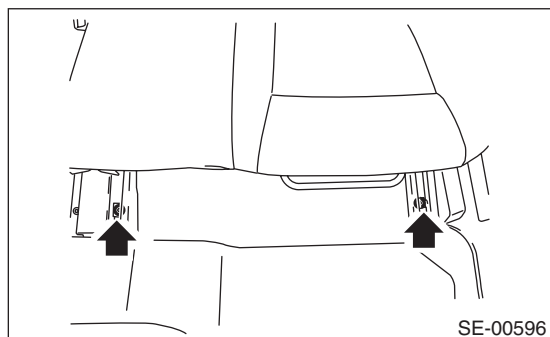

- 5) Remove the seat from vehicle.

#### 2. RH SEAT

- 1) Tilt the backrest forward, and move the seat forward.
- 2) Remove the slide rail cover at the seat rear side, and remove the two bolts.
- 3) Move the seat to the rear end.
- 4) Remove the slide rail cover at the seat front side, and remove the two bolts.

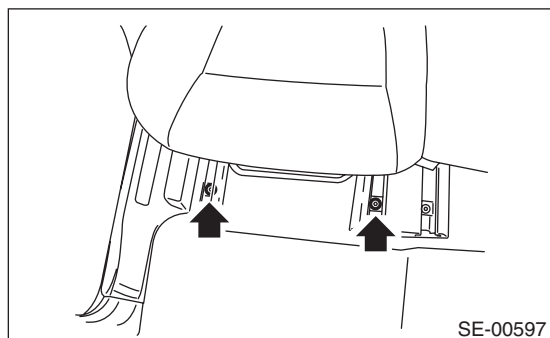

- 5) Remove the seat from vehicle.

### B: INSTALLATION

Install in the reverse order of removal.

#### Tightening torque:

Refer to "COMPONENT" of "General Description". <Ref. to SE-2, COMPONENT, General Description.>

#### NOTE:

Tighten the slide rail bolts diagonally in two or three steps by gradually increasing the torque, until they reach the specified torque.

### C: DISASSEMBLY

#### 1. LH SEAT

- 1) Remove the seat from vehicle. <Ref. to SE-13, LH&CTR SEAT, REMOVAL, Second Seat.>
- 2) Remove the headrest.
- 3) Remove the hinge outer cover.

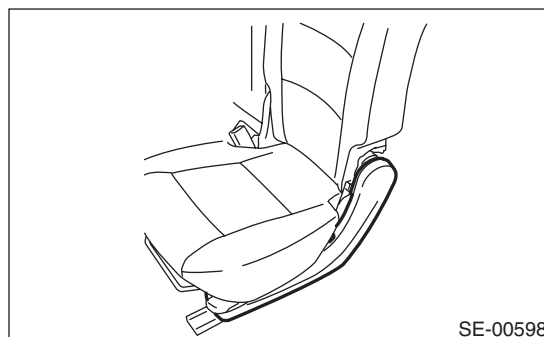

- 4) Remove the two reclining hinge bolts of 2nd seat CTR, then remove the seat backrest.

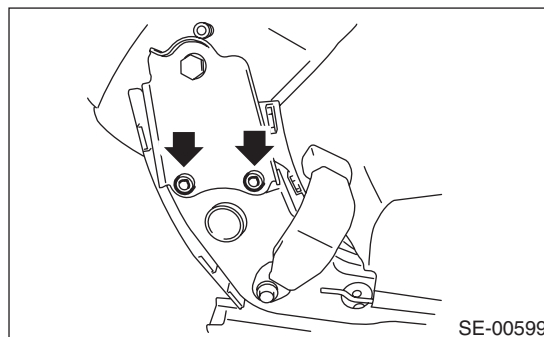

- 5) Remove the two reclining hinge bolts of 2nd seat LH on each of the left and right sides, then remove the seat backrest.

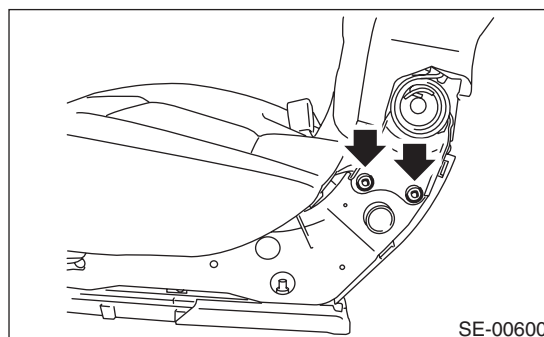

## Second Seat

### SEATS

6) Remove the backrest back cover.

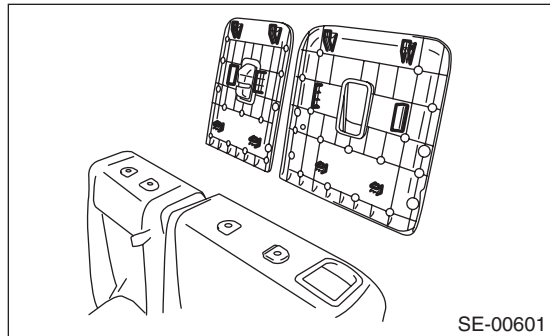

7) Remove the stopper.

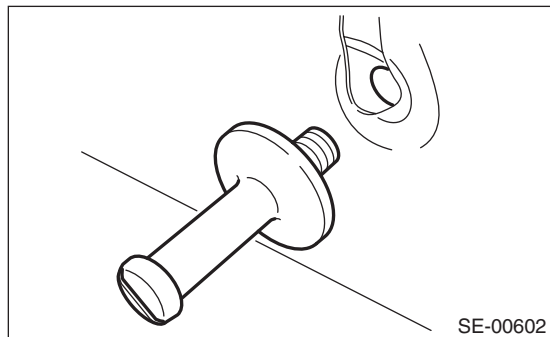

8) Remove the hog rings (A) and hooks at the rear face of the backrest.

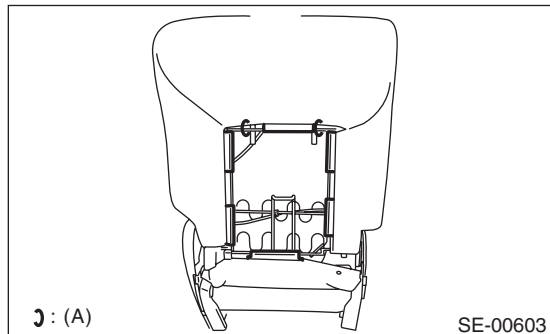

9) Remove the two screws securing the reclining lever.

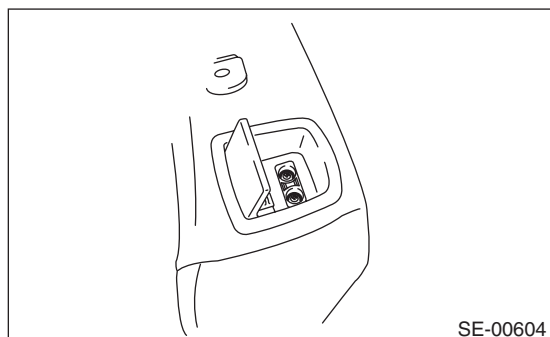

10) Disconnect the wire connected to the reclining lever, then remove the reclining lever.

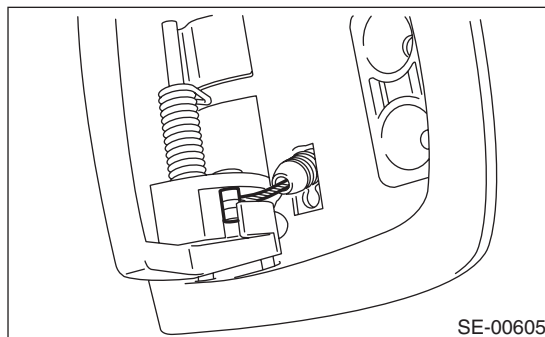

11) Remove the screws securing the walk-in knob and walk-in lever cover.

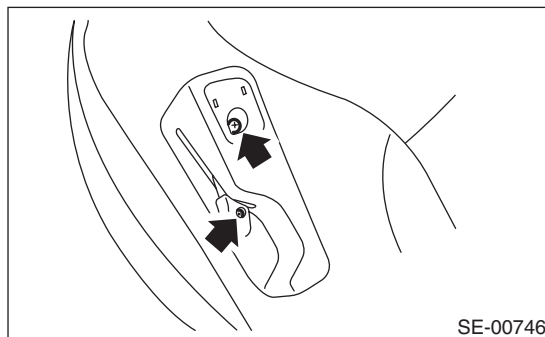

12) Remove the walk-in knob and walk-in lever cover.

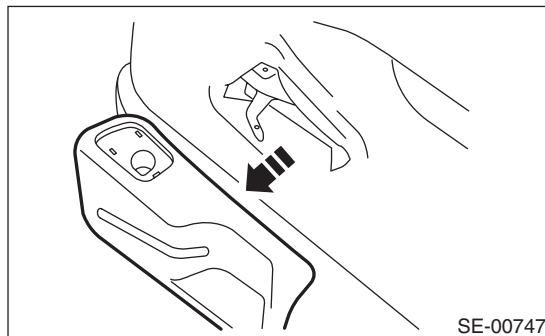

13) Remove the headrest lock bushing.

NOTE:

Push outside to remove it from the inside of seat.

14) Pull out the frame from the backrest.

15) Remove the hog rings (A) of backrest, and then remove the backrest cover from backrest.

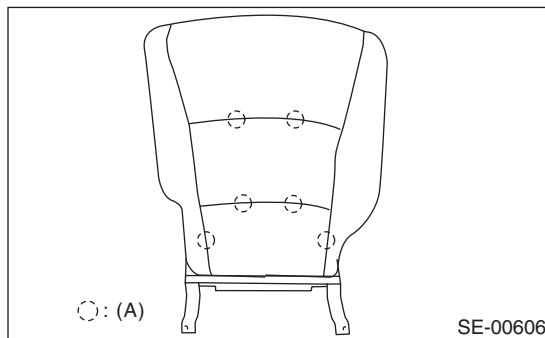

16) Remove the hooks and hog rings (A) from the rear side of seat cushion.

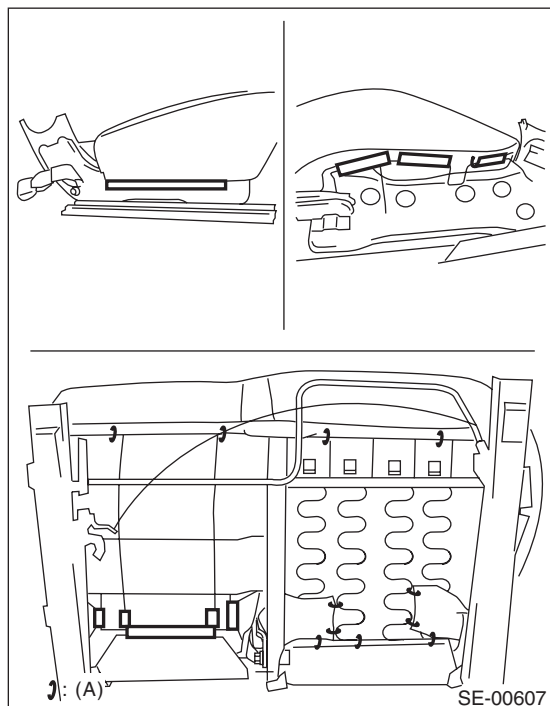

17) Remove the seat cushion from the slide rail assembly.

18) Remove the seat cushion hog rings (A), and then remove the seat cushion cover from seat cushion.

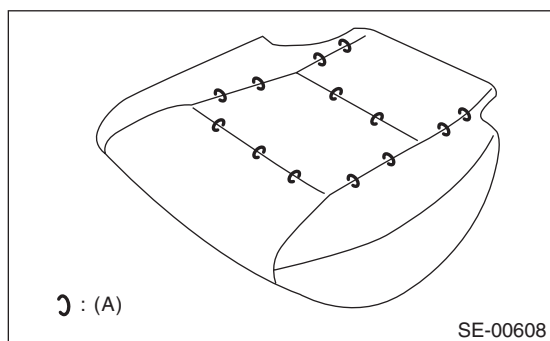

## 2. CTR SEAT

1) Remove the seat from vehicle. <Ref. to SE-13, LH&CTR SEAT, REMOVAL, Second Seat.>

2) Remove the hinge outer cover.

3) Remove the two reclining hinge bolts of 2nd seat CTR, then remove the seat backrest.

4) Remove the backrest back cover.

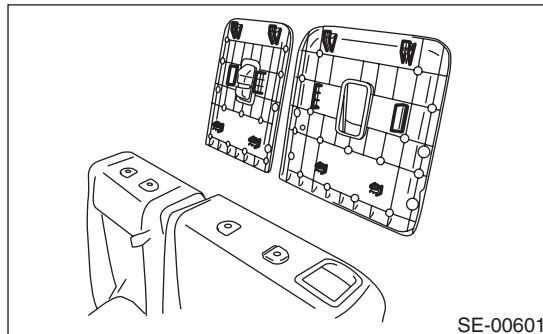

5) Remove the hooks and hog rings (A) at the rear side of backrest.

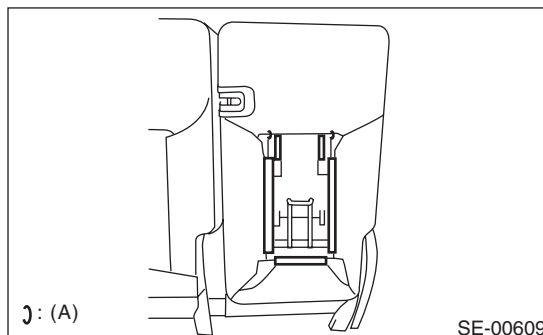

6) Remove the nut, then remove the armrest and arm rest rear board.

7) Remove the four screws securing the arm rest.

8) Remove the nut, then remove the armrest rear board and arm rest.

9) Remove the seat back latch cover.

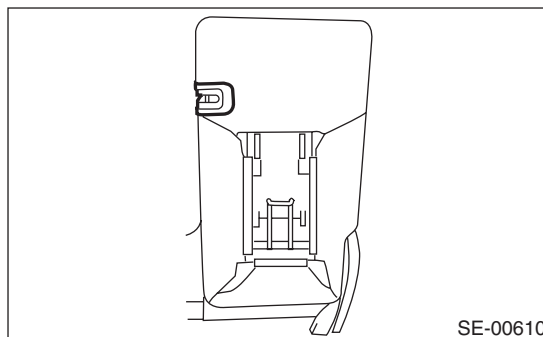

10) Remove the hog rings (A) on the front face of the backrest, and then remove the backrest cover from the backrest.

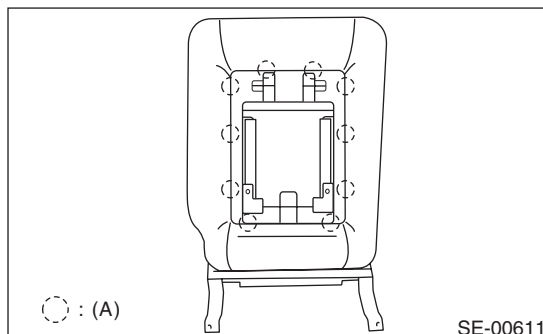

## Second Seat

### SEATS

11) Remove the two bolts securing the seat backrest latch, then remove the seat backrest latch.

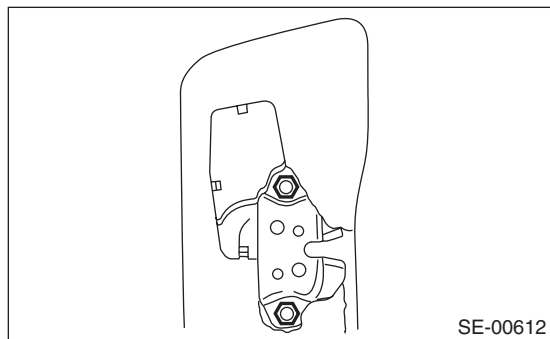

7) Disconnect the wire connected to the reclining lever, then remove the reclining lever.

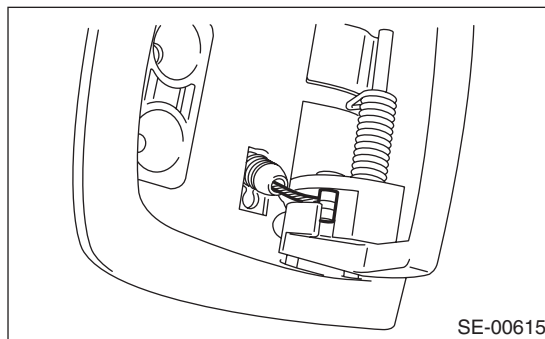

### 3. RH SEAT

1) Remove the seat from vehicle. <Ref. to SE-13, RH SEAT, REMOVAL, Second Seat.>

2) Remove the headrest.

3) Remove the hinge outer cover.

4) Remove the backrest back cover.

5) Remove the hog rings (A) and hooks at the rear face of the backrest.

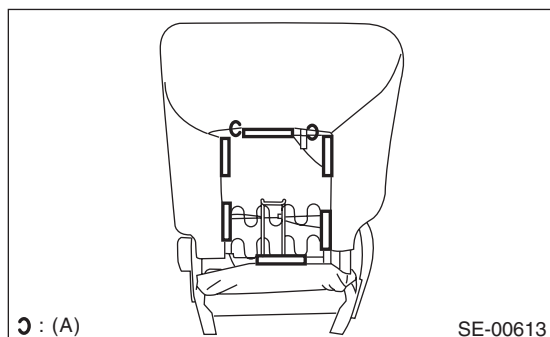

8) Disconnect the wire connected to the reclining hinge.

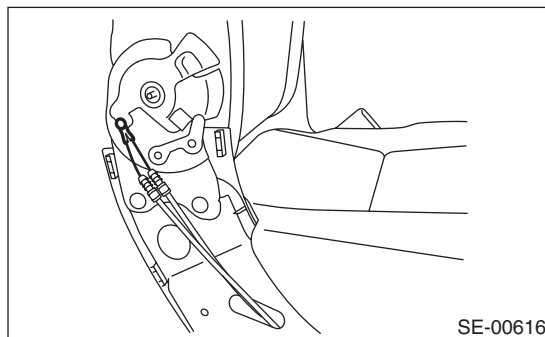

9) Remove the four reclining hinge bolts of 2nd seat RH, then remove the seat backrest.

10) Remove the two screws securing the walk-in knob and walk-in lever cover.

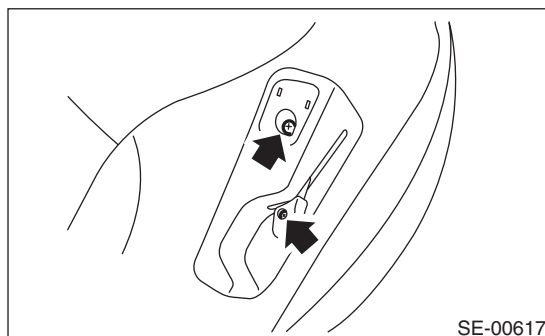

6) Remove the two screws securing the reclining lever.

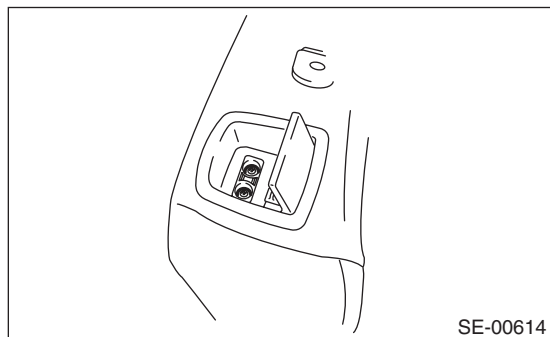

11) Remove the walk-in knob and walk-in lever cover.

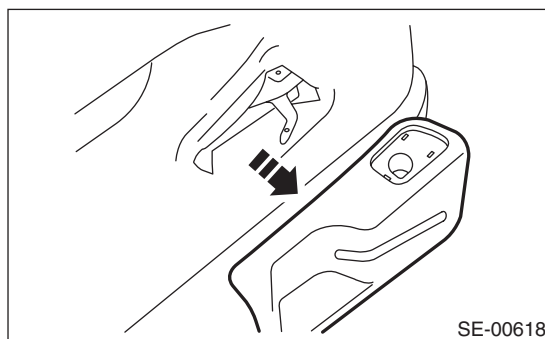

12) Remove the headrest lock bushing.

**NOTE:**

Push outside to remove it from the inside of seat.

13) Pull out the frame from the backrest.

14) Remove the hog rings (A) of backrest, and then remove the backrest cover from backrest.

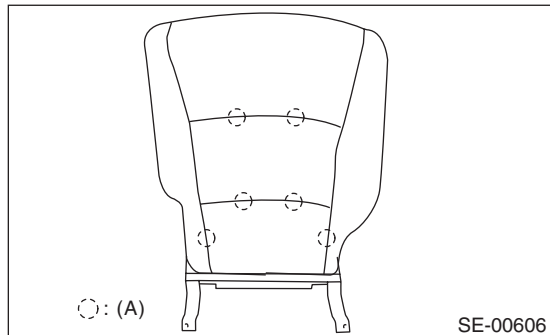

15) Remove the hooks and hog rings (A) from the rear side of seat cushion.

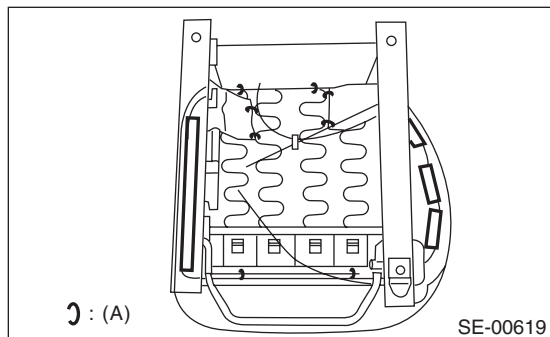

16) Remove the seat cushion from the slide rail assembly.

17) Remove the seat cushion hog rings (A), and then remove the seat cushion cover from seat cushion.

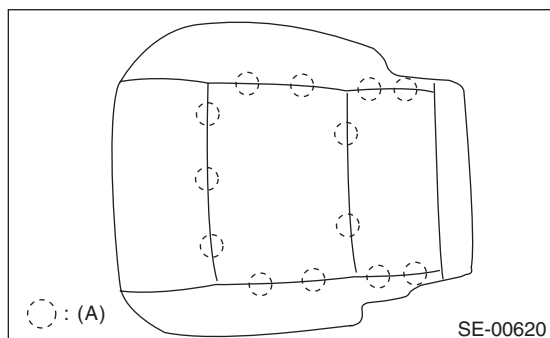

## D: ASSEMBLY

**CAUTION:**

- Be careful not to stain or damage the backrest cover during assembly.
- Always use new hog rings.
- Secure the hog ring using hog ring pliers.
- Install the hog rings to the specified points securely and make sure that no wrinkle or twisting on backrest cover.

1) Assemble the seat cushion in the reverse order of disassembly.

2) Assemble the backrest in the reverse order of disassembly.

3) Temporarily tighten the reclining hinge bolts in the order of (1) through (4) to an extent that the seat backrest assembly is not held securely.

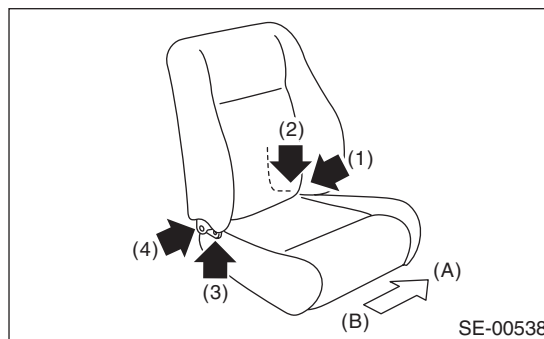

(A) Vehicle inside

(B) Vehicle outside

4) Use the reclining lever to place the backrest in the most upright position, and check the first lock position of recliner.

5) Hold the seat cushion assembly securely, and tighten the reclining hinge bolts in the order described above until they reach the specified torque.

**CAUTION:**

**Do not touch the backrest assembly when tightening the reclining hinge bolts.**

6) Assemble each harness, inner belt assembly and each cover in the reverse order of removal.

**Tightening torque:**

*Refer to "COMPONENT" of "General Description". <Ref. to SE-2, COMPONENT, General Description.>*

## E: INSPECTION

Check that there is no tear or fray on the seat cover.