

# General Description

## POWER ASSISTED SYSTEM (POWER STEERING)

### 1. General Description

#### A: SPECIFICATION

Whole system	Minimum turning radius		m (ft)	5.7 (18.7)
	Steering angle	Inner wheel		37.0°±1.5°
		Outer wheel		32.0°±1.5
	Steering wheel diameter		mm (in)	375 (14.76)
	Lock to lock turn			3.44
Gearbox	Type		Rack and Pinion, Integral	
	Backlash		0 (Automatic adjusting)	
	Valve (Power steering system)		Rotary valve	
Pump (Power steering system)	Type		Vane pump	
	Oil tank		Installed on body	
	Specific output	cm <sup>3</sup> (cu in)/rev.	9.6 (0.586)	
	Relief pressure	kPa (kg/cm <sup>2</sup> , psi)	8,800 — 9,400 (90 — 96, 1,276 — 1,363)	
	Hydraulic fluid control		Engine speed sensitive	
	Hydraulic fluid	ℓ (US qt, Imp qt)	1,000 rpm: 7.0 (7.4, 6.2) 3,000 rpm: 6.0 (6.3, 5.3)	
	RPM Range		rpm	500 — 8,600
Direction of rotation		Clockwise		
Hydraulic oil (Power steering system)	Capacity ℓ (US qt, Imp qt)	Oil tank	0.2 (0.2, 0.2)	
		Whole system	0.9 (1.0, 0.8)	

Steering wheel	Free play	mm (in)	17 (0.67)
Steering shaft	Clearance between the steering wheel and column cover	mm (in)	3.0 (0.12)
Steering gearbox (Power steering system)	Sliding resistance		N (kgf, lb) 400 (41, 90) or less Difference between right and left sliding resistance: 20% or less
	Rack shaft play in the radial direction	Right-turn steering	mm (in) 0.19 (0.0075) or less
		Left-turn steering	mm (in) Horizontal movement: 0.6 (0.024) or less Vertical movement: 0.4 (0.016) or less
	Input shaft play	In radial direction	mm (in) 0.18 (0.0071) or less
		In axial direction	mm (in) 0.5 (0.0197) or less
Rotation resistance		N (kgf, lb)	Maximum allowable value: 10.5 (1.07, 2.36) or less Difference between right and left sliding resistance: 20% or less
Oil pump (Power steering system)	Pulley shaft	Radial play	mm (in) 0.2 (0.008) or less
		Axial play	mm (in) 0.6 (0.024) or less
	Pulley	Ditch deflection	mm (in) 1.0 (0.039) or less
		Rotation resistance	N (kgf, lb) 9.22 (0.94, 2.07) or less
Regular pressure (Unloaded)		kPa (kg/cm <sup>2</sup> , psi)	981 (10, 142) or less
Steering wheel effort (Power steering system)	At standstill with engine idling on paved road	N (kgf, lb)	29.4 (3.0, 6.6) or less
	At standstill with engine stalled on paved road	N (kgf, lb)	294.2 (30, 66.2) or less

Recommended power steering fluid
SUBARU ATF or ATF DEXRON III

# General Description

POWER ASSISTED SYSTEM (POWER STEERING)

## B: COMPONENT

### 1. STEERING WHEEL AND COLUMN

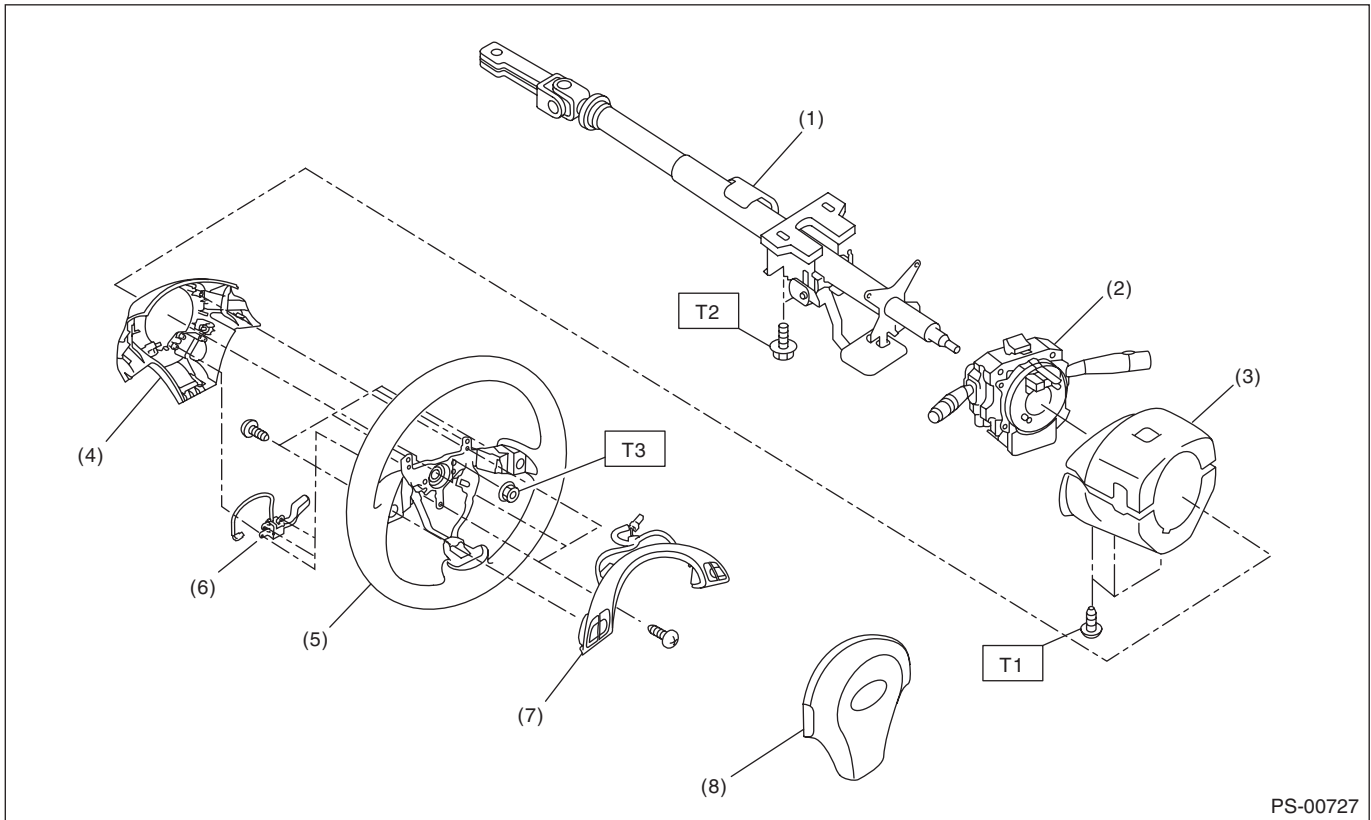

- |                                |                           |
|--------------------------------|---------------------------|
| (1) Steering shaft             | (5) Steering wheel        |
| (2) Steering roll connector    | (6) Cruise control switch |
| (3) Column cover               | (7) Satellite switch      |
| (4) Steering wheel lower cover | (8) Airbag module         |

**Tightening torque: N·m (kgf-m, ft-lb)**

**T1: 1.2 (0.12, 0.9)**

**T2: 25 (2.5, 18.1)**

**T3: 45 (4.6, 33.2)**

# General Description

## POWER ASSISTED SYSTEM (POWER STEERING)

### 2. POWER ASSISTED SYSTEM

- Hose and tank

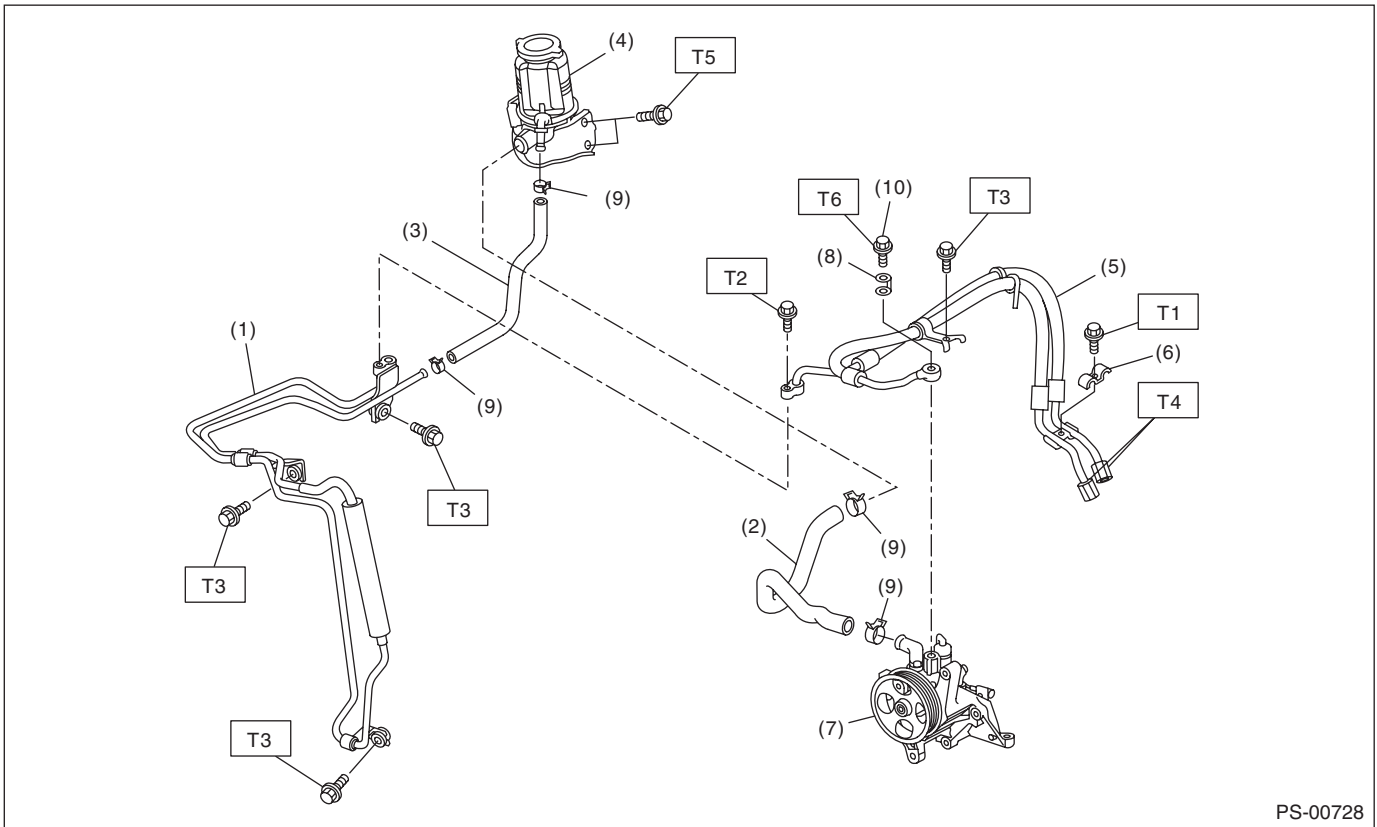

PS-00728

- |                     |                     |
|---------------------|---------------------|
| (1) Oil cooler pipe | (8) Eye bolt gasket |
| (2) Suction hose    | (9) Clip            |
| (3) Return hose     | (10) Eye bolt       |
| (4) Reservoir tank  |                     |
| (5) Hose            |                     |
| (6) Clamp E         |                     |
| (7) Oil pump        |                     |

**Tightening torque: N·m (kgf·m, ft·lb)**

**T1: 8 (0.82, 5.9)**

**T2: 10 (1.02, 7.4)**

**T3: 13 (1.32, 9.6)**

**T4: 15 (1.5, 10.8)**

**T5: 33 (3.37, 24.3)**

**T6: 40 (4.08, 29.5)**

# General Description

## POWER ASSISTED SYSTEM (POWER STEERING)

### • Gearbox

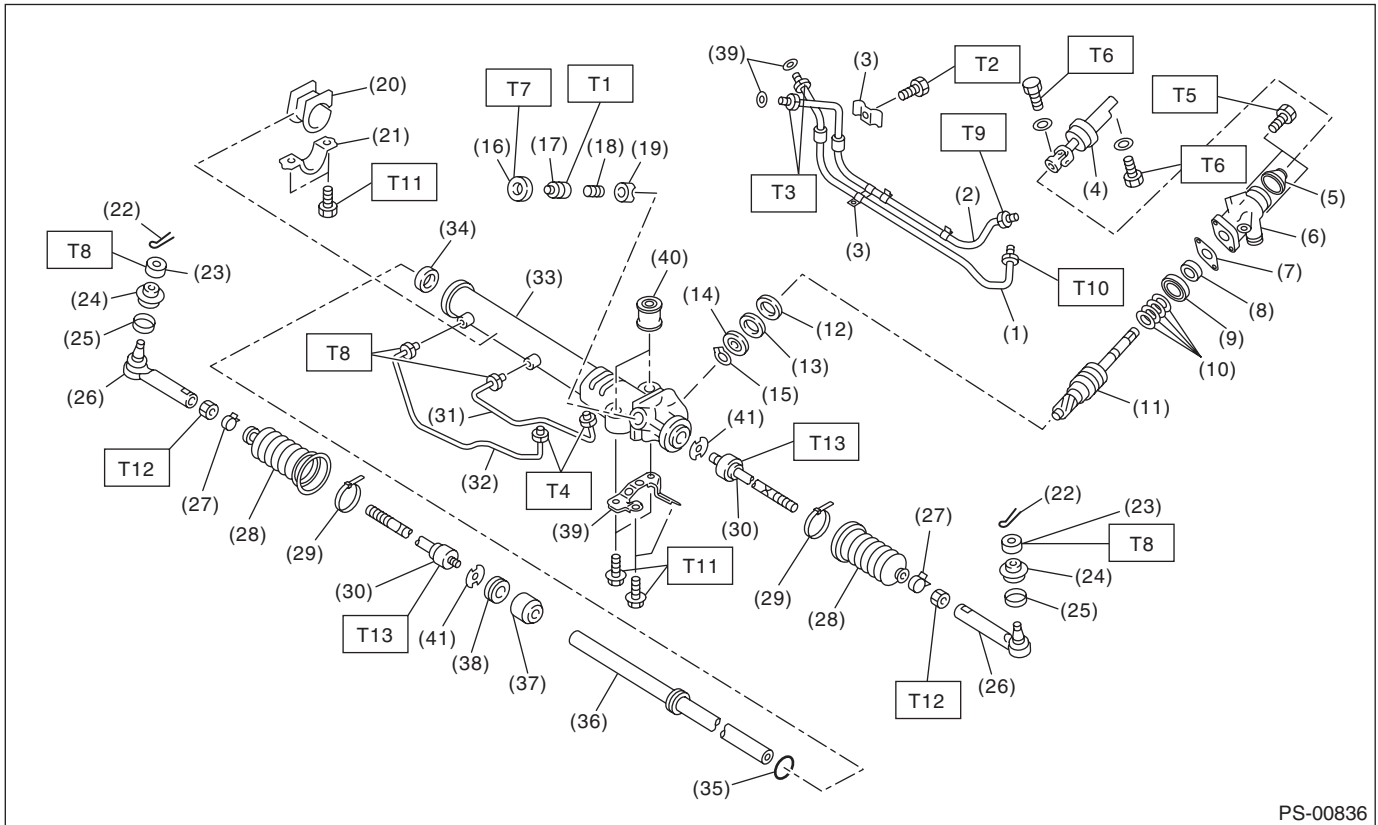

PS-00836

(1) Pipe C	(20) Adapter	(39) Bracket
(2) Pipe D	(21) Clamp	(40) Bushing
(3) Clamp plate	(22) Cotter pin	(41) Lock washer
(4) Universal joint	(23) Castle nut	
(5) Dust seal	(24) Dust cover	
(6) Valve housing	(25) Clip	
(7) Gasket	(26) Tie-rod end	
(8) Oil seal	(27) Clip	
(9) Bushing	(28) Boot	
(10) Seal ring	(29) Band	
(11) Pinion and valve ASSY	(30) Tie-rod	
(12) Oil seal	(31) Pipe B	
(13) Back-up washer	(32) Pipe A	
(14) Ball bearing	(33) Steering body	
(15) Snap ring	(34) Oil seal	
(16) Lock nut	(35) Piston ring	
(17) Adjusting screw	(36) Rack	
(18) Spring	(37) Rack bushing	
(19) Sleeve	(38) Holder	

#### **Tightening torque:N·m (kgf·m, ft·lb)**

**T1: 5.9 (0.6, 4.4)**

**T2: 9 (0.9, 6.6)**

**T3: 15 (1.5, 10.8)**

**T4: 17 (1.7, 12.5)**

**T5: 20 (2.0, 14.8)**

**T6: 24 (2.4, 17.4)**

**T7: 25 (2.5, 18.1)**

**T8: 27 (2.75, 19.9)**

**T9: 29 (3.0, 21.4)**

**T10: 37 (3.8, 27.3)**

**T11: 60 (6.1, 44.1)**

**T12: 85 (8.7, 62.7)**

**T13: 128 (13.1, 94.4)**

# General Description

## POWER ASSISTED SYSTEM (POWER STEERING)

### 3. OIL PUMP

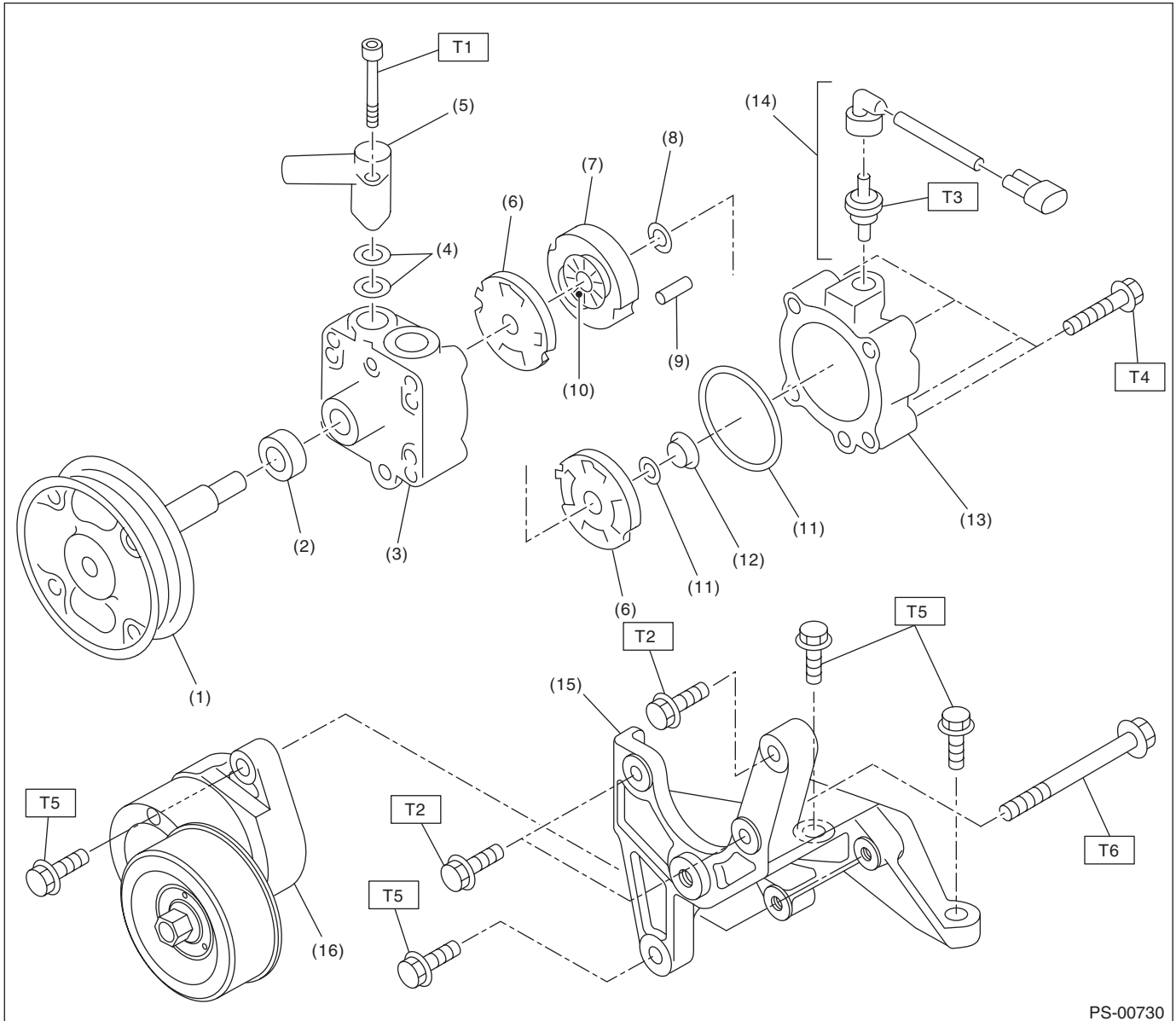

PS-00730

- |                    |                     |
|--------------------|---------------------|
| (1) Pulley         | (9) Straight pin    |
| (2) Oil seal       | (10) Rotor          |
| (3) Front casing   | (11) O-ring         |
| (4) O-ring         | (12) Seal ring      |
| (5) Socket         | (13) Rear body      |
| (6) Pressure plate | (14) Connector      |
| (7) Cam ring       | (15) Bracket        |
| (8) Snap ring      | (16) Belt tensioner |

#### **Tightening torque: N·m (kgf·m, ft·lb)**

**T1: 3.73 (0.38, 2.75)**

**T2: 15.7 (1.6, 11.6)**

**T3: 19.6 (2.0, 14.5)**

**T4: 27.5 (2.8, 20.3)**

**T5: 33 (3.37, 24.3)**

**T6: 36.8 (3.75, 27.1)**

### **C: CAUTION**

Please clearly understand and adhere to the following general precautions. They must be strictly followed to avoid any injury to the person doing the work or people in the area.

#### **1. OPERATION**

- Wear appropriate work clothing, including a cap, protective goggles and protective shoes when performing any work.
- Before removal, installation or disassembly, be sure to clarify the failure. Avoid unnecessary removal, installation, disassembly and replacement.
- Vehicle components are extremely hot after driving. Be wary of receiving burns from heated parts.
- Use SUBARU genuine power steering fluid, grease etc. or the equivalent. Do not mix fluid, grease etc. of different grades or manufacturers.
- Be sure to tighten fasteners including bolts and nuts to the specified torque.
- Place shop jacks or rigid racks at the specified points.
- Before securing a part on a vise, place cushioning material such as wooden blocks, aluminum plate or cloth between the part and the vise.

#### **2. OIL**

When handling oil, follow the rules below to prevent unexpected accidents.

- Prepare container and waste cloths when performing work which oil could possibly spill. If oil spills, wipe it off immediately to prevent from penetrating into floor or flowing outside, for environmental protection.
- Follow all government and local regulations concerning waste disposal.

# General Description

POWER ASSISTED SYSTEM (POWER STEERING)

## D: PREPARATION TOOL

### 1. SPECIAL TOOL

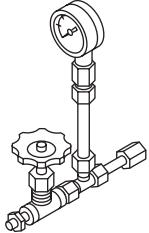
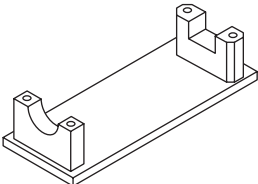
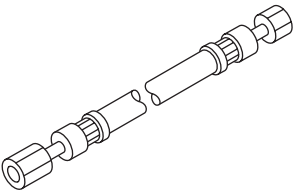
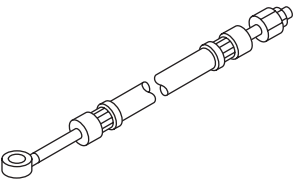
ILLUSTRATION	TOOL NUMBER	DESCRIPTION	REMARKS
 <p style="text-align: center;">ST-925711000</p>	925711000	PRESSURE GAUGE	Used for measuring oil pressure.
 <p style="text-align: center;">ST-926200000</p>	926200000	STAND	<ul style="list-style-type: none"> <li>• Used when inspecting characteristic of gear-box assembly and disassembling it.</li> <li>• Used with BOSS D (34199AG000).</li> </ul>
 <p style="text-align: center;">ST34099AC010</p>	34099AC010	ADAPTER HOSE A	Used with PRESSURE GAUGE (925711000).
 <p style="text-align: center;">ST34099AC020</p>	34099AC020	ADAPTER HOSE B	Used with PRESSURE GAUGE (925711000).

# General Description

## POWER ASSISTED SYSTEM (POWER STEERING)

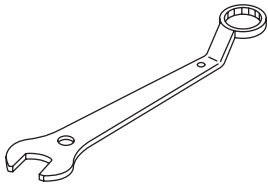
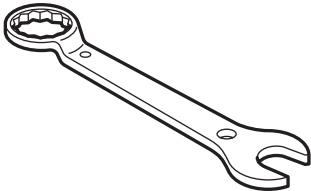
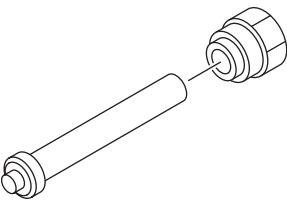
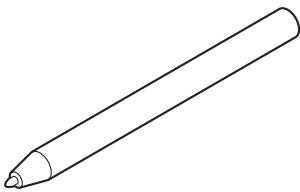
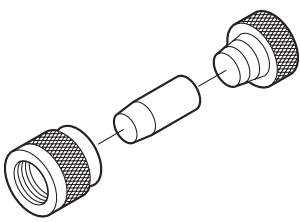
ILLUSTRATION	TOOL NUMBER	DESCRIPTION	REMARKS
 <p data-bbox="337 520 467 541">ST-926230000</p>	926230000	SPANNER	For the lock nut when adjusting backlash of gearbox.
 <p data-bbox="328 871 467 892">ST34099PA100</p>	34099PA100	SPANNER	Used when measuring the rotating resistance of gearbox assembly.
 <p data-bbox="337 1222 467 1243">ST-926420000</p>	926420000	PLUG	When fluid leaks from pinion side of gearbox assembly, remove pipe B from valve housing, attach this tool and check fluid leaking points.
 <p data-bbox="328 1572 467 1593">ST34099FA060</p>	34099FA060	PUNCH HOLDER	Used for crimping.
 <p data-bbox="328 1925 467 1946">ST34199FE040</p>	34199FE040	INSTALLER A, B, C	Used for installing the oil seal to the rack assembly.



## General Description

### POWER ASSISTED SYSTEM (POWER STEERING)

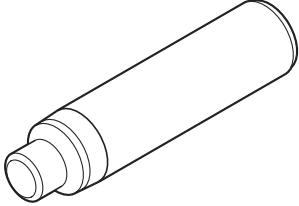
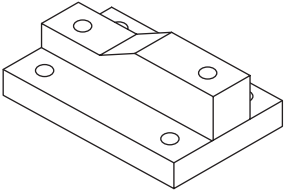
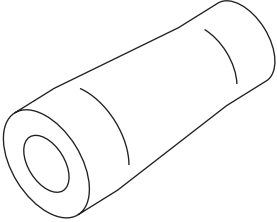
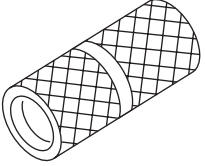
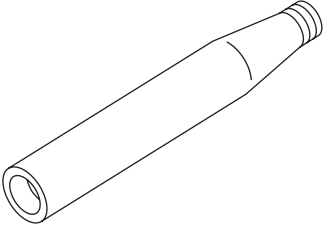
ILLUSTRATION	TOOL NUMBER	DESCRIPTION	REMARKS
 <p style="text-align: center;">ST34199XA030</p>	34199XA030	INSTALLER & REMOVER 44	Used for removing and installing the rack oil seal (outer & inner).
 <p style="text-align: center;">ST34199AG000</p>	34199AG000	BOSS D	<ul style="list-style-type: none"> <li>• Used when inspecting characteristic of gear-box assembly and disassembling it.</li> <li>• Used with STAND (926200000).</li> </ul>
 <p style="text-align: center;">ST34199XA010</p>	34199XA010	GUIDE 44	Used for installing seal ring of rack.
 <p style="text-align: center;">ST34199AG070</p>	34199AG070	FORMER	Used for forming seal ring of pinion.
 <p style="text-align: center;">ST34199AG020</p>	34199AG020	GUIDE	Used for installing seal ring of pinion.

# General Description

## POWER ASSISTED SYSTEM (POWER STEERING)

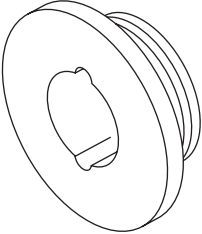
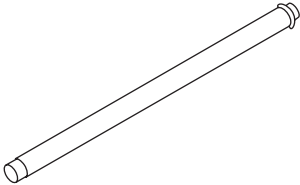
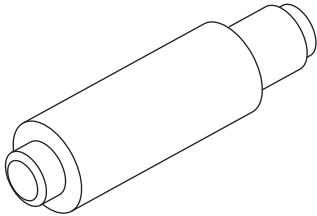
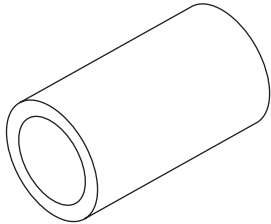
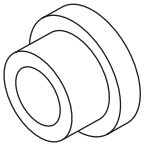
ILLUSTRATION	TOOL NUMBER	DESCRIPTION	REMARKS
 <p style="text-align: center;">ST34199AG060</p>	34199AG060	GUIDE G (26)	<ul style="list-style-type: none"> <li>• Used for forming seal ring of rack.</li> <li>• Used with FORMER PISTON (34199XA020).</li> </ul>
 <p style="text-align: center;">ST34199XA060</p>	34199XA060	OIL SEAL REMOVER	Used for removing oil seal.
 <p style="text-align: center;">ST34199AG090</p>	34199AG090	INSTALLER & REMOVER	<ul style="list-style-type: none"> <li>• Used for installing oil seal of valve housing.</li> <li>• Used for installing ball bearing of valve housing.</li> <li>• Used for removing oil seal and ball bearing from valve housing.</li> </ul>
 <p style="text-align: center;">ST34199XA020</p>	34199XA020	FORMER PISTON 44	<ul style="list-style-type: none"> <li>• Used for forming seal ring of rack.</li> <li>• Used together with GUIDE G (26) (34199AG060).</li> </ul>
 <p style="text-align: center;">ST34199XA000</p>	34199XA000	INSTALLER 44	Used for pressing-fit oil seal of gearbox cylinder.

# General Description

## POWER ASSISTED SYSTEM (POWER STEERING)

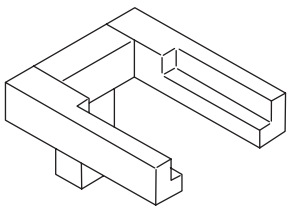
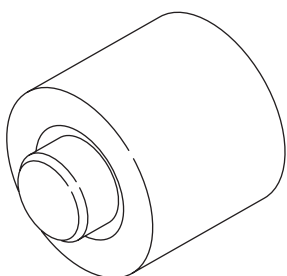
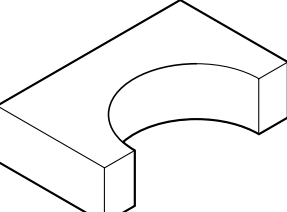
ILLUSTRATION	TOOL NUMBER	DESCRIPTION	REMARKS
 ST34199AE020	34199AE020	MOUNT	Used for removing oil pump.
 ST34199AE030	34199AE030	INSTALLER	Used for installing the oil seal to the oil pump.
 ST34199XA050	34199XA050	BASE	Used for crimping.