

45.Oil Pump Chain

A: REMOVAL

- 1) Remove the transmission assembly from the vehicle. <Ref. to CVT-55, REMOVAL, Automatic Transmission Assembly.>
- 2) Remove the torque converter assembly. <Ref. to CVT-135, REMOVAL, Torque Converter Assembly.>
- 3) Remove the oil pump chain cover.

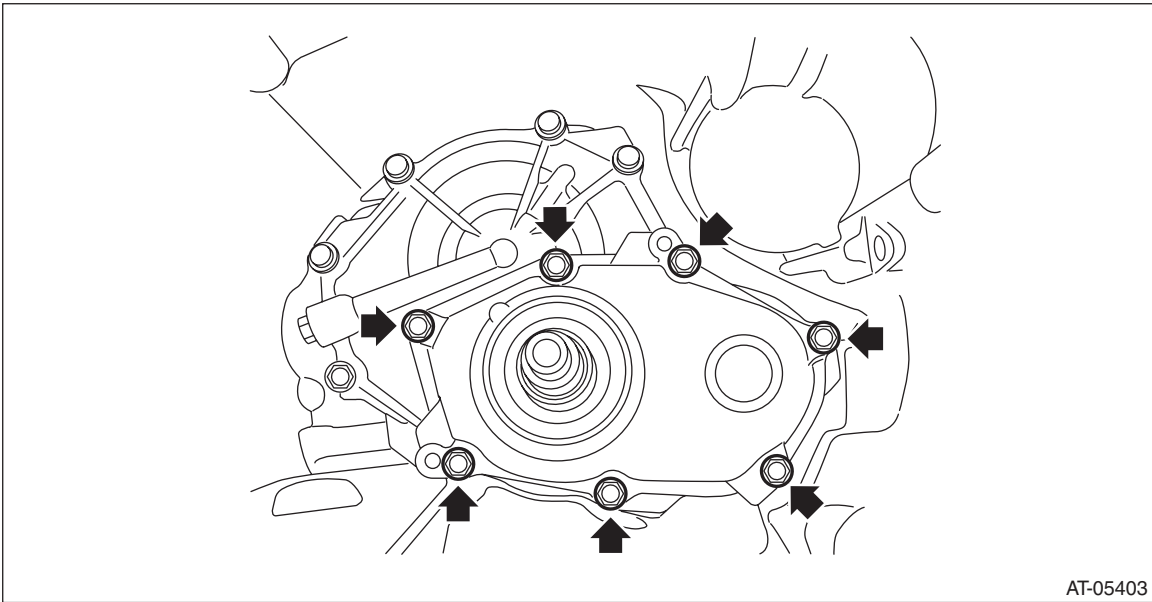

AT-05403

- 4) Remove the seal ring from center support COMPL.

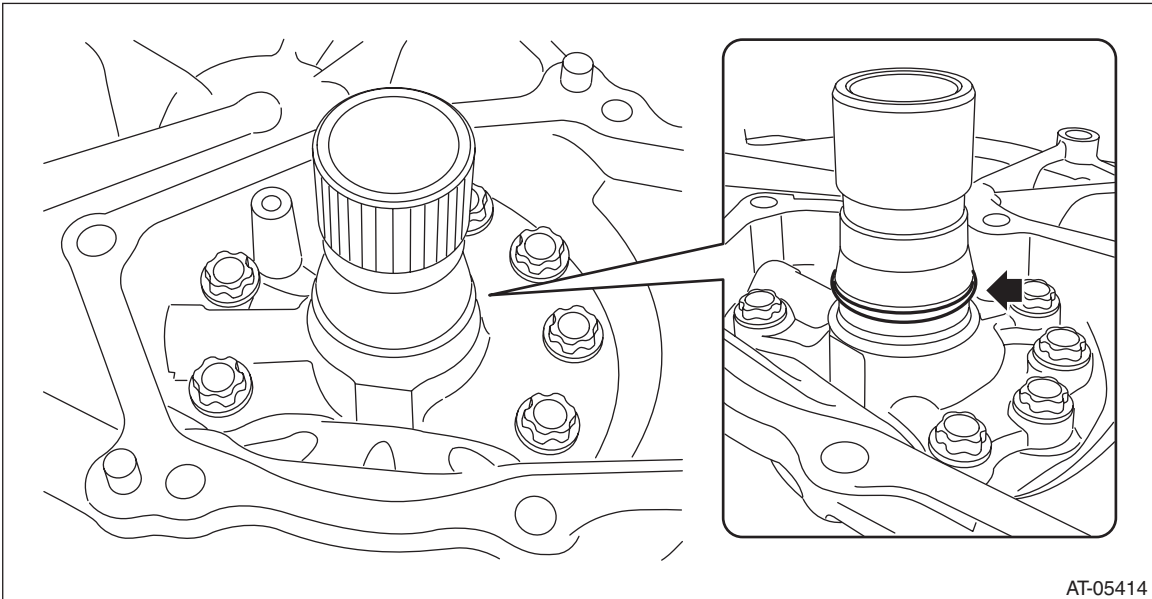

AT-05414

Oil Pump Chain

CONTINUOUSLY VARIABLE TRANSMISSION

5) Remove the driven sprocket from oil pump chain cover to remove the oil pump chain.

NOTE:

The driven sprocket is replaced as an assembly only, because it is a non-disassembly part.

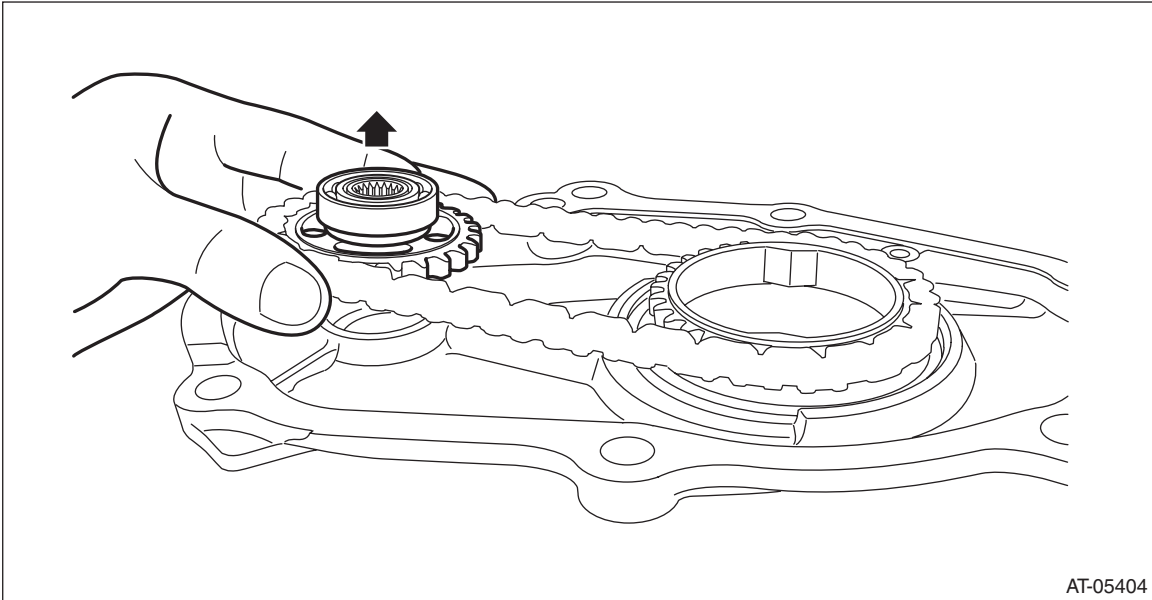

AT-05404

6) Remove the snap ring.

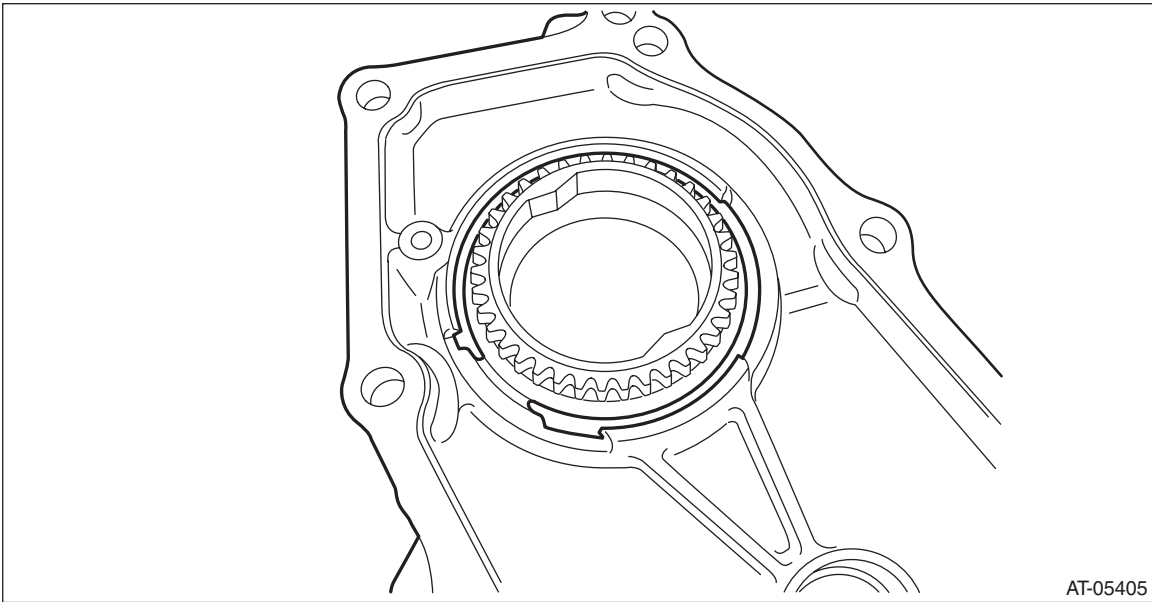

AT-05405

Oil Pump Chain

CONTINUOUSLY VARIABLE TRANSMISSION

7) Remove the drive sprocket.

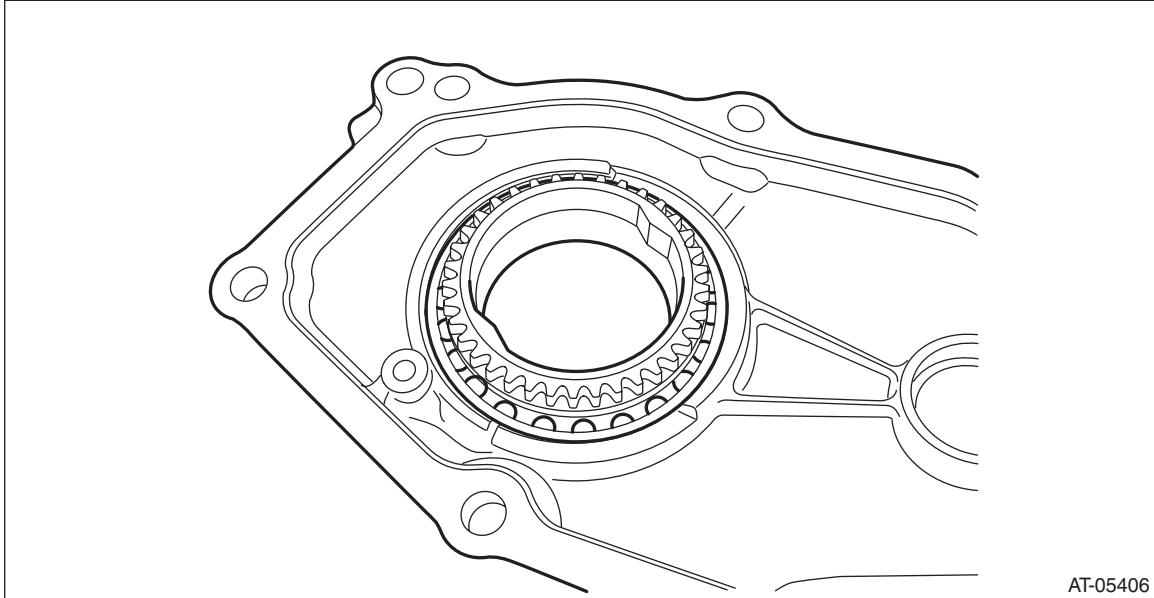

AT-05406

8) Remove the oil seal from the oil pump chain cover.

B: INSTALLATION

1) Clean the mating surface of oil pump chain cover and converter case cover.

2) Using the ST, install the oil seal.

ST 499755602 PRESS SNAP RING

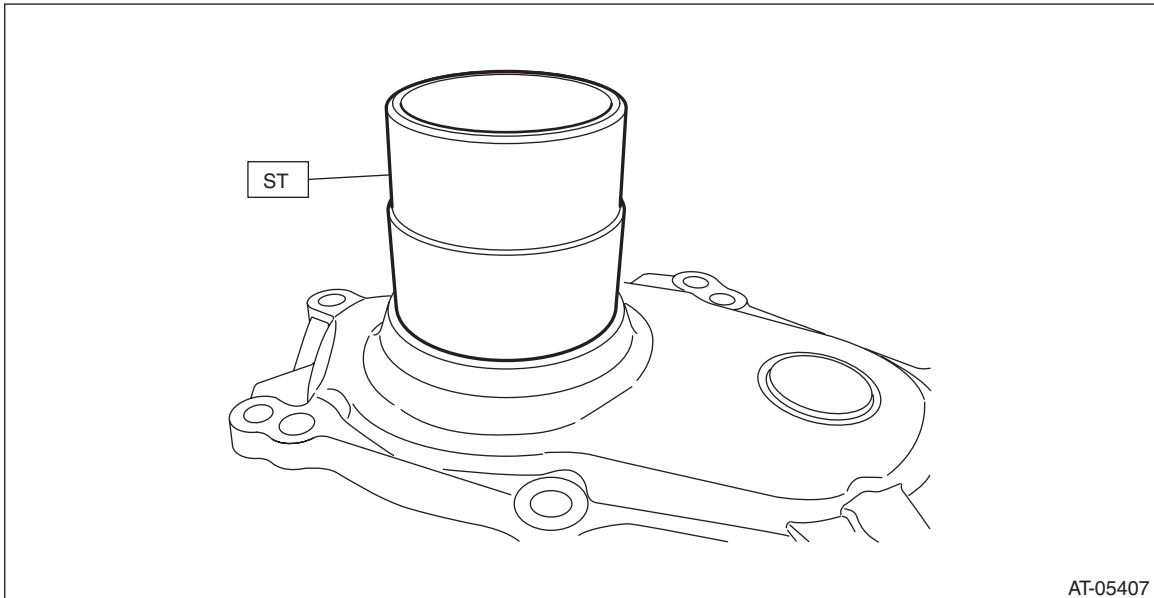

AT-05407

Oil Pump Chain

CONTINUOUSLY VARIABLE TRANSMISSION

3) Install the drive sprocket and install the snap ring.

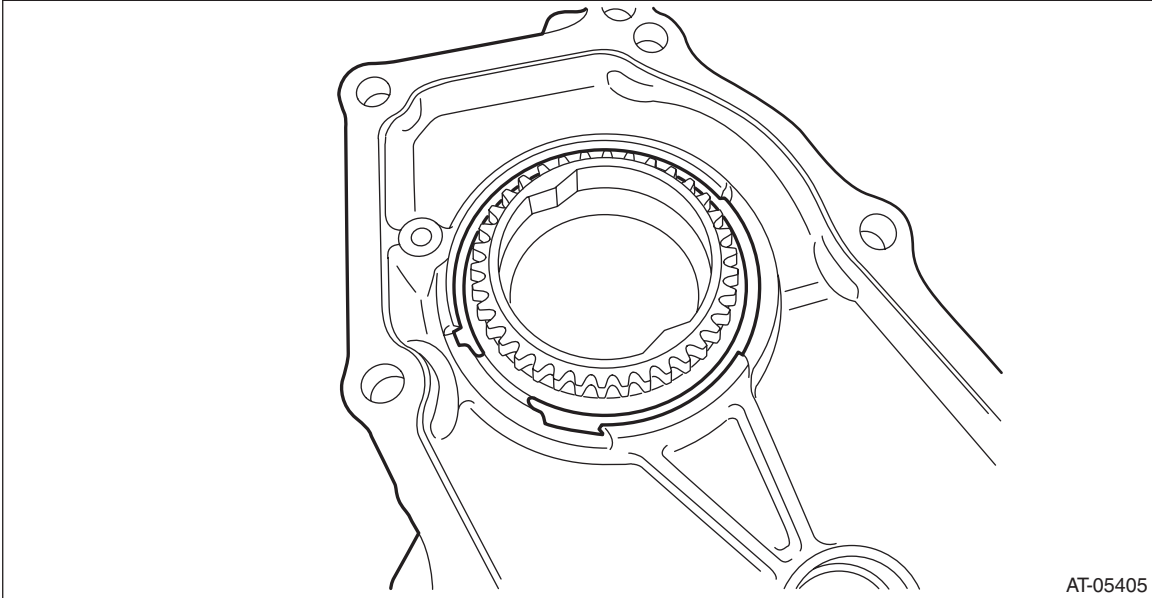

4) Place the oil pump chain on drive sprocket.

5) Place the oil pump chain on driven sprocket and install the driven sprocket to oil pump chain cover.

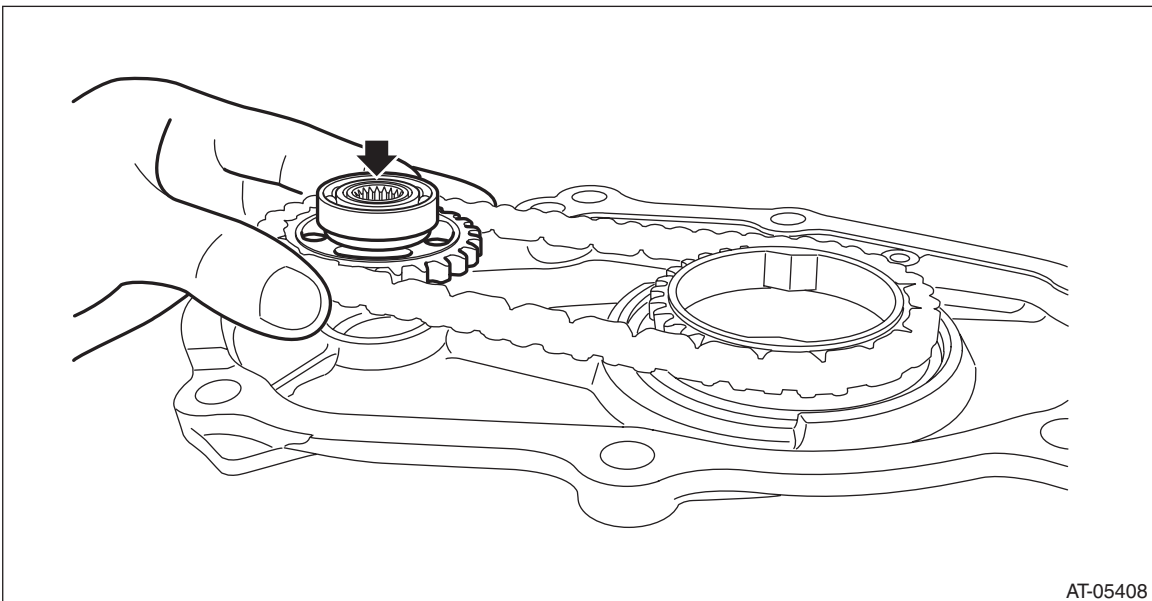

Oil Pump Chain

CONTINUOUSLY VARIABLE TRANSMISSION

6) Install the seal ring to center support COMPL.

NOTE:

- Use a new seal ring.
- Apply CVTF to the seal rings.

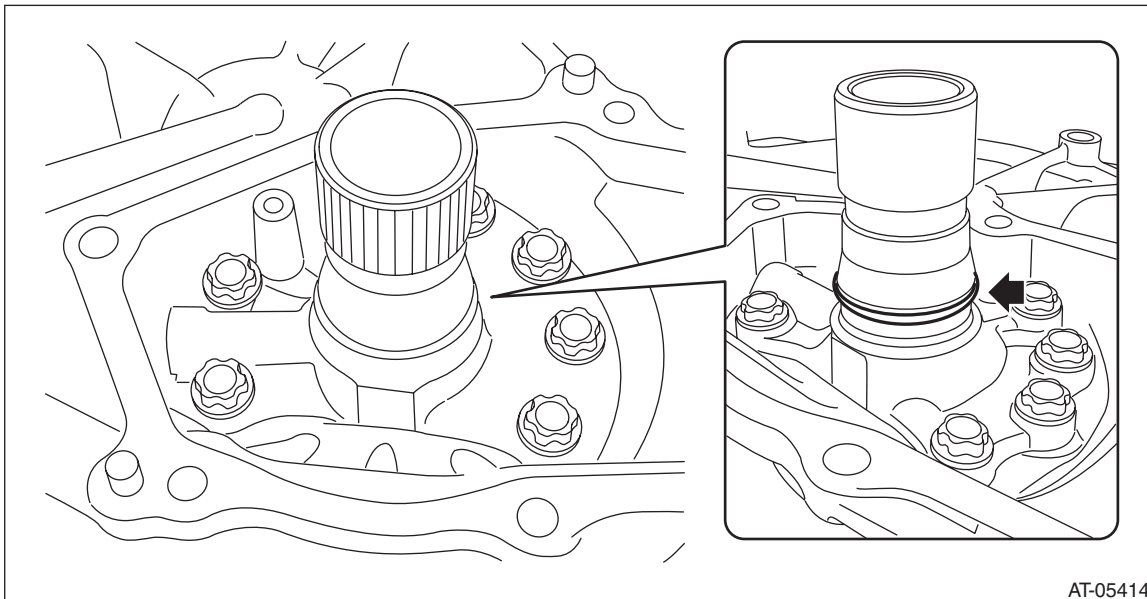

7) Apply liquid gasket seamlessly to the mating surface of oil pump chain cover.

CAUTION:

Do not apply liquid gasket at the arrowed hole.

Liquid gasket:

THREE BOND 1215 (Part No. 004403007) or equivalent

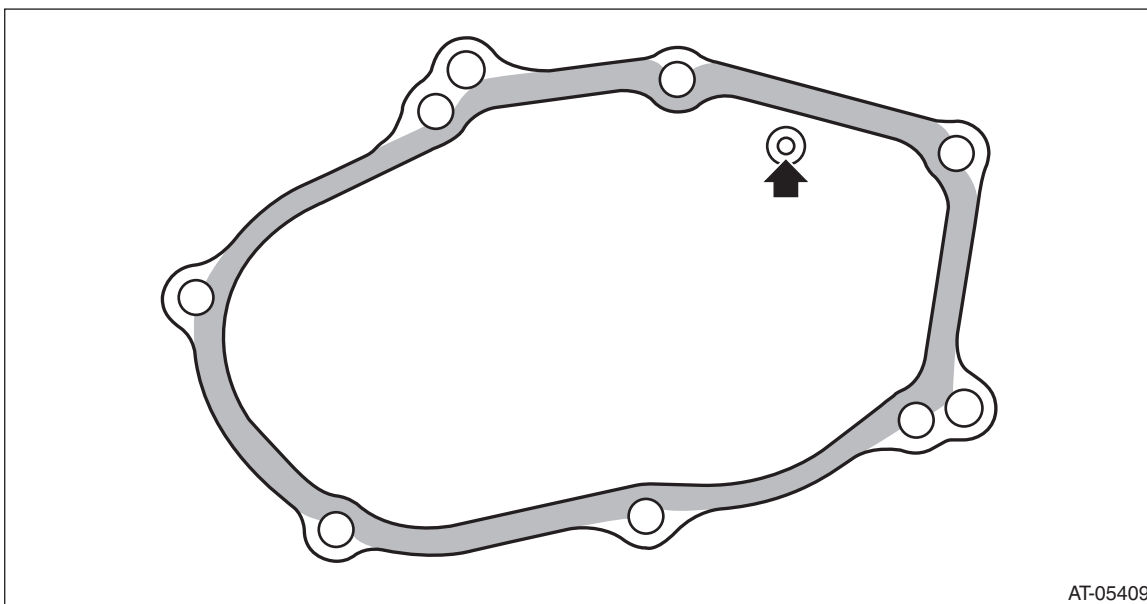

Oil Pump Chain

CONTINUOUSLY VARIABLE TRANSMISSION

8) Install the oil pump chain cover.

NOTE:

There are two types of bolt.

Tightening torque:

24 N·m (2.4 kgf·m, 17.7 ft·lb)

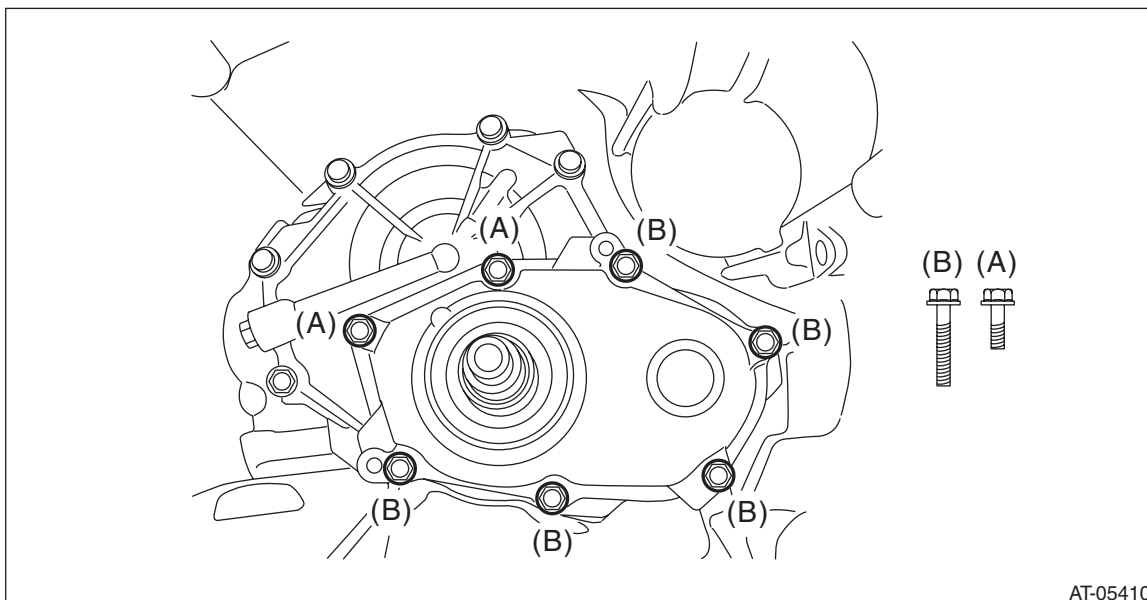

9) Install the torque converter assembly. <Ref. to CVT-135, INSTALLATION, Torque Converter Assembly.>

10) Install the transmission assembly to the vehicle. <Ref. to CVT-69, INSTALLATION, Automatic Transmission Assembly.>

C: DISASSEMBLY

1. DRIVE SPROCKET

1) Remove the ball bearing using ST.

ST1 498077600 REMOVER

ST2 399513600 INSTALLER

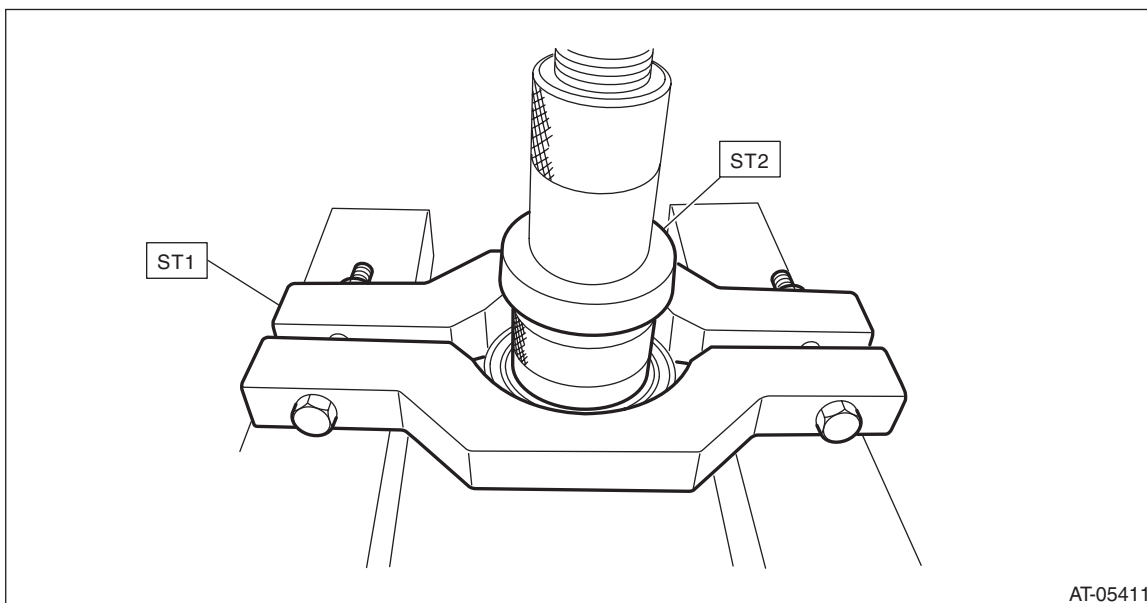

D: ASSEMBLY

1. DRIVE SPROCKET

1) Using the ST, install the ball bearing.

NOTE:

Use a new ball bearing.

ST 499755602 PRESS SNAP RING

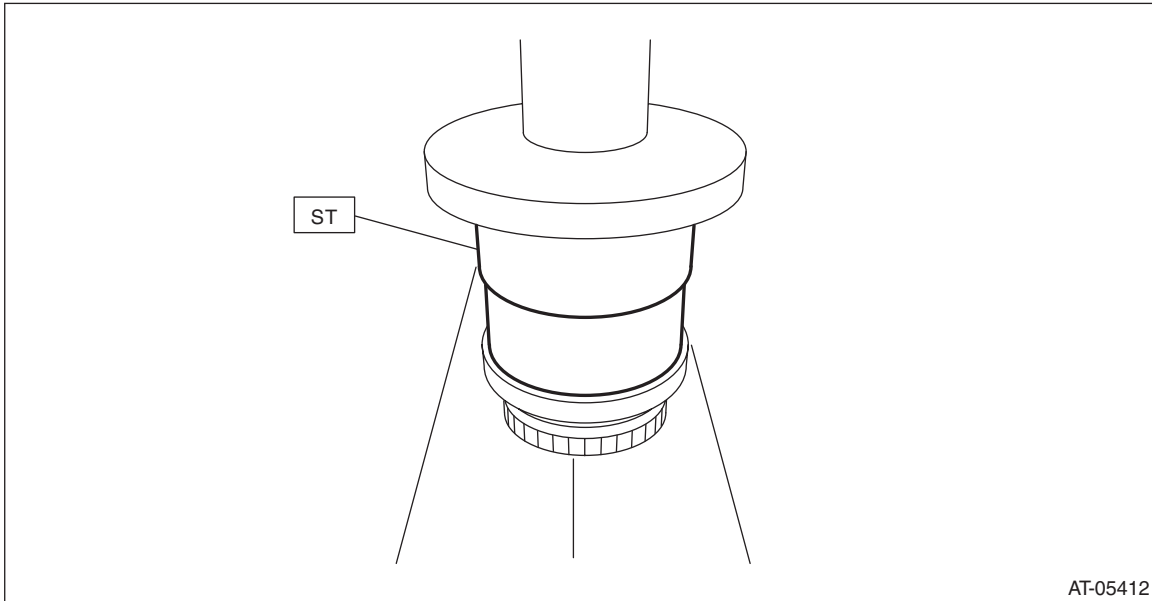

E: INSPECTION

- Check the oil pump chain for damage.
- Replace if gear teeth are broken, damaged, sharpen or excessively worn.
- Check the bearing for seizure or wear.
- Apply CVTF to bearing and rotate the bearing to check for noise or dragging etc.
- Check the oil pump chain cover for damage.
- Check for leakage of CVTF from the mating surface of oil pump chain cover.
- Check the oil seal for damage.