

## 37.Reduction Driven Gear

### A: REMOVAL

- 1) Remove the transmission from the vehicle. <Ref. to CVT-55, REMOVAL, Automatic Transmission Assembly.>
- 2) Remove the extension case. <Ref. to CVT-137, REMOVAL, Extension Case.>
- 3) Remove the rear drive shaft. <Ref. to CVT-140, REMOVAL, Rear Drive Shaft.>
- 4) Remove the transfer clutch assembly. <Ref. to CVT-145, REMOVAL, Transfer Clutch.>
- 5) Remove the transfer reduction driven gear assembly. <Ref. to CVT-157, REMOVAL, Transfer Reduction Driven Gear.>
- 6) Remove the intermediate case. <Ref. to CVT-164, REMOVAL, Intermediate Case.>
- 7) Remove the forward clutch assembly. <Ref. to CVT-179, REMOVAL, Forward Clutch Assembly.>
- 8) Remove the snap ring.

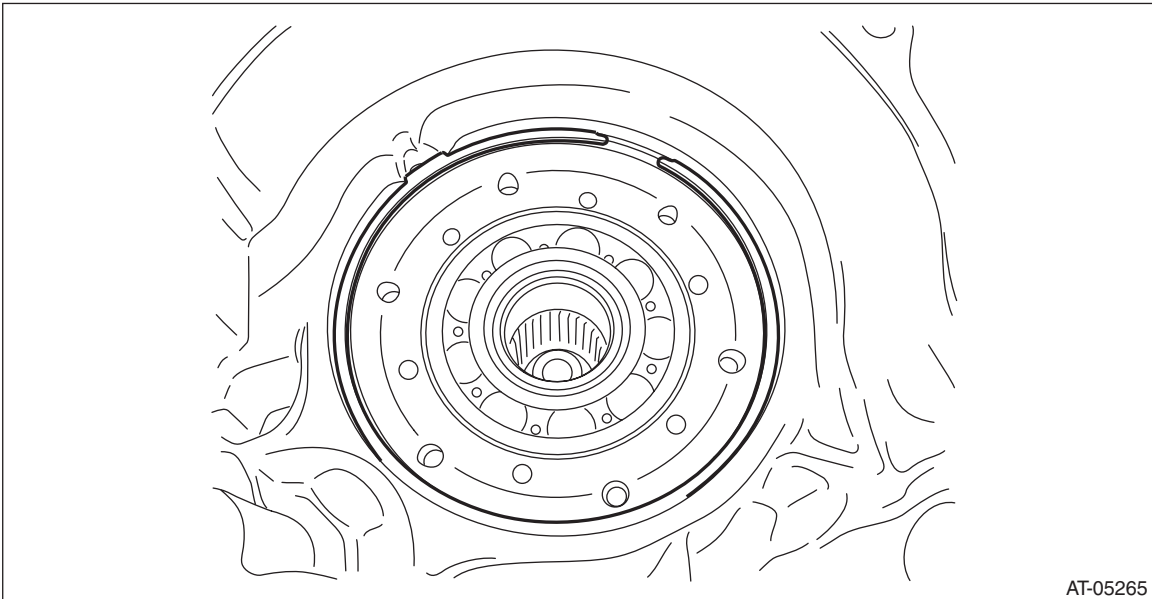

- 9) Remove the reduction driven gear assembly.

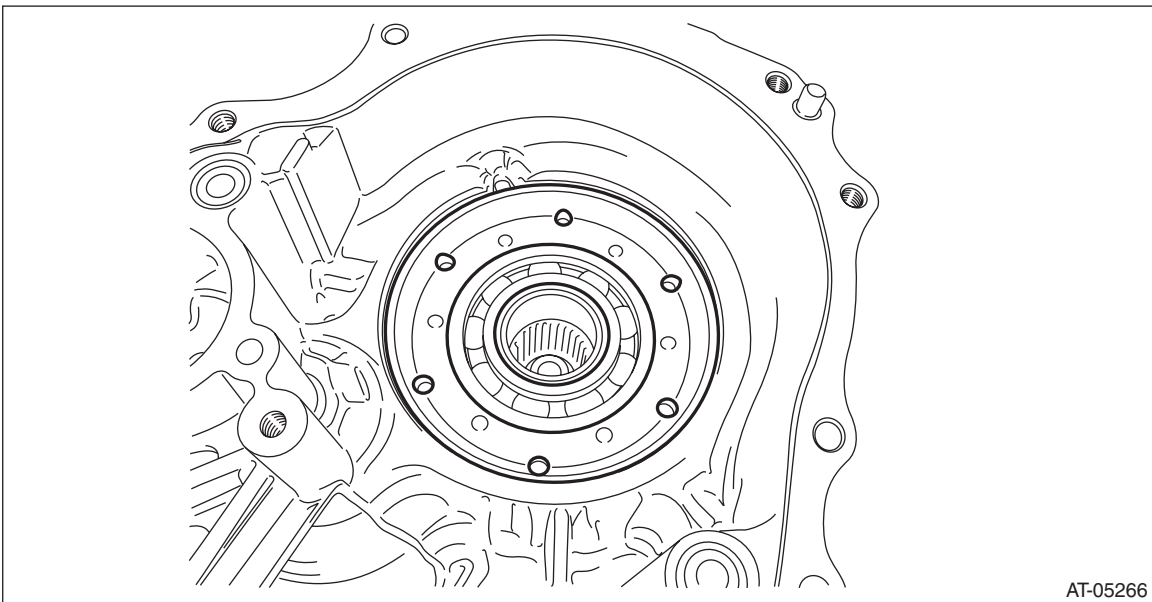

# Reduction Driven Gear

CONTINUOUSLY VARIABLE TRANSMISSION

---

10) Remove the straight pin.

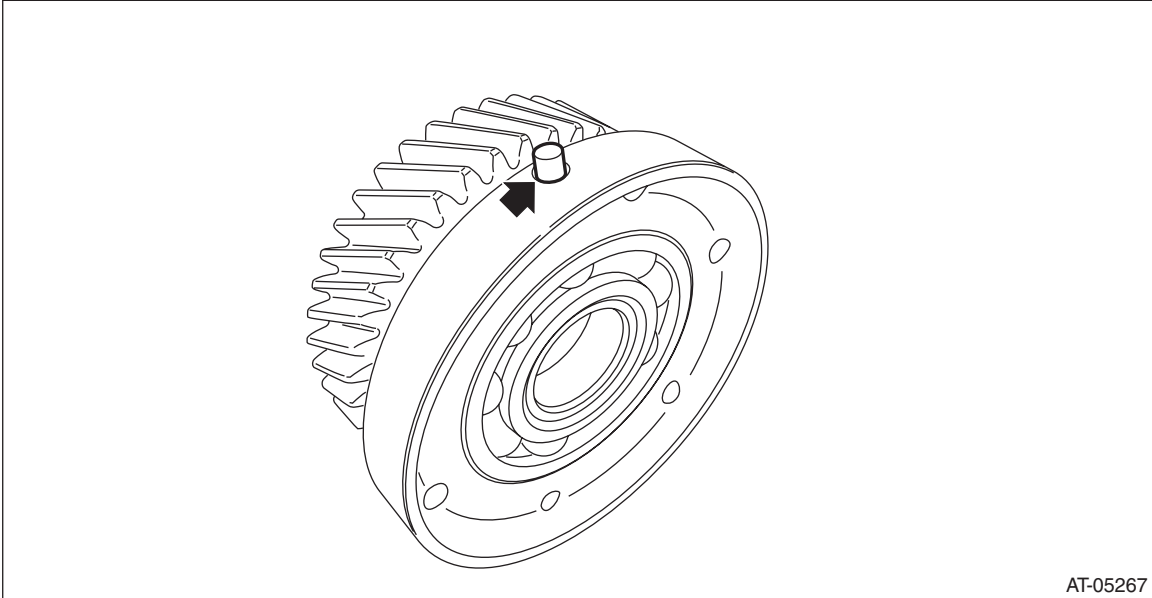

AT-05267

## B: INSTALLATION

1) Install the straight pin to reduction driven gear assembly.

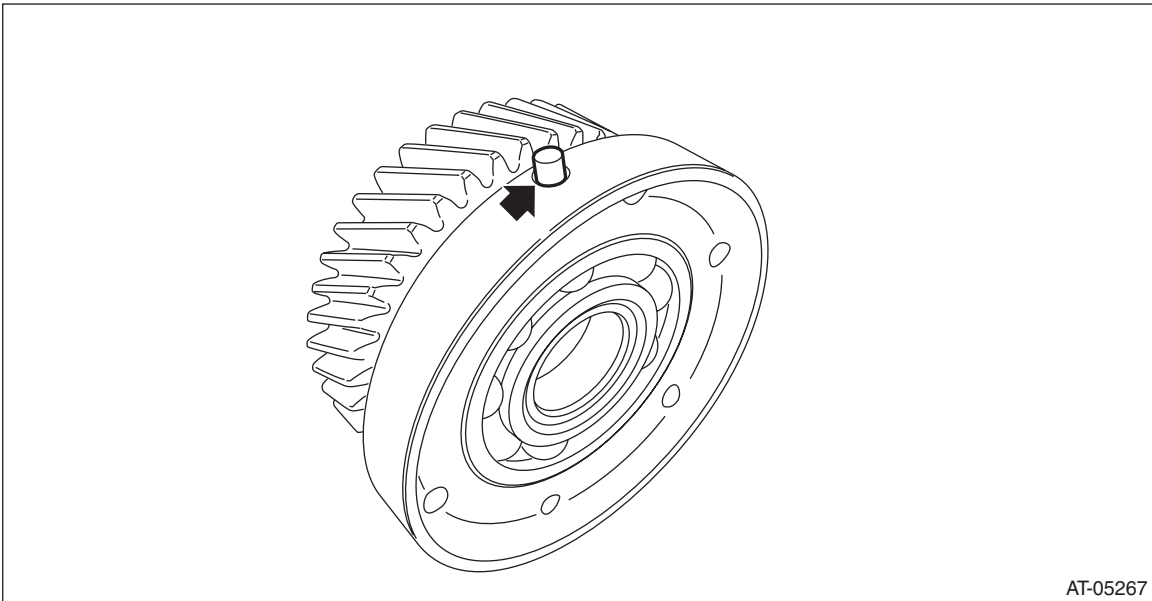

AT-05267

## Reduction Driven Gear

CONTINUOUSLY VARIABLE TRANSMISSION

2) Fit the straight pin portion to the recess portion of transmission case and install the reduction driven gear and install the snap ring.

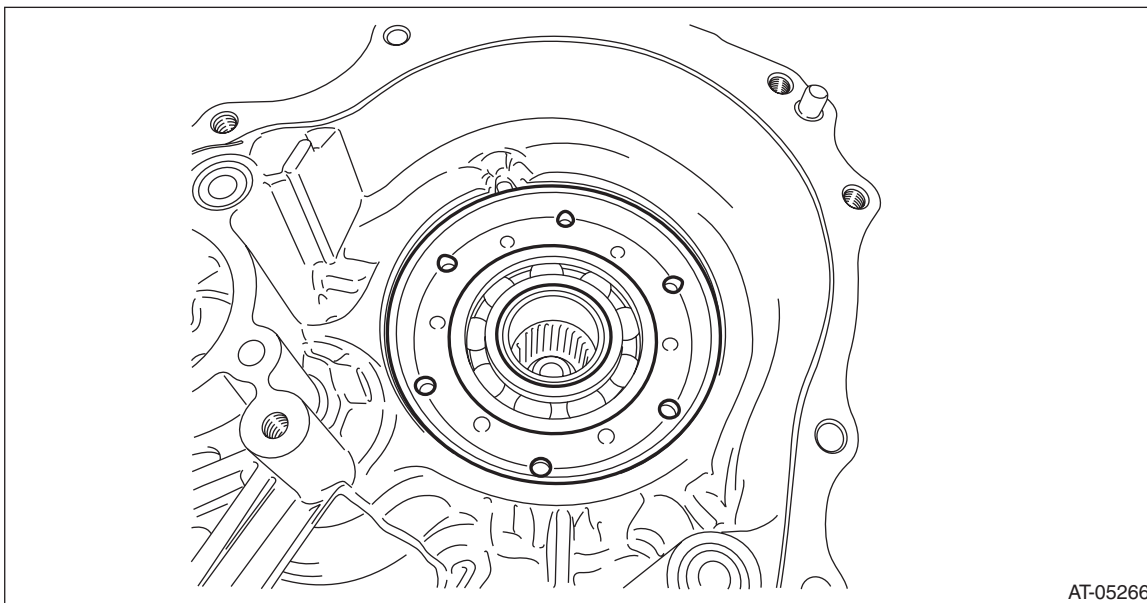

3) Select the snap ring. <Ref. to CVT-204, ADJUSTMENT, Reduction Driven Gear.>

4) Replace with the selected snap ring.

### NOTE:

If the clearance measured in Step 3) is within standard, the snap ring replacement is not necessary.

5) Install the forward clutch assembly. <Ref. to CVT-180, INSTALLATION, Forward Clutch Assembly.>

6) Install the intermediate case. <Ref. to CVT-165, INSTALLATION, Intermediate Case.>

7) Install the transfer reduction driven gear assembly. <Ref. to CVT-157, INSTALLATION, Transfer Reduction Driven Gear.>

8) Install the transfer clutch assembly. <Ref. to CVT-146, INSTALLATION, Transfer Clutch.>

9) Install the rear drive shaft. <Ref. to CVT-140, INSTALLATION, Rear Drive Shaft.>

10) Install the extension case. <Ref. to CVT-137, INSTALLATION, Extension Case.>

11) Install the transmission to vehicle. <Ref. to CVT-69, INSTALLATION, Automatic Transmission Assembly.>

# Reduction Driven Gear

CONTINUOUSLY VARIABLE TRANSMISSION

## C: DISASSEMBLY

1) Remove the bearing retainer using ST1, ST2 and ST3.

ST1 899864100 REMOVER

ST2 398497701 SEAT

ST3 18767AA000 REMOVER

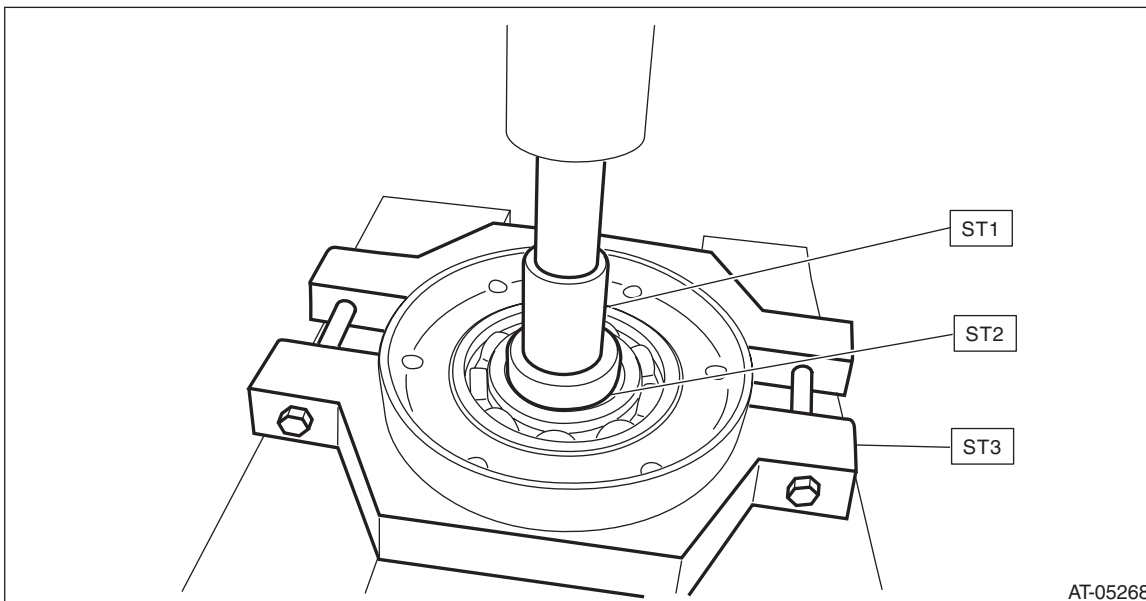

2) Remove the snap ring.

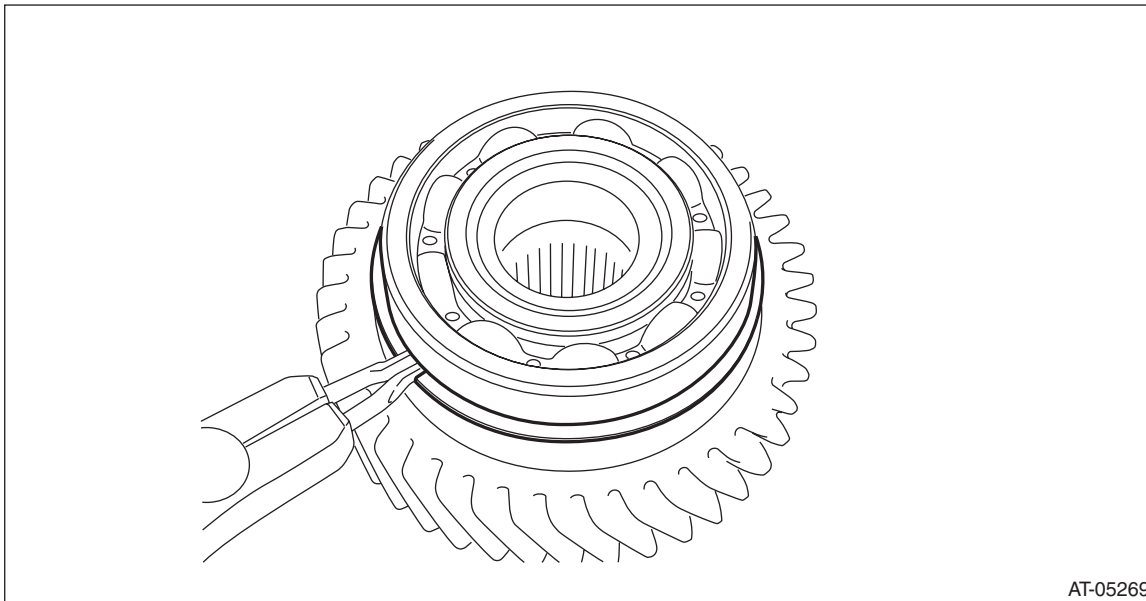

# Reduction Driven Gear

CONTINUOUSLY VARIABLE TRANSMISSION

3) Remove the ball bearing using ST1, ST2 and ST3.

ST1 899864100 REMOVER

ST2 398497701 Seat

ST3 498077600 REMOVER

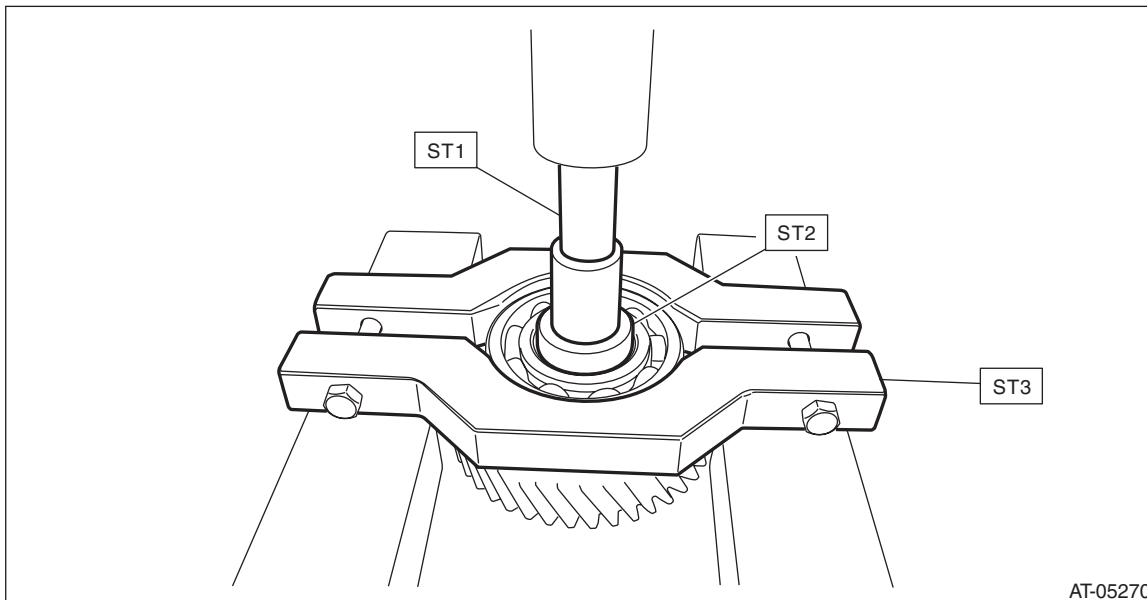

## D: ASSEMBLY

1) Using the ST, install the ball bearing to bearing retainer.

ST 398177700 INSTALLER

NOTE:

- Use a new ball bearing.
- Make sure to install the ball bearing in the right direction.
- Apply CVTF to the press-fitting area.

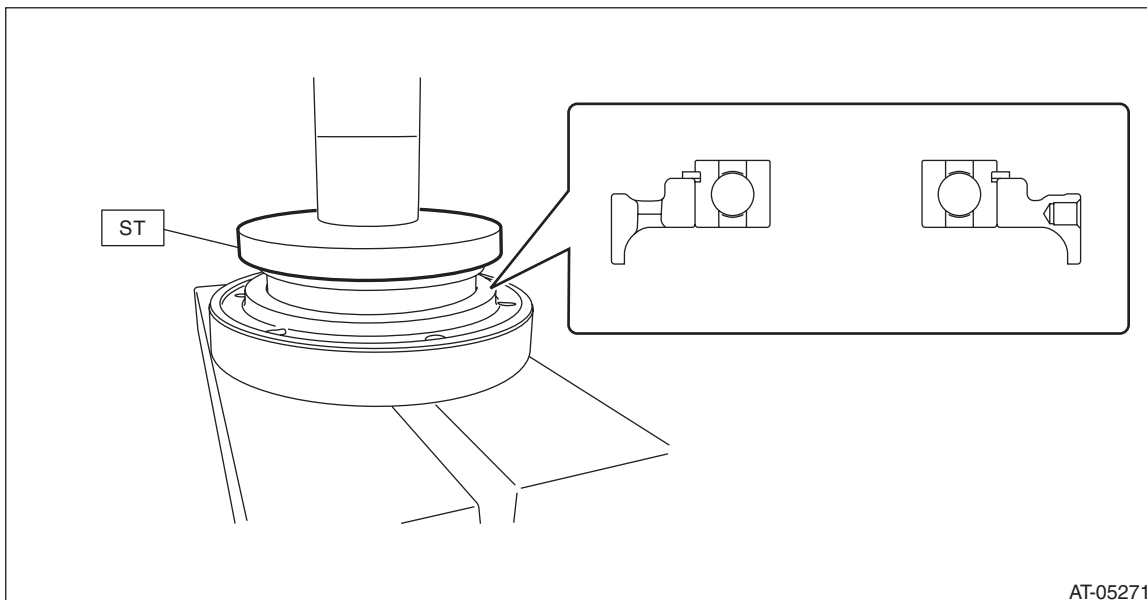

# Reduction Driven Gear

## CONTINUOUSLY VARIABLE TRANSMISSION

2) Using the ST, install the reduction driven gear.  
ST 499277200 INSTALLER

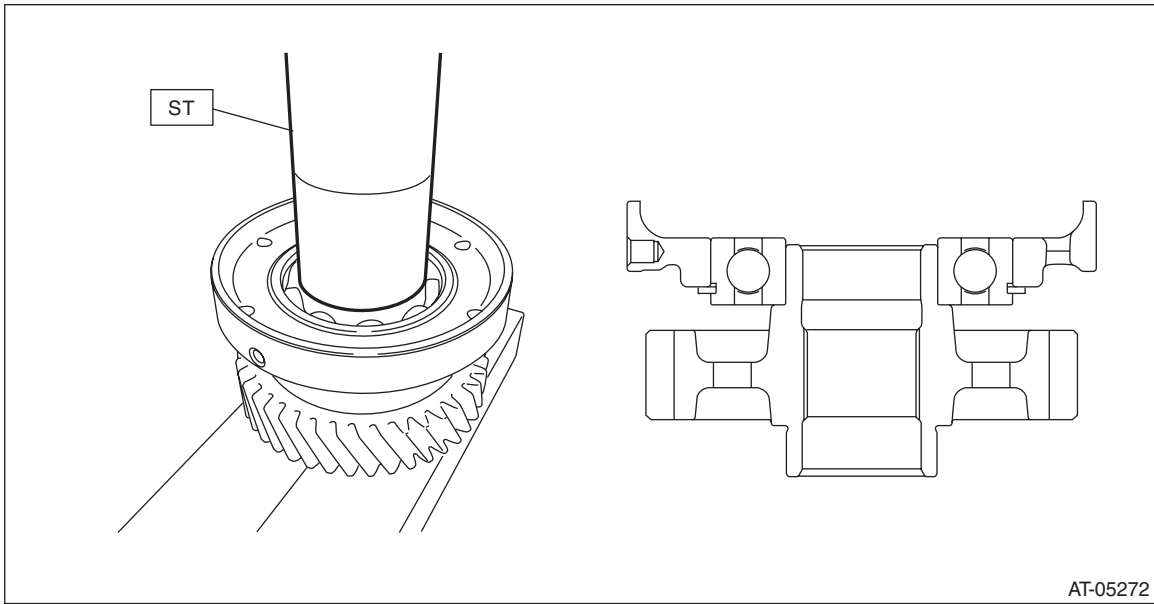

### E: INSPECTION

- Check the ball bearing for smooth rotation.
- Check the ball bearing for excessive looseness.
- Check the reduction driven gear for breakage or damage.
- Check the clearance between snap ring and transmission case and replace the snap ring as necessary.

### F: ADJUSTMENT

1) Measure clearance "A" between snap ring and transmission case.

#### Specification:

**0.05 — 0.25 mm (0.002 — 0.01 in)**

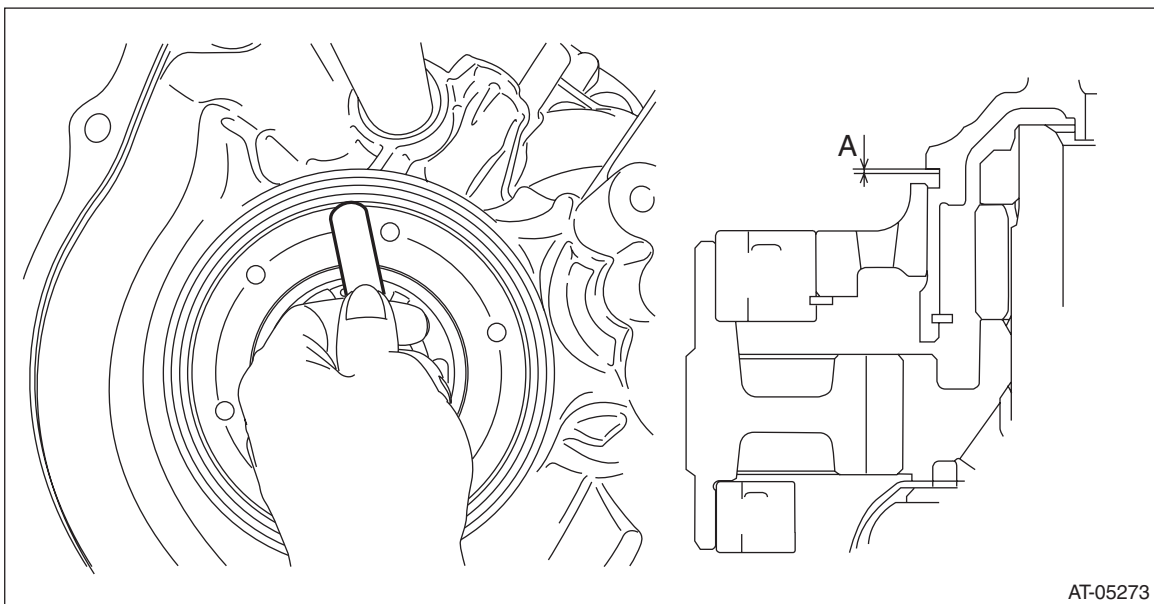

# Reduction Driven Gear

CONTINUOUSLY VARIABLE TRANSMISSION

---

2) If clearance "A" is out of standard, select the snap ring within standard.

Snap ring	
Part number	Thickness mm (in)
805100460	2.0 (0.079)
805100461	2.1 (0.083)
805100462	2.2 (0.087)
805100463	2.3 (0.091)
805100464	2.4 (0.094)