

# Rear Drive Shaft

CONTINUOUSLY VARIABLE TRANSMISSION

## 29.Rear Drive Shaft

### A: REMOVAL

- 1) Remove the transmission assembly from vehicle body. <Ref. to CVT-55, REMOVAL, Automatic Transmission Assembly.>
- 2) Remove the extension case. <Ref. to CVT-137, REMOVAL, Extension Case.>
- 3) Remove the rear drive shaft.

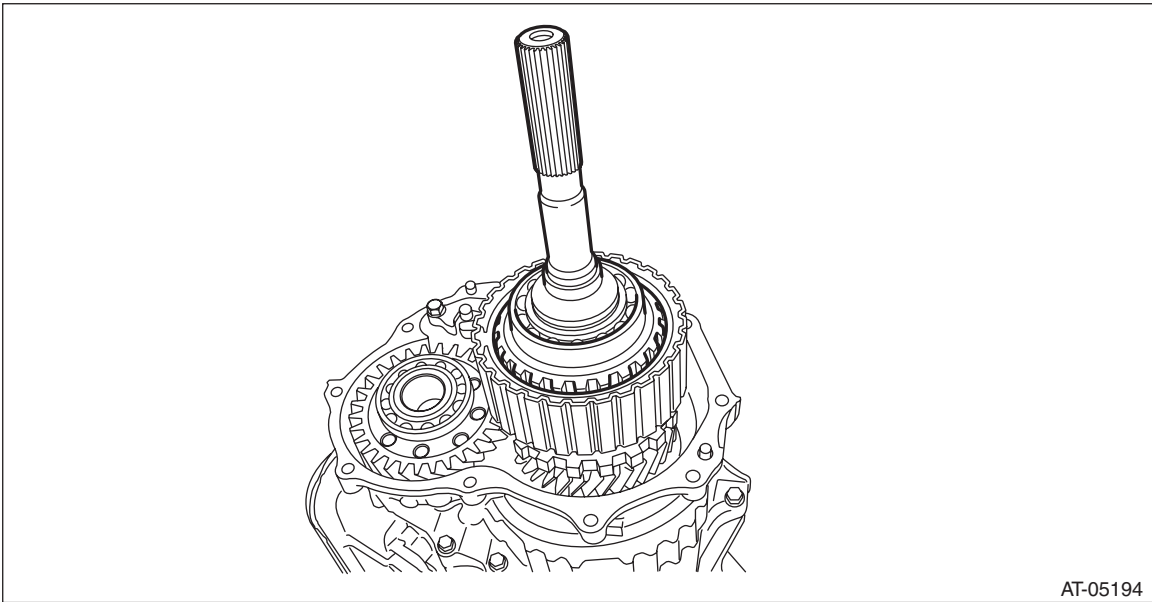

AT-05194

### B: INSTALLATION

- 1) Select the thrust needle bearing. <Ref. to CVT-142, ADJUSTMENT, Rear Drive Shaft.>
- 2) Install the selected thrust needle bearing to transfer clutch assembly.

#### NOTE:

Install the thrust needle bearing in the correct direction.

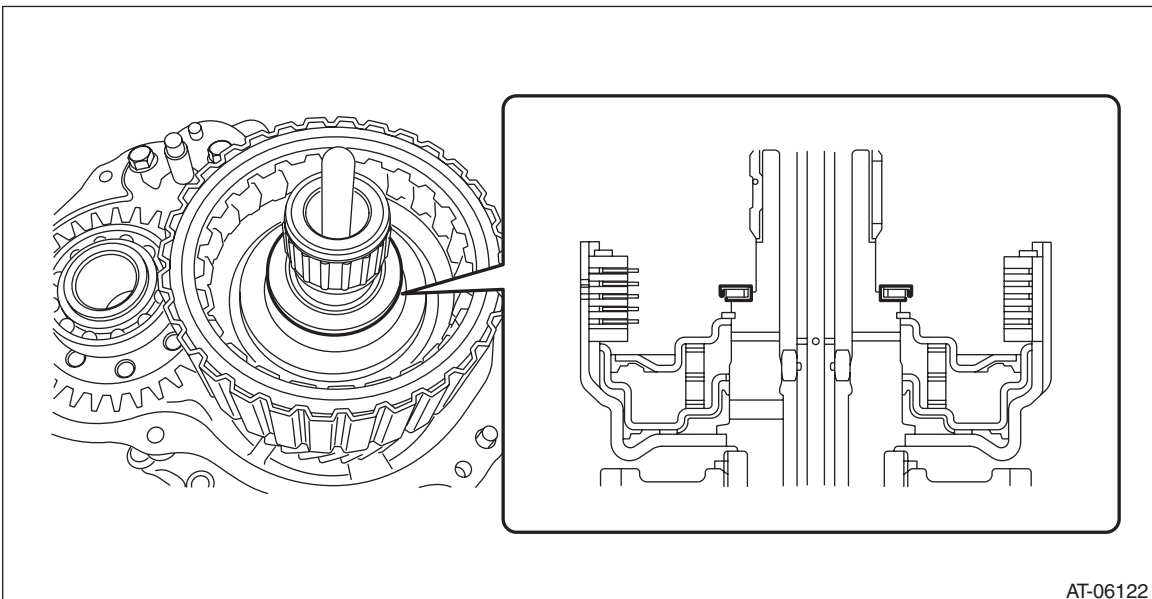

AT-06122

# Rear Drive Shaft

CONTINUOUSLY VARIABLE TRANSMISSION

3) Install the rear drive shaft.

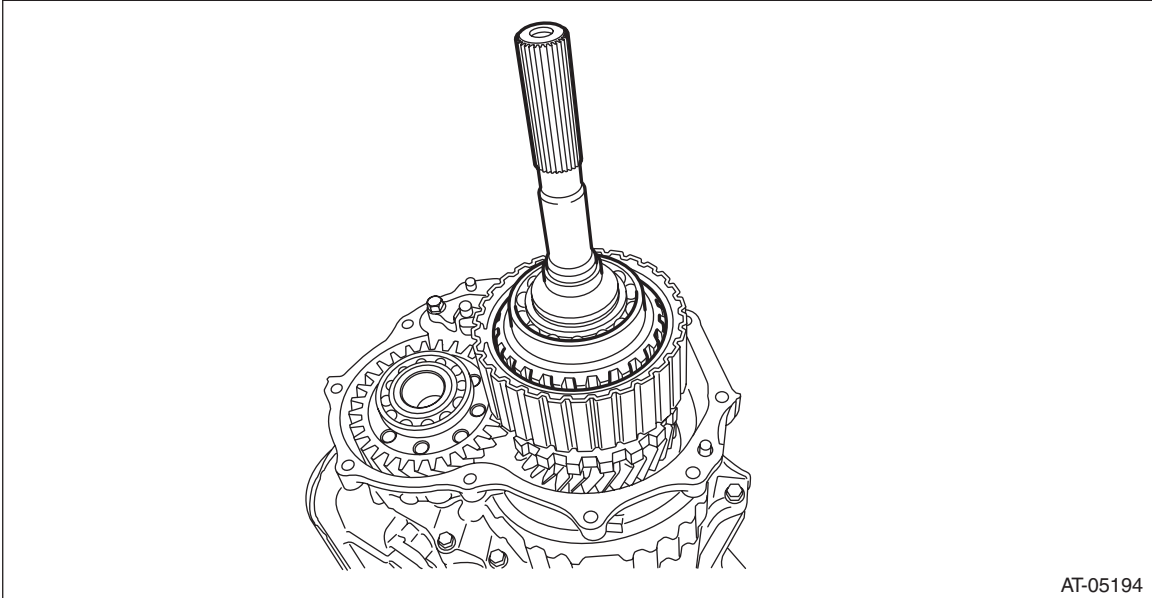

AT-05194

4) Install the extension case. <Ref. to CVT-137, INSTALLATION, Extension Case.>

5) Install the transmission assembly to the vehicle. <Ref. to CVT-69, INSTALLATION, Automatic Transmission Assembly.>

## C: DISASSEMBLY

1) Remove the ball bearing using ST.

ST 498077600 REMOVER

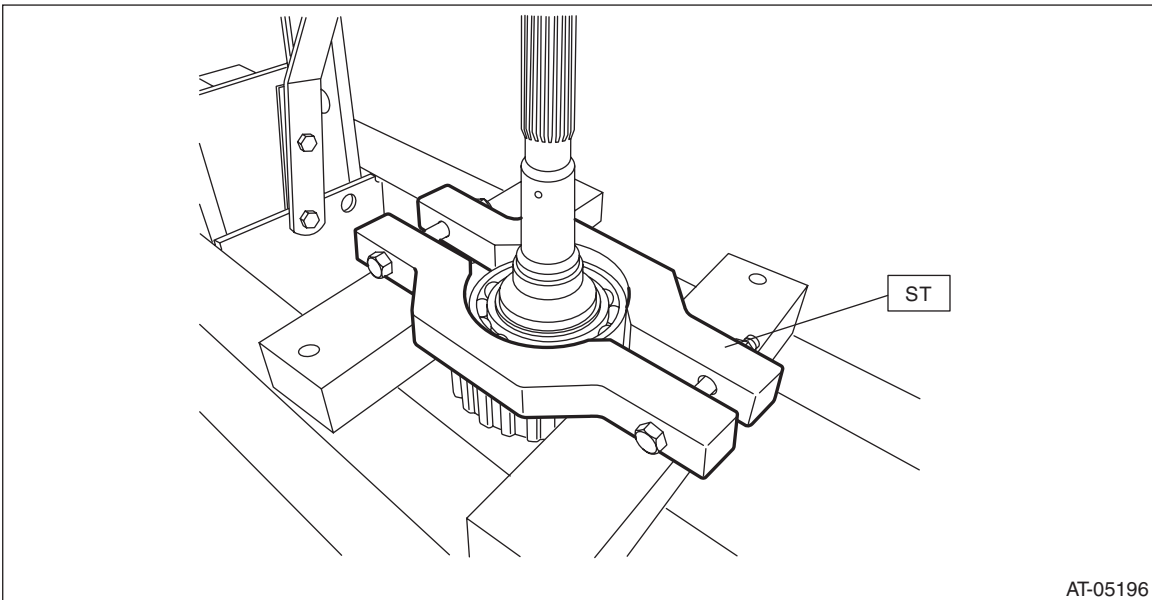

AT-05196

# Rear Drive Shaft

CONTINUOUSLY VARIABLE TRANSMISSION

## D: ASSEMBLY

1) Using the ST, install the ball bearing.

NOTE:

- Use a new ball bearing.
- Apply CVTF to press-fitting surface of ball bearing.

ST 399513600 INSTALLER

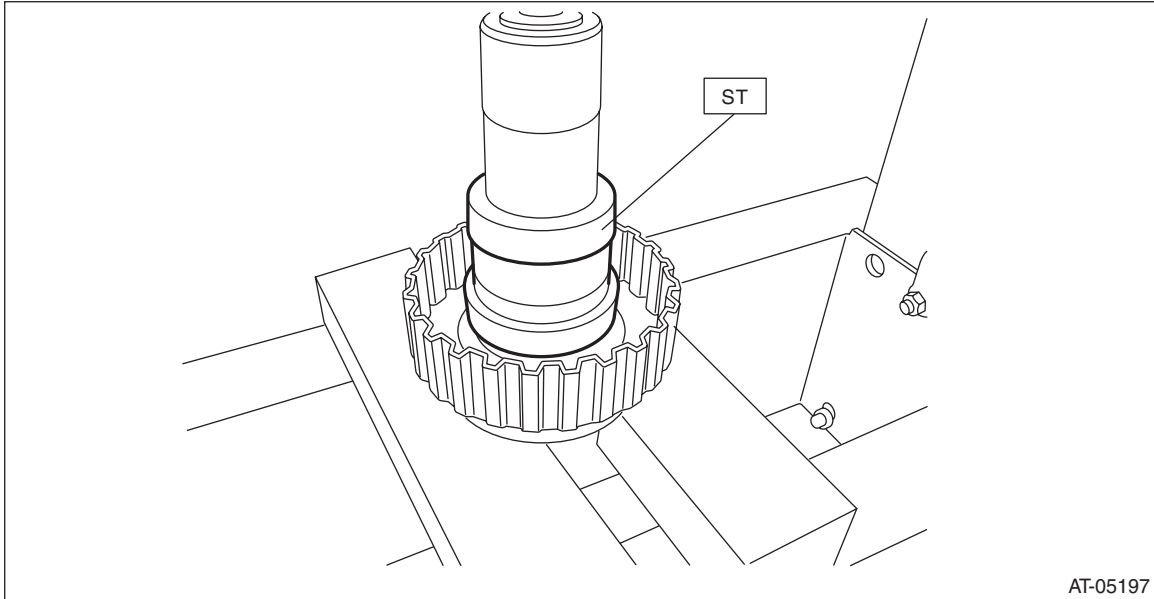

## E: INSPECTION

- Check each part for crack, damage or dust.
- Check the ball bearing for smooth rotation.
- Check the ball bearing for excessive looseness.

## F: ADJUSTMENT

NOTE:

When replacing the rear drive shaft or bearing, select the thrust needle bearing.

1) Using the ST, measure the distance "A" from ST end face to rear drive shaft thrust needle bearing catch surface.

ST 398643600 GAUGE

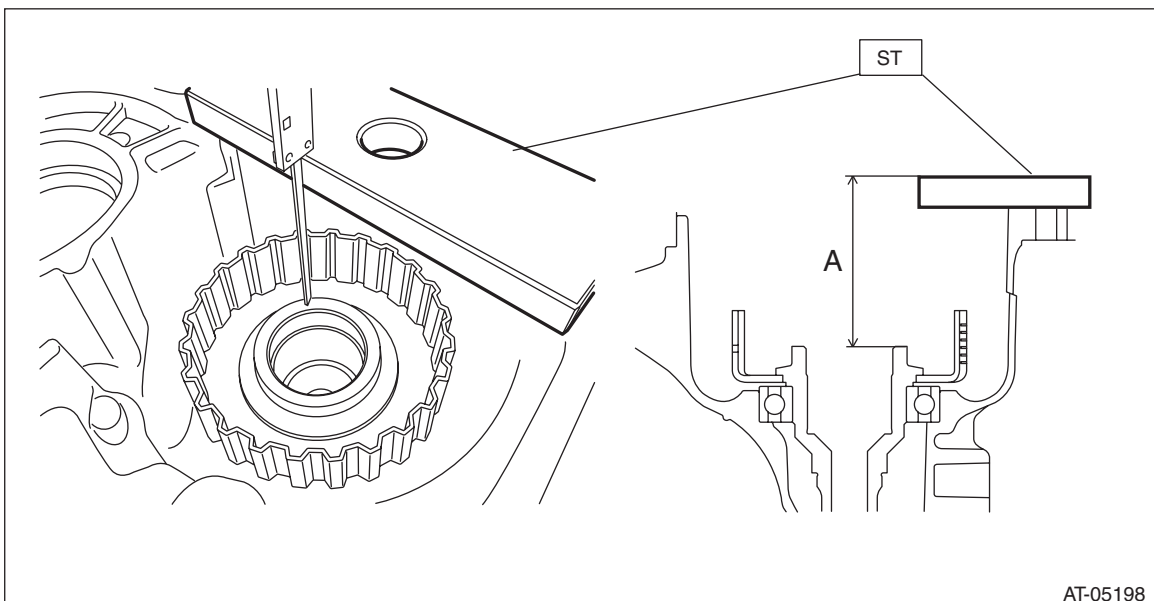

# Rear Drive Shaft

CONTINUOUSLY VARIABLE TRANSMISSION

2) Using the ST, measure the height "B" from the intermediate case mating surface to the ST end face.

NOTE:

Place the measurement tool at the dent on ST upper side to measure.

ST 499737100 PULLER SET

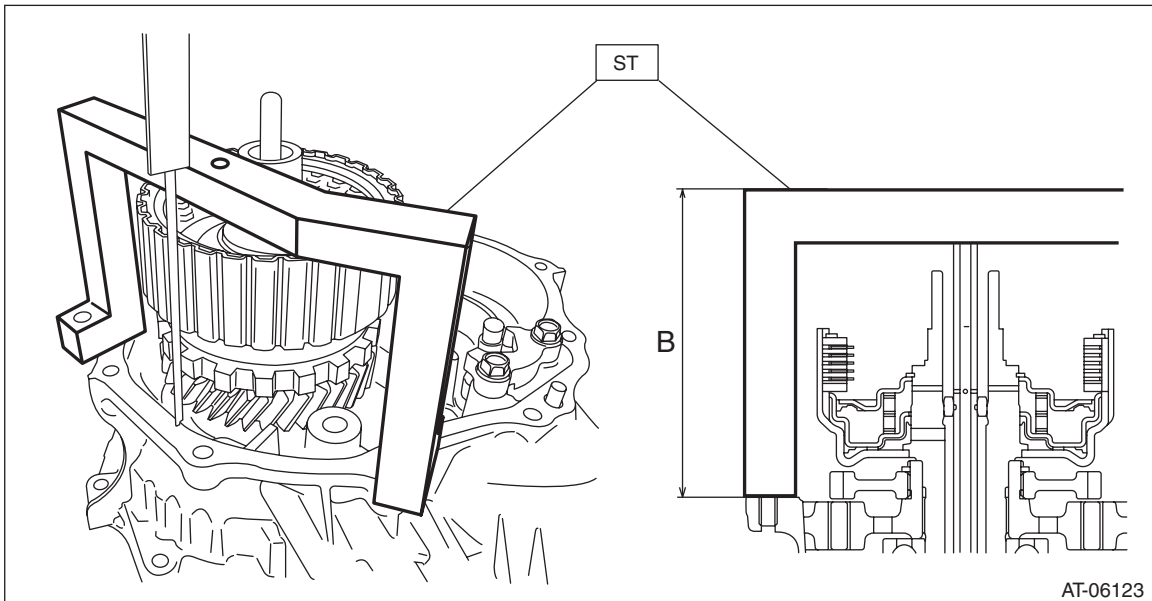

3) Using the ST, measure the height "C" from ST end face to transfer clutch assembly thrust needle bearing catch surface.

NOTE:

Place the measurement tool at the dent on ST upper side to measure.

ST 499737100 PULLER SET

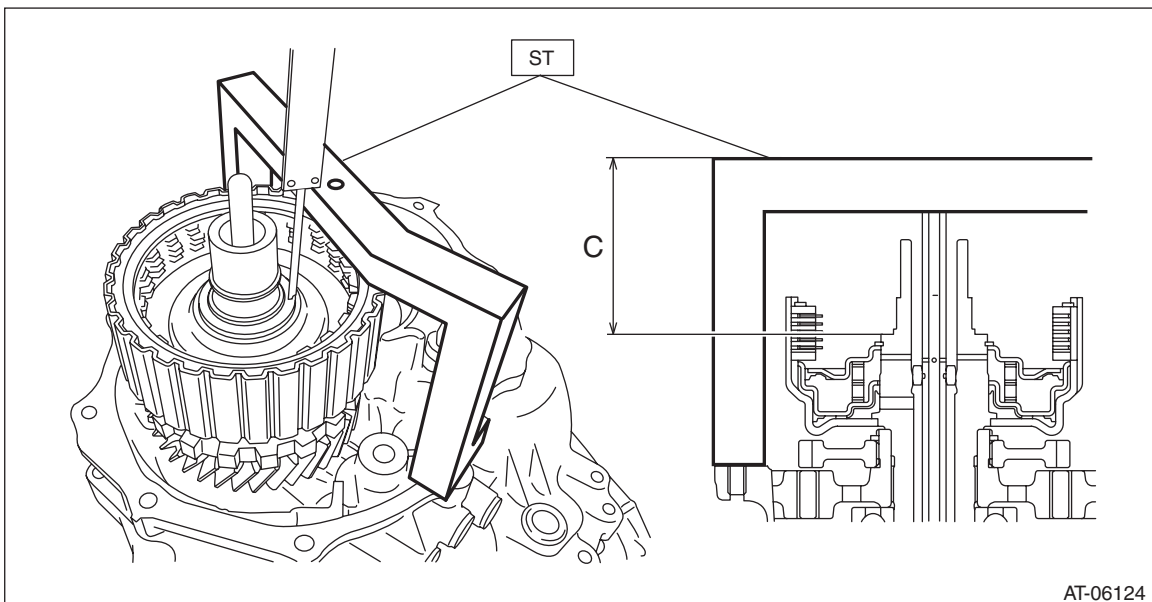

## Rear Drive Shaft

### CONTINUOUSLY VARIABLE TRANSMISSION

---

4) Obtain the thickness of thrust bearing using the following formula to select the thrust bearing.

$$T \text{ mm} = (A - 15) - (B - C) - (0.05 - 0.25)$$

$$[T \text{ in} = (A - 0.59) - (B - C) - (0.002 - 0.01)]$$

T: Thrust bearing thickness

A: Height from the ST end face to the rear drive shaft thrust needle bearing catch surface

B: Height from the mating surface of the intermediate case to the ST end face

C: Height from the ST end face to the transfer clutch assembly thrust needle bearing catch surface

15 mm (0.591 in): Thickness of ST

0.05 — 0.25 mm (0.002 — 0.01 in): Clearance

Thrust bearing	
Part No.	Thickness mm (in)
806536020	3.8 (0.15)
806535030	4.0 (0.157)
806535040	4.2 (0.165)
806535050	4.4 (0.173)
806535060	4.6 (0.181)
806535070	4.8 (0.189)
806535090	5.0 (0.197)