

Air Breather Hose

CONTINUOUSLY VARIABLE TRANSMISSION

25. Air Breather Hose

A: REMOVAL

- 1) Remove the air intake boot assembly. <Ref. to IN(H4SO)-8, REMOVAL, Air Intake Boot.>
- 2) Remove the two air breather hoses.

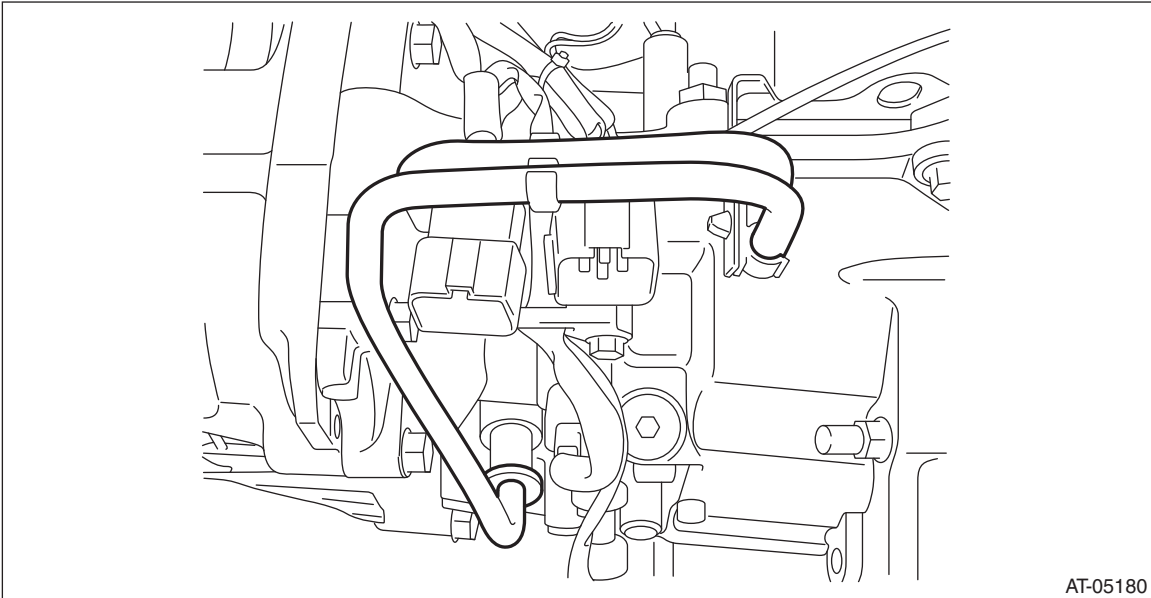

- 3) Remove the oil cap.

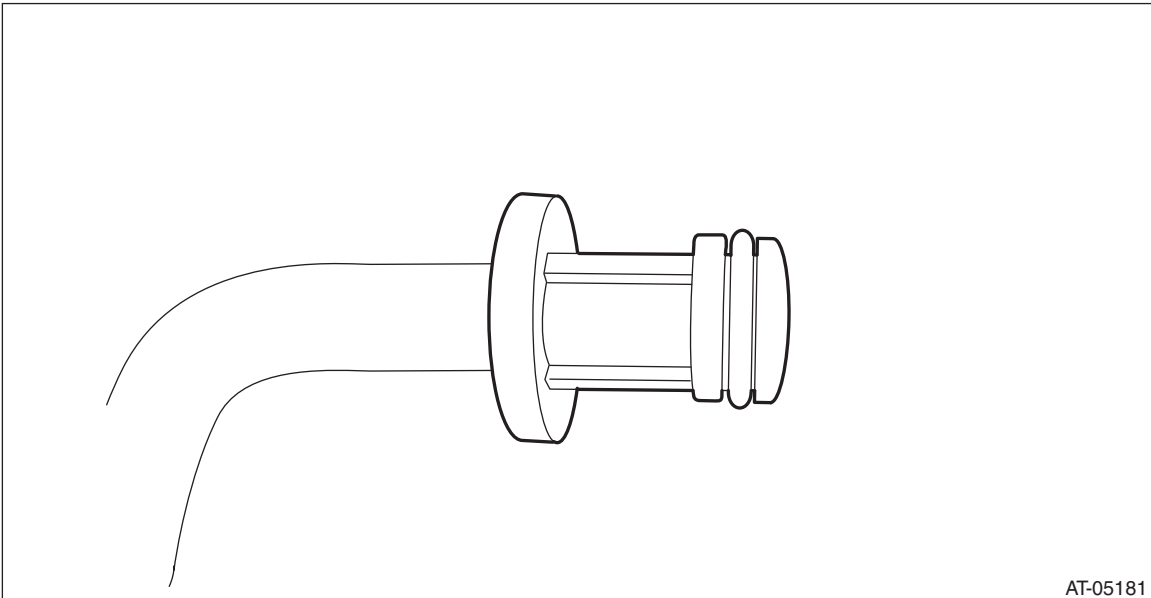

B: INSTALLATION

Install in the reverse order of removal.

NOTE:

Use new O-rings.

C: INSPECTION

- Check the hose for peeling, crack or clogging.
- Check the oil cap is not cracked or clogged.
- Check O-ring of oil cap is not damaged.