

### 3. Datum Dimensions

Use a tram tracking gauge to measure all dimensions. If a measuring tape is used, be extremely careful because it tends to deflect or twist, which results in a false reading.

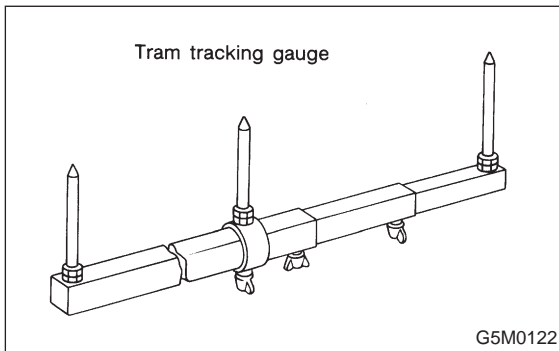

**NOTE:**

- A suffix character “R” or “L” refers to the right or the left.
- All dimensions refer to the distance between the centers of holes measured in a straight line
- Each dimension indicates a projected dimension between hole centers.

### A: FRONT STRUCTURE

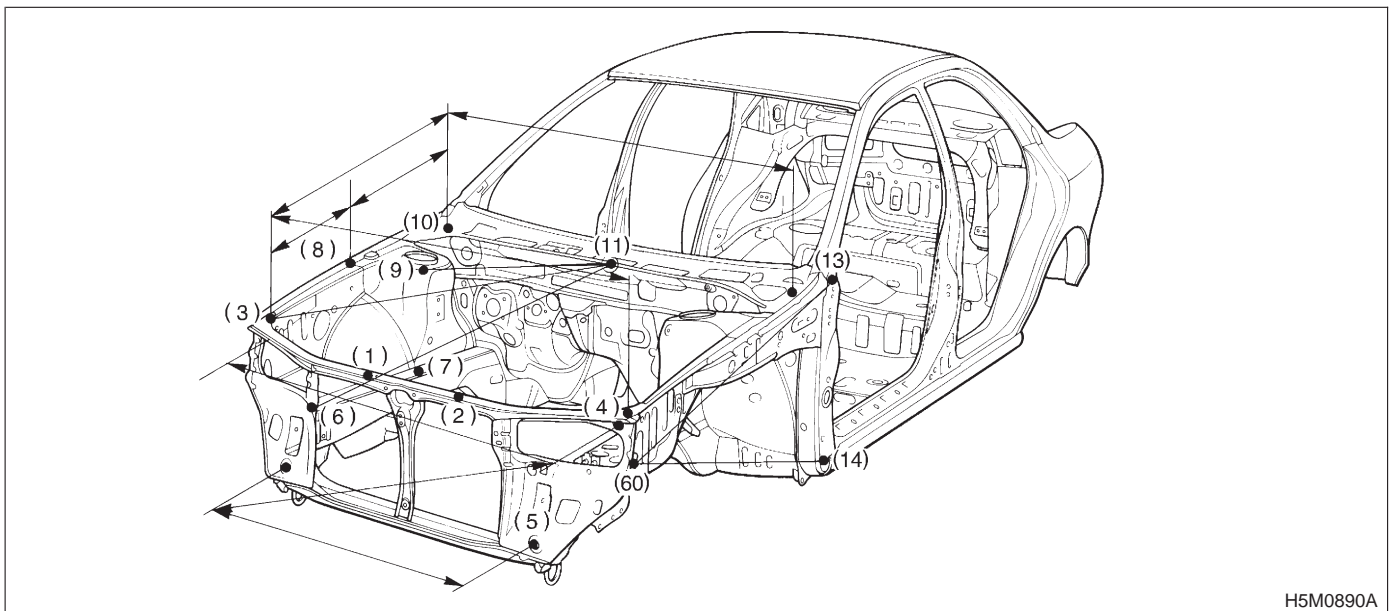

		Unit: mm (in)	
Point to point	Dimension	Point to point	Dimension
(11) to (9) R	525 (20.67)	(10) R to (10) L	1,382 (54.41)
(11) to (9) L	525 (20.67)	(3) R to (3) L	1,336 (52.60)
(11) to (6) R	988 (38.90)	(5) R to (5) L	942 (37.09)
(11) to (6) L	988 (38.90)	(5) R to (4) R	1,174 (46.22)
(11) to (3) R	990 (38.98)	(5) L to (4) L	1,174 (46.22)
(11) to (3) L	990 (38.98)	(4) R to (4) L	1,269 (49.96)
(10) R to (3) R	829 (32.64)	(60) R to (13) R	1,113 (43.82)
(10) L to (3) L	829 (32.64)	(60) L to (13) L	1,113 (43.82)
(10) R to (8) R	567 (22.32)	(60) R to (14) R	1,076 (42.36)
(10) L to (8) L	567 (22.32)	(60) L to (14) L	1,076 (42.36)
(8) R to (3) R	264 (10.39)	(1) to (11)	882 (34.72)
(8) L to (3) L	264 (10.39)	(2) to (11)	913 (35.94)

B: CENTER STRUCTURE

Unit: mm (in)

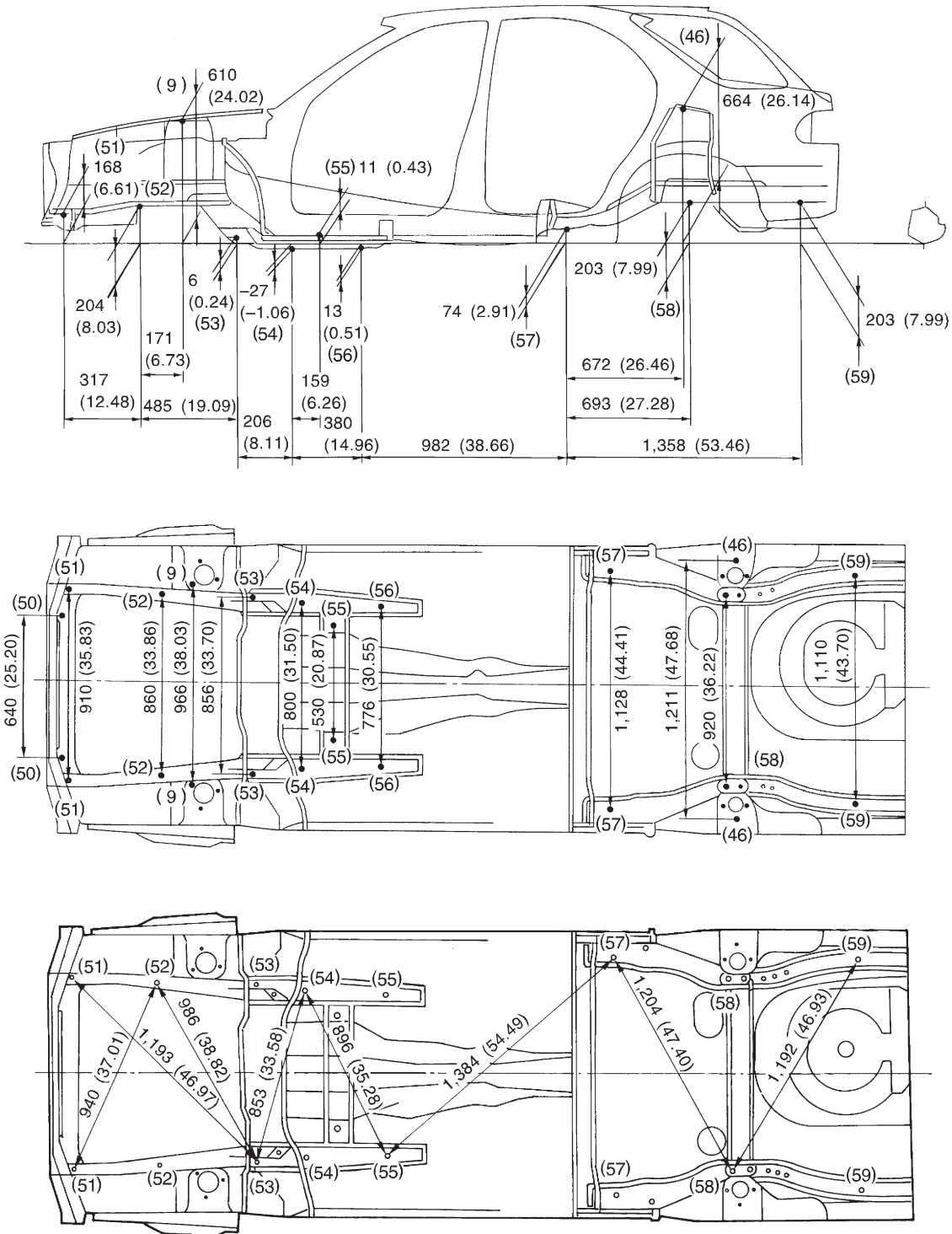

H5M0891A

C: DOORS AND REAR QUARTER

1. SEDAN AND WAGON

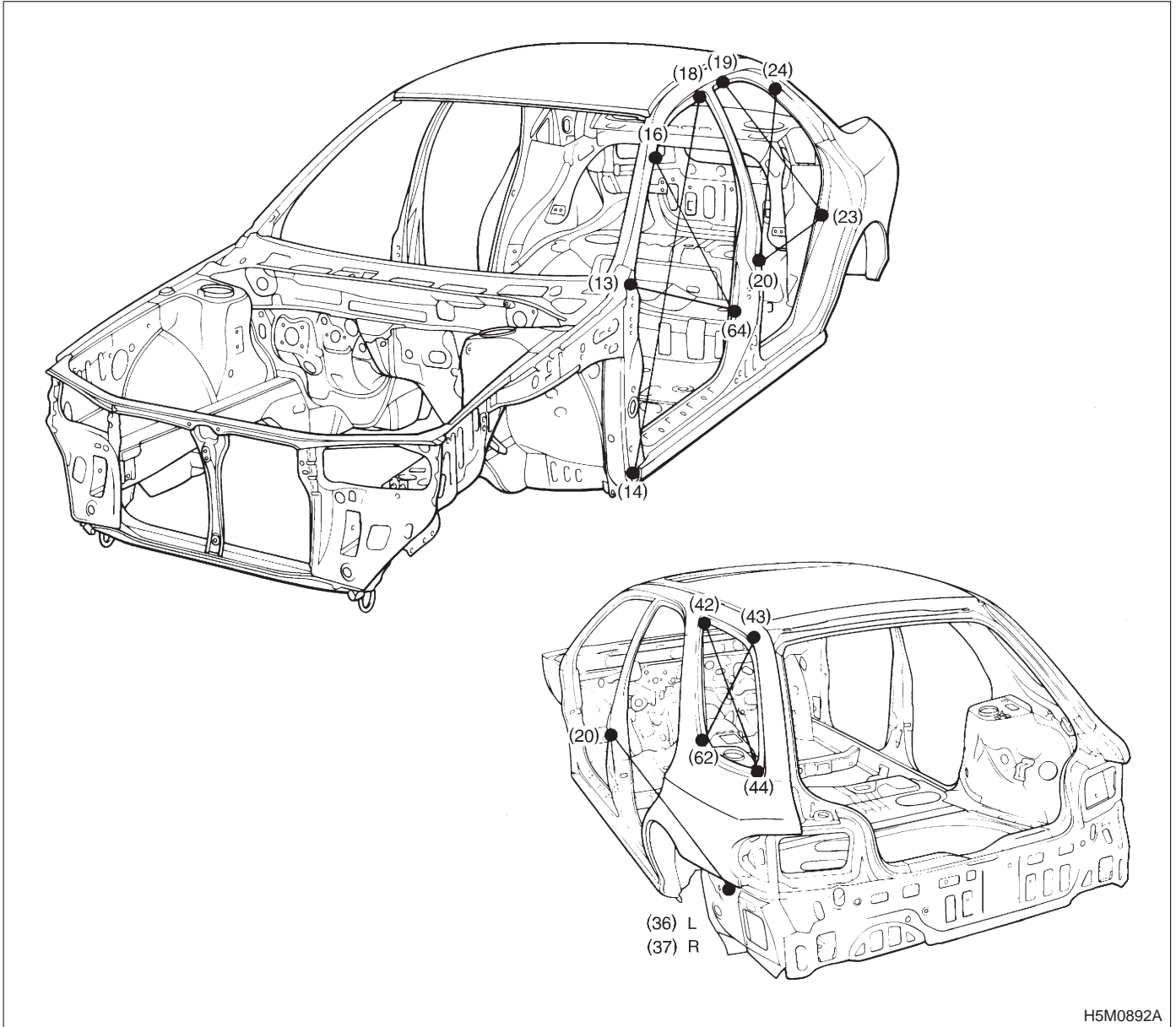

H5M0892A

		Unit: mm (in)	
Point to point	Dimension	Point to point	Dimension
(14) to (18)	1,495 (58.86)	(19) to (23)	912 (35.91)
(13) to (64)	947 (37.28)	(20) to (36) L*	1,462 (57.56)
(16) to (64)	976 (38.43)	(20) R to (37) R*	1,481 (58.31)
(20) to (23)	803 (31.61)	(62) to (43) *	377 (14.84)
(20) to (24)	829 (32.64)	(42) to (44) *	847 (33.35)

\*: Wagon only

2. COUPE

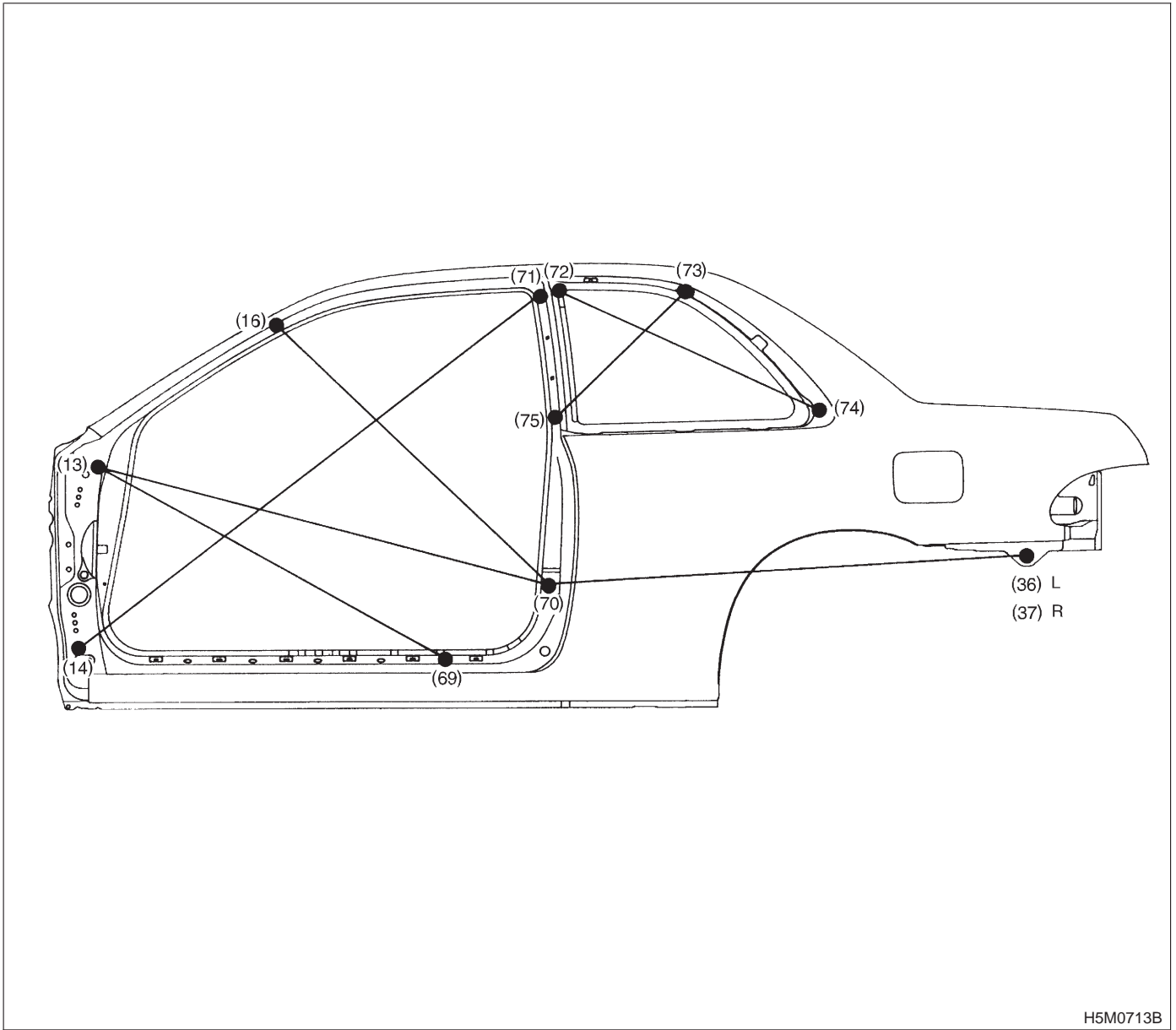

H5M0713B

		Unit: mm (in)	
Point to point	Dimension	Point to point	Dimension
(14) to (71)	1,576 (62.05)	(72) to (74)	778 (30.63)
(13) to (70)	1,251 (49.25)	(73) to (75)	512 (20.16)
(16) to (70)	997 (39.25)	(70) to (36) L	1,295 (50.98)
(13) to (69)	1,063 (41.85)	(70) to (37) R	1,243 (48.94)

D: FRONT WINDSHIELD AND REAR WINDOW

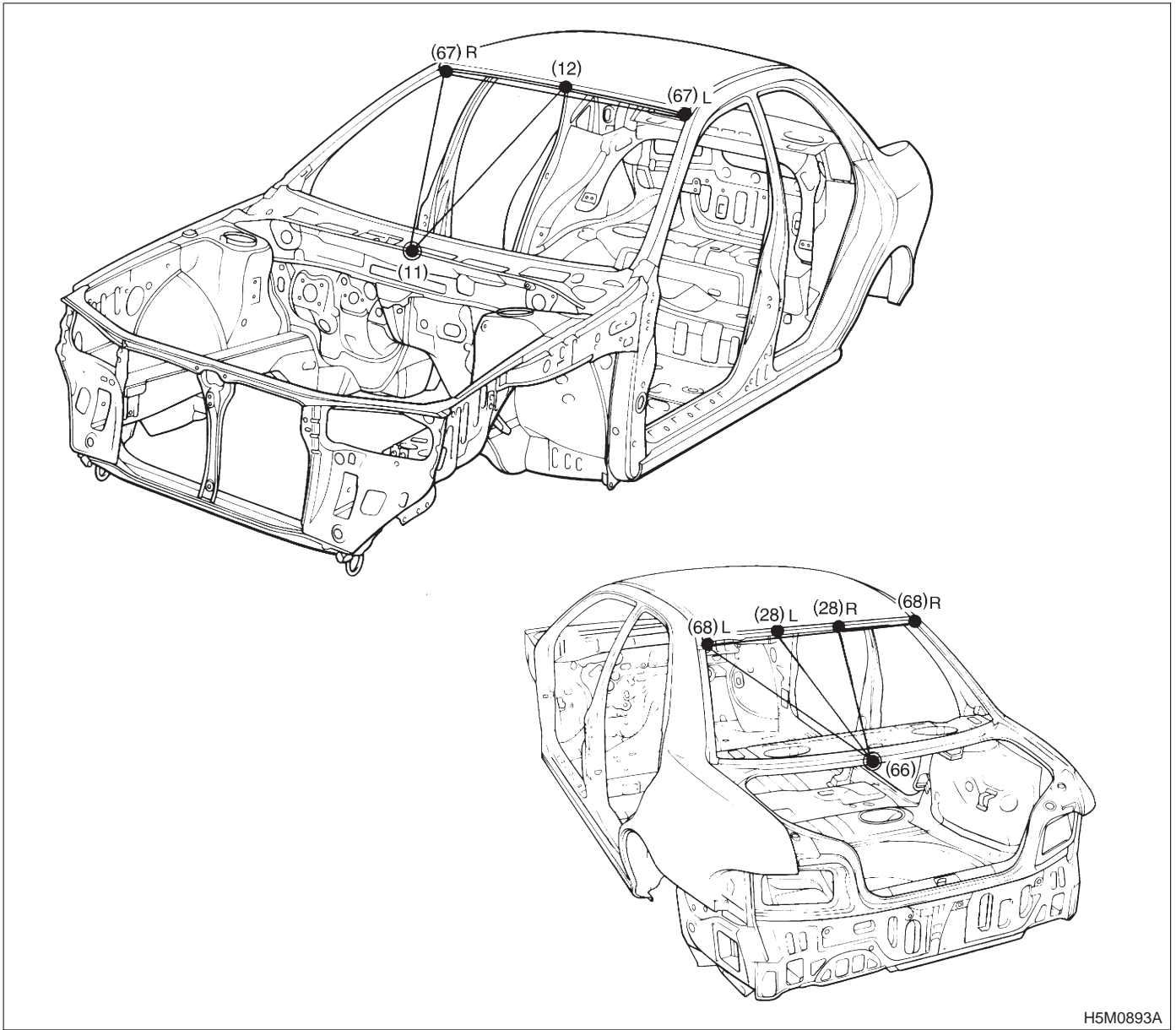

H5M0893A

		Unit: mm (in)	
Point to point	Dimension	Point to point	Dimension
(11) to (12)	989 (38.94)	(66) to (28) L	714 (28.11)
(67) R to (67) L	1,012 (39.84)	(66) to (68) R	856 (33.70)
(11) to (67) R	1,116 (43.94)	(66) to (68) L	856 (33.70)
(11) to (67) L	1,116 (43.94)	(68) R to (68) L	1,012 (39.84)
(66) to (28) R	714 (28.11)		

E: TRUNK LID AND REAR GATE

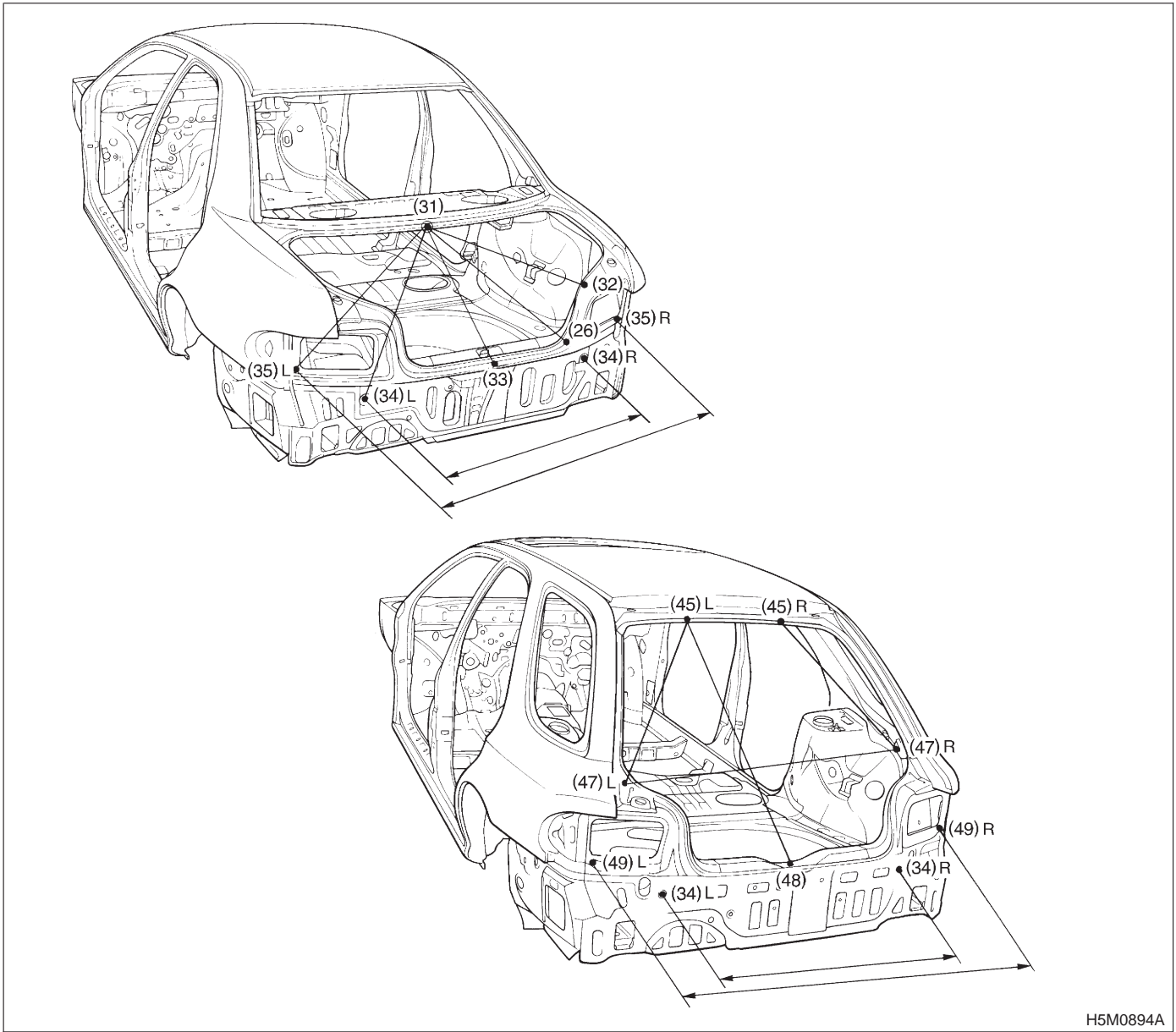

H5M0894A

		Unit: mm (in)	
Point to point	Dimension	Point to point	Dimension
(31) to (32) R	575 (22.64)	(35) R to (35) L	1,364 (53.70)
(31) to (32) L	575 (22.64)	(45) R to (48)	988 (38.90)
(31) to (26) R	812 (31.97)	(45) L to (48)	988 (38.90)
(31) to (26) L	812 (31.97)	(45) R to (47) R	926 (36.46)
(31) to (33)	522 (20.55)	(45) L to (47) L	926 (36.46)
(31) to (35) R	794 (31.26)	(47) R to (47) L	1,043 (41.06)
(31) to (35) L	794 (31.26)	(49) R to (49) L	1,355 (52.56)
(34) R to (34)L	890 (35.04)	(34) R to (34) L	890 (35.04)

F: COMPARTMENT

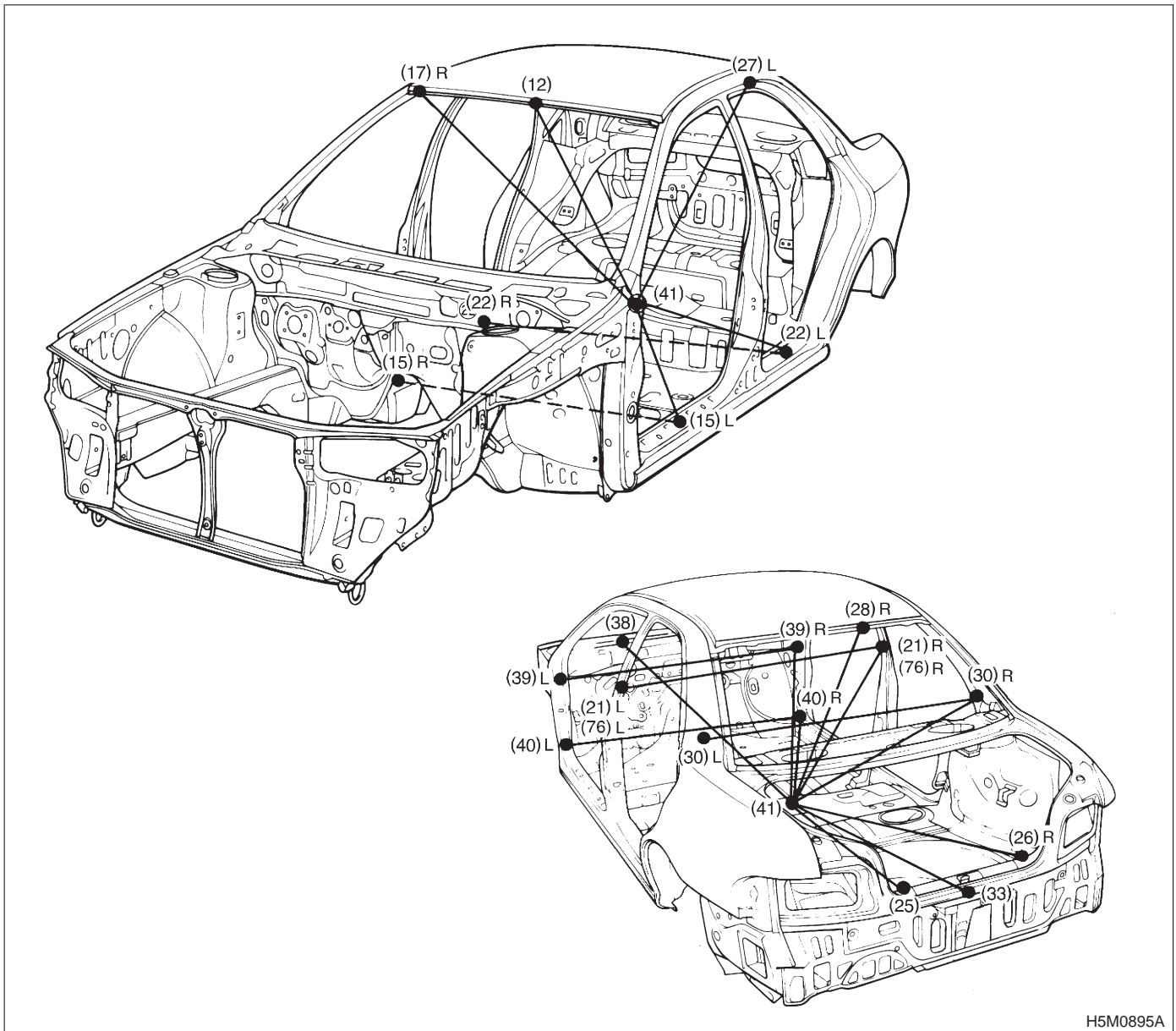

H5M0895A

				Unit: mm (in)	
Point to point	Dimension	Point to point	Dimension	Point to point	Dimension
(30) R to (30) L	1,197 (47.13)	(41) to (15) R	1,140 (44.88)	(41) to (30) L*	1,168 (45.98)
(21) R to (21) L	1,061 (41.77)	(41) to (15) L	1,140 (44.88)	(41) to (28) R*	1,050 (41.34)
(15) R to (15) L	1,453 (57.20)	(41) to (22) R	733 (28.86)	(41) to (28) L*	1,050 (41.34)
(22) R to (22) L	1,453 (57.20)	(41) to (22) L	733 (28.86)	(41) to (21) R	1,038 (40.87)
(39) R to (39) L	1,388 (54.65)	(41) to (12)	1,156 (45.51)	(41) to (21) L	1,038 (40.87)
(40) R to (40) L	1,401 (55.16)	(41) to (27) R	1,085 (42.72)	(41) to (17) R	1,208 (47.56)
(41) to (38)	1,527 (60.12)	(41) to (27) L	1,085 (42.72)	(41) to (17) L	1,208 (47.56)
(41) to (39) R	1,524 (60.00)	(41) to (26) R	1,568 (61.73)	(41) to (33) *	1,569 (61.77)
(41) to (39) L	1,524 (60.00)	(41) to (26) L	1,568 (61.73)	(76) R to (76) L☆	1,212 (47.72)
(41) to (40) R	1,756 (69.13)	(41) to (25)	1,184 (46.61)		
(41) to (40) L	1,756 (69.13)	(41) to (30) R*	1,168 (45.98)		

\*: Sedan only ☆ : Coupe only

G: LUGGAGE ROOM

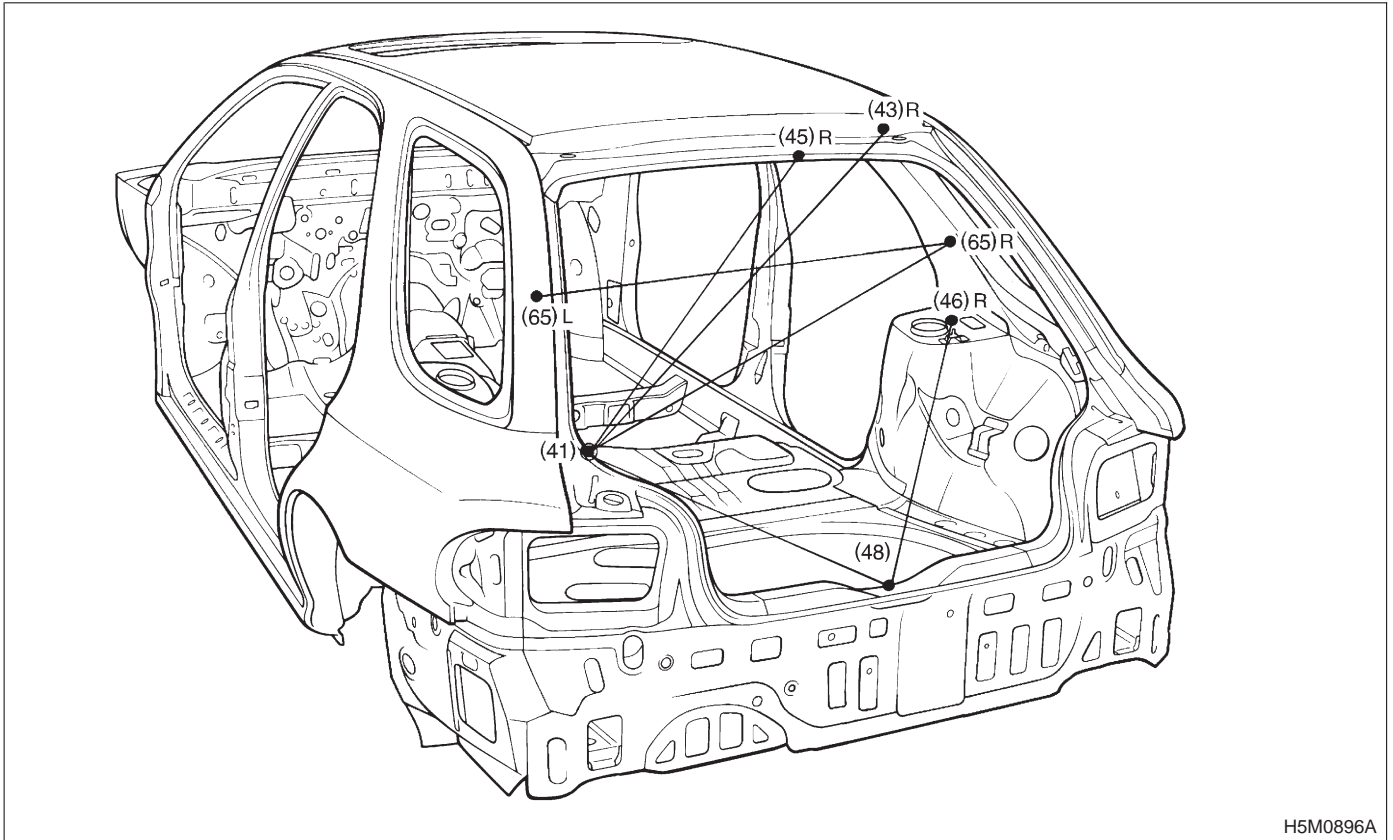

H5M0896A

		Unit: mm (in)	
Point to point	Dimension	Point to point	Dimension
(41) to (65) R	1,122 (44.17)	(41) to (43) R	1,237 (48.70)
(41) to (65) L	1,122 (44.17)	(41) to (43) L	1,237 (48.70)
(41) to (45) R	1,225 (48.23)	(48) to (46) R	971 (38.23)
(41) to (45) L	1,225 (48.23)	(48) to (46) L	971 (38.23)
(41) to (48)	1,446 (56.93)	(65) R to (65) L	1,235 (48.62)