

# GENERAL DESCRIPTION

INTAKE (INDUCTION)

## 1. General Description

### A: COMPONENT

#### 1. AIR CLEANER

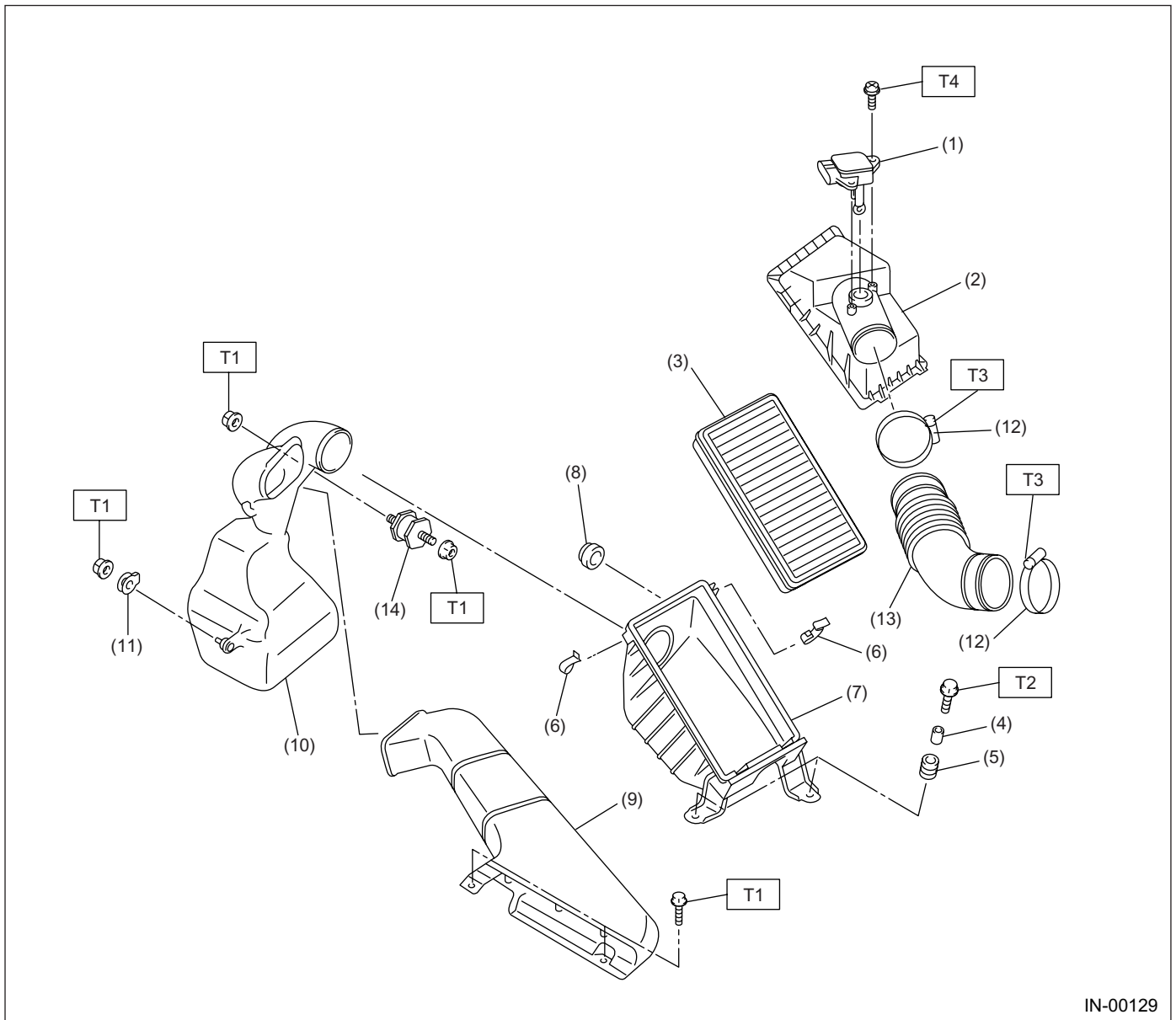

- |   |                             |
|---|-----------------------------|
| (1) Mass air flow and intake air temperature sensor | (8) Cushion rubber          |
| (2) Air cleaner upper cover                         | (9) Air intake duct         |
| (3) Air cleaner element                             | (10) Resonator chamber ASSY |
| (4) Spacer  | (11) Cushion rubber         |
| (5) Bush  | (12) Clamp                  |
| (6) Clip  | (13) Air intake boot        |
| (7) Air cleaner lower case                          | (14) Cushion                |

**Tightening torque: N·m (kgf·m, ft·lb)**

**T1: 7.5 (0.76, 5.5)**

**T2: 33 (3.4, 25)**

**T3: 2.5 (0.25, 1.8)**

**T4: 1.7 (0.17, 1.2)**

2. INTAKE DUCT

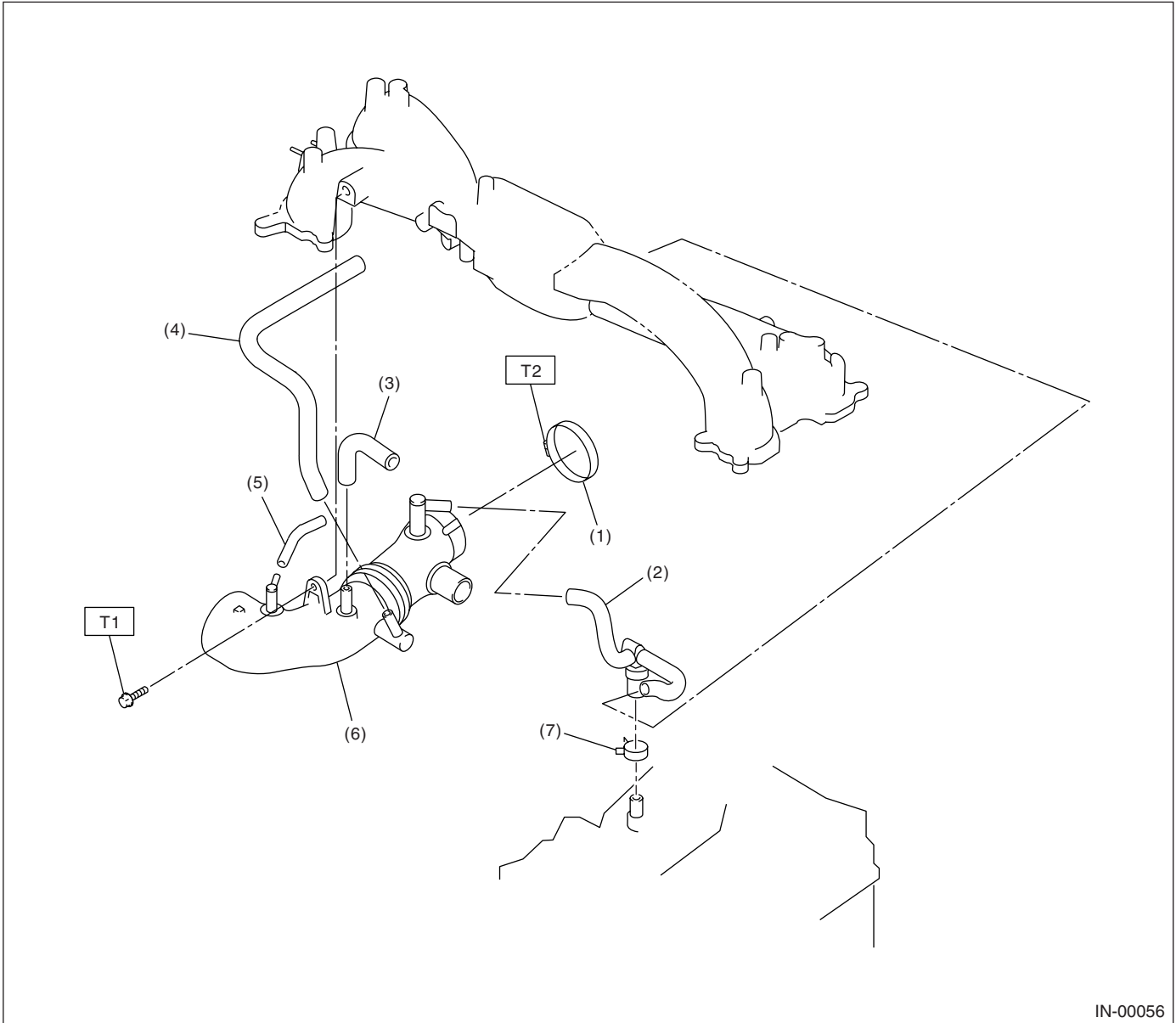

IN-00056

- |                        |                        |
|------------------------|------------------------|
| (1) Clamp              | (5) Air by-pass hose C |
| (2) PCV hose ASSY      | (6) Intake duct        |
| (3) Air by-pass hose A | (7) Clamp              |
| (4) Air by-pass hose B |                        |

**Tightening torque: N·m (kgf-m, ft-lb)**

**T1: 19 (1.9, 13.7)**

**T2: 3 (0.3, 2.2)**

# GENERAL DESCRIPTION

INTAKE (INDUCTION)

## 3. INTERCOOLER

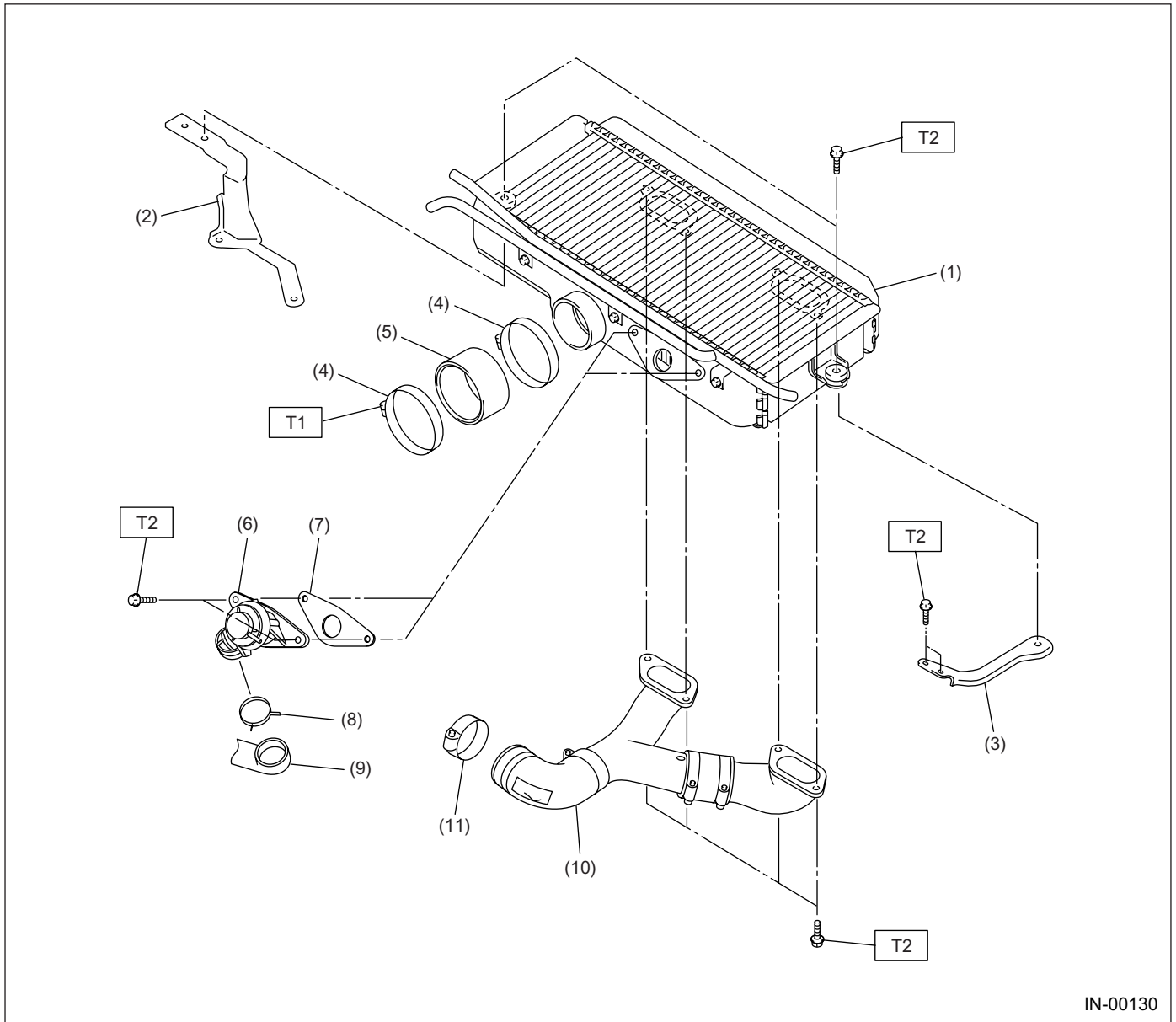

- |                            |                        |
|----------------------------|------------------------|
| (1) Intercooler            | (7) Gasket             |
| (2) Intercooler bracket RH | (8) Clamp              |
| (3) Intercooler bracket LH | (9) Air by-pass hose A |
| (4) Clamp                  | (10) Intercooler duct  |
| (5) Air intake duct        | (11) Clamp             |
| (6) Air by-pass valve      |                        |

**Tightening torque: N·m (kgf·m, ft·lb)**

**T1: 3 (0.22, 1.6)**

**T2: 16 (1.6, 11.7)**

## 4. TURBOCHARGER

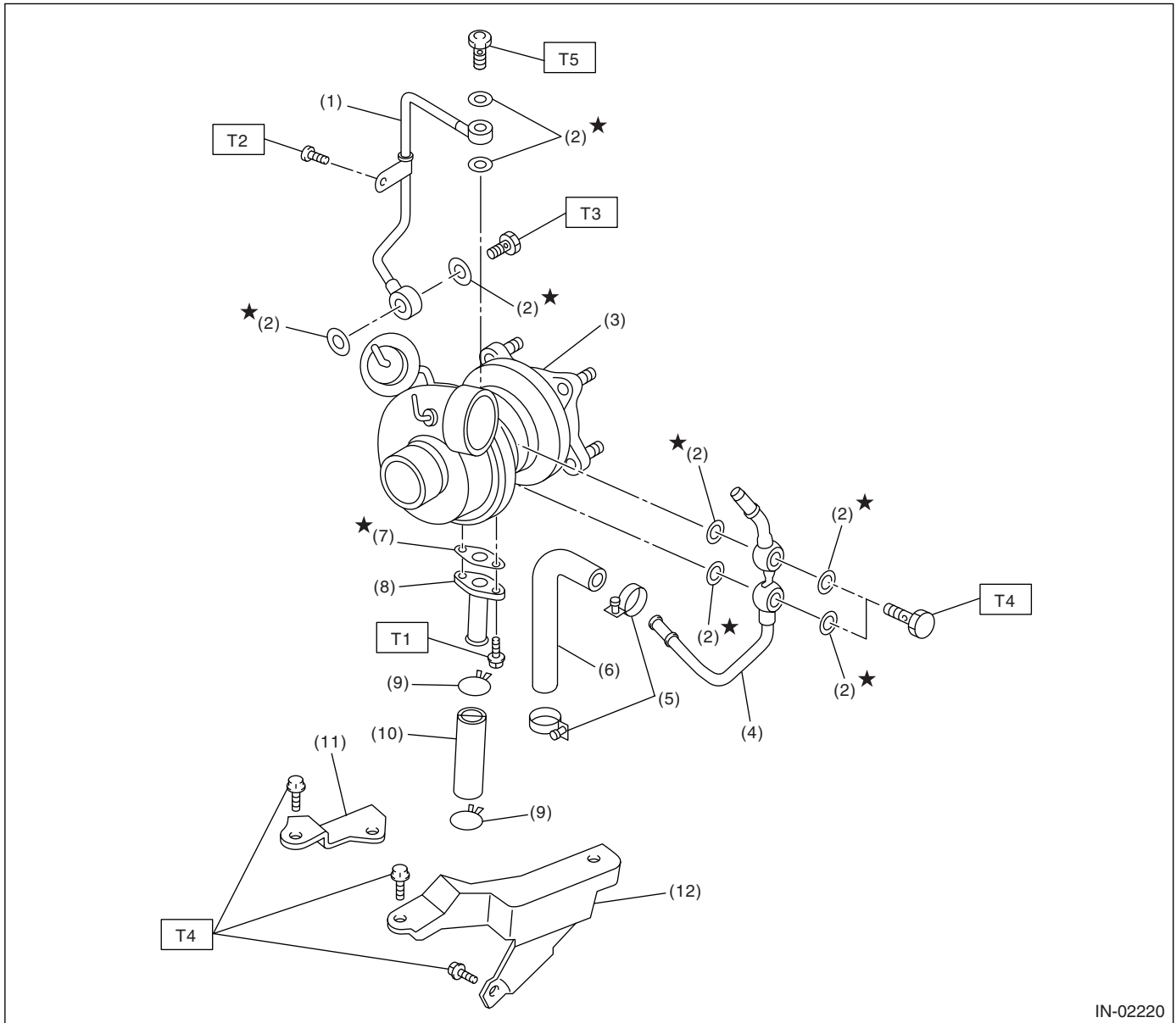

IN-02220

- |                         |                              |
|-------------------------|------------------------------|
| (1) Oil inlet pipe      | (8) Oil outlet pipe          |
| (2) Metal gasket        | (9) Clip                     |
| (3) Turbocharger        | (10) Oil outlet hose         |
| (4) Water pipe          | (11) Turbocharger bracket RH |
| (5) Clamp               | (12) Turbocharger bracket LH |
| (6) Engine coolant hose |                              |
| (7) Gasket              |                              |

**Tightening torque: N·m (kgf·m, ft·lb)**

**T1: 4.4 (0.45, 3.3)**

**T2: 4.9 (0.50, 3.6)**

**T3: 29 (3.0, 21.7)**

**T4: 33 (3.4, 24.6)**

**T5: 16 (1.6, 11.7)**

## GENERAL DESCRIPTION

### INTAKE (INDUCTION)

---

#### **B: CAUTION**

- Wear working clothing, including a cap, protective goggles, and protective shoes during operation.
- Remove contamination including dirt and corrosion before removal, installation or disassembly.
- Keep the disassembled parts in order and protect them from dust or dirt.
- Before removal, installation or disassembly, be sure to clarify the failure. Avoid unnecessary removal, installation, disassembly, and replacement.
- Be careful not to burn your hands, because each part on the vehicle is hot after running.
- Be sure to tighten fasteners including bolts and nuts to the specified torque.
- Place shop jacks or safety stands at the specified points.
- Before disconnecting electrical connectors of sensor or units, be sure to disconnect negative terminal from battery.