

17. Instrument Panel Assembly

A: REMOVAL

WARNING:

- All airbag system wiring harness and connectors are colored yellow. Do not use electrical test equipment on these circuits.
- Be careful not to damage the airbag system harness when servicing the instrument panel.

- 1) Disconnect the ground terminal from battery.
- 2) Loosen the screws and clips to remove the lower cover.

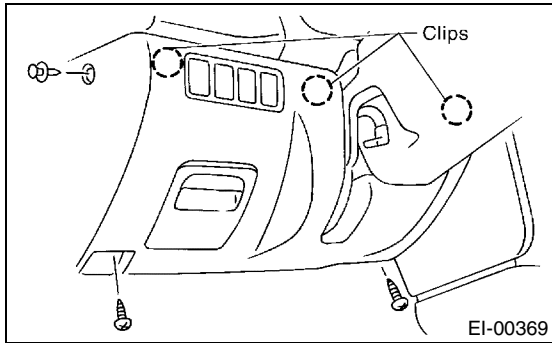

- 3) Remove the glove box. <Ref. to EI-40, REMOVAL, Glove Box.>
- 4) Remove the center console panel. <Ref. to AC-26, REMOVAL, Control Unit.>
- 5) Remove the passenger airbag module. <Ref. to AB-13, Passenger's Airbag Module.>
- 6) Loosen the four screws and two nuts to remove the lower console panel.

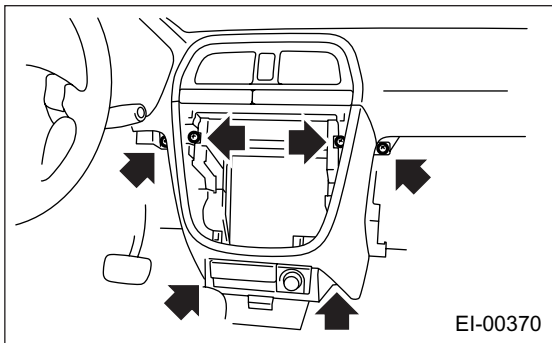

- 7) Loosen the hooks to remove the defroster panel.

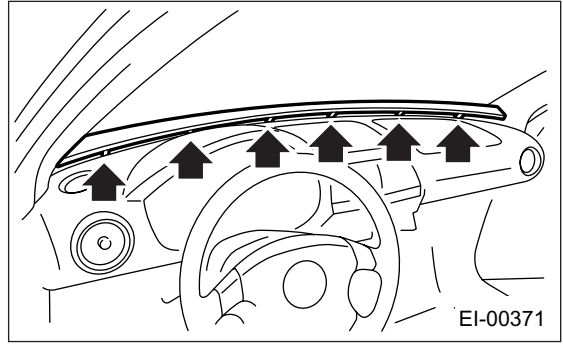

- 8) Remove the two nuts and disconnect the two connectors.

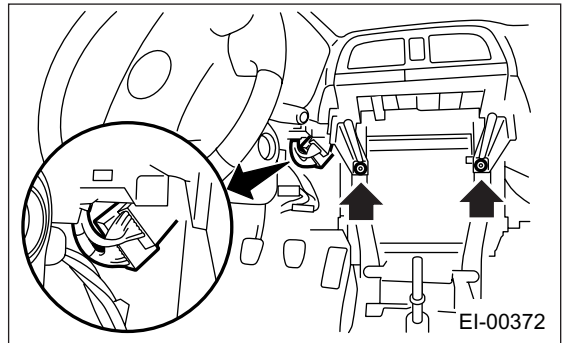

INSTRUMENT PANEL ASSEMBLY

EXTERIOR/INTERIOR TRIM

9) Remove the instrument panel mounting bolts.

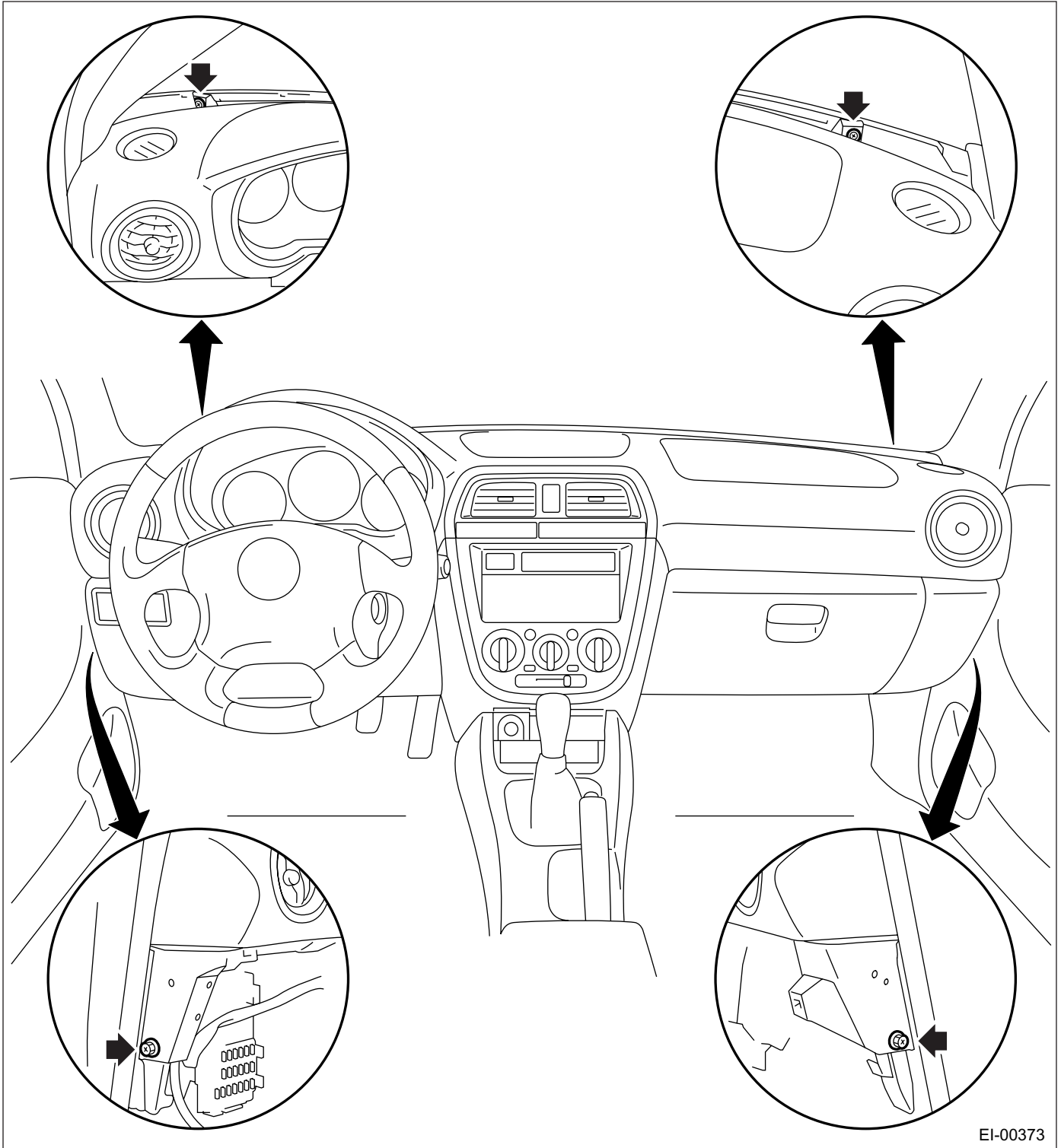

EI-00373

10) Remove the instrument panel.

CAUTION:
Do not pull the harness when disconnecting the connector.

NOTE:
If necessary, make matching marks for easy reassembly.

CAUTION:

- Take care not to scratch the instrument panel and related parts.

- When storing the removed instrument panel, place it standing up on the floor.

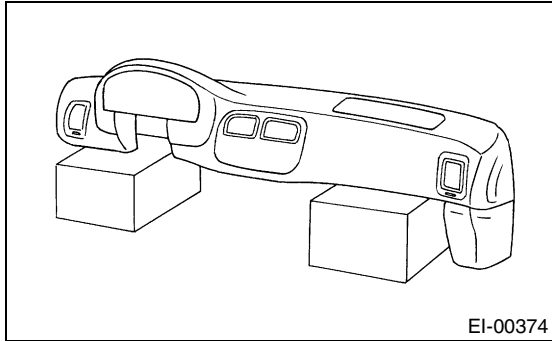

B: INSTALLATION

Install in the reverse order of removal.

CAUTION:

- Be careful not to snag the harness.
- Make sure to connect the harness connector.
- Take care not to scratch the instrument panel and related parts.

NOTE:

When setting the instrument panel into position, push the hook into grommet (A) on the body panel.

