

# SUPPLEMENTAL RESTRAINT SYSTEM

# 5-5

---

	Page
<b>T</b> <b>DIAGNOSTICS</b> .....	2
1. Electrical Components Location.....	2
2. Schematic.....	3
3. Tools for Diagnostics .....	4
4. Diagnostics Chart for On-board Diagnostic System .....	9
5. Diagnostics Chart with Trouble Code .....	14

# 1. Electrical Components Location

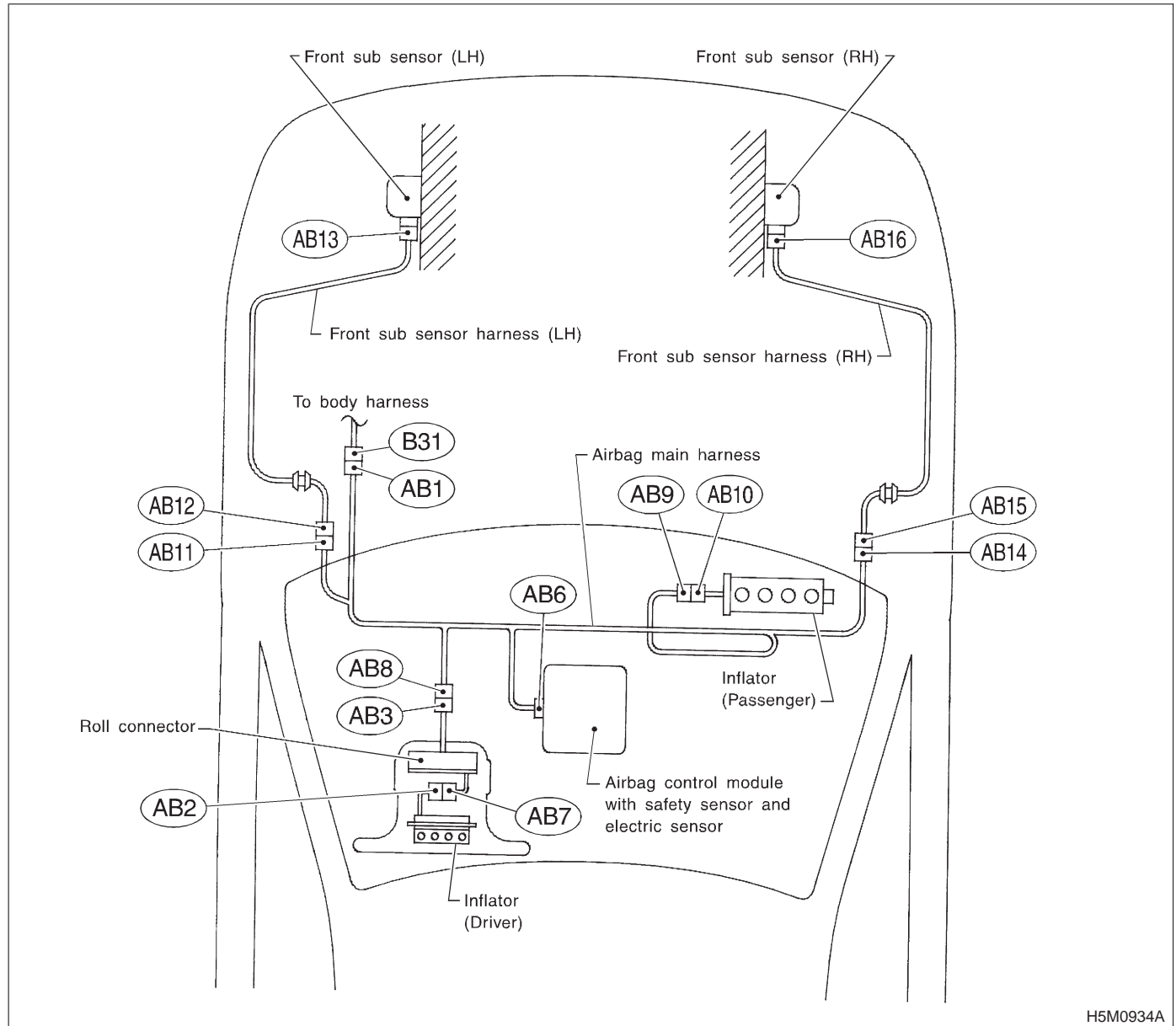

Connector No.	(AB1)	(AB2)	(AB3)	(AB6)	(AB7)	(AB8)	(AB9)
Pole	7	2	2	20	2	2	2
Color	Yellow	Yellow	Yellow	Yellow	Yellow	Yellow	Yellow
Male/Female	Male	Male	Male	Female	Female	Female	Female
Connector No.	(AB10)	(AB11)	(AB12)	(AB13)	(AB14)	(AB15)	(AB16)
Pole	2	2	2	2	2	2	2
Color	Yellow	Blue	Blue	Yellow	Blue	Blue	Yellow
Male/Female	Male	Female	Male	Female	Female	Male	Female

2. Schematic

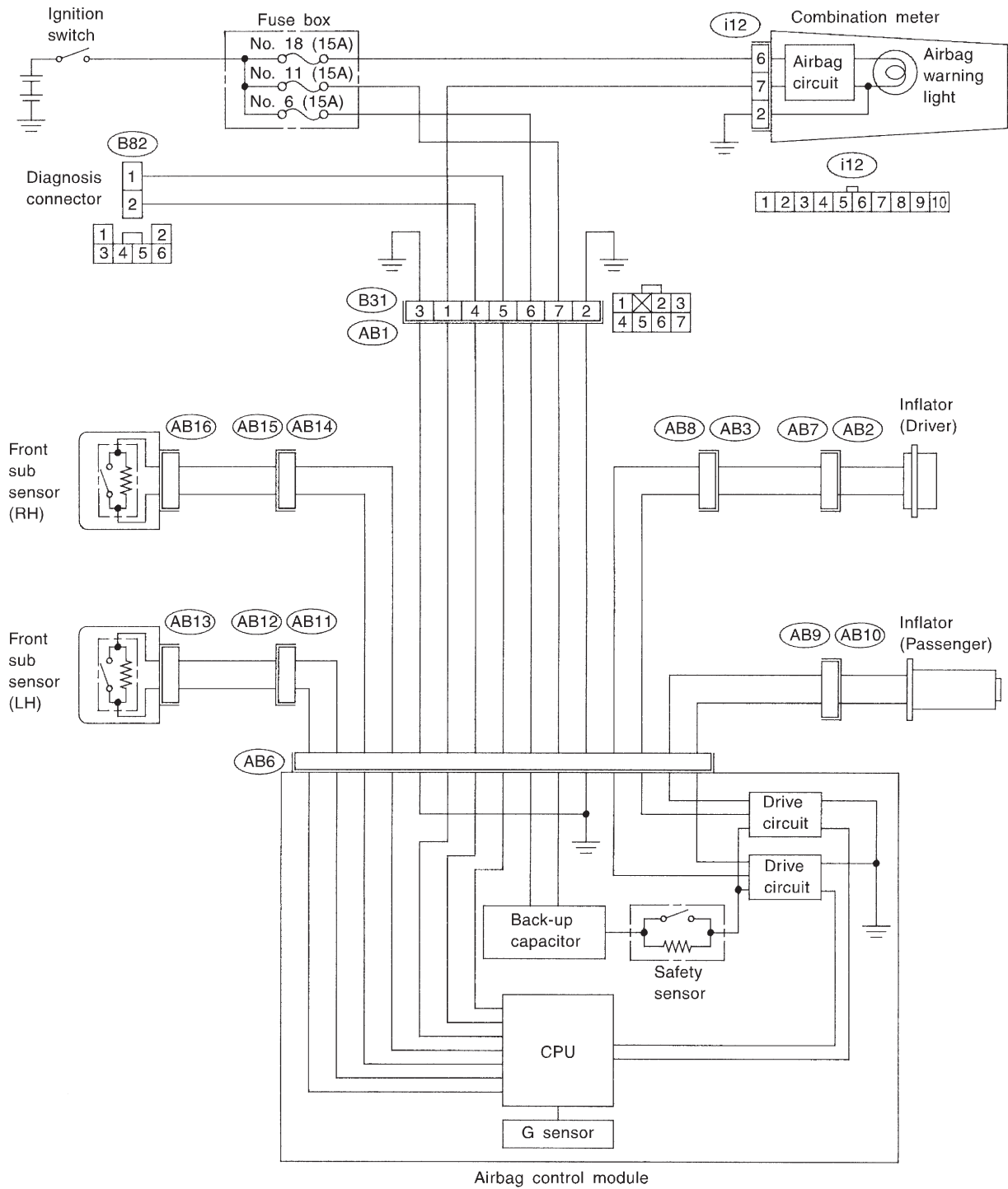

H5M0935A

### 3. Tools for Diagnostics

**CAUTION:**

Be sure to use specified test harness A, E, F and H when measuring voltage, resistance, etc. of AIRBAG system component parts.

#### A: TEST HARNESS A

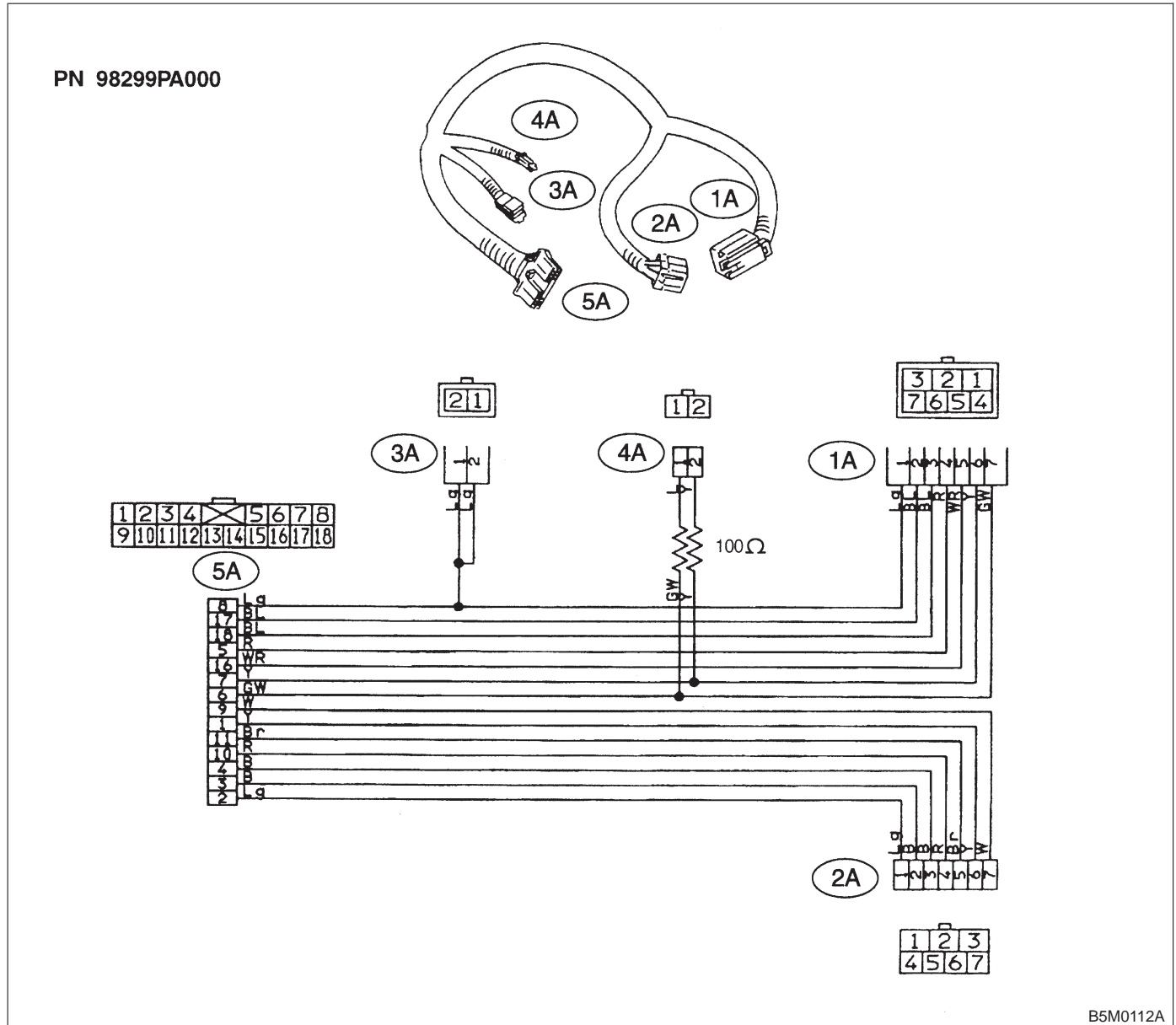

B5M0112A

B: TEST HARNESS E

PN 98299FC000

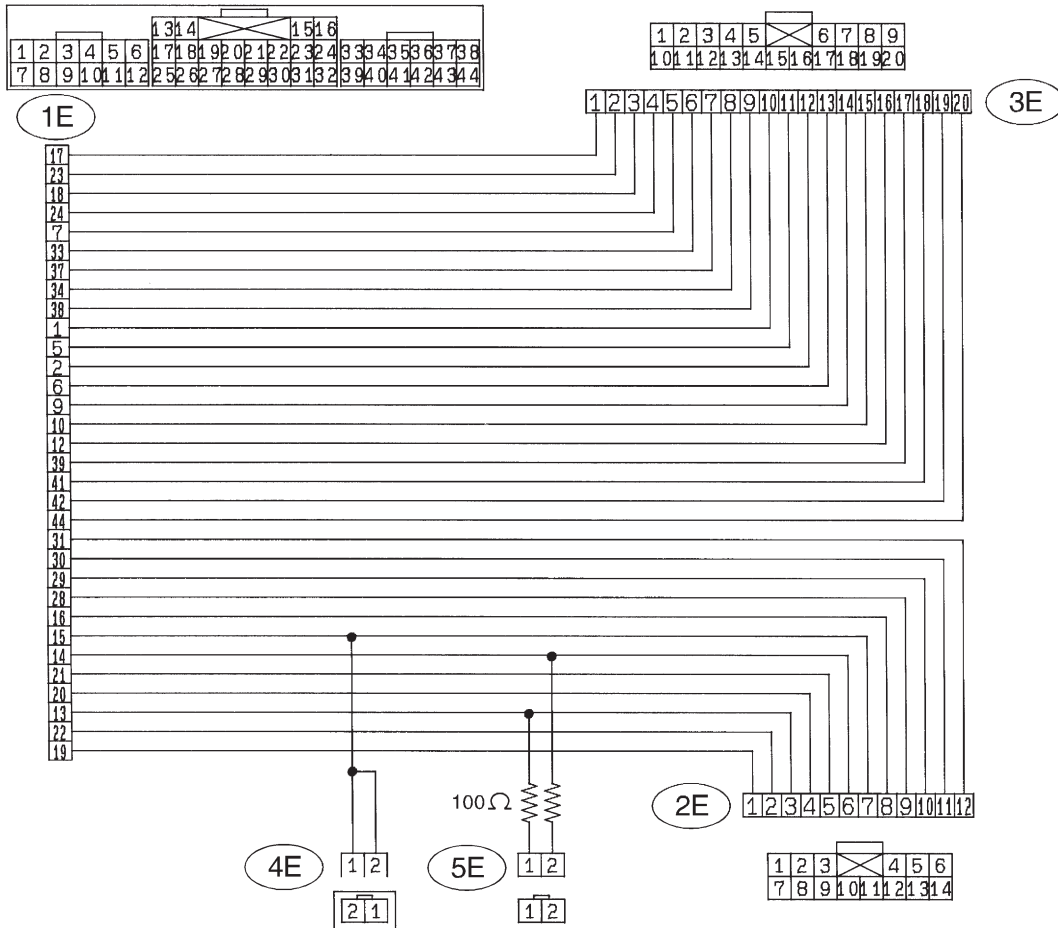
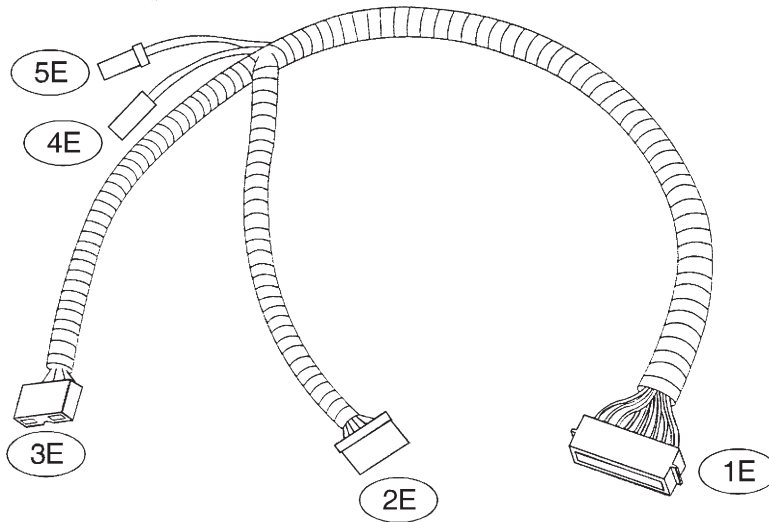

S5M0246A

C: TEST HARNESS F

PN 98299FC010

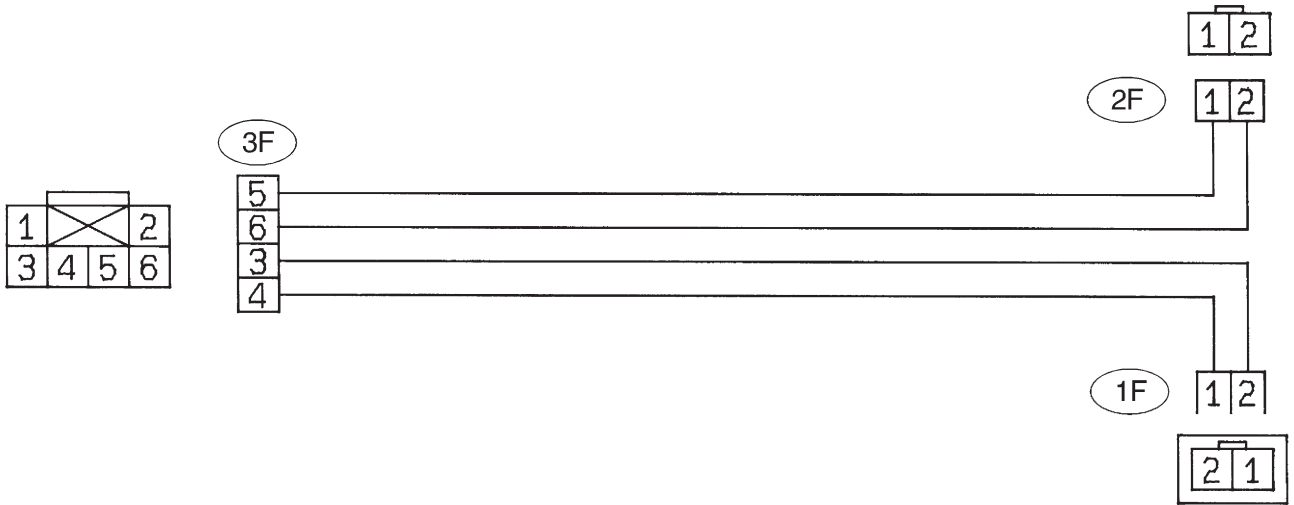
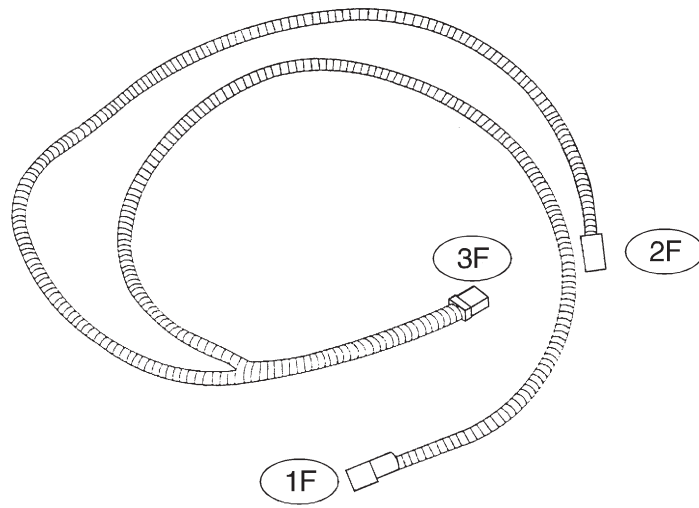

S5M0247A

D: TEST HARNESS H

PN 98299FC030

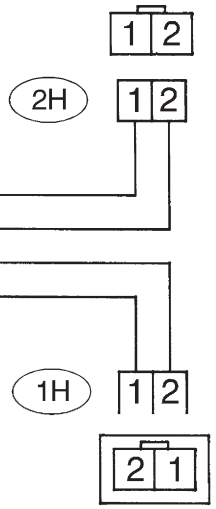
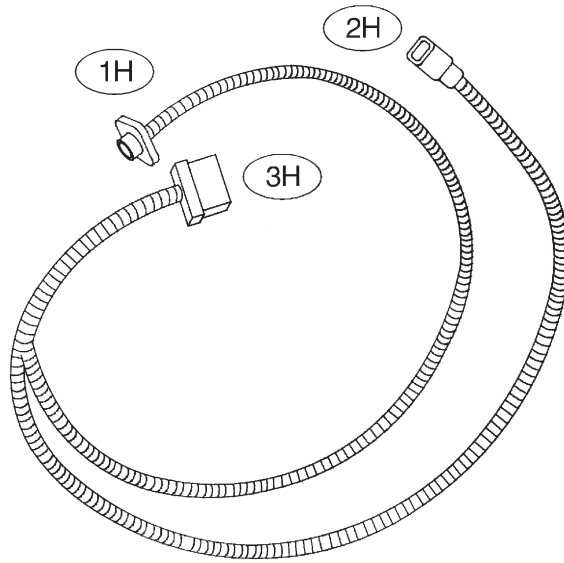

B5M0553A

### E: AIRBAG RESISTOR

The airbag resistor is used during diagnostics. The airbag resistor has the same resistance as the airbag module and thus provides safety when used instead of the airbag module. It also makes it possible to finish, diagnostics in less time.

PN 98299PA040

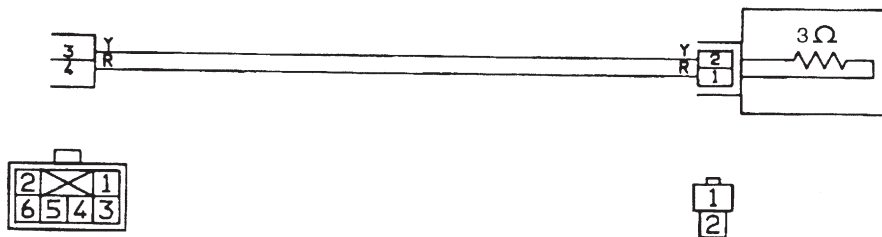
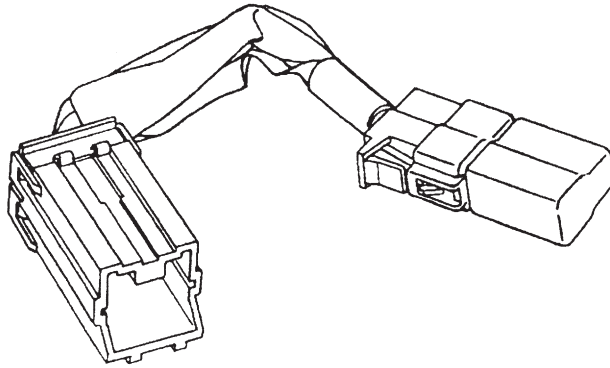

B5M0114A



## 4. Diagnostics Chart for On-board Diagnostic System

### A: BASIC DIAGNOSTICS PROCEDURE

#### 4A1 : CHECK AIRBAG WARNING LIGHT ILLUMINATES.

- 1) Airbag warning light comes ON.
- 2) Turn ignition switch to ON (engine OFF).
- 3) Check airbag warning light illuminates.

**CHECK** : *Does airbag warning light stay ON after about 7 seconds or remain OFF, or come back ON after 30 seconds?*

**YES** : Repair and replace. <Ref. to 5-5 [T4D0].>

**NO** : Go to step 4A2.

#### 4A2 : CHECK TROUBLE CODE INDICATES.

Perform ON-BOARD DIAGNOSTICS. <Ref. to 5-5 [T4B0].>

**CHECK** : *Does trouble code indicate? <Ref. to 5-5 [T5A0].>*

**YES** : Repair and replace. <Ref. to 5-5 [T5Q0].> Then Go to step 4A3.

**NO** : Repair and replace. <Ref. to 5-5 [T5R0].> Then Go to step 4A3.

#### 4A3 : CHECK AIRBAG WARNING LIGHT ILLUMINATES.

- 1) Turn ignition switch to ON (engine OFF).
- 2) Check airbag warning light illuminates.

**CHECK** : *Does airbag warning light stay ON after about 7 seconds or come back ON after 30 seconds?*

**YES** : Repair and replace. <Ref. to 5-5 [T4D0].>

**NO** : Go to step 4A4.

#### 4A4 : CHECK AIRBAG WARNING LIGHT ILLUMINATES.

Check airbag warning light illuminates.

**CHECK** : *Does airbag warning light come ON for about 7 seconds, then go out and stay out?*

**YES** : Perform clear memory. <Ref. to 5-5 [T4C0].>

**NO** : Go to step 4A1.

### B: ON-BOARD DIAGNOSTIC

When the airbag system is in functioning condition, the airbag warning light will remain on for about 7 seconds and go out when the ignition switch is set to ON.

If there is any malfunction, the airbag warning light will either stay on or off continuously. In such cases, perform on-board diagnostic in accordance with the specified procedure to determine trouble codes.

- 1) Turn ignition switch ON (with engine OFF).
- 2) Connect DIAG. terminal to No. 1 terminal of diagnosis connector located inside lower cover.

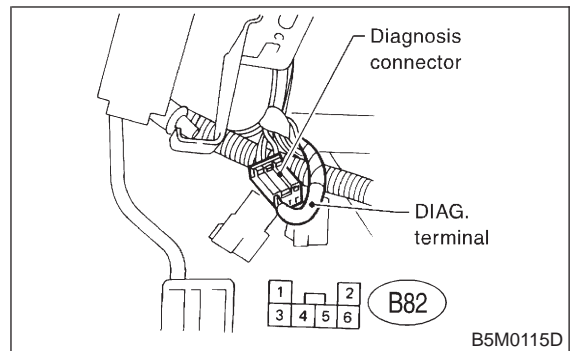

3) Check in accordance with the trouble code indicated by the AIRBAG warning light, and record the trouble codes.

4) Turn the ignition switch "OFF" and remove the DIAG. terminal from No.1 terminal of diagnosis connector.

### C: CLEAR MEMORY

After eliminating problem as per trouble code, clear memory as follows:

- 1) Make sure ignition switch is ON (and engine off). Connect one DIAG. terminal "A" on diagnosis connector terminal No. 1. While warning light is flashing, connect the other DIAG. terminal "B" on terminal No. 2 for at least three seconds.

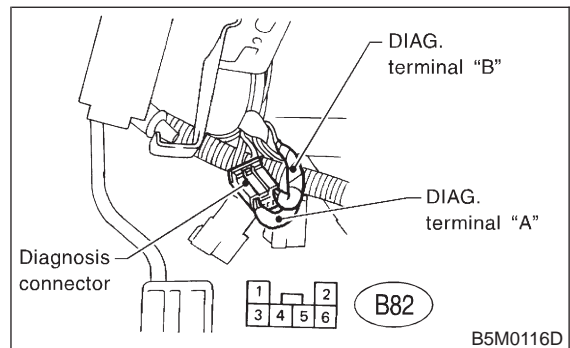

- 2) After memory is cleared, normal warning light flashing rate resumes. (Warning light flashes every 0.6 seconds ON-OFF operation.) Memory cannot be cleared if any problem exists.
- 3) After clear memory and then DIAG. terminals

“A” and “B”, extract from diagnosis connector.

## D: DIAGNOSTICS PROCEDURE

### 4D1 : CHECK TROUBLE CODE INDICATES.

- 1) Perform on-board diagnostic. <Ref. to 5-5 [T4B0].>
- 2) Check trouble code indicates.

**CHECK** : **Are trouble codes 4, 12, 13, 22, 34, 41, 42, or 43 indicated?** <Ref. to 5-5 [T5A2].>

**YES** : Go to step 4D2.

**NO** : Perform diagnostics and repair according to indicated trouble code. <Ref. to 5-5 [T5A0].> Go to step 4D10.

### 4D2 : CHECK TROUBLE CODE INDICATES.

Check trouble code indicates.

**CHECK** : **Are trouble codes 4, 22, 34, 42 indicated?** <Ref. to 5-5 [T5A2].>

**YES** : Go to step 4D3.

**NO** : Go to step 4D7.

### 4D3 : CHECK TROUBLE CODE INDICATES.

Check trouble code indicates.

**CHECK** : **Are trouble codes 12, 13, 41, 43 indicated?** <Ref. to 5-5 [T5A2].>

**YES** : Go to step 4D4.

**NO** : Go to step 4D8.

### 4D4 : CHECK AIRBAG WARNING LIGHT ILLUMINATES.

- 1) Turn ignition switch to OFF. Disconnect battery ground cable, and wait 20 seconds.
- 2) Disconnect passenger's airbag module connector (AB9) to (AB10). <Ref. to 5-5 [W3A2].>
- 3) Connect test harness F connector (1F) to (AB9).
- 4) Connect airbag resistor to test harness F connector (3F).

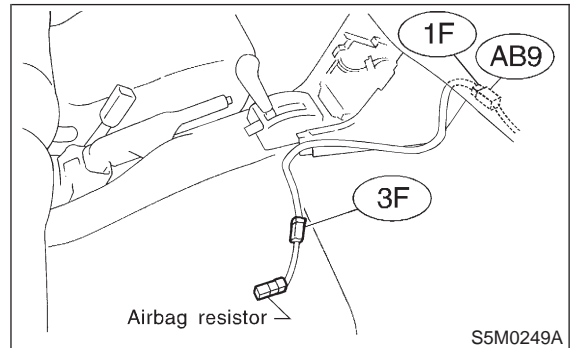

- 5) Remove lower cover panel <Ref. to 5-4 [W1A0].> and connect test harness F connector (1F) to (AB8) with airbag resistor attached to test harness F connector (3F).

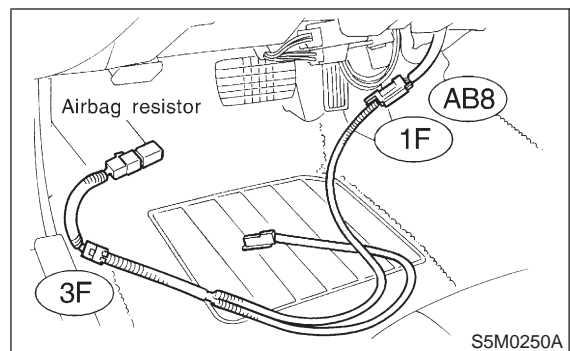

- 6) Connect battery ground cable and turn ignition switch to ON.
- 7) Check airbag warning light illuminates.

#### NOTE:

In some cases the airbag warning light will go OFF after about 7 seconds but will turn ON again within 30 seconds. In this case continue diagnostics with the basic diagnostics procedures or trouble code procedures.

**CHECK** : **Does airbag warning light go off after about 7 seconds and remain off for more than 30 seconds?**

**YES** : Go to step 4D5.

**NO** : Perform diagnostics and repair according to indicated trouble code. <Ref. to 5-5 [T5A0].> Go to step 4D10.

**4D5 : CHECK AIRBAG WARNING LIGHT ILLUMINATES.**

- 1) Turn ignition switch to OFF. Disconnect battery ground cable, and wait 20 seconds.
- 2) Connect passenger's airbag module connector (AB9) to (AB10).
- 3) Connect battery ground cable and turn ignition switch to ON.
- 4) Check airbag warning light illuminates.

**NOTE:**

In some cases the airbag warning light will go OFF after about 7 seconds but will turn ON again within 30 seconds. In this case continue diagnostics with the basic diagnostics procedures or trouble code procedures.

- CHECK** : *Does airbag warning light go off after about 7 seconds and remain off for more than 30 seconds?*
- YES** : Go to step **4D6**.
- NO** : Replace with a new passenger's airbag module. <Ref. to 5-5 [W3A2].> Go to step **4D5**.

**4D6 : CHECK AIRBAG WARNING LIGHT ILLUMINATES.**

- 1) Turn ignition switch to "OFF". Disconnect battery ground cable, and wait 20 seconds.
- 2) Connect connector (AB8) to (AB3).
- 3) Remove driver's airbag module and connect test harness F connector (1F) to (AB7). <Ref. to 5-5 [W3A1].>
- 4) Connect airbag resistor to test harness F connector (3F).

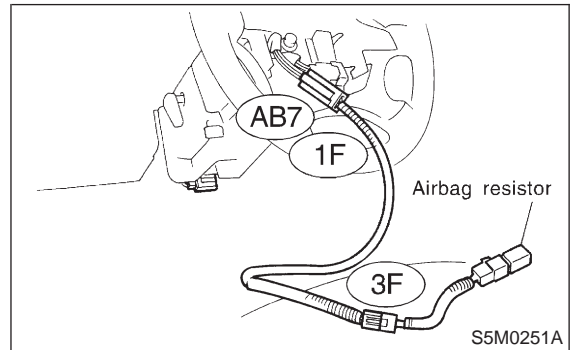

- 5) Connect battery ground cable and turn ignition switch to ON.
- 6) Check airbag warning light illuminates.

**NOTE:**

In some cases the airbag warning light will go OFF after about 7 seconds but will turn ON again within 30 seconds. In this case continue diagnostics with the basic diagnostics procedures or trouble code procedures.

- CHECK** : *Does airbag warning light go off after about 7 seconds and remain off for more than 30 seconds?*
- YES** : Replace with a new driver's airbag module. <Ref. to 5-5 [W3A1].> Go to step **4D10**.
- NO** : Replace with a new combination switch. <Ref. to 5-5 [W600].> and install driver's airbag module. <Ref. to 5-5 [W3A1].> Go to step **4D9**.

**4D7 : CHECK AIRBAG WARNING LIGHT ILLUMINATES.**

- 1) Turn ignition switch to OFF. Disconnect battery ground cable, and wait 20 seconds.
- 2) Remove lower cover panel and connect test harness F connector (1F) to (AB8) <Ref. to 5-4 [W1A0].> with airbag resistor attached to test harness F connector (3F).

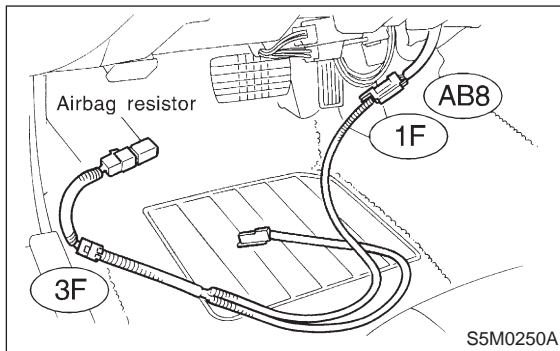

- 3) Connect battery ground cable and turn ignition switch to ON.
- 4) Check airbag warning light illuminates.

**NOTE:**

In some cases the airbag warning light will go OFF after about 7 seconds but will turn ON again within 30 seconds. In this case continue diagnostics with the basic diagnostics procedures or trouble code procedures.

**CHECK** : **Does airbag warning light go off after about 7 seconds and remain off for more than 30 seconds?**

**YES** : Go to step 4D6.

**NO** : Perform diagnostics and repair according to indicated trouble code. <Ref. to 5-5 [T5A0].> Go to step 4D10.

**4D8 : CHECK AIRBAG WARNING LIGHT ILLUMINATES.**

- 1) Turn ignition switch to OFF. Disconnect battery ground cable, and wait 20 seconds.
- 2) Disconnect passenger's airbag module connector (AB9) to (AB10). <Ref. to 5-5 [W3A2].>
- 3) Connect test harness F connector (1F) to (AB9).
- 4) Connect airbag resistor to test harness F connector (3F).

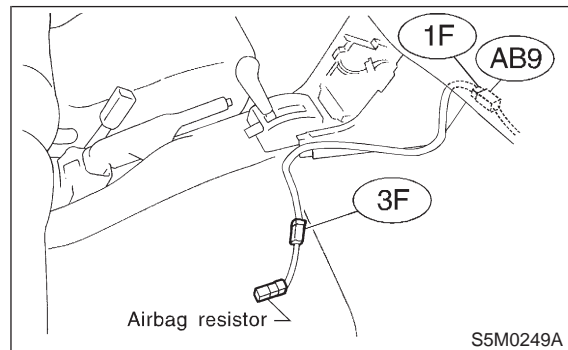

- 5) Connect battery ground cable and turn ignition switch to ON.
- 6) Check airbag warning light illuminates.

**NOTE:**

In some cases the airbag warning light will go OFF after about 7 seconds but will turn ON again within 30 seconds. In this case continue diagnostics with the basic diagnostics procedures or trouble code procedures.

**CHECK** : **Does airbag warning light go off after about 7 seconds and remain off for more than 30 seconds?**

**YES** : Replace with a new passenger's airbag module. <Ref. to 5-5 [W3A2].> Go to step 4D10.

**NO** : Perform diagnostics and repair according to indicated trouble code. <Ref. to 5-5 [T5A0].> Go to step 4D10.

**4D9 : CHECK AIRBAG WARNING LIGHT ILLUMINATES.**

- 1) Connect battery ground cable and turn ignition switch to ON.
- 2) Check airbag warning light illuminates.

**NOTE:**

In some cases the airbag warning light will go OFF after about 7 seconds but will turn ON again within 30 seconds. In this case continue diagnostics with the basic diagnostics procedures or trouble code procedures.

**CHECK** : *Does airbag warning light go off after about 7 seconds and remain off for more than 30 seconds?*

**YES** : Perform clear memory. <Ref. to 5-5 [T4C0].>

**NO** : Replace with a new driver's airbag module. <Ref. to 5-5 [W3A1].> Go to step **4D10**.

**4D10 : CHECK AIRBAG WARNING LIGHT ILLUMINATES.**

- 1) Connect battery ground cable and turn ignition switch to ON.
- 2) Check airbag warning light illuminates.

**NOTE:**

In some cases the airbag warning light will go OFF after about 7 seconds but will turn ON again within 30 seconds. In this case continue diagnostics with the basic diagnostics procedures or trouble code procedures.

**CHECK** : *Does airbag warning light go off after about 7 seconds and remain off for more than 30 seconds?*

**YES** : Perform clear memory. <Ref. to 5-5 [T4C0].>

**NO** : Go to step **4D1**.

## 5. Diagnostics Chart with Trouble Code

### A: TROUBLE CODES

#### 1. LIST OF TROUBLE CODES

Trouble code/ Contents of troubles	Memory function	Contents of diagnosis	Index No.
04	Provided.	<ul style="list-style-type: none"> <li>● Airbag main harness circuit is shorted.</li> <li>● Airbag module harness (Passenger) circuit is shorted.</li> <li>● Airbag control module is faulty.</li> </ul>	<Ref. to 5-5 [T5B0].>
11	Provided.	<ul style="list-style-type: none"> <li>● Airbag control module is faulty.</li> <li>● Airbag main harness circuit is open.</li> <li>● Fuse No. 6 is blown. (In joint box)</li> <li>● Body harness circuit is open.</li> </ul>	<Ref. to 5-5 [T5C0].>
12	Provided.	<ul style="list-style-type: none"> <li>● Airbag main harness circuit is open.</li> <li>● Airbag module harness (Driver) circuit is open.</li> <li>● Roll connector circuit is open.</li> <li>● Airbag control module is faulty.</li> </ul>	<Ref. to 5-5 [T5D0].>
13	Provided.	<ul style="list-style-type: none"> <li>● Airbag main harness circuit is shorted.</li> <li>● Airbag module harness (Driver) is shorted.</li> <li>● Roll connector circuit is shorted.</li> <li>● Airbag control module is faulty.</li> </ul>	<Ref. to 5-5 [T5E0].>
14	Not provided.	(AB6) is not connected properly to airbag control module.	<Ref. to 5-5 [T5F0].>
21	Provided.	Airbag control module is faulty.	<Ref. to 5-5 [T5G0].>
22	Provided.	<ul style="list-style-type: none"> <li>● Airbag main harness circuit is open.</li> <li>● Airbag module harness (Passenger) circuit is open.</li> <li>● Airbag control module is faulty.</li> </ul>	<Ref. to 5-5 [T5H0].>
31	Not provided.	<ul style="list-style-type: none"> <li>● Airbag control module is faulty.</li> <li>● Airbag main harness circuit is open.</li> <li>● Fuse No. 11 is blown. (In joint box)</li> <li>● Body harness circuit is open.</li> </ul>	<Ref. to 5-5 [T5I0].>
33	Provided.	Airbag module is inflated.	<Ref. to 5-5 [T5J0].>
34	Provided.	<ul style="list-style-type: none"> <li>● Airbag main harness (Passenger) circuit is shorted to power supply.</li> <li>● Airbag module harness (Passenger) is shorted to power supply.</li> <li>● Airbag control module is faulty.</li> </ul>	<Ref. to 5-5 [T5K0].>
41	Provided.	<ul style="list-style-type: none"> <li>● Airbag main harness (Driver) circuit is shorted to ground.</li> <li>● Airbag module harness (Driver) circuit is shorted to ground.</li> <li>● Roll connector circuit is shorted to ground.</li> <li>● Airbag control module is faulty.</li> </ul>	<Ref. to 5-5 [T5L0].>
42	Provided.	<ul style="list-style-type: none"> <li>● Airbag main harness (Passenger) circuit is shorted to ground.</li> <li>● Airbag module harness (Passenger) circuit is shorted to ground.</li> <li>● Airbag control module is faulty.</li> </ul>	<Ref. to 5-5 [T5M0].>
43	Provided.	<ul style="list-style-type: none"> <li>● Airbag main harness (Driver) circuit is shorted to power supply.</li> <li>● Airbag module harness (Driver) circuit is shorted to power supply.</li> <li>● Roll connector is shorted to power supply.</li> <li>● Airbag control module is faulty.</li> </ul>	<Ref. to 5-5 [T5N0].>



Trouble code/ Contents of troubles	Memory function	Contents of diagnosis	Index No.
Airbag warning light remains on.	Not provided.	<ul style="list-style-type: none"> <li>● Airbag warning light is faulty.</li> <li>● Airbag control module to airbag warning light harness circuit is shorted or open.</li> <li>● Grounding circuit is faulty.</li> <li>● Airbag control module is faulty.</li> <li>● (AB1) and (B31) are not connected properly.</li> <li>● (AB6) is not connected properly to airbag control module.</li> </ul>	<Ref. to 5-5 [T5O0].>
Airbag warning light remains off.	Not provided.	<ul style="list-style-type: none"> <li>● Fuse No. 18 is blown. (In joint box)</li> <li>● Body harness circuit is open.</li> <li>● Airbag warning light is faulty.</li> <li>● Airbag main harness is faulty.</li> <li>● Airbag control module is faulty.</li> </ul>	<Ref. to 5-5 [T5P0].>
Warning light indicates trouble code, then normal code. (Flashing trouble code.)	Provided.	Airbag system component parts are faulty.	<Ref. to 5-5 [T5Q0].>
Warning light indicates trouble code, then normal code. (Flashing normal code.)	Not provided.	<ul style="list-style-type: none"> <li>● Airbag connector is faulty.</li> <li>● Fuse No. 11 is blown. (In joint box)</li> <li>● Airbag main harness is faulty.</li> <li>● Airbag control module is faulty.</li> <li>● Body harness is faulty.</li> </ul>	<Ref. to 5-5 [T5R0].>
03	Provided.	<ul style="list-style-type: none"> <li>● Front sub sensor harness is faulty.</li> <li>● Front sub sensor is faulty.</li> </ul>	<Ref. to 5-5 [T5S0].>

**2. HOW TO READ TROUBLE CODES**

The AIRBAG warning light flashes a code corresponding to the faulty parts.

The long segment (1.2 sec on) indicates a “ten”, and the short segment (0.3 sec on) indicates a “one”.

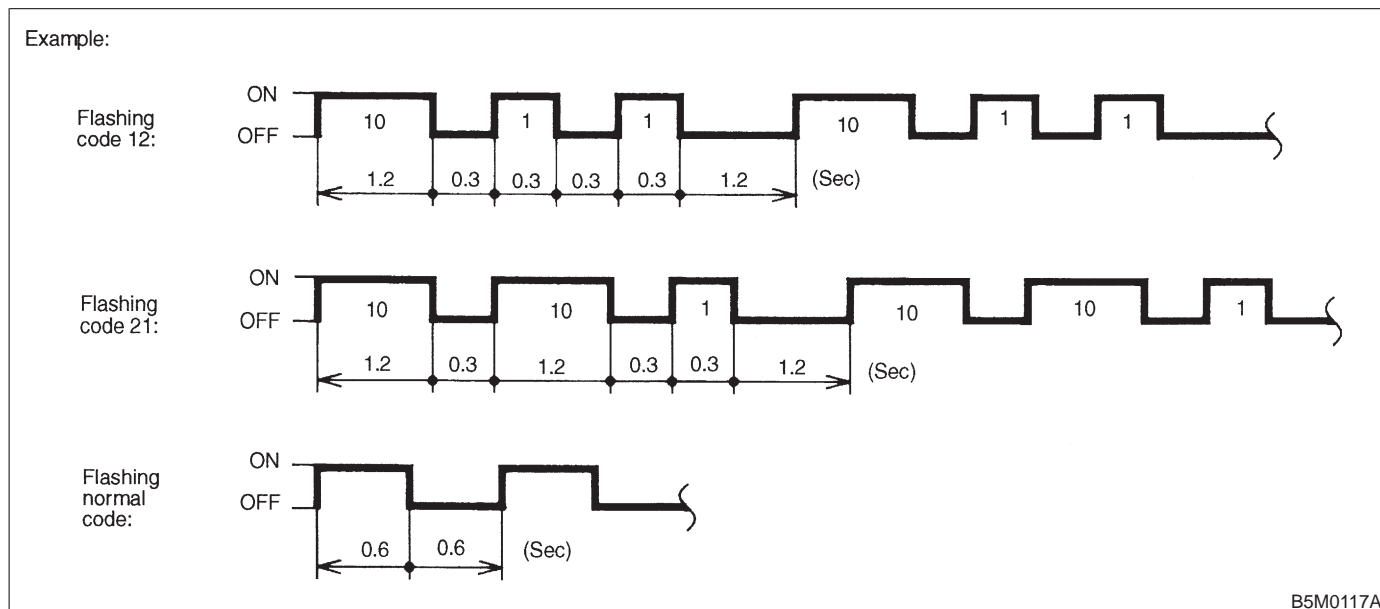

**B: TROUBLE CODE 04**

**DIAGNOSIS:**

- Airbag main harness circuit is shorted.
- Airbag module harness (Passenger) circuit is shorted.
- Airbag control module is faulty.

**CAUTION:**

Before performing diagnostics on airbag system, turn ignition switch "OFF", disconnect battery ground cable and then wait at least 20 seconds.

After 20 seconds elapse, remove instrument panel lower cover, and disconnect (AB3) and (AB8), (AB9) and (AB10).

**5B1 : AIRBAG MAIN HARNESS INSPECTION**

- 1) Disconnect connector (AB6) from airbag control module <Ref. to 5-5 [W5A0].>, and connect it to test harness E connector (1E).
- 2) Measure resistance between test harness E connector (2E) terminal.

**Connector & terminal**

**(2E) No. 2 — (2E) No. 5:**

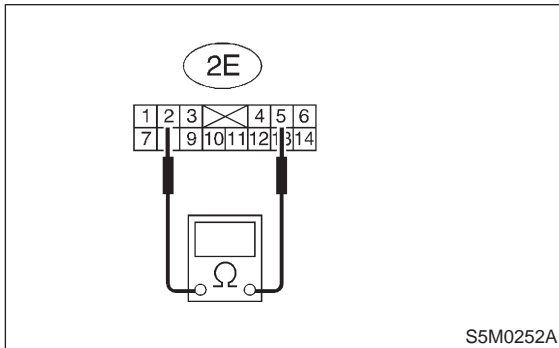

- CHECK** : **Is resistance more than 10 kΩ?**
- YES** : Replace airbag control module. <Ref. to 5-5 [W5A0].>
- NO** : Replace airbag main harness. <Ref. to 5-5 [W4A0].>

**C: TROUBLE CODE 11**

**DIAGNOSIS:**

- Airbag control module is faulty.
- Airbag main harness circuit is open.
- Fuse No. 6 is blown. (In joint box)
- Body harness circuit is open.

**CAUTION:**

Before performing diagnostics on airbag system, turn ignition switch "OFF", disconnect battery ground cable and then wait at least 20 seconds.

After 20 seconds elapse, remove instrument panel lower cover, and disconnect (AB3) and (AB8), (AB9) and (AB10).

**5C1 : AIRBAG CONTROL MODULE INSPECTION**

- 1) Disconnect connector (AB6) from airbag control module <Ref. to 5-5 [W5A0].> and connect it to test harness E connector (1E).
- 2) Connect battery ground cable and turn ignition switch "ON". (engine off)
- 3) Measure voltage across connector (2E) terminal and chassis ground.

**Connector & terminal**

**(2E) No. 6 (+) — Chassis ground (-):**

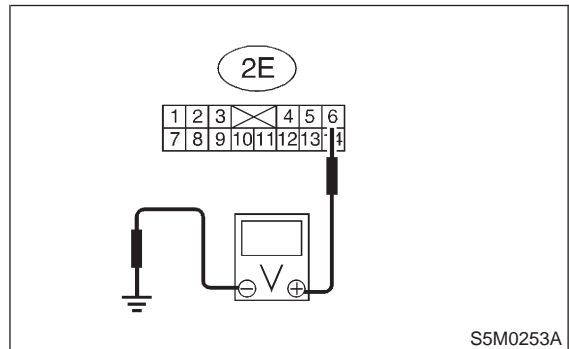

- CHECK** : **Is voltage more than 10 V?**
- YES** : Replace airbag control module. <Ref. to 5-5 [W5A0].>
- NO** : Go to step **5C2**.



**5C2 : AIRBAG MAIN HARNESS INSPECTION**

1) Go to following procedure after performing diagnostics on airbag system as per diagnosis procedure under "5C1 AIRBAG CONTROL MODULE INSPECTION" <Ref. to 5-5 [T5C1].> previously outlined.

2) Turn ignition switch "OFF", disconnect battery ground terminal and then wait at least 20 seconds.

3) Disconnect body harness connector (B31) from connector (AB1) at front lower pillar, and connect connector (AB1) to test harness A connector (2A).

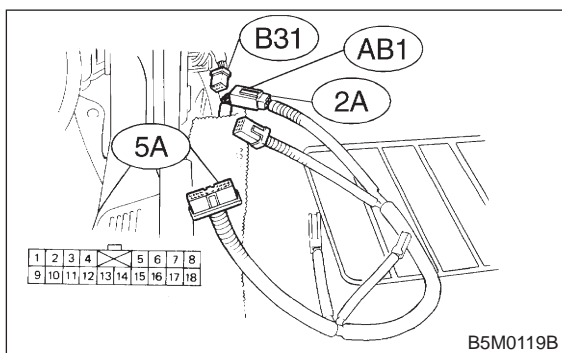

4) Measure resistance between test harness A connector (5A) terminal and test harness E connector (2E) terminal.

**Connector & terminal**

**(5A) No. 1 — (2E) No. 6:**

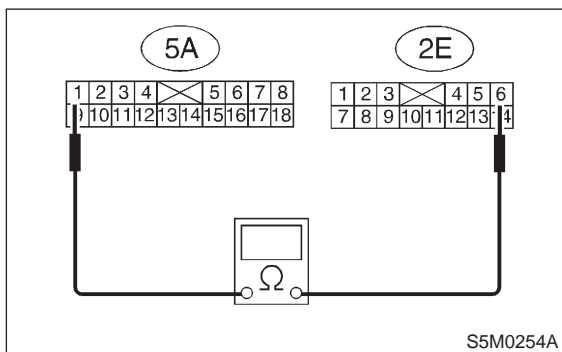

**CHECK** : **Is resistance less than 10 Ω?**

**YES** : Go to step **5C3**.

**NO** : Replace airbag main harness. <Ref. to 5-5 [W4A0].>

**5C3 : AIRBAG MAIN HARNESS INSPECTION**

Measure resistance between (5A) connector terminal and chassis ground.

**Connector & terminal**

**(5A) No. 1 (+) — Chassis ground (-):**

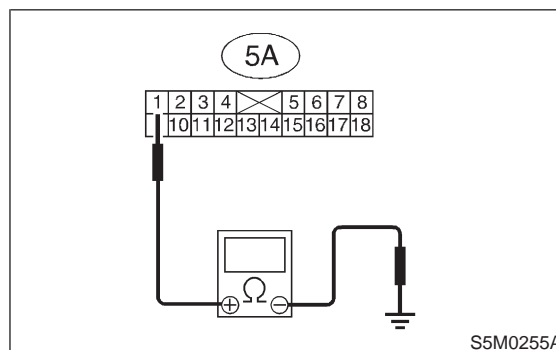

**CHECK** : **Is resistance more than 10 kΩ?**

**YES** : Go to step **5C4**.

**NO** : Replace airbag main harness. <Ref. to 5-5 [W4A0].>

**5C4 : AIRBAG MAIN HARNESS INSPECTION**

Measure resistance between (2E) connector terminal and chassis ground.

**Connector & terminal**

**(2E) No. 6 (+) — Chassis ground (-):**

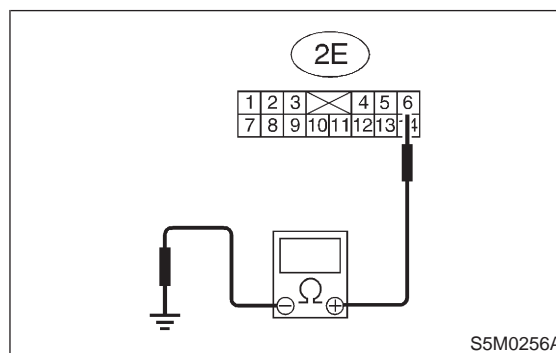

**CHECK** : **Is resistance more than 10 kΩ?**

**YES** : Go to step **5C5**.

**NO** : Replace airbag main harness. <Ref. to 5-5 [W4A0].>

**5C5 : FUSE NO. 6 (IN JOINT BOX) INSPECTION**

- 1) Turn ignition switch "OFF".
- 2) Remove and visually check fuse No. 6 (in joint box).

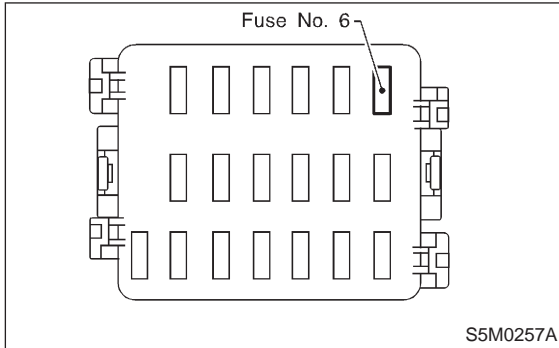

- CHECK** : *Is fuse No. 6 blown?*
- YES** : Replace fuse No. 6 if fuse No. 6 blows again, repair body harness.
- NO** : Repair body harness.

**D: TROUBLE CODE 12**

**DIAGNOSIS:**

- Airbag main harness circuit is open.
- Airbag module harness (Driver) circuit is open.
- Roll connector circuit is open.
- Airbag control module is faulty.

**CAUTION:**

**Before performing diagnostics on airbag system, turn ignition switch "OFF", disconnect battery ground cable and then wait at least 20 seconds.**

**5D1 : AIRBAG MAIN HARNESS INSPECTION**

- 1) Remove lower cover panel <Ref. to 5-4 [W1A0].>, and connect connector (AB8) below steering column to test harness F connector (1F).

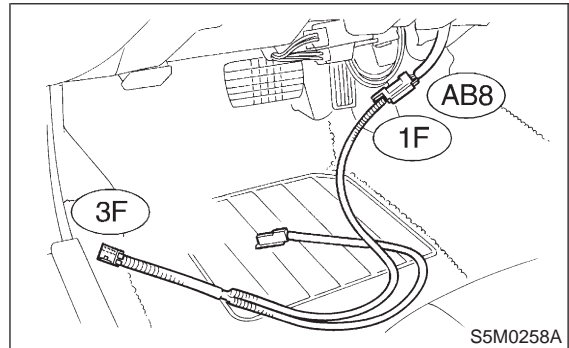

- 2) Disconnect connector (AB6) <Ref. to 5-5 [W5A0].> from airbag control module, and connect it to test harness E connector (1E) terminal.
- 3) Measure resistance between test harness E connector (2E) and test harness F connector (3F) terminals.

**Connector & terminal**

**(2E) No. 1 — (3F) No. 3:**

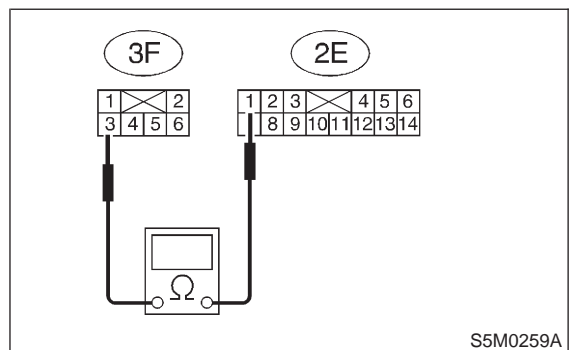

- CHECK** : *Is resistance less than 10 Ω?*
- YES** : Go to step 5D2.
- NO** : Replace airbag main harness. <Ref. to 5-5 [W4A0].>

**5D2 : AIRBAG MAIN HARNESS INSPECTION**

Measure resistance between test harness E connector (2E) and test harness F connector (3F) terminals.

**Connector & terminal**  
**(2E) No. 4 — (3F) No. 4:**

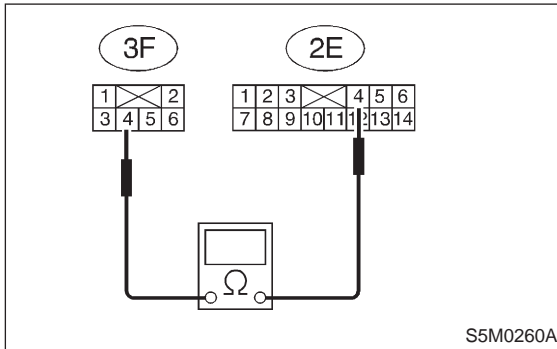

- CHECK** : **Is resistance less than 10 Ω?**
- YES** : Replace airbag control module. <Ref. to 5-5 [W5A0].>
- NO** : Replace airbag main harness. <Ref. to 5-5 [W4A0].>

**E: TROUBLE CODE 13**

**DIAGNOSIS:**

- Airbag main harness circuit is shorted.
- Airbag module harness (Driver) is shorted.
- Roll connector circuit is shorted.
- Airbag control module is faulty.

**CAUTION:**

Before performing diagnostics on airbag system, turn ignition switch “OFF”, disconnect battery ground cable and then wait at least 20 seconds.

After 20 seconds elapse, remove instrument panel lower cover, and disconnect (AB3) and (AB8), (AB9) and (AB10).

**5E1 : AIRBAG MAIN HARNESS INSPECTION**

- 1) Disconnect connector (AB6) from airbag control module <Ref. to 5-5 [W5A0].>, and connect it to test harness E connector (1E).
- 2) Measure resistance between test harness E connector (2E) terminal.

**Connector & terminal**  
**(2E) No. 1 — (2E) No. 4:**

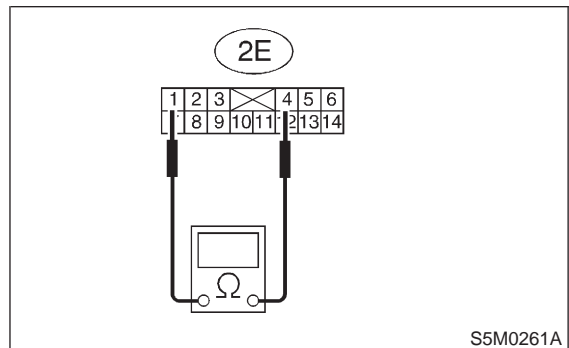

- CHECK** : **Is resistance more than 10 kΩ?**
- YES** : Replace airbag control module. <Ref. to 5-5 [W5A0].>
- NO** : Replace airbag main harness. <Ref. to 5-5 [W4A0].>

**F: TROUBLE CODE 14****DIAGNOSIS:**

(AB6) is not connected properly to airbag control module.

**CAUTION:**

Before performing diagnostics on airbag system, turn ignition switch "OFF", disconnect battery ground cable and then wait at least 20 seconds.

**5F1 : CHECK POOR CONTACT IN CONNECTOR (AB6).**

Check connector (AB6) connected to airbag control module. <Ref. to 5-5 [W5A0].>

- CHECK** : *Is there poor contact in connector (AB6)?*
- YES** : Repair poor contact in connector (AB6).
- NO** : Replace airbag control module. <Ref. to 5-5 [W5A0].>

**G: TROUBLE CODE 21****DIAGNOSIS:**

Airbag control module is faulty.

**CAUTION:**

Before performing diagnostics on airbag system, turn ignition switch "OFF", disconnect battery ground terminal, and then wait at least 20 seconds.

**5G1 : CHECK IF TROUBLE CODE 21 IS INDICATED.**

Confirm flashing trouble code according to "BASIC DIAGNOSTICS PROCEDURE". <Ref. to 5-5 [T4A0].>

- CHECK** : *Is airbag warning light trouble code 21 indicated?*
- YES** : Replace airbag control module. <Ref. to 5-5 [W5A0].>
- NO** : Perform clear memory. <Ref. to 5-5 [T4C0].>

**H: TROUBLE CODE 22**

**DIAGNOSIS:**

- Airbag main harness circuit is open.
- Airbag module harness (Passenger) circuit is open.
- Airbag control module is faulty.

**CAUTION:**

Before performing diagnostics on airbag system, turn ignition switch "OFF", disconnect battery ground cable and then wait at least 20 seconds.

**5H1 : AIRBAG MAIN HARNESS INSPECTION**

- 1) Remove glove box. <Ref. to 5-4 [W1A0].>
- 2) Disconnect connector (AB9) and (AB10) <Ref. to 5-5 [W3A2].> and connect connector (AB9) to test harness F connector (1F).
- 3) Disconnect connector (AB6) <Ref. to 5-5 [W5A0].> from airbag control module, and connect it to test harness E connector (1E) terminal.
- 4) Measure resistance between test harness E connector (2E) and test harness F connector (3F) terminals.

**Connector & terminal**

**(2E) No. 2 — (3F) No. 3:**

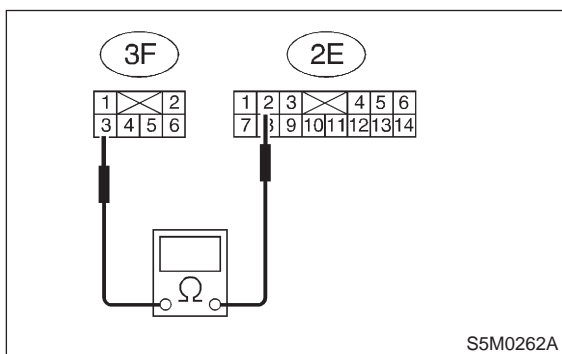

- CHECK** : Is resistance less than 10 Ω?
- YES** : Go to step 5H2.
- NO** : Replace airbag main harness. <Ref. to 5-5 [W4A0].>

**5H2 : AIRBAG MAIN HARNESS INSPECTION**

Measure resistance between test harness E connector (2E) and test harness F connector (3F) terminals.

**Connector & terminal**

**(2E) No. 5 — (3F) No. 4:**

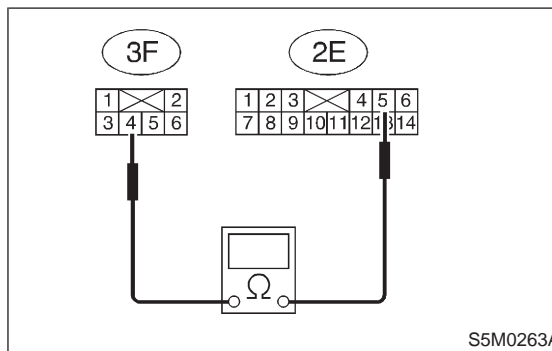

- CHECK** : Is resistance less than 10 Ω?
- YES** : Replace airbag control module. <Ref. to 5-5 [W5A0].>
- NO** : Replace airbag main harness. <Ref. to 5-5 [W4A0].>

**I: TROUBLE CODE 31**

**DIAGNOSIS:**

- Airbag control module is faulty.
- Airbag main harness circuit is open.
- Fuse No. 11 is blown. (In joint box)
- Body harness circuit is open.

**CAUTION:**

**Before performing diagnostics on airbag system, turn ignition switch "OFF", disconnect battery ground cable and then wait at least 20 seconds.**

**After 20 seconds elapse, remove instrument panel lower cover, and disconnect (AB3) and (AB8), (AB9) and (AB10).**

**5I1 : AIRBAG CONTROL MODULE INSPECTION**

- 1) Disconnect connector (AB6) from airbag control module <Ref. to 5-5 [W5A0].>, and connect it to test harness E connector (1E).
- 2) Connect battery ground cable and turn ignition switch "ON" (engine off).
- 3) Measure voltage across connector (2E) terminal and chassis ground.

**Connector & terminal**

**(2E) No. 3 (+) — Chassis ground (-):**

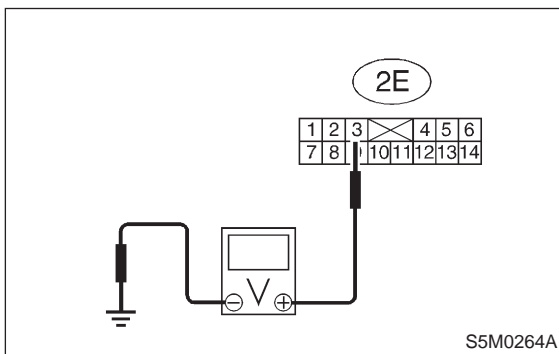

- CHECK** : **Is voltage more than 10 V?**
- YES** : Replace airbag control module. <Ref. to 5-5 [W5A0].>
- NO** : Go to step 5I2.

**5I2 : AIRBAG MAIN HARNESS INSPECTION**

- 1) Go to following procedure after performing diagnostics on airbag system as per diagnosis procedure under "5I1 AIRBAG CONTROL MODULE INSPECTION" <Ref. to 5-5 [T511].> previously outlined.
- 2) Turn ignition switch "OFF", disconnect battery ground cable and then wait at least 20 seconds.
- 3) Disconnect connector (AB1) from body harness connector (B31) at front lower pillar (driver side), and connect connector (AB1) to test harness A connector (2A).
- 4) Measure resistance between test harness A connector (5A) and test harness E connector (2E) terminals.

**Connector & terminal**

**(5A) No. 9 — (2E) No. 3:**

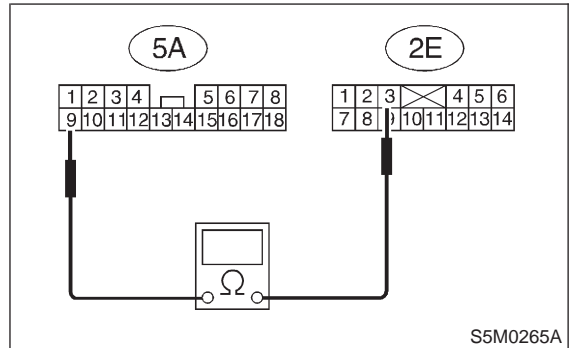

- CHECK** : **Is resistance less than 10 Ω?**
- YES** : Go to step 5I3.
- NO** : Replace airbag main harness. <Ref. to 5-5 [W4A0].>

**5I3 : AIRBAG MAIN HARNESS INSPECTION**

Measure resistance between each terminal of connectors (5A) and chassis ground.

**Connector & terminal**

**(5A) No. 9 (+) — Chassis ground (-):**

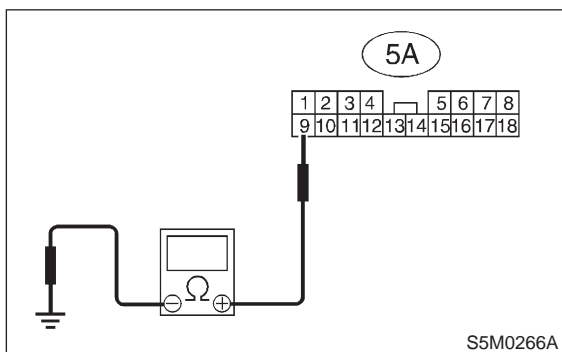

- CHECK** : **Is resistance more than 10 kΩ?**
- YES** : Go to step 5I4.
- NO** : Replace airbag main harness. <Ref. to 5-5 [W4A0].>

**5I4 : AIRBAG MAIN HARNESS INSPECTION**

Measure resistance between each terminal of connectors (2E) and chassis ground.

**Connector & terminal**

**(2E) No. 3 (+) — Chassis ground (-):**

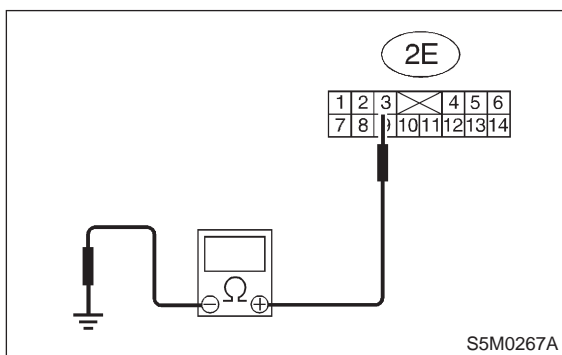

- CHECK** : **Is resistance more than 10 kΩ?**
- YES** : Go to step 5I5.
- NO** : Replace airbag main harness. <Ref. to 5-5 [W4A0].>

**5I5 : FUSE NO. 11 (IN JOINT BOX) INSPECTION**

Make sure ignition switch is turned "OFF", then remove and visually check fuse No. 11 (in joint box).

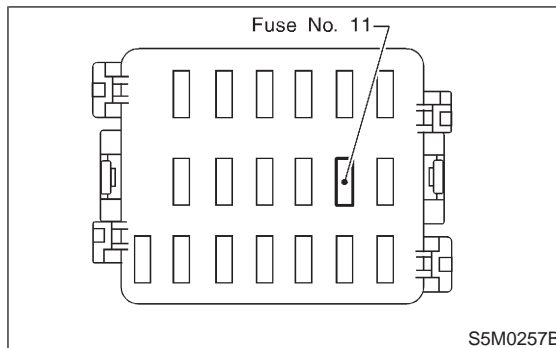

- CHECK** : **Is fuse No. 11 blown?**
- YES** : Replace fuse No. 11. If fuse No. 11 blows again, repair body harness.
- NO** : Repair body harness.

**J: TROUBLE CODE 33****DIAGNOSIS:**

Airbag module is inflated.

**CAUTION:**

Before performing diagnostics on airbag system, turn ignition switch "OFF", disconnect battery ground terminal, and then wait at least 20 seconds.

**5J1 : CHECK IF TROUBLE CODE 33 IS INDICATED.**

Confirm flashing trouble code according to "BASIC DIAGNOSTICS PROCEDURE". <Ref. to 5-5 [T4A0].>

- CHECK** : Is airbag warning light trouble code 33 indicated?
- YES** : Replace airbag control module. <Ref. to 5-5 [W5A0].>
- NO** : Perform clear memory. <Ref. to 5-5 [T4C0].>

**K: TROUBLE CODE 34****DIAGNOSIS:**

- Airbag main harness circuit (Passenger) is shorted to power supply.
- Airbag module harness (Passenger) is shorted to power supply.
- Airbag control module is faulty.

**CAUTION:**

Before performing diagnostics on airbag system, turn ignition switch "OFF", disconnect battery ground terminal and then wait at least 20 seconds.

After 20 seconds elapse, remove instrument panel lower cover, and disconnect (AB3) and (AB8), (AB9) and (AB10).

**5K1 : AIRBAG MAIN HARNESS INSPECTION**

- 1) Disconnect connector (AB6) from airbag control module <Ref. to 5-5 [W5A0].>, and connect it to test harness E connector (1E).
- 2) Connect battery ground cable and turn ignition switch "ON" (engine off).
- 3) Measure voltage across each test harness E connector (2E) terminal and chassis ground.

**Connector & terminal**

**(2E) No. 2 (+) — Chassis ground (-):**

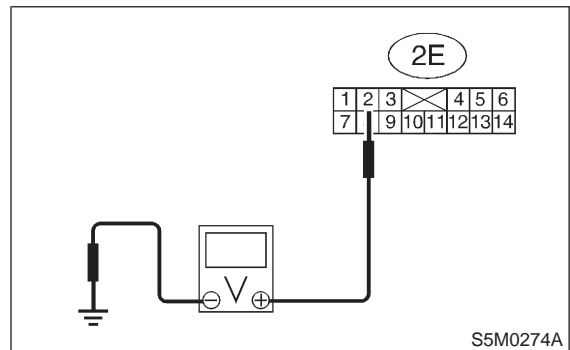

- CHECK** : Is voltage less than 1 V?
- YES** : Go to step 5K2.
- NO** : Replace airbag main harness. <Ref. to 5-5 [W4A0].>



**5K2 : AIRBAG MAIN HARNESS INSPECTION**

Measure voltage across each test harness E connector (2E) terminal and chassis ground.

**Connector & terminal**

**(2E) No. 5 (+) — Chassis ground (-):**

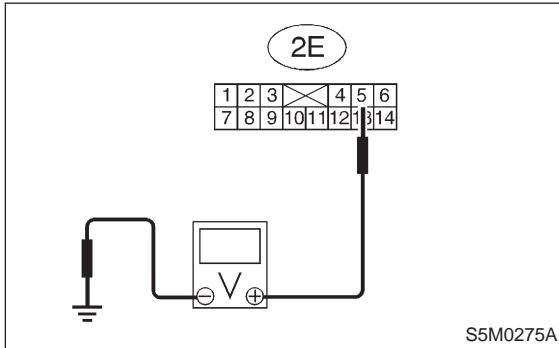

- CHECK** : *Is voltage less than 1 V?*
- YES** : Replace airbag control module. <Ref. to 5-5 [W5A0].>
- NO** : Replace airbag main harness. <Ref. to 5-5 [W4A0].>

**L: TROUBLE CODE 41**

**DIAGNOSIS:**

- Airbag main harness (Driver) circuit is shorted to ground.
- Airbag module harness (Driver) circuit is shorted to ground.
- Roll connector circuit is shorted to ground.
- Airbag control module is faulty.

**CAUTION:**

**Before performing diagnostics on airbag system, turn ignition switch “OFF”, disconnect battery ground cable and then wait at least 20 seconds.**

**After 20 seconds elapse, remove instrument panel lower cover, and disconnect (AB3) and (AB8), (AB9) and (AB10).**

**5L1 : AIRBAG MAIN HARNESS INSPECTION**

- 1) Disconnect connector (AB6) from airbag control module <Ref. to 5-5 [W5A0].>, and connect it to test harness E connector (1E).
- 2) Measure resistance between test harness E connector (2E) terminals and chassis ground.

**Connector & terminal**

**(2E) No. 4 (+) — Chassis ground (-):**

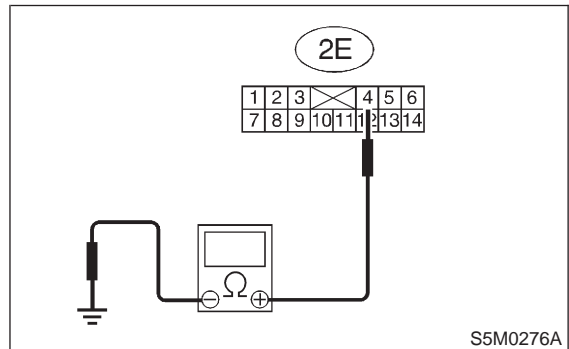

- CHECK** : *Is resistance more than 200 Ω?*
- YES** : Go to step 5L2.
- NO** : Replace airbag main harness. <Ref. to 5-5 [W4A0].>

**5L2 : AIRBAG MAIN HARNESS INSPECTION**

Measure resistance between test harness E connector (2E) terminals and chassis ground.

**Connector & terminal**

**(2E) No. 1 (+) — Chassis ground (-):**

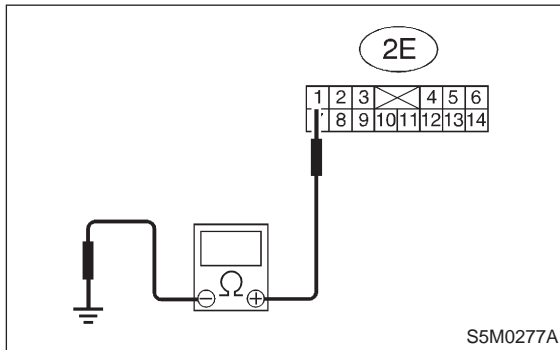

- CHECK** : **Is resistance more than 200  $\Omega$ ?**
- YES** : Replace airbag control module. <Ref. to 5-5 [W5A0].>
- NO** : Replace airbag main harness. <Ref. to 5-5 [W4A0].>

**M: TROUBLE CODE 42****DIAGNOSIS:**

- Airbag main harness (Passenger) circuit is shorted to ground.
- Airbag module harness (Passenger) circuit is shorted to ground.
- Airbag control module is faulty.

**CAUTION:**

**Before performing diagnostics on airbag system, turn ignition switch "OFF", disconnect battery ground cable and then wait at least 20 seconds.**

**After 20 seconds elapse, remove instrument panel lower cover, and disconnect (AB3) and (AB8), (AB9) and (AB10).**

**5M1 : AIRBAG MAIN HARNESS INSPECTION**

- 1) Disconnect connector (AB6) from airbag control module <Ref. to 5-5 [W5A0].>, and connect it to test harness E connector (1E).
- 2) Measure resistance between test harness E connector (2E) terminals and chassis ground.

**Connector & terminal**

**(2E) No. 2 (+) — Chassis ground (-):**

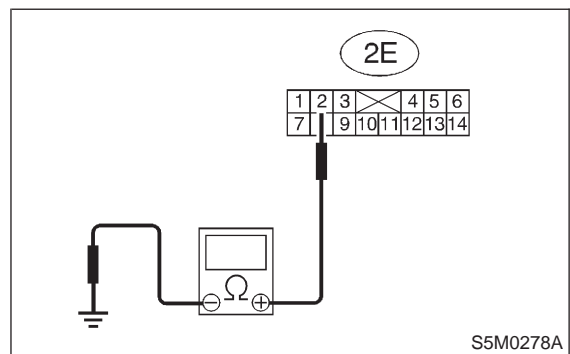

- CHECK** : **Is resistance more than 200  $\Omega$ ?**
- YES** : Go to step **5M2**.
- NO** : Replace airbag main harness. <Ref. to 5-5 [W4A0].>

**5M2 : AIRBAG MAIN HARNESS INSPECTION**

Measure resistance between test harness E connector (2E) terminals and chassis ground.

**Connector & terminal**

**(2E) No. 5 (+) — Chassis ground (-):**

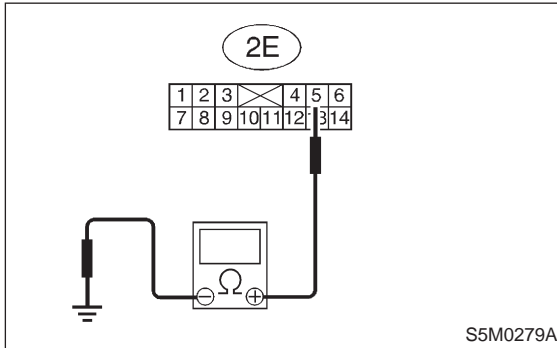

- CHECK** : **Is resistance more than 200 Ω?**
- YES** : Replace airbag control module. <Ref. to 5-5 [W5A0].>
- NO** : Replace airbag main harness. <Ref. to 5-5 [W4A0].>

**N: TROUBLE CODE 43**

**DIAGNOSIS:**

- Airbag main harness (Driver) circuit is shorted to power supply.
- Airbag module harness (Driver) circuit is shorted to power supply.
- Roll connector is shorted to power supply.
- Airbag control module is faulty.

**CAUTION:**

**Before performing diagnostics on airbag system, turn ignition switch “OFF”, disconnect battery ground terminal and then wait at least 20 seconds.**

**After 20 seconds elapse, remove instrument panel lower cover, and disconnect (AB3) and (AB8), (AB9) and (AB10).**

**5N1 : AIRBAG MAIN HARNESS INSPECTION**

- 1) Disconnect connector (AB6) from airbag control module <Ref. to 5-5 [W5A0].>, and connect it to test harness E connector (1E).
- 2) Connect battery ground cable and turn ignition switch “ON” (engine off).
- 3) Measure voltage across each test harness E connector (2E) terminal and chassis ground.

**Connector & terminal**

**(2E) No. 4 (+) — Chassis ground (-):**

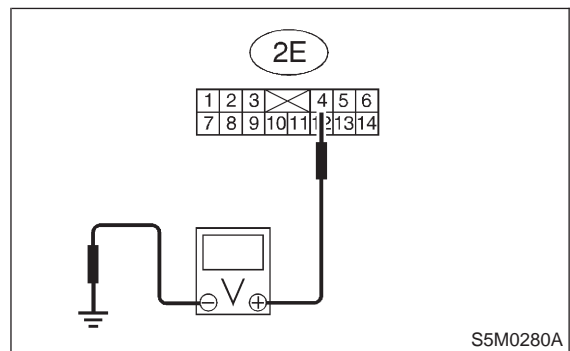

- CHECK** : **Is voltage less than 1 V?**
- YES** : Go to step 5N2.
- NO** : Replace airbag main harness. <Ref. to 5-5 [W4A0].>

**5N2 : AIRBAG MAIN HARNESS INSPECTION**

Measure voltage across each test harness E connector (2E) terminal and chassis ground.

**Connector & terminal**

**(2E) No. 1 (+) — Chassis ground (-):**

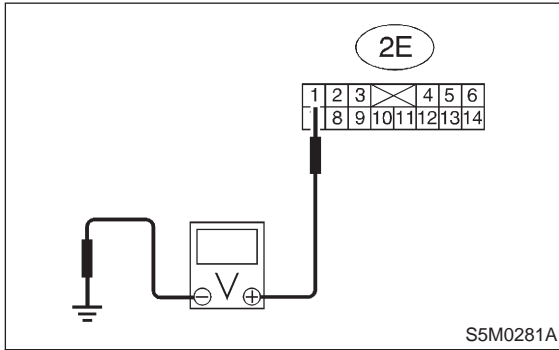

- CHECK** : *Is voltage less than 1 V?*
- YES** : Replace airbag control module. <Ref. to 5-5 [W5A0].>
- NO** : Replace airbag main harness. <Ref. to 5-5 [W4A0].>

**O: AIRBAG WARNING LIGHT REMAINS ON.**

**DIAGNOSIS:**

- Airbag warning light is faulty.
- Airbag control module to airbag warning light harness circuit is shorted or open.
- Grounding circuit is faulty.
- Airbag control module is faulty.
- (AB1) and (B31) are not connected properly.
- (AB6) is not connected properly to airbag control module.

**CAUTION:**

**Before performing diagnostics on airbag system, turn ignition switch "OFF", disconnect battery ground cable and then wait at least 20 seconds.**

**5O1 : CHECK POOR CONTACT IN CONNECTORS (AB1) AND (B31).**

- 1) Remove front pillar lower trim (Driver side).
- 2) Check poor contact in connectors (AB1) and (B31).

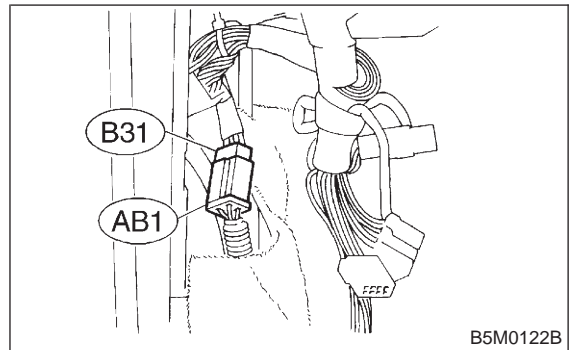

- CHECK** : *Is there poor contact in double lock of connectors (AB1) and (B31)?*
- YES** : Repair poor contact in double lock of connectors (AB1) and (B31).
- NO** : Go to step **5O2**.

**502 : INSPECTION OF AIRBAG WARNING LIGHT**

1) Turn ignition switch "OFF" and connect body harness connector (B31) to test connector A connector (1A).

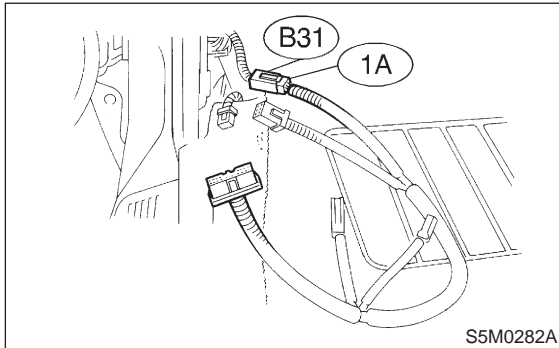

2) Connect battery ground cable and turn ignition switch "ON", (engine off) and connect connectors (3A) and (4A).

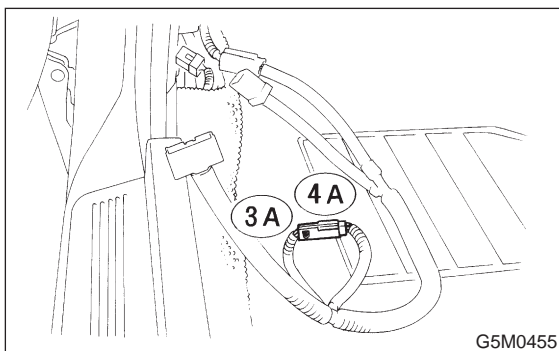

- CHECK** : *Does the airbag warning light come off?*
- YES** : Go to step **504**.
- NO** : Go to step **503**.

**503 : INSPECTION OF BODY HARNESS**

Check body harness.

**NOTE:**

After problem has been eliminated, disconnect connectors (3A) and (4A).

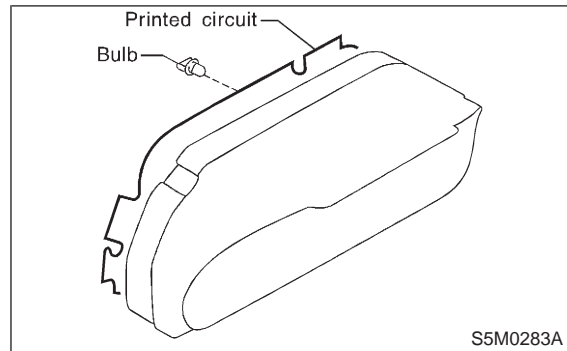

- CHECK** : *Is there anything unusual to body harness?*
- YES** : Repair body harness.
- NO** : Replace airbag warning light bulb <Ref. to 6-2 [W8B0].> or combination meter printed circuit.

**504 : CHECK POOR CONTACT IN CONNECTOR (AB6).**

Check connector (AB6) connected to airbag control module. <Ref. to 5-5 [W5A0].>

- CHECK** : *Is there poor contact in connector (AB6)?*
- YES** : Repair poor contact in connector (AB6).
- NO** : Go to step **505**.

**505 : INSPECTION OF AIRBAG MAIN HARNESS**

- 1) Turn ignition switch "OFF", disconnect battery ground cable and then wait at least 20 seconds, and re-connect connectors (AB1) and (B31).
- 2) Remove instrument panel lower cover and disconnect (AB3) with (AB8), then disconnect connector (AB6) from airbag control module, <Ref. to 5-5 [W5A0].> and connect it to test harness E connector (1E).
- 3) Connect battery ground cable and turn ignition switch "ON", (engine off) and connect connectors (4E) and (5E).

**NOTE:**

After problem has been eliminated, disconnect connectors (4E) and (5E).

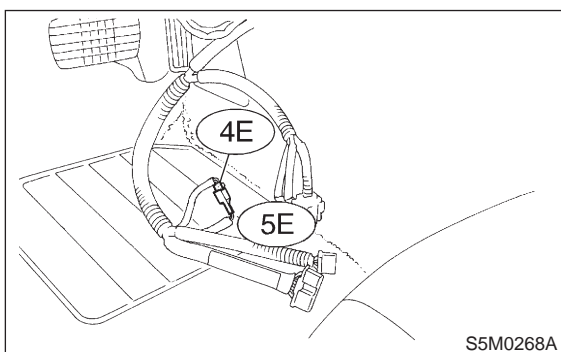

- CHECK** : Does the airbag warning light come on?
- YES** : Go to step 506.
- NO** : Replace airbag main harness. <Ref. to 5-5 [W4A0].>

**506 : GROUNDING CIRCUIT INSPECTION**

- 1) Turn ignition switch "OFF", disconnect battery ground cable and then wait at least 20 seconds.
- 2) Disconnect connector (AB1) from body harness connector (B31), and connect connector (B31) to test harness A connector (1A).
- 3) Measure resistance between connector (5A) terminal and chassis ground.

**Connector & terminal**

**(5A) No. 17 (+) — Chassis ground (-):**

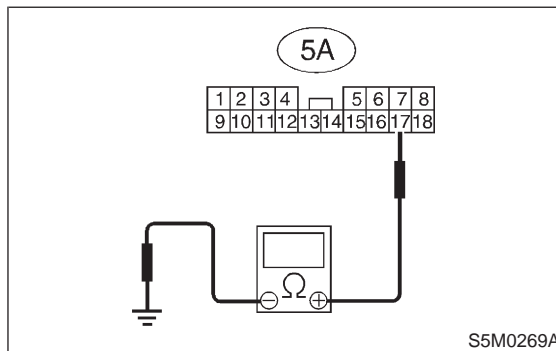

- CHECK** : Is resistance less than 10 Ω?
- YES** : Go to step 507.
- NO** : Repair body grounding circuit.

**507 : GROUNDING CIRCUIT INSPECTION**

Measure resistance between connector (5A) terminal and chassis ground.

**Connector & terminal**

**(5A) No. 18 (+) — Chassis ground (-):**

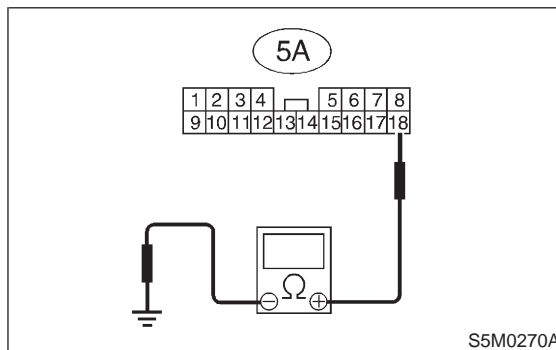

- CHECK** : Is resistance less than 10 Ω?
- YES** : Go to step 508.
- NO** : Repair body grounding circuit.

**508 : INSPECTION OF AIRBAG MAIN HARNESS**

- 1) Connect connectors (AB1) and (B31). Disconnect connector (AB6) from airbag control module <Ref. to 5-5 [W5A0].>, and connect it to test harness E connector (1E).
- 2) Measure resistance between each test harness E connector (2E) terminal and chassis ground.

**Connector & terminal**

**(2E) No. 9 (+) — Chassis ground (-):**

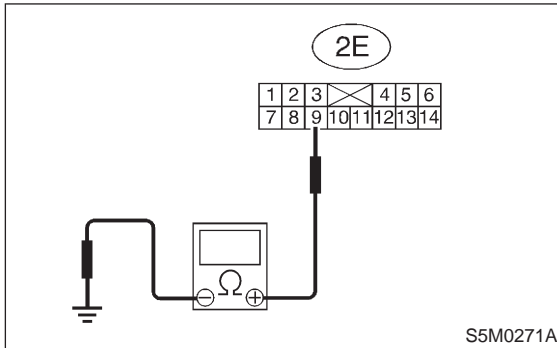

- CHECK** : **Is resistance less than 10 Ω?**
- YES** : Go to step **509**.
- NO** : Replace airbag main harness. <Ref. to 5-5 [W4A0].>

**509 : INSPECTION OF AIRBAG MAIN HARNESS**

Measure resistance between each test harness E connector (2E) terminal and chassis ground.

**Connector & terminal**

**(2E) No. 10 (+) — Chassis ground (-):**

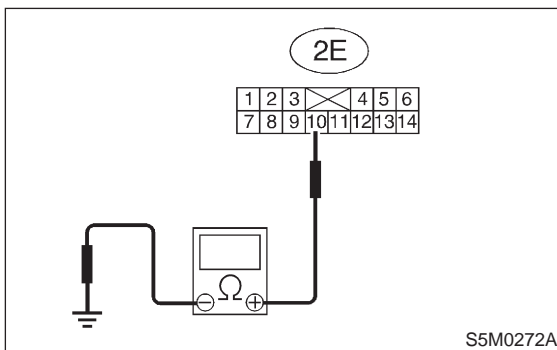

- CHECK** : **Is resistance less than 10 Ω?**
- YES** : Replace airbag control module. <Ref. to 5-5 [W5A0].>
- NO** : Replace airbag main harness. <Ref. to 5-5 [W4A0].>

**P: AIRBAG WARNING LIGHT REMAINS OFF.**

**DIAGNOSIS:**

- Fuse No. 18 is blown. (In joint box)
- Body harness circuit is open.
- Airbag warning light is faulty.
- Airbag main harness is faulty.
- Airbag control module is faulty.

**CAUTION:**

**Before performing diagnostics on airbag system, turn ignition switch “OFF”, disconnect battery ground terminal, and then wait at least 20 seconds.**

**5P1 : FUSE NO. 18 (IN JOINT BOX) INSPECTION**

Remove and visually check fuse No. 18 (In joint box).

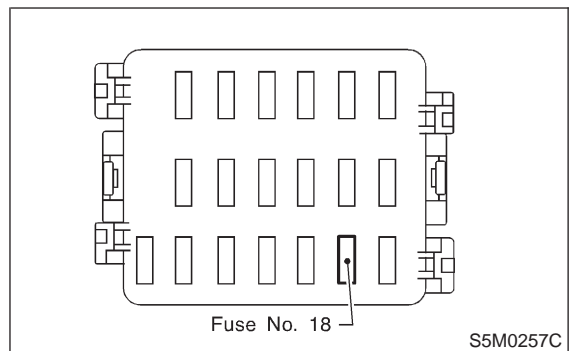

- CHECK** : **Is fuse No. 18 blown?**
- YES** : Replace fuse No. 18. If fuse No. 18 blows again, Go to step **5P2**.
- NO** : Go to step **5P2**.

**5P2 : BODY HARNESS INSPECTION**

Turn ignition switch “ON” (engine off) to make sure other warning lights (in combination meter) illuminate.

- CHECK** : **Do all the warning lights (in combination meter) except airbag warning light come on?**
- YES** : Go to step **5P3**.
- NO** : Repair body harness.

### 5P3 : AIRBAG WARNING LIGHT MODULE (IN COMBINATION METER) INSPECTION

- 1) Turn ignition switch "OFF", disconnect battery ground cable and then wait at least 20 seconds.
- 2) Disconnect body harness connector (B31) from connector (AB1).

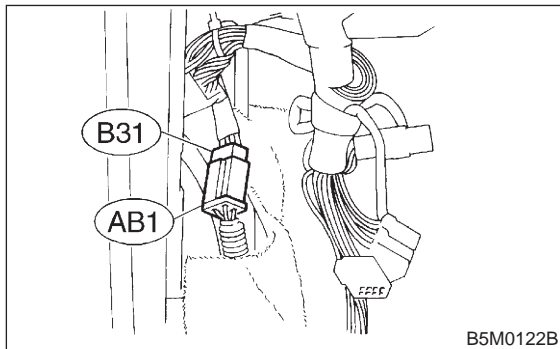

- 3) Connect battery ground cable and turn ignition switch "ON" (engine off) to make sure airbag warning light illuminates.

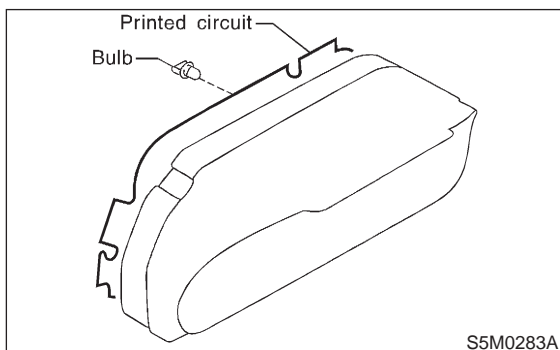

- CHECK** : Does the airbag warning light come on?
- YES** : Go to step **5P4**.
- NO** : Replace airbag warning light bulb <Ref. to 6-2 [W8B0].> or combination meter printed circuit.

### 5P4 : AIRBAG MAIN HARNESS INSPECTION

- 1) Turn ignition switch "OFF", disconnect battery ground cable and then wait at least 20 seconds.
- 2) Connect body harness connector (B31) and connector (AB1).
- 3) Disconnect connectors (AB3) and (AB8) below steering column. <Ref. to 5-5 [M2F2].>

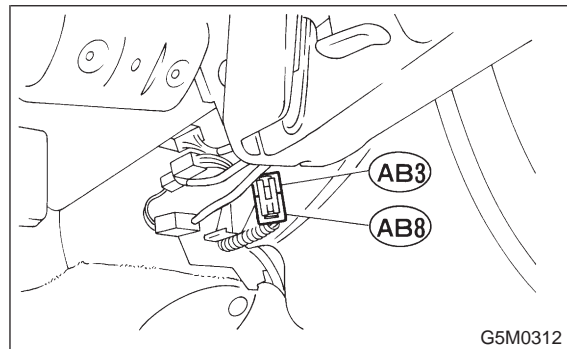

- 4) Disconnect connector (AB6) from airbag control module. <Ref. to 5-5 [W5A0].>
- 5) Connect battery ground cable and turn ignition switch "ON" to make sure airbag warning light illuminates.

- CHECK** : Does the airbag warning light come on?
- YES** : Replace airbag control module. <Ref. to 5-5 [W5A0].>
- NO** : Replace airbag main harness. <Ref. to 5-5 [W4A0].>



**Q: WARNING LIGHT INDICATES TROUBLE CODE, THEN NORMAL CODE. (FLASHING TROUBLE CODE.)**

**DIAGNOSIS:**

Airbag system component parts are faulty.

**CAUTION:**

**Before performing diagnostics on airbag system, turn ignition switch “OFF”, disconnect battery ground cable, and then wait at least 20 seconds.**

**5Q1 : AIRBAG COMPONENT PARTS APPEARANCE INSPECTION**

- 1) Conduct on-board diagnostic and call up trouble codes stored in memory. <Ref. to 5-5 [T4B0].>
- 2) Select trouble code required to check airbag component parts from those listed in table and reproduce symptom.

Trouble codes	Check parts	Index. No.
03	<ul style="list-style-type: none"> <li>● Airbag main harness</li> <li>● Front sub sensor and front sub sensor harness (Both sides)</li> </ul>	<Ref. to 5-5 [W400].> <Ref. to 5-5 [W700].>
04	<ul style="list-style-type: none"> <li>● Airbag module (Passenger)</li> <li>● Airbag main harness</li> <li>● Airbag control module</li> </ul>	<Ref. to 5-5 [W300].> <Ref. to 5-5 [W400].> <Ref. to 5-5 [W500].>
11	<ul style="list-style-type: none"> <li>● Fuse No. 6</li> <li>● Airbag main harness</li> <li>● Airbag control module</li> <li>● Body harness</li> </ul>	<Ref. to 5-5 [T5C5].> <Ref. to 5-5 [W400].> <Ref. to 5-5 [W500].> —
12	<ul style="list-style-type: none"> <li>● Roll connector</li> <li>● Airbag module (Driver)</li> <li>● Airbag main harness</li> <li>● Airbag control module</li> </ul>	<Ref. to 5-5 [W600].> <Ref. to 5-5 [W300].> <Ref. to 5-5 [W400].> <Ref. to 5-5 [W500].>
13	<ul style="list-style-type: none"> <li>● Airbag module (Driver)</li> <li>● Roll connector</li> <li>● Airbag main harness</li> <li>● Airbag control module</li> </ul>	<Ref. to 5-5 [W300].> <Ref. to 5-5 [W600].> <Ref. to 5-5 [W400].> <Ref. to 5-5 [W500].>
21	<ul style="list-style-type: none"> <li>● Airbag control module</li> </ul>	<Ref. to 5-5 [W500].>
22	<ul style="list-style-type: none"> <li>● Airbag module (Passenger)</li> <li>● Airbag main harness</li> <li>● Airbag control module</li> </ul>	<Ref. to 5-5 [W300].> <Ref. to 5-5 [W400].> <Ref. to 5-5 [W500].>
33	<ul style="list-style-type: none"> <li>● Airbag control module</li> </ul>	<Ref. to 5-5 [W500].>
34	<ul style="list-style-type: none"> <li>● Airbag main harness</li> <li>● Airbag module (Passenger)</li> <li>● Airbag control module</li> </ul>	<Ref. to 5-5 [W400].> <Ref. to 5-5 [W300].> <Ref. to 5-5 [W500].>
41	<ul style="list-style-type: none"> <li>● Airbag module (Driver)</li> <li>● Roll connector</li> <li>● Airbag main harness</li> <li>● Airbag control module</li> </ul>	<Ref. to 5-5 [W300].> <Ref. to 5-5 [W600].> <Ref. to 5-5 [W400].> <Ref. to 5-5 [W500].>
42	<ul style="list-style-type: none"> <li>● Airbag module (Passenger)</li> <li>● Airbag main harness</li> <li>● Airbag control module</li> </ul>	<Ref. to 5-5 [W300].> <Ref. to 5-5 [W400].> <Ref. to 5-5 [W500].>
43	<ul style="list-style-type: none"> <li>● Airbag module (Driver)</li> <li>● Roll connector</li> <li>● Airbag main harness</li> <li>● Airbag control module</li> </ul>	<Ref. to 5-5 [W300].> <Ref. to 5-5 [W600].> <Ref. to 5-5 [W400].> <Ref. to 5-5 [W500].>

3) Conduct appearance inspection on parts selected.

**NOTE:**

Also check connector terminals, wiring harness, case, etc. for damage.

**CHECK** : *Is there anything unusual about the appearance of airbag component parts?*

**YES** : Replace faulty airbag component parts.

**NO** : Go to step **5Q2**.

### 5Q2 : AIRBAG COMPONENT PARTS VIBRATION INSPECTION

- 1) Gently shake check parts (to determine faults.).
- 2) To check airbag module or roll connector, turn and tilt steering wheel.

**CAUTION:**

**Do not shake or vibrate airbag control module.**

**CHECK** : *Does the component malfunction again when shaking?*

**YES** : Replace faulty airbag component parts.

**NO** : Go to step 5Q3.

### 5Q3 : SHOWERING INSPECTION TO BODY

Spray water on vehicle body.

**CAUTION:**

**Do not directly spray water on airbag components.**

**NOTE:**

Also check wiring harnesses as water may leak along them and get airbag component parts wet.



**CHECK** : *Does water leak into the passenger compartment when showering vehicle?*

**YES** : Replace faulty airbag component parts.

**NO** : Perform clear memory. <Ref. to 5-5 [T4C0].>

### R: WARNING LIGHT INDICATES TROUBLE CODE, THEN NORMAL CODE. (FLASHING NORMAL CODE.)

**DIAGNOSIS:**

- Airbag connector is faulty.
- Fuse No. 11 is blown. (In joint box)
- Airbag main harness is faulty.
- Airbag control module is faulty.
- Body harness is faulty.

**CAUTION:**

**Before performing diagnostics on airbag system, turn ignition switch "OFF", disconnect battery ground cable, and then wait at least 20 seconds.**

### 5R1 : AIRBAG CONNECTOR APPEARANCE INSPECTION

Conduct appearance inspection on airbag connectors (AB2) through (AB8). <Ref. to 5-5 [T100].>

**NOTE:**

Check terminals, case and wiring harnesses for damage.

**CHECK** : *Is there anything unusual about the appearance of connectors (AB2) through (AB8)?*

**YES** : Replace faulty airbag component parts.

**NO** : Go to step 5R2.

### 5R2 : AIRBAG CONNECTOR VIBRATION INSPECTION

Conduct vibration inspection on airbag connectors (AB2) through (AB8). <Ref. to 5-5 [T100].>

**NOTE:**

Gently shake each airbag connector.

**CHECK** : *Do the connectors (AB2) through (AB8) malfunction again when shaking?*

**YES** : Replace faulty airbag component parts.

**NO** : Go to step 5R3.

**5R3 : SHOWERING INSPECTION TO BODY**

Spray water on vehicle body.

**CAUTION:**

**Do not directly spray water on airbag components.**

**NOTE:**

If leaks are noted, also check wiring harnesses as water may leak along them and wet airbag connectors.



**CHECK** : *Does water leak into the passenger compartment when showering vehicle?*

**YES** : Replace faulty airbag component parts.

**NO** : Go to step 5R4.

**5R4 : FUSE NO. 11 (IN JOINT BOX), AIR-BAG MAIN HARNESS, AIRBAG CONTROL MODULE, BODY HARNESS APPEARANCE INSPECTION**

Conduct appearance inspection on fuse No. 11 <Ref. to 5-5 [T5I5].>, airbag main harness <Ref. to 5-5 [W4A0].>, airbag control module <Ref. to 5-5 [W5A0].> and body harness.

**NOTE:**

Also check connectors, terminals, wiring harness and case for damage.

**CHECK** : *Is there anything unusual about the appearance of fuse No. 11, airbag main harness, airbag control module or body harness?*

**YES** : Replace faulty airbag component parts.

**NO** : Go to step 5R5.

**5R5 : FUSE NO. 11 (IN JOINT BOX), AIR-BAG MAIN HARNESS, BODY HARNESS VIBRATION INSPECTION**

Conduct vibration inspection on fuse No. 11, airbag main harness and body harness.

**CAUTION:**

**Do not shake or vibrate airbag control module.**

**NOTE:**

Gently shake each part.

**CHECK** : *Do fuse No. 11, airbag main harness or body harness malfunction again when shaking?*

**YES** : Replace faulty airbag component parts.

**NO** : Go to step 5R6.

**5R6 : SHOWERING INSPECTION TO BODY**

Spray water on vehicle body.

**CAUTION:**

**Do not directly spray water on each part.**

**NOTE:**

If leaks are noted, check wiring harnesses as water may leak along them and get parts wet.

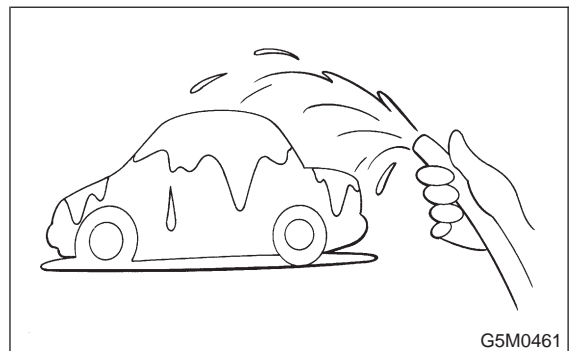

**CHECK** : *Does water leak into the passenger compartment when showering vehicle?*

**YES** : Replace faulty airbag component parts.

**NO** : Go to step 5R7.

**5R7 : WARNING LIGHT ILLUMINATION CHECK**

Turn ignition switch "ON" (engine off) and observe airbag warning light.

- CHECK** : *Does the airbag warning light come on for about 7 seconds, then go out and stay out?*
- YES** : Perform clear memory. <Ref. to 5-5 [T4C0].>
- NO** : Go to "DIAGNOSTICS PROCEDURE". <Ref. to 5-5 [T4D0].>

**S: TROUBLE CODE 03**
**DIAGNOSIS:**

- Front sub sensor harness is faulty.
- Front sub sensor is faulty.

**CAUTION:**

Before performing diagnostics on airbag system, turn ignition switch "OFF", disconnect battery ground terminal, and then wait at least 20 seconds.

**5S1 : FRONT SUB SENSOR (RH) AND FRONT SUB SENSOR HARNESS (RH) INSPECTION**

- 1) Disconnect connector (AB6) from airbag control module <Ref. to 5-5 [W5A0].>, and connect it to test harness E connector (1E).
- 2) Measure resistance between test harness E connector (3E) terminal.

**Connector & terminal**

**(3E) No. 2 — (3E) No. 4:**

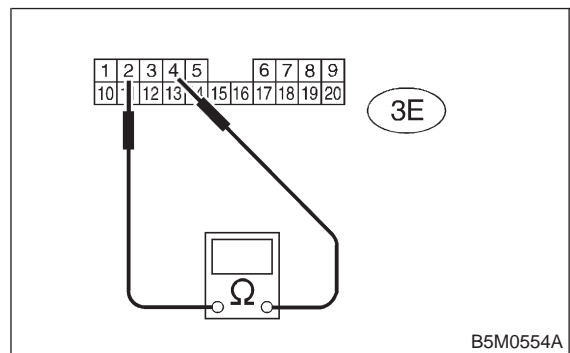

- CHECK** : *Is the resistance between 750 Ω and 1 kΩ?*
- YES** : Go to step 5S2.
- NO** : Go to step 5S2.

**5S2 : FRONT SUB SENSOR (RH) AND FRONT SUB SENSOR HARNESS (RH) INSPECTION**

Measure resistance across test harness E connector (3E) terminal and chassis ground.

**Connector & terminal**

**(3E) No. 2 (+) — Chassis ground (-):**

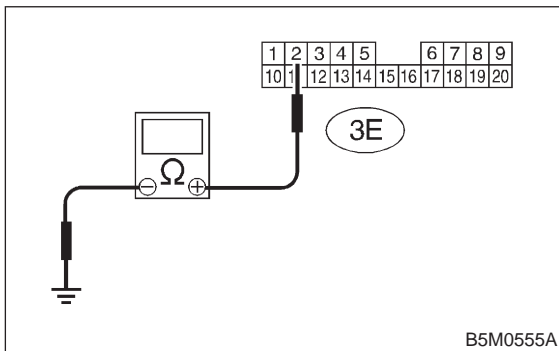

- CHECK** : Is the resistance more than 10 kΩ?
- YES** : Go to step 5S3.
- NO** : Go to step 5S3.

**5S3 : FRONT SUB SENSOR (RH) AND FRONT SUB SENSOR HARNESS (RH) INSPECTION**

Measure resistance across test harness E connector (3E) terminal and chassis ground.

**Connector & terminal**

**(3E) No. 4 (+) — Chassis ground (-):**

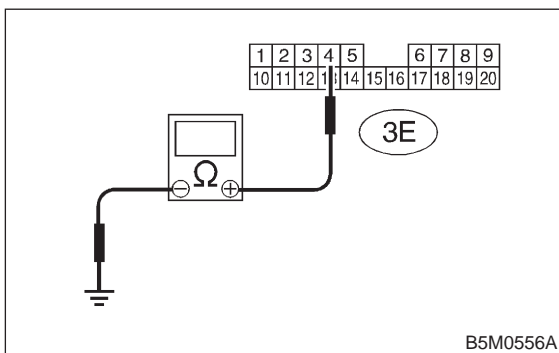

- CHECK** : Is the resistance more than 10 kΩ?
- YES** : Go to step 5S4.
- NO** : Go to step 5S4.

**5S4 : FRONT SUB SENSOR (LH) AND FRONT SUB SENSOR HARNESS (LH) INSPECTION**

Measure resistance between test harness E connector (3E) terminal.

**Connector & terminal**

**(3E) No. 1 — (3E) No. 3:**

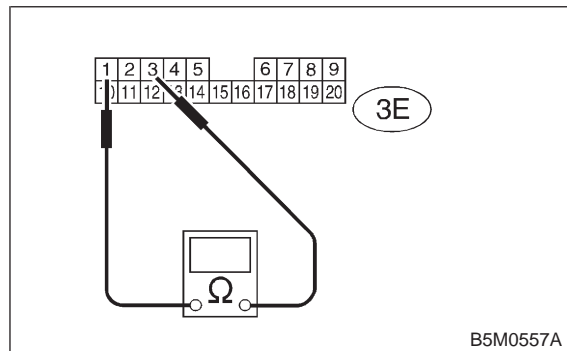

- CHECK** : Is the resistance between 750 Ω and 1 kΩ?
- YES** : Go to step 5S5.
- NO** : Go to step 5S5.

**5S5 : FRONT SUB SENSOR (LH) AND FRONT SUB SENSOR HARNESS (LH) INSPECTION**

Measure resistance across test harness E connector (3E) terminal and chassis ground.

**Connector & terminal**

**(3E) No. 1 (+) — Chassis ground (-):**

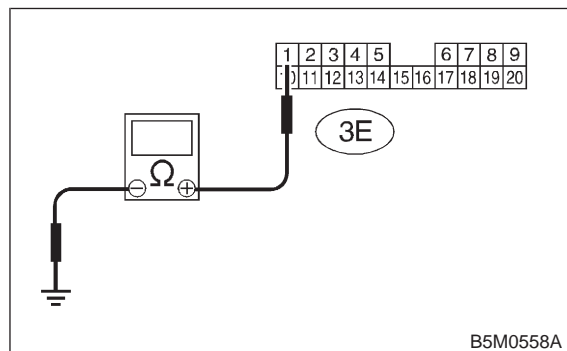

- CHECK** : Is the resistance more than 10 kΩ?
- YES** : Go to step 5S6.
- NO** : Go to step 5S6.

**5S6 : FRONT SUB SENSOR (LH) AND FRONT SUB SENSOR HARNESS (LH) INSPECTION**

Measure resistance across test harness E connector (3E) terminal and chassis ground.

**Connector & terminal**

**(3E) No. 3 (+) — Chassis ground (-):**

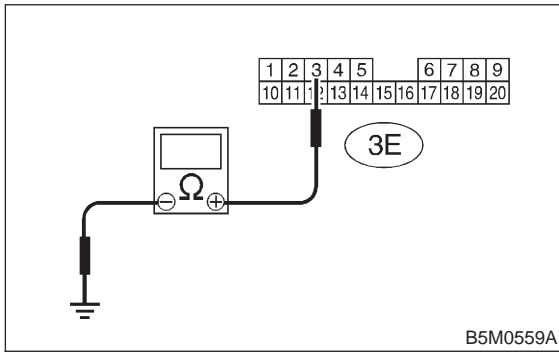

- CHECK** : Is the resistance more than 10 kΩ?
- YES** : Replace airbag control module. <Ref. to 5-5 [W5A0].>
- NO** : Go to step 5S7.

**5S7 : AIRBAG MAIN HARNESS INSPECTION**

1) Disconnect connector (AB14) and (AB15), then connect test harness F connector (2F) and connector (AB14).

2) Measure resistance between test harness E connector (3E) terminal and test harness F connector (3F) terminal.

**Connector & terminal**

**(3E) No. 2 — (3F) No. 6:**

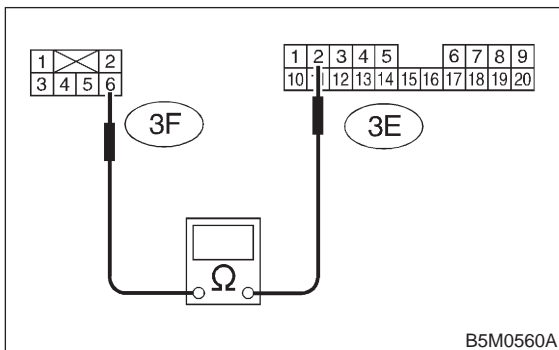

- CHECK** : Is the resistance less than 10 Ω?
- YES** : Go to step 5S8.
- NO** : Replace airbag main harness. <Ref. to 5-5 [W4A0].>

**5S8 : AIRBAG MAIN HARNESS INSPECTION**

Measure resistance between test harness E connector (3E) terminal and test harness F connector (3F) terminal.

**Connector & terminal**

**(3E) No. 4 — (3F) No. 5:**

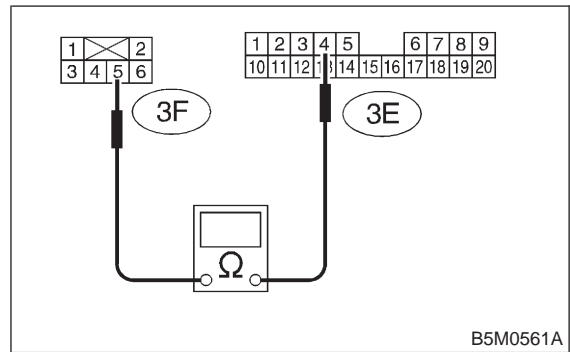

- CHECK** : Is the resistance less than 10 Ω?
- YES** : Go to step 5S9.
- NO** : Replace airbag main harness. <Ref. to 5-5 [W4A0].>

**5S9 : AIRBAG MAIN HARNESS INSPECTION**

Measure resistance across test harness E connector (3E) terminal and chassis ground.

**Connector & terminal**

**(3E) No. 2 (+) — Chassis ground (-):**

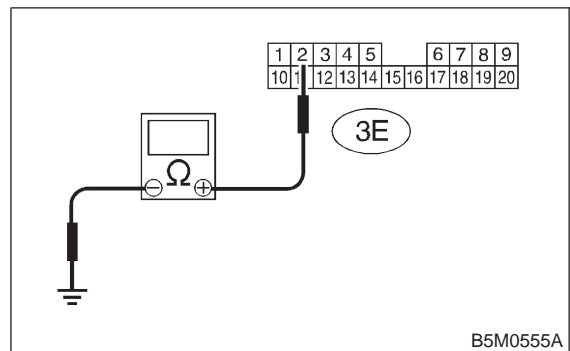

- CHECK** : Is the resistance more than 10 kΩ?
- YES** : Go to step 5S10.
- NO** : Replace airbag main harness. <Ref. to 5-5 [W4A0].>

**5S10 : AIRBAG MAIN HARNESS INSPECTION**

Measure resistance across test harness E connector (3E) terminal and chassis ground.

**Connector & terminal**

**(3E) No. 4 (+) — Chassis ground (-):**

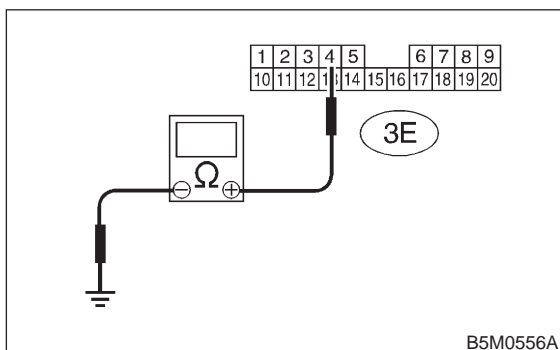

- CHECK** : *Is the resistance more than 10 kΩ?*
- YES** : Go to step **5S11**.
- NO** : Replace airbag main harness. <Ref. to 5-5 [W4A0].>

**5S11 : FRONT SUB SENSOR HARNESS (RH) INSPECTION**

- 1) Connect test harness F connector (1F) and connector (AB15).
- 2) Disconnect connector (AB16) from front sub sensor (RH) <Ref. to 5-5 [W7A0].> and then test harness H connector (1H) and connector (AB16).
- 3) Measure resistance between test harness F connector (3F) terminal and test harness H connector (3H) terminal.

**Connector & terminal**

**(3F) No. 3 — (3H) No. 5:**

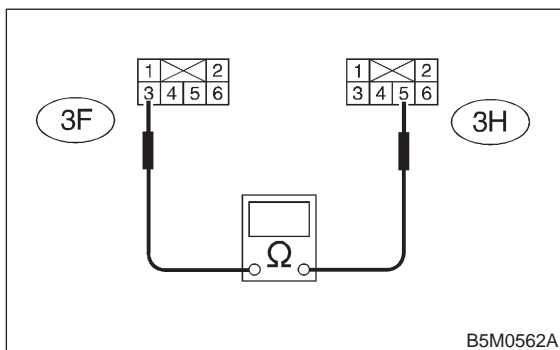

- CHECK** : *Is the resistance less than 10 Ω?*
- YES** : Go to step **5S12**.
- NO** : Replace front sub sensor harness (RH). <Ref. to 5-5 [W7A0].>

**5S12 : FRONT SUB SENSOR HARNESS (RH) INSPECTION**

Measure resistance between test harness F connector (3F) terminal and test harness H connector (3H) terminal.

**Connector & terminal**

**(3F) No. 4 — (3H) No. 6:**

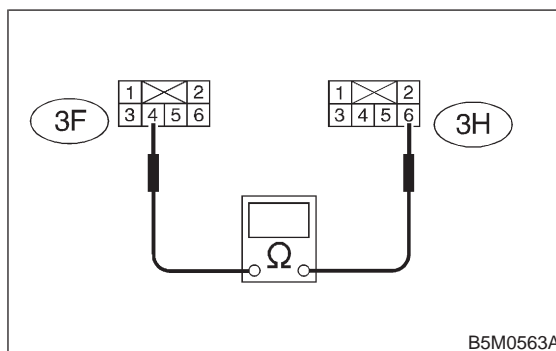

- CHECK** : *Is the resistance less than 10 Ω?*
- YES** : Go to step **5S13**.
- NO** : Replace front sub sensor harness (RH). <Ref. to 5-5 [W7A0].>

**5S13 : FRONT SUB SENSOR HARNESS (RH) INSPECTION**

Measure resistance across test harness F connector (3F) terminal and chassis ground.

**Connector & terminal**

**(3F) No. 3 (+) — Chassis ground (-):**

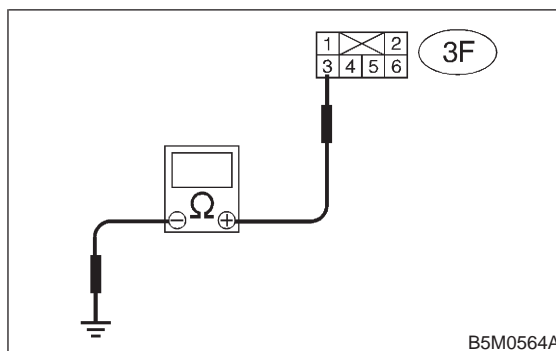

- CHECK** : *Is the resistance more than 10 kΩ?*
- YES** : Go to step **5S14**.
- NO** : Replace front sub sensor harness (RH). <Ref. to 5-5 [W7A0].>



**5S14 : FRONT SUB SENSOR HARNESS (RH) INSPECTION**

Measure resistance across test harness F connector (3F) terminal and chassis ground.

**Connector & terminal**

**(3F) No. 4 (+) — Chassis ground (-):**

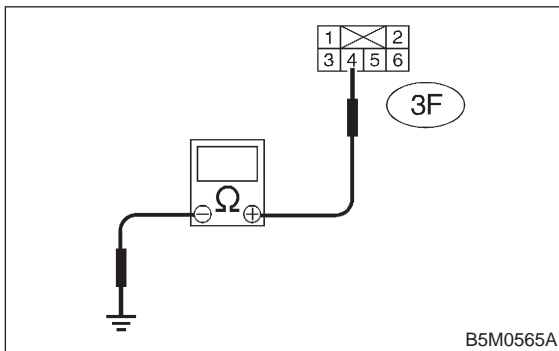

- CHECK** : Is the resistance more than 10 kΩ?
- YES** : Go to step 5S15.
- NO** : Replace front sub sensor harness (RH). <Ref. to 5-5 [W7A0].>

**5S15 : FRONT SUB SENSOR (RH) INSPECTION**

- 1) Connect test harness H connector (2H) and front sub sensor (RH).
- 2) Measure resistance between test harness H connector (3H) terminal.

**Connector & terminal**

**(3H) No. 3 — (3H) No. 4:**

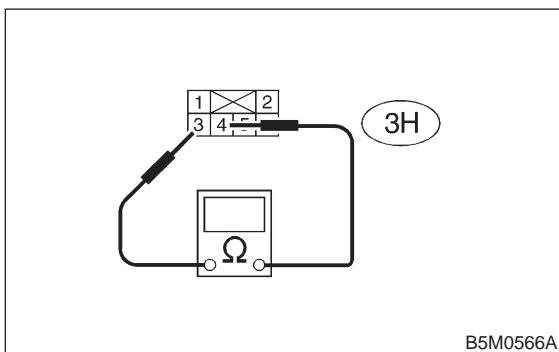

- CHECK** : Is the resistance between 750 Ω and 1 kΩ?
- YES** : Go to step 5S16.
- NO** : Replace front sub sensor (RH). <Ref. to 5-5 [W7A0].>

**5S16 : FRONT SUB SENSOR (RH) INSPECTION**

Measure resistance across test harness H connector (3H) terminal and chassis ground.

**Connector & terminal**

**(3H) No. 3 (+) — Chassis ground (-):**

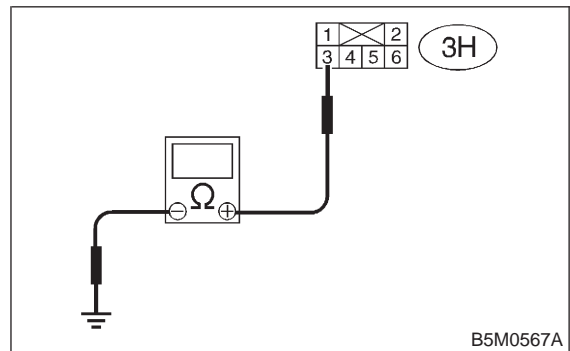

- CHECK** : Is the resistance more than 10 kΩ?
- YES** : Go to step 5S17.
- NO** : Replace front sub sensor (RH). <Ref. to 5-5 [W7A0].>

**5S17 : FRONT SUB SENSOR (RH) INSPECTION**

Measure resistance across test harness H connector (3H) terminal and chassis ground.

**Connector & terminal**

**(3H) No. 4 (+) — Chassis ground (-):**

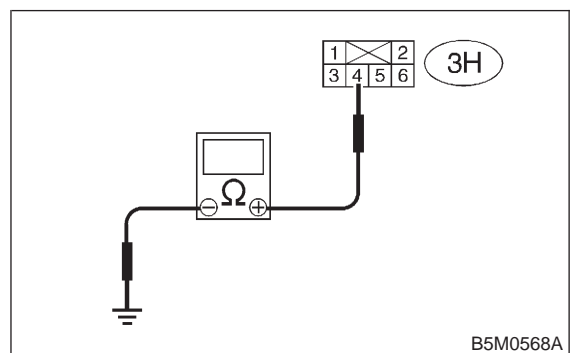

- CHECK** : Is the resistance more than 10 kΩ?
- YES** : Go to step 5S18.
- NO** : Replace front sub sensor (RH). <Ref. to 5-5 [W7A0].>



**5S18 : AIRBAG MAIN HARNESS INSPECTION**

- 1) Disconnect connector (AB11) and (AB12), then connect test harness F connector (2F) and connector (AB11).
- 2) Measure resistance between test harness E connector (3E) terminal and test harness F connector (3F) terminal.

**Connector & terminal**  
**(3E) No. 3 — (3F) No. 6:**

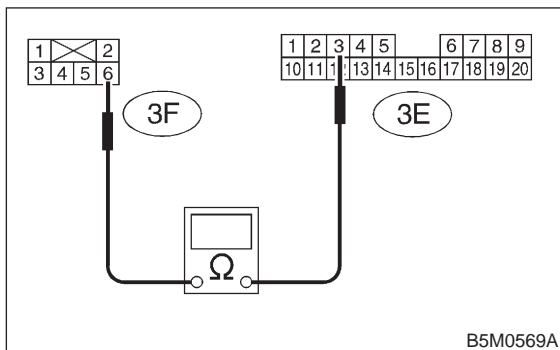

- CHECK** : Is the resistance less than 10 Ω?
- YES** : Go to step 5S19.
- NO** : Replace airbag main harness. <Ref. to 5-5 [W4A0].>

**5S19 : AIRBAG MAIN HARNESS INSPECTION**

Measure resistance between test harness E connector (3E) terminal and test harness F connector (3F) terminal.

**Connector & terminal**  
**(3E) No. 1 — (3F) No. 5:**

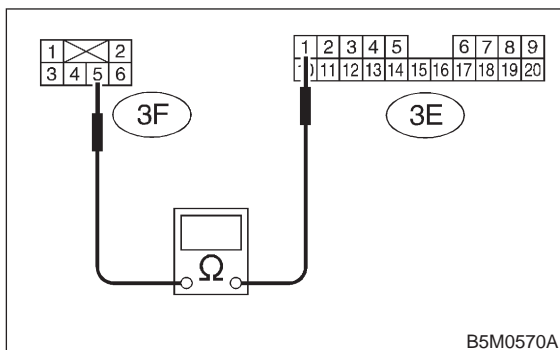

- CHECK** : Is the resistance less than 10 Ω?
- YES** : Go to step 5S20.
- NO** : Replace airbag main harness. <Ref. to 5-5 [W4A0].>

**5S20 : AIRBAG MAIN HARNESS INSPECTION**

Measure resistance across test harness E connector (3E) terminal and chassis ground.

**Connector & terminal**  
**(3E) No. 3 (+) — Chassis ground (-):**

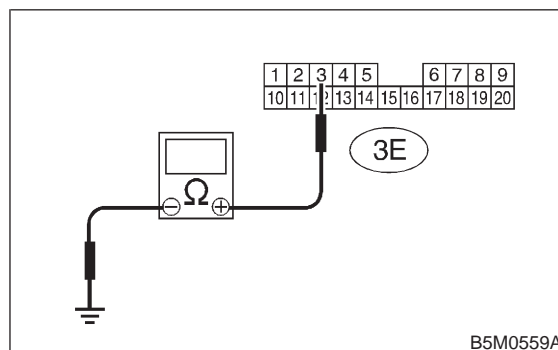

- CHECK** : Is the resistance more than 10 kΩ?
- YES** : Go to step 5S21.
- NO** : Replace airbag main harness. <Ref. to 5-5 [W4A0].>

**5S21 : AIRBAG MAIN HARNESS INSPECTION**

Measure resistance across test harness E connector (3E) terminal and chassis ground.

**Connector & terminal**  
**(3E) No. 1 (+) — Chassis ground (-):**

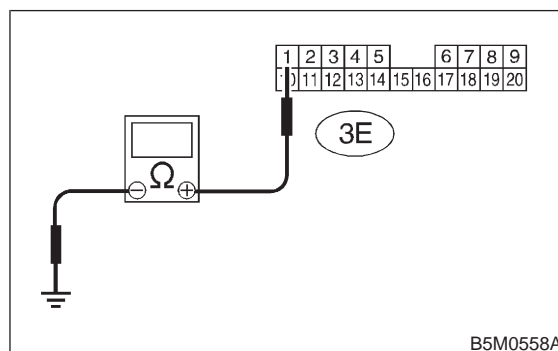

- CHECK** : Is the resistance more than 10 kΩ?
- YES** : Go to step 5S22.
- NO** : Replace airbag main harness. <Ref. to 5-5 [W4A0].>

**5S22 : FRONT SUB SENSOR HARNESS (LH) INSPECTION**

- 1) Connect test harness F connector (1F) and connector (AB12).
- 2) Disconnect connector (AB13) from front sub sensor (LH) <Ref. to 5-5 [W7A0].> and then test harness H connector (1H) and connector (AB13).
- 3) Measure resistance between test harness F connector (3F) terminal and test harness H connector (3H) terminal.

**Connector & terminal**

**(3F) No. 3 — (3H) No. 5:**

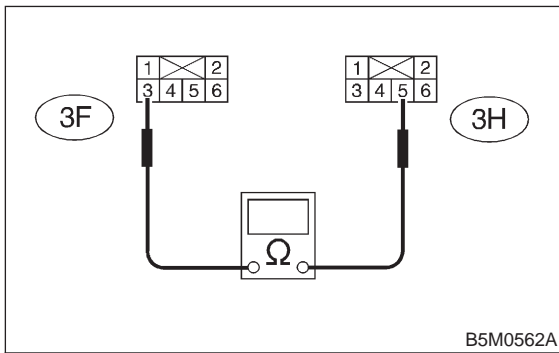

- CHECK** : Is the resistance less than 10 Ω?
- YES** : Go to step 5S23.
- NO** : Replace front sub sensor harness (LH). <Ref. to 5-5 [W7A0].>

**5S23 : FRONT SUB SENSOR HARNESS (LH) INSPECTION**

Measure resistance between test harness F connector (3F) terminal and test harness H connector (3H) terminal.

**Connector & terminal**

**(3F) No. 4 — (3H) No. 6:**

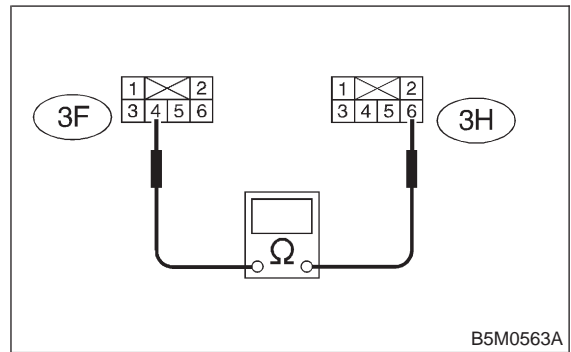

- CHECK** : Is the resistance less than 10 Ω?
- YES** : Go to step 5S24.
- NO** : Replace front sub sensor harness (LH). <Ref. to 5-5 [W7A0].>

**5S24 : FRONT SUB SENSOR HARNESS (LH) INSPECTION**

Measure resistance across test harness F connector (3F) terminal and chassis ground.

**Connector & terminal**

**(3F) No. 3 (+) — Chassis ground (-):**

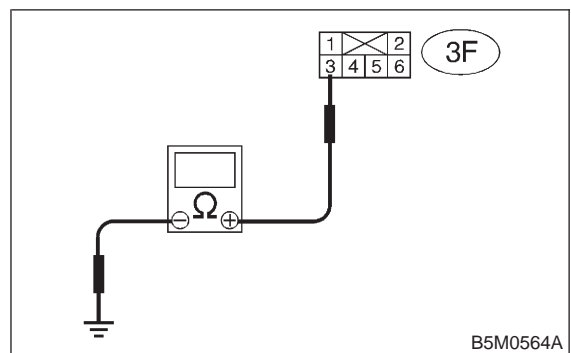

- CHECK** : Is the resistance more than 10 kΩ?
- YES** : Go to step 5S25.
- NO** : Replace front sub sensor harness (LH). <Ref. to 5-5 [W7A0].>

**5S25 : FRONT SUB SENSOR HARNESS (LH) INSPECTION**

Measure resistance across test harness F connector (3F) terminal and chassis ground.

**Connector & terminal**

**(3F) No. 4 (+) — Chassis ground (-):**

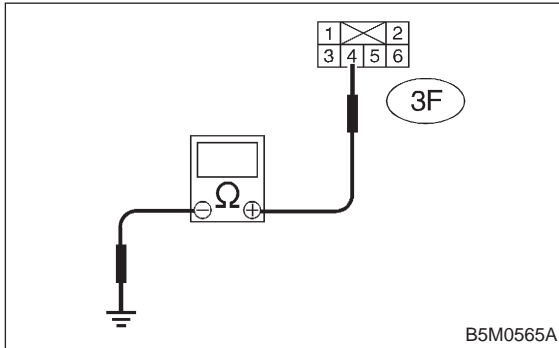

- CHECK** : *Is the resistance more than 10 kΩ?*
- YES** : Go to step **5S26**.
- NO** : Replace front sub sensor harness (LH). <Ref. to 5-5 [W7A0].>

**5S26 : FRONT SUB SENSOR (LH) INSPECTION**

- 1) Connect test harness H connector (2H) and front sub sensor (LH).
- 2) Measure resistance between test harness H connector (3H) terminal.

**Connector & terminal**

**(3H) No. 3 — (3H) No. 4:**

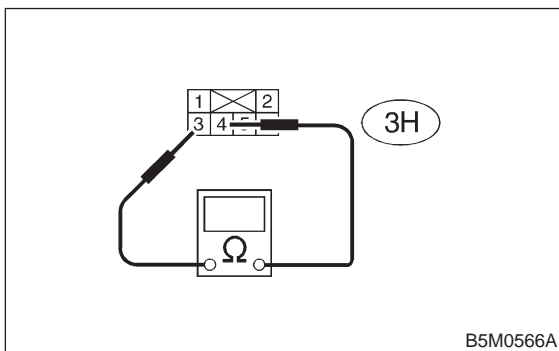

- CHECK** : *Is the resistance between 750 Ω and 1 kΩ?*
- YES** : Go to step **5S27**.
- NO** : Replace front sub sensor (LH). <Ref. to 5-5 [W7A0].>

**5S27 : FRONT SUB SENSOR (LH) INSPECTION**

Measure resistance across test harness H connector (3H) terminal and chassis ground.

**Connector & terminal**

**(3H) No. 3 (+) — Chassis ground (-):**

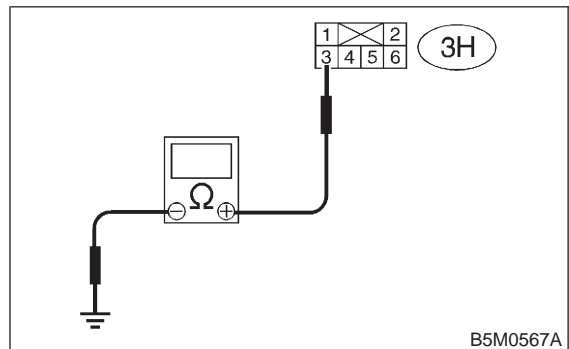

- CHECK** : *Is the resistance more than 10 kΩ?*
- YES** : Go to step **5S28**.
- NO** : Replace front sub sensor (LH). <Ref. to 5-5 [W7A0].>

**5S28 : FRONT SUB SENSOR (LH) INSPECTION**

Measure resistance across test harness H connector (3H) terminal and chassis ground.

**Connector & terminal**

**(3H) No. 4 (+) — Chassis ground (-):**

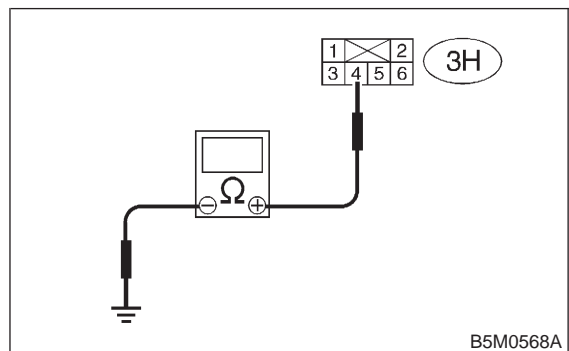

- CHECK** : *Is the resistance more than 10 kΩ?*
- YES** : Perform clear memory. <Ref. to 5-5 [T4C0].>
- NO** : Replace front sub sensor (LH). <Ref. to 5-5 [W7A0].>

MEMO:

**WIRING DIAGRAM SECTION****FOREWORD**

This portion of the service manual has been prepared to provide SUBARU service personnel with the necessary information and data for the correct maintenance and repair of SUBARU vehicles.

This manual includes the procedures for maintenance disassembling, reassembling, inspection and adjustment of components and diagnostics for guidance of both the fully qualified and the less-experienced mechanics.

Please peruse and utilize this manual fully to ensure complete repair work for satisfying our customers by keeping their vehicle in optimum condition. When replacement of parts during repair work is needed, be sure to use SUBARU genuine parts.

All information, illustration and specifications contained in this manual are based on the latest product information available at the time of publication approval.

**FUJI HEAVY INDUSTRIES LTD.**

**WIRING DIAGRAM****6-3**

---

## Important safety notice

---

- Providing appropriate service and repair is a matter of great importance in the serviceman's safety maintenance and safe operation, function and performance which the SUBARU vehicle possesses.
- In case the replacement of parts or replenishment of consumables is required, genuine SUBARU parts whose parts numbers are designated or their equivalents must be utilized.
- It must be made well known that the safety of the serviceman and the safe operation of the vehicle would be jeopardized if the used any service parts, consumables, special tools and work procedure manuals which are not approved or designated by SUBARU.

All right reserved. This book may not be reproduced or copied, in whole or in part, without the written permission of FUJI HEAVY INDUSTRIES LTD., TOKYO JAPAN

SUBARU,  and  are trademarks of FUJI HEAVY INDUSTRIES LTD.

© Copyright 1997 FUJI HEAVY INDUSTRIES LTD.