



*EyeSight*<sup>®</sup>

and

Driver Assist Technology

Quick Guide

2018

**Love.** It's what makes a Subaru, a Subaru.



# Table of Contents

---

## EyeSight

- 2 EyeSight and EyeSight Functions
- 3 EyeSight Operation
- 4-5 Steering Wheel Controls
- 6 Lane Departure Warning and Pre-Collision Braking System OFF Switches
- 7 EyeSight Limitations
- 7 Stereo Color Cameras Precautions
- 8-9 Windshield Glass and Dashboard

## Other Driver Assist Technologies

- 10 Rear Cross Traffic Alert (RCTA)  
Lane Change Assist (LCA)  
Blind Spot Detection (BSD)
- 11 Reverse Automatic Braking (RAB) System  
High Beam Assist (HBA)  
Steering Responsive Headlights (SRH)  
Steering Responsive Foglights (SRF)

# EyeSight

EyeSight is a driving support system that uses a range of functions to assist the driver in making decisions in order to provide for more safe and comfortable driving and to reduce driver fatigue. It is designed to help assist drivers, not replace them.

## EyeSight Functions

### Pre-Collision Braking System

This function can recognize an impending collision with an obstacle, such as a motorcycle or pedestrian, or with a vehicle traveling in the same lane ahead of the EyeSight vehicle. It informs the driver with audible and visual alerts. If the driver takes no corrective action, the system will automatically apply the brakes to help avoid the collision or minimize impact when a collision is inevitable.

### Pre-Collision Brake Assist

If EyeSight recognizes an impending collision with an obstacle or a vehicle traveling in the same lane ahead of the EyeSight vehicle, and the driver applies the brakes but not with enough brake pedal force, Pre-Collision Brake Assist automatically applies up to full braking pressure in order to try to reduce stopping distance.

### Pre-Collision Throttle Management

This function is designed to help prevent drivers from unintentionally accelerating into a stopped vehicle or other obstacle in front of the EyeSight vehicle. It simultaneously warns the driver and reduces engine power until the driver applies the brakes to help avoid an impact.

Pre-Collision Throttle Management is helpful when:

- The driver inadvertently selects Drive instead of Reverse and starts to accelerate toward a parked car, wall or parking structure.
- Starting to merge onto another road when the vehicle ahead accelerates, but suddenly stops.

### Lane Departure Warning

Lane Departure Warning works at speeds of approximately 30 mph or greater to alert the driver when the vehicle unintentionally moves out of its travel lane. It takes no corrective vehicle action other than issuing visual and audible warnings.

### Lane Sway Warning

Lane Sway Warning works at speeds of approximately 38 mph or greater. It detects repetitive or unusual side-to-side vehicle movement within the driver's lane of travel that is usually indicative of a drowsy driver.

### Lane Keep Assist with Lane Departure Prevention

By detecting lane markings in the lane of travel, the system assists the steering operation to help keep the vehicle within its lane. If the vehicle is about to deviate from a driving lane and starts crossing the road lines, steering assistance control is triggered in the opposite direction, helping to avoid lane deviation. A departure warning sound and display in the instrument cluster occur to alert the driver. These features are designed to function at speeds of approximately 40 mph or greater, it is best used on freeways, expressways or interstate highways.

**Note:** This is a driver selectable feature and must be turned on to be functional.

## Adaptive Cruise Control and Conventional Cruise Control

This function combines the benefits of Cruise Control with active monitoring of the road ahead by EyeSight. The system works at speeds above approximately 20 mph and issues warnings and activates automatic braking when needed.

When turned on by the driver, Adaptive Cruise Control can regulate the driver set speed in order to keep the driver-selected gap between the EyeSight vehicle and the vehicle ahead traveling in the same lane. It does not replace Conventional Cruise Control, which can still be used when desired.

Conventional Cruise Control maintains a constant driver set speed. It does not mirror the speed of a vehicle traveling in the same lane ahead of the EyeSight vehicle. See the Owner's Manual for additional information.

## Lead Vehicle Start Alert

Lead Vehicle Start Alert notifies the driver when the vehicle in front has started moving but the EyeSight driver's vehicle has not.

## EyeSight Operation

EyeSight uses stereo color cameras to process 3-D images and to identify objects such as the vehicle in front, obstacles, traffic lanes and other items. Under the right circumstances, if the driver takes no corrective action, EyeSight will apply the brakes or decrease the throttle to help avoid a collision or help reduce the severity of a collision.



Stereo color camera

Stereo color camera

# Steering Wheel Controls

The shape of the steering wheel controls is based on your vehicle model. Consult the Owner's Manual for more detailed information.

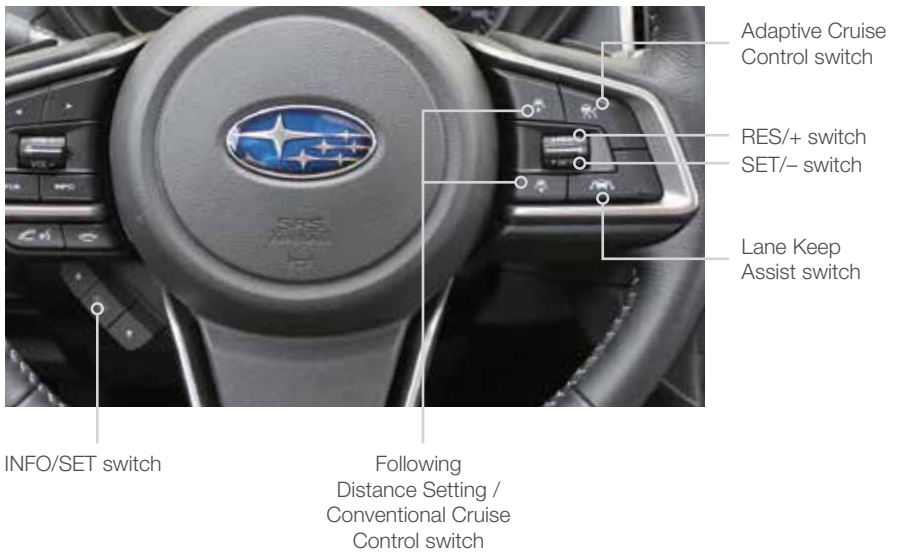

## **INFO/SET switches**

Use the arrows above and below to set the volume of the EyeSight warnings and to view information on other vehicle functions in the multi-information display.

## **Adaptive Cruise Control switch**

Press to activate or deactivate Adaptive Cruise Control function.

## **RES/+ switch**

Press to resume set speed or to increase set speed while in either Adaptive or Conventional Cruise Control.

## **SET/- switch**

Press to set current speed or to reduce set speed while in either Adaptive or Conventional Cruise Control.

## **Lane Keep Assist switch (if equipped)**

Press to activate or deactivate Lane Keep Assist.

## **Following Distance Setting / Conventional Cruise Control switch**

- Press to change the following distance setting while using Adaptive Cruise Control.
- Press and hold to activate or deactivate Conventional Cruise Control.

# Lane Departure Warning and Pre-Collision Braking System OFF Switches



The location of the switches is based on your vehicle model. They are either in the overhead console or in the lower left instrument panel. Consult the Owner's Manual for more detailed information.

## Lane Departure Warning OFF switch



Press and hold this switch for two seconds to turn off the Lane Departure Warning and the Lane Sway Warning functions.

Press and hold the switch again for two seconds to turn the functions back on.

## Pre-Collision Braking System OFF switch



Press and hold this switch for two seconds to turn off the Pre-Collision Braking System and Pre-Collision Throttle Management.

Press and hold the switch again for two seconds to turn the systems back on.

## Indicator Lights



When these functions are off, the indicator light on the instrument panel illuminates.

Pre-Collision Braking System OFF light

Lane Departure Warning OFF light

## EyeSight Limitations\*

- The EyeSight system needs time to recognize an object or potential obstacle. When the vehicle speed differential with an obstacle in front is greater than approximately 30 mph, it may not be possible to avoid an impending collision.
- Sun glare, inclement weather such as heavy rain, blinding snow or fog, or a dirty windshield will hinder EyeSight operation. A cracked windshield, oil film on the glass or reflections may impede EyeSight performance. In these conditions, EyeSight may not operate properly or EyeSight may temporarily stop operating. If you cannot see, EyeSight cannot see.
- EyeSight may not recognize low-contrast objects, those with regularly spaced patterns, no pattern, horizontal lines, backlit objects, very small objects (less than 3 feet tall) or non-standard shaped vehicles, such as cement mixers or car-carrier trucks.
- Cargo loaded on the vehicle roof must be positioned so as to not interfere with or obstruct the camera's view.
- Non-approved aftermarket vehicle accessories, such as hood protectors, and water-repellent glass coatings should not be used with EyeSight-equipped vehicles. EyeSight may not operate properly or EyeSight may temporarily stop operating.

*\*Please refer to the disclaimer information on the back cover.*

## Stereo Color Cameras Precautions

The stereo color camera lenses are precision components. When the system detects that the stereo color camera lenses are dirty, no EyeSight functions will be activated.

Always observe the following precautions:

- Do not touch or try to clean the EyeSight camera lenses inside the vehicle. Extra precaution should be used when cleaning the inside of the windshield. Over-spray from cleaners may impair or even damage the cameras' lenses. Such damage is not covered under any vehicle warranty.
- Do not attempt to remove or disassemble the stereo color cameras.
- Do not attempt to change the position where the stereo color cameras are installed or modify any of the surrounding structures.
- Do not install any interior rearview mirror (such as a wide-type mirror) other than a genuine SUBARU rearview mirror. Also, adjust the rearview mirror so it does not obstruct the stereo color cameras. Failure to do so may affect the stereo color cameras' field of vision and could prevent the EyeSight system from functioning properly.

For more detailed information, please consult your EyeSight Owner's Manual.



# Windshield Glass and Dashboard

There must be no oil film, dirt, scratch or fogging that obstructs the forward visibility of the stereo color cameras.

Do not stick or attach aftermarket parts on the prohibited areas shown in gray on the windshield and top of the dashboard in the image in this section.

Even outside the prohibited area, if abnormal operation occurs due to the reflection of the light or the reflection on the glass, change the adhering position or installation position.

- Application of stickers or antennas, installation of wide-type mirror
  - This will affect the visibility of the stereo color cameras and may impair functionality.
- Placement of an aftermarket navigation unit, cellphone or similar on the dashboard
  - These things may be reflected on the windshield glass, affecting the recognition of the stereo color cameras, thus causing its function to not operate as designed.

## FRONT VIEW (Crosstrek, WRX)

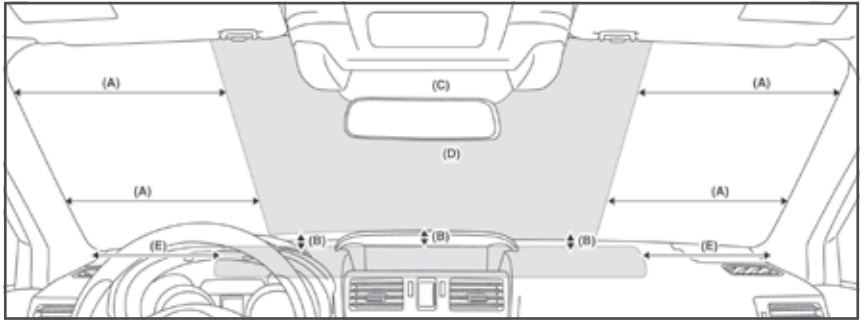

(A) 300 mm (11.8 in)

(C) Ceramic area

(E) 200 mm (7.9 in)

(B) 120 mm (4.7 in)

(D) Prohibited area (in gray)

**FRONT VIEW (Forester)**

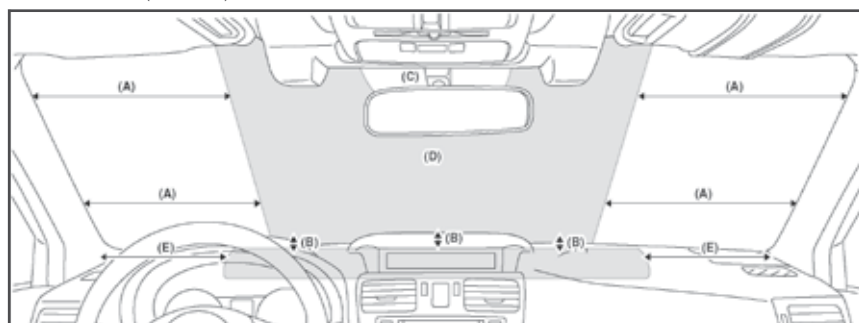

- (A) 350 mm (13.8 in)      (C) Ceramic area      (E) 120 mm (4.7 in)  
(B) 120 mm (4.7 in)      (D) Prohibited area (in gray)

**FRONT VIEW (Legacy, Outback)**

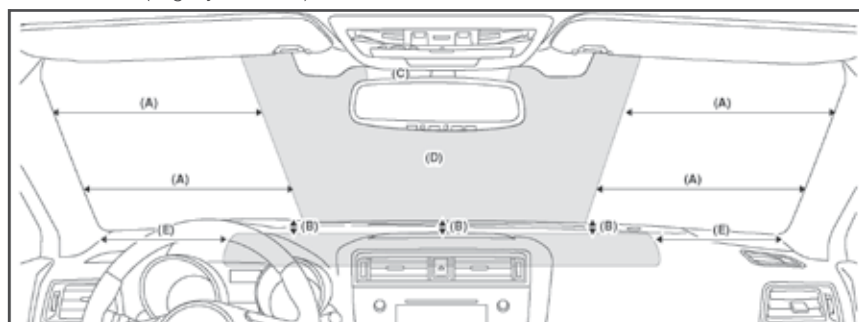

- (A) 360 mm (14 in)      (C) Ceramic area      (E) 230 mm (9 in)  
(B) 70 mm (2.7 in)      (D) Prohibited area (in gray)

**FRONT VIEW (Impreza)**

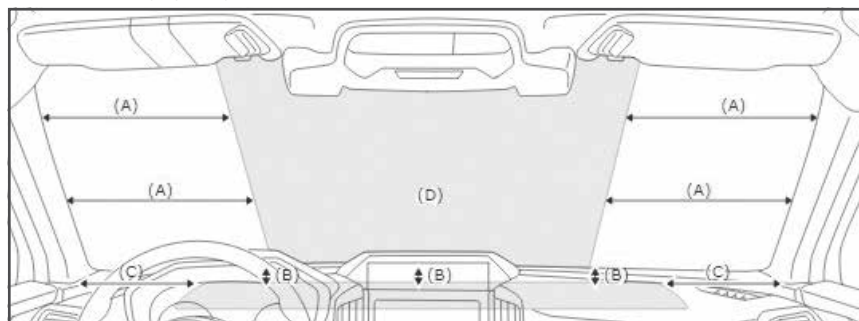

- (A) 355 mm (13.2 in)      (C) 243 mm (9.6 in)  
(B) 139 mm (5.5 in)      (D) Prohibited area (in gray)

# Other Driver Assist Technologies

## Rear Cross Traffic Alert (RCTA)

(if equipped)

Rear Cross Traffic Alert (RCTA) notifies the driver of a collision danger if a vehicle is detected approaching from either direction, perpendicular to the reversing vehicle. The system uses radar detection sensors located in the left rear and right rear of the vehicle. The system uses an audible and visual warning to alert the driver.

## Lane Change Assist (LCA)

(if equipped)

Lane Change Assist (LCA) notifies the driver of an approaching vehicle in an adjacent lane or lanes. The system uses radar detection sensors located in the left rear and right rear of the vehicle. The sensors illuminate a vehicle icon in the exterior mirror on the side in which the oncoming vehicle is detected. When the driver uses the turn signal indicator to switch lanes, and a vehicle is in their path, the radar detection sensor flashes the vehicle icon only in the exterior mirror on the side the oncoming vehicle is detected.

## Blind Spot Detection (BSD)

(if equipped)

Blind Spot Detection (BSD) assists the driver by detecting vehicles located on either side of the vehicle that are hidden to the driver's view in the exterior mirror. The system uses radar detection sensors located in the left rear and right rear of the vehicle. The sensors illuminate a vehicle icon only in the exterior mirror on the side the oncoming vehicle is detected. When the driver uses the turn signal indicator to switch lanes, and a vehicle is in their path, the radar detection sensor flashes the vehicle icon only in the exterior mirror on the side the oncoming vehicle is detected.

## **Reverse Automatic Braking (RAB) System**

(if equipped)

The Reverse Automatic Braking (RAB) system is designed to assist the driver by detecting objects, to help avoid a possible collision, when the vehicle is moving in a low speed reverse direction. The system will provide automatic vehicle braking, if a obstacle is detected within its range.

This system is not a substitute for safe and attentive driving. System effectiveness depends on many factors, such as vehicle maintenance, weather, and road conditions. Always exercise caution and use vehicle mirrors and the Rear-Vision Camera when backing up. See the Owner's Manual for complete details on system operation and limitations.

## **High Beam Assist (HBA)**

(if equipped)

High Beam Assist automatically switches the headlights between the high and low beams when the headlight switch is in the high beam position. The system works in conjunction with the EyeSight system. The EyeSight system detects a vehicle ahead, or oncoming vehicles, and switches the headlights automatically from high beam to low beam. See the Owner's Manual for complete details on system operation and limitations.

## **Steering Responsive Headlights (SRH)**

(if equipped)

The Steering Responsive Headlights (SRH) system aims the headlight beams in the direction of the vehicle travel on curved roads to help improve visibility at night. See the Owner's Manual for complete details on system operation and limitations.

## **Steering Responsive Foglights (SRF)**

(if equipped)

When the vehicle's headlights are turned on, or the headlights are in the automatic mode in the low beam position, foglights off, the Steering Responsive Foglights (SRF) system is active. The system monitors vehicle speed and steering angle and activates the left or right foglight independently, respective to cornering left or right. This helps provide increased visibility in the direction of the turn. The system functions independently from the turn signals and will not function if the turn signals are used. See the Owner's Manual for complete details on system operation and limitations.



EyeSight® is a driver assist system that may not operate optimally under all driving conditions. The driver is always responsible for safe and attentive driving. System effectiveness depends on many factors such as vehicle maintenance, tire condition, and weather and road conditions. See the Owner's Manual for complete details on system operation and limitations.

All information contained within this EyeSight® guide was accurate at the time of publication. Subaru of America, Inc. reserves the right to change features, operation and/or functionality of any vehicle specification at any time without incurring any obligation to make the same or similar changes to products previously sold. Your Subaru Retailer is the best source for the most current information. For detailed operating and safety information, always consult the Owner's Manual.



MSA5B1814A  
Issued March 2017  
Printed in USA 03/17

