

Wheel Bearing

PERIODIC MAINTENANCE SERVICES

21. Wheel Bearing

A: INSPECTION

1. FRONT WHEEL BEARING

NOTE:

Inspect the condition of front wheel bearing grease.

- 1) Jack-up the front side of vehicle.
- 2) While holding the front wheel by hand, swing it in and out to check bearing free play.
- 3) Loosen the wheel nuts, and remove the front wheel.
- 4) If the bearing free play exists in step 2) above, attach a dial gauge to the hub and measure axial play in axial direction.

Service limit:

***Straight-ahead position within 0.05 mm
(0.0020 in)***

- 5) Remove the bolts and self-locking nuts, and extract the front arm from front crossmember.
 - 6) Remove the transmission-side joint of the front drive shaft from the transmission. <Ref. to DS-19, Front Axle.>
 - 7) While supporting the front drive shaft horizontally with one hand, turn the hub with the other hand to check for noise or binding.
- If the hub is noisy or binds, replace the front axle.

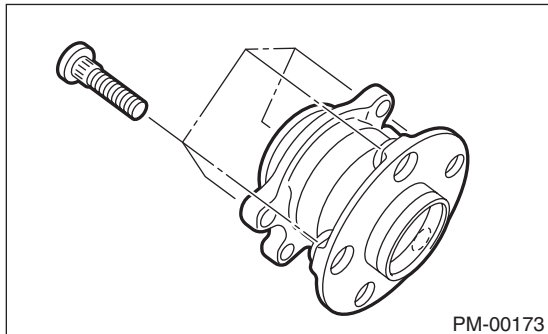

2. REAR WHEEL BEARING

- 1) Jack-up the rear side of vehicle.
- 2) While holding the rear wheel by hand, swing it in and out to check bearing free play.
- 3) Loosen the wheel nuts, and remove the rear wheel.
- 4) If the bearing free play exists in step 2) above, attach a dial gauge to the hub and measure axial play in axial direction.

Service limit:

***Straight-ahead position within 0.05 mm
(0.0020 in)***

- 5) Remove the DOJ of rear drive shaft from rear differential. <Ref. to DS-65, Rear Drive Shaft.>
 - 6) While supporting rear drive shaft horizontally with one hand, turn the hub with the other hand to check for noise or binding.
- If the hub is noisy or binds, replace the rear axle.

