

SECTION **RAX**  
REAR AXLE

A  
B  
C

RAX

CONTENTS

E

<b>PRECAUTIONS</b> .....	<b>2</b>	<b>REAR DRIVE SHAFT</b> .....	<b>8</b>	F
Caution .....	2	Removal and Installation .....	8	
<b>PREPARATION</b> .....	<b>3</b>	COMPONENT .....	8	
Special Service Tools [SST] .....	3	REMOVAL .....	8	G
Commercial Service Tools .....	3	INSPECTION AFTER REMOVAL .....	8	
<b>NOISE, VIBRATION AND HARSHNESS (NVH)</b>		INSTALLATION .....	9	
<b>TROUBLESHOOTING</b> .....	<b>4</b>	Disassembly and Assembly .....	9	H
NVH Troubleshooting Chart .....	4	COMPONENT .....	9	
<b>WHEEL HUB</b> .....	<b>5</b>	DISASSEMBLY .....	9	
On-Vehicle Inspection and Service .....	5	INSPECTION AFTER DISASSEMBLY .....	10	I
WHEEL BEARING INSPECTION .....	5	ASSEMBLY .....	11	
Removal and Installation .....	5	<b>SERVICE DATA</b> .....	<b>14</b>	J
COMPONENT .....	5	Wheel Bearing .....	14	
REMOVAL .....	5	Drive Shaft .....	14	
INSPECTION AFTER REMOVAL .....	6			
INSTALLATION .....	7			

K  
L  
M

# PRECAUTIONS

---

## PRECAUTIONS

PFP:00001

### Caution

NDS000FM

Observe the following precautions when disassembling and assembling drive shaft.

- Joint sub-assembly does not disassemble because it is non-overhaul parts.
- Perform work in a location which is as dust-free as possible.
- Before disassembling and assembling, clean the outside of parts.
- Prevention of the entry of foreign objects must be taken into account during disassembly of the service location.
- Disassembled parts must be carefully reassembled in the correct order. If work is interrupted, a clean cover must be placed over parts.
- Paper shop cloths must be used. Fabric shop cloths must not be used because of the danger of lint adhering to parts.
- Disassembled parts (except for rubber parts) should be cleaned with kerosene which shall be removed by blowing with air or wiping with paper shop cloths.

# PREPARATION

## PREPARATION

PFP:00002

### Special Service Tools [SST]

NDS000FN

The actual shapes of Kent-Moore tools may differ from those of special service tools illustrated here.

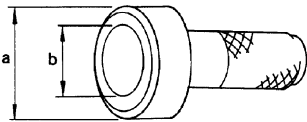
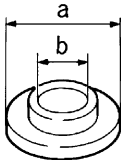
Tool number (Kent-Moore No.) Tool name	Description
KV38100500 ( — ) Drift a: 80 mm (3.15 in) dia. b: 60 mm (2.36 in) dia.	 <p style="text-align: center;">ZZA0701D</p> Installing drive shaft plug
KV38102200 ( — ) Drift a: 90 mm (3.54 in) dia. b: 31 mm (1.22 in) dia.	 <p style="text-align: center;">ZZA0920D</p> Installing drive shaft plug

### Commercial Service Tools

NDS000FO

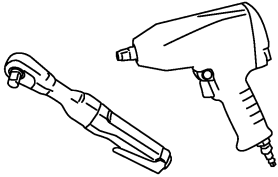
Tool name	Description
Power tool	 <p style="text-align: center;">PBIC0190E</p> <ul style="list-style-type: none"> <li>● Removing wheel nuts</li> <li>● Removing brake caliper assembly</li> <li>● Removing suspension links</li> <li>● Removing drive shaft</li> </ul>

A  
B  
C  
RAX  
E  
F  
G  
H  
I  
J  
K  
L  
M

# NOISE, VIBRATION AND HARSHNESS (NVH) TROUBLESHOOTING

## NOISE, VIBRATION AND HARSHNESS (NVH) TROUBLESHOOTING

PFP:00003

### NVH Troubleshooting Chart

NDS000FP

Use chart below to help you find the cause of the symptom. If necessary, repair or replace these parts.

Symptom		Possible cause and SUSPECTED PARTS													
		Excessive joint angle	Joint sliding resistance	Imbalance	Improper installation, looseness	Parts interference	PROPELLER SHAFT	DIFFERENTIAL	REAR AXLE AND REAR SUSPENSION	REAR AXLE	TIRES	ROAD WHEEL	DRIVE SHAFT	BRAKES	STEERING
DRIVE SHAFT	Noise	x	x				x	x	x	x	x	x		x	x
	Shake	x		x			x		x	x	x		x	x	
REAR AXLE	Noise				x	x	x	x		x	x	x	x	x	x
	Shake				x	x	x		x		x	x	x	x	x
	Vibration				x	x	x		x		x		x		x
	Shimmy				x	x			x		x	x		x	x
	Judder				x				x		x	x		x	x
	Poor quality ride or handling				x	x			x		x	x			
Reference page		—	RAX-10	—	RAX-8	—	NVH in PR section.	NVH in RFD section.	NVH in RAX and RSU sections.	Refer to REAR AXLE in this chart.	NVH in WT section.	NVH in WT section.	Refer to DRIVE SHAFT in this chart.	NVH in BR section.	NVH in PS section.

x: Applicable

# WHEEL HUB

## WHEEL HUB

PFP:43202

### On-Vehicle Inspection and Service

NDS000FQ

Make sure the mounting conditions (looseness, back lash) of each component and component conditions (wear, damage) are normal.

### WHEEL BEARING INSPECTION

- Move wheel hub and bearing assembly in the axial direction by hand. Make sure there is no looseness of wheel bearing.

**Axial end play : 0.05 mm (0.002 in) or less**

- Rotate wheel hub, and make sure that is no unusual noise or other irregular conditions. If there is any of irregular conditions, replace wheel hub and bearing assembly.

### Removal and Installation COMPONENT

NDS000FR

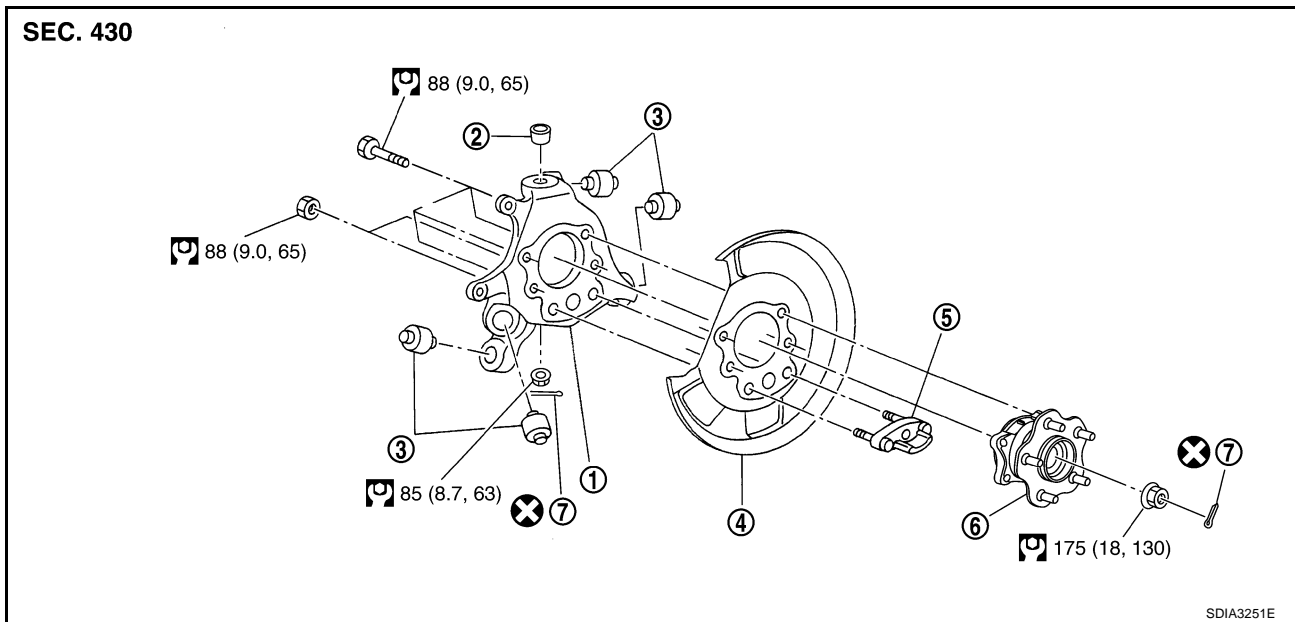

- |                 |                 |                                   |
|-----------------|-----------------|-----------------------------------|
| 1. Axle housing | 2. Ball seat    | 3. Bushing                        |
| 4. Back plate   | 5. Anchor block | 6. Wheel hub and bearing assembly |
| 7. Cotter pin   |                 |                                   |

Refer to GI section for symbol marks in the figure. Refer to [GI-9, "HOW TO USE THIS MANUAL"](#) .

### REMOVAL

#### Wheel Hub and Bearing Assembly

1. Remove tire from vehicle with a power tool.
2. Remove rear brake caliper with a power tool. Hang it in a place where it will not interfere with work. Refer to [BR-31, "Removal and Installation of Brake Caliper Assembly"](#) .

#### **CAUTION:**

**Do not depress brake pedal while brake caliper is removed.**

# WHEEL HUB

3. Put matching mark on disc rotor and the wheel hub and bearing assembly then removing disc rotor.
4. Remove cotter pin, then loosen hub lock nut with a power tool.

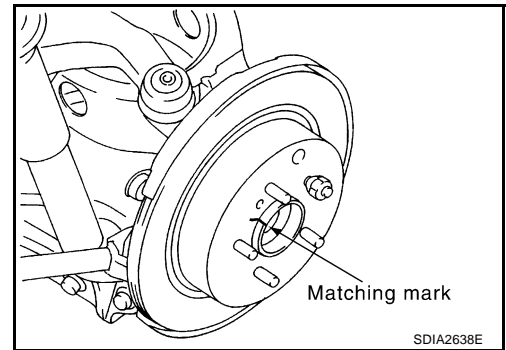

5. Separate the wheel hub and bearing assembly from drive shaft by lightly tapping the end with a hammer (suitable tool) and wood block, and then remove hub lock nut.

### CAUTION:

- Do not place drive shaft joint at an extreme angle. Also be careful not to overextend slide joint.
- Do not allow drive shaft to hang down without support for housing (or joint sub-assembly), shaft and other parts.

### NOTE:

Use a puller (suitable tool), if the wheel hub and bearing assembly and drive shaft cannot be separated even after performing the above procedure.

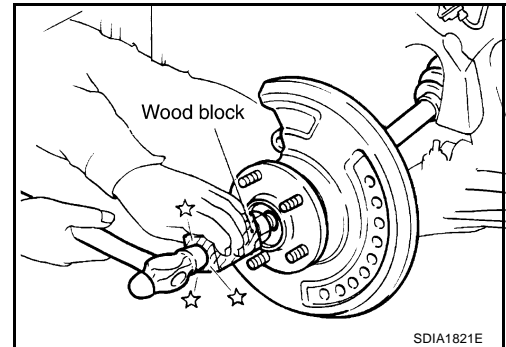

6. Remove the wheel hub and bearing assembly mounting bolts.
7. Remove the wheel hub and bearing assembly.

## Axle Housing

1. Refer to the procedure from 1 to 5 in "Wheel Hub and Bearing Assembly". [RAX-5, "REMOVAL"](#) .
2. Remove parking brake shoe and parking brake cable from back plate. Refer to [PB-5, "PARKING BRAKE SHOE"](#) , Refer to [PB-3, "PARKING BRAKE CONTROL"](#) .
3. Remove coil spring. Refer to [RSU-16, "REAR LOWER LINK & COIL SPRING"](#) .
4. Remove mounting bolt and nut in axle side of shock absorber with a power tool.
5. Remove axle side nuts and bolts on radius rod and front lower link with a power tool. Refer to [RSU-14, "RADIUS ROD"](#) , [RSU-15, "FRONT LOWER LINK"](#) .
6. Remove cotter pin, then loosen suspension arm mounting nut of axle housing.
7. Remove suspension arm from axle housing so as not to damage ball joint boot using ball joint remover (suitable tool), and then remove axle housing from the vehicle.

### CAUTION:

- Temporarily tighten nuts to prevent damage to threads and to prevent ball joint remover (suitable tool) from coming off.
  - Do not place drive shaft joint at an extreme angle. Also be careful not to overextend slide joint.
  - Do not allow drive shaft to hang down without support for counterpart such as joint sub-assembly, and other parts.
8. Remove the wheel hub and bearing assembly from axle housing.
  9. Remove anchor block mounting nuts, and then remove anchor block and backplate from axle housing.

## INSPECTION AFTER REMOVAL

### Wheel Hub and Bearing Assembly

Check the wheel hub and bearing assembly for wear, cracks, and damage. Replace if there are.

### Axle Housing

Check axle housing for wear, cracks, and damage. Replace if there are.

### Ball Joint Inspection

Check for boot breakage, axial looseness, and torque of suspension arm ball joint. Refer to [RSU-12, "SUSPENSION ARM"](#) .

# WHEEL HUB

## INSTALLATION

### Wheel Hub and Bearing Assembly

- Installation is the reverse order of removal. For tightening torque refer to [RAX-5, "COMPONENT"](#) .

**CAUTION:**

**Do not reuse non-reusable parts.**

- Assemble disc rotor and the wheel hub and bearing assembly by aligning each matching mark as shown in the figure when installing disc rotor.

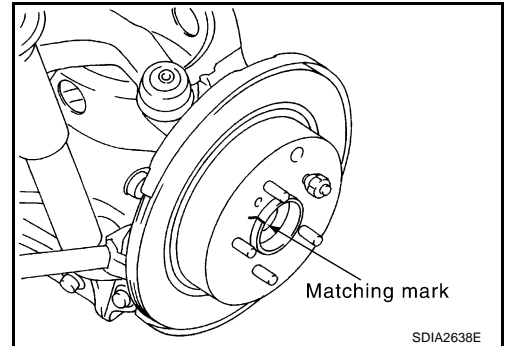

### Axle Housing

- Installation is the reverse order of removal. For tightening torque refer to [RAX-5, "COMPONENT"](#) .

**CAUTION:**

**Do not reuse non-reusable parts.**

- Assemble disc rotor and the wheel hub and bearing assembly by aligning each matching mark as shown in the figure when installing disc rotor.
- Perform final tightening of nuts and bolts on each link mounting part (rubber bushing) under unladen conditions with tires on level ground. Check wheel alignment. Refer to [FSU-6, "Wheel Alignment Inspection"](#) .
- Adjust neutral position of steering angle sensor after checking wheel alignment. Refer to [BRC-6, "ON-VEHICLE SERVICE"](#) .

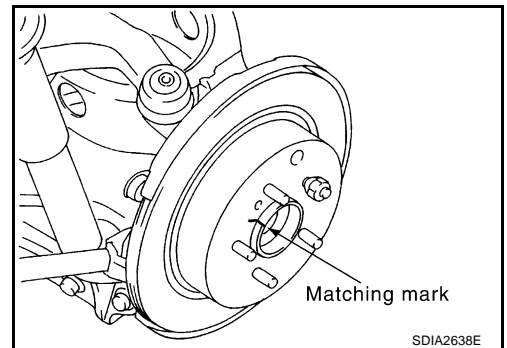

A  
B  
C  
RAX  
E  
F  
G  
H  
I  
J  
K  
L  
M

# REAR DRIVE SHAFT

PFP:39600

NDS000FS

## REAR DRIVE SHAFT

### Removal and Installation COMPONENT

#### VQ35DE model

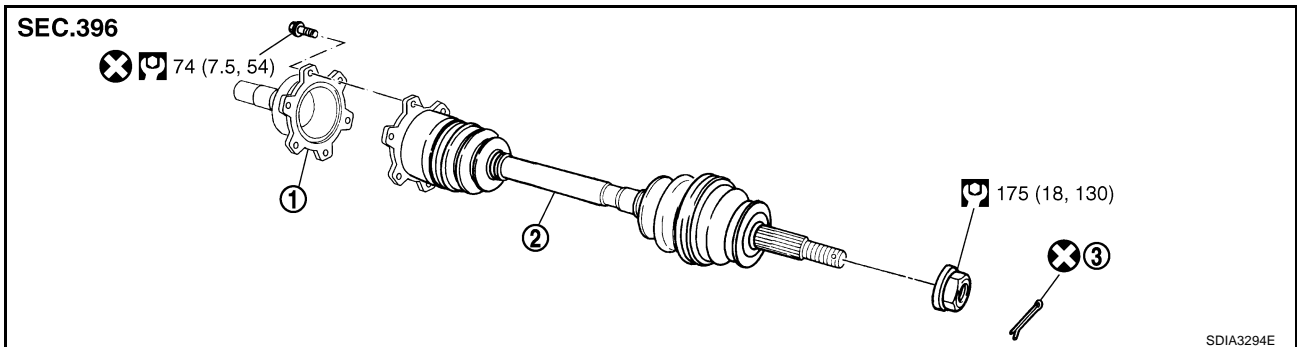

1. Side flange

2. Drive shaft

3. Cotter pin

Refer to GI section for symbol marks in the figure. Refer to [GI-9, "HOW TO USE THIS MANUAL"](#).

#### VK45DE model

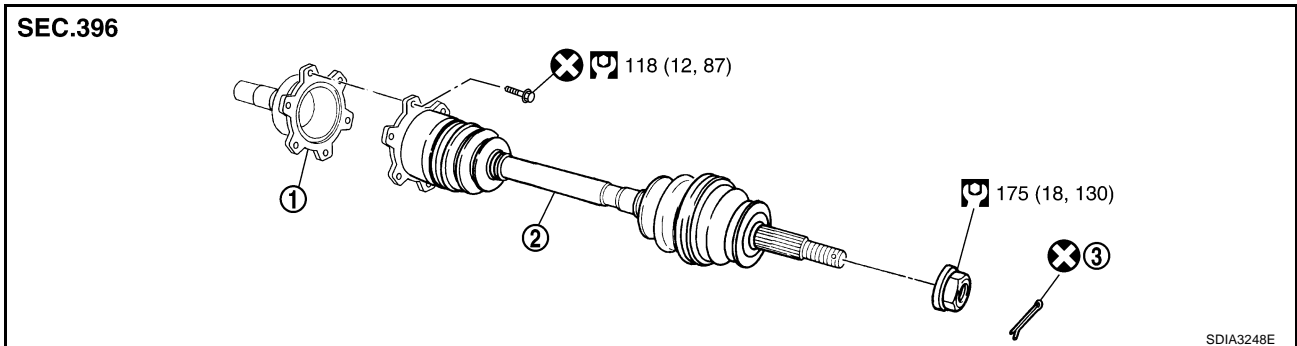

1. Side flange

2. Drive shaft

3. Cotter pin

Refer to GI section for symbol marks in the figure. Refer to [GI-9, "HOW TO USE THIS MANUAL"](#).

## REMOVAL

1. Remove tire from vehicle with a power tool.
2. Remove cotter pin, then loosen hub lock nut with a power tool.
3. Remove stabilizer connecting rod mounting bracket fixing bolt and free stabilizer connecting rod. Refer to [RSU-7, "Components"](#).
4. Separate the wheel hub and bearing assembly from drive shaft by lightly tapping the end with a suitable tool hammer and wood block, and then remove hub lock nut.

### CAUTION:

- Do not place drive shaft joint at an extreme angle. Also be careful not to overextend slide joint.
- Do not allow drive shaft to hang down without support for counterpart such as joint sub-assembly, and other parts.

### NOTE:

Using a puller (suitable tool) if the wheel hub and bearing assembly and drive shaft cannot be separated even after performing the above procedure.

5. Remove mounting bolts between side flange and drive shaft with a power tool.

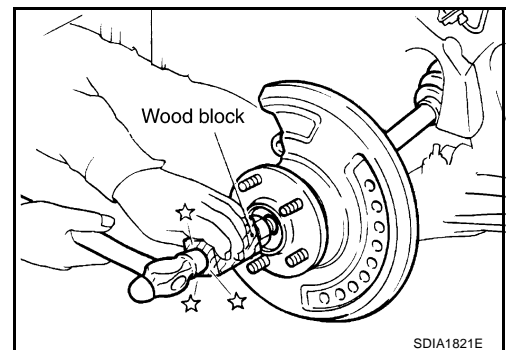

## INSPECTION AFTER REMOVAL

- Move joint up/down, left/right, and in the axial direction. Check for any rough movement or significant looseness.



# REAR DRIVE SHAFT

- Check boot for cracks or other damage, and also for grease leakage.
- If a malfunction is found, disassemble drive shaft, and then replace with new one.

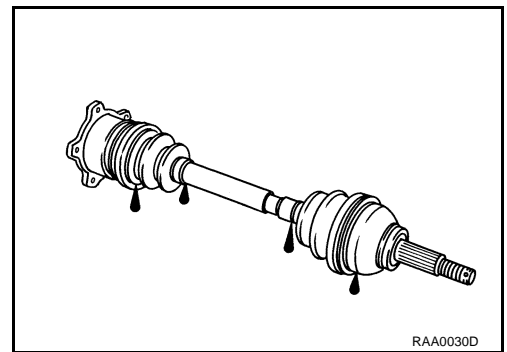

A  
B  
C

RAX

## INSTALLATION

Installation is the reverse order of removal. For tightening torque. Refer to [RAX-8, "COMPONENT"](#) .

### CAUTION:

Do not reuse non-reusable parts.

## Disassembly and Assembly COMPONENT

NDS000FT

E  
F  
G  
H  
I  
J  
K  
L  
M

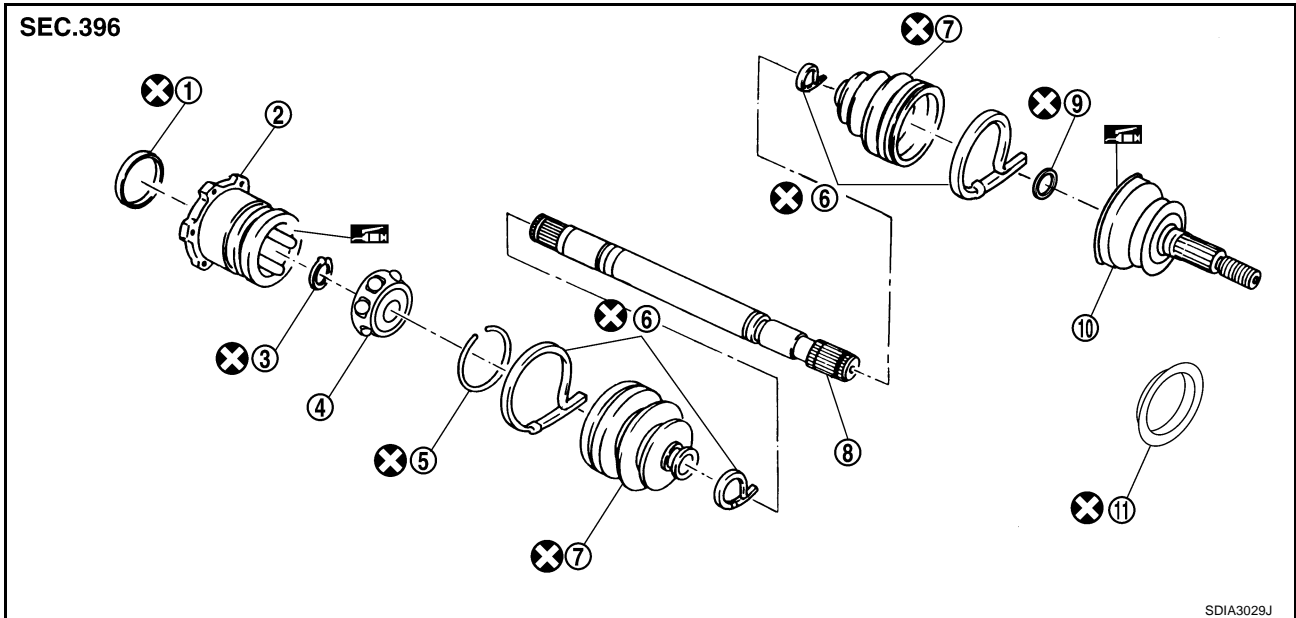

- |  |                 |                  |
|--|-----------------|------------------|
| 1. Plug  | 2. Housing      | 3. Snap ring     |
| 4. Ball cage, steel ball and Inner race assembly | 5. Stopper ring | 6. Boot band     |
| 7. Boot  | 8. Shaft        | 9. Circular clip |
| 10. Joint sub-assembly                           | 11. Dust shield |                  |

: NISSAN genuine grease or equivalent

Refer to GI section for symbol marks except in the above. Refer to [GI-9, "HOW TO USE THIS MANUAL"](#) .

## DISASSEMBLY

### Final Drive Side

1. Secure shaft in a vise.

### CAUTION:

Protect shaft when securing in a vise using aluminum or copper plates.

2. Remove boot bands, and then remove boot from housing.
3. If plug needs to be removed, move boot to wheel side, and take it out with a plastic hammer.
4. Put matching marks on housing and shaft.

### CAUTION:

Use paint or similar substance for matching marks. Do not scratch the surface.

## REAR DRIVE SHAFT

5. Remove stopper ring with a flat-bladed screwdriver, and pull out housing.

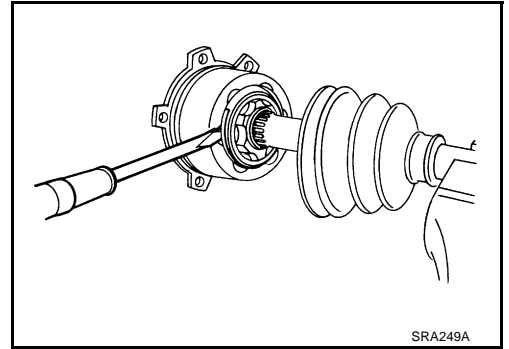

6. Put matching marks on ball cage, steel ball and Inner race assembly and shaft.

**CAUTION:**

**Use paint or similar substance for matching marks. Do not scratch the surface.**

7. Remove snap ring, then remove ball cage, steel ball and Inner race assembly from shaft.
8. Remove boot from shaft.
9. Remove old grease on housing with paper towels.

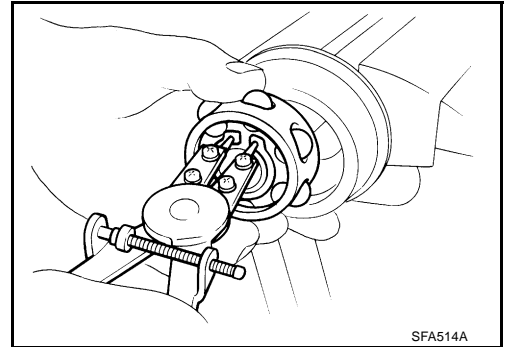

### Wheel Side

1. Remove dust shield from drive shaft.
2. Secure shaft in a vise.

**CAUTION:**

**Protect shaft when securing in a vise using aluminum or copper plates.**

3. Remove boot bands. Then remove boot from joint sub-assembly.
4. Screw a drive shaft puller 30 mm (1.18 in) or more into threaded part of joint sub-assembly. Pull joint sub-assembly out of shaft.

**CAUTION:**

- If joint sub-assembly cannot be removed after five or more unsuccessful attempts, replace shaft and joint sub-assembly as a set.
- Align sliding hammer and drive shaft and remove them by pulling directory.

5. Remove boot from shaft.
6. Remove circular clip from shaft.
7. While rotating ball cage, remove old grease on joint sub-assembly with paper towels.

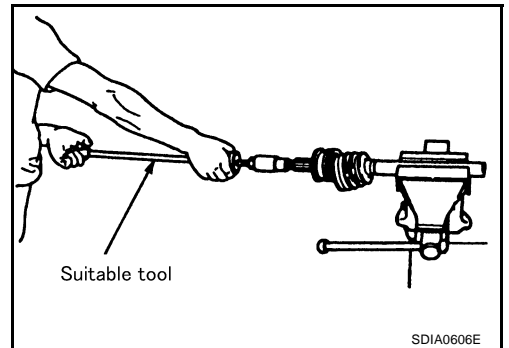

### INSPECTION AFTER DISASSEMBLY

#### Shaft

Replace shaft if there is any runout, cracking, or other damage.

#### Joint Sub-Assembly (Wheel Side)

Check the following:

- Joint sub-assembly for rough rotation and excessive axial looseness.
- The inside of the joint sub-assembly for entry of foreign material.
- Joint sub-assembly for compression scars, cracks, and fractures inside of joint sub-assembly.

Replace joint sub-assembly if there are any non-standard conditions of components

# REAR DRIVE SHAFT

## CAUTION:

If there are any irregular conditions of joint sub-assembly components, replace the entire joint sub-assembly.

## Final Drive Side

- Make sure there are compression scars, cracks, fractures or unusual wear of ball rolling surface.
- Make sure there is no damage to shaft screws.
- Make sure there is no deformation of boot installation parts.

## Ball Cage

Make sure there are compression scars, cracks, fractures of sliding surface.

## Steel Ball

Make sure there are compression scars, cracks, fractures or unusual wear.

## Inner Race

- Check ball sliding surface for compression scars, cracks or fractures.
- Make sure there is no damage to serrated part.

## CAUTION:

If there are any irregular conditions in the component, replace with a new set of housing and the ball cage, steel ball and inner race assembly.

## ASSEMBLY

### Final Drive Side

1. If plug has been removed, use a drift [SST] to press in a new one.

## CAUTION:

Do not reuse plug.

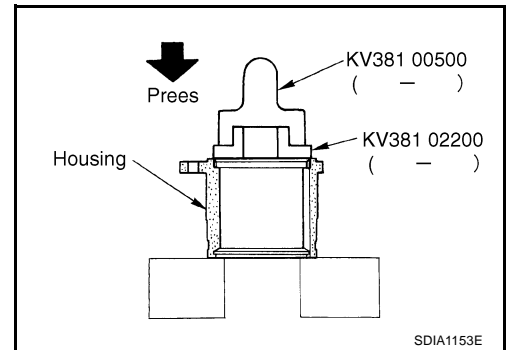

2. Wrap serrated part of shaft with tape. Install boot band and boot to shaft. Be careful not to damage boot.

## CAUTION:

Do not reuse boot band and boot.

3. Remove protective tape wrapped around serrated part of shaft.

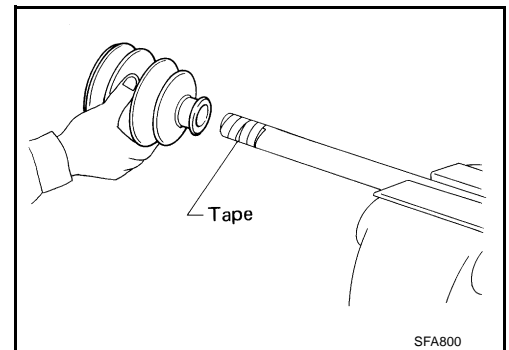

4. Install ball cage, steel ball and inner race assembly to shaft, and secure them tightly with a snap ring.

## CAUTION:

Do not reuse snap ring.

## NOTE:

Align matching marks painted when ball cage, steel ball and inner race assembly were removed.

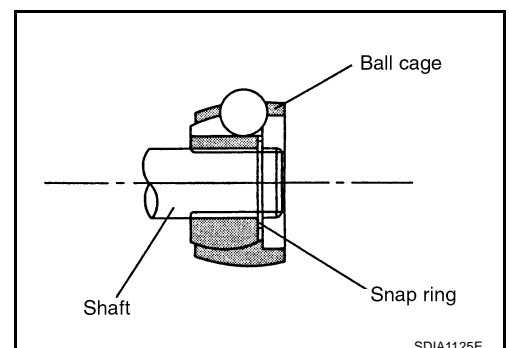

A  
B  
C  
RAX  
E  
F  
G  
H  
I  
J  
K  
L  
M

## REAR DRIVE SHAFT

5. Apply the specified amount of grease (NISSAN genuine grease or equivalent) onto housing (\* point) and install it to shaft.

**NOTE:**

Align matching marks painted when housing were removed.

**Grease amount**

**VQ35DE model : 130 - 150 g (4.59 - 5.29 oz)**

**VK45DE model : 155 - 175 g (5.47 - 6.17 oz)**

6. Install stopper ring to housing.
7. After installed, pull shaft to check engagement between joint sub-assembly and stopper ring.
8. Install boot securely into grooves (indicated by \* marks) shown in the figure.

**CAUTION:**

**If there is grease on boot mounting surfaces (indicated by\* marks) of shaft and housing, boot may come off. Remove all grease from the surfaces.**

9. Make sure boot installation length "L" is the length indicated below. Insert a flat-bladed screwdriver or similar tool into inside of boot from the large diameter side of boot. Bleed air from boot to prevent boot deformation.

**Boot installation Length "L"**

**VQ35DE model : 145 mm (5.709 in)**

**VK45DE model : 148 mm (5.827 in)**

**CAUTION:**

- **Boot may break if boot installation length is less than standard value.**
- **Take care not to touch the tip of screwdriver to inside of boot.**

10. Secure large and small ends of boot with new boot bands as shown in the figure.

**CAUTION:**

**Do not reuse boot band.**

11. After installing housing and shaft, rotate boot to check whether or not the actual position is correct. If boot position is not correct, secure boot with new boot band again.

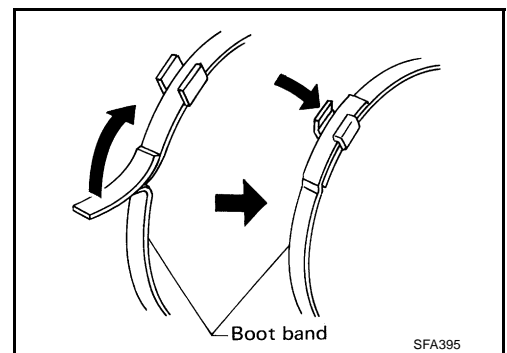
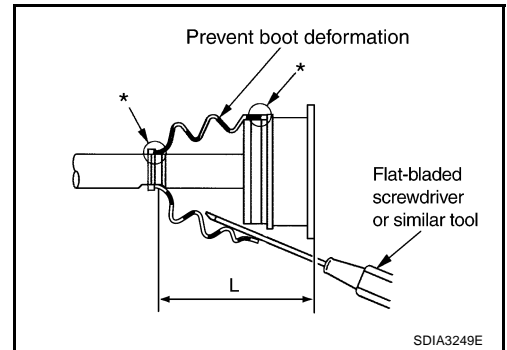
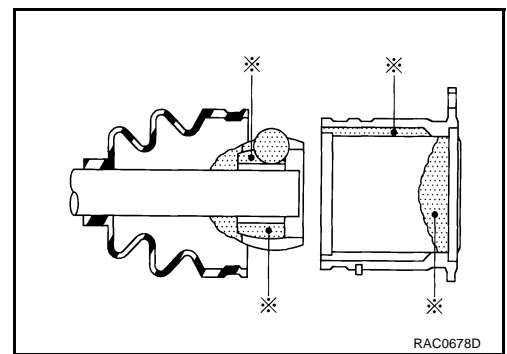

### Wheel Side

1. Apply the specified amount of grease (NISSAN genuine grease or equivalent) into joint sub-assembly serration hole until grease begins to ooze from ball groove and serration hole. After applying grease, use a shop cloth to wipe off old grease that has oozed out.

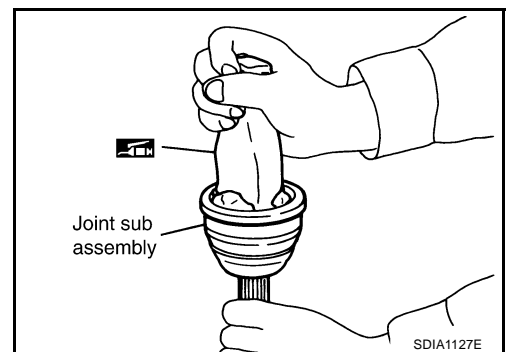

## REAR DRIVE SHAFT

- Wrap serrated part of shaft with tape. Install boot band and boot to shaft. Be careful not to damage boot.

**CAUTION:**

**Do not reuse boot band and boot.**

- Remove protective tape wrapped around serrated part of shaft.

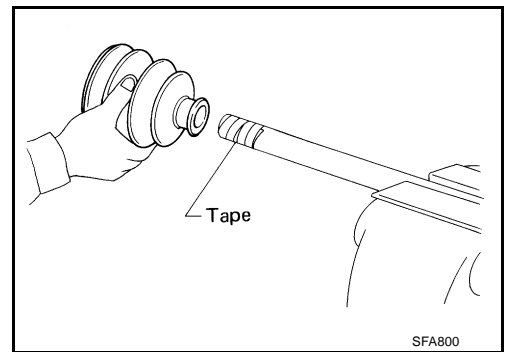

- Attach circular clip to shaft. At this time, circular clip must fit securely into shaft groove. Attach nut to joint sub-assembly. Use a wooden hammer to press-fit.

**CAUTION:**

**Do not reuse circular clip.**

- Apply the specified amount of grease (NISSAN genuine grease or equivalent) into housing from large end of boot.

**Grease amount**

**VQ35DE model : 115 - 135 g (4.06 - 4.76 oz)**

**VK45DE model : 155 - 175 g (5.47 - 6.17 oz)**

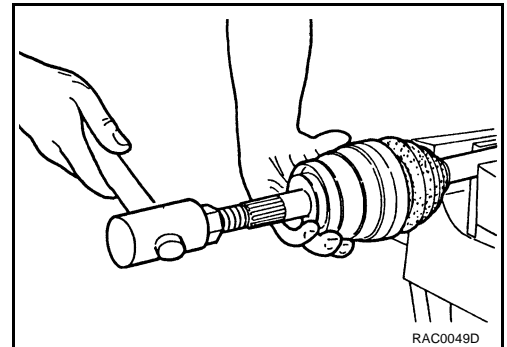

- Install boot securely into grooves (indicated by \* marks) shown in the figure.

**CAUTION:**

**If there is grease on boot mounting surfaces (indicated by \* marks) of shaft and housing, boot may come off. Remove all grease from the surfaces.**

- Make sure boot installation length "L" is the length indicated below. Insert a flat-bladed screwdriver or similar tool into inside of boot from the large diameter side of the boot. Bleed air from boot to prevent boot deformation.

**Boot installation Length "L"**

**VQ35DE model : 136 mm (5.354 in)**

**VK45DE model : 145 mm (5.709 in)**

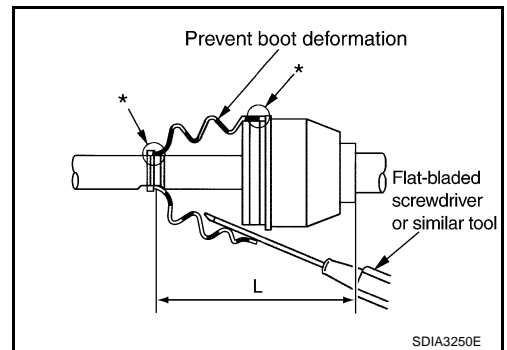

**CAUTION:**

- **Boot may brake if boot installation length is less than standard value.**
- **Be careful that screwdriver tip does not contact inside surface of boot.**

- Secure large and small ends of boot with new boot bands as shown in the figure.

**CAUTION:**

**Do not reuse boot band.**

- After installing joint sub-assembly and shaft, rotate boot to check whether or not the actual position is correct. If boot position is not correct, secure boot with new boot bands again.

- Install dust shield to drive shaft.

**CAUTION:**

**Do not reuse dust shield.**

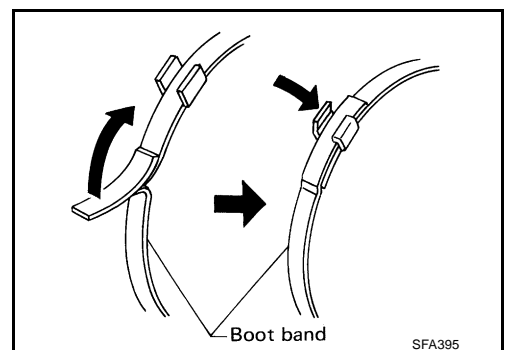

# SERVICE DATA

## SERVICE DATA

PFP:00030

### Wheel Bearing

NDS000FU

Axial end play

0.05 mm (0.002 in) or less

### Drive Shaft

NDS000FV

Joint type	Wheel side		Final drive side	
	VQ35DE model	VK45DE model	VQ35DE model	VK45DE model
Grease quantity	115 - 135 g (4.06 - 4.76 oz)	155 - 175 g (5.47 - 6.17 oz)	130 - 150 g (4.59 - 5.29 oz)	155 - 175 g (5.47 - 6.17 oz)
Boots installed length	136 mm (5.354 in)	145 mm (5.709 in)	145 mm (5.709 in)	148 mm (5.827 in)