

A
B
C

SECTION PR

PROPELLER SHAFT

PR

CONTENTS

2WD		
PREPARATION	2	NOISE, VIBRATION AND HARSHNESS (NVH)
Special Service Tools	2	TROUBLESHOOTING
Commercial Service Tools	2	NVH Troubleshooting Chart
NOISE, VIBRATION AND HARSHNESS (NVH)		FRONT PROPELLER SHAFT
TROUBLESHOOTING	3	On-Vehicle Inspection
NVH Troubleshooting Chart	3	APPEARANCE AND NOISE INSPECTION
REAR PROPELLER SHAFT	4	PROPELLER SHAFT VIBRATION
On-Vehicle Inspection	4	Components
APPEARANCE AND NOISE INSPECTION	4	Removal and Installation
PROPELLER SHAFT VIBRATION	4	REMOVAL
Components	5	INSPECTION
Removal and Installation	5	INSTALLATION
REMOVAL	5	REAR PROPELLER SHAFT
INSPECTION	6	On-Vehicle Inspection
INSTALLATION	7	APPEARANCE AND NOISE INSPECTION
Disassembly and Assembly of Center Bearing	8	PROPELLER SHAFT VIBRATION
DISASSEMBLY	8	Components
ASSEMBLY	9	Removal and Installation
SERVICE DATA AND SPECIFICATIONS (SDS)	10	REMOVAL
General Specifications	10	INSPECTION
Journal Axial Play	10	INSTALLATION
Propeller Shaft Runout	10	Disassembly and Assembly of Center Bearing
		DISASSEMBLY
AWD		ASSEMBLY
PREPARATION	11	SERVICE DATA AND SPECIFICATIONS (SDS)
Special Service Tools	11	General Specifications
Commercial Service Tools	11	Journal Axial Play
		Propeller Shaft Runout

E
F
G
H
I
J
K
L
M

PREPARATION

[2WD]

PFP:00002

PREPARATION

Special Service Tools

NDS0003I

The actual shapes of Kent-Moore tools may differ from those of special service tools illustrated here.

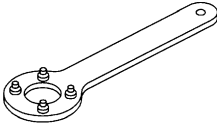
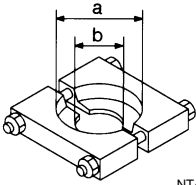
Tool number (Kent-Moore No.) Tool name	Description
ST38060002 (J-34311) Flange wrench <div style="text-align: center;">  NT113 </div>	Removing and installing center flange lock nut
ST30031000 (J-22912-01) Puller a: 90 mm (3.54 in) dia. b: 50 mm (1.97 in) dia. <div style="text-align: center;">  NT411 </div>	Remove rear propeller shaft center bearing

Commercial Service Tools

NDS0003J

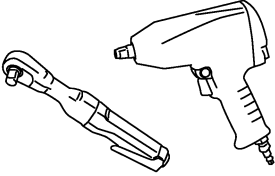
Tool name	Description
Power tool <div style="text-align: center;">  PBIC0190E </div>	Loosening bolts and nuts

NOISE, VIBRATION AND HARSHNESS (NVH) TROUBLESHOOTING

[2WD]

NOISE, VIBRATION AND HARSHNESS (NVH) TROUBLESHOOTING

PF0:00003

NVH Troubleshooting Chart

NDS0003K

Use the chart below to help you find the cause of the symptom. If necessary, repair or replace these parts.

Symptom		Possible cause and SUSPECTED PARTS													
		Uneven rotating torque	Center bearing improper installation	Excessive center bearing axial end play	Center bearing mounting (insulator) cracks, damage or deterioration	Excessive joint angle	Rotation imbalance	Excessive runout	DIFFERENTIAL	AXLE AND SUSPENSION	TIRES	ROAD WHEEL	DRIVE SHAFT	BRAKES	STEERING
Reference page	Noise	PR-4	PR-7	—	PR-5	—	PR-4	PR-6	NVH in RFD section	NVH in FAX, RAX, FSU, and RSU section	NVH in WT section	NVH in WT section	NVH in RAX section	NVH in BR section	NVH in PS section
	Shake														
	Vibration	x	x	x	x	x	x	x		x	x		x		x

x: Applicable

A
B
C
PR
E
F
G
H
I
J
K
L
M

REAR PROPELLER SHAFT

PFP:37000

On-Vehicle Inspection

NDS0003L

APPEARANCE AND NOISE INSPECTION

- Check the propeller shaft tube surface for dents or cracks. If damaged, replace propeller shaft assembly.
- If center bearing is noisy or damaged, replace center bearing.

PROPELLER SHAFT VIBRATION

If vibration is present at high speed, inspect propeller shaft runout first.

1. Measure propeller shaft runout at runout measuring points by rotating final drive companion flange with hands.

Propeller shaft runout limit : 0.8 mm (0.031 in) or less

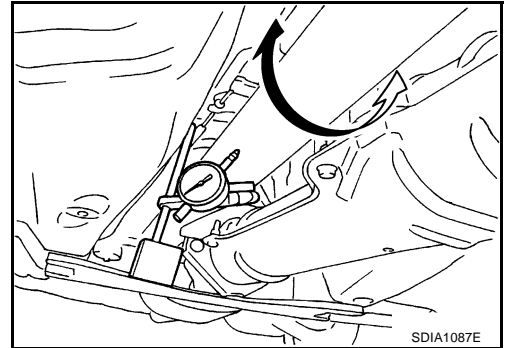

Propeller shaft runout measuring points

Dimension A: 192 mm (7.56 in)

B: 172 mm (6.77 in)

C: 170 mm (6.69 in)

2. If runout still exceeds specifications, separate propeller shaft at final drive companion flange; then rotate companion flange 90, 180, 270 degrees and install propeller shaft.
3. Check runout again. If runout still exceeds specifications, replace propeller shaft assembly.
4. Check the vibration by driving vehicle.

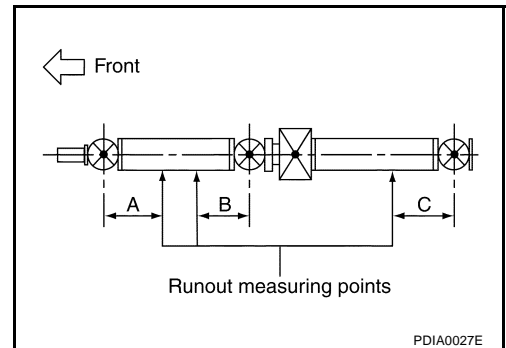

REAR PROPELLER SHAFT

[2WD]

NDS0003M

Components

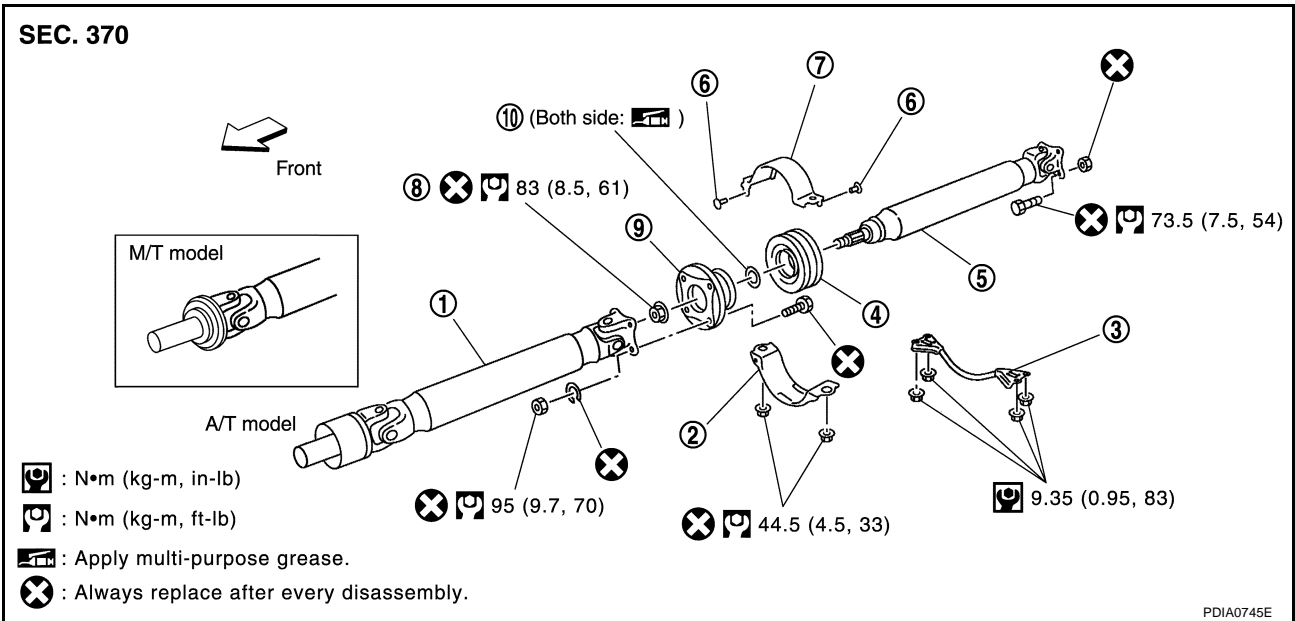

- | | | |
|--|--|---------------------|
| 1. Propeller shaft (1st shaft) | 2. Center bearing mounting bracket (Lower) | 3. Floor rain force |
| 4. Center bearing | 5. Propeller shaft (2nd shaft) | 6. Clip |
| 7. Center bearing mounting bracket (Upper) | 8. Lock nut | 9. Center flange |
| 10. Washer | | |

NOTE:

- The joint cannot be disassembled.
- The center bearing can be disassembled. Refer to [PR-8, "Disassembly and Assembly of Center Bearing"](#).

Removal and Installation

REMOVAL

NDS0003N

1. Move A/T selector lever to N position or set M/T shift lever to neutral position.
2. Release parking brake.
3. Remove the center muffler with power tool. Refer to [EX-4, "Removal and Installation"](#).
4. Loosen mounting nuts of center bearing mounting brackets with power tool.

CAUTION:

Tighten mounting nuts temporarily.

5. Put matching marks on propeller shaft flange yoke with final drive companion flange.

CAUTION:

For matching mark, use paint. Do not damage propeller shaft flange yoke and companion flange.

6. Remove propeller shaft fixing bolts and nuts.
7. Remove center bearing mounting bracket fixing nuts.
8. Remove propeller shaft.

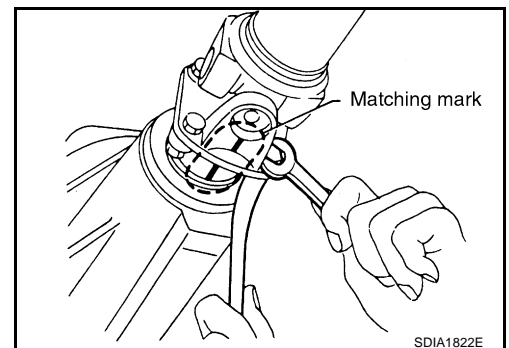

INSPECTION

- Inspect propeller shaft runout at measuring points. If runout exceeds specifications, replace propeller shaft assembly.

Propeller shaft runout limit : 0.8 mm (0.031 in) or less

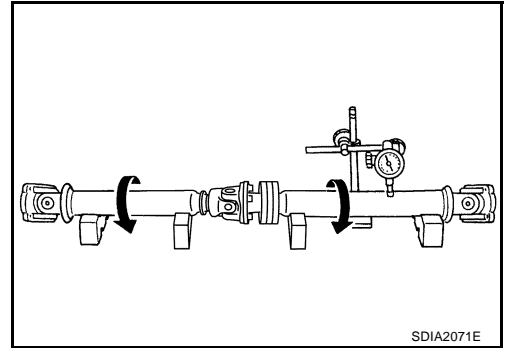

Propeller shaft runout measuring points

Dimension A: 192 mm (7.56 in)

B: 172 mm (6.77 in)

C: 170 mm (6.69 in)

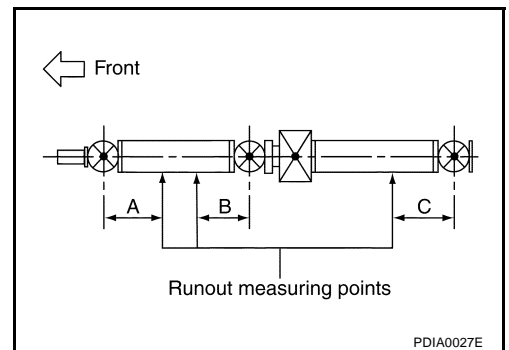

- As shown in the figure, while fixing yoke on one side, check axial play of joint. If outside the standard, replace relevant propeller shaft.

Journal axial play : 0 mm (0 in)

- Check propeller shaft for bend and damage. If damage is detected, replace relevant propeller shaft.

CAUTION:

Do not disassemble joints.

- Check center bearing for noise and damage. If noise or damage is detected, replace center bearing. Refer to [PR-8, "Disassembly and Assembly of Center Bearing"](#).

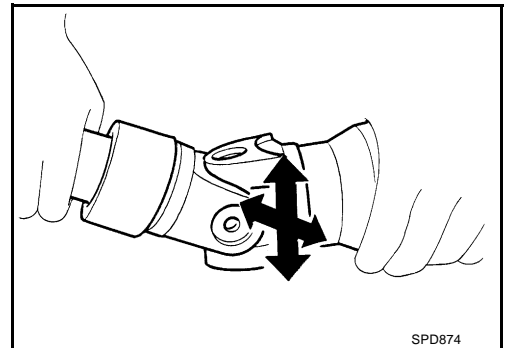

INSTALLATION

Note the following, and install in the reverse order of removal.

- Align matching marks to install propeller shaft to final drive companion flange, and then tighten to specified torque. Refer to [PR-5, "Components"](#).
- Install center bearing mounting bracket (Upper) with its arrow mark facing forward.
- Adjust position of mounting bracket sliding back and forth to prevent play in thrust direction of center bearing insulator. Install bracket to vehicle.
- After assembly, perform a driving test to check propeller shaft vibration. If vibration occurred, separate propeller shaft from final drive. Reinstall companion flange after rotating it by 90, 180, 270 degrees. Then perform driving test and check propeller shaft vibration again at each point.

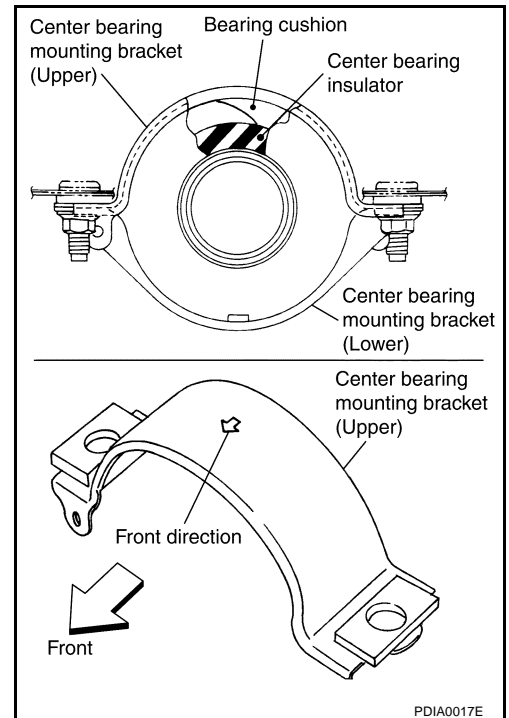

- If propeller shaft or final drive has been replaced, connect them as follows:

1. Install propeller shaft while aligning its matching mark A with the matching mark B on the joint as close as possible.
2. Temporarily tighten bolts and nuts.

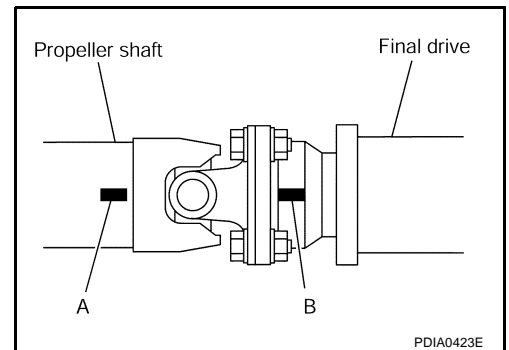

3. Press down propeller shaft with matching mark C facing upward. Then tighten fixing bolts and nuts to the specified torque. Refer to [PR-5, "Components"](#).

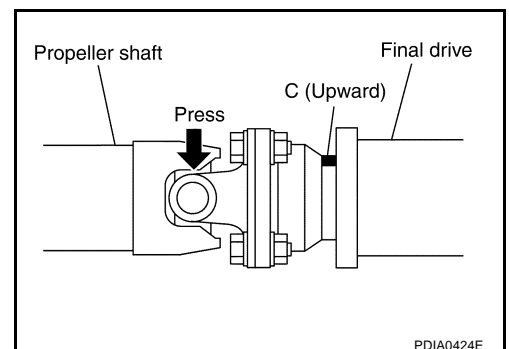

A
B
C
PR
E
F
G
H
I
J
K
L
M

Disassembly and Assembly of Center Bearing DISASSEMBLY

1. Put matching marks on propeller shaft and center flange, then disassemble the 1st and 2nd propeller shaft.

CAUTION:

For matching mark, use paint. Do not damage the propeller shaft flange and center flange.

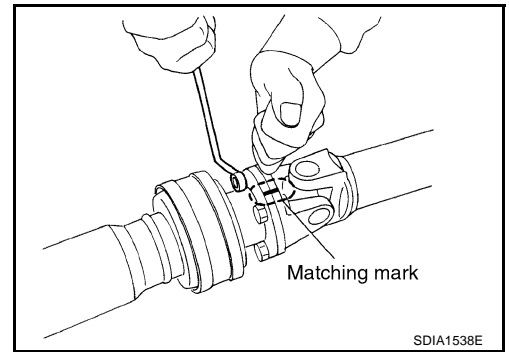

2. Put matching marks onto the center flange and propeller shaft end as shown.

CAUTION:

For matching mark, use paint. Do not damage propeller shaft end and center flange.

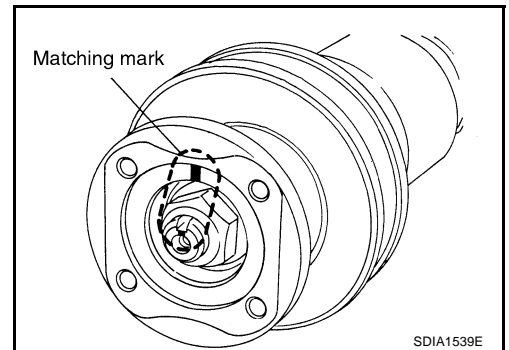

3. Hold the center flange using the flange wrench, and remove the lock nut.

Tool number : ST38060002 (J-34311)

4. Remove the center flange using a commercial available bearing puller then remove washer.

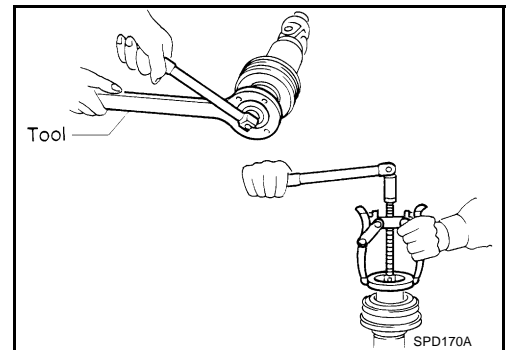

5. Press out the center bearing using the puller and hydraulic press.

Tool number : ST30031000 (J-22912-01)

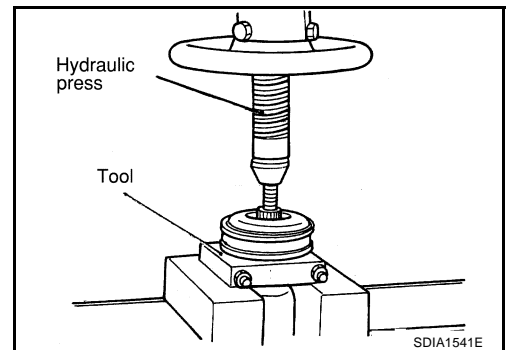

REAR PROPELLER SHAFT

[2WD]

ASSEMBLY

1. Install the center bearing with its "F" mark facing the rear of the vehicle.
2. Apply multi-purpose grease to the each face of the washer, then install washer.
3. Install the center flange onto the propeller shaft with aligning the marks that are marked while removal.
4. Install and tighten the lock nut to specified torque. Refer to [PR-5, "Components"](#).

CAUTION:

Do not use the lock nut.

5. Place a piece of wood under the center flange, stake the lock nut against the propeller shaft groove.

6. Assemble the 1st and 2nd shaft propeller shafts while aligning the matching marks that are marked during removal.
7. Install and tighten the bolts/nuts and tighten them to specified torque. Refer to [PR-5, "Components"](#).

CAUTION:

Do not reuse the bolts, nuts and washers.

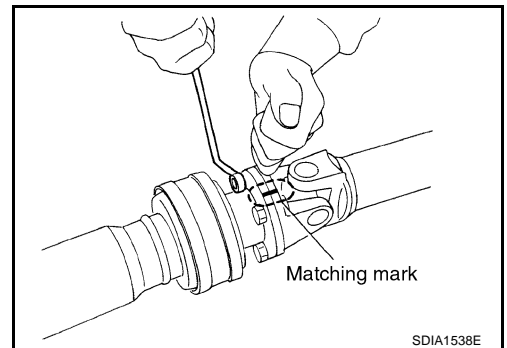
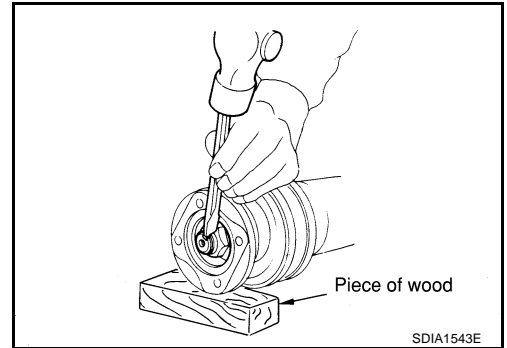
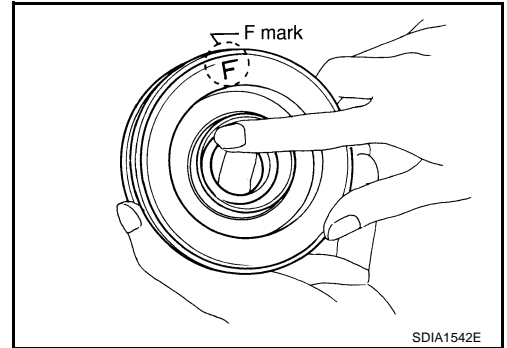

A
B
C
PR
E
F
G
H
I
J
K
L
M

SERVICE DATA AND SPECIFICATIONS (SDS)

[2WD]

SERVICE DATA AND SPECIFICATIONS (SDS)

PFP:00030

General Specifications

NDS0003P

Applied model		VQ35DE	
		M/T	A/T
Propeller shaft model		3S80A	
Number of joints		3	
Coupling method with transmission		Sleeve type	
Shaft length	1st (Spider to spider)	619 mm (24.37 in)	581 mm (22.87 in)
	2nd (Spider to spider)	902 mm (35.51 in)	
Shaft outer diameter	1st	82.6 mm (3.25 in)	
	2nd	82.6 mm (3.25 in)	

Journal Axial Play

NDS0003Q

Model	3S80A
Journal axial play	0 mm (0 in)

Propeller Shaft Runout

NDS0003R

Model	3S80A
Propeller shaft runout limit	0.8 mm (0.031 in) or less

PREPARATION

[AWD]

PREPARATION

PF0:00002

Special Service Tools

NDS0003S

The actual shapes of Kent-Moore tools may differ from those of special service tools illustrated here.

Tool number (Kent-Moore No.) Tool name	Description
KV40104000 (—) Flange wrench a: 85 mm (3.35 in) b: 65 mm (2.56 in)	Removing and installing center flange lock nut
ST30031000 (J-22912-01) Puller a: 90 mm (3.54 in) dia. b: 50 mm (1.97 in) dia.	Removing rear propeller shaft center bearing

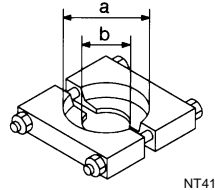
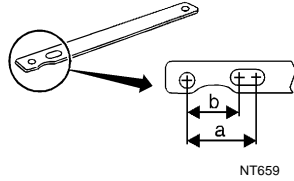

Commercial Service Tools

NDS0003T

Tool name	Description
Power tool	Loosening bolts and nuts

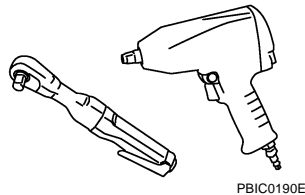

A
B
C
PR
E
F
G
H
I
J
K
L
M

NOISE, VIBRATION AND HARSHNESS (NVH) TROUBLESHOOTING

[AWD]

NOISE, VIBRATION AND HARSHNESS (NVH) TROUBLESHOOTING

PFP:00003

NVH Troubleshooting Chart

NDS0003U

Use the chart below to help you find the cause of the symptom. If necessary, repair or replace these parts.

Reference page		Front													
		Rear	PR-16	PR-19	PR-17	PR-13	PR-15	NVH in FFD and RFD section	NVH in FAX, RAX, FSU, and RSU section	NVH in WT section	NVH in WT section	NVH in RAX section	NVH in BR section	NVH in PS section	
Possible cause and SUSPECTED PARTS			PR-13	—	—	—	—	PR-13	PR-15						
			PR-16	PR-19	PR-17	PR-13	PR-15								
			PR-16	PR-19	PR-17	PR-13	PR-15								
			PR-16	PR-19	PR-17	PR-13	PR-15								
			PR-16	PR-19	PR-17	PR-13	PR-15								
			PR-16	PR-19	PR-17	PR-13	PR-15								
			PR-16	PR-19	PR-17	PR-13	PR-15								
			PR-16	PR-19	PR-17	PR-13	PR-15								
			PR-16	PR-19	PR-17	PR-13	PR-15								
			PR-16	PR-19	PR-17	PR-13	PR-15								
			PR-16	PR-19	PR-17	PR-13	PR-15								
			PR-16	PR-19	PR-17	PR-13	PR-15								
			PR-16	PR-19	PR-17	PR-13	PR-15								
Symptom		Noise	×	×	×	×	×	×	×	×	×	×	×	×	
		Shake		×			×			×	×	×	×	×	
		Vibration	×	×	×	×	×	×	×	×	×	×	×	×	

×: Applicable

FRONT PROPELLER SHAFT

PFP:37200

On-Vehicle Inspection

NDS0003V

APPEARANCE AND NOISE INSPECTION

- Check the propeller shaft tube surface for dents or cracks. If damaged, replace propeller shaft assembly.

PROPELLER SHAFT VIBRATION

If vibration is present at high speed, inspect propeller shaft runout first.

1. Measure propeller shaft runout at runout measuring point by rotating final drive companion flange with hands.

Propeller shaft runout limit : 0.8 mm (0.031 in) or less

Propeller shaft runout measuring point

Dimension A: 381.5 mm (15.01 in)

2. If runout still exceeds specifications, separate propeller shaft at final drive companion flange; then rotate companion flange 90, 180, 270 degrees and install propeller shaft.
3. Check runout again. If runout still exceeds specifications, replace propeller shaft assembly.
4. Check the vibration by driving vehicle.

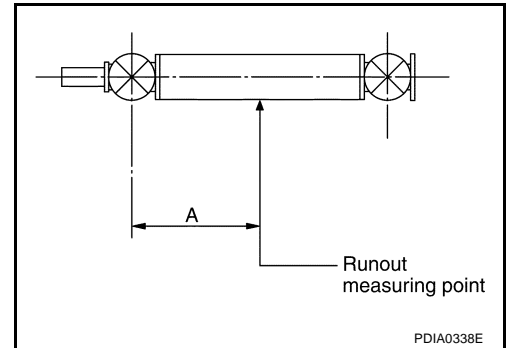

A
B
C
PR
E
F
G
H
I
J
K
L
M

FRONT PROPELLER SHAFT

[AWD]

Components

NDS0003W

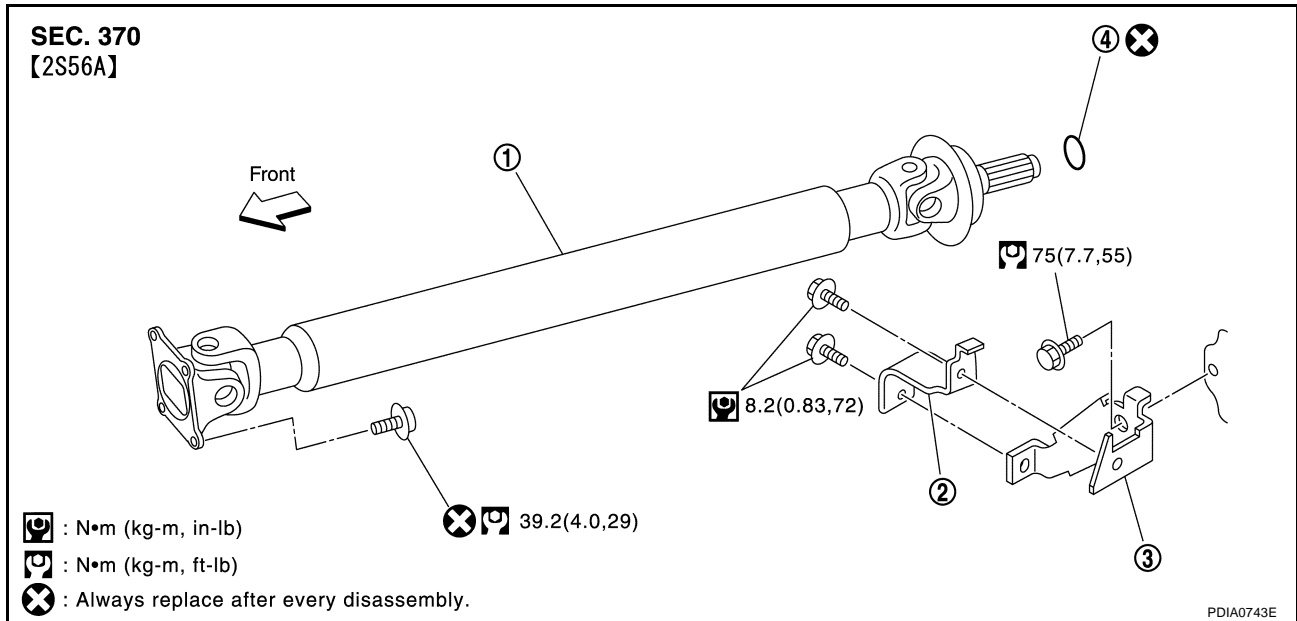

1. Propeller shaft assembly
2. Heat bracket (A)
3. Heat bracket (B)
4. O-ring

Removal and Installation

REMOVAL

NDS0003X

1. Remove the engine undercover with a power tool.
2. Remove three way catalyst (right bank) with power tool. Refer to [EM-27, "Removal and Installation"](#).
3. Put matching marks onto propeller shaft flange yoke and final drive companion flange.

CAUTION:

For matching mark, use paint. Do not damage propeller shaft flange and companion flange.

4. Remove the propeller shaft fixing bolts.

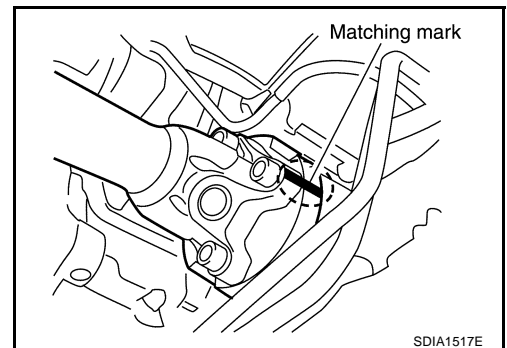

5. Set the transmission jack at the transfer, remove rear engine mounting bolts, and then lower transmission jack about 40-50 mm (0.16 - 0.21 in).
6. Remove propeller shaft from the front final drive and transfer.

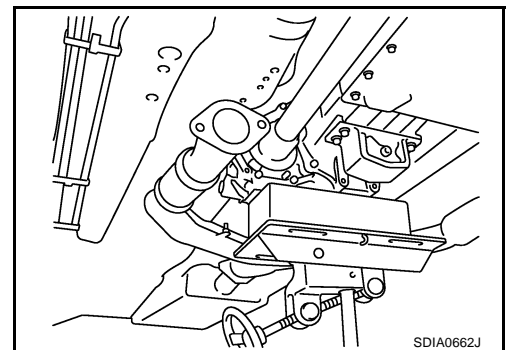

FRONT PROPELLER SHAFT

[AWD]

INSPECTION

- Inspect propeller shaft runout at measuring point. If runout exceeds specifications, replace propeller shaft assembly.

Propeller shaft runout limit : 0.8 mm (0.031 in) or less

Propeller shaft runout measuring point

Dimension A: 381.5 mm (15.01 in)

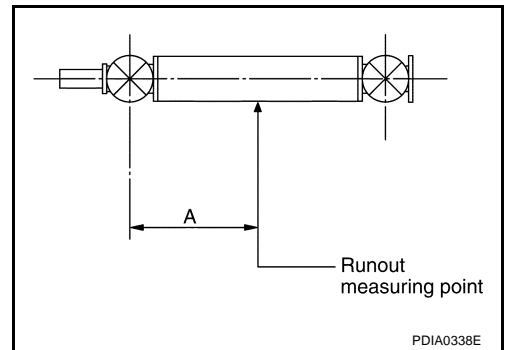
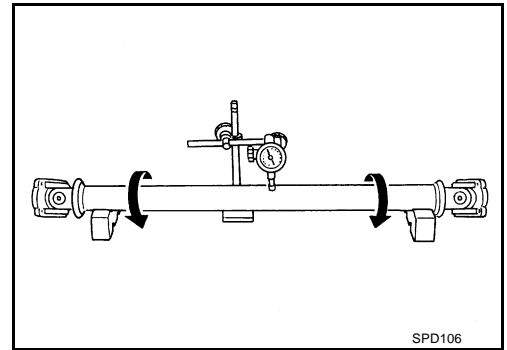

- As shown in the figure, while fixing yoke on one side, check axial play of joint. If outside the standard, replace propeller shaft assembly.

Journal axial play : 0 mm (0 in)

- Check propeller shaft for bend and damage. If damage is detected, replace propeller shaft assembly.

CAUTION:

Do not disassemble joints.

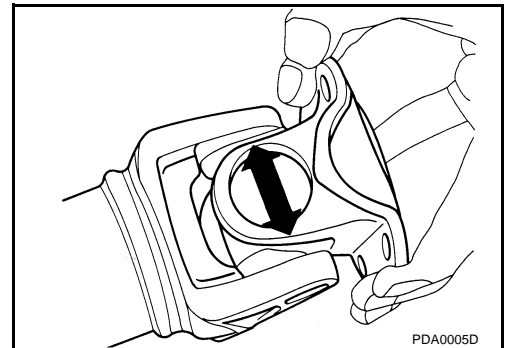

INSTALLATION

Note the following, install in the reverse order of removal.

- Align matching marks to install propeller shaft to final drive companion flange, and then tighten to specified torque. Refer to [PR-14, "Components"](#).

CAUTION:

Do not reuse the bolts.

- After assembly, perform a driving test to check propeller shaft vibration. If vibration occurred, separate propeller shaft from final drive or transfer. Reinstall companion flange after rotating it by 90, 180, 270 degrees. Then perform driving test and check propeller shaft vibration again at each point.

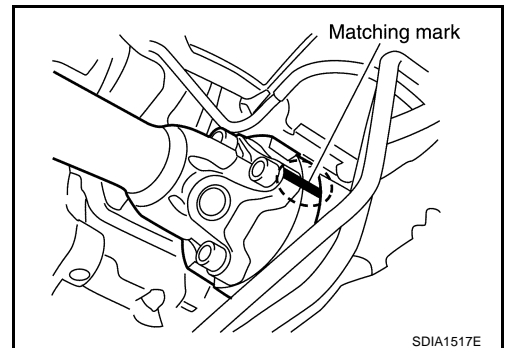

REAR PROPELLER SHAFT

PFP:37000

On-Vehicle Inspection

NDS0003Y

APPEARANCE AND NOISE INSPECTION

- Check the propeller shaft tube surface for dents or cracks. If damaged, replace propeller shaft assembly.
- If center bearing is noisy or damaged, replace center bearing.

PROPELLER SHAFT VIBRATION

If vibration is present at high speed, inspect propeller shaft runout first.

1. Measure propeller shaft runout at runout measuring points by rotating final drive companion flange with hands.

Propeller shaft runout limit : 0.8 mm (0.031 in) or less

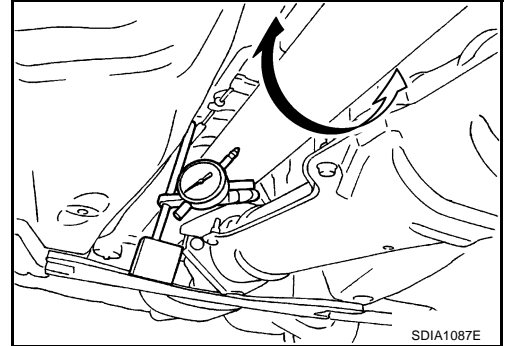

Propeller shaft runout measuring points

Dimension A: 162 mm (6.38 in)
B: 245 mm (9.65 in)
C: 185 mm (7.28 in)

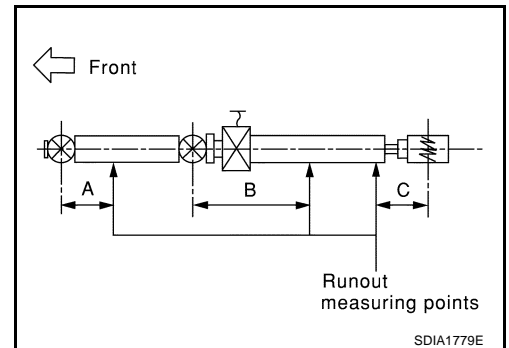

2. If runout still exceeds specifications, separate propeller shaft at final drive companion flange; then rotate companion flange 60, 120, 180, 240, 300 degrees and install propeller shaft.
3. Check runout again. If runout still exceeds specifications, replace propeller shaft assembly.
4. Check the vibration by driving vehicle.

REAR PROPELLER SHAFT

[AWD]

Components

NDS0003Z

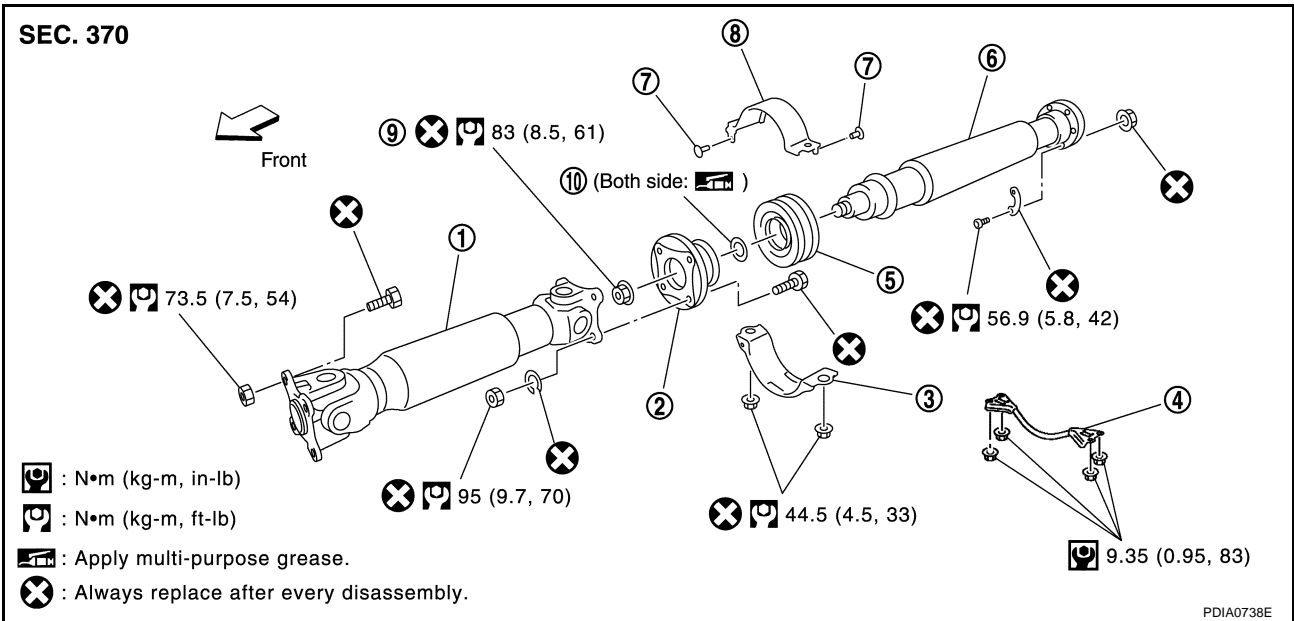

- | | | |
|--------------------------------|--|--|
| 1. Propeller shaft (1st shaft) | 2. Center flange | 3. Center bearing mounting bracket (Lower) |
| 4. Floor rain force | 5. Center bearing assembly | 6. Propeller shaft (2nd shaft) |
| 7. Clip | 8. Center bearing mounting bracket (Upper) | 9. Lock nut |
| 10. Washer | | |

NOTE:

- The joint cannot be disassembled.
- The center bearing can be disassembled. Refer to [PR-20, "Disassembly and Assembly of Center Bearing"](#).

Removal and Installation

REMOVAL

1. Move the A/T select lever to N position and release the parking brake.
2. Remove floor rain force.
3. Remove the center muffler with power tool. Refer to [EX-4, "Removal and Installation"](#).
4. Loosen mounting nuts of center bearing mounting brackets with power tool.

CAUTION:

Tighten mounting nuts temporarily.

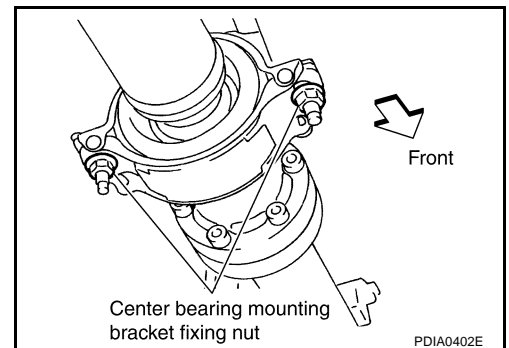

REAR PROPELLER SHAFT

[AWD]

- Put matching marks on propeller shaft flange yoke with transfer companion flange and on rebro joint with final drive companion flange.

CAUTION:

For matching mark, use paint. Do not damage propeller shaft flange yoke, rebro joint and companion flanges.

- Remove propeller shaft fixing bolts and nuts.
- Remove center bearing mounting bracket fixing nuts.
- Remove propeller shaft.

CAUTION:

If constant velocity joint was bent during propeller shaft assembly removal, installation, or transportation, its boot may be damaged. Wrap boot interference area to metal part with shop cloth or rubber to protect boot from breakage.

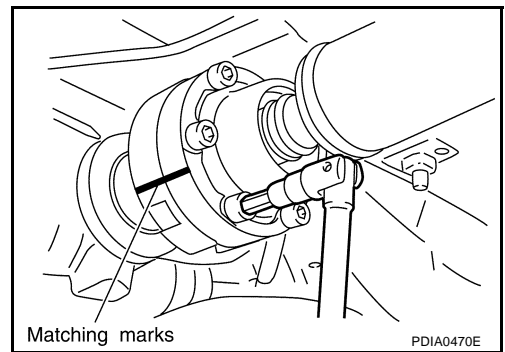

INSPECTION

- Inspect propeller shaft runout at measuring points. If runout exceeds specifications, replace propeller shaft assembly.

Propeller shaft runout limit : 0.8 mm (0.031 in) or less

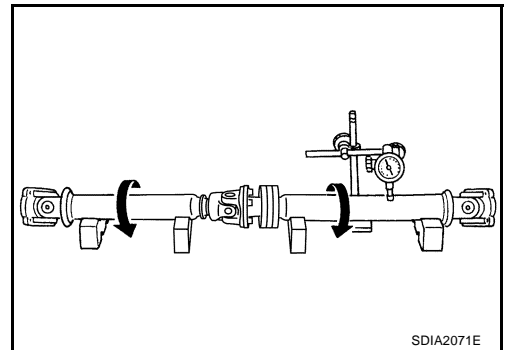

Propeller shaft runout measuring points

Dimension A: 162 mm (6.38 in)
B: 245 mm (9.65 in)
C: 185 mm (7.28 in)

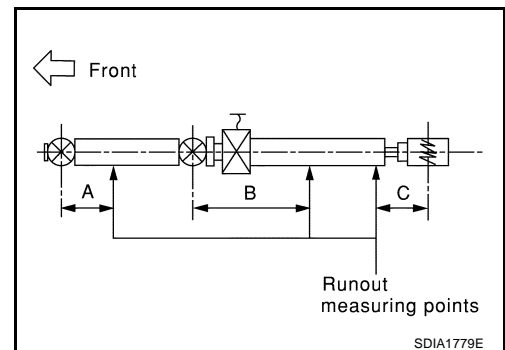

- As shown in the figure, while fixing yoke on one side, check axial play of joint. If outside the standard, replace relevant propeller shaft.

Journal axial play : 0 mm (0 in)

- Check propeller shaft for bend and damage. If damage is detected, replace relevant propeller shaft.

CAUTION:

Do not disassemble joints.

- Check center bearing for noise and damage. If noise or damage is detected, replace center bearing. Refer to [PR-20, "Disassembly and Assembly of Center Bearing"](#).

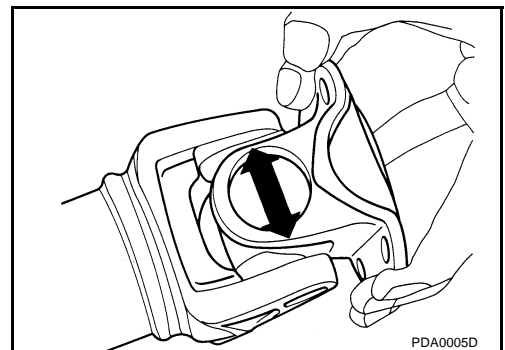

INSTALLATION

Note the following, and install in the reverse order of removal.

CAUTION:

Avoid damaging the rebro joint boot, protect it with a shop towel or equivalent.

- Align matching marks to install propeller shaft to final drive and transfer companion flanges, and then tighten to specified torque. Refer to [PR-17, "Components"](#).
- Install center bearing mounting bracket (Upper) with its arrow mark facing forward.
- Adjust position of mounting bracket sliding back and forth to prevent play in thrust direction of center bearing insulator. Install bracket to vehicle.
- After assembly, perform a driving test to check propeller shaft vibration. If vibration occurred, separate propeller shaft from final drive. Reinstall companion flange after rotating it by 60, 120, 180, 240, 300 degrees. Then perform driving test and check propeller shaft vibration again at each point.

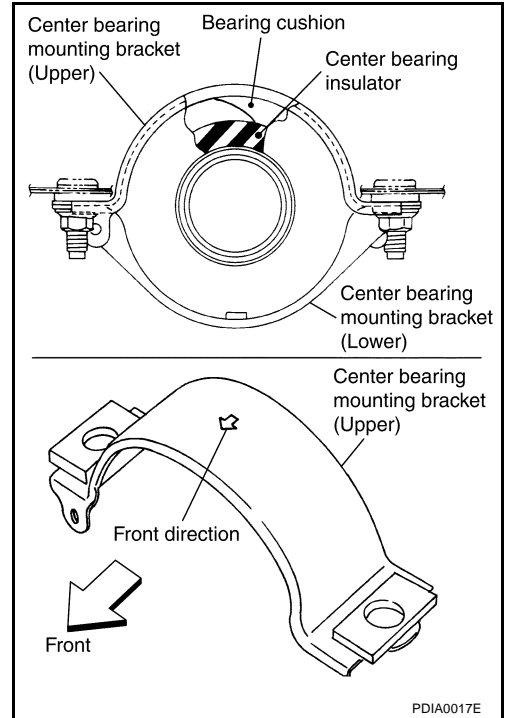

- If propeller shaft or final drive has been replaced, connect them as follows:

1. Install the propeller shaft while aligning its matching mark A with the matching mark B on the joint as close as possible.
2. Tighten the joint bolts to the specified torque. Refer to [PR-17, "Components"](#).

CAUTION:

Do not reuse the bolts, nuts and washers.

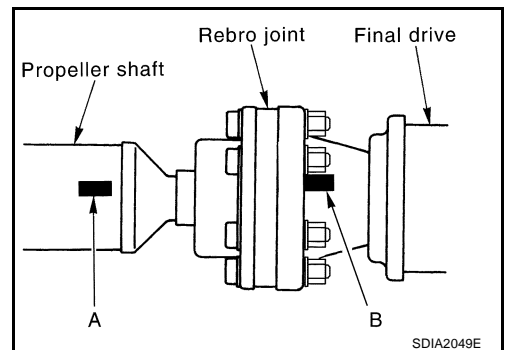

A
B
C
PR
E
F
G
H
I
J
K
L
M

Disassembly and Assembly of Center Bearing DISASSEMBLY

1. Put matching marks on propeller shaft and center flange, then disassemble the 1st and 2nd propeller shaft.

CAUTION:

For matching mark, use paint. Do not damage the propeller shaft flange and center flange.

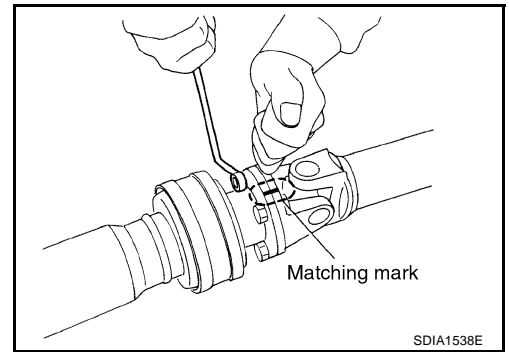

2. Put matching marks onto the center flange and propeller shaft end as shown.

CAUTION:

For matching mark, use paint. Do not damage propeller shaft end and center flange.

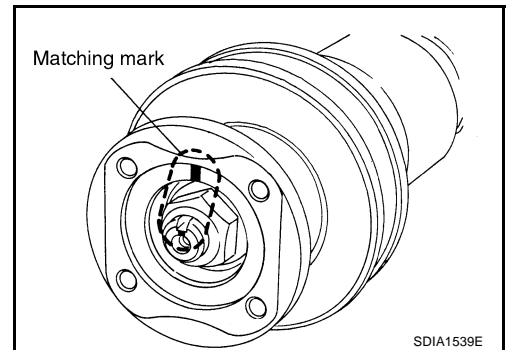

3. Hold the center flange using the flange wrench, and remove the lock nut.

Tool number : KV40104000 (—)

4. Remove the center flange using a commercial available bearing puller then remove washer.

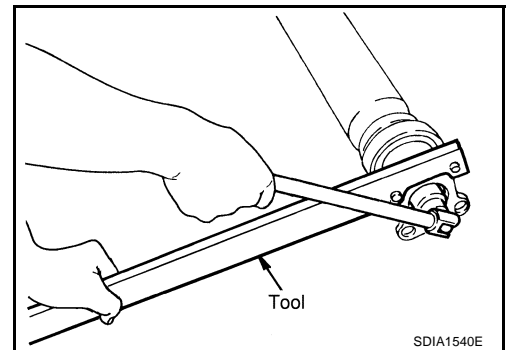

5. Press out the center bearing using the puller and hydraulic press.

Tool number : ST30031000 (J-22912-01)

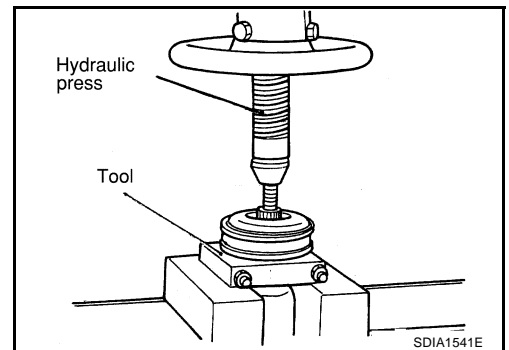

REAR PROPELLER SHAFT

[AWD]

ASSEMBLY

1. Install the center bearing with its "F" mark facing the rear of the vehicle.
2. Apply multi-purpose grease to the each face of the washer, then install washer.
3. Install the center flange onto the propeller shaft with aligning the marks that are marked while removal.
4. Install and tighten the lock nut to specified torque. Refer to [PR-17, "Components"](#).

CAUTION:

Do not use the lock nut.

5. Place a piece of wood under the center flange, stake the lock nut against the propeller shaft groove.

6. Assemble the 1st and 2nd shaft propeller shafts while aligning the matching marks that are marked during removal.
7. Install and tighten the bolts/nuts and tighten them to specified torque. Refer to [PR-17, "Components"](#).

CAUTION:

Do not reuse the bolts, nuts and washers.

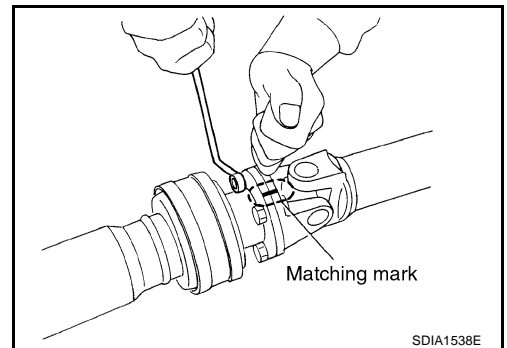
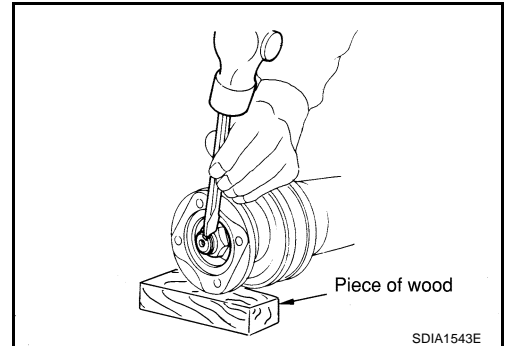
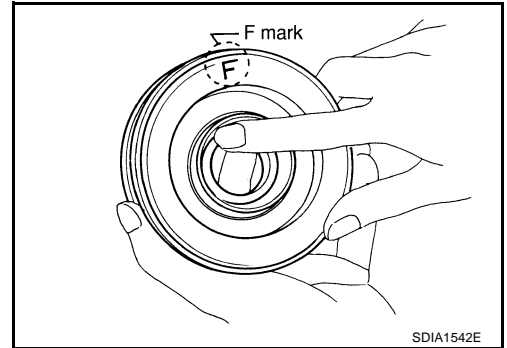

A
B
C
PR
E
F
G
H
I
J
K
L
M

SERVICE DATA AND SPECIFICATIONS (SDS)

[AWD]

SERVICE DATA AND SPECIFICATIONS (SDS)

PFP:00030

General Specifications

NDS00042

Applied model		VQ35DE	
Front	Propeller shaft model	2S56A	
	Number of joints	2	
	Coupling method with transfer	Sleeve type	
	Coupling method with front final drive	Flange type	
	Shaft length (Spider to spider)	763 mm (30.04 in)	
	Shaft outer diameter	42.7 mm (1.68 in)	
Rear	Propeller shaft model	3F80A-1VL107	
	Number of joints	3	
	Coupling method with transfer	Flange type	
	Coupling method with rear final drive	Rebro joint type	
	Shaft length	1st (Spider to spider)	399 mm (15.71 in)
		2nd (Spider to rebro joint center)	753 mm (29.65 in)
	Shaft outer diameter	1st	82.6 mm (3.25 in)
2nd		82.6 mm (3.25 in)	

Journal Axial Play

NDS00043

Model	Front propeller shaft	Rear propeller shaft
		2S56A
Journal axial play	0 mm (0 in)	

Propeller Shaft Runout

NDS00044

Model	Front propeller shaft	Rear propeller shaft
		2S56A
Propeller shaft runout limit	0.8 mm (0.031 in) or less	