

SECTION **RAX**
REAR AXLE

A
B
C

RAX

CONTENTS

E

PRECAUTIONS	2	On-Vehicle Inspection	10	F
Caution	2	REAR WHEEL BEARING	10	
PREPARATION	3	Removal and Installation	10	
Special Service Tools (SST)	3	REMOVAL	11	G
NOISE, VIBRATION AND HARSHNESS (NVH)		INSTALLATION	11	
TROUBLESHOOTING	5	Disassembly and Assembly	11	
NVH Troubleshooting Chart	5	DISASSEMBLY	11	H
WHEEL HUB (2WD)	6	INSPECTION AFTER DISASSEMBLY	12	
On-Vehicle Inspection and Service	6	ASSEMBLY	12	
WHEEL BEARING INSPECTION	6	REAR DRIVE SHAFT	14	I
Removal and Installation	6	Removal and Installation	14	
COMPONENT	6	REMOVAL	14	
REMOVAL	6	INSPECTION AFTER REMOVAL	14	J
INSPECTION AFTER REMOVAL	6	INSTALLATION	14	
INSTALLATION	7	Disassembly and Assembly	15	
Disassembly and Assembly	7	DISASSEMBLY	15	K
DISASSEMBLY	7	INSPECTION AFTER DISASSEMBLY	16	
INSPECTION AFTER DISASSEMBLY	8	ASSEMBLY	16	
ASSEMBLY	8	SERVICE DATA AND SPECIFICATIONS (SDS)	19	L
INSPECTION AFTER ASSEMBLY	8	Wheel Bearing	19	
WHEEL HUB (4WD)	10	Drive Shaft	19	

M

PRECAUTIONS

PRECAUTIONS

PFP:00001

Caution

BDS0060

- When installing rubber parts, final tightening must be carried out under unladen condition* with tires on ground.
*: Fuel, radiator coolant and engine oil full. Spare tire, jack, hand tools and mats in designated positions.

- After installing removed suspension parts, check wheel alignment and adjust if necessary.

Observe the following precautions when disassembling and servicing drive shaft.

- Perform work in a location which is as dust-free and dirt-free as possible.
- Before disassembling and servicing, clean the outside of parts.
- The disassembly and service location must be clean. Care must be taken to prevent parts from becoming dirty and to prevent the entry of foreign objects.
- Disassembled parts must be carefully reassembled in the correct order. If work is interrupted, a clean cover must be placed over parts.
- Paper shop cloths must be used. Fabric shop cloths must not be used because of the danger of lint adhering to parts.
- Disassembled parts (except for rubber parts) should be cleaned with kerosene which shall be removed by blowing with air or wiping with paper shop cloths.

PREPARATION

PREPARATION

PPF:00002

Special Service Tools (SST)

BDS00061

A
B
C
RAX
E
F
G
H
I
J
K
L
M

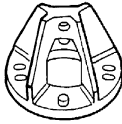
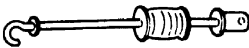
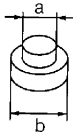
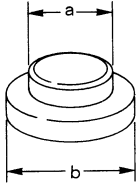
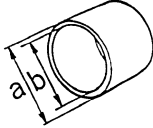
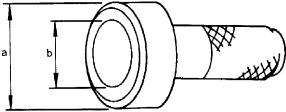
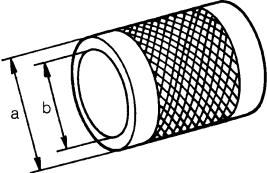
Tool number Tool name	Description
KV40104100 Attachment <div style="text-align: center;">  <p>ZZA0804D</p> </div>	Removing wheel hub and bearing assembly
ST36230000 Sliding hammer <div style="text-align: center;">  <p>ZZA0803D</p> </div>	Removing wheel hub and bearing assembly
ST33061000 Drift a: 28.5 mm (1.122 in) dia. b: 38.0 mm (1.496 in) dia. <div style="text-align: center;">  <p>ZZA0969D</p> </div>	Removing inner race on outer side of wheel bearings
ST15242000 Drift b: 69 mm (2.72 in) dia. <div style="text-align: center;">  <p>ZZA0881D</p> </div>	Removing wheel bearing
KV40105310 Drift a: 75 mm (2.95 in) dia. b: 62 mm (2.44 in) dia. <div style="text-align: center;">  <p>ZZA1003D</p> </div>	<ul style="list-style-type: none"> ● Removing wheel bearing ● Installing wheel hubs
ST30720000 Drift a: 77.0 mm (3.031 in) dia. b: 55.5 mm (2.185 in) dia. <div style="text-align: center;">  <p>ZZA0811D</p> </div>	Removing wheel bearing
Drift ST33200000 a: 60.0 mm (2.362 in) dia. b: 44.5 mm (1.752 in) dia. <div style="text-align: center;">  <p>ZZA1002D</p> </div>	Installing wheel hub

PREPARATION

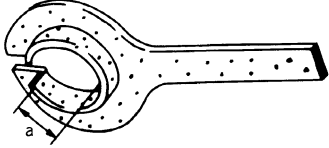
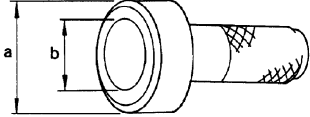
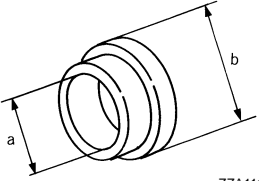
Tool number Tool name	Description
<p>KV38107800 Protector a: 29 mm (1.41 in) dia.</p>  <p style="text-align: right; font-size: small;">ZZA0835D</p>	Installing drive shaft
<p>Drift KV38100500 a: 80 mm (3.15 in) dia. b: 60 mm (2.36 in) dia.</p>  <p style="text-align: right; font-size: small;">ZZA0701D</p>	Installing sensor rotor
<p>KV40101840 Collar a: 67 mm (2.64 in) dia. b: 85 mm (3.35 in) dia.</p>  <p style="text-align: right; font-size: small;">ZZA1113D</p>	Installing sensor rotor

NOISE, VIBRATION AND HARSHNESS (NVH) TROUBLESHOOTING

NOISE, VIBRATION AND HARSHNESS (NVH) TROUBLESHOOTING

PFP:00003

NVH Troubleshooting Chart

BDS00062

Use the chart below to help you find the cause of the symptom. If necessary, repair or replace these parts.

Reference page			—	RAX-16	—	RAX-10 , RAX-14	—	NVH in PR section.	NVH in RFD section.	NVH in FAX and FSU sections.	Refer to REAR AXLE in this chart.	NVH in WT section.	NVH in WT section.	Refer to DRIVE SHAFT in this chart.	NVH in BR section.	NVH in PS section.	
Possible cause and SUSPECTED PARTS			Excessive joint angle	Joint sliding resistance	Imbalance	Improper installation, looseness	Parts interference	PROPELLER SHAFT	DIFFERENTIAL	FRONT AXLE AND FRONT SUSPENSION	REAR AXLE	TIRES	ROAD WHEEL	DRIVE SHAFT	BRAKES	STEERING	
Symptom	DRIVE SHAFT	Noise	x	x				x	x	x	x	x	x		x	x	
		Shake	x		x			x		x	x	x	x		x	x	
	REAR AXLE	Noise				x	x	x	x	x		x	x	x	x	x	x
		Shake				x	x	x		x		x	x	x	x	x	x
		Vibration				x	x	x		x		x		x		x	x
		Shimmy				x	x				x		x	x		x	x
		Judder				x					x		x	x		x	x
		Poor quality ride or handling				x	x				x		x	x			

x: Applicable

A
B
C
RAX
E
F
G
H
I
J
K
L
M

WHEEL HUB (2WD)

PFP:43200

WHEEL HUB (2WD)

On-Vehicle Inspection and Service

BDS00063

Make sure that the mounting conditions (looseness, backlash) of each component and component status (wear, damage) are normal.

WHEEL BEARING INSPECTION

- Move wheel hub in the axial direction by hand. Make sure there is no looseness of wheel bearing.

Axial end play : 0.05 mm (0.002 in) or less

- Rotate wheel hub and make sure that is no unusual noise or other irregular conditions. If there are any irregular conditions, replace wheel bearing.

Removal and Installation COMPONENT

BDS00064

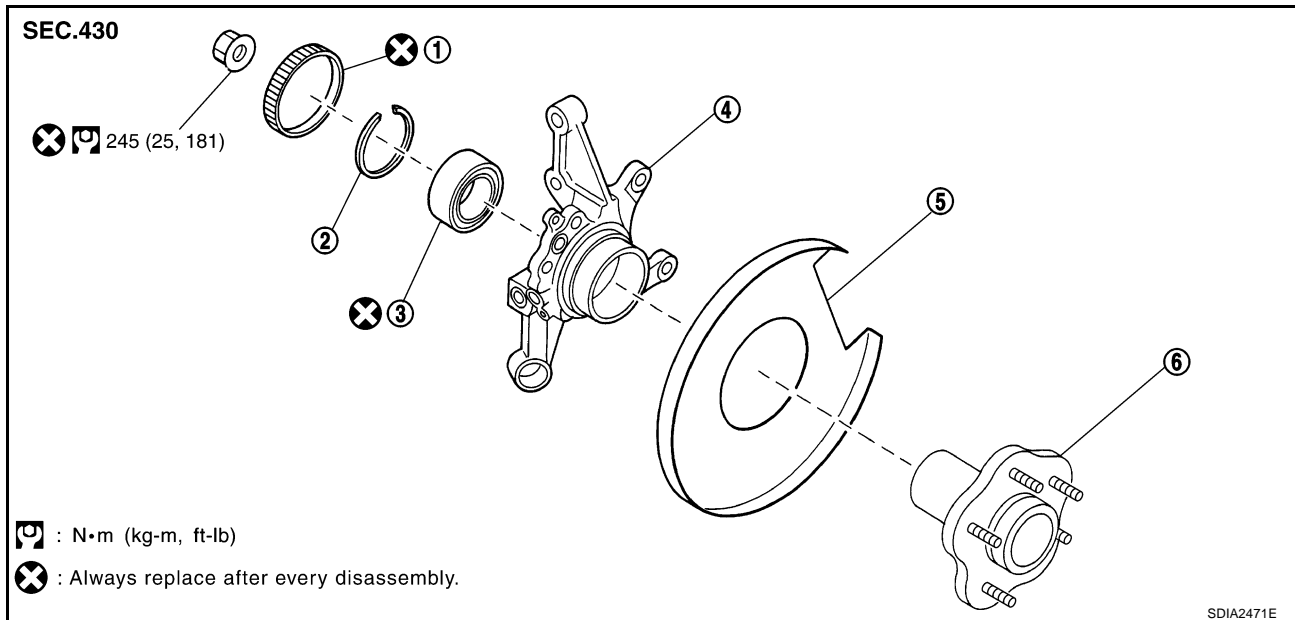

1. Sensor rotor
2. Snap ring
3. Wheel bearing
4. Axle housing
5. Back plate
6. Wheel hub

REMOVAL

1. Remove tire from the vehicle with power tool.
2. Remove wheel sensor from axle housing. Refer to [BRC-41, "WHEEL SENSORS"](#).

CAUTION:

Do not pull on wheel sensor harness.

3. Remove torque member fixing bolts with power tool. Hang it in a place where it will not interfere with work. Refer to [BR-30, "REAR DISC BRAKE"](#).

NOTE:

Avoid depressing brake pedal while brake caliper is removed.

4. Remove disc rotor.
5. Remove anchor block mounting nuts, and then remove anchor block and back plate from axle housing.
6. Remove fixing bolts and nuts, and then remove strut from axle housing. Refer to [RSU-8, "COIL SPRING AND STRUT"](#).
7. Remove nut and bolt from axle housing side of radius rod. Refer to [RSU-12, "RADIUS ROD"](#).
8. Remove fixing bolt, washer and nut from axle housing side of front and rear parallel links. Remove axle housing from vehicle.

INSPECTION AFTER REMOVAL

Check components for deformation, cracks and other damage. Replace if there.

WHEEL HUB (2WD)

INSTALLATION

- Install in the reverse order of removal. For tightening torque refer to [RAX-6, "COMPONENT"](#) .
- Perform final tightening of nuts and bolts on each link mounting part (rubber bushing) under unladen conditions with tires on level ground. Check wheel alignment. Refer to [RSU-6, "Wheel Alignment"](#) .
- Check wheel sensor harness for proper connection. Refer to [BRC-41, "WHEEL SENSORS"](#) .

Disassembly and Assembly

BDS00065

CAUTION:

Do not disassemble if wheel bearing has no trouble.

1. Remove caulked of lock nut, and then remove lock nut from axle housing.
2. Remove sensor rotor from axle housing.
3. Set axle housing on vise at point where strut is attached. Using a sliding hammer [SST] and attachment [SST] to remove wheel hub from axle housing.

CAUTION:

When placing on vise, be careful not to damage strut mounting surface of axle housing. Use an aluminum plate or suitable tool.

4. Using a drift [SST] and a puller (suitable tool), press wheel bearing outer side inner race from wheel hub.
5. Using a flat-bladed screwdriver or similar tool to remove snap ring from axle housing.

6. Using a drift [SST] and a press wheel bearing from axle housing.

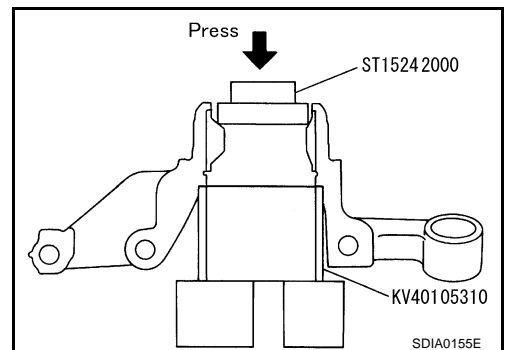
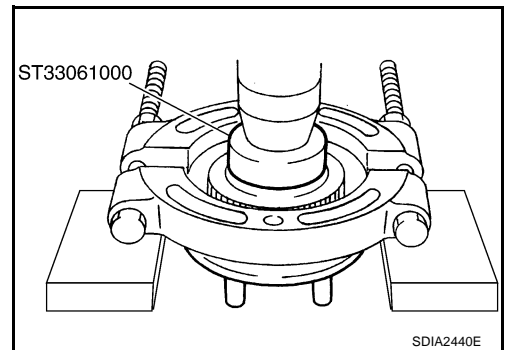
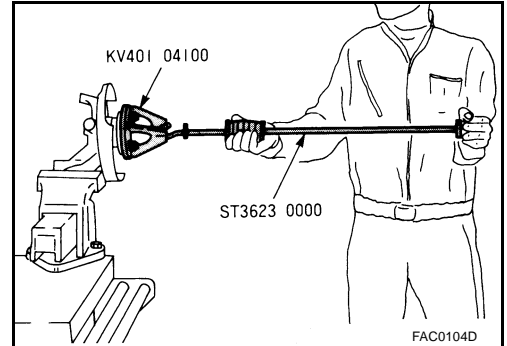

A

B

C

RAX

E

F

G

H

I

J

K

L

M

WHEEL HUB (2WD)

INSPECTION AFTER DISASSEMBLY

Check for deformity, cracks and damage of each parts, replace if there are.

Wheel Hub

Check wheel hub for deformation, cracks, and other damage. If any irregular conditions are found, replace if there are.

Axle Housing

Inspect axle housing for deformation, cracks, and other damage. If any irregular conditions are found, replace axle housing.

Snap Ring

Check snap ring for wear or other damage. If any irregular conditions are found, replace snap ring.

ASSEMBLY

1. Using a flat-bladed screwdriver or similar tool, install snap ring securely to the ditch of axle housing inner side.
2. Using a drift [SST] to press wheel bearing securely from axle housing inner side as far as it will go.

NOTE:

- Do not reuse wheel bearing.
- Final press load guideline 49,033 N (5,000 kg, 11,000 lb)

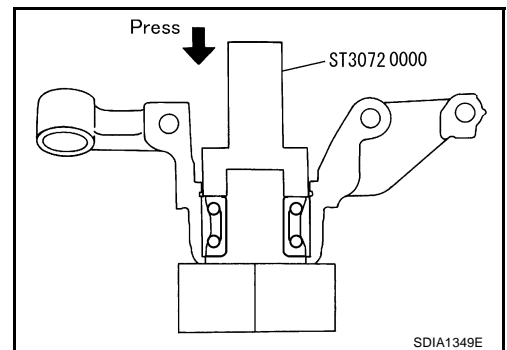

3. Using a drift [SST] to press wheel hub onto axle housing.

NOTE:

Final press load guideline 49,033 N (5,000 kg, 11,000 lb).

4. Set sensor rotor to axle housing.

NOTE:

Do not reuse sensor rotor.

5. Install lock nut to axle housing.

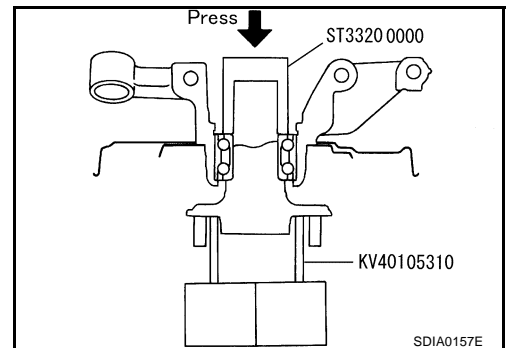

6. After installation of lock nut, be sure to perform caulking. Refer to figure for caulking procedure.

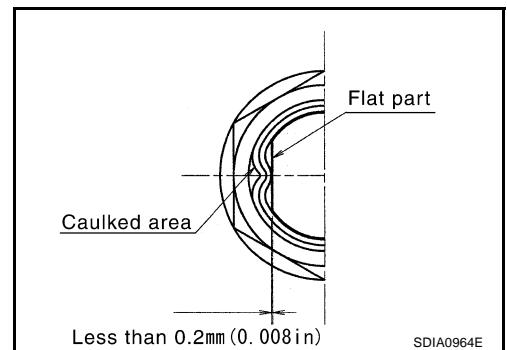

INSPECTION AFTER ASSEMBLY

1. With wheel hub pressed into wheel bearing, apply 49,030 N (5,000 kg, 11,025 lb) to wheel hub and rotate both clockwise and counterclockwise 10 times to minimize resistance.
2. At a rotating speed of 8 – 12 rpm, place a spring balance at the point where strut is joined (upper side bolt hole). Measure rotating torque.

WHEEL HUB (2WD)

Rotation torque : 1.96 N·m (0.20 kg-m, 17 in-lb) or less

Spring balance reading : 12.8 N (1.30 kg, 2.87 lb) or less

NOTE:

If a load of 49,030 N (5,000 kg 11,025 lb) cannot be applied, carry out the following actions.

- Install to drive shaft and tighten wheel hub lock nut to specified torque. Rotate in forward and reverse direction 10 times each to ensure a good fit.
- At a rotating speed of 8 - 12 rpm, place a spring balance on hub bolt and measure rotating torque.

Rotating torque : 1.126 N·m (0.11 kg-m, 10 in-lb)

Spring balance reading : 19.70 N (2.01 kg, 4.43 lb)

A

B

C

RAX

E

F

G

H

I

J

K

L

M

WHEEL HUB (4WD)

PFP:43202

WHEEL HUB (4WD)

On-Vehicle Inspection

BDS00066

Inspect to check that there is no excessive play, cracking, wear, or other damage to rear axle.

- Turn rear wheels (left/right) and check the play.

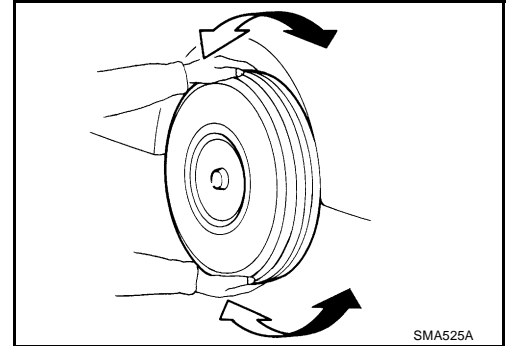

REAR WHEEL BEARING

With vehicle raised, inspect the following.

- Move wheel hub in the axial direction by hand. Check that there is no looseness of rear wheel bearing.

Axial end play : 0.05 mm (0.002 in) or less

- Rotate wheel hub and check that there is no unusual noise or other irregular condition. If there are any irregular condition, replace wheel bearing.

Removal and Installation

BDS00067

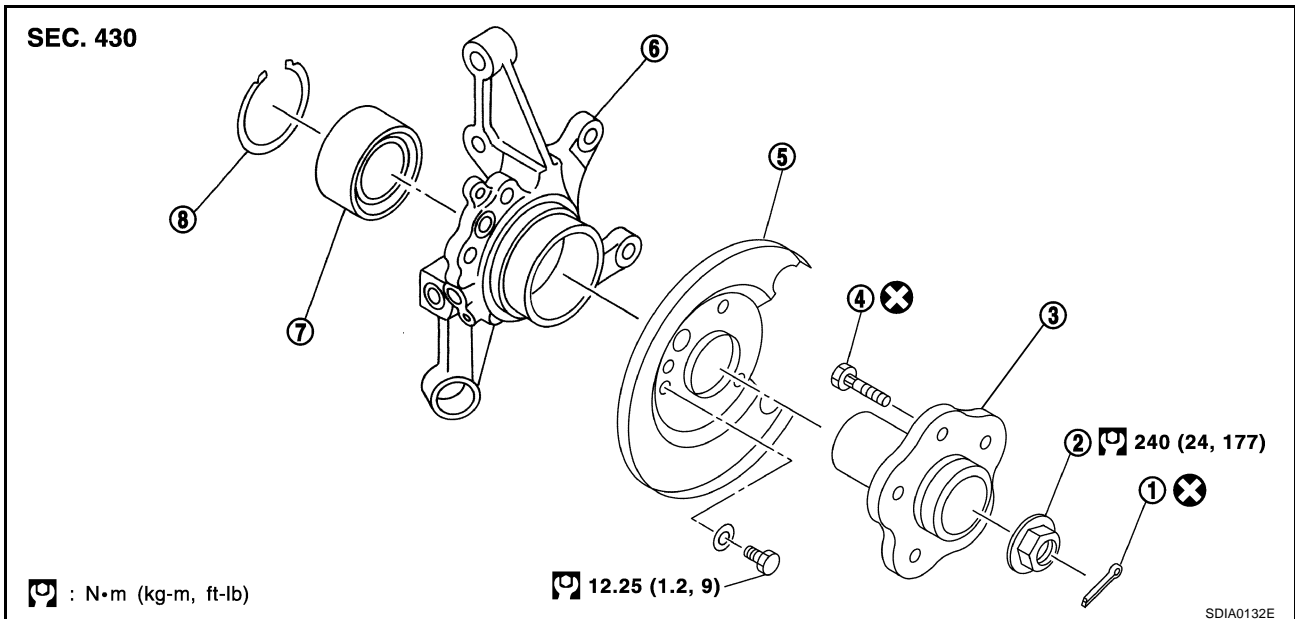

1. Cotter pin

4. Hub bolt

7. Wheel bearing

2. Lock nut

5. Back plate

8. Snap ring

3. Wheel hub

6. Axle housing

WHEEL HUB (4WD)

REMOVAL

1. Remove tyre.
2. Remove wheel hub lock nut.

CAUTION:

Discard the old hub lock nut; replace with new one.

3. Remove brake caliper from axle housing and hang it up somewhere.

CAUTION:

Avoid depressing the brake pedal while the brake caliper is removed.

4. Remove disc rotor and parking brake assembly from back plate and axle housing.
5. Remove wheel sensor from axle housing.
6. Remove axle housing from strut.
7. Remove nut and bolt from axle housing side of radius rod.
8. Remove nuts and bolts from axle housing side of front and rear parallel link. Remove axle housing from vehicle.

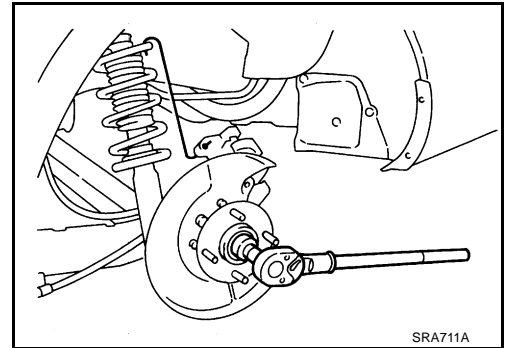

INSTALLATION

- Refer to component parts drawing for tightening torque. For installation, follow removal procedure in reverse order.

Disassembly and Assembly DISASSEMBLY

1. Set axle housing on bench vise. As shown in the figure, use attachment (SST) and sliding hammer (SST) to remove wheel hub and bearing assembly from axle housing.

CAUTION:

When placing onto bench vise, be careful not to damage strut mounting surface of steering knuckle. Use an aluminum plate or another suitable tool.

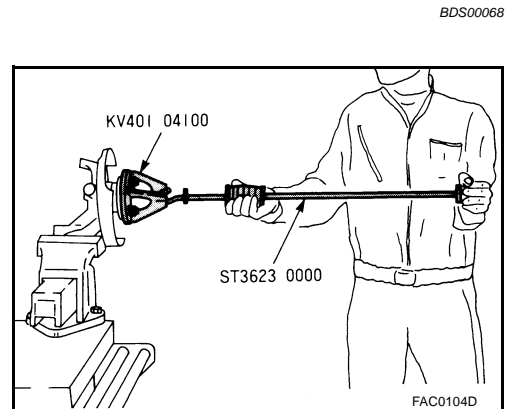

2. Use a bearing replacer (suitable tool), puller (suitable tool), and drift (SST) to remove inner race of outer-wheel bearing from wheel hub.
3. Remove back plate installation bolt and anchor block. Remove back plate from axle housing. Refer to [PB-4, "Components"](#)
4. Use a flat-bladed screwdriver or similar tool to remove snap ring.

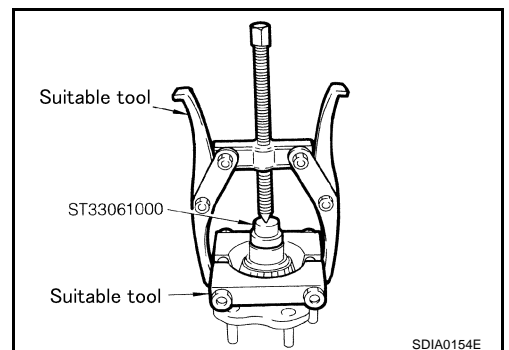

A
B
C
RAX
E
F
G
H
I
J
K
L
M

WHEEL HUB (4WD)

5. Use a drift (SST) to remove wheel bearing from axle housing.

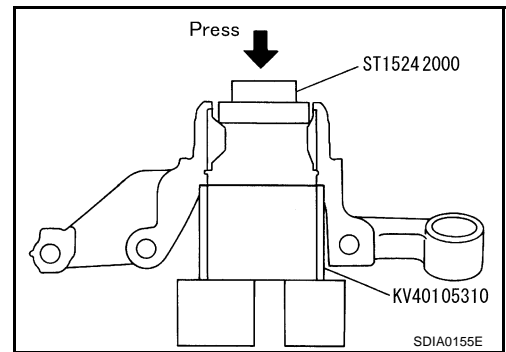

INSPECTION AFTER DISASSEMBLY

Wheel Hub

- Inspect wheel hub for deformation, cracks, and other damage. If any irregular conditions are found, replace wheel hub.

Axle Housing

- Inspect axle housing for deformation, cracks, and other damage. If any irregular conditions are found, replace axle housing.

Snap Ring

- Check snap ring for deformation, cracks, and other damage. If any irregular conditions are found, replace snap ring.

ASSEMBLY

1. Use a drift (SST) to press fit wheel bearing into axle housing.

CAUTION:

Discard the old wheel bearing; replace with a new one.

2. Use a flat-bladed screwdriver or similar tool to install the snap ring.
3. Install back plate and anchor block onto axle housing. Refer to [PB-4, "Components"](#).

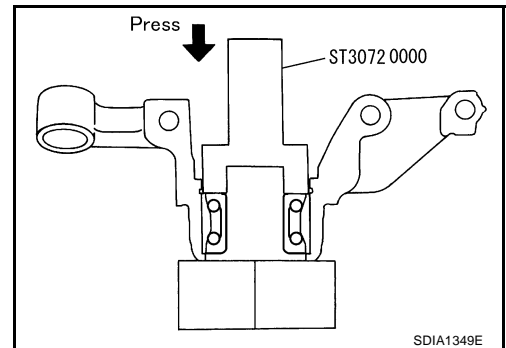

4. Use a drift (SST) to install wheel hub onto axle housing.
5. After completing step 4, apply an additional load of 49,030 N (5,000 kg, 11,025 lb). Rotate axle housing in forward and reverse directions 10 times each to ensure a good fit.

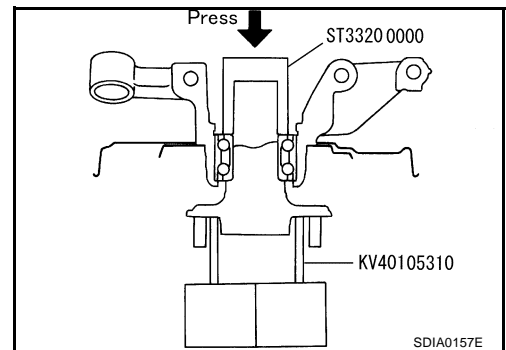

6. Place a spring balance at the point where the strut is joined (upper side bolt hole) and measure rotating torque when spring is pulled at a speed of 8 -12 rpm. Refer to the [RAX-19, "Wheel Bearing"](#) item.

Rotating torque : 1.96 N-m (0.20 kg-m, 17 in-lb) or less

Spring balance reading : 12.8 N (1.30 kg, 2.87 lb) or less

NOTE:

If a load of 49,030 N (5,000 kg, 11,025 lb) cannot be applied:

- Install to drive shaft and tighten wheel hub lock nut to specified torque. Rotate in forward and reverse direction 10 times each to ensure a good fit.
- At a rotating speed of 8 - 12 rpm, place a spring balance on hub bolt and measure rotating torque.

WHEEL HUB (4WD)

Rotating torque : 1.126 N·m (0.11 kg-m, 10 in-lb)
Spring balance reading : 19.70 N (2.01 kg, 4.43 lb)

A

B

C

RAX

E

F

G

H

I

J

K

L

M

REAR DRIVE SHAFT

REAR DRIVE SHAFT

PFP:39600

Removal and Installation

BDS00069

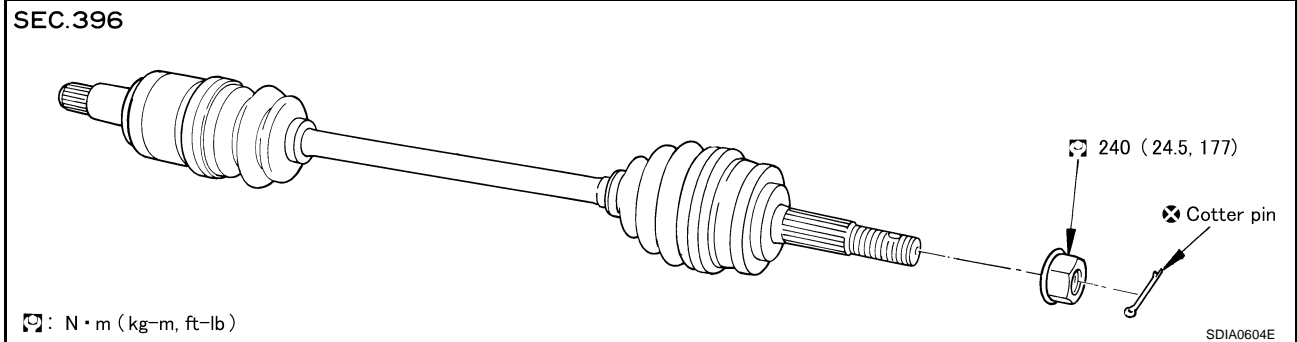

REMOVAL

1. Remove axle housing. Refer to [RAX-11, "REMOVAL"](#).

NOTE:

In order to remove the rear drive shaft assembly, the rear axle is removed. At this time it is recommended that front and rear parallel links on axle side be loosened (not removed). This will facilitate wheel alignment inspection and adjustment which are carried out later.

2. As shown in the figure, use a wheel wrench or similar tool to remove drive shaft from rear final drive.

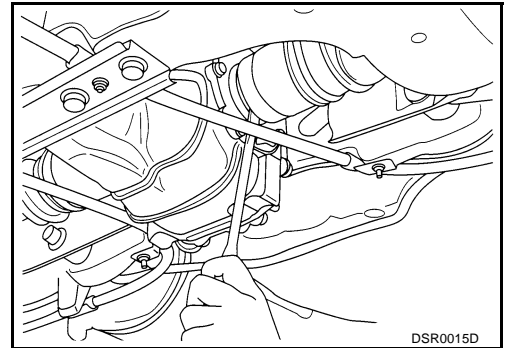

INSPECTION AFTER REMOVAL

- Move the joint in the up/down, left/right, and axial directions. Check for any rough movement or significant looseness.
- Check boot for cracks or other damage, and also for grease leakage.

INSTALLATION

1. In order to prevent damage to rear final drive side oil seal, first fit a protector (SST) onto oil seal before inserting drive shaft. Slide drive shaft into slide joint and tap with a hammer to install securely.

CAUTION:

Be sure to check that circular clip is securely fastened.

2. Install rear axle. Refer to [RAX-11, "INSTALLATION"](#).

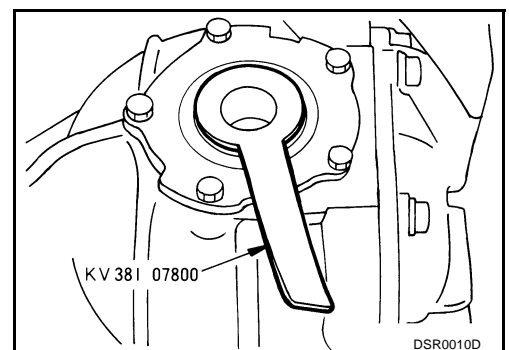

REAR DRIVE SHAFT

Disassembly and Assembly

BDS0006A

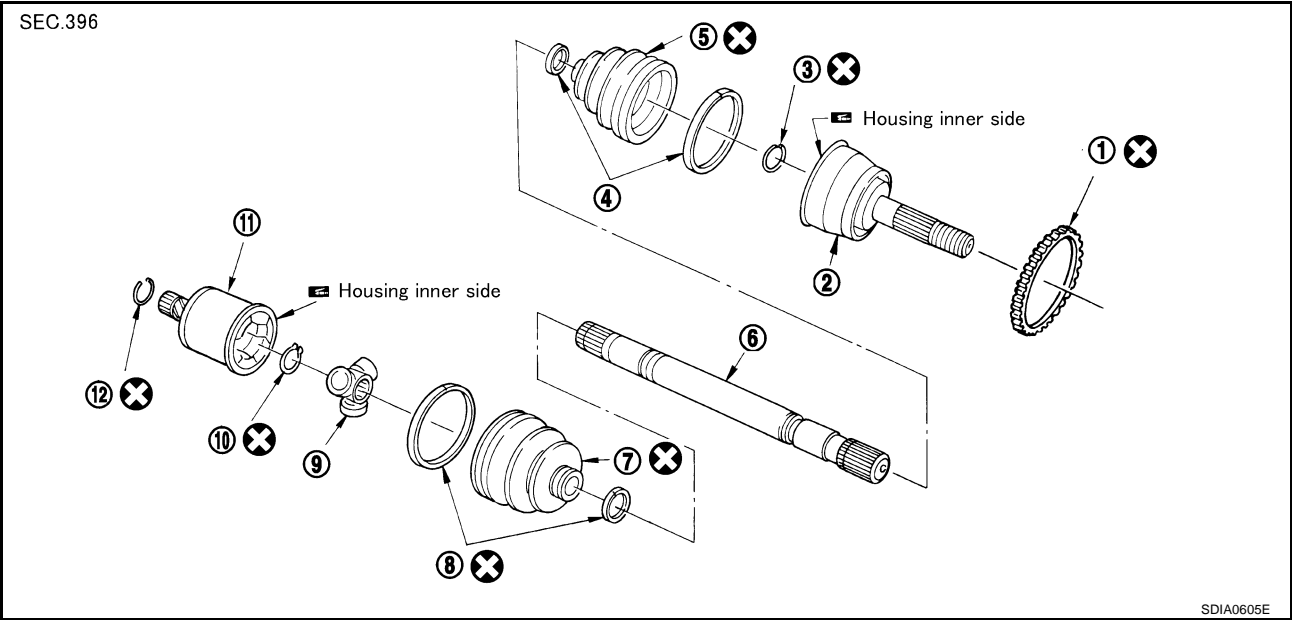

- | | | |
|-----------------|---------------------------|--------------------|
| 1. Sensor rotor | 2. Joint sub assembly | 3. Circular clip |
| 4. Boot bands | 5. Boot | 6. Shaft |
| 7. Boot | 8. Boot bands | 9. Spider assembly |
| 10. Snap ring | 11. Housing (Slide joint) | 12. Circular clip |

DISASSEMBLY

Final Drive Side

1. Remove boot bands.
2. Fix shaft to bench vise.

CAUTION:

When fixing shaft to bench vise, be sure to protect it with a copper or aluminum sheet.

3. Make alignment marks on shaft and spider assembly.

CAUTION:

Use paint or similar substance for alignment marks. Do not scratch the surface.

4. Remove snap ring. Remove spider assembly from shaft.
5. Remove boot from shaft.
6. Remove old grease on slide joint assembly with paper towels.
7. Remove circular clip and dust shield from slide joint assembly.

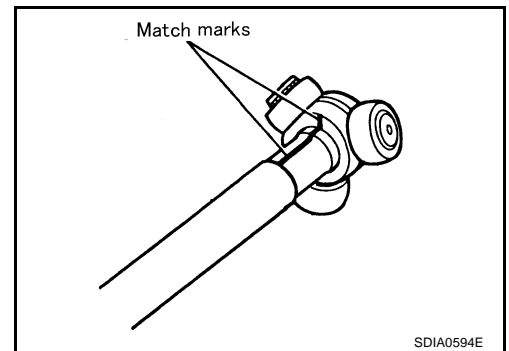

Wheel Side

1. As shown in the figure, use a bearing replacer (suitable tool) and puller (suitable tool) to remove sensor rotor from drive shaft.
2. Fix shaft to bench vise.

CAUTION:

When fixing shaft to bench vise, be sure to protect it with a copper or aluminum sheet.

3. Remove boot bands. Remove boot from joint sub-assembly.

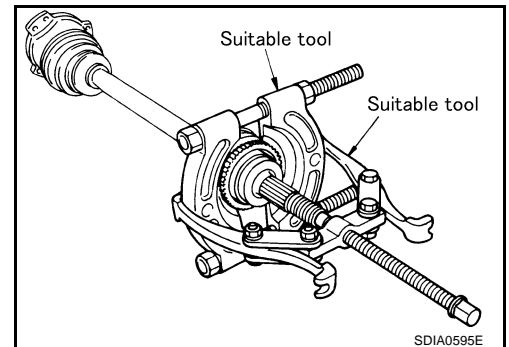

A
B
C
RAX
E
F
G
H
I
J
K
L
M

REAR DRIVE SHAFT

4. Screw a drive shaft puller (suitable tool) 30 mm (1.18 in) or more into threaded part of joint sub-assembly. Pull joint sub-assembly out of shaft.

CAUTION:

If joint sub assembly cannot be removed after five or more unsuccessful attempts, replace the entire drive shaft assembly.

5. Remove boot from shaft.
6. Remove circular clip from shaft.
7. Remove old grease.

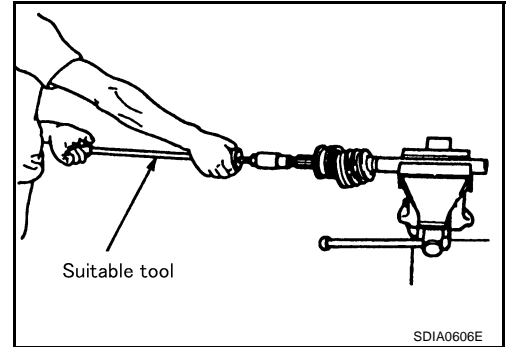

INSPECTION AFTER DISASSEMBLY

Shaft

- Replace shaft if there is any runout, cracking, or other damage.

Joint Sub-Assembly

- Check that there is no rough rotation or unusual axial looseness.
- Check that there is no foreign material inside joint.

CAUTION:

If there are any irregular conditions of joint assembly components, replace the entire joint assembly.

Slide Joint Side

Housing and spider assembly

- If roller or roller surface of spider assembly has scratch or wear, replace housing and spider assembly.

NOTE:

Housing and spider assembly are components which are used as a set.

ASSEMBLY

Final Drive Side

1. Wind serrated part of drive shaft with tape. Install boot band and boot to shaft. Be careful not to damage boot.

CAUTION:

Discard the old boot band and boot; replace with new ones.

2. Remove protective tape wound around serrated part of shaft.

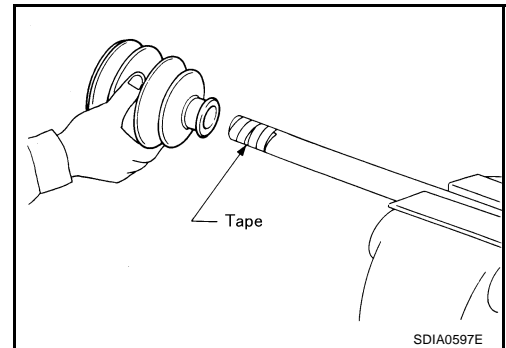

3. Line up alignment marks which were made when spider assembly was removed. Install spider assembly, with serration chamfer facing drive shaft.

4. Secure spider assembly with snap ring.

CAUTION:

Discard the old snap ring; replace with a new one.

5. Apply grease (Nissan genuine grease or equivalent) to spider assembly and sliding surface.
6. Install housing to spider assembly. Add remaining grease (Nissan genuine grease or equivalent) up to the amount listed below.

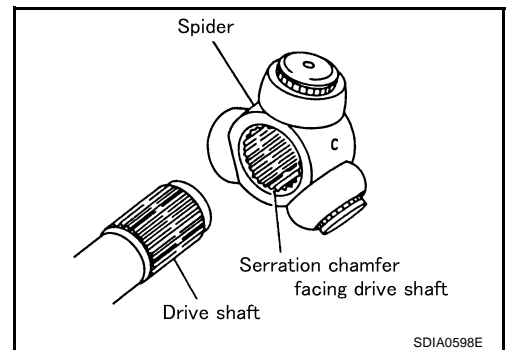

Grease amount : 40 - 50 g (1.41 - 1.77 oz)

REAR DRIVE SHAFT

7. Install boot securely into grooves (indicated by * marks) shown in the figure.

CAUTION:

If there is grease on boot mounting surfaces (indicated by * marks) of joint, boot may come off. Remove all grease from surfaces.

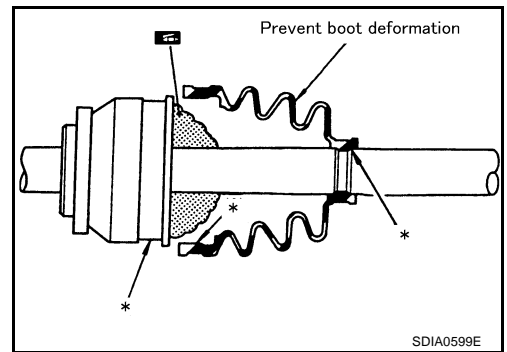

8. Check that boot installation length "L" is the length indicated below. Insert a flat-bladed screwdriver or similar tool into smaller side of boot to prevent boot deformation.

Boot installation length:

78.6 - 80.6 mm (3.094 - 3.173 in)

CAUTION:

- Boot may break if boot installation length is less than standard value.
- Be careful that screwdriver tip does not contact inside surface of boot.

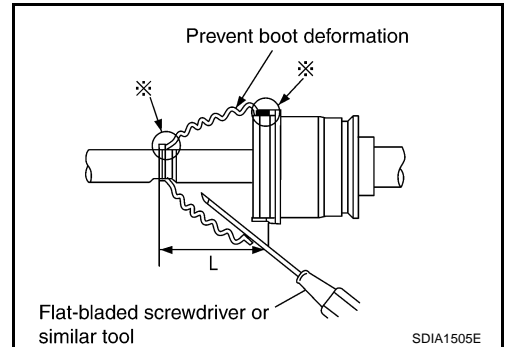

9. Secure big and small ends of boot with new boot bands as shown in figure.

CAUTION:

Rotate housing and check that boot installation position does not change. If position changes, reinstall boot bands.

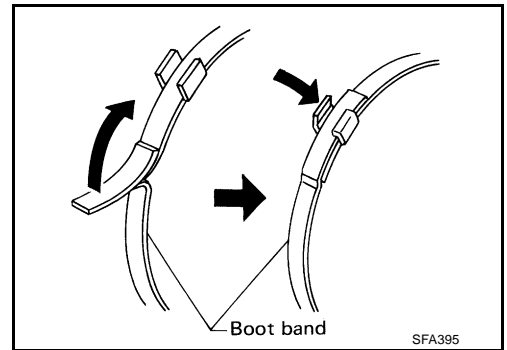

Wheel Side

1. Use a drift (SST) to press-fit sensor rotor into joint sub-assembly.

CAUTION:

Discard the old sensor rotor; replace with a new one.

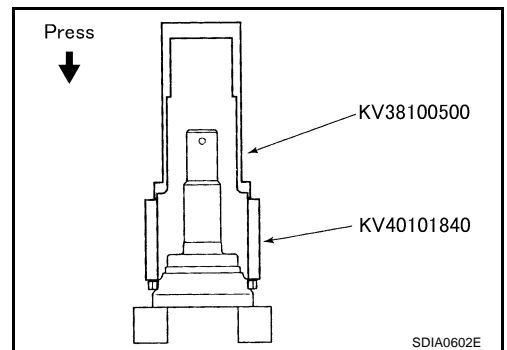

A
B
C
RAX
E
F
G
H
I
J
K
L
M

REAR DRIVE SHAFT

2. Wind serrated part of drive shaft with tape. Install boot band and boot to shaft. Be careful not to damage boot.

CAUTION:

Discard the old boot band and boot; replace with new ones.

3. Remove protective tape wound around serrated part of shaft.

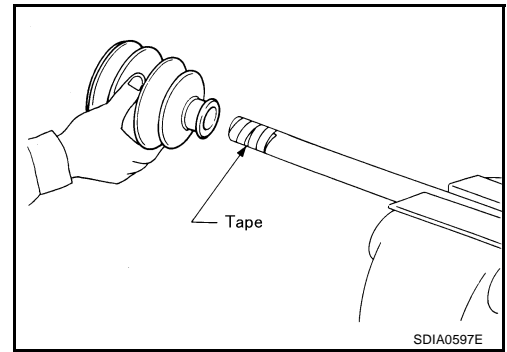

4. Attach circular clip to shaft. At this time, circular clip must fit securely into the shaft groove. Attach nut to joint sub-assembly. Use a wooden hammer to press-fit.

CAUTION:

Discard the old circular clip; replace with a new one.

5. Insert the amount of grease (Nissan genuine grease or equivalent) listed below into housing from large end of boot.

Grease amount : 35 - 45 g (1.23 - 1.59 oz)

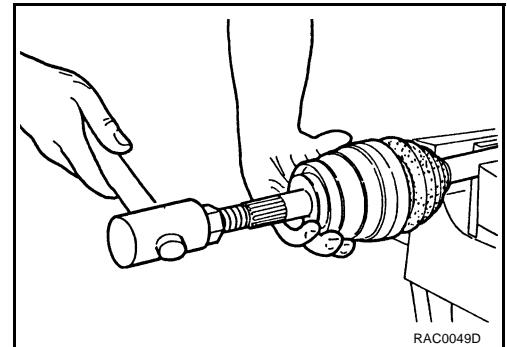

6. Install boot securely into grooves (indicated by * marks) shown in the figure.

CAUTION:

If there is grease on boot mounting surfaces (indicated by * marks) of joint sub-assembly, boot may come off. Remove all grease from surfaces.

7. Check that boot installation length "L" is the length indicated below. Insert a flat-bladed screwdriver or similar tool into smaller side of boot. Remove air from boot to prevent boot deformation.

Boot installation length:

66.7 - 68.7 mm (2.626 - 2.705 in)

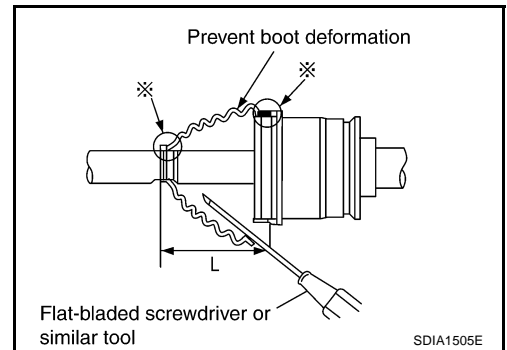

CAUTION:

- Boot may break if boot installation length is less than standard value.
- Be careful that screwdriver tip does not contact inside surface of boot.

8. Secure big and small ends of boot with new boot bands as shown in the figure.

CAUTION:

Rotate housing and check that boot installation position does not change. If position changes, reinstall boot bands.

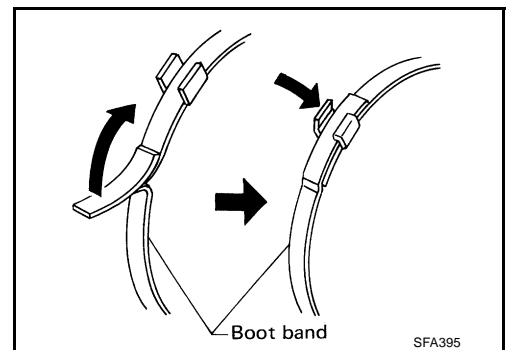

SERVICE DATA AND SPECIFICATIONS (SDS)

SERVICE DATA AND SPECIFICATIONS (SDS)

PFP:00030

Wheel Bearing

BDS0006B

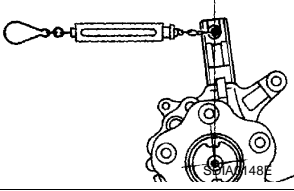
Rotation torque	1.96 N-m (0.20 kg-m, 17 in-lb) or less
Spring balance reading	12.8 N (1.30 kg) or less
Installation location of spring balance mm (in)	
Axial end play	0.05 mm (0.0020 in) or less

Drive Shaft

BDS0006C

Specified amount of grease	Final drive side	40 - 50 g (1.41 - 1.77 oz)
	Wheel side	35 - 45 g (1.23 - 1.59 oz)
Boot length	Final drive side (L ₂)	78.6 - 80.6 mm (3.094 - 3.173 in)
	Wheel side (L ₁)	66.7 - 68.7 mm (2.626 - 2.705 in)

Final drive side

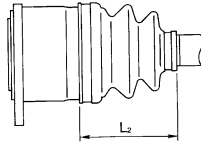

Wheel drive side

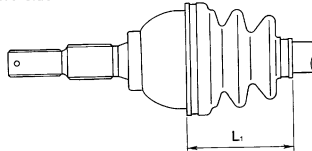

SDIA0618E

SERVICE DATA AND SPECIFICATIONS (SDS)
