

TF
SECTION
TRANSFER

A
B
C

TF

CONTENTS

E
F
G
H
I
J
K
L
M

PRECAUTIONS 3	BASIC CONCEPT 20
Precautions for Supplemental Restraint System (SRS) "AIR BAG" and "SEAT BELT PRE-TENSIONER" 3	Location of Electrical Parts 21
Precautions 3	Circuit Diagram 22
Service Notice 4	Wiring Diagram — 4WD — 23
Wiring Diagrams and Trouble Diagnosis 4	LHD MODELS 23
PREPARATION 5	RHD MODELS 26
Special Service Tools 5	Trouble Diagnosis Chart for Symptoms 29
Commercial Service Tools 8	4WD Control Unit Input/Output Signal Reference Values 30
NOISE, VIBRATION AND HARSHNESS (NVH)	4WD CONTROL UNIT INSPECTION TABLE 30
TROUBLESHOOTING 9	CONSULT-II Function (ALL MODE AWD/4WD) 31
NVH Troubleshooting Chart 9	FUNCTION 31
TRANSFER OIL 10	CONSULT-II SETTING PROCEDURE 31
Replacement 10	SELF-DIAG RESULT MODE 32
DRAINING 10	DATA MONITOR MODE 33
FILLING 10	ACTIVE TEST MODE 34
Inspection 10	4WD CONTROL UNIT PART NUMBER 34
OIL LEAKAGE AND OIL LEVEL 10	TROUBLE DIAGNOSIS FOR SYSTEM 35
ALL MODE 4X4 SYSTEM 11	Power Supply Circuit for 4WD Control Unit 35
Power Transfer Diagram 11	CONSULT-II REFERENCE VALUE IN DATA MONITOR MODE 35
System Description 11	DIAGNOSTIC PROCEDURE 35
ELECTRIC CONTROLLED COUPLING 11	4WD Control Unit 36
4WD CONTROL UNIT 11	DIAGNOSTIC PROCEDURE 36
4WD MODE SWITCH 12	ABS System 36
4WDINDICATORLAMPANDLOCKINDICATOR LAMP 12	DIAGNOSTIC PROCEDURE 36
4WD WARNING LAMP 12	4WD Solenoid 37
System Diagram 13	CONSULT-II REFERENCE VALUE IN DATA MONITOR MODE 37
COMPONENTS FUNCTION DESCRIPTION 14	DIAGNOSTIC PROCEDURE 37
CAN Communication 14	COMPONENT INSPECTION 39
SYSTEM DESCRIPTION 14	4WD Actuator Relay 40
CAN Communication Unit 14	CONSULT-II REFERENCE VALUE IN DATA MONITOR MODE 40
TYPE 1/TYPE 2 15	DIAGNOSTIC PROCEDURE 40
TYPE 3 16	4WD Mode Switch 42
TYPE 4/TYPE 5 17	CONSULT-II REFERENCE VALUE IN DATA MONITOR MODE 42
TYPE 6 18	DIAGNOSTIC PROCEDURE 42
TROUBLE DIAGNOSIS 20	COMPONENT INSPECTION 44
Fail-Safe Function 20	
How to Perform Trouble Diagnosis 20	

Engine Control Signal	44	4WD CONTROL UNIT	54
DIAGNOSTIC PROCEDURE	44	Removal and Installation	54
CAN Communication Line	45	REMOVAL	54
DIAGNOSTIC PROCEDURE	45	INSTALLATION	54
TROUBLE DIAGNOSIS FOR SYMPTOMS	46	SIDE OIL SEAL	55
4WD Indicator Lamp and LOCK Indicator Lamp Do Not Turn ON for Approx. 1 Second When The Igni- tion Switch Is Turned to ON	46	Removal and Installation	55
DIAGNOSTIC PROCEDURE	46	REMOVAL	55
4WD Warning Lamp Does Not Turn ON When The Ignition Switch Is Turned to ON	47	INSTALLATION	55
DIAGNOSTIC PROCEDURE	47	AIR BREATHER HOSE	56
4WD Warning Lamp Does Not Turn OFF Several Seconds after Engine Started	48	Components	56
DIAGNOSTIC PROCEDURE	48	Removal and Installation	56
4WD Mode Cannot Be Switched after Engine Is Started	49	TRANSFER ASSEMBLY	57
DIAGNOSTIC PROCEDURE	49	Removal and Installation	57
Heavy Tight-Corner Braking Symptom Occurs When the Vehicle Is Driven in AUTO Mode and the Steering Wheel Is Turned Fully to Either Side after the Engine Is Started	50	COMPONENTS	57
DIAGNOSTIC PROCEDURE	50	REMOVAL	57
Vehicle Does Not Enter 4WD Mode Even Though 4WD Warning Lamp Turned to OFF	51	INSTALLATION	58
DIAGNOSTIC PROCEDURE	52	Disassembly and Assembly	59
While Driving, 4WD Warning Lamp Flashes Rapidly (When Flashing in Approx. 1 Minute and Then Turn- ing OFF)	52	COMPONENTS	59
While Driving, 4WD Warning Lamp Flashes Slowly (When Continuing to Flash until Turning Ignition Switch OFF)	53	ASSEMBLY INSPECTION	60
DIAGNOSTIC PROCEDURE	53	DISASSEMBLY	64
		INSPECTION AFTER DISASSEMBLY	68
		SELECTING ADJUSTING SHIMS	69
		ASSEMBLY	70
		SERVICE DATA AND SPECIFICATIONS (SDS)	76
		General Specifications	76
		Inspection and Adjustment	76
		PRELOAD TORQUE BEFORE DISASSEMBLY...	76
		PRELOAD TORQUE AFTER DISASSEMBLY AND REASSEMBLY	76
		BACKLASH	76
		COMPANION FLANGE RUNOUT	76
		SELECTIVE PARTS	76

PRECAUTIONS

PRECAUTIONS

PPF:00001

Precautions for Supplemental Restraint System (SRS) “AIR BAG” and “SEAT BELT PRE-TENSIONER”

EDS001W1

The Supplemental Restraint System such as “AIR BAG” and “SEAT BELT PRE-TENSIONER”, used along with a front seat belt, helps to reduce the risk or severity of injury to the driver and front passenger for certain types of collision. Information necessary to service the system safely is included in the SRS and SB section of this Service Manual.

WARNING:

- To avoid rendering the SRS inoperative, which could increase the risk of personal injury or death in the event of a collision which would result in air bag inflation, all maintenance must be performed by an authorized NISSAN/INFINITI dealer.
- Improper maintenance, including incorrect removal and installation of the SRS, can lead to personal injury caused by unintentional activation of the system. For removal of Spiral Cable and Air Bag Module, see the SRS section.
- Do not use electrical test equipment on any circuit related to the SRS unless instructed to in this Service Manual. SRS wiring harnesses can be identified by yellow and/or orange harnesses or harness connectors.

Precautions

EDS001V6

- Before connecting or disconnecting the 4WD control unit harness connector, turn ignition switch “OFF” and disconnect battery ground cable. Because battery voltage is applied to 4WD control unit even if ignition switch is turned “OFF”.

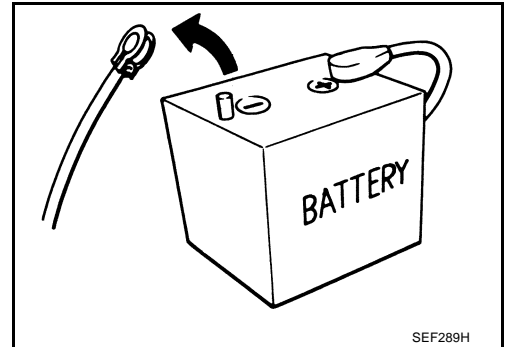

- When connecting or disconnecting pin connectors into or from 4WD control unit, take care not to damage pin terminals (bend or break). When connecting pin connectors, make sure that there are no bends or breaks on 4WD control unit pin terminal.

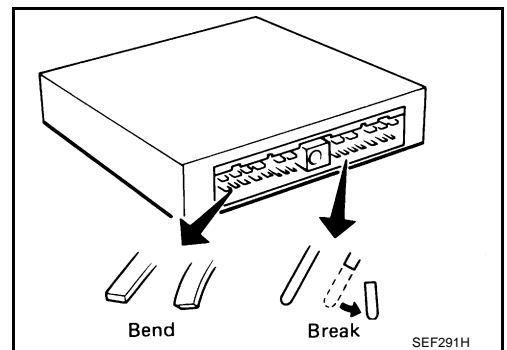

- Before replacing 4WD control unit, perform 4WD control unit input/output signal inspection and make sure whether 4WD control unit functions properly or not. Refer to [TF-30, "4WD Control Unit Input/Output Signal Reference Values"](#).

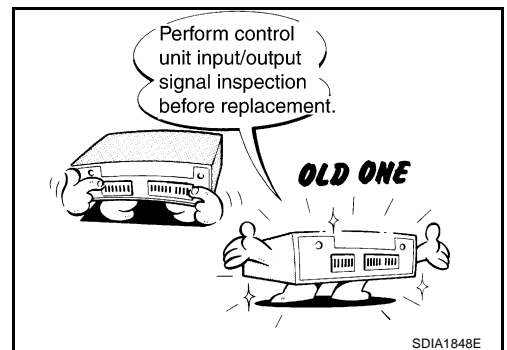

PRECAUTIONS

Service Notice

EDS001V7

- After overhaul refill the transfer with new transfer oil.
- Check the oil level or replace the oil only with the vehicle parked on level ground.
- During removal or installation, keep inside of transfer clear of dust or dirt.
- Replace all tires at the same time. Always use tires of the proper size and the same brand and pattern. Fitting improper size and unusual wear tires applies excessive force to vehicle mechanism and can cause longitudinal vibration.
- Disassembly should be done in a clean work area.
- Before proceeding with disassembly, thoroughly clean the transfer. It is important to prevent the internal parts from becoming contaminated by dirt or other foreign matter.
- Check for the correct installation status prior to removal or disassembly. If matching marks are required, be certain they do not interfere with the function of the parts when applied.
- All parts should be carefully cleaned with a general purpose, non-flammable solvent before inspection or reassembly.
- Check appearance of the disassembled parts for damage, deformation, and unusual wear. Replace them with a new ones if necessary.
- Gaskets, seals, O-rings and lock nuts should be replaced any time when the transfer is disassembled.
- In principle, tighten bolts or nuts gradually in several steps working diagonally from inside to outside. If tightening sequence is specified, use it.
- Observe the specified torque when assembling.
- Clean and flush the parts sufficiently and blow-dry them.
- Be careful not to damage sliding surfaces and mating surfaces.
- Use lint-free cloth or towels for wiping parts clean. Common shop rags can leave fibers that could interfere with the operation of the transfer.

Wiring Diagrams and Trouble Diagnosis

EDS001V8

When reading wiring diagrams, refer to the following:

- [GI-14, "How to Read Wiring Diagrams"](#).
- [PG-2, "POWER SUPPLY ROUTING"](#).

When performing trouble diagnosis, refer to the following:

- [GI-10, "How to Follow Trouble Diagnoses"](#).
- [GI-23, "How to Perform Efficient Diagnosis for an Electrical Incident"](#).

PREPARATION

PREPARATION

PFP:00002

Special Service Tools

EDS002V6

Tool number Tool name	Description
ST3127S000 Preload gauge	Measuring preload torque
ST33220000 Drift a: 37 mm (1.46 in) dia. b: 31 mm (1.22 in) dia. c: 22 mm (0.87 in) dia.	Removing drive pinion
KV381054S0 Puller	<ul style="list-style-type: none"> ● Removing pinion rear bearing outer race ● Removing pinion front bearing outer race ● Removing gear ring oil seal
ST30031000 Replacer	Removing pinion front bearing inner race
ST33200000 Drift a: 60 mm (2.36 in) dia. b: 44.5 mm (1.752 in) dia.	<ul style="list-style-type: none"> ● Removing gear ring bearing inner race (adapter case side) ● Installing companion flange
ST33061000 Drift a: 38 mm (1.50 in) dia. b: 28.5 mm (1.122 in) dia.	Removing gear ring bearing inner race (transfer case side)

A
B
C
TF
E
F
G
H
I
J
K
L
M

PREPARATION

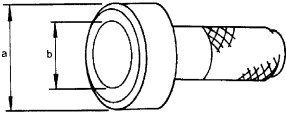
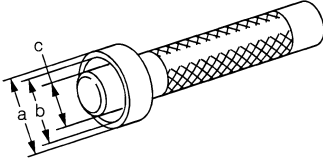
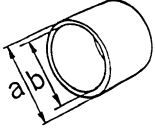
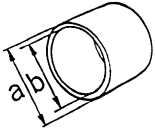
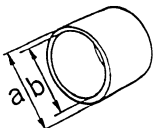
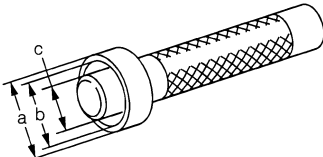
Tool number Tool name	Description
ST30720000 Drift a: 77 mm (3.03 in) dia. b: 55.5 mm (2.185 in) dia.  <p style="text-align: right; margin-right: 50px;">ZZA0811D</p>	<ul style="list-style-type: none"> ● Installing gear ring bearing outer race (transfer case side) ● Installing gear ring bearing inner race (transfer case side) ● Installing gear ring bearing inner race (adapter case side) ● Installing gear ring bearing outer race (adapter case side) ● Installing transfer case oil seal
ST33230000 Drift a: 51 mm (2.01 in) dia. b: 41 mm (1.61 in) dia. c: 28.5 mm (1.122 in) dia.  <p style="text-align: right; margin-right: 50px;">ZZA1046D</p>	Installing gear ring oil seal
ST27863000 Drift a: 74.5 mm (2.933 in) dia. b: 62.5 mm (2.461 in) dia.  <p style="text-align: right; margin-right: 50px;">ZZA1003D</p>	Installing gear ring bearing inner race (transfer case side)
KV40101630 Drift a: 68 mm (2.68 in) dia. b: 60 mm (2.36 in) dia.  <p style="text-align: right; margin-right: 50px;">ZZA1003D</p>	Installing gear ring bearing inner race (transfer case side)
KV38102510 Drift a: 71 mm (2.80 in) dia. b: 65 mm (2.56 in) dia.  <p style="text-align: right; margin-right: 50px;">ZZA1003D</p>	Installing gear ring bearing inner race (adapter case side)
KV38100300 Drift a: 54 mm (2.13 in) dia. b: 46 mm (1.81 in) dia. c: 32 mm (1.26 in) dia.  <p style="text-align: right; margin-right: 50px;">ZZA1046D</p>	Installing pinion rear bearing outer race

PREPARATION

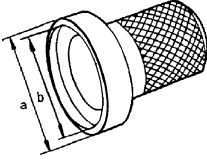
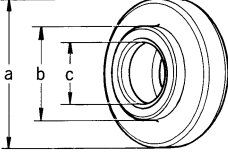
Tool number Tool name	Description
<p>ST33400001 Drift a: 60 mm (2.36 in) dia. b: 47 mm (1.85 in) dia.</p>  <p style="text-align: right; font-size: small;">ZZA0814D</p>	<ul style="list-style-type: none"> ● Installing pinion front bearing outer race ● Installing pinion sleeve oil seal
<p>ST30901000 Drift a: 79 mm (3.11 in) dia. b: 45 mm (1.77 in) dia. c: 35.2 mm (1.386 in) dia.</p>  <p style="text-align: right; font-size: small;">ZZA0978D</p>	<ul style="list-style-type: none"> ● Installing pinion front bearing outer race ● Installing pinion front bearing inner race

A
B
C
TF
E
F
G
H
I
J
K
L
M

PREPARATION

Commercial Service Tools

EDS002V7

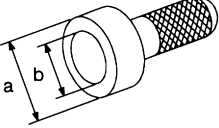
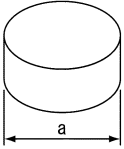
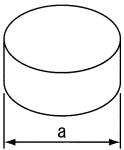
Tool name	Description
<p>Drift a: 80 mm (3.15 in) dia. b: 73 mm (2.87 in) dia.</p>  <p>NT115</p>	<p>Installing side oil seal (installing adapter case oil seal)</p>
<p>Drift a: 85 mm (3.35 in) dia.</p>  <p>PDIA0893E</p>	<p>Installing gear ring bearing outer race (transfer case side)</p>
<p>Drift a: 90 mm (3.54 in) dia.</p>  <p>PDIA0893E</p>	<p>Installing gear ring bearing outer race (adapter case side)</p>

NOISE, VIBRATION AND HARSHNESS (NVH) TROUBLESHOOTING

NOISE, VIBRATION AND HARSHNESS (NVH) TROUBLESHOOTING

PFP:00003

NVH Troubleshooting Chart

EDS001V9

Use the chart below to help you find the cause of the symptom. The numbers indicate the order of the inspection. If necessary, repair or replace these parts.

Reference page		TF-10			TF-59	TF-59	TF-59	TF-68	TF-68
SUSPECTED PARTS (Possible cause)		TRANSFER OIL (Level low)	TRANSFER OIL (Wrong)	TRANSFER OIL (Level too high)	LIQUID GASKET (Damaged)	O-RING (Worn or damaged)	OIL SEAL (Worn or damaged)	GEAR (Worn or damaged)	BEARING (Worn or damaged)
Symptom	Noise	1	2					3	3
	Transfer oil leakage		3	1	2	2	2		

A
B
C
TF
E
F
G
H
I
J
K
L
M

TRANSFER OIL

TRANSFER OIL

PF:KLD30

Replacement DRAINING

EDS001W2

CAUTION:

When draining oil, protect exhaust tube with cover.

1. Run the vehicle to warm up the transfer body sufficiently.
2. Stop engine, and remove drain plug to drain the transfer oil.
3. Apply recommended sealant to drain plug. Install drain plug on transfer and tighten to the specified torque. Refer to [TF-59, "COMPONENTS"](#).

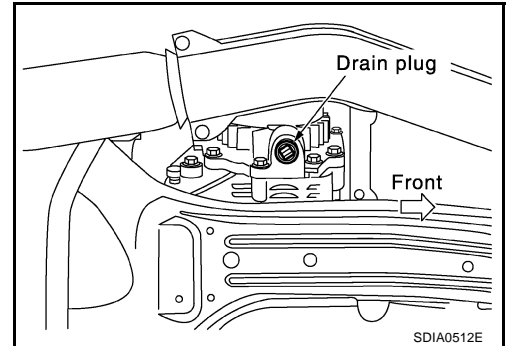

FILLING

1. Remove filler plug and add gear oil until oil level reaches the specified limit near filler plug mounting hole.

Oil grade and Viscosity

: Refer to [MA-17, "Fluids and Lubricants"](#).

Oil capacity

: Approx. 0.31 l (1/2 Imp pt)

CAUTION:

Carefully fill the oil. (Fill up for approx. 3 minutes)

2. Leave the vehicle for 3 minutes, and check the oil level again.
3. Apply recommended sealant to filler plug. Install filler plug on transfer and tighten to the specified torque. Refer to [TF-59, "COMPONENTS"](#).

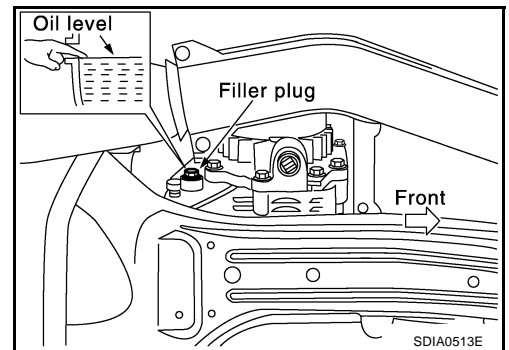

Inspection

OIL LEAKAGE AND OIL LEVEL

EDS001W3

1. Check oil level from filler plug mounting hole as shown in the figure.

CAUTION:

Do not start engine while checking oil level.

2. Before installing filler plug, apply recommended sealant. Install filler plug on transfer and tighten to the specified torque. Refer to [TF-59, "COMPONENTS"](#).

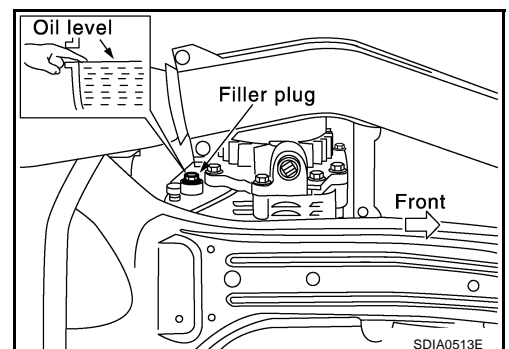

ALL MODE 4X4 SYSTEM

PPF:47850

Power Transfer Diagram

EDS001VA

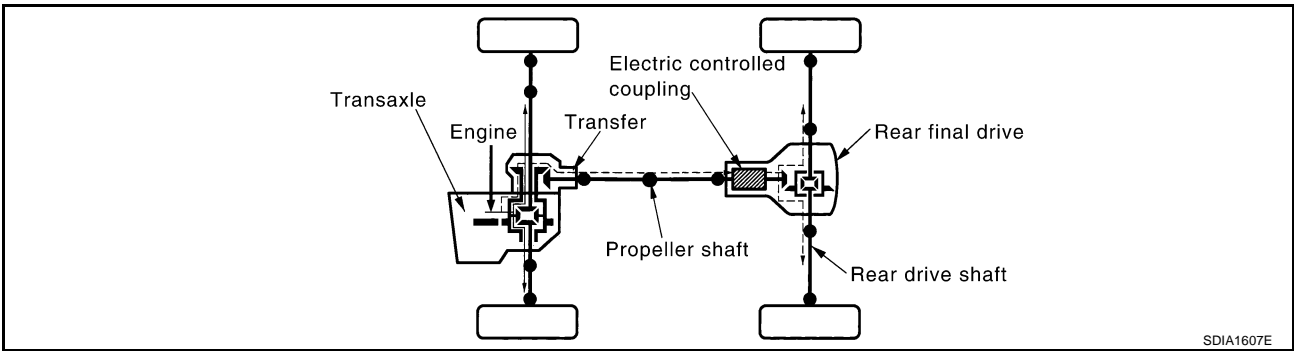

System Description ELECTRIC CONTROLLED COUPLING

EDS001VB

Operation Principle

1. The 4WD control unit supplies command current to electric controlled coupling (4WD solenoid).
2. The control clutch is engaged by electromagnet and torque is detected in control clutch.
3. The cam operates in response to control clutch torque and applies pressure to main clutch.
4. The main clutch transmits torque to front wheels according to pressing power.

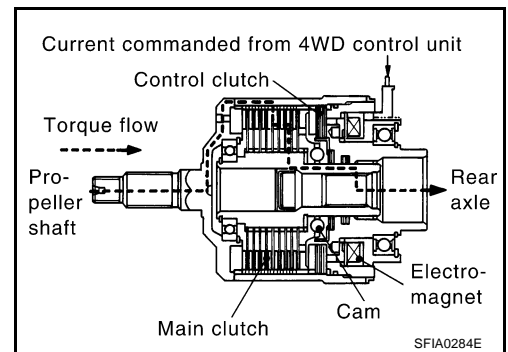

- Transmission torque to the rear wheels is determined according to command current.

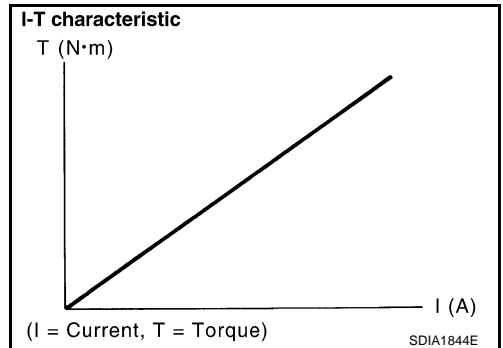

4WD CONTROL UNIT

- 4WD controls distribution of drive power between front-wheel drive (100:0) and 4WD (50:50) conditions according to signals from sensors.
- Self-diagnosis can be done with CONSULT-II.

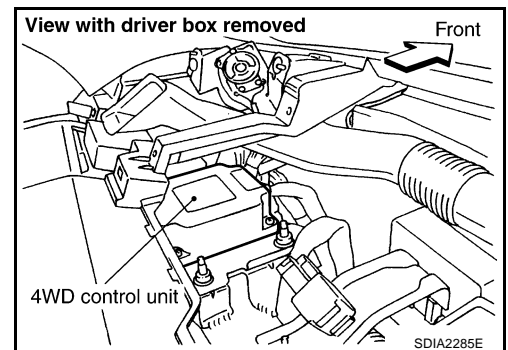

ALL MODE 4X4 SYSTEM

4WD MODE SWITCH

AUTO Mode

- Electronic control allows optimal distribution of torque to front/rear wheels to match road conditions.
- 4WD mode makes possible stable driving, with no wheel spin, on snowy roads or other slippery surfaces.
- On roads which do not require 4WD, AUTO mode contributes to improved fuel economy by driving in conditions close to front-wheel drive.
- Sensor inputs determine the vehicle's turning condition, and tight cornering/braking are controlled by distributing optimum torque to rear wheels.

LOCK Mode

- Front/rear wheel torque distribution is fixed, ensuring stable driving when climbing slopes.
- Vehicle will switch automatically to AUTO mode if vehicle speed increases. If vehicle speed then decreases, the vehicle automatically returns to direct 4-wheel driving conditions.
- LOCK mode will change to AUTO mode automatically, when the vehicle speed exceeds approx. 30 km/h (19 MPH). The LOCK indicator light keeps illuminating.

NOTE:

If there is a significant difference in pressure or wear between tires, full vehicle performance is not available. LOCK mode may be prohibited, or speeds at which LOCK mode is enabled may be restricted detecting tire conditions.

2WD Mode

Vehicle is in front-wheel drive.

NOTE:

- If front wheels are slipping in 2WD mode, do not switch to AUTO or LOCK. This can cause difficulties for the system.
- Even if the 4WD mode switch is in 2WD mode, the 4WD control unit occasionally automatically change to AUTO mode depending on the driving condition (For example; Depressing the acceleration firmly). This is not malfunction. However, 4WD indicator lamp dose not illuminate.

4WD INDICATOR LAMP AND LOCK INDICATOR LAMP

The following is the indications of indicator lamp.

Condition	4WD indicator lamp	LOCK indicator lamp
AUTO mode	ON	OFF
LOCK mode	ON	ON
2WD mode	OFF	OFF
Lamp check	Turns ON for approx. 1 second when ignition switch is turned ON.	

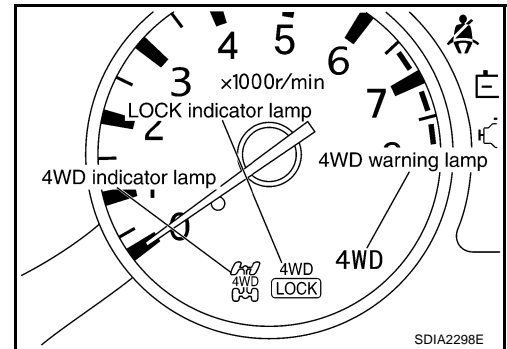

4WD WARNING LAMP

Turns ON when there is a malfunction in 4WD system. It indicates that the vehicle is in fail-safe mode and change to front-wheel drive or shifting driving force-4WD (Rear-wheels still have some driving torque). Also turns ON when ignition switch is turned ON, for purpose of lamp check. Turns OFF approximately for 1 seconds after the engine starts if system is normal.

4WD Warning Lamp Indication

Condition	4WD warning lamp
Lamp check	Turns ON when ignition switch is turned ON. Turns OFF approx. 1 seconds after engine start.
4WD system malfunction	ON
Protection function is activated due to heavy load to electric controlled coupling. (4WD system is not malfunctioning and 4WD system changes to 2WD mode.)	Rapid flashing: 2 times/second (Flashing in approx. 1 minute and then turning OFF.)

ALL MODE 4X4 SYSTEM

Condition	4WD warning lamp
Large difference in diameter of front/rear tires	Slow flashing: 1 time/2 seconds (Continuing to flash until turning ignition switch OFF)
Other than above (system normal)	OFF

System Diagram

EDS001VC

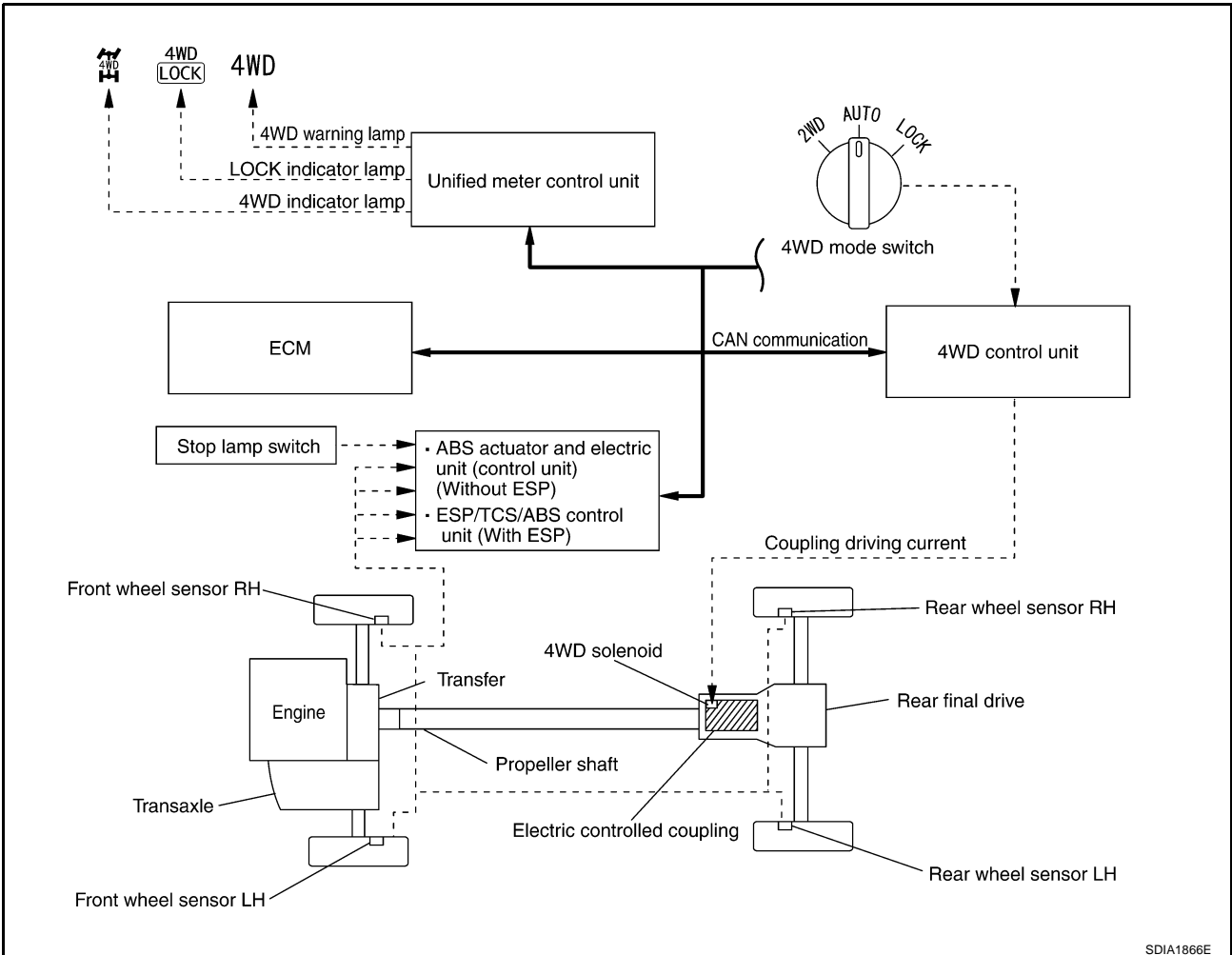

SDIA1866E

A
B
C
TF
E
F
G
H
I
J
K
L
M

ALL MODE 4X4 SYSTEM

COMPONENTS FUNCTION DESCRIPTION

Component parts	Function
4WD control unit	<ul style="list-style-type: none"> ● Controls driving force distribution by signals from each sensor and switch from front wheel driving mode (100:0) to 4WD mode (50:50). ● 2WD mode is available by fail-safe function if malfunction is detected in electrical system.
Wheel sensors	Detects wheel speed.
4WD solenoid	Controls electric controlled coupling by operation signal from 4WD control unit.
Electric controlled coupling	Transmits driving force to rear final drive.
4WD mode switch	Able to select from 2WD, AUTO or LOCK mode.
4WD warning lamp	<ul style="list-style-type: none"> ● Illuminates if malfunction is detected in electrical system of 4WD system. ● There is 1 blink in 2 seconds if rotation difference of front wheels and rear wheels is large. ● There are 2 blinks in 1 second if load is still applied to driving parts.
4WD indicator lamp	Indicate operation with optimal distribution of torque to front/rear wheels.
LOCK indicator lamp	Indicate that 4WD system is under direct 4-wheel driving mode.
ABS actuator and electric unit (control unit) (without ESP) or ESP/TCS/ABS control unit (with ESP)	Transmits the following signals via CAN communication to 4WD control unit. <ul style="list-style-type: none"> ● Vehicle speed signal ● Stop lamp switch signal (brake signal)
ECM	Transmits the following signals via CAN communication to 4WD control unit. <ul style="list-style-type: none"> ● Accelerator pedal position signal ● Engine speed signal
Unified meter control unit	Transmits conditions of parking brake switch via CAN communication to 4WD control unit.

CAN Communication SYSTEM DESCRIPTION

EDS0027K

CAN (Controller Area Network) is a serial communication line for real time application. It is an on-vehicle multiplex communication line with high data communication speed and excellent error detection ability. Many electronic control units are equipped onto a vehicle, and each control unit shares information and links with other control units during operation (not independent). In CAN communication, control units are connected with 2 communication lines (CAN H line, CAN L line) allowing a high rate of information transmission with less wiring. Each control unit transmits/receives data but selectively reads required data only.

CAN Communication Unit

EDS002XA

Body type	Wagon					
Axle	4WD					
Engine	YD22DDTi	QR20DE/QR25DE		YD22DDTi	QR25DE	
Transmission	M/T		A/T	M/T		A/T
Brake control	ABS			ESP		
CAN system type	1	2	3	4	5	6

ALL MODE 4X4 SYSTEM

TYPE 1/TYPER 2 System diagram

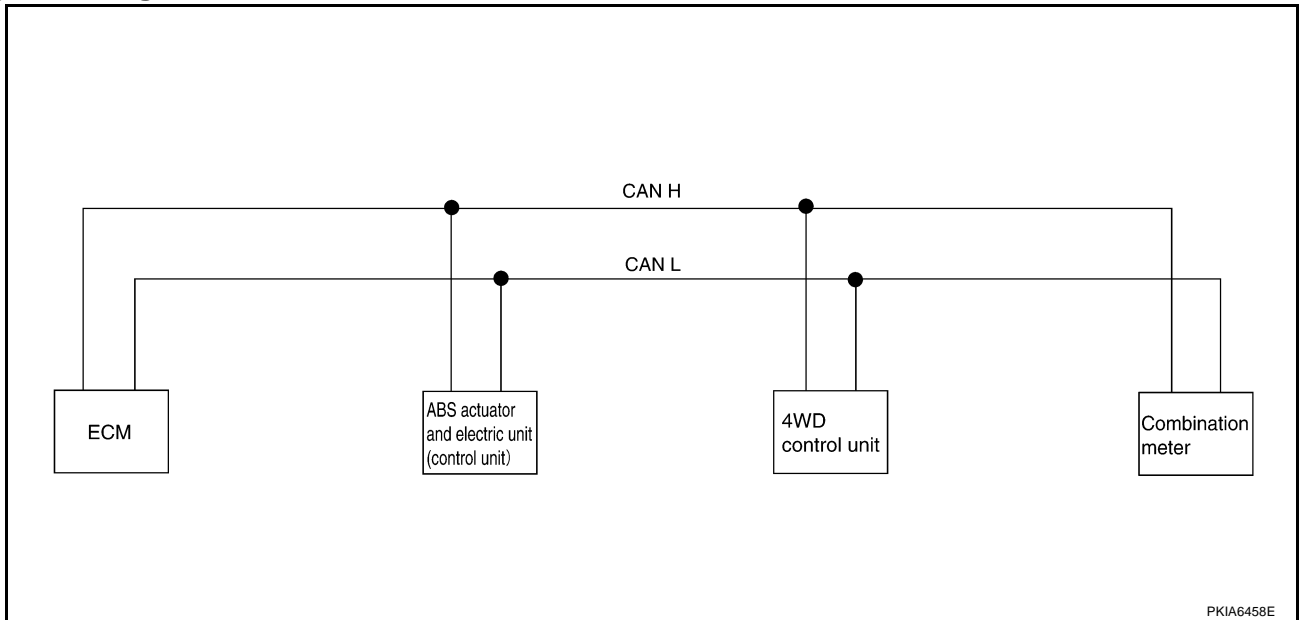

Input/output signal chart

T: Transmit R: Receive

Signals	ECM	ABS actuator and electric unit (control unit)	4WD control unit	Combination meter
4WD mode indicator lamp signal			T	R
4WD warning lamp signal			T	R
A/C compressor feedback signal	T			R
ABS warning lamp signal		T		R
Accelerator pedal position signal	T		R	
Engine coolant temperature signal	T			R
Engine speed signal	T		R	R
MI signal	T			R
Parking brake switch signal			R	T
Stop lamp switch signal		T	R	
Vehicle speed signal		T	R	R
	R			T
ASCD SET lamp signal	T			R
Stop lamp switch signal	T			R
Glow indicator lamp signal*	T			R
A/C switch signal*	R			T

*: YD engine models only

ALL MODE 4X4 SYSTEM

TYPE 3

System diagram

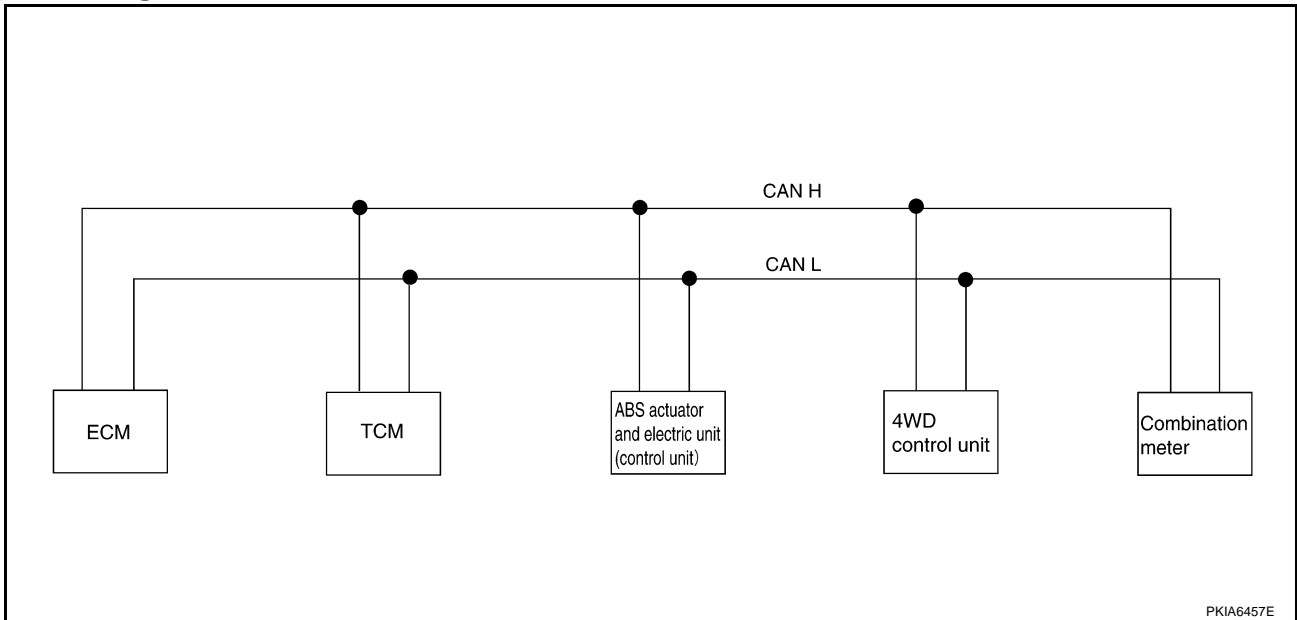

Input/output signal chart

T: Transmit R: Receive

Signals	ECM	TCM	ABS actuator and electric unit (control unit)	4WD control unit	Combination meter
4WD mode indicator lamp signal				T	R
4WD warning lamp signal				T	R
A/C compressor feedback signal	T				R
A/T position indicator lamp signal		T			R
A/T self-diagnosis signal	R	T			
ABS warning lamp signal			T		R
Accelerator pedal position signal	T			R	
Closed throttle position signal	T	R			
Engine A/T integrated control signal	T	R			
	R	T			
Engine coolant temperature signal	T				R
Engine speed signal	T			R	R
MI signal	T				R
O/D OFF indicator signal		T			R
Output shaft revolution signal	R	T			
Overdrive control switch signal		R			T
P-N range signal		R			T
Parking brake switch signal				R	T
Stop lamp switch signal		R			T
			T	R	
Vehicle speed signal			T	R	R
	R				T
Wide open throttle position signal	T	R			

ALL MODE 4X4 SYSTEM

Signals	ECM	TCM	ABS actuator and electric unit (control unit)	4WD control unit	Combination meter
ASCD SET lamp signal	T				R
ASCD CRUISE lamp signal	T				R

TYPE 4/TYPE 5 System diagram

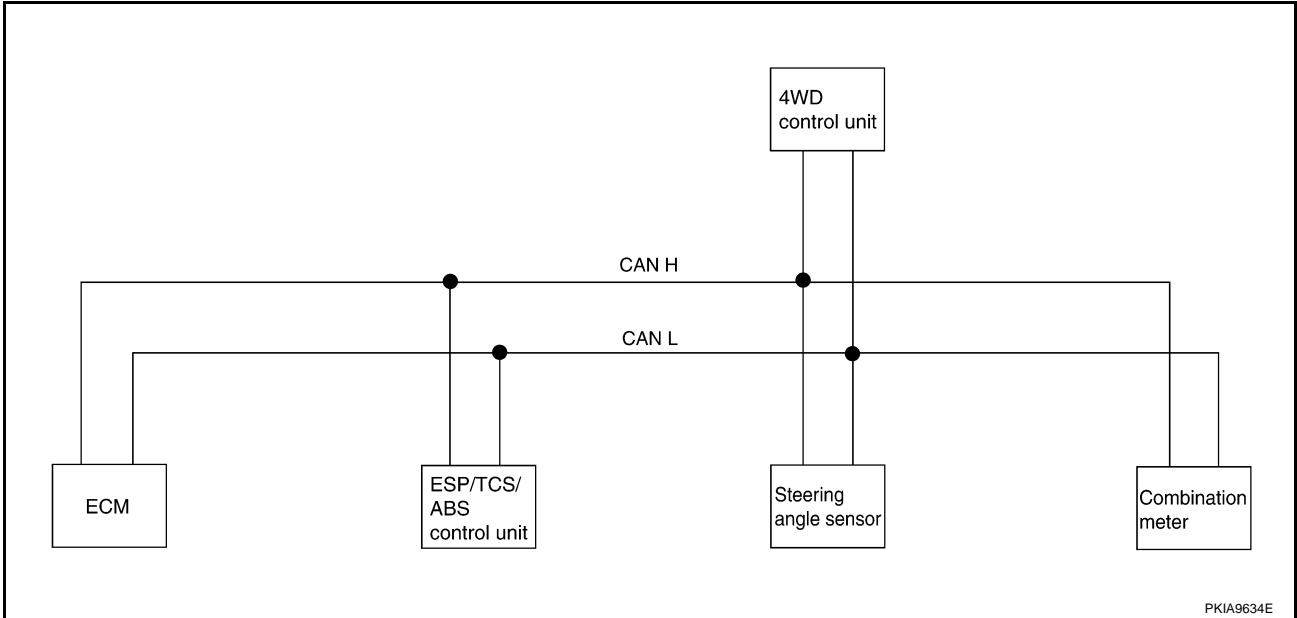

Input/output signal chart

T: Transmit R: Receive

Signals	ECM	ESP/TCS/ABS control unit	Steering angle sensor	4WD control unit	Combination meter
4WD mode indicator lamp signal				T	R
4WD warning lamp signal				T	R
A/C compressor feedback signal*2	T				R
A/C switch signal*1	R				T
ABS warning lamp signal		T			R
Accelerator pedal position signal	T	R		R	
Brake warning lamp signal		T			R
Engine coolant temperature signal	T				R
Engine speed signal	T	R		R	R
ESP OFF indicator lamp signal		T			R
Glow indicator lamp signal*1	T				R
MI signal	T				R
Stop lamp switch signal		T		R	
Vehicle speed signal		T		R	R
	R				T
SLIP indicator lamp signal		T			R
Parking brake switch signal				R	T
Steering angle sensor signal		R	T		
ASCD SET lamp signal	T				R
ASCD CRUISE lamp signal	T				R

ALL MODE 4X4 SYSTEM

*1: YD engine models only

*2: QR engine models only

TYPE 6

System diagram

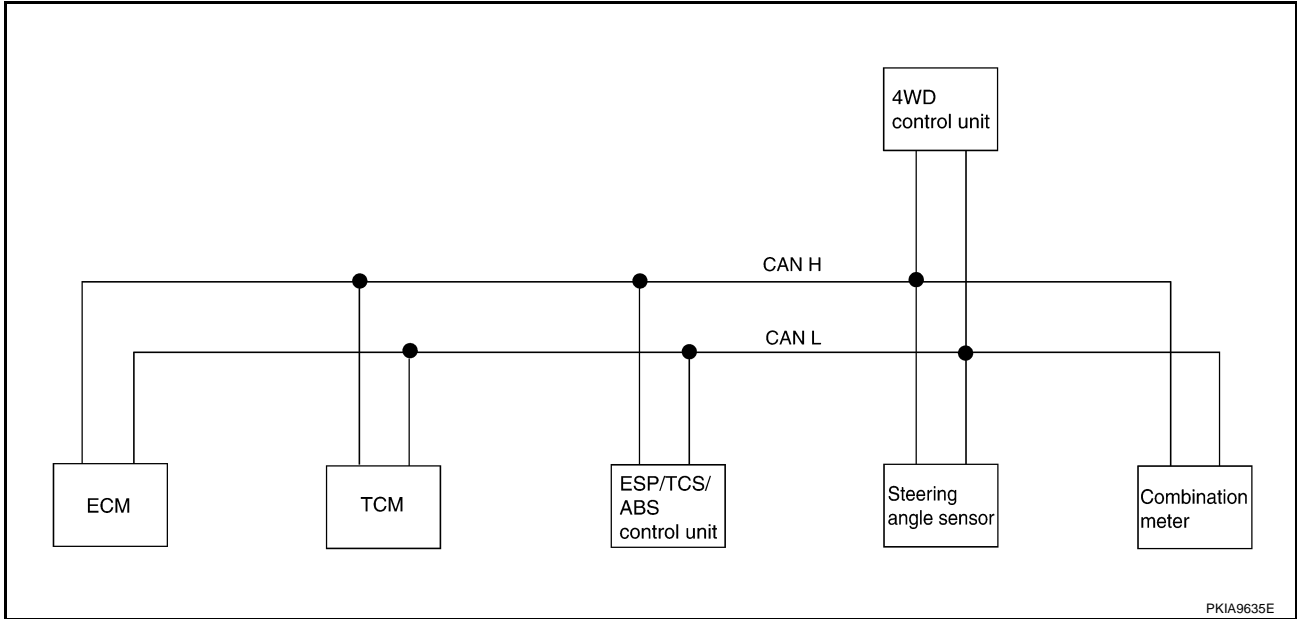

Input/output signal chart

T: Transmit R: Receive

Signals	ECM	TCM	ESP/TCS/ ABS control unit	Steering angle sensor	4WD control unit	Combination meter
4WD mode indicator lamp signal					T	R
4WD warning lamp signal					T	R
A/C compressor feedback signal	T					R
A/T position indicator lamp signal		T	R			R
A/T self-diagnosis signal	R	T				
ABS warning lamp signal			T			R
Accelerator pedal position signal	T		R		R	
Brake warning lamp signal			T			R
Closed throttle position signal	T	R				
Engine and A/T integrated	T	R				
	R	T				
Engine coolant temperature signal	T					R
Engine speed signal	T		R		R	R
ESP OFF indicator lamp signal			T			R
MI signal	T					R
O/D OFF indicator signal		T				R
Output shaft revolution signal	R	T				
Overdrive control switch signal		R				T
P-N range signal		R				T
SLIP indicator lamp signal			T			R
Steering angle sensor signal			R	T		

ALL MODE 4X4 SYSTEM

Signals	ECM	TCM	ESP/TCS/ ABS control unit	Steering angle sensor	4WD control unit	Combination meter
Stop lamp switch signal		R				T
			T		R	
Vehicle speed signal			T		R	R
	R					T
Parking brake switch signal					R	T
Wide open throttle position signal	T	R				
ASCD SET lamp signal	T					R
ASCD CRUISE lamp signal	T					R

A
B
C
TF
E
F
G
H
I
J
K
L
M

TROUBLE DIAGNOSIS

PFP:00004

Fail-Safe Function

EDS001VF

- If any malfunction occurs in 4WD electrical system, and control unit detects the malfunction, 4WD warning lamp on combination meter turns ON to indicate system malfunction.
- When 4WD warning lamp is ON, vehicle changes to front-wheel drive or shifting driving force-4WD (Rear-wheels still have some driving torque).

How to Perform Trouble Diagnosis BASIC CONCEPT

EDS001VF

- To perform trouble diagnosis, it is the most important to have understanding about vehicle systems (control and mechanism) thoroughly.
- It is also important to clarify customer complaints before inspection.

First of all, reproduce symptoms, and understand them fully. Ask customer about his/her complaints carefully. In some cases, it will be necessary to check symptoms by driving vehicle with customer.

CAUTION:

Customers are not professional. It is dangerous to make an easy guess like "maybe the customer means that...," or "maybe the customer mentions this symptom".

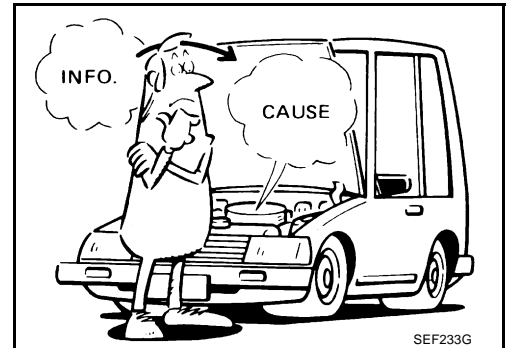

- It is essential to check symptoms right from the beginning in order to repair malfunctions completely. For intermittent malfunctions, reproduce symptoms based on interview with customer and past examples. Do not perform inspection on ad hoc basis. Most intermittent malfunctions are caused by poor contacts. In this case, it will be effective to shake suspected harness or connector by hand. When repairing without any symptom diagnosis, you cannot judge if malfunctions have actually been eliminated.
- After completing diagnosis, always erase diagnostic memory. Refer to [TF-33, "How to Erase Self-diagnostic Results"](#).
- For intermittent malfunctions, move harness or harness connector by hand. Then check for poor contact or reproduced open circuit.

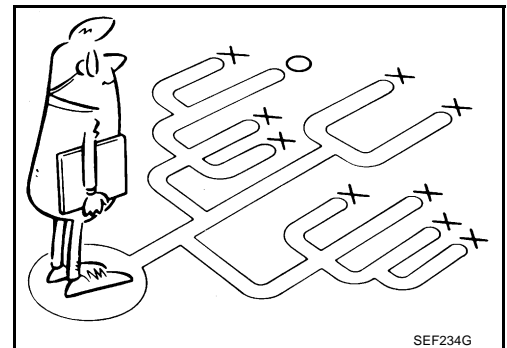

TROUBLE DIAGNOSIS

Location of Electrical Parts

EDS001VG

A
B
C
TF
E
F
G
H
I
J
K
L
M

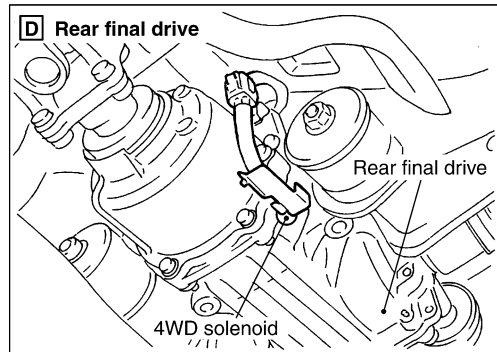
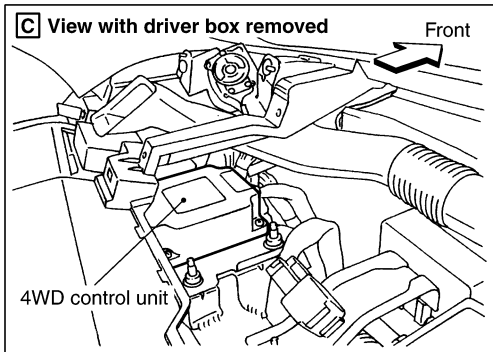
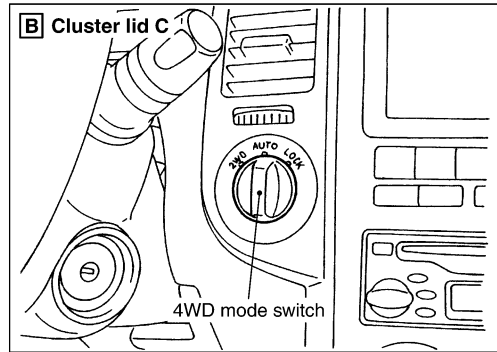
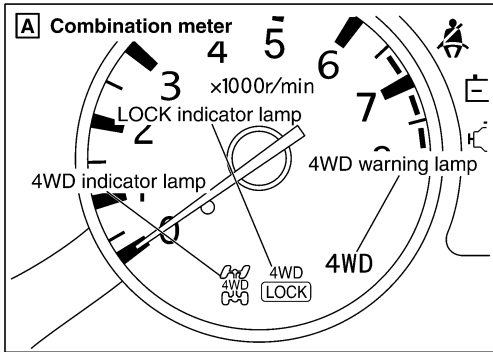
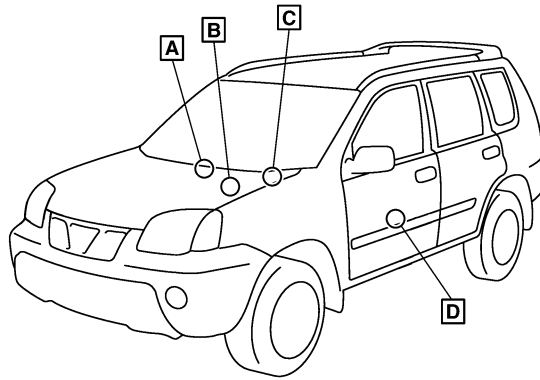

SDIA2299E

TROUBLE DIAGNOSIS

Circuit Diagram

EDS001VH

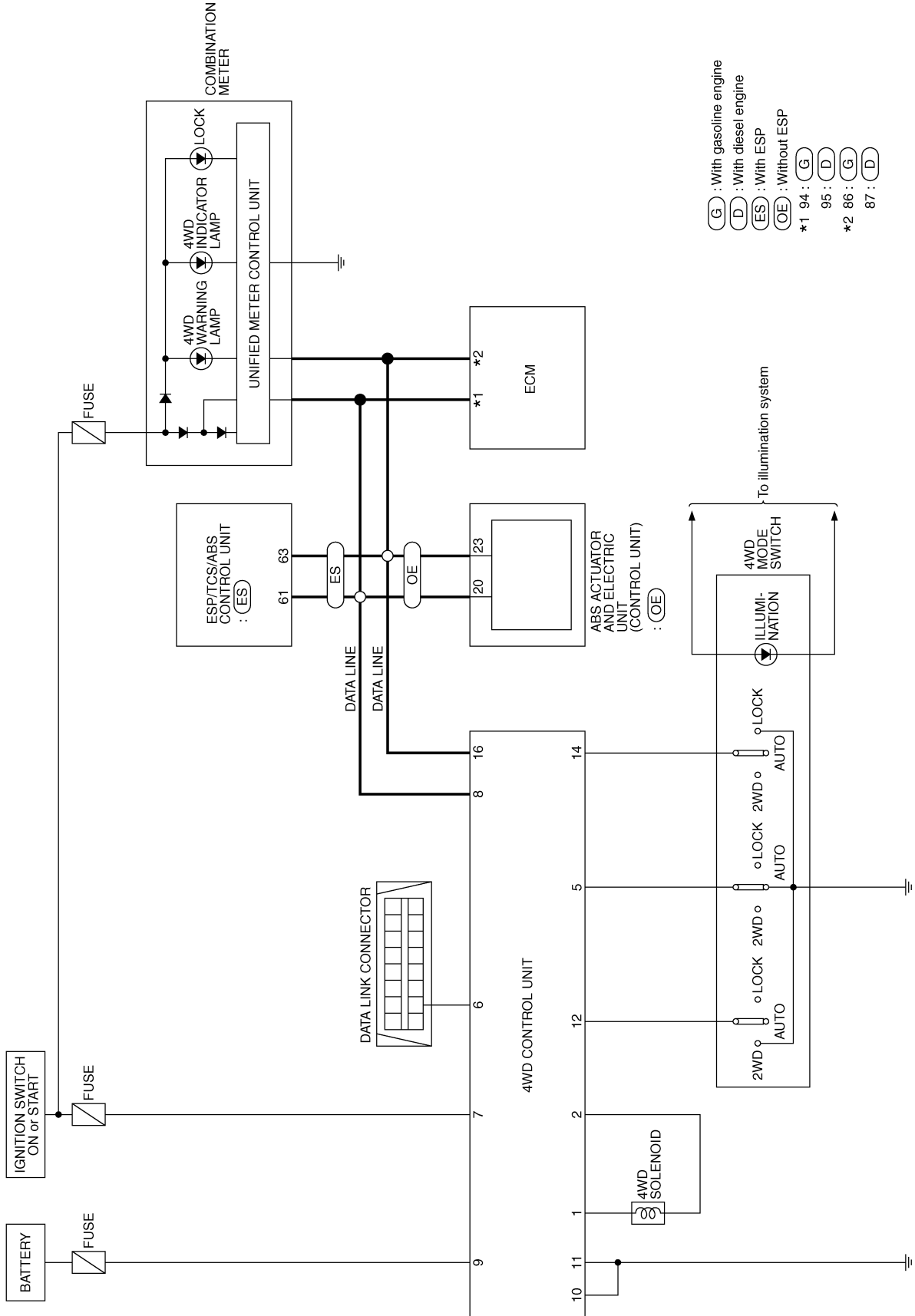

- (G) : With gasoline engine
- (D) : With diesel engine
- (ES) : With ESP
- (OE) : Without ESP
- *1 94 : (G)
- 95 : (D)
- *2 86 : (G)
- 87 : (D)

TDWB0010E

TROUBLE DIAGNOSIS

Wiring Diagram — 4WD — LHD MODELS

EDS001VI

TF-4WD-01

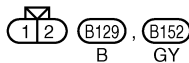
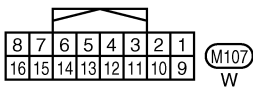
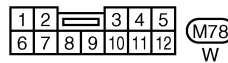
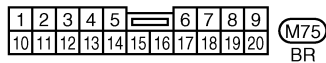
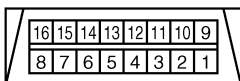
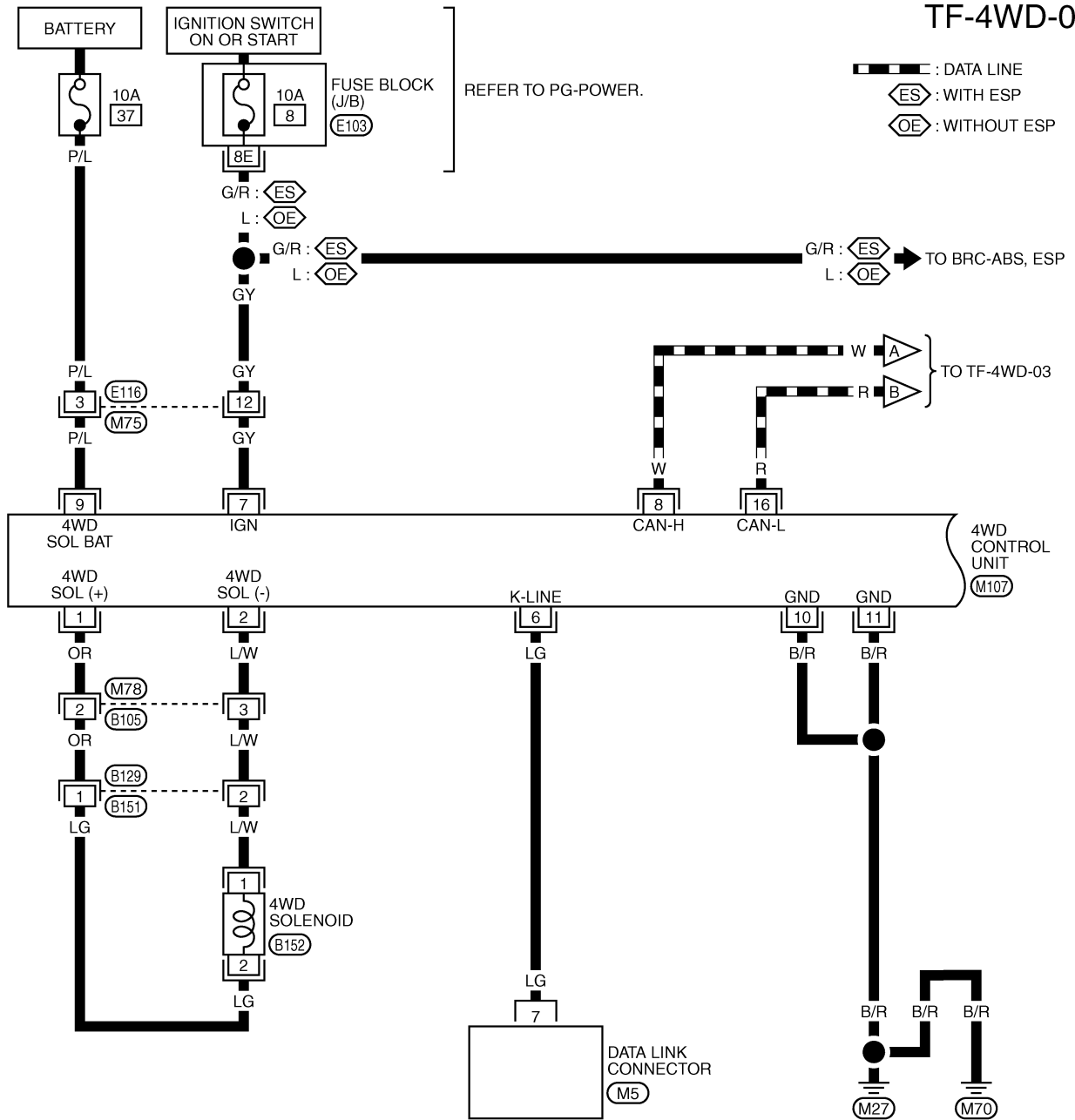

REFER TO THE FOLLOWING.
E103 - FUSE BLOCK-JUNCTION BOX (J/B)

TROUBLE DIAGNOSIS

TF-4WD-02

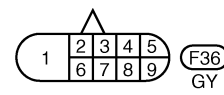
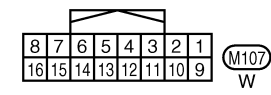
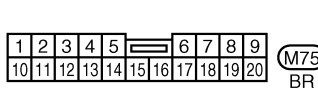
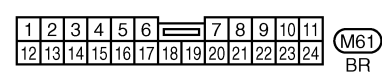
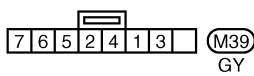
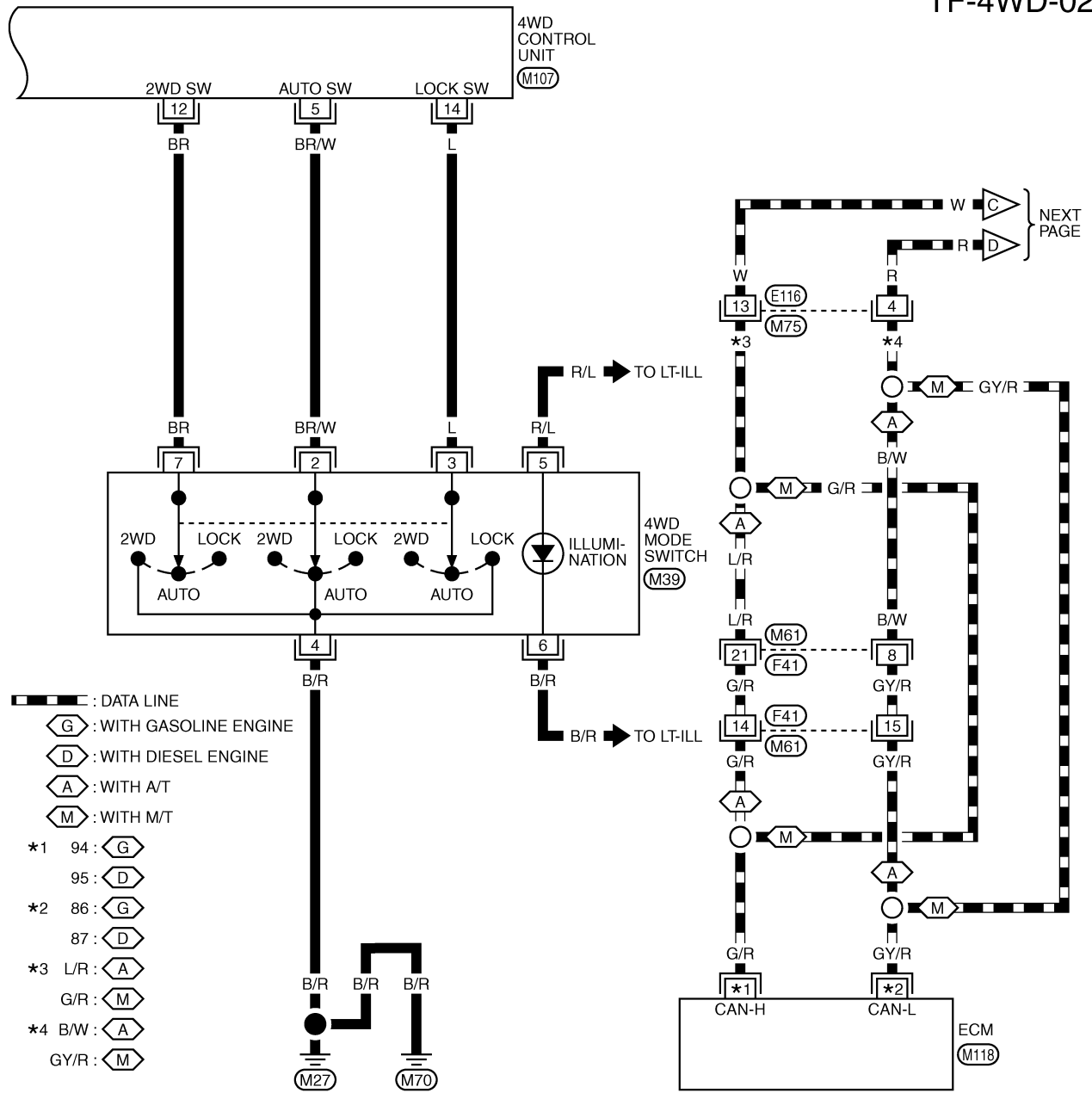

REFER TO THE FOLLOWING.
 (M118) -ELECTRICAL UNITS

TROUBLE DIAGNOSIS

TF-4WD-03

A
B
C
TF
E
F
G
H
I
J
K
L
M

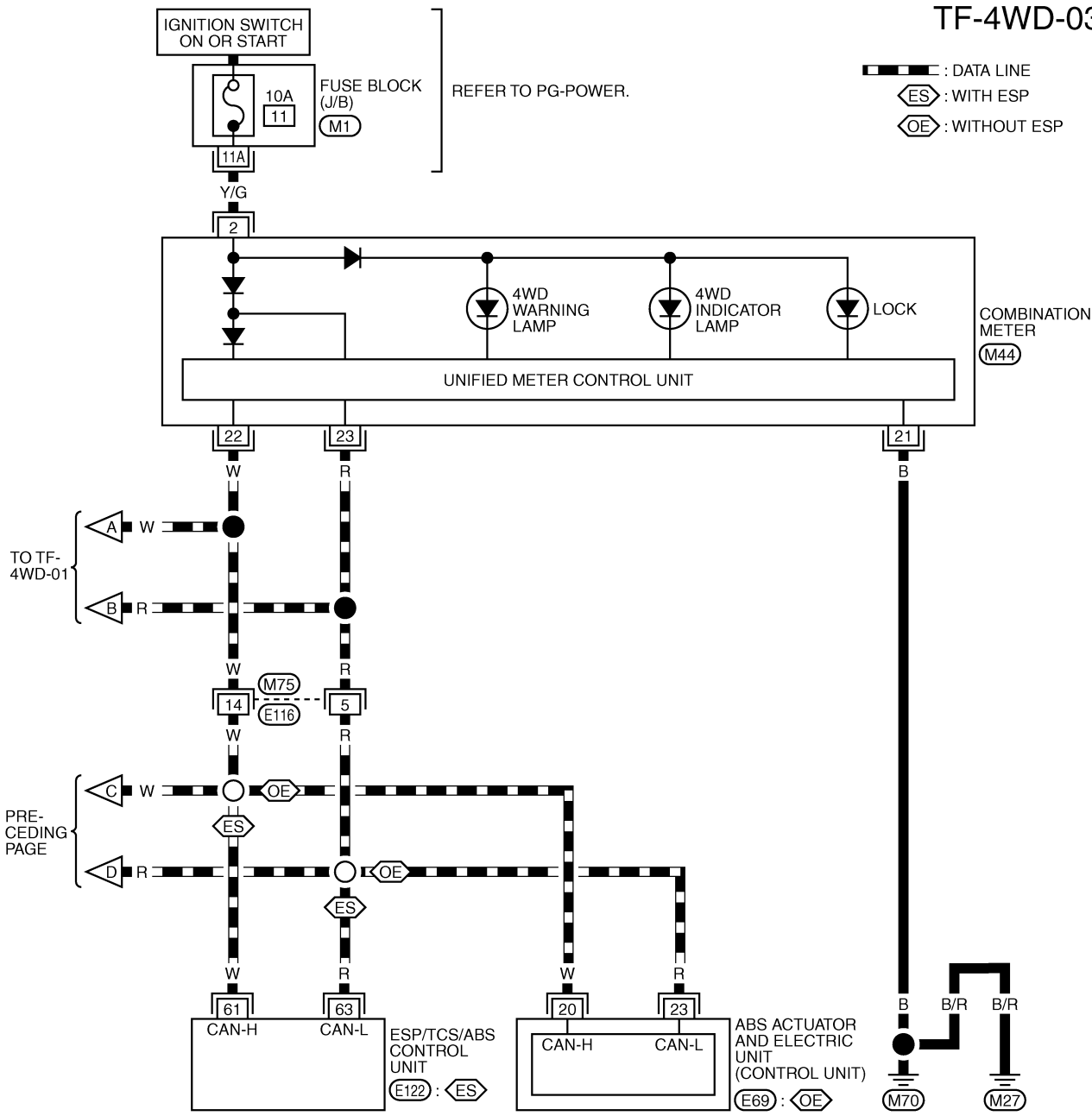

1	2	3	4	5	6	7	8	9	10	11	12	13	14	15	16	17	18	19	20
21	22	23	24	25	26	27	28	29	30	31	32	33	34	35	36	37	38	39	40

(M44) W

1	2	3	4	5	6	7	8	9		
10	11	12	13	14	15	16	17	18	19	20

(M75) BR

REFER TO THE FOLLOWING.

(M1) - FUSE BLOCK-JUNCTION BOX (J/B)

(E69), (E122) - ELECTRICAL UNITS

TROUBLE DIAGNOSIS

RHD MODELS

TF-4WD-04

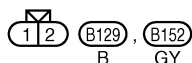
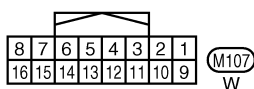
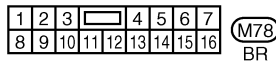
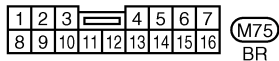
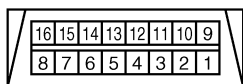
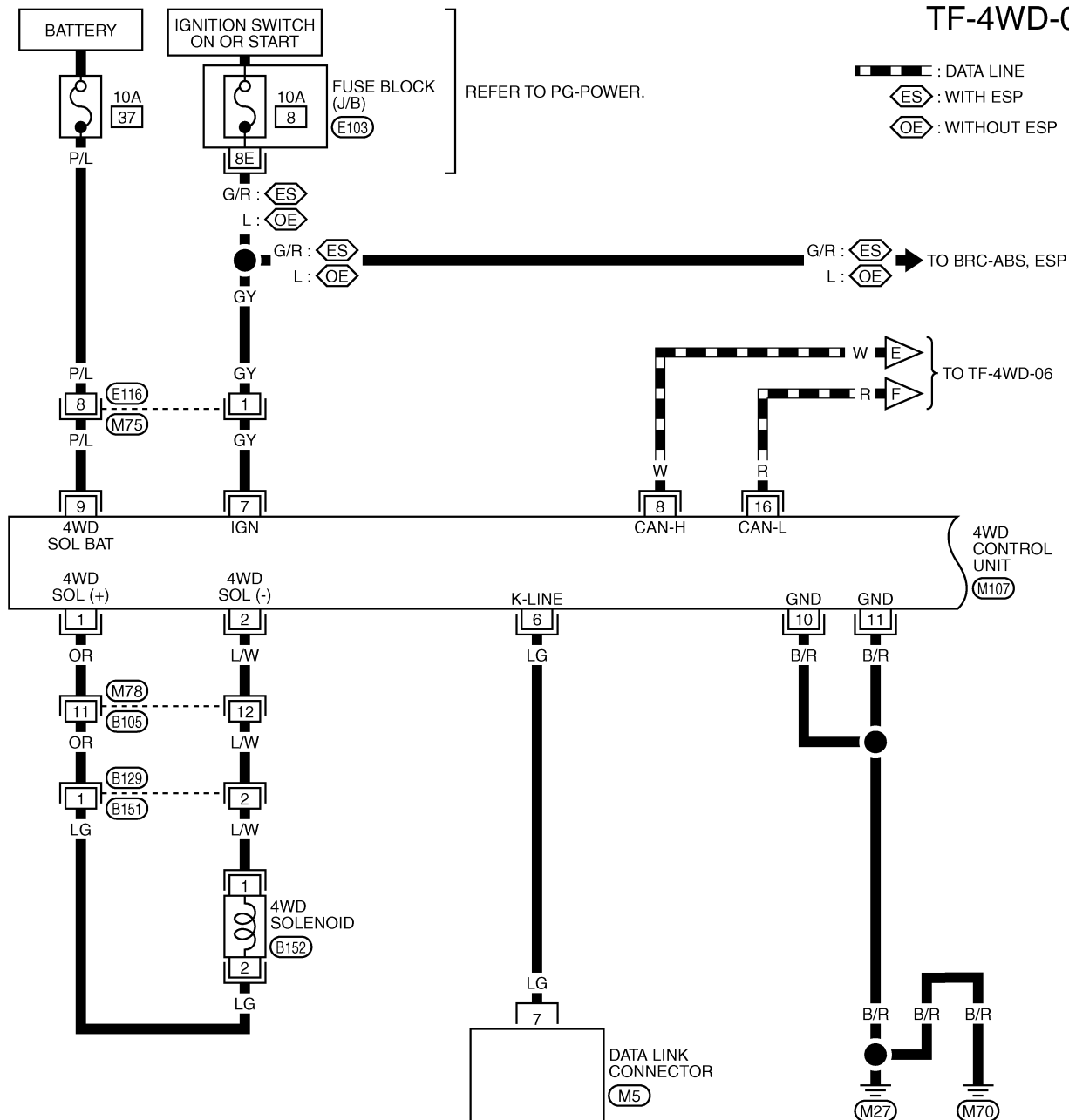

REFER TO THE FOLLOWING.
 (E103) - FUSE BLOCK-JUNCTION BOX (J/B)

TROUBLE DIAGNOSIS

TF-4WD-05

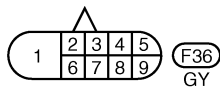
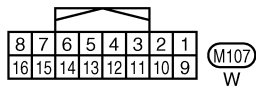
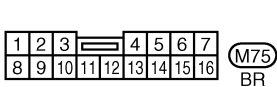
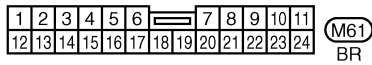
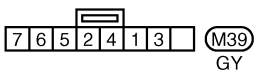
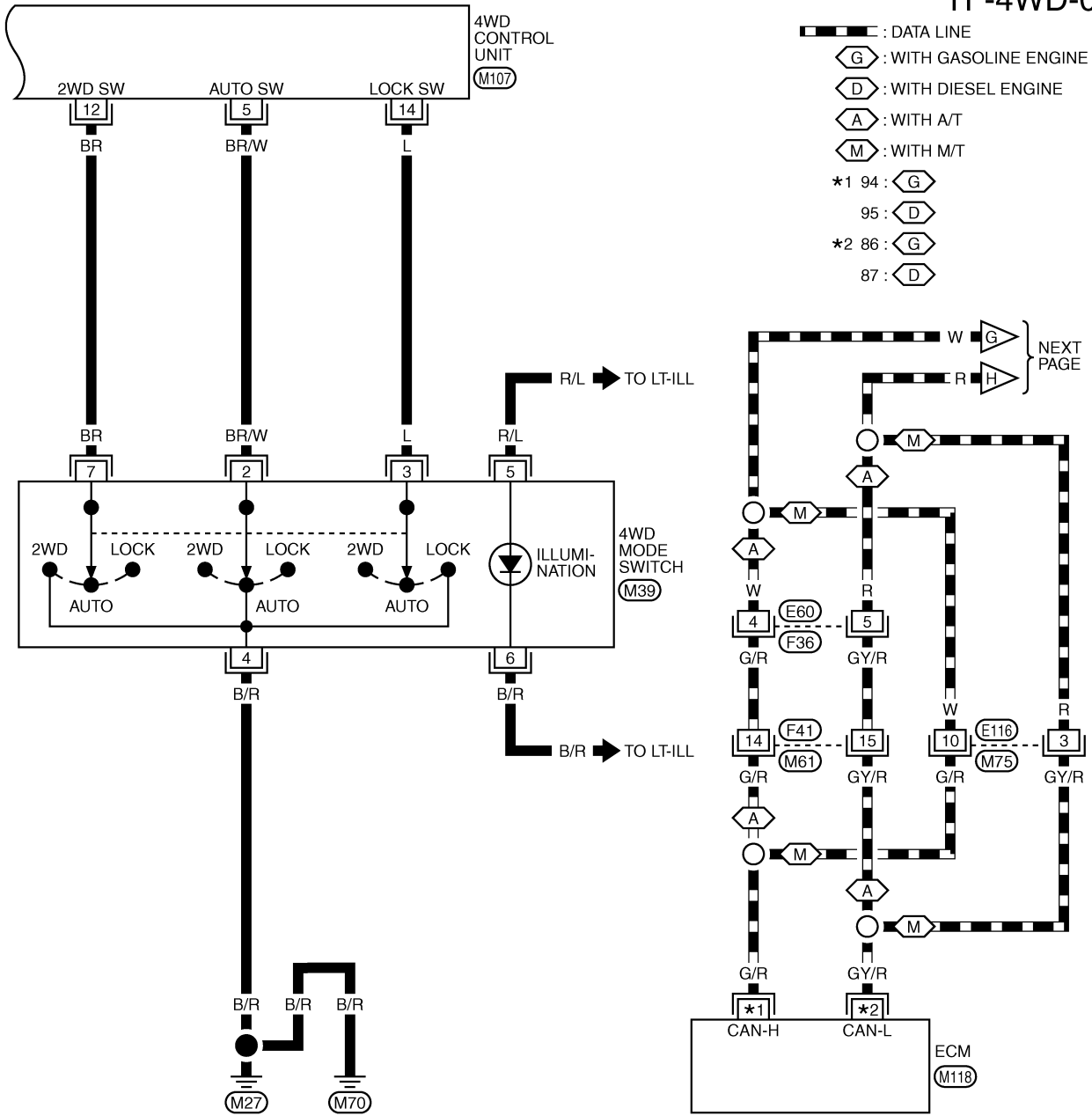

REFER TO THE FOLLOWING.
M118 -ELECTRICAL UNITS

TROUBLE DIAGNOSIS

TF-4WD-06

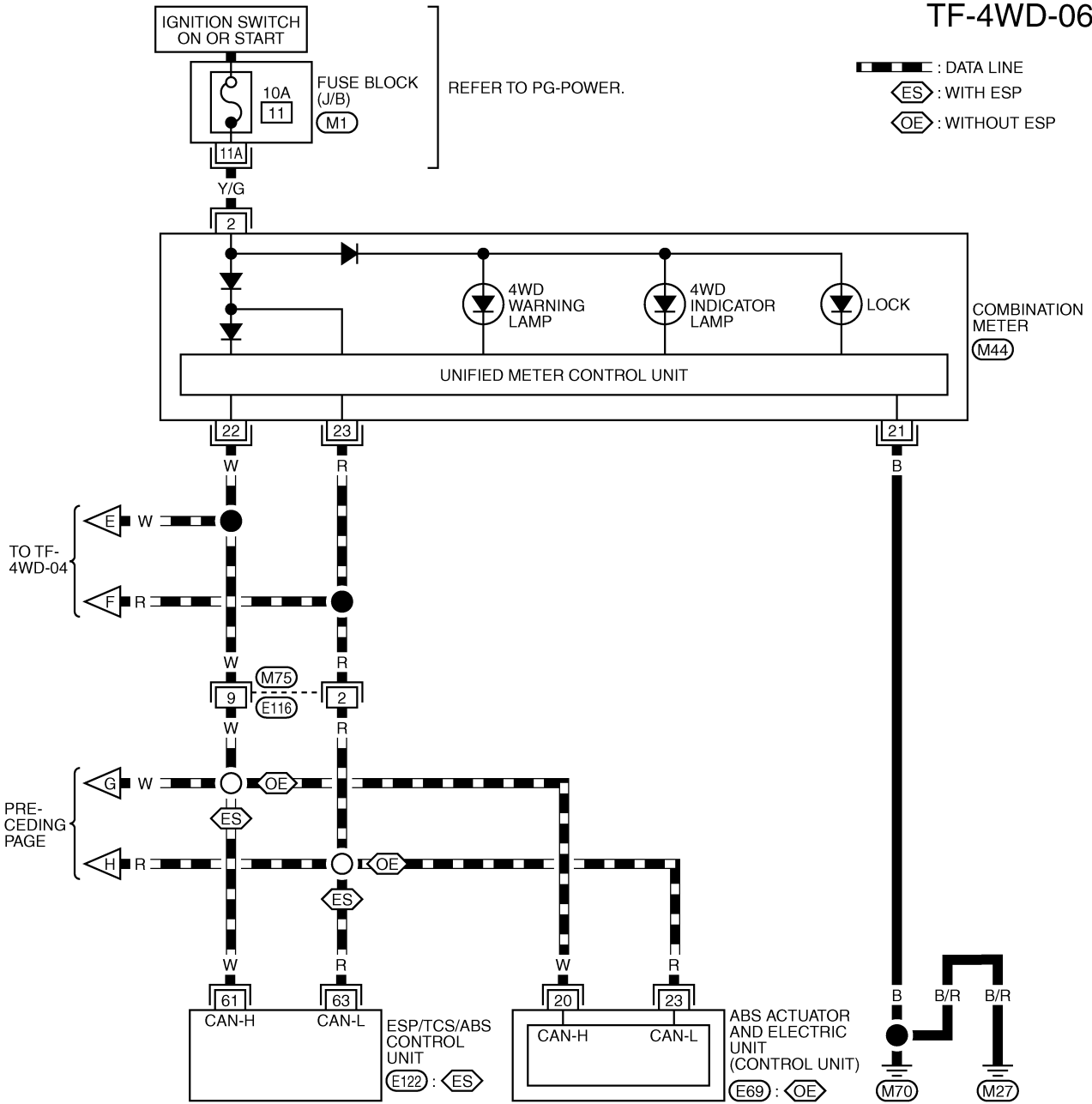

1	2	3	4	5	6	7	8	9	10	11	12	13	14	15	16	17	18	19	20
21	22	23	24	25	26	27	28	29	30	31	32	33	34	35	36	37	38	39	40

(M44) W

1	2	3	4	5	6	7		
8	9	10	11	12	13	14	15	16

(M75) BR

REFER TO THE FOLLOWING.

(M1) - FUSE BLOCK-JUNCTION BOX (J/B)

(E69), (E122) - ELECTRICAL UNITS

TROUBLE DIAGNOSIS

Trouble Diagnosis Chart for Symptoms

EDS001VJ

If 4WD warning lamp turns ON, perform self-diagnosis. Refer to [TF-32. "SELF-DIAG RESULT MODE"](#) .

Symptom	Condition	Check item	Reference page
4WD indicator lamp and LOCK indicator lamp do not turn ON for approx. 1 second when the ignition switch is turned to ON. (4WD indicator lamp and LOCK indicator lamp check)	Ignition switch: ON	CAN communication line	TF-46
		Power supply and ground for 4WD control unit	
		Unified meter control unit	
4WD warning lamp does not turn ON when the ignition switch is turned to ON. (4WD warning lamp check)	Ignition switch: ON	CAN communication line	TF-47
		Unified meter control unit	
4WD warning lamp does not turn OFF several seconds after engine started.	Engine running	CAN communication line	TF-48
		Power supply and ground for 4WD control unit	
		Unified meter control unit	
		4WD solenoid	
		4WD actuator relay (integrated in 4WD control unit)	
		Wheel sensor	
4WD mode cannot be switched after engine is started.	Engine running	4WD mode switch	TF-49
		CAN communication line	
		Unified meter control unit	
Heavy tight-corner braking symptom occurs when the vehicle is driven in AUTO mode and the steering wheel is turned fully to either side after the engine is started. (See NOTE.)	<ul style="list-style-type: none"> ● While driving ● AUTO mode ● Steering wheel is turned fully to either sides 	CAN communication line	TF-50
		4WD mode switch	
		Accelerator pedal position signal	
		4WD solenoid	
		Mechanical malfunction of electric controlled coupling (clutch sticking etc.)	
Vehicle does not enter 4WD mode even though 4WD warning lamp turned to OFF.	Vehicle speed: 10 km/h (6 MPH) or less	4WD solenoid	TF-51
	Vehicle speed: 10 km/h (6 MPH) or more	Mechanical malfunction of electric controlled coupling (Mechanical engagement of clutch is not possible.)	
		Operating condition of parking brake	
		4WD solenoid	
While driving, 4WD warning lamp flashes rapidly. (When flashing in approx. 1 minute and then turning OFF.) Rapid flashing: 2 times/second	<ul style="list-style-type: none"> ● While driving ● AUTO mode and LOCK mode 	Protection function is activated due to heavy load to electric controlled coupling. (4WD system is not malfunctioning.)	TF-52
		While driving, 4WD warning lamp flashes slowly. (When continuing to flash until turning ignition switch OFF) Slow flashing: 1 time/2 seconds	

NOTE:

- Light tight-corner braking symptom may occur depending on driving conditions in AUTO mode. This is not malfunction.
- Heavy tight-corner braking symptom occurs when vehicle is driven in the following conditions: LOCK mode, steering wheel is turned fully to either sides, and accelerator pedal was depressed.

TROUBLE DIAGNOSIS

4WD Control Unit Input/Output Signal Reference Values

EDS001VK

4WD CONTROL UNIT INSPECTION TABLE

Specifications with CONSULT-II

Monitor item [Unit]	Content	Condition	Display value	
FR RH SENSOR [km/h] or [mph]	Wheel speed (Front wheel right)	Vehicle stopped	0.00 km/h (0.00 mph)	
		Vehicle running CAUTION: Check air pressure of tire under standard condition.	Approximately equal to the indication on speedometer (Inside of ±10%)	
FR LH SENSOR [km/h] or [mph]	Wheel speed (Front wheel left)	Vehicle stopped	0.00 km/h (0.00 mph)	
		Vehicle running CAUTION: Check air pressure of tire under standard condition.	Approximately equal to the indication on speedometer (Inside of ±10%)	
RR RH SENSOR [km/h] or [mph]	Wheel speed (Rear wheel right)	Vehicle stopped	0.00 km/h (0.00 mph)	
		Vehicle running CAUTION: Check air pressure of tire under standard condition.	Approximately equal to the indication on speedometer (Inside of ±10%)	
RR LH SENSOR [km/h] or [mph]	Wheel speed (Rear wheel left)	Vehicle stopped	0.00 km/h (0.00 mph)	
		Vehicle running CAUTION: Check air pressure of tire under standard condition.	Approximately equal to the indication on speedometer (Inside of ±10%)	
BATTERY VOLT [V]	Power supply voltage for 4WD control unit	Ignition switch: ON	Battery voltage	
THRTL POS SEN [%]	Throttle opening condition	When depressing accelerator pedal (Value rises gradually in response to throttle position.)	0 - 100%	
ETS SOLENOID [A]	Monitored value of current at 4WD solenoid	Engine speed : At idle	2WD	Approx. 0.000A
			AUTO	Approx. 0.000A
			LOCK	Approx. 0.000A
		Engine speed : 3,000 rpm or more constant	2WD	Approx. 0.000A
			AUTO	Approx. 0.000 - 1.500A*
			LOCK	Approx. 2.800A
STOP LAMP SW [ON/OFF]	Condition of brake pedal operation	Brake pedal: Depressed	ON	
		Brake pedal: Released	OFF	
ENG SPEED SIG [RUN/STOP]	Condition of engine running	Engine stopped (Engine speed: Less than 400 rpm)	STOP	
		Engine running (Engine speed: 400 rpm or more)	RUN	
ETS ACTUATOR [ON/OFF]	Operating condition of 4WD actuator relay (integrated in 4WD control unit)	Engine stopped (Ignition switch: ON)	OFF	
		Engine running	ON	
4WD WARN LAMP [ON/OFF]	4WD warning lamp condition	4WD warning lamp: ON	ON	
		4WD warning lamp: OFF	OFF	
4WD MODE SW [2WD/AUTO/LOCK]	Input condition from 4WD mode switch	4WD mode switch	2WD	2WD
			AUTO	AUTO
			LOCK	LOCK

TROUBLE DIAGNOSIS

Monitor item [Unit]	Content	Condition	Display value
4WD MODE MON [2WD/AUTO/LOCK]	Control status of 4WD (Output condition of 4WD indicator lamp and LOCK indicator lamp signal)	4WD mode switch (Engine running)	2WD
			AUTO
			LOCK
DIS-TIRE MONI [mm]	Improper size tire installed condition	Vehicle running with normal size tire installed	0-4 mm
		Vehicle running with improper size tire installed (Front/rear tire size difference, wear condition)	4-8 mm, 8- mm
P BRAKE SW [ON/OFF]	Condition of parking brake	Parking brake operated	ON
		Parking brake not operated	OFF

*: The values are changed by throttle opening and engine speed.

CONSULT-II Function (ALL MODE AWD/4WD) FUNCTION

EDS001VL

CONSULT-II can display each diagnostic item using the diagnostic test modes shown following.

Diagnostic test mode	Function	Reference page
Self-diagnostic results	● Self-diagnostic results can be read and erased quickly.	TF-32
Data monitor	● Input/Output data in the 4WD control unit can be read.	TF-33
CAN diagnostic support monitor	● The results of transmit/receive diagnosis of CAN communication can be read.	—
Active test	● Diagnostic Test Mode in which CONSULT-II drives some actuators apart from the 4WD control unit and also shifts some parameters in a specified range.	TF-34
ECU part number	● 4WD control unit part number can be read.	TF-34

CONSULT-II SETTING PROCEDURE

- For details, refer to the separate “CONSULT-II Operations Manual”.
1. Turn ignition switch “OFF”.
 2. Connect CONSULT-II and CONSULT-II CONVERTER to data link connector on vehicle.
 3. Turn ignition switch “ON”.
-
4. Touch “START (NISSAN BASED VHCL)”.

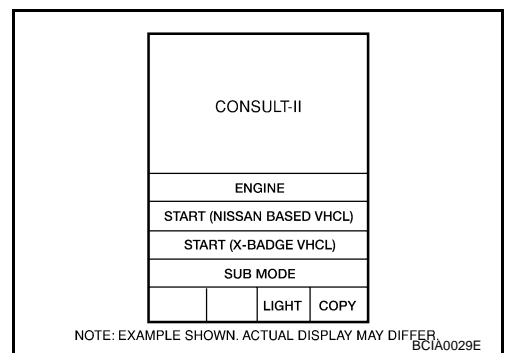
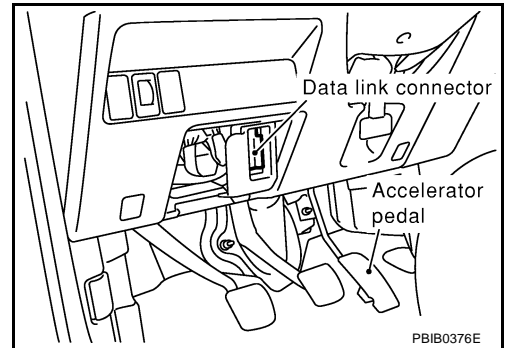

TROUBLE DIAGNOSIS

5. Touch "ALL MODE AWD/4WD".
If "ALL MODE AWD/4WD" is not indicated, go to [GI-35, "CONSULT-II Data Link Connector \(DLC\) Circuit"](#).
6. Perform each diagnostic test mode according to each service procedure.

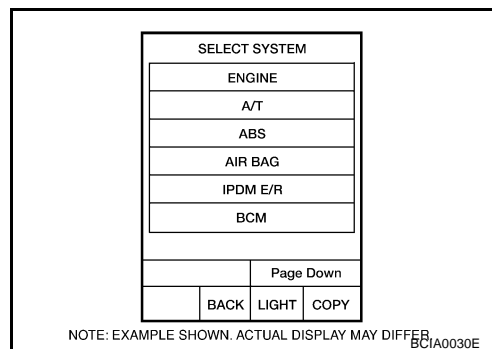

SELF-DIAG RESULT MODE

Operation Procedure

1. Perform "CONSULT-II SETTING PROCEDURE". Refer to [TF-31, "CONSULT-II SETTING PROCEDURE"](#).
2. Start engine and drive at 30 km/h (19 MPH) or more for approx. 1 minute.
3. Stop vehicle. With engine at idle, touch "SELF-DIAG RESULTS". Display shows malfunction experienced since the last erasing operation.

NOTE:

- The details for "TIME" are as follow:

- "0": Error currently detected with 4WD control unit.
- Except for "0": Error detected in the past and memorized with 4WD control unit.
Detects frequency of driving after DTC occurs (frequency of turning ignition switch "ON/OFF").

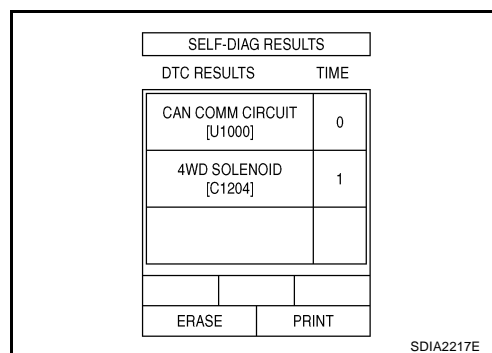

Display Item List

Items (CONSULT-II screen terms)	Diagnostic item is detected when...	Check item
CONTROLLER FAILURE [C1201]	Malfunction has occurred inside 4WD control unit.	TF-36, "4WD Control Unit"
ABS SYSTEM [C1203]	Malfunction related to wheel sensor has been detected by ABS actuator and electric unit (control unit) (without ESP) or ESP/TCS/ABS control unit (with ESP).	TF-36, "ABS System"
4WD SOLENOID [C1204]	Malfunction related to 4WD solenoid has been detected.	TF-37, "4WD Solenoid"
4WD ACTUATOR RLY [C1205]	Malfunction has been detected from 4WD actuator relay integrated with 4WD control unit, or malfunction related to 4WD solenoid has been detected.	TF-40, "4WD Actuator Relay" or TF-37, "4WD Solenoid"
MODE SW [C1209]	More than two switch inputs are simultaneously detected due to short circuit of 4WD mode switch.	TF-42, "4WD Mode Switch"
ENGINE SIGNAL 1 [C1210]	Malfunction has been detected from ECM.	TF-44, "Engine Control Signal"
CAN COMM CIRCUIT [U1000]	Malfunction has been detected from CAN communication line.	TF-45, "CAN Communication Line"
NO DTC IS DETECTED. FURTHER TESTING MAY BE REQUIRED.	No NG item has been detected.	—

CAUTION:

- If "CAN COMM CIRCUIT [U1000]" is displayed with other DTCs, first perform the trouble diagnosis for CAN communication line.
- Make sure that ABS warning lamp turns OFF by driving for a minute at vehicle speed of 30 km/h (19 MPH) or more after turning ignition switch "OFF" if 4WD warning lamp turns ON with system malfunction of "ABS SYSTEM [C1203]". 4WD warning lamp may not turn OFF if it is normal unless ignition switch turns OFF at once and engine restarts after that.

TROUBLE DIAGNOSIS

How to Erase Self-diagnostic Results

1. Perform applicable inspection of malfunctioning item and then repair or replace.
2. Start engine and drive at 30 km/h (19 MPH) or more for approx. 1 minute.
3. Make sure that ABS warning lamp turns OFF.

NOTE:

Make sure that ABS warning lamp turns OFF by driving for a minute at vehicle speed of 30 km/h (19 MPH) or more after turning ignition switch "OFF" if 4WD warning lamp turns ON with system malfunction of "ABS SYSTEM [C1203]". 4WD warning lamp may not turn OFF if it is normal unless ignition switch turns OFF at once and engine restarts after that.

4. Turn ignition switch "OFF" to erase memory.
5. Start engine and select "SELF-DIAG RESULTS" mode for "ALL MODE AWD/4WD" with CONSULT-II.
6. Touch "ERASE" on CONSULT-II screen to erase DTC memory.

CAUTION:

If memory cannot be erased, perform applicable diagnosis.

7. Drive at 30 km/h (19 MPH) or more for approx. 1 minute. Be sure 4WD warning lamp is OFF.

DATA MONITOR MODE

Operation Procedure

1. Perform "CONSULT-II SETTING PROCEDURE". Refer to [TF-31, "CONSULT-II SETTING PROCEDURE"](#).
2. Touch "DATA MONITOR".
3. Select from "SELECT MONITOR ITEM", screen of data monitor mode is displayed.

NOTE:

When malfunction is detected, CONSULT-II performs REAL-TIME DIAGNOSIS. Also, any malfunction detected while in this mode will be displayed at real time.

Display Item List

×: Standard -: Not applicable

Monitor item (Unit)	SELECT MONITOR ITEM			Remarks
	ECU INPUT SIGNALS	MAIN SIGNALS	SELECTION FROM MENU	
FR RH SENSOR [km/h] or [mph]	×	×	×	Wheel speed calculated by front wheel sensor RH signal is displayed.
FR LH SENSOR [km/h] or [mph]	×	×	×	Wheel speed calculated by front wheel sensor LH signal is displayed.
RR RH SENSOR [km/h] or [mph]	×	×	×	Wheel speed calculated by rear wheel sensor RH signal is displayed.
RR LH SENSOR [km/h] or [mph]	×	×	×	Wheel speed calculated by rear wheel sensor LH signal is displayed.
BATTERY VOLT [V]	-	-	×	Power supply voltage for 4WD control unit.
THRTL POS SEN [%]	-	-	×	Throttle opening status is displayed.
ETS SOLENOID [A]	-	-	×	Monitored value of current at 4WD solenoid.
STOP LAMP SW [ON/OFF]	-	-	×	Stop lamp switch signal status via CAN communication line is displayed.
ENG SPEED SIG [RUN/STOP]	-	-	×	Engine status is displayed.
ETS ACTUATOR [ON/OFF]	-	-	×	Operating condition of 4WD actuator relay (integrated in 4WD control unit) is displayed.
4WD WARN LAMP [ON/OFF]	-	-	×	Control status of 4WD warning lamp is displayed.
4WD MODE SW [2WD/AUTO/LOCK]	-	-	×	4WD lock switch signal status via CAN communication line is displayed.

TROUBLE DIAGNOSIS

Monitor item (Unit)	SELECT MONITOR ITEM			Remarks
	ECU INPUT SIGNALS	MAIN SIGNALS	SELECTION FROM MENU	
4WD MODE MON [2WD/AUTO/LOCK]	-	-	×	Control status of 4WD is displayed. (Output condition of 4WD LOCK indicator lamp signal)
DIS-TIRE MONI [mm]	-	-	×	Improper size tire installed condition is displayed.
P BRAKE SW [ON/OFF]	-	-	×	Parking switch signal status via CAN communication line is displayed.
Voltage [V]	-	-	×	The value measured by the voltage probe is displayed.
Frequency [Hz]	-	-	×	The value measured by the pulse probe is displayed.
DUTY-HI (high) [%]	-	-	×	
DUTY-LOW (low) [%]	-	-	×	
PLS WIDTH-HI [msec]	-	-	×	
PLS WIDTH-LOW [msec]	-	-	×	

ACTIVE TEST MODE

Description

Use this mode to determine and identify the details of a malfunction based on self-diagnostic results or data monitor. 4WD control unit gives drive signal to actuator with receiving command from CONSULT-II to check operation of actuator.

Test Item

Test item	Condition	Description
ETS S/V (Detects 4WD solenoid)	<ul style="list-style-type: none"> ● Vehicle stopped ● Engine running ● No DTC detected 	<ul style="list-style-type: none"> ● Change command current value to 4WD solenoid, and then change driving mode. (Monitor value is normal if it is within approximately $\pm 10\%$ of command value.) <p>Qu: Increase current value in increments of 0.20A Qd: Decrease current value in increments of 0.20A UP: Increase current value in increments of 0.02A DOWN: Decrease current value in increments of 0.02A</p>

CAUTION:

Do not continuously energize for a long time.

4WD CONTROL UNIT PART NUMBER

Ignore the 4WD control unit part number displayed in the "ECU PART NUMBER". Refer to parts catalog to order the 4WD control unit.

TROUBLE DIAGNOSIS FOR SYSTEM

TROUBLE DIAGNOSIS FOR SYSTEM

PPF:00000

Power Supply Circuit for 4WD Control Unit CONSULT-II REFERENCE VALUE IN DATA MONITOR MODE

EDS001VM

Data are reference value.

Monitor item [Unit]	Condition	Display value (Approx.)
BATTERY VOLT [V]	Ignition switch: ON	Battery voltage

DIAGNOSTIC PROCEDURE

1. CHECK POWER SUPPLY

1. Turn ignition switch "OFF".
2. Disconnect 4WD control unit harness connector.
3. Turn ignition switch "ON". (Do not start engine.)
4. Check voltage between 4WD control unit harness connector terminals and ground.

Connector	Terminal (Wire color)	Voltage (Approx.)
M107	7 (GY) - Ground	Battery voltage
	9 (P/L) - Ground	

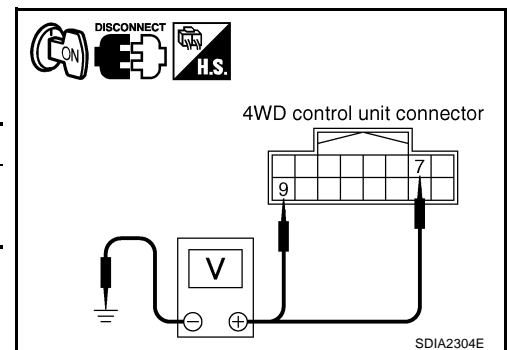

5. Turn ignition switch "OFF".
6. Check voltage between 4WD control unit harness connector terminals and ground.

Connector	Terminal (Wire color)	Voltage (Approx.)
M107	7 (GY) - Ground	0V
	9 (P/L) - Ground	Battery voltage

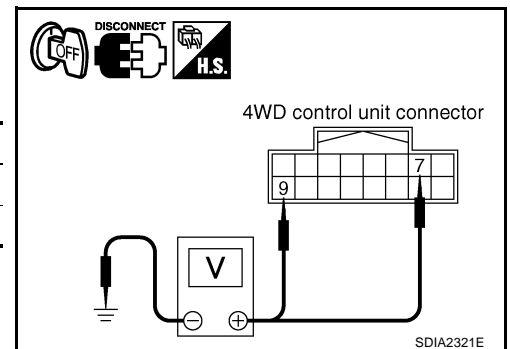

OK or NG

OK >> GO TO 2.

NG >> Check the following. If any items are damaged, repair or replace damaged parts.

- 10A fuse (No. 8, located in the fuse block (J/B) or No. 37, located in the fuse and fusible link box)
- Harness for short or open between battery and 4WD control unit harness connector terminal 9
- Harness for short or open between ignition switch and 4WD control unit harness connector terminal 7
- Ignition switch. Refer to [PG-2, "POWER SUPPLY ROUTING"](#).

TROUBLE DIAGNOSIS FOR SYSTEM

2. CHECK GROUND CIRCUIT

1. Turn ignition switch "OFF".
2. Disconnect 4WD control unit harness connector.
3. Check continuity between 4WD control unit harness connector M107 terminals 10 (B/R), 11 (B/R) and ground.

Continuity should exist.

Also check harness for short to ground and short to power.

OK or NG

OK >> GO TO 3.

NG >> Repair open circuit or short to ground or short to power in harness or connectors.

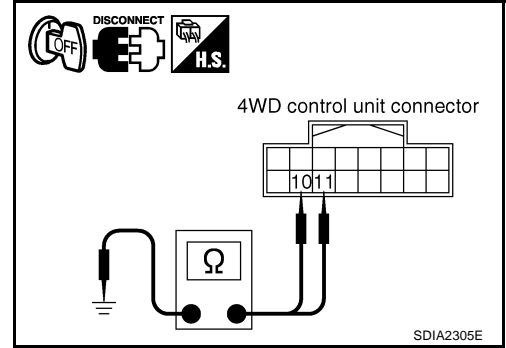

3. CHECK DTC

Start engine.

Does 4WD warning lamp turn OFF?

YES >> **INSPECTION END**

NO >> Perform the self-diagnosis, repair or replace damaged parts. Refer to [TF-32, "SELF-DIAG RESULT MODE"](#).

4WD Control Unit DIAGNOSTIC PROCEDURE

EDS001VN

- Check the following if "CONTROLLER FAILURE [C1201]" is displayed in self-diagnosis results of CONSULT-II.

1. PERFORM SELF-DIAGNOSIS

With CONSULT-II

1. Turn ignition switch "ON". (Do not start engine.)
2. Select "SELF-DIAG RESULTS" mode for "ALL MODE AWD/4WD" with CONSULT-II.
3. Touch "ERASE".
4. Turn ignition switch "OFF" and wait at least 10 seconds.
5. Perform the self-diagnosis again.

Is the "CONTROLLER FAILURE [C1201]" displayed?

YES >> Replace 4WD control unit. Refer to [TF-54, "4WD CONTROL UNIT"](#).

NO >> **INSPECTION END**

ABS System DIAGNOSTIC PROCEDURE

EDS001VO

- Check the following if "ABS SYSTEM [C1203]" is displayed in self-diagnosis results of CONSULT-II.

1. CHECK DTC WITH ABS ACTUATOR AND ELECTRIC UNIT (CONTROL UNIT) OR ESP/TCS/ABS/CONTROL UNIT

Perform self-diagnosis with ABS actuator and electric unit (control unit) (without ESP) or ESP/TCS/ABS control unit (with ESP). Refer to [BRC-28, "SELF-DIAGNOSIS"](#) (without ESP) or [BRC-81, "SELF-DIAGNOSIS"](#) (with ESP).

Is any malfunction detected by self-diagnosis?

YES >> Check the malfunctioning system.

NO >> GO TO 2.

TROUBLE DIAGNOSIS FOR SYSTEM

2. CHECK DTC AFTER DRIVING

1. Turn ignition switch "OFF".
2. Start engine and drive vehicle at 30 km/h (19 MPH) for at least 1 minute.
3. Make sure that ABS warning lamp turns OFF.
4. Perform erase self-diagnostic results. Refer to [TF-33, "How to Erase Self-diagnostic Results"](#).
5. Stop vehicle and turn ignition switch "OFF".
6. Turn ignition switch "ON".
7. Perform self-diagnosis.

Is the "ABS SYSTEM [C1203]" displayed?

- YES >> GO TO 3.
NO >> **INSPECTION END**

3. CHECK 4WD CONTROL UNIT

Check 4WD control unit input/output signal. Refer to [TF-30, "4WD Control Unit Input/Output Signal Reference Values"](#).

OK or NG

- OK >> GO TO 4.
NG >> Check 4WD control unit pin terminals for damage or loose connection with harness connector. If any items are damaged, repair or replace damaged parts.

4. CHECK DTC

Perform the self-diagnosis, after driving a vehicle for a while.

OK or NG

- OK >> **INSPECTION END**
NG >> Perform self-diagnosis with ABS actuator and electric unit (control unit) (without ESP) or ESP/TCS/ABS control unit (with ESP) again. Refer to [BRC-28, "SELF-DIAGNOSIS"](#) (without ESP) or [BRC-81, "SELF-DIAGNOSIS"](#) (with ESP).

4WD Solenoid

CONSULT-II REFERENCE VALUE IN DATA MONITOR MODE

EDS002VH

Data are reference value.

Monitor item [Unit]	Condition	Display value	
ETS SOLENOID [A]	Engine speed: At idle	2WD mode	Approx. 0.000A
		AUTO mode	
		LOCK mode	
	Engine speed: 3,000 rpm or more constant	2WD mode	Approx. 0.000A
		AUTO mode	Approx. 0.000 - 1.500A*
		LOCK mode	Approx. 2.800A

*: The values are changed by throttle opening and engine speed.

DIAGNOSTIC PROCEDURE

- Check the following if "4WD SOLENOID [C1204]" is detected in self-diagnosis results of CONSULT-II.

TROUBLE DIAGNOSIS FOR SYSTEM

1. CHECK 4WD SOLENOID SIGNAL

With CONSULT-II

1. Start engine.
2. Select "DATA MONITOR" mode for "ALL MODE AWD/4WD" with CONSULT-II.
3. Read out the value of "ETS SOLENOID".

Condition		Display value
Engine speed: At idle	2WD mode	Approx. 0.000A
	AUTO mode	
	LOCK mode	
Engine speed: 3,000 rpm or more constant	2WD mode	Approx. 0.000A
	AUTO mode	Approx. 0.000 - 1.500A*
	LOCK mode	Approx. 2.800A

*: The values are changed by throttle opening and engine speed.

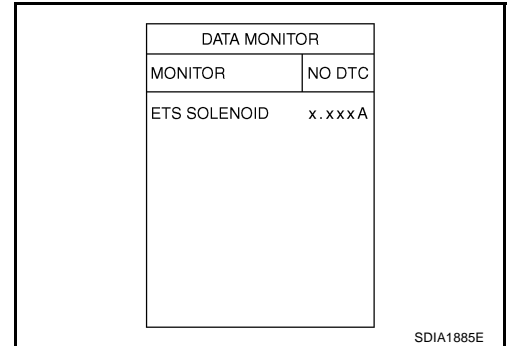

OK or NG

- OK >> GO TO 6.
 NG >> GO TO 2.

2. CHECK POWER SUPPLY

1. Turn ignition switch "OFF".
2. Disconnect 4WD control unit harness connector.
3. Turn ignition switch "ON". (Do not start engine.)
4. Check voltage between 4WD control unit harness connector terminal 9 and ground.

Connector	Terminal (wire color)	Voltage (Approx.)
M107	9 (P/L) - Ground	Battery voltage

OK or NG

- OK >> GO TO 3.
 NG >> Check the following. If any items are damaged, repair or replace damaged parts.
- 10A fuse (No. 37, located in the fuse and fusible link box)
 - Harness for short or open between battery and 4WD control unit harness connector terminal 9

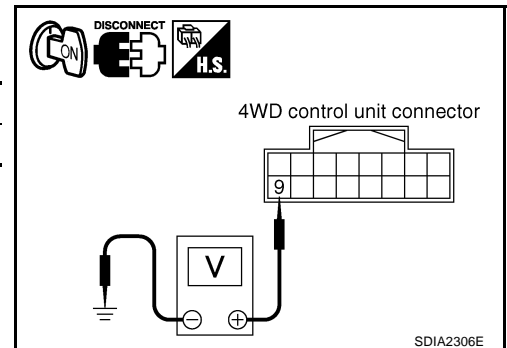

3. CHECK 4WD SOLENOID CIRCUIT

1. Turn ignition switch "OFF".
2. Disconnect 4WD control unit harness connector.
3. Check resistance between 4WD control unit harness connector terminals 1 and 2.

Connector	Terminal (wire color)	Resistance (Approx.)
M107	1 (OR) - 2 (L/W) (Ground)	2.45 Ω

OK or NG

- OK >> GO TO 6.
 NG >> GO TO 4.

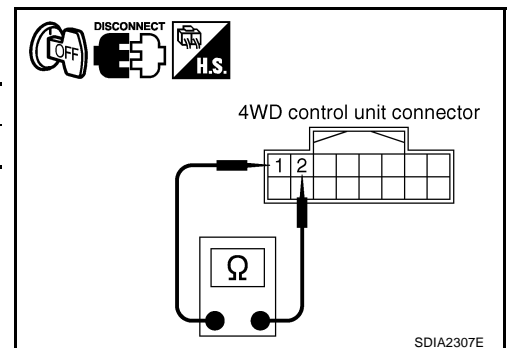

TROUBLE DIAGNOSIS FOR SYSTEM

4. CHECK 4WD SOLENOID

1. Turn ignition switch "OFF".
2. Disconnect 4WD solenoid harness connector.
3. Check resistance between 4WD solenoid harness connector B152 terminals 1 and 2.

1 - 2 : Approx. 2.45Ω

OK or NG

OK >> GO TO 5.

NG >> 4WD solenoid is malfunctioning. Replace electric controlled coupling. Refer to [RFD-22, "Disassembly and Assembly"](#).

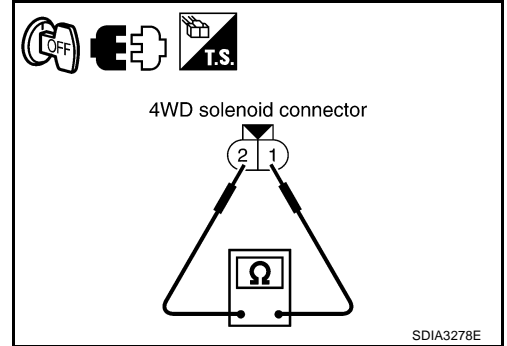

5. CHECK HARNESS BETWEEN 4WD CONTROL UNIT AND 4WD SOLENOID

1. Turn ignition switch "OFF".
2. Disconnect 4WD control unit harness connector and 4WD solenoid harness connector.
3. Check continuity between the following terminals.
 - 4WD control unit harness connector M107 terminal 1 (OR) and 4WD solenoid harness connector B152 terminal 2 (LG).
 - 4WD control unit harness connector M107 terminal 2 (L/W) and 4WD solenoid harness connector B152 terminal 1 (L/W).

1 (OR) - 2 (LG) : Continuity should exist.

2 (L/W) - 1 (L/W) : Continuity should exist.

Also check harness for short to ground and short to power.

OK or NG

OK >> GO TO 6.

NG >> Repair or replace damaged parts.

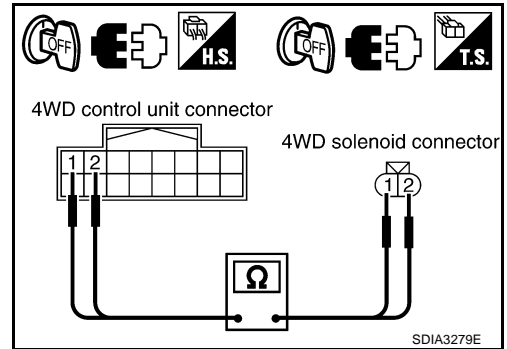

6. CHECK 4WD CONTROL UNIT

Check 4WD control unit input/output signal. Refer to [TF-30, "4WD Control Unit Input/Output Signal Reference Values"](#).

OK or NG

OK >> GO TO 7.

NG >> Check 4WD control unit pin terminals for damage or loose connection with harness connector. If any items are damaged, repair or replace damaged parts.

7. CHECK DTC

Perform the self-diagnosis, after driving a vehicle for a while.

OK or NG

OK >> **INSPECTION END**

NG >> Replace 4WD control unit.

COMPONENT INSPECTION

1. Turn ignition switch "OFF".
2. Disconnect 4WD solenoid harness connector.

TROUBLE DIAGNOSIS FOR SYSTEM

3. Check resistance between 4WD solenoid harness connector B152 terminals 1 and 2.

1 - 2 : Approx. 2.45Ω

4. If NG, replace the electric controlled coupling. Refer to [RFD-22, "Disassembly and Assembly"](#) .

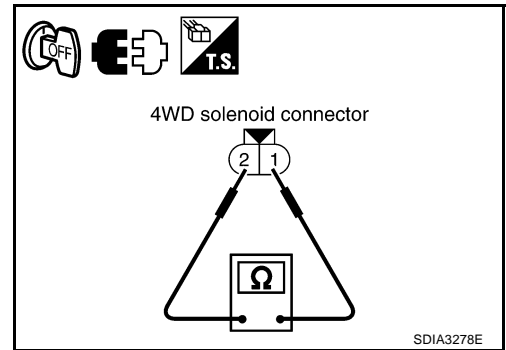

4WD Actuator Relay CONSULT-II REFERENCE VALUE IN DATA MONITOR MODE

EDS001V0

Data are reference value.

Monitor item	Condition	Display value
ETS ACTUATOR [ON/OFF]	Engine stopped (Ignition switch: ON)	OFF
	Engine running	ON

DIAGNOSTIC PROCEDURE

- Check the following if "4WD ACTUATOR RLY [C1205]" is displayed in self-diagnosis results of CONSULT-II.

1. CHECK 4WD SOLENOID SYSTEM

Perform self-diagnosis. Refer to [TF-32, "SELF-DIAG RESULT MODE"](#) .

Is the "4WD SOLENOID [C1204]" displayed?

- YES >> Perform trouble diagnosis for 4WD solenoid. Refer to [TF-37, "4WD Solenoid"](#) .
 NO >> GO TO 2.

2. CHECK 4WD ACTUATOR RELAY SIGNAL

With CONSULT-II

- Turn ignition switch "ON". (Do not start engine.)
- Select "DATA MONITOR" mode for "ALL MODE AWD/4WD" with CONSULT-II.
- Start engine and read out ON/OFF signaling action of "ETS ACTUATOR".

Monitor item	Condition	Display value
ETS ACTUATOR	Engine stopped (Ignition switch: ON)	OFF
	Engine running	ON

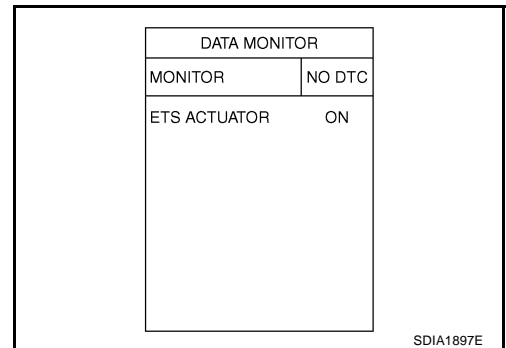

OK or NG

- OK >> GO TO 4.
 NG >> GO TO 3.

3. CHECK 4WD CONTROL UNIT

Check 4WD control unit input/output signal. Refer to [TF-30, "4WD Control Unit Input/Output Signal Reference Values"](#) .

OK or NG

- OK >> GO TO 4.
 NG >> Check 4WD control unit pin terminals for damage or loose connection with harness connector. If any items are damaged, repair or replace damaged parts.

TROUBLE DIAGNOSIS FOR SYSTEM

4. CHECK DTC

Perform the self-diagnosis, after driving a vehicle for a while.

OK or NG

- OK >> **INSPECTION END**
- NG >> Replace 4WD control unit.

A
B
C
TF
E
F
G
H
I
J
K
L
M

TROUBLE DIAGNOSIS FOR SYSTEM

EDS002VI

4WD Mode Switch

CONSULT-II REFERENCE VALUE IN DATA MONITOR MODE

Data are reference value.

Monitor item	Condition	Display value
4WD MODE SW [2WD/AUTO/LOCK]	4WD mode switch	2WD
		AUTO
		LOCK

DIAGNOSTIC PROCEDURE

- Check the following if "MODE SW [C1209]" is detected in self-diagnosis results of CONSULT-II.

1. CHECK 4WD MODE SWITCH SIGNAL

With CONSULT-II

- Turn ignition switch "ON". (Do not start engine.)
- Select "DATA MONITOR" mode for "ALL MODE AWD/4WD" with CONSULT-II.
- Read out monitor "4WD MODE SW" with operating 4WD mode switch.

Monitor item	Condition	Display value
4WD MODE SW	4WD mode switch	2WD
		AUTO
		LOCK

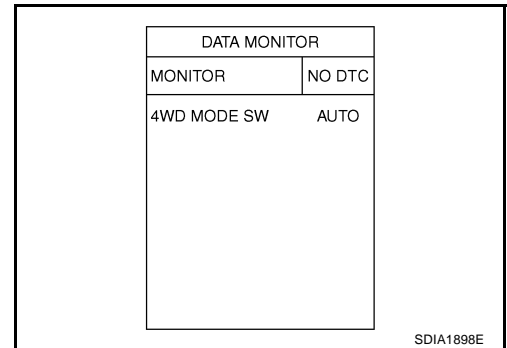

OK or NG

- OK >> GO TO 6.
 NG >> GO TO 2.

2. CHECK 4WD MODE SWITCH CIRCUIT

- Turn ignition switch "OFF".
- Disconnect 4WD control unit harness connector.
- Operate 4WD mode switch and check continuity between 4WD control unit harness connector terminals and ground.

Connector	Terminal (wire color)	Condition	Continuity
M107	5 (BR/W) - Ground	4WD mode switch: AUTO	Yes
		Except the above	No
	12 (BR) - Ground	4WD mode switch: 2WD	Yes
		Except the above	No
	14 (L) - Ground	4WD mode switch: LOCK	Yes
		Except the above	No

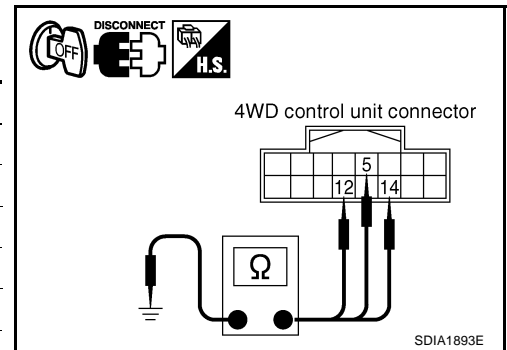

OK or NG

- OK >> GO TO 5.
 NG >> GO TO 3.

TROUBLE DIAGNOSIS FOR SYSTEM

3. CHECK 4WD MODE SWITCH

1. Turn ignition switch "OFF".
2. Disconnect 4WD mode switch harness connector.
3. Operate 4WD mode switch and check continuity between 4WD mode switch harness connector terminals.

Connector	Terminal	Condition	Continuity
M39	2 - 4	4WD mode switch: AUTO	Yes
		Except the above	No
	3 - 4	4WD mode switch: LOCK	Yes
		Except the above	No
	4 - 7	4WD mode switch: 2WD	Yes
		Except the above	No

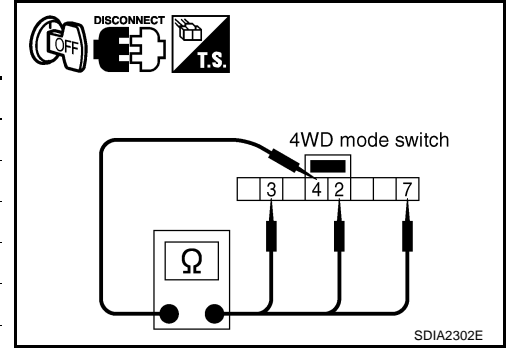

OK or NG

- OK >> GO TO 4.
- NG >> Replace 4WD mode switch.

4. CHECK HARNESS BETWEEN 4WD CONTROL UNIT AND 4WD MODE SWITCH

1. Turn ignition switch "OFF".
2. Disconnect 4WD control unit harness connector and 4WD mode switch harness connector.
3. Check continuity between the following terminals.
 - 4WD control unit harness connector M107 terminal 5 (BR/W) and 4WD mode switch harness connector M39 terminal 2 (BR/W).
 - 4WD control unit harness connector M107 terminal 12 (BR) and 4WD mode switch harness connector M39 terminal 7 (BR).
 - 4WD control unit harness connector M107 terminal 14 (L) and 4WD mode switch harness connector M39 terminal 3 (L).

- 5 (BR/W) - 2 (BR/W) : Continuity should exist.**
- 12 (BR) - 7 (BR) : Continuity should exist.**
- 14 (L) - 3 (L) : Continuity should exist.**

Also check harness for short to ground and short to power.

OK or NG

- OK >> GO TO 5.
- NG >> Repair or replace damaged parts.

5. CHECK 4WD CONTROL UNIT

Check 4WD control unit input/output signal. Refer to [TF-30, "4WD Control Unit Input/Output Signal Reference Values"](#).

OK or NG

- OK >> GO TO 6.
- NG >> Check 4WD control unit pin terminals for damage or loose connection with harness connector. If any items are damaged, repair or replace damaged parts.

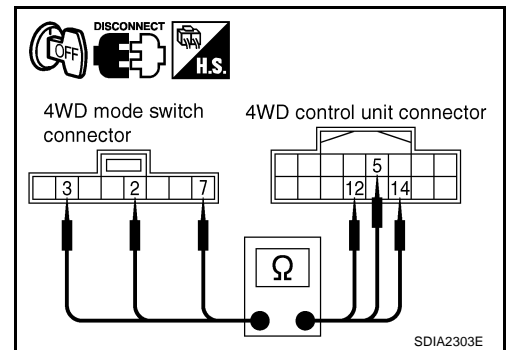

TROUBLE DIAGNOSIS FOR SYSTEM

6. CHECK 4WD INDICATOR LAMP AND LOCK INDICATOR LAMP

1. Turn ignition switch "OFF".
2. Check 4WD indicator lamp and LOCK indicator lamp "ON" for approx. 1 second when turned ignition switch "ON".

Do 4WD indicator lamp and LOCK indicator lamp "ON" for approx. 1 second?

YES >> **INSPECTION END**

NO >> Go to [TF-46, "4WD Indicator Lamp and LOCK Indicator Lamp Do Not Turn ON for Approx. 1 Second When The Ignition Switch Is Turned to ON"](#) .

COMPONENT INSPECTION

1. Turn ignition switch "OFF".
2. Disconnect 4WD mode switch harness connector.
3. Operate 4WD mode switch and check continuity between 4WD mode switch harness connector terminals.

Connector	Terminal	Condition	Continuity
M39	2 - 4	4WD mode switch: AUTO	Yes
		Except the above	No
	3 - 4	4WD mode switch: LOCK	Yes
		Except the above	No
	4 - 7	4WD mode switch: 2WD	Yes
		Except the above	No

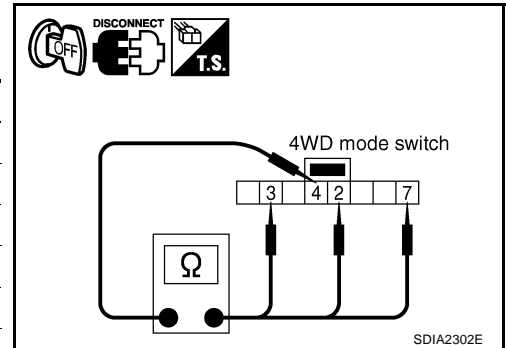

4. If NG, replace 4WD mode switch.

Engine Control Signal DIAGNOSTIC PROCEDURE

EDS002VJ

- Check the following if "ENGINE SIGNAL 1 [C1210]" is displayed in self-diagnosis results of CONSULT-II.

1. CHECK DTC WITH ECM

Perform self-diagnosis with ECM. Refer to [EC-53, "Emission-related Diagnostic Information"](#) (QR engine models with EURO-OBD), [EC-565, "Emission-related Diagnostic Information"](#) (QR engine models without EURO-OBD), [EC-996, "Emission-related Diagnostic Information"](#) (YD engine models with EURO-OBD), [EC-1372, "Diagnostic Trouble Code \(DTC\)"](#) (YD engine models without EURO-OBD).

Is any malfunction detected by self-diagnosis?

YES >> Check the malfunctioning system.

NO >> GO TO 2.

2. CHECK 4WD CONTROL UNIT

Check 4WD control unit input/output signal. Refer to [TF-30, "4WD Control Unit Input/Output Signal Reference Values"](#) .

OK or NG

OK >> GO TO 3.

NG >> Check 4WD control unit pin terminals for damage or loose connection with harness connector. If any item is damaged, repair or replace damaged parts.

3. CHECK DTC

Perform the self-diagnosis, after driving a vehicle for a while.

OK or NG

OK >> **INSPECTION END**

NG >> Perform self-diagnosis with ECM again. Refer to [EC-53, "Emission-related Diagnostic Information"](#) (QR engine models with EURO-OBD), [EC-565, "Emission-related Diagnostic Information"](#) (QR engine models without EURO-OBD), [EC-996, "Emission-related Diagnostic Information"](#) (YD engine models with EURO-OBD), [EC-1372, "Diagnostic Trouble Code \(DTC\)"](#) (YD engine models without EURO-OBD).

TROUBLE DIAGNOSIS FOR SYSTEM

engine models with EURO-OBD), [EC-1372, "Diagnostic Trouble Code \(DTC\)"](#) (YD engine models without EURO-OBD).

A

CAN Communication Line DIAGNOSTIC PROCEDURE

EDS002VK

- Check the following if "CAN COMM CIRCUIT [U1000]" is detected in self-diagnosis results of CONSULT-II.

B

1. CHECK CAN COMMUNICATION CIRCUIT

C

④ With CONSULT-II

1. Turn ignition switch "ON" and start engine.
2. Select "SELF-DIAG RESULTS" mode for "ALL MODE AWD/4WD" with in CONSULT-II.
3. Perform the self-diagnosis.

TF

Is "CAN COMM CIRCUIT [U1000]" displayed?

- YES >> Print out CONSULT-II screen and go to [TF-14, "CAN Communication Unit"](#) .
- NO >> **INSPECTION END**

E

SELF-DIAG RESULTS	
DTC RESULTS	TIME
CAN COMM CIRCUIT [U1000]	0
ERASE	PRINT

SDIA1850E

F

G

H

I

J

K

L

M

TROUBLE DIAGNOSIS FOR SYMPTOMS

PDF:00007

TROUBLE DIAGNOSIS FOR SYMPTOMS

4WD Indicator Lamp and LOCK Indicator Lamp Do Not Turn ON for Approx. 1 Second When The Ignition Switch Is Turned to ON DIAGNOSTIC PROCEDURE

EDS001VT

1. CHECK SYSTEM FOR CAN COMMUNICATION LINE

Perform self-diagnosis. Refer to [TF-32, "SELF-DIAG RESULT MODE"](#).

Is the "CAN COMM CIRCUIT [U1000]" displayed?

YES >> Perform trouble diagnosis for CAN communication line. Refer to [TF-14, "CAN Communication Unit"](#).

NO >> GO TO 2.

2. CHECK 4WD CONTROL UNIT POWER SUPPLY CIRCUIT

1. Turn ignition switch "OFF".
2. Disconnect 4WD control unit harness connector.
3. Turn ignition switch "ON". (Do not start engine.)
4. Check voltage between 4WD control unit harness connector terminals and ground.

Connector	Terminal (Wire color)	Voltage (Approx.)
M107	7 (GY) - Ground	Battery voltage
	9 (P/L) - Ground	

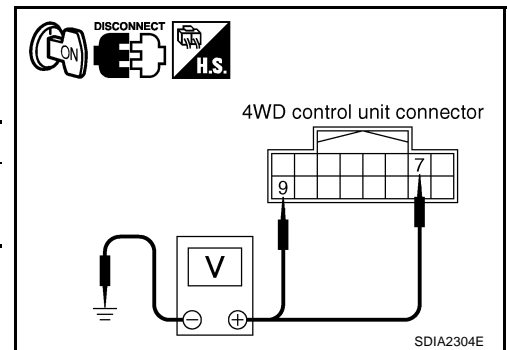

5. Turn ignition switch "OFF".
6. Check voltage between 4WD control unit harness connector terminals and ground.

Connector	Terminal (Wire color)	Voltage (Approx.)
M107	7 (GY) - Ground	0V
	9 (P/L) - Ground	Battery voltage

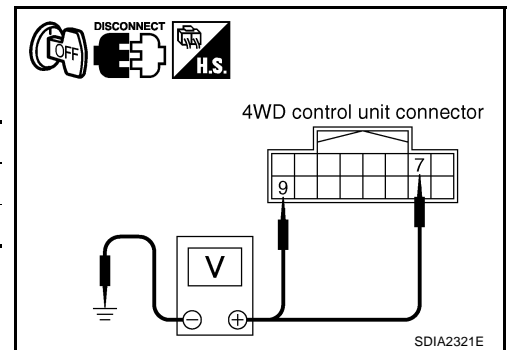

OK or NG

OK >> GO TO 3.

NG >> Check the following. If any items are damaged, repair or replace damaged parts.

- 10A fuse (No. 8 located in the fuse block (J/B) or No. 37, located in the fuse and fusible link box)
- Harness for short or open between battery and 4WD control unit harness connector terminal 9
- Harness for short or open between ignition switch and 4WD control unit harness connector terminal 7
- Ignition switch. Refer to [PG-2, "POWER SUPPLY ROUTING"](#).

TROUBLE DIAGNOSIS FOR SYMPTOMS

3. CHECK 4WD CONTROL UNIT GROUND CIRCUIT

1. Turn ignition switch "OFF".
2. Disconnect 4WD control unit harness connector.
3. Check continuity between 4WD control unit harness connector M107 terminals 10 (B/R), 11 (B/R) and ground.

Continuity should exist.

Also check harness for short to ground and short to power.

OK or NG

OK >> GO TO 4.

NG >> Repair open circuit or short to ground or short to power in harness or connectors.

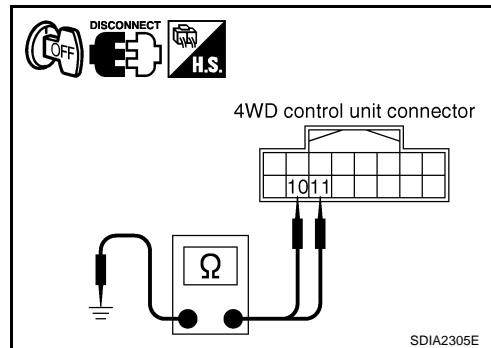

4. CHECK 4WD CONTROL UNIT

Check 4WD control unit input/output signal. Refer to [TF-30, "4WD Control Unit Input/Output Signal Reference Values"](#).

OK or NG

OK >> GO TO 5.

NG >> Check 4WD control unit pin terminals for damage or loose connection with harness connector. If any items are damaged, repair or replace damaged parts.

5. SYMPTOM CHECK

Check again.

OK or NG

OK >> **INSPECTION END**

NG >> Replace unified meter control unit assembly. Refer to [DI-34, "Disassembly and Assembly for Combination Meter"](#).

4WD Warning Lamp Does Not Turn ON When The Ignition Switch Is Turned to ON

EDS001VU

DIAGNOSTIC PROCEDURE

1. CHECK SYSTEM FOR CAN COMMUNICATION LINE

Perform self-diagnosis. Refer to [TF-32, "SELF-DIAG RESULT MODE"](#).

Is the "CAN COMM CIRCUIT [U1000]" displayed?

YES >> Perform trouble diagnosis for CAN communication line. Refer to [TF-14, "CAN Communication Unit"](#).

NO >> GO TO 2.

2. CHECK 4WD CONTROL UNIT

Check 4WD control unit input/output signal. Refer to [TF-30, "4WD Control Unit Input/Output Signal Reference Values"](#).

OK or NG

OK >> GO TO 3.

NG >> Check 4WD control unit pin terminals for damage or loose connection with harness connector. If any items are damaged, repair or replace damaged parts.

TROUBLE DIAGNOSIS FOR SYMPTOMS

3. SYMPTOM CHECK

Check again.

OK or NG

OK >> **INSPECTION END**

NG >> Replace unified meter control unit assembly. Refer to [DI-34, "Disassembly and Assembly for Combination Meter"](#) .

4WD Warning Lamp Does Not Turn OFF Several Seconds after Engine Started

EDS001VV

DIAGNOSTIC PROCEDURE

1. CHECK SELF-DIAGNOSTIC RESULTS

Perform self-diagnosis. Refer to [TF-32, "SELF-DIAG RESULT MODE"](#) .

Is any malfunction detected by self-diagnosis?

YES >> Check the malfunctioning system.

NO >> GO TO 2.

2. CHECK 4WD CONTROL UNIT POWER SUPPLY CIRCUIT

1. Turn ignition switch "OFF".
2. Disconnect 4WD control unit harness connector.
3. Turn ignition switch "ON". (Do not start engine.)
4. Check voltage between 4WD control unit harness connector terminals and ground.

Connector	Terminal (Wire color)	Voltage (Approx.)
M107	7 (GY) - Ground	Battery voltage
	9 (P/L) - Ground	

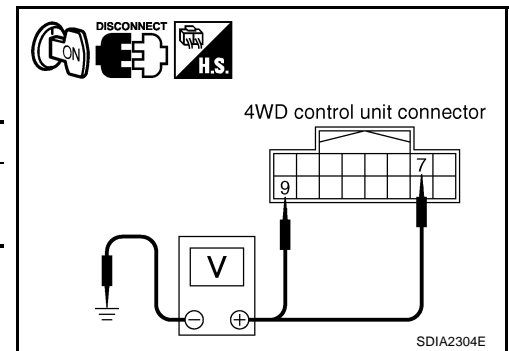

5. Turn ignition switch "OFF".
6. Check voltage between 4WD control unit harness connector terminals and ground.

Connector	Terminal (Wire color)	Voltage (Approx.)
M107	7 (GY) - Ground	0V
	9 (P/L) - Ground	Battery voltage

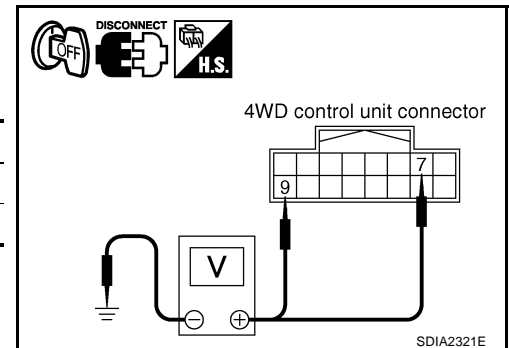

OK or NG

OK >> GO TO 3.

NG >> Check the following. If any items are damaged, repair or replace damaged parts.

- 10A fuse (No. 8 located in the fuse block (J/B) or No. 37, located in the fuse and fusible link box)
- Harness for short or open between battery and 4WD control unit harness connector terminal 9
- Harness for short or open between ignition switch and 4WD control unit harness connector terminal 7
- Ignition switch. Refer to [PG-2, "POWER SUPPLY ROUTING"](#) .

TROUBLE DIAGNOSIS FOR SYMPTOMS

3. CHECK 4WD CONTROL UNIT GROUND CIRCUIT

1. Turn ignition switch "OFF".
2. Disconnect 4WD control unit harness connector.
3. Check continuity between 4WD control unit harness connector M107 terminals 10 (B/R), 11 (B/R) and ground.

Continuity should exist.

Also check harness for short to ground and short to power.

OK or NG

- OK >> GO TO 4.
NG >> Repair open circuit or short to ground or short to power in harness or connectors.

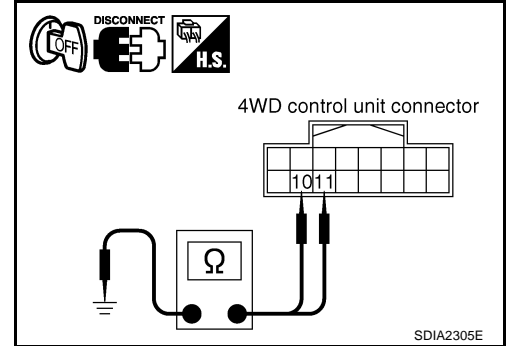

4. CHECK 4WD CONTROL UNIT

Check 4WD control unit input/output signal. Refer to [TF-30, "4WD Control Unit Input/Output Signal Reference Values"](#).

OK or NG

- OK >> GO TO 5.
NG >> Check 4WD control unit pin terminals for damage or loose connection with harness connector. If any items are damaged, repair or replace damaged parts.

5. SYMPTOM CHECK

Check again.

OK or NG

- OK >> **INSPECTION END**
NG >> Replace unified meter control unit assembly. Refer to [DI-34, "Disassembly and Assembly for Combination Meter"](#).

4WD Mode Cannot Be Switched after Engine Is Started

EDS001VW

1. CHECK 4WD WARNING LAMP

Confirm 4WD warning lamp.

Does 4WD warning lamp turn on?

- YES >> Go to [TF-48, "4WD Warning Lamp Does Not Turn OFF Several Seconds after Engine Started"](#).
NO >> GO TO 2.

2. CHECK SYSTEM FOR 4WD MODE SWITCH

Perform trouble diagnosis for 4WD mode switch system. Refer to [TF-42, "4WD Mode Switch"](#).

OK or NG

- OK >> GO TO 3.
NG >> Repair or replace damaged parts.

3. CHECK SYSTEM FOR CAN COMMUNICATION LINE

Perform self-diagnosis. Refer to [TF-32, "SELF-DIAG RESULT MODE"](#).

Is the "CAN COMM CIRCUIT [U1000]" displayed?

- YES >> Perform trouble diagnosis for CAN communication line. Refer to [TF-14, "CAN Communication Unit"](#).
NO >> GO TO 4.

TROUBLE DIAGNOSIS FOR SYMPTOMS

4. CHECK 4WD CONTROL UNIT

Check 4WD control unit input/output signal. Refer to [TF-30, "4WD Control Unit Input/Output Signal Reference Values"](#) .

OK or NG

OK >> GO TO 5.

NG >> Check 4WD control unit pin terminals for damage or loose connection with harness connector. If any items are damaged, repair or replace damaged parts.

5. SYMPTOM CHECK

Check again.

OK or NG

OK >> **INSPECTION END**

NG >> Replace unified meter control unit assembly. Refer to [DI-34, "Disassembly and Assembly for Combination Meter"](#) .

Heavy Tight-Corner Braking Symptom Occurs When the Vehicle Is Driven in AUTO Mode and the Steering Wheel Is Turned Fully to Either Side after the Engine Is Started

EDS001VX

NOTE:

- Light tight-corner braking symptom may occur depending on driving conditions in AUTO mode. This is not malfunction.
- Heavy tight-corner braking symptom occurs when vehicle is driven in the following conditions: LOCK mode, steering wheel is turned fully to either sides, and accelerator pedal was depressed.

DIAGNOSTIC PROCEDURE

1. CHECK SYSTEM FOR CAN COMMUNICATION LINE

Perform self-diagnosis. Refer to [TF-32, "SELF-DIAG RESULT MODE"](#) .

Is the "CAN COMM CIRCUIT [U1000]" displayed?

YES >> Perform trouble diagnosis for CAN communication line. Refer to [TF-14, "CAN Communication Unit"](#) .

NO >> GO TO 2.

2. CHECK SYSTEM FOR 4WD MODE SWITCH

Perform trouble diagnosis for 4WD mode switch system. Refer to [TF-42, "4WD Mode Switch"](#) .

OK or NG

OK >> GO TO 3.

NG >> Repair or replace damaged parts.

3. CHECK ACCELERATOR PEDAL POSITION SIGNAL CIRCUIT

Perform self-diagnosis for ECM. Refer to [EC-53, "Emission-related Diagnostic Information"](#) (QR engine models with EURO-OBD), [EC-565, "Emission-related Diagnostic Information"](#) (QR engine models without EURO-OBD), [EC-996, "Emission-related Diagnostic Information"](#) (YD engine models with EURO-OBD) or [EC-1372, "Diagnostic Trouble Code \(DTC\)"](#) (YD engine models without EURO-OBD).

Is any malfunction detected by self-diagnosis?

YES >> Check the malfunctioning system.

NO >> GO TO 4.

TROUBLE DIAGNOSIS FOR SYMPTOMS

4. CHECK SYSTEM FOR 4WD SOLENOID

Perform trouble diagnosis for 4WD solenoid system. Refer to [TF-37, "4WD Solenoid"](#) .

OK or NG

- OK >> GO TO 5.
- NG >> Repair or replace damaged parts.

5. CHECK ELECTRIC CONTROLLED COUPLING

1. Turn ignition switch "OFF".
2. Set the selector lever (shift lever) to "N" (neutral) position and disengage the parking brake.
3. Lift up the vehicle.
4. Rotate the propeller shaft by hand.
5. Hold rear wheel of right and left lightly.

Does rear wheel rotate?

- YES >> Replace electric controlled coupling for mechanical malfunction (clutch sticking etc.). Refer to [RFD-22, "Disassembly and Assembly"](#) .
- NO >> GO TO 6.

6. SYMPTOM CHECK

Check again.

OK or NG

- OK >> **INSPECTION END**
- NG >> GO TO 7.

7. CHECK 4WD CONTROL UNIT

Check 4WD control unit input/output signal. Refer to [TF-30, "4WD Control Unit Input/Output Signal Reference Values"](#) .

OK or NG

- OK >> **INSPECTION END**
- NG >> Check 4WD control unit pin terminals for damage or loose connection with harness connector. If any items are damaged, repair or replace damaged parts.

Vehicle Does Not Enter 4WD Mode Even Though 4WD Warning Lamp Turned to OFF

EDS001VY

CAUTION:

Make sure that parking brake is securely released if the symptom has occurred at vehicle speed of 10 km/h (6 MPH) or more.

TROUBLE DIAGNOSIS FOR SYMPTOMS

DIAGNOSTIC PROCEDURE

1. CHECK PARKING BRAKE SWITCH SIGNAL

Ⓟ With CONSULT-II

1. Turn ignition switch "ON".
2. Select "DATA MONITOR" mode for "ALL MODE AWD/4WD" with CONSULT-II.
3. Operate parking brake and read out monitor "P BRAKE SW".

Monitor item	Condition	Display value
P BRAKE SW	Parking brake operated	ON
	Parking brake not operated	OFF

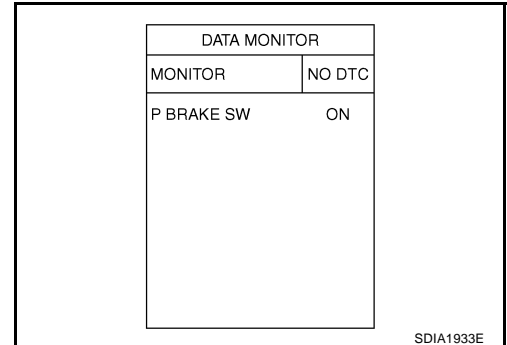

OK or NG

OK >> GO TO 2.

NG >> Check the following. If any items are damaged, repair or replace damaged parts.

- Parking brake switch
- Brake warning lamp circuit. Refer to [DI-36, "Wiring Diagram — WARN —/LHD Models"](#) or [DI-44, "Wiring Diagram — WARN —/RHD Models"](#).

2. CHECK 4WD SOLENOID

Check 4WD solenoid. Refer to [TF-39, "COMPONENT INSPECTION"](#).

OK or NG

OK >> GO TO 3.

NG >> Replace electric controlled coupling for malfunction of 4WD solenoid. Refer to [RFD-22, "Disassembly and Assembly"](#).

3. CHECK 4WD CONTROL UNIT

Check 4WD control unit input/output signal. Refer to [TF-30, "4WD Control Unit Input/Output Signal Reference Values"](#).

OK or NG

OK >> GO TO 4.

NG >> Check 4WD control unit pin terminals for damage or loose connection with harness connector. If any items are damaged, repair or replace damaged parts.

4. SYMPTOM CHECK

Check again.

OK or NG

OK >> **INSPECTION END**

NG >> Replace electric controlled coupling for mechanical malfunction (mechanical engagement of clutch is not possible.). Refer to [RFD-22, "Disassembly and Assembly"](#).

While Driving, 4WD Warning Lamp Flashes Rapidly (When Flashing in Approx. 1 Minute and Then Turning OFF)

EDS001VZ

NOTE:

Rapid flashing: 2 times/second

This symptom protects drivetrain parts when a heavy load is applied to the electric controlled coupling and multiple disc clutch temperature increases. It is not a malfunction.

When this symptom occurs, stop vehicle and allow it to idle for some times. Flashing will stop and system will be restored.

TROUBLE DIAGNOSIS FOR SYMPTOMS

While Driving, 4WD Warning Lamp Flashes Slowly (When Continuing to Flash until Turning Ignition Switch OFF)

EDS001W0

A
B
C

NOTE:

Slow flashing: 1 time/2 seconds

DIAGNOSTIC PROCEDURE

1. CHECK TIRE

Check the following.

- Tire pressure
- Wear condition
- Longitudinal tire size (There shall be no difference of tire size between front and rear tires.)

OK or NG

OK >> GO TO 2.

NG >> Drive at vehicle speed of 20 km/h (12 MPH) or more for 5 seconds or more after repairing or replacing damaged parts. (Initialize improper size tire information.)

TF

2. CHECK INPUT SIGNAL OF TIRE DIAMETER

With CONSULT-II

1. Start engine.
2. Drive at 20 km/h (12 MPH) or more for approx. 200 seconds.
3. Select "DATA MONITOR" mode for "ALL MODE AWD/4WD" with CONSULT-II.
4. Check monitor "DIS-TIRE MONI".

Display of "DIS-TIRE MONI"

"0-4mm">>**INSPECTION END**

Except for "0-4mm">>GO TO 3.

DATA MONITOR	
MONITOR	NO DTC
DIS-TIRE MONI	0-4mm

SDIA1900E

E
F
G
H
I
J
K
L
M

3. CHECK 4WD CONTROL UNIT

Check 4WD control unit input/output signal. Refer to [TF-30, "4WD Control Unit Input/Output Signal Reference Values"](#).

OK or NG

OK >> GO TO 4.

NG >> Check 4WD control unit pin terminals for damage or loose connection with harness connector. If any items are damaged, repair or replace damaged parts.

4. SYMPTOM CHECK

Check again.

OK or NG

OK >> **INSPECTION END**

NG >> Replace 4WD control unit.

4WD CONTROL UNIT

4WD CONTROL UNIT

PFP:41650

Removal and Installation

EDS001W4

REMOVAL

1. Remove cluster lid "A". Refer to [IP-11, "Removal and Installation"](#) .
2. Remove front speaker grille. Refer to [IP-11, "Removal and Installation"](#) .
3. Remove driver box. Refer to [IP-11, "Removal and Installation"](#) .
4. Disconnect 4WD control unit connector.
5. Remove 4WD control unit.

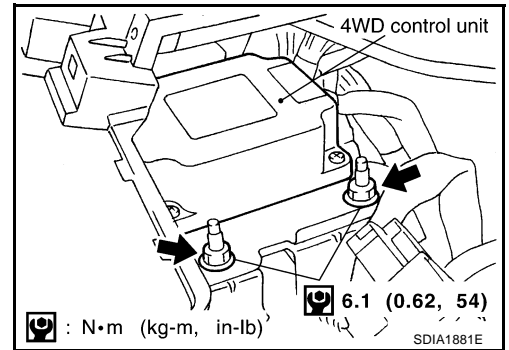

INSTALLATION

Install in the reverse order of removal.

SIDE OIL SEAL

SIDE OIL SEAL

PFP:33142

Removal and Installation

EDS0004S

NOTE:

Transaxle side oil seal is attached to transaxle assembly. Replace it when transfer assembly is removed from vehicle.

REMOVAL

1. Remove RH drive shaft. Refer to [FAX-11, "Removal and Installation"](#) .
2. Remove side shaft. Refer to [FAX-11, "Removal and Installation"](#) .

CAUTION:

Be careful not to damage gear ring oil seal inside of transfer.

3. Remove oil seal with a flat-bladed screwdriver.

CAUTION:

Be careful not to damage adapter case.

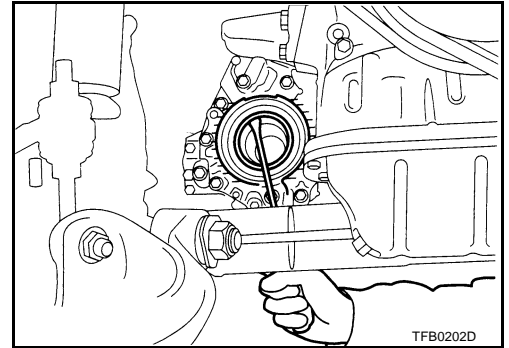

INSTALLATION

1. Apply multi-purpose grease to oil seal lips. As shown in the figure, install oil seal so that it becomes flush with the case end surface, using suitable drift.

CAUTION:

- Do not reuse oil seal.
- When installing, do not incline oil seal.

2. Install side shaft. Refer to [FAX-11, "Removal and Installation"](#) .

CAUTION:

Be careful not to damage gear ring oil seal inside of transfer.

3. Install RH drive shaft. Refer to [FAX-11, "Removal and Installation"](#) .
4. Check oil level. Refer to [TF-10, "Inspection"](#) .

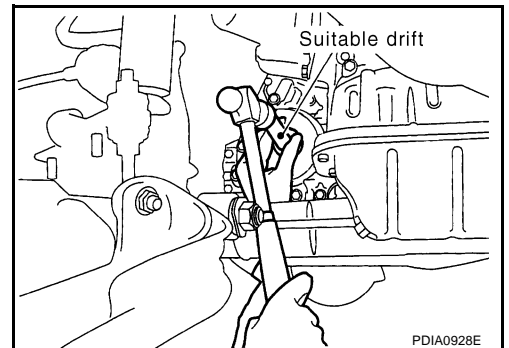

AIR BREATHER HOSE

AIR BREATHER HOSE

PFP:31098

Components

EDS001YM

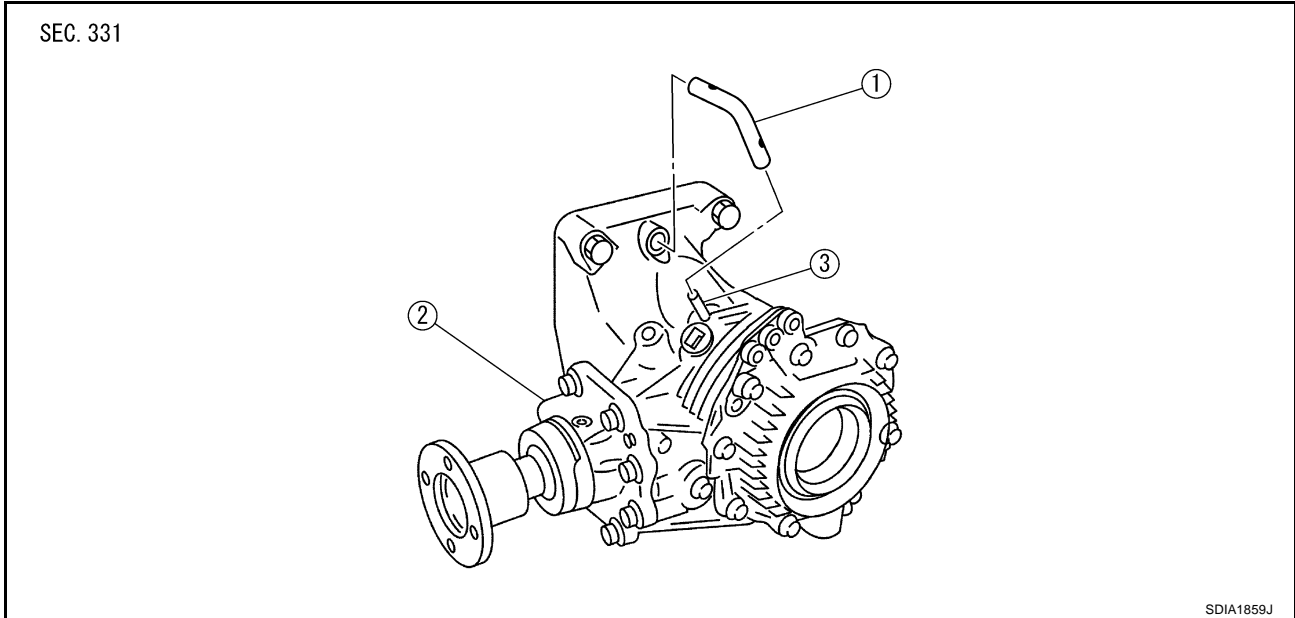

1. Air breather hose

2. Transfer assembly

3. Breather tube

Removal and Installation

EDS0004T

Note the following, when removal and installation.

CAUTION:

Make sure there are no pinched or restricted areas on the air breather hose caused by bending or winding when installing it.

- Be sure to insert air breather hose into breather tube (metal connector) until hose end reaches the tube's base.

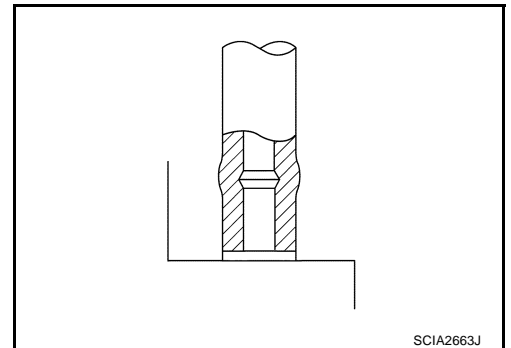

- Be sure to insert the hose till the paint mark.

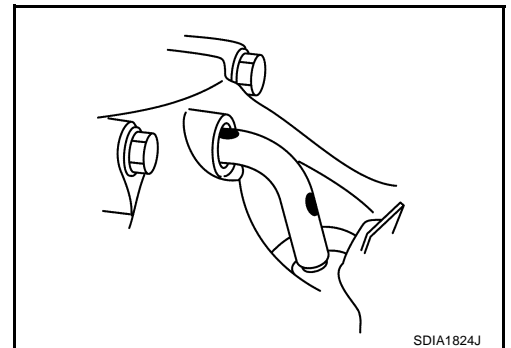

TRANSFER ASSEMBLY

PFP:33100

TRANSFER ASSEMBLY

Removal and Installation COMPONENTS

EDS0004U

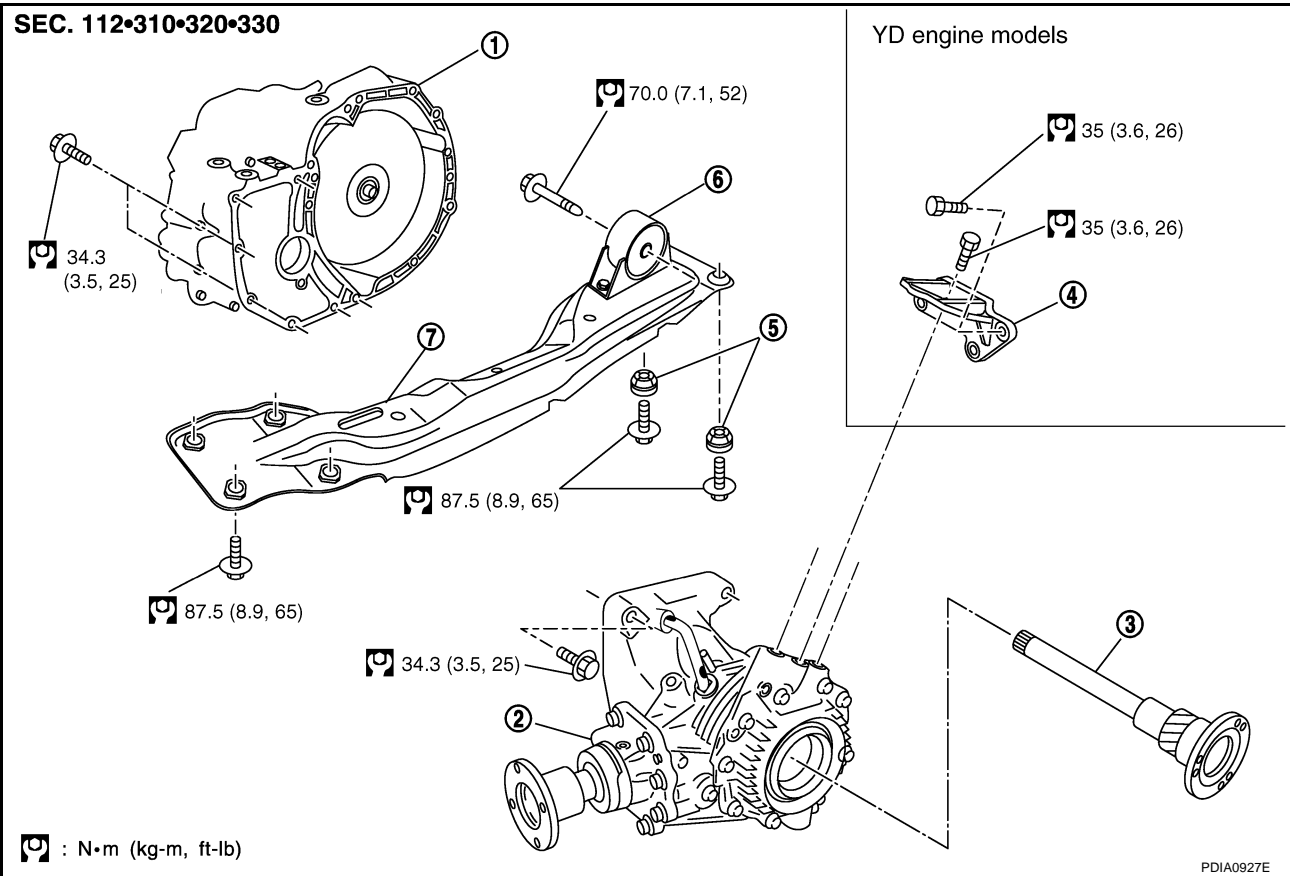

- | | | |
|---|----------------------|---------------|
| 1. Transaxle assembly | 2. Transfer assembly | 3. Side shaft |
| 4. Transfer gusset
(YD engine models only) | 5. Grommet | 6. Insulator |
| 7. Center member | | |

REMOVAL

1. Remove exhaust front tube. Refer to [EX-2, "Removal and Installation"](#).
2. Remove propeller shaft. Refer to [PR-4, "Removal and Installation"](#).
3. Remove RH drive shaft. Refer to [FAX-11, "Removal and Installation"](#).
4. Remove side shaft. Refer to [FAX-11, "Removal and Installation"](#).

CAUTION:

Be careful not to damage oil seal.

5. Remove air breather hose. Refer to [TF-56, "AIR BREATHER HOSE"](#).
6. Remove transfer gusset (YD engine models only).
7. Support transaxle assembly with a jack.
8. Remove center member. Refer to [EM-81, "ENGINE ASSEMBLY"](#) (QR engine models), [EM-222, "ENGINE ASSEMBLY"](#) (YD engine models).
9. Remove suspension member. Refer to [FSU-12, "FRONT SUSPENSION MEMBER"](#).
10. Remove rear engine mounting bracket. Refer to [EM-81, "ENGINE ASSEMBLY"](#) (QR engine models), [EM-222, "ENGINE ASSEMBLY"](#) (YD engine models).
11. Support transfer assembly with a jack.
12. Remove bolts fixing transaxle assembly and transfer assembly.
13. Remove the transfer assembly from vehicle.

CAUTION:

Be careful not to damage oil seal of transaxle.

TRANSFER ASSEMBLY

INSTALLATION

Note the following, and install in the reverse order of removal.

- When installing the transfer to the transaxle, install the mounting bolts following the standard below.

Bolt No.	1	2
Quantity	4	2
Bolt length "ℓ" mm (in)	65 (2.56)	40 (1.57)
Tightening torque N·m (kg-m, ft-lb)	34.3 (3.5, 25)	

CAUTION:

When installing transfer to transaxle, be careful not to damage oil seal of transaxle.

- When installing transfer gusset, tighten mounting bolts with the specified torque. Refer to [TF-57, "COMPONENTS"](#) . (YD engine models only)
- After the installation, check the oil level and oil leakage. Refer to [TF-10, "Inspection"](#) .

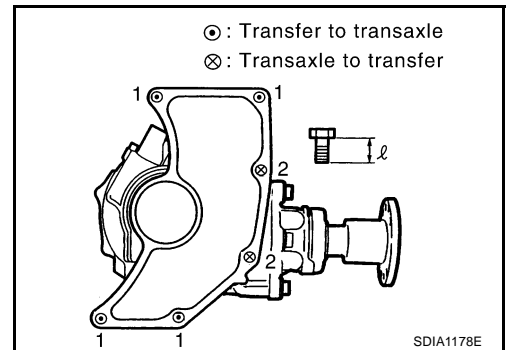

TRANSFER ASSEMBLY

EDS001YQ

Disassembly and Assembly COMPONENTS

A
B
C
TF
E
F
G
H
I
J
K
L
M

SEC.330•331•332

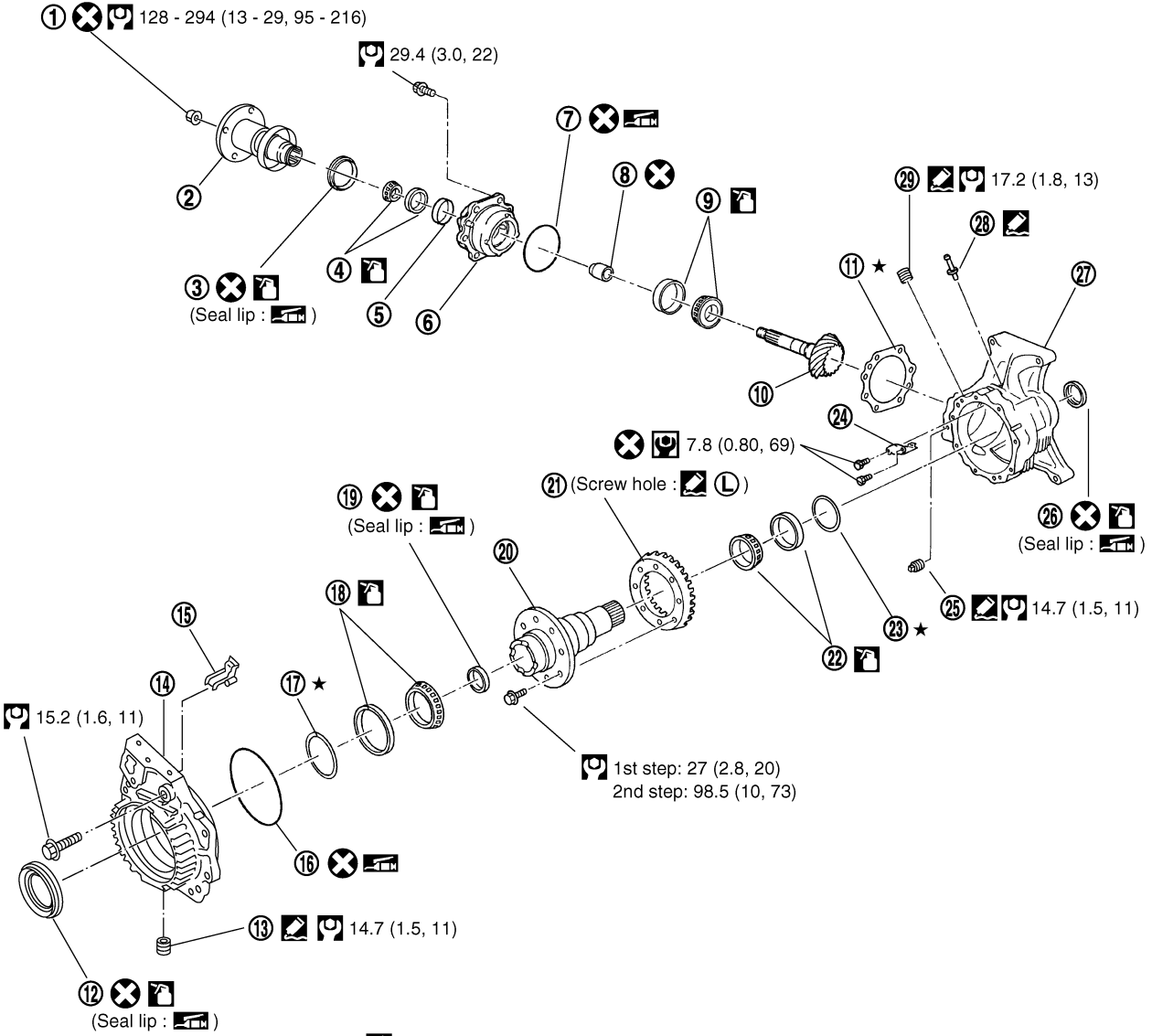

- : N•m (kg-m, in-lb)
- : N•m (kg-m, ft-lb)
- : Lubricate with new gear oil.
- : Select with proper thickness.
- : Apply Genuine Liquid Gasket, Three Bond TB1215 or equivalent.
- : Apply Genuine High Strength Thread Locking Sealant, Loctite 270 or equivalent.
- : Apply multi-purpose grease.
- : Always replace after every disassembly.

SDIA3122E

- | | | |
|--|---|---|
| 1. Pinion lock nut | 2. Companion flange | 3. Pinion sleeve oil seal |
| 4. Pinion rear bearing | 5. Dust cover | 6. Pinion sleeve |
| 7. O-ring | 8. Collapsible spacer | 9. Pinion front bearing |
| 10. Drive pinion | 11. Pinion sleeve shim | 12. Adapter case oil seal |
| 13. Drain plug | 14. Adapter case | 15. Oil gutter |
| 16. O-ring | 17. Gear ring bearing adjusting shim (Adapter case side) | 18. Gear ring bearing (Adapter case side) |
| 19. Gear ring oil seal | 20. Gear ring | 21. Drive gear |
| 22. Gear ring bearing (Transfer case side) | 23. Gear ring bearing adjusting shim (Transfer case side) | 24. Oil defense |
| 25. Filler plug | 26. Transfer case oil seal | 27. Transfer case |
| 28. Breather tube | | |
| | 29. Plug | |

TRANSFER ASSEMBLY

ASSEMBLY INSPECTION

Backlash

1. Install a bolt to the companion flange.
2. Fit a dial indicator onto the bolt.
3. Measure the circumference backlash of the companion flange, and make sure it satisfies the standard below.

Backlash : 0.13 - 0.19 mm (0.0051 - 0.0075 in)

- If measured value is out of the specification, disassemble it to check and adjust each part.

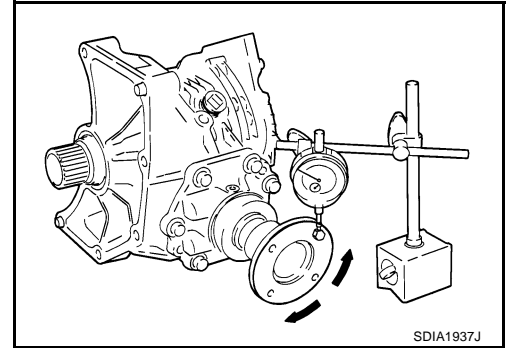

Tooth Contact

1. Remove the pinion sleeve assembly. Refer to [TF-64, "Pinion Sleeve Assembly"](#).
2. Apply red lead to the drive gear.





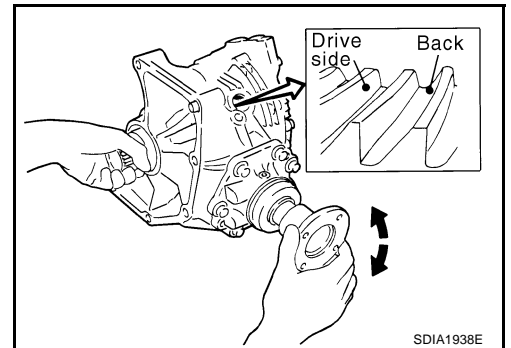
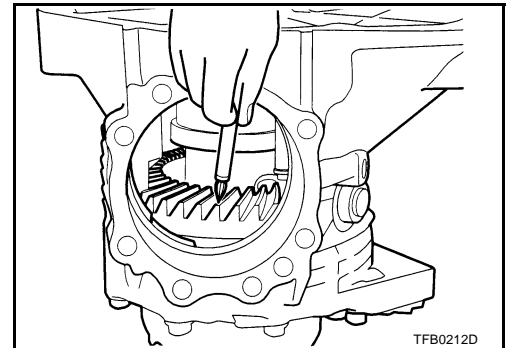

CAUTION:

Apply red lead to both the faces of 3 to 4 gears at 4 locations evenly spaced on the drive gear.

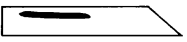
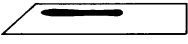
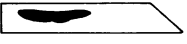
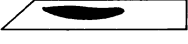
3. Install the pinion sleeve shims and pinion sleeve assembly. Refer to [TF-74, "Pinion Sleeve Assembly"](#).
4. Remove the plug on the upper side of the transfer case. When installing plug, apply recommended sealant on screw part, and tighten it at the specified torque. Refer to [TF-59, "COMPONENTS"](#).
5. Rotate the companion flange back and forth several times, and check the drive pinion gear to drive gear tooth contact by viewing from the plug hole.

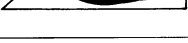
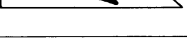
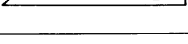
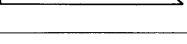
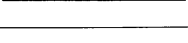
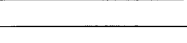
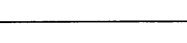
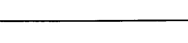

TRANSFER ASSEMBLY

Pinion sleeve shim selection value mm (in)		Tooth contact condition		Need for adjustment
		Drive side	Back	
↑ Thicker	+0.12 (+0.0047)	Heel side 	Toe side 	Yes
	+0.09 (+0.0035)			
	+0.06 (+0.0024)			
	+0.03 (+0.0012)			
↓ Thinner	0 (0.0)			No
	-0.03 (-0.0012)			
	-0.06 (-0.0024)			
	-0.09 (-0.0035)			
	-0.12 (-0.0047)			

SDIA0520E

6. If tooth contact is poorly adjusted, adjust pinion height (dimension X) in the following manner.

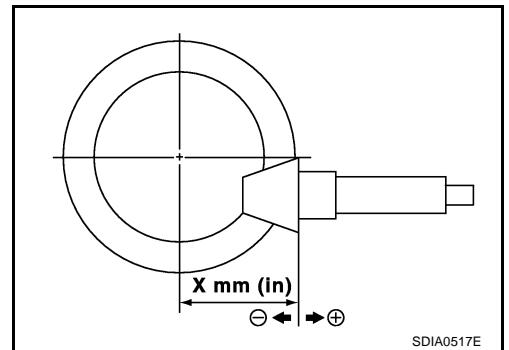

A
B
C
TF
E
F
G
H
I
J
K
L
M

TRANSFER ASSEMBLY

- If the tooth contact is near the face (face contact), or near the heel (heel contact), thin the pinion sleeve shims to move the drive pinion closer to the drive gear.
Refer to [TF-77, "Pinion Sleeve Shim"](#) .

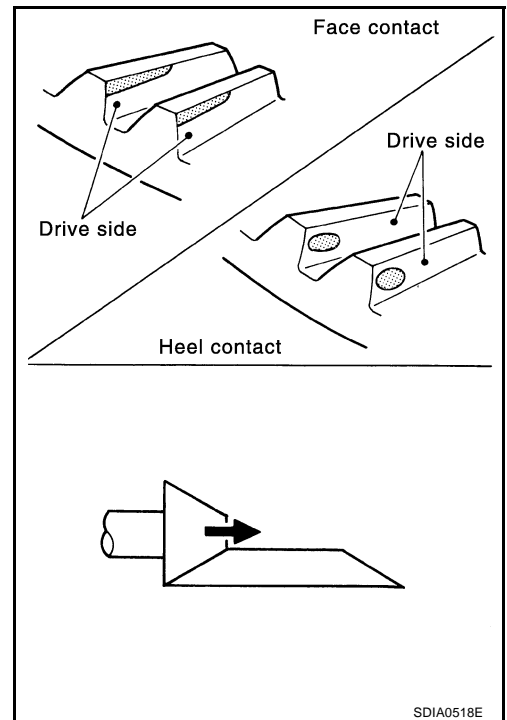

- If the tooth contact is near the flank (flank contact), or near the toe (toe contact), thicken the pinion sleeve shims to move the drive pinion farther from the drive gear.
Refer to [TF-77, "Pinion Sleeve Shim"](#) .

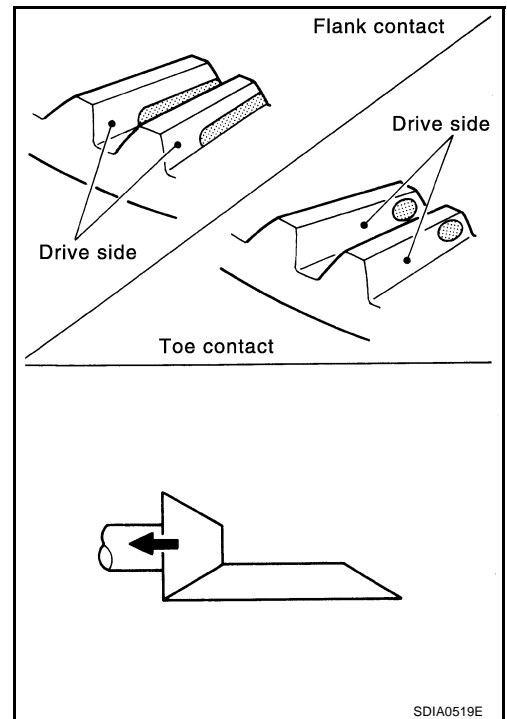

Pinion Bearing Preload Torque

1. Remove the pinion sleeve assembly. Refer to [TF-64, "Pinion Sleeve Assembly"](#) .
2. Rotate the companion flange back and forth 2 to 3 times. Check for unusual noise, rotation malfunction, and other malfunctions.
3. Rotate the companion flange at least 20 times to check for smooth operation of the bearing.

TRANSFER ASSEMBLY

- Using the preload gauge, measure the preload torque of the pinion bearing.

Tool number : ST3127S000

Preload torque

: 0.10 - 0.39 N·m (0.01 - 0.04 kg·m, 1 - 3 in·lb)

CAUTION:

Every rotational part shall rotate smoothly with the specified gear oil.

- If measured value is out of the specification, disassemble the pinion sleeve assembly to check and adjust each part.

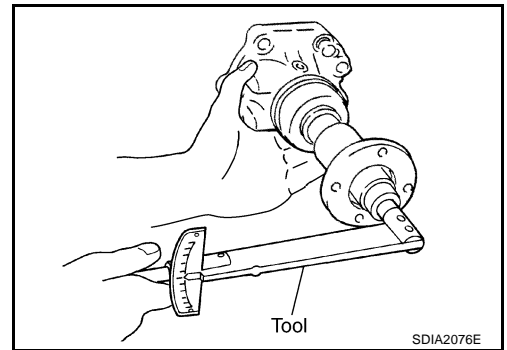

A
B
C

TF

Total Preload Torque

- Measure pinion bearing preload torque (P1). Refer to [TF-62, "Pinion Bearing Preload Torque"](#).

Pinion bearing preload torque (P1)

: 0.10 - 0.39 N·m (0.01 - 0.04 kg·m, 1 - 3 in·lb)

- Install the pinion sleeve shims and pinion sleeve assembly.
- Rotate the companion flange at least 20 times to check for smooth operation of the bearing.
- Using the preload gauge, measure the total preload torque.

Tool number : ST3127S000

Total preload torque

With all oil seals

: P1 + 0.16 - 0.22 N·m (0.016 - 0.023 kg·m, 1.4 - 1.9 in·lb)

Without transfer case oil seal and adapter case oil seal

: P1 + 0.06 - 0.12 N·m (0.006 - 0.013 kg·m, 0.6 - 1.1 in·lb)

- If measured value is out of the specification, disassemble it to check and adjust each part. If measuring the total preload torque after the disassembly, measure it with the transfer case oil seals and gear ring oil seals removed, then install the oil seals.

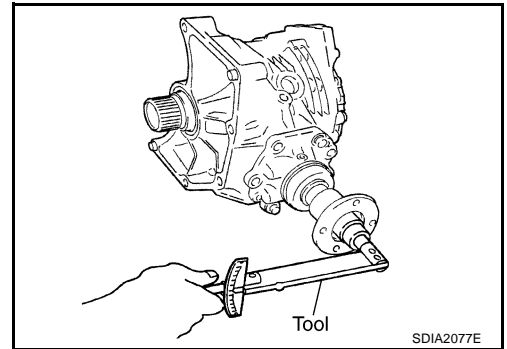

E

F

G

H

I

J

K

Companion Flange Runout

- Fit a dial indicator onto the companion flange face (inner side of the propeller shaft mounting bolt holes).
- Rotate the companion flange to check for runout.

Runout limit : 0.1 mm (0.004 in)

- Fit a test indicator to the inner side of the companion flange (socket diameter).
- Rotate the companion flange to check for runout.

Runout limit : 0.1 mm (0.004 in)

- If the runout value is outside the repair limit, follow the procedure below to adjust.
 - While changing the phase between companion flange and drive pinion gear by 90° at a time, check runout and determine which phase angle minimizes the runout.
 - If the runout value is still outside of the limit after the phase has been changed, replace the companion flange.
 - If the runout is out of the specification after replacement of companion flange, adjust the assembly status of the pinion bearings and drive pinion gear, or replace the pinion bearings.

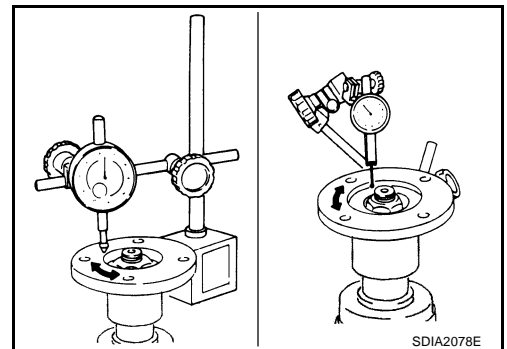

L

M

TRANSFER ASSEMBLY

DISASSEMBLY

Pinion Sleeve Assembly

1. Remove pinion sleeve mounting bolts.

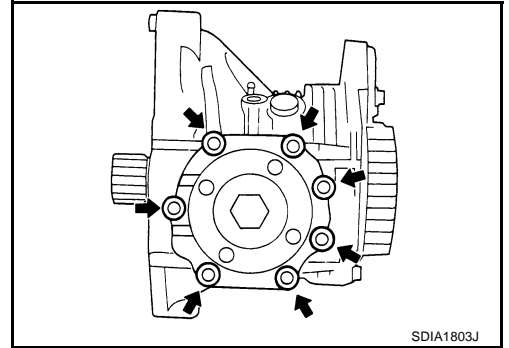

2. Using a plastic hammer, tap companion flange to remove pinion sleeve assembly.

3. Remove the pinion sleeve shim.

4. Remove the pinion lock nut.

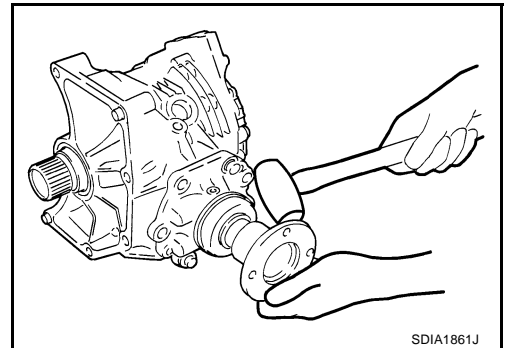

5. Using the drift, remove drive pinion assembly from pinion sleeve with a press.

Tool number : ST33220000

6. Remove companion flange.

7. Remove the O-ring from pinion sleeve.

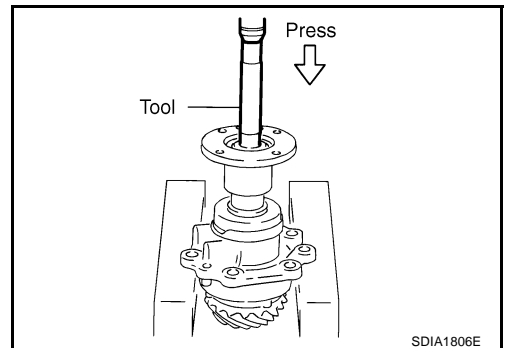

8. Using a flat-bladed screwdriver, remove the pinion sleeve oil seal.

CAUTION:

Be careful not to damage the pinion sleeve.

9. Remove the pinion rear bearing inner race.

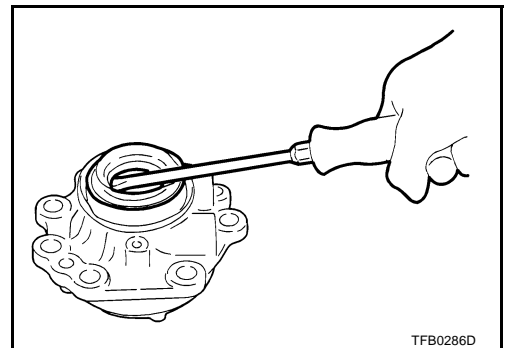

TRANSFER ASSEMBLY

10. Using the puller, remove the pinion rear bearing outer race.

Tool number : KV381054S0

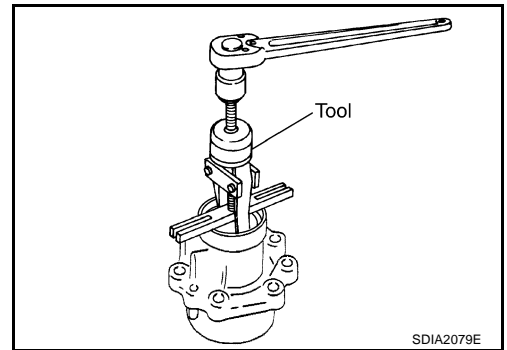

A
B
C

11. Using the puller, remove the pinion front bearing outer race.

Tool number : KV381054S0

12. Remove dust cover.

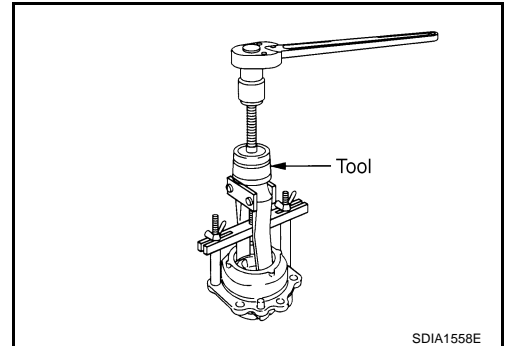

TF

E
F
G

13. Remove the collapsible spacer from the drive pinion.

14. Using the replacer, press the pinion front bearing inner race out of the drive pinion.

Tool number : ST30031000

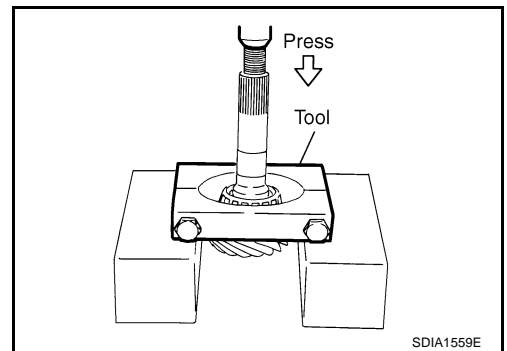

H
I
J
K

Adapter Case

1. Remove the adapter case mounting bolts.

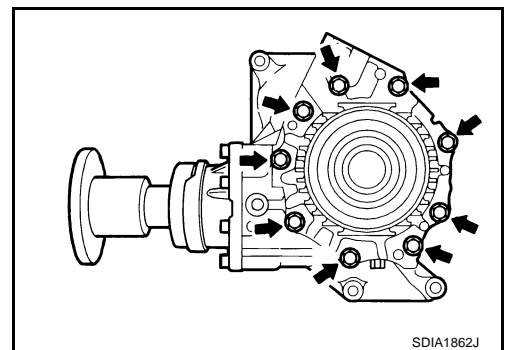

L
M

TRANSFER ASSEMBLY

- Using a plastic hammer, tap the adapter case to remove.
- Remove the O-ring.

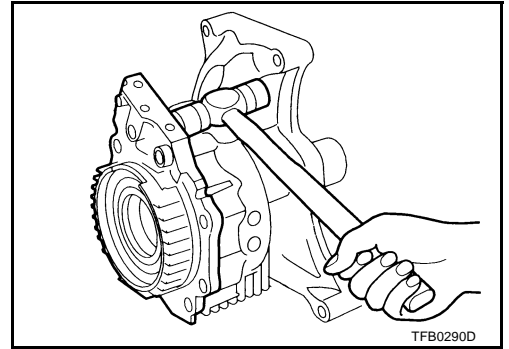

- Using a flat-bladed screwdriver, remove the adapter case oil seal.

CAUTION:

Be careful not to damage the adapter case.

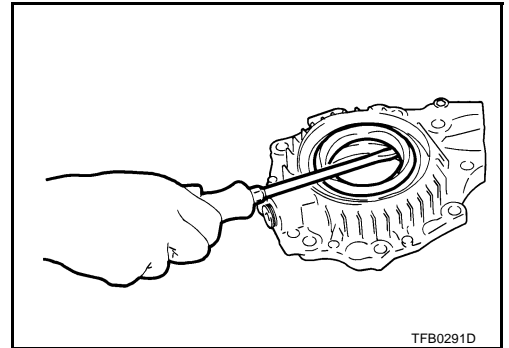

- Using a brass rod, tap the gear ring bearing adjusting shim from the cutout on the adapter case to remove the gear ring bearing adjusting shim and gear ring bearing outer race.

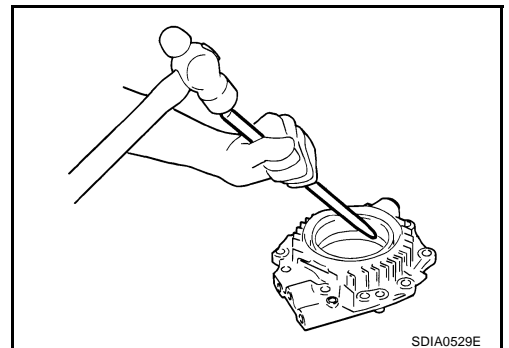

- Remove the oil gutter.
- Remove the drain plug.

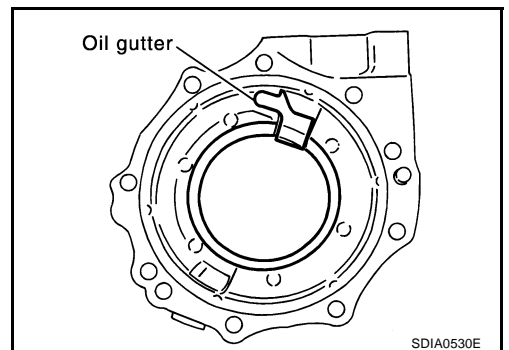

Drive Gear Assembly

- Remove the adapter case. Refer to [TF-65, "Adapter Case"](#).
- Remove the drive gear assembly from the transfer case.

TRANSFER ASSEMBLY

3. Using the drift and replacer, remove the gear ring bearing inner race (adapter case side) on the gear ring.

Tool number : ST33200000

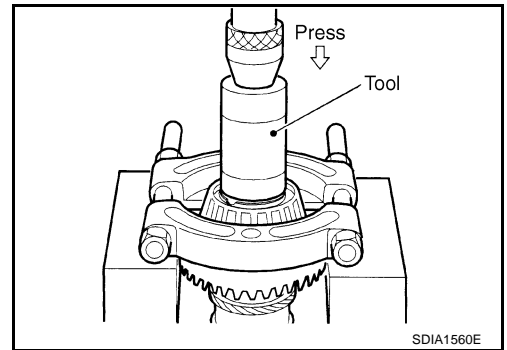

A
B
C

4. Using the drift and puller, remove the gear ring bearing inner race (transfer case side) on the gear ring.

Tool number : ST33061000

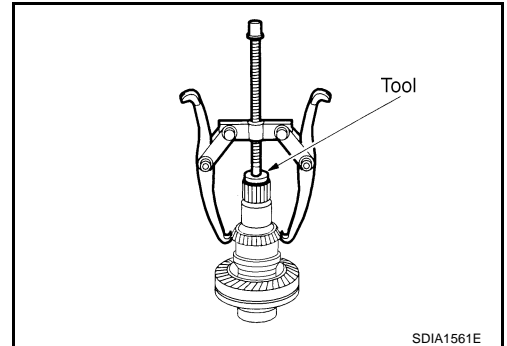

TF

E
F
G

5. Remove the drive gear mounting bolts.
6. Using a plastic hammer, tap the drive gear to remove the drive gear from the gear ring.

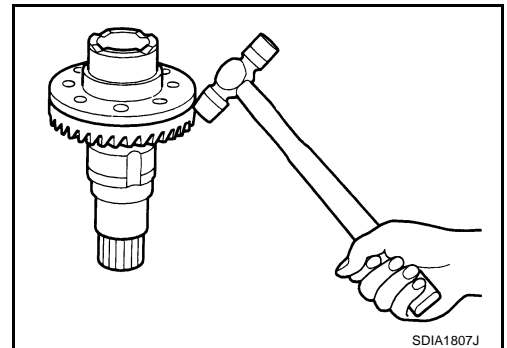

H
I
J
K

7. Using the puller, remove the gear ring oil seal from the gear ring.

Tool number : KV381054S0

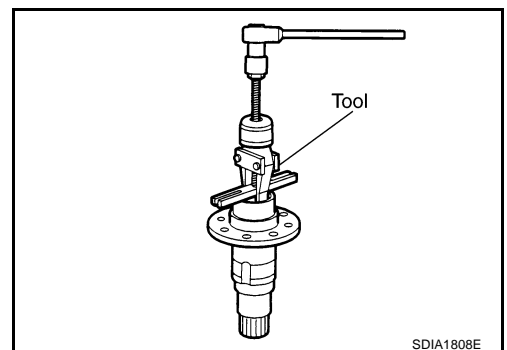

L
M

Transfer Case

1. Remove the pinion sleeve assembly. Refer to [TF-64, "Pinion Sleeve Assembly"](#) .
2. Remove the adapter case. Refer to [TF-65, "Adapter Case"](#) .
3. Remove the drive gear assembly from the transfer case. Refer to [TF-66, "Drive Gear Assembly"](#) .

TRANSFER ASSEMBLY

- Using a flat-bladed screwdriver, remove the transfer case oil seal.

CAUTION:

Be careful not to damage the transfer case.

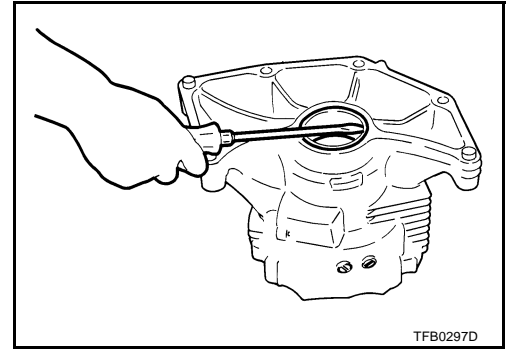

- Remove the oil defense.

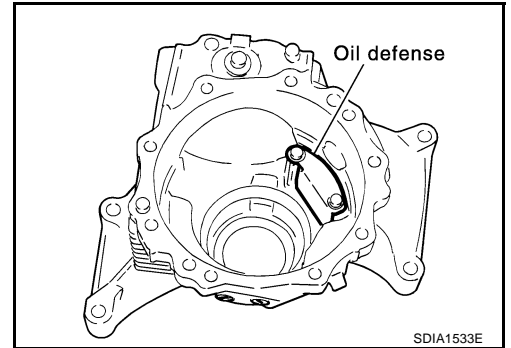

- Using a brass rod, tap the gear ring bearing adjusting shim evenly from the 2 cutouts on the transfer case to remove the gear ring bearing adjusting shim and gear ring bearing outer race.
- Remove the filler plug, plug and breather tube.

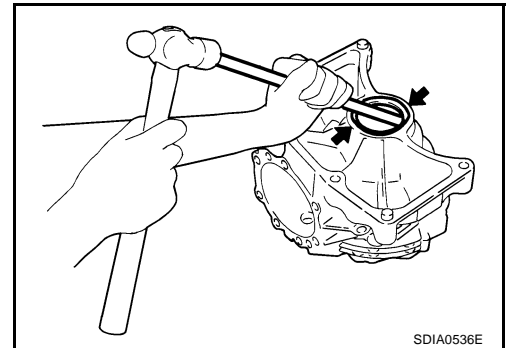

INSPECTION AFTER DISASSEMBLY

Gears

- Check the gear faces and shaft for wear, cracks, damage, and seizure.

CAUTION:

If a malfunction is detected on the drive gear or drive pinion, replace the drive gear and drive pinion as a set.

Bearings

- Check for seizure, peeling, wear, corrosion, sticking/abnormal noise/roughness in hand turning, and other damage.

CAUTION:

When replacing the bearing, always replace the inner race and outer race as a pair.

Washers and Shims

- Check for seizure, damage, and unusual wear.

Oil Seals

- Discard old oil seals, replace with new ones.
- If wear, deterioration of adherence (sealing force of lips), or damage is detected on the lips, replace them.

TRANSFER ASSEMBLY

SELECTING ADJUSTING SHIMS

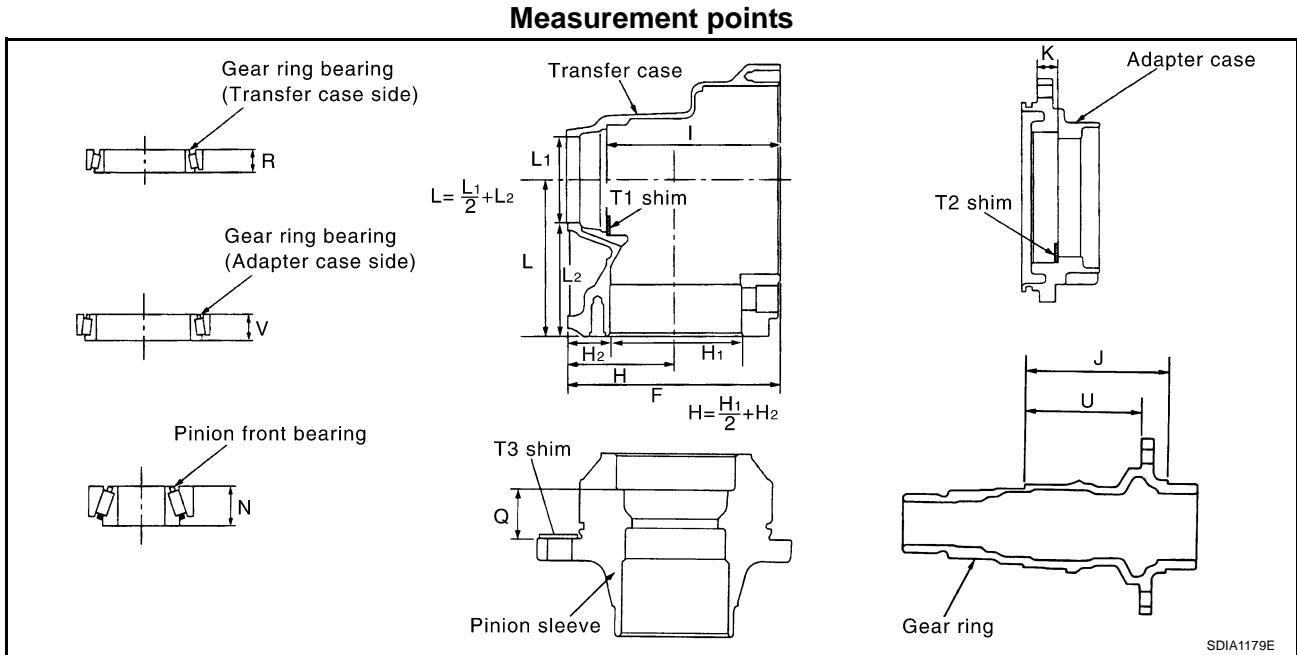

Gear Ring Bearing Adjusting Shim (Transfer Case Side)

1. Measure the points F, H, I, R and U shown in the measurement points.
2. Convert the values F, H, I, R and U according to the standards below.

F: Value obtained by subtracting 163.00 mm (6.42 in) from the reading [in increments of 0.01 mm (0.0004 in)].

H: Value obtained by subtracting 83.00 mm (3.27 in) from the reading [in increments of 0.01 mm (0.0004 in)].

I: Value obtained by subtracting 131.90 mm (5.19 in) from the reading [in increments of 0.01 mm (0.0004 in)].

R: Value obtained by subtracting 17.00 mm (0.67 in) from the reading [in increments of 0.01 mm (0.0004 in)].

U: Value obtained by subtracting 89.50 mm (3.524 in) from the reading [in increments of 0.01 mm (0.0004 in)].

3. Check dimension Z on the drive gear side face.

NOTE:

Dimension Z indicates the difference between the optimum engagement and the standard dimensions in increments of 0.01mm (0.0004 in) written on the drive gear side face.

4. Use the formula below to calculate gear ring bearing adjusting shim (transfer case side) thickness T1 .

$$T_1 = (I - F + H + Z - U - R) \times 0.01 \text{ mm (0.0004 in)} + 1.49 \text{ mm (0.0587 in)}$$

5. Select the gear ring bearing adjusting shim (transfer case side).

- For information on selecting an adjusting shim, refer to [TF-76, "Gear ring Bearing Adjusting Shim \(Transfer Case Side\)"](#) .

CAUTION:

- Only one adjusting shim can be selected.
- If no adjusting shim with the calculated value is available, select the thicker and closest one.

Gear Ring Bearing Adjusting Shim (Adapter Case Side)

1. Measure the points F, H, J, K, U and V shown in the measurement points.
2. Convert the values F, H, J, K, U and V according to the standards below.

TRANSFER ASSEMBLY

- F: Value obtained by subtracting 163.00 mm (6.42 in) from the reading [in increments of 0.01 mm (0.0004 in)].
- H: Value obtained by subtracting 83.00 mm (3.27 in) from the reading [in increments of 0.01 mm (0.0004 in)].
- J: Value obtained by subtracting 109.50 mm (4.31 in) from the reading [in increments of 0.01 mm (0.0004 in)].
- K: Value obtained by subtracting 14.40 mm (0.5669 in) from the reading [in increments of 0.01 mm (0.0004 in)].
- U: Value obtained by subtracting 89.50 mm (3.524 in) from the reading [in increments of 0.01 mm (0.0004 in)].
- V: Value obtained by subtracting 17.00 mm (0.67 in) from the reading [in increments of 0.01 mm (0.0004 in)].

3. Check dimension Z on the drive gear side face.

NOTE:

Dimension Z indicates the difference between the optimum engagement and the standard dimensions in increments of 0.01mm (0.0004 in) written on the drive gear side face.

4. Use the formula below to calculate gear ring bearing adjusting shim (adapter case side) thickness T₂ .

$$T_2 = (K + F - H - Z + U - J - V) \times 0.01 \text{ mm (0.0004 in)} + 1.49 \text{ mm (0.0587 in)}$$

5. Select the gear ring bearing adjusting shim (adapter case side).

- For information on selecting an adjusting shim, refer to [TF-77, "Gear ring Bearing Adjusting Shim \(Adapter Case Side\)"](#) .

CAUTION:

- Only one adjusting shim can be selected.
- If no adjusting shim with the calculated value is available, select the thicker and closest one.

Pinion Sleeve Shim

1. Measure the points L, N and Q shown in the measurement points.
2. Check the dimension S written on the gear end of the drive pinion.

NOTE:

The dimension S indicates the difference between the optimum engagement and the standard dimensions in increments of 0.01 mm (0.0004 in) written on the gear end of the drive pinion.

3. Use the formula below to calculate pinion sleeve shim thickness T₃ .

$$T_3 = [74.6 \text{ mm (2.937 in)} + S] + N + Q - L$$

4. Select the pinion sleeve shim.

- For information on selecting a pinion sleeve shim, refer to [TF-77, "Pinion Sleeve Shim"](#) .

CAUTION:

- Only one pinion sleeve shim can be selected.

ASSEMBLY

Transfer Case

1. Select the gear ring bearing adjusting shim (transfer case side). Refer to [TF-69, "SELECTING ADJUSTING SHIMS"](#) .

TRANSFER ASSEMBLY

- Using the drifts, install the selected gear ring bearing adjusting shim (transfer case side) and gear ring bearing outer race (transfer case side).

Tool number : ST30720000

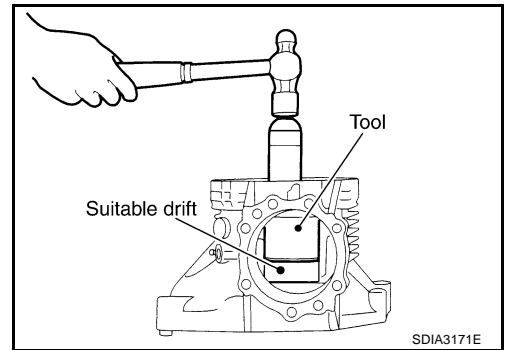

- Install the oil defense, and tighten the mounting bolts to the specified torque. Refer to [TF-59, "COMPONENTS"](#). The clearance between the oil defense and transfer case (dimension A) should be the following.

Clearance between oil defense and transfer case

Dimension A : 1.0 - 3.5 mm (0.04 - 0.138 in)

CAUTION:

Do not reuse the mounting bolts.

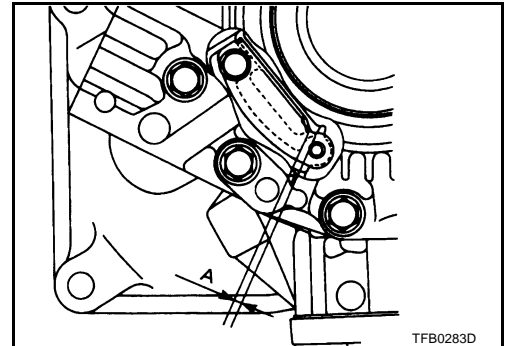

- Using the drift, drive the transfer case oil seal until it becomes flush with the case end.

Tool number : ST30720000

CAUTION:

- When checking the total preload torque, measure it without the oil seal, then install the oil seal.
- Do not reuse the oil seal.
- Apply multi-purpose grease onto oil seal lips, and gear oil onto the circumference of the oil seal.

- Apply recommended sealant to filler plug and plug before installing them to the transfer case. Refer to [TF-59, "COMPONENTS"](#).

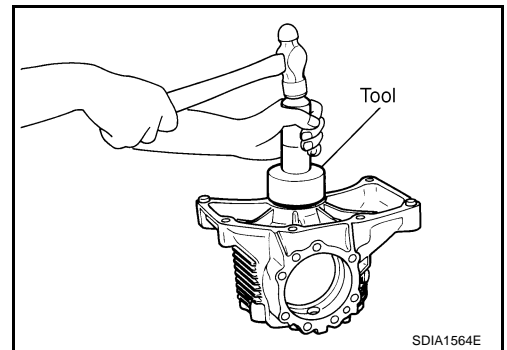

- Apply recommended sealant to breather tube and install it to the transfer case.
- Install the drive gear assembly. Refer to [TF-71, "Drive Gear Assembly"](#).
- Install the adapter case. Refer to [TF-72, "Adapter Case"](#).
- Install the pinion sleeve assembly. Refer to [TF-74, "Pinion Sleeve Assembly"](#).
- Check backlash, preload torque, tooth contact, and companion flange runout. Refer to [TF-60, "ASSEMBLY INSPECTION"](#).

CAUTION:

Measure the total preload torque without the oil seal.

Drive Gear Assembly

- Using the drift, drive the gear ring oil seal into the gear ring.

Tool number : ST33230000

CAUTION:

- Do not reuse the oil seal.
- Apply multi-purpose grease onto oil seal lips, and gear oil onto the circumference of the oil seal.
- The oil seal back position after the installation shall be 56.5 mm (2.22 in) from the gear ring end.

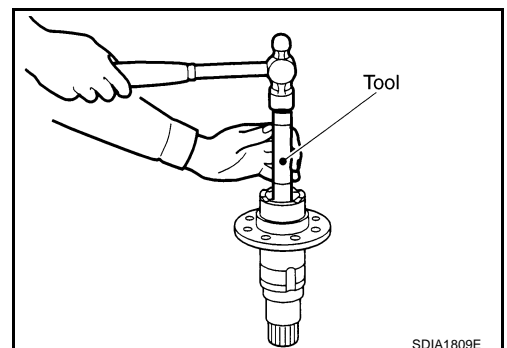

TRANSFER ASSEMBLY

2. Apply recommended thread locking sealant into the thread hole for the drive gear.
 - a. Completely clean and degrease the drive gear back face, thread holes, and drive gear mounting bolts.
 - b. Apply recommended thread locking sealant onto the first and second threads under the thread hole chamfering of the drive gear on 3 or more different points.
3. Install the drive gear to gear ring, and apply anti-corrosive oil onto threads and seats on the mounting bolts, and then tighten to the specified torque. Refer to [TF-59, "COMPONENTS"](#) .

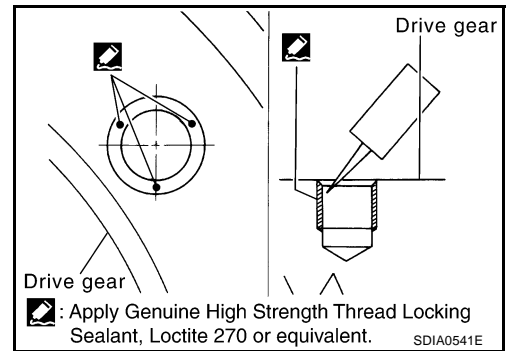

CAUTION:

- Temporary installation before tightening the bolts through to the completion of the tightening should be within 90 seconds.
- If the thread locking sealant is applied aside, quickly wipe it off.

4. Apply gear oil to gear ring bearing inner race (transfer case side). Using the drifts, install gear ring bearing inner race.

Tool number **A: ST30720000**
 B: ST27863000
 C: KV40101630

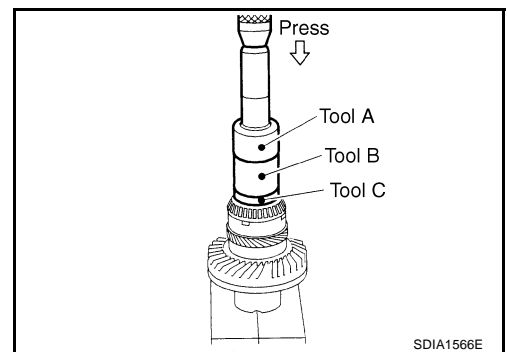

5. Apply gear oil to gear ring bearing inner race (adapter case side). Using the drifts, install gear ring bearing inner race.

Tool number **A: ST30720000**
 B: KV38102510

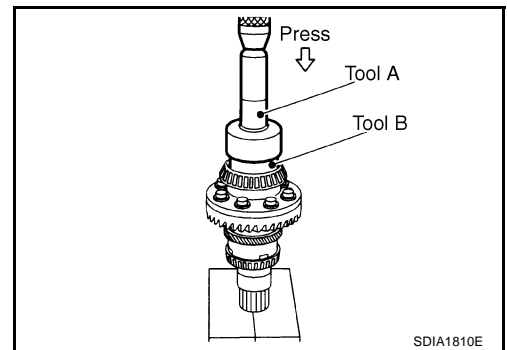

6. Install the drive gear assembly to the transfer case.
7. Install the adapter case.
8. Check backlash, preload torque, tooth contact, and companion flange runout. Refer to [TF-60, "ASSEMBLY INSPECTION"](#) .

CAUTION:

Measure the total preload torque without the oil seal.

Adapter Case

1. Select the gear ring bearing adjusting shim (adapter case side). Refer to [TF-69, "SELECTING ADJUSTING SHIMS"](#) .
2. Install the oil gutter.
3. Using the drifts, install the selected gear ring bearing adjusting shim (adapter case side) and gear ring bearing outer race (adapter case side).

Tool number **: ST30720000**

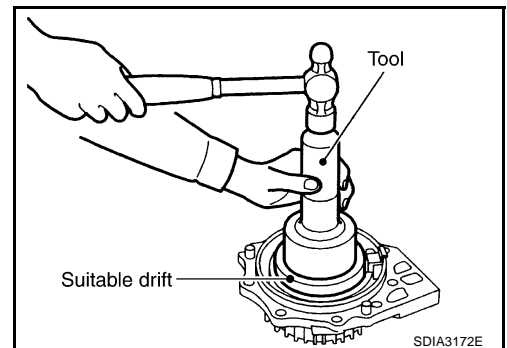

TRANSFER ASSEMBLY

4. Using the suitable drift, drive the adapter case oil seal until it becomes flush with the case end.

CAUTION:

- When checking the total preload torque, measure it without the oil seal, then install the oil seal.
- Do not reuse the oil seal.
- Apply multi-purpose grease onto oil seal lips, and gear oil onto the circumference of the oil seal.

5. Apply recommended sealant on drain plug and install it to the adapter case. Refer to [TF-59, "COMPONENTS"](#) .
6. Apply multi-purpose grease lightly and evenly onto an O-ring, and install it to the adapter case.

CAUTION:

Do not reuse the O-ring.

7. Install the adapter case to the transfer case, and apply anti-corrosive oil onto threads and seats on the mounting bolts. Tighten to the specified torque.

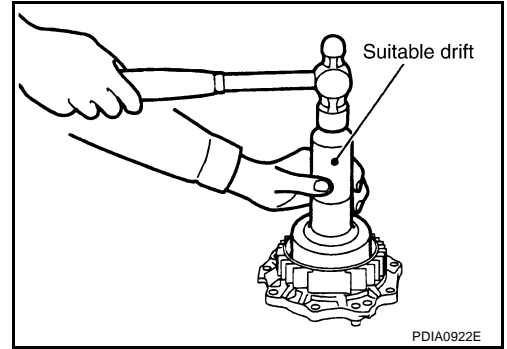

A
B
C

TF

Bolt symbol	Bolt length "ℓ" mm (in)	Tightening torque N·m (kg-m, ft-lb)
A	35 (1.38)	15.2 (1.6, 11)
B	30 (1.18)	

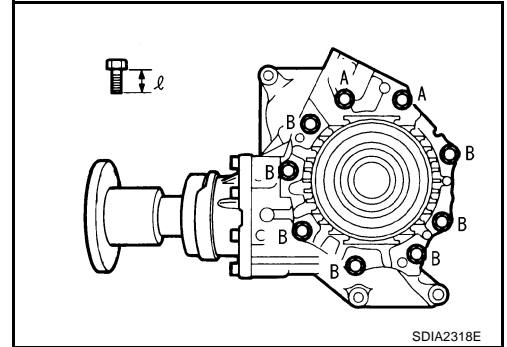

E
F
G
H
I
J
K
L
M

8. Check backlash, preload torque, tooth contact, and companion flange runout. Refer to [TF-60, "ASSEMBLY INSPECTION"](#) .

CAUTION:

Measure the total preload torque without the oil seal.

TRANSFER ASSEMBLY

Pinion Sleeve Assembly

1. Select the pinion sleeve shim. Refer to [TF-69, "SELECTING ADJUSTING SHIMS"](#).
2. Install dust cover.
3. Using the drift, install the pinion rear bearing outer race.

Tool number : KV38100300

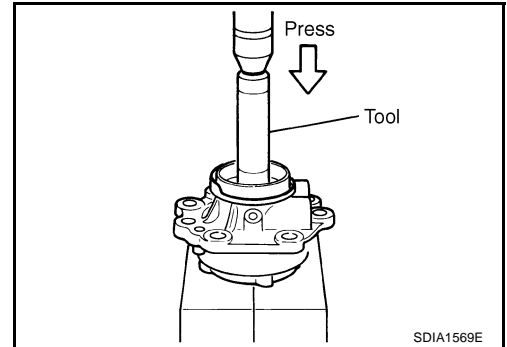

4. Using the drifts, install the pinion front bearing outer race.

Tool number A: ST33400001
B: ST30901000

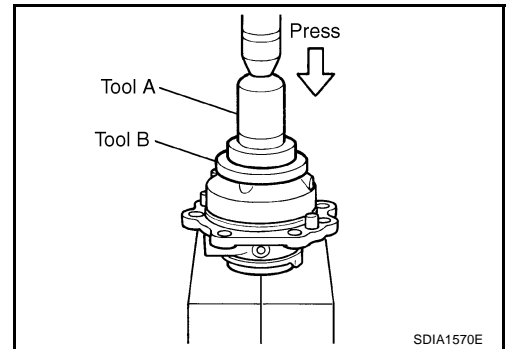

5. Apply gear oil to pinion front bearing inner race and mating position on the drive pinion. Using the drift, install pinion front bearing inner race to the drive pinion.

Tool number : ST30901000

6. Install a collapsible spacer to the drive pinion.

CAUTION:
Do not reuse the collapsible spacer.

7. Apply gear oil to pinion rear bearing inner race and install it to the pinion sleeve.

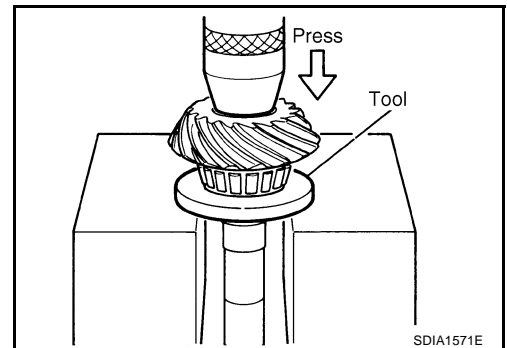

8. Using the drift, install pinion sleeve oil seal to the pinion sleeve.

Tool number : ST33400001

- CAUTION:**
- Do not reuse the oil seal.
 - Apply multi-purpose grease onto oil seal lips, and gear oil onto the circumference of the oil seal.

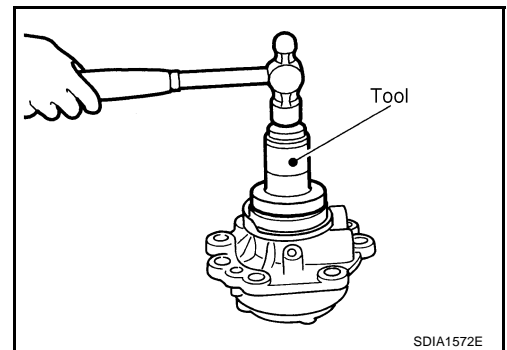

TRANSFER ASSEMBLY

9. Using the drift and press in the companion flange.

Tool number : ST33200000

10. Apply anti-corrosion oil onto threads and seat of the pinion lock nut and adjust the pinion lock nut tightening torque and pinion bearing preload torque (P'1), using a preload gauge.

Pinion lock nut tightening torque

 : 128 - 294 N·m (13 - 29 kg·m, 95 - 216 ft·lb)

Pinion bearing preload torque (P'1)

: 0.40 - 0.78 N·m (0.04 - 0.08 kg·m, 4 - 6 in·lb)

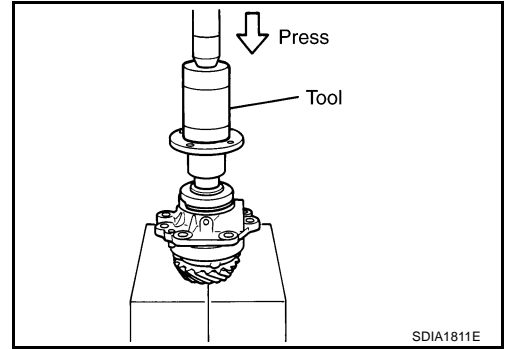

CAUTION:

- Do not reuse the pinion lock nut.
 - Adjust the lower limit of the pinion lock nut tightening torque first.
 - While confirming the preload torque, tighten pinion lock nut by 5° to 10°. Because preload will increase suddenly.
 - If specified preload torque is exceeded, replace the collapsible spacer and tighten again. Never loosen the pinion lock nut for further preload torque adjustment.
 - After the adjustment, rotate the companion flange back and forth 2 to 3 times to check for unusual noise, rotation malfunction, and other malfunctions.
11. Apply multi-purpose grease lightly and evenly onto an O-ring, and install it to the pinion sleeve.

CAUTION:

Do not reuse the old O-ring.

12. Assemble the selected pinion sleeve shim.
13. Install the pinion sleeve assembly, and apply anti-corrosive oil onto threads and seats on the mounting bolts. Tighten to the specified torque. Refer to [TF-59, "COMPONENTS"](#).
14. Check backlash, preload torque, tooth contact and companion flange runout. Refer to [TF-60, "ASSEMBLY INSPECTION"](#).

The total preload torque is as follows:

Total preload torque

With all oil seals installed : P'1 + 0.45 - 0.47 N·m (0.045 - 0.048 kg·m, 3.9 - 4.1 in·lb)

Without transfer case oil seal and adapter case oil seal

: P'1 + 0.35 - 0.37 N·m (0.035 - 0.038 kg·m, 3.1 - 3.2 in·lb)

SERVICE DATA AND SPECIFICATIONS (SDS)

SERVICE DATA AND SPECIFICATIONS (SDS)

PF0:00030

General Specifications

EDS00016

Applied model	QR20DE	QR25DE	YD22DDTi
Transfer model	TY20A		
Oil capacity (Approx.)	ℓ (Imp pt)		
	0.31 (1/2)		
Gear ratio	0.404		
Number of teeth	Drive pinion	17	
	Drive gear	42	

Inspection and Adjustment PRELOAD TORQUE BEFORE DISASSEMBLY

EDS0004Y

Item	Specification [N·m (kg·m, in·lb)]
Pinion bearing (P ₁)	0.10 - 0.39 (0.01 - 0.04, 1 - 3)
Gear ring bearing to pinion bearing (Total preload)	With all oil seals
	Without transfer case oil seal and adapter case oil seal
	P ₁ + 0.16 - 0.22 (0.016 - 0.023, 1.4 - 1.9)
	P ₁ + 0.06 - 0.12 (0.006 - 0.013, 0.6 - 1.1)

PRELOAD TORQUE AFTER DISASSEMBLY AND REASSEMBLY

Item	Specification [N·m (kg·m, in·lb)]
Pinion bearing (P' ₁)	0.40 - 0.78 (0.04 - 0.08, 4 - 6)
Gear ring bearing to pinion bearing (Total preload)	With all oil seals
	Without transfer case oil seal and adapter case oil seal
	P' ₁ + 0.45 - 0.47 (0.045 - 0.048, 3.9 - 4.1)
	P' ₁ + 0.35 - 0.37 (0.035 - 0.038, 3.1 - 3.2)

BACKLASH

Unit: mm (in)

Item	Specification
Drive gear to drive pinion gear	0.13 - 0.19 (0.0051 - 0.0075)

COMPANION FLANGE RUNOUT

Unit: mm (in)

Item	Runout limit
Companion flange face	0.1 (0.004)
Inner side of the companion flange	0.1 (0.004)

SELECTIVE PARTS

Gear ring Bearing Adjusting Shim (Transfer Case Side)

Unit: mm (in)

Thickness	Part number*	Thickness	Part number*	Thickness	Part number*
0.80 (0.0315)	33147 AD300	1.22 (0.0480)	33147 AD314	1.64 (0.0646)	33147 AD363
0.83 (0.0327)	33147 AD301	1.25 (0.0492)	33147 AD315	1.67 (0.0657)	33147 AD364
0.86 (0.0339)	33147 AD302	1.28 (0.0504)	33147 AD316	1.70 (0.0669)	33147 AD365
0.89 (0.0350)	33147 AD303	1.31 (0.0516)	33147 AD317	1.73 (0.0681)	33147 AD366
0.92 (0.0362)	33147 AD304	1.34 (0.0528)	33147 AD318	1.76 (0.0693)	33147 AD367
0.95 (0.0374)	33147 AD305	1.37 (0.0539)	33147 AD319	1.79 (0.0705)	33147 AD368
0.98 (0.0386)	33147 AD306	1.40 (0.0551)	33147 AD320	1.82 (0.0717)	33147 AD369
1.01 (0.0398)	33147 AD307	1.43 (0.0563)	33147 AD321	1.85 (0.0728)	33147 AD370
1.04 (0.0409)	33147 AD308	1.46 (0.0575)	33147 AD322	1.88 (0.0740)	33147 AD371
1.07 (0.0421)	33147 AD309	1.49 (0.0587)	33147 AD323	1.91 (0.0752)	33147 AD372
1.10 (0.0433)	33147 AD310	1.52 (0.0598)	33147 AD324	1.94 (0.0764)	33147 AD373
1.13 (0.0445)	33147 AD311	1.55 (0.0610)	33147 AD360	1.97 (0.0776)	33147 AD374
1.16 (0.0457)	33147 AD312	1.58 (0.0622)	33147 AD361	2.00 (0.0787)	33147 AD375
1.19 (0.0469)	33147 AD313	1.61 (0.0634)	33147 AD362	2.03 (0.0799)	33147 AD376

*: Always check with the Parts Department for the latest parts information.

SERVICE DATA AND SPECIFICATIONS (SDS)

Gear ring Bearing Adjusting Shim (Adapter Case Side)

Unit: mm (in)

Thickness	Part number*	Thickness	Part number*	Thickness	Part number*
0.80 (0.0315)	33147 5V200	1.25 (0.0492)	33147 5V215	1.70 (0.0669)	33123 5V265
0.83 (0.0327)	33147 5V201	1.28 (0.0504)	33147 5V216	1.73 (0.0681)	33123 5V266
0.86 (0.0339)	33147 5V202	1.31 (0.0516)	33147 5V217	1.76 (0.0693)	33123 5V267
0.89 (0.0350)	33147 5V203	1.34 (0.0528)	33123 5V218	1.79 (0.0705)	33123 5V268
0.92 (0.0362)	33147 5V204	1.37 (0.0539)	33123 5V219	1.82 (0.0717)	33123 5V269
0.95 (0.0374)	33147 5V205	1.40 (0.0551)	33123 5V220	1.85 (0.0728)	33123 5V270
0.98 (0.0386)	33147 5V206	1.43 (0.0563)	33123 5V221	1.88 (0.0740)	33123 5V271
1.01 (0.0398)	33147 5V207	1.46 (0.0575)	33123 5V222	1.91 (0.0752)	33123 5V272
1.04 (0.0409)	33147 5V208	1.49 (0.0587)	33123 5V223	1.94 (0.0764)	33123 5V273
1.07 (0.0421)	33147 5V209	1.52 (0.0598)	33123 5V224	1.97 (0.0776)	33123 5V274
1.10 (0.0433)	33147 5V210	1.55 (0.0610)	33123 5V260	2.00 (0.0787)	33123 5V275
1.13 (0.0445)	33147 5V211	1.58 (0.0622)	33123 5V261	2.03 (0.0799)	33123 5V276
1.16 (0.0457)	33147 5V212	1.61 (0.0634)	33123 5V262	2.06 (0.0811)	33123 5V277
1.19 (0.0469)	33147 5V213	1.64 (0.0646)	33123 5V263	2.09 (0.0811)	33123 5V278
1.22 (0.0480)	33147 5V214	1.67 (0.0657)	33123 5V264		

*: Always check with the Parts Department for the latest parts information.

Pinion Sleeve Shim

Unit: mm (in)

Thickness	Part number*	Thickness	Part number*	Thickness	Part number*
0.77 (0.0303)	33155 5V214	0.98 (0.0386)	33155 5V206	1.19 (0.0469)	33155 5V213
0.80 (0.0315)	33155 5V200	1.01 (0.0398)	33155 5V207	1.22 (0.0480)	33155 5V215
0.83 (0.0327)	33155 5V201	1.04 (0.0409)	33155 5V208	1.25 (0.0492)	33155 5V216
0.86 (0.0339)	33155 5V202	1.07 (0.0421)	33155 5V209	1.28 (0.0504)	33155 5V217
0.89 (0.0350)	33155 5V203	1.10 (0.0433)	33155 5V210	1.31 (0.0516)	33155 5V218
0.92 (0.0362)	33155 5V204	1.13 (0.0445)	33155 5V211	1.34 (0.0528)	33155 5V219
0.95 (0.0374)	33155 5V205	1.16 (0.0457)	33155 5V212		

*: Always check with the Parts Department for the latest parts information.

SERVICE DATA AND SPECIFICATIONS (SDS)
