

SECTION **BRC**

BRAKE CONTROL SYSTEM

A
B
C
D
E
BRC
G
H
I
J
K
L
M

CONTENTS

ABS		
PRECAUTIONS	4	
Precautions for Supplemental Restraint System (SRS) "AIR BAG" and "SEAT BELT PRE-TENSIONER"	4	
Precautions for Brake System	4	
Precautions for Brake Control	4	
PREPARATION	5	
Special Service Tools	5	
SYSTEM DESCRIPTION	6	
System Diagram	6	
ABS Function	6	
EBD Function	6	
Fail-Safe Function	6	
ABS, EBD SYSTEM	6	
Hydraulic Circuit Diagram	7	
CAN COMMUNICATION	8	
System Description	8	
CAN Communication Unit	8	
TYPE 1/TYPE 2	8	
TYPE 3	9	
TYPE 7/TYPE 8	10	
TROUBLE DIAGNOSIS	12	
How to Proceed With Diagnosis	12	
BASIC CONCEPT	12	
DIAGNOSIS FLOWCHART	13	
ASKING COMPLAINTS	14	
EXAMPLE OF DIAGNOSIS SHEET	14	
Component Parts Location	15	
Schematic	16	
Wiring Diagram — ABS —	17	
LHD MODEL	17	
RHD MODEL	21	
Control Unit Input/Output Signal Standard	25	
REFERENCE VALUE FROM CONSULT-II	25	
CONSULT- II Functions	26	
CONSULT-II MAIN FUNCTION	26	
CONSULT-II BASIC OPERATION PROCEDURE	26	
SELF-DIAGNOSIS	28	
DATA MONITOR	30	
ACTIVE TEST	32	
Correct and Quick Diagnosis	34	
DIAGNOSIS PRECAUTIONS	34	
Basic Inspection	35	
BASIC INSPECTION 1 BRAKE FLUID AMOUNT, LEAKS, AND BRAKE PADS INSPECTION	35	
BASIC INSPECTION 2 POWER SYSTEM TERMINAL LOOSENESS AND BATTERY INSPECTION	35	
BASIC INSPECTION 3 ABS WARNING LAMP... ..	35	
Inspection 1: Wheel Sensor System	36	
INSPECTION PROCEDURE	36	
Inspection 2: ABS Actuator and Electric Unit (Control Unit) 1	38	
Inspection 3: ABS Actuator and Electric Unit (Control Unit) Power Supply and Ground Circuit	38	
Inspection 4: ABS Actuator Relay or ABS Motor Relay Power System	39	
Inspection 5: ABS Actuator and Electric Unit (Control Unit) 2	40	
Inspection 6: G Sensor System	41	
Inspection 7: CAN Communication System	43	
Symptom 1: ABS Works Frequently	43	
Symptom 2: Unexpected Pedal Reaction	44	
Symptom 3: Longer Stopping Distance	44	
Symptom 4: ABS Does Not Work	45	
Symptom 5: Pedal Vibration and ABS Operation Noise	45	
WHEEL SENSORS	46	
Removal and Installation	46	
REMOVAL	46	
INSTALLATION	46	
G SENSOR	47	
Removal and Installation	47	
REMOVAL	47	
INSTALLATION	47	

SENSOR ROTOR	48
Removal and Installation	48
REMOVAL	48
INSTALLATION	48
ABS ACTUATOR AND ELECTRIC UNIT (ASSEMBLY)	49
Removal and Installation	49

ESP/TCS/ABS

PRECAUTIONS	50
Precautions for Supplemental Restraint System (SRS) "AIR BAG" and "SEAT BELT PRE-TENSIONER"	50
Precautions for Brake System	50
Precautions for Brake Control	50
PREPARATION	51
Special Service Tools	51
ON-VEHICLE SERVICE	52
Adjustment of Steering Angle Sensor Neutral Position	52
SYSTEM DESCRIPTION	53
System Diagram	53
ESP Function	53
TCS Function	53
ABS Function	54
EBD Function	54
Fail-Safe Function	54
ESP/ TCS SYSTEM	54
ABS, EBD SYSTEM	54
Hydraulic Circuit Diagram	55
CAN COMMUNICATION	56
System Description	56
CAN Communication Unit	56
TYPE 4/TYPE 5	56
TYPE 6	57
TYPE 9	58
TROUBLE DIAGNOSIS	60
How to Proceed With Diagnosis	60
BASIC CONCEPT	60
DIAGNOSIS FLOWCHART	61
ASKING COMPLAINTS	62
EXAMPLE OF DIAGNOSIS SHEET	62
Component Parts and Harness Connector Location	63
Schematic	64
Wiring Diagram —ESP/TCS/ABS—	65
LHD MODEL	65
RHD MODEL	71
Control Unit Input/Output Signal Standard	77
REFERENCE VALUE FROM CONSULT-II	77
CONSULT-II Functions	79
CONSULT-II MAIN FUNCTION	79
CONSULT-II BASIC OPERATION PROCEDURE	79
SELF-DIAGNOSIS	81
DATA MONITOR	83
ACTIVE TEST	86
For Fast and Accurate Diagnosis	88

PRECAUTIONS FOR DIAGNOSIS	88
Basic Inspection	89
BASIC INSPECTION 1 BRAKE FLUID AMOUNT, LEAKS, AND BRAKE PADS INSPECTION	89
BASIC INSPECTION 2 POWER SYSTEM TERMINAL LOOSENESS AND BATTERY INSPECTION	89
BASIC INSPECTION 3 ABS WARNING LAMP, ESP OFF INDICATOR LAMP, SLIP INDICATOR LAMP AND BRAKE WARNING LAMP INSPECTION	90
Inspection 1 Wheel Sensor System	91
INSPECTION PROCEDURE	91
Inspection 2 Engine System	93
Inspection 3 ESP/TCS/ABS Control Unit System	93
Inspection 4 Pressure Sensor and the Circuit between Pressure Sensor and ESP/TCS/ABS Control Unit.	93
Inspection 5 Steering Angle Sensor and Circuit between Steering Angle Sensor and ESP/TCS/ABS Control Unit.	95
Inspection 6 Yaw Rate/Side G sensor and the Circuit between Yaw Rate/Side G sensor and ESP/TCS/ABS Control Unit.	97
Inspection 7 Solenoid Valve, ESP Switch-over Solenoid Valve and Circuit	98
Inspection 8 Actuator Motor, Motor Relay and Circuit	101
Inspection 9 Actuator Relay and Circuit	103
Inspection 10 Stop Lamp Switch and Circuit	105
Inspection 11 ESP/TCS/ABS Control Unit Power Supply Circuit	105
Inspection 12 When "EMERGENCY BRAKE" is indicated in the Self-Diagnostic Results	107
Inspection 13 When "ST ANG SEN SIGNAL" is indicated in the Self-Diagnostic Results	107
Inspection 14 Brake Fluid Level of Reservoir Tank, Communication Circuit between ESP/TCS/ABS Control Unit and Brake Fluid Level Warning Switch	108
Inspection 15 CAN Communication Circuit, ESP/TCS/ABS Control Unit and Steering Angle Sensor	109
Component Check	109
ESP OFF SWITCH	109
ESP RELAY BOX	109
ESP ACTUATOR	110
Symptom 1: ABS Works Frequently	112
Symptom 2: Unexpected Pedal Reaction	113
Symptom 3: Longer Stopping Distance	113
Symptom 4: ABS Does Not Work	113
Symptom 5: Pedal Vibration and ABS Operation Noise	113
Symptom 6: ESP OFF Indicator Lamp Does Not Illuminate	114
Symptom 7: SLIP Indicator Lamp Does Not Illuminate	114
Symptom 8: Vehicle Jerks During ESP/TCS/ABS Control	115

WHEEL SENSORS	116	YAW RATE/SIDE G SENSOR	120
Removal and Installation	116	Removal and Installation	120
REMOVAL	116	REMOVAL	120
INSTALLATION	116	INSTALLATION	120
SENSOR ROTOR	117	ESP OFF SWITCH	121
Removal and Installation	117	Removal and Installation	121
REMOVAL	117	REMOVAL	121
INSTALLATION	117	INSTALLATION	121
ESP/TCS/ABS CONTROL UNIT	118	STEERING ANGLE SENSOR	122
Removal and Installation	118	Removal and Installation	122
REMOVAL	118	REMOVAL	122
INSTALLATION	118	INSTALLATION	122
ESP/TCS/ABS ACTUATOR AND RELAY BOX	119		
Removal and Installation	119		

A
B
C
D
E
G
H
I
J
K
L
M

BRC

PRECAUTIONS

PFP:00001

Precautions for Supplemental Restraint System (SRS) “AIR BAG” and “SEAT BELT PRE-TENSIONER”

EFS005X6

The Supplemental Restraint System such as “AIR BAG” and “SEAT BELT PRE-TENSIONER”, used along with a front seat belt, helps to reduce the risk or severity of injury to the driver and front passenger for certain types of collision. Information necessary to service the system safely is included in the SRS and SB section of this Service Manual.

WARNING:

- To avoid rendering the SRS inoperative, which could increase the risk of personal injury or death in the event of a collision which would result in air bag inflation, all maintenance must be performed by an authorized NISSAN/INFINITI dealer.
- Improper maintenance, including incorrect removal and installation of the SRS, can lead to personal injury caused by unintentional activation of the system. For removal of Spiral Cable and Air Bag Module, see the SRS section.
- Do not use electrical test equipment on any circuit related to the SRS unless instructed to in this Service Manual. SRS wiring harnesses can be identified by yellow and/or orange harnesses or harness connectors.

Precautions for Brake System

EFS004GX

- Recommended fluid is brake fluid “DOT 3” or “DOT 4”.
- Do not reuse drained brake fluid.
- Be careful not to splash brake fluid on painted areas such as body. If brake fluid is splashed, wipe it off and flush area with water immediately.
- Do not use mineral oils such as gasoline or kerosene to clean. They will ruin rubber parts and cause improper operation.
- Using a flare nut torque wrench, securely tighten brake tube flare nuts.
- Brake system is an important safety part. If a brake fluid leak is detected, always disassemble the affected part. If a malfunction is detected, replace part with a new one.
- Before working, turn ignition switch OFF and disconnect harness connectors of ABS actuator and electric unit (control unit) or battery cable from negative terminal.
- When installing brake piping, be sure to check torque.

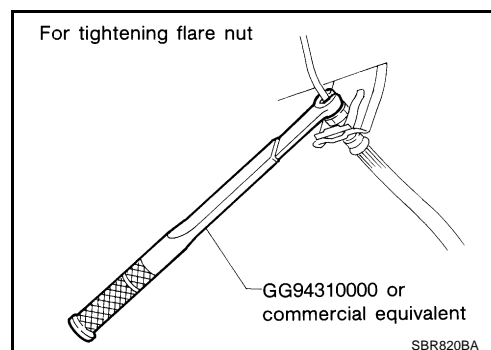

Precautions for Brake Control

EFS004FV

- During ABS operation, brake pedal lightly vibrates and a mechanical noise may be heard. This is normal.
- Just after starting vehicle after ignition switch ON, brake pedal may vibrate or motor operating noise may be heard from engine compartment. This is a normal status of operation check.
- Stopping distance may be longer than that of vehicles without ABS when vehicle drives on rough, gravel, or snow-covered (fresh, deep snow) roads.
- When an malfunction is indicated by ABS or another warning lamp, collect all necessary information from customer (what symptoms are present under what conditions) and check for simple causes before starting diagnostic servicing. Besides electrical system inspection, check booster operation, brake fluid level, and oil leaks.
- If tyre size and type are used in an improper combination, or brake pads are not Genuine NISSAN parts, stopping distance or steering stability may deteriorate.
- If there is a radio, antenna, or antenna lead-in wire (including wiring) near control module, ABS function may have a malfunction.
- If aftermarket parts (car stereo, CD player, etc.) Have been installed, check for incidents such as harness pinches, open circuits, and improper wiring.

PREPARATION

[ABS]

PREPARATION

PFP:00002

Special Service Tools

EFS004GU

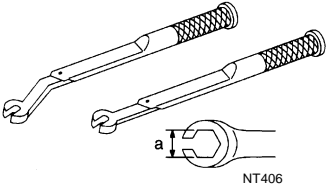
Tool number Tool name	Description
GG94310000 Flare nut torque wrench a: 10mm (0.39 in)	 <p>Installing each brake piping</p>

A
B
C
D
E
G
H
I
J
K
L
M

BRC

SYSTEM DESCRIPTION

PFP:00000

System Diagram

EFS004FZ

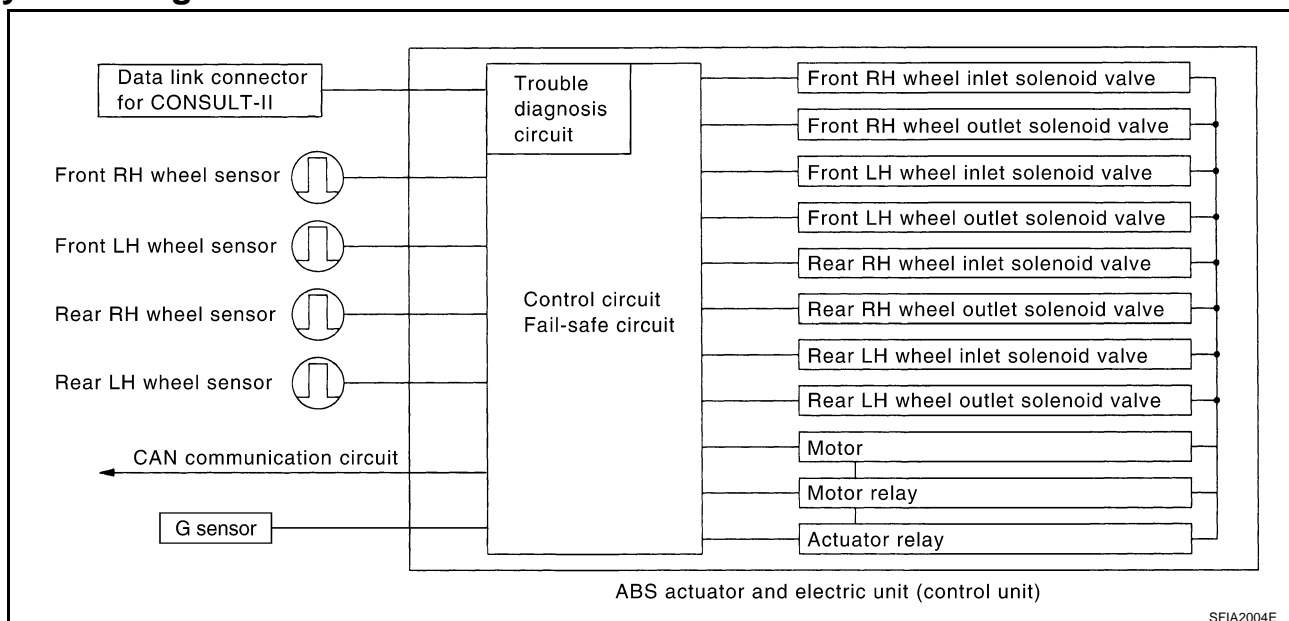

ABS Function

EFS004G0

- The Anti-Lock Brake System is a function that detects wheel revolution while braking, and it improves handling stability during sudden braking by electrically preventing 4 wheel lock. Maneuverability is also improved for avoiding obstacles.
- In case of the electrical system breaks down, then the Fail-Safe function starts, the ABS becomes inoperative, and the ABS warning lamp turns on.
- Electrical System Diagnosis by CONSULT-II is available.

EBD Function

EFS004G1

- Electronic Brake Distributor is a function that detects subtle slippages between the front and rear wheels during braking, and it improves handling stability by electronically controlling the Brake Fluid Pressure which results in reduced rear wheel slippage.
- In case of the electrical system break down, then the Fail-Safe function is starts, the EBD and ABS becomes inoperative, and the ABS warning lamp is turned on.
- Electrical System Diagnosis by CONSULT-II is available.

Fail-Safe Function ABS, EBD SYSTEM

EFS004G2

In case of the electrical problems with the ABS, the ABS warning lamp will turn on. In case of electrical problem with the EBD, ABS warning lamp will turn on. Simultaneously, the ABS become one of the following conditions of the Fail-Safe function.

1. For ABS trouble, only the EBD is activated and the condition of the vehicle is the same condition of vehicles without ABS equipment.
2. For EBD trouble, the EBD and ABS become inoperative, and the condition of the vehicle is the same as the condition of vehicles without ABS, EBD equipment.

NOTE:

In condition 1 described above, an ABS self diagnosis sound may be heard. That is a normal condition because a self diagnosis for "Ignition switch ON" and "the First Starting" are being performed.

SYSTEM DESCRIPTION

[ABS]

Hydraulic Circuit Diagram

EFS004G3

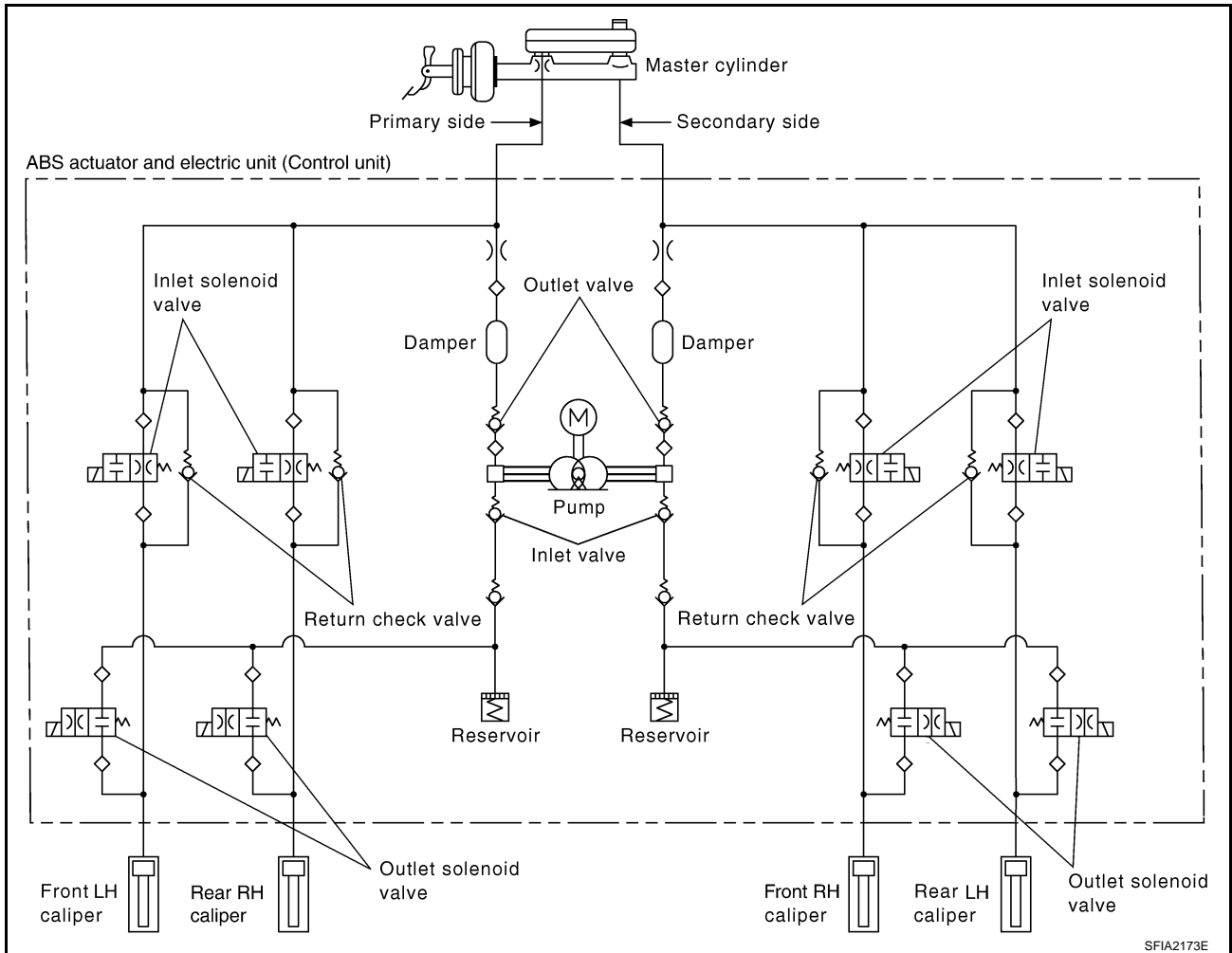

SFIA2173E

A
B
C
D
E
BRC
G
H
I
J
K
L
M

CAN COMMUNICATION

System Description

EFS0067G

CAN (Controller Area Network) is a serial communication line for real time application. It is an on-vehicle multiplex communication line with high data communication speed and excellent error detection ability. Many electronic control units are equipped onto a vehicle, and each control unit shares information and links with other control units during operation (not independent). In CAN communication, control units are connected with 2 communication lines (CAN H line, CAN L line) allowing a high rate of information transmission with less wiring. Each control unit transmits/receives data but selectively reads required data only.

CAN Communication Unit

EFS0067H

Body type	Wagon				
Axle	4WD		2WD		
Engine	YD22DDTi	QR20DE/QR25DE	QR20DE	YD22DDTi	
Transmission	M/T	A/T	M/T		
Brake control	ABS				
CAN system type	1	2	3	7	8
ECM	×	×	×	×	×
TCM			×		
ESP/TCS/ABS control unit					
ABS actuator and electric unit (control unit)	×	×	×	×	×
Steering angle sensor					
4WD control unit	×	×	×		
Combination meter	×	×	×	×	×

TYPE 1/TYPE 2

System diagram

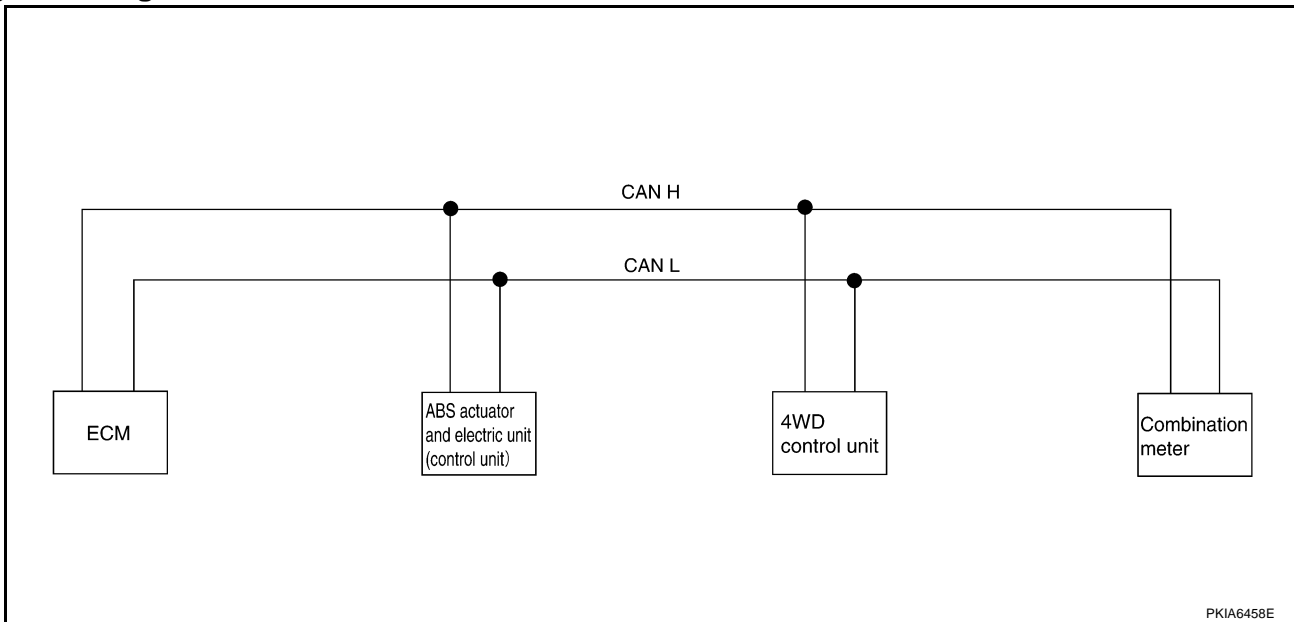

Input/output signal chart

T: Transmit R: Receive

Signals	ECM	ABS actuator and electric unit (control unit)	4WD control unit	Combination meter
4WD mode indicator lamp signal			T	R
4WD warning lamp signal			T	R

CAN COMMUNICATION

[ABS]

Signals	ECM	ABS actuator and electric unit (control unit)	4WD control unit	Combination meter
A/C compressor feedback signal	T			R
ABS warning lamp signal		T		R
Accelerator pedal position signal	T		R	
Engine coolant temperature signal	T			R
Engine speed signal	T		R	R
MI signal	T			R
Parking brake switch signal			R	T
Stop lamp switch signal		T	R	
Vehicle speed signal		T	R	R
	R			T
ASCD SET lamp signal	T			R
ASCD CRUISE lamp signal	T			R
Stop lamp switch signal	T			R
Glow indicator lamp signal*	T			R
A/C switch signal*	R			T

*: YD engine models only

TYPE 3

System diagram

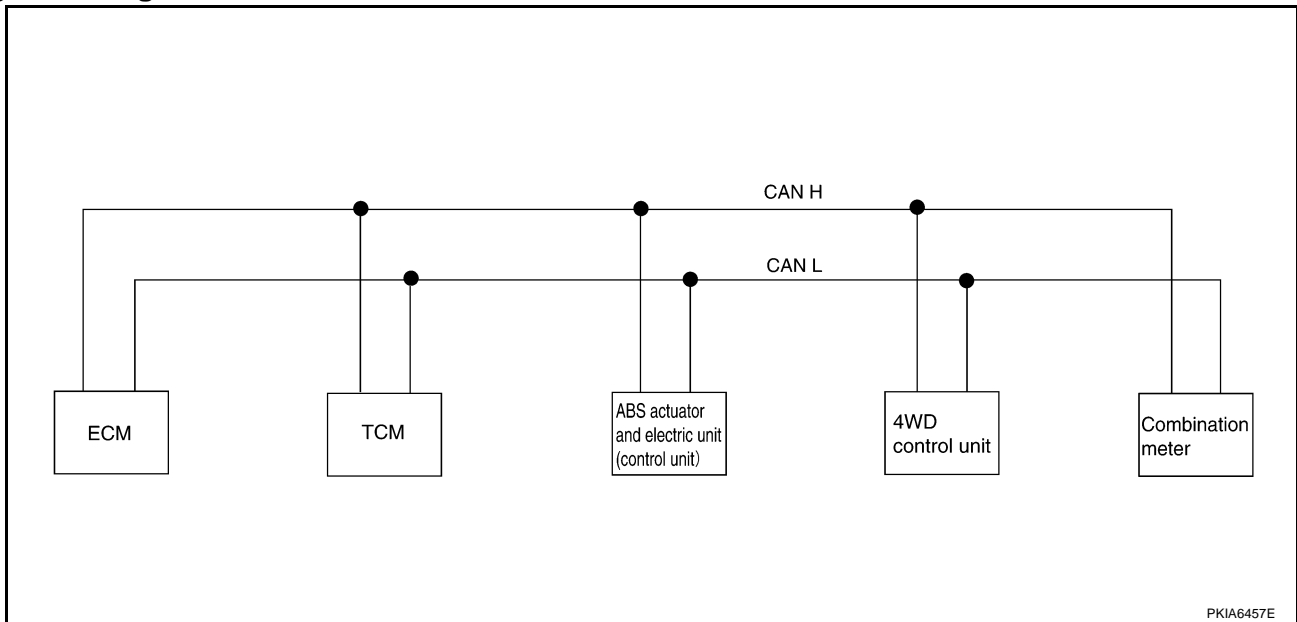

Input/output signal chart

T: Transmit R: Receive

Signals	ECM	TCM	ABS actuator and electric unit (control unit)	4WD control unit	Combination meter
4WD mode indicator lamp signal				T	R
4WD warning lamp signal				T	R
A/C compressor feedback signal	T				R
A/T position indicator lamp signal		T			R
A/T self-diagnosis signal	R	T			
ABS warning lamp signal			T		R

CAN COMMUNICATION

[ABS]

Signals	ECM	TCM	ABS actuator and electric unit (control unit)	4WD control unit	Combination meter
Accelerator pedal position signal	T			R	
Closed throttle position signal	T	R			
Engine A/T integrated control signal	T	R			
	R	T			
Engine coolant temperature signal	T				R
Engine speed signal	T			R	R
MI signal	T				R
O/D OFF indicator signal		T			R
Output shaft revolution signal	R	T			
Overdrive control switch signal		R			T
P-N range signal		R			T
Parking brake switch signal				R	T
Stop lamp switch signal		R			T
			T	R	
Vehicle speed signal			T	R	R
	R				T
Wide open throttle position signal	T	R			
ASCEND SET lamp signal	T				R
ASCEND CRUISE lamp signal	T				R

TYPE 7/TYPE 8

System diagram

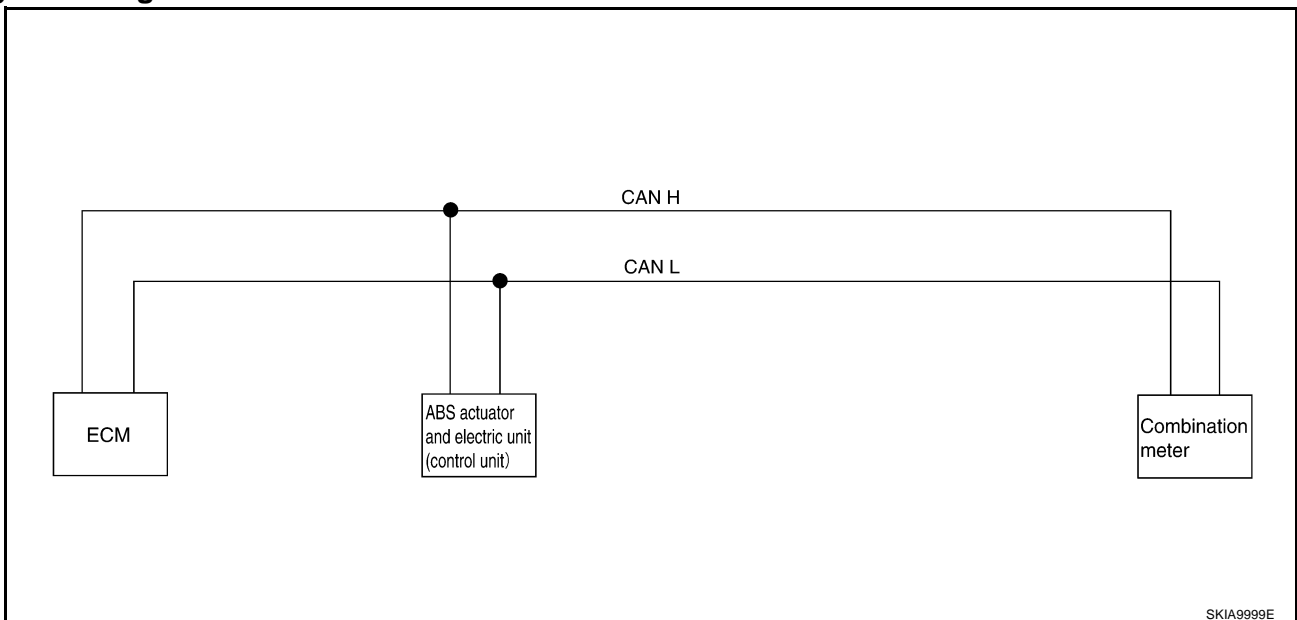

SKIA9999E

Input/output signal chart

T: Transmit R: Receive

Signals	ECM	ABS actuator and electric unit (control unit)	Combination meter
A/C compressor feedback signal	T		R
ABS warning lamp signal		T	R
Engine coolant temperature signal	T		R
Engine speed signal	T		R

CAN COMMUNICATION

[ABS]

Signals	ECM	ABS actuator and electric unit (control unit)	Combination meter
MI signal	T		R
Vehicle speed signal		T	R
	R		T
ASCD SET lamp signal	T		R
ASCD CRUISE lamp signal	T		R
Stop lamp switch signal	T		R
Glow indicator lamp signal*	T		R
A/C switch signal*	R		T

*: YD engine models only

A
B
C
D
E
G
H
I
J
K
L
M

BRC

TROUBLE DIAGNOSIS

How to Proceed With Diagnosis BASIC CONCEPT

- Most important point to perform diagnosis is to understand systems (control and mechanism) in vehicle thoroughly.
- It is also important to clarify customer complaints before inspection.
First of all, reproduce symptom, and understand it fully.
Ask customer about his/her complaints carefully. In some cases, it will be necessary to check symptom by driving vehicle with customer.

NOTE:

Customers are not professionals. Do not assume “maybe customer means...” or “maybe customer mentioned this symptom”.

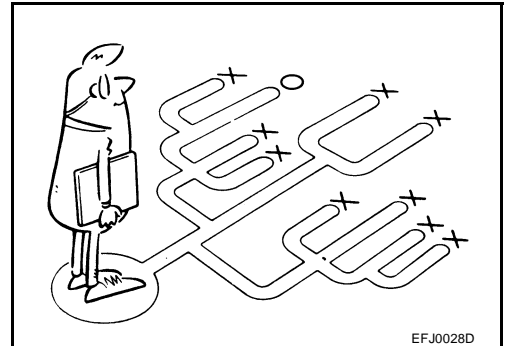

EFJ0028D

- It is essential to check symptoms right from beginning in order to repair a malfunction completely.
For an intermittent malfunction, it is important to reproduce symptom based on interview with customer and past examples. Do not perform inspection on ad hoc basis. Most intermittent malfunctions are caused by poor contacts. In this case, it will be effective to shake suspected harness or connector by hand. When repairs are performed without any symptom check, no one can judge if malfunction has actually been eliminated.
- After diagnosis, make sure to carry out “erase memory”. Refer to [BRC-28, "Operation Procedure"](#) .
- Always read “GI General Information” to confirm general precautions. Refer to [GI-4, "General Precautions"](#) .

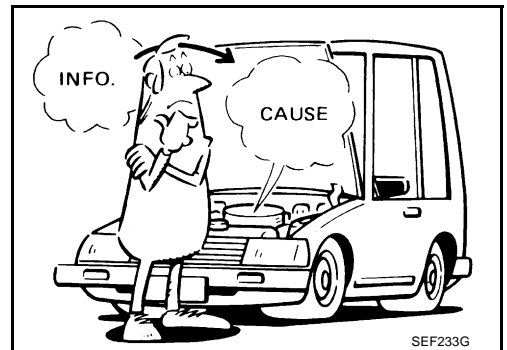

SEF233G

TROUBLE DIAGNOSIS

[ABS]

DIAGNOSIS FLOWCHART

A
B
C
D
E
F
G
H
I
J
K
L
M

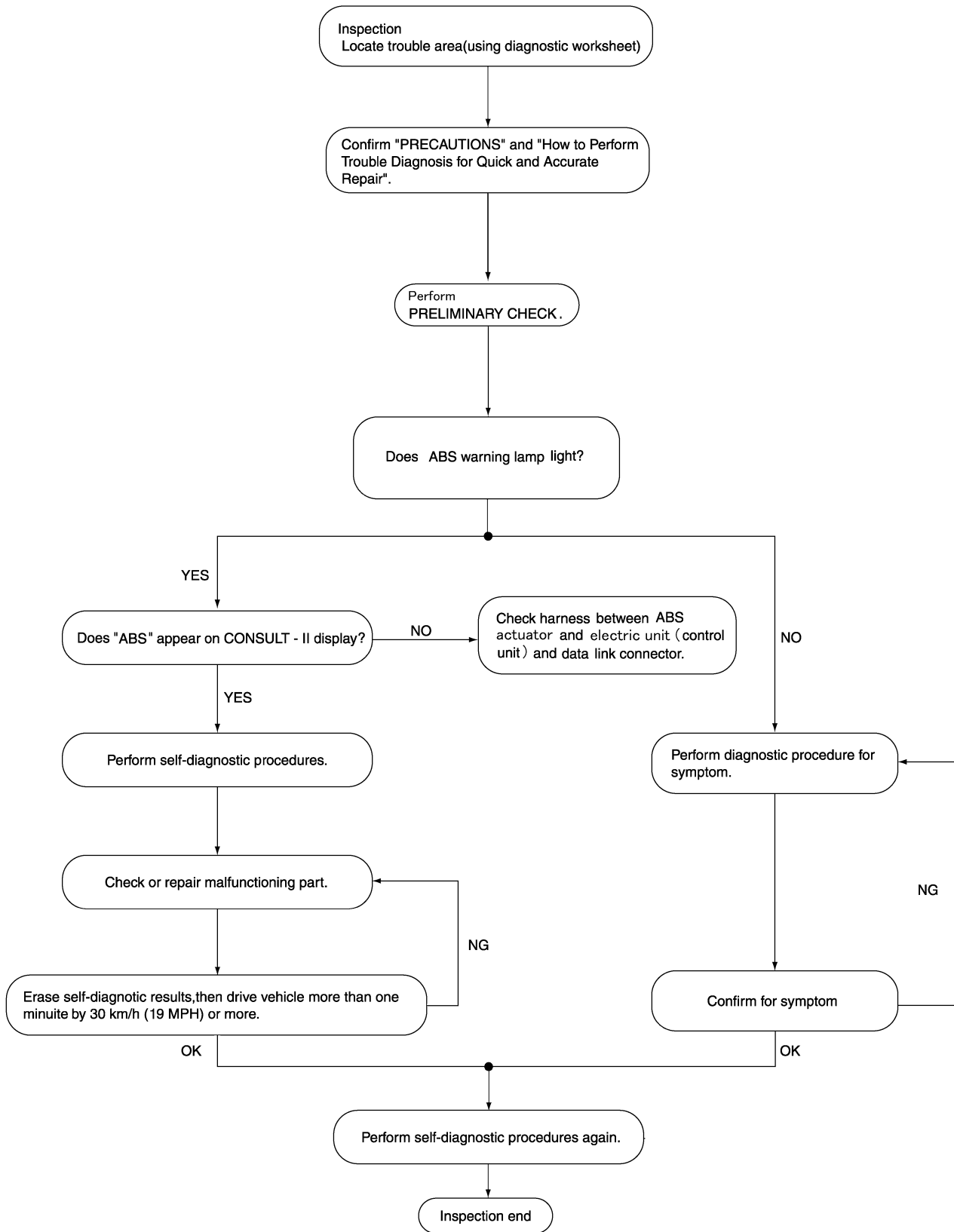

BRC

TROUBLE DIAGNOSIS

[ABS]

ASKING COMPLAINTS

- Complaints against malfunction vary depending on each person. It is important to clarify customer complaints.
- Ask customer about what symptoms are present and under what conditions. Use information to reproduce symptom while driving.
- It is also important to use diagnosis sheet so as not to miss information.

KEY POINTS

WHAT Vehicle model
WHEN Date, Frequencies
WHERE Road conditions
HOW Operating conditions,
 Weather conditions,
 Symptoms

SBR339B

EXAMPLE OF DIAGNOSIS SHEET

Customer name MR/MS	Model & Year	VIN	
Engine #	Trans.	Mileage	
Incident Date	Manuf. Date	In Service Date	
Symptoms	<input type="checkbox"/> Noise and vibration (from engine compartment) <input type="checkbox"/> Noise and vibration (from axle)	<input type="checkbox"/> Warning / Indicator activate	<input type="checkbox"/> Firm pedal operation <input type="checkbox"/> Large stroke pedal operation
	<input type="checkbox"/> ABS does not work (Wheels lock when braking)	<input type="checkbox"/> ABS does not work (wheels slip when braking)	<input type="checkbox"/> Lack of sense of acceleration
Engine conditions	<input type="checkbox"/> When starting <input type="checkbox"/> After starting		
Road conditions	<input type="checkbox"/> Low friction road (<input type="checkbox"/> Snow <input type="checkbox"/> Gravel <input type="checkbox"/> Other) <input type="checkbox"/> Bumps / potholes		
Driving conditions	<input type="checkbox"/> Full-acceleration <input type="checkbox"/> High speed cornering <input type="checkbox"/> Vehicle speed: Greater than 10 km/h (6 MPH) <input type="checkbox"/> Vehicle speed: 10 km/h (6 MPH) or less <input type="checkbox"/> Vehicle is stopped		
Applying brake conditions	<input type="checkbox"/> Suddenly <input type="checkbox"/> Gradually		
Other conditions	<input type="checkbox"/> Operation of electrical equipment <input type="checkbox"/> Shift change <input type="checkbox"/> Other descriptions		

LFIA0176E

Component Parts Location

EFS004G7

A
B
C
D
E
BRC
G
H
I
J
K
L
M

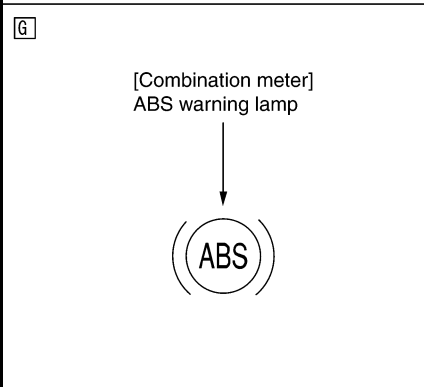
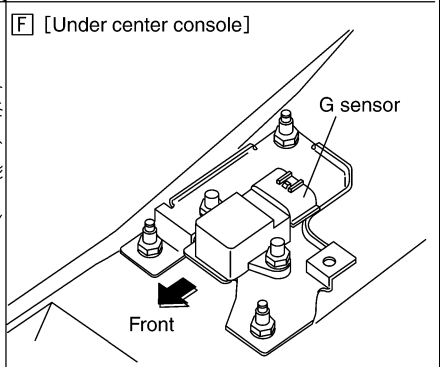
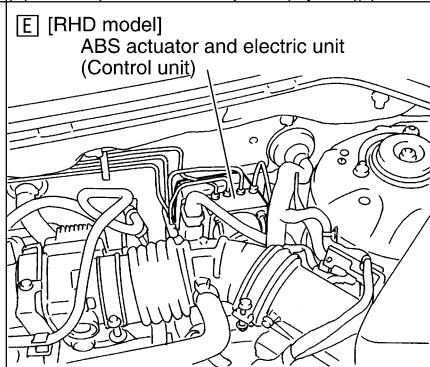
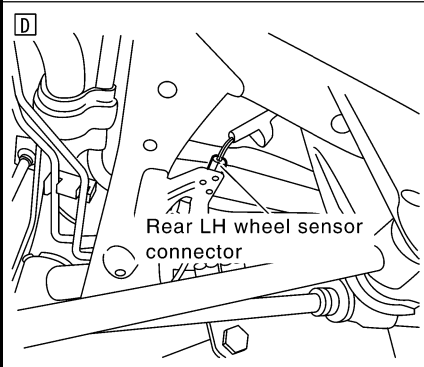
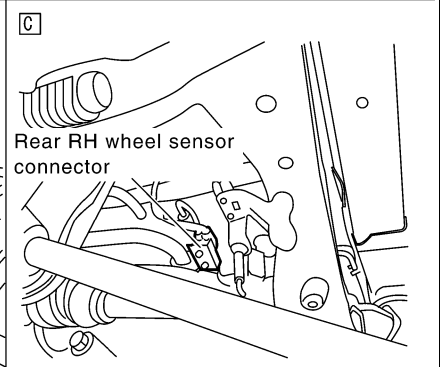
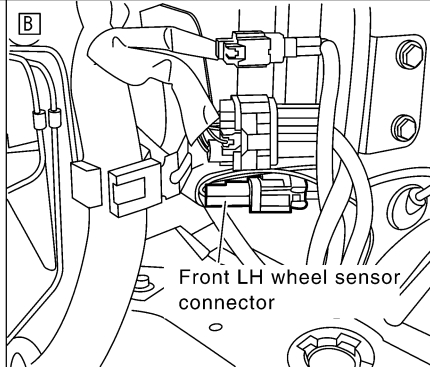
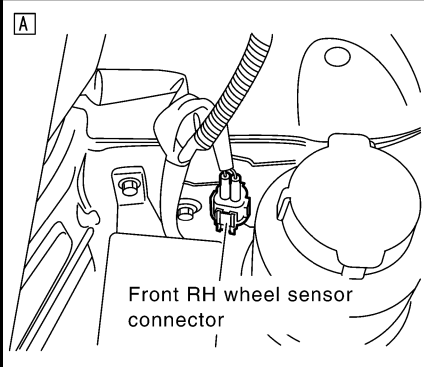
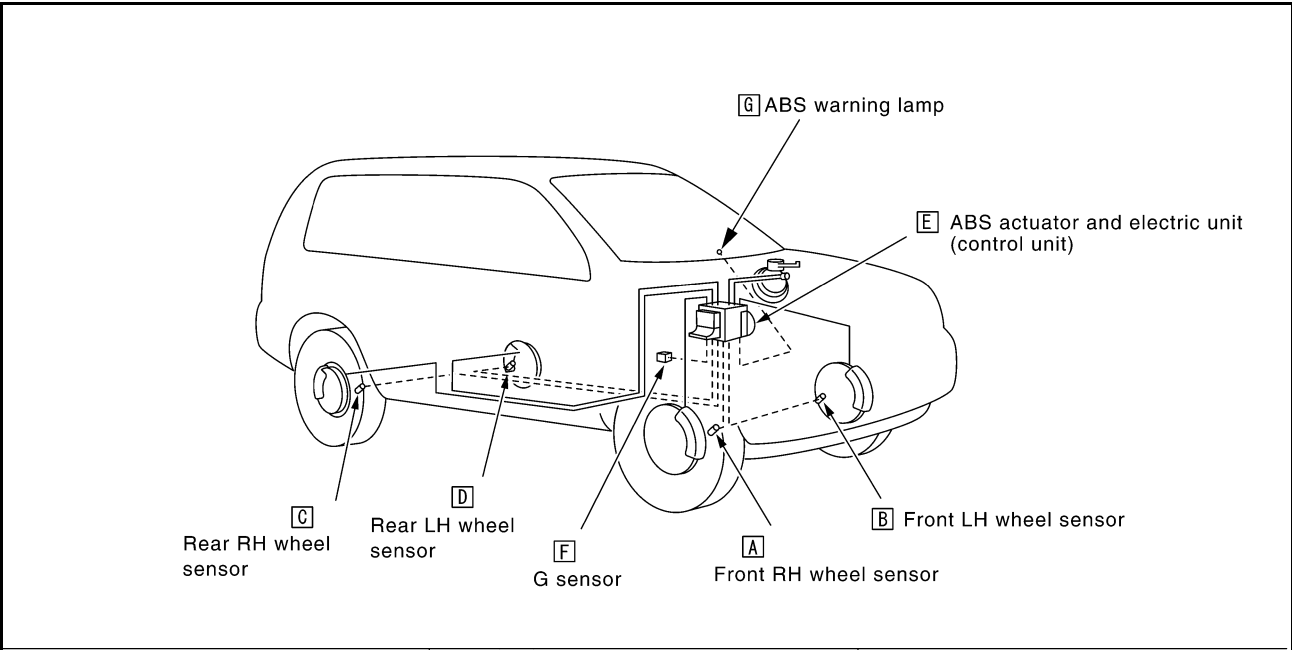

SFIA2201E

Schematic

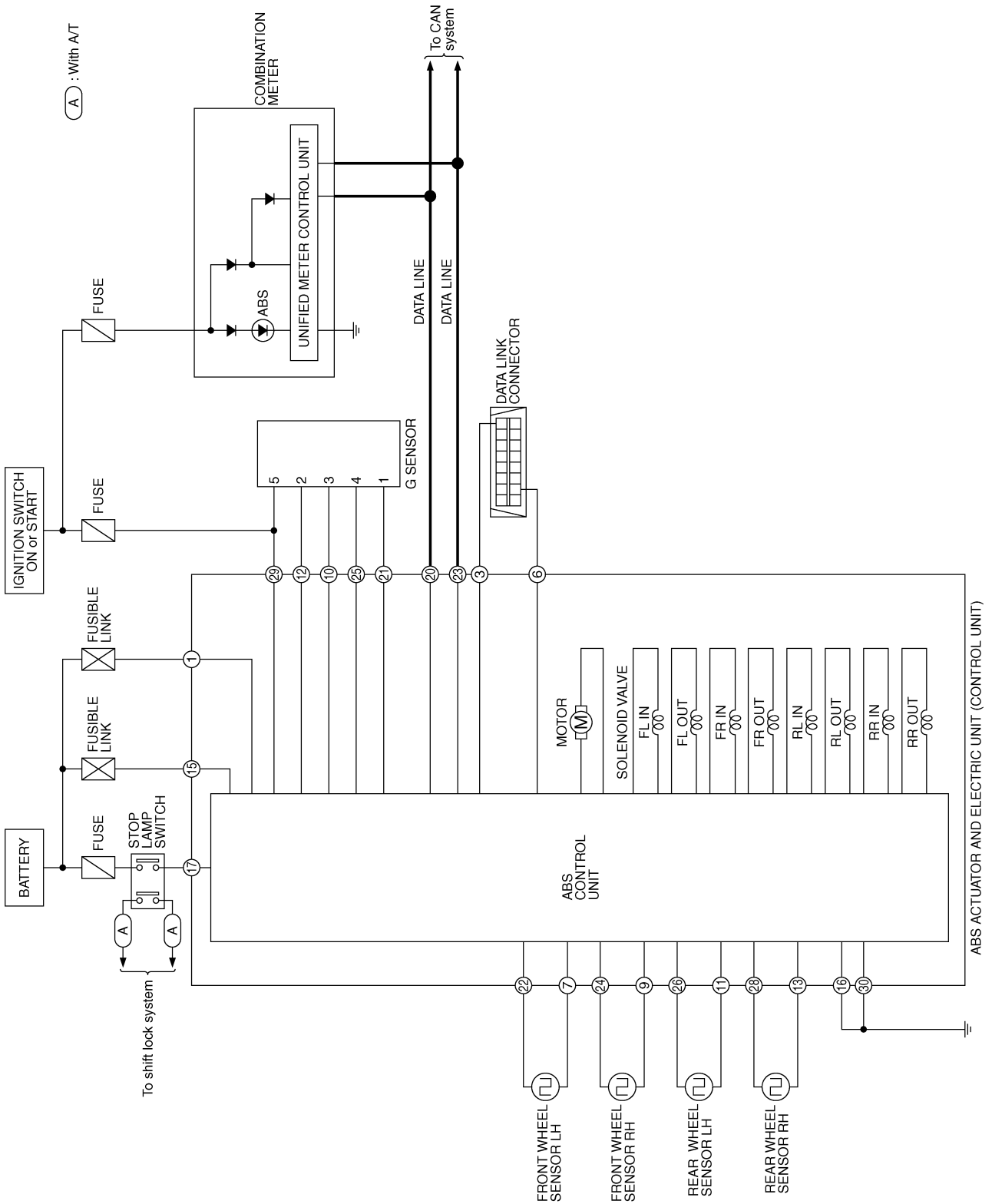

TROUBLE DIAGNOSIS

[ABS]

EFS004G9

Wiring Diagram — ABS — LHD MODEL

BRC-ABS-01

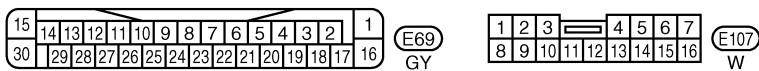
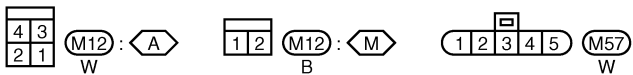
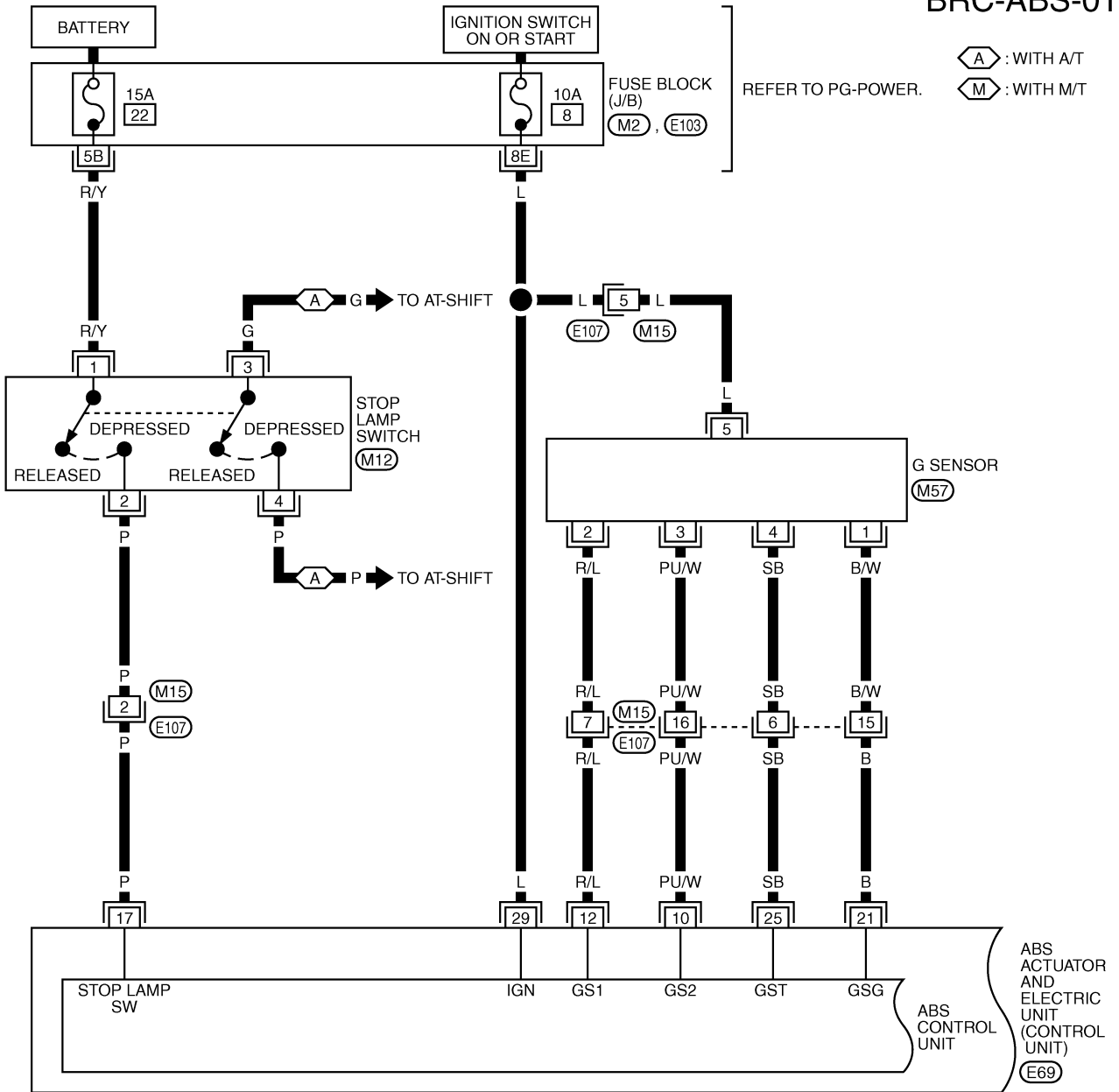

REFER TO THE FOLLOWING.
(M2), (E103) - FUSE BLOCK-JUNCTION BOX (J/B)

A
B
C
D
E
BRC
G
H
I
J
K
L
M

TROUBLE DIAGNOSIS

[ABS]

BRC-ABS-02

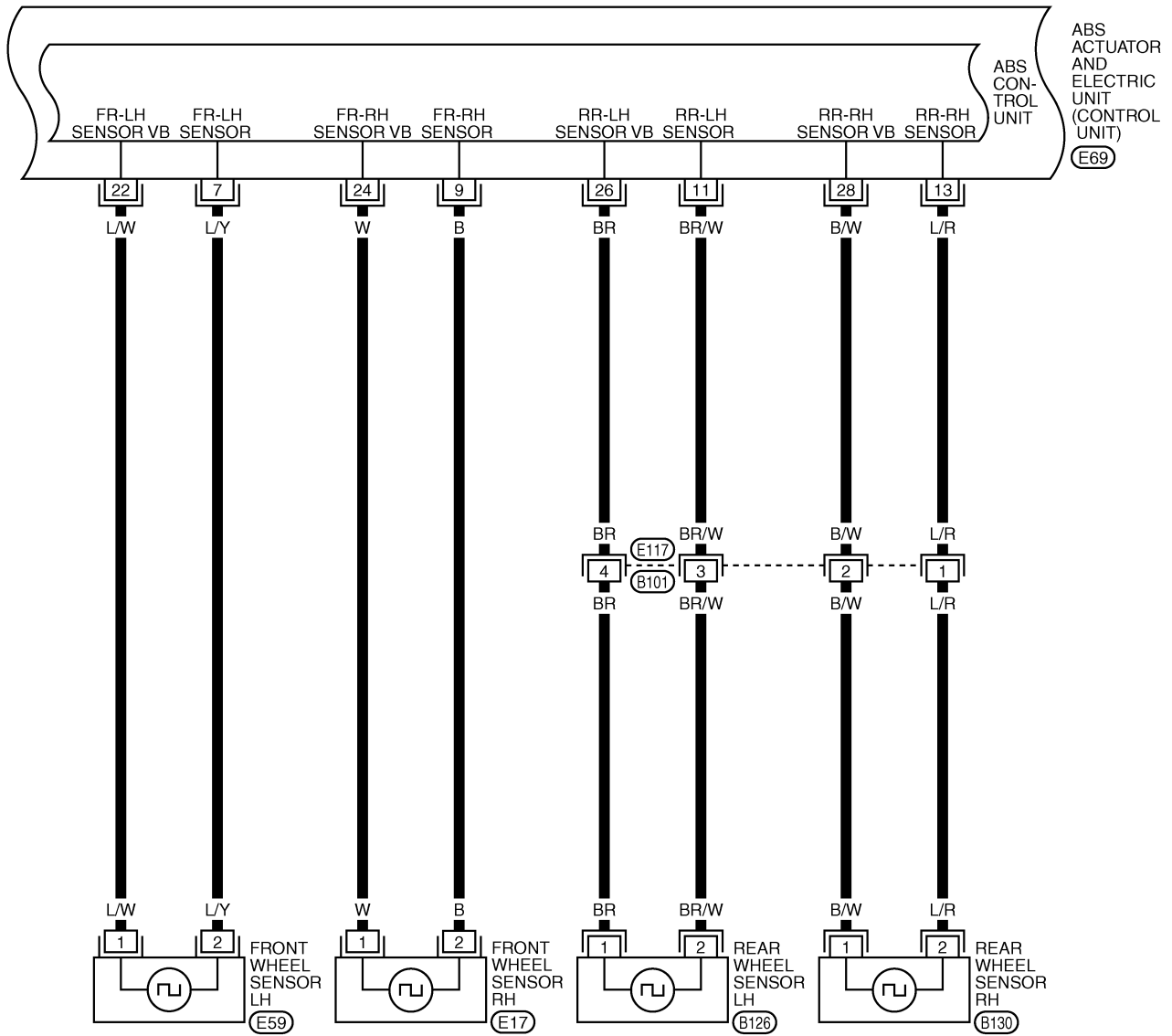

TROUBLE DIAGNOSIS

[ABS]

BRC-ABS-03

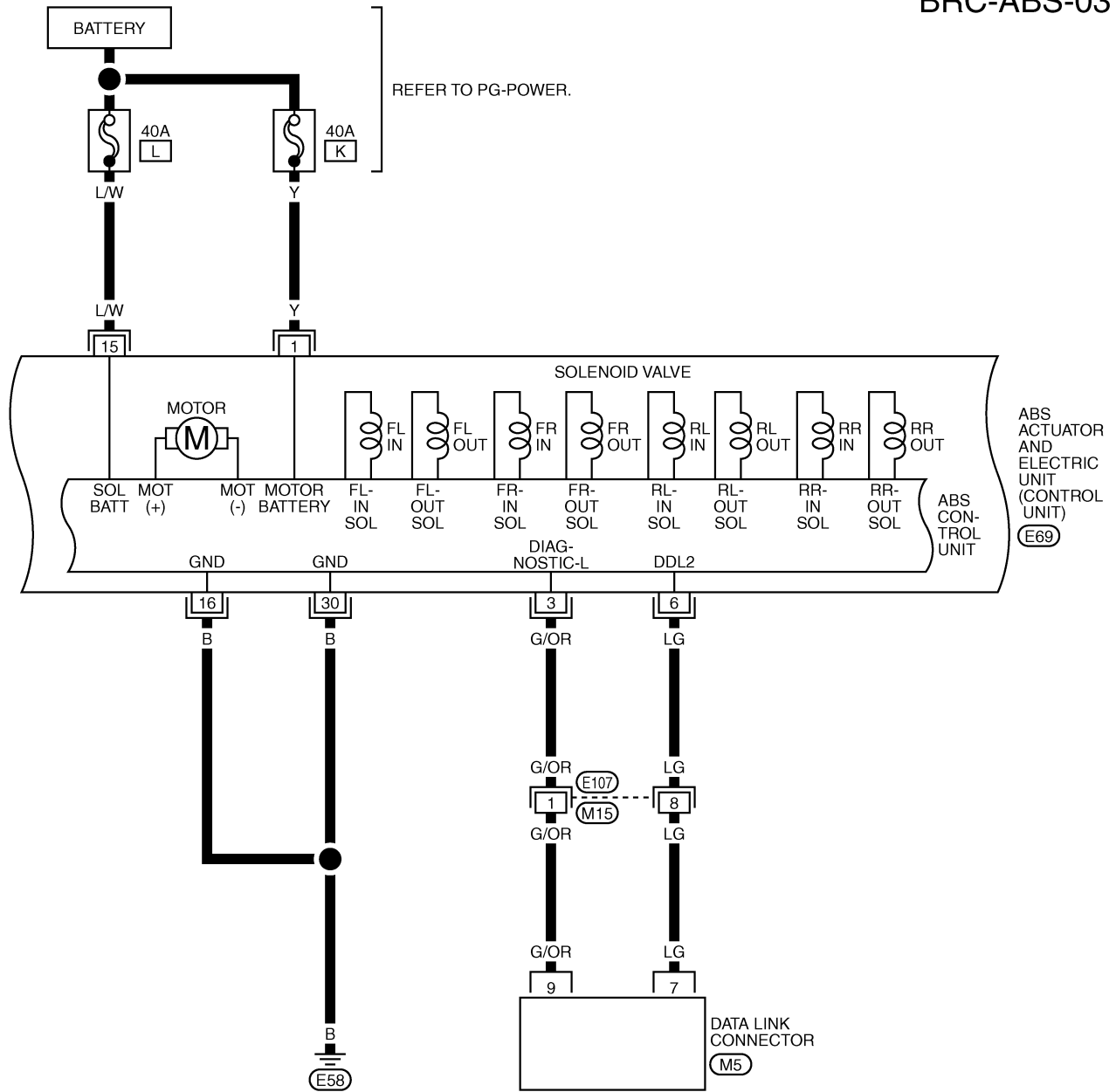

A
B
C
D
E
F
G
H
I
J
K
L
M

BRC

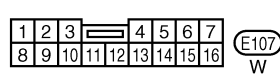
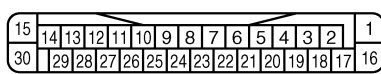
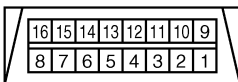

TROUBLE DIAGNOSIS

[ABS]

BRC-ABS-04

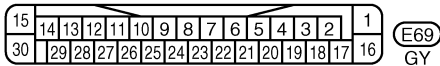
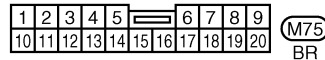
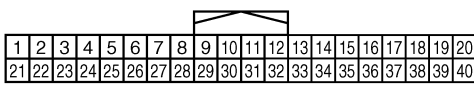
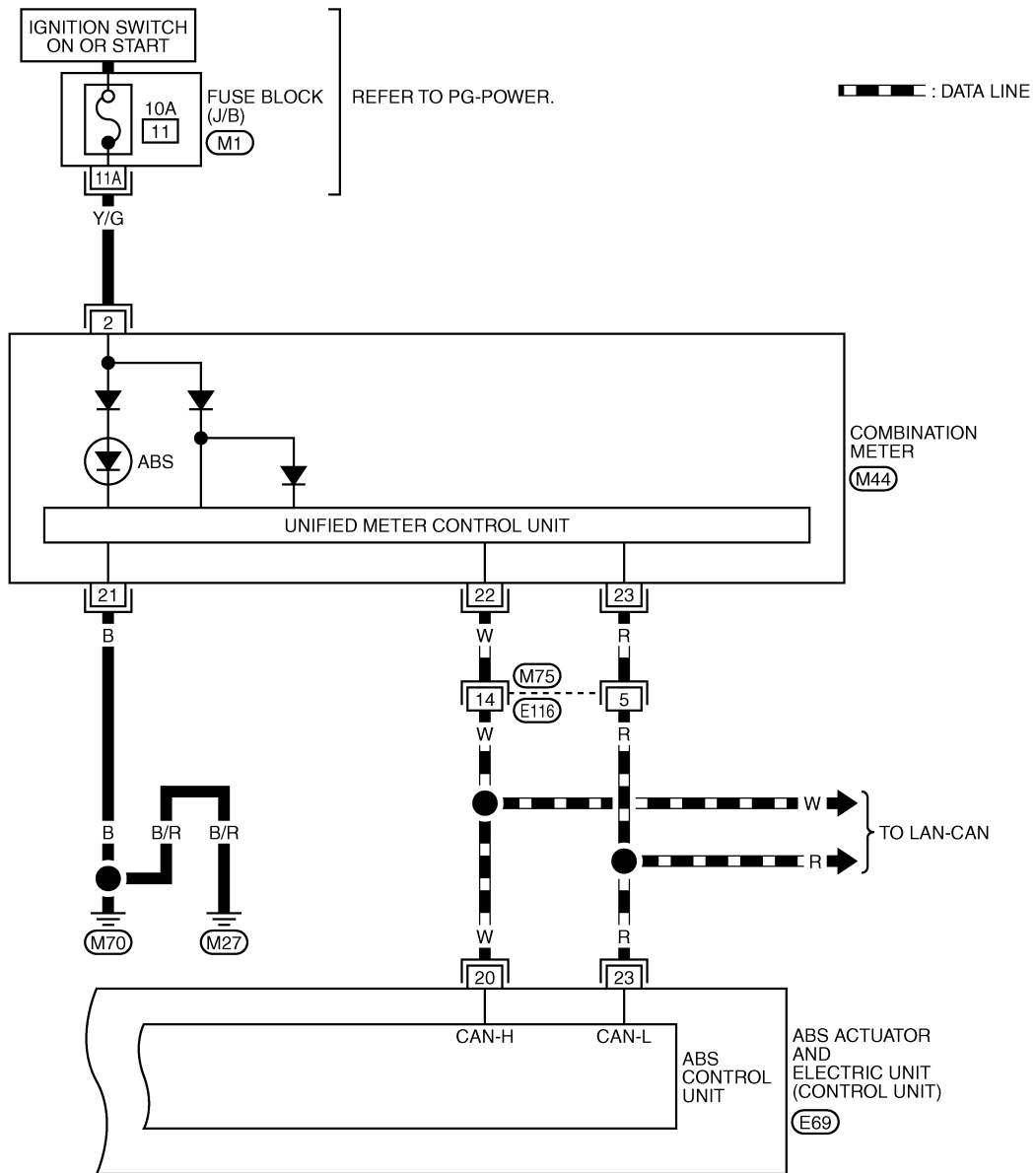

REFER TO THE FOLLOWING.
(M1) - FUSE BLOCK-JUNCTION BOX (J/B)

TROUBLE DIAGNOSIS

[ABS]

RHD MODEL

BRC-ABS-05

A
B
C
D
E
G
H
I
J
K
L
M

BRC

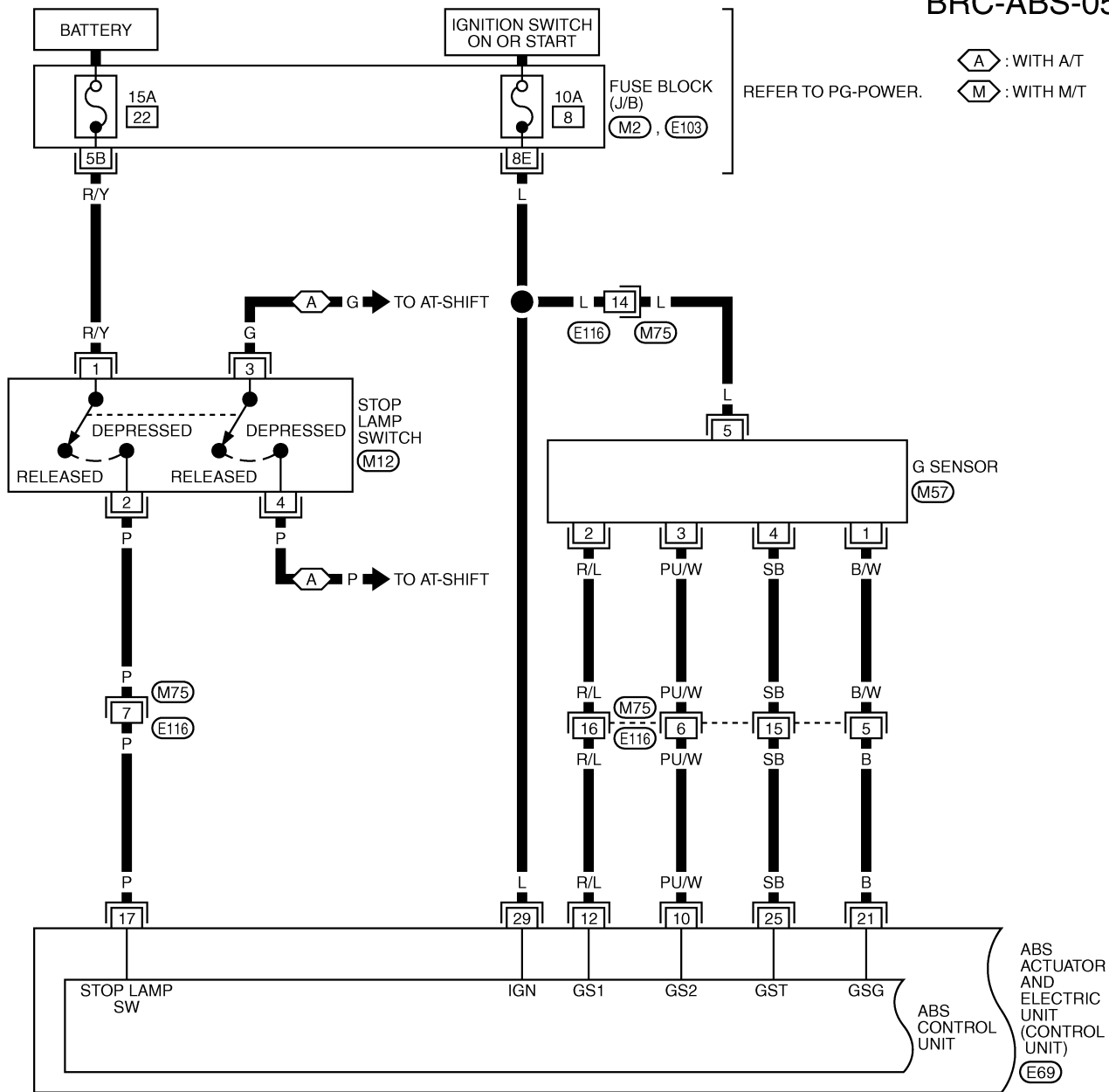

REFER TO PG-POWER.

⬡ (A) : WITH A/T
⬡ (M) : WITH M/T

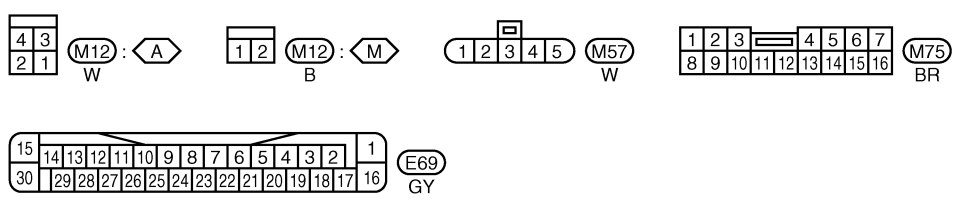

REFER TO THE FOLLOWING.
⬡ (M2), ⬡ (E103) - FUSE BLOCK-JUNCTION BOX (J/B)

TROUBLE DIAGNOSIS

[ABS]

BRC-ABS-06

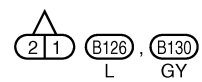
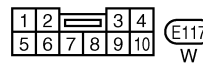
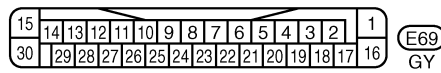
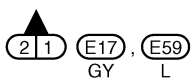
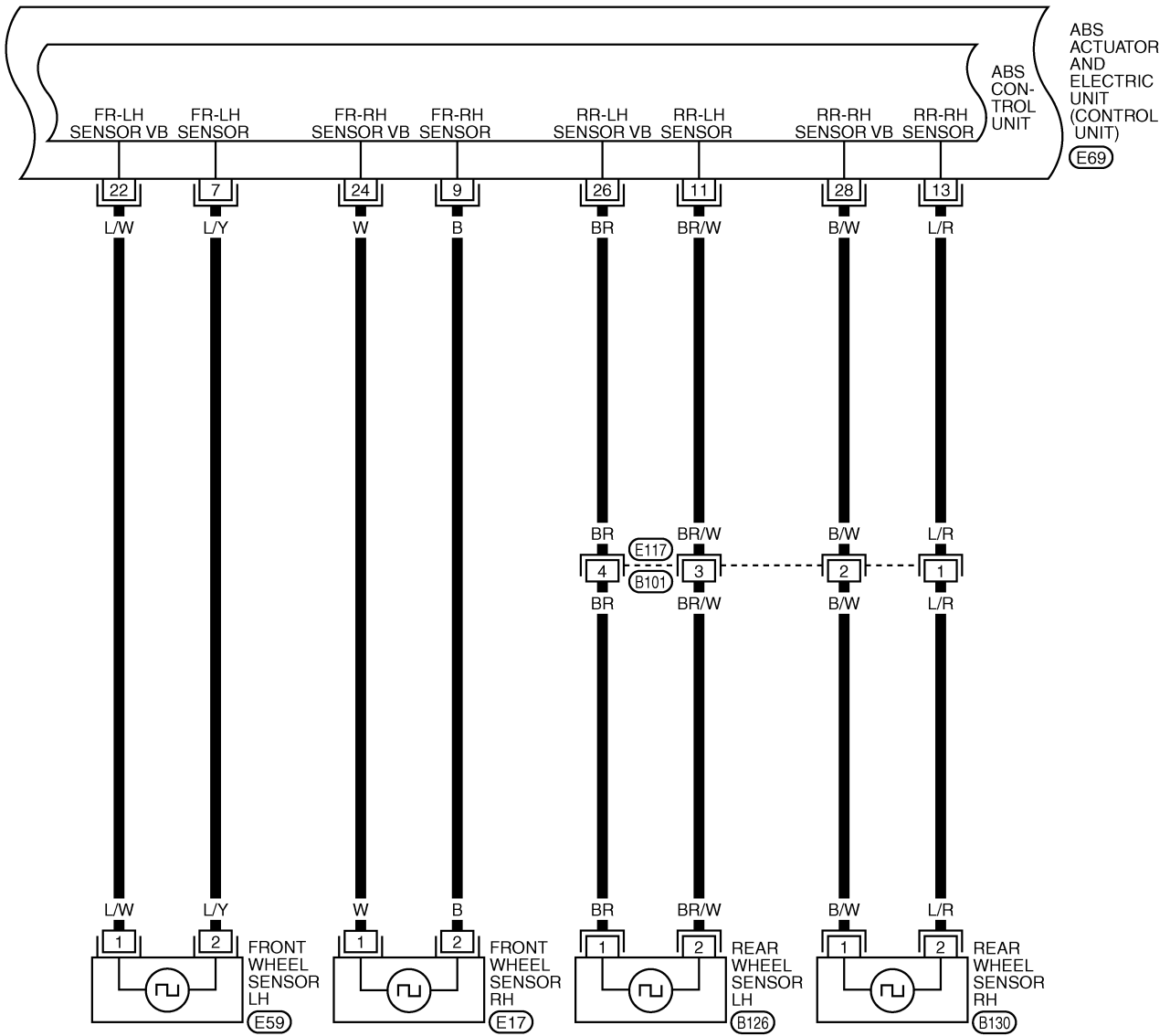

TFWA0084E

TROUBLE DIAGNOSIS

[ABS]

BRC-ABS-07

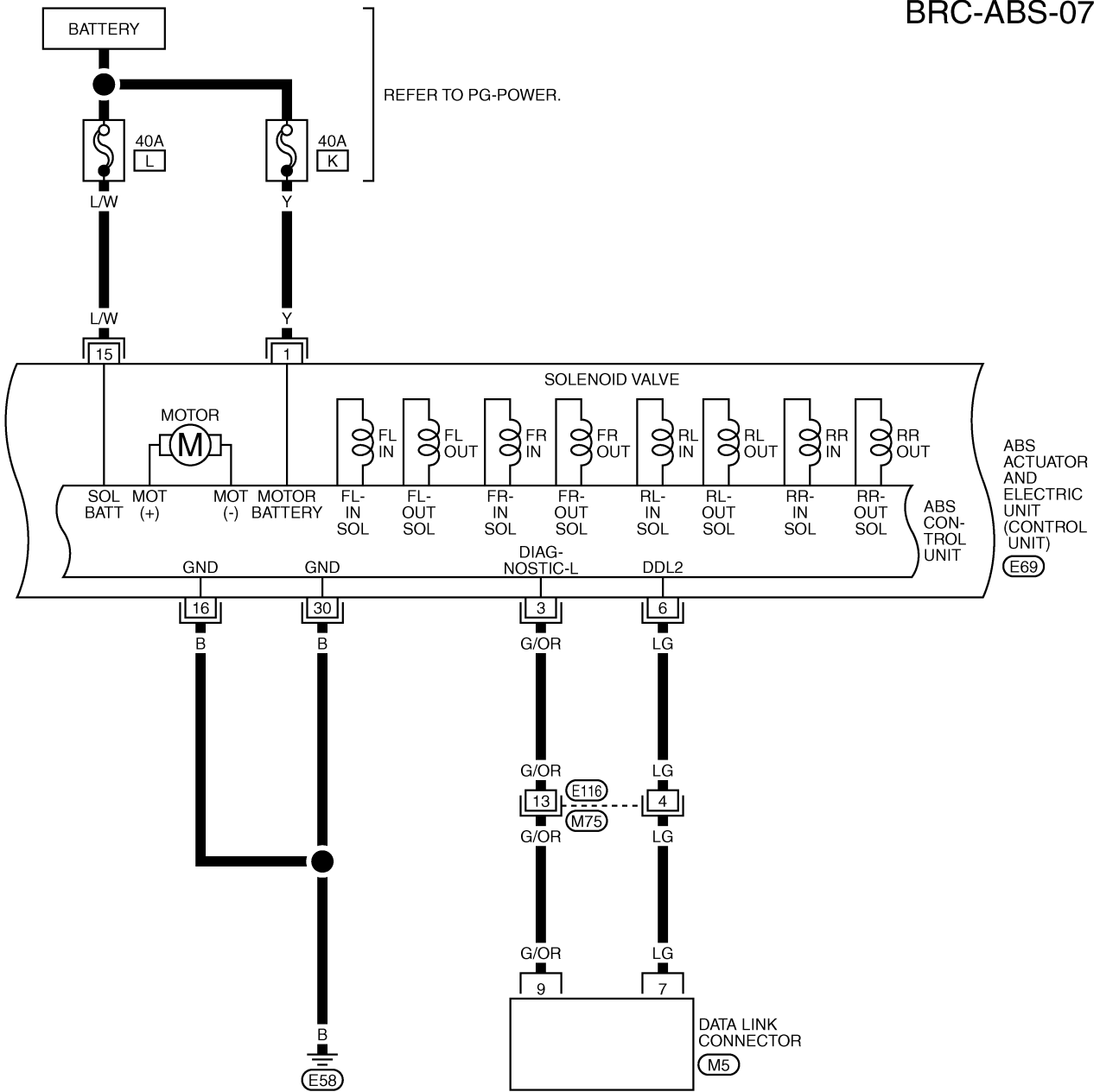

A
B
C
D
E
F
G
H
I
J
K
L
M

BRC

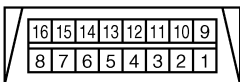

M5
W

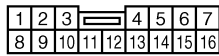

M75
BR

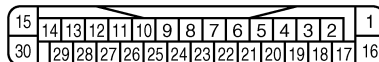

E69
GY

TROUBLE DIAGNOSIS

[ABS]

BRC-ABS-08

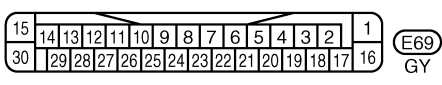
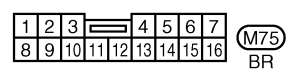
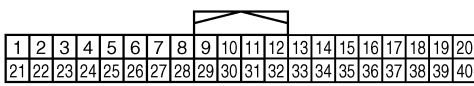
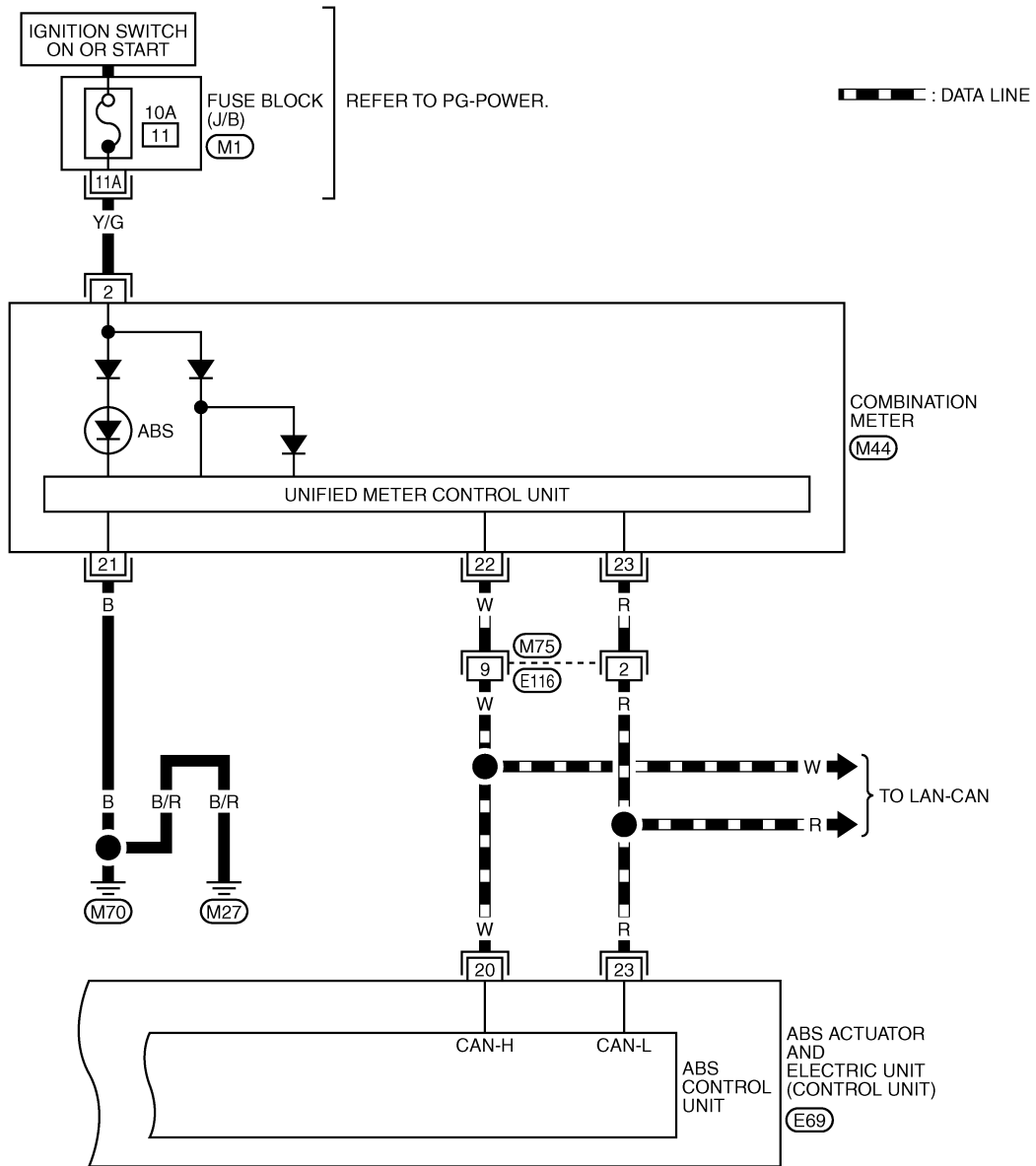

REFER TO THE FOLLOWING.
 (M1) - FUSE BLOCK-JUNCTION BOX (J/B)

TROUBLE DIAGNOSIS

[ABS]

Control Unit Input/Output Signal Standard

EFS004GA

REFERENCE VALUE FROM CONSULT-II

CAUTION:

The display shows the control unit calculation data, so a normal value might be displayed even in the event the output circuit (harness) is open or short - circulated.

Monitor item	Display Content	Data monitor		Reference: Inspection checklist
		Condition	Reference values for normal operation	
FR LH SENSOR FR RH SENSOR RR LH SENSOR RR RH SENSOR	Wheel speed calculated using signals from all four wheel sensors	Vehicle stopped	0 km/h (0 MPH)	BRC-36, "Inspection 1: Wheel Sensor System"
		While driving (Note 1)	Nearly matches the speedometer display (± 10% or less)	
DOCILE G-SEN. 1 DOCILE G-SEN. 2 (4WD model)	Fore-and-aft G detected by G sensor	When vehicle is stopped on level ground	OFF	BRC-41, "Inspection 6: G Sensor System"
		When G sensor is tilted toward the front with G sensor mounting bolt removed	ON	
ABS IN SOL ABS OUT SOL	Operation status of all solenoids	When the actuator solenoid operates or during a fail-safe	ON	BRC-39, "Inspection 4: ABS Actuator Relay or ABS Motor Relay Power System"
		When the actuator relay operates and the actuator solenoid does not operate	OFF	
STOP LAMP SW	Brake pedal operation	Brake pedal depressed	ON	Stop lamp switch circuit
		Brake pedal not depressed	OFF	
MOTOR RELAY	Motor and motor relay operation status	When the motor relay and motor are operating	ON	BRC-39, "Inspection 4: ABS Actuator Relay or ABS Motor Relay Power System"
		When the motor relay and motor are not operating	OFF	
ACTUATOR RELAY	Actuator relay operation status	When the actuator relay is operating	OFF	BRC-39, "Inspection 4: ABS Actuator Relay or ABS Motor Relay Power System"
		When the actuator relay is not operating	ON	
ABS WARN LAMP	ABS warning lamp on condition (Note 2)	ABS warning lamp ON	ON	BRC-35, "BASIC INSPECTION 3 ABS WARNING LAMP"
		ABS warning lamp OFF	OFF	
BATTERY VOLT	Battery voltage supplied to ABS actuator and electric unit (control unit)	Ignition switch ON	10 - 16V	BRC-38, "Inspection 3: ABS Actuator and Electric Unit (Control Unit) Power Supply and Ground Circuit"
EBD FAIL SIG ABS FAIL SIG	Fail signal status	EBD Fail ABS Fail	ON	EBD system ABS system
		EBD normal ABS normal	OFF	
EBD SIGNAL ABS SIGNAL	EBD operation ABS operation	EBD active ABS active	ON	
		EBD not active ABS not active	OFF	

Note 1: Confirm tyre pressure is normal.

Note 2: ABS warning lamp ON/OFF timing

ON: For approximately 1 second after the ignition switch is turned on or when an malfunction is detected.

OFF: Approximately 1 second after the ignition switch is turned on (when system is normal).

CONSULT- II Functions CONSULT-II MAIN FUNCTION

In a diagnosis function (main function), there are “SELF-DIAG RESULTS”, “DATA MONITOR”, “CAN DIAG SUPPORT MNTR”, “ACTIVE TEST”, “FUNCTION TEST”, “ECU PART NUMBER”.

Diagnostic test mode	Function	Reference
SELF-DIAG RESULTS	Self-diagnostic results can be read and erased quickly.	BRC-28. "SELF-DIAGNOSIS"
DATA MONITOR	Input/Output data in the ABS actuator and electric unit (control unit) can be read.	BRC-30. "DATA MONITOR"
CAN DIAG SUPPORT MNTR	The results of transmit/receive diagnosis of communication can be read.	—
ACTIVE TEST	Diagnostic Test Mode in which CONSULT-II drives some actuators apart from the ABS actuator and electric unit (control unit) and also shifts some parameters in a specified range.	BRC-32. "ACTIVE TEST"
FUNCTION TEST	Conducted by CONSULT-II instead of a technician to determine whether each system is “OK” or “NG”.	—
ECU PART NUMBER	ABS actuator and electric unit (control unit) part number can be read.	—

CONSULT-II BASIC OPERATION PROCEDURE

1. Turn ignition switch OFF.
2. Connect CONSULT-II and CONSULT-II CONVERTER to the data link connector.

CAUTION:

If CONSULT-II is used with no connection of CONSULT-II CONVERTER, malfunctions might be detected in self-diagnosis depending on control unit which carry out CAN communication.

3. Turn ignition switch ON.
4. Touch “START (NISSAN BASED VHCL)”.

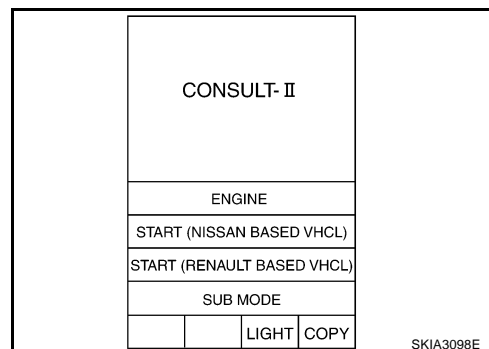

5. Touch “ABS” in the “SELECT SYSTEM” screen.
If “ABS” is not indicated, go to [GI-35. "CONSULT-II Data Link Connector \(DLC\) Circuit"](#) .

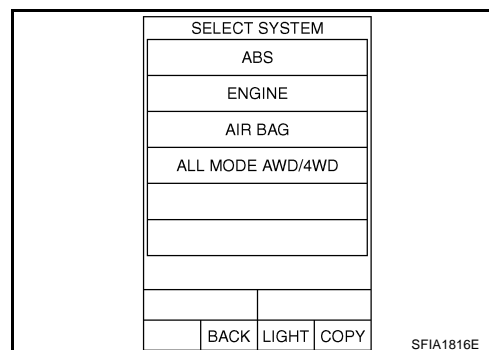

TROUBLE DIAGNOSIS

[ABS]

6. Select the required diagnostic location from the "SELECT DIAG MODE" screen.
For further information, see the CONSULT-II Operation Manual.

SELECT DIAG MODE			
SELF-DAIG RESULTS			
DATA MONITOR			
CAN DIAG SUPPORT MNTR			
ACTIVE TEST			
FUNCTION TEST			
ECU PART NUMBER			
BACK	LIGHT	COPY	
SFIA2435E			

A
B
C
D

E

BRC

G

H

I

J

K

L

M

SELF-DIAGNOSIS**Description**

If an malfunction is detected in the system, ABS warning lamp on the combination meter turn on. In this case, perform self-diagnosis as follows:

Operation Procedure

1. Turn ignition switch OFF.
2. Connect CONSULT-II and CONSULT-II CONVERTER to the data link connector.

CAUTION:

If CONSULT-II is used with no connection of CONSULT-II CONVERTER, malfunctions might be detected in self-diagnosis depending on control unit which carry out CAN communication.

3. Turn ignition switch ON.
4. Start engine and drive at 30 km/h (19 MPH) or more for approximately 1 minute.
5. After stopping the vehicle, with the engine running, touch "START (NISSAN BASED VHCL)", "ABS", "SELF-DIAG RESULTS" in order on the CONSULT-II screen.

CAUTION:

If "START (NISSAN BASED VHCL)" is touched immediately after starting the engine or turning on the ignition switch, "ABS" might not be displayed in the System Selection screen. In this case, repeat the operation from step 1.

6. The self-diagnostic results are displayed. (If necessary, the self-diagnostic results can be printed out by touching "PRINT".)
 - When "NO FAILURE" is displayed, check the ABS warning lamp.
7. Conduct the appropriate inspection from the display item list, and repair or replace the malfunctioning component.
8. Start engine and drive at 30 km/h (19 MPH) or more for approximately 1 minute.

CAUTION:

● When a wheel sensor "short-circuit" is detected, if the vehicle is not driven at 30 km/h (19 MPH) for at least 1 minute, the ABS warning lamp will not turn off even if everything is normal.

9. Turn ignition switch OFF to prepare for erasing the memory.
10. Start the engine and touch "START (NISSAN BASED VHCL)", "ABS", "SELF-DIAG RESULTS", "ERASE MEMORY" in order on the CONSULT-II screen to erase the diagnostic memory.

CAUTION:

If the diagnostic memory is not erased, re-conduct the operation from step 4.

11. For the final inspection, drive at 30 km/h (19 MPH) or more for approximately 1 minute and confirm that the ABS warning lamp a off.

TROUBLE DIAGNOSIS

[ABS]

Display Item List

Suspect Systems	Malfunction detecting condition	Inspection system
RR RH SENSOR-1	When the circuit in the rear RH wheel sensor is open.	
RR LH SENSOR-1	When the circuit in the rear LH wheel sensor is open.	
FR RH SENSOR-1	When the circuit in the front RH wheel sensor is open.	
FR LH SENSOR-1	When the circuit in the front LH wheel sensor is open.	
FR LH SENSOR-2	When the circuit in the front LH wheel sensor is short-circuited. Or when the sensor power voltage is outside the standard. When the distance between the wheel sensor and sensor rotor is too large and the sensor pulse cannot be recognized by the control unit.	
RR RH SENSOR-2	When the circuit in the rear RH wheel sensor is short-circuited. Or when the sensor power voltage is outside the standard. When the distance between the wheel sensor and sensor rotor is too large and the sensor pulse cannot be recognized by the control unit.	
FR RH SENSOR-2	When the circuit in the front RH wheel sensor is short-circuited. Or when the sensor power voltage is outside the standard. When the distance between the wheel sensor and sensor rotor is too large and the sensor pulse cannot be recognized by the control unit.	
RR LH SENSOR-2	When the circuit in the rear LH wheel sensor is short-circuited. Or when the sensor power voltage is outside the standard. When the distance between the wheel sensor and sensor rotor is too large and the sensor pulse cannot be recognized by the control unit.	
MAIN RELAY	When the control unit detects an malfunction in the actuator relay system.	
FR LH IN ABS SOL	When the control unit detects an malfunction in the front left inlet solenoid system.	
FR LH OUT ABS SOL	When the control unit detects an malfunction in the front left outlet solenoid system.	
RR RH IN ABS SOL	When the control unit detects an malfunction in the rear right inlet solenoid system.	
RR RH OUT ABS SOL	When the control unit detects an malfunction in the rear right outlet solenoid system.	
FR RH IN ABS SOL	When the control unit detects an malfunction in the front right inlet solenoid system.	
FR RH OUT ABS SOL	When the control unit detects an malfunction in the front right outlet solenoid system.	
RR LH IN ABS SOL	When the control unit detects an malfunction in the rear left inlet solenoid system.	
RR LH OUT ABS SOL	When the control unit detects an malfunction in the rear left outlet solenoid system.	
LOW POWER VOLTAGE	When the ABS actuator and electric unit power voltage is lower than normal.	BRC-38, "Inspection 3: ABS Actuator and Electric Unit (Control Unit) Power Supply and Ground Circuit"
EMERGENCY BRAKE	When the ABS actuator and electric unit malfunctions (pressure increase is too much or too little).	BRC-40, "Inspection 5: ABS Actuator and Electric Unit (Control Unit) 2"
ABS CONTROLLER	When there is an internal malfunction in the ABS actuator and electric unit.	BRC-38, "Inspection 2: ABS Actuator and Electric Unit (Control Unit) 1"

A
B
C
D
E
F
G
H
I
J
K
L
M

BRC

TROUBLE DIAGNOSIS

[ABS]

Suspect Systems	Malfunction detecting condition	Inspection system
CAN COMM CIRCUIT	When there is an malfunction in the CAN communication system.	BRC-43, "Inspection 7: CAN Communication System" (Note 2)
PUMP MOTOR	During actuator motor operation with ON, when actuator motor turns OFF or when control line for actuator motor relay is open.	BRC-39, "Inspection 4: ABS Actuator Relay or ABS Motor Relay Power System"
G - SENSOR (4WD model)	Decel G-sensor is malfunctioning, or signal line of Decel G-sensor is open or shorted.	BRC-41, "Inspection 6: G Sensor System"

Note 1: After completing repairs of shorted sensor circuit, when ignition switch is turned ON, ABS warning lamp turns on. Check that ABS warning lamp turns off while driving vehicle at 30 km/h (19 MPH) or more for approximately 1 minute according to self-diagnosis procedure. In addition, if wheel sensor 2 is displayed for wheels, check wheel sensor circuit and also check control unit power voltage.

Note 2: When malfunctions are detected in several systems, including CAN communication system [U1000], troubleshoot CAN communication system.

DATA MONITOR

Operation Procedure

1. Touch "ABS", "DATA MONITOR" in order on the CONSULT-II screen.
2. Return to the Monitor Item Selection screen, and touch "ECU INPUT SIGNALS", "MAIN SIGNALS" or "SELECTION FROM MENU". Refer to the following information.
3. When "START" is touched, the data monitor screen is displayed.

Display Item List

Item (Unit)	SELECT MONITOR ITEM			Remarks
	ECU INPUT SIGNALS	MAIN SIGNALS	SELECTION FROM MENU	
FR LH SENSOR [km/h]	×	×	×	Wheel speed calculated by front LH wheel sensor signal is displayed.
FR RH SENSOR [(km/h]	×	×	×	Wheel speed calculated by front RH wheel sensor signal is displayed.
RR LH SENSOR [km/h]	×	×	×	Wheel speed calculated by Rear LH wheel sensor signal is displayed.
RR RH SENSOR [km/h]	×	×	×	Wheel speed calculated by Rear RH wheel sensor signal is displayed.
DECEL G-SEN 1 (ON/OFF) (4WD model)	×	×	×	Decel G-sensor 1 (ON/OFF) status is displayed.
DECEL G-SEN 2 (ON/OFF) (4WD model)	×	×	×	Decel G-sensor 2 (ON/OFF) status is displayed.
FR LH IN SOL (ON/OFF)	–	×	×	Front left inlet ABS solenoid valve (ON/OFF) status is displayed.
FR LH OUT SOL (ON/OFF)	–	×	×	Front left outlet ABS solenoid valve (ON/OFF) status is displayed.
RR RH IN SOL (ON/OFF)	–	×	×	Rear right inlet ABS solenoid valve (ON/OFF) status is displayed.
RR RH OUT SOL (ON/OFF)	–	×	×	Rear right outlet ABS solenoid valve (ON/OFF) status is displayed.

TROUBLE DIAGNOSIS

[ABS]

Item (Unit)	SELECT MONITOR ITEM			Remarks
	ECU INPUT SIGNALS	MAIN SIGNALS	SELECTION FROM MENU	
FR RH IN SOL (ON/OFF)	–	×	×	Front right inlet ABS solenoid valve (ON/OFF) status is displayed.
FR RH OUT SOL (ON/OFF)	–	×	×	Front right outlet ABS solenoid valve (ON/OFF) status is displayed.
RR LH IN SOL (ON/OFF)	–	×	×	Rear left rear inlet ABS solenoid valve (ON/OFF) status is displayed.
RR LH OUT SOL (ON/OFF)	–	×	×	Rear left outlet ABS solenoid valve (ON/OFF) status is displayed.
STOP LAMP SW (ON/OFF)	×	×	×	Stop lamp switch (ON/OFF) status is displayed.
MOTOR RELAY (ON/OFF)	–	×	×	ABS motor relay (ON/OFF) condition is displayed.
ACTUATOR RLY (ON/OFF)	–	×	×	ABS actuator relay (ON/OFF) status is displayed.
ABS WARN LAMP (ON/OFF)	–	×	×	ABS warning lamp (ON/OFF) status is displayed.
BATTERY VOLT (V)	×	×	×	The voltage supplied to the ABS control unit is displayed.
EBD SIGNAL (ON/OFF)	–	–	×	EBD operation (ON/OFF) status is displayed.
ABS SIGNAL (ON/OFF)	–	–	×	ABS operation (ON/OFF) status is displayed.
EBD FAIL SIG (ON/OFF)	–	–	×	EBD fail-safe signal (ON/OFF) status is displayed.
ABS FAIL SIG (ON/OFF)	–	–	×	ABS fail-safe signal (ON/OFF) status is displayed.

×: Applicable
 –: Not applicable

A
 B
 C
 D
 E
BRC
 G
 H
 I
 J
 K
 L
 M

ACTIVE TEST

CAUTION:

- Do not perform active test while driving.
- Make sure to completely bleed air from the brake system.
- Active test can not be performed with ABS warning lamp on.

Operation Procedure

1. Touch "ABS", "ACTIVE TEST" in order on the CONSULT-II screen.
2. The test item selection screen is displayed.
3. Touch necessary test item.

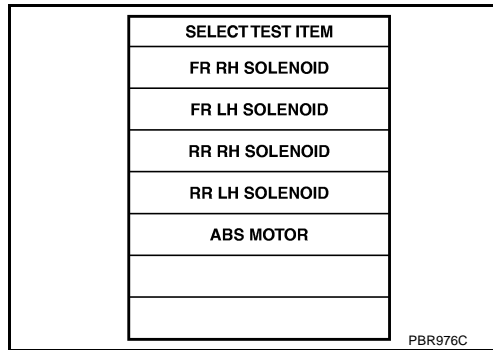

4. With the "MAIN SIGNALS" display shown in reverse, touch "START".
5. The Active Test screen will be displayed, so conduct the following test.

NOTE:

- When the active test is conducted while depressing pedal, pedal depression amount will change, but this is normal.
- Approximately 10 seconds after the operation is begun, "TEST STOP" will be displayed.
- To conduct a retest after "TEST STOP" is displayed, touch "BACK" and conduct the from the step 3.

Test Item

Solenoid valve

CAUTION:

The example shown is for the front right wheel. The procedure for the other wheels is the same as given below.

1. For ABS solenoid valve, touch "UP", "KEEP", and "DOWN". Then use screen monitor to check that solenoid valve operates as shown in Solenoid Valve Operation Chart. Refer to "Solenoid Valve Operation Chart".

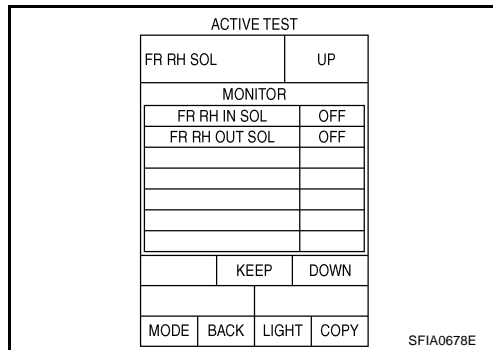

Operation		ABS solenoid valve		
		UP	KEEP	DOWN
FR RH SOL	FR RH IN SOL	OFF	ON	ON
	FR RH OUT SOL	OFF	OFF	ON*

*: ON for 1 to 2 seconds after the touch, and then OFF

TROUBLE DIAGNOSIS

[ABS]

ABS Motor

Touch "ON", "OFF" on the display screen and make sure ABS motor relay is operating as shown in the table below.

Operation	ON	OFF
MOTOR RELAY	ON	OFF
ACTUATOR RLY	ON	ON

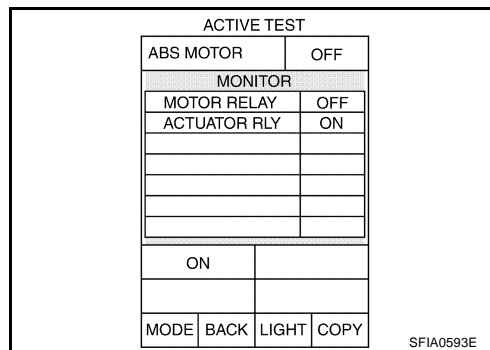

A
B
C
D
E
G
H
I
J
K
L
M

BRC

Correct and Quick Diagnosis DIAGNOSIS PRECAUTIONS

- Before performing the trouble diagnosis, always read the general information (GI) to confirm the general precautions. Refer to [GI-4, "General Precautions"](#).
- After completing service, always erase the self-diagnosis results. Refer to [BRC-28, "Operation Procedure"](#).
- When inspection of the continuity or voltage between units is performed, check connector terminals for disconnection, looseness, bend, or collapse. If any non-standard condition is detected, repair or replace applicable part.
- Intermittent malfunctions may be caused by a poor connection in the harness, connector, or terminal. Move harnesses, harness connectors, or terminals by hand to make sure all connections are solid and undamaged.
- If a circuit tester is used for the check, be careful not to forcibly extend any connector terminal.
- While a phenomena like those shown in the following table may occur, this is not malfunction because the system is working normally.

Symptom	Symptom description	Result
Motor operation noise	This is the sound of the motor operating inside ABS actuator, and there may be some low sounds while the ABS is operating.	Normal
	Just after the engine starts, the motor operating noise may be heard. This is a normal status of the system operation check.	
System operation check noise	When the engine is started, you may barely be able to hear a slight thudding sound from the engine room, but this sound is made by the system operation check and is normal.	Normal
ABS operation (longer stopping distance)	Stopping distance may be longer for vehicles with ABS when the vehicle drives on rough or snow-covered roads. Use lower speeds when driving on these kinds of roads.	Normal

ON and OFF Timing for ABS Warning Lamp

×: ON -: OFF

Condition	ABS warning lamp	Remarks
Ignition switch OFF	-	—
For approximately "1" second after ignition switch ON	×	—
After approximately "1" second after ignition switch ON. (When system is normal)	-	Turns off 1 second after engine start
ABS malfunction	×	When there is an ABS actuator and electric unit malfunction (power or ground malfunction)
EBD malfunction	×	-

Basic Inspection**BASIC INSPECTION 1 BRAKE FLUID AMOUNT, LEAKS, AND BRAKE PADS INSPECTION**

1. Check fluid level in the brake reservoir tank. If fluid level is low, refill the brake fluid.
2. Check the brake piping and around the ABS actuator for leaks. If there is leaking or oozing fluid, check the following items.
 - If ABS actuator and electric unit (control unit) connection is loose, tighten the piping to the specified torque and re-conduct the leak inspection to make sure there are no leaks.
 - If there is damage to the connection flare nut or ABS actuator and electric unit (control unit) screw, replace the damaged part and re-conduct the leak inspection to make sure there are no leaks.
 - When there is fluid leaking or oozing from a part other than ABS actuator and electric unit (control unit) connection, if the fluid is just oozing out, use a clean cloth to wipe off the oozing fluid and re-check for leaks. If fluid is still oozing out, replace the damaged part.

CAUTION:

ABS actuator and electric unit (control unit) cannot be disassembled.

3. Check the brake pad degree of wear. Refer to [BR-27, "PAD THICKNESS"](#) in "Front Disc Brake" and [BR-32, "PAD WEAR INSPECTION"](#) in "Rear Disc Brake".

BASIC INSPECTION 2 POWER SYSTEM TERMINAL LOOSENESS AND BATTERY INSPECTION

Make sure the battery positive cable, negative cable and ground connection are not loose. In addition, check the battery voltage to make sure it has not dropped.

BASIC INSPECTION 3 ABS WARNING LAMP

1. Make sure that when the ignition switch is turned ON, the ABS warning lamp turns on for approximately 1 second. If they do not turn on, perform CAN communication system diagnosis. Refer to [BRC-43, "Inspection 7: CAN Communication System"](#).
2. Check if the ABS warning lamp turns off approximately 1 second after the ignition switch is turned ON, If it do not turn off, perform self-diagnosis.
3. if ABS warning lamp has not turned off 10 seconds after the engine has been started, perform self-diagnosis of the ABS actuator and electric unit (control unit).
4. Always erase the self-diagnostic results after completing self-diagnosis. Refer to [BRC-28, "Operation Procedure"](#).

Inspection 1: Wheel Sensor System

INSPECTION PROCEDURE

Check each part according to CONSULT-II self-diagnostic results, and then identify the parts to be replaced.

CAUTION:

Do not check between wheel sensor terminals.

1. CHECK TYRE

Check air pressure, wear and size.

Are air pressure, wear and size within standard?

YES >> GO TO 2.

NO >> Adjust air pressure, or replace tyre.

2. CHECK SENSOR AND SENSOR ROTOR

- Check sensor and sensor rotor.
- Check sensor rotor rubber for damage.
- Check sensor for disconnection or looseness.

OK or NG

OK >> GO TO 3.

NG >> Repair sensor mount or replace sensor rotor.

3. CHECK SELF-DIAGNOSIS RESULTS

Check the self-diagnostic results.

Self-diagnosis results
FR RH SENSOR-1,-2
FR LH SENSOR-1,-2
RR RH SENSOR-1,-2
RR LH SENSOR-1,-2

Is above displayed on self-diagnosis displayed?

YES >> GO TO 4.

NO >> INSPECTION END

4. CHECK CONNECTOR

1. Turn ignition switch OFF, disconnect connector between ABS actuator and electric unit (control unit) and malfunctioning wheel sensor, and check for deformation, disconnection and looseness. Repair or replace if necessary.
2. Reconnect connectors, drive vehicle at 30 km/h (19 MPH) or more for approximately 1 minute, and then perform self-diagnosis.

OK or NG

OK >> Poor connection of connector terminal

NG >> GO TO 5.

5. CHECK WHEEL SENSOR HARNESS

1. Turn ignition switch OFF and disconnect malfunctioning wheel sensor connector and ABS actuator and electric unit (control unit) connector.
2. Check continuity between terminals. (Also check continuity when the steering wheel is turned right and left and when the sensor harness inside the wheel house is moved.)

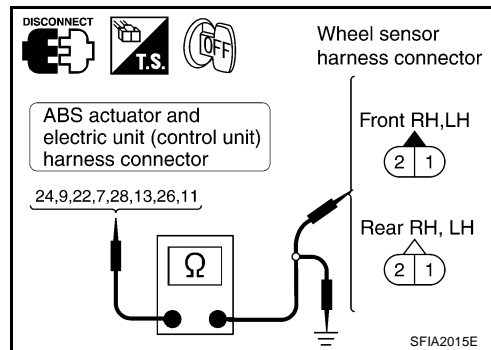

Wheel	Power supply circuit		Signal circuit		Ground circuit	
	ABS actuator and electric unit (control unit) harness connector E69	Wheel sensor harness connector	ABS actuator and electric unit (control unit) harness connector E69	Wheel sensor harness connector	ABS actuator and electric unit (control unit) harness connector E69 (Signal)	Ground
Front RH (E17)	24 (W)	1 (W)	9 (B)	2 (B)	9 (B), 24 (W)	—
Front LH (E59)	22 (L/W)	1 (L/W)	7 (L/Y)	2 (L/Y)	7 (L/Y), 22 (L/W)	
Rear RH (B130)	28 (B/W)	1 (B/W)	13 (L/R)	2 (L/R)	13 (L/R), 28 (B/W)	
Rear LH (B126)	26 (BR)	1 (BR)	11 (BR/W)	2 (BR/W)	11 (BR/W), 26 (BR)	

- Power supply circuit** : Continuity should exist.
Signal circuit : Continuity should exist.
Ground circuit : Continuity should not exist.

OK or NG

- OK >> GO TO 6.
 NG >> Repair or replace harness and connector that have malfunction.

6. CHECK WHEEL SENSOR

1. Replace wheel sensor that resulted in malfunction by self-diagnosis.
2. Reconnect connectors, drive vehicle at 30 km/h (19 MPH) or more for approximately 1 minute, and then perform self-diagnosis.

Is above displayed on self-diagnosis display?

- OK >> Wheel sensor has malfunction.
 NG >> ● Replace ABS actuator and electric unit (control unit).
 ● Perform to self-diagnosis again, and make sure that the result shows "NO DTC IS DETECTED. FURTHER TESTING MAY BE REQUIRED".

Inspection 2: ABS Actuator and Electric Unit (Control Unit) 1

INSPECTION PROCEDURE

1. CHECK SELF-DIAGNOSTIC RESULTS

Check self-diagnostic results.

Self-diagnostic results

ABS CONTROLLER

Is above displayed on self-diagnosis display?

- YES >> Replace ABS actuator and electric unit (control unit). Perform self-diagnosis again.
- NO >> INSPECTION END

Inspection 3: ABS Actuator and Electric Unit (Control Unit) Power Supply and Ground Circuit

INSPECTION PROCEDURE

1. CHECK SELF-DIAGNOSTIC RESULTS

Check self-diagnostic results.

Self-diagnostic results

LOW POWER VOLTAGE

Is above displayed on self-diagnosis display?

- YES >> GO TO 2.
- NO >> INSPECTION END

2. CHECK CONNECTOR

1. Turn ignition switch OFF, disconnect the ABS actuator and electric unit (control unit) connector, and check the terminal for deformation, disconnection, looseness, and so on. If there is a malfunction, repair or replace the terminal.
2. Connect the connector securely and perform self-diagnosis again.

OK or NG

- OK >> Poor connection of connector terminal
- NG >> GO TO 3.

3. CHECK ABS ACTUATOR AND ELECTRIC UNIT POWER SUPPLY AND GROUND CIRCUIT

1. Turn ignition switch OFF and disconnect ABS actuator and electric unit (control unit) connector.
2. Turn ignition switch ON or OFF, and then check continuity and voltage between each connector terminal and ground.

Signal	ABS actuator and electric unit (control unit) harness connector E69	Ground	Measurement condition	Measured value
Power supply	29 (L)	—	Ignition switch ON	Battery voltage (Approx. 12V)
			Ignition switch OFF	Approx. 0V

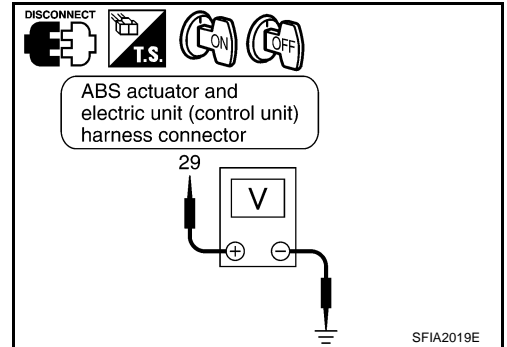

Signal	ABS actuator and electric unit (control unit) harness connector E69	Ground	Measurement condition	Measured value
Ground	16 (B),30 (B)	—	Ignition switch OFF	Continuity should exist.

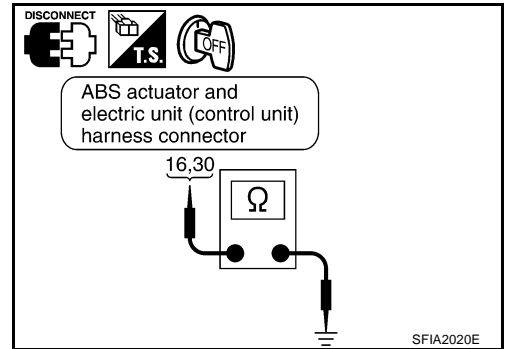

OK or NG

- OK >> Check battery for terminal looseness, low voltage, etc. If any malfunction is found, repair malfunctioning parts.
- NG >> Corresponding harness circuit malfunctions. Repair circuit.

Inspection 4: ABS Actuator Relay or ABS Motor Relay Power System

EF5004HE

INSPECTION PROCEDURE

1. CHECK SELF-DIAGNOSTIC RESULTS

Check the self-diagnostic results.

Self-diagnostic results
IN ABS SOL
OUT ABS SOL
MAIN RELAY (ACTUATOR RELAY)
PUMP MOTOR

Is above displayed on self-diagnosis display?

- YES >> GO TO 2.
- NO >> INSPECTION END

2. CHECK CONNECTOR

1. Turn ignition switch OFF, disconnect the ABS actuator and electric unit (control unit) connector, and check the terminal for deformation, disconnection, looseness, and so on. If there is a malfunction, repair or replace the terminal.
2. Connect the connector securely and perform self-diagnosis again.

OK or NG

- OK >> Poor connection of connector terminal
- NG >> GO TO 3.

3. CHECK ABS ACTUATOR RELAY OR ABS MOTOR RELAY POWER SUPPLY CIRCUIT

1. Turn ignition switch OFF and disconnect ABS actuator and electric unit (control unit) connectors.
2. For the ABS actuator relay, measure voltage between harness connector E69 terminal 15 (L/W) and ground. For the ABS motor relay, measure voltage between harness connector E69 terminal 1 (Y) and the ground.

ABS actuator and electric unit (control unit) harness connector E69	Ground	Voltage
1 (Y), 15 (L/W)	—	Battery voltage (Approx. 12V)

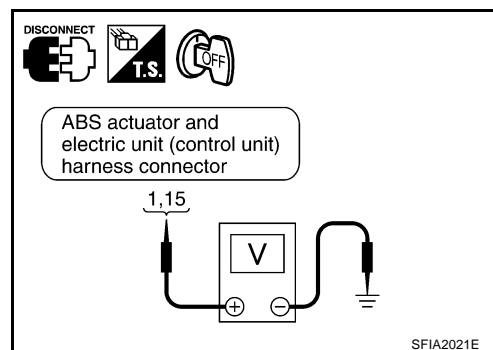

OK or NG

- OK >> GO TO 4.
- NG >> Circuit malfunction between the battery and ABS actuator and electric unit (control unit). Repair circuit.

4. CHECK ABS ACTUATOR AND ELECTRIC UNIT (CONTROL UNIT) GROUND CIRCUIT

Check continuity between ABS actuator and electric unit (control unit) harness connector E69 terminals 16 (B), 30 (B) and ground.

ABS actuator and electric unit (control unit) harness connector E69	Ground	Continuity
16 (B), 30 (B)	—	Yes

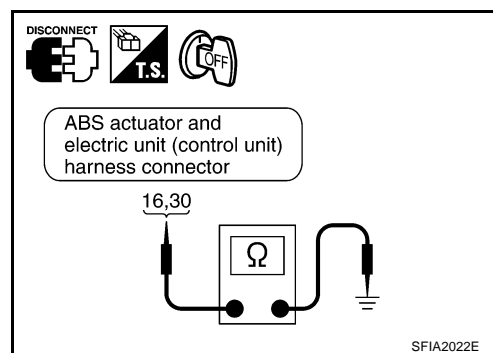

OK or NG

- OK >> Replace ABS actuator and electric unit (control unit).
- NG >> Open or short in harness. Repair or replace the harness.

Inspection 5: ABS Actuator and Electric Unit (Control Unit) 2

EFS004HG

INSPECTION PROCEDURE

1. CHECK SELF-DIAGNOSTIC RESULTS

Check the self-diagnostic results.

Self-diagnostic results
EMERGENCY BRAKE

Even when “EMERGENCY BRAKE” and any other items are indicated in self-diagnosis display (Note), replace control unit.

Note: Emergency brake is indicated when the control unit itself detects an internal malfunction.

Is above displayed on self-diagnosis display?

- YES >> Replace ABS actuator and electric unit (control unit). Perform self-diagnosis again.
- NO >> INSPECTION END

Inspection 6: G Sensor System

INSPECTION PROCEDURE

1. CHECK SELF-DIAGNOSIS RESULTS

Check the self-diagnostic results.

Self-diagnostic results
G - SENSOR

Is above displayed on self-diagnosis display?

- YES >> GO TO 2.
- NO >> INSPECTION END

2. CHECK CONNECTOR

1. Turn ignition switch OFF, disconnect the ABS actuator and electric unit (control unit) and G sensor connector, and check the terminal for deformation, disconnection, looseness, and so on. If there is a malfunction, repair or replace the terminal.
2. Reconnect connector securely, and perform self-diagnosis.

OK or NG

- OK >> Poor connection of connector terminal
- NG >> GO TO 3.

3. CHECK CIRCUIT BETWEEN G SENSOR AND ABS ACTUATOR AND ELECTRIC UNIT

1. Turn ignition switch OFF and disconnect G sensor and ABS actuator and electric unit (control unit) connectors.
2. Check continuity between G sensor harness connector M57 and ABS actuator and electric unit (control unit) harness connector E69.

G sensor harness connector M57	ABS actuator and electric unit (control unit) harness connector E69	Measured value
1 (B/W)	21 (B)	Continuity should exist.
2 (R/L)	12 (R/L)	
3 (PU/W)	10 (PU/W)	
4 (SB)	25 (SB)	

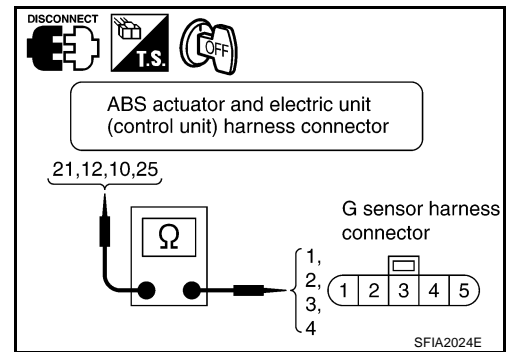

OK or NG

- OK >> GO TO 4.
- NG >> Circuit malfunction of G sensor. Repair harness.

4. CHECK G SENSOR POWER SUPPLY CIRCUIT

1. Turn ignition switch ON.
2. Check voltage between G sensor harness connector M57 terminal 5 (L) and ground.

Voltage : Battery voltage (Approx. 12V)

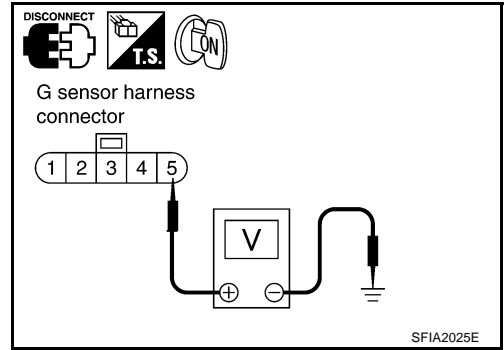

OK or NG

- OK >> GO TO 5.
- NG >> G sensor power supply circuit malfunction. Repair circuit.

5. CHECK G SENSOR

1. Remove G sensor from the vehicle. Refer to [BRC-47, "G SENSOR"](#) .
2. Connect the following terminals between G sensor and connector.

G sensor connector	Harness connector M57
1	1 (B)
2	2 (R/L)
5	5 (L)

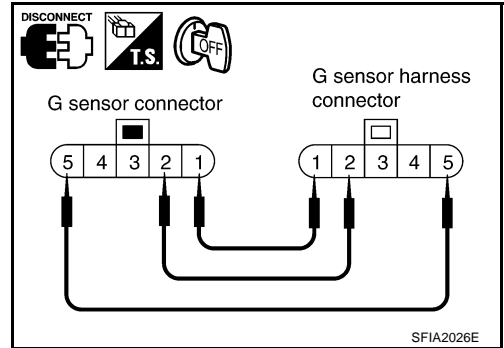

3. Check voltage between the following G sensor terminals when ignition switch turns ON and G sensor is in the following condition.

G sensor status	G sensor harness connector M57 terminals 5 (L) - 4 (SB)	G sensor harness connector M57 terminals 5 (L) - 3 (PU/W)
Horizontal	Approx. 5V	Approx. 5V
Longitudinally tilt by 20°	Approx. 10V	Approx. 10V
Longitudinally tilt by 40°	Approx. 5V	Approx. 10V

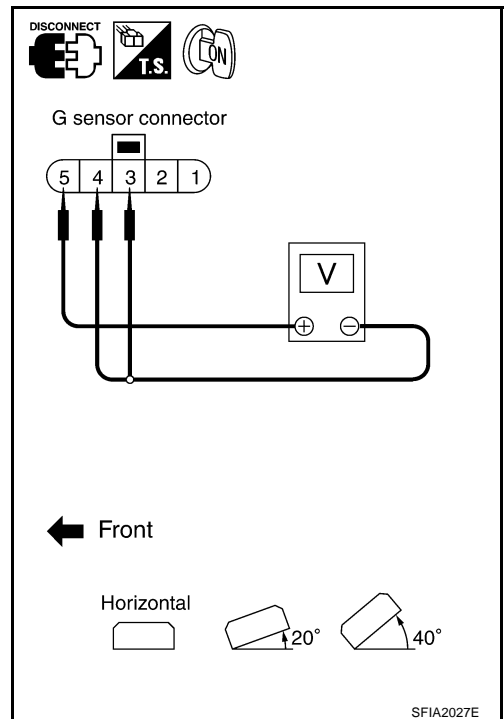

OK or NG

OK >> ABS actuator and electric unit (control unit) malfunction. Replace ABS actuator and electric unit (control unit).

NG >> G sensor malfunction. Replace G sensor.

Inspection 7: CAN Communication System

EFS004HI

INSPECTION PROCEDURE

1. CHECK CONNECTOR

1. Turn ignition switch OFF, disconnect the ABS actuator and electric unit (control unit) connector, and check the terminal for deformation, disconnection, looseness, and so on. If there is a malfunction, repair or replace the terminal.

2. Reconnect connector to perform self-diagnosis.

Is "CAN COMM CIRCUIT" displayed in the self-diagnosis display items?

YES >> Print out the self-diagnostic results, and refer to [BRC-8, "CAN COMMUNICATION"](#).

NO >> Connector terminal connector is loose, damaged, open, or shorted.

Symptom 1: ABS Works Frequently

EFS004HJ

1. CHECK START

Check longitudinal brake force distribution using a brake tester.

OK or NG

OK >> GO TO 2.

NG >> Check brake system.

2. CHECK FRONT AND REAR AXLE

Check to make sure that there is no excessive play in the front and rear axles. Refer to Front: [FAX-7, "On-Vehicle Inspection"](#), Rear: [RAX-6, "WHEEL BEARING INSPECTION"](#) (2WD), [RAX-10, "REAR WHEEL BEARING"](#) (4WD).

OK or NG

OK >> GO TO 3.

NG >> Repair.

3. CHECK WHEEL SENSOR AND SENSOR ROTOR

Check wheel sensor and sensor rotor for the following.

- Sensor installation for damage
- Sensor rotor installation for damage
- Sensor connector engagement
- Sensor harness

OK or NG

OK >> GO TO 4.

NG >> ● Replace wheel sensor or sensor rotor.

- Repair harness.

4. CHECK ABS WARNING LAMP DISPLAY

Make sure that the warning lamp turns off approximately 1 second after the key switch is turned on or when driving.

OK or NG

OK >> Normal

NG >> Perform self-diagnosis. Refer to [BRC-28, "SELF-DIAGNOSIS"](#).

Symptom 2: Unexpected Pedal Reaction

EFS004HK

1. CHECK BRAKE PEDAL STROKE

Check brake pedal stroke. Refer to [BR-6, "On-Vehicle Inspection and Adjustment"](#) .

Is the stroke too large?

- YES >> ● Bleed air from the brake piping. Refer to [BR-9, "Bleeding Brake System"](#) .
- Check brake pedal, brake booster, and master cylinder for mount play, looseness, brake system fluid leakage, etc. Repair if necessary. Refer to Brake pedal: [BR-7, "Components"](#) , brake booster and master cylinder: [BR-23, "Removal and Installation"](#) .
- NO >> GO TO 2.

2. PERFORMANCE CHECK

Disconnect ABS actuator and electric unit (control unit) connector to deactivate ABS. Check if braking force is normal in this condition. Connect connector after inspection.

OK or NG

- OK >> GO TO 3. Wheel Sensor Inspection in [BRC-43, "Symptom 1: ABS Works Frequently"](#) .
- NG >> Check brake system.

Symptom 3: Longer Stopping Distance

EFS004HL

CAUTION:

The stopping distance on slippery road surfaces might be longer with the ABS operating than when the ABS is not operating.

1. PERFORMANCE CHECK

Turn ignition switch OFF. Disconnect ABS actuator and electric unit (control unit) connector to deactivate ABS. In this condition, check stopping distance. After inspection, connect connector.

OK or NG

- OK >> GO TO [BRC-43, "Symptom 1: ABS Works Frequently"](#) .
- NG >> ● Bleed air from the brake piping. Refer to [BR-9, "Bleeding Brake System"](#) .
- Check brake system.

Symptom 4: ABS Does Not Work

EFS004HM

CAUTION:

ABS does not operate when speed is 10 km/h or lower.

1. CHECK ABS WARNING LAMP DISPLAY

Make sure that the warning lamp turns off approximately 1 second after the key switch is turned on or when driving.

OK or NG

OK >> GO TO 3. Check wheel sensor and sensor rotor in [BRC-43, "Symptom 1: ABS Works Frequently"](#)

NG >> Perform self-diagnosis. Refer to [BRC-28, "SELF-DIAGNOSIS"](#) .

Symptom 5: Pedal Vibration and ABS Operation Noise

EFS004HM

CAUTION:

Under the following conditions, ABS is activated and vibration is felt when brake pedal is lightly depressed (just place a foot on it). However, this is normal.

- When shifting gears
- When driving on slippery road
- During cornering at high speed
- When passing over bumps or grooves (Approx. 50 mm or more)
- When pulling away just after starting engine (Approx. 10 km/h or more)

1. SYMPTOM CHECK 1

Check if pedal vibration or operation sounds occur when the engine is started.

OK or NG

OK >> GO TO 2.

NG >> Perform self-diagnosis. Refer to [BRC-28, "SELF-DIAGNOSIS"](#) .

2. SYMPTOM CHECK 2

Check symptoms when electrical component (headlamps, etc.) Switches are operated.

Do symptoms occur?

YES >> Check if there is a radio, antenna, antenna lead wire, or wiring close to the control unit. If there is, move it farther away.

NG >> GO TO 3. Check wheel sensor and sensor rotor in [BRC-43, "Symptom 1: ABS Works Frequently"](#)

WHEEL SENSORS

Removal and Installation

SEC. 476
Front

Detail A
Front wheel sensor (LH) harness connector
Fix the connector on the engine room (LH).

Push and lock the rubber clamp.

17.7 - 23.5
(1.8 - 2.3, 13 - 17)

Check the white line as white line in the figure while viewing from the outside of vehicle.

Front wheel sensor (LH)

Detail B
Front wheel sensor (RH) harness connector
Fix the connector on the engine room (RH).

Rear

Detail B
Rear wheel sensor (LH) harness connector
Fix the connector on the rear suspension member (LH).

Push and lock the rubber clamp.

17.7 - 23.5 (1.8 - 2.3, 13 - 17)

Check the white line as the figure C while viewing from the outside of vehicle.

Figure C
Drive shaft
Parallel link

Rear wheel sensor (LH)

Detail C
Rear wheel sensor (RH) harness connector
Fix the connector on the rear suspension member (RH).

Ⓜ : N·m (kg·m, ft·lb)

Do not twist the white line parts. (※ hatching)

SFIA1100E

REMOVAL

Pay attention to the following when removing sensor.

CAUTION:

- As much as possible, avoid rotating sensor when removing it. Pull sensors out without pulling on sensor harness.
- Take care to avoid damaging sensor edges or rotor teeth. Remove wheel sensor first before removing front or rear wheel hub. This is to avoid damage to sensor wiring and loss of sensor function.

INSTALLATION

Pay attention to the following when installing sensor. Tighten installation bolts to specified torques.

- When installing, check that there is no foreign material such as iron chips on pick-up and mounting hole of the sensor. Check that no foreign material has been caught in the sensor rotor. Remove any foreign material and clean the mount.
- When installing front sensor, be sure to press rubber grommets in until they lock at the three locations shown in the figure (2 at strut and 1 at body panel). When installed, harness must not be twisted.

G SENSOR**Removal and Installation****CAUTION:**

- Do not drop or strike the G sensor, because it is sensitive to impact.
- Do not use power tool, etc. Because G sensor is weak for the impact.

REMOVAL

1. Remove center console. Refer to [IP-10, "INSTRUMENT PANEL ASSEMBLY"](#).
2. Disconnect G sensor connector.
3. Remove mounting nuts and remove G sensor.

NOTE:

There is not need to detach the G sensor main body from a bracket.

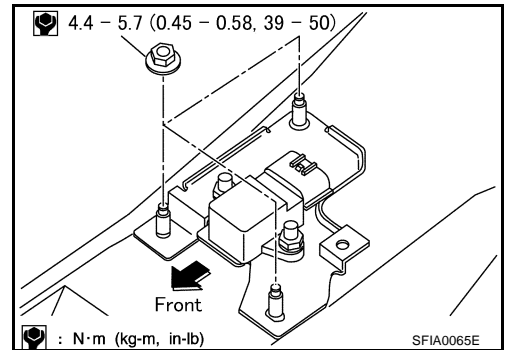
**INSTALLATION**

Install in the reverse order of removal observing the precautions above.

A

B

C

D

E

BRC

G

H

I

J

K

L

M

SENSOR ROTOR

Removal and Installation

REMOVAL

Front

1. Remove drive shaft. Refer to [FAX-11, "Removal and Installation"](#) in "FAX Front axle/Drive shaft".
2. Remove sensor rotor from drive shaft. Refer to "FAX Front axle/Drive shaft" [FAX-13, "Disassembly and Assembly"](#) .

Rear (2WD Model)

1. Remove wheel hub. Refer to [RAX-6, "Removal and Installation"](#) .
2. Remove sensor rotor from wheel hub. Refer to [RAX-7, "Disassembly and Assembly"](#) .

Rear (4WD Model)

1. Remove drive shaft. Refer to [RAX-14, "Removal and Installation"](#) in "RAX Rear axle/Drive shaft".
2. Remove sensor rotor from drive shaft. Refer to "RAX Rear axle/Drive shaft" [RAX-15, "Disassembly and Assembly"](#) .

INSTALLATION

Front

1. Install sensor rotor to drive shaft. Refer to "FAX Front axle/Drive shaft" [FAX-13, "Disassembly and Assembly"](#)
2. Connect drive shaft. Refer to [FAX-11, "Removal and Installation"](#) in "FAX Front axle/Drive shaft".

Rear (2WD Model)

1. Install sensor rotor to wheel hub. Refer to [RAX-7, "Disassembly and Assembly"](#) .
2. Install wheel hub. Refer to [RAX-6, "Removal and Installation"](#) .

Rear (4WD Model)

1. Install sensor rotor to drive shaft. Refer to "RAX Rear axle/Drive shaft" [RAX-15, "Disassembly and Assembly"](#)
2. Connect drive shaft. Refer to [RAX-14, "Removal and Installation"](#) in "RAX Rear axle/Drive shaft".

ABS ACTUATOR AND ELECTRIC UNIT (ASSEMBLY)

PF:47660

Removal and Installation

EFS004GT

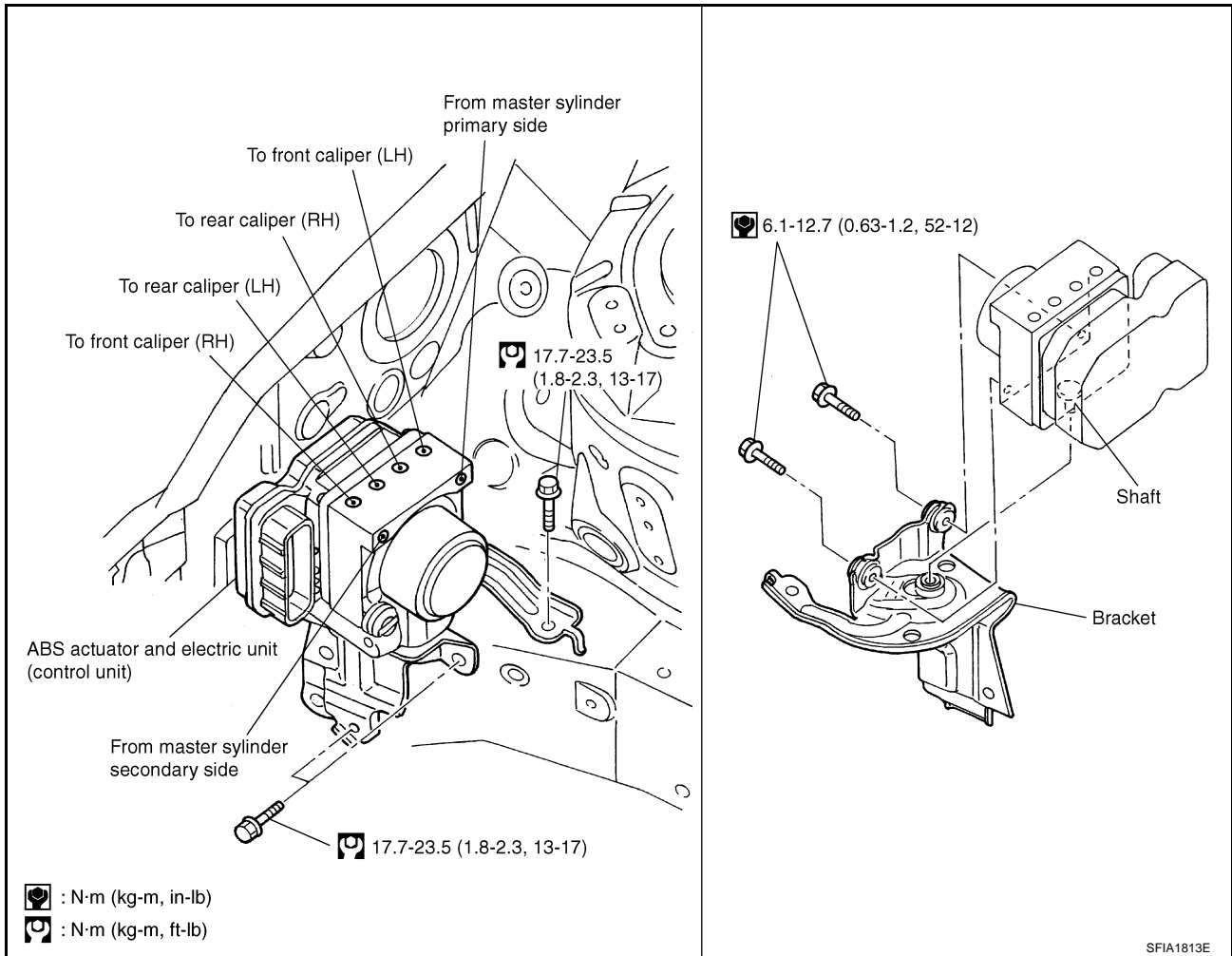

A
B
C
D
E
BRC
G
H
I
J
K
L
M

- The above figure shows RH model. LH model figure is the mirror image.
- Pay attention to the following when removing actuator.

CAUTION:

- Before servicing, disconnect battery terminals.
- To remove brake tube, use flare nut wrench to prevent flare nuts and brake tube from being damaged. To install, use flare nut torque wrench (special service tool).
- Do not apply excessive impact to actuator, such as dropping it.
- Do not remove and install ABS actuator and electric unit (control unit) by holding harness.
- After work is completed, bleed air from brake piping. Refer to [BR-9, "Bleeding Brake System"](#).

PRECAUTIONS

PFP:00001

Precautions for Supplemental Restraint System (SRS) “AIR BAG” and “SEAT BELT PRE-TENSIONER”

EFS004H7

The Supplemental Restraint System such as “AIR BAG” and “SEAT BELT PRE-TENSIONER”, used along with a front seat belt, helps to reduce the risk or severity of injury to the driver and front passenger for certain types of collision. Information necessary to service the system safely is included in the SRS and SB section of this Service Manual.

WARNING:

- To avoid rendering the SRS inoperative, which could increase the risk of personal injury or death in the event of a collision which would result in air bag inflation, all maintenance must be performed by an authorized NISSAN/INFINITI dealer.
- Improper maintenance, including incorrect removal and installation of the SRS, can lead to personal injury caused by unintentional activation of the system. For removal of Spiral Cable and Air Bag Module, see the SRS section.
- Do not use electrical test equipment on any circuit related to the SRS unless instructed to in this Service Manual. SRS wiring harnesses can be identified by yellow and/or orange harnesses or harness connectors.

Precautions for Brake System

EFS00190

- Recommended fluid is brake fluid “DOT 3” or “DOT 4”.
- Do not reuse drained brake fluid.
- Be careful not to splash brake fluid on painted areas; it may cause paint damage. If brake fluid is splashed on painted areas, wash it away with water immediately.
- Do not use mineral oils such as gasoline or kerosene. They will ruin rubber parts of hydraulic system.
- Using a flare nut torque wrench, securely tighten brake tube flare nuts.
- When installing brake piping, be sure to check torque.
- Before working, turn the ignition switch OFF and disconnect the connectors for the ESP/TCS/ABS control unit and control unit or the battery negative terminal.
- Burnish the brake pad contact surfaces after refinishing or replacing drums or rotors, after replacing pads or linings, or if a soft pedal occurs at very low mileage. Refer to [BR-31, "BRAKE BURNISHING PROCEDURE"](#).

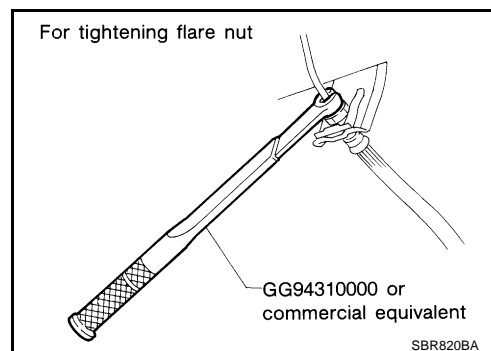

WARNING:

Clean brakes with a vacuum dust collector to minimize risk of health hazard from powder caused by friction.

Precautions for Brake Control

EFS0019P

- During the ESP/TCS/ABS operation, the brake pedal vibrates lightly and its mechanical noise may be heard. This is a normal condition.
- Just after starting the vehicle after ignition switch ON, the brake pedal may vibrate or the motor operating noise may be heard from the engine compartment. This is a normal status of the operation check.
- The stopping distance may be longer than that of vehicles without ABS when the vehicle drives on rough, gravel, or snowy (fresh deep snow) road.
- If a malfunction is indicated by the ABS warning lamp, or other warning lamps, collect the necessary information from the customer (what symptoms are present under what conditions) and find out the possible causes before starting the service. Besides the electrical system inspection, check the booster operation, brake fluid level, and oil leaks.
- If the tyre size and type are used in a improper combination, or the brake pads are not NISSAN genuine parts, the stopping distance or steering stability may deteriorate.
- If there is a radio, antenna, or antenna lead-in wire (including wiring) near the control unit, the ESP/TCS/ABS function may have a malfunction.
- If aftermarket parts (car stereo, CD player, etc.) have been installed, check harnesses for pinches, open, and improper wiring.

PREPARATION

PFP:00002

Special Service Tools

EFS00219

Tool number Tool name	Description
GG94310000 Flare nut torque wrench a:10mm (0.39 in) / 12mm (0.47 in)	Installing each brake piping

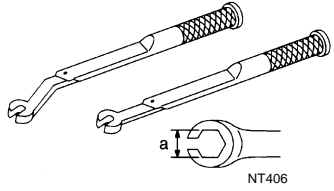

A
B
C
D
E
G
H
I
J
K
L
M

BRC

ON-VEHICLE SERVICE

PFP:00000

Adjustment of Steering Angle Sensor Neutral Position

EFS0019R

In case of doing work that applies to the list below, make sure to adjust neutral position of steering angle sensor before running vehicle.

Situation	Adjustment of Steering Angle Sensor Neutral Position
Removing/Installing ESP/TCS/ABS control unit	-
Replacing ESP/TCS/ABS control unit	-
Removing/Installing steering angle sensor	×
Removing/Installing steering components	×
Removing/Installing suspension components	×
Change tyre to new ones	-
Tyre rotation	-
Adjusting wheel alignment	×

×: Required

-: Not required

CAUTION:

To adjust neutral position of steering angle sensor, make sure to use CONSULT-II. (Adjustment cannot be done without CONSULT-II.)

1. Stop vehicle with front wheels in straight-ahead position.
2. Connect CONSULT-II and CONSULT-II CONVERTER to data link connector on vehicle, and turn ignition switch ON (do not start engine).

CAUTION:

If CONSULT-II is used with no connection of CONSULT-II CONVERTER, malfunctions might be detected in self-diagnosis depending on control unit which carry out CAN communication.

3. Touch "ABS", "WORK SUPPORT" and "ST ANGLE SENSOR ADJUSTMENT" on CONSULT-II screen in this order. Refer to [BRC-79, "CONSULT-II BASIC OPERATION PROCEDURE"](#).
4. Touch "START".

CAUTION:

Do not touch steering wheel while adjusting steering angle sensor.

5. After approximately 10 seconds, touch "END". (After approximately 60 seconds, it ends automatically.)
6. Turn ignition switch OFF, then turn it ON again.

CAUTION:

Be sure to carry out above operation.

7. Run vehicle with front wheels in straight-ahead position, then stop.
8. Select "DATA MONITOR", "SELECTION FROM MENU", and "STR ANGLE SIG" on CONSULT-II screen. Then make sure "STR ANGLE SIG" is within 0 ± 3.5 deg. If value is more than specification, repeat steps 1 to 7.
9. Erase memory of ESP/TCS/ABS control unit and ECM.
10. Turn ignition switch OFF.

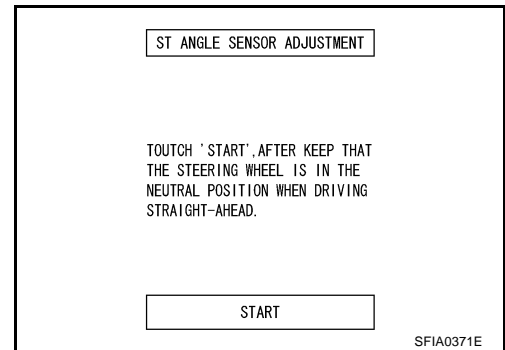

SYSTEM DESCRIPTION

PFP:00000

System Diagram

EFS0019X

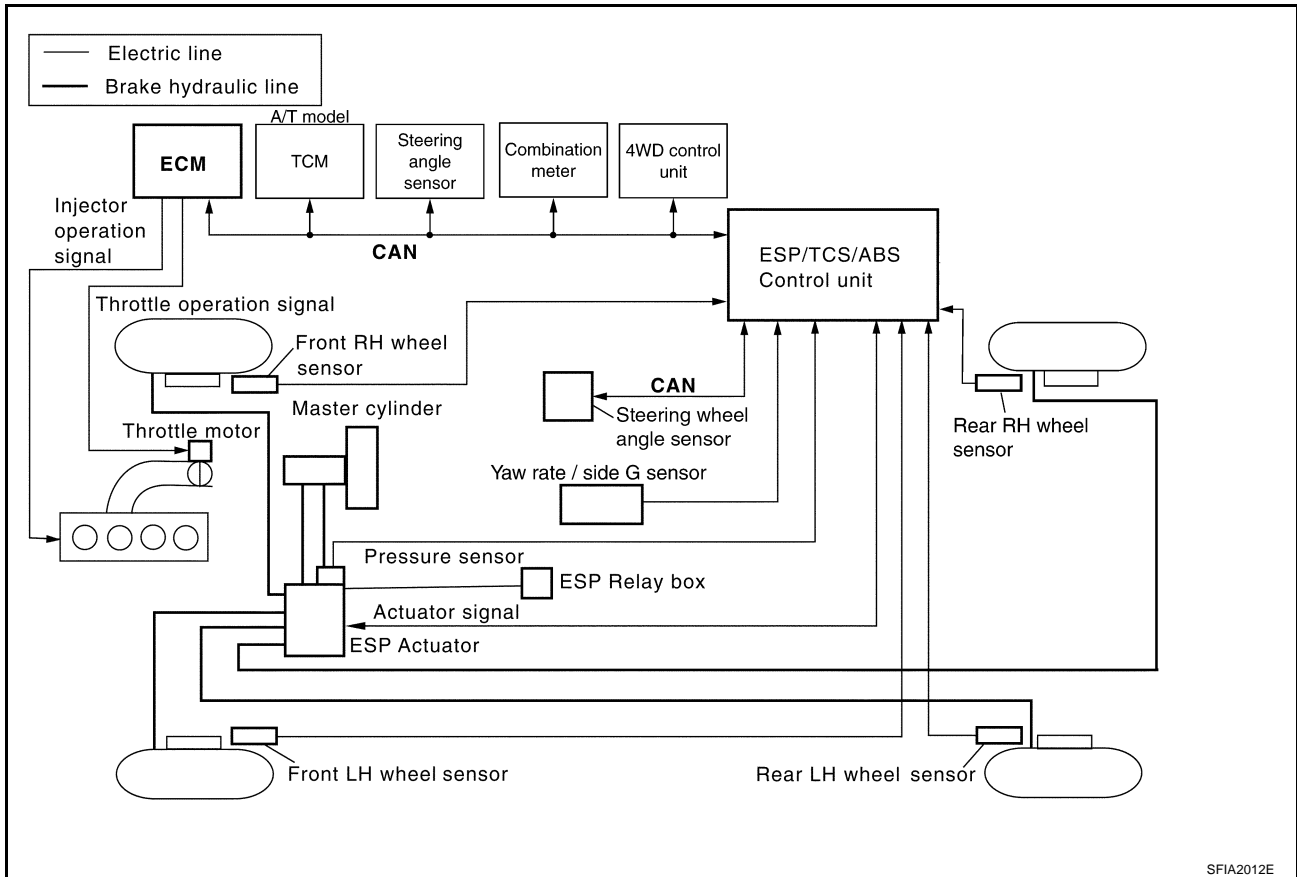

SFIA2012E

ESP Function

EFS0019W

1. The Electronic Stability Program is called the ESP for short. ESP is indicated as ESP on CONSULT-II screen.
2. In addition to the ABS/TCS function, ESP detects a driver's steering operation amount and brake operation amount from steering angle sensor and pressure sensor. Using the information from yaw rate/side G sensor and wheel sensors, ESP judges the driving condition (conditions of understeer and oversteer) to improve the stability by controlling brake on 4 wheels and engine output.
3. During ESP operation, SLIP indicator lamp flashes to inform the driver of the operation.

CAUTION:

- During ESP operation, body and the brake pedal lightly vibrate and their mechanical noise may be heard. This is a normal condition.
- If vehicle is rotated on a turn table, or rolled and rocked on a ship, the ABS warning lamp, ESP OFF indicator lamp, and SLIP indicator lamp may turn on. In this case, start engine on a normal road again. If the ABS warning lamp, ESP OFF indicator lamp, and SLIP indicator lamp turn off after the restart, it is normal.
- When driving in a steep slope such as a bank, ABS warning lamp, ESP OFF indicator lamp, and SLIP indicator lamp may turn on. In this case, start the engine on a normal road again. If ABS warning lamp, ESP OFF indicator lamp, and SLIP indicator lamp turn off after the restart, it is normal.

TCS Function

EFS0019V

1. With the wheel sensor signals from 4 wheels, the ESP/TCS/ABS control unit detects a wheel spin. If a wheel spins, the control unit controls brake fluid pressure to the spinning wheel, and cuts the fuel to the engine. It also closes the throttle valve to reduce the engine torque. Furthermore, throttle position is controlled to the appropriate engine torque.
2. If a wheel spins, the TCS system works and function by applying brake fluid pressure to the spinning wheel.

3. During TCS operation, it informs a driver of system operation by flashing SLIP indicator lamp.

CAUTION:

- During TCS operation, body and brake pedal lightly vibrate and the mechanical noise may be heard. This is a normal condition.
- Depending on road circumstances, a driver may have a sluggish feel. This is not malfunction, because the optimum traction has the highest priority by TCS operation.
- When the vehicle is passing through a road where the surface friction coefficient varies, down-shifting or depressing the accelerator pedal fully may activate TCS temporarily.

ABS Function

EFS0019U

1. In cases of braking suddenly or braking on slippery road (ice road), ABS functions prevent wheels from lock, improve the stability in sudden braking, and make efficient avoidance of obstacles with steering manipulation by detecting wheel speed and controlling brake fluid pressure.
2. EBD is integrated in ESP/TCS/ABS system.

CAUTION:

- During ABS operation, brake pedal lightly vibrates and its mechanical noise may be heard. This is a normal condition.
- When starting engine, or just after starting vehicle, brake pedal may vibrate or the motor operating noise may be heard from engine compartment. This is a normal status of the operation check.
- The stopping distance may be longer than that of vehicles without ABS when vehicle drives on rough, gravel, or snowy (fresh deep snow) road.

EBD Function

EFS004HO

- Electronic Brake Distributor is a function that detects subtle slippages between front and rear wheels during braking, and it improves handling stability by electronically controlling the brake fluid pressure which results in reduced rear wheel slippage.
- In case of electrical system break down, the fail-safe function is activated, EBD and ABS becomes inoperative, and ABS warning lamp and brake warning lamp are turned on.
- Electrical System Diagnosis by CONSULT-II is available.

Fail-Safe Function

EFS004HP

ESP/ TCS SYSTEM

In case of throttle control system trouble, ESP OFF indicator lamp and SLIP indicator lamp are turned on, and the condition of vehicle is the same as the condition of vehicles without ESP/TCS equipment. In case of trouble to the throttle control system, the ABS control continues to operate normally without ESP/TCS control.

CAUTION:

If the fail-safe function is activated, then perform the self- diagnosis for ESP/TCS/ABS control system.

ABS, EBD SYSTEM

In case of electrical malfunctions with the ABS, ABS warning lamp, ESP OFF indicator lamp and SLIP indicator lamp will turn on. In case of electrical malfunctions with the EBD, brake warning lamp, ABS warning lamp, ESP OFF indicator lamp and SLIP indicator lamp will turn on. Simultaneously, the ESP/ TCS/ABS become one of the following conditions of the fail-safe function.

1. For ABS trouble, only the EBD is activated and the condition of vehicle is the same condition of vehicles without ESP/TCS/ABS equipment.
2. For EBD trouble, the EBD and ABS become inoperative, and the condition of vehicle is the same as the condition of vehicles without ESP/TCS/ABS, EBD equipment.

NOTE:

In condition 1 described above, an ABS self-diagnosis sound may be heard. That is a normal condition because a self-diagnosis for "Ignition switch ON" and "The first starting" are being performed.

Hydraulic Circuit Diagram

EFS0019T

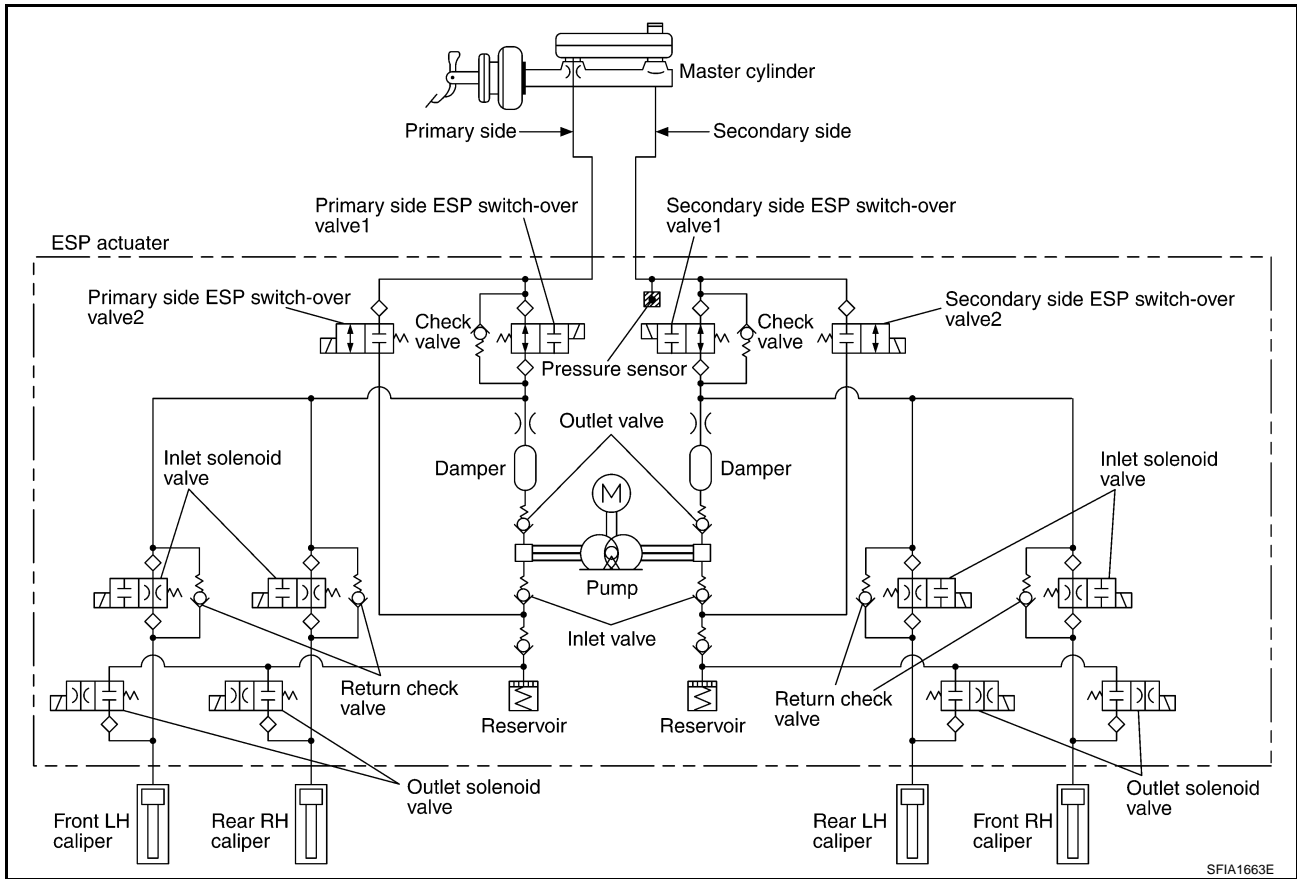

A
B
C
D
E
BRC
G
H
I
J
K
L
M

CAN COMMUNICATION

PFP:23710

System Description

EFS0067I

CAN (Controller Area Network) is a serial communication line for real time application. It is an on-vehicle multiplex communication line with high data communication speed and excellent error detection ability. Many electronic control units are equipped onto a vehicle, and each control unit shares information and links with other control units during operation (not independent). In CAN communication, control units are connected with 2 communication lines (CAN H line, CAN L line) allowing a high rate of information transmission with less wiring. Each control unit transmits/receives data but selectively reads required data only.

CAN Communication Unit

EFS0067J

Body type	Wagon			
Axle	4WD		2WD	
Engine	YD22DDTi	QR25DE		YD22DDTi
Transmission	M/T		A/T	M/T
Brake control	ESP			
CAN system type	4	5	6	9
ECM	×	×	×	×
TCM			×	
ESP/TCS/ABS control unit	×	×	×	×
ABS actuator and electric unit (control unit)				
Steering angle sensor	×	×	×	×
4WD control unit	×	×	×	
Combination meter	×	×	×	×

TYPE 4/TYPE 5

System diagram

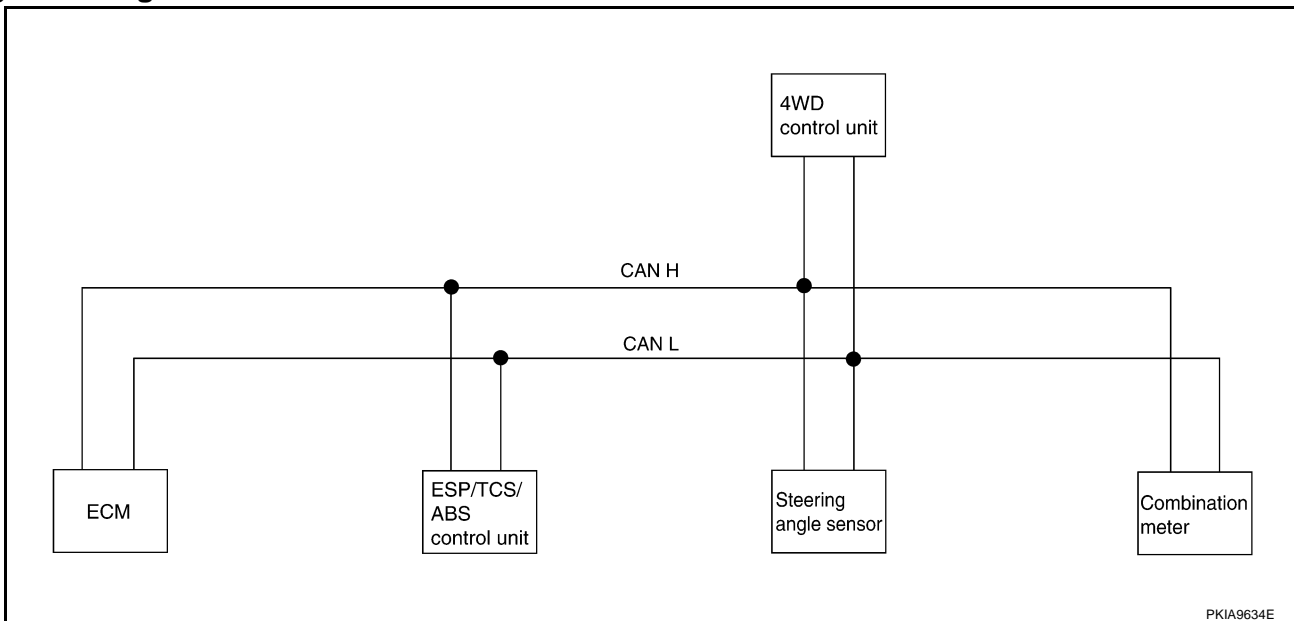

Input/output signal chart

T: Transmit R: Receive

Signals	ECM	ESP/TCS/ABS control unit	Steering angle sensor	4WD control unit	Combination meter
4WD mode indicator lamp signal				T	R
4WD warning lamp signal				T	R
A/C compressor feedback signal*2	T				R

CAN COMMUNICATION

[ESP/TCS/ABS]

Signals	ECM	ESP/TCS/ABS control unit	Steering angle sensor	4WD control unit	Combination meter
A/C switch signal*1	R				T
ABS warning lamp signal		T			R
Accelerator pedal position signal	T	R		R	
Brake warning lamp signal		T			R
Engine coolant temperature signal	T				R
Engine speed signal	T	R		R	R
ESP OFF indicator lamp signal		T			R
Glow indicator lamp signal*1	T				R
MI signal	T				R
Stop lamp switch signal		T		R	
Vehicle speed signal		T		R	R
	R				T
SLIP indicator lamp signal		T			R
Parking brake switch signal				R	T
Steering angle sensor signal		R	T		
ASCD SET lamp signal	T				R
ASCD CRUISE lamp signal	T				R

*1: YD engine models only

*2: QR engine models only

TYPE 6

System diagram

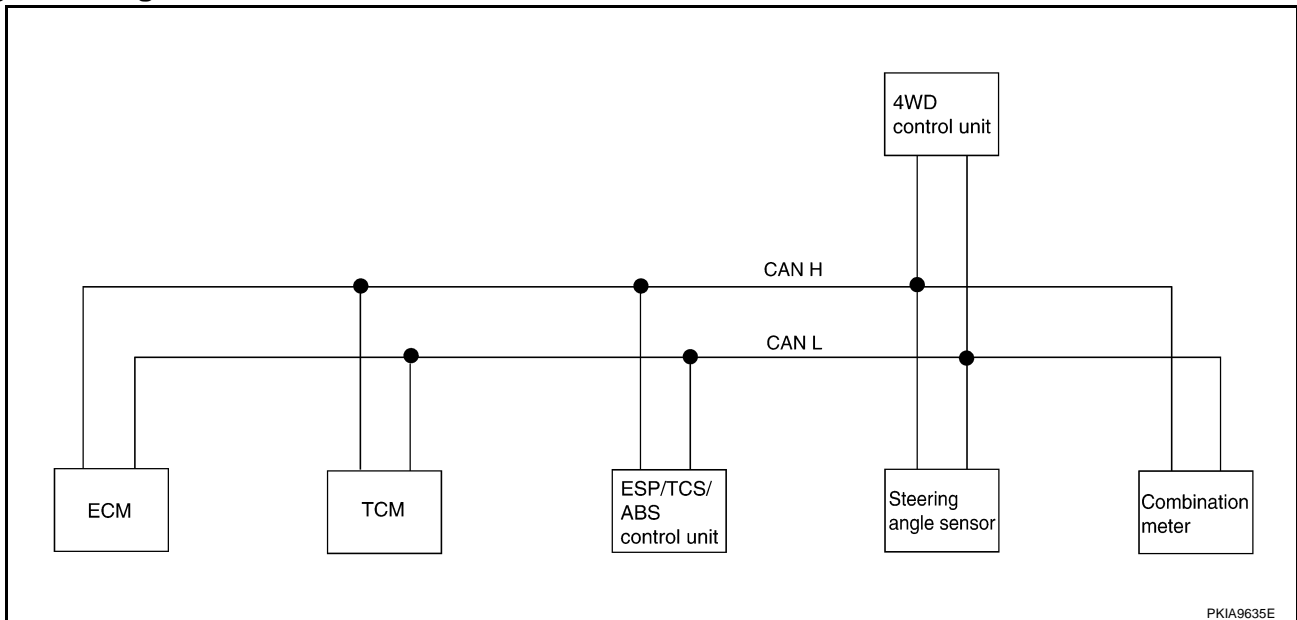

Input/output signal chart

T: Transmit R: Receive

Signals	ECM	TCM	ESP/TCS/ABS control unit	Steering angle sensor	4WD control unit	Combination meter
4WD mode indicator lamp signal					T	R
4WD warning lamp signal					T	R
A/C compressor feedback signal	T					R

CAN COMMUNICATION

[ESP/TCS/ABS]

Signals	ECM	TCM	ESP/TCS/ ABS control unit	Steering angle sensor	4WD control unit	Combination meter
A/T position indicator lamp signal		T	R			R
A/T self-diagnosis signal	R	T				
ABS warning lamp signal			T			R
Accelerator pedal position signal	T		R		R	
Brake warning lamp signal			T			R
Closed throttle position signal	T	R				
Engine and A/T integrated	T	R				
	R	T				
Engine coolant temperature signal	T					R
Engine speed signal	T		R		R	R
ESP OFF indicator lamp signal			T			R
MI signal	T					R
O/D OFF indicator signal		T				R
Output shaft revolution signal	R	T				
Overdrive control switch signal		R				T
P-N range signal		R				T
SLIP indicator lamp signal			T			R
Steering angle sensor signal			R	T		
Stop lamp switch signal		R				T
			T		R	
Vehicle speed signal			T		R	R
	R					T
Parking brake switch signal					R	T
Wide open throttle position signal	T	R				
ASCEND SET lamp signal	T					R
ASCEND CRUISE lamp signal	T					R

TYPE 9

System diagram

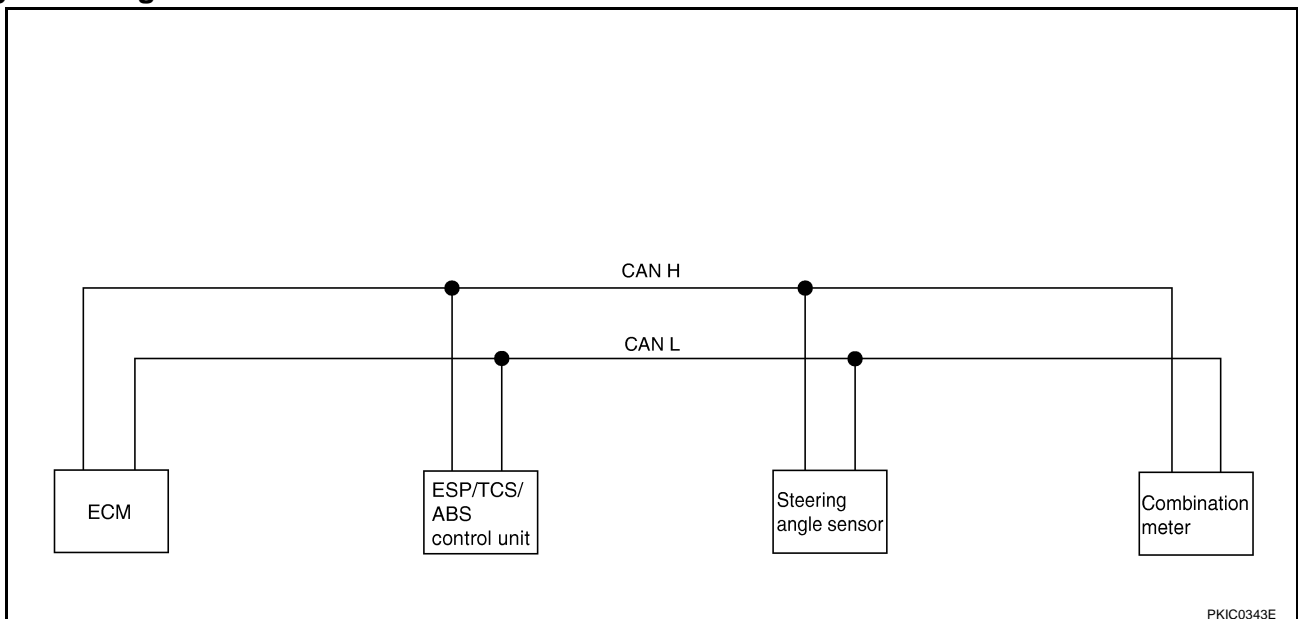

CAN COMMUNICATION

[ESP/TCS/ABS]

Input/output signal chart

T: Transmit R: Receive

Signals	ECM	ESP/TCS/ABS control unit	Steering angle sensor	Combination meter
A/C switch signal	R			T
ABS warning lamp signal		T		R
Accelerator pedal position signal	T	R		
Brake warning lamp signal		T		R
Engine coolant temperature signal	T			R
Engine speed signal	T	R		R
ESP OFF indicator lamp signal		T		R
Glow indicator lamp signal	T			R
MI signal	T			R
Vehicle speed signal		T		R
	R			T
SLIP indicator lamp signal		T		R
Steering angle sensor signal		R	T	
ASCD SET lamp signal	T			R
ASCD CRUISE lamp signal	T			R

A

B

C

D

E

BRC

G

H

I

J

K

L

M

TROUBLE DIAGNOSIS

PFP:00004

How to Proceed With Diagnosis

BASIC CONCEPT

EFS005VY

- Most important point to perform diagnosis is to understand systems (control and mechanism) in vehicle thoroughly.

- It is also important to clarify customer complaints before inspection.

First of all, reproduce symptom, and understand it fully.

Ask customer about his/her complaints carefully. In some cases, it will be necessary to check symptom by driving vehicle with customer.

NOTE:

Customers are not professionals. Do not assume “maybe customer means...” or “maybe customer mentioned this symptom”.

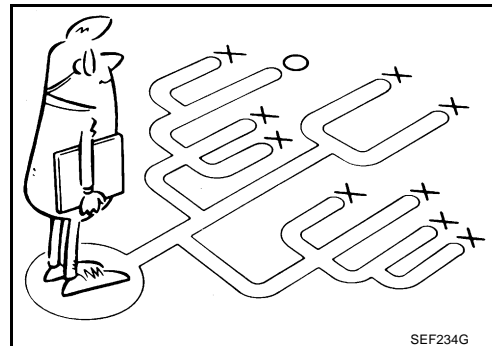

SEF234G

- It is essential to check symptoms right from beginning in order to repair a malfunction completely.

For an intermittent malfunction, it is important to reproduce symptom based on interview with customer and past examples. Do not perform inspection on ad hoc basis. Most intermittent malfunctions are caused by poor contacts. In this case, it will be effective to shake suspected harness or connector by hand. When repairs are performed without any symptom check, no one can judge if malfunction has actually been eliminated.

- After diagnosis, make sure to carry out “erase memory”. Refer to [BRC-28, "SELF-DIAGNOSIS"](#).

- For an intermittent malfunction, move harness or harness connector by hand to check poor contact or false open circuit.

- Always read “GI General Information” to confirm general precautions. Refer to [GI-4, "General Precautions"](#).

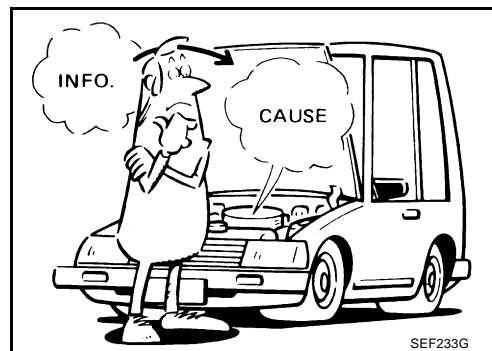

SEF233G

TROUBLE DIAGNOSIS

[ESP/TCS/ABS]

DIAGNOSIS FLOWCHART

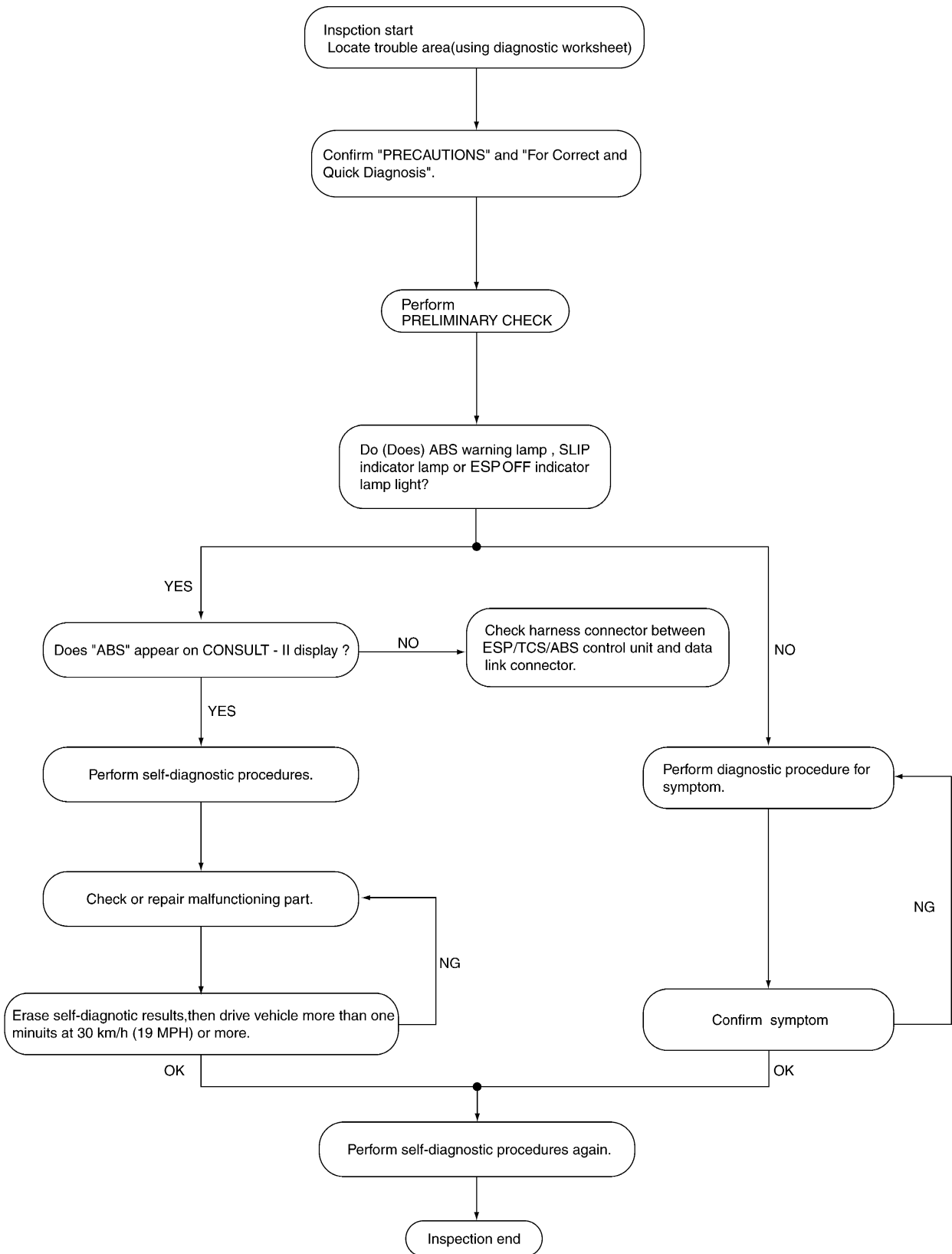

A
B
C
D
E
BRC
G
H
I
J
K
L
M

TROUBLE DIAGNOSIS

[ESP/TCS/ABS]

ASKING COMPLAINTS

- Complaints against malfunction vary depending on each person. It is important to clarify customer complaints.
- Ask customer about what symptoms are present and under what conditions. Use information to reproduce symptom while driving.
- It is also important to use diagnosis sheet so as not to miss information.

KEY POINTS

WHAT Vehicle model
WHEN Date, Frequencies
WHERE Road conditions
HOW Operating conditions,
 Weather conditions,
 Symptoms

SBR339B

EXAMPLE OF DIAGNOSIS SHEET

Customer name MR/MS	Model & Year	VIN	
Engine #	Trans.	Mileage	
Incident Date	Manuf. Date	In Service Date	
Symptoms	<input type="checkbox"/> Noise and vibration (from engine compartment) <input type="checkbox"/> Noise and vibration (from axle)	<input type="checkbox"/> Warning / Indicator activate	<input type="checkbox"/> Firm pedal operation Large stroke pedal operation
	<input type="checkbox"/> EPS/TCS does not work (Drive wheels slip when accelerating, etc.)	<input type="checkbox"/> ABS does not work. (wheels slip when braking)	<input type="checkbox"/> Lack of sense of acceleration
Engine conditions	<input type="checkbox"/> When starting <input type="checkbox"/> After starting		
Road conditions	<input type="checkbox"/> Low friction road (<input type="checkbox"/> Snow <input type="checkbox"/> Gravel <input type="checkbox"/> Other) <input type="checkbox"/> Bumps / potholes		
Driving conditions	<input type="checkbox"/> Full-acceleration <input type="checkbox"/> High speed cornering <input type="checkbox"/> Vehicle speed: Greater than 10 km/h (6 MPH) <input type="checkbox"/> Vehicle speed: 10 km/h (6 MPH) or less <input type="checkbox"/> Vehicle is stopped		
Applying brake conditions	<input type="checkbox"/> Suddenly <input type="checkbox"/> Gradually		
Other conditions	<input type="checkbox"/> Operation of electrical equipment <input type="checkbox"/> Shift change <input type="checkbox"/> Other descriptions		

SFIA2202E

Component Parts and Harness Connector Location

EFS005VZ

A
B
C
D
E
G
H
I
J
K
L
M

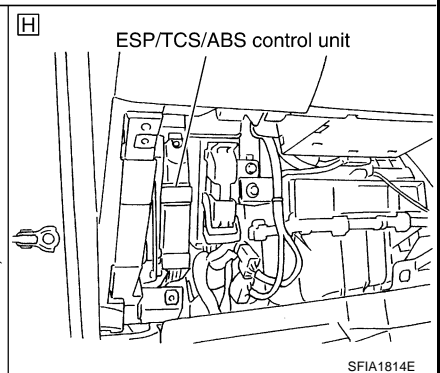
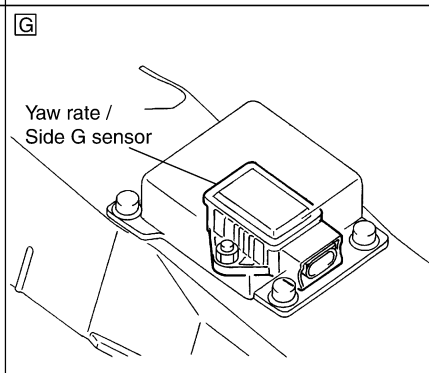
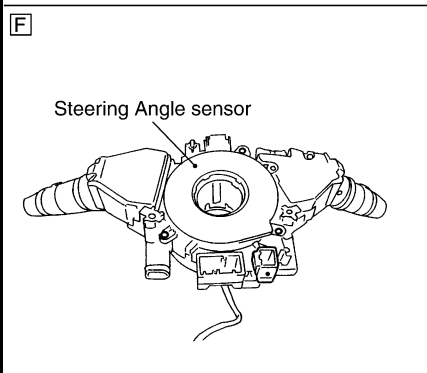
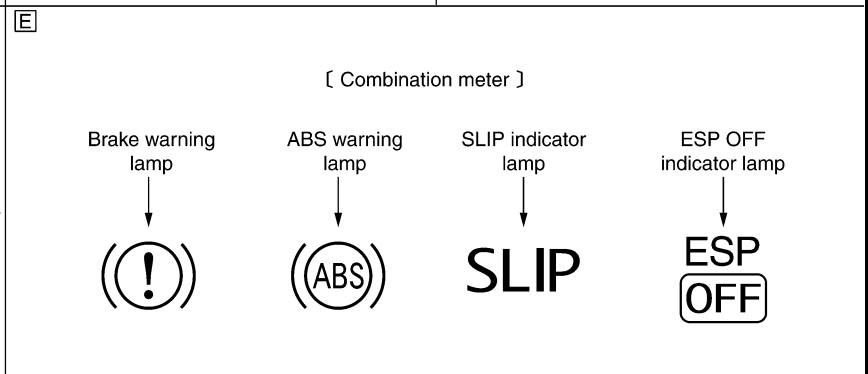
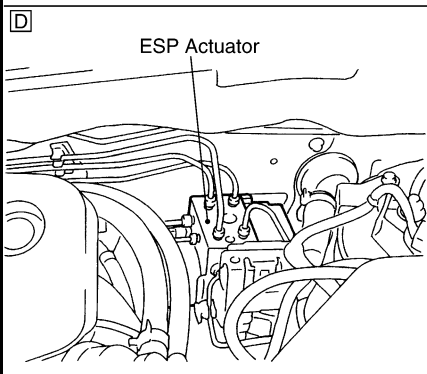
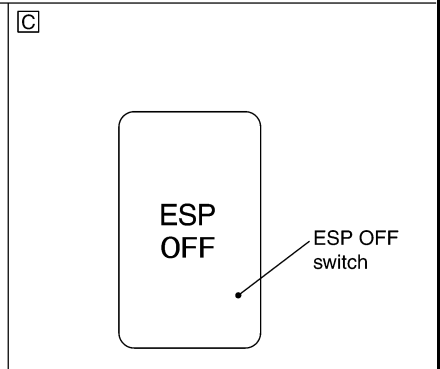
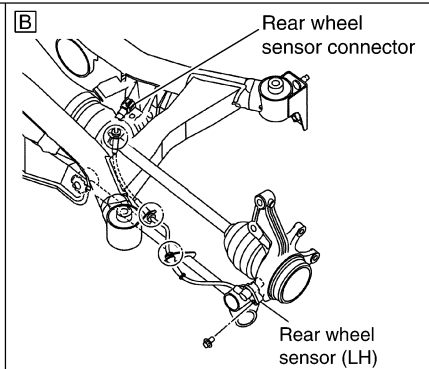
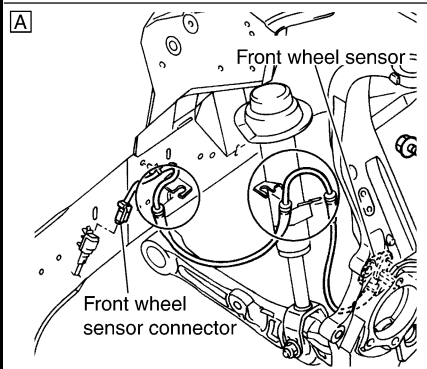
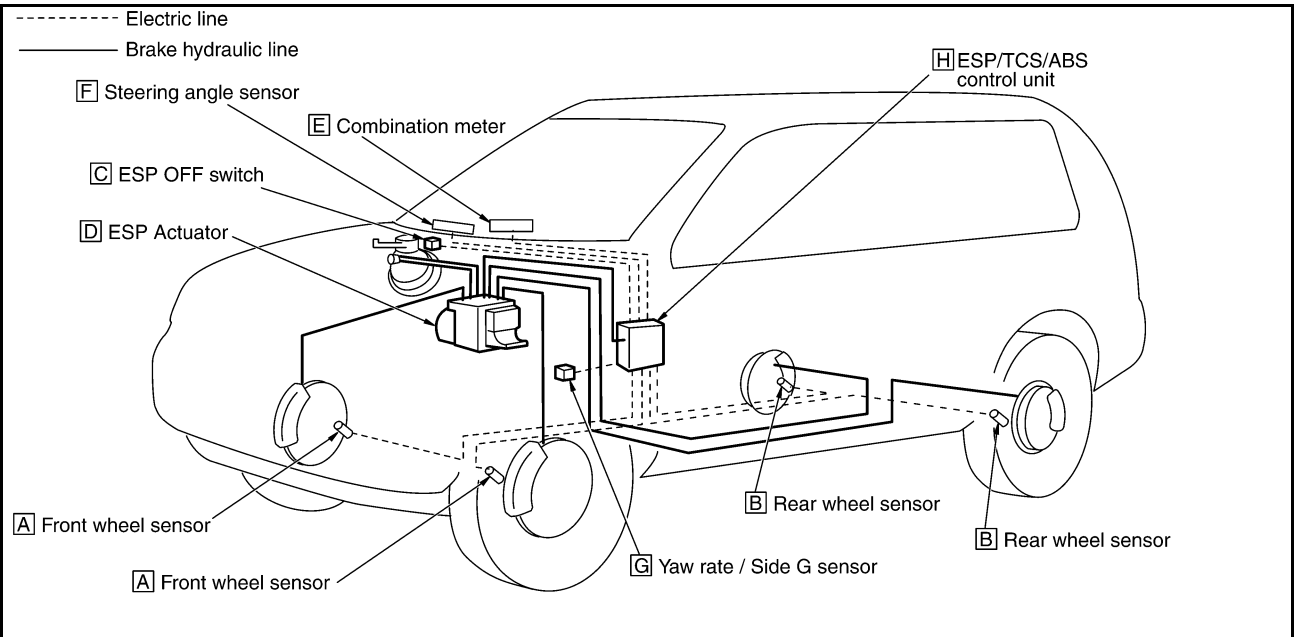

SFIA1814E

BRC

Schematic

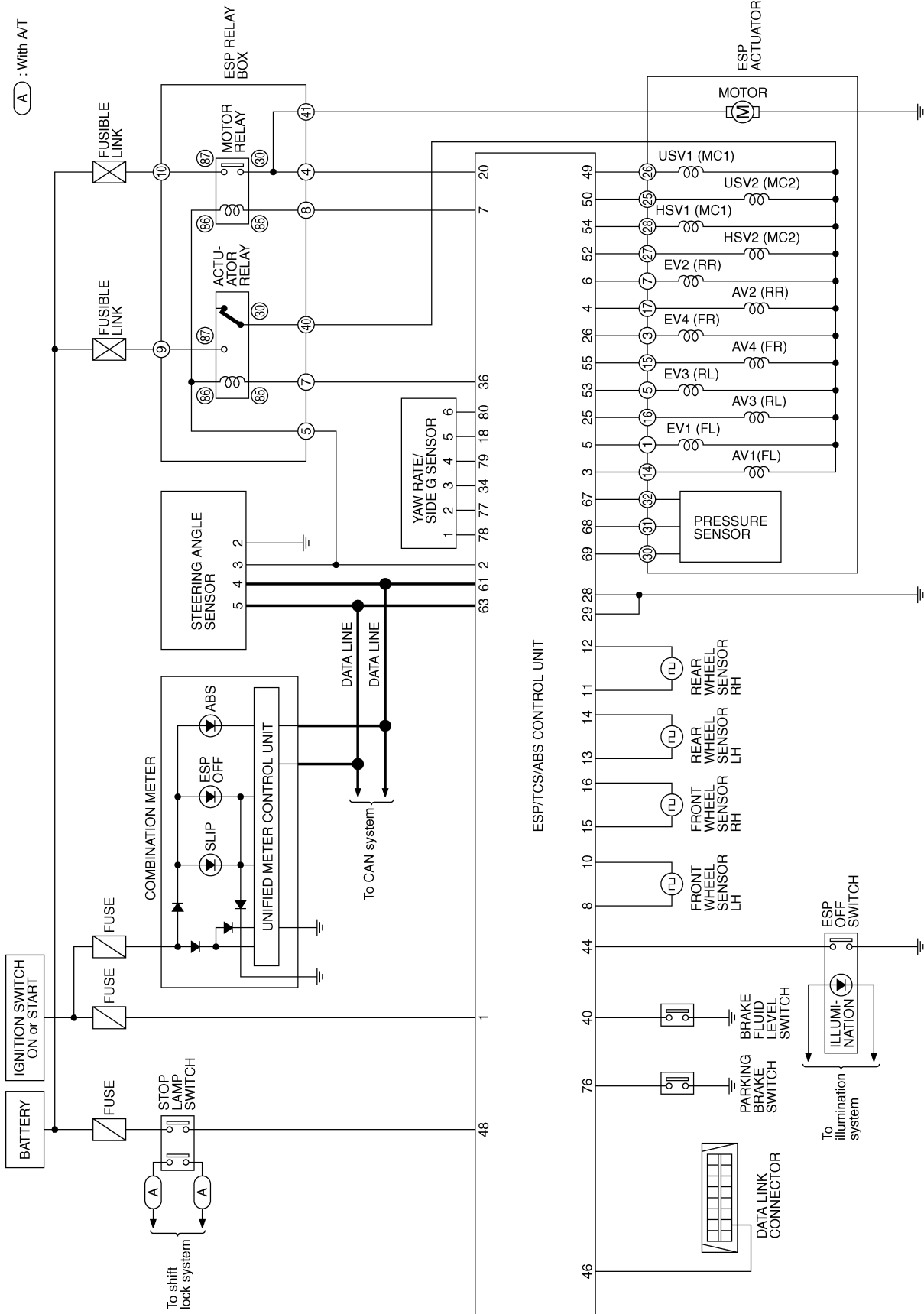

TROUBLE DIAGNOSIS

[ESP/TCS/ABS]

EFS005W1

Wiring Diagram —ESP/TCS/ABS— LHD MODEL

BRC-ESP-01

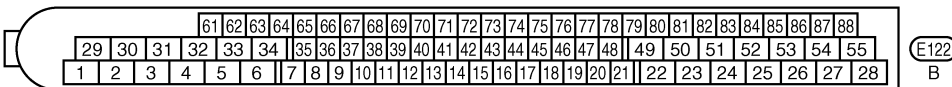
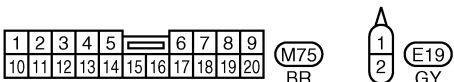
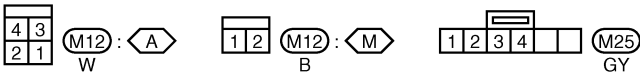
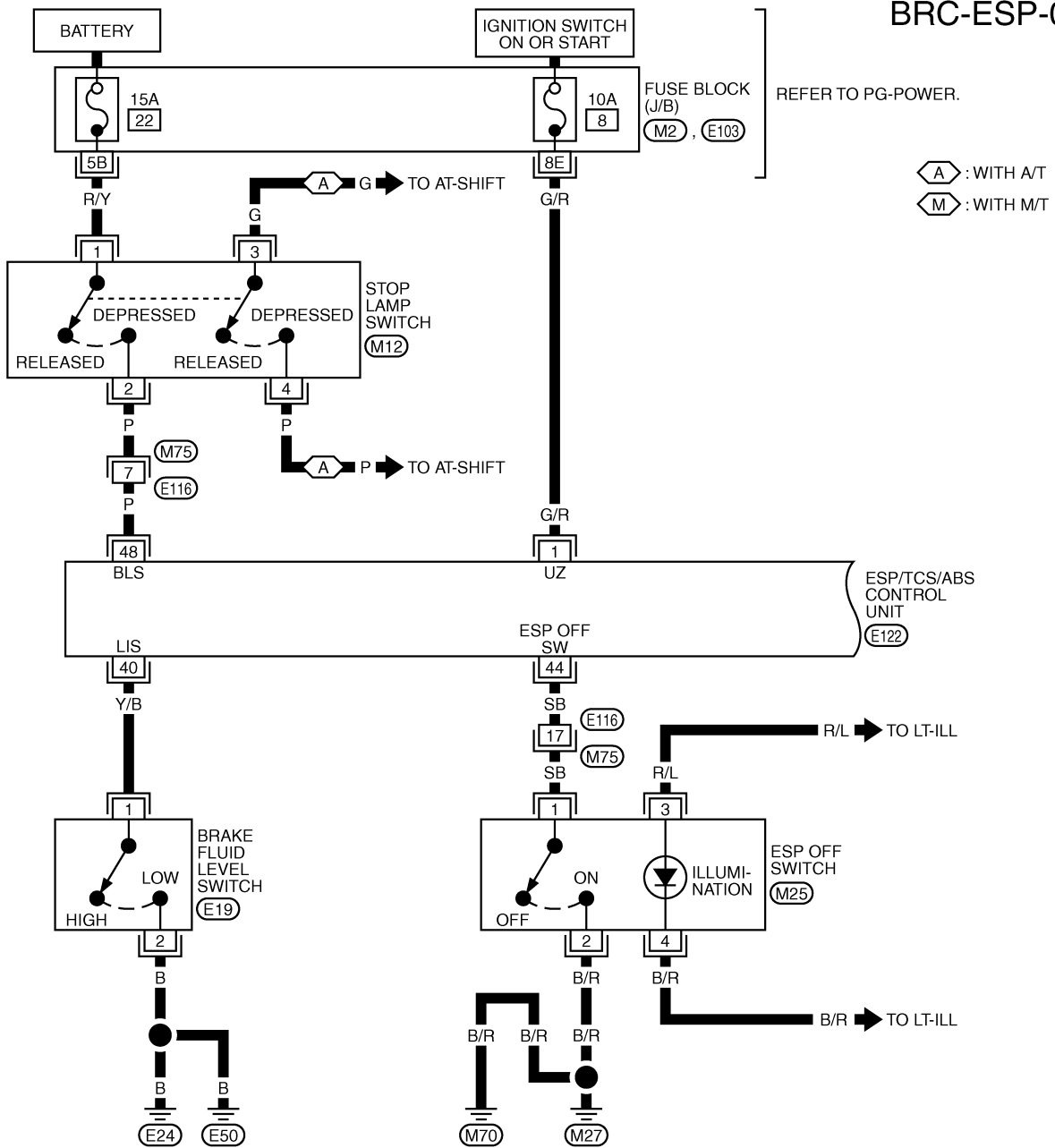

REFER TO THE FOLLOWING.
 (M2), (E103) - FUSE BLOCK-
 JUNCTION BOX (J/B)

A
B
C
D
E
G
H
I
J
K
L
M

BRC

TROUBLE DIAGNOSIS

[ESP/TCS/ABS]

BRC-ESP-02

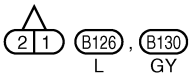
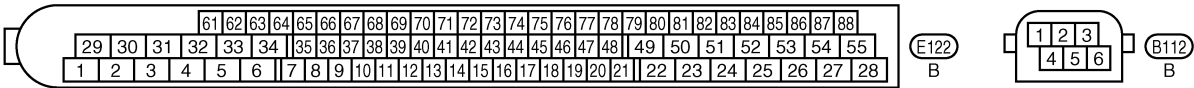
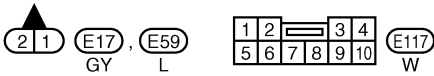
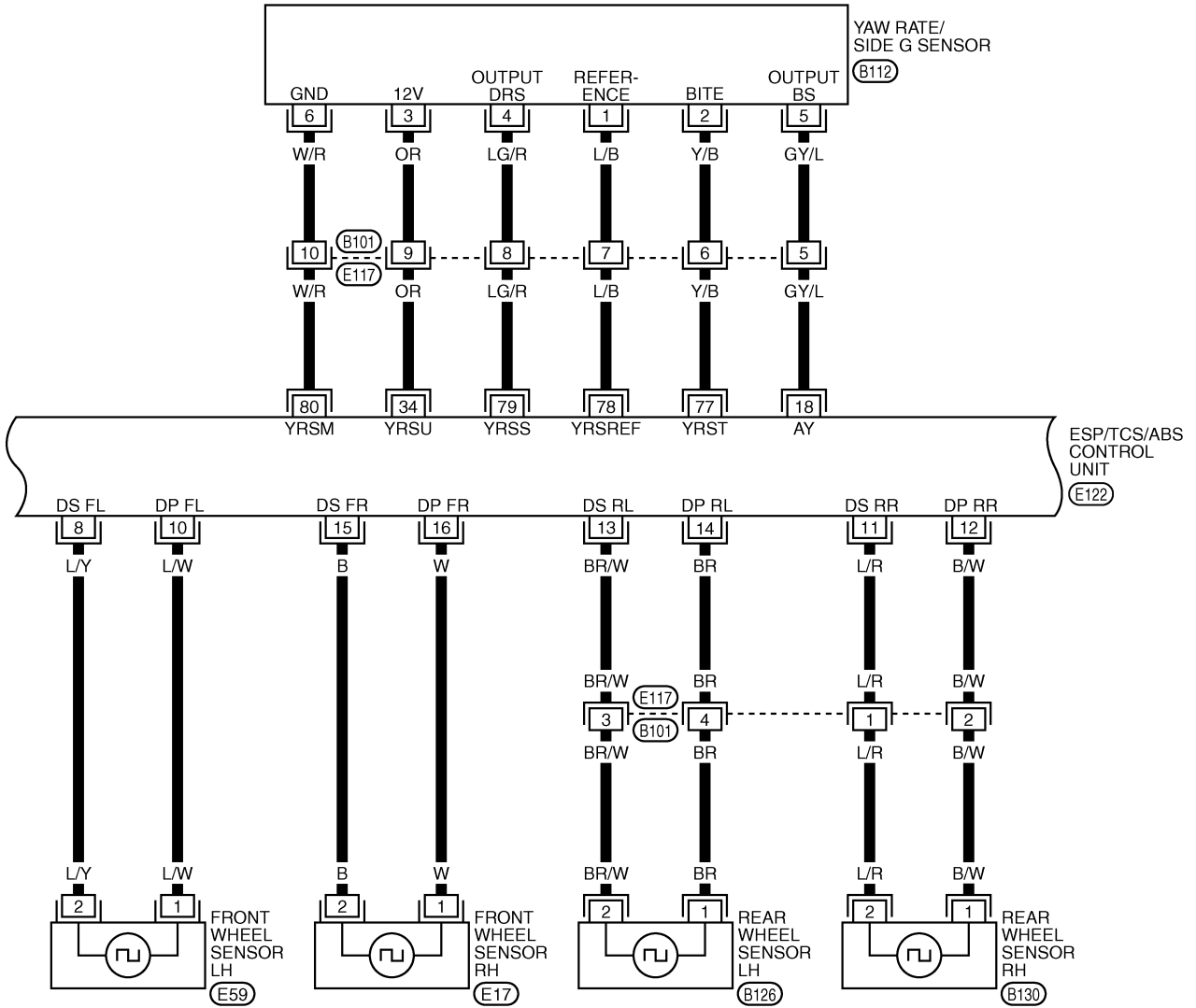

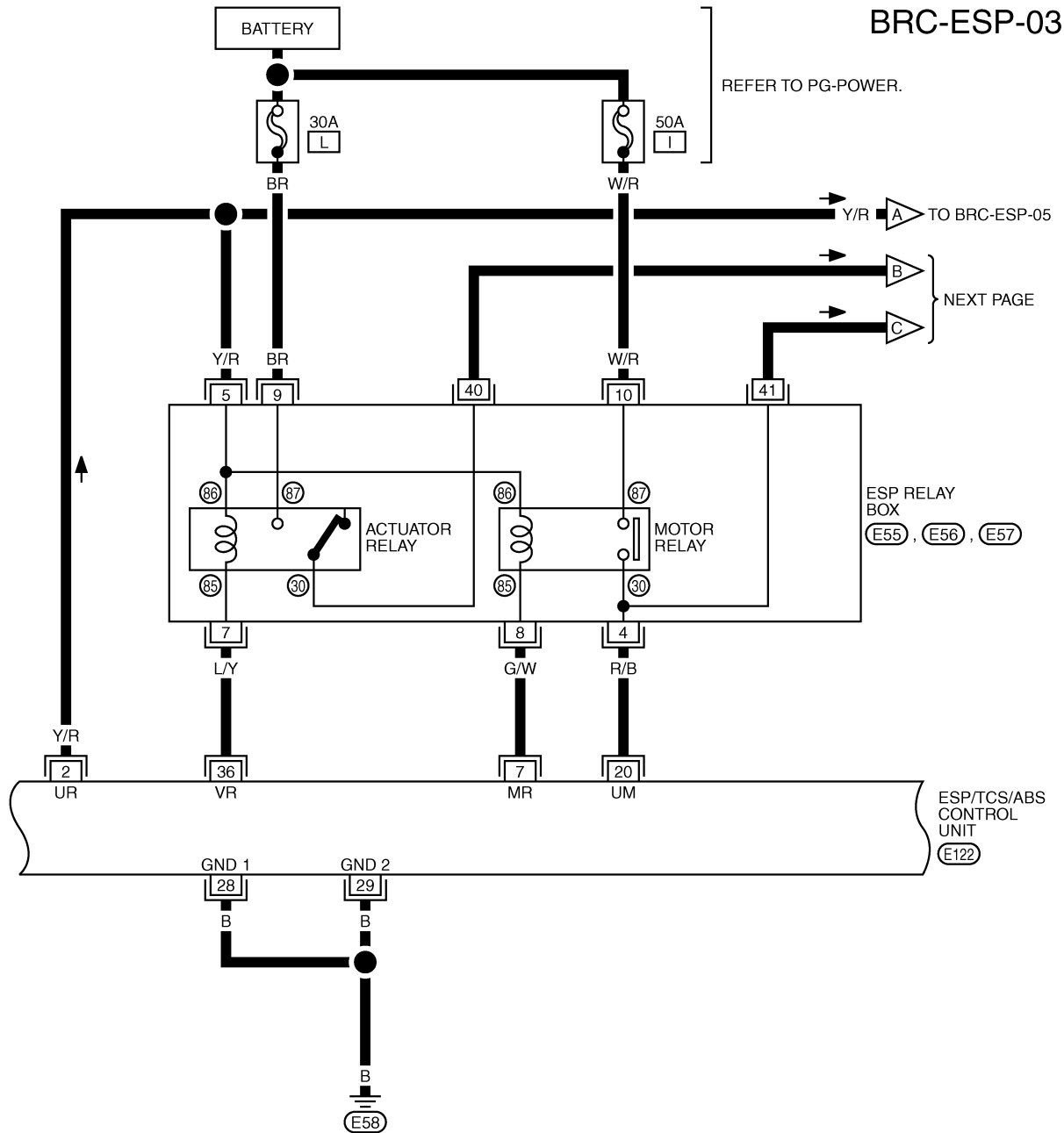

A
B
C
D
E
G
H
I
J
K
L
M

BRC

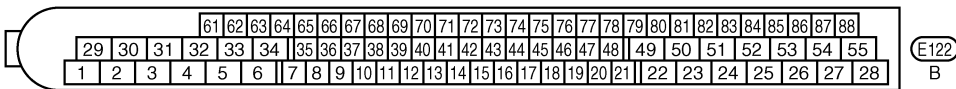
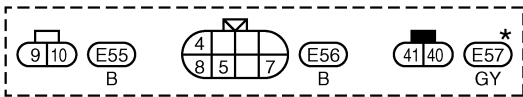

*: THIS CONNECTOR IS NOT SHOWN IN "HARNESS LAYOUT", PG SECTION.

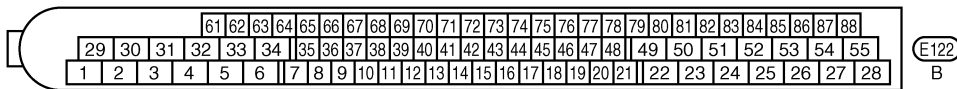
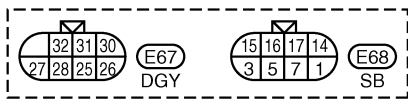
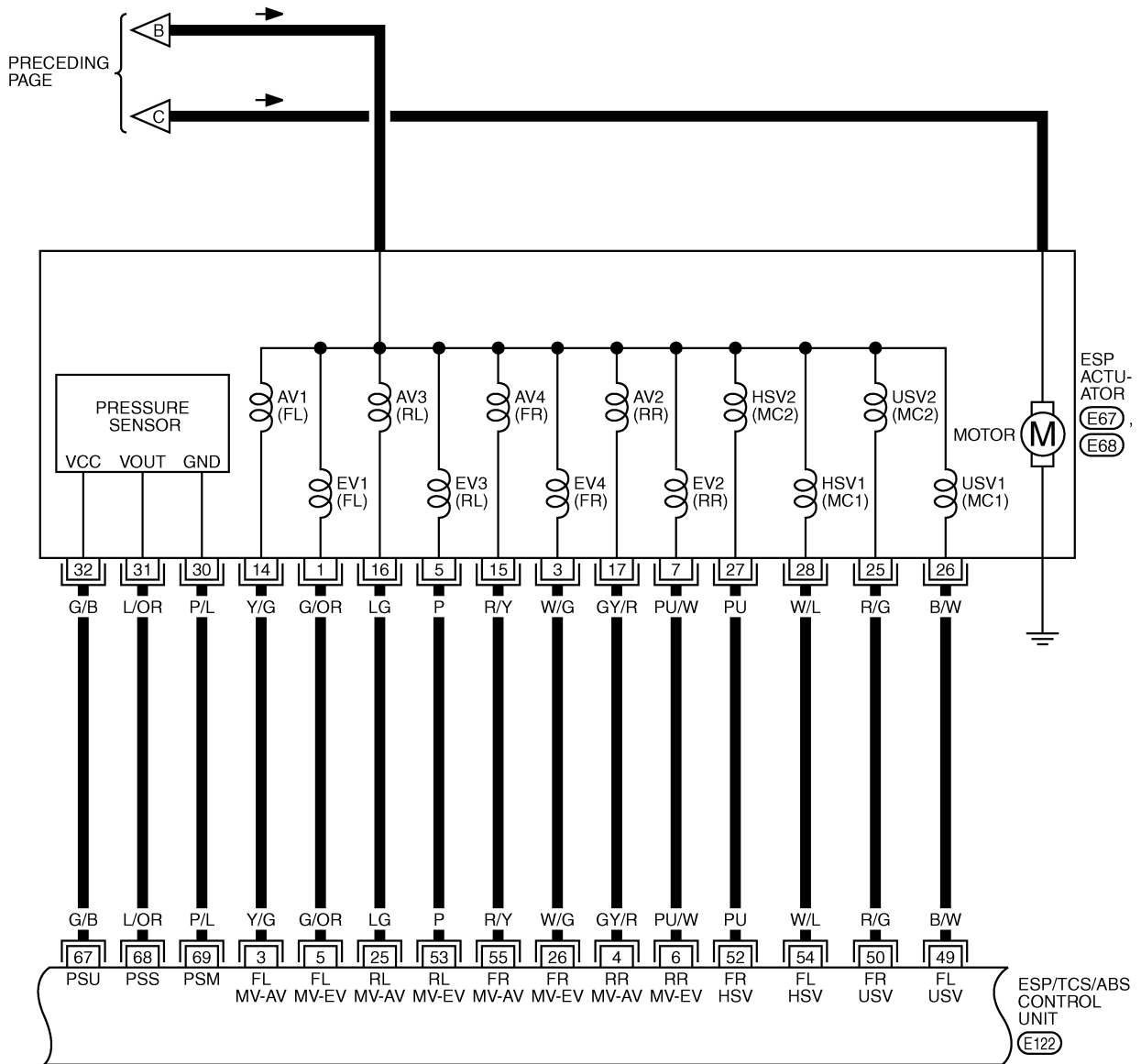

TROUBLE DIAGNOSIS

[ESP/TCS/ABS]

BRC-ESP-05

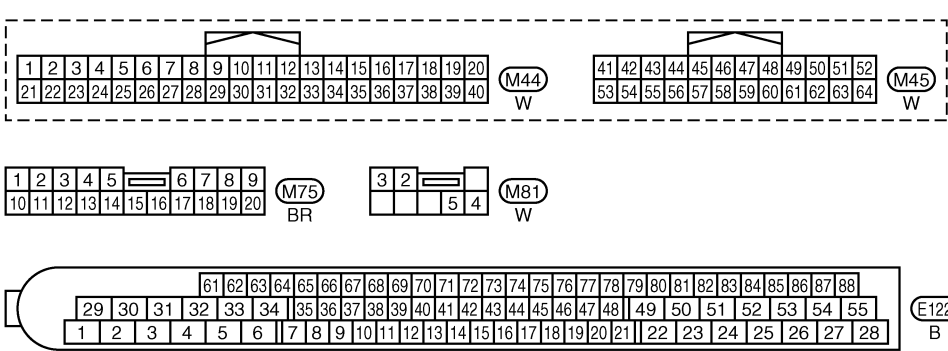
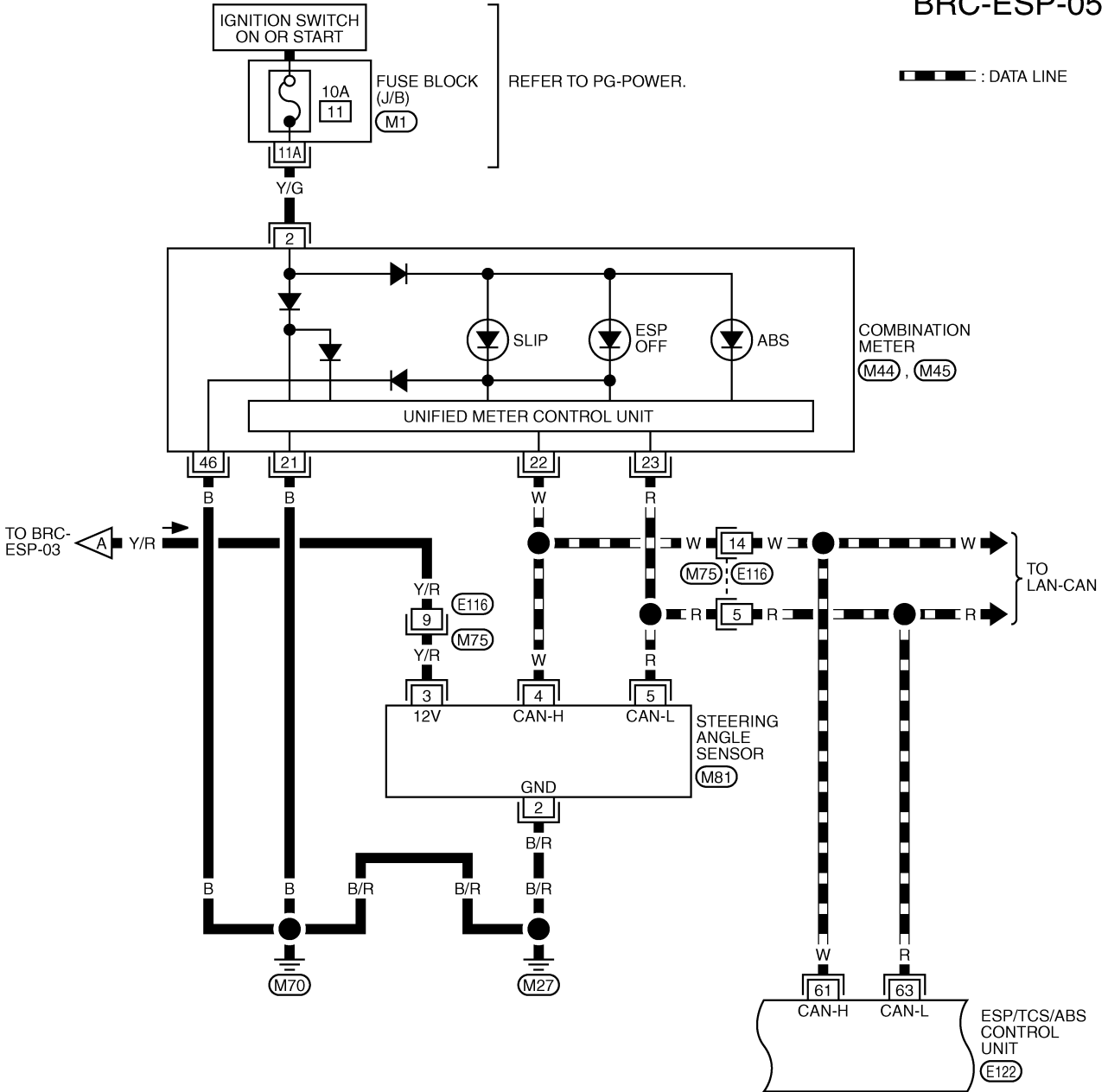

REFER TO THE FOLLOWING.

M1 - FUSE BLOCK-JUNCTION BOX (J/B)

A

B

C

D

E

BRC

G

H

I

J

K

L

M

TROUBLE DIAGNOSIS

[ESP/TCS/ABS]

BRC-ESP-06

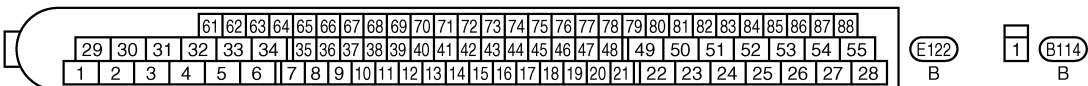
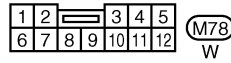
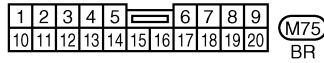
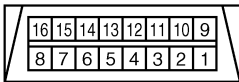
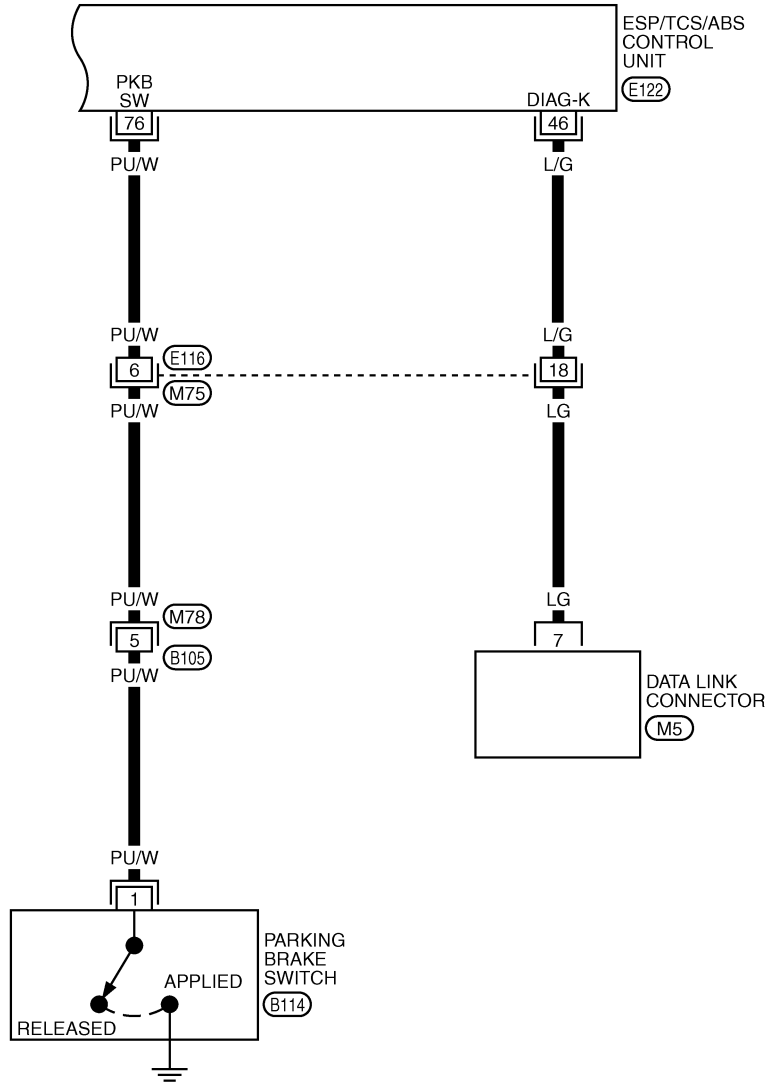

TROUBLE DIAGNOSIS

[ESP/TCS/ABS]

RHD MODEL

BRC-ESP-07

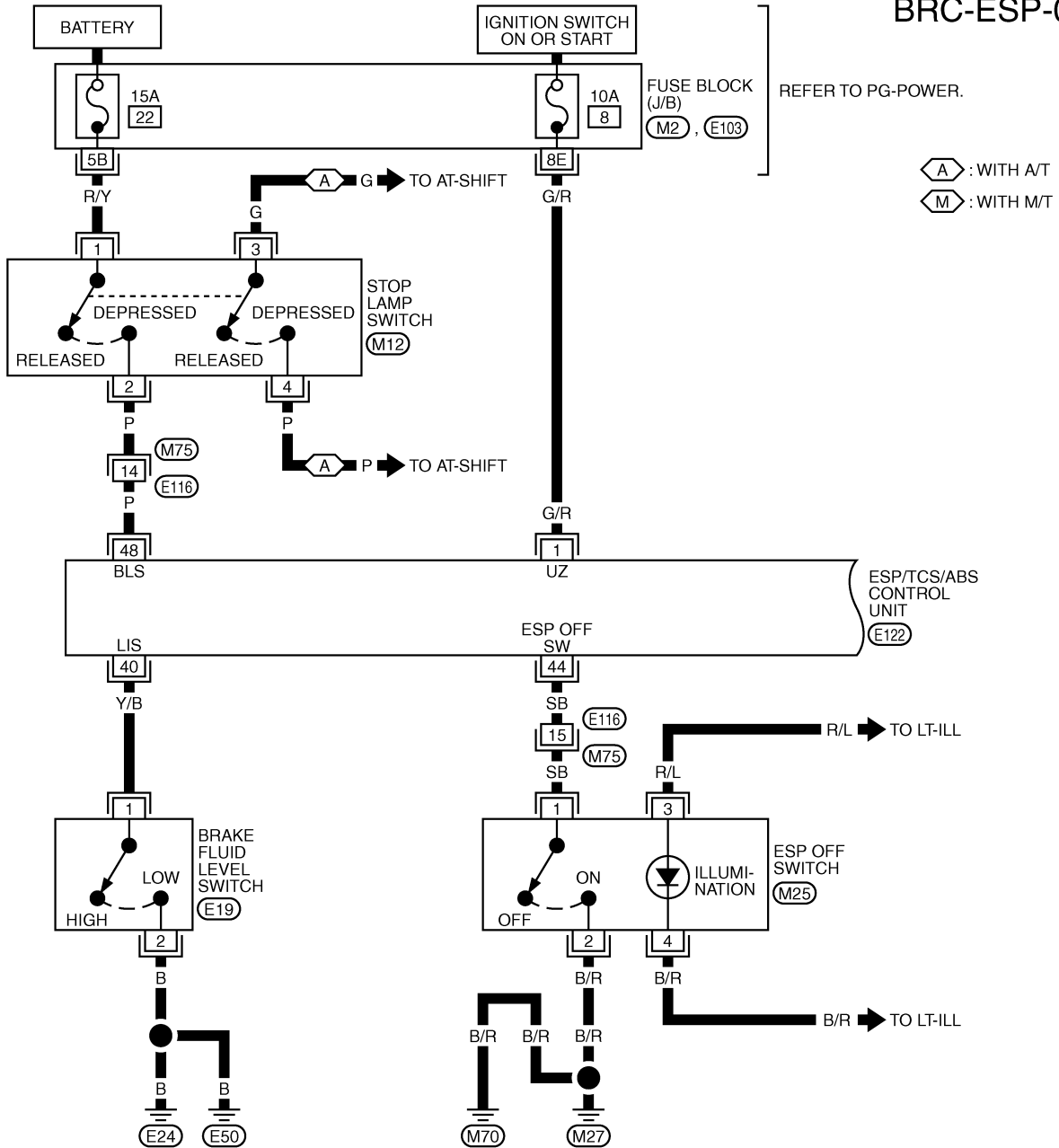

⬡ A : WITH A/T
⬡ M : WITH M/T

ESP/TCS/ABS CONTROL UNIT (E122)

REFER TO THE FOLLOWING.
⬡ M2, ⬡ E103 - FUSE BLOCK-JUNCTION BOX (J/B)

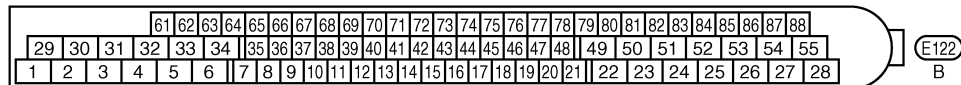
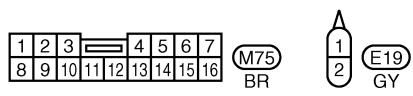
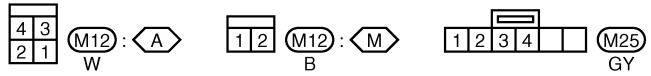

A
B
C
D
E
G
H
I
J
K
L
M

BRC

TROUBLE DIAGNOSIS

[ESP/TCS/ABS]

BRC-ESP-08

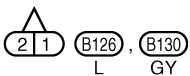
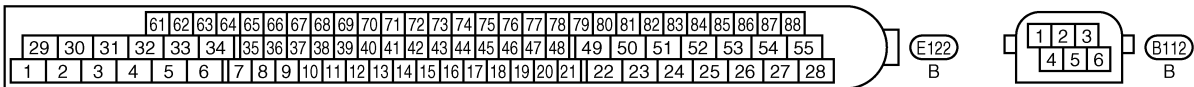
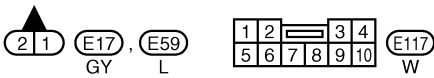
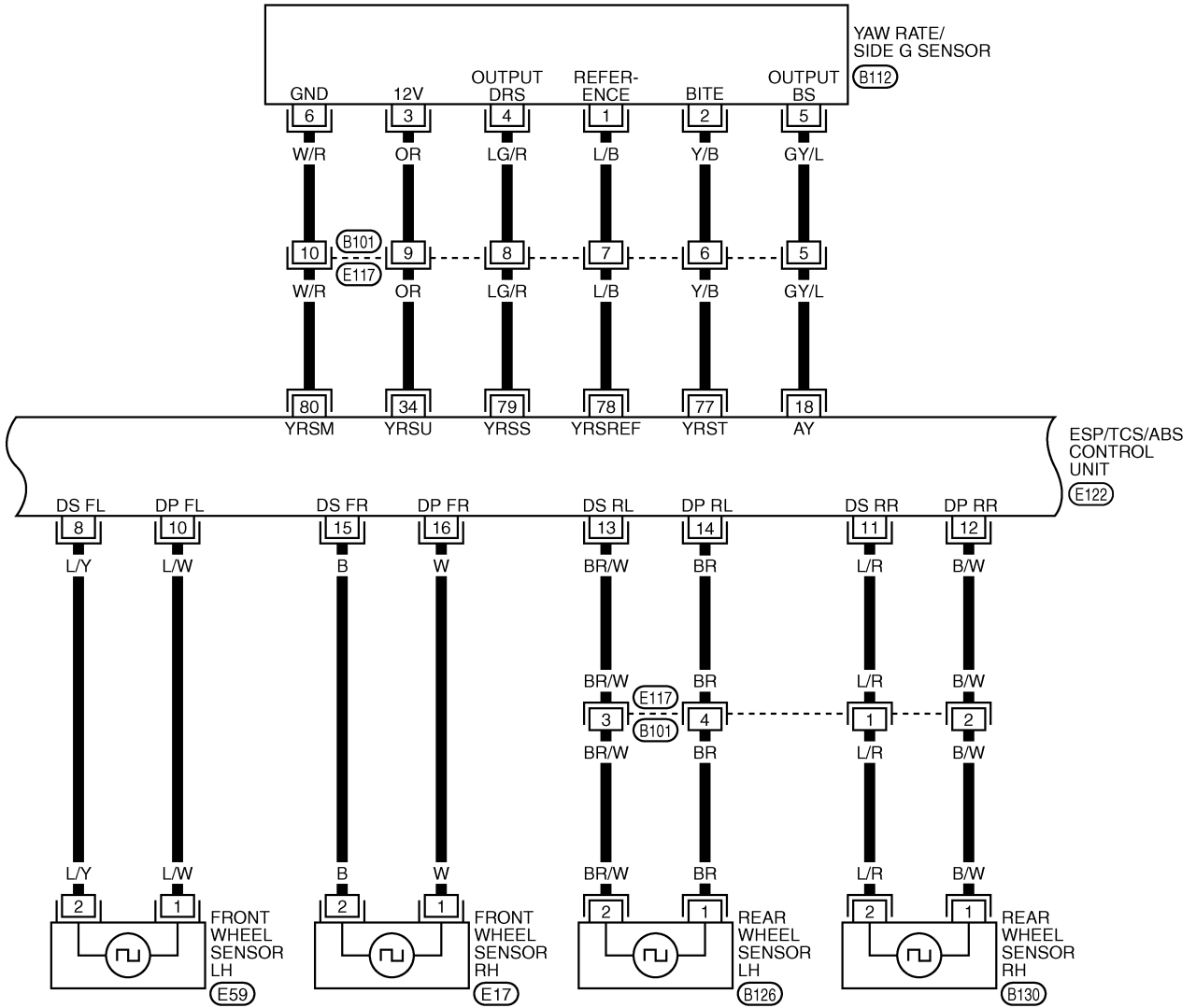

BRC-ESP-09

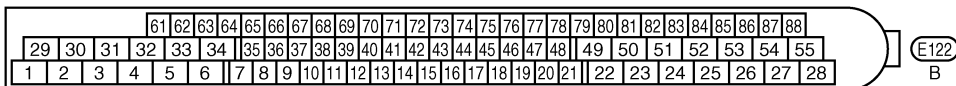
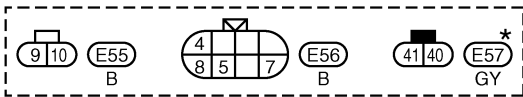
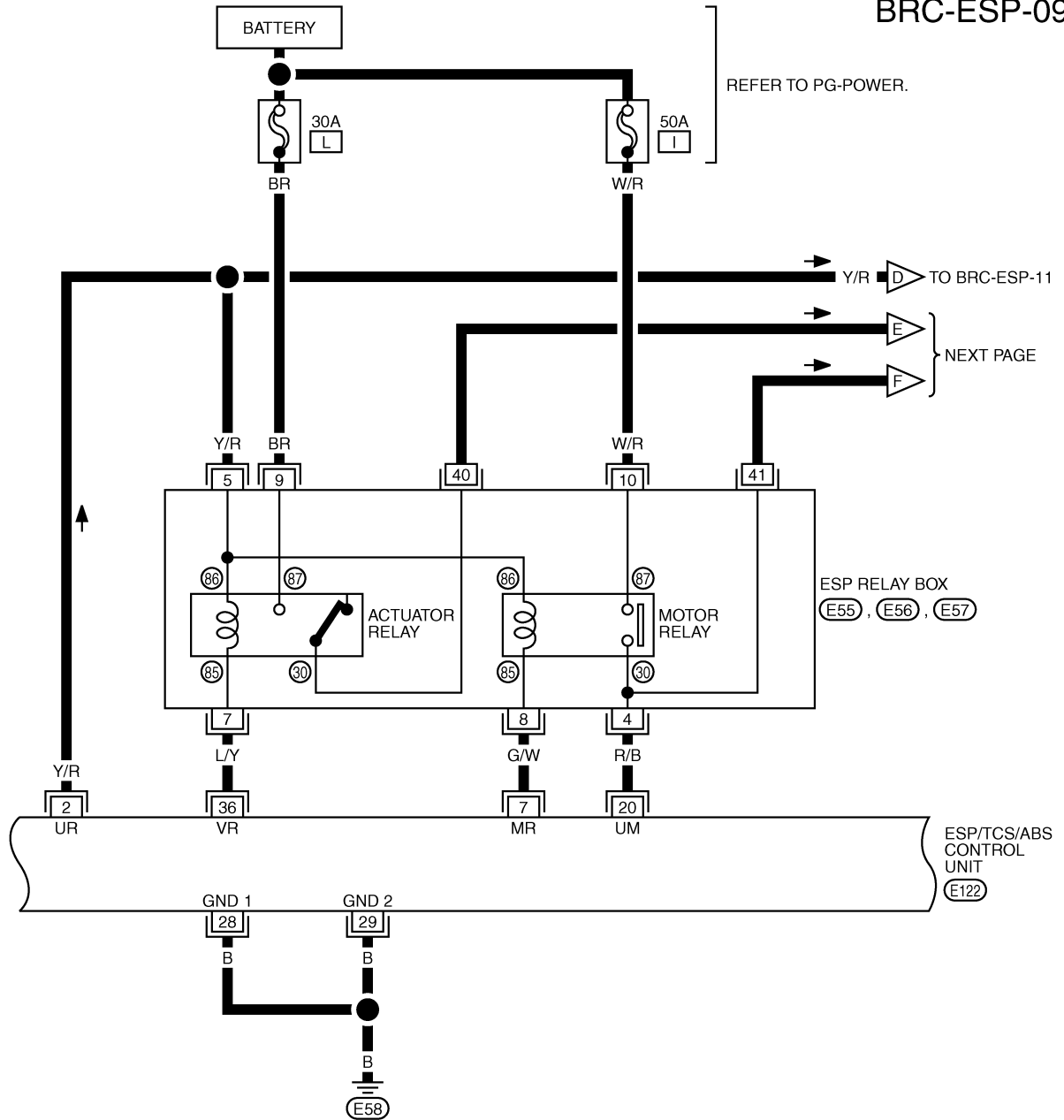

*: THIS CONNECTOR IS NOT SHOWN IN "HARNESS LAYOUT", PG SECTION.

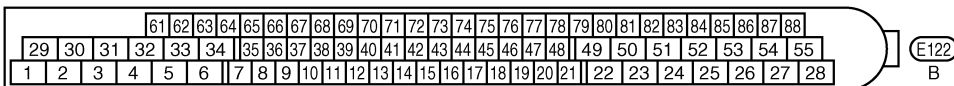
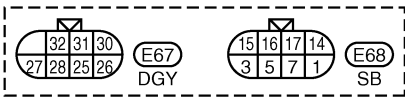
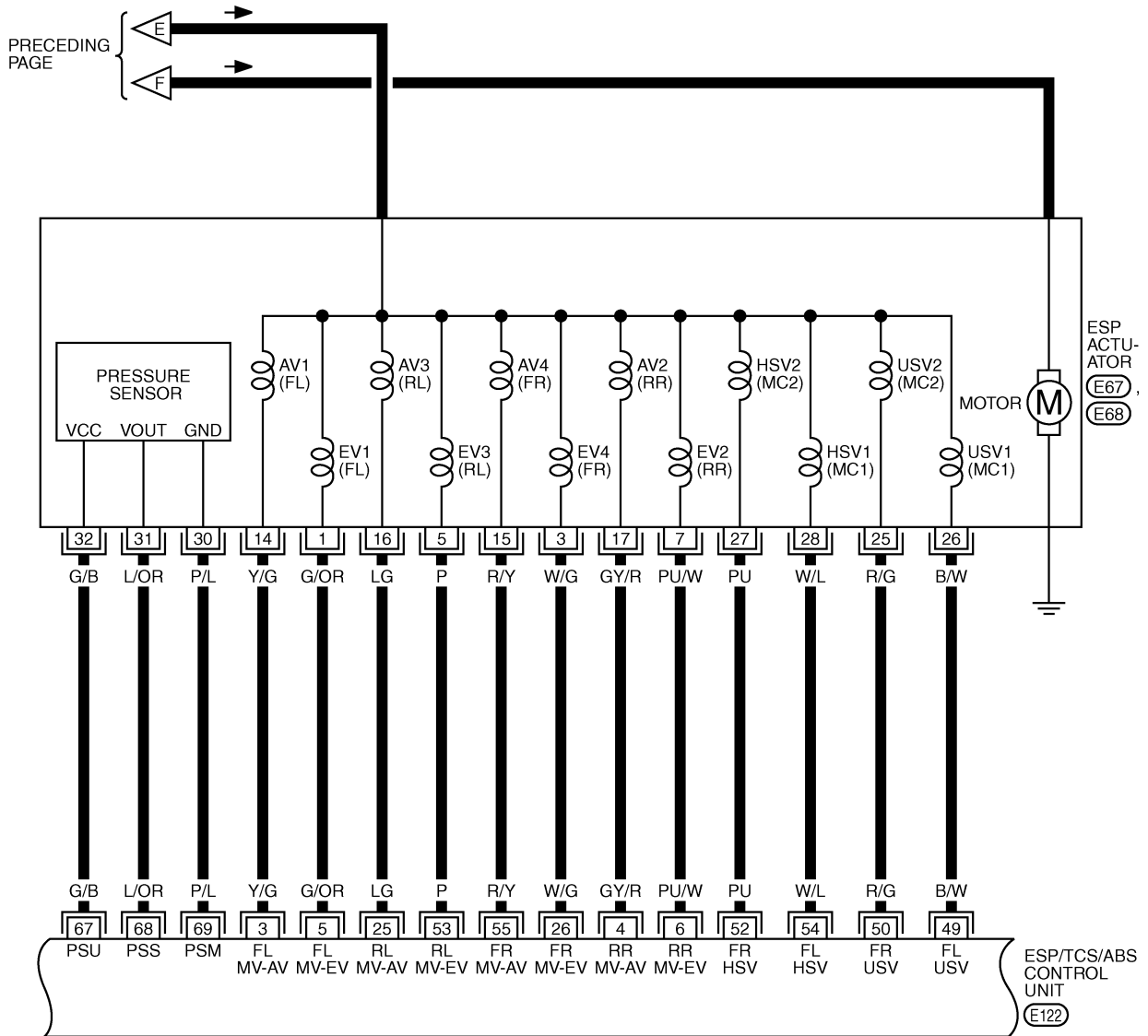

TROUBLE DIAGNOSIS

[ESP/TCS/ABS]

BRC-ESP-11

A
B
C
D
E
G
H
I
J
K
L
M

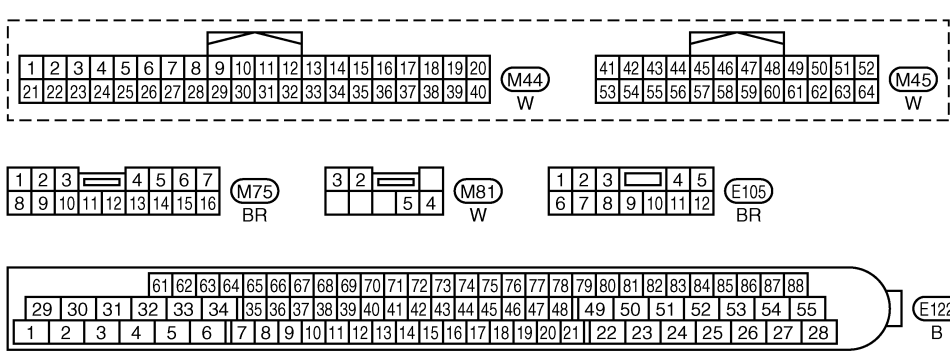
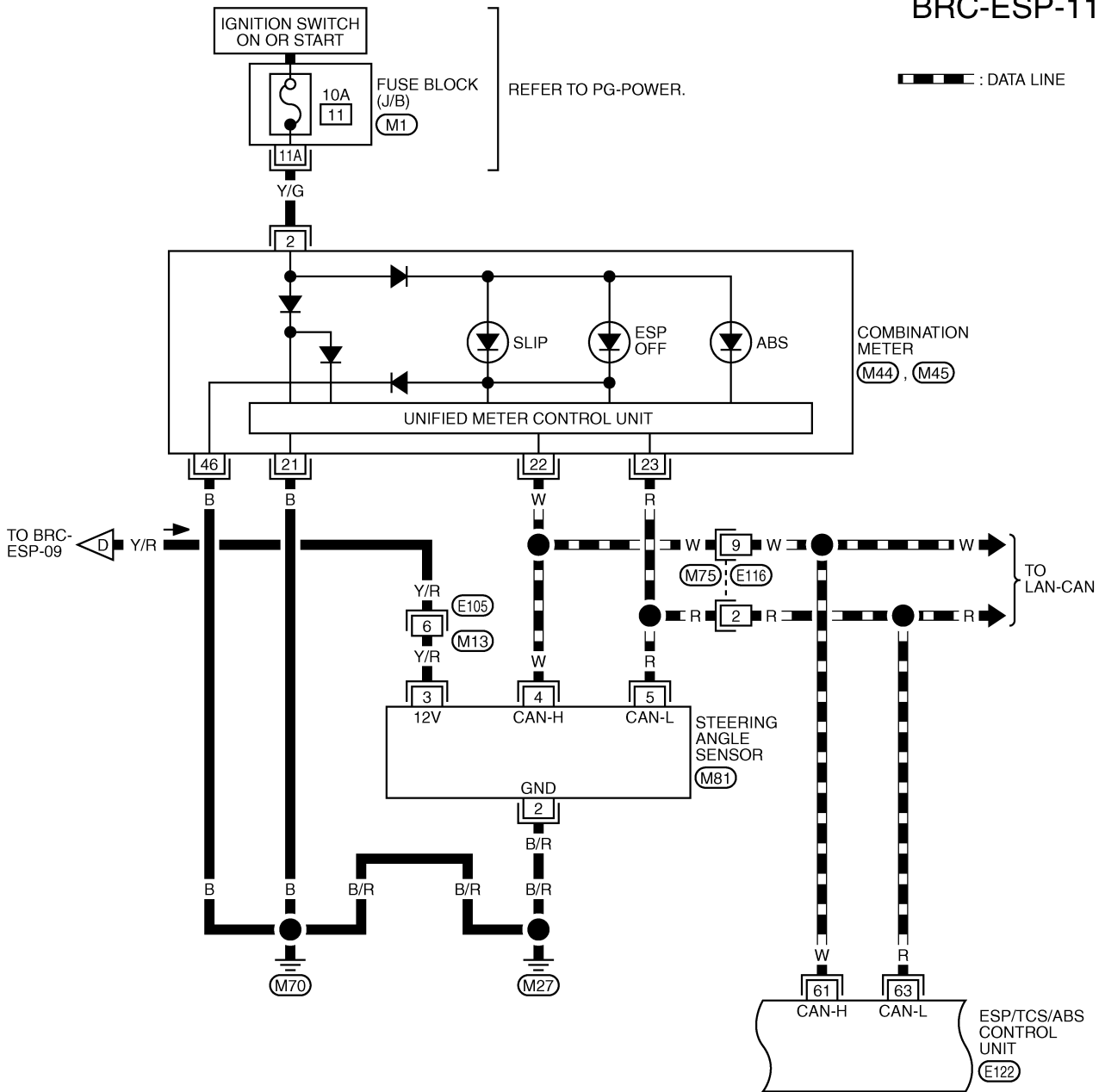

REFER TO THE FOLLOWING.
 (M1) - FUSE BLOCK-JUNCTION BOX (J/B)

TROUBLE DIAGNOSIS

[ESP/TCS/ABS]

BRC-ESP-12

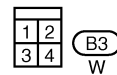
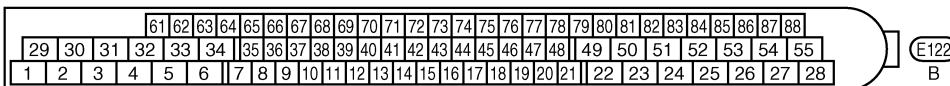
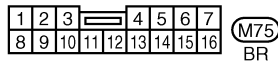
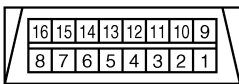
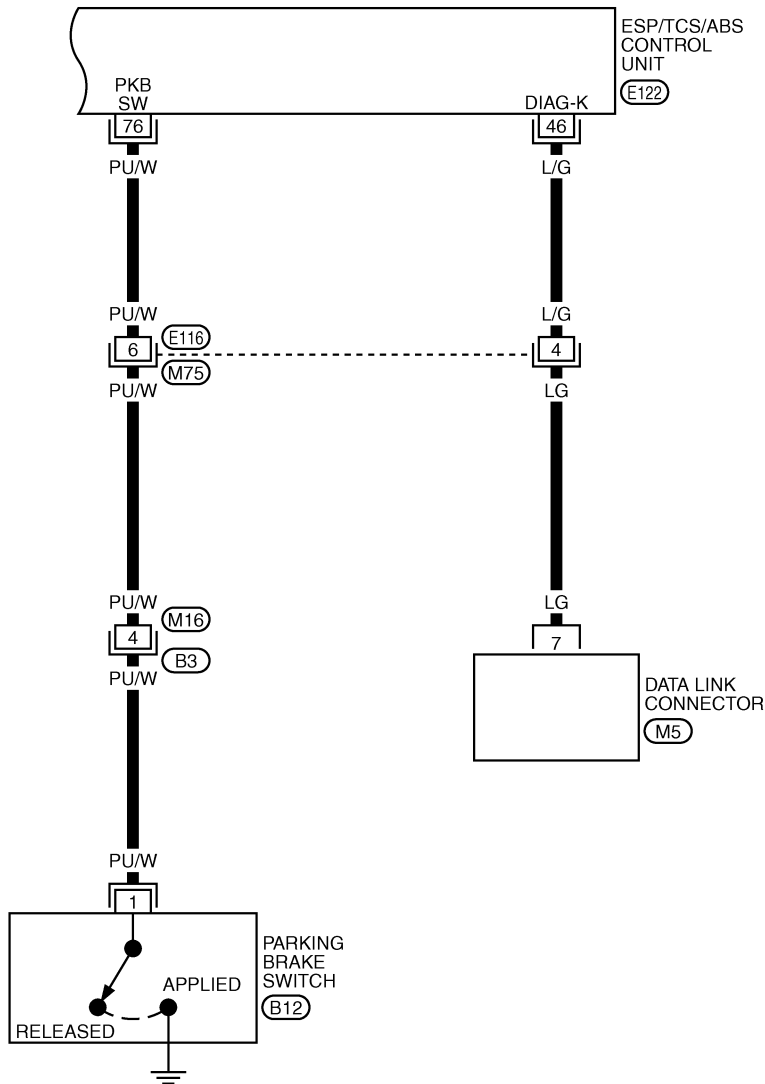

TFWB0093E

Control Unit Input/Output Signal Standard

REFERENCE VALUE FROM CONSULT-II

EFS005W2

CAUTION:

The displayed item is the data calculated by the control unit, so it may indicate a normal value even if an output circuit (harness) is open or shorted.

Data monitor item	Contents	Data monitor		(Reference) Check items for malfunction
		Condition	Reference value in normal operation	
FR RH SENSOR FR LH SENSOR RR RH SENSOR RR LH SENSOR	Wheel speed	Vehicle stopped	0 [km/h]	Wheel sensor circuit
		During driving (Note 1)	Almost in accordance with the speedometer display (within $\pm 10\%$)	
ACCEL POS SIG	Open/close condition of throttle valve (linked with accelerator pedal)	Accelerator pedal not depressed (ignition switch is ON)	0%	Control unit communication circuit between the ESP/TCS/ABS control unit and ECM
		Accelerator pedal depressed (ignition switch is ON)	0 – 100%	
ENG RPM	With the engine running	With the engine stopped	0rpm	Engine speed signal circuit
		Engine running	Almost in accordance with tachometer display	
STR ANGLE SIG	Steering wheel angle detected by steering angle sensor	Straight-ahead condition	Approx. 0 °	Steering angle sensor and circuit
		Steering	- 720 to 720°	
YAW RATE SEN	Yaw rate detected by yaw rate sensor	Vehicle stopped	Approx. 0 d/s	Yaw rate sensor and circuit
		During driving	- 70 to 70d/s	
SIDE G-SENSOR	Transverse acceleration detected by side G sensor	Vehicle stopped	Approx. 0 m/s ²	Side G sensor and circuit
		During driving	- 24.3 to 24.1m/s ²	
PRESS SENSOR	Brake fluid pressure detected by pressure sensor	With the ignition switch turned ON and brake pedal released.	Approx. 0 bar	Pressure sensor and circuit
		With the ignition switch turned ON and brake pedal depressed.	- 40 to 300bar	
BATTERY VOLT	Battery voltage supplied to the ESP/TCS/ABS control unit	Ignition switch ON	10 – 16V	ESP/TCS/ABS control unit power supply circuit and ground circuit
MOTOR RELAY	Motor relay ON/OFF condition	ABS not activated.	OFF	Motor relay and circuit
		ABS activated.	ON	
ACTUATOR RLY	Actuator relay ON/OFF condition	Ignition ON and Vehicle stopped.	OFF	Actuator relay and circuit
		Engine running and Vehicle stopped.	ON	
STOP LAMP SW	Operating status of brake pedal	Depress brake pedal.	ON	Stop lamp switch circuit
		Release the brake pedal.	OFF	
PARK BRAKE SW	Parking brake status	Parking brake activated	ON	Parking brake switch circuit
		Parking brake not activated	OFF	

TROUBLE DIAGNOSIS

[ESP/TCS/ABS]

Data monitor item	Contents	Data monitor		(Reference) Check items for malfunction
		Condition	Reference value in normal operation	
OFF SW	ESP OFF SW ON/OFF condition	ESP OFF switch ON (When ESP OFF indicator lamp is ON.)	ON	ESP OFF switch circuit
		ESP OFF switch OFF (When ESP OFF indicator lamp is OFF.)	OFF	
ABS WARN LAMP	ABS warning lamp status (Note 2)	When ABS warning lamp is ON.	ON	ABS warning lamp circuit
		When ABS warning lamp is OFF.	OFF	
OFF LAMP	ESP OFF indicator lamp status (Note 3)	When ESP OFF indicator lamp is ON.	ON	ESP OFF indicator lamp circuit
		When ESP OFF indicator lamp is OFF.	OFF	
SLIP LAMP	SLIP indicator lamp status (Note 4)	When SLIP indicator lamp is ON	ON	SLIP indicator lamp circuit
		When SLIP indicator lamp is OFF.	OFF	
FR LH IN SOL FR LH OUT SOL FR RH IN SOL FR RH OUT SOL RR LH IN SOL RR LH OUT SOL RR RH IN SOL RR RH OUT SOL	Solenoid valve operation	Actuator (solenoid valve) is active ("Active Test "with CONSULT-II) or actuator relay is inactive (in fail-safe mode).	ON	Solenoid valve and circuit
		When the actuator (solenoid valve) is not active and actuator relay is active (ignition switch ON).	OFF	
USV [FR-RL] USV [FL-RR] HSV [FR-RL] HSV [FL-RR]	ESP switch-over solenoid valve status	When the actuator (switch-over solenoid valve) is active ("Active test" with CONSULT-II) or the actuator relay is inactive (when fail-safe mode).	ON	Switch-over solenoid valve and circuit
		When the actuator (switch-over solenoid valve) is inactive or the actuator relay is active (ignition switch ON).	OFF	
V/R OUTPUT	Actuator relay activated (ON/OFF)	When the actuator relay is active (the engine is running).	ON	Actuator relay and circuit
		When the actuator relay is not active (before the engine get started and in the fail-safe mode).	OFF	
M/R OUTPUT	Actuator motor and motor relay status (ON/OFF)	When the actuator motor and motor relay are active ("Active test" with CONSULT-II).	ON	Actuator motor, motor relay, and circuit
		When the actuator motor and motor relay are inactive.	OFF	
FLUID LEV SW	Brake fluid level warning switch status.	When brake fluid level warning switch is ON.	ON	Brake fluid level warning switch, brake warning lamp and circuit.
		When brake fluid lever warning switch is OFF.	OFF	
EBD FAIL SIG ABS FAIL SIG TCS FAIL SIG VDC FAIL SIG	System fail signal status	Malfunctions condition (When system failed)	OFF	EBD system ABS system TCS system ESP system

(Note 1): Check the pressure of the tyre in normal condition.

(Note 2): ON/OFF timing of the ABS warning lamp

ON: For approximately 2 seconds after the ignition switch is turned ON, or when a malfunction is detected.

OFF: Approximately 2 seconds after the ignition switch is turned ON (when the system is in normal operation).

(Note 3): ON/OFF timing of the ESP OFF indicator lamp

ON: For approximately 2 seconds after the ignition switch is turned ON, or when a malfunction is detected ESP OFF switch is ON.

OFF: Approximately 2 seconds after the ignition switch is turned ON (when the system is in normal operation) or when ESP OFF switch is OFF.

(Note 4): SLIP indicator lamp ON/OFF timing

ON: For approximately 2 seconds after the ignition switch is turned ON, or when a malfunction is detected.

OFF: Approximately 2 seconds after the ignition switch is turned ON (when the system is in normal operation) and ESP/TCS function is not activated.

Flashing: ESP/TCS function is active during driving.

CONSULT-II Functions CONSULT-II MAIN FUNCTION

EFS005W3

In a diagnosis function (main function), there are "WORK SUPPORT", "SELF-DIAG RESULTS", "DATA MONITOR", "CAN DIAG SUPPORT MNTR", "ACTIVE TEST", "FUNCTION TEST", "ECU PART NUMBER".

Diagnostic test mode	Function	Reference
WORK SUP-PORT	This mode enables a technician to adjust some devices faster and more accurately by following the indications on CONSULT-II.	BRC-52. "Adjustment of Steering Angle Sensor Neutral Position"
SELF-DIAG RESULTS	Self-diagnostic results can be read and erased quickly.	BRC-81. "SELF-DIAGNOSIS"
DATA MONI-TOR	Input/Output data in the ESP/TCS/ABS control unit can be read.	BRC-83. "DATA MONITOR"
CAN DIAG SUPPORT MNTR	The results of transmit/receive diagnosis of communication can be read.	—
ACTIVE TEST	Diagnostic Test Mode in which CONSULT-II drives some actuators apart from the ESP/TCS/ABS control unit and also shifts some parameters in a specified range.	BRC-86. "ACTIVE TEST"
FUNCTION TEST	Conducted by CONSULT-II instead of a technician to determine whether each system is "OK" or "NG".	—
ECU PART NUMBER	ESP/TCS/ABS control unit part number can be read.	—

CONSULT-II BASIC OPERATION PROCEDURE

1. Turn ignition switch OFF.
2. Connect CONSULT-II and CONSULT-II CONVERTER to data link connector.

CAUTION:

If CONSULT-II is used with no connection of CONSULT-II CONVERTER, malfunctions might be detected in self-diagnosis depending on control unit which carry out CAN communication.

3. Turn ignition switch ON.
4. Touch "START (NISSAN BASED VHCL)".

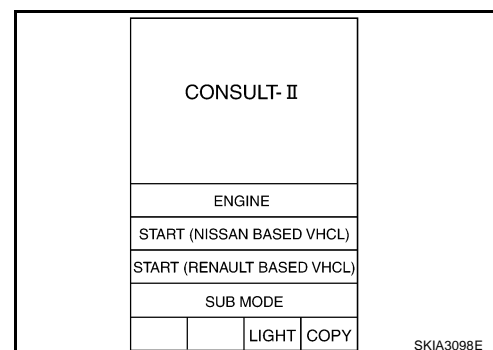

TROUBLE DIAGNOSIS

[ESP/TCS/ABS]

5. Touch "ABS" in the "SELECT SYSTEM" screen.
If "ABS" is not indicated, go to [GI-35, "CONSULT-II Data Link Connector \(DLC\) Circuit"](#).

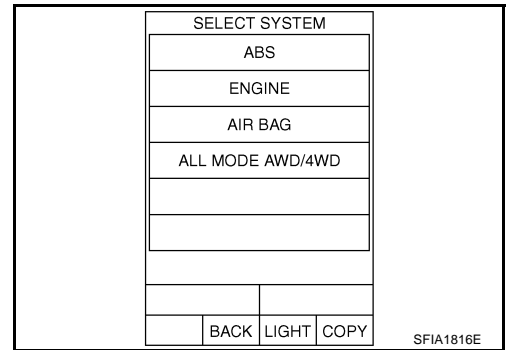

6. Select the required diagnostic location from the "SELECT DIAG MODE" screen.
For further information, see CONSULT-II Operation Manual.

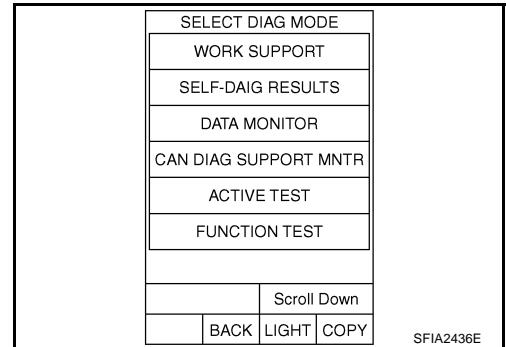

SELF-DIAGNOSIS**Description**

- If an malfunction is detected in the system, ABS warning lamp, ESP OFF indicator lamp and SLIP indicator lamp on the combination meter turn on. In this case, perform self-diagnosis as follows:
- While CONSULT-II is used, ABS warning lamp, ESP OFF indicator lamp, SLIP indicator lamp may be turned on in a case of no malfunctioning.

Operation Procedure

1. Turn ignition switch OFF.
2. Connect CONSULT-II and CONSULT-II CONVERTER to data link connector.

CAUTION:

If CONSULT-II is used with no connection of CONSULT-II CONVERTER, malfunctions might be detected in self-diagnosis depending on control unit which carry out CAN communication.

3. Turn ignition switch ON.
4. Start engine and drive at 30 km/h (19 MPH) or more for approximately 1 minute.
5. After stopping vehicle, with the engine running, touch "START (NISSAN BASED VHCL)", "ABS", "SELF-DIAG RESULTS" in order on the CONSULT-II screen.

CAUTION:

If "START (NISSAN BASED VHCL)" is touched immediately after starting engine or turning on the ignition switch, "ABS" might not be displayed in the System Selection screen. In this case, repeat the operation from step 1. If it cannot be shown after several attempts, ESP/TCS/ABS control unit may have malfunctioned.

6. The self-diagnostic results are displayed. (If necessary, the self-diagnostic results can be printed out by touching "PRINT".)
 - When "NO FAILURE" is displayed, check ABS warning lamp, ESP OFF indicator lamp and SLIP indicator lamp.
7. Perform the appropriate inspection from the display item list, and repair or replace the malfunctioning component.
8. Drive the vehicle at 30 km/h (19 MPH) or more for approximately 1 minute.

CAUTION:

In a case that a wheel sensor is malfunctioning, ABS warning lamp, ESP OFF indicator lamp, SLIP indicator lamp will turn on. If vehicle is not driven at approximately 30 km/h (19 MPH) or more for at least approximately 1 minute after repair of the wheel sensor system, ABS warning lamp, ESP OFF indicator lamp and SLIP indicator lamp may not turn off even if everything is normal. Check again to make sure that there is no malfunction on other parts.

9. Turn ignition switch OFF to prepare for erasing the memory.
10. Start engine and touch "START (NISSAN BASED VHCL)", "ABS", "SELF-DIAG RESULTS", "ERASE MEMORY" in order on the CONSULT-II screen to erase the diagnostic memory.
If "ABS" is not indicated, go to [GI-35, "CONSULT-II Data Link Connector \(DLC\) Circuit"](#).

CAUTION:

If the diagnostic memory is not erased, re-perform the operation from step 5.

11. For the final inspection, drive at 30 km/h (19 MPH) or more for approximately 1 minute and confirm that ABS warning lamp, ESP OFF indicator lamp and SLIP indicator lamp are OFF.

TROUBLE DIAGNOSIS

[ESP/TCS/ABS]

Display Item List

Self-Diagnostic item	Malfunction detecting condition	Check route
FR LH SENSOR – 1	Circuit of front LH wheel sensor is open.	Wheel sensor and circuit. Refer to BRC-91
RR RH SENSOR – 1	Circuit of rear RH wheel sensor is open.	
FR RH SENSOR – 1	Circuit of front RH wheel sensor is open.	
RR LH SENSOR – 1	Circuit of rear LH wheel sensor is open.	
FR LH SENSOR – 2	Front LH wheel sensor is shorted or input signal is malfunction.	
RR RH SENSOR – 2	Rear RH wheel sensor is shorted or input signal is malfunction.	
FR RH SENSOR – 2	Front RH wheel sensor is shorted or input signal is malfunction.	
RR LH SENSOR – 2	Rear LH wheel sensor is shorted or input signal is malfunction.	
MAIN RELAY	During the actuator relay operating with OFF, when the actuator relay turns ON. Or when the control line for the relay is shorted to the ground.	Actuator relay and circuit. Refer to BRC-103
	During the actuator relay operating with ON, when the actuator relay turns OFF, or when the control line for the relay is open.	
STOP LAMP SW	Stop lamp switch circuit is open.	Stop lamp switch and circuit. Refer to BRC-105
PRESS SEN CIRCUIT	Pressure sensor signal line is open or shorted, or pressure sensor is malfunction.	Pressure sensor and circuit. Refer to BRC-93
ST ANGLE SEN CIRCUIT	Neutral position of steering angle sensor is dislocated, or the steering angle sensor is malfunction.	Steering angle sensor and circuit. Refer to BRC-95
YAW RATE SENOR	Yaw rate sensor is malfunction, or the yaw rate sensor signal line is open or shorted.	Yaw rate/side G sensor and circuit. Refer to BRC-97
FR LH IN ABS SOL	Circuit of front LH wheel inlet solenoid valve is open or shorted, or the control line is open or shorted to the power supply or the ground.	Solenoid valve and circuit. Refer to BRC-98
FR LH OUT ABS SOL	Circuit of front LH wheel outlet solenoid valve is open or shorted, or the control line is open or shorted to the power supply or the ground.	
RR RH IN ABS SOL	Circuit of rear RH wheel inlet solenoid valve is open or shorted, or the control line is open or shorted to the power supply or the ground.	
RR RH OUT ABS SOL	Circuit of rear RH wheel outlet solenoid valve is open or shorted, or the control line is open or shorted to the power supply or the ground.	
FR RH IN ABS SOL	Circuit of front RH wheel inlet solenoid valve is open or shorted, or the control line is open or shorted to the power supply or the ground.	
FR RH OUT ABS SOL	Circuit of front RH wheel outlet solenoid valve is open or shorted, or the control line is open or shorted to the power supply or the ground.	
RR LH IN ABS SOL	Circuit of rear LH wheel inlet solenoid valve is open or shorted, or the control line is open or shorted to the power supply or the ground.	
RR LH OUT ABS SOL	Circuit of rear LH wheel outlet solenoid valve is open or shorted, or the control line is open or shorted to the power supply or the ground.	

TROUBLE DIAGNOSIS

[ESP/TCS/ABS]

Self-Diagnostic item	Malfunction detecting condition	Check route
USV LINE [FL-RR]	ESP switch-over solenoid valve 1 on the primary side is open circuit or shorted, or the control line is open or shorted to the power supply or the ground.	ESP switch-over solenoid valve and circuit. Refer to BRC-98 .
USV LINE [FR-RL]	ESP switch-over solenoid valve 1 on the secondary side is open circuit or shorted, or the control line is open or shorted to the power supply or the ground.	
HSV LINE [FL-RR]	ESP switch-over solenoid valve 2 on the primary side is open circuit or shorted, or the control line is open or shorted to the power supply or the ground.	
HSV LINE [FR-RL]	ESP switch-over solenoid valve 2 on the secondary side is open circuit or shorted, or the control line is open or shorted to the power supply or the ground.	
PUMP MOTOR ACTUATOR RLY (note)	<p>During the actuator motor operating with ON, when the actuator motor turns OFF, or when the control line for actuator motor relay is open.</p> <p>During the actuator motor operating with OFF, when the actuator motor turns ON, or when the control line for relay is shorted to ground.</p>	Actuator motor, motor relay, and circuit. Refer to BRC-101
ABS SENSOR [ABNORMAL SIGNAL]	Wheel sensor input is malfunction.	Wheel sensor and circuit. Refer to BRC-91
BATTERY VOLTAGE [ABNORMAL]	ESP/TCS/ABS control unit battery voltage is too low.	ESP/TCS/ABS control unit battery voltage circuit and ground circuit. Refer to BRC-105
ST ANGLE SEN SIGNAL	Neutral position correction of steering angle sensor is not finished.	Neutral position adjustment of steering angle sensor. Refer to BRC-107
ST ANG SEN COM CIR	CAN communication system or steering angle sensor is malfunction.	Steering angle sensor and CAN communication circuit. Refer to BRC-109
SIDE G-SEN CIRCUIT	Side G sensor is malfunction, or circuit of side G sensor is open or shorted.	Yaw rate/ Side G sensor and circuit. Refer to BRC-97
EMERGENCY BRAKE	ESP/TCS/ABS control unit malfunction (pressure increase is too much or too little.)	ESP/TCS/ABS control unit. Refer to BRC-107
CONTROLLER FAILURE	ESP/TCS/ABS internal malfunction of control unit	ESP/TCS/ABS control unit. Refer to BRC-93
CAN COMM CIRCUIT	<ul style="list-style-type: none"> CAN communication line is open or shorted. ESP/TCS/ABS control unit internal malfunction. Battery voltage for ECM is interrupted instantaneously for Approx. 0.5 seconds or more. 	Communication circuit between ESP/TCS/ABS control unit and units. Refer to BRC-109
BR FLUID LEVEL LOW	Brake fluid level drops or communication line between the ESP/TCS/ABS control unit and brake fluid level warning switch is open or shorted.	Communication circuit between the ESP/TCS/ABS control unit and the brake fluid level warning switch. Reservoir tank fluid. Refer to BRC-108
ENGINE SIGNAL 1-4, 6	Major engine components are malfunction	Engine system. Refer to BRC-93

(note) "ACTUATOR RLY" on the CONSULT-II self-diagnosis results indicates the malfunction of the actuator motor relay and circuit.

DATA MONITOR

For details of the data monitor function, refer to CONSULT-II Instruction Manual.

Operation Procedure

1. After turning OFF ignition switch, connect CONSULT-II and CONVERTER to data link connector.

CAUTION:

If CONSULT-II is used with no connection of CONSULT-II CONVERTER, malfunctions might be detected in self-diagnosis depending on control unit which carry out CAN communication.

2. Turn ignition switch ON.
3. Touch "START (NISSAN BASED VHCL)", "ABS", "DATA MONITOR" in order on the CONSULT-II screen. If "ABS" is not indicated, go to [GI-35, "CONSULT-II Data Link Connector \(DLC\) Circuit"](#).

CAUTION:

When "START (NISSAN BASED VHCL)" is touched immediately after starting engine or turning on ignition switch, "ABS" might not be displayed in the system selection screen. In this case, repeat the operation from step 1.

4. Return to the Monitor Item Selection screen, and touch "ECU INPUT SIGNALS", "MAIN SIGNALS" or "SELECTION FROM MENU". Refer to the following information.
5. When "START" is touched, the data monitor screen is displayed.

Display Item List

Data Monitor Item (Unit)	Data Monitor item selection			Remarks
	ECU INPUT SIGNALS	MAIN SIGNALS	SELECTION FROM MENU	
GEAR (A/T MODEL)	×	×	×	The gear position determined from A/T PNP switch signal is displayed.
SLCT LVR POSI (A/T MODEL)	×	×	×	Shift position determined from the A/T PNP switch signal is displayed.
FR RH SENSOR [km/h]	×	×	×	Wheel speed calculated by front RH wheel sensor signal is displayed.
FR LH SENSOR [km/h]	×	×	×	Wheel speed calculated by front LH wheel sensor signal is displayed.
RR RH SENSOR [km/h]	×	×	×	Wheel speed calculated by rear RH wheel sensor signal is displayed.
RR LH SENSOR [km/h]	×	×	×	Wheel speed calculated by rear LH wheel sensor signal is displayed.
ACCEL POS SIG (%)	×	–	–	Throttle valve open/close status judged by the CAN communication signal is displayed.
ENGINE RPM (rpm)	×	–	×	Engine speed judged by the CAN communication signal is displayed.
CAN COM START (ON/OFF)	–	–	×	Communication status of CAN communication is displayed.
STR ANGLE SIG (°)	×	–	×	Steering wheel angle detected by the steering angle sensor is displayed.
YAW RATE SEN (d/s)	×	×	–	Yaw rate detected by the yaw rate sensor is displayed.
SIDE G-SENSOR (m/s ²)	×	–	×	Transverse acceleration detected by the side G sensor is displayed.
PRESS SENSOR (bar)	×	–	×	Brake fluid pressure detected by the pressure sensor is displayed.

TROUBLE DIAGNOSIS

[ESP/TCS/ABS]

Data Monitor Item (Unit)	Data Monitor item selection			Remarks
	ECU INPUT SIGNALS	MAIN SIGNALS	SELECTION FROM MENU	
BATTERY VOLT (V)	×	×	×	Voltage supplied to ESP/TCS/ABS control unit is displayed.
MOTOR RELAY (ON/OFF)	–	×	×	Motor relay signal (ON/OFF) status is displayed.
ACTUATOR RLY (ON/OFF)	–	×	×	Actuator relay signal (ON/OFF) status is displayed.
STOP LAMP SW (ON/OFF)	×	×	×	Stop lamp switch (ON/OFF) status is displayed.
PARK BRAKE SW (ON/OFF)	×	–	×	Parking brake switch (ON/OFF) status is displayed.
OFF SW (ON/OFF)	×	×	×	ESP OFF switch (ON/OFF) status is displayed.
ABS WARN LAMP (ON/OFF)	–	×	×	ABS warning lamp (ON/OFF) status is displayed.
OFF LAMP (ON/OFF)	–	×	×	ESP OFF indicator lamp (ON/OFF) status is displayed.
SLIP LAMP (ON/OFF)	–	×	×	SLIP indicator lamp (ON/OFF) status is displayed.
FR LH IN SOL (ON/OFF)	–	×	×	Front LH wheel inlet solenoid valve (ON/OFF) status is displayed.
FR LH OUT SOL (ON/OFF)	–	×	×	Front LH wheel outlet solenoid valve (ON/OFF) status is displayed.
RR RH IN SOL (ON/OFF)	–	×	×	Rear RH wheel inlet solenoid valve (ON/OFF) status is displayed.
RR RH OUT SOL (ON/OFF)	–	×	×	Rear RH wheel outlet solenoid valve (ON/OFF) status is displayed.
FR RH IN SOL (ON/OFF)	–	×	×	Front RH wheel inlet solenoid valve (ON/OFF) status is displayed.
FR RH OUT SOL (ON/OFF)	–	×	×	Front RH wheel outlet solenoid valve (ON/OFF) status is displayed.
RR LH IN SOL (ON/OFF)	–	×	×	Rear LH wheel inlet solenoid valve (ON/OFF) status is displayed.
RR LH OUT SOL (ON/OFF)	–	×	×	Rear LH wheel outlet solenoid valve (ON/OFF) status is displayed.
M/R OUTPUT (ON/OFF)	–	–	×	Motor relay activation signal (ON/OFF) status is displayed.
FLUID LEV SW (ON/OFF)	×	–	×	Brake fluid level warning switch (ON/OFF) status is displayed.
SNOW MODE SW (ON/OFF)	–	–	×	“OFF” is displayed.
BST OPER SIG (ON/OFF)	–	–	×	“OFF” is displayed.
M MODE SIG (ON/OFF)	–	–	×	“OFF” is displayed.

A
B
C
D
E
G
H
I
J
K
L
M

BRC

TROUBLE DIAGNOSIS

[ESP/TCS/ABS]

Data Monitor Item (Unit)	Data Monitor item selection			Remarks
	ECU INPUT SIGNALS	MAIN SIGNALS	SELECTION FROM MENU	
OD OFF SW (ON/OFF)	–	–	×	“OFF” is displayed.
EBD SIGNAL (ON/OFF)	–	–	×	EBD operation (ON/OFF) status is displayed.
ABS SIGNAL (ON/OFF)	–	–	×	ABS operation (ON/OFF) status is displayed.
TCS SIGNAL (ON/OFF)	–	–	×	TCS operation (ON/OFF) status is displayed.
VDC SIGNAL (ON/OFF)	–	–	×	ESP operation (ON/OFF) status is displayed.

×: Applicable

–: Not applicable

ACTIVE TEST

CAUTION:

- Do not perform active test while driving.
- Make sure to completely bleed air from the brake system.
- Active test cannot be performed when EBD, ABS, TCS or ESP operation is malfunction.
- ABS and brake warning lamps turn on during the active test.

Operation Procedure

1. Connect CONSULT-II and CONVERTER to data link connector and start engine.

CAUTION:

If CONSULT-II is used with no connection of CONSULT-II CONVERTER, malfunctions might be detected in self-diagnosis depending on control unit which carry out CAN communication.

2. Touch “START (NISSAN BASED VHCL)” on the display screen.
3. Touch “ABS”.
If “ABS” is not indicated, go to [GI-35, "CONSULT-II Data Link Connector \(DLC\) Circuit"](#).
4. Touch “ACTIVE TEST”.
5. The test item selection screen is displayed.
6. Touch necessary test item.

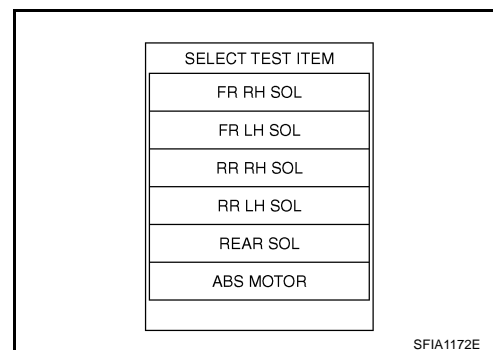

7. With the “MAIN SIGNALS” display shown in reverse, touch “START”.
8. The “ACTIVE TEST” screen will be displayed, so perform the following test.

NOTE:

- When the active test is performed while depressing pedal, the pedal depression amount will change, but this is normal.
- Approximately 10 seconds after the operation is begun, “TEST STOP” will be displayed.
- To perform a retest after “TEST STOP” is displayed, touch “BACK” and perform the test from the step 6.

Test Item

Solenoid valve

TROUBLE DIAGNOSIS

[ESP/TCS/ABS]

CAUTION:

The example shown is for front right wheel. The procedure for the other wheels is the same as given below.

- When performing an active test of the ABS function, select the main item for each test item. In addition, when performing an active test of the ESP/TCS function, select the item menu for each test item.
- For ABS solenoid valve, touch “UP”, “KEEP”, “DOWN” on the display screen.
For ABS solenoid valve (ACT), touch “UP”, “ACT UP”, “ACT KEEP” and confirm that solenoid valves (IN, OUT, USV, HSV) operate as shown in the table below.

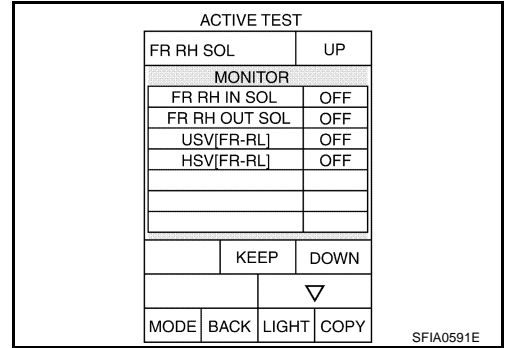

A
B
C
D
E
G
H
I
J
K
L
M

BRC

Operation	ABS solenoid valve			ABS solenoid valve (ACT)		
	UP	KEEP	DOWN	UP	ACT UP	ACT KEEP
FR RH IN SOL	OFF	ON	ON	OFF	OFF	OFF
FR RH OUT SOL	OFF	OFF	ON*	OFF	OFF	OFF
USV [FR - RL]	OFF	OFF	OFF	OFF	ON	ON
HSV [FR - RL]	OFF	OFF	OFF	OFF	ON*	OFF

*: ON for 1 to 2 seconds after the touch, and then OFF

ABS Motor

Touch “ON”, “OFF” on the display screen and make sure ABS motor relay is operating as shown in the table below.

Operation	ON	OFF
MOTOR RELAY	ON	OFF
ACTUATOR RELAY	ON	ON

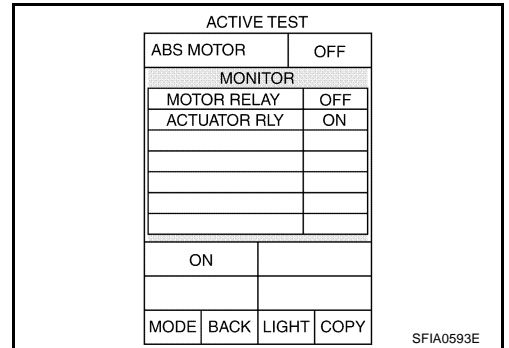

For Fast and Accurate Diagnosis

PRECAUTIONS FOR DIAGNOSIS

- Before performing diagnosis, always read precautions. Refer to [BRC-60, "How to Proceed With Diagnosis"](#) .
- If ESP/TCS/ABS control unit steering angle sensor, steering system parts or suspension system parts have been replaced, or if alignment has been adjusted, be sure to adjust neutral position of steering angle sensor before driving. Refer to [BRC-52, "Adjustment of Steering Angle Sensor Neutral Position"](#) .
- After diagnosis is finished, be sure to erase memory. Refer to [BRC-81, "SELF-DIAGNOSIS"](#) .
- When checking continuity and voltage between units, be sure to check for disconnection, looseness, bend, or collapse of connector terminals. If any malfunction is found, repair or replace connector terminals.
- For intermittent symptoms, possible cause is malfunction in harness, harness connector, or terminals. Move harness, harness connector, and terminals to check for poor connections.
- If a circuit tester is used for the check, be careful not to forcibly extend any connector terminal.
- To use CONSULT-II to perform self-diagnosis of ESP/TCS/ABS control unit active tests, or work support, first stop work, then connect CONSULT-II and select "ABS".
- While self-diagnostic results of CONSULT-II shows malfunction, if CONSULT-II active test is performed, an engine system malfunction may be indicated. In this case, start engine to resume the normal screen.
- ESP/TCS/ABS system electronically controls brake operation and engine output. The following symptoms may be caused by normal operations:

Symptom	Symptom description	Result
Motor operation noise	This is noise of motor inside ESP/TCS/ABS control unit. Slight noise may occur during ESP, TCS, and ABS operation.	Normal
	When the vehicle speed goes over 20 km/h (12.5 MPH), motor and valves operating noise may be heard. It happens only once after ignition switch is ON. This is a normal status of the system operation check.	
System operation check noise	When engine starts, slight "click" noise may be heard from engine room. This is normal and is part of system operation check.	Normal
ESP/TCS operation (SLIP indicator lamp blinking)	TCS may activate momentarily if wheel speed changes when driving over location where friction coefficient varies, when downshifting, or when fully depressing accelerator pedal.	Normal Cancel the ESP/TCS function for the inspection on a chassis dynamometer.
	When checking speed meter etc. with a 2-wheel-drive chassis dynamometer, vehicle speed is not increased by pressing down on the accelerator.	
ABS operation (Longer stopping distance)	On roads with low friction coefficients, such as snowy roads or gravel roads, vehicles with ABS may require a longer stopping distance. Therefore, when driving on such roads, avoid overconfidence and keep speed sufficiently low.	Normal
Insufficient feeling of acceleration	Depending on road conditions, driver may feel that feeling of acceleration is insufficient. This is because traction control, which controls engine and brakes to achieve optimal traction, has the highest priority (for safety). As a result, there may be times when acceleration is slightly less than usual for the same accelerator pedal operation.	Normal

ON and OFF Timing for ABS Warning Lamp, ESP OFF Indicator Lamp, SLIP Indicator Lamp, Brake Warning Lamp

×: ON -: OFF

Condition	ABS warning lamp	ESP OFF indicator lamp	SLIP indicator lamp	Brake warning lamp [Note 1]	Remarks
Ignition SW OFF.	-	-	-	-	-
Approx. 2 seconds after ignition switch is turned ON.	×	×	×	× [Note 2]	-
Approx. 2 seconds later after ignition switch ON.	-	-	-	× [Note 2]	Go out 2 seconds after ignition switch is turned ON.

TROUBLE DIAGNOSIS

[ESP/TCS/ABS]

Condition	ABS warning lamp	ESP OFF indicator lamp	SLIP indicator lamp	Brake warning lamp [Note 1]	Remarks
ESP OFF SW is turned ON. (ESP/TCS function is OFF.)	–	×	–	–	–
ESP/TCS/ABS malfunction.	×	×	×	–	There is an ESP/TCS/ABS control unit malfunction. (Power, ground or system malfunction)
When ESP/TCS is not functioning normally.	–	×	×	–	–
EBD malfunction.	×	×	×	×	–

NOTE:

1. Brake warning lamp will turn on in case of operating parking brake (switch turned ON) or of actuating brake fluid level switch (brake fluid is insufficient).
2. After starting engine, turn off.

Basic Inspection

EFS005W5

BASIC INSPECTION 1 BRAKE FLUID AMOUNT, LEAKS, AND BRAKE PADS INSPECTION

1. Check fluid level in the brake reservoir tank. If fluid level is low, refill brake fluid.
 2. Check brake piping and around ESP actuator for leaks. If there is leaking or oozing fluid, check the following items.
 - If ESP actuator connection is loose, tighten piping to the specified torque and re-perform the leak inspection to make sure there are no leaks.
 - If there is damage to the connection flare nut or ESP actuator screw, replace the damaged part and re-perform the leak inspection to make sure there are no leaks.
 - When there is fluid leaking or oozing from a part other than ESP actuator connection, if fluid is just oozing out, use a clean cloth to wipe off the oozing fluid and re-check for leaks. If fluid is still oozing out, replace the damaged part.
- CAUTION:**
ESP actuator body cannot be disassembled.
3. Check brake pad degree of wear. Refer to [BR-27, "PAD THICKNESS"](#) in "Front Disc Brake" and [BR-32, "PAD WEAR INSPECTION"](#) in "Rear Disc Brake"

BASIC INSPECTION 2 POWER SYSTEM TERMINAL LOOSENESS AND BATTERY INSPECTION

Make sure battery positive cable, negative cable and ground connection are not loose. If looseness is detected, tighten the cables. In addition, check the battery voltage to make sure it has not dropped and alternator is normal.

BASIC INSPECTION 3 ABS WARNING LAMP, ESP OFF INDICATOR LAMP, SLIP INDICATOR LAMP AND BRAKE WARNING LAMP INSPECTION

1. Make sure ABS warning lamp, ESP OFF indicator lamp (when ESP OFF switch is OFF), and SLIP indicator lamp turns on approximately 2 second, and brake warning lamp turns on when ignition switch is turned ON. If they do not, check ESP OFF indicator lamp and then ESP OFF switch. Refer to [BRC-109, "ESP OFF SWITCH"](#) . Check CAN communications. Refer to "CAN Communication Inspection". If there are no malfunctions with ESP OFF switch and CAN communication system, check combination meter. Refer to [DI-4, "COMBINATION METERS"](#) .
2. Make sure ABS warning lamp, ESP OFF indicator lamp, SLIP indicator lamp turn off approximately 2 second after turn ignition switch ON, and brake warning lamp turns off after engine starts. If lamps do not turn off, perform self-diagnosis.
3. With engine running, make sure ESP OFF indicator lamp turns on and off when ESP OFF switch is turned ON and OFF. If indicator lamp status does not correspond to switch operation, check the ESP OFF switch system. Refer to [BRC-109, "ESP OFF SWITCH"](#) .
4. Make sure ABS warning lamp, ESP OFF indicator lamp, and SLIP indicator lamp turn off 2 seconds after engine is started. If ABS warning lamp, ESP OFF indicator lamp, and SLIP indicator lamp have not turned off 10 seconds after engine has been started, perform self-diagnosis of ESP/TCS/ABS control unit.
5. After performing the self-diagnosis, be sure to erase the diagnostic memory. Refer to [BRC-28, "SELF-DIAGNOSIS"](#) .

CAUTION:

Brake warning lamp turns on when parking brake is operated (switch on) and brake fluid level switch is activated (leak of brake fluid).

Inspection 1 Wheel Sensor System**INSPECTION PROCEDURE**

Check each part according to CONSULT-II self-diagnostic results, and then identify the parts to be replaced.

CAUTION:

Do not check between wheel sensor terminals.

1. CHECK TYRE

Check air pressure, wear and size.

Are air pressure, wear and size within standard?

YES >> GO TO 2.

NO >> Adjust air pressure, or replace tyre.

2. CHECK SENSOR AND SENSOR ROTOR

- Check sensor and sensor rotor.
- Check sensor rotor rubber for damage.
- Check sensor for disconnection or looseness.

Is inspection result OK?

OK >> GO TO 3.

NG >> Repair sensor mount or replace sensor rotor.

3. CHECK SELF-DIAGNOSTIC RESULTS

Check the self-diagnostic results.

Self-diagnostic results
ABS SENSOR [ABNORMAL SIGNAL]
FR RH SENSOR-1
FR RH SENSOR-2
FR LH SENSOR-1
FR LH SENSOR-2
RR RH SENSOR-1
RR RH SENSOR-2
RR LH SENSOR-1
RR LH SENSOR-2

Is above displayed on self-diagnosis displayed?

YES >> GO TO 4.

NO >> INSPECTION END

4. CHECK CONNECTOR

1. Turn ignition switch OFF, disconnect connector between ESP/TCS/ABS control unit and malfunctioning wheel sensor, and check for deformation, disconnection and looseness. Repair or replace if necessary.
2. Reconnect connectors, drive vehicle at 30 km/h or more for approximately 1 minute, and then perform self-diagnosis.

OK or NG

OK >> Poor connection of connector terminal

NG >> GO TO 5.

5. CHECK WHEEL SENSOR HARNESS

1. Turn ignition switch OFF and disconnect malfunctioning wheel sensor connector and ESP/TCS/ABS control unit connector.
2. Check continuity between terminals. (Also check continuity when the steering wheel is turned right and left and when the sensor harness inside the wheel house is moved.)

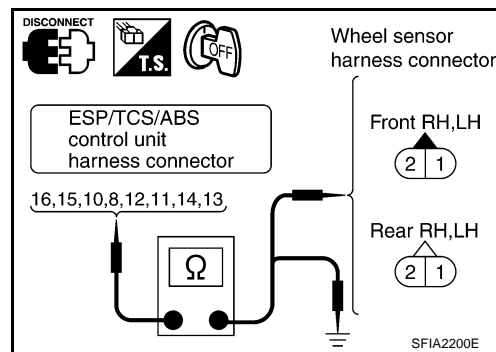

Wheel	Power supply circuit		Signal circuit		Ground circuit	
	ESP/TCS/ABS control unit (harness connector E122)	Wheel sensor (harness connector)	ESP/TCS/ABS control unit (harness connector E122)	Wheel sensor (harness connector)	ESP/TCS/ABS control unit (harness connector E122) (Signal)	Ground
Front RH (E17)	16 (W)	1 (W)	15 (B)	2 (B)	15 (B), 16 (W)	—
Front LH (E59)	10 (L/W)	1 (L/W)	8 (L/Y)	2 (L/Y)	8 (L/Y), 10 (L/W)	
Rear RH (B130)	12 (B/W)	1 (B/W)	11 (L/R)	2 (L/R)	11 (L/R), 12 (B/W)	
Rear LH (B126)	14 (BR)	1 (BR)	13 (BR/W)	2 (BR/W)	13 (BR/W), 14 (BR)	

- Power supply circuit** : Continuity should exist.
Signal circuit : Continuity should exist.
Ground circuit : Continuity should not exist.

Is inspection result OK?

- OK >> GO TO 6.
 NG >> Repair or replace harness and connector that have malfunction.

6. CHECK WHEEL SENSOR

1. Replace wheel sensor that resulted in malfunction by self-diagnosis.
2. Reconnect connectors, drive vehicle at 30 km/h (19 MPH) or more for approximately 1 minute, and then perform self-diagnosis.

Is above displayed on self-diagnosis display?

- OK >> Wheel sensor has malfunction.
 NG >> ● Replace ESP/TCS/ABS control unit.
 ● Perform to self-diagnosis again, and make sure that the result shows "NO DTC IS DETECTED. FURTHER TESTING MAY BE REQUIRED."

Inspection 2 Engine System

EFS005W7

INSPECTION PROCEDURE

1. SELF-DIAGNOSTIC RESULT CHECK 1

Check the self-diagnostic results.

Self-diagnostic results
ENGINE SYSTEM 1
ENGINE SYSTEM 2
ENGINE SYSTEM 3
ENGINE SYSTEM 4
ENGINE SYSTEM 6

Are any items other than above indicated in the self-diagnosis results?

- YES >> Repair or replace affected items.
NO >> GO TO 2.

2. SELF-DIAGNOSTIC RESULT CHECK 2

1. Perform the ECM self-diagnosis and repair or replace affected items, then perform the ECM self-diagnosis again.
2. Perform the ESP/TCS/ABS control unit self-diagnosis again.

Is inspection result OK?

- YES >> INSPECTION END
NO >> Repair or replace affected items. Perform the self-diagnosis again.

Inspection 3 ESP/TCS/ABS Control Unit System

EFS005W8

INSPECTION PROCEDURE

1. SELF-DIAGNOSTIC RESULT CHECK

Check the self-diagnostic results.

Self-diagnostic results
CONTROLLER FAILURE

Are any items other than "CONTROLLER FAILURE" indicated in the self-diagnosis results?

- YES >> Repair or replace affected items. Perform the self-diagnosis again.
NO >> Replace ESP/TCS/ABS control unit and perform ESP/TCS/ABS control unit self-diagnosis again.

Inspection 4 Pressure Sensor and the Circuit between Pressure Sensor and ESP/TCS/ABS Control Unit.

EFS005W9

INSPECTION PROCEDURE

1. SELF-DIAGNOSTIC RESULT CHECK 1

Check the self-diagnostic results.

Self-diagnostic results
PRESS SEN CIRCUIT

Is "PRESS SEN CIRCUIT" indicated in the self-diagnosis results?

- >> GO TO 2.

A

B

C

D

E

BRC

G

H

I

J

K

L

M

2. SELF-DIAGNOSTIC RESULT CHECK 2

1. Disconnect connectors of pressure sensor and ESP/TCS/ABS control unit, and connect them again correctly.
2. Perform ESP/TCS/ABS control unit self-diagnosis again.

Is inspection result OK?

- YES >> Repair or replace the poorly connected connector, then perform the self-diagnosis again.
 NO >> GO TO 3.

3. PRESSURE SENSOR CIRCUIT INSPECTION

1. Disconnect connectors of pressure sensor and ESP/TCS/ABS control unit.
2. Check for continuity between ESP/TCS/ABS control unit and pressure sensor (harness connector E67).

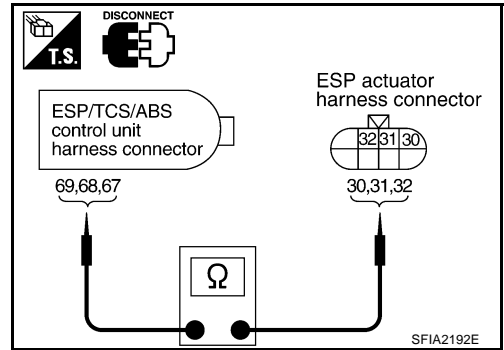

ESP/TCS/ABS control unit (harness connector E122)	Pressure sensor (ESP actuator harness connector E67)	Continuity
69 (P/L)	30 (P/L)	Yes
68 (L/OR)	31 (L/OR)	
67 (G/B)	32 (G/B)	

Is inspection result OK?

- YES >> GO TO 4.
 NO >> Repair or replace the disconnected harness.

4. PRESSURE SENSOR INSPECTION

Check the "PRESS SENSOR" value in "DATA MONITOR".

Condition	PRESS SENSOR (Data monitor)
Brake pedal depressed	Positive value
Brake pedal released	Approx. 0 bar

Is inspection result OK?

- YES >> Perform ESP/TCS/ABS control unit self-diagnosis again.
 NO >> Pressure sensor malfunction. Replace ESP actuator (with the pressure sensor).

Inspection 5 Steering Angle Sensor and Circuit between Steering Angle Sensor and ESP/TCS/ABS Control Unit.

EFS005WA

INSPECTION PROCEDURE

1. SELF-DIAGNOSTIC RESULT CHECK 1

Check the self-diagnostic results.

Self-diagnostic results
ST ANGLE SEN CIRCUIT

Perform the inspection 15.

Refer to [BRC-109, "Inspection 15 CAN Communication Circuit, ESP/TCS/ABS Control Unit and Steering Angle Sensor"](#).

Is "ST ANG SEN CIRCUIT" indicated in the self-diagnosis results.

>> GO TO 2.

2. SELF-DIAGNOSTIC RESULT CHECK 2

1. Repair or replace the poorly connected connector
 - Check connector housing for disconnect, loose, bent and collapse terminals
If any malfunction are detected, repair or replace the applicable part.
2. Perform the ESP/TCS/ABS control unit self-diagnosis again.

Is inspection result OK?

YES >> INSPECTION END

NO >> GO TO 3.

A

B

C

D

E

BRC

G

H

I

J

K

L

M

3. STEERING ANGLE SENSOR CIRCUIT CHECK

1. Disconnect ESP/TCS/ABS control unit connector and steering angle sensor connector.
2. Check for continuity between ESP/TCS/ABS control unit and steering angle sensor (harness connector M81).

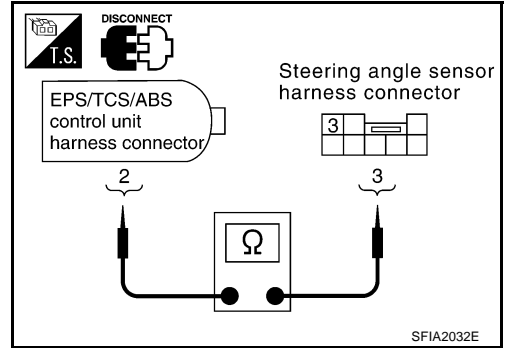

ESP/TCS/ABS control unit (harness connector E122)	Steering angle sensor (harness connector M81)	Continuity
2 (Y/R)	3 (Y/R)	Yes

3. Check for the continuity between the steering angle sensor and ground.

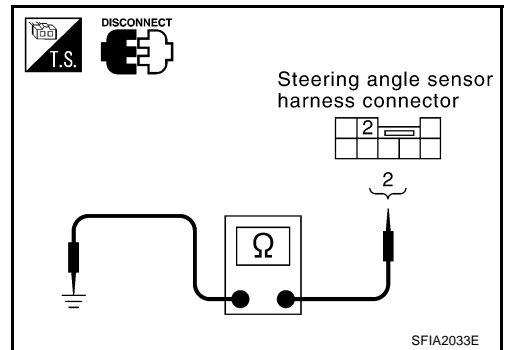

Steering angle sensor (harness connector M81)	ground	Continuity
2 (B/R)	—	Yes

Is inspection result OK?

- YES >> GO TO 4.
- NO >> Repair or replace the disconnected harness.

4. DATA MONITOR CHECK

Perform the "STR ANGLE SIG" value in "DATA MONITOR" and check that it is in normal condition.

Steering condition	STR ANGLE SIG (Data monitor)
Straight-ahead	- 5 ° to + 5 °
Turn the wheel to the right by 90°	Approx. + 90 °
Turn the wheel to the left by 90°	Approx. - 90 °

Is inspection result OK?

- YES >> Perform the ESP/TCS/ABS control unit self-diagnosis again.
- NO >> Replace the spiral cable (with the steering angle sensor) and adjust the neutral position of steering angle sensor. [BRC-52, "Adjustment of Steering Angle Sensor Neutral Position"](#).

Inspection 6 Yaw Rate/Side G sensor and the Circuit between Yaw Rate/Side G sensor and ESP/TCS/ABS Control Unit.

INSPECTION PROCEDURE

1. SELF-DIAGNOSTIC RESULT CHECK 1

Check the self-diagnostic results.

Self-diagnostic results
YAW RATE SEN
SIDE G-SEN CIRCUIT

CAUTION:

When vehicle on a turn-table at an entrance of parking lot or on a moving unit, ESP OFF indicator lamp turns ON, and the self-diagnosis with CONSULT-II may indicate that yaw rate sensor system is malfunction. In this case, yaw rate sensor is not malfunction. Move the vehicle from the turn-table or other moving unit, and restart the engine. This will return the status normal.

Are " YAW RATE SENSOR " and " SIDE G-SEN CIRCUIT " indicated in the self-diagnosis results.

- YES >> GO TO 2.
- NO >> INSPECTION END

2. SELF-DIAGNOSTIC RESULT CHECK 2

1. Disconnect connectors of yaw rate/side G sensor and ESP/TCS/ABS control unit.
2. Check for continuity between ESP/TCS/ABS control unit and yaw rate/side G sensor.

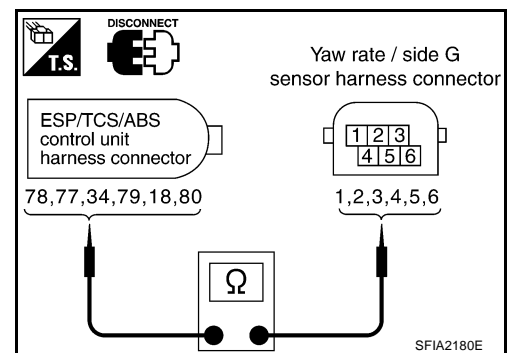

ESP/TCS/ABS control unit (harness connector E122)	Yaw rate/side G-sensor (harness connector B112)	Continuity
78 (L/B)	1 (L/B)	Yes
77 (Y/B)	2 (Y/B)	
34 (OR)	3 (OR)	
79 (LG/R)	4 (LG/R)	
18 (GY/L)	5 (GY/L)	
80 (W/R)	6 (W/R)	

Is inspection result OK?

- YES >> GO TO 3.
- NO >> Repair or replace the disconnected harness.

3. YAW RATE SENSOR/SIDE G SENSOR CIRCUIT CHECK

Check that “YAW RATE SEN” and “SIDE G-SENSOR” are in normal operation in “DATA MONITOR”.

Vehicle status	YAW RATE SEN (DATA MONITOR)	SIDE G-SENSOR (DATA MONITOR)
While the vehicle is stopped	- 4 to + 4 °/s	-1.1 to + 1.1 m/s ²
Right turn	Negative value	Negative value
Left turn	Positive value	Positive value

Is inspection result OK?

YES >> Perform ESP/TCS/ABS control unit self-diagnosis again.

NO >> The yaw rate/side G sensor malfunction. After replacing the sensor, perform the self-diagnosis of ESP/TCS/ABS control unit again.

Inspection 7 Solenoid Valve, ESP Switch-over Solenoid Valve and Circuit EFS005WC

INSPECTION PROCEDURE

1. SELF-DIAGNOSTIC RESULT CHECK 1

Check the self-diagnostic results.

Self-diagnostic results
FR LH IN ABS SOL
FR LH OUT ABS SOL
RR RH IN ABS SOL
RR RH OUT ABS SOL
FR RH IN ABS SOL
FR RH OUT ABS SOL
RR LH IN ABS SOL
RR LH OUT ABS SOL
USV LINE [FL-RR]
USV LINE [FR-RL]
HSV LINE [FL-RR]
HSV LINE [FR-RL]

Are any self-diagnosis result items above indicated?

YES >> GO TO 2.

NO >> INSPECTION END

2. SELF-DIAGNOSTIC RESULT CHECK 2

1. Disconnect ESP/TCS/ABS control unit connector and solenoid valve connectors. Securely connect them again.
2. Perform the self-diagnosis again.

Are any self-diagnosis result items indicated again?

YES >> GO TO 3.

NO >> Repair or replace the poorly connected connector.

3. SOLENOID VALVE INPUT SIGNAL CHECK.

1. Disconnect ESP/TCS/ABS control unit connector.
2. Turn ignition switch ON and check the voltage between ESP/TCS/ABS control unit and body ground.

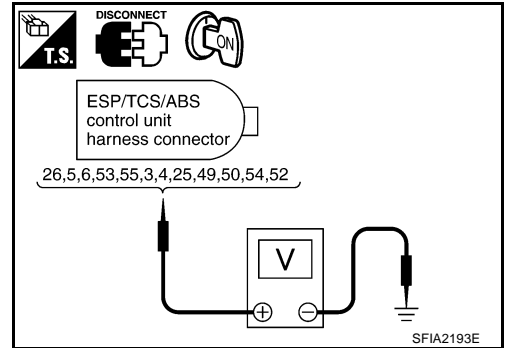

ESP/TCS/ABS control unit (harness connector E122)	Body ground	Voltage
26 (W/G)	-	Battery voltage (approx.12V)
5 (G/OR)		
6 (PU/W)		
53 (P)		
55 (R/Y)		
3 (Y/G)		
4 (GY/R)		
25 (LG)		
49 (B/W)		
50 (R/G)		
54 (W/L)		
52 (PU)		

Is inspection result OK?

- YES >> Check ESP/TCS/ABS control unit power supply circuit.
 NO >> GO TO 4.

4. SOLENOID VALVE LINE CHECK

1. Disconnect connectors for ESP/TCS/ABS control unit and ESP actuator.
2. Check for continuity between ESP/TCS/ABS control unit and ESP actuator (harness connector E67 and E68).

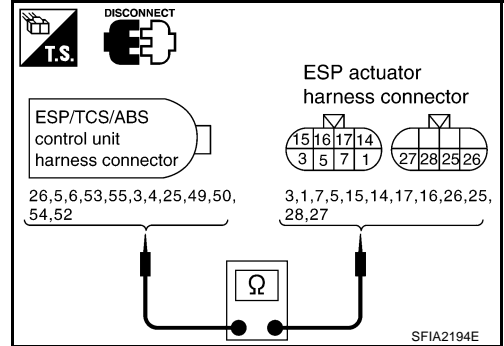

ESP/TCS/ABS control unit (harness connector E122)	ESP actuator (harness connector E67 and E68)	Continuity
26 (W/G)	3 (W/G)	Yes
5 (G/OR)	1 (G/OR)	
6 (PU/W)	7 (PU/W)	
53 (P)	5 (P)	
55 (R/Y)	15 (R/Y)	
3 (Y/G)	14 (Y/G)	
4 (GY/R)	17 (GY/R)	
25 (LG)	16 (LG)	
49 (B/W)	26 (B/W)	
50 (R/G)	25 (R/G)	
54 (W/L)	28 (W/L)	
52 (PU)	27 (PU)	

Is inspection result OK?

YES >> GO TO 5.

NO >> Harness disconnection between ESP/TCS/ABS control unit and the ESP actuator

5. ACTUATOR SOLENOID INSPECTION

1. Disconnect ESP actuator connector and ESP relay box harness connector.
2. Check the resistance value at ESP actuator.

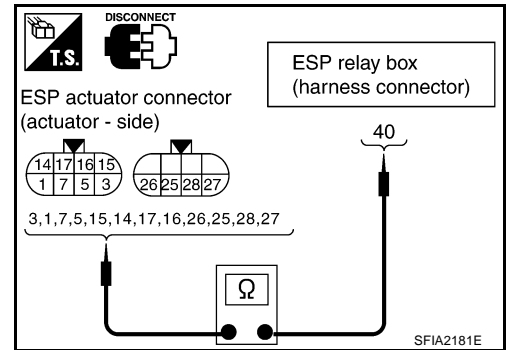

ESP Actuator (Actuator side)	ESP Relay box (harness connector E57)	Resistance
3(W/G)	40	6.0 – 11Ω
1(G/OR)		
7(PU/W)		
5(P)		
26(B/W)		
25(R/G)		3.0 – 5.0Ω
15(R/Y)		
14(Y/G)		
17(GY/R)		
16(LG)		
28(W/L)		
27(PU)		

Is inspection result OK?

- YES >> Perform ESP/TCS/ABS control unit self-diagnosis again.
 NO >> Replace ESP actuator assembly.

Inspection 8 Actuator Motor, Motor Relay and Circuit

EFS005WD

INSPECTION PROCEDURE

1. SELF-DIAGNOSTIC RESULT CHECK 1

Check the self-diagnostic results.

Self-diagnostic results
PUMP MOTOR
ACTUATOR RLY (NOTE)

NOTE:

“ACTUATOR RLY” on the CONSULT-II self-diagnosis results indicates the malfunction of the actuator relay and circuit.

Are “PUMP MOTOR” and “ACTUATOR RLY” (NOTE) indicated in the self-diagnosis results?

- YES >> GO TO 2.
 NO >> INSPECTION END

2. SELF-DIAGNOSTIC RESULT CHECK 2

1. Disconnect connectors for ESP/TCS/ABS control unit and the actuator. Securely connect them again.
2. Perform the self-diagnosis again.

Are any self-diagnosis items indicated again?

YES >> GO TO 3.

NO >> Repair or replace the poorly connected connector.

3. ACTUATOR MOTOR, MOTOR RELAY POWER SUPPLY CIRCUIT INSPECTION

1. Disconnect relay box harness connectors.
2. Check the voltage between the harness connector E55 and body ground.

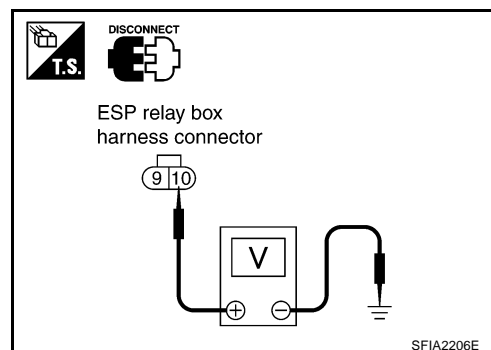

ESP Relay box (harness connector E55)	Body ground	Voltage value
10 (W/R)	–	Battery voltage (approx. 12V)

Is inspection result OK?

YES >> GO TO 4.

NO >> ● Check the fuse 50A.

- Check for the continuity between battery and relay box terminal No. 10.

4. ACTUATOR MOTOR AND MOTOR RELAY CIRCUIT CHECK

1. Disconnect connectors for ESP/TCS/ABS control unit and the relay box.
2. Check for continuity between ESP/TCS/ABS control unit, the relay.

ESP/TCS/ABS control unit (harness connector E122)	ESP relay box (harness connector E56and E57)	Continuity
20 (R/B)	4 (R/B)	Yes
7 (G/W)	8 (G/W)	

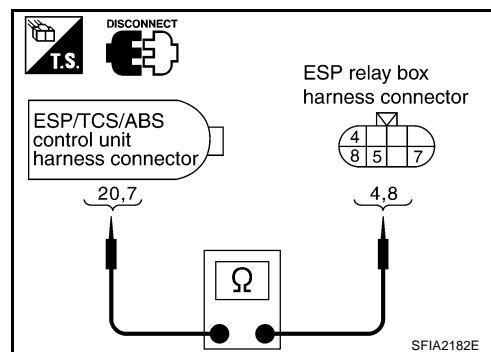

Is inspection result OK?

YES >> GO TO 5.

NO >> Harness malfunction between ESP/TCS/ABS control unit, the ESP relay box.

5. MOTOR RELAY UNIT INSPECTION

Check the motor relay as a unit.

Is inspection result OK?

YES >> Check ESP/TCS/ABS control unit power supply circuit.

NO >> Replace the motor relay.

Inspection 9 Actuator Relay and Circuit

INSPECTION PROCEDURE

1. SELF-DIAGNOSTIC RESULT CHECK 1

Check the self-diagnostic results.

Self-diagnostic results
MAIN RELAY

Is "MAIN RELAY" indicated in the self-diagnosis results?

- YES >> GO TO 2.
- NO >> INSPECTION END

2. SELF-DIAGNOSTIC RESULT CHECK 2

1. Disconnect ESP/TCS/ABS control unit connector. Securely connect them again.
2. Perform ESP/TCS/ABS control unit self-diagnosis again.

Is the same self-diagnosis item indicated?

- YES >> GO TO 3.
- NO >> Repair or replace the poorly connected connector.

3. ESP/TCS/ABS CONTROL UNIT GROUND CIRCUIT INSPECTION

1. Disconnect ESP/TCS/ABS control unit connector.
2. Check ESP/TCS/ABS control unit ground circuit.

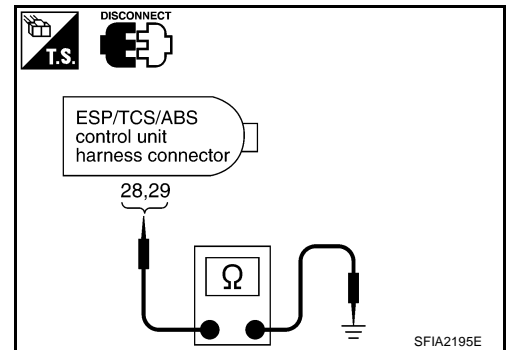

ESP/TCS/ABS control unit (harness connector E122)	Body ground	Continuity
28 (B)	-	Yes
29 (B)		

Is inspection result OK?

- YES >> GO TO 4.
- NO >> Poor connection on ESP/TCS/ABS control unit connector or harness disconnection.

A
B
C
D
E
G
H
I
J
K
L
M

BRC

4. ACTUATOR RELAY POWER SUPPLY CIRCUIT INSPECTION

1. Disconnect the relay box connectors.
2. Check the voltage between the harness connector and body ground.

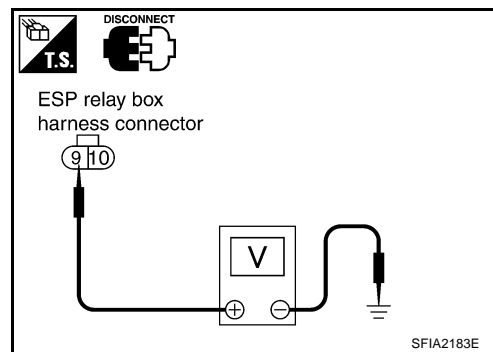

ESP relay box (harness connector E55)	Body ground	Voltage value
9 (BR)	—	Battery voltage (approx. 12V)

Is inspection result OK?

YES >> GO TO 5.

NO >> ● Check the fuse 30A.

- Check for the continuity between battery and the relay box terminal No. 9. If it is not OK, replace the fuse or harness.

5. ACTUATOR RELAY POWER CIRCUIT CHECK

1. Disconnect connectors for ESP/TCS/ABS control unit and the relay box.
2. Check for continuity between ESP/TCS/ABS control unit and the relay box.

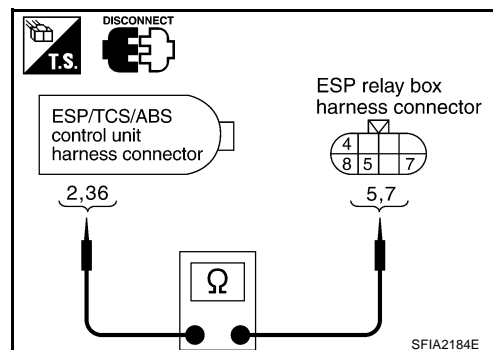

ESP/TCS/ABS control unit (harness connector E122)	ESP relay box (harness connector E56)	Continuity
2 (Y/R)	5 (Y/R)	Yes
36 (L/Y)	7 (L/Y)	

Is inspection result OK?

YES >> GO TO 6.

NO >> The harness disconnection between ESP/TCS/ABS control unit and the relay box.

6. ACTUATOR RELAY UNIT INSPECTION

Check the actuator relay as a unit.

Is inspection result OK?

YES >> Check ESP/TCS/ABS control unit power supply circuit.

NO >> Replace the actuator relay.

Inspection 10 Stop Lamp Switch and Circuit

EFS005WF

INSPECTION PROCEDURE

1. SELF-DIAGNOSTIC RESULT CHECK

Check the self-diagnostic results.

Self-diagnostic results

STOP LAMP SW

Is "STOP LAMP SW" indicated in the self-diagnosis results?

- YES >> GO TO 2.
- NO >> INSPECTION END

2. STOP LAMP INSPECTION

1. Disconnect connectors for stop lamp switch and ESP/TCS/ABS control unit.
2. Securely connect them again.
3. Start the engine.
4. Repeat depressing brake pedal carefully several times, then perform the self-diagnosis again.

Is the same self-diagnosis item indicated?

- YES >> GO TO 3.
- NO >> Repair or replace the poorly connected connector.

3. STOP LAMP SWITCH CIRCUIT CHECK

1. Disconnect connectors for stop lamp switch and ESP/TCS/ABS control unit.
2. Check for the continuity between the stop lamp switch and ESP/TCS/ABS control unit.

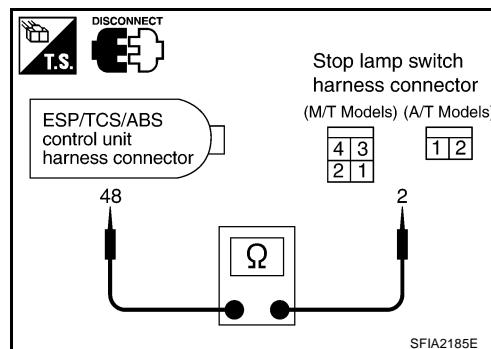

ESP/TCS/ABS control unit (harness connector E122)	STOP LAMP SW (harness connector M12)	Continuity
48 (P)	2 (P)	Yes

Is inspection result OK?

- YES >> Perform ESP/TCS/ABS control unit self-diagnosis again.
- NO >> The harness disconnection between ESP/TCS/ABS control unit and stop lamp switch.

Inspection 11 ESP/TCS/ABS Control Unit Power Supply Circuit

EFS005WG

INSPECTION PROCEDURE

1. SELF-DIAGNOSTIC RESULT CHECK 1

Check the self-diagnostic results.

Self-diagnostic results

BATTERY VOLTAGE [ABNORMAL]

Is "BATTERY VOLTAGE [ABNORMAL]" indicated in the self-diagnosis results?

- YES >> GO TO 2.
- NO >> INSPECTION END

2. SELF-DIAGNOSTIC RESULT CHECK 2

1. Disconnect ESP/TCS/ABS control unit connector. Securely connect them again.
2. Perform the self-diagnosis.

Is the same self-diagnosis item indicated?

- YES >> GO TO 3.
 NO >> Repair or replace the poorly connected connector.

3. ESP/TCS/ABS CONTROL UNIT POWER SUPPLY CIRCUIT INSPECTION 1

1. Disconnect ESP/TCS/ABS control unit connector.
2. Turn ignition switch ON (engine not running), and check the voltage between ESP/TCS/ABS control unit and body ground.

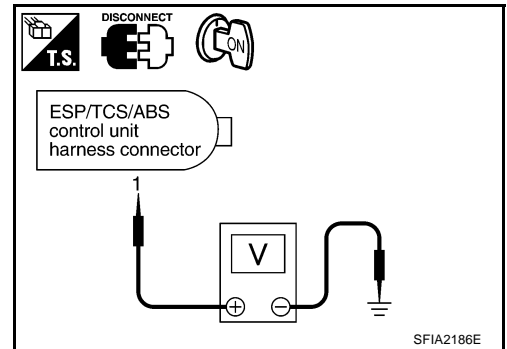

ESP/TCS/ABS control unit (harness connector E122)	Body ground	Voltage value
1 (G/R)	-	Battery voltage (approx. 12V)

Is inspection result OK?

- YES >> GO TO 4.
 NO >> GO TO 5.

4. ESP/TCS/ABS CONTROL UNIT GROUND CIRCUIT INSPECTION 1

Check ESP/TCS/ABS control unit ground circuit.

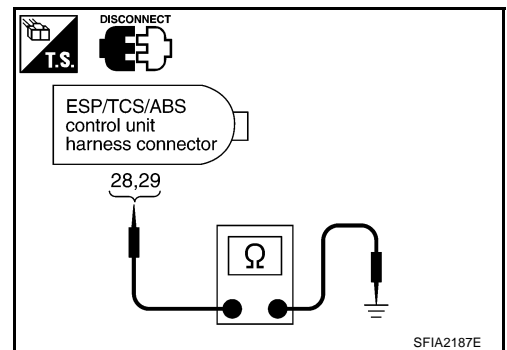

ESP/TCS/ABS control unit (harness connector E122)	Body ground	Continuity
28 (B)	-	Yes
29 (B)		

Is inspection result OK?

- YES >> Perform the ESP/TCS/ABS control unit self-diagnosis again.
 NO >> Harness disconnection or improper installation of the ESP/TCS/ABS control unit.

5. ESP/TCS/ABS CONTROL UNIT POWER SUPPLY CIRCUIT INSPECTION 2

1. Check the fuse 10A.
2. Check for continuity between the battery positive terminal and ESP/TCS/ABS control unit.

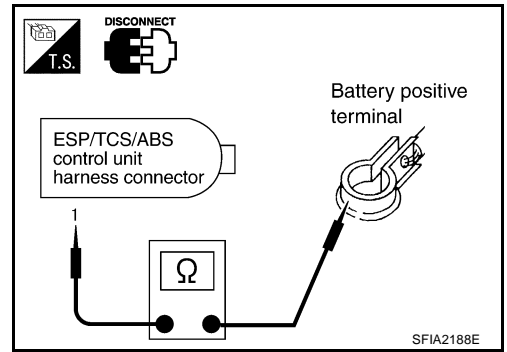

ESP/TCS/ABS control unit (harness connector E122)	Battery terminal	Continuity
1 (G/R)	positive	Yes

Is inspection result OK?

- YES >> Check battery for a loose terminal and low voltage or malfunction.
 NO >> ● Replace the fuse 10A.
 ● Harness disconnection

Inspection 12 When “EMERGENCY BRAKE” is indicated in the Self-Diagnostic Results

EFS005WH

INSPECTION PROCEDURE

1. SELF-DIAGNOSTIC RESULT CHECK

Check the self-diagnostic results.

Self-diagnostic results
EMERGENCY BRAKE

When any items other than “EMERGENCY BRAKE” is displayed in the self-diagnosis results, follow the instructions below.

CAUTION:

“EMERGENCY BRAKE” is indicated when the control unit itself is detected internal malfunction. If this display item was indicated, replace the control unit.

Is “EMERGENCY BRAKE” is indicated in the self-diagnosis results?

- YES >> Replace ESP/TCS/ABS control unit, and perform the self-diagnosis again.
 NO >> INSPECTION END

Inspection 13 When “ST ANG SEN SIGNAL” is Indicated in the Self-Diagnostic Results

EFS005WI

INSPECTION PROCEDURE

1. SELF-DIAGNOSTIC RESULT CHECK 1

Check the self-diagnostic results.

Self-diagnostic results
ST ANGLE SEN SIGNAL

When any items other than “ST ANGLE SEN SIGNAL” is displayed in the self-diagnosis results:

- YES >> Check and repair the applicable items. Perform the self-diagnosis again.
 NO >> Perform the steering angle sensor neutral position adjustment. GO TO 2.

2. SELF-DIAGNOSTIC RESULT CHECK 2

Turn ignition switch OFF, and ON to erase the self-diagnosis results. And perform the ESP/TCS/ABS control unit self-diagnosis again.

Is the same self-diagnosis item indicated again?

- YES >> After replacing spiral cable (with the steering angle sensor), perform the neutral position adjustment. Then conduct the self-diagnosis again.
- NO >> INSPECTION END

Inspection 14 Brake Fluid Level of Reservoir Tank, Communication Circuit between ESP/TCS/ABS Control Unit and Brake Fluid Level Warning Switch

EF5005WJ

INSPECTION PROCEDURE

1. SELF-DIAGNOSTIC RESULT CHECK 1

Check the self-diagnostic results.

Self-diagnostic results
BR FLUID LEVER LOW

Does the brake warning lamp turn on?

- YES >> Check the pad for wear. Check the brake fluid for leakage.
- NO >> GO TO 2.

2. SELF-DIAGNOSTIC RESULT CHECK 2

1. Disconnect connectors for the brake fluid level switch and ESP/TCS/ABS control unit.
2. Securely connect connectors. Perform the ESP/TCS/ABS control unit self-diagnosis again.

Is the same self-diagnosis item indicated again?

- YES >> GO TO 3.
- NO >> Poor connection of connector. Repair or replace the poorly connected connector.

3. CIRCUIT CHECK BETWEEN BRAKE FLUID LEVEL WARNING SWITCH AND ESP/TCS/ABS CONTROL UNIT

1. Disconnect connectors for brake fluid level switch and ESP/TCS/ABS control unit.

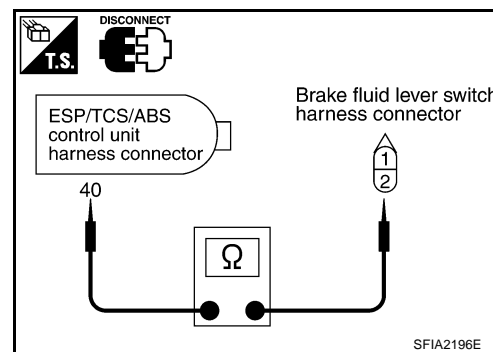

2. Check for the continuity between the brake fluid level switch and the ESP/TCS/ABS control unit.

ESP/TCS/ABS control unit (harness connector E122)	Brake fluid level switch (harness connector E19)	Continuity
40 (Y/B)	1 (Y/B)	Yes

Is inspection result OK?

- YES >> Perform the ESP/TCS/ABS control unit self-diagnosis again.
- NO >> Repair or replace the disconnected harness.

Inspection 15 CAN Communication Circuit, ESP/TCS/ABS Control Unit and Steering Angle Sensor

EFS005WK

INSPECTION PROCEDURE

1. CHECK CONNECTOR

1. Turn ignition switch OFF, disconnect the ESP/TCS/ABS control unit connector, and check the terminal for deformation, disconnection, looseness, and so on. If there is a malfunction, repair or replace the terminal.
2. Reconnect connector to perform self-diagnosis.

Is "CAN COMM CIRCUIT" or "ST ANG SEN COM CIR" displayed in the self-diagnosis display items?

- YES >> Print out the self-diagnostic results, and refer to [BRC-56. "CAN COMMUNICATION"](#) .
- NO >> Connector terminal connection is loose, damaged, open, or shorted.

Component Check
ESP OFF SWITCH

EFS005WL

- Disconnect the ESP OFF switch connector. Check for continuity between the terminal No. 1 and No. 2.

1 - 2 : Pressing the switch will make a continuity, and releasing it will stop the continuity.

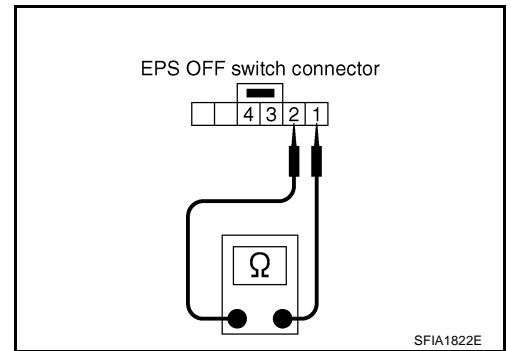

ESP RELAY BOX

Disconnect the relay box connectors. Check for continuity, resistance value, and insulation between any pair of terminals in the relay box.

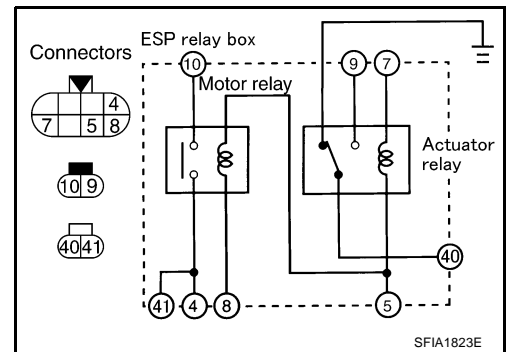

Continuity and resistance

Item	ESP relay box										Condition		
	40	2	4	1	9	4	41	10	5	7		8	
Actuator relay	○ — X — ○								Open (0V) ○ — ○			Between terminal No.5 and No.7 Open (0V)	
	○ — ○								12V ○ — ○				Between terminal No.5 and No.7 Add 12V
Motor relay						○ — ○						—	
						○ — X — ○			Open (0V) ○ — ○				Between terminal No.5 and No.8 Open (0V)
						○ — ○			12V ○ — ○				
Relay coil									Approx. 100Ω ○ — Ω — ○ Approx. 80Ω ○ — Ω — ○			—	
											Approx. 100Ω ○ — Ω — ○ : Resistance between terminals is 100Ω		
											○ — ○ : Conductivity ○ — ○ : Open between terminals (0V)		
											○ — X — ○ : Not conductivity ○ — 12V — ○ : Add 12V between terminals		

SFIA0907E

ESP ACTUATOR

Take each connector off from the actuator. Then check electric circulation and resistance in between terminals.

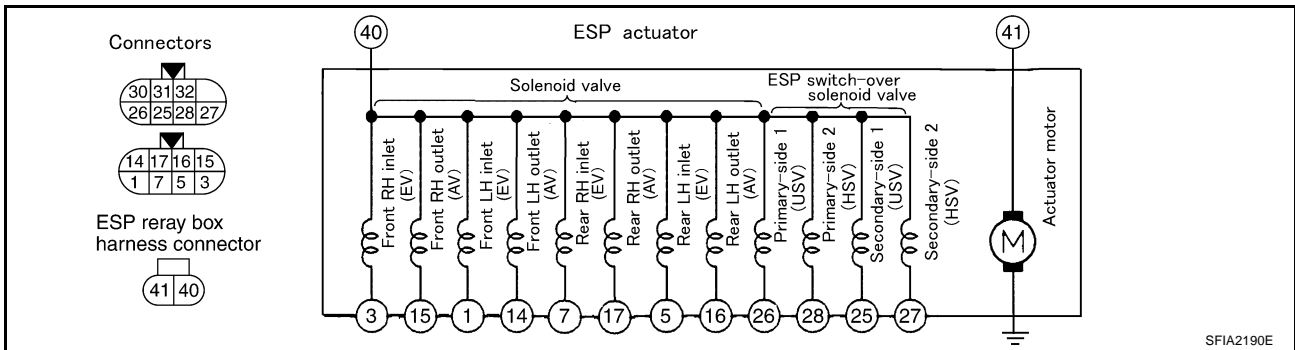

SFIA2190E

CAUTION:

Confirm that the earth of actuator motor is completely removed.

TROUBLE DIAGNOSIS

[ESP/TCS/ABS]

Continuity and resistance

Item	ESP actuator and ESP relay box connector terminals number	Condition
	40 3 15 1 14 7 17 5 16 26 25 28 27 41 Body ground	
Solenoid valve	$6.0 \sim 11.0 \Omega$ 	Check the Resistance
	$3.0 \sim 5.0 \Omega$ 	
	$6.0 \sim 11.0 \Omega$ 	
	$3.0 \sim 5.0 \Omega$ 	
	$6.0 \sim 11.0 \Omega$ 	
	$3.0 \sim 5.0 \Omega$ 	
	$6.0 \sim 11.0 \Omega$ 	
	$3.0 \sim 5.0 \Omega$ 	
ESP switch-over solenoid valve	$6.0 \sim 11.0 \Omega$ 	Check the Resistance
	$6.0 \sim 11.0 \Omega$ 	
	$3.0 \sim 5.0 \Omega$ 	
	$3.0 \sim 5.0 \Omega$ 	
Actuator motor		—

(Resistance)
 : Continuity: Yes
 : Continuity: Yes

SFIA0909E

Check the resistance

Standard value (Ω)

Solenoid valves

Outlet ~ Outlet : 6.0 - 10.0

Outlet ~ Inlet : 9.0 - 16.0

Inlet ~ Inlet : 12.0 - 22.0

ESP switch-over solenoid valve

Primary-side 1 - Secondary-side 1 : 12.0 - 22.0

Primary-side 2 - Secondary-side 2 : 6.0 - 10.0

Primary-side 1 - Primary-side 2, Secondary-side 2 : 9.0 - 16.0

Secondary-side 1 - Primary-side 2, Secondary-side 2 : 9.0 - 16.0

Actuator operation check

1. Connect 9 and 10 terminals of actuator to 40 and 41 terminals of relay box.
2. Measure the motor voltage (No.4 terminal to body earth) with oscilloscope. Then check the motor reverse voltage occasioned time.
The motor reverse voltage occasioned time is more than 0.1 sec.

CAUTION:

- Perform checking of motor relay unit. Then confirm that relay functions.
- Driving actuator motor is with in 4 sec. to prevent heating up.
- Standard condition of the motor reverse voltage occasioned time is: Battery voltage is 12V. Temperature 20°. when the battery voltage or temperature is lower than the standard, the motor reverse voltage occasioned time becomes slightly shorter.

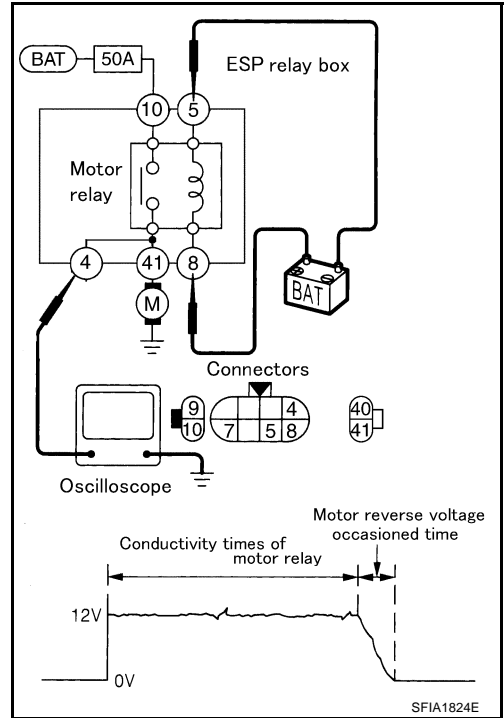

Symptom 1: ABS Works Frequently

1. CHECK START

Check longitudinal brake force distribution using a brake tester.

OK or NG

- OK >> GO TO 2.
- NG >> Check brake system.

2. CHECK FRONT AND REAR AXLE

Check to make sure that there is no excessive play in the front and rear axles. Refer to Front: [FAX-7, "On-Vehicle Inspection"](#) , Rear: [RAX-6, "WHEEL BEARING INSPECTION"](#) (2WD), [RAX-10, "REAR WHEEL BEARING"](#) (4WD).

OK or NG

- OK >> GO TO 3.
- NG >> Repair.

3. CHECK WHEEL SENSOR AND SENSOR ROTOR

Check wheel sensor and sensor rotor for the following.

- Sensor installation for damage
- Sensor rotor installation for damage
- Sensor connector engagement
- Sensor harness

OK or NG

- OK >> GO TO 4.
- NG >> ● Replace wheel sensor or sensor rotor.
 - Repair harness.

4. CHECK ABS WARNING LAMP DISPLAY

Make sure that the warning lamp turns off approximately 2 second after the key switch is turned on or when driving.

OK or NG

OK >> Normal

NG >> Perform self-diagnosis. Refer to [BRC-81, "SELF-DIAGNOSIS"](#) .

Symptom 2: Unexpected Pedal Reaction

EFS005WN

1. CHECK BRAKE PEDAL STROKE

Check brake pedal stroke. Refer to [BR-6, "On-Vehicle Inspection and Adjustment"](#) .

Is the stroke too large?

YES >> ● Bleed air from the brake piping. Refer to [BR-9, "Bleeding Brake System"](#) .

- Check brake pedal, brake booster, and master cylinder for mount play, looseness, brake system fluid leakage, etc. Repair if necessary. Refer to Brake pedal: [BR-6, "BRAKE PEDAL"](#) , brake booster and master cylinder: [BR-23, "BRAKE BOOSTER"](#) .

NO >> GO TO 2.

2. PERFORMANCE CHECK

Disconnect ESP/TCS/ABS control unit connector to deactivate ABS. Check if braking force is normal in this condition. Connect connector after inspection.

OK or NG

OK >> GO TO 3. Wheel Sensor Inspection in Refer to [BRC-91, "Inspection 1 Wheel Sensor System"](#) .

NG >> Check brake system.

Symptom 3: Longer Stopping Distance

EFS005WO

CAUTION:

The stopping distance on slippery road surfaces might be longer with the ABS operating than when the ABS is not operating.

1. PERFORMANCE CHECK

Turn ignition switch OFF. Disconnect ESP/TCS/ABS control unit connector to deactivate ABS. In this condition, check stopping distance. After inspection, connect connector.

OK or NG

OK >> GO TO [BRC-112, "Symptom 1: ABS Works Frequently"](#) .

NG >> ● Bleed air from the brake piping. Refer to [BR-9, "Bleeding Brake System"](#) .

- Check brake system.

Symptom 4: ABS Does Not Work

EFS005WP

CAUTION:

ABS does not operate when speed is 10 km/h or lower.

1. CHECK ABS WARNING LAMP DISPLAY

Make sure that the warning lamp turns off approximately 2 second after the key switch is turned on or when driving.

OK or NG

OK >> GO TO 3. Check wheel sensor and sensor rotor in Refer to [BRC-91, "Inspection 1 Wheel Sensor System"](#) .

NG >> Perform self-diagnosis. Refer to [BRC-81, "SELF-DIAGNOSIS"](#) .

Symptom 5: Pedal Vibration and ABS Operation Noise

EFS005WQ

CAUTION:

Under the following conditions, ABS is activated and vibration is felt when brake pedal is lightly depressed (just place a foot on it). However, this is normal.

- When shifting gears
- When driving on slippery road
- During cornering at high speed
- When passing over bumps or grooves (Approx. 50 mm or more)
- When pulling away just after starting engine (Approx. 10 km/h or more)

1. SYMPTOM CHECK 1

Check if pedal vibration or operation sounds occur when the engine is started.

OK or NG

OK >> GO TO 2.

NG >> Perform self-diagnosis. Refer to [BRC-81, "SELF-DIAGNOSIS"](#) .

2. SYMPTOM CHECK 2

Check symptoms when electrical component (headlamps, etc.) Switches are operated.

Do symptoms occur?

YES >> Check if there is a radio, antenna, antenna lead wire, or wiring close to the control unit. If there is, move it farther away.

NG >> GO TO 3. Check wheel sensor and sensor rotor in Refer to [BRC-91, "Inspection 1 Wheel Sensor System"](#) .

Symptom 6: ESP OFF Indicator Lamp Does Not Illuminate

EFS005WR

INSPECTION PROCEDURE

1. ESP OFF INDICATOR LAMP INSPECTION

Disconnect ESP/TCS/ABS control unit connector.

Does ABS warning lamp and ESP OFF indicator lamp illuminate?

YES >> ESP/TCS/ABS control unit malfunction. Repair or replace the control unit.

NO >> Combination meter system malfunction. Check the combination meter.

Symptom 7: SLIP Indicator Lamp Does Not Illuminate

EFS005WS

INSPECTION PROCEDURE

1. SLIP INDICATOR LAMP CONNECTOR INSPECTION

Check connectors for ESP/TCS/ABS control unit and meter vehicle-side harness.

Is inspection result OK?

YES >> GO TO 2.

NO >> Repair or replace the disconnected connector.

2. SLIP INDICATOR LAMP POWER CIRCUIT INSPECTION

Disconnect the meter connector. Check that the voltage between the vehicle-side harness terminal and body ground is battery voltage (Approx. 12V).

Is inspection result OK?

YES >> GO TO Refer to [BRC-109, "Inspection 15 CAN Communication Circuit, ESP/TCS/ABS Control Unit and Steering Angle Sensor"](#) .

NO >> ● Fuse inspection

- Inspection for harness and connectors between fuse block and meter
- Check the power supply circuit (battery and ignition switch circuit).

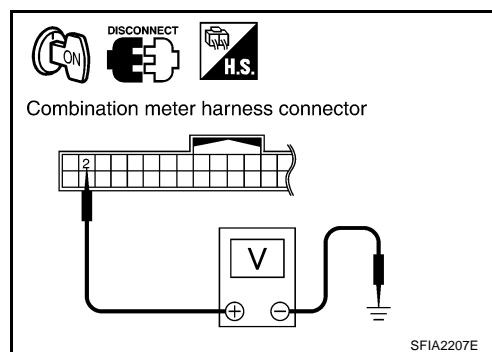

Symptom 8: Vehicle Jerks During ESP/TCS/ABS Control

EFS005WT

1. SYMPTOM CHECK 1

Check if the vehicle jerks during ESP/TCS/ABS control.

OK or NG

- OK >> Normal
 NG >> GO TO 2.

2. CHECK SELF-DIAGNOSTIC RESULTS

Perform self-diagnostic of ESP/TCS/ABS control unit.

Are self-diagnostic results indicated?

- YES >> Check the corresponding items, make repairs, and perform ESP/TCS/ABS control unit self-diagnosis.
 NO >> GO TO 3.

3. CHECK CONNECTOR

- Turn ignition switch OFF, disconnect the ESP/TCS/ABS control unit connector and check the terminal for deformation, disconnection, looseness, and so on. If there is a malfunction.
- Securely connect connectors. Perform ESP/TCS/ABS control unit self-diagnosis.

Are self-diagnostic results indicated?

- YES >> If poor contact, damage, open or short circuit of connector terminal is found, repair or replace.
 NO >> GO TO 4.

4. CHECK ECM AND A/T SELF-DIAGNOSIS RESULT

Perform ECM and A/T self-diagnosis.

ECM self-diagnosis	
QR engine (With EURO-OBD)	: EC-73. "TROUBLE DIAGNOSIS"
QR engine (Without EURO-OBD)	: EC-572. "TROUBLE DIAGNOSIS"
YD engine (With EURO-OBD)	: EC-1007. "TROUBLE DIAGNOSIS"
YD engine (Without EURO-OBD)	: EC-1378. "TROUBLE DIAGNOSIS"
A/T self-diagnosis	
EURO-OBD	: AT-40. "ON BOARD DIAGNOSTIC SYSTEM DESCRIPTION"
EXC.F/EURO-OBD	: AT-242. "ON BOARD DIAGNOSTIC SYSTEM DESCRIPTION"

Are self-diagnostic results indicated?

- YES >> Check the corresponding items, make repairs.
 NO >> Replace ESP/TCS/ABS control unit and perform to self-diagnosis again.

WHEEL SENSORS

Removal and Installation

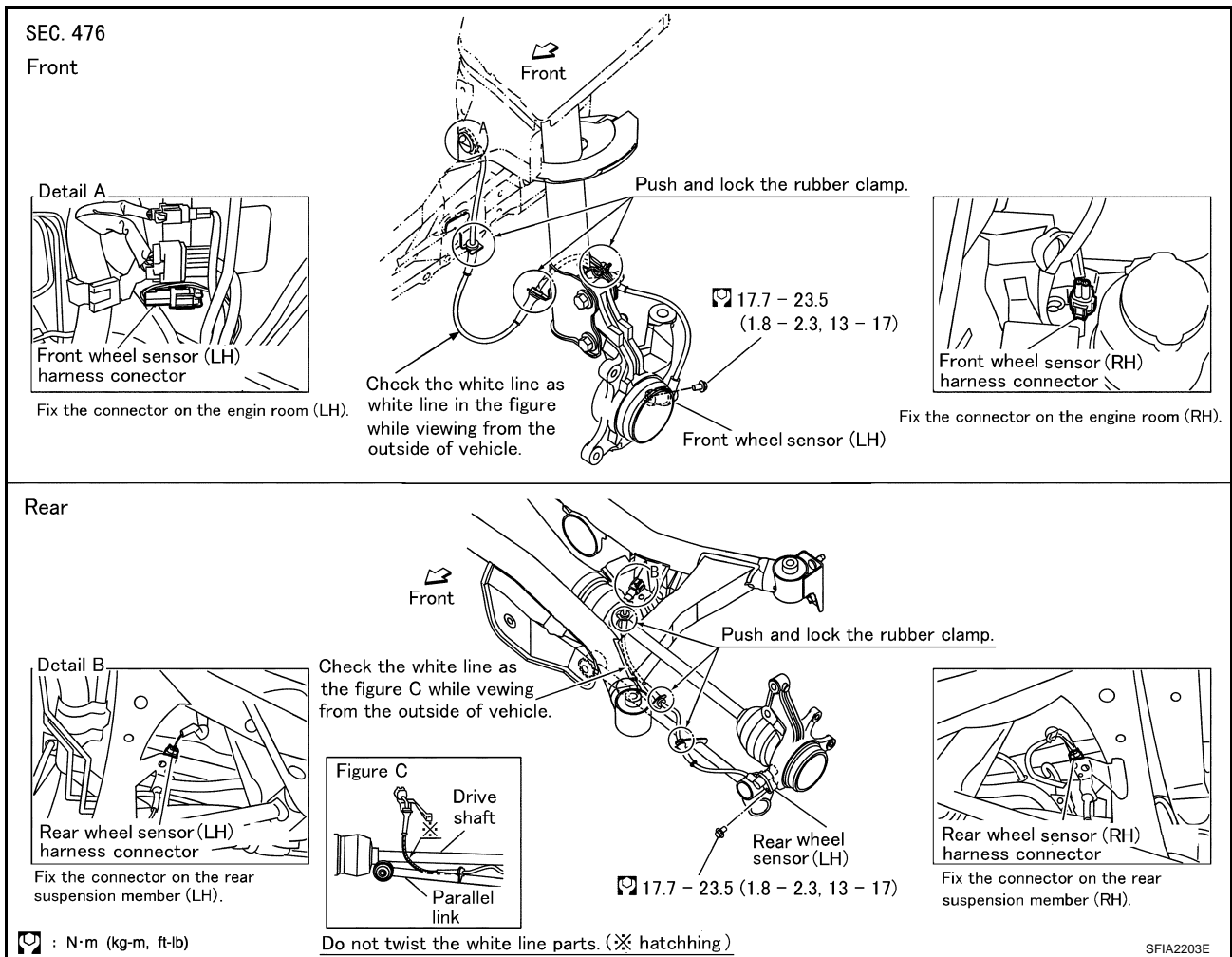

REMOVAL

Pay attention to the following when removing sensor.

CAUTION:

- As much as possible, avoid rotating sensor when removing it. Pull sensors out without pulling on sensor harness.
- Take care to avoid damaging sensor edges or rotor teeth. Remove wheel sensor first before removing front or rear wheel hub. This is to avoid damage to sensor wiring and loss of sensor function.

INSTALLATION

Pay attention to the following when installing sensor. Tighten installation bolts to specified torques.

- When installing, check that there is no foreign material such as iron chips on pick-up and mounting hole of the sensor. Check that no foreign material has been caught in the sensor rotor. Remove any foreign material and clean the mount.
- When installing front sensor, be sure to press rubber grommets in until they lock at the three locations shown in the figure (2 at strut and 1 at body panel). When installed, harness must not be twisted.

SENSOR ROTOR

PF:47970

Removal and Installation

EFS001CE

REMOVAL

Front

1. Remove drive shaft. Refer to [FAX-11, "REMOVAL"](#) in "FAX Front axle/Drive Shaft".
2. Remove sensor rotor from drive shaft. Refer to "FAX Front axle/Drive shaft " [FAX-13, "DISASSEMBLY"](#)

Rear (2WD Model)

1. Remove wheel hub. Refer to [RAX-6, "Removal and Installation"](#) .
2. Remove sensor rotor from wheel hub. Refer to [RAX-7, "Disassembly and Assembly"](#) .

Rear (4WD Model)

1. Remove drive shaft. Refer to [RAX-14, "REMOVAL"](#) in "RAX Rear Axle/Drive Shaft".
2. Remove sensor rotor from drive shaft. Refer to "RAX Rear axle/Drive shaft" [RAX-15, "DISASSEMBLY"](#) .

INSTALLATION

Front

1. Install sensor rotor to drive shaft. Refer to "FAX Front axle/Drive shaft" [FAX-15, "ASSEMBLY"](#)
2. Connect drive shaft. Refer to [FAX-12, "INSTALLATION"](#) in "FAX Front Axle/Drive Shaft".

Rear (2WD Model)

1. Install sensor rotor to wheel hub. Refer to [RAX-7, "Disassembly and Assembly"](#) .
2. Install wheel hub. Refer to [RAX-14, "Removal and Installation"](#) .

Rear (4WD Model)

1. Install sensor rotor to drive shaft. Refer to "RAX Rear axle/Drive shaft" [RAX-16, "ASSEMBLY"](#) .
2. Connect drive shaft. Refer to [RAX-14, "INSTALLATION"](#) in "RAX Rear Axle/Drive Shaft".

A
B
C
D
E
G
H
I
J
K
L
M

BRC

ESP/TCS/ABS CONTROL UNIT

PFP:47660

Removal and Installation

EFS001B0

REMOVAL

1. Remove the glove box. Refer to IP-3.
2. Remove the instrument lower panel. Refer to IP-3.
3. Remove the glove box cover. Refer to IP-3.
4. Remove the ESP/TCS/ABS control unit.

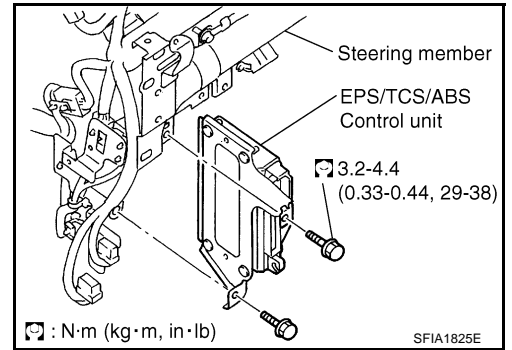

INSTALLATION

- Installation is the reverse order of removal.

ESP/TCS/ABS ACTUATOR AND RELAY BOX

PPF:47850

Removal and Installation

EFS001CR

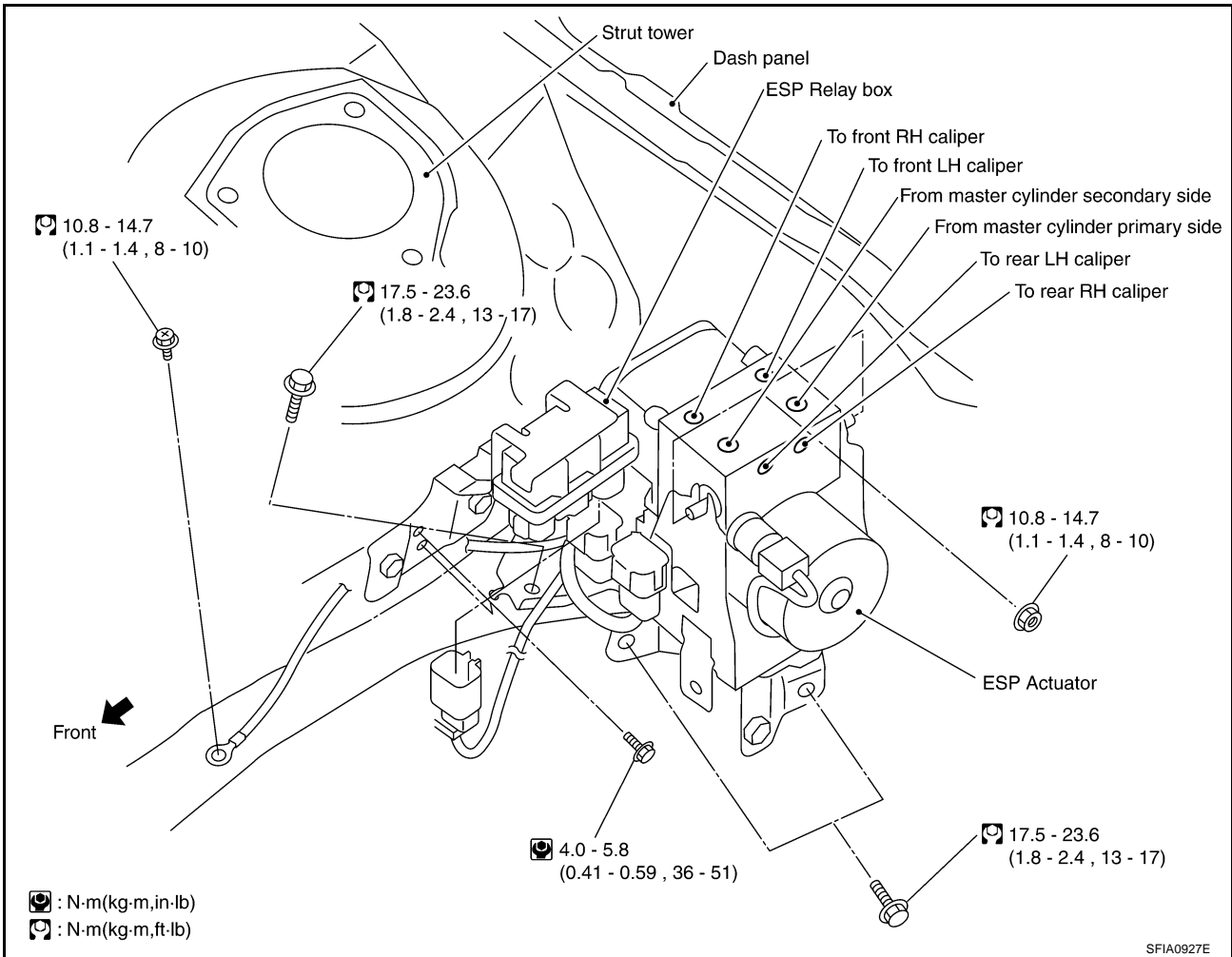

- The above figure shows LH model. RH model figure is the mirror image.
- Pay attention to the following when removing actuator.

Be careful of the following.

CAUTION:

- Before servicing, disconnect the battery terminals.
- To remove the brake tube, use a flare nut wrench to prevent the flare nuts and brake tube from being damaged. To install, use a brake tube torque wrench.
- Do not remove and install the actuator by holding the harness.
- After completing the work, bleed the brake piping of air. Refer to [BR-9, "Bleeding Brake System"](#).
- Make sure to connect the ground terminal securely.

YAW RATE/SIDE G SENSOR

PFP:47931

Removal and Installation

EFS001CS

CAUTION:

- Do not drop or strike the yaw rate/side G sensor, because it is sensitive to impact.
- Do not use power tool, etc. Because yaw rate/side G sensor is weak for the impact.

REMOVAL

1. Remove the diagnosis sensor unit. Refer to [SRS-41, "DIAGNOSIS SENSOR UNIT"](#).
2. Disconnect the harness connector.
3. Remove the mounting bolts, and remove the yaw rate/side G sensor.

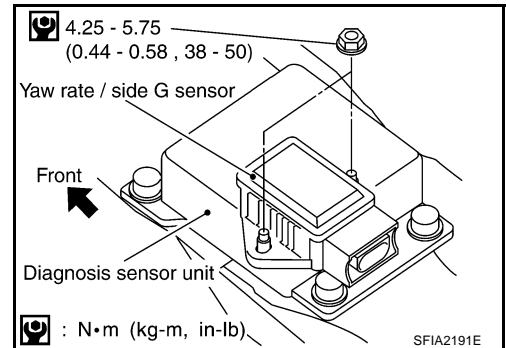
**INSTALLATION**

- Installation is the reverse order of removal.

ESP OFF SWITCH

PPF:25145

Removal and Installation

EF5001CQ

REMOVAL

1. Remove the instrument driver lower panel. Refer to [IP-13, "Instrument Driver Lower Panel"](#).
2. Push the ESP OFF switch's pawls and remove the switch from the instrument lower driver panel.

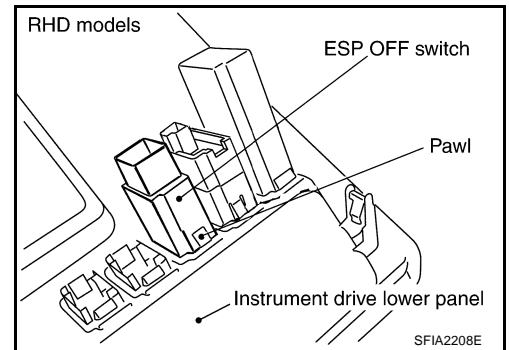

INSTALLATION

Installation is the reverse order of removal.

A
B
C
D
E
G
H
I
J
K
L
M

BRC

STEERING ANGLE SENSOR

PFP:25554

Removal and Installation

EFS004HA

REMOVAL

1. Remove spiral cable assembly. Refer to [SRS-33, "SPIRAL CABLE"](#) .
2. Remove steering angle sensor from spiral cable assembly.

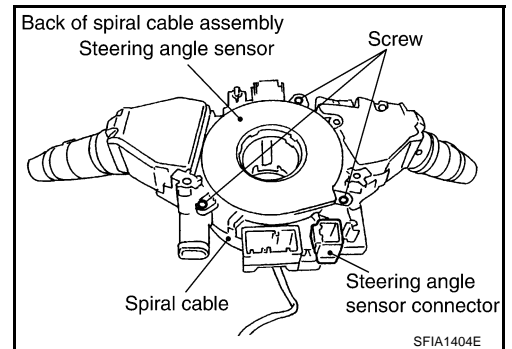

INSTALLATION

Install in the reverse order of removal.

NOTE:

After work, make sure to adjust neutral position of steering angle sensor. Refer to [BRC-52, "Adjustment of Steering Angle Sensor Neutral Position"](#) .