

**BACK DOOR WINDOW DEFOGGER****SPECIFICATIONS****GENERAL SPECIFICATIONS**

N08PB-

Items	Specifications
Back door window defogger switch Type Rated current    A	Seesaw type 20
Back door window glass with defogger No. of printed heater lines Power consumption [20°C(68°F)]    W	11 112–148

TROUBLESHOOTING

DEFOGGER CIRCUIT  
CIRCUIT DIAGRAM

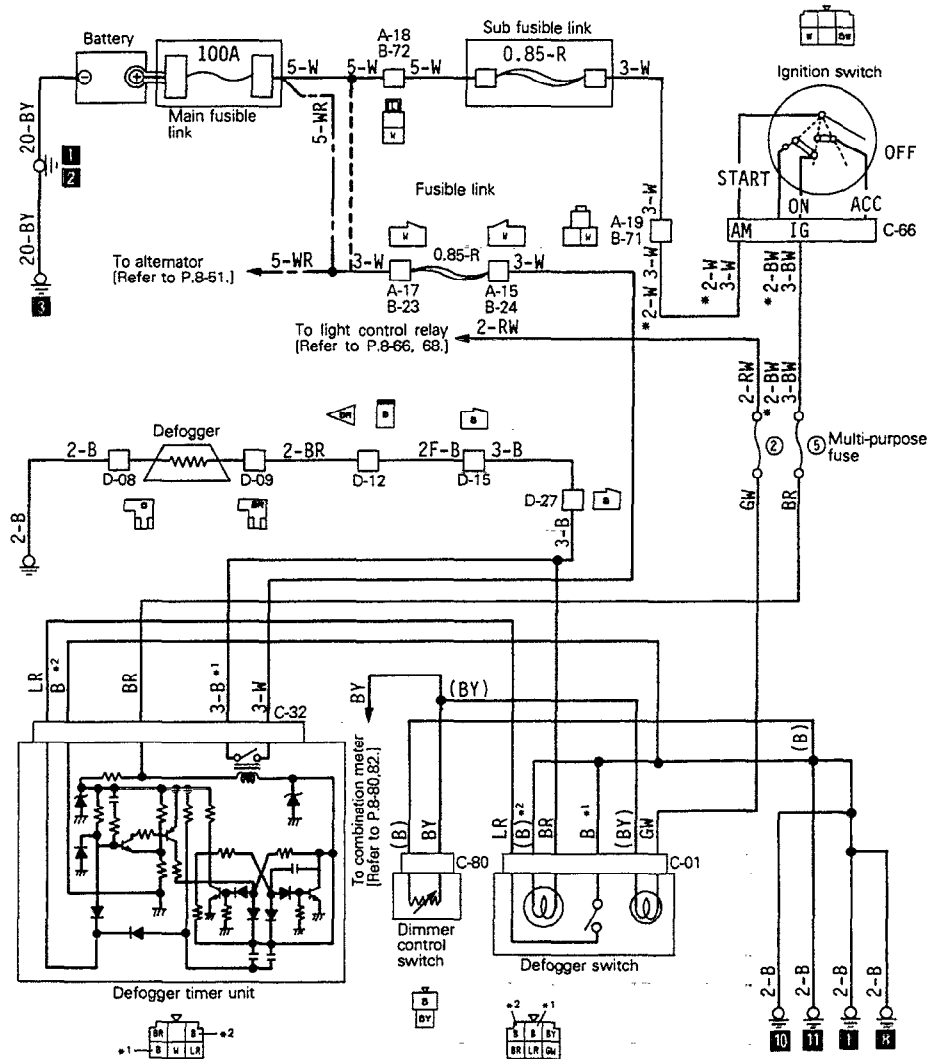

Remarks

- (1) The broken line (----) and lines indicated by the \* symbol are applicable to 2.6-liter models.
- (2) The chain line (-----) is applicable to 3.0-liter models.
- (3) For information concerning the ground points (example: **1**), refer to P.8-12, 14.

Wiring color code

B: Black	Br: Brown	G: Green	Gr: Gray	L: Blue	Lg: Light green
Ll: Light blue	O: Orange	P: Pink	R: Red	Y: Yellow	W: White

OPERATION

- With the ignition switch at the "ON" position, voltage is applied, through fuse No. 5 and the defogger timer unit, to the defogger switch.
- When the defogger switch is switched ON (automatic return), current flows to fuse No. 5, the defogger timer unit, the defogger switch, and ground, and the timer switch (within the defogger timer unit) operates for ten minutes.
- When the timer switch is activated, current flows to the fusible link, the defogger timer unit, the defogger, and ground, and the defogger is activated.

TROUBLESHOOTING HINTS

1. Both defogger and indicator light do not operate
  - (1) Blower motor also does not operate
    - Check fuse.
  - (2) Blower motor operates
    - Check defogger switch.
2. Defogger does not operate
  - (1) Indicator light goes on
    - Check defogger.

**DEFOGGER SWITCH  
REMOVAL AND INSTALLATION**

◀▶ 1. Defogger switch

NOTE  
◀▶ : Refer to "Service Points of Removal".

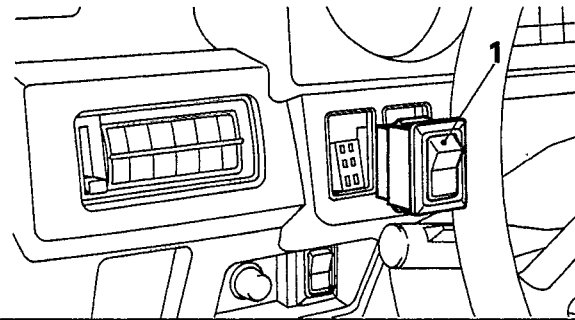

N08PJAD

16W932

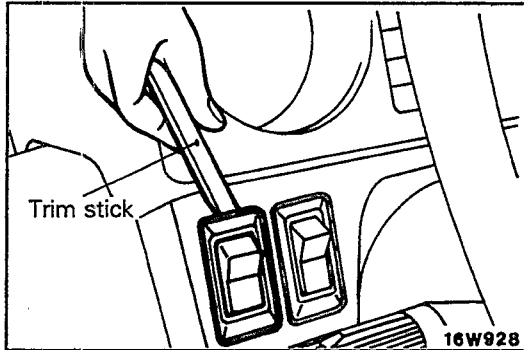

Trim stick

16W928

**SERVICE POINTS OF REMOVAL**

**1. REMOVAL OF DEFOGGER SWITCH**

Insert the trim stick into the switch and pry the switch to remove it from the instrument panel.

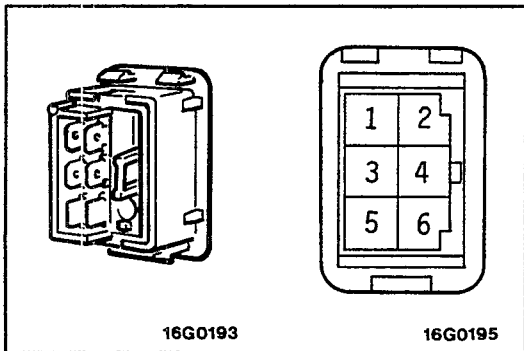

16G0193

16G0195

**INSPECTION**

**DEFOGGER SWITCH**

- (1) Remove the defogger switch from the instrument panel and connect an ohmmeter to the switch side connector.
- (2) Operate the switch and check the continuity between the terminals.

\*: Indicator light  
\*\*: Illumination light

Terminal	3	4	5	*	6	1	**	2
Switch position			○—○	○—○	○—○	○—○	○—○	○—○
OFF			○—○	○—○	○—○	○—○	○—○	○—○
ON	○—○	○—○	○—○	○—○	○—○	○—○	○—○	○—○

NOTE  
○—○ indicates that there is continuity between the terminals.

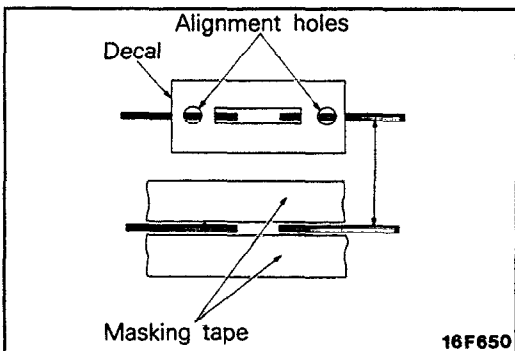
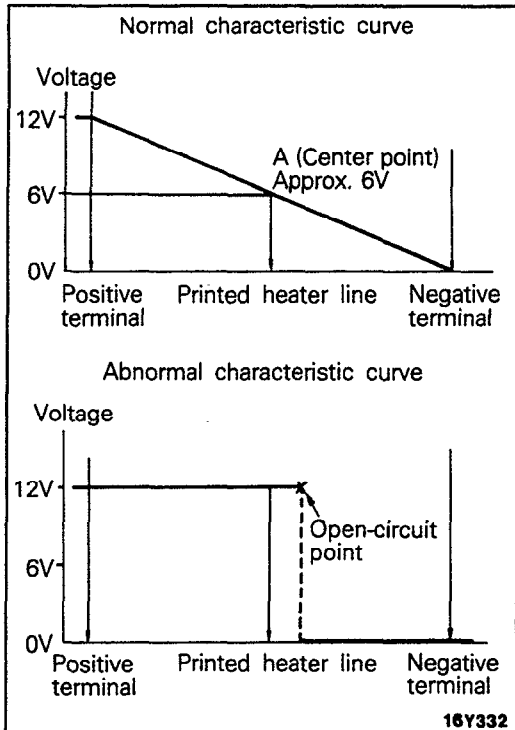

## PRINTED HEATER LINES

### INSPECTION

N08PKAA

1. The printed heater lines should be tested while the engine is running at 2,000 rpm and the battery is being charged.
2. Turn the defogger switch to the "ON" position, and use voltmeter to measure the voltage of each printed heater line at the back door window glass center point "A".
3. If all of the heater lines indicate approximately 6V, the back door window printed heater lines are functioning properly.
4. If a voltage of 12V is indicated at point "A", the heater line is broken between point "A" and the negative (-) terminal. Move the test probe gradually toward the negative (-) terminal, and search for the place where there is a sudden change in the voltage (to 0 V).
5. This place where the voltage suddenly changes indicates the location of the broken heater line.
6. If 0V is indicated at point "A", the heater line is broken between point "A" and the positive (+) terminal. Find the point where there is a sudden change in the voltage (to 12V), as described in step 4. above.

### REPAIR

1. Prepare the following items:
  - Conductive paint
  - Paint thinner
  - Masking tape, decal, etc.
  - Unleaded gasoline
  - Thin brush

Wipe the glass adjacent to the broken heater line, clean with unleaded gasoline, and bond a decal or masking tape as shown.

2. Shake the electroconductive paint container well, and remove the amount of paint needed. Dilute it with a small quantity of paint thinner, and apply three coats with the brush at intervals of about 15 minutes.
3. Remove the tape or decal and leave the repaired defogger unused for a while before supplying power.
4. For a better finish, scrape away excess deposits with a knife after drying is complete (one day later).

### Caution

**After repair, clean the glass with a soft dry shop towel or wipe along the printed heater line with a slightly moistened shop towel.**