

**SYMPTOM PROCEDURES**

**Inspection procedure 1: Communication with ECM only is not possible**

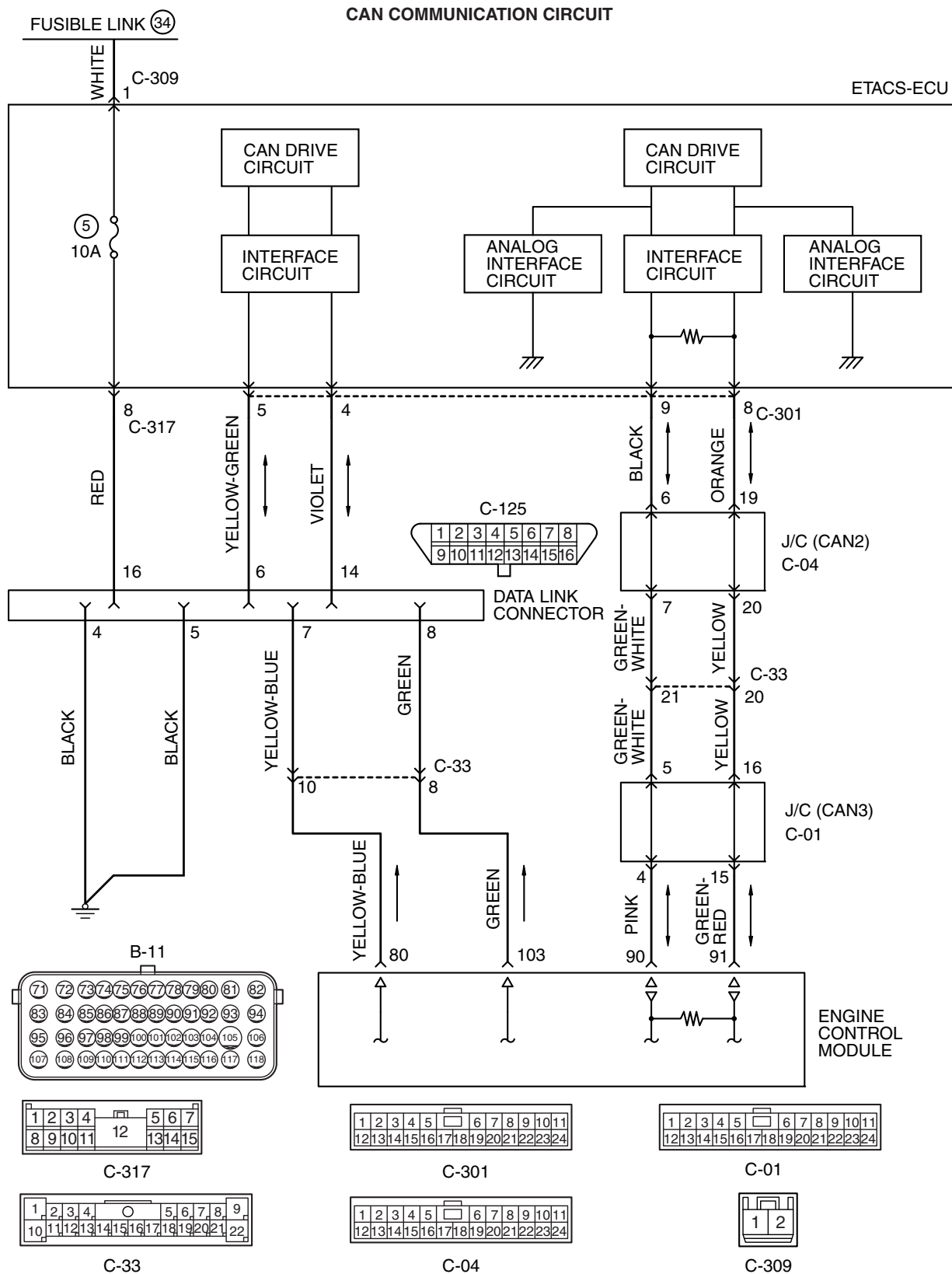

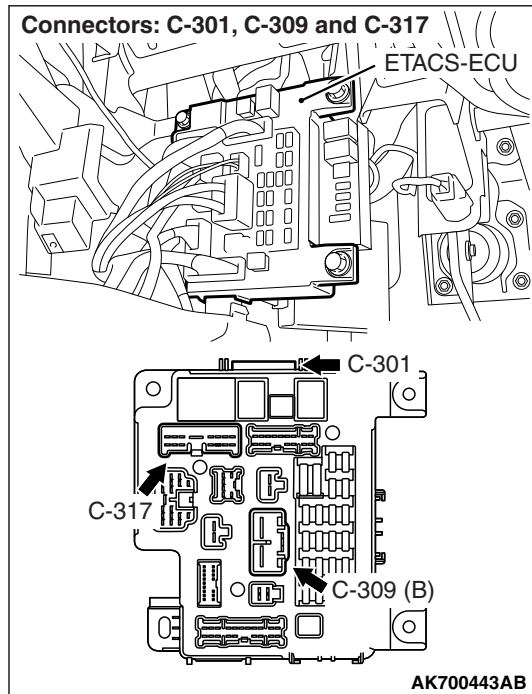
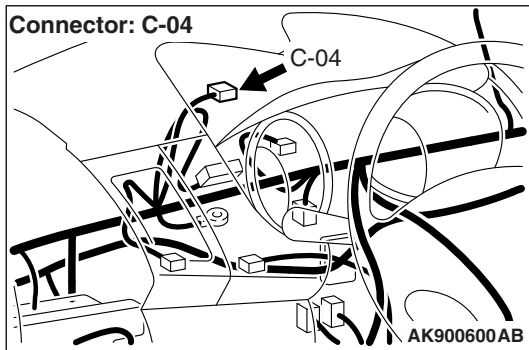
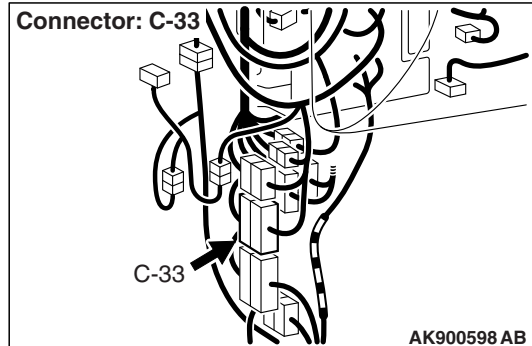
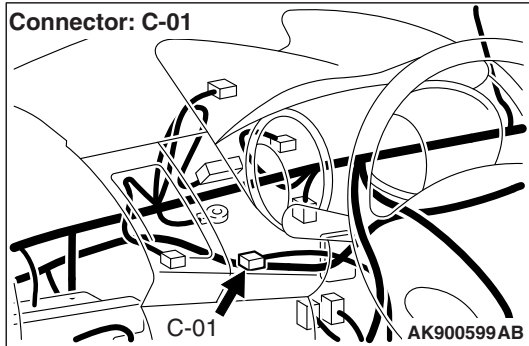
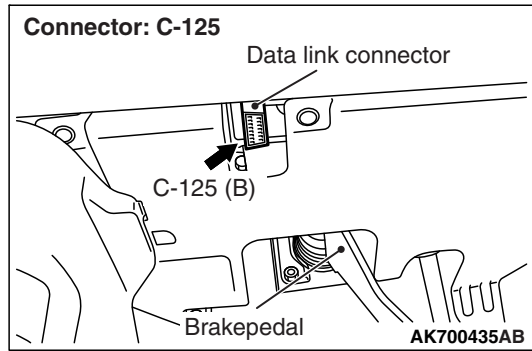
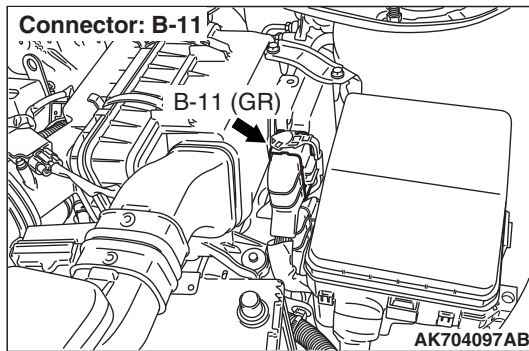

**CIRCUIT OPERATION**

- Battery voltage is applied to the diagnosis connector (terminal No. 16).
- The diagnosis connector (terminal No. 4 and No. 5) is grounded to the vehicle body.

**COMMENT**

- When the communication between M.U.T.-III and ECM is impossible, it can be suspected that the CAN bus line, power supply circuit of the diagnosis connector, and/or grounding circuit are defective.
- Communication can not be achieved either, if a wrong vehicle type is selected on M.U.T.-III.

**TROUBLESHOOTING HINTS (The most likely causes for this case:)**

- Malfunction of the data link connector.

- Open/short circuit or poor contact in the data link connector.
- Malfunction of the scan tool.
- Malfunction of the CAN communication.
- Malfunction of the ECM.

## DIAGNOSIS

### Required Special Tools:

- MB991958: Scan tool (M.U.T.-III Sub Assembly)
  - MB991824: V.C.I.
  - MB991827: USB Cable
  - MB991910: Main Harness A

### STEP 1. Check the vehicle communication interface (V.C.I.) MB991824 operations.

- (1) Connect the Scan tool to the data link connector.
- (2) When the power of V.C.I. is turned to ON, the indicator lamp of the V.C.I. illuminates in green.
  - The indicator lamp of the V.C.I. illuminates in green.

#### Q: Is the indicator lamp of the V.C.I. illuminates in green?

**YES** : Go to Step 2.

**NO** : Use scan tool, perform CAN bus line diagnosis.

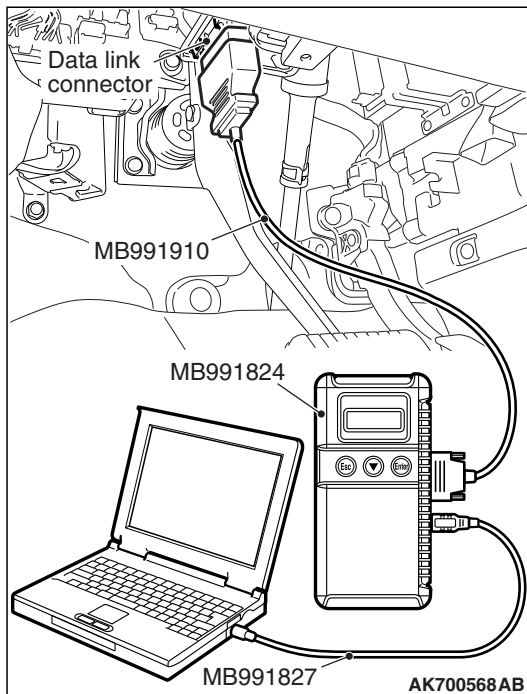

### STEP 2. Measure the battery positive voltage.

- (1) Measure the battery positive voltage during cranking.
  - The voltage should be 8 volts or more.

#### Q: Is the measured voltage 8 volts or more?

**YES** : Go to Step 3.

**NO** : Check the battery. Refer to GROUP 54A, Battery – On-vehicle Service – Battery Check P.54A-7. Then confirm that the malfunction symptom is eliminated.

### STEP 3. Check harness connector C-125 at data link connector for damage.

#### Q: Is the harness connector in good condition?

**YES** : Go to Step 4.

**NO** : Repair or replace it. Refer to GROUP 00E, Harness Connector Inspection P.00E-2. Then confirm that the malfunction symptom is eliminated.

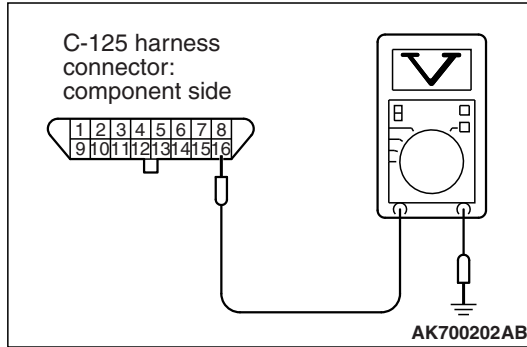
**STEP 4. Measure the power supply voltage at data link connector C-125.**

- (1) Measure voltage between terminal No. 16 and ground.
- Voltage should be battery positive voltage.

**Q: Is battery positive voltage (approximately 12 volts) present?**

**YES :** Go to Step 5.

**NO :** Repair an open circuit between ETACS-ECU connector C-317 (terminal No. 8) and data link connector C-125 (terminal No. 16). Then confirm that the malfunction symptom is eliminated.

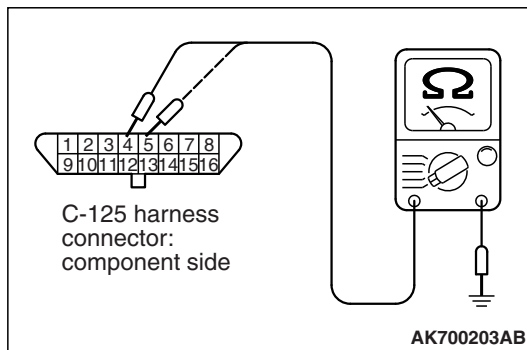
**STEP 5. Check the continuity at data link connector C-125.**

- (1) Check for the continuity between terminal No. 4, No. 5 and ground.
- Should be less than 2 ohms.

**Q: Does continuity exist?**

**YES :** Check and replace the scan tool. Then confirm that the malfunction symptom is eliminated.

**NO :** Repair an open circuit or harness damage between data link connector C-125 (terminal No. 4, No. 5) and ground. Then confirm that the malfunction symptom is eliminated.

**Inspection procedure 2: The malfunction indicator lamp (SERVICE ENGINE SOON or check engine lamp) does not illuminate right after the ignition switch is turned to the "ON" position****CIRCUIT OPERATION**

- The combination meter causes the malfunction indicator lamp (SERVICE ENGINE SOON or Check Engine Lamp) to illuminate immediately after the ignition switch is turned to the "ON" position occurred.

**TROUBLESHOOTING HINTS (The most likely causes for this case:)**

- Malfunction of the malfunction indicator lamp (SERVICE ENGINE SOON or Check Engine Lamp).
- Open or shorted malfunction indicator lamp (SERVICE ENGINE SOON or Check Engine Lamp) circuit.

---

## DIAGNOSIS

---

### STEP 1. Check the trouble symptoms.

- (1) Turn the ignition switch to the "ON" position.
  - The malfunction indicator lamp (SERVICE ENGINE SOON or Check Engine Lamp) should illuminate immediately after the ignition switch is turned to the "ON" position.
- (2) Turn the ignition switch to the "LOCK" (OFF) position.

### Q: Does the malfunction indicator lamp (SERVICE ENGINE SOON or Check Engine Lamp) illuminate?

- YES** : It can be assumed that this malfunction is intermittent. Refer to GROUP 00, How to Use Troubleshooting/Inspection Service Points – How to Cope with Intermittent Malfunctions [P.00-15](#).
- NO** : Replace the combination meter.

---

**Inspection procedure 3: The malfunction indicator lamp (SERVICE ENGINE SOON or check engine lamp) remains illuminated and never goes out**

---

### COMMENT

- In cases such as the above, the cause is probably that the ECM is detecting a problem in a sensor or actuator, or that one of the malfunctions listed below has probably occurred.

### TROUBLESHOOTING HINTS (The most likely causes for this case:)

- Shorted malfunction indicator lamp (SERVICE ENGINE SOON or Check Engine Lamp) circuit.

## DIAGNOSIS

### Required Special Tools:

- Scan Tool (M.U.T.-III Sub Assembly)
  - MB991824: V.C.I.
  - MB991827: USB Cable
  - MB991910: Main Harness A

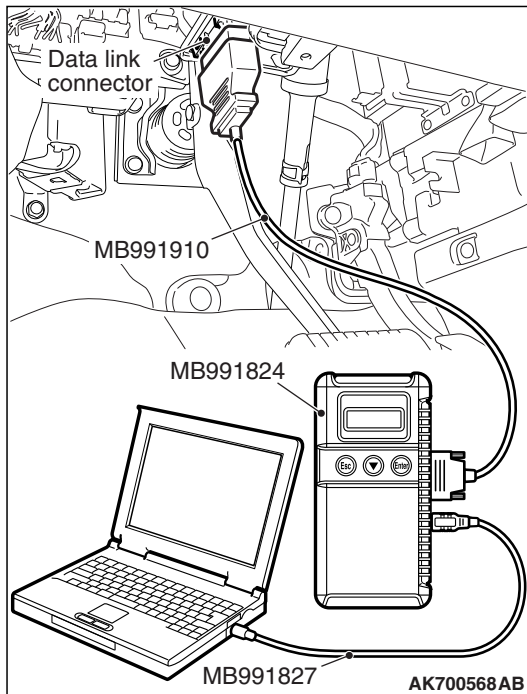

**STEP 1.** Using scan tool MB991958, read the diagnostic trouble code (DTC).

**⚠ CAUTION**

To prevent damage to scan tool MB991958, always turn the ignition switch to the "LOCK" (OFF) position before connecting or disconnecting scan tool MB991958.

- (1) Connect scan tool MB991958 to the data link connector.
- (2) Turn the ignition switch to the "ON" position.
- (3) Read the DTC.
- (4) Turn the ignition switch to the "LOCK" (OFF) position.

**Q: Is any DTC set?**

**YES :** Refer to Diagnostic Trouble Code Chart [P.13A-49](#).

**NO :** Go to Step 2.

**STEP 2. Check the trouble symptoms.**

- (1) Turn the ignition switch to the "ON" position.
  - The malfunction indicator lamp (SERVICE ENGINE SOON or Check Engine Lamp) should go out when 20 seconds have passed after the ignition switch was turned to the "ON" position.
- (2) Turn the ignition switch to the "LOCK" (OFF) position.

**Q: Does the malfunction indicator lamp (SERVICE ENGINE SOON or Check Engine Lamp) go out?**

**YES :** It can be assumed that this malfunction is intermittent. Refer to GROUP 00, How to Use Troubleshooting/Inspection Service Points – How to Cope with Intermittent Malfunctions [P.00-15](#).

**NO :** Replace the combination meter.

Inspection procedure 4: Cranks, won't start

**Cranks, Won't Start Circuit**

- Refer to Ignition circuit [P.13A-807](#).

**CIRCUIT OPERATION**

- Refer to Ignition circuit [P.13A-807](#).

**COMMENT**

- In cases such as the above, the cause is probably no spark, fuel delivery, or fuel quality problems. In addition, foreign materials (water, kerosene, etc.) may be mixed with the fuel.

**TROUBLESHOOTING HINTS (The most likely causes for this case:)**

- Malfunction of the battery.
- Malfunction of the immobilizer system.
- Malfunction of the fuel pump system.
- Malfunction of the ignition system.
- Malfunction of the injector system.
- Poor compression
- Contaminated fuel.
- Timing chain in out of place.
- Malfunction of the ECM.

**DIAGNOSIS**

**Required Special Tools:**

- MB991958: Scan Tool (M.U.T.-III Sub Assembly)
  - MB991824: V.C.I.
  - MB991827: USB Cable
  - MB991910: Main Harness A

**STEP 1. Using scan tool MB991958, read the diagnostic trouble code (DTC).**

**⚠ CAUTION**

To prevent damage to scan tool MB991958, always turn the ignition switch to the "LOCK" (OFF) position before connecting or disconnecting scan tool MB991958.

- (1) Connect scan tool MB991958 to the data link connector.
- (2) Turn the ignition switch to the "ON" position after cranking the engine for at least 2 sec.
- (3) Read the DTC.
- (4) Turn the ignition switch to the "LOCK" (OFF) position.

**Q: Is DTC set?**

**YES** : Refer to Diagnostic Trouble Code Chart [P.13A-49](#).

**NO** : Go to Step 2.

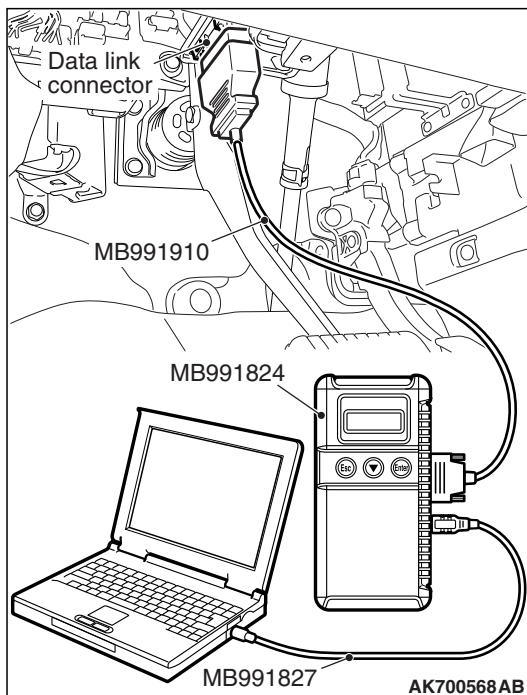

**STEP 2. Check harness connector B-101, B-120, B-103, B-116 at injector for damage.**

**Q: Is the harness connector in good condition?**

**YES :** Go to Step 3.

**NO :** Repair or replace it. Refer to GROUP 00E, Harness Connector Inspection [P.00E-2](#). Then confirm that the malfunction symptom is eliminated.

**STEP 3. Check the injector.**

- (1) Disconnect the injector connector B-101, B-120, B-103, B-116.
- (2) Measure the resistance between injector side connector terminal No. 1 and No. 2.

**Standard value: 10.5 – 13.5 ohms [at 20°C (68°F)]**

**Q: Is the measured resistance between 10.5 and 13.5 ohms [at 20°C (68°F)]?**

**YES :** Go to Step 4.

**NO :** Replace the faulty injector. Then confirm that the malfunction symptom is eliminated.

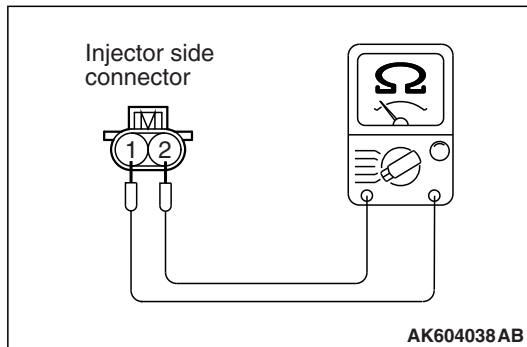

**STEP 4. Measure the power supply voltage at injector connector.**

- (1) Disconnect connector B-101, B-120, B-103, B-116 and measure at the harness side.
- (2) Turn the ignition switch to the "ON" position.
- (3) Measure the voltage between terminal No. 1 and ground.
  - Voltage should be battery positive voltage.
- (4) Turn the ignition switch to the "LOCK" (OFF) position.

**Q: Is battery positive voltage (approximately 12 volts) present?**

**YES :** Go to Step 14.

**NO :** Go to Step 5.

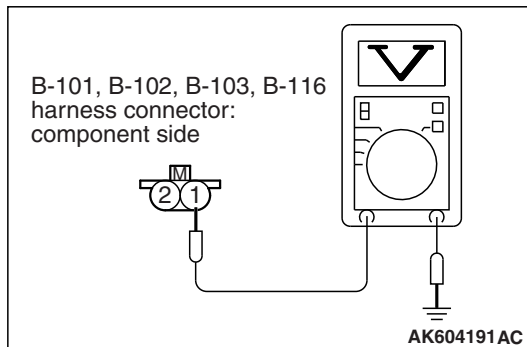

**STEP 5. Check harness connector A-24X at injector relay for damage.**

**Q: Is the harness connector in good condition?**

**YES :** Go to Step 6.

**NO :** Repair or replace it. Refer to GROUP 00E, Harness Connector Inspection [P.00E-2](#). Then confirm that the malfunction symptom is eliminated.



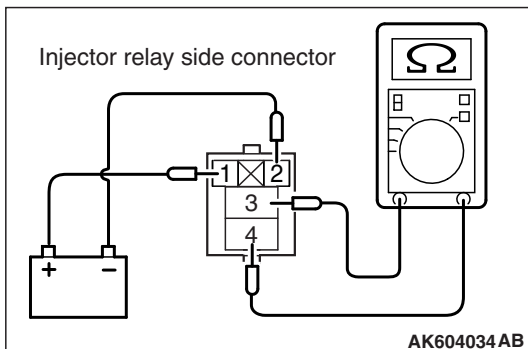
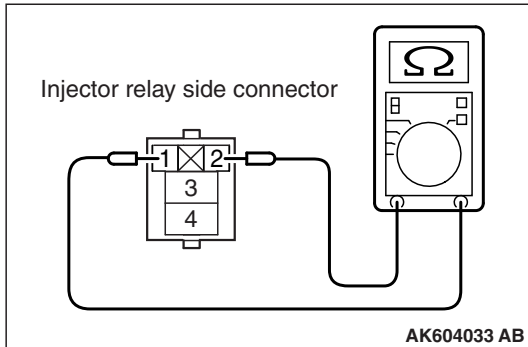

**STEP 6. Check the injector relay.**

- (1) Remove the injector relay.
- (2) Check for continuity between the injector relay terminal No. 1 and No. 2.  
There should be continuity.

- (3) Use jumper wires to connect injector relay terminal No. 1 to the positive battery terminal and terminal No. 2 to the negative battery terminal.
- (4) Check for continuity between the injector relay terminal No. 3 and No. 4 while connecting and disconnecting the jumper wire at the negative battery terminal.
  - Continuity (2 ohms or less). <Negative battery terminal connected>
  - Should be open loop. <Negative battery terminal disconnected>
- (5) Install the injector relay.

**Q: Is the measured resistance normal?**

**YES :** Go to Step 7.

**NO :** Replace the injector relay. Then confirm that the malfunction symptom is eliminated.

**STEP 7. Check for continuity at injector relay harness side connector A-24X.**

- (1) Disconnect the connector A-24X and measure at the harness side.
- (2) Check for the continuity between terminal No. 2 and ground.
  - Continuity (2 ohms or less).

**Q: Does continuity exist?**

**YES :** Go to Step 8.

**NO :** Repair harness wire between injector relay connector A-24X (terminal No. 2) and ground because of open circuit or harness damage. Then confirm that the malfunction symptom is eliminated.

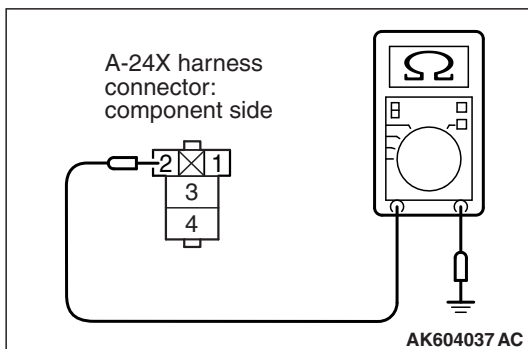

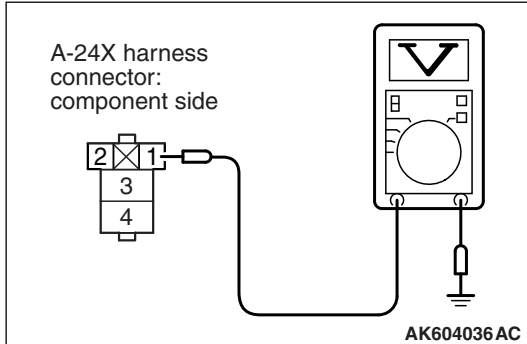
**STEP 8. Measure the power supply voltage at injector relay harness side connector A-24X.**

- (1) Disconnect the connector A-24X and measure at the harness side.
- (2) Turn the ignition switch to the "ON" position.
- (3) Measure the voltage between terminal No. 1 and ground.
  - Voltage should be battery positive voltage.

**Q: Is battery positive voltage (approximately 12 volts) present?****YES** : Go to Step 10.**NO** : Go to Step 9.**STEP 9. Check harness connector C-304 at ETACS-ECU for damage.****Q: Is the harness connector in good condition?**

**YES** : Repair harness wire between injector relay connector A-24X (terminal No. 1) and ETACS-ECU connector C-304 (terminal No. 10) because of open circuit or short circuit to ground. Then confirm that the malfunction symptom is eliminated.

**NO** : Repair or replace it. Refer to GROUP 00E, Harness Connector Inspection [P.00E-2](#). Then confirm that the malfunction symptom is eliminated.

**STEP 10. Measure the power supply voltage at injector relay harness side connector A-24X.**

- (1) Disconnect the connector A-24X and measure at the harness side.
- (2) Turn the ignition switch to the "ON" position.
- (3) Measure the voltage between terminal No. 4 and ground.
  - Voltage should be battery positive voltage.

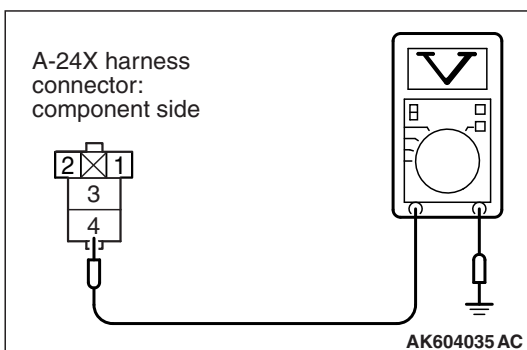
**Q: Is battery positive voltage (approximately 12 volts) present?****YES** : Go to Step 12.**NO** : Go to Step 11.

---

**STEP 11. Check harness connector A-33X at MFI relay for damage.**

**Q: Is the harness connector in good condition?**

**YES :** Repair harness wire between MFI relay connector A-33X (terminal No. 2) and injector relay connector A-24X (terminal No. 4) because of open circuit or short circuit to ground. Then confirm that the malfunction symptom is eliminated.

**NO :** Repair or replace it. Refer to GROUP 00E, Harness Connector Inspection [P.00E-2](#). Then confirm that the malfunction symptom is eliminated.

---

**STEP 12. Check for open circuit and short circuit to ground between injector relay connector and injector connector.**

*NOTE: Check harness connector after checking intermediate connector A-13. If intermediate connector is damaged, repair or replace it. Refer to GROUP 00E, Harness Connector Inspection [P.00E-2](#). Then confirm that the malfunction symptom is eliminated.*

- a. Injector relay connector A-24X (terminal No. 3) and No. 1 cylinder injector connector B-101 (terminal No. 1).
- b. Injector relay connector A-24X (terminal No. 3) and No. 2 cylinder injector connector B-120 (terminal No. 1).
- c. Injector relay connector A-24X (terminal No. 3) and No. 3 cylinder injector connector B-103 (terminal No. 1).
- d. Injector relay connector A-24X (terminal No. 3) and No. 4 cylinder injector connector B-116 (terminal No. 1).

**Q: Is the harness wire in good condition?**

**YES :** Go to Step 13.

**NO :** Repair it. Then confirm that the malfunction symptom is eliminated.

---

**STEP 13. Check harness connector C-304 at ETACS-ECU for damage.**

**Q: Is the harness connector in good condition?**

**YES :** Repair harness wire between injector relay connector A-24X (terminal No. 1) and ETACS-ECU connector C-304 (terminal No. 10) because of harness damage. Then confirm that the malfunction symptom is eliminated.

**NO :** Repair or replace it. Refer to GROUP 00E, Harness Connector Inspection [P.00E-2](#). Then confirm that the malfunction symptom is eliminated.

---

**STEP 14. Check harness connector A-33X at MFI relay for damage.**

**Q: Is the harness connector in good condition?**

**YES :** Go to Step 15.

**NO :** Repair or replace it. Refer to GROUP 00E, Harness Connector Inspection [P.00E-2](#). Then confirm that the malfunction symptom is eliminated.

---

**STEP 15. Check for harness damage between MFI relay connector A-33X (terminal No. 2) and injector relay connector A-24X (terminal No. 4).**

**Q: Is the harness wire in good condition?**

**YES :** Go to Step 16.

**NO :** Repair it. Then confirm that the malfunction symptom is eliminated.

---

**STEP 16. Check for harness damage between injector relay connector and injector connector.**

*NOTE: Check harness after checking intermediate connector A-13. If intermediate connector is damaged, repair or replace it. Refer to GROUP 00E, Harness Connector Inspection [P.00E-2](#). Then confirm that the malfunction symptom is eliminated.*

- a. Injector relay connector A-24X (terminal No. 3) and No. 1 cylinder injector connector B-101 (terminal No. 1).
- b. Injector relay connector A-24X (terminal No. 3) and No. 2 cylinder injector connector B-120 (terminal No. 1).
- c. Injector relay connector A-24X (terminal No. 3) and No. 3 cylinder injector connector B-103 (terminal No. 1).
- d. Injector relay connector A-24X (terminal No. 3) and No. 4 cylinder injector connector B-116 (terminal No. 1).

**Q: Is the harness wire in good condition?**

**YES :** Go to Step 17.

**NO :** Repair it. Then confirm that the malfunction symptom is eliminated.

---

**STEP 17. Using scan tool MB991958, check data list.**

- (1) Turn the ignition switch to the "ON" position.
- (2) Check the following items in the data List. Refer to Data List Reference Table [P.13A-818](#).
  - a. Item 1: Power Supply Voltage
- (3) Turn the ignition switch to the "LOCK" (OFF) position.

**Q: Are they operating properly?**

**YES :** Go to Step 18.

**NO :** Repair or replace it. Then confirm that the malfunction symptom is eliminated.

---

**STEP 18. Using scan tool MB991958, check actuator test.**

- (1) Turn the ignition switch to the "ON" position.
- (2) Check the following items in the actuator test. Refer to Actuator Test Reference Table [P.13A-838](#).
  - a. Item 9: Fuel pump
- (3) Turn the ignition switch to the "LOCK" (OFF) position.

**Q: Is the actuator operating properly?**

**YES** : Go to Step 19.

**NO** : Repair or replace it. Then confirm that the malfunction symptom is eliminated.

---

**STEP 19. Check the fuel pressure.**

Refer to Fuel Pressure Test [P.13A-868](#).

**Q: Is the fuel pressure normal?**

**YES** : Go to Step 20.

**NO** : Repair or replace it. Then confirm that the malfunction symptom is eliminated.

---

**STEP 20. Check the ignition system.**

- (1) Connect the timing light to terminal No. 3 of the ignition coil connector B-01, B-19, B-04 or B-18 in order.
- (2) Crank the engine.
  - The timing light flashes.
- (3) Turn the ignition switch to the "LOCK" (OFF) position.

**Q: Does the timing light flash?**

**YES** : Go to Step 21.

**NO** : Refer to inspection procedure 25 – Ignition circuit system [P.13A-807](#).

---

**STEP 21. Check the spark plugs.**

Refer to GROUP 16, Ignition System – On-vehicle Service – Spark Plug Check And Cleaning [P.16-45](#).

**Q: Are there any abnormalities?**

**YES** : Replace the spark plug. Then confirm that the malfunction symptom is eliminated.

**NO** : Go to Step 22.

---

**STEP 22. Check the ignition coil.**

Refer to GROUP 16, Ignition System – On-vehicle Service – Ignition Coil Check [P.16-44](#).

**Q: Are there any abnormalities?**

**YES** : Replace the ignition coil. Then confirm that the malfunction symptom is eliminated.

**NO** : Go to Step 23.

**STEP 23. Check the compression pressure.**

Refer to GROUP 11A, On-vehicle Service – Compression Pressure Check [P.11A-18](#).

**Q: Is the compression pressure normal?**

**YES** : Go to Step 24.

**NO** : Repair it. Then confirm that the malfunction symptom is eliminated.

**STEP 24. Check the ignition timing.**

Refer to GROUP 11A, On-vehicle Service – Ignition Timing Check [P.11A-13](#).

**Q: Is the ignition timing normal?**

**YES** : Check the following items, and repair or replace the defective items.

a. Check if the injectors are clogged.

b. Check if fuel is contaminated.

Then confirm that the malfunction symptom is eliminated.

**NO** : Check for installed conditions of the timing chain. Then confirm that the malfunction symptom is eliminated.

---

**Inspection procedure 5: Starts up and dies**

---

**COMMENT**

- In such cases as the above, the cause is usually improper air/fuel mixture. It is possible, though less likely, that the spark plugs are generating sparks but the sparks are weak.

- Malfunction of the ignition system.
- Malfunction of the injector system.
- Poor compression.
- Malfunction of the EGR system.
- Contaminated fuel.
- Dirtiness around throttle valve.
- Malfunction of the ECM.

**TROUBLESHOOTING HINTS (The most likely causes for this case:)**

- Malfunction of the fuel pump system.

**DIAGNOSIS****Required Special Tools:**

- MB991958: Scan Tool (M.U.T.-III Sub Assembly)
  - MB991824: V.C.I.
  - MB991827: USB Cable
  - MB991910: Main Harness A

**STEP 1. Check if the EGR valve sounds during initialization.****Q: Is the initialization sound heard in the EGR valve?**

**YES** : Go to Step 2.

**NO** : Refer to GROUP 17, Emission Control – Exhaust Gas Recirculation (EGR) System – EGR Valve (Stepper Motor) Check [P.17-81](#).

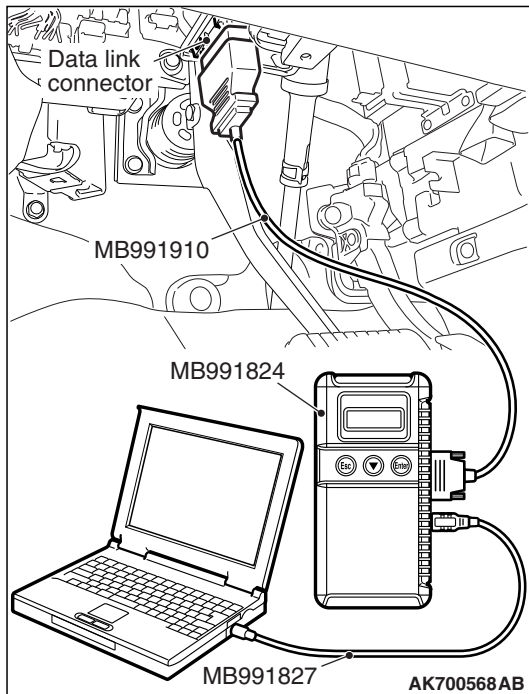

**STEP 2. Using scan tool MB991958, read the diagnostic trouble code (DTC).**

**⚠ CAUTION**

To prevent damage to scan tool MB991958, always turn the ignition switch to the "LOCK" (OFF) position before connecting or disconnecting scan tool MB991958.

- (1) Connect scan tool MB991958 to the data link connector.
- (2) Turn the ignition switch to the "ON" position.
- (3) Read the DTC.
- (4) Turn the ignition switch to the "LOCK" (OFF) position.

**Q: Is DTC set?**

**YES :** Refer to Diagnostic Trouble Code Chart [P.13A-49](#).

**NO :** Go to Step 3.

**STEP 3. Using scan tool MB991958, check data list.**

- (1) Turn the ignition switch to the "ON" position.
- (2) Check the following items in the data list. Refer to Data List Reference Table [P.13A-818](#).
  - a. Item 1: Power Supply Voltage
  - b. Item 6: Engine Coolant Temperature Sensor
- (3) Turn the ignition switch to the "LOCK" (OFF) position.

**Q: Is the sensor operating properly?**

**YES :** Go to Step 4.

**NO :** Repair or replace it. Then confirm that the malfunction symptom is eliminated.

**STEP 4. Using scan tool MB991958, check actuator test.**

- (1) Turn the ignition switch to the "ON" position.
- (2) Check the following items in the actuator test. Refer to Actuator Test Reference Table [P.13A-838](#).
  - a. Item 9: Fuel Pump.
- (3) Turn the ignition switch to the "LOCK" (OFF) position.

**Q: Is the actuator operating properly?**

**YES :** Go to Step 5.

**NO :** Repair or replace it. Then confirm that the malfunction symptom is eliminated.

**STEP 5. Inspection of throttle body (throttle valve area) for dirtiness.**

**Q: Is the throttle valve area dirty?**

**YES :** Refer to Throttle Body (Throttle Valve Area) Cleaning [P.13A-865](#).

**NO :** Go to Step 6.

**STEP 6. Check the ignition timing.**

Refer to GROUP 11A, On-vehicle Service – Ignition Timing Check [P.11A-13](#).

**Q: Is the ignition timing normal?**

**YES :** Go to Step 7.

**NO :** Check for installed conditions of the timing chain. Then confirm that the malfunction symptom is eliminated.

**STEP 7. Check the fuel pressure.**

Refer to Fuel Pressure Test [P.13A-868](#).

**Q: Is the fuel pressure normal?**

**YES :** Go to Step 8.

**NO :** Repair or replace it. Then confirm that the malfunction symptom is eliminated.

**STEP 8. Check harness connector B-101, B-120, B-103, B-116 at injector for damage.**

**Q: Is the harness connector in good condition?**

**YES :** Go to Step 9.

**NO :** Repair or replace it. Refer to GROUP 00E, Harness Connector Inspection [P.00E-2](#). Then confirm that the malfunction symptom is eliminated.

**STEP 9. Check the injector resistance.**

(1) Disconnect the left bank injector connector B-101, B-120, B-103, B-116.

(2) Measure the resistance between each injector side connector terminal No. 1 and No. 2.

**Standard value: 10.5 – 13.5  $\Omega$  [at 20°C (68°F)]**

**Q: Is the measured resistance between 10.5 and 13.5 ohms [at 20°C (68°F)]?**

**YES :** Go to Step 10.

**NO :** Replace the faulty injector. Then confirm that the malfunction symptom is eliminated.

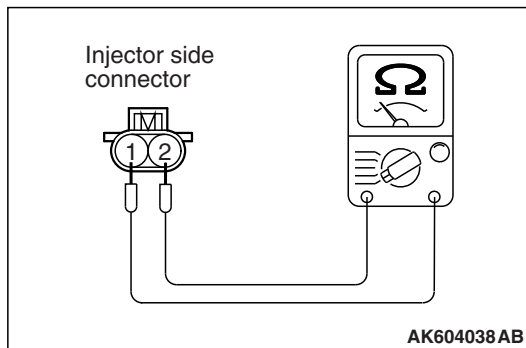



---

**STEP 10. Check harness connector A-33X at MFI relay and harness connector A-24X at injector relay connector for damage.**

**Q: Is the harness connector in good condition?**

**YES :** Go to Step 11.

**NO :** Repair or replace it. Refer to GROUP 00E, Harness Connector Inspection [P.00E-2](#). Then confirm that the malfunction symptom is eliminated.

---

**STEP 11. Check for harness damage between MFI relay connector A-33X (terminal No. 2) and injector relay connector A-24X (terminal No. 4).**

**Q: Is the harness wire in good condition?**

**YES :** Go to Step 12.

**NO :** Repair it. Then confirm that the malfunction symptom is eliminated.

---

**STEP 12. Check for harness damage between injector relay connector and injector connector.**

*NOTE: Check harness after checking intermediate connector A-13. If intermediate connector is damaged, repair or replace it. Refer to GROUP 00E, Harness Connector Inspection [P.00E-2](#). Then confirm that the malfunction symptom is eliminated.*

- a. Injector relay connector A-24X (terminal No. 3) and No. 1 cylinder injector connector B-101 (terminal No. 1).
- b. Injector relay connector A-24X (terminal No. 3) and No. 2 cylinder injector connector B-120 (terminal No. 1).
- c. Injector relay connector A-24X (terminal No. 3) and No. 3 cylinder injector connector B-103 (terminal No. 1).
- d. Injector relay connector A-24X (terminal No. 3) and No. 4 cylinder injector connector B-116 (terminal No. 1).

**Q: Is the harness wire in good condition?**

**YES :** Go to Step 13.

**NO :** Repair it. Then confirm that the malfunction symptom is eliminated.

---

**STEP 13. Check the spark plugs.**

Refer to GROUP 16, Ignition System – On-vehicle Service – Spark Plug Check And Cleaning [P.16-45](#).

**Q: Are there any abnormalities?**

**YES :** Replace the spark plug. Then confirm that the malfunction symptom is eliminated.

**NO :** Go to Step 14.

**STEP 14. Check the ignition coil.**

- (1) Remove the intake manifold.
- (2) Refer to GROUP 16, Ignition System – On-vehicle Service – Ignition Coil Check [P.16-44](#).

**Q: Are there any abnormalities?**

**YES** : Replace the ignition coil. Then confirm that the malfunction symptom is eliminated.

**NO** : Go to Step 15.

**STEP 15. Check the compression pressure.**

Refer to GROUP 11A, On-vehicle Service – Compression Pressure Check [P.11A-18](#).

**Q: Is the compression pressure normal?**

**YES** : Check the following items, and repair or replace the defective items.

- a. Check fuel lines for clogging.
- b. Check if fuel is contaminated.
- c. Check if the injectors are clogged.

Then confirm that the malfunction symptom is eliminated.

**NO** : Repair it. Then confirm that the malfunction symptom is eliminated.

**Inspection procedure 6: Hard starting****COMMENT**

- In cases such as the above, the cause is usually either weak spark, improper air-fuel mixture or low compression.

- Malfunction of the ignition system.
- Malfunction of the injector system.
- Poor compression
- Malfunction of the EGR system
- Contaminated fuel.
- Malfunction of the ECM.

**TROUBLESHOOTING HINTS (The most likely causes for this case:)**

- Malfunction of the fuel pump system.

**DIAGNOSIS****Required Special Tools:**

- MB991958: Scan Tool (M.U.T.-III Sub Assembly)
  - MB991824: V.C.I.
  - MB991827: USB Cable
  - MB991910: Main Harness A

**STEP 1. Check if the EGR valve sounds during initialization.****Q: Is the initialization sound heard in the EGR valve?**

**YES** : Go to Step 2.

**NO** : Refer to GROUP 17, Emission Control – Exhaust Gas Recirculation (EGR) System – EGR Valve (Stepper Motor) Check [P.17-81](#).

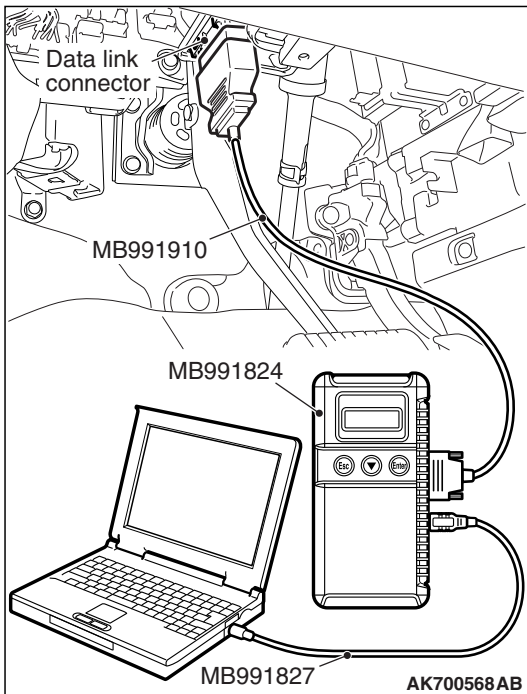

**STEP 2. Using scan tool MB991958, read the diagnostic trouble code (DTC).**

**⚠ CAUTION**

To prevent damage to scan tool MB991958, always turn the ignition switch to the "LOCK" (OFF) position before connecting or disconnecting scan tool MB991958.

- (1) Connect scan tool MB991958 to the data link connector.
- (2) Turn the ignition switch to the "ON" position.
- (3) Read the DTC.
- (4) Turn the ignition switch the "LOCK" (OFF) position.

**Q: Is any DTC set?**

**YES :** Refer to Diagnostic Trouble Code Chart [P.13A-49](#).

**NO :** Go to Step 3.

**STEP 3. Using scan tool MB991958, check data list.**

- (1) Turn the ignition switch the "ON" position.
- (2) Check the following items in the data list. Refer to Data List Reference Table [P.13A-818](#).
  - a. Item 1: Power Supply Voltage.
  - b. Item 6: Engine Coolant Temperature Sensor.
- (3) Turn the ignition switch the "LOCK" (OFF) position.

**Q: Is the sensor operating properly?**

**YES :** Go to Step 4.

**NO :** Repair or replace. Then confirm that the malfunction symptom is eliminated.

**STEP 4. Using scan tool MB991958, check actuator test.**

- (1) Turn the ignition switch to the "ON" position.
- (2) Check the following items in the actuator test. Refer to Actuator Test Reference Table [P.13A-838](#).
  - a. Item 9: Fuel Pump.
- (3) Turn the ignition switch to the "LOCK" (OFF) position.

**Q: Is the actuator operating properly?**

**YES :** Go to Step 5.

**NO :** Repair or replace. Then confirm that the malfunction symptom is eliminated.

**STEP 5. Check the ignition timing.**

Refer to GROUP 11A, On-vehicle Service – Ignition Timing  
Check [P.11A-13](#).

**Q: Is the ignition timing normal?**

**YES** : Go to Step 6.

**NO** : Repair or replace. Then confirm that the malfunction symptom is eliminated.

**STEP 6. Check the fuel pressure.**

Refer to Fuel Pressure Test [P.13A-868](#).

**Q: Is the fuel pressure normal?**

**YES** : Go to Step 7.

**NO** : Repair or replace. Then confirm that the malfunction symptom is eliminated.

**STEP 7. Check harness connector B-101, B-120, B-103, B-116 at injector for damage.****Q: Is the harness connector in good condition?**

**YES** : Go to Step 8.

**NO** : Repair or replace it. Refer to GROUP 00E, Harness Connector Inspection [P.00E-2](#). Then confirm that the malfunction symptom is eliminated.

**STEP 8. Check the injector resistance.**

- (1) Disconnect the left bank injector connector B-101, B-120, B-103, B-116.
- (2) Measure the resistance between each injector side connector terminal No. 1 and No. 2.

**Standard value: 10.5 – 13.5  $\Omega$  [at 20°C (68°F)]**

**Q: Is the measured resistance between 10.5 and 13.5 ohms [at 20°C (68°F)]?**

**YES** : Go to Step 9.

**NO** : Replace the faulty injector. Then confirm that the malfunction symptom is eliminated.

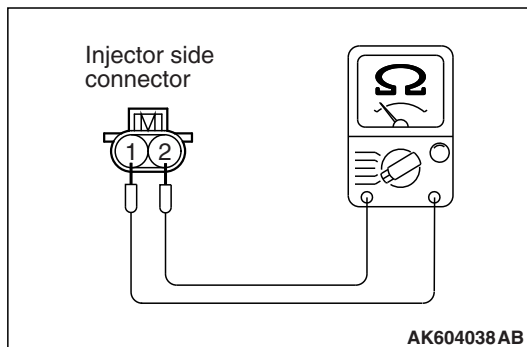
**STEP 9. Check harness connector A-24X at injector relay for damage.****Q: Is the harness connector in good condition?**

**YES** : Go to Step 10.

**NO** : Repair or replace it. Refer to GROUP 00E, Harness Connector Inspection [P.00E-2](#). Then confirm that the malfunction symptom is eliminated.

---

**STEP 10. Check for harness damage between injector relay connector and injector connector.**

*NOTE: Check harness after checking intermediate connector A-13. If intermediate connector is damaged, repair or replace it. Refer to GROUP 00E, Harness Connector Inspection P.00E-2. Then confirm that the malfunction symptom is eliminated.*

- a. Injector relay connector A-24X (terminal No. 3) and No. 1 cylinder injector connector B-101 (terminal No. 1).
- b. Injector relay connector A-24X (terminal No. 3) and No. 2 cylinder injector connector B-120 (terminal No. 1).
- c. Injector relay connector A-24X (terminal No. 3) and No. 3 cylinder injector connector B-103 (terminal No. 1).
- d. Injector relay connector A-24X (terminal No. 3) and No. 4 cylinder injector connector B-116 (terminal No. 1).

**Q: Is the harness wire in good condition?**

**YES :** Go to Step 11.

**NO :** Repair it. Then confirm that the malfunction symptom is eliminated.

---

**STEP 11. Check harness connector B-10 at ECM for damage.**

**Q: Is the harness connector in good condition?**

**YES :** Go to Step 12.

**NO :** Repair or replace it. Refer to GROUP 00E, Harness Connector Inspection P.00E-2. Then confirm that the malfunction symptom is eliminated.

---

**STEP 12. Check for open circuit and short circuit to ground and harness damage between injector connector and ECM connector.**

- a. No. 1 cylinder injector connector B-101 (terminal No. 2) and ECM connector B-10 (terminal No. 2).
- b. No. 2 cylinder injector connector B-120 (terminal No. 2) and ECM connector B-10 (terminal No. 3).
- c. No. 3 cylinder injector connector B-103 (terminal No. 2) and ECM connector B-10 (terminal No. 18).
- d. No. 4 cylinder injector connector B-116 (terminal No. 2) and ECM connector B-10 (terminal No. 19).

**Q: Is the harness wire in good condition?**

**YES :** Go to Step 13.

**NO :** Repair it. Then confirm that the malfunction symptom is eliminated.

**STEP 13. Check the ignition system.**

- (1) Connect the timing light to terminal No. 3 of the ignition coil connector B-01, B-19, B-04 or B-18 in order.
- (2) Crank the engine.
  - The timing light flashes.
- (3) Turn the ignition switch to the "LOCK" (OFF) position.

**Q: Does the timing light flash?**

**YES** : Go to Step 14.

**NO** : Refer to Inspection procedure 25 – Ignition circuit system [P.13A-807](#).

---

**STEP 14. Check the spark plugs.**

Refer to GROUP 16, Ignition System – On-vehicle Service – Spark Plug Check And Cleaning [P.16-45](#).

**Q: Are there any abnormalities?**

**YES** : Replace the spark plug. Then confirm that the malfunction symptom is eliminated.

**NO** : Go to Step 15.

---

**STEP 15. Check the ignition coil.**

Refer to GROUP 16, Ignition System – On-vehicle Service – Ignition Coil Check [P.16-44](#).

**Q: Are there any abnormalities?**

**YES** : Replace the ignition coil. Then confirm that the malfunction symptom is eliminated.

**NO** : Go to Step 16.

---

**STEP 16. Check the compression pressure.**

Refer to GROUP 11A, On-vehicle Service – Compression Pressure Check [P.11A-18](#).

**Q: Is the compression pressure normal?**

**YES** : Check the following items, and repair or replace the defective items.

a. Check if fuel is contaminated.

b. Check if the injectors are clogged.

Then confirm that the malfunction symptom is eliminated.

**NO** : Repair it. Then confirm that the malfunction symptom is eliminated.

---

**Inspection procedure 7: Unstable idle (rough idle, hunting)**

---

**COMMENT**

- In cases such as the above, the cause is probably the air/fuel mixture. Other systems affecting idle quality include the ignition system and compression.

**TROUBLESHOOTING HINTS (The most likely causes for this case:)**

- Malfunction of the fuel pump system.
- Malfunction of the ignition system.

- Malfunction of the injector system.
- Poor compression
- Malfunction of the purge control system
- Malfunction of the EGR system
- Improper operation of the PCV valve.
- Malfunction of the charging system.
- Vacuum leak.
- Contaminated fuel.
- Malfunction of variable valve timing control (MIVEC) system.
- Malfunction of the ECM.

**DIAGNOSIS**

**Required Special Tools:**

- MB991958: Scan Tool (M.U.T.-III Sub Assembly)
  - MB991824: V.C.I.
  - MB991827: USB Cable
  - MB991910: Main Harness A
- MB992110: Power Plant ECU Check Harness

---

**STEP 1. Check if the EGR valve sounds during initialization.**

**Q: Is the initialization sound heard in the EGR valve?**

**YES :** Go to Step 2.

**NO :** Refer to GROUP 17, Emission Control – Exhaust Gas Recirculation (EGR) System – EGR Valve (Stepper Motor) Check [P.17-81](#).

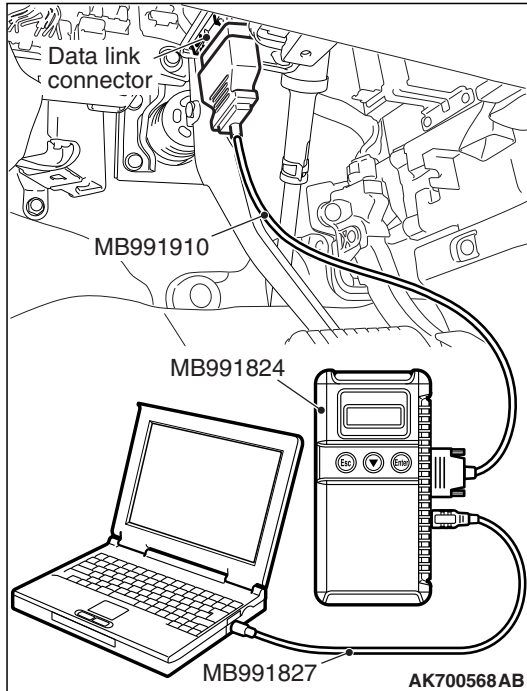

**STEP 2. Using scan tool MB991958, read the diagnostic trouble code (DTC)**

**⚠ CAUTION**

To prevent damage to scan tool MB991958, always turn the ignition switch to the "LOCK" (OFF) position before connecting or disconnecting scan tool MB991958.

- (1) Connect scan tool MB991958 to the data link connector.
- (2) Turn the ignition switch to the "ON" position.
- (3) Read the DTC.
- (4) Turn the ignition switch to the "LOCK" (OFF) position.

**Q: Is any DTC set?**

**YES :** Refer to Diagnostic Trouble Code Chart [P.13A-49](#).

**NO :** Go to Step 3.

**STEP 3. Using scan tool MB991958, check actuator test.**

- (1) Turn the ignition switch to the "ON" position.
- (2) Check following items in the actuator test. Refer to Actuator Test Reference Table [P.13A-838](#).
  - a. Item 1: Injector.
  - b. Item 10: Evaporative emission purge solenoid
- (3) Turn the ignition switch to the "LOCK" (OFF) position.

**Q: Are they operating properly?**

**YES :** Go to Step 4.

**NO :** Repair or replace it. Then confirm that the malfunction symptom is eliminated.



---

**STEP 4. Using scan tool MB991958, check data list.**

- (1) Turn the ignition switch to the "ON" position.
- (2) Check the following items in the data list. Refer to Data List Reference Table [P.13A-818](#).
  - a. Item 5: Intake Air Temperature Sensor.
  - b. Item 6: Engine Coolant Temperature Sensor.
  - c. Item 10: Mass Airflow Sensor
  - d. Item 36: Intake V.V.T. phase angle
  - e. Item 39: Exhaust V.V.T. phase angle
  - f. Item 76: A/C Switch
- (3) Turn the ignition switch to the "LOCK" (OFF) position.

**Q: Are they operating properly?**

**YES** : Go to Step 5.

**NO** : Repair or replace it. Then confirm that the malfunction symptom is eliminated.

---

**STEP 5. Check the fuel pressure.**

Refer to Fuel Pressure Test [P.13A-868](#).

**Q: Is the fuel pressure normal?**

**YES** : Go to Step 6.

**NO** : Repair or replace it. Then confirm that the malfunction symptom is eliminated.

---

**STEP 6. Check the ignition timing.**

Refer to GROUP 11A, On-vehicle Service – Ignition Timing Check [P.11A-13](#).

**Q: Is the ignition timing normal?**

**YES** : Go to Step 7.

**NO** : Check for installed conditions of the timing chain.  
Then confirm that the malfunction symptom is eliminated.

---

**STEP 7. Measure the voltage at ECM connector B-10 by using check harness special tool MB992110.**

- (1) Disconnect all ECM connectors. Connect the check harness special tool MB992110 between the separated connectors.

- (2) Start the engine and run at idle.

*NOTE: Vehicles for Canada, the headlight, taillight, etc. remain lit even when the lighting switch is in "OFF" position but this is no problem for checks.*

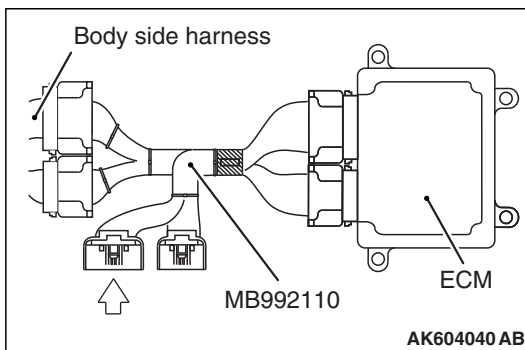

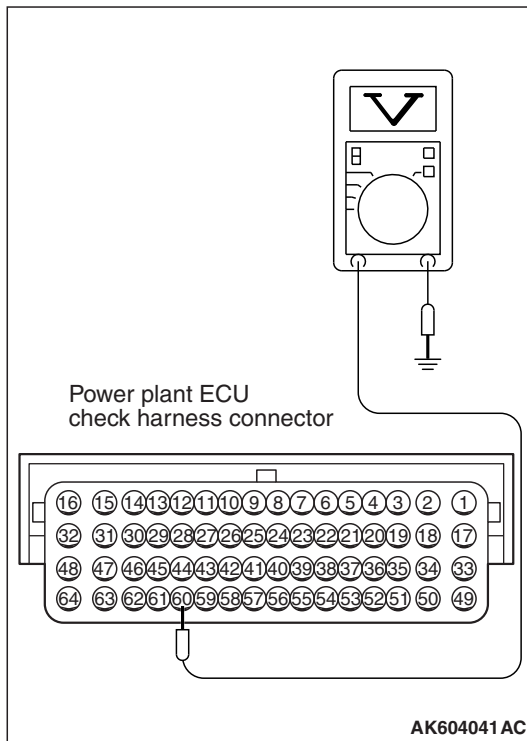

- (3) Measure the voltage between terminal No. 60 and ground.
  - a. Engine: warming up, idling
  - b. Radiator fan: stopped
  - c. Headlight: OFF to ON
  - d. Stop light: OFF to ON
  - e. Rear defogger switch: OFF to ON
    - Voltage increases
- (4) Turn the ignition switch to the "LOCK" (OFF) position.

**Q: Is the harness measured voltage within the specified range?**

**YES :** Go to Step 8.

**NO :** Replace the generator. Then confirm that the malfunction symptom is eliminated.

---

**STEP 8. Check the spark plugs.**

Refer to GROUP 16, Ignition System – On-vehicle Service – Spark Plug Check And Cleaning [P.16-45](#).

**Q: Are there any abnormalities?**

**YES :** Replace the spark plug. Then confirm that the malfunction symptom is eliminated.

**NO :** Go to Step 9.

---

**STEP 9. Check the ignition coil.**

(1) Remove the intake manifold.

(2) Refer to GROUP 16, Ignition System – On-vehicle Service – Ignition Coil Check And Cleaning [P.16-44](#).

**Q: Are there any abnormalities?**

**YES :** Replace the ignition coil. Then confirm that the malfunction symptom is eliminated.

**NO :** Go to Step 10.

---

**STEP 10. Check the compression pressure.**

Refer to GROUP 11A, On-vehicle Service – Compression Pressure Check [P.11A-18](#).

**Q: Is the compression pressure normal?**

**YES :** Go to Step 11.

**NO :** Repair it. Then confirm that the malfunction symptom is eliminated.

---

**STEP 11. Check the positive crankcase ventilation system.**

Refer to GROUP 17, Emission Control System – Positive Crankcase Ventilation System – Positive Crankcase Ventilation System Check [P.17-74](#).

**Q: Is the positive crankcase ventilation system?**

**YES** : Go to Step 12.

**NO** : Repair it. Then confirm that the malfunction symptom is eliminated.

---

**STEP 12. Check the purge control system.**

Refer to GROUP 17, Emission Control System – Evaporative Emission Control System – Purge Control System Check (Purge Flow Check) [P.17-77](#).

**Q: Is the purge control system normal?**

**YES** : Check the following items, and repair or replace the defective items.

1. Vacuum leak.
2. Check if fuel is contaminated.
3. Check if the injectors are clogged.

Then confirm that the malfunction symptom is eliminated.

**NO** : Repair it. Then confirm that the malfunction symptom is eliminated.

---

**Inspection procedure 8: Idle speed is high (improper idle speed)**

---

**COMMENT**

- In such cases as the above, the cause is probably that the intake air volume during idle is too great.

**TROUBLESHOOTING HINTS (The most likely causes for this case:)**

- Malfunction of the engine coolant temperature sensor signal.

- Malfunction of the accelerator pedal position sensor (main) signal.
- Malfunction of the accelerator pedal position sensor (sub) signal.
- Malfunction of the A/C switch signal.
- Malfunction of the power steering pressure switch signal.
- Malfunction of the evaporative emission control system.
- Malfunction of the ECM.

**DIAGNOSIS**

**Required Special Tools:**

- MB991958: Scan Tool (M.U.T.-III Sub Assembly)
  - MB991824: V.C.I.
  - MB991827: USB Cable
  - MB991910: Main Harness A

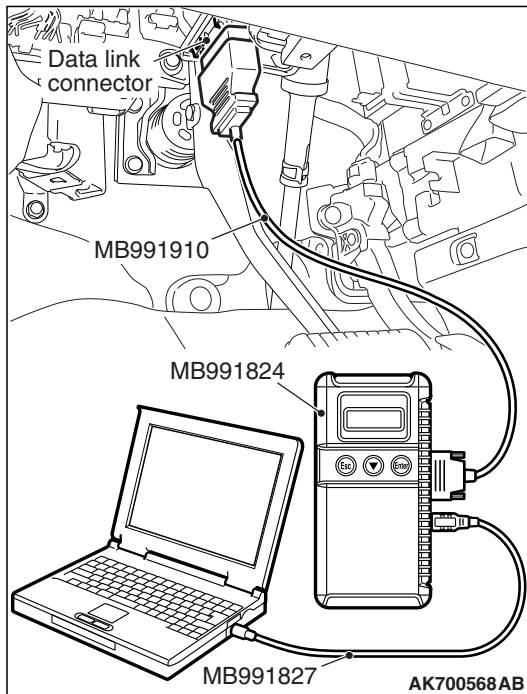

**STEP 1. Using scan tool MB991958, read the diagnostic trouble code (DTC).**

**⚠ CAUTION**

To prevent damage to scan tool MB991958, always turn the ignition switch to the "LOCK" (OFF) position before connecting or disconnecting scan tool MB991958.

- (1) Connect scan tool MB991958 to the data link connector.
- (2) Turn the ignition switch to the "ON" position.
- (3) Read the DTC.
- (4) Turn the ignition switch to the "LOCK" (OFF) position.

**Q: Is any DTC set?**

**YES :** Refer to Diagnostic Trouble Code Chart [P.13A-49](#).

**NO :** Go to Step 2.

**STEP 2. Using scan tool MB991958, check data list.**

- (1) Turn the ignition switch to the "ON" position.
- (2) Check the following item in the data list. Refer to Data List Reference Table [P.13A-818](#).
  - a. Item 6: Engine Coolant Temperature Sensor.
  - b. Item 11: Accelerator pedal position sensor (main)
  - c. Item 12: Accelerator pedal position sensor (sub)
  - d. Item 76: A/C switch
  - e. Item 83: Power steering pressure switch
- (3) Turn the ignition switch to the "LOCK" (OFF) position.

**Q: Is the sensor operating properly?**

**YES :** Refer to GROUP 17, Emission Control System – Evaporative Emission Control System – Evaporative Emission Purge Solenoid Check [P.17-78](#).

**NO :** Repair or replace it. Then confirm that the malfunction symptom is eliminated.

**Inspection procedure 9: Idle speed is low (improper idle speed)**

**COMMENT**

- In cases such as the above, the cause is probably that the intake air volume during idle is too small.

**TROUBLESHOOTING HINTS (The most likely causes for this case:)**

- Malfunction of the engine coolant temperature sensor signal.
- Malfunction of the torque converter.
- Dirtiness around throttle valve.
- Malfunction of the ECM.

**DIAGNOSIS**

**Required Special Tools:**

- MB991958: Scan Tool (M.U.T.-III Sub Assembly)
  - MB991824: V.C.I.
  - MB991827: USB Cable
  - MB991910: Main Harness A

**STEP 1. Using scan tool MB991958, read the diagnostic trouble code (DTC).**

**⚠ CAUTION**

To prevent damage to scan tool MB991958, always turn the ignition switch to the "LOCK" (OFF) position before connecting or disconnecting scan tool MB991958.

- (1) Connect scan tool MB991958 to the data link connector.
- (2) Turn the ignition switch to the "ON" position.
- (3) Read the DTC.
- (4) Turn the ignition switch to the "LOCK" (OFF) position.

**Q: Is any DTC set?**

**YES** : Refer to Diagnostic Trouble Code Chart [P.13A-49](#).

**NO** : Go to Step 2.

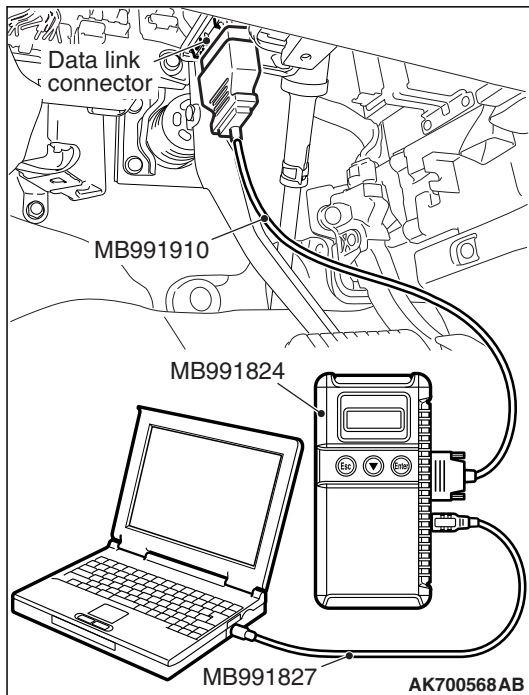

**STEP 2. Using scan tool MB991958, check data list.**

- (1) Turn the ignition switch to the "ON" position.
- (2) Check the following item in the data list. Refer to Data List Reference Table [P.13A-818](#).
  - a. Item 6: Engine Coolant Temperature Sensor.
- (3) Turn the ignition switch to the "LOCK" (OFF) position.

**Q: Is the sensor operating properly?**

**YES** : Refer to GROUP 23A, Diagnosis – Torque Converter Stall Test [P.23A-25](#).

**NO** : Repair or replace it. Then confirm that the malfunction symptom is eliminated.

---

**Inspection procedure 10: When the engine is cold, it stalls at idle (die out)**

---

**COMMENT**

- In such cases as the above, the air/fuel mixture may be inappropriate when the engine is cold.

- Malfunction of the ignition system.
- Poor compression.
- Malfunction of the EGR system.
- Improper engine oil viscosity.
- Malfunction of the ECM.

**TROUBLESHOOTING HINTS (The most likely causes for this case:)**

- Malfunction of the fuel pump system.

**DIAGNOSIS****Required Special Tools:**

- MB991958: Scan Tool (M.U.T.-III Sub Assembly)
  - MB991824: V.C.I.
  - MB991827: USB Cable
  - MB991910: Main Harness A

---

**STEP 1. Check if the EGR valve sounds during initialization.****Q: Is the initialization sound heard in the EGR valve?**

**YES** : Go to Step 2.

**NO** : Refer to GROUP 17, Emission Control – Exhaust Gas Recirculation (EGR) System – EGR Valve (Stepper Motor) Check [P.17-81](#).

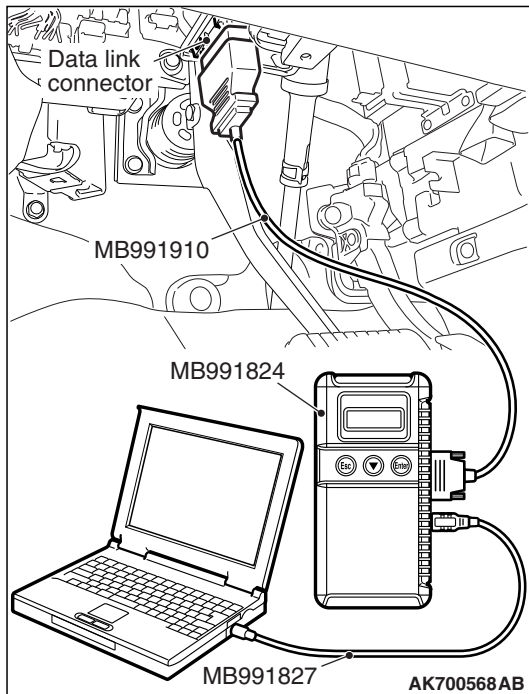

**STEP 2. Using scan tool MB991958, read the diagnostic trouble code (DTC).**

**⚠ CAUTION**

To prevent damage to scan tool MB991958, always turn the ignition switch to the "LOCK" (OFF) position before connecting or disconnecting scan tool MB991958.

- (1) Connect scan tool MB991958 to the data link connector.
- (2) Turn the ignition switch to the "ON" position.
- (3) Read the DTC.
- (4) Turn the ignition switch to the "LOCK" (OFF) position.

**Q: Is any DTC set?**

**YES :** Refer to Diagnostic Trouble Code Chart [P.13A-49](#).

**NO :** Go to Step 3.

**STEP 3. Using scan tool MB991958, check actuator test.**

- (1) Turn the ignition switch to the "ON" position.
- (2) Check following items in the actuator test. Refer to Actuator Test Reference Table [P.13A-838](#).
  - a. Item 1: Injector.
- (3) Turn the ignition switch to the "LOCK" (OFF) position.

**Q: Are they operating properly?**

**YES :** Go to Step 4.

**NO :** Repair or replace it. Then confirm that the malfunction symptom is eliminated.

**STEP 4. Using scan tool MB991958, check data list.**

- (1) Turn the ignition switch to the "ON" position.
- (2) Check the following items in the data list. Refer to Data List Reference Table [P.13A-818](#).
  - a. Item 6: Engine Coolant Temperature Sensor.
- (3) Turn the ignition switch to the "LOCK" (OFF) position.

**Q: Is the sensor operating properly?**

**YES :** Go to Step 5.

**NO :** Repair or replace it. Then confirm that the malfunction symptom is eliminated.

---

**STEP 5. Check the ignition timing.**

Refer to GROUP 11A, On-vehicle Service – Ignition Timing  
Check [P.11A-13](#).

**Q: Is the ignition timing normal?**

**YES** : Go to Step 6.

**NO** : Check for installed conditions of the timing chain.  
Then confirm that the malfunction symptom is eliminated.

---

**STEP 6. Check the fuel pressure.**

Refer to Fuel Pressure Test [P.13A-868](#).

**Q: Is the fuel pressure normal?**

**YES** : Go to Step 7.

**NO** : Repair or replace it. Then confirm that the malfunction symptom is eliminated.

---

**STEP 7. Check the spark plugs.**

Refer to GROUP 16, Ignition System – On-vehicle Service –  
Spark Plug Check And Cleaning [P.16-45](#).

**Q: Are there any abnormalities?**

**YES** : Replace the spark plug. Then confirm that the  
malfunction symptom is eliminated.

**NO** : Go to Step 8.

---

**STEP 8. Check the ignition coil.**

Refer to GROUP 16, Ignition System – On-vehicle Service –  
Ignition Coil Check [P.16-44](#).

**Q: Are there any abnormalities?**

**YES** : Replace the ignition coil. Then confirm that the  
malfunction symptom is eliminated.

**NO** : Go to Step 9.

---

**STEP 9. Check the compression pressure.**

Refer to GROUP 11A, On-vehicle Service – Compression  
Pressure Check [P.11A-18](#).

**Q: Is the compression pressure normal?**

**YES** : Check the engine oil viscosity, and replace the engine  
oil.

Then confirm that the malfunction symptom is  
eliminated.

**NO** : Repair it. Then confirm that the malfunction symptom  
is eliminated.



**Inspection procedure 11: When the engine is hot, it stalls at idle die out)**

**COMMENT**

- In cases such as the above, the ignition system, air/fuel mixture or compression pressure may be faulty. In addition, if the engine suddenly stalls, the cause may also be a connector damage.

- Malfunction of the ignition system.
- Poor compression
- Malfunction of the EGR system.
- Improper operation of the PCV valve.
- Vacuum leak.
- Dirtiness around throttle valve.
- Malfunction of the ECM.

**TROUBLESHOOTING HINTS (The most likely causes for this case:)**

- Malfunction of the fuel pump system.

**DIAGNOSIS**

**Required Special Tools:**

- MB991958: Scan Tool (M.U.T.-III Sub Assembly)
  - MB991824: V.C.I.
  - MB991827: USB Cable
  - MB991910: Main Harness A

**STEP 1. Check if the EGR valve sounds during initialization.**

**Q: Is the initialization sound heard in the EGR valve?**

**YES** : Go to Step 2.

**NO** : Refer to GROUP 17, Emission Control – Exhaust Gas Recirculation (EGR) System – EGR Valve (Stepper Motor) Check [P.17-81](#).

**STEP 2. Using scan tool MB991958, read the diagnostic trouble code (DTC).**

**⚠ CAUTION**

To prevent damage to scan tool MB991958, always turn the ignition switch to the "LOCK" (OFF) position before connecting or disconnecting scan tool MB991958.

- (1) Connect scan tool MB991958 to the data link connector.
- (2) Turn the ignition switch to the "ON" position.
- (3) Read the DTC.
- (4) Turn the ignition switch to the "LOCK" (OFF) position.

**Q: Is any DTC set?**

**YES** : Refer to Diagnostic Trouble Code Chart [P.13A-49](#).

**NO** : Go to Step 3.

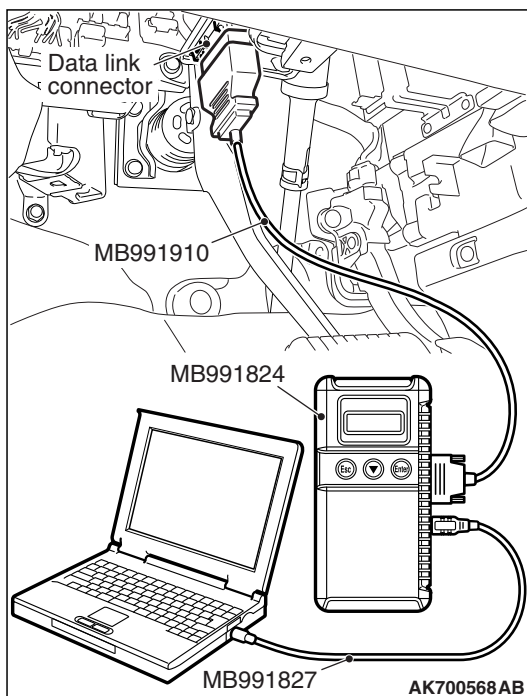

---

**STEP 3. Using scan tool MB991958, check actuator test item 1: injector.**

- (1) Turn the ignition switch to the "ON" position.
- (2) Check following items in the actuator test. Refer to Actuator Test Reference Table [P.13A-838](#).
  - a. Item 1: Injector.
- (3) Turn the ignition switch to the "LOCK" (OFF) position.

**Q: Are they operating properly?****YES** : Go to Step 4.**NO** : Repair or replace it. Then confirm that the malfunction symptom is eliminated.

---

**STEP 4. Using scan tool MB991958, check data list.**

- (1) Turn the ignition switch to the "ON" position.
- (2) Check the following items in the data list. Refer to Data List Reference Table [P.13A-818](#).
  - a. Item 5: Intake Air Temperature Sensor.
  - b. Item 6: Engine Coolant Temperature Sensor.
  - c. Item 13: Throttle position sensor (main).
- (3) Turn the ignition switch to the "LOCK" (OFF) position.

**Q: Are they operating properly?****YES** : Go to Step 5.**NO** : Repair or replace it. Then confirm that the malfunction symptom is eliminated.

---

**STEP 5. Inspection of throttle body (throttle valve area) for dirtiness.****Q: Is the throttle valve area dirty?****YES** : Refer to On-vehicle Service – Throttle Body (Throttle Valve Area) Cleaning [P.13A-865](#).**NO** : Go to Step 6.

---

**STEP 6. Check the fuel pressure.**Refer to Fuel Pressure Test [P.13A-868](#).**Q: Is the fuel pressure normal?****YES** : Go to Step 7.**NO** : Repair or replace it. Then confirm that the malfunction symptom is eliminated.

---

**STEP 7. Check the ignition timing.**Refer to GROUP 11A, On-vehicle Service – Ignition Timing Check [P.11A-13](#).**Q: Is the ignition timing normal?****YES** : Go to Step 8.**NO** : Check for installed conditions of the timing chain. Then confirm that the malfunction symptom is eliminated.

---

**STEP 8. Check the spark plugs.**

Refer to GROUP 16, Ignition System – On-vehicle Service – Spark Plug Check And Cleaning [P.16-45](#).

**Q: Are there any abnormalities?**

**YES** : Replace the spark plug. Then confirm that the malfunction symptom is eliminated.

**NO** : Go to Step 9.

---

**STEP 9. Check the ignition coil.**

Refer to GROUP 16, Ignition System – On-vehicle Service – Ignition Coil Check [P.16-44](#).

**Q: Are there any abnormalities?**

**YES** : Replace the ignition coil. Then confirm that the malfunction symptom is eliminated.

**NO** : Go to Step 10.

---

**STEP 10. Check the compression pressure.**

Refer to GROUP 11A, On-vehicle Service – Compression Pressure Check [P.11A-18](#).

**Q: Is the compression pressure normal?**

**YES** : Go to Step 11.

**NO** : Repair it. Then confirm that the malfunction symptom is eliminated.

---

**STEP 11. Check the positive crankcase ventilation system.**

Refer to GROUP 17, Emission Control – Positive Crankcase Ventilation System – Positive Crankcase Ventilation System Check [P.17-74](#).

**Q: Is the positive crankcase ventilation system?**

**YES** : Go to Step 12.

**NO** : Repair it. Then confirm that the malfunction symptom is eliminated.

**STEP 12. Engine stall reproduction test.****Q: Is it easy to reproduce the engine stall?**

**YES :** Check the following items, and repair or replace the defective items.

- a. Vacuum leak.
- b. Check if fuel is contaminated.
- c. Check if the injectors are clogged.
- d. Check if the foreign materials (water, kerosene, etc.) got into fuel.

Then confirm that the malfunction symptom is eliminated.

**NO :** Check if the following signals change suddenly by wiggling the circuit harness and connectors.

- a. Crankshaft position sensor signal.
- b. Mass airflow sensor signal.
- c. Injector drive signal.
- d. Primary and secondary ignition signal.
- e. Fuel pump drive signal.
- f. ECM power supply voltage.

Then confirm that the malfunction symptom is eliminated.

**Inspection procedure 12: The engine stalls accelerating (pass out)****COMMENT**

- In case such as the above, the cause is probably misfiring due to a weak spark, or an inappropriate air/fuel mixture when the accelerator pedal is depressed.

**TROUBLESHOOTING HINTS (The most likely causes for this case:)**

- Malfunction of the ignition system.
- Malfunction of the evaporative emission control system.
- Malfunction of the EGR system
- Improper operation of the PCV valve.
- Vacuum leak.
- Malfunction of the ECM.

**DIAGNOSIS****Required Special Tools:**

- MB991958: Scan Tool (M.U.T.-III Sub Assembly)
  - MB991824: V.C.I.
  - MB991827: USB Cable
  - MB991910: Main Harness A

**STEP 1. Check if the EGR valve sounds during initialization.****Q: Is the initialization sound heard in the EGR valve?**

**YES :** Go to Step 2.

**NO :** Refer to GROUP 17, Emission Control – Exhaust Gas Recirculation (EGR) System – EGR Valve (Stepper Motor) Check [P.17-81](#).

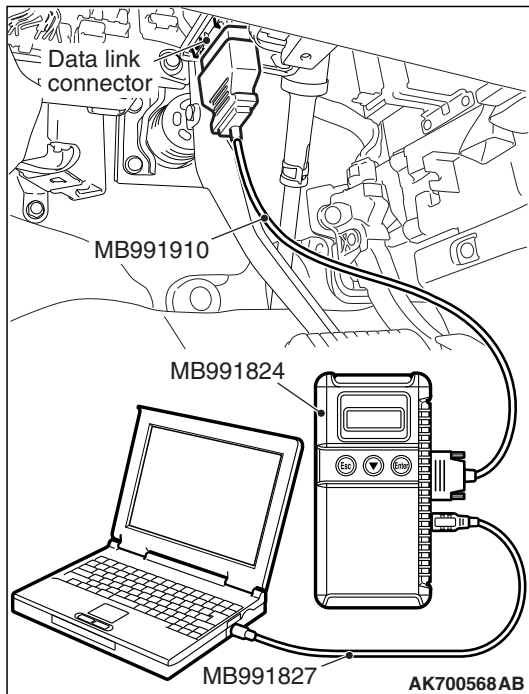

**STEP 2. Using scan tool MB991958, read the diagnostic trouble code (DTC).**

**⚠ CAUTION**

To prevent damage to scan tool MB991958, always turn the ignition switch to the "LOCK" (OFF) position before connecting or disconnecting scan tool MB991958.

- (1) Connect scan tool MB991958 to the data link connector.
- (2) Turn the ignition switch to the "ON" position.
- (3) Read the DTC.
- (4) Turn the ignition switch to the "LOCK" (OFF) position.

**Q: Is any DTC set?**

**YES :** Refer to Diagnostic Trouble Code Chart [P.13A-49](#).

**NO :** Go to Step 3.

**STEP 3. Using scan tool MB991958, check actuator test.**

- (1) Turn the ignition switch to the "ON" position.
- (2) Check the following item in the actuator test. Refer to Actuator Test Reference Table [P.13A-838](#).
  - a. Item 10: Evaporative Emission Purge Solenoid.
- (3) Turn the ignition switch to the "LOCK" (OFF) position.

**Q: Is the actuator operating properly?**

**YES :** Go to Step 4.

**NO :** Repair or replace it. Then confirm that the malfunction symptom is eliminated.

**STEP 4. Check the spark plugs.**

Refer to GROUP 16, Ignition System – On-vehicle Service – Spark Plug Check And Cleaning [P.16-45](#).

**Q: Are there any abnormalities?**

**YES :** Replace the spark plug. Then confirm that the malfunction symptom is eliminated.

**NO :** Go to Step 5.

**STEP 5. Check the ignition coil.**

Refer to GROUP 16, Ignition System – On-vehicle Service – Ignition Coil Check [P.16-44](#).

**Q: Are there any abnormalities?**

**YES :** Replace the ignition coil. Then confirm that the malfunction symptom is eliminated.

**NO :** Go to Step 6.

**STEP 6. Check the positive crankcase ventilation system.**

Refer to GROUP 17, Emission Control – Positive Crankcase Ventilation System – Positive Crankcase Ventilation System Check [P.17-74](#).

**Q: Is the positive crankcase ventilation system?**

**YES** : Check the following items, and repair or replace the defective items.

- a. Vacuum leak.

Then confirm that the malfunction symptom is eliminated.

**NO** : Repair it. Then confirm that the malfunction symptom is eliminated.

---

**Inspection procedure 13: The engine stalls decelerating**

---

**COMMENT**

- Abnormal air/fuel ratio or other similar defects due to insufficient intake air volume and defective EGR system is suspected to be the causes.

**TROUBLESHOOTING HINTS (The most likely causes for this case:)**

- Malfunction of the ignition system.
- Dirtiness around throttle valve.
- Malfunction of the EGR system.
- Malfunction of the ECM.

**DIAGNOSIS****Required Special Tools:**

- MB991958: Scan Tool (M.U.T.-III Sub Assembly)
  - MB991824: V.C.I.
  - MB991827: USB Cable
  - MB991910: Main Harness A

---

**STEP 1. Check if the EGR valve sounds during initialization.****Q: Is the initialization sound heard in the EGR valve?**

**YES** : Go to Step 2.

**NO** : Refer to GROUP 17, Emission Control – Exhaust Gas Recirculation (EGR) System – EGR Valve (Stepper Motor) Check [P.17-81](#).

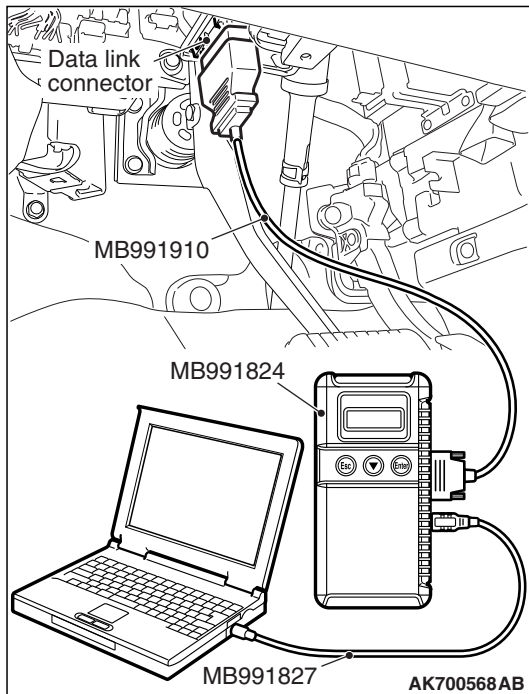

**STEP 2. Using scan tool MB991958, read the diagnostic trouble code (DTC).**

**⚠ CAUTION**

To prevent damage to scan tool MB991958, always turn the ignition switch to the "LOCK" (OFF) position before connecting or disconnecting scan tool MB991958.

- (1) Connect scan tool MB991958 to the data link connector.
- (2) Turn the ignition switch to the "ON" position.
- (3) Read the DTC.
- (4) Turn the ignition switch to the "LOCK" (OFF) position.

**Q: Is any DTC set?**

**YES :** Refer to Diagnostic Trouble Code Chart [P.13A-49](#).

**NO :** Go to Step 3.

**STEP 3. Inspection of throttle body (throttle valve area) for dirtiness.**

**Q: Is the throttle valve area dirty?**

**YES :** Refer to Throttle Body (Throttle Valve Area) Cleaning [P.13A-865](#).

**NO :** Go to Step 4.

**STEP 4. Using scan tool MB991958, check data list.**

- (1) Turn the ignition switch to the "ON" position.
- (2) Check the following items in the data list. Refer to Data List Reference Table [P.13A-818](#).
  - a. Item 11: Accelerator Pedal Position Sensor (main).
  - b. Item 12: Accelerator Pedal Position Sensor (sub).
  - c. Item 13: Throttle Position Sensor (main).
  - d. Item 15: Throttle Position Sensor (sub).
- (3) Turn the ignition switch to the "LOCK" (OFF) position.

**Q: Are they operating properly?**

**YES :** Go to Step 5.

**NO :** Repair or replace it. Then confirm that the malfunction symptom is eliminated.

**STEP 5. Check the spark plugs.**

Refer to GROUP 16, Ignition System – On-vehicle Service – Spark Plug Check [P.16-45](#).

**Q: Are there any abnormalities?**

**YES** : Replace the spark plug. Then confirm that the malfunction symptom is eliminated.

**NO** : Check the ignition coil (Refer to GROUP 16, Ignition System – On-vehicle Service – Ignition Coil Check [P.16-44](#)). Then confirm that the malfunction symptom is eliminated.

**Inspection procedure 14: Hesitation, sag, stumble, poor acceleration or surge****COMMENT**

- Defective ignition system, abnormal air/fuel ratio, poor compression pressure, etc. are suspected.

**TROUBLESHOOTING HINTS (The most likely causes for this case:)**

- Malfunction of the fuel pump system.
- Malfunction of the ignition system.

- Poor compression.
- Malfunction of the EGR system.
- Improper operation of the PCV valve.
- Vacuum leak.
- Clogged air cleaner.
- Clogged exhaust system.
- Malfunction of the CVT system.
- Malfunction of the ECM.

**DIAGNOSIS****Required Special Tools:**

- MB991958: Scan tool (M.U.T.-III Sub Assembly)
  - MB991824: V.C.I.
  - MB991827: USB Cable
  - MB991910: Main Harness A

*NOTE: To protect the CVT, the TCM outputs, into the ECM, the request signal to reduce the engine torque according to the operation condition. Based on the signal, the ECM closes the throttle valve, retards the ignition or carries out fuel cut. At that time, the engine output seems to temporarily reduce, but there is no malfunction.*

**STEP 1. Check if the EGR valve sounds during initialization.****Q: Is the initialization sound heard in the EGR valve?**

**YES** : Go to Step 2.

**NO** : Refer to GROUP 17, Emission Control – Exhaust Gas Recirculation (EGR) System – EGR Valve (Stepper Motor) Check [P.17-81](#).



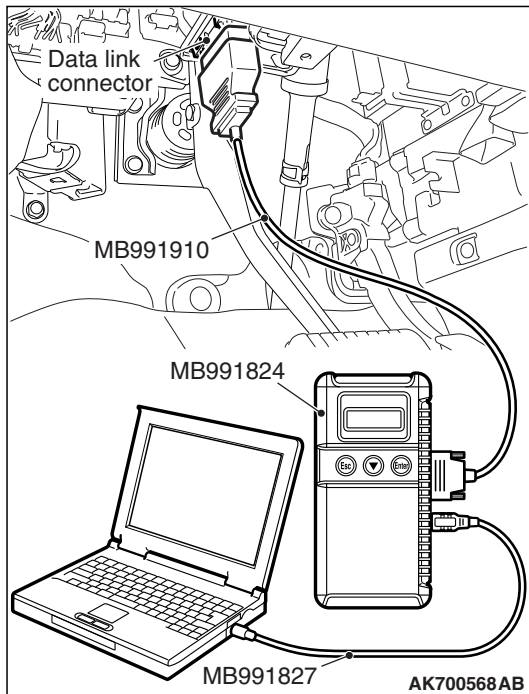

**STEP 2.** Using scan tool MB991958, read the diagnostic trouble code (DTC).

**⚠ CAUTION**

To prevent damage to scan tool MB991958, always turn the ignition switch to the "LOCK" (OFF) position before connecting or disconnecting scan tool MB991958.

- (1) Connect scan tool MB991958 to the data link connector.
- (2) Turn the ignition switch to the "ON" position.
- (3) Read the DTC.
- (4) Turn the ignition switch to the "LOCK" (OFF) position.

**Q: Is any DTC set?**

**YES :** Refer to Diagnostic Trouble Code Chart [P.13A-49](#).

**NO :** Go to Step 3.

**STEP 3.** Using scan tool MB991958, read the diagnostic trouble code (DTC).

*NOTE: When the CVT has a malfunction, the TCM might output the request signal of reducing the engine torque in order to protect the CVT.*

- (1) Turn the ignition switch to the "ON" position.
- (2) Read the TCM-DTC.
- (3) Turn the ignition switch to the "LOCK" (OFF) position.

**Q: Is the TCM-DTC set?**

**YES :** Refer to GROUP 23A, Diagnosis – Diagnostic Trouble Code Chart [P.23A-29](#).

**NO :** Go to Step 4 .

**STEP 4.** Using scan tool MB991958, check actuator test item 1: injector.

- (1) Turn the ignition switch to the "ON" position.
- (2) Test Reference Table [P.13A-838](#).
  - a. Item 1: Injector.
- (3) Turn the ignition switch to the "LOCK" (OFF) position.

**Q: Are thy operating properly?**

**YES :** Go to Step 5.

**NO :** Repair or replace it. Then confirm that the malfunction symptom is eliminated.

**STEP 5. Check the ignition timing.**

- (1) Refer to GROUP 11A, On-vehicle Service – Ignition Timing Check [P.11A-13](#).

**Q: Is the ignition timing normal?**

**YES** : Go to Step 6.

**NO** : Check for installed conditions of the timing chain. Then confirm that the malfunction symptom is eliminated.

---

**STEP 6. Using scan tool MB991958, check data list and actuator test.**

- (1) Turn the ignition switch to the "ON" position.  
(2) Check the following items in the data list. Refer to Data List Reference Table [P.13A-818](#).
- Item 5: Intake Air Temperature Sensor.
  - Item 6: Engine Coolant Temperature Sensor.
  - Item 11: Accelerator Pedal Position Sensor (main).
  - Item 12: Accelerator Pedal Position Sensor (sub).
  - Item 13: Throttle Position Sensor (main).
  - Item 15: Throttle Position Sensor (sub).
- (3) Turn the ignition switch to the "LOCK" (OFF) position.

**Q: Are they operating properly?**

**YES** : Go to Step 7.

**NO** : Repair or replace it. Then confirm that the malfunction symptom is eliminated.

---

**STEP 7. Check the fuel pressure.**

Refer to Fuel Pressure Test [P.13A-868](#).

**Q: Is the fuel pressure normal?**

**YES** : Go to Step 8.

**NO** : Repair or replace it. Then confirm that the malfunction symptom is eliminated.

---

**STEP 8. Check the spark plugs.**

Refer to GROUP 16, Ignition System – On-vehicle Service – Spark Plug Check And Cleaning [P.16-45](#).

**Q: Are there any abnormalities?**

**YES** : Replace the spark plug. Then confirm that the malfunction symptom is eliminated.

**NO** : Go to Step 9.

---

**STEP 9. Check the ignition coil.**

- (1) Remove the intake manifold.  
(2) Refer to GROUP 16, Ignition System – On-vehicle Service – Ignition Coil Check [P.16-44](#).

**Q: Are there any abnormalities?**

**YES** : Replace the ignition coil. Then confirm that the malfunction symptom is eliminated.

**NO** : Go to Step 10.

---

**STEP 10. Check the positive crankcase ventilation system.**  
Refer to GROUP 17, Emission Control System – Positive Crankcase Ventilation System – Positive Crankcase Ventilation System Check [P.17-74](#).

**Q: Is the positive crankcase ventilation system?**

**YES :** Check the following items, and repair or replace the defective items.

- a. Vacuum leak.
- b. Clogged air cleaner.
- c. Clogged exhaust system.
- d. Check if fuel is contaminated.
- e. Check if the injectors are clogged.
- f. Check if the foreign materials (water, kerosene, etc.) got into fuel.

Then confirm that the malfunction symptom is eliminated.

**NO :** Repair it. Then confirm that the malfunction symptom is eliminated.

---

### Inspection procedure 15: Acceleration shock

---

#### COMMENT

- There may be an ignition leak accompanying the increase in the spark plug demand voltage during acceleration.

#### TROUBLESHOOTING HINTS (The most likely causes for this case:)

- Malfunction of the ignition system.
- Malfunction of the CVT system.
- Malfunction of the ECM.

#### DIAGNOSIS

##### Required Special Tools:

- MB991958: Scan Tool (M.U.T.-III Sub Assembly)
  - MB991824: V.C.I.
  - MB991827: USB Cable
  - MB991910: Main Harness A

*NOTE: To protect the CVT, the TCM outputs, into the ECM, the request signal to reduce the engine torque according to the operation condition. Based on the signal, the ECM closes the throttle valve, retards the ignition or carries out fuel cut. At that time, the engine output seems to temporarily reduce, but there is no malfunction.*

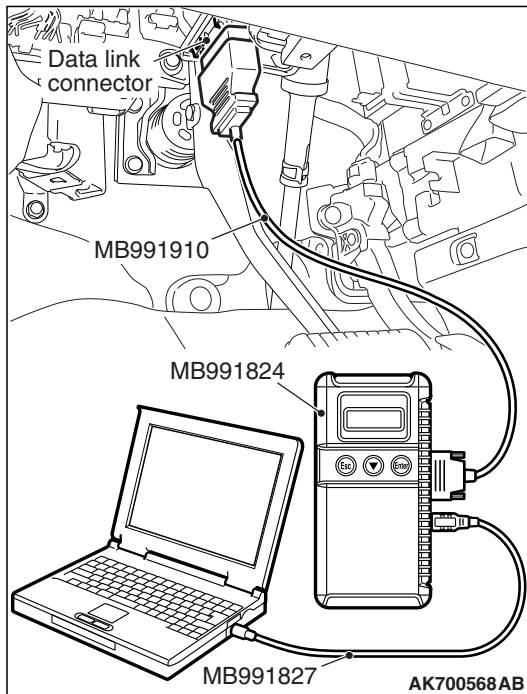

**STEP 1.** Using scan tool MB991958, read the diagnostic trouble code (DTC).

**⚠ CAUTION**

To prevent damage to scan tool MB991958, always turn the ignition switch to the "LOCK" (OFF) position before connecting or disconnecting scan tool MB991958.

- (1) Connect scan tool MB991958 to the data link connector.
- (2) Turn the ignition switch to the "ON" position.
- (3) Read the DTC.
- (4) Turn the ignition switch to the "LOCK" (OFF) position.

**Q: Is any DTC set?**

**YES :** Refer to Diagnostic Trouble Code Chart [P.13A-49](#).

**NO :** Go to Step 2.

**STEP 2.** Using scan tool MB991958, read the diagnostic trouble code (DTC).

*NOTE: When the CVT has a malfunction, the TCM might output the request signal of reducing the engine torque in order to protect the CVT.*

- (1) Turn the ignition switch to the "ON" position.
- (2) Read the TCM-DTC.
- (3) Turn the ignition switch to the "LOCK" (OFF) position.

**Q: Is the TCM-DTC set?**

**YES :** Refer to GROUP 23A, Diagnosis – Diagnostic Trouble Code Chart [P.23A-29](#).

**NO :** Go to Step 3 .

**STEP 3. Check the spark plugs.**

Refer to GROUP 16, Ignition System – On-vehicle Service – Spark Plug Check And Cleaning [P.16-45](#).

**Q: Are there any abnormalities?**

**YES :** Replace the spark plug. Then confirm that the malfunction symptom is eliminated.

**NO :** Go to Step 4.

**STEP 4. Check the ignition coil.**

- (1) Remove the intake manifold.
- (2) Refer to GROUP 16, Ignition System – On-vehicle Service – Ignition Coil Check [P.16-44](#).

**Q: Are there any abnormalities?**

**YES :** Replace the ignition coil. Then confirm that the malfunction symptom is eliminated.

**NO :** Check for occurrence of ignition leak. Then confirm that the malfunction symptom is eliminated.

**Inspection procedure 16: Knocking**

**COMMENT**

- Incases such as the above, the cause is probably that the detonation control is defective or the heat value of the spark plug is inappropriate.

**TROUBLESHOOTING HINTS (The most likely causes for this case:)**

- Defective knock sensor.
- Incorrect heat value of the spark plug.
- Poor compression.
- Malfunction of the ECM.

**DIAGNOSIS**

**Required Special Tools:**

- MB991958: Scan Tool (M.U.T.-III Sub Assembly)
  - MB991824: V.C.I.
  - MB991827: USB Cable
  - MB991910: Main Harness A

**STEP 1. Using the scan tool MB991958, read the diagnostic trouble code (DTC).**

**⚠ CAUTION**

**To prevent damage to scan tool MB991958, always turn the ignition switch to the "LOCK" (OFF) position before connecting or disconnecting scan tool MB991958.**

- (1) Connect scan tool MB991958 to the data link connector.
- (2) Turn the ignition switch to the "ON" position.
- (3) Read the DTC.
- (4) Turn the ignition switch to the "LOCK" (OFF) position.

**Q: Is any DTC set?**

**YES :** Refer to Diagnostic Trouble Code Chart [P.13A-49](#).

**NO :** Go to Step 2.

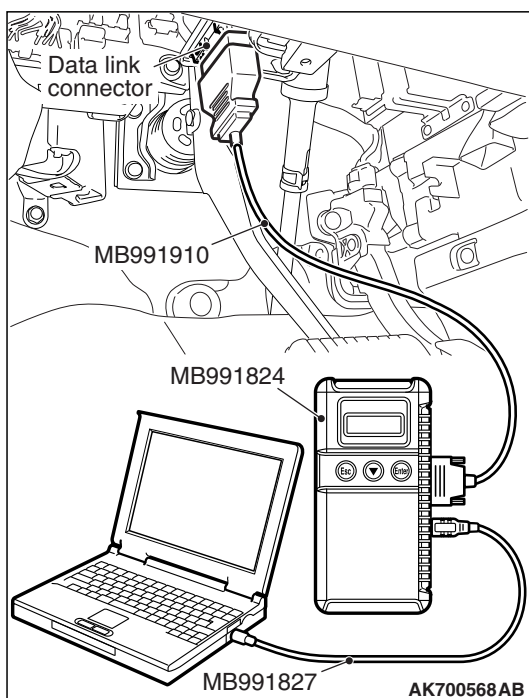

**STEP 2. Using scan tool MB991958, check data list.**

- (1) Turn the ignition switch to the "ON" position.
- (2) Check the following items of the data list. Refer to Data List Reference Table [P.13A-818](#).
  - a. Item 32: Knock retard.
- (3) Turn the ignition switch to the "LOCK" (OFF) position.

**Q: Is the sensor operating properly?****YES** : Go to Step 3.**NO** : Refer to DTC P0327 – Knock Sensor Circuit Low Input [P.13A-364](#), DTC P0328 - Knock Sensor Circuit High Input [P.13A-368](#).**STEP 3. Check the spark plugs.**Refer to GROUP 16, Ignition System – On-vehicle Service – Spark Plug Check And Cleaning [P.16-45](#).**Q: Are there any abnormalities?****YES** : Replace the spark plug. Then confirm that the malfunction symptom is eliminated.**NO** : Go to Step 4.**STEP 4. Check the compression pressure.**Refer to GROUP 11A, On-vehicle Service – Compression Pressure Check [P.11A-18](#).**Q: Is the compression pressure normal?****YES** : Check the following items, and repair or replace the defective items.

- a. Check if fuel is contaminated.
- b. Check if the foreign materials (water, kerosene, etc.) got into fuel.

Then confirm that the malfunction symptom is eliminated.

**NO** : Repair it. Then confirm that the malfunction symptom is eliminated.

---

**Inspection procedure 17: Too high CO and HC concentration when idling**

---

**COMMENT**

- Abnormal air/fuel ratio is suspected.

**TROUBLESHOOTING HINTS (The most likely causes for this case:)**

- Malfunction of the fuel pump system.
- Malfunction of the heated oxygen sensor.

- Malfunction of the ignition system.
- Poor compression.
- Malfunction of the EGR system.
- Improper operation of the PCV valve.
- Malfunction of the evaporative emission control system.
- Malfunction of the ECM.

**DIAGNOSIS****Required Special Tools:**

- MB991958: Scan Tool (M.U.T.-III Sub Assembly)
- MB991824: V.C.I.

- MB991827: USB Cable
- MB991910: Main Harness A

---

**STEP 1. Check if the EGR valve sounds during initialization.**

**Q: Is the initialization sound heard in the EGR valve?**

**YES :** Go to Step 2.

**NO :** Refer to GROUP 17, Emission Control – Exhaust Gas Recirculation (EGR) System – EGR Valve (Stepper Motor) Check [P.17-81](#).

---

**STEP 2. Using scan tool MB991958, read the diagnostic trouble code (DTC).**

**⚠ CAUTION**

To prevent damage to scan tool MB991958, always turn the ignition switch to the "LOCK" (OFF) position before connecting or disconnecting scan tool MB991958.

- (1) Connect scan tool MB991958 to the data link connector.
- (2) Turn the ignition switch to the "ON" position.
- (3) Read the DTC.
- (4) Turn the ignition switch to the "LOCK" (OFF) position.

**Q: Is any DTC set?**

**YES :** Refer to Diagnostic Trouble Code Chart [P.13A-49](#).

**NO :** Go to Step 3.

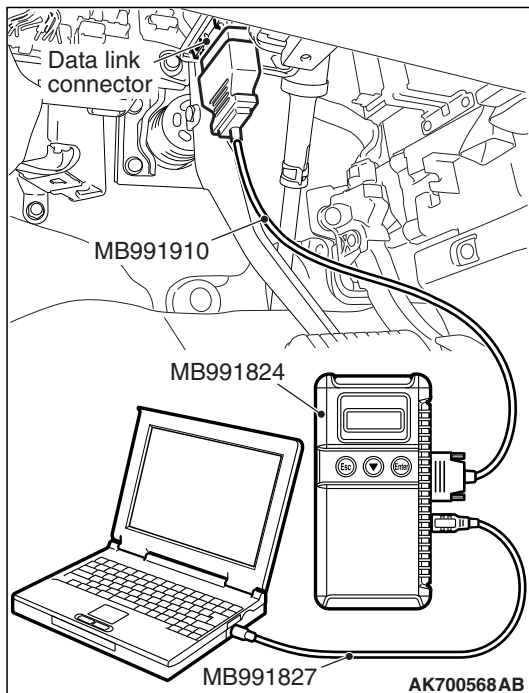

---

**STEP 3. Check the ignition timing.**

Refer to GROUP 11A, On-vehicle Service – Ignition Timing Check [P.11A-13](#).

**Q: Is the ignition timing normal?**

**YES :** Go to Step 4.

**NO :** Check for installed conditions of the timing chain. Then confirm that the malfunction symptom is eliminated.

**STEP 4. Using scan tool MB991958, check data list.**

- (1) Turn the ignition switch to the "ON" position.
- (2) Check the following items in the data list. Refer to Data List Reference Table [P.13A-818](#).
  - a. Item 5: Intake Air Temperature Sensor.
  - b. Item 6: Engine Coolant Temperature Sensor.
  - c. Item AD: Heated Oxygen Sensor (rear).
  - d. Item E1: Linear Air-fuel Ratio Sensor.
- (3) Turn the ignition switch to the "LOCK" (OFF) position.

**Q: Are they operating properly?****YES** : Go to Step 5.**NO** : Repair or replace it. Then confirm that the malfunction symptom is eliminated.

---

**STEP 5. Check the fuel pressure.**Refer to Fuel Pressure Test [P.13A-868](#).**Q: Is the fuel pressure normal?****YES** : Go to Step 6.**NO** : Repair or replace it. Then confirm that the malfunction symptom is eliminated.

---

**STEP 6. Check the spark plugs.**Refer to GROUP 16, Ignition System – On-vehicle Service – Spark Plug Check And Cleaning [P.16-45](#).**Q: Are there any abnormalities?****YES** : Replace the spark plug. Then confirm that the malfunction symptom is eliminated.**NO** : Go to Step 7.

---

**STEP 7. Check the ignition coil.**Refer to GROUP 16, Ignition System – On-vehicle Service – Ignition Coil Check [P.16-44](#).**Q: Are there any abnormalities?****YES** : Replace the ignition coil. Then confirm that the malfunction symptom is eliminated.**NO** : Go to Step 8.

---

**STEP 8. Check the compression pressure.**Refer to GROUP 11A, On-vehicle Service – Compression Pressure Check [P.11A-18](#).**Q: Is the compression pressure normal?****YES** : Go to Step 9.**NO** : Repair it. Then confirm that the malfunction symptom is eliminated.



---

**STEP 9. Check the positive crankcase ventilation system.**  
Refer to GROUP 17, Emission Control – Positive Crankcase Ventilation System – Positive Crankcase Ventilation System Check [P.17-74](#).

**Q: Is the positive crankcase ventilation system?**

**YES :** Go to Step 10.

**NO :** Repair it. Then confirm that the malfunction symptom is eliminated.

---

**STEP 10. Check the evaporative emission control system.**  
Refer to GROUP 17, Emission Control – Evaporative Emission Control System – Purge Control System Check (Purge Flow Check) [P.17-77](#).

**Q: Is the purge control system normal?**

**YES :** Check the following items, and repair or replace the defective items.

a. Check if the injectors are clogged.

Then confirm that the malfunction symptom is eliminated.

**NO :** Repair it. Then confirm that the malfunction symptom is eliminated.

---

### Inspection procedure 18: Transient, mass emission tailpipe test failure

---

#### COMMENT

- The test is failed when the air/fuel ratio is not controlled to the ideal air/fuel ratio. This occurs due to the feedback control by heated oxygen sensor signals, insufficient EGR flow rate, or deteriorated catalyst.

*NOTE: If the three-way catalyst temperature is low when checking the exhaust gas, the three-way catalyst cannot sufficiently clean the emissions. Warm up the engine sufficiently before checking the exhaust, and check immediately.*

#### TROUBLESHOOTING HINTS (The most likely causes for this case:)

- Malfunction of air/fuel ratio control system.
- Malfunction of the fuel pump system.
- Malfunction of the ignition system.
- Poor compression.
- Malfunction of the EGR system.
- Improper operation of the PCV valve
- Malfunction of the evaporative emission control system
- Deteriorated catalyst.

#### DIAGNOSIS

##### Required Special Tools:

- MB991958: Scan Tool (M.U.T.-III Sub Assembly)
  - MB991824: V.C.I.
  - MB991827: USB Cable
  - MB991910: Main Harness A

---

**STEP 1. Check the exhaust gas with the engine at normal operating temperature.**

**Q: Was the exhaust gas checked with engine warmed sufficiently?**

**YES :** Go to Step 2.

**NO :** Check it again after enough warm up.

**STEP 2. Check the following items.**

- (1) Check the following items.
- a. Check all vacuum hoses and connectors.
  - b. Check electrical wires and connectors for obvious problems.

**Q: Are they normal?****YES** : Go to Step 3.**NO** : Repair or replace it. Then confirm that the malfunction symptom is eliminated.**STEP 3. Check the driveability.****Q: Is the driveability normal?****YES** : Go to Step 4.**NO** : Refer to Trouble Symptom Chart [P.13A-54](#).**STEP 4. Using scan tool MB991958, read the diagnostic trouble code (DTC).****⚠ CAUTION**

To prevent damage to scan tool MB991958, always turn the ignition switch to the "LOCK" (OFF) position before connecting or disconnecting scan tool MB991958.

- (1) Connect scan tool MB991958 to the data link connector.
- (2) Turn the ignition switch to the "ON" position.
- (3) Read the DTC.
- (4) Turn the ignition switch to the "LOCK" (OFF) position.

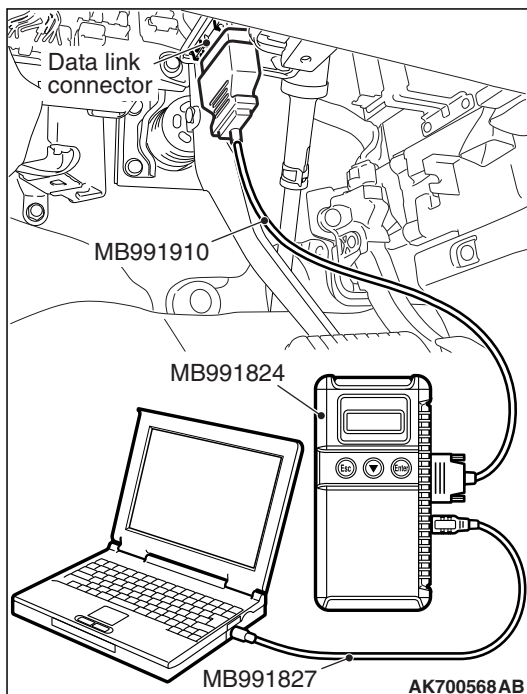
**Q: Is any DTC set?****YES** : Refer to Diagnostic Trouble Code Chart [P.13A-49](#).**NO** : Go to Step 5.**STEP 5. Check the ignition timing.**

Refer to GROUP 11A, On-vehicle Service – Ignition Timing Check [P.11A-13](#).

**Q: Is the ignition timing normal?****YES** : Go to Step 6.**NO** : Check that the crankshaft position sensor and timing chain case are in the correct position. Then confirm that the malfunction symptom is eliminated.

---

**STEP 6. Using scan tool MB991958, check data list.**

- (1) Turn the ignition switch to the "ON" position.
- (2) Check the following items in the data list. Refer to Data List Reference Table [P.13A-818](#).
  - a. Item 5: Intake Air Temperature Sensor.
  - b. Item 6: Engine Coolant Temperature Sensor.
  - c. Item BB: Barometric Pressure Sensor
  - d. Item E1: Linear Air-fuel Ratio Sensor.
- (3) Turn the ignition switch to the "LOCK" (OFF) position.

**Q: Are they operating properly?**

**YES** : Go to Step 7.

**NO** : Repair or replace it. Then confirm that the malfunction symptom is eliminated.

---

**STEP 7. Using scan tool MB991958, check data list item**

**AD: Heated oxygen sensor (rear).**

- (1) Start the engine and run at idle.
- (2) Set scan tool MB991958 to the data reading mode for item AD, Heated Oxygen Sensor (rear).
  - a. Transaxle: 2nd
  - b. Drive with wide open throttle
  - c. Engine: 3,500 r/min
    - The output voltages should be between 0.6 and 1.0 volt.
- (3) Turn the ignition switch to the "LOCK" (OFF) position.

**Q: Is the sensor operating properly?**

**YES** : Go to Step 8

**NO** : Refer to, P0137 – Heated Oxygen Sensor (rear) Circuit Low Voltage [P.13A-241](#), DTC P0138 – Heated Oxygen Sensor (rear) Circuit High Voltage [P.13A-249](#), DTC P0139 – Heated Oxygen Sensor (rear) Circuit Slow Response [P.13A-253](#), DTC P0140 – Heated Oxygen Sensor (rear) Circuit No Activity Detected [P.13A-258](#).

---

**STEP 8. Check the EGR system.**

Refer to GROUP 17, Emission Control – Exhaust Gas Recirculation (EGR) System – General Description (EGR System) [P.17-80](#).

**Q: Is the EGR system normal?**

**YES** : Go to Step 9.

**NO** : Repair or replace it. Then confirm that the malfunction symptom is eliminated.

---

**STEP 9. Check the fuel pressure.**

Refer to Fuel Pressure Test [P.13A-868](#).

**Q: Is the fuel pressure normal?**

**YES** : Go to Step 10.

**NO** : Repair or replace it. Then confirm that the malfunction symptom is eliminated.

---

**STEP 10. Check the spark plugs.**

Refer to GROUP 16, Ignition System – On-vehicle Service – Spark Plug Check And Cleaning [P.16-45](#).

**Q: Are there any abnormalities?**

**YES** : Replace the spark plug. Then confirm that the malfunction symptom is eliminated.

**NO** : Go to Step 11.

---

**STEP 11. Check the ignition coil.**

Refer to GROUP 16, Ignition System – On-vehicle Service – Ignition Coil Check [P.16-44](#).

**Q: Are there any abnormalities?**

**YES** : Replace the ignition coil. Then confirm that the malfunction symptom is eliminated.

**NO** : Go to Step 12.

---

**STEP 12. Check the compression pressure.**

Refer to GROUP 11A, On-vehicle Service – Compression Pressure Check [P.11A-18](#).

**Q: Is the compression pressure normal?**

**YES** : Go to Step 13.

**NO** : Repair it. Then confirm that the malfunction symptom is eliminated.

---

**STEP 13. Check the positive crankcase ventilation system.**

Refer to GROUP 17, Emission Control – Positive Crankcase Ventilation System – Positive Crankcase Ventilation System Check [P.17-74](#).

**Q: Is the positive crankcase ventilation system,?**

**YES** : Go to Step 14.

**NO** : Repair it. Then confirm that the malfunction symptom is eliminated.

---

**STEP 14. Check the evaporative emission control system.**

Refer to GROUP 17, Emission Control – Evaporative Emission Control System –Purge Control System Check (Purge Flow Check) [P.17-77](#).

**Q: Is the purge control system normal?**

**YES** : Go to Step 15.

**NO** : Repair it. Then confirm that the malfunction symptom is eliminated.

---

**STEP 15. Check the following items.**

(1) Check the following items.

- a. Check the injectors for fuel leakage.
- b. Check if the injectors are clogged.

**Q: Are there any abnormalities?**

**YES :** Replace it. Then confirm that the malfunction symptom is eliminated.

Then confirm that the malfunction symptom is eliminated.

**NO :** Replace the catalytic converter. Then confirm that the malfunction symptom is eliminated.

---

**Inspection procedure 19: Purge flow test of the evaporative emission canister failure**

---

**COMMENT**

- The test fails when the purge line or purge port is clogged or if the evaporative emission purge solenoid fails.

**TROUBLESHOOTING HINTS (The most likely causes for this case:)**

- Purge line or purge port is clogged.
- Malfunction of the evaporative emission purge solenoid.
- Evaporative emission canister is clogged.

**DIAGNOSIS**

**Required Special Tools:**

- MB991958: Scan Tool (M.U.T.-III Sub Assembly)
  - MB991824: V.C.I.
  - MB991827: USB Cable
  - MB991910: Main Harness A

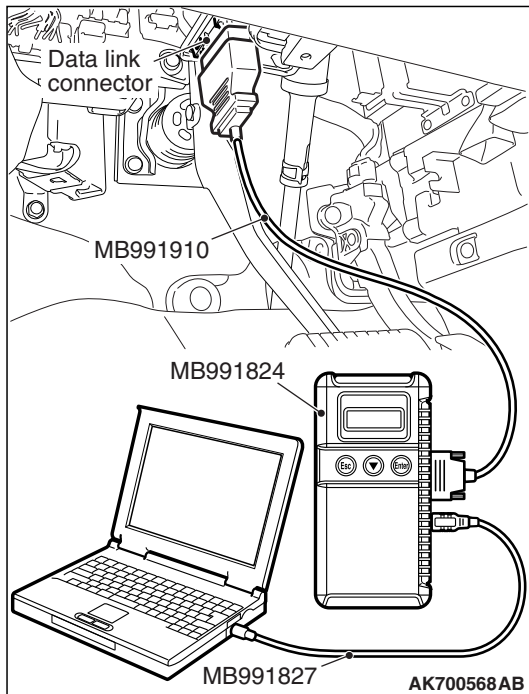

**STEP 1.** Using scan tool MB991958, read the diagnostic trouble code (DTC).

**⚠ CAUTION**

To prevent damage to scan tool MB991958, always turn the ignition switch to the "LOCK" (OFF) position before connecting or disconnecting scan tool MB991958.

- (1) Connect scan tool MB991958 to the data link connector.
- (2) Turn the ignition switch to the "ON" position.
- (3) Read the DTC.
- (4) Turn the ignition switch to the "LOCK" (OFF) position.

**Q: Is any DTC set?**

**YES :** Refer to Diagnostic Trouble Code Chart [P.13A-49](#).

**NO :** Refer to GROUP 17, Emission Control – Evaporative Emission Control System –Purge Control System Check (Purge Flow Check) [P.17-77](#).

## Inspection procedure 20: Pressure test of the evaporative system failure

### COMMENT

- The test fails if there is a leak from the fuel tank or vapor line.

### TROUBLESHOOTING HINTS (The most likely causes for this case:)

- Loose fuel tank filler tube cap.
- Broken seal in fuel tank, vapor line evaporative emission canister.

### DIAGNOSIS

**STEP 1. Check the evaporative emission purge solenoid.**

Refer to GROUP 17, Emission Control – Evaporative Emission Control System – Evaporative Emission Purge Solenoid Check [P.17-78](#).

**Q: Is the evaporative emission purge solenoid normal?**

**YES :** Go to Step 2.

**NO :** Repair or replace it. Then confirm that the malfunction symptom is eliminated.

**STEP 2. Check the evaporative emission ventilation solenoid.**

Refer to GROUP 17, Emission Control – Evaporative Emission Canister And Fuel Tank Pressure Relief Valve – Inspection P.17-88.

**Q: Is the evaporative emission ventilation solenoid normal?**

**YES :** Check the following items, and repair or replace the defective items.

- a. Check for leaks from the vapor line or evaporative emission canister.
- b. Check for leaks from the fuel tank.

Then confirm that the malfunction symptom is eliminated.

**NO :** Repair or replace it. Then confirm that the malfunction symptom is eliminated.

**Inspection procedure 21: Generator output voltage is low (approximately 12.3 volts).**

**GENERATOR CIRCUIT**

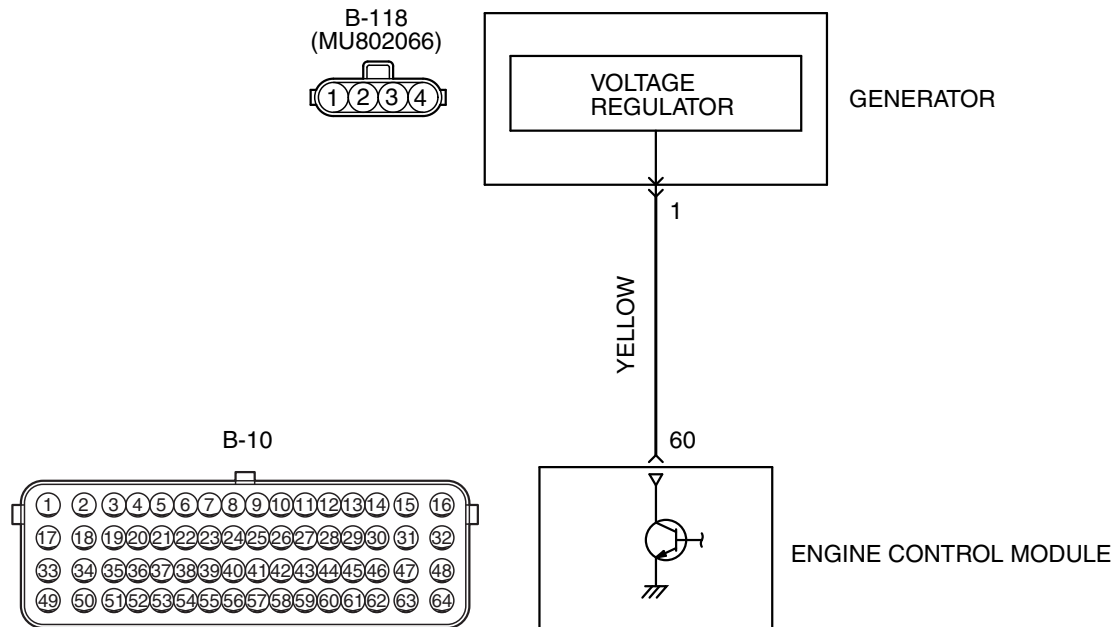

AK704301AB

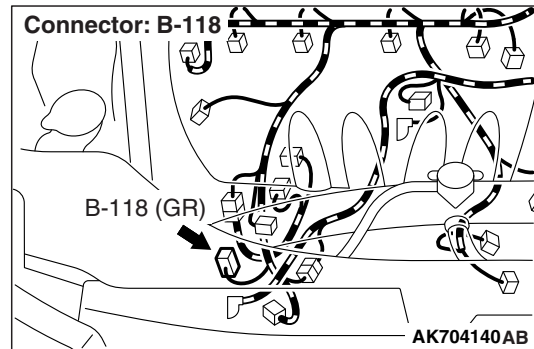
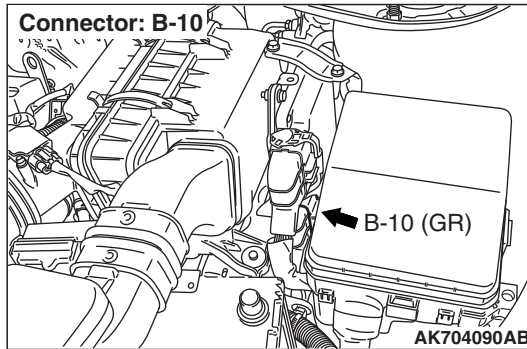

### CIRCUIT OPERATION

- The ECM controls generator output current by duty-controlling continuity between the generator G terminal (terminal No. 1) and ground.

### TROUBLESHOOTING HINTS (The most likely causes for this charging system:)

- Malfunction of the charging system.
- Short circuit in harness between generator G terminal and ECM.
- Malfunction of the ECM.

### DIAGNOSIS

#### Required Special Tool:

- MB991923: Power Train ECU Check Harness



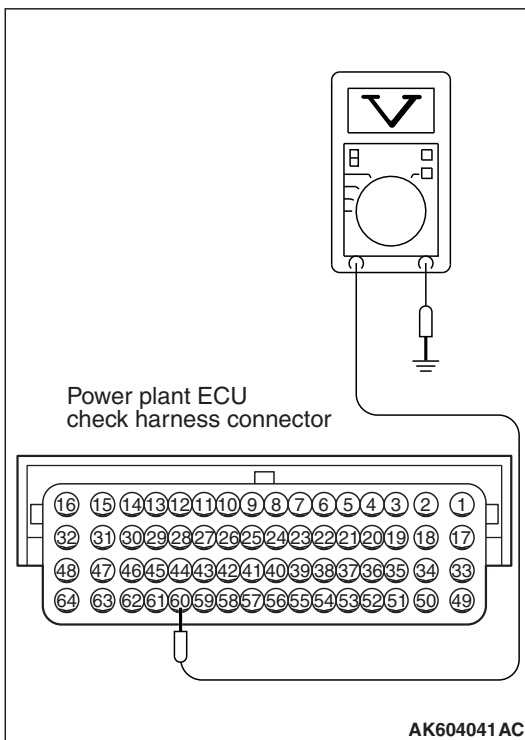
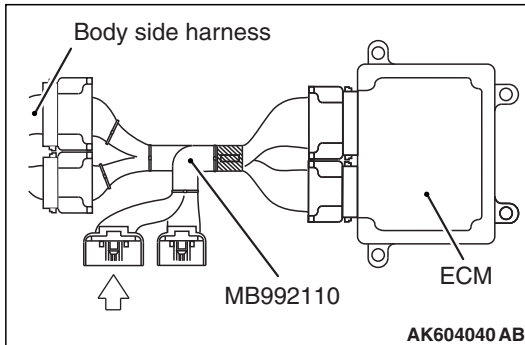

**STEP 1. Measure the voltage at ECM connector B-10 by using power plant ECU check harness special tool MB992110.**

- (1) Disconnect all ECM connectors. Connect the power plant ECU check harness special tool MB992110 between the separated connectors.
- (2) Start the engine and run at idle.

- (3) Measure the voltage between terminal No. 60 and ground.  
*NOTE: Vehicle for Canada, the headlight, taillight, etc. remain lit even when the lighting switch is in "OFF" position but this is no problem for checks.*

- a. Engine: warming up, idling
- b. Radiator fan: stopped
- c. Headlight: OFF to ON
- d. Stop light: OFF to ON
- e. Rear defogger switch: OFF to ON
  - Voltage increases

- (4) Turn the ignition switch to the "LOCK" (OFF) position.

**Q: Is the measured voltage within the specified range?**

**YES :** Go to Step 2.

**NO :** Replace the generator. Then confirm that the malfunction symptom is eliminated.

**STEP 2. Check harness connector B-10 at ECM connector and harness connector B-118 at generator connector for damage.**

**Q: Is the harness connector in good condition?**

**YES :** Go to Step 3.

**NO :** Repair or replace it. Refer to GROUP 00E, Harness Connector Inspection P.00E-2. Then confirm that the malfunction symptom is eliminated.

**STEP 3. Check for short circuit to ground between generator connector B-118 (terminal No. 1) and ECM connector B-10 (terminal No. 60).**

**Q: Is the harness wire in good condition?**

**YES :** Replace the ECM. When the ECM is replaced, register the ID code. Refer to GROUP 42B, Diagnosis – ID Code Registration Judgment Table <Vehicles with KOS> [P.42B-15](#) or GROUP 42C, Diagnosis – ID Codes Registration Judgment Table <Vehicles with WCM> [P.42C-10](#).

**NO :** Repair it. Then confirm that the malfunction symptom is eliminated.

Inspection procedure 22: Power supply system and ignition switch-IG system

POWER SUPPLY AND IGNITION SWITCH-IG CIRCUIT

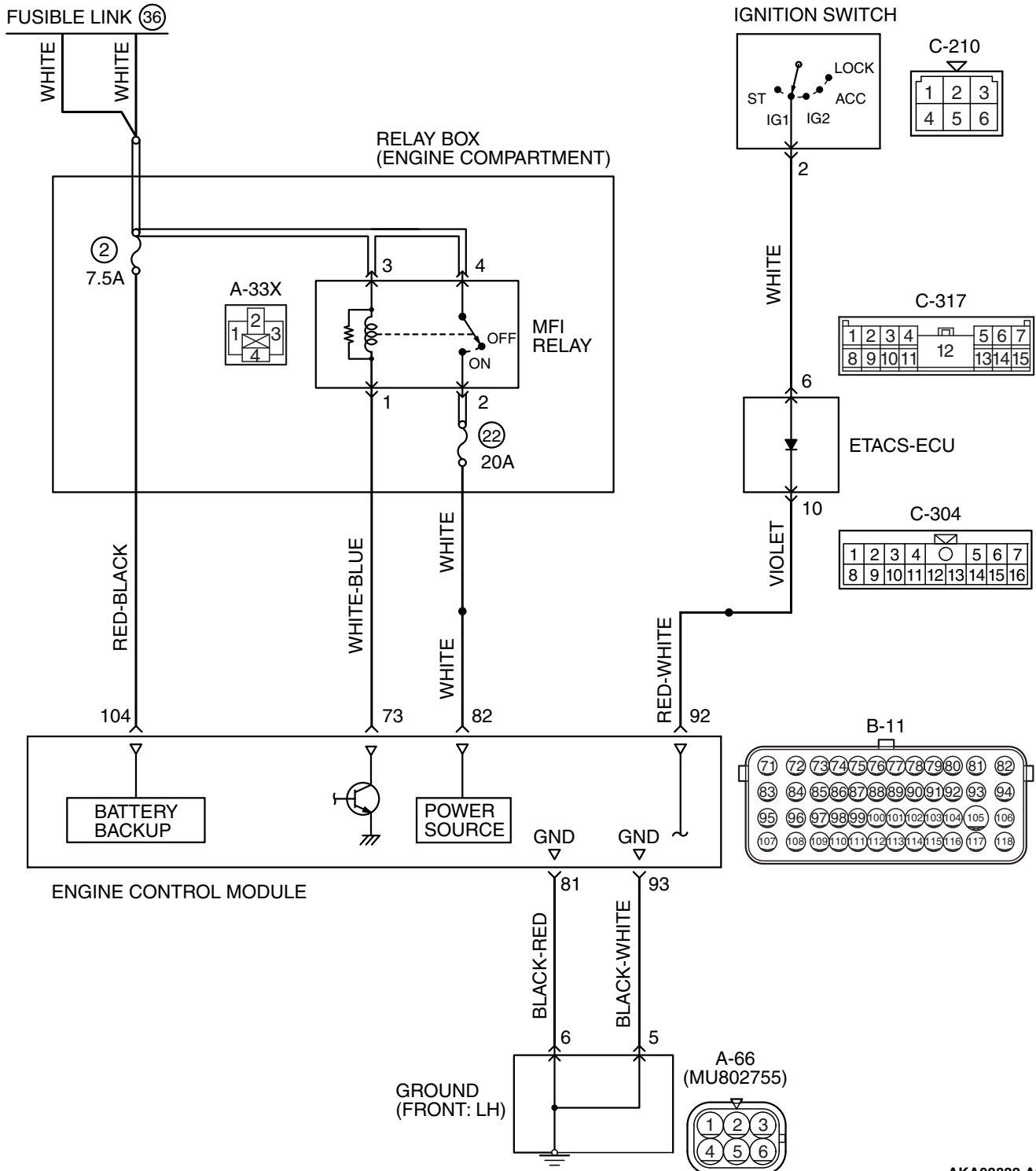

AKA00832 AC

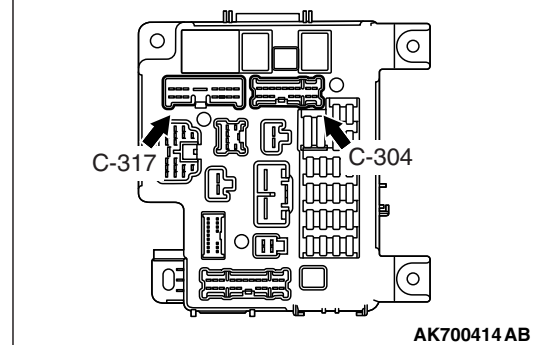
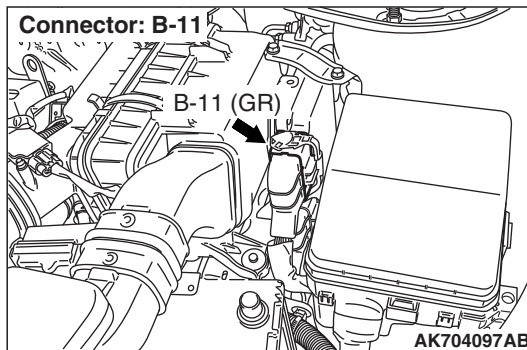
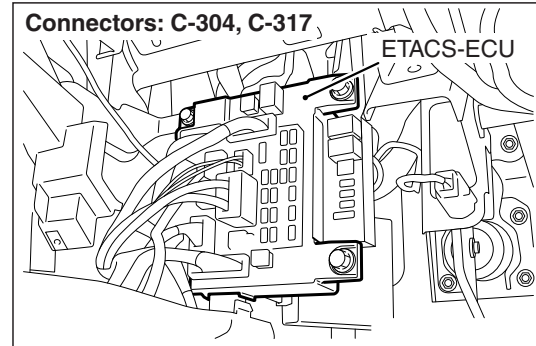
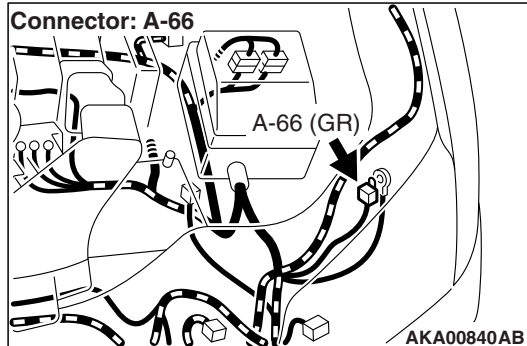
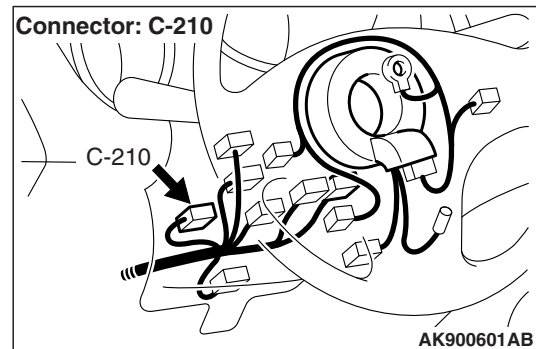
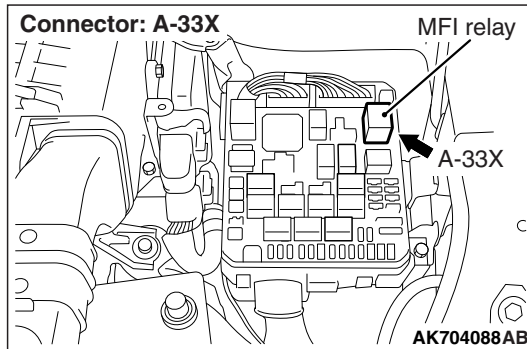

## CIRCUIT OPERATION

- Battery positive voltage is applied to the MFI relay (terminals No. 3, No. 4).
- When the ignition switch is turned to the "ON" position, battery positive voltage is applied to the ECM (terminal No. 92). When battery positive voltage is applied, the ECM turns the power transistor in the ECM "ON" and grounds the MFI relay coil. With this, the MFI relay turns "ON" the battery positive voltage is supplied to the ECM (terminals No. 82) from the MFI relay (terminal No. 2).
- A battery positive voltage is constantly supplied to the ECM (terminal No. 104) as the backup power.
- The ECM (terminals No. 81, No. 93) is grounded to the vehicle body.

## COMMENT

- When the ignition switch "ON" signal is input into the ECM via ETACS-ECU, the ECM turns "ON" the MFI relay. This causes battery positive voltage to be supplied to the ECM, sensor and actuator.

## TROUBLESHOOTING HINTS (The most likely causes for this code to be set are:)

- Malfunction of the ignition switch.
- Malfunction of the MFI relay.
- Open or shorted power supply and ignition Switch-IG circuit, harness damage, or connector damage.
- Malfunction of the ECM.

## DIAGNOSIS

**STEP 1. Check harness connector A-33X at MFI relay for damage.**

**Q: Is the connector in good condition?**

**YES :** Go to Step 2.

**NO :** Repair or replace it. Refer to GROUP 00E, Harness Connector Inspection P.00E-2. Then confirm that the malfunction symptom is eliminated.

**STEP 2. Check the MFI relay.**

(1) Remove the MFI relay.

(2) Check for continuity between the MFI relay terminals No. 1 and No. 3.

- There should be continuity.

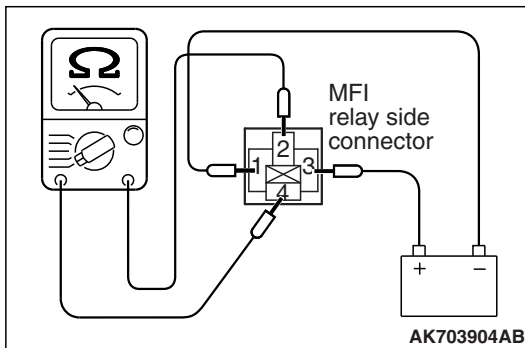
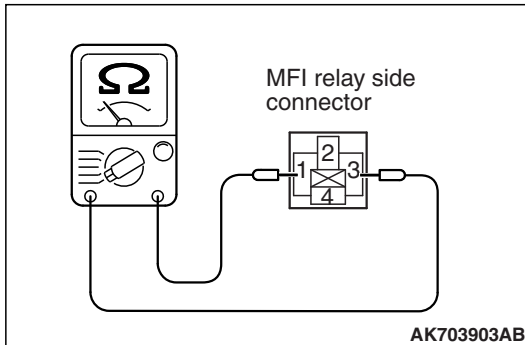

(3) Use jumper wires to connect MFI relay terminal No. 3 to the positive battery terminal and terminal No. 1 to the negative battery terminal.

(4) Check for continuity between the MFI relay terminals No. 4 and No. 2 while connecting and disconnecting the jumper wire at the negative battery terminal.

- Continuity (2  $\Omega$  or less) <Negative battery terminal connected>
- Should be open loop. <Negative battery terminal disconnected>

(5) Install the MFI relay.

**Q: Is the measured resistance within the specified range?**

**YES :** Go to Step 3.

**NO :** Replace the MFI relay. Then confirm that the malfunction symptom is eliminated.

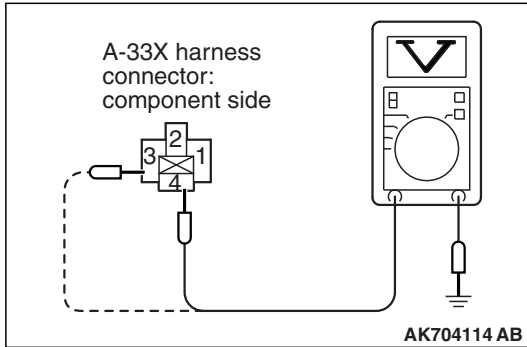

**STEP 3. Measure the power supply voltage at MFI relay harness side connector A-33X.**

- (1) Disconnect the connector A-33X and measure at the harness side.
- (2) Measure the voltage between terminals No. 3, No. 4 and ground.
  - Voltage should be battery positive voltage.

**Q: Is battery positive voltage (approximately 12 volts) present?**

**YES :** Go to Step 4.

**NO :** Repair harness wire between fusible link (36) and MFI relay connector A-33X (terminals No. 3, No. 4) because of open circuit or short circuit to ground. Then confirm that the malfunction symptom is eliminated.

**STEP 4. Check harness connector B-11 at ECM for damage.**

**Q: Is the harness connector in good condition?**

**YES :** Go to Step 5.

**NO :** Repair or replace it. Refer to GROUP 00E, Harness Connector Inspection P.00E-2. Then confirm that the malfunction symptom is eliminated.

**STEP 5. Measure the ignition switch-IG signal voltage at ECM harness side connector B-11.**

- (1) Disconnect the connector B-11 and measure at the harness side.
- (2) Turn the ignition switch to the "ON" position.
- (3) Measure the voltage between terminal No. 92 and ground.
  - Voltage should be battery positive voltage.
- (4) Turn the ignition switch to the "LOCK" (OFF) position.

**Q: Is battery positive voltage (approximately 12 volts) present?**

**YES :** Go to Step 11.

**NO :** Go to Step 6.

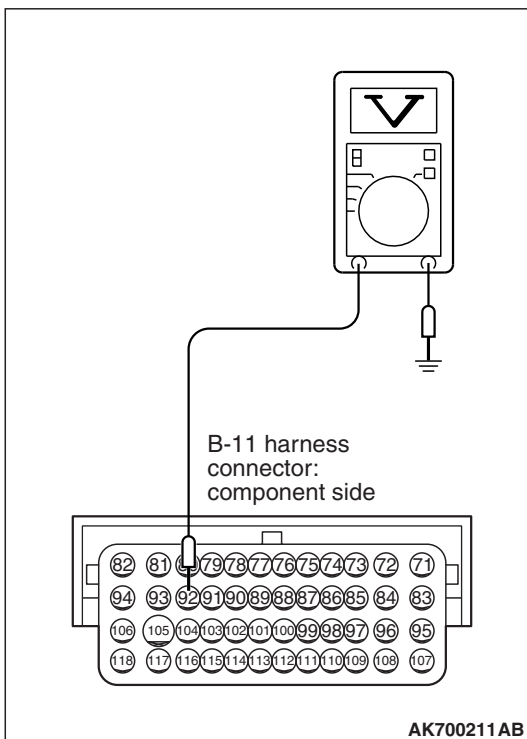

---

**STEP 6. Check harness connector C-304, C-317 at ETACS-ECU connector for damage.**

**Q: Is the connector in good condition?**

**YES :** Go to Step 7.

**NO :** Repair or replace it. Refer to GROUP 00E, Harness Connector Inspection [P.00E-2](#). Then confirm that the malfunction symptom is eliminated.

---

**STEP 7. Measure the ignition switch-IG signal voltage at ETACS-ECU harness side connector C-317.**

- (1) Disconnect the connector C-317 and measure at the harness side.
- (2) Turn the ignition switch to the "ON" position.
- (3) Measure the voltage between terminal No. 6 and ground.
  - Voltage should be battery positive voltage
- (4) Turn the ignition switch to the "LOCK" (OFF) position.

**Q: Is battery positive voltage (approximately 12 volts) present?**

**YES :** Go to Step 10.

**NO :** Go to Step 8.

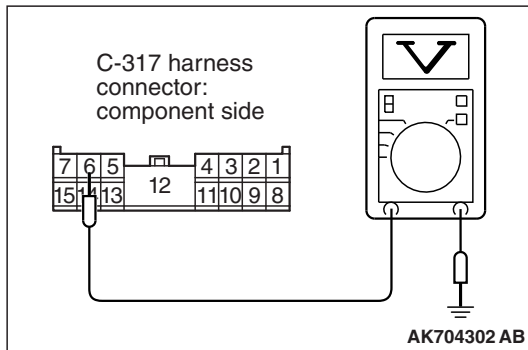

---

**STEP 8. Check harness connector C-210 ignition switch connector for damage.**

**Q: Is the connector in good condition?**

**YES :** Go to Step 9.

**NO :** Repair or replace it. Refer to GROUP 00E, Harness Connector Inspection [P.00E-2](#). Then confirm that the malfunction symptom is eliminated.

---

**STEP 9. Check the ignition switch**

Refer to GROUP 54A, Ignition Switch – Inspection – Ignition Switch Continuity Check [P.54A-26](#).

**Q: Are there any abnormalities?**

**YES :** Replace the Ignition Switch. Then confirm that the malfunction symptom is eliminated.

**NO :** Repair harness wire between Ignition Switch connector C-210 (terminal No. 2) and ETACS-ECU connector C-317 (terminal No. 6) because of open circuit or short circuit to ground. Then confirm that the malfunction symptom is eliminated.

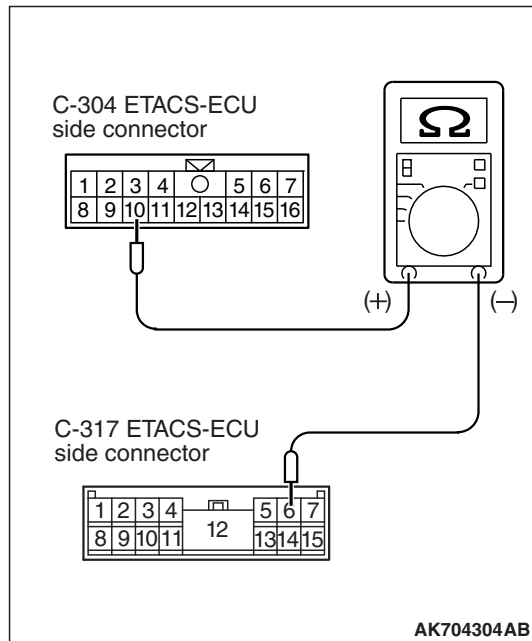

---

**STEP 10. Check for continuity at ETACS-ECU side connector C-304 and C-317.**

- (1) Disconnect the connector C-304, C-317 and measure at the ETACS-ECU side.
- (2) Measure the resistance between connector C-304 (terminal No. 10) and connector C-317 (terminal No. 6).

*NOTE: Connect the (+) side of circuit tester to connector C-304 (terminal No. 10).*

- Should be less than 2 ohms

**Q: Is the harness wire in good condition?**

**YES :** Repair harness wire between ETACS-ECU connector C-304 (terminal No. 10) and ECM connector B-11 (terminal No. 92) because of open circuit or short circuit to ground. Then confirm that the malfunction symptom is eliminated.

**NO :** Replace the ETACS-ECU. Then confirm that the malfunction symptom is eliminated.

---

**STEP 11. Check harness connector C-304, C-317 at ETACS-ECU connector for damage.**
**Q: Is the connector in good condition?**

**YES :** Go to Step 12.

**NO :** Repair or replace it. Refer to GROUP 00E, Harness Connector Inspection [P.00E-2](#). Then confirm that the malfunction symptom is eliminated.



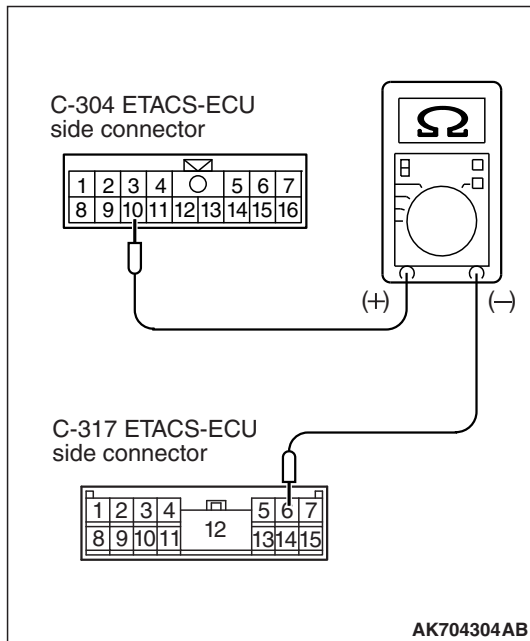

**STEP 12. Check for continuity at ETACS-ECU side connector C-304 and C-317.**

- (1) Disconnect the connector C-304, C-317 and measure at the ETACS-ECU side.
- (2) Measure the resistance between connector C-304 (terminal No. 10) and connector C-317 (terminal No. 6).

*NOTE: Connect the (+) side of circuit tester to connector C-304 (terminal No. 10).*

- Should be less than 2 ohms

**Q: Is the harness wire in good condition?**

**YES :** Go to Step 13.

**NO :** Repair or replace it. Refer to GROUP 00E, Harness Connector Inspection [P.00E-2](#).

**STEP 13. Check harness connector C-210 ignition switch connector for damage.**

**Q: Is the connector in good condition?**

**YES :** Go to Step 14.

**NO :** Repair or replace it. Refer to GROUP 00E, Harness Connector Inspection [P.00E-2](#). Then confirm that the malfunction symptom is eliminated.

**STEP 14. Check for harness damage between ignition switch connector C-210 (terminal No. 2) and ETACS-ECU connector C-317 (terminal No. 6).**

**Q: Is the harness wire in good condition?**

**YES :** Go to Step 15.

**NO :** Repair it. Then confirm that the malfunction symptom is eliminated.

**STEP 15. Check for harness damage between ETACS-ECU connector C-304 (terminal No. 10) and ECM connector B-11 (terminal No. 92).**

**Q: Is the harness wire in good condition?**

**YES :** Go to Step 16.

**NO :** Repair it. Then confirm that the malfunction symptom is eliminated.

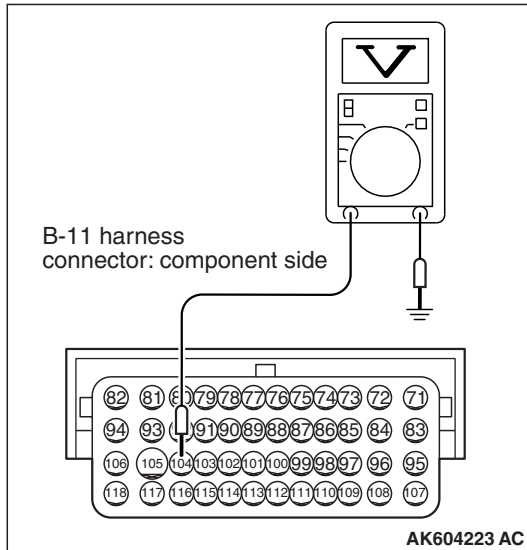

**STEP 16. Measure the backup power supply voltage at ECM harness side connector B-11.**

- (1) Disconnect the connector B-11 and measure at the harness side.
- (2) Measure the voltage between terminal No. 104 and ground.
  - Voltage should be battery positive voltage.

**Q: Is battery positive voltage (approximately 12 volts) present?**

**YES :** Go to Step 17.

**NO :** Repair harness wire between fusible link (36) and ECM connector B-11 (terminal No. 104) because of short circuit to ground. Then confirm that the malfunction symptom is eliminated.

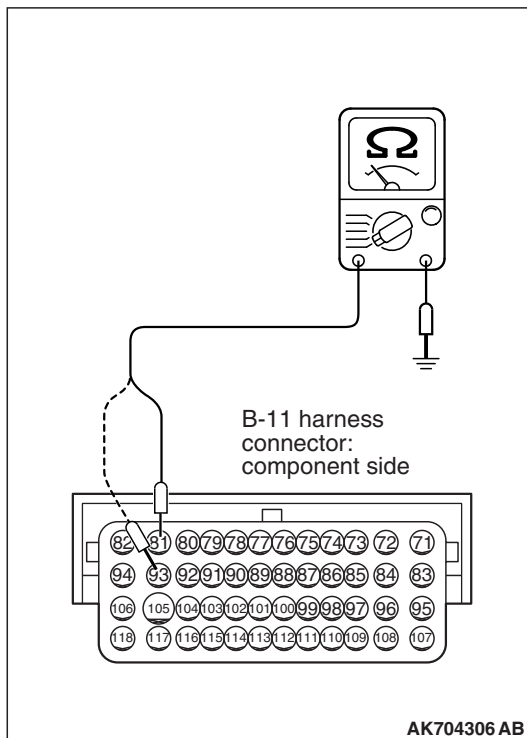

**STEP 17. Check for continuity at ECM harness side connector B-11.**

- (1) Disconnect the connector B-11 and measure at the harness side.
- (2) Check for the continuity between terminals (No. 81, No. 93) and ground.
  - Continuity ( $2 \Omega$  or less)

**Q: Does continuity exist?**

**YES :** Go to Step 18.

**NO :** Check harness connector A-66 at intermediate connector for damage, and repair or replace as required. Refer to GROUP 00E, Harness Connector Inspection [P.00E-2](#). If intermediate connector is in good condition, repair harness wire between ECM connector B-11 (terminal No. 81, No. 93) and ground because of open circuit or harness damage. Then confirm that the malfunction symptom is eliminated.

**STEP 18. Measure the power supply voltage at ECM harness side connector B-11.**

- (1) Disconnect the connector B-11 and measure at the harness side.
- (2) Measure the voltage between terminal No. 73 and ground.
  - Voltage should be battery positive voltage.

**Q: Is battery positive voltage (approximately 12 volts) present?**

**YES :** Go to Step 19.

**NO :** Repair harness wire between MFI relay connector A-33X (terminal No. 1) and ECM connector B-11 (terminal No. 73) because of open circuit. Then confirm that the malfunction symptom is eliminated.

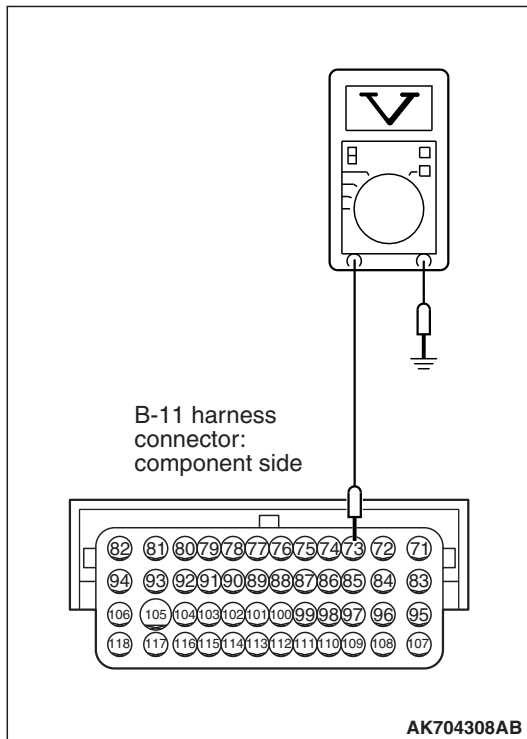

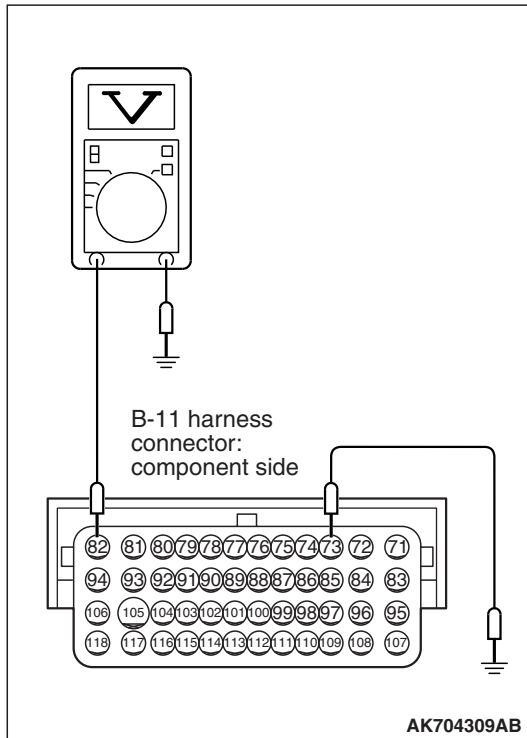

---

**STEP 19. Measure the power supply voltage at ECM harness side connector B-11.**

- (1) Disconnect the connector B-11 and measure at the harness side.
- (2) Using a jumper wire, connect terminal No. 73 to ground.
- (3) Measure the voltage between terminal No. 82 and ground.
  - Voltage should be battery positive voltage.

**Q: Is battery positive voltage (approximately 12 volts) present?**

**YES :** Go to Step 22.

**NO :** Go to Step 20.

---

**STEP 20. Check for open circuit and short circuit to ground between MFI relay connector A-33X (terminal No. 2) and ECM connector B-11 (terminal No. 82).**

**Q: Is the harness wire in good condition?**

**YES :** Go to Step 21.

**NO :** Repair it. Then confirm that the malfunction symptom is eliminated.

---

**STEP 21. Check for harness damage between fusible link (36) and MFI relay connector A-33X (terminal No. 3, No. 4).**

**Q: Is the harness wire in good condition?**

**YES :** Repair harness wire between MFI relay connector A-33X (terminal No. 1) and ECM connector (terminal No. 73) because of harness damage. Then confirm that the malfunction symptom is eliminated.

**NO :** Repair it. Then confirm that the malfunction symptom is eliminated.

---

**STEP 22. Check for harness damage between MFI relay connector A-33X (terminal No. 2) and ECM connector B-11 (terminal No. 82).**

**Q: Is the harness wire in good condition?**

**YES :** Replace the ECM. When the ECM is replaced, register the ID code. Refer to GROUP 42B, Diagnosis – ID Code Registration Judgment Table <Vehicles with KOS> [P.42B-15](#) or GROUP 42C, Diagnosis – ID Codes Registration Judgment Table <Vehicles with WCM> [P.42C-10](#). Then confirm that the malfunction symptom is eliminated.

**NO :** Repair it. Then confirm that the malfunction symptom is eliminated.

Inspection procedure 23: Fuel pump system

FUEL PUMP CIRCUIT

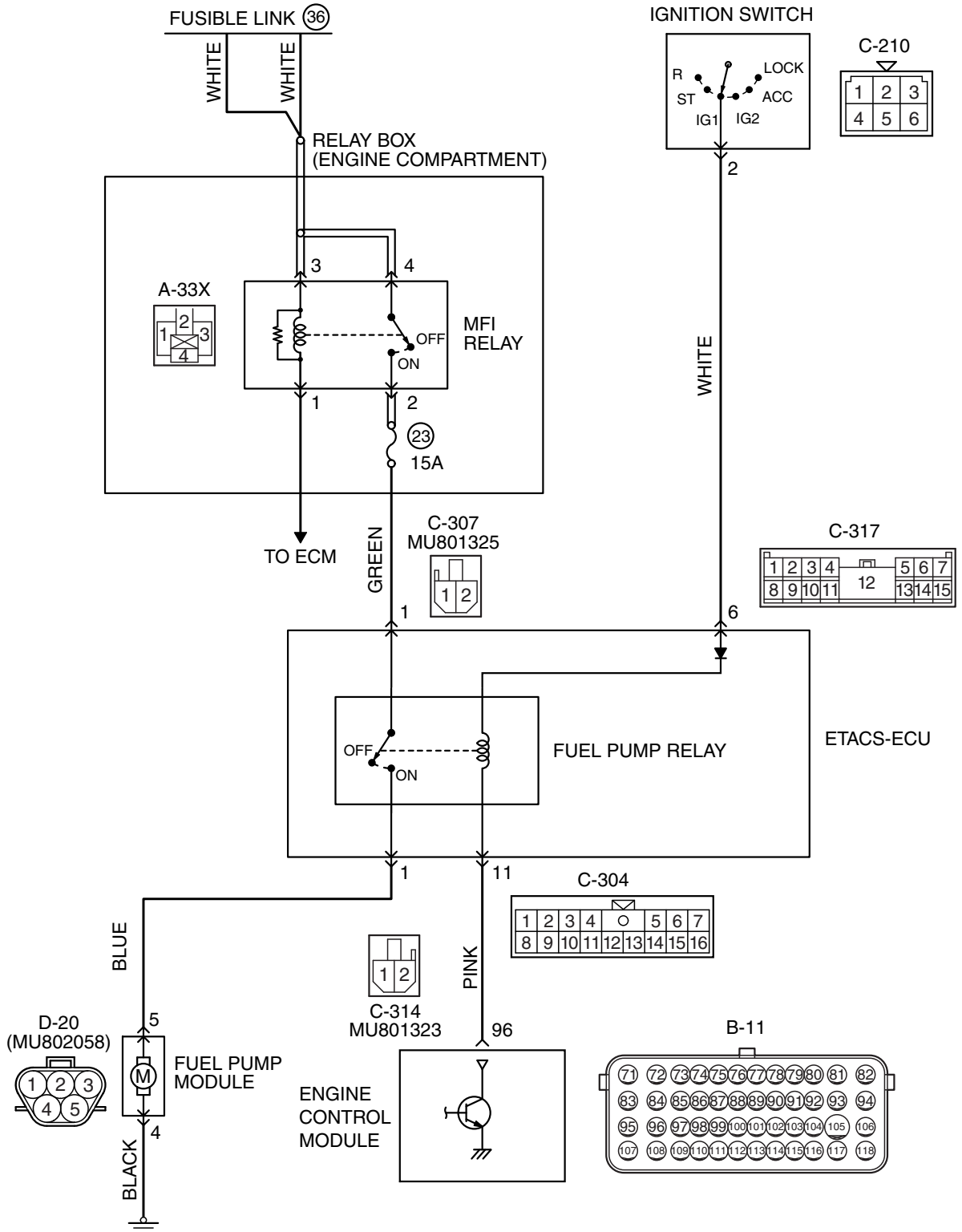

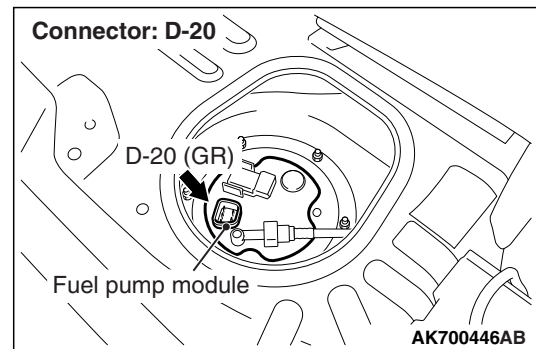
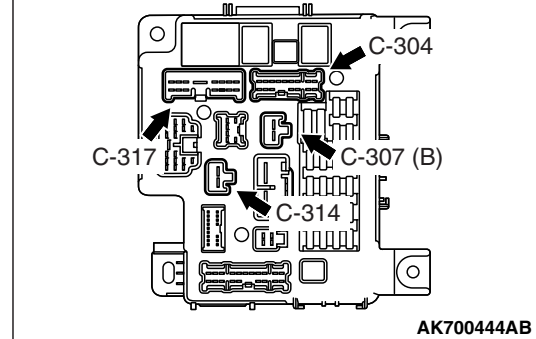
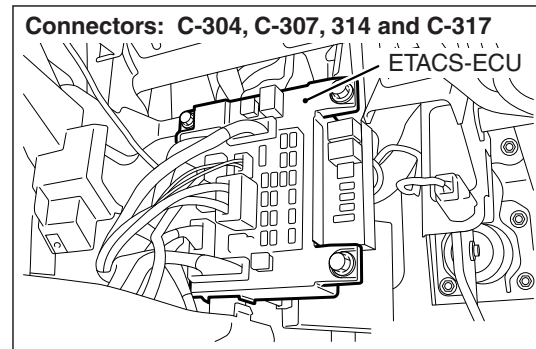
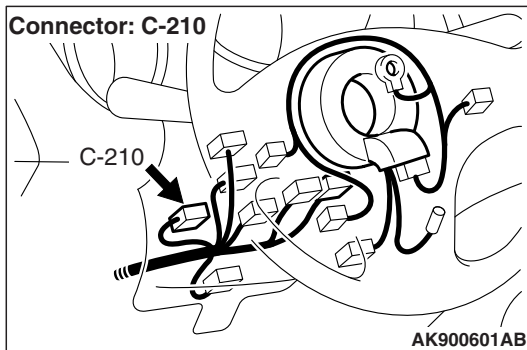
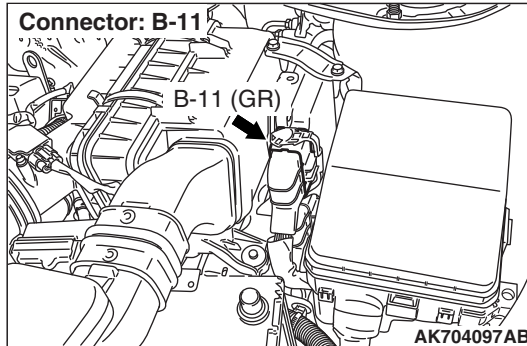
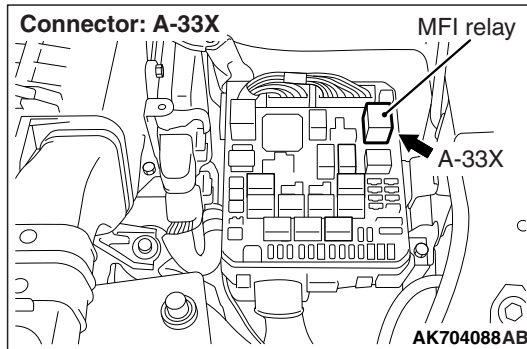

## CIRCUIT OPERATION

- The fuel pump drive power is supplied from MFI relay (terminal No. 2) to fuel pump relay (C-307 ETACS-ECU connector terminal No. 1) in the ETACS-ECU.
- The battery positive voltage is applied by the ignition switch to the fuel pump coil (C-317 ETACS-ECU connector terminal No. 6) in the ETACS-ECU. The ECM turns "ON" the relay by turning "ON" the power transistor in the unit so as to conduct power to the fuel pump relay coil (via the C-304 ETACS-ECU connector terminal No. 11).
- When the fuel pump relay is turned "ON", the battery positive voltage will be supplied from the fuel pump relay (C-314 ETACS-ECU connector terminal No. 5) to the fuel pump.

## COMMENT

- When the ignition switch ON signal is inputted into the ECM, the ECM turns ON the fuel pump relay. This causes the battery voltage to be supplied to the fuel pump.

## TROUBLESHOOTING HINTS (The most likely causes for this code to be set are:)

- Malfunction of the fuel pump relay.
- Malfunction of the fuel pump.
- Open or shorted fuel pump circuit, harness damage, or connector damage.
- Malfunction of the ECM.

**DIAGNOSIS****Required Special Tools:**

- MB991958: Scan Tool (M.U.T.-III Sub Assembly)
  - MB991824: V.C.I.
  - MB991827: USB Cable
  - MB991910: Main Harness A

**STEP 1. Using scan tool MB991958, check actuator test item 9: Fuel Pump.****⚠ CAUTION**

To prevent damage to scan tool MB991958, always turn the ignition switch to the "LOCK" (OFF) position before connecting or disconnecting scan tool MB991958.

- (1) Connect scan tool MB991958 to the data link connector.
- (2) Turn the ignition switch to the "ON" position.
- (3) Set scan tool MB991958 to the actuator test mode for item 9, Fuel Pump.
  - An operation sound of the fuel pump should be heard.
- (4) Turn the ignition switch to the "LOCK" (OFF) position.

**Q: Is the fuel pump operating properly?**

**YES :** That this malfunction is intermittent. Refer to GROUP 00, How to Use Troubleshooting/Inspection Service Points – How to Cope with Intermittent Malfunctions [P.00-15](#).

**NO :** Go to Step 2.

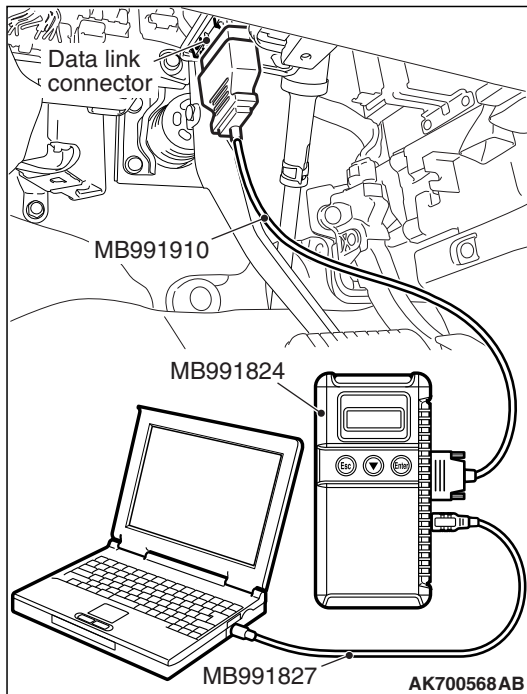
**STEP 2. Check harness connector C-304, C-307, C-314 and C-317 at ETACS-ECU for damage.****Q: Is the harness connector in good condition?**

**YES :** Go to Step 3.

**NO :** Repair or replace it. Refer to GROUP 00E, Harness Connector Inspection [P.00E-2](#). Then confirm that the malfunction symptom is eliminated.



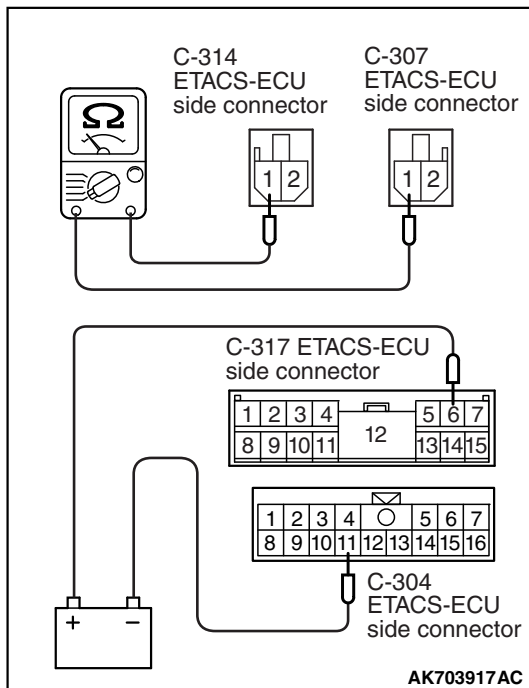

**STEP 3. Check the fuel pump relay.**

- (1) Remove the ETACS-ECU.
- (2) Use jumper wires to connect C-317 ETACS-ECU terminal No. 6 to the positive battery terminal and C-304 ETACS-ECU terminal No. 11 to the negative battery terminal.
- (3) Check for continuity between the C-307 ETACS-ECU terminal No. 1 and C-314 ETACS-ECU terminal No. 1 while connecting and disconnecting the jumper wire at the negative battery terminal.
  - Continuity (2 Ω or less) <Negative battery terminal connected>
  - Should be open loop. <Negative battery terminal disconnected>
- (4) Install the ETACS-ECU.

**Q: Is the measured resistance normal?**

**YES :** Go to Step 4.

**NO :** Replace the ETACS-ECU. Then confirm that the malfunction symptom is eliminated.

**STEP 4. Check harness connector B-11 at ECM connector for damage.**

**Q: Is the connector in good condition?**

**YES :** Go to Step 5.

**NO :** Repair or replace it. Refer to GROUP 00E, Harness Connector Inspection [P.00E-2](#). Then confirm that the malfunction symptom is eliminated.

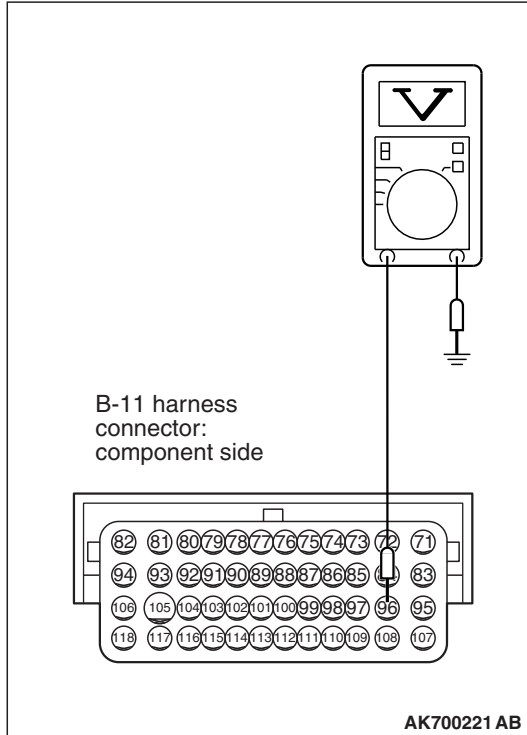
**STEP 5. Measure the power supply voltage at ECM connector B-11.**

- (1) Disconnect the connector B-11 and measure at the harness side.
- (2) Turn the ignition switch to the "ON" position.
- (3) Measure the voltage between terminal No. 96 and ground.
  - Voltage should be battery positive voltage.
- (4) Turn the ignition switch to the "LOCK" (OFF) position.

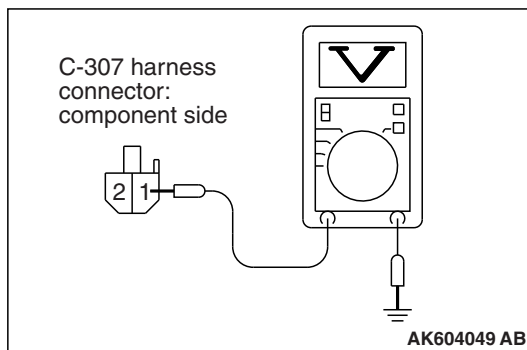
**Q: Is battery positive voltage (approximately 12 volts) present?****YES :** Go to Step 6.**NO :** Repair harness wire between ETACS-ECU connector C-304 (terminal No. 11) and ECM connector B-11 (terminal No. 96) because of open circuit or short circuit to ground. Then confirm that the malfunction symptom is eliminated.**STEP 6. Measure the power supply voltage at ETACS-ECU connector C-307.**

- (1) Disconnect the connector C-307 and measure at the harness side.
- (2) Turn the ignition switch to the "ON" position.
- (3) Measure the voltage between terminal No. 1 and ground.
  - Voltage should be battery positive voltage.
- (4) Turn the ignition switch to the "LOCK" (OFF) position.

**Q: Is battery positive voltage (approximately 12 volts) present?****YES :** Go to Step 8.**NO :** Go to Step 7.

**STEP 7. Check harness connector A-33X at MFI relay connector for damage.**

**Q: Is the connector in good condition?**

**YES :** Repair harness wire between MFI relay connector A-33X (terminal No. 2) and ETACS-ECU connector C-307 (terminal No. 1) because of open circuit or short circuit to ground. Then confirm that the malfunction symptom is eliminated.

**NO :** Repair or replace it. Refer to GROUP 00E, Harness Connector Inspection P.00E-2. Then confirm that the malfunction symptom is eliminated.

**STEP 8. Check harness connector D-20 at fuel pump connector for damage.**

**Q: Is the connector in good condition?**

**YES :** Go to Step 9.

**NO :** Repair or replace it. Refer to GROUP 00E, Harness Connector Inspection P.00E-2. Then confirm that the malfunction symptom is eliminated.

**STEP 9. Check the fuel pump operation.**

- (1) Disconnect fuel pump connector D-20.
- (2) Use jumper wires to connect fuel pump connector terminal No. 5 to the positive battery terminal and terminal No. 4 to the negative battery terminal.
  - An operating sound of the fuel pump should be heard.

**Q: Is the fuel pump operating properly?**

**YES :** Go to Step 10.

**NO :** Replace the fuel pump. Then confirm that the malfunction symptom is eliminated.

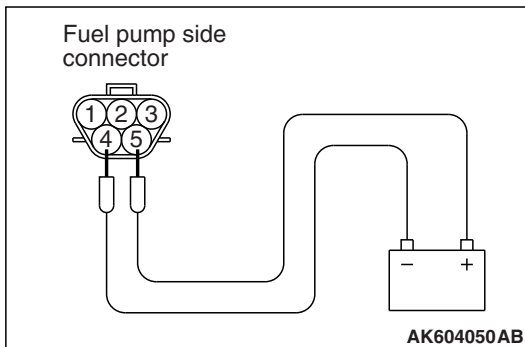

**STEP 10. Check for continuity at fuel pump harness side connector D-20.**

- (1) Disconnect the connector D-20 and measure at the harness side.
- (2) Check for the continuity between terminal No. 4 and ground.
  - Should be less than 2 ohms.

**Q: Does continuity exist?**

**YES :** Go to Step 11.

**NO :** Repair harness wire between fuel pump connector D-20 (terminal No. 4) and ground because of open circuit or harness damage. Then confirm that the malfunction symptom is eliminated.

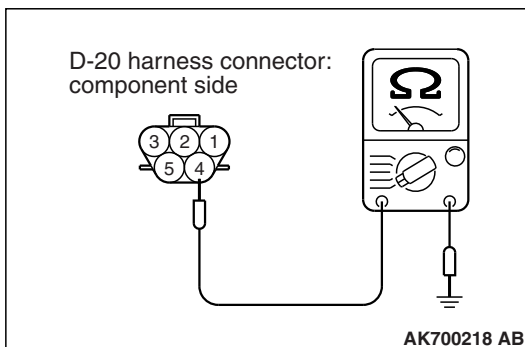

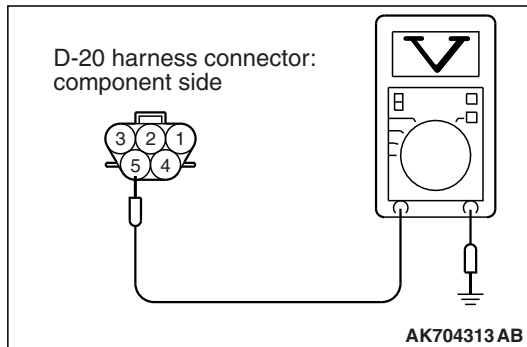
**STEP 11. Measure the power supply voltage at fuel pump connector D-20.**

- (1) Disconnect the connector D-20 and measure at the harness side.
- (2) Turn the ignition switch to the "ON" position.
- (3) Measure the voltage between terminal No. 5 and ground.
  - Voltage should be battery positive voltage.
- (4) Turn the ignition switch to the "LOCK" (OFF) position.

**Q: Is battery positive voltage (approximately 12 volts) present?****YES** : Go to Step 13.**NO** : Go to Step 12.**STEP 12. Check for harness damage between ETACS-ECU connector C-304 (terminal No. 11) and ECM connector B-11 (terminal No. 96)****Q: Is the harness wire in good condition?**

**YES** : Replace the ECM. When the ECM is replaced, register the ID code. Refer to GROUP 42B, Diagnosis – ID Code Registration Judgment Table <Vehicles with KOS> [P.42B-15](#) or GROUP 42C, Diagnosis – ID Codes Registration Judgment Table <Vehicles with WCM> [P.42C-10](#). Then confirm that the malfunction symptom is eliminated.

**NO** : Repair it. Then confirm that the malfunction symptom is eliminated.

**STEP 13. Check harness connector A-33X at MFI relay connector for damage.****Q: Is the connector in good condition?****YES** : Go to Step 14.

**NO** : Repair or replace it. Refer to GROUP 00E, Harness Connector Inspection [P.00E-2](#). Then confirm that the malfunction symptom is eliminated.

**STEP 14. Check for harness damage between MFI relay connector A-33X (terminal No. 2) and ETACS-ECU connector C-307 (terminal No. 1).****Q: Is the harness wire in good condition?**

**YES** : Repair harness wire between ETACS-ECU connector C-314 (terminal No. 1) and fuel pump connector (terminal No. 5) because of harness damage. Then confirm that the malfunction symptom is eliminated.

**NO** : Repair it. Then confirm that the malfunction symptom is eliminated.

Inspection procedure 24: Ignition switch-ST system and starter relay system

STARTING SYSTEM CIRCUIT

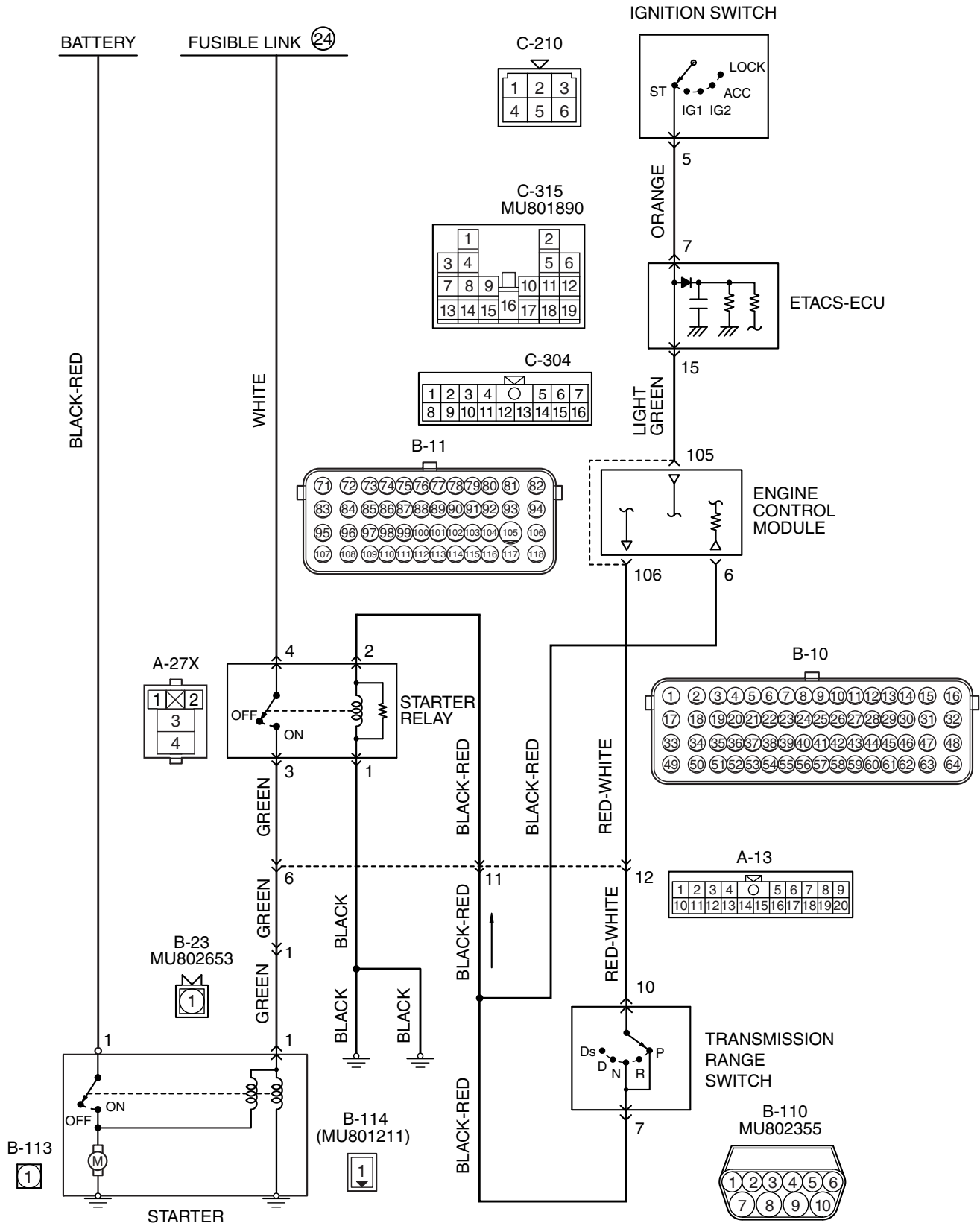

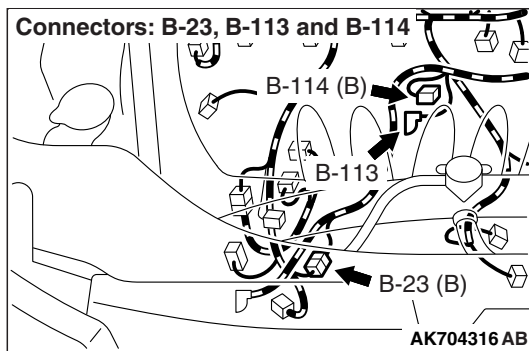
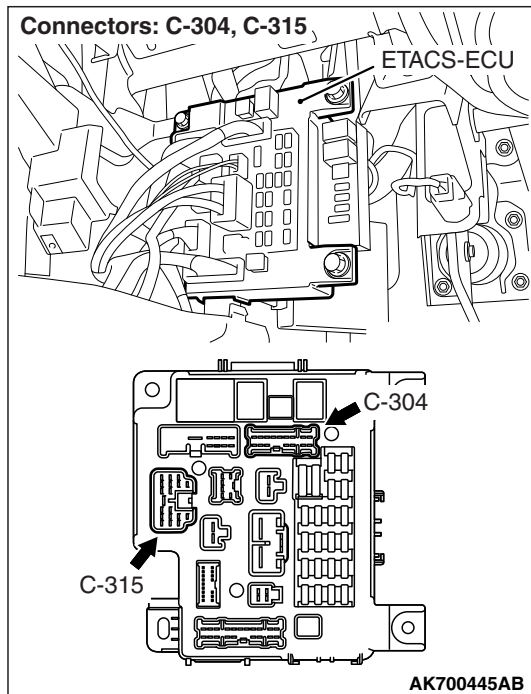
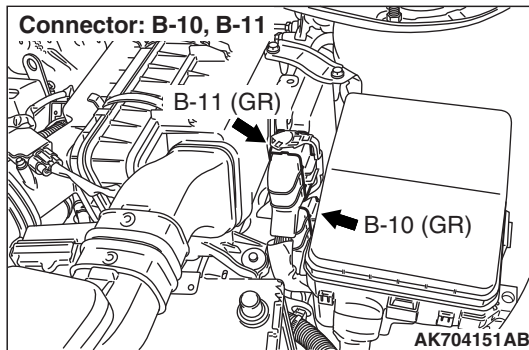
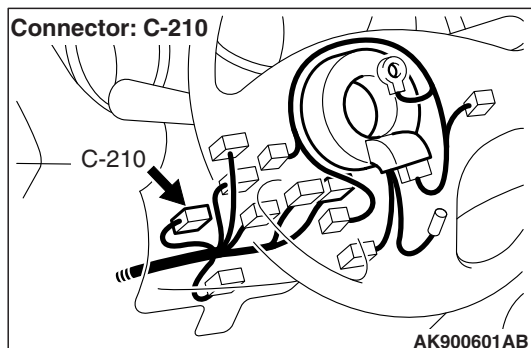
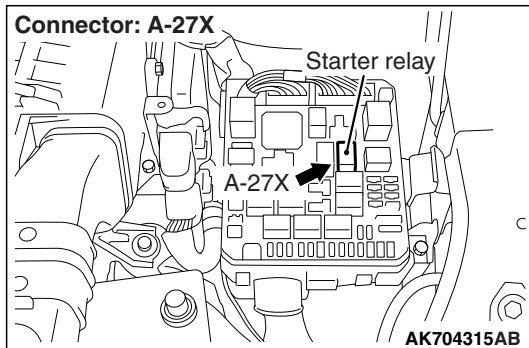
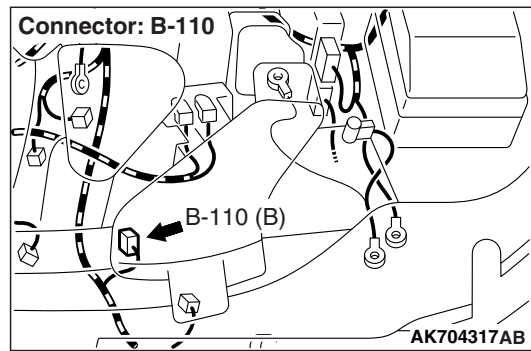
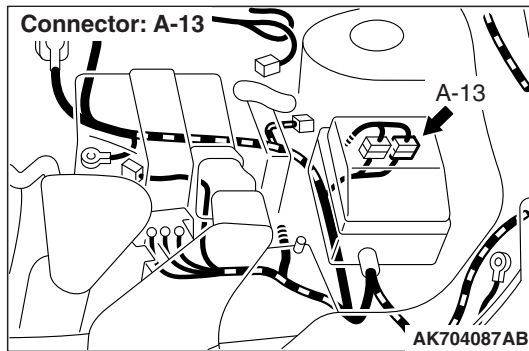

**CIRCUIT OPERATION**

- If the selector lever is moved to "P" or "N" range and the ignition switch is turned to "START" position, battery positive voltage is supplied to starter relay coil. With this, the starter relay turns "ON" the battery positive voltage is supplied to the starter motor (terminal No. 1) from the battery.

**COMMENT**

- Faulty starting system and the related circuit are suspected to be the causes.

## TROUBLESHOOTING HINTS (The most likely causes for this case:)

- Battery failed
- Malfunction of the starter motor relay.
- Malfunction of the starter motor.
- Open or shorted starting system circuit, harness damage, or connector damage.
- Malfunction of the transmission range switch.
- Malfunction of the ECM

## DIAGNOSIS

Required Special Tools:

- MB991958: Scan Tool (M.U.T.-III Sub Assembly)
  - MB991824: V.C.I.
  - MB991827: USB Cable
  - MB991910: Main Harness A

**STEP 1. Using scan tool MB991958, check data list item 79: Cranking signal.**

### ⚠ CAUTION

To prevent damage to scan tool MB991958, always turn the ignition switch to the "LOCK" (OFF) position before connecting or disconnecting scan tool MB991958.

- (1) Connect scan tool MB991958 to the data link connector
- (2) Turn the ignition switch to the "ON" position.
- (3) Set scan tool MB991958 to the data reading mode for item 79, Cranking Signal.
  - When the engine is stopped, "OFF" will be displayed.
  - When the engine is cranked, "ON" will be displayed.
- (4) Turn the ignition switch to the "LOCK" (OFF) position.

**Q: Is the operating properly?**

**YES :** Go to Step 9.

**NO :** Go to Step 2.

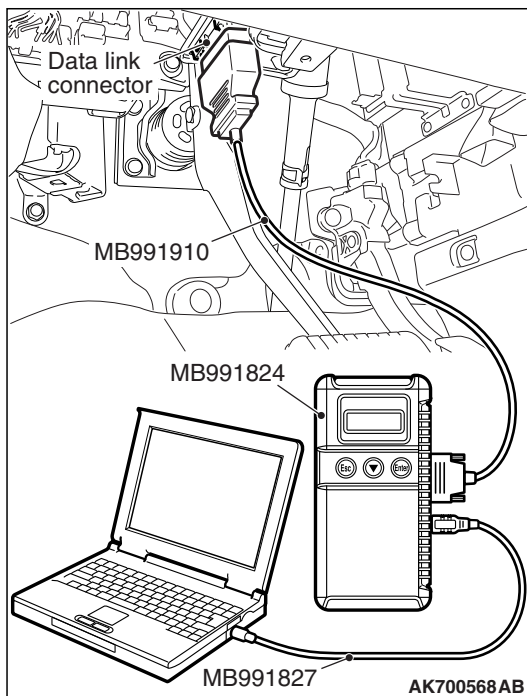

**STEP 2. Check harness connector C-304, C-315 at ETACS-ECU connector for damage.**

**Q: Is the connector in good condition?**

**YES :** Go to Step 3.

**NO :** Repair or replace it. Refer to GROUP 00E, Harness Connector Inspection P.00E-2. Then confirm that the malfunction symptom is eliminated.

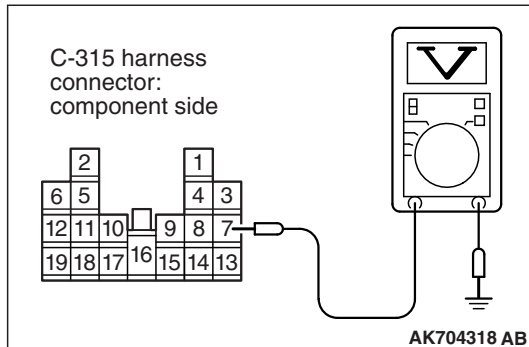

---

**STEP 3. Measure the ignition switch-ST signal voltage at ETACS-ECU harness side connector C-315.**

- (1) Disconnect the connector C-315 and measure at the harness side.
- (2) Turn the ignition switch to the "START" position.
- (3) Measure the voltage between terminal No. 7 and ground.
  - Voltage should be battery positive voltage
- (4) Turn the ignition switch to the "LOCK" (OFF) position.

**Q: Is battery positive voltage (approximately 12 volts) present?**

**YES :** Go to Step 6.

**NO :** Go to Step 4.

---

**STEP 4. Check harness connector C-210 ignition switch connector for damage.**

**Q: Is the connector in good condition?**

**YES :** Go to Step 5.

**NO :** Repair or replace it. Refer to GROUP 00E, Harness Connector Inspection [P.00E-2](#). Then confirm that the malfunction symptom is eliminated.

---

**STEP 5. Check the ignition switch**

Refer to GROUP 54A, Ignition Switch – Inspection – Ignition Switch Continuity Check [P.54A-26](#).

**Q: Are there any abnormalities?**

**YES :** Replace the Ignition Switch. Then confirm that the malfunction symptom is eliminated.

**NO :** Repair harness wire between Ignition Switch connector C-210 (terminal No. 5) and ETACS-ECU connector C-315 (terminal No. 7) because of open circuit or short circuit to ground. Then confirm that the malfunction symptom is eliminated

---

**STEP 6. Check for harness damage between ignition switch connector C-210 (terminal No. 5) and ETACS-ECU connector C-315 (terminal No. 7).**

**Q: Is the harness wire in good condition?**

**YES :** Go to Step 7.

**NO :** Repair it. Then confirm that the malfunction symptom is eliminated.



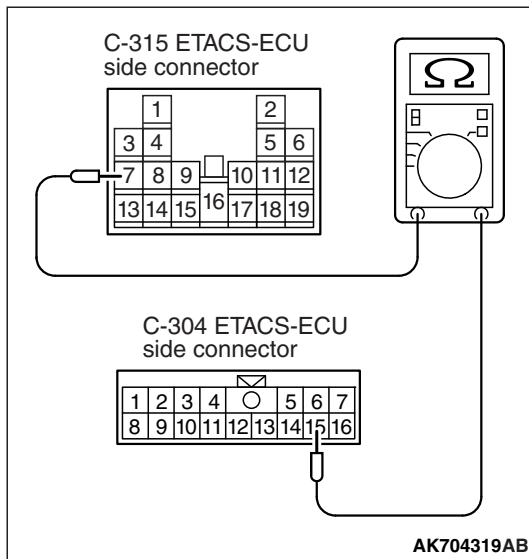

**STEP 7. Check for continuity at ETACS-ECU side connector C-304 and C-315.**

- (1) Disconnect the connector C-304, C-315 and measure at the ETACS-ECU side.
- (2) Measure the resistance between connector C-304 (terminal No. 15) and connector C-315 (terminal No. 7).
  - Should be less than 2 ohms

**Q: Is the harness wire in good condition?**

**YES :** Go to Step 8.

**NO :** Replace the ETACS-ECU. Then confirm that the malfunction symptom is eliminated.

**STEP 8. Check harness connector B-11 ECM connector for damage.**

**Q: Is the connector in good condition?**

**YES :** Repair harness wire between ETACS-ECU connector C-304 (terminal No. 15) and ECM connector B-11 (terminal No. 105) because of open circuit or short circuit to ground or harness damage. Then confirm that the malfunction symptom is eliminated.

**NO :** Repair or replace it. Refer to GROUP 00E, Harness Connector Inspection [P.00E-2](#). Then confirm that the malfunction symptom is eliminated.

**STEP 9. Check harness connector A-27X at starter relay connector for damage.**

**Q: Is the connector in good condition?**

**YES :** Go to Step 10.

**NO :** Repair or replace it. Refer to GROUP 00E, Harness Connector Inspection [P.00E-2](#). Then confirm that the malfunction symptom is eliminated.

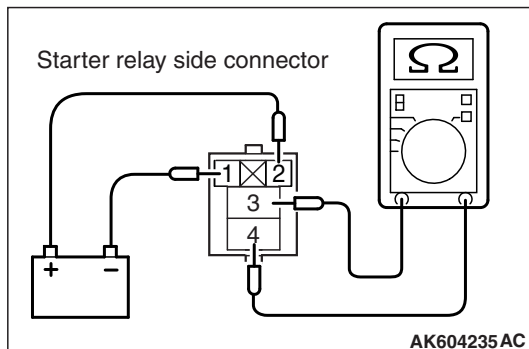
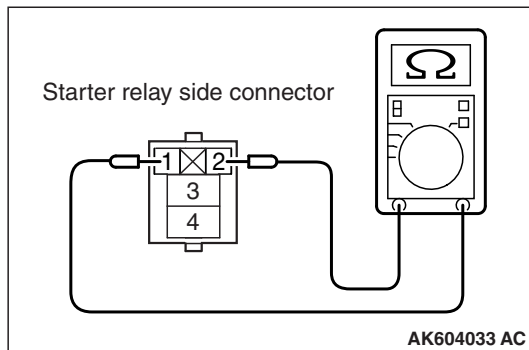
**STEP 10. Check the starter relay.**

- (1) Remove the starter relay.
- (2) Check for continuity between the starter relay terminals No. 1 and No. 2.
  - There should be continuity.

- (3) Use jumper wires to connect starter relay terminal No. 2 to the positive battery terminal and terminal No. 1 to the negative battery terminal.
- (4) Check for continuity between the starter relay terminals No. 3 and No. 4 while connecting and disconnecting the jumper wire at the negative battery terminal.
  - Should be less than 2 ohms. (Negative battery terminal connected)
  - Should be open loop. (Negative battery terminal disconnected)
- (5) Install the starter relay.

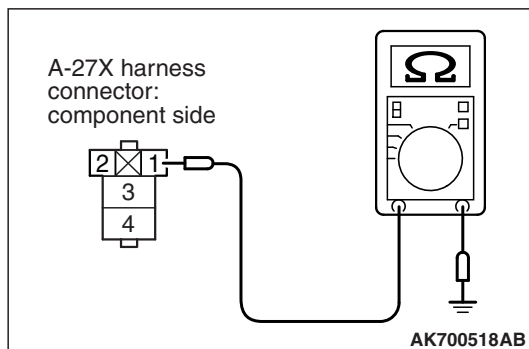
**Q: Is the measured resistance within the specified range?****YES** : Go to Step 11.**NO** : Replace the starter relay. Then confirm that the malfunction symptom is eliminated.**STEP 11. Check for continuity at starter relay harness side connector A-27X.**

- (1) Disconnect the connector A-27X and measure at the harness side.
- (2) Check for the continuity between terminal No. 1 and ground.
  - Should be less than 2 ohms.

**Q: Does continuity exist?****YES** : Go to Step 12.**NO** : Repair harness wire between starter relay connector A-27X (terminal No. 1) and ground because of open circuit or harness damage. Then confirm that the malfunction symptom is eliminated.

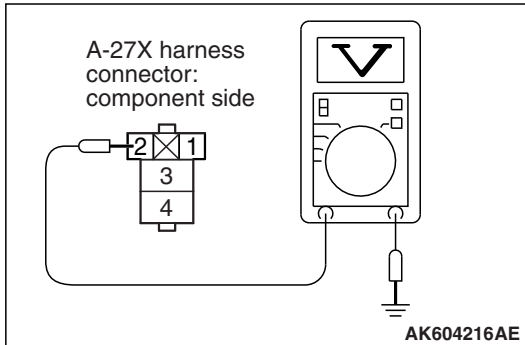

**STEP 12. Measure the power supply voltage at starter relay harness side connector A-27X.**

- (1) Disconnect the connector A-27X and measure at the harness side.
- (2) Turn the ignition switch to the "START" position.
- (3) Measure the voltage between terminal No. 2 and ground.
  - Voltage should be battery positive voltage
- (4) Turn the ignition switch to the "LOCK" (OFF) position.

**Q: Is battery positive voltage (approximately 12 volts) present?**

**YES :** Go to Step 20.

**NO :** Go to Step 13.

**STEP 13. Check harness connector B-110 at transmission range switch connector for damage.**

**Q: Is the connector in good condition?**

**YES :** Go to Step 14.

**NO :** Repair or replace it. Refer to GROUP 00E, Harness Connector Inspection [P.00E-2](#). Then confirm that the malfunction symptom is eliminated.

**STEP 14. Check the transmission range switch.**

Refer to GROUP 23A, On-vehicle Service – Essential Service – Transmission Range Switch Continuity Check [P.23A-143](#).

**Q: Are there any abnormalities?**

**YES :** Repair or replace it. Then confirm that the malfunction symptom is eliminated.

**NO :** Go to Step 15.

**STEP 15. Measure the power supply voltage at transmission range switch harness side connector B-110.**

- (1) Disconnect the connector B-110 and measure at the harness side.
- (2) Turn the ignition switch to the "START" position.
- (3) Measure the voltage between terminal No. 10 and ground.
  - Voltage should be battery positive voltage
- (4) Turn the ignition switch to the "LOCK" (OFF) position.

**Q: Is battery positive voltage (approximately 12 volts) present?**

**YES :** Go to Step 18.

**NO :** Go to Step 16.

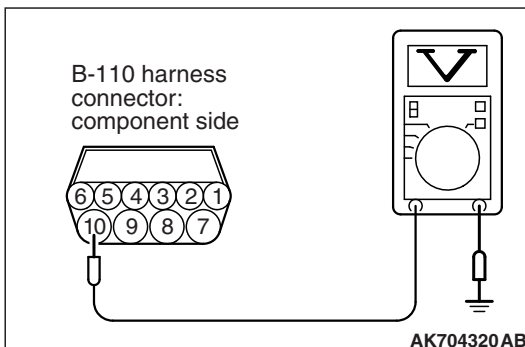

---

**STEP 16. Check harness connector B-11 at ECM connector for damage.**

**Q: Is the connector in good condition?**

**YES :** Go to Step 17.

**NO :** Repair or replace it. Refer to GROUP 00E, Harness Connector Inspection [P.00E-2](#). Then confirm that the malfunction symptom is eliminated.

---

**STEP 17. Check for open circuit and short circuit to ground between ECM connector B-11 (terminal No. 106) and transmission range switch connector B-110 (terminal No. 10).**

*NOTE: Check harness after checking intermediate connector A-13. If intermediate connector is damaged, repair or replace it. After to GROUP 00E, Harness Connector Inspection [P.00E-2](#). Then check that the malfunction is eliminated.*

**Q: Is the harness wire in good condition?**

**YES :** Replace the ECM. When the ECM is replaced, register the ID code. Refer to GROUP 42B, Diagnosis – ID Code Registration Judgment Table <Vehicles with KOS> [P.42B-15](#) or GROUP 42C, Diagnosis – ID Codes Registration Judgment Table <Vehicles with WCM> [P.42C-10](#). Then confirm that the malfunction symptom is eliminated.

**NO :** Repair it. Then confirm that the malfunction symptom is eliminated.

---

**STEP 18. Check for open circuit and short circuit to ground between transmission range switch connector B-110 (terminal No. 7) and starter relay A-27X (terminal No. 2).**

*NOTE: Check harness after checking intermediate connector A-13. If intermediate connector is damaged, repair or replace it. After to GROUP 00E, Harness Connector Inspection [P.00E-2](#). Then check that the malfunction is eliminated.*

**Q: Is the harness wire in good condition?**

**YES :** Go to Step 19.

**NO :** Repair it. Then confirm that the malfunction symptom is eliminated.

**STEP 19. Check harness connector B-10 at ECM connector for damage.**

**Q: Is the connector in good condition?**

**YES :** Check harness connector A-13 at intermediate connector for damage, and repair or replace as required. Refer to, GROUP 00E, Harness Connector Inspection [P.00E-2](#). If intermediate connector is in good condition, repair harness wire between ECM connector B-10 (terminal No. 6) and starter relay connector A-27X (terminal No. 2) because of short circuit to ground. Then confirm that the malfunction symptom is eliminated.

**NO :** Repair or replace it. Refer to GROUP 00E, Harness Connector Inspection [P.00E-2](#). Then confirm that the malfunction symptom is eliminated.

**STEP 20. Check harness connector B-114 at starter connector for damage.**

**Q: Is the connector in good condition?**

**YES :** Go to Step 21.

**NO :** Repair or replace it. Refer to GROUP 00E, Harness Connector Inspection [P.00E-2](#). Then confirm that the malfunction symptom is eliminated.

**STEP 21. Measure the power supply voltage at starter harness side connector B-114.**

- (1) Disconnect the connector B-114 and measure at the harness side.
- (2) Turn the ignition switch to the "START" position.
- (3) Measure the voltage between terminal No. 1 and ground.
  - Voltage should be battery positive voltage
- (4) Turn the ignition switch to the "LOCK" (OFF) position.

**Q: Is battery positive voltage (approximately 12 volts) present?**

**YES :** Go to Step 26.

**NO :** Go to Step 22.

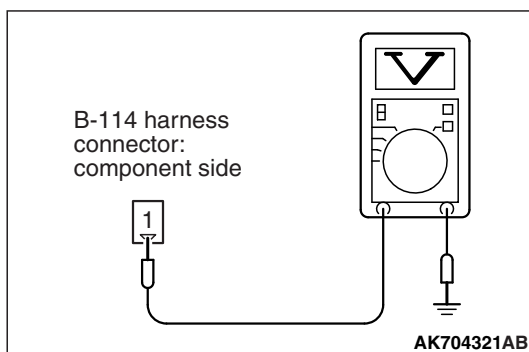

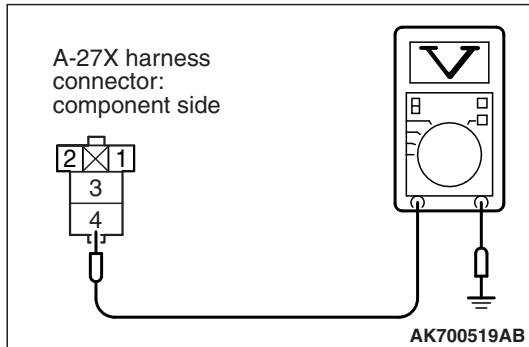

---

**STEP 22. Measure the power supply voltage at starter relay harness side connector A-27X.**

- (1) Disconnect the connector A-27X and measure at the harness side.
- (2) Measure the voltage between terminal No. 4 and ground.
  - Voltage should be battery positive voltage

**Q: Is battery positive voltage (approximately 12 volts) present?**

**YES :** Go to Step 23.

**NO :** Repair harness wire between fusible link (24) and starter relay connector A-27X (terminal No. 4) because of open circuit or short circuit to ground. Then confirm that the malfunction symptom is eliminated.

---

**STEP 23. Check for open circuit and short circuit to ground between starter relay connector A-27X (terminal No. 3) and starter connector B-114 (terminal No. 1)**

*NOTE: Check harness after checking intermediate connector A-13, B-23. If intermediate connector is damaged, repair or replace it. After to GROUP 00E, Harness Connector Inspection P.00E-2. Then check that the malfunction is eliminated.*

**Q: Is the harness wire in good condition?**

**YES :** Go to Step 24.

**NO :** Repair it. Then confirm that the malfunction symptom is eliminated.

---

**STEP 24. Check harness connector B-11 at ECM connector and harness connector B-110 at transmission range switch connector for damage.**
**Q: Is the connector in good condition?**

**YES :** Go to Step 25.

**NO :** Repair or replace it. Refer to GROUP 00E, Harness Connector Inspection P.00E-2. Then confirm that the malfunction symptom is eliminated.

---

**STEP 25. Check for harness damage between ECM connector B-11 (terminal No. 106) and transmission range switch connector B-110 (terminal No. 10).**

*NOTE: Check harness after checking intermediate connector A-13. If intermediate connector is damaged, repair or replace it. After to GROUP 00E, Harness Connector Inspection P.00E-2. Then check that the malfunction is eliminated.*

**Q: Is the harness wire in good condition?**

**YES :** Check harness connector A-13 at intermediate connector for damage, and repair or replace as required. Refer to, GROUP 00E, Harness Connector Inspection P.00E-2. If intermediate connector is in good condition, repair harness wire between transmission range switch connector B-110 (terminal No. 7) and starter relay connector A-27X (terminal No. 2) because of harness damage. Then confirm that the malfunction symptom is eliminated.

**NO :** Repair it. Then confirm that the malfunction symptom is eliminated.

---

**STEP 26. Check for harness damage between starter relay connector A-27X (terminal No. 3) and starter connector B-114 (terminal No. 1)**

*NOTE: Check harness after checking intermediate connector A-13, B-23. If intermediate connector is damaged, repair or replace it. After to GROUP 00E, Harness Connector Inspection P.00E-2. Then check that the malfunction is eliminated.*

**Q: Is the harness wire in good condition?**

**YES :** Go to Step 27.

**NO :** Repair it. Then confirm that the malfunction symptom is eliminated.

---

**STEP 27. Check for harness damage between fusible link (24) and starter relay connector A-27X (terminal No. 4)**

**Q: Is the harness wire in good condition?**

**YES :** Go to Step 28.

**NO :** Repair it. Then confirm that the malfunction symptom is eliminated.

---

**STEP 28. Check harness connector B-113 at starter connector for damage.**

**Q: Is the connector in good condition?**

**YES :** Go to Step 29.

**NO :** Repair or replace it. Refer to GROUP 00E, Harness Connector Inspection P.00E-2. Then confirm that the malfunction symptom is eliminated.

---

**STEP 29. Check for open circuit and short circuit to ground and harness damage between battery and starter connector B-113 (terminal No. 1)**

**Q: Is the harness wire in good condition?**

**YES** : Replace the starter.

**NO** : Repair it. Then confirm that the malfunction symptom is eliminated.



Inspection procedure 25: Ignition circuit system

IGNITION CIRCUIT

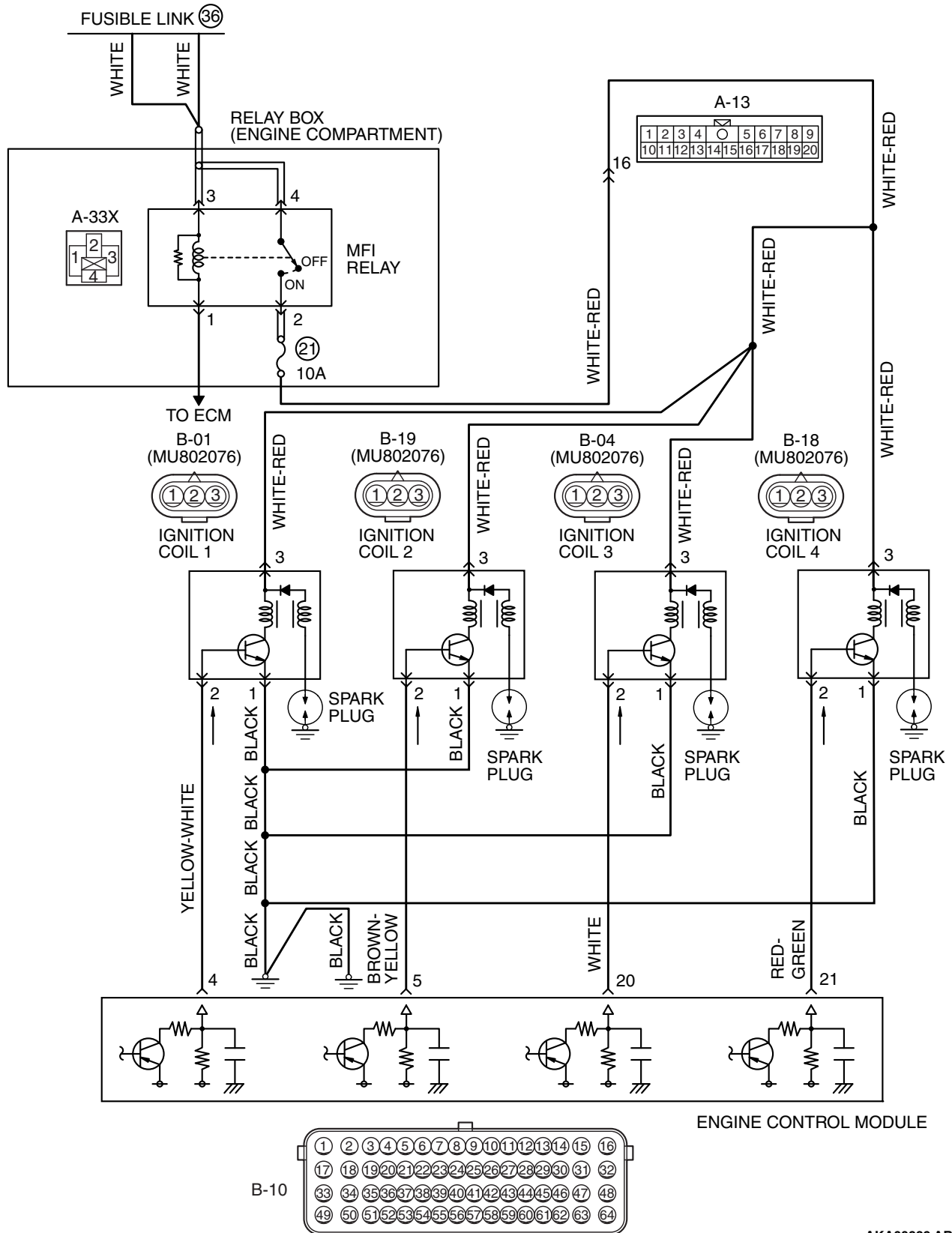

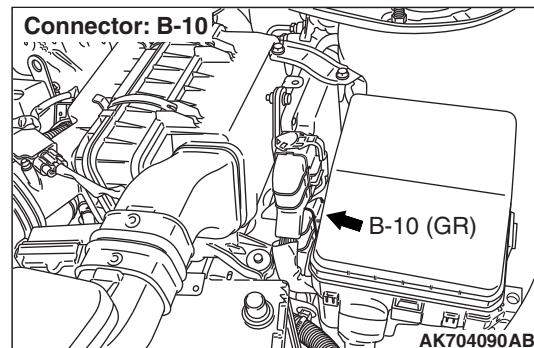
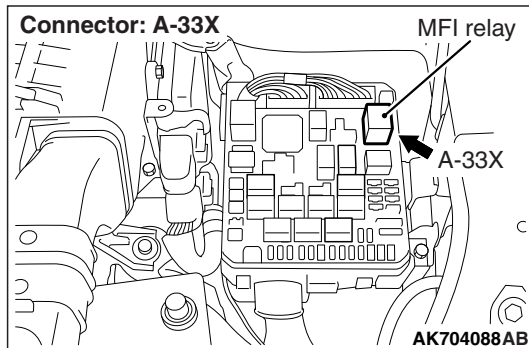
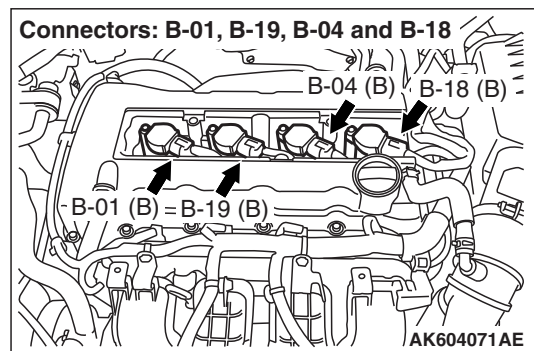
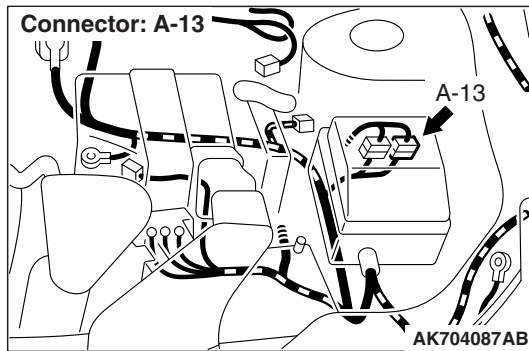

## CIRCUIT OPERATION

- The battery positive voltage is applied from the MFI relay to the ignition coil (terminal No.3) and is grounded to the vehicle body via the ignition coil (terminal No.1).
- A power voltage of 5 V is applied to the ignition coil (terminal No. 2) from the ECM (terminal No. 4, No. 5, No. 20 and No. 21).

- When the power transistor in the ignition coil is turned to ON with any signal from the ECM, the primary voltage will be applied through the ignition coil. When the power transistor in the ignition coil is turned OFF, the primary current is blocked and high voltage is generated in the secondary coil.

## COMMENT

- When the ECM turns the power transistor in the unit to OFF, the battery positive voltage is applied to the power transistor in the ignition coil, resulting that the power transistor is ON. And, when the ECM turns the power transistor in the unit to ON, the power transistor in the ignition coil will be turned OFF.

## TROUBLESHOOTING HINTS (The most likely causes for this case:)

- Malfunction of the ignition coil.
- Open or shorted ignition circuit, harness damage, or connector damage.
- Malfunction of the ECM.

## DIAGNOSIS

### STEP 1. Check the ignition coil.

Refer to GROUP 16, Ignition System – On-vehicle Service – Ignition Coil Check [P.16-44](#).

#### Q: Are there any abnormalities?

**YES** : Replace the ignition coil. Then confirm that the malfunction symptom is eliminated.

**NO** : Go to Step 2.

**STEP 2. Check harness connector B-01, B-19, B-04 and B-18 at ignition coil for damage.**

**Q: Is the harness connector in good condition?**

**YES :** Go to Step 3.

**NO :** Repair or replace it. Refer to GROUP 00E, Harness Connector Inspection [P.00E-2](#). Then confirm that the malfunction symptom is eliminated.

**STEP 3. Measure the power supply voltage at ignition coil connectors B-01, B-19, B-04 and B-18.**

- (1) Disconnect the connector B-01, B-19, B-04 and B-18 and measure at the harness side.
- (2) Turn the ignition switch to the "ON" position.
- (3) Measure the voltage between terminal No. 3 and ground.
  - Voltage should be battery positive voltage.
- (4) Turn the ignition switch to the "LOCK" (OFF) position.

**Q: Is battery positive voltage (approximately 12 volts) present?**

**YES :** Go to Step 4.

**NO :** Check harness connector A-13 at intermediate connector for damage, and repair or replace as required. Refer to, GROUP 00E, Harness Connector Inspection [P.00E-2](#). If intermediate connector is in good condition, repair harness wire between MFI relay connector A-33X (terminal No. 2) and ignition coil connectors B-01, B-19, B-04 and B-18 (terminal No. 3) because of open circuit or short circuit to ground. Then confirm that the malfunction symptom is eliminated.

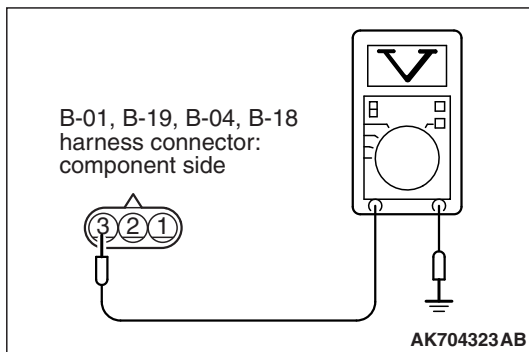

**STEP 4. Check the circuit at ignition coil harness side connector B-01, B-19, B-04 and B-18.**

- (1) Disconnect the connectors B-01, B-19, B-04 and B-18 and measure at the harness side.
- (2) Engine: 3,000 r/min
- (3) Measure the voltage between terminal No. 2 and ground.
  - Voltage should be 0.3 and 3.0 volts.
- (4) Turn the ignition switch to the "LOCK" (OFF) position.

**Q: Is the measured voltage between 0.3 and 3.0 volts?**

**YES :** Go to Step 7.

**NO :** Go to Step 5.

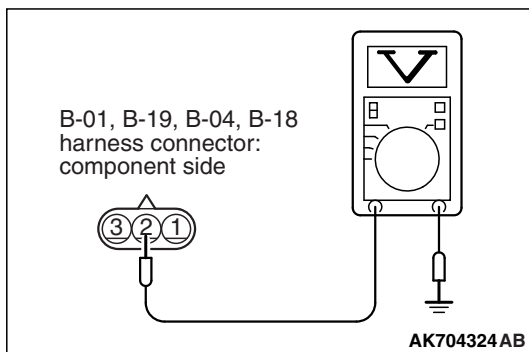

**STEP 5. Check harness connector B-10 at ECM for damage.****Q: Is the harness connector in good condition?****YES** : Go to Step 6.**NO** : Repair or replace it. Refer to GROUP 00E, Harness Connector Inspection [P.00E-2](#). Then confirm that the malfunction symptom is eliminated.**STEP 6. Check for open circuit and short circuit to ground between ignition coil connector and ECM connector.**

- Check the harness wire between ignition coil connector B-01 (terminal No. 2) and ECM connector B-10 (terminal No. 4) at ignition coil 1.
- Check the harness wire between ignition coil connector B-19 (terminal No. 2) and ECM connector B-10 (terminal No. 5) at ignition coil 2.
- Check the harness wire between ignition coil connector B-04 (terminal No. 2) and ECM connector B-10 (terminal No. 20) at ignition coil 3.
- Check the harness wire between ignition coil connector B-18 (terminal No. 2) and ECM connector B-10 (terminal No. 21) at ignition coil 4.

**Q: Is the harness wire in good condition?****YES** : Replace the ECM. When the ECM is replaced, register the ID code. Refer to GROUP 42B, Diagnosis – ID Code Registration Judgment Table <Vehicles with KOS> [P.42B-15](#) or GROUP 42C, Diagnosis – ID Codes Registration Judgment Table <Vehicles with WCM> [P.42C-10](#). Then confirm that the malfunction symptom is eliminated.**NO** : Repair it. Then confirm that the malfunction symptom is eliminated.**STEP 7. Check for continuity at ignition coil harness side connector B-01, B-19, B-04 and B-18.**

- Disconnect the connectors B-01, B-19, B-04 and B-18 and measure at the harness side.
- Check for the continuity between terminal No. 1 and ground.
  - Should be less than 2 ohms.

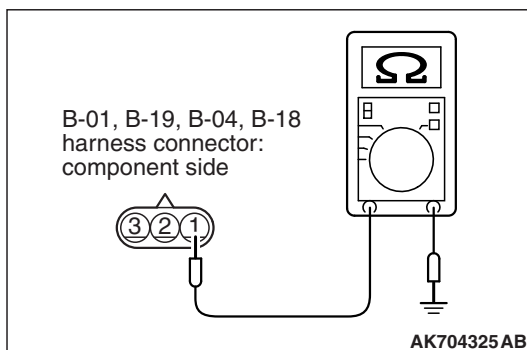
**Q: Does continuity exist?****YES** : Go to Step 8.**NO** : Repair harness wire between ignition coil connectors B-01, B-19, B-04 and B-18 (terminal No. 1) and ground because of open circuit or harness damage. Then confirm that the malfunction symptom is eliminated.

---

**STEP 8. Check for harness damage between MFI relay connector A-33X (terminal No. 2) and ignition coil connector B-01, B-19, B-04 and B-18 (terminal No. 3)**

*NOTE: Check harness after checking intermediate connector A-13. If intermediate connector is damaged, repair or replace it. After to GROUP 00E, Harness Connector Inspection P.00E-2. Then check that the malfunction is eliminated.*

**Q: Is the harness wire in good condition?**

**YES** : Go to Step 9.

**NO** : Repair it. Then confirm that the malfunction symptom is eliminated.

---

**STEP 9. Check for harness damage between ignition coil connector and ECM connector.**

- a. Check the harness wire between ignition coil connector B-01 (terminal No. 2) and ECM connector B-10 (terminal No. 151) at ignition coil 1.
- b. Check the harness wire between ignition coil connector B-19 (terminal No. 2) and ECM connector B-10 (terminal No. 143) at ignition coil 2.
- c. Check the harness wire between ignition coil connector B-04 (terminal No. 2) and ECM connector B-10 (terminal No. 150) at ignition coil 3.
- d. Check the harness wire between ignition coil connector B-18 (terminal No. 2) and ECM connector B-10 (terminal No. 148) at ignition coil 4.

**Q: Is the harness wire in good condition?**

**YES** : Replace the ECM. When the ECM is replaced, register the ID code. Refer to GROUP 42B, Diagnosis – ID Code Registration Judgment Table <Vehicles with KOS> P.42B-15 or GROUP 42C, Diagnosis – ID Codes Registration Judgment Table <Vehicles with WCM> P.42C-10. Then confirm that the malfunction symptom is eliminated.

**NO** : Repair it. Then confirm that the malfunction symptom is eliminated.

Inspection procedure 26: A/C system

A/C COMPRESSOR CLUTCH RELAY CIRCUIT

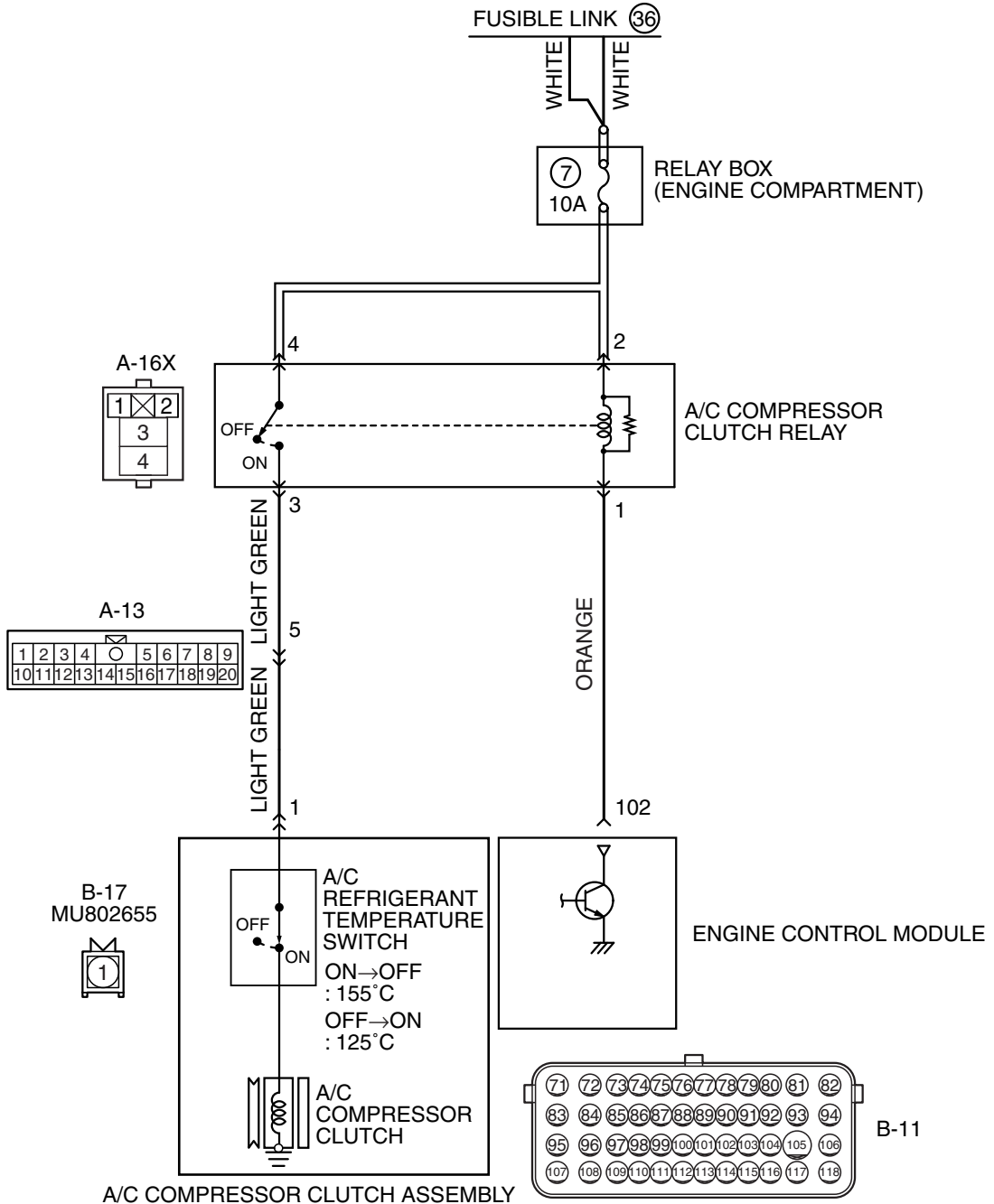

AK900376AC

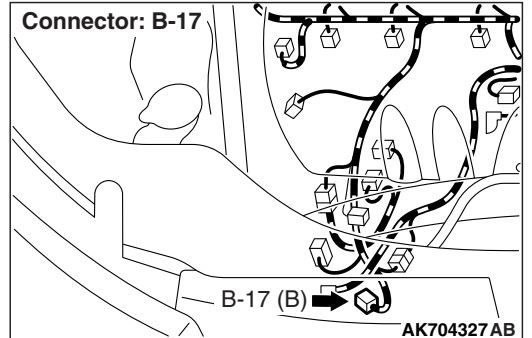
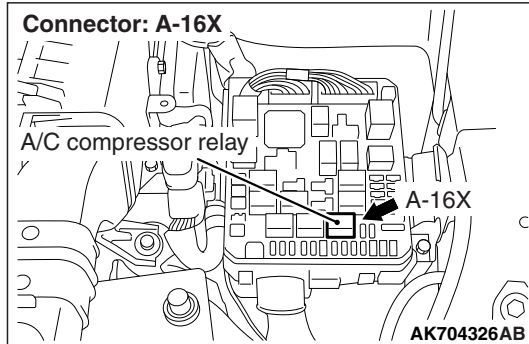
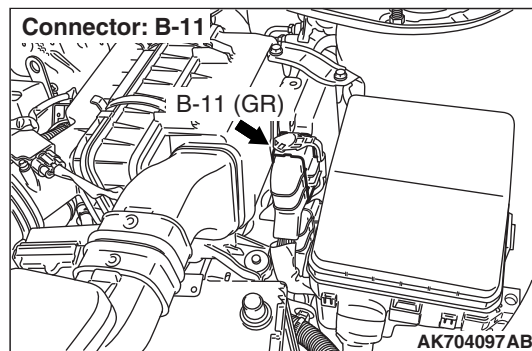
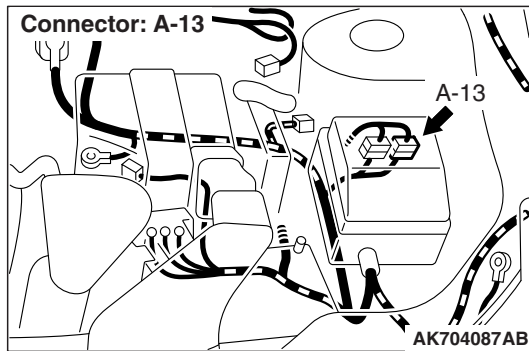

## CIRCUIT OPERATION

- When the A/C switch ON signal is input into the ECM, the ECM turns ON the A/C compressor relay. This causes battery positive voltage to be supplied to the A/C compressor and the magnet clutch actuates.

## COMMENT

- When the A/C is "ON" the ECM turns "ON" the power transistor in the ECM. The ECM delays A/C engagement momentarily while it increases idle speed. Then the A/C compressor clutch relay coil will be energized.

With this, the A/C compressor clutch relay turns "ON", and the A/C compressor clutch operates.

## TROUBLESHOOTING HINTS (The most likely causes for this case: )

- Malfunction of the A/C control system.
- Open or shorted A/C compressor relay circuit, harness damage, or connector damage.
- Malfunction of the ECM.

## DIAGNOSIS

**STEP 1.** Check harness connector B-11 at ECM for damage.

**Q:** Is the harness connector in good condition?

**YES :** Go to Step 2.

**NO :** Repair or replace it. Refer to GROUP 00E, Harness Connector Inspection [P.00E-2](#). Then confirm that the malfunction symptom is eliminated.

**STEP 2. Check the circuit at ECM connector B-11.**

- (1) Disconnect the connectors B-11 and measure at the harness side.
- (2) Turn the ignition switch to the "ON" position.
- (3) Measure the voltage between terminal No. 102 and ground.
  - Voltage should be battery positive voltage.
- (4) Using a jumper wire, connect terminal No. 102 to ground.
  - A/C compressor clutch relay should turn "ON".
- (5) Turn the ignition switch to the "LOCK" (OFF) position.

**Q: Is the voltage and A/C compressor relay condition normal?**

**YES :** Replace the ECM. When the ECM is replaced, register the ID code. Refer to GROUP 42B, Diagnosis – ID Code Registration Judgment Table <Vehicles with KOS> P.42B-15 or GROUP 42C, Diagnosis – ID Codes Registration Judgment Table <Vehicles with WCM> P.42C-10. Then confirm that the malfunction symptom is eliminated.

**NO :** Refer to GROUP 55A, Manual A/C Diagnosis – Introduction To Heater, Air Conditioning And Ventilation Diagnosis P.55A-6 <Manual A/C>, 55B, Automatic A/C Diagnosis – Introduction To Heater, Air Conditioning And Ventilation Diagnosis P.55B-3 <Automatic A/C>. Then confirm that the malfunction symptom is eliminated.

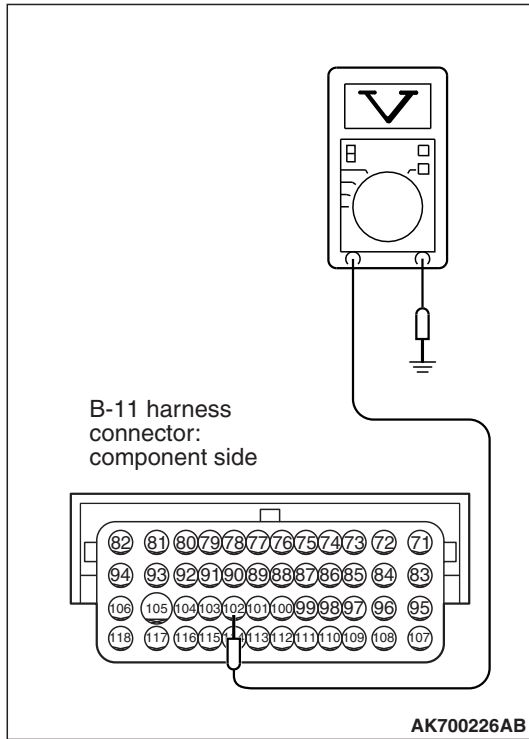

**Inspection procedure 27: Engine oil pressure switch system**

**ENGINE OIL PRESSURE SWITCH CIRCUIT**

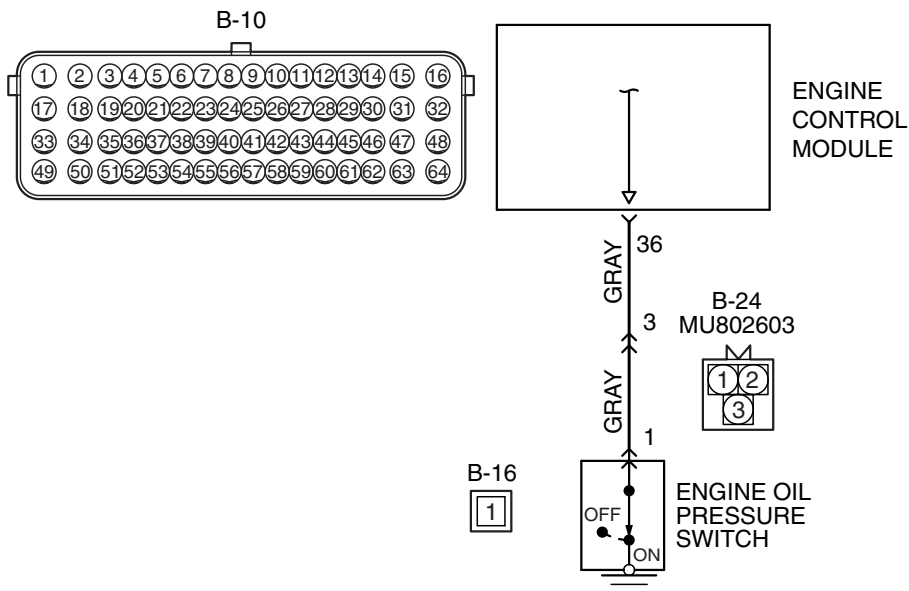

AK604021 AC



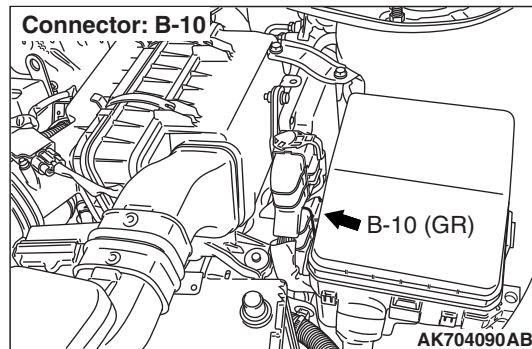
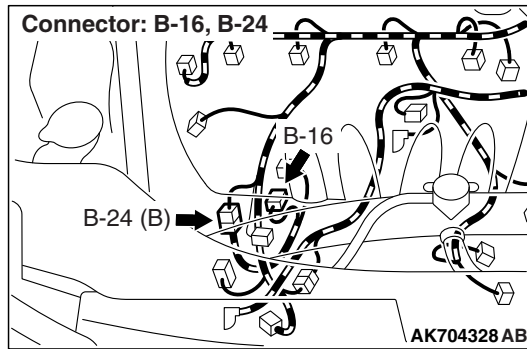

## CIRCUIT OPERATION

- Battery voltage is applied to the oil pressure switch (terminal No. 1) from the engine-ECU (terminal No. 36).

## COMMENT

- Detect the engine oil pressure conditions and enter the result into the ECM. After starting the engine if the oil pressure rises to higher than the given pressure, the engine oil pressure switch turns OFF. Under this condition the ECM sends the command of turning off the oil warning lamp to the combination meter via CAN.

## TROUBLESHOOTING HINTS (The most likely causes for this code to be set are:)

- Engine oil pressure switch failed.
- Open or shorted engine oil pressure switch circuit, harness damage, or connector damage.
- ECM failed.

## DIAGNOSIS

### Required Special Tools:

- MB991958: Scan Tool (M.U.T.-III Sub Assembly)
  - MB991824: V.C.I.
  - MB991827: USB Cable
  - MB991910: Main Harness A

**STEP 1. Check harness connector B-16 at engine oil pressure switch for damage.**

**Q: Is the harness connector in good condition?**

**YES :** Go to Step 2.

**NO :** Repair or replace it. Refer to GROUP 00E, Harness Connector Inspection [P.00E-2](#). Then go to Step 5 .

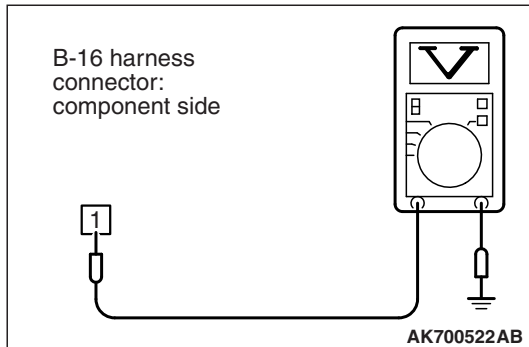

---

**STEP 2. Measure the power supply voltage at engine oil pressure switch connector B-16.**

- (1) Disconnect the connector B-16 measure at the harness side.
- (2) Turn the ignition switch to the "ON" position.
- (3) Measure the voltage between terminal No. 1 and ground.
  - The voltage should equal battery positive voltage.
- (4) Turn the ignition switch to the "LOCK" (OFF) position.

**Q: Is battery positive voltage (approximately 12 volts) present?**

**YES :** Go to Step 5.

**NO :** Go to Step 3.

---

**STEP 3. Check harness connector B-10 ECM connector for damage.**

**Q: Is the connector in good condition?**

**YES :** Go to Step 4.

**NO :** Repair or replace it. Refer to GROUP 00E, Harness Connector Inspection [P.00E-2](#). Then confirm that the malfunction symptom is eliminated.

---

**STEP 4. Check for open circuit and short circuit to ground between ECM connector B-10 (terminal No. 36) and engine oil pressure switch connector B-16 (terminal No. 1)**

*NOTE: Check harness after checking intermediate connector B-24. If intermediate connector is damaged, repair or replace it. After to GROUP 00E, Harness Connector Inspection [P.00E-2](#). Then check that the malfunction is eliminated.*

**Q: Is the harness wire in good condition?**

**YES :** Replace the ECM. When the ECM is replaced, register the ID code. Refer to GROUP 42B, Diagnosis – ID Code Registration Judgment Table <Vehicles with KOS> [P.42B-15](#) or GROUP 42C, Diagnosis – ID Codes Registration Judgment Table <Vehicles with WCM> [P.42C-10](#). Then confirm that the malfunction symptom is eliminated.

**NO :** Repair it. Then confirm that the malfunction symptom is eliminated.

---

**STEP 5. Check harness connector B-10 ECM connector for damage.**

**Q: Is the connector in good condition?**

**YES :** Go to Step 6.

**NO :** Repair or replace it. Refer to GROUP 00E, Harness Connector Inspection [P.00E-2](#). Then confirm that the malfunction symptom is eliminated.

**STEP 6. Check for harness damage between ECM connector B-10 (terminal No. 36) and engine oil pressure switch connector B-16 (terminal No. 1)**

*NOTE: Check harness after checking intermediate connector B-24. If intermediate connector is damaged, repair or replace it. After to GROUP 00E, Harness Connector Inspection [P.00E-2](#). Then check that the malfunction is eliminated.*

**Q: Is the harness wire in good condition?**

**YES** : Replace the engine oil pressure switch. Then confirm that the malfunction symptom is eliminated.

**NO** : Repair it. Then confirm that the malfunction symptom is eliminated.

DATA LIST REFERENCE TABLE

**⚠ CAUTION**

- When shifting the selector lever to D range, the brakes should be applied so that the vehicle does not move forward.

- Driving tests always need two persons: one driver and one observer.

NOTE: \*1: In a new vehicle [driven approximately 500 km (311 mile) or less], the mass airflow sensor output value is sometimes 10% higher than the standard value.

NOTE: \*2: The injector drive time represents the time when the cranking speed is at 250 r/min or below when the power supply voltage is 11 volts.

NOTE: \*3: In a new vehicle [driven approximately 500 km (311 mile) or less], the injector drive time is sometimes 10% longer than the standard time.

NOTE: \*4: Vehicles for Canada, the headlight, taillight, etc. remain lit even when the lighting switch is in "OFF" position but this is no problem for checks.

NOTE: \*5: Data items are displayed on M.U.T.-III display, but the in-line 4 engine is not applicable and its data is displayed as "N/A".

NOTE: \*6: Data items are displayed on the scan tool display, but the electric power steering is not mounted. The data are displayed as "0 A".

M.U.T.-III SCAN TOOL DISPLAY	ITEM NO.	INSPECTION ITEM	INSPECTION REQUIREMENT		NORMAL CONDITION	INSPECTION PROCEDURE NO.	REFERENCE PAGE
A/C compressor or relay	93	A/C compressor clutch relay	<ul style="list-style-type: none"> <li>• Engine: warming up, idling</li> <li>• A/C switch: "OFF"</li> </ul>		OFF	Procedure No. 26	<a href="#">P.13A-812</a>
			<ul style="list-style-type: none"> <li>• Engine: warming up, idling</li> <li>• A/C switch: "ON"</li> </ul>	A/C compressor clutch is not operating	OFF		
				A/C compressor clutch is operating	ON		
A/C SW	76	A/C switch	<ul style="list-style-type: none"> <li>• Engine: warming up, idling</li> <li>• A/C switch: "OFF"</li> </ul>		OFF	Procedure No. 26	<a href="#">P.13A-812</a>
			<ul style="list-style-type: none"> <li>• Engine: warming up, idling</li> <li>• A/C switch: "ON"</li> </ul>	A/C compressor clutch is not operating	OFF		
				A/C compressor clutch is operating	ON		
Absolute load value	72	Absolute load value	Engine: warming up	Engine is idling	10 – 20 %	–	–
				2,500 r/min	10 – 20 %		
				Revvng engine	Load value increases according to amount of revving.		

**MULTIPOINT FUEL INJECTION (MFI) <2.4L ENGINE>  
MULTIPOINT FUEL INJECTION (MFI) DIAGNOSIS**

**13A-819**

M.U.T.-III SCAN TOOL DISPLAY	ITEM NO.	INSPECTION ITEM	INSPECTION REQUIREMENT	NORMAL CONDITION	INSPECTION PROCEDURE NO.	REFERENCE PAGE	
Airflow sensor	10	Mass airflow sensor* <sup>1</sup>	<ul style="list-style-type: none"> <li>• Engine coolant temperature: 80 – 95°C (176 – 203°F)</li> <li>• Lights, electric cooling fan and all accessories: "OFF"*<sup>4</sup></li> <li>• Transaxle: "P" range</li> </ul>	Engine is idling	1,350 – 1,670 mV	–	–
				2,500 r/min	1,620 – 2,020 mV		
				Engine is revved	Increases in response to revving		
Airflow sensor	AA	Mass airflow sensor* <sup>1</sup>	<ul style="list-style-type: none"> <li>• Engine coolant temperature: 80 – 95°C (176 – 203°F)</li> <li>• Lights, electric cooling fan and all accessories: "OFF"*<sup>4</sup></li> <li>• Transaxle: "P" range</li> </ul>	Engine is idling	1.3 – 5.3 g/s	–	–
				2,500 r/min	5.0 – 13.0 g/s		
				Engine is revved	Increases in response to revving		
APP sensor (main)	11	Accelerator pedal position sensor (main)	Ignition switch: "ON"	Release the accelerator pedal	900 – 1,100 mV	Code No. P2122, P2123	P.13A-633 , P.13A-639
				Depress the accelerator pedal gradually	Increases in response to the pedal depression stroke		
				Depress the accelerator pedal fully	4,000 mV or more		
APP sensor (main)	BE	Accelerator pedal position sensor (main)	Ignition switch: "ON"	Release the accelerator pedal	18 – 22 %	Code No. P2122, P2123	P.13A-633 , P.13A-639
				Depress the accelerator pedal gradually	Increases in response to the pedal depression stroke		
				Depress the accelerator pedal fully	80 % or more		

M.U.T.-III SCAN TOOL DISPLAY	ITEM NO.	INSPECTION ITEM	INSPECTION REQUIREMENT		NORMAL CONDITION	INSPECTION PROCEDURE NO.	REFERENCE PAGE
APP sensor (sub)	12	Accelerator pedal position sensor (sub)	Ignition switch: "ON"	Release the accelerator pedal	400 – 600 mV	Code No. P2127, P2128	P.13A-644 , P.13A-650
				Depress the accelerator pedal gradually	Increases in response to the pedal depression stroke		
				Depress the accelerator pedal fully	2,000 mV or more		
APP sensor (sub)	BF	Accelerator pedal position sensor (sub)	Ignition switch: "ON"	Release the accelerator pedal	8 – 12 %	Code No. P2127, P2128	P.13A-644 , P.13A-650
				Depress the accelerator pedal gradually	Increases in response to the pedal depression stroke		
				Depress the accelerator pedal fully	40 % or more		
Barometric pressure sensor	BB	Barometric pressure sensor	Ignition switch: "ON"	Engine stopped [At altitude of 0 m (0 ft.)]	101 kPa (29.8 in.Hg)	Code No. P2228, P2229	P.13A-667 , P.13A-669
				Engine stopped [At altitude of 600 m (1,969 ft.)]	95 kPa (28.1 in.Hg)		
				Engine stopped [At altitude of 1,200 m (3,937 ft.)]	88 kPa (26.0 in.Hg)		
				Engine stopped [At altitude of 1,800 m (5,906 ft.)]	81 kPa (23.9 in.Hg)		
BATT.curr ent SNSR(lear ned value)	118	Battery current sensor (learned value)	Indicates the learning value of battery current sensor calibration.	Ignition switch: ON	–2.5 to 2.5 A (Display range)	–	–

M.U.T.-III SCAN TOOL DISPLAY	ITEM NO.	INSPECTION ITEM	INSPECTION REQUIREMENT		NORMAL CONDITION	INSPECTION PROCEDURE NO.	REFERENCE PAGE
Battery current SNSR.calibration	119	Battery current sensor calibration	<ul style="list-style-type: none"> <li>• Indicates learning conditions of battery current sensor calibration.</li> <li>• Message "Completed" means learning has been completed.</li> <li>• Message "Not completed" means learning has been not completed</li> </ul>	Ignition switch: ON	Varies depending on the learning conditions.	-	-
Brake light switch	74	Brake light switch	Ignition switch: "ON"	Depress the brake pedal fully	ON	-	-
				Release the brake pedal	OFF		
Calculated load value	73	Calculated load value	Engine: warming up	Engine is idling	15 – 30 %	-	-
				2,500 r/min	12 – 22 %		
Closed throttle position switch	84	Closed throttle position signal	Ignition switch: "ON"	Release the accelerator pedal	ON	-	-
				Depress the accelerator pedal fully	OFF		
Cranking signal	79	Cranking signal (ignition switch-ST)	Ignition switch: "ON"	Engine: stopped	OFF	Procedure No. 24	<a href="#">P.13A-795</a>
				Engine: cranking	ON		

M.U.T.-III SCAN TOOL DISPLAY	ITEM NO.	INSPECTION ITEM	INSPECTION REQUIREMENT	NORMAL CONDITION	INSPECTION PROCEDURE NO.	REFERENCE PAGE	
Crankshaft position sensor	2	Crankshaft position sensor	<ul style="list-style-type: none"> <li>• Engine: cranking</li> <li>• Tachometer: connected</li> </ul>	Engine speeds displayed on the scan tool and tachometer are identical.	Code No. P0335	<a href="#">P.13A-372</a>	
			Engine: idling	Engine coolant temperature is -20°C (-4°F)			1,300 – 1,500 r/min
				Engine coolant temperature is 0°C (32°F)			1,250 – 1,500 r/min
				Engine coolant temperature is 20°C (68°F)			1,100 – 1,500 r/min
				Engine coolant temperature is 40°C (104°F)			950 – 1,350 r/min
				Engine coolant temperature is 80°C (176°F)			550 – 750 r/min



M.U.T.-III SCAN TOOL DISPLAY	ITEM NO.	INSPECTION ITEM	INSPECTION REQUIREMENT	NORMAL CONDITION	INSPECTION PROCEDURE NO.	REFERENCE PAGE		
ECT sensor	6	Engine coolant temperature sensor	Ignition switch: "ON" or with engine running	Engine coolant temperature is -20°C (-4°F)	-20°C (-4°F)	Code No. P0116, P0117, P0118	<a href="#">P.13A-177</a> , <a href="#">P.13A-183</a> , <a href="#">P.13A-187</a>	
				Engine coolant temperature is 0°C (32°F)				0°C (32°F)
				Engine coolant temperature is 20°C (68°F)				20°C (68°F)
				Engine coolant temperature is 40°C (104°F)				40°C (104°F)
				Engine coolant temperature is 80°C (176°F)				80°C (176°F)
EGR step motor	31	EGR valve (stepper motor)	<ul style="list-style-type: none"> <li>• Engine coolant temperature: 80 – 95°C (176 – 203°F)</li> <li>• Lights, electric cooling fan and all accessories: "OFF"*4</li> <li>• Transaxle: "P" range</li> </ul>	Engine is idling	2 – 8 Step	Code No. P0489, P0490	<a href="#">P.13A-500</a> , <a href="#">P.13A-508</a>	
				2,500 r/min	2 – 8 Step			
Electric power steering current*6	21	–	–	–	–	–	–	
Engine control relay	95	MFI relay	Ignition switch: "ON"	ON	–	–	–	
Engine oil pressure switch	90	Engine oil pressure switch	Ignition switch: "ON"	ON	Procedure No. 27	<a href="#">P.13A-814</a>		
			Engine is idling	OFF				

M.U.T.-III SCAN TOOL DISPLAY	ITEM NO.	INSPECTION ITEM	INSPECTION REQUIREMENT	NORMAL CONDITION	INSPECTION PROCEDURE NO.	REFERENCE PAGE
Equivalence Ratio (LAFS)	E0	Linear air-fuel ratio sensor equivalence ratio	Engine: warming up (Air/fuel mixture is made leaner when decelerating and is made richer when revving)	When the engine is running at 4,000 r/min, decelerate suddenly.	1.3 or more → 0.96 or less (After several seconds have elapsed)	Code No. P0130, P0131, P0132, P0133, P0134, P2237, P2243, P2251  P.13A-218 , P.13A-223 , P.13A-228 , P.13A-233 , P.13A-236 , P.13A-672 , P.13A-677 , P.13A-682
				When engine is suddenly revved	0.96 or less	
			Engine: warming up (the linear air-fuel ratio sensor signal is used to check the air/fuel mixture ratio, and control condition is also checked by the ECM.)	Engine is idling 2,500 r/min	Equivalence ratio changes repeatedly between 0.99 or less and 1.005 or more.	
ETV relay	96	Throttle actuator control motor relay	Ignition switch: "ON"	ON	–	–
EVAP. emission purge SOL. duty	49	Evaporative emission purge solenoid duty	Engine: warming up with Open loop drive condition, without EVAP leak monitor	1 % or more	–	–
Exhaust VVT angle (bank 1)	39	Exhaust MIVEC phase angle	Engine warming up, idle	–2.5 to 2.5°CA (ATDC)	Code No. P0014	P.13A-74
			Engine warming up, sudden revving	Increases (retards)		
Fan duty	47	Fan motor duty	Engine: warming up • The duty ratio of the fan motor driving is shown.	0 – 100 % (Display range)	–	–
Fuel level gauge	51	Fuel level gauge	Ignition switch: "ON" • The residual fuel amount in the tank is shown. • "0 %" means "Empty" and "100 %" means "Full".	0 – 100 % (Display range)	–	–
Fuel level input	121	Fuel level input	Ignition switch: "ON" • The residual fuel amount in the tank is shown. • "0 %" means "Empty" and "100 %" means "Full".	0 – 100 % (Display range)	–	–
Fuel pump relay	97	Fuel pump relay	Ignition switch: "ON"	OFF	–	–
			Engine: cranking	ON		

**MULTIPOINT FUEL INJECTION (MFI) <2.4L ENGINE>  
MULTIPOINT FUEL INJECTION (MFI) DIAGNOSIS**

**13A-825**

M.U.T.-III SCAN TOOL DISPLAY	ITEM NO.	INSPECTION ITEM	INSPECTION REQUIREMENT		NORMAL CONDITION	INSPECTION PROCEDURE NO.	REFERENCE PAGE
Fuel system status (bank 1)	105	Fuel control system status (bank 1)	Engine: warming up	2,500 r/min	CL: Using O2S	-	-
				When engine is suddenly revved	OL: DRV condition		
Fuel system status (bank 2) <sup>5</sup>	106	Fuel control system status (bank 2)	-		-	-	-
Fuel tank differential PRS. SNSR	52	Fuel tank differential pressure sensor	<ul style="list-style-type: none"> <li>Ignition switch: "ON"</li> <li>Fuel cap removal</li> </ul>		1,500 – 3,500 mV	-	-
Fuel tank temperatur e sensor	53	Fuel tank temperature sensor	<ul style="list-style-type: none"> <li>In cold state</li> <li>Ignition switch: "ON"</li> </ul>		Approximately the same as the outdoor temperature	Code No. P0181, P0182, P0183	<a href="#">P.13A-274</a> , <a href="#">P.13A-280</a> , <a href="#">P.13A-285</a>
Ignition switch	85	Ignition switch (IG1)	Ignition switch: "ON"		ON	-	-
Injectors	17	Injectors* <sup>2</sup>	Engine: cranking	When engine coolant temperature is 0°C (32°F)	46 – 66 ms	-	-
				When engine coolant temperature is 20°C (68°F)	23 – 43 ms		
				When engine coolant temperature is 80°C (176°F)	6 – 12 ms		
		Injectors* <sup>3</sup>	<ul style="list-style-type: none"> <li>Engine coolant temperature: 80 – 95°C (176 – 203°F)</li> <li>Lights, electric cooling fan and all accessories: "OFF"</li> <li>Transaxle: "P" range</li> </ul>	Engine is idling	1.3 – 3.3 ms		
				2,500 r/min	1.0 – 3.0 ms		
				When engine is suddenly revved	Increases		

M.U.T.-III SCAN TOOL DISPLAY	ITEM NO.	INSPECTION ITEM	INSPECTION REQUIREMENT	NORMAL CONDITION	INSPECTION PROCEDURE NO.	REFERENCE PAGE		
Intake air temperature sensor 1	5	Intake air temperature sensor	Ignition switch: "ON" or with engine running	Intake air temperature is -20°C (-4°F)	-20°C (-4°F)	Code No. P0111, P0112, P0113	P.13A-161 , P.13A-167 , P.13A-171	
				Intake air temperature is 0°C (32°F)				0°C (32°F)
				Intake air temperature is 20°C (68°F)				20°C (68°F)
				Intake air temperature is 40°C (104°F)				40°C (104°F)
				Intake air temperature is 80°C (176°F)				80°C (176°F)
Intake VVT angle (bank 1)	36	Intake MIVEC phase angle	Engine warming up, idle	-3 to 3°C (ATDC)	Code No. P0011	P.13A-64		
			Engine warming up, sudden revving	Decreases (advances)				
ISC learned value (A/C OFF)	68	Idle speed control learned value (A/C OFF)	Ignition switch: "ON" <ul style="list-style-type: none"> <li>Indicates the learning value to compensate for the opening angle of idling speed control (opening angle of throttle valve).</li> <li>The negative side shows "close" side, while the positive side shows "open" side.</li> </ul>	-1 to 2.4 L/s (Display range)	-	-		
ISC learned value (A/C ON)	69	Idle speed control learned value (A/C ON)	Ignition switch: "ON" <ul style="list-style-type: none"> <li>Indicates the learning value to compensate for the opening angle of idling speed control (opening angle of throttle valve) with the air conditioner turned ON.</li> <li>The negative side shows "close" side, while the positive side shows "open" side.</li> </ul>	-1 to 2.4 L/s (Display range)	-	-		
Knock retard	32	Knock retard	Engine: warming up, sudden revving	According to acceleration, knock retard is increased.	-	-		

M.U.T.-III SCAN TOOL DISPLAY	ITEM NO.	INSPECTION ITEM	INSPECTION REQUIREMENT	NORMAL CONDITION	INSPECTION PROCEDURE NO.	REFERENCE PAGE	
LAFS (front)	E1	Linear air-fuel ratio sensor	Engine: warming up (Air/fuel mixture is made leaner when decelerating and is made richer when revving)	When the engine is running at 4,000 r/min, decelerate suddenly.	3.5 V or more → 2.0 V or less (After several seconds have elapsed)	Code No. P0130, P0131, P0132, P0133, P0134, P2237, P2243, P2251	P.13A-218 , P.13A-223 , P.13A-228 , P.13A-233 , P.13A-236 , P.13A-672 , P.13A-677 , P.13A-682
				When engine is suddenly revved	2.0 V or less		
			Engine: warming up (the linear air-fuel ratio sensor signal is used to check the air/fuel mixture ratio, and control condition is also checked by the ECM.)	Engine is idling 2,500 r/min	Voltage changes repeatedly between 2.25 V or less and 2.35 V or more.		
Learned knock retard	33	Knock control learned value	Ignition switch: "ON" <ul style="list-style-type: none"> <li>The learning value is shown, which compensates the ignition time based on the knock sensor.</li> <li>"0 %" means "retard angle" and "100 %" means "advance angle".</li> </ul>	0 – 100 % (Display range)	–	–	
Long term fuel trim (bank 1)	26	Long-term fuel trim	Engine: warming up, 2,500 r/min without any load (during closed loop)	– 12.5 to 12.5 %	Code No. P0171, P0172	P.13A-262 , P.13A-268	

M.U.T.-III SCAN TOOL DISPLAY	ITEM NO.	INSPECTION ITEM	INSPECTION REQUIREMENT		NORMAL CONDITION	INSPECTION PROCEDURE NO.	REFERENCE PAGE
MAP sensor	8	Manifold absolute pressure sensor	Ignition switch: "ON"	Engine stopped [At altitude of 0 m (0 ft.)]	101 kPa (29.8 in.Hg)	Code No. P0106, P0107, P0108	P.13A-139 , P.13A-148 , P.13A-156
				Engine stopped [At altitude of 600 m (1,969 ft.)]	95 kPa (28.1 in.Hg)		
				Engine stopped [At altitude of 1,200 m (3,937 ft.)]	88 kPa (26.0 in.Hg)		
				Engine stopped [At altitude of 1,800 m (5,906 ft.)]	81 kPa (23.9 in.Hg)		
			Engine: warming up, idling		16 – 36 kPa (4.7 – 10.6 in.Hg)		
			When engine is suddenly revved		Manifold pressure varies		
Neutral switch	87	Neutral switch	Ignition switch: "ON"	Shift lever: "P" or "N"	ON	–	–
				Shift lever: except "P" and "N"	OFF		
Normally closed brake switch	89	Normally closed brake switch	Ignition switch: "ON"	Depress the brake pedal	ON	–	–
				Release the brake pedal	OFF		
Oxygen sensor (bank1 sensor2)	AD	Heated oxygen sensor (rear)	<ul style="list-style-type: none"> <li>• Transaxle: 2 nd</li> <li>• Drive with wide open throttle</li> <li>• Engine: 3,500 r/min or more</li> </ul>		0.6 – 1.0 V	Code No. P0137, P0138, P0139, P0140	P.13A-241 , P.13A-249 , P.13A-253 , P.13A-258
Power steering switch	83	Power steering pressure switch	Engine: idling	Steering wheel stationary	OFF	Code No. P0551	P.13A-528
				Steering wheel turning	ON		

M.U.T.-III SCAN TOOL DISPLAY	ITEM NO.	INSPECTION ITEM	INSPECTION REQUIREMENT		NORMAL CONDITION	INSPECTION PROCEDURE NO.	REFERENCE PAGE
Power supply voltage	1	Power supply voltage	Ignition switch: "ON"		Battery positive voltage	Procedure No. 22	<a href="#">P.13A-777</a>
Relative APP sensor	DD	Relative accelerator pedal position sensor	Ignition switch: "ON"	Release the accelerator pedal	0 – 5 %	–	–
				Depress the accelerator pedal gradually	Increases in response to the pedal depression stroke		
				Depress the accelerator pedal fully	95 – 100%		
Relative TP sensor	BC	Relative throttle position sensor	<ul style="list-style-type: none"> <li>• Remove the intake air hose at the throttle body</li> <li>• Disconnect the throttle position sensor connector, and then connect terminals numbers No. 3, No. 4, No. 5 and No. 6 with the use of the special tool: MB991658.</li> <li>• Ignition switch: "ON"</li> </ul>	Fully close the throttle valve with your finger	0 – 5 %	–	–
				Fully open the throttle valve with your finger	88 % or more		
Short term fuel trim (bank 1)	28	Short-term fuel trim	Engine: warming up, 2,500 r/min without any load (during closed loop)		–7.4 to 7.4 %	Code No. P0171, P0172	<a href="#">P.13A-262</a> , <a href="#">P.13A-268</a>
Spark advance	16	Ignition timing advance	<ul style="list-style-type: none"> <li>• Engine: warming up</li> <li>• Timing light is set (to check actual ignition timing)</li> <li>• Transaxle: "P" range</li> </ul>	Engine is idling	2 – 18° CA (BTDC)	–	–
				2,500 r/min	34 – 46° CA (BTDC)		
Starter relay	102	Starter relay	Ignition switch: "ON"		OFF	Procedure No. 24	<a href="#">P.13A-795</a>
			Engine: Cranking		ON		

M.U.T.-III SCAN TOOL DISPLAY	ITEM NO.	INSPECTION ITEM	INSPECTION REQUIREMENT	NORMAL CONDITION	INSPECTION PROCEDURE NO.	REFERENCE PAGE	
Target EGR	BA	Target EGR valve (stepper motor)	<ul style="list-style-type: none"> <li>The target duty ratio of the EGR valve driving is shown.</li> <li>"0 %" means "fully closed EGR valve" and "100 %" means "fully opened EGR valve".</li> </ul>	0 – 100 % (Display range)	–	–	
Target ETV value	59	Throttle actuator control motor target value	Engine: warming up <ul style="list-style-type: none"> <li>The target opening degree of the throttle valve is shown.</li> <li>"0 V" means "fully closed throttle valve" and "5 V" means "fully opened throttle valve".</li> </ul>	0 – 5 V (Display range)	–	–	
Target idle speed	3	Target idle speed	Engine: idling	Engine coolant temperature is –20°C (–4°F)	1,300 – 1,500 r/min	–	–
			Engine coolant temperature is 0°C (32°F)	1,250 – 1,500 r/min			
			Engine coolant temperature is 20°C (68°F)	1,100 – 1,500 r/min			
			Engine coolant temperature is 40°C (104°F)	950 – 1,350 r/min			
			Engine coolant temperature is 80°C (176°F)	550 – 750 r/min			
Throttle actuator	58	Throttle actuator control motor	Engine: warming up <ul style="list-style-type: none"> <li>The target opening degree of the throttle valve is shown.</li> <li>"0 %" means "fully closed throttle valve" and "100 %" means "fully opened throttle valve".</li> </ul>	0 – 100 % (Display range)	–	–	



M.U.T.-III SCAN TOOL DISPLAY	ITEM NO.	INSPECTION ITEM	INSPECTION REQUIREMENT	NORMAL CONDITION	INSPECTION PROCEDURE NO.	REFERENCE PAGE		
TP sensor (main)	13	Throttle position sensor (main)	<ul style="list-style-type: none"> <li>Remove the intake air hose at the throttle body</li> <li>Disconnect the throttle position sensor connector, and then connect terminal numbers No. 3, No. 4, No. 5 and No. 6 with the use of the special tool: MB991658.</li> <li>Ignition switch: "ON"</li> </ul>	Fully close the throttle valve with your finger	300 – 700 mV	Code No. P0122, P0123	P.13A-197 , P.13A-201	
				Fully open the throttle valve with your finger	4,000 mV or more			
				Engine: warming up, idling	No load			500 – 660 mV
				A/C switch: "OFF" → "ON"	Voltage rises			
			Shift lever: "N" → "D"					
TP sensor (main)	AB	Throttle position sensor (main)	<ul style="list-style-type: none"> <li>Remove the intake air hose at the throttle body</li> <li>Disconnect the throttle position sensor connector, and then connect terminals numbers No. 3, No. 4, No. 5 and No. 6 with the use of the special tool: MB991658.</li> <li>Ignition switch: "ON"</li> </ul>	Fully close the throttle valve with your finger	6 – 14 %	Code No. P0122, P0123	P.13A-197 , P.13A-201	
				Fully open the throttle valve with your finger	80 % or more			

M.U.T.-III SCAN TOOL DISPLAY	ITEM NO.	INSPECTION ITEM	INSPECTION REQUIREMENT	NORMAL CONDITION	INSPECTION PROCEDURE NO.	REFERENCE PAGE	
TP sensor (main) learned value	14	Throttle position sensor (main) mid opening learning value	This item shows the throttle valve opening learning value when the vehicle enters into the limp home mode.		–	–	
TP sensor (sub)	15	Throttle position sensor (sub)	<ul style="list-style-type: none"> <li>• Remove the intake air hose at the throttle body</li> <li>• Disconnect the throttle position sensor connector, and then connect terminal numbers No. 3, No. 4, No. 5 and No. 6 with the use of the special tool: MB991658.</li> <li>• Ignition switch: "ON"</li> </ul>	Fully close the throttle valve with your finger	4,000 mV or more	Code No. P0222, P0223	P.13A-335 , P.13A-341
				Fully open the throttle valve with your finger	1,000 mV or less		
TP sensor (sub)	BD	Throttle position sensor (sub)	<ul style="list-style-type: none"> <li>• Remove the intake air hose at the throttle body</li> <li>• Disconnect the throttle position sensor connector, and then connect terminals numbers No. 3, No. 4, No. 5 and No. 6 with the use of the special tool: MB991658.</li> <li>• Ignition switch: "ON"</li> </ul>	Fully close the throttle valve with your finger	6 – 14 %	Code No. P0222, P0223	P.13A-335 , P.13A-341
				Fully open the throttle valve with your finger	80 % or more		
Vehicle speed	4	Vehicle speed	Drive at 40 km/h (25 mph).	Approximately 40 km/h (25 mph)	–	–	

**GENERAL SCAN TOOL (GST) MODE 01 REFERENCE TABLE**

M1131156000555

The purpose of this service of to allow access to current emission-related data values, including analogue inputs and outputs, digital inputs and outputs, and system status information.

The request for information includes a parameter identification (PID) value that indicates to the on-board system the specific information requested.

The ECM will respond to this message by transmitting the requested data value last determined by the system. All data values returned for sensor readings will be actual readings, not default or substitute values used by the system because of a fault with that sensor.

*NOTE: GST MODE 01 can be accessed through the use of a general scan tool.*

PARAMETER IDENTIFICATION (PID)	DESCRIPTION	COMMON EXAMPLE OF GENERAL SCAN TOOL DISPLAY	INSPECTION CONDITION	NORMAL CONDITION
01	Number of emission-related DTCs and MIL status	DTC and MIL status:	-	
	# of DTCs stored in this ECU	DTC_CNT: xxd		
	Malfunction Indicator Lamp (MIL) Status	MIL: OFF or ON		
	Supported tests which are continuous	Support status of continuous monitors:		
	Misfire monitoring supported	MIS_SUP: YES		
	Fuel system monitoring supported	FUEL_SUP: YES		
	Comprehensive component monitoring supported	CCM_SUP: YES		
	Status of continuous monitoring tests since DTC cleared	Completion status of continuous monitors since DTC cleared:		
	Misfire monitoring ready	MIS_RDY: YES or NO		
	Fuel system monitoring ready	FUEL_RDY: YES or NO		
	Comprehensive component monitoring ready	CCM_RDY: YES or NO		
	Supported tests run at least once per trip	Support status of non-continuous monitors:		
	Catalyst monitoring supported	CAT_SUP: YES		
	Heated catalyst monitoring supported	HCAT_SUP: NO		

PARAMETER IDENTIFICATION (PID)	DESCRIPTION	COMMON EXAMPLE OF GENERAL SCAN TOOL DISPLAY	INSPECTION CONDITION	NORMAL CONDITION
01	Evaporative system monitoring supported	EVAP_SUP: YES	-	
	Secondary air system monitoring supported	AIR_SUP: NO		
	Oxygen sensor monitoring supported	O2S_SUP: YES		
	Oxygen sensor heater monitoring supported	HTR_SUP: YES		
	EGR and/or VVT system monitoring supported	EGR_SUP: YES		
	Status of tests run at least once per trip	Completion status of non-continuous monitors since DTC cleared:		
	Catalyst monitoring ready	CAT_RDY: YES or NO		
	Heated catalyst monitoring ready	HCAT_RDY: YES		
	Evaporative system monitoring ready	EVAP_RDY: YES or NO		
	Secondary air system monitoring ready	AIR_RDY: YES		
	Oxygen sensor monitoring ready	O2S_RDY: YES or NO		
	Oxygen sensor heater monitoring ready	HTR_RDY: YES or NO		
	EGR and/or VVT system monitoring ready	EGR_RDY: YES or NO		
03	Fuel system 1 status	FUELSYS1: OL/CL/OL-Drive/OL-Fault/ L-Fault	See M.U.T.-III item No. 105.	
04	Calculated LOAD Value	LOAD_PCT: xxx.x%	See M.U.T.-III item No. 73.	
05	Engine Coolant Temperature	ECT: xxx°C (xxx°F)	See M.U.T.-III item No. 6.	
06	Short Term Fuel Trim–Bank 1	SHRTFT1: xxx.x%	See M.U.T.-III item No. 28.	
07	Long Term Fuel Trim–Bank 1	LONGFT1: xxx.x%	See M.U.T.-III item No. 26.	
0B	Intake Manifold Absolute Pressure	MAP: xxxx.x kPa (xxx.x inHg)	See M.U.T.-III item No. 8.	
0C	Engine RPM	RPM: xxxxx min <sup>-1</sup>	See M.U.T.-III item No. 2.	
0D	Vehicle Speed Sensor	VSS: xxx km/h (xxx mph)	See M.U.T.-III item No. 4.	
0E	Ignition Timing Advance for #1 Cylinder	SPARKADV: xx.x°	See M.U.T.-III item No. 16.	
0F	Intake Air Temperature	IAT: xxx°C (xxx°F)	See M.U.T.-III item No. 5.	

**MULTIPOINT FUEL INJECTION (MFI) <2.4L ENGINE>  
MULTIPOINT FUEL INJECTION (MFI) DIAGNOSIS**

**13A-835**

PARAMETER IDENTIFICATION (PID)	DESCRIPTION	COMMON EXAMPLE OF GENERAL SCAN TOOL DISPLAY	INSPECTION CONDITION	NORMAL CONDITION
10	Air Flow Rate from Mass Air Flow Sensor	MAF: xxxx.xx g/s (xxxx.x lb/min)	See M.U.T.-III item No. AA.	
11	Absolute Throttle Position	TP: xxx.x%	See M.U.T.-III item No. AB.	
13	Location of Oxygen Sensors	O2SLOC: O2Sxx	Ignition switch: "ON"	O2S11/O2S12
15	Bank 1 – Sensor 2	O2S12: x.xxx V	See M.U.T.-III item No. AD.	
1C	OBD requirements to which vehicle or engine is certified	OBDSUP: OBD II	Ignition switch: "ON"	OBD II
1F	Time Since Engine Start	RUNTM: xxxxx sec.	–	
21	Distance Traveled While MIL is Activated	MIL_DIST: xxxxx km (xxxxx miles)	–	
24	Bank 1 – Sensor 1 (wide range O2S)	LAMBDA11: xxx.xxx	See M.U.T.-III item No. E0.	
		O2S11: xxx.xxx V	See M.U.T.-III item No. E1.	
2C	Commanded EGR	EGR_PCT: xxx.x%	See M.U.T.-III item No. BA.	
2E	Commanded Evaporative Purge	EVAP_PCT: xxx.x%	See M.U.T.-III item No. 49.	
2F	Fuel Level Input	FLI: xxx.x%	See M.U.T.-III item No. 51.	
30	Number of warm-ups since DTCs cleared	WARM_UPS: xxx	–	
31	Distance traveled since DTCs cleared	CLR_DIST: xxxxx km (xxxxx miles)	–	
32	Evap System Vapor Pressure	EVAP_VP: xxxx.x Pa (xx.xxx in H2O)	<ul style="list-style-type: none"> <li>• Ignition switch: "ON"</li> <li>• Fuel cap removal</li> </ul>	–3.3 to 3.3 kPa (–13.2 to 13.2 in.H2O)
33	Barometric Pressure	BARO: xxx kPa (xx.x inHg)	See M.U.T.-III item No. BB.	

PARAMETER IDENTIFICATION (PID)	DESCRIPTION	COMMON EXAMPLE OF GENERAL SCAN TOOL DISPLAY	INSPECTION CONDITION	NORMAL CONDITION	
41	Monitor status this driving cycle		-		
	Enable status of continuous monitors this monitoring cycle:	Enable status of continuous monitors this monitoring cycle: NO means disable for rest of this monitoring cycle or not supported in PID 01, YES means enable for this monitoring cycle.			
	Misfire monitoring enabled	MIS_ENA: NO or YES			
	Fuel system monitoring enabled	FUEL_ENA: NO or YES			
	Comprehensive component monitoring enabled	CCM_ENA: NO or YES			
	Completion status of continuous monitors this monitoring cycle:				Completion status of continuous monitors this monitoring cycle:
	Misfire monitoring completed	MIS_CMPL: YES or NO			
	Fuel system monitoring completed	FUELCMPL: YES or NO			
	Comprehensive component monitoring completed	CCM_CMPL: YES or NO			
	Enable status of non-continuous monitors this monitoring cycle:				Enable status of non-continuous monitors this monitoring cycle:
	Catalyst monitoring	CAT_ENA: YES			
	Heated catalyst monitoring	HCAT_ENA: NO			
	Evaporative system monitoring	EVAP_ENA: YES			
	Secondary air system monitoring	AIR_ENA: NO			
	Oxygen sensor monitoring	O2S_ENA: YES			
	Oxygen sensor heater monitoring	HTR_ENA: YES			
	EGR and/or VVT system monitoring	EGR_ENA: YES			
	Completion status of non-continuous monitors this monitoring cycle:				Completion status of non-continuous monitors this monitoring cycle:

PARAMETER IDENTIFICATION (PID)	DESCRIPTION	COMMON EXAMPLE OF GENERAL SCAN TOOL DISPLAY	INSPECTION CONDITION	NORMAL CONDITION
41	Catalyst monitoring completed	CAT_CMPL: YES or NO	-	
	Heated catalyst monitoring completed	HCATCMPL: YES		
	Evaporative system monitoring completed	EVAPCMPL: YES or NO		
	Secondary air system monitoring completed	AIR_CMPL: YES		
	Oxygen sensor monitoring completed	O2S_CMPL: YES or NO		
	Oxygen sensor heater monitoring completed	HTR_CMPL: YES or NO		
	EGR and/or VVT system monitoring completed	EGR_CMPL: YES or NO		
42	Control module voltage	VPWR: xx.xx V	See M.U.T.-III item No. 1.	
43	Absolute Load Value	LOAD_ABS: xxxxx.x %	See M.U.T.-III item No. 72.	
44	Fuel/Air Commanded Equivalence Ratio	LAMBDA: xxx.xxx	Engine: running <ul style="list-style-type: none"> <li>"1" means "stoichiometric air fuel ratio". The smaller air fuel ratio, the rich return. The more air fuel ratio, the lean return.</li> </ul>	0 – 1.999 (Display range)
45	Relative Throttle Position	TP_R: xxx.x%	See M.U.T.-III item No. BC.	
46	Ambient air temperature	AAT: xxx°C (xxx°F)	<ul style="list-style-type: none"> <li>Ignition switch: "ON"</li> <li>Engine is cold state</li> </ul>	The value displayed approximately matches the ambient temperature
47	Absolute Throttle Position B	TP_B: xxx.x%	See M.U.T.-III item No. BD.	
49	Accelerator Pedal Position D	APP_D: xxx.x%	See M.U.T.-III item No. BE.	
4A	Accelerator Pedal Position E	APP_E: xxx.x%	See M.U.T.-III item No. BF.	
4C	Commanded Throttle Actuator Control	TAC_PCT: xxx.x%	See M.U.T.-III item No. 58.	
5A	Relative Accelerator Pedal Position	APP_R: xxx.x%	See M.U.T.-III item No. DD.	

## ACTUATOR TEST REFERENCE TABLE

M1131152503063

NOTE: \*: Continues for 27 minutes. Can be released by pressing the CLEAR key.

M.U.T.-III SCAN TOOL DISPLAY	ITEM NO.	INSPECTION ITEM	DRIVE CONTENTS	INSPECTION REQUIREMENT		NORMAL CONDITION	INSPECTION PROCEDURE NO.	REFERENCE PAGE
A/C relay	16	A/C compressor clutch relay	A/C compressor clutch relay turns from OFF to ON.	Ignition switch: "ON"		Clicks when A/C compressor clutch is driven.	Procedure No. 26	<a href="#">P.13A-812</a>
Cooling fan	14	Radiator fan, A/C condenser fan	Drive the fan motor.	Ignition switch: "ON"		Radiator fan and A/C condenser fan rotate.	—	—
EVAP. emission purge SOL. Valve	10	Evaporative emission purge solenoid	Solenoid valve turns from OFF to ON.	Ignition switch: "ON"		Clicks when solenoid valve is driven.	Code No. P0443	<a href="#">P.13A-419</a>
EVAP. emission ventilation SOL.	15	Evaporative emission ventilation solenoid	Solenoid valve turns from OFF to ON.	Ignition switch: "ON"		Clicks when solenoid valve is driven.	Code No. P0446	<a href="#">P.13A-426</a>
Fuel pump	9	Fuel pump	Fuel pump operates and fuel is recirculated .	Ignition switch: "ON"	Listen near the fuel tank for the sound of fuel pump operati on.	Sound of operation is heard.	Procedure No. 23	<a href="#">P.13A-788</a>



**MULTIPOINT FUEL INJECTION (MFI) <2.4L ENGINE>  
MULTIPOINT FUEL INJECTION (MFI) DIAGNOSIS**

**13A-839**

M.U.T.-III SCAN TOOL DISPLAY	ITEM NO.	INSPECTION ITEM	DRIVE CONTENTS	INSPECTION REQUIREMENT	NORMAL CONDITION	INSPECTION PROCEDURE NO.	REFERENCE PAGE
Ignition timing 5 BTDC	11*	Basic ignition timing	Set to ignition timing adjustment mode.	<ul style="list-style-type: none"> <li>• Engine: idling</li> <li>• Connect timing light</li> </ul>	5°BTDC	—	—
Injector stop	1	Injectors	Specified injector is stopped.	Engine: warm up, idle. (cut the fuel supply to each injector in turn and check cylinders which don't affect idling)	Idle condition is changed by stopping selected cylinder: this can cause an unstable condition and the engine may stall.	Code No. P0201, Code No. P0202, Code No. P0203, Code No. P0204	<a href="#">P.13A-292</a> , <a href="#">P.13A-302</a> , <a href="#">P.13A-312</a> , <a href="#">P.13A-322</a>
Oil control valve	17	Intake engine oil control valve, exhaust engine oil control valve	Switch the intake engine oil control valve and exhaust engine oil control valve from OFF to ON.	Ignition switch: ON	When the valve is actuated, operating noise is audible.	Code No. P0010, P0013	<a href="#">P.13A-58</a> , <a href="#">P.13A-68</a>

**CHECK AT THE ENGINE CONTROL MODULE (ECM)**

1. Disconnect the ECM connectors B-10 and B-11, and connect check harness special tool MB992110 between the ECM connectors.
2. Measure the voltage between each check harness connector terminal and check harness connector ground terminal (No. 81 or No. 93).

**TERMINAL VOLTAGE CHECK CHART**

NOTE: \*1: The average voltage through an analog voltmeter is described in this service manual (because the average voltage would be not constantly shown on a digital voltmeter).

NOTE: \*2: Vehicles for Canada, the headlight, taillight, etc. remain lit even when the lighting switch is in "OFF" position but is no problem for checks.

NOTE: \*3: If the battery is fully charged, the output reading may be incorrect.

Check Harness Special Tool MB992110 Connector Terminal Arrangement

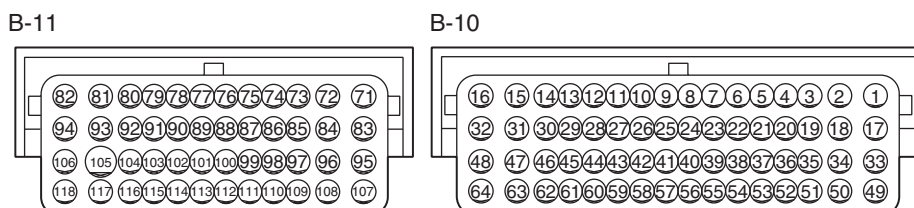

AK700419AB

TERMINAL NO.	INSPECTION ITEM	INSPECTION CONDITION (ENGINE CONDITION)	NORMAL CONDITION
1	Intake engine oil control valve	Engine: Warming up, idling	B+
		Engine: Warming up, under the high load operation.	4 – 10 V*1
2	No. 1 injector	Engine: While engine is idling after having warmed up, suddenly depress the accelerator pedal.	From 9 – 15 V*1, it is slightly reduced temporarily.
3	No. 2 injector		
18	No. 3 injector		
19	No. 4 injector		
4	Ignition coil No. 1 (ignition power transistor)	Engine: 3,000 r/min	0.3 – 3.0 V*1
5	Ignition coil No. 2 (ignition power transistor)		
20	Ignition coil No. 3 (ignition power transistor)		
21	Ignition coil No. 4 (ignition power transistor)		
6	Starter active signal	Engine: cranking	B+
		Engine: idling	1 V or less
7	Exhaust camshaft position sensor	Engine: cranking	2.0 – 4.8 V*1
		Engine: idling	2.0 – 3.0 V*1

<b>TERMINAL NO.</b>	<b>INSPECTION ITEM</b>	<b>INSPECTION CONDITION (ENGINE CONDITION)</b>		<b>NORMAL CONDITION</b>
8	Crankshaft position sensor	Engine: cranking		0.4 – 4.0 V*1
		Engine: idling		2.0 – 3.0 V*1
9	Sensor supplied voltage	Ignition switch: "ON"		B+
10	Throttle position sensor (main)	<ul style="list-style-type: none"> <li>• Remove the intake air hose at the throttle body</li> <li>• Disconnect the throttle position sensor connector, and then connect terminal numbers No. 3, No. 4, No. 5 and No. 6 with the use of the special tool: MB991658.</li> <li>• Ignition switch: "ON"</li> </ul>	Fully close the throttle valve with your finger	0.3 – 0.7 V
			Fully open the throttle valve with your finger	4.0 V or more
11	Throttle position sensor (sub)	<ul style="list-style-type: none"> <li>• Remove the intake air hose at the throttle body</li> <li>• Disconnect the throttle position sensor connector, and then connect terminal numbers No. 3, No. 4, No. 5 and No. 6 with the use of the special tool: MB991658.</li> <li>• Ignition switch: "ON"</li> </ul>	Fully close the throttle valve with your finger	4 V or more
			Fully open the throttle valve with your finger	1 V or less
12	Power supply voltage applied to throttle position sensor	Ignition switch: "ON"		4.9 – 5.1 V
14	Intake camshaft position sensor	Engine: cranking		2.0 – 4.8 V
		Engine: idling		2.0 – 3.0 V

TERMINAL NO.	INSPECTION ITEM	INSPECTION CONDITION (ENGINE CONDITION)	NORMAL CONDITION	
15	Throttle actuator control motor (+)	Ignition switch: "ON" Accelerator pedal: fully opened → fully closed	Decreases slightly (Approximately 2 V) from battery voltage.	
16	Throttle actuator control motor (-)	Ignition switch: "ON" Accelerator pedal: fully closed → fully opened	Decreases slightly (Approximately 2 V) from battery voltage.	
17	Exhaust engine oil control valve	Engine: warming up, idling	B+	
		Engine: Warming up, under the high load operation.	4.0 – 10 V* <sup>1</sup>	
26	Engine coolant temperature sensor	Ignition switch: "ON"	When engine coolant temperature is -20°C (-4°F)	3.9 – 4.5 V
			When engine coolant temperature is 0°C (32°F)	3.2 – 3.8 V
			When engine coolant temperature is 20°C (68°F)	2.3 – 2.9 V
			When engine coolant temperature is 40°C (104°F)	1.3 – 1.9 V
			When engine coolant temperature is 60°C (140°F)	0.7 – 1.3 V
			When engine coolant temperature is 80°C (176°F)	0.3 – 0.9 V
31	EGR valve [stepper motor coil (A)]	Ignition switch: "LOCK" (OFF) → "ON"	5 – 8 V* <sup>1</sup> (changes about three seconds repeatedly)	
32	EGR valve [stepper motor coil (B)]			
47	EGR valve [stepper motor coil (C)]			
48	EGR valve [stepper motor coil (D)]			
34	Linear air-fuel ratio sensor heater	Engine: warming up, idling (1 minute after starting engine)	8 – 11 V* <sup>1</sup>	
		Engine: revving	From 8 – 11 V* <sup>1</sup> , it is slightly reduced temporarily.	
35	Heated oxygen sensor (rear) heater	Engine warming up, idling (20 seconds after starting engine)	9 – 11 V* <sup>1</sup>	
		Engine: revving	9 – 11 V* <sup>1</sup> → B+ (momentarily)	
36	Engine oil pressure switch	Ignition switch: "ON"	0 – 0.1 V	
		Engine: idling	B+	

<b>TERMINAL NO.</b>	<b>INSPECTION ITEM</b>	<b>INSPECTION CONDITION (ENGINE CONDITION)</b>		<b>NORMAL CONDITION</b>
37	Evaporative emission purge solenoid	Ignition switch: "ON"		B+
		Engine: warming up, 3,000 r/min (with 3 minutes after the engine starting sequence is completed)		Voltage drops
40	Heated oxygen sensor (rear)	<ul style="list-style-type: none"> <li>• Transaxle: 2nd</li> <li>• Drive with wide open throttle</li> <li>• Engine: 3,500 r/min or more</li> </ul>		1.0 – 1.5 V
41	Heated oxygen sensor (rear) offset voltage	Ignition switch: "ON"		0.4 – 0.6 V
44	Power supply voltage applied to manifold absolute pressure sensor	Ignition switch: "ON"		4.9 – 5.1 V
45	Manifold absolute pressure sensor	Ignition switch: "ON"	At altitude of 0 m (0 ft.)	3.8 – 4.2 V
			At altitude of 600 m (1,969 ft.)	3.5 – 3.9 V
			At altitude of 1,200 m (3,937 ft.)	3.3 – 3.7 V
			At altitude of 1,800 m (5,906 ft.)	3.0 – 3.4 V
		Engine: warming up, idling		0.6 – 1.4 V
		When engine is suddenly revved		Voltage varies
58	Power steering pressure switch	Engine: warming up, idling	When steering wheel is not turned	B+
			When steering wheel is turned	1 V or less
60	Generator G terminal	<ul style="list-style-type: none"> <li>• Engine: warming up, idling</li> <li>• Radiator fan: stopped</li> <li>• Headlight: OFF to ON*2</li> <li>• Stop light: OFF to ON</li> <li>• Rear defogger switch: OFF to ON</li> </ul>		Voltage increases
61	Generator FR terminal	<ul style="list-style-type: none"> <li>• Engine: warming up, idling</li> <li>• Radiator fan: stopped</li> <li>• Headlight: OFF to ON*2</li> <li>• Stop light: OFF to ON</li> <li>• Rear defogger switch: OFF to ON</li> </ul>		Voltage drops
62	Generator L terminal	Ignition switch: "ON"		0.5 – 2.0 V
		Engine: idling		B+
72	Power supply voltage applied to throttle actuator control motor	Ignition switch: "ON"		B+

TERMINAL NO.	INSPECTION ITEM	INSPECTION CONDITION (ENGINE CONDITION)		NORMAL CONDITION
73	MFI relay (power supply)	Ignition switch: "LOCK" (OFF)		B+
		Ignition switch: "ON"		1 V or less
74	Accelerator pedal position sensor (main)	Ignition switch: "ON"	Release the accelerator pedal	0.9 – 1.1 V
			Depress the accelerator pedal fully	4 V or more
75	Power supply voltage applied to accelerator pedal position sensor (main)	Ignition switch: "ON"		4.9 – 5.1 V
77	Accelerator pedal position sensor (sub)	Ignition switch: "ON"	Release the accelerator pedal	0.4 – 0.6 V
			Depress the accelerator pedal fully	2 V or more
78	Power supply voltage applied to accelerator pedal position sensor (sub)	Ignition switch: "ON"		4.9 – 5.1 V
82	Power supply	Ignition switch: "ON"		B+
84	Throttle actuator control motor relay	Ignition switch: "ON" → "LOCK" (OFF)		1 V or less → B+ → 1 V or less
87	Mass airflow sensor	Engine is revved		Voltage increases in response to revving
89	Intake air temperature sensor	Ignition switch: "ON"	When intake air temperature is –20°C (–4°F)	3.8 – 4.4 V
			When intake air temperature is 0°C (32°F)	3.2 – 3.8 V
			When intake air temperature is 20°C (68°F)	2.3 – 2.9 V
			When intake air temperature is 40°C (104°F)	1.5 – 2.1 V
			When intake air temperature is 60°C (140°F)	0.8 – 1.4 V
			When intake air temperature is 80°C (176°F)	0.4 – 1.0 V
92	Ignition switch-IG	Ignition switch: "ON"		B+
96	Fuel pump relay	Ignition switch: "ON"		B+
		Engine: idling		1.0 V or less

<b>TERMINAL NO.</b>	<b>INSPECTION ITEM</b>	<b>INSPECTION CONDITION (ENGINE CONDITION)</b>	<b>NORMAL CONDITION</b>	
98	Battery temperature sensor	Ignition switch: "ON"	When the intake air temperature is -20°C (-4°F)	3.8 – 4.4 V
			When the intake air temperature is 0°C (32°F)	3.2 – 3.8 V
			When the intake air temperature is 20°C (68°F)	2.3 – 2.9 V
			When the intake air temperature is 40°C (104°F)	1.5 – 2.1 V
			When the intake air temperature is 60°C (140°F)	0.8 – 1.4 V
			When the intake air temperature is 80°C (176°F)	0.4 – 1.0 V
100	Battery current sensor	The battery is being discharged. <ul style="list-style-type: none"> <li>• Engine: Cranking</li> </ul>	The value changes by the value less than 3.5 V.	
		The battery is being charged. <ul style="list-style-type: none"> <li>• Leave the ignition switch being in the ON position for several minutes, and then after the engine start.</li> </ul>	The value gradually increases from the value more than 3.5 V*3	
102	A/C compressor clutch relay	<ul style="list-style-type: none"> <li>• Engine: idling</li> <li>• A/C switch: OFF → ON (A/C compressor is operating)</li> </ul>	B+ → 1 V or less as A/C clutch cycles	
104	Backup power supply	Ignition switch: "LOCK" (OFF)	B+	
105	Ignition switch-ST	Ignition switch: cranking	8 V or more	
106	Starter relay	Engine: cranking	B+	
		Engine: idling	1 V or less	
112	Fuel tank differential pressure sensor	<ul style="list-style-type: none"> <li>• Ignition switch: "ON"</li> <li>• Fuel cap removal</li> </ul>	1.5 – 3.5 V	
114	Power supply voltage applied to fuel tank differential pressure sensor	Ignition switch: "ON"	4.9 – 5.1 V	

TERMINAL NO.	INSPECTION ITEM	INSPECTION CONDITION (ENGINE CONDITION)		NORMAL CONDITION
115	Fuel tank temperature sensor	Ignition switch: "ON"	When fuel tank temperature is 0°C (32°F)	2.7 – 3.1 V
			When fuel tank temperature is 20°C (68°F)	2.1 – 2.5 V
			When fuel tank temperature is 40°C (104°F)	1.6 – 2.0 V
			When fuel tank temperature is 80°C (176°F)	0.8 – 1.2 V
117	Evaporative emission ventilation solenoid	Ignition switch: "ON"		B+
		Carry out the actuator test to drive the solenoid valve.		1 V or less (Approximately 6 seconds)



**TERMINAL RESISTANCE AND CONTINUITY CHECK**

ECM Harness side Connector Terminal Arrangement

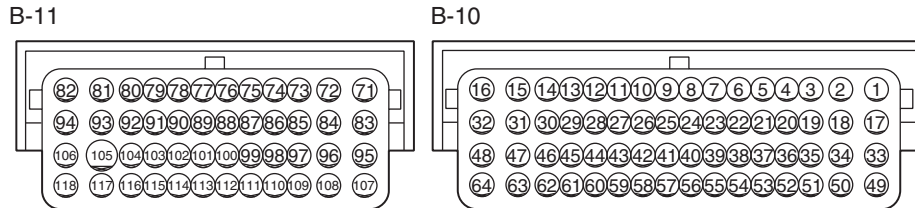

AK700420AB

TERMINAL NO.	INSPECTION ITEM	NORMAL CONDITION (INSPECTION CONDITION)
1 – 82	Intake engine oil control valve	6.9 – 7.9 Ω [at 20°C (68°F)]
15 – 16	Throttle actuator control motor	0.3 – 80 Ω [at 20°C (68°F)]
17 – 82	Exhaust engine oil control valve	6.9 – 7.9 Ω [at 20°C (68°F)]
26 – 27	Engine coolant temperature sensor	14 – 17 kΩ [when engine coolant temperature is –20°C (–4°F)]
		5.1 – 6.5 kΩ [when engine coolant temperature is 0°C (32°F)]
		2.1 – 2.7 kΩ [when engine coolant temperature is 20°C (68°F)]
		0.9 – 1.3 kΩ [when engine coolant temperature is 40°C (104°F)]
		0.48 – 0.68 kΩ [when engine coolant temperature is 60°C (140°F)]
		0.26 – 0.36 kΩ [when engine coolant temperature is 80°C (176°F)]
31 – 82	EGR valve [Stepper motor coil (A)]	20 – 24 Ω [at 20°C (68°F)]
32 – 82	EGR valve [Stepper motor coil (B)]	
47 – 82	EGR valve [Stepper motor coil (C)]	
48 – 82	EGR valve [Stepper motor coil (D)]	
34 – 82	Linear air-fuel ratio sensor heater	2.3 – 4.2 Ω [at 20°C (68°F)]
35 – 82	Heated oxygen sensor (rear) heater	4.5 – 8.0 Ω [at 20°C (68°F)]
37 – 82	Evaporative emission purge solenoid	22 – 26 Ω [at 20°C (68°F)]
71 – Body ground	ECM ground	Continuity (2 Ω or less)
81 – Body ground		
83 – Body ground		
93 – Body ground		
82 – 117	Evaporative emission ventilation solenoid	17 – 21 Ω [at 20°C (68°F)]

TERMINAL NO.	INSPECTION ITEM	NORMAL CONDITION (INSPECTION CONDITION)
88 – 89	Intake air temperature sensor	13 – 17 kΩ [when intake air temperature is -20°C (-4°F)]
		5.4 – 6.6 kΩ [when intake air temperature is 0°C (32°F)]
		2.3 – 3.0 kΩ [when intake air temperature is 20°C (68°F)]
		1.0 – 1.65 kΩ [when intake air temperature is 40°C (104°F)]
		0.56 – 0.76 kΩ [when intake air temperature is 60°C (140°F)]
		0.31 – 0.43 kΩ [when intake air temperature is 80°C (176°F)]
98 – 101	Battery temperature sensor	4.9 – 5.3 kΩ [when intake air temperature is 0°C (32°F)]
		2.2 – 2.6 kΩ [when intake air temperature is 20°C (68°F)]
		1.0 – 1.4 kΩ [when intake air temperature is 40°C (104°F)]

**INSPECTION PROCEDURE USING AN OSCILLOSCOPE**

M1131154502248

**INTAKE CAMSHAFT POSITION SENSOR AND CRANKSHAFT POSITION SENSOR**

**Required Special Tools:**

- MB991709: Test Harness
- MB992110: Power Plant ECU Check Harness

**Measurement Method**

1. Disconnect the intake camshaft position sensor connector, and connect the test harness special tool (MB991709) between the separated connector (All terminals should be connected).
2. Connect the oscilloscope probe to intake camshaft position sensor connector terminal No. 3.
3. Disconnect the crankshaft position sensor connector, and connect the test harness special tool (MB991709) between the separated connector.
4. Connect the oscilloscope probe to crankshaft position sensor connector terminal No. 3.

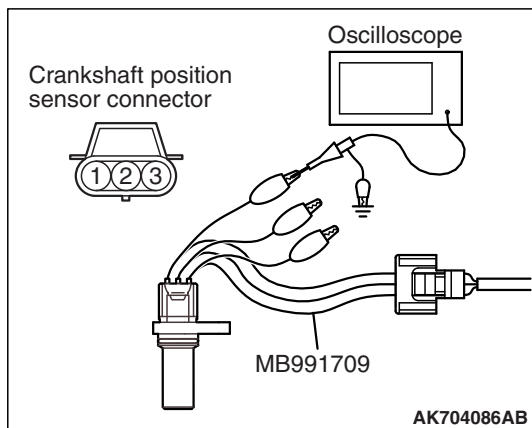
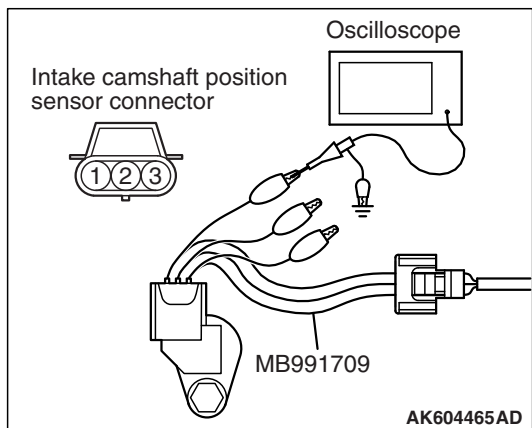

**Alternate method**

1. Disconnect all ECM connectors. Connect the check harness special tool (MB992110) between the separated connectors.

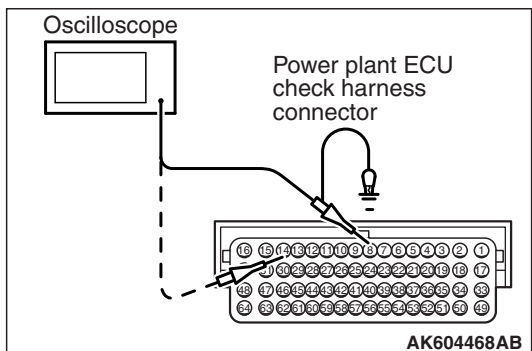
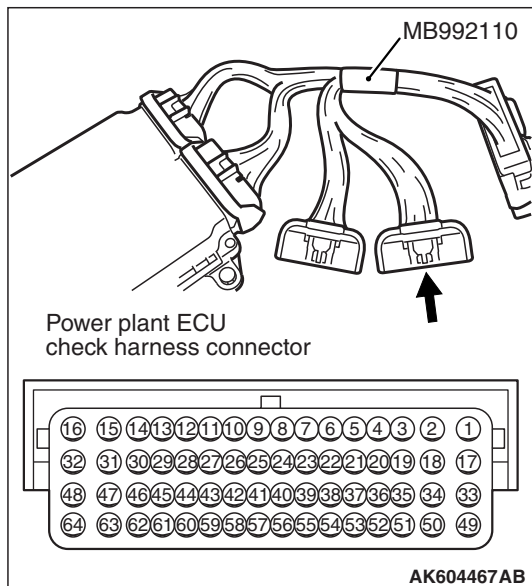

2. Connect the oscilloscope to check harness terminal No. 14. (Check the intake camshaft position sensor signal wave pattern.)
3. Connect the oscilloscope to check harness terminal No. 8. (Check the crankshaft position sensor signal wave pattern.)

**Standard Wave Pattern**

Observation condition	
Function	Special pattern
Pattern height	Low
Pattern selector	Display
Engine condition	Idle

Standard wave pattern

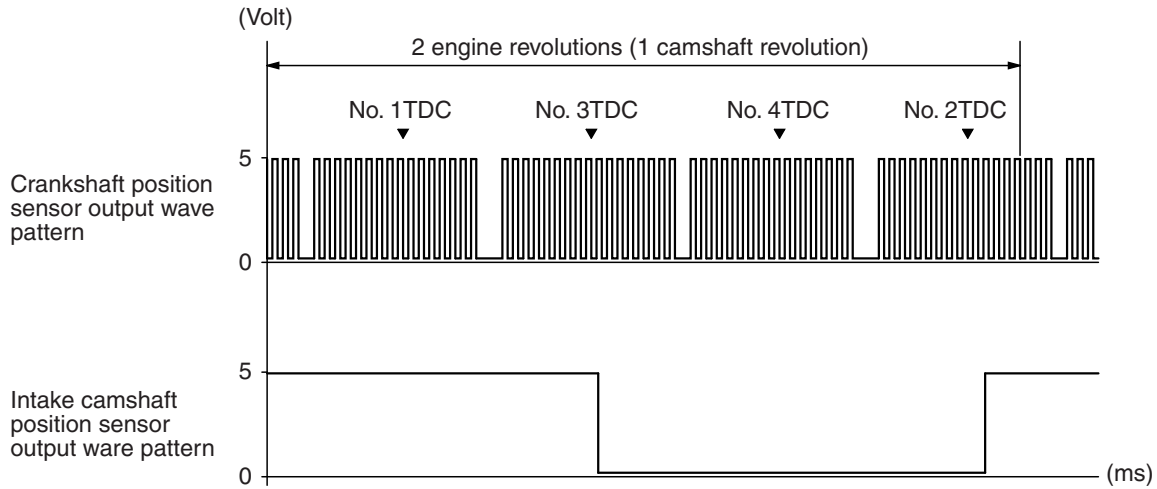

AK703715AB

Wave Pattern Observation Points

1. Check that cycle time becomes shorter when the engine speed increased.

Examples of Abnormal Wave Patterns

Example 1

Cause of problem

- Sensor interface malfunction.

Wave pattern characteristics

- Rectangular wave pattern is output even when the engine is not started.

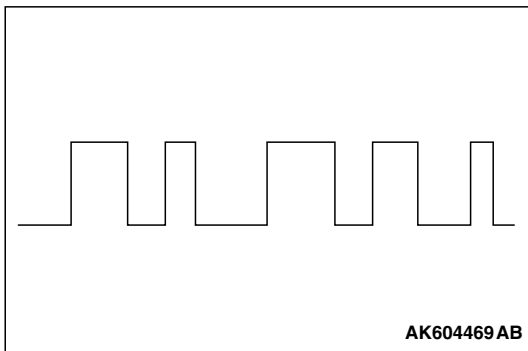

AK604469AB

Example 2

Cause of problem

- Loose timing belt.
- Abnormality in sensor disc.

Wave pattern characteristics

- Wave pattern is displaced to the left or right.

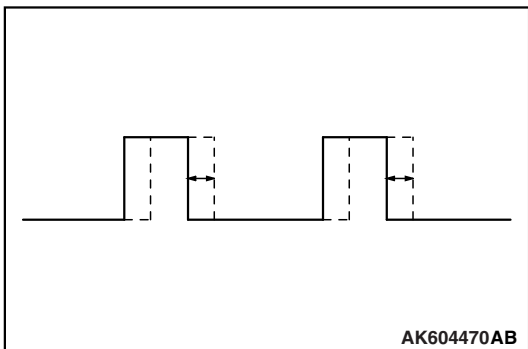

AK604470AB

## EXHAUST CAMSHAFT POSITION SENSOR AND CRANKSHAFT POSITION SENSOR

### Required Special Tools:

- MB991709: Test Harness
- MB992110: Power Plant ECU Check Harness

### Measurement Method

1. Disconnect the exhaust camshaft position sensor connector, and connect the test harness special tool (MB991709) between the separated connector (All terminals should be connected).
2. Connect the oscilloscope probe to exhaust camshaft position sensor connector terminal No. 3.
3. Disconnect the crankshaft position sensor connector, and connect the test harness special tool (MB991709) between the separated connector.
4. Connect the oscilloscope probe to crankshaft position sensor connector terminal No. 3.

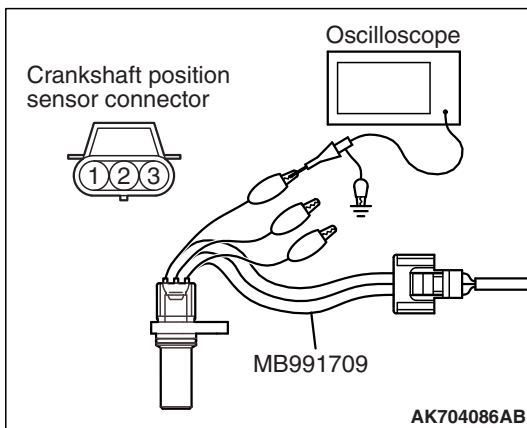
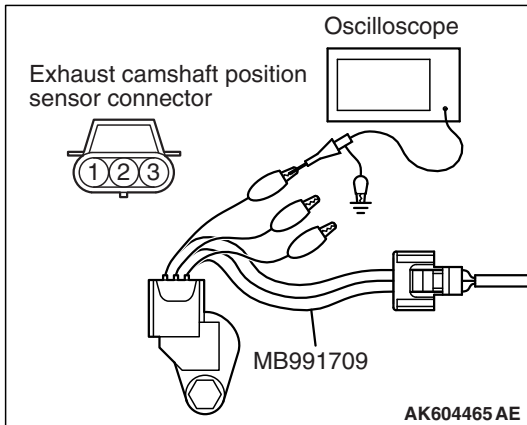

### Alternate method

1. Disconnect all ECM connectors. Connect the check harness special tool (MB992110) between the separated connectors.

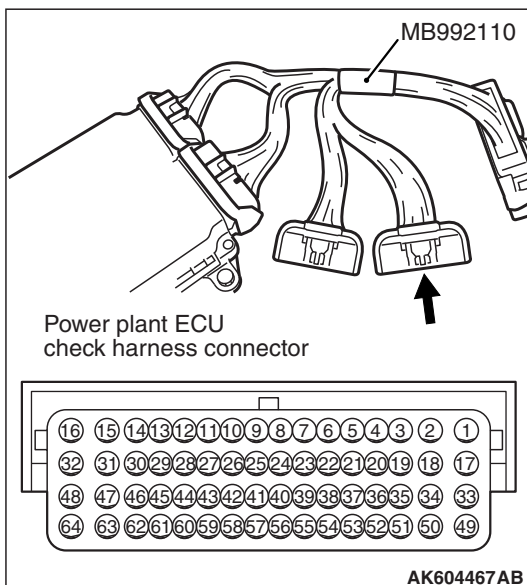

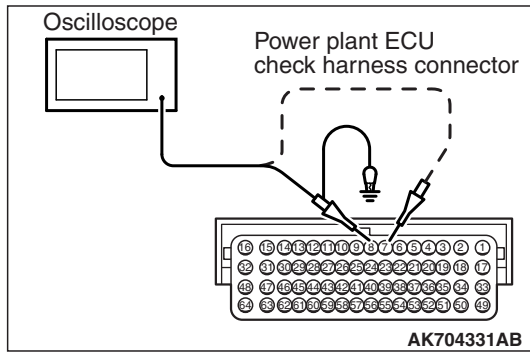

2. Connect the oscilloscope to check harness terminal No. 7. (Check the exhaust camshaft position sensor signal wave pattern.)
3. Connect the oscilloscope to check harness terminal No. 8. (Check the crankshaft position sensor signal wave pattern.)

**Standard Wave Pattern**

Observation condition	
Function	Special pattern
Pattern height	Low
Pattern selector	Display
Engine condition	Idle

**Standard wave pattern**

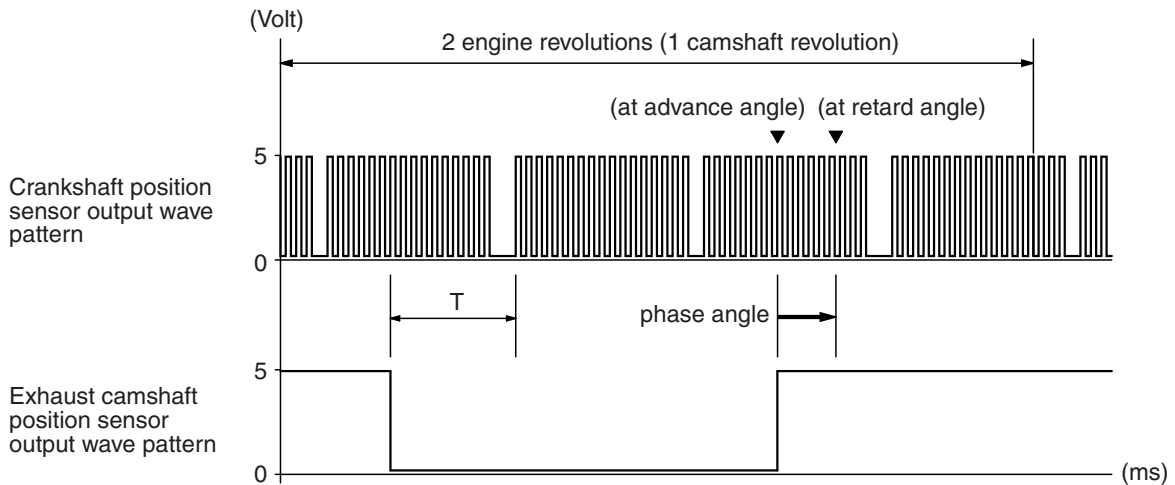

AK704329AB

**Wave Pattern Observation Points**

- Verify that, toward the engine speed of 2,500 r/min, time difference T from when the crankshaft position sensor output wave falls to when the exhaust camshaft position sensor output wave falls becomes less.

## Examples of Abnormal Wave Patterns

### Example 1

Cause of problem

- Sensor interface malfunction.

Wave pattern characteristics

- Rectangular wave pattern is output even when the engine is not started.

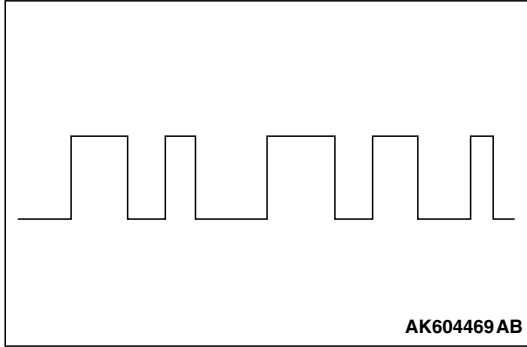

### Example 2

Cause of problem

- Loose timing belt.
- Abnormality in sensor disc.

Wave pattern characteristics

- Wave pattern is displaced to the left or right.

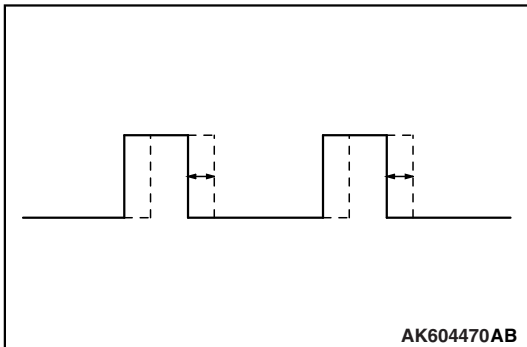

## INJECTOR

### Required Special Tools:

- MB991658: Test Harness
- MB992110: Power Plant ECU Check Harness

### Measurement Method

1. Disconnect the injector connector, and connect the test harness special tool (MB991658) between the separated connector. (All terminals should be connected.)
2. Connect the oscilloscope probe to injector connector terminal No. 2.

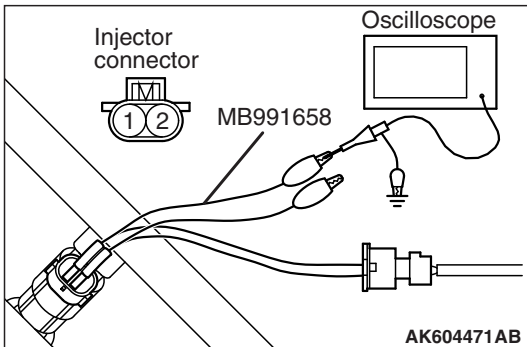

**Alternate method**

1. Disconnect all ECM connectors. Connect the check harness special tool (MB992110) between the separated connectors.

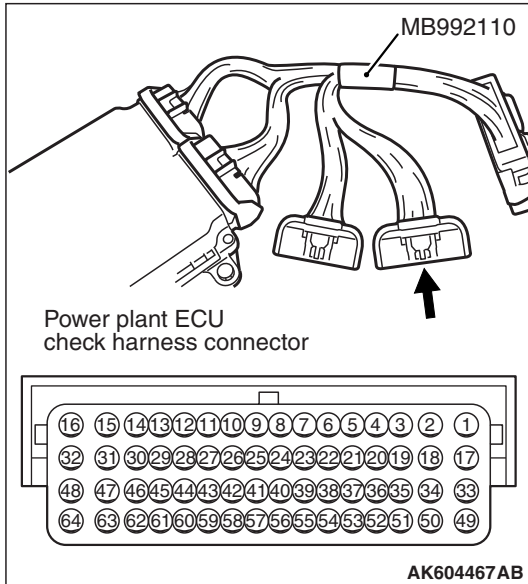

2. Connect the oscilloscope probe to each check harness connector terminal to analyze each cylinder:

- Terminal No. 2 for the number 1 cylinder.
- Terminal No. 3 for the number 2 cylinder.
- Terminal No. 18 for the number 3 cylinder.
- Terminal No. 19 for the number 4 cylinder.

**Standard Wave Pattern**

Observation conditions	
Function	Special pattern
Pattern height	Variable
Variable knob	Adjust while viewing the wave pattern
Pattern selector	Display
Engine condition	Idle

**Standard wave pattern**

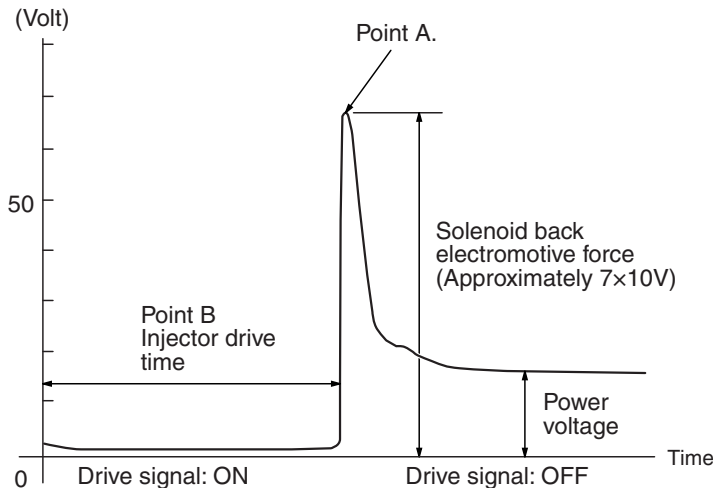

AK301250AF



**Wave Pattern Observation Points**

Point A: Height of injector coil induced voltage.

CONTRAST WITH STANDARD WAVE PATTERN	PROBABLE CAUSE
Injector coil induced voltage is low or doesn't appear at all	Short in the injector solenoid

Point B: Injector drive time

1. The injector drive time should be synchronized with the scan tool tester display.
2. When the engine is suddenly revved, the drive time will be greatly extended at first, but the drive time will soon return to original length.

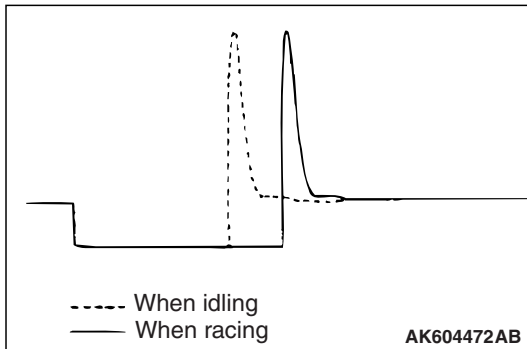

**EGR VALVE (STEPPER MOTOR)**

**Required Special Tools:**

- MB991658: Test Harness
- MB992110: Power Plant ECU Check Harness

**Measurement Method**

1. Disconnect the EGR valve connector, and connect the test harness special tool (MB991658) between the separated connector (All terminals should be connected).
2. Connect the oscilloscope probe to the EGR valve connector terminal No. 1, terminal No. 3, terminal No. 4, terminal No. 6 respectively.

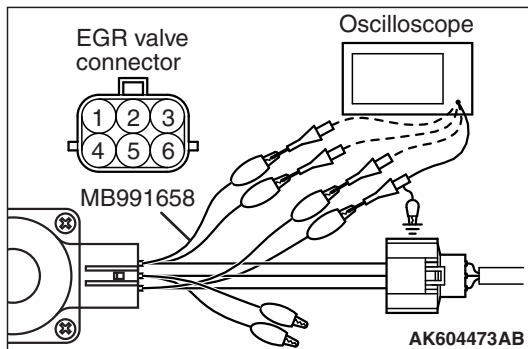

**Alternate method**

1. Disconnect all ECM connectors. Connect the check harness special tool (MB992110 between the separated connectors.

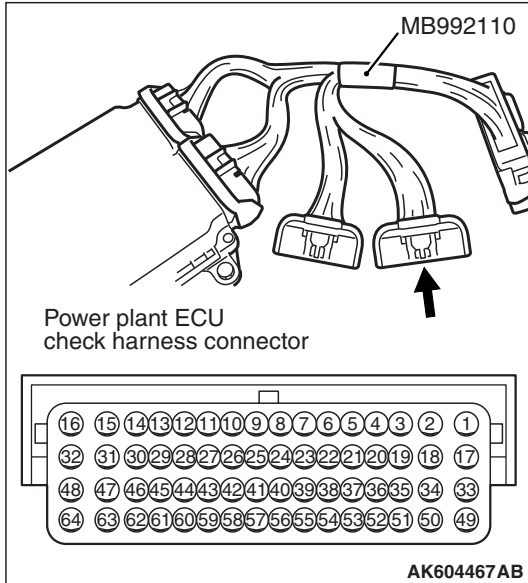

2. Connect the oscilloscope probe to check harness terminal No. 31, No. 32, No. 47 and No. 48.

**Standard Wave Pattern**

Observation condition	
Function	Special pattern
Pattern height	High
Pattern selector	Display
Engine condition	Revving

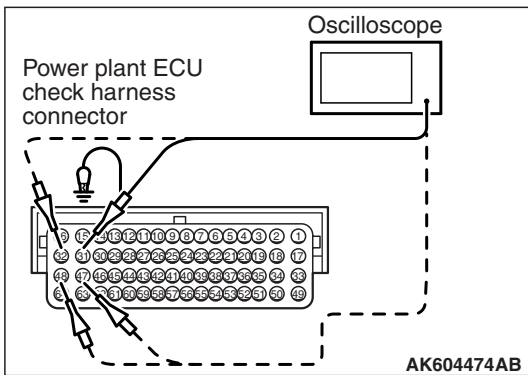

**Standard wave pattern**

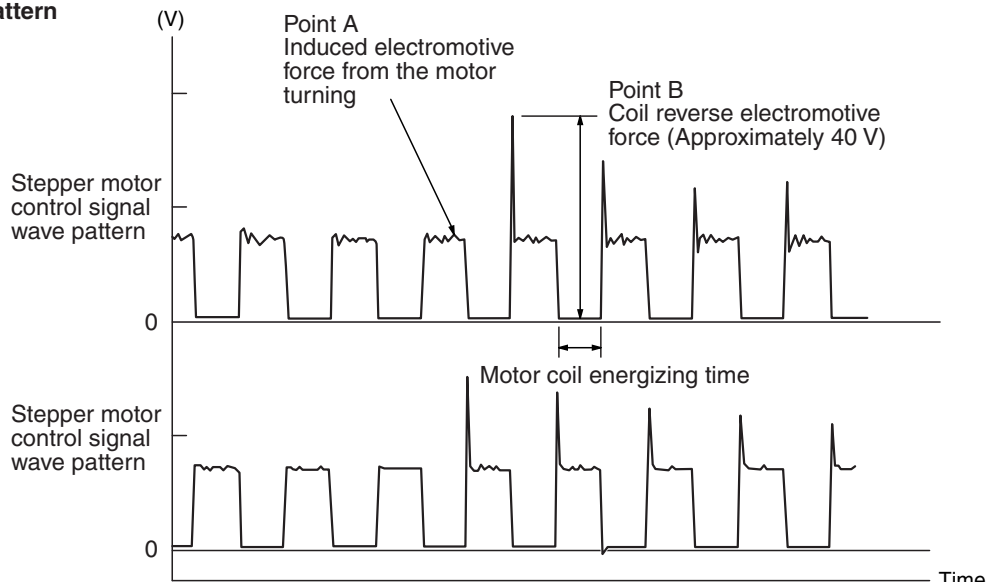

AK301251AG

**Wave Pattern Observation Points**

1. Check that the standard wave pattern appears when the EGR valve is operating.

Point A: Presence or absence of induced electromotive force from the motor turning. (Refer to abnormal wave pattern.)

CONTRAST WITH STANDARD WAVE PATTERN	PROBABLE CAUSE
Induced electromotive force does not appear or is extremely small	Malfunction of motor

Point B: Height of coil back electromotive force

CONTRAST WITH STANDARD WAVE PATTERN	PROBABLE CAUSE
Coil reverse electromotive force does not appear or is extremely small	Short in the coil

### Examples of Abnormal Wave Patterns

#### Example 1

Cause of problem

- Malfunction of motor. (Motor is not operating.)

Wave pattern characteristics

- Induced electromotive force from the motor turning does not appear.

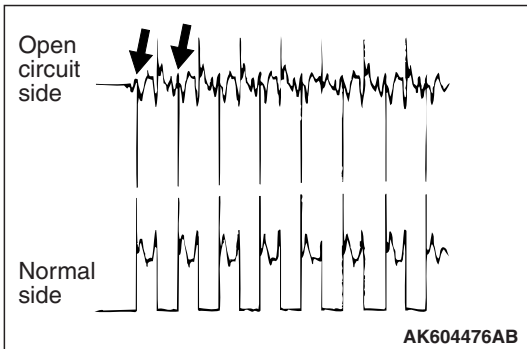
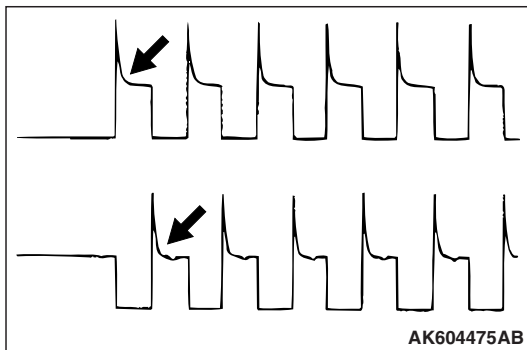

#### Example 2

Cause of problem

- Open circuit in the line between the EGR valve and the ECM.

Wave pattern characteristics

- Current is not supplied to the motor coil on the open circuit side. (Voltage does not drop to 0 volt.) Furthermore, the induced electromotive force wave pattern at the normal side is slightly different from the normal wave pattern.

### IGNITION COIL AND IGNITION POWER TRANSISTOR

Required Special Tools:

- MB991658: Test Harness
- MB992110: Power Plant ECU Check Harness

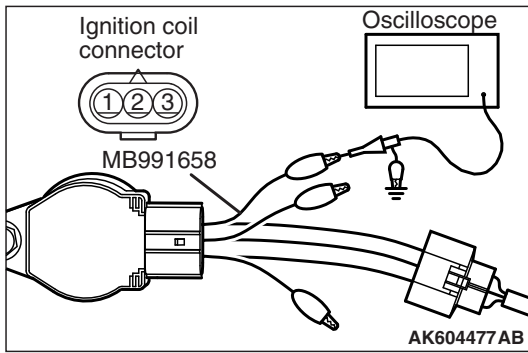

**Measurement Method**

1. Disconnect the ignition coil connector, and connect test harness special tool (MB991658) between the separated connector. (All terminals should be connected.)
2. Connect the oscilloscope probe to ignition coil connector terminal No. 2.

**Alternate method**

1. Disconnect all ECM connectors. Connect the check harness special tool (MB992110) between the separated connectors.

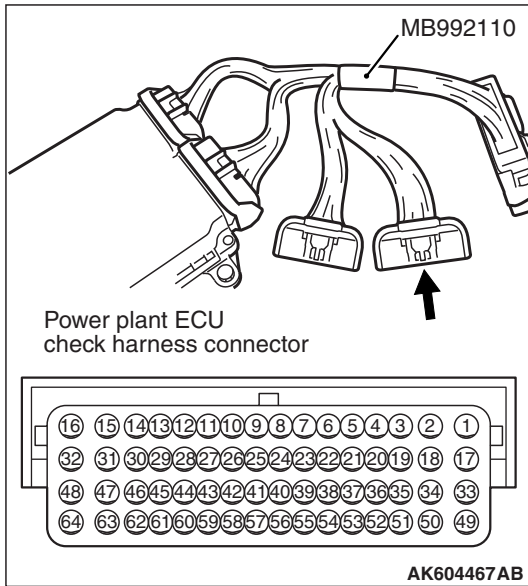

2. Connect the oscilloscope probe to each check harness connector terminal to analyze each cylinder:
  - Terminal No. 4 for the number 1 cylinder.
  - Terminal No. 5 for the number 2 cylinder.
  - Terminal No. 20 for the number 3 cylinder.
  - Terminal No. 21 for the number 4 cylinder.

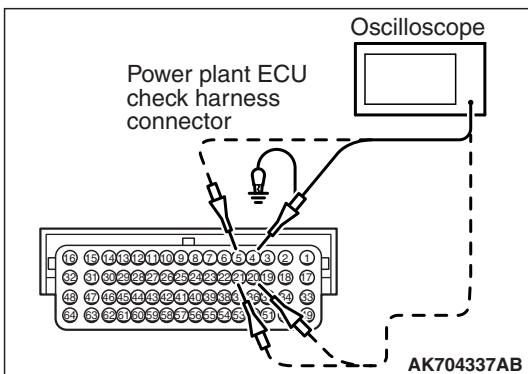

**Standard Wave Pattern**

Observation condition	
Function	Special pattern
Pattern height	Low
Pattern selector	Display
Engine condition	Idle

**Standard wave pattern**

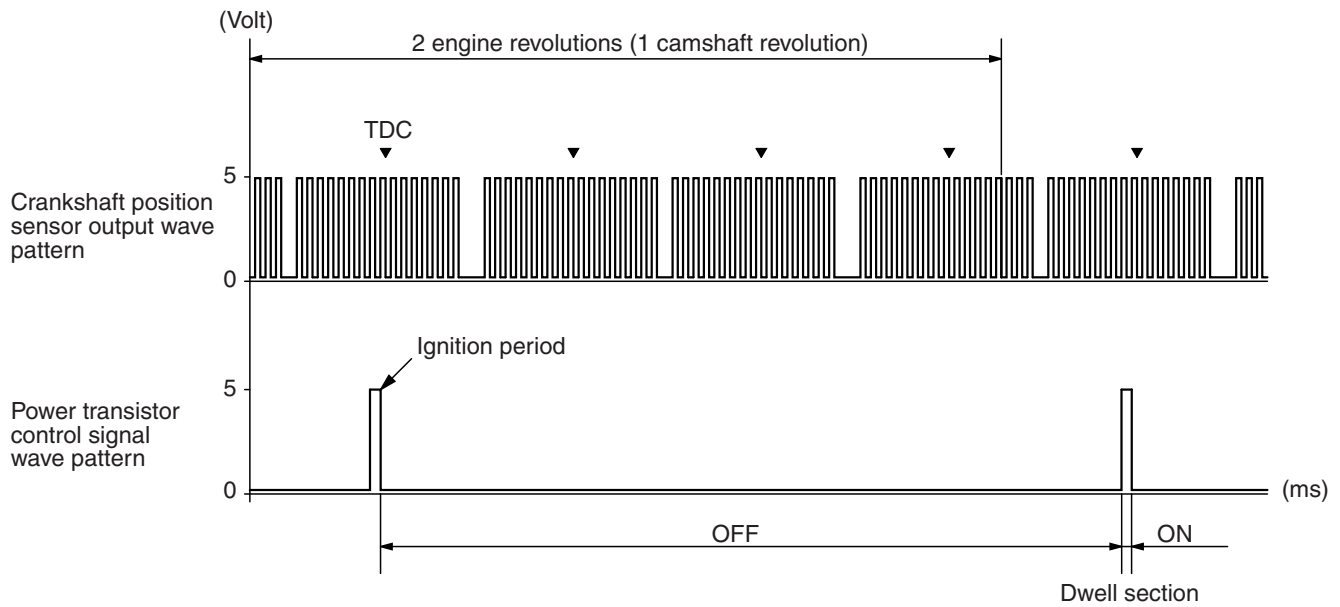

AK704330AB

**Wave Pattern Observation Points**

Point: The power transistor control signal (ignition timing) is advanced when the engine speed is increased.

CONDITION OF WAVE PATTERN BUILD-UP SECTION AND MAXIMUM VOLTAGE	PROBABLE CAUSE
Voltage value is too low	Open-circuit in ignition primary circuit

**Examples of Abnormal Wave Patterns**

**Example 1 (Wave pattern during engine cranking)**

- Cause of problem  
Open-circuit in ignition primary circuit
- Wave pattern characteristics  
Voltage value is too low.

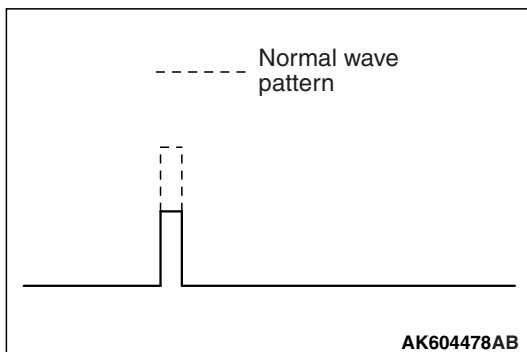

**ON-VEHICLE SERVICE****COMPONENT LOCATION**

M1131002103665

NAME	SYMBOL	NAME	SYMBOL
Accelerator pedal position sensor	U	Ignition coil	B
A/C compressor clutch relay	I	Injector	N
Battery current sensor (incorporating battery temperature sensor)	Q	Injector relay	I
Crankshaft position sensor	C	Intake camshaft position sensor	D
Data link connector	S	Intake engine oil control valve	J
Engine control module	H	Knock sensor	L
Engine coolant temperature sensor	F	Linear air-fuel ratio sensor	V
ETACS-ECU (incorporating fuel pump relay)	R	Malfunction Indicator Lamp (SERVICE ENGINE SOON or Check Engine Lamp)	T
Evaporative emission purge solenoid	O	Manifold absolute pressure sensor	M
Evaporative emission ventilation solenoid	Y	Mass airflow sensor (incorporating intake air temperature sensor)	G
Exhaust camshaft position sensor	E	MFI relay	I
Exhaust engine oil control valve	A	Power steering pressure switch	K
Exhaust gas recirculation (EGR) valve	O	Starter relay	I
Fuel pump module (incorporating fuel level sensor and fuel tank temperature sensor)	X	Throttle actuator control motor relay	I
Fuel tank differential pressure sensor	X	Throttle body assembly (incorporating throttle position sensor and throttle actuator control motor)	P
Heated oxygen sensor (rear)	W		

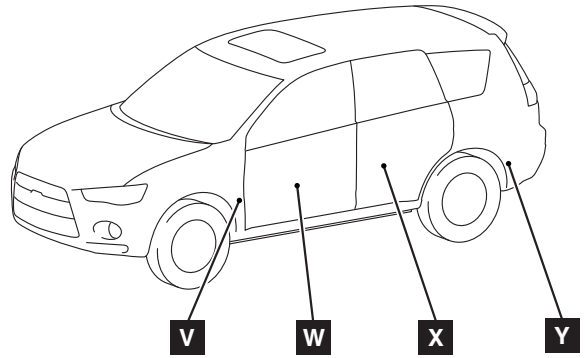
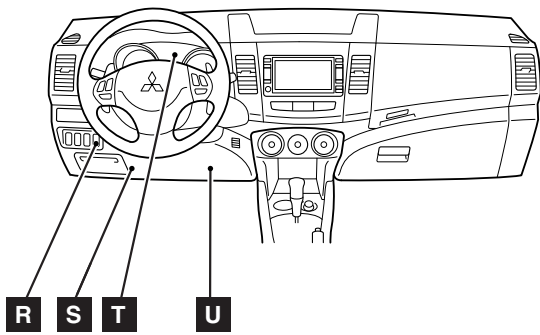
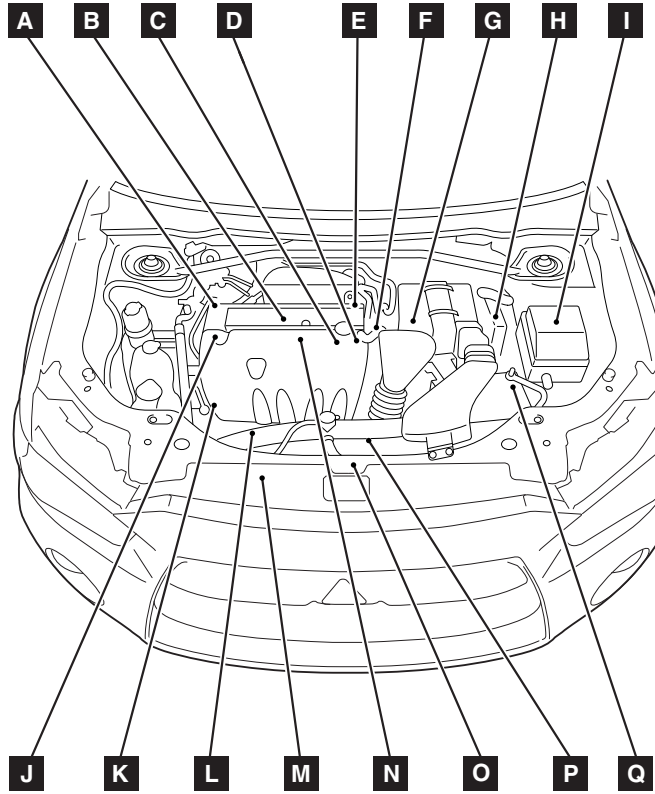

AK900664AC

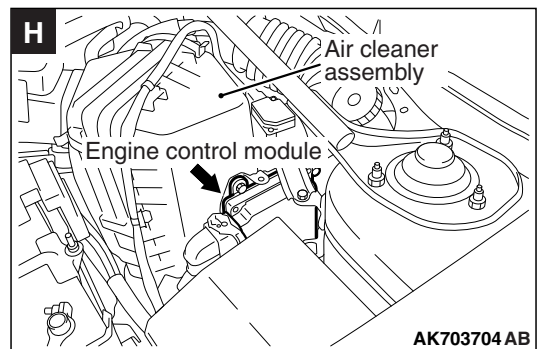
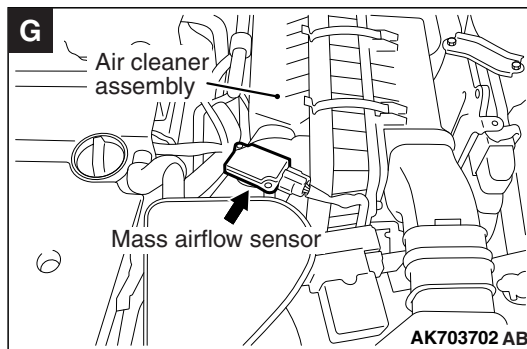
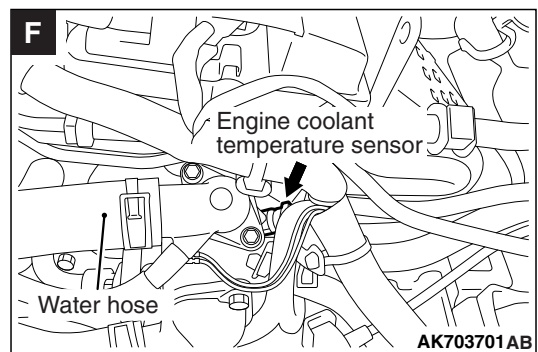
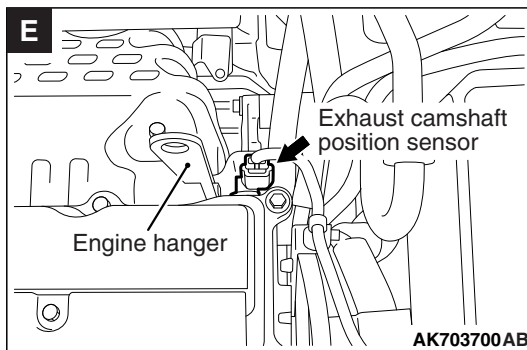
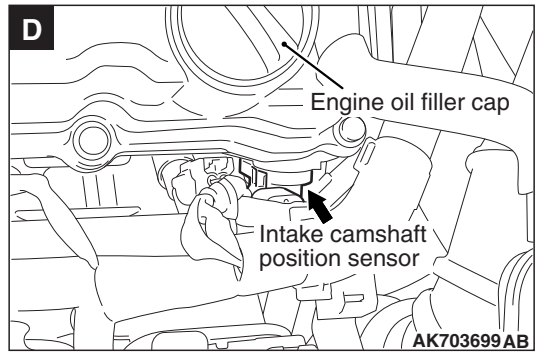
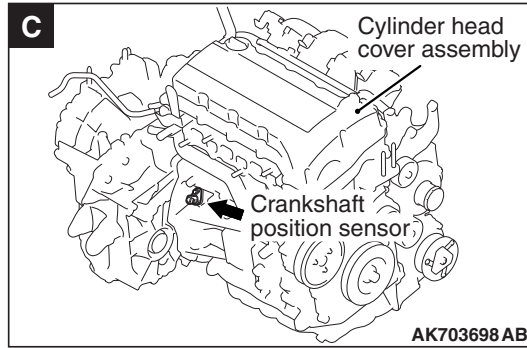
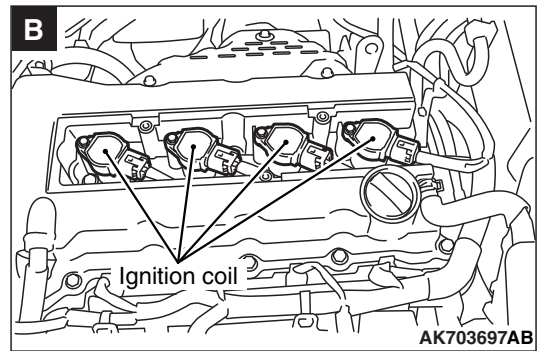
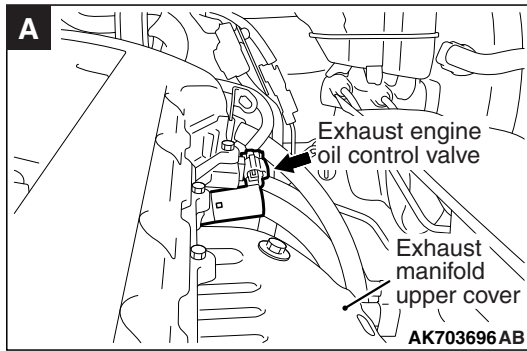



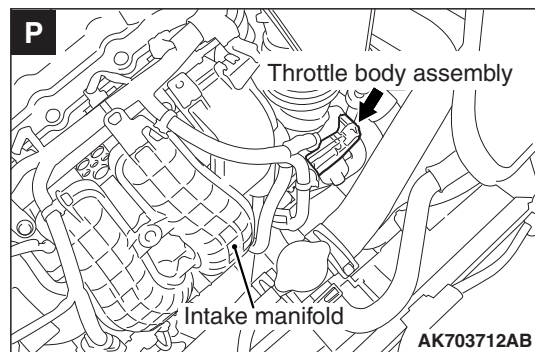
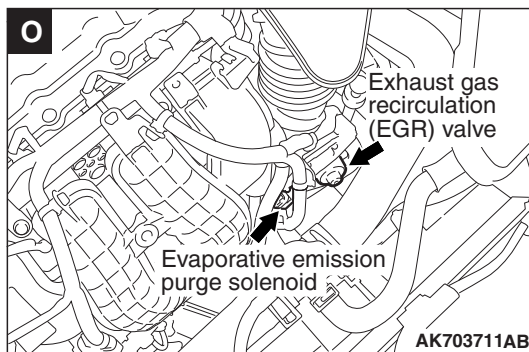
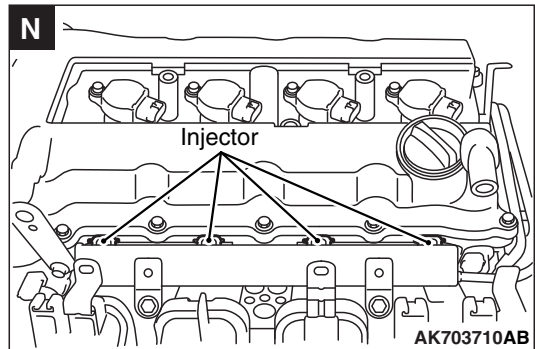
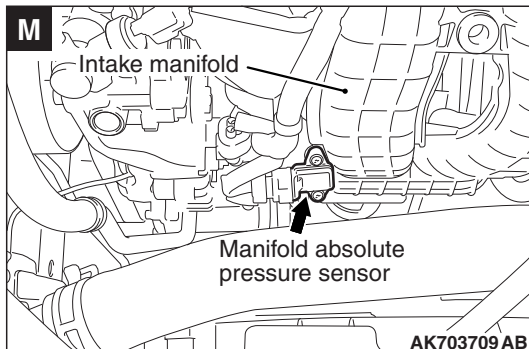
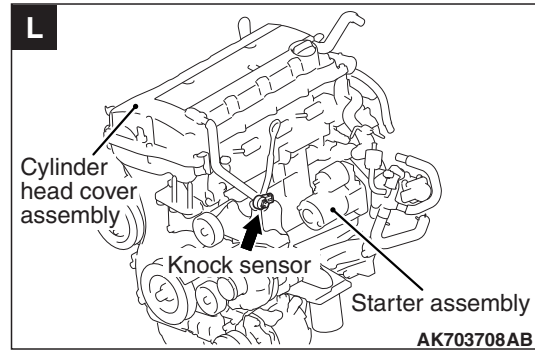
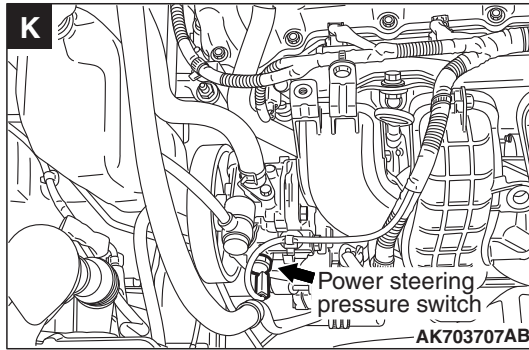
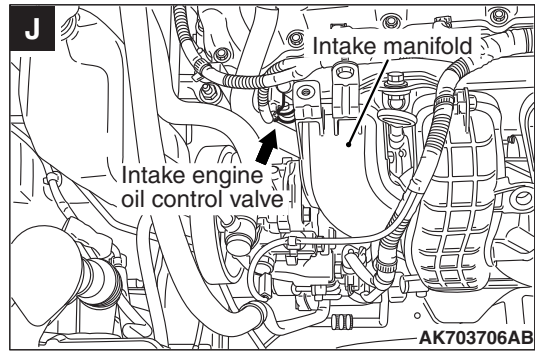
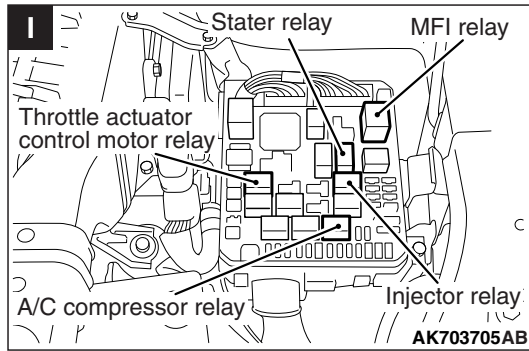

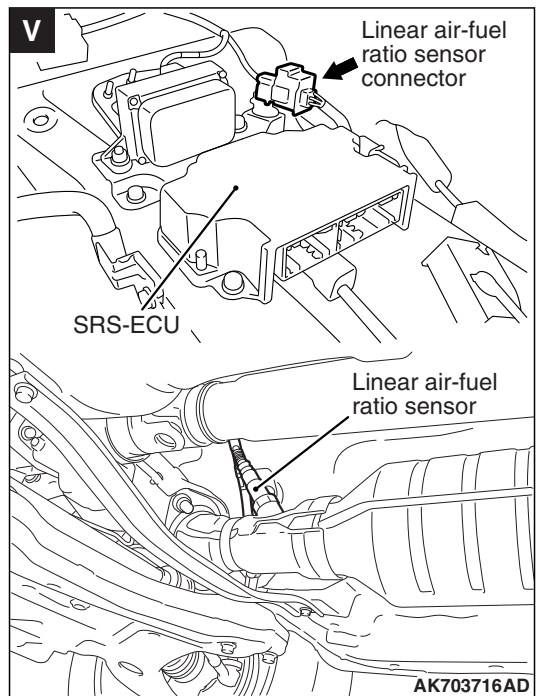
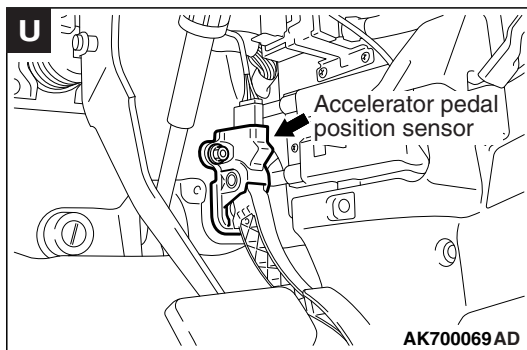
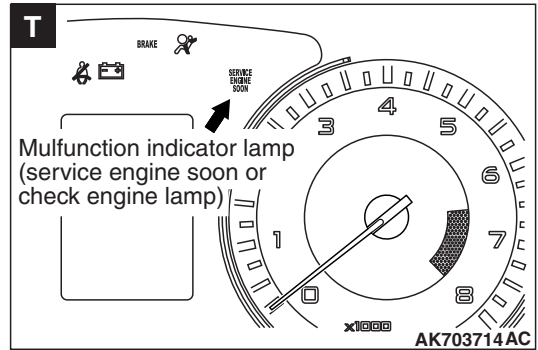
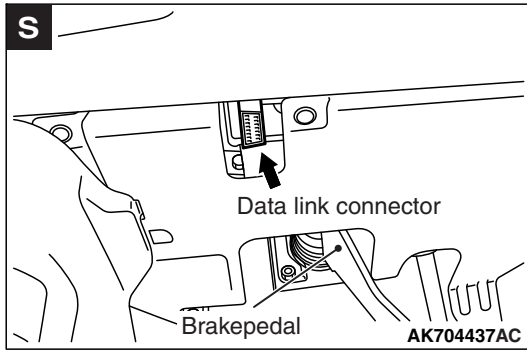
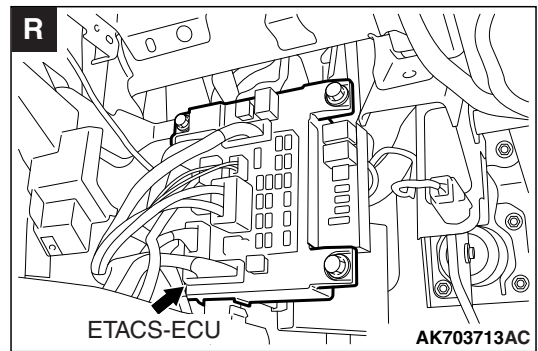
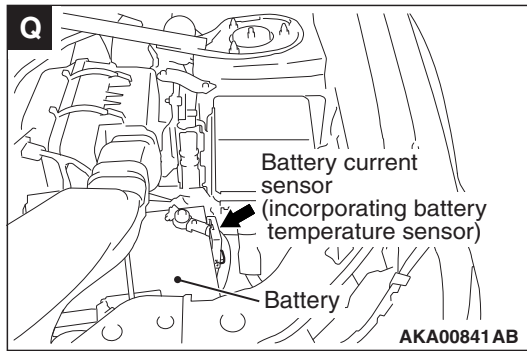

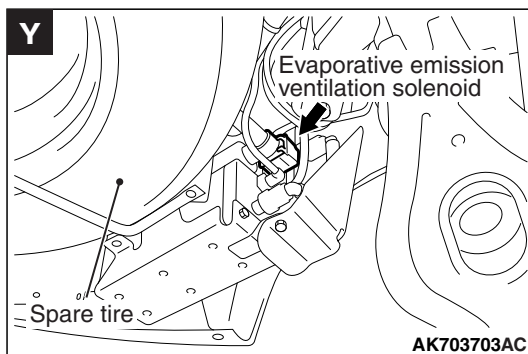
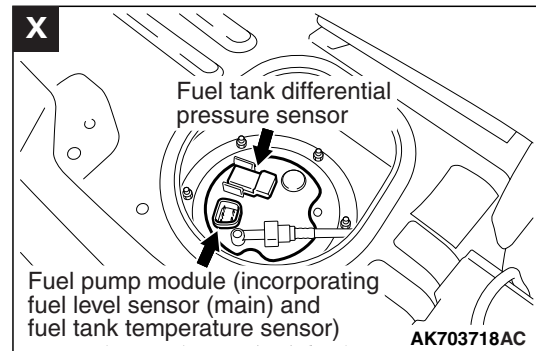
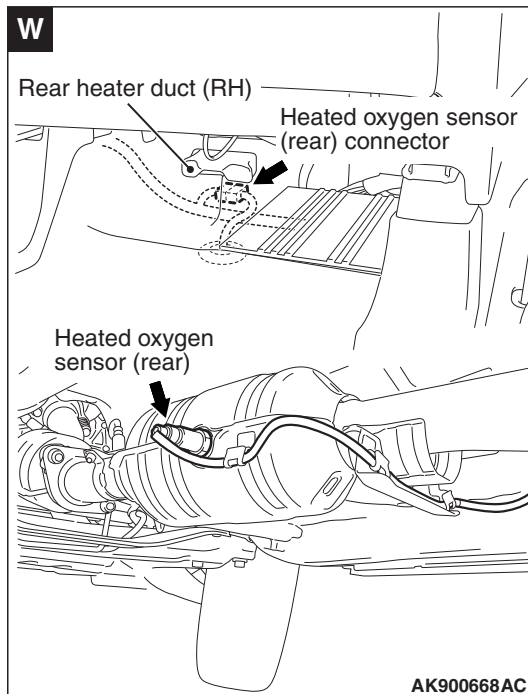

## THROTTLE BODY (THROTTLE VALVE AREA) CLEANING

M1131001001595

### **⚠ WARNING**

*When touching the throttle valve, surely shut off the driving circuits of the throttle valve. In the event that the throttle valve is operated, a finger might be injured as the result of being caught by the throttle valve.*

### **⚠ CAUTION**

When the throttle body cleaning is performed, use scan tool MB991958 to initialize the learning value (Refer to **GROUP 00, Precautions Before Service – Initialization Procedure for Learning Value in MFI Engine P.00-53**).

1. Disconnect the electronic-controlled throttle valve connector.
2. Remove the air intake hose from the throttle body.
3. Remove the throttle body.

**⚠ CAUTION**

Do not spray the cleaning solvent directly to the throttle valve.

4. Spray cleaning solvent on a clean cloth.

**⚠ CAUTION**

- Make sure the cleaning solvent does not enter the motor and the sensor through the shaft.
- Do not remove molybdenum, which is applied around the throttle valve of the throttle body.

5. Wipe off the dirt around the throttle valve with the cloth sprayed with cleaning solvent.

6. Install the throttle body.

7. Install the air intake hose.

8. Connect electronic-controlled throttle valve connector.

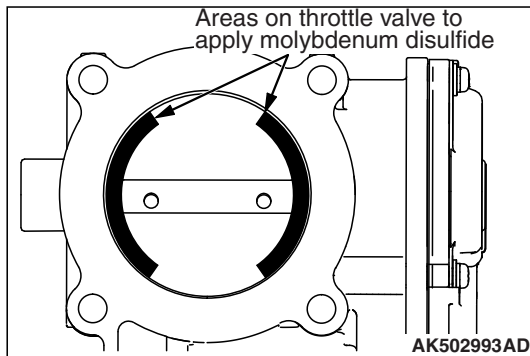

### FUEL PUMP CONNECTOR DISCONNECTION (HOW TO REDUCE PRESSURIZED FUEL LINES)

M1131000902101

When removing the fuel pipes and fuel hoses, follow the procedure below to release fuel pressure in the line and prevent fuel from running out, because fuel pressure in the fuel line is high.

1. Remove the second seat assembly (Refer to GROUP 52A, Second Seat Assembly P.52A-25) and turn up the floor carpet.
2. Remove the floor inspection lid (LH).

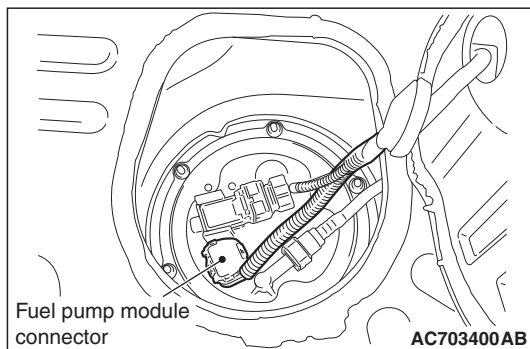
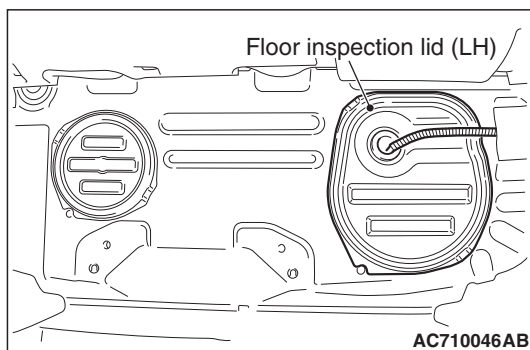

3. Disconnect the fuel pump module connector.
4. Crank the engine for at least two seconds.
5. If the engine does not start, turn the ignition switch to the "LOCK" (OFF) position.
6. If the engine starts, turn the ignition switch to the "LOCK" (OFF) position after the engine stops.
7. Connect the fuel pump module connector.
8. Install the floor inspection lid (LH).
9. Return the floor carpet to the original condition and install the second seat assembly (Refer to GROUP 52A, Second Seat Assembly P.52A-25).

## FUEL TANK PUMP OPERATION CHECK

### Required Special Tool:

MB991958: Scan Tool (M.U.T.-III Sub Assembly)

- MB991824: V.C.I.
- MB991827: M.U.T.-III USB Cable
- MB991910: M.U.T.-III Main Harness A

1. Using the scan tool MB991958, activate the fuel tank pump (integrated in the fuel tank pump module) to check the fuel tank pump operation.

2. If the fuel tank pump does not operate, follow the procedure below to check the pump for operation. If it is normal, check the driving circuit.

(1) Turn the ignition switch to the "LOCK" (OFF) position.

(2) Remove the second seat assembly (Refer to GROUP 52A, Second Seat Assembly P.52A-25) and turn up the floor carpet.

(3) Remove the floor inspection lid (LH).

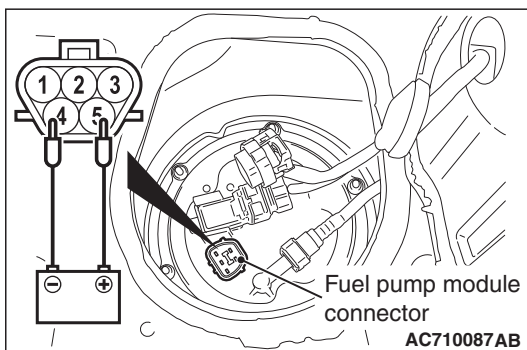
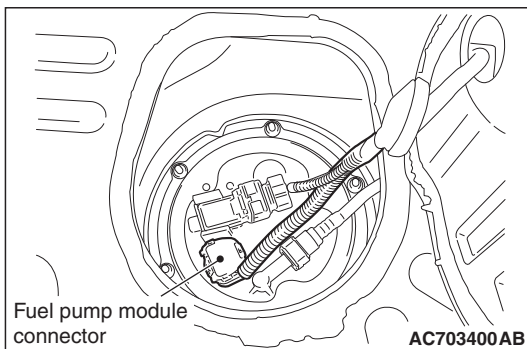
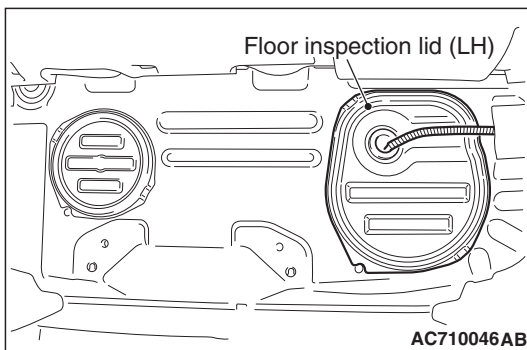

(4) Disconnect the fuel pump module connector.

(5) When the battery is connected to the fuel pump module connector (fuel pump module side), check that the pump operating sound can be heard. When the pump operating sound cannot be heard, replace the fuel pump module (Refer to GROUP 13C, On-Vehicle Service – Fuel Pump Module Replacement P.13C-9) <FWD> or (Refer to GROUP 13C, On-Vehicle Service – Fuel Pump Module Replacement P.13C-11) <AWD>.

*NOTE: The operating sound of the fuel pump is difficult to be heard because the pump is in-tank type. Therefore, remove the fuel filler cap to check the sound from the fuel filler port.*

(6) Connect the fuel pump module connector.

(7) Install the floor inspection lid (LH).

- (8) Return the floor carpet to the original condition and install the second seat assembly (Refer to GROUP 52A, Second Seat Assembly [P.52A-25](#)).

## FUEL PRESSURE TEST

M1131001901963

### Required Special Tools:

- MB991958: Scan Tool (M.U.T.-III Sub Assembly)
  - MB991824: V.C.I.
  - MB991827: USB Cable
  - MB991910: Main Harness A
- MB991981: Fuel Pressure Gauge Set
- MB992001: Hose Adapter
- MB992049: Quick Connector
- MB992076: Injector Test Set
- MD998709: Hose Adapter

1. Release residual pressure from the fuel pipe line to prevent fuel spray. (Refer to [P.13A-866](#).)

### **⚠ WARNING**

**To prevent a fire, cover the hose connection with shop towels to prevent splashing of fuel that could be caused by some residual pressure in the fuel pipe line.**

2. Disconnect the fuel high-pressure hose at the fuel rail side.

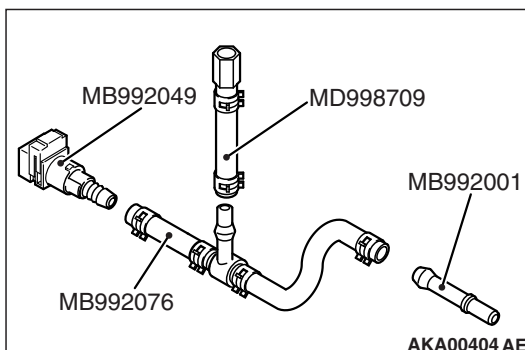
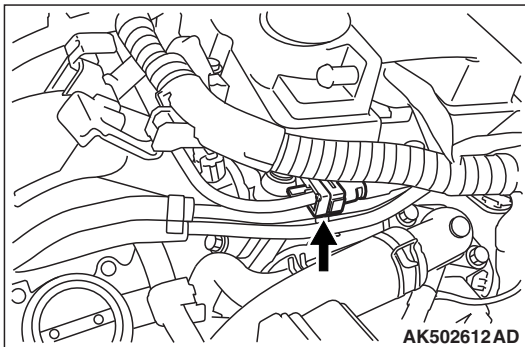

3. Assemble the special tool MB992076 (injector test set) as shown in figure according to the following procedure.
  - (1) Remove the injector installation adapter from the hose. Remove another hose together with the adapter and remove the adapter from the remaining hose.
  - (2) Install the special tool MB992049 (quick connector) and the special tool MB992001 (hose adapter) to the hose without the adapter.
  - (3) Remove the nipple of the bolt of the special tool MD998709 (hose adapter).
  - (4) Install the special tool prepared in the procedure (3) to the nipple that was removed together with hose in the procedure (1).
4. Install the special tool assembled in step 3 between the fuel rail and the fuel high-pressure hose.

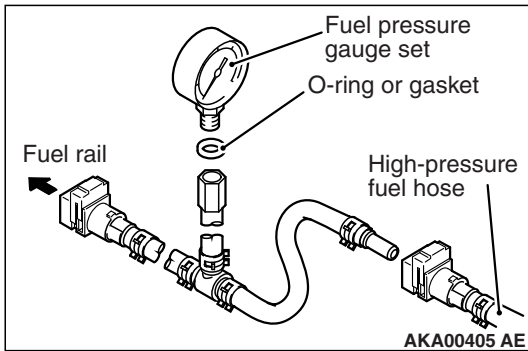

<When using the fuel pressure gauge>

- a. Via a suitable O-ring or gasket, install the fuel pressure gauge to the special tool that has already assembled as described.

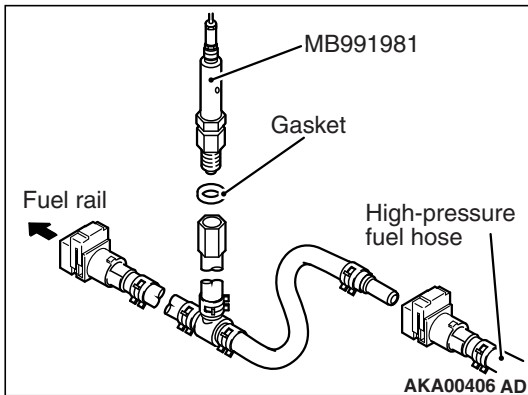

<When using the special tool MB991981 (fuel pressure gauge set)>

- a. Via a gasket, install the special tool MB991981 (fuel pressure gauge set) into the special tool that has already assembled as described.
- b. Connect the leads from the fuel pressure gauge set to the power supply (cigarette lighter socket) and special tool MB991824 (V.C.I.).

**CAUTION**

To prevent damage to scan tool MB991958, always turn the ignition switch to the "LOCK" (OFF) position before connecting or disconnecting scan tool MB991958.

5. Connect scan tool MB991958 to the data link connector.
6. Turn the ignition switch to the ON position (But do not start the engine).
7. Use Actuator test "item number 9" to drive the fuel pump. Check that there is no fuel leaking from any section when the fuel pump is operating.
8. Finish the actuator test or turn the ignition switch to the LOCK (OFF) position.
9. Start the engine and run at idle.
10. Measure fuel pressure while the engine is running at idle.  
**Standard value: Approximately 324 kPa (47 psi) at curb idle**
11. Check to see that fuel pressure at idle does not drop even after the engine has been revved several times.
12. If any of fuel pressure measured in Step 10 to 11 is out of specification, troubleshoot and repair according to the table below.

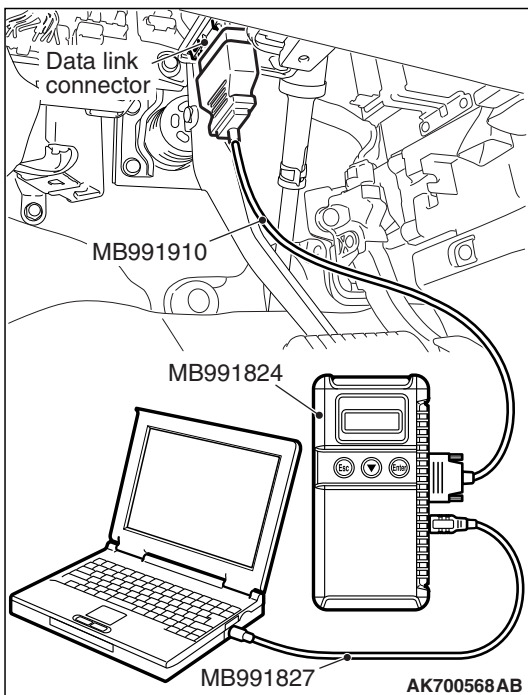

SYMPTOM	PROBABLE CAUSE	REMEDY
<ul style="list-style-type: none"> <li>Fuel pressure too low</li> <li>Fuel pressure drops after revving</li> </ul>	Clogged fuel filter	Replace fuel filter
	Fuel leaking to return side due to poor fuel regulator valve seating or settled spring	Replace fuel pressure regulator (integrated in the fuel tank pump module)
	Low fuel pump delivery pressure	Replace fuel pump
Fuel pressure too high	Binding valve in fuel pressure regulator	Replace fuel pressure regulator (integrated in the fuel tank pump module)

13. Stop the engine and observe fuel pressure gauge reading. It is normal if the reading does not drop within two minutes. If it does, observe the rate of drop and troubleshoot and repair according to the table below. Start, then stop the engine.

SYMPTOM	PROBABLE CAUSE	REMEDY
Fuel pressure drops gradually after engine is stopped	Leaky injector	Replace injector
	Leaky fuel regulator valve seat	Replace fuel pressure regulator (integrated in the fuel tank pump module)
Fuel pressure drops sharply immediately after engine is stopped	Check valve in fuel pump is held open	Replace fuel pump

14. Release residual pressure from the fuel pipe line. (Refer to [P.13A-866.](#))

**⚠ WARNING**

***To prevent a fire, cover the hose connection with shop towels to prevent splash of fuel that could be caused by some residual pressure in the fuel pipe line.***

15. Remove the fuel pressure gauge and special tool from the fuel rail.

16. Fit the fuel high-pressure hose to the fuel rail.

17. Check for fuel leaks.

(1) Use scan tool MB991958 to operate the fuel pump.

(2) Check the fuel line for leaks and repair as needed.

18. Disconnect scan tool MB991958.



**MULTIPOINT FUEL INJECTION (MFI) RELAY  
CONTINUITY CHECK**

M1131050001401

Inspect the MFI relay for continuity in accordance with the chart shown below.

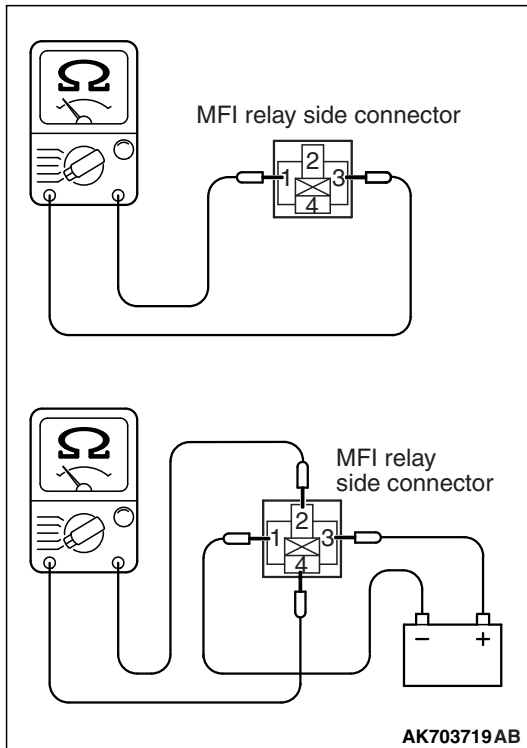

BATTERY VOLTAGE	TERMINAL NO. TO BE CONNECTED TO BATTERY	TERMINAL NO. TO BE CONDUCTED
Not supplied	–	1 – 3
Supplied	1 – 3	2 – 4

**FUEL PUMP RELAY CONTINUITY CHECK**

M1131033001453

Inspect the fuel pump relay for continuity in accordance with the chart shown below.

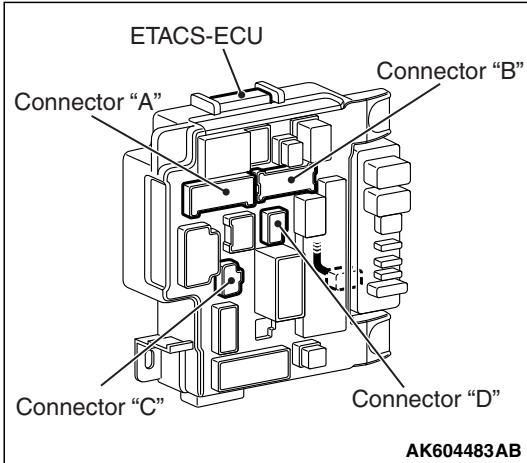

AK604483AB

BATTERY VOLTAGE	TERMINAL NO. TO BE CONNECTED TO BATTERY	TERMINAL NO. TO BE CONDUCTED
Supplied	6 (Connector "A") – 11 (Connector "B")	1 (Connector "C") – 1 (Connector "D")

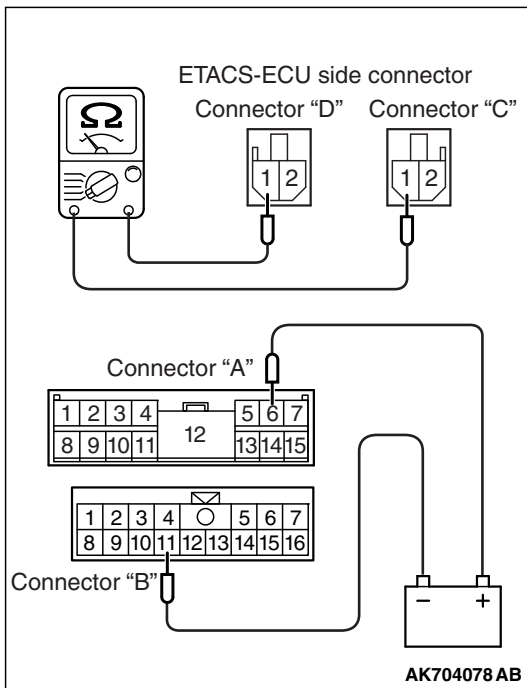

AK704078AB

**INJECTOR RELAY CONTINUITY CHECK**

M1131054600231

Inspect the Injector relay and throttle actuator control motor relay for continuity in accordance with the chart shown below.

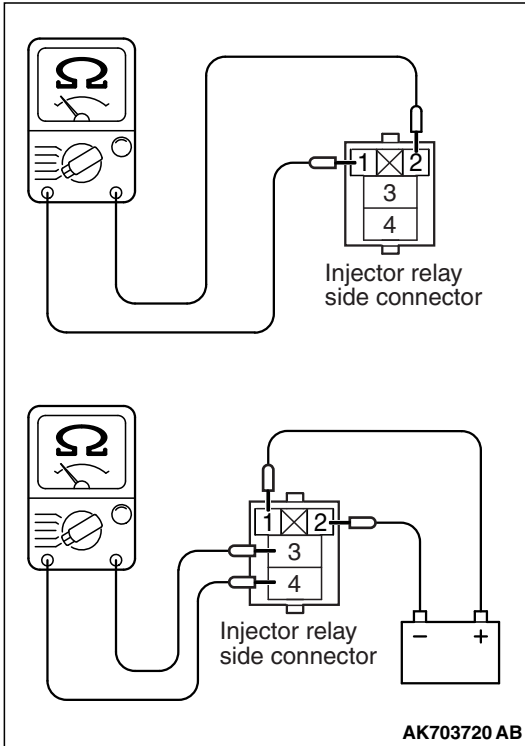

BATTERY VOLTAGE	TERMINAL NO. TO BE CONNECTED TO BATTERY	TERMINAL NO. TO BE CONDUCTED
Not supplied	–	1 – 2
Supplied	1 – 2	3 – 4

**THROTTLE ACTUATOR CONTROL MOTOR RELAY CONTINUITY CHECK**

M1131054900016

Inspect the Injector relay and throttle actuator control motor relay for continuity in accordance with the chart shown below.

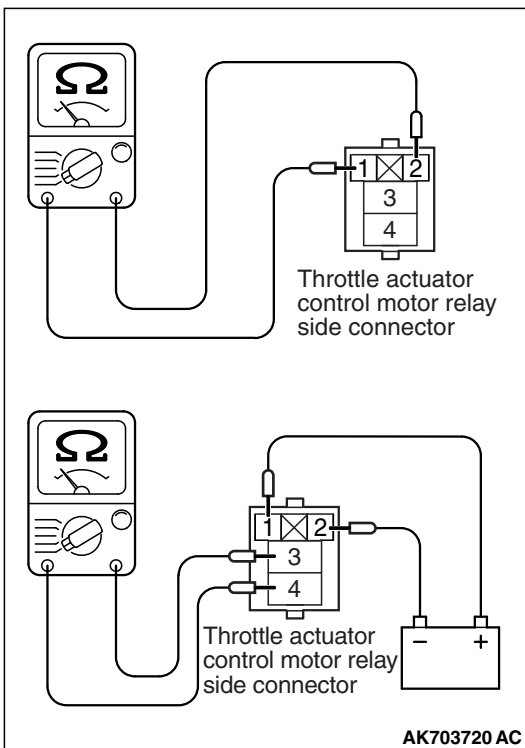

BATTERY VOLTAGE	TERMINAL NO. TO BE CONNECTED TO BATTERY	TERMINAL NO. TO BE CONDUCTED
Not supplied	–	1 – 2
Supplied	1 – 2	3 – 4

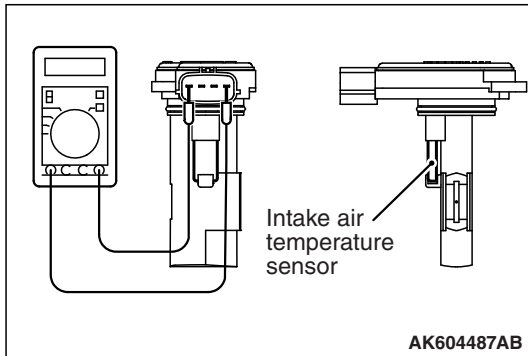
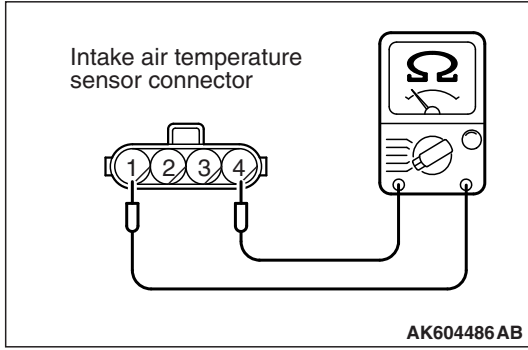

**INTAKE AIR TEMPERATURE SENSOR CHECK**

M1131002801635

1. Disconnect the mass airflow sensor connectors.
2. Measure resistance between terminal No. 1 and No. 4.

**Standard value:**

- 13 – 17 kΩ [at -20°C (-4°F)]
- 5.3 – 6.7 kΩ [at 0°C (32°F)]
- 2.3 – 3.0 kΩ [at 20°C (68°F)]
- 1.0 – 1.5 kΩ [at 40°C (104°F)]
- 0.56 – 0.76 kΩ [at 60°C (140°F)]
- 0.30 – 0.45 kΩ [at 80°C (176°F)]

3. If not within specifications, replace the mass airflow sensor.
4. Measure resistance while heating the sensor using a hair dryer.

**Normal condition:**

TEMPERATURE	RESISTANCE (kΩ)
Higher	Smaller

5. If resistance does not decrease as heat increases, replace the mass airflow sensor.

**ENGINE COOLANT TEMPERATURE SENSOR CHECK**

M1131003101640

**Required Special Tools:**

- MB992042: Engine coolant temperature sensor wrench

**⚠ CAUTION**

**Be careful not to touch the connector (resin section) with the tool when removing and installing.**

1. Drain engine coolant, then remove the engine coolant temperature sensor using the special tool MB992042 (engine coolant temperature sensor wrench).

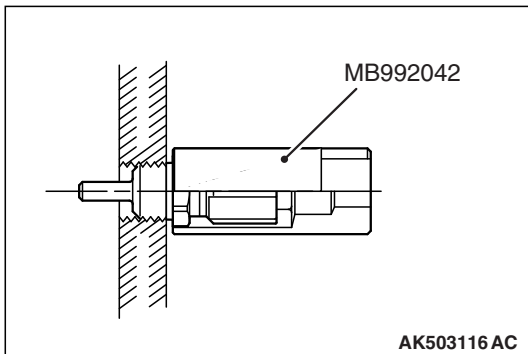

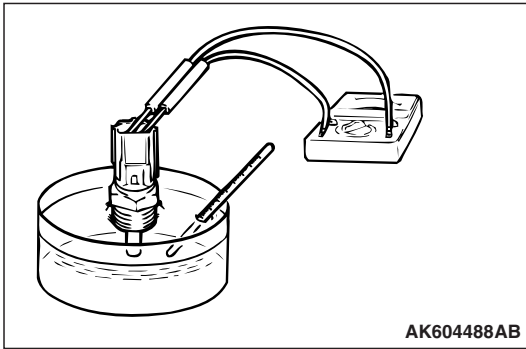

2. With the temperature sensing portion of engine coolant temperature sensor immersed in hot water, check the resistance.

**Standard value:**

- 14 – 17 k $\Omega$  [at -20°C (-4°F)]
- 5.1 – 6.5 k $\Omega$  [at 0°C (32°F)]
- 2.1 – 2.7 k $\Omega$  [at 20°C (68°F)]
- 0.9 – 1.3 k $\Omega$  [at 40°C (104°F)]
- 0.48 – 0.68 k $\Omega$  [at 60°C (140°F)]
- 0.26 – 0.36 k $\Omega$  [at 80°C (176°F)]

3. If resistance deviates from the standard value greatly, replace the sensor.
4. Apply LOCTITE 262 or equivalent to threaded portion.
5. With the special tool MB992042 (engine coolant temperature sensor wrench) tighten the engine coolant temperature sensor to the specified torque.

**Tightening torque: 30 ± 9 N·m (22 ± 6 ft-lb)**

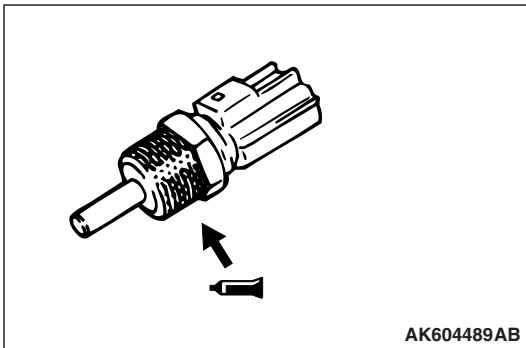

**HEATED OXYGEN SENSOR CHECK**

M1131005003775

**Required Special Tool:**

- MB991658: Test Harness

**Heated oxygen sensor (rear)**

1. Disconnect the heated oxygen sensor connector and connect special tool MB991658 to the connector on the heated oxygen sensor side.
2. Measure the resistance between terminal No. 1 and terminal No. 2.

**Standard value: 4.5 – 8.0  $\Omega$  [at 20 °C (68 °F)]**

3. If the resistance deviates from standard value, replace the heated oxygen sensor.
4. Warm up the engine until engine coolant is 80°C (176°F) or higher.

5. Drive at 50 km/h (31 mph) or more for 10 minutes.
6. Connect a digital voltage meter between terminal No. 3 and terminal No. 4.

7. Measure the output voltage of the heated oxygen sensor under the following driving.

- Transaxle: 2nd
- Drive with wide open throttle

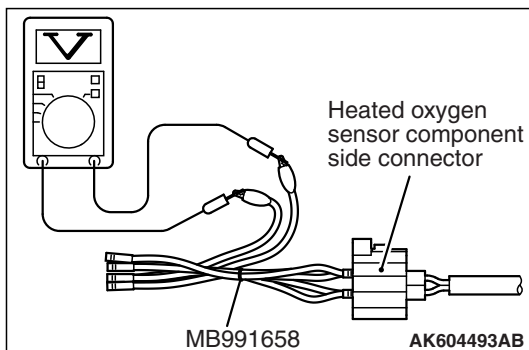
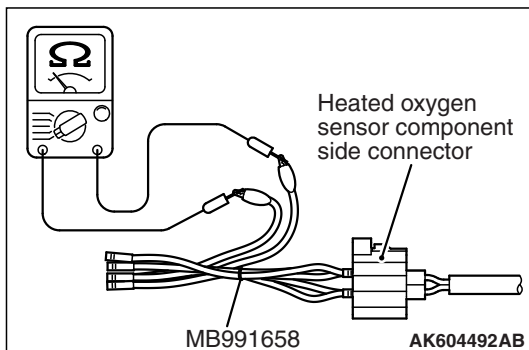

- Engine: 3,500 r/min or more

**Standard value:**

HEATED OXYGEN SENSOR OUTPUT VOLTAGE	REMARKS
0.6 – 1.0 V	High load operation makes air/fuel ratio richer and normal heated oxygen sensor also can output voltage of 0.6 – 1.0 V.

*NOTE: If the temperature of sensing area does not reach the high temperature [of approximately 400 °C (752 °F) or more] even though the heated oxygen sensor is normal, the output voltage would be possibly low in spite of the rich air-fuel ratio.*

*NOTE: When the vehicle is driven with high loads, the temperature of the sensing area of the heated oxygen sensor is sufficiently high. Thus, it is not necessary to apply the voltage to the heater.*

8. If the output voltage is not within the standard value, replace the heated oxygen sensor.

*NOTE: For removal and installation of the heated oxygen sensor, refer to GROUP 15, Exhaust Pipe and Main Muffler – Removal and Installation <2.4L ENGINE> P.15-22.*

**LINEAR AIR-FUEL RATIO SENSOR CHECK**

M1131055300040

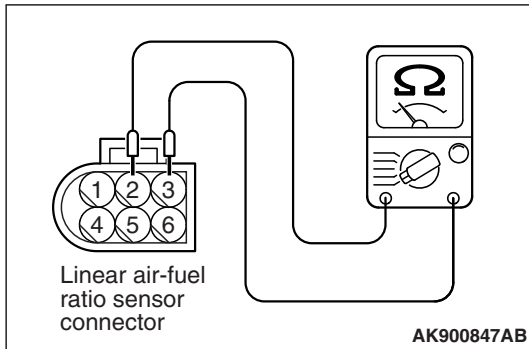

1. Disconnect the linear air-fuel ratio sensor connector and connect special tool MB991658 to the connector on the linear air-fuel ratio sensor side.
2. Measure the resistance between terminal No. 2 and terminal No. 3.

**Standard value: 2.3 – 4.2 Ω [at 20 °C (68°F)]**

3. If the resistance deviates from standard value, replace the linear air-fuel ratio sensor.

*NOTE: For removal and installation of the linear air-fuel ratio sensor, refer to GROUP 15, Exhaust Pipe and Main Muffler – Removal and Installation <2.4L ENGINE> P.15-22.*

## INJECTOR CHECK

M1131005201988

### <Checking the Operation Sound>

Using a stethoscope or long blade screwdriver, check the operation sound ("tick-tick-tick") of injectors during idling or during cranking. Check that as the engine speed increases, the frequency of the operating sound also increases.

1. If the injector you are checking is not operating, you may hear the operating sound of the other injectors.
2. If no operating sound is heard from the injector that is being checked, check the injector drive circuit. If there is nothing wrong with the circuit, a defective injector or ECM is suspected.

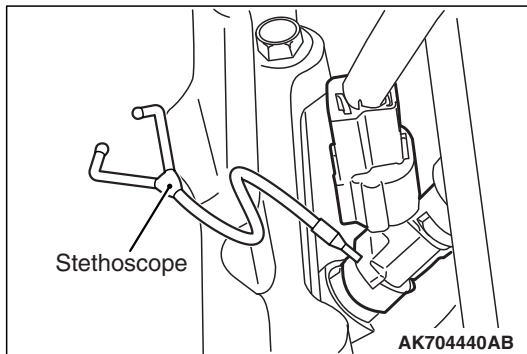

### <Checking the Coil Resistance>

1. Disconnect the injector connector.
2. Measure the resistance between injector side connector terminals 1 and 2.

**Standard value: 10.5 – 13.5 Ω [at 20°C (68°F)]**

3. Connect the injector connector.

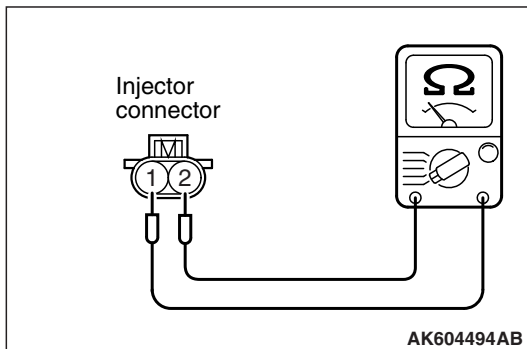

## THROTTLE ACTUATOR CONTROL MOTOR CHECK

M1131051000810

### <Operation Inspection>

#### **⚠ WARNING**

**When checking the throttle valve operation, never insert fingers into the throttle valve. The extremely strong power of the throttle valve motor might trap and injure fingers.**

1. Disconnect the air intake hose from the throttle body.
2. Set the ignition switch to the "ON" position.
3. Operate the accelerator pedal and confirm that the throttle valve is opening and closing accordingly.

### <Checking the Terminal Resistance>

#### **⚠ WARNING**

**If the throttle valve is operated in service, a finger might be injured as the result of being caught by the throttle valve. Make sure that the ignition switch is surely in "LOCK" (OFF) position before the service in order that the throttle valve cannot be operated.**

1. Disconnect the throttle position sensor connector.

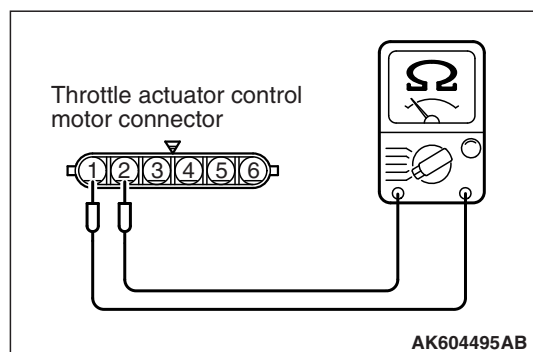

2. Measure the resistance between terminal No. 1 and No. 2.

**Standard value: 0.3 – 80  $\Omega$  [at 20°C (68°F)]**

*NOTE: If the measured resistance deviates from the standard value, fully open the throttle valve with your finger more than five times, then check the result again. If the throttle valve control servo is not used for an extended period of time, the resistance may be increased as a result of internal forming of oxide film. Therefore, it means that the oxide film can be removed through a self cleaning capability of the throttle valve control servo, if forcibly moved.*

3. If resistance is outside the standard value, replace the throttle body assembly.

## ENGINE OIL CONTROL VALVE CHECK

M1131053200605

### Required Special Tools:

- MB991658: Test Harness

### Intake engine oil control valve

#### <Checking the Operation Sound>

1. Disconnect the intake engine oil control valve connector.

#### **CAUTION**

**To prevent the coil from burning, keep the duration of the voltage application as short as possible.**

2. Check that the operation sound of the intake engine oil control valve can be heard when the positive battery voltage is supplied to the intake engine oil control valve. (Use the special tool MB991658 to connect terminal No. 2 of the intake engine oil control valve connector to the positive battery terminal and terminal No. 1 to the negative battery terminal.)
3. If the operation sound cannot be heard, replace the intake engine oil control valve.

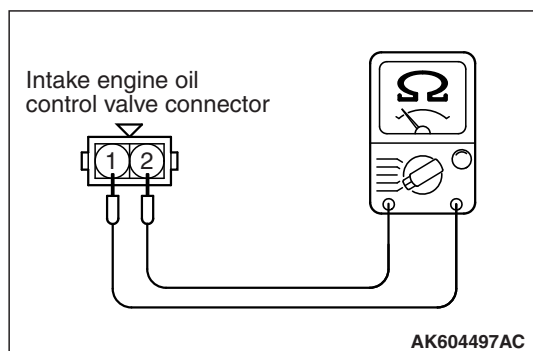
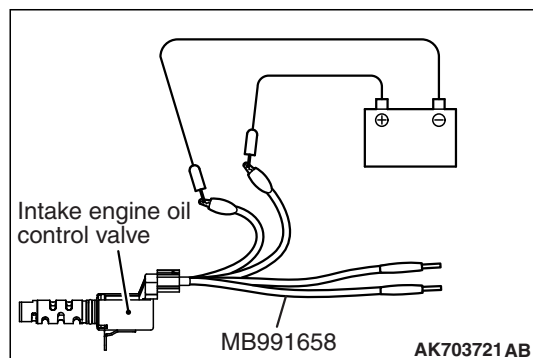

#### <Checking the Coil Resistance>

1. Disconnect the intake engine oil control valve connector.
2. Measure resistance between terminal No. 1 and terminal No. 2 of the connector at the intake engine oil control valve side.

**Standard value: 6.9 – 7.9  $\Omega$  [at 20°C (68°F)]**

3. If resistance is not within the standard value, replace the intake engine oil control valve.

### Exhaust engine oil control valve

#### <Checking the Operation Sound>

1. Disconnect the exhaust engine oil control valve connector.



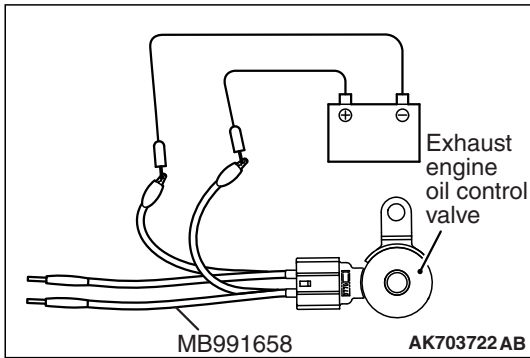

**CAUTION**

To prevent the coil from burning, keep the duration of the voltage application as short as possible.

2. Check that the operation sound of the exhaust engine oil control valve can be heard when the positive battery voltage is supplied to the exhaust engine oil control valve. (Use the special tool MB991658 to connect terminal No. 2 of the exhaust engine oil control valve connector to the positive battery terminal and terminal No. 1 to the negative battery terminal.)
3. If the operation sound cannot be heard, replace the exhaust engine oil control valve.

**<Checking the Coil Resistance>**

1. Disconnect the exhaust engine oil control valve connector.
2. Measure resistance between terminal No. 1 and terminal No. 2 of the connector at the exhaust engine oil control valve side.

**Standard value: 6.9 – 7.9 Ω [at 20°C (68°F)]**

3. If resistance is not within the standard value, replace the exhaust engine oil control valve.

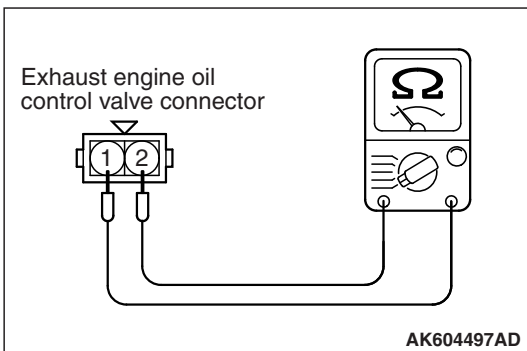

**EVAPORATIVE EMISSION VENTILATION SOLENOID CHECK**

M1131012800428

Refer to GROUP 17, Emission Control System – Evaporative Emission Canister and Fuel Tank Pressure Relief Valve – Inspection P.17-88.

**EVAPORATIVE EMISSION PURGE SOLENOID CHECK**

M1131005600499

Refer to GROUP 17, Emission Control System – Evaporative Emission System – Evaporative Emission Purge Solenoid Check P.17-78.

**EGR VALVE CHECK**

M1131051500194

Refer to GROUP 17, Emission Control System – Exhaust Gas Recirculation (EGR) System – EGR Valve (Stepper Motor) Check P.17-81.

# INJECTOR

## REMOVAL AND INSTALLATION

M1131007102861

### Pre-removal operation

- Fuel Pump Connector Disconnection (How to Reduce Pressurized Fuel Lines) (Refer to P.13A-866).
- Engine Upper Cover Removal (Refer to GROUP 11A, Camshaft P.11A-26).
- Air Cleaner Intake Hose Removal (Refer to GROUP 15, Air Cleaner <2.4L Engine>P.15-4).

### Post-installation operation

- Air Cleaner Intake Hose Installation (Refer to GROUP 15, Air Cleaner <2.4L Engine>P.15-4).
- Fuel Leak Check
- Engine Upper Cover Installation (Refer to GROUP 11A, Camshaft P.11A-26).

 Apply new engine oil to the O-ring before installation.

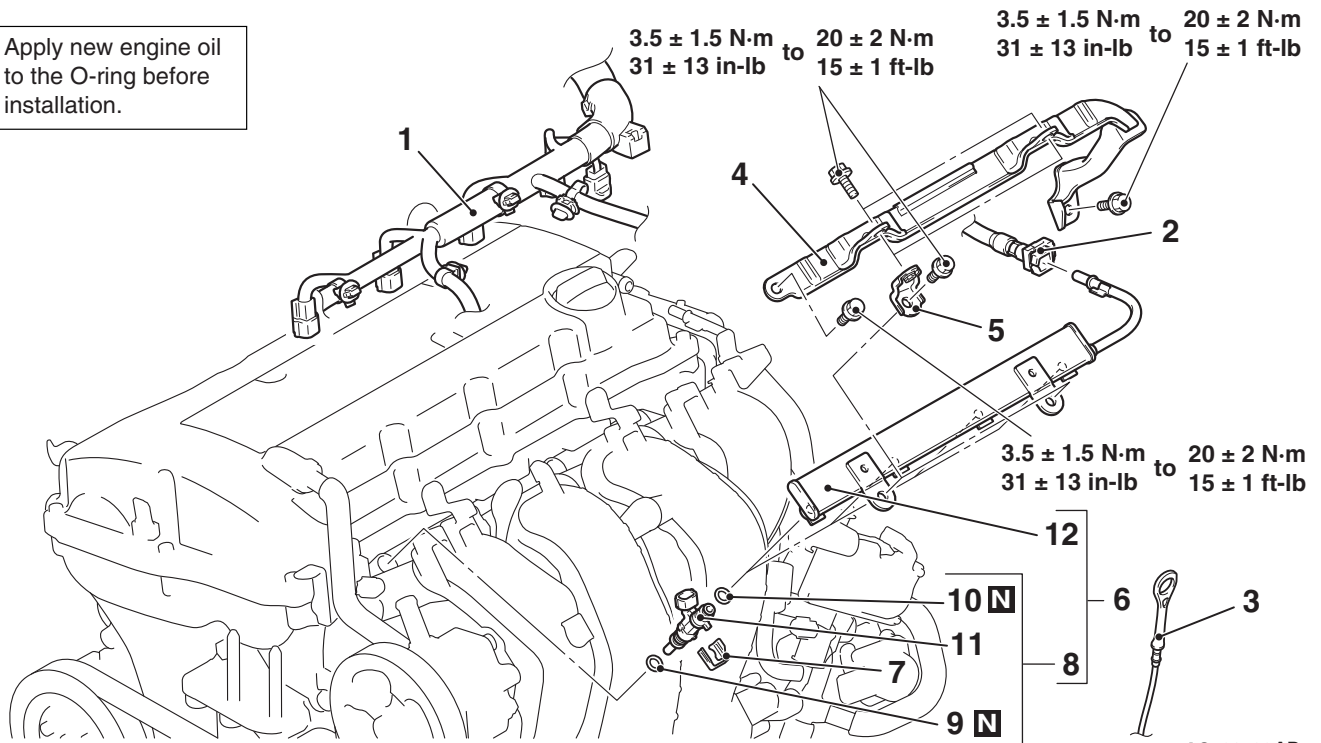

### Removal steps

- |       |       |   |
|-------|-------|---|
| <<A>> | >>F<< | 1. Control wiring harness connection    |
|       |       | 2. Fuel high-pressure hose connection   |
|       |       | 3. Engine oil level gauge               |
|       | >>E<< | 4. Injector protector rear              |
|       | >>E<< | 5. Bracket                              |
| <<B>> | >>E<< | 6. Fuel rail and fuel injector assembly |

### Removal steps (Continued)

- |       |                           |
|-------|---------------------------|
| >>D<< | 7. Fuel injector support  |
| >>C<< | 8. Fuel injector assembly |
| >>B<< | 9. O-ring                 |
| >>A<< | 10. O-ring                |
|       | 11. Fuel injector         |
|       | 12. Fuel rail             |

### Required Special Tool:

- MB992106: O-ring Installer

## REMOVAL SERVICE POINTS

### <<A>> FUEL HIGH-PRESSURE HOSE DISCONNECTION

1. Follow the steps below to unlock the fuel high-pressure hose connector.

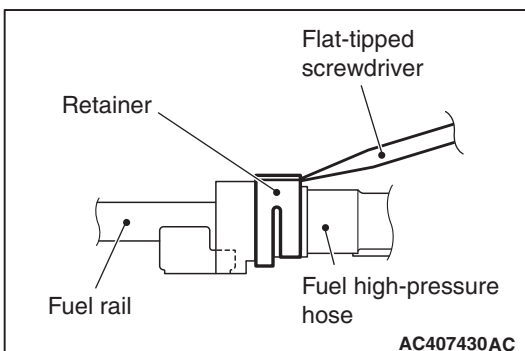
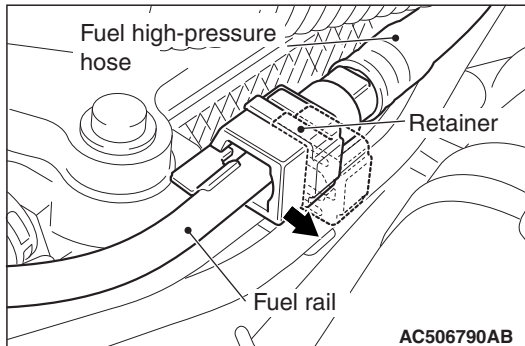

- (1) Insert a flat-tipped screwdriver [6 mm (0.24 inch) wide and 1 mm (0.04inch) thick] into the retainer of the fuel high-pressure hose connector.

#### **CAUTION**

When pushing up the retainer of the fuel high-pressure hose connector, pay attention to avoid damage to the retainer.

- (2) Turn the flat-tipped screwdriver inserted into the retainer by 90 degrees to push up the retainer and unlock the fuel high-pressure hose connector.
2. Disconnect the fuel high-pressure hose.

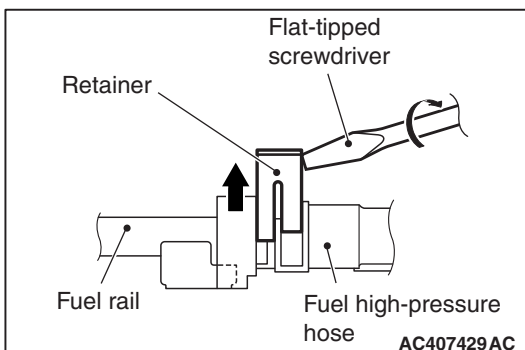

### <<B>> FUEL RAIL AND FUEL INJECTOR ASSEMBLY REMOVAL

#### **CAUTION**

Do not drop the fuel injector.

Remove the fuel rail with the fuel injectors attached to it.

## INSTALLATION SERVICE POINTS

## &gt;&gt;A&lt;&lt; O-RING INSTALLATION

1. Apply a small amount of new engine oil to the O-ring.
2. While turning the fuel injector to right and left, install the O-ring to the fuel injector with care to avoid damage to the O-ring.

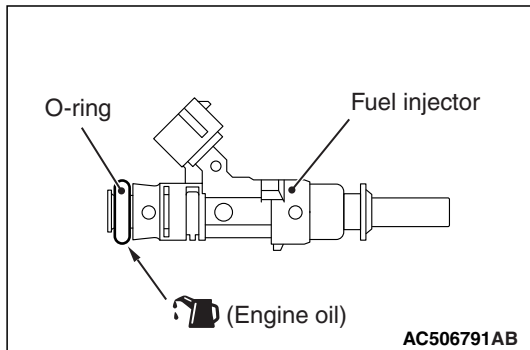

## &gt;&gt;B&lt;&lt; O-RING INSTALLATION

1. Apply a small amount of new engine oil to the O-ring.
2. Using special tool MB992106, install the o-ring onto the fuel injector paying attention to avoid damage to the O-ring.

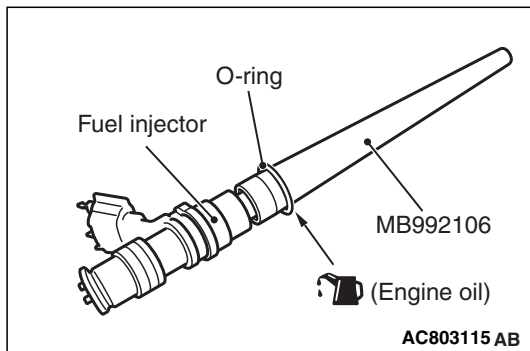
>>C<< FUEL INJECTOR ASSEMBLY  
INSTALLATION**⚠ CAUTION**

**When applying the engine oil, make sure not to allow the engine oil to enter the fuel rail inside.**

1. Apply a small amount of new engine oil to the O-ring.
2. Turning the fuel injector assembly to right and left, install it to the fuel rail with care not to damage the O-ring. After the installation, check for its smooth rotation. At this time, check that the projection of the fuel injector assembly is in the center.
3. If the rotation is not smooth, the O-ring may be caught. Remove the fuel injector assembly and check the O-ring for damage. After this, re-insert it to the fuel rail and check for its smooth rotation.

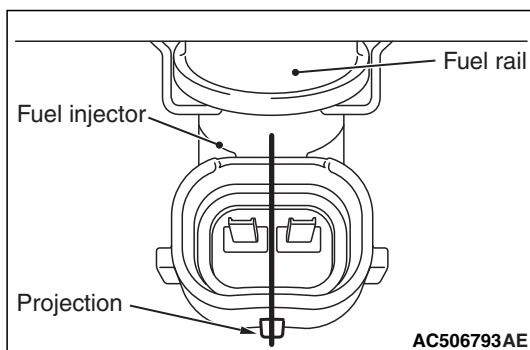

## >>D<< FUEL INJECTOR SUPPORT INSTALLATION

Install the fuel injector support to the fuel injector groove and fuel rail flange, and fix the fuel injector assembly and fuel rail.

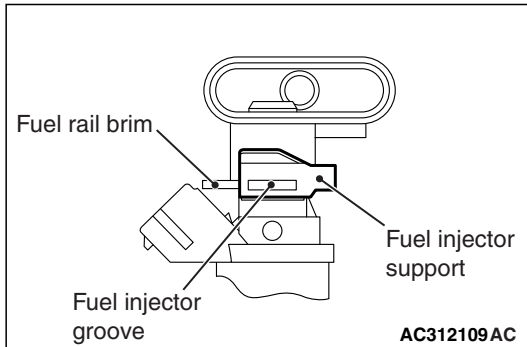

## >>E<< FUEL RAIL AND FUEL INJECTOR ASSEMBLY/BACKET/INJECTOR PROTECTOR REAR INSTALLATION

### ⚠ CAUTION

When applying the engine oil, make sure not to allow the engine oil to enter the intake manifold inside.

1. Apply a small amount of new engine oil to the O-ring at the end of fuel injector assembly.

### ⚠ CAUTION

When installing the fuel rail and fuel injector assembly to the intake manifold, pay attention to avoid damage to the O-ring at the end of the fuel injector assembly.

2. Install the fuel rail and fuel injector assembly to the intake manifold.
3. Install the bracket and injector protector rear.
4. Loosen the intake manifold mounting bolts and nuts (Bolts and nuts 1, 2, 3, and 9 shown in the figure).
5. Remove the EGR valve (Refer to GROUP 17, Emission Control – Exhaust Gas Recirculation (EGR) Valve <2.4L Engine>P.17-84 ).
6. Loosen the EGR valve support and intake manifold coupling bolts (Refer to GROUP 17, Emission Control – Exhaust Gas Recirculation (EGR) Valve <2.4L Engine>P.17-84 ).
7. Loosen the intake manifold stay mounting bolts (Refer to GROUP 15, Intake Manifold <2.4L Engine>P.15-9 ).
8. Temporarily tighten the mounting bolts and nuts of the inlet manifold, bracket, fuel rail and injector protector rear to the specified torque in the order of number shown in the figure.

**Tightening torque: 3.5 ± 1.5 N·m (31 ± 13 in-lb)**

9. Tighten the mounting bolts and nuts of the inlet manifold, bracket, fuel rail and injector protector rear to the specified torque in the order of number shown in the figure again.

**Tightening torque: 20 ± 2 N·m (15 ± 1 ft-lb)**

10. Tighten the inlet manifold stay mounting bolts to the specified torque (Refer to GROUP 15, Intake Manifold <2.4L Engine>P.15-9 ).

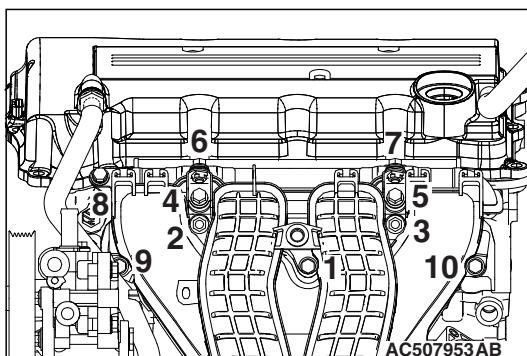

**Tightening torque: 20 ± 2 N·m (15 ± 1 ft-lb)**

11. Tighten the EGR valve support and intake manifold coupling bolts to the specified torque (Refer to GROUP 17, Emission Control – Exhaust Gas Recirculation (EGR) Valve <2.4L Engine>P.17-84 ).

**Tightening torque: 20 ± 2 N·m (15 ± 1 ft-lb)**

12. Install the EGR valve (Refer to GROUP 17, Emission Control – Exhaust Gas Recirculation (EGR) Valve <2.4L Engine>P.17-84 ).

## >>F<< FUEL HIGH-PRESSURE HOSE CONNECTION

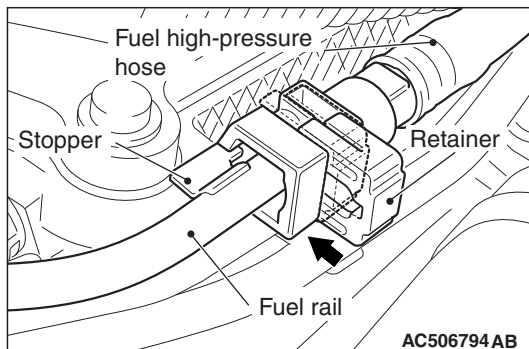
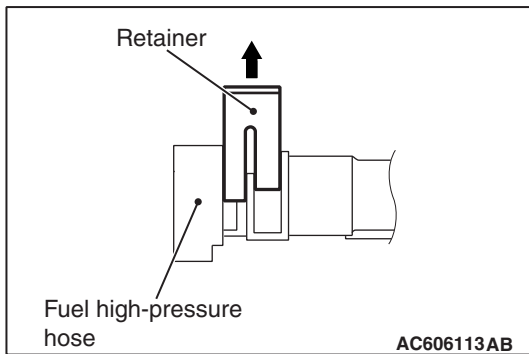

1. Pull up the retainer of fuel high-pressure hose to unlock before installing.

2. Securely insert the fuel rail stopper into the fuel high-pressure hose connector groove to install the fuel high-pressure hose to the fuel rail.

### **CAUTION**

- When pushing in the retainer of the fuel high-pressure hose connector, pay attention to avoid damage to the retainer.
  - After the installation of the fuel high-pressure hose, slightly pull the fuel high-pressure hose to check that it is connected securely. At this time, also check that there is approximately 1 mm (0.04inch) play.
3. Push in the retainer of the fuel high-pressure hose connector to lock the fuel high-pressure hose and fuel rail.

# THROTTLE BODY ASSEMBLY

## REMOVAL AND INSTALLATION

M1131007702261

### CAUTION

- When the throttle body assembly replacement is performed, use scan tool MB991958 to initialize the learning value (Refer to GROUP 00, Precautions Before Service – Initialization Procedure for Learning Value in MFI Engine P.00-53).
- Never loosen the screw fixing the throttle body assembly resin cover. If the screw is loosened, the sensor incorporated in the resin cover is misaligned and the throttle body assembly does not work normally.

#### Pre-removal operation

- Engine Upper Cover Removal (Refer to GROUP 11A, Camshaft P.11A-26).
- Engine Coolant Draining (Refer to GROUP 14, On-vehicle Service – Engine Coolant Replacement P.14-26).
- Air Cleaner Intake Hose Removal (Refer to GROUP 15, Air Cleaner <2.4L Engine>P.15-4).

#### Post-installation operation

- Air Cleaner Intake Hose Installation (Refer to GROUP 15, Air Cleaner <2.4L Engine>P.15-4).
- Engine Coolant Refilling (Refer to GROUP 14, On-vehicle Service – Engine Coolant Replacement P.14-26).
- Engine Upper Cover Installation (Refer to GROUP 11A, Camshaft P.11A-26).

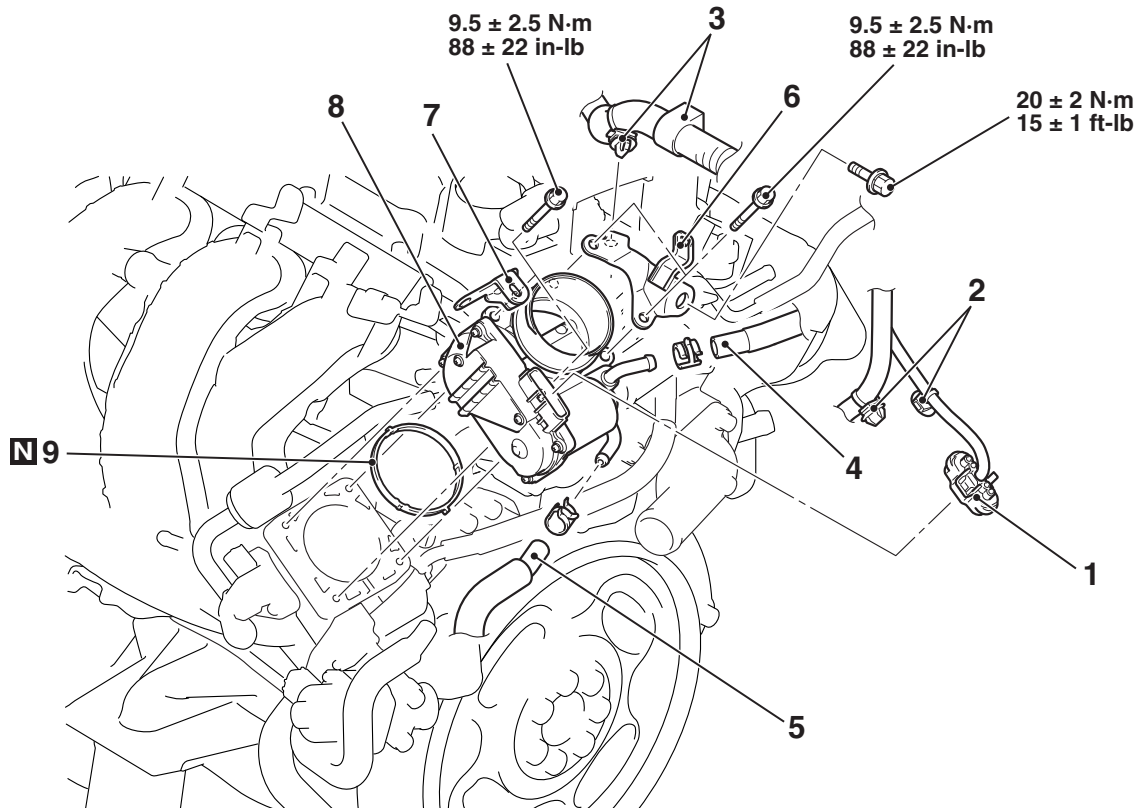

AC609824AB

- >>B<<
- Removal steps**
- Initialization operation (only at installation)
1. Throttle body assembly connector connection
  2. Control wiring harness clip connection
  3. Battery wiring harness clamp connection

- >>A<<
- Removal steps (Continued)**
4. Throttle body water feed hose connection
  5. Throttle body water return hose connection
  6. Throttle body stay
  7. Throttle body wiring harness connector bracket
  8. Throttle body assembly
  9. Throttle body gasket

**INSTALLATION SERVICE POINTS****>>A<< THROTTLE BODY GASKET INSTALLATION**

Fit the throttle body gasket in the intake manifold groove securely with neither twisting nor damage given.

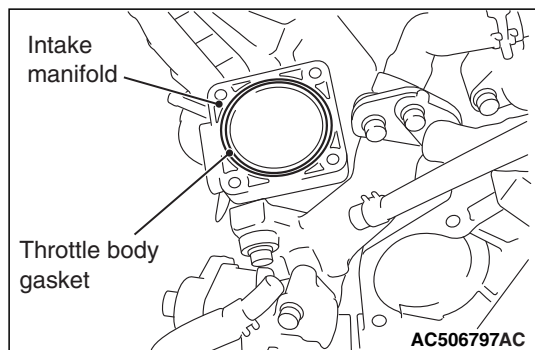
**>>B<< INITIALIZATION OPERATION**

Turn the ignition switch to the "ON" position and then to "LOCK" (OFF) position and hold it for at least 10 seconds.



## ENGINE CONTROL MODULE (ECM)

### REMOVAL AND INSTALLATION

M1131033802065

#### ⚠ CAUTION

- When the ECM is replaced, do not replace the immobilizer ECU (WCM) or KOS-ECU simultaneously. When multiple ECUs are to be replaced, always replace only one ECU at a time and complete necessary ID registration using scan tool MB991958 (Refer to GROUP 42B, Troubleshooting – ID Code Registration Necessity Judgment Table P.42B-15) <Vehicle with KOS installed> (Refer to GROUP 42C, Troubleshooting – ID Code Registration Necessity Judgment Table P.42C-10) <Vehicle with WCM installed>.
- After the ECM replacement, register a key code using scan tool MB991958 [Refer to GROUP 00, Precautions before Service – How to Perform Vehicle Identification Number (VIN) Writing P.00-40].
- When the ECM is replaced, save the vehicle identification number and perform the variant coding.
- When the ECM are replaced, make the battery current sensor calibration by using scan tool MB991958 (Refer to GROUP 00, Precautions before Service, Battery Current Sensor Calibration P.00-56).
- After the ECM replacement, idling speed may be unstable because the MFI engine learning is not completed. To make it stable, let the system learn the idling (Refer to GROUP 00, Precautions before Service – Learning Procedure for Idling in MFI Engine P.00-54).

#### Pre-removal and post-installation operation

- Air Cleaner Assembly Removal and Installation (Refer to GROUP 15, Air Cleaner <2.4L Engine>P.15-4 ).

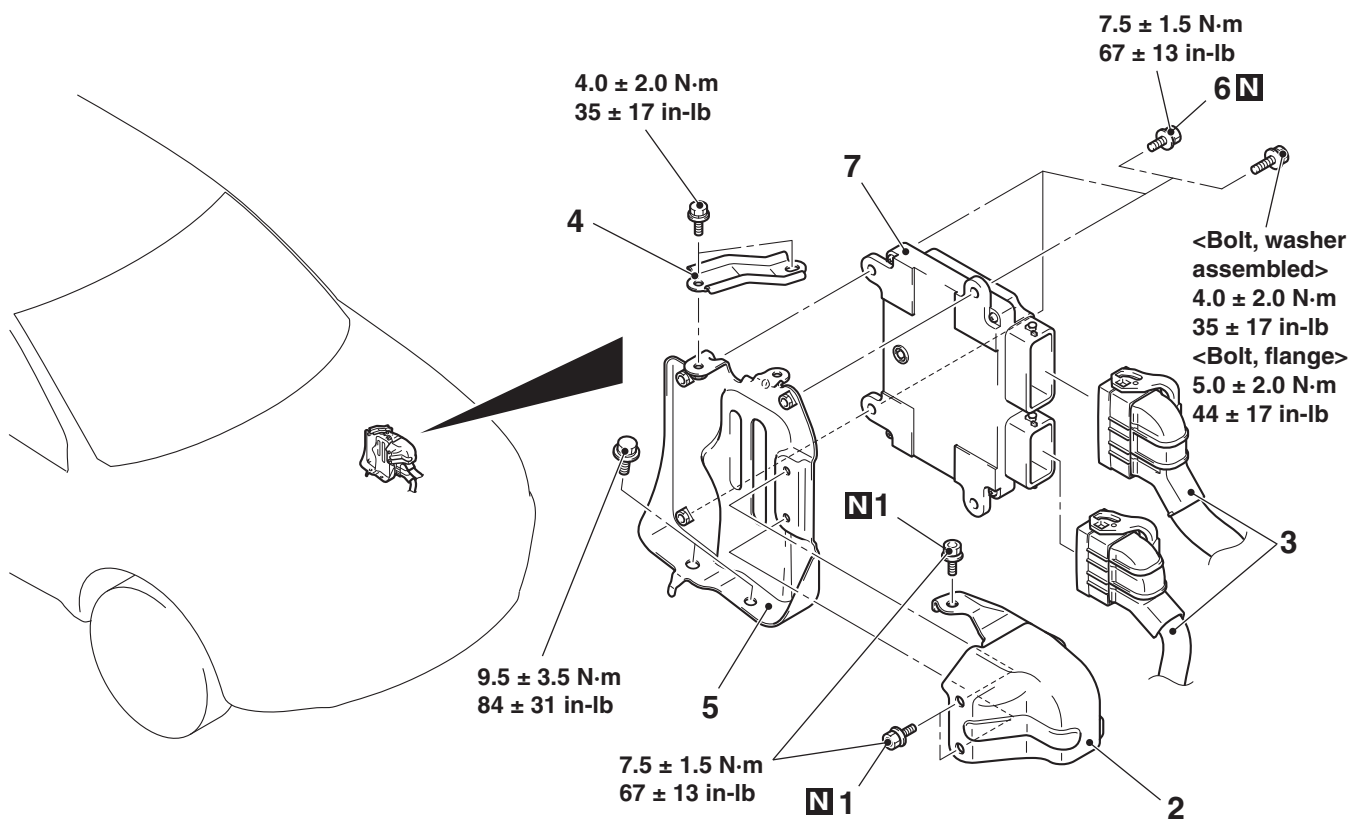

AC901366AB

- |       |  |             |   |
|-------|--|-------------|---|
|       | <b>Removal steps</b>   |             | <b>Removal steps (Continued)</b>  |
| >>B<< | <ul style="list-style-type: none"> <li>Initialization operation (only at installation)</li> </ul>  |             | <ul style="list-style-type: none"> <li>4. ECM stay</li> <li>5. ECM bracket assembly</li> </ul>                  |
| <<A>> | <ul style="list-style-type: none"> <li>1. Break off bolt &lt;Vehicles for Canada&gt;</li> <li>2. ECM connector cover &lt;Vehicles for Canada&gt;</li> <li>3. ECM connector connection</li> </ul> | <<A>> >>A<< | <ul style="list-style-type: none"> <li>6. Break off bolt &lt;Vehicles for Canada&gt;</li> <li>7. ECM</li> </ul> |

**REMOVAL SERVICE POINT**

**<<A>> BREAK-OFF BOLT REMOVAL <VEHICLES FOR CANADA>**

- <When using recommended tool screw extractor set (MB992678) or equivalent>
  - Drill in the break-off bolt a hole deep enough for the tap to stand.
  - Use recommended tool screw extractor set (MB992678) or equivalent to remove the break-off bolt.
- <When using the flat-tipped screwdriver>
  - Apply force towards the direction to loose the bolt by a flat-tipped screwdriver.
  - Remove the break-off bolt.

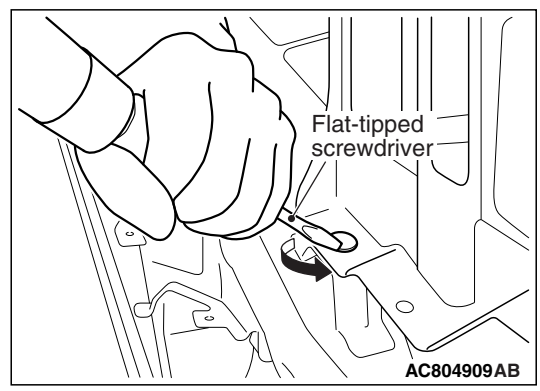
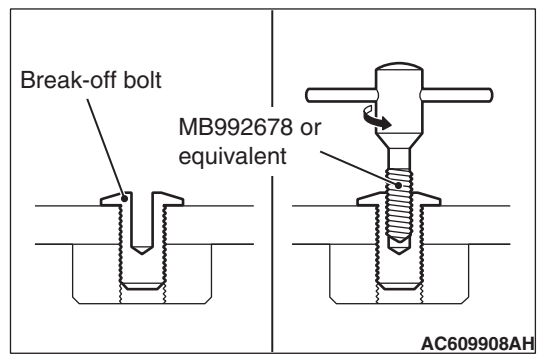

## INSTALLATION SERVICE POINTS

### >>A<< BREAK-OFF BOLT INSTALLATION <VEHICLES FOR CANADA>

Tighten until the head of break-off bolt is broken off.

### >>B<< INITIALIZATION OPERATION

Turn the ignition switch to the "ON" position and then to "LOCK" (OFF) position and hold it for at least 10 seconds.

---

## NOTES