

## GROUP 35A

# BASIC BRAKE SYSTEM

## CONTENTS

<b>GENERAL INFORMATION</b> .....	<b>35A-2</b>	<b>BRAKE PEDAL</b> .....	<b>35A-12</b>
<b>SERVICE SPECIFICATIONS</b> .....	<b>35A-3</b>	REMOVAL AND INSTALLATION .....	35A-12
<b>LUBRICANTS</b> .....	<b>35A-3</b>	INSPECTION .....	35A-12
<b>SEALANT</b> .....	<b>35A-3</b>	<b>MASTER CYLINDER ASSEMBLY AND BRAKE BOOSTER</b> .....	<b>35A-13</b>
<b>SPECIAL TOOLS</b> .....	<b>35A-4</b>	REMOVAL AND INSTALLATION .....	35A-13
<b>ON-VEHICLE SERVICE</b> .....	<b>35A-4</b>	MASTER CYLINDER .....	35A-15
BRAKE PEDAL CHECK AND ADJUSTMENT .....	35A-4	INSPECTION .....	35A-15
BRAKE BOOSTER OPERATING TEST ...	35A-5	<b>FRONT DISC BRAKE ASSEMBLY</b> ..	<b>35A-16</b>
CHECK VALVE OPERATION CHECK ...	35A-6	REMOVAL AND INSTALLATION .....	35A-16
BLEEDING .....	35A-6	INSPECTION .....	35A-17
BRAKE FLUID LEVEL SENSOR CHECK ..	35A-7	DISASSEMBLY AND REASSEMBLY .....	35A-18
DISC BRAKE PAD CHECK AND REPLACEMENT .....	35A-7	INSPECTION .....	35A-20
DISC BRAKE ROTOR CHECK .....	35A-9	<b>REAR DISC BRAKE ASSEMBLY</b> ...	<b>35A-21</b>
		REMOVAL AND INSTALLATION .....	35A-21
		INSPECTION .....	35A-22
		DISASSEMBLY AND REASSEMBLY .....	35A-23
		INSPECTION .....	35A-25

## GENERAL INFORMATION

M1351000100406

The brake system offers high dependability and durability along with improved braking performance and brake sensitivity.

## CONFIGURATION DIAGRAM

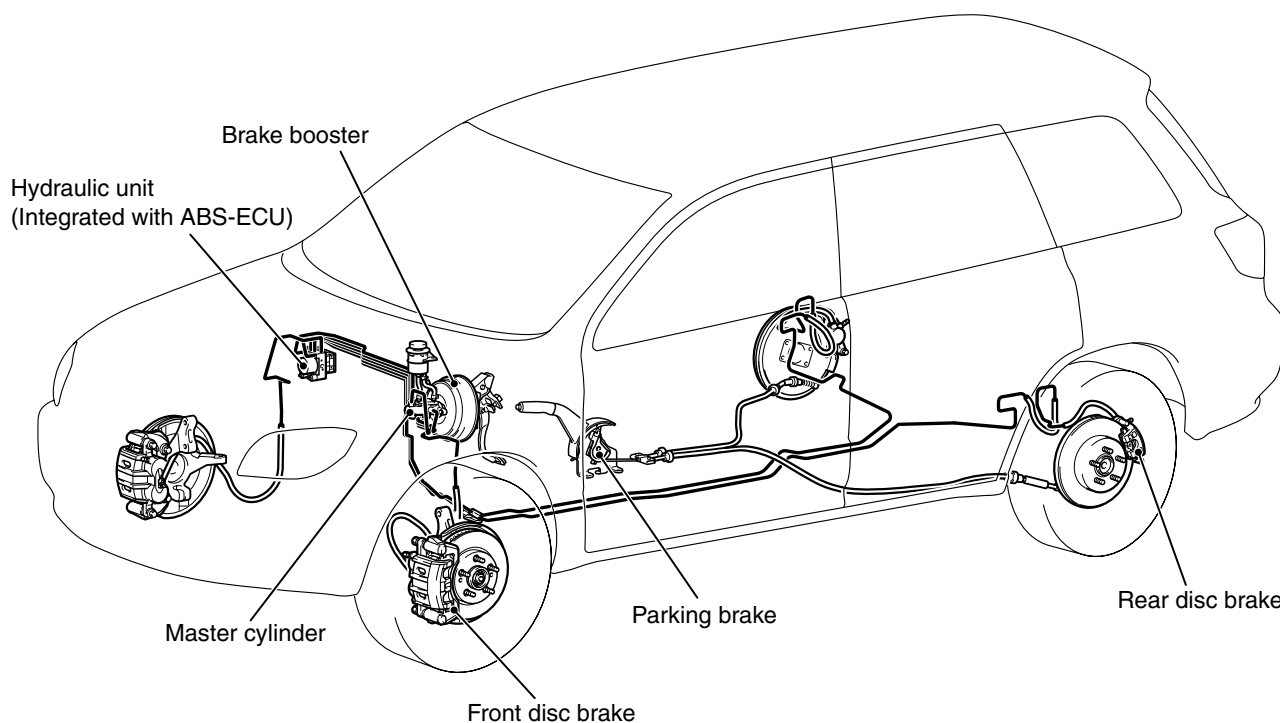

AC300584 AC

## SPECIFICATIONS

Item	Specification	
Master cylinder	Type	Tandem type
	I.D. mm	25.4
Brake booster	Type	Vacuum type, tandem
	Effective dia. of power cylinder mm	205 + 230
	Boosting ratio	7.5
Rear wheel hydraulic control method		Electronic brake-force distribution (EBD)
Front brakes	Type	Floating caliper, 2 piston, ventilated disc
	Disc effective diameter × thickness mm	246 × 24
	Wheel cylinder I.D. mm	42.9
	Clearance adjustment	Automatic
Rear disc brakes	Type	Floating caliper, 1 piston, solid disc
	Disc effective dia. × thickness mm	226 × 10
	Wheel cylinder I.D. mm	38.1
	Clearance adjustment	Automatic

## SERVICE SPECIFICATIONS

M1351000300433

Item		Standard value	Limit
Brake pedal height mm		150 – 153	–
Brake pedal free play mm		3 – 8	–
Brake pedal to floor board clearance mm		100 or more	–
Disc brake pad thickness mm		10.0	2.0
Disc brake disc thickness mm	Front	24.0	22.4
	Rear	10.0	8.4
Disc brake disc run-out mm	Front	–	0.04
	Rear	–	0.05
Disc brake drag force N	Front/Rear	68 or less	–
Wheel bearing axial play mm	Front/Rear	–	0.05
Brake booster push rod protruding length mm (When applying negative pressure of 66.7 kPa to the brake booster)		10.15 – 10.40	–

## LUBRICANTS

M1351000400377

Item	Specified lubricant
Brake fluid	DOT3 or DOT4
Guide pin	Repair kit grease
Lock pin	
Guide pin boot inner surface	
Lock pin boot inner surface	
Piston boot mounting grooves	
Brake piston boot inner surface	
Guide pin bush inner surface	

## SEALANT

M1351000500329

Item	Specified sealant	Remark
Rear hub cap <2WD>	3M ATD Part No.8661, 8663 or equivalent	Semi-drying sealant
Fitting thread part		

## SPECIAL TOOLS

M1351000600326

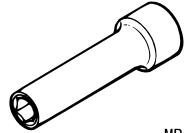
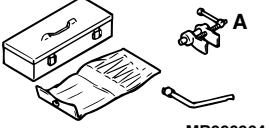
Tool	Number	Name	Use
 MB991568	MB991568	Push rod adjusting socket	Adjustment of the brake booster push rod protrusion amount
 MB990964	MB990964 A: MB990520	Brake tool set A: Disc brake piston expander	Pushing-in of the disc brake piston

## ON-VEHICLE SERVICE

BRAKE PEDAL CHECK AND  
ADJUSTMENT

M1351000900394

## BRAKE PEDAL HEIGHT

1. Turn up the carpet, etc. under the brake pedal.

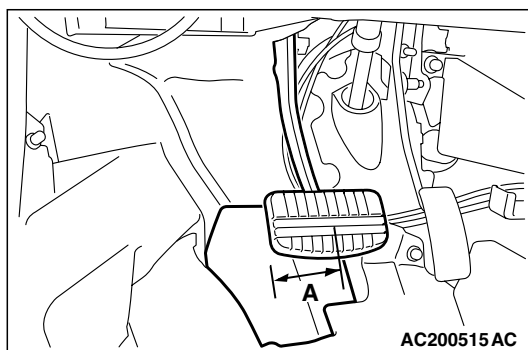

2. Measure the brake pedal height as illustrated.

**Standard value (A): 150 – 153 mm**  
**[From the surface of floor board to the face of pedal pad]**

3. If the brake pedal height is not within the standard value, follow the procedure below.

- (1) Disconnect the stop lamp switch connector.
- (2) Remove the brake booster (Refer to P.35A-13).

*NOTE: With the master cylinder and brake pipe connected, remove the brake booster only.*

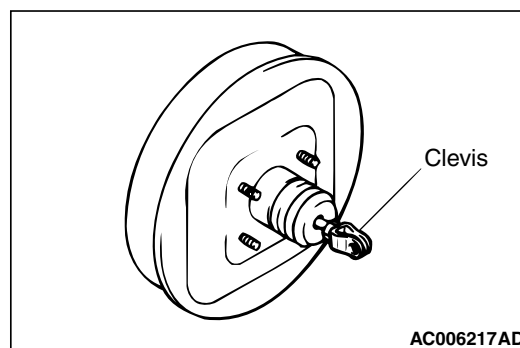

- (3) Adjust the brake pedal height by turning the clevis.

*NOTE: When the clevis is turned 180°, the pedal height is changed approximately 2.4 mm.*

- (4) Install the brake booster (Refer to P.35A-13).
- (5) Measure the brake pedal height, and ensure that the measured value is within the standard value. When it is out of the standard value, repeat Step (2) - (5).

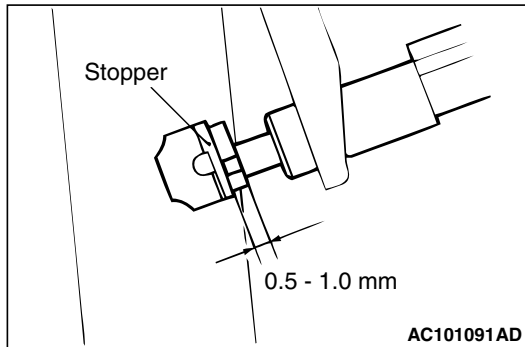

- (6) Screw in the stop lamp switch until its thread contacts the stopper, and fix the stop lamp switch by turning it approximately one quarter of a turn clockwise.
- (7) Check that the clearance between the stop lamp switch and the stopper is as shown.

**CAUTION**

Check that the stop lamp does not illuminate when the brake pedal is not depressed.

- (8) Connect the connector at the stop lamp switch.
4. Return the carpet, etc.

**BRAKE PEDAL FREE PLAY**

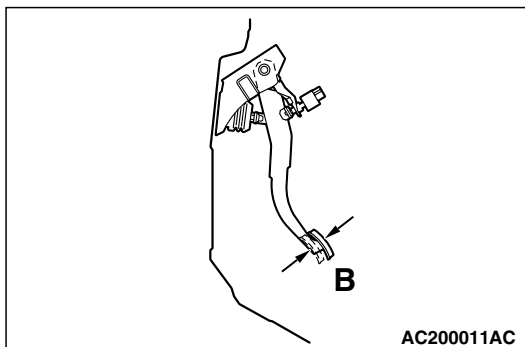

1. Turn the ignition switch to the "LOCK" (OFF) position, depress the brake pedal two or three times. After eliminating the vacuum in the brake booster, press the pedal down by hand, and confirm that the amount of movement before resistance is met (free play) is within the standard value range.

**Standard value: 3 – 8 mm**

2. If the brake pedal play is not within the standard value, check the following, and adjust or replace if necessary:
  - Excessive play between the brake pedal and the clevis pin, or between the clevis pin and the brake booster operating rod
  - Brake pedal height
  - Installation position of the stop lamp switch, etc.

**CLEARANCE BETWEEN BRAKE PEDAL AND FLOOR BOARD**

1. Turn up the carpet, etc. under the brake pedal.

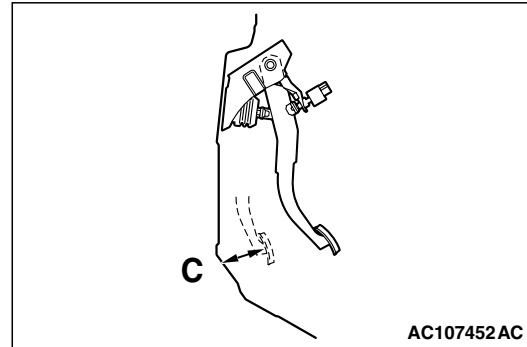

2. Start the engine, depress the brake pedal with approximately 490 N of force, and measure the clearance between the brake pedal and the floor board.

**Standard value (C): 100 mm or more**  
[From the surface of floor board to the face of pedal pad]

3. If the clearance is outside the standard value, check for air trapped in the brake line, thickness of the disc brake pad, clearance between the lining and the drum and dragging in the parking brake. And then adjust and replace defective parts as required.
4. Return the carpet etc. to its original position.

**BRAKE BOOSTER OPERATING TEST**

M1351001000327

1. For simple checking of the brake booster operation, carry out the following tests:

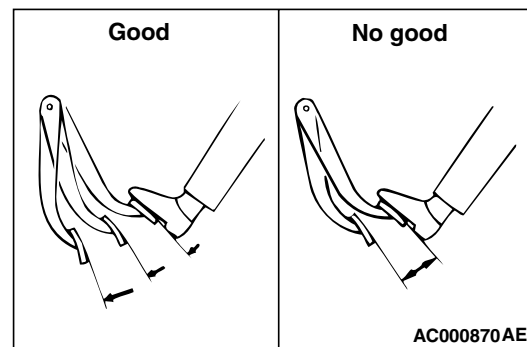

- (1) Run the engine for one or two minutes, and then stop it. If the pedal depresses fully the first time but gradually becomes higher when depressed succeeding times, the booster is operating properly. If the pedal height remains unchanged, the booster is defective. Go to step 2.

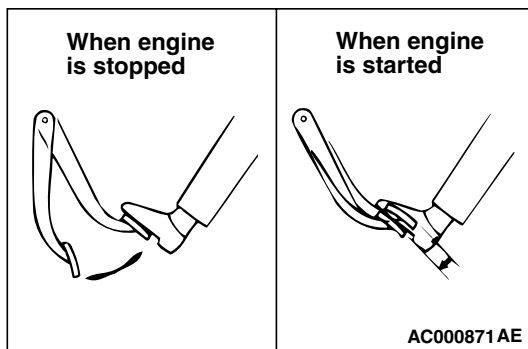

- (2) With the engine stopped, step on the brake pedal several times. Then step on the brake pedal and start the engine. If the pedal moves downward slightly, the booster is in good condition. If there is no change, the booster is defective. Go to step 3.

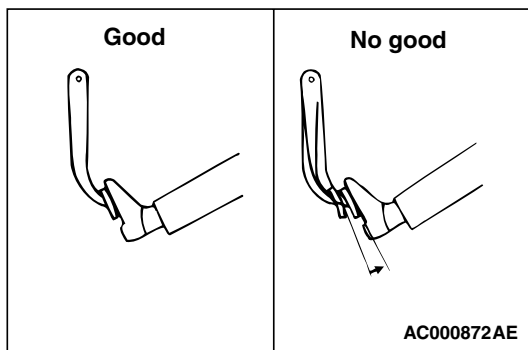

- (3) With the engine running, step on the brake pedal and then stop the engine. Hold the pedal depressed for 30 seconds. If the pedal height does not change, the booster is in good condition, if the pedal rises, the booster is defective.

2. If the above three tests are okay, the booster is OK. If one of the above three tests is not okay, the check valve, vacuum hose, or booster is defective. Check the check valve (Refer to P.35A-6), vacuum hose for leaks, high volume engine vacuum applied to booster. Repair or replace as necessary. If these are OK, replace the booster and repeat this test starting at Step 1.

### CHECK VALVE OPERATION CHECK

M1351009000321

#### CAUTION

The check valve should not be removed from the vacuum hose.

1. Remove the vacuum hose (Refer to P.35A-13).

#### CAUTION

If the check valve is defective, replace it as an assembly unit together with the vacuum hose.

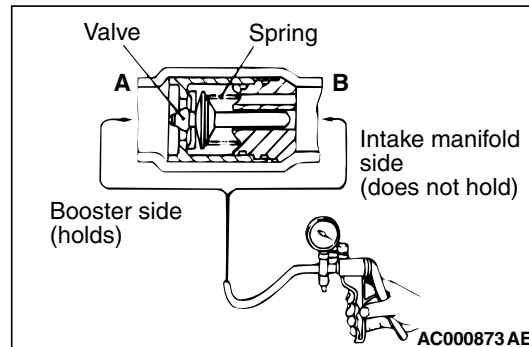

2. Check the operation of the check valve by using a vacuum pump.

Vacuum pump connection	Accept/reject criteria
Connection at the brake booster side (A)	A negative pressure (vacuum) is created and held.
Connection at the intake manifold side (B)	A negative pressure (vacuum) is not created.

### BLEEDING

M1351001400400

#### CAUTION

Use only brake fluid DOT 3 or DOT 4. Never mix the specified brake fluid with other fluid as it will influence the braking performance significantly.

### MASTER CYLINDER BLEEDING

The master cylinder used has no check valve, so if bleeding is carried out by the following procedure, bleeding of air from the brake pipeline will become easier (When brake fluid is not contained in the master cylinder).

1. Fill the reserve tank with brake fluid.
2. Keep the brake pedal depressed.

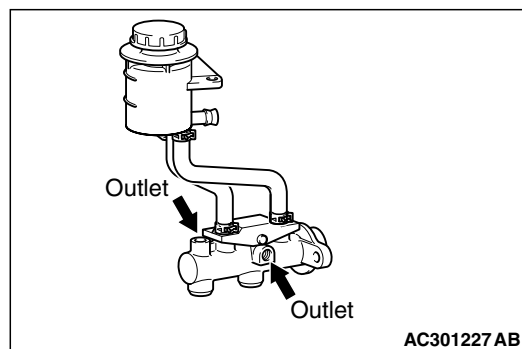

3. Have another person cover the master cylinder outlet with a finger.

4. With the outlet still closed, release the brake pedal.
5. Repeat steps 2 – 4 three or four times to fill the inside of the master cylinder with brake fluid.

### BRAKE LINE BLEEDING

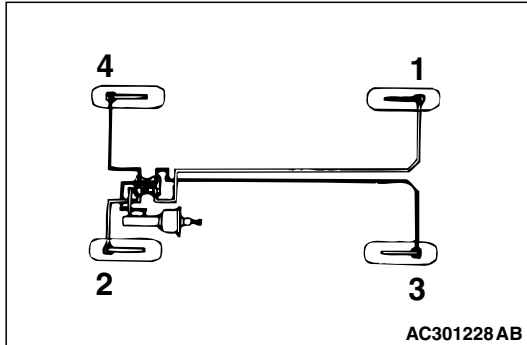

Start the engine and bleed the air in the sequence shown in the figure.

### BRAKE FLUID LEVEL SENSOR CHECK

M1351009100351

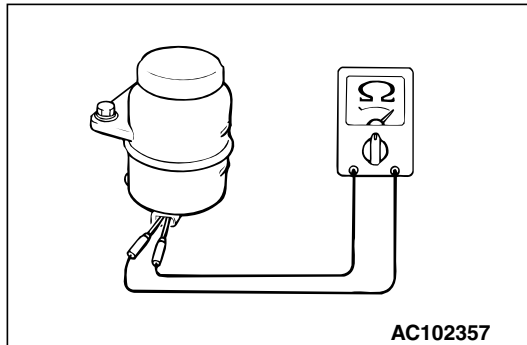

The brake fluid level sensor is in good condition if there is no continuity when the float surface is above "MIN" and if there is continuity when the float surface is below "MIN".

### DISC BRAKE PAD CHECK AND REPLACEMENT

M1351002300343

NOTE:

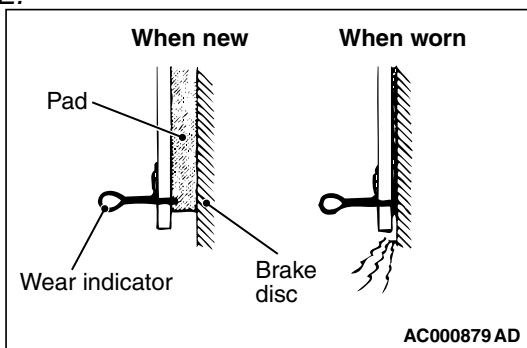

The brake pads have indicators that contact the brake disc when the brake pad thickness becomes 2 mm, and emit a squealing sound to warn the driver.

### CAUTION

- Whenever a pad must be replaced, replace both LH and RH wheel pads as a set to prevent the vehicle from pulling to one side when braking.
- If there is a significant difference in the thicknesses of the pads on the left and right sides, check the sliding condition of the piston and slide pins.

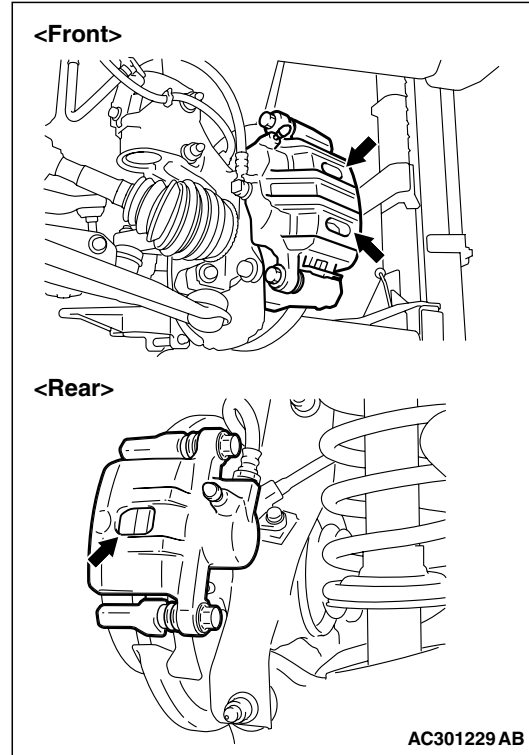

1. Check the brake pad thickness through the caliper body check port.

**Standard value: 10.0 mm**

**Minimum limit: 2.0 mm**

**CAUTION**

Do not wipe off the special grease that is on the lock pin or allow it to contaminate the lock pin.

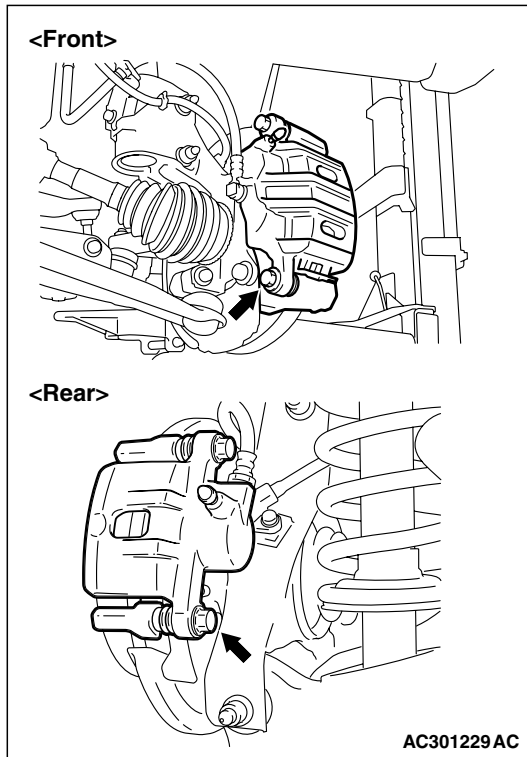

2. Remove the guide/lock pin bolt. Pivot the caliper assembly and hold it with wires.

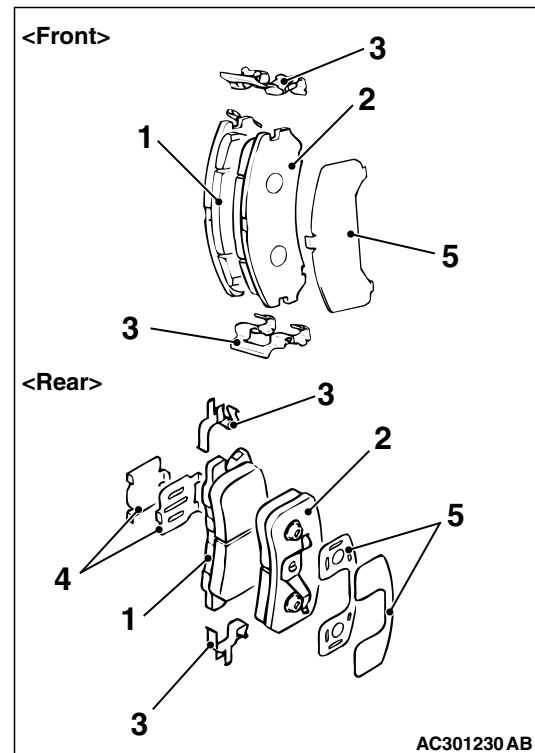

3. Remove the following parts from caliper support.
  - (1) Pad assembly or Pad and wear indicator assembly
  - (2) Pad assembly
  - (3) Clip
  - (4) Inner shim
  - (5) Outer shim
4. In order to measure the brake drag force after pad installation, measure the rotary-sliding resistance of the hub with the pads removed. For the front brakes, refer to [P.35A-16](#). For the rear brakes, refer to [P.35A-21](#).
5. Install the pads and caliper assembly, and then check the brake drag force. For the front brakes, refer to [P.35A-16](#). For the rear brakes, refer to [P.35A-21](#).



**DISC BRAKE ROTOR CHECK**

M1351002900293

**⚠ CAUTION**

**Disc brakes must be kept within the allowable service values in order to maintain normal brake operation.**

Before turning the brake disc, the following conditions should be checked.

Inspection item	Remark
Scratches, rust, saturated lining materials and wear	<ul style="list-style-type: none"> <li>• If the vehicle is not driven for a long period of time, sections of the discs that are not in contact with the pads will become rusty, causing noise and shuddering.</li> <li>• If grooves and scratches resulting from excessive disc wear are not removed prior to installing a new pad assembly, there will be inadequate contact between the disc and the lining (pad) until the pads conform to the disc.</li> </ul>
Run-out	Excessive run-out of the discs will increase the pedal depression resistance due to piston kick-back.
Change in thickness (parallelism)	If the thickness of the disc changes, this will cause pedal pulsation, shuddering and surging.
Inset or warping (flatness)	Overheating and improper handling while servicing will cause warping or distortion.

**BRAKE DISC THICKNESS CHECK**

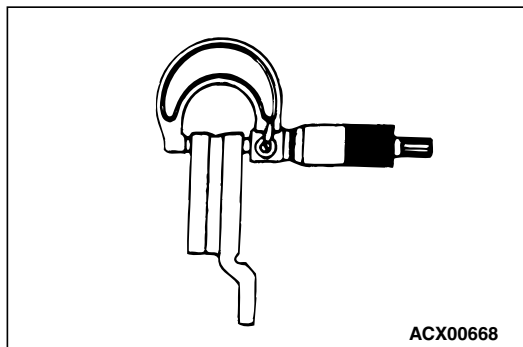

1. Using a micrometer, measure disc thickness at eight positions, approximately 45° apart and 10 mm in from the outer edge of the disc.

**Standard value:**

- <Front> 24.0 mm
- <Rear> 10.0 mm

**Minimum limit:**

- <Front> 22.4 mm
- <Rear> 8.4 mm

*NOTE: Thickness variation (at least 8 positions) should not be more than 0.015 mm.*

2. If the disc thickness is less than the limits, replace it with a new one.

**CAUTION**

- After a new brake disc is installed, always grind the brake disc with on-the-car type brake lathe. If this step is not carried out, the brake disc run-out exceeds the specified value, resulting in judder.

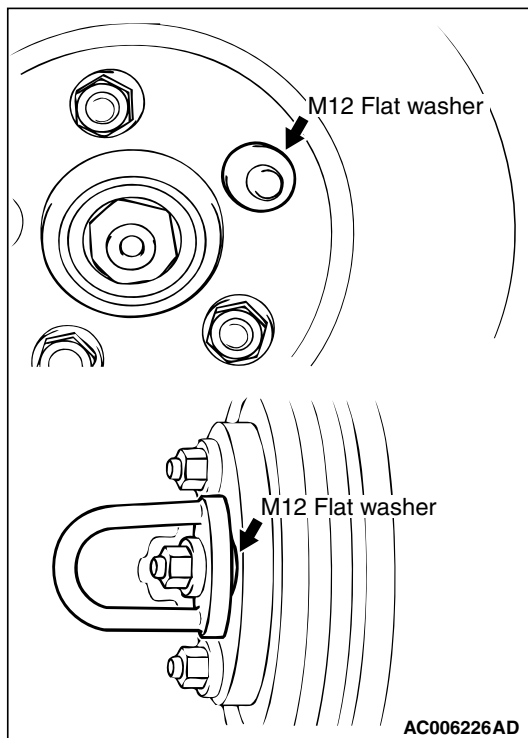

- When the on-the-car type lathe is used, first install M12 flat washer on the stud bolt in the brake disc side according to the figure, and then install the adapter. If the adapter is installed with M12 flat washer not seated, the brake disc rotor may be deformed, resulting in inaccurate grinding.
- Grind the brake disc with all wheel nuts diagonally and equally tightened to the specified torque 100 N·m. When all numbers of wheel nuts are not used, or the tightening torque is excessive or not equal, the brake disc rotor or drum may be deformed, resulting in judder.

3. If thickness variation exceeds the specification, turn rotor with an on-the-car type brake lathe ("MAD, DL-8700PF" or equivalent). If the calculated final thickness after turning the rotor is less than the standard value, replace the disc.

**BRAKE DISC RUN-OUT CHECK AND CORRECTION**

1. Remove the brake caliper assembly, and then hold it with wire.
2. Temporarily install the disc with the hub nut.

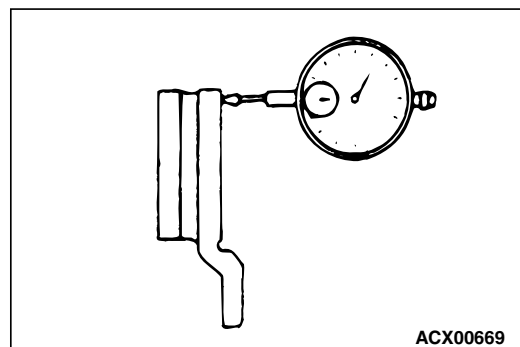

3. Place a dial gauge approximately 5 mm from the outer circumference of the brake disc, and measure the run-out of the disc.

**Limit:**

- <Front> 0.04 mm
- <Rear> 0.05 mm

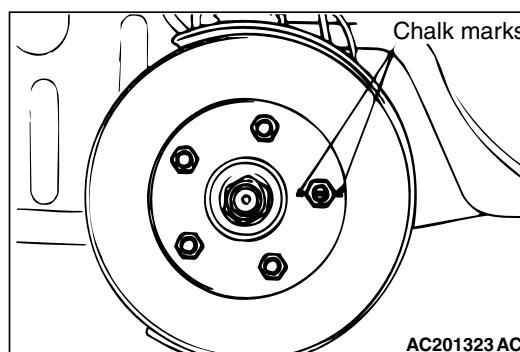

4. If the brake disc run-out exceeds the limit, correct it as follows:
  - (1) Chalk phase marks on the wheel stud and the brake disc, which run-out is excessive as shown.

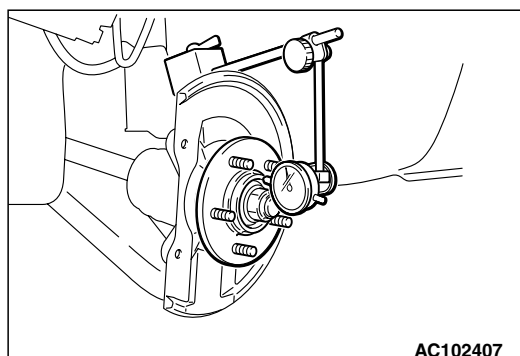

- (2) Remove the brake disc. Then place a dial gauge as shown, and measure the wheel bearing axial play by pushing and pulling the wheel hub.

**Limit: 0.05 mm**

- (3) If the axial play exceeds the limit, disassemble the hub and knuckle/trailing arm assembly to check each part.

- (4) If the axial play does not exceed the limit, dephase the brake disc and secure it. Then recheck the brake disc run-out.

**CAUTION**

- After a new brake disc is installed, always grind the brake disc with on-the-car type brake lathe. If this step is not carried out, the brake disc run-out exceeds the specified value, resulting in judder.

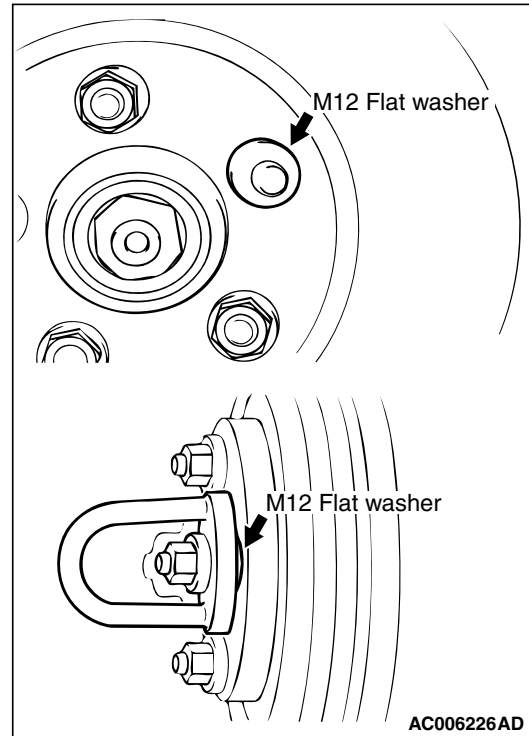

- When the on-the-car type lathe is used, first install M12 flat washer on the stud bolt in the brake disc side according to the figure, and then install the adapter. If the adapter is installed with M12 flat washer not seated, the brake disc rotor may be deformed, resulting in inaccurate grinding.
  - Grind the brake disc with all wheel nuts diagonally and equally tightened to the specified torque 100 N·m. When all numbers of wheel nuts are not used, or the tightening torque is excessive or not equal, the brake disc rotor or drum may be deformed, resulting in judder.
5. If the run-out cannot be corrected by changing the phase of the brake disc, replace the brake disc or grind it with the on-the-car type brake lathe ("MAD, DL-8700PF" or equivalent).

# BRAKE PEDAL

## REMOVAL AND INSTALLATION

M1351003400354

**Post-installation Operation**

- Brake Pedal Adjustment (Refer to P.35A-4).

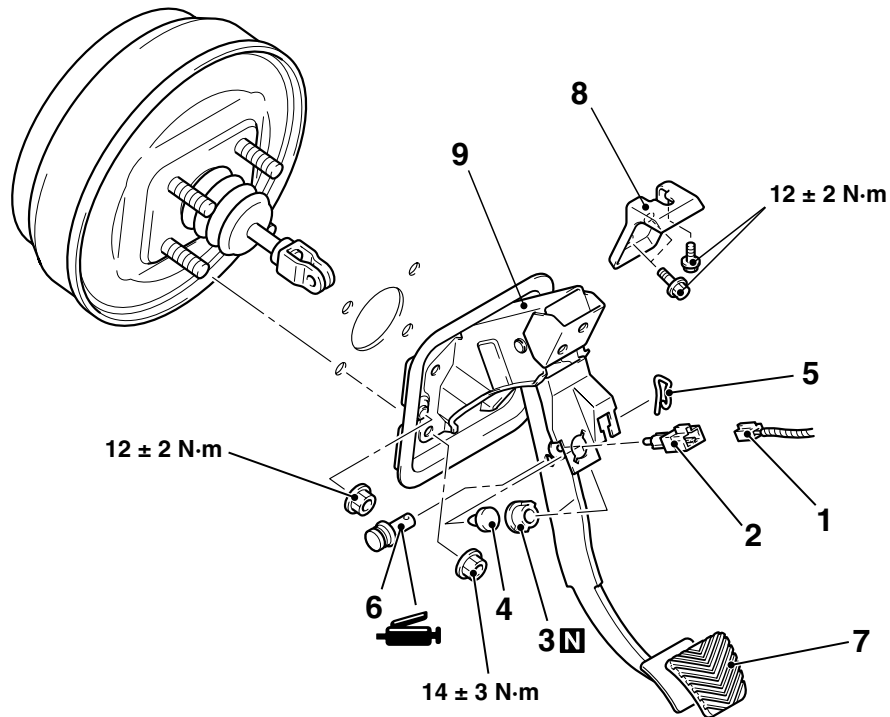

AC301350AB

**Removal steps**

1. Harness connector
2. Stop lamp switch
3. Adjuster
4. Pedal stopper
5. Snap pin

**Removal steps (Continued)**

6. Pin assembly
7. Pedal pad
8. Reinforced bracket
9. Brake pedal and pedal support member

## INSPECTION

### STOP LAMP SWITCH CHECK

M1351003500180

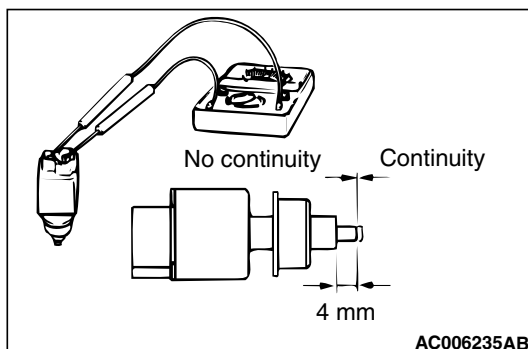

AC006235AB

1. Connect an ohmmeter between the stop lamp switch connector terminals.

2. There should be no continuity between the terminals when the plunger is pushed in as shown. There should be continuity when it is released.

# MASTER CYLINDER ASSEMBLY AND BRAKE BOOSTER REMOVAL AND INSTALLATION

M1351003700355

### Pre-removal Operation

- Air Intake Hose and Air Cleaner Removal (Refer to GROUP 15, Air Cleaner P.15-3).
- Brake Fluid Draining

### Post-installation Operation

- Brake Fluid Supplying and Air Bleeding (Refer to P.35A-6).
- Brake Pedal Adjustment (Refer to P.35A-4).
- Air Intake Hose and Air Cleaner Installation (Refer to GROUP 15, Air Cleaner P.15-3).

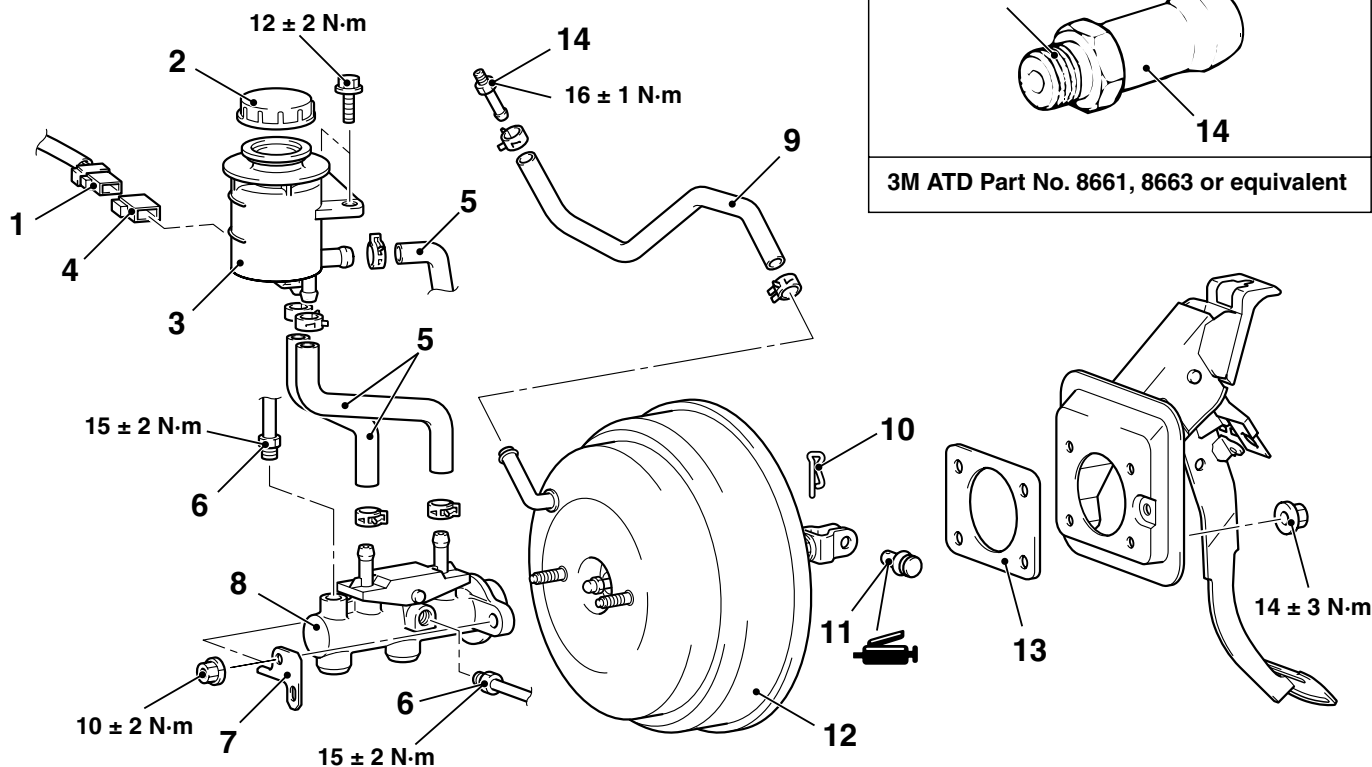

AC301351AB

### Master cylinder removal steps

- >>C<<
1. Brake fluid level sensor connector
  2. Reservoir cap assembly
  3. Reservoir
  4. Brake fluid level sensor
  5. Reservoir hose
  6. Brake pipe connection
  7. Bracket
  8. Master cylinder

### Brake booster removal steps

1. Brake fluid level sensor connector
6. Brake pipe connection
7. Bracket
8. Master cylinder

### Brake booster removal steps

- >>B<<
- Push rod protrusion amount check and adjustment
- >>A<<
9. Vacuum hose (with built-in check valve)
  10. Snap pin
  11. Pin assembly
  12. Brake booster
  13. Sealer

### Fitting removal steps

- >>A<<
9. Vacuum hose (with built-in check valve)
  14. Fitting

## INSTALLATION SERVICE POINTS

### >>A<< VACUUM HOSE CONNECTION

Insert vacuum hose with its paint mark facing upward.

### >>B<< PUSH ROD PROTRUSION AMOUNT CHECK AND ADJUSTMENT

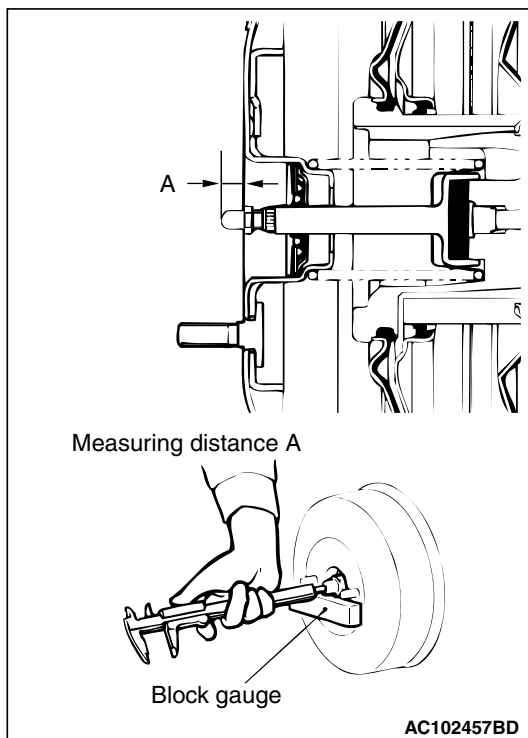

1. Use the vacuum pump to measure dimension "A" applying a negative pressure of 66.7 kPa to the brake booster.

**Standard value (A): 10.15 – 10.40 mm**

*NOTE: When a negative pressure of 66.7 kPa is not applied to the brake booster, the push rod protrusion amount (A) should be 8.85 - 9.10 mm.*

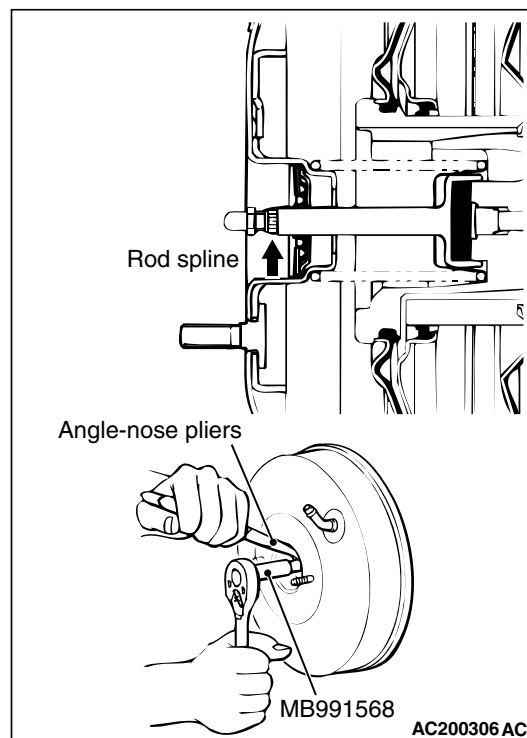

2. If the protrusion amount is not within the standard value range, adjust the push rod length by turning the push rod. Use special tool push rod adjusting socket (MB991568) to turn the push rod while holding the rod spline with angle-nose pliers.

### >>C<< RESERVOIR HOSE CONNECTION

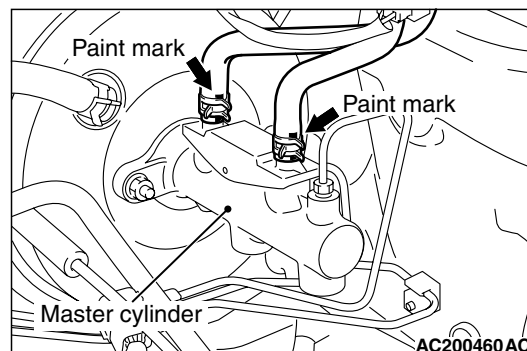

Insert the reservoir hose with its paint mark facing front of the vehicle.

## MASTER CYLINDER

M1351004200320

## DISASSEMBLY AND REASSEMBLY

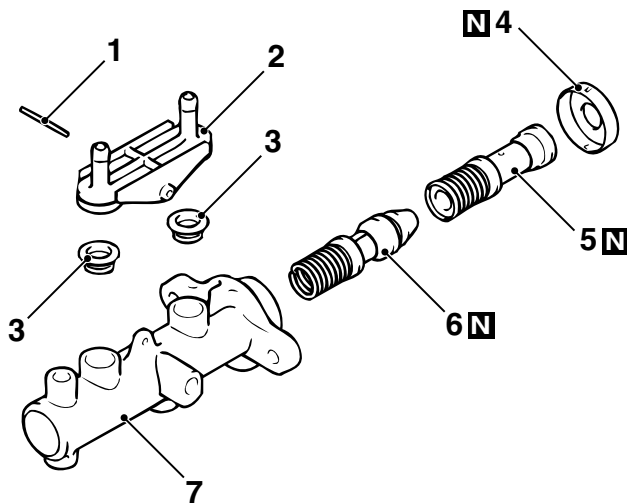

### Disassembly steps

1. Spring pin
2. Nipple
3. Reservoir seal
4. Piston retainer

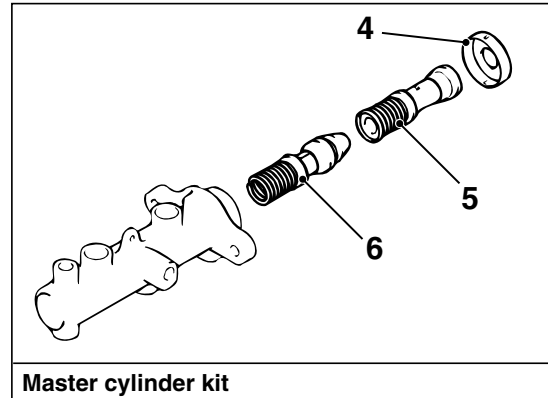

Master cylinder kit

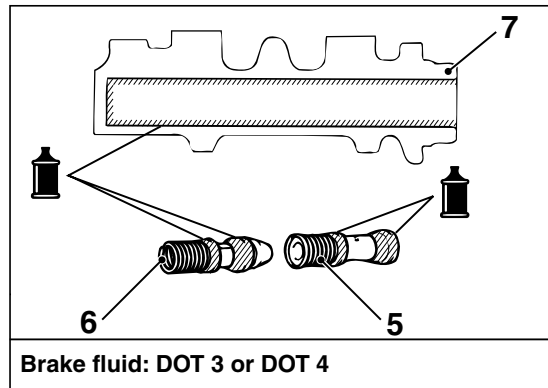

Brake fluid: DOT 3 or DOT 4

AC102644 AE

### Disassembly steps (Continued)

5. Primary piston assembly
6. Secondary piston assembly
7. Master cylinder body

## INSPECTION

- Check the inner surface of master cylinder body for rust or pitting.
- Check the primary and secondary pistons for rust, scoring, wear or damage.

M1351004300253

## FRONT DISC BRAKE ASSEMBLY

## REMOVAL AND INSTALLATION

M1351006000377

## Pre-removal Operation

- Brake Fluid Draining

## Post-installation Operation

- Brake Fluid Supplying and Air Bleeding (Refer to P.35A-6).

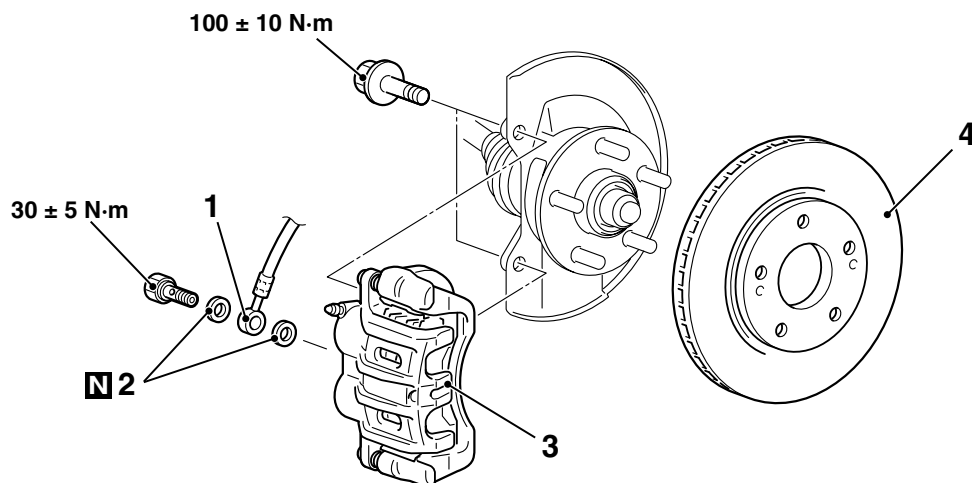

AC301353 AB

## Removal steps

1. Brake hose connection
2. Gasket

## Removal steps (Continued)

- >>A<< 3. Brake caliper assembly  
4. Brake disc

## INSTALLATION SERVICE POINT

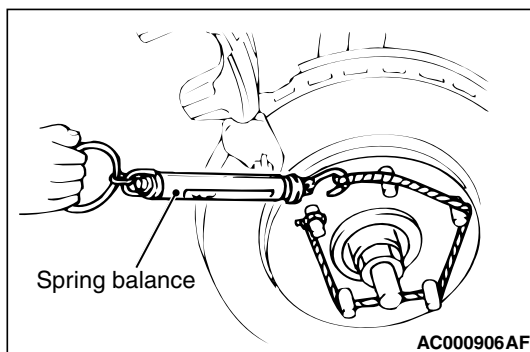
>>A<< BRAKE CALIPER ASSEMBLY  
INSTALLATION

1. In order to measure the brake drag torque, measure the hub torque with the pads removed by the following procedure.

Use a spring balance to measure the hub torque in the forward direction. Record hub torque with pads removed.

**CAUTION**

Do not let any oil, grease or other contamination get onto the friction surfaces of the pads and brake discs.

2. After re-installing the caliper support to the knuckle, install the pad clips and the pads to the caliper support.

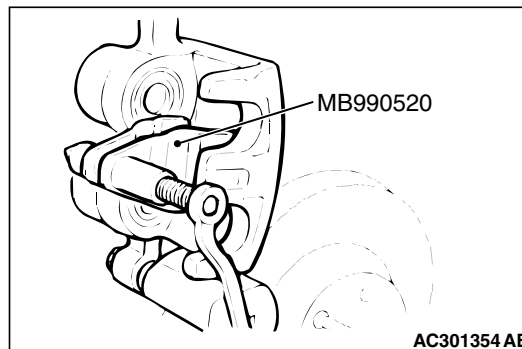

3. Clean the piston and insert into cylinder with special tool disc brake piston expander (MB990520).
4. Be careful that the piston boot does not become caught, when lowering the caliper assembly and installing the guide pin bolt.



5. Check the brake drag force as follows.
  - (1) Start the engine and hold the brake pedal down for 5 seconds. (Pedal depression force: approximately 200 N)
  - (2) Stop the engine.
  - (3) Turn the brake disc forward 10 times.

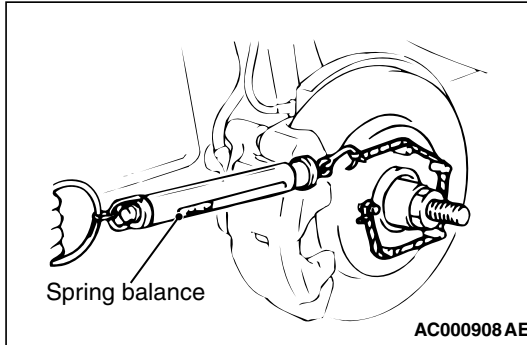

- (4) Use a spring balance to measure the hub torque with pads installed in the same direction as earlier.

- (5) Calculate the drag force of the disc brake [difference between hub torque with pads installed and hub torque with pads removed].

**Standard value: 68 N or less**

6. If the brake drag force exceeds the standard value, disassemble and clean the piston. Check for corrosion or worn piston seal, and check the sliding condition of the lock pin and guide pin.

## INSPECTION

M1351006100277

### BRAKE DISC CHECK

- Disc wear (Refer to [P.35A-9](#)).
- Disc run-out (Refer to [P.35A-9](#)).

DISASSEMBLY AND REASSEMBLY

M1351006200423

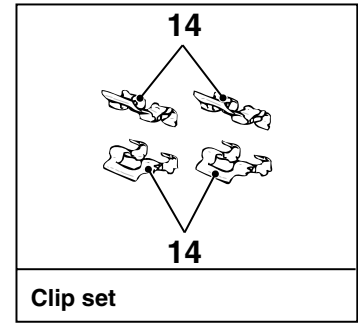
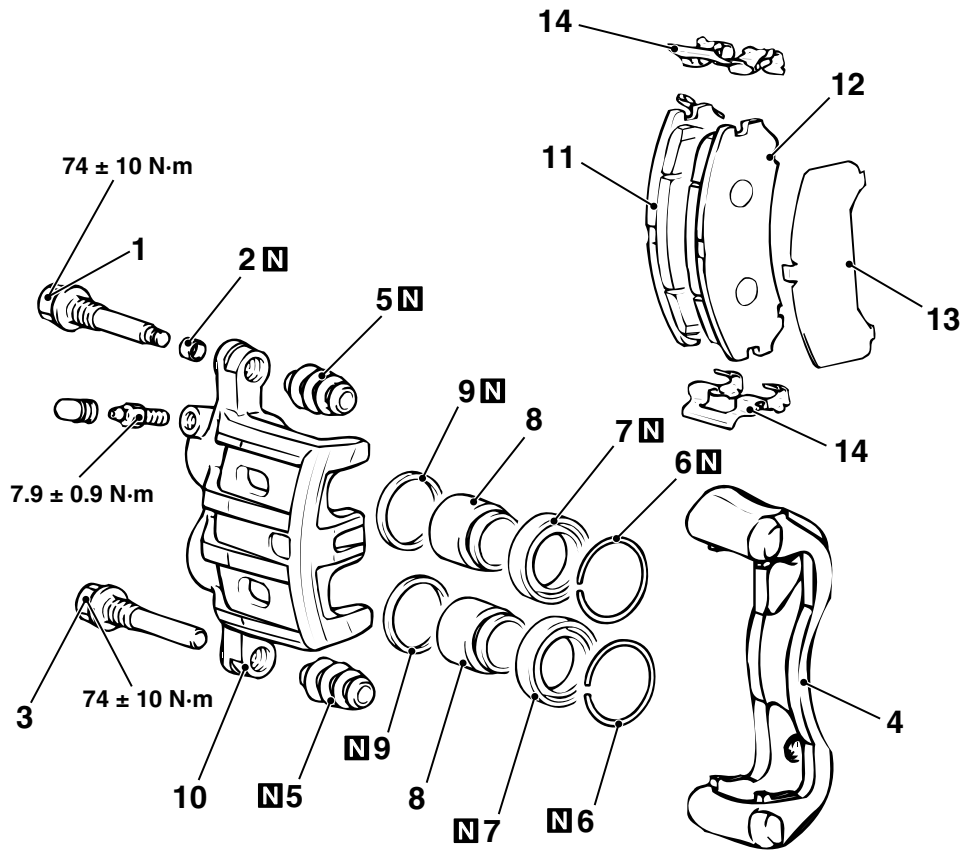

AC202238 AD

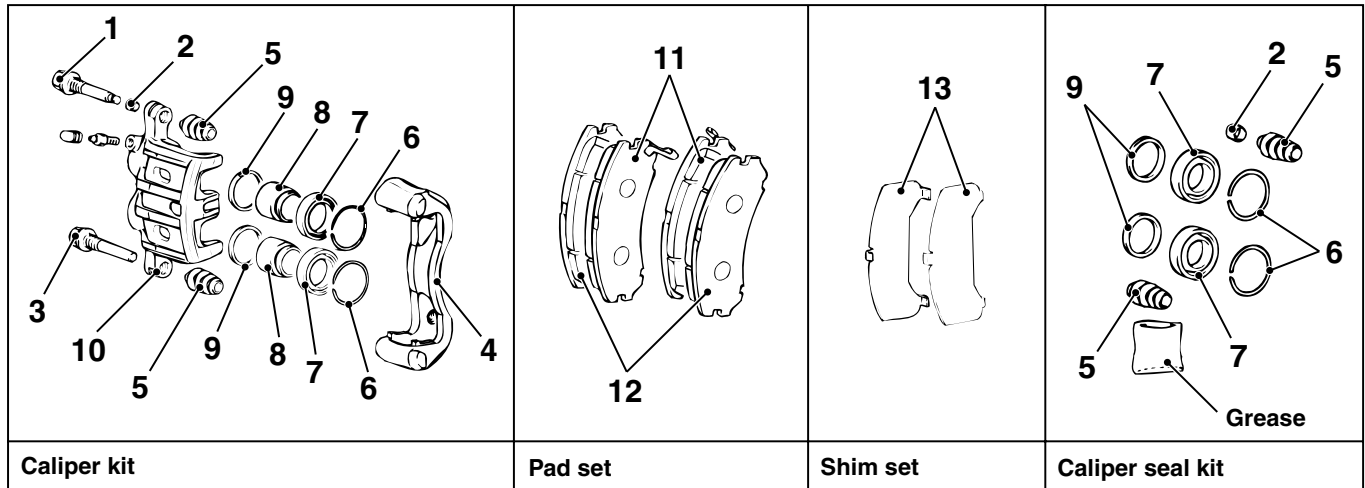

Disassembly steps

1. Lock pin
2. Bushing
3. Guide pin
4. Caliper support (including pad, clip, and shim)
5. Pin boot
6. Boot ring
7. Piston boot
8. Piston

<<A>>  
<<A>>

<<B>>

Disassembly steps (Continued)

9. Piston seal
10. Caliper body
11. Pad and wear indicator assembly
12. Pad assembly
13. Outer shim
14. Clip

LUBRICATION POINTS

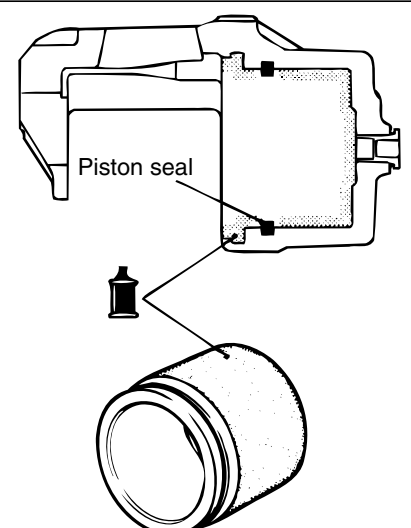

Piston seal

**CAUTION**  
The piston seal inside the caliper seal kit is coated with a special grease. Do not wipe this grease off.

Brake fluid: DOT 3 or DOT 4

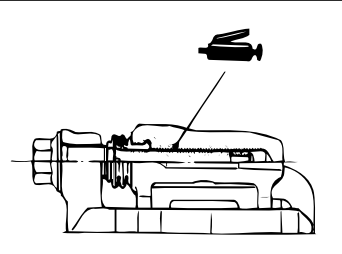

Grease: Repair kit grease

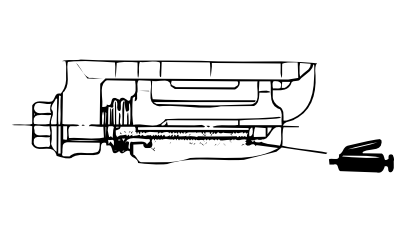
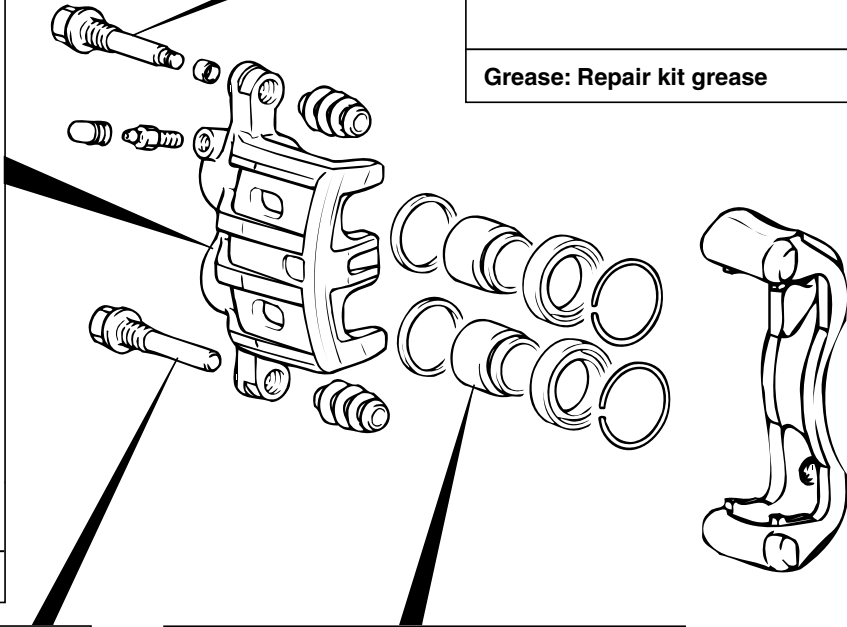

Grease: Repair kit grease

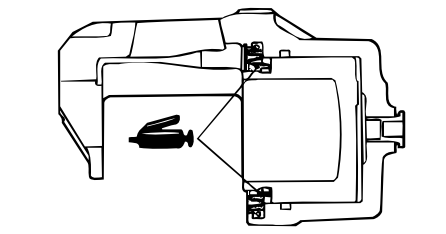

Grease: Repair kit grease

AC202239 AD

**DISASSEMBLY SERVICE POINTS**

When disassembling the disc brakes, disassemble both sides (left and right) as a set.

**<<A>> PISTON BOOT/PISTON REMOVAL****⚠ CAUTION**

- Blow air little by little to remove the pistons. The pistons will rush out if a force of air is applied suddenly.
- If one piston has been removed completely, it will become impossible to remove the second piston.

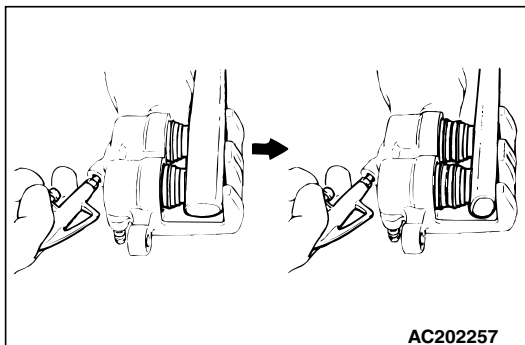

Remove the pistons and the piston boots by pumping in air from the brake hose connection. Be sure to use the handle of a plastic hammer and adjust the height of the two pistons so that the pistons protrude evenly.

**<<B>> PISTON SEAL REMOVAL****⚠ CAUTION**

Do not use a flat-tipped screwdriver or similar tool to remove the piston seal. These may damage the inner side of the cylinder.

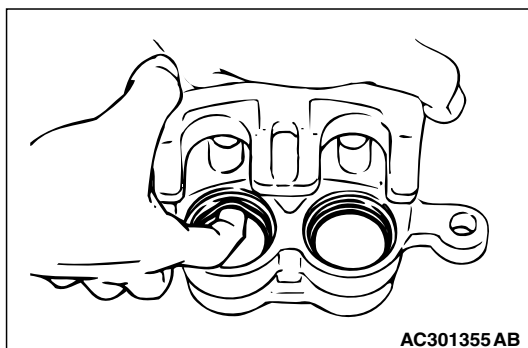

1. Remove the piston seal with your finger tip.
2. Clean the piston surface and inner cylinder with alcohol or brake fluid DOT 3 or DOT 4.

**INSPECTION**

M1351006300345

- Check the cylinder for wear, damage or rust.
- Check the piston surface for wear, damage or rust.
- Check the caliper body or sleeve for wear.
- Check the pad for damage or adhesion of grease, check the backing metal for damage.

**PAD WEAR CHECK****⚠ WARNING**

- *Always replace both brake pads on each wheel as a set. Failure to do so will result in uneven braking, which may cause unreliable brake operation.*
- *If there is significant difference in the thickness of the pads on the left and right sides, check the sliding condition of the piston and slide pins.*

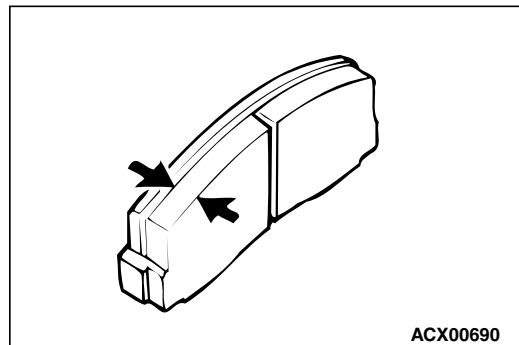

1. Measure thickness at the thinnest and most worn area of the pad.

**Standard value: 10.0 mm**

**Minimum limit: 2.0 mm**

2. Replace the pad assembly if pad thickness is less than the limit value.

# REAR DISC BRAKE ASSEMBLY

## REMOVAL AND INSTALLATION

M1351007000239

### Pre-removal Operation

- Brake Fluid Draining

### Post-installation Operation

- Brake Fluid Supplying and Air Bleeding (Refer to P.35A-6).

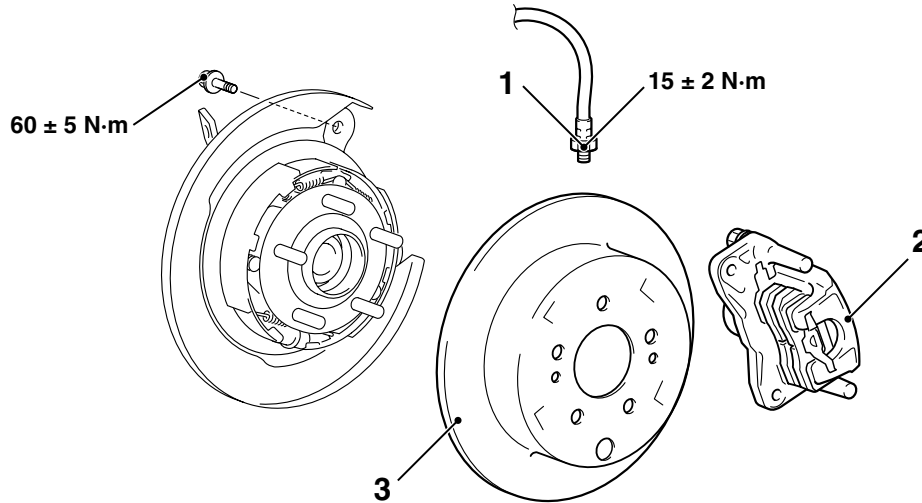

AC201830 AC

### Removal steps

1. Brake hose connection

### Removal steps (Continued)

- >>A<<
2. Brake caliper assembly
  3. Brake disc

## INSTALLATION SERVICE POINT

### >>A<< BRAKE CALIPER ASSEMBLY INSTALLATION

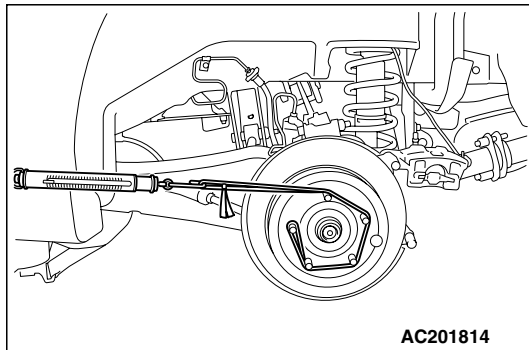

1. In order to measure the brake drag torque, measure the hub torque with the pads removed by the following procedure.

Use a spring balance to measure the hub torque in the forward direction. Record hub torque with pads removed.

### ⚠ CAUTION

Do not let any oil, grease or other contamination get onto the friction surfaces of the pads and brake discs.

2. After re-installing the caliper support to the backing plate, install the pad clips and the pads to the caliper support.

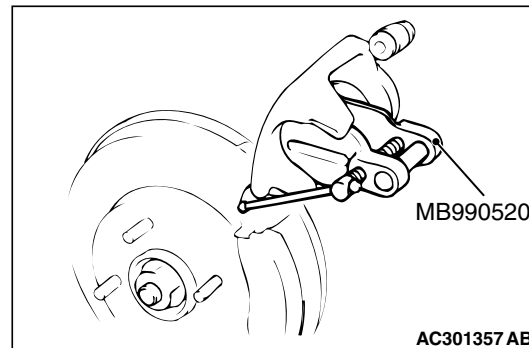

3. Clean the piston and insert into cylinder with special tool disc brake piston expander (MB990520).
4. Be careful that the piston boot does not become caught, when lowering the caliper assembly and installing the lock pin.

5. Check the brake drag force as follows.
  - (1) Start the engine and hold the brake pedal down for 5 seconds. (Pedal depression force: approximately 200 N)
  - (2) Stop the engine.
  - (3) Turn the brake disc forward 10 times.

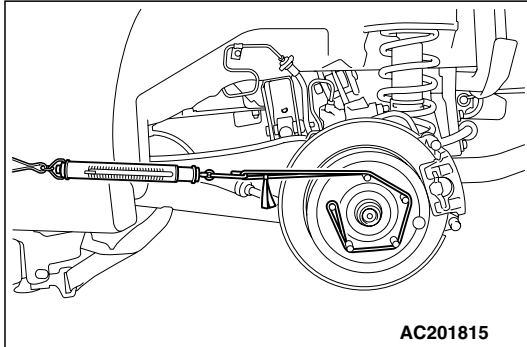

- (4) Use a spring balance to measure the hub torque with pads installed in the same direction as earlier.

- (5) Calculate the drag force of the disc brake [difference between hub torque with pads installed and hub torque with pads removed].

**Standard value: 68 N or less**

6. If the brake drag force exceeds the standard value, disassemble and clean the piston. Check for corrosion or worn piston seal, and check the sliding condition of the lock pin and guide pin.

## INSPECTION

M1351007100236

### BRAKE DISC CHECK

- Disc wear (Refer to [P.35A-9](#)).
- Disc run-out (Refer to [P.35A-9](#)).

DISASSEMBLY AND REASSEMBLY

M1351007200233

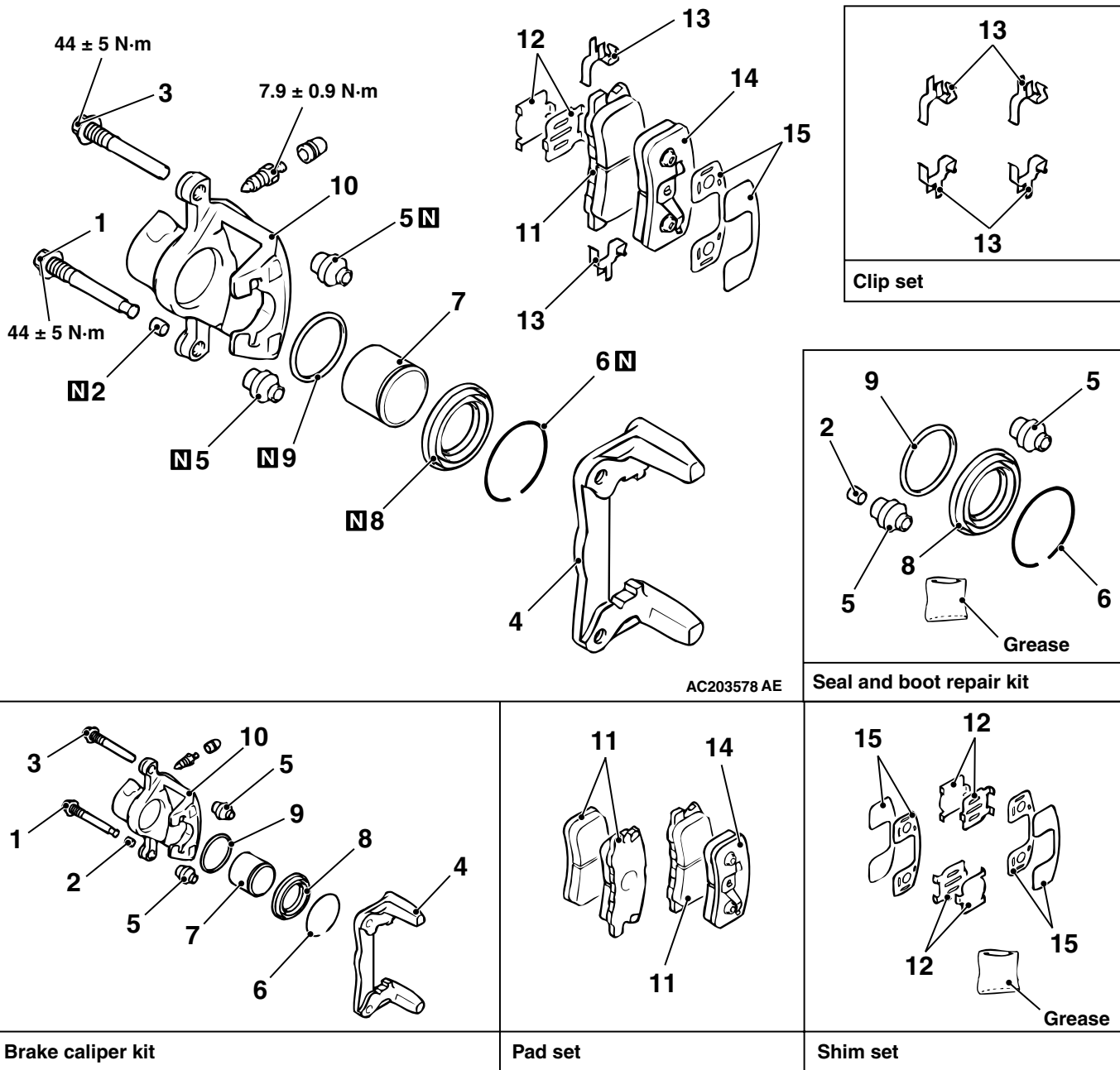

Disassembly steps

1. Lock pin
2. Bushing
3. Guide pin
4. Caliper support
5. Pin boot
6. Boot ring
7. Piston
8. Piston boot

<<A>>  
<<A>>

<<B>>

Disassembly steps (Continued)

9. Piston seal
10. Caliper body
11. Pad and wear indicator assembly
12. Inner shim
13. Clip
14. Pad assembly
15. Outer shim

### LUBRICATION POINTS

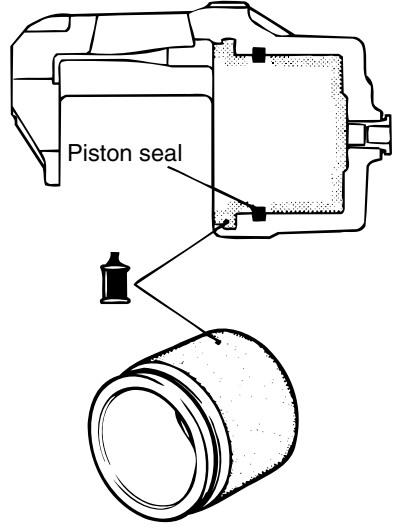

Piston seal

**CAUTION**  
The piston seal inside the seal and boot kit is coated with a special grease. Do not wipe this grease off.

Brake fluid: DOT 3 or DOT 4

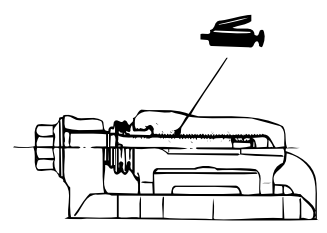

Grease: Repair kit grease

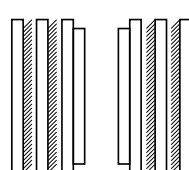

AC203550

Grease: Repair kit grease

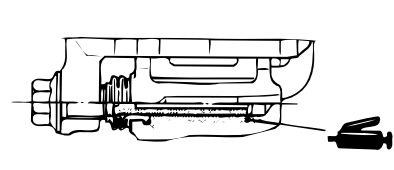
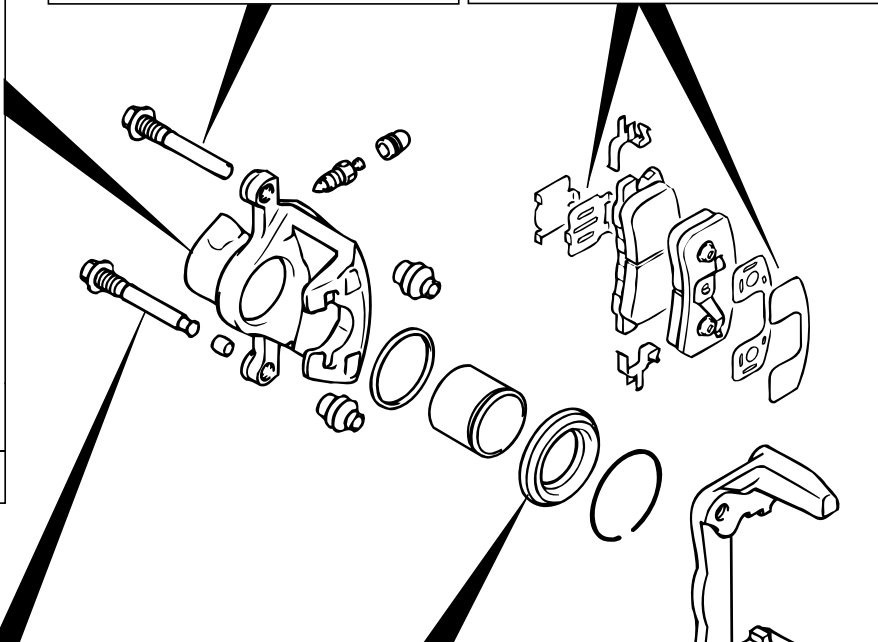

Grease: Repair kit grease

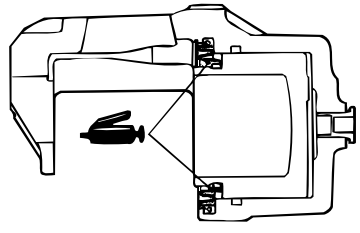

Grease: Repair kit grease

AC202232 AC



## DISASSEMBLY SERVICE POINTS

When disassembling the disc brakes, disassemble both sides (left and right) as a set.

### <<A>> PISTON BOOT/PISTON REMOVAL

#### **⚠ CAUTION**

Blow air little by little to remove the piston. The piston will rush out if a force of air is applied suddenly.

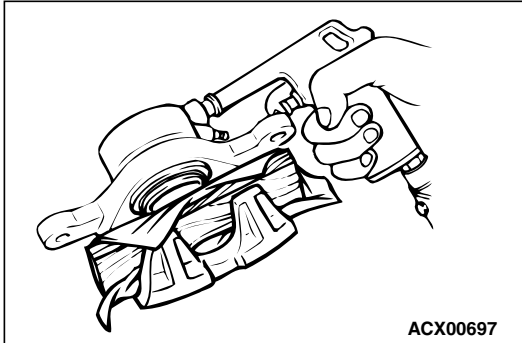

Place a piece of wood, etc. against the caliper body as shown. Blow compressed air through the brake hose to remove the piston boot and piston.

### <<B>> PISTON SEAL REMOVAL

#### **⚠ CAUTION**

Do not use a flat-tipped screwdriver or similar tool to remove piston seal. These may damage the inner side of the cylinder.

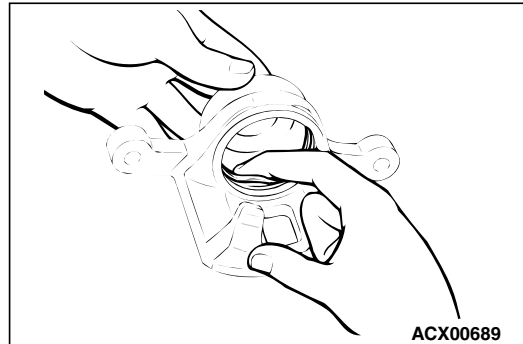

1. Remove the piston seal with your finger tip.
2. Clean the piston surface and inner cylinder with alcohol or brake fluid DOT 3 or DOT 4.

## INSPECTION

Refer to [P.35A-20](#).

M1351007300229

---

**NOTES**