

# FOREWORD

***FW***

---

	<b>Page</b>
1. Foreword .....	2

## 1. Foreword

### A: FOREWORD

These manuals are used when performing maintenance, repair or diagnosis of SUBARU IMPREZA WRX and SUBARU IMPREZA WRX STI.

Applicable model: 2012 MY GVE\*\*\*\*\*, GVF\*\*\*\*\*, GRE\*\*\*\*\*, GRF\*\*\*\*\*

The manuals contain the latest information at the time of publication. Changes in the specifications, methods, etc. may be made without notice.



# HOW TO USE THIS MANUALS

# *HU*

---

1. How to Use This Manuals .....	<b>Page</b> 2
----------------------------------	------------------

# How to Use This Manuals

HOW TO USE THIS MANUALS

---

## **1. How to Use This Manuals**

### **A: HOW TO USE THIS MANUALS**

#### **1. STRUCTURE**

Each section consists of SCT that are broken down into SC that are divided into sections for each component. The specification, maintenance and other information for the components are included, and the diagnostic information has also been added where necessary.

#### **2. CONTENTS**

The first page has an index with tabs.

## 3. COMPONENT

Illustrations are provided for each component. The information necessary for repair work (tightening torque, grease up points, etc.) is described on these illustrations. Information is described using symbol.

To order parts, refer to parts catalogue.

**Example:**

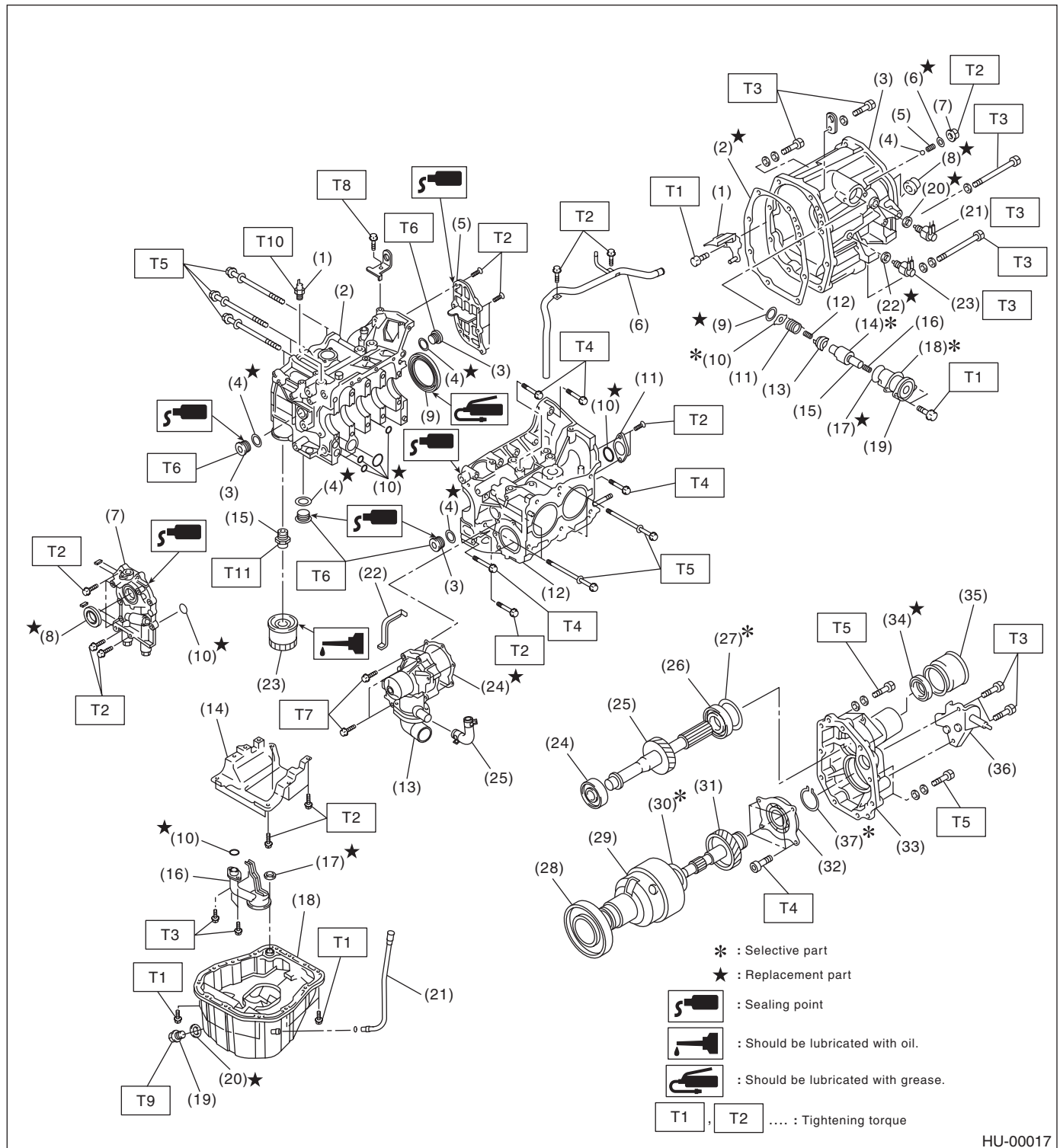

HU-00017

# How to Use This Manuals

## HOW TO USE THIS MANUALS

---

### **4. DEFINITIONS OF “NOTE”, “CAUTION” AND “WARNING”**

- **NOTE:**

Describes additional information to make works easier.

- **CAUTION:**

Describes prohibited matters to prevent vehicle or parts damage, or matters that requires special attention during work.

- **WARNING:**

Describes matters that may cause serious damage to the operator or other person, or that may cause damage or accident.

### **5. SPECIFICATIONS**

If necessary, specifications are also included.

### **6. INSPECTION**

Inspections to be carried out before and after maintenance are included.

## 7. MAINTENANCE

- Maintenance instructions for serviceable parts describe work area and detailed step with illustration. It also describes the use of special tool, tightening torque, caution for each procedure.
- If many serviceable parts are included in one service procedure, appropriate reference is provided for each part.

### Example:

**15.Main Shaft** ← (A)

**A: REMOVAL** ← (B)

1) Remove the manual transmission assembly from vehicle. <Ref. to MT-33, REMOVAL, Manual Transmission Assembly.> ← (C)

11) Tighten the lock nuts to the specified torque using ST1 and ST2.

**NOTE:** ← (D)

Secure the lock nuts in two places after tightening.

ST1 498937000 TRANSMISSION HOLDER

ST2 499987003<sup>(E)</sup> SOCKET WRENCH (35)<sup>(F)</sup>

**Tightening torque:**

**118 N·m (12.0 kgf-m, 86.8 ft-lb)** ← (G)

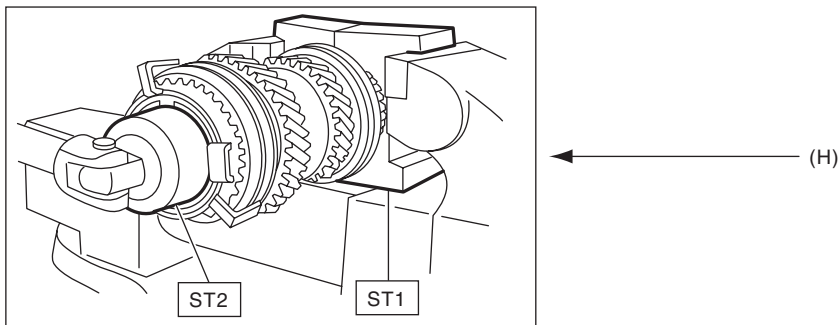

HU-00020

(A) Component

(B) Process

(C) Reference

(D) Cautions

(E) Tool number of special tool

(F) Name of special tool

(G) Tightening torque

(H) Illustration

# How to Use This Manuals

## HOW TO USE THIS MANUALS

---

### 8. DIAGNOSIS

Step-by-step process is employed for easier diagnosis.

### 9. SI UNITS

Measurements in these manuals are according to the SI units. Metric and yard/pound measurements are also included.

#### Example:

#### *Tightening torque:*

**44 N·m (4.5 kgf·m, 33 ft·lb)**

#### List of SI unit

Item	SI units	Conventional unit	Remarks
Force	N (Newton)	kgf	1 kgf = 9.807 N
Mass (Weight)	kg, g	kg, g	
Capacity	ℓ, mℓ or cm <sup>3</sup>	ℓ or cc	1 cc = 1 cm <sup>3</sup> = 1 mℓ
Torque	N·m	kgf·m, kgf·cm	1 kgf·m = 9.807 N·m
Rotating speed	rpm	rpm	
Pressure	kPa (Kilopascal)	kgf/cm <sup>2</sup>	1 kgf/cm <sup>2</sup> = 98.07 kPa
		mmHg	1 mmHg = 0.1333 kPa
Power	W	PS	1 PS = 0.7355 kW
Calorie	W·h	cal	1 kcal = 1.163 W·h
Fuel consumption rate	g/kW·h	g/PS·h	1 g/PS·h = 1.3596 g/kW·h

The figure used in these manuals are described in the SI units and conventional units are described in ( ).

## 10.EXPLANATION OF TERMINOLOGY

### List

2ndr	Secondary
AAI	Air Assist Injection
AAR	Angular Adjusted Roller
A/B	Airbag
ABS	Anti-lock Brake System
A/C	Air Conditioner
AC	Angular Contact
ACC	Accessory
A/F	Air Fuel Ratio
ALT	Generator
APS	Accessory Power Supply Socket
ASSY	Assembly
AT	Automatic Transmission
ATF	Automatic Transmission Fluid
AUX	Auxiliary Storage Unit (External storage)
AVCS	Active Valve Control System
AWD	All Wheel Drive
BATT	Battery
BCM	Brake Control Module
BJ	Bell Joint
CAN	Controller Area Network
CD	Compact Disc
CD-R/RW	CD Recordable/Rewritable
COMPL	Complete
CPC	Canister Purge Control Solenoid Valve
CPU	Central Processing Unit
DCCD	Driver's Control Center Differential
DOHC	Double Overhead Camshaft
DOJ	Double Offset Joint
DTC	Diagnosis Trouble Code
DVD	Digital Versatile Disc or Digital Video Disc
EBD	Electronic Brake Distribution
EBJ	High-efficiency Compact Ball Fixed Joint
ECM	Engine Control Module
EDJ	High-efficiency Compact Double Offset Joint
E/G	Engine
EGI	Electronic Gasoline Injection
EGR	Exhaust Gas Recirculation
ELR	Emergency Locking Retractor
ETC	Electronic Throttle Control
EX	Exhaust
F/B	Fuse & Joint Box
FL	Fusible Link
Ft	Front
FWD	Front Wheel Drive
GPS	Global Positioning System
HI	High
HID	High-Intensity Discharge

H/L	Headlight
H/U	Hydraulic Unit
HVAC	Heater, Ventilator and Air Conditioner
I/F	Interface
IG	Ignition
IN	Intake
INT	Intermittent
I/O	Input / Output
IR	Infrared Ray
ISC	Idle Speed Control
LAN	Local Area Network
LCD	Liquid Crystal Display
LED	Light Emitting Diode
LH	LH (Left Hand)
LHD	Left Hand Drive
LSD	Limited Slip Differential
M/B	Main Fuse & Relay Box
MD	Mini Disc
MID	Multi Information Display
MFI	Multi-Point Fuel Injection
MP-T	Multi-Plate Transfer
MT	Manual Transmission
NA	Natural Aspiration
NC	Normal Close (Relay)
NO	Normal Open (Relay)
OBD	On-Board Diagnosis
OP	Option Parts
PC	Personal Computer
PCD	Pitch Circle Diameter
PCV	Positive Crankcase Ventilation
PID	Parameter Identification
Pr	Primary
P/S	Power Steering
PTJ	Pillow Tripod Joint
P/W	Power Window
RAM	Random Access Memory
RH	RH (Right Hand)
RHD	Right Hand Drive
ROM	Read Only Memory
rpm	Revolution Per Minute
Rr	Rear
SDI	Subaru Diagnostic Interface
SI	Subaru Intelligent
SOHC	Single Overhead Camshaft
SRS	Supplemental Restraint System
SSM	Subaru Select Monitor
ST	Special Tool
STD	Standard
SW	Switch

# How to Use This Manuals

## HOW TO USE THIS MANUALS

---

T/B	Turbocharger
TCS	Traction Control System
TCM	Transmission Control Module
TGV	Tumble Generator Valve
T/M	Transmission
TPMS	Tire Pressure Monitoring System
UJ	Universal Joint
UV	Ultraviolet
VDC	Vehicle Dynamics Control
V.I.N.	Vehicle Identification Number
ViS-C	Viscous Coupling
VSV	Vacuum Switching Valve
VTD	Variable Torque Distribution
W/H	Wiring Harness



# SPECIFICATIONS

# *SPC*

---

	<b>Page</b>
1. Impreza .....	2

# Impreza

## SPECIFICATIONS

### 1. Impreza

#### A: DIMENSION

Model		4 door		5 door	
		WRX-S, WRX	STI-S, SE	WRX	STI, SE
Overall length	mm (in)	4,580 (180.3)		4,415 (173.8)	
Overall width	mm (in)	1,795 (70.7)		1,795 (70.7)	
Overall height (at C.W.)	mm (in)	1,475 (58.1)	1,470 (57.9)	1,475 (58.1)	1,470 (57.9)
Compartment	Length	mm (in)	1,985 (78.1)		1,985 (78.1)
	Width	mm (in)	1,475 (58.1)		1,475 (58.1)
	Height	mm (in)	1,200 (47.2), 1,170 (46.1) <sup>*1</sup>		1,200 (47.2), 1,170 (46.1) <sup>*1</sup>
Wheelbase	mm (in)	2,625 (103.3)		2,625 (103.3)	
Tread	Front	mm (in)	1,530 (60.2)		1,530 (60.2)
	Rear	mm (in)	1,540 (60.6)		1540 (60.6)
Minimum road clearance	mm (in)	155 (6.1)	150 (5.9)	155 (6.1)	150 (5.9)

\*1: Model with sunroof

#### B: ENGINE

Model	2.5 L turbo (WRX-S, WRX model)	2.5 L high power turbo (STI-S, STI, SE model)
Engine type	Horizontally opposed, liquid cooled, 4-cylinder, 4-stroke gasoline engine	
Valve arrangement	DOHC	
Bore × stroke	mm (in) 99.5 × 79 (3.92 × 3.11)	
Displacement	cm <sup>3</sup> (cu in) 2,457 (149.94)	
Compression ratio	8.4	8.2
Ignition order	1 — 3 — 2 — 4	
Idle speed	rpm 700±100	
Maximum output	kW (HP)/rpm 198 (265)/6,000	227 (305)/6,000
Maximum torque	N·m (kgf·m, ft·lb)/rpm 330 (33.7, 244)/4,000	394 (40.2, 290)/4,000

#### C: ELECTRICAL

Model	2.5 L turbo (WRX-S, WRX model)	2.5 L high power turbo (STI-S, STI, SE model)
Ignition timing (at idling)	BTDC 12°±10°	15°±10°
Spark plug	Type and manufacturer	NGK: SILFR6A
Generator	12 V — 110 A	
Battery	Type and capacity (5HR)	12 V — 48 AH (55D23L)

**D: TRANSMISSION**

Transmission type		6MT	5MT
Clutch type		DSPD	
Gear ratio	1st	3.636	3.166
	2nd	2.235	1.882
	3rd	1.521	1.296
	4th	1.137	0.972
	5th	0.971	0.738
	6th	0.756	—
	Reverse	3.545	3.333
Reduction gear (Front)	Final reduction	Type of gear	Hypoid
		Gear ratio	3.900
Reduction gear (Rear)	Transfer reduction	Type of gear	Helical
		Gear ratio	1.103      1.000
	Final reduction	Type of gear	Hypoid
		Gear ratio	3.545      3.900

6MT: 6-forward speeds and 1-reverse with synchromesh

5MT: 5-forward speeds and 1-reverse with synchromesh

DSPD: Dry Single Plate Diaphragm

**E: STEERING**

Type		Rack and pinion	
Turns, lock to lock		2.8	
Minimum turning diameter	m (ft)	Curb to curb	11.0 (36.1)
		Wall to wall	11.8 (38.7)

**F: SUSPENSION**

Front	Macpherson strut type suspension
Rear	Double-wishbone type suspension

# Impreza

## SPECIFICATIONS

### G: BRAKE

Model	WRX-S, WRX	STI-S, STI, SE
Service brake system	Dual circuit hydraulic with vacuum suspended power unit	
Front	Ventilated disc brake	
Rear	Disc brake	Ventilated disc brake
Parking brake	Mechanical on rear brakes	

### H: TIRE

Rim size	17 × 8 J	18 × 8 1/2J
Tire size	235/45R17	245/40R18
Type	Tubeless, Steel belted radial	

### I: CAPACITY

Model		WRX-S, WRX	STI-S, STI, SE
Fuel tank	ℓ (US gal, Imp gal)	64 (16.9, 14.1)	
Engine oil	Total capacity (at overhaul)	ℓ (US qt, Imp qt)	5.0 (5.3, 4.4)
	When replacing engine oil and oil filter	ℓ (US qt, Imp qt)	4.2 (4.4, 3.7)      4.3 (4.5, 3.8)
	When replacing engine oil only	ℓ (US qt, Imp qt)	4.0 (4.2, 3.5)
Transmission gear oil	ℓ (US qt, Imp qt)	3.5 (3.7, 3.1)	4.1 (4.3, 3.6)
Rear differential gear oil	ℓ (US qt, Imp qt)	0.8 (0.8, 0.7)	1.0 (1.1, 0.9)
Power steering fluid	ℓ (US qt, Imp qt)	0.7 (0.7, 0.6)	
Engine coolant	ℓ (US qt, Imp qt)	7.4 (7.8, 6.5)	7.7 (8.1, 6.8)

## J: WEIGHT

Model		4 door									
		2.5 L DOHC turbo									
		WRX	WRX-S								
		5MT	5MT								
OP code		U4	C0	C0	C4	U4	U4	U4	U4	U4	
		XX	XR	CH	4H	XX	4 R	5 R	OH	QH	
Vehicle weight (C.W.)	Total	kg (lb)	1,455 (3,208)	1,455 (3,208)	1,475 (3,252)	1,475 (3,252)	1,455 (3,208)	1,470 (3,241)	1,470 (3,241)	1,475 (3,252)	1,475 (3,252)
	Front	kg (lb)	830 (1,830)	830 (1,830)	840 (1,852)	840 (1,852)	830 (1,830)	835 (1,841)	835 (1,841)	840 (1,852)	840 (1,852)
	Rear	kg (lb)	625 (1,378)	625 (1,378)	635 (1,400)	635 (1,400)	625 (1,378)	635 (1,400)	635 (1,400)	635 (1,400)	635 (1,400)
Gross vehicle weight (G.V.W.)		kg (lb)	1,990 (4,387)	1,990 (4,387)	1,990 (4,387)	1,990 (4,387)	1,990 (4,387)	1,990 (4,387)	1,990 (4,387)	1,990 (4,387)	1,990 (4,387)
Gross axle weight (G.A.W.)	Front	kg (lb)	1,020 (2,249)	1,020 (2,249)	1,020 (2,249)	1,020 (2,249)	1,020 (2,249)	1,020 (2,249)	1,020 (2,249)	1,020 (2,249)	1,020 (2,249)
	Rear	kg (lb)	1,030 (2,271)	1,030 (2,271)	1,030 (2,271)	1,030 (2,271)	1,030 (2,271)	1,030 (2,271)	1,030 (2,271)	1,030 (2,271)	1,030 (2,271)
Option	Aluminum wheel 18 in (BBS)		—	—	—	—	—	—	—	—	—
	Navigation		—	—	—	—	—	—	○	—	○
	Sunroof		—	—	○	○	—	○	○	○	○
	HID		—	—	—	—	—	—	—	○	○
	Front fog light		—	—	○	○	—	○	○	○	○
	Genuine leather seat		—	—	○	○	—	—	—	○	○
	Seat heater		—	○	○	○	—	○	○	○	○
	Cold weather package		—	○	○	○	—	○	○	○	○
	Satellite tuner		—	—	○	—	—	—	—	—	—

# Impreza

## SPECIFICATIONS

Model		4 door									
		2.5 L DOHC high power turbo									
		STI-S						SE			
		6MT						6MT			
OP code		C0	C4	U4	U4	U4	U4	U4	C0	U4	
		OR	SH	3 R	MR	SH	UH	VR	XR	XX	
Vehicle weight (C.W.)	Total	kg (lb)	1,550 (3,417)	1,550 (3,417)	1,535 (3,384)	1,535 (3,384)	1,550 (3,417)	1,550 (3,417)	1,535 (3,384)	1,535 (3,384)	1,535 (3,384)
	Front	kg (lb)	890 (1,962)	890 (1,962)	885 (1,951)	885 (1,951)	890 (1,962)	890 (1,962)	885 (1,951)	885 (1,951)	885 (1,951)
	Rear	kg (lb)	660 (1,455)	660 (1,455)	650 (1,433)	650 (1,433)	660 (1,455)	660 (1,455)	650 (1,433)	650 (1,433)	650 (1,433)
Gross vehicle weight (G.V.W.)		kg (lb)	2,030 (4,475)	2,030 (4,475)	2,030 (4,475)	2,030 (4,475)	2,030 (4,475)	2,030 (4,475)	2,030 (4,475)	2,030 (4,475)	2,030 (4,475)
Gross axle weight (G.A.W.)	Front	kg (lb)	1,050 (2,315)	1,050 (2,315)	1,050 (2,315)	1,050 (2,315)	1,050 (2,315)	1,050 (2,315)	1,050 (2,315)	1,050 (2,315)	1,050 (2,315)
	Rear	kg (lb)	1,040 (2,293)	1,040 (2,293)	1,040 (2,293)	1,040 (2,293)	1,040 (2,293)	1,040 (2,293)	1,040 (2,293)	1,040 (2,293)	1,040 (2,293)
Option	Aluminum wheel 18 in (BBS)		—	○	○	—	○	○	—	—	—
	Navigation		—	—	○	—	—	○	○	—	—
	Sunroof		○	○	—	—	○	○	—	—	—
	HID		○	○	○	○	○	○	○	—	—
	Front fog light		○	○	○	—	○	○	—	—	—
	Genuine leather seat		—	○	—	—	○	○	—	—	—
	Seat heater		○	○	○	○	○	○	○	○	—
	Cold weather package		○	○	○	○	○	○	○	○	—
Satellite tuner		—	—	—	—	—	—	—	—	—	

# Impreza

## SPECIFICATIONS

Model		5 door								
		2.5 L DOHC turbo								
		WRX								
		5MT								
OP code		C0	C0	C4	U4	U4	U4	U4	U4	
		XR	CH	4H	XX	4 R	5 R	OH	QH	
Vehicle weight (C.W.)	Total	kg (lb)	1,455 (3,208)	1,475 (3,252)	1,475 (3,252)	1,455 (3,208)	1,470 (3,241)	1,470 (3,241)	1,475 (3,252)	1,475 (3,252)
	Front	kg (lb)	830 (1,830)	840 (1,852)	840 (1,852)	830 (1,830)	835 (1,841)	835 (1,841)	840 (1,852)	840 (1,852)
	Rear	kg (lb)	625 (1,378)	635 (1,400)	635 (1,400)	625 (1,378)	635 (1,400)	635 (1,400)	635 (1,400)	635 (1,400)
Gross vehicle weight (G.V.W.)		kg (lb)	1,990 (4,387)	1,990 (4,387)	1,990 (4,387)	1,990 (4,387)	1,990 (4,387)	1,990 (4,387)	1,990 (4,387)	1,990 (4,387)
Gross axle weight (G.A.W.)	Front	kg (lb)	1,020 (2,249)	1,020 (2,249)	1,020 (2,249)	1,020 (2,249)	1,020 (2,249)	1,020 (2,249)	1,020 (2,249)	1,020 (2,249)
	Rear	kg (lb)	1,030 (2,271)	1,030 (2,271)	1,030 (2,271)	1,030 (2,271)	1,030 (2,271)	1,030 (2,271)	1,030 (2,271)	1,030 (2,271)
Option	Aluminum wheel 18 in (BBS)		—	—	—	—	—	—	—	—
	Navigation		—	—	—	—	—	○	—	○
	Sunroof		—	○	○	—	○	○	○	○
	HID		—	—	—	—	—	—	○	○
	Front fog light		—	○	○	—	○	○	○	○
	Genuine leather seat		—	○	○	—	—	—	○	○
	Seat heater		○	○	○	—	○	○	○	○
	Cold weather package		○	○	○	—	○	○	○	○
Satellite tuner		—	○	—	—	—	—	—	—	

# Impreza

## SPECIFICATIONS

Model		5 door						
		2.5 L DOHC high power turbo						
		STI			SE			
		6MT			6MT			
OP code		C0	C4	U4	U4	C0	U4	
		OR	SH	3 R	RR	XR	XX	
Vehicle weight (C.W.)	Total	kg (lb)	1,545 (3,406)	1,545 (3,406)	1,530 (3,373)	1,530 (3,373)	1,530 (3,373)	1,530 (3,373)
	Front	kg (lb)	890 (1,962)	890 (1,962)	885 (1,951)	885 (1,951)	885 (1,951)	885 (1,951)
	Rear	kg (lb)	655 (1,444)	655 (1,444)	645 (1,422)	645 (1,422)	645 (1,422)	645 (1,422)
Gross vehicle weight (G.V.W.)		kg (lb)	2,030 (4,475)	2,030 (4,475)	2,030 (4,475)	2,030 (4,475)	2,030 (4,475)	2,030 (4,475)
Gross axle weight (G.A.W.)	Front	kg (lb)	1,050 (2,315)	1,050 (2,315)	1,050 (2,315)	1,050 (2,315)	1,050 (2,315)	1,050 (2,315)
	Rear	kg (lb)	1,040 (2,293)	1,040 (2,293)	1,040 (2,293)	1,040 (2,293)	1,040 (2,293)	1,040 (2,293)
Option	Aluminum wheel 18 in (BBS)		—	○	○	○	—	—
	Navigation		—	—	○	—	—	—
	Sunroof		○	○	—	—	—	—
	HID		○	○	○	○	—	—
	Front fog light		○	○	○	○	—	—
	Genuine leather seat		—	○	—	—	—	—
	Seat heater		○	○	○	○	○	—
	Cold weather package		○	○	○	○	○	—
Satellite tuner		—	—	—	—	—	—	



# PRECAUTION

# *PC*

---

	<b>Page</b>
1. Precaution .....	2

# Precaution

## PRECAUTION

---

### 1. Precaution

#### A: CAUTION

Please clearly understand and adhere to the following general precautions for environmental protection and to avoid minor or serious injury to the person doing the work or people in the area.

#### 1. VEHICLE DYNAMICS CONTROL (VDC)

Handle the VDC as a total system. Do not disassemble or attempt to repair individual parts. Follow the directions in this manual when performing maintenance on the VDCCM&H/U. When parts other than those specified are disassembled, it is possible that the VDC system will not operate when needed or cause it to operate incorrectly and result in injury.

#### 2. BRAKE FLUID

If brake fluid gets in your eyes or on your skin, do the following:

- Wash eyes and seek immediate medical attention.
- Wash your skin with soap and then rinse thoroughly with water.

#### 3. RADIATOR FAN

The radiator fan may rotate without warning, even when the engine is not ON. Do not place your hand, cloth, tools or other items near the fan at any time.

#### 4. ROAD TEST

Always conduct road tests in accordance with traffic rules and regulations to avoid bodily injury and interrupting traffic.

#### 5. AIRBAG

To prevent bodily injury from unexpected deployment of airbags and unnecessary maintenance, follow the instructions in this manual when performing maintenance on the airbag components or nearby, around front of the vehicle (radiator panel, front wheel apron, front side frame, bumper, hood, front fender), around side of the vehicle (front door, rear door, center pillar, rear fender, side sill, rear wheel apron), around rear of the vehicle (rear seat cushion, rear floor, rear crossmember) and the airbag wiring harnesses or nearby.

To prevent unexpected deployment, turn the ignition switch to OFF and disconnect the ground cable from battery, then wait at least 60 seconds before starting work.

#### 6. AIRBAG DISPOSAL

To prevent bodily injury from unexpected airbag deployment, do not dispose the airbag modules in the same way as other waste. Follow all government regulations concerning disposal of refuse.

#### 7. AIRBAG MODULE

Adhere to the following when handling and storing the airbag module to prevent bodily injury from unexpected deployment:

- Do not hold the harnesses or connectors to carry the module.
- Do not face the bag in the direction that it opens towards yourself or other people.
- Do not face the bag in the direction that it opens towards the floor or walls.

#### 8. AIRBAG SPECIAL TOOL

To prevent unexpected deployment, only use special tools.

#### 9. WINDOW

Always wear safety glasses when working around any glass to prevent glass fragments from damaging your eyes.

#### 10. WINDOW ADHESIVE

Always use the recommended or equivalent adhesive when attaching glass to prevent it from falling off, resulting in accidents and injury.

#### 11. OIL

When handling oil, adhere to the following to prevent unexpected accident.

- Prepare a container and cloth to prevent scattering of oil when performing work where oil can be spilled. If the oil spills, wipe it off immediately to prevent from penetrating into floor or flowing out for environmental protection.
- Follow all government and local regulations concerning disposal of refuse when disposing.

#### 12. FUEL

When handling and storing fuel, adhere to the following to prevent from unexpected accident.

- Be careful with fire.
- Prepare a container and cloth to prevent scattering of fuels when performing work where fuels can be spilled. If the oil spills, wipe it off immediately to prevent from penetrating into floor or flowing out for environmental protection.
- Follow all government and local regulations concerning disposal of refuse when disposing.

### 13. ENGINE COOLANT

When handling engine coolant, adhere to the following to prevent from unexpected accident.

- Never remove the radiator cap since engine coolant may blow out when it is hot.
- Prepare a container and cloth to prevent scattering of engine coolant when performing work where engine coolant can be spilled. If the oil spills, wipe it off immediately to prevent from penetrating into floor or flowing out for environmental protection.
- Follow all government and local regulations concerning disposal of refuse when disposing.

### 14. AIR CONDITIONER REFRIGERANT

In order to prevent from global warming, avoid releasing air conditioner refrigerant into the atmosphere. Using a refrigerant recovery system, discharge and recycle it.

### 15. REMOVAL AND INSTALLATION OPERATION OF HOSES, ETC.

#### 1. Before the removal and installation operation of hoses, etc.

- If you keep using the damaged or deformed hose, it results bleeds or leakage of the fat adheres or disconnection of the hose. Be careful not to spill fat adheres on exhaust pipes, etc. during maintenance to prevent emitting smoke or causing fires.
- Perform the operation with the hose removed. If the operation is performed without removing the hose, it may damage inner surface of the hose.

#### 2. Removal and installation operation of hoses, etc. during the inspection

- Follow the instructions below when removing hose.
  - Do not use a pointed hose remover (hose plucker) when using a general hose remover. It may damage the pipe surface or the hose.

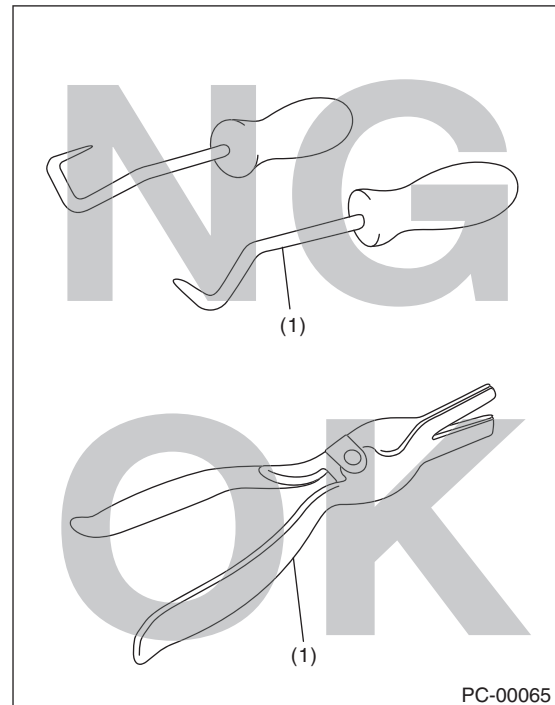

(1) Hose remover

- When draining hose using pliers, be sure to cover the hose with cloth and rotate the hose slightly to extract straight.

# Precaution

## PRECAUTION

- **If you keep using the hose, perform the inspection below and replace the hose with a new part if faulty.**

- Replace the hose with a new part if it rides over the stay or spool.

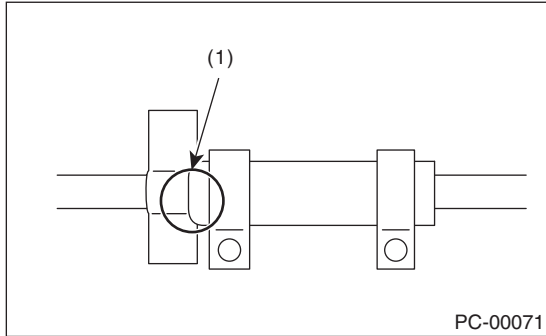

(1) Hose rides over the stay

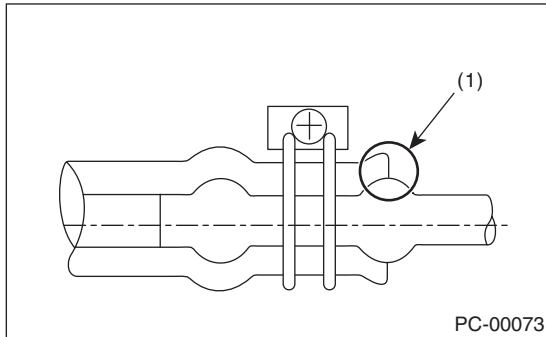

(1) Hose rides over the spool

- Check if the surface and the inner surface of the hose are damaged, cracked, bend, hardened, softened, swelled, peeled or deformed due to the adherence or the entry of the foreign matter by bending the hose. Replace with the new part if faulty.

- **Follow the instructions below during installation.**

- Check carefully for assembling position.
- Never use lubricants.
- Insert the hose to the specified position (stopper or spool) securely.

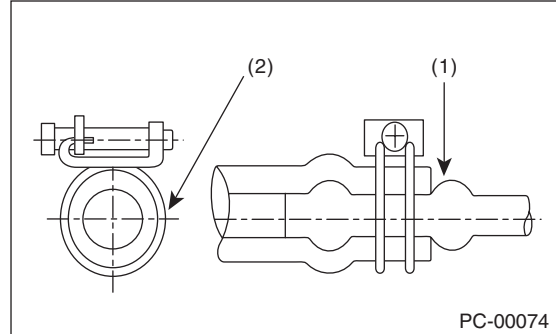

PC-00074

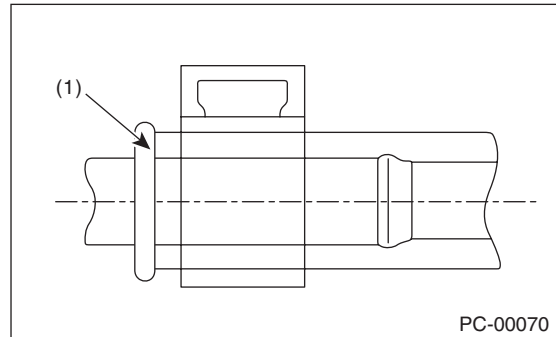

PC-00070

- (1) Push against the spool. (Insert the hose and prevent it from becoming wrinkled.)
- (2) Tighten the hose outwards and apply force thoroughly.

- Check if the position, direction and hose layout of the hose clamp are correct. (Check if the position, direction, length and the gap around are correct, or if it is different from the condition before the work)
- After the installation, check that the hose is installed securely and there is no leakage. (Check if it is fixed securely with the clamp)
- **For hose clips and hose clamps, perform the inspection below and replace them with a new part if faulty.**
  - Check for deformation, rust, damage or foreign matters.
  - For hose clip, check if it works and has clamping force.
  - For hose clamp, check if it can tighten screw, not ovalized or the screw is not damaged.
- **For hose pipes, perform the inspection below and replace with a new part if faulty.**

Check if the pipe is not damaged, rusted, peeled (peeled plates included), covered with foreign matter, bent, compressed or cracked.

- For the parts below, replaces with a new part when the hose is removed or the installation position is changed.

Engine oil cooler hose, power steering suction hose, power steering return hose, fuel hose (delivery/return)

## 16.HANDLING PRECAUTIONS FOR SILICON-CONTAINING SPRAY

When silicon contained in the lubricant, rust inhibitor or glazing agent adheres to the electrical contact of the relay or switch, nonconducting silica dioxide ( $\text{SiO}_2$ ) film will be formed, which may lead to poor continuity. Therefore, the following precautions must be observed when using the silicon-containing spray.

- Never spray directly to the electrical equipment.
- When using the spray close to the electrical equipment, always put the cover on it. Be sure to put the cover on the electrical equipment especially when using the spray to the locations shown in the figure below and their surrounding areas.

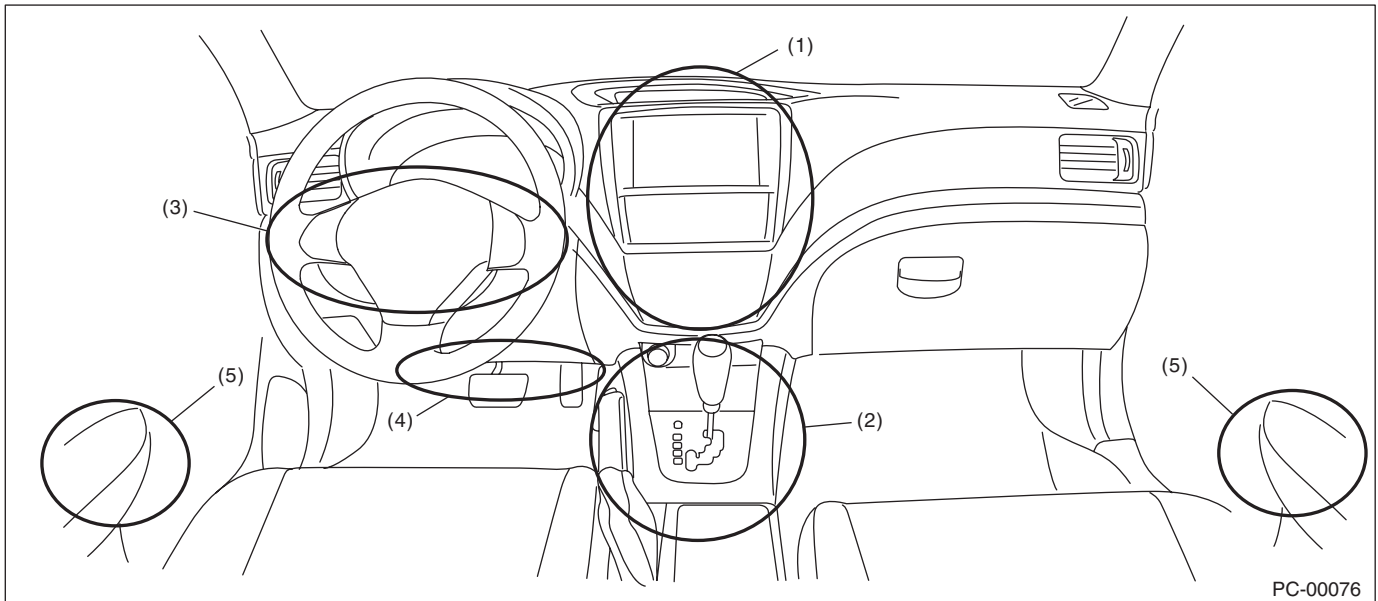

PC-00076

- |   |   |                         |
|---|---|-------------------------|
| (1) Audio, heater control switch              | (3) Combination switch, steering switch   | (5) Power window switch |
| (2) Shift/select lever switch, parking switch | (4) Stop light switch, brake light switch |                         |

- If the residual silicon remains in the vicinity of the electrical equipment after the spray has been used, the vaporized silicon stands around the electrical equipment and it may adhere to electrical contact. After using the spray, be sure to wipe the silicon off with a cloth.
- Even when using the spray to the place away from the electrical equipment, the droplet of the spray may be splashed to the periphery. Use as small amount of spray as possible, and take care not to splash the silicon to the periphery.

### NOTE:

The "silicon" used in this section refers to "silicone", that is, silicon polymer.

# Precaution

PRECAUTION

---

# NOTE

# *NT*

---

	<b>Page</b>
1. Note .....	2

## 1. Note

### A: NOTE

This information will improve the efficiency of maintenance and assure the sound work.

### 1. FASTENERS NOTICE

Fasteners are used to prevent the parts from damage, dislocation and play due to looseness. Fasteners must be tightened to the specified torque. Do not apply paint, lubricant, rust retardant or other substance to the surface around bolts, nuts, etc. Doing so will make it difficult to obtain the correct torque and result in looseness and other problem.

### 2. STATIC ELECTRICITY DAMAGE

Do not touch the control modules, connectors, logic boards and other such parts when there is a risk of static electricity. Always use a static electricity prevention cord or touch grounded metal for the elimination of static electricity before conducting work.

### 3. BATTERY

When removing the battery cables, always be sure to turn the ignition switch to OFF to prevent electrical damage to the control module from overcurrent. Be sure to remove the battery ground cable first.

### 4. SERVICE PARTS

Use genuine parts for maximum performance and maintenance when conducting repairs. Subaru/FHI will not be responsible for poor performance resulting from the use of parts except for genuine parts.

### 5. PROTECTING VEHICLE UNDER MAINTENANCE

Make sure to attach the fender cover, seat covers, etc. before work.

### 6. ENSURING SECURITY DURING WORK

When working in a group of two or more, perform the work with calling each other to ensure mutual safety.

### 7. LIFT AND JACK

When using a lift or shop jack to raise a vehicle or using rigid rack to support a vehicle, always follow instructions concerning jack-up points and weight limits to prevent the vehicle from falling, which could result in injury. Be especially careful that the vehicle is balanced before raising it. Be sure to set the wheel stoppers when jacking-up only the front or rear side of the vehicle.

### CAUTION:

Not to let the side sill cover interfere with the lift arm, use an attachment. When the side sill interferes with the lift arm, a grooveless attachment can be used. In this case, perform the operation carefully because the dislocation from the side sill flange may occur.

### NOTE:

- When using a lift, follow its operation manual.
- When using, insert the body flange to the attachment groove.
- When the side sill spoiler contacts the lift arm, use a lift attachment.
- Do not work or leave unattended while the vehicle is supported with jack, support it with rigid racks.
- Be sure to use the rigid racks with rubber attached to cradle to support the vehicle.
- When using a plate lift, use a rubber attachment. Place the attachment to the specified position of the vehicle, by adjusting front/rear and left/right sides accordingly.

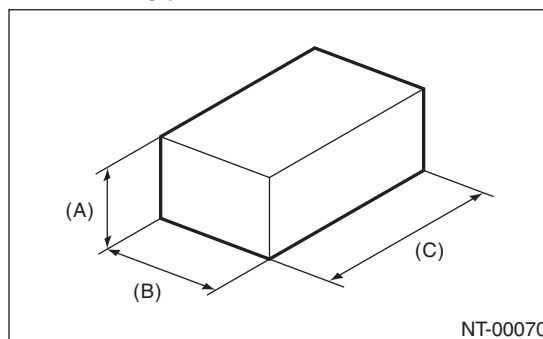

- (A) 80 mm (3.1 in) or more
- (B) 80 — 100 mm (3.15 — 3.94 in)
- (C) 120 — 170 mm (4.72 — 6.69 in)

- When using an attachment, align the center of attachment (A) with the center of vehicle rib (the center of spoiler rib).

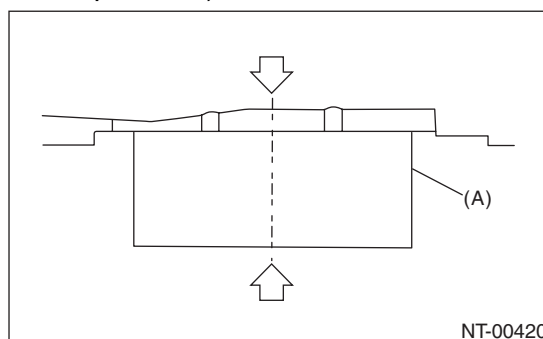



## Note

NOTE

- Do not use the plate lift whose attachment does not reach the supporting locations.  
Support locations

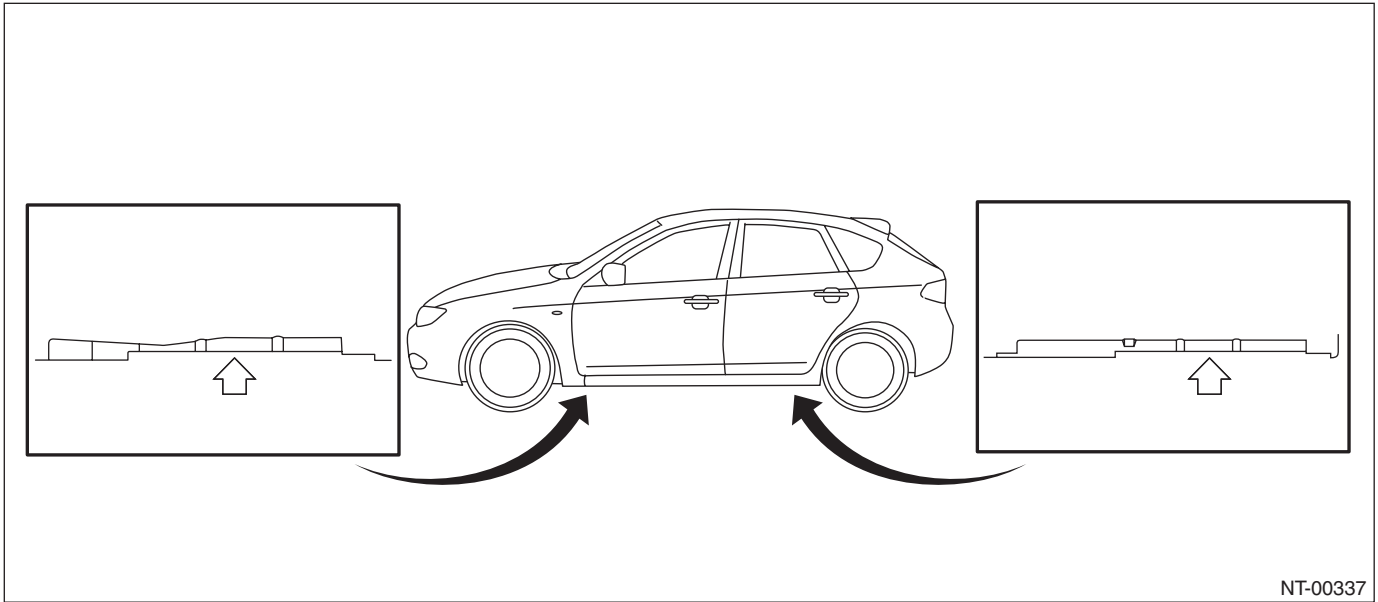

Pantograph jack  
Set the jacks between protruding portions.

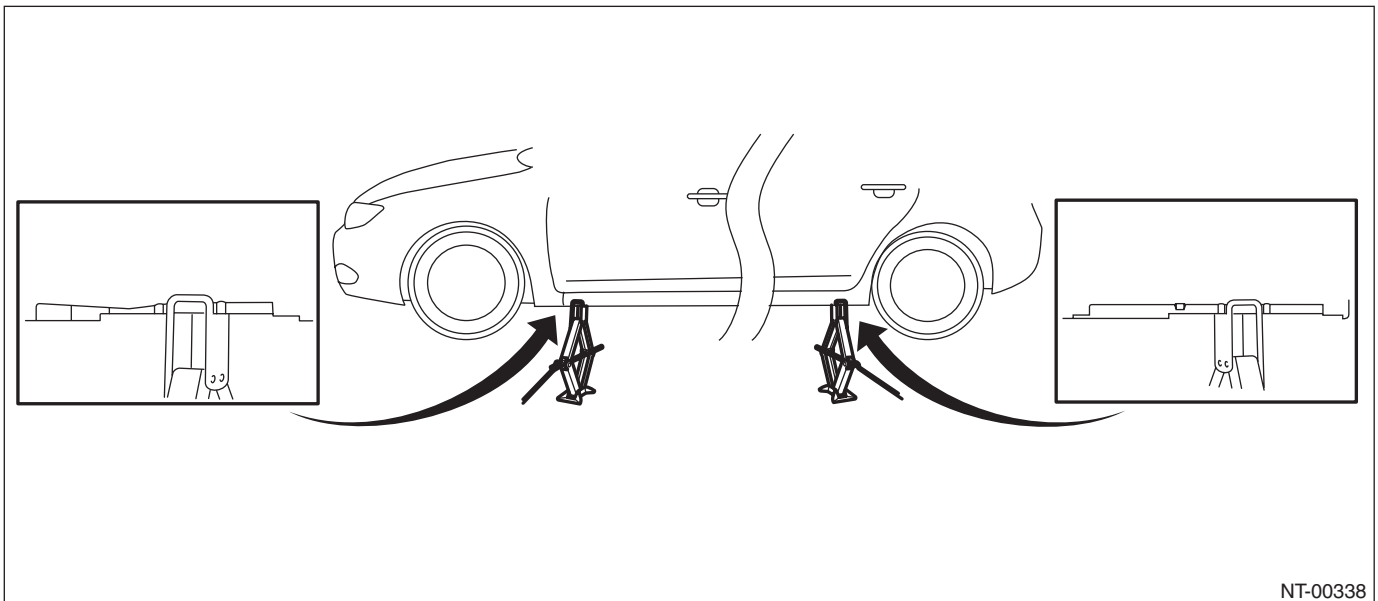

NT-3

Brought to you by Ebay Seller "SubaruManuals"

# Note

NOTE

Lift

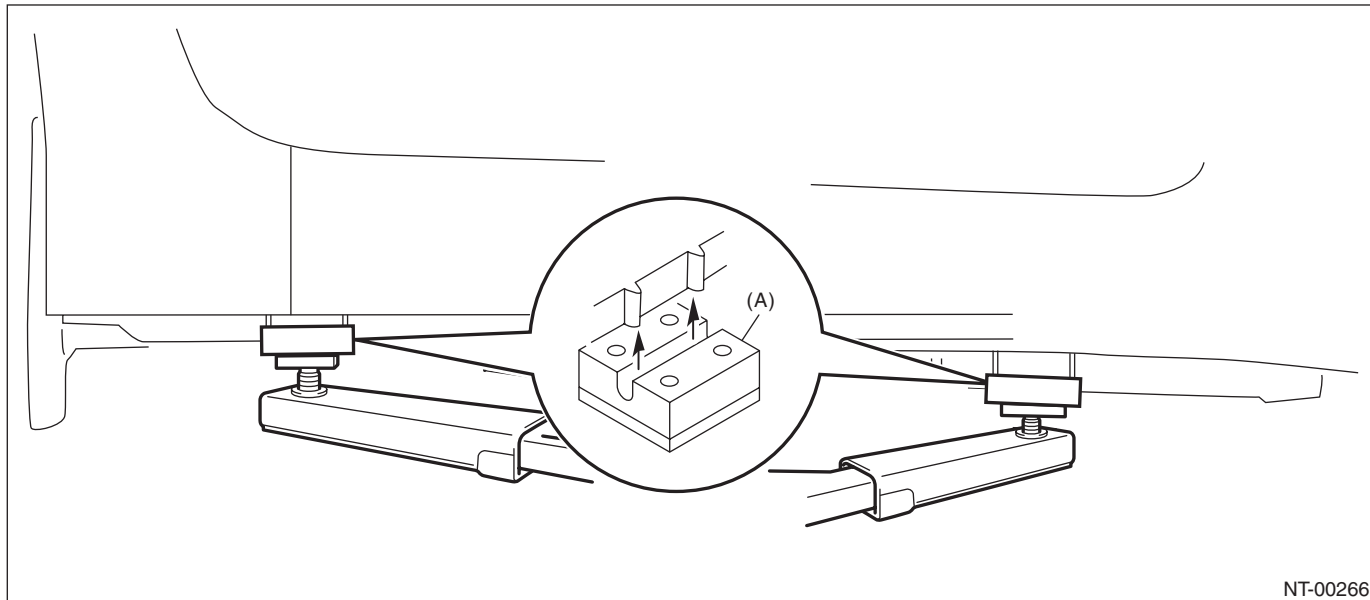

(A) Attachment

Rigid rack

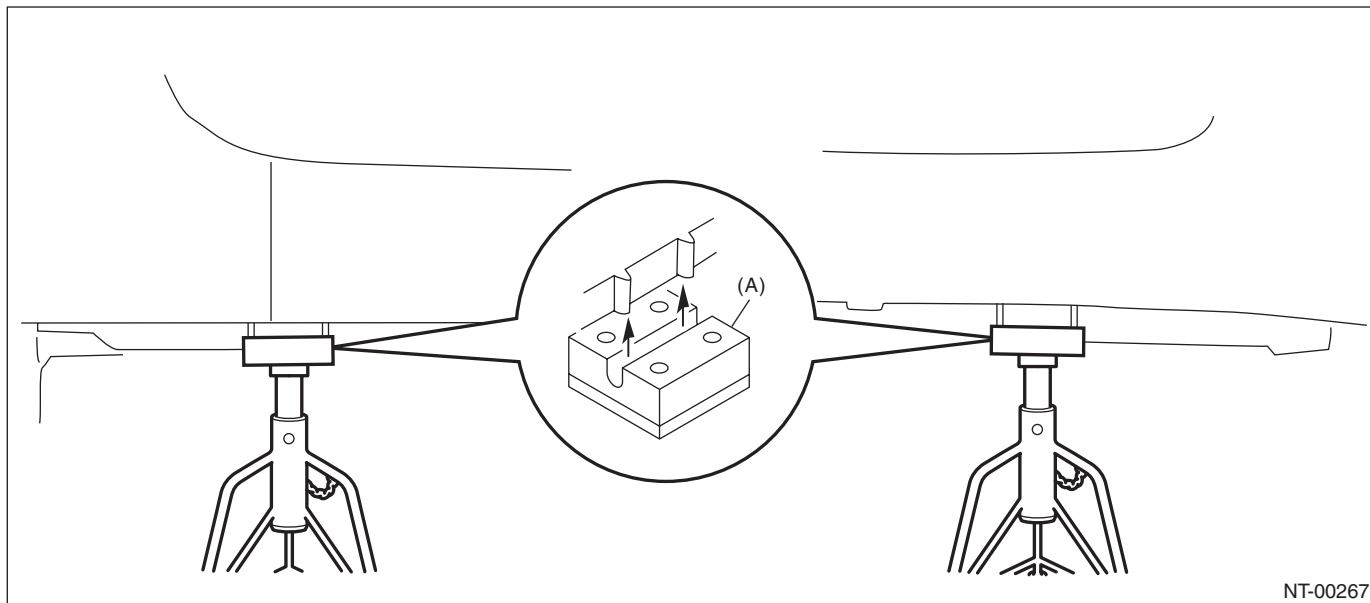

(A) Attachment

NT-4

Brought to you by Ebay Seller "SubaruManuals"

Plate lift

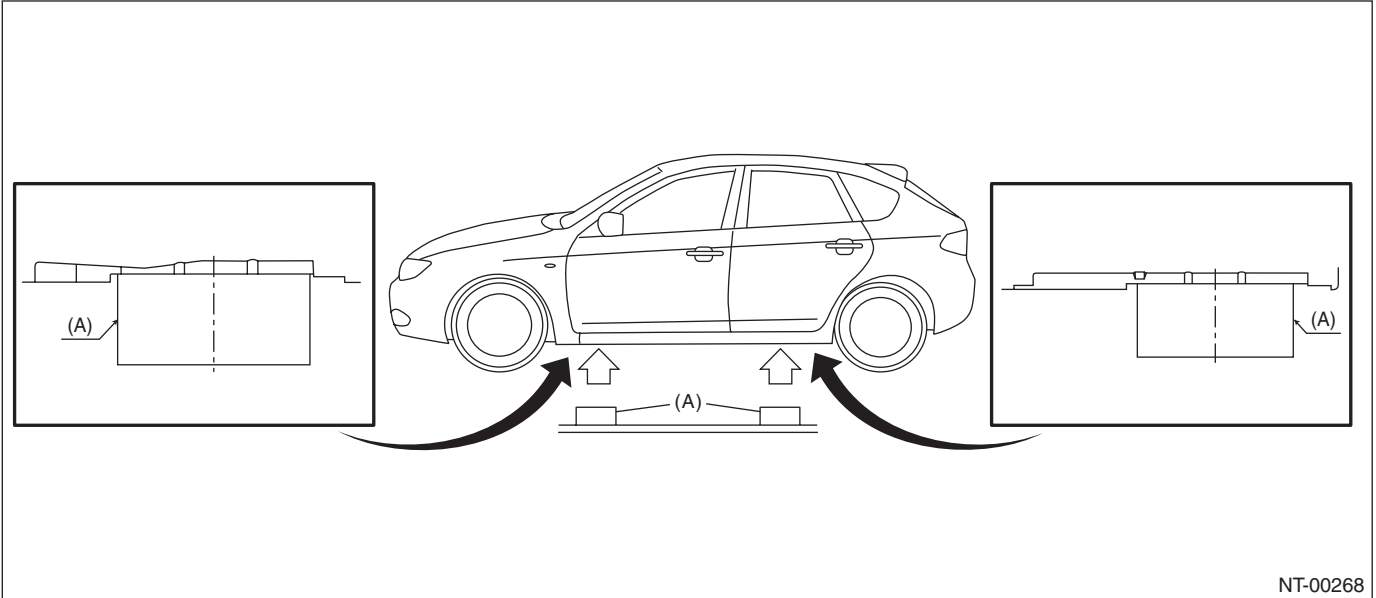

NT-00268

(A) Attachment

Garage jack

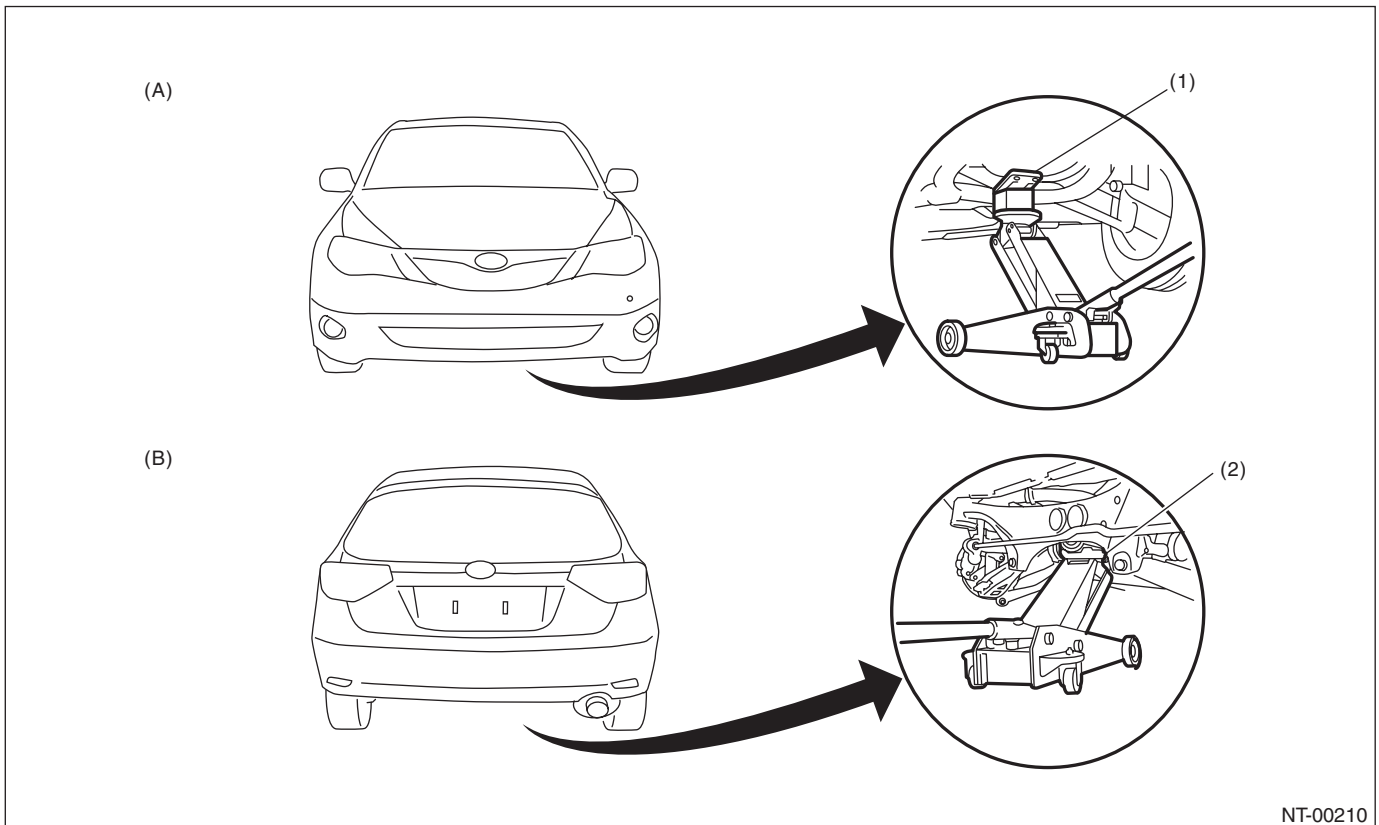

NT-00210

(A) Front

(B) Rear

(1) Front crossmember

(2) Rear differential

## Note

NOTE

### 8. TIE-DOWNS

The tie-down hooks are used when transporting vehicles and when using the chassis dynamo. Attach tie-down only to the specified locations on the vehicle.

- Tie-down location

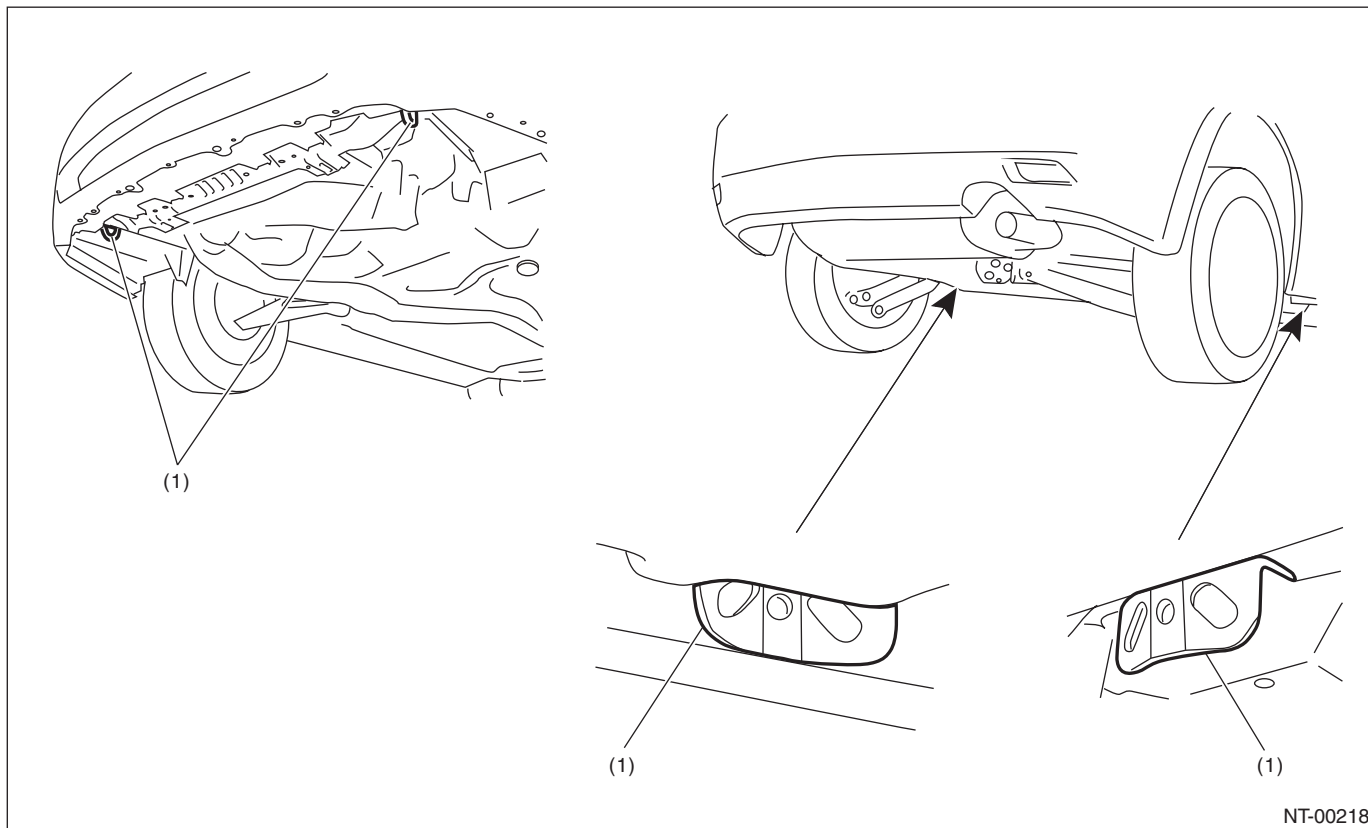

(1) Hook for tie-down

• Tie-down hook & eye bolt

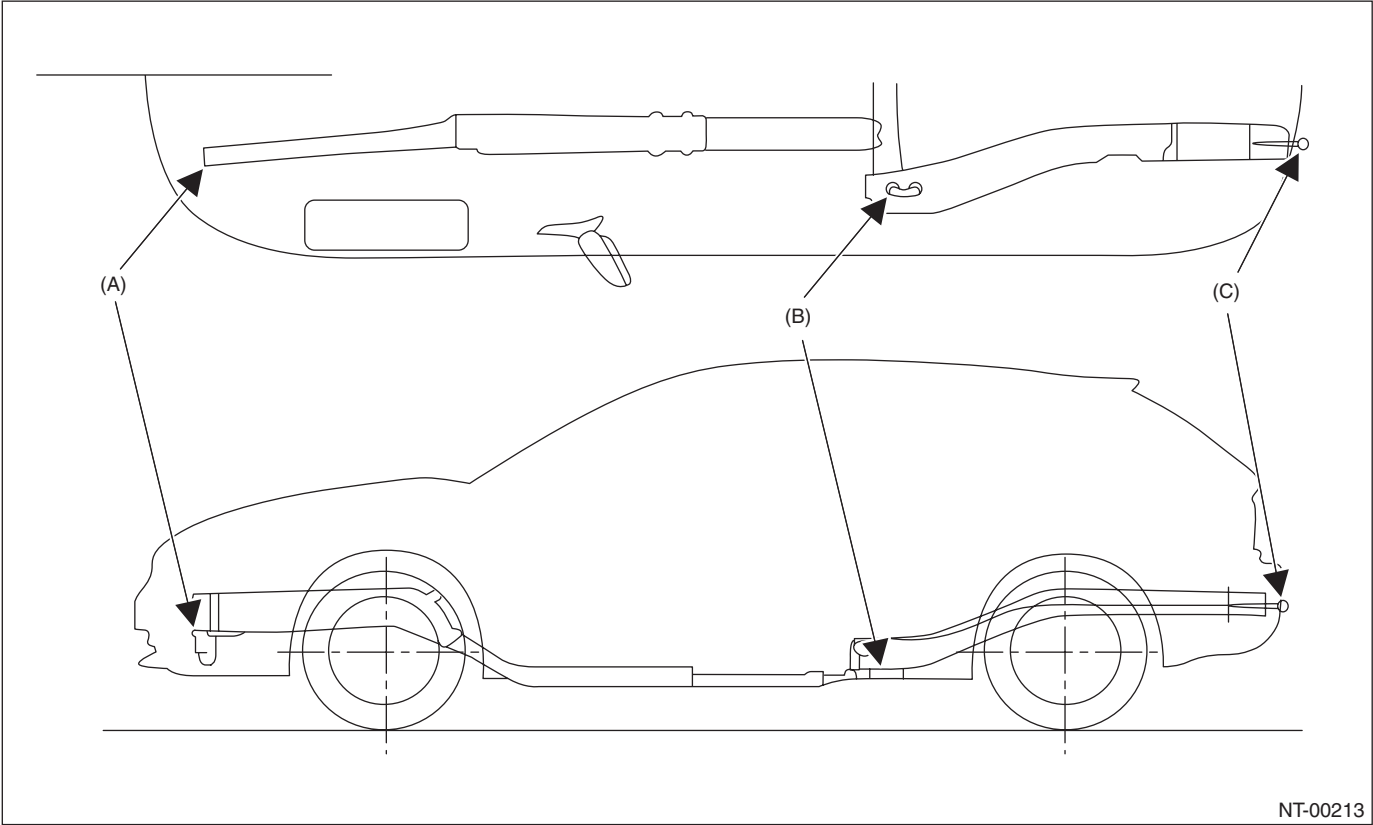

(A) Front tie-down hook

(B) Rear tie-down hook

(C) Eye bolt

## Note

### NOTE

---

- Tie-down direction

### CAUTION:

- Pull the front and rear of the vehicle in the opposite direction, and pull the left and right of the vehicle in the same direction.
- Patterns except for the followings (recommended) are not allowed.

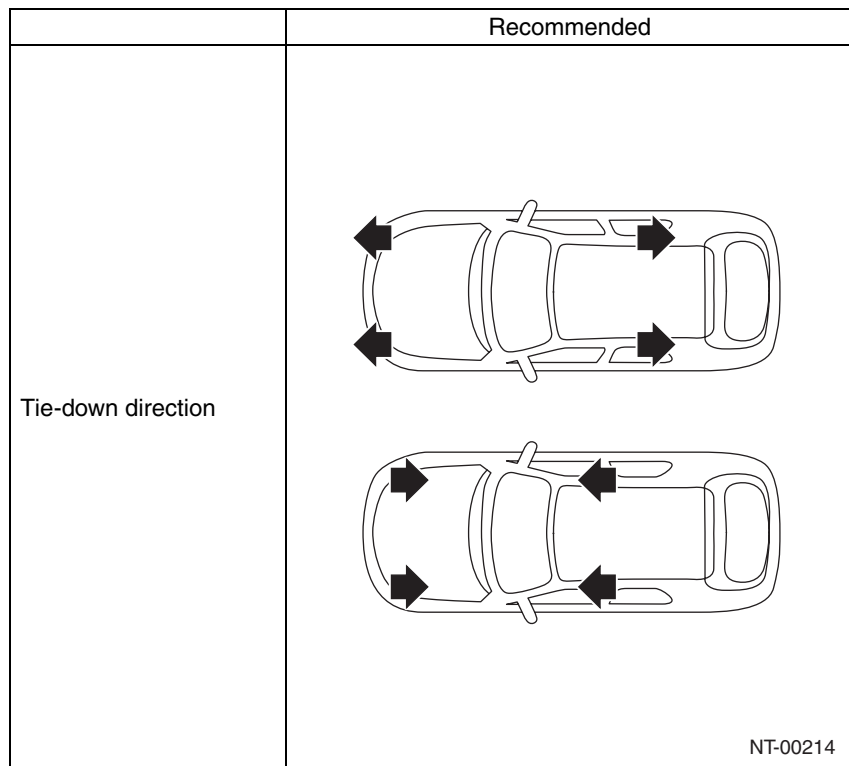

• Tie-down range

For ground transportation

**CAUTION:**

When the vehicle is tied down from vehicle inside, hook the hooks of tie-down chain on the rear tie-down hooks from vehicle inside. When the vehicle is tied down from vehicle outside, hook the hooks of tie-down chain on the rear tie-down hooks from vehicle outside.

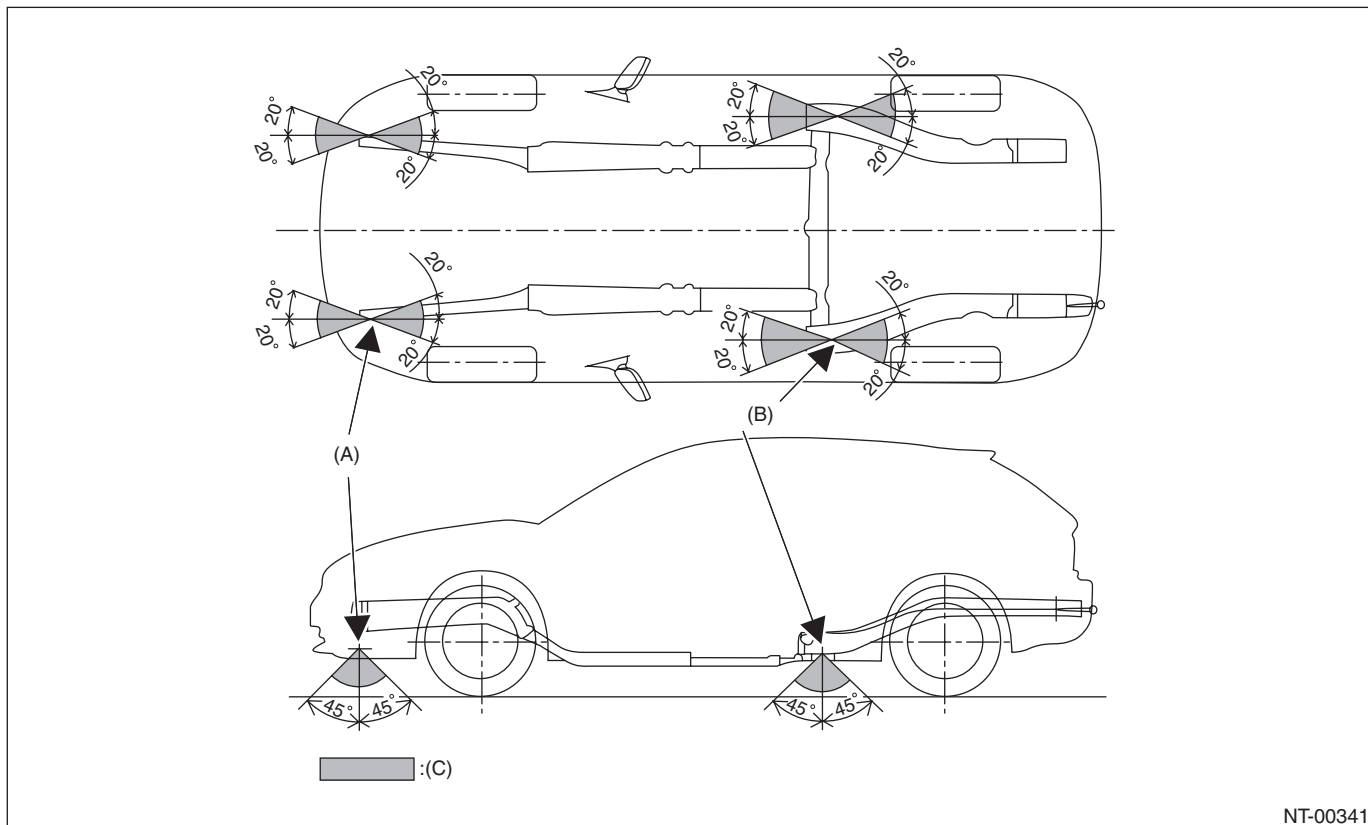

NT-00341

(A) Front tie-down hook

(B) Rear tie-down hook

(C) Chain pulling range at tie-down condition

# Note

## NOTE

For sea transportation

### CAUTION:

The eye bolts are exclusively used for towing and sea transportation tie-down, and do not use them for ground and freight transportation.

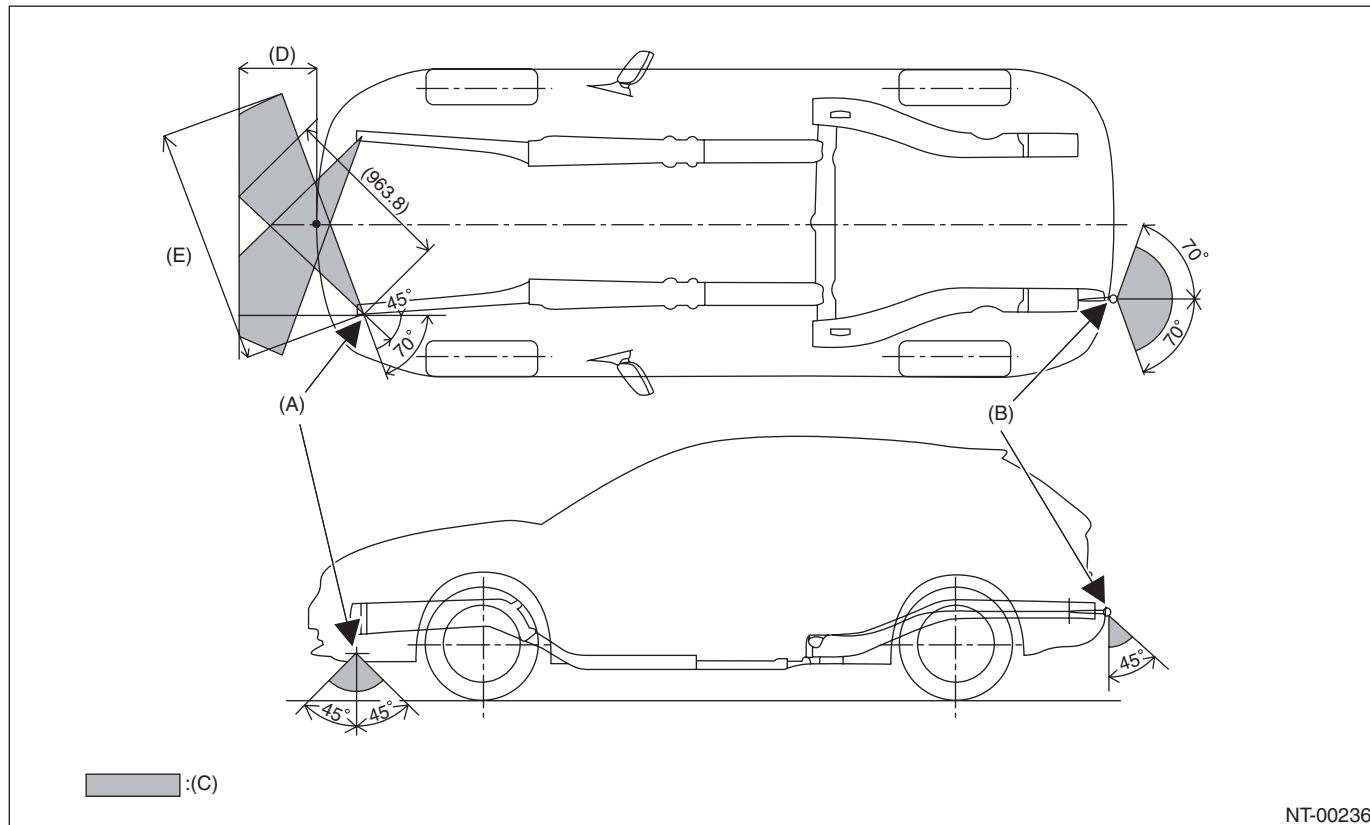

NT-00236

- |                         |   |                        |
|-------------------------|---|------------------------|
| (A) Front tie-down hook | (C) Chain pulling range at tie-down condition | (E) 1,320 mm (52.0 in) |
| (B) Eye bolt            | (D) 400 mm (15.7 in)                          |                        |



• **Vehicle sinking volume at tie-down condition**

**CAUTION:**

The vehicle sinking volume at tie-down condition should be less than 50 mm (1.97 in) and make sure to fix the vehicle securely.

Check to see if the tensions of chains or belts at tie-down condition are appropriate in the following procedures.

- 1) Before tie-down, measure the distance between the highest tire point and highest arch point at the center of wheel.
- 2) After tie-down, measure the distance between the highest tire point and highest arch point at the center of wheel.
- 3) If the distance (A) between the measured value of 1) and 2) above, is less than 50 mm (1.97 in), it is judged as OK. If the distance is 50 mm (1.97 in) or more, it is judged as NG because the tension is too high.

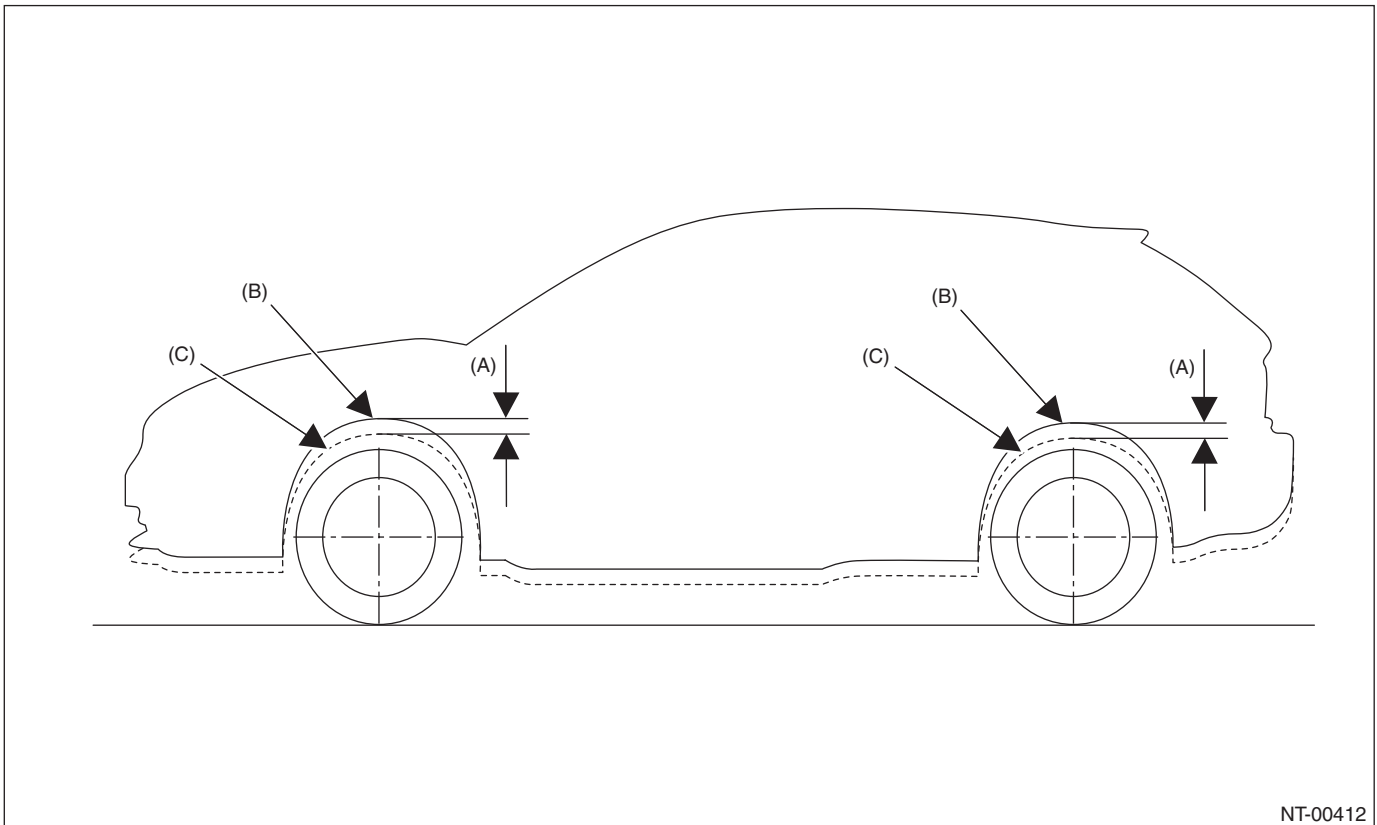

NT-00412

(B) Arch position before tie-down

(C) Arch position after tie-down

## Note

### NOTE

- **Notes for the use of tie-down hook**

When the vehicle is tied down from the rear side, use the holes at the rear side, and when the vehicle is tied down from the front side, use the holes at the front side.

When the vehicle is tied down from vehicle inside, hook the hooks of tie-down chain from vehicle inside, and when the vehicle is tied down from vehicle outside, hook the hooks of tie-down chain from vehicle outside.

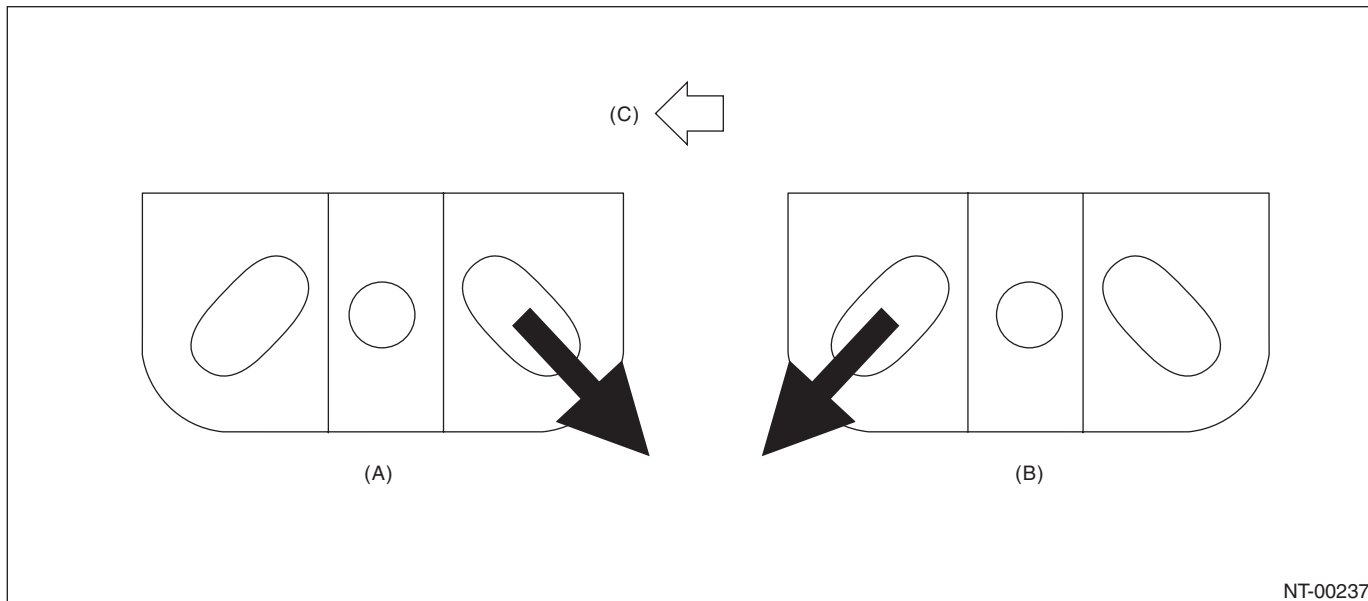

NT-00237

(A) When the vehicle is tied down towards the rear side

(B) When the vehicle is tied down towards the front side

(C) Vehicle front

## 9. TOWING

Avoid towing vehicles except when the vehicle cannot be driven. When towing other vehicles, pay attention to the following to prevent eye bolt or vehicle damage resulting from excessive weight.

- Do not tow other vehicles with a front tie-down hook.
- Make sure the vehicle towing is heavier than the vehicle being towed.

### • Front

Remove the hook cover, and install the towing hook (eye bolt).

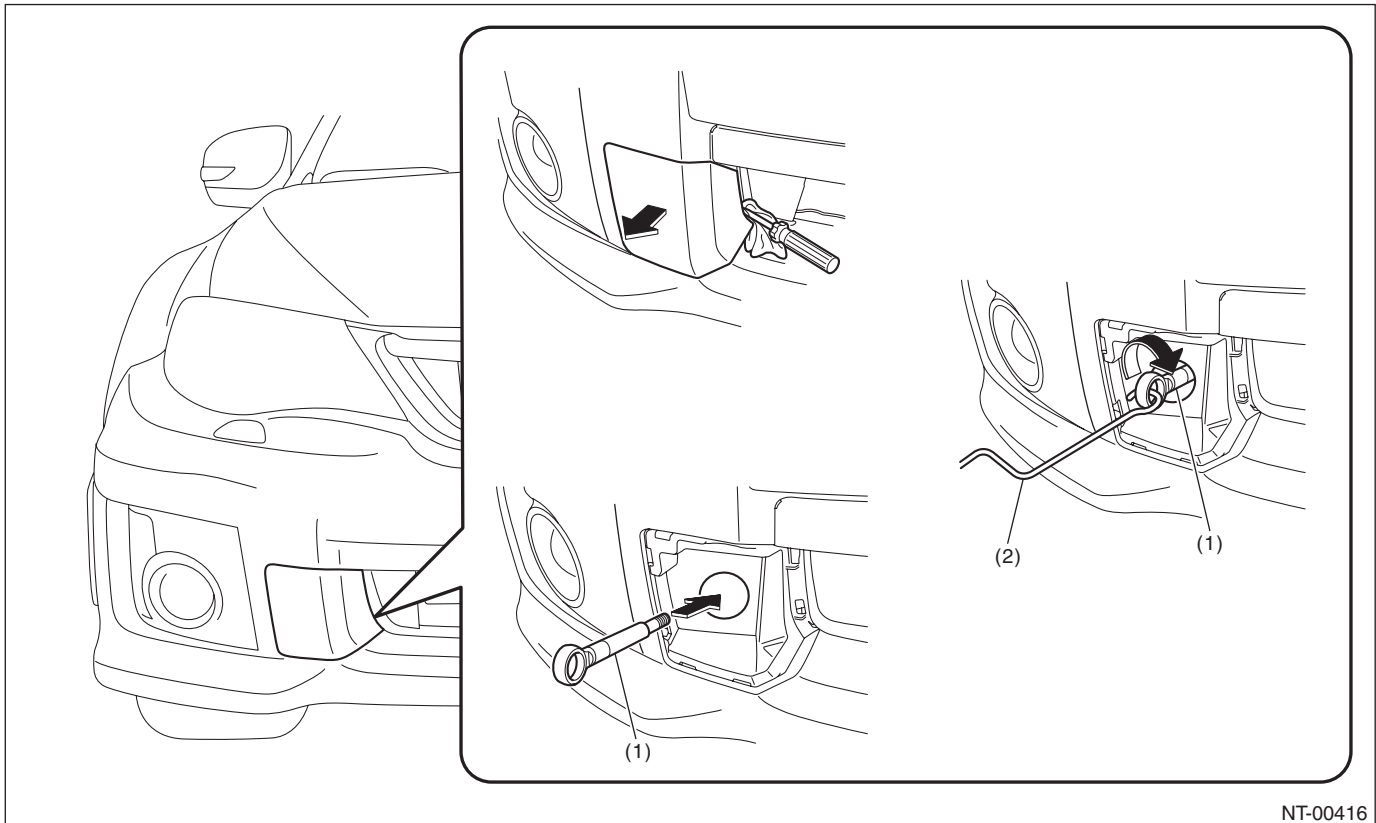

NT-00416

(1) Towing hook (eyebolt)

(2) Jack handle

# Note

NOTE

## • Rear

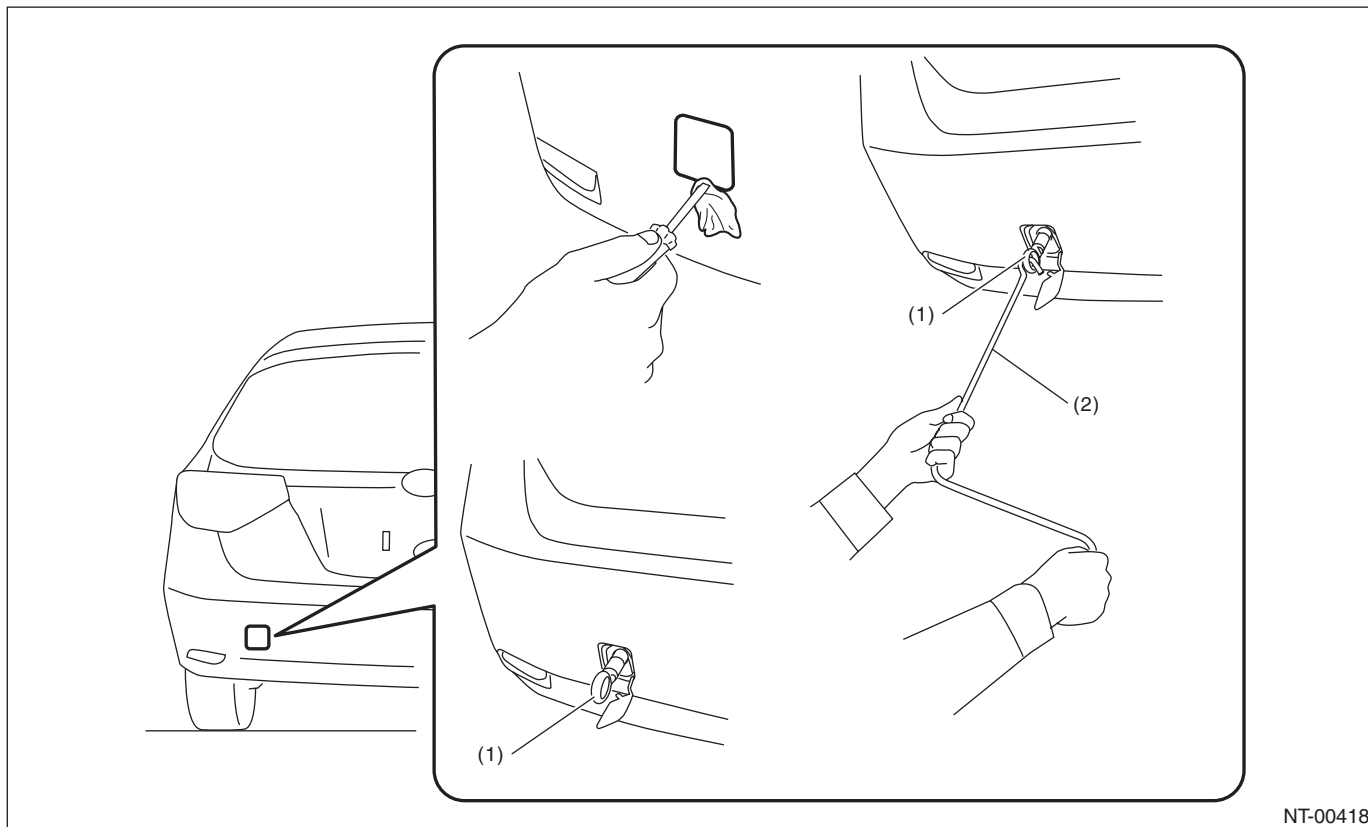

(1) Towing hook (eyebolt)

(2) Jack handle

### CAUTION:

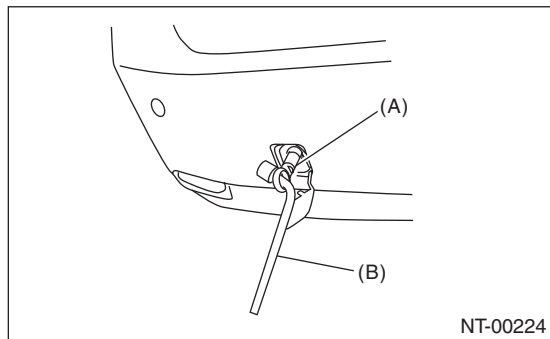

When tightening the eye bolt using a wheel wrench, be careful not to scratch the bumper.



(A) Towing hook (eyebolt)

(B) Wheel wrench

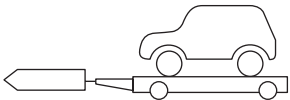
## Precautions

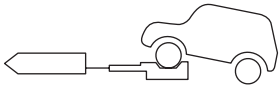
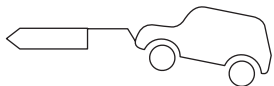
Towing	Precautions	AWD
		MT
Lifting up four wheels (On a trailer)    NT-00023	Towing the vehicle after lifting up all four wheels is a basic rule for AWD model. <b>CAUTION:</b> When carrying the vehicle onto a car carrier truck, refer to "LOADING ONTO CAR CARRIER TRUCK". <Ref. to NT-17, LOADING ONTO CAR CARRIER TRUCK, NOTE, Note.>	○
Rope    NT-00024	Check if both front and rear wheels are rotated normally.	○
Raising the front wheels    NT-00025	Prohibited for full-time AWD model.	×
Lifting up the front wheels    NT-00026	Prohibited, due to damage on bumper, front grille, etc.	×

○ mark: OK, × mark: Prohibited

## Note

NOTE

---

### CAUTION:

- Place the shift lever in “N” position during towing.
- Do not lift up the rear wheels to avoid unsteady rotation.
- Turn the ignition key to “ACC”, then check the steering wheel moves freely.
- Release the parking brake to avoid tire dragging.
- Since the power steering does not work, be careful for the heavy steering effort. (When engine is stopped)
- Since the servo brake does not work, be careful that the brake is not applied effectively. (When engine is stopped)
- In case of the malfunction of internal transmission or drive system, lift up four wheels (on a trailer) for towing.
- Do not use the towing hook (eye bolt) except when towing.
- Make sure to detach the towing hook (eye bolt) after towing. If it remains attached, airbag may not operate properly when receiving a shock. And it may also affect the crash performance of the vehicle.

## 10. LOADING ONTO CAR CARRIER TRUCK

When carrying the vehicle onto a car carrier truck, observe the following precautions.

### CAUTION:

- When carrying the vehicle onto a car carrier truck, perform the operation being careful with the gap between the height of the carrier's floor and the vehicle lower side because of little clearance under the front bumper.

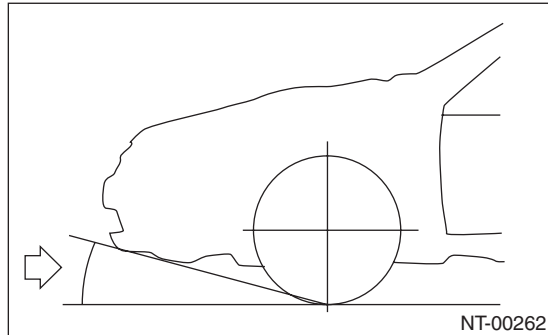

- Use a supporting board (rubber) where the clearance is too small.
- Perform the operation being careful with the position shown in the figure below.

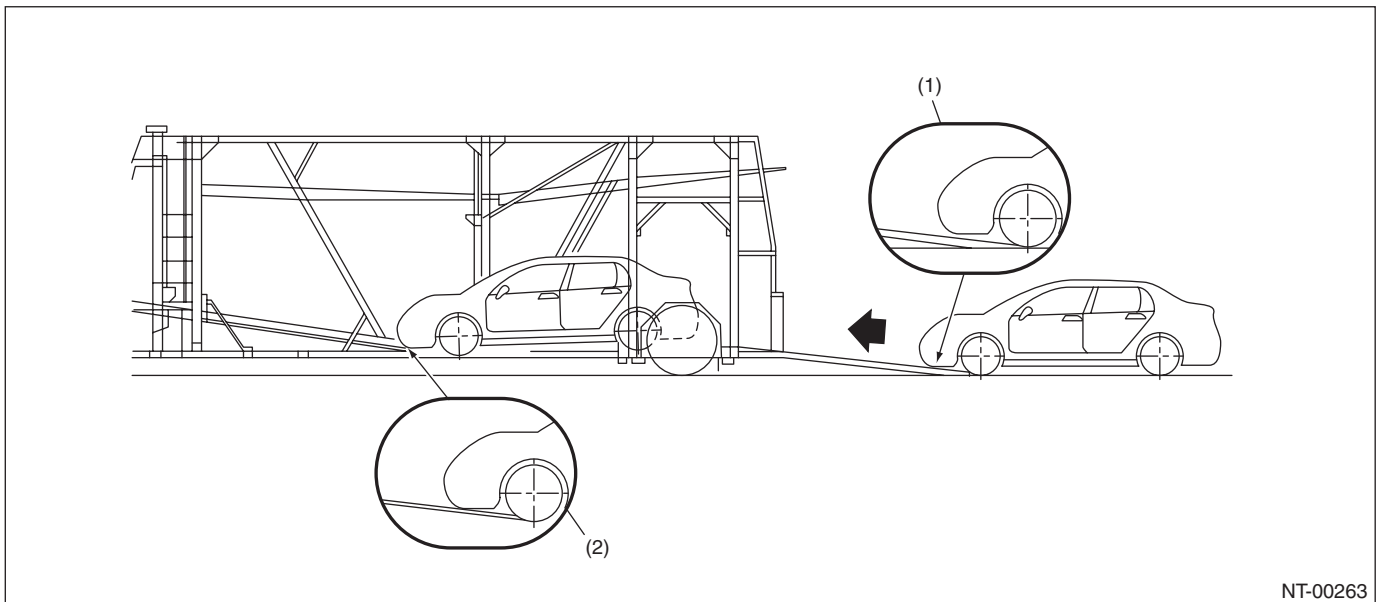

(1) Use a supporting board (rubber) to ensure clearance from the ramp.

(2) Before carrying the vehicle completely, lower the lower center floor until it is level to make clearance.

Before lowering the vehicle from the carrier car, perform the following operations.

### CAUTION:

**Always perform the following operations before lowering the vehicle from the carrier car. Otherwise, the power unit will rotate reversely, which may cause the damage to the engine, vacuum pump, and transmission.**

1) Start the engine.

2) Set the transmission shift position into driving direction of the vehicle. (When the vehicle drives forward, do not set the transmission into R range. When the vehicle drives rearward, do not set the transmission into 1 — 6 speed.)

### CAUTION:

**Be sure to perform 2) mentioned above even if the engine cannot be started in some reasons.**

## Note

NOTE

### 11.FRONT HOOD DAMPER STAY

1) Always perform works such as inspections and maintenance with both damper stays attached.

#### CAUTION:

- At the inspection and general maintenance, do not detach the damper stays.

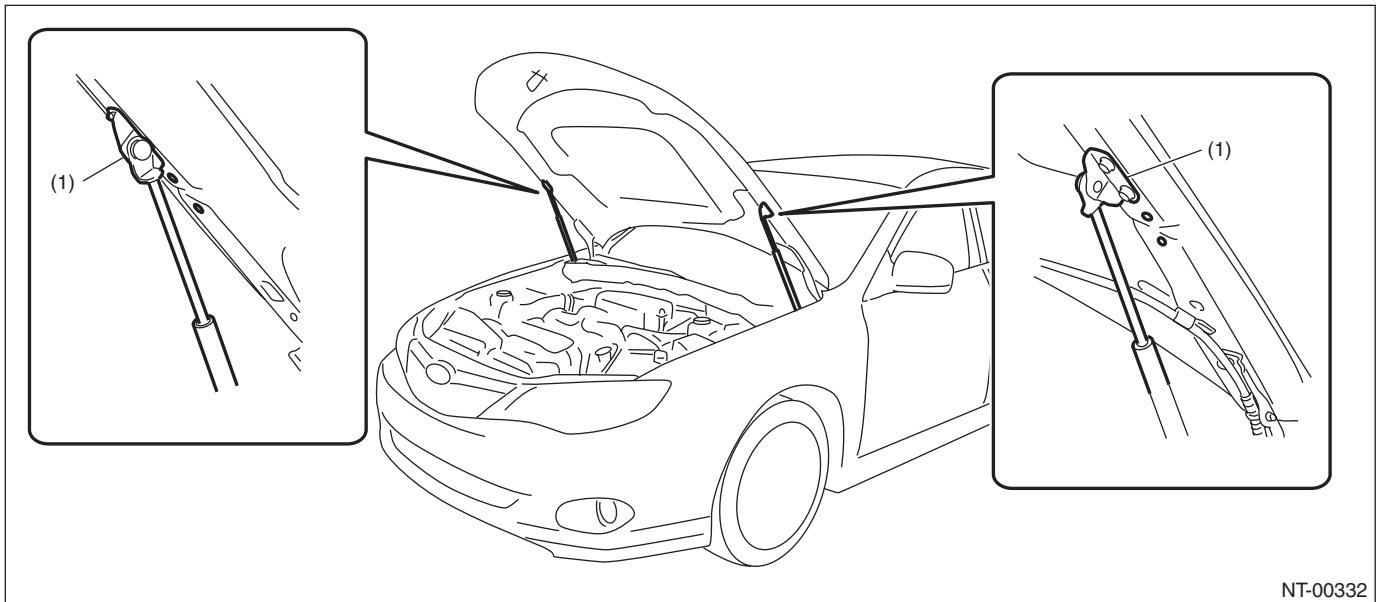

NT-00332

(1) Normal attached position



2) When wider hood opening is necessary, set the damper stay below as shown in the figure.

**Tightening torque:**

<Ref. to EB-8, FRONT HOOD, COMPONENT, General Description.>

**CAUTION:**

- Always perform works such as inspections and maintenance with both damper stays attached.
- Do not leave one side of damper stay removed.
- The hood cannot be closed with the hood damper on the full open side. When it is necessary to close, tie the hood striker and the radiator panel with a string etc. to fix them.
- After work, set the damper stays back to the normal position and tighten the bolts to the specified torque.

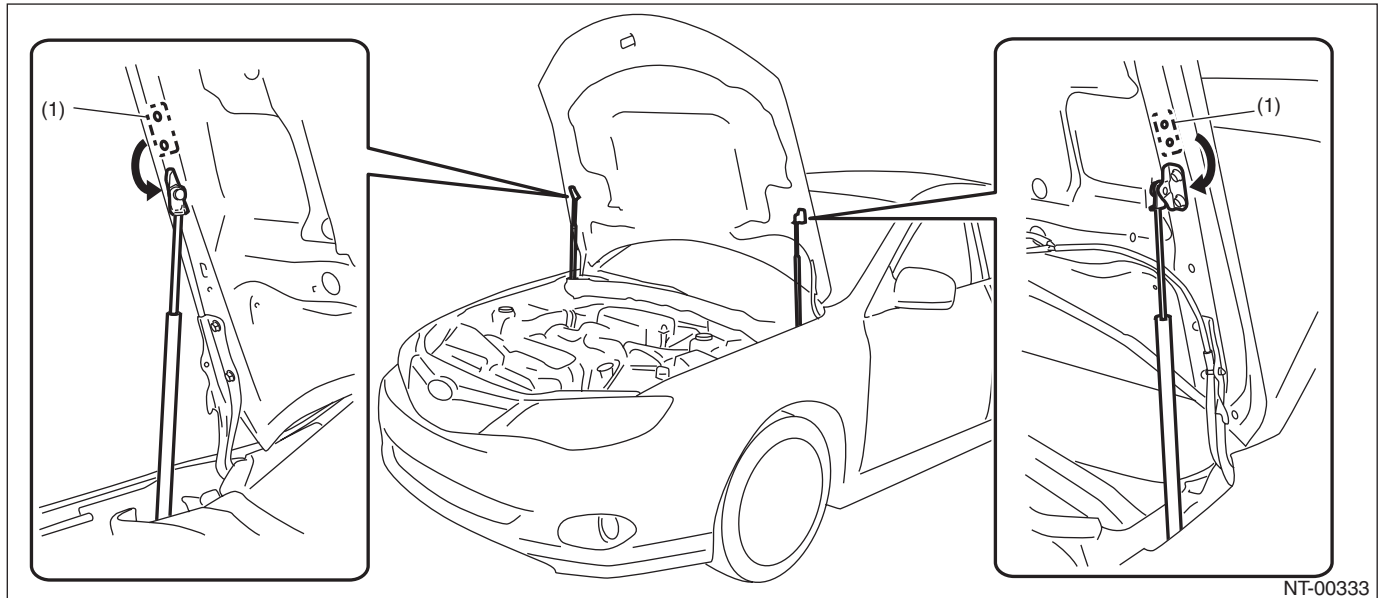

(1) Normal attached position

**12. TRAINING**

For an information about training, contact a dealer or agent.

**13. GENERAL SCAN TOOL**

Using general scan tools will greatly improve the efficiency of repairing engine electronic controls. Subaru Select Monitor can be used to diagnose the engine, VDC and other electronically controlled parts.

## Note

NOTE

---

**NT-20**

Brought to you by Ebay Seller "SubaruManuals"

# IDENTIFICATION

***ID***

---

	<b>Page</b>
1. Identification .....	2

# Identification

## IDENTIFICATION

### 1. Identification

#### A: IDENTIFICATION

##### 1. IDENTIFICATION NUMBER & LABEL LOCATIONS

The V.I.N. (Vehicle Identification Numbers) is used to classify the vehicle.

##### • POSITIONING OF THE LABEL FOR IDENTIFICATION

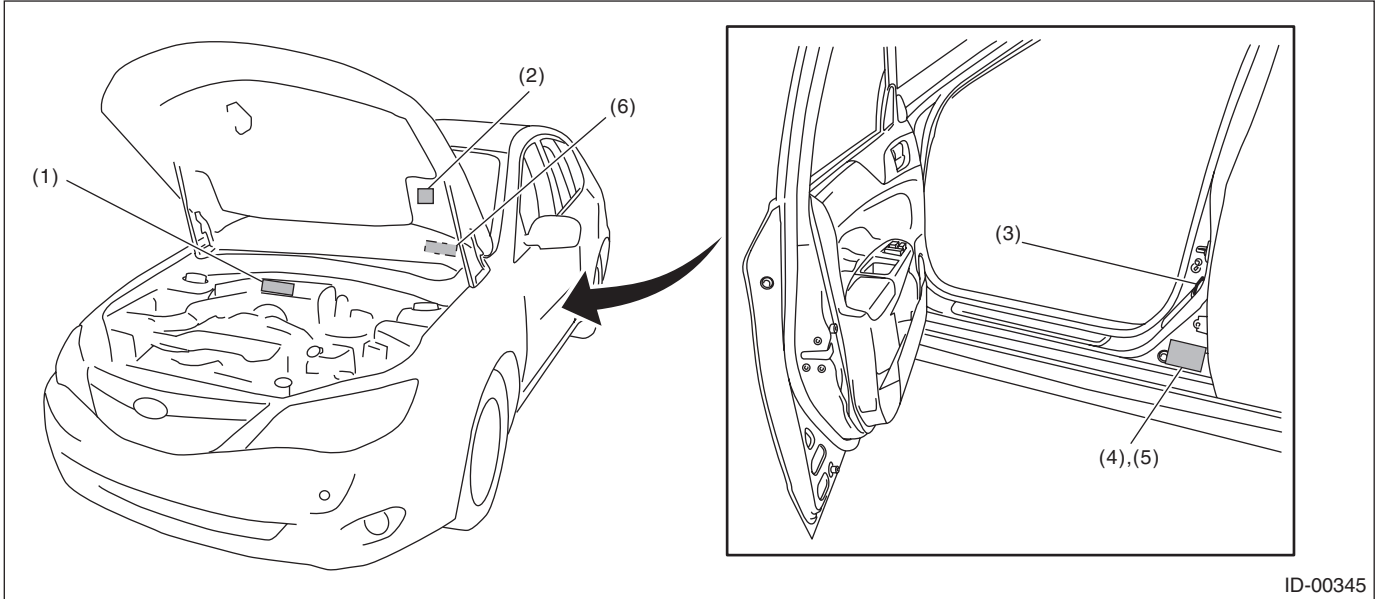

(1) Vehicle identification number (V.I.N.)

(2) Emission control label

(3) Tire inflation pressure label

(4) MVSS label (Apply on the left side of center pillar outer)

(5) Model number label (Apply on the right side of center pillar outer)

(6) Vehicle identification number (V.I.N. PLATE)

• **Engine**

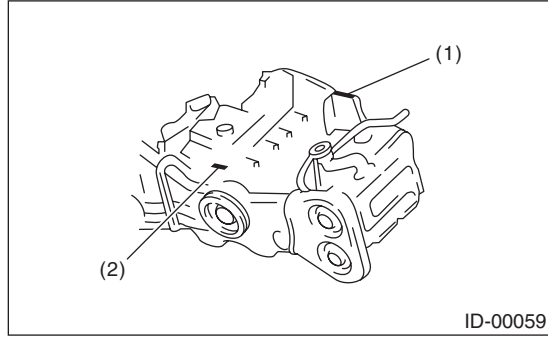

- (1) Engine serial number
- (2) Engine type (casting) crankcase upper side

ID-00059

• **Rear differential**

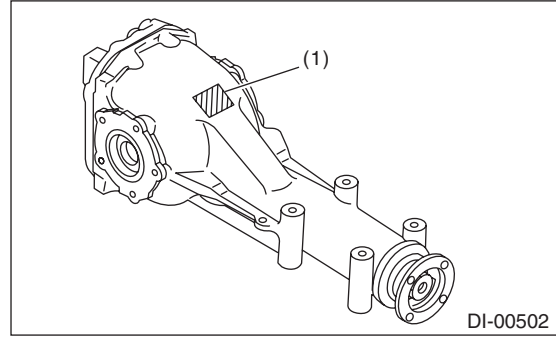

- (1) Identification (white paint)

DI-00502

• **Manual transmission**

6MT

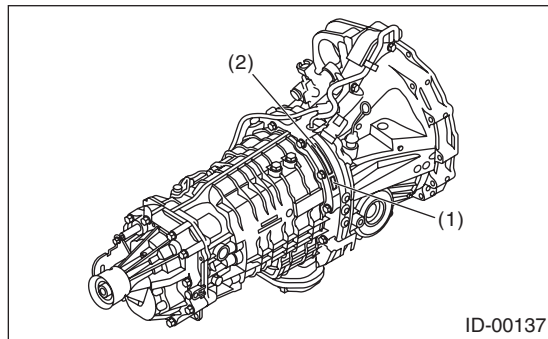

- (1) Transmission serial No.
- (2) MT type label

ID-00137

5MT

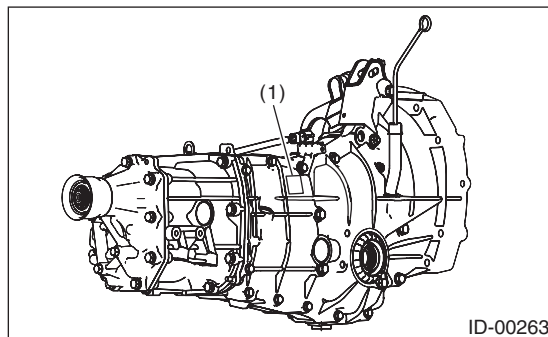

- (1) MT type and transmission serial number label

ID-00263

• **Model number label**

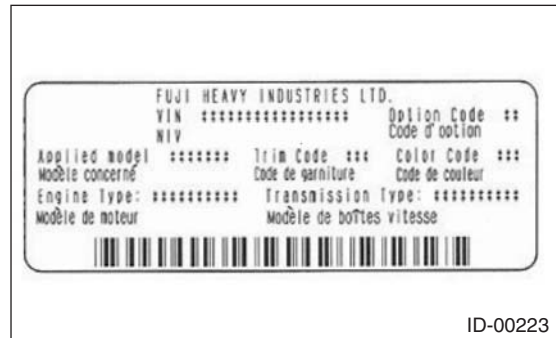

ID-00223

• **MVSS label**

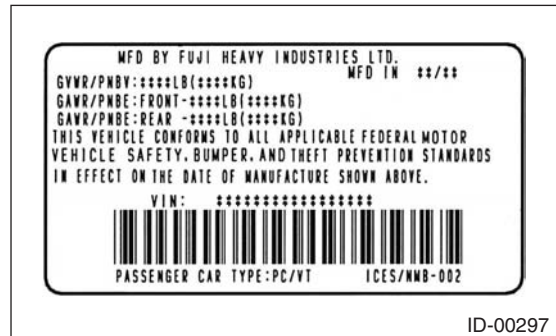

ID-00297

# Identification

## IDENTIFICATION

### 2. MEANING OF V.I.N.

The meaning of the V.I.N. is as follows:

**JF1GR8H6XCL200001**[

The starting and ending brackets ( [ ] ) are stop marks.

Digits	Code	Meaning	Details
1 — 3	JF1	Manufacturer body area	JF1: Passenger car, FHI made
4	G	Car line	G: IMPREZA
5	R	Body type	V: 4 door wide body R: 5 door wide body
6	8	Displacement	7: 2.5 L AWD turbo 8: 2.5 L AWD high power turbo
7	H	Grade	E: WRX F: WRX-S G: SE H: STI J: STI-S
8	6	Restraint	6: Manual belts, dual airbag, side airbag, curtain airbag
9	X	Check digit	0 — 9&X
10	C	Model year	C: 2012MY
11	L	Transmission type	G: Full-time AWD single range 5MT L: Full-time AWD 6MT
12 — 17	200001	Serial number	002001 — 199999: 4 door 200001 — 399999: 5 door

### 3. MODEL NUMBER LABEL

The model number label indicates: the applied model, the option code, the trim code, the engine type, the transmission type, and the exterior color code. This information is helpful when placing orders for parts.

**GRFEYEH**

Digits	Code	Meaning	Details
1	G	Series	G: IMPREZA
2	R	Body type	V: 4 door wide body R: 5 door wide body
3	F	Total engine displacement Drive system Suspension system	E: 2.5 L AWD turbo F: 2.5 L AWD high power turbo
4	E	Model year	E: 2012MY
5	Y	Destination	Y: U.S., Canada
6	E	Grade	E: STI F: WRX G: WRX-S T: SE V: STI-S
7	H	Transmission, fuel feed system	D: MFI turbo 5MT AWD H: MFI high power turbo 6MT AWD

The engine and transmission type are as follows.

## Engine

### EJ257BG5LB

Digits	Code	Meaning	Details
1 and 2	EJ	Engine type symbol	EJ: 4 cylinder
3 and 4	25	Displacement	25: 2.5 L
5	7	Fuel feed device	5: MFI turbo 7: MFI high power turbo
6	B	Exhaust regulations	B: U.S. (FED, CAL)
7	G	Mounted transmission	E: 5MT G: 6MT
8 — 10	5LB	Detailed specifications	Used when ordering parts. For details, refer to the parts catalog.

## Transmission (MT)

### TY856UW1MA

Digits	Code	Meaning	Details
1	T	Transmission	T: Transmission
2	Y	Transmission system	Y: Full-time AWD MT center differential
3 and 4	85	Distance between gear center	75: Between main shaft and drive pinion 85: Between main shaft and drive pinion
5	6	Classification	6: 6MT 8: 5MT
6	U	Transmission specifications	U: Full-time AWD single range 6MT with driver's control center differential V: Full-time AWD single range 5MT with viscous coupling center differential
7	W	Mounted engine	W: 925 DOHC turbo
8 — 10	1MA	Detailed specifications	Used when ordering parts. For details, refer to the parts catalog.

## Rear differential

Code	Reduction gear ratio	LSD
H3	3.545	Torsen
B2	3.900	None

# Identification

## IDENTIFICATION

---

### Option code

#### MH

- 1-digit number

OP code	M	O	Q	R	S	U	V	3	4	5
18 in Tire & Aluminum wheel (BBS)	—	—	—	○	○	○	—	○	—	—
Navigation	—	—	○	—	—	○	○	○	—	○
Sunroof	—	○	○	—	○	○	—	—	○	○
HID headlight	○	○	○	○	○	○	○	○	—	—
Front fog light	—	○	○	○	○	○	—	○	○	○

- 2-digit number

OP code	H	R
Genuine leather seat	○	—
Seat heater	○	○
Cold weather package	○	○
Satellite tuner	—	—



# RECOMMENDED MATERIALS

# *RM*

---

	<b>Page</b>
1. Recommended Materials .....	2

# Recommended Materials

## RECOMMENDED MATERIALS

### 1. Recommended Materials

#### A: RECOMMENDED MATERIALS

##### 1. GENERAL

To insure the best performance, always use the specified oil, gasoline, adhesive, sealant, etc. or a substitute of equivalent quality.

##### 2. FUEL



Always use gasoline of the same or higher octane value than specified in the owner's manual. Ignoring the specifications below will result in damage or poor performance of engine and fuel injection system. To gain proper performance, always use specified gasoline.

##### UNLEADED GASOLINE

In order to reduce air pollution, use unleaded gasoline for the vehicle equipped with catalytic converter. Using leaded gasoline may damage the catalytic converter.

##### 3. LUBRICANT

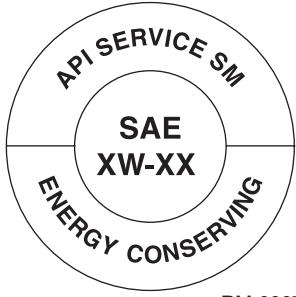
Use the lubricants shown in the table below, or equivalent. See the table below to choose the correct SAE viscosity.

Lubricant	Recommended materials	
	API standard	ILSAC standard
Engine oil Choose oil suitable for the standard from the right.	SN or SM grade "Resource conserving" or "Energy conserving"    RM-00076 Those with the above API service labels	GF-5 or GF-4    RM-00002 Those with the above ILSAC certification mark (Starburst mark)
Manual transmission oil	GL-5	—
Rear differential gear oil	GL-5	—

# Recommended Materials

RECOMMENDED MATERIALS

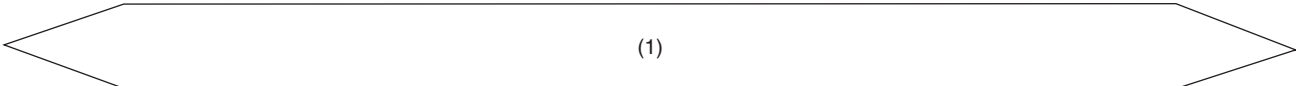
SAE viscosity No. and applicable temperature								
Engine oil								
(°C)	-30	-20	-10	0	10	20	30	40
(°F)	-22	-4	14	32	50	68	86	104
								
RM-00075								
(1) 5W-30 (synthetic oil) Required								

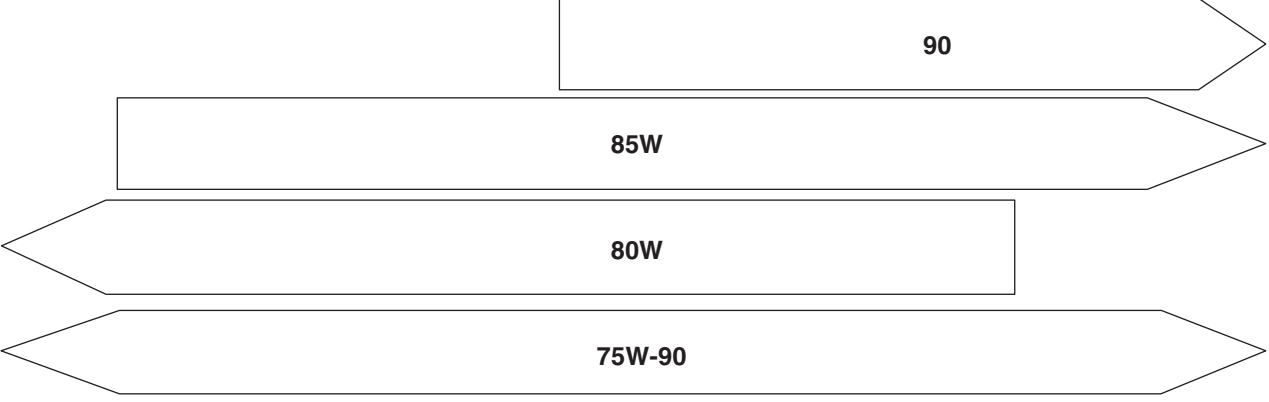
Manual transmission gear oil, front differential gear oil and rear differential gear oil								
(°C)	-30	-20	-10	0	10	20	30	40
(°F)	-22	-4	14	32	50	68	86	104
								
RM-00058								

## Recommended Materials

### RECOMMENDED MATERIALS

---

#### 4. FLUID

Use the fluids specified in the table below. Do not mix two different kinds or makes of fluid.

Fluid	Recommended materials	Alternative	Remarks
Power steering fluid	SUBARU ATF	DEXRON III	—
Brake fluid	FMVSS No. 116 DOT3, or DOT4	—	—
Clutch fluid	FMVSS No. 116 DOT3	FMVSS No. 116 DOT4	—

#### 5. COOLANT

Use the coolants specified in the table below to protect the engine.

Coolant	Recommended materials	Item number	Alternative
Coolant	SUBARU SUPER COOLANT (Concentrated type)	—	—
	SUBARU SUPER COOLANT (Diluted type)	K0670Y0001	
Water for dilution	Distilled water	—	Soft water or tap water
Cooling system protective agent	Cooling system conditioner	SOA345001	—

#### 6. REFRIGERANT

Standard air conditioners on Subaru vehicles use HFC134a refrigerant. Do not mix it with other refrigerants. Also, do not use any compressor oil except for DH-PR.

Air Conditioner	Recommended materials	Item number	Alternative
Refrigerant	HFC134a	—	None
Compressor oil	DH-PR	—	None

# Recommended Materials

RECOMMENDED MATERIALS

## 7. GREASE

Use grease and supplementary lubricants shown in the table below.

Grease	Application point	Recommended materials	Item number	Alternative
Supplementary lubricants	Oxygen sensor	Spray type lubricant	004301003	—
Grease	<ul style="list-style-type: none"> <li>• MT main shaft (spline portion)</li> <li>• MT main shaft (oil seal lip)</li> <li>• Clutch release lever</li> <li>• Clutch release bearing</li> <li>• Clutch operating cylinder</li> </ul>	NICHIMOLY N-130	—	—
	Clutch master cylinder push rod	SILICONE GREASE G-40M	—	—
	<ul style="list-style-type: none"> <li>• Gear shift lever</li> <li>• Clutch pedal</li> <li>• Brake pedal</li> <li>• Release bearing</li> </ul>	NIGHTIGHT LYW No. 2 grease	—	—
	Steering gearbox	VALIANT GREASE M-2	003608001	ONE LUBER SG
	Disc brake (Lock pin, guide pin, piston boot)	NIGLUBE RX-2	000041000	—
	Brake pad end surface	Molykote M7439	K0770YA000	—
	Between brake pad and shim	Molykote AS880N	K0777YA010	—
	Parking brake	Brake grease	—	—
	Rear axle EBJ	NKG814	—	—
	Front axle AAR	One-Luber GKN-C	—	—
	Front axle PTJ	NKG302	—	—
	Rear axle EDJ	NKG814	—	—
	<ul style="list-style-type: none"> <li>• Door latch</li> <li>• Door striker</li> </ul>	SILICONE GREASE G-30M	004404002	—

## 8. ADHESIVE

Use the adhesives shown in the table below, or equivalent.

Adhesive	Application point	Recommended materials	Item number	Alternative
Adhesive	Windshield, rear quarter glass, rear window glass, rear gate glass and body	Dow Automotive's Adhesive: ESSEX U-400HV or equivalent Glass primer: U-401 and U-402 Painted surface primer: U-413	—	—
	Rearview mirror base	REPAIR KIT IN MR	65029FC000	—

## Recommended Materials

### RECOMMENDED MATERIALS

#### 9. SEAL MATERIAL

Use the seal material shown in the table below, or equivalent.

Seal material	Application point	Recommended materials	Item number	Alternative
Seal material	<ul style="list-style-type: none"> <li>• Transmission case</li> <li>• Transmission oil pan (6MT)</li> <li>• MT extension case</li> <li>• Clutch housing (6MT)</li> </ul>	THREE BOND 1215	004403007	DOW CORNING No. 7038
	<ul style="list-style-type: none"> <li>• Rear differential</li> <li>• Oil pressure switch</li> </ul>	THREE BOND 1324	004403042	—
	<ul style="list-style-type: none"> <li>• Service hole plug</li> <li>• PCV nipple</li> <li>• Intake manifold nipple (STI model)</li> <li>• Rear differential</li> </ul>	THREE BOND 1105	004403010	DOW CORNING No. 7038
	Rear differential (side retainer bolt)	THREE BOND 1110B	K0879Y0020	—
	Steering adjusting screw	THREE BOND 1102	004403006	THREE BOND 1215
	<ul style="list-style-type: none"> <li>• Front door sealing cover</li> <li>• Rear door sealing cover</li> </ul>	3M Butyl Rubber 8626	—	—
	<ul style="list-style-type: none"> <li>• Engine oil pan</li> <li>• Separator cover</li> <li>• Camshaft cap</li> <li>• Cylinder block</li> <li>• Oil pump</li> <li>• DOHC rocker cover</li> </ul>	THREE BOND 1217G	K0877Y0100	—

# PRE-DELIVERY INSPECTION

*PI*

---

	<b>Page</b>
1. Pre-delivery Inspection .....	2

# Pre-delivery Inspection

## PRE-DELIVERY INSPECTION

### 1. Pre-delivery Inspection

#### A: GENERAL DESCRIPTION

The purposes of the pre-delivery inspection (PDI) are as follows.

- Remove the additional parts used for ensuring the vehicle quality during transportation and restore the vehicle to its normal condition.
- Check the vehicle before delivery is in normal condition.
- Check the vehicle or parts for any damage occurred during transportation or storage.
- Check the vehicle after repair is in normal condition.
- Make sure to provide a complete vehicle to customer.

For above reasons, all SOAs (dealerships) must carry out the PDIs before delivery of vehicle.

Refer to this manual unless otherwise specified.

#### B: PRE-DELIVERY INSPECTION (PDI) PROCEDURE

Perform the procedures indicated in the table below.

##### Static Checks Just after Vehicle Receipt

Operation	Check point
1. Appearance	<ol style="list-style-type: none"><li>1. If the vehicle is covered with protective coating, visually check the vehicle body for damage and dents. If the protective coating has been removed, visually check the painted body surfaces in detail for damage or rust.</li><li>2. Visually check the glass and light lenses for any damage, cracks or excessive gaps between body panels.</li><li>3. Visually check the plated parts for any damage.</li><li>4. Check the instrument panel, console and trim for stains or dirt.</li></ol>
2. Tire	<ol style="list-style-type: none"><li>1. Check the tires for damage, defective, and dents on wheels.</li><li>2. Check the tire air pressure.</li></ol>
3. Fuses	If the vehicle is about to be delivered to customer, attach the room light fuse.
4. Door lock/unlock & open/close	<ol style="list-style-type: none"><li>1. Using the key, check the door can be locked or unlocked normally.</li><li>2. Open and close all doors to check that there are no problems.</li><li>3. Operate the power door lock switch to check that the rear gate locks and unlocks normally.</li></ol>
5. Child safety lock system	Check the child safety lock system operates normally.
6. Rear gate lock/unlock & open/close	<ol style="list-style-type: none"><li>1. Check if the rear gate can be unlocked normally through the emergency hole.</li><li>2. Open and close the rear gate to check that there are no problems.</li></ol>
7. Fuel lid opener lock release lever	Operate the fuel lid opener to check that the fuel filler lid can be unlocked normally.
8. Accessory	Check that the following accessories are equipped. <ul style="list-style-type: none"><li>• Owner's manual</li><li>• Warranty booklet</li><li>• Maintenance note</li><li>• Spare key</li><li>• Key No. plate</li><li>• Jack</li><li>• Jack handle</li><li>• Tool set</li><li>• Spare tire</li><li>• Towing hook (eyebolt)</li><li>• Security ID plate</li></ul>
9. Front hood lock release system	Operate the front hood lock release lever to check that the front hood opens normally.
10. Battery	Check the battery for any abnormal conditions such as rust or traces of battery fluid leaks.
11. Brake fluid	Check the fluid level.
12. Engine oil	Check the engine oil amount.
13. Transmission gear oil	<ul style="list-style-type: none"><li>• Check that the transmission gear oil level is normal. (5MT model)</li><li>• Check for leakage of the transmission gear oil. (6MT model)</li></ul>
14. Differential gear oil	Check for leakage of gear oil from the rear differential.



# Pre-delivery Inspection

PRE-DELIVERY INSPECTION

Operation	Check point
15. Engine coolant	Check the engine coolant level.
16. Clutch fluid	Check the clutch fluid amount.
17. Window washer fluid	Check the window washer fluid amount.
18. Front hood latch	Check that the front hood is closed normally and locked securely.
19. Keyless entry system	Check that the keyless entry system operates normally.
20. Security system	Check that the security system operates normally.
21. Seat	1. Check the seat surfaces for stains or dirt. 2. Check the seat installation conditions and functionality.
22. Seat belt	Check the seat belt installation conditions and functionality.
23. TPMS (U.S. models only)	1. Turn the TPMS transmitter power supply to ON. 2. If the display of TPMS warning light does not operate normally, perform the diagnosis by referring to TPMS (Diagnosis).
24. ECM protector	For Canada model, check the ECM protector installation conditions.

## Checks with the Engine Running

Operation	Check point
25. Delivery (test) mode connector	Turn the ignition switch to ON and check that the malfunction indicator light starts blinking.
26. Immobilizer system	1. Check that the engine starts with all keys that are equipped on vehicle. 2. 60 seconds after turning ignition switch from ON to ACC or OFF, or immediately after removing the key, check that the security indicator light is blinking.
27. Starting condition	Start the engine and check that the engine starts smoothly.
28. Exhaust system	Check that the exhaust noise is normal and no leaks are found.
29. Indicator light and warning lights	Check that all indicator lights and warning lights are operating correctly.
30. Heater & ventilation	Check that the heater & ventilation system operates normally.
31. Air conditioner	Check that the air conditioner operates normally.
32. Clock	Check that the clock operates normally.
33. Audio	Check the radio and AUX operate normally.
34. Navigation	Check the navigation and AUX operate normally.
35. Front accessory power supply socket	Check that the front accessory power supply socket operates normally.
36. Lighting system	Check that the lighting system operates normally.
37. Window washer	Check that the window washer system operates normally.
38. Wiper	Check that the wiper system operates normally.
39. Power window	Check that the power window operates normally.
40. Sunroof	Check that the sunroof operates normally.
41. Rear defogger system	Check that the rear defogger system operates normally.
42. Parking brake	Check the parking brake for normal operations.

## Dynamic Test with the Vehicle Running

Operation	Check point
43. Brake test	Check the foot brake for normal operations.
44. Shift control	Check that the shift patterns are correct.
45. Cruise control	Check that the cruise control system operates normally.

## Checks after Dynamic Test

Operation	Check point
46. Power steering fluid level	Check that the power steering fluid level is normal.
47. Fluid leakage	Check for fluid/oil leaks.
48. Water leakage	Spray the vehicle with water and check for water leaks.
49. Appearance 2	1. Remove the protective coating (if equipped). 2. Check the body paints for damage and stain. 3. Check the plated parts for damage and rust.

# Pre-delivery Inspection

## PRE-DELIVERY INSPECTION

### 1. APPEARANCE

- If the vehicle is covered with protective coating, visually check the vehicle body for damage and dents.
- When there is no protective coating, check the body paints for damage or stains in detail and repair as necessary.
- Check the window glass, door glass, and lights for any cracks or damage, and replace as necessary.
- Visually check the plated parts, such as the grilles and door knobs, for damage or loss of gloss and replace the parts as necessary.
- Check the instrument panel, console and trim for stains or dirt.

### 2. TIRE

- Check for damage on the outside surface of the tires.
- Check and correct the tire size, spare tire and tire air pressure described on the tire air pressure label (driver's side).

### 3. FUSE

Fuses for the room light circuit on initially delivered vehicles are removed to prevent battery discharge. Attach the 20 A fuse (A) as shown in the figure.

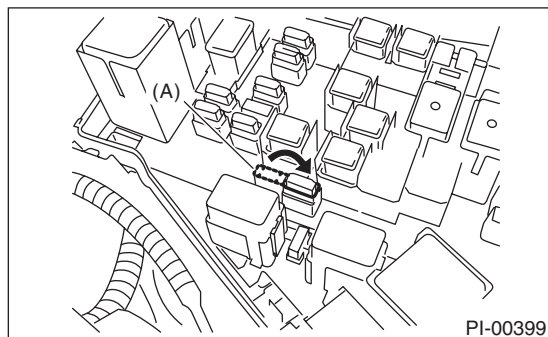

### 4. DOOR LOCK/UNLOCK AND OPEN/CLOSE OPERATIONS

1) Using the key, lock and unlock the door several times to check for normal operation. Open and close the door several times for smooth movement.

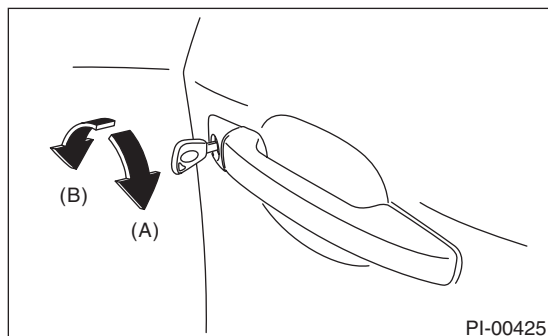

- (A) Unlock
- (B) Lock

2) Close the door of driver seat completely, and place the door lock knob (A) to the lock position. Then pull the inner remote (B) to ensure that doors will not open.

For other doors, place the door lock knob (A) to lock position and then pull the inner remote (B) to ensure that doors will not open.

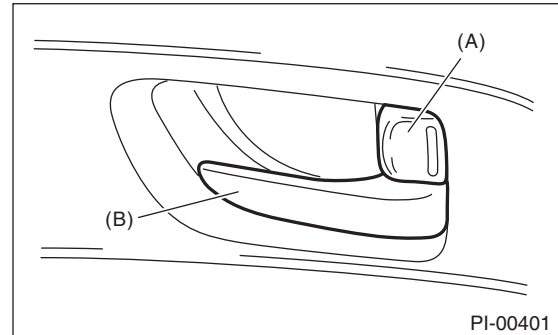

- (A) Door lock knob
- (B) Inner remote

3) Close all doors, and press the lock side of power door lock switch on the driver's and passenger's sides. Check that all doors (including the rear gate) lock.

- Driver's side

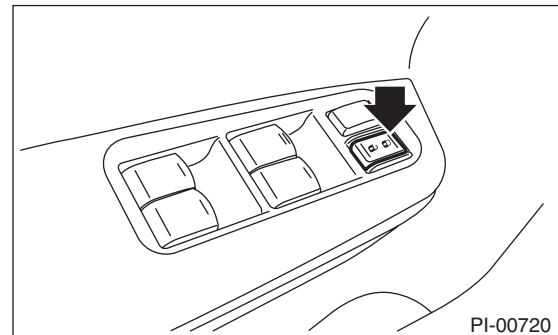

- Passenger's side

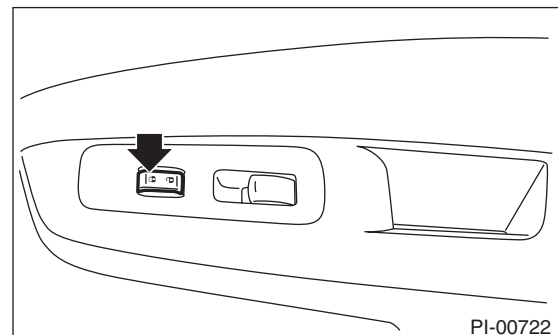

4) Press the unlock side of the power door lock switch on the driver and passenger sides. Check that all doors including rear gate are unlocked.

**NOTE:**

Pressing the release button will open the rear gate.

- Driver's side

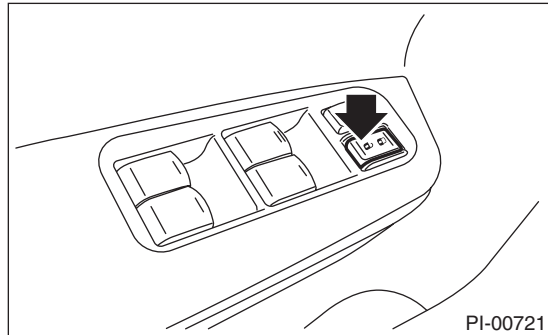

- Passenger's side

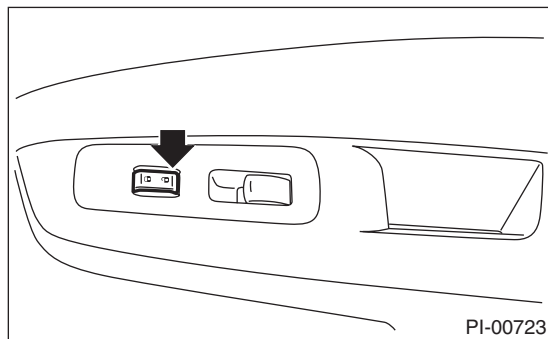

## 5. CHILD SAFETY LOCK SYSTEM

- 1) Set the child safety lock lever on both rear doors to the lock position.
- 2) Close the rear doors completely.
- 3) Check that the lock levers of the rear doors are in the unlock position. Then, pull inner remote of rear doors to ensure that doors will not open.
- 4) Pull the outer handles to ensure that doors will open.

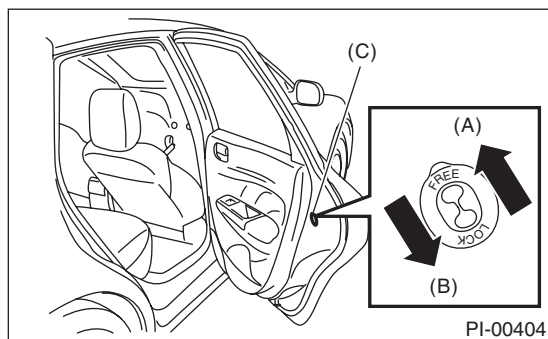

- (A) Unlock
- (B) Lock
- (C) Child safety lock lever

## 6. REAR GATE LOCK/UNLOCK AND OPEN/CLOSE OPERATIONS

- 1) Open and close the rear gate several times for smooth movement.
- 2) Operate the rear gate emergency release lever to check that the rear gate can be locked and unlocked properly.

- (1) Remove the cover inside the rear gate.

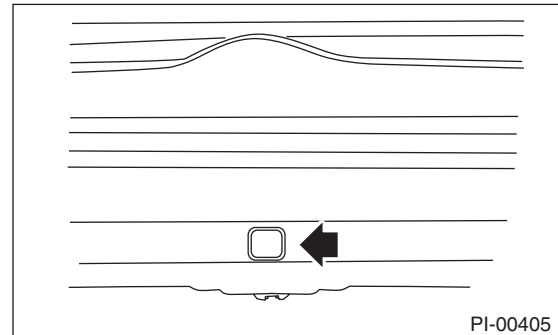

- (2) Operate the lever using a tool such as a screwdriver to check that the rear gate is unlocked normally.

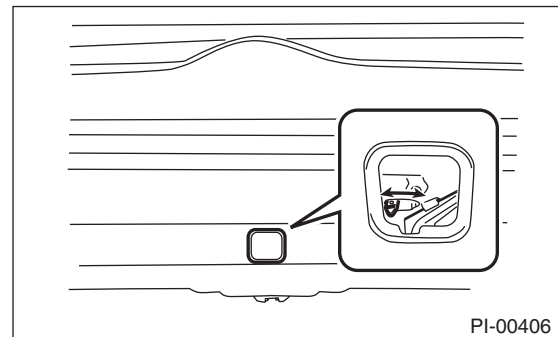

## 7. FUEL LID OPENER LOCK RELEASE LEVER

Operate the fuel lid opener to check that the fuel lid is unlocked normally. Check that the filler cap is securely closed.

# Pre-delivery Inspection

## PRE-DELIVERY INSPECTION

### 8. ACCESSORY

Check that the following accessories are provided.

- Owner's manual
- Warranty booklet
- Maintenance note
- Spare key
- Tool set
- Towing hook (eyebolt)
- Spare tire
- Key No. plate
- Security ID plate
- Jack
- Jack handle

4 door model

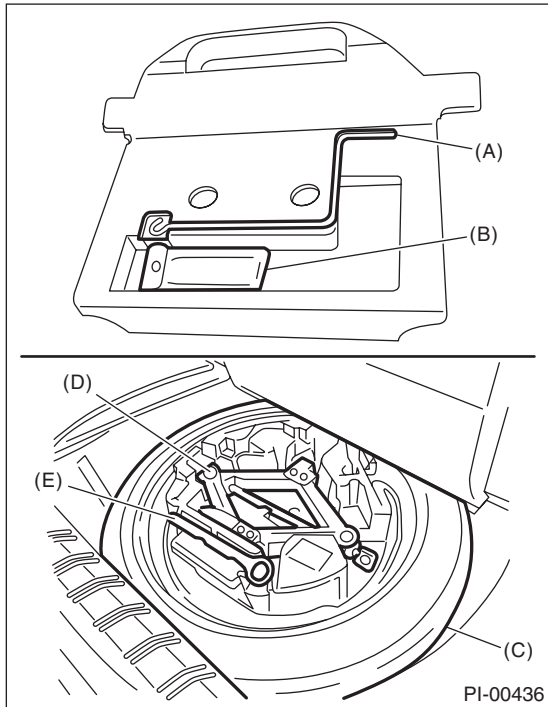

- (A) Jack handle
- (B) Tool set
- (C) Spare tire
- (D) Jack
- (E) Towing hook (eyebolt)

5 door model

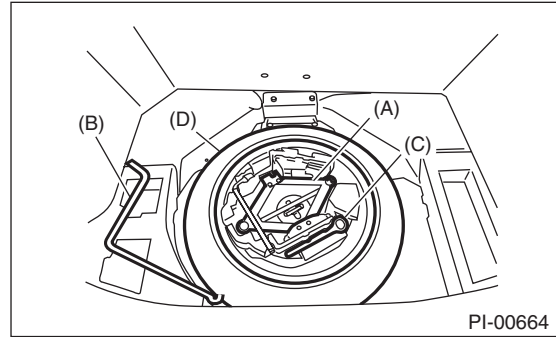

- (A) Jack
- (B) Jack handle
- (C) Towing hook (eyebolt)
- (D) Spare tire

### 9. FRONT HOOD LOCK RELEASE SYSTEM

Operate the front hood release knob to check that the front hood will unlock properly.

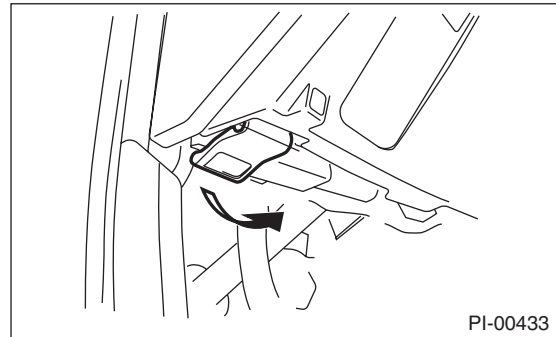

Operate the lever (A) and check that the front hood is opened normally.

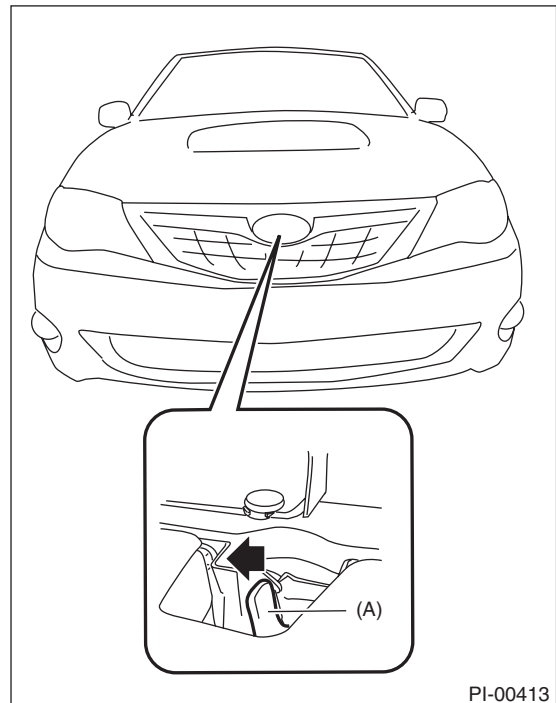

## 10. BATTERY

Check the battery terminals to make sure that there are no rust or corruptions due to fluid leaks. Check that the battery caps are securely tightened.

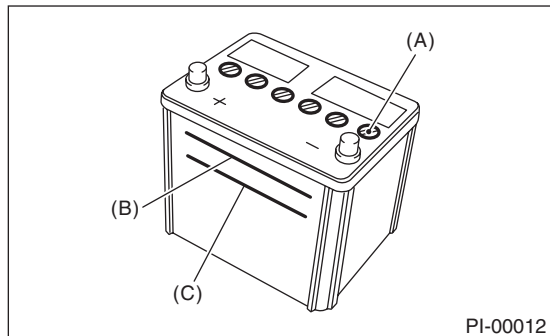

- (A) Cap
- (B) Upper level
- (C) Lower level

## 11. BRAKE FLUID

Check the brake fluid amount. If the amount is insufficient, carry out a brake line test to identify brake fluid leaks and check the brake operation. After that, refill the brake fluid tank with the specified type of fluid.

### CAUTION:

**If the brake fluid is spilt over exhaust pipe, wipe it off with cloth to avoid emitting smoke or causing a fire.**

## 12. ENGINE OIL

Check the engine oil amount. If the amount of oil is insufficient, check that no leaks are found. Then, add the necessary amount of the specified engine oil.

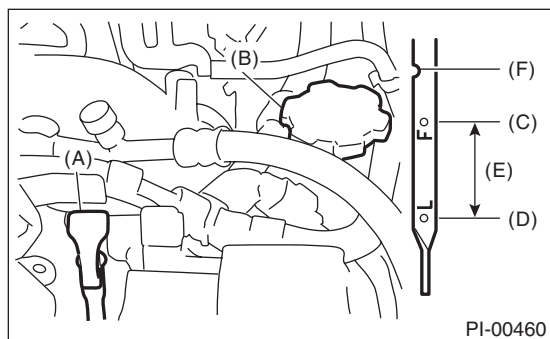

- (A) Oil level gauge
- (B) Engine oil filler cap
- (C) "F" line
- (D) "L" line
- (E) Approx. 1.0 ℓ (1.1 US qt, 0.9 Imp qt)
- (F) Notch mark

### CAUTION:

**If any engine oil is spilled on the exhaust pipe, under cover, wipe off completely to prevent fires or emission of smoke.**

## 13. TRANSMISSION GEAR OIL

### 5MT model

Check the transmission gear oil amount. If the amount of oil is insufficient, check that no leaks are found. Then add the necessary amount of the specified transmission gear oil.

### CAUTION:

**If gear oil is spilt over the exhaust pipe, wipe it off with a cloth to avoid emitting smoke or causing a fire.**

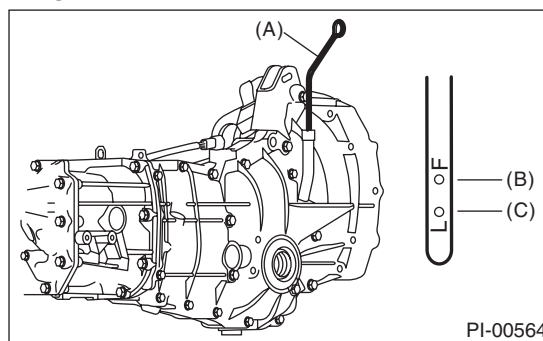

- (A) Oil level gauge
- (B) Upper level
- (C) Lower level

### 6MT model

Check for leakage of the transmission gear oil.

## 14. REAR DIFFERENTIAL GEAR OIL

Check for leakage of gear oil from the rear differential.

## 15. ENGINE COOLANT

Check the coolant amount on the reservoir. If the amount of engine coolant is insufficient, check that no leaks are found. Then, add the necessary amount of coolant with the specified concentration.

### CAUTION:

**If any engine coolant is spilled on the exhaust pipe, wipe off completely to prevent fires or emission of smoke.**

# Pre-delivery Inspection

## PRE-DELIVERY INSPECTION

### 16. CLUTCH FLUID

Check the clutch fluid amount. If the amount of fluid is insufficient, check that no leaks are found. Then, add the necessary amount of specified fluid.

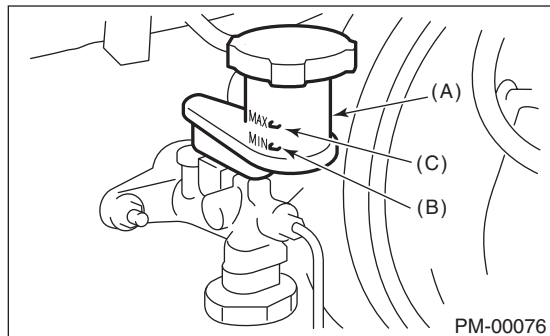

- (A) Reservoir tank
- (B) MIN. level
- (C) MAX. level

#### CAUTION:

**If any clutch fluid is spilled on the exhaust pipe, wipe off completely to prevent fires or emission of smoke.**

### 17. WINDOW WASHER FLUID

Check the window washer fluid amount. If the amount is insufficient, check that no leaks are found. Then, add the necessary amount of washer fluid.

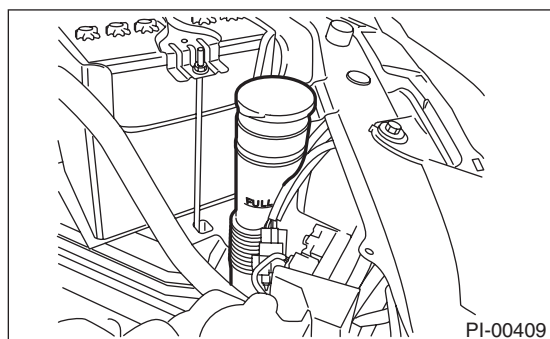

### 18. FRONT HOOD LATCH

Close the front hood. Check that the front hood is completely latched.

### 19. KEYLESS ENTRY SYSTEM

Check the keyless entry system operations as follows:

- Fully open all the door windows.
- Remove the key from the ignition switch and close all the doors including rear gate.
- Press the "LOCK/ARM" button momentarily on the keyless transmitter. Check that all the doors become locked, the buzzer sounds once, and the hazard lights flash once.

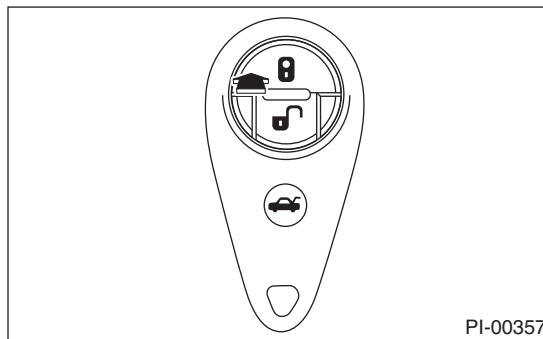

- Press the "UNLOCK/DISARM" button momentarily on the keyless transmitter. Check that the driver's door is unlocked, the buzzer sounds twice, and the hazard lights flash twice.

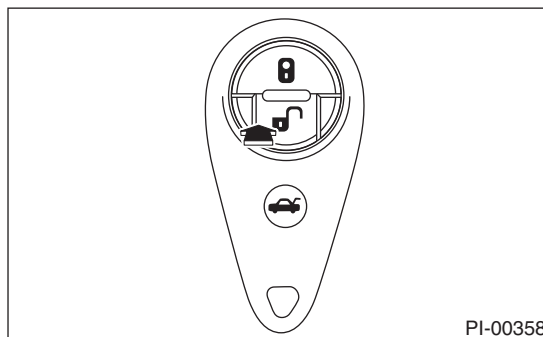

- Within 5 seconds, press the "UNLOCK/DISARM" button momentarily on the keyless transmitter. Check that all doors (including rear gate) are unlocked.
- Lock all the doors including rear gate. Press the rear gate unlock button to unlock the rear gate. Check that the buzzer sounds twice, and the hazard lights flash twice. Press the release button and check that the rear gate opens. (Wagon model)

- Check that the buzzer sounds twice, and the hazard lights flash twice, when the trunk lid unlock button is held down to unlock the trunk lid. (Sedan model)

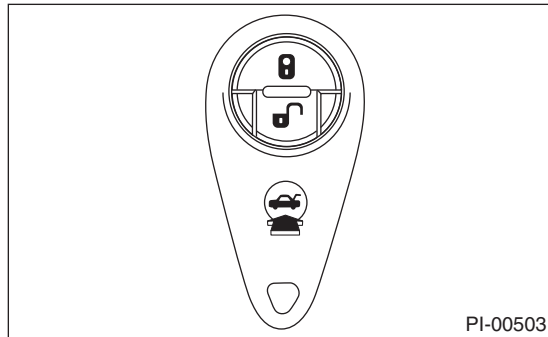

- Press the “PANIC” button of the keyless transmitter. Check that the panic mode (the horn keeps sounding) is initiated. Also, check that this condition continues for 30 seconds or until when any of the buttons on the keyless transmitter are pressed.

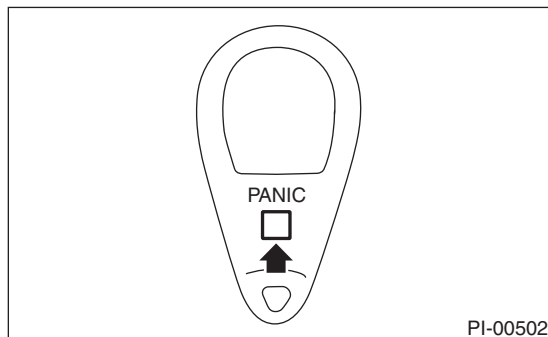

- Press the “LOCK/ARM” button momentarily on the keyless transmitter with one of the doors (including the rear gate) opened. Check that the buzzer sounds 5 times, and the hazard light flashes 5 times to notify the door not being fully closed. Next, close all the doors including rear gate. Check if all doors are locked and buzzer sounds once and the hazard light flashes once.
- With one of the doors open (including the rear gate), press the “LOCK” side of the power door lock switch. Next, close all the doors including rear gate. Check if all doors are locked and buzzer sounds once and the hazard light flashes once.

- Driver’s side

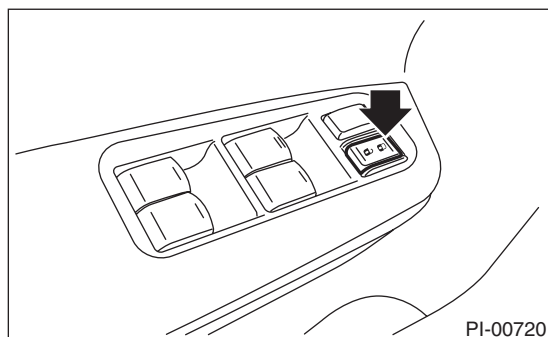

- Passenger’s side

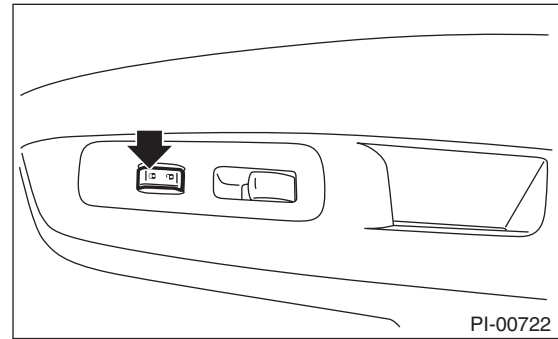

### Alarm sound operational check

- The system uses the buzzer and sounds the alarm when the door is locked or unlocked. The alarm sound can be turned OFF. To turn the alarm sound from ON to OFF, close all doors, (with the key not inserted in the key cylinder), hold down the “UNLOCK” side of the power door lock switch and insert the key in the key cylinder. Within 10 seconds, insert and take out the key for 5 times or more, and within 10 seconds after that, open and close the driver’s door. With the door closed, the hazard light will flash 3 times, indicating that the alarm sound has been turned OFF. To turn the alarm sound from OFF to ON, perform this procedure again. The hazard light will flash 3 times, indicating that the alarm has been turned ON.

## 20.SECURITY SYSTEM

Check that the security system operates as indicated below.

- 1) Fully open all the door windows.
- 2) Remove the key from the ignition switch and close all the doors including rear gate.
- 3) Press the “LOCK/ARM” button on the keyless transmitter once.

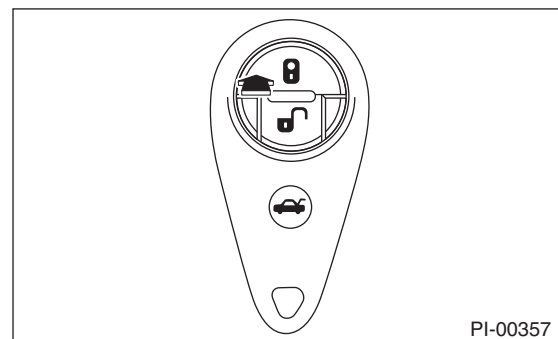



# Pre-delivery Inspection

## PRE-DELIVERY INSPECTION

4) If all doors lock, buzzer sounds once, the hazard light flashes once, and the security display light flashes as indicated below, the alarm system is in the monitoring condition.



- Alarm system monitoring prepared condition

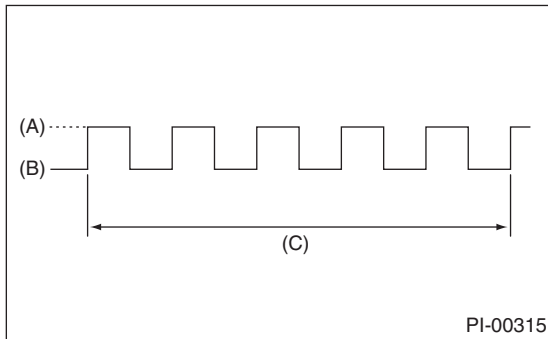

- (A) Light ON
- (B) Light OFF
- (C) 2 seconds

5) Check that the system enters monitoring condition 30 seconds after the condition in 4).

- Alarm system monitoring condition (all models)

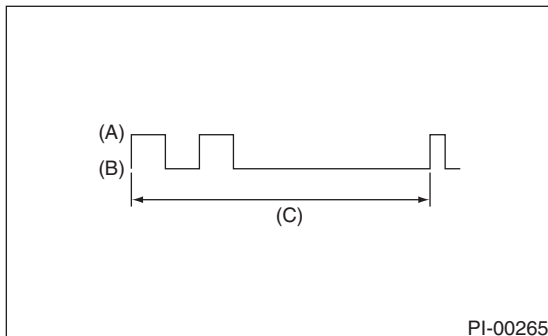

- (A) Light ON
- (B) Light OFF
- (C) 2 seconds

6) Press the "UNLOCK/DISARM" button on the keyless transmitter once.

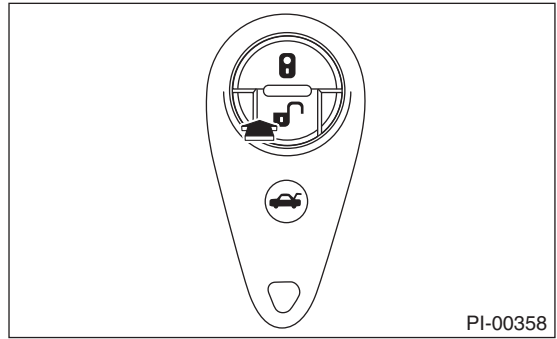

7) The alarm system is in the non-monitoring condition if the driver's door is unlocked, the buzzer sounds twice, the hazard light flashes twice, the room light turns on, and the security display light flashes according to the following figure.



- Alarm system non-monitoring condition

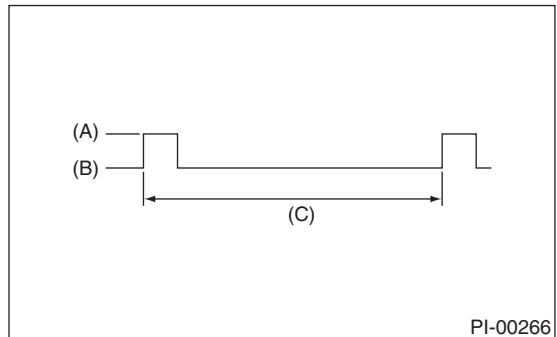

- (A) Light ON
- (B) Light OFF
- (C) 3 seconds



8) Press the “LOCK/ARM” button once on the keyless transmitter with one of the doors (including the rear gate) opened.

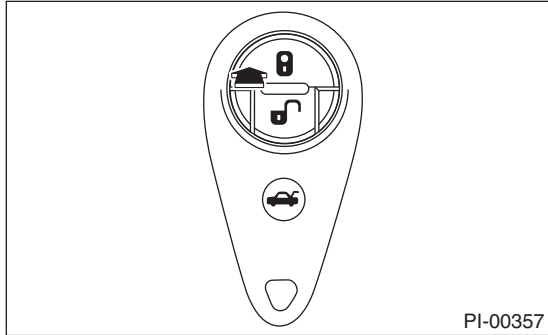

13) Press the “UNLOCK/DISARM” button on the keyless transmitter once and turn into non-monitoring condition.

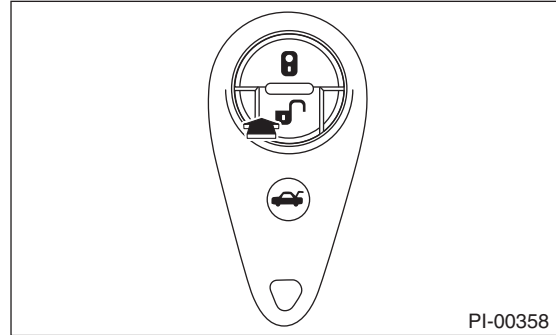

9) Check that the buzzer sounds 5 times to give the door not fully closed warning.

10) Close all the doors including rear gate.

11) Check that the system is in the monitoring condition (all the doors become locked and the buzzer sounds once, and the hazard light flashes once).

- Alarm system monitoring prepared condition

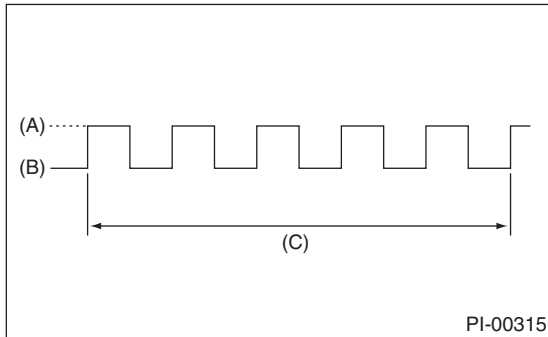

- (A) Light ON
- (B) Light OFF
- (C) 2 seconds

12) Check that the system enters monitoring condition 30 seconds after the condition in 11).

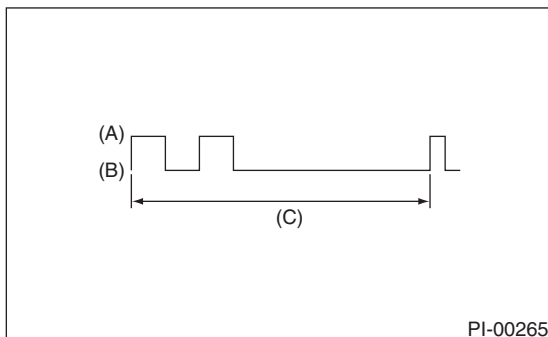

- (A) Light ON
- (B) Light OFF
- (C) 2 seconds

14) With one of all the doors open (including the rear gate), press the “LOCK” side of the power door lock switch.

- Driver’s side

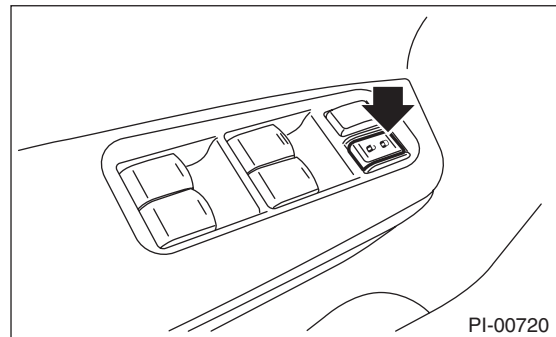

- Passenger’s side

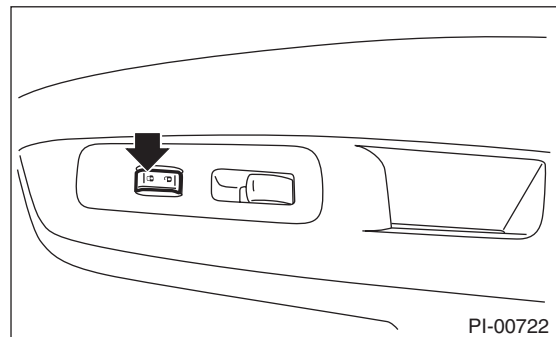

15) Close all the doors including rear gate.

# Pre-delivery Inspection

## PRE-DELIVERY INSPECTION

16) If all doors become locked, the buzzer sounds once, and the hazard light flashes once, the alarm system is in the monitoring prepared condition.

- Alarm system monitoring prepared condition

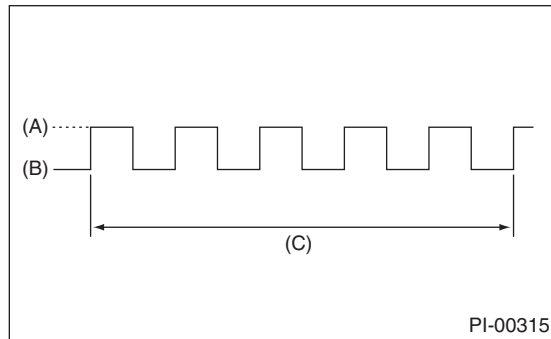

- (A) Light ON
- (B) Light OFF
- (C) 2 seconds

17) Check that the system enters monitoring condition 30 seconds after the condition in 16).

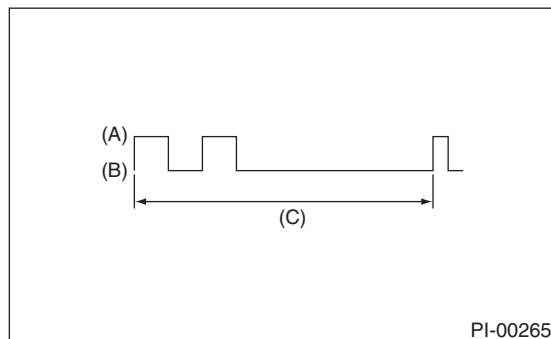

- (A) Light ON
- (B) Light OFF
- (C) 2 seconds

18) When the alarm system is in the monitoring condition, use the inner lock knob or the key to unlock the door, and open the door.

19) Check that the alarm condition occurs (horn sounds continuously, hazard light flashes, security indicator illuminates).

20) Check that the condition in 19) continues for 30 seconds or more, or until the "UNLOCK/DISARM" button of the keyless transmitter is pressed, or until the ignition switch is turned ON with the correct ignition key.

21) On models equipped with an impact sensor, hit the windshield glass with your hand with the alarm system in the monitoring condition, to check that the alarm condition occurs.

22) When none of above is applicable, perform troubleshooting for the security system. <Ref. to SL-26, INSPECTION, Security System.>

## 21. SEAT

1) Check that each seat provides full functionality in sliding and reclining. Check all available functions of the rear seat such as a trunk-through center armrest.

2) Check the passenger's seat occupant detection system.

(1) Empty the passenger's seat and turn the ignition switch to ON.

(2) Check that the passenger airbag ON/OFF indicator lights both turn on simultaneously for approximately six seconds, and after turning off for two seconds, only the OFF light illuminates.

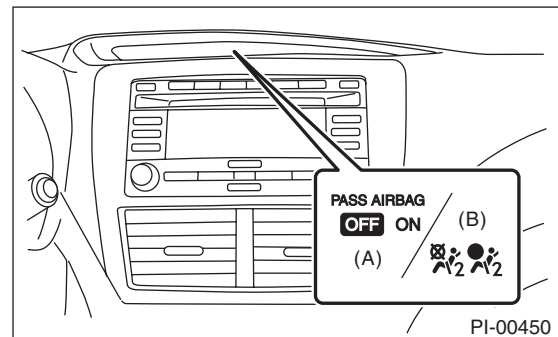

- (A) Airbag ON/OFF indicator light (U.S. model)
- (B) Airbag ON/OFF indicator light (Canada, Mexico model)

3) With a person weighing approximately 70 kg (155 lb) or more sitting in the passenger's seat, check whether the ON light of the passenger's airbag ON/OFF indicator illuminates or not.

4) Have the passenger get out of the passenger's seat, and check whether the OFF light of the passenger side airbag ON/OFF indicator illuminates.

## 22. SEAT BELT

1) Pull out the seat belt and then release it. Check that the belt retracts smoothly.

2) Check seat warning system

(1) Turn the ignition switch to ON without driver's and passenger's seat belts on.

(2) Check the seat belt warning lights of the driver's and the passenger's blink for approximately six seconds and the buzzer sounds intermittently.

(3) Then check that the seat belt warning lights illuminate and blink in a cycle of approximately 15 seconds. (If no one is seated on the passenger's seat, the seat belt warning light of the passenger's will not operate.)

### 23. TPMS (U.S. MODELS ONLY)

1) Turn the ignition switch to ON, and check that the TPMS warning light is in a normal operation condition.

- Normal operation (IGN ON (Light check))

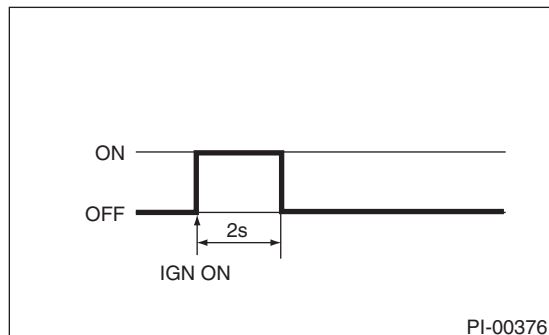

2) If the TPMS warning light display does not operate normally, check and repair the system. <Ref. to TPM(diag)-2, Basic Diagnostic Procedure.>

### 24. ECM PROTECTOR

For Canada model, check the ECM protector installation conditions. Make sure that the special nut and the plastic cover of ECM protector are securely installed.

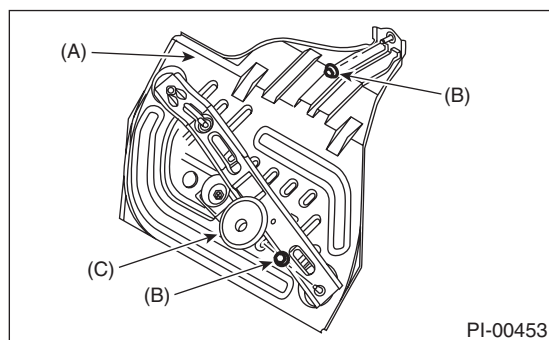

- (A) ECM protector
- (B) Special nut
- (C) Plastic cover

### 25. DELIVERY (TEST) MODE CONNECTOR

- 1) Turn the ignition switch to ON and check that the malfunction indicator light starts blinking.
- 2) If the light blinks, return the ignition key to LOCK.
- 3) Disconnect the delivery (test) mode connector under the passenger's seat.
- 4) Then, turn the ignition key to ON again.
- 5) If the malfunction indicator light blinks even though the delivery (test) mode connector is disconnected, carry out an engine diagnosis.

6) Put the disconnected delivery (test) mode connector behind the ECM protector.

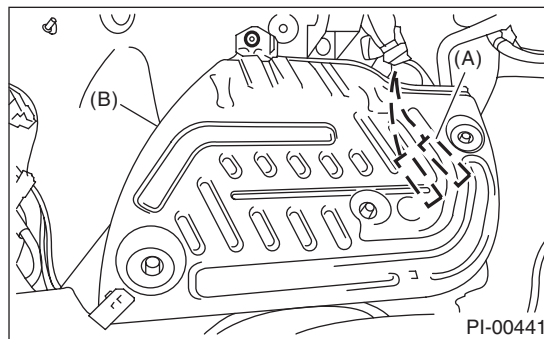

- (A) Delivery (test) mode connector
- (B) ECM protector

### 26. IMMOBILIZER SYSTEM

- 1) Check that the engine starts with all keys that are equipped on vehicle.
- 2) 60 seconds after turning ignition switch from ON to ACC or OFF, or immediately after removing the key, check that the security indicator light is blinking.

#### NOTE:

If malfunctions occur, refer to "IMMOBILIZER (DIAGNOSIS)". <Ref. to IM(diag)-2, Basic Diagnostic Procedure.>

### 27. STARTING CONDITION

Start the engine and check that the engine starts smoothly. If the battery voltage is low, recharge or replace the battery. If any noises are observed, immediately stop the engine and check and repair the abnormal components.

### 28. EXHAUST SYSTEM

Listen to the exhaust noise to see if no noises are observed.

Check that no leaks are found.

### 29. INDICATOR AND WARNING LIGHTS

Check that all indicator lights and warning lights are operating correctly.

### 30. HEATER & VENTILATION

Operate the heater & ventilation system to check for normal airflow outlet control, air inlet control, airflow capacity and heating performance.

# Pre-delivery Inspection

## PRE-DELIVERY INSPECTION

### 31. AIR CONDITIONER

Operate the air conditioner. Check that the A/C compressor operates normally and enough cooling is provided.

#### NOTE:

To prevent the insufficient lubrication of the air conditioner, operate the air conditioner for five minutes at idling.

### 32. CLOCK

Check the clock for normal operations and enough accuracy.

### 33. AUDIO

- 1) Check if the AM/FM radio broadcasting can be heard.
- 2) Check that all the radio functions work properly and the noise level is normal.
- 3) Check the CD and AUX for normal operation.
- 4) Check that the AUX is installed into the console without looseness.

### 34. NAVIGATION SYSTEM

- 1) Check all display functions for normal operation. (Refer to the operation manual.)
- 2) Check that the navigation system operates normally.
- 3) Check the radio, CD (DVD) player and AUX for normal operation.
- 4) Check that the AUX is installed into the console without looseness.

### 35. FRONT ACCESSORY POWER SUPPLY SOCKET

Check the operation of the front accessory power supply socket.

### 36. LIGHTING SYSTEM

- 1) Check the headlight operations. When pulling out the key, check if the headlight illuminates by turning the headlight switch from OFF to ON.
- 2) Check the stop light operation.
- 3) Check other lights for normal operations.
- 4) Check that the manual leveler operates normally.

### 37. WINDOW WASHER

Check that the window washer system injects washer fluid to the specified area of the windshield shown in the figure.

#### Front spray position:

**A: 250 mm (9.8 in)**

**B: 315 mm (12.4 in)**

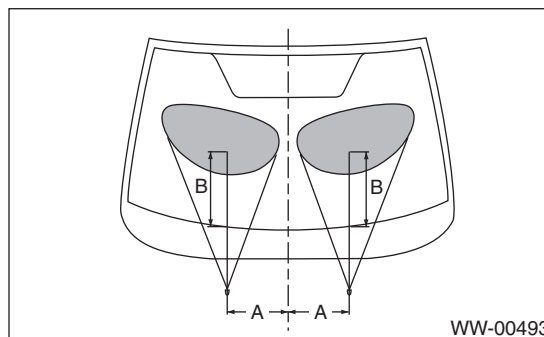

#### Rear spray position:

**A: 140 mm (5.5 in)**

**B: 70°**

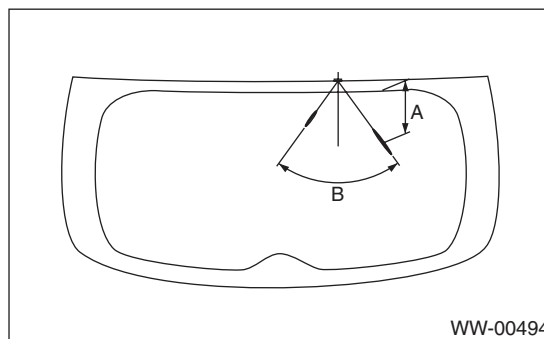

### 38. WIPER

Check the front and rear wipers for normal operations.

### 39. POWER WINDOW

Operate the power window switches one by one to check that each of the power windows goes up and down without noises.

### 40. SUNROOF

Check that the sunroof operates normally.

### 41. REAR DEFOGGER SYSTEM

Check that the rear defogger system operates normally.

### 42. PARKING BRAKE

Check the parking brake for normal operations. When pulling the parking brake lever with a force of 200 N (20 kgf, 45 lb), check that the lever stroke of parking brake lever is 7 to 8 notches.

### 43. BRAKE TEST

Check the foot brake for normal operations.

**44.SHIFT CONTROL**

- 1) Check for smooth operation to each position.
- 2) Check that the lever cannot be moved to the reverse position unless the slider is pulled up. (6MT model)
- 3) Check that the lever can be moved to the reverse position when the slider is pulled up. (6MT model)

**45.CRUISE CONTROL**

Operate the cruise control system. Check that the system is activated and deactivated correctly.

**46.POWER STEERING FLUID LEVEL**

Check that the power steering fluid level is normal. If insufficient, check for leaks. Then add the necessary amount of the specified power steering fluid.

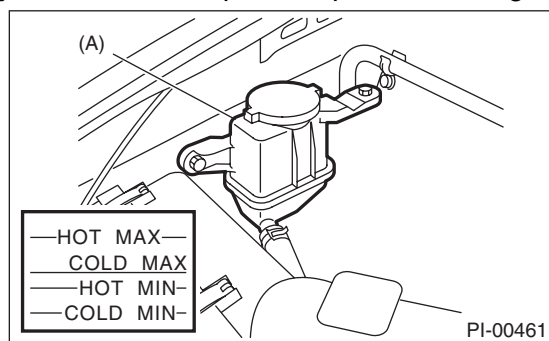

(A) Reservoir tank

**CAUTION:**

**If the power steering fluid is spilt over exhaust pipe, wipe it off with cloth to avoid emitting smoke or causing a fire.**

**47.FLUID LEAKAGE**

Check entire areas of the vehicle for any trace of coolant/oil (such as engine and gear oil)/fluid (such as brake) leaks.

**48.WATER LEAKAGE**

Spray the vehicle with water using a hose and check that no water enters the passenger compartment.

- Before performing the water leakage test, remove anything that may obstruct the operation or which must be kept dry.
- Close all the windows and doors securely. Close the front hood, trunk lid and rear gate before starting the test.
- Connect a hose to a tap, and spray water on the vehicle. The rate of water spray must be approx. 20 — 25 ℓ (5.3 — 6.6 US gal, 4.4 — 5.5 Imp gal) per minute.

When spraying water on areas adjacent to the floor and wheel house, increase the pressure. When spraying water on areas other than the floor and wheel house, decrease the pressure. But the force of water must be made strong occasionally by pressing the end of the hose.

**NOTE:**

Be sure to keep the hose at least 10 cm (3.9 in) away from vehicle.

Check the following areas.

- Front window and body framework mating portion
- Door mating portions
- Glass mating portions
- Rear quarter window mating portions
- Rear window and body framework mating portion
- Around roof drips

If any dampness in the compartments is discovered after the water has been applied, carefully check all the areas that may have possibly contributed to the leak.

# Pre-delivery Inspection

## PRE-DELIVERY INSPECTION

---

### 49. APPEARANCE 2

1) If protective coating (lap guard) is applied, remove it.

#### NOTE:

- When removing the lap guard, using steam will make it easier to remove.
- Vehicle left for an extended period or at low temperatures, spray the vehicle with water heated 50 — 60°C (122 — 140°F) to raise the surface temperature before peeling off the wrap guard. Do not use the water heated to over 60°C (140°F).
- If the adhesive remains on the coated surface, soak a flannel rag, etc. with a small amount of coating wax or solvent such as oil benzene and IPA, put the soaked cloth on the remains lightly, and then wipe them off with a flannel rag etc.
- Keep solvent from touching the resin or rubber parts. Do not use coating wax or solvents while the component surface temperature is hot due to hot weather etc.
- If the coated surface is swollen out due to seams or moisture, expose the vehicle to the sunlight for a few hours or heat the seam and swollen portions using a dryer etc.
- Dispose of the peeled wrap guard as burnable industrial garbage.

2) Check the whole vehicle body for flaking paint, damage by transportation, corrosion, dirt, cracks or blisters.

#### NOTE:

- It is better to determine an inspection pattern in order to avoid missing an area, since the total inspection area is wide.
- Do not repair the body paint unless absolutely necessary. Also, if the vehicle is in need of repair to remove scratches or corroded paint, the repair area must be limited to the minimum. Re-painting and spray painting must be avoided as much as possible.

3) Check each window glass for scratches carefully. Slight damage may be removed by polishing with cerium oxide. (Fill a cup half with cerium oxide, and add warm water to it. Then agitate the content until it turns to wax. Apply this wax to a soft cloth, and polish the glass with it.)

4) Check each portion of the vehicle body and underside components for the formation of rust. If rust is discovered, remove it with sandpaper of #80 to #180 and treat the surface with rust preventive. After this treatment is completed, flush the portion thoroughly, and prepare the surface for repair painting.

5) Check each portion of body and all of the exterior parts for deformation or distortion. Also, check each light lens for cracks.

6) Peel the identification seal attached to the rear combination light and front fog light.

# PERIODIC MAINTENANCE SERVICES

# PM

---

	<b>Page</b>
1. General Description .....	2
2. Schedule .....	3
3. Engine Oil .....	5
4. Engine Oil Filter .....	7
5. Spark Plug .....	8
6. V-belt .....	10
7. Timing Belt .....	12
8. Fuel Line .....	14
9. Fuel Filter .....	15
10. Air Cleaner Element .....	16
11. Cooling System .....	17
12. Engine Coolant .....	19
13. Clutch System .....	20
14. Transmission Gear Oil .....	21
15. Front & Rear Differential Gear Oil .....	23
16. Brake Line .....	26
17. Brake Fluid .....	28
18. Disc Brake Pad and Disc .....	29
19. Parking Brake .....	30
20. Suspension .....	31
21. Wheel Bearing .....	33
22. Axle Boots & Joints .....	34
23. Tire Rotation .....	35
24. Steering System (Power Steering) .....	36
25. A/C Filter .....	39

## General Description

PERIODIC MAINTENANCE SERVICES

---

### 1. General Description

#### A: GENERAL DESCRIPTION

Be sure to perform periodic maintenance in order to maintain vehicle performance and find problems before they occur.



# Schedule

## PERIODIC MAINTENANCE SERVICES

## 2. Schedule

### A: MAINTENANCE SCHEDULE 1

#### 1. U.S.

	Months	Maintenance interval [Number of months or km (miles), whichever occurs first]																	Remarks
		3	7.5	15	22.5	30	37.5	45	52.5	60	67.5	75	82.5	90	97.5	105	112.5	120	
		× 1,000 km	4.8	12	24	36	48	60	72	81.4	96	108	120	132	144	156	168	180	
	× 1,000 miles	3	7.5	15	22.5	30	37.5	45	52.5	60	67.5	75	82.5	90	97.5	105	112.5	120	
1	Engine oil		R	R	R	R	R	R	R	R	R	R	R	R	R	R	R	R	
2	Engine oil filter		R	R	R	R	R	R	R	R	R	R	R	R	R	R	R	R	
3	Spark plug									R								R	
4	Drive belt(s)					I				I				I		R			
5	Camshaft drive belt					I				I				I		R			
6	Fuel line					(I)				(I)				(I)				I	Note (1)
7	Fuel filter									R								R	
8	Air cleaner element					R				R				R				R	Note (2)
9	Cooling system					I				I				I				I	
10	Engine coolant																		Note (5)
11	Clutch system			I		I		I		I		I		I		I		I	
12	Transmission gear oil					I				I				I				I	
13	Front and rear differential oil					I				I				I				I	
14	Brake line			I		I		I		I		I		I		I		I	
15	Brake fluid					R				R				R				R	
16	Disc brake pad and disc			I		I		I		I		I		I		I		I	
17	Parking brake			I		I		I		I		I		I		I		I	
18	Suspension			I		I		I		I		I		I		I		I	
19	Wheel bearing									(I)								(I)	
20	Axle boots and joints			I		I		I		I		I		I		I		I	
21	Tire rotation		P	P	P	P	P	P	P	P	P	P	P	P	P	P	P	P	Note (3)
22	Steering system (power steering)			I		I		I		I		I		I		I		I	
23	A/C filter	Check every 12 months or every 12,000 km (7,500 miles).																	Note (4)

Symbols used:

R: Replace

I: Inspection

P: Perform

(I): Inspections recommended for vehicle safety

NOTE:

1. This inspection is not required to maintain emission warranty eligibility and it does not affect the manufacturer's obligations under EPA's in-use compliance program.

2. When the vehicle is used in extremely dusty conditions, the air cleaner element should be replaced more often.

3. A tire should be replaced when the tread wear indicator appears as a solid band across the tread. The indicators appear when the remaining tread has been worn to 1.6 mm (0.063 in) or less.

4. When the vehicle is used under extremely dusty conditions, the A/C filter should be replaced more often.

5. Replace the first time after 11 years or every 220,000 km (137,500 miles), and thereafter every six years or every 120,000 km (75,000 miles).

## Schedule

### PERIODIC MAINTENANCE SERVICES

### **B: MAINTENANCE SCHEDULE 2**

Item	Maintenance interval	Repeat short distance drive	Repeat rough/muddy road drive	Extremely cold weather area	Salt or other corrosive used or coastal area	High humidity or mountain area	Repeat towing trailer
Engine oil	3.75 months	R		R			R
	6,000 km						
	3,750 miles						
Engine oil filter	3.75 months	R		R			R
	6,000 km						
	3,750 miles						
Fuel line	7.5 months				I		
	12,000 km						
	7,500 miles						
Transmission gear oil	15 months						R
	24,000 km						
	15,000 miles						
Front and rear differential oil	15 months						R
	24,000 km						
	15,000 miles						
Brake line	7.5 months				I		
	12,000 km						
	7,500 miles						
Brake fluid	15 months					R	
	24,000 km						
	15,000 miles						
Disc brake pad and disc	7.5 months	I	I		I		I
	12,000 km						
	7,500 miles						
Parking brake	7.5 months	I	I		I		I
	12,000 km						
	7,500 miles						
Suspension	7.5 months		I	I	I		I
	12,000 km						
	7,500 miles						
Axle boots and joints	7.5 months	I	I	I	I		I
	12,000 km						
	7,500 miles						
Steering system (power steering)	7.5 months	I	I	I	I		
	12,000 km						
	7,500 miles						

## 3. Engine Oil

### A: REPLACEMENT

- 1) Set the vehicle on a lift.
- 2) Open the engine oil filter cap for quick draining of engine oil.

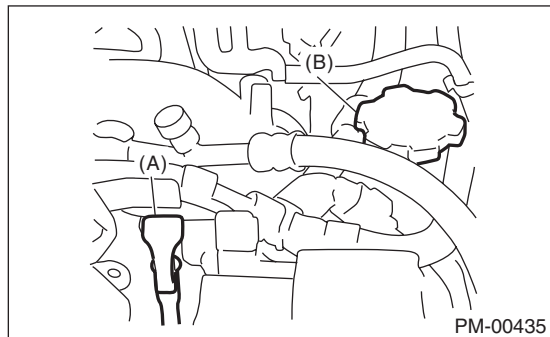

- (A) Oil level gauge  
(B) Oil filler cap

#### CAUTION:

If any engine oil is spilled on the exhaust pipe, under cover, wipe off completely to prevent fires or emission of smoke.

- 3) Lift up the vehicle.
- 4) Drain engine oil by loosening the engine oil drain plug.

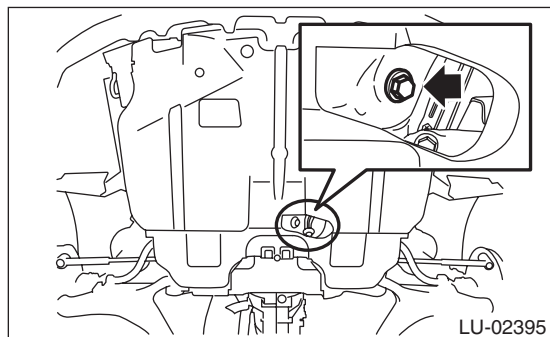

#### NOTE:

Prepare the container for draining of engine oil.

- 5) Replace the drain plug gasket.

#### NOTE:

Use a new drain plug gasket.

- 6) Tighten the engine oil drain plug after draining engine oil.

#### Tightening torque:

**44 N·m (4.5 kgf·m, 32.5 ft·lb)**

- 7) Using engine oil of proper quality and viscosity, fill engine oil through the oil filler duct to the "F" line on oil level gauge. Place the vehicle on a level surface when checking oil level.

#### Recommended oil:

Refer to "RM" section for the engine oil viscosity. <Ref. to RM-2, LUBRICANT, RECOMMENDED MATERIALS, Recommended Materials.>

#### Engine oil capacity

Refer to "SPC" section for the engine oil capacity. <Ref. to SPC-4, CAPACITY, Impreza.>

#### NOTE:

- The proper viscosity helps vehicle get good cold and hot starting by reducing viscous friction and thus increasing cranking speed.
  - When replenishing oil, it does not matter if the oil to be added is a different brand from that in the engine; however, use oil having the API standard and SAE viscosity No. designated by SUBARU.
  - If vehicle is used in desert areas with very high temperatures or for other heavy duty applications, the following viscosity oils may be used:  
API standard: SN, SM, or SL  
ILSAC standard: GF-4 or GF-5  
SAE viscosity No.: 30, 40, 20W-40, 20W-50
- 8) Close the engine oil filler cap.
  - 9) Start the engine and warm it up for a time.
  - 10) Stop the engine to inspect the oil level again. <Ref. to PM-6, INSPECTION, Engine Oil.>

# Engine Oil

## PERIODIC MAINTENANCE SERVICES

### B: INSPECTION

#### CAUTION:

If any engine oil is spilled on the exhaust pipe, under cover, wipe off completely to prevent fires or emission of smoke.

- 1) Park the vehicle on a level surface.
- 2) Remove the oil level gauge and wipe it clean.
- 3) Reinsert the oil level gauge all the way. Be sure that the oil level gauge is correctly inserted and properly orientated.
- 4) Remove the level gauge again and record the oil level. If the engine oil level is below the "L" line, add oil to bring the level up to but not over the "F" line.
- 5) Start the engine and warm it up for a time.
- 6) After turning off the engine, wait a few minutes for the oil to return to the oil pan before checking the level.

#### NOTE:

- Just after driving or while the engine is warm, engine oil level shows in the range between the "F" line and the notch mark. This is caused by thermal expansion of engine oil.
  - As the oil level gauge is used for daily maintenance, the "F" and "L" lines are set assuming that the engine is cold.
- 7) To prevent overfilling the engine oil, do not add oil above the "F" line when the engine is cold.

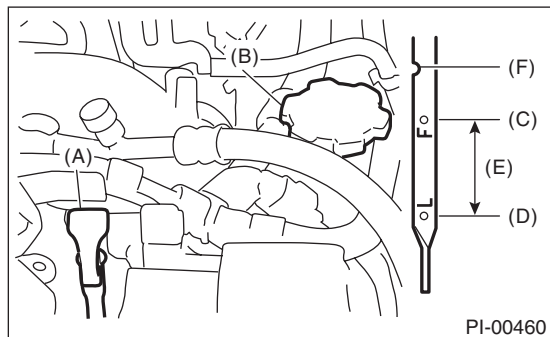

- (A) Oil level gauge
- (B) Oil filler cap
- (C) "F" line
- (D) "L" line
- (E) Approx. 1 ℓ (1.1 US qt, 0.9 Imp qt)
- (F) Notch mark

## 4. Engine Oil Filter

### A: REPLACEMENT

- 1) Lift up the vehicle.
- 2) Remove the under cover.
- 3) Remove the oil filter using ST.

- Oil filter (Black)

ST 18332AA000 OIL FILTER WRENCH  
(OUTER DIAMETER: 68 MM  
(2.68 IN) FOR OIL FILTER)

- Oil filter (Blue)

General tool Oil filter wrench  
(65/67 mm 14 Flutes)

#### CAUTION:

**If any engine oil is spilled on the exhaust pipe, under cover, wipe off completely to prevent fires or emission of smoke.**

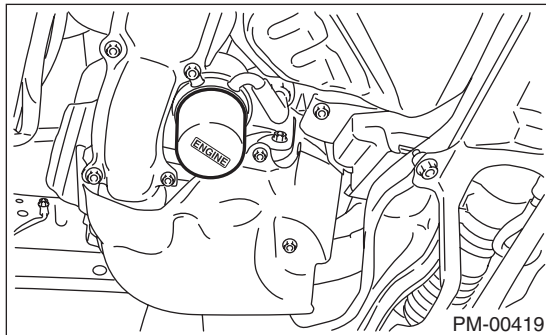

- 4) Clean the oil filter installation surface of the oil cooler.
- 5) Obtain a new engine oil filter and apply a thin coat of engine oil to the seal rubber.
- 6) Install the oil filter by turning it by hand, being careful not to damage seal rubber.
  - Tighten the oil filter (Black) 68 mm (2.68 in) in diameter (approx. one rotation) after the seal rubber of the oil filter comes in contact with the oil cooler. When using a torque wrench, tighten to 14 N·m (1.4 kgf-m, 10.3 ft-lb).
  - Tighten the oil filter (Blue) with an outer diameter of 67.4 mm (2.65 in) (approx. 7/8 rotation) after the seal rubber of the oil filter comes in contact with cylinder block. When using a torque wrench, tighten to 12 N·m (1.2 kgf-m, 8.9 ft-lb).

#### CAUTION:

**Do not tighten excessively. Excessive tightening may cause oil to leak.**

- 7) Run the engine and make sure that no oil is leaking around seal rubber.

#### NOTE:

The filter element and filter case are permanently jointed; therefore, interior cleaning is not necessary.

- 8) Check the engine oil level. <Ref. to PM-6, INSPECTION, Engine Oil.>

# Spark Plug

## PERIODIC MAINTENANCE SERVICES

### 5. Spark Plug

#### A: REPLACEMENT

##### 1. RH SIDE

- 1) Disconnect the ground cable from battery.

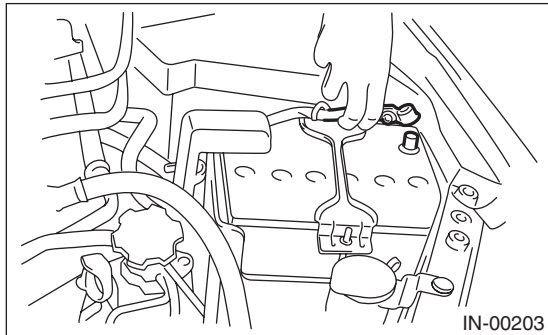

- 2) Remove the air cleaner case. <Ref. to IN(STI)-8, REMOVAL, Air Cleaner Case.>
- 3) Disconnect the connector from ignition coil.
- 4) Remove the ignition coil.

#### NOTE:

Turn #3 ignition coil by 180 degrees to remove it.

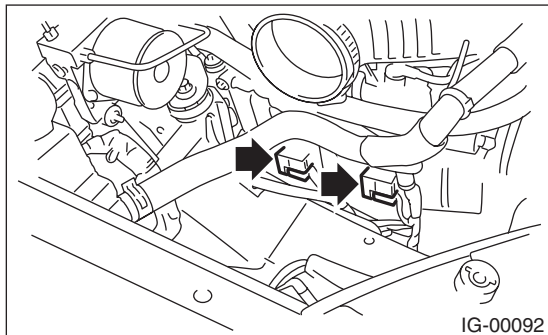

- 5) Remove the spark plug with a spark plug socket.
- 6) Install in the reverse order of removal.

**Tightening torque (Spark plug):**  
**21 N·m (2.1 kgf-m, 15.5 ft-lb)**

**Tightening torque (Ignition coil):**  
**16 N·m (1.6 kgf-m, 11.8 ft-lb)**

##### 2. LH SIDE

- 1) Remove the battery. <Ref. to SC(STI)-27, REMOVAL, Battery.>
  - 2) Remove the secondary air pump. <Ref. to EC(STI)-27, REMOVAL, Secondary Air Pump.> <Ref. to EC(w/o STI)-29, REMOVAL, Secondary Air Pump.>
  - 3) Remove the bolts that secure the air duct to the rocker cover (LH), and lift the air duct.
- STI model

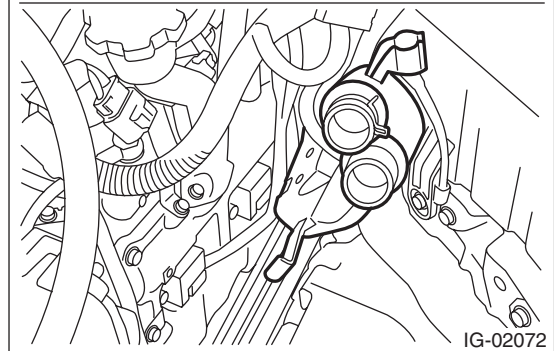
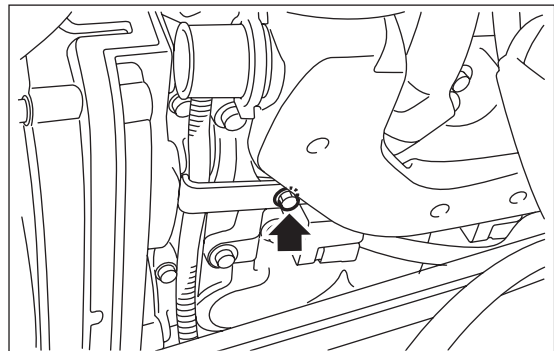

- Except for STI model

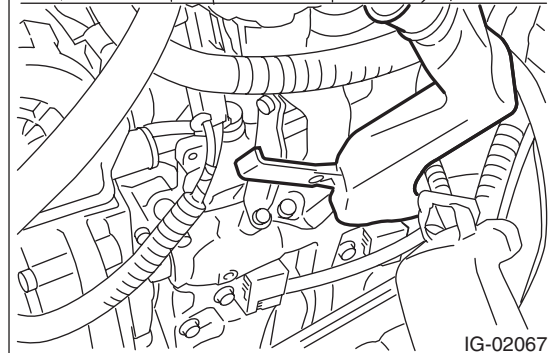
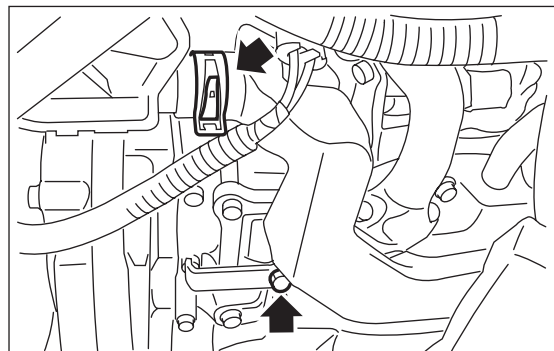

- 4) Disconnect the connector from ignition coil.
- 5) Remove the ignition coil.

**NOTE:**

Turn #4 ignition coil by 180 degrees to remove it.

- STI model

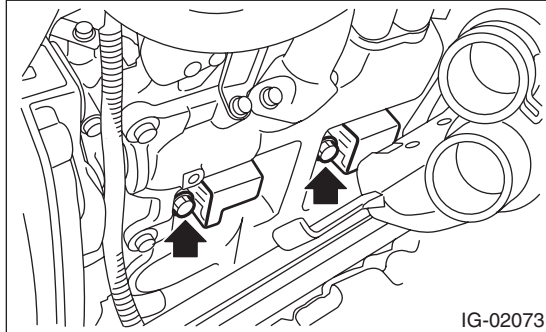

- Except for STI model

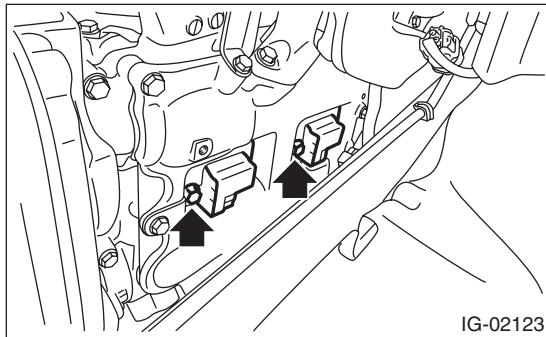

- 6) Remove the spark plug with a spark plug socket.
- 7) Install in the reverse order of removal.

**Tightening torque (Spark plug):**  
**21 N·m (2.1 kgf-m, 15.5 ft-lb)**

**Tightening torque (Ignition coil):**  
**16 N·m (1.6 kgf-m, 11.8 ft-lb)**

**Tightening torque (Air duct):**  
**6.4 N·m (0.7 kgf-m, 4.7 ft-lb)**

## 6. V-belt

### A: INSPECTION

**CAUTION:**

Check and adjust the front side belt tension so that it is within the specified range. Using the belt with a tension out of the specified range may result in a fault such as the following:

- If the front side belt tension is higher, unexpected force is generated at the power steering oil pump, generator and crankshaft bearing, causing abnormal noise due to abnormal wear of the bearing.
- If the front side belt tension is lower, the front side belt and crank pulley slip, causing abnormally high temperature on the crank pulley due to frictional heat. If this condition repeatedly occurs, the front side belt may abnormally wear, causing abnormal noise, front side belt damage or crank pulley damage.

**NOTE:**

Since the rear belt is a stretch type belt, it does not require tension check and adjustment.

### 1. PROCEDURE (WITHOUT BELT TENSION GAUGE)

- 1) Replace the belts if cracks, fraying or wear are found.
- 2) Check the V-belt tension and adjust it if necessary by changing the generator installing position or idler pulley installing position. <Ref. to PM-10, REPLACEMENT, V-belt.>

**When pressing with belt tension 98 N (10 kgf, 22 lbf)**

**When replacing: 7 — 9 mm (0.276 — 0.354 in)**

**When reusing: 9 — 11 mm (0.354 — 0.433 in)**

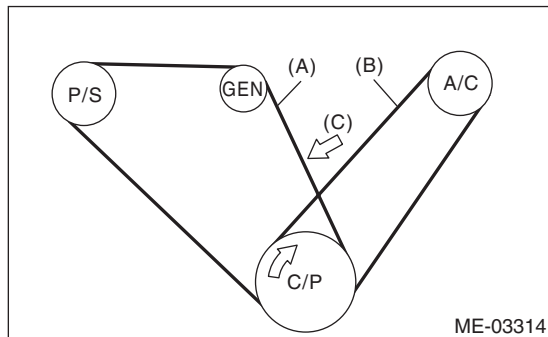

- (A) Front side belt
- (B) Rear side belt
- (C) 98 N (10 kgf, 22 lbf)
- C/P Crank pulley
- GEN Generator pulley
- P/S Power steering oil pump pulley
- A/C A/C compressor pulley

### 2. PROCEDURE (WITH BELT TENSION GAUGE)

- 1) Replace the belts if cracks, fraying or wear are found.
- 2) Remove the V-belt covers and radiator reservoir tank.
- 3) Check the belt tension, using the belt tension gauge. Adjust the tension, if necessary by changing the generator installing position or idler pulley installing position.

**Belt tension**

**When installing new parts:**

**640 — 780 N (65 — 80 kgf, 144 — 175 lbf)**

**At inspection:**

**490 — 640 N (50 — 65 kgf, 110 — 144 lbf)**

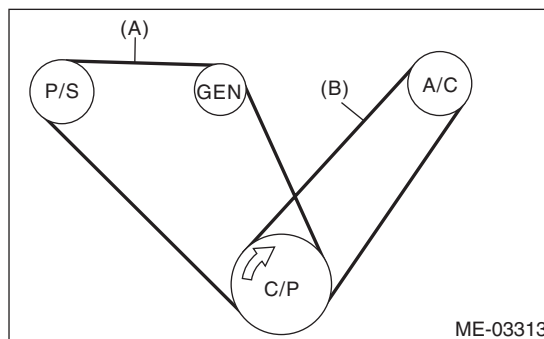

- (A) Front side belt
- (B) Rear side belt
- C/P Crank pulley
- GEN Generator pulley
- P/S Power steering oil pump pulley
- A/C A/C compressor pulley

### B: REPLACEMENT

#### 1. FRONT SIDE BELT (FOR POWER STEERING OIL PUMP AND GENERATOR)

**NOTE:**

Wipe off any oil or water on the belt and pulley.

- 1) Remove the V-belt covers.

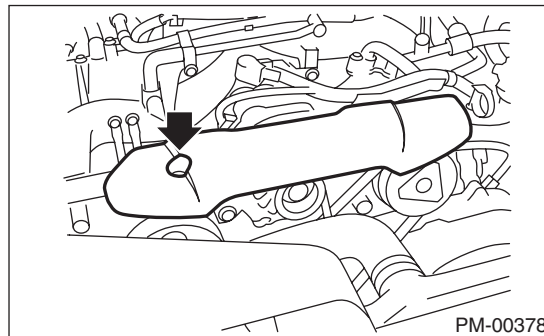

- 2) Loosen the lock bolt (A).
- 3) Loosen the slider bolt (B).
- 4) Remove the front side belt (C).



- 5) Install a new belt, and tighten the slider bolt so as to obtain the specified belt tension.
- 6) Tighten the lock bolt (A).
- 7) Tighten the slider bolt (B).

**Tightening torque:****Lock bolt**

**25 N·m (2.5 kgf-m, 18.4 ft-lb)**

**Slider bolt**

**8 N·m (0.8 kgf-m, 5.9 ft-lb)**

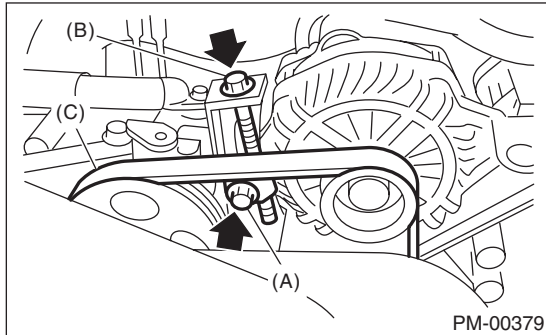

- 8) Start and run the engine for approximately five minutes to allow the V-belt to become fitted. (When using the gauge)
- 9) Stop the engine, check the belt tension and adjust as necessary. (When using the gauge)
- 10) Start and run the engine for approximately one minute to allow the V-belt to become fitted. (When using the gauge)
- 11) Stop the engine and check that the belt tension is within the specification. (When using the gauge)
- 12) Adjust until the specified belt tension is obtained. (When using the gauge)

**2. REAR SIDE BELT (FOR A/C)****CAUTION:****Always use new rear side belt.**

- 1) Remove the front side belts.
- 2) Cut the rear side belt.
- 3) Install a new belt using an installation jig. <Ref. to ME(STI)-41, REAR SIDE BELT, INSTALLATION, V-belt.> <Ref. to ME(w/o STI)-40, REAR SIDE BELT, INSTALLATION, V-belt.>
- 4) Install the front side belt. <Ref. to ME(STI)-40, INSTALLATION, V-belt.> <Ref. to ME(w/o STI)-39, INSTALLATION, V-belt.>

# Timing Belt

## PERIODIC MAINTENANCE SERVICES

### 7. Timing Belt

#### A: INSPECTION

##### 1. CHECK TIMING BELT POSITION

- 1) Remove the timing belt cover (LH) and (RH).
- 2) Turn the crank pulley and align single line mark (A) on the intake cam sprocket (RH) with notch (B) on timing belt cover and check the following.
  - (1) Make sure double lines (C) on intake and exhaust cam sprocket (RH side) are aligned.
  - (2) Make sure single line (D) on exhaust cam sprocket (RH side) is aligned to timing belt cover notch (E).

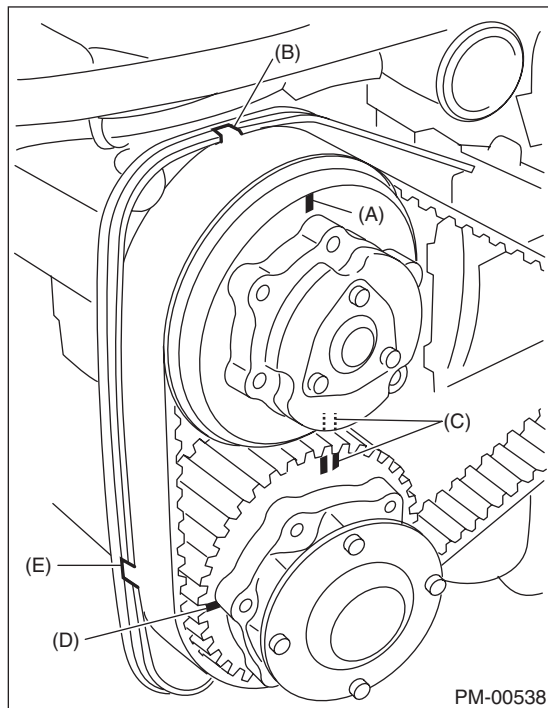

- (3) Make sure single line (A) on intake cam sprocket (LH side) is aligned to timing belt cover notch (B).
- (4) Make sure double lines (C) on intake and exhaust cam sprocket (LH side) are aligned.

- (5) Check that the single line mark (D) on the exhaust cam sprocket (LH side) and notch (E) on the timing belt cover are aligned.

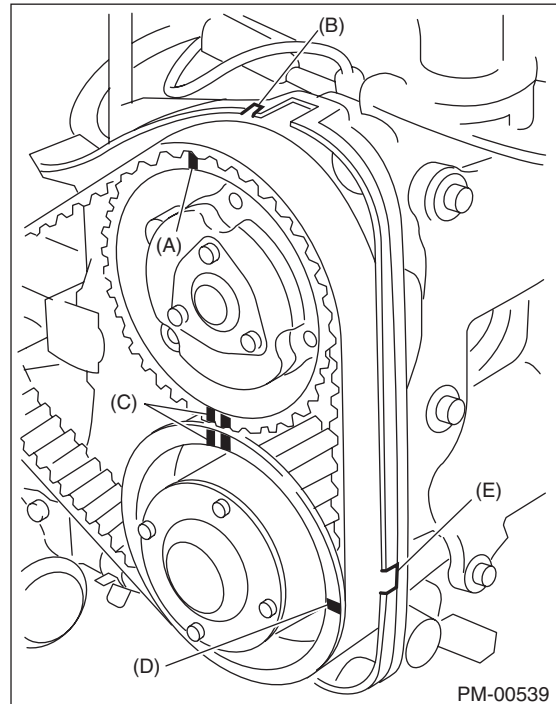

- 3) When cam sprocket position is offset, check for any defect, and repair or replace as required.

##### 2. OTHER INSPECTIONS

- 1) Remove the timing belt cover (LH).
- 2) While cranking engine at least four rotations, check the timing belt back surface for cracks or damage. Replace faulty timing belts with new parts as required.
- 3) When the side part of timing belt (arrow direction shown in the figure) is abnormally worn (fluff or jumping out of core) or damaged, check the idlers, tensioner, water pump pulley and cam sprocket to determine idler alignment (squareness). Replace the worn timing belt with new part.

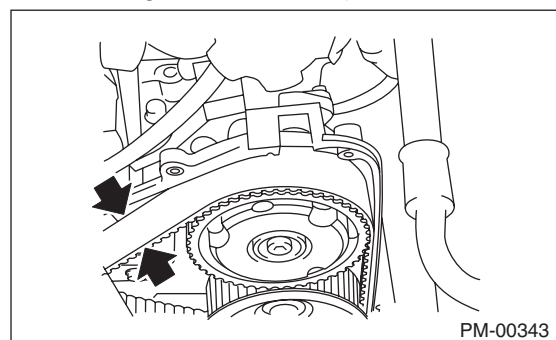

- 4) Install the timing belt cover (LH).

## B: REPLACEMENT

- 1) Remove the radiator fan and air conditioner fan. <Ref. to CO(STI)-23, Radiator Main Fan and Fan Motor.> <Ref. to CO(STI)-25, Radiator Sub Fan and Fan Motor.> <Ref. to CO(w/o STI)-23, Radiator Main Fan and Fan Motor.> <Ref. to CO(w/o STI)-25, Radiator Sub Fan and Fan Motor.>
- 2) Protect the radiator with cardboard and blanket.
- 3) Remove the V-belt covers.

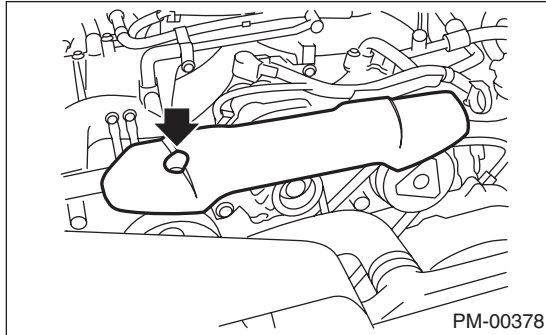

- 4) Remove the V-belts. <Ref. to ME(STI)-40, V-belt.> <Ref. to ME(w/o STI)-39, V-belt.>
- 5) Remove the crank pulley. <Ref. to ME(STI)-47, REMOVAL, Crank Pulley.> <Ref. to ME(w/o STI)-46, REMOVAL, Crank Pulley.>
- 6) Remove the timing belt cover. <Ref. to ME(STI)-49, REMOVAL, Timing Belt Cover.> <Ref. to ME(w/o STI)-48, REMOVAL, Timing Belt Cover.>
- 7) Using ST, turn the crankshaft and align the alignment marks on crankshaft and left and right cam sprockets with alignment marks of belt cover and oil pump.

ST 499987500 CRANKSHAFT SOCKET

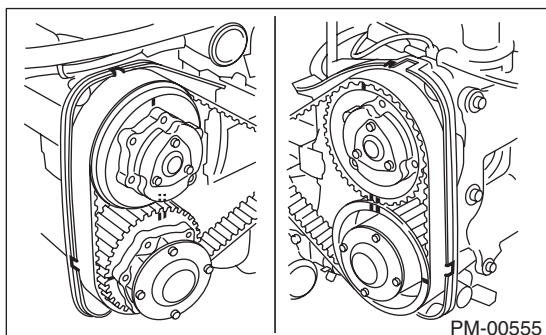
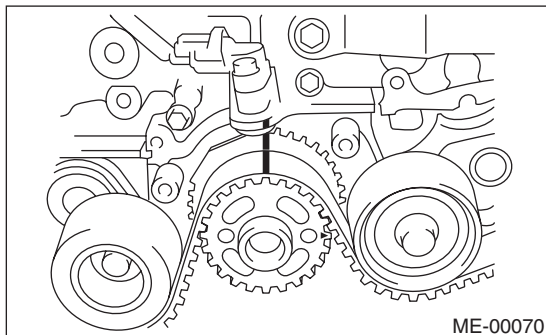

- 8) Remove the belt idler.

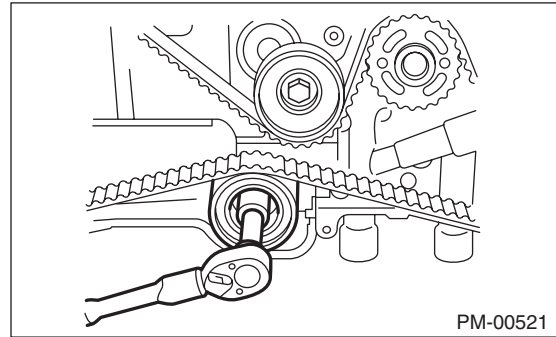

- 9) Remove the timing belt.
- 10) Remove the automatic belt tension adjuster assembly.

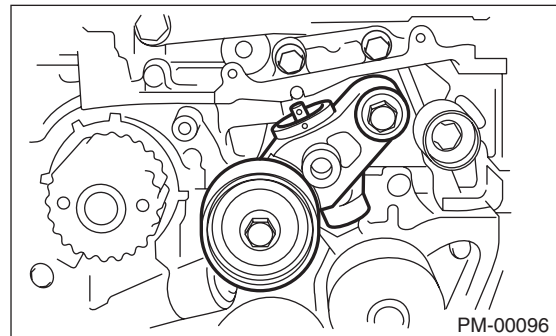

- 11) Install in the reverse order of removal. <Ref. to ME(STI)-52, INSTALLATION, Timing Belt.> <Ref. to ME(w/o STI)-51, INSTALLATION, Timing Belt.>

### CAUTION:

**When installing the timing belt, be sure to align all alignment marks on the belt with corresponding marks on the sprockets. If incorrectly installed, interference between pistons and valves may occur.**

### **8. Fuel Line**

#### **A: INSPECTION**

For fuel line, check pipes, areas near pipes, and engine compartment piping for rust, hose damage, loose band, etc. If faulty parts are found, repair or replace them. <Ref. to FU(STI)-93, Fuel Delivery, Return and Evaporation Lines.>

## 9. Fuel Filter

### A: REPLACEMENT

For fuel filter replacement procedure, refer to FU section. <Ref. to FU(STI)-85, Fuel Filter.>

# Air Cleaner Element

## PERIODIC MAINTENANCE SERVICES

### 10. Air Cleaner Element

#### A: REPLACEMENT

1) Disconnect the ground cable from battery.

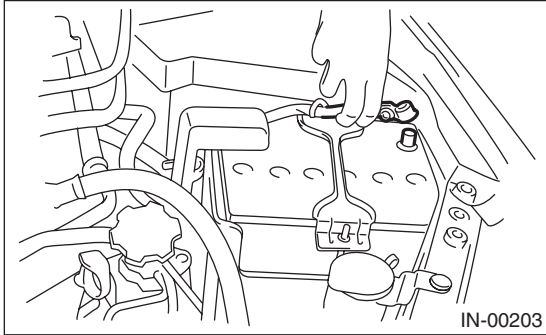

2) Remove the air intake duct. <Ref. to IN(STI)-10, REMOVAL, Air Intake Duct.>

3) Disconnect the connector (A) from mass air flow and intake air temperature sensor.

4) Remove the clip (B) from the air cleaner case.

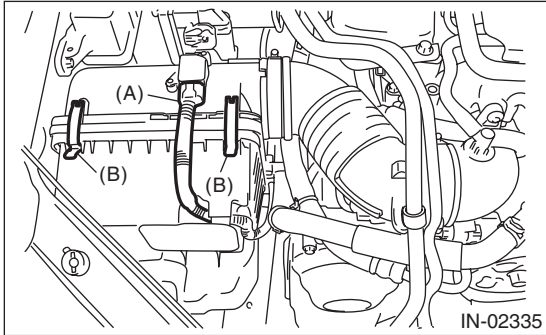

5) Open the air cleaner case, and remove the air cleaner element.

6) Install in the reverse order of removal.

#### CAUTION:

Be sure to use **SUBARU** genuine air cleaner element depending on the engine type when replacing the air cleaner elements. Using other air cleaner element may affect the engine performance.

#### NOTE:

- Check that there are no foreign objects in the air cleaner case.
- When installing the air cleaner case (rear), align the protrusion of the air cleaner case (rear) to the hole on the air cleaner case (front) to install.

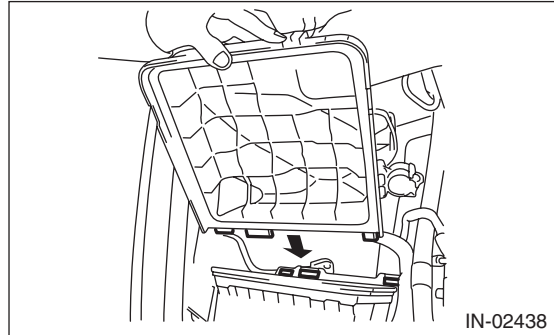

## 11. Cooling System

### A: INSPECTION

1) To check the radiator for leakage, fill it with engine coolant, and attach the radiator cap tester to the filler neck, and apply pressure. Check the following points:

**Pressure:**

**122 kPa (1.2 kgf/cm<sup>2</sup>, 18 psi)**

- Each portion of radiator for leakage
- Hose joints and other connections for leakage

**CAUTION:**

- If any engine coolant is spilled on the exhaust pipe or under cover, wipe off completely to prevent fires or emission of smoke.
- Be careful not to deform the filler neck of filler tank when installing and removing the tester, and while operating the tester.

**NOTE:**

- Be sure to install the tester to filler tank side.
- STI model

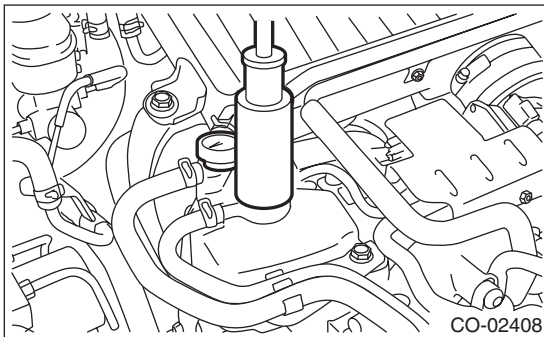

- Except for STI model

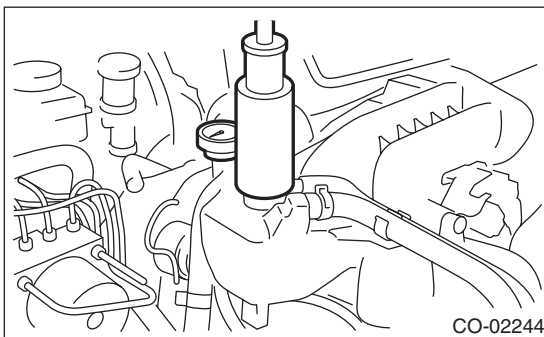

- When performing this check, be sure to keep the engine stationary and fill radiator with coolant.
- Wipe off check points before applying pressure.
- Use care not to spill coolant when detaching tester from filler tank.
- Do not remove the radiator side cap.

2) Check the radiator cap valve open pressure using radiator cap tester.

**NOTE:**

Rust or dirt on the cap may prevent valve from functioning normally. Be sure to clean the cap before testing.

Raise the pressure until the needle of gauge stops and see if the pressure can be retained for five to six seconds. The radiator cap is normal if a pressure above the limit value has been maintained for this period. Replace the radiator cap if the pressure is below the limit.

**Radiator cap valve open pressure**

**Filler tank side**

**Specification:**

**93 — 123 kPa (0.95 — 1.25 kgf/cm<sup>2</sup>, 14 — 18 psi)**

**Service limit:**

**83 kPa (0.85 kgf/cm<sup>2</sup>, 12 psi)**

**Radiator side**

**Specification:**

**122 — 152 kPa (1.24 — 1.55 kgf/cm<sup>2</sup>, 18 — 22 psi)**

**Service limit:**

**112 kPa (1.14 kgf/cm<sup>2</sup>, 16 psi)**

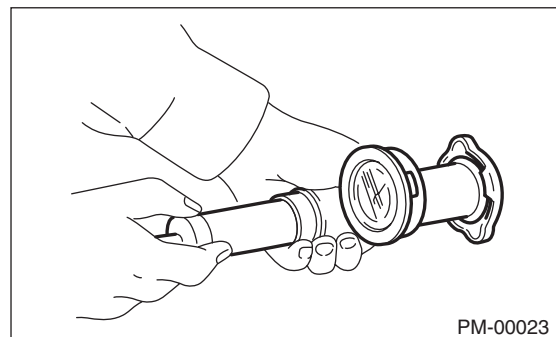

3) Start the engine, and then inspect that it does not overheat or it is not cooled excessively. If it overheats or it is cooled excessively, check the cooling system.

<Ref. to CO(STI)-15, Water Pump.> <Ref. to CO(STI)-17, Thermostat.> <Ref. to CO(STI)-19, Radiator.> <Ref. to CO(STI)-22, Radiator Cap.> <Ref. to CO(w/o STI)-15, Water Pump.> <Ref. to CO(w/o STI)-17, Thermostat.> <Ref. to CO(w/o STI)-19, Radiator.>

# Cooling System

## PERIODIC MAINTENANCE SERVICES

---

4) Check the radiator fan operates using Subaru Select Monitor, when the coolant temperature exceeds the specified value. If it does not operate, check the radiator fan system. <Ref. to CO(STI)-7, Radiator Fan System.> <Ref. to CO(w/o STI)-7, Radiator Fan System.>

### **Engine coolant temperature:**

#### ***Except for STI model***

***<Ref. to CO(w/o STI)-8, INSPECTION, Radiator Fan System.>***

#### ***STI model***

***<Ref. to CO(STI)-8, INSPECTION, Radiator Fan System.>***



## 12.Engine Coolant

### A: REPLACEMENT

#### WARNING:

**The radiator is of the pressurized type. Do not attempt to open the radiator cap immediately after the engine has been stopped.**

- 1) Lift up the vehicle.
- 2) Remove the under cover.
- 3) Place a container under drain pipe.
- 4) Loosen and remove the drain cock to drain engine coolant into container.

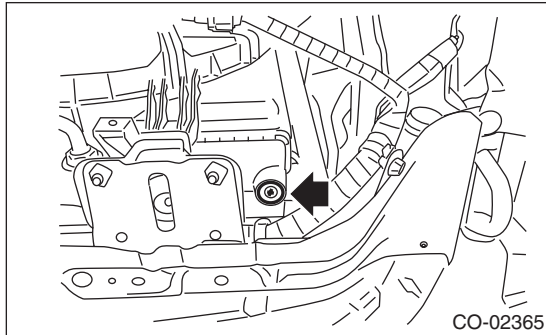

- 5) For quick draining, open the radiator cap.

#### CAUTION:

**If any engine coolant is spilled on the exhaust pipe, wipe off completely to prevent fires or emission of smoke.**

#### NOTE:

- Be sure to open the radiator cap on the filler tank side.
  - Be careful not to spill coolant on the floor.
- 6) Drain the coolant from reservoir tank.
  - 7) Tighten the radiator drain cock securely after draining coolant.
  - 8) Pour cooling system conditioner through the filler neck.

#### **Cooling system protective agent:**

##### **Cooling system conditioner (SOA345001)**

- 9) Fill the engine coolant into coolant filler tank up to the filler neck position.
- 10) Fill engine coolant into the reservoir tank up to "FULL" level.

#### **Recommended engine coolant:**

**Refer to "RM" section. <Ref. to RM-4, COOLANT, RECOMMENDED MATERIALS, Recommended Materials.>**

#### **Coolant capacity (fill up to "FULL" level):**

**Refer to "SPC" section. <Ref. to SPC-4, CAPACITY, Impreza.>**

#### NOTE:

The SUBARU Super Coolant contains anti-freeze and anti-rust agents, and is especially made for Subaru engines with an aluminum cylinder block. Always use SUBARU Super Coolant since other engine coolant may cause corrosion.

- 11) Close the coolant filler tank cap, and start the engine. Race 5 to 6 times at 3,000 rpm or less, then stop the engine. (Complete this operation within 40 seconds.)
- 12) Wait for one minute after the engine stops, then open the coolant filler tank cap. If the engine coolant level drops, add engine coolant into the coolant filler tank up to the filler neck position.
- 13) Perform the procedures 11) and 12) again.
- 14) Install the coolant filler tank cap and reservoir tank cap properly.
- 15) Start the engine and operate the heater at maximum hot position and the blower speed setting to "LO".
- 16) Run the engine at 2,000 rpm or less until radiator fan starts and stops.

#### NOTE:

- Be careful with the engine coolant temperature gauge to prevent overheating.
  - If the radiator hose becomes hardened with the pressure of engine coolant, air bleeding operation seems to be almost completed.
- 17) Stop the engine and wait until the engine coolant temperature lowers to 30°C (86°F) or less.
  - 18) Open the coolant filler tank cap. If the engine coolant level drops, add engine coolant into the coolant filler tank up to the filler neck position and the reservoir tank to "FULL" level.
  - 19) Install the coolant filler tank cap and reservoir tank cap properly.
  - 20) Set the heater setting to maximum hot position and the blower speed setting to "LO" and start the engine. Perform racing at 3,000 rpm or less. If the flowing sound is heard from heater core, repeat the procedures from step 16).

# Clutch System

## PERIODIC MAINTENANCE SERVICES

### 13. Clutch System

#### A: INSPECTION AND ADJUSTMENT

1) Push the release lever to retract the push rod of the operating cylinder and check if the fluid level in the clutch reservoir tank rises or not.

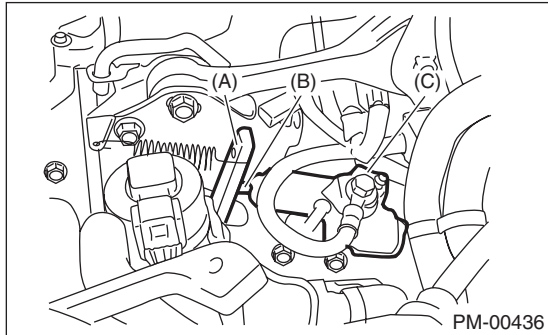

- (A) Release lever
- (B) Push rod
- (C) Operating cylinder

2) If the fluid level rises, pedal free play is correct.  
3) If the fluid level does not rise, or the push rod cannot be retracted, adjust the clutch pedal. <Ref. to CL-29, Clutch Pedal.>  
4) Check the fluid level using the scale on the outside of the clutch reservoir tank (A). If the level is below "MIN" (B), inspect the clutch master cylinder, operating cylinder and hydraulic line for fluid leaks. If fluid leaks are found, repair or replace. If fluid leaks are not found, add clutch fluid to bring it up to "MAX" (C) of clutch reservoir tank.

#### **Recommended clutch fluid:**

**Refer to "RM" section. <Ref. to RM-4, FLUID, RECOMMENDED MATERIALS, Recommended Materials.>**

#### **CAUTION:**

- Prevent the clutch fluid from being splashed over vehicle body. If clutch fluid is splashed over vehicle body, flush it, and then wipe it up.
- If any clutch fluid is spilled on the exhaust pipe, wipe off completely to prevent fires or emission of smoke.
- Avoid mixing brake fluid of different brands to prevent fluid performance from degrading.
- Be careful not to allow dirt or dust to get into the reservoir tank.

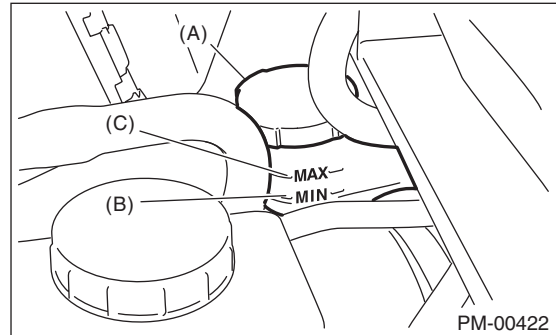

- (A) Reservoir tank
- (B) MIN. level
- (C) MAX. level

## 14. Transmission Gear Oil

### A: INSPECTION

#### 1. 6MT MODEL

Check the gear oil for leaks.

#### 2. 5MT MODEL

Check the transmission gear oil amount. If the amount of gear oil is insufficient, check for leaks. Then, add the necessary amount of the specified gear oil.

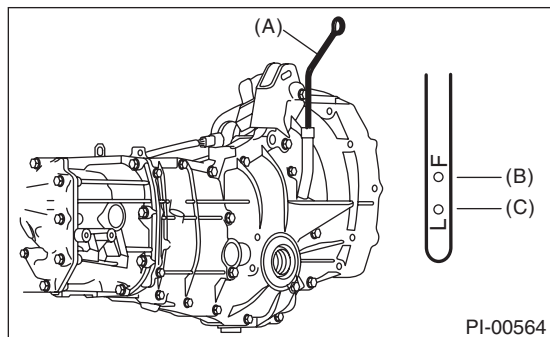

- (A) Oil level gauge
- (B) Upper level
- (C) Lower level

### B: REPLACEMENT

#### 1. 6MT MODEL

##### CAUTION:

If transmission gear oil is spilt over the exhaust pipe, wipe it off with a cloth to avoid emitting smoke or causing a fire.

##### NOTE:

Before starting work, cool off the transmission gear oil well.

- 1) Drain the gear oil by removing drain plug (A) and (B).

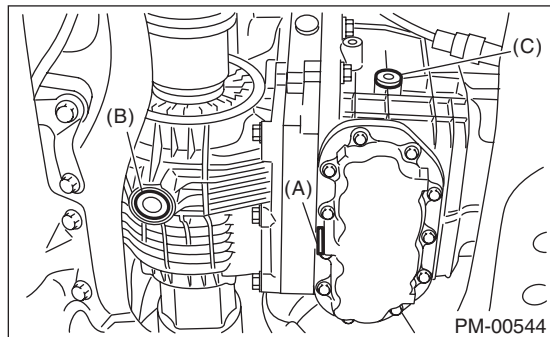

- (A) Drain plug (oil pan side)
- (B) Drain plug (clutch housing side)
- (C) Filler plug

- 2) Replace the gasket with new part, and then tighten the drain plug (A) and (B) to specified torque.

##### Tightening torque:

###### Oil pan side

50 N·m (5.1 kgf-m, 36.9 ft-lb)

###### Clutch housing side

70 N·m (7.1 kgf-m, 51.6 ft-lb)

- 3) Remove the filler plug and add transmission gear oil up to the lower edge of the filler plug hole.

##### CAUTION:

- Carefully refill oil while watching the level. Excessive or insufficient oil must be avoided.
- Make sure to check the fluid level with the vehicle parked at a flat horizontal position.

##### Recommended gear oil:

Refer to "RM" section. <Ref. to RM-2, LUBRICANT, RECOMMENDED MATERIALS, Recommended Materials.>

##### NOTE:

Each oil manufacturer has its base oil and additives. Thus, do not mix two or more brands.

##### Gear oil capacity:

<Ref. to SPC-4, CAPACITY, Impreza.>

- 4) Replace the gasket with new part, and then tighten the filler plug to specified torque.

##### Tightening torque:

50 N·m (5.1 kgf-m, 36.9 ft-lb)

#### 2. 5MT MODEL

##### CAUTION:

If transmission gear oil is spilt over the exhaust pipe, wipe it off with a cloth to avoid emitting smoke or causing a fire.

##### NOTE:

Before starting work, cool off the transmission gear oil well.

- 1) Drain the gear oil by removing drain plug.
- 2) Remove the drain plug using TORX® bit T70, and then drain gear oil.

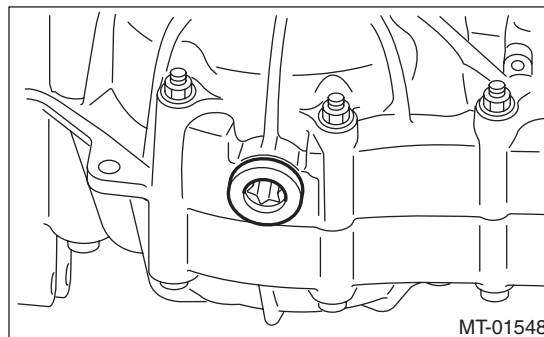

MT-01548

# Transmission Gear Oil

## PERIODIC MAINTENANCE SERVICES

---

3) Replace the gasket with new part, and then tighten the drain plug to specified torque.

### **Tightening torque:**

**44 N·m (4.5 kgf·m, 32.5 ft·lb) (Aluminum gasket silver)**

**70 N·m (7.1 kgf·m, 51.6 ft·lb) (Copper gasket brown)**

**70 N·m (7.1 kgf·m, 51.6 ft·lb) (Metal gasket black)**

4) Fill the transmission gear oil through the oil level gauge hole up to the upper point of level gauge.

### **Recommended gear oil:**

**Refer to "RM" section. <Ref. to RM-2, LUBRICANT, RECOMMENDED MATERIALS, Recommended Materials.>**

### **NOTE:**

Each oil manufacturer has its base oil and additives. Thus, do not mix two or more brands.

### **Gear oil capacity:**

**<Ref. to SPC-4, CAPACITY, Impreza.>**

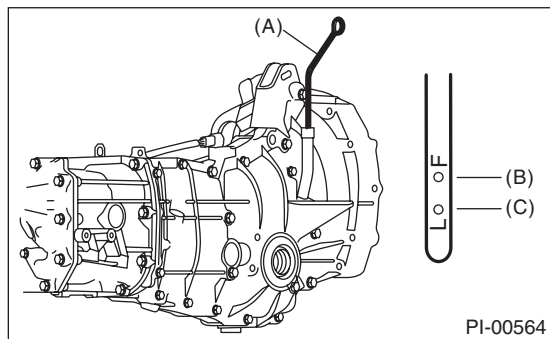

- (A) Oil level gauge
- (B) Upper level
- (C) Lower level

## 15. Front & Rear Differential Gear Oil

### A: INSPECTION

#### 1. FRONT DIFFERENTIAL

As well as transmission oil, differential oil is used to lubricate the differential. Refer to "Transmission Oil". <Ref. to PM-21, Transmission Gear Oil.>

#### 2. REAR DIFFERENTIAL

##### STI model

1) Disconnect the oil temperature switch connector.

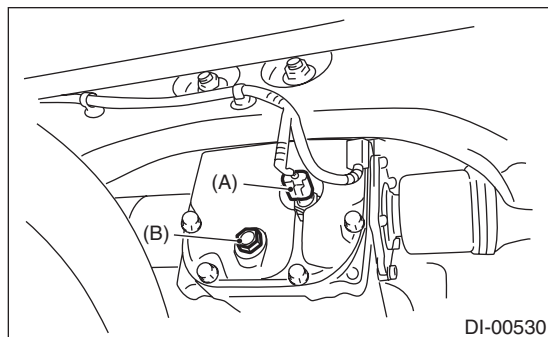

(A) Connector  
(B) Oil drain plug

2) Remove the oil temperature switch and check the gear oil. Replace the gear oil if it is contaminated or deteriorated. <Ref. to PM-24, REPLACEMENT, Front & Rear Differential Gear Oil.>

##### CAUTION:

- Gear oil is extremely hot just after driving. Be wary of receiving burns.
- If differential oil spills on exhaust pipes, wipe it off with a cloth to avoid generating smoke or causing a fire.

##### NOTE:

Remove the oil temperature switch and adapter as a unit.

3) Check that the gear oil level is within -5 mm (-0.2 in) from the bottom of the filler plug hole. If the level is low, make sure that there is no leakage, and refill up to the bottom of the filler plug hole.

##### Recommended gear oil:

<Ref. to RM-2, LUBRICANT, RECOMMENDED MATERIALS, Recommended Materials.>

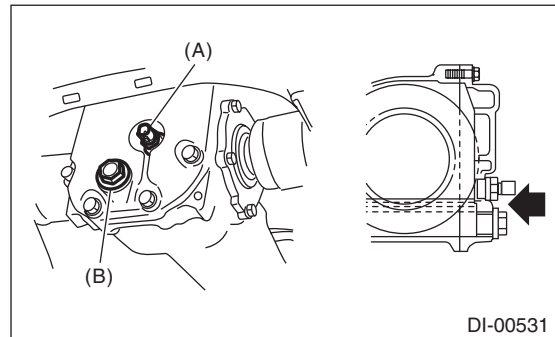

(A) Oil temperature switch  
(B) Oil drain plug

4) Install the oil temperature switch.

##### NOTE:

- Install the oil temperature switch and the filler plug as a unit.
- Use a new gasket.

##### Tightening torque:

**60 N·m (6.1 kgf·m, 44.3 ft·lb)**

5) Connect the oil temperature switch connector.

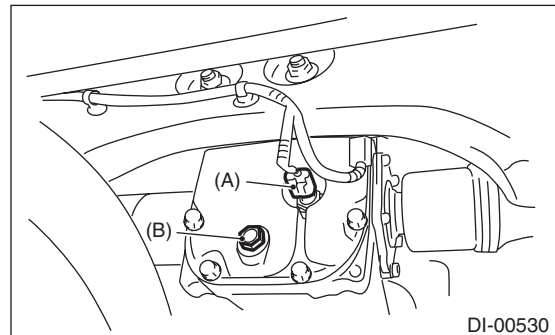

(A) Oil temperature switch  
(B) Oil drain plug

# Front & Rear Differential Gear Oil

## PERIODIC MAINTENANCE SERVICES

### Except for STI model

1) Remove the filler plug, and then check the gear oil. Replace the gear oil if it is contaminated or deteriorated.

#### CAUTION:

- Gear oil is extremely hot just after driving. Be wary of receiving burns.
- If differential oil spills on exhaust pipes, wipe it off with a cloth to avoid generating smoke or causing a fire.

2) Check that the gear oil level is up to the bottom of the filler plug hole. If the level is low, refill up to the bottom of filler plug.

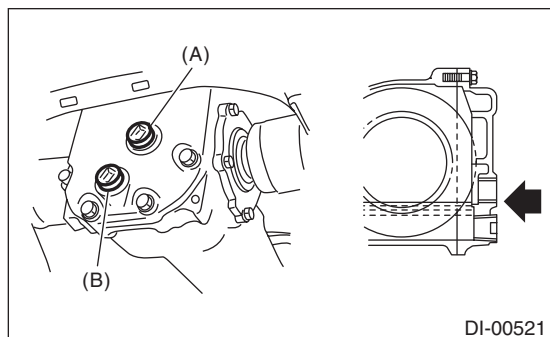

- (A) Filler plug
- (B) Drain plug

## B: REPLACEMENT

### 1. FRONT DIFFERENTIAL

As well as transmission oil, differential oil is used to lubricate the differential. Refer to "Transmission Oil". <Ref. to PM-21, Transmission Gear Oil.>

### 2. REAR DIFFERENTIAL

#### • STI model

1) Disconnect the oil temperature switch connector.

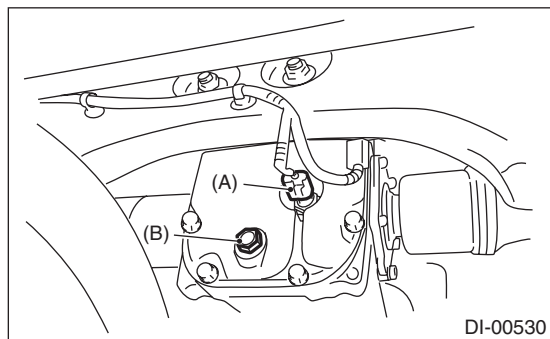

- (A) Connector
- (B) Oil drain plug

2) Remove the oil drain plug and oil temperature switch, and drain the gear oil.

#### CAUTION:

**Gear oil is extremely hot just after driving. Be wary of receiving burns.**

#### NOTE:

Remove the oil temperature switch and adapter as a unit.

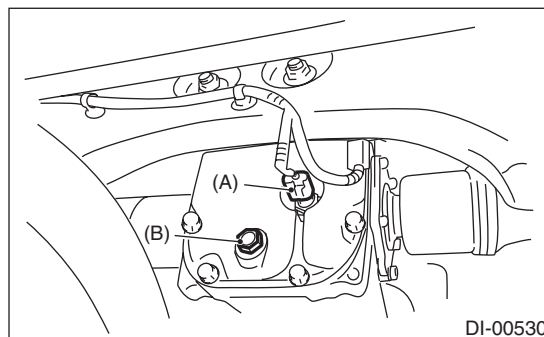

- (A) Oil temperature switch
- (B) Oil drain plug

3) Tighten the oil drain plug.

#### NOTE:

Use a new gasket.

#### Tightening torque:

**60 N·m (6.1 kgf·m, 44.3 ft·lb)**

4) Fill the differential carrier with gear oil to the bottom of oil temperature switch hole.

#### NOTE:

Carefully refill oil while watching the level. Excessive or insufficient oil must be avoided.

#### Recommended gear oil:

**Refer to "RM" section. <Ref. to RM-2, LUBRICANT, RECOMMENDED MATERIALS, Recommended Materials.>**

#### Oil capacity:

**<Ref. to SPC-4, CAPACITY, Impreza.>**

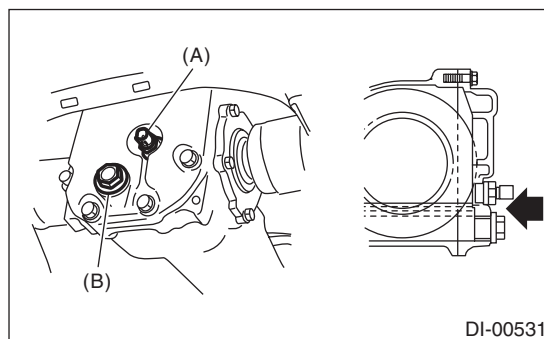

- (A) Oil temperature switch
- (B) Oil drain plug



# Front & Rear Differential Gear Oil

PERIODIC MAINTENANCE SERVICES

5) Install the oil temperature switch.

**NOTE:**

- Use a new gasket.
- Install the oil temperature switch and adapter as a unit.

**Tightening torque:**

**60 N·m (6.1 kgf·m, 44.3 ft·lb)**

6) Connect the oil temperature switch connector.

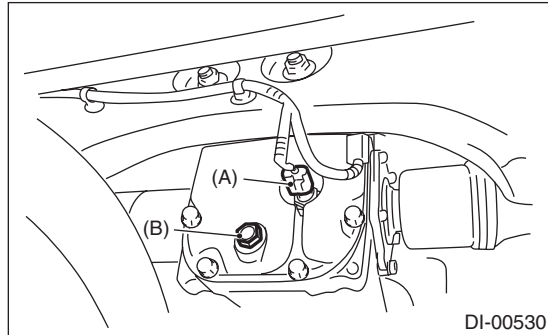

- (A) Oil temperature switch
- (B) Oil drain plug

**Except for STI model**

- 1) Drain the oil by removing oil drain plug.
- 2) Remove the filler plug for quick draining oil.
- 3) Install the drain plug after draining oil.

**NOTE:**

Apply liquid gasket to the drain plug threads.

**Liquid gasket:**

**THREE BOND 1105 (Part No. 004403010) or equivalent**

**Tightening torque:**

**49 N·m (5.0 kgf·m, 36.1 ft·lb)**

4) After installing the drain plug onto rear differential gear case firmly, fill oil up fully to the mouth of filler plug.

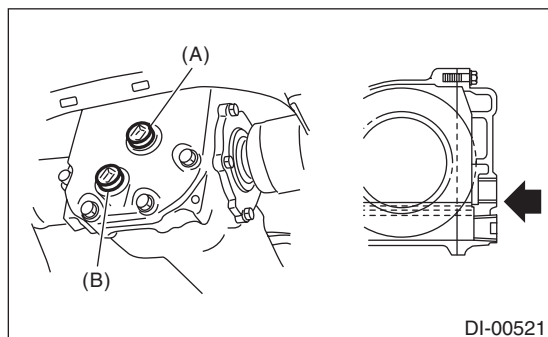

- (A) Filler plug
- (B) Oil drain plug

**Recommended gear oil:**

**<Ref. to RM-2, LUBRICANT, RECOMMENDED MATERIALS, Recommended Materials.>**

**Oil capacity:**

**<Ref. to SPC-4, CAPACITY, Impreza.>**

**NOTE:**

Each oil manufacturer has its base oil and additives. Thus, do not mix two or more brands.

5) Attach the filler plug to the rear differential case securely.

**NOTE:**

Apply liquid gasket to the drain plug threads.

**Liquid gasket:**

**THREE BOND 1105 (Part No. 004403010) or equivalent**

**Tightening torque:**

**49 N·m (5.0 kgf·m, 36.1 ft·lb)**

## 16. Brake Line

### A: INSPECTION

#### 1. BRAKE LINE

- 1) Check for scratches, swelling, corrosion, traces of fluid leakage on the brake hoses or pipe joints.
- 2) Check the possibility of adjacent parts interfering with brake pipes/hoses during driving, and loose connections/clamps.
- 3) Check any trace of fluid leakage, scratches, etc. on master cylinder and wheel cylinder.

**NOTE:**

- When the brake fluid level in the reservoir tank is lower than specified limit, the brake warning light on the combination meter will illuminate.
- Visually check the brake hose for damage. (Use a mirror where it is difficult to see)

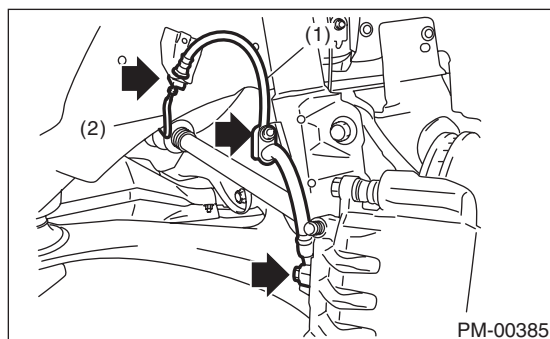

- (1) Front brake hose
- (2) Front brake pipe

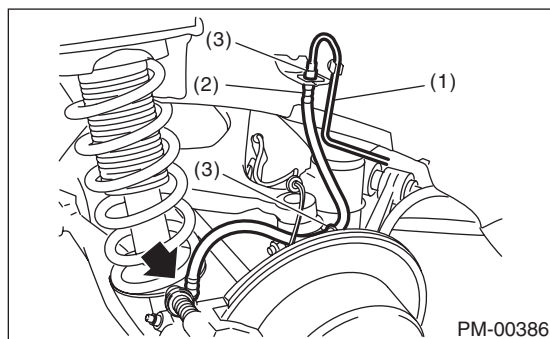

- (1) Rear brake pipe
- (2) Rear brake hose
- (3) Clamp

#### 2. SERVICE BRAKE

- 1) Move to the pull-up direction with the force of 10 N (1 kgf, 2 lbf) or less and check the free play.

**Brake pedal play**

**0.5 — 2.0 mm (0.02 — 0.08 in)**

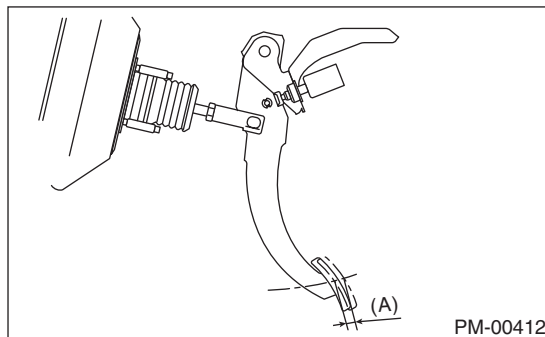

(A) Pedal free play

- 2) If the free play is out of specifications above, adjust the brake pedal. <Ref. to BR-45, INSPECTION, Brake Pedal.>

- 3) Check the pedal stroke.

While the engine is idling, depress the brake pedal with a 490 N (50 kgf, 110 lbf) load and measure the distance between the brake pedal and steering wheel. With the brake pedal released, measure the distance between pedal and steering wheel again. The difference between the two measured values must be the specified value or less. If the measured value is specification or more, there is possibility of entering air in hydraulic unit.

**Brake pedal stroke A:**

**95 mm (3.74 in)/ 490 N (50 kgf, 110 lbf) or less**

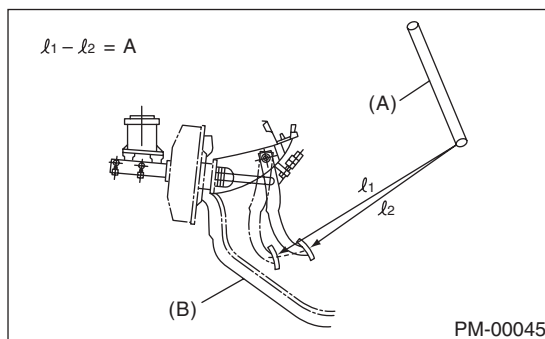

- (A) Steering wheel
- (B) Toe board

- 4) Check to see if air is in the hydraulic brake line by the feel of pedal operation. If air appears to exist in the line, bleed it from the system.

- 5) Check for even operation of all brakes, using a brake tester or by driving the vehicle for a short distance on a straight road.



## 3. BRAKE SERVO SYSTEM

1) With the engine off, depress the brake pedal several times applying the same pedal force. Make sure the travel distance should not change.

2) With the brake pedal depressed, start the engine. Make sure the pedal should move slightly toward the floor.

3) With the brake pedal depressed, stop the engine and keep the pedal depressed for 30 seconds. Make sure the pedal height should not change.

4) A check valve is built into the vacuum hose. Disconnect the vacuum hose to inspect function of check valve.

Blow compressed air into vacuum hose from the end of brake booster side. Check that the air flows from the air hose on engine side. Next blow air into hose from engine side: Check that the air does not flow from the hose.

Replace the both check valve and vacuum hose if the check valve is faulty. Engine side of vacuum hose is indicated by marking "ENG" as shown.

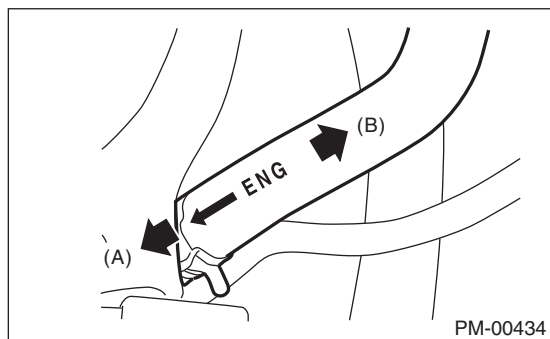
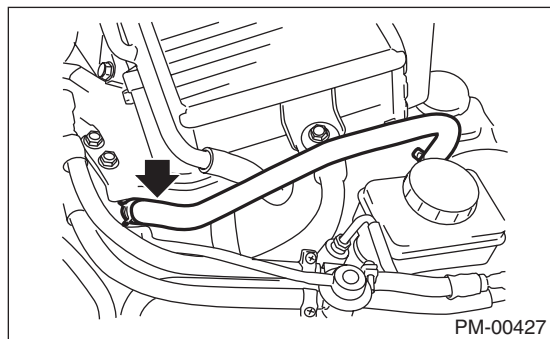

- (A) Engine side
- (B) Brake booster side

5) Check the vacuum hose for cracks or other damage.

### NOTE:

When installing the vacuum hose on the engine and brake booster, do not use soapy water or lubricating oil on their connections.

6) Check the vacuum hose to make sure it is tightly secured.

# Brake Fluid

## PERIODIC MAINTENANCE SERVICES

### 17.Brake Fluid

#### A: INSPECTION

1) Check that the amount of brake fluid is between the lines of "MIN" and "MAX". If out of the specified range, refill or drain the fluid. If the fluid level is close to "MIN", check the brake pad for wear and refill the fluid.

2) Check the fluid for discoloration. If the fluid is extremely discolored, replace with the new fluid.

#### B: REPLACEMENT

##### CAUTION:

- Do not let brake fluid come into contact with the painted surface of the vehicle body. Wash away with water immediately and wipe off if it is spilled by accident.
- Avoid mixing brake fluid of different brands to prevent fluid performance from degrading.
- Be careful not to allow dirt or dust to enter the reservoir tank.
- If the brake fluid is spilt over exhaust pipe, wipe it off with cloth to avoid emitting smoke or causing a fire.

##### NOTE:

- During the operation, keep the reservoir tank filled with brake fluid to prevent entry of air.
  - Operate the brake pedal slowly.
  - For convenience and safety, perform the work with 2 people.
  - The required amount of brake fluid is approximately 500 m<sup>l</sup> (16.9 US fl oz, 17.6 Imp fl oz) for the entire brake system.
- 1) Either jack-up the vehicle and place a rigid rack under it, or have the vehicle lifted.
  - 2) Remove all the wheels.
  - 3) Drain brake fluid from the reservoir tank.
  - 4) Refill the reservoir tank with recommended brake fluid.

##### **Recommended brake fluid:**

**Refer to "RM" section. <Ref. to RM-4, FLUID, RECOMMENDED MATERIALS, Recommended Materials.>**

Perform the same procedure as for bleeding the brake line, until new brake fluid comes out from vinyl tube. <Ref. to BR-39, PROCEDURE, Air Bleeding.>

##### NOTE:

Perform brake fluid replacement starting in the order from the farthest wheel cylinder from the master cylinder.

5) Install one end of a vinyl tube onto the air bleeder and insert the other end of the tube into a container to collect the brake fluid.

##### NOTE:

For calipers with two air bleeder screws, bleed air from the inner side first and then the outer side.

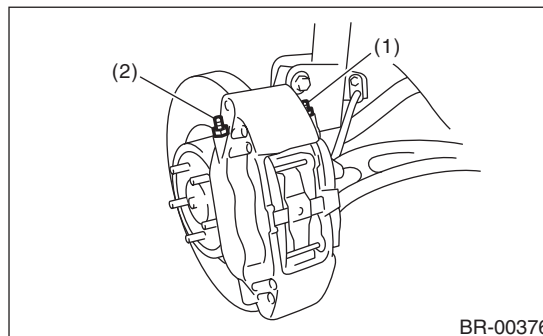

- (1) Inner side air bleeder screw
- (2) Outer side air bleeder screw

6) Instruct your co-worker to depress the brake pedal slowly two or three times and then hold it depressed.

7) Loosen the bleeder screw approximately 1/4 turn until a small amount of brake fluid drains into the container, and then quickly tighten the screw.

8) Repeat steps 6) and 7) until there are no air bubbles in drained brake fluid and new fluid flows through vinyl tube.

##### NOTE:

Add brake fluid as necessary while performing the air bleed operation, in order to prevent the tank from running short of brake fluid.

9) After completing the bleeding operation, hold the brake pedal depressed and tighten the screw and install bleeder cap.

##### **Tightening torque:**

**20 N·m (2.0 kgf·m, 14.8 ft·lb)**

10) Bleed air from each wheel cylinder by following steps from 5) to 9).

11) Depress the brake pedal with a force of approx. 294 N (30 kgf, 66 lbf) and hold it there for approx. 20 seconds. At this time check the pedal to see if it makes any unusual movement. Visually inspect the bleeder screws and brake pipe joints to confirm there is no fluid leakage.

## 18. Disc Brake Pad and Disc

### A: INSPECTION

#### 1. DISC BRAKE PAD AND DISC

1) Jack-up the vehicle and support it with rigid racks. Remove the wheels.

2) Visually check the pad thickness through inspection hole of disc brake assembly. Replace the pad if necessary.

#### NOTE:

When replacing a pad, always replace the pads for both the left and right wheels at the same time. Also replace the pad clips if they are twisted or worn.

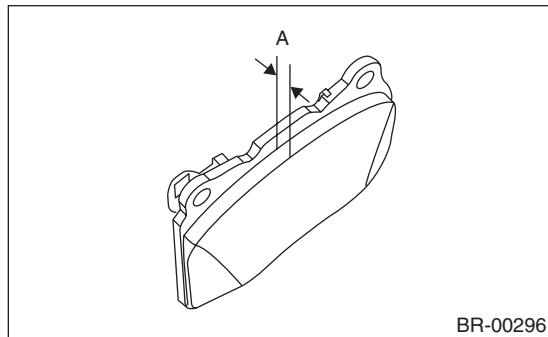

(A) Pad thickness

- Front (back metal not included)  
17-inch type

Pad thickness	mm (in)
Standard	8.9 (0.350)
Wear limit	1.2 (0.047)

- 16-inch type

Pad thickness	mm (in)
Standard	11 (0.43)
Wear limit	1.5 (0.059)

- Rear (back metal not included)  
17-inch type

Pad thickness	mm (in)
Standard	9.0 (0.354)
Wear limit	1.2 (0.047)

- 15-inch type

Pad thickness	mm (in)
Standard	9.0 (0.354)
Wear limit	1.5 (0.059)

3) Check the disc rotor, and correct or replace if it is damaged or worn.

- Front  
17-inch type

Disc rotor thickness	mm (in)
Standard	30 (1.18)
Wear limit	28 (1.10)

- 16-inch type

Disc rotor thickness	mm (in)
Standard	24 (0.94)
Wear limit	22 (0.87)

- Rear  
17-inch type

Disc rotor thickness	mm (in)
Standard	20 (0.79)
Wear limit	18 (0.71)

- 15-inch type

Disc rotor thickness	mm (in)
Standard	10 (0.39)
Wear limit	8.5 (0.33)

4) Remove the caliper body. <Ref. to BR-18, Front Disc Brake Assembly.> <Ref. to BR-28, Rear Disc Brake Assembly.>

5) Tighten the wheel nuts to secure disc rotor.

6) Set a dial gauge at a point of 10 mm (0.39 in) or less from outer periphery of the rotor, and then measure the disc rotor runout.

#### Disc rotor runout limit:

##### STI model

**Front: 0.075 mm (0.0030 in)**

**Rear: 0.070 mm (0.0028 in)**

##### Except for STI model

**Front: 0.050 mm (0.0020 in)**

**Rear: 0.050 mm (0.0020 in)**

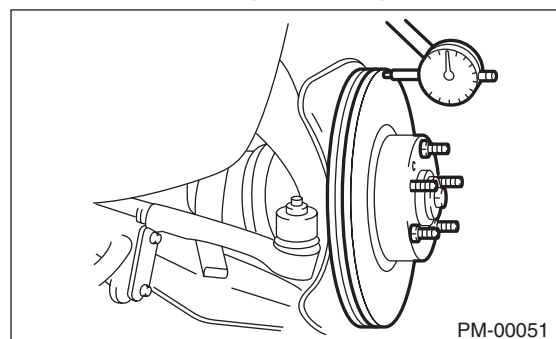

# Parking Brake

## PERIODIC MAINTENANCE SERVICES

### 19. Parking Brake

#### A: INSPECTION

1) Measure the inner diameter of the brake disc rotor. If scoring or worn is found on the disk, replace the brake disc rotor.

##### **Disc rotor inner diameter:**

###### **Standard**

**190 mm (7.48 in)**

###### **Service limit**

**191 mm (7.52 in)**

2) Measure the lining thickness. If it exceeds the limit, replace the brake shoe.

##### **Lining thickness:**

###### **Standard**

**2.8 mm (0.11 in)**

###### **Service limit**

**1.5 mm (0.059 in)**

#### NOTE:

Replace the right and left primary and secondary brake shoes as a set.

#### B: ADJUSTMENT

For rear disc brake, adjust the parking brake after bleeding air.

- 1) Return the parking brake pedal fully.
- 2) Loosen the adjusting nut, and make the cable free.
- 3) Remove the adjusting hole cover from the disc rotor.
- 4) Using a flat tip screwdriver, turn the adjusting screw in the direction of the arrow (shoe extension direction) as shown in the figure until it is locked slightly (until the disc no longer rotates with both hands).

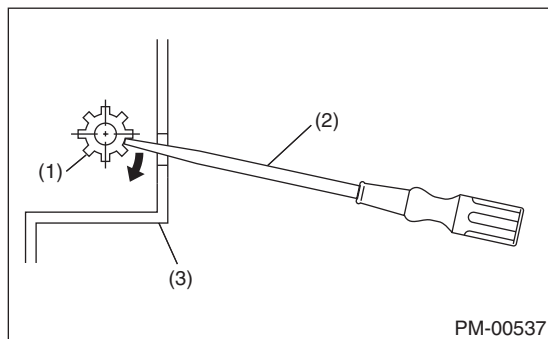

- (1) Adjusting screw
- (2) Flat tip screwdriver
- (3) Disc rotor

5) Loosen the adjusting screw by 5 notches to opposite direction of arrow.

#### CAUTION:

- Check there is no brake drag.
- If the amount that the adjusting screw is turned back is little, securely loosen it by 5 notches to avoid dragging.

6) Install the adjusting hole cover to the disc rotor.  
7) Adjust the parking brake lever stroke. <Ref. to PB-8, LEVER STROKE, ADJUSTMENT, Parking Brake Assembly (Rear Disc Brake).>

## 20. Suspension

### A: INSPECTION

#### 1. SUSPENSION BALL JOINT

- 1) Jack up the vehicle until front tires are off ground.
- 2) Grasp the bottom of tire and move it in and out in axial direction. If relative movement (B) is observed between the brake disc cover (A) and end of front arm (D), ball joint (C) may be excessively worn.

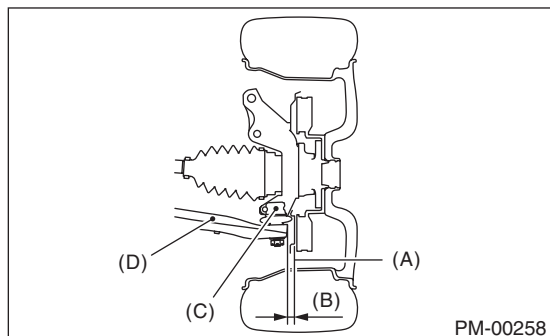

- 3) Grasp the end of front arm and move it up and down. Relative movement (A) between the housing (D) and front arm (C) boss indicates ball joint (B) may be excessively worn.

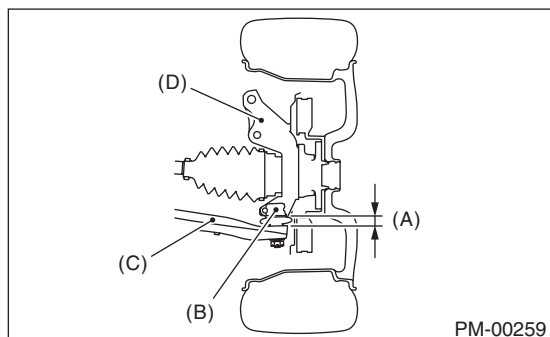

- 4) If the relative movement is observed in the preceding two steps, remove and inspect the ball joint. If the free play exceeds standard value, replace the ball joint. <Ref. to FS-18, Front Ball Joint.>

#### 5) Damage of dust cover

Visually inspect the ball joint dust cover. If it is damaged, remove the front arm. <Ref. to FS-20, Front Arm.> Measure the play of the ball joint. <Ref. to FS-18, Front Ball Joint.>

- (1) If the free play exceeds standard value, replace the ball joint.
- (2) If the dust cover is damaged, replace with a new ball joint.

#### NOTE:

When the front arm ball joint has been removed or replaced, check the toe of front wheel. If the front wheel toe is outside the specified range, <Ref. to FS-8, Wheel Alignment.> adjust toe-in.

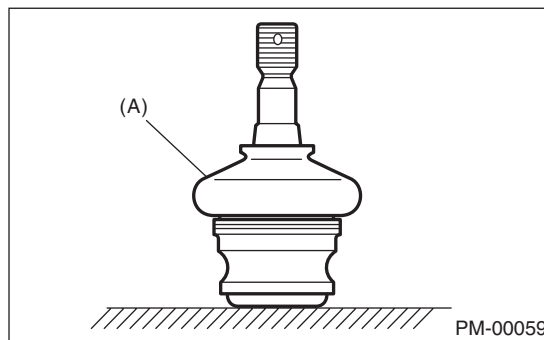

(A) Dust cover

#### 2. FRONT, REAR SUSPENSION BUSHING

Apply pressure with tire lever or similar tool to inspect the bushing for fatigue or other damage. If defective, replace the bushing.

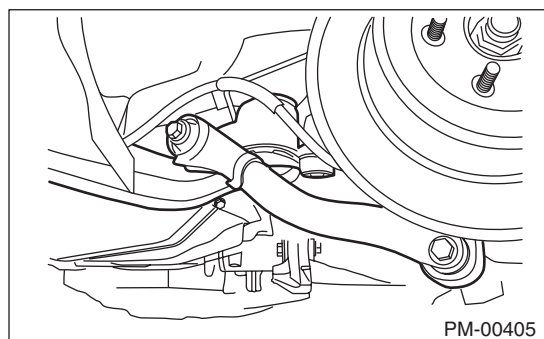

#### 3. WHEEL ARCH HEIGHT

- 1) Unload the vehicle, so that it is at curb weight.
- 2) Check the wheel arch height of the front and rear suspensions to ensure that they are within tolerance. <Ref. to FS-8, Wheel Alignment.>
- 3) If the wheel arch height is out of the specification, visually check the following components and replace deformed parts.
  - Suspension components [Front strut assembly and rear shock absorber assembly]
  - Parts connecting suspension and body
- 4) When no components are deformed, adjust the wheel arch height by replacing the suspension for which the wheel arch height is not within tolerance. <Ref. to FS-8, Wheel Alignment.>

# Suspension

## PERIODIC MAINTENANCE SERVICES

---

### 4. WHEEL ALIGNMENT OF FRONT SUSPENSION

1) Check the alignment of front suspension to make sure the following items are within tolerance.

- Toe-in
- Camber
- Caster (Referential Value)
- Steering angle

<Ref. to FS-8, Wheel Alignment.>

2) When the caster angle does not conform to the reference value obviously, visually inspect the following components and replace deformed parts.

- Suspension components [Strut assembly, cross-member, front arm, etc.]
- Parts connecting suspension and body

3) When the toe-in and camber are outside of the tolerance value, adjust each one so that they conform to the specified value.

4) When the rotating angles of the right and left tires are not within tolerance, adjust them to standard.

### 5. WHEEL ALIGNMENT OF REAR SUSPENSION

1) Inspect the alignment of the rear suspension and check the following items are within the specified range.

- Toe-in
- Camber
- Thrust angle

<Ref. to RS-8, Wheel Alignment.>

2) If camber is out of the specification, visually check the items listed below. If the deformation is found, replace the damaged part.

- Suspension component [shock absorber, front lateral link, rear lateral link, upper arm, trailing link, sub frame etc.]
- Parts connecting suspension and body

3) If the toe-in or thrust angle is out of the specification, adjust to the standard value.

### 6. OIL LEAKAGE OF STRUT AND SHOCK ABSORBER

Visually inspect the front strut and rear shock absorber for oil leakage. Replace the front strut and rear shock absorber if oil leaks excessively.

### 7. TIGHTNESS OF BOLTS AND NUTS

Check the bolts and nuts for looseness. Retighten the bolts and nuts to specified torque. If the self-locking nuts and bolts are removed, replace them with new parts.

Front suspension: <Ref. to FS-2, General Description.>

Rear suspension: <Ref. to RS-2, General Description.>

### 8. DAMAGE TO SUSPENSION PARTS

Check the following parts and the fastening portion of the vehicle body for deformation or excessive rusting which impairs the suspension. If necessary, replace the damaged parts with new parts. If minor rust formation, pitting, etc. are noted, remove the rust and take rust prevention measure.

- Front suspension
  - Front arm
  - Crossmember
  - Strut
- Rear suspension
  - Sub frame
  - Front lateral link
  - Rear lateral link
  - Upper arm
  - Trailing link
  - Shock absorber
- In the area where salt is sprayed to melt snow on a road in winter, check suspension parts for damage caused by rust every 12 months after lapse of 60 months. Take rust prevention measures as required.

## 21. Wheel Bearing

### A: INSPECTION

#### 1. FRONT HUB UNIT

- 1) Jack-up the front side of vehicle.
- 2) While holding the front wheel by hand, swing it in and out to check that there is no bearing free play.
- 3) Loosen the wheel nuts, and remove the front wheel.
- 4) If the bearing free play exists in step 2) above, attach a dial gauge to hub and measure the looseness in the axial direction.

**Service limit:**

***Straight-ahead position within 0.05 mm  
(0.0020 in)***

- 5) Remove the bolts and self-locking nuts, and extract transverse link from the front crossmember.
  - 6) Remove the AAR of front drive shaft from transmission. <Ref. to DS-14, Front Axle.>
  - 7) While supporting the front drive shaft horizontally with one hand, turn the hub with the other hand to check for noise or binding.
- If the hub is noisy or binds, replace the front hub unit.

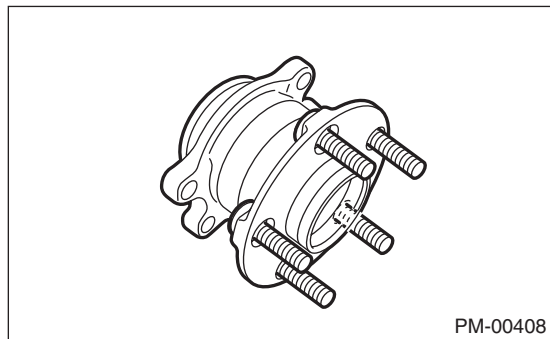

#### 2. REAR HUB UNIT

- 1) Jack-up the rear side of vehicle.
- 2) While holding the rear wheel by hand, swing it in and out to check bearing free play.
- 3) Loosen the wheel nuts, and remove the rear wheel.
- 4) If the bearing free play exists in step 2) above, attach a dial gauge to hub and measure the looseness in the axial direction.

**Service limit:**

***Straight-ahead position within 0.05 mm  
(0.0020 in)***

- 5) Remove the EDJ of the rear drive shaft from the rear differential. <Ref. to DS-34, Rear Drive Shaft.>

- 6) While supporting rear drive shaft horizontally with one hand, turn the hub with the other to check for noise or binding.

If the hub is noisy or binds, replace the rear hub unit.

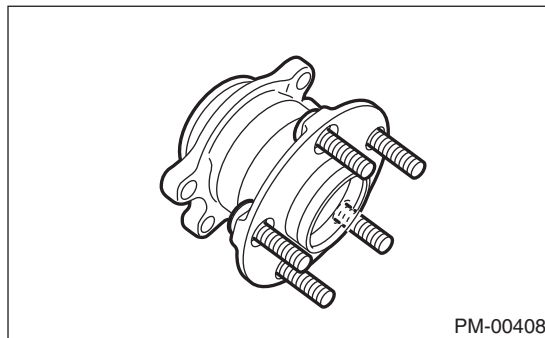



## 22. Axle Boots & Joints

### A: INSPECTION

#### 1. FRONT AND REAR AXLE BOOTS

Inspect the front axle boots (A) and rear axle boots (B) for deformation, damage or failure. If faulty, replace with new part. <Ref. to DS-27, Front Drive Shaft.> <Ref. to DS-34, Rear Drive Shaft.>

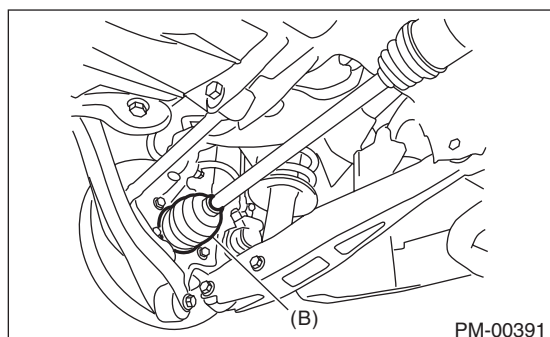
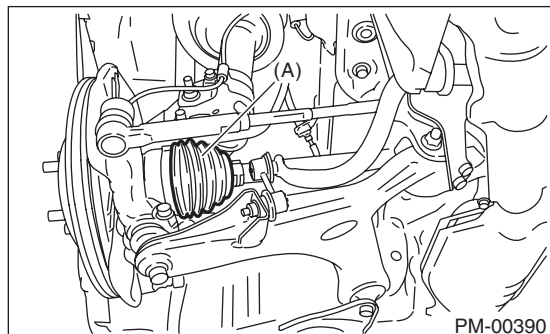

#### 2. PROPELLER SHAFT

Inspect the propeller shaft for damage or failure. If faulty, replace with new part. <Ref. to DS-11, Propeller Shaft.>



## 23. Tire Rotation

### A: INSPECTION

1) When the tread has worn down to less than 1.6 mm (0.063 in) or the wear indicator appears across the tread, replace the tire. (Replace the right and left tires as a set.)

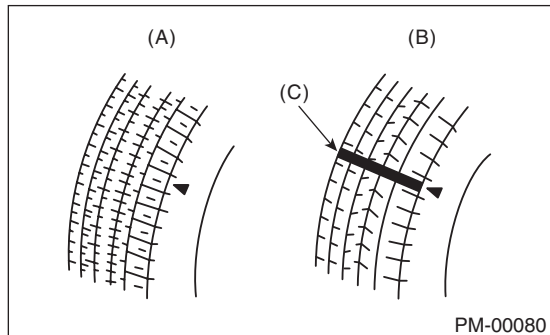

- (A) New tread
- (B) Damaged tread
- (C) Tread wear indicator

2) If the tire appears to be worn unevenly, adjust the wheel alignment.

3) Next, make a tire rotation between front and rear as shown in the figure, make sure tires are worn evenly.

- When the direction of tire rotation is not specified

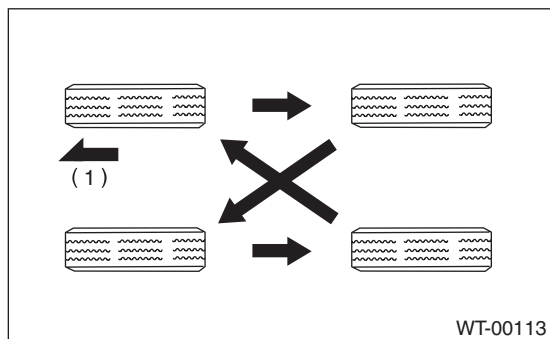

(1) Front

- When the direction of tire rotation is specified

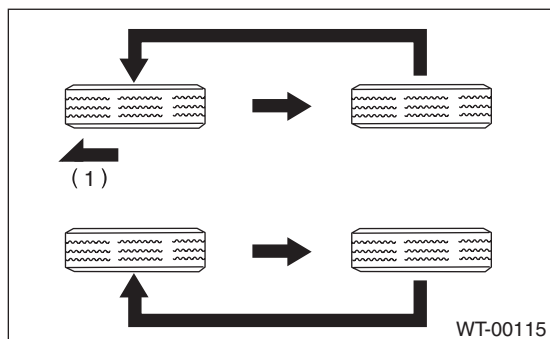

(1) Front

# Steering System (Power Steering)

## PERIODIC MAINTENANCE SERVICES

### 24. Steering System (Power Steering)

#### A: INSPECTION

##### 1. STEERING WHEEL

1) Set the steering wheel in a straight-ahead position, and check the wheel spokes to make sure they are correctly set in their specified positions.

2) Lightly turn the steering wheel to the left and right to determine the point where front wheels start to move.

Measure the distance of the movement of steering wheel at the outer periphery of wheel.

**Steering wheel free play:**

**0 — 17 mm (0 — 0.67 in)**

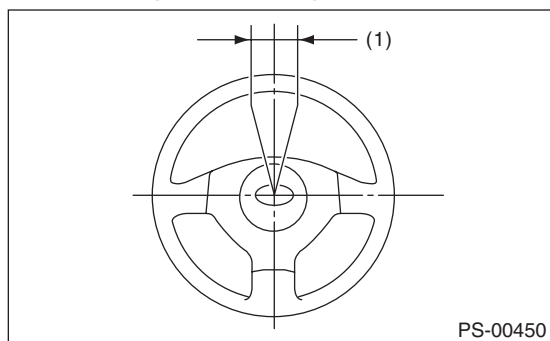

(1) Steering wheel free play

Move the steering wheel vertically toward the shaft to ascertain if there is play in the direction.

**Maximum permissible play:**

**0.5 mm (0.020 in)**

3) Drive the vehicle and check the following items during operation.

(1) Steering force:

The effort required for steering should be smooth and even at all points, and should not vary.

(2) Pulled to one side:

Steering wheel should not be pulled to either side while driving on a level surface.

(3) Wheel runout:

Steering wheel should not show any sign of runout.

(4) Return factor:

Steering wheel should return to its original position after it has been turned and then released.

##### 2. STEERING SHAFT JOINT

If steering wheel play is excessive, disconnect the universal joint of steering shaft and then check the play where the joints cross and yawing torque. Also, check the seal for damage or serrations for wear. If loose joints, tighten the mounting bolts to specified torque.

**Tightening torque:**

**24 N·m (2.4 kgf·m, 17.7 ft·lb)**

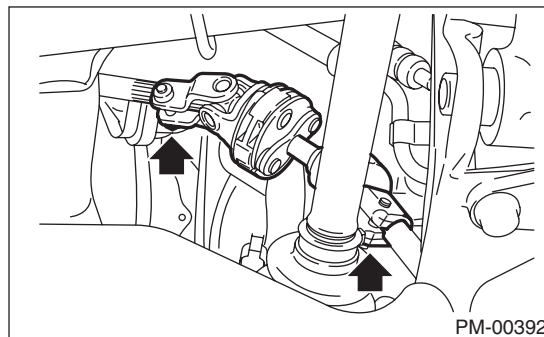

##### 3. GEARBOX

1) With the vehicle placed on a level surface, turn the steering wheel 90° in both the left and right directions.

While the wheel is being rotated, reach under the vehicle and check for looseness in gearbox.

**Tightening torque:**

**60 N·m (6.1 kgf·m, 44.3 ft·lb)**

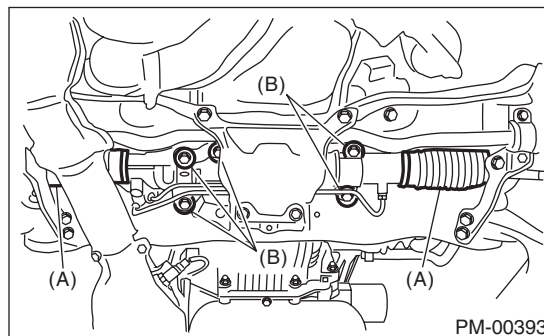

(A) Boot

(B) Gearbox mounting bolt

2) Check the boot for damage, cracks or deterioration.

# Steering System (Power Steering)

PERIODIC MAINTENANCE SERVICES

3) With the vehicle placed on a level surface, quickly turn the steering wheel to the left and right. While steering wheel is being rotated, check the gear backlash. If any noise is noticed, adjust the gear backlash in the following manner.

(1) Loosen the adjusting screw, and apply liquid gasket to at least 1/3 of the entire perimeter of adjusting screw thread.

**Liquid gasket:**

**THREE BOND 1102 or 1215**

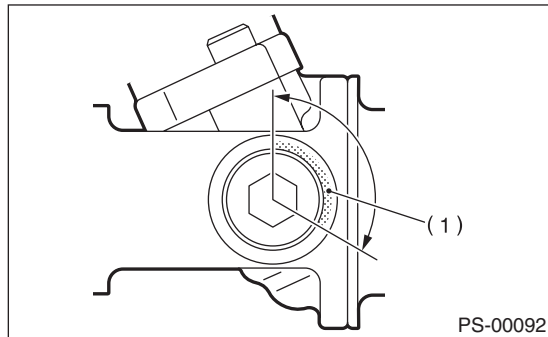

(1) Apply liquid gasket to 1/3 or more of the entire perimeter.

(2) Tighten the adjusting screw, then loosen it.

**CAUTION:**

**Adjust the steering rack to the straight forward position.**

**Tightening torque:**

**9.8 N·m (1.0 kgf-m, 7.2 ft-lb)**

(3) Tighten the adjusting screw, then loosen it.

**Tightening torque:**

**4.9 N·m (0.5 kgf-m, 3.5 ft-lb)**

(4) Tighten the adjusting screw.

**Tightening torque:**

**4.9 N·m (0.5 kgf-m, 3.5 ft-lb)**

(5) Then, return the adjusting screw by 30° and fix it.

(6) Install the lock nut. While holding the adjusting screw with wrench, tighten the lock nut using ST.

ST 926230000 SPANNER

**Tightening torque (lock nut):**

**40 N·m (4.1 kgf-m, 29.5 ft-lb)**

Hold the adjusting screw with wrench to prevent it from turning while tightening the lock nut.

## 4. TIE-ROD

1) Check the tie-rod and tie-rod end for bend, cracks or other damages.

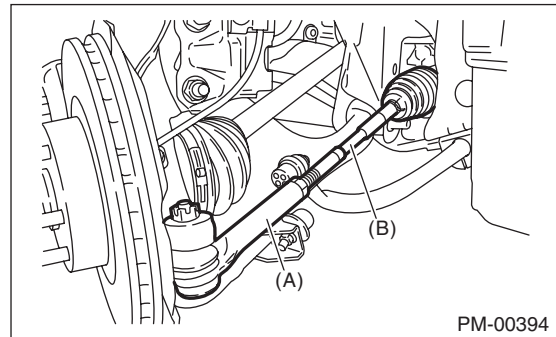

(A) Tie-rod end

(B) Tie-rod

2) Make sure there is free play at the connection of knuckle ball joint and check the dust seal for damage, and the ball stud for play. If loose castle nut, tighten it to the specified tightening torque, and tighten further within 60° until the cotter pin hole is aligned.

**Tightening torque:**

**27 N·m (2.75 kgf-m, 19.9 ft-lb)**

3) Check the tightening of tie-rod end lock nut. If it is loose, tighten it to the specified torque.

**Tightening torque:**

**85 N·m (8.7 kgf-m, 62.7 ft-lb)**

## 5. POWER STEERING FLUID LEVEL

NOTE:

• At power steering fluid temperature 20°C (68°F); read the fluid level on the "COLD" side.

• At power steering fluid temperature 80°C (176°F); read the fluid level on the "HOT" side.

1) Place the vehicle with engine "OFF" on a level surface.

2) Check the fluid level using the scale on the outside of the reservoir tank (A). If the level is below "MIN", fill fluid up to "MAX" level.

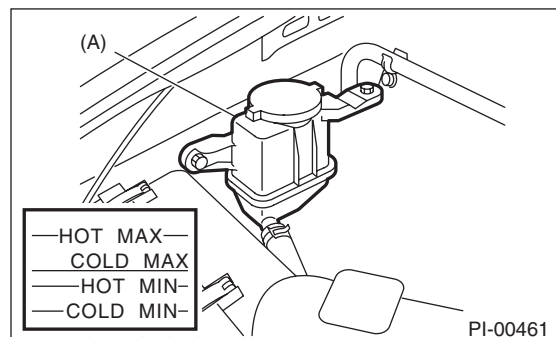

# Steering System (Power Steering)

## PERIODIC MAINTENANCE SERVICES

### CAUTION:

If the power steering fluid is spilled over exhaust pipe, wipe it off with cloth to avoid emitting smoke or causing a fire.

### NOTE:

If fluid level is at MAX level or above, drain fluid to keep the level in the specified range of indicator by using a syringe or the like.

### Recommended fluid:

Refer to "RM" section. <Ref. to RM-4, FLUID, RECOMMENDED MATERIALS, Recommended Materials.>

### Fluid capacity:

0.7 ℓ (0.7 US qt, 0.6 Imp qt)

## 6. POWER STEERING FLUID FOR LEAKS

Inspect the underside of oil pump and gearbox of power steering system, hoses, pipes and their couplings for fluid leaks.

If fluid leakage is found, tighten the mounting bolt (or nut) again or replace with a new part.

### NOTE:

- Wipe the leaked fluid off after correcting fluid leaks.
- When inspecting the fluid leakage, be careful of the clearance between the hose (or piping) and other parts.

## 7. HOSES OF OIL PUMP FOR DAMAGES

Check the pressure hose and return hose of oil pump for crack, swell or damage. Replace the hose with a new part if necessary.

### NOTE:

Prevent hoses from turning and/or bending when installing hoses.

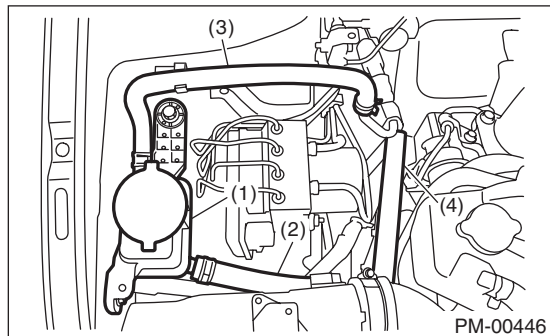

- (1) Reservoir tank
- (2) Suction hose
- (3) Return hose
- (4) Pressure hose

## 8. POWER STEERING PIPES FOR DAMAGES

Check the power steering pipes for corrosion and damage.

Replace the pipe with a new part if necessary.

## 9. GEARBOX BOOTS

Inspect both sides of the gearbox boot as follows, and correct the defects if necessary.

1) Positions (A) and (B) of the gearbox boot are fitted correspondingly in grooves (A) and (B) of the gearbox and rod (C).

2) Clips are fitted outside of positions (A) and (B) of boot.

3) Boot does not have crack or hole.

### NOTE:

Rotate (B) position of gearbox boot against the torsion produced by the adjustment of toe-in etc. Apply grease to the groove (C).

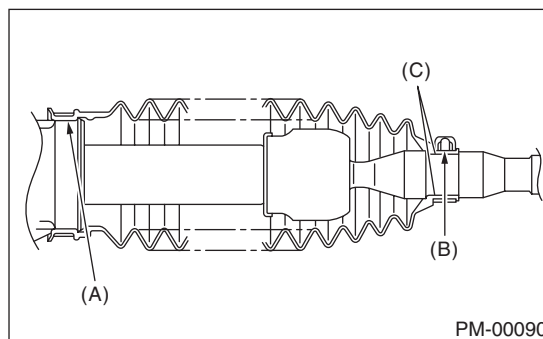

## 10. FITTING BOLTS AND NUTS

Inspect the fitting bolts and nuts of oil pump and bracket for looseness, and retighten them if necessary.

Inspect and/or retighten them when engine is cold.

## 25.A/C Filter

### A: REPLACEMENT

1) Remove the glove box damper.

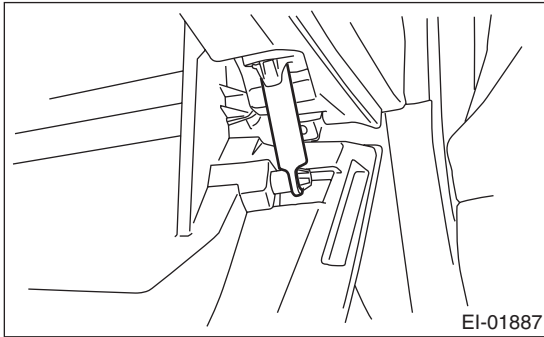

2) Disengage the stopper section and pull the glove box lid to remove it.

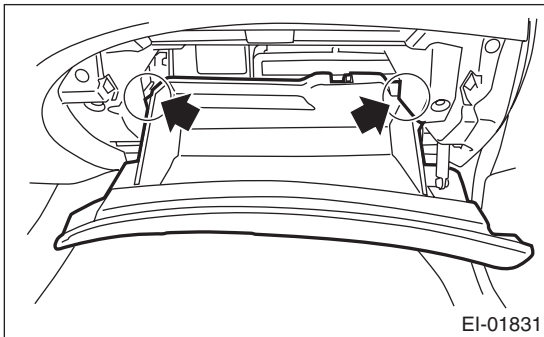

3) Pinch the claw to unlock and remove the A/C filter.

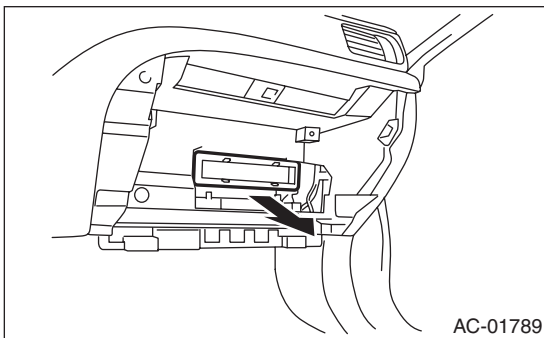

4) Install in the reverse order of removal.

## A/C Filter

PERIODIC MAINTENANCE SERVICES

---

**PM-40**

Brought to you by Ebay Seller "SubaruManuals"

**ENGINE 1 SECTION**

This service manual has been prepared to provide SUBARU service personnel with the necessary information and data for the correct maintenance and repair of SUBARU vehicles.

This manual includes the procedures for maintenance, disassembling, reassembling, inspection and adjustment of components and diagnostics for guidance of experienced mechanics.

Please peruse and utilize this manual fully to ensure complete repair work for satisfying our customers by keeping their vehicle in optimum condition. When replacement of parts during repair work is needed, be sure to use SUBARU genuine parts.

All information, illustration and specifications contained in this manual are based on the latest product information available at the time of publication approval.

**FUEL INJECTION (FUEL SYSTEMS) FU(STI)**

**EMISSION CONTROL (AUX. EMISSION CONTROL DEVICES) EC(STI)**

**INTAKE (INDUCTION) IN(STI)**

**MECHANICAL ME(STI)**

**EXHAUST EX(STI)**

**COOLING CO(STI)**

**LUBRICATION LU(STI)**

**SPEED CONTROL SYSTEMS SP(STI)**

**IGNITION IG(STI)**

**STARTING/CHARGING SYSTEMS SC(STI)**

# FUEL INJECTION (FUEL SYSTEMS)

# *FU(STI)*

---

	<b>Page</b>
1. General Description .....	2
2. Throttle Body .....	15
3. Intake Manifold .....	17
4. Engine Coolant Temperature Sensor .....	34
5. Crankshaft Position Sensor .....	35
6. Camshaft Position Sensor .....	37
7. Knock Sensor .....	40
8. Throttle Position Sensor .....	41
9. Mass Air Flow and Intake Air Temperature Sensor .....	42
10. Manifold Absolute Pressure Sensor .....	43
11. Fuel Injector .....	45
12. Tumble Generator Valve Assembly .....	48
13. Tumble Generator Valve Actuator .....	49
14. Oil Flow Control Solenoid Valve .....	50
15. Wastegate Control Solenoid Valve .....	52
16. Front Oxygen (A/F) Sensor .....	54
17. Rear Oxygen Sensor .....	56
18. SI-DRIVE (SUBARU Intelligent Drive) Selector .....	58
19. Engine Control Module (ECM) .....	59
20. Main Relay .....	60
21. Fuel Pump Relay .....	62
22. Electronic Throttle Control Relay .....	64
23. Fuel Pump Control Unit .....	66
24. Fuel .....	67
25. Fuel Tank .....	70
26. Fuel Filler Pipe .....	77
27. Fuel Pump .....	80
28. Fuel Level Sensor .....	82
29. Fuel Sub Level Sensor .....	83
30. Fuel Filter .....	85
31. Pulsation Damper Assembly .....	89
32. Pressure Regulator & Damper Assembly .....	90
33. Purge Damper .....	92
34. Fuel Delivery, Return and Evaporation Lines .....	93
35. Fuel System Trouble in General .....	98



## General Description

FUEL INJECTION (FUEL SYSTEMS)

---

### 1. General Description

#### A: SPECIFICATION

Fuel tank	Capacity	64 ℓ (16.9 US gal, 14.1 Imp gal)
	Install locations	Under rear seat
Fuel pump	Type	Impeller
	Shutoff discharge pressure	900 kPa (9.18 kg/cm <sup>2</sup> , 130.5 psi) or less
	Discharge rate	175 ℓ (46.2 US gal, 38.5 Imp gal)/h or more [12 V at 300 kPa (3.06 kg/cm <sup>2</sup> , 43.5 psi)]
Fuel filter		Intank type

### B: COMPONENT

#### 1. INTAKE MANIFOLD

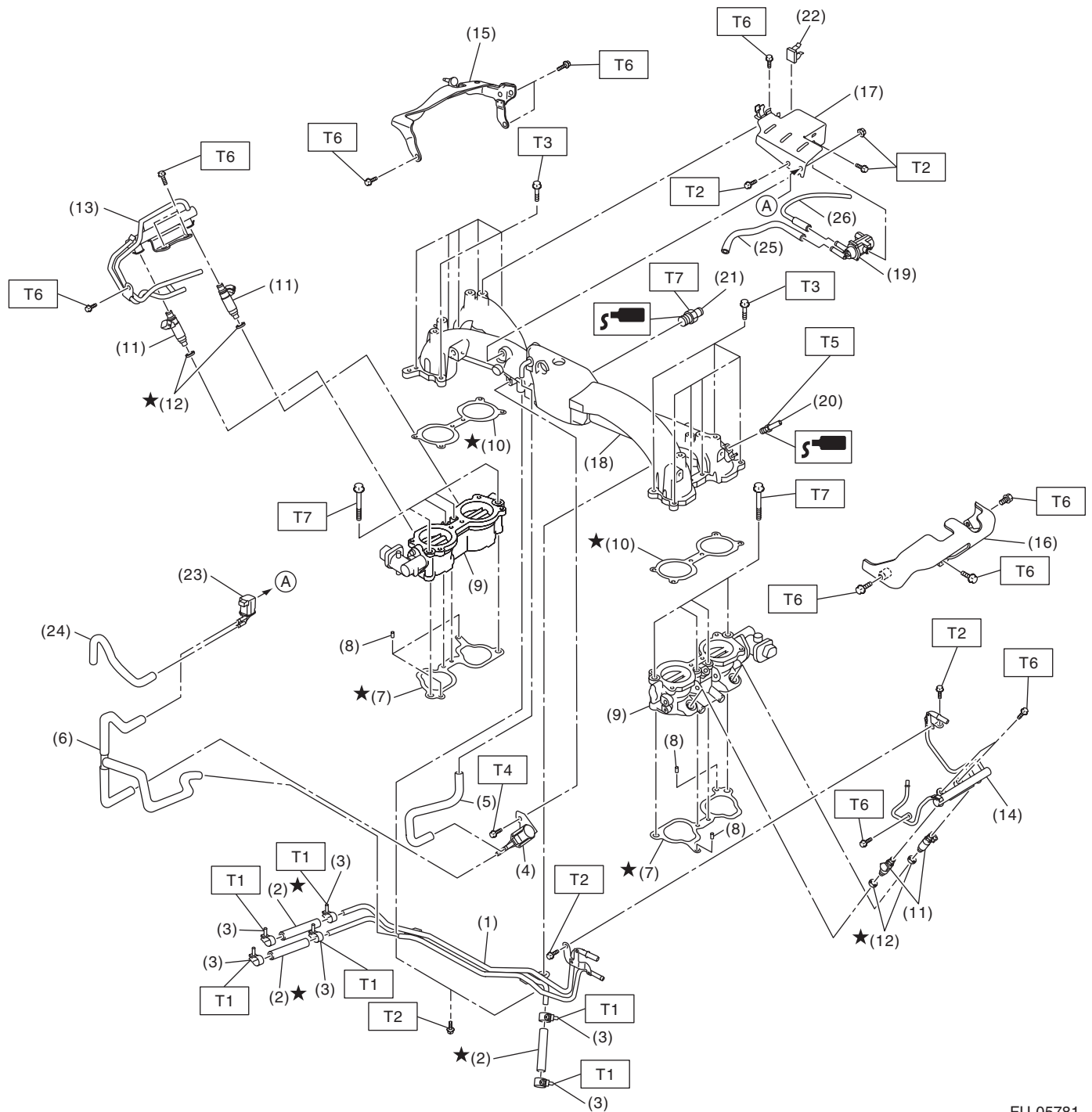

FU-05781

## General Description

### FUEL INJECTION (FUEL SYSTEMS)

---

(1) Fuel pipe ASSY	(13) Fuel injector pipe RH	(24) Vacuum hose
(2) Fuel hose	(14) Fuel injector pipe LH	(25) Vacuum hose
(3) Clamp	(15) Fuel pipe protector RH	(26) Air control hose
(4) Purge control solenoid valve 1	(16) Fuel pipe protector LH	
(5) Vacuum hose A	(17) Solenoid valve bracket	<hr/> <b>Tightening torque:N·m (kgf-m, ft-lb)</b>
(6) Vacuum control hose	(18) Intake manifold	<b>T1: 1.25 (0.1, 0.9)</b>
(7) Intake manifold gasket	(19) Wastegate control solenoid valve	<b>T2: 6.4 (0.7, 4.7)</b>
(8) Guide pin	(20) Nipple	<b>T3: 8.25 (0.8, 6.1)</b>
(9) Tumble generator valve ASSY	(21) Nipple	<b>T4: 16 (1.6, 11.8)</b>
(10) Tumble generator valve gasket	(22) Clip	<b>T5: 17 (1.7, 12.5)</b>
(11) Fuel injector	(23) Purge control solenoid valve 2	<b>T6: 19 (1.9, 14.0)</b>
(12) O-ring		<b>T7: 25 (2.5, 18.4)</b> <hr/>

## 2. AIR INTAKE SYSTEM

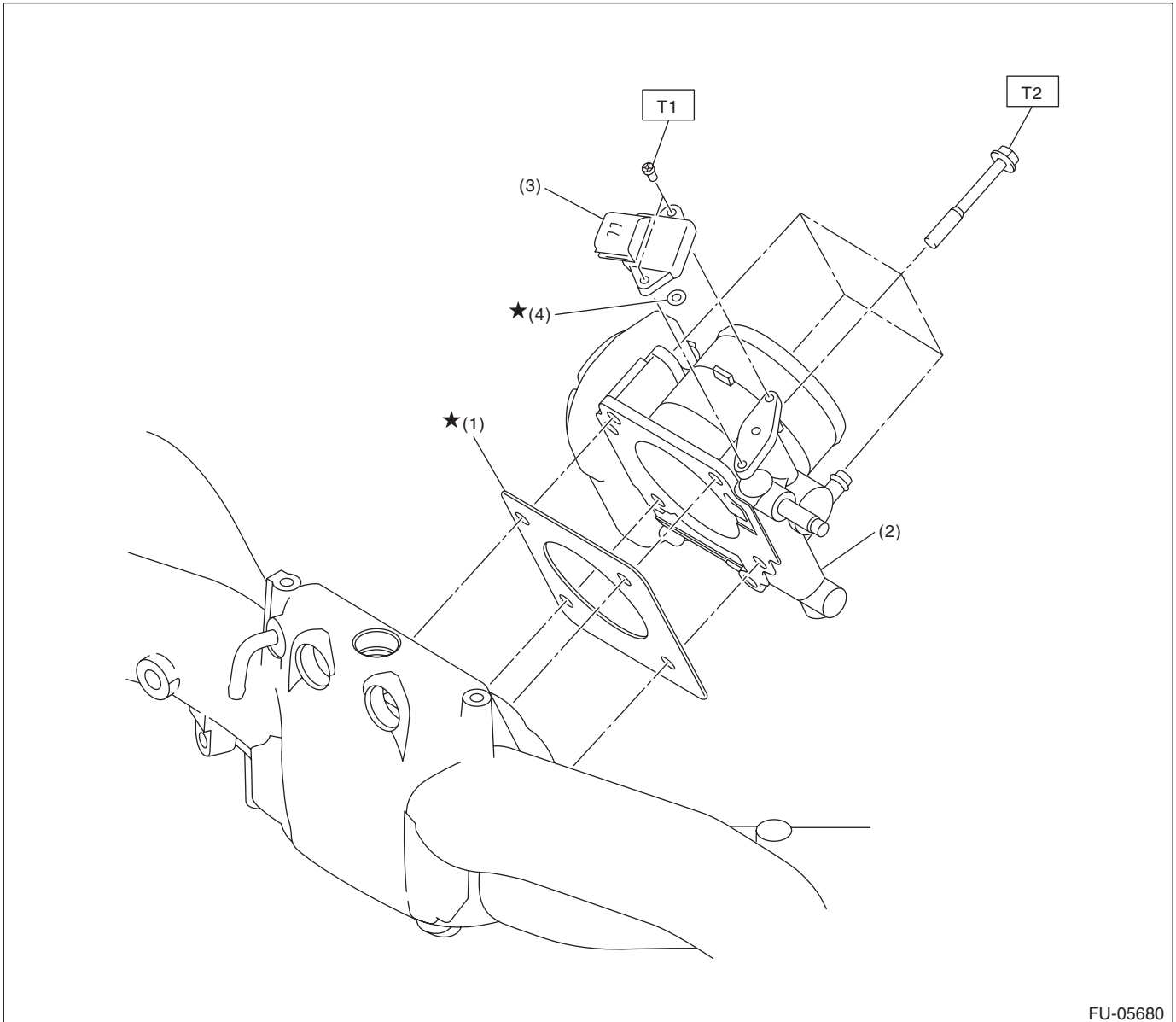

FU-05680

- (1) Gasket
- (2) Throttle body

- (3) Manifold absolute pressure sensor
- (4) O-ring

**Tightening torque: N·m (kgf-m, ft-lb)**

**T1: 2 (0.2, 1.5)**

**T2: 8 (0.8, 5.9)**

# General Description

## FUEL INJECTION (FUEL SYSTEMS)

### 3. CRANKSHAFT POSITION, CAMSHAFT POSITION AND KNOCK SENSORS

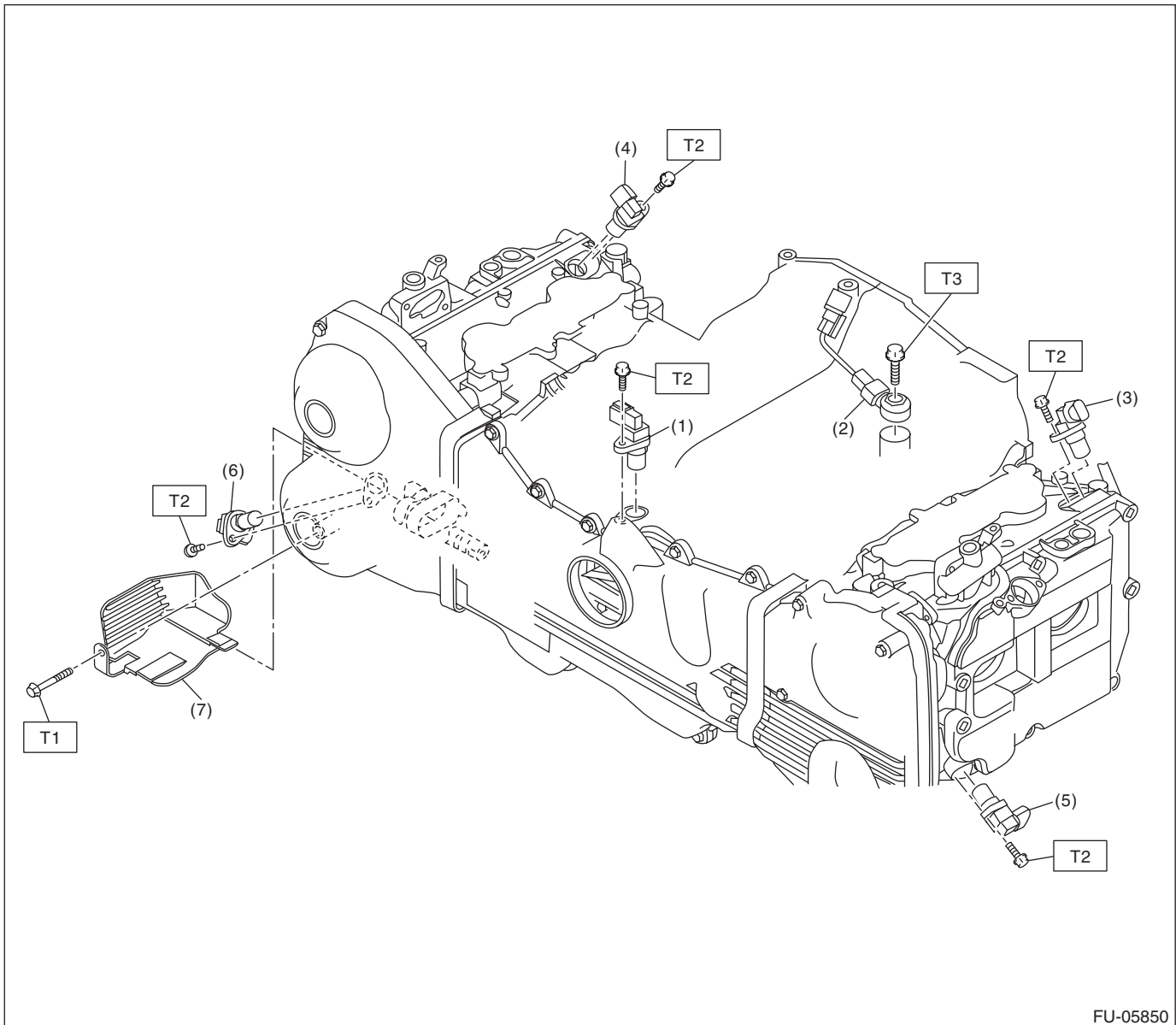

FU-05850

(1) Crankshaft position sensor	(5) Exhaust camshaft position sensor LH	<b>Tightening torque: N·m (kgf-m, ft-lb)</b>
(2) Knock sensor	(6) Exhaust camshaft position sensor RH	
(3) Intake camshaft position sensor LH	(7) Engine harness cover	
(4) Intake camshaft position sensor RH		<b>T1: 5 (0.5, 3.7)</b>
		<b>T2: 6.4 (0.7, 4.7)</b>
		<b>T3: 24 (2.4, 17.7)</b>

**FU(STI)-6**

Brought to you by Ebay Seller "SubaruManuals"

# General Description

## 4. FUEL TANK

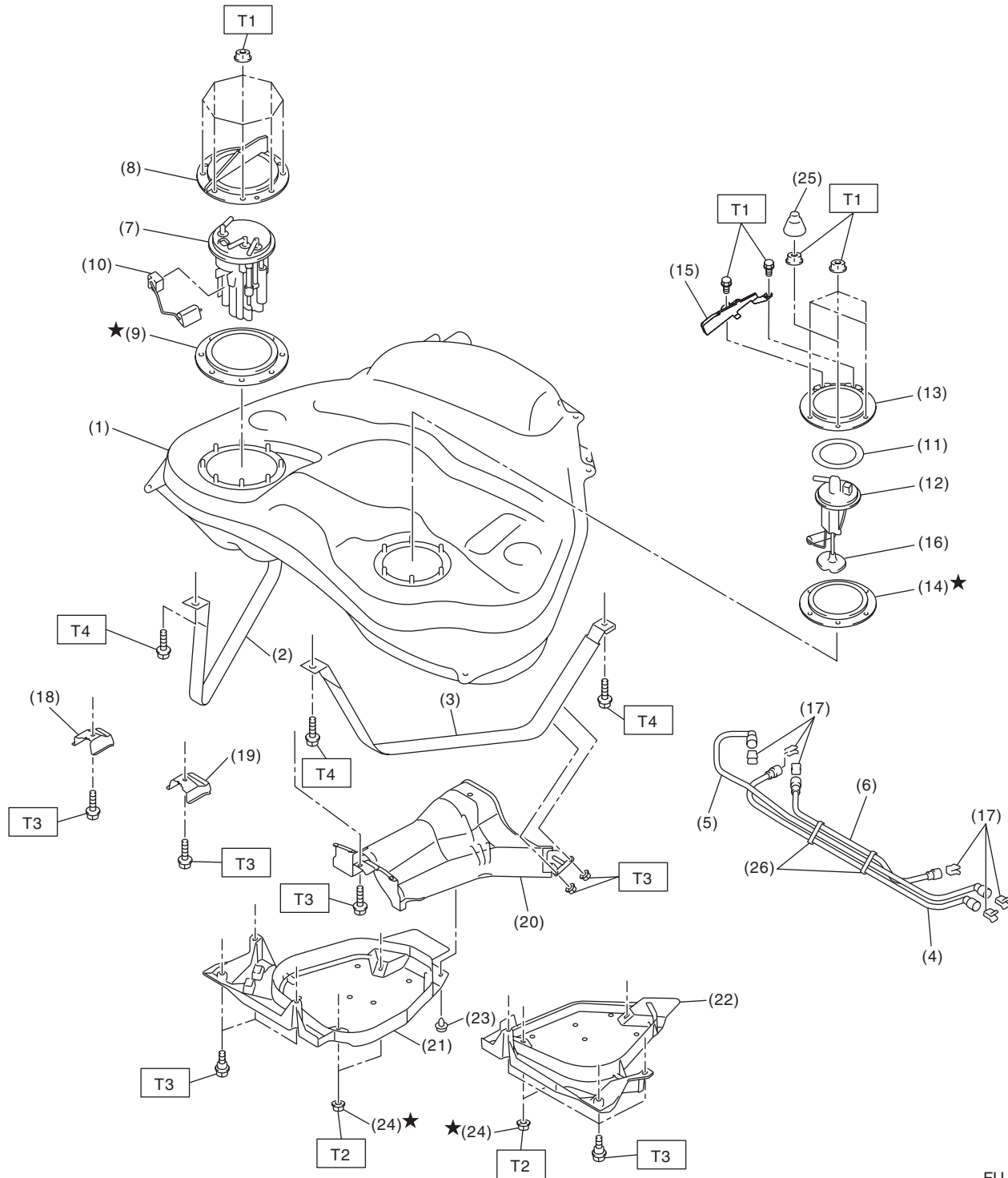

FU-06739

# General Description

## FUEL INJECTION (FUEL SYSTEMS)

---

(1) Fuel tank	(12) Fuel sub level sensor	(23) Clip
(2) Fuel tank band RH	(13) Fuel sub level sensor upper plate	(24) Self-locking nut
(3) Fuel tank band LH	(14) Fuel sub level sensor gasket	(25) Rubber cap
(4) Fuel delivery tube	(15) Fuel sub level sensor protector	(26) Tube clamp
(5) Fuel return tube	(16) Fuel sub level sensor filter	
(6) Jet pump tube	(17) Retainer	<hr/> <b>Tightening torque:N-m (kgf-m, ft-lb)</b>
(7) Fuel pump ASSY	(18) Stopper RH	<b>T1: 4.4 (0.4, 3.2)</b>
(8) Fuel pump upper plate	(19) Stopper LH	<b>T2: 9 (0.9, 6.6)</b>
(9) Fuel pump gasket	(20) Heat shield cover	<b>T3: 18 (1.8, 13.3)</b>
(10) Fuel level sensor	(21) Fuel tank protector RH	<b>T4: 33 (3.4, 24.3)</b>
(11) Fuel sub level sensor upper plate cushion	(22) Fuel tank protector LH	<hr/>





# General Description

## FUEL INJECTION (FUEL SYSTEMS)

---

(1) Fuel delivery hose A	(27) Fuel return hose B	(53) Drain separator
(2) Clamp	(28) Fuel pipe ASSY	(54) Drain separator bracket
(3) Pulsation damper A	(29) Fuel pipe front grommet	(55) Hose connector
(4) Fuel pipe gasket	(30) Pipe clamp	(56) Hose connector
(5) Fuel by-pass pipe	(31) Pipe clamp	(57) Grommet
(6) Fuel delivery hose B	(32) Pipe clamp	(58) Drain tube A
(7) Hose clamp	(33) Pipe clamp	(59) Leak check valve ASSY bracket
(8) Clip	(34) Fuel pipe rear grommet	(60) Drain tube B
(9) Evaporation hose A	(35) Bracket	(61) Leak check valve ASSY
(10) Clip	(36) Clip	(62) Canister tube ASSY
(11) Evaporation hose B	(37) Evaporation hose C	(63) Canister
(12) Clip	(38) Clamp	(64) Canister cover LH
(13) Purge damper	(39) Fuel filler hose	(65) Center canister cover
(14) Collar	(40) Clamp	(66) Canister cover RH
(15) Purge damper bracket	(41) PCV drain tube	
(16) Bushing	(42) Grommet	<hr/> <b>Tightening torque:N·m (kgf-m, ft-lb)</b>
(17) Damper bracket	(43) Hose connector	<b>T1: 1.25 (0.1, 0.9)</b>
(18) Fuel hose	(44) Clip	<b>T2: 2 (0.2, 1.5)</b>
(19) Fuel return hose A	(45) Hose clamp	<b>T3: 2.5 (0.3, 1.8)</b>
(20) Vacuum hose	(46) Evaporation hose D	<b>T4: 6.4 (0.7, 4.7)</b>
(21) Pressure regulator	(47) Evaporation hose E	<b>T5: 7.5 (0.8, 5.5)</b>
(22) Fuel pipe protector	(48) Pressure control solenoid valve ASSY	<b>T6: 8 (0.8, 5.9)</b>
(23) O-ring	(49) Clip	<b>T7: 13 (1.3, 9.6)</b>
(24) Pulsation damper B	(50) Evaporation hose F	<b>T8: 18 (1.8, 13.3)</b>
(25) Fuel holder ASSY	(51) Evaporation hose G	<b>T9: 21.6 (2.2, 15.9)</b>
(26) Damper holder	(52) Drain hose	<hr/>

\* It can be reused if the quick connector side is disconnected.

# General Description

FUEL INJECTION (FUEL SYSTEMS)

## 6. FUEL FILLER PIPE

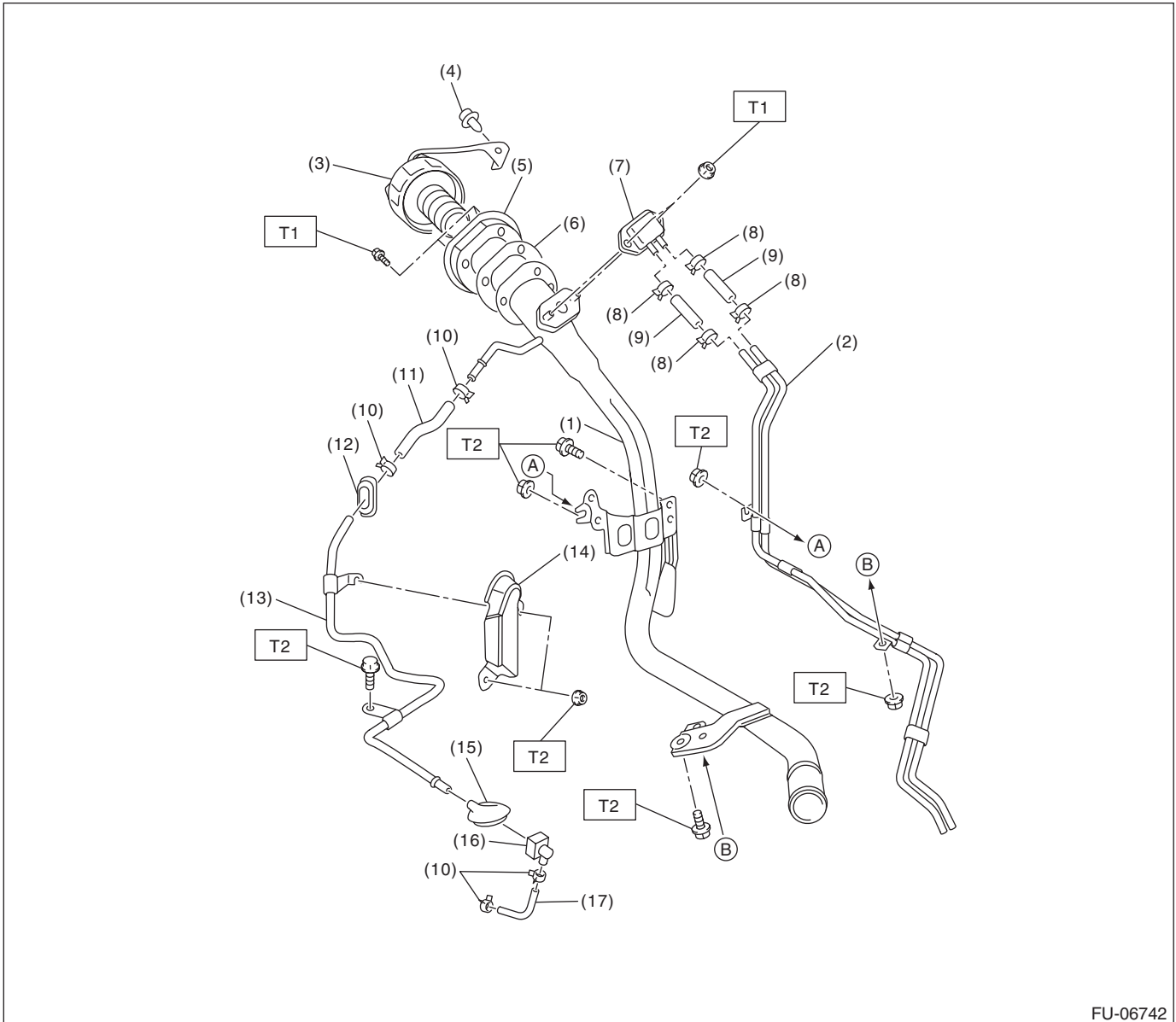

FU-06742

- |                        |                                 |                         |
|------------------------|---------------------------------|-------------------------|
| (1) Fuel filler pipe   | (8) Clip                        | (15) Grommet            |
| (2) Evaporation pipe A | (9) Evaporation hose A          | (16) Quick connector    |
| (3) Fuel filler cap    | (10) Clip                       | (17) Evaporation hose C |
| (4) Clip               | (11) Evaporation hose B         |                         |
| (5) Filler ring        | (12) Grommet                    |                         |
| (6) Filler pipe gasket | (13) Evaporation pipe B         |                         |
| (7) Shut valve         | (14) Evaporation pipe protector |                         |

**Tightening torque: N·m (kgf-m, ft-lb)**

**T1: 4.4 (0.4, 3.2)**

**T2: 7.5 (0.8, 5.5)**

**FU(STI)-11**

Brought to you by Ebay Seller "SubaruManuals"

# General Description

## FUEL INJECTION (FUEL SYSTEMS)

### 7. FUEL PUMP

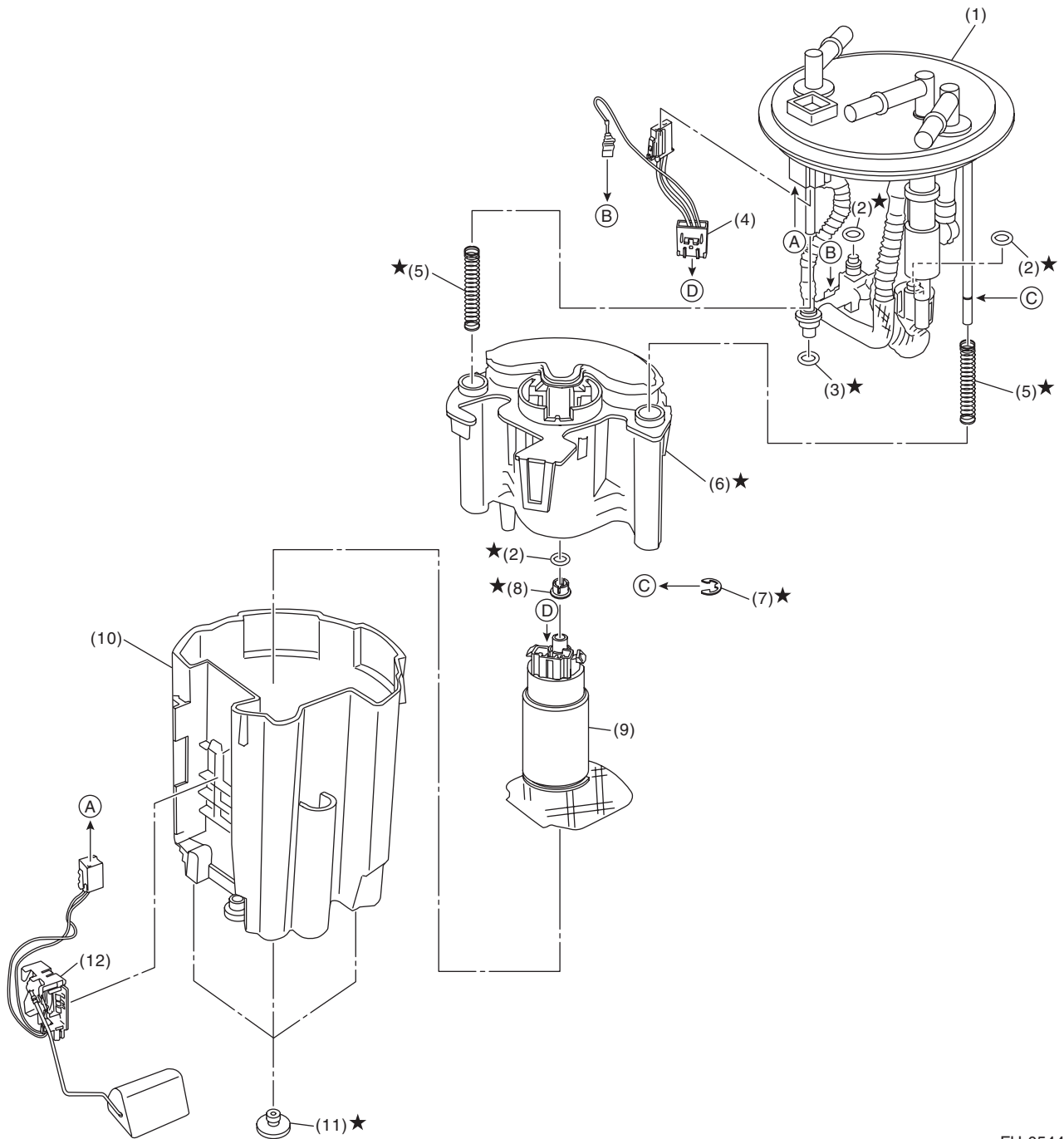

FU-05444

- |                           |                 |                        |
|---------------------------|-----------------|------------------------|
| (1) Sub tank bracket ASSY | (5) Spring      | (9) Pump ASSY          |
| (2) O-ring                | (6) Fuel filter | (10) Sub tank          |
| (3) O-ring                | (7) Clip        | (11) Cushion           |
| (4) Fuel pump harness     | (8) Spacer      | (12) Fuel level sensor |

**FU(STI)-12**

Brought to you by Ebay Seller "SubaruManuals"

### **C: CAUTION**

- Wear appropriate work clothing, including a cap, protective goggles and protective shoes when performing any work.
- Remove contamination including dirt and corrosion before removal, installation or disassembly.
- Keep the disassembled parts in order and protect them from dust and dirt.
- Before removal, installation or disassembly, be sure to clarify the failure. Avoid unnecessary removal, installation, disassembly and replacement.
- Vehicle components are extremely hot after driving. Be wary of receiving burns from heated parts.
- Be sure to tighten fasteners including bolts and nuts to the specified torque.
- Place shop jacks or rigid racks at the specified points.
- Before disconnecting connectors of sensors or units, be sure to disconnect the ground cable from the battery.
- Place "NO OPEN FLAMES" signs near the working area.
- Prepare a container and cloth to prevent scattering of fuels when performing work where fuels can be spilled. If the fuel spills, wipe it off immediately to prevent from penetrating into floor or flowing out for environmental protection.
- Follow all government and local regulations concerning disposal of refuse when disposing fuel.

# General Description

## FUEL INJECTION (FUEL SYSTEMS)

### D: PREPARATION TOOL

#### 1. SPECIAL TOOL

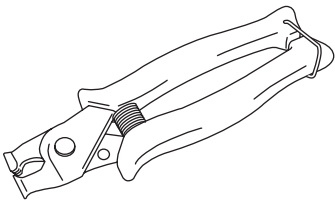
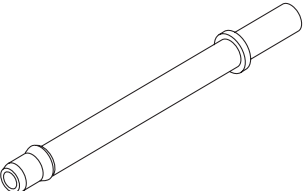
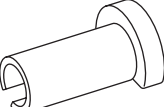
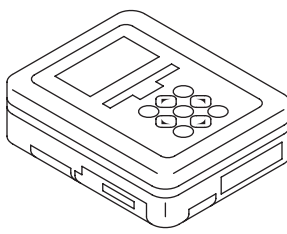
ILLUSTRATION	TOOL NUMBER	DESCRIPTION	REMARKS
 <p style="text-align: center;">ST18353AA000</p>	18353AA000	CLAMP PLIERS	<ul style="list-style-type: none"> <li>• Used for removing and installing the PCV hose.</li> <li>• This tool is made by the French company CAILLAU. (code) 54.0.000.205</li> </ul> To make it easier to obtain, it has been provided with a tool number.
 <p style="text-align: center;">ST18471AA000</p>	18471AA000	FUEL PIPE ADAPTER	Used for draining fuel.
 <p style="text-align: center;">ST42099AE000</p>	42099AE000	QUICK CONNECTOR RELEASE	Used for removing the quick connector.
 <p style="text-align: center;">ST1B022XU0</p>	1B022XU0	SUBARU SELECT MONITOR III KIT	Used for draining fuel and each inspection.

#### 2. GENERAL TOOL

TOOL NAME	REMARKS
Circuit tester	Used for measuring resistance and voltage.
Oscilloscope	Used for inspecting the waveform of each sensor.

## 2. Throttle Body

### A: REMOVAL

- 1) Disconnect the ground cable from battery.

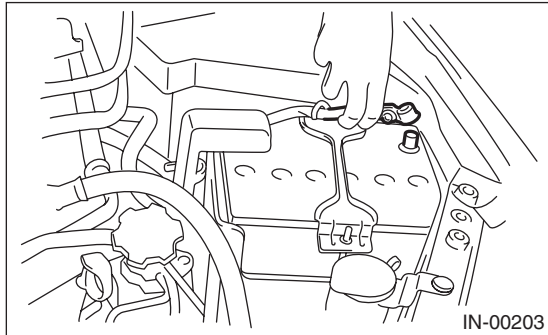

- 2) Lift up the vehicle.
- 3) Remove the under cover. <Ref. to EI-28, REMOVAL, Front Under Cover.>
- 4) Drain approximately 3.0 ℓ (3.2 US qt, 2.6 Imp qt) of coolant. <Ref. to CO(STI)-13, DRAINING OF ENGINE COOLANT, REPLACEMENT, Engine Coolant.>
- 5) Remove the intercooler. <Ref. to IN(STI)-12, REMOVAL, Intercooler.>
- 6) Disconnect the connector (A) from the throttle position sensor, and the connector (B) from the manifold pressure sensor.

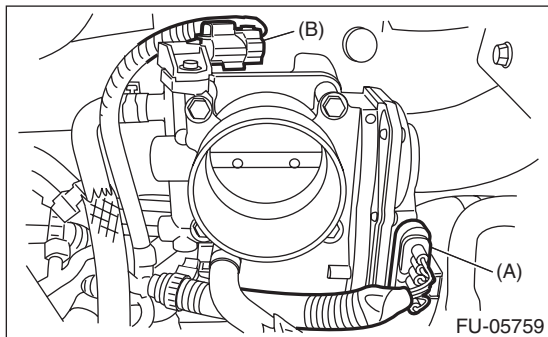

- 7) Disconnect the engine coolant hose from throttle body.

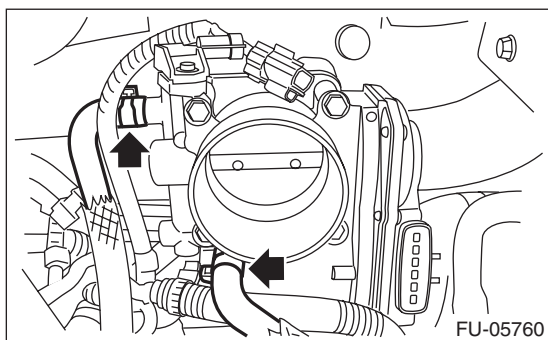

- 8) Remove the throttle body from the intake manifold.

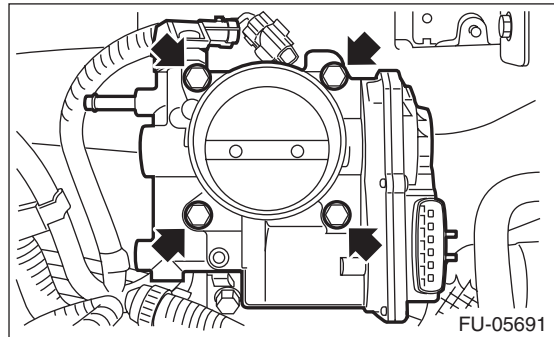

### B: INSTALLATION

Install in the reverse order of removal.

#### NOTE:

Use a new gasket.

#### Tightening torque:

**8 N·m (0.8 kgf-m, 5.9 ft-lb)**

### C: INSPECTION

#### 1. THROTTLE SENSOR INSPECTION (METHOD WITH CIRCUIT TESTER)

- 1) Remove the lower inner trim of passenger's side. <Ref. to EI-57, REMOVAL, Lower Inner Trim.>
- 2) Turn over the floor mat of passenger's seat.
- 3) Remove the protect cover.

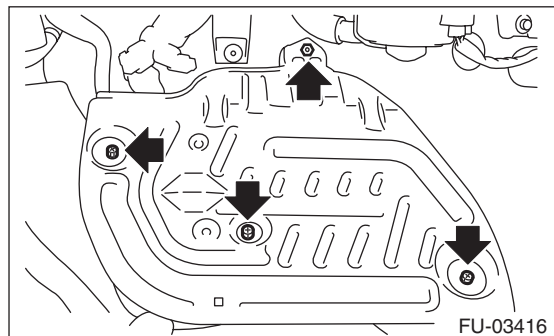

- 4) Remove the nuts and bolts which hold the ECM to the bracket.

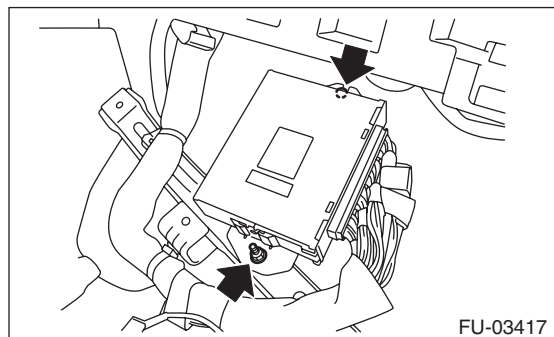

- 5) Turn the ignition switch to ON. (engine OFF)

# Throttle Body

## FUEL INJECTION (FUEL SYSTEMS)

6) Measure the voltage between ECM connector terminals.

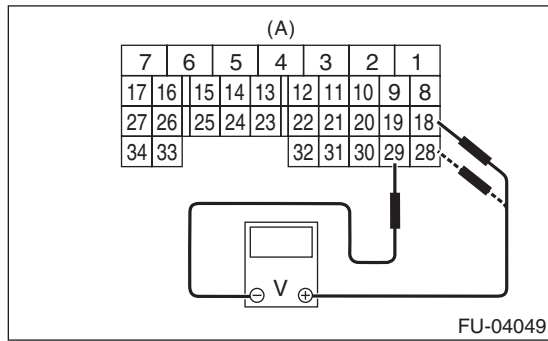

(A) To ECM connector

Throttle sensor	Accelerator pedal	Terminal No.	Standard
Main	Not depressed (Full closed)	18 (+) and 29 (-)	Approx. 0.6 V
	Depressed (Full opened)		Approx. 3.96 V
Sub	Not depressed (Full closed)	28 (+) and 29 (-)	Approx. 1.48 V
	Depressed (Full opened)		Approx. 4.17 V

7) After inspection, install the related parts in the reverse order of removal.

### **Tightening torque:**

**7.5 N·m (0.8 kgf-m, 5.5 ft-lb)**

## 2. THROTTLE SENSOR INSPECTION (METHOD WITH SUBARU SELECT MONITOR)

- 1) Turn the ignition switch to ON. (engine OFF)
- 2) Read the throttle opening angle signal and voltage of throttle sensor using Subaru Select Monitor. <Ref. to EN(H4DOTC)(diag)-41, READ CURRENT DATA FOR ENGINE (NORMAL MODE), OPERATION, Subaru Select Monitor.>

Throttle sensor	Throttle opening angle signal	Standard
Main	0.0%	Approx. 0.6 V
	100.0%	Approx. 3.96 V
Sub	0.0%	Approx. 1.48 V
	100.0%	Approx. 4.17 V

## 3. OTHER INSPECTIONS

- 1) Check that the throttle body has no deformation, cracks or other damages.
- 2) Check that the engine coolant hose has no cracks, damage or loose part.

## 3. Intake Manifold

### A: REMOVAL

1) Remove the V-belt covers.

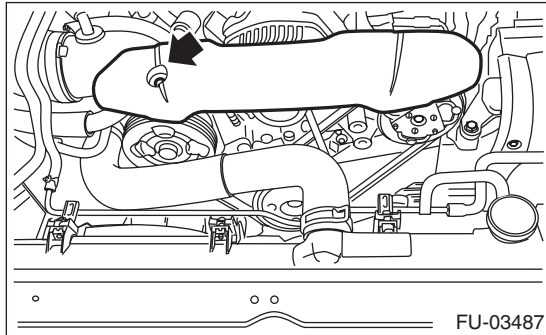

2) Collect the refrigerant from A/C system. <Ref. to AC-20, PROCEDURE, Refrigerant Recovery Procedure.>

3) Release the fuel pressure. <Ref. to FU(STI)-67, RELEASING OF FUEL PRESSURE, PROCEDURE, Fuel.>

4) Disconnect the ground cable from battery.

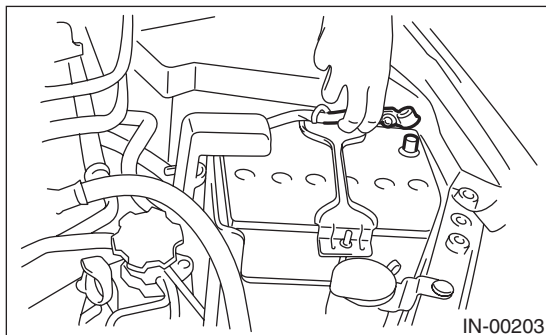

5) Open the fuel filler lid and remove the fuel filler cap.

6) Lift up the vehicle.

7) Remove the under cover. <Ref. to EI-28, REMOVAL, Front Under Cover.>

8) Drain approximately 3.0 ℓ (3.2 US qt, 2.6 Imp qt) of coolant. <Ref. to CO(STI)-13, DRAINING OF ENGINE COOLANT, REPLACEMENT, Engine Coolant.>

9) Remove the air intake duct. <Ref. to IN(STI)-10, REMOVAL, Air Intake Duct.>

10) Remove the air intake boot.

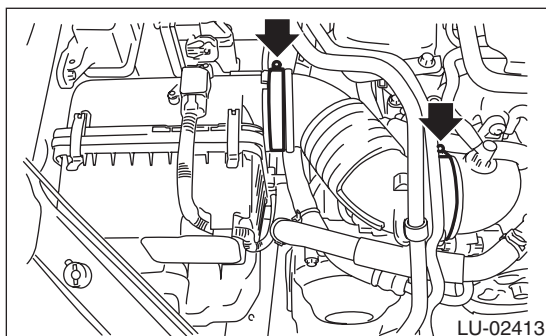

11) Remove the intercooler. <Ref. to IN(STI)-12, REMOVAL, Intercooler.>

12) Remove the generator. <Ref. to SC(STI)-21, REMOVAL, Generator.>

13) Remove the coolant filler tank. <Ref. to CO(STI)-28, REMOVAL, Coolant Filler Tank.>

14) Disconnect the A/C pressure hoses from A/C compressor. <Ref. to AC-40, REMOVAL, Hose and Pipe.>

15) Disconnect the engine coolant hose from throttle body.

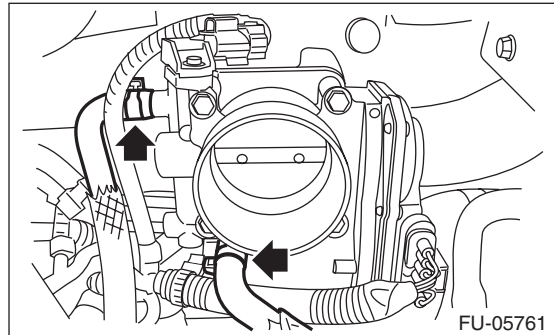

16) Disconnect the brake booster vacuum hose (A) and pressure regulator vacuum hose (B) from the intake manifold.

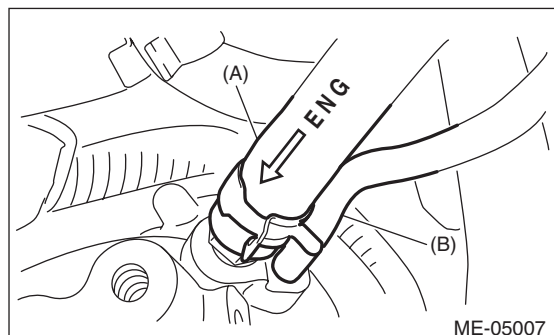

17) Disconnect the connector from the PCV hose assembly A.





# Intake Manifold

## FUEL INJECTION (FUEL SYSTEMS)

18) Remove the PCV hose assembly A from clip (A), and remove the vacuum hose from clip (B).

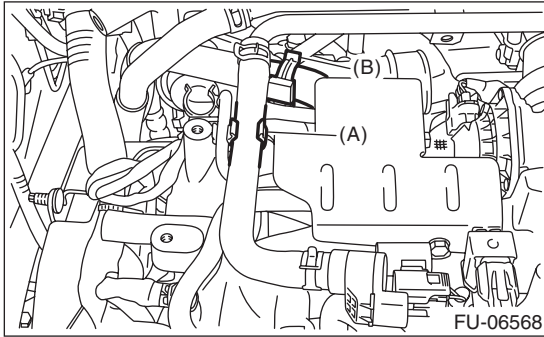

19) Disconnect the vacuum hose (A) and the connector (B) from the PCV hose assembly B.

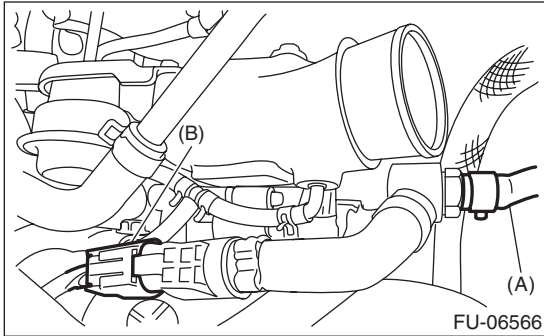

20) Disconnect the air control hose (A) from the waste gate actuator, and loosen the clamp which holds the intake duct to the turbocharger.

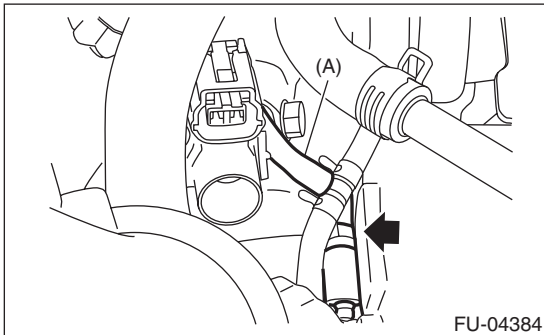

21) Remove the engine coolant hose from the water tank pipe.

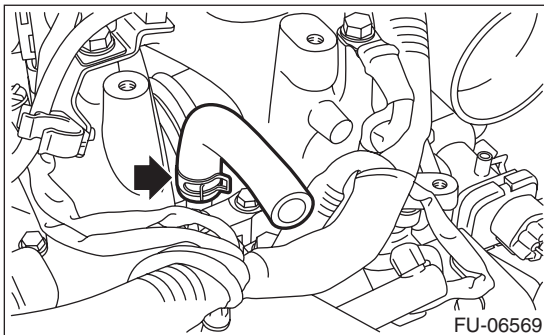

22) Remove the engine harness from clip (A).

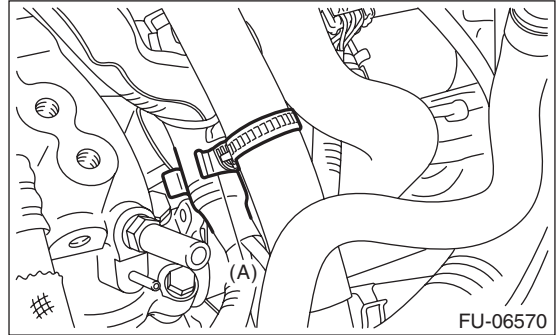

23) Disconnect the bulkhead harness connectors from the engine harness connectors.

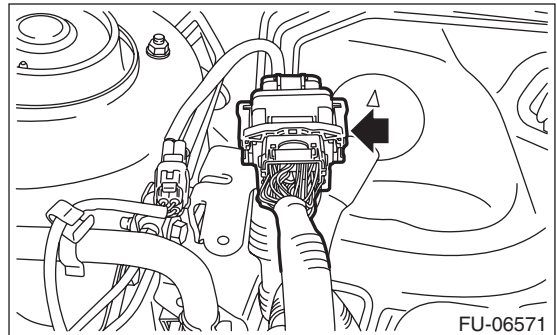

24) Remove the engine harness connector from the engine harness bracket.

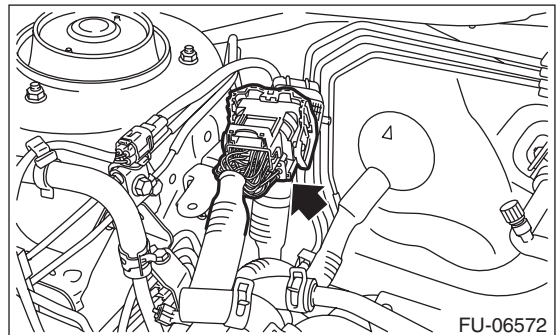

25) Disconnect the connector (A) from the engine coolant temperature sensor, connector (B) from the oil pressure switch, and connector (C) from the crankshaft position sensor.

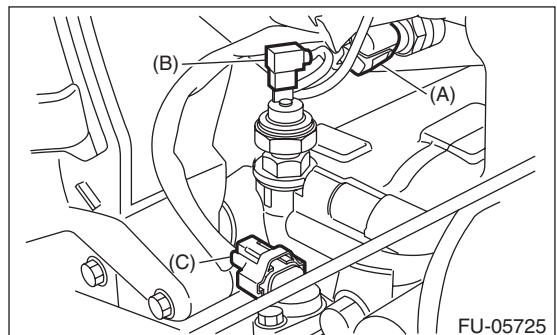

# Intake Manifold

## FUEL INJECTION (FUEL SYSTEMS)

26) Disconnect the connector from power steering pump switch.

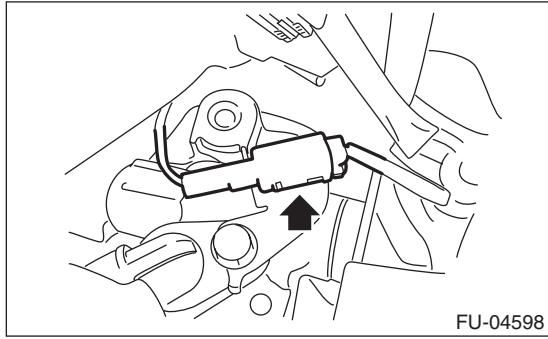

27) Disconnect the connector from the knock sensor.

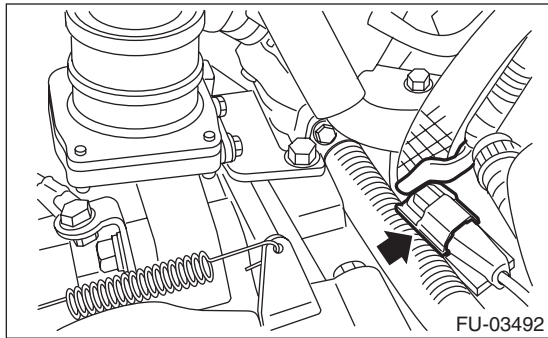

28) Disconnect the connector from the secondary air combination valve.

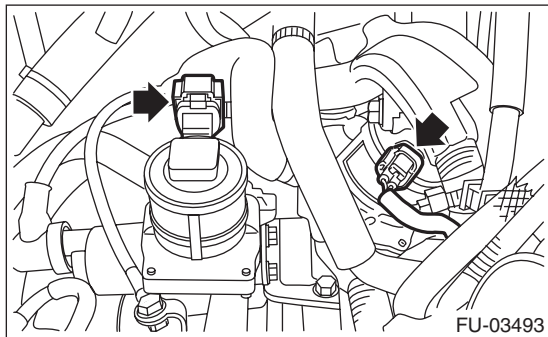

29) Disconnect the connector from the intake camshaft position sensor.

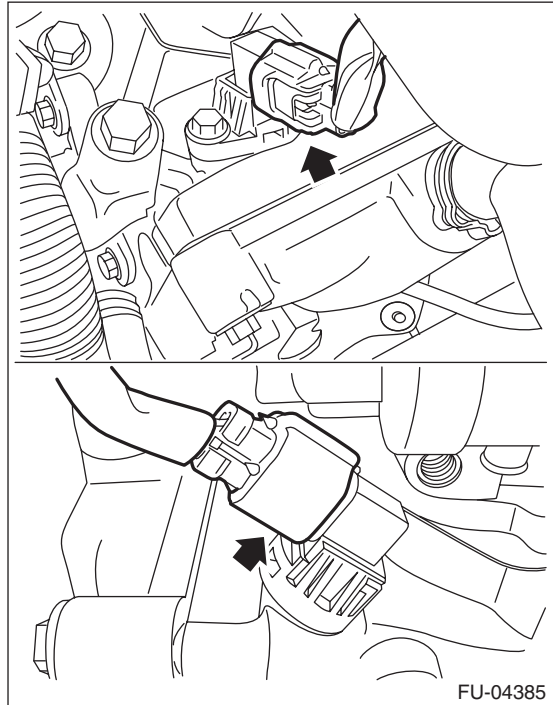

30) Disconnect the connector from the intake oil flow control solenoid valve.

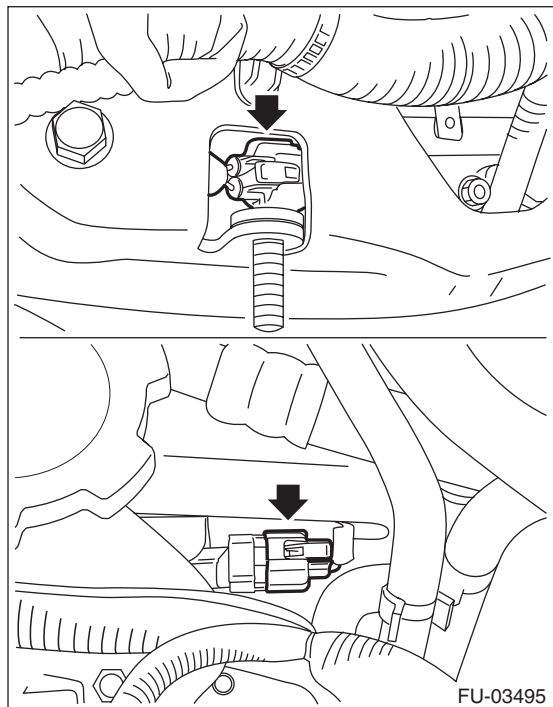

31) Lift up the vehicle.

# Intake Manifold

## FUEL INJECTION (FUEL SYSTEMS)

32) Remove the engine harness cover. (right side only.)

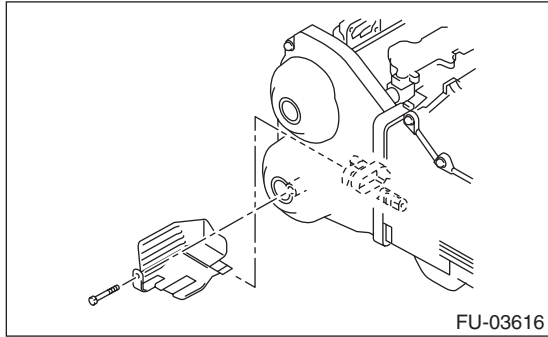

33) Disconnect connector (A) from the exhaust camshaft position sensor, connector (B) from the exhaust oil flow control solenoid valve, and connector (C) from the ignition coil.

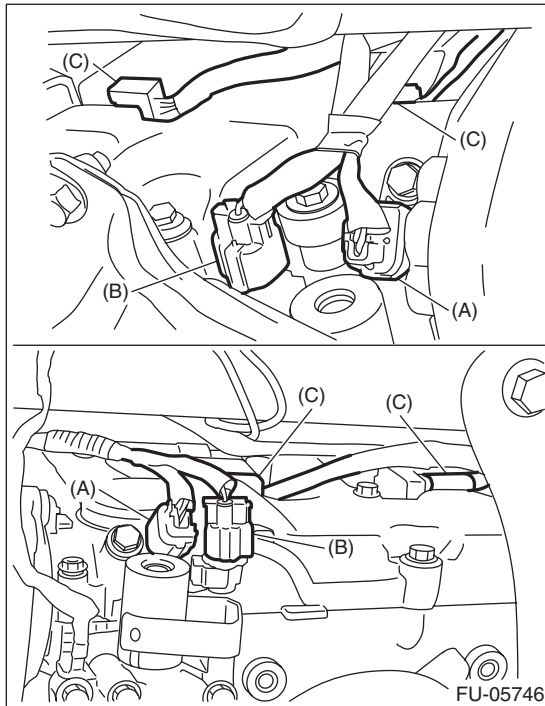

34) Lower the vehicle.

35) Remove the clip (A) which hold the engine harness to the rocker cover RH.

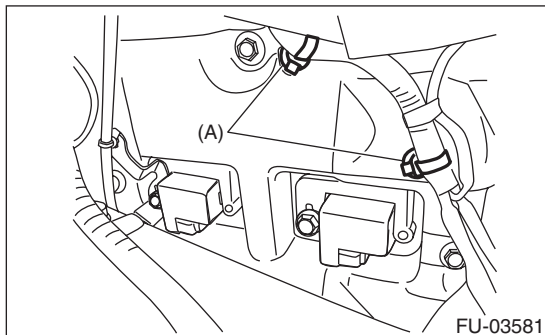

36) Remove the bolts that secure the air duct to the rocker cover LH, and remove the engine harness.

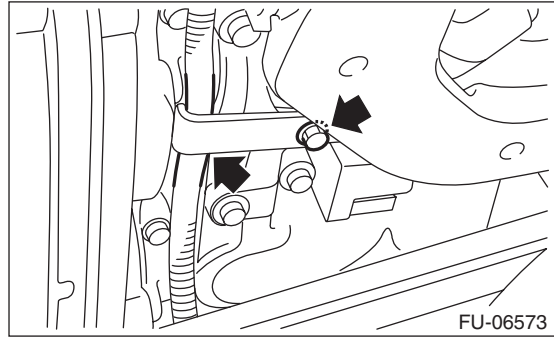

37) Disconnect the fuel delivery hose, fuel return hose and evaporation hose.

### CAUTION:

- Be careful not to spill fuel.
- Catch the fuel from hoses using a container or cloth.

(1) Set the ST to the fuel pipe.

ST 42099AE000 QUICK CONNECTOR RELEASE

(2) Disconnect the quick connector of the fuel delivery hose and fuel return hose by pushing the ST in the direction of the arrow.

(3) Remove the clip and disconnect the evaporation hose from the fuel pipe.

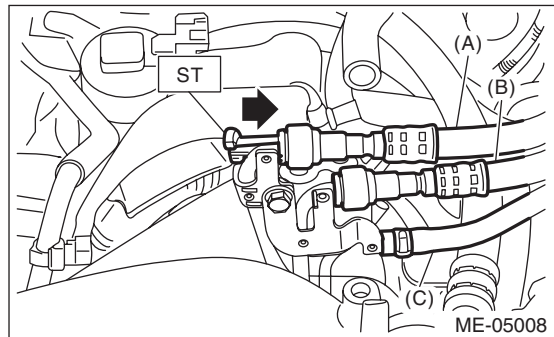

- (A) Fuel delivery hose
- (B) Fuel return hose
- (C) Evaporation hose

# Intake Manifold

## FUEL INJECTION (FUEL SYSTEMS)

38) Remove the intake manifold from cylinder head.

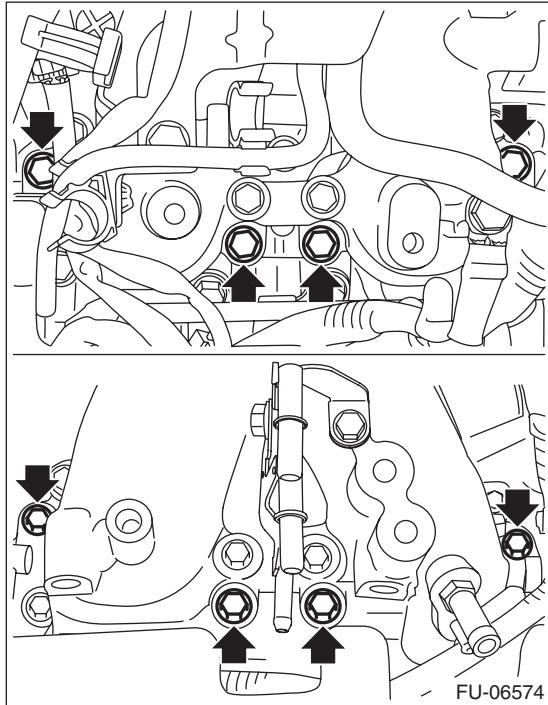

2) Connect the fuel delivery hose, fuel return hose, and evaporation hose.

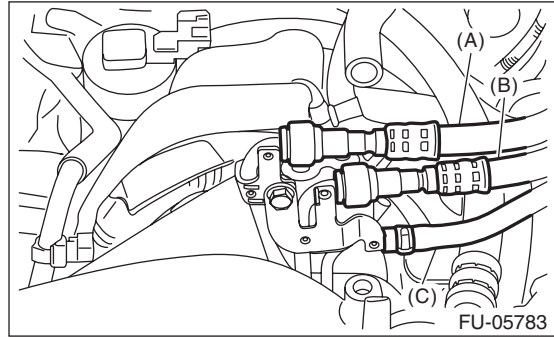

- (A) Fuel delivery hose
- (B) Fuel return hose
- (C) Evaporation hose

3) Fix the engine harness to the rocker cover LH with the air duct.

**Tightening torque:**  
**6.4 N·m (0.7 kgf·m, 4.7 ft·lb)**

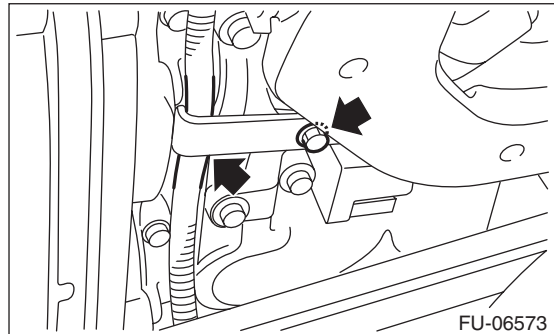

## B: INSTALLATION

1) Install the intake manifold onto cylinder heads.

NOTE:

Use a new gasket.

**Tightening torque:**  
**25 N·m (2.5 kgf·m, 18.4 ft·lb)**

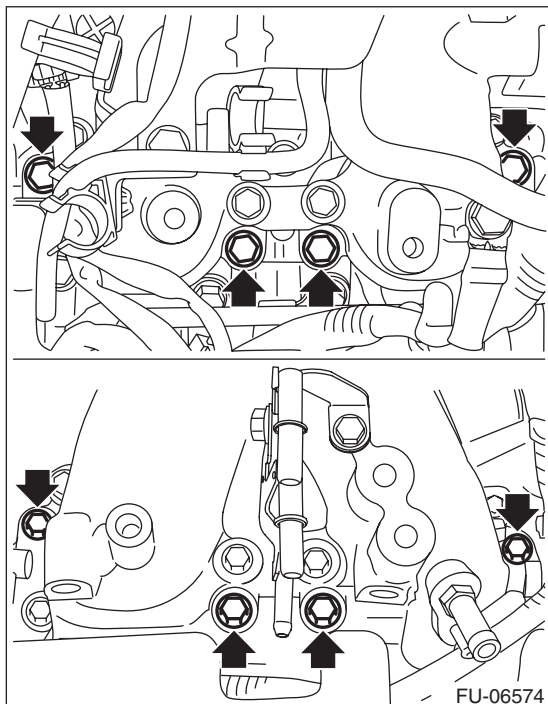

4) Fix the engine harness to the rocker cover RH with clips (A).

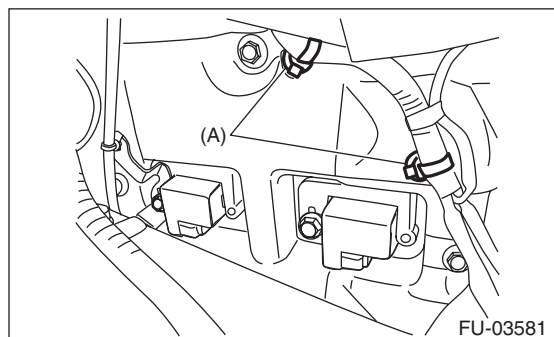

5) Lift up the vehicle.



# Intake Manifold

## FUEL INJECTION (FUEL SYSTEMS)

6) Connect connector (A) to the exhaust camshaft position sensor, connector (B) to the exhaust oil flow control solenoid valve, connector (C) to the ignition coil.

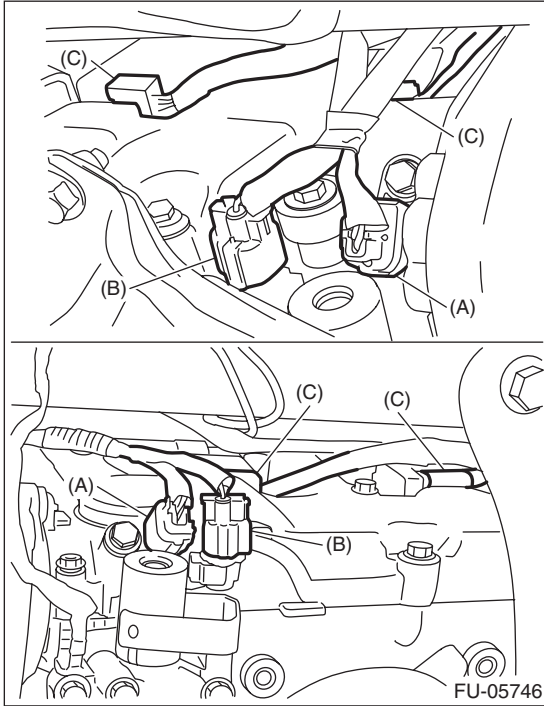

7) Install the engine harness cover. (right side only.)

**Tightening torque:**

**5 N·m (0.5 kgf·m, 3.7 ft·lb)**

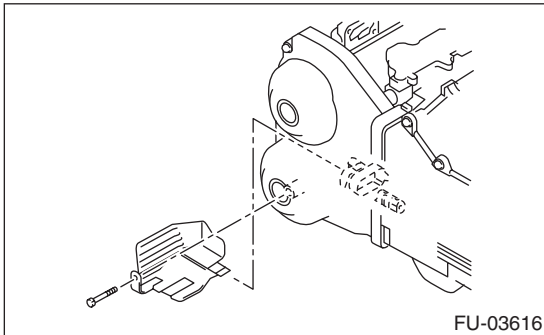

8) Lower the vehicle.

9) Connect the connector to the intake oil flow control solenoid valve.

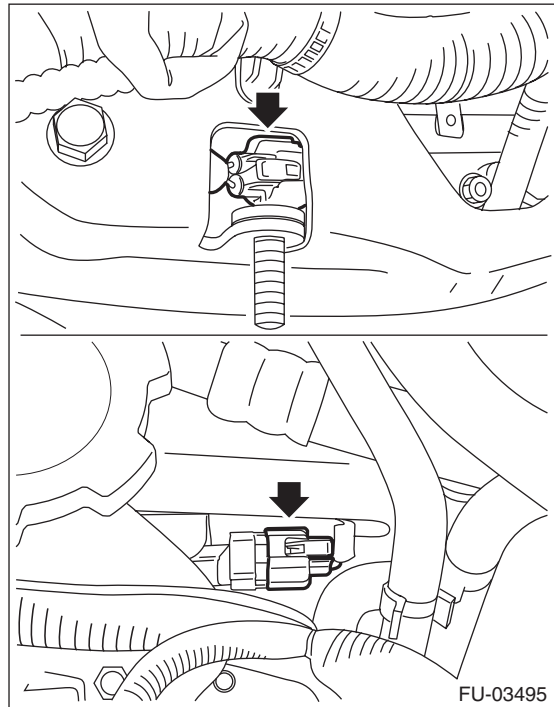

10) Connect the connector to the intake camshaft position sensor.

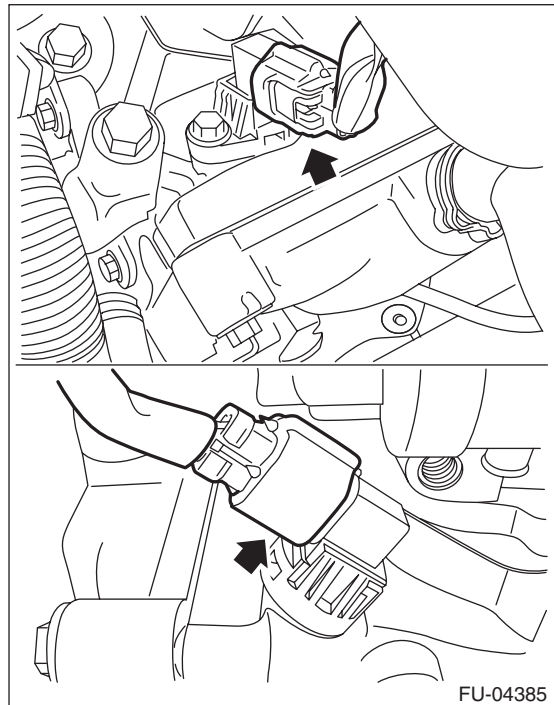

# Intake Manifold

## FUEL INJECTION (FUEL SYSTEMS)

11) Connect the connector to the secondary air combination valve.

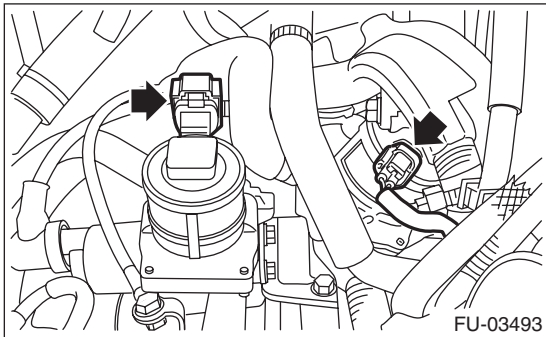

12) Connect the connector to the knock sensor.

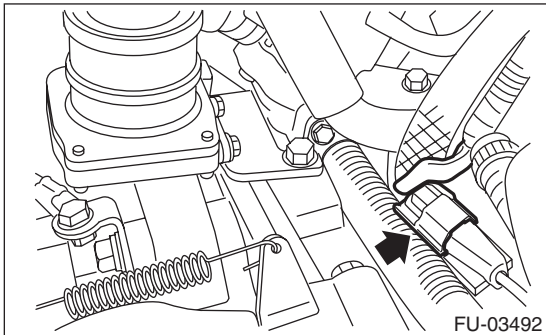

13) Connect the connector to the power steering pump switch.

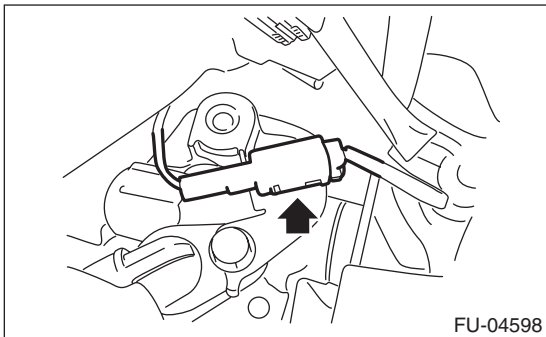

14) Connect the connector (A) to the engine coolant temperature sensor, connector (B) to the oil pressure switch, and the connector (C) to the crankshaft position sensor.

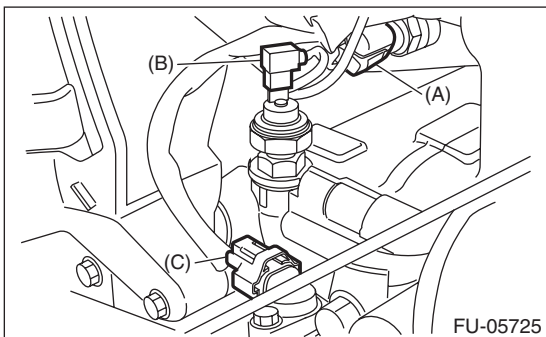

15) Install the engine harness connector to engine harness bracket, then connect the bulkhead harness connector to the engine harness connector.

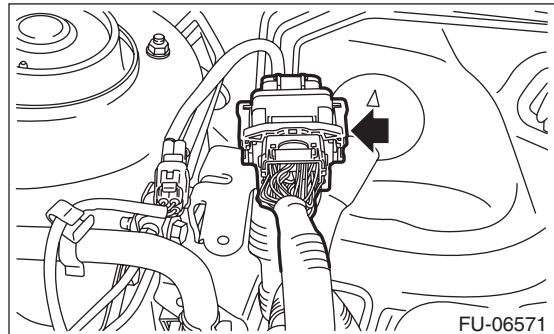

16) Install the engine harness to clip (A).

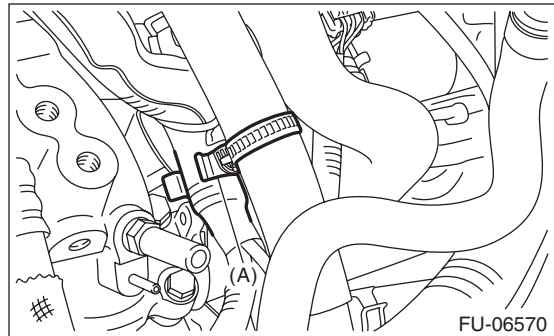

17) Install the engine coolant hose to the water tank pipe.

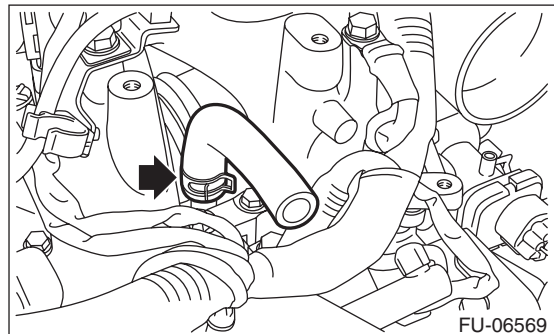

18) Connect the air control hose (A) to the wastegate actuator, and install the turbocharger to the intake duct.

**Tightening torque:**  
**3 N·m (0.3 kgf·m, 2.2 ft·lb)**

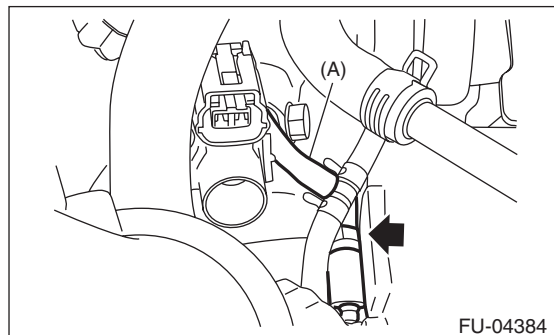

# Intake Manifold

## FUEL INJECTION (FUEL SYSTEMS)

19) Connect the vacuum hose (A) and connector (B) to the PCV hose assembly B.

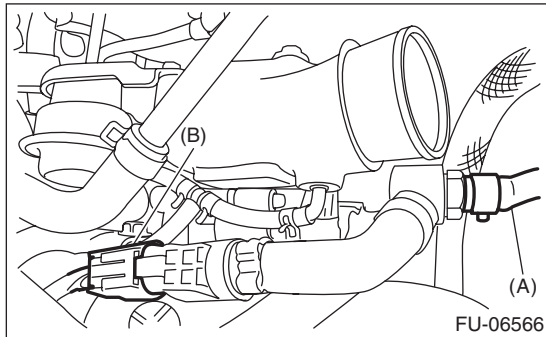

20) Install the vacuum hose to clip (B), and install the PCV hose assembly A to clip (A).

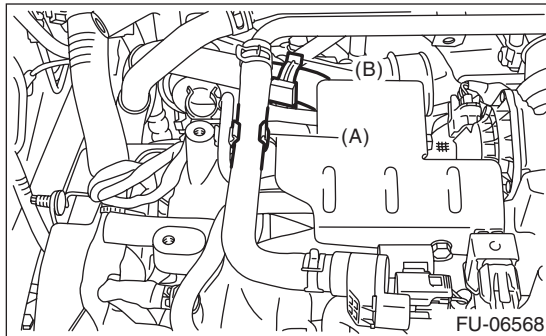

21) Connect the connector to the PCV hose assembly A.

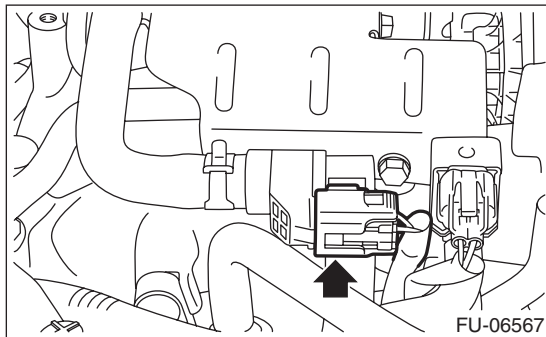

22) Connect the brake booster vacuum hose (A) and pressure regulator vacuum hose (B) to the intake manifold.

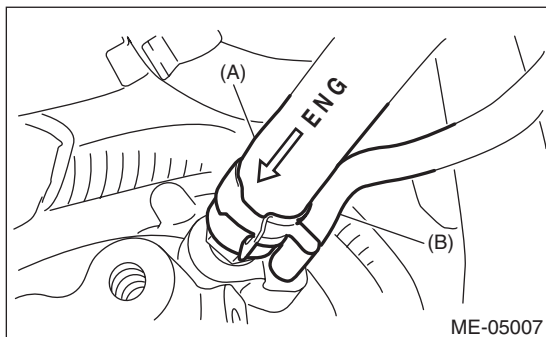

23) Connect the engine coolant hoses to throttle body.

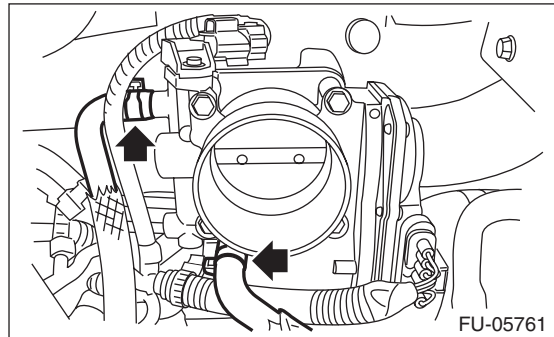

24) Install the A/C pressure hoses to A/C compressor. <Ref. to AC-40, INSTALLATION, Hose and Pipe.>

25) Install the coolant filler tank. <Ref. to CO(STI)-28, INSTALLATION, Coolant Filler Tank.>

26) Install the generator. <Ref. to SC(STI)-21, INSTALLATION, Generator.>

27) Install the intercooler. <Ref. to IN(STI)-13, INSTALLATION, Intercooler.>

28) Install the air intake boot.

### Tightening torque:

**2.5 N·m (0.3 kgf·m, 1.8 ft·lb)**

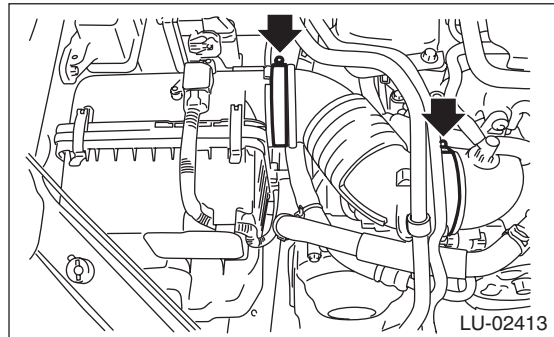

29) Install the air intake duct. <Ref. to IN(STI)-10, INSTALLATION, Air Intake Duct.>

30) Connect the battery ground terminal.

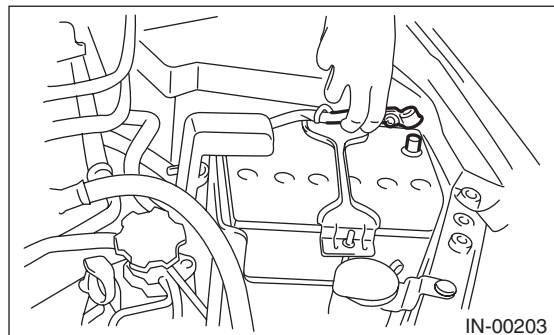

31) Lift up the vehicle.

32) Install the under cover. <Ref. to EI-28, INSTALLATION, Front Under Cover.>

33) Lower the vehicle.

34) Install the V-belt cover.

# Intake Manifold

FUEL INJECTION (FUEL SYSTEMS)

## Tightening torque:

13 N·m (1.3 kgf·m, 9.6 ft·lb)

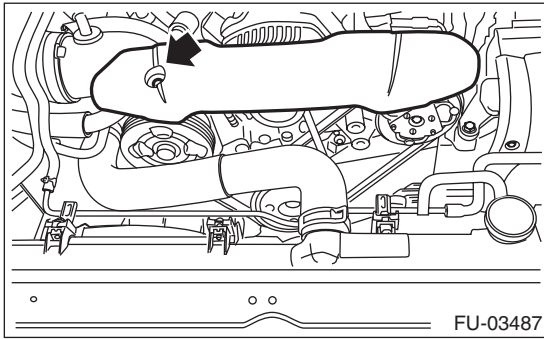

35) Fill engine coolant. <Ref. to CO(STI)-13, FILLING OF ENGINE COOLANT, REPLACEMENT, Engine Coolant.>

36) Charge the A/C system with refrigerant. <Ref. to AC-21, PROCEDURE, Refrigerant Charging Procedure.>

## C: DISASSEMBLY

1) Remove clamp (A) holding the fuel pipe protector RH to the engine harness, and remove the fuel pipe protector RH.

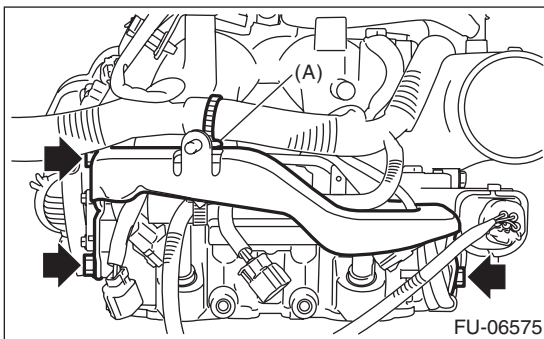

2) Remove the fuel pipe protector LH.

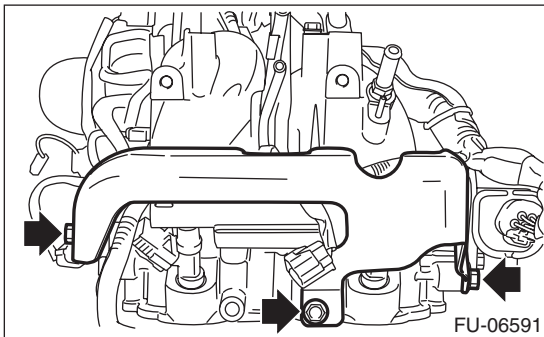

3) Remove the connector from the intake duct.

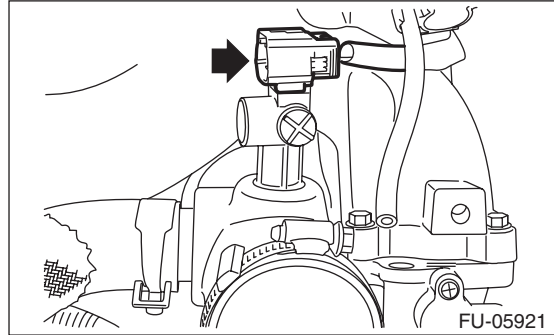

4) Remove the connector from the PCV hose assembly.

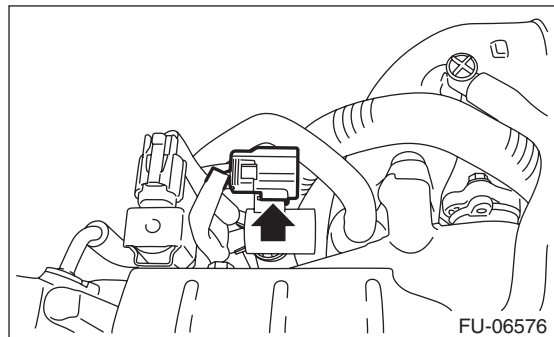

5) Remove purge control solenoid valve 1 (A) and purge control solenoid valve 2 (B).

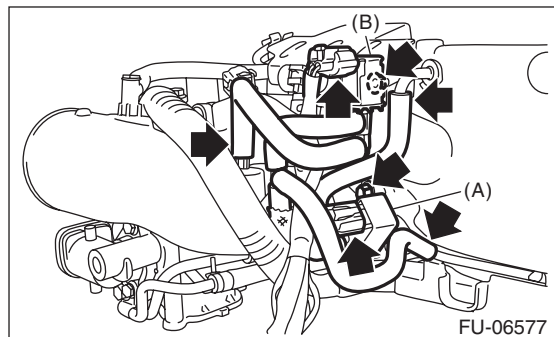

6) Disconnect the connector (A) from the wastegate control solenoid valve, and disconnect the vacuum hose (B) from the intake duct.

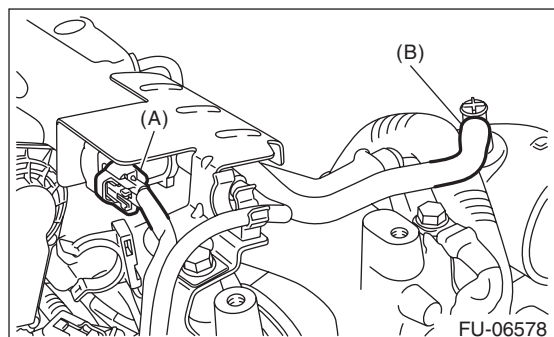



# Intake Manifold

## FUEL INJECTION (FUEL SYSTEMS)

7) Remove the solenoid valve bracket together with the wastegate control solenoid valve.

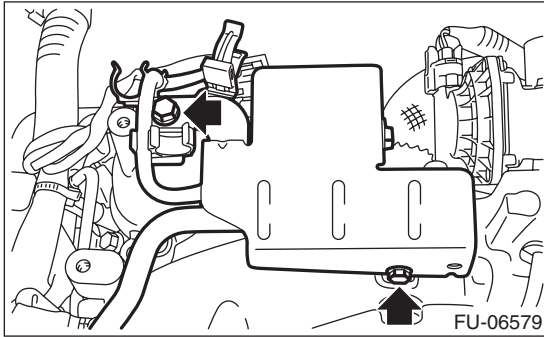

8) Remove the engine ground terminals from the intake manifold.

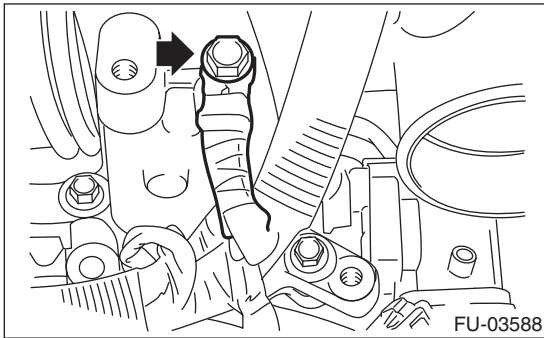

9) Disconnect the connector (A) from the throttle position sensor, and the connector (B) from the manifold pressure sensor.

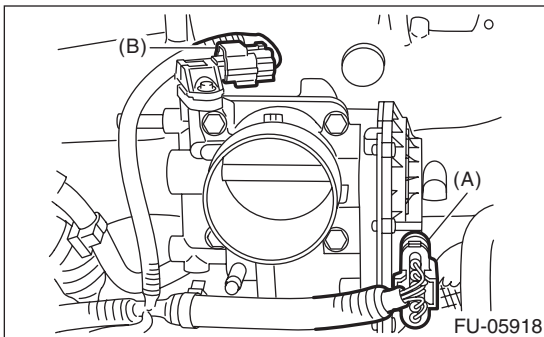

10) Remove clip (A) holding the engine harness and vacuum hose, clip (B) holding the engine harness to the engine harness stay, and the bolt holding the engine harness to the intake manifold.

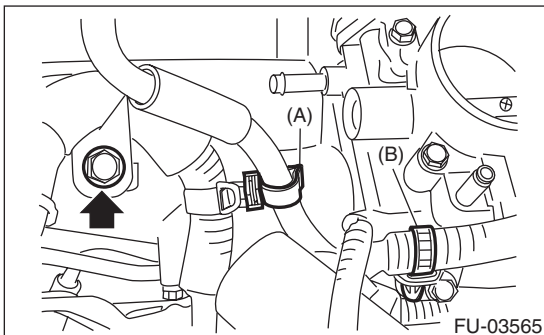

11) Remove the throttle body from the intake manifold.

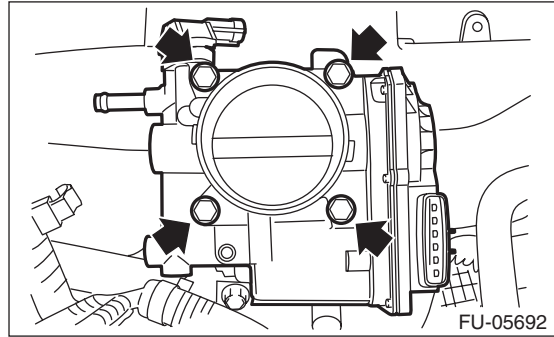

12) Remove the harness band (A) which holds the engine harness to the fuel injector pipe.

- RH side

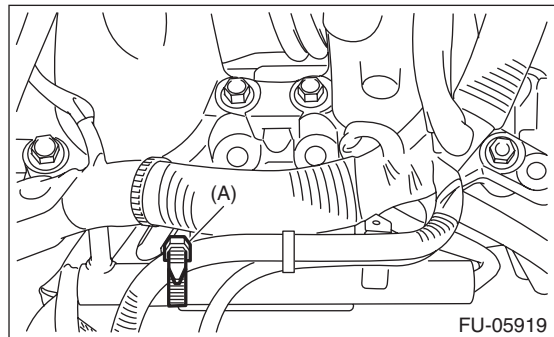

- LH side

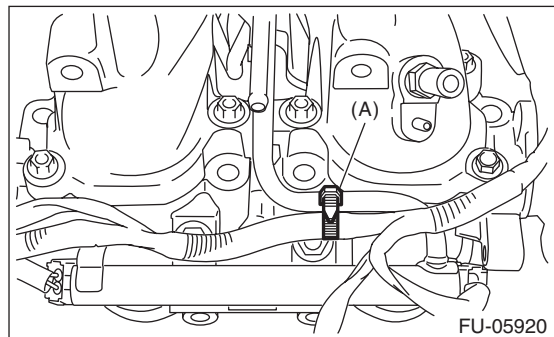

13) Disconnect the connector from fuel injector.

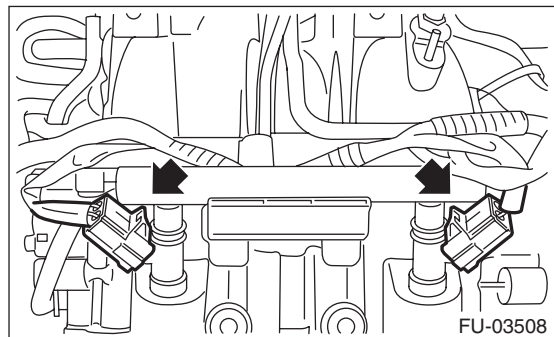

# Intake Manifold

## FUEL INJECTION (FUEL SYSTEMS)

14) Disconnect the connector from the tumble generator valve assembly.

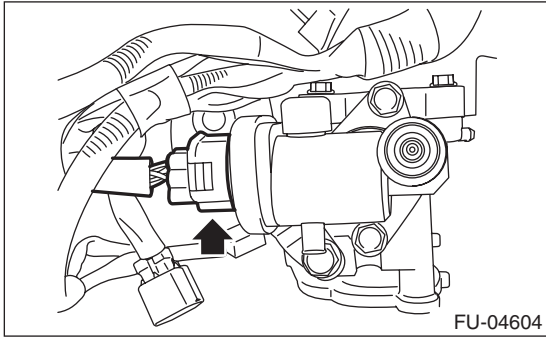

15) Remove the bolts which hold fuel injector pipe.

• RH side

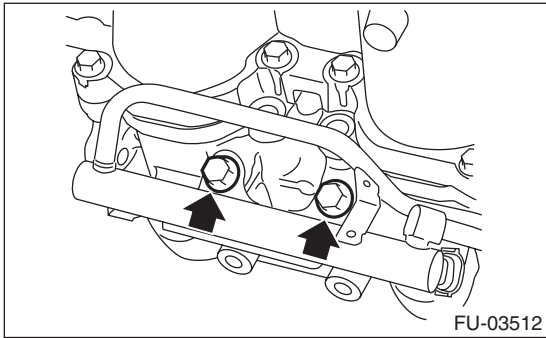

• LH side

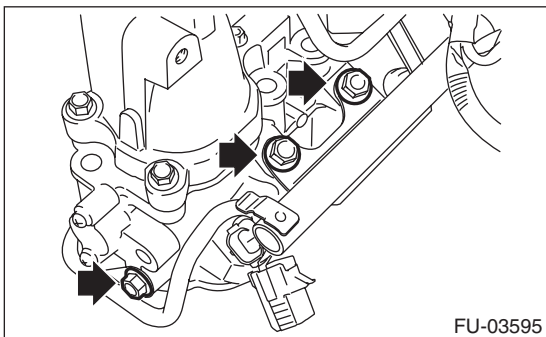
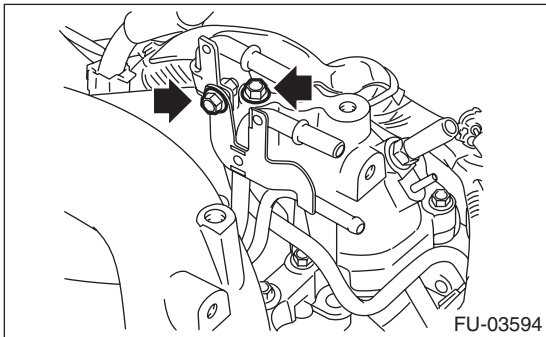

16) Remove the fuel injector.

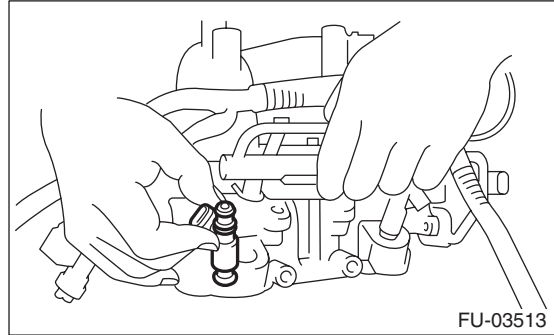

17) Remove the harness brackets holding the engine harness to the intake manifold, and remove the engine harness.

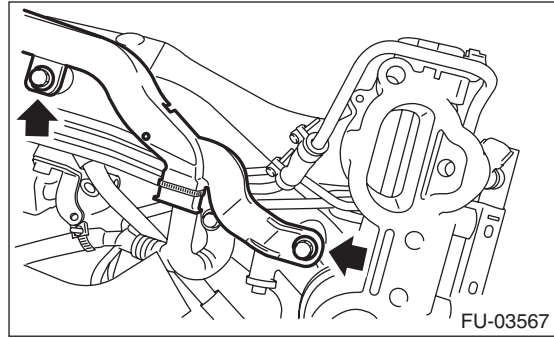

18) Loosen the clamp holding the RH side fuel hose to the fuel injector pipe RH, and remove the fuel injector pipe RH.

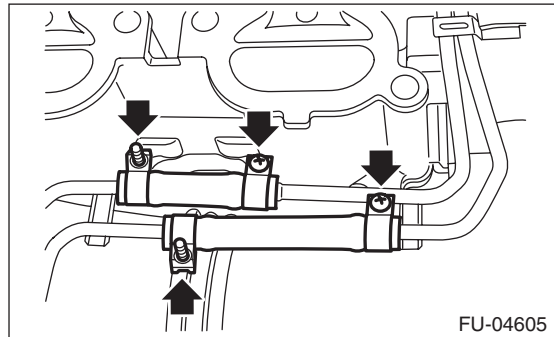

19) Loosen the clamp holding the LH side fuel hose to the fuel injector pipe LH, and remove the fuel injector pipe LH.

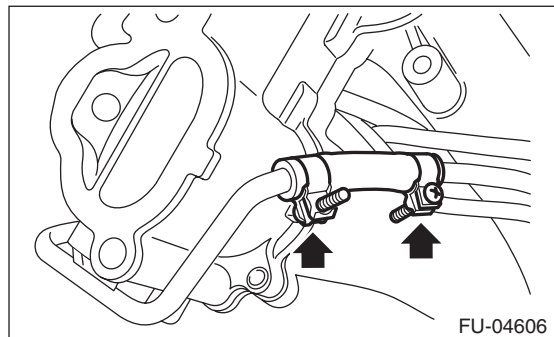

# Intake Manifold

## FUEL INJECTION (FUEL SYSTEMS)

20) Remove the bolts holding the fuel pipe assembly to the intake manifold, and remove the fuel pipe assembly.

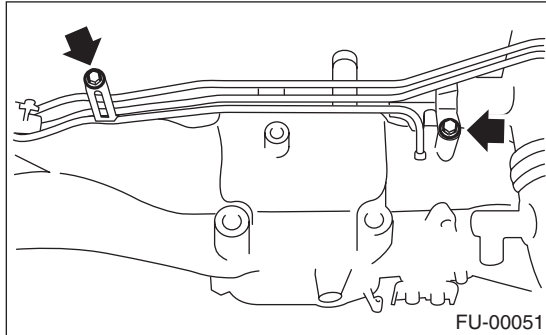

21) Remove the intake duct from intake manifold.

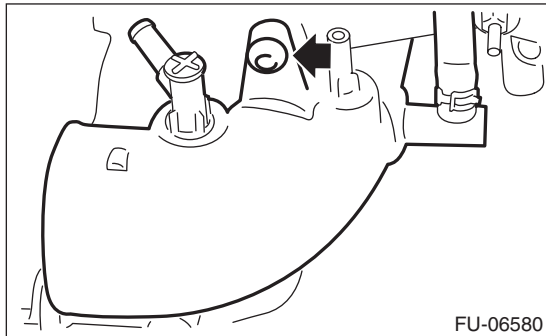

22) Remove the tumble generator valve assembly from the intake manifold.

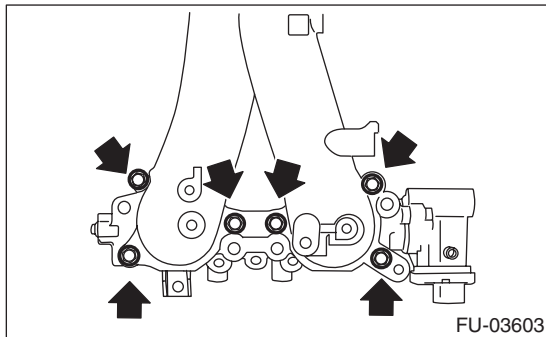

23) Remove the nipple from the intake manifold.

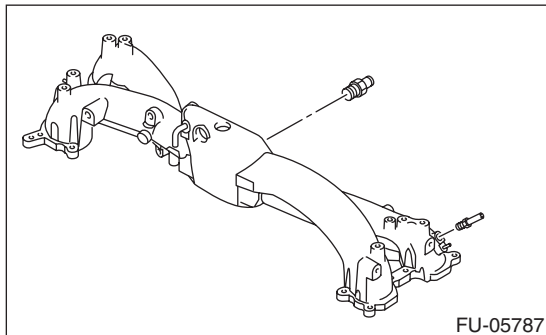

## D: ASSEMBLY

1) Apply liquid gasket to the nipple threads, and install the nipple to the intake manifold.

**Liquid gasket:**

**THREE BOND 1105 (Part No. 004403010)**

**Tightening torque:**

**T1: 17 N·m (1.7 kgf-m, 12.5 ft-lb)**

**T2: 25 N·m (2.5 kgf-m, 18.4 ft-lb)**

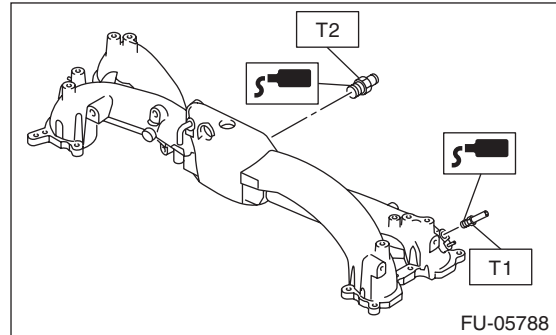

2) Install the tumble generator valve assembly onto intake manifold.

**NOTE:**

Use a new gasket.

**Tightening torque:**

**8.25 N·m (0.8 kgf-m, 6.1 ft-lb)**

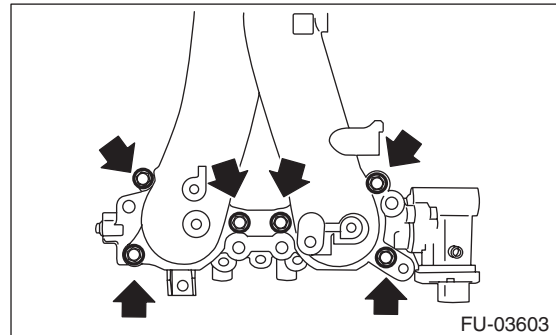

3) Install the air intake duct to the intake manifold.

**Tightening torque:**

**17 N·m (1.7 kgf-m, 12.5 ft-lb)**

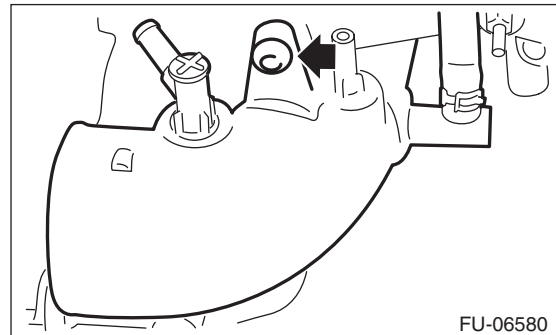

# Intake Manifold

## FUEL INJECTION (FUEL SYSTEMS)

4) Install the fuel pipe assembly to the intake manifold.

**Tightening torque:**

**6.4 N·m (0.7 kgf-m, 4.7 ft-lb)**

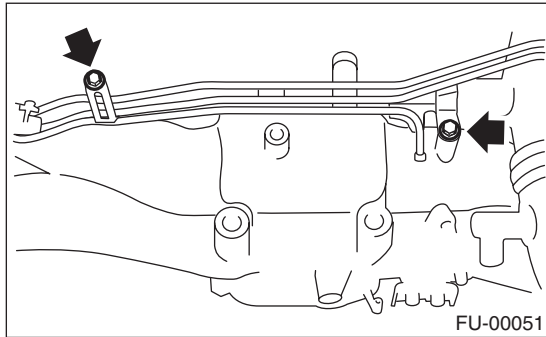

5) Install the fuel injector pipe LH and connect the LH side fuel hose to the fuel injector pipe LH. <Ref. to FU(STI)-97, CONNECTING FUEL DELIVERY HOSE, FUEL RETURN HOSE AND FUEL HOSE, INSTALLATION, Fuel Delivery, Return and Evaporation Lines.>

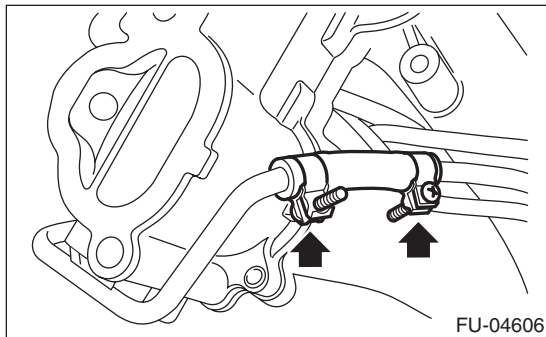

6) Install the fuel injector pipe RH and connect the RH side fuel hose to the fuel injector pipe RH. <Ref. to FU(STI)-97, CONNECTING FUEL DELIVERY HOSE, FUEL RETURN HOSE AND FUEL HOSE, INSTALLATION, Fuel Delivery, Return and Evaporation Lines.>

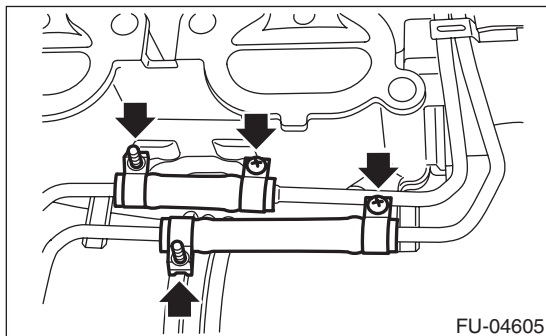

7) Install the engine harness to the intake manifold and attach the harness brackets holding the engine harness.

**Tightening torque:**

**19 N·m (1.9 kgf-m, 14.0 ft-lb)**

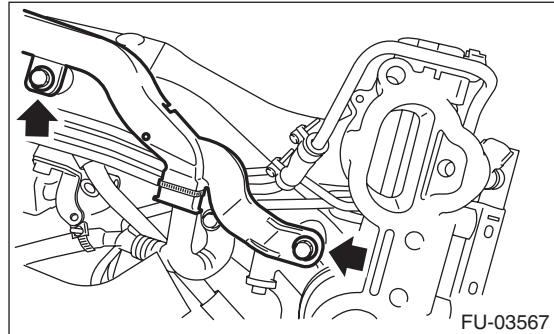

8) Install the fuel injector.

**NOTE:**

Use new O-rings.

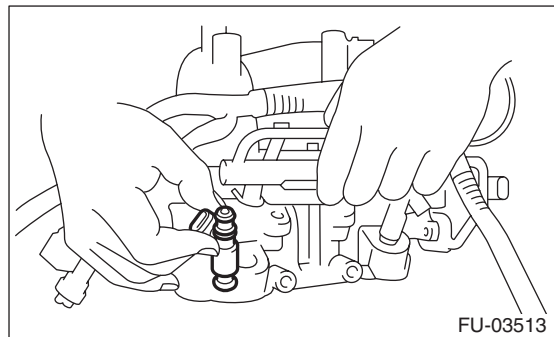

9) Install the bolts which hold fuel injector pipe.  
• RH side

**Tightening torque:**

**19 N·m (1.9 kgf-m, 14.0 ft-lb)**

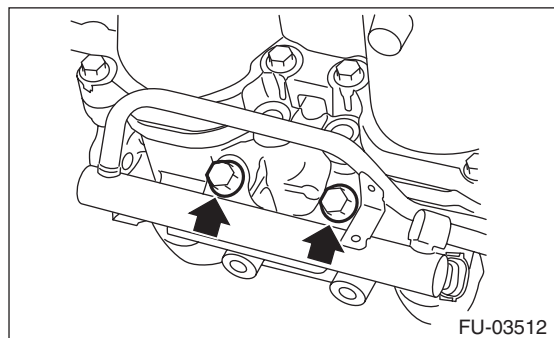

# Intake Manifold

## FUEL INJECTION (FUEL SYSTEMS)

- LH side

**Tightening torque:**

**6.4 N·m (0.7 kgf·m, 4.7 ft·lb)**

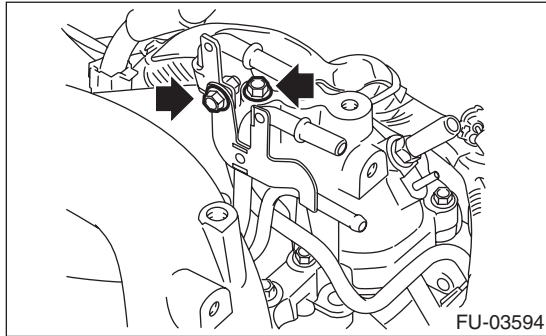

**Tightening torque:**

**19 N·m (1.9 kgf·m, 14.0 ft·lb)**

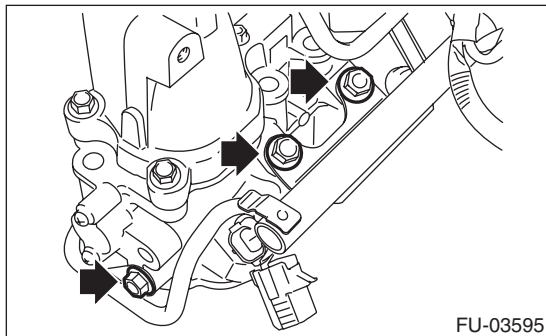

- 10) Connect the connector to the tumble generator valve assembly.

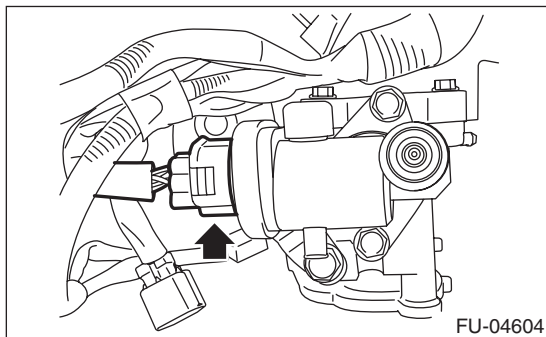

- 11) Connect the connectors to the fuel injector.

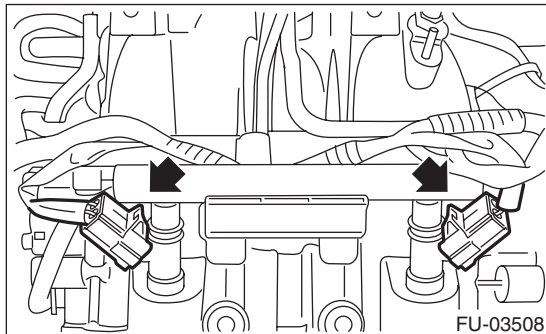

- 12) Secure the engine harness to the fuel injector pipe with the harness band (A).

- RH side

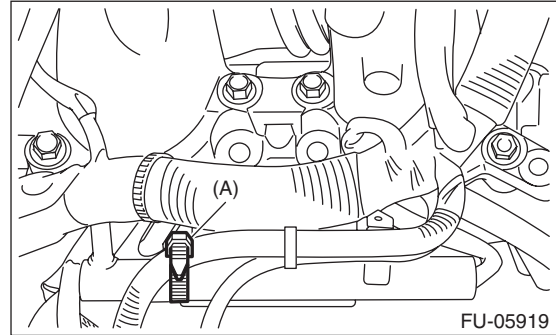

- LH side

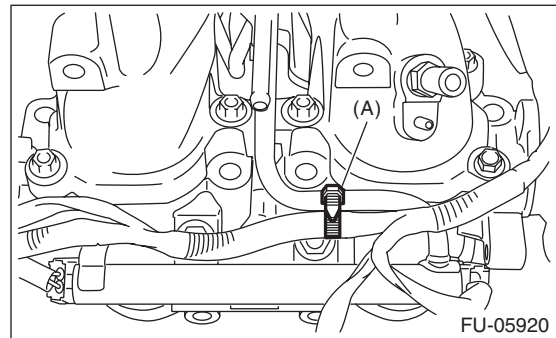

- 13) Install the throttle body to the intake manifold.

**NOTE:**

Use a new gasket.

**Tightening torque:**

**8 N·m (0.8 kgf·m, 5.9 ft·lb)**

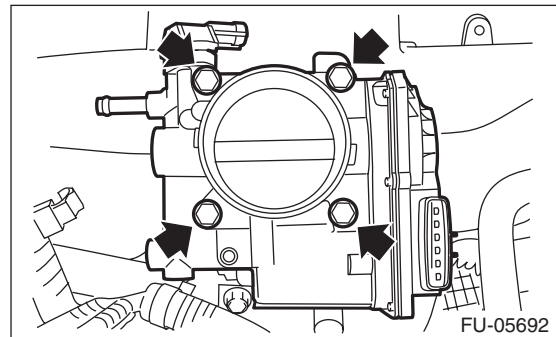

**FU(STI)-30**

Brought to you by Ebay Seller "SubaruManuals"



# Intake Manifold

## FUEL INJECTION (FUEL SYSTEMS)

14) Secure the engine harness and vacuum hose using the clip (A), and secure the engine harness to the engine harness stay using the clip (B), and install the bolt which holds the engine harness to the intake manifold.

**Tightening torque:**

**19 N·m (1.9 kgf-m, 14.0 ft-lb)**

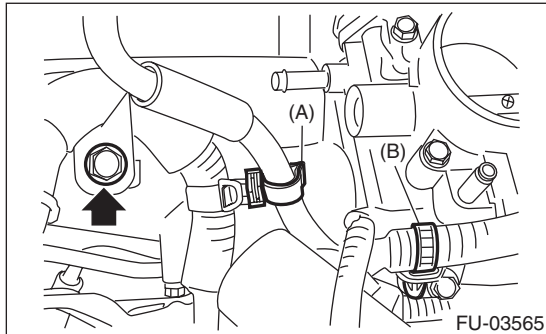

15) Connect connector (A) to the throttle position sensor and connector (B) to the manifold pressure sensor.

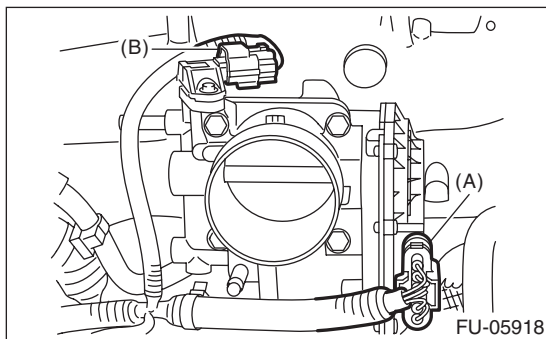

16) Install the engine ground terminal to intake manifold.

**Tightening torque:**

**19 N·m (1.9 kgf-m, 14.0 ft-lb)**

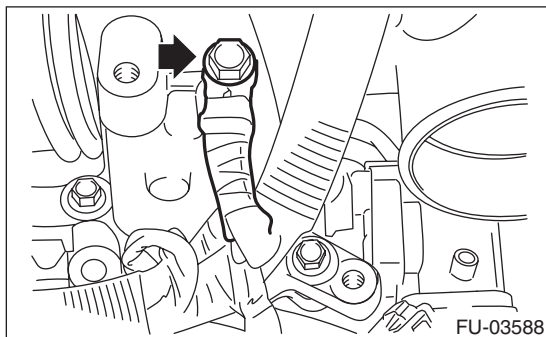

17) Install the solenoid valve bracket together with the wastegate control solenoid valve.

**Tightening torque:**

**T1: 6.4 N·m (0.7 kgf-m, 4.7 ft-lb)**

**T2: 19 N·m (1.9 kgf-m, 14.0 ft-lb)**

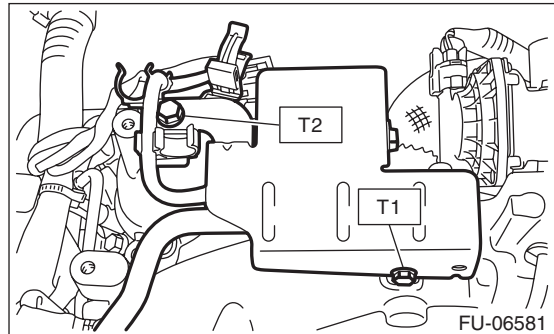

18) Connect the vacuum hose (B) to the intake duct, then connect the connector (A) to the wastegate control solenoid valve.

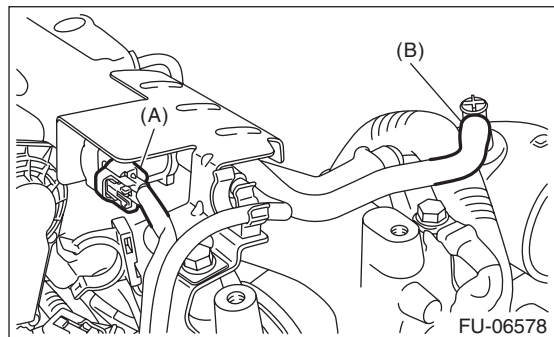

# Intake Manifold

## FUEL INJECTION (FUEL SYSTEMS)

19) Install purge control solenoid valve 1 and purge control solenoid valve 2.

### NOTE:

Connect the vacuum hose and vacuum control hose as shown in the figure.

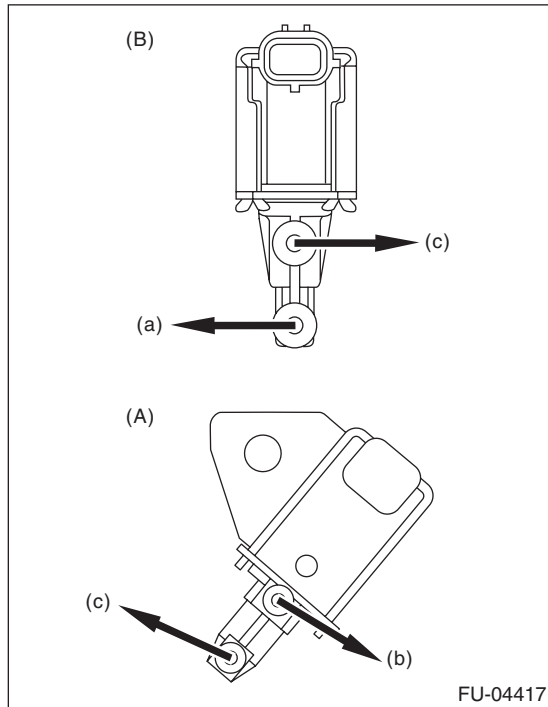

- (A) Purge control solenoid valve 1
- (B) Purge control solenoid valve 2
- (a) To intake duct
- (b) To intake manifold
- (c) To branching pipe → fuel pipe

### Tightening torque:

**T1: 6.4 N·m (0.7 kgf-m, 4.7 ft-lb)**

**T2: 16 N·m (1.6 kgf-m, 11.8 ft-lb)**

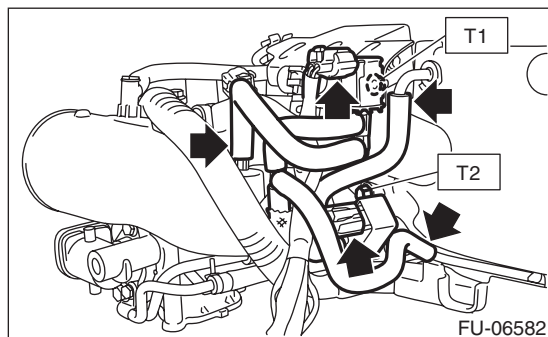

20) Attach the connector to the PCV hose assembly.

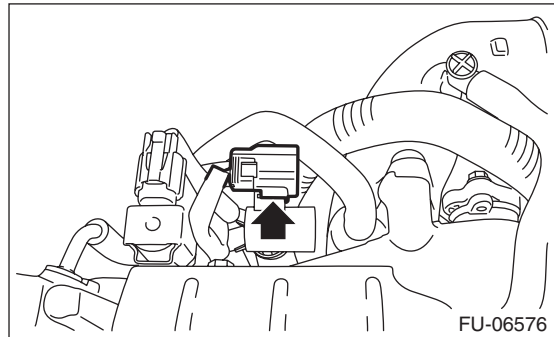

21) Install the connector to the intake duct.

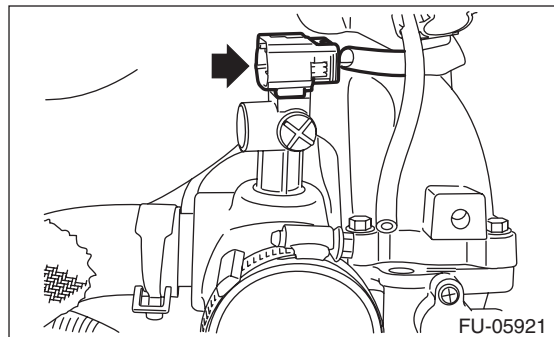

22) Install the fuel pipe protector LH.

### Tightening torque:

**19 N·m (1.9 kgf-m, 14.0 ft-lb)**

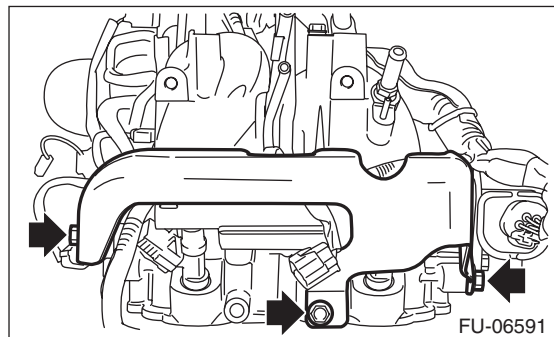

23) Install the fuel pipe protector RH, and secure the engine harness to the fuel pipe protector RH using the clip (A).

### Tightening torque:

**19 N·m (1.9 kgf-m, 14.0 ft-lb)**

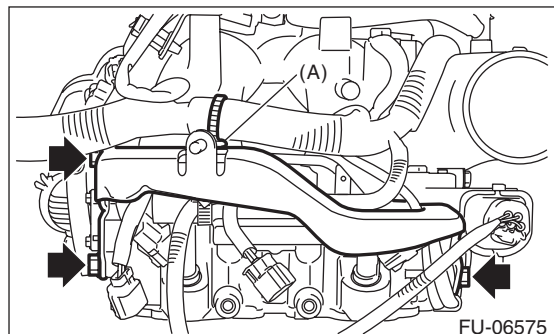

## **E: INSPECTION**

- 1) Check that the intake manifold and fuel pipe have no deformation, cracks and other damages.
- 2) Check that the hose has no cracks, damage or loose part.



# Engine Coolant Temperature Sensor

FUEL INJECTION (FUEL SYSTEMS)

## 4. Engine Coolant Temperature Sensor

### A: REMOVAL

1) Disconnect the ground cable from battery.

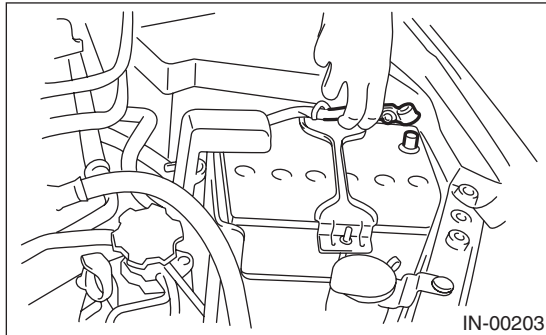

2) Remove the generator. <Ref. to SC(STI)-21, REMOVAL, Generator.>

3) Drain engine coolant. <Ref. to CO(STI)-13, DRAINING OF ENGINE COOLANT, REPLACEMENT, Engine Coolant.>

4) Disconnect the connector (A) from the engine coolant temperature sensor, and remove the engine coolant temperature sensor.

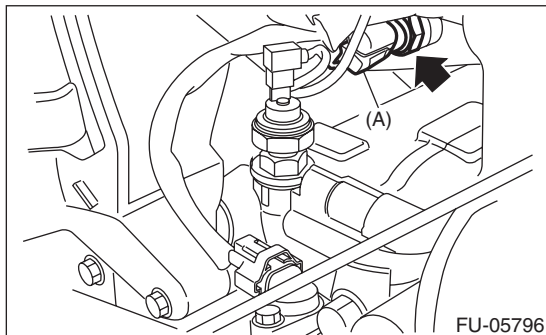

### B: INSTALLATION

Install in the reverse order of removal.

NOTE:

Use a new gasket.

**Tightening torque:**

**18 N·m (1.8 kgf·m, 13.3 ft·lb)**

### C: INSPECTION

1) Check that the engine coolant temperature sensor has no deformation, cracks or other damages.

2) Immerse the engine coolant temperature sensor and a thermometer in water.

**CAUTION:**

Take care not to allow water to get into the engine coolant temperature sensor connector. Completely remove any water inside.

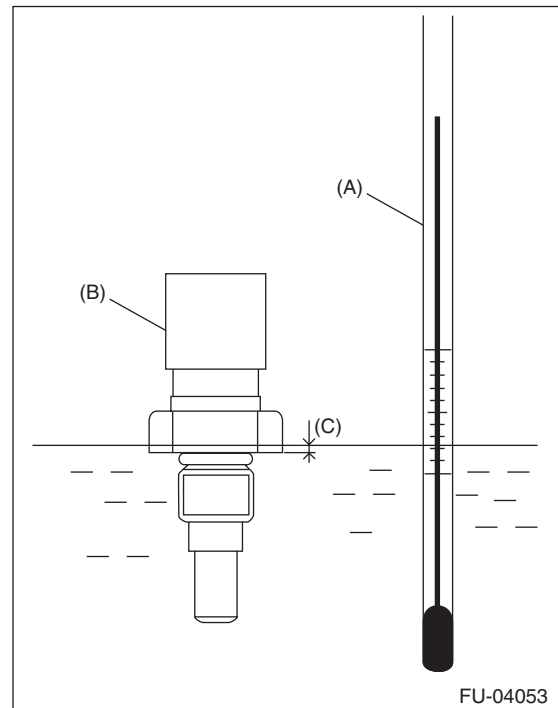

(A) Thermometer

(B) Engine coolant temperature sensor

(C) Hexagonal part height: To approx.  $\frac{1}{3}$

3) Raise water temperature gradually, measure the resistance between the engine coolant temperature sensor terminals when the temperature is 20°C (68°F) and 80°C (176°F).

NOTE:

Agitate the water for even temperature distribution.

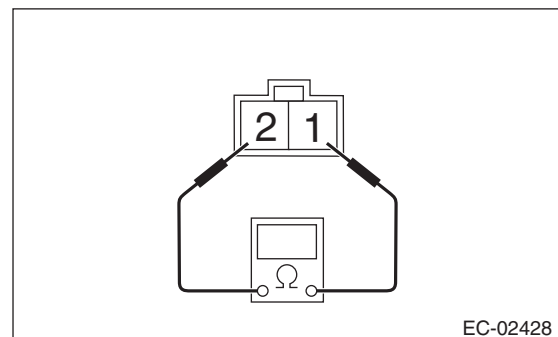

Water temperature	Terminal No.	Standard
20°C (68°F)	1 and 2	2.45±0.2 kΩ
80°C (176°F)		0.318±0.013 kΩ

# Crankshaft Position Sensor

FUEL INJECTION (FUEL SYSTEMS)

## 5. Crankshaft Position Sensor

### A: REMOVAL

- 1) Disconnect the ground cable from battery.

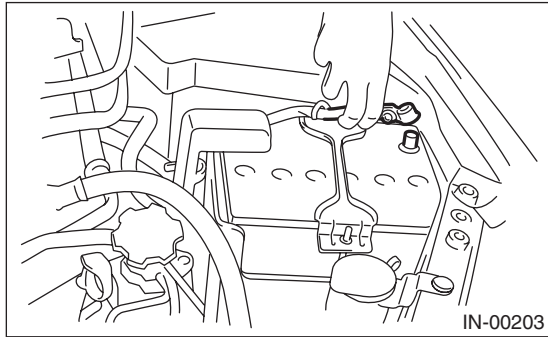

- 2) Remove the bolt which secures crankshaft position sensor to oil pump.

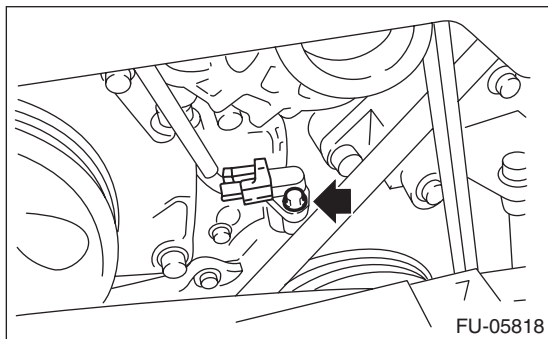

- 3) Remove the crankshaft position sensor, and disconnect the connector from the crankshaft position sensor.

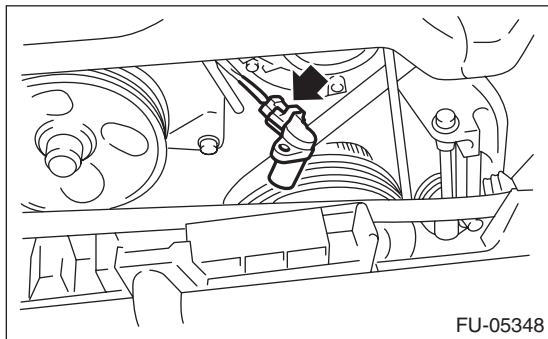

### B: INSTALLATION

Install in the reverse order of removal.

**Tightening torque:**

**6.4 N·m (0.7 kgf·m, 4.7 ft·lb)**

### C: INSPECTION

#### 1. CRANKSHAFT POSITION SENSOR (METHOD WITH CIRCUIT TESTER)

Measure the resistance between crankshaft position sensor terminals.

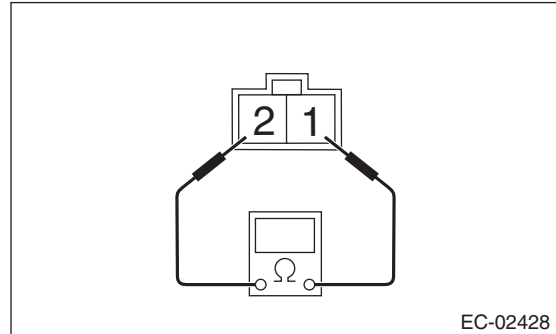

Terminal No.	Standard
1 and 2	2.04±0.204 kΩ

#### 2. CRANKSHAFT POSITION SENSOR (METHOD WITH OSCILLOSCOPE)

- 1) Prepare an oscilloscope.
- 2) Remove the lower inner trim of passenger's side. <Ref. to EI-57, REMOVAL, Lower Inner Trim.>
- 3) Turn over the floor mat of passenger's seat.
- 4) Remove the protect cover.

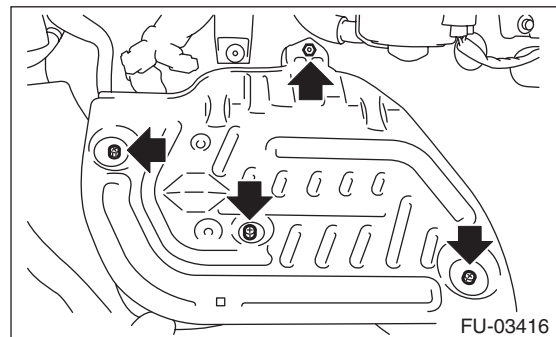

- 5) Remove the nuts and bolts which hold the ECM to the bracket.

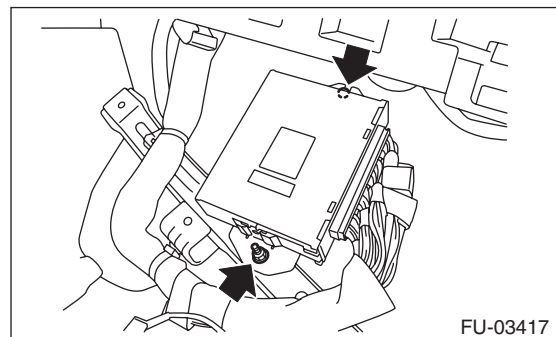

# Crankshaft Position Sensor

## FUEL INJECTION (FUEL SYSTEMS)

6) Connect the probe to ECM connector.

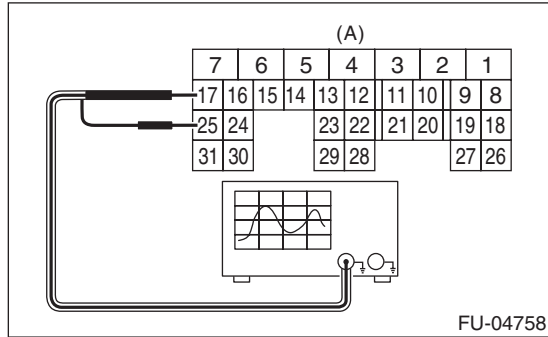

(A) To ECM connector

Terminal No.	Probe
17	+
25	-

7) Start the engine and let it idle.

8) Check the pattern is the same as the waveform and voltage shown below.

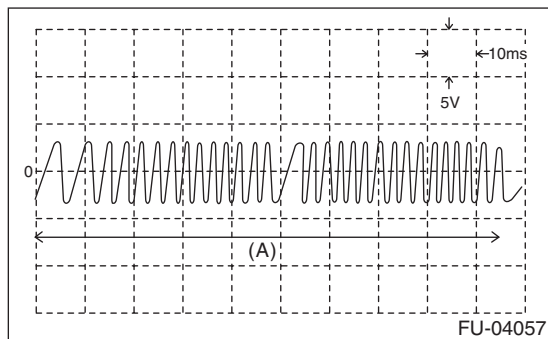

(A) One crankshaft rotation

9) After inspection, install the related parts in the reverse order of removal.

### **Tightening torque:**

**7.5 N·m (0.8 kgf·m, 5.5 ft·lb)**

### 3. OTHER INSPECTIONS

Check that the crankshaft position sensor has no deformation, cracks or other damages.

# Camshaft Position Sensor

FUEL INJECTION (FUEL SYSTEMS)

## 6. Camshaft Position Sensor

### A: REMOVAL

#### 1. INTAKE SIDE

##### • Camshaft position sensor RH

1) Disconnect the ground cable from battery.

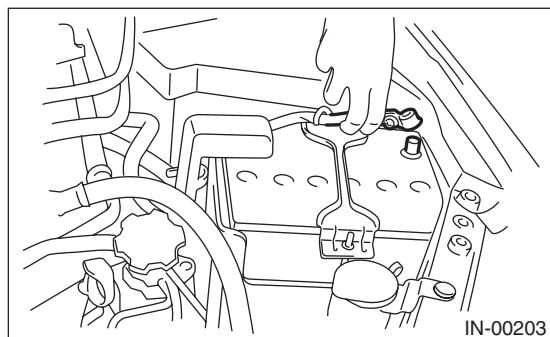

2) Disconnect the connector (A) from the camshaft position sensor RH, and remove the camshaft position sensor RH from the rear side of the cylinder head.

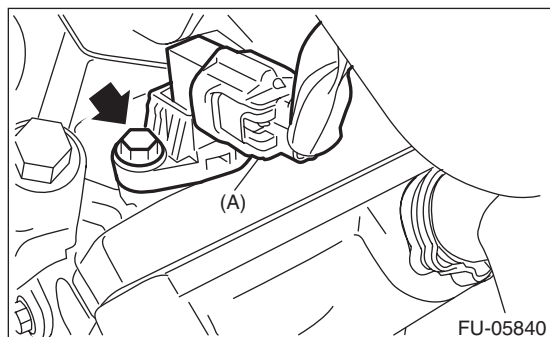

##### • Camshaft position sensor LH

1) Disconnect the ground cable from battery.

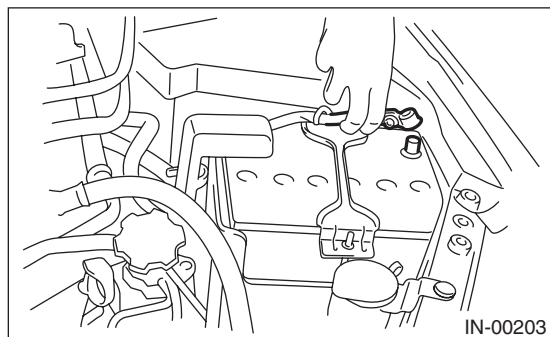

2) Remove the intake manifold. <Ref. to FU(STI)-17, REMOVAL, Intake Manifold.>

3) Remove the camshaft position sensor LH.

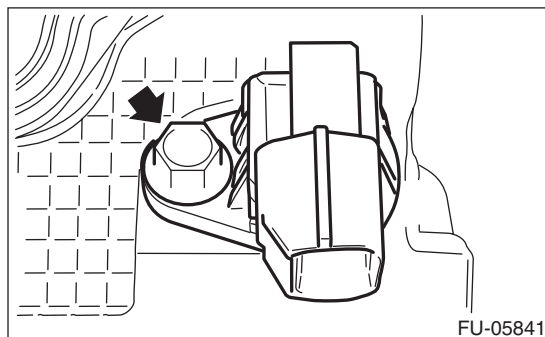

#### 2. EXHAUST SIDE

1) Disconnect the ground cable from battery.

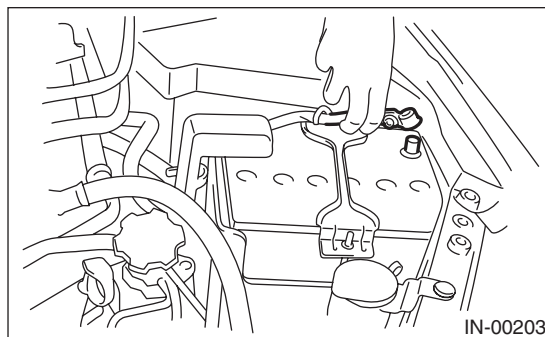

2) Lift up the vehicle.

3) Remove the under cover. <Ref. to EI-28, REMOVAL, Front Under Cover.>

4) Remove the engine harness cover. (right side only.)

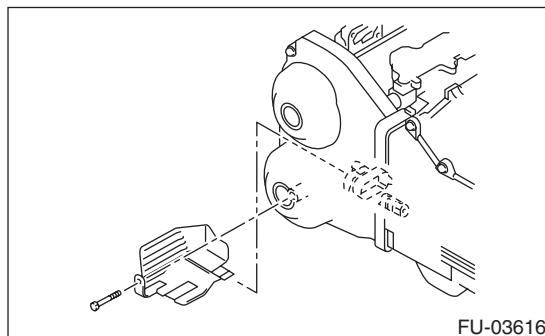

5) Disconnect connector (A) from the camshaft position sensor, and remove the camshaft position sensor from under the cylinder head.

##### • RH side

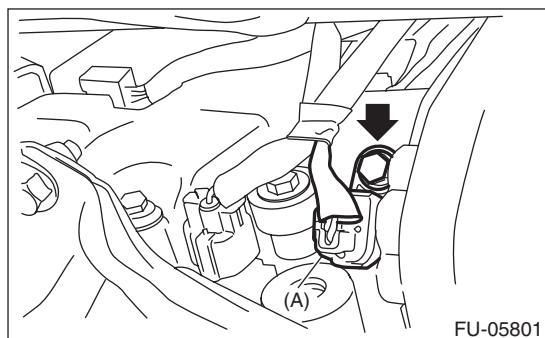

# Camshaft Position Sensor

## FUEL INJECTION (FUEL SYSTEMS)

- LH side

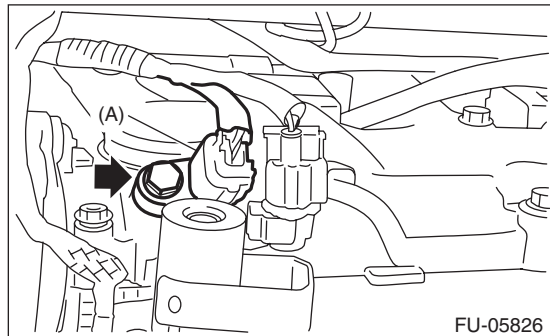

## B: INSTALLATION

### 1. INTAKE SIDE

Install in the reverse order of removal.

**Tightening torque:**

**6.4 N·m (0.7 kgf-m, 4.7 ft-lb)**

### 2. EXHAUST SIDE

Install in the reverse order of removal.

**Tightening torque:**

**6.4 N·m (0.7 kgf-m, 4.7 ft-lb)**

- RH side

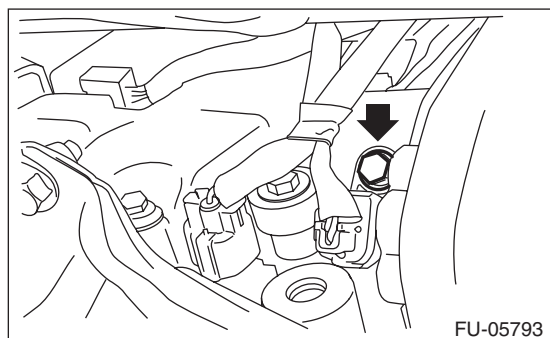

- LH side

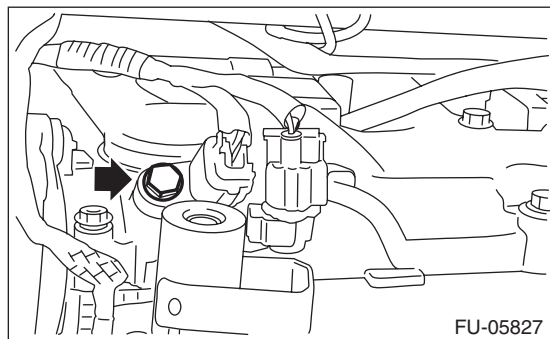

**Tightening torque:**

**5 N·m (0.5 kgf-m, 3.7 ft-lb)**

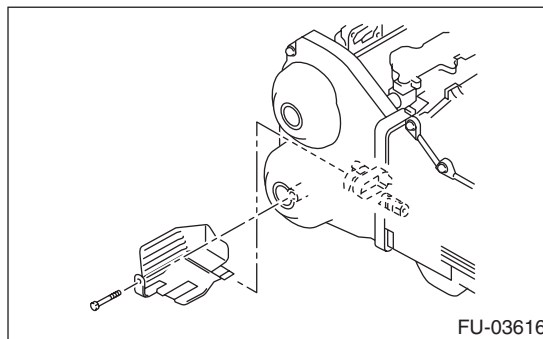

## C: INSPECTION

### 1. CAMSHAFT POSITION SENSOR (METHOD WITH OSCILLOSCOPE)

- 1) Prepare an oscilloscope.
- 2) Remove the lower inner trim of passenger's side. <Ref. to EI-57, REMOVAL, Lower Inner Trim.>
- 3) Turn over the floor mat of passenger's seat.
- 4) Remove the protect cover.

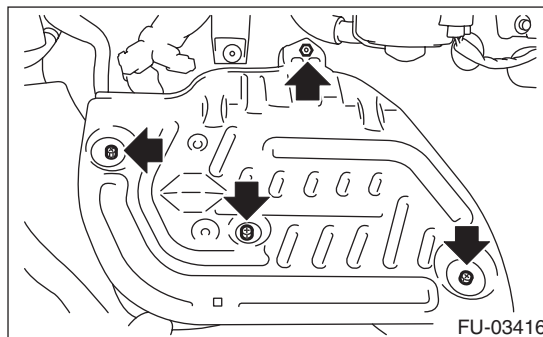

- 5) Remove the nuts and bolts which hold the ECM to the bracket.

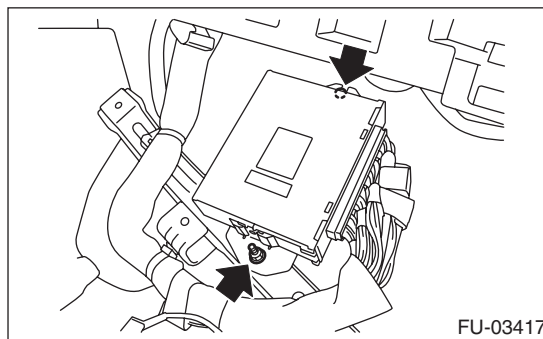

- 6) Connect the probe to ECM connector.

# Camshaft Position Sensor

FUEL INJECTION (FUEL SYSTEMS)

- Intake camshaft position sensor

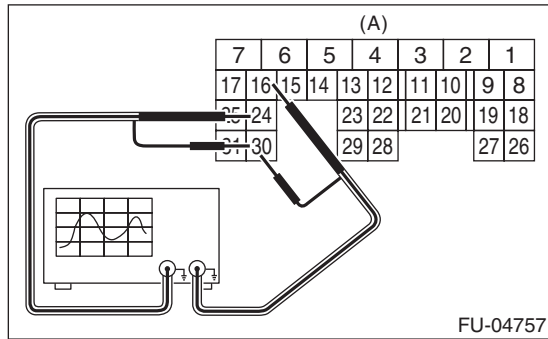

(A) To ECM connector

- Exhaust camshaft position sensor

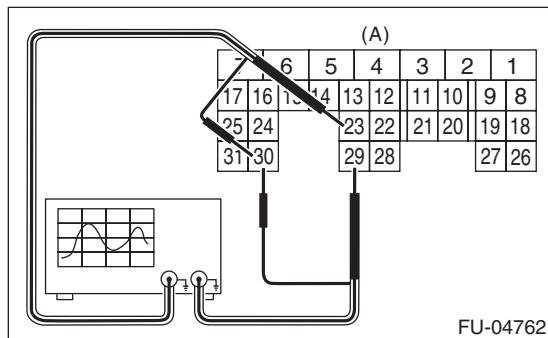

(A) To ECM connector

9) After inspection, install the related parts in the reverse order of removal.

### Tightening torque:

**7.5 N·m (0.8 kgf·m, 5.5 ft·lb)**

## 2. OTHER INSPECTIONS

Check that the camshaft position sensor has no deformation, cracks or other damages.

Camshaft position sensor		Terminal No.	Probe
Intake	RH	24	+
	LH	16	+
Exhaust	RH	23	+
	LH	29	+
RH and LH		30	-

7) Start the engine and let it idle.

8) Check the pattern is the same as the waveform and voltage shown below.

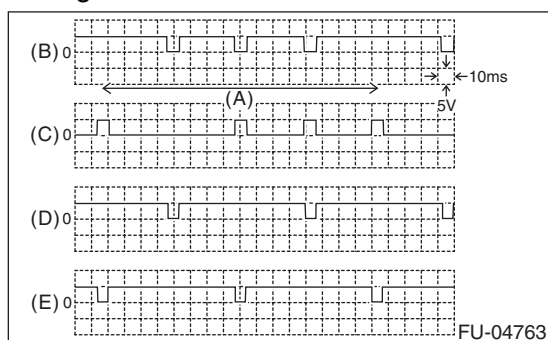

- (A) One camshaft rotation
- (B) Intake camshaft position sensor RH
- (C) Intake camshaft position sensor LH
- (D) Exhaust camshaft position sensor RH
- (E) Exhaust camshaft position sensor LH



# Knock Sensor

## FUEL INJECTION (FUEL SYSTEMS)

### 7. Knock Sensor

#### A: REMOVAL

1) Disconnect the ground cable from battery.

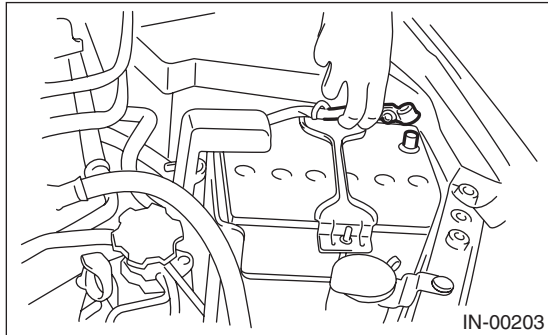

2) Remove the intercooler. <Ref. to IN(STI)-12, REMOVAL, Intercooler.>

3) Remove the intake manifold. <Ref. to FU(STI)-17, REMOVAL, Intake Manifold.>

4) Remove the secondary air combination valve RH. <Ref. to EC(STI)-29, REMOVAL, Secondary Air Combination Valve.>

5) Remove the knock sensor from cylinder block.

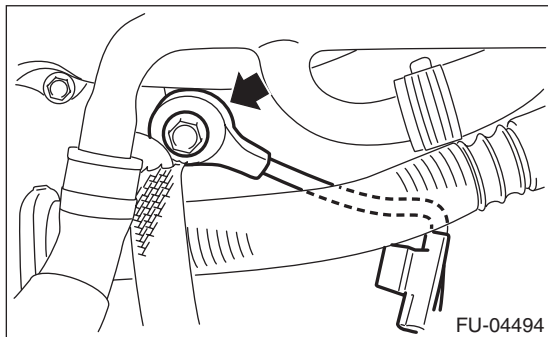

#### B: INSTALLATION

1) Install the knock sensor to the cylinder block.

##### NOTE:

The portion of the knock sensor cord that is pulled out must be positioned at a 60° angle relative to the engine rear.

##### Tightening torque:

**24 N·m (2.4 kgf·m, 17.7 ft·lb)**

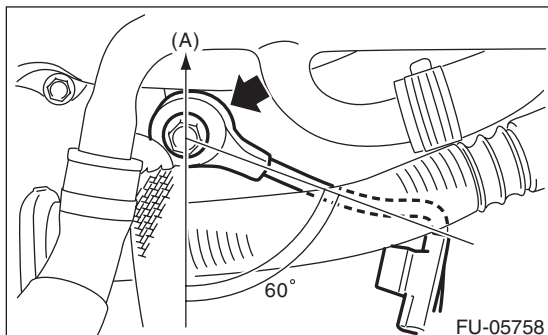

(A) Front side of vehicle

2) Install the secondary air combination valve RH. <Ref. to EC(STI)-30, SECONDARY AIR COMBINATION VALVE RH, INSTALLATION, Secondary Air Combination Valve.>

3) Install the intake manifold. <Ref. to FU(STI)-21, INSTALLATION, Intake Manifold.>

4) Install the intercooler. <Ref. to IN(STI)-13, INSTALLATION, Intercooler.>

5) Connect the battery ground terminal.

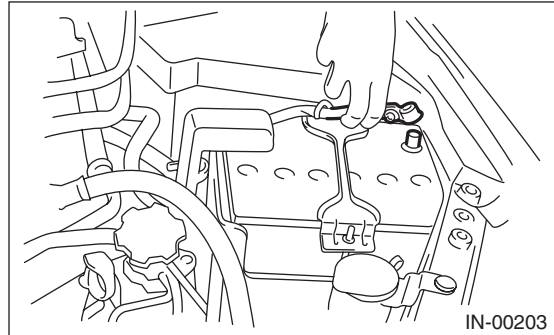

#### C: INSPECTION

1) Check that the knock sensor has no deformation, cracks or other damages.

2) Measure the resistance between knock sensor terminals.

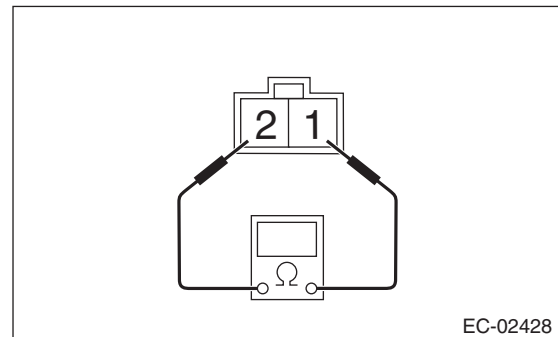

Terminal No.	Standard
1 and 2	560±28 kΩ

## 8. Throttle Position Sensor

### A: SPECIFICATION

Throttle body is a non-disassembled part, so do not remove the throttle position sensor from throttle body.

Refer to "Throttle Body" for removal and installation procedure. <Ref. to FU(STI)-15, REMOVAL, Throttle Body.> <Ref. to FU(STI)-15, INSTALLATION, Throttle Body.>



# Mass Air Flow and Intake Air Temperature Sensor

FUEL INJECTION (FUEL SYSTEMS)

## 9. Mass Air Flow and Intake Air Temperature Sensor

### A: REMOVAL

1) Disconnect the ground cable from battery.

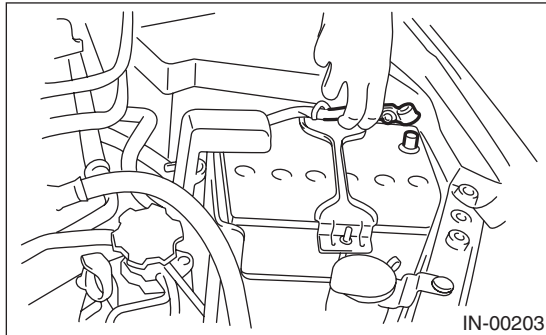

2) Disconnect the connector (A) from the mass air flow and intake air temperature sensor, and remove the mass air flow and intake air temperature sensor.

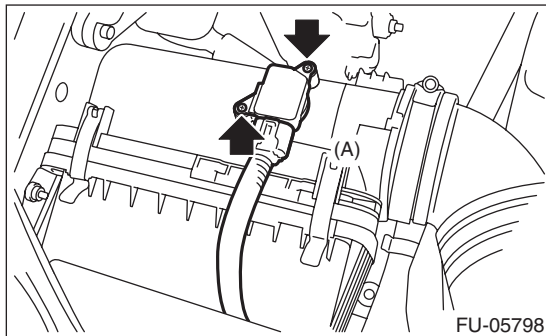

### B: INSTALLATION

Install in the reverse order of removal.

**Tightening torque:**

1 N·m (0.1 kgf·m, 0.7 ft·lb)

### C: INSPECTION

#### 1. CHECK THE MASS AIR FLOW SENSOR UNIT

1) Connect the battery positive terminal to terminal No. 3 and the battery ground terminal to terminal No. 4, the circuit tester positive terminal to terminal No. 5 and the circuit tester ground terminal to terminal No. 4.

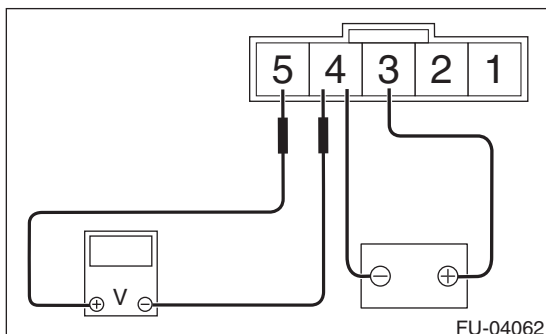

2) Check the voltage changes when air is blown to the mass air flow sensor unit in arrow direction.

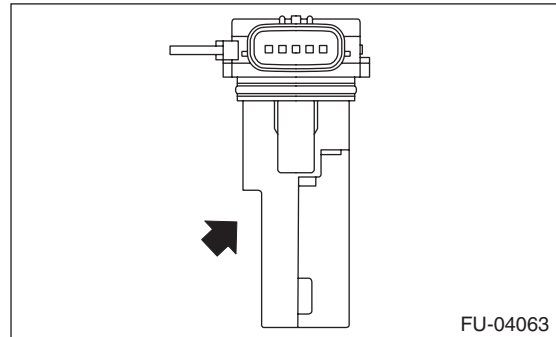

#### 2. CHECK THE INTAKE AIR TEMPERATURE SENSOR UNIT

Measure the resistance between intake air temperature sensor terminals.

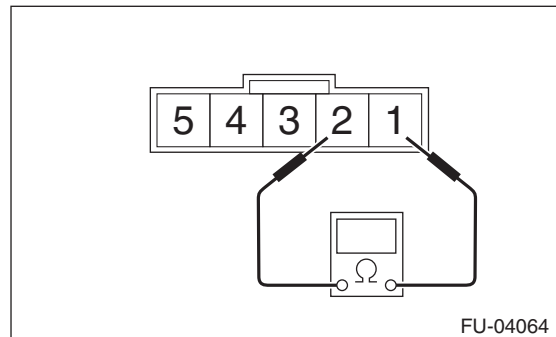

Temperature	Terminal No.	Standard
-20°C (-4°F)	1 and 2	16.0±2.4 kΩ
20°C (68°F)		2.45±0.24 kΩ
60°C (140°F)		0.580±0.087 kΩ

#### 3. OTHER INSPECTIONS

1) Check that the mass air flow and intake air temperature sensor has no deformation, cracks or other damages.

2) Check that the mass air flow and intake air temperature sensor has no dirt.

FU(STI)-42

Brought to you by Ebay Seller "SubaruManuals"

## 10. Manifold Absolute Pressure Sensor

### A: REMOVAL

1) Disconnect the ground cable from battery.

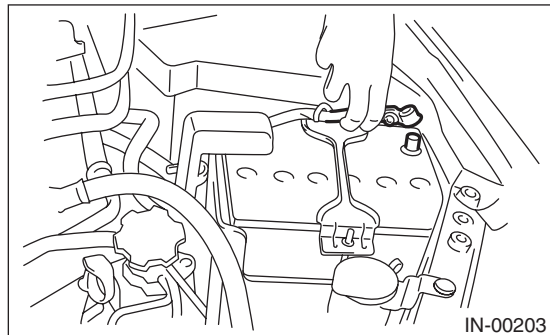

2) Disconnect the connector (A) from the manifold absolute pressure sensor, and remove the manifold absolute pressure sensor from throttle body.

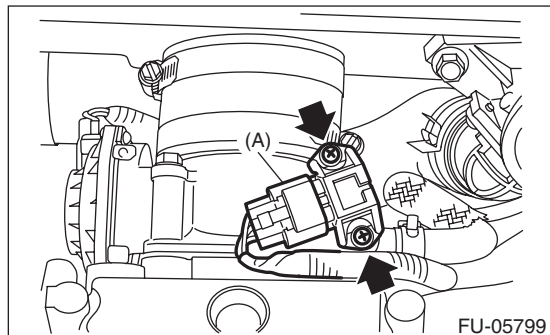

### B: INSTALLATION

Install in the reverse order of removal.

NOTE:

Use new O-rings.

**Tightening torque:**

**2 N·m (0.2 kgf·m, 1.5 ft·lb)**

### C: INSPECTION

- 1) Check that the manifold absolute pressure sensor has no deformation, cracks or other damages.
- 2) Connect dry-cell battery positive terminal to terminal No. 3 and dry-cell battery ground terminal to terminal No. 2, circuit tester positive terminal to terminal No. 1 and the circuit tester negative terminal to terminal No. 2.

NOTE:

- Use new dry-cell batteries.
- Using circuit tester, check the voltage of a single dry-cell battery is 1.6 V or more. And also check the voltage of three batteries in series is between 4.8 V and 5.2 V.

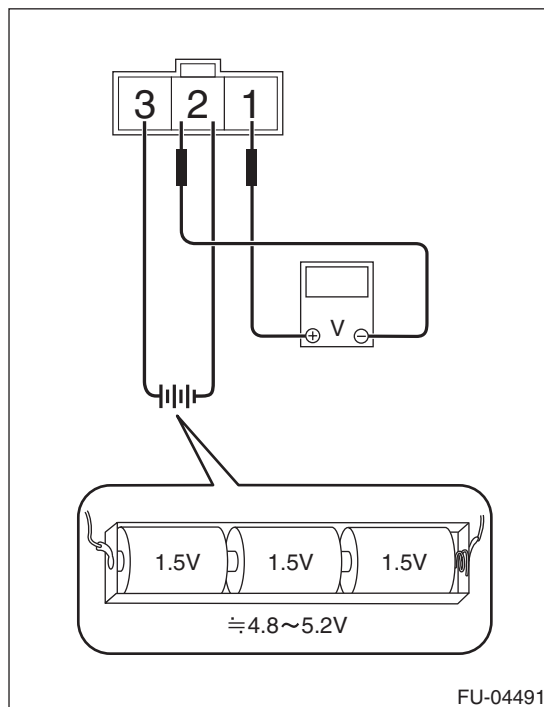

3) Check the voltage at a normal atmospheric pressure.

NOTE:

The atmospheric pressure at higher altitude is lower than normal. Therefore, the voltage is lower than the standard value.

Terminal No.	Standard
1 (+) and 2 (-)	Approx. 2.0 V (when 25°C (77°F))

# Manifold Absolute Pressure Sensor

## FUEL INJECTION (FUEL SYSTEMS)

---

4) Connect the Mighty Vac to the pressure port (A) of manifold absolute pressure sensor.

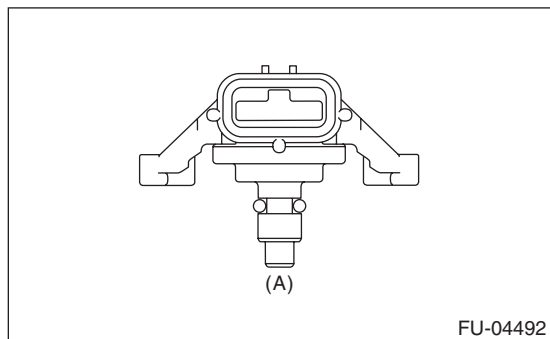

5) Check the voltage when generating vacuum and positive pressure using Mighty Vac.

### CAUTION:

**Do not apply vacuum of less than  $-88$  —  $200$  kPa ( $-0.9$  —  $2.04$  kgf/cm<sup>2</sup>,  $-12.8$  —  $29.0$  psi). Doing so may damage the manifold absolute pressure sensor.**

### NOTE:

When vacuum occurs at the pressure port of manifold absolute pressure sensor, the voltage will drop from the value as in step 3). When positive pressure occurs, on the other hand, the voltage will rise.

Pressure	Terminal No.	Standard
$-88$ kPa ( $-0.9$ kgf/cm <sup>2</sup> , $-12.8$ psi)	1 (+) and 2 (-)	Approx. 0.8 V (when 25°C (77°F))
181 kPa (1.85 kgf/cm <sup>2</sup> , 26.2 psi)		Approx. 4.7 V (when 25°C (77°F))

## 11. Fuel Injector

### A: REMOVAL

#### 1. RH SIDE

1) Release the fuel pressure. <Ref. to FU(STI)-67, RELEASING OF FUEL PRESSURE, PROCEDURE, Fuel.>

2) Disconnect the ground cable from battery.

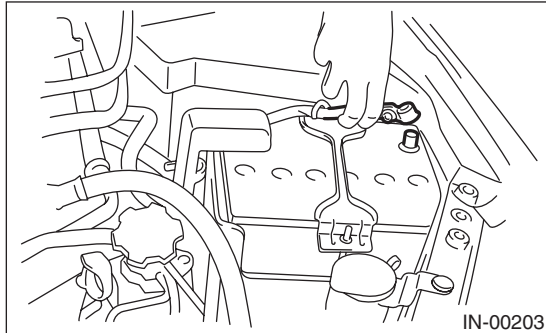

3) Open the fuel filler lid and remove the fuel filler cap.

4) Remove the intake manifold. <Ref. to FU(STI)-17, REMOVAL, Intake Manifold.>

5) Remove clip (A) holding the engine harness to the fuel pipe protector RH, and remove the fuel pipe protector RH from the intake manifold.

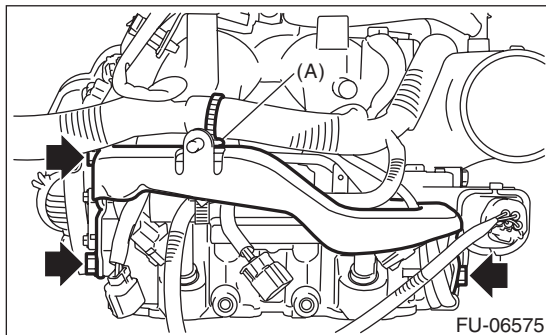

6) Remove the harness band (A) which holds the engine harness to the fuel injector pipe RH.

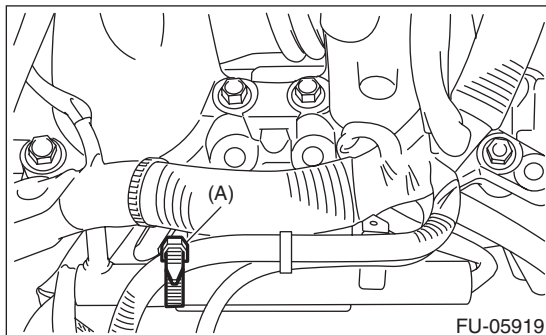

7) Disconnect the connector from fuel injector.

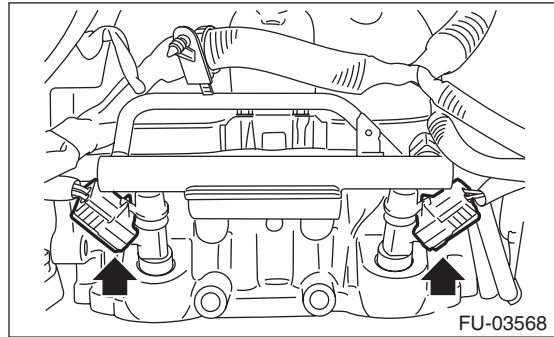

8) Remove the bolts which hold fuel injector pipe RH.

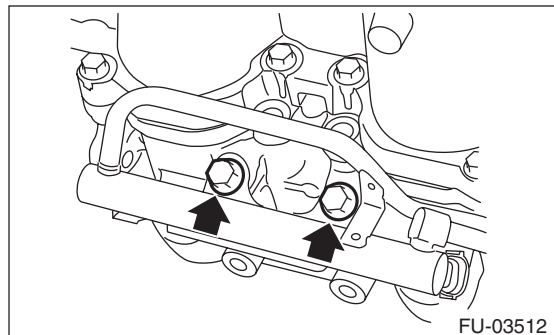

9) Remove the fuel injector.

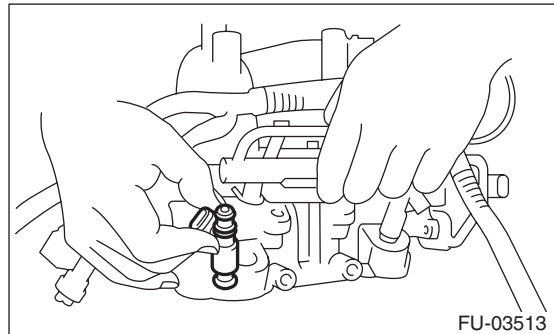

#### 2. LH SIDE

1) Release the fuel pressure. <Ref. to FU(STI)-67, RELEASING OF FUEL PRESSURE, PROCEDURE, Fuel.>

2) Disconnect the ground cable from battery.

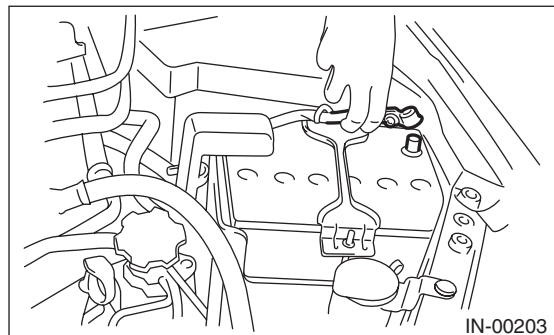

3) Open the fuel filler lid and remove the fuel filler cap.

# Fuel Injector

## FUEL INJECTION (FUEL SYSTEMS)

4) Remove the intake manifold. <Ref. to FU(STI)-17, REMOVAL, Intake Manifold.>

5) Remove the fuel pipe protector LH from the intake manifold.

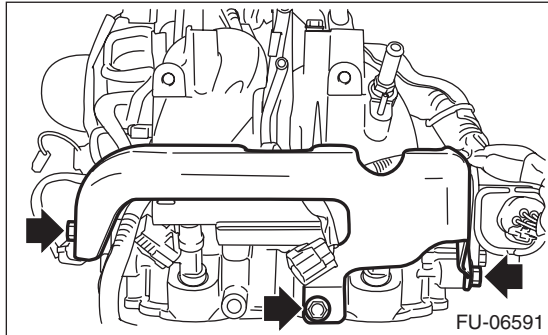

6) Remove the harness band (A) which holds the engine harness to the fuel injector pipe LH.

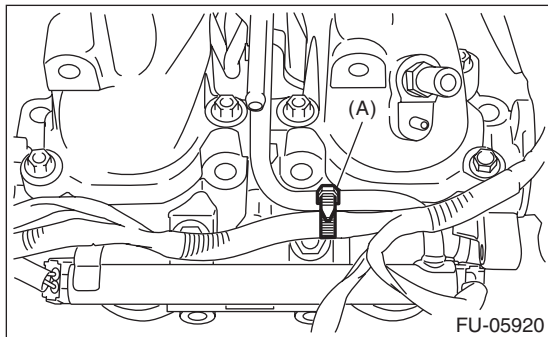

7) Disconnect the connector from fuel injector.

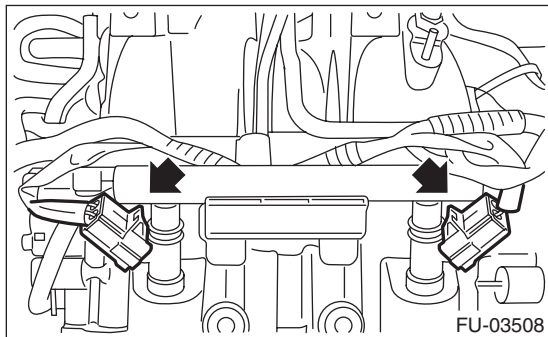

8) Remove the bolts which hold fuel injector pipe LH.

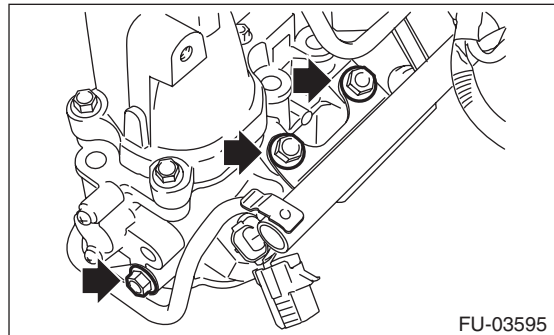
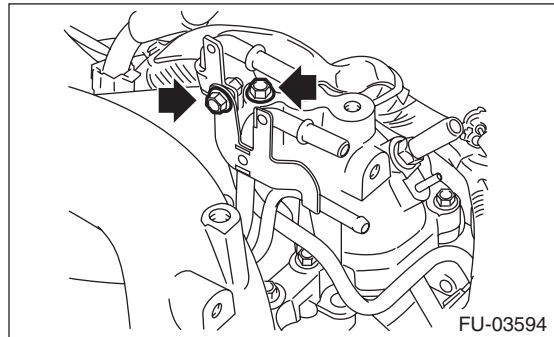

9) Remove the fuel injector.

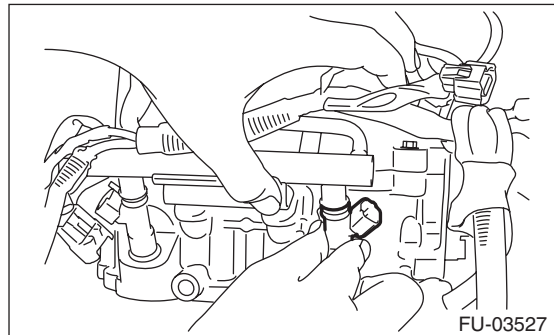

## B: INSTALLATION

### 1. RH SIDE

Install in the reverse order of removal.

NOTE:

Use new O-rings.

**Tightening torque:**

**19 N·m (1.9 kgf-m, 14.0 ft-lb)**

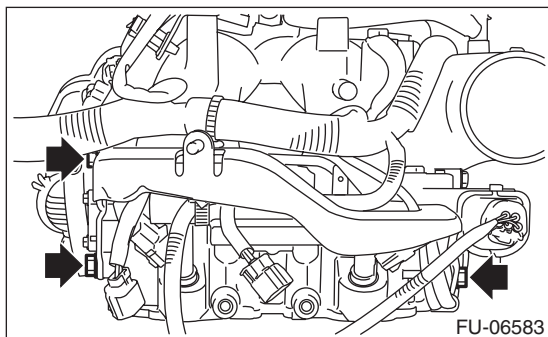
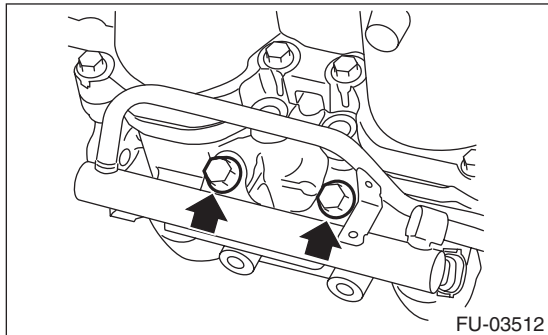

### 2. LH SIDE

Install in the reverse order of removal.

NOTE:

Use new O-rings.

**Tightening torque:**

**6.4 N·m (0.7 kgf-m, 4.7 ft-lb)**

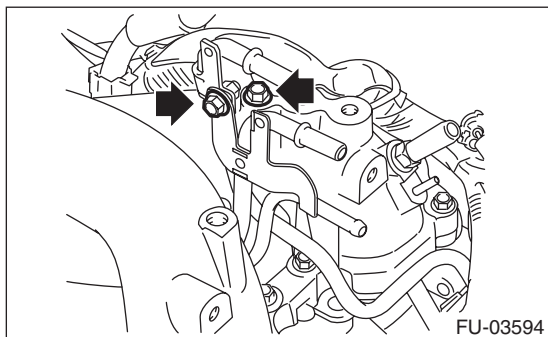

**Tightening torque:**

**19 N·m (1.9 kgf-m, 14.0 ft-lb)**

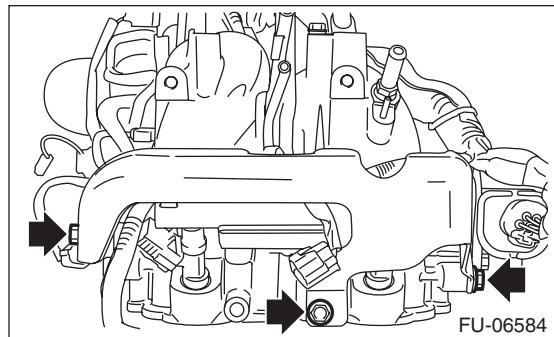
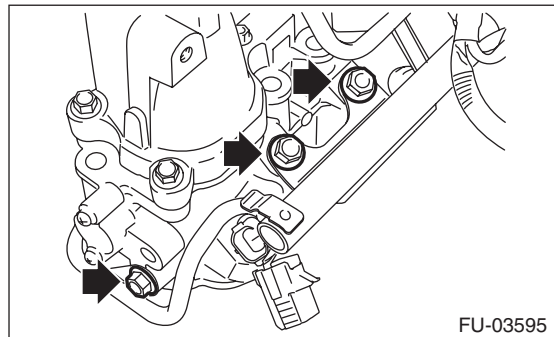

## C: INSPECTION

- 1) Check that the fuel injector has no deformation, cracks or other damages.
- 2) Measure the resistance between fuel injector terminals.

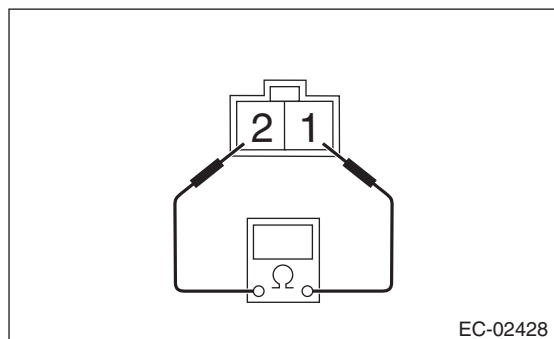

Terminal No.	Standard
1 and 2	Approx. 12.0 Ω (when 20°C (68°F))



# Tumble Generator Valve Assembly

FUEL INJECTION (FUEL SYSTEMS)

## 12. Tumble Generator Valve Assembly

### A: REMOVAL

- 1) Release the fuel pressure. <Ref. to FU(STI)-67, RELEASING OF FUEL PRESSURE, PROCEDURE, Fuel.>
- 2) Disconnect the ground cable from battery.

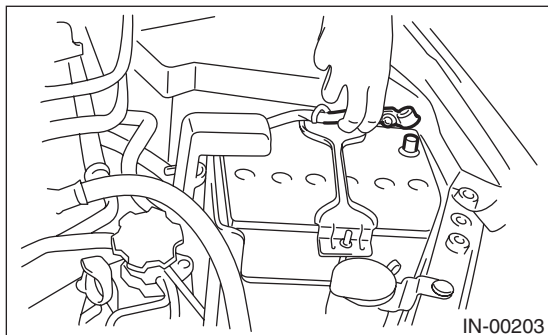

- 3) Open the fuel filler lid and remove the fuel filler cap.
- 4) Remove the intake manifold. <Ref. to FU(STI)-17, REMOVAL, Intake Manifold.>
- 5) Disconnect the connector from the tumble generator valve assembly.

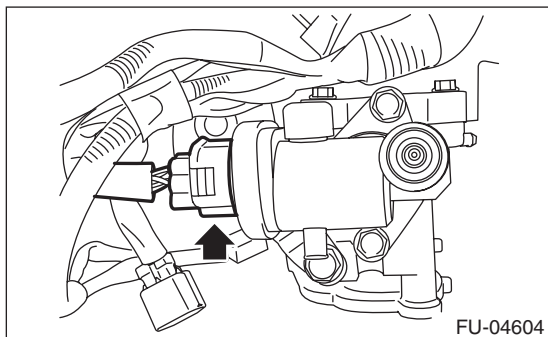

- 6) Remove the fuel injector. <Ref. to FU(STI)-45, REMOVAL, Fuel Injector.>
- 7) Remove the tumble generator valve assembly from the intake manifold.

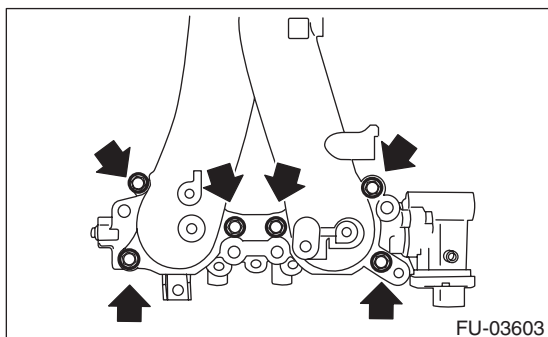

### B: INSTALLATION

Install in the reverse order of removal.

NOTE:

Use a new gasket.

**Tightening torque:**

**8.25 N·m (0.8 kgf-m, 6.1 ft-lb)**

### C: INSPECTION

- 1) Check that the tumble generator valve assembly has no deformation, cracks or other damages.
- 2) Check tumble generator valve for contamination or clogging.

## 13. Tumble Generator Valve Actuator

### A: SPECIFICATION

The tumble generator valve assembly cannot be disassembled.

Refer to "Tumble Generator Valve Assembly" for removal and installation procedures. <Ref. to FU(STI)-48, REMOVAL, Tumble Generator Valve Assembly.> <Ref. to FU(STI)-48, INSTALLATION, Tumble Generator Valve Assembly.>



# Oil Flow Control Solenoid Valve

FUEL INJECTION (FUEL SYSTEMS)

## 14. Oil Flow Control Solenoid Valve

### A: REMOVAL

#### 1. INTAKE SIDE

Oil flow control solenoid valve is a unit with front camshaft cap.

Refer to "Camshaft" for removal procedures. <Ref. to ME(STI)-61, REMOVAL, Camshaft.>

#### 2. EXHAUST SIDE

1) Disconnect the ground cable from battery.

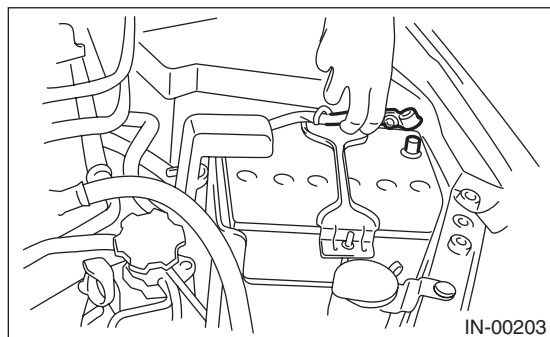

2) Lift up the vehicle.

3) Remove the under cover. <Ref. to EI-28, REMOVAL, Front Under Cover.>

4) Remove the front exhaust pipe. (right side only.) <Ref. to EX(STI)-6, REMOVAL, Front Exhaust Pipe.>

5) Remove the engine harness cover. (right side only.)

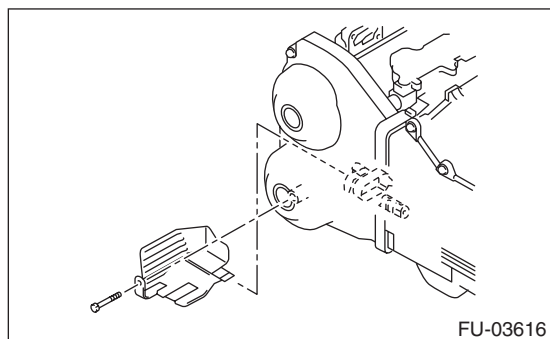

6) Disconnect the ground cable (A). (left side only)

7) Disconnect the connector (B) from the oil flow control solenoid valve, and remove the oil flow control solenoid valve from the cylinder head.

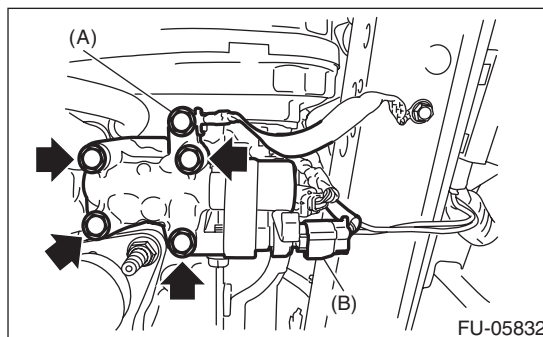

### B: INSTALLATION

#### 1. INTAKE SIDE

Refer to "Camshaft" for installation procedure. <Ref. to ME(STI)-64, INSTALLATION, Camshaft.>

#### 2. EXHAUST SIDE

Install in the reverse order of removal.

NOTE:

Use a new gasket.

**Tightening torque:**

**T1: 7.5 N·m (0.8 kgf-m, 5.5 ft-lb)**

**T2: 10 N·m (1.0 kgf-m, 7.4 ft-lb)**

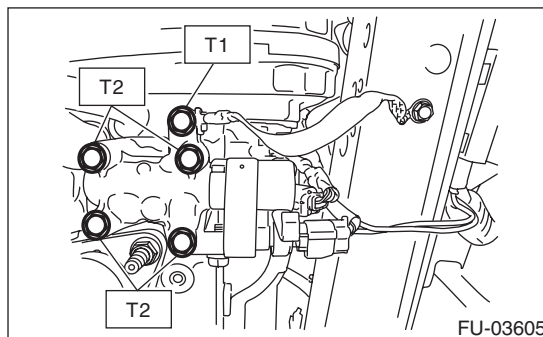

**Tightening torque:**

**5 N·m (0.5 kgf-m, 3.7 ft-lb)**

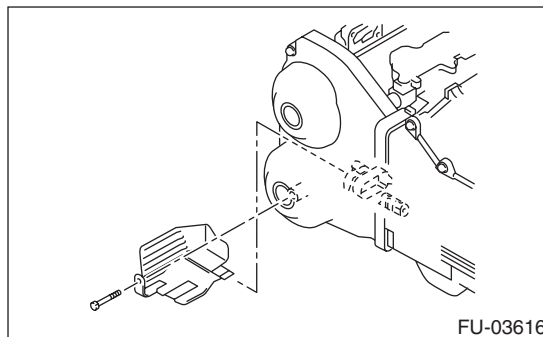

# Oil Flow Control Solenoid Valve

FUEL INJECTION (FUEL SYSTEMS)

## C: DISASSEMBLY

### 1. INTAKE SIDE

1) Remove the two mounting bolts securing oil return cover, and remove the oil return cover and gasket.

2) Remove the bolt securing oil flow control solenoid valve, and remove the oil flow control solenoid valve.

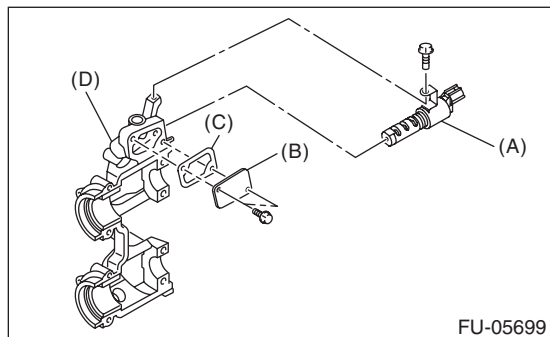

- (A) Oil flow control solenoid valve
- (B) Oil return cover
- (C) Gasket
- (D) Front camshaft cap

### 2. EXHAUST SIDE

The oil flow control solenoid valve on the exhaust side cannot be disassembled.

## D: ASSEMBLY

### 1. INTAKE SIDE

1) Install the oil flow control solenoid valve.

**Tightening torque:**

**6.4 N·m (0.7 kgf-m, 4.7 ft-lb)**

2) Apply liquid gasket to the two bolts securing oil return cover.

**Liquid gasket:**

**THREE BOND 1324 (Part No. 004403042)**

3) Attach the oil return cover and gasket.

**Tightening torque:**

**9 N·m (0.9 kgf-m, 6.6 ft-lb)**

NOTE:

Use a new gasket.

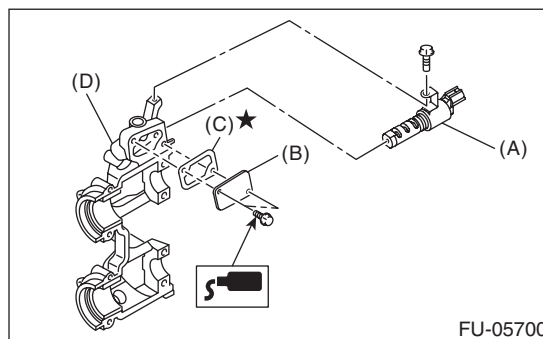

- (A) Oil flow control solenoid valve
- (B) Oil return cover
- (C) Gasket
- (D) Front camshaft cap

### 2. EXHAUST SIDE

The oil flow control solenoid valve on the exhaust side cannot be disassembled.

## E: INSPECTION

1) Check that the oil flow control solenoid valve has no deformation, cracks or other damages.

2) Measure the resistance between the oil flow control solenoid valve terminals.

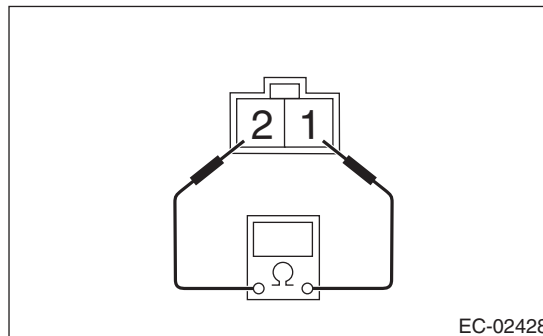

Terminal No.	Standard
1 and 2	7.4±0.5 Ω (when 20°C (68°F))

# Wastegate Control Solenoid Valve

## FUEL INJECTION (FUEL SYSTEMS)

### 15. Wastegate Control Solenoid Valve

#### A: REMOVAL

1) Disconnect the ground cable from battery.

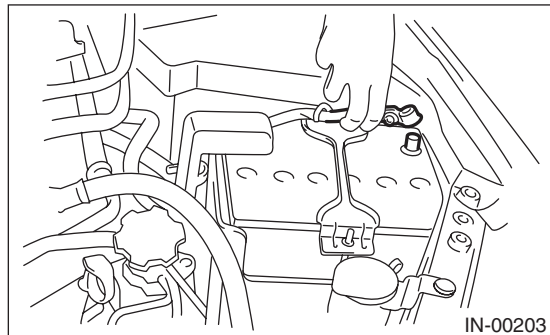

2) Remove the vacuum hose from clip (A), and remove the bolt (B) which secures the wastegate control solenoid valve.

3) Remove the bolts (C) which secure solenoid valve bracket onto intake manifold.

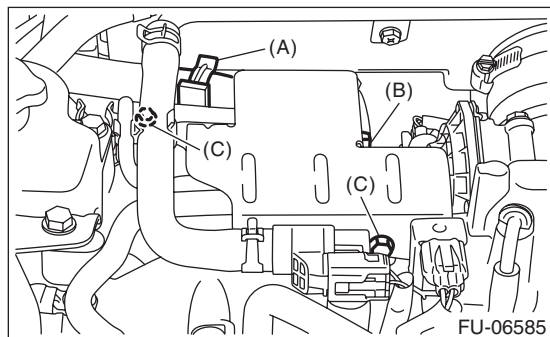

4) Disconnect the connector (A) from the wastegate control solenoid valve.

5) Disconnect the vacuum hose (B) and air control hose (C) from the wastegate control solenoid valve, and remove the wastegate control solenoid valve.

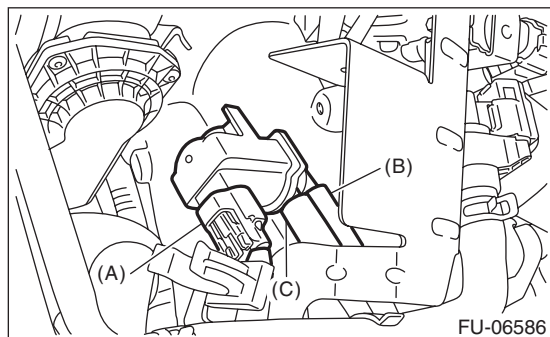

#### B: INSTALLATION

Install in the reverse order of removal.

**Tightening torque:**

**T1: 6.4 N·m (0.7 kgf-m, 4.7 ft-lb)**

**T2: 19 N·m (1.9 kgf-m, 14.0 ft-lb)**

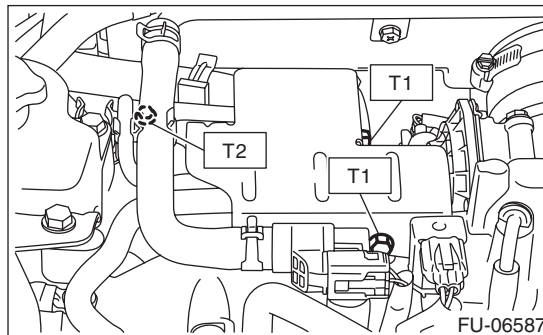

#### C: INSPECTION

##### 1. WASTEGATE CONTROL SOLENOID VALVE

1) Check that the wastegate control solenoid valve has no deformation, cracks or other damages.

2) Check the resistance between the wastegate control solenoid valve terminals.

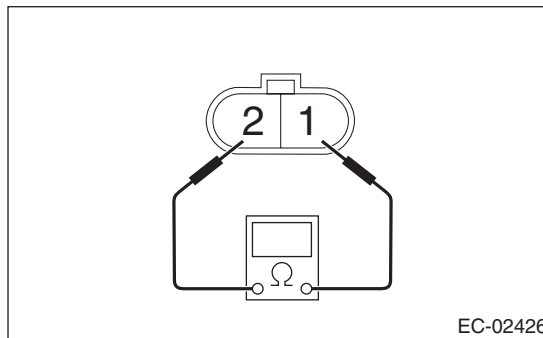

Terminal No.	Standard
1 and 2	28±2 Ω (when 20°C (68°F))

3) Check that air does not come out from (B) when air is blown into (A).

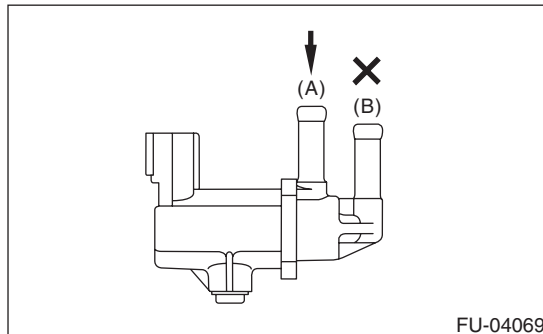

# Wastegate Control Solenoid Valve

FUEL INJECTION (FUEL SYSTEMS)

4) Connect the battery positive terminal to the terminal No. 1 and the battery ground terminal to the terminal No. 2. Check that air is discharged from (B), when supplying air to (A).

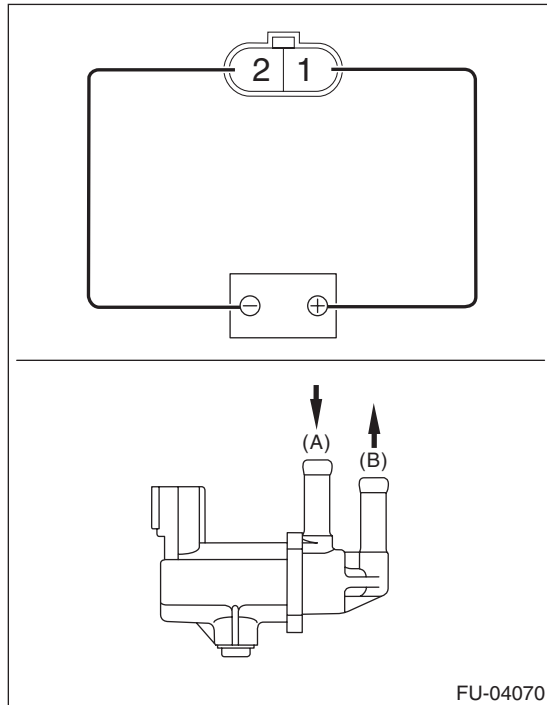

## 2. OTHER INSPECTIONS

Check that the vacuum hose and air control hose have no cracks, damage or loose part.

# Front Oxygen (A/F) Sensor

FUEL INJECTION (FUEL SYSTEMS)

## 16. Front Oxygen (A/F) Sensor

### A: REMOVAL

1) Disconnect the ground cable from battery.

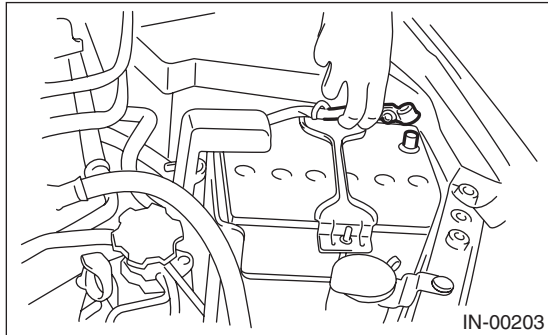

2) Disconnect the connector from the front oxygen (A/F) sensor, and remove the clip (A) holding the return hose and front oxygen (A/F) sensor harness.

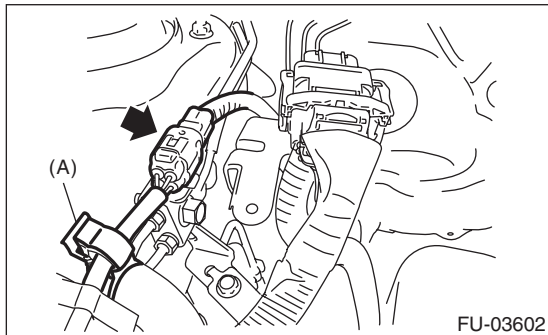

3) Remove the clips (A) holding the front oxygen (A/F) sensor harness to the engine harness stay.

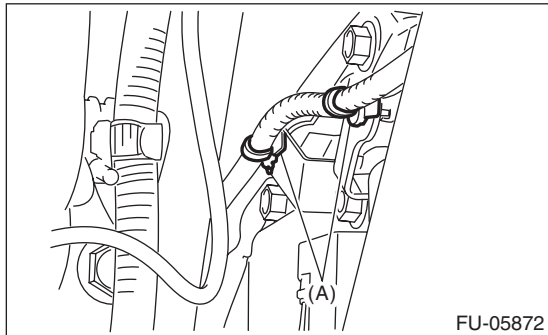

4) Lift up the vehicle.

5) Remove the under cover. <Ref. to EI-28, REMOVAL, Front Under Cover.>

6) Apply spray-type lubricant to the threaded portion of front oxygen (A/F) sensor, and leave it for one minute or more.

7) Remove the front oxygen (A/F) sensor.

### CAUTION:

When removing the front oxygen (A/F) sensor, wait until exhaust pipe cools, otherwise it will damage the exhaust pipe.

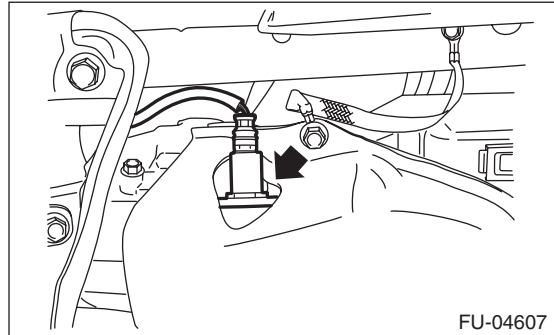

### B: INSTALLATION

#### CAUTION:

If lubricant is spilt onto the exhaust pipe, wipe it off completely with cloth to avoid emission of smoke or causing a fire.

1) Before installing front oxygen (A/F) sensor, apply anti-seize compound only to the threaded portion of front oxygen (A/F) sensor to make the next removal easier.

#### CAUTION:

Never apply anti-seize compound to the protector of front oxygen (A/F) sensor.

#### Anti-seize compound:

**NEVER-SEEZ NSN, JET LUBE SS-30 or equivalent**

2) Install the front oxygen (A/F) sensor.

#### Tightening torque:

**30 N·m (3.1 kgf·m, 22.1 ft·lb)**

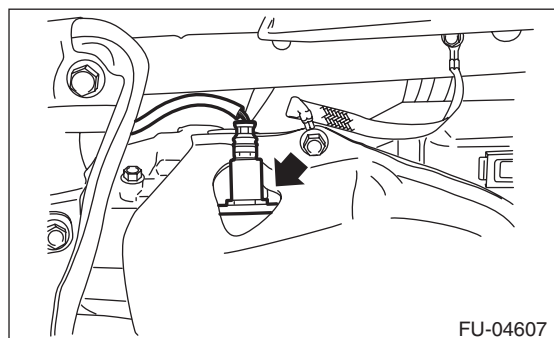

3) Install the under cover. <Ref. to EI-28, INSTALLATION, Front Under Cover.>

4) Lower the vehicle.

# Front Oxygen (A/F) Sensor

FUEL INJECTION (FUEL SYSTEMS)

5) Secure the front oxygen (A/F) sensor harness to the engine harness stay using the clips (A).

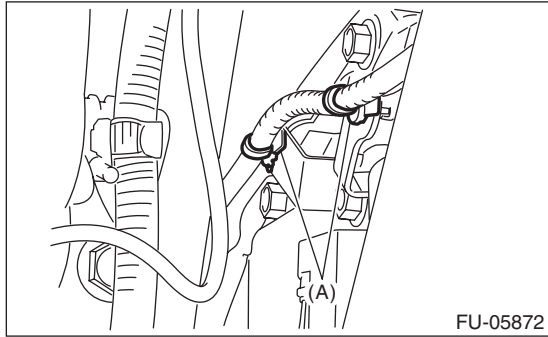

6) Connect the connector to the front oxygen (A/F) sensor, and secure the return hose and front oxygen (A/F) sensor harness using the clip (A).

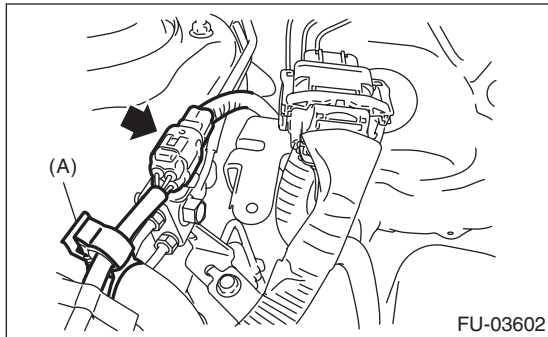

7) Connect the battery ground terminal.

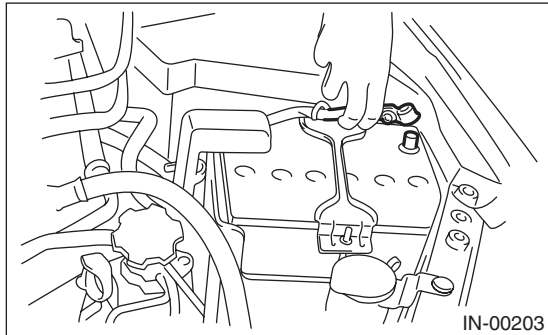

## C: INSPECTION

- 1) Check that the front oxygen (A/F) sensor has no deformation, cracks or other damages.
- 2) Measure the resistance between front oxygen (A/F) sensor terminals.

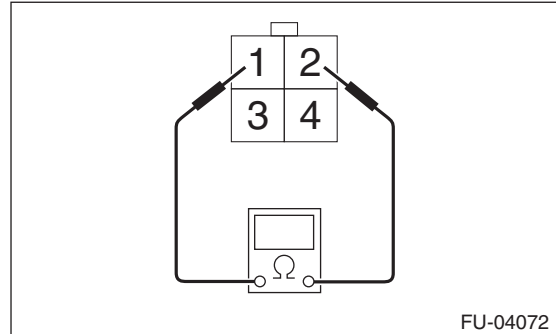

Terminal No.	Standard
1 and 2	$2.4 \pm 0.24 \Omega$ (when 20°C (68°F))



# Rear Oxygen Sensor

FUEL INJECTION (FUEL SYSTEMS)

## 17.Rear Oxygen Sensor

### A: REMOVAL

- 1) Disconnect the ground cable from battery.

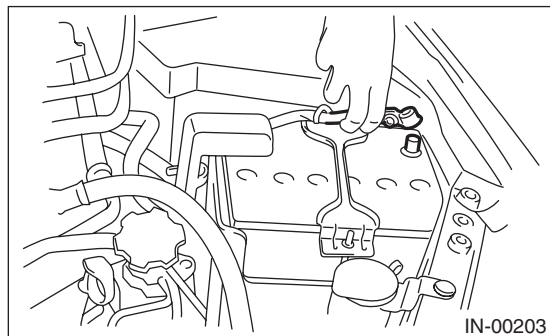

- 2) Lift up the vehicle.
- 3) Remove the transmission under cover.
- 4) Disconnect the connector from the rear oxygen sensor, and remove the clip (A) holding the rear oxygen sensor harness.

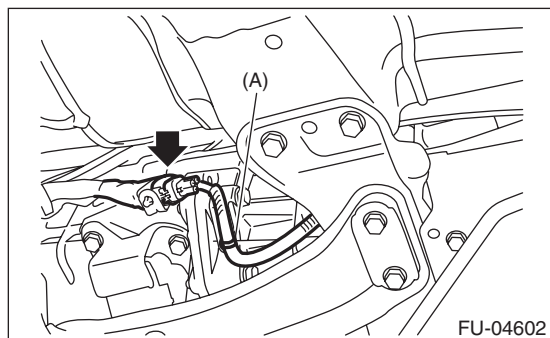

- 5) Apply spray-type lubricant to the threaded portion of rear oxygen sensor, and leave it for one minute or more.
- 6) Remove the rear oxygen sensor.

### CAUTION:

**When removing the rear oxygen sensor, wait until exhaust pipe cools, otherwise it will damage the exhaust pipe.**

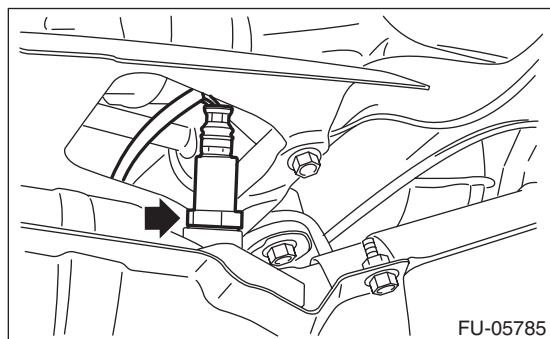

### B: INSTALLATION

#### CAUTION:

**If lubricant is spilled onto the exhaust pipe, wipe it off completely with cloth to avoid emission of smoke or causing a fire.**

- 1) Before installing rear oxygen sensor, apply the anti-seize compound only to the threaded portion of rear oxygen sensor to make the next removal easier.

#### CAUTION:

**Never apply anti-seize compound to the protector of rear oxygen sensor.**

#### Anti-seize compound:

**NEVER-SEEZ NSN, JET LUBE SS-30 or equivalent**

- 2) Install the rear oxygen sensor.

#### Tightening torque:

**21 N·m (2.1 kgf-m, 15.5 ft-lb)**

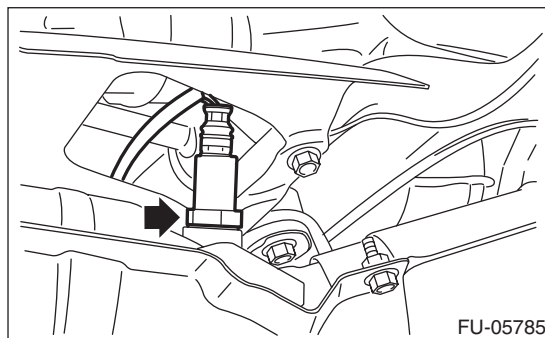

- 3) Connect the connector to the rear oxygen sensor, and hold the rear oxygen sensor harness with the clip (A).

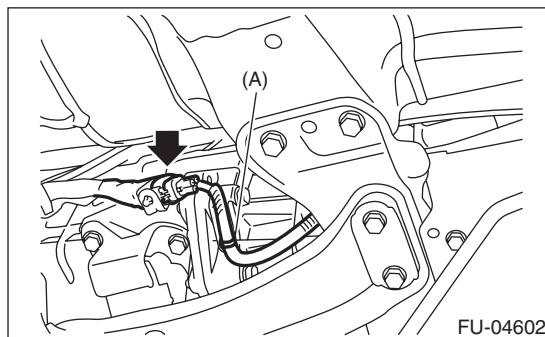

- 4) Install the transmission under cover.

#### Tightening torque:

**18 N·m (1.8 kgf-m, 13.3 ft-lb)**

- 5) Lower the vehicle.

# Rear Oxygen Sensor

6) Connect the battery ground terminal.

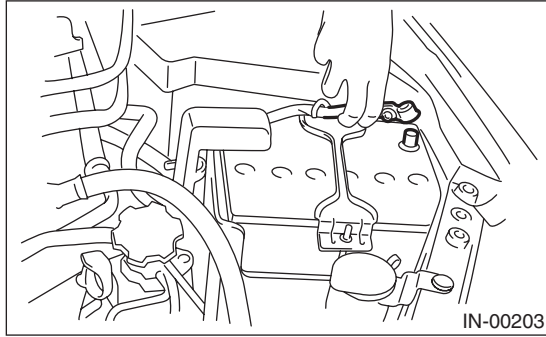

## C: INSPECTION

- 1) Check that the rear oxygen sensor has no deformation, cracks or other damages.
- 2) Measure the resistance between rear oxygen sensor terminals.

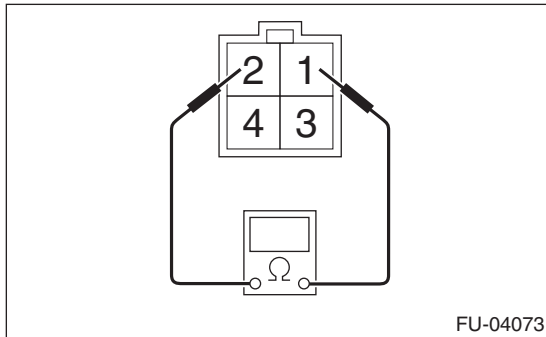

Terminal No.	Standard
1 and 2	$5.6^{+0.8}_{-0.6} \Omega$ (when 20°C (68°F))



# SI-DRIVE (SUBARU Intelligent Drive) Selector

FUEL INJECTION (FUEL SYSTEMS)

## 18.SI-DRIVE (SUBARU Intelligent Drive) Selector

### A: REMOVAL

1) Disconnect the ground cable from the battery.

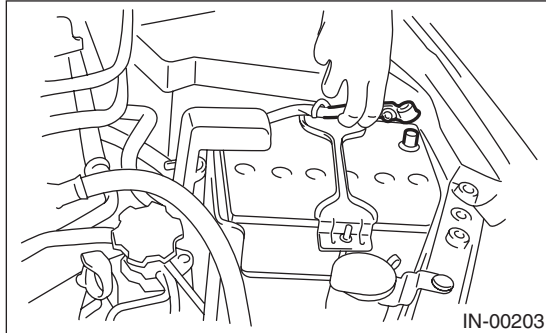

2) Remove the console box. <Ref. to EI-51, REMOVAL, Console Box.>

3) Remove the multi-selector switch connector from the console box.

4) Remove the screws and tabs holding the multi-selector switch to the console box and the multi-selector switch.

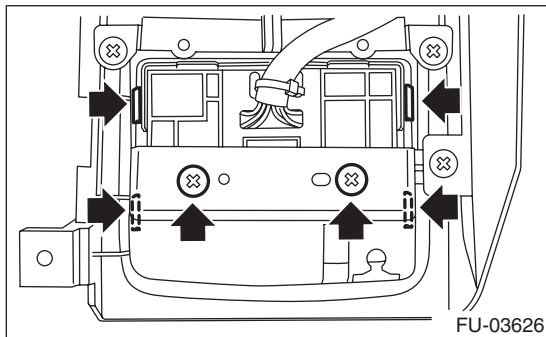

### B: INSTALLATION

Install in the reverse order of removal.

**Tightening torque:**

**1.5 N·m (0.2 kgf·m, 1.1 ft·lb)**

### C: INSPECTION

1) Check that the multi select switch does not have deformation, cracks, or damage.

2) Check the resistance between the terminals at the SI-DRIVE selector.

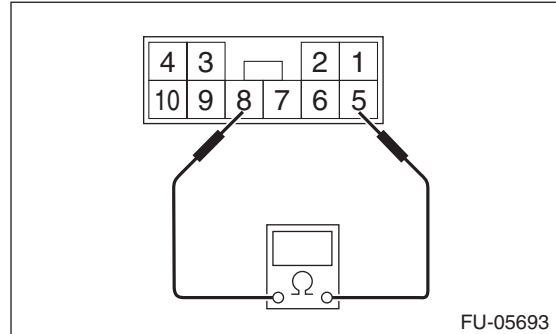

Switch position	Terminal No.	Standard
Sport (When turning the SI-DRIVE selector to the left)	5 and 8	Less than 1 $\Omega$
Intelligent (When pressing the SI-DRIVE selector)		$1 \pm 0.05$ k $\Omega$
Sport Sharp (When turning the SI-DRIVE selector to the right)		$3.67 \pm 0.1835$ k $\Omega$

## 19.Engine Control Module (ECM)

### A: REMOVAL

- 1) Disconnect the ground cable from battery.

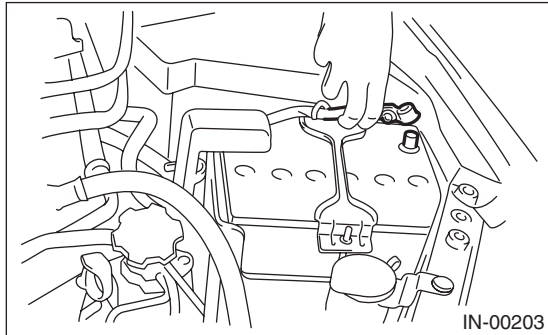

- 2) Remove the lower inner trim of passenger's side. <Ref. to EI-57, REMOVAL, Lower Inner Trim.>
- 3) Turn over the floor mat of passenger's seat.
- 4) Remove the protect cover.

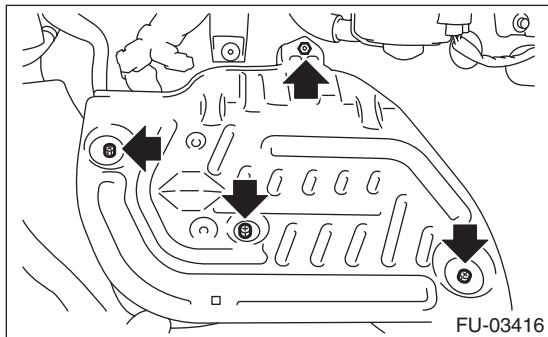

- 5) Remove the nuts and bolts which hold the ECM to the bracket.

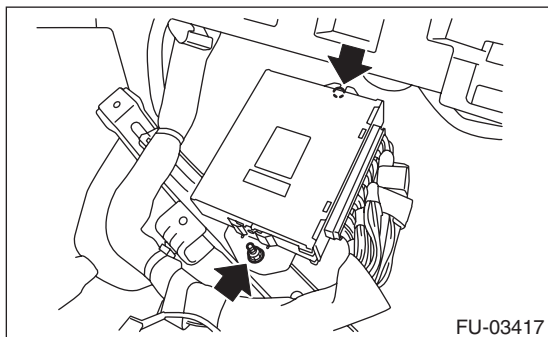

- 6) Disconnect the ECM connectors, and take out the ECM.

### B: INSTALLATION

Install in the reverse order of removal.

#### CAUTION:

- When the ECM of model with immobilizer has been replaced, be sure to perform the registration of immobilizer system. (Refer to "PC application help for Subaru Select Monitor".)
- When replacing the ECM or bracket, replace both parts with new parts.
- After installing the bracket to the ECM, do not separate the bracket.
- If the bracket has been installed to the ECM in the wrong direction, replace both parts with new parts.

#### NOTE:

When replacing the ECM, be careful not to use the wrong spec. ECM to avoid any damage on the fuel injection system.

#### Tightening torque:

*7.5 N·m (0.8 kgf·m, 5.5 ft·lb)*

### C: INSPECTION

Check that the ECM has no deformation, cracks or other damages.

# Main Relay

FUEL INJECTION (FUEL SYSTEMS)

## 20.Main Relay

### A: REMOVAL

1) Disconnect the ground cable from battery.

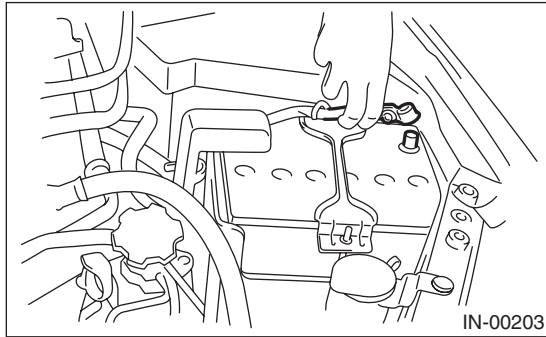

2) Remove the main relay from the relay block on the back side of the glove box.

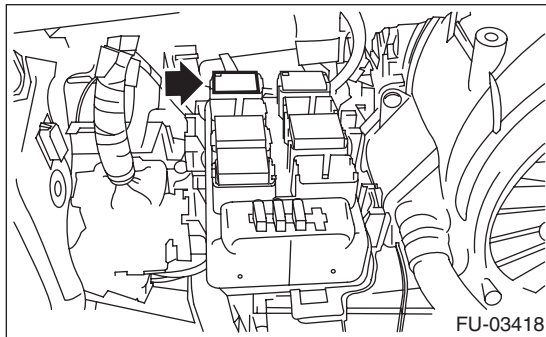

### B: INSTALLATION

Install in the reverse order of removal.

### C: INSPECTION

- 1) Check that the main relay has no deformation, cracks or other damages.
- 2) Measure the resistance between main relay terminals.

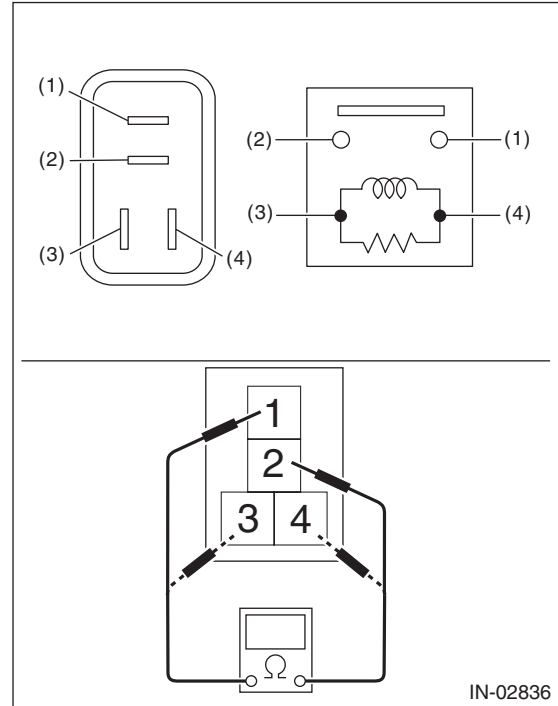

Terminal No.	Standard
1 and 2	1 M $\Omega$ or more
3 and 4	130.4 — 230.8 $\Omega$ (when 20°C (68°F))

# Main Relay

3) Connect battery positive terminal to terminal No. 3 and battery ground terminal to terminal No. 4, and measure the resistance between the main relay terminals.

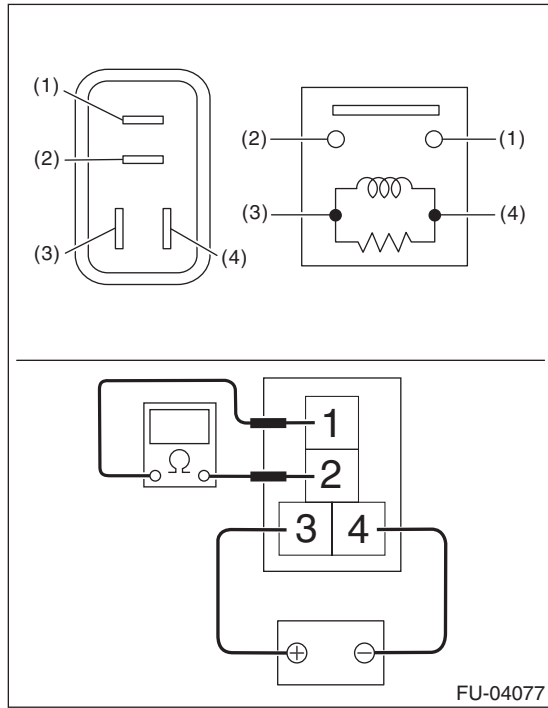

Terminal No.	Standard
1 and 2	Less than 1 $\Omega$

# Fuel Pump Relay

FUEL INJECTION (FUEL SYSTEMS)

## 21. Fuel Pump Relay

### A: REMOVAL

1) Disconnect the ground cable from battery.

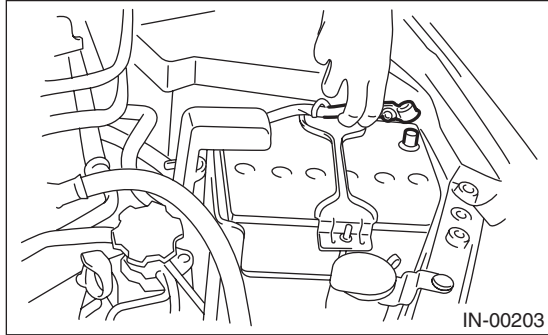

2) Remove the fuel pump relay from the relay block on the back side of the glove box.

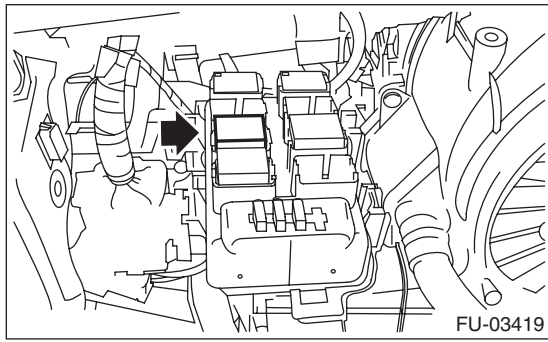

### B: INSTALLATION

Install in the reverse order of removal.

### C: INSPECTION

- 1) Check that the fuel pump relay has no deformation, cracks or other damages.
- 2) Measure the resistance between fuel pump relay terminals.

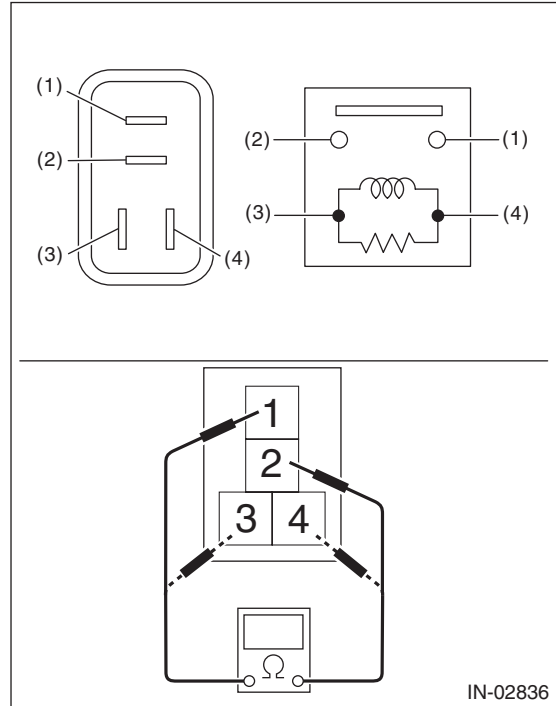

Terminal No.	Standard
1 and 2	1 M $\Omega$ or more
3 and 4	93.8 — 136.4 $\Omega$ (when 20°C (68°F))

# Fuel Pump Relay

3) Connect battery positive terminal to terminal No. 3 and battery ground terminal to terminal No. 4, and measure the resistance between the fuel pump relay terminals.

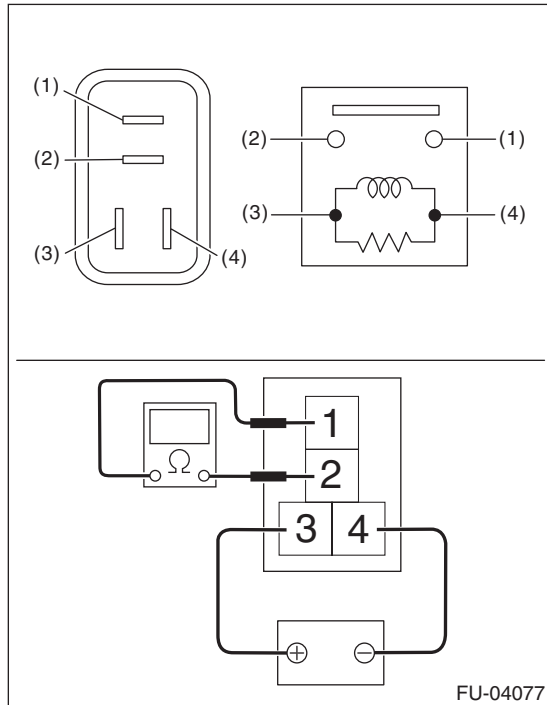

Terminal No.	Standard
1 and 2	Less than 1 $\Omega$

# Electronic Throttle Control Relay

FUEL INJECTION (FUEL SYSTEMS)

## 22. Electronic Throttle Control Relay

### A: REMOVAL

1) Disconnect the ground cable from battery.

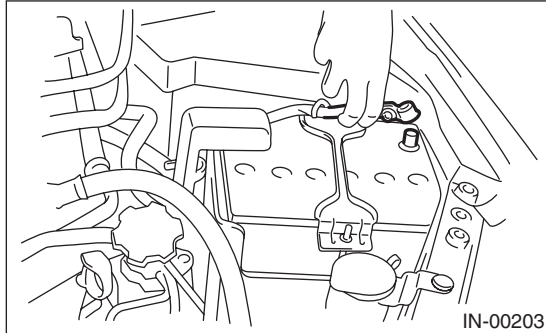

2) Remove the electronic throttle control relay from the relay block on the back side of the glove box.

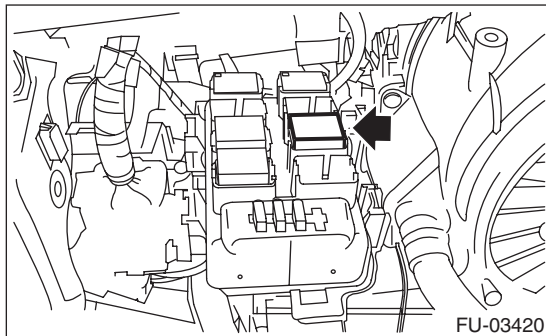

### B: INSTALLATION

Install in the reverse order of removal.

### C: INSPECTION

- 1) Check that the electronic throttle control relay has no deformation, cracks or other damages.
- 2) Measure the resistance between electronic throttle control relay terminals.

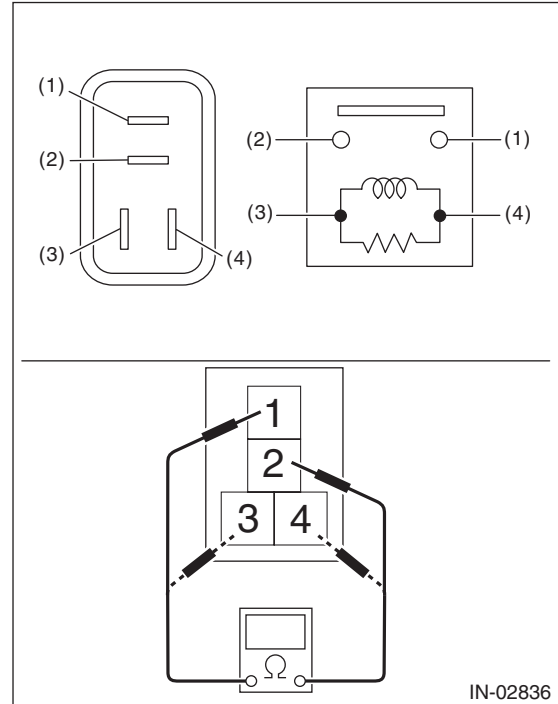

Terminal No.	Standard
1 and 2	1 M $\Omega$ or more
3 and 4	93.8 — 136.4 $\Omega$ (when 20°C (68°F))

# Electronic Throttle Control Relay

FUEL INJECTION (FUEL SYSTEMS)

3) Connect battery positive terminal to terminal No. 3 and battery ground terminal to terminal No. 4, and measure the resistance between the electronic throttle control relay terminals.

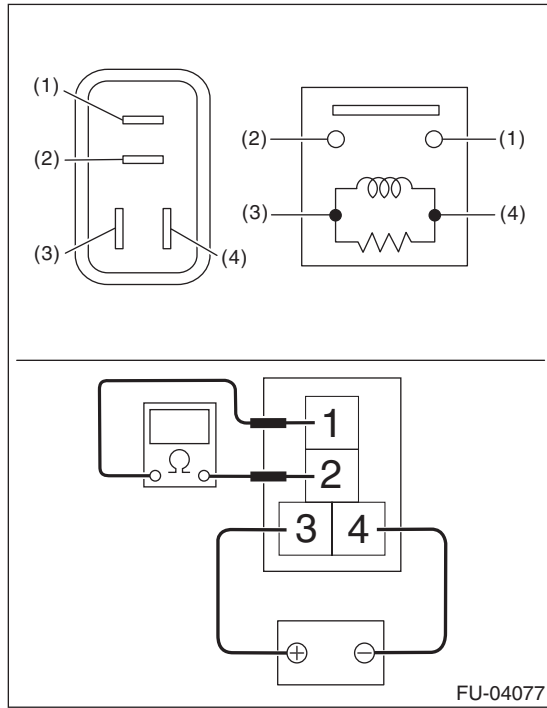

Terminal No.	Standard
1 and 2	Less than 1 $\Omega$



# Fuel Pump Control Unit

FUEL INJECTION (FUEL SYSTEMS)

## 23. Fuel Pump Control Unit

### A: REMOVAL

1) Disconnect the ground cable from battery.

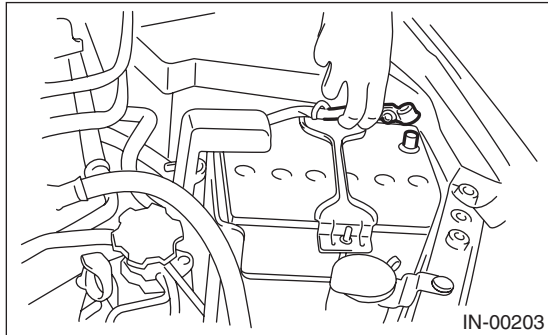

2) Remove the right side trunk side trim. (4 door model) <Ref. to EI-63, REMOVAL, Trunk Room Trim.>

3) Remove the right side rear quarter trim. (5 door model) <Ref. to EI-60, REMOVAL, Rear Quarter Trim.>

4) Disconnect the connector (A) from the fuel pump control unit, and remove the fuel pump control unit.

- 4 door model

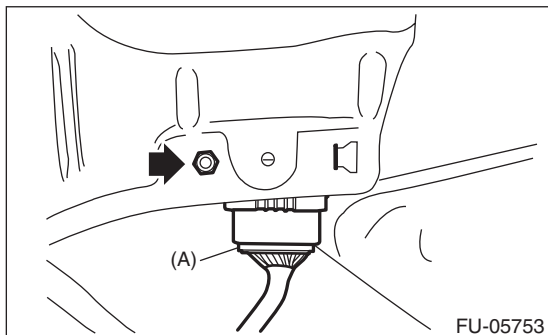

- 5 door model

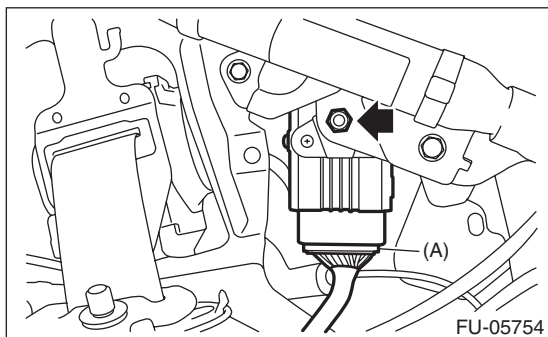

### B: INSTALLATION

Install in the reverse order of removal.

**Tightening torque:**

**5 N·m (0.5 kgf·m, 3.7 ft·lb)**

### C: INSPECTION

Check that the fuel pump control unit has no deformation, cracks or other damages.

**FU(STI)-66**

Brought to you by Ebay Seller "SubaruManuals"

## 24. Fuel

### A: PROCEDURE

#### 1. RELEASING OF FUEL PRESSURE

##### WARNING:

Place "NO OPEN FLAMES" signs near the working area.

##### CAUTION:

**Be careful not to spill fuel.**

1) Remove the fuse of fuel pump from main fuse box.

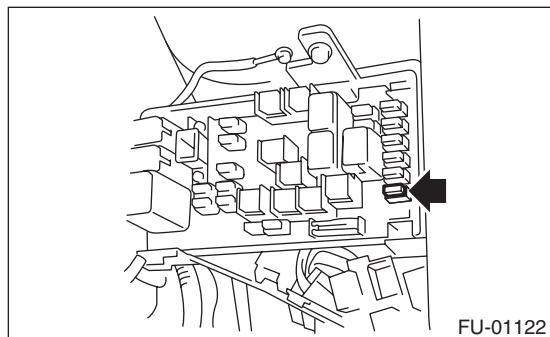

- 2) Start the engine and run it until it stalls.
- 3) After the engine stalls, crank it for five more seconds.
- 4) Turn the ignition switch to OFF.
- 5) Install the fuse of fuel pump to the main fuse box.

#### 2. DRAINING FUEL (WITH SUBARU SELECT MONITOR)

##### WARNING:

Place "NO OPEN FLAMES" signs near the working area.

##### CAUTION:

**Be careful not to spill fuel.**

##### NOTE:

- If the fuel pump cannot be driven, refer to the procedures for draining from the fuel filler hose. <Ref. to FU(STI)-68, DRAINING FUEL (THROUGH THE FUEL FILLER HOSE), PROCEDURE, Fuel.>

- Be careful not to let the battery run-out.

1) Release the fuel pressure. <Ref. to FU(STI)-67, RELEASING OF FUEL PRESSURE, PROCEDURE, Fuel.>

2) Attach ST to the fuel delivery pipe and push ST in the direction of arrow mark to disconnect the fuel delivery hose.

ST 42099AE000 QUICK CONNECTOR RELEASE

##### CAUTION:

- Be careful not to spill fuel.
- Catch the fuel from hoses using a container or cloth.

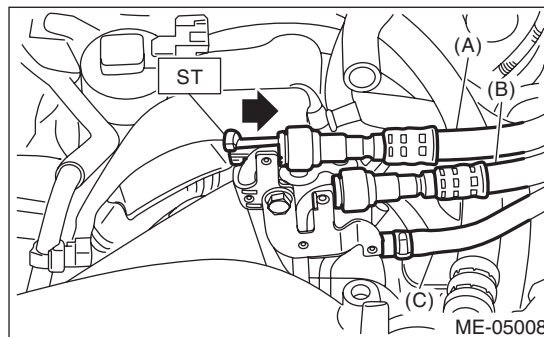

- (A) Fuel delivery hose
- (B) Fuel return hose
- (C) Evaporation hose

3) Connect ST to the fuel delivery hose.

ST 18471AA000 FUEL PIPE ADAPTER

4) Connect the gasoline proof hose to ST and put the end of the hose in the container.

5) Drive the fuel pump and drain the fuel using Subaru Select Monitor. <Ref. to EN(H4DOTC)(diag)-64, FUEL PUMP CONTROL (ON/OFF DRIVE), OPERATION, System Operation Check Mode.>

##### CAUTION:

**Be careful not to spill fuel.**

6) Install the related parts in the reverse order after draining the fuel.

# Fuel

## FUEL INJECTION (FUEL SYSTEMS)

### 3. DRAINING FUEL (THROUGH THE FUEL FILLER HOSE)

- 4 door model

#### WARNING:

Place "NO OPEN FLAMES" signs near the working area.

#### CAUTION:

- Be careful not to spill fuel.
- Fuel may remain in the fuel filler pipe. Draining the fuel from the fuel filler pipe through the fill opening using the gasoline proof pump and the gasoline proof hose ( $\varnothing 10$  or less) before the operation.

- 1) Lift up the vehicle.
- 2) Remove the rear exhaust pipe and muffler. <Ref. to EX(STI)-13, REMOVAL, Rear Exhaust Pipe.> <Ref. to EX(STI)-15, REMOVAL, Muffler.>
- 3) Remove the rear sub frame. <Ref. to RS-17, REMOVAL, Rear Sub Frame.>
- 4) Open the fuel filler lid and remove the fuel filler cap.
- 5) Drain the fuel from the fuel filler pipe through the filler opening using the gasoline proof pump and the gasoline proof hose ( $\varnothing 10$  or less).
- 6) Disconnect the fuel filler hose from the fuel filler pipe assembly.

#### CAUTION:

- Be careful not to spill fuel.
- Catch the fuel from hoses using a container or cloth.

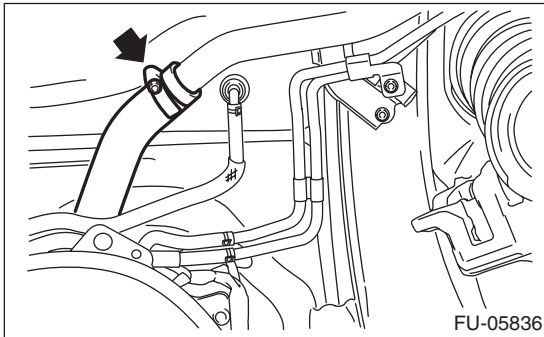

- 7) Set the container under the vehicle and insert the gasoline proof hose ( $\varnothing 10$  or less) into the fuel filler hose to drain the fuel.

#### CAUTION:

Be careful not to spill fuel.

- 8) Install the related parts in the reverse order after draining the fuel.

#### NOTE:

Correctly insert the fuel filler hose to spool, and then install the clamp as shown in the figure.

#### Tightening torque:

2.5 N·m (0.3 kgf·m, 1.8 ft·lb)

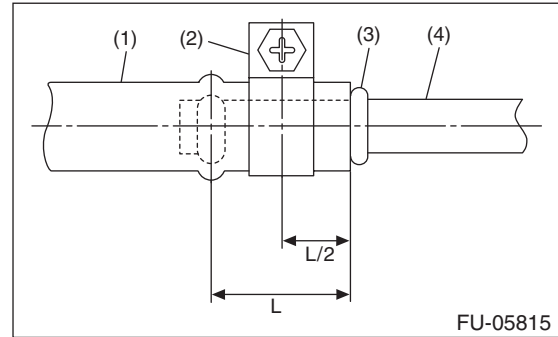

- (1) Fuel filler hose
- (2) Clamp
- (3) Spool
- (4) Fuel filler pipe

- 5 door model

#### WARNING:

Place "NO OPEN FLAMES" signs near the working area.

#### CAUTION:

- Be careful not to spill fuel.
- Fuel may remain in the fuel filler pipe. Draining the fuel from the fuel filler pipe through the fill opening using the gasoline proof pump and the gasoline proof hose ( $\varnothing 10$  or less) before the operation.

- 1) Lift up the vehicle.
- 2) Remove the rear exhaust pipe and muffler. <Ref. to EX(STI)-13, REMOVAL, Rear Exhaust Pipe.> <Ref. to EX(STI)-15, REMOVAL, Muffler.>
- 3) Open the fuel filler lid and remove the fuel filler cap.
- 4) Drain the fuel from the fuel filler pipe through the filler opening using the gasoline proof pump and the gasoline proof hose ( $\varnothing 10$  or less).
- 5) Disconnect the fuel filler hose from the fuel filler pipe assembly.

#### CAUTION:

- Be careful not to spill fuel.
- Catch the fuel from hoses using a container or cloth.

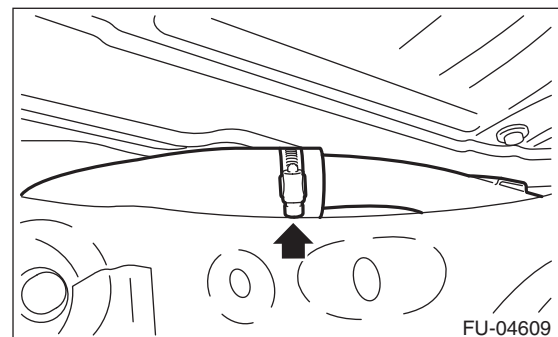

6) Set the container under the vehicle and insert the gasoline proof hose (ø10 or less) into the fuel filler hose to drain the fuel.

**CAUTION:**

**Be careful not to spill fuel.**

7) Install the related parts in the reverse order after draining the fuel.

**NOTE:**

Correctly insert the fuel filler hose to spool, and then install the clamp as shown in the figure.

**Tightening torque:**

**2.5 N·m (0.3 kgf·m, 1.8 ft·lb)**

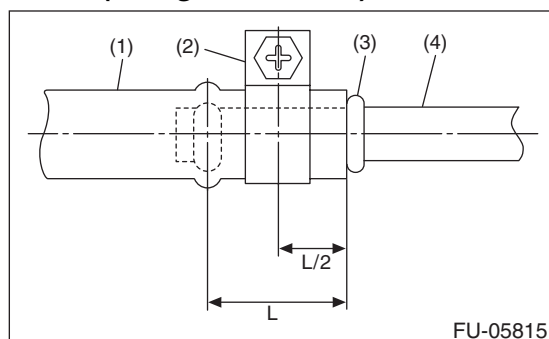

- (1) Fuel filler hose
- (2) Clamp
- (3) Spool
- (4) Fuel filler pipe

# Fuel Tank

## FUEL INJECTION (FUEL SYSTEMS)

### 25. Fuel Tank

#### A: REMOVAL

##### WARNING:

Place "NO OPEN FLAMES" signs near the working area.

##### CAUTION:

Be careful not to spill fuel.

1) Release the fuel pressure. <Ref. to FU(STI)-67, RELEASING OF FUEL PRESSURE, PROCEDURE, Fuel.>

2) Drain fuel. <Ref. to FU(STI)-67, DRAINING FUEL (WITH SUBARU SELECT MONITOR), PROCEDURE, Fuel.>

3) Disconnect the ground cable from battery.

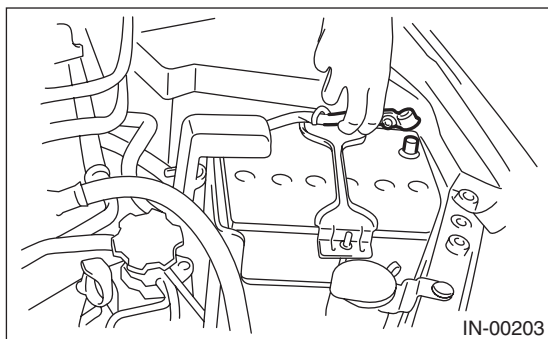

4) Remove the rear seat cushion. <Ref. to SE-13, REMOVAL, Rear Seat.>

5) Remove the service hole cover of fuel pump.

(1) Disconnect fuel pump connector (A), and remove clip (B).

(2) Remove the screw (C).

(3) Push the grommet (D) down and remove the service hole cover.

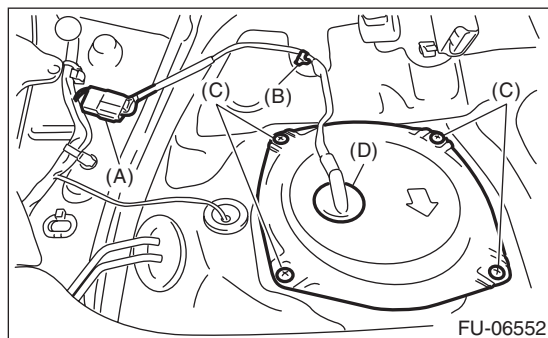

6) Remove the service hole cover of fuel sub level sensor.

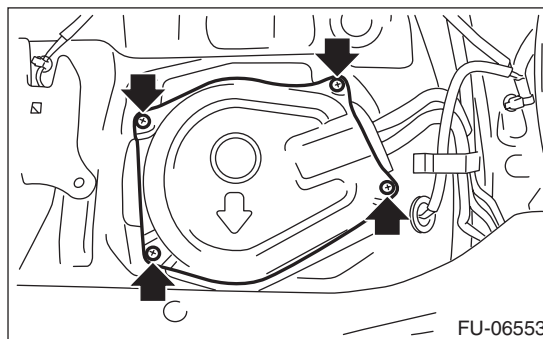

7) Disconnect the quick connector of fuel delivery tube (A) and fuel return tube (B). <Ref. to FU(STI)-93, REMOVAL, Fuel Delivery, Return and Evaporation Lines.>

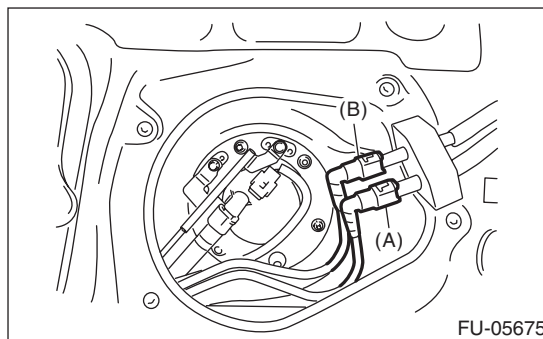

8) Remove the rear wheels.

9) Lift up the vehicle.

10) Remove the rear ABS wheel speed sensor from the rear housing.

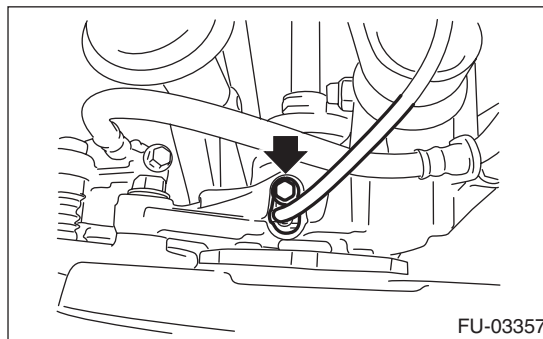

11) Remove the rear brake hose bracket from rear housing.

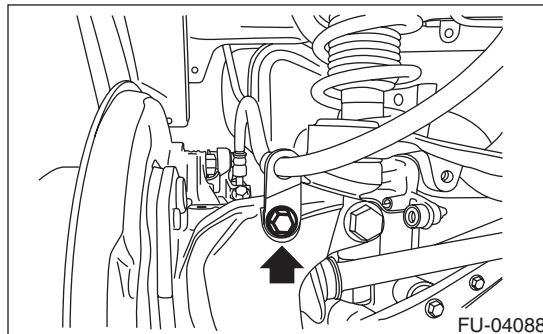

# Fuel Tank

## FUEL INJECTION (FUEL SYSTEMS)

12) Remove the rear disc brake assembly and tie it to the body side of the vehicle.

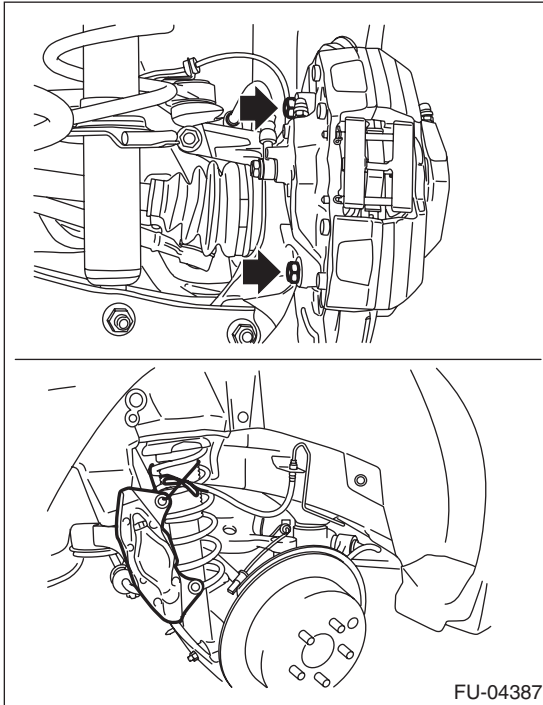

13) Remove the parking brake cable from parking brake assembly. <Ref. to PB-6, REMOVAL, Parking Brake Assembly (Rear Disc Brake).>

14) Remove the rear exhaust pipe and muffler. <Ref. to EX(STI)-13, REMOVAL, Rear Exhaust Pipe.> <Ref. to EX(STI)-15, REMOVAL, Muffler.>

15) Remove the propeller shaft. <Ref. to DS-11, REMOVAL, Propeller Shaft.>

16) Remove the heat shield cover and fuel tank protector.

17) Disconnect the connector from the rear ABS wheel speed sensor.

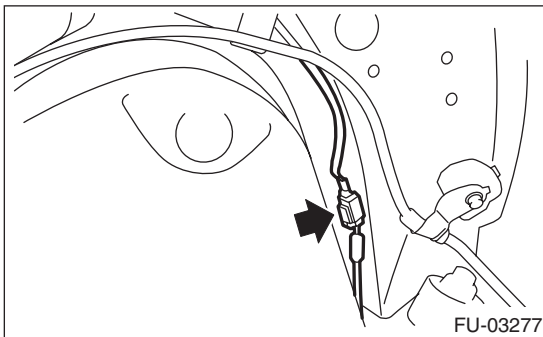

18) Remove the parking brake cable clamp from the body.

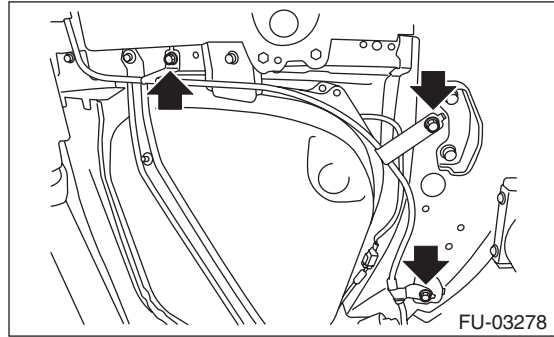

19) Disconnect the connectors from oil temperature switch (A) and ground (B), and remove the clips (C) which secure the harness.

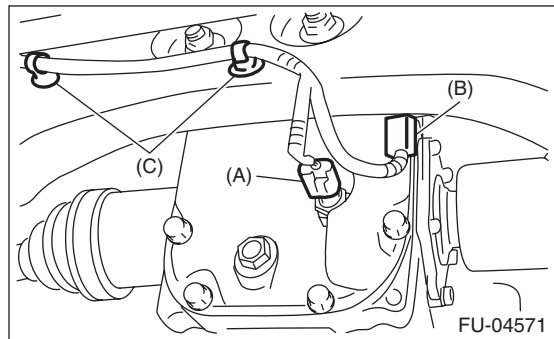

20) Remove the rear suspension assembly.

### WARNING:

**A helper is required to perform this work.**

(1) Support the rear differential with the transmission jack.

(2) Remove the bolt and nut which secures rear shock absorber to rear suspension arm.

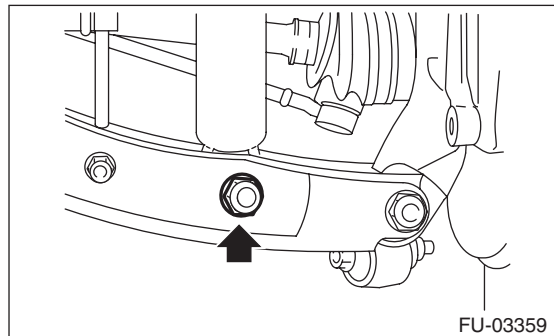



# Fuel Tank

## FUEL INJECTION (FUEL SYSTEMS)

(3) Remove the bolts which secure the rear suspension assembly to the body.

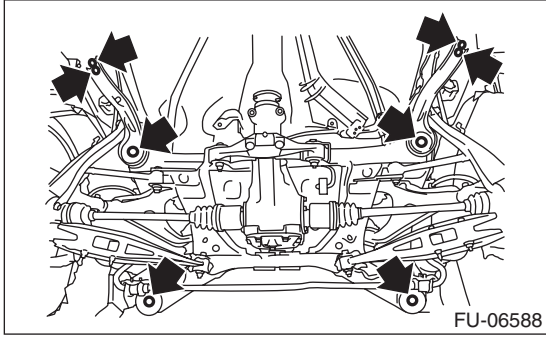

(4) Remove the rear suspension assembly.

21) Disconnect the evaporation hose (B) from hose connector (A).

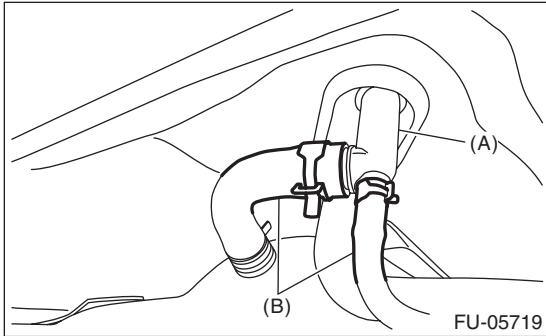

22) Disconnect the quick connector of the evaporation hose from the evaporation pipe.

### NOTE:

Disconnect the quick connector as shown in the figure.

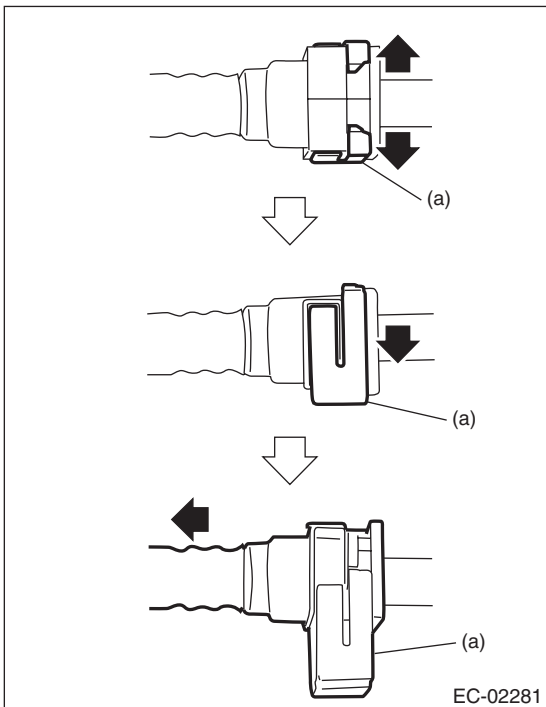

(a) Retainer

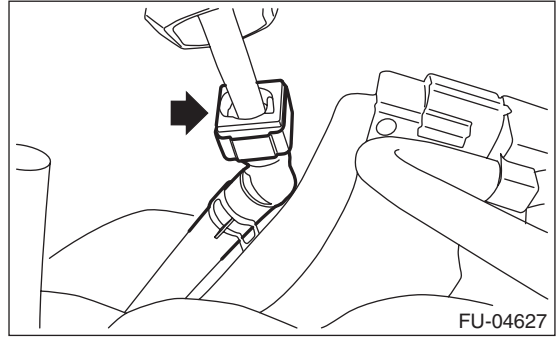

23) Disconnect the fuel filler hose (A) and evaporation hose (B).

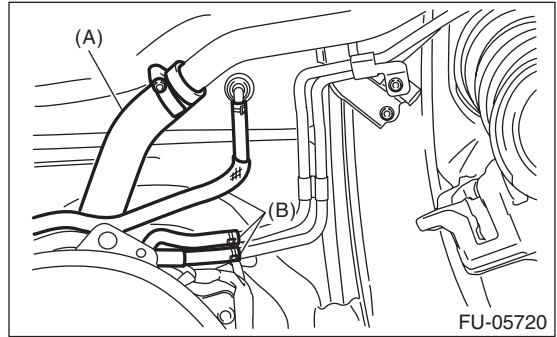

24) Support the fuel tank with a transmission jack, remove the fuel tank band, and remove the fuel tank from the vehicle.

### WARNING:

- A helper is required to perform this work.
- Fuel may remain in the fuel tank. This will cause the left and right sides to be unbalanced. Be careful not to drop the fuel tank.

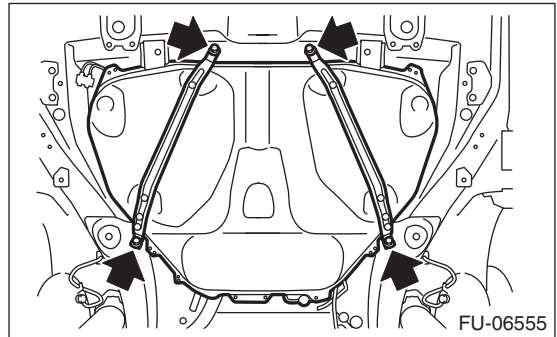

## B: INSTALLATION

1) Support the fuel tank with a transmission jack, set the fuel tank and the fuel tank band in place, and temporarily tighten the bolts of the fuel tank band.

### WARNING:

A helper is required to perform this work.

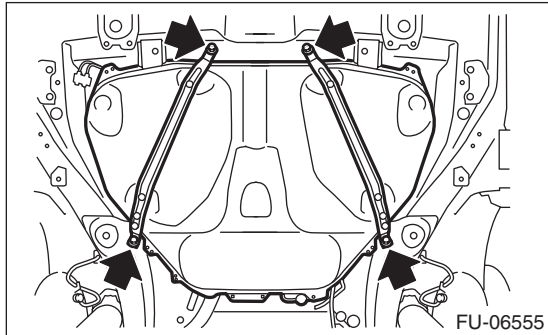

2) Securely insert the fuel filler hose (A) and evaporation hose (B) until the hose end contacts the spool, then attach the clamp or clip as shown in the figure.

### Tightening torque:

**2.5 N·m (0.3 kgf·m, 1.8 ft·lb)**

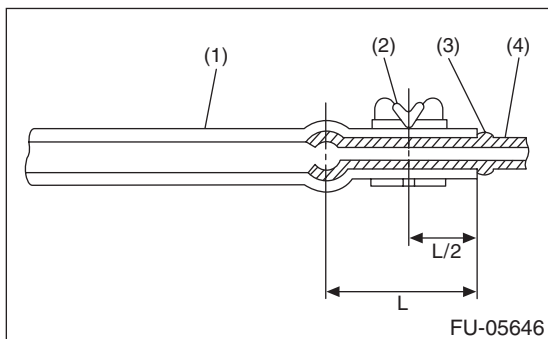
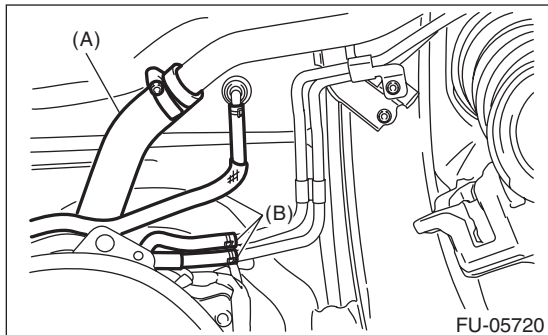

- (1) Hose
- (2) Clamp or clip
- (3) Spool
- (4) Pipe

3) Connect the quick connector of the evaporation hose to the evaporation pipe.

### CAUTION:

- Check that there is no damage or dust on the quick connector. If necessary, clean the seal surface of the pipe.
- When connecting the quick connector, securely insert the pipe all the way before locking the retainer.
- When it is difficult to lock the retainer, make sure that the pipe is securely inserted.
- Make sure that the quick connector is securely connected.

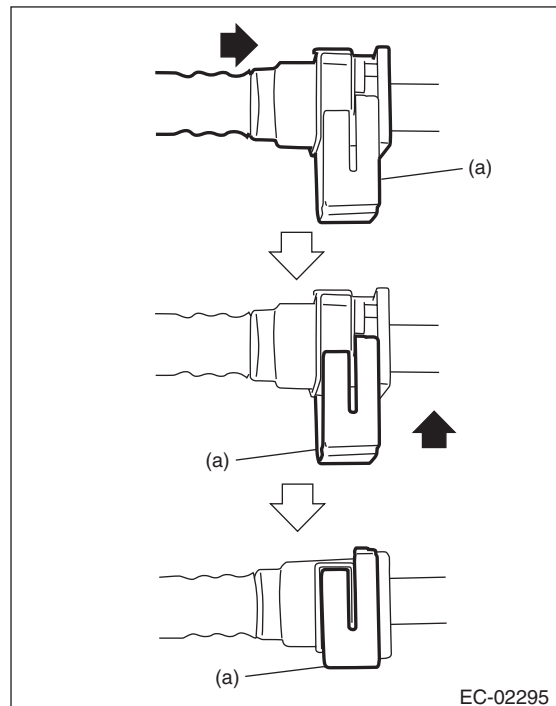

(a) Retainer

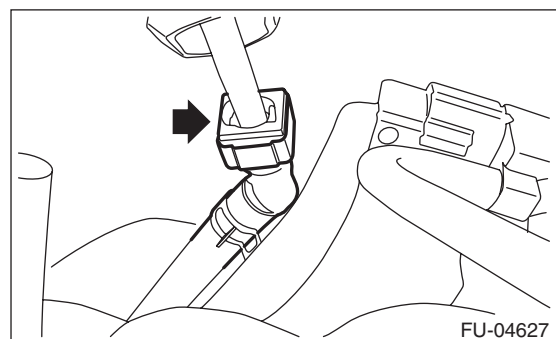



# Fuel Tank

## FUEL INJECTION (FUEL SYSTEMS)

4) Connect the evaporation hose (B) to hose connector (A).

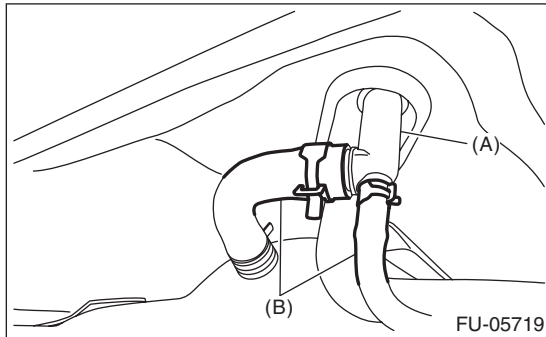

5) Tighten the bolts of the fuel tank band in the order shown in the figure.

**Tightening torque:**  
**33 N·m (3.4 kgf-m, 24.3 ft-lb)**

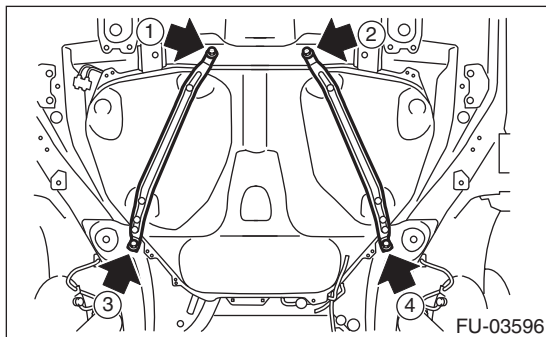

6) Install the rear suspension assembly.

### WARNING:

**A helper is required to perform this work.**

- (1) Support the rear differential with the transmission jack.
- (2) Support the rear suspension assembly and install the rear suspension assembly to the body.

**Tightening torque:**

**T1: 70 N·m (7.1 kgf-m, 51.6 ft-lb)**

**T2: 145 N·m (14.8 kgf-m, 106.9 ft-lb)**

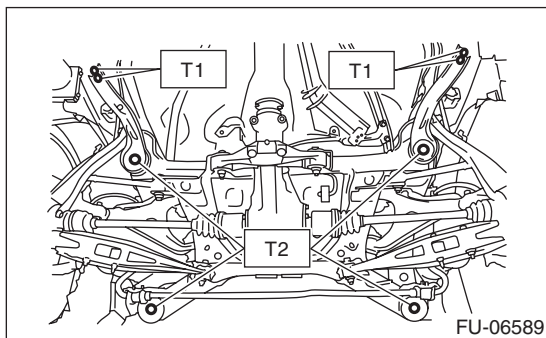

(3) Install the rear shock absorber to the rear suspension arm.

### NOTE:

Use a new self-locking nut.

**Tightening torque:**

**120 N·m (12.2 kgf-m, 88.5 ft-lb)**

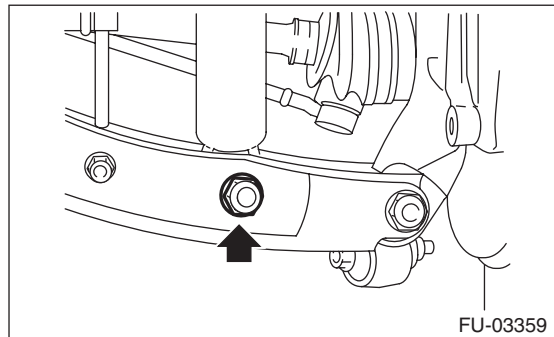

7) Connect the connectors to oil temperature switch (A) and ground (B), and secure the harness with clips (C).

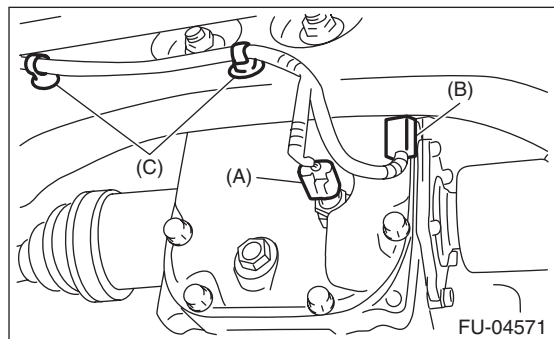

8) Install the parking brake cable clamp to the body.

**Tightening torque:**

**18 N·m (1.8 kgf-m, 13.3 ft-lb)**

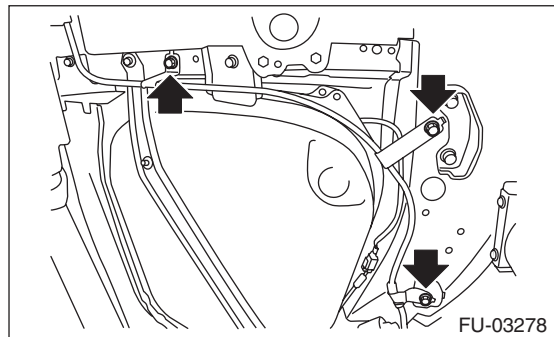

# Fuel Tank

## FUEL INJECTION (FUEL SYSTEMS)

9) Connect the connector to the rear ABS wheel speed sensor.

**NOTE:**

Prevent the harness identification (line) from being twisted when installing. (RH: White line, LH: Yellow line)

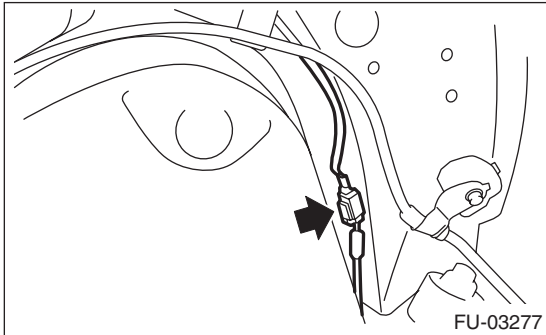

10) Install the heat shield cover.

**Tightening torque:**

**18 N·m (1.8 kgf-m, 13.3 ft-lb)**

11) Install the fuel tank protector.

**NOTE:**

Use a new self-locking nut.

**Tightening torque:**

**Nut: 9 N·m (0.9 kgf-m, 6.6 ft-lb)**

**Bolt: 18 N·m (1.8 kgf-m, 13.3 ft-lb)**

12) Install the propeller shaft. <Ref. to DS-12, INSTALLATION, Propeller Shaft.>

13) Install the rear exhaust pipe and muffler. <Ref. to EX(STI)-13, INSTALLATION, Rear Exhaust Pipe.> <Ref. to EX(STI)-15, INSTALLATION, Muffler.>

14) Lower the vehicle.

15) Connect the parking brake cable to the parking brake assembly. <Ref. to PB-7, INSTALLATION, Parking Brake Assembly (Rear Disc Brake).>

16) Install the rear disc brake assembly.

**Tightening torque:**

**65 N·m (6.6 kgf-m, 47.9 ft-lb)**

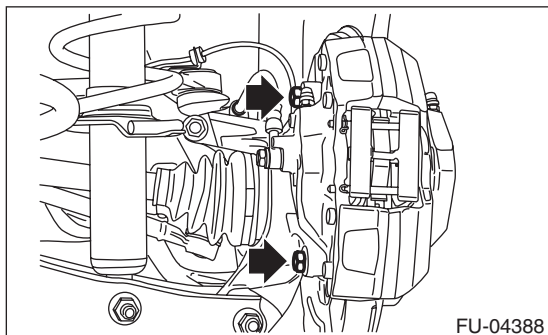

17) Install the rear brake hose bracket to the rear housing.

**Tightening torque:**

**33 N·m (3.4 kgf-m, 24.3 ft-lb)**

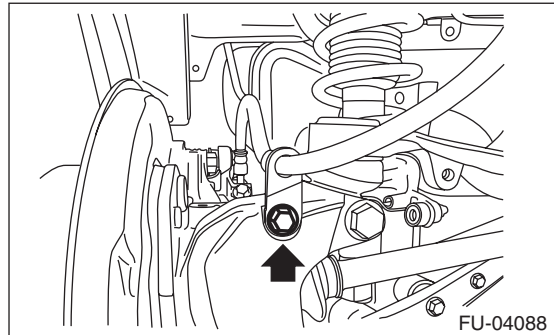

18) Attach the rear ABS wheel speed sensor to the rear housing.

**NOTE:**

Prevent the harness identification (line) from being twisted when installing. (RH: White line, LH: Yellow line)

**Tightening torque:**

**7.5 N·m (0.8 kgf-m, 5.5 ft-lb)**

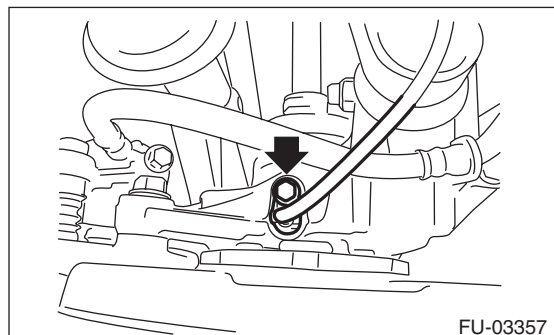

19) Install the rear wheels.

**Tightening torque:**

**100 N·m (10.2 kgf-m, 73.8 ft-lb)**

20) Connect the quick connector of fuel delivery tube (A) and fuel return tube (B). <Ref. to FU(STI)-96, INSTALLATION, Fuel Delivery, Return and Evaporation Lines.>

**NOTE:**

When connecting, be careful not to reverse the delivery side and return side.

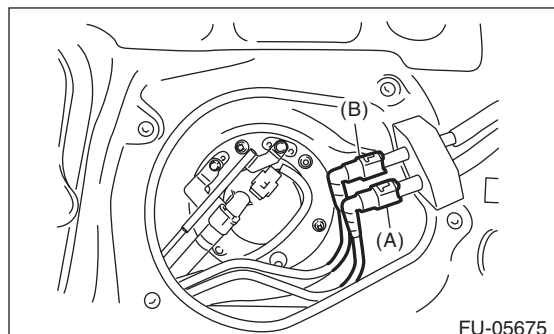

**FU(STI)-75**

Brought to you by Ebay Seller "SubaruManuals"

# Fuel Tank

## FUEL INJECTION (FUEL SYSTEMS)

21) Install the service hole cover of fuel sub level sensor.

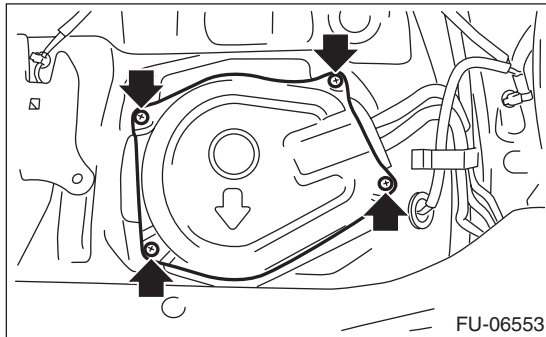

22) Attach the service hole cover of the fuel pump, and attach the connector and clip.

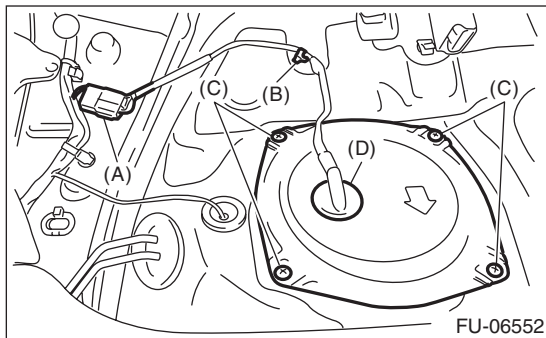

- (A) Connector
- (B) Clip
- (C) Screw
- (D) Grommet

23) Install the rear seat cushion. <Ref. to SE-14, INSTALLATION, Rear Seat.>

24) Connect the battery ground terminal.

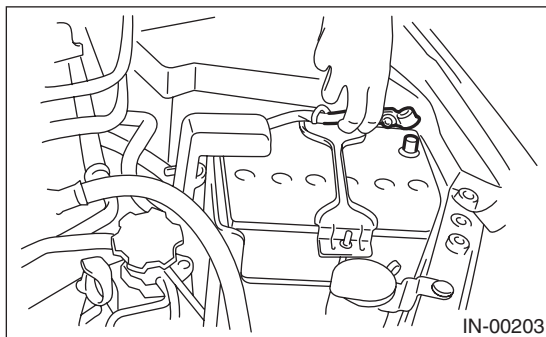

25) Inspect the wheel alignment and adjust if necessary.

### C: INSPECTION

- 1) Check that the fuel tank and fuel pipe have no deformation, cracks and other damages.
- 2) Check that the fuel hose has no cracks, damage or loose part.

## 26. Fuel Filler Pipe

### A: REMOVAL

**WARNING:**

Place "NO OPEN FLAMES" signs near the working area.

**CAUTION:**

Be careful not to spill fuel.

1) Release the fuel pressure. <Ref. to FU(STI)-67, RELEASING OF FUEL PRESSURE, PROCEDURE, Fuel.>

2) Drain fuel. <Ref. to FU(STI)-67, DRAINING FUEL (WITH SUBARU SELECT MONITOR), PROCEDURE, Fuel.>

3) Disconnect the ground cable from battery.

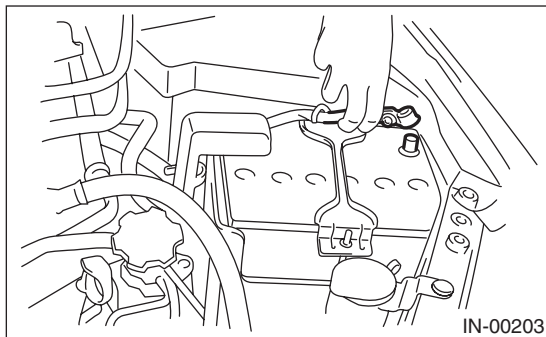

4) Open the fuel filler lid, and remove the filler cap.

5) Remove the screws which secure the fuel filler ring, and then remove the fuel filler ring.

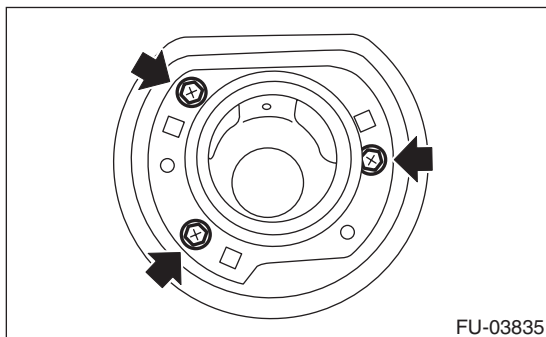

6) Remove the rear wheel RH.

7) Lift up the vehicle.

8) Remove the rear mud guard RH. <Ref. to EI-30, REAR MUD GUARD, REMOVAL, Mud Guard.>

9) Remove the rear sub frame. <Ref. to RS-17, REMOVAL, Rear Sub Frame.>

10) Remove the bolts and nuts which secure fuel filler pipe assembly onto the vehicle body.

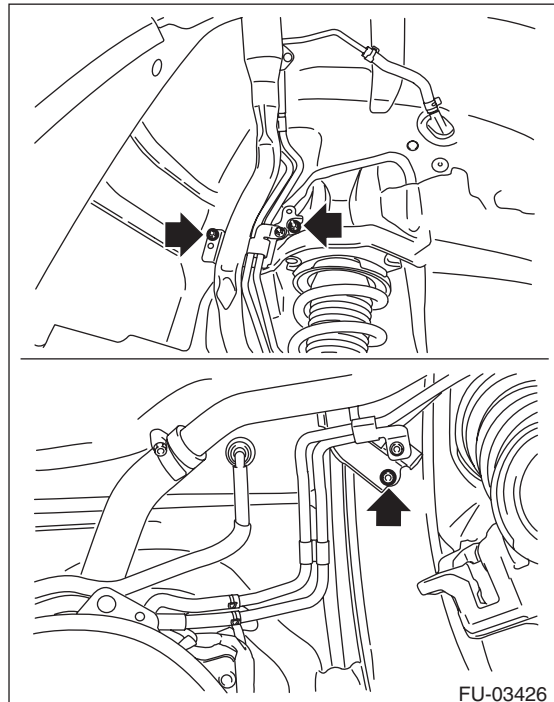

11) Disconnect the fuel filler hose (A) and evaporation hose (B) from the fuel filler pipe assembly.

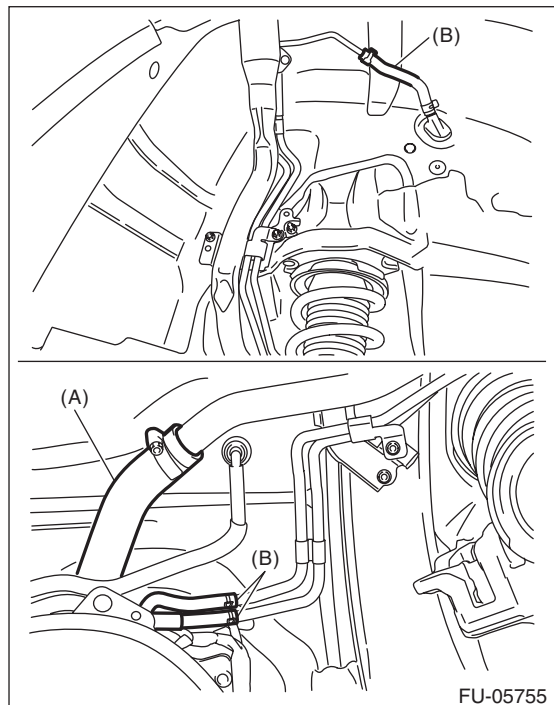

12) Remove the fuel filler pipe assembly from the underside of the vehicle.

# Fuel Filler Pipe

## FUEL INJECTION (FUEL SYSTEMS)

### B: INSTALLATION

- 1) Open the fuel filler lid.
- 2) Attach the fuel filler pipe gasket to the fuel filler pipe assembly, and insert the fuel filler pipe assembly from inside of the rear fender.
- 3) Install the fuel filler ring to the fuel filler pipe assembly.

#### NOTE:

If the edges of rubber gasket are folded toward inside, straighten it with a flat tip screwdriver.

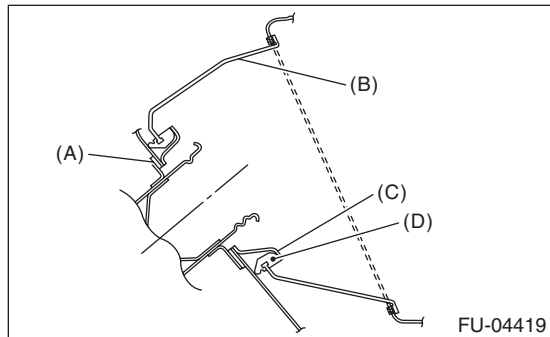

- (A) Fuel filler pipe gasket
- (B) Fuel saucer
- (C) Fuel filler ring
- (D) Rubber gasket

#### Tightening torque:

**4.4 N·m (0.4 kgf-m, 3.2 ft-lb)**

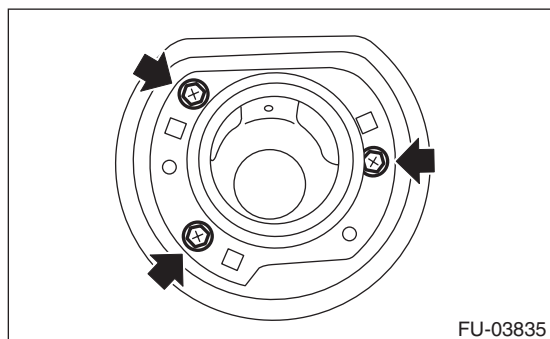

- 4) Securely insert the fuel filler hose (A) and evaporation hose (B) until the hose end contacts the spool, then attach the clamp or clip as shown in the figure.

#### Tightening torque:

**2.5 N·m (0.3 kgf-m, 1.8 ft-lb)**

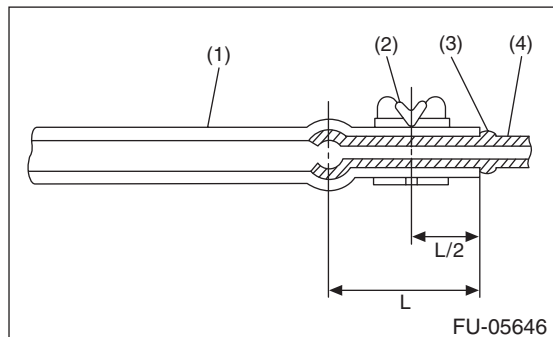
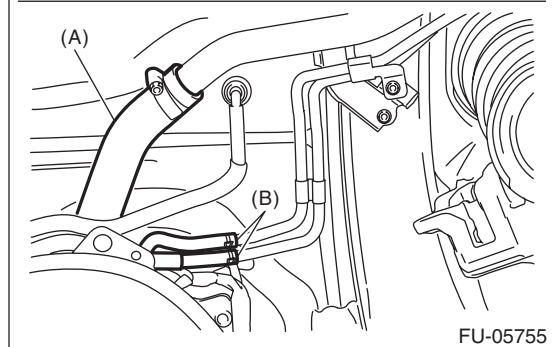
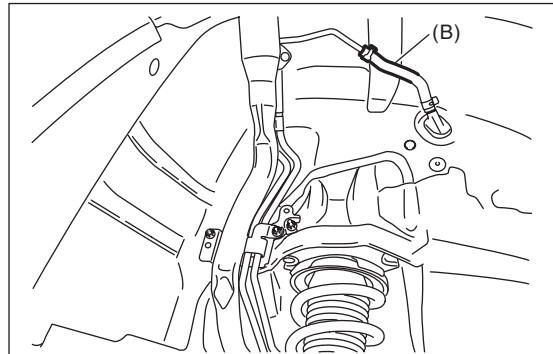

- (1) Hose
- (2) Clamp or clip
- (3) Spool
- (4) Pipe



5) Install the fuel filler pipe assembly to vehicle body.

**Tightening torque:**

**7.5 N·m (0.8 kgf-m, 5.5 ft-lb)**

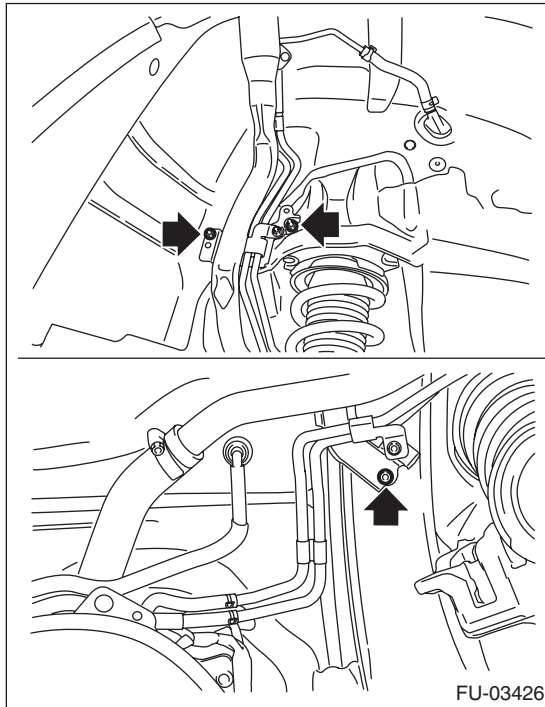

6) Install the rear sub frame. <Ref. to RS-18, INSTALLATION, Rear Sub Frame.>

7) Install the rear mud guard RH. <Ref. to EI-30, INSTALLATION, Mud Guard.>

8) Lower the vehicle.

9) Install the rear wheel RH.

**Tightening torque:**

**100 N·m (10.2 kgf-m, 73.8 ft-lb)**

10) Connect the battery ground terminal.

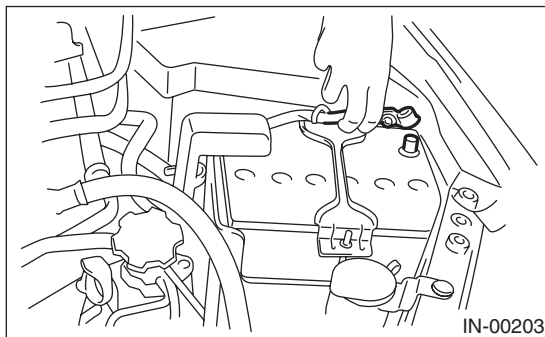

11) Inspect the wheel alignment and adjust if necessary.

## C: DISASSEMBLY

1) Remove the shut valve from the fuel filler pipe. <Ref. to EC(STI)-18, REMOVAL, Shut Valve.>

2) Remove the evaporation pipe from the fuel filler pipe.

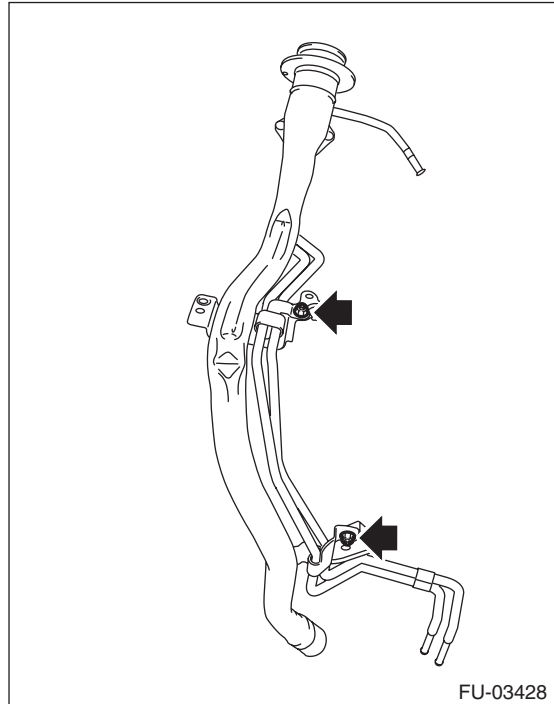

## D: ASSEMBLY

Assemble in the reverse order of disassembly.

**Tightening torque:**

**7.5 N·m (0.8 kgf-m, 5.5 ft-lb)**

## E: INSPECTION

1) Check that the fuel filler pipe and evaporation pipe have no deformation, cracks or other damages.

2) Check that the hose has no cracks, damage or loose part.

# Fuel Pump

FUEL INJECTION (FUEL SYSTEMS)

## 27. Fuel Pump

### A: REMOVAL

#### WARNING:

Place "NO OPEN FLAMES" signs near the working area.

#### CAUTION:

- Be careful not to spill fuel.
- If the fuel gauge indicates that two thirds or more of the fuel is remaining, be sure to drain fuel before starting work to avoid the fuel to spill.

#### NOTE:

Fuel pump assembly consists of fuel pump, fuel filter and fuel level sensor.

- 1) Release the fuel pressure. <Ref. to FU(STI)-67, RELEASING OF FUEL PRESSURE, PROCEDURE, Fuel.>
- 2) Drain fuel. <Ref. to FU(STI)-67, DRAINING FUEL (WITH SUBARU SELECT MONITOR), PROCEDURE, Fuel.>
- 3) Disconnect the ground cable from battery.

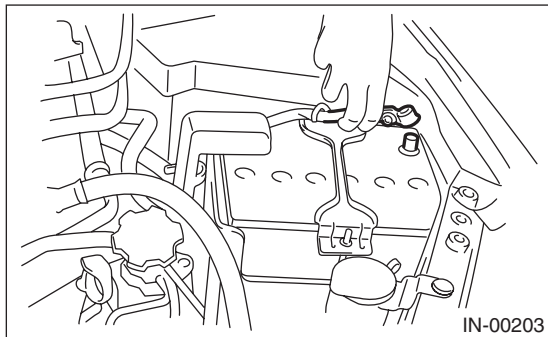

- 4) Remove the rear seat cushion. <Ref. to SE-13, REMOVAL, Rear Seat.>
- 5) Remove the service hole cover.

- (1) Remove the screws (A).
- (2) Push the grommet (B) down and remove service hole cover.

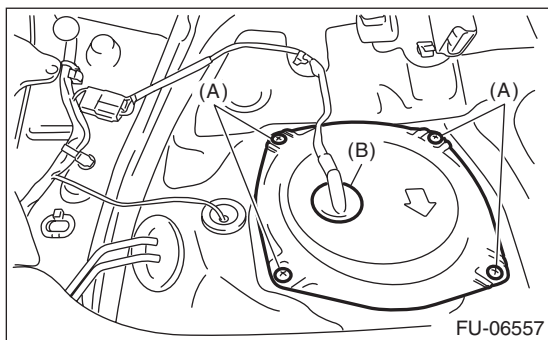

- 6) Disconnect the connector from fuel pump.

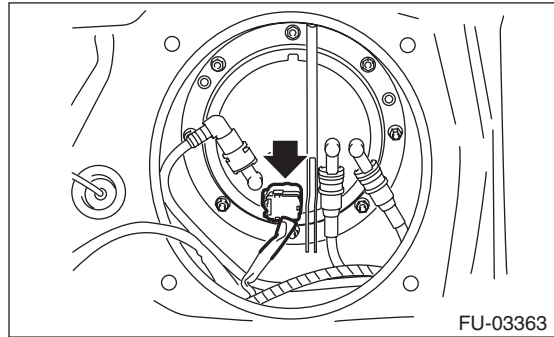

- 7) Disconnect the quick connectors of fuel delivery tube (A), fuel return tube (B), and jet pump tube (C). <Ref. to FU(STI)-93, REMOVAL, Fuel Delivery, Return and Evaporation Lines.>

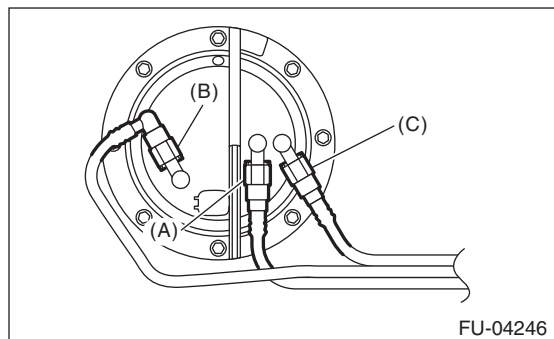

- 8) Remove the nuts which hold the fuel pump upper plate to the fuel tank.

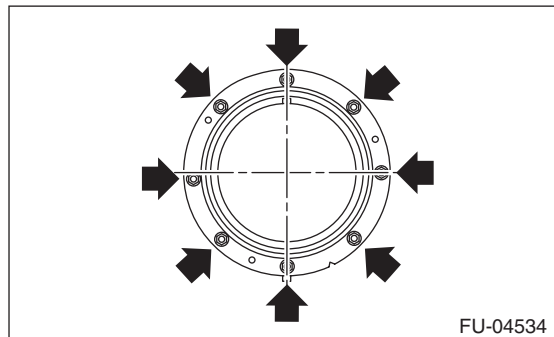

- 9) Remove the fuel pump assembly from the fuel tank.

FU(STI)-80

Brought to you by Ebay Seller "SubaruManuals"

## B: INSTALLATION

Install in the reverse order of removal while being careful of the following.

- Make sure the sealing portion is free from fuel or foreign matter before installation.
- Align protrusion (A) of the gasket to the position shown in the figure.
- Insert the protrusion (B) of gasket to the fuel pump upper plate. (3 places)
- Align the protrusion (C) of fuel pump assembly with the cutout on the fuel pump upper plate.
- Tighten the nuts to the specified torque in the order as shown in the figure.

NOTE:

Use a new gasket.

**Tightening torque:**

**4.4 N·m (0.4 kgf·m, 3.2 ft·lb)**

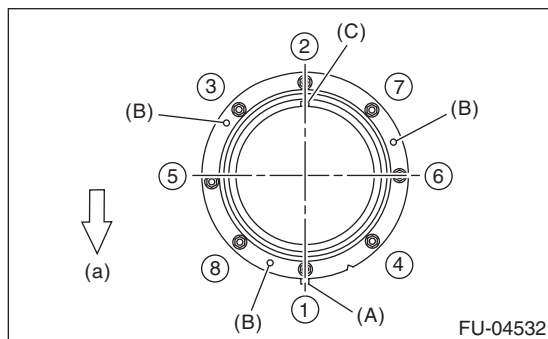

(a) Front side of vehicle

## C: INSPECTION

- 1) Check that the fuel pump has no deformation, cracks or other damages.
- 2) Connect the battery positive terminal to terminal No. 5 and the battery ground terminal to terminal No. 6, and inspect the fuel pump operation.

**WARNING:**

- **Wipe off fuel completely.**
- **Keep the battery as far apart from fuel pump as possible.**
- **Do not run the fuel pump for a long time under non-load condition.**

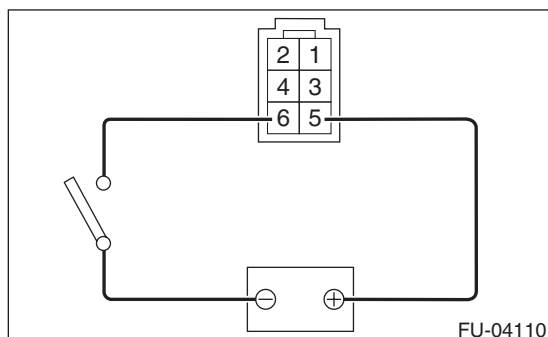



# Fuel Level Sensor

FUEL INJECTION (FUEL SYSTEMS)

## 28. Fuel Level Sensor

### A: REMOVAL

**WARNING:**

Place "NO OPEN FLAMES" signs near the working area.

**CAUTION:**

- Be careful not to spill fuel.
- If the fuel gauge indicates that two thirds or more of the fuel is remaining, be sure to drain fuel before starting work to avoid the fuel to spill.

**NOTE:**

The fuel level sensor is built in fuel pump assembly.

- 1) Remove the fuel pump assembly. <Ref. to FU(STI)-80, REMOVAL, Fuel Pump.>
- 2) Disconnect the fuel level sensor connector.

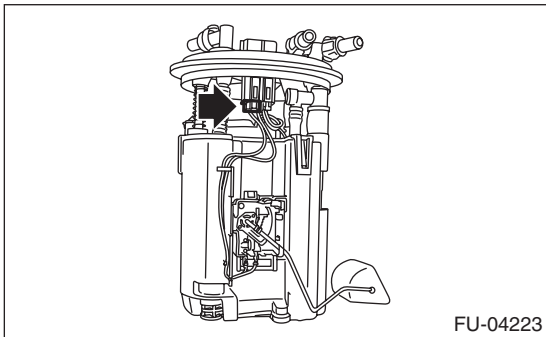

3) Slide the fuel level sensor in the direction of the arrow and remove the fuel level sensor by pressing the claw (A) of the fuel level sensor.

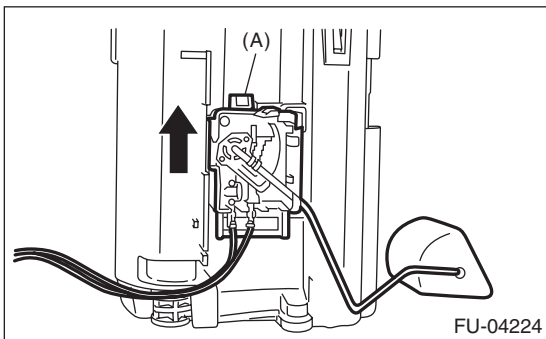

### B: INSTALLATION

Install in the reverse order of removal.

### C: INSPECTION

- 1) Check that the fuel level sensor has no damage.
- 2) Measure the fuel level sensor float position.

**NOTE:**

When inspecting the fuel level sensor, perform the work with the sensor installed to the fuel pump.

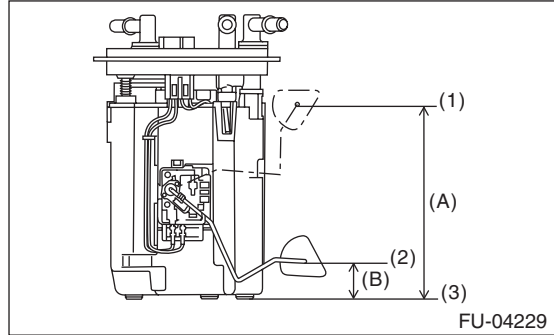

- (1) FULL
- (2) EMPTY
- (3) Fuel tank seating surface

Float position	Standard
FULL to Fuel tank seating surface (A)	135±4 mm (5.315±0.157 in)
EMPTY to Fuel tank seating surface (B)	23.7±4 mm (0.933±0.157 in)

3) Measure the resistance between fuel level sensor terminals.

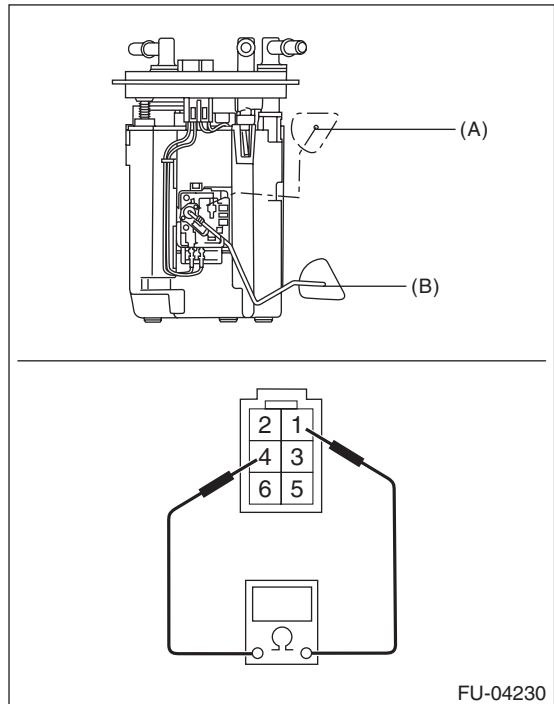

Float position	Terminal No.	Standard
FULL (A)	1 and 4	2.0±1.0 Ω
EMPTY (B)		31.9±1.0 Ω

## 29. Fuel Sub Level Sensor

### A: REMOVAL

**WARNING:**

Place "NO OPEN FLAMES" signs near the working area.

**CAUTION:**

- Be careful not to spill fuel.
- If the fuel gauge indicates that two thirds or more of the fuel is remaining, be sure to drain fuel before starting work to avoid the fuel to spill.

1) Release the fuel pressure. <Ref. to FU(STI)-67, RELEASING OF FUEL PRESSURE, PROCEDURE, Fuel.>

2) Drain fuel. <Ref. to FU(STI)-67, DRAINING FUEL (WITH SUBARU SELECT MONITOR), PROCEDURE, Fuel.>

3) Disconnect the ground cable from battery.

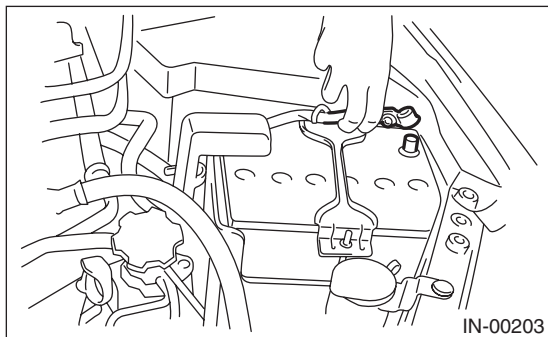

4) Remove the rear seat cushion. <Ref. to SE-13, REMOVAL, Rear Seat.>

5) Remove the service hole cover.

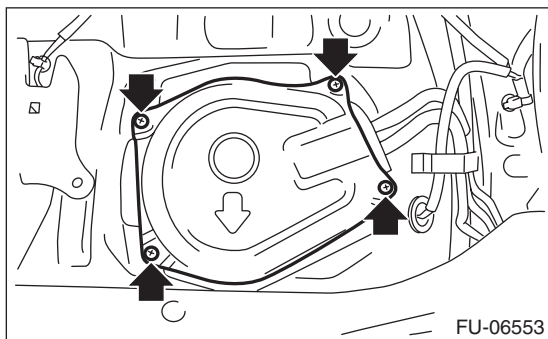

6) Disconnect the connector from the fuel sub level sensor.

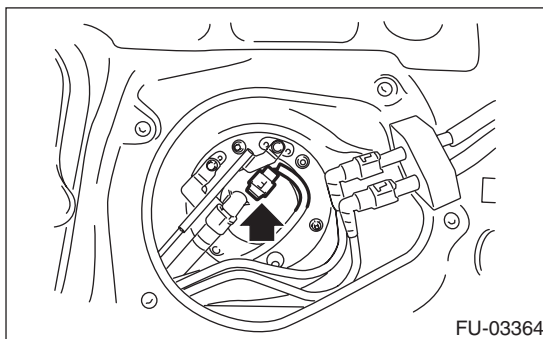

7) Disconnect the quick connectors of fuel delivery tube (A), fuel return tube (B), and jet pump tube (C). <Ref. to FU(STI)-93, REMOVAL, Fuel Delivery, Return and Evaporation Lines.>

8) Remove the rubber cap (D) from the nut.

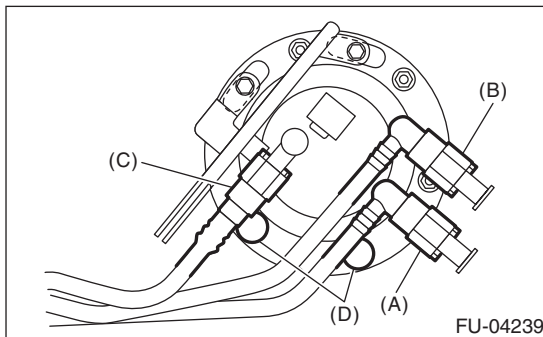

9) Remove the bolts and nuts which hold fuel sub level sensor protector and fuel sub level sensor upper plate to the fuel tank.

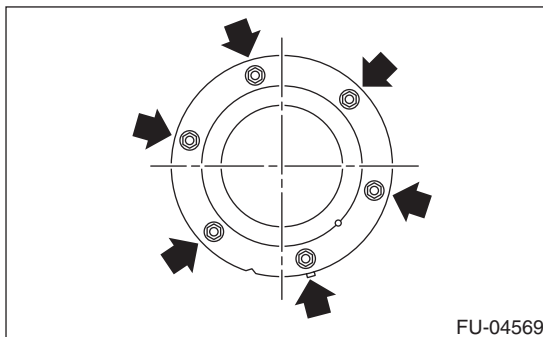
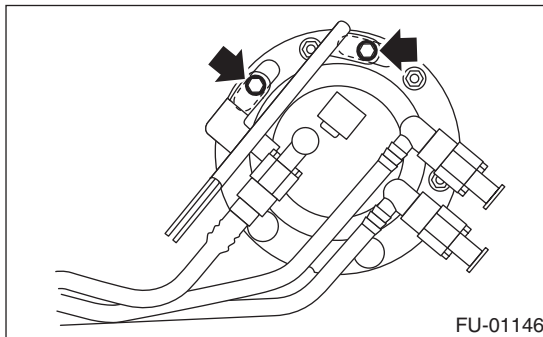

10) Remove the fuel sub level sensor from the fuel tank.

# Fuel Sub Level Sensor

## FUEL INJECTION (FUEL SYSTEMS)

### B: INSTALLATION

Install in the reverse order of removal while being careful of the following.

- Make sure the sealing portion is free from fuel or foreign matter before installation.
- Align protrusion (A) of the gasket to the position shown in the figure.
- Align protrusion (B) of the fuel sub level sensor to the cutout in the fuel sub level sensor upper plate.
- Tighten the nuts and bolts to the specified torque in the order as shown in the figure.
- After tightening, install the rubber cap (C) at the position shown in the figure.

#### NOTE:

- Use a new gasket.
- Do not forget to install rubber cap (C).

#### Tightening torque:

**4.4 N·m (0.4 kgf·m, 3.2 ft·lb)**

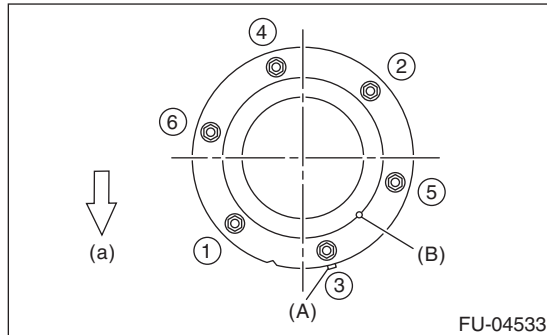

(a) Front side of vehicle

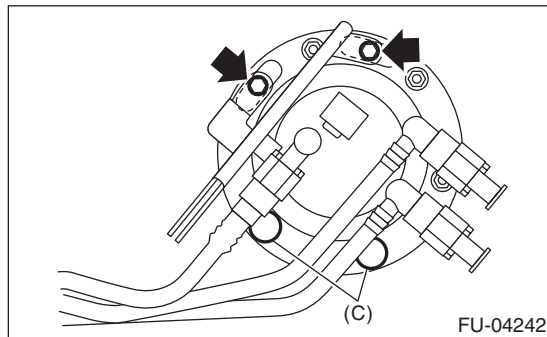

### C: INSPECTION

- 1) Check that the fuel sub level sensor has no damage.
- 2) Measure the fuel sub level sensor float position.

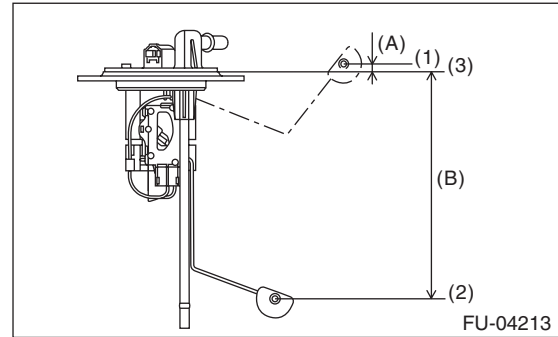

- (1) FULL
- (2) EMPTY
- (3) Datum points

Float position	Standard
FULL to Datum point (A)	5.31±3.5 mm (0.209±0.138 in)
EMPTY to Datum point (B)	160.6±3.5 mm (6.323±0.138 in)

- 3) Measure the resistance between fuel sub level sensor terminals.

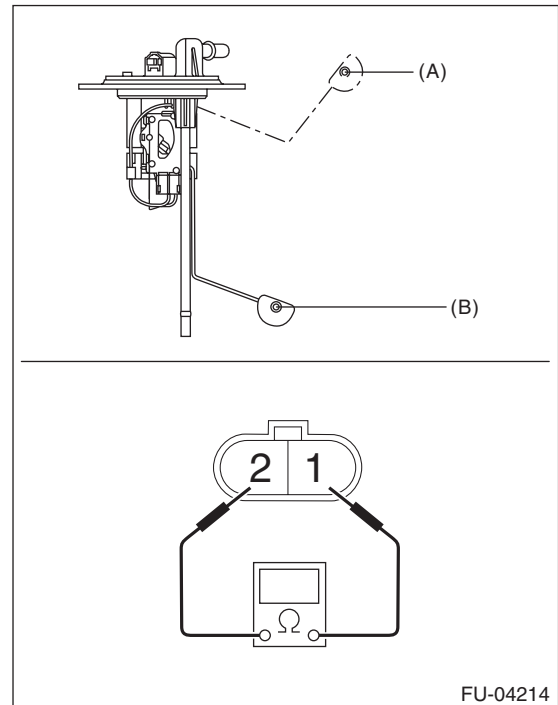

Float position	Terminal No.	Standard
FULL (A)	1 and 2	2.0 <sup>+0.5</sup> <sub>-1.0</sub> Ω
EMPTY (B)		62.1±1.0 Ω

## 30. Fuel Filter

### A: REMOVAL

**WARNING:**

Place "NO OPEN FLAMES" signs near the working area.

**CAUTION:**

- Be careful not to spill fuel.
- If the fuel gauge indicates that two thirds or more of the fuel is remaining, be sure to drain fuel before starting work to avoid the fuel to spill.
- Be careful not to drop or apply any impact to the fuel pump during work. This may deteriorate its performance.

**NOTE:**

The fuel filter is built in fuel pump assembly.

- 1) Remove the fuel pump assembly. <Ref. to FU(STI)-80, REMOVAL, Fuel Pump.>
- 2) Remove the fuel level sensor. <Ref. to FU(STI)-82, REMOVAL, Fuel Level Sensor.>
- 3) Disconnect the pump assembly connector from sub tank bracket assembly.

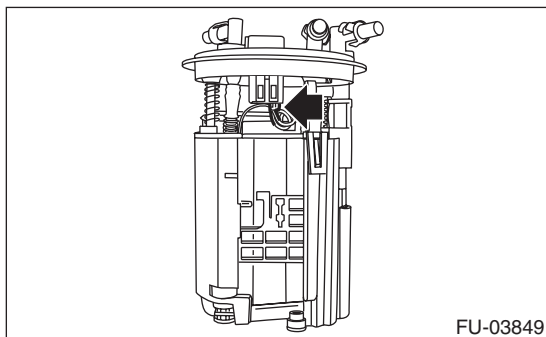

- 4) Cut off the tab holders connecting the sub tank bracket assembly and the sub tank in four locations, and separate the sub tank bracket assembly and the sub tank.

**CAUTION:**

Be careful not to damage the sub tank.

**NOTE:**

If the O-ring is remaining on the sub tank, remove.

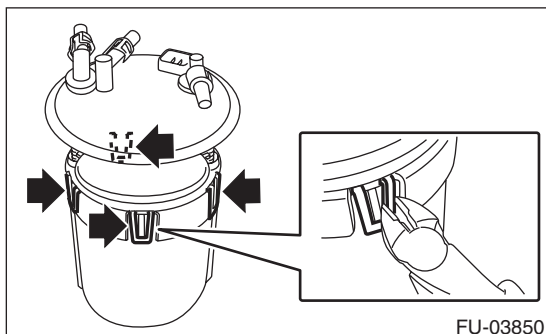

- 5) Disconnect two connectors of fuel delivery pipe from fuel filter assembly.

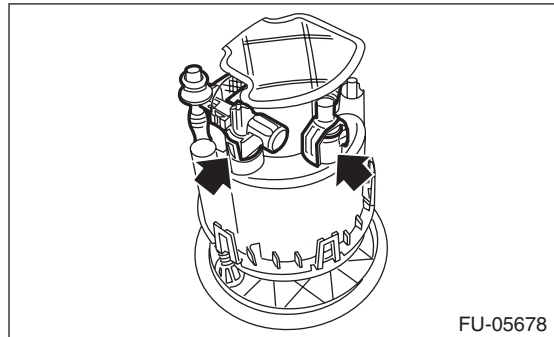

- 6) Push to compress the fuel filter assembly in the direction of the arrow, remove clip (A), and separate the sub tank bracket assembly and the fuel filter assembly.

**CAUTION:**

When separating the sub tank bracket assembly and the fuel filter assembly, be careful not to damage the ground wire.

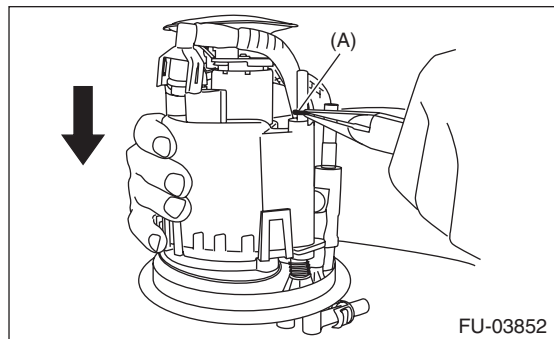

- 7) Disconnect the connector from the pump assembly.

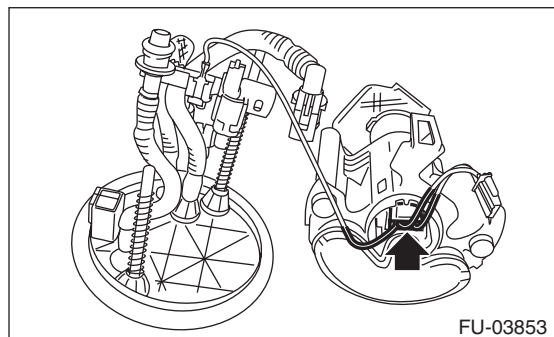

# Fuel Filter

## FUEL INJECTION (FUEL SYSTEMS)

8) Lift the two tab holders connecting the pump assembly to the fuel filter using a flat tip screwdriver (with a shaft diameter of approx. 3 mm (0.12 in)), etc., and separate the fuel filter and pump assembly.

### CAUTION:

- To prevent damaging the tabs of the pump assembly, wrap the tip of flat tip screwdriver (A), etc. with tape (B).

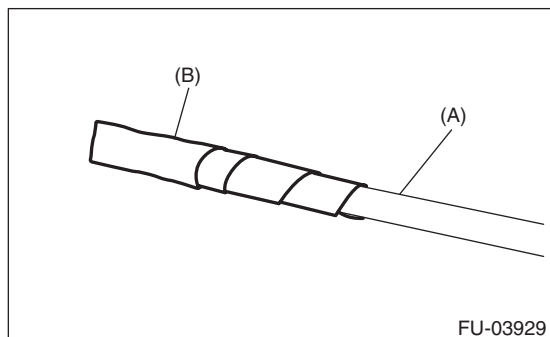

- Be careful not to drop or apply any impact to the pump assembly.

### NOTE:

If the spacer and O-ring is remaining on the pump assembly, remove these.

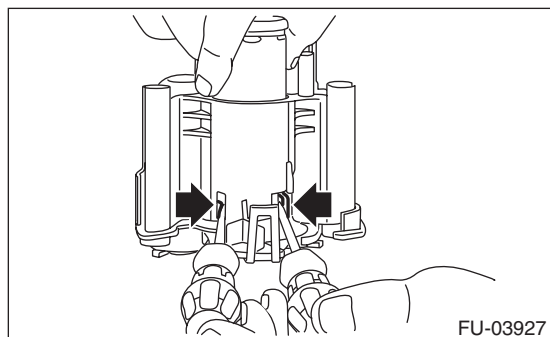

## B: INSTALLATION

1) Assemble O-ring (A) and spacer (B) to the pump assembly and attach the pump assembly to the fuel filter.

### NOTE:

- Use new O-rings (8 mm (0.31 in) inner diameter).
- Use a new spacer.
- Apply gasoline to the O-ring.
- Insert the pump assembly until a click is heard.

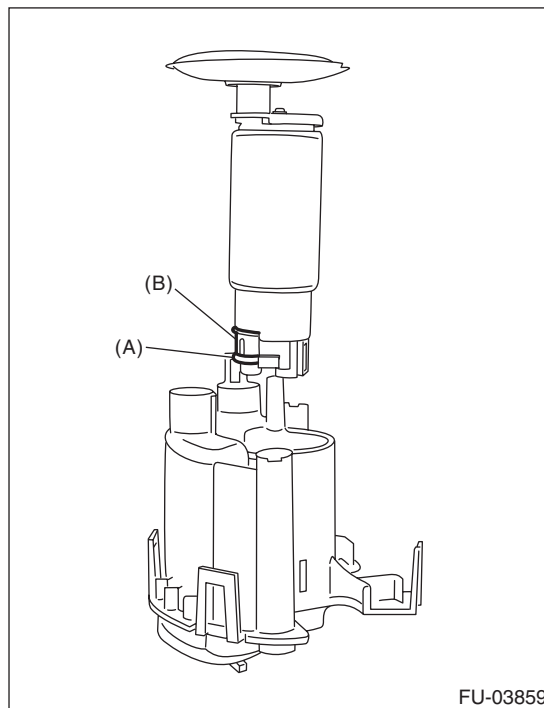

2) Connect the connector to the pump assembly.

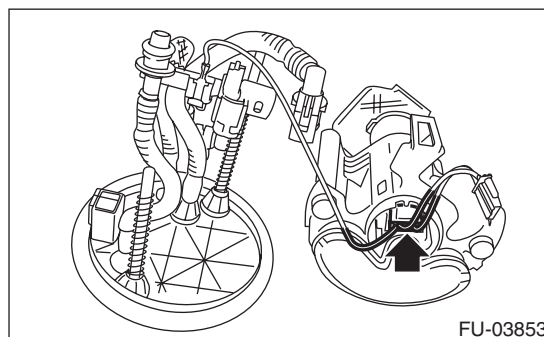

# Fuel Filter

FUEL INJECTION (FUEL SYSTEMS)

3) Attach spring (A) to the metal rod of the sub tank bracket assembly, and assemble the fuel filter assembly.

NOTE:

Use a new spring.

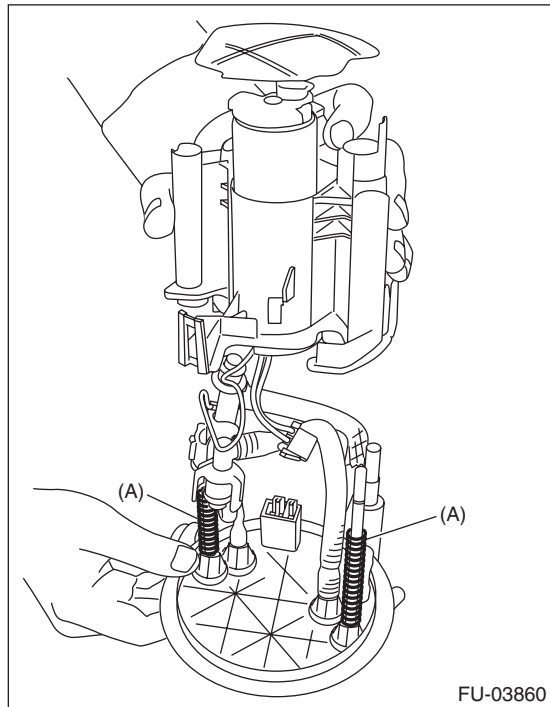

4) Push the fuel filter assembly in the direction of the arrow to compress, and attach clip (A).

NOTE:

Use a new clip.

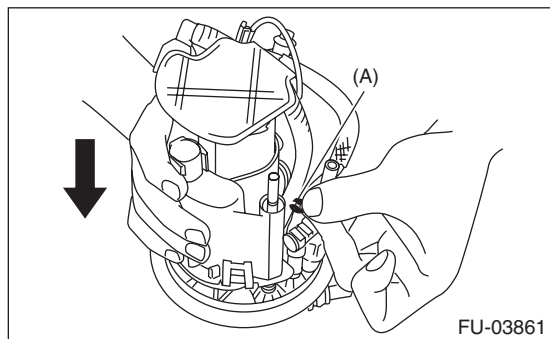

5) Connect the fuel piping connector to the fuel filter assembly.

NOTE:

- Use new O-rings.
- Apply gasoline to the O-ring.
- The O-rings of the black and white connectors are identified by a difference in diameter. Be careful not to confuse the two during assembly.

**O-ring inner diameter:**

**Black connector O-ring [Approx. 7 mm (0.28 in)]**

**White connector O-ring [Approx. 8 mm (0.31 in)]**

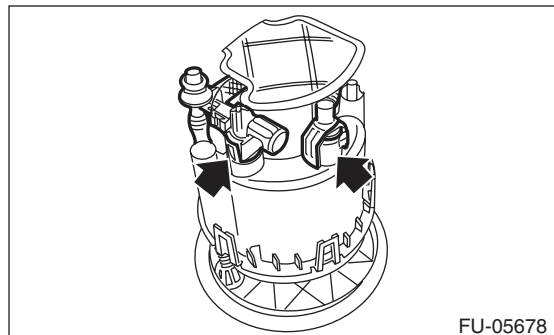

6) Attach the O-ring (A) to the fuel filter assembly, and attach the sub tank to the sub tank bracket assembly.

NOTE:

- Use new O-rings (8 mm (0.31 in) inner diameter).
- Apply gasoline to the O-ring.
- Insert the pump assembly until a "pop" is heard.

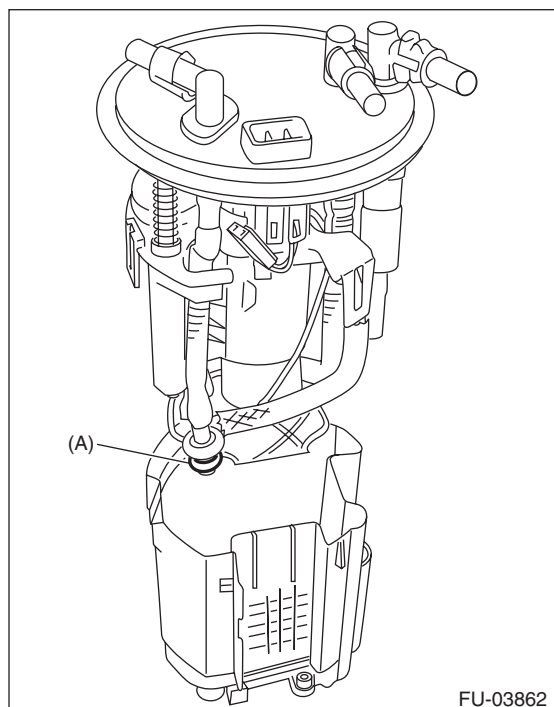

**FU(STI)-87**

Brought to you by Ebay Seller "SubaruManuals"

## Fuel Filter

### FUEL INJECTION (FUEL SYSTEMS)

---

7) Replace the cushion on the rear face of the sub tank with a new cushion.

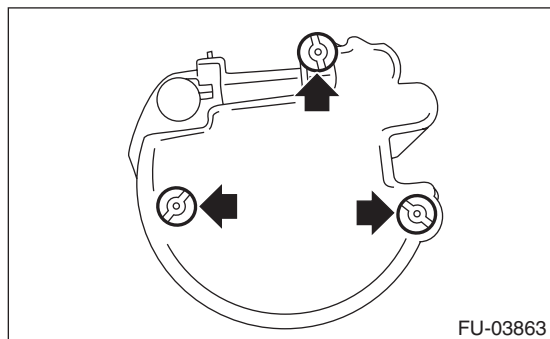

8) Connect the pump assembly connector to the sub tank bracket assembly.

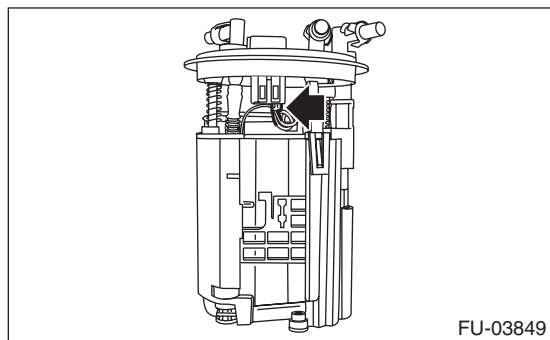

9) Install the fuel level sensor. <Ref. to FU(STI)-82, INSTALLATION, Fuel Level Sensor.>

10) Inspect the fuel level sensor. <Ref. to FU(STI)-82, INSPECTION, Fuel Level Sensor.>

11) Install the fuel pump assembly. <Ref. to FU(STI)-81, INSTALLATION, Fuel Pump.>



# Pulsation Damper Assembly

FUEL INJECTION (FUEL SYSTEMS)

## 31. Pulsation Damper Assembly

### A: REMOVAL

#### WARNING:

Place "NO OPEN FLAMES" signs near the working area.

#### CAUTION:

- Be careful not to spill fuel.
- Catch the fuel from hoses using a container or cloth.

1) Release the fuel pressure. <Ref. to FU(STI)-67, RELEASING OF FUEL PRESSURE, PROCEDURE, Fuel.>

2) Disconnect the fuel delivery hose (A) and fuel hose (B) from the pulsation damper assembly, and remove the pulsation damper assembly.

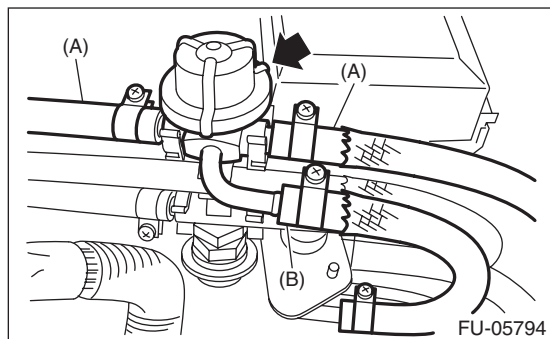

### B: INSTALLATION

Install in the reverse order of removal.

#### NOTE:

For the information about connecting the fuel delivery hose and fuel hose, refer to "Fuel Delivery, Return & Evaporation Lines". <Ref. to FU(STI)-97, CONNECTING FUEL DELIVERY HOSE, FUEL RETURN HOSE AND FUEL HOSE, INSTALLATION, Fuel Delivery, Return and Evaporation Lines.>

### C: DISASSEMBLY

Remove the pulsation damper and fuel pipe gasket from the fuel by-pass pipe.

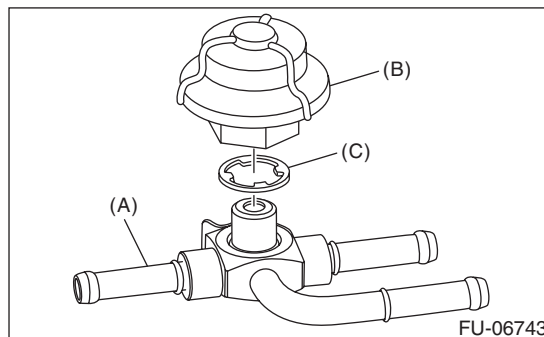

- (A) Fuel by-pass pipe
- (B) Pulsation damper
- (C) Fuel pipe gasket

### D: ASSEMBLY

Install the fuel pipe gasket and pulsation damper to the fuel by-pass pipe.

#### NOTE:

Use a new fuel pipe gasket.

#### Tightening torque:

**21.6 N·m (2.2 kgf-m, 15.9 ft-lb)**

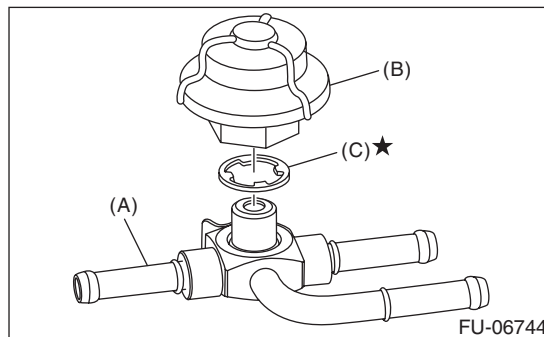

- (A) Fuel by-pass pipe
- (B) Pulsation damper
- (C) Fuel pipe gasket

### E: INSPECTION

- 1) Check that the pulsation damper assembly has no deformation, cracks or other damages.
- 2) Check that the fuel delivery hose and fuel hose have no cracks, damage or loose part.



# Pressure Regulator & Damper Assembly

FUEL INJECTION (FUEL SYSTEMS)

## 32. Pressure Regulator & Damper Assembly

### A: REMOVAL

#### WARNING:

Place "NO OPEN FLAMES" signs near the working area.

#### CAUTION:

- Be careful not to spill fuel.
- Catch the fuel from hoses using a container or cloth.

1) Release the fuel pressure. <Ref. to FU(STI)-67, RELEASING OF FUEL PRESSURE, PROCEDURE, Fuel.>

2) Disconnect the vacuum hose (A) from the pressure regulator and damper assembly.

3) Disconnect the fuel return hose (B) and fuel hose (C) from the pressure regulator & damper assembly, and remove the fuel regulator & damper assembly.

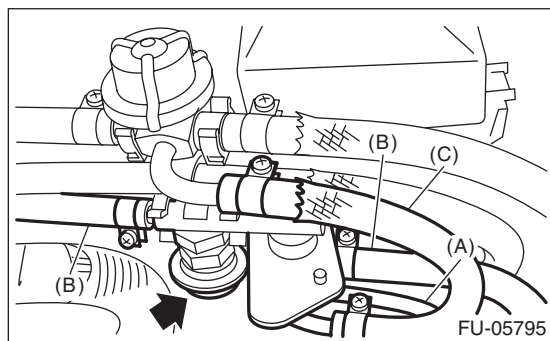

### B: INSTALLATION

Install in the reverse order of removal.

#### NOTE:

For the information about connecting the fuel return hose and fuel hose, refer to "Fuel Delivery, Return & Evaporation Lines". <Ref. to FU(STI)-97, CONNECTING FUEL DELIVERY HOSE, FUEL RETURN HOSE AND FUEL HOSE, INSTALLATION, Fuel Delivery, Return and Evaporation Lines.>

### C: DISASSEMBLY

1) Remove the fuel pipe protector from the pressure regulator and damper assembly.

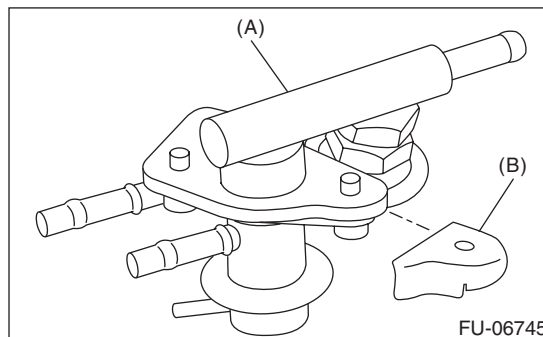

(A) Pressure regulator & damper ASSY

(B) Fuel pipe protector

2) Remove the pulsation damper and fuel pipe gasket from the fuel holder assembly, and remove the pressure regulator from the fuel holder assembly.

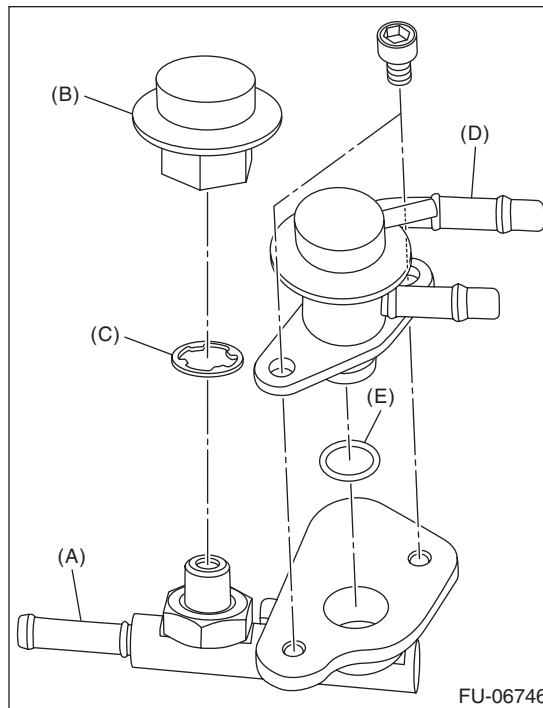

(A) Fuel holder ASSY

(B) Pulsation damper

(C) Fuel pipe gasket

(D) Pressure regulator

(E) O-ring

# Pressure Regulator & Damper Assembly

FUEL INJECTION (FUEL SYSTEMS)

## D: ASSEMBLY

1) Install the pressure regulator to the fuel holder assembly, and install the fuel pipe gasket and pulsation damper to the fuel holder assembly.

### NOTE:

- Use new O-rings and fuel pipe gaskets.
- Apply a thin coat of engine oil to the pressure regulator installation hole of fuel holder assembly.

### Tightening torque:

**T1: 6.4 N·m (0.7 kgf-m, 4.7 ft-lb)**

**T2: 21.6 N·m (2.2 kgf-m, 15.9 ft-lb)**

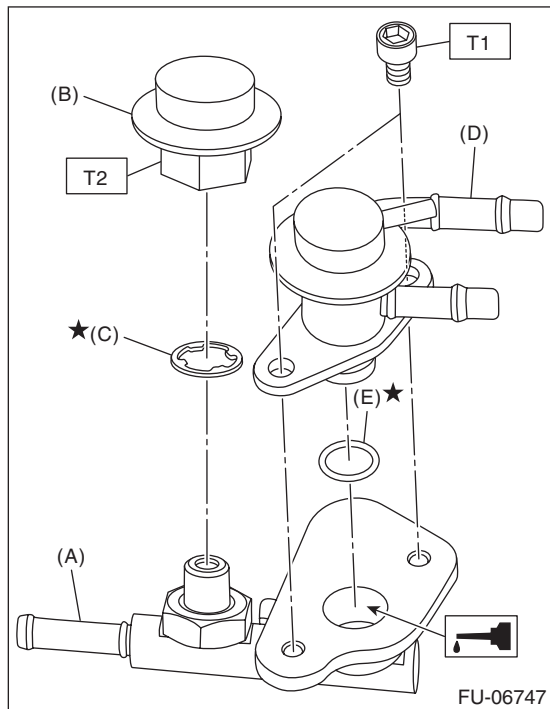

- (A) Fuel holder ASSY
- (B) Pulsation damper
- (C) Fuel pipe gasket
- (D) Pressure regulator
- (E) O-ring

2) Install the fuel pipe protector to the pressure regulator and damper assembly.

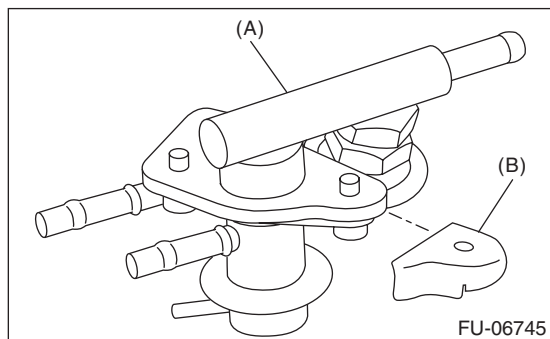

- (A) Pressure regulator & damper ASSY
- (B) Fuel pipe protector

## E: INSPECTION

- 1) Check that the pressure regulator and damper assembly has no deformation, cracks or other damages.
- 2) Check that the vacuum hose, fuel return hose and fuel hose have no cracks, damage or loose part.

**FU(STI)-91**

Brought to you by Ebay Seller "SubaruManuals"

# Purge Damper

FUEL INJECTION (FUEL SYSTEMS)

## 33.Purge Damper

### A: REMOVAL

#### WARNING:

Place "NO OPEN FLAMES" signs near the working area.

1) Remove the bolts which secure the purge damper to the purge damper bracket.



2) Disconnect the evaporation hose from the purge damper and remove the purge damper.

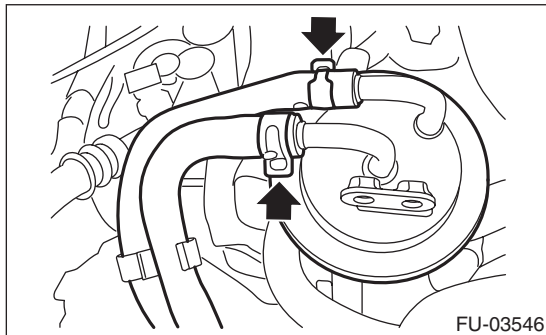

### B: INSTALLATION

Install in the reverse order of removal.

#### Tightening torque:

**13 N·m (1.3 kgf·m, 9.6 ft·lb)**

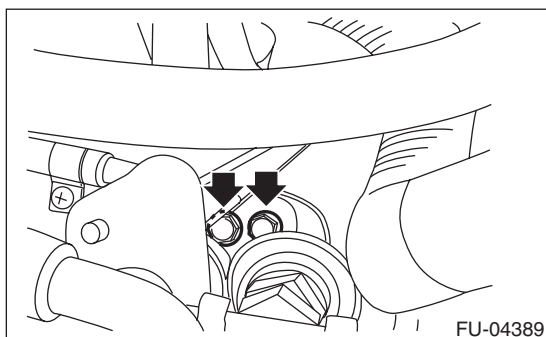

### C: INSPECTION

1) Check that the purge damper has no deformation, cracks or other damages.

2) Check that the evaporation hose has no cracks, damage or loose part.

## 34. Fuel Delivery, Return and Evaporation Lines

### A: REMOVAL

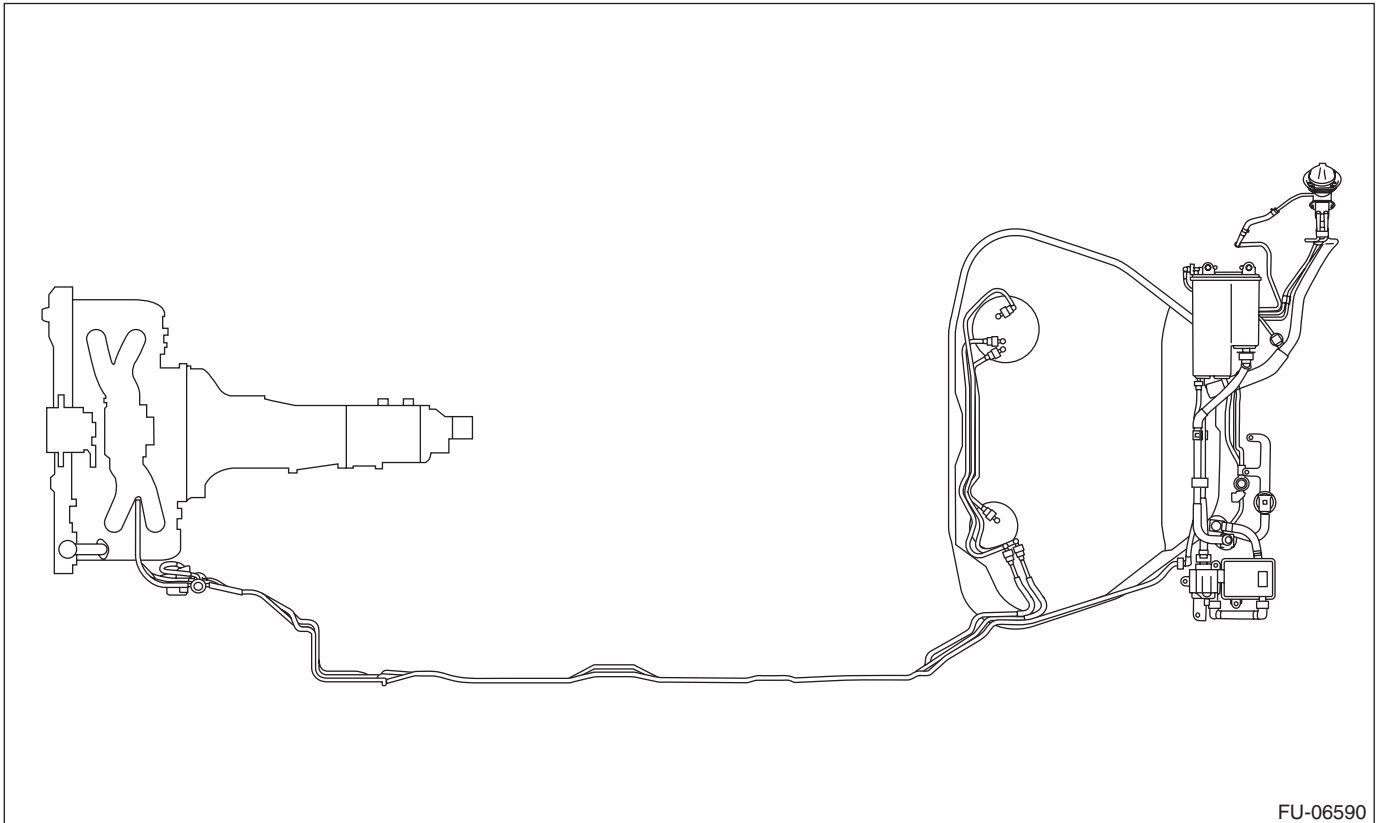

**WARNING:**  
Place "NO OPEN FLAMES" signs near the working area.

**CAUTION:**  
Be careful not to spill fuel.

# Fuel Delivery, Return and Evaporation Lines

## FUEL INJECTION (FUEL SYSTEMS)

- 1) Release the fuel pressure. <Ref. to FU(STI)-67, RELEASING OF FUEL PRESSURE, PROCEDURE, Fuel.>
- 2) Open the fuel filler lid and remove the fuel filler cap.
- 3) Remove the floor mat. <Ref. to EI-71, REMOVAL, Floor Mat.>
- 4) In the engine compartment, disconnect the fuel delivery hoses, fuel return hoses and evaporation hoses.

### CAUTION:

- Be careful not to spill fuel.
- Catch the fuel from hoses using a container or cloth.

(1) Set the ST to the fuel pipe.

ST 42099AE000 QUICK CONNECTOR RELEASE

(2) Disconnect the quick connector of the fuel delivery hose and fuel return hose by pushing the ST in the direction of the arrow.

(3) Remove the clip and disconnect the evaporation hose from the fuel pipe.

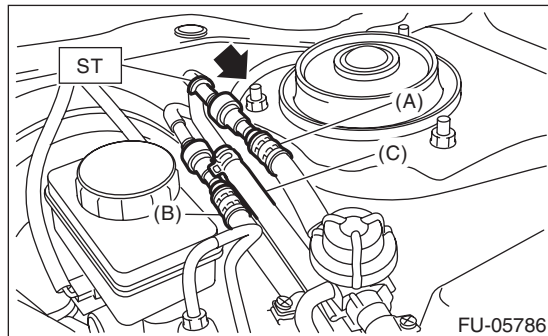

- (A) Fuel delivery hose
- (B) Fuel return hose
- (C) Evaporation hose

- 5) Remove the canister. <Ref. to EC(STI)-7, REMOVAL, Canister.>
- 6) Remove the fuel tank. <Ref. to FU(STI)-70, REMOVAL, Fuel Tank.>
- 7) Remove the fuel pipe assembly from vehicle.
- 8) Disconnect the quick connector, then disconnect the fuel delivery tube, fuel return tube and jet pump tube from the fuel tank.

- When using ST
- 1. Attach ST to the pipe and push ST in the direction of arrow mark to disconnect the quick connector.

ST 42099AE000 QUICK CONNECTOR RELEASE

### CAUTION:

- Be careful not to spill fuel.
- Catch the fuel from hoses using a container or cloth.
- To disconnect the connector, hold (C) shown in the figure and pull in axial direction.
- If the connector and pipe are sticking to each other, push and pull the connector with ST pushed, and then pull the connector after it starts moving freely.
- When disconnecting the connector, do not bend or twist the tube forcibly. If the tube is bent, replace with a new part.

### NOTE:

Clean the pipe and quick connector, if they are covered with dust.

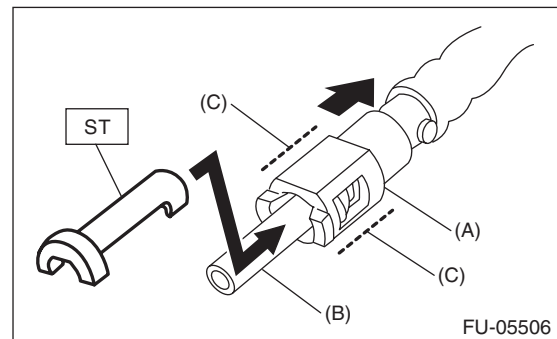

- (A) Quick connector
- (B) Pipe
- (C) Connector holding position

2. To prevent from damaging or entering foreign matter, wrap the pipes and quick connectors with plastic bag etc.

### CAUTION:

When reusing the retainer, do not disconnect the retainer from the connector.

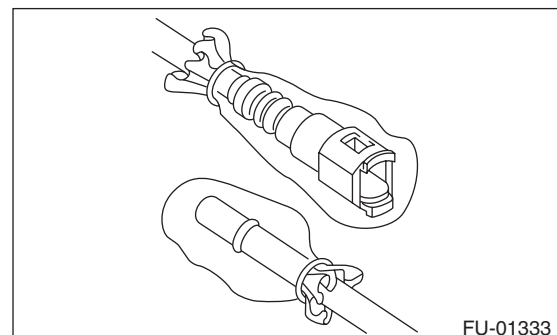

# Fuel Delivery, Return and Evaporation Lines

FUEL INJECTION (FUEL SYSTEMS)

- When not using ST

1. Push the retainer in the direction of the arrow, disconnect the quick connector from pipe.

### CAUTION:

- Be careful not to spill fuel.
- Catch the fuel from hoses using a container or cloth.
- To disconnect the connector, hold (D) shown in the figure and pull in axial direction.
- If the connector and pipe are sticking to each other, push and pull the connector with the retainer pushed in the direction of the arrow, and then pull the connector after it starts moving freely.
- When disconnecting the connector, do not bend or twist the tube forcibly. If the tube is bent, replace with a new part.

### NOTE:

Clean the pipe and quick connector, if they are covered with dust.

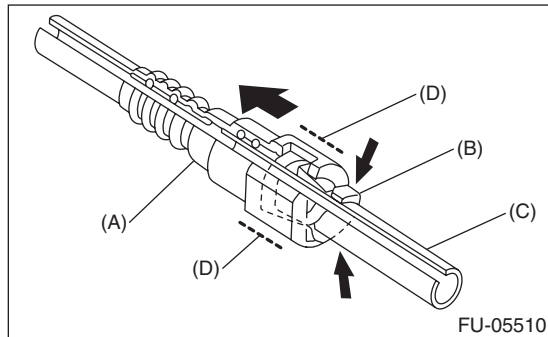

- (A) Quick connector
- (B) Retainer
- (C) Pipe
- (D) Connector holding position

2. To prevent from damaging or entering foreign matter, wrap the pipes and quick connectors with plastic bag etc.

### CAUTION:

When reusing the retainer, do not disconnect the retainer from the pipe.

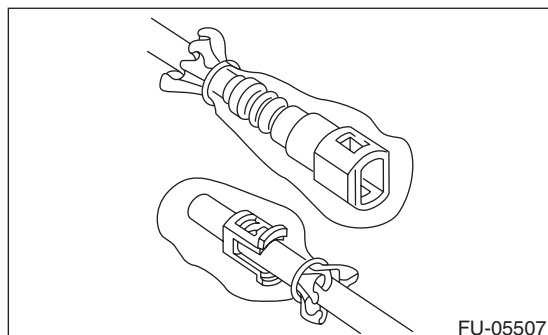

9) Remove the evaporation pipe.

- (1) Remove the rear mud guard RH. <Ref. to EI-30, REMOVAL, Mud Guard.>
- (2) Disconnect the evaporation hose.

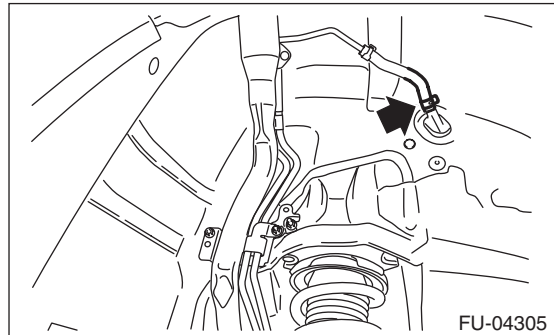

- (3) Remove the right side rear quarter trim. <Ref. to EI-60, REMOVAL, Rear Quarter Trim.>
- (4) Remove the evaporation pipe protector.

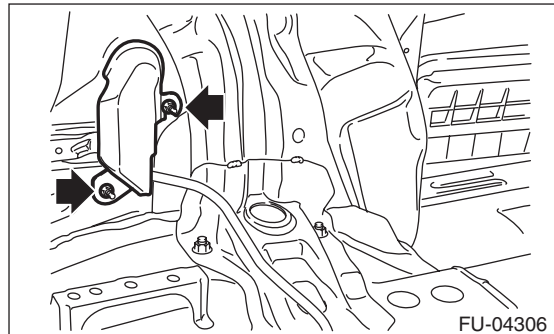

(5) Remove the evaporation pipe from vehicle.

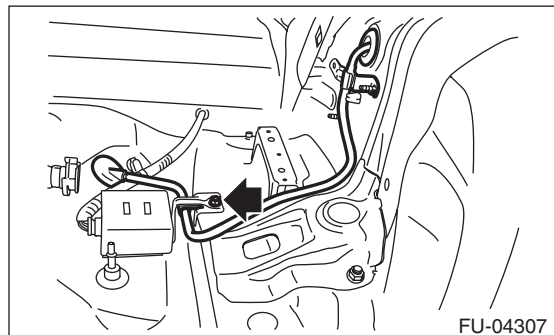

# Fuel Delivery, Return and Evaporation Lines

## FUEL INJECTION (FUEL SYSTEMS)

### B: INSTALLATION

Install in the reverse order of removal while being careful of the following.

#### 1. EVAPORATION PIPE INSTALLATION

1) Install the evaporation pipe to the vehicle.

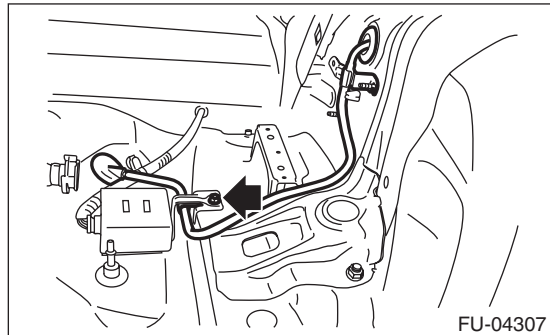

2) Install the evaporation pipe protector.

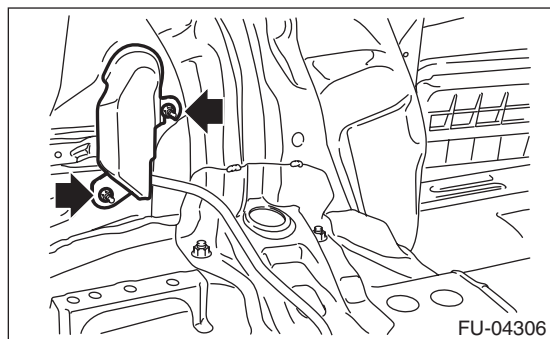

3) Install the right side rear quarter trim. <Ref. to EI-61, INSTALLATION, Rear Quarter Trim.>

4) Connect the evaporation hose.

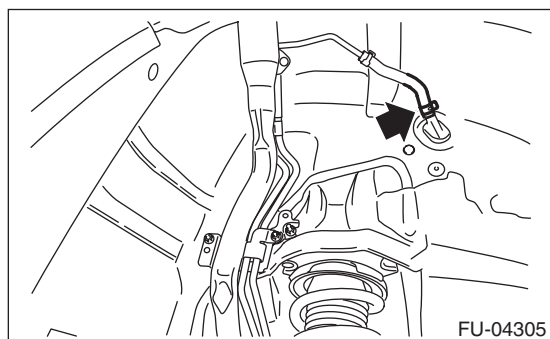

5) Install the rear mud guard RH. <Ref. to EI-30, INSTALLATION, Mud Guard.>

#### 2. CONNECTING THE FUEL LINE QUICK CONNECTOR

##### CAUTION:

- Make sure there are no damage or dust on connections. If necessary, clean seal surface of pipe.

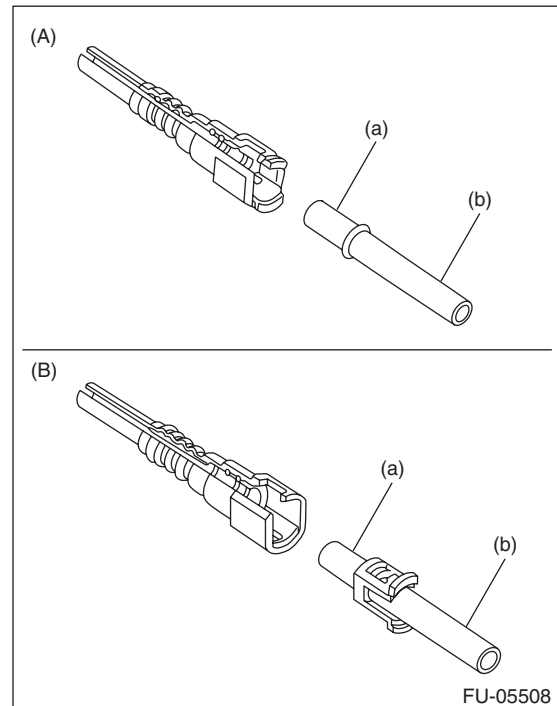

- (A) When removed using the ST  
(B) When removed without using the ST  
(a) Seal surface  
(b) Pipe

- When reusing the retainer, make sure that neither scratches nor deformation exist on the retainer. If it is faulty, use a new part.

1) Connect the quick connector to pipe.

##### CAUTION:

- Make sure that the quick connector is securely connected.

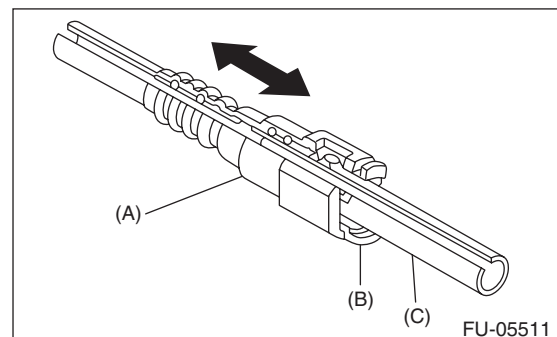

- (A) Quick connector  
(B) Retainer  
(C) Pipe



# Fuel Delivery, Return and Evaporation Lines

FUEL INJECTION (FUEL SYSTEMS)

- Make sure the two retainer pawls are engaged in their mating positions in the quick connector.
- Be sure to inspect tubes and their connections for any leakage of fuel.
- To connect the connector, hold (d) shown in the figure and push in axial direction.
- When connecting the connector, do not bend or twist the tube forcibly. If the tube is bent, replace with a new part.

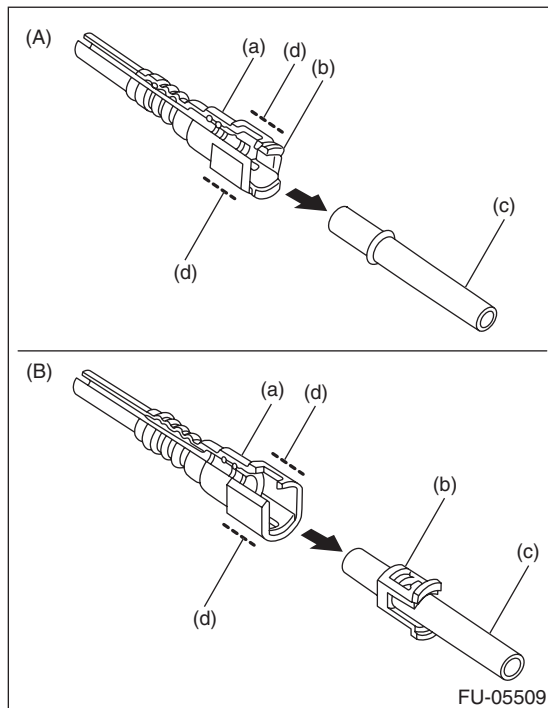

- (A) When removed using the ST  
(B) When removed without using the ST  
(a) Quick connector  
(b) Retainer  
(c) Pipe  
(d) Connector holding position

## 3. CONNECTING FUEL DELIVERY HOSE, FUEL RETURN HOSE AND FUEL HOSE

Connect the fuel delivery hose, fuel return hose, and fuel hose as shown in the figure.

### CAUTION:

- If the connection portion has a spool or stopper, do not allow the end of the hose to bend or ride over by inserting the hose too deep.
- Be sure to inspect hoses and their connections for any leakage of fuel.

### NOTE:

Use new fuel delivery hose, fuel return hose, and fuel hose.

### Tightening torque:

$1.25 \text{ N}\cdot\text{m}$  (0.1 kgf-m, 0.9 ft-lb)

$L1: 2.5 \pm 1.5 \text{ mm}$  (0.098 ± 0.059 in)

$L2: 22.5 \pm 2.5 \text{ mm}$  (0.886 ± 0.098 in)

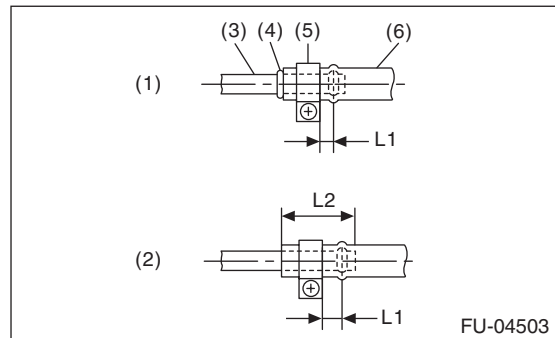

- (1) When there is a spool or bump  
(2) When there is no spool or bump  
(3) Pipe  
(4) Spool or bump  
(5) Clamp  
(6) Hose

## 4. EVAPORATION HOSE CONNECTION

Connect the evaporation hose to the pipe with an overlap of 15 to 20 mm (0.59 to 0.79 in).

$L = 17.5 \pm 2.5 \text{ mm}$  (0.689 ± 0.098 in)

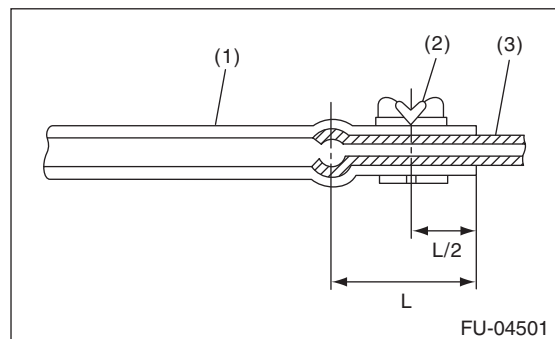

- (1) Hose  
(2) Clip  
(3) Pipe

## C: INSPECTION

- 1) Check that the fuel pipe has no deformation, cracks or other damages.
- 2) Check that the hose and tube have no cracks, damage or loose part.



# Fuel System Trouble in General

FUEL INJECTION (FUEL SYSTEMS)

## 35. Fuel System Trouble in General

### A: INSPECTION

Trouble	Possible cause	Corrective action
Insufficient fuel supply to fuel injector	a. Fuel pump does not operate.	
	○ Defective terminal contact	Inspect contact, especially ground, and tighten it securely.
	○ Trouble in electromagnetic or electronic circuit parts	Replace the faulty parts.
	b. Decline of fuel pump function	Replace the fuel pump.
	c. Clogged fuel filter	Replace the fuel filter. Clean or replace the fuel tank if necessary.
	d. Clogged or bent fuel line pipe, hose or tube	Clean, correct or replace the fuel line pipe, hose or tube.
	e. Air is mixed in fuel system.	Check the fuel line connections, correct or replace the defective part.
Leakage or blow out of fuel	f. Damaged diaphragm of pressure regulator	Replace the pressure regulator.
	a. Loose connections of fuel line pipe, hose or tube	Check the fuel line connections, correct or replace the defective part.
	b. Cracked fuel line pipe, hose or tube	Replace the fuel line pipe, hose or tube.
	c. Cracked fuel tank or defective welding part	Replace the fuel tank.
Gasoline smell inside of compartment	d. Clogged or bent fuel line pipe, hose or tube	Clean, correct or replace the fuel line pipe, hose or tube.
	a. Loose connections of fuel line pipe, hose or tube	Check the fuel line connections, correct or replace the defective part.
	b. Defective gasket of fuel saucer or fuel filler pipe assembly	Correct or replace the gasket.
Defective fuel gauge	c. Defective canister	Replace the canister.
	a. Defective operation of fuel level sensor	Replace the fuel level sensor.
Noise	b. Defective operation of combination meter	Replace the combination meter.
	a. Large operation noise or vibration of fuel pump	Replace the fuel pump.

#### NOTE:

- When the vehicle is left unattended for an extended period of time, water may accumulate in the fuel tank. Fill fuel fully to prevent the problem.
- In snow-covered areas, mountainous areas, skiing areas, etc. where ambient temperatures drop to 0°C (32°F) or less throughout the winter season, use a water removing agent in the fuel system to prevent freezing fuel system and accumulating water.
- When water is accumulated in fuel filter, fill the water removing agent in the fuel tank.
- Before using water removing agent, follow the cautions noted on the bottle.

# EMISSION CONTROL (AUX. EMISSION CONTROL DEVICES)

# *EC(STI)*

---

	<b>Page</b>
1. General Description .....	2
2. Front Catalytic Converter .....	5
3. Rear Catalytic Converter .....	6
4. Canister .....	7
5. Purge Control Solenoid Valve .....	11
6. Fuel Level Sensor .....	14
7. Fuel Sub Level Sensor .....	15
8. Pressure Control Solenoid Valve Assembly .....	16
9. Drain Filter .....	17
10. Shut Valve .....	18
11. Leak Check Valve Assembly .....	19
12. Drain Separator .....	23
13. PCV Hose Assembly .....	24
14. PCV Valve .....	26
15. Secondary Air Pump .....	27
16. Secondary Air Combination Valve .....	29

# General Description

EMISSION CONTROL (AUX. EMISSION CONTROL DEVICES)

## 1. General Description

### A: COMPONENT

#### 1. SECONDARY AIR PUMP

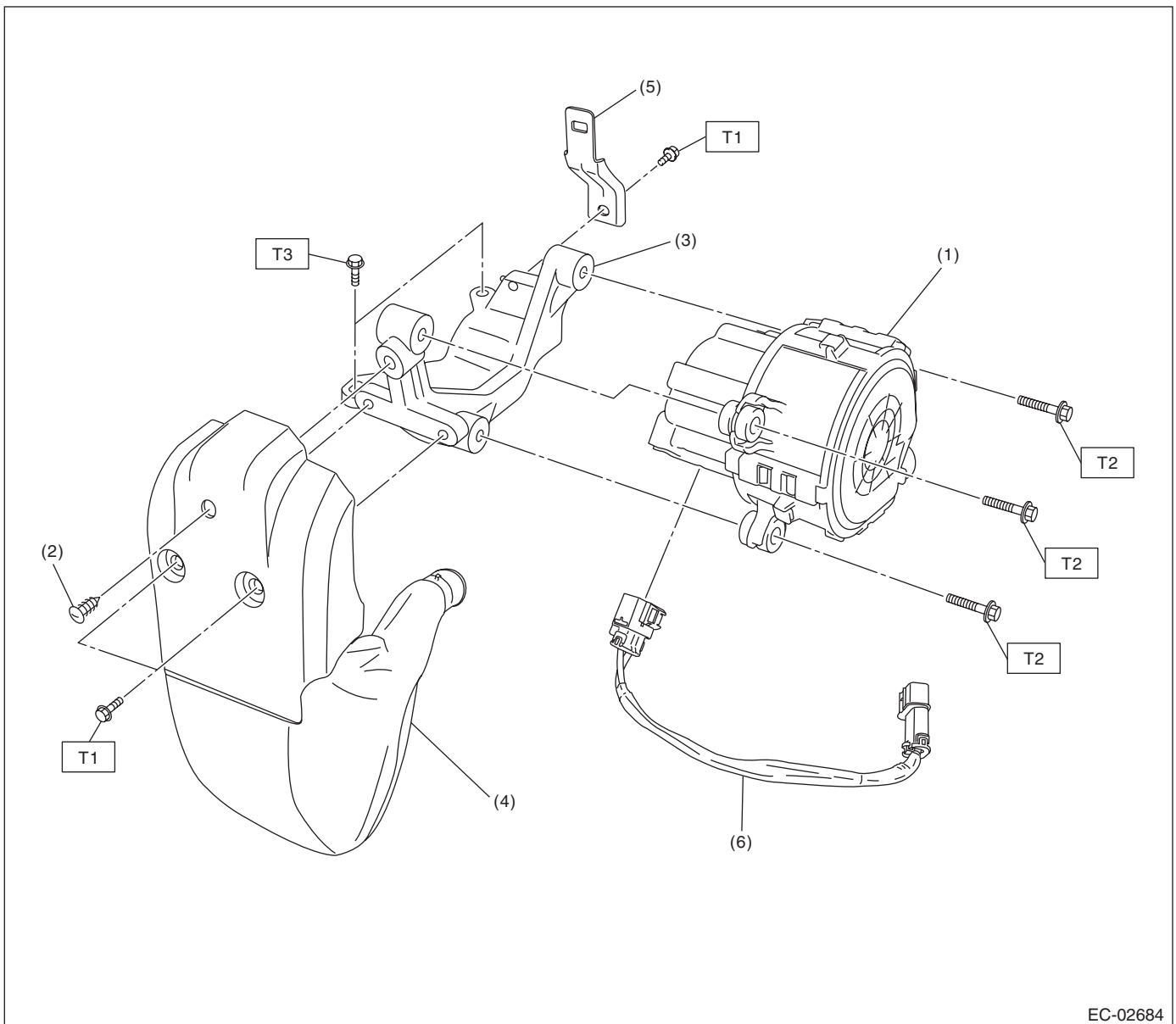

- |                                |                                |
|--------------------------------|--------------------------------|
| (1) Secondary air pump         | (4) Resonator                  |
| (2) Clip                       | (5) Harness stay               |
| (3) Secondary air pump bracket | (6) Secondary air pump harness |

**Tightening torque: N·m (kgf·m, ft·lb)**

**T1: 6.4 (0.7, 4.7)**

**T2: 9 (0.9, 6.6)**

**T3: 19 (1.9, 14.0)**

**EC(STI)-2**

Brought to you by Ebay Seller "SubaruManuals"

# General Description

EMISSION CONTROL (AUX. EMISSION CONTROL DEVICES)

## 2. SECONDARY AIR COMBINATION VALVE

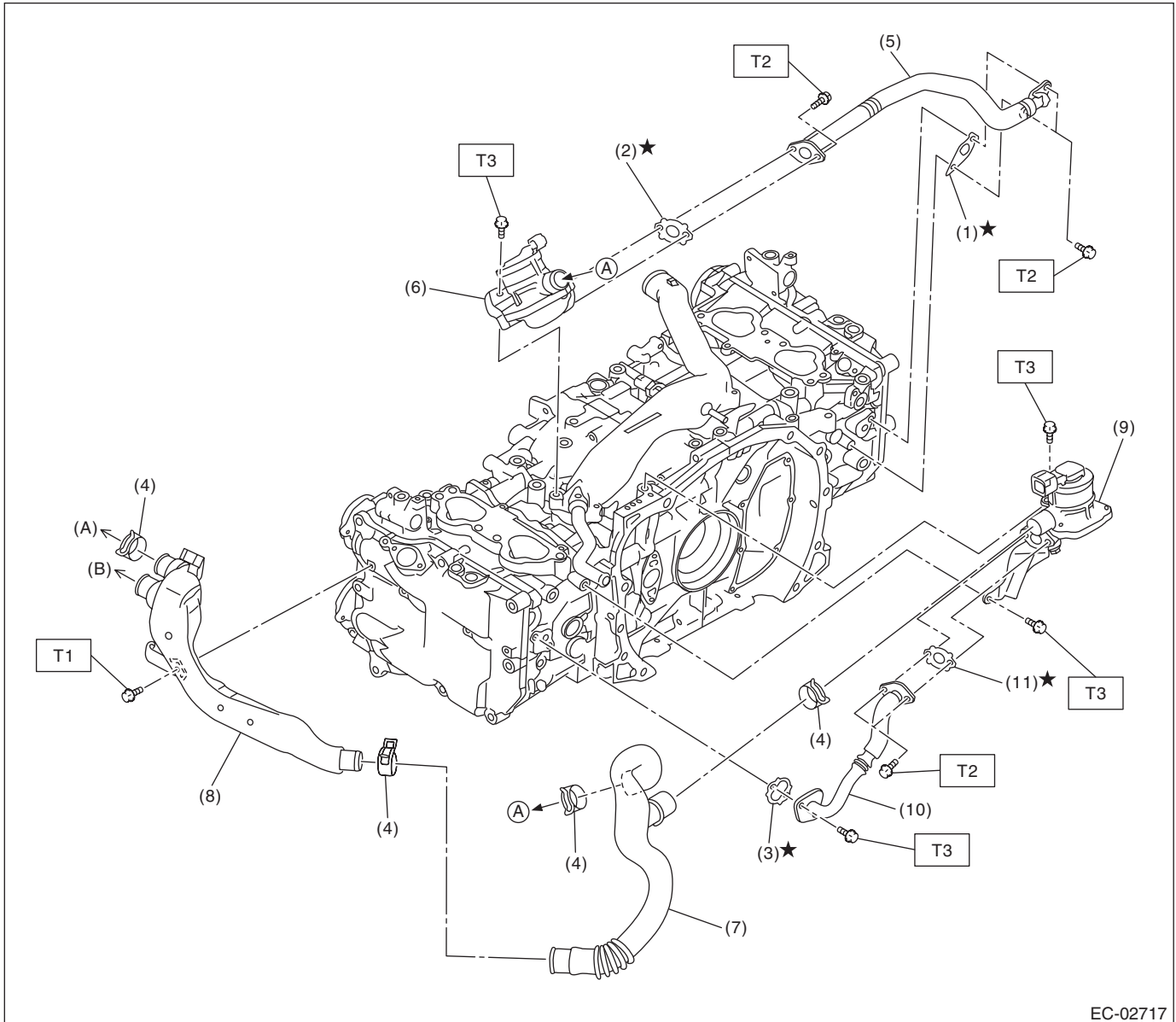

EC-02717

(A) To secondary air pump

(B) To resonator

(1) Gasket

(7) Air duct A

(2) Gasket

(8) Air duct B

(3) Gasket

(9) Secondary air combination valve LH

(4) Clip

(10) Secondary air pipe LH

(5) Secondary air pipe RH

(11) Gasket

(6) Secondary air combination valve RH

**Tightening torque: N·m (kgf·m, ft·lb)**

**T1: 6.4 (0.7, 4.7)**

**T2: 9 (0.9, 6.6)**

**T3: 19 (1.9, 14.0)**

**EC(STI)-3**

Brought to you by Ebay Seller "SubaruManuals"

## General Description

EMISSION CONTROL (AUX. EMISSION CONTROL DEVICES)

### B: CAUTION

- Wear appropriate work clothing, including a cap, protective goggles and protective shoes when performing any work.
- Remove contamination including dirt and corrosion before removal, installation or disassembly.
- Keep the disassembled parts in order and protect them from dust and dirt.
- Before removal, installation or disassembly, be sure to clarify the failure. Avoid unnecessary removal, installation, disassembly and replacement.
- Vehicle components are extremely hot after driving. Be wary of receiving burns from heated parts.
- Be sure to tighten fasteners including bolts and nuts to the specified torque.
- Place shop jacks or rigid racks at the specified points.
- Before disconnecting connectors of sensors or units, be sure to disconnect the ground cable from the battery.

### C: PREPARATION TOOL

#### 1. SPECIAL TOOL

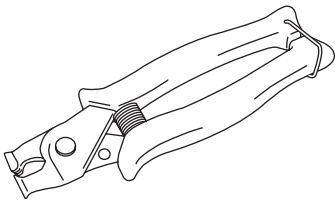
ILLUSTRATION	TOOL NUMBER	DESCRIPTION	REMARKS
 ST18353AA000	18353AA000	CLAMP PLIERS	<ul style="list-style-type: none"><li>• Used for removing and installing the PCV hose.</li><li>• This tool is made by the French company CAILLAU. (code) 54.0.000.205 To make it easier to obtain, it has been provided with a tool number.</li></ul>

#### 2. GENERAL TOOL

TOOL NAME	REMARKS
Circuit tester	Used for measuring resistance.
Mighty Vac	Used for inspecting the fuel tank pressure sensor.

# Front Catalytic Converter

EMISSION CONTROL (AUX. EMISSION CONTROL DEVICES)

---

## 2. Front Catalytic Converter

### A: REMOVAL

The front catalytic converter is integrated into the center exhaust pipe (front). Refer to "Center Exhaust Pipe" for removal procedures. <Ref. to EX(STI)-8, REMOVAL, Center Exhaust Pipe.>

### B: INSTALLATION

The front catalytic converter is integrated into the center exhaust pipe (front). Refer to "Center Exhaust Pipe" for installation procedures. <Ref. to EX(STI)-9, INSTALLATION, Center Exhaust Pipe.>

### C: INSPECTION

- 1) Check the connections and welds for exhaust leaks.
- 2) Make sure there are no holes or rusting.

## Rear Catalytic Converter

EMISSION CONTROL (AUX. EMISSION CONTROL DEVICES)

---

### 3. Rear Catalytic Converter

#### A: REMOVAL

The rear catalytic converter is integrated into the center exhaust pipe (rear). Refer to "Center Exhaust Pipe" for removal procedures. <Ref. to EX(STI)-8, REMOVAL, Center Exhaust Pipe.>

#### B: INSTALLATION

The rear catalytic converter is integrated into the center exhaust pipe (rear). Refer to "Center Exhaust Pipe" for installation procedures. <Ref. to EX(STI)-9, INSTALLATION, Center Exhaust Pipe.>

#### C: INSPECTION

- 1) Check the connections and welds for exhaust leaks.
- 2) Make sure there are no holes or rusting.

# Canister

EMISSION CONTROL (AUX. EMISSION CONTROL DEVICES)

## 4. Canister

### A: REMOVAL

1) Disconnect the ground cable from battery.

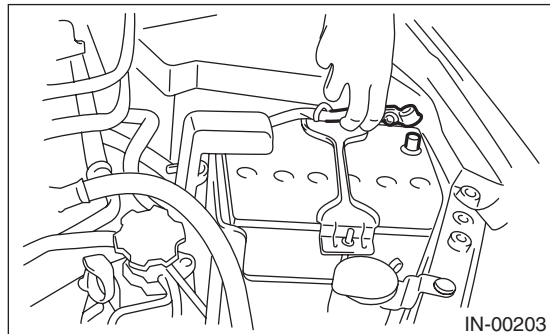

2) Open the trunk, and remove the trunk room mat. (4 door model)

3) Open the rear gate, and remove the luggage floor mat. (5 door model)

4) Tilt the rear seat backrest forward.

5) Remove the sub trunk box and spacers. (4 door model)

6) Remove the luggage floor box and spacers. (5 door model)

7) Remove the center canister cover.

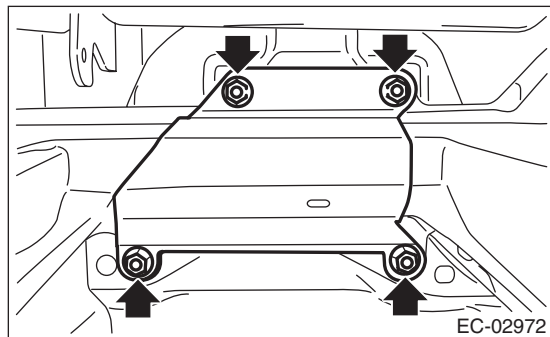

8) Remove the canister cover RH.

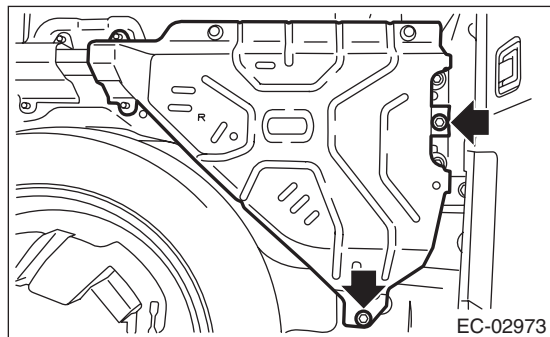

9) Disconnect the purge tube (A), vent tube (B), drain tube A (C) and PCV drain tube (D).

NOTE:

Disconnect the quick connector as shown in the figure.

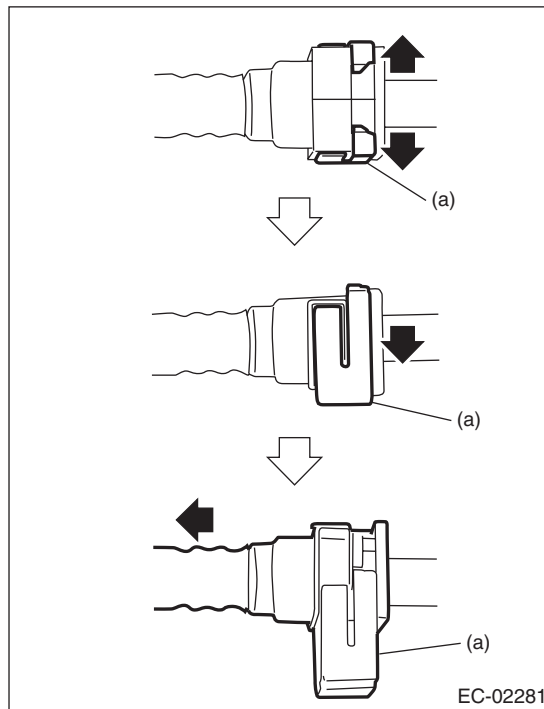

(a) Retainer

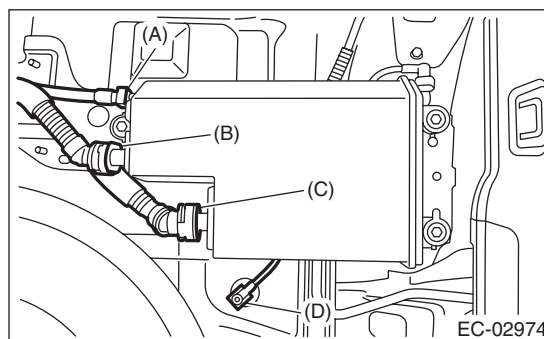

10) Remove the canister.

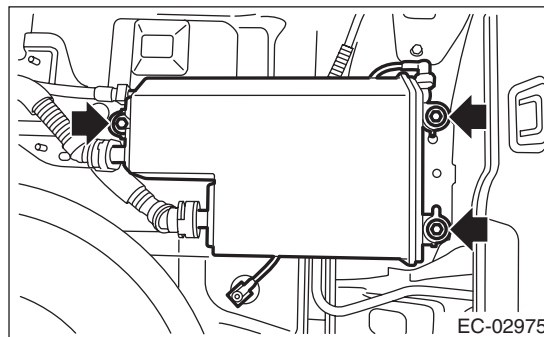



# Canister

## EMISSION CONTROL (AUX. EMISSION CONTROL DEVICES)

11) Remove the canister cover LH.

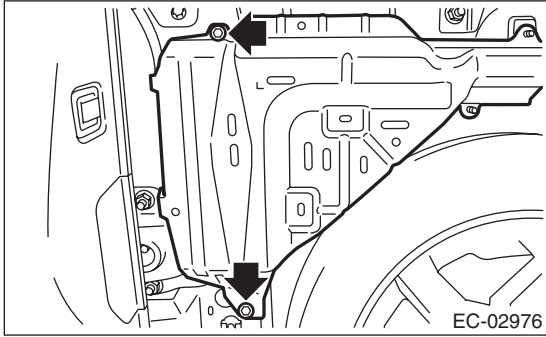

12) Disconnect drain tube A (A) and drain tube B (B).

**NOTE:**

Disconnect the quick connector as shown in the figure.

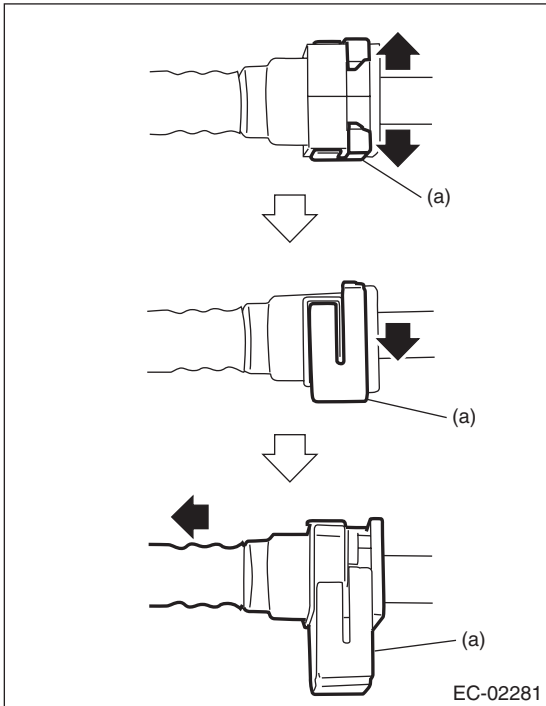

(a) Retainer

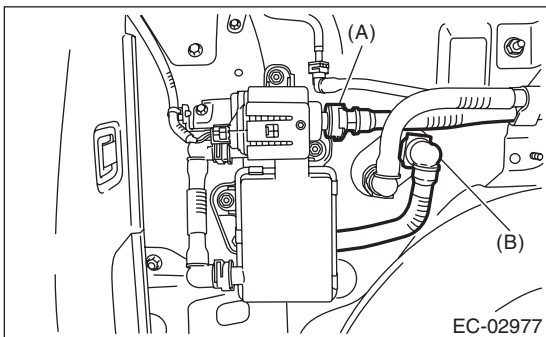

13) Disconnect the connector (A) from leak check valve assembly, and remove the leak check valve assembly.

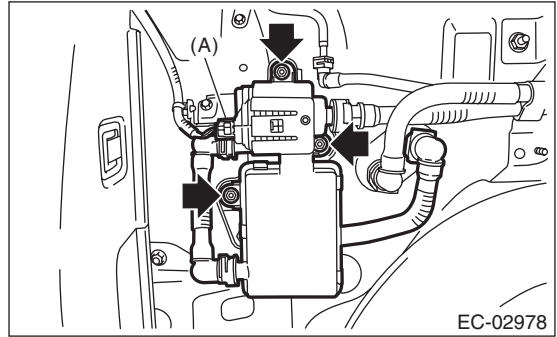

14) Remove the clip (A), which secures the leak check valve assembly harness, from the valve bracket, and remove the valve bracket.

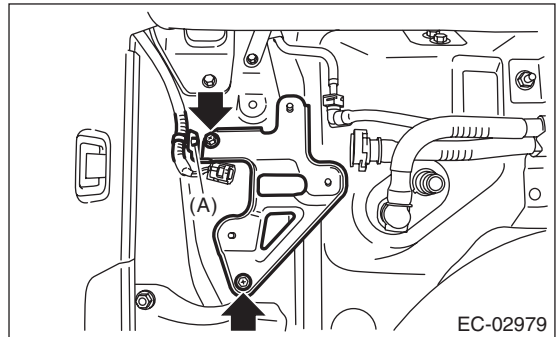

# Canister

EMISSION CONTROL (AUX. EMISSION CONTROL DEVICES)

15) Disconnect purge tube (A) and vent tube (B).

### NOTE:

Disconnect the quick connector as shown in the figure.

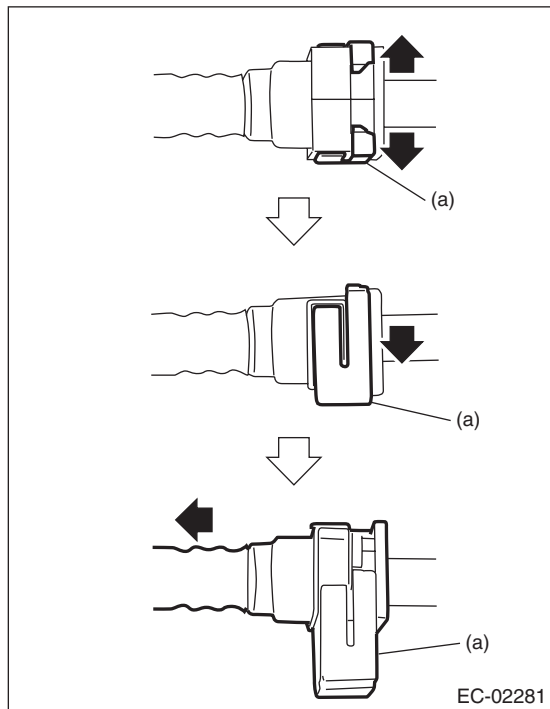

(a) Retainer

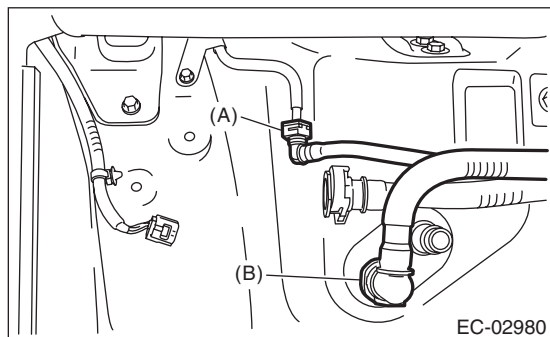

16) Remove purge tube (A), vent tube (B), and drain tube A (C).

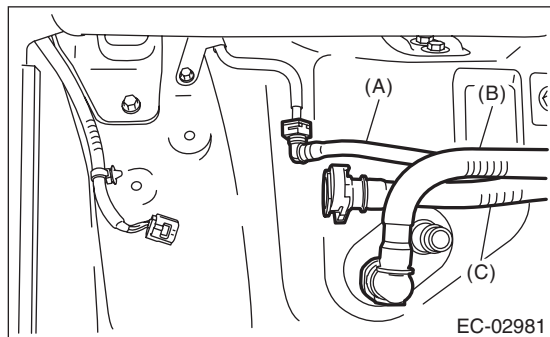

## B: INSTALLATION

Install in the reverse order of removal while being careful of the following.

- Connect the quick connector as shown in the figure.

### CAUTION:

- Check that there is no damage or dust on the quick connector. If necessary, clean the seal surface of the pipe.
- When connecting the quick connector, securely insert the pipe all the way before locking the retainer.
- When it is difficult to lock the retainer, make sure that the pipe is securely inserted.
- Make sure that the quick connector is securely connected.

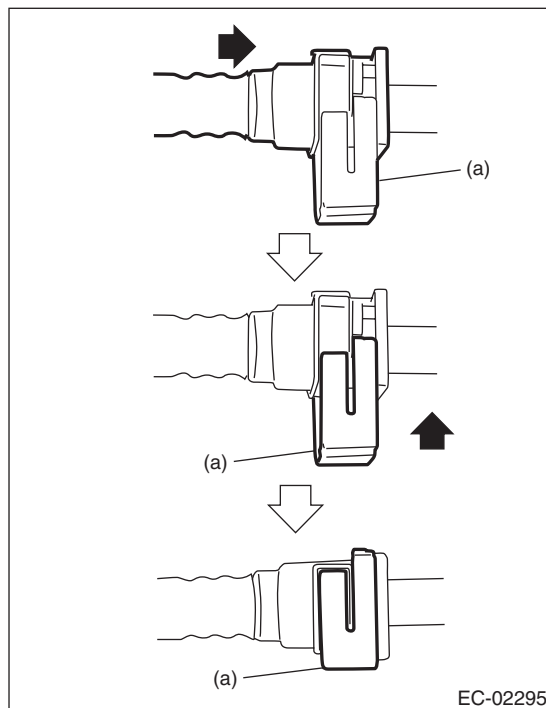

(a) Retainer

# Canister

EMISSION CONTROL (AUX. EMISSION CONTROL DEVICES)

**Tightening torque:**  
**7.5 N·m (0.8 kgf·m, 5.5 ft·lb)**

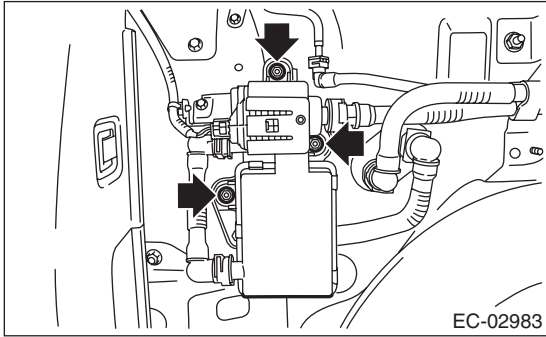
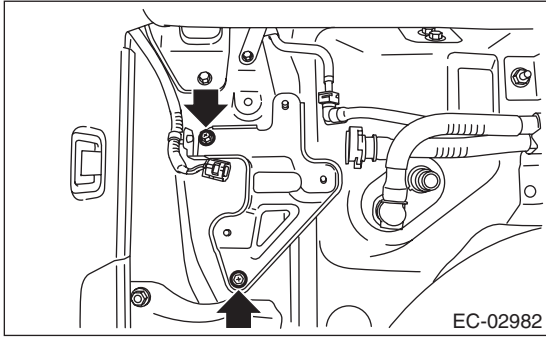

**Tightening torque:**  
**18 N·m (1.8 kgf·m, 13.3 ft·lb)**

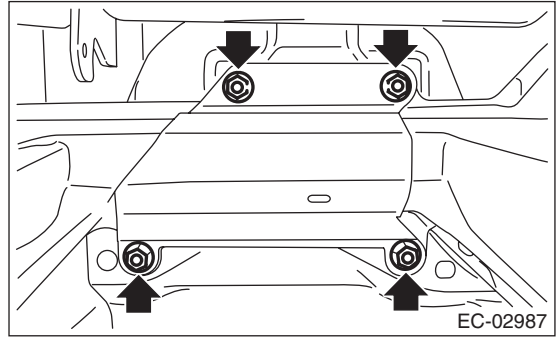
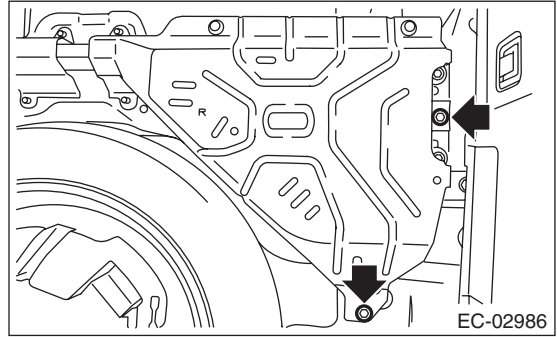

**Tightening torque:**  
**18 N·m (1.8 kgf·m, 13.3 ft·lb)**

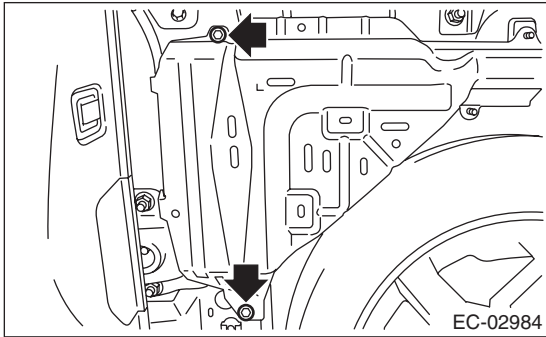

## C: INSPECTION

- 1) Check that the canister and leak check valve assembly have no deformation, cracks or other damages.
- 2) Check that the tube has no cracks, damage or loose part.

**Tightening torque:**  
**8 N·m (0.8 kgf·m, 5.9 ft·lb)**

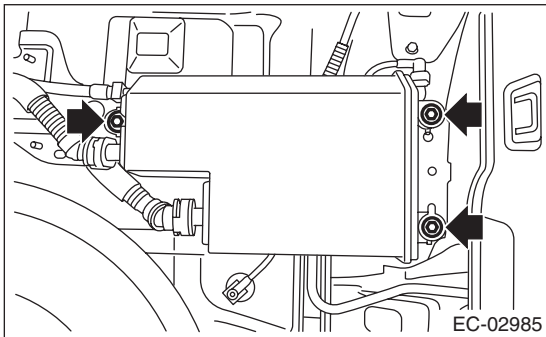

# Purge Control Solenoid Valve

EMISSION CONTROL (AUX. EMISSION CONTROL DEVICES)

## 5. Purge Control Solenoid Valve

### A: REMOVAL

#### 1. PURGE CONTROL SOLENOID VALVE 1

1) Disconnect the ground cable from battery.

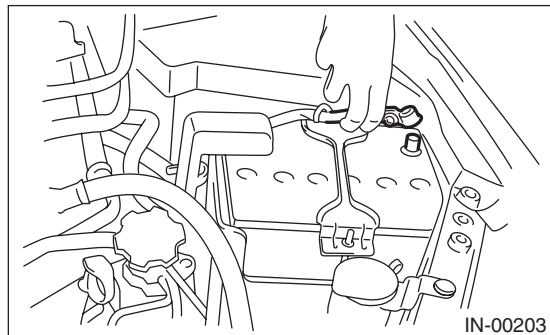

2) Remove the bolts which secure purge control solenoid valve 1 to the intake manifold, and disconnect the connector from the purge control solenoid valve 1.

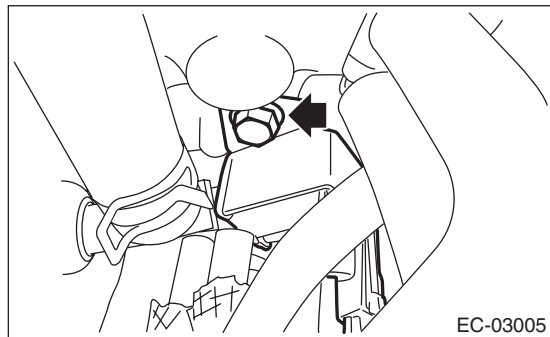

3) Disconnect the vacuum hose and the vacuum control hose from purge control solenoid valve 1.

#### 2. PURGE CONTROL SOLENOID VALVE 2

1) Disconnect the ground cable from battery.

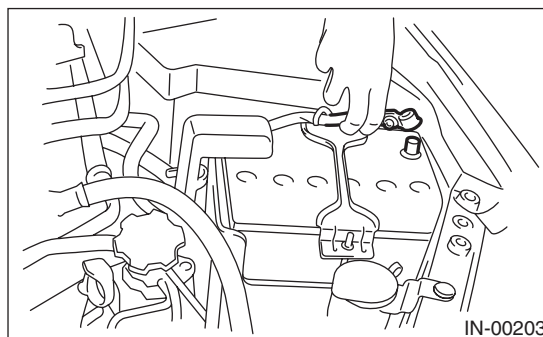

2) Disconnect connector (A), vacuum hose (B), and vacuum control hose (C) from purge control solenoid valve 2.

3) Remove purge control solenoid valve 2 from the solenoid valve bracket.

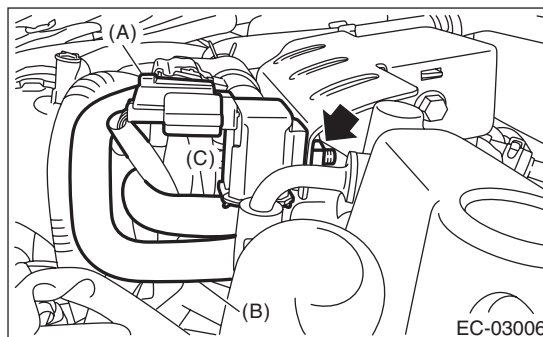

### B: INSTALLATION

#### 1. PURGE CONTROL SOLENOID VALVE 1

Install in the reverse order of removal.

#### NOTE:

Connect the vacuum hose and vacuum control hose as shown in the figure.

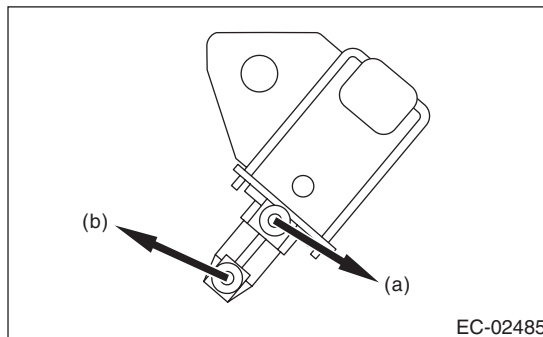

(a) To intake manifold

(b) To branching pipe → fuel pipe

#### Tightening torque:

19 N·m (1.9 kgf-m, 14.0 ft-lb)

# Purge Control Solenoid Valve

EMISSION CONTROL (AUX. EMISSION CONTROL DEVICES)

## 2. PURGE CONTROL SOLENOID VALVE 2

Install in the reverse order of removal.

NOTE:

Connect the vacuum hose and vacuum control hose as shown in the figure.

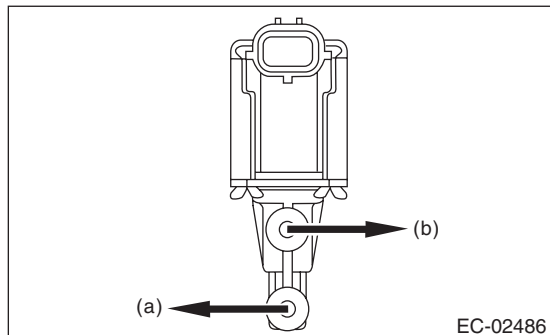

- (a) To intake duct
- (b) To branching pipe → fuel pipe

**Tightening torque:**

**6.4 N·m (0.7 kgf-m, 4.7 ft-lb)**

## C: INSPECTION

### 1. PURGE CONTROL SOLENOID VALVE

- 1) Check that the purge control solenoid valve has no deformation, cracks or other damages.
- 2) Measure the resistance between the purge control solenoid valve terminals.

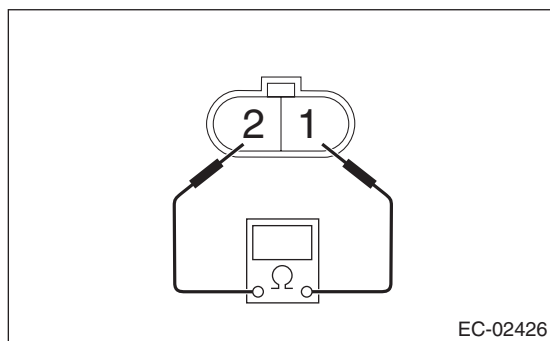

	Terminal No.	Standard
Purge control solenoid valve 1	1 and 2	32 ± 2 Ω (when 20°C (68°F))
Purge control solenoid valve 2		24 ± 3 Ω (when 20°C (68°F))

- 3) Check that air does not come out from (B) when air is blown into (A).

- Purge control solenoid valve 1

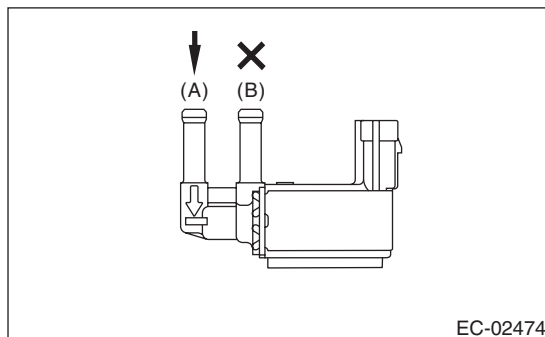

- Purge control solenoid valve 2

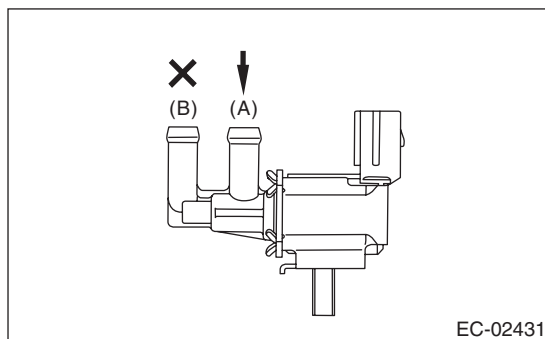

- 4) Connect the battery positive terminal to the terminal No. 1 and the battery negative terminal to the terminal No. 2. Check that air is discharged from (B), when supplying air to (A).

- Purge control solenoid valve 1

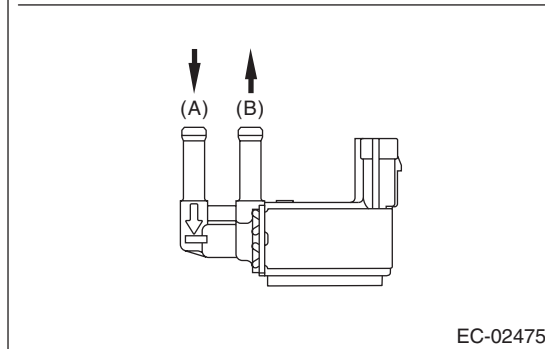
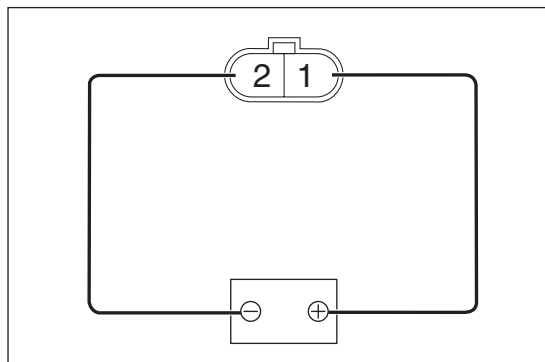

# Purge Control Solenoid Valve

EMISSION CONTROL (AUX. EMISSION CONTROL DEVICES)

- Purge control solenoid valve 2

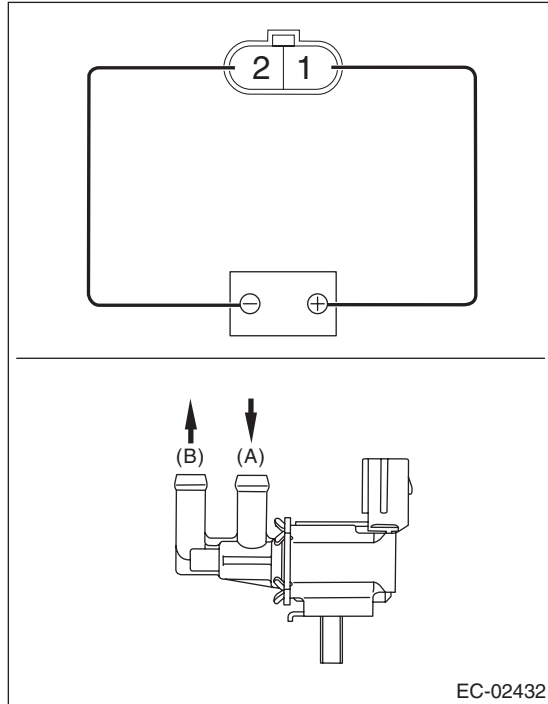

## 2. OTHER INSPECTIONS

Make sure the vacuum hoses and vacuum control hoses are not cracked or loose.

# Fuel Level Sensor

EMISSION CONTROL (AUX. EMISSION CONTROL DEVICES)

---

## 6. Fuel Level Sensor

### A: REMOVAL

For removal procedures, refer to the "FU(STI)" section. <Ref. to FU(STI)-82, REMOVAL, Fuel Level Sensor.>

### B: INSTALLATION

For installation procedures, refer to the "FU(STI)" section. <Ref. to FU(STI)-82, INSTALLATION, Fuel Level Sensor.>

### C: INSPECTION

For inspection procedures, refer to the "FU(STI)" section. <Ref. to FU(STI)-82, INSPECTION, Fuel Level Sensor.>

# Fuel Sub Level Sensor

EMISSION CONTROL (AUX. EMISSION CONTROL DEVICES)

---

## 7. Fuel Sub Level Sensor

### A: REMOVAL

For removal procedures, refer to the "FU(STI)" section. <Ref. to FU(STI)-83, REMOVAL, Fuel Sub Level Sensor.>

### B: INSTALLATION

For installation procedures, refer to the "FU(STI)" section. <Ref. to FU(STI)-84, INSTALLATION, Fuel Sub Level Sensor.>

### C: INSPECTION

For inspection procedures, refer to the "FU(STI)" section. <Ref. to FU(STI)-84, INSPECTION, Fuel Sub Level Sensor.>



# Pressure Control Solenoid Valve Assembly

EMISSION CONTROL (AUX. EMISSION CONTROL DEVICES)

## 8. Pressure Control Solenoid Valve Assembly

### A: REMOVAL

1) Disconnect the ground cable from battery.

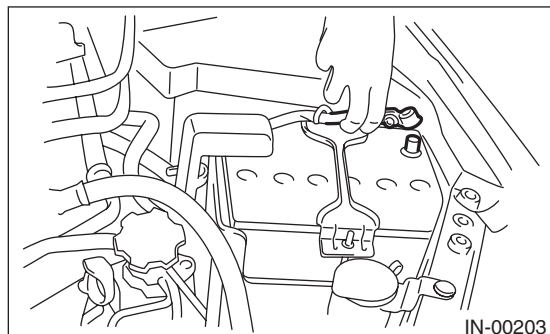

2) Lift up the vehicle.

3) Disconnect the connector (A) and evaporation hose (B) from the pressure control solenoid valve assembly.

4) Remove the nut (C) securing the bracket to the fuel tank and remove the pressure control solenoid valve assembly.

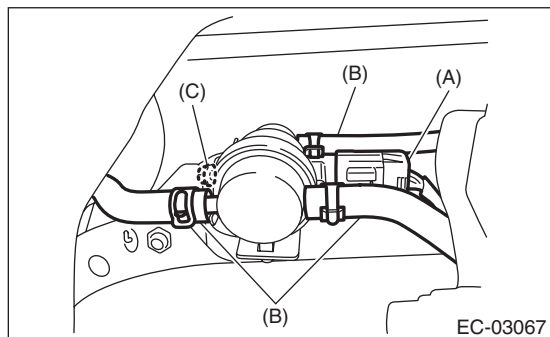

### B: INSTALLATION

Install in the reverse order of removal.

**Tightening torque:**

**2.5 N·m (0.3 kgf·m, 1.8 ft·lb)**

### C: INSPECTION

#### 1. PRESSURE CONTROL SOLENOID VALVE ASSEMBLY

1) Check that the pressure control solenoid valve assembly has no deformation, cracks or other damages.

2) Check the resistance between the pressure control solenoid valve assembly terminals.

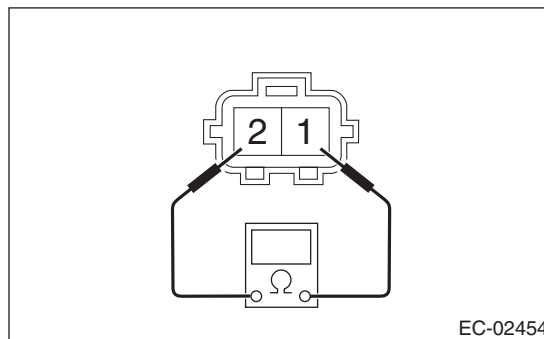

Terminal No.	Standard
1 and 2	20 — 30 Ω

#### 2. OTHER INSPECTIONS

Check that the evaporation hose has no cracks, damage or loose part.

### 9. Drain Filter

#### A: SPECIFICATION

The leak check valve assembly is a non-disassembled part. Do not remove the drain filter from the leak check valve assembly. Refer to "Canister" for removal and installation procedures. <Ref. to EC(STI)-7, REMOVAL, Canister.> <Ref. to EC(STI)-9, INSTALLATION, Canister.>

# Shut Valve

EMISSION CONTROL (AUX. EMISSION CONTROL DEVICES)

---

## 10.Shut Valve

### A: REMOVAL

#### WARNING:

Place "NO OPEN FLAMES" signs near the working area.

#### CAUTION:

Be careful not to spill fuel.

- 1) Remove the fuel filler pipe. <Ref. to FU(STI)-77, REMOVAL, Fuel Filler Pipe.>
- 2) Disconnect the evaporation hose from the shut valve.

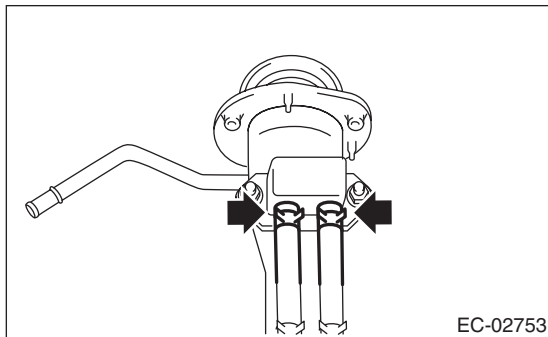

- 3) Remove the shut valve from the fuel filler pipe.

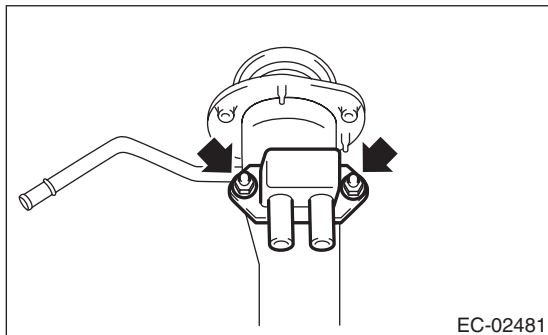

### B: INSTALLATION

Install in the reverse order of removal.

#### Tightening torque:

**4.5 N·m (0.5 kgf-m, 3.3 ft-lb)**

### C: INSPECTION

- 1) Check that the shut valve has no deformation, cracks or other damages.
- 2) Check that the evaporation hose has no cracks, damage or loose part.

# Leak Check Valve Assembly

EMISSION CONTROL (AUX. EMISSION CONTROL DEVICES)

## 11. Leak Check Valve Assembly

### A: REMOVAL

Refer to "Canister" for removal procedures. <Ref. to EC(STI)-7, REMOVAL, Canister.>

### B: INSTALLATION

Refer to "Canister" for installation procedures. <Ref. to EC(STI)-9, INSTALLATION, Canister.>

### C: DISASSEMBLY

Disconnect the drain tube from the leak check valve assembly.

#### NOTE:

Disconnect the quick connector as shown in the figure.

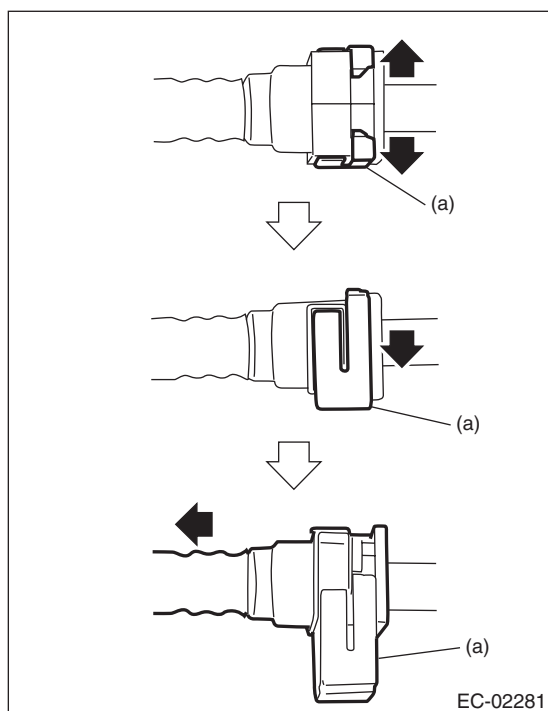
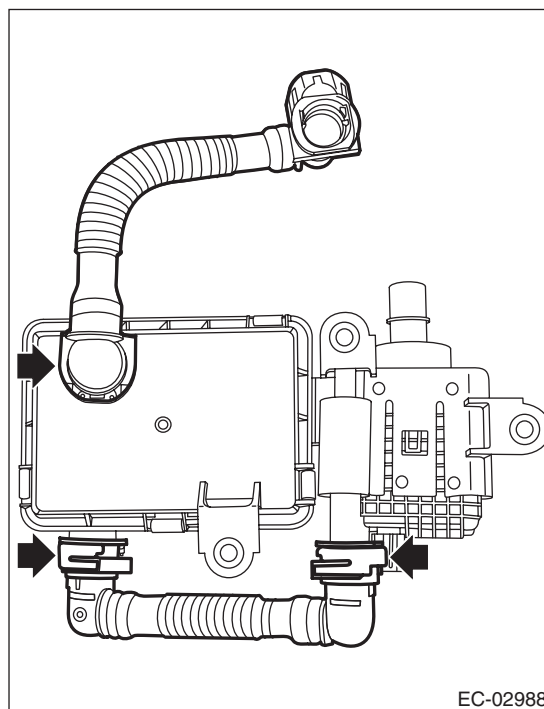

(a) Retainer

# Leak Check Valve Assembly

EMISSION CONTROL (AUX. EMISSION CONTROL DEVICES)

## D: ASSEMBLY

Assemble the parts in the reverse order of disassembly while being careful of the following.

- Connect the quick connector as shown in the figure.

### CAUTION:

- Check that there is no damage or dust on the quick connector. If necessary, clean the seal surface of the pipe.
- When connecting the quick connector, securely insert the pipe all the way before locking the retainer.
- When it is difficult to lock the retainer, make sure that the pipe is securely inserted.
- Make sure that the quick connector is securely connected.

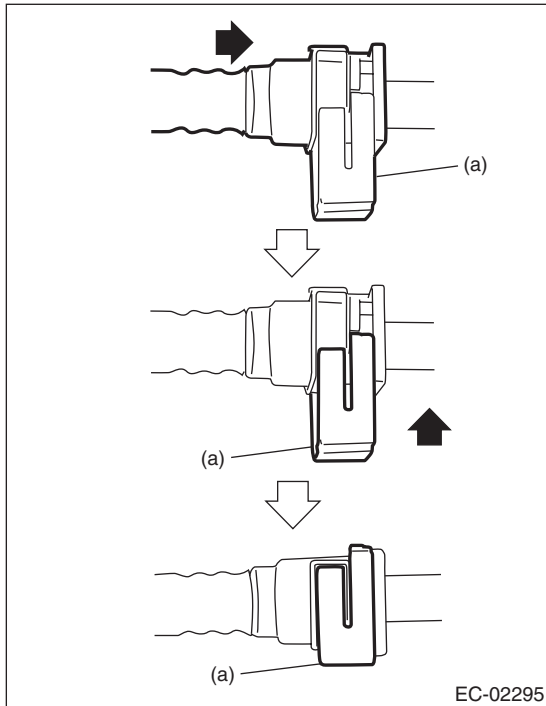

(a) Retainer

## E: INSPECTION

### 1. CHECK SWITCHING VALVE

- 1) Check the resistance between switching valve terminals.

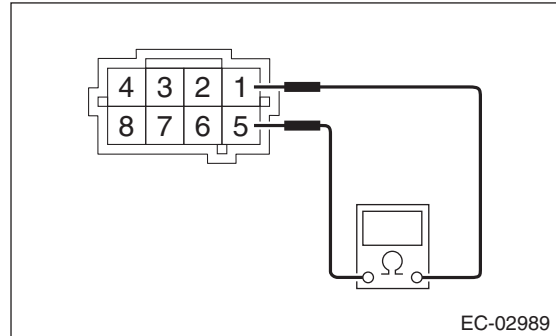

Terminal No.	Standard
1 and 5	$27^{+3}_{-2} \Omega$ (when 20°C (68°F))
	$31 \pm 4 \Omega$ (when 60°C (140°F))

- 2) Disconnect the drain tube from the leak check valve assembly.

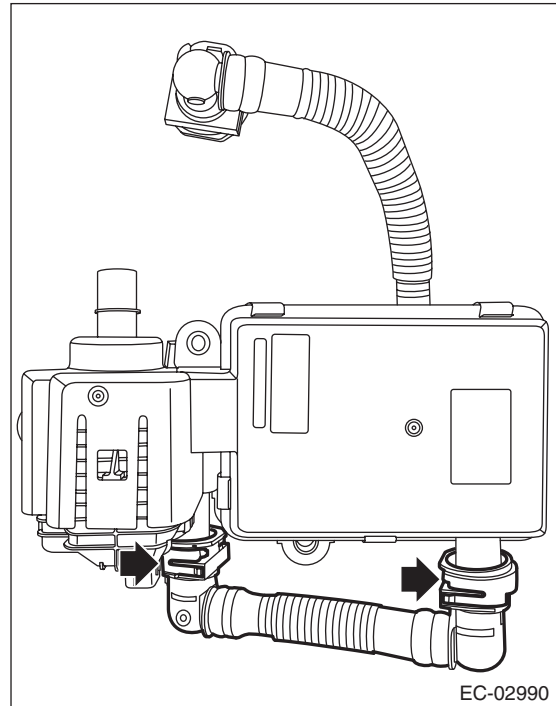

EC(STI)-20

Brought to you by Ebay Seller "SubaruManuals"

# Leak Check Valve Assembly

EMISSION CONTROL (AUX. EMISSION CONTROL DEVICES)

3) Check that air does not come out from (B) when air is blown into (A).

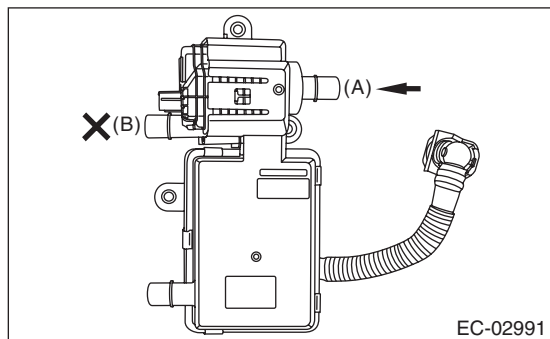

4) Connect the battery positive terminal to the terminal No. 5 and the battery negative terminal to the terminal No. 1. Check that air is discharged from (B), when supplying air to (A).

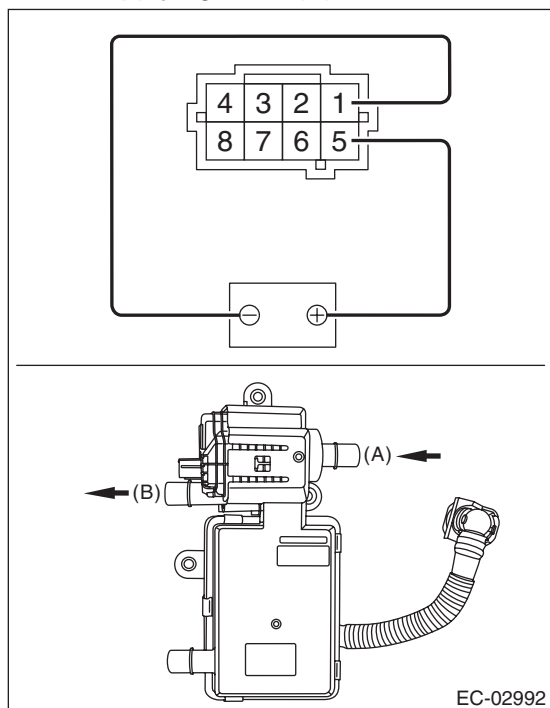

## 2. CHECK VACUUM PUMP

1) Connect the battery positive terminal to terminal No. 3 and the battery ground terminal to terminal No. 4, and inspect the vacuum pump operation.

### CAUTION:

Do not operate the vacuum pump for 5 minutes or more.

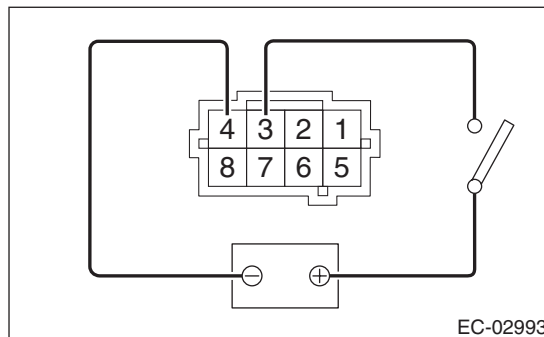

## 3. CHECK PRESSURE SENSOR

1) Connect dry-cell battery positive terminal to terminal No. 6 and dry-cell battery ground terminal to terminal No. 8, circuit tester positive terminal to terminal No. 7 and the circuit tester negative terminal to terminal No. 8.

### NOTE:

- Use new dry-cell batteries.
- Using circuit tester, check the voltage of a single dry-cell battery is 1.6 V or more. And also check the voltage of three batteries in series is between 4.8 V and 5.2 V.

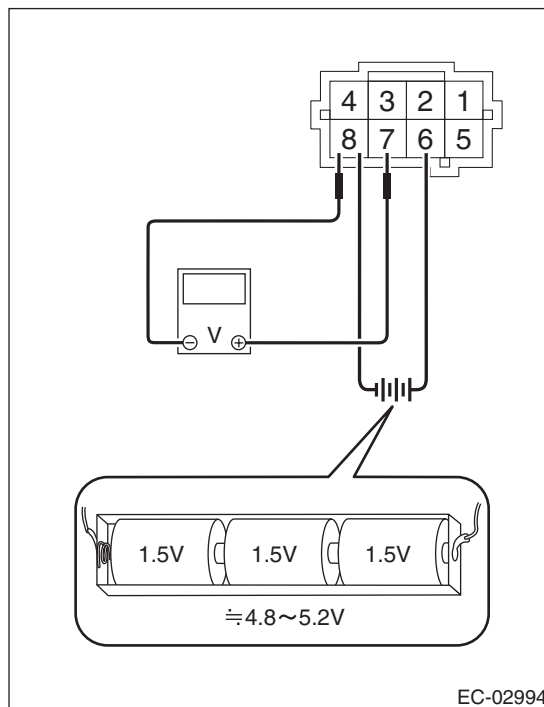

# Leak Check Valve Assembly

EMISSION CONTROL (AUX. EMISSION CONTROL DEVICES)

---

2) Check the voltage at a normal atmospheric pressure.

**NOTE:**

The atmospheric pressure at higher altitude is lower than normal. Therefore, the voltage is lower than the standard value.

Terminal No.	Standard
7 (+) and 8 (-)	Approx. 3.5 V (when 25°C (77°F))

3) Connect the battery positive terminal to terminal No. 3 and the battery ground terminal to terminal No. 4, and check that there is a voltage drop from the voltage measured in step 2) when the vacuum pump is operated.

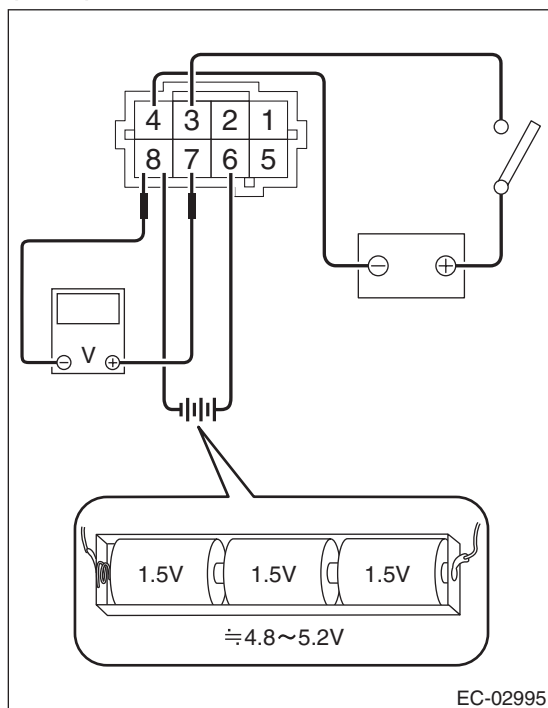

## 4. OTHER INSPECTIONS

Check that the drain tube has no cracks, damage or loose part.

# Drain Separator

EMISSION CONTROL (AUX. EMISSION CONTROL DEVICES)

## 12. Drain Separator

### A: REMOVAL

- 1) Lift up the vehicle.
- 2) Remove the rear differential. <Ref. to DI-22, REMOVAL, Rear Differential (T-type).>
- 3) Disconnect the drain hose from the connector.

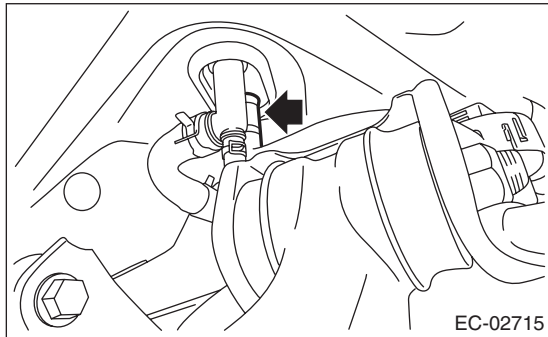

- 4) Remove the drain separator from the vehicle.

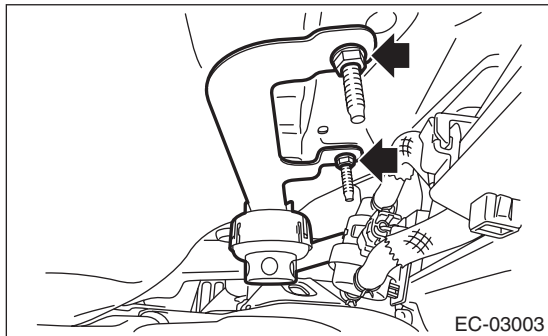

### B: INSTALLATION

Install in the reverse order of removal.

**Tightening torque:**

**7.5 N·m (0.8 kgf·m, 5.5 ft·lb)**

### C: DISASSEMBLY

- 1) Remove the drain hose from the drain separator.

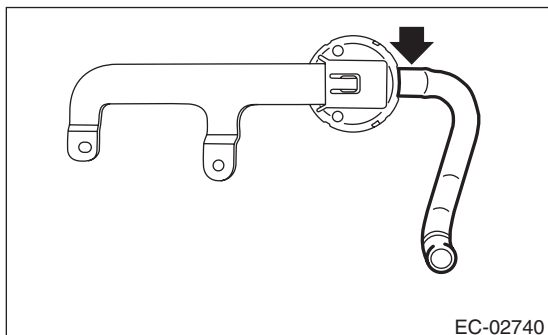

- 2) Lift up the claw (A) of the drain separator and slide the drain separator in the direction of the arrow to remove the drain separator.

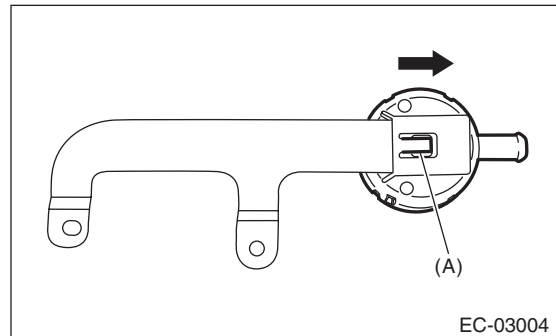

### D: ASSEMBLY

Assemble in the reverse order of disassembly.

### E: INSPECTION

- 1) Check that the drain separator and drain separator bracket have no deformation, crack, or other damage.
- 2) Check that the drain hose has no crack, damage, or looseness.
- 3) Check that no foreign substances are clogged in the drain separator.



# PCV Hose Assembly

EMISSION CONTROL (AUX. EMISSION CONTROL DEVICES)

## 13.PCV Hose Assembly

### A: REMOVAL

#### CAUTION:

**Do not remove unless the hose and the diagnostics connector are broken.**

- 1) Disconnect the connector (A) from the PCV hose assembly A.
- 2) Remove the PCV hose assembly A from the clip (B), and remove the PCV hose assembly A from the PCV pipe.

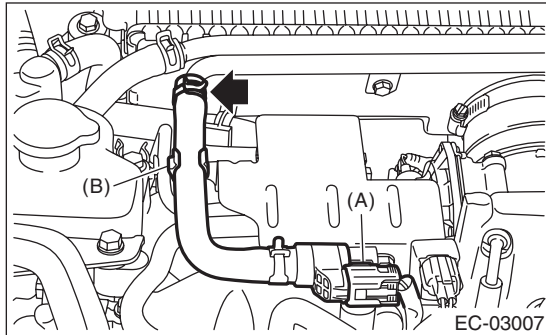

- 3) Remove the connector from the PCV hose assembly B.

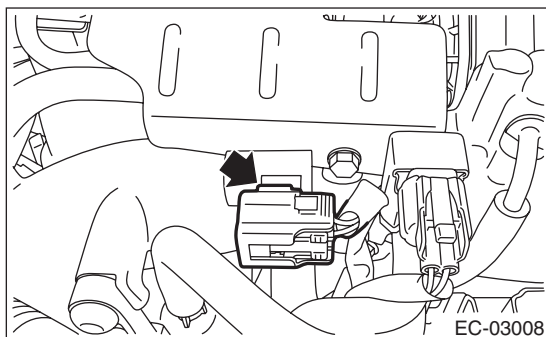

- 4) Remove the PCV hose assembly B from the intake duct.

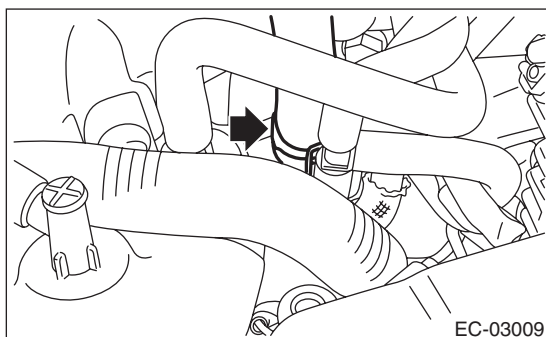

- 5) Remove the intake manifold. <Ref. to FU(STI)-17, REMOVAL, Intake Manifold.>
- 6) Remove the turbocharger. <Ref. to IN(STI)-15, REMOVAL, Turbocharger.>

- 7) Remove the PCV hose assembly C from the cylinder block RH.

#### NOTE:

Pinch the clamp of the PCV hose assembly C by fitting the cut out in the ST with the protrusion on the clamp as shown in the figure, and unlock the clamp.

ST 18353AA000 CLAMP PLIERS

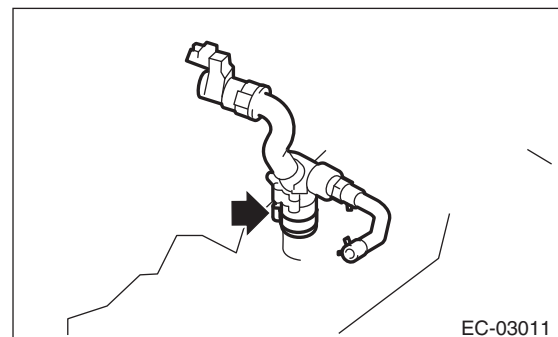
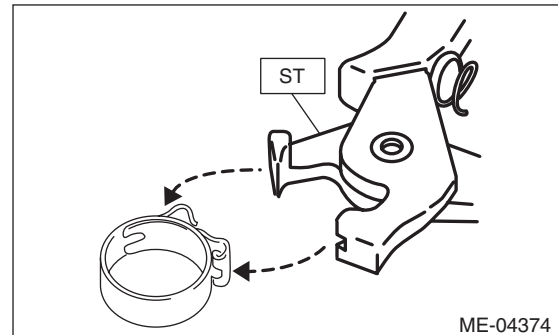

# PCV Hose Assembly

EMISSION CONTROL (AUX. EMISSION CONTROL DEVICES)

## B: INSTALLATION

1) Install the PCV hose assembly C onto the cylinder block RH.

### NOTE:

Use a new clamp for the PCV hose assembly C, fit the cut out in the ST with the protrusion on the clamp as shown in the figure, and lock the clamp.

ST 18353AA000 CLAMP PLIERS

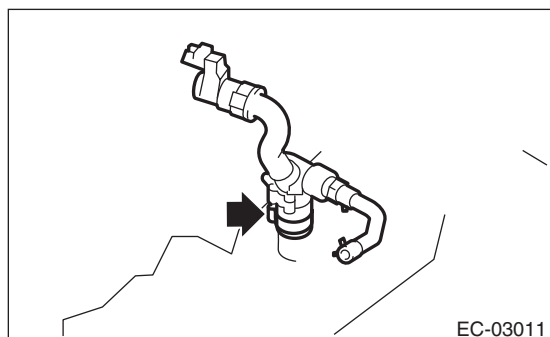
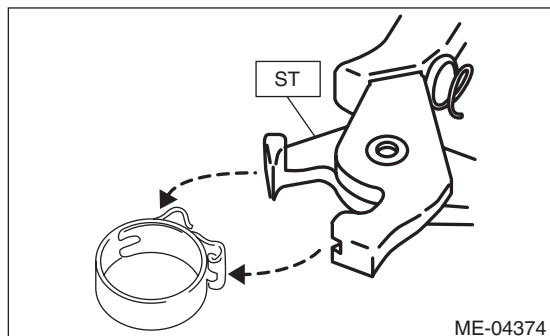

2) Install the turbocharger. <Ref. to IN(STI)-16, INSTALLATION, Turbocharger.>

3) Install the intake manifold. <Ref. to FU(STI)-21, INSTALLATION, Intake Manifold.>

4) Install the PCV hose assembly B onto the intake duct.

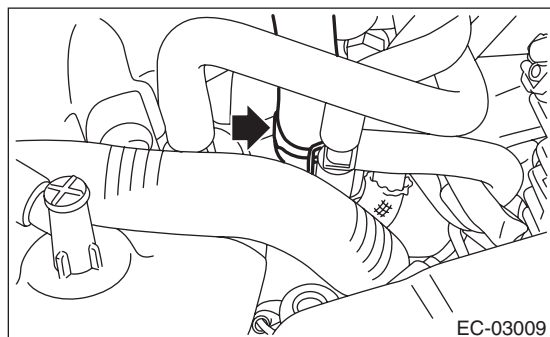

5) Connect the connector to the PCV hose assembly B.



6) Install the PCV hose assembly A to the PCV pipe, and install the PCV hose assembly A to the clip (B).

7) Connect the connector (A) to the PCV hose assembly A.

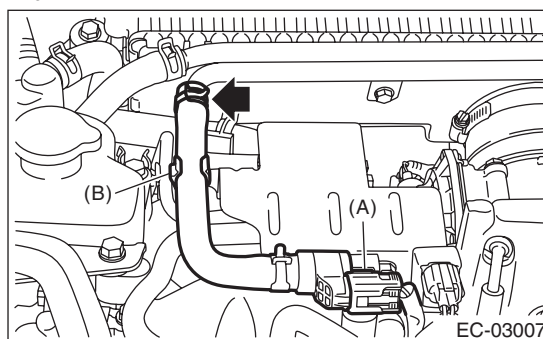

## C: INSPECTION

### 1. DIAGNOSIS CONNECTOR

1) Check that the diagnosis connector has no deformation, cracks and any other damage.

2) Check the resistance between the diagnosis connector terminals.

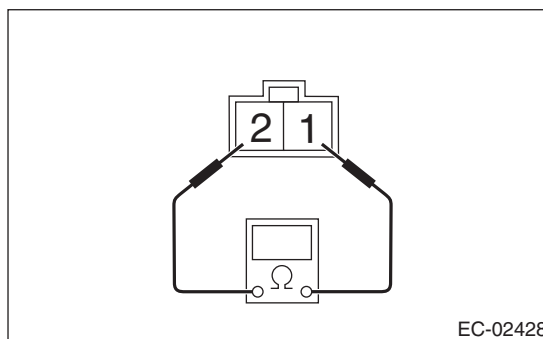

Terminal No.	Standard
1 and 2	Less than 1 Ω

### 2. OTHER INSPECTIONS

1) Check that the PCV connector has no deformation, cracks or other damages.

2) Check that the hose has no cracks, damage or loose part.

EC(STI)-25

Brought to you by Ebay Seller "SubaruManuals"

# PCV Valve

EMISSION CONTROL (AUX. EMISSION CONTROL DEVICES)

## 14.PCV Valve

### A: REMOVAL

#### CAUTION:

**Do not remove unless the PCV valve is broken.**

- 1) Remove the intercooler. <Ref. to IN(STI)-12, REMOVAL, Intercooler.>
- 2) Disconnect the vacuum hose (A) from the PCV valve and remove the PCV valve from the PCV connector.

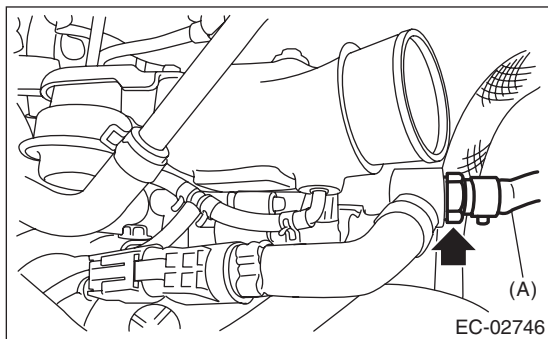

### B: INSTALLATION

- 1) Install the PCV valve to the PCV connector and connect the vacuum hose (A) to the PCV valve.

#### NOTE:

Apply liquid gasket to the bolt threads of PCV valve.

#### Liquid gasket:

**THREE BOND 1324 (Part No. 004403042) or equivalent**

#### Tightening torque:

**22.5 N·m (2.3 kgf-m, 16.6 ft-lb)**

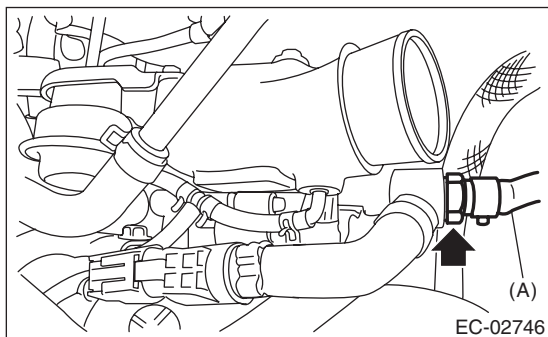

- 2) Install the intercooler. <Ref. to IN(STI)-13, INSTALLATION, Intercooler.>

## C: INSPECTION

### 1. PCV VALVE

- 1) Check that the PCV valve has no deformation, cracks or other damages.
- 2) Check that air is discharged from (B) when air is blown into (A).

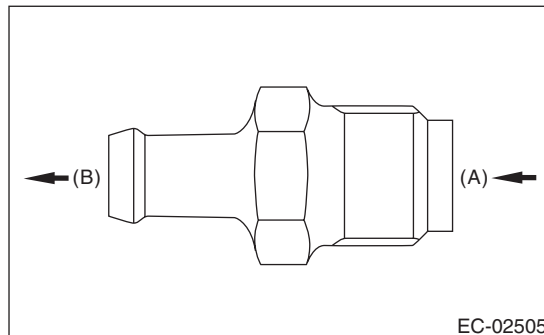

- 3) Check that air does not come out from (B) when air is blown into (A).

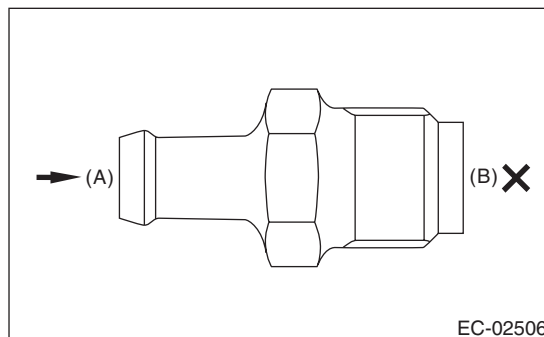

### 2. OTHER INSPECTIONS

Check the vacuum hose for cracks, damage or looseness.

# Secondary Air Pump

EMISSION CONTROL (AUX. EMISSION CONTROL DEVICES)

## 15. Secondary Air Pump

### A: REMOVAL

1) Disconnect the ground cable from battery.

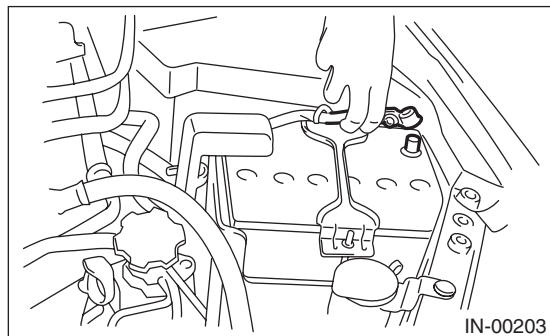

2) Remove the clip (A) which holds the harness on the harness stay and remove the bolt (B) which holds the secondary air pump on the vehicle.

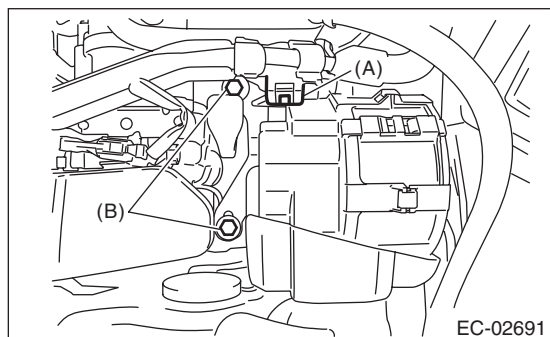

3) Disconnect the connector (A) and air duct (B) from secondary air pump.

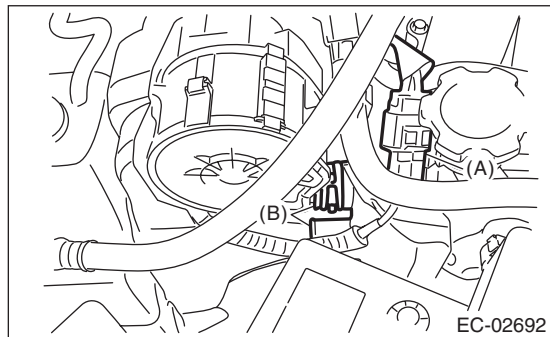

4) Remove the secondary air pump from the vehicle and the resonator from the secondary air pump.

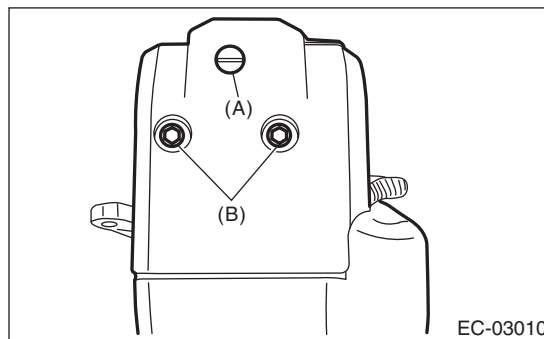

(A) Clip  
(B) Bolt

### B: INSTALLATION

Install in the reverse order of removal.

**Tightening torque:**

**6.4 N·m (0.7 kgf-m, 4.7 ft-lb)**

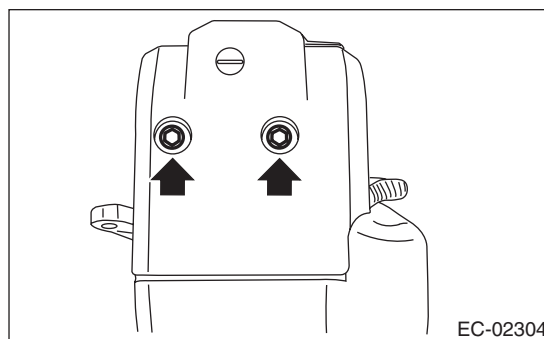

**Tightening torque:**

**19 N·m (1.9 kgf-m, 14.0 ft-lb)**

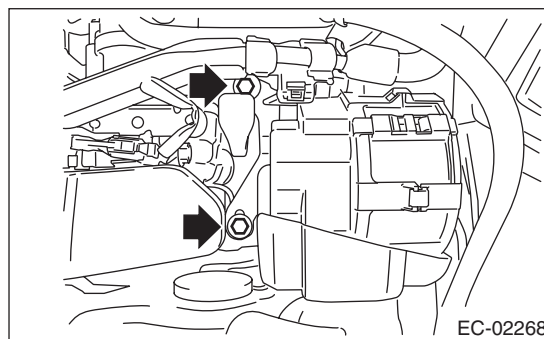

# Secondary Air Pump

EMISSION CONTROL (AUX. EMISSION CONTROL DEVICES)

---

## C: INSPECTION

### 1. SECONDARY AIR PUMP

- 1) Check that the secondary air pump has no deformation, cracks or other damages.
- 2) Connect battery positive terminal to the terminal No. 2 and battery negative terminal to the terminal No. 1, and inspect the secondary air pump operation.

#### CAUTION:

**Do not operate the secondary air pump continuously for 80 seconds or more.**

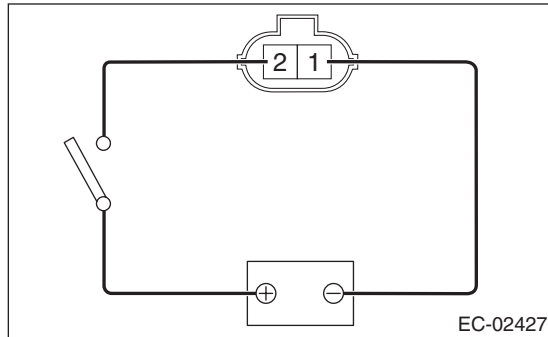

### 2. OTHER INSPECTIONS

Check that the air duct or resonator has no cracks, damage or loose part.

# Secondary Air Combination Valve

EMISSION CONTROL (AUX. EMISSION CONTROL DEVICES)

## 16. Secondary Air Combination Valve

### A: REMOVAL

#### 1. SECONDARY AIR COMBINATION VALVE LH

1) Disconnect the ground cable from battery.

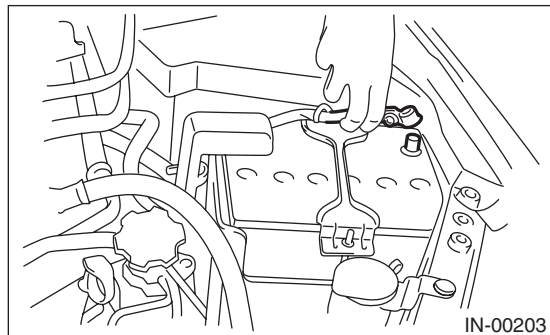

2) Remove the intercooler. <Ref. to IN(STI)-12, REMOVAL, Intercooler.>

3) Disconnect the connector from the secondary air combination valve LH.

4) Disconnect the air duct A.

5) Remove the secondary air pipe LH.

6) Remove the secondary air combination valve LH.

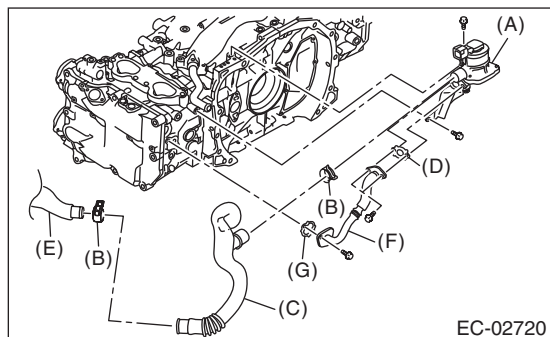

- (A) Secondary air combination valve LH
- (B) Clip
- (C) Air duct A
- (D) Gasket
- (E) Air duct B
- (F) Secondary air pipe LH
- (G) Gasket

#### 2. SECONDARY AIR COMBINATION VALVE RH

1) Disconnect the ground cable from battery.

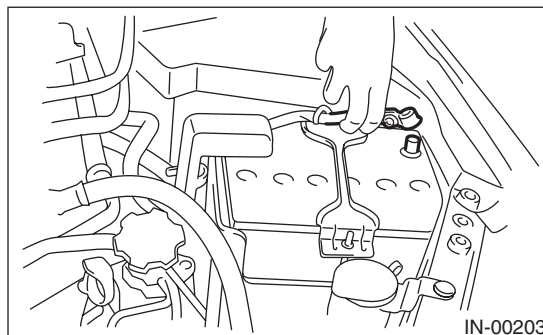

2) Remove the intercooler. <Ref. to IN(STI)-12, REMOVAL, Intercooler.>

3) Remove the intake manifold. <Ref. to FU(STI)-17, REMOVAL, Intake Manifold.>

4) Disconnect the air duct A.

5) Disconnect the secondary air pipe RH.

6) Remove the secondary air combination valve RH.

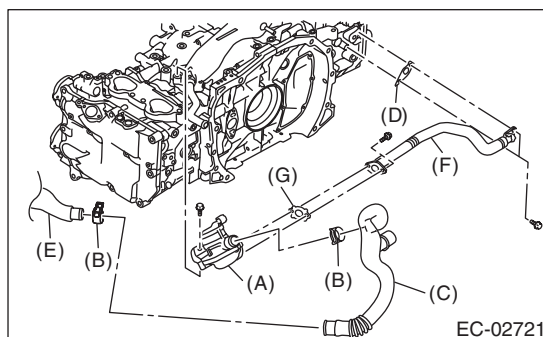

- (A) Secondary air combination valve RH
- (B) Clip
- (C) Air duct A
- (D) Gasket
- (E) Air duct B
- (F) Secondary air pipe RH
- (G) Gasket

# Secondary Air Combination Valve

EMISSION CONTROL (AUX. EMISSION CONTROL DEVICES)

## B: INSTALLATION

### 1. SECONDARY AIR COMBINATION VALVE LH

Install in the reverse order of removal.

NOTE:

Use a new gasket.

**Tightening torque:**

**T1: 9 N·m (0.9 kgf-m, 6.6 ft-lb)**

**T2: 19 N·m (1.9 kgf-m, 14.0 ft-lb)**

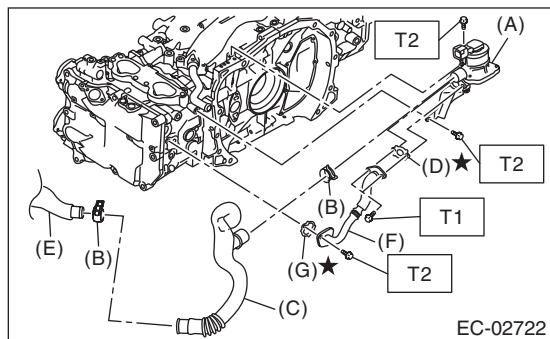

- (A) Secondary air combination valve LH
- (B) Clip
- (C) Air duct A
- (D) Gasket
- (E) Air duct B
- (F) Secondary air pipe LH
- (G) Gasket

### 2. SECONDARY AIR COMBINATION VALVE RH

Install in the reverse order of removal.

NOTE:

Use a new gasket.

**Tightening torque:**

**T1: 9 N·m (0.9 kgf-m, 6.6 ft-lb)**

**T2: 19 N·m (1.9 kgf-m, 14.0 ft-lb)**

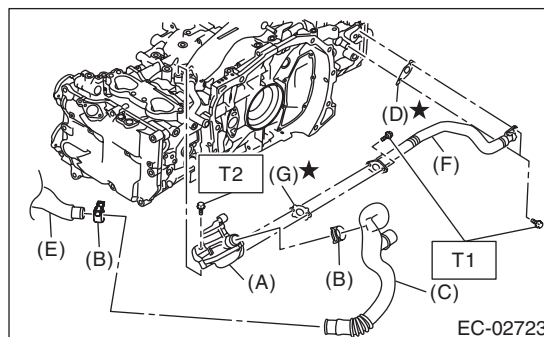

- (A) Secondary air combination valve RH
- (B) Clip
- (C) Air duct A
- (D) Gasket
- (E) Air duct B
- (F) Secondary air pipe RH
- (G) Gasket

## C: INSPECTION

### 1. SECONDARY AIR COMBINATION VALVE LH

- 1) Check that the secondary air combination valve LH has no deformation, cracks or other damages.
- 2) Check the resistance between the terminals of secondary air combination valve LH.

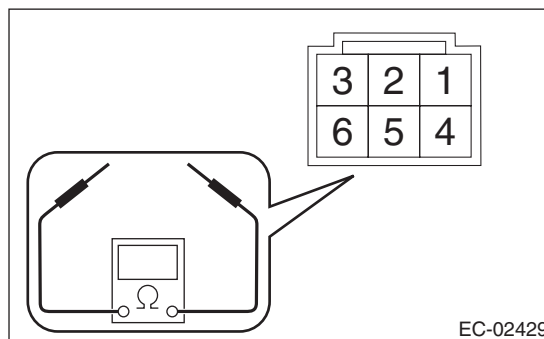

Terminal No.	Standard
4 and 6	5.0±0.5 Ω (when 20°C (68°F))
2 and 3	15 kΩ or less
1 and 2	4.5 kΩ or less

EC(STI)-30

Brought to you by Ebay Seller "SubaruManuals"



# Secondary Air Combination Valve

EMISSION CONTROL (AUX. EMISSION CONTROL DEVICES)

3) Check that air does not come out from (B) when air is blown into (A).

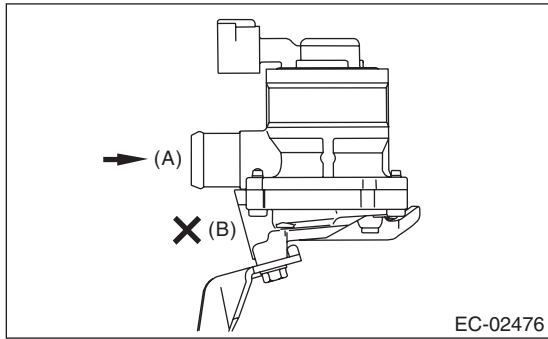

4) Connect the battery positive terminal to the terminal No. 6 and the battery negative terminal to the terminal No. 4. Check that air is discharged from (B), when supplying air to (A).

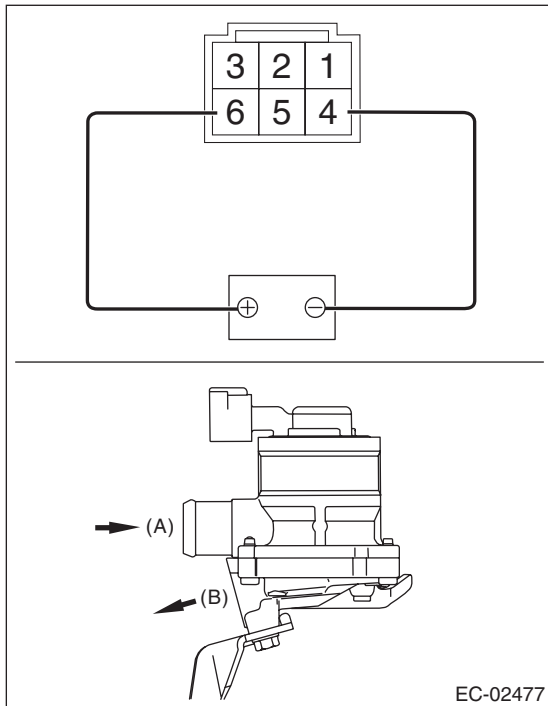

## 2. SECONDARY AIR COMBINATION VALVE RH

1) Check that the secondary air combination valve RH has no deformation, cracks or other damages.

2) Check the resistance between the terminals of secondary air combination valve RH.

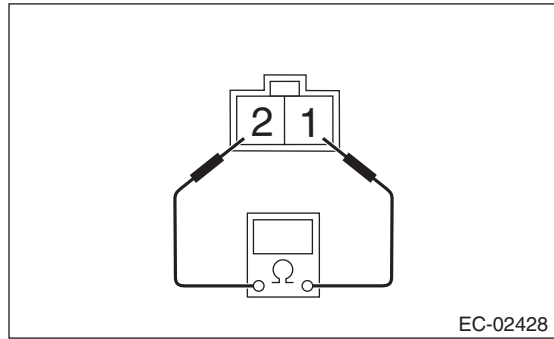

Terminal No.	Standard
1 and 2	$5.0 \pm 0.5 \Omega$ (when 20°C (68°F))

3) Check that air does not come out from (B) when air is blown into (A).

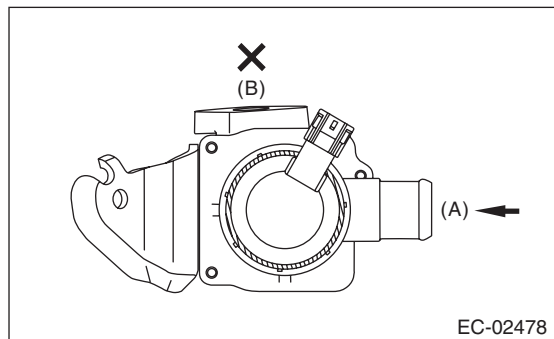

4) Connect the battery positive terminal to the terminal No. 2 and the battery negative terminal to the terminal No. 1. Check that air is discharged from (B), when supplying air to (A).

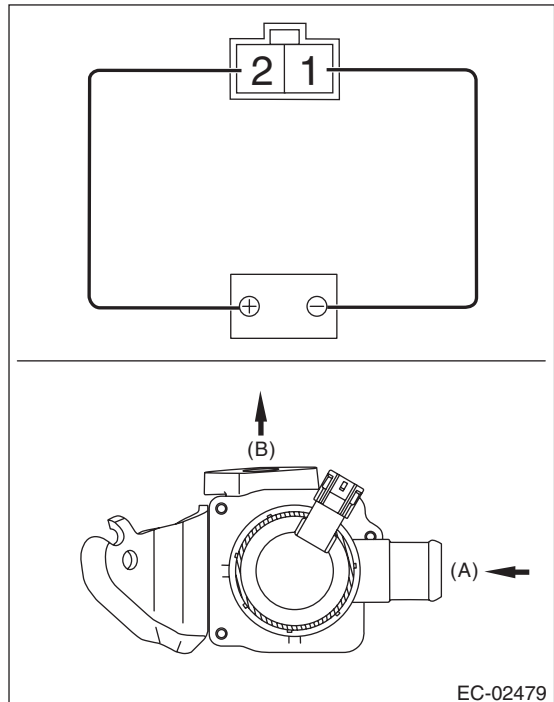



## Secondary Air Combination Valve

EMISSION CONTROL (AUX. EMISSION CONTROL DEVICES)

---

### 3. OTHER INSPECTIONS

- 1) Check that the secondary air pipe has no deformation, cracks or other damages.
- 2) Check that the air duct has no cracks, damage or loose part.

# INTAKE (INDUCTION)

# *IN(STI)*

---

	<b>Page</b>
1. General Description .....	2
2. Air Cleaner Element .....	7
3. Air Cleaner Case .....	8
4. Air Intake Duct .....	10
5. Intake Duct .....	11
6. Intercooler .....	12
7. Turbocharger .....	15
8. Air By-pass Valve .....	19
9. Resonator Chamber .....	20

# General Description

INTAKE (INDUCTION)

## 1. General Description

### A: COMPONENT

#### 1. AIR CLEANER

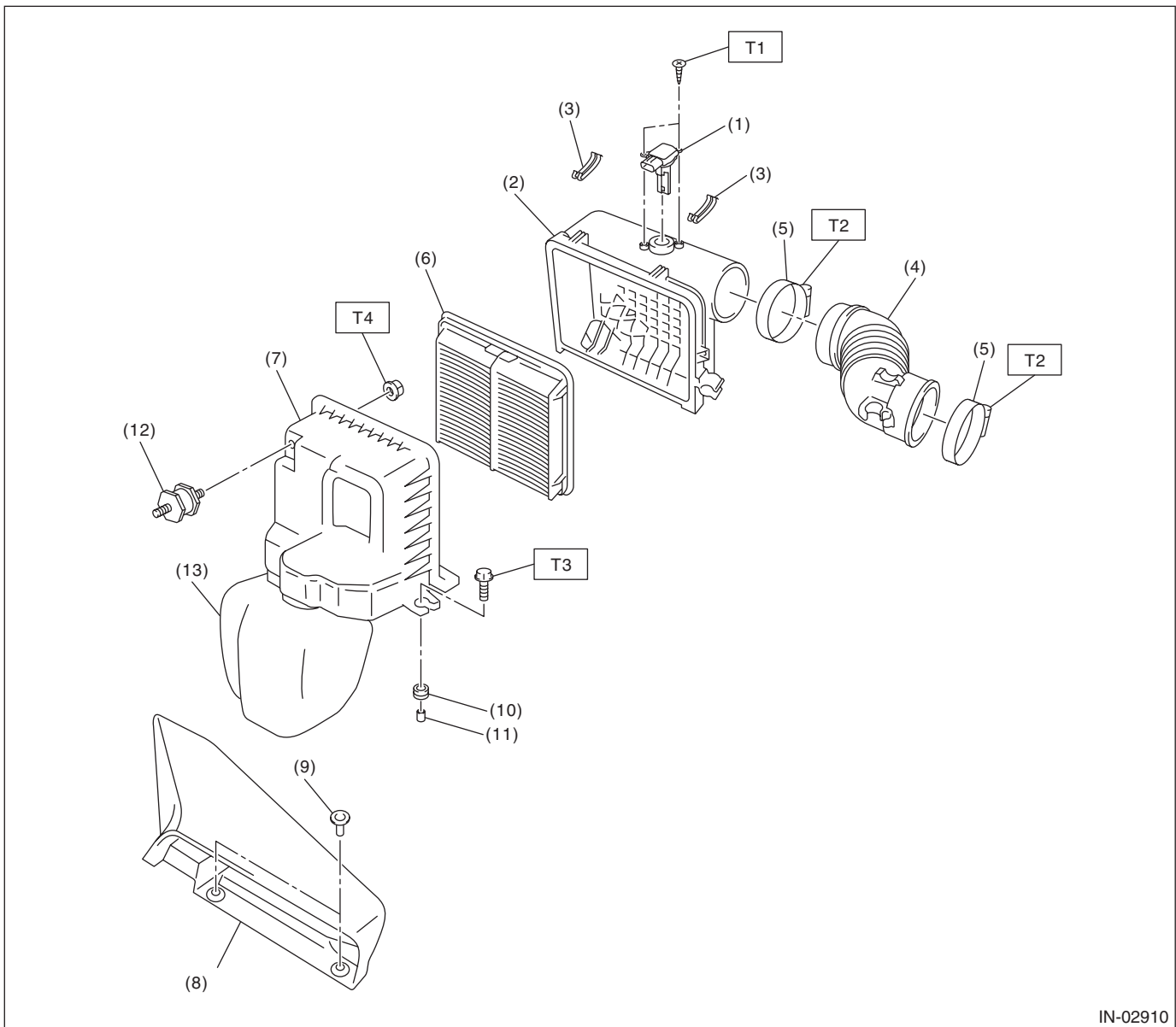

IN-02910

- |   |                        |
|---|------------------------|
| (1) Mass air flow and intake air temperature sensor | (8) Air intake duct    |
| (2) Air cleaner case (rear)                         | (9) Clip               |
| (3) Clip  | (10) Cushion           |
| (4) Air intake boot                                 | (11) Spacer            |
| (5) Clamp   | (12) Cushion           |
| (6) Air cleaner element                             | (13) Resonator chamber |
| (7) Air cleaner case (front)                        |                        |

**Tightening torque: N·m (kgf·m, ft·lb)**

**T1: 1 (0.1, 0.7)**

**T2: 2.5 (0.3, 1.8)**

**T3: 6 (0.6, 4.4)**

**T4: 7.5 (0.8, 5.5)**

IN(STI)-2

Brought to you by Ebay Seller "SubaruManuals"

## 2. INTAKE DUCT

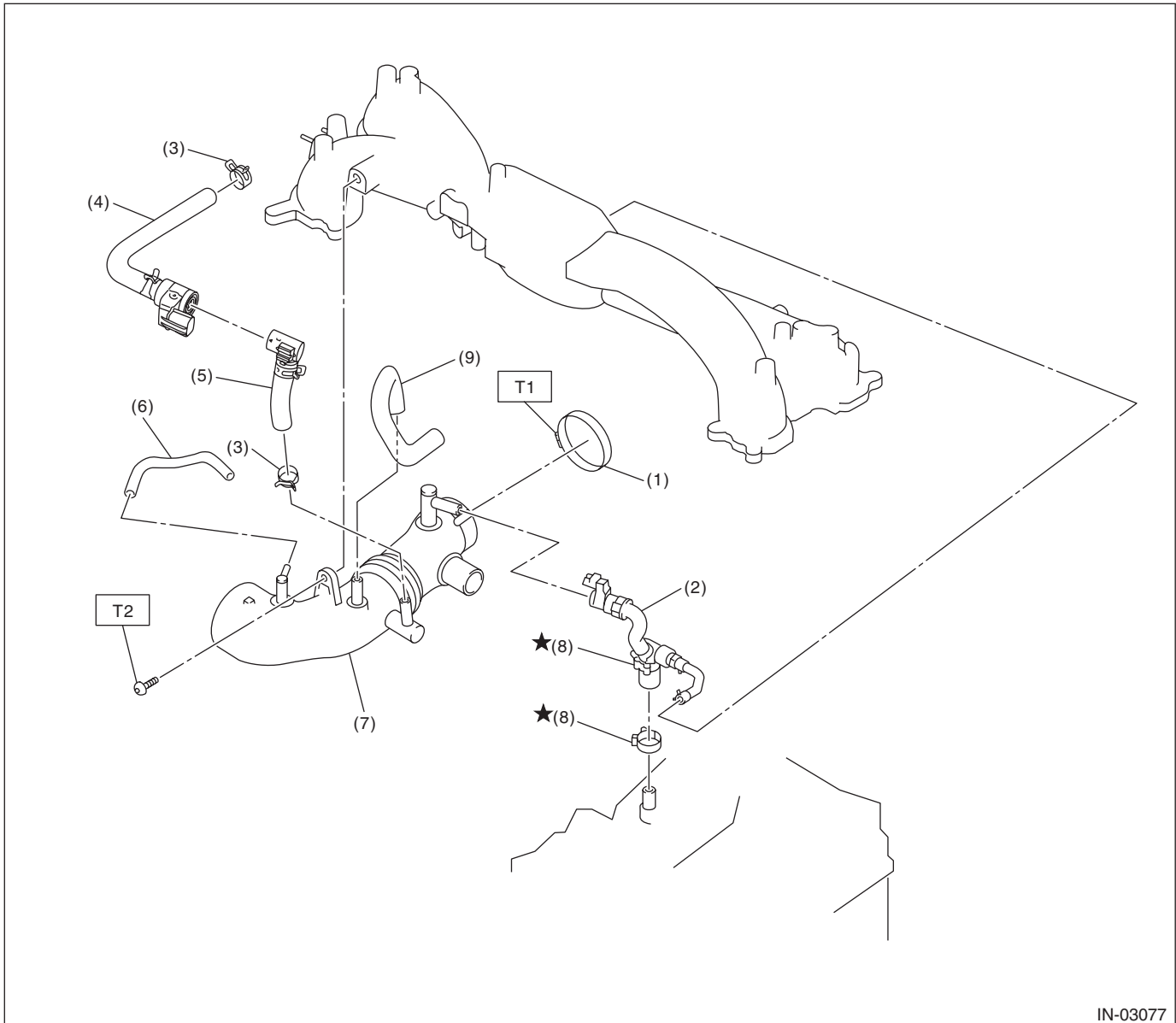

IN-03077

- |                     |                   |
|---------------------|-------------------|
| (1) Clamp           | (6) Vacuum hose A |
| (2) PCV hose ASSY A | (7) Intake duct   |
| (3) Clip            | (8) Clamp         |
| (4) PCV hose ASSY B | (9) Vacuum hose B |
| (5) PCV hose ASSY C |                   |

**Tightening torque: N·m (kgf·m, ft·lb)**

**T1: 3 (0.3, 2.2)**

**T2: 17 (1.7, 12.5)**

# General Description

## INTAKE (INDUCTION)

### 3. INTERCOOLER

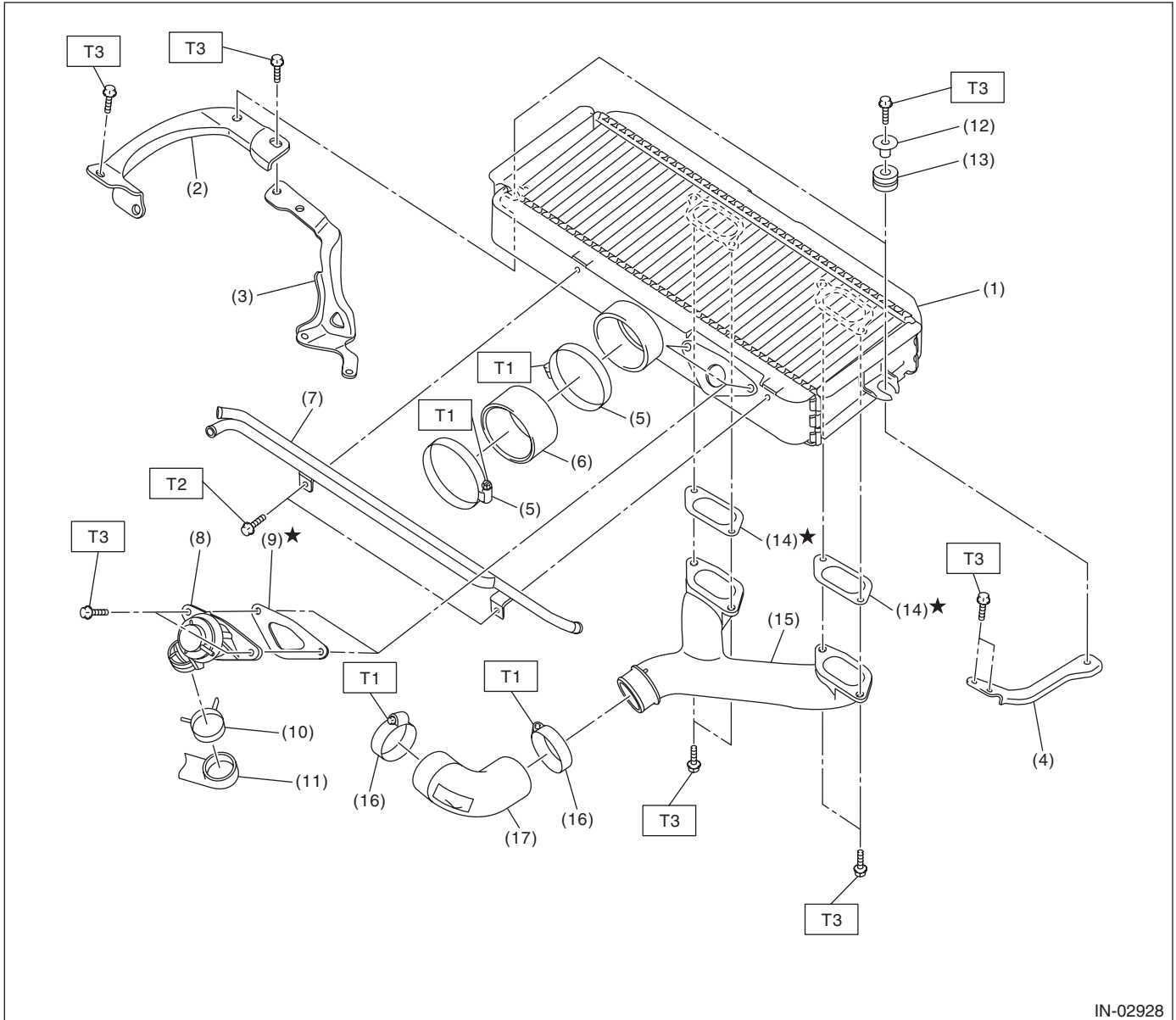

IN-02928

- |                        |                       |                  |
|------------------------|-----------------------|------------------|
| (1) Intercooler        | (9) Gasket            | (16) Clamp       |
| (2) Intercooler stay A | (10) Clip             | (17) Intake duct |
| (3) Intercooler stay B | (11) Air by-pass hose |                  |
| (4) Intercooler stay C | (12) Spacer           |                  |
| (5) Clamp              | (13) Cushion          |                  |
| (6) Air duct hose      | (14) Gasket           |                  |
| (7) PCV pipe           | (15) Intercooler duct |                  |
| (8) Air by-pass valve  |                       |                  |

**Tightening torque: N·m (kgf·m, ft·lb)**

**T1: 3 (0.3, 2.2)**

**T2: 5.5 (0.6, 4.1)**

**T3: 16 (1.6, 11.8)**

**IN(STI)-4**

Brought to you by Ebay Seller "SubaruManuals"

## 4. TURBOCHARGER

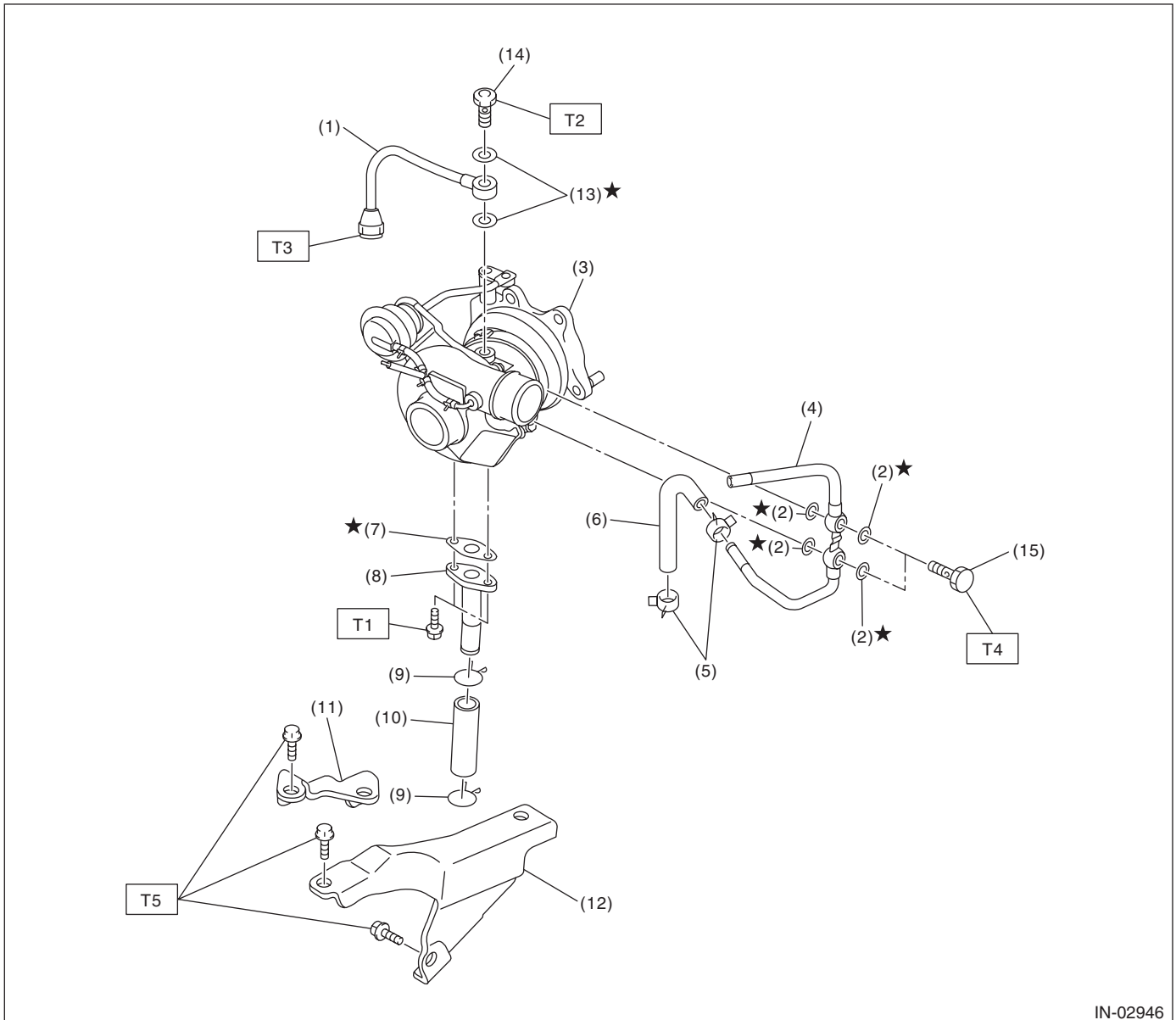

IN-02946

- |                         |                           |
|-------------------------|---------------------------|
| (1) Oil inlet pipe      | (9) Clip                  |
| (2) Gasket              | (10) Oil outlet hose      |
| (3) Turbocharger        | (11) Turbocharger stay RH |
| (4) Water pipe          | (12) Turbocharger stay LH |
| (5) Clip                | (13) Gasket               |
| (6) Engine coolant hose | (14) Union bolt A         |
| (7) Gasket              | (15) Union bolt B         |
| (8) Oil outlet pipe     |                           |

**Tightening torque: N·m (kgf·m, ft·lb)**

**T1: 4.9 (0.5, 3.6)**

**T2: 16 (1.6, 11.8)**

**T3: 20 (2.0, 14.8)**

**T4: 23 (2.3, 17.0)**

**T5: 33 (3.4, 24.3)**

## General Description

INTAKE (INDUCTION)

---

### B: CAUTION

- Wear appropriate work clothing, including a cap, protective goggles and protective shoes when performing any work.
- Remove contamination including dirt and corrosion before removal, installation or disassembly.
- Keep the disassembled parts in order and protect them from dust and dirt.
- Before removal, installation or disassembly, be sure to clarify the failure. Avoid unnecessary removal, installation, disassembly and replacement.
- Vehicle components are extremely hot after driving. Be wary of receiving burns from heated parts.
- Be sure to tighten fasteners including bolts and nuts to the specified torque.
- Place shop jacks or rigid racks at the specified points.
- Before disconnecting connectors of sensors or units, be sure to disconnect the ground cable from the battery.

### C: PREPARATION TOOL

#### 1. GENERAL TOOL

TOOL NAME	REMARKS
Mighty Vac	Used for checking waste gate actuator and air by-pass valve.

## 2. Air Cleaner Element

### A: REMOVAL

- 1) Disconnect the ground cable from battery.

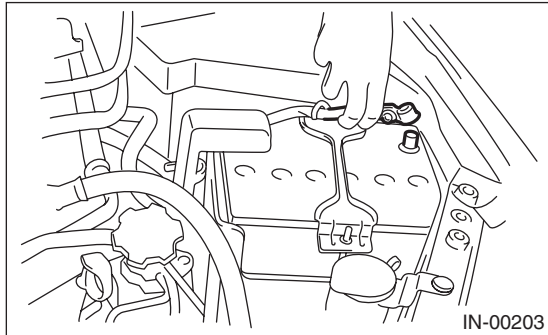

- 2) Remove the air intake duct. <Ref. to IN(STI)-10, REMOVAL, Air Intake Duct.>

- 3) Disconnect the connector (A) from air flow and intake air temperature sensor.

- 4) Remove the clips (B) from the air cleaner case (front).

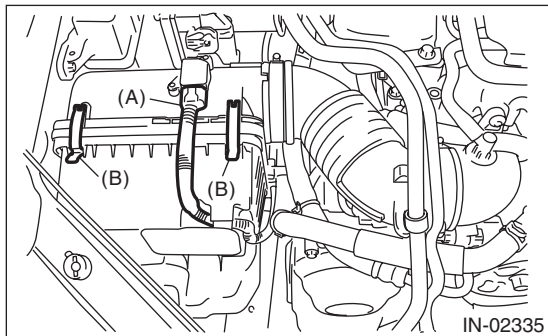

- 5) Open the air cleaner case, and remove the air cleaner element.

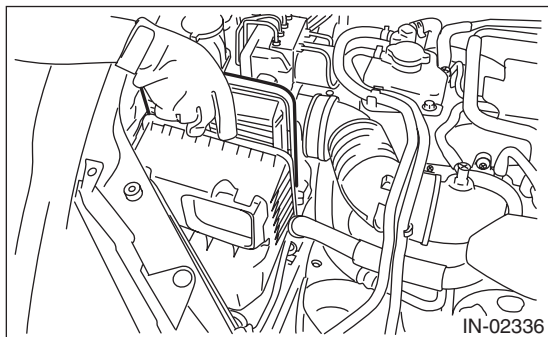

### B: INSTALLATION

Install in the reverse order of removal.

#### CAUTION:

Be sure to use **SUBARU** genuine air cleaner element depending on the engine type when replacing the air cleaner elements. Using other air cleaner element may affect the engine performance.

#### NOTE:

- Check that there are no foreign objects in the air cleaner case.
- If the protrusion of the air cleaner case (rear) is removed when removing the air cleaner element, align the protrusion of the air cleaner case (rear) to the hole on the air cleaner case (front) to install.

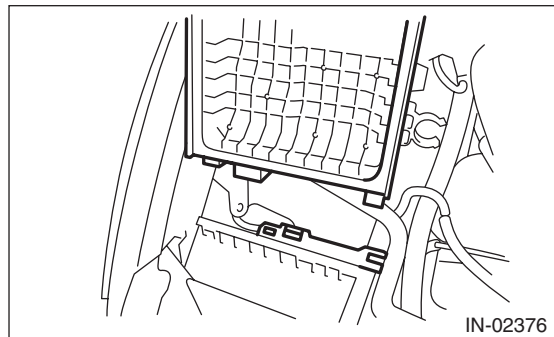

### C: INSPECTION

- 1) Check that the air cleaner element has no deformation, cracks or other damages.
- 2) Check the air cleaner element for excessive dirt.



# Air Cleaner Case

INTAKE (INDUCTION)

## 3. Air Cleaner Case

### A: REMOVAL

1) Disconnect the ground cable from battery.

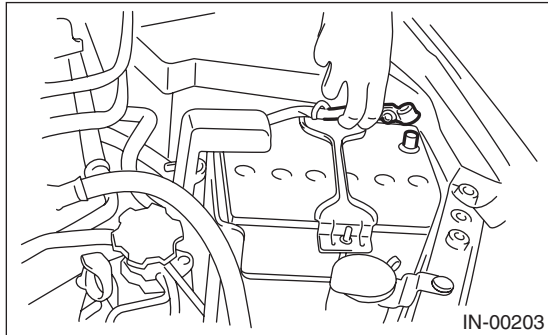

2) Remove the air intake duct. <Ref. to IN(STI)-10, REMOVAL, Air Intake Duct.>

3) Disconnect the connector (A) from air flow and intake air temperature sensor.

4) Loosen the clamp (B) which holds the air intake boot.

5) Remove the clip (C) from the air cleaner case (front).

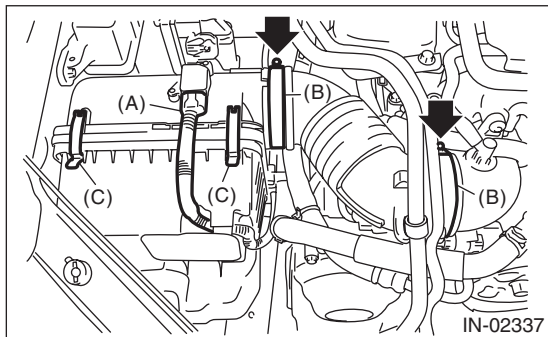

6) Remove the air cleaner case (rear) and air intake boot.

7) Remove the air cleaner element.

8) Remove bolts (A) and nuts (B) which secure the air cleaner case (front) to the body, and remove the air cleaner case (front).

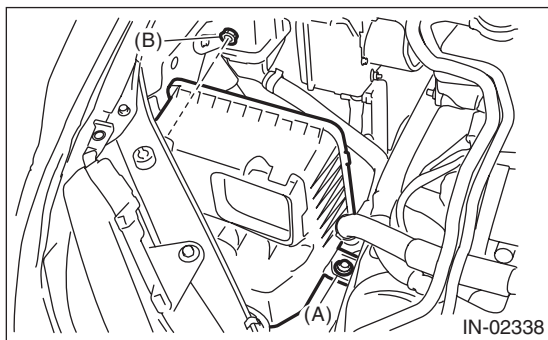

### B: INSTALLATION

1) Install the bolt (A) and nut (B) which secure the air cleaner case (front) to the body.

**Tightening torque:**

**Bolt (A)**

**6 N·m (0.6 kgf-m, 4.4 ft-lb)**

**Nut (B)**

**7.5 N·m (0.8 kgf-m, 5.5 ft-lb)**

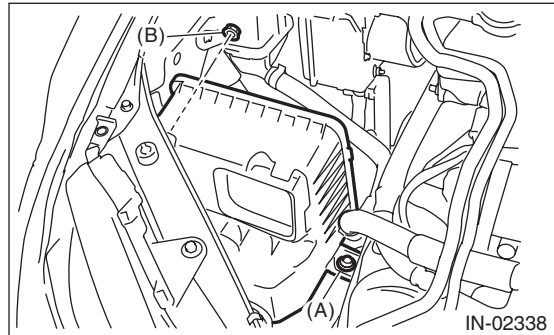

2) Install the air cleaner element.

3) Install the air cleaner case (rear) and air intake boot.

**NOTE:**

When installing the air cleaner case (rear), align the protrusion of the air cleaner case (rear) to the hole on the air cleaner case (front) to install.

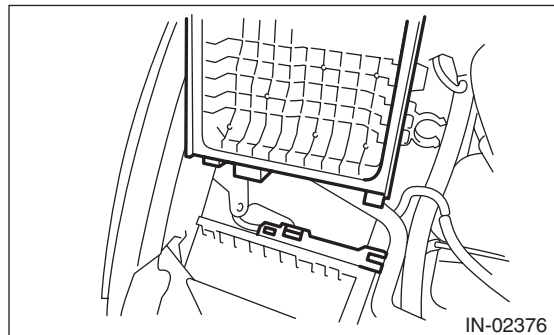

**Tightening torque:**

**2.5 N·m (0.3 kgf-m, 1.8 ft-lb)**

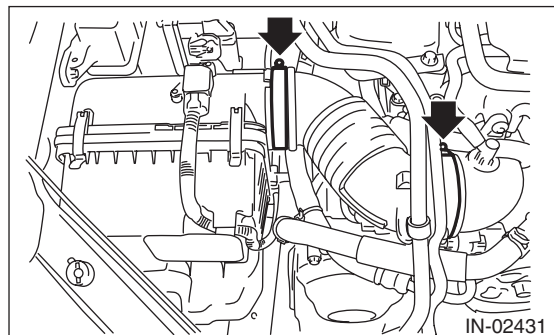

4) Install the clip (B) to the air cleaner case (front).

IN(STI)-8

Brought to you by Ebay Seller "SubaruManuals"

5) Connect the connector (A) to the mass air flow and intake air temperature sensor.

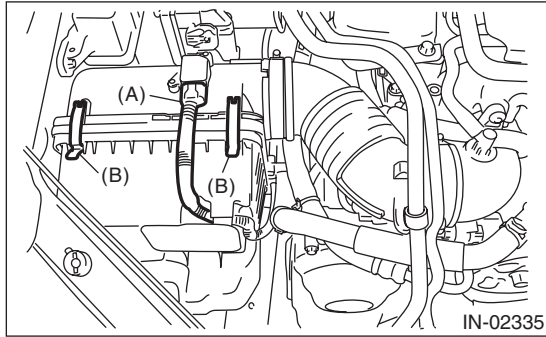

6) Install the air intake duct. <Ref. to IN(STI)-10, INSTALLATION, Air Intake Duct.>

7) Connect the ground cable to battery.

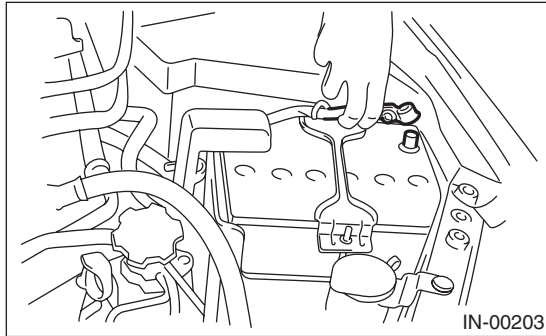

### C: INSPECTION

- 1) Check that the air cleaner case has no deformation, cracks or other damages.
- 2) Check that the air intake boot has no cracks, damage or loose part.

# Air Intake Duct

INTAKE (INDUCTION)

---

## 4. Air Intake Duct

### A: REMOVAL

Remove the clip which secures the air intake duct, and remove the air intake duct.

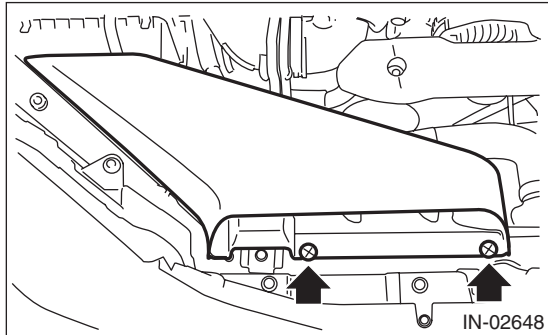

### B: INSTALLATION

Install in the reverse order of removal.

### C: INSPECTION

- 1) Check that the air intake duct has no deformation, cracks or other damages.
- 2) Inspect that no foreign objects are mixed in the air intake duct.

## 5. Intake Duct

### A: REMOVAL

1) Disconnect the ground cable from battery.

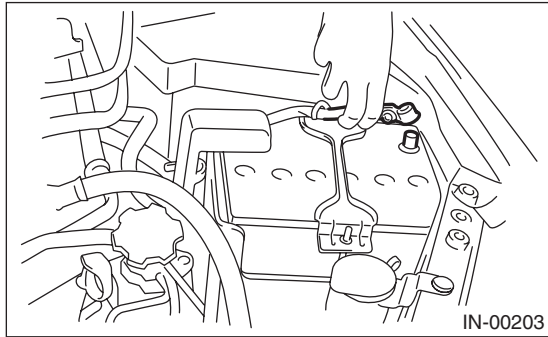

2) Remove the intake manifold. <Ref. to FU(STI)-17, REMOVAL, Intake Manifold.>

3) Remove the sensor, engine harness and fuel pipe from the intake manifold. <Ref. to FU(STI)-25, DISASSEMBLY, Intake Manifold.>

4) Remove the intake duct from intake manifold.

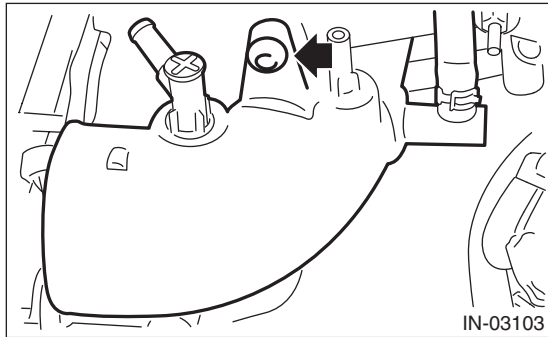

5) Remove the PCV hose assembly and air bypass hose from the intake duct.

### B: INSTALLATION

Install in the reverse order of removal.

#### *Tightening torque:*

**17 N·m (1.7 kgf·m, 12.5 ft·lb)**

### C: INSPECTION

Check that the intake duct has no deformation, cracks or other damages.

# Intercooler

## INTAKE (INDUCTION)

### 6. Intercooler

#### A: REMOVAL

1) Remove the bolts holding the PCV pipe to the intercooler.

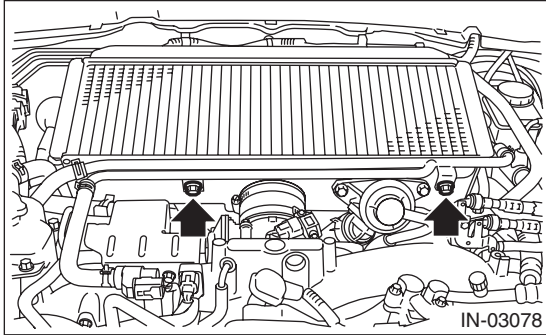

2) Remove the clip (A) which holds the air by-pass hose on the air by-pass valve and disconnect vacuum hose (B) from the air by-pass valve.

3) Loosen the clamp (C) holding the intake duct to the turbocharger.

4) Loosen the clamp (D) holding the air duct hose to the intercooler.

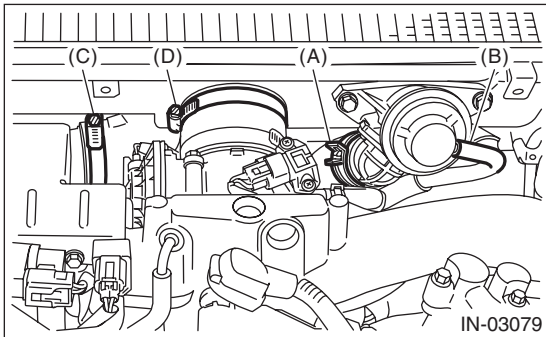

5) Remove the bolts which secure the intercooler to the intercooler stay, and remove the intercooler.

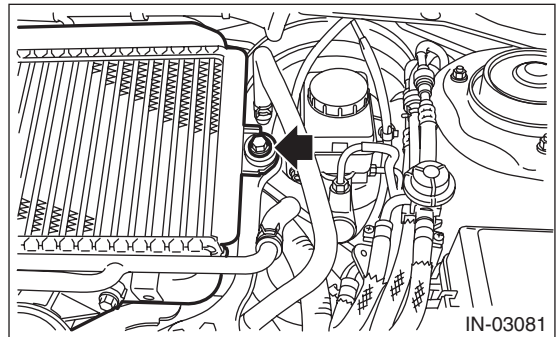
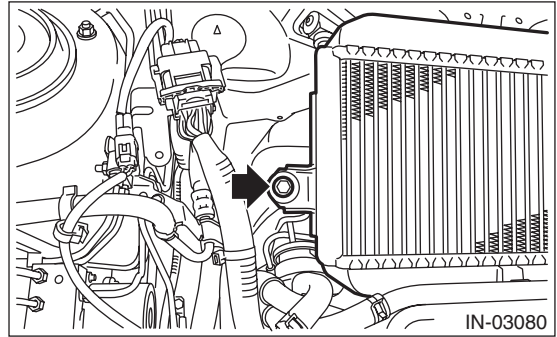

6) Remove the air duct hose from the throttle body.

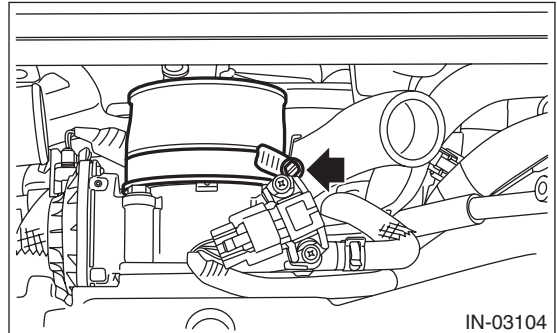

7) Remove clip (A) holding the engine harness to the intercooler stay RH, and remove the intercooler stay RH.

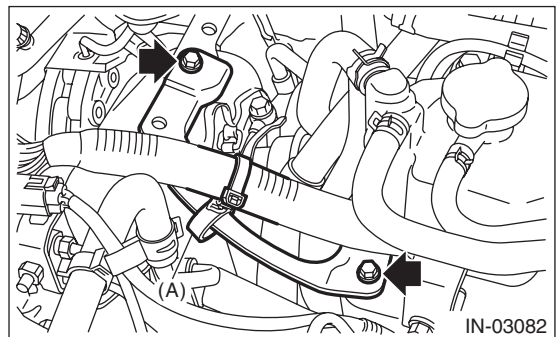



8) Remove the intercooler stay LH.

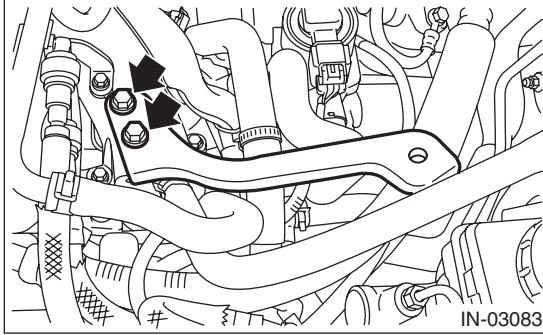

**Tightening torque:**  
**16 N·m (1.6 kgf-m, 11.8 ft-lb)**

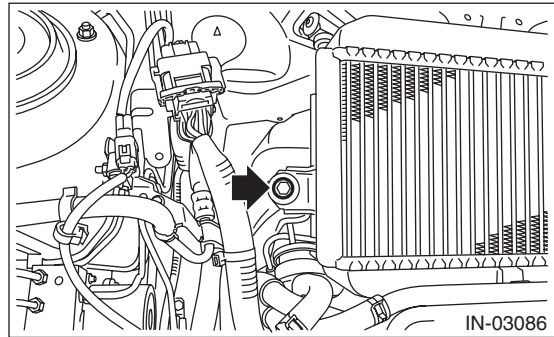

## B: INSTALLATION

Install in the reverse order of removal.

**Tightening torque:**  
**16 N·m (1.6 kgf-m, 11.8 ft-lb)**

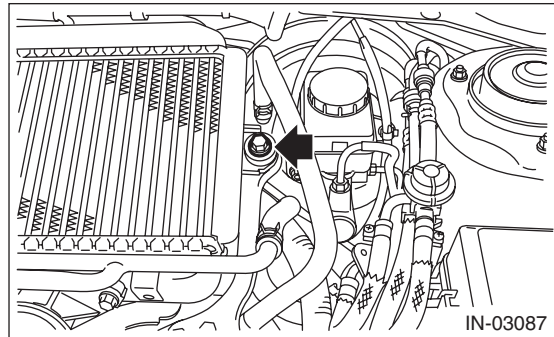
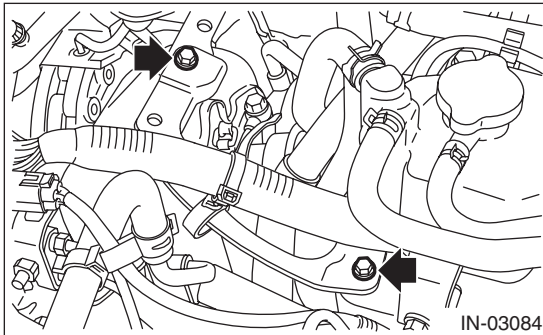

**Tightening torque:**  
**3 N·m (0.3 kgf-m, 2.2 ft-lb)**

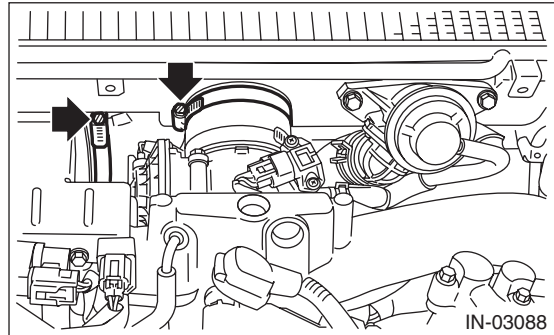
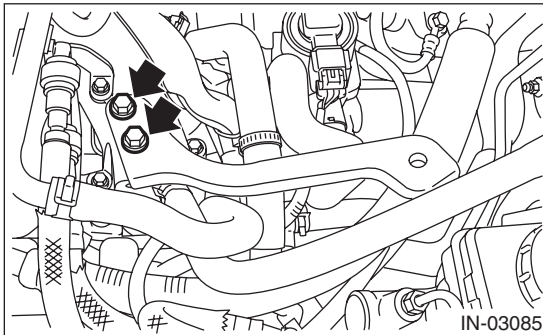

**Tightening torque:**  
**5.5 N·m (0.6 kgf-m, 4.1 ft-lb)**

**Tightening torque:**  
**3 N·m (0.3 kgf-m, 2.2 ft-lb)**

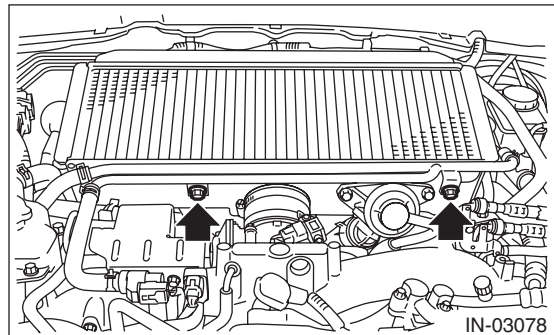
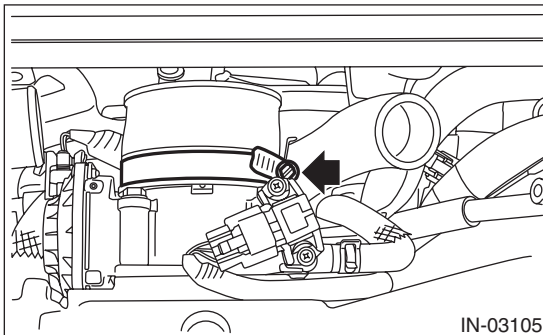

# Intercooler

## INTAKE (INDUCTION)

### C: DISASSEMBLY

- 1) Remove the intercooler duct from the intercooler.

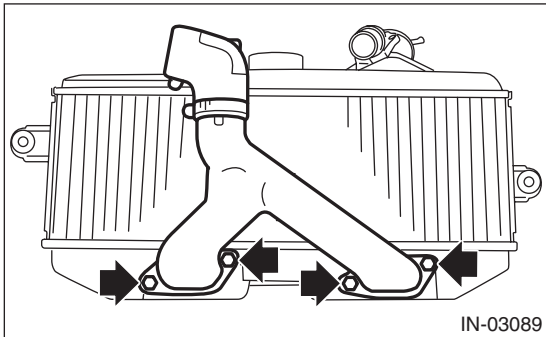

- 2) Remove the air by-pass valve from intercooler.

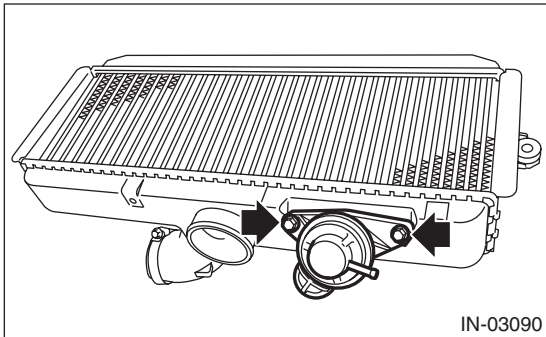

- 3) Remove the intake duct from intercooler duct.

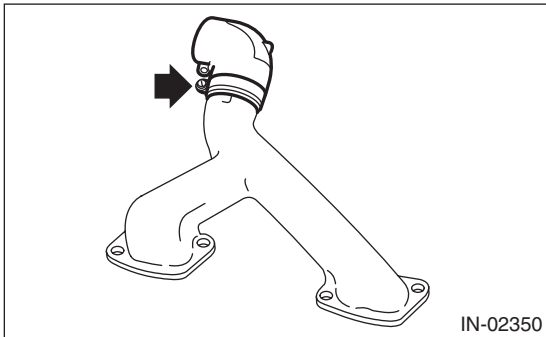

### D: ASSEMBLY

- 1) Install the intake duct to the intercooler duct.

**Tightening torque:**

**3 N·m (0.3 kgf·m, 2.2 ft·lb)**

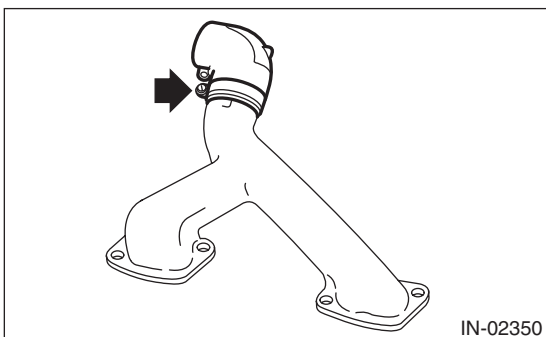

- 2) Install the air by-pass valve to the intercooler.

**NOTE:**

Use a new gasket.

**Tightening torque:**

**16 N·m (1.6 kgf·m, 11.8 ft·lb)**

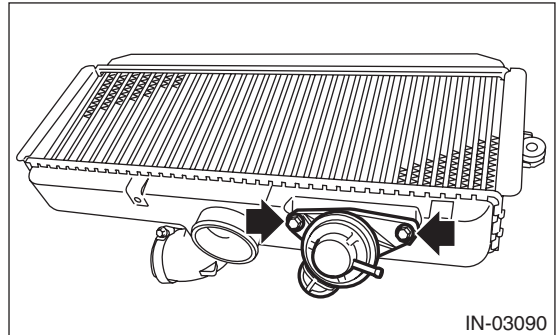

- 3) Install the intercooler duct to the intercooler.

**NOTE:**

Use a new gasket.

**Tightening torque:**

**16 N·m (1.6 kgf·m, 11.8 ft·lb)**

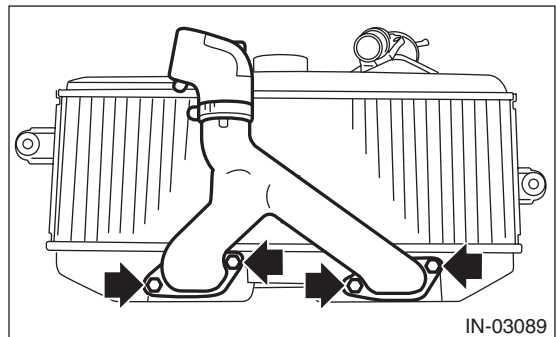

### E: INSPECTION

- 1) Check that the intercooler and intercooler duct have no deformation, cracks or other damages.
- 2) Check that the hose and intake duct have no cracks, damage or loose part.

## 7. Turbocharger

### A: REMOVAL

1) Disconnect the ground cable from battery.

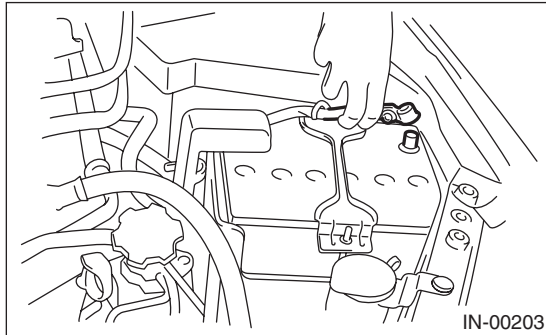

2) Lift up the vehicle.

3) Drain approximately 3.0 ℓ (3.2 US qt, 2.6 Imp qt) of coolant. <Ref. to CO(STI)-13, DRAINING OF ENGINE COOLANT, REPLACEMENT, Engine Coolant.>

4) Lower the vehicle.

5) Remove the intercooler. <Ref. to IN(STI)-12, REMOVAL, Intercooler.>

6) Remove the intercooler stay.

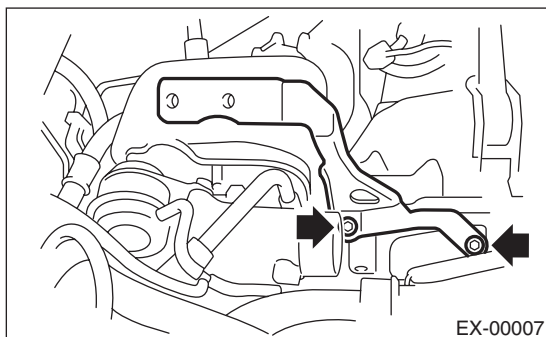

7) Remove the center exhaust pipe. <Ref. to EX(STI)-8, REMOVAL, Center Exhaust Pipe.>

8) Lower the vehicle.

9) Remove the joint pipe from the turbocharger.

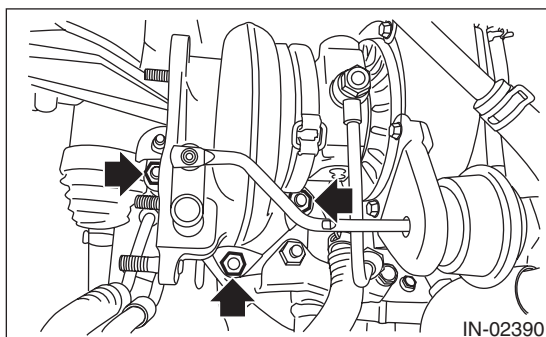

10) Disconnect the engine coolant hose from the upper side of the water pipe.

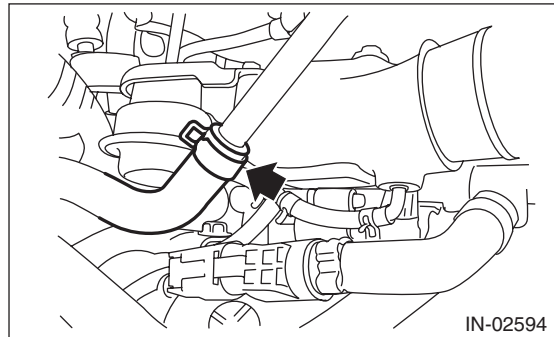

11) Disconnect the air control hose (A), and loosen the clamp holding the intake duct to the turbocharger.

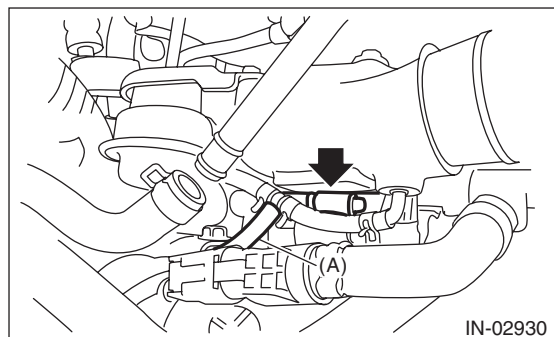

12) Remove the oil inlet pipe from the turbocharger.

#### CAUTION:

In order to prevent damaging the oil pipe on the cylinder head side, fix the section (a) shown in the figure when loosening the oil inlet pipe flare nut, and avoid the part from rotating together while loosening the nut.

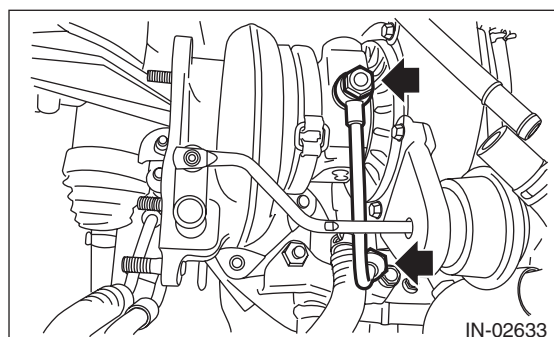
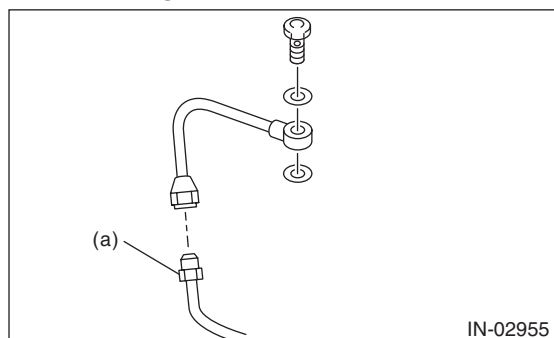



# Turbocharger

## INTAKE (INDUCTION)

13) Disconnect the engine coolant hose from the lower side of the water pipe.

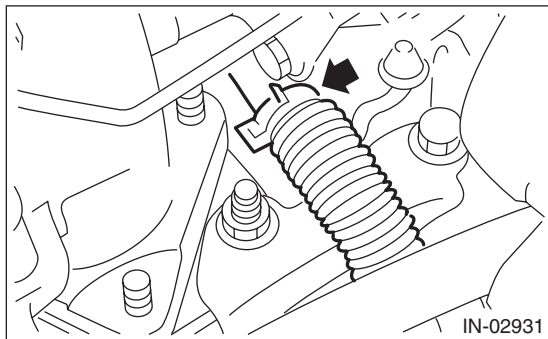

14) Disconnect the oil outlet hose from the oil outlet pipe, and remove the turbocharger.

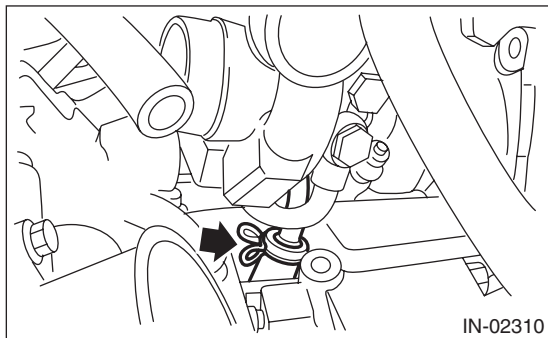

15) Remove the turbocharger stay.

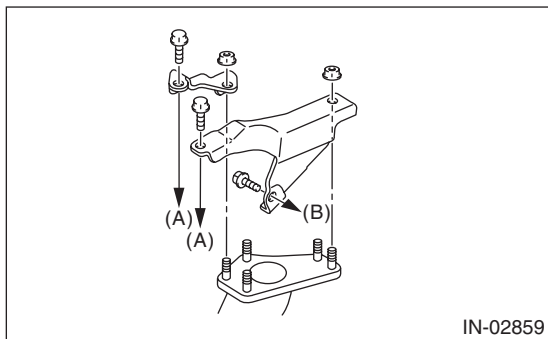

- (A) To cylinder head RH
- (B) To cylinder block RH

## B: INSTALLATION

1) Install the turbocharger stay.

**Tightening torque:**

**T1: 33 N·m (3.4 kgf·m, 24.3 ft·lb)**

**T2: 42.5 N·m (4.3 kgf·m, 31.3 ft·lb)**

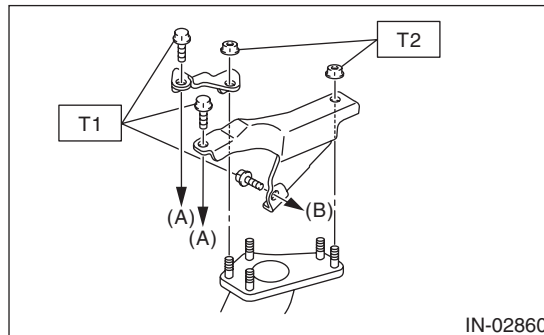

- (A) To cylinder head RH
- (B) To cylinder block RH

2) Connect the oil outlet hose to the oil outlet pipe.

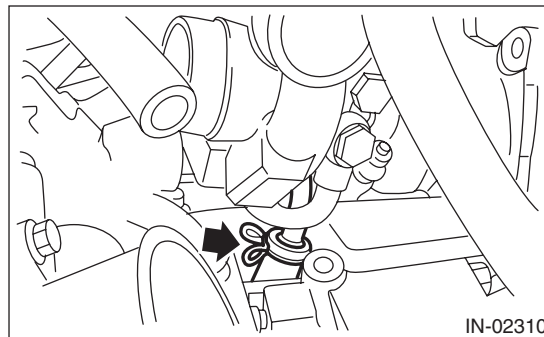

3) Connect the engine coolant hose to the lower side of the water pipe.

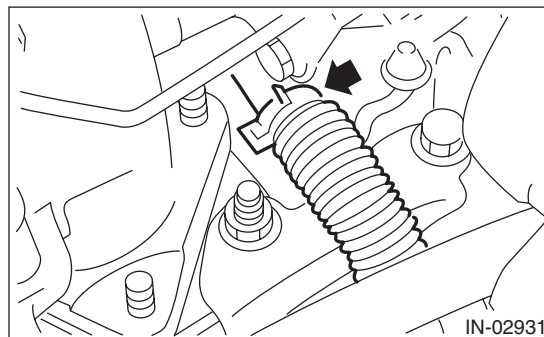

4) Temporarily tighten the union bolts and flare nuts which secure the oil inlet pipe to the turbocharger.

**NOTE:**

Use a new gasket.

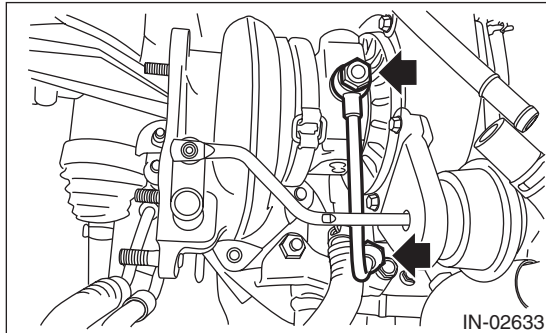

5) Tighten the union bolts and flare nuts which secure the oil inlet pipe to the turbocharger.

**CAUTION:**

In order to prevent damaging the oil pipe on the cylinder head side, fix the section (a) shown in the figure when tightening the oil inlet pipe flare nut, and avoid the part from rotating together while tightening the nut.

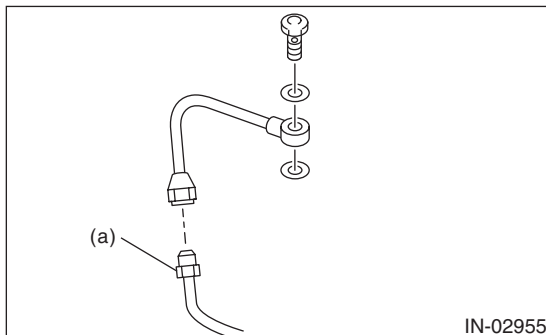

**Tightening torque:**

**T1: 16 N·m (1.6 kgf·m, 11.8 ft·lb)**

**T2: 20 N·m (2.0 kgf·m, 14.8 ft·lb)**

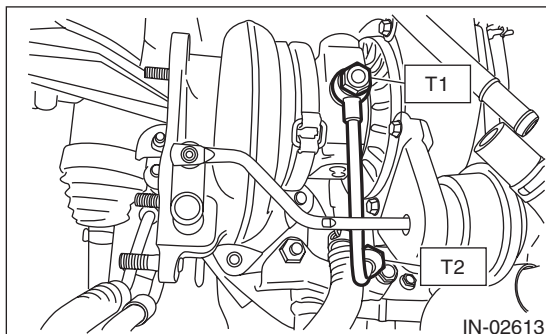

6) Connect the air control hose (A), and install the intake duct to the turbocharger.

**Tightening torque:**

**3 N·m (0.3 kgf·m, 2.2 ft·lb)**

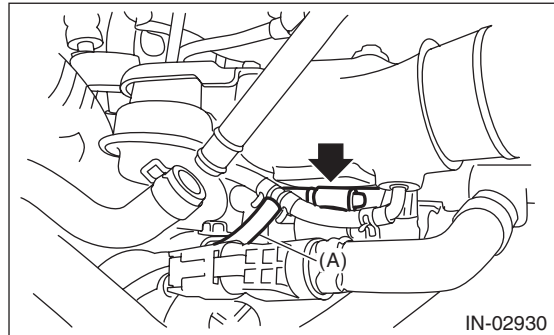

7) Connect the engine coolant hoses to the upper side of the water pipe.

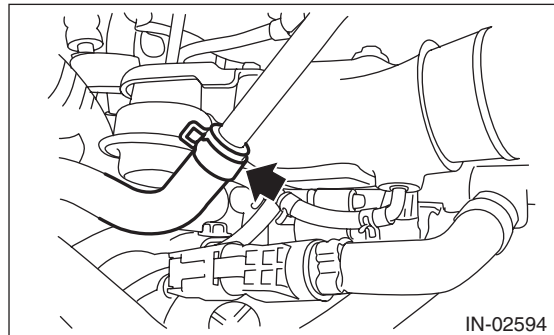

8) Install the joint pipe to turbocharger.

**NOTE:**

Use a new gasket.

**Tightening torque:**

**42.5 N·m (4.3 kgf·m, 31.3 ft·lb)**

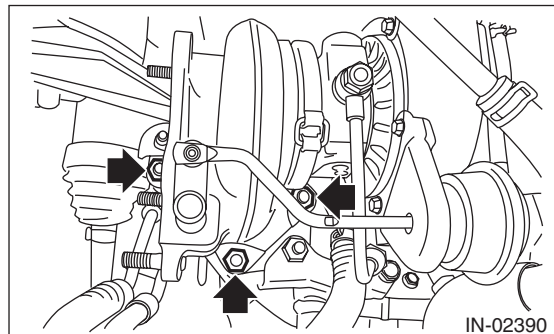

9) Lift up the vehicle.

10) Install the center exhaust pipe. <Ref. to EX(STI)-9, INSTALLATION, Center Exhaust Pipe.>

11) Lower the vehicle.

# Turbocharger

## INTAKE (INDUCTION)

12) Install the intercooler stay.

### Tightening torque:

**16 N·m (1.6 kgf·m, 11.8 ft·lb)**

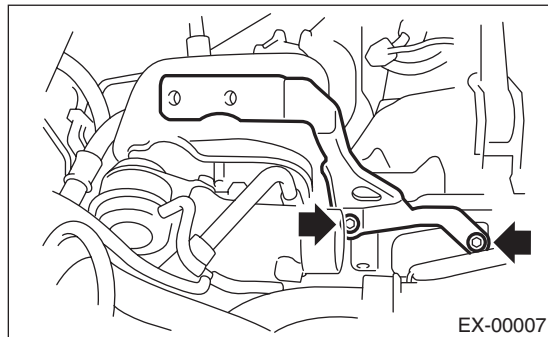

13) Install the intercooler. <Ref. to IN(STI)-13, INSTALLATION, Intercooler.>

14) Connect the battery ground terminal.

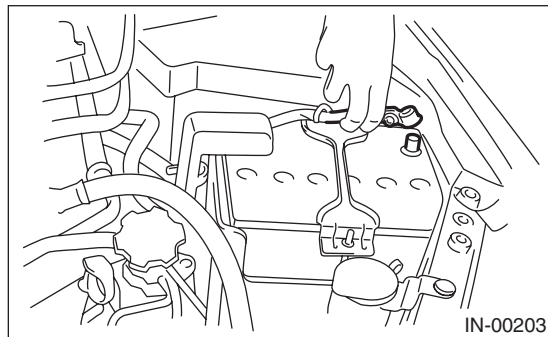

15) Fill engine coolant. <Ref. to CO(STI)-13, FILLING OF ENGINE COOLANT, REPLACEMENT, Engine Coolant.>

## C: INSPECTION

### 1. WASTE GATE ACTUATOR

1) Remove the intercooler. <Ref. to IN(STI)-12, REMOVAL, Intercooler.>

2) Remove the turbocharger upper cover.

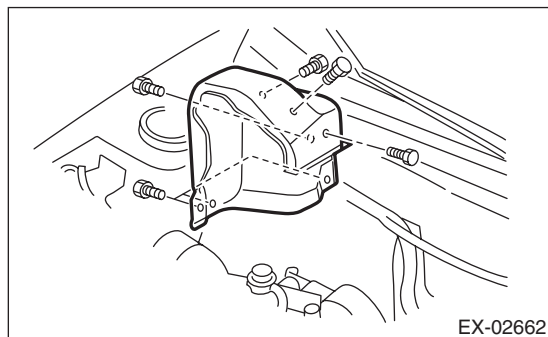

3) Remove the boost hose (B) from the waste gate actuator (A) of the turbocharger, and connect the Mighty Vac to the waste gate actuator (A).

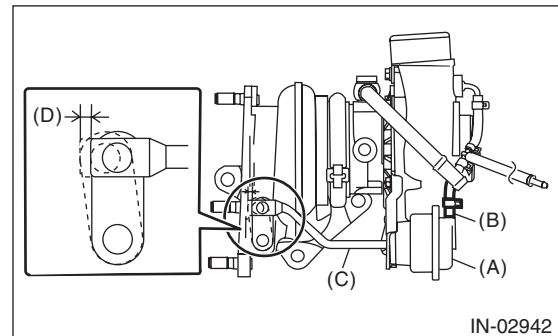

(A) Waste gate actuator

(B) Boost hose

(C) Control rod

(D) Control rod stroke

4) Pressurize slowly with the Mighty Vac, and measure the pressure when the control rod stroke (D) becomes 2 mm (0.08 in). If it is not within the standard, replace the turbocharger assembly.

### CAUTION:

**Do not pressurize over 89.9 kPa (0.92 kgf/cm<sup>2</sup>, 13.0 psi) to prevent damaging the waste gate actuator.**

**Operating pressure (control rod stroke 2 mm (0.08 in)):**

#### Standard

**74.7 — 80.8 kPa (0.76 — 0.82 kgf/cm<sup>2</sup>, 10.8 — 11.7 psi)**

5) After inspection, install the related parts in the reverse order of removal.

### Tightening torque:

**7.5 N·m (0.8 kgf·m, 5.5 ft·lb)**

### 2. OTHER INSPECTIONS

1) Check that the turbocharger, turbocharger stay and pipe have no deformation, cracks or other damages.

2) Check that the hose and intake duct have no cracks, damage or loose part.

3) Check that there are no oil leakage or water leakage from the pipe attachment section.

## 8. Air By-pass Valve

### A: REMOVAL

Remove the air by-pass valve from the intercooler, and then disconnect air by-pass hose (A) and vacuum hose (B) from the air by-pass valve.

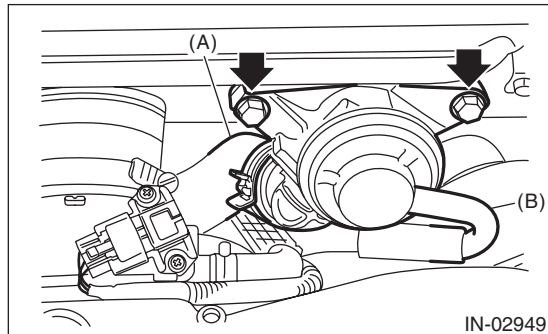

### B: INSTALLATION

Install in the reverse order of removal.

NOTE:

Use a new gasket.

**Tightening torque:**

**16 N·m (1.6 kgf·m, 11.8 ft·lb)**

### C: INSPECTION

#### 1. AIR BY-PASS VALVE

- 1) Check that the air by-pass valve has no deformation, cracks or other damages.
- 2) Connect the Mighty Vac to the nipple (A) of the air by-pass valve.

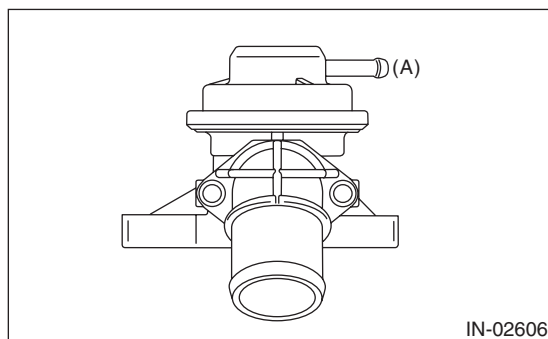

- 3) Using the Mighty Vac, generate the negative pressure to  $-93.3 \text{ kPa}$  ( $-0.95 \text{ kgf/cm}^2$ ,  $-13.5 \text{ psi}$ ). Check that the Mighty Vac gauge needle holds 10 seconds without falling by  $-92.6 \text{ kPa}$  ( $-0.94 \text{ kgf/cm}^2$ ,  $-13.4 \text{ psi}$ ).

- 4) Set a dial gauge to the end of valve rod of the air by-pass valve.

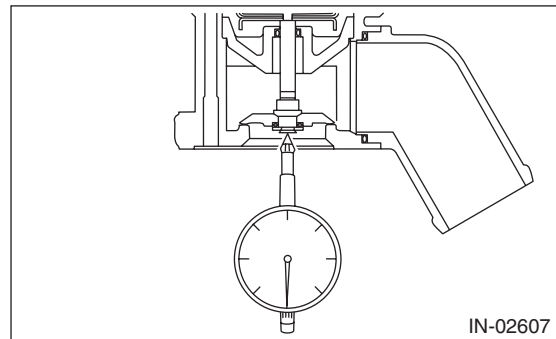

- 5) Slowly generate negative pressure with the Mighty Vac and check the pressure when the needle of the dial gauge (valve stroke) becomes  $0.5 \text{ mm}$  ( $0.02 \text{ in}$ ). If it is not within the standard, replace the air by-pass valve.

**Opening pressure (valve stroke  $0.5 \text{ mm}$  ( $0.02 \text{ in}$ )):**  
**Standard**

$-62.7 \text{ — } -70.7 \text{ kPa}$  ( $-0.64 \text{ — } -0.72 \text{ kgf/cm}^2$ ,  
 $-9.09 \text{ — } -10.3 \text{ psi}$ )

- 6) Increase negative pressure more than 5) and check the pressure when the needle of the dial gauge (valve stroke) becomes  $7.5 \text{ mm}$  ( $0.3 \text{ in}$ ). If it is not within the standard, replace the air by-pass valve.

**Full open pressure (valve stroke  $7.5 \text{ mm}$  ( $0.3 \text{ in}$ )):**  
**Standard**

$-102.7 \text{ — } -117.3 \text{ kPa}$   
 $(-1.05 \text{ — } -1.20 \text{ kgf/cm}^2, -14.9 \text{ — } -17.0 \text{ psi})$

#### 2. OTHER INSPECTIONS

Check that the vacuum hose and air by-pass pipe have no cracks, damage or loose part.

### 9. Resonator Chamber

#### A: REMOVAL

The resonator chamber and air cleaner case are integrated into one unit; therefore, refer to "Air Cleaner Case" for removal procedure. <Ref. to IN(STI)-8, REMOVAL, Air Cleaner Case.>

#### B: INSTALLATION

The resonator chamber and air cleaner case are integrated into one unit; therefore, refer to "Air Cleaner Case" for installation procedure. <Ref. to IN(STI)-8, INSTALLATION, Air Cleaner Case.>

#### C: INSPECTION

Check that the resonator chamber has no deformation, cracks or other damages.

# MECHANICAL

# ME(STI)

---

	<b>Page</b>
1. General Description .....	2
2. Compression .....	20
3. Idle Speed .....	21
4. Ignition Timing .....	22
5. Intake Manifold Vacuum .....	23
6. Engine Oil Pressure .....	24
7. Fuel Pressure .....	25
8. Valve Clearance .....	26
9. Engine Assembly .....	30
10. Engine Mounting .....	38
11. Preparation for Overhaul .....	39
12. V-belt .....	40
13. Crank Pulley .....	47
14. Timing Belt Cover .....	49
15. Timing Belt .....	50
16. Cam Sprocket .....	59
17. Crank Sprocket .....	60
18. Camshaft .....	61
19. Cylinder Head .....	70
20. Cylinder Block .....	79
21. Intake and Exhaust Valve .....	102
22. Piston .....	103
23. Connecting Rod .....	104
24. Crankshaft .....	105
25. Engine Trouble in General .....	106
26. Engine Noise .....	112

# General Description

MECHANICAL

## 1. General Description

### A: SPECIFICATION

Engine	Model		2.5 L		
	Cylinder arrangement		Horizontally opposed, liquid cooled, 4-cylinder, 4-stroke gasoline engine		
	Valve system mechanism		Belt driven, double overhead camshaft, 4-valve/cylinder		
	Bore × Stroke		mm (in)	99.5 × 79.0 (3.92 × 3.11)	
	Displacement		cm <sup>3</sup> (cu in)	2,457 (149.94)	
	Compression ratio		8.2		
	Compression pressure (at 200 — 300 rpm)		kPa (kg/cm <sup>2</sup> , psi) Standard	981 — 1,177 (10 — 12, 142 — 171)	
	Number of piston rings		Pressure ring: 2, Oil ring: 1		
	Intake valve timing		Open	Max. retard	ATDC 5°
				Min. advance	BTDC 25°
			Close	Max. retard	ABDC 65°
				Min. advance	ABDC 35°
	Exhaust valve timing		Open	Max. retard	BBDC 32°
				Min. advance	BBDC 72°
			Close	Max. retard	ATDC 28°
				Min. advance	BTDC 12°
	Valve clearance		Inspection value	Intake	0.20 <sup>+0.04</sup> <sub>-0.06</sub> (0.0079 <sup>+0.0016</sup> <sub>-0.0024</sub> )
Exhaust				0.35±0.05 (0.0138±0.0020)	
Adjustment value			Intake	0.20 <sup>+0.01</sup> <sub>-0.03</sub> (0.0079 <sup>+0.0004</sup> <sub>-0.0012</sub> )	
			Exhaust	0.35±0.02 (0.0138±0.0008)	
Idle speed (Gear shift lever in neutral position)		No load	Standard	700±100	
		A/C ON	Standard	750±100	
Ignition order				1 → 3 → 2 → 4	
Ignition timing		BTDC/rpm	Standard	15°±10°/700	

ME(STI)-2

Brought to you by Ebay Seller "SubaruManuals"

# General Description

MECHANICAL

NOTE:

OS: Oversize    US: Undersize

Belt tension adjuster	Adjuster rod protrusion amount	mm (in)		5.2 — 6.2 (0.205 — 0.244)	
Camshaft	Bending limit	mm (in)		0.020 (0.00079)	
	Cam lobe height	mm (in)	Intake	Standard	46.55 — 46.65 (1.833 — 1.837)
			Exhaust	Standard	46.75 — 46.85 (1.841 — 1.844)
	Cam base circle diameter	mm (in)	Standard	37.0 (1.457)	
	Journal O.D.	mm (in)	Front	Standard	37.946 — 37.963 (1.4939 — 1.4946)
			Center, rear	Standard	29.946 — 29.963 (1.1790 — 1.1796)
	Oil clearance	mm (in)	Standard	0.037 — 0.072 (0.0015 — 0.0028)	
Thrust clearance	mm (in)	Standard	0.068 — 0.116 (0.0027 — 0.0047)		
Cylinder head	Warping limit (Mating surface with cylinder block)	mm (in)		0.035 (0.0014)	
	Grinding limit	mm (in)		0.3 (0.012)	
	Standard height	mm (in)		127.5 (5.02)	
Valve seat	Seating angle between valve and valve seat			90°	
	Contacting width between valve and valve seat	mm (in)	Intake	Standard	0.6 — 1.4 (0.024 — 0.055)
			Exhaust	Standard	1.2 — 1.8 (0.047 — 0.071)
Valve guide	Clearance between the valve guide and valve stem	mm (in)	Intake	Standard	0.030 — 0.057 (0.0012 — 0.0022)
			Exhaust	Standard	0.040 — 0.067 (0.0016 — 0.0026)
	Inside diameter	mm (in)		6.000 — 6.012 (0.2362 — 0.2367)	
	Valve stem outer diameters	mm (in)	Intake		5.955 — 5.970 (0.2344 — 0.2350)
			Exhaust		5.945 — 5.960 (0.2341 — 0.2346)
Valve guide protrusion amount	mm (in)		15.8 — 16.2 (0.622 — 0.638)		
Valve	Head edge thickness	mm (in)	Intake	Standard	1.0 — 1.4 (0.039 — 0.055)
			Exhaust	Standard	1.3 — 1.7 (0.051 — 0.067)
	Overall length	mm (in)	Intake		104.4 (4.110)
			Exhaust		104.65 (4.1201)
Valve spring	Free length	mm (in)		53.48 (2.106)	
	Tension/spring height	N (kgf, lb)/mm (in)	Set		204.6 — 235.4 (20.86 — 24.00, 46.00 — 52.93)/36.0 (1.417)
			Lift		363.5 — 401.7 (37.07 — 40.96, 81.73 — 90.32)/26.7 (1.051)
	Squareness			2.5°, 2.3 mm (0.091 in) or less	
Valve lifter	Outer diameter	mm (in)	Standard	34.959 — 34.975 (1.3763 — 1.3770)	
	Valve lifter mating surface inner diameter	mm (in)	Standard	34.994 — 35.016 (1.3777 — 1.3786)	
	Valve lifter and valve lifter mating surface clearance	mm (in)	Standard	0.019 — 0.057 (0.0007 — 0.0022)	
Cylinder block	Warping limit (Mating surface with cylinder head)	mm (in)		0.025 (0.0098)	
	Grinding limit	mm (in)		0.1 (0.004)	
	Standard height	mm (in)		201.0 (7.91)	
	Cylindricity	mm (in)	Limit	0.015 (0.0006)	
	Out-of-roundness	mm (in)	Limit	0.010 (0.0004)	
	Clearance between cylinder and piston at 20°C (68°F)	mm (in)	Standard	-0.010 — 0.010 (-0.00039 — 0.00039)	
	Cylinder inner diameter boring limit (diameter)	mm (in)		To 100.005 (3.9372)	

**ME(STI)-3**

Brought to you by Ebay Seller "SubaruManuals"



# General Description

## MECHANICAL

Piston	Piston grade point		mm (in)	38.2 (1.50)		
	Outer diameter	mm (in)	Standard	A	99.505 — 99.515 (3.9175 — 3.9179)	
				B	99.495 — 99.505 (3.9171 — 3.9175)	
			0.25 (0.0098) OS		99.745 — 99.765 (3.9270 — 3.9278)	
		0.50 (0.0197) OS		99.995 — 100.015 (3.9368 — 3.9376)		
Piston pin	Degree of fit			Piston pin must be fitted into position with thumb at 20°C (68°F).		
	Clearance between piston pin hole and piston pin		mm (in)	Standard	0.004 — 0.008 (0.0002 — 0.0003)	
Piston ring	Piston ring gap	mm (in)	Top ring	Standard	0.23 — 0.28 (0.0091 — 0.0110)	
			Second ring	Standard	0.37 — 0.52 (0.015 — 0.0203)	
			Oil ring	Standard	0.20 — 0.50 (0.0079 — 0.0197)	
	Clearance between piston ring and piston ring groove	mm (in)	Top ring	Standard	0.040 — 0.080 (0.0016 — 0.0031)	
			Second ring	Standard	0.030 — 0.070 (0.0012 — 0.0028)	
Connecting rod and connecting rod bearing	Bend or twist per 100 mm (3.94 in) in length		mm (in)	Limit	0.1 (0.0039)	
	Thrust clearance		mm (in)	Standard	0.070 — 0.330 (0.0028 — 0.0130)	
	Oil clearance		mm (in)	Standard	0.017 — 0.045 (0.0007 — 0.0018)	
	Bearing size (Thickness at center)	mm (in)	Standard		1.490 — 1.506 (0.0587 — 0.0593)	
			0.03 (0.0012) US		1.504 — 1.512 (0.0592 — 0.0595)	
			0.05 (0.0020) US		1.514 — 1.522 (0.0596 — 0.0599)	
0.25 (0.0098) US			1.614 — 1.622 (0.0635 — 0.0639)			
Bushing of small end	Clearance between piston pin and bushing		mm (in)	Standard	0 — 0.022 (0 — 0.0009)	
	Bending limit			mm (in)	0.035 (0.0014)	
Crankshaft and crankshaft bearing	Crank pin	Cylindricity		mm (in)	Limit	0.004 (0.0002)
		Out-of-roundness		mm (in)	Limit	0.003 (0.0001)
		Grinding limit (dia.)		mm (in)		To 51.750 (2.0374)
	Crank journal	Cylindricity		mm (in)	Limit	0.006 (0.0002)
		Out-of-roundness		mm (in)	Limit	0.005 (0.0002)
		Grinding limit (dia.)		mm (in)		To 59.758 (2.3527)
	Crank pin outer diameter	mm (in)		Standard		51.976 — 52.000 (2.0463 — 2.0472)
				0.03 (0.0012) US		51.954 — 51.970 (2.0454 — 2.0461)
				0.05 (0.0020) US		51.934 — 51.950 (2.0447 — 2.0453)
				0.25 (0.0098) US		51.734 — 51.750 (2.0368 — 2.0374)
	Crank journal outer diameter	mm (in)		Standard		59.984 — 60.008 (2.3616 — 2.3625)
				0.03 (0.0012) US		59.962 — 59.978 (2.3607 — 2.3613)
				0.05 (0.0020) US		59.942 — 59.958 (2.3599 — 2.3605)
				0.25 (0.0098) US		59.742 — 59.758 (2.3520 — 2.3527)
	Bearing size (Thickness at center)	#1, #3	mm (in)	Standard		1.998 — 2.015 (0.0787 — 0.0793)
0.03 (0.0012) US				2.017 — 2.020 (0.0794 — 0.0795)		
0.05 (0.0020) US				2.027 — 2.030 (0.0798 — 0.0799)		
0.25 (0.0098) US				2.127 — 2.130 (0.0837 — 0.0839)		
#2, #4, #5		mm (in)	Standard		2.000 — 2.017 (0.0787 — 0.0794)	
			0.03 (0.0012) US		2.019 — 2.022 (0.0795 — 0.0796)	
			0.05 (0.0020) US		2.029 — 2.032 (0.0799 — 0.0800)	
			0.25 (0.0098) US		2.129 — 2.132 (0.0838 — 0.0839)	
Thrust clearance		mm (in)	Standard	0.030 — 0.115 (0.0012 — 0.0045)		
Oil clearance		mm (in)	Standard	0.010 — 0.030 (0.00039 — 0.0012)		

**ME(STI)-4**

Brought to you by Ebay Seller "SubaruManuals"

## B: COMPONENT

### 1. TIMING BELT

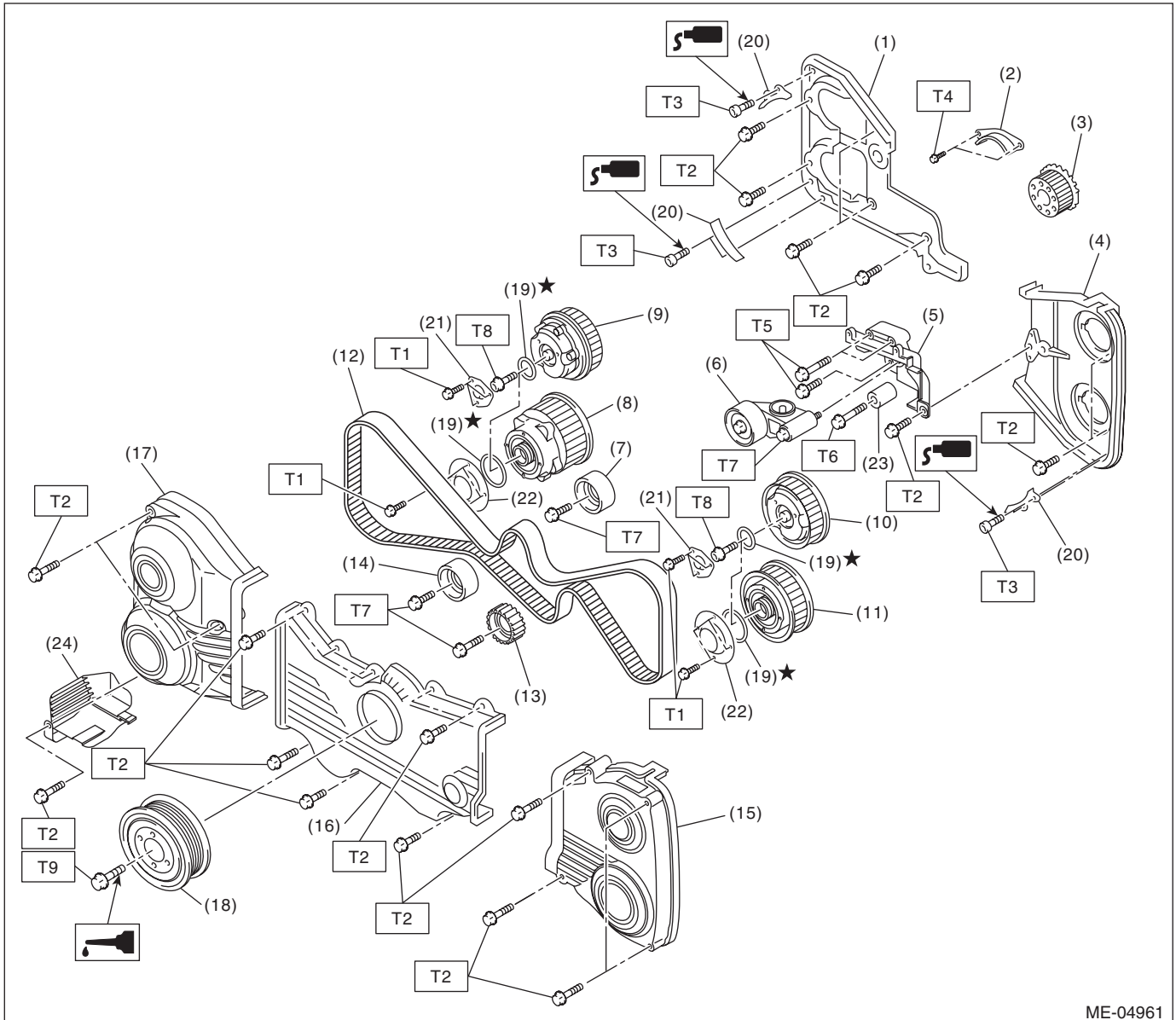

ME-04961

# General Description

## MECHANICAL

---

(1) Timing belt cover No. 2 RH	(13) Belt idler No. 2	<hr/> <b>Tightening torque:N·m (kgf-m, ft-lb)</b> <b>T1: 3.4 (0.3, 2.5)</b> <b>T2: 5 (0.5, 3.7)</b> <b>T3: 6.4 (0.7, 4.7)</b> <b>T4: 9.75 (1.0, 7.2)</b> <b>T5: 24.5 (2.5, 18.1)</b>  <b>T6: 25 (2.5, 18.4)</b> <b>T7: 39 (4.0, 28.8)</b> <b>T8: &lt;Ref. to ME(STI)-59, INSTALLATION, Cam Sprocket.&gt;</b> <b>T9: &lt;Ref. to ME(STI)-47, INSTALLATION, Crank Pulley.&gt;</b> <hr/>
(2) Timing belt guide	(14) Belt idler	
(3) Crank sprocket	(15) Timing belt cover LH	
(4) Timing belt cover No. 2 LH	(16) Front belt cover	
(5) Tensioner bracket	(17) Timing belt cover RH	
(6) Automatic belt tension adjuster ASSY	(18) Crank pulley	
(7) Belt idler	(19) O-ring	
(8) Exhaust cam sprocket RH	(20) Timing belt guide	
(9) Intake cam sprocket RH	(21) Intake actuator cover	
(10) Intake cam sprocket LH	(22) Exhaust actuator cover	
(11) Exhaust cam sprocket LH	(23) Belt idler	
(12) Timing belt	(24) Engine harness cover	

## 2. CYLINDER HEAD AND CAMSHAFT

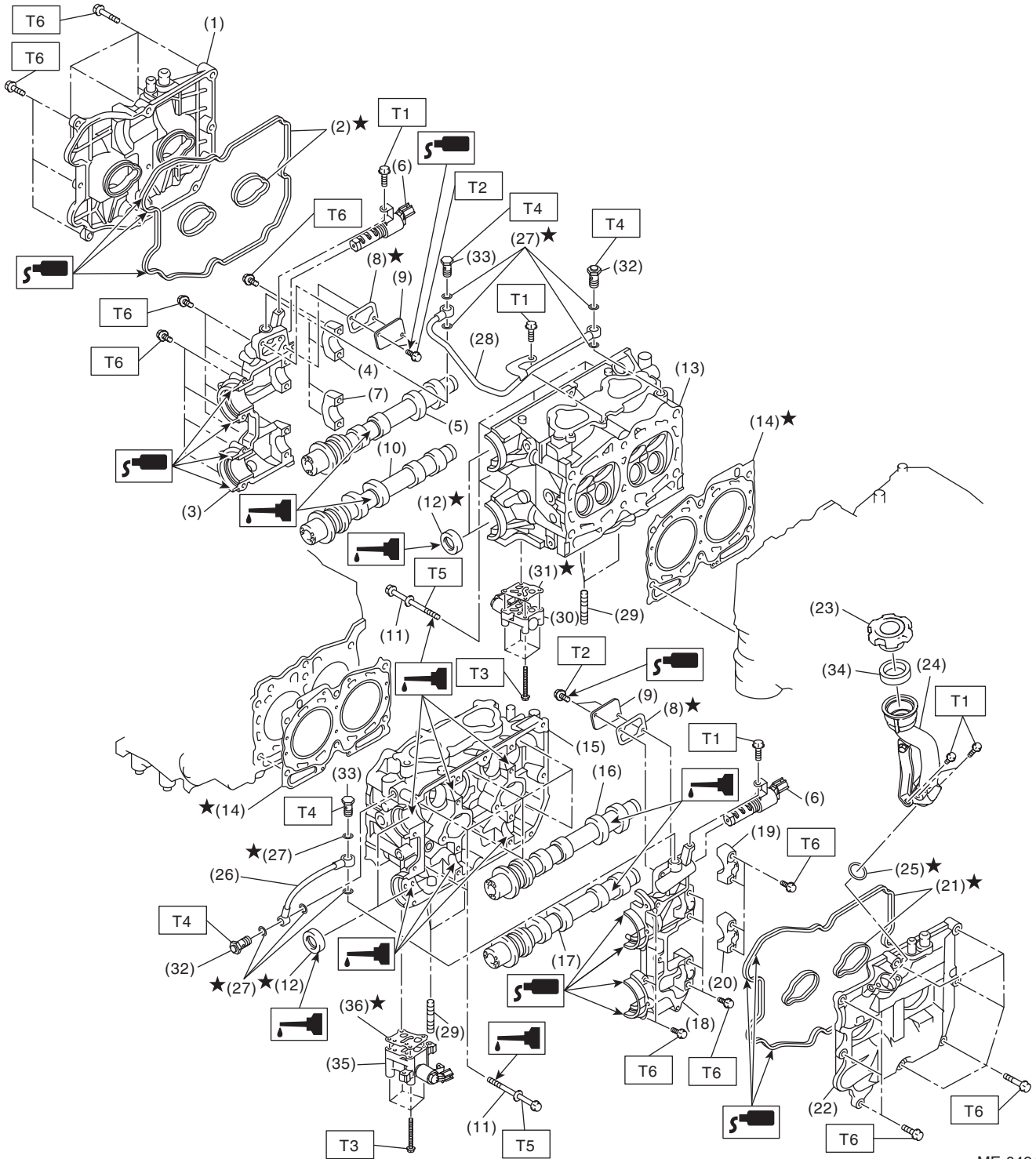

ME-04944

# General Description

## MECHANICAL

---

(1) Rocker cover RH	(16) Intake camshaft LH	(31) Gasket RH
(2) Rocker cover gasket RH	(17) Exhaust camshaft LH	(32) Union bolt with filter (with protrusion)
(3) Front camshaft cap RH	(18) Front camshaft cap LH	(33) Union bolt without filter (without protrusion)
(4) Intake camshaft cap RH	(19) Intake camshaft cap LH	(34) Gasket
(5) Intake camshaft RH	(20) Exhaust camshaft cap LH	(35) Exhaust oil flow control solenoid valve LH
(6) Intake oil flow control solenoid valve	(21) Rocker cover gasket LH	(36) Gasket LH
(7) Exhaust camshaft cap RH	(22) Rocker cover LH	
(8) Gasket	(23) Oil filler cap	<hr/> <b>Tightening torque:N·m (kgf-m, ft-lb)</b>
(9) Oil return cover	(24) Oil filler duct	<b>T1: 6.4 (0.7, 4.7)</b>
(10) Exhaust camshaft RH	(25) O-ring	<b>T2: 9 (0.9, 6.6)</b>
(11) Cylinder head bolt	(26) Oil pipe LH	<b>T3: 10 (1.0, 7.4)</b>
(12) Oil seal	(27) Gasket	<b>T4: 29 (3.0, 21.4)</b>
(13) Cylinder head RH	(28) Oil pipe RH	<b>T5: &lt;Ref. to ME(STI)-70, INSTALLATION, Cylinder Head.&gt;</b>
(14) Cylinder head gasket	(29) Stud bolt	<b>T6: &lt;Ref. to ME(STI)-64, INSTALLATION, Camshaft.&gt;</b>
(15) Cylinder head LH	(30) Exhaust oil flow control solenoid valve RH	<hr/>

## 3. CYLINDER HEAD AND VALVE ASSEMBLY

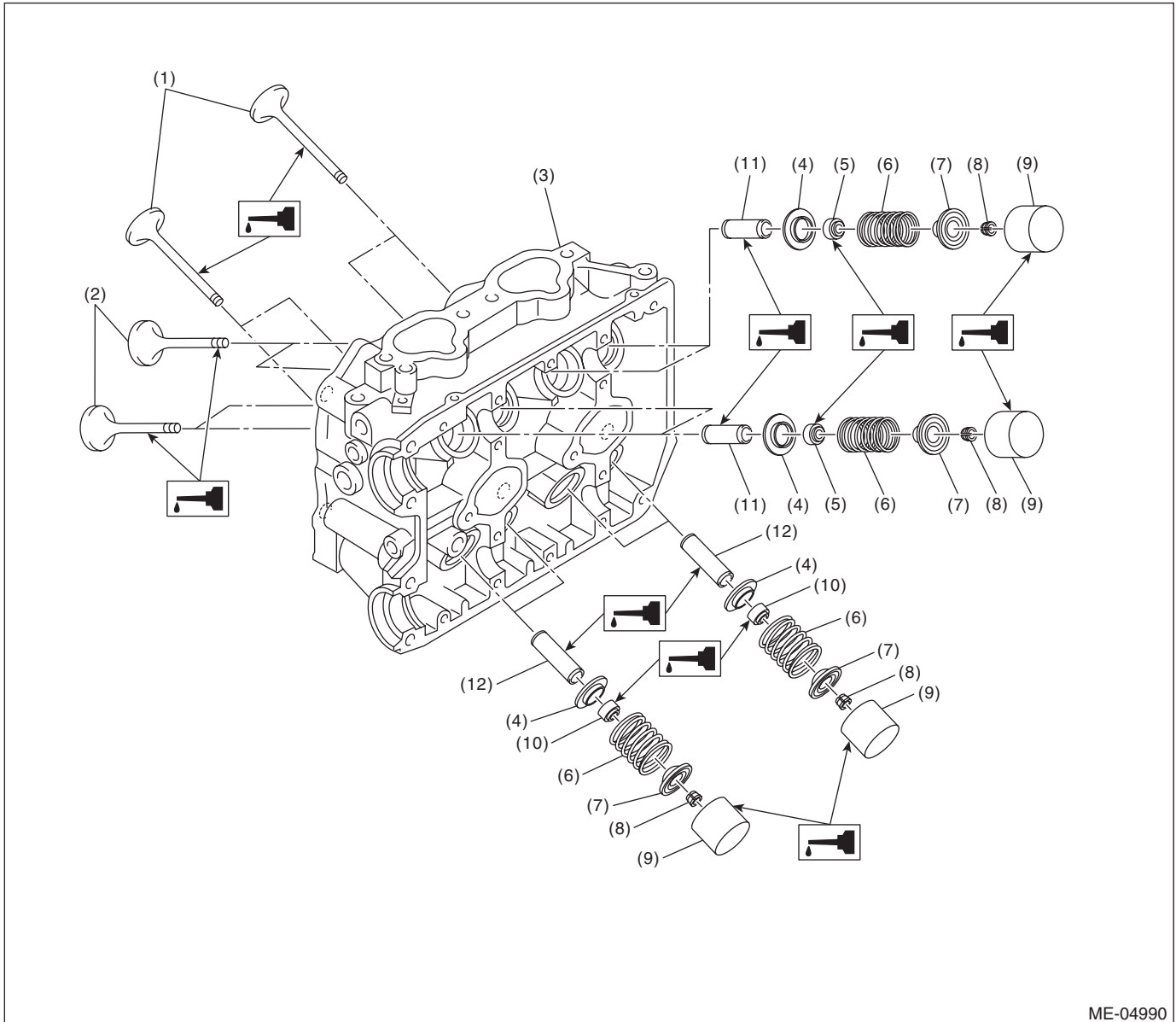

ME-04990

- |                       |                               |                             |
|-----------------------|-------------------------------|-----------------------------|
| (1) Exhaust valve     | (5) Intake valve oil seal     | (9) Valve lifter            |
| (2) Intake valve      | (6) Valve spring              | (10) Exhaust valve oil seal |
| (3) Cylinder head     | (7) Valve spring retainer     | (11) Intake valve guide     |
| (4) Valve spring seat | (8) Valve spring retainer key | (12) Exhaust valve guide    |

# General Description

MECHANICAL

## 4. CYLINDER BLOCK

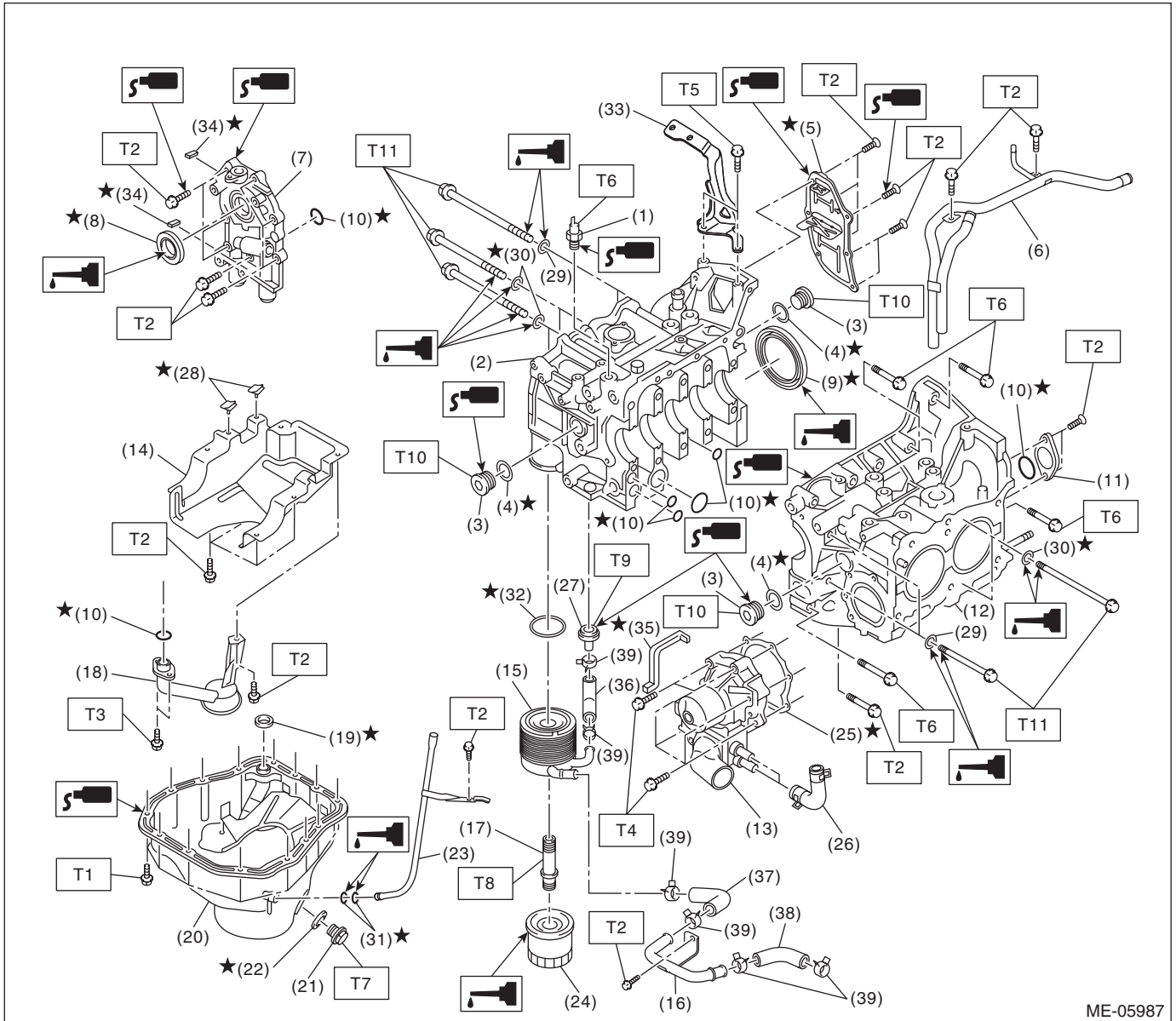

ME-05987

ME(STI)-10

Brought to you by Ebay Seller "SubaruManuals"

# General Description

MECHANICAL

---

(1) Oil pressure switch	(19) Gasket	(37) Oil cooler hose B
(2) Cylinder block RH	(20) Oil pan	(38) Oil cooler hose C
(3) Service hole plug	(21) Drain plug	(39) Clip
(4) Gasket	(22) Drain plug gasket	
(5) Oil separator cover	(23) Oil level gauge guide	
(6) Water by-pass pipe	(24) Oil filter	
(7) Oil pump	(25) Gasket	
(8) Front oil seal	(26) Water pump hose	
(9) Rear oil seal	(27) Nipple	
(10) O-ring	(28) Seal	
(11) Service hole cover	(29) Washer	
(12) Cylinder block LH	(30) Seal washer	
(13) Water pump	(31) O-ring	
(14) Baffle plate	(32) Gasket	
(15) Oil cooler	(33) Intercooler stay (engine rear hanger)	
(16) Oil cooler pipe	(34) Oil pump seal	
(17) Connector	(35) Water pump sealing	
(18) Oil strainer	(36) Oil cooler hose A	

---

**Tightening torque:N·m (kgf-m, ft-lb)**

**T1: 5 (0.5, 3.7)**

**T2: 6.4 (0.7, 4.7)**

**T3: 10 (1.0, 7.4)**

**T4: First 12 (1.2, 8.9)**

**Second 12 (1.2, 8.9)**

**T5: 16 (1.6, 11.8)**

**T6: 25 (2.5, 18.4)**

**T7: 44 (4.5, 32.5)**

**T8: 54 (5.5, 39.8)**

**T9: 69 (7.0, 50.9)**

**T10: 70 (7.1, 51.6)**

**T11: <Ref. to ME(STI)-83, INSTALLATION, Cylinder Block.>**

---



# General Description

MECHANICAL

## 5. CRANKSHAFT AND PISTON

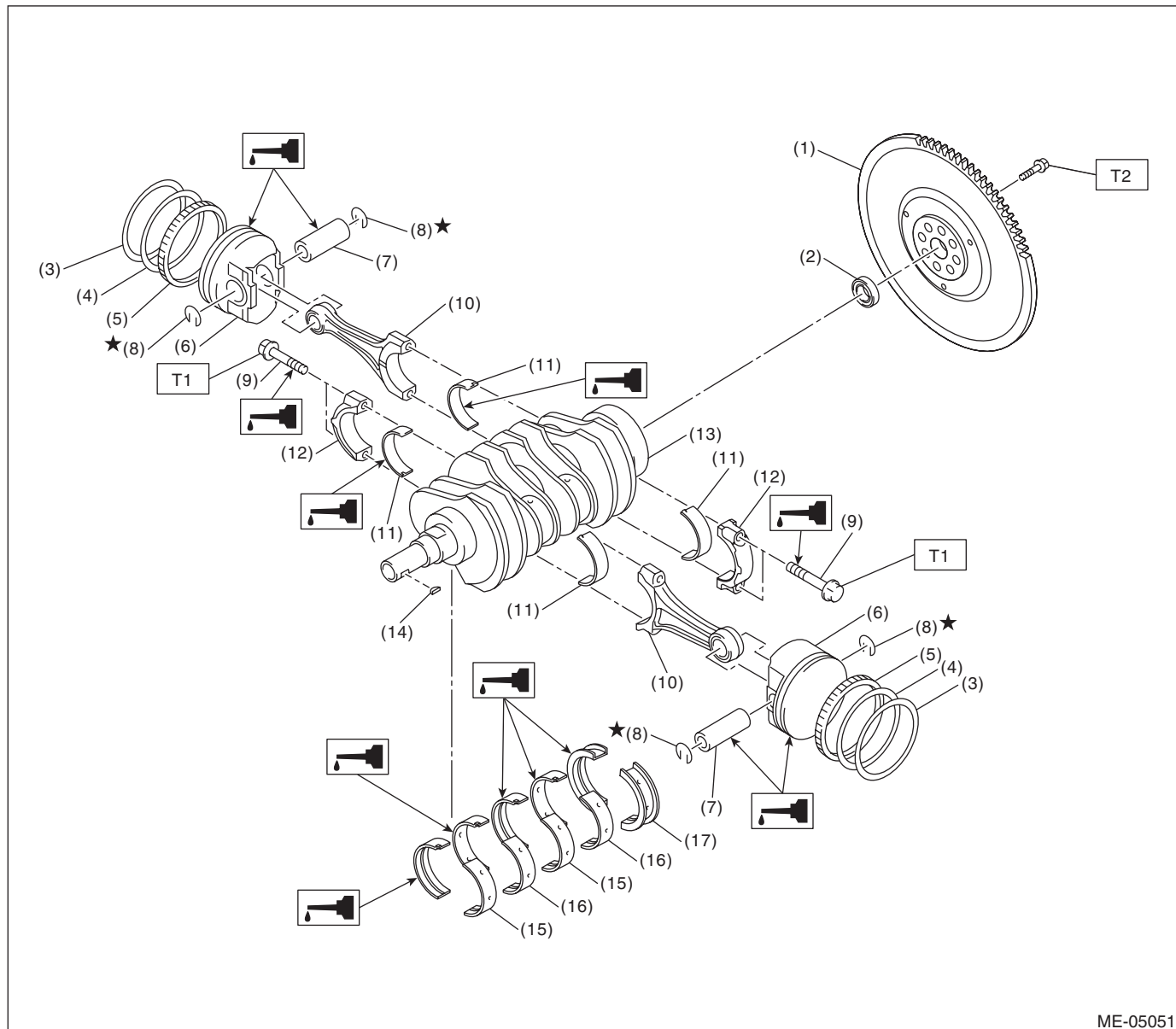

ME-05051

- |                  |                             |                                |
|------------------|-----------------------------|--------------------------------|
| (1) Flywheel     | (8) Snap ring               | (15) Crankshaft bearing #1, #3 |
| (2) Ball bearing | (9) Connecting rod bolt     | (16) Crankshaft bearing #2, #4 |
| (3) Top ring     | (10) Connecting rod         | (17) Crankshaft bearing #5     |
| (4) Second ring  | (11) Connecting rod bearing |                                |
| (5) Oil ring     | (12) Connecting rod cap     |                                |
| (6) Piston       | (13) Crankshaft             |                                |
| (7) Piston pin   | (14) Woodruff key           |                                |

**Tightening torque: N·m (kgf·m, ft·lb)**

**T1: 52 (5.3, 38.4)**

**T2: <Ref. to CL-14, INSTALLATION, Flywheel.>**

**ME(STI)-12**

Brought to you by Ebay Seller "SubaruManuals"

## 6. ENGINE MOUNTING

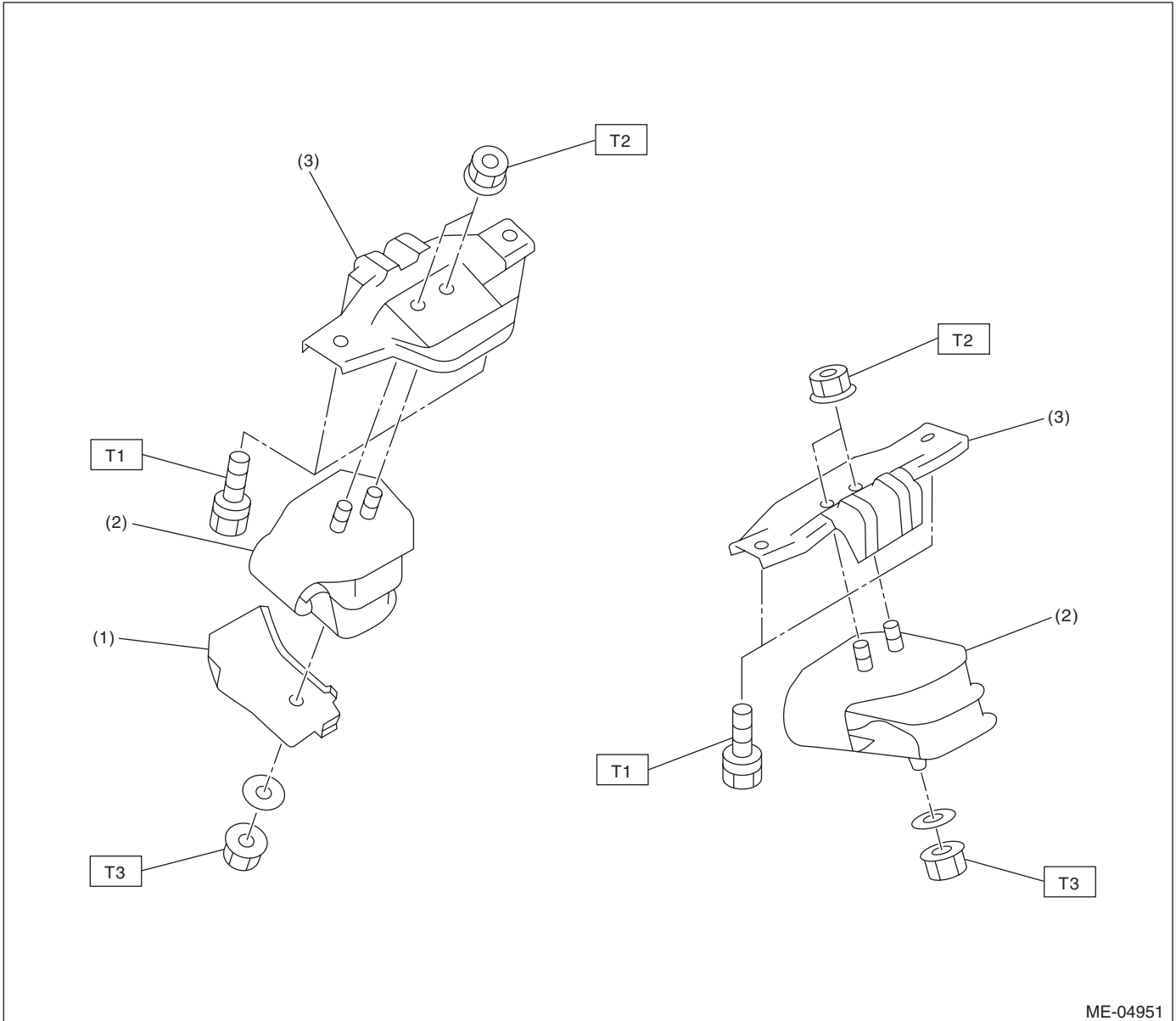

ME-04951

- (1) Heat shield cover
- (2) Front cushion rubber

- (3) Front engine mounting bracket

**Tightening torque: N·m (kgf·m, ft·lb)**

**T1: 35 (3.6, 25.8)**

**T2: 42 (4.3, 31.0)**

**T3: 85 (8.7, 62.7)**

# General Description

## MECHANICAL

### C: CAUTION

- Wear appropriate work clothing, including a cap, protective goggles and protective shoes when performing any work.
- Remove contamination including dirt and corrosion before removal, installation or disassembly.
- Keep the disassembled parts in order and protect them from dust and dirt.
- Before removal, installation or disassembly, be sure to clarify the failure. Avoid unnecessary removal, installation, disassembly and replacement.
- Vehicle components are extremely hot after driving. Be wary of receiving burns from heated parts.
- Be sure to tighten fasteners including bolts and nuts to the specified torque.
- Place shop jacks or rigid racks at the specified points.
- Before disconnecting connectors of sensors or units, be sure to disconnect the ground cable from the battery.
- All parts should be thoroughly cleaned, paying special attention to engine oil passages, pistons and bearings.
- Rotating parts and sliding parts such as piston, bearing and gear should be coated with oil prior to assembly.
- Be careful not to let oil, grease or engine coolant contact the timing belt, clutch disc and flywheel.
- All removed parts, if to be reused, should be reinstalled in the original positions and directions.
- Bolts, nuts and washers should be replaced with new parts as required.
- Even if necessary inspections have been made in advance, proceed with assembly work while making rechecks.
- Remove or install the engine in an area where chain hoists, lifting devices, etc. are available for ready use.
- Be sure not to damage coated surfaces of body panels with tools, or not to stain seats and windows with coolant or oil. Place a cover over fender, as required, for protection.
- Prior to starting work, prepare the following:

Service tools, clean cloth, containers to catch coolant and oil, wire ropes, chain hoist, transmission jacks, etc.

- Lift up or lower the vehicle when necessary. Make sure to support the correct positions.

### D: PREPARATION TOOL

#### 1. SPECIAL TOOL

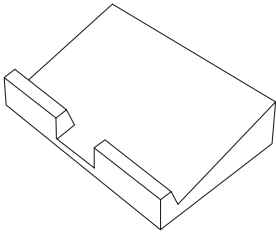
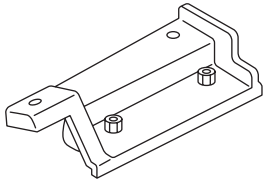
ILLUSTRATION	TOOL NUMBER	DESCRIPTION	REMARKS
 ST-498267600	498267600	CYLINDER HEAD TABLE	<ul style="list-style-type: none"><li>• Used for replacing valve guides.</li><li>• Used for removing and installing valve spring.</li></ul>
 ST-498457000	498457000	ENGINE STAND ADAPTER RH	Used together with ENGINE STAND (499817100).

# General Description

MECHANICAL

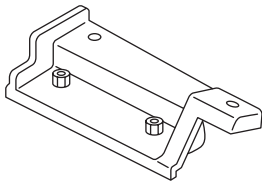
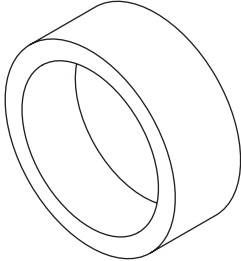
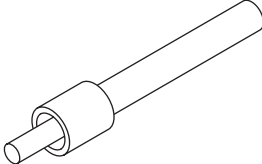
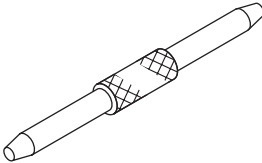
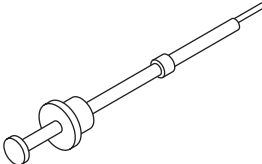
ILLUSTRATION	TOOL NUMBER	DESCRIPTION	REMARKS
 <p data-bbox="337 520 472 541">ST-498457100</p>	498457100	ENGINE STAND ADAPTER LH	Used together with ENGINE STAND (499817100).
 <p data-bbox="337 871 472 892">ST-498747300</p>	498747300	PISTON GUIDE	Used for installing the piston into the cylinder.
 <p data-bbox="337 1222 472 1243">ST-498857100</p>	498857100	VALVE OIL SEAL GUIDE	Used for press-fitting of intake valve guide oil seals and exhaust valve guide oil seals.
 <p data-bbox="337 1572 472 1593">ST-499017100</p>	499017100	PISTON PIN GUIDE	Used for installing piston pin, piston and connecting rod.
 <p data-bbox="337 1923 472 1944">ST-499097700</p>	499097700	PISTON PIN REMOVER ASSY	Used for removing piston pin.

**ME(STI)-15**

Brought to you by Ebay Seller "SubaruManuals"

# General Description

## MECHANICAL

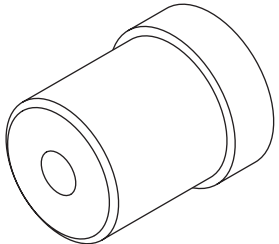
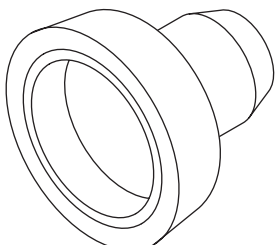
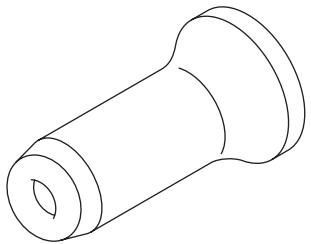
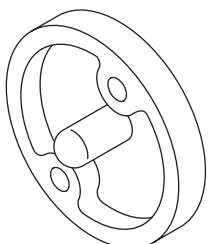
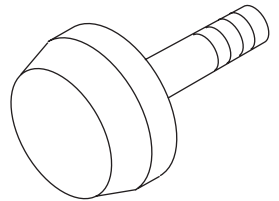
ILLUSTRATION	TOOL NUMBER	DESCRIPTION	REMARKS
 <p style="text-align: center;">ST-499587100</p>	499587100	OIL SEAL INSTALLER	Used for installing oil pump oil seal.
 <p style="text-align: center;">ST-499587200</p>	499587200	CRANKSHAFT OIL SEAL INSTALLER	<ul style="list-style-type: none"> <li>• Used for installing crankshaft oil seal.</li> <li>• Used together with CRANKSHAFT OIL SEAL GUIDE (499597100).</li> </ul>
 <p style="text-align: center;">ST-499587600</p>	499587600	OIL SEAL INSTALLER	Used for installing the camshaft oil seal.
 <p style="text-align: center;">ST-499597100</p>	499597100	CRANKSHAFT OIL SEAL GUIDE	<ul style="list-style-type: none"> <li>• Used for installing crankshaft oil seal.</li> <li>• Used together with CRANKSHAFT OIL SEAL INSTALLER (499587200).</li> </ul>
 <p style="text-align: center;">ST-499597200</p>	499597200	OIL SEAL GUIDE	<ul style="list-style-type: none"> <li>• Used for installing the camshaft oil seal.</li> <li>• Used together with OIL SEAL INSTALLER (499587600).</li> </ul>

**ME(STI)-16**

Brought to you by Ebay Seller "SubaruManuals"

# General Description

MECHANICAL

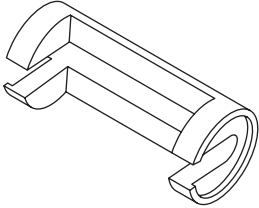
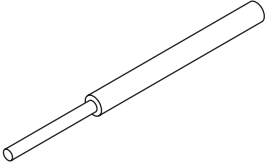
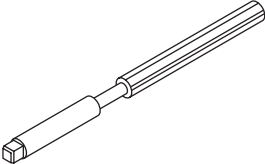
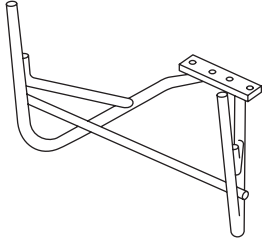
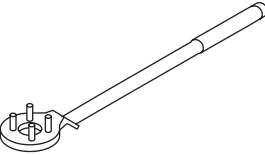
ILLUSTRATION	TOOL NUMBER	DESCRIPTION	REMARKS
 <p style="text-align: center;">ST-499718000</p>	499718000	VALVE SPRING REMOVER	Used for removing and installing valve spring.
 <p style="text-align: center;">ST-499767200</p>	499767200	VALVE GUIDE REMOVER	Used for removing valve guides.
 <p style="text-align: center;">ST-499767400</p>	499767400	VALVE GUIDE REAMER	Used for reaming valve guides.
 <p style="text-align: center;">ST-499817100</p>	499817100	ENGINE STAND	<ul style="list-style-type: none"> <li>• Used for disassembling and assembling engine.</li> <li>• Used together with ENGINE STAND ADAPTER RH (498457000) &amp; LH (498457100).</li> </ul>
 <p style="text-align: center;">ST-499977100</p>	499977100	CRANK PULLEY WRENCH	Used for removing and installing the crank pulley.

**ME(STI)-17**

Brought to you by Ebay Seller "SubaruManuals"

# General Description

## MECHANICAL

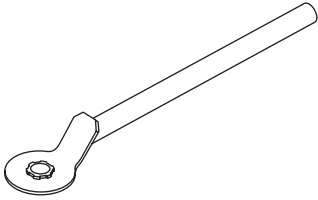
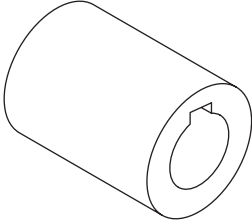
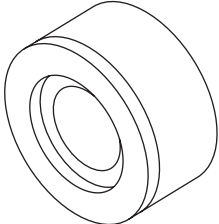
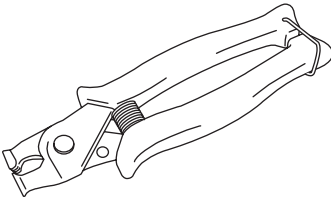
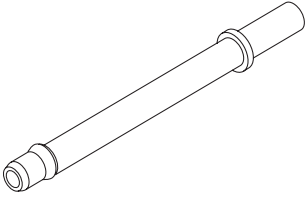
ILLUSTRATION	TOOL NUMBER	DESCRIPTION	REMARKS
 <p style="text-align: center;">ST-499977500</p>	499977500	CAM SPROCKET WRENCH	Used for removing and installing intake cam sprocket and exhaust cam sprocket.
 <p style="text-align: center;">ST-499987500</p>	499987500	CRANKSHAFT SOCKET	Used for rotating crankshaft.
 <p style="text-align: center;">ST18251AA020</p>	18251AA020	VALVE GUIDE ADJUSTER	Used for installing intake valve guides and exhaust valve guides.
 <p style="text-align: center;">ST18353AA000</p>	18353AA000	CLAMP PLIERS	<ul style="list-style-type: none"> <li>• Used for removing and installing the PCV hose.</li> <li>• This tool is made by the French company CAILLAU. (code) 54.0.000.205</li> </ul> To make it easier to obtain, it has been provided with a tool number.
 <p style="text-align: center;">ST18471AA000</p>	18471AA000	FUEL PIPE ADAPTER	Used for inspecting the fuel pressure.

**ME(STI)-18**

Brought to you by Ebay Seller "SubaruManuals"

# General Description

MECHANICAL

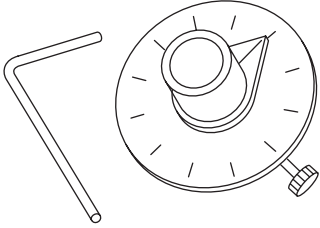
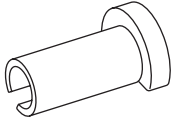
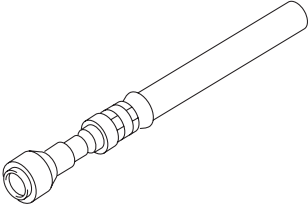
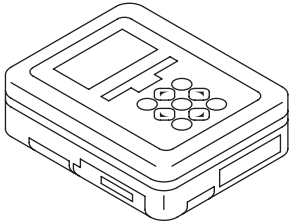
ILLUSTRATION	TOOL NUMBER	DESCRIPTION	REMARKS
 <p>ST18854AA000</p>	18854AA000	ANGLE GAUGE	Used for installing the crank pulley.
 <p>ST42099AE000</p>	42099AE000	QUICK CONNECTOR RELEASE	Used for removing the quick connector.
 <p>ST42075AG690</p>	42075AG690	FUEL HOSE	Used for inspecting the fuel pressure. NOTE: This is the SUBARU genuine part.
 <p>ST1B022XU0</p>	1B022XU0	SUBARU SELECT MONITOR III KIT	Used for various inspections.

## 2. GENERAL TOOL

TOOL NAME	REMARKS
Compression gauge	Used for measuring compression.
Timing light	Used for measuring ignition timing.
Vacuum gauge	Used for measuring intake manifold vacuum.
Oil pressure gauge	Used for measuring engine oil pressure.
Fuel pressure gauge	Used for measuring fuel pressure.

**ME(STI)-19**

Brought to you by Ebay Seller "SubaruManuals"



# Compression

MECHANICAL

## 2. Compression

### A: INSPECTION

#### CAUTION:

**After warming-up, engine becomes very hot. Be careful not to burn yourself during measurement.**

- 1) After warming-up the engine, turn the ignition switch to OFF.
- 2) Make sure that the battery is fully charged.
- 3) Remove the fuse of fuel pump from main fuse box.

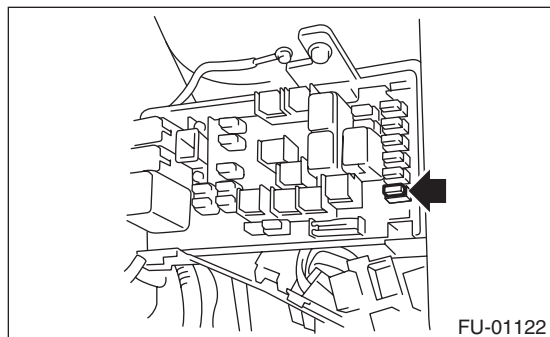

- 4) Start the engine and run it until it stalls.
- 5) After the engine stalls, crank it for five more seconds.
- 6) Turn the ignition switch to OFF.
- 7) Remove all spark plugs. <Ref. to IG(STI)-4, REMOVAL, Spark Plug.>
- 8) Fully open the throttle valve.
- 9) Check the starter motor for satisfactory performance and operation.
- 10) Install the compression gauge to the spark plug hole.

#### NOTE:

When using a screw-in type compression gauge, the screw should be less than 18 mm (0.71 in) long.

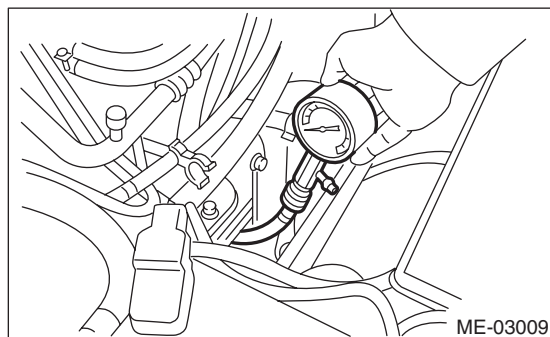

- 11) Crank the engine by starter motor and read the value when the needle of the compression gauge becomes stable.

#### NOTE:

- Perform at least two measurements per cylinder, and make sure that the values are correct.
- If the compression pressure is out of standard, check or adjust the pistons, valves and cylinders.

#### **Compression (fully open throttle):**

##### **Standard**

**981 — 1,177 kPa (10 — 12 kgf/cm<sup>2</sup>, 142 — 171 psi)**

##### **Difference between cylinders**

**49 kPa (0.5 kgf/cm<sup>2</sup>, 7 psi) or less**

- 12) After inspection, install the related parts in the reverse order of removal.

### 3. Idle Speed

#### A: INSPECTION

1) Before checking the idle speed, check the following item:

(1) Check the air cleaner element is free from clogging, ignition timing is correct, spark plugs are in good condition, and hoses are connected properly.

(2) Check the malfunction indicator light does not illuminate.

2) Warm up the engine.

3) Read the engine idle speed using Subaru Select Monitor. <Ref. to EN(H4DOTC)(diag)-41, READ CURRENT DATA FOR ENGINE (NORMAL MODE), OPERATION, Subaru Select Monitor.>

#### NOTE:

- Idle speed cannot be adjusted manually, because the idle speed is automatically adjusted.

- If idle speed is out of standard, refer to the General Diagnosis Table under "Engine Control System". <Ref. to EN(H4DOTC)(diag)-2, Basic Diagnostic Procedure.>

(1) Check the idle speed when no-loaded.

(Headlight, heater fan, rear defroster, radiator fan, A/C and etc. are OFF)

***Idle speed (No load and gear shift lever in neutral position):***

#### ***Standard***

***700±100 rpm***

(2) Check the idle speed when loaded. (Turn the A/C switch to "ON" and operate the compressor for at least one minute before measurement.)

***Idle speed (A/C ON and gear shift lever in neutral position):***

#### ***Standard***

***750±100 rpm***

# Ignition Timing

MECHANICAL

## 4. Ignition Timing

### A: INSPECTION

#### CAUTION:

After warming-up, engine becomes very hot. Be careful not to burn yourself at measurement.

#### 1. METHOD WITH SUBARU SELECT MONITOR

1) Before checking the ignition timing, check the following item:

(1) Check the air cleaner element is free from clogging, spark plugs are in good condition, and hoses are connected properly.

(2) Check the malfunction indicator light does not illuminate.

2) Warm up the engine.

3) Read the ignition timing using Subaru Select Monitor. <Ref. to EN(H4DOTC)(diag)-41, READ CURRENT DATA FOR ENGINE (NORMAL MODE), OPERATION, Subaru Select Monitor.>

#### NOTE:

If ignition timing is out of standard, check the ignition control system. Refer to "Engine Control System". <Ref. to EN(H4DOTC)(diag)-2, Basic Diagnostic Procedure.>

#### Ignition timing [BTDC/rpm]:

##### Standard

$15^{\circ} \pm 10^{\circ} / 700$

#### 2. METHOD WITH TIMING LIGHT

1) Before checking the ignition timing, check the following item:

(1) Check the air cleaner element is free from clogging, spark plugs are in good condition, and hoses are connected properly.

(2) Check the malfunction indicator light does not illuminate.

2) Warm up the engine.

3) Stop the engine, and turn the ignition switch to OFF.

4) Disconnect the ground cable from battery.

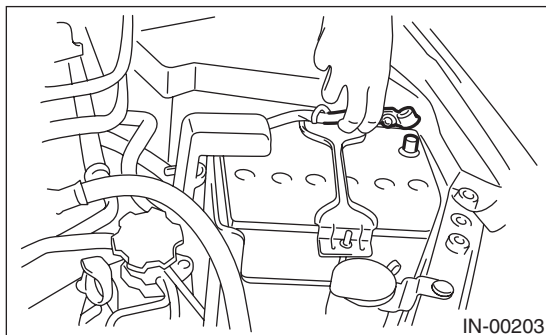

5) Remove the air intake duct. <Ref. to IN(STI)-10, REMOVAL, Air Intake Duct.>

6) Remove the air cleaner case. <Ref. to IN(STI)-8, REMOVAL, Air Cleaner Case.>

7) Connect the timing light to the power wire of #1 ignition coil.

8) Install the air cleaner case. <Ref. to IN(STI)-8, INSTALLATION, Air Cleaner Case.>

9) Connect the battery ground terminal.

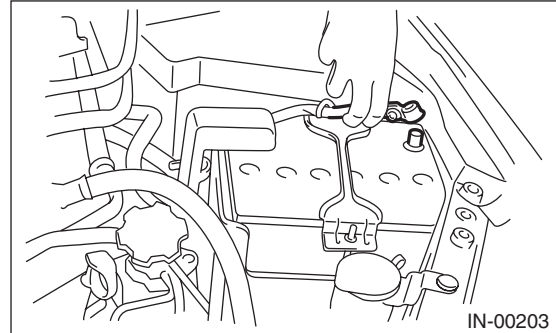

10) Start the engine, turn the timing light to the crank pulley, and check the ignition timing through the timing belt cover gauge.

#### NOTE:

If ignition timing is out of standard, check the ignition control system. Refer to "Engine Control System". <Ref. to EN(H4DOTC)(diag)-2, Basic Diagnostic Procedure.>

#### Ignition timing [BTDC/rpm]:

##### Standard

$15^{\circ} \pm 10^{\circ} / 700$

11) After inspection, install the related parts in the reverse order of removal.

## 5. Intake Manifold Vacuum

### A: INSPECTION

- 1) Warm up the engine.
- 2) Disconnect the brake booster vacuum hose from the intake manifold, and attach the vacuum gauge.

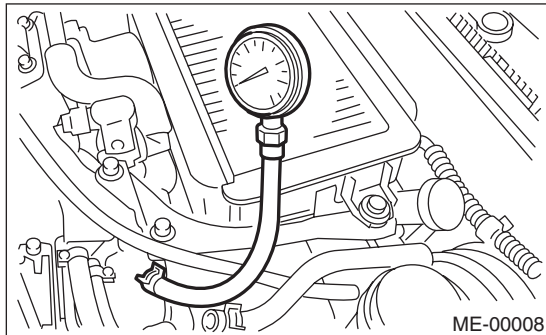

- 3) Keep the engine at idle speed and read the vacuum gauge indication.

**NOTE:**

Condition of engine inside can be diagnosed by observing the behavior of the vacuum gauge needle as described in table below.

***Intake manifold vacuum (at idling, A/C OFF):***

***Standard***

***–65.3 kPa (–490 mmHg, –19.29 inHg) or more***

- 4) After inspection, install the related parts in the reverse order of removal.

<b>Diagnosis of engine condition by inspection of intake manifold vacuum</b>	
Vacuum gauge needle behavior	Possible engine condition
1. Needle is steady but lower than standard value. This tendency becomes more evident as engine temperature rises.	Leakage around intake manifold gasket, disconnection or damage of vacuum hose
2. Needle intermittently drops to position lower than standard value.	Leakage around cylinder
3. Needle drops suddenly and intermittently from standard value.	Sticky valve
4. When engine speed is gradually increased, needle begins to vibrate rapidly at certain speed, and then vibration increases as engine speed increases.	Weak or broken valve springs
5. Needle vibrates above and below standard value in narrow range.	Defective ignition system

# Engine Oil Pressure

MECHANICAL

## 6. Engine Oil Pressure

### A: INSPECTION

1) Disconnect the ground cable from battery.

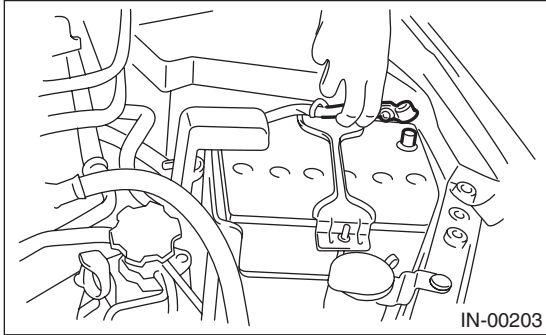

2) Remove the oil pressure switch. <Ref. to LU(STI)-22, REMOVAL, Oil Pressure Switch.>

3) Install the oil pressure gauge to cylinder block.

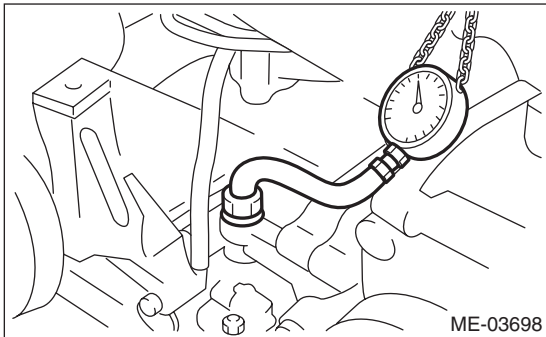

4) Connect the battery ground terminal.

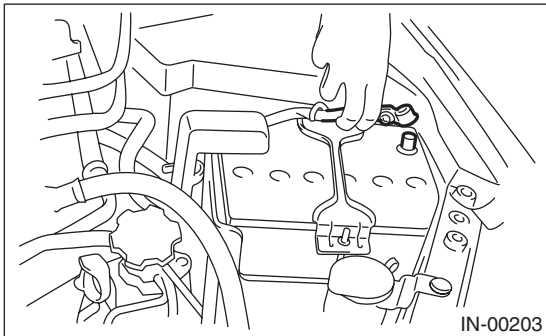

5) Start the engine, and check the oil pressure.

#### NOTE:

- Standard value is based on an engine oil temperature of 80°C (176°F).
- If the oil pressure is out of specification, check oil pump, oil filter and lubrication line. <Ref. to LU(STI)-33, INSPECTION, Engine Lubrication System Trouble in General.>
- If the oil pressure warning light is ON and oil pressure is within specification, check the oil pressure switch. <Ref. to LU(STI)-33, INSPECTION, Engine Lubrication System Trouble in General.>

**Engine oil pressure:**

#### Standard

**98 kPa (1.0 kgf/cm<sup>2</sup>, 14 psi) or more (at 600 rpm)**

**392 kPa (4.0 kgf/cm<sup>2</sup>, 57 psi) or more (at 6,000 rpm)**

6) After inspection, install the related parts in the reverse order of removal.

## 7. Fuel Pressure

### A: INSPECTION

#### CAUTION:

- Before removing the fuel pressure gauge, release the fuel pressure.
- Be careful not to spill fuel.
- Catch the fuel from hoses using a container or cloth.

1) Release the fuel pressure. <Ref. to FU(STI)-67, RELEASING OF FUEL PRESSURE, PROCEDURE, Fuel.>

2) Open the fuel filler lid and remove the fuel filler cap.

3) Disconnect the fuel delivery hose from the fuel delivery pipe, and connect the fuel pressure gauge.

#### CAUTION:

- Be careful not to spill fuel.
- Catch the fuel from hoses using a container or cloth.

(1) Attach ST to the fuel delivery pipe and push ST in the direction of arrow mark to disconnect the quick connector of the fuel delivery hose.

ST 42099AE000 QUICK CONNECTOR RELEASE

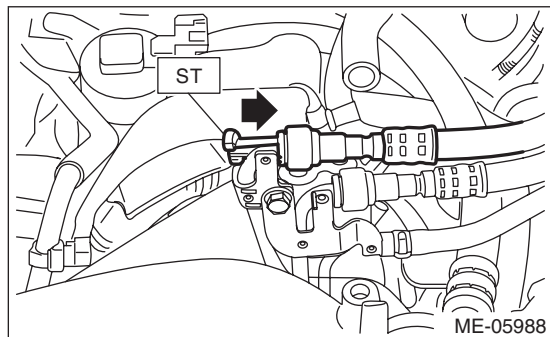

(2) Connect the fuel pressure gauge with ST1 and ST2.

#### NOTE:

ST1 is a SUBARU genuine part.

ST1 42075AG690 FUEL HOSE

ST2 18471AA000 FUEL PIPE ADAPTER

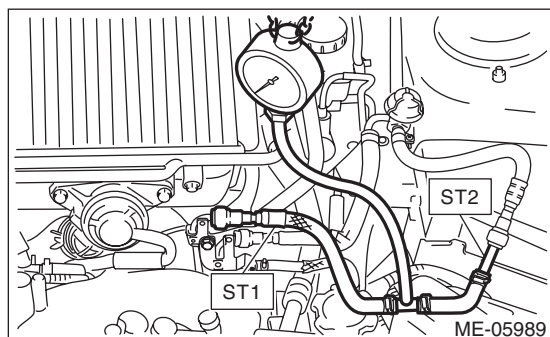

4) Start the engine.

5) Check the fuel pressure while disconnecting pressure regulator vacuum hose from intake manifold.

#### NOTE:

• The fuel pressure gauge registers 10 to 20 kPa (0.1 to 0.2 kgf/cm<sup>2</sup>, 1 to 3 psi) higher than standard values during high-altitude operations.

• If the fuel pressure is out of specification, check or replace the fuel pump, fuel line, pressure regulator & damper assembly, and pressure regulator vacuum hose.

#### Fuel pressure:

##### Standard

**284 — 314 kPa (2.9 — 3.2 kgf/cm<sup>2</sup>, 41 — 46 psi)**

6) After connecting the vacuum hose to the pressure regulator, check the fuel pressure again.

#### NOTE:

• The fuel pressure gauge registers 10 to 20 kPa (0.1 to 0.2 kgf/cm<sup>2</sup>, 1 to 3 psi) higher than standard values during high-altitude operations.

• If the fuel pressure is out of specification, check or replace the fuel pump, fuel line, pressure regulator & damper assembly, and pressure regulator vacuum hose.

#### Fuel pressure:

##### Standard

**230 — 260 kPa (2.4 — 2.7 kgf/cm<sup>2</sup>, 33 — 38 psi)**

7) After inspection, install the related parts in the reverse order of removal.

# Valve Clearance

MECHANICAL

## 8. Valve Clearance

### A: INSPECTION

- 1) Disconnect the ground cable from battery.

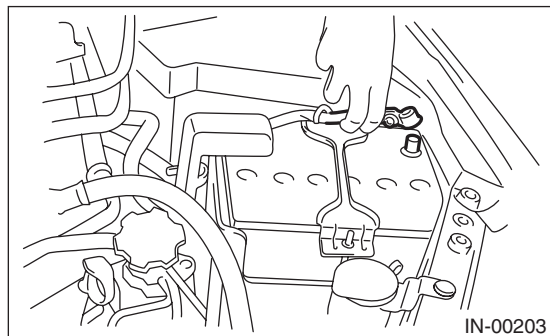

- 2) Remove the engine from vehicle. <Ref. to ME(STI)-30, REMOVAL, Engine Assembly.>

- 3) Remove the timing belt cover RH. <Ref. to ME(STI)-49, REMOVAL, Timing Belt Cover.>

- 4) When inspecting #1 and #3 cylinders

- (1) Disconnect the connector (A) from the exhaust camshaft position sensor RH and the connector (B) from the exhaust oil flow control solenoid valve RH.

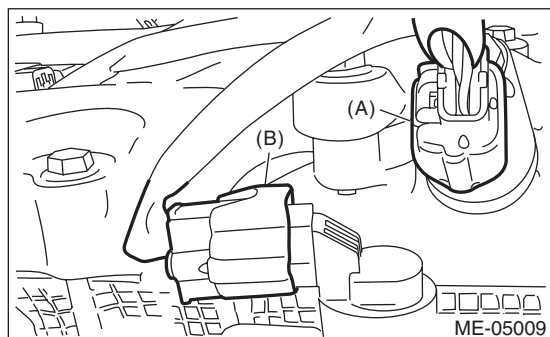

- (2) Remove the clip (A) which hold the engine harness to the rocker cover RH.

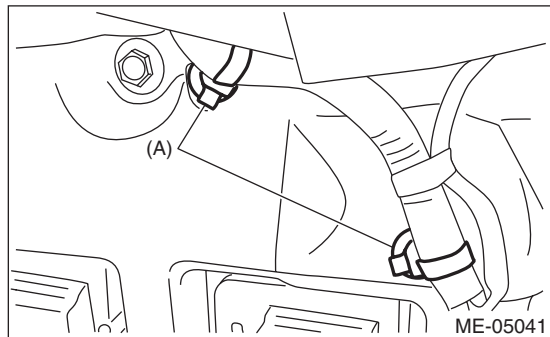

- (3) Remove the ignition coil. <Ref. to IG(STI)-7, REMOVAL, Ignition Coil.>

- (4) Disconnect PCV hose (A) and vacuum hose (B) from the rocker cover RH.

### NOTE:

Pinch the clamp of the PCV hose (A) by fitting the cut out in the ST with the protrusion on the clamp as shown in the figure, and unlock the clamp.

ST 18353AA000 CLAMP PLIERS

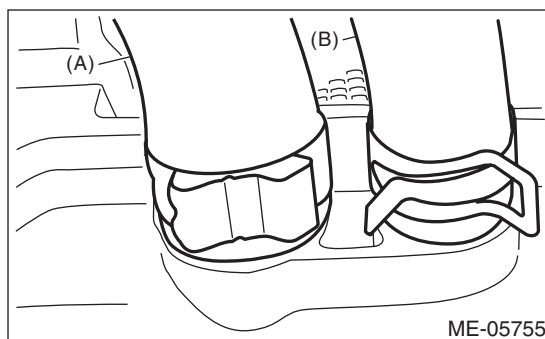
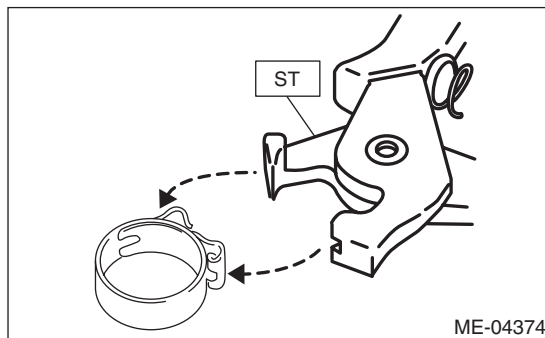

- (5) Remove the rocker cover RH.

- 5) When inspecting #2 and #4 cylinders

- (1) Remove the secondary air pump. <Ref. to EC(STI)-27, REMOVAL, Secondary Air Pump.>

- (2) Disconnect the connector (A) from the exhaust camshaft position sensor LH and the connector (B) from the exhaust oil flow control solenoid valve LH.

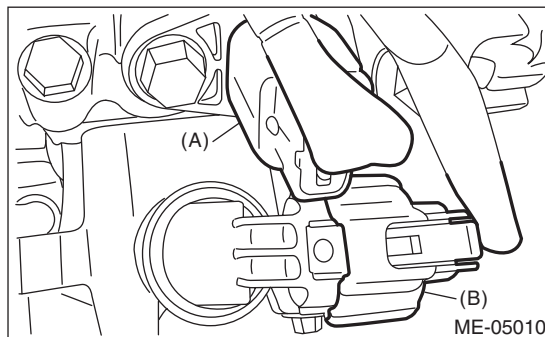



(3) Remove the air duct B (B) from the rocker cover LH and the air duct A (A).

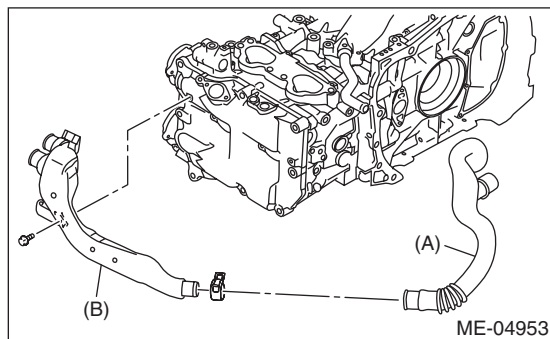

(4) Remove the ignition coil. <Ref. to IG(STI)-7, REMOVAL, Ignition Coil.>

(5) Disconnect PCV hose (A) and vacuum hose (B) from the rocker cover LH.

**NOTE:**

Pinch the clamp of the PCV hose (A) by fitting the cut out in the ST with the protrusion on the clamp as shown in the figure, and unlock the clamp.

ST 18353AA000 CLAMP PLIERS

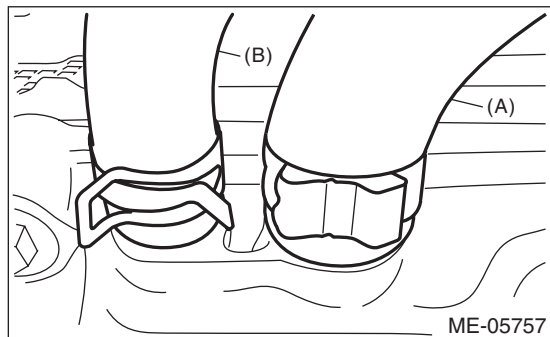
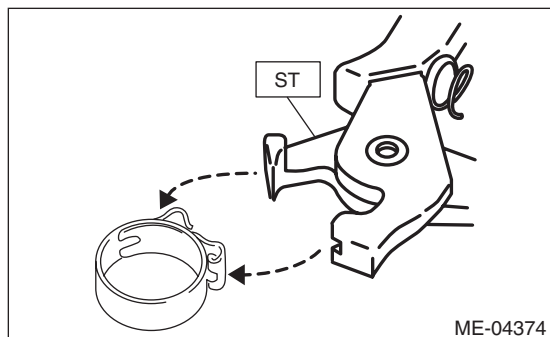

(6) Remove the rocker cover LH.

6) Turn the crank pulley clockwise until the round mark and arrow mark on the cam sprocket are set to position shown in the figure.

**NOTE:**

Turn the crank pulley using a socket wrench.

- Measurement of clearance of #1 cylinder intake valve and #3 cylinder exhaust valve

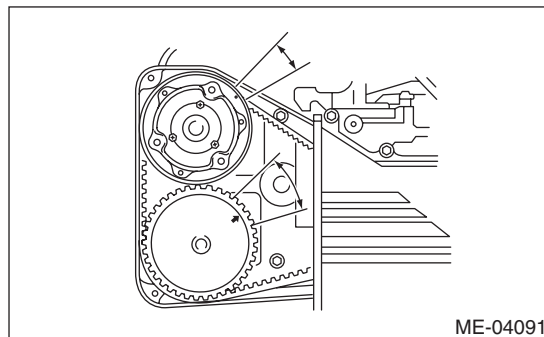

- Measurement of clearance of #2 cylinder exhaust valve and #3 cylinder intake valve

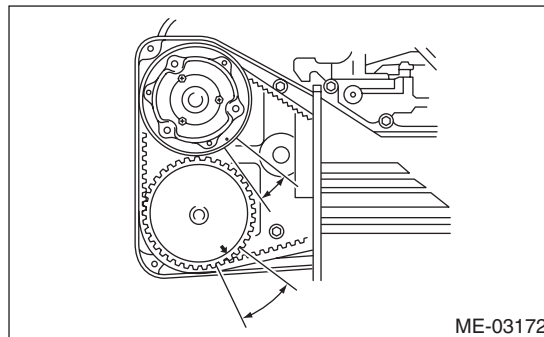

- Measurement of clearance of #2 cylinder intake valve and #4 cylinder exhaust valve

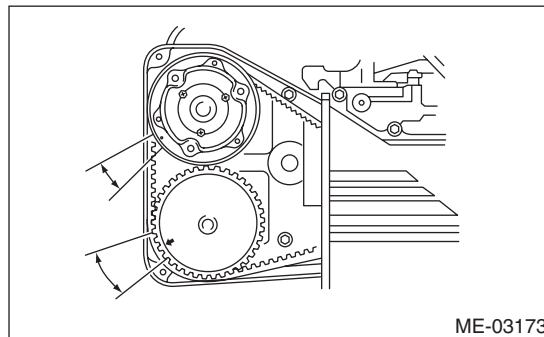

- Measurement of clearance of #1 cylinder exhaust valve and #4 cylinder intake valve

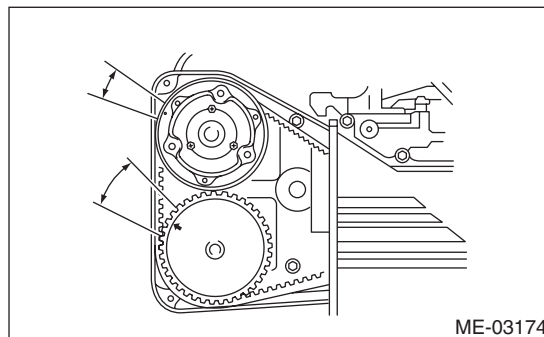



# Valve Clearance

## MECHANICAL

7) Measure the clearance of intake valve and exhaust valve using thickness gauge (A).

### NOTE:

- Insert a thickness gauge in a direction as horizontal as possible with respect to the valve lifter.
- Lift up the vehicle, and then measure the exhaust valve clearances.
- If the measured value is not within the inspection value, take notes of the value in order to adjust the valve clearance later on.

### Valve clearance (inspection value):

#### Intake

$0.20^{+0.04}_{-0.06}$  mm ( $0.0079^{+0.0016}_{-0.0024}$  in)

#### Exhaust

$0.35 \pm 0.05$  mm ( $0.0138 \pm 0.0020$  in)

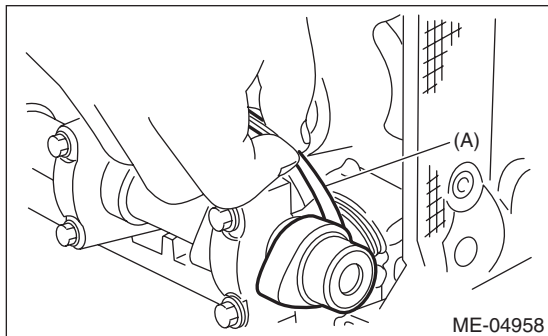

8) If necessary, adjust the valve clearance. <Ref. to ME(STI)-29, ADJUSTMENT, Valve Clearance.>

9) After inspection, install the related parts in the reverse order of removal.

### NOTE:

- Refer to "Camshaft" when installing the rocker cover. <Ref. to ME(STI)-64, INSTALLATION, Camshaft.>

- Use a new clamp for the PCV hose (A), fit the cut out in the ST with the protrusion on the clamp as shown in the figure, and lock the clamp.

ST 18353AA000 CLAMP PLIERS

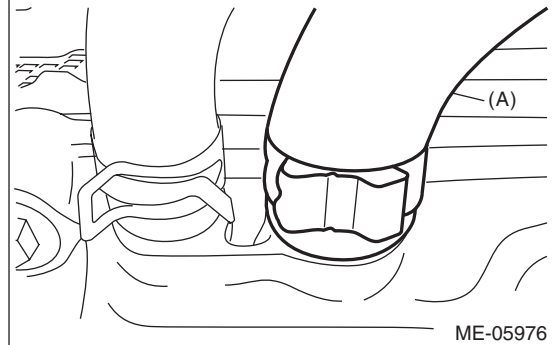
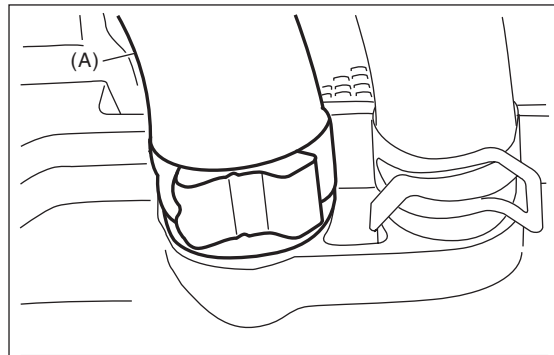
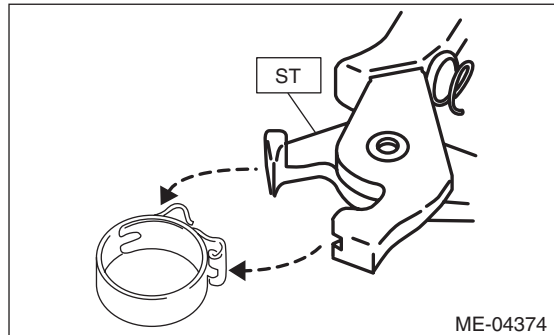

### Tightening torque:

**6.4 N·m (0.7 kgf·m, 4.7 ft·lb)**

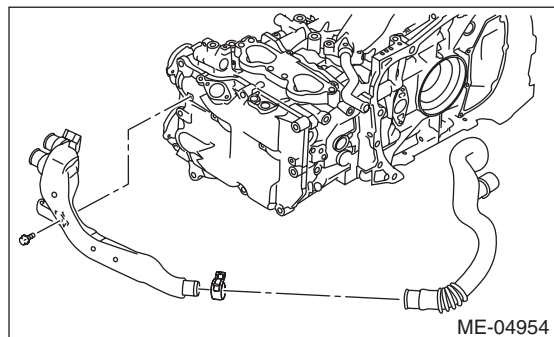

## B: ADJUSTMENT

1) Measure all the valve clearances. <Ref. to ME(STI)-26, INSPECTION, Valve Clearance.>

**NOTE:**

Record the measured value of each valve clearance.

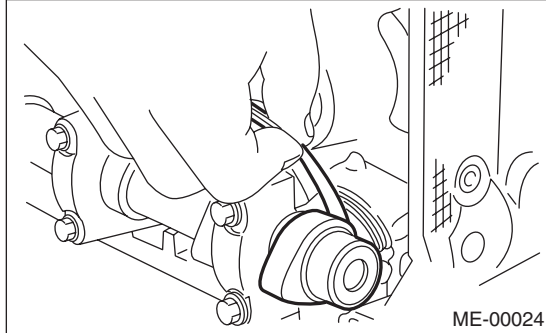

**Valve clearance (adjustment value):**

**Intake**  
 $0.20^{+0.01} \text{ } ^{-0.03} \text{ mm (} 0.0079^{+0.0004} \text{ } ^{-0.0012} \text{ in)}$

**Exhaust**  
 $0.35 \pm 0.02 \text{ mm (} 0.0138 \pm 0.0008 \text{ in)}$

10) After adjustment, install the related parts in the reverse order of removal.

2) Remove the camshaft. <Ref. to ME(STI)-61, REMOVAL, Camshaft.>

3) Remove the valve lifter.

4) Measure the thickness of valve lifter using micrometer.

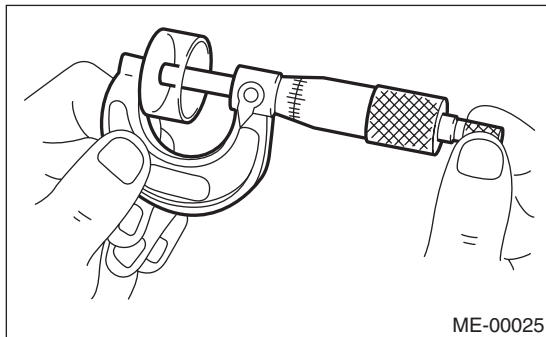

5) Select a valve lifter of suitable thickness using the measured valve clearance and valve lifter thickness, and install it.

**NOTE:**

Use a new valve lifter.

Unit: mm (in)
Intake valve: $S = (V + T) - 0.19$ (0.0075)
Exhaust valve: $S = (V + T) - 0.35$ (0.0138)
S: Valve lifter thickness required
V: Measured valve clearance
T: Valve lifter thickness to be used

6) Install the camshaft. <Ref. to ME(STI)-64, INSTALLATION, Camshaft.>

7) Install the cam sprocket. <Ref. to ME(STI)-59, INSTALLATION, Cam Sprocket.>

8) Install the timing belt. <Ref. to ME(STI)-53, TIMING BELT, INSTALLATION, Timing Belt.>

9) Measure all valves for valve clearance again at this time. If the valve clearance is not within the adjustment value, repeat the procedure over again from step 2).

# Engine Assembly

MECHANICAL

## 9. Engine Assembly

### A: REMOVAL

1) Change the bolt installation position from (A) to (B), then open the front hood completely.

**Tightening torque:**

**7.5 N·m (0.8 kgf-m, 5.5 ft-lb)**

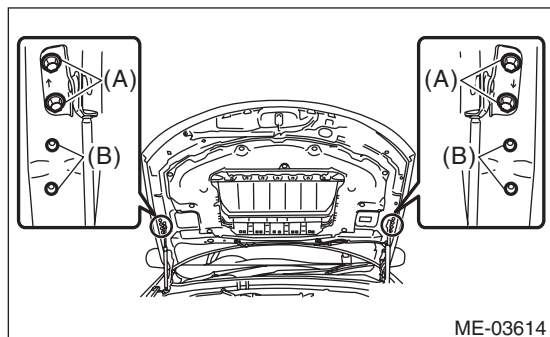

2) Remove the V-belt covers.

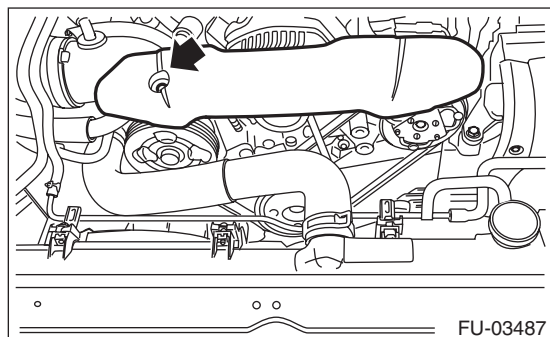

3) Collect the refrigerant from A/C system. <Ref. to AC-20, Refrigerant Recovery Procedure.>

4) Release the fuel pressure. <Ref. to FU(STI)-67, RELEASING OF FUEL PRESSURE, PROCEDURE, Fuel.>

5) Remove the battery. <Ref. to SC(STI)-27, REMOVAL, Battery.>

6) Open the fuel filler lid and remove the fuel filler cap.

7) Remove the air intake duct and air cleaner case. <Ref. to IN(STI)-10, REMOVAL, Air Intake Duct.> <Ref. to IN(STI)-8, REMOVAL, Air Cleaner Case.>

8) Remove the intercooler. <Ref. to IN(STI)-12, REMOVAL, Intercooler.>

9) Remove the radiator. <Ref. to CO(STI)-19, REMOVAL, Radiator.>

10) Remove the coolant filler tank. <Ref. to CO(STI)-28, REMOVAL, Coolant Filler Tank.>

11) Disconnect the bulkhead harness connectors from the engine harness connectors.

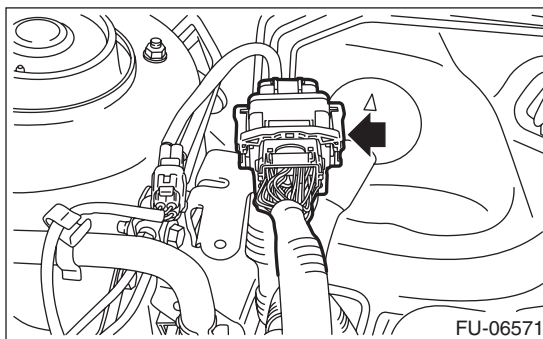

12) Remove the engine harness connector from the engine harness bracket.

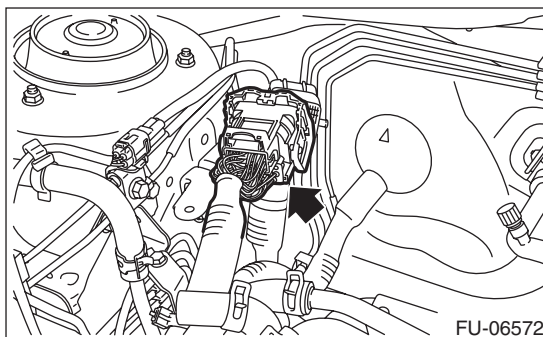

13) Disconnect the following connectors and terminals.

(1) Generator connector and terminal

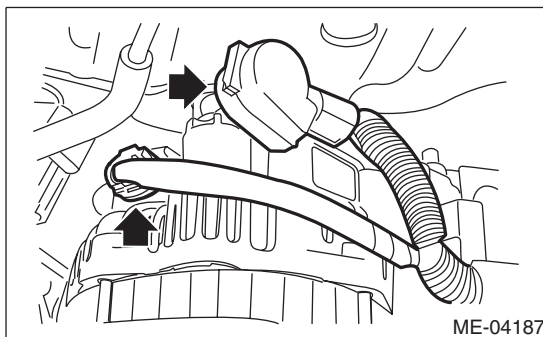

(2) Secondary air pump connector

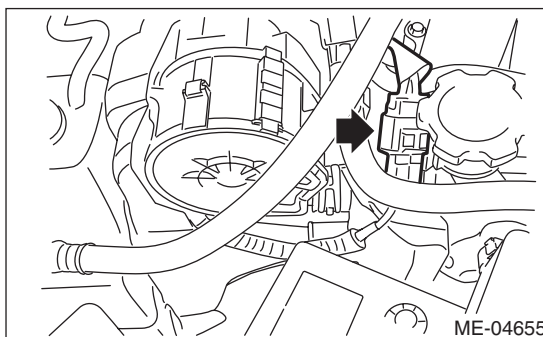

14) Disconnect the connector (A) from the A/C compressor, and remove the clip (B) securing the generator cord.

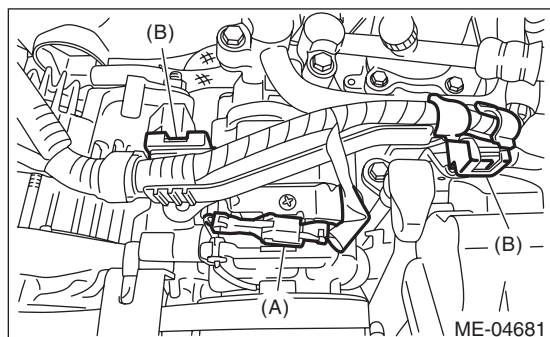

15) Disconnect the following hoses.

- (1) A/C pressure hose <Ref. to AC-40, REMOVAL, Hose and Pipe.>
- (2) Brake booster vacuum hose (A) and pressure regulator vacuum hose (B)

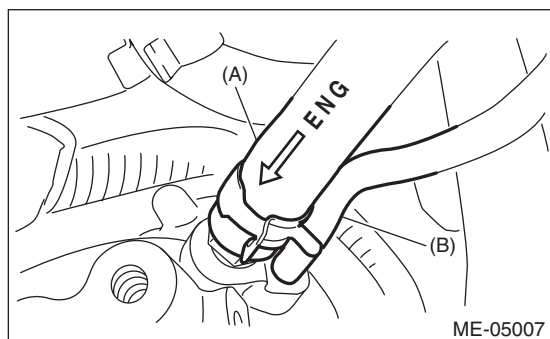

(3) Heater inlet hose and heater outlet hose

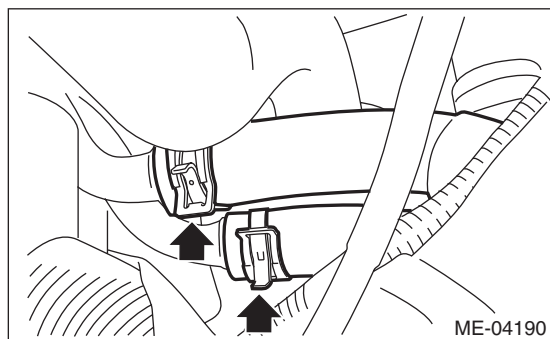

16) Remove the power steering pump.

- (1) Remove the front side belts. <Ref. to ME(STI)-40, FRONT SIDE BELT, REMOVAL, V-belt.>

(2) Disconnect the connector from power steering pump switch.

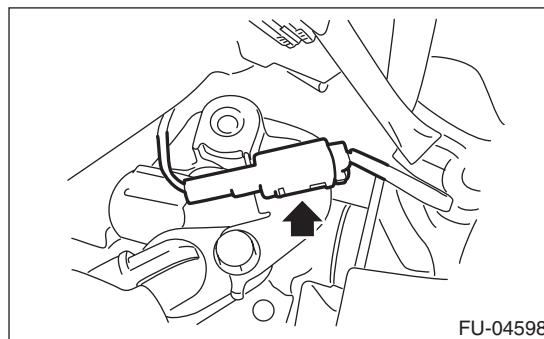

(3) Remove the power steering pump from the engine.

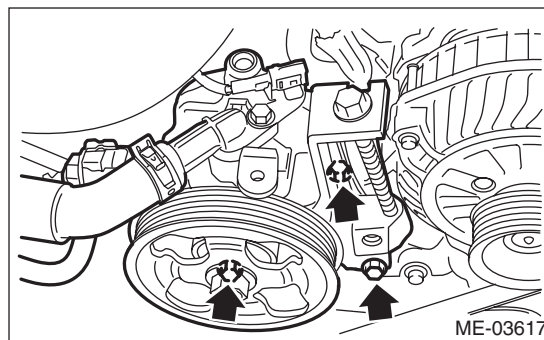

(4) Place the power steering pump on the right side wheel apron.

17) Remove the center exhaust pipe. <Ref. to EX(STI)-8, REMOVAL, Center Exhaust Pipe.>

18) Remove the turbocharger. <Ref. to IN(STI)-15, REMOVAL, Turbocharger.>

19) Remove the joint pipe and front exhaust pipe. <Ref. to EX(STI)-12, REMOVAL, Joint Pipe.> <Ref. to EX(STI)-6, REMOVAL, Front Exhaust Pipe.>

20) Disconnect the ground cable on the engine side.

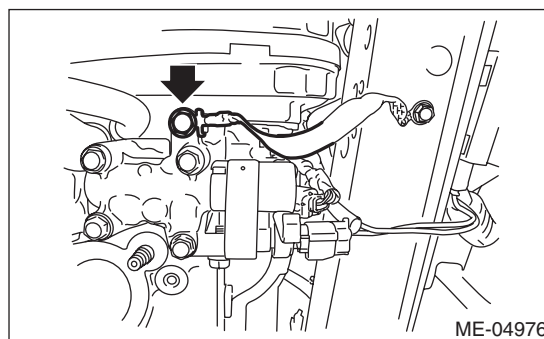

# Engine Assembly

## MECHANICAL

21) Remove the bolts and nuts which hold the lower side of transmission to the engine.

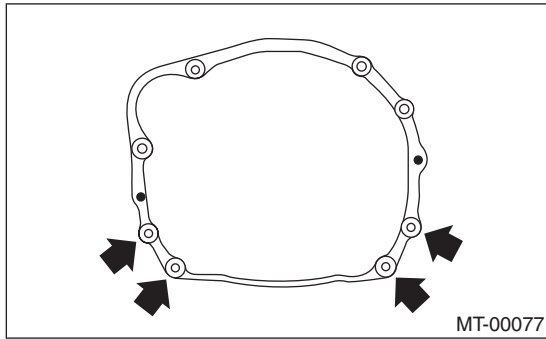

22) Remove the nuts which secure the engine mounting to the front crossmember.

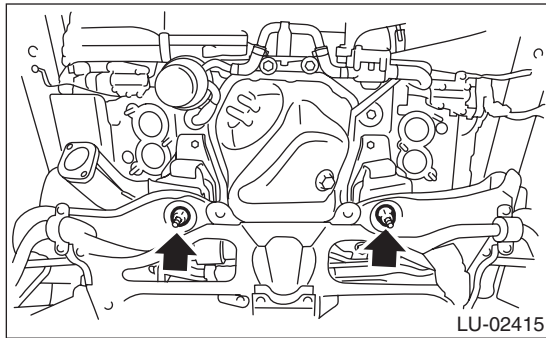

23) Lower the vehicle.

24) Remove the starter. <Ref. to SC(STI)-7, REMOVAL, Starter.>

25) Separate the clutch release fork from the release bearing.

(1) Remove the clutch operating cylinder from the transmission.

(2) Remove the service hole plug using a hexagon wrench (10 mm).

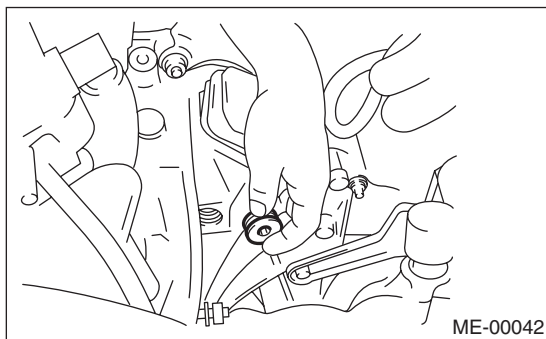

(3) Screw-in the 6 mm dia. bolt into the release fork shaft to remove.

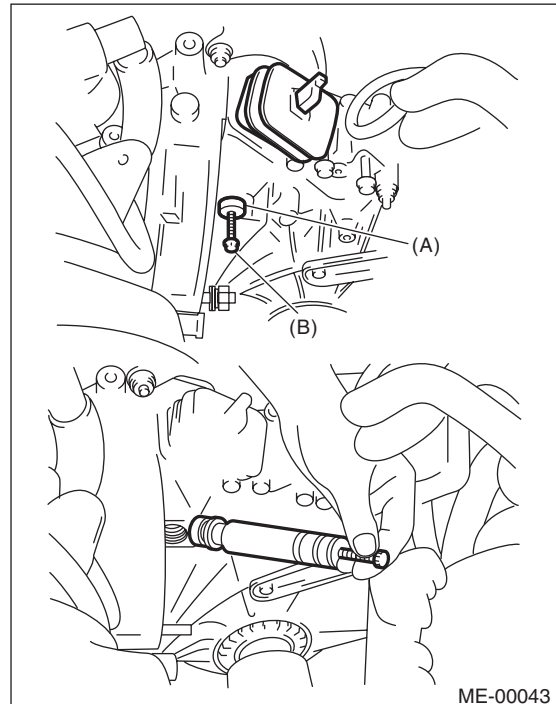

(A) Release fork shaft

(B) Bolt

(4) Raise the release fork, unlock the release bearing tab, then remove the release fork.

### NOTE:

Step (4) is required to avoid interference with the engine when removing the engine from the transmission.

26) Remove the pitching stopper.

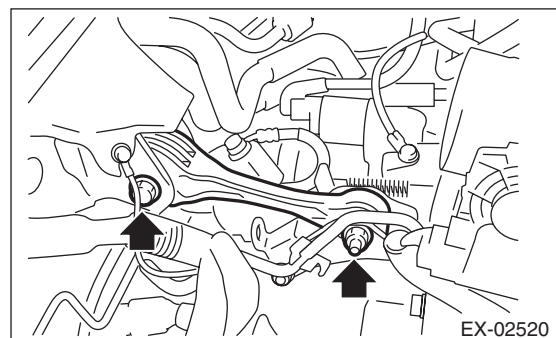

27) Disconnect the fuel delivery hose, fuel return hose and evaporation hose.

### CAUTION:

- Be careful not to spill fuel.
- Catch the fuel from hoses using a container or cloth.

(1) Set the ST to the fuel pipe.

ST 42099AE00 QUICK CONNECTOR RELEASE



(2) Disconnect the quick connector of the fuel delivery hose and fuel return hose by pushing the ST in the direction of the arrow.

(3) Remove the clip and disconnect the evaporation hose from the fuel pipe.

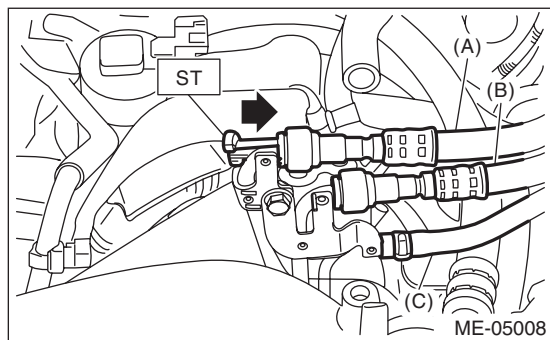

- (A) Fuel delivery hose
- (B) Fuel return hose
- (C) Evaporation hose

28) Support the engine with a lifting device and wire ropes.

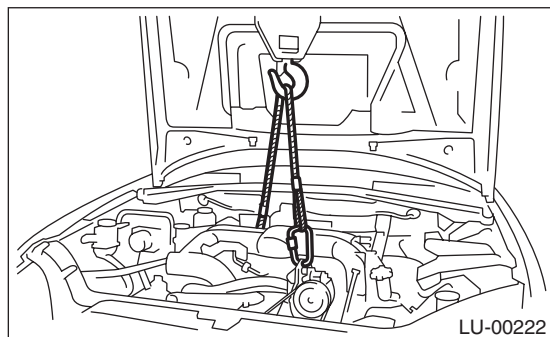

29) Support the transmission with a garage jack.

**CAUTION:**

Be sure to perform this procedure to prevent the transmission from lowering by its own weight.

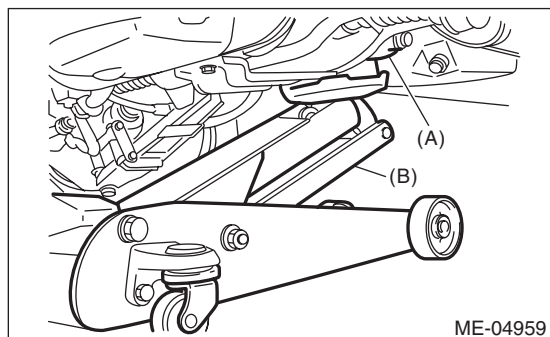

- (A) Transmission
- (B) Garage jack

30) Remove the bolts which hold the upper side of the transmission to the engine.

**CAUTION:**

Before removing the engine away from transmission, check to be sure no work has been overlooked.

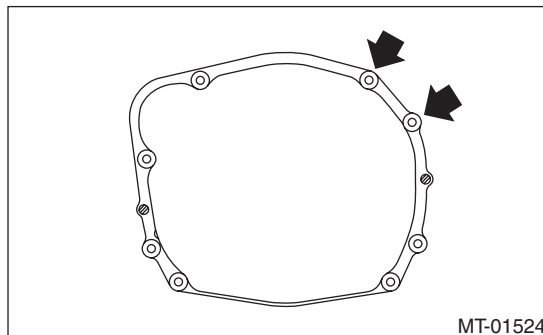

31) Remove the engine from the vehicle.

**NOTE:**

Be careful not to damage adjacent parts or body panels with crank pulley, oil level gauge, etc.

- (1) Slightly raise the engine.
- (2) Raise the transmission with garage jack.
- (3) Move the engine horizontally until main shaft is withdrawn from clutch cover.
- (4) Slowly move the engine away from engine compartment.

32) Remove the engine mounting from the engine.

**B: INSTALLATION**

1) Install the clutch release fork and bearing to the transmission.

- (1) Using a flat tip screwdriver, remove the release bearing from the clutch cover.

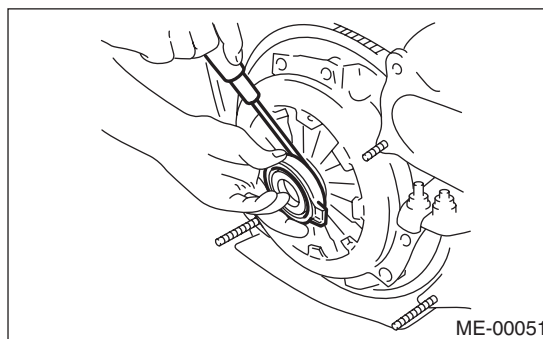

- (2) Attach the release bearing to the transmission.

# Engine Assembly

## MECHANICAL

(3) Install the release fork into the release bearing tab.

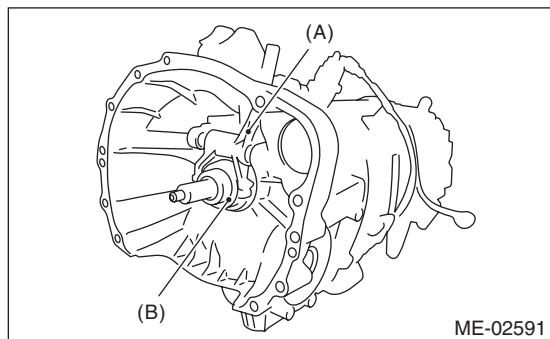

- (A) Release fork
- (B) Release bearing

(4) Apply grease to the specified areas.

### Grease:

#### Spline part

**NICHIMOLY N-130 or equivalent**

#### Shaft part

**KOPR-KOTE or equivalent**

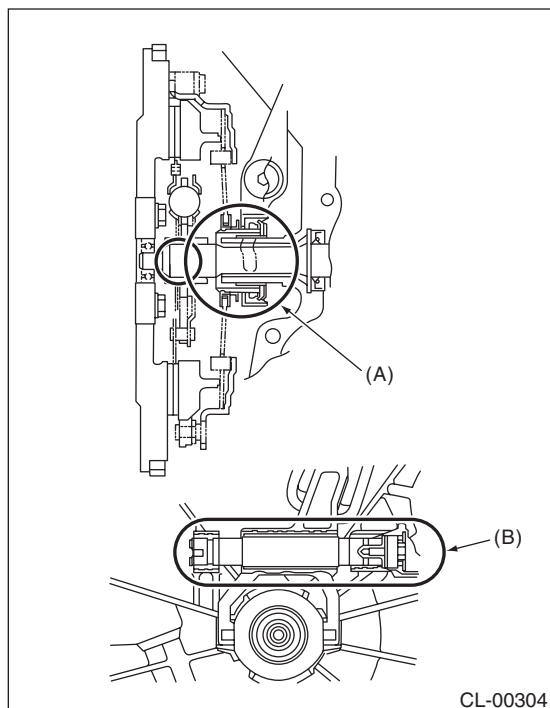

- (A) Spline
- (B) Shaft

(5) Insert the release shaft to release fork.

### NOTE:

Allow the cutout portion of release shaft to come into contact with the spring pin.

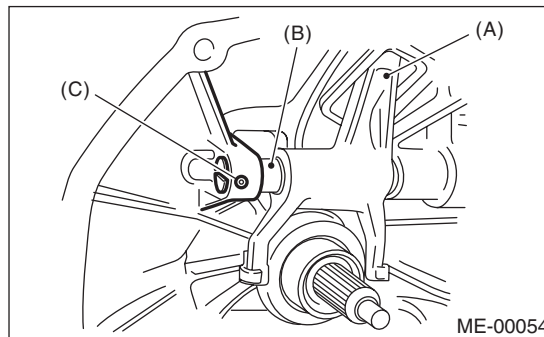

- (A) Release fork
- (B) Release shaft
- (C) Spring pin

(6) Install the service hole plug.

### Tightening torque:

**44 N·m (4.5 kgf-m, 32.5 ft-lb)**

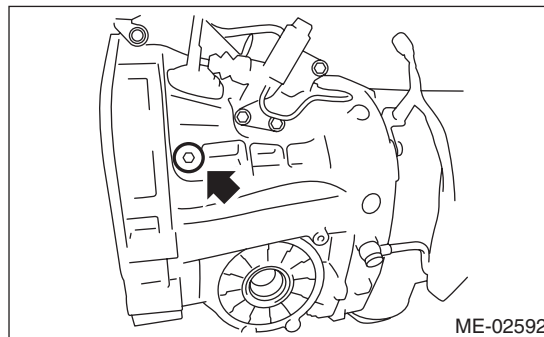

2) Install the engine mounting onto the engine.

### Tightening torque:

**35 N·m (3.6 kgf-m, 25.8 ft-lb)**

3) Apply a small amount of grease to splines of main shaft.

### Grease:

**NICHIMOLY N-130 or equivalent**

4) Position the engine in engine compartment and align it with transmission.

### NOTE:

Be careful not to damage adjacent parts or body panels with crank pulley, oil level gauge, etc.

5) Tighten the bolts which hold upper side of transmission to engine.

**Tightening torque:**

**50 N·m (5.1 kgf-m, 36.9 ft-lb)**

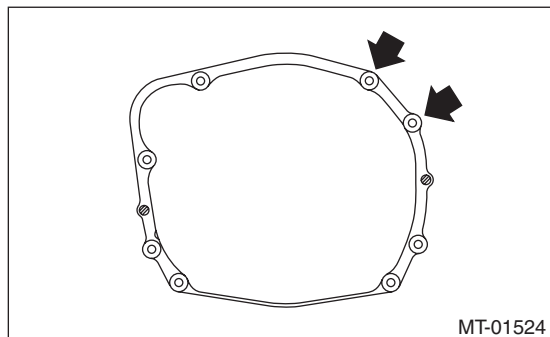

MT-01524

6) Remove the lifting device and wire ropes.

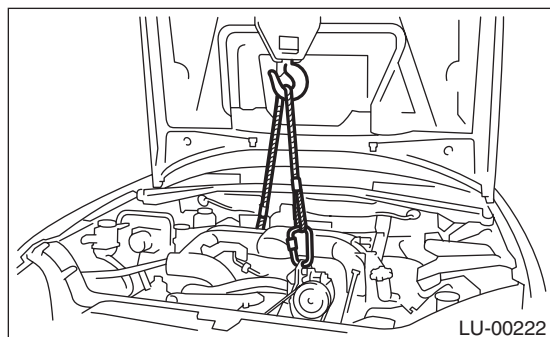

LU-00222

7) Remove the garage jack.

8) Install the pitching stopper.

**Tightening torque:**

**T1: 50 N·m (5.1 kgf-m, 36.9 ft-lb)**

**T2: 58 N·m (5.9 kgf-m, 42.8 ft-lb)**

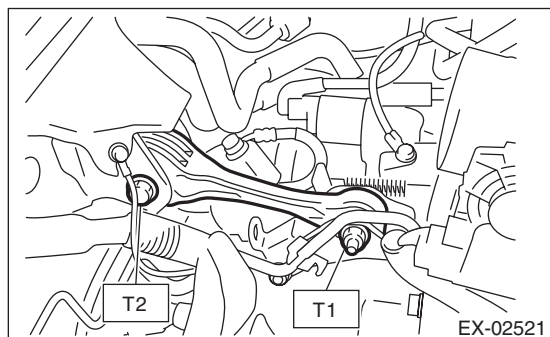

EX-02521

9) Install the starter. <Ref. to SC(STI)-7, INSTALLATION, Starter.>

10) Install the power steering pump.

(1) Install the power steering pump onto the engine.

**Tightening torque:**

**Refer to "COMPONENT" of "Power Steering" for the tightening torque. <Ref. to PS-3, COMPONENT, General Description.>**

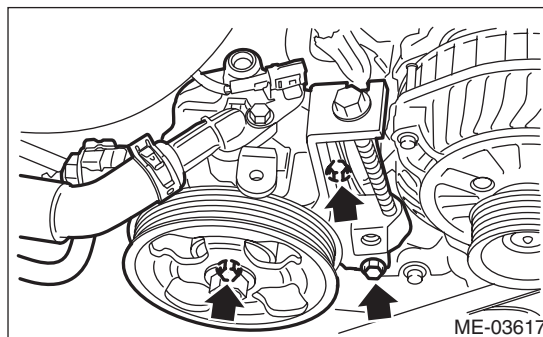

ME-03617

(2) Connect the connector to the power steering pump switch.

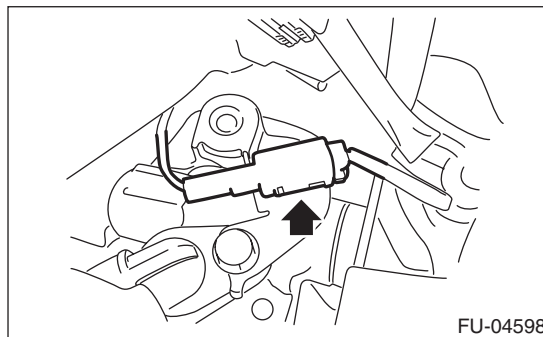

FU-04598

(3) Install the front side belt. <Ref. to ME(STI)-40, FRONT SIDE BELT, INSTALLATION, V-belt.>

11) Lift up the vehicle.

12) Install the bolts and nuts which hold lower side of the transmission to engine.

**Tightening torque:**

**50 N·m (5.1 kgf-m, 36.9 ft-lb)**

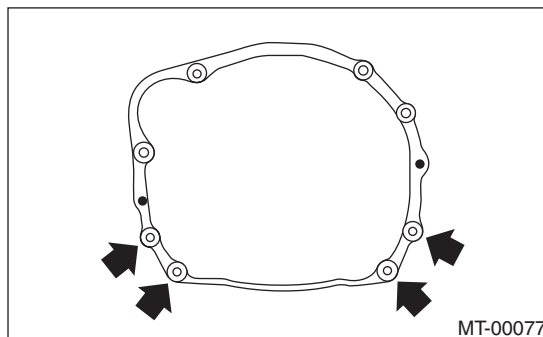

MT-00077



# Engine Assembly

## MECHANICAL

13) Install the nuts which hold the engine mounting to the crossmember.

### **Tightening torque:**

**85 N·m (8.7 kgf-m, 62.7 ft-lb)**

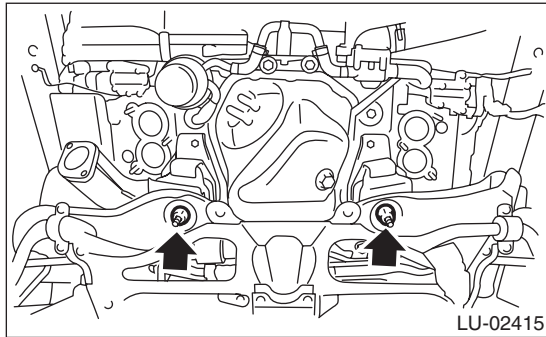

14) Connect the ground cable.

### **Tightening torque:**

**7.5 N·m (0.8 kgf-m, 5.5 ft-lb)**

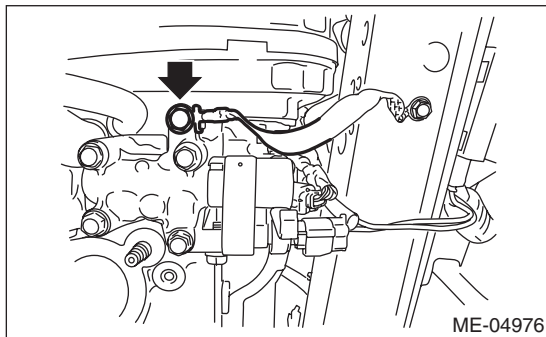

15) Install the joint pipe and front exhaust pipe. <Ref. to EX(STI)-6, INSTALLATION, Front Exhaust Pipe.> <Ref. to EX(STI)-12, INSTALLATION, Joint Pipe.>

16) Install the turbocharger. <Ref. to IN(STI)-16, INSTALLATION, Turbocharger.>

17) Install the center exhaust pipe. <Ref. to EX(STI)-9, INSTALLATION, Center Exhaust Pipe.>

18) Connect the following hoses.

- (1) Fuel delivery hose, fuel return hose and evaporation hose
- (2) Heater inlet hose and heater outlet hose
- (3) Brake booster vacuum hose and pressure regulator vacuum hose
- (4) A/C pressure hose <Ref. to AC-40, INSTALLATION, Hose and Pipe.>

19) Secure the generator cord using the clip (B) and connect the connector (A) to A/C compressor.

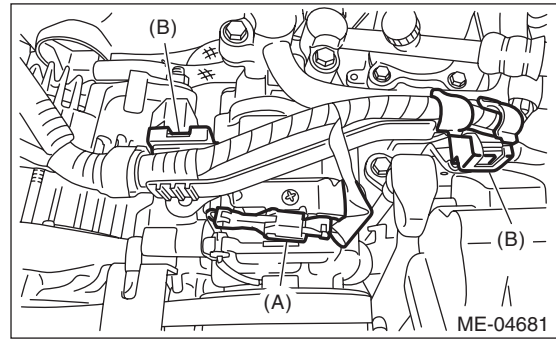

20) Connect the following connectors and terminals.

- (1) Generator connector and terminal

### **Tightening torque:**

**15 N·m (1.5 kgf-m, 11.1 ft-lb)**

- (2) Secondary air pump connector

21) Install the engine harness connector to engine harness bracket, then connect the bulkhead harness connector to the engine harness connector.

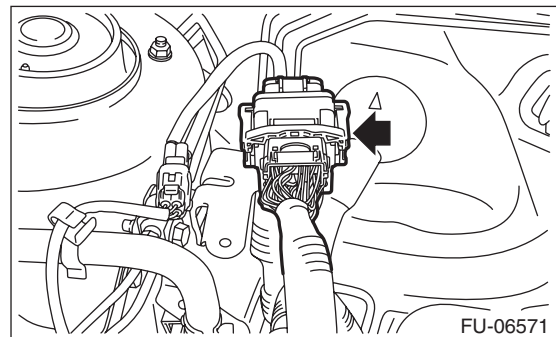

22) Install the intercooler. <Ref. to IN(STI)-13, INSTALLATION, Intercooler.>

23) Install the radiator. <Ref. to CO(STI)-20, INSTALLATION, Radiator.>

24) Install the coolant filler tank. <Ref. to CO(STI)-28, INSTALLATION, Coolant Filler Tank.>

25) Install the air cleaner case and air intake duct. <Ref. to IN(STI)-8, INSTALLATION, Air Cleaner Case.> <Ref. to IN(STI)-10, INSTALLATION, Air Intake Duct.>

26) Install the battery. <Ref. to SC(STI)-27, INSTALLATION, Battery.>

27) Fill engine coolant. <Ref. to CO(STI)-13, FILLING OF ENGINE COOLANT, REPLACEMENT, Engine Coolant.>

28) Charge the A/C system with refrigerant. <Ref. to AC-21, PROCEDURE, Refrigerant Charging Procedure.>

29) Install the V-belt cover.

**Tightening torque:**

**13 N·m (1.3 kgf·m, 9.6 ft·lb)**

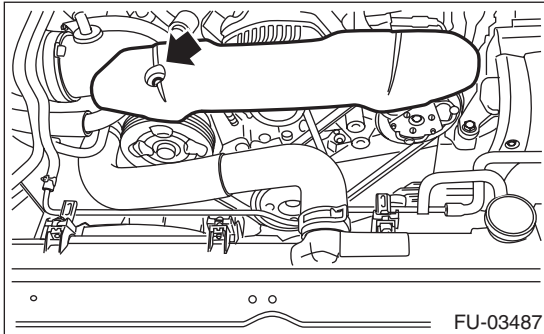

30) Change the bolt installation position from (B) to (A), then close the front hood.

**Tightening torque:**

**7.5 N·m (0.8 kgf·m, 5.5 ft·lb)**

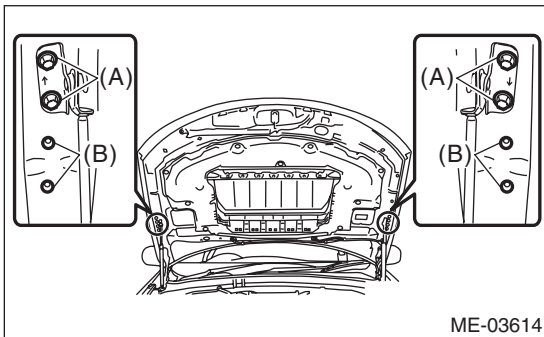

## C: INSPECTION

- 1) Check that pipes, hoses, connectors and clamps are installed firmly.
- 2) Check the engine coolant is at specified level.
- 3) Start the engine and check for exhaust gas, engine coolant, leaks of fuel, etc. Also check for noise and vibrations.

## 10.Engine Mounting

### A: REMOVAL

- 1) Remove the engine from the vehicle. <Ref. to ME(STI)-30, REMOVAL, Engine Assembly.>
- 2) Remove the engine mounting from the engine.

### B: INSTALLATION

Install in the reverse order of removal.

#### *Tightening torque:*

*35 N·m (3.6 kgf-m, 25.8 ft-lb)*

### C: INSPECTION

Make sure that no crack or other damages do not exist.

## 11. Preparation for Overhaul

### A: PROCEDURE

1) After removing the engine from vehicle body, attach the ST to the engine as shown in the figure.

ST1 498457000 ENGINE STAND ADAPTER  
RH

ST2 498457100 ENGINE STAND ADAPTER  
LH

ST3 499817100 ENGINE STAND

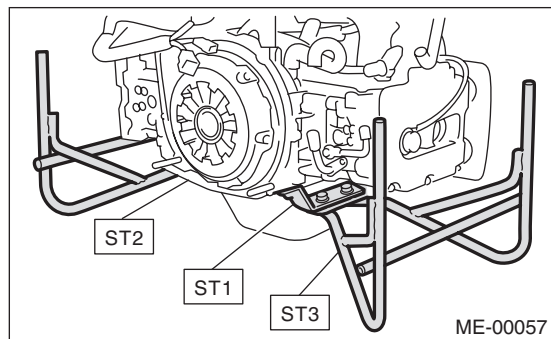

2) In this section the procedures described under each index are all connected and stated in order. The procedure for overhauling of the engine will be completed when you go through all steps in the process.

Therefore, in this section, to conduct the particular procedure within the flow of a section, you need to go back and conduct the procedure described previously in order to do that particular procedure.

## 12.V-belt

### A: REMOVAL

#### NOTE:

When replacing a single part, perform the work with the engine assembly installed to body.

#### 1. FRONT SIDE BELT

- 1) Remove the V-belt covers.

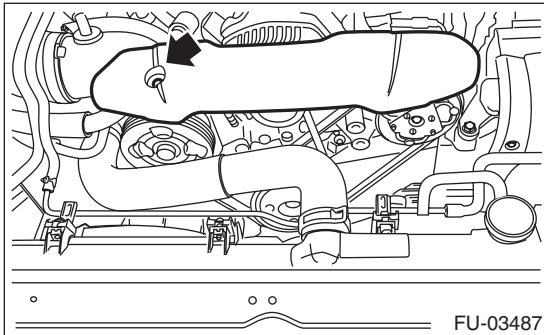

- 2) Remove the air intake duct. <Ref. to IN(STI)-10, REMOVAL, Air Intake Duct.>

- 3) Loosen the bolt (A).

- 4) Loosen the slider bolt (B).

- 5) Remove the front side belt (C).

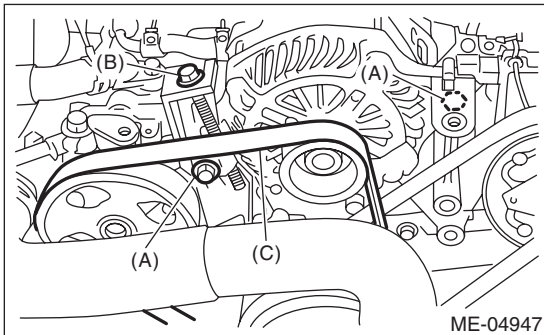

#### 2. REAR SIDE BELT

- 1) Remove the front side belts. <Ref. to ME(STI)-40, FRONT SIDE BELT, REMOVAL, V-belt.>

- 2) Cut the rear side belt with a wire cutter, etc., and discard.

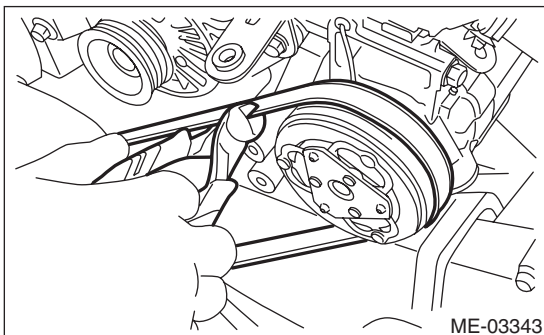

### B: INSTALLATION

#### 1. FRONT SIDE BELT

#### CAUTION:

- When reusing the front side belt, wipe off dust and water with cloth.
- Do not use the front side belt if there is any oil, grease or coolant on the belt.
- Be careful not to rub the belt end surface with bare hands; exposed core may cause injury.

- 1) Wipe off any dust, oil and water on the groove of each pulley with cloth.

- 2) Install the front side belt (C), and adjust the slider bolt (B) so as to obtain the specified belt tension. <Ref. to ME(STI)-46, INSPECTION, V-belt.>

- 3) Tighten the bolt (A).

- 4) Tighten the slider bolt (B).

#### Tightening torque:

##### Bolt (A)

**25 N·m (2.5 kgf-m, 18.4 ft-lb)**

##### Slider bolt (B)

**8 N·m (0.8 kgf-m, 5.9 ft-lb)**

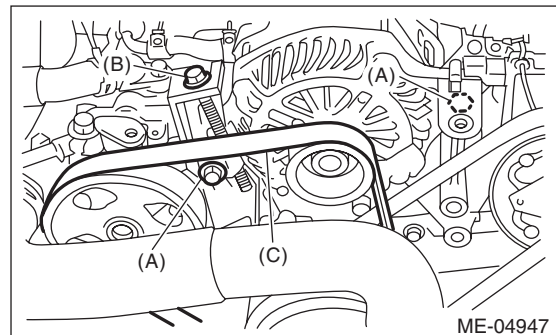

- 5) Install the air intake duct. <Ref. to IN(STI)-10, INSTALLATION, Air Intake Duct.>

- 6) Install the V-belt cover.

#### Tightening torque:

**13 N·m (1.3 kgf-m, 9.6 ft-lb)**

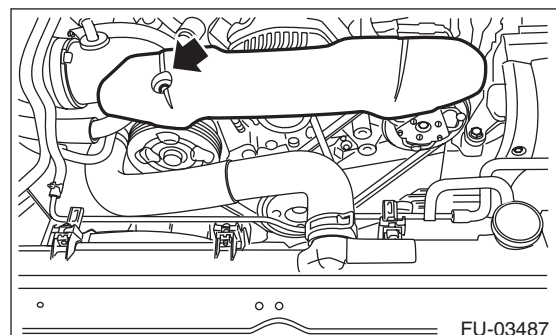

## 2. REAR SIDE BELT

### CAUTION:

- Do not re-use the rear side belt.
- Be careful not to let oil, grease or coolant contact a new rear side belt.
- Be careful not to rub the belt end surface with bare hands; exposed core may cause injury.
- To install the rear side belt, always use the provided tools (belt stopper, belt guide, belt guide holder, and bolt).

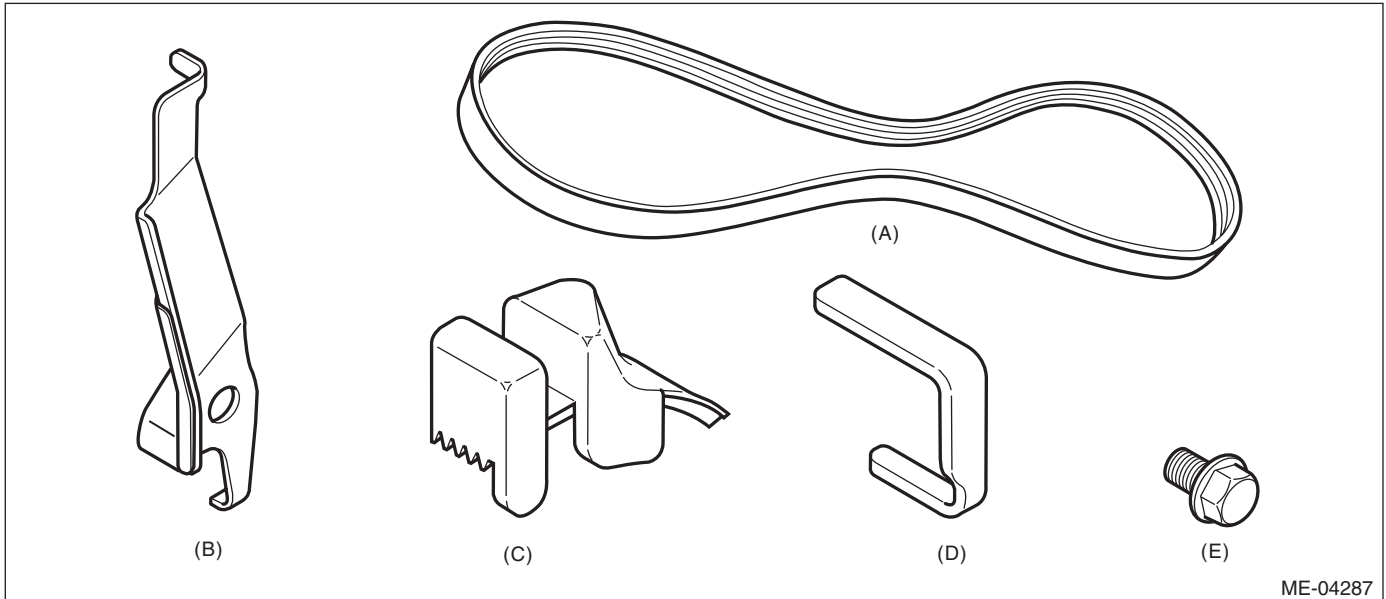

ME-04287

(A) Rear side belt

(C) Belt guide

(E) Bolt

(B) Belt stopper

(D) Belt guide holder

- 1) Wipe off any dust, oil and water on the groove of each pulley with cloth.
- 2) Wipe off any oil, water, dirt, and rust on the front of the crank pulley with cloth.
- 3) Slowly turn the crank pulley clockwise so that the service hole of the crank pulley comes around the top.

### CAUTION:

**Do not turn the crank pulley counterclockwise.**

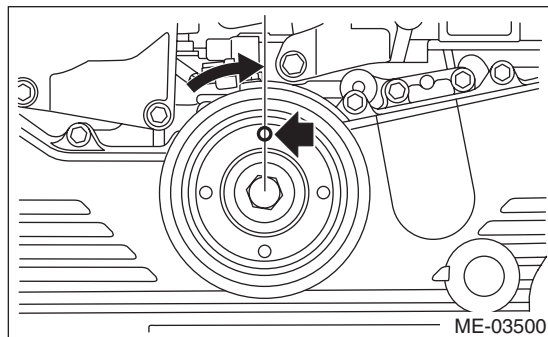

ME-03500

## V-belt

### MECHANICAL

4) Hook a new rear side belt on the A/C compressor pulley.

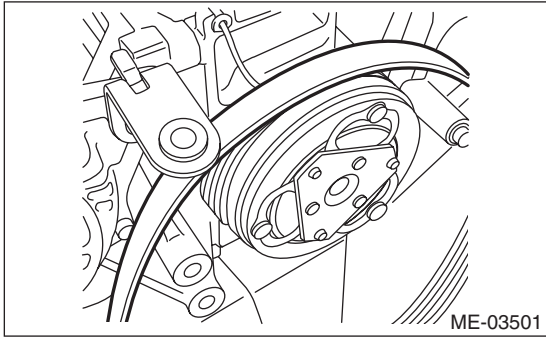

5) As shown in the figure, insert the claw of the belt stopper (A) to the lower hole (B) of the compressor bracket, then attach with bolt (C).

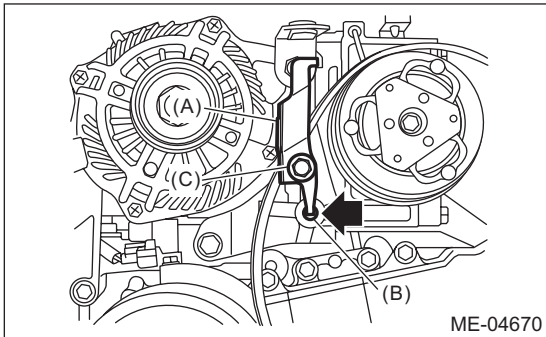

6) Place the belt guide while aligning it with the belt line of the crank pulley on the front side belt side.

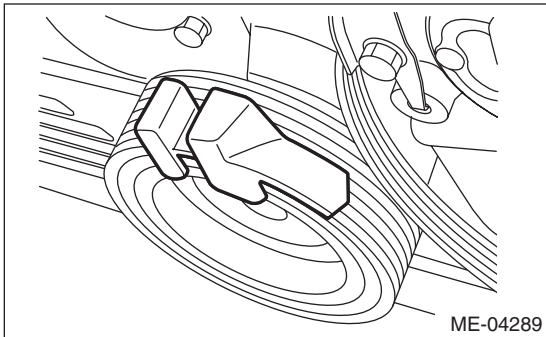

7) Insert the belt guide holder into the service hole of the crank pulley so that the belt guide comes in between.

#### NOTE:

Place the belt guide holder with the longer side up.

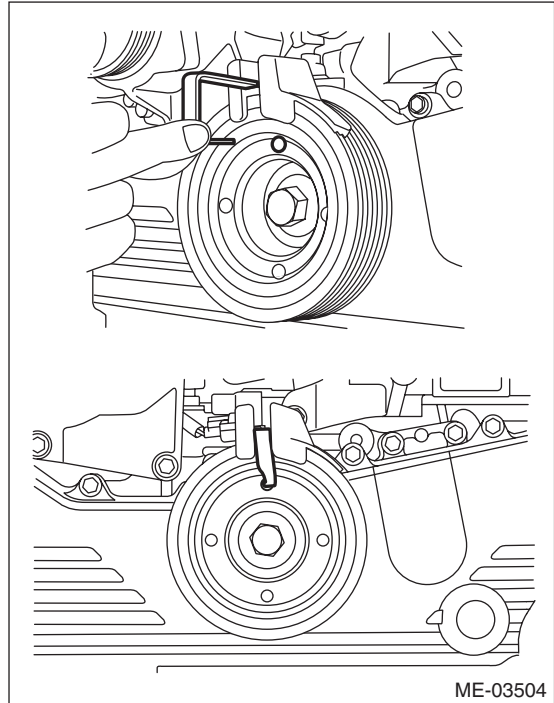

8) Slowly turn the crank pulley clockwise until the belt guide comes to approximately 45°.

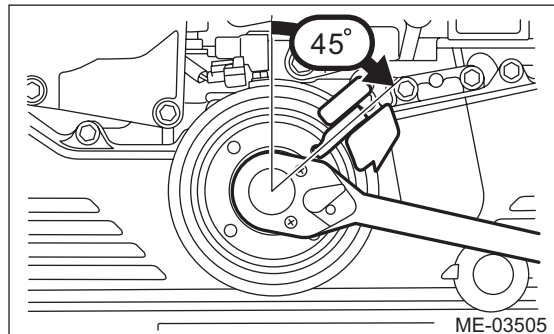

9) Place the rib surface of the rear side belt into the crank pulley groove, so that the rear side belt comes in between the belt guide holder.



**CAUTION:**

When it is difficult to place the rear side belt to the crank pulley groove, pull out the belt guide holder half way, then place the rear side belt into the groove so that it comes in between the belt guide holder.

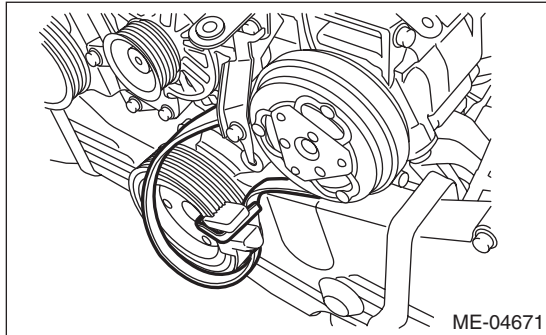

10) Place the tool through the loop of the rear side belt, and set on the crank pulley bolt.

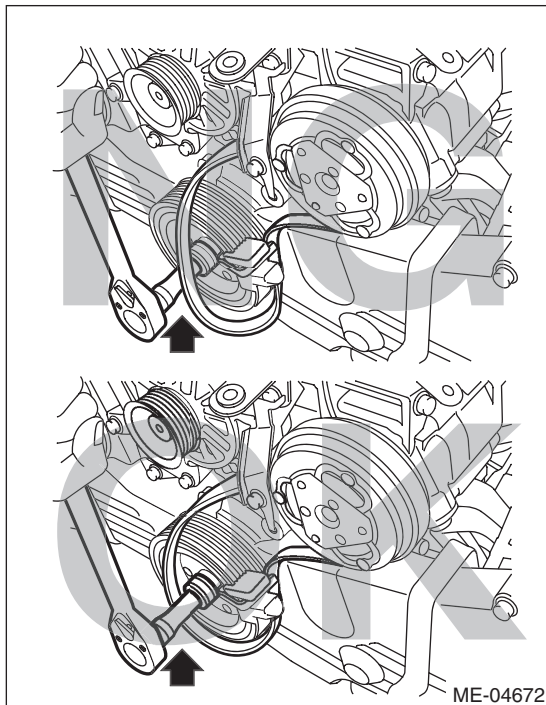

11) While checking the following, slowly turn the crank pulley approximately 90° clockwise so that the belt guide comes to the position shown in the figure.

**CAUTION:**

When turning the crank pulley, always make sure that the belt guide is not off from the crank pulley groove.

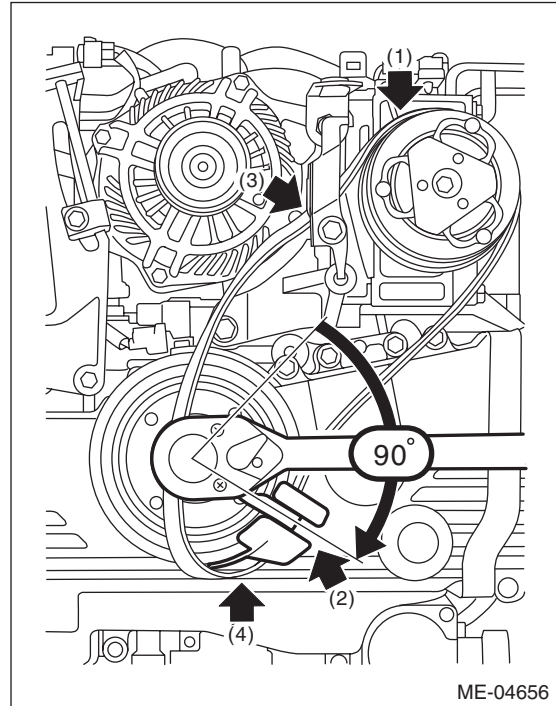

(1) The rib of the rear side belt is securely placed on the groove of the A/C compressor pulley.

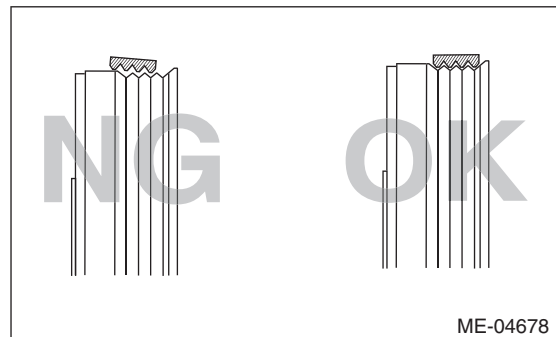

(2) The rib of the rear side belt is securely placed on the groove of the crank pulley.

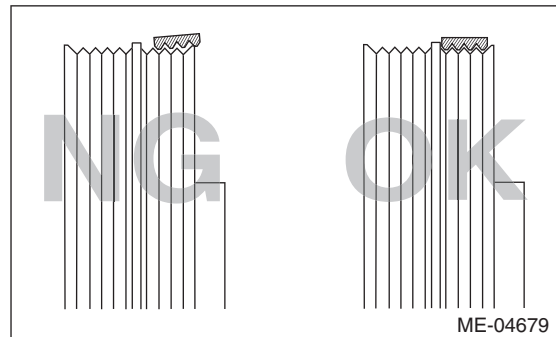



## V-belt

### MECHANICAL

(3) The surface of the rear side belt is held by the belt stopper.

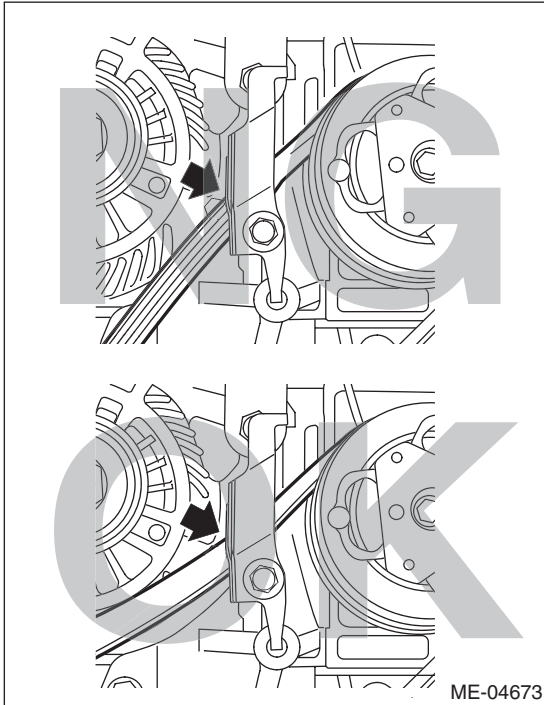

(4) The rear side belt is securely placed on the belt guide.

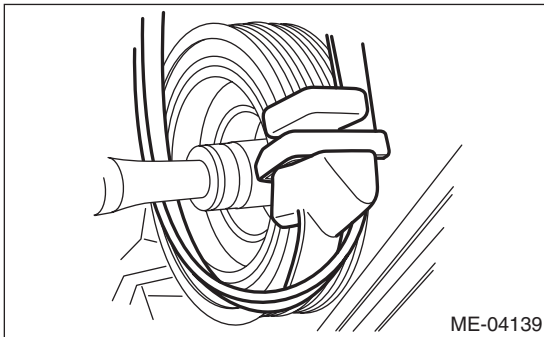

12) While checking the following, slowly turn the crank pulley approximately 90° clockwise so that the belt guide comes to the position shown in the figure.

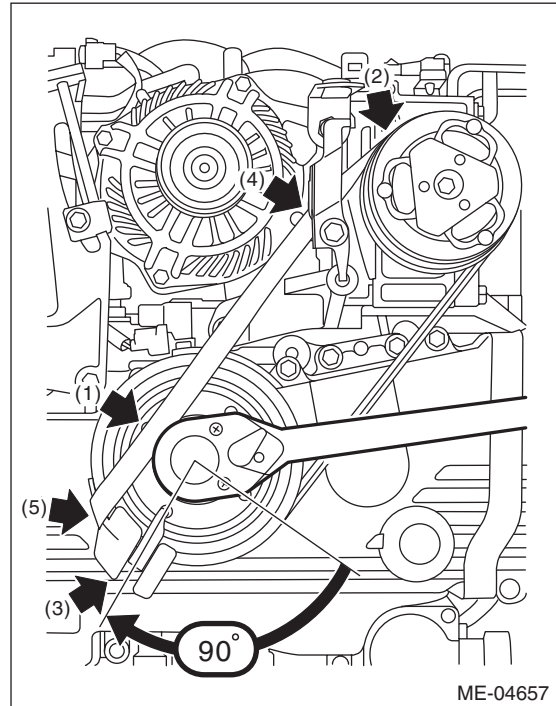

(1) The rear side belt is not twisted.

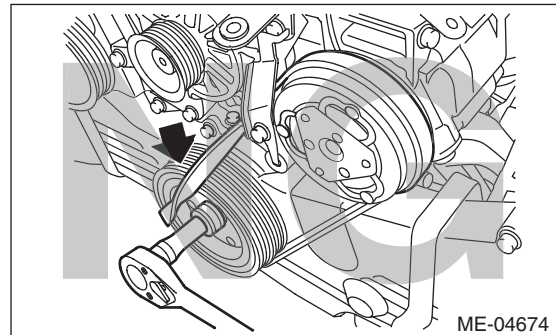

(2) The rib of the rear side belt is securely placed on the groove of the A/C compressor pulley.

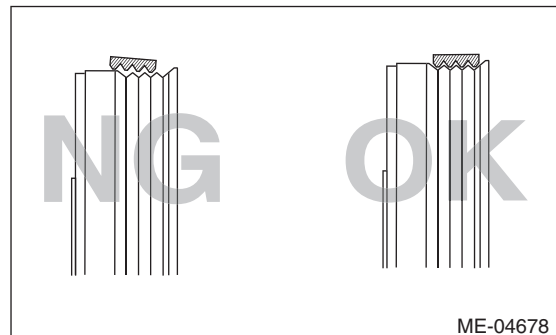

(3) The rib of the rear side belt is securely placed on the groove of the crank pulley.

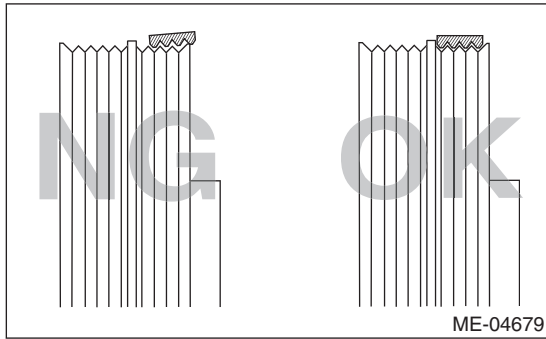

(4) The surface of the rear side belt is held by the belt stopper.

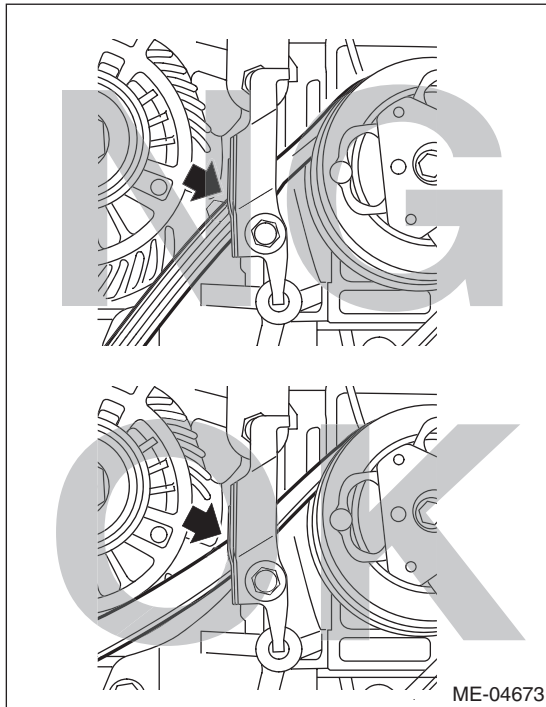

(5) The rear side belt is securely placed on the belt guide.

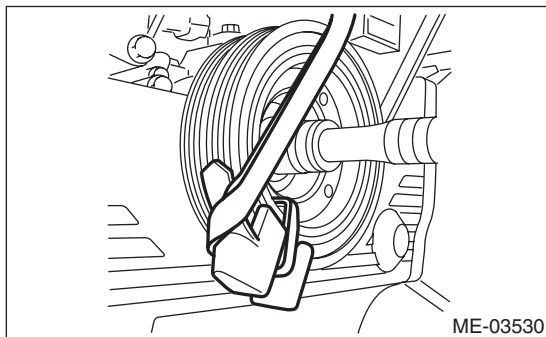

13) Slowly turn the crank pulley clockwise, and install the rear side belt.

**CAUTION:**

Be careful that the total of procedures 8), 11), 12) and 13) does not exceed 330°; failure to do so may cause damage to the rear side belt and fall of the belt guide holder.

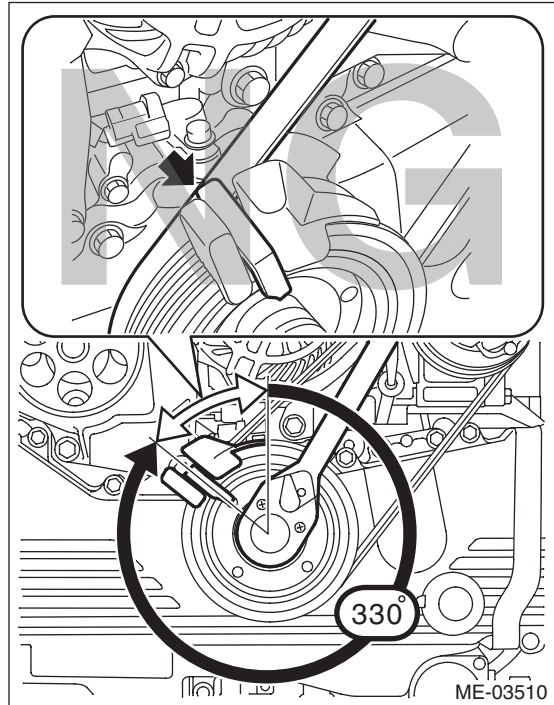

14) Remove the belt guide and belt guide holder from the crank pulley.

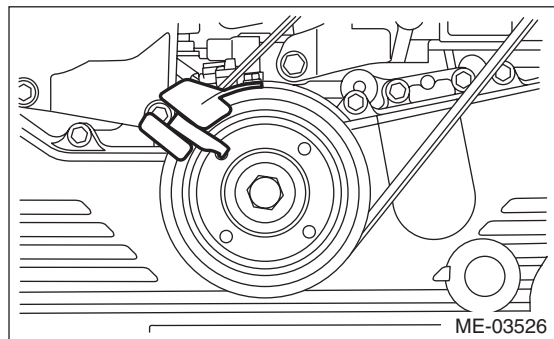

15) Remove the belt stopper from the compressor bracket.

**CAUTION:**

Always remove the belt stopper; failure to do so may cause smoke, fire, or belt cutting.

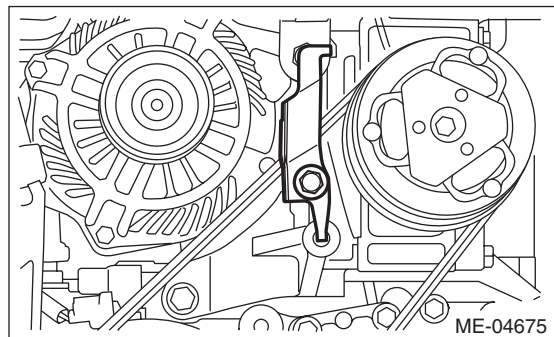

## V-belt

### MECHANICAL

16) Make sure that the belt rib is securely installed on the groove of each pulley, then turn the crank pulley slowly, twice in the clockwise direction, to seat the rear side belt properly.

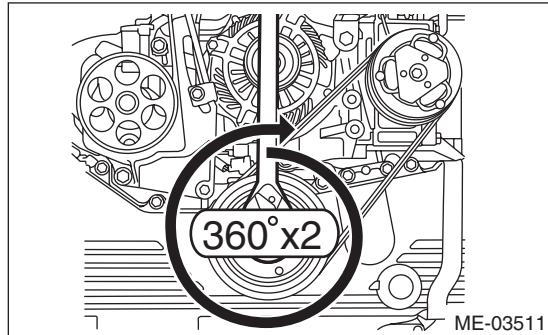

17) Discard the provided tools (belt stopper, belt guide, belt guide holder, and bolt) that are used.

18) Install the front side belt. <Ref. to ME(STI)-40, FRONT SIDE BELT, INSTALLATION, V-belt.>

## C: INSPECTION

### 1. FRONT SIDE BELT

#### CAUTION:

Check and adjust the front side belt tension so that it is within the specified range. Using the belt with a tension out of the specified range may result in a fault such as the following:

- If the front side belt tension is higher, unexpected force is generated at the power steering oil pump, generator and crankshaft bearing, causing abnormal noise due to abnormal wear of the bearing.

- If the front side belt tension is lower, the front side belt and crank pulley slip, causing abnormally high temperature on the crank pulley due to frictional heat. If this condition repeatedly occurs, the front side belt may abnormally wear, causing abnormal noise, front side belt damage or crank pulley damage.

1) Replace the front side belt, if crack, fraying or wear is found.

2) Check the front side belt tension and adjust it if necessary by changing the generator installing position.

**Front side belt tension (with belt tension gauge):**

**When installing new parts**

**640 — 780 N (65 — 80 kgf, 144 — 175 lbf)**

**At inspection**

**490 — 640 N (50 — 65 kgf, 110 — 144 lbf)**

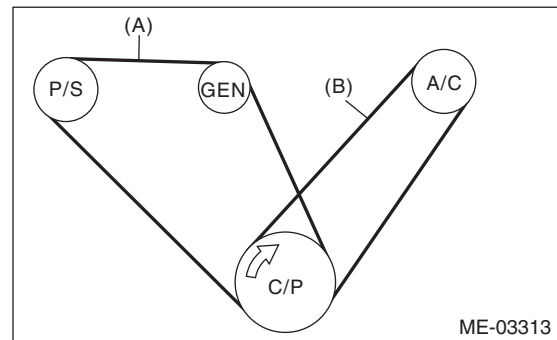

(A) Front side belt

(B) Rear side belt

C/P Crank pulley

GEN Generator pulley

P/S Power steering oil pump pulley

A/C A/C compressor pulley

**Front side belt tension (without belt tension gauge):**

**When installing new parts**

**7 — 9 mm (0.276 — 0.354 in)**

**At inspection**

**9 — 11 mm (0.354 — 0.433 in)**

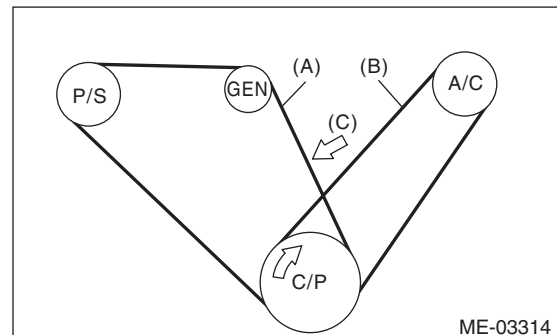

(A) Front side belt

(B) Rear side belt

(C) 98 N (10 kgf, 22 lbf)

C/P Crank pulley

GEN Generator pulley

P/S Power steering oil pump pulley

A/C A/C compressor pulley

### 2. REAR SIDE BELT

Replace the rear side belt, if crack, fraying or wear is found, or noise is emitted.

**NOTE:**

For the rear side belt, a stretch type belt is used, and therefore, it is not necessary to check deflection nor tension.

## 13. Crank Pulley

### A: REMOVAL

**NOTE:**

When replacing a single part, perform the work with the engine assembly installed to body.

1) Remove the V-belts. <Ref. to ME(STI)-40, REMOVAL, V-belt.>

2) Use the ST to lock the crank pulley, and remove the crank pulley bolt.

ST 499977100 CRANK PULLEY WRENCH

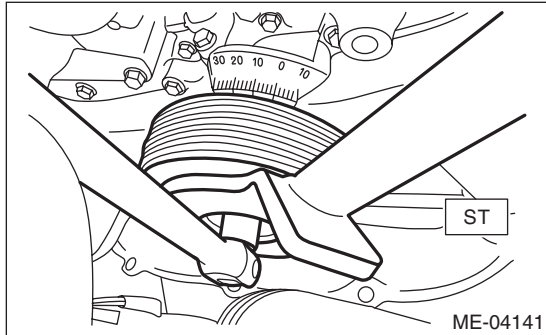

3) Remove the crank pulley.

### B: INSTALLATION

#### 1. METHOD WITHOUT ANGLE GAUGE

1) Clean the crankshaft thread using compressed air.

2) Install the crank pulley.

3) Apply engine oil to the crank pulley bolt seat and thread.

4) Tighten the crank pulley bolts.

(1) Use the ST to lock the crank pulley, and temporarily tighten the crank pulley bolt.

ST 499977100 CRANK PULLEY WRENCH

**Tightening torque:**

**47 N·m (4.8 kgf·m, 34.7 ft·lb)**

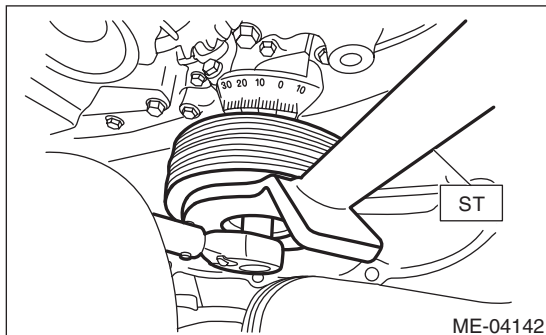

(2) Draw reference lines (A) and (B) using a marker to set the socket to the crank pulley bolt as shown in the figure.

**NOTE:**

Set the socket onto the crank pulley bolt so that reference lines (A) and (B) is visible.

ST 499977100 CRANK PULLEY WRENCH

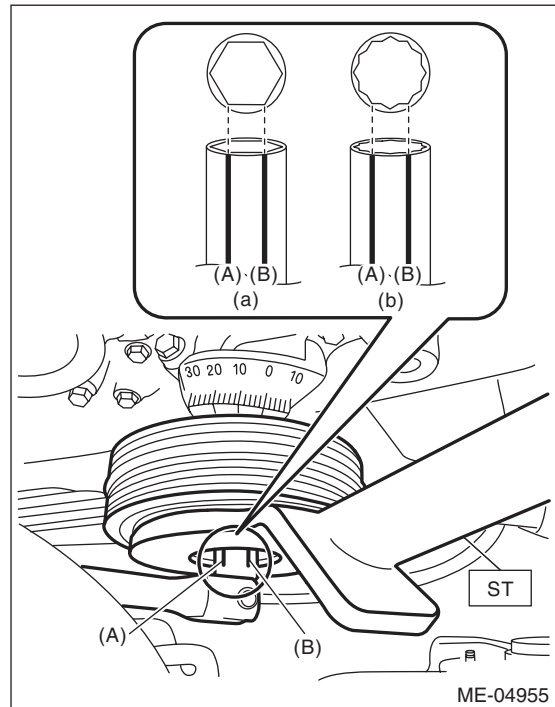

(a) When using 6-point socket

(b) When using 12-point socket

(3) Draw end line (C) on ST using a marker at the same position as reference line (B) drawn on the socket in step (2).

ST 499977100 CRANK PULLEY WRENCH

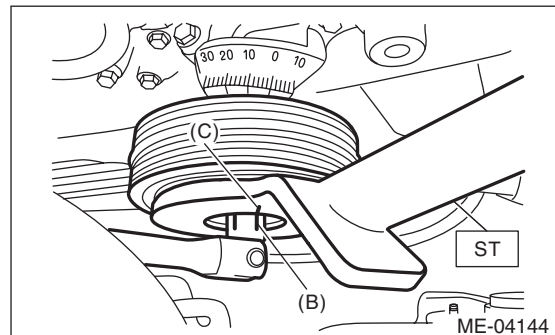

# Crank Pulley

## MECHANICAL

- (4) Use the ST to lock the crank pulley, and tighten the crank pulley bolt to the angle where reference line (A) and end line (C) are aligned.

### NOTE:

It should be approx.  $60^\circ$  when reference line (A) and end line (C) are aligned.

ST 499977100 CRANK PULLEY WRENCH

### Tightening angle:

$60^\circ \pm 5^\circ$

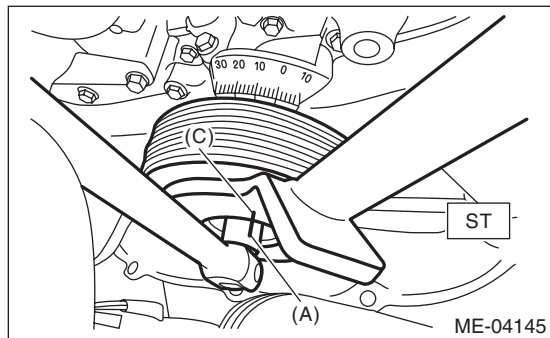

- 5) Install the V-belts. <Ref. to ME(STI)-40, INSTALLATION, V-belt.>

## 2. METHOD WITH ANGLE GAUGE

- 1) Clean the crankshaft thread using compressed air.
- 2) Install the crank pulley.
- 3) Apply engine oil to the crank pulley bolt seat and thread.
- 4) Tighten the crank pulley bolts.

- (1) Remove the radiator main fan motor assembly and radiator sub fan motor assembly. <Ref. to CO(STI)-23, REMOVAL, Radiator Main Fan and Fan Motor.> <Ref. to CO(STI)-25, REMOVAL, Radiator Sub Fan and Fan Motor.>

- (2) Use the ST1 to lock the crank pulley, and temporarily tighten the crank pulley bolt.

ST1 499977100 CRANK PULLEY WRENCH

### Tightening torque:

$47\text{ N}\cdot\text{m}$  (4.8 kgf-m, 34.7 ft-lb)

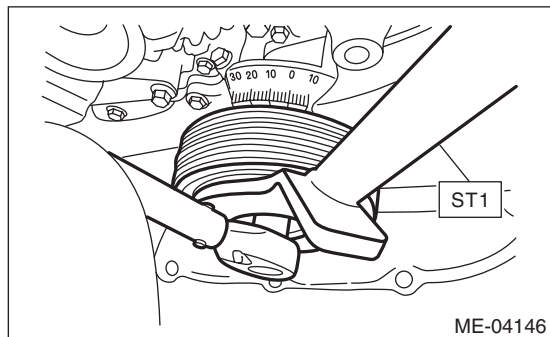

- (3) Set the ST2, use the ST1 to lock the crank pulley, and tighten the crank pulley bolt to the specified angle.

### NOTE:

Attach the magnet used for securing the ST2 (ANGLE GAUGE) to ST1.

ST1 499977100 CRANK PULLEY WRENCH

ST2 18854AA000 ANGLE GAUGE

### Tightening angle:

$60^\circ \pm 5^\circ$

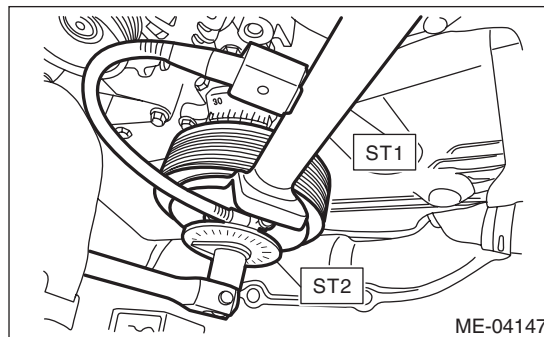

- (4) Install the radiator main fan motor assembly and radiator sub fan motor assembly. <Ref. to CO(STI)-23, INSTALLATION, Radiator Main Fan and Fan Motor.> <Ref. to CO(STI)-25, INSTALLATION, Radiator Sub Fan and Fan Motor.>

- 5) Install the V-belts. <Ref. to ME(STI)-40, INSTALLATION, V-belt.>

## C: INSPECTION

- 1) Check that the crank pulley has no deformation, cracks or other damages.



## 14. Timing Belt Cover

### A: REMOVAL

**NOTE:**

When replacing a single part, perform the work with the engine assembly installed to body.

- 1) Remove the secondary air pump. <Ref. to EC(STI)-27, REMOVAL, Secondary Air Pump.>
- 2) Remove the crank pulley. <Ref. to ME(STI)-47, REMOVAL, Crank Pulley.>
- 3) Remove the timing belt cover RH (B) together with the engine harness cover (A).
- 4) Remove the timing belt cover LH (C).
- 5) Remove the front timing belt cover (D).

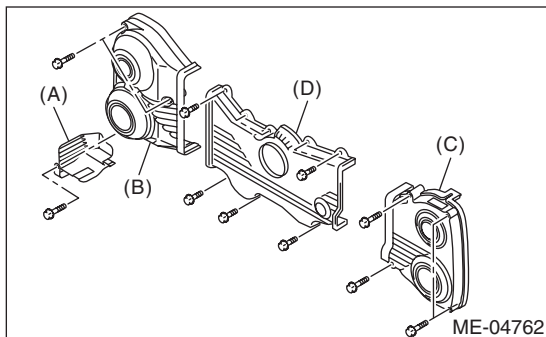

### B: INSTALLATION

- 1) Install the front timing belt cover (D).

**Tightening torque:**

**5 N·m (0.5 kgf·m, 3.7 ft·lb)**

- 2) Install the timing belt cover LH (C).

**Tightening torque:**

**5 N·m (0.5 kgf·m, 3.7 ft·lb)**

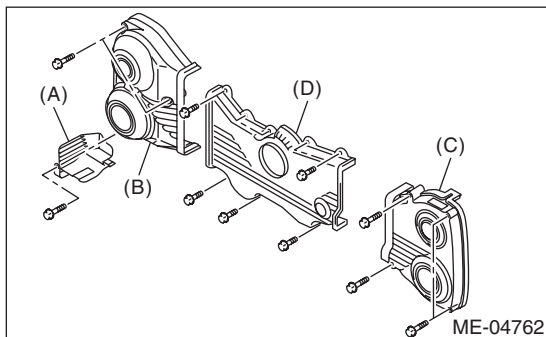

- 3) Install the timing belt cover RH (B) together with the engine harness cover (A).

**Tightening torque:**

**5 N·m (0.5 kgf·m, 3.7 ft·lb)**

- 4) Install the crank pulley. <Ref. to ME(STI)-47, INSTALLATION, Crank Pulley.>
- 5) Install the secondary air pump. <Ref. to EC(STI)-27, INSTALLATION, Secondary Air Pump.>

# Timing Belt

MECHANICAL

## 15. Timing Belt

### A: REMOVAL

#### NOTE:

- When replacing a single part, perform the work with the engine assembly installed to body.
- When performing the work with the engine installed to body, the following parts must also be removed/installed.
  - Radiator main fan motor assembly <Ref. to CO(STI)-23, REMOVAL, Radiator Main Fan and Fan Motor.> <Ref. to CO(STI)-23, INSTALLATION, Radiator Main Fan and Fan Motor.>
  - Radiator sub fan motor assembly <Ref. to CO(STI)-25, REMOVAL, Radiator Sub Fan and Fan Motor.> <Ref. to CO(STI)-25, INSTALLATION, Radiator Sub Fan and Fan Motor.>
- When performing the work with the engine installed to body, protect the radiator with cardboards or blankets.

### 1. TIMING BELT

- 1) Remove the crank pulley. <Ref. to ME(STI)-47, REMOVAL, Crank Pulley.>
- 2) Remove the timing belt cover. <Ref. to ME(STI)-49, REMOVAL, Timing Belt Cover.>
- 3) Remove the timing belt guide.

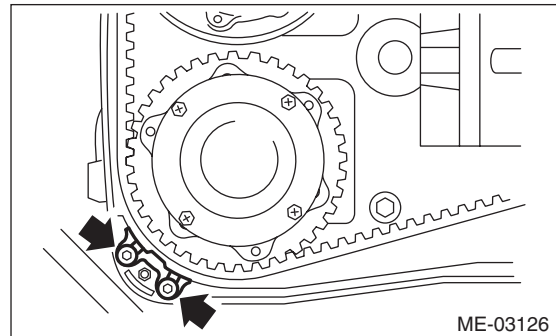
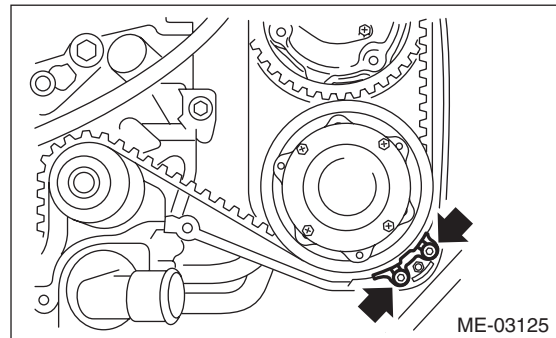
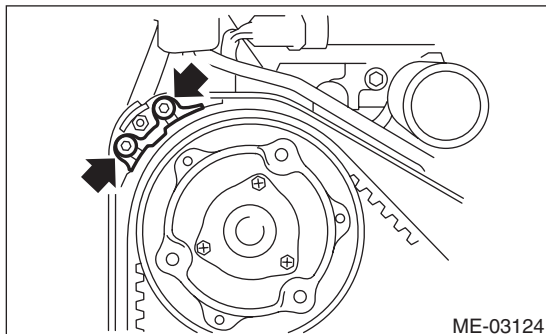
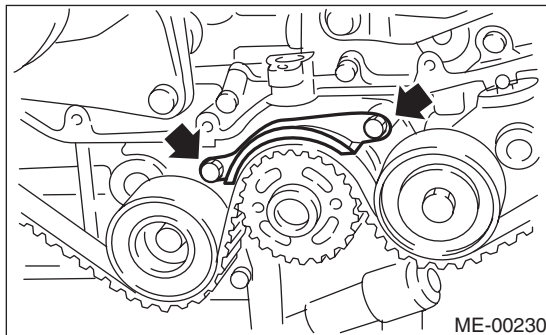

- 4) If the alignment mark or arrow mark (which indicates the direction of rotation) on timing belt fade away, put new marks before removing the timing belt as shown in procedures below.

(1) Turn the crankshaft using ST, and align the alignment marks on crank sprocket, intake cam sprocket LH, exhaust cam sprocket LH, intake cam sprocket RH and exhaust cam sprocket RH with marks on oil pump and notches of timing belt cover.

ST 499987500 CRANKSHAFT SOCKET

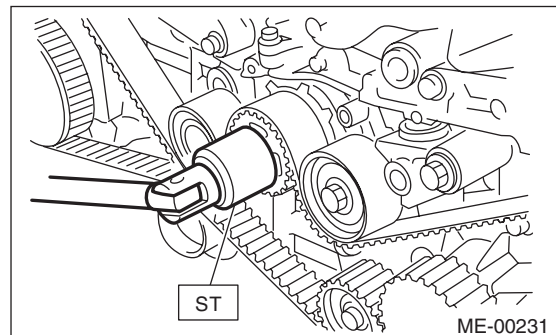

ME(STI)-50

Brought to you by Ebay Seller "SubaruManuals"

(2) Using white paint, put an alignment mark or an arrow mark on timing belts in relation to the crank sprocket and cam sprockets.

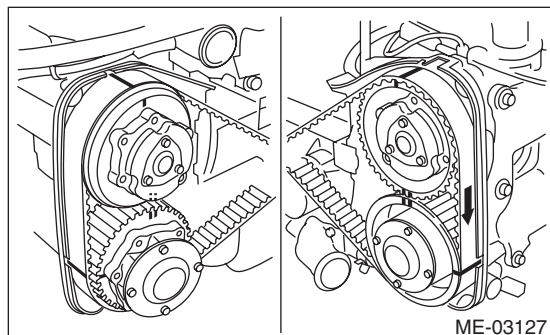
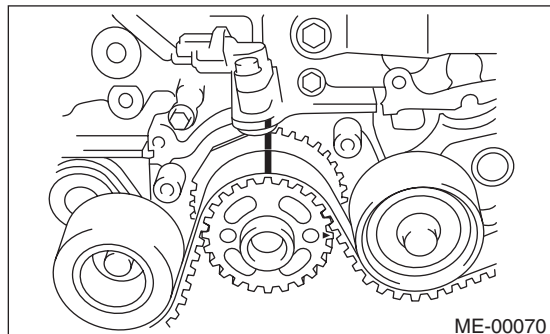

**Z<sub>1</sub>: 54.5 teeth**

**Z<sub>2</sub>: 51 teeth**

**Z<sub>3</sub>: 28 teeth**

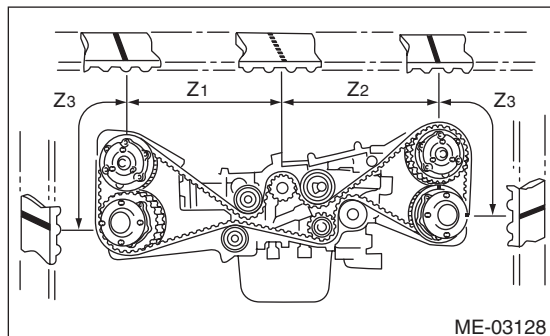

5) Remove the belt idler (A).

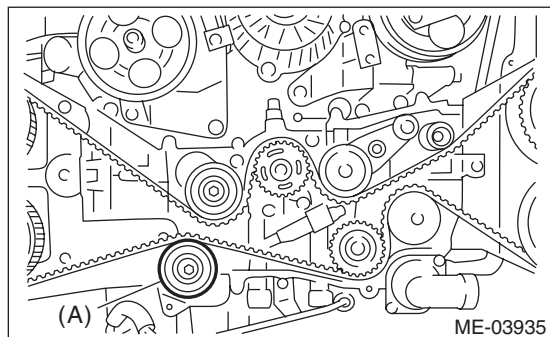

6) Remove the timing belt.

**CAUTION:**

After the timing belt has been removed, never rotate the intake and exhaust sprocket. If the cam sprocket is rotated, the intake and exhaust valve heads strike together and valve stems are bent.

**2. AUTOMATIC BELT TENSION ADJUST-ER ASSEMBLY AND BELT IDLER**

1) Remove the belt idler (A) and (B).

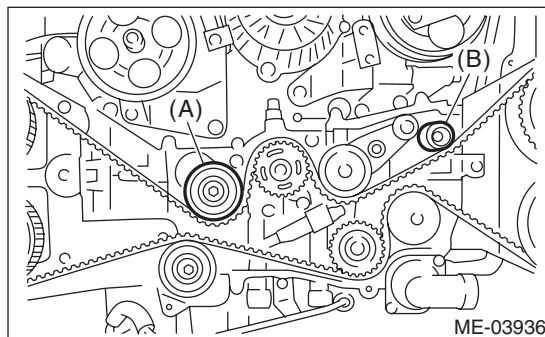

2) Remove the belt idler No. 2.

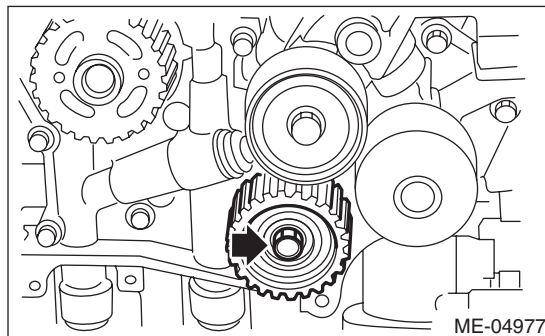

3) Remove the automatic belt tension adjuster assembly.

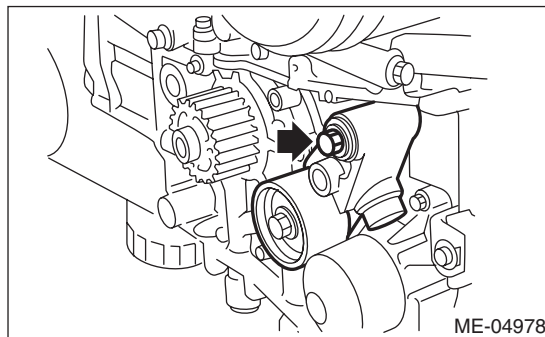



# Timing Belt

MECHANICAL

## B: INSTALLATION

### 1. AUTOMATIC BELT TENSION ADJUST-ER ASSEMBLY AND BELT IDLER

1) Prepare for installation of the automatic belt tension adjuster assembly.

#### CAUTION:

- Always use a vertical type pressing tool to move the adjuster rod down.
- Do not use a lateral type vise.
- Push the adjuster rod vertically.
- Press-in the push adjuster rod gradually taking three minutes or more.
- Do not allow press pressure to exceed 9,807 N (1,000 kgf, 2,205 lbf).
- Push in the adjuster rod to the end face of the cylinder. However, do not press the adjuster rod below the end face of the cylinder. Doing so may damage the cylinder.
- Do not release the press pressure until stopper pin is completely inserted.

(1) Attach the automatic belt tension adjuster assembly to vertical pressing tool.

(2) Slowly push in the adjuster rod with a pressure of 165 N (16.8 kgf, 37.1 lbf) or more until the adjuster rod is aligned with the stopper pin hole in the cylinder.

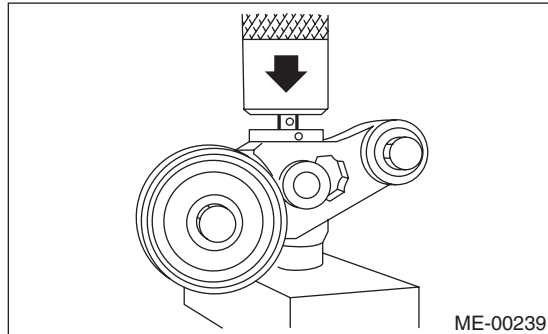

(3) With a 2 mm (0.08 in) dia. stopper pin or a 2 mm (nominal) dia. hex wrench inserted into the stopper pin hole in cylinder, secure the adjuster rod.

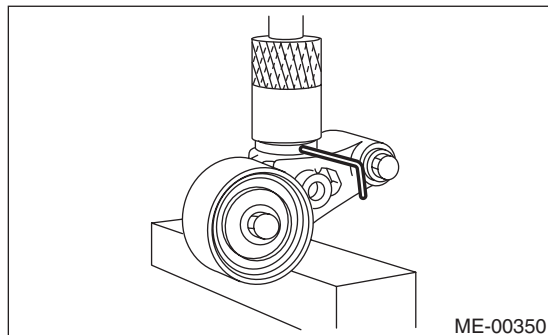

2) Install the automatic belt tension adjuster assembly.

**Tightening torque:**

**39 N·m (4.0 kgf·m, 28.8 ft·lb)**

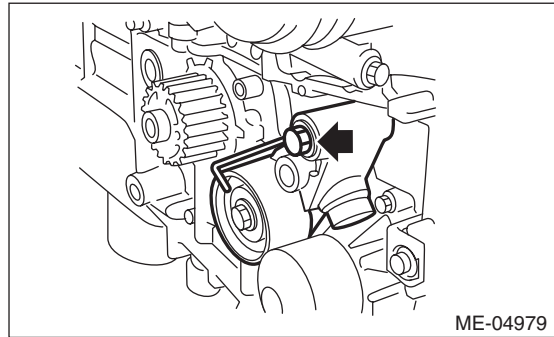

3) Install the belt idler No. 2.

**Tightening torque:**

**39 N·m (4.0 kgf·m, 28.8 ft·lb)**

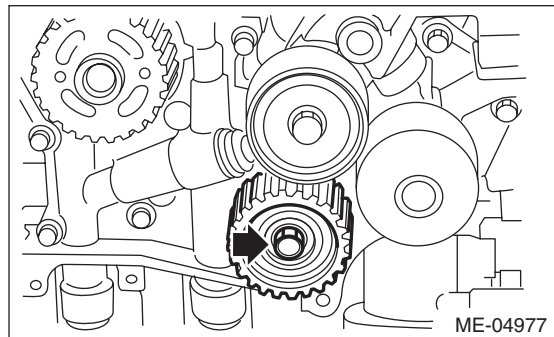

4) Install the belt idlers.

**Tightening torque:**

**39 N·m (4.0 kgf·m, 28.8 ft·lb)**

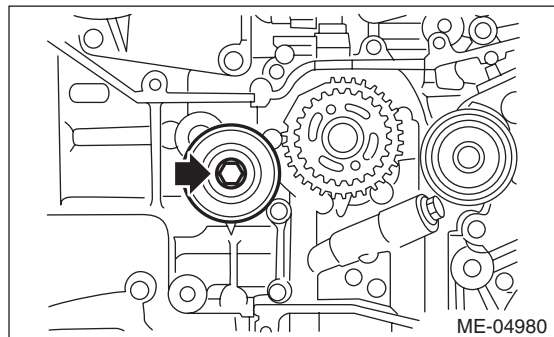

**Tightening torque:**

**25 N·m (2.5 kgf·m, 18.4 ft·lb)**

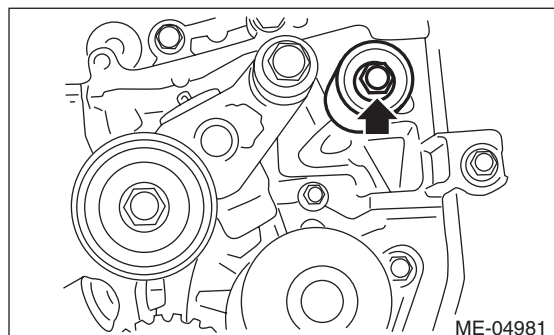

ME(STI)-52

Brought to you by Ebay Seller "SubaruManuals"

## 2. TIMING BELT

1) Prepare for installation of the automatic belt tension adjuster assembly. <Ref. to ME(STI)-52, AUTOMATIC BELT TENSION ADJUSTER ASSEMBLY AND BELT IDLER, INSTALLATION, Timing Belt.>

2) Align the mark (B) on crank sprocket with the mark (A) on oil pump.

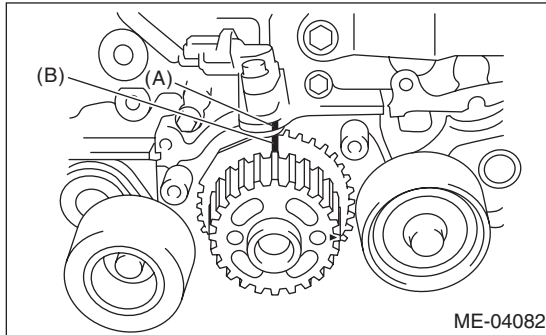

3) Align the single line mark (B) on the exhaust cam sprocket RH with notch (A) on the timing belt cover.

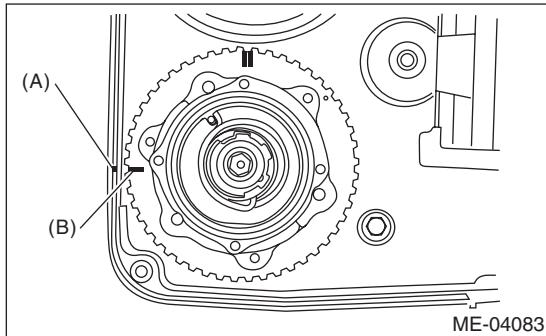

4) Align the single line mark (B) on the intake cam sprocket RH with notch (A) on the timing belt cover. Make sure that the double line marks (C) on intake and exhaust cam sprockets are aligned.

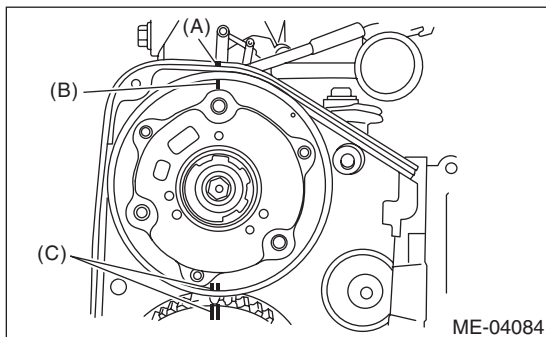

5) Align the single line mark (B) on exhaust cam sprocket LH with notch (A) on the timing belt cover by turning the sprocket counterclockwise (as viewed from front of engine).

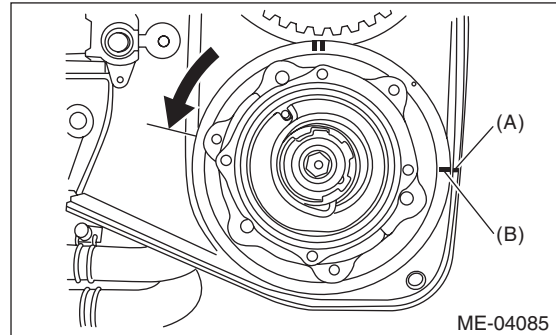

6) Align the single line mark (B) on intake cam sprocket LH with notch (A) on the timing belt cover by turning the sprocket clockwise (as viewed from front of engine). Make sure the double line marks (C) on the intake and exhaust cam sprockets are aligned.

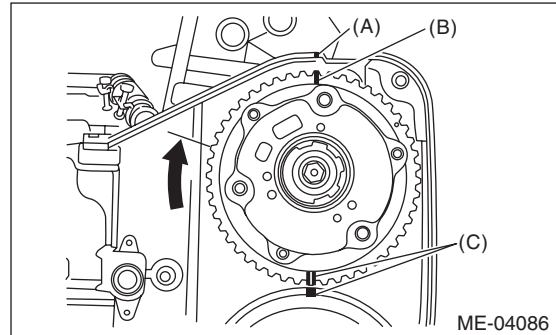

# Timing Belt

## MECHANICAL

7) Make sure that the cam and crank sprockets are positioned properly.

### CAUTION:

- Intake and exhaust camshafts for this DOHC engine can be independently rotated with the timing belts removed. As can be seen from the figure, if the intake and exhaust valves are lifted simultaneously, heads will interfere with each other, resulting in bent valves.

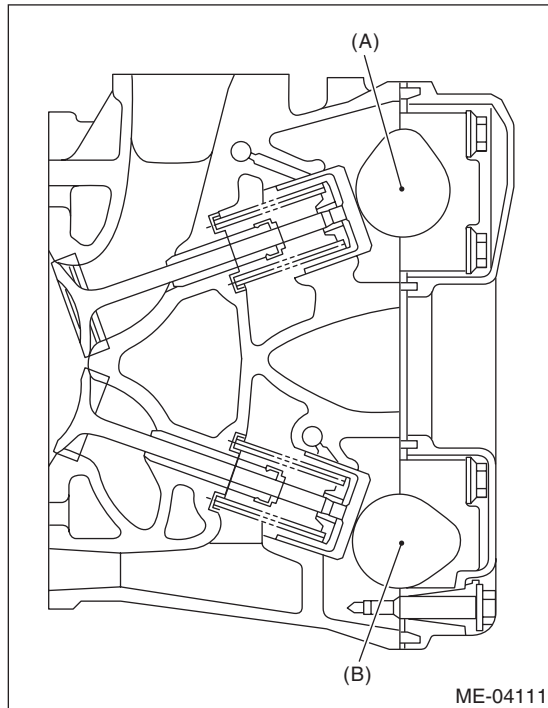

- (A) Intake camshaft
- (B) Exhaust camshaft

- When the timing belts are not installed, four camshafts are held at the “zero-lift” position, where all cams on camshafts are not pushing down on the intake and exhaust valves. (Under this condition, all valves remain unlifted.)
- When the camshafts are rotated to install the timing belts, #2 intake and #4 exhaust cam of camshaft LH are held, pushing their corresponding valves down. (Under this condition, these valves are held lifted.) Camshaft RH are held so that their cams do not push the valves down.
- Camshafts LH must be rotated from the zero-lift position to the position where the timing belt is to be installed with the smallest possible angle, in order to prevent mutual interference of intake and exhaust valve heads.

- Do not allow the camshafts to rotate in the direction shown in the upper figure. Doing this may cause both the intake and exhaust valves to lift simultaneously, resulting in mutual interference of valve heads.

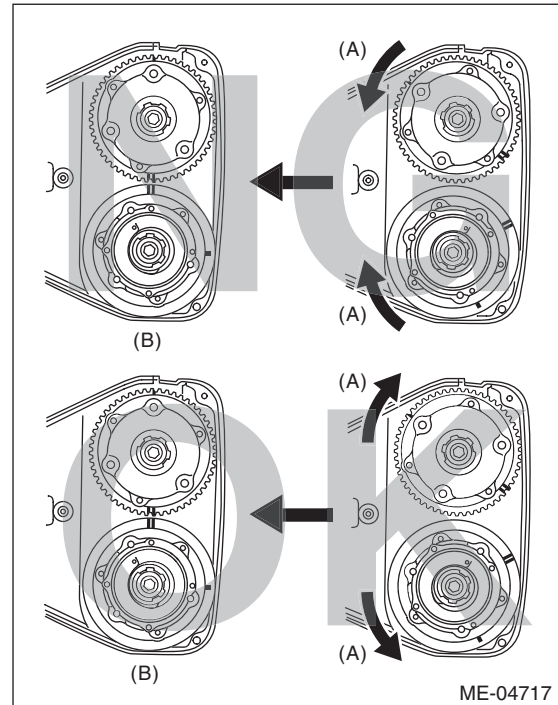

- (A) Direction of rotation
- (B) Timing belt installation position

# Timing Belt

MECHANICAL

8) Align the alignment mark on the timing belt with marks on the sprockets in the alphabetical order shown in the figure. While aligning marks, position the timing belt properly, and install the timing belt.

### CAUTION:

- If the timing belt slips by 1 or more teeth, the valve and piston may hit each other.
- Make sure that the direction of belt rotation is correct.

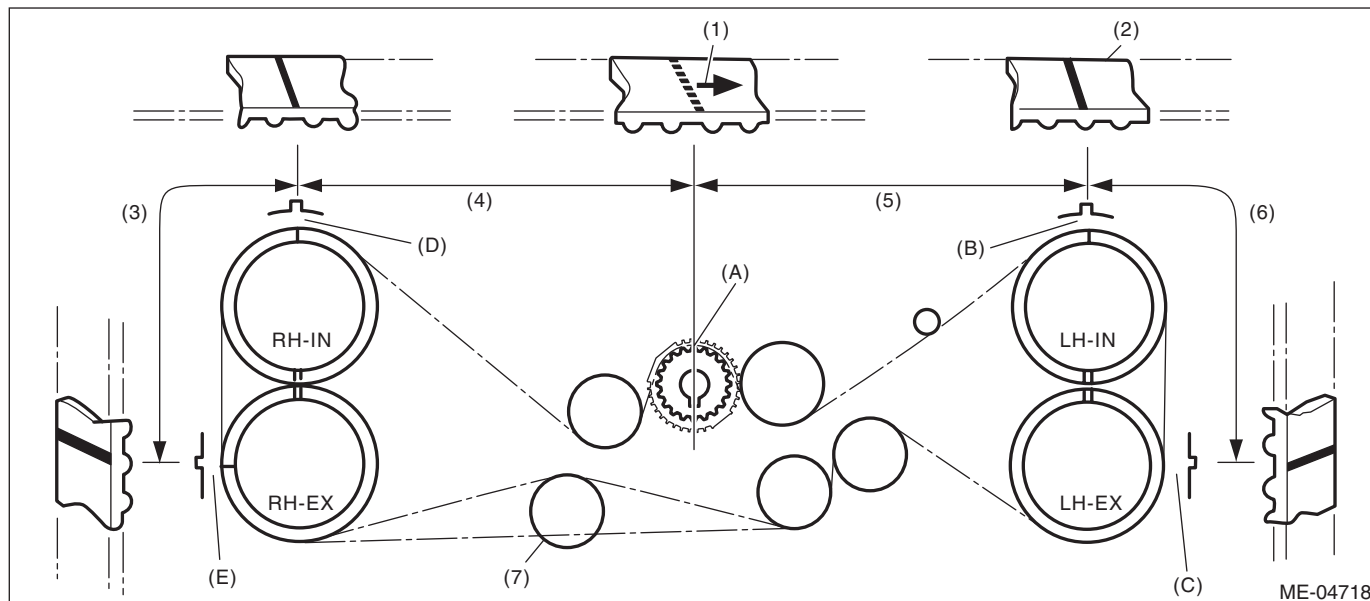

- |                 |                |                           |
|-----------------|----------------|---------------------------|
| (1) Arrow mark  | (4) 54.5 teeth | (6) 28 teeth              |
| (2) Timing belt | (5) 51 teeth   | (7) Install it in the end |
| (3) 28 teeth    |                |                           |

9) Install the belt idlers.

### Tightening torque:

**39 N·m (4.0 kgf·m, 28.8 ft·lb)**

### NOTE:

Make sure that the marks on the timing belt and sprockets are aligned.

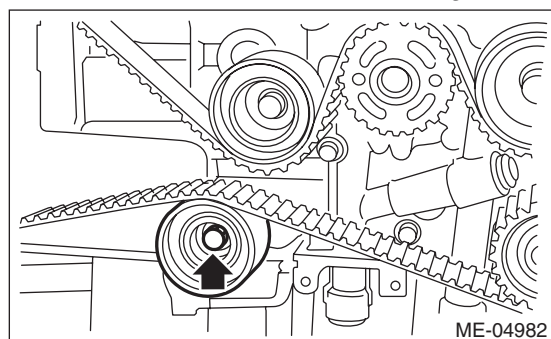

**ME(STI)-55**

Brought to you by Ebay Seller "SubaruManuals"

# Timing Belt

## MECHANICAL

10) After ensuring that the marks on the timing belt and sprockets are aligned, remove the stopper pin from tensioner adjuster.

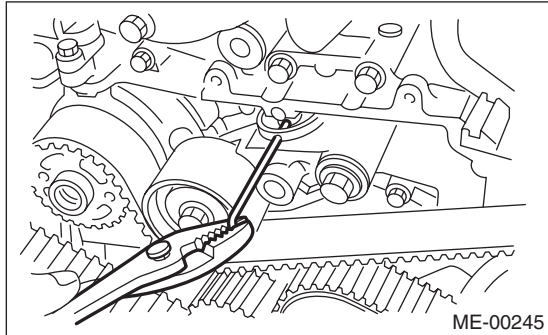

**Liquid gasket:**  
**THREE BOND 1324 (Part No. 004403042) or equivalent**

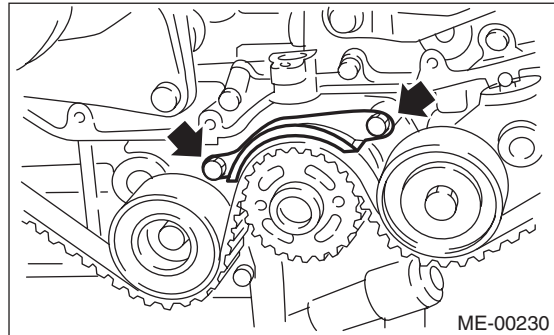

11) Install the timing belt guide.

(1) Temporarily tighten the bolts mounting the timing belt guide.

### NOTE:

- Before installing the timing belt guide, clean the timing belt guide mounting bolt holes of the timing belt cover No. 2.
- Apply liquid gasket to the thread of the timing belt guide mounting bolt on the cam sprocket section. (when reusing bolts)

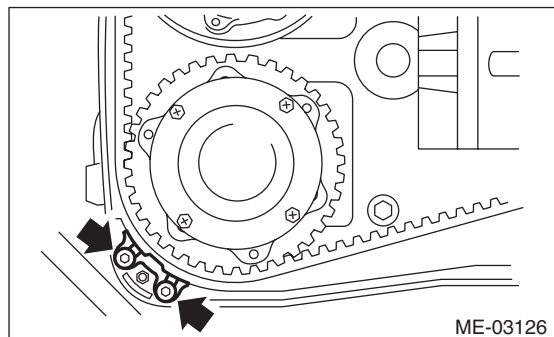
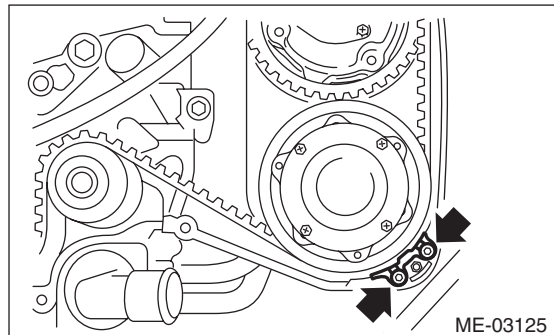
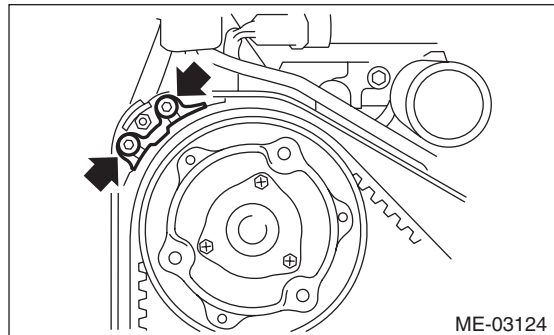

(2) Adjust the clearance between timing belt and timing belt guide using a thickness gauge and tighten.



# Timing Belt

MECHANICAL

**Clearance:**

**$1.0 \pm 0.5$  mm ( $0.039 \pm 0.020$  in)**

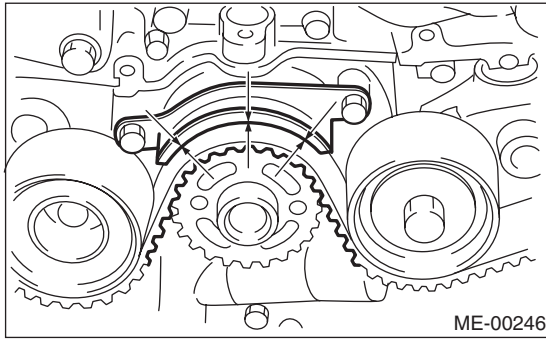

**Tightening torque:**

**$9.75$  N·m ( $1.0$  kgf·m,  $7.2$  ft·lb)**

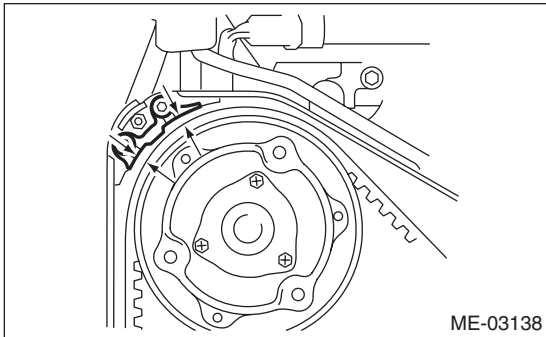
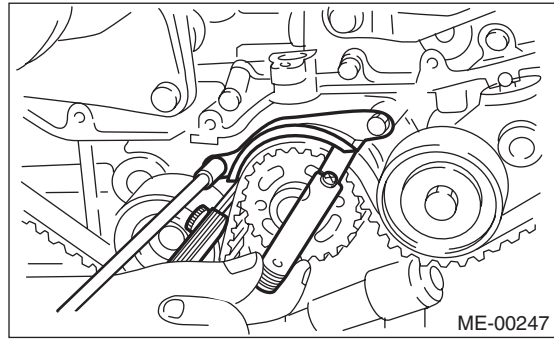

**Tightening torque:**

**$6.4$  N·m ( $0.7$  kgf·m,  $4.7$  ft·lb)**

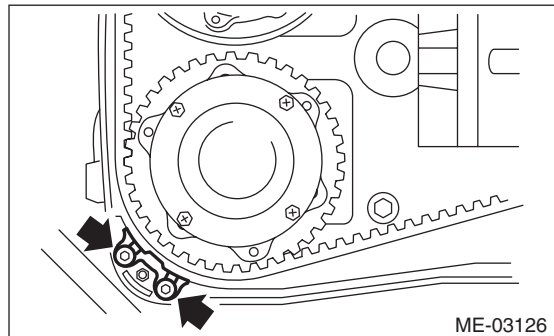
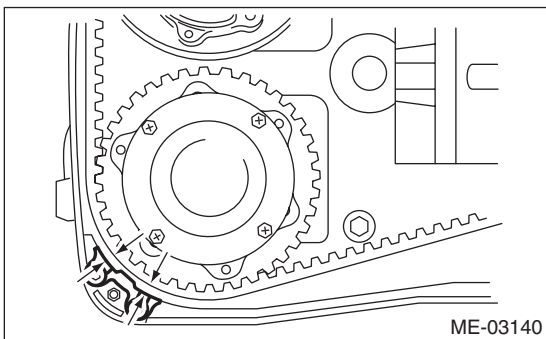
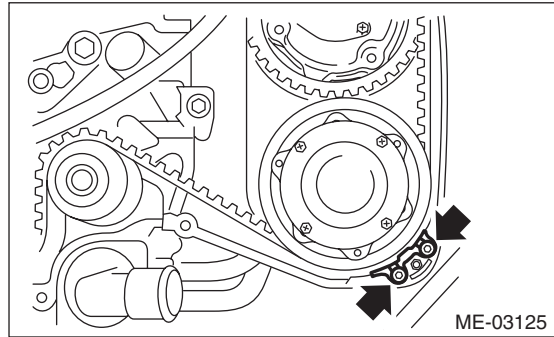
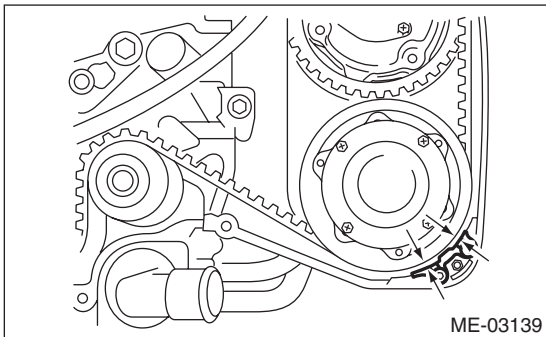
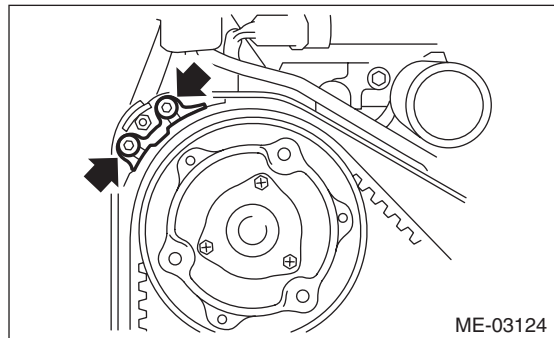

12) Install the timing belt cover. <Ref. to ME(STI)-49, INSTALLATION, Timing Belt Cover.>

13) Install the crank pulley. <Ref. to ME(STI)-47, INSTALLATION, Crank Pulley.>

**ME(STI)-57**

Brought to you by Ebay Seller "SubaruManuals"

# Timing Belt

MECHANICAL

## C: INSPECTION

### 1. TIMING BELT

- 1) Check the timing belt teeth for breaks, cracks or wear. If any fault is found, replace the timing belt.
- 2) Check the condition on the back surface of the timing belt. If cracks are found, replace the timing belt.

#### CAUTION:

- Be careful not to let oil, grease or coolant contact the timing belt. Remove quickly and thoroughly if this happens.
- Do not bend the timing belt sharply.

*In radial diameter h:*

**60 mm (2.36 in) or more**

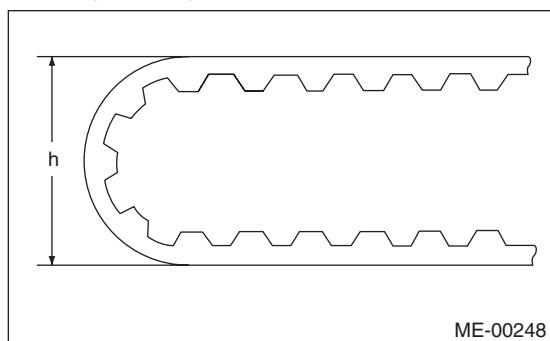

### 2. AUTOMATIC BELT TENSION ADJUST-ER

- 1) Visually check the oil seals for leaks, and rod ends for abnormal wear and scratches. If necessary, replace the automatic belt tension adjuster assembly.

#### NOTE:

Slight traces of oil at the rod oil seal does not indicate a problem.

- 2) Check that the adjuster rod does not move when a pressure of 165 N (16.8 kgf, 37.1 lbf) is applied to it. This is to check adjuster rod stiffness.

- 3) If the adjuster rod is not stiff enough and moves freely when applying 165 N (16.8 kgf, 37.1 lbf), check it using the following procedures:

- (1) Slowly press the adjuster rod down to the end surface of cylinder. Repeat this operation two to three times.

- (2) With the adjuster rod moved all the way up, apply a pressure of 165 N (16.8 kgf, 37.1 lbf) to it, and check the adjuster rod stiffness.

- (3) If the adjuster rod is not stiff and moves down, replace the automatic belt tension adjuster assembly with a new part.

#### CAUTION:

- Always use a vertical type pressing tool to move the adjuster rod down.
- Do not use a lateral type vise.
- Push the adjuster rod vertically.
- Press-in the push adjuster rod gradually taking three minutes or more.
- Do not allow press pressure to exceed 9,807 N (1,000 kgf, 2,205 lbf).
- Push in the adjuster rod to the end face of the cylinder. However, do not press the adjuster rod below the end face of the cylinder. Doing so may damage the cylinder.

- 4) Measure the amount of adjuster rod protrusion "L" from the end surface of the cylinder. If it is not within specifications, replace the automatic belt tension adjuster assembly with a new part.

**Protrusion amount of adjuster rod L:**

**5.2 — 6.2 mm (0.205 — 0.244 in)**

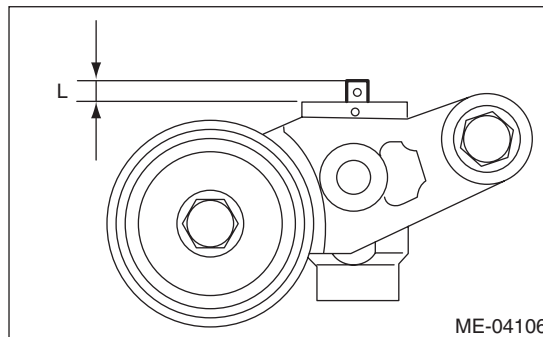

### 3. BELT TENSION PULLEY

- 1) Check the mating surfaces of timing belt and contact point of adjuster rod for abnormal wear or scratches. Replace the automatic belt tension adjuster assembly with a new part if faulty.

- 2) Check the belt tension pulley for smooth rotation. Replace the automatic belt tension adjuster assembly with a new part if abnormal noise or excessive play occurs.

- 3) Check the belt tension pulley for grease leakage.

### 4. BELT IDLER

- 1) Check the belt idler for smooth rotation. Replace if noise or excessive play occurs.

- 2) Check the outer contacting surfaces of idler pulley for abnormal wear and scratches.

- 3) Check the belt idler for grease leakage.

ME(STI)-58

Brought to you by Ebay Seller "SubaruManuals"

## 16. Cam Sprocket

### A: REMOVAL

#### NOTE:

When replacing a single part, perform the work with the engine assembly installed to body.

- 1) Remove the crank pulley. <Ref. to ME(STI)-47, REMOVAL, Crank Pulley.>
- 2) Remove the timing belt cover. <Ref. to ME(STI)-49, REMOVAL, Timing Belt Cover.>
- 3) Remove the timing belt. <Ref. to ME(STI)-50, REMOVAL, Timing Belt.>
- 4) Remove the actuator covers of the intake and exhaust cam sprockets.
- 5) Use the ST to lock the cam sprocket, and remove the cam sprocket bolt.

ST 499977500 CAM SPROCKET WRENCH

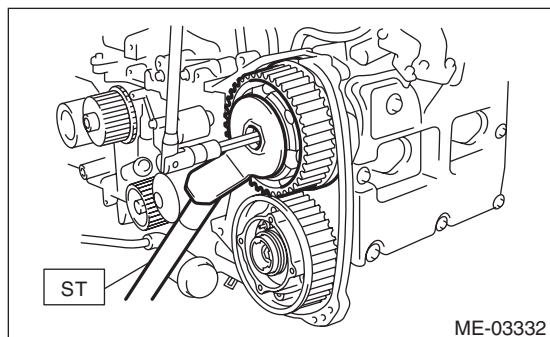

- 6) Remove the cam sprocket.

### B: INSTALLATION

- 1) Install the cam sprocket.
- 2) Use the ST to lock the cam sprocket, and install the cam sprocket bolt.

#### NOTE:

Do not confuse cam sprockets (LH) and (RH), and (INT) and (EXH) during installation.

ST 499977500 CAM SPROCKET WRENCH

#### Tightening torque:

**Tighten to 30 N·m (3.1 kgf-m, 22.1 ft-lb) of torque, and then tighten further by 45°.**

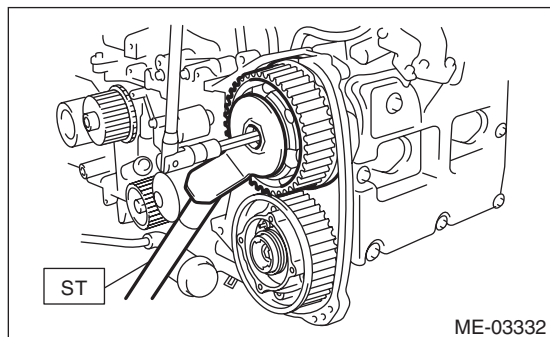

- 3) Attach the actuator covers of the intake and exhaust cam sprockets.

#### NOTE:

Use new O-rings.

#### Tightening torque:

**3.4 N·m (0.3 kgf-m, 2.5 ft-lb)**

- 4) Install the timing belt. <Ref. to ME(STI)-52, INSTALLATION, Timing Belt.>
- 5) Install the timing belt cover. <Ref. to ME(STI)-49, INSTALLATION, Timing Belt Cover.>
- 6) Install the crank pulley. <Ref. to ME(STI)-47, INSTALLATION, Crank Pulley.>

### C: INSPECTION

- 1) Check the cam sprocket teeth for abnormal wear and scratches.
- 2) Make sure there is no free play between cam sprocket and key.



## 17.Crank Sprocket

### A: REMOVAL

**NOTE:**

When replacing a single part, perform the work with the engine assembly installed to body.

- 1) Remove the crank pulley. <Ref. to ME(STI)-47, REMOVAL, Crank Pulley.>
- 2) Remove the timing belt cover. <Ref. to ME(STI)-49, REMOVAL, Timing Belt Cover.>
- 3) Remove the timing belt. <Ref. to ME(STI)-50, REMOVAL, Timing Belt.>
- 4) Remove the crank sprocket.

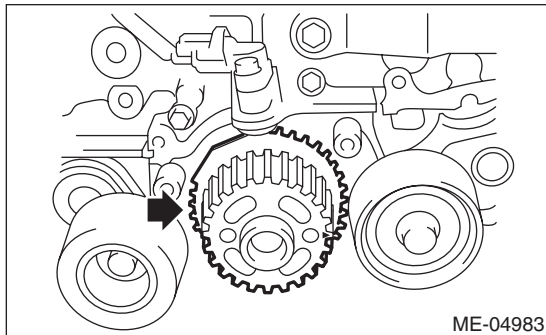

### B: INSTALLATION

- 1) Install the crank sprocket.

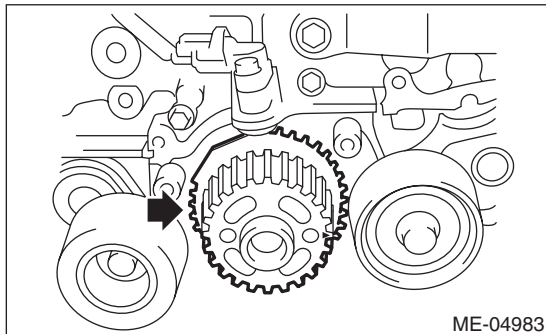

- 2) Install the timing belt. <Ref. to ME(STI)-52, INSTALLATION, Timing Belt.>
- 3) Install the timing belt cover. <Ref. to ME(STI)-49, INSTALLATION, Timing Belt Cover.>
- 4) Install the crank pulley. <Ref. to ME(STI)-47, INSTALLATION, Crank Pulley.>

### C: INSPECTION

- 1) Check the crank sprocket teeth for abnormal wear and scratches.
- 2) Make sure there is no free play between crank sprocket and key.
- 3) Check the crank sprocket protrusion used for sensor for damage and contamination of foreign matter.

## 18. Camshaft

### A: REMOVAL

- 1) Remove the engine from the vehicle. <Ref. to ME(STI)-30, REMOVAL, Engine Assembly.>
- 2) Remove the rear side belt. <Ref. to ME(STI)-40, REAR SIDE BELT, REMOVAL, V-belt.>
- 3) Remove the crank pulley. <Ref. to ME(STI)-47, REMOVAL, Crank Pulley.>
- 4) Remove the timing belt cover. <Ref. to ME(STI)-49, REMOVAL, Timing Belt Cover.>
- 5) Remove the timing belt. <Ref. to ME(STI)-50, REMOVAL, Timing Belt.>
- 6) Remove the cam sprocket. <Ref. to ME(STI)-59, REMOVAL, Cam Sprocket.>
- 7) Disconnect the connector from the intake oil flow control solenoid valve.

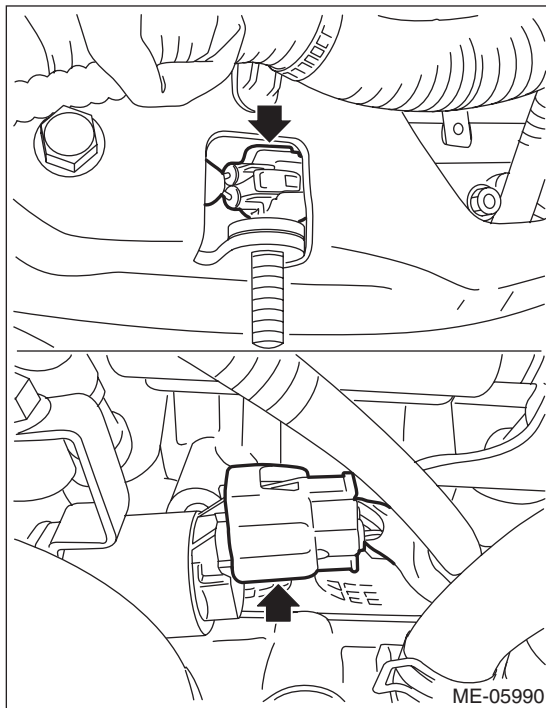

- 8) Disconnect the connector (A) from the exhaust camshaft position sensor and the connector (B) from the exhaust oil flow control solenoid valve.

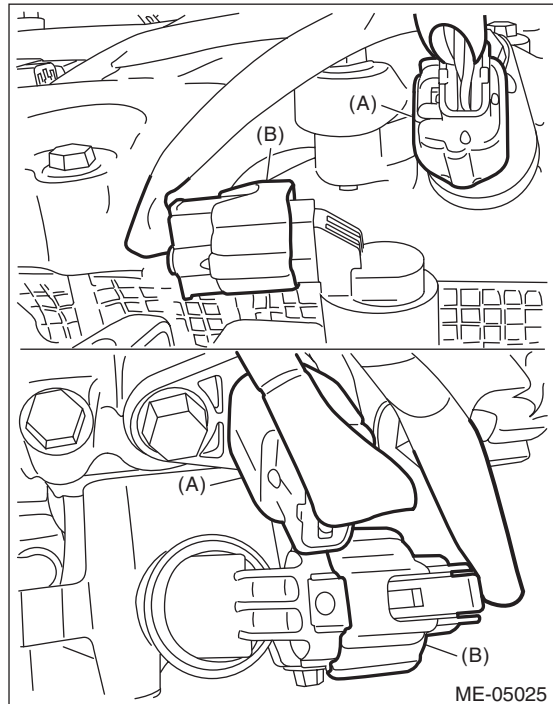

- 9) Remove the timing belt cover No. 2 RH (A) and timing belt cover No. 2 LH (B).

**NOTE:**

When removing the timing belt cover, be careful not to damage the seal rubber.

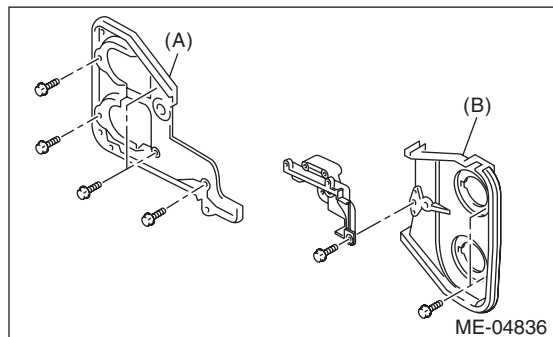

- 10) Remove the tensioner bracket.

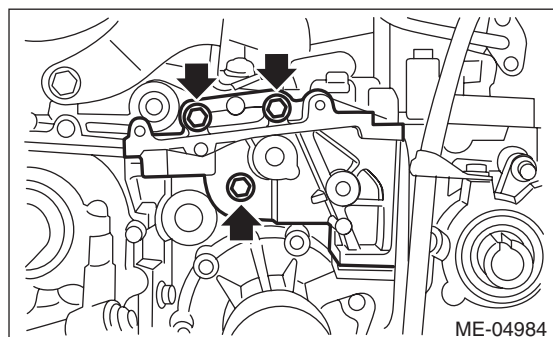

# Camshaft

## MECHANICAL

- 11) Remove the clip (A) which hold the engine harness to the rocker cover RH.

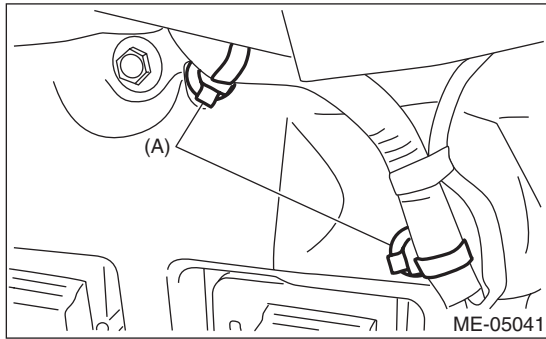

- 12) Remove the air duct B (B) from the rocker cover LH and the air duct A (A).

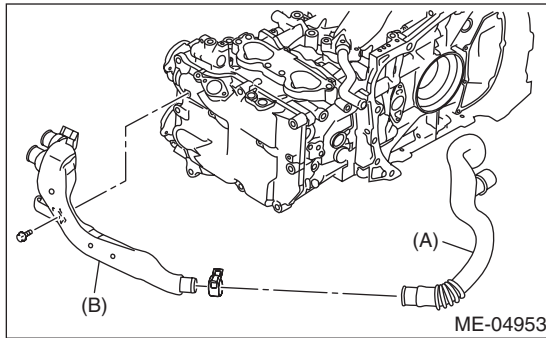

- 13) Remove the ignition coil. <Ref. to IG(STI)-7, REMOVAL, Ignition Coil.>  
14) Disconnect PCV hose (A) and vacuum hose (B) from the rocker cover.

### NOTE:

Pinch the clamp of the PCV hose (A) by fitting the cut out in the ST with the protrusion on the clamp as shown in the figure, and unlock the clamp.

ST 18353AA000 CLAMP PLIERS

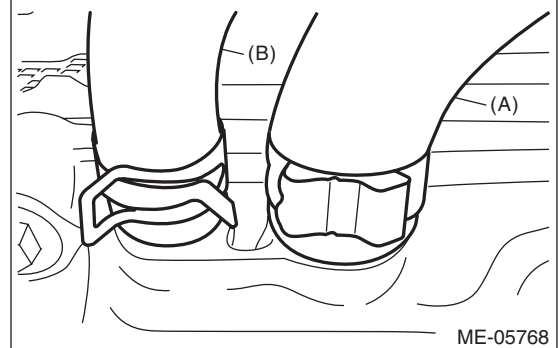
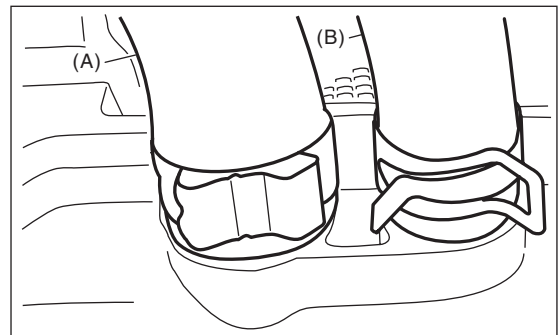
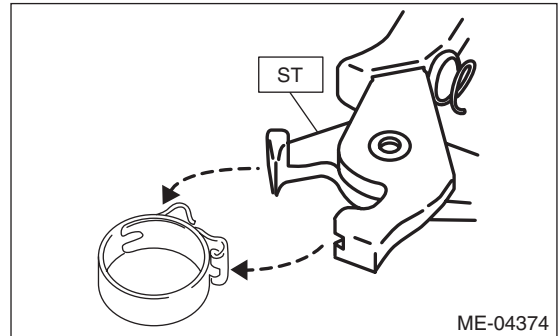

- 15) Remove the rocker cover.

16) Remove the union bolt without filter (without protrusion) which secures the oil pipe to the front camshaft cap.

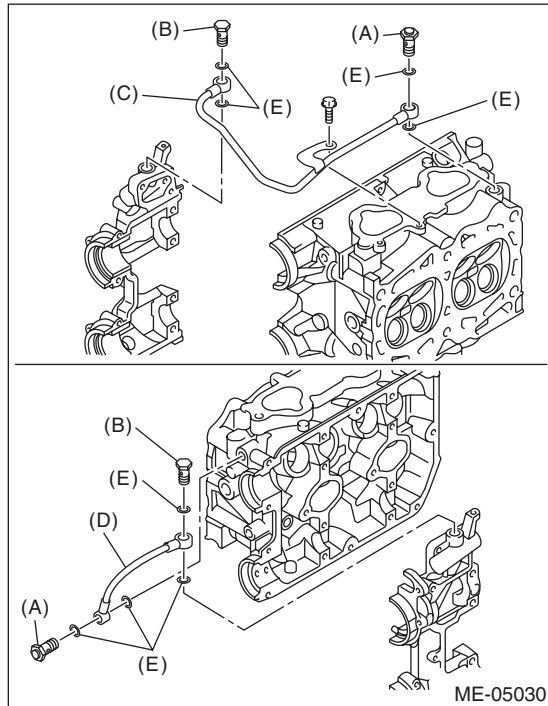

- (A) Union bolt with filter (with protrusion)
- (B) Union bolt without filter (without protrusion)
- (C) Oil pipe RH
- (D) Oil pipe LH
- (E) Gasket

17) Loosen the upper side of the front camshaft cap and the intake camshaft cap bolts equally, a little at a time in alphabetical sequence shown in the figure.

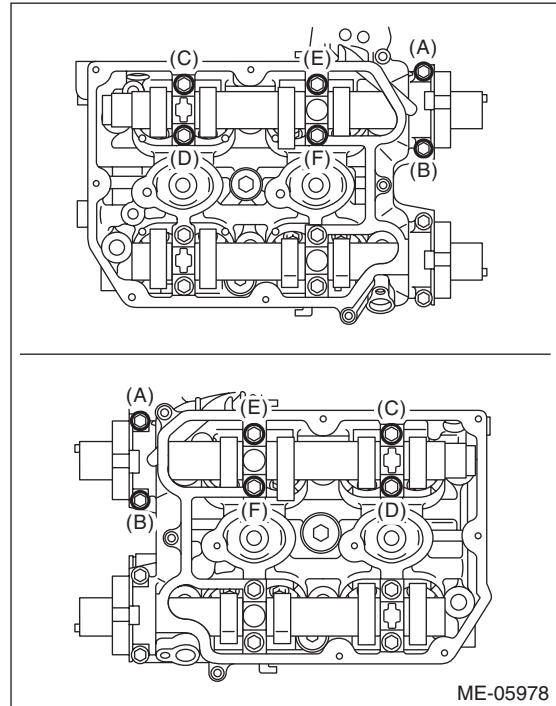

18) Loosen the lower side of the front camshaft cap and the exhaust camshaft cap bolts equally, a little at a time in alphabetical sequence shown in the figure.

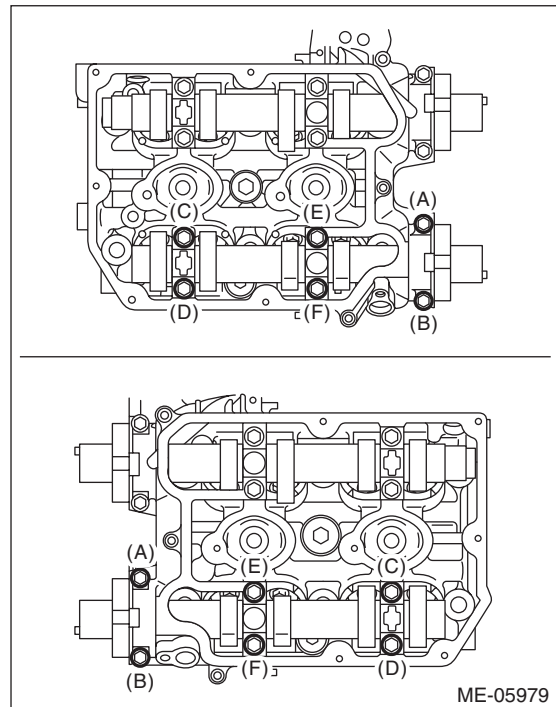

# Camshaft

## MECHANICAL

- 19) Remove the front camshaft cap.
- 20) Remove the intake camshaft caps and intake camshaft.
- 21) Remove the exhaust camshaft caps and exhaust camshaft.

### NOTE:

Arrange camshaft caps in order so that they can be installed in their original positions.

- 22) Remove the oil seal.

### CAUTION:

**Do not scratch the journal surface when removing the oil seal.**

## B: INSTALLATION

- 1) Install the camshaft.

Apply engine oil to the cylinder head at camshaft journal installation location before installing the camshaft. Install the camshaft so that each valve is close to or in contact with base circle of the cam lobe.

### NOTE:

- Set the camshaft to the position shown in the figure.
- When set at the position shown in the figure, it is not necessary to rotate the camshaft RH when installing the timing belt, but it is necessary to rotate the camshaft LH slightly.

### **Intake camshaft LH:**

**Rotate 80° clockwise.**

### **Exhaust camshaft LH:**

**Rotate 45° counterclockwise.**

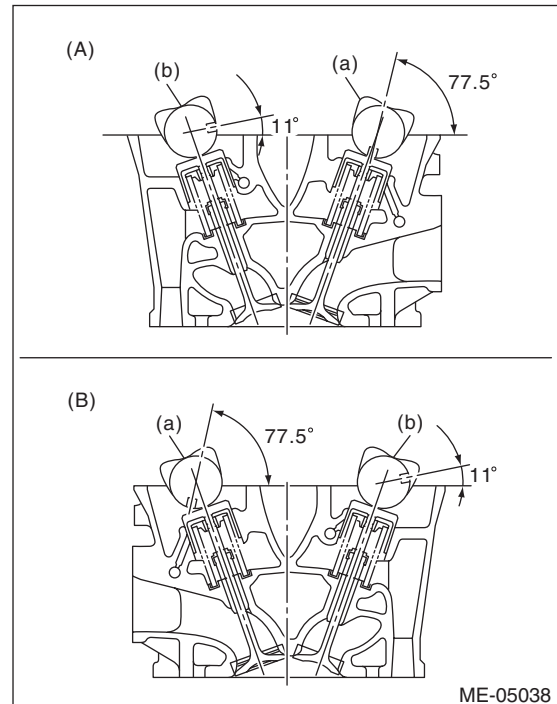

- (A) Cylinder head RH  
(B) Cylinder head LH  
(a) Intake camshaft  
(b) Exhaust camshaft

- 2) Install the camshaft cap.

- (1) Apply small amount of liquid gasket to the mating surface of cap.

### NOTE:

- Install within 5 min. after applying liquid gasket.
- Do not apply liquid gasket excessively. Applying excessively may cause excess gasket to come out and flow toward oil seal, resulting in oil leak.

### **Liquid gasket:**

**THREE BOND 1217G (Part No. K0877Y0100)  
or equivalent**

**Liquid gasket applying diameter:**  
**Mating surfaces other than ranges A and B**  
 $2 \pm 0.5 \text{ mm (0.0787} \pm 0.0197 \text{ in)}$   
**Mating surfaces of ranges A and B**  
 $3 \pm 1 \text{ mm (0.1181} \pm 0.0394 \text{ in)}$

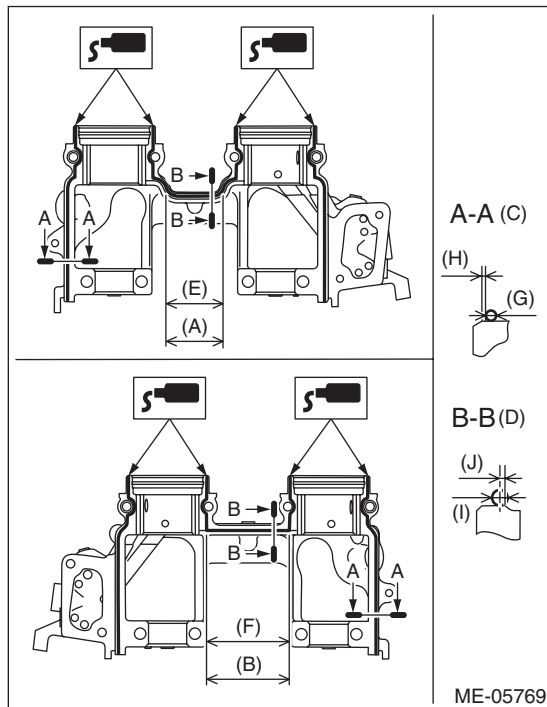

- (A) Range A
- (B) Range B
- (C) Liquid gasket applying position of mating surfaces of ranges other than A and B
- (D) Liquid gasket applying position of mating surfaces of ranges A and B
- (E) 44.8 mm (1.7638 in)
- (F) 65 mm (2.5591 in)
- (G)  $\phi 2 \pm 0.5 \text{ mm (0.0787} \pm 0.0197 \text{ in)}$
- (H)  $0.5 \pm 0.5 \text{ mm (0.0197} \pm 0.0197 \text{ in)}$
- (I)  $\phi 3 \pm 1 \text{ mm (0.1181} \pm 0.0394 \text{ in)}$
- (J) 1 mm (0.0394 in) or less

(2) Apply a thin coat of engine oil to the cap journal surface, and install the camshaft cap to the camshaft.

(3) Gradually tighten the camshaft cap in at least two steps, in alphabetical order shown in the figure, and then tighten to the specified torque.

**Tightening torque:**  
**T1: 9.75 N·m (1.0 kgf·m, 7.2 ft-lb)**  
**T2: 20 N·m (2.0 kgf·m, 14.8 ft-lb)**

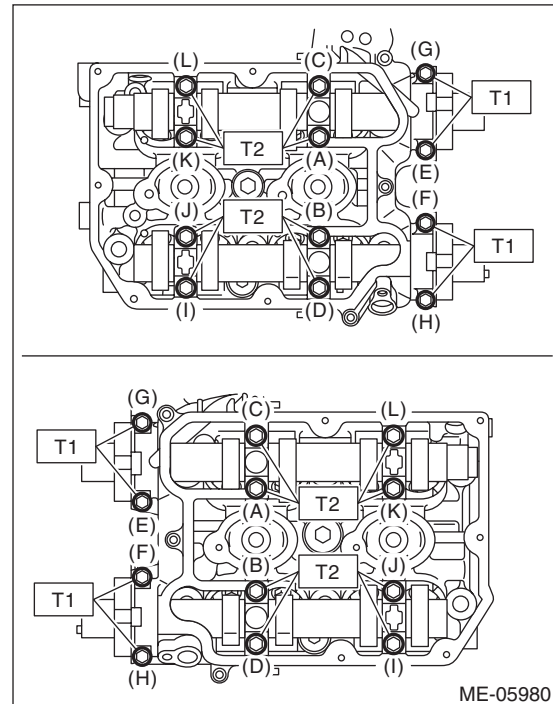

(4) After tightening the camshaft cap, ensure the camshaft rotates only slightly while holding it at base circle.

3) Apply a thin coat of engine oil to the periphery of the camshaft oil seal and oil seal lip, and install the oil seal on the camshaft using ST1 and ST2.

**NOTE:**  
 Use a new oil seal.  
 ST1 499587600 OIL SEAL INSTALLER  
 ST2 499597200 OIL SEAL GUIDE

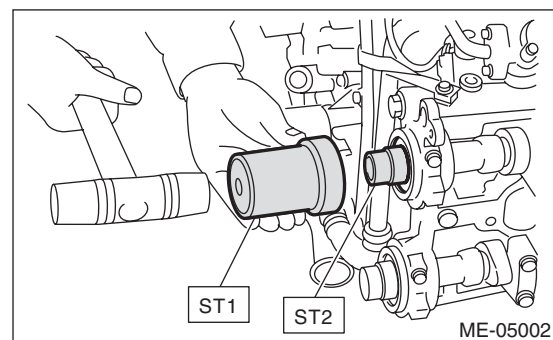



# Camshaft

## MECHANICAL

4) Install the oil pipe to the front camshaft cap using the union bolt without filter (without protrusion).

### NOTE:

Use a new gasket.

### Tightening torque:

**29 N·m (3.0 kgf·m, 21.4 ft·lb)**

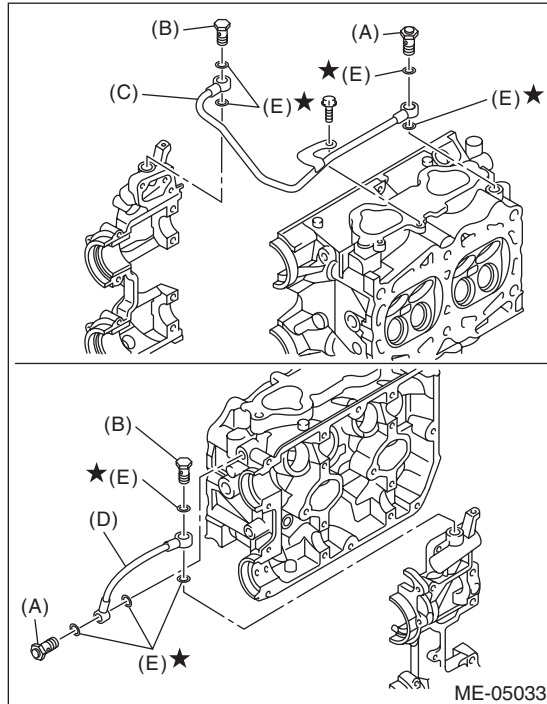

- (A) Union bolt with filter (with protrusion)
- (B) Union bolt without filter (without protrusion)
- (C) Oil pipe RH
- (D) Oil pipe LH
- (E) Gasket

5) Install the tensioner bracket.

### Tightening torque:

**24.5 N·m (2.5 kgf·m, 18.1 ft·lb)**

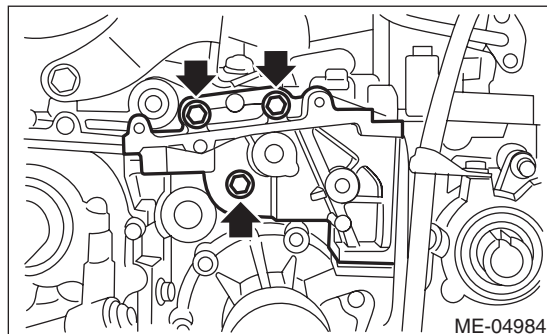

6) Install the timing belt cover No. 2 RH (A) and timing belt cover No. 2 LH (B).

### Tightening torque:

**5 N·m (0.5 kgf·m, 3.7 ft·lb)**

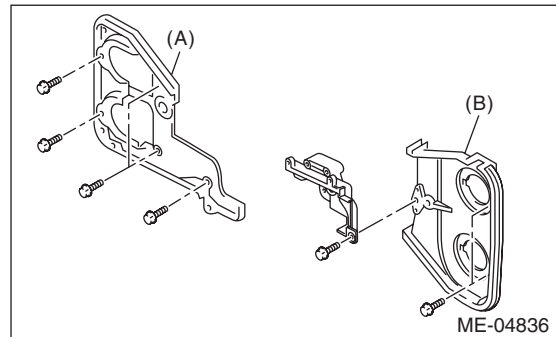

7) Install the cam sprocket. <Ref. to ME(STI)-59, INSTALLATION, Cam Sprocket.>

8) Install the timing belt. <Ref. to ME(STI)-52, INSTALLATION, Timing Belt.>

9) Adjust the valve clearance. <Ref. to ME(STI)-29, ADJUSTMENT, Valve Clearance.>

10) Install the rocker cover.

(1) Install the rocker cover gasket to the rocker cover. (outer section and ignition coil section)

### NOTE:

Use a new rocker cover gasket.

(2) Apply liquid gasket to the specified point of the cylinder head.

### NOTE:

Install within 5 min. after applying liquid gasket.

### Liquid gasket:

**THREE BOND 1217G (Part No. K0877Y0100) or equivalent**

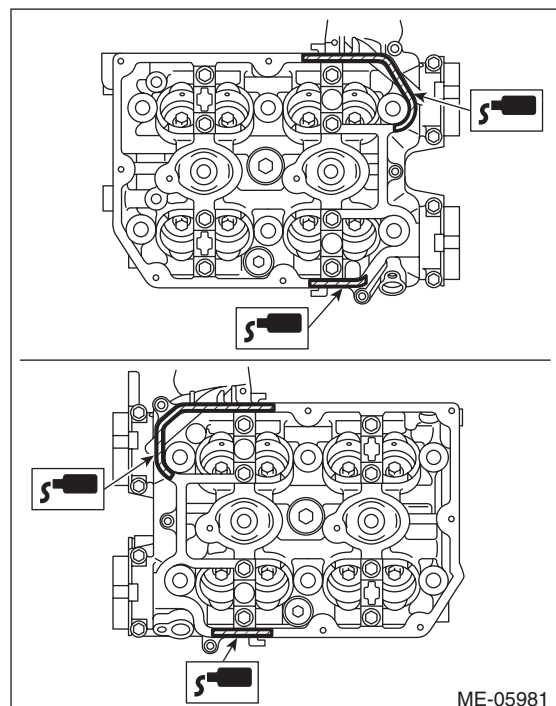

(3) Install the rocker cover onto cylinder heads. Ensure the gasket is properly positioned during installation.

(4) Temporarily tighten the rocker cover bolts in alphabetical order shown in the figure, and then tighten to specified torque in alphabetical order.

**Tightening torque:**

**6.4 N·m (0.7 kgf·m, 4.7 ft·lb)**

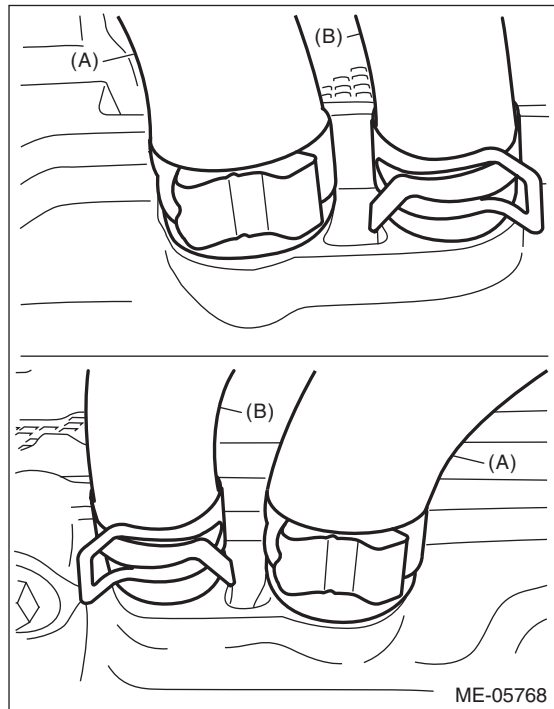
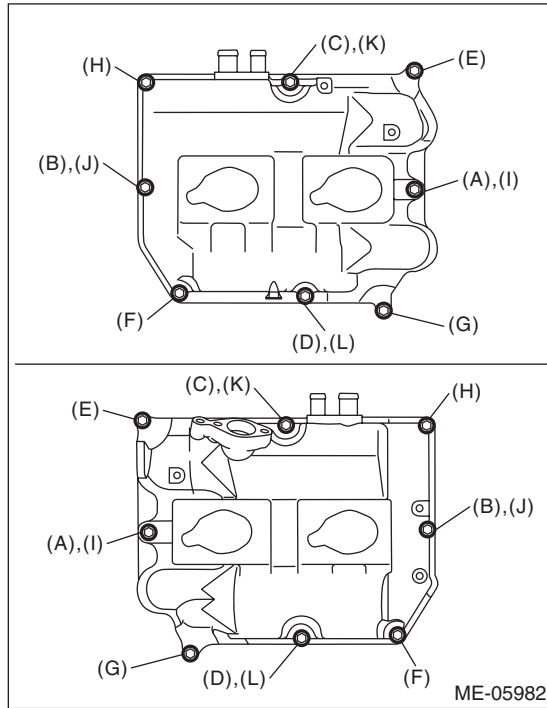

12) Connect the connector to the intake oil flow control solenoid valve.

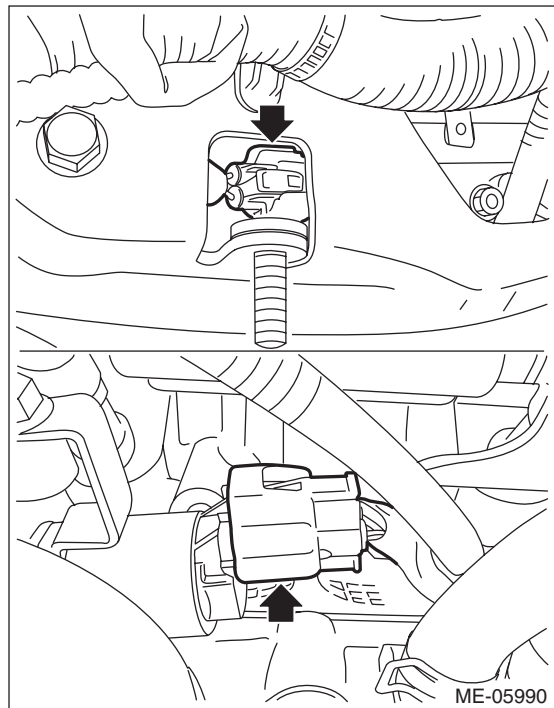

11) Connect the PCV hose (A) and vacuum hose (B) to the rocker cover.

**NOTE:**

Use a new clamp for the PCV hose (A), fit the cut out in the ST with the protrusion on the clamp as shown in the figure, and lock the clamp.

ST 18353AA000 CLAMP PLIERS

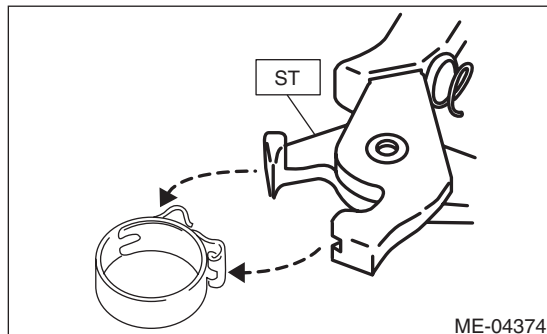



# Camshaft

## MECHANICAL

13) Connect the connector (A) to the exhaust camshaft position sensor and the connector (B) to the exhaust oil flow control solenoid valve.

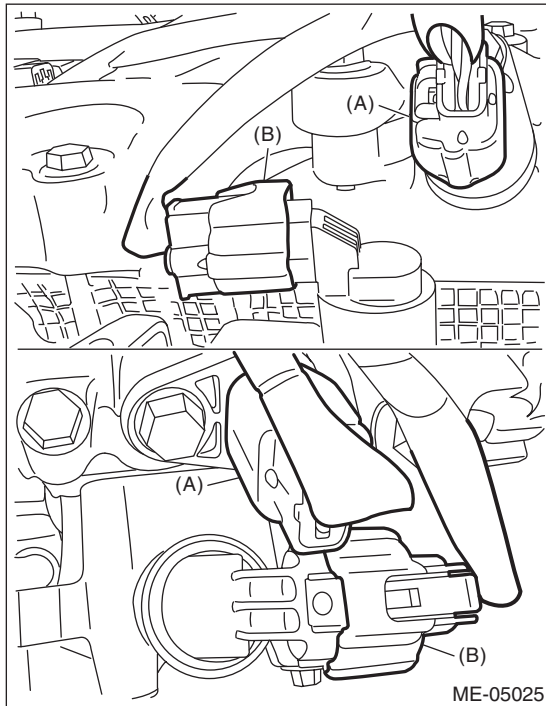

14) Install the ignition coil. <Ref. to IG(STI)-7, INSTALLATION, Ignition Coil.>

15) Install the air duct B (B) to the rocker cover LH and the air duct A (A).

### Tightening torque:

**6.4 N·m (0.7 kgf·m, 4.7 ft·lb)**

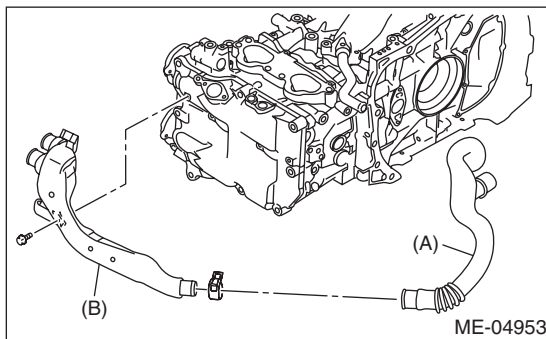

16) Fix the engine harness to the rocker cover RH with clips (A).

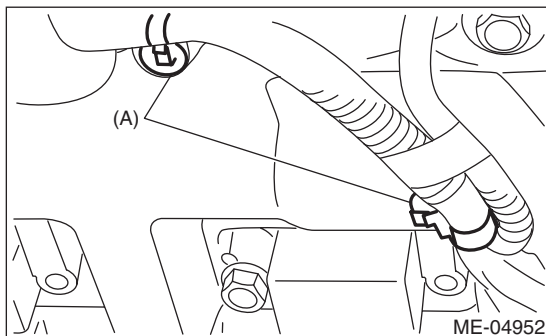

17) Install the timing belt cover. <Ref. to ME(STI)-49, INSTALLATION, Timing Belt Cover.>

18) Install the crank pulley. <Ref. to ME(STI)-47, INSTALLATION, Crank Pulley.>

19) Install the rear side belt. <Ref. to ME(STI)-41, REAR SIDE BELT, INSTALLATION, V-belt.>

20) Install the engine to the vehicle. <Ref. to ME(STI)-33, INSTALLATION, Engine Assembly.>

## C: INSPECTION

1) Measure the bend, and repair or replace if necessary.

### Camshaft bend limit:

**0.020 mm (0.00079 in)**

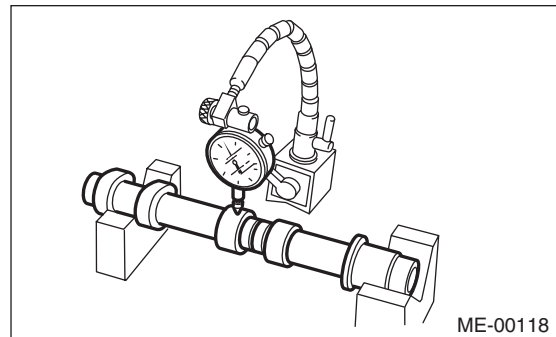

2) Check the journal for damage and wear. Replace if faulty.

3) Check the cutout portion used for camshaft sensor for damage. Replace if faulty.

4) Check the cam face condition, and remove the minor faults by grinding with oil stone. If offset wear occurs, replace it.

5) Measure the cam lobe height "H" and cam base circle diameter "A". If it exceeds the standard or offset wear occurs, replace it.

### Cam lobe height H:

#### Standard

##### Intake

**46.55 — 46.65 mm (1.833 — 1.837 in)**

##### Exhaust

**46.75 — 46.85 mm (1.841 — 1.844 in)**

### Cam base circle diameter A:

#### Standard

**37.0 mm (1.457 in)**

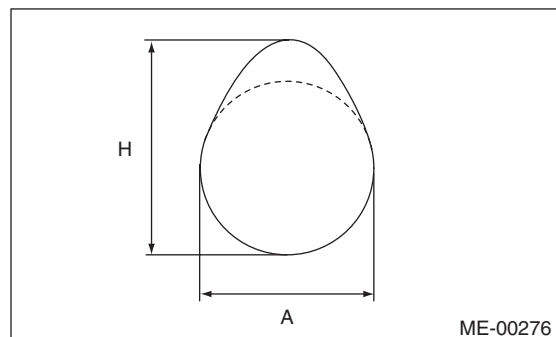

6) Measure the outside diameter of camshaft journal. If the journal diameter is not within specification, check the oil clearance.

	Camshaft journal	
	Front	Center, rear
Standard	37.946 — 37.963	29.946 — 29.963
mm (in)	(1.4939 — 1.4946)	(1.1790 — 1.1796)

- 7) Measure the oil clearance of camshaft journal.
- (1) Clean the camshaft cap and cylinder head camshaft journal.
  - (2) Place the camshaft on cylinder head. (Without installing the valve lifter)
  - (3) Place a plastigauge across each camshaft journals.
  - (4) Gradually tighten the camshaft cap in at least two steps, in alphabetical order shown in the figure, and then tighten to the specified torque. Do not turn the camshaft.

**Tightening torque:**

**T1: 9.75 N·m (1.0 kgf-m, 7.2 ft-lb)**

**T2: 20 N·m (2.0 kgf-m, 14.8 ft-lb)**

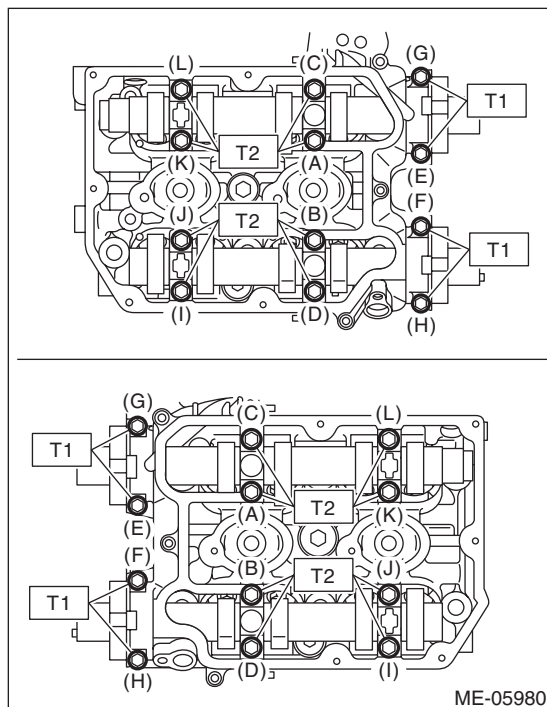

(5) Remove the camshaft cap.

(6) Measure the widest point of the plastigauge on each journal. If oil clearance exceeds the standard, replace the camshaft. If necessary, replace the camshaft caps and cylinder head as a set.

**Camshaft oil clearance:**

**Standard**

**0.037 — 0.072 mm (0.0015 — 0.0028 in)**

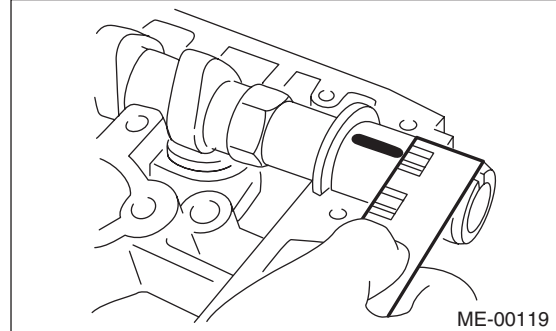

(7) Completely remove the plastigauge.

8) Measure the thrust clearance with setting the dial gauge at end surface of camshaft. If the thrust clearance is not within the standard or there is off-set wear, replace the camshaft caps and cylinder head as a set. If necessary replace the camshaft.

**Camshaft thrust clearance:**

**Standard**

**0.068 — 0.116 mm (0.0027 — 0.0047 in)**

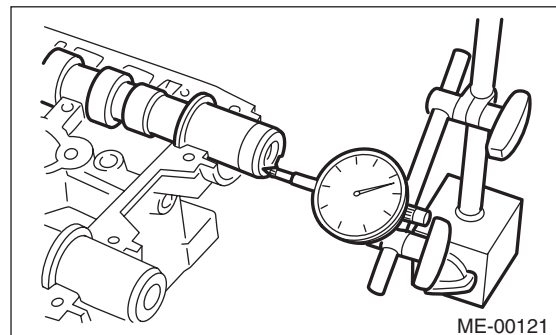

# Cylinder Head

MECHANICAL

## 19. Cylinder Head

### A: REMOVAL

- 1) Remove the engine from the vehicle. <Ref. to ME(STI)-30, REMOVAL, Engine Assembly.>
- 2) Remove the rear side belt. <Ref. to ME(STI)-40, REAR SIDE BELT, REMOVAL, V-belt.>
- 3) Remove the intake manifold. <Ref. to FU(STI)-17, REMOVAL, Intake Manifold.>
- 4) Remove the crank pulley. <Ref. to ME(STI)-47, REMOVAL, Crank Pulley.>
- 5) Remove the timing belt cover. <Ref. to ME(STI)-49, REMOVAL, Timing Belt Cover.>
- 6) Remove the timing belt. <Ref. to ME(STI)-50, REMOVAL, Timing Belt.>
- 7) Remove the cam sprocket. <Ref. to ME(STI)-59, REMOVAL, Cam Sprocket.>
- 8) Remove the secondary air combination valve. <Ref. to EC(STI)-29, REMOVAL, Secondary Air Combination Valve.>
- 9) Remove the bolts which secure A/C compressor bracket to cylinder head.
- 10) Remove the oil pipe. <Ref. to LU(STI)-25, REMOVAL, Oil Pipe.>
- 11) Remove the camshaft. <Ref. to ME(STI)-61, REMOVAL, Camshaft.>
- 12) Remove the oil level gauge guide. (LH side only)
- 13) Remove the cylinder head bolts in alphabetical order shown in the figure.

#### NOTE:

Leave the bolts (A) and (D) engaged by three or four threads to prevent the cylinder head from falling.

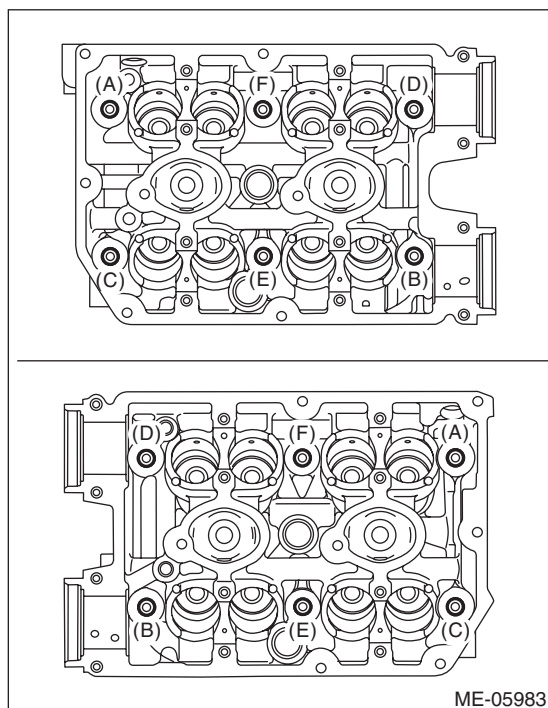

- 14) While tapping the cylinder head with a plastic hammer, separate it from cylinder block. Remove the bolts (A) and (D) to remove cylinder head.

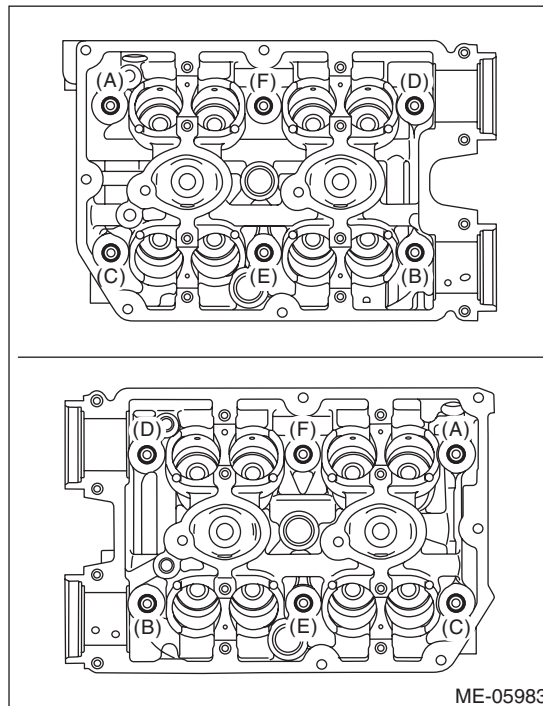

- 15) Remove the cylinder head gasket.

#### CAUTION:

Be careful not to scratch the mating surface of cylinder head and cylinder block.

### B: INSTALLATION

- 1) Install the cylinder head to the cylinder block.

#### CAUTION:

Be careful not to scratch the mating surface of cylinder head and cylinder block.

#### NOTE:

Use a new cylinder head gasket.

- (1) Clean the bolt threads and the bolt holes in the cylinder block

#### CAUTION:

To avoid erroneous tightening of the bolts, clean out the bolt holes sufficiently by blowing with compressed air to eliminate engine coolant etc.

- (2) Apply a sufficient coat of engine oil to the washer and bolt thread.
- (3) Tighten all bolts to 40 N·m (4.1 kgf-m, 29.5 ft-lb) in alphabetical order.
- (4) Retighten all bolts to 95 N·m (9.7 kgf-m, 70.1 ft-lb) in alphabetical order.

ME(STI)-70

Brought to you by Ebay Seller "SubaruManuals"

**CAUTION:**

If the bolt makes stick-slip sound during tightening, repeat the procedure from step (1). In this case, the cylinder head gasket can be re-used.

- (5) Loosen all the bolts by 180° in the reverse order of installing, and loosen them further by 180°.
- (6) Tighten all bolts to 10 N·m (1.0 kgf-m, 7.4 ft-lb) in alphabetical order.
- (7) Retighten all bolts to 30 N·m (3.1 kgf-m, 22.1 ft-lb) in alphabetical order.
- (8) Retighten all bolts to 70 N·m (7.1 kgf-m, 51.6 ft-lb) in alphabetical order.
- (9) Retighten all bolts by 80 — 90° in alphabetical order.
- (10) Retighten all bolts by 40 — 45° in alphabetical order.

**CAUTION:**

The tightening angle of the bolt should not exceed 45°.

- (11) Retighten bolts (A) and (B) by 40 — 45°.

**CAUTION:**

Make sure the total “tightening angle” of steps (10) and (11) does not exceed 90°.

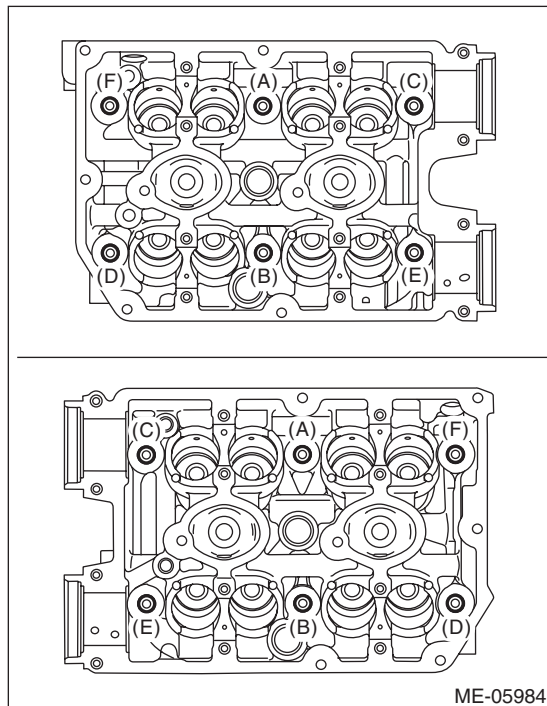

- 2) Install the oil level gauge guide. (LH side only)

**Tightening torque:**

**6.4 N·m (0.7 kgf-m, 4.7 ft-lb)**

- 3) Install the camshaft. <Ref. to ME(STI)-64, INSTALLATION, Camshaft.>
- 4) Install the oil pipe. <Ref. to LU(STI)-27, INSTALLATION, Oil Pipe.>

- 5) Install the A/C compressor bracket on cylinder head.

**Tightening torque:**

**36 N·m (3.7 kgf-m, 26.6 ft-lb)**

- 6) Install the secondary air combination valve. <Ref. to EC(STI)-30, INSTALLATION, Secondary Air Combination Valve.>
- 7) Install the cam sprocket. <Ref. to ME(STI)-59, INSTALLATION, Cam Sprocket.>
- 8) Install the timing belt. <Ref. to ME(STI)-52, INSTALLATION, Timing Belt.>
- 9) Adjust the valve clearance. <Ref. to ME(STI)-29, ADJUSTMENT, Valve Clearance.>
- 10) Install the rocker cover.
  - (1) Install the rocker cover gasket to the rocker cover. (outer section and ignition coil section)

**NOTE:**

Use a new rocker cover gasket.

- (2) Apply liquid gasket to the specified point of the cylinder head.

**NOTE:**

Install within 5 min. after applying liquid gasket.

**Liquid gasket:**

**THREE BOND 1217G (Part No. K0877Y0100) or equivalent**

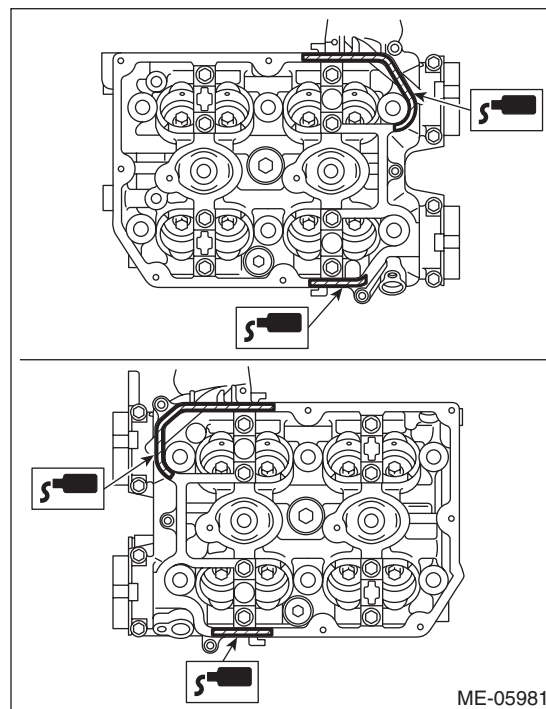

- (3) Install the rocker cover onto cylinder heads. Ensure the gasket is properly positioned during installation.

# Cylinder Head

## MECHANICAL

(4) Temporarily tighten the rocker cover bolts in alphabetical order shown in the figure, and then tighten to specified torque in alphabetical order.

### Tightening torque:

**6.4 N·m (0.7 kgf·m, 4.7 ft·lb)**

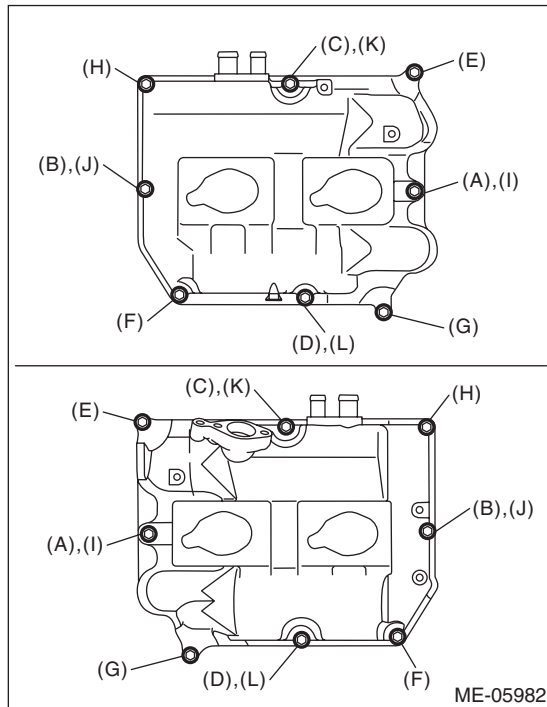

11) Connect the PCV hose (A) and vacuum hose (B) to the rocker cover.

### NOTE:

Use a new clamp for the PCV hose (A), fit the cut out in the ST with the protrusion on the clamp as shown in the figure, and lock the clamp.

ST 18353AA000 CLAMP PLIERS

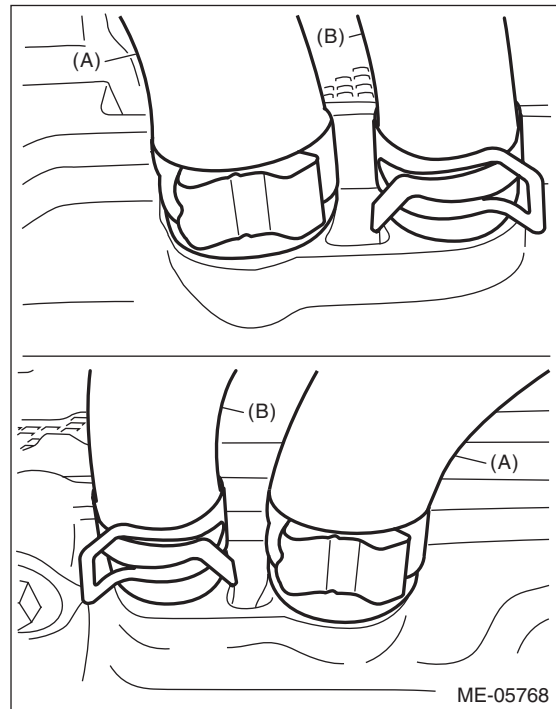
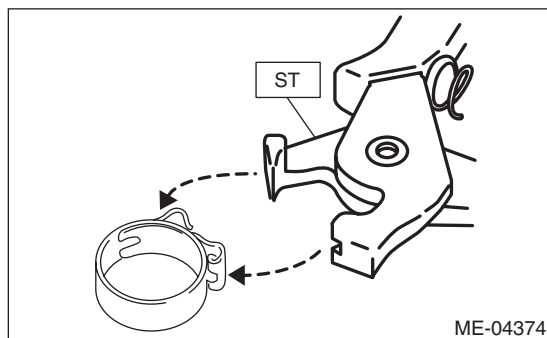

12) Install the timing belt cover. <Ref. to ME(STI)-49, INSTALLATION, Timing Belt Cover.>

13) Install the crank pulley. <Ref. to ME(STI)-47, INSTALLATION, Crank Pulley.>

14) Install the intake manifold. <Ref. to FU(STI)-21, INSTALLATION, Intake Manifold.>

15) Install the rear side belt. <Ref. to ME(STI)-41, REAR SIDE BELT, INSTALLATION, V-belt.>

16) Install the engine to the vehicle. <Ref. to ME(STI)-33, INSTALLATION, Engine Assembly.>



## C: DISASSEMBLY

1) Remove the valve lifter.

2) Place the cylinder head on ST1.

ST1 498267600 CYLINDER HEAD TABLE

3) Using ST2, compress the valve spring and remove the valve spring retainer key. Remove each valve and valve spring.

ST2 499718000 VALVE SPRING REMOVER

### NOTE:

- Mark each valve to prevent confusion.
- Pay careful attention not to damage the lips of intake valve oil seals and exhaust valve oil seals.
- Keep all the removed parts in order for re-installing in their original positions.
- For removal and installation procedures of the valve guide, intake valve oil seal and exhaust valve oil seal, refer to "INSPECTION". <Ref. to ME(STI)-75, VALVE GUIDE, INSPECTION, Cylinder Head.> <Ref. to ME(STI)-77, INTAKE AND EXHAUST VALVE OIL SEAL, INSPECTION, Cylinder Head.>

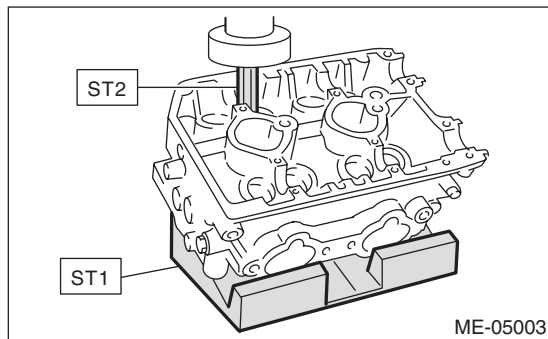

# Cylinder Head

MECHANICAL

## D: ASSEMBLY

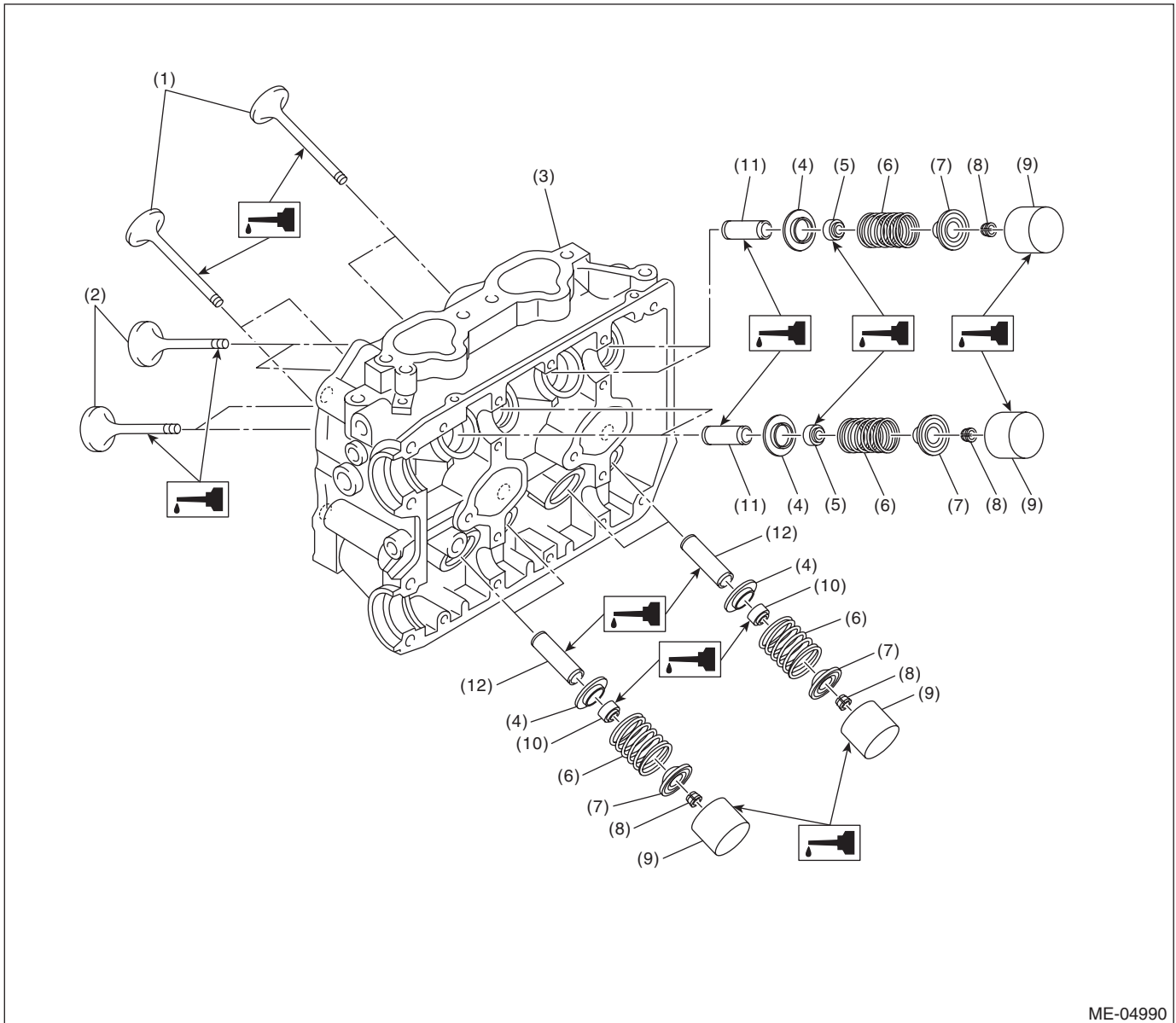

ME-04990

- |                       |                               |                             |
|-----------------------|-------------------------------|-----------------------------|
| (1) Exhaust valve     | (5) Intake valve oil seal     | (9) Valve lifter            |
| (2) Intake valve      | (6) Valve spring              | (10) Exhaust valve oil seal |
| (3) Cylinder head     | (7) Valve spring retainer     | (11) Intake valve guide     |
| (4) Valve spring seat | (8) Valve spring retainer key | (12) Exhaust valve guide    |

1) Install the valve spring and valve.

(1) Coat the valve stem of each valve with engine oil and insert the valve into valve guide.

NOTE:

When inserting the valve into valve guide, use special care not to damage the oil seal lip.

(2) Set the cylinder head on ST1.

ST1 498267600 CYLINDER HEAD TABLE

(3) Install the valve spring and valve spring retainer.

NOTE:

Be sure to install the valve spring with its close-coiled end facing the cylinder head side.

**ME(STI)-74**

Brought to you by Ebay Seller "SubaruManuals"

- (4) Set the ST2 on valve spring.  
 ST2 499718000 VALVE SPRING REMOVER

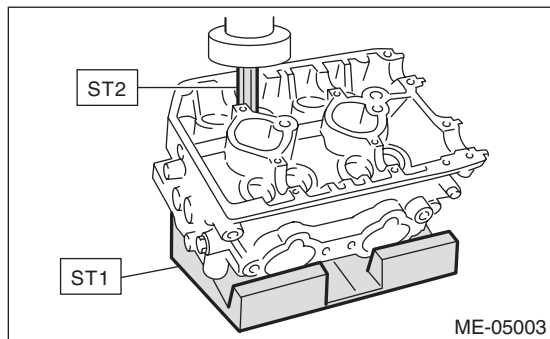

- (5) Compress the valve spring and fit the valve spring retainer key.  
 (6) After installing, tap the valve spring retainers lightly with a plastic hammer for better seating.  
 2) Apply oil to the surface of valve lifter.  
 3) Install the valve lifter.

## E: INSPECTION

### 1. CYLINDER HEAD

- 1) Check for cracks or damage. Use liquid penetrant tester on the important sections to check for fissures. Check that there are no marks of gas leaking or water leaking on gasket installing surface.  
 2) Measure the warping of the cylinder head surface that mates with cylinder block using a straight edge (A) and thickness gauge (B).  
 If the warping exceeds the limit, correct the surface by grinding it with a surface grinder.

**Warping limit:**  
 0.035 mm (0.0014 in)

**Grinding limit:**  
 0.3 mm (0.012 in)

**Standard height of cylinder head:**  
 127.5 mm (5.02 in)

**NOTE:**

Uneven torque for the cylinder head bolts can cause warping. When reinstalling, pay special attention to the torque so as to tighten evenly.

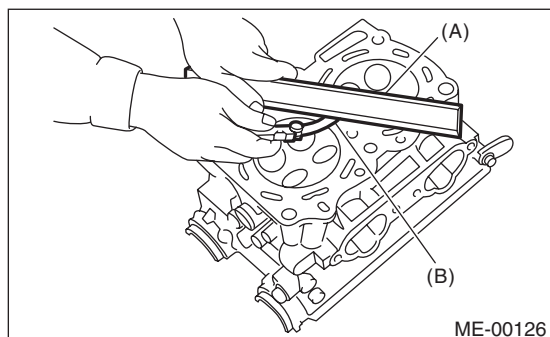

### 2. VALVE SEAT

Inspect the intake and exhaust valve seats, and correct the contact surfaces with a valve seat cutter if they are defective or when valve guides are replaced.

**Contacting width W between valve and valve seat:**

- Standard**  
**Intake**  
 0.6 — 1.4 mm (0.024 — 0.055 in)  
**Exhaust**  
 1.2 — 1.8 mm (0.047 — 0.071 in)

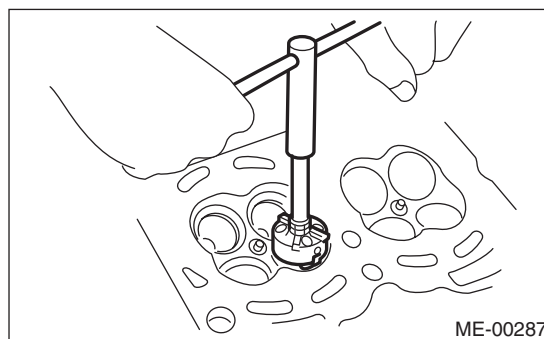
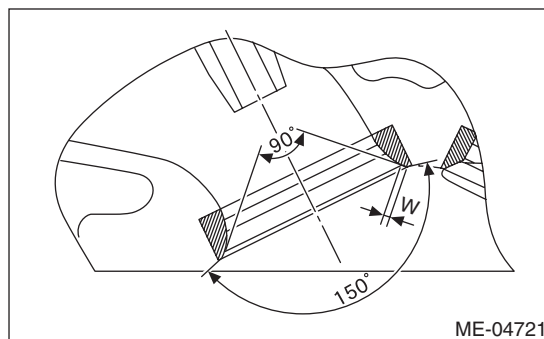

### 3. VALVE GUIDE

- 1) Check the clearance between valve guide and valve stem. The clearance can be checked by measuring respectively the outer diameter of valve stem with a micrometer and the inner diameter of valve guide with a caliper gauge.

**Clearance between the valve guide and valve stem:**

- Standard**  
**Intake**  
 0.030 — 0.057 mm (0.0012 — 0.0022 in)  
**Exhaust**  
 0.040 — 0.067 mm (0.0016 — 0.0026 in)



# Cylinder Head

## MECHANICAL

2) If the clearance between valve guide and valve stem exceeds the standard, replace the valve guide or valve itself, whichever shows the greater amount of wear or damage. See the following procedure for valve guide replacement.

### Valve guide inner diameter:

**6.000 — 6.012 mm (0.2362 — 0.2367 in)**

### Valve stem outer diameters:

#### Intake

**5.955 — 5.970 mm (0.2344 — 0.2350 in)**

#### Exhaust

**5.945 — 5.960 mm (0.2341 — 0.2346 in)**

(1) Place the cylinder head on ST1 with the combustion chamber upward so that valve guides fit the holes in ST1.

(2) Insert the ST2 into valve guide and press it down to remove the valve guide.

ST1 498267600 CYLINDER HEAD TABLE  
ST2 499767200 VALVE GUIDE REMOVER

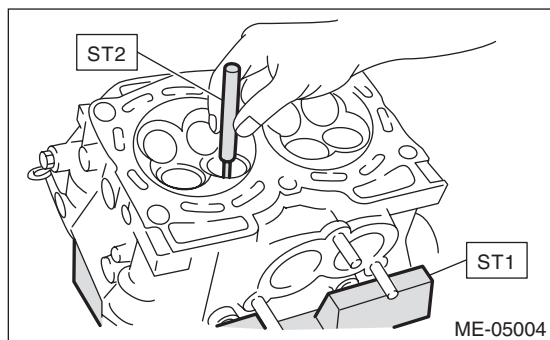

(3) Turn the cylinder head upside down and place the ST as shown in the figure.

ST 18251AA020 VALVE GUIDE ADJUSTER

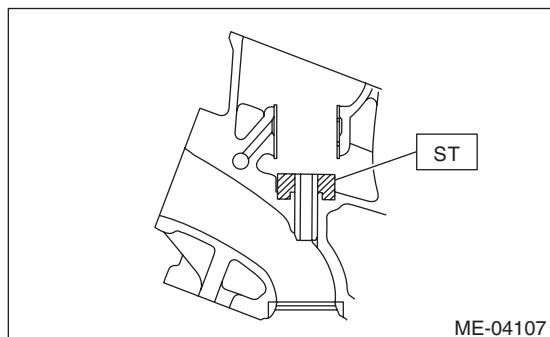

(4) Before installing a new valve guide, make sure that neither scratches nor damages exist on the inner surface of valve guide holes in cylinder head.

(5) Put a new valve guide, coated with sufficient oil, in the cylinder head, and insert the ST1 into valve guide. Press in until the valve guide upper end is flush with the upper surface of ST2.

ST1 499767200 VALVE GUIDE REMOVER  
ST2 18251AA020 VALVE GUIDE ADJUSTER

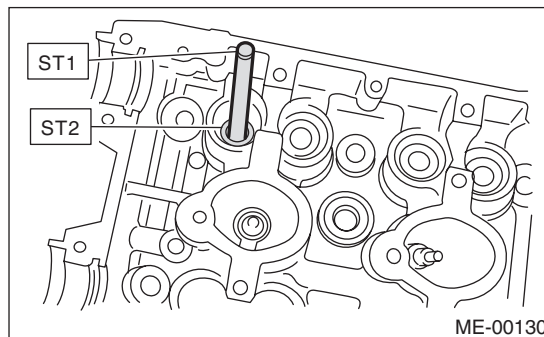

(6) Check the valve guide protrusion amount "L".

### Valve guide protrusion amount L:

**15.8 — 16.2 mm (0.622 — 0.638 in)**

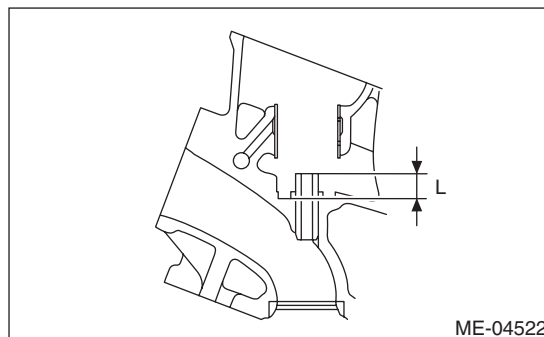

(7) Ream the inside of valve guide using ST. Put the ST in valve guide, and rotate the ST slowly clockwise while pushing it lightly. Bring the ST back while rotating it clockwise.

### NOTE:

- Apply engine oil to the ST when reaming.
- If the inner surface of valve guide is damaged, the edge of ST should be slightly ground with oil stone.
- If the inner surface of valve guide becomes lustrous and the ST does not chip, use a new ST or remedy the ST.

ST 499767400 VALVE GUIDE REAMER

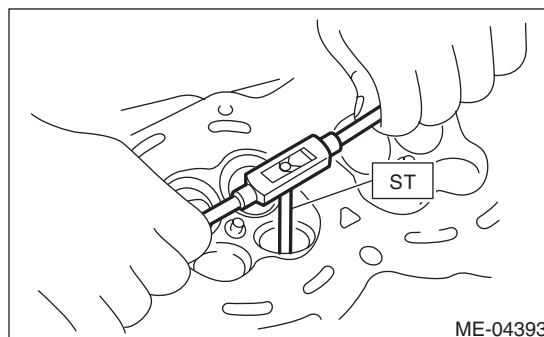

**ME(STI)-76**

Brought to you by Ebay Seller "SubaruManuals"

(8) After reaming, clean the valve guide to remove chips.

(9) Recheck the contact condition between valve and valve seat after replacing the valve guide.

## 4. INTAKE AND EXHAUST VALVE

1) Inspect the flange of valve and valve stem, and replace the valve with a new part if damaged, worn, deformed, or if dimension "H" in the figure is outside of the specified limit.

**Head edge thickness H:**

**Standard**

**Intake (A)**

**1.0 — 1.4 mm (0.039 — 0.055 in)**

**Exhaust (B)**

**1.3 — 1.7 mm (0.051 — 0.067 in)**

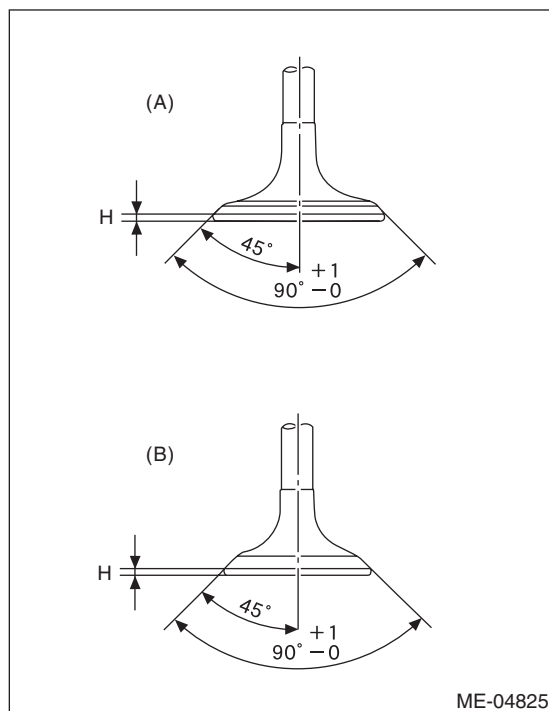

2) Put a small amount of grinding compound on the valve seat surface, and lap the valve and valve seat surface. Replace with a new valve oil seal after lapping.

**NOTE:**

It is possible to differentiate between the intake valve and the exhaust valve by their overall length.

**Valve overall length:**

**Intake**

**104.4 mm (4.110 in)**

**Exhaust**

**104.65 mm (4.1201 in)**

## 5. VALVE SPRING

1) Check the valve springs for damage, free length, and tension. Replace the valve spring if it is not within the standard value presented in the table.

2) To measure the squareness of the valve spring, stand the valve spring on a surface plate and measure its deflection at the top of the valve spring using a try square.

Free length	mm (in)	53.48 (2.106)
Tension/spring height N (kgf, lbf)/mm (in)	Set	204.6 — 235.4 (20.86 — 24.00, 46.00 — 52.93)/36.0 (1.417)
	Lift	363.5 — 401.7 (37.07 — 40.96, 81.73 — 90.32)/26.7 (1.051)
Squareness		2.5°, 2.3 mm (0.091 in) or less

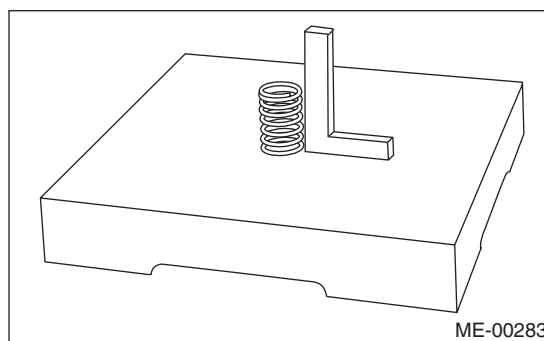

## 6. INTAKE AND EXHAUST VALVE OIL SEAL

1) For the following, replace the oil seal with a new part. See the procedure 2) and subsequent for replacement procedures.

- When the lip is damaged.
- When the spring is out of the specified position.
- When readjusting the surfaces of valve and valve seat.
- When replacing the valve guide.

# Cylinder Head

## MECHANICAL

2) Place the cylinder head on ST1, and use ST2 to press-fit the oil seal.

ST1 498267600 CYLINDER HEAD TABLE  
ST2 498857100 VALVE OIL SEAL GUIDE

### NOTE:

- Apply engine oil to oil seal before press-fitting.
- When press-fitting the oil seal, do not use a hammer to strike in.
- The intake valve oil seals and exhaust valve oil seals are distinguished by their colors.

### Color of rubber part:

**Intake [Gray]**

**Exhaust [Green]**

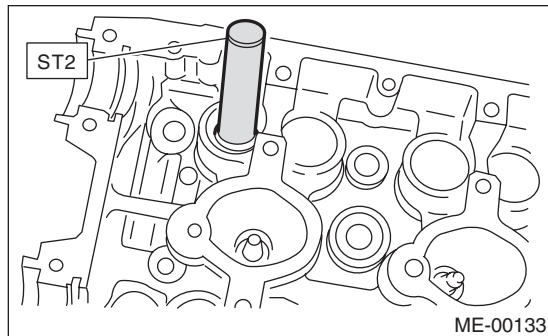

## 7. VALVE LIFTER

- 1) Check the valve lifter visually.
- 2) Measure the outer diameter of valve lifter.

### Outer diameter of valve lifter:

#### Standard

**34.959 — 34.975 mm (1.3763 — 1.3770 in)**

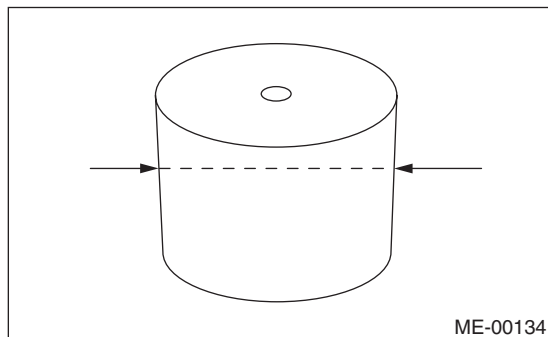

- 3) Measure the inner diameter of valve lifter mating surface on cylinder head.

### Valve lifter mating surface inner diameter:

#### Standard

**34.994 — 35.016 mm (1.3777 — 1.3786 in)**

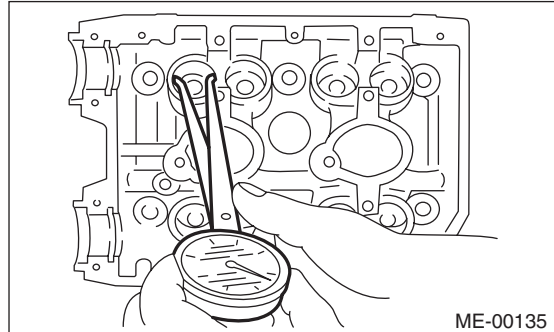

- 4) Check the clearance between valve lifter and valve lifter mating surface. The clearance can be checked by measuring the outer diameter of valve lifter and the inner diameter of valve lifter. If it exceeds the standard or offset wear occurs, replace the cylinder head.

### Valve lifter and valve lifter mating surface clearance:

#### Standard

**0.019 — 0.057 mm (0.0007 — 0.0022 in)**

## 20. Cylinder Block

### A: REMOVAL

**NOTE:**

Before conducting this procedure, drain the engine oil completely.

- 1) Remove the engine from the vehicle. <Ref. to ME(STI)-30, REMOVAL, Engine Assembly.>
- 2) Remove the rear side belt. <Ref. to ME(STI)-40, REAR SIDE BELT, REMOVAL, V-belt.>
- 3) Remove the intake manifold. <Ref. to FU(STI)-17, REMOVAL, Intake Manifold.>
- 4) Remove the crank pulley. <Ref. to ME(STI)-47, REMOVAL, Crank Pulley.>
- 5) Remove the timing belt cover. <Ref. to ME(STI)-49, REMOVAL, Timing Belt Cover.>
- 6) Remove the timing belt. <Ref. to ME(STI)-50, REMOVAL, Timing Belt.>
- 7) Remove the cam sprocket. <Ref. to ME(STI)-59, REMOVAL, Cam Sprocket.>
- 8) Remove the crank sprocket. <Ref. to ME(STI)-60, REMOVAL, Crank Sprocket.>
- 9) Remove the generator and A/C compressor with their brackets.
- 10) Remove the camshaft. <Ref. to ME(STI)-61, REMOVAL, Camshaft.>
- 11) Remove the cylinder head. <Ref. to ME(STI)-70, REMOVAL, Cylinder Head.>
- 12) Remove the clutch disc and cover. <Ref. to CL-11, REMOVAL, Clutch Disc and Cover.>
- 13) Remove the flywheel. <Ref. to CL-14, REMOVAL, Flywheel.>
- 14) Remove the oil separator cover.
- 15) Remove the water by-pass pipe for heater.
- 16) Remove the oil filter. <Ref. to LU(STI)-32, REMOVAL, Engine Oil Filter.>
- 17) Remove the oil cooler. <Ref. to LU(STI)-24, REMOVAL, Engine Oil Cooler.>
- 18) Remove the water pump. <Ref. to CO(STI)-15, REMOVAL, Water Pump.>

- 19) Remove the bolts which secure oil pump to cylinder block.

**NOTE:**

When disassembling and checking the oil pump, loosen the relief valve plug before removing the oil pump.

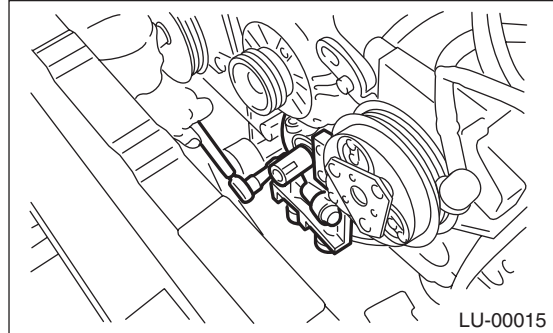

- 20) Remove the oil pump from cylinder block using a flat tip screwdriver.

**CAUTION:**

**Be careful not to scratch the mating surface of the cylinder block and oil pump.**

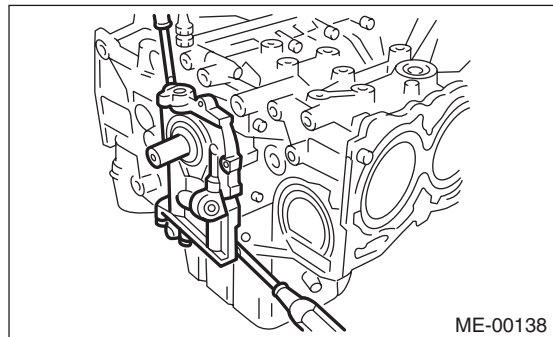

- 21) Remove the front oil seal from the oil pump.
- 22) Remove the oil pan.
  - (1) Set the part so that the cylinder block LH is on the upper side.
  - (2) Remove the bolts which secure oil pan to cylinder block.
  - (3) Insert an oil pan cutter blade between cylinder block-to-oil pan clearance and remove the oil pan.

**CAUTION:**

**Do not use a screwdriver or similar tools in place of oil pan cutter.**

- 23) Remove the oil strainer.
- 24) Remove the baffle plate.

# Cylinder Block

## MECHANICAL

25) Remove the water tank pipe assembly from the cylinder block RH.

### NOTE:

Pinch the clamp of the water tank pipe assembly by fitting the cut out in the ST with the protrusion on the clamp as shown in the figure, and unlock the clamp.

ST 18353AA000 CLAMP PLIERS

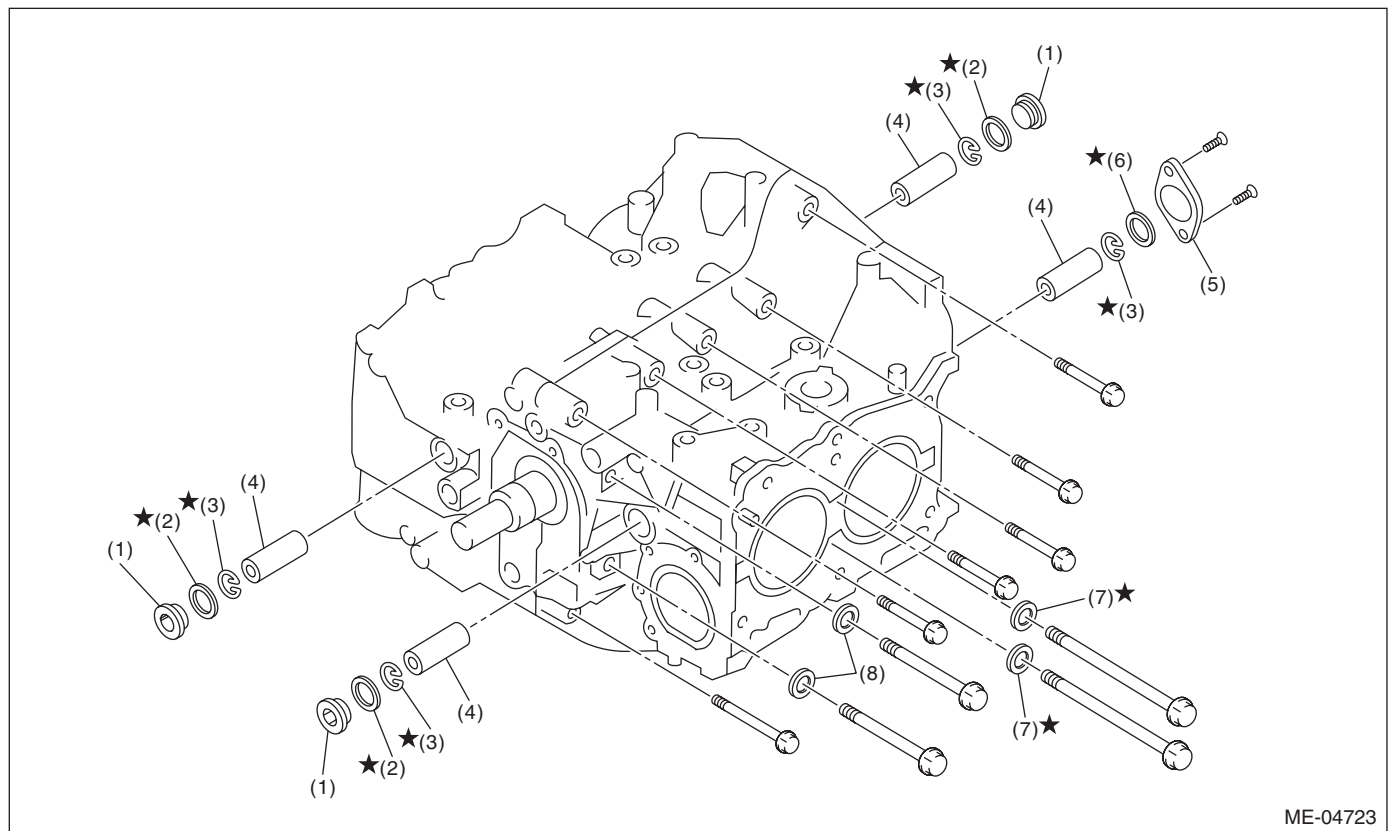
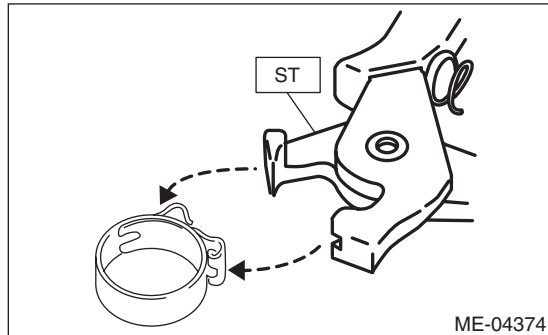

- (1) Service hole plug
- (2) Gasket
- (3) Snap ring

- (4) Piston pin
- (5) Service hole cover
- (6) O-ring

- (7) Seal washer
- (8) Washer

**ME(STI)-80**

Brought to you by Ebay Seller "SubaruManuals"

26) Remove the service hole plugs using a hexagon wrench [14 mm].

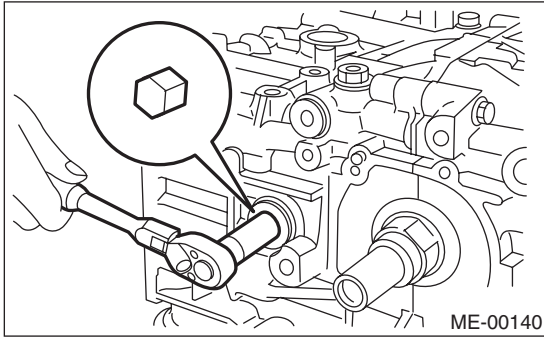

27) Remove the service hole cover.

28) Rotate the crankshaft to bring #1 and #2 pistons to bottom dead center position, then remove the piston snap ring through service hole of #1 and #2 cylinders.

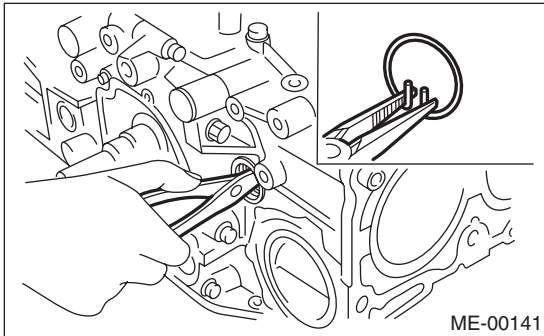

29) Draw out the piston pin from #1 and #2 pistons using ST.

ST 499097700 PISTON PIN REMOVER ASSY

**NOTE:**

Be careful not to confuse the original combination of piston, piston pin and cylinder.

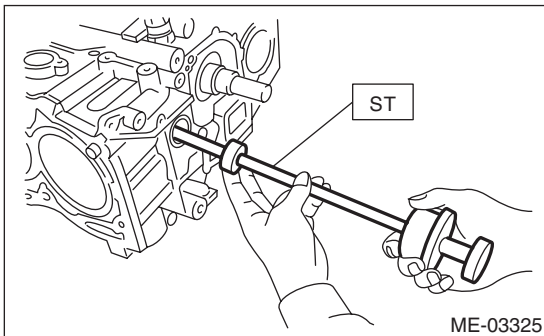

30) Similarly draw out the piston pins from #3 and #4 pistons.

31) Remove the cylinder block connecting bolt on the RH side.

32) Loosen the cylinder block connecting bolt on the LH side by 2 to 3 turns.

33) Set the part so that the cylinder block LH is on the upper side, and remove the cylinder block connecting bolt.

# Cylinder Block

## MECHANICAL

34) Separate the cylinder block LH and RH.

### NOTE:

When separating the cylinder block, do not allow the connecting rod to fall or damage the cylinder block.

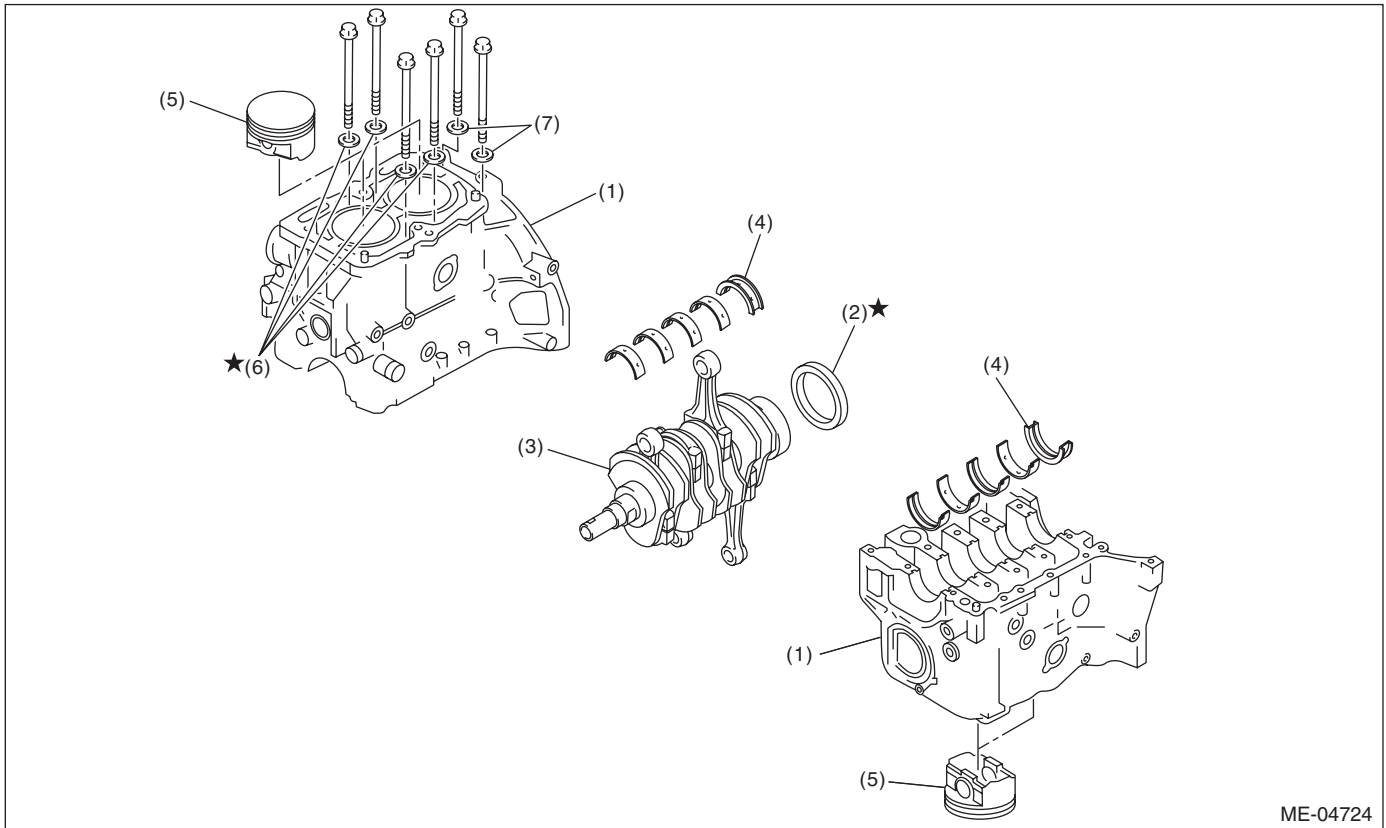

ME-04724

- |                    |                        |                 |
|--------------------|------------------------|-----------------|
| (1) Cylinder block | (4) Crankshaft bearing | (6) Seal washer |
| (2) Rear oil seal  | (5) Piston             | (7) Washer      |
| (3) Crankshaft     |                        |                 |

35) Remove the rear oil seal.

36) Remove the crankshaft together with connecting rod.

37) Remove the crankshaft bearings from cylinder block using a hammer handle.

### NOTE:

- Press the crankshaft bearing at the end opposite to locking lip to remove.
- Be careful not to confuse the crankshaft bearing combination.

38) Remove each piston from the cylinder block using a wooden bar or hammer handle.

### NOTE:

Be careful not to confuse the original combination of piston and cylinder.



## B: INSTALLATION

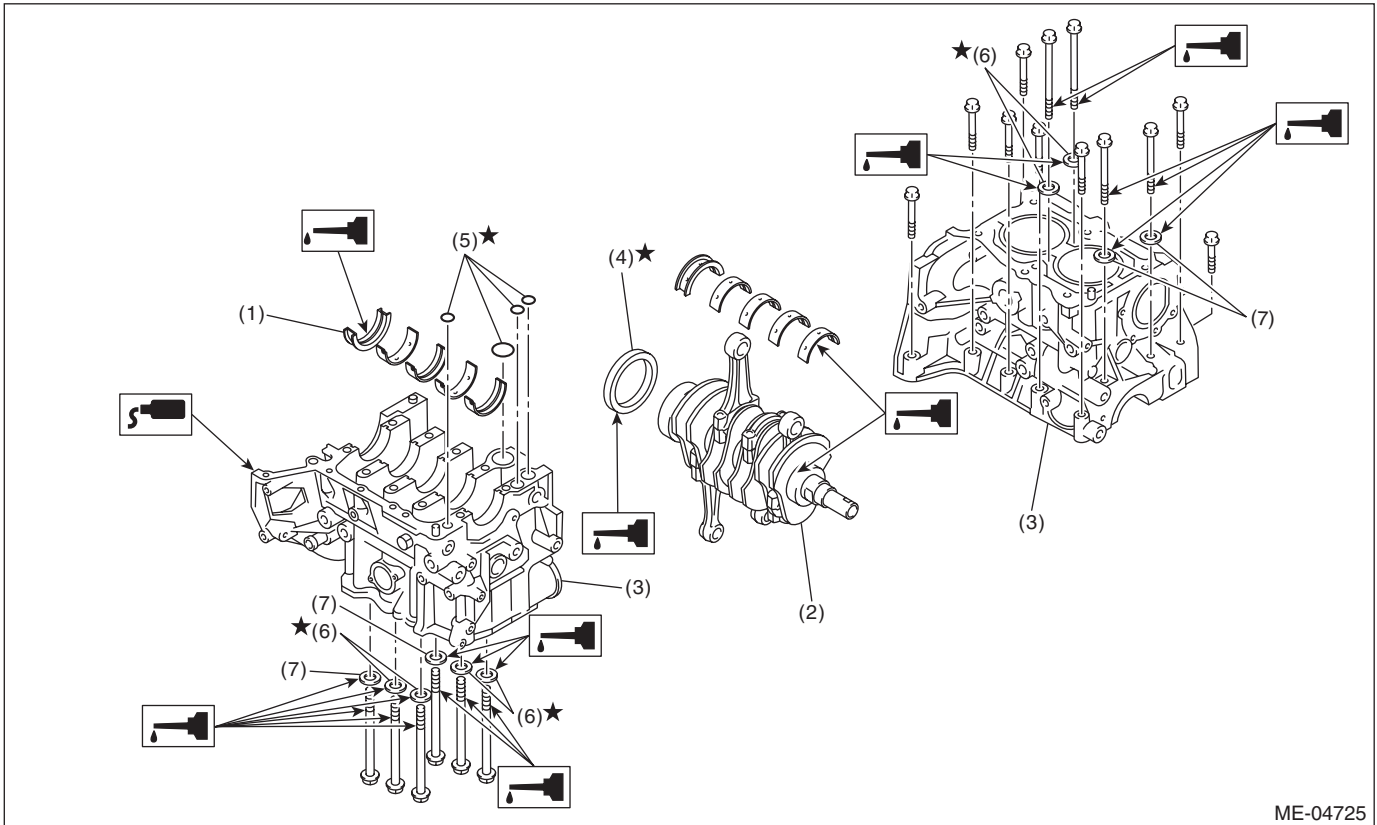

- |                        |                   |                 |
|------------------------|-------------------|-----------------|
| (1) Crankshaft bearing | (4) Rear oil seal | (6) Seal washer |
| (2) Crankshaft         | (5) O-ring        | (7) Washer      |
| (3) Cylinder block     |                   |                 |

1) Remove oil on the mating surface of cylinder block before installation. Apply a coat of engine oil to the bearing and crankshaft journal.

2) Position the crankshaft and O-ring on cylinder block RH.

**NOTE:**

Use new O-rings.

3) Apply liquid gasket to the mating surfaces of cylinder block RH, and position cylinder block LH.

**NOTE:**

- Install within 5 min. after applying liquid gasket.
- Do not allow liquid gasket to jut into O-ring grooves, oil passages, bearing grooves, etc.

**Liquid gasket:**

**THREE BOND 1217G (Part No. K0877Y0100) or equivalent**

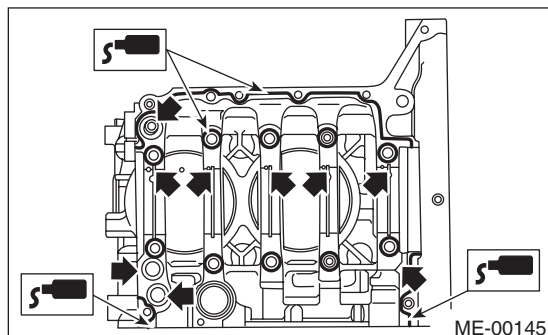



# Cylinder Block

## MECHANICAL

4) Apply a coat of engine oil to the washer and bolt thread.

### NOTE:

Use a new seal washer.

5) Tighten the 10 mm cylinder block connecting bolts on the LH side (A — D) in alphabetical order.

### Tightening torque:

**10 N·m (1.0 kgf·m, 7.4 ft·lb)**

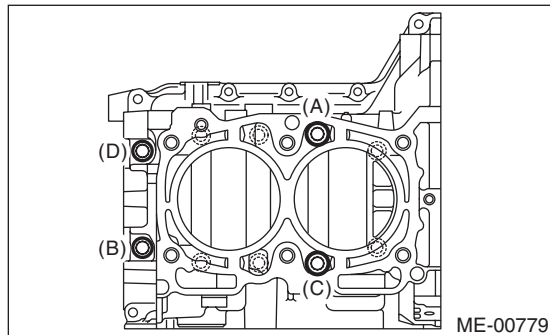

6) Tighten the 10 mm cylinder block connecting bolts on the RH side (E — J) in alphabetical order.

### Tightening torque:

**10 N·m (1.0 kgf·m, 7.4 ft·lb)**

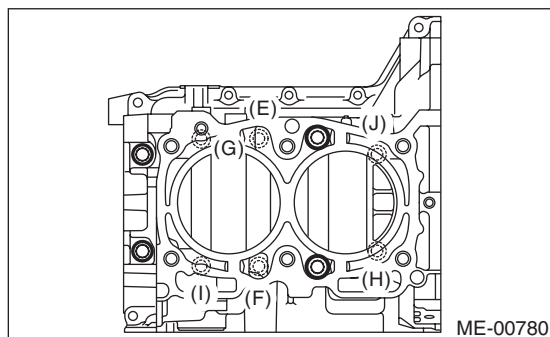

7) Tighten the LH side cylinder block connecting bolts (A — D) further in alphabetical order.

### Tightening torque:

**18 N·m (1.8 kgf·m, 13.3 ft·lb)**

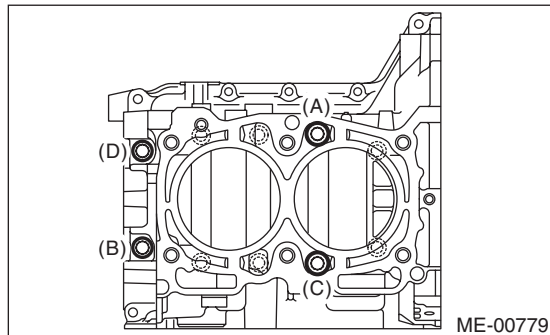

8) Tighten the RH side cylinder block connecting bolts (E — J) further in alphabetical order.

### Tightening torque:

**18 N·m (1.8 kgf·m, 13.3 ft·lb)**

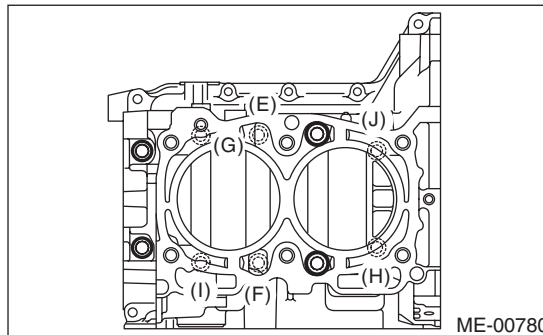

9) Tighten the LH side cylinder block connecting bolts (A — D) further in alphabetical order.

- (A), (C): Angle tightening

### Tightening angle:

**90°**

- (B), (D): Torque tightening

### Tightening torque:

**40 N·m (4.1 kgf·m, 29.5 ft·lb)**

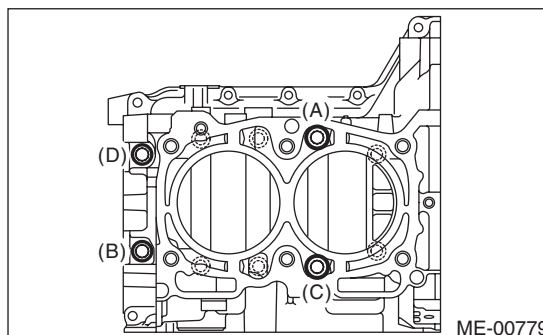

10) Tighten the RH side cylinder block connecting bolts (E — J) further in alphabetical order.

### Tightening angle:

**90°**

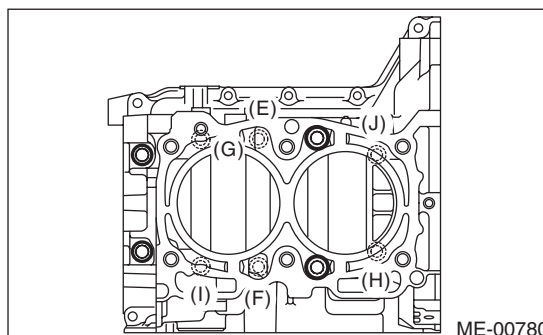

# Cylinder Block

MECHANICAL

11) Tighten the 8 mm and 6 mm cylinder block connecting bolts on the LH side (A — H) in alphabetical order.

**Tightening torque:**

(A) — (G): 25 N·m (2.5 kgf·m, 18.4 ft·lb)

(H): 6.4 N·m (0.7 kgf·m, 4.7 ft·lb)

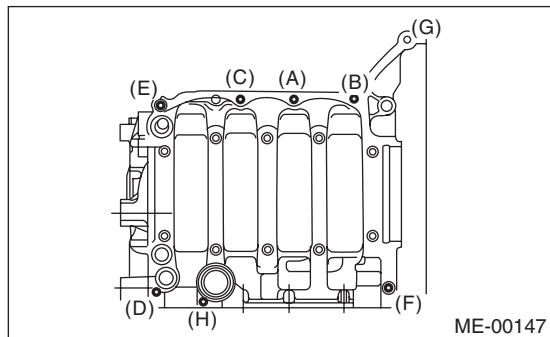

12) Apply a coat of engine oil to the oil seal inner periphery and outer periphery, and install the rear oil seal using ST1 and ST2.

**NOTE:**

Use a new rear oil seal.

ST1 499597100 CRANKSHAFT OIL SEAL GUIDE

ST2 499587200 CRANKSHAFT OIL SEAL INSTALLER

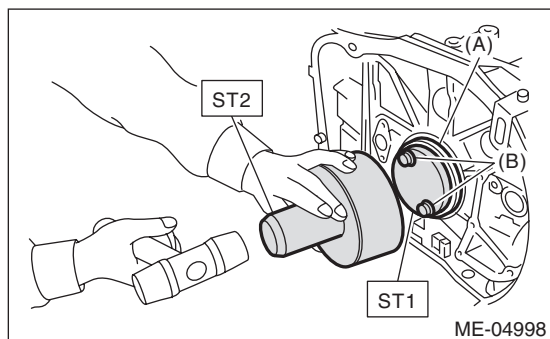

- (A) Rear oil seal
- (B) Flywheel attachment bolt

13) Position the top ring gap at (A) or (B) in the figure.

14) Position the second ring gap at 180° on the reverse side the top ring gap.

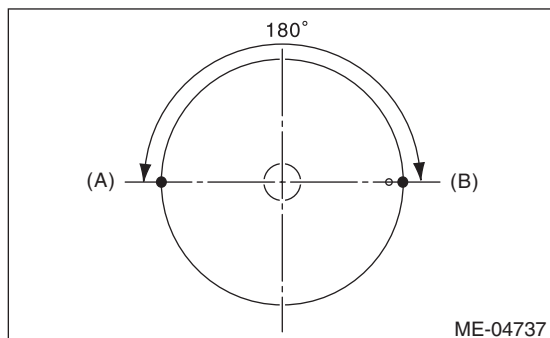

15) Position the upper rail gap at (C) in the figure.

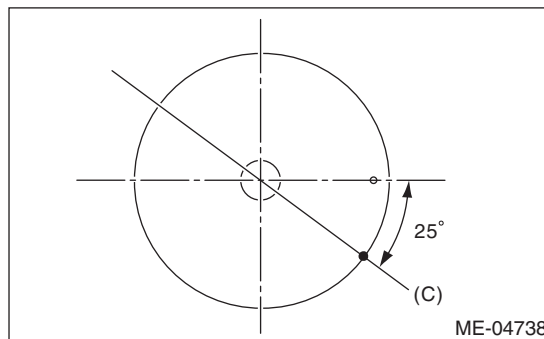

16) Align the upper rail spin stopper (E) to the side hole (D) on the piston.

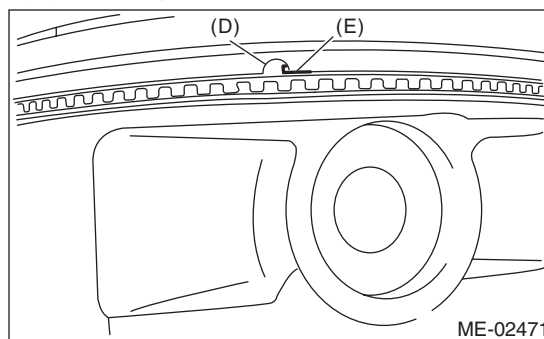

17) Position the expander gap at (F) in the figure on the 180° opposite direction of (C).

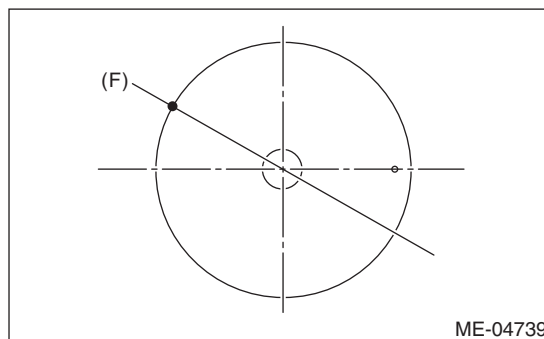

18) Set the lower rail gap at position (G), located 120° clockwise from (C) in the figure.

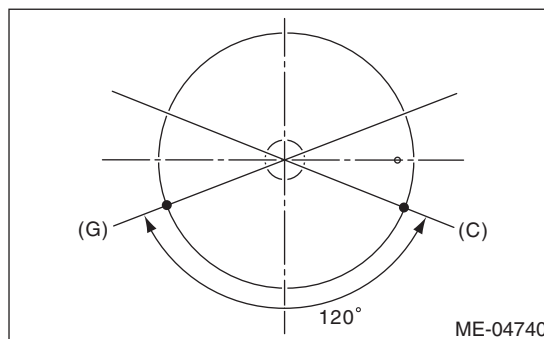

**NOTE:**

- Make sure ring gaps do not face the same direction.
- Make sure ring gaps are not within the piston skirt area.

**ME(STI)-85**

Brought to you by Ebay Seller "SubaruManuals"

# Cylinder Block

## MECHANICAL

19) Install the snap ring.

Before positioning the piston on the cylinder block, attach the snap ring in the service hole of the cylinder block, and the piston hole on the opposite side.

### NOTE:

Use new snap rings.

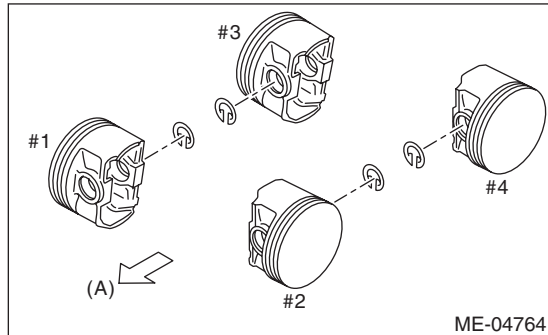

(A) Front side

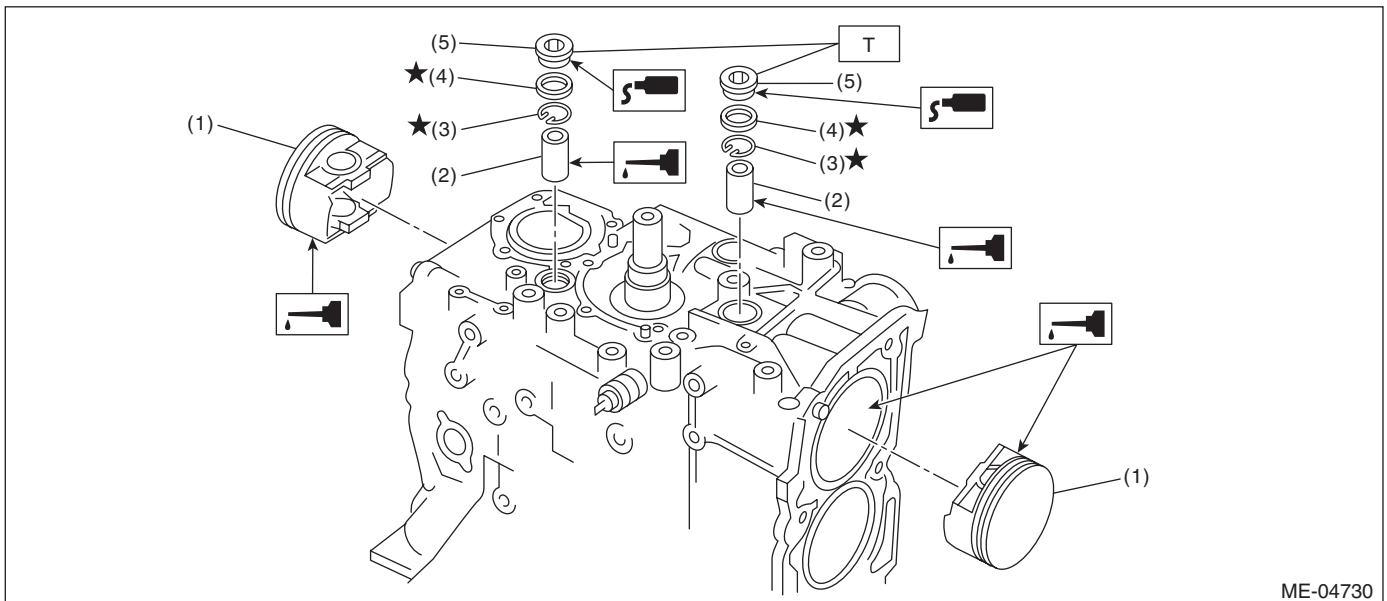

ME-04730

- |                |                       |
|----------------|-----------------------|
| (1) Piston     | (4) Gasket            |
| (2) Piston pin | (5) Service hole plug |
| (3) Snap ring  |                       |

**Tightening torque: N·m (kgf·m, ft·lb)**

**T: 70 (7.1, 51.6)**

20) Install the piston.

- (1) Set the parts so that the #1 and #2 cylinders are on the upper side.
- (2) Using the ST1, turn the crankshaft so that #1 and #2 connecting rods are set at bottom dead center.

ST1 499987500 CRANKSHAFT SOCKET

- (3) Apply a coat of engine oil to the pistons and cylinders and insert pistons in their cylinders using ST2.

ST2 498747300 PISTON GUIDE

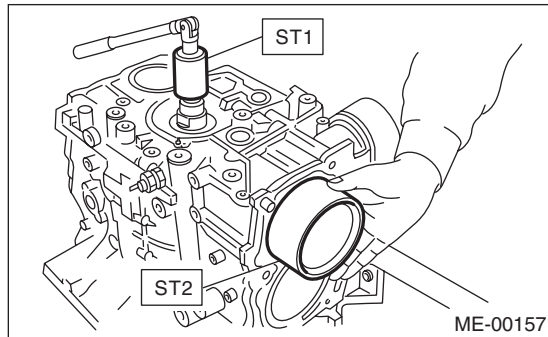

NOTE:

Face the piston front mark towards the front of the engine.

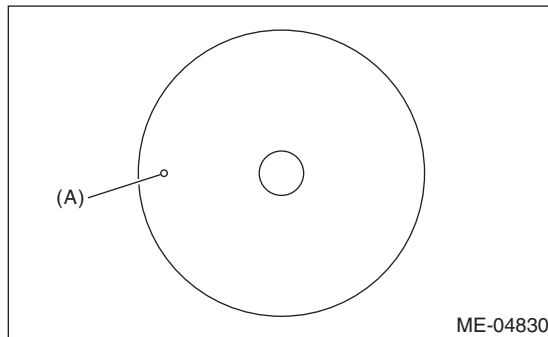

(A) Front mark

21) Install the piston pin.

- (1) Apply a coat of engine oil to ST3.
- (2) Insert ST3 into the service hole to align the piston pin hole and the connecting rod small end.

ST3 499017100 PISTON PIN GUIDE

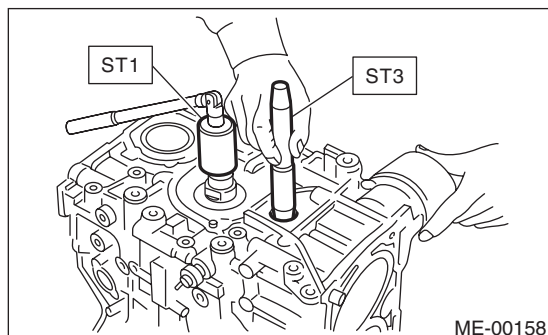

- (3) Apply a thin coat of engine oil to piston pin, and insert the piston pin into piston and connecting rod through service hole.
- (4) Install the snap ring.

NOTE:

Use new snap rings.

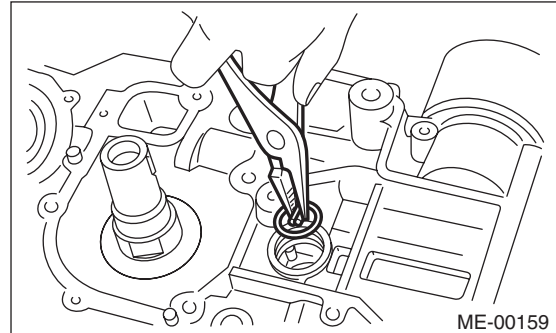

- (5) Apply liquid gasket to the threaded portion of the service hole plug.

**Liquid gasket:**

**THREE BOND 1105 (Part No. 004403010) or equivalent**

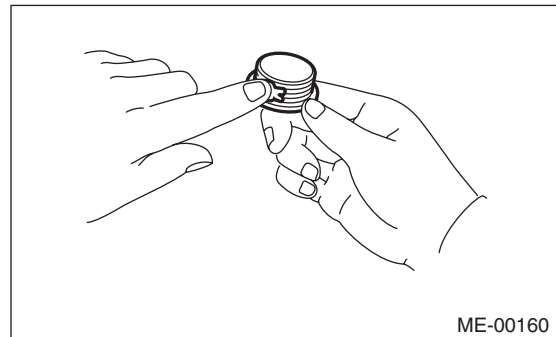

# Cylinder Block

## MECHANICAL

(6) Install the service hole plug and gasket.

### NOTE:

Use a new gasket.

### Tightening torque:

**70 N·m (7.1 kgf·m, 51.6 ft·lb)**

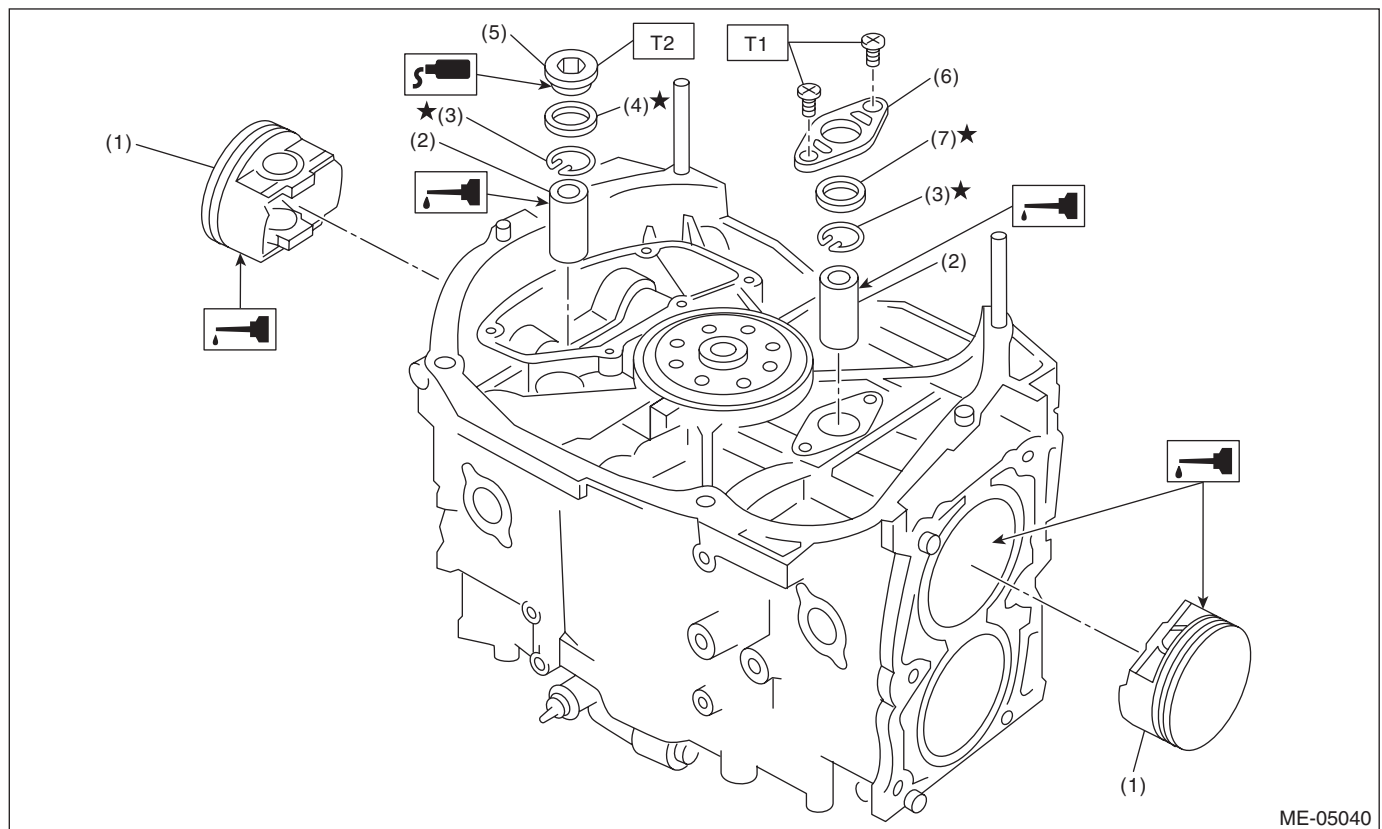
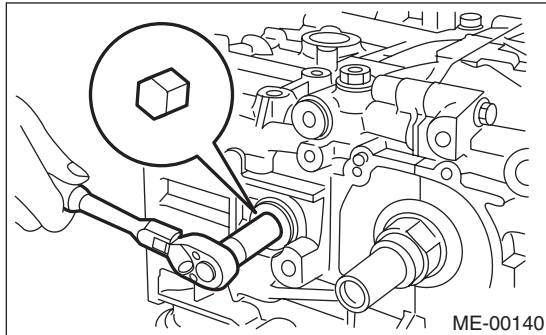

- |                |                        |
|----------------|------------------------|
| (1) Piston     | (5) Service hole plug  |
| (2) Piston pin | (6) Service hole cover |
| (3) Snap ring  | (7) O-ring             |
| (4) Gasket     |                        |

### Tightening torque: N·m (kgf·m, ft·lb)

**T1: 6.4 (0.7, 4.7)**

**T2: 70 (7.1, 51.6)**

(7) Set the parts so that the #3 and #4 cylinders are on the upper side. Following the same procedures as used for #1 and #2 cylinders, install the pistons and piston pins.

(8) Install the service hole cover.

### NOTE:

Use new O-rings.

### Tightening torque:

**6.4 N·m (0.7 kgf·m, 4.7 ft·lb)**

**ME(STI)-88**

Brought to you by Ebay Seller "SubaruManuals"

22) Install the water tank pipe assembly onto the cylinder block RH.

**NOTE:**

Use a new clamp for the water tank pipe assembly clamp, fit the cut out in the ST with the protrusion on the clamp as shown in the figure, and lock the clamp.

ST 18353AA000 CLAMP PLIERS

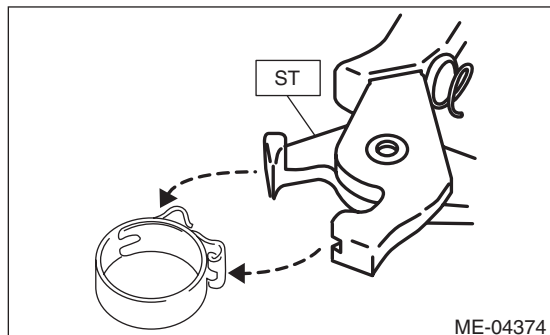

23) Install the baffle plate.

**Tightening torque:**

**6.4 N·m (0.7 kgf·m, 4.7 ft·lb)**

24) Install the oil strainer.

**NOTE:**

Use new O-rings.

**Tightening torque:**

**10 N·m (1.0 kgf·m, 7.4 ft·lb)**

25) Tighten the oil strainer stay together with the baffle plate.

**Tightening torque:**

**6.4 N·m (0.7 kgf·m, 4.7 ft·lb)**

26) Apply liquid gasket to the mating surfaces of oil pan, and install the oil pan.

**NOTE:**

Install within 5 min. after applying liquid gasket.

**Liquid gasket:**

**THREE BOND 1217G (Part No. K0877Y0100) or equivalent**

**Tightening torque:**

**5 N·m (0.5 kgf·m, 3.7 ft·lb)**

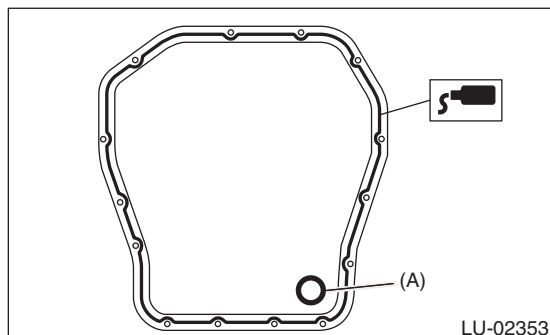

(A) Gasket

27) Apply liquid gasket to the mating surface of oil separator cover and the threaded portion of bolt (A) shown in the figure (when reusing the bolt), and then install the oil separator cover.

**NOTE:**

- Install within 5 min. after applying liquid gasket.
- Use new oil separator cover.

**Liquid gasket:**

**Mating surface**

**THREE BOND 1217G (Part No. K0877Y0100) or equivalent**

**Bolt thread (A) (when reusing the bolt)**

**THREE BOND 1324 (Part No. 004403042) or equivalent**

**Tightening torque:**

**6.4 N·m (0.65 kgf·m, 4.7 ft·lb)**

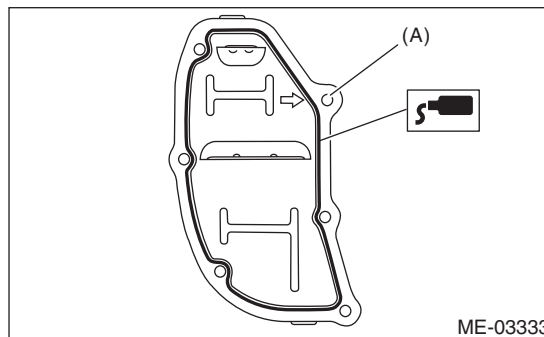

28) Install the flywheel. <Ref. to CL-14, INSTALLATION, Flywheel.>

29) Install the clutch disc and cover. <Ref. to CL-11, INSTALLATION, Clutch Disc and Cover.>

30) Install the oil pump.

(1) Using the ST, install the front oil seal.

ST 499587100 OIL SEAL INSTALLER

**NOTE:**

Use a new front oil seal.

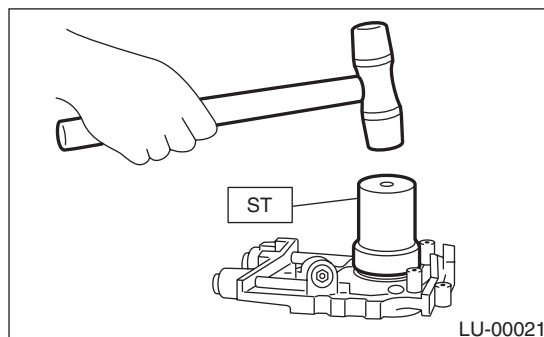



# Cylinder Block

## MECHANICAL

(2) Apply liquid gasket to the mating surfaces of oil pump.

### NOTE:

Install within 5 min. after applying liquid gasket.

### Liquid gasket:

**THREE BOND 1217G (Part No. K0877Y0100) or equivalent**

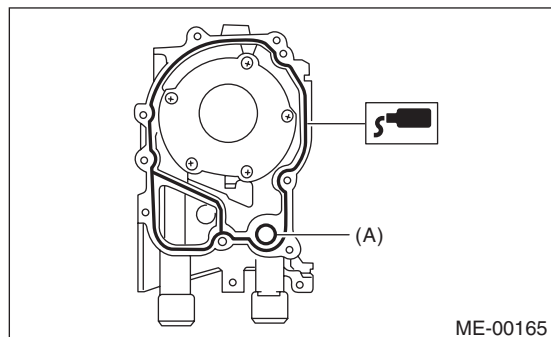

(A) O-ring

(3) Apply a thin coat of engine oil to the inside of front oil seal.

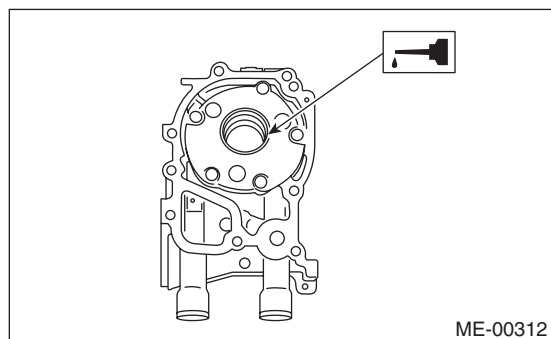

(4) Install the oil pump to cylinder block.

### CAUTION:

- Be careful not to damage the front oil seal during installation.
- Make sure the front oil seal lip is not folded.

### NOTE:

- Align the flat surface of oil pump's inner rotor with that of crankshaft before installation.
- Use new O-rings.
- Do not forget to assemble O-rings.

(5) Apply liquid gasket to the three bolts thread shown in figure. (when reusing bolts)

### Liquid gasket:

**THREE BOND 1324 (Part No. 004403042) or equivalent**

### Tightening torque:

**6.4 N·m (0.7 kgf-m, 4.7 ft-lb)**

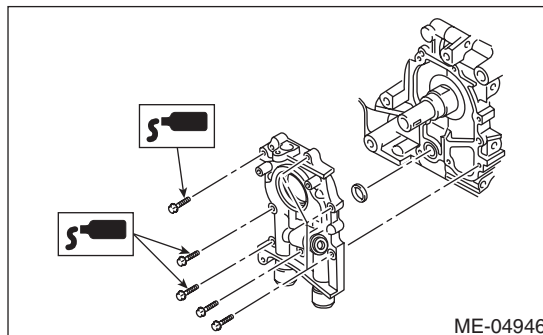

31) Install the water pump and gasket.

### NOTE:

- When installing the water pump, tighten bolts in two stages in alphabetical order as shown in the figure.
- Use a new gasket.

### Tightening torque:

**First: 12 N·m (1.2 kgf-m, 8.9 ft-lb)**

**Second: 12 N·m (1.2 kgf-m, 8.9 ft-lb)**

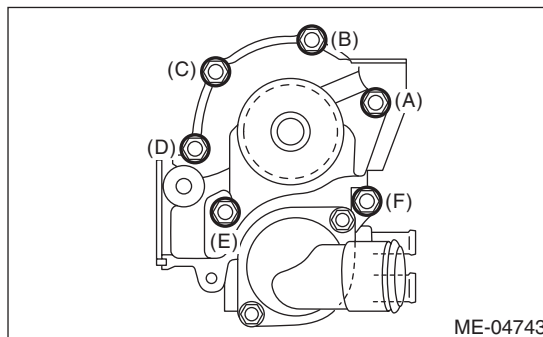

32) Install the water by-pass pipe for heater.

### Tightening torque:

**6.4 N·m (0.7 kgf-m, 4.7 ft-lb)**

33) Install the oil cooler. <Ref. to LU(STI)-24, INSTALLATION, Engine Oil Cooler.>

34) Install the oil filter. <Ref. to LU(STI)-32, INSTALLATION, Engine Oil Filter.>

35) Install the cylinder head. <Ref. to ME(STI)-70, INSTALLATION, Cylinder Head.>

36) Install the camshaft. <Ref. to ME(STI)-64, INSTALLATION, Camshaft.>

37) Install the generator and A/C compressor with their brackets.

### Tightening torque:

**36 N·m (3.7 kgf-m, 26.6 ft-lb)**

**ME(STI)-90**

Brought to you by Ebay Seller "SubaruManuals"

- 38) Install the crank sprocket. <Ref. to ME(STI)-60, INSTALLATION, Crank Sprocket.>
- 39) Install the cam sprocket. <Ref. to ME(STI)-59, INSTALLATION, Cam Sprocket.>
- 40) Install the timing belt. <Ref. to ME(STI)-52, INSTALLATION, Timing Belt.>
- 41) Adjust the valve clearance. <Ref. to ME(STI)-29, ADJUSTMENT, Valve Clearance.>
- 42) Install the rocker cover.
  - (1) Install the rocker cover gasket to the rocker cover. (outer section and ignition coil section)

**NOTE:**

Use a new rocker cover gasket.

- (2) Apply liquid gasket to the specified point of the cylinder head.

**NOTE:**

Install within 5 min. after applying liquid gasket.

**Liquid gasket:**

**THREE BOND 1217G (Part No. K0877Y0100) or equivalent**

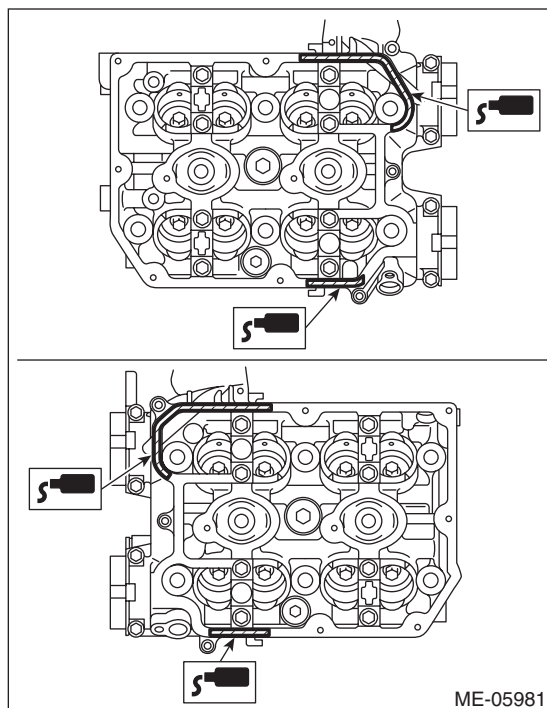

- (3) Install the rocker cover onto cylinder heads. Ensure the gasket is properly positioned during installation.

- (4) Temporarily tighten the rocker cover bolts in alphabetical order shown in the figure, and then tighten to specified torque in alphabetical order.

**Tightening torque:**

**6.4 N·m (0.7 kgf·m, 4.7 ft·lb)**

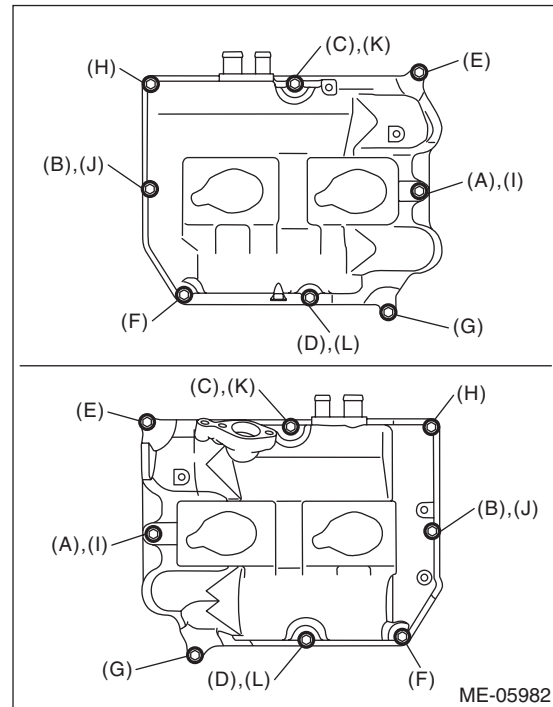



# Cylinder Block

## MECHANICAL

43) Connect the PCV hose (A) and vacuum hose (B) to the rocker cover.

### NOTE:

Use a new clamp for the PCV hose (A), fit the cut out in the ST with the protrusion on the clamp as shown in the figure, and lock the clamp.

ST 18353AA000 CLAMP PLIERS

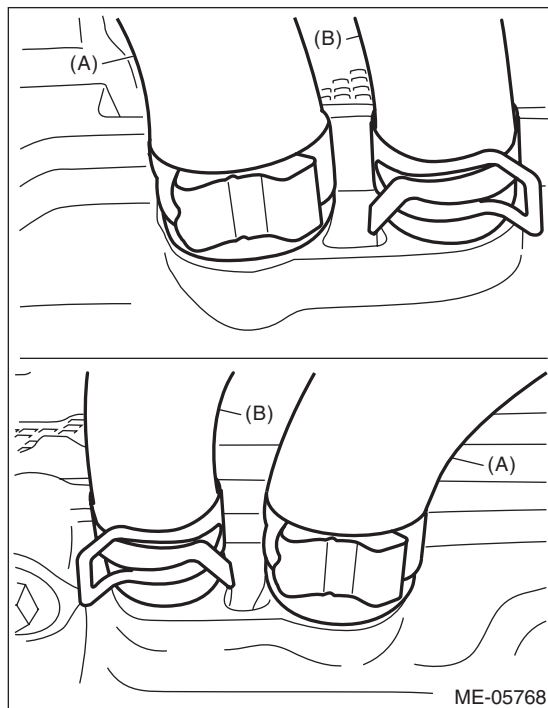
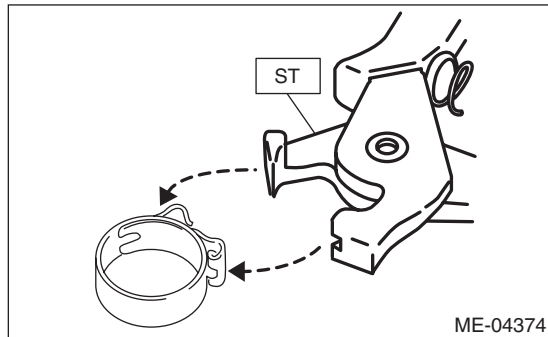

44) Install the timing belt cover. <Ref. to ME(STI)-49, INSTALLATION, Timing Belt Cover.>

45) Install the crank pulley. <Ref. to ME(STI)-47, INSTALLATION, Crank Pulley.>

46) Install the intake manifold. <Ref. to FU(STI)-21, INSTALLATION, Intake Manifold.>

47) Install the rear side belt. <Ref. to ME(STI)-41, REAR SIDE BELT, INSTALLATION, V-belt.>

48) Install the engine to the vehicle. <Ref. to ME(STI)-33, INSTALLATION, Engine Assembly.>

## C: DISASSEMBLY

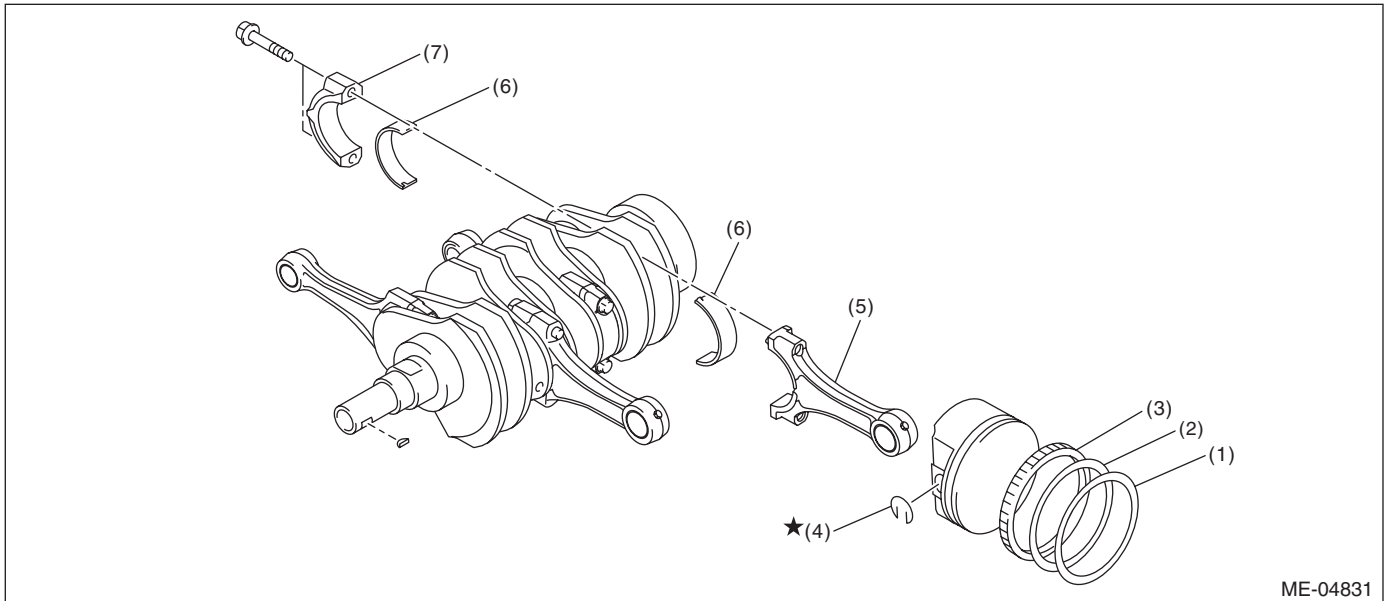

ME-04831

- |                 |                    |                            |
|-----------------|--------------------|----------------------------|
| (1) Top ring    | (4) Snap ring      | (6) Connecting rod bearing |
| (2) Second ring | (5) Connecting rod | (7) Connecting rod cap     |
| (3) Oil ring    |                    |                            |

- 1) Remove the connecting rod cap.
- 2) Remove the connecting rod bearing.

**NOTE:**

Keep the removed connecting rods, connecting rod caps and bearings in order so that they are kept in their original combinations/groups, and not mixed together.

3) Remove the piston rings using piston ring expander.

4) Remove the oil ring by hand.

**NOTE:**

Arrange the removed piston rings in proper order, to prevent confusion.

5) Remove the snap ring.

# Cylinder Block

MECHANICAL

## D: ASSEMBLY

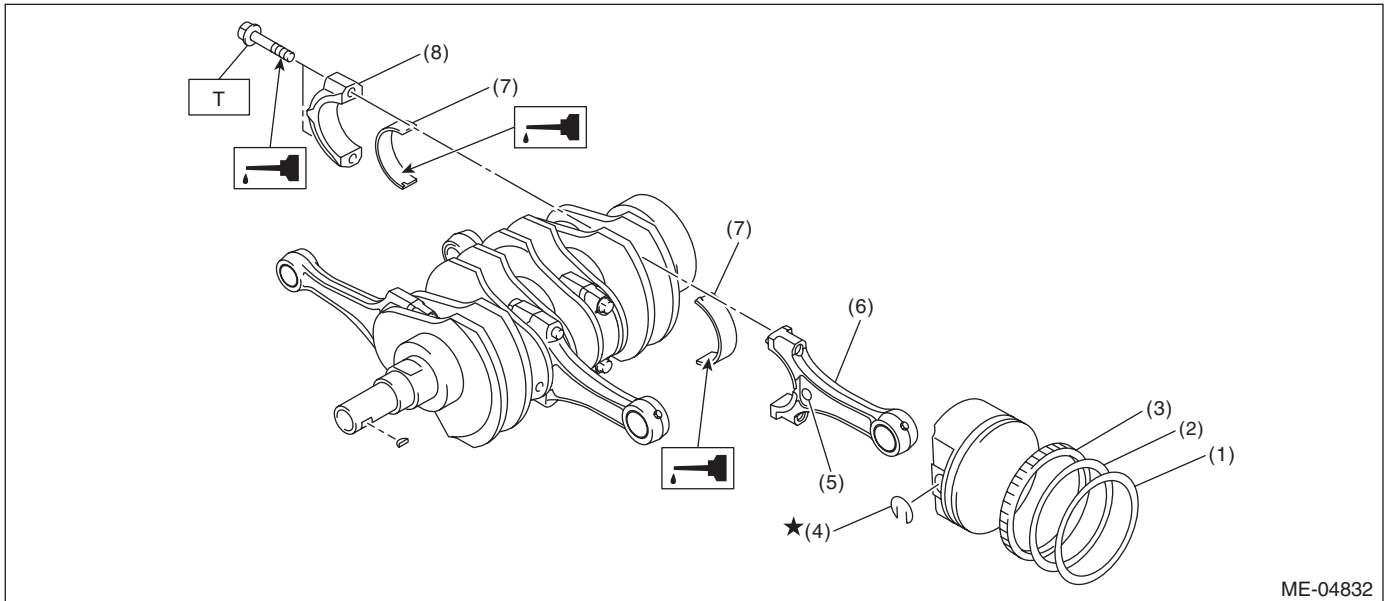

ME-04832

- |                 |                            |
|-----------------|----------------------------|
| (1) Top ring    | (5) Side mark              |
| (2) Second ring | (6) Connecting rod         |
| (3) Oil ring    | (7) Connecting rod bearing |
| (4) Snap ring   | (8) Connecting rod cap     |

**Tightening torque: N·m (kgf·m, ft·lb)**

**T: 52 (5.3, 38.4)**

- 1) Apply engine oil to the surface of the connecting rod bearings, and install the connecting rod bearings on connecting rods and connecting rod caps.
- 2) Position each connecting rod with the side with a side mark facing forward, and install it.
- 3) Attach the connecting rod cap and tighten it with connecting rod bolt. Make sure the arrow on connecting rod cap faces the front during installation.

### NOTE:

- Each connecting rod has its own mating cap. Make sure that they are assembled correctly by checking their matching number.
- When tightening the connecting rod bolts, apply oil on the threads.

### Tightening torque:

**52 N·m (5.3 kgf·m, 38.4 ft·lb)**

- 4) Install the oil ring upper rail, expander and lower rail by hand.
- 5) Install the second ring and top ring using piston ring expander.

### NOTE:

Assemble so that the piston ring mark "R" faces the top side of the piston.

**ME(STI)-94**

Brought to you by Ebay Seller "SubaruManuals"

## E: INSPECTION

### 1. CYLINDER BLOCK

- 1) Check for cracks or damage. Use liquid penetrant tester on the important sections to check for fissures. Check that there are no marks of gas leaking or water leaking on gasket installing surface.
- 2) Check the oil passages for clogging.
- 3) Inspect the cylinder block surface that mates with cylinder head for warping by using a straight edge, and correct by grinding if necessary.

**Warping limit:**  
**0.025 mm (0.00098 in)**

**Grinding limit:**  
**0.1 mm (0.004 in)**

**Standard height of cylinder block:**  
**201.0 mm (7.91 in)**

### 2. CYLINDER AND PISTON

- 1) The cylinder bore size is stamped on the front upper face of the cylinder block.

**NOTE:**

- Measurement should be performed at a temperature of 20°C (68°F).
- Standard sized pistons are classified into two grades, "A" and "B". These grades should be used as guide lines in selecting a standard piston.

**Standard diameter:**

**A: 99.505 — 99.515 mm (3.9175 — 3.9179 in)**

**B: 99.495 — 99.505 mm (3.9171 — 3.9175 in)**

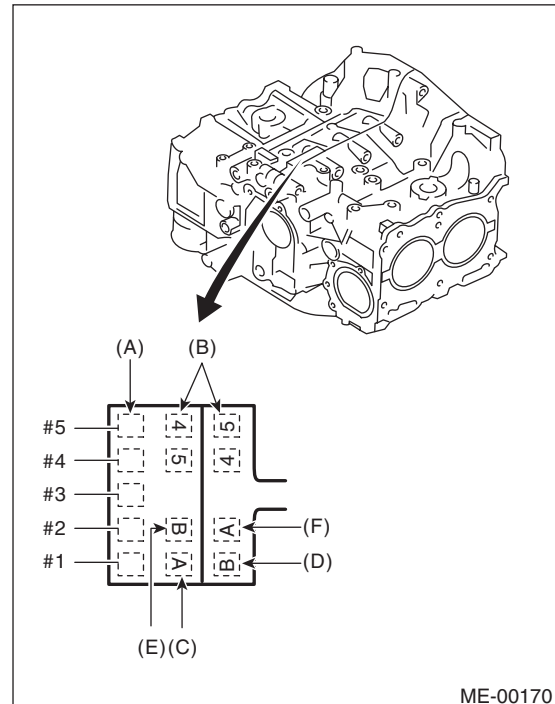

- (A) Main journal size mark
- (B) Cylinder block (RH) – (LH) combination mark
- (C) #1 cylinder bore size mark
- (D) #2 cylinder bore size mark
- (E) #3 cylinder bore size mark
- (F) #4 cylinder bore size mark

# Cylinder Block

## MECHANICAL

2) Measure inner diameter of each cylinder. Measure the inner diameter of each cylinder in both the thrust and piston pin directions at the heights as shown in the figure, using a cylinder bore gauge.

### NOTE:

Measurement should be performed at a temperature of 20°C (68°F).

### Cylindricity:

#### Limit

**0.015 mm (0.0006 in)**

### Out-of-roundness:

#### Limit

**0.010 mm (0.0004 in)**

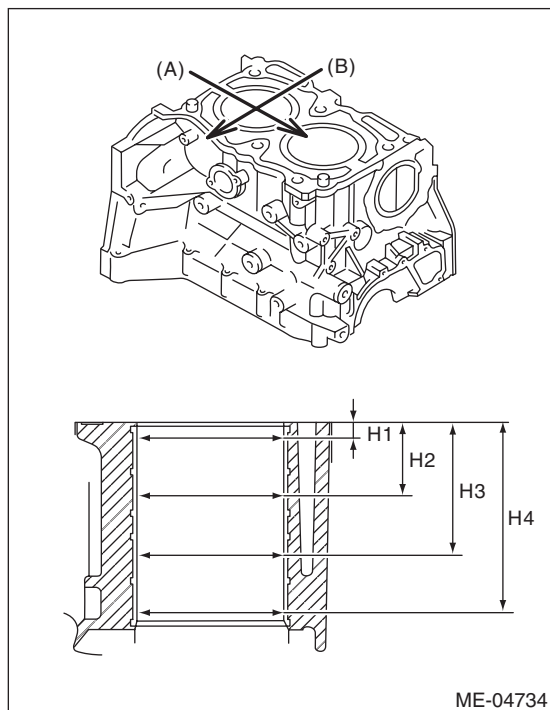

(A) Piston pin direction

(B) Thrust direction

H1: 10 mm (0.39 in)

H2: 45 mm (1.77 in)

H3: 80 mm (3.15 in)

H4: 115 mm (4.53 in)

3) When the piston is to be replaced due to general or cylinder wear, select a suitable sized piston by measuring the piston clearance.

4) Measure outer diameter of each piston.

Measure the outer diameter of each piston at the height as shown in the figure. (Thrust direction)

### NOTE:

Measurement should be performed at a temperature of 20°C (68°F).

### Piston grade point H:

**38.2 mm (1.50 in)**

### Piston outer diameter:

#### Standard

**A: 99.505 — 99.515 mm (3.9175 — 3.9179 in)**

**B: 99.495 — 99.505 mm (3.9171 — 3.9175 in)**

**0.25 mm (0.0098 in) oversize**

**99.745 — 99.765 mm (3.9270 — 3.9278 in)**

**0.50 mm (0.0197 in) oversize**

**99.995 — 100.015 mm (3.9368 — 3.9376 in)**

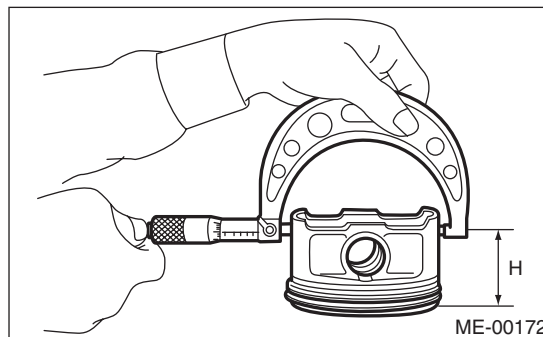

5) Calculate the clearance between cylinder and piston.

### NOTE:

Measurement should be performed at a temperature of 20°C (68°F).

### Clearance between cylinder and piston at 20°C (68°F):

#### Standard

**-0.010 — 0.010 mm (-0.00039 — 0.00039 in)**

6) Boring and honing

(1) If any of the measured value of cylindricity, out-of-roundness or cylinder-to-piston clearance is out of standard or if there is any damage on the cylinder wall, rebore it to replace with an oversize piston.

### CAUTION:

**When any of the cylinders needs reboring, all other cylinders must be bored at the same time, and replaced with oversize pistons.**

(2) If the cylinder inner diameter exceeds the limit after boring and honing, replace the cylinder block.

**NOTE:**

Immediately after reboring, the cylinder diameter may differ from its real diameter due to temperature rise. Thus, when measuring the cylinder diameter, wait until it has cooled to room temperature.

**Cylinder inner diameter boring limit (diameter):  
To 100.005 mm (3.9372 in)**

### 3. PISTON AND PISTON PIN

- 1) Check the piston and piston pin for damage, cracks or wear. Replace if faulty.
- 2) Check the piston ring groove for wear or damage. Replace if faulty.
- 3) Make sure that the piston pin can be inserted into the piston pin hole with a thumb at 20°C (68°F). Replace if faulty.

**Clearance between piston pin hole and piston pin:**

**Standard**

**0.004 — 0.008 mm (0.0002 — 0.0003 in)**

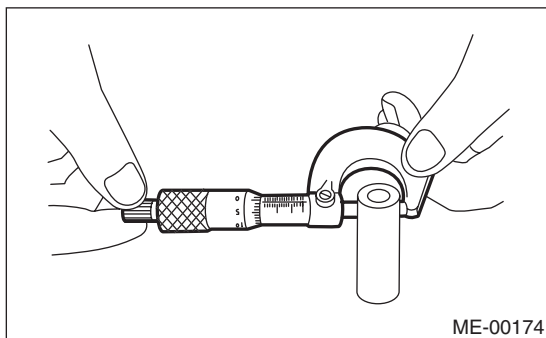
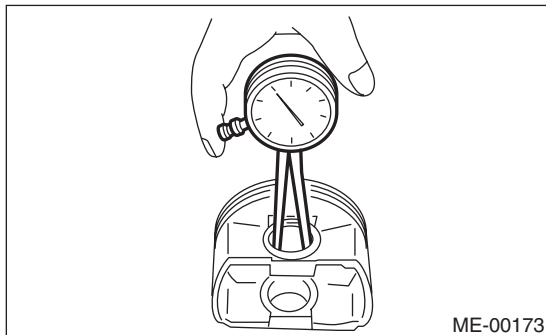

4) Check the snap ring installation groove (A) on the piston for burr. If necessary, remove burr from the groove so that the piston pin can lightly move.

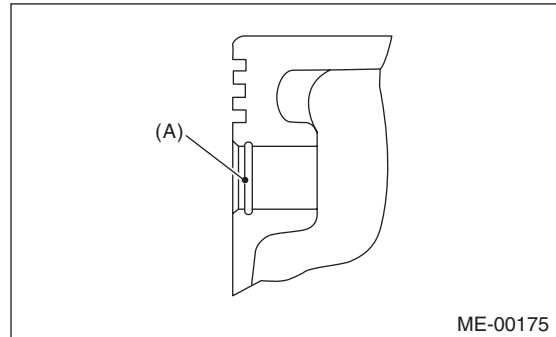

5) Check the snap ring for distortion, cracks and wear.

### 4. PISTON RING

1) If the piston ring is broken, damaged or worn, or if its tension is insufficient, or when the piston is replaced, replace the piston ring with a new part of the same size as piston.

**NOTE:**

- The top ring and second ring have the mark to determine the direction for installing. When installing the ring to piston, face marks to the top side.
- Oil ring consists of the upper rail, expander and lower rail. When installing oil ring on piston, be careful of the direction of each rail.

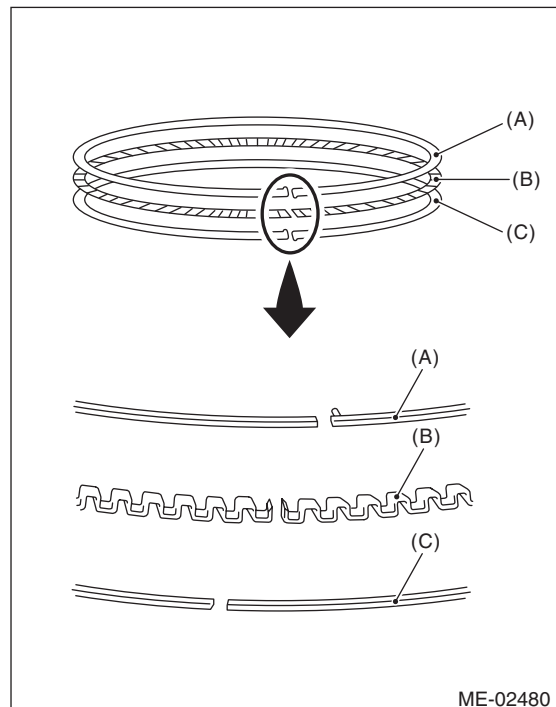

- (A) Upper rail
- (B) Expander
- (C) Lower rail

# Cylinder Block

## MECHANICAL

2) Using the piston, insert the piston ring and oil ring into the cylinder block so that they are perpendicular to the cylinder wall, and measure the piston ring gap using a thickness gauge.

		Standard mm (in)
Piston ring gap	Top ring	0.23 — 0.28 (0.0091 — 0.0110)
	Second ring	0.37 — 0.52 (0.015 — 0.020)
	Oil ring rail	0.20 — 0.50 (0.0079 — 0.0197)

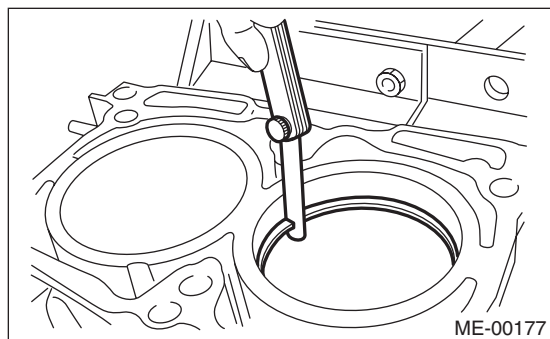

3) Fit the piston ring straight into the piston ring groove, then measure the clearance between piston ring and piston ring groove with a thickness gauge.

### NOTE:

Before measuring the clearance, clean the piston ring groove and piston ring.

		Standard mm (in)
Clearance between piston ring and piston ring groove	Top ring	0.040 — 0.080 (0.0016 — 0.0031)
	Second ring	0.030 — 0.070 (0.0012 — 0.0028)

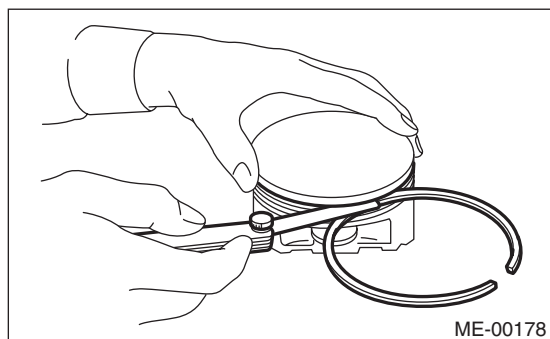

## 5. CONNECTING ROD

- 1) Replace the connecting rod, if the large or small end thrust surface is damaged.
- 2) Check for bend or twist using a connecting rod aligner. Replace the connecting rod if the bend or twist exceeds the limit.

**Limit of bend or twist per 100 mm (3.94 in) in length:**

**0.10 mm (0.0039 in)**

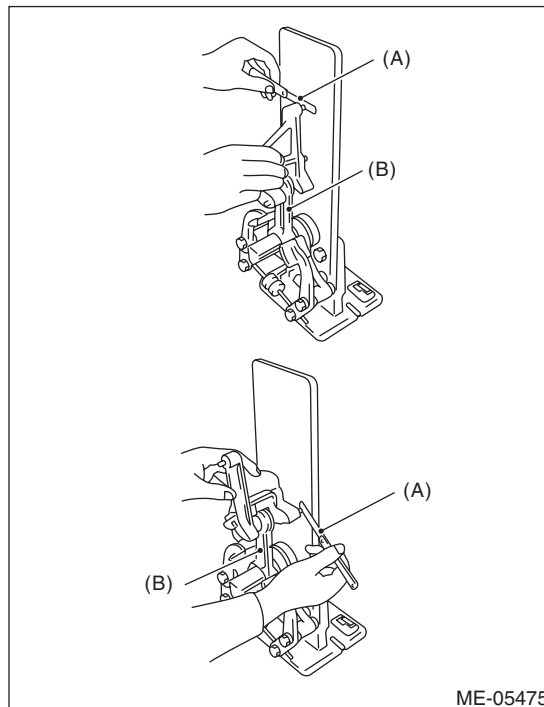

- (A) Thickness gauge  
(B) Connecting rod

3) Install the connecting rod with bearings attached to the crankshaft, and using a thickness gauge, measure the thrust clearance. If the thrust clearance exceeds the standard or uneven wear is found, replace the connecting rod.

**Connecting rod thrust clearance:**

**Standard**

**0.070 — 0.330 mm (0.0028 — 0.0130 in)**

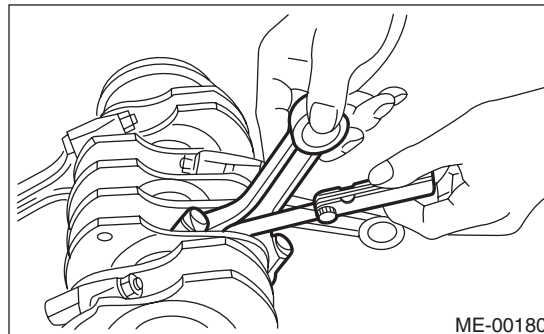

4) Inspect the connecting rod bearing for scar, peeling, seizure, melting, wear, etc.

**ME(STI)-98**

Brought to you by Ebay Seller "SubaruManuals"

5) Measure the oil clearance on each connecting rod bearing using plastigauge. If any oil clearance is not within the standard, replace the defective bearing with a new part of standard size or under-size as necessary.

**Connecting rod oil clearance:**  
**Standard**

**0.017 — 0.045 mm (0.0007 — 0.0018 in)**

Unit: mm (in)		
Bearing	Bearing size (Thickness at center)	Outer diameter of crank pin
Standard	1.490 — 1.506 (0.0587 — 0.0593)	51.976 — 52.000 (2.0463 — 2.0472)
0.03 (0.0012) Undersize	1.504 — 1.512 (0.0592 — 0.0595)	51.954 — 51.970 (2.0454 — 2.0461)
0.05 (0.0020) Undersize	1.514 — 1.522 (0.0596 — 0.0599)	51.934 — 51.950 (2.0447 — 2.0453)
0.25 (0.0098) Undersize	1.614 — 1.622 (0.0635 — 0.0639)	51.734 — 51.750 (2.0368 — 2.0374)

6) Inspect the bushing at connecting rod small end, and replace the connecting rod if it is worn or damaged.

7) Measure the piston pin clearance at connecting rod small end. If the measured value is not within the standard, replace the connecting rod and piston pin as a set.

**Clearance between piston pin and bushing:**  
**Standard**

**0 — 0.022 mm (0 — 0.0009 in)**

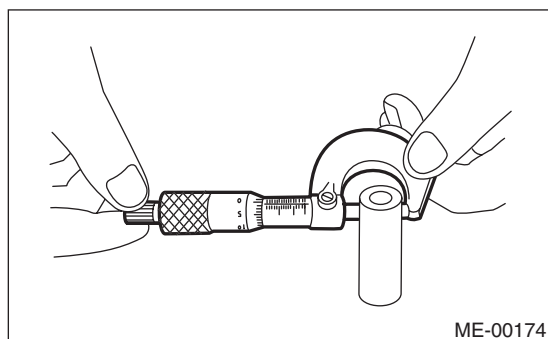
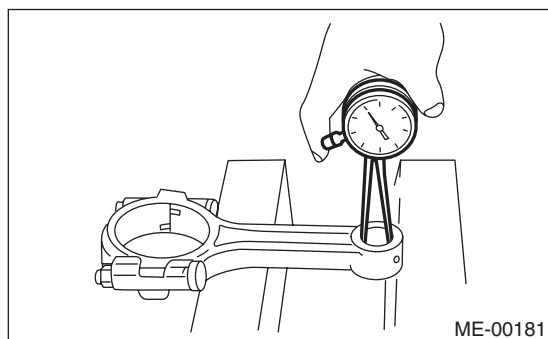

**6. CRANKSHAFT AND CRANKSHAFT BEARING**

1) Clean the crankshaft completely, and check it for cracks using liquid penetrant tester. If defective, replace the crankshaft.

2) Measure warping of the crankshaft. If it exceeds the limit, correct or replace it.

**NOTE:**

If a suitable V-block is not available, using just the #1 and #5 crankshaft bearings on cylinder block, position the crankshaft on cylinder block. Then, measure the crankshaft bend using a dial gauge.

**Crankshaft bend limit:**  
**0.035 mm (0.0014 in)**

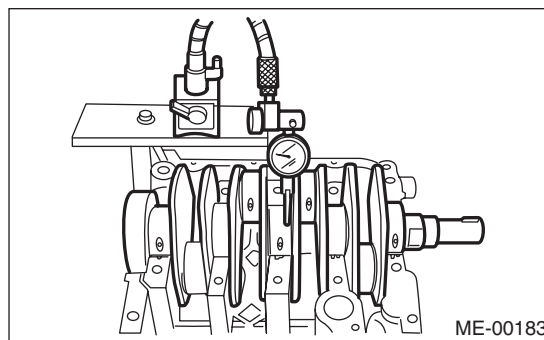



# Cylinder Block

## MECHANICAL

3) Inspect the crank journal and crank pin for wear. If they are not within the standard, replace the bearing with a suitable (undersize) one, and replace or grind to correct the crankshaft as necessary. When grinding the crank journal or crank pin, finish them to the specified dimensions according to the undersize bearing to be used.

### Crank pin:

#### Cylindricity

##### Limit

0.004 mm (0.0002 in)

#### Out-of-roundness

##### Limit

0.003 mm (0.0001 in)

#### Grinding limit (dia.)

To 51.750 mm (2.0374 in)

### Crank journal:

#### Cylindricity

##### Limit

0.006 mm (0.0002 in)

#### Out-of-roundness

##### Limit

0.005 mm (0.0002 in)

#### Grinding limit (dia.)

To 59.758 mm (2.3527 in)

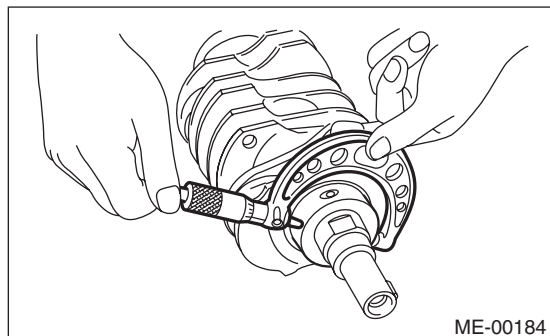

		Unit: mm (in)		
		Crank journal diameter		Crank pin outer diameter
		#1, #3	#2, #4, #5	
Standard	Journal O.D.	59.984 — 60.008 (2.3616 — 2.3625)	59.984 — 60.008 (2.3616 — 2.3625)	51.976 — 52.000 (2.0463 — 2.0472)
	Bearing size (Thickness at center)	1.998 — 2.015 (0.0787 — 0.0793)	2.000 — 2.017 (0.0787 — 0.0794)	1.490 — 1.506 (0.0587 — 0.0593)
0.03 (0.0012) Undersize	Journal O.D.	59.962 — 59.978 (2.3607 — 2.3613)	59.962 — 59.978 (2.3607 — 2.3613)	51.954 — 51.970 (2.0454 — 2.0461)
	Bearing size (Thickness at center)	2.017 — 2.020 (0.0794 — 0.0795)	2.019 — 2.022 (0.0795 — 0.0796)	1.504 — 1.512 (0.0592 — 0.0595)
0.05 (0.0020) Undersize	Journal O.D.	59.942 — 59.958 (2.3599 — 2.3605)	59.942 — 59.958 (2.3599 — 2.3605)	51.934 — 51.950 (2.0447 — 2.0453)
	Bearing size (Thickness at center)	2.027 — 2.030 (0.0798 — 0.0799)	2.029 — 2.032 (0.0799 — 0.0800)	1.514 — 1.522 (0.0596 — 0.0599)
0.25 (0.0098) Undersize	Journal O.D.	59.742 — 59.758 (2.3520 — 2.3527)	59.742 — 59.758 (2.3520 — 2.3527)	51.734 — 51.750 (2.0368 — 2.0374)
	Bearing size (Thickness at center)	2.127 — 2.130 (0.0837 — 0.0839)	2.129 — 2.132 (0.0838 — 0.0839)	1.614 — 1.622 (0.0635 — 0.0639)

4) Use a thickness gauge to measure the thrust clearance of crankshaft at #5 crank journal bearing. If clearance exceeds the standard, replace the bearing.

**Crankshaft thrust clearance:**

**Standard**

**0.030 — 0.115 mm (0.0012 — 0.0045 in)**

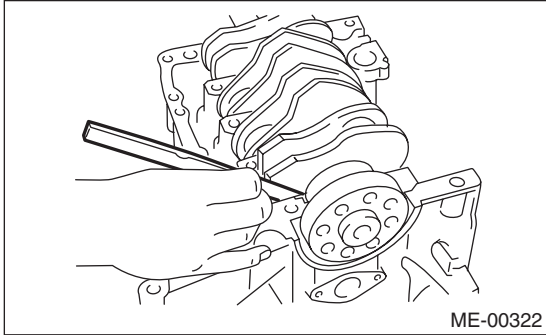

5) Inspect individual crankshaft bearings for signs of flaking, seizure, melting and wear.

6) Measure the oil clearance on each crankshaft bearing using plastigauge. If the measured value is out of standard, replace the defective bearing with an undersize one, and replace or grind to correct the crankshaft as necessary.

**Crankshaft oil clearance:**

**Standard**

**0.010 — 0.030 mm (0.00039 — 0.0012 in)**

## 21. Intake and Exhaust Valve

### A: SPECIFICATION

Refer to "Cylinder Head" for removal and installation procedures of the intake and exhaust valves.

<Ref. to ME(STI)-70, REMOVAL, Cylinder Head.>

<Ref. to ME(STI)-70, INSTALLATION, Cylinder Head.>

## 22.Piston

### A: SPECIFICATION

Refer to "Cylinder Block" for removal and installation procedures of pistons. <Ref. to ME(STI)-79, REMOVAL, Cylinder Block.> <Ref. to ME(STI)-83, INSTALLATION, Cylinder Block.>

## 23. Connecting Rod

### A: SPECIFICATION

Refer to "Cylinder Block" for removal and installation procedures of connecting rod. <Ref. to ME(STI)-79, REMOVAL, Cylinder Block.> <Ref. to ME(STI)-83, INSTALLATION, Cylinder Block.>

## 24.Crankshaft

### A: SPECIFICATION

Refer to "Cylinder Block" for removal and installation procedures of the crankshaft. <Ref. to ME(STI)-79, REMOVAL, Cylinder Block.> <Ref. to ME(STI)-83, INSTALLATION, Cylinder Block.>

# Engine Trouble in General

MECHANICAL

## 25.Engine Trouble in General

### A: INSPECTION

NOTE:

The "RANK" shown in the chart shows the possibilities of the cause of trouble in order from "Very often" to "Rarely".

A — Very often

B — Sometimes

C — Rarely

Symptoms	Problem parts etc.	Possible cause	RANK
1. Engine does not start.			
1) Starter does not turn.	Starter	Defective battery-to-starter harness	B
		Defective starter switch	C
		Defective starter	B
	Battery	Improper connection of terminal	A
		Run-down battery	A
		Defective charging system	B
	Friction	Seizure of crankshaft and connecting rod bearing	C
		Seized camshaft	C
		Seized or stuck piston and cylinder	C
		Immobilizer system <Ref. to IM(diag)-2, Basic Diagnostic Procedure.>	A
2) Initial combustion does not occur.	Starter	Defective starter	C
		Engine control system <Ref. to EN(H4DOTC)(diag)-2, Basic Diagnostic Procedure.>	A
	Fuel line	Defective fuel pump and relay	A
		Clogged fuel line	C
		Lack of fuel or insufficient fuel	B
	Timing belt	Degradation, etc.	B
		Defective timing	B
	Compression	Incorrect valve clearance	C
		Loosened spark plug or defective gasket	C
		Loosened cylinder head bolt or defective cylinder head gasket	C
		Improper valve sealing	C
		Defective valve stem	C
		Worn or broken valve spring	B
		Worn or stuck piston rings, cylinder and piston	C
Incorrect valve timing		B	
Improper engine oil (low viscosity)		B	

# Engine Trouble in General

MECHANICAL

Symptoms	Problem parts etc.	Possible cause	RANK
3) Initial combustion occurs.	Engine control system <Ref. to EN(H4DOTC)(diag)-2, Basic Diagnostic Procedure.>		A
	Intake system	Defective intake manifold gasket	B
		Defective throttle body gasket	B
	Fuel line	Defective fuel pump and relay	C
		Clogged fuel line	C
		Lack of fuel or insufficient fuel	B
	Timing belt	Degradation, etc.	B
		Defective timing	B
	Compression	Incorrect valve clearance	C
		Loosened spark plug or defective gasket	C
		Loosened cylinder head bolt or defective cylinder head gasket	C
		Improper valve sealing	C
		Defective valve stem	C
		Worn or broken valve spring	B
Worn or stuck piston rings, cylinder and piston		C	
Incorrect valve timing		B	
Improper engine oil (low viscosity)	B		
4) Engine stalls after initial combustion.	Engine control system <Ref. to EN(H4DOTC)(diag)-2, Basic Diagnostic Procedure.>		A
	Intake system	Loosened or cracked intake duct	B
		Loosened or cracked PCV hose	C
		Loosened or cracked vacuum hose	C
		Defective intake manifold gasket	B
		Defective throttle body gasket	B
		Dirty air cleaner element	C
	Fuel line	Clogged fuel line	C
		Lack of fuel or insufficient fuel	B
	Timing belt	Degradation, etc.	B
		Defective timing	B
	Compression	Incorrect valve clearance	C
		Loosened spark plug or defective gasket	C
		Loosened cylinder head bolt or defective cylinder head gasket	C
		Improper valve sealing	C
		Defective valve stem	C
		Worn or broken valve spring	B
		Worn or stuck piston rings, cylinder and piston	C
Incorrect valve timing		B	
Improper engine oil (low viscosity)	B		



# Engine Trouble in General

## MECHANICAL

Symptoms	Problem parts etc.	Possible cause	RANK
2. Rough idle and engine stall	Engine control system <Ref. to EN(H4DOTC)(diag)-2, Basic Diagnostic Procedure.>		A
	Intake system	Loosened or cracked intake duct	A
		Loosened or cracked PCV hose	A
		Loosened or cracked vacuum hose	A
		Defective intake manifold gasket	B
		Defective throttle body gasket	B
		Defective PCV valve	C
		Loosened oil filler cap	B
		Dirty air cleaner element	C
	Fuel line	Defective fuel pump and relay	C
		Clogged fuel line	C
		Lack of fuel or insufficient fuel	B
	Timing belt	Defective timing	C
	Compression	Incorrect valve clearance	B
		Loosened spark plug or defective gasket	B
		Loosened cylinder head bolt or defective cylinder head gasket	B
		Improper valve sealing	B
		Defective valve stem	C
		Worn or broken valve spring	B
		Worn or stuck piston rings, cylinder and piston	B
		Incorrect valve timing	A
	Improper engine oil (low viscosity)	B	
	Lubrication system	Incorrect oil pressure	B
Defective rocker cover gasket		C	
Cooling system	Over-heating	C	
Others	Evaporative emission control system malfunction	A	
	Stuck or damaged throttle valve	B	

# Engine Trouble in General

MECHANICAL

Symptoms	Problem parts etc.	Possible cause	RANK
3. Low output, hesitation and poor acceleration	Engine control system <Ref. to EN(H4DOTC)(diag)-2, Basic Diagnostic Procedure.>		A
	Intake system	Loosened or cracked intake duct	A
		Loosened or cracked PCV hose	A
		Loosened or cracked vacuum hose	B
		Defective intake manifold gasket	B
		Defective throttle body gasket	B
		Defective PCV valve	B
		Loosened oil filler cap	B
		Dirty air cleaner element	A
	Fuel line	Defective fuel pump and relay	B
		Clogged fuel line	B
		Lack of fuel or insufficient fuel	C
	Timing belt	Defective timing	B
	Compression	Incorrect valve clearance	B
		Loosened spark plug or defective gasket	B
		Loosened cylinder head bolt or defective cylinder head gasket	B
		Improper valve sealing	B
		Defective valve stem	C
		Worn or broken valve spring	B
		Worn or stuck piston rings, cylinder and piston	C
		Incorrect valve timing	A
	Improper engine oil (low viscosity)	B	
	Lubrication system	Incorrect oil pressure	B
Cooling system	Over-heating	C	
	Over-cooling	C	
Others	Evaporative emission control system malfunction	A	

# Engine Trouble in General

## MECHANICAL

Symptoms	Problem parts etc.	Possible cause	RANK
4. Surging	Engine control system <Ref. to EN(H4DOTC)(diag)-2, Basic Diagnostic Procedure.>		A
	Intake system	Loosened or cracked intake duct	A
		Loosened or cracked PCV hose	A
		Loosened or cracked vacuum hose	A
		Defective intake manifold gasket	B
		Defective throttle body gasket	B
		Defective PCV valve	B
		Loosened oil filler cap	B
		Dirty air cleaner element	B
	Fuel line	Defective fuel pump and relay	B
		Clogged fuel line	B
		Lack of fuel or insufficient fuel	C
	Timing belt	Defective timing	B
	Compression	Incorrect valve clearance	B
		Loosened spark plug or defective gasket	C
		Loosened cylinder head bolt or defective cylinder head gasket	C
		Improper valve sealing	C
		Defective valve stem	C
		Worn or broken valve spring	C
		Worn or stuck piston rings, cylinder and piston	C
Incorrect valve timing		A	
Improper engine oil (low viscosity)	B		
Cooling system	Over-heating	B	
Others	Evaporative emission control system malfunction	C	
5. Engine does not return to idle.	Engine control system <Ref. to EN(H4DOTC)(diag)-2, Basic Diagnostic Procedure.>		A
	Intake system	Loosened or cracked vacuum hose	A
	Others	Stuck or damaged throttle valve	A
6. Dieseling (Run-on)	Engine control system <Ref. to EN(H4DOTC)(diag)-2, Basic Diagnostic Procedure.>		A
	Cooling system	Over-heating	B
	Others	Evaporative emission control system malfunction	B
7. After burning in exhaust system	Engine control system <Ref. to EN(H4DOTC)(diag)-2, Basic Diagnostic Procedure.>		A
	Intake system	Loosened or cracked intake duct	C
		Loosened or cracked PCV hose	C
		Loosened or cracked vacuum hose	B
		Defective PCV valve	B
		Loosened oil filler cap	C
	Timing belt	Defective timing	B
	Compression	Incorrect valve clearance	B
		Loosened spark plug or defective gasket	C
		Loosened cylinder head bolt or defective cylinder head gasket	C
		Improper valve sealing	B
		Defective valve stem	C
		Worn or broken valve spring	C
		Worn or stuck piston rings, cylinder and piston	C
		Incorrect valve timing	A
	Lubrication system	Incorrect oil pressure	C
	Cooling system	Over-cooling	C
Others	Evaporative emission control system malfunction	C	

# Engine Trouble in General

MECHANICAL

Symptoms	Problem parts etc.	Possible cause	RANK
8. Knocking	Engine control system <Ref. to EN(H4DOTC)(diag)-2, Basic Diagnostic Procedure.>		A
	Intake system	Loosened oil filler cap	B
	Timing belt	Defective timing	B
	Compression	Incorrect valve clearance	C
		Incorrect valve timing	B
Cooling system	Over-heating	A	
9. Excessive engine oil consumption	Intake system	Loosened or cracked PCV hose	A
		Defective PCV valve	B
		Loosened oil filler cap	C
	Compression	Defective valve stem	A
		Worn or stuck piston rings, cylinder and piston	A
	Lubrication system	Loosened oil pump attaching bolts and defective gasket	B
		Defective oil filter gasket	B
		Defective crankshaft oil seal	B
		Defective rocker cover gasket	B
		Loosened oil drain plug or defective gasket	B
Loosened oil pan fitting bolts or defective oil pan	B		
10. Excessive fuel consumption	Engine control system <Ref. to EN(H4DOTC)(diag)-2, Basic Diagnostic Procedure.>		A
	Intake system	Dirty air cleaner element	A
	Timing belt	Defective timing	B
	Compression	Incorrect valve clearance	B
		Loosened spark plug or defective gasket	C
		Loosened cylinder head bolt or defective cylinder head gasket	C
		Improper valve sealing	B
		Defective valve stem	C
		Worn or broken valve spring	C
		Worn or stuck piston rings, cylinder and piston	B
		Incorrect valve timing	B
	Lubrication system	Incorrect oil pressure	C
	Cooling system	Over-cooling	C

# Engine Noise

MECHANICAL

## 26.Engine Noise

### A: INSPECTION

Type of sound	Condition	Possible cause
Regular clicking sound	Sound increases as engine speed increases.	<ul style="list-style-type: none"> <li>Valve mechanism is defective.</li> <li>Incorrect valve clearance</li> <li>Worn camshaft</li> <li>Broken valve spring</li> </ul>
Heavy and dull clank	Oil pressure is low.	<ul style="list-style-type: none"> <li>Worn crankshaft main bearing</li> <li>Worn connecting rod bearing (large end)</li> </ul>
	Oil pressure is normal.	<ul style="list-style-type: none"> <li>Loosened flywheel mounting bolt</li> <li>Damaged engine mounting</li> </ul>
High-pitched clank	Sound is noticeable when accelerating with an overload condition.	<ul style="list-style-type: none"> <li>Ignition timing advanced</li> <li>Accumulation of carbon inside combustion chamber</li> <li>Wrong heat range of spark plug</li> <li>Improper octane value gasoline</li> </ul>
Clank when engine speed is between 1,000 and 2,000 rpms.	Sound is reduced when the fuel injector connector of the noisy cylinder is disconnected.*	<ul style="list-style-type: none"> <li>Worn crankshaft main bearing</li> <li>Worn connecting rod bearing (large end)</li> </ul>
Knocking sound when engine is operating under idling speed and engine is warm	Sound is reduced when the fuel injector connector of the noisy cylinder is disconnected.*	<ul style="list-style-type: none"> <li>Worn cylinder liner and piston ring</li> <li>Broken or stuck piston ring</li> <li>Worn piston pin and hole at piston end of connecting rod</li> </ul>
	Sound is not reduced if each fuel injector connector is disconnected in turn.*	<ul style="list-style-type: none"> <li>Unusually worn valve lifter</li> <li>Worn cam sprocket</li> <li>Worn camshaft journal bore in cylinder head</li> </ul>
Squeaky sound	—	<ul style="list-style-type: none"> <li>Insufficient generator lubrication</li> </ul>
Rubbing sound	—	<ul style="list-style-type: none"> <li>Poor contact of generator brush and rotor</li> </ul>
Gear scream when starting engine	—	<ul style="list-style-type: none"> <li>Defective ignition starter switch</li> <li>Worn gear and starter pinion</li> </ul>
Sound like polishing glass with a dry cloth	—	<ul style="list-style-type: none"> <li>Loose V-belt</li> <li>Defective water pump shaft</li> </ul>
Hissing sound	—	<ul style="list-style-type: none"> <li>Insufficient compression</li> <li>Air leakage in air intake system, hose, connection or manifold</li> </ul>
Timing belt noise	—	<ul style="list-style-type: none"> <li>Loose timing belt</li> <li>Timing belt contacting with adjacent part</li> </ul>
Valve noise	—	<ul style="list-style-type: none"> <li>Incorrect valve clearance</li> </ul>

\* When disconnecting the fuel injector connector, the malfunction indicator light illuminates and DTC is stored in ECM memory. Therefore, perform the Clear Memory Mode <Ref. to EN(H4DOTC)(diag)-62, OPERATION, Clear Memory Mode.> and Inspection Mode <Ref. to EN(H4DOTC)(diag)-48, PROCEDURE, Inspection Mode.> after connecting the fuel injector connector.

# EXHAUST

# *EX(STI)*

---

	<b>Page</b>
1. General Description .....	2
2. Front Exhaust Pipe .....	6
3. Center Exhaust Pipe .....	8
4. Joint Pipe .....	12
5. Rear Exhaust Pipe .....	13
6. Muffler .....	15

# General Description

## EXHAUST

### 1. General Description

#### A: COMPONENT

#### 1. FRONT EXHAUST PIPE

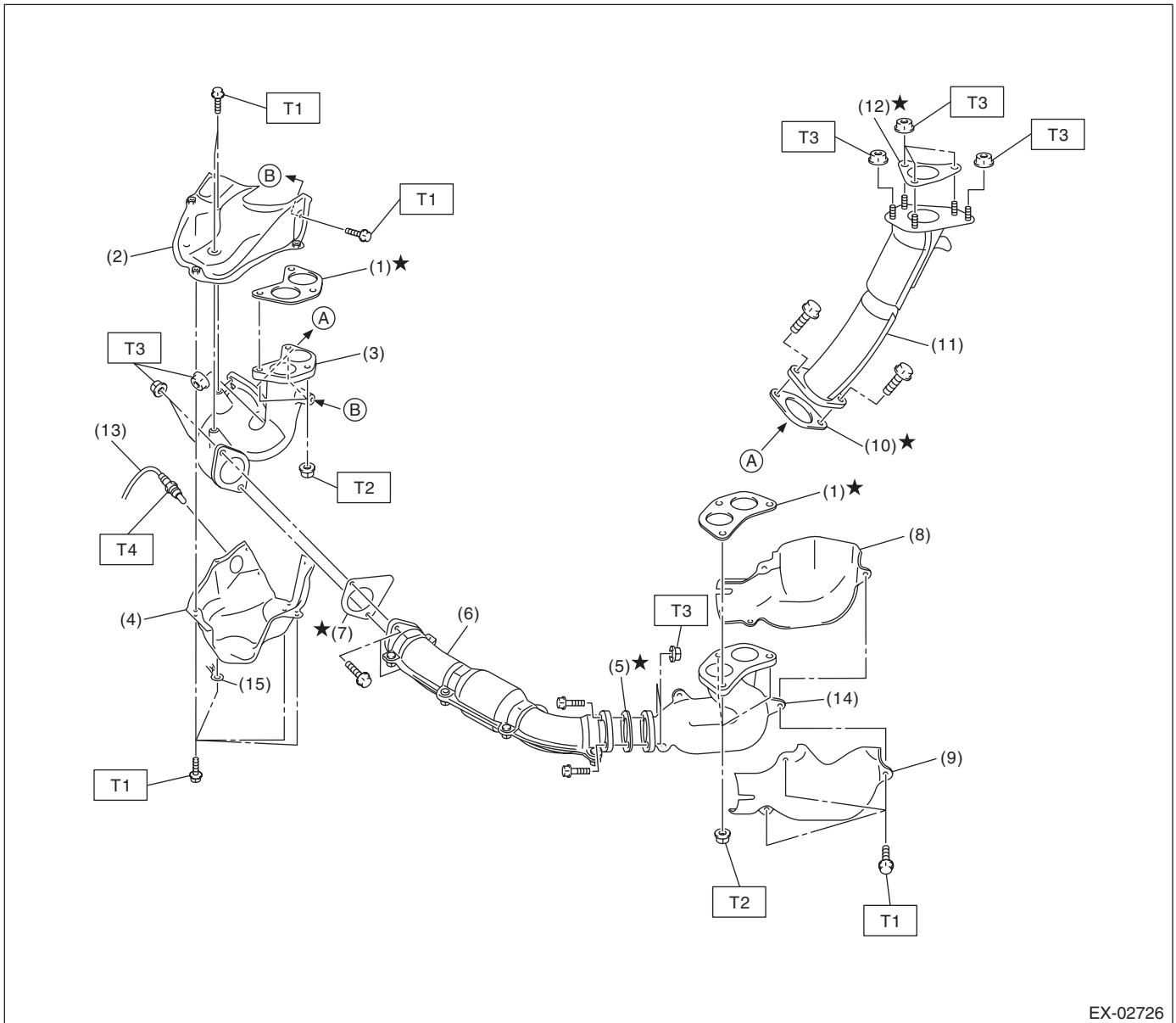

- |                                     |                                     |                   |
|-------------------------------------|-------------------------------------|-------------------|
| (1) Gasket                          | (8) Exhaust manifold LH inner cover | (15) Ground cable |
| (2) Exhaust manifold RH upper cover | (9) Exhaust manifold LH outer cover |                   |
| (3) Exhaust manifold RH             | (10) Gasket                         |                   |
| (4) Exhaust manifold RH lower cover | (11) Joint pipe                     |                   |
| (5) Gasket                          | (12) Gasket                         |                   |
| (6) Front exhaust pipe              | (13) Front oxygen (A/F) sensor      |                   |
| (7) Gasket                          | (14) Exhaust manifold LH            |                   |

---

#### **Tightening torque: N·m (kgf·m, ft·lb)**

**T1: 19 (1.9, 14.0)**

**T2: 40 (4.1, 29.5)**

**T3: 42.5 (4.3, 31.3)**

**T4: <Ref. to FU(STI)-54, INSTALLATION, Front Oxygen (A/F) Sensor.> <Ref. to FU(w/o STI)-54, INSTALLATION, Front Oxygen (A/F) Sensor.>**

---

**EX(STI)-2**

Brought to you by Ebay Seller "SubaruManuals"

## 2. CENTER AND REAR EXHAUST PIPE, AND MUFFLER

- 4 door model

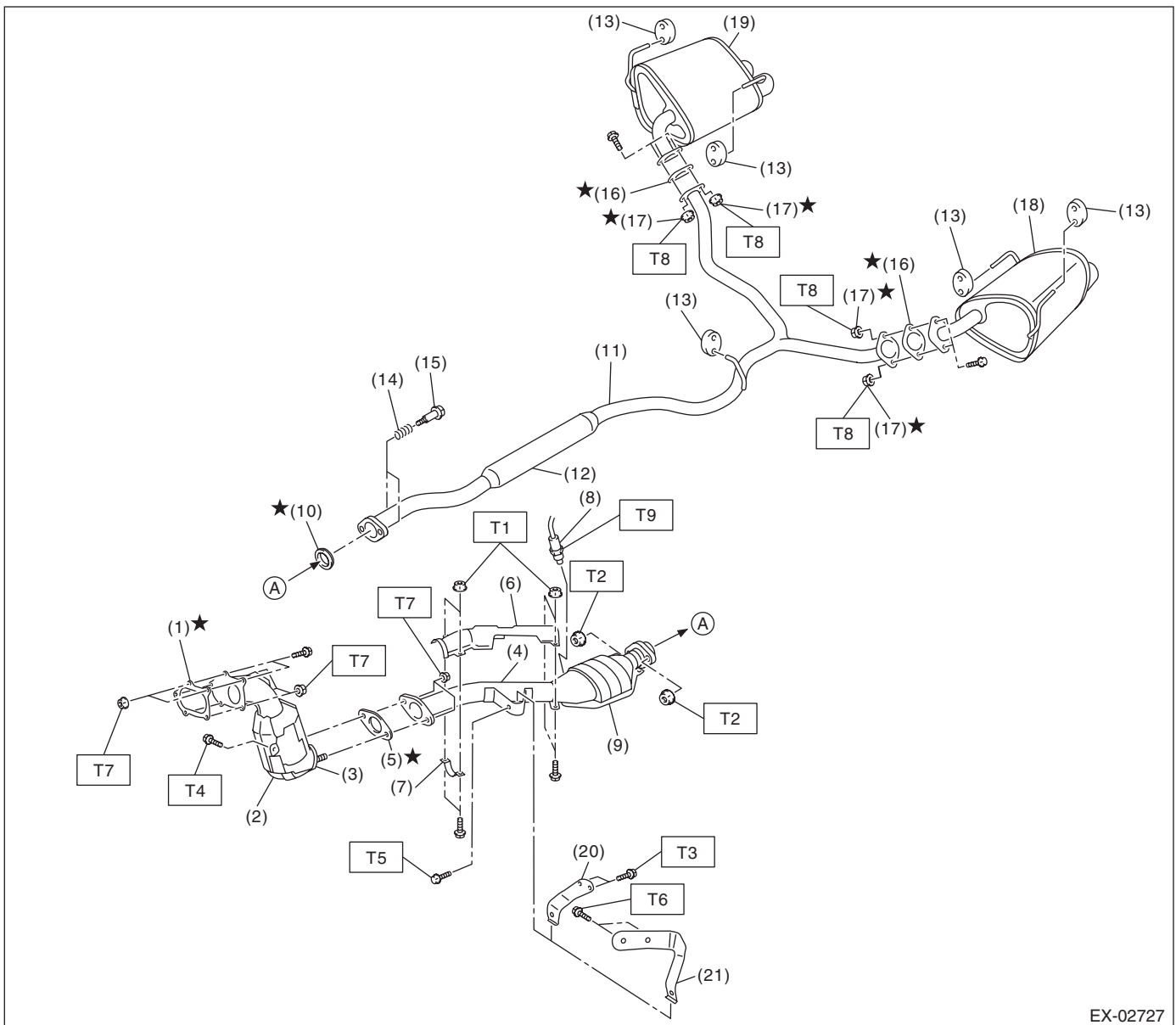

EX-02727

- |                                     |                                 |
|-------------------------------------|---------------------------------|
| (1) Gasket                          | (12) Chamber                    |
| (2) Front catalytic converter       | (13) Cushion rubber             |
| (3) Center exhaust pipe (front)     | (14) Spring                     |
| (4) Center exhaust pipe (rear)      | (15) Bolt                       |
| (5) Gasket                          | (16) Gasket                     |
| (6) Center exhaust pipe upper cover | (17) Self-locking nut           |
| (7) Clamp                           | (18) Muffler LH                 |
| (8) Rear oxygen sensor              | (19) Muffler RH                 |
| (9) Rear catalytic converter        | (20) Hanger bracket (5MT model) |
| (10) Gasket                         | (21) Hanger bracket (6MT model) |
| (11) Rear exhaust pipe              |                                 |

**Tightening torque: N·m (kgf·m, ft·lb)**

**T1: 13 (1.3, 9.6)**

**T2: 18 (1.8, 13.3)**

**T3: 23 (2.3, 17.0)**

**T4: 30 (3.1, 22.1)**

**T5: 35 (3.6, 25.8)**

**T6: 40 (4.1, 29.5)**

**T7: 42.5 (4.3, 31.3)**

**T8: 48 (4.9, 35.4)**

**T9: <Ref. to FU(STI)-56, INSTALLATION, Rear Oxygen Sensor.>**

**<Ref. to FU(w/o STI)-56, INSTALLATION, Rear Oxygen Sensor.>**

**EX(STI)-3**

Brought to you by Ebay Seller "SubaruManuals"



# General Description

## EXHAUST

- 5 door model

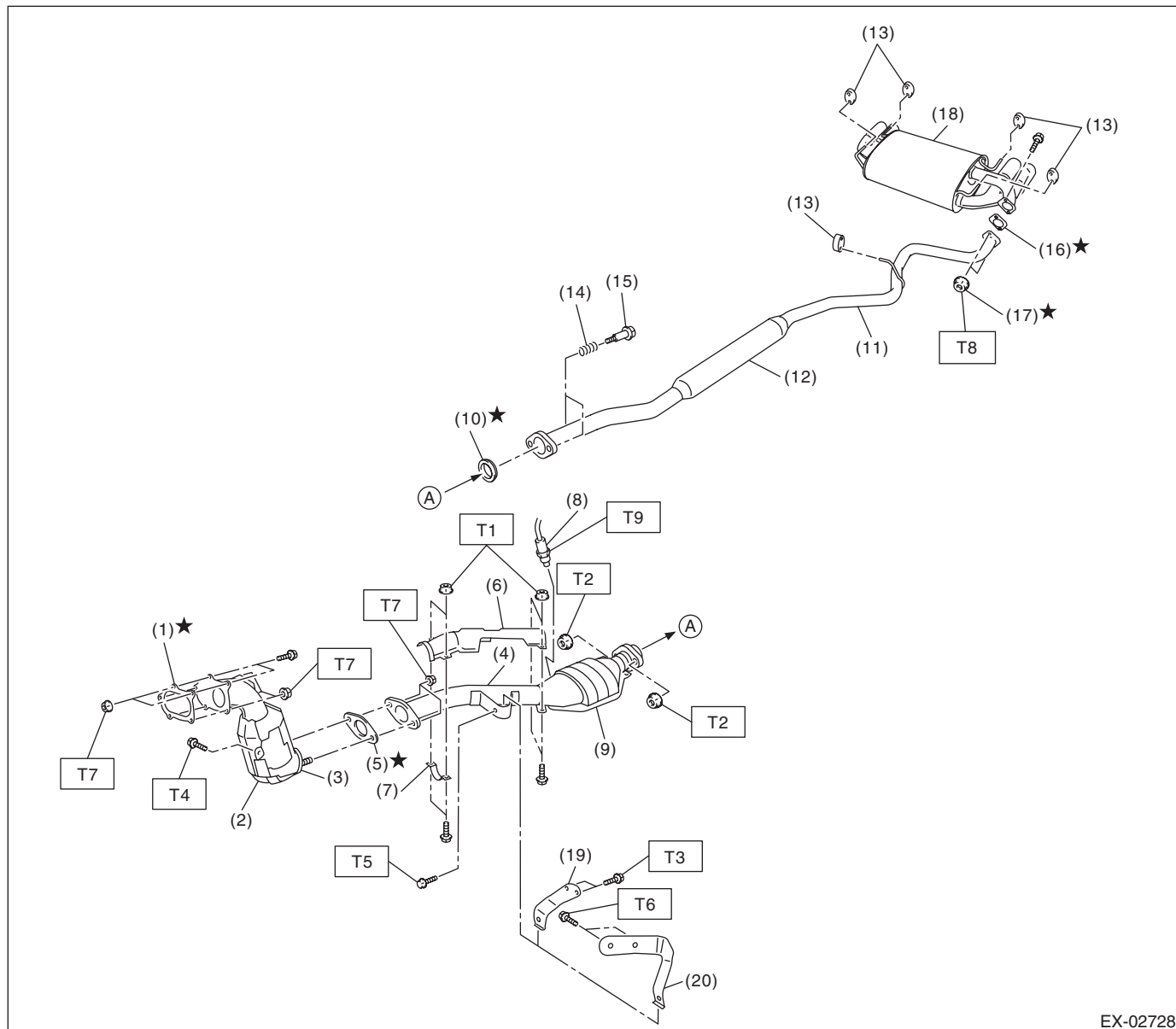

EX-02728

- |                                     |                                 |
|-------------------------------------|---------------------------------|
| (1) Gasket                          | (11) Rear exhaust pipe          |
| (2) Front catalytic converter       | (12) Chamber                    |
| (3) Center exhaust pipe (front)     | (13) Cushion rubber             |
| (4) Center exhaust pipe (rear)      | (14) Spring                     |
| (5) Gasket                          | (15) Bolt                       |
| (6) Center exhaust pipe upper cover | (16) Gasket                     |
| (7) Clamp                           | (17) Self-locking nut           |
| (8) Rear oxygen sensor              | (18) Muffler                    |
| (9) Rear catalytic converter        | (19) Hanger bracket (5MT model) |
| (10) Gasket                         | (20) Hanger bracket (6MT model) |

### **Tightening torque: N·m (kgf·m, ft·lb)**

- T1: 13 (1.3, 9.6)**  
**T2: 18 (1.8, 13.3)**  
**T3: 23 (2.3, 17.0)**  
**T4: 30 (3.1, 22.1)**  
**T5: 35 (3.6, 25.8)**  
**T6: 40 (4.1, 29.5)**  
**T7: 42.5 (4.3, 31.3)**  
**T8: 48 (4.9, 35.4)**  
**T9: <Ref. to FU(STI)-56, INSTALLATION, Rear Oxygen Sensor.>**  
**<Ref. to FU(w/o STI)-56, INSTALLATION, Rear Oxygen Sensor.>**

**EX(STI)-4**

Brought to you by Ebay Seller "SubaruManuals"

### **B: CAUTION**

- Wear appropriate work clothing, including a cap, protective goggles and protective shoes when performing any work.
- Remove contamination including dirt and corrosion before removal, installation or disassembly.
- Keep the disassembled parts in order and protect them from dust and dirt.
- Before removal, installation or disassembly, be sure to clarify the failure. Avoid unnecessary removal, installation, disassembly and replacement.
- Vehicle components are extremely hot after driving. Be wary of receiving burns from heated parts.
- Be sure to tighten fasteners including bolts and nuts to the specified torque.
- Place shop jacks or rigid racks at the specified points.
- Before disconnecting connectors of sensors or units, be sure to disconnect the ground cable from the battery.
- If any oil or grease is spilled on the exhaust pipe, wipe off completely to prevent fires.

# Front Exhaust Pipe

EXHAUST

## 2. Front Exhaust Pipe

### A: REMOVAL

#### CAUTION:

Vehicle components are extremely hot after driving. Be wary of receiving burns from heated parts.

1) Disconnect the ground cable from battery.

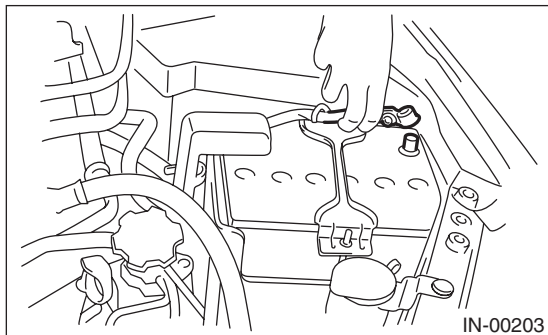

2) Lift up the vehicle.

3) Remove the under cover. <Ref. to EI-28, REMOVAL, Front Under Cover.>

4) Remove the front oxygen (A/F) sensor. <Ref. to FU(STI)-54, REMOVAL, Front Oxygen (A/F) Sensor.> <Ref. to FU(w/o STI)-54, REMOVAL, Front Oxygen (A/F) Sensor.>

5) Remove the exhaust manifold RH lower cover and exhaust manifold LH cover.

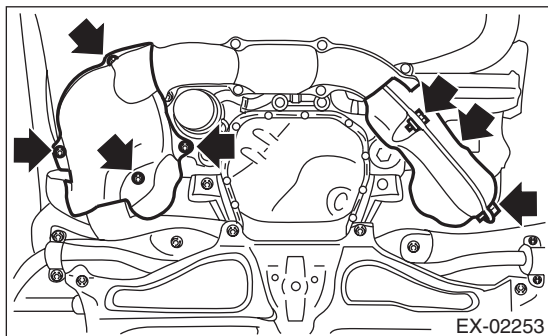

6) Remove the bolts and nuts which hold joint pipe onto exhaust manifold RH.

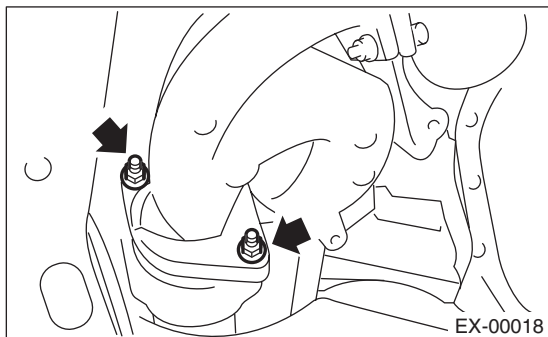

7) While holding the front exhaust pipe with one hand, remove the nuts which hold the exhaust manifold to the cylinder head exhaust port and remove the front exhaust pipe.

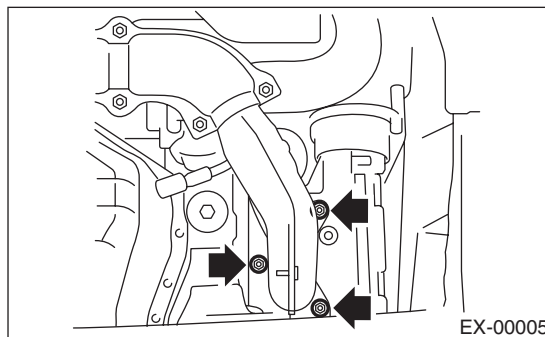
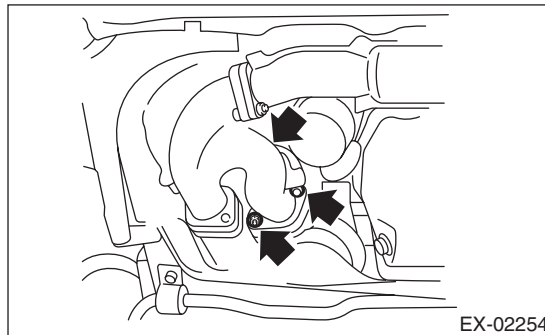

### B: INSTALLATION

1) Install the front exhaust pipe.

#### NOTE:

Use a new gasket.

#### Tightening torque:

40 N·m (4.1 kgf-m, 29.5 ft-lb)

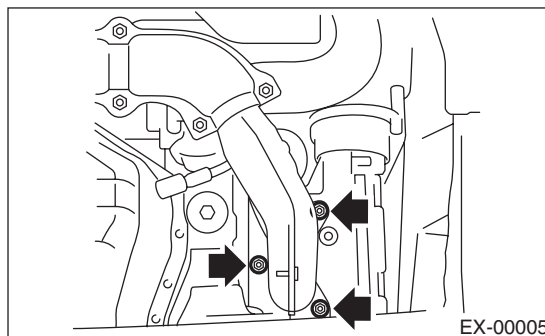
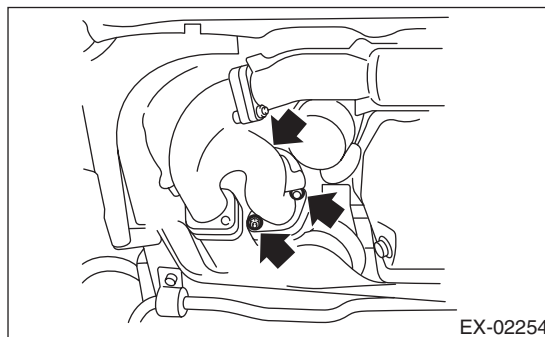

EX(STI)-6

Brought to you by Ebay Seller "SubaruManuals"

2) Install the joint pipe to the exhaust manifold RH.

NOTE:

Use a new gasket.

**Tightening torque:**

**42.5 N·m (4.3 kgf-m, 31.3 ft-lb)**

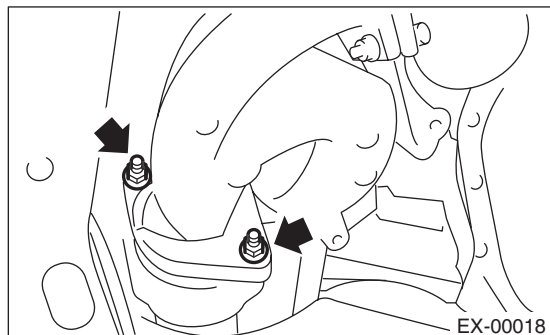

3) Install the exhaust manifold RH lower cover and exhaust manifold LH cover.

**Tightening torque:**

**19 N·m (1.9 kgf-m, 14.0 ft-lb)**

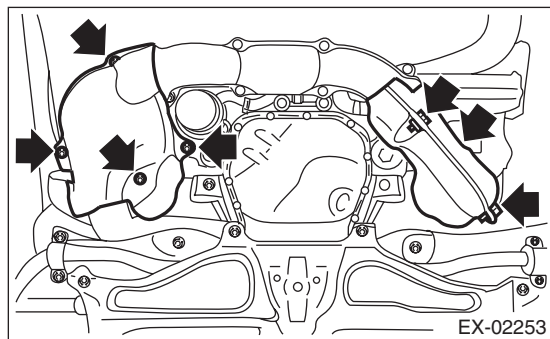

4) Install the front oxygen (A/F) sensor. <Ref. to FU(STI)-54, INSTALLATION, Front Oxygen (A/F) Sensor.> <Ref. to FU(w/o STI)-54, INSTALLATION, Front Oxygen (A/F) Sensor.>

5) Install the under cover. <Ref. to EI-28, INSTALLATION, Front Under Cover.>

6) Lower the vehicle.

7) Connect the battery ground terminal.

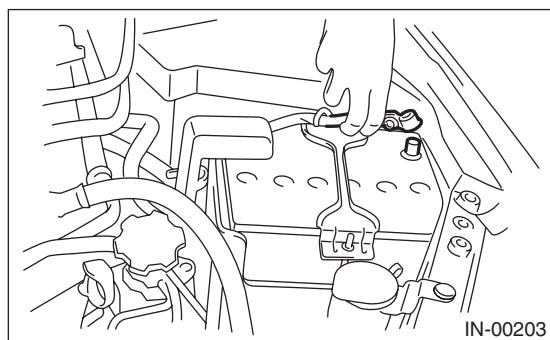

## C: DISASSEMBLY

- 1) Remove the exhaust manifold RH upper cover.
- 2) Remove the exhaust manifold RH and the exhaust manifold LH from the front exhaust pipe.

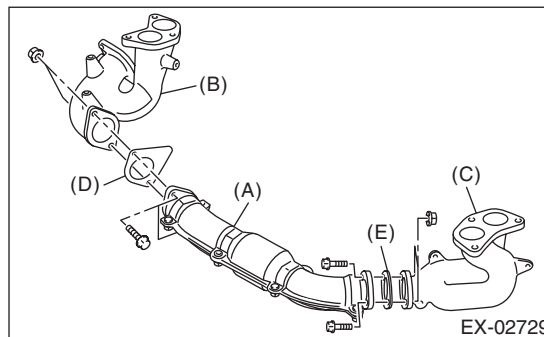

- (A) Front exhaust pipe
- (B) Exhaust manifold RH
- (C) Exhaust manifold LH
- (D) Gasket
- (E) Gasket

## D: ASSEMBLY

- 1) Install the exhaust manifold RH and the exhaust manifold LH to the front exhaust pipe.

NOTE:

Use a new gasket.

**Tightening torque:**

**42.5 N·m (4.3 kgf-m, 31.3 ft-lb)**

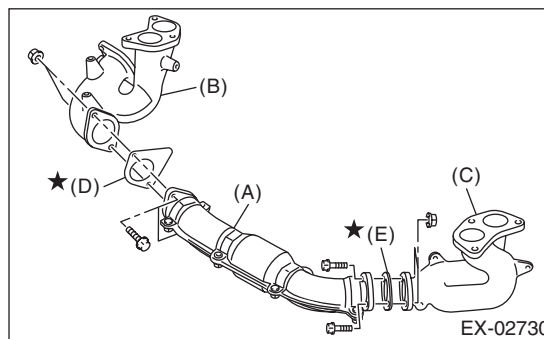

- (A) Front exhaust pipe
- (B) Exhaust manifold RH
- (C) Exhaust manifold LH
- (D) Gasket
- (E) Gasket

- 2) Install the exhaust manifold RH upper cover.

**Tightening torque:**

**19 N·m (1.9 kgf-m, 14.0 ft-lb)**

## E: INSPECTION

- 1) Check the connections and welds for exhaust leaks.
- 2) Make sure there are no holes or rusting.

# Center Exhaust Pipe

EXHAUST

## 3. Center Exhaust Pipe

### A: REMOVAL

#### CAUTION:

Vehicle components are extremely hot after driving. Be wary of receiving burns from heated parts.

1) Disconnect the ground cable from battery.

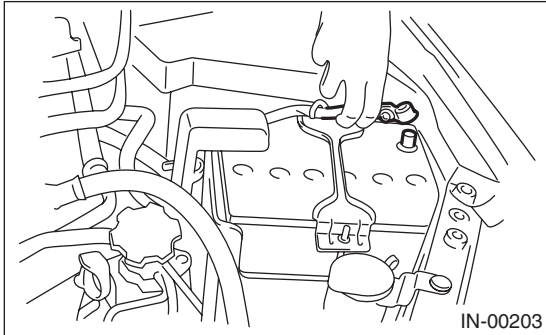

2) Remove the intercooler. <Ref. to IN(STI)-12, REMOVAL, Intercooler.> <Ref. to IN(w/o STI)-12, REMOVAL, Intercooler.>

3) Lift up the vehicle.

4) Remove the transmission under cover. (6MT model)

5) Remove the bolts which secure the lower side of the turbocharger lower cover.

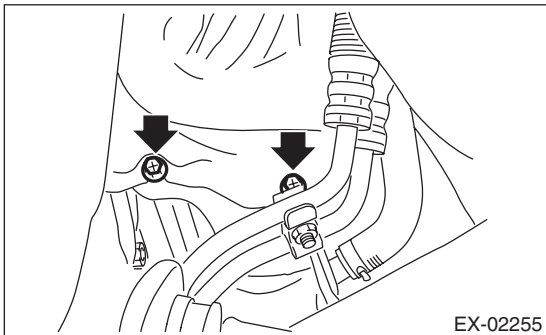

6) Lower the vehicle.

7) Remove the turbocharger upper cover.

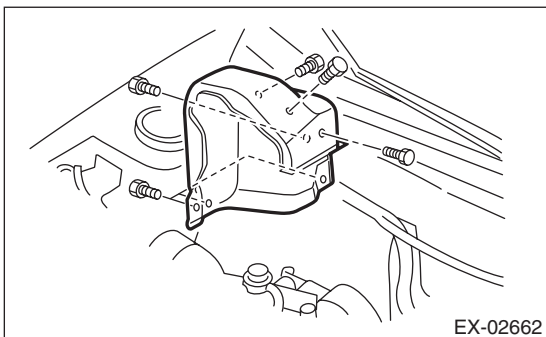

8) Remove the bolts which hold the upper side of the turbocharger lower cover.

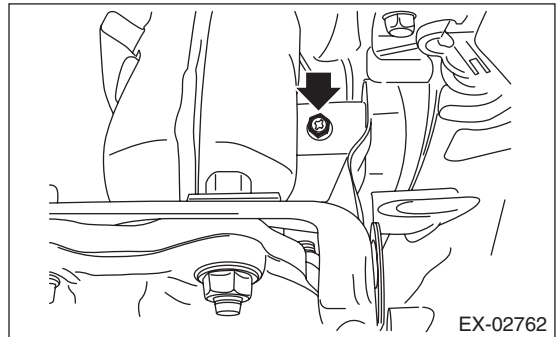

9) Remove the upper side bolts and nuts that hold the center exhaust pipe on the turbocharger, and remove the turbocharger cover stay (A).

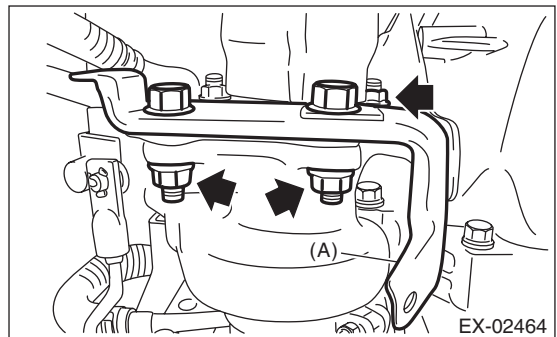

10) Lift up the vehicle.

11) Remove the lower side nuts (two places) that hold the center exhaust pipe on the turbocharger.

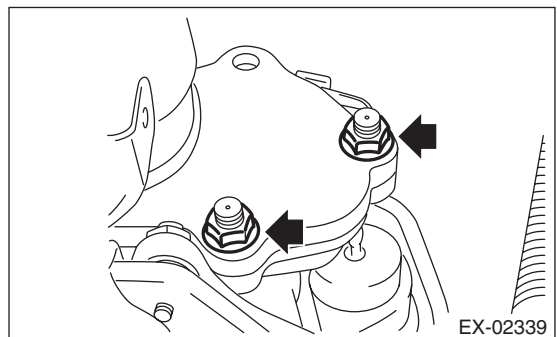

12) Disconnect the connector from the rear oxygen sensor, and remove the clip (A) holding the rear oxygen sensor harness.

- 5MT model

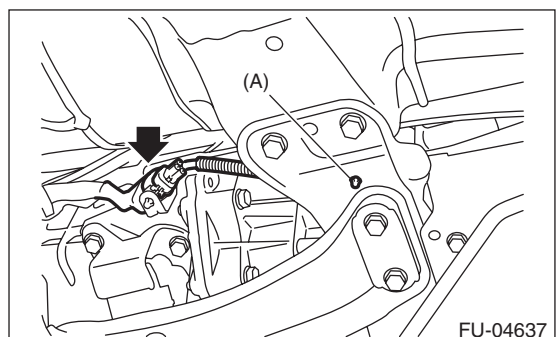

EX(STI)-8

Brought to you by Ebay Seller "SubaruManuals"

- 6MT model

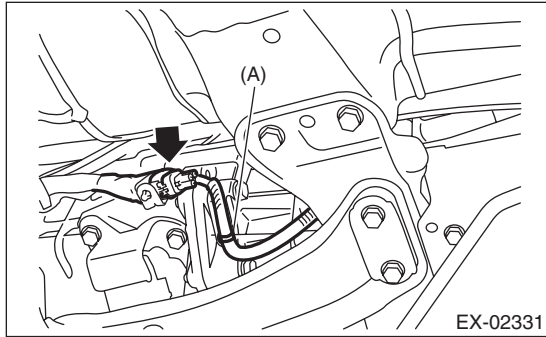

- 13) Remove the rear exhaust pipe from center exhaust pipe.

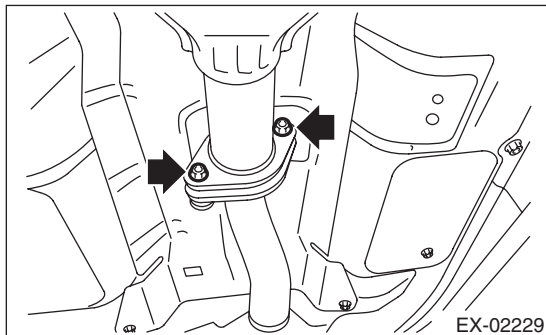

- 14) Remove the bolt which holds center exhaust pipe to transmission.

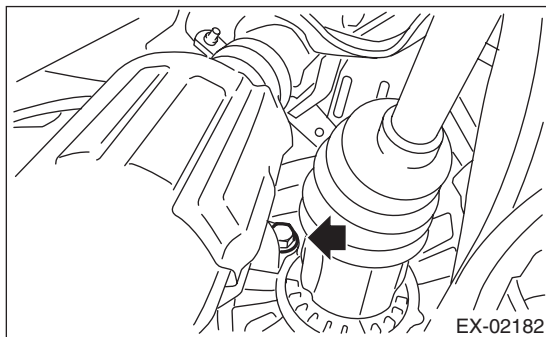

- 15) Remove the bolt which holds center exhaust pipe to hanger bracket, and remove the center exhaust pipe.

**CAUTION:**  
Be careful not to drop the center exhaust pipe.

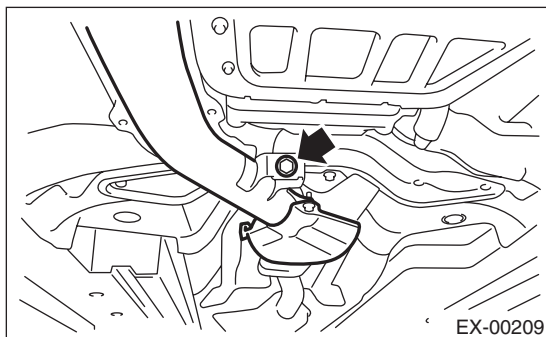

- 16) Remove the turbocharger lower cover.

## B: INSTALLATION

- 1) Set the turbocharger lower cover, and temporarily tighten the bolts that hold the lower side of the turbocharger lower cover.
- 2) Install the center exhaust pipe and temporarily tighten the bolt which holds center exhaust pipe to hanger bracket.
- 3) Temporarily tighten the bolt which holds the center exhaust pipe to the transmission.
- 4) Install the center exhaust pipe along with the turbocharger cover stay (A) to the turbocharger.

**NOTE:**  
Use a new gasket.

**Tightening torque:**

**42.5 N·m (4.3 kgf-m, 31.3 ft-lb)**

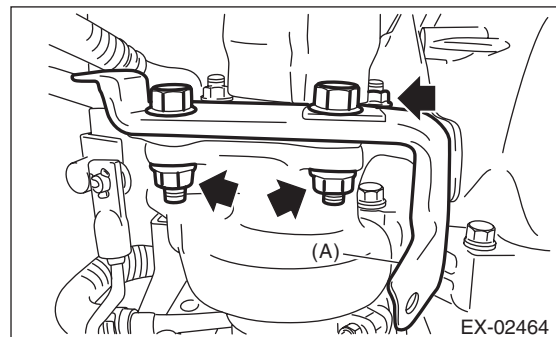
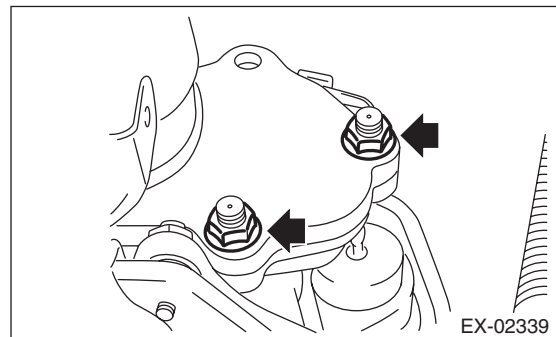

- 5) Install the rear exhaust pipe to center exhaust pipe.

**NOTE:**  
Use a new gasket.

**Tightening torque:**

**18 N·m (1.8 kgf-m, 13.3 ft-lb)**

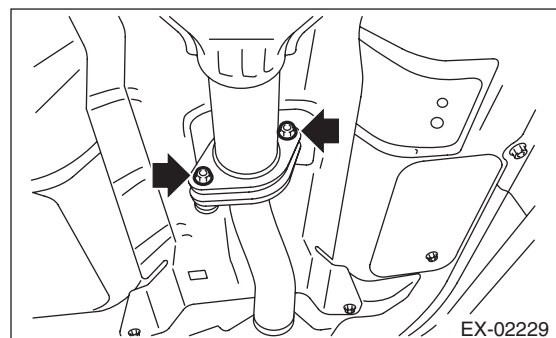



# Center Exhaust Pipe

## EXHAUST

6) Connect the connector to the rear oxygen sensor, and hold the rear oxygen sensor harness with the clip (A).

- 5MT model

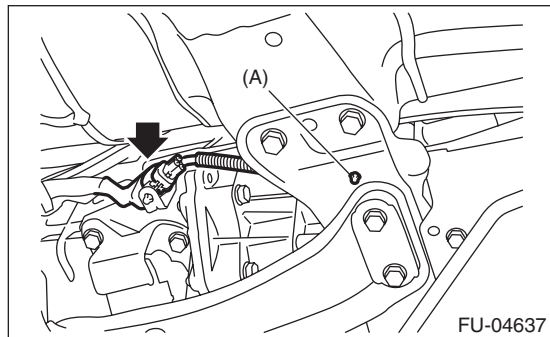

- 6MT model

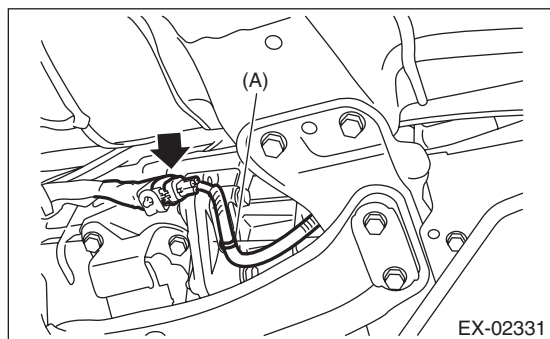

7) Tighten the bolt which holds center exhaust pipe to transmission.

**Tightening torque:**

**30 N·m (3.1 kgf-m, 22.1 ft-lb)**

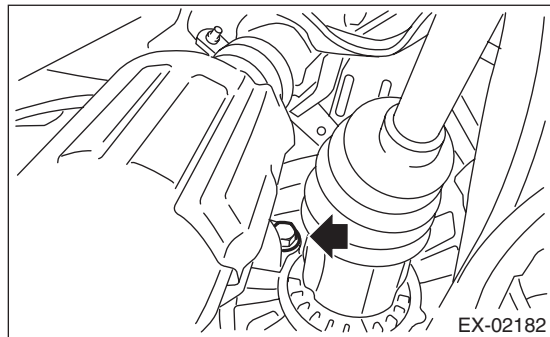

8) Tighten the bolts which secure the center exhaust pipe to the hanger bracket.

**Tightening torque:**

**35 N·m (3.6 kgf-m, 25.8 ft-lb)**

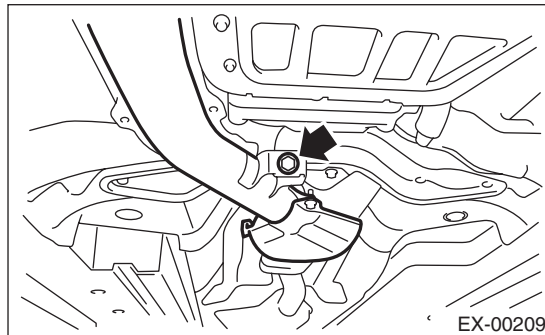

9) Lower the vehicle.

10) Attach the bolt which holds the upper side of the turbocharger lower cover.

**Tightening torque:**

**7.5 N·m (0.8 kgf-m, 5.5 ft-lb)**

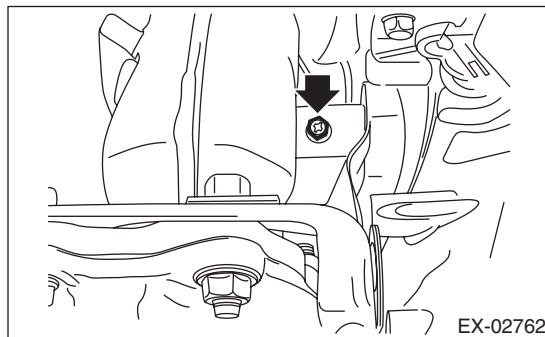

11) Attach the turbocharger upper cover.

**Tightening torque:**

**7.5 N·m (0.8 kgf-m, 5.5 ft-lb)**

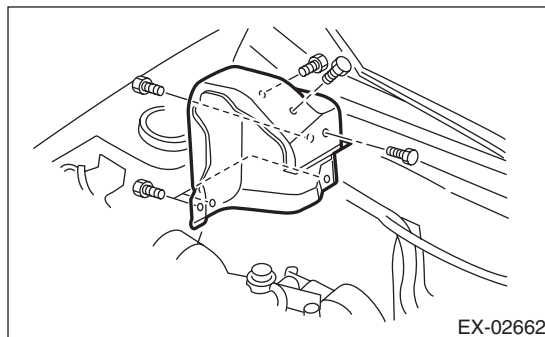

12) Lift up the vehicle.

13) Tighten the bolts that secure the lower side of the turbocharger lower cover.

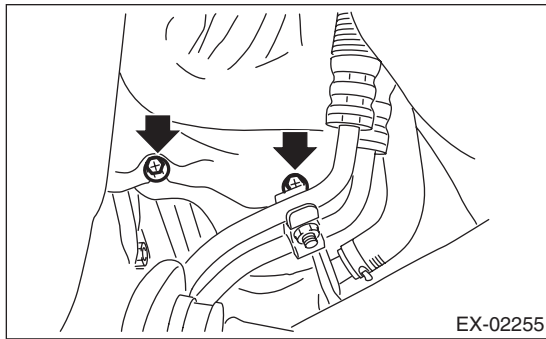
**Tightening torque:****7.5 N·m (0.8 kgf-m, 5.5 ft-lb)**

14) Install the transmission under cover. (6MT model)

**Tightening torque:****18 N·m (1.8 kgf-m, 13.3 ft-lb)**

15) Lower the vehicle.

16) Install the intercooler. <Ref. to IN(STI)-13, INSTALLATION, Intercooler.> <Ref. to IN(w/o STI)-12, INSTALLATION, Intercooler.>

17) Connect the battery ground terminal.

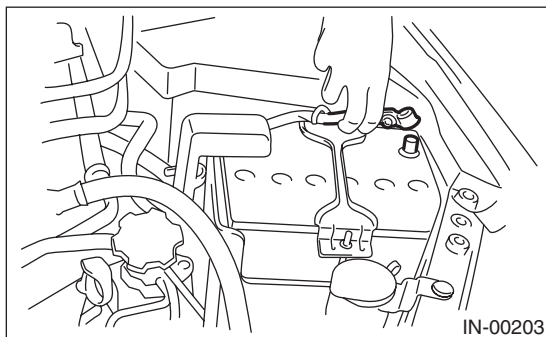
**C: DISASSEMBLY**

1) Remove the rear O<sub>2</sub> sensor from the center exhaust pipe (rear). <Ref. to FU(STI)-56, REMOVAL, Rear Oxygen Sensor.> <Ref. to FU(w/o STI)-56, REMOVAL, Rear Oxygen Sensor.>

2) Remove the center exhaust pipe upper cover.

3) Remove the center exhaust pipe (rear) from the center exhaust pipe (front).

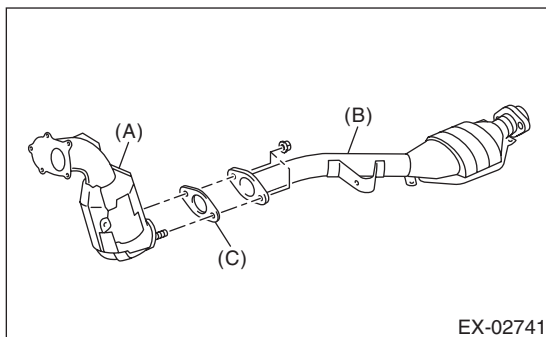

- (A) Center exhaust pipe (front)
- (B) Center exhaust pipe (rear)
- (C) Gasket

**D: ASSEMBLY**

1) Assemble the center exhaust pipe (rear) to the center exhaust pipe (front).

**NOTE:**

Use a new gasket.

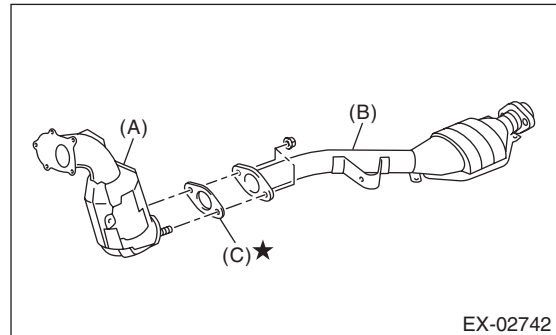
**Tightening torque:****42.5 N·m (4.3 kgf-m, 31.3 ft-lb)**

- (A) Center exhaust pipe (front)
- (B) Center exhaust pipe (rear)
- (C) Gasket

2) Install the center exhaust pipe upper cover.

**Tightening torque:****13 N·m (1.3 kgf-m, 9.6 ft-lb)**

3) Install the rear O<sub>2</sub> sensor to the center exhaust pipe (rear). <Ref. to FU(STI)-56, INSTALLATION, Rear Oxygen Sensor.> <Ref. to FU(w/o STI)-56, INSTALLATION, Rear Oxygen Sensor.>

**E: INSPECTION**

1) Check the connections and welds for exhaust leaks.

2) Make sure there are no holes or rusting.



# Joint Pipe

EXHAUST

## 4. Joint Pipe

### A: REMOVAL

#### CAUTION:

Vehicle components are extremely hot after driving. Be wary of receiving burns from heated parts.

- 1) Disconnect the ground cable from battery.

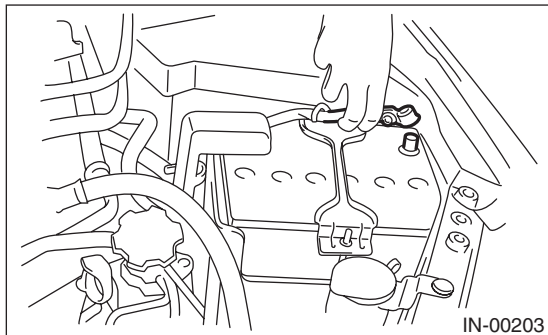

- 2) Lift up the vehicle.
- 3) Remove the under cover. <Ref. to EI-28, REMOVAL, Front Under Cover.>
- 4) Remove the front oxygen (A/F) sensor. <Ref. to FU(STI)-54, REMOVAL, Front Oxygen (A/F) Sensor.> <Ref. to FU(w/o STI)-54, REMOVAL, Front Oxygen (A/F) Sensor.>
- 5) Remove the exhaust manifold RH lower cover.

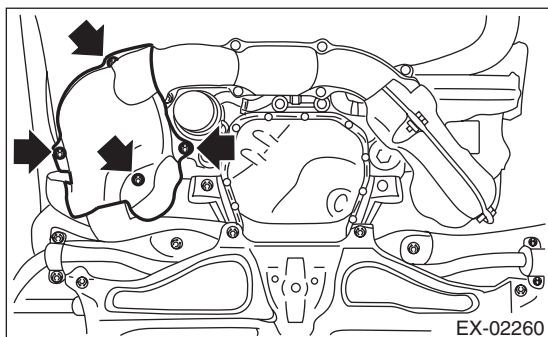

- 6) Remove the bolts and nuts which hold exhaust manifold RH onto joint pipe.

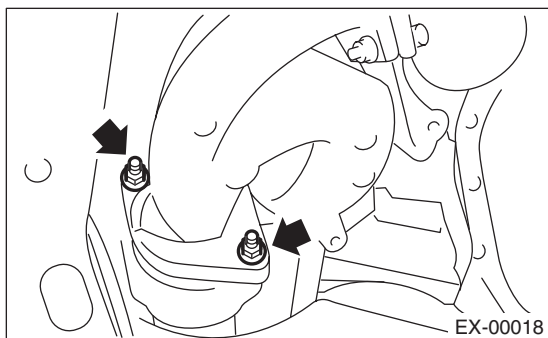

- 7) Remove the center exhaust pipe. <Ref. to EX(STI)-8, REMOVAL, Center Exhaust Pipe.>
- 8) Remove the turbocharger. <Ref. to IN(STI)-15, REMOVAL, Turbocharger.> <Ref. to IN(w/o STI)-14, REMOVAL, Turbocharger.>

- 9) Take off the joint pipe in the upward direction.

### B: INSTALLATION

Install in the reverse order of removal.

#### NOTE:

Use a new gasket.

#### Tightening torque:

**42.5 N·m (4.3 kgf-m, 31.3 ft-lb)**

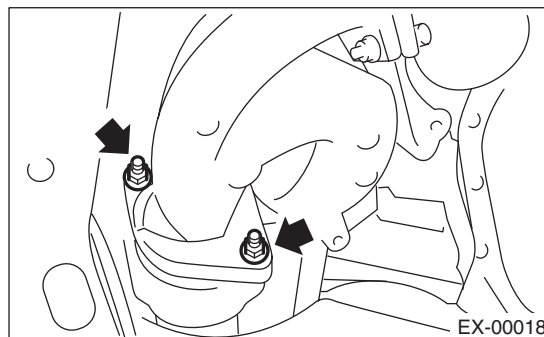

#### Tightening torque:

**19 N·m (1.9 kgf-m, 14.0 ft-lb)**

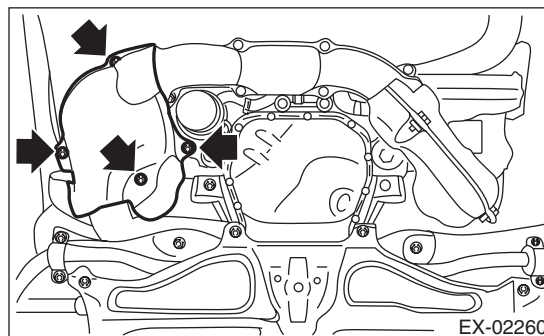

### C: INSPECTION

- 1) Check the connections and welds for exhaust leaks.
- 2) Make sure there are no holes or rusting.

EX(STI)-12

Brought to you by Ebay Seller "SubaruManuals"

## 5. Rear Exhaust Pipe

### A: REMOVAL

**CAUTION:**

Vehicle components are extremely hot after driving. Be wary of receiving burns from heated parts.

- 1) Lift up the vehicle.
- 2) Remove the center exhaust pipe from rear exhaust pipe.

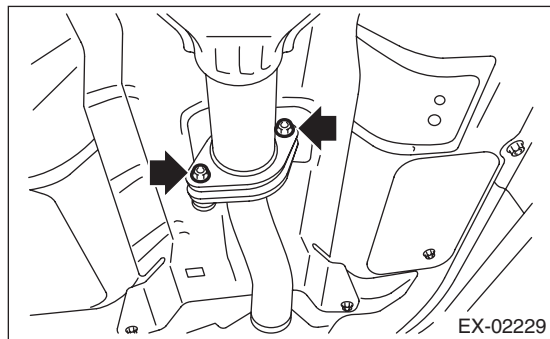

- 3) Remove the muffler from rear exhaust pipe.

**CAUTION:**

Be careful not to drop the rear exhaust pipe.

- 4 door model

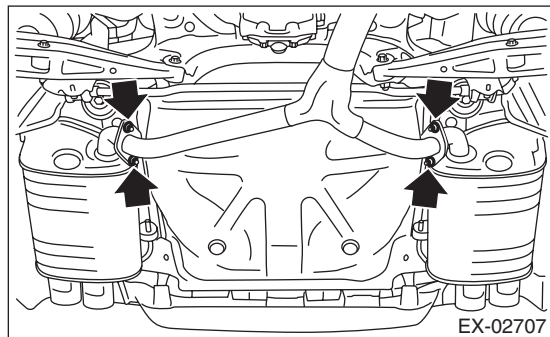

- 5 door model

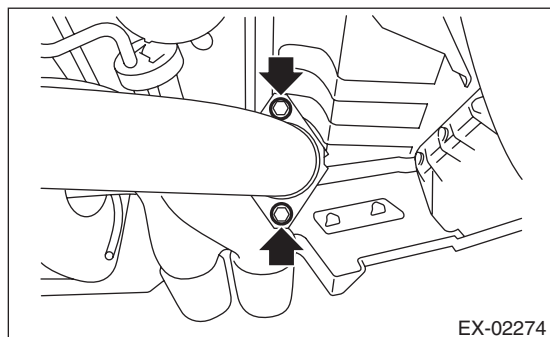

- 4) Apply a coat of spray type lubricant to the mating area of cushion rubber.

- 5) Remove the rear exhaust pipe from the cushion rubber.

**CAUTION:**

Be careful not to let the muffler contact the rear bumper.

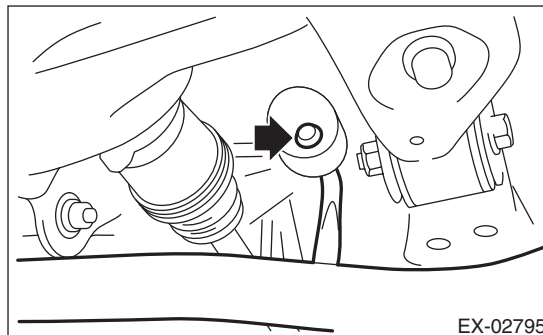

### B: INSTALLATION

- 1) Apply a coat of spray type lubricant to the mating area of cushion rubber.
- 2) Install the rear exhaust pipe to cushion rubber.

**NOTE:**

After assembling, degrease the lubricant which was applied to the cushion rubber while removing/installing.

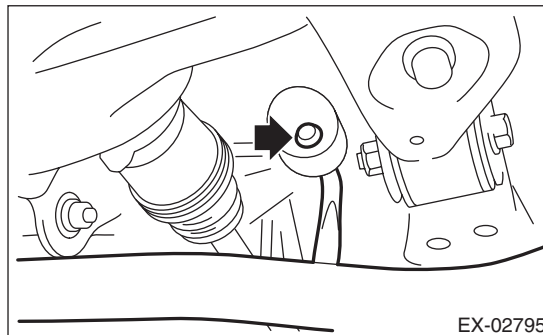

# Rear Exhaust Pipe

## EXHAUST

---

3) Install the rear exhaust pipe to the muffler.

**NOTE:**

Use a new gasket and self-locking nut.

**Tightening torque:**

**48 N·m (4.9 kgf·m, 35.4 ft·lb)**

- 4 door model

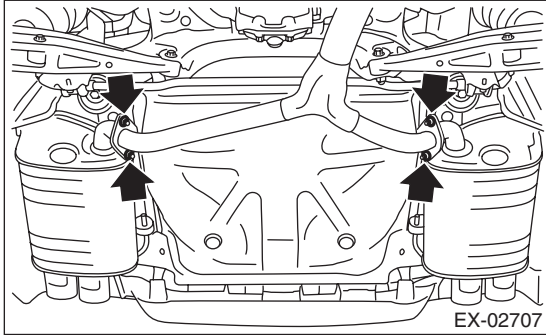

- 5 door model

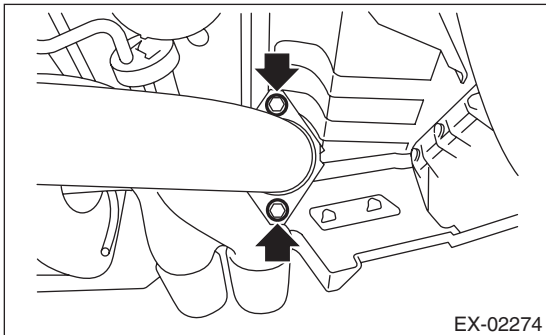

4) Install the center exhaust pipe to rear exhaust pipe.

**NOTE:**

Use a new gasket.

**Tightening torque:**

**18 N·m (1.8 kgf·m, 13.3 ft·lb)**

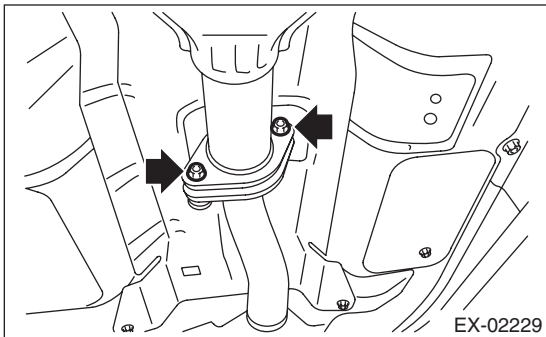

5) Lower the vehicle.

## C: INSPECTION

- 1) Check the connections and welds for exhaust leaks.
- 2) Make sure there are no holes or rusting.
- 3) Check the cushion rubber for wear or crack.

## 6. Muffler

### A: REMOVAL

**CAUTION:**

Vehicle components are extremely hot after driving. Be wary of receiving burns from heated parts.

- 1) Lift up the vehicle.
- 2) Remove the rear exhaust pipe from the muffler.

- 4 door model

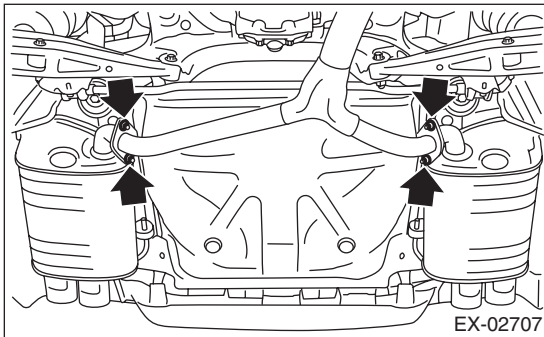

- 5 door model

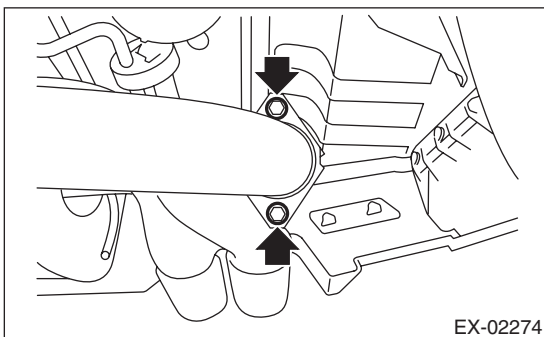

- 3) Apply a coat of spray type lubricant to the mating area of cushion rubber.

- 4) Remove the muffler from the cushion rubber.

**CAUTION:**

Be careful not to drop the muffler during removal.

- 4 door model

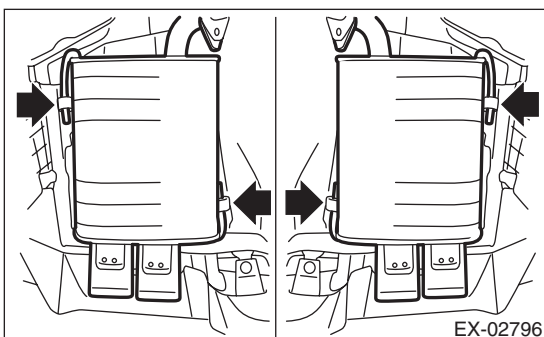

- 5 door model

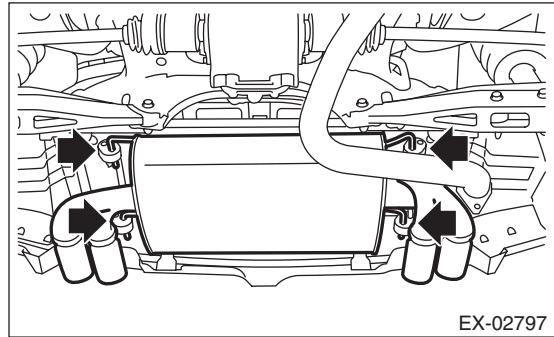

### B: INSTALLATION

Install in the reverse order of removal.

**NOTE:**

- Use a new gasket and self-locking nut.
- After assembling, degrease the lubricant which was applied to the cushion rubber while removing/installing.

**Tightening torque:**

**48 N·m (4.9 kgf-m, 35.4 ft-lb)**

- 4 door model

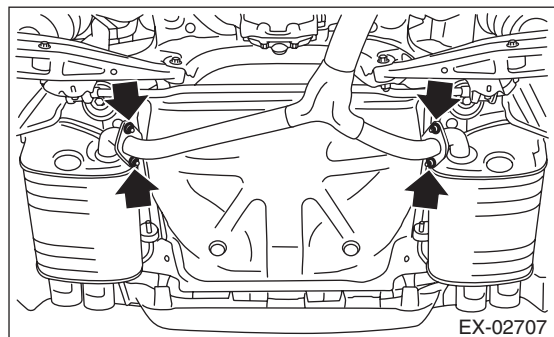

- 5 door model

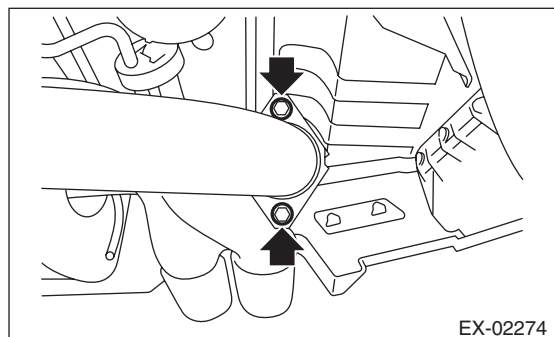

### C: INSPECTION

- 1) Check the connections and welds for exhaust leaks.
- 2) Make sure there are no holes or rusting.
- 3) Check the cushion rubber for wear or crack.

# Muffler

EXHAUST

---

**EX(STI)-16**

Brought to you by Ebay Seller "SubaruManuals"

# COOLING

# CO(STI)

---

	<b>Page</b>
1. General Description .....	2
2. Radiator Fan System .....	7
3. Engine Coolant .....	13
4. Water Pump .....	15
5. Thermostat .....	17
6. Radiator .....	19
7. Radiator Cap .....	22
8. Radiator Main Fan and Fan Motor .....	23
9. Radiator Sub Fan and Fan Motor .....	25
10. Reservoir Tank .....	27
11. Coolant Filler Tank .....	28
12. Engine Cooling System Trouble in General .....	29

# General Description

## COOLING

### 1. General Description

#### A: SPECIFICATION

Cooling system				Electric fan + Forced engine coolant circulation system			
Total engine coolant capacity				ℓ (US qt, Imp qt)			
				Approx. 7.7 (8.1, 6.8)			
Water pump	Type		Centrifugal impeller type				
	Discharge performance	Discharge rate		ℓ (US gal, Imp gal) /min.			
				200 (52.8, 44.0)			
		Pump speed — Discharge pressure		6,000 rpm — 225.4 kPa (23.0 mAq)			
	Engine coolant temperature		80°C (176°F)				
	Impeller diameter		mm (in)		76 (2.99)		
	Number of impeller vanes		8				
	Pump pulley diameter		mm (in)		60 (2.36)		
Clearance between impeller and pump case		mm (in)		Standard			
				0.5 — 1.5 (0.020 — 0.059)			
Thermostat	Type		Wax pellet type				
	Starting temperature to open		76 — 80°C (169 — 176°F)				
	Fully opens		91°C (196°F)				
	Valve lift		mm (in)		9.0 (0.354) or more		
	Valve bore		mm (in)		35 (1.38)		
Radiator fan	Motor input	Main fan		W			
		Sub fan		W			
	Fan diameter / Blade	Main fan		318.5 mm (12.54 in)/9			
		Sub fan		318.5 mm (12.54 in)/11			
Radiator	Type		Down flow				
	Core dimensions		Width × Height × Thickness		mm (in)		
					687.4 × 340 × 16 (27.06 × 13.39 × 0.63)		
	Pressure range in which cap valve is open	Coolant filler tank side	kPa (kg/cm <sup>2</sup> , psi)	Positive pressure side	Standard	93 — 123 (0.95 — 1.25, 14 — 18)	
				Limit	83 (0.85, 12)		
		Radiator side	kPa (kg/cm <sup>2</sup> , psi)	Negative pressure side	Standard	-1.0 — -4.9 (-0.01 — -0.05, -0.1 — -0.7)	
				Positive pressure side only	Standard	122 — 152 (1.24 — 1.55, 18 — 22)	
				Limit			
				112 (1.14, 16)			
Fins		Corrugated fin type					
Reservoir tank	Capacity		ℓ (US qt, Imp qt)		0.45 (0.48, 0.40)		

	Recommended materials	Item number	Alternative
Coolant	SUBARU SUPER COOLANT (Concentrated type)	—	—
	SUBARU SUPER COOLANT (Diluted type)	K0670Y0001	
Water for dilution	Distilled water	—	Soft water or tap water
Cooling system protective agent	Cooling system conditioner	SOA345001	—

## B: COMPONENT

### 1. WATER PUMP

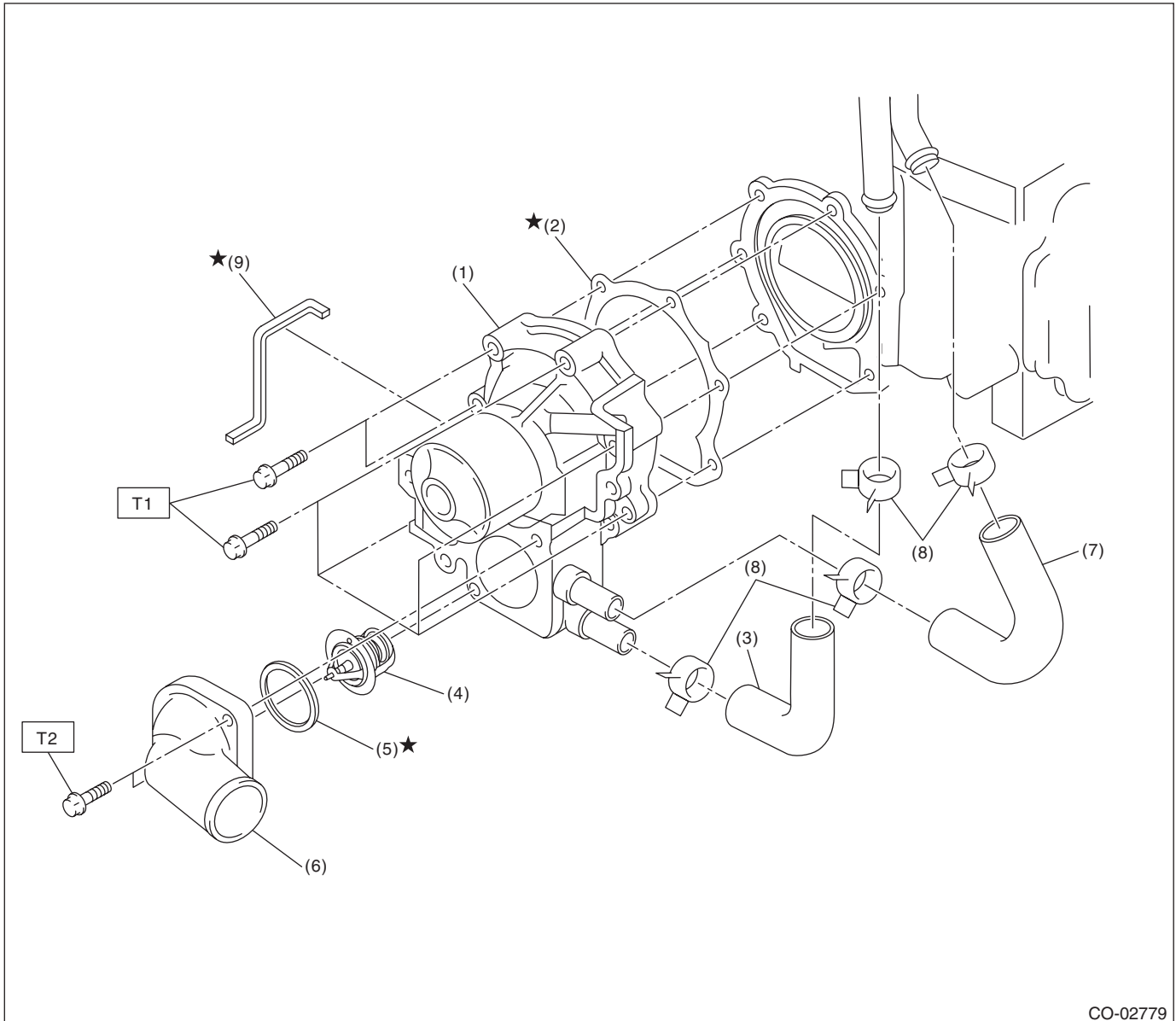

CO-02779

- |                         |                                 |
|-------------------------|---------------------------------|
| (1) Water pump ASSY     | (6) Thermostat cover            |
| (2) Gasket              | (7) Coolant filler by-pass hose |
| (3) Heater by-pass hose | (8) Clip                        |
| (4) Thermostat          | (9) Water pump sealing          |
| (5) Gasket              |                                 |

**Tightening torque: N·m (kgf·m, ft·lb)**

**T1: First 12 (1.2, 8.9)**

**Second 12 (1.2, 8.9)**

**T2: 12 (1.2, 8.9)**



# General Description

## COOLING

### 2. RADIATOR AND RADIATOR FAN

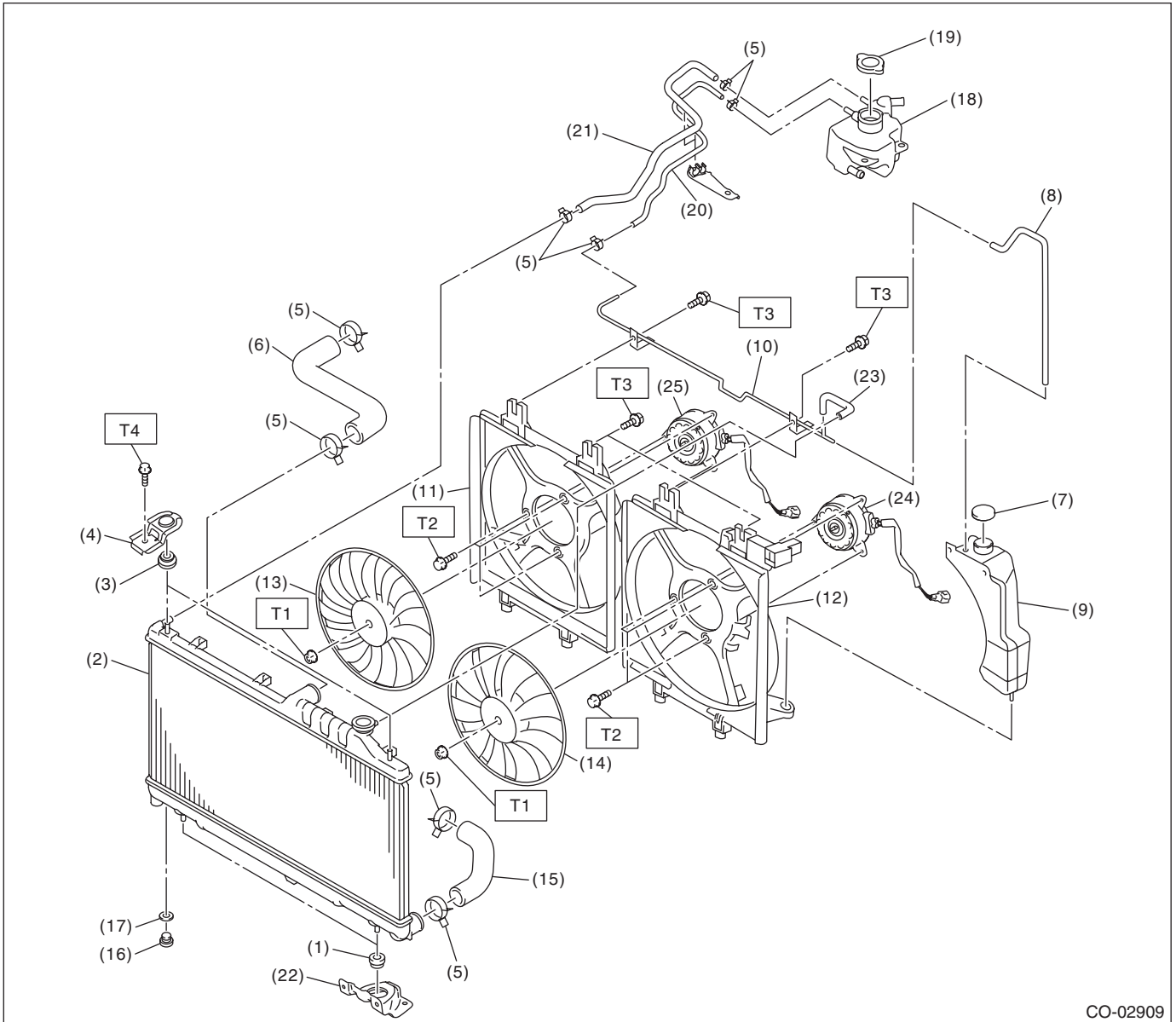

CO(STI)-4

Brought to you by Ebay Seller "SubaruManuals"

# General Description

COOLING

(1) Radiator lower cushion	(12) Radiator main fan shroud	(23) Over flow hose B
(2) Radiator	(13) Radiator sub fan	(24) Main fan motor
(3) Radiator upper cushion	(14) Radiator main fan	(25) Sub fan motor
(4) Radiator upper bracket	(15) Radiator outlet hose	
(5) Clip	(16) Radiator drain plug	
(6) Radiator inlet hose	(17) O-ring	
(7) Engine coolant reservoir tank cap	(18) Engine coolant filler tank	
(8) Over flow hose A	(19) Radiator cap (coolant filler tank cap)	
(9) Engine coolant reservoir tank	(20) Engine coolant hose A	
(10) Over flow pipe	(21) Engine coolant hose B	
(11) Radiator sub fan shroud	(22) Radiator lower bracket	

---

**Tightening torque:N·m (kgf-m, ft-lb)**

**T1: 3.4 (0.3, 2.5)**

**T2: 4.41 (0.45, 3.25)**

**T3: 7.5 (0.8, 5.5)**

---

**T4: 12 (1.2, 8.9)**

## C: CAUTION

- Wear appropriate work clothing, including a cap, protective goggles and protective shoes when performing any work.
- Remove contamination including dirt and corrosion before removal, installation or disassembly.
- Keep the disassembled parts in order and protect them from dust and dirt.
- Before removal, installation or disassembly, be sure to clarify the failure. Avoid unnecessary removal, installation, disassembly and replacement.
- Vehicle components are extremely hot after driving. Be wary of receiving burns from heated parts.
- Be sure to tighten fasteners including bolts and nuts to the specified torque.
- Place shop jacks or rigid racks at the specified points.
- Before disconnecting connectors of sensors or units, be sure to disconnect the ground cable from the battery.
- Prepare a container and cloth to prevent scattering of engine coolant when performing work where engine coolant can be spilled. If the fuel spills, wipe it off immediately to prevent from penetrating into floor or flowing out for environmental protection.
- Follow all government and local regulations concerning disposal of refuse when disposing engine coolant.

# General Description

COOLING

## D: PREPARATION TOOL

### 1. SPECIAL TOOL

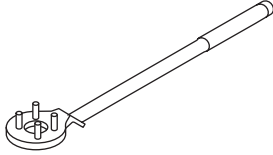
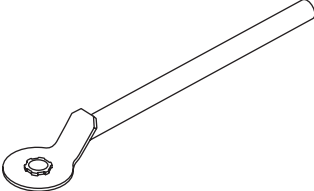
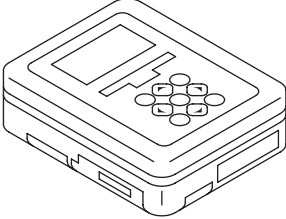
ILLUSTRATION	TOOL NUMBER	DESCRIPTION	REMARKS
 ST-499977100	499977100	CRANK PULLEY WRENCH	Used for removing and installing the crank pulley.
 ST-499977500	499977500	CAM SPROCKET WRENCH	Used for removing and installing intake cam sprocket and exhaust cam sprocket.
 ST1B022XU0	1B022XU0	SUBARU SELECT MONITOR III KIT	Used for troubleshooting the electrical system.

### 2. GENERAL TOOL

TOOL NAME	REMARKS
Circuit tester	Used for measuring resistance and voltage.
Radiator cap tester	Used for checking radiator and radiator cap.

CO(STI)-6

Brought to you by Ebay Seller "SubaruManuals"

## 2. Radiator Fan System

### A: WIRING DIAGRAM

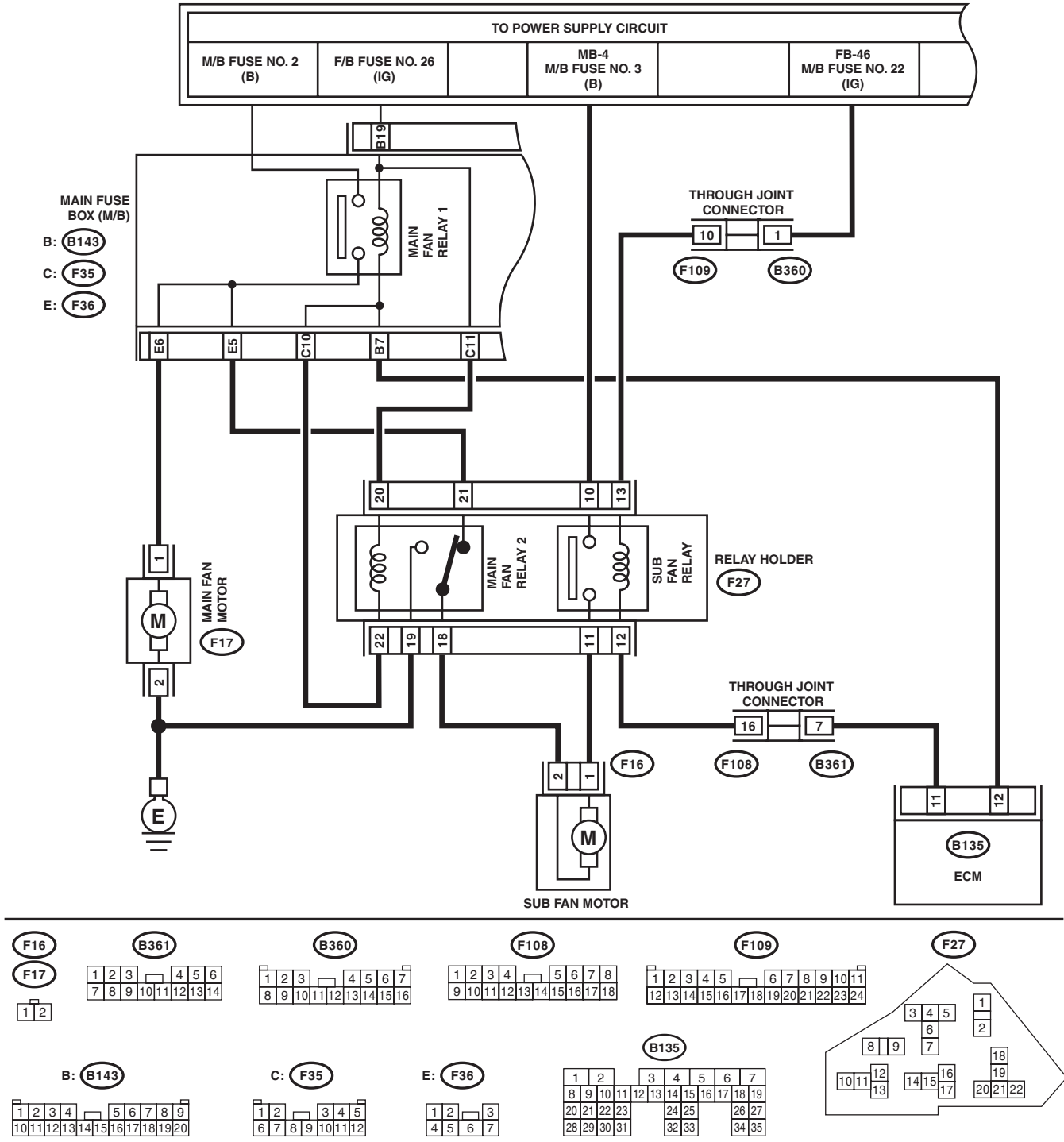

CO-02773

# Radiator Fan System

COOLING

## B: INSPECTION

Operating condition:

Vehicle speed	A/C compressor load	Engine coolant temperature		
		Increase: 89°C (192°F) or less Decrease: 87°C (189°F) or less	Increase: 90 — 95°C (194 — 203°F) Decrease: 88 — 90°C (190 — 194°F)	Increase: 96°C (205°F) or more Decrease: 91°C (196°F) or more
		Radiator fan operation	Radiator fan operation	Radiator fan operation
During acceleration: 19 km/h (12 MPH) or less During deceleration: 10 km/h (6 MPH) or less	OFF	OFF	Low-Speed	High-Speed
	Low	Low-Speed	Low-Speed	High-Speed
	High	High-Speed	High-Speed	High-Speed
During acceleration: 20 — 69 km/h (12 — 43 MPH) During deceleration: 11 — 64 km/h (7 — 40 MPH)	OFF	OFF	Low-Speed	High-Speed
	Low	High-Speed	High-Speed	High-Speed
	High	High-Speed	High-Speed	High-Speed
During acceleration: 70 — 105 km/h (43 — 65 MPH) During deceleration: 65 — 100 km/h (40 — 62 MPH)	OFF	OFF	Low-Speed	High-Speed
	Low	High-Speed	High-Speed	High-Speed
	High	High-Speed	High-Speed	High-Speed
During acceleration: 106 km/h (66 MPH) or more During deceleration: 101 km/h (63 MPH) or more	OFF	OFF	High-Speed	High-Speed
	Low	High-Speed	High-Speed	High-Speed
	High	High-Speed	High-Speed	High-Speed

## DIAGNOSIS:

Radiator main fan and radiator sub fans do not rotate under the above operating conditions.

Step	Check	Yes	No
<b>1 CHECK OPERATION OF RADIATOR FAN.</b> 1) Connect the delivery (test) mode connector. 2) Turn the ignition switch to ON. 3) Perform the compulsory operation check for the radiator fan relay using Subaru Select Monitor.  <b>NOTE:</b> <ul style="list-style-type: none"> <li>When performing a forced operation radiator fan relay check using the Subaru Select Monitor, the radiator main fan and radiator sub fan will repeat low speed revolution → high speed revolution → OFF in this order.</li> <li>Subaru Select Monitor</li> </ul> Refer to "Compulsory Valve Operation Check Mode" for detailed procedures. <Ref. to EN(H4DOTC)(diag)-63, Compulsory Valve Operation Check Mode.>	Do the radiator main fans and radiator sub fans rotate at low speed?	Go to step 2.	Go to step 3.

# Radiator Fan System

COOLING

Step	Check	Yes	No
<b>2 CHECK OPERATION OF RADIATOR FAN.</b> 1) Connect the delivery (test) mode connector. 2) Turn the ignition switch to ON. 3) Perform the compulsory operation check for the radiator fan relay using Subaru Select Monitor.  NOTE: • When performing a forced operation radiator fan relay check using the Subaru Select Monitor, the radiator main fan and radiator sub fan will repeat low speed revolution → high speed revolution → OFF in this order. • Subaru Select Monitor Refer to "Compulsory Valve Operation Check Mode" for detailed procedures. <Ref. to EN(H4DOTC)(diag)-63, Compulsory Valve Operation Check Mode.>	Do the radiator main fans and radiator sub fans rotate at high speed?	Radiator main fan system is normal.	Go to step 27.
<b>3 CHECK POWER SUPPLY TO SUB FAN RELAY.</b> 1) Turn the ignition switch to OFF. 2) Remove the sub fan relay from the relay holder. 3) Measure the voltage between sub fan relay connector and chassis ground.  <b>Connector &amp; terminal</b> <b>(F27) No. 10 (+) — Chassis ground (-):</b>	Is the voltage 10 V or more?	Go to step 4.	Go to step 5.
<b>4 CHECK POWER SUPPLY TO SUB FAN RELAY.</b> 1) Turn the ignition switch to ON. 2) Measure the voltage between sub fan relay connector and chassis ground.  <b>Connector &amp; terminal</b> <b>(F27) No. 13 (+) — Chassis ground (-):</b>	Is the voltage 10 V or more?	Go to step 7.	Go to step 6.
<b>5 CHECK FUSE.</b> 1) Turn the ignition switch to OFF. 2) Remove the fuse No. 3. 3) Check the condition of fuse.	Is the fuse blown out?	Replace the fuse.	Repair the power supply line.
<b>6 CHECK FUSE.</b> 1) Turn the ignition switch to OFF. 2) Remove the fuse No. 22. 3) Check the condition of fuse.	Is the fuse blown out?	Replace the fuse.	Repair the power supply line.
<b>7 CHECK SUB FAN RELAY.</b> 1) Turn the ignition switch to OFF. 2) Measure the resistance between sub fan relay terminals.  <b>Terminals</b> <b>No. 10 — No. 11:</b>	Is the resistance 1 M $\Omega$ or more?	Go to step 8.	Replace the sub fan relay.
<b>8 CHECK SUB FAN RELAY.</b> 1) Connect the battery to terminals No. 13 and No. 12 of the sub fan relay. 2) Measure the resistance between sub fan relay terminals.  <b>Terminals</b> <b>No. 10 — No. 11:</b>	Is the resistance less than 1 $\Omega$ ?	Go to step 9.	Replace the sub fan relay.

# Radiator Fan System

## COOLING

Step	Check	Yes	No
<b>9 CHECK HARNESS BETWEEN SUB FAN RELAY CONNECTOR AND SUB FAN MOTOR CONNECTOR.</b> 1) Disconnect the connector from the sub fan motor. 2) Measure the resistance of harness between sub fan relay connector and sub fan motor connector. <i>Connector &amp; terminal (F16) No. 1 — (F27) No. 11:</i>	Is the resistance less than 1 $\Omega$ ?	Go to step 10.	Repair the open circuit of harness between sub fan relay connector and sub fan motor connector.
<b>10 CHECK HARNESS BETWEEN SUB FAN MOTOR CONNECTOR AND MAIN FAN RELAY 2 CONNECTOR.</b> 1) Remove main fan relay 2 from the relay holder. 2) Measure the resistance of harness between sub fan motor connector and main fan relay 2 connector. <i>Connector &amp; terminal (F16) No. 2 — (F27) No. 18:</i>	Is the resistance less than 1 $\Omega$ ?	Go to step 11.	Repair the open circuit of the harness between sub fan motor connector and main fan relay 2 connector.
<b>11 CHECK FOR POOR CONTACT.</b> Check poor contact of sub fan motor connector.	Is there poor contact of the sub fan motor connector?	Repair the poor contact of sub fan motor connector.	Go to step 12.
<b>12 CHECK SUB FAN MOTOR.</b> Connect the battery positive (+) terminal to terminal No. 1 of the sub fan motor, and the ground (-) terminal to terminal No. 2.	Does the radiator sub fan rotate?	Go to step 13.	Replace the sub fan motor.
<b>13 CHECK MAIN FAN RELAY 2.</b> Measure the resistance between main fan relay 2 terminals. <i>Terminals No. 21 — No. 18:</i>	Is the resistance less than 1 $\Omega$ ?	Go to step 14.	Replace the main fan relay 2.
<b>14 CHECK HARNESS BETWEEN MAIN FAN RELAY 2 CONNECTOR AND MAIN FAN MOTOR CONNECTOR.</b> 1) Disconnect the connector from the main fan motor. 2) Measure the resistance of the harness between main fan relay 2 connector and main fan motor connector. <i>Connector &amp; terminal (F17) No. 1 — (F27) No. 21:</i>	Is the resistance less than 1 $\Omega$ ?	Go to step 15.	Repair the open circuit of the harness between main fan relay 2 connector and main fan motor connector.
<b>15 CHECK MAIN FAN MOTOR AND GROUND CIRCUIT.</b> Measure the resistance between main fan motor connector and chassis ground. <i>Connector &amp; terminal (F17) No. 2 — Chassis ground:</i>	Is the resistance less than 5 $\Omega$ ?	Go to step 16.	Repair the open circuit of the harness between main fan motor connector and chassis ground.
<b>16 CHECK FOR POOR CONTACT.</b> Check poor contact of main fan motor connector.	Is there poor contact of the main fan motor connector?	Repair the poor contact of main fan motor connector.	Go to step 17.
<b>17 CHECK MAIN FAN MOTOR.</b> Connect the battery positive (+) terminal to terminal No. 1 of the main fan motor, and the ground (-) terminal to terminal No. 2.	Does the radiator main fan rotate?	Go to step 18.	Replace the main fan motor.

# Radiator Fan System

COOLING

Step	Check	Yes	No
<b>18 CHECK HARNESS BETWEEN SUB FAN RELAY CONNECTOR AND ECM.</b> 1) Disconnect the connector from ECM. 2) Measure the resistance between the sub fan relay connector and ECM connector. <i>Connector &amp; terminal (B135) No. 11 — (F27) No. 12:</i>	Is the resistance less than 1 Ω?	Go to step 19.	Repair the open circuit of harness between sub fan relay connector and ECM.
<b>19 CHECK FOR POOR CONTACT.</b> Check for poor contact of ECM connector.	Is there poor contact of ECM connector?	Repair the poor contact of ECM connector.	Check the DTC. Repair the trouble cause. <Ref. to EN(H4DOTC)(diag)-47, Read Diagnostic Trouble Code (DTC).>
<b>20 CHECK MAIN FAN RELAY 1.</b> 1) Turn the ignition switch to OFF. 2) Remove main fan relay 1 from the main fuse box. 3) Measure the resistance between terminals of main fan relay 1 switch.	Is the resistance 1 MΩ or more?	Go to step 21.	Replace the main fan relay 1.
<b>21 CHECK MAIN FAN RELAY 1.</b> 1) Connect the main fan relay 1 coil side terminal to the battery. 2) Measure the resistance between terminals of main fan relay 1 switch.	Is the resistance less than 1 Ω?	Go to step 22.	Replace the main fan relay 1.
<b>22 CHECK HARNESS BETWEEN MAIN FAN RELAY 1 CONNECTOR AND MAIN FAN MOTOR CONNECTOR.</b> 1) Disconnect the connector from the main fan motor. 2) Measure the resistance of the harness between main fan relay 1 connector and main fan motor connector. <i>Connector &amp; terminal (F17) No. 1 — (F36) No. 6:</i>	Is the resistance less than 1 Ω?	Go to step 23.	Repair the open circuit of the harness between main fan relay 1 connector and main fan motor connector.
<b>23 CHECK HARNESS BETWEEN MAIN FAN RELAY 1 CONNECTOR AND ECM.</b> 1) Disconnect the connector from ECM. 2) Measure the resistance between the main fan relay 1 connector and ECM connector. <i>Connector &amp; terminal (B135) No. 12 — (B143) No. 7:</i>	Is the resistance less than 1 Ω?	Go to step 24.	Repair the open circuit of the harness between main fan relay 1 connector and ECM.
<b>24 CHECK HARNESS BETWEEN MAIN FAN RELAY 2 CONNECTOR AND ECM.</b> Measure the resistance between the main fan relay 2 connector and ECM connector. <i>Connector &amp; terminal (B135) No. 12 — (F27) No. 22:</i>	Is the resistance less than 1 Ω?	Go to step 25.	Repair the open circuit of the harness between main fan relay 2 connector and ECM.
<b>25 CHECK FUSE.</b> 1) Turn the ignition switch to OFF. 2) Remove the fuse No. 2 and No. 26. 3) Check the condition of fuse.	Is the fuse blown out?	Replace the fuse.	Go to step 26.
<b>26 CHECK FOR POOR CONTACT.</b> Check for poor contact of ECM connector.	Is there poor contact of ECM connector?	Repair the poor contact of ECM connector.	Repair the power supply circuit to the main fuse box.
<b>27 CHECK OPERATION OF RADIATOR FAN.</b> If the both fans do not rotate at high speed in the condition of step 2, check whether the radiator sub fan is rotating.	Does the radiator sub fan rotate?	Go to step 20.	Go to step 28.

CO(STI)-11

Brought to you by Ebay Seller "SubaruManuals"



# Radiator Fan System

## COOLING

Step	Check	Yes	No
<b>28 CHECK GROUND CIRCUIT OF MAIN FAN RELAY 2.</b> 1) Remove main fan relay 2 from the relay holder. 2) Measure the resistance between main fan relay 2 connector and chassis ground. <b>Connector &amp; terminal</b> <b>(F27) No. 19 — Chassis ground:</b>	Is the resistance less than 1 Ω?	Go to step 29.	Repair the open circuit of harness between main fan relay 2 connector and chassis ground.
<b>29 CHECK POWER SUPPLY TO MAIN FAN RELAY 2.</b> 1) Turn the ignition switch to ON. 2) Measure the voltage between main fan relay 2 connector and chassis ground. <b>Connector &amp; terminal</b> <b>(F27) No. 20 (+) — Chassis ground (-):</b>	Is the voltage 10 V or more?	Go to step 30.	Repair the power supply line.
<b>30 CHECK MAIN FAN RELAY 2.</b> 1) Turn the ignition switch to OFF. 2) Remove the main fan relay 2. 3) Measure the resistance between main fan relay 2 terminals. <b>Terminals</b> <b>No. 18 — No. 19:</b>	Is the resistance 1 MΩ or more?	Go to step 31.	Replace the main fan relay 2.
<b>31 CHECK MAIN FAN RELAY 2.</b> 1) Connect the battery to terminals No. 20 and No. 22 of the main fan relay 2. 2) Measure the resistance between main fan relay 2 terminals. <b>Terminals</b> <b>No. 18 — No. 19:</b>	Is the resistance less than 1 Ω?	Go to step 23.	Replace the main fan relay 2.

## 3. Engine Coolant

### A: REPLACEMENT

#### 1. DRAINING OF ENGINE COOLANT

- 1) Lift up the vehicle.
- 2) Remove the under cover. <Ref. to EI-28, REMOVAL, Front Under Cover.>
- 3) Remove the drain plug to drain engine coolant into container.

**NOTE:**

Remove the coolant filler tank cap so that engine coolant will drain faster.

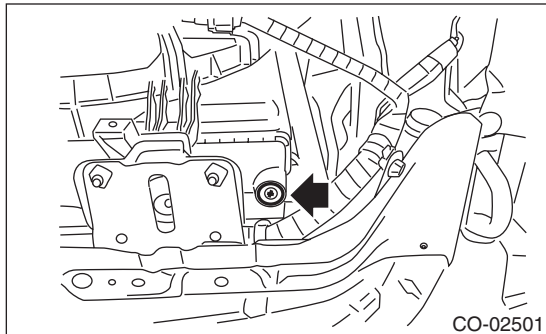

- 4) Install the drain plug.
- 5) Install the under cover. <Ref. to EI-28, INSTALLATION, Front Under Cover.>

#### 2. FILLING OF ENGINE COOLANT

- 1) Pour cooling system conditioner through the filler neck of coolant filler tank.

**Cooling system protective agent:**

Refer to "SPECIFICATION" for cooling system protective agent. <Ref. to CO(STI)-2, SPECIFICATION, General Description.>

- 2) Fill the engine coolant into coolant filler tank up to the filler neck position.

**Recommended engine coolant:**

Refer to "SPECIFICATION" for recommended engine coolant. <Ref. to CO(STI)-2, SPECIFICATION, General Description.>

**Engine coolant level:**

Refer to "SPECIFICATION" for engine coolant level. <Ref. to CO(STI)-2, SPECIFICATION, General Description.>

**Engine coolant concentration:**

Refer to "ADJUSTMENT" for the recommended engine coolant concentration. <Ref. to CO(STI)-14, ADJUSTMENT, Engine Coolant.>

**CAUTION:**

Do not confuse the cap of coolant filler tank and cap of radiator.

**NOTE:**

- When pouring the engine coolant, the radiator side cap must not be removed.
  - The SUBARU Super Coolant contains anti-freeze and anti-rust agents, and is especially made for Subaru engines with an aluminum cylinder block. Be sure to use SUBARU Super Coolant, since other coolant may cause corrosion.
- 3) Fill engine coolant into the reservoir tank up to "FULL" level.

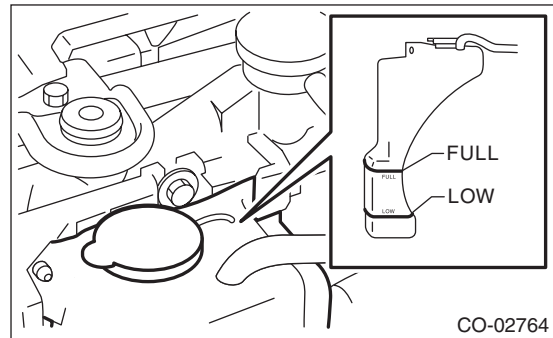

- 4) Close the coolant filler tank cap, and start the engine. Race 5 to 6 times at 3,000 rpm or less, then stop the engine. (Complete this operation within 40 seconds.)
- 5) Wait for one minute after the engine stops, then open the coolant filler tank cap. If the engine coolant level drops, add engine coolant into coolant filler tank up to the filler neck position.
- 6) Perform the procedures 4) and 5) again.
- 7) Install the coolant filler tank cap and reservoir tank cap properly.
- 8) Start the engine and operate the heater at maximum hot position and the blower speed setting to "LO".
- 9) Run the engine at 2,000 rpm or less until radiator fan starts and stops.

**NOTE:**

Be careful with the engine coolant temperature to prevent overheating.

- 10) Stop the engine and wait until the engine coolant temperature lowers to 30°C (86°F) or less.
- 11) Open the coolant filler tank cap. If the engine coolant level drops, add engine coolant into the coolant filler tank up to the filler neck position and the reservoir tank to "FULL" level.
- 12) Install the coolant filler tank cap and reservoir tank cap properly.
- 13) Set the heater setting to maximum hot position and the blower speed setting to "LO" and start the engine. Perform racing at 3,000 rpm or less. If the flowing sound is heard from the heater core, repeat the procedures from step 9).

# Engine Coolant

COOLING

---

## B: ADJUSTMENT

### 1. PROCEDURE TO ADJUST THE CONCENTRATION OF THE SUBARU SUPER COOLANT

#### CAUTION:

**Use the Subaru Super Coolant with a 50 — 60% concentration in order to obtain maximum anti-freeze and anti-rust performance.**

To adjust the concentration of Subaru Super Coolant according to temperature, select the proper Subaru Super Coolant concentration from the table, and add the amount of diluting water corresponding to the required concentration to the Subaru Super Coolant (concentrated type).

Relationship of Subaru Super Coolant concentration and freezing temperature			
Subaru Super Coolant concentration	50%	55%	60%
Freezing temp.	-36°C (-33°F)	-41°C (-42°F)	-50°C (-58°F)

#### ***Engine coolant and diluting water:***

***Refer to "SPECIFICATION" for the recommended engine coolant and diluting water. <Ref. to CO(STI)-2, SPECIFICATION, General Description.>***

## 4. Water Pump

### A: REMOVAL

- 1) Remove the radiator. <Ref. to CO(STI)-19, REMOVAL, Radiator.>
- 2) Remove the V-belts. <Ref. to ME(STI)-40, REMOVAL, V-belt.>
- 3) Remove the crank pulley. <Ref. to ME(STI)-47, REMOVAL, Crank Pulley.>
- 4) Remove the timing belt cover. <Ref. to ME(STI)-49, REMOVAL, Timing Belt Cover.>
- 5) Remove the timing belt. <Ref. to ME(STI)-50, REMOVAL, Timing Belt.>
- 6) Remove the automatic belt tension adjuster (A).
- 7) Remove the belt idler (B).
- 8) Remove the belt idler No. 2 (C).

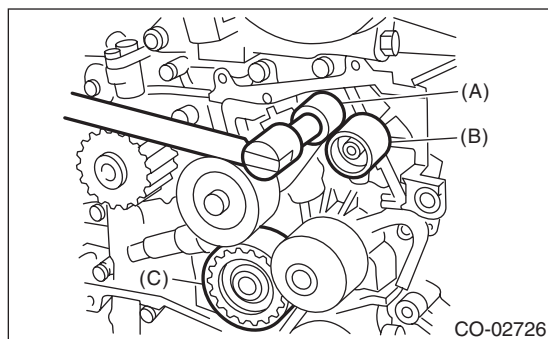

- 9) Remove the cam sprocket LH. <Ref. to ME(STI)-59, REMOVAL, Cam Sprocket.>
- 10) Remove the belt cover No. 2 LH.

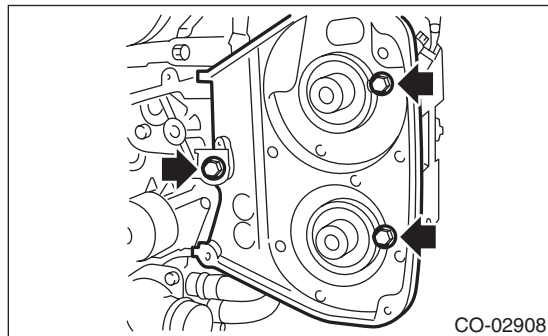

- 11) Remove the tensioner bracket.

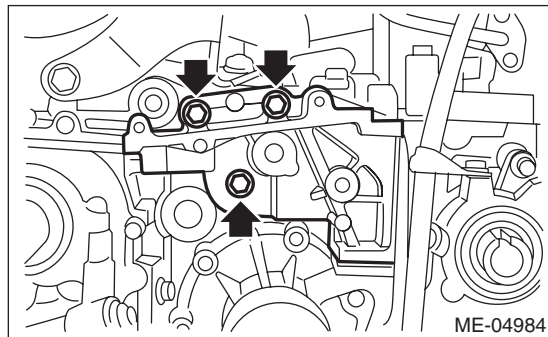

- 12) Disconnect the hose from water pump.

- 13) Remove the water pump.

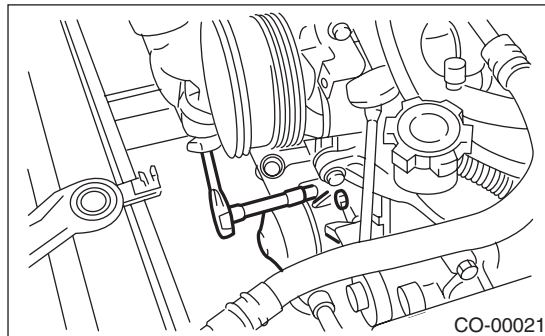

### B: INSTALLATION

- 1) Install the water pump onto cylinder block LH.

#### NOTE:

- Use a new gasket.
- When installing the water pump, tighten the bolts in two stages in alphabetical sequence as shown in figure.

#### Tightening torque:

##### First:

**12 N·m (1.2 kgf-m, 8.9 ft-lb)**

##### Second:

**12 N·m (1.2 kgf-m, 8.9 ft-lb)**

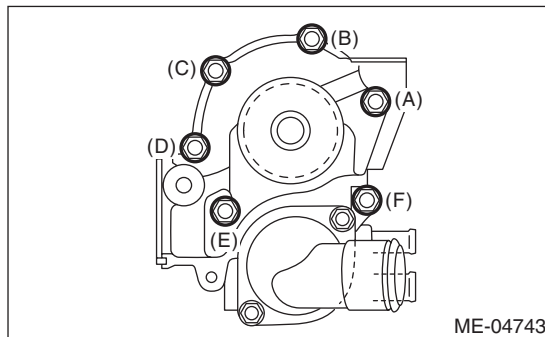

- 2) Install the hose to water pump.
- 3) Install the tensioner bracket.

#### Tightening torque:

**24.5 N·m (2.5 kgf-m, 18.1 ft-lb)**

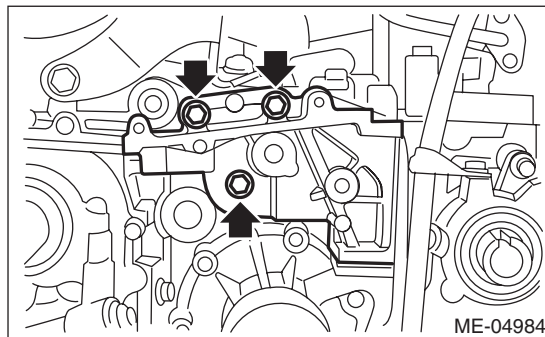

# Water Pump

## COOLING

4) Install the belt cover No. 2 LH.

**Tightening torque:**

**5 N·m (0.5 kgf·m, 3.7 ft·lb)**

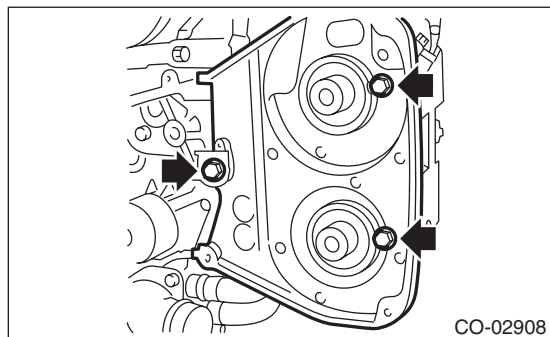

5) Install the cam sprocket LH. <Ref. to ME(STI)-59, INSTALLATION, Cam Sprocket.>

6) Install the belt idler No. 2 (C).

**Tightening torque:**

**39 N·m (4.0 kgf·m, 28.8 ft·lb)**

7) Install the belt idler (B).

**Tightening torque:**

**25 N·m (2.5 kgf·m, 18.4 ft·lb)**

8) Install the automatic belt tension adjuster (A) with the tension rod held by a pin. <Ref. to ME(STI)-52, AUTOMATIC BELT TENSION ADJUSTER ASSEMBLY AND BELT IDLER, INSTALLATION, Timing Belt.>

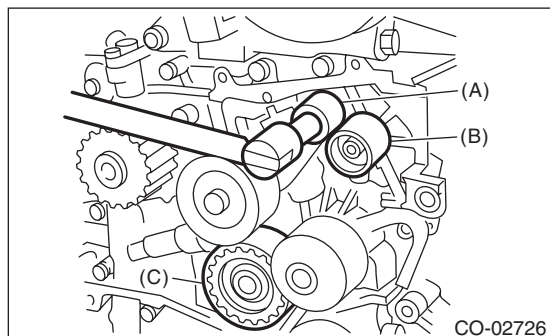

9) Install the timing belt. <Ref. to ME(STI)-53, TIMING BELT, INSTALLATION, Timing Belt.>

10) Install the timing belt cover. <Ref. to ME(STI)-49, INSTALLATION, Timing Belt Cover.>

11) Install the crank pulley. <Ref. to ME(STI)-47, INSTALLATION, Crank Pulley.>

12) Install the V-belts. <Ref. to ME(STI)-40, INSTALLATION, V-belt.>

13) Install the radiator. <Ref. to CO(STI)-20, INSTALLATION, Radiator.>

## C: INSPECTION

- 1) Check the water pump bearing for smooth rotation.
- 2) Check the water pump pulley for abnormalities.
- 3) Make sure the impeller is not abnormally deformed or damaged.
- 4) Inspect the clearance between impeller and pump case.

**Clearance between impeller and pump case:**

**Standard**

**0.5 — 1.5 mm (0.020 — 0.059 in)**

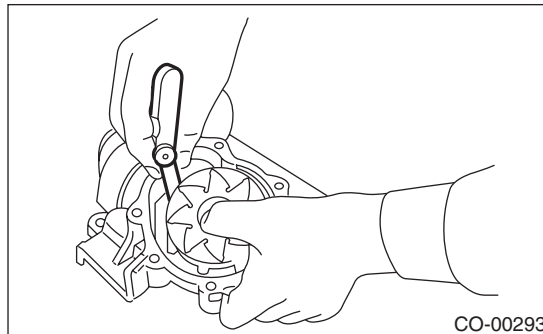

5) After water pump installation, check pulley shaft for engine coolant leaks or noise. If leaks or noise are noted, replace the water pump assembly.

## 5. Thermostat

### A: REMOVAL

- 1) Lift up the vehicle.
- 2) Remove the under cover. <Ref. to EI-28, REMOVAL, Front Under Cover.>
- 3) Drain engine coolant. <Ref. to CO(STI)-13, DRAINING OF ENGINE COOLANT, REPLACEMENT, Engine Coolant.>
- 4) Disconnect the radiator outlet hose from thermostat cover.

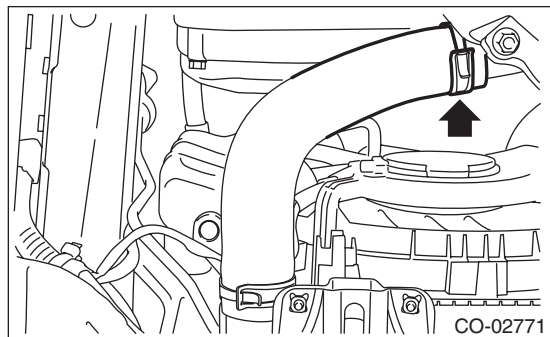

- 5) Remove the thermostat cover, and then remove the gasket and thermostat.

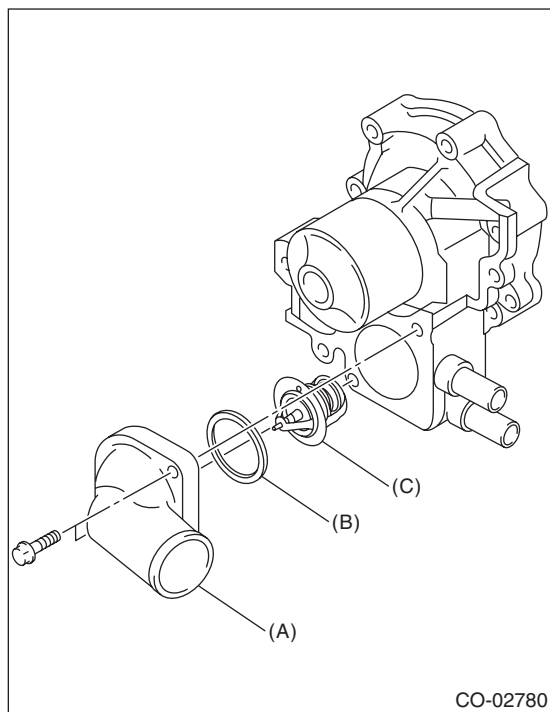

- (A) Thermostat cover
- (B) Gasket
- (C) Thermostat

### B: INSTALLATION

- 1) Install a gasket to thermostat.

**NOTE:**

Use a new gasket.

- 2) Install the thermostat and thermostat cover.

**NOTE:**

Install the parts with the jiggle pin facing upward.

**Tightening torque:**

**12 N·m (1.2 kgf·m, 8.9 ft·lb)**

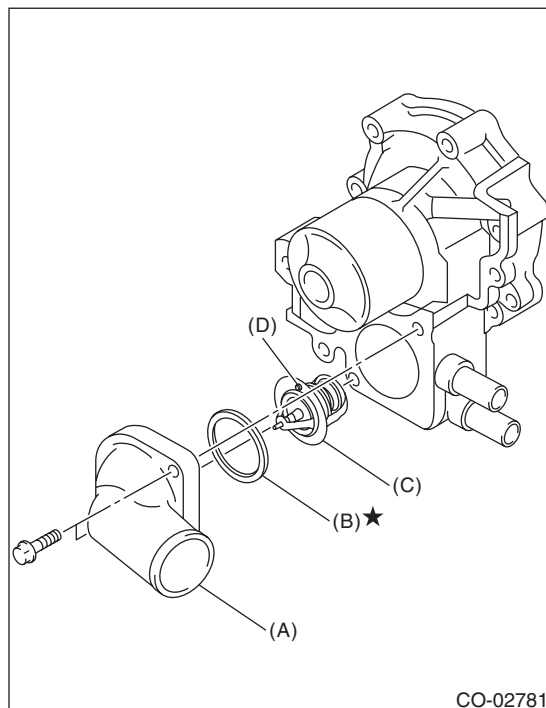

- (A) Thermostat cover
- (B) Gasket
- (C) Thermostat
- (D) Jiggle pin

- 3) Connect the radiator outlet hose to thermostat cover.
- 4) Install the under cover. <Ref. to EI-28, INSTALLATION, Front Under Cover.>
- 5) Lower the vehicle.
- 6) Fill engine coolant. <Ref. to CO(STI)-13, FILLING OF ENGINE COOLANT, REPLACEMENT, Engine Coolant.>

# Thermostat

## COOLING

---

### C: INSPECTION

- 1) Check that the thermostat does not have deformation, cracks or damage.
- 2) Check that the thermostat valve closes completely at an ambient temperature.
- 3) Immerse the thermostat and a thermometer in water. Raise water temperature gradually, and check the temperature and valve lift when the valve begins to open and when the valve is fully opened. Replace the thermostat if faulty.

#### NOTE:

- During the test, agitate the water for even temperature distribution.
- Leave the thermostat in the boiling water for five minutes or more before measuring the valve lift.
- Hold the thermostat with a wire or the like to avoid contacting the container.

#### **Starting temperature to open:**

**76 — 80°C (169 — 176°F)**

#### **Full open temperature:**

**91°C (196°F)**

#### **Total valve lift:**

**9.0 mm (0.354 in) or more**

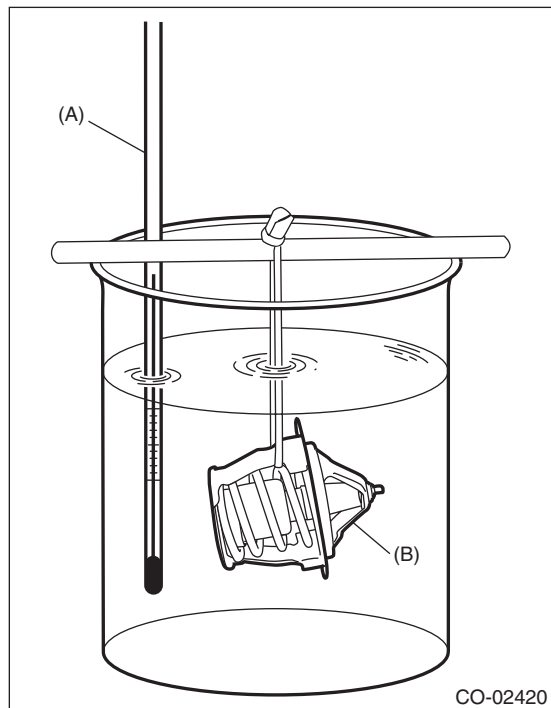

(A) Thermometer

(B) Thermostat



## 6. Radiator

### A: REMOVAL

#### CAUTION:

The radiator is pressurized when the engine and radiator are hot. Wait until engine and radiator cool down before working on the radiator.

1) Disconnect the ground cable from battery.

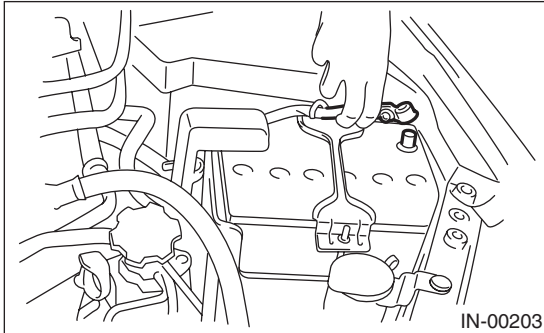

2) Lift up the vehicle.

3) Remove the under cover. <Ref. to EI-28, REMOVAL, Front Under Cover.>

4) Drain engine coolant. <Ref. to CO(STI)-13, DRAINING OF ENGINE COOLANT, REPLACEMENT, Engine Coolant.>

5) Disconnect the connector (A) from the main fan motor and the connector (B) from the sub fan motor.

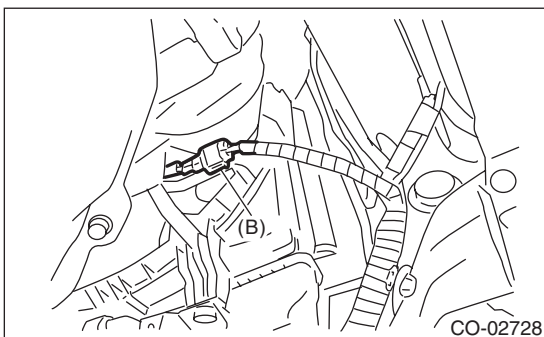
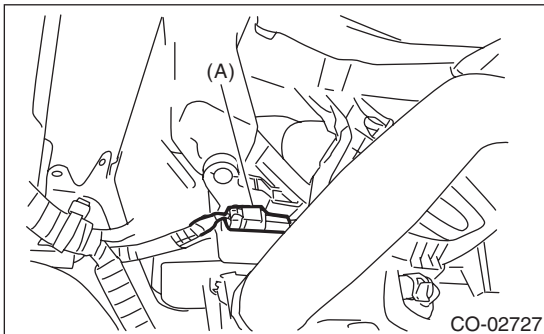

6) Disconnect the radiator outlet hose from thermostat cover.

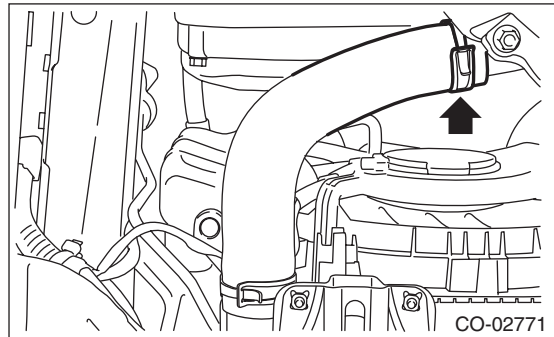

7) Lower the vehicle.

8) Remove the air intake duct. <Ref. to IN(STI)-10, REMOVAL, Air Intake Duct.>

9) Remove the reservoir tank. <Ref. to CO(STI)-27, REMOVAL, Reservoir Tank.>

10) Disconnect the radiator inlet hose from the radiator.

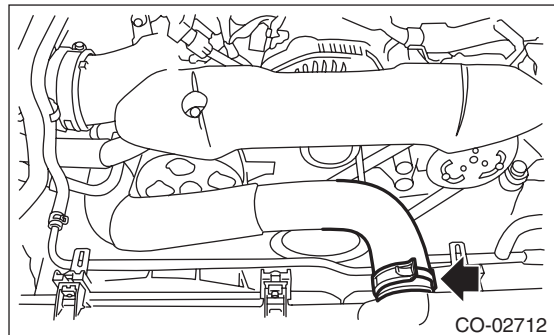

11) Disconnect the two engine coolant hoses from the radiator.

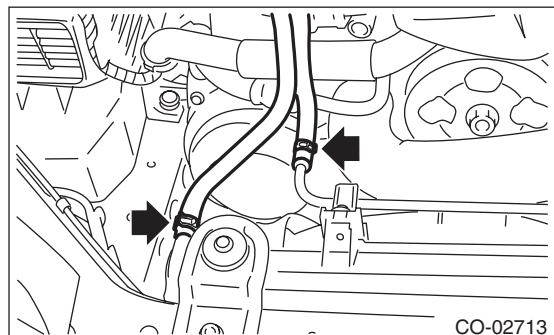

12) Remove the radiator upper brackets.

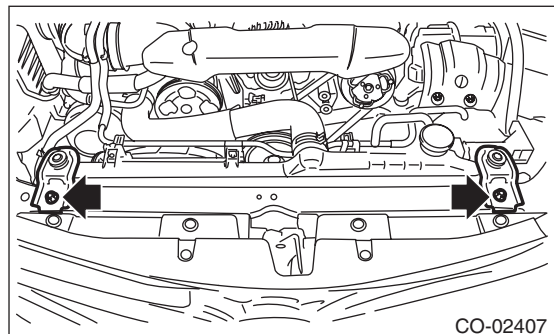



# Radiator

## COOLING

- 13) Move the radiator to the left while lifting it upward.
- 14) Lift the radiator up and remove the radiator from vehicle.
- 15) Remove the radiator lower cushion from the radiator lower bracket.

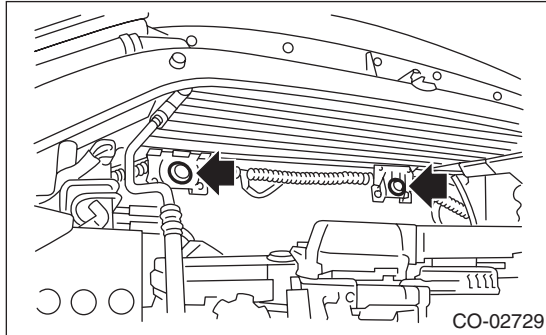

## B: INSTALLATION

- 1) Attach the radiator lower cushion to the radiator lower bracket.

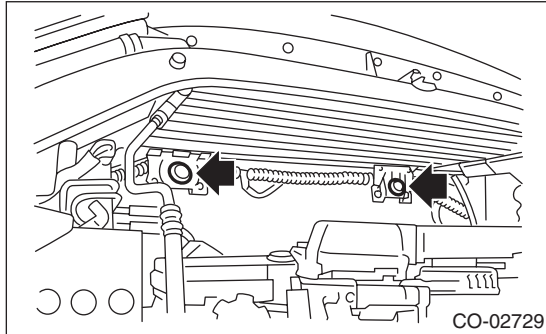

- 2) Install the radiator to vehicle.

### NOTE:

Make pins on the lower side of radiator be fitted into the radiator lower cushions.

- 3) Install the radiator upper brackets.

### Tightening torque:

**12 N·m (1.2 kgf·m, 8.9 ft·lb)**

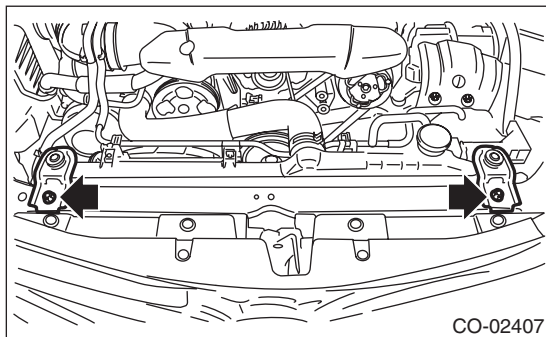

- 4) Connect the two engine coolant hoses to the radiator.

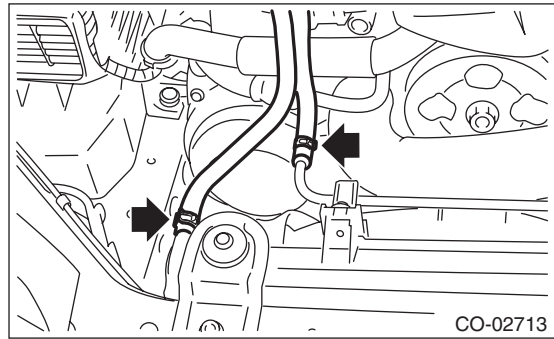

- 5) Connect the radiator inlet hose.

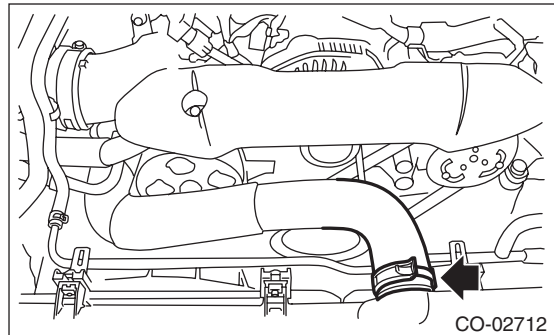

- 6) Install the reservoir tank. <Ref. to CO(STI)-27, INSTALLATION, Reservoir Tank.>

- 7) Install the air intake duct. <Ref. to IN(STI)-10, INSTALLATION, Air Intake Duct.>

- 8) Lift up the vehicle.

- 9) Connect the radiator outlet hose.

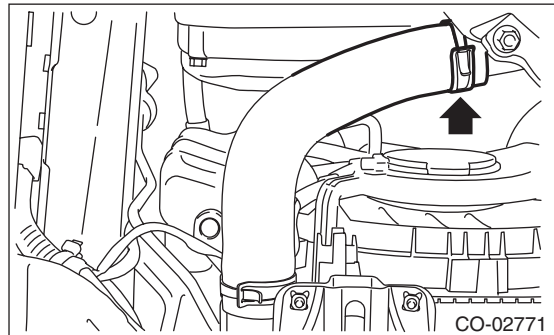

10) Connect the connector (A) to the main fan motor and the connector (B) to the sub fan motor connector.

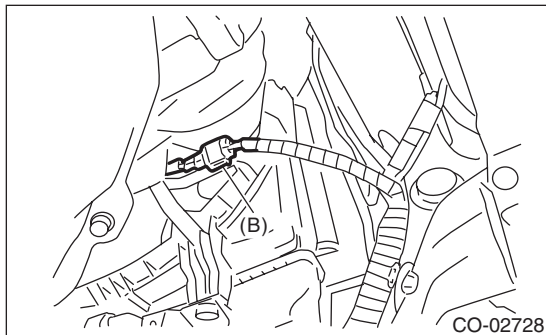
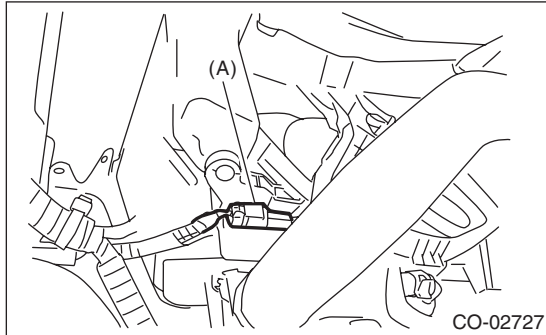

11) Install the under cover. <Ref. to EI-28, INSTALLATION, Front Under Cover.>

12) Lower the vehicle.

13) Connect the battery ground terminal.

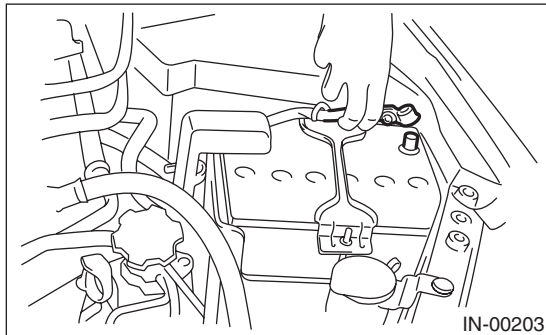

14) Fill engine coolant. <Ref. to CO(STI)-13, FILLING OF ENGINE COOLANT, REPLACEMENT, Engine Coolant.>

## C: INSPECTION

- 1) Check that the radiator does not have deformation, cracks or damage.
- 2) Check that the hose has no cracks, damage or loose part.
- 3) Remove the coolant filler tank cap, fill the coolant filler tank with engine coolant, then install the radiator cap tester to the filler neck of coolant filler tank.

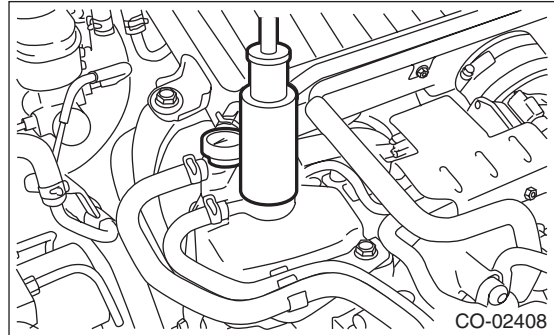

4) Apply a pressure of 122 kPa (1.2 kg/cm<sup>2</sup>, 18 psi) to the radiator and check the following points:

- Leakage from the radiator or its vicinity
- Leakage from the hose or its connections

### CAUTION:

- Inspection must be carried out at the side of coolant filler tank, not at the side of radiator.
- Engine should be turned off.
- Wipe engine coolant from check points in advance.
- Be careful not to deform the filler neck of the coolant filler tank when installing and removing the radiator cap tester.
- Be careful of engine coolant from spurting out when removing the radiator cap tester.

## 7. Radiator Cap

### A: INSPECTION

- 1) Check that the radiator cap does not have deformation, cracks or damage.
- 2) Attach the radiator cap tester to radiator cap.

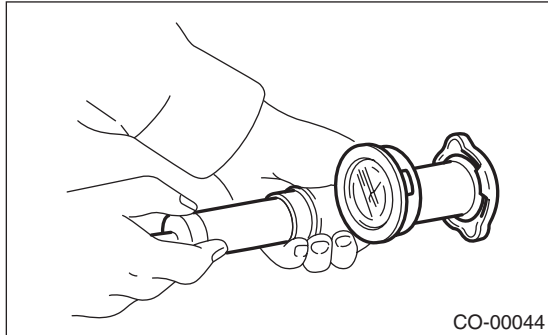

- 3) Increase pressure until the radiator cap tester gauge needle stops. Radiator cap is functioning properly if it holds the service limit pressure for 5 — 6 seconds. Replace the radiator cap if its valve opens at less than the service limit.

#### **Coolant filler tank side:**

##### **Standard**

**93 — 123 kPa (0.95 — 1.25 kg/cm<sup>2</sup>, 14 — 18 psi)**

##### **Limit**

**83 kPa (0.85 kg/cm<sup>2</sup>, 12 psi)**

#### **Radiator side:**

##### **Standard**

**122 — 152 kPa (1.24 — 1.55 kg/cm<sup>2</sup>, 18 — 22 psi)**

##### **Limit**

**112 kPa (1.14 kg/cm<sup>2</sup>, 16 psi)**

#### **CAUTION:**

- Be sure to remove foreign matter and rust from the cap in advance. Otherwise, results of pressure test will be incorrect.
- Do not confuse the cap of coolant filler tank and cap of radiator.

## 8. Radiator Main Fan and Fan Motor

### A: REMOVAL

- 1) Disconnect the ground cable from battery.

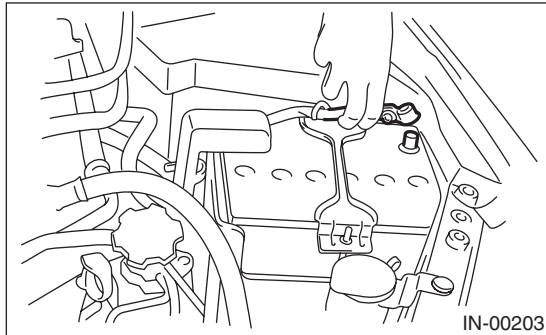

- 2) Lift up the vehicle.
- 3) Remove the under cover. <Ref. to EI-28, REMOVAL, Front Under Cover.>
- 4) Disconnect the connector from the main fan motor.

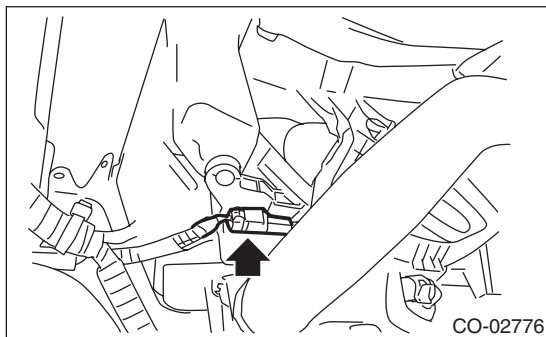

- 5) Lower the vehicle.
- 6) Remove the air intake duct. <Ref. to IN(STI)-10, REMOVAL, Air Intake Duct.>
- 7) Remove the reservoir tank. <Ref. to CO(STI)-27, REMOVAL, Reservoir Tank.>
- 8) Remove the bolts which secure the radiator main fan motor assembly and the over flow pipe.

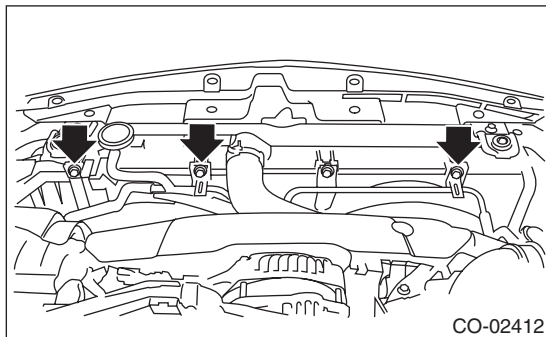

- 9) Remove the radiator main fan motor assembly from the upper side of the vehicle.

### B: INSTALLATION

Install in the reverse order of removal.

#### CAUTION:

Check if the radiator hose and the over flow hose are properly connected.

#### Tightening torque:

7.5 N·m (0.8 kgf-m, 5.5 ft-lb)

### C: DISASSEMBLY

- 1) Remove the clip which holds the main fan motor connector onto the radiator main fan shroud.
- 2) Disconnect the radiator main fan from the main fan motor.

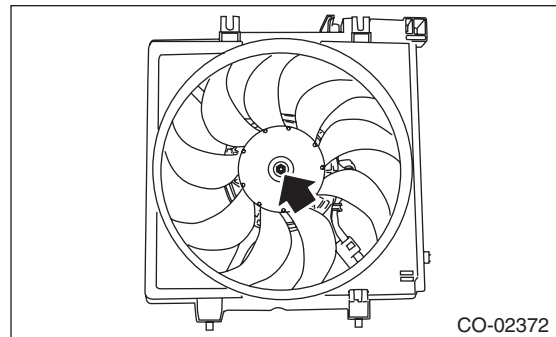

- 3) Disconnect the main fan motor from the radiator main fan shroud.

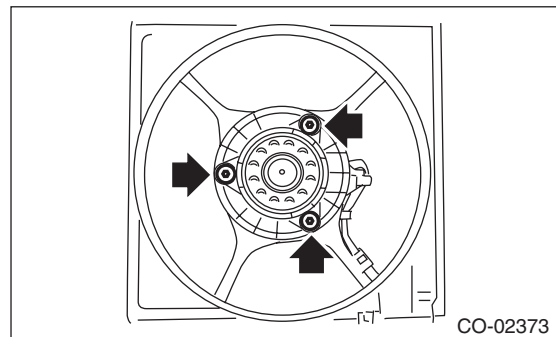

# Radiator Main Fan and Fan Motor

COOLING

---

## D: ASSEMBLY

Assemble in the reverse order of disassembly.

**Tightening torque:**

**4.41 N·m (0.45 kgf-m, 3.25 ft-lb)**

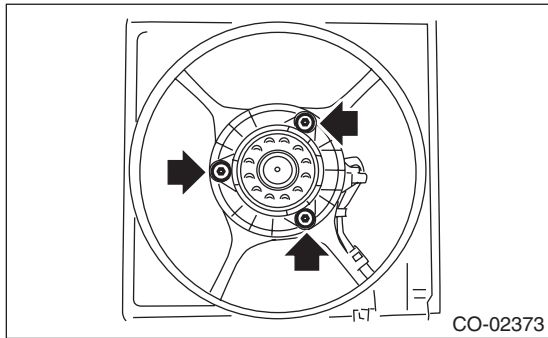

**Tightening torque:**

**3.4 N·m (0.3 kgf-m, 2.5 ft-lb)**

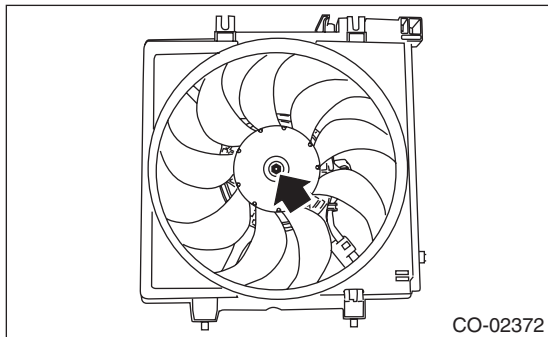

## E: INSPECTION

Check that the radiator main fan, radiator main fan shroud and main fan motor do not have deformation, cracks or damage.

## 9. Radiator Sub Fan and Fan Motor

### A: REMOVAL

- 1) Disconnect the ground cable from battery.

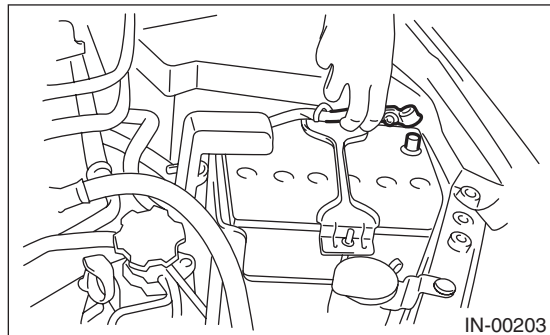

- 2) Lift up the vehicle.
- 3) Remove the under cover. <Ref. to EI-28, REMOVAL, Front Under Cover.>
- 4) Disconnect the connector from the sub fan motor.

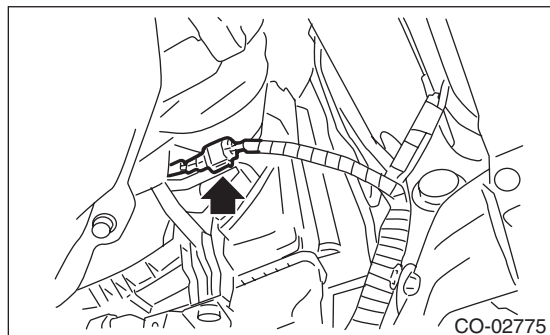

- 5) Lower the vehicle.
- 6) Remove the air intake duct. <Ref. to IN(STI)-10, REMOVAL, Air Intake Duct.>
- 7) Remove the bolts which secure the radiator sub fan motor assembly and the over flow pipe.

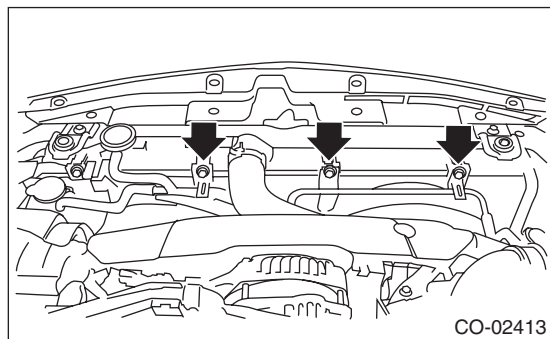

- 8) Raise the radiator sub fan motor assembly slightly, remove the pin at the lower part of the radiator sub fan motor assembly from the radiator hole, and remove the radiator sub fan motor assembly from the lower side of the vehicle.

### B: INSTALLATION

Install in the reverse order of removal.

#### CAUTION:

Check if the radiator hose and the over flow hose are properly connected.

#### Tightening torque:

7.5 N·m (0.8 kgf·m, 5.5 ft·lb)

### C: DISASSEMBLY

- 1) Remove the clip which holds the sub fan motor connector onto the radiator sub fan shroud.
- 2) Disconnect the radiator sub fan from the sub fan motor.

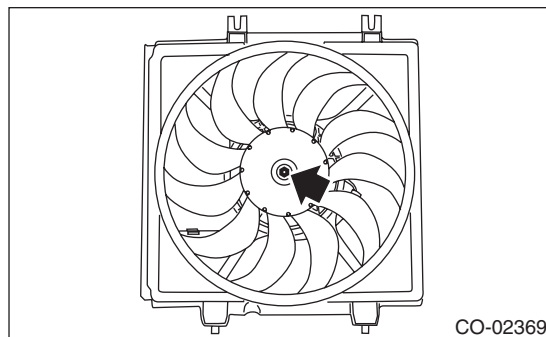

- 3) Disconnect the sub fan motor from the radiator sub fan shroud.

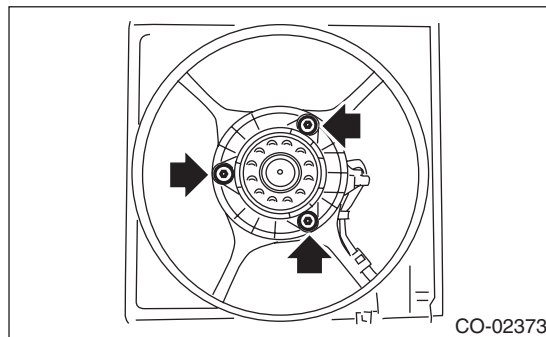

# Radiator Sub Fan and Fan Motor

COOLING

---

## D: ASSEMBLY

Assemble in the reverse order of disassembly.

**Tightening torque:**

**4.41 N·m (0.45 kgf-m, 3.25 ft-lb)**

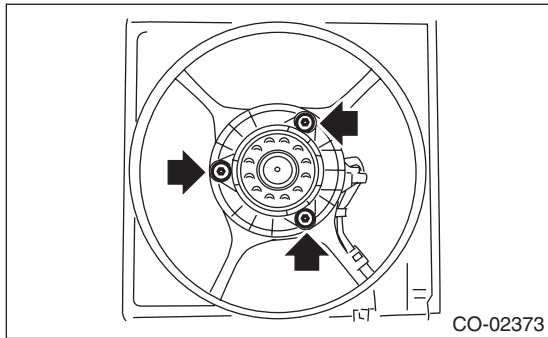

**Tightening torque:**

**3.4 N·m (0.3 kgf-m, 2.5 ft-lb)**

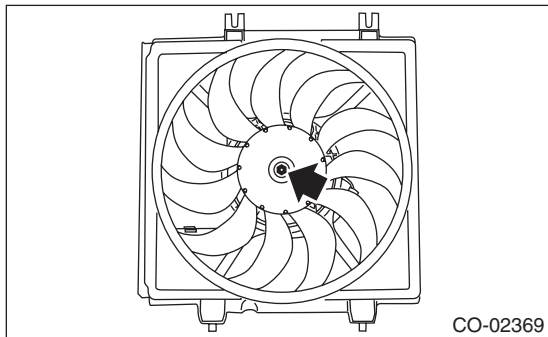

## E: INSPECTION

Check that the radiator sub fan, radiator sub fan shroud and sub fan motor do not have deformation, cracks or damage.



## 10. Reservoir Tank

### A: REMOVAL

- 1) Pull out the over flow hose (A).
- 2) Pull out the reservoir tank to the arrow direction while pushing the claw (B).

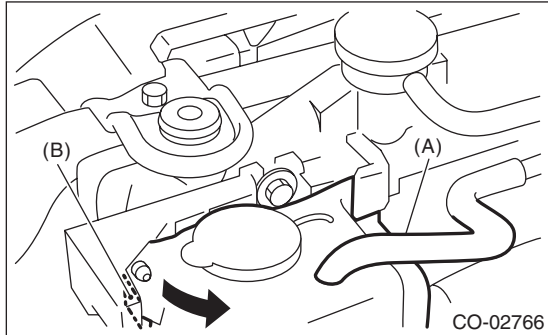

### B: INSTALLATION

Install in the reverse order of removal.

### C: INSPECTION

- 1) Check that the reservoir tank does not have deformation, cracks or damage.
- 2) Make sure the over flow hoses are not cracked, damaged or loose.
- 3) Make sure the engine coolant level is between "FULL" and "LOW".



## 11. Coolant Filler Tank

### A: REMOVAL

#### CAUTION:

The coolant filler tank is pressurized when the engine and radiator are hot. Wait until engine and radiator cool down before working on the coolant filler tank.

- 1) Drain approximately 3.0 ℓ (3.2 US qt, 2.6 Imp qt) of coolant. <Ref. to CO(STI)-13, DRAINING OF ENGINE COOLANT, REPLACEMENT, Engine Coolant.>
- 2) Disconnect the engine coolant hoses from coolant filler tank.
- 3) Remove the bolt and nut which secure the coolant filler tank.
- 4) Remove the coolant filler tank.

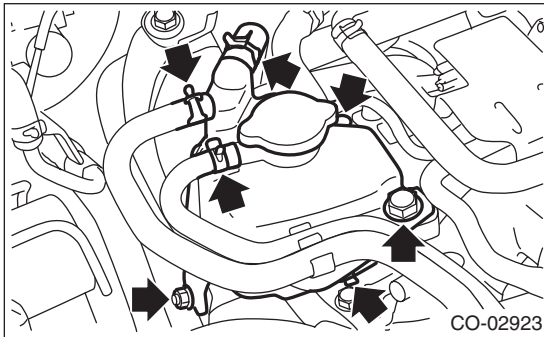

### B: INSTALLATION

- 1) Install in the reverse order of removal.

#### *Tightening torque:*

**16 N·m (1.6 kgf·m, 11.8 ft·lb)**

### C: INSPECTION

- 1) Check that the coolant filler tank does not have deformation, cracks or damage.
- 2) Check that the engine coolant hose has no cracks, damage or loose part.

## 12.Engine Cooling System Trouble in General

### A: INSPECTION

Trouble	Possible cause	Corrective action
Over-heating	a. Insufficient engine coolant	Replenish engine coolant, inspect for leakage, and repair it if necessary.
	b. Loose timing belt	Repair or replace timing belt tensioner.
	c. Oil on timing belt	Replace.
	d. Malfunction of thermostat	Replace.
	e. Malfunction of water pump	Replace.
	f. Clogged engine coolant passage	Clean.
	g. Improper ignition timing	Inspect and repair ignition control system. <Ref. to EN(H4DOTC)(diag)-2, PROCEDURE, Basic Diagnostic Procedure.>
	h. Clogged or leaking radiator	Clean, repair or replace.
	i. Defective radiator fan	Replace.
	j. Improper engine oil in engine coolant	Replace the engine coolant. If ineffective, check, repair or replace engine components.
	k. Air/fuel mixture ratio too lean	Inspect and repair the fuel injection system. <Ref. to EN(H4DOTC)(diag)-2, PROCEDURE, Basic Diagnostic Procedure.>
	l. Excessive back pressure in exhaust system	Clean or replace.
	m. Insufficient clearance between piston and cylinder	Adjust or replace.
	n. Slipping clutch	Repair or replace.
o. Dragging brake	Adjust.	
p. Defective radiator fan	Inspect the radiator fan relay, engine coolant temperature sensor or fan motor and replace them.	
Over-cooling	a. Ambient temperature extremely low	Partly cover radiator front area.
	b. Defective thermostat	Replace.
Engine coolant leaks	a. Loosened or damaged connecting units on hoses	Repair or replace.
	b. Leakage from water pump	Replace.
	c. Leakage from water pipe	Repair or replace.
	d. Leakage around cylinder head gasket	Retighten cylinder head bolts or replace cylinder head gasket.
	e. Damaged or cracked cylinder head and cylinder block	Repair or replace.
	f. Damaged or cracked thermostat cover	Repair or replace.
	g. Leakage from radiator	Repair or replace.
Noise	a. Timing belt problem	Replace.
	b. Defective radiator fan	Replace.
	c. Defective water pump bearing	Replace water pump.
	d. Defective water pump mechanical seal	Replace water pump.

# Engine Cooling System Trouble in General

COOLING

---

**CO(STI)-30**

Brought to you by Ebay Seller "SubaruManuals"

# LUBRICATION

# *LU(STI)*

---

	<b>Page</b>
1. General Description .....	2
2. Oil Pressure System .....	9
3. Engine Oil .....	11
4. Oil Pump .....	13
5. Oil Pan and Strainer .....	18
6. Oil Pressure Switch .....	22
7. Engine Oil Cooler .....	24
8. Oil Pipe .....	25
9. Engine Oil Filter .....	32
10. Engine Lubrication System Trouble in General .....	33

# General Description

## LUBRICATION

### 1. General Description

#### A: SPECIFICATION

##### 1. STI MODEL

Lubrication method				Forced lubrication	
Oil pump	Pump type			Trochoid type	
	Number of teeth	Inner rotor		9	
		Outer rotor		10	
	Outer rotor diameter × thickness			mm (in) 78 × 11 (3.07 × 0.43)	
	Tip clearance between inner and outer rotors		mm (in) Standard	0.04 — 0.14 (0.0016 — 0.0055)	
	Case clearance between outer rotor and pump case		mm (in) Standard	0.10 — 0.175 (0.0039 — 0.0069)	
	Side clearance between inner rotor and pump case		mm (in) Standard	0.02 — 0.07 (0.0008 — 0.0028)	
	Relief valve spring	Free length		mm (in) 73.7 (2.902)	
		Installed length		mm (in) 54.7 (2.154)	
		Load when installed		N (kgf, lbf) 93.1 (9.49, 20.93)	
	Performance (Oil temperature 80°C (176°F))	600 rpm	Discharge pressure		kPa (kg/cm <sup>2</sup> , psi) 98 (1.0, 14)
			Discharge rate		ℓ (US qt, Imp qt)/min. 6.4 (6.8, 5.6) or more
		6,000 rpm	Discharge pressure		kPa (kg/cm <sup>2</sup> , psi) 392 (4.0, 56.8)
			Discharge rate		ℓ (US qt, Imp qt)/min. 63.0 (66.6, 55.4) or more
Relief valve working pressure			kPa (kg/cm <sup>2</sup> , psi) 538 (5.5, 78)		
Oil filter	Filter type			Full-flow filter type	
	Filtration area	cm <sup>2</sup> (sq in) Outer diameter: 68 mm (2.68 in) (Black)		800 (124)	
		Outer diameter: 67.4 mm (2.65 in) (Blue)		555 (86)	
	By-pass valve opening pressure			kPa (kg/cm <sup>2</sup> , psi) 160 (1.63, 23.2)	
	Outer diameter × width	mm (in) Outer diameter: 68 mm (2.68 in) (Black)		68 × 65 (2.68 × 2.56)	
		Outer diameter: 67.4 mm (2.65 in) (Blue)		67.4 × 65.3 (2.65 × 2.57)	
Installation screw specifications			M 20 × 1.5		
Oil pressure switch	Type			Immersed contact point type	
	Operating voltage — power consumption			12 V — 3.4 W or less	
	Warning light operating pressure		kPa (kg/cm <sup>2</sup> , psi)	14.7 (0.15, 2.1)	
	Proof pressure		kPa (kg/cm <sup>2</sup> , psi)	981 (10, 142) or more	
Engine oil	Total capacity (at overhaul)		ℓ (US qt, Imp qt) 5.0 (5.3, 4.4)		
	When replacing engine oil and oil filter		ℓ (US qt, Imp qt) 4.3 (4.5, 3.8)		
	When replacing engine oil only		ℓ (US qt, Imp qt) 4.0 (4.2, 3.5)		

# General Description

LUBRICATION

## 2. EXCEPT FOR STI MODEL

Lubrication method			Forced lubrication		
Oil pump	Pump type		Trochoid type		
	Number of teeth	Inner rotor	9		
		Outer rotor	10		
	Outer rotor diameter × thickness		mm (in)	76 × 10 (2.99 × 0.39)	
	Tip clearance between inner and outer rotors	mm (in)	Standard	0.04 — 0.14 (0.0016 — 0.0055)	
	Case clearance between outer rotor and pump case	mm (in)	Standard	0.10 — 0.175 (0.0039 — 0.0069)	
	Side clearance between inner rotor and pump case	mm (in)	Standard	0.02 — 0.07 (0.0008 — 0.0028)	
	Relief valve spring	Free length		mm (in)	73.7 (2.902)
		Installed length		mm (in)	54.7 (2.154)
		Load when installed		N (kgf, lbf)	93.1 (9.49, 20.93)
	Performance (Oil temperature 80°C (176°F))	600 rpm	Discharge pressure	kPa (kg/cm <sup>2</sup> , psi)	98 (1.0, 14)
			Discharge rate	ℓ (US qt, Imp qt)/min.	4.6 (4.9, 4.0) or more
		5,000 rpm	Discharge pressure	kPa (kg/cm <sup>2</sup> , psi)	294 (3.0, 43)
Discharge rate			ℓ (US qt, Imp qt)/min.	47.0 (49.7, 41.4) or more	
Relief valve working pressure		kPa (kg/cm <sup>2</sup> , psi)	588 (6.0, 85)		
Oil filter	Filter type		Full-flow filter type		
	Filtration area	cm <sup>2</sup> (sq in)	Outer diameter: 68 mm (2.68 in) (Black)	800 (124)	
			Outer diameter: 67.4 mm (2.65 in) (Blue)	555 (86)	
	By-pass valve opening pressure		kPa (kg/cm <sup>2</sup> , psi)	160 (1.63, 23.2)	
	Outer diameter × width	mm (in)	Outer diameter: 68 mm (2.68 in) (Black)	68 × 65 (2.68 × 2.56)	
			Outer diameter: 67.4 mm (2.65 in) (Blue)	67.4 × 65.3 (2.65 × 2.57)	
Installation screw specifications			M 20 × 1.5		
Oil pressure switch	Type		Immersed contact point type		
	Operating voltage — power consumption		12 V — 3.4 W or less		
	Warning light operating pressure		kPa (kg/cm <sup>2</sup> , psi)	14.7 (0.15, 2.1)	
	Proof pressure		kPa (kg/cm <sup>2</sup> , psi)	981 (10, 142) or more	
Engine oil	Total capacity (at overhaul)		ℓ (US qt, Imp qt)	5.0 (5.3, 4.4)	
	When replacing engine oil and oil filter		ℓ (US qt, Imp qt)	4.2 (4.4, 3.7)	
	When replacing engine oil only		ℓ (US qt, Imp qt)	4.0 (4.2, 3.5)	

**LU(STI)-3**

Brought to you by Ebay Seller "SubaruManuals"



# General Description

## LUBRICATION

### **Recommended oil:**

#### **CAUTION:**

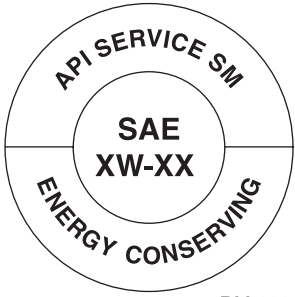
- Use 5W-30 (synthetic oil).
- It is acceptable to fill an engine with oil of another brand when replacing the oil, but make sure to use the following engine oil specified by Subaru.

Engine oil standard	SAE viscosity No.
<div data-bbox="186 409 479 703"></div> <p data-bbox="402 699 500 720">RM-00076</p> <p data-bbox="159 730 506 814">Those with the API standard SM "Energy Conserving" or SN "Resource Conserving" logo.</p> <p data-bbox="565 583 587 609">or</p> <div data-bbox="665 399 974 703"></div> <p data-bbox="889 699 987 720">RM-00002</p> <p data-bbox="625 730 1015 814">Those with the ILSAC standard GF-4 or GF-5 "starburst mark" displayed on top of the container.</p>	<p data-bbox="1153 342 1364 369">SAE viscosity No.</p> <p data-bbox="1153 380 1377 407">5W-30 (synthetic oil)</p>

#### **NOTE:**

The proper viscosity oil helps the engine maintain its ideal temperature, and cranking speed increased by reducing viscosity friction in hot condition.

## B: COMPONENT

### 1. OIL PUMP AND OIL PAN

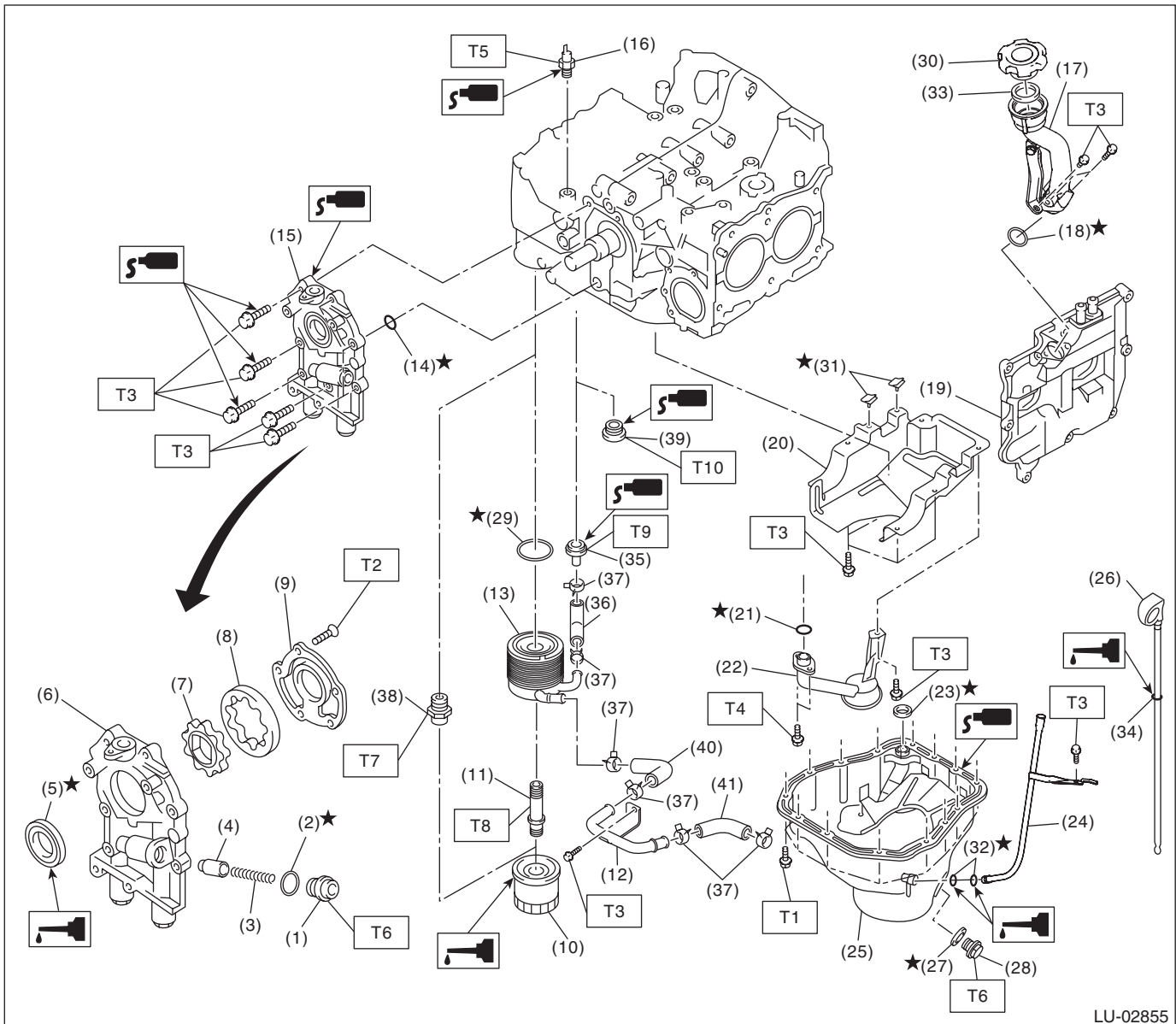

LU-02855

LU(STI)-5

Brought to you by Ebay Seller "SubaruManuals"



# General Description

## LUBRICATION

---

(1) Plug	(19) Rocker cover	(37) Clip (model with oil cooler)
(2) Gasket	(20) Baffle plate	(38) Oil filter connector (model without oil cooler)
(3) Relief valve spring	(21) O-ring	(39) Plug (model without oil cooler)
(4) Relief valve	(22) Oil strainer	(40) Oil cooler hose B (model with oil cooler)
(5) Front oil seal	(23) Gasket	(41) Oil cooler hose C (model with oil cooler)
(6) Oil pump case	(24) Oil level gauge guide	
(7) Inner rotor	(25) Oil pan	<hr/> <b>Tightening torque: N·m (kgf-m, ft-lb)</b>
(8) Outer rotor	(26) Oil level gauge	<b>T1: 5 (0.5, 3.7)</b>
(9) Oil pump cover	(27) Drain plug gasket	<b>T2: 5.4 (0.6, 4.0)</b>
(10) Oil filter	(28) Drain plug	<b>T3: 6.4 (0.7, 4.7)</b>
(11) Oil cooler connector (model with oil cooler)	(29) Gasket (model with oil cooler)	<b>T4: 10 (1.0, 7.0)</b>
(12) Oil cooler pipe (model with oil cooler)	(30) Oil filler cap	<b>T5: 25 (2.5, 18.4)</b>
(13) Oil cooler (model with oil cooler)	(31) Seal	<b>T6: 44 (4.5, 32.5)</b>
(14) O-ring	(32) O-ring	<b>T7: 45 (4.6, 33.2)</b>
(15) Oil pump ASSY	(33) Gasket	<b>T8: 54 (5.5, 39.8)</b>
(16) Oil pressure switch	(34) O-ring	<b>T9: 69 (7.0, 50.9)</b>
(17) Oil filler duct	(35) Nipple (model with oil cooler)	<b>T10: 70 (7.1, 51.6)</b>
(18) O-ring	(36) Oil cooler hose A (model with oil cooler)	<hr/>

## 2. OIL PIPE

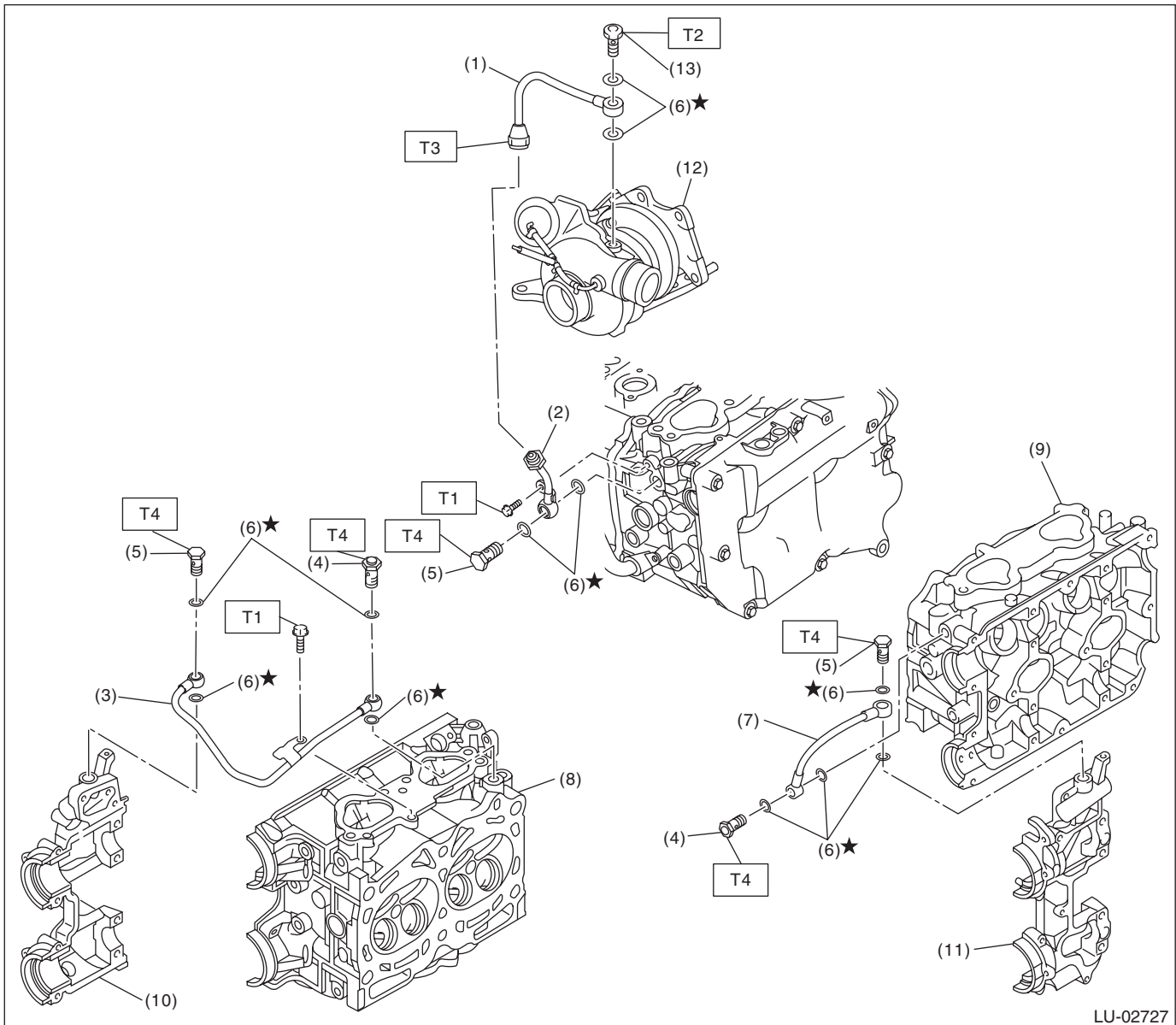

LU-02727

- |  |  |
|--|--|
| (1) Oil inlet pipe                                 | (8) Cylinder head RH                             |
| (2) Turbocharger oil pipe                          | (9) Cylinder head LH                             |
| (3) Oil pipe RH                                    | (10) Front camshaft cap RH                       |
| (4) Union bolt with filter (with protrusion)       | (11) Front camshaft cap LH                       |
| (5) Union bolt without filter (without protrusion) | (12) Turbocharger                                |
| (6) Gasket   | (13) Union bolt without filter (with protrusion) |
| (7) Oil pipe LH                                    |  |

**Tightening torque: N·m (kgf-m, ft-lb)**

**T1: 6.4 (0.7, 4.7)**

**T2: 16 (1.6, 11.8)**

**T3: 20 (2.0, 14.8)**

**T4: 29 (3.0, 21.4)**

# General Description

## LUBRICATION

### C: CAUTION

- Wear appropriate work clothing, including a cap, protective goggles and protective shoes when performing any work.
- Remove contamination including dirt and corrosion before removal, installation or disassembly.
- Keep the disassembled parts in order and protect them from dust and dirt.
- Before removal, installation or disassembly, be sure to clarify the failure. Avoid unnecessary removal, installation, disassembly and replacement.
- Vehicle components are extremely hot after driving. Be wary of receiving burns from heated parts.
- Be sure to tighten fasteners including bolts and nuts to the specified torque.
- Place shop jacks or rigid racks at the specified points.
- Before disconnecting connectors of sensors or units, be sure to disconnect the ground cable from battery.
- If the engine oil is spilt over exhaust pipe or the under cover, wipe it off with cloth to avoid emitting smoke or causing a fire.
- Prepare a container and cloth to prevent scattering of oil when performing work where oil can be spilled. If the oil spills, wipe it off immediately to prevent from penetrating into floor or flowing out for environmental protection.
- Follow all government and local regulations concerning disposal of refuse when disposing of oil.

### D: PREPARATION TOOL

#### 1. SPECIAL TOOL

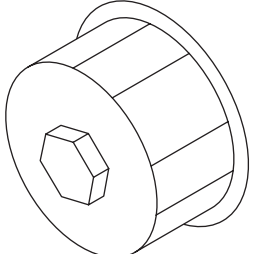
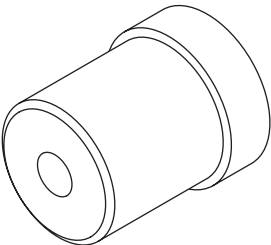
ILLUSTRATION	TOOL NUMBER	DESCRIPTION	REMARKS
 <p>ST18332AA000</p>	18332AA000	OIL FILTER WRENCH	Used for removing and installing oil filter (Black). (Outer diameter: 68 mm (2.68 in))
 <p>ST-499587100</p>	499587100	OIL SEAL INSTALLER	Used for installing oil seal into oil pump.

#### 2. GENERAL TOOL

TOOL NAME	REMARKS
Oil filter wrench (65/67 mm 14 Flutes)	Used for removing and installing oil filter (Blue). (Outer diameter: 67.4 mm (2.65 in))
Circuit tester	Used for measuring resistance and voltage.

LU(STI)-8

Brought to you by Ebay Seller "SubaruManuals"

## 2. Oil Pressure System

### A: WIRING DIAGRAM

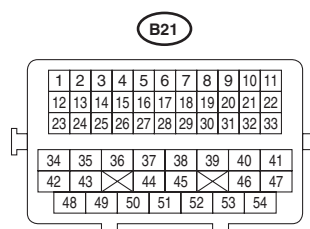
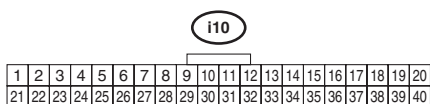
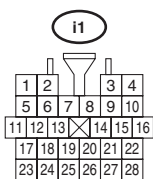
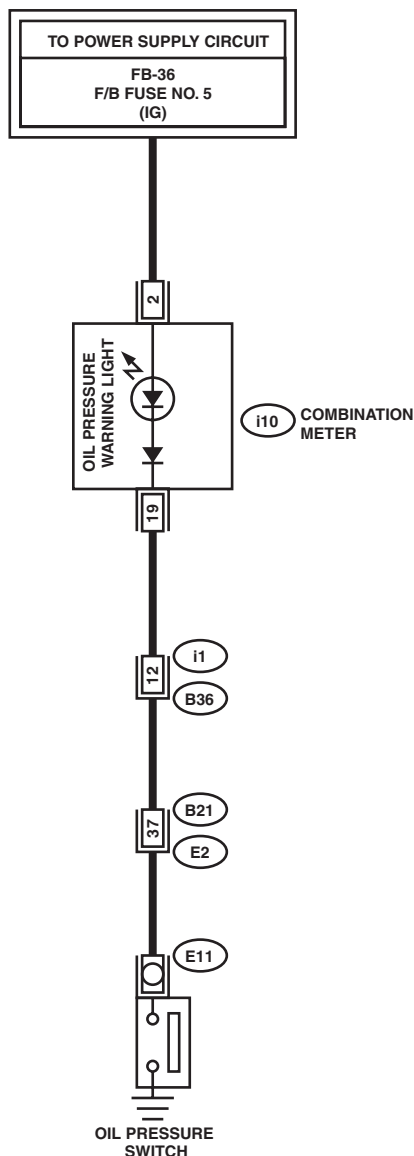

LU-02703

# Oil Pressure System

LUBRICATION

## B: INSPECTION

Step	Check	Yes	No
<b>1</b> <b>CHECK COMBINATION METER.</b> 1) Turn the ignition switch to ON (engine OFF). 2) Check other warning lights.	Does the warning light illuminate?	Go to step 2.	Repair or replace the combination meter. <Ref. to IDI-5, INSPECTION, Combination Meter System.>
<b>2</b> <b>CHECK HARNESS CONNECTOR BETWEEN THE COMBINATION METER AND THE OIL PRESSURE SWITCH.</b> 1) Turn the ignition switch to OFF. 2) Disconnect the connector from oil pressure switch. 3) Turn the ignition switch to ON. 4) Measure the voltage of harness between oil pressure switch connector and chassis ground. <b>Connector &amp; terminal</b> <b>(E11) No. 1 (+) — Chassis ground (-):</b>	Is the voltage 10 V or more?	Replace the oil pressure switch. <Ref. to LU(STI)-22, Oil Pressure Switch.>	Go to step 3.
<b>3</b> <b>CHECK COMBINATION METER.</b> 1) Turn the ignition switch to OFF. 2) Remove the combination meter. 3) Measure the resistance of combination meter. <b>Terminals</b> <b>No. 2 — No. 19:</b>	Is the resistance less than 10 $\Omega$ ?	Repair the harness and connector. NOTE: In this case, repair the following item: • Open circuit of harness between combination meter and oil pressure switch • Poor contact of combination meter connector • Poor contact of oil pressure switch connector • Poor contact of coupling connector	Repair or replace the combination meter. <Ref. to IDI-5, INSPECTION, Combination Meter System.>

## 3. Engine Oil

### A: INSPECTION

#### CAUTION:

If the engine oil is spilt over exhaust pipe or the under cover, wipe it off with cloth to avoid emitting smoke or causing a fire.

- 1) Park the vehicle on a level surface.
- 2) Remove the oil level gauge and wipe away the oil.
- 3) Reinsert the oil level gauge all the way. Be sure that the oil level gauge is correctly inserted and properly orientated.
- 4) Pull out the oil level gauge again, and check the oil level. If the engine oil level is below "L" line, make sure that there is no oil leakage from the engine, then add oil to raise the level up to the "F" line.
- 5) Start the engine, and spread the oil in engine room.
- 6) After turning off the engine, wait a few minutes for the oil to return to the oil pan before checking the level.

#### NOTE:

- Just after driving or while the engine is warm, engine oil level shows in the range between the F line and the notch mark. This is caused by thermal expansion of engine oil.
- To prevent overfilling of engine oil, do not add oil above "F" line when the engine is cold.
- As the oil level gauge is used for daily maintenance, "F" line and "L" line is set assuming that the engine is cold.

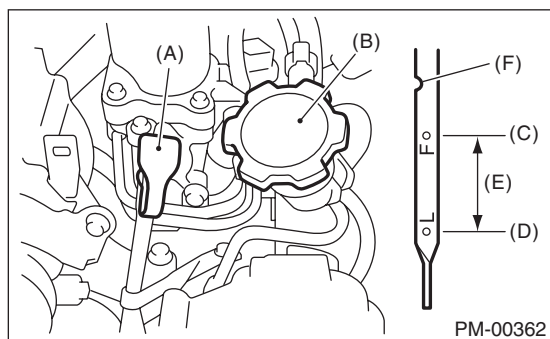

- (A) Oil level gauge
- (B) Engine oil filler cap
- (C) "F" line
- (D) "L" line
- (E) Approx. 1.0 ℓ (1.1 US qt, 0.9 Imp qt)
- (F) Notch mark

### B: REPLACEMENT

#### CAUTION:

If the engine oil is spilt over exhaust pipe or the under cover, wipe it off with cloth to avoid emitting smoke or causing a fire.

- 1) Open the engine oil filler cap for quick draining of engine oil.
- 2) Lift up the vehicle.
- 3) Drain engine oil by loosening the engine oil drain plug.

#### NOTE:

Prepare the container for draining of engine oil.

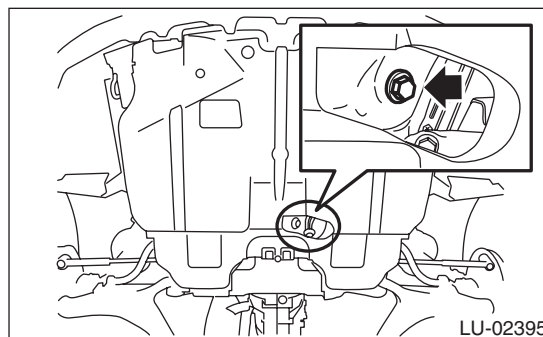

- 4) Tighten the engine oil drain plug after draining engine oil.

#### NOTE:

Use a new drain plug gasket.

#### Tightening torque:

**44 N·m (4.5 kgf·m, 32.5 ft·lb)**

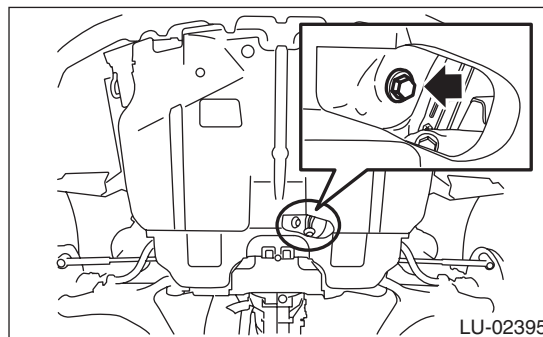

- 5) Lower the vehicle.
- 6) Using engine oil of proper quality and viscosity, fill engine oil through the filler duct to the "F" line on the oil level gauge. Make sure that the vehicle is parked on a level surface when checking oil level.

#### Recommended oil:

Refer to "SPECIFICATION" for recommended oil. <Ref. to LU(STI)-2, SPECIFICATION, General Description.>

#### Engine oil capacity:

Refer to "SPECIFICATION" for engine oil capacity. <Ref. to LU(STI)-2, SPECIFICATION, General Description.>

- 7) Close the engine oil filler cap.

# Engine Oil

## LUBRICATION

---

8) Start the engine to circulate the oil in engine room.

9) After stopping the engine, recheck the oil level. If necessary, add engine oil up to the "F" line on oil level gauge.

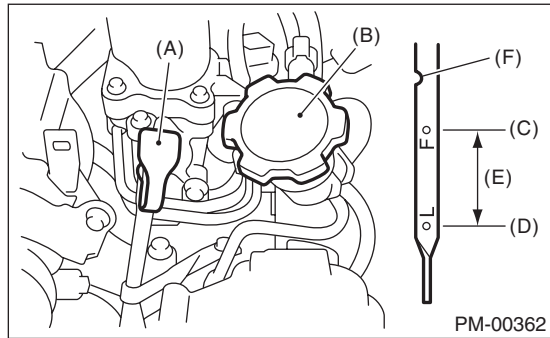

- (A) Oil level gauge
- (B) Engine oil filler cap
- (C) "F" line
- (D) "L" line
- (E) Approx. 1.0 ℓ (1.1 US qt, 0.9 Imp qt)
- (F) Notch mark

## 4. Oil Pump

### A: REMOVAL

1) Disconnect the ground cable from battery.

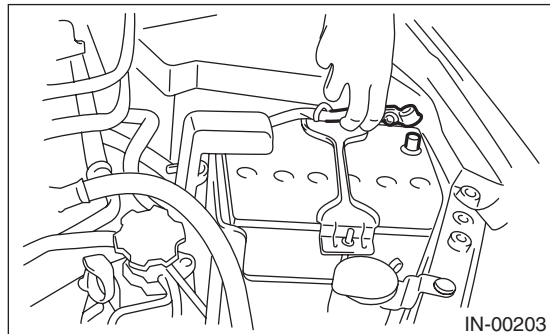

2) Remove the radiator. <Ref. to CO(STI)-19, REMOVAL, Radiator.> <Ref. to CO(w/o STI)-19, REMOVAL, Radiator.>

3) Lift up the vehicle.

4) Remove the bolt (B) which secures oil cooler pipe (A) to oil pump. (Model with oil cooler)

5) Remove the oil cooler pipe (A) and hose (C). (Model with oil cooler)

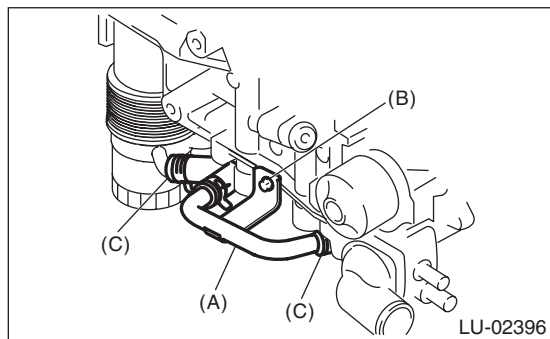

6) Lower the vehicle.

7) Remove the crankshaft position sensor.

<Ref. to FU(STI)-35, REMOVAL, Crankshaft Position Sensor.> <Ref. to FU(w/o STI)-36, REMOVAL, Crankshaft Position Sensor.>

8) Remove the water pump. <Ref. to CO(STI)-15, REMOVAL, Water Pump.> <Ref. to CO(w/o STI)-15, REMOVAL, Water Pump.>

9) Remove the crank sprocket. <Ref. to ME(STI)-60, REMOVAL, Crank Sprocket.> <Ref. to ME(w/o STI)-59, REMOVAL, Crank Sprocket.>

10) Remove the bolts which install oil pump onto cylinder block.

#### NOTE:

When disassembling and checking the oil pump, loosen the relief valve plug before removing the oil pump.

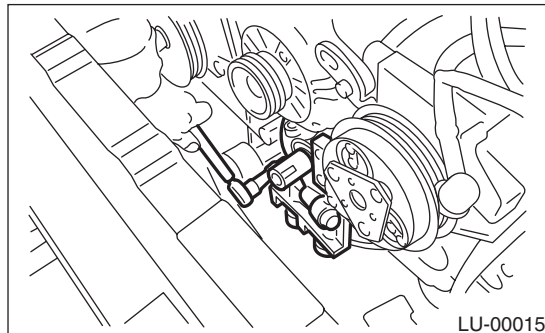

11) Remove the oil pump by using flat tip screwdriver.

#### CAUTION:

Be careful not to scratch mating surfaces of cylinder block and oil pump.

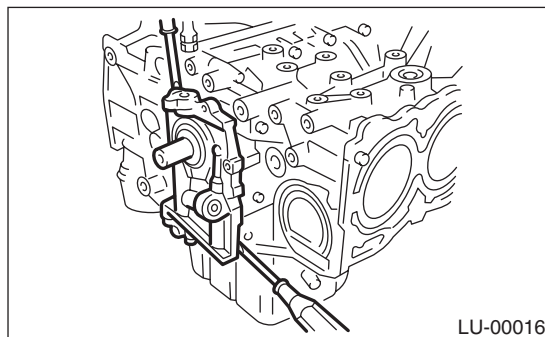

12) Remove the front oil seal from the oil pump.



# Oil Pump

## LUBRICATION

### B: INSTALLATION

1) Using the ST, install the front oil seal.  
ST 499587100 OIL SEAL INSTALLER

NOTE:

Use a new front oil seal.

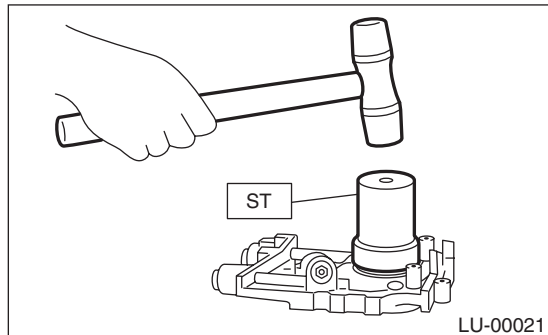

2) Apply liquid gasket to the mating surfaces of oil pump.

NOTE:

Install within 5 min. after applying liquid gasket.

**Liquid gasket:**

**THREE BOND 1217G (Part No. K0877Y0100)  
or equivalent**

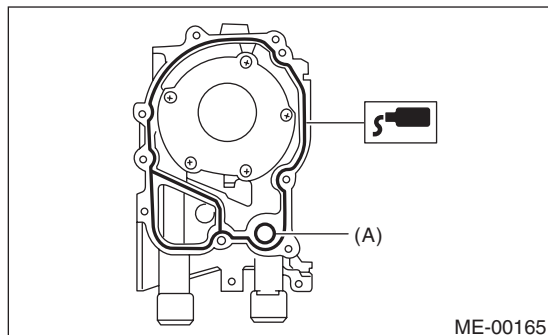

(A) O-ring

3) Apply a coat of engine oil to the inside of front oil seal.

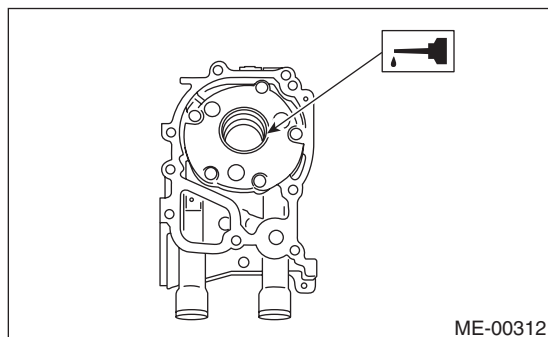

4) Install the oil pump to cylinder block.

**CAUTION:**

- Be careful not to damage the front oil seal during installation.
- Make sure the front oil seal lip is not folded.

NOTE:

- Align the flat surface of oil pump's inner rotor with that of crankshaft before installation.
  - Use new O-rings.
  - Do not forget to install O-rings.
- 5) Apply liquid gasket to the three bolts thread shown in figure. (when reusing bolts)

**Liquid gasket:**

**THREE BOND 1324 (Part No. 004403042) or equivalent**

**Tightening torque:**

**6.4 N-m (0.7 kgf-m, 4.7 ft-lb)**

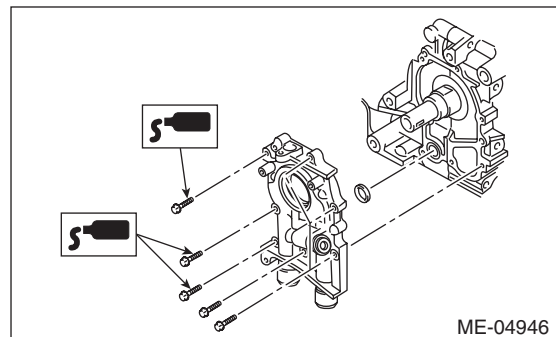

6) Install the crank sprocket. <Ref. to ME(STI)-60, INSTALLATION, Crank Sprocket.> <Ref. to ME(w/o STI)-59, INSTALLATION, Crank Sprocket.>

7) Install the water pump. <Ref. to CO(STI)-15, INSTALLATION, Water Pump.> <Ref. to CO(w/o STI)-15, INSTALLATION, Water Pump.>

8) Install the crankshaft position sensor. <Ref. to FU(STI)-35, INSTALLATION, Crankshaft Position Sensor.> <Ref. to FU(w/o STI)-36, INSTALLATION, Crankshaft Position Sensor.>

9) Lift up the vehicle.

10) Install oil cooler pipe (A) and hose (C). (Model with oil cooler)

11) Install the oil cooler pipe (A) to oil pump using the bolts (B). (Model with oil cooler)

**Tightening torque:**

**6.4 N-m (0.7 kgf-m, 4.7 ft-lb)**

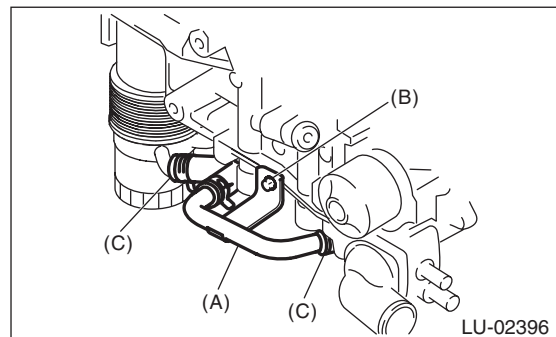

12) Lower the vehicle.

13) Install the radiator. <Ref. to CO(STI)-20, INSTALLATION, Radiator.> <Ref. to CO(w/o STI)-20, INSTALLATION, Radiator.>

**LU(STI)-14**

Brought to you by Ebay Seller "SubaruManuals"

14) Connect the battery ground terminal.

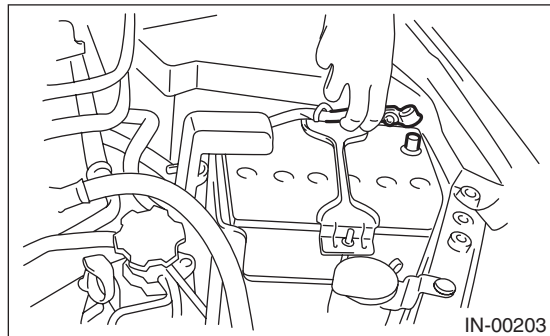

## C: DISASSEMBLY

Remove the screw which secures oil pump cover and then disassemble oil pump. Inscribe alignment marks on the inner rotor and outer rotor so that they can be replaced in their original positions during re-assembly.

### NOTE:

Before disassembling the oil pump, remove the relief valve.

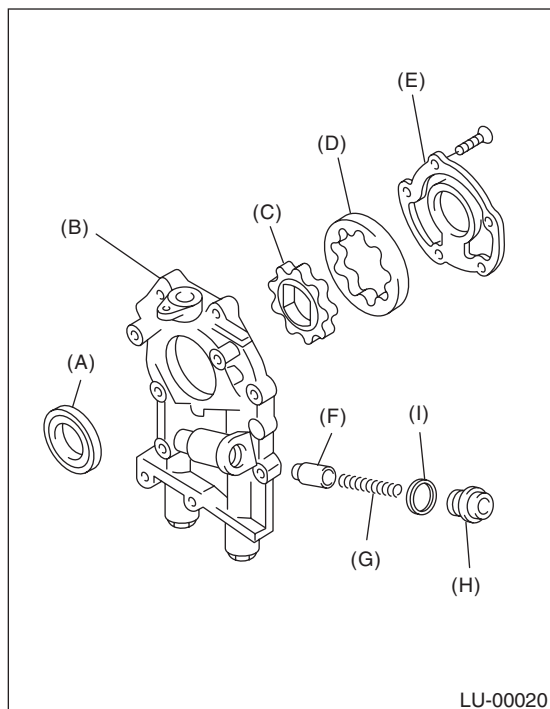

- (A) Front oil seal
- (B) Oil pump case
- (C) Inner rotor
- (D) Outer rotor
- (E) Oil pump cover
- (F) Relief valve
- (G) Relief valve spring
- (H) Plug
- (I) Gasket

## D: ASSEMBLY

1) Using the ST, install the front oil seal.  
ST 499587100 OIL SEAL INSTALLER

### NOTE:

Use a new front oil seal.

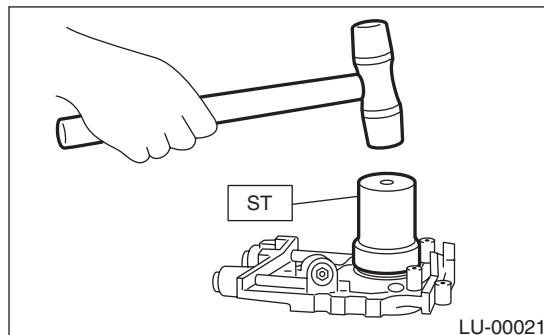

2) Apply a coat of engine oil to the inner rotor and outer rotor.

3) Install the inner rotor and outer rotor.

4) Assemble the oil relief valve and install relief valve spring and plug.

### NOTE:

Use a new gasket.

# Oil Pump

## LUBRICATION

5) Install the oil pump cover.

### Tightening torque:

**T1: 5.4 N·m (0.6 kgf-m, 4.0 ft-lb)**

**T2: 44 N·m (4.5 kgf-m, 32.5 ft-lb)**

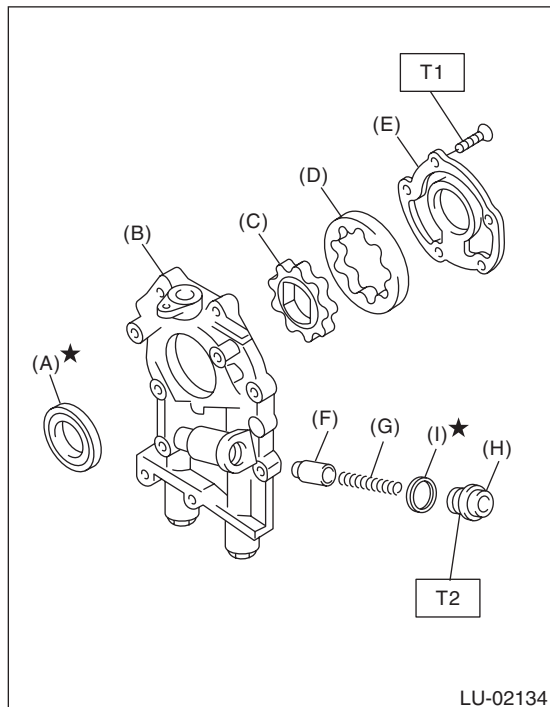

- (A) Front oil seal
- (B) Oil pump case
- (C) Inner rotor
- (D) Outer rotor
- (E) Oil pump cover
- (F) Relief valve
- (G) Relief valve spring
- (H) Plug
- (I) Gasket

## E: INSPECTION

### 1. TIP CLEARANCE

Measure the tip clearance of rotors. If the clearance is out of standard, replace the rotors as a set.

**Tip clearance between inner and outer rotors:**

**Standard**

**0.04 — 0.14 mm (0.0016 — 0.0055 in)**

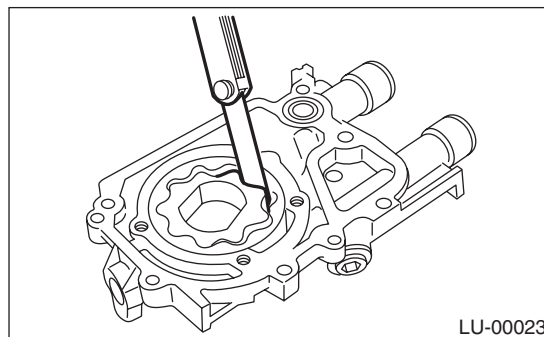

### 2. CASE CLEARANCE

Measure the clearance between outer rotor and oil pump case. If clearance exceeds the standard, replace the oil pump case.

**Case clearance between outer rotor and pump case:**

**Standard**

**0.10 — 0.175 mm (0.0039 — 0.0069 in)**

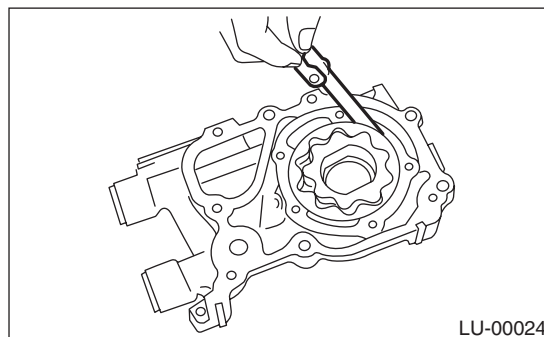

### 3. SIDE CLEARANCE

Measure the gap between the inner rotor and the oil pump case to measure the clearance between the inner rotor and the oil pump cover as shown in the figure. If clearance is out of standard, replace the rotor or the oil pump case.

**Side clearance between inner rotor and pump case:**

**Standard**

**0.02 — 0.07 mm (0.0008 — 0.0028 in)**

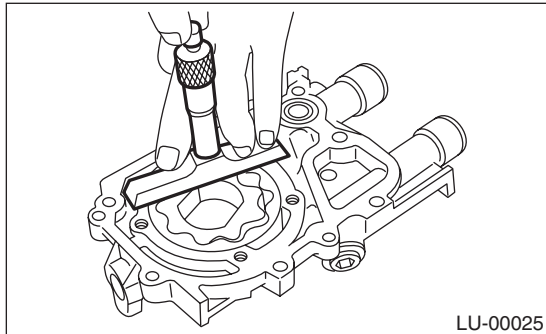

### 4. OIL RELIEF VALVE

Check the valve for assembly condition and damage, and the relief valve spring for damage and deterioration.

Replace the parts if defective.

**Relief valve spring:**

**Free length**

**73.7 mm (2.902 in)**

**Installed length**

**54.7 mm (2.154 in)**

**Load when installed**

**93.1 N (9.49 kgf, 20.93 lbf)**

### 5. OIL PUMP CASE

Check for worn shaft hole, clogged oil passage, worn rotor chamber, cracks and other faults.

### 6. FRONT OIL SEAL

Check the front oil seal lips for deformation, hardening, wear, etc. and replace if defective.

# Oil Pan and Strainer

## LUBRICATION

### 5. Oil Pan and Strainer

#### A: REMOVAL

1) Disconnect the ground cable from battery.

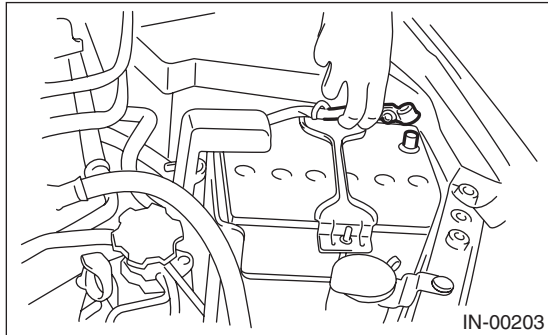

2) Remove the air intake duct. <Ref. to IN(STI)-10, REMOVAL, Air Intake Duct.> <Ref. to IN(w/o STI)-10, REMOVAL, Air Intake Duct.>

3) Remove the air intake boot.

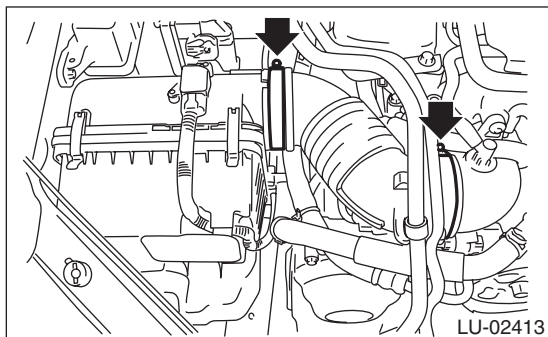

4) Remove the intercooler. <Ref. to IN(STI)-12, REMOVAL, Intercooler.> <Ref. to IN(w/o STI)-12, REMOVAL, Intercooler.>

5) Remove the pitching stopper.

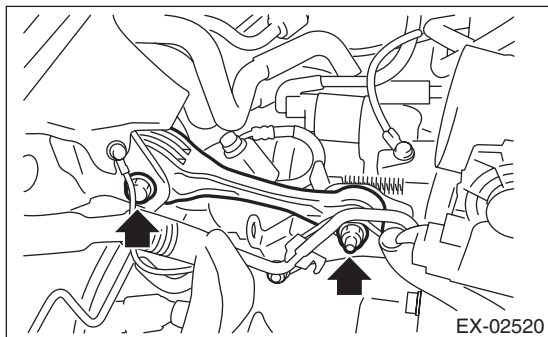

6) Remove the radiator upper brackets.

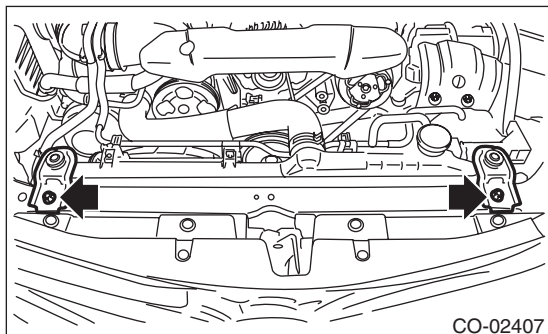

7) Support the engine with a lifting device and wire ropes.

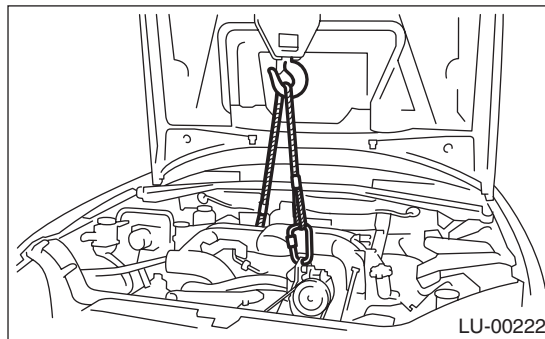

8) Lift up the vehicle.

#### CAUTION:

**When lifting up the vehicle, raise up wire ropes at the same time.**

9) Remove the under cover. <Ref. to EI-28, REMOVAL, Front Under Cover.>

10) Drain the engine oil. <Ref. to LU(STI)-11, REPLACEMENT, Engine Oil.>

11) Remove the front exhaust pipe. <Ref. to EX(STI)-6, REMOVAL, Front Exhaust Pipe.>

12) Remove the nuts which secure the engine mounting to the front crossmember.

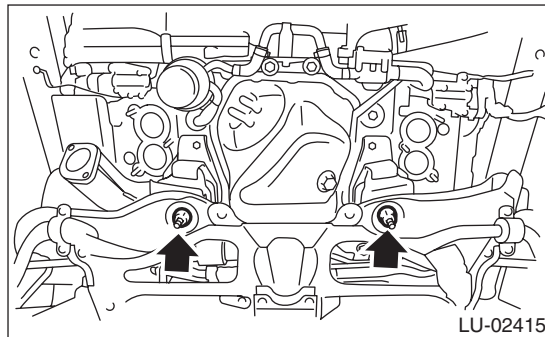

13) Remove the bolts which secure oil pan on cylinder block with the engine raised up.

14) Insert an oil pan cutter blade between cylinder block-to-oil pan clearance and remove the oil pan.

#### CAUTION:

**Do not use a screwdriver or similar tool in place of oil pan cutter.**

15) Remove the oil strainer.

16) Remove the baffle plate.

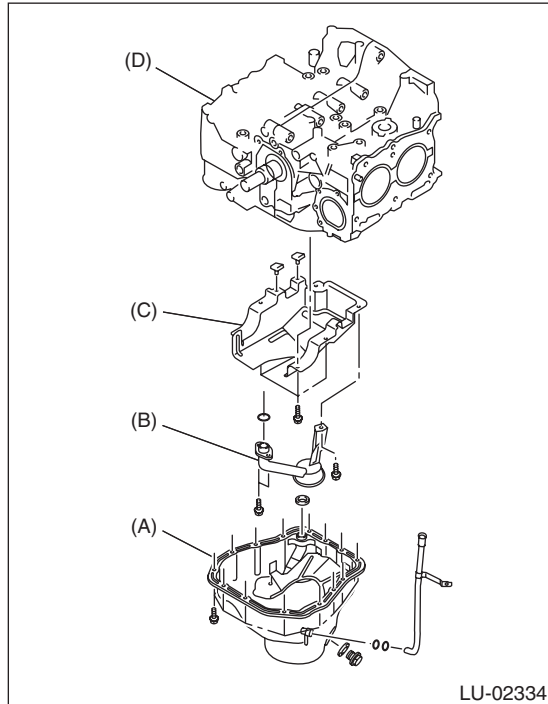

- (A) Oil pan
- (B) Oil strainer
- (C) Baffle plate
- (D) Cylinder block

LU-02334

3) Install the oil strainer to cylinder block.

NOTE:  
Use new O-rings.

**Tightening torque:**  
**10 N·m (1.0 kgf-m, 7.4 ft-lb)**

4) Tighten the oil strainer stay together with the baffle plate.

**Tightening torque:**  
**6.4 N·m (0.7 kgf-m, 4.7 ft-lb)**

5) Apply liquid gasket to the mating surfaces of oil pan, and install the oil pan.

NOTE:

- Use a new gasket.
- Install within 5 min. after applying liquid gasket.

**Liquid gasket:**  
**THREE BOND 1217G (Part No. K0877Y0100)**  
**or equivalent**

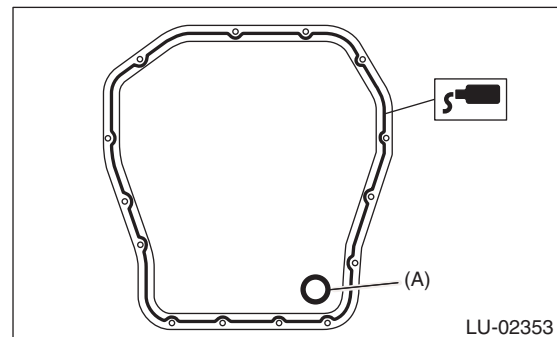

(A) Gasket

LU-02353

## B: INSTALLATION

NOTE:

Before installing the oil pan, clean the mating surface of oil pan and engine block.

1) Make sure that the seals (A) are installed securely on the baffle plate in a direction as shown in the figure below.

NOTE:

Use a new seal.

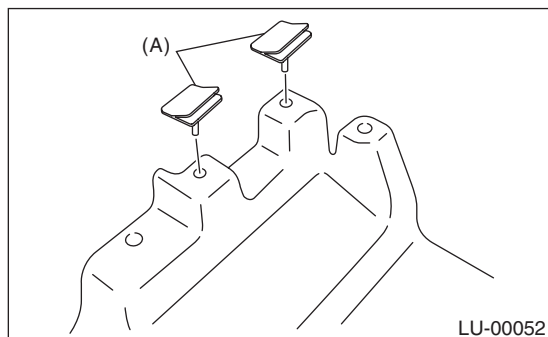

LU-00052

2) Install the baffle plate.

**Tightening torque:**  
**6.4 N·m (0.7 kgf-m, 4.7 ft-lb)**



# Oil Pan and Strainer

## LUBRICATION

6) Tighten the bolts which install oil pan to cylinder block.

### Tightening torque:

**T1: 5 N·m (0.5 kgf-m, 3.7 ft-lb)**

**T2: 6.4 N·m (0.7 kgf-m, 4.7 ft-lb)**

**T3: 10 N·m (1.0 kgf-m, 7.4 ft-lb)**

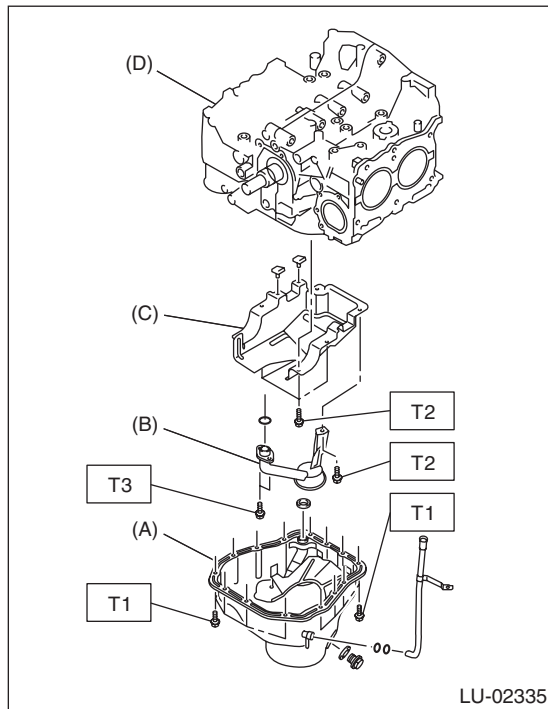

- (A) Oil pan
- (B) Oil strainer
- (C) Baffle plate
- (D) Cylinder block

7) Lower the engine onto front crossmember.

8) Install the nuts which hold the engine mounting to the front crossmember.

### Tightening torque:

**85 N·m (8.7 kgf-m, 62.7 ft-lb)**

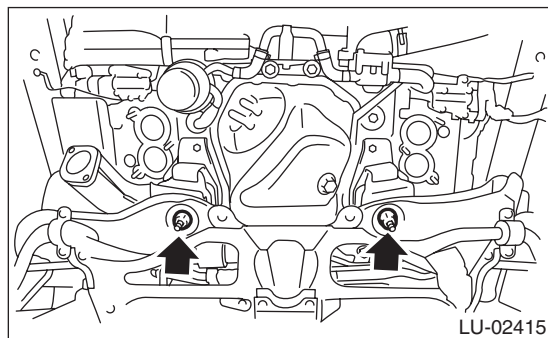

9) Install the front exhaust pipe. <Ref. to EX(STI)-6, INSTALLATION, Front Exhaust Pipe.>

10) Install the under cover. <Ref. to EI-28, INSTALLATION, Front Under Cover.>

11) Lower the vehicle.

### CAUTION:

When lowering the vehicle, lower the lift up device and wire ropes at the same time.

12) Remove the lifting device and wire ropes.

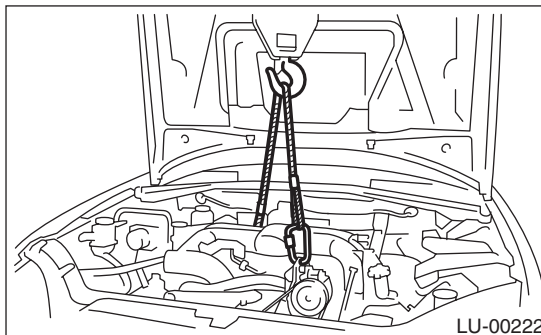

13) Install the pitching stopper.

### Tightening torque:

**T1: 50 N·m (5.1 kgf-m, 36.9 ft-lb)**

**T2: 58 N·m (5.9 kgf-m, 42.8 ft-lb)**

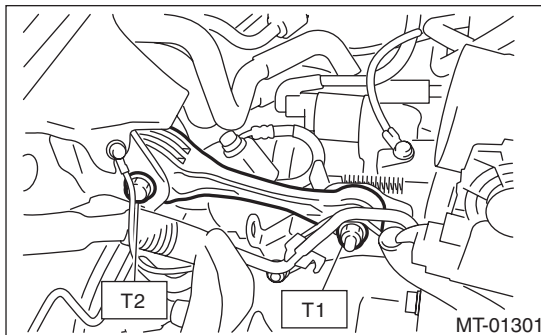

14) Install the radiator upper brackets.

### Tightening torque:

**12 N·m (1.2 kgf-m, 8.9 ft-lb)**

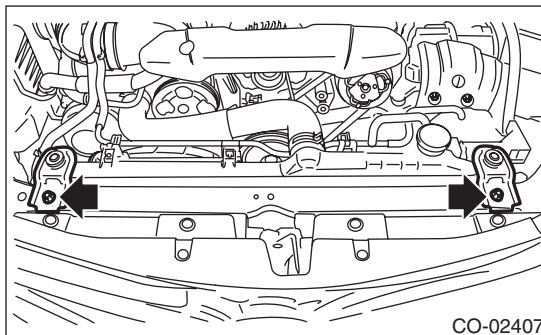

15) Install the intercooler. <Ref. to IN(STI)-13, INSTALLATION, Intercooler.> <Ref. to IN(w/o STI)-12, INSTALLATION, Intercooler.>

16) Install the air intake boot.

**Tightening torque:**

**2.5 N·m (0.3 kgf-m, 1.8 ft-lb)**

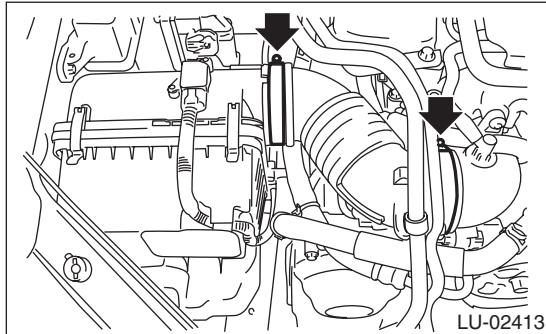

17) Install the air intake duct. <Ref. to IN(STI)-10, INSTALLATION, Air Intake Duct.> <Ref. to IN(w/o STI)-10, INSTALLATION, Air Intake Duct.>

18) Connect the battery ground terminal.

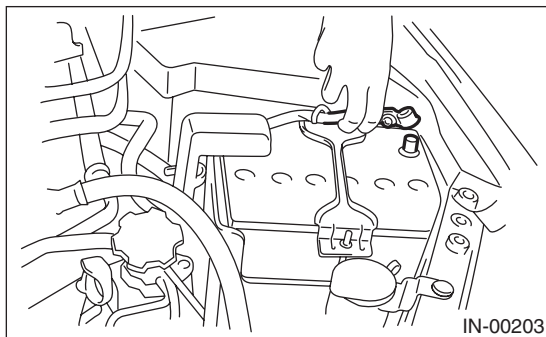

19) Refill the engine oil. <Ref. to LU(STI)-11, INSPECTION, Engine Oil.>

## **C: INSPECTION**

Check that the oil pan, oil strainer and baffle plate do not have deformation, cracks or damage.



# Oil Pressure Switch

LUBRICATION

## 6. Oil Pressure Switch

### A: REMOVAL

- 1) Disconnect the ground cable from battery.

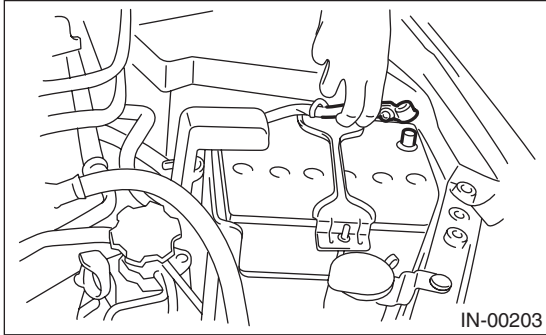

- 2) Remove the generator from the bracket. <Ref. to SC(STI)-21, REMOVAL, Generator.>
- 3) Disconnect the terminal from oil pressure switch.

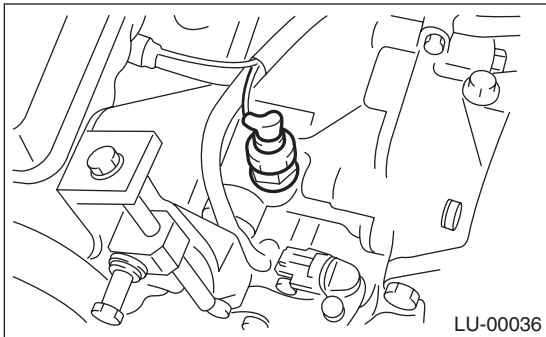

- 4) Remove the oil pressure switch.

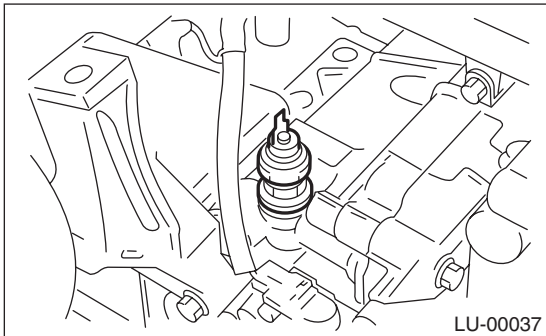

### B: INSTALLATION

- 1) Apply liquid gasket to the oil pressure switch threads.

**Liquid gasket:**

**THREE BOND 1324 (Part No. 004403042) or equivalent**

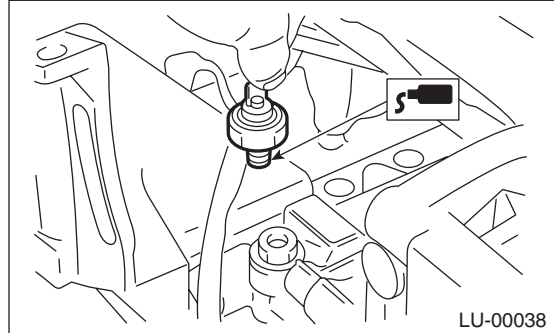

- 2) Install the oil pressure switch to cylinder block.

**Tightening torque:**

**25 N·m (2.5 kgf·m, 18.4 ft·lb)**

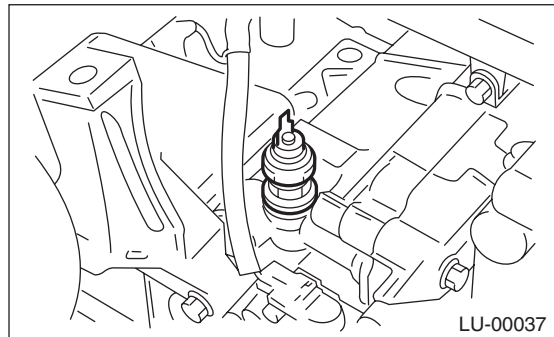

- 3) Connect the terminal to the oil pressure switch.

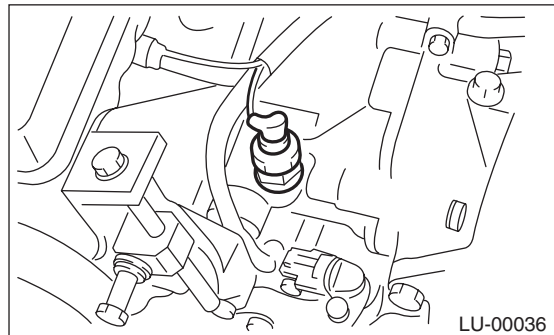

- 4) Install the generator to the bracket. <Ref. to SC(STI)-21, INSTALLATION, Generator.>

**LU(STI)-22**

Brought to you by Ebay Seller "SubaruManuals"

5) Connect the ground cable to battery.

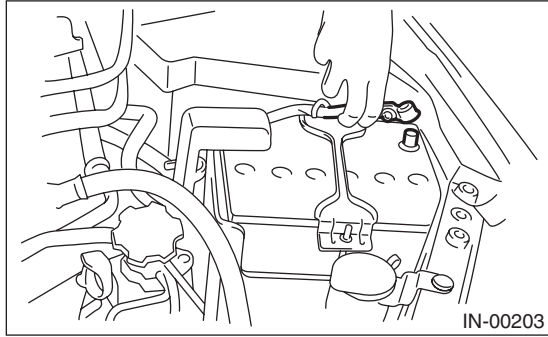

## C: INSPECTION

- 1) Check that the oil pressure switch does not have deformation, cracks or damage.
- 2) Check the oil pressure switch installation portion for oil leakage and oil seepage.

# Engine Oil Cooler

LUBRICATION

## 7. Engine Oil Cooler

### A: REMOVAL

#### CAUTION:

If engine oil is spilt onto the exhaust pipe, wipe it off with cloth to avoid emission of smoke or causing a fire.

#### NOTE:

STI model is equipped with engine oil cooler.

- 1) Lift up the vehicle.
- 2) Remove the under cover. <Ref. to EI-28, REMOVAL, Front Under Cover.>
- 3) Drain engine coolant. <Ref. to CO(STI)-13, DRAINING OF ENGINE COOLANT, REPLACEMENT, Engine Coolant.>
- 4) Remove the engine oil filter. <Ref. to LU(STI)-32, REMOVAL, Engine Oil Filter.>
- 5) Remove the bolt (B) holding the oil cooler pipe (A) to the oil pump.
- 6) Remove the oil cooler pipe (A), oil cooler hose A (C), oil cooler hose B (H), and oil cooler hose C (I).
- 7) Remove the oil cooler connector (D) and oil cooler (E).

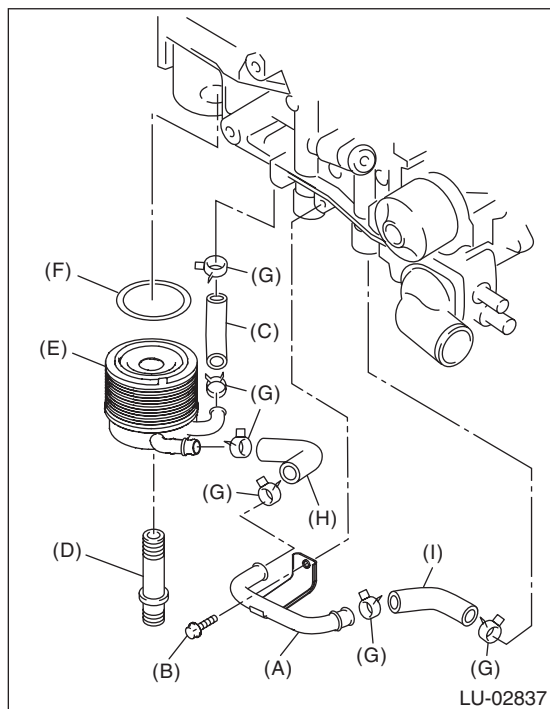

- (A) Oil cooler pipe
- (B) Bolt
- (C) Oil cooler hose A
- (D) Oil cooler connector
- (E) Oil cooler
- (F) Gasket
- (G) Clip
- (H) Oil cooler hose B
- (I) Oil cooler hose C

### B: INSTALLATION

Install in the reverse order of removal.

#### NOTE:

- Use a new gasket.
- After installing, check the engine oil level and replenish it if necessary. <Ref. to LU(STI)-11, INSPECTION, Engine Oil.>

#### Tightening torque:

**T1: 6.4 N·m (0.7 kgf·m, 4.7 ft·lb)**

**T2: 54 N·m (5.5 kgf·m, 39.8 ft·lb)**

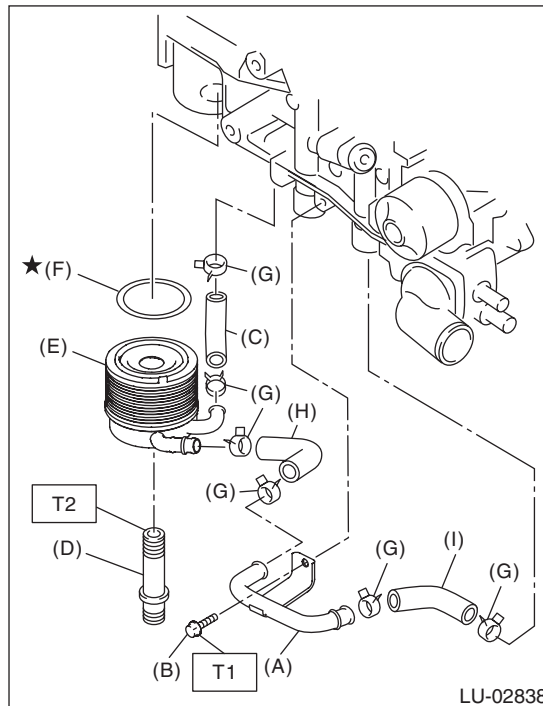

- (A) Oil cooler pipe
- (B) Bolt
- (C) Oil cooler hose A
- (D) Oil cooler connector
- (E) Oil cooler
- (F) Gasket
- (G) Clip
- (H) Oil cooler hose B
- (I) Oil cooler hose C

### C: INSPECTION

- 1) Check that the engine oil cooler, oil cooler pipe and oil cooler connector do not have deformation, cracks or damage.
- 2) Make sure the oil cooler hoses are not cracked, damaged or loose.
- 3) Blow with compressed air to make sure the coolant passages are not clogged.
- 4) Make sure the mating surfaces of the cylinder block do not have damage.

LU(STI)-24

Brought to you by Ebay Seller "SubaruManuals"

## 8. Oil Pipe

### A: REMOVAL

1) Disconnect the ground cable from battery.

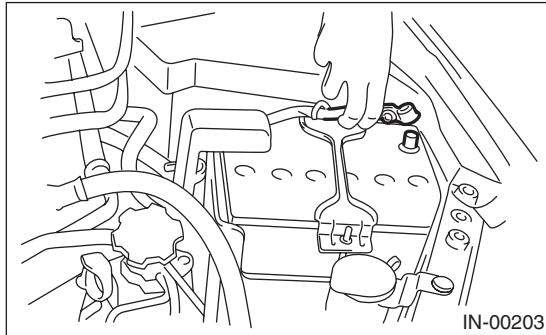

2) Remove the intercooler. <Ref. to IN(STI)-12, REMOVAL, Intercooler.> <Ref. to IN(w/o STI)-12, REMOVAL, Intercooler.>

3) Remove the turbocharger upper cover.

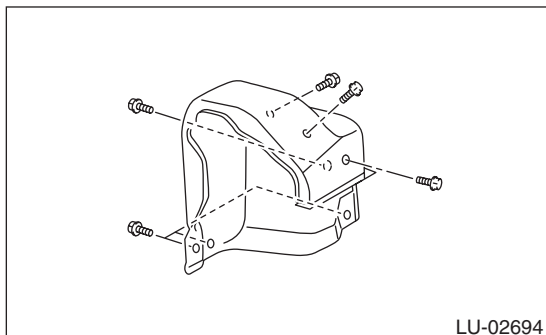

4) Remove the oil inlet pipe from the turbocharger.

#### CAUTION:

In order to prevent damaging the oil pipe on the cylinder head side, fix the section (a) shown in the figure when loosening the oil inlet pipe flare nut, and avoid the part from rotating together while loosening the nut.

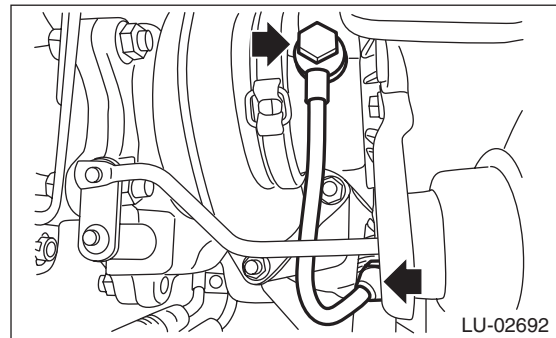
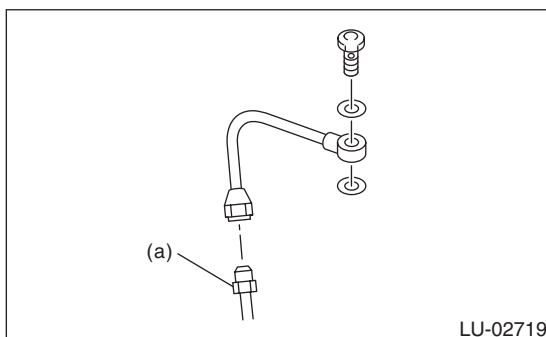

5) Remove the turbocharger stay.

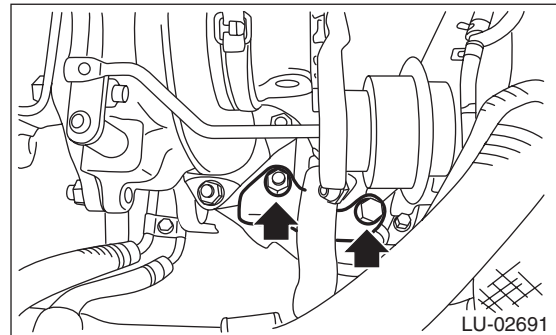

6) Remove the turbocharger oil pipe.

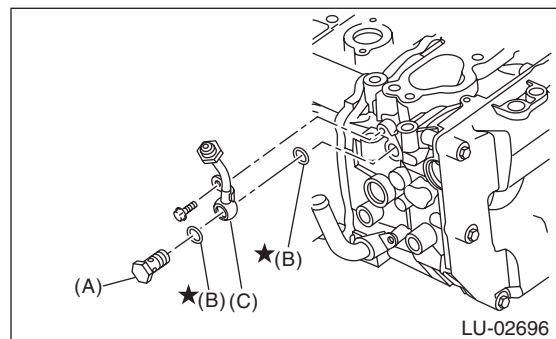

- (A) Union bolt without filter (without protrusion)
- (B) Gasket
- (C) Turbocharger oil pipe

7) Drain engine coolant. <Ref. to CO(STI)-13, DRAINING OF ENGINE COOLANT, REPLACEMENT, Engine Coolant.> <Ref. to CO(w/o STI)-13, DRAINING OF ENGINE COOLANT, REPLACEMENT, Engine Coolant.>

8) Remove the intake manifold. <Ref. to FU(STI)-17, REMOVAL, Intake Manifold.> <Ref. to FU(w/o STI)-18, REMOVAL, Intake Manifold.>

9) Remove the secondary air pump. (Oil pipe LH only) <Ref. to EC(STI)-27, REMOVAL, Secondary Air Pump.> <Ref. to EC(w/o STI)-29, REMOVAL, Secondary Air Pump.>

# Oil Pipe

## LUBRICATION

10) Remove the blow-by pipe and water pipe assembly. (Oil pipe RH only)

### NOTE:

Do not remove the vacuum hose, radiator inlet hose, and heater outlet hose.

- STI model

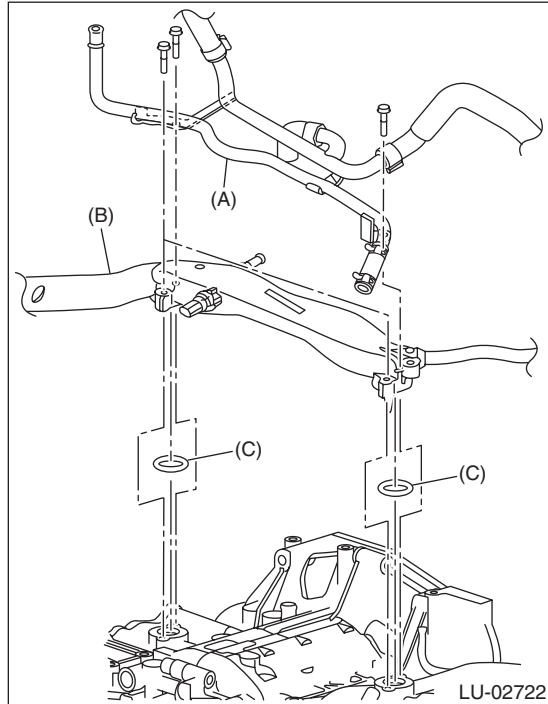

- (A) Water tank pipe ASSY
- (B) Water pipe ASSY
- (C) O-ring

- Except for STI model

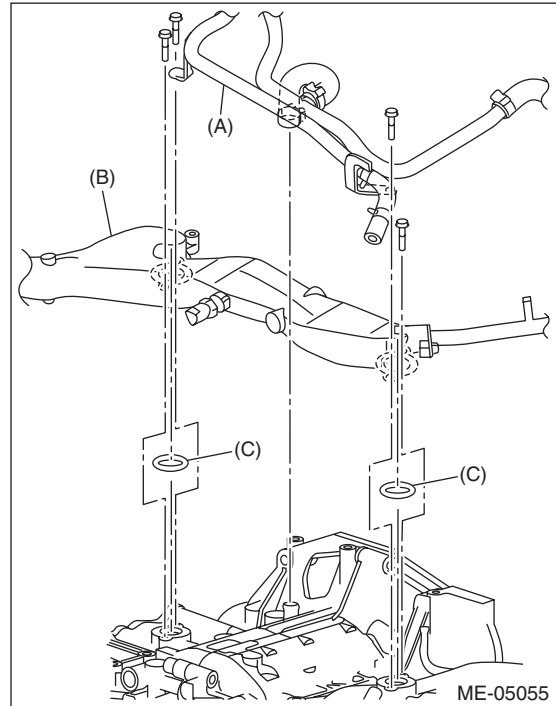

- (A) Water tank pipe ASSY
- (B) Water pipe ASSY
- (C) O-ring

11) Remove the radiator main fan and radiator sub fan. <Ref. to CO(STI)-23, REMOVAL, Radiator Main Fan and Fan Motor.> <Ref. to CO(STI)-25, REMOVAL, Radiator Sub Fan and Fan Motor.> <Ref. to CO(w/o STI)-23, REMOVAL, Radiator Main Fan and Fan Motor.> <Ref. to CO(w/o STI)-25, REMOVAL, Radiator Sub Fan and Fan Motor.>

12) Remove the V-belts. <Ref. to ME(STI)-40, REMOVAL, V-belt.> <Ref. to ME(w/o STI)-39, REMOVAL, V-belt.>

13) Remove the crank pulley. <Ref. to ME(STI)-47, REMOVAL, Crank Pulley.> <Ref. to ME(w/o STI)-46, REMOVAL, Crank Pulley.>

14) Remove the timing belt cover. <Ref. to ME(STI)-49, REMOVAL, Timing Belt Cover.> <Ref. to ME(w/o STI)-48, REMOVAL, Timing Belt Cover.>

15) Remove the timing belt. <Ref. to ME(STI)-50, REMOVAL, Timing Belt.> <Ref. to ME(w/o STI)-49, REMOVAL, Timing Belt.>

16) Remove the cam sprocket LH. <Ref. to ME(STI)-59, REMOVAL, Cam Sprocket.> <Ref. to ME(w/o STI)-58, REMOVAL, Cam Sprocket.>

17) Remove the timing belt cover No. 2 LH.

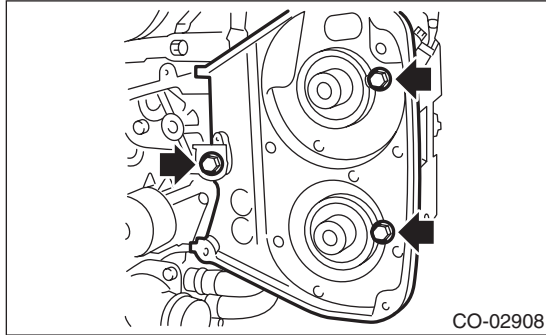

18) Remove the oil pipe.

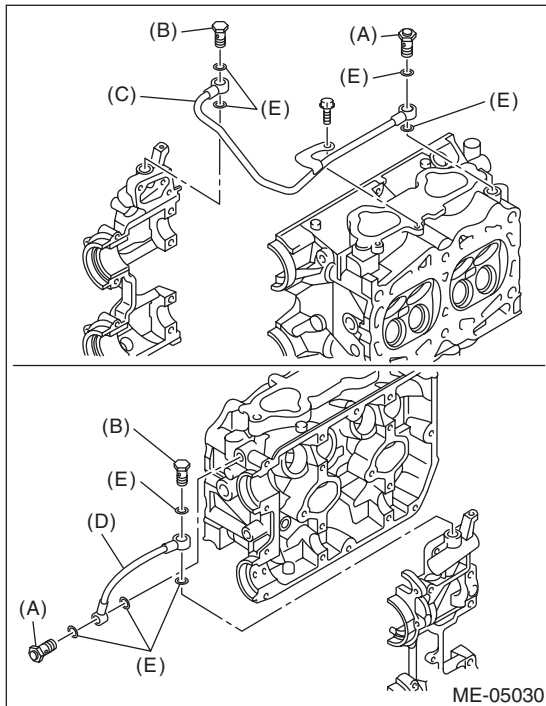

- (A) Union bolt with filter (with protrusion)
- (B) Union bolt without filter (without protrusion)
- (C) Oil pipe RH
- (D) Oil pipe LH
- (E) Gasket

## B: INSTALLATION

1) Inspect the union bolt with filter. <Ref. to LU(STI)-31, INSPECTING UNION BOLT WITH FILTER, INSPECTION, Oil Pipe.>

2) Install the oil pipe.

### NOTE:

- Be careful of the install location of the union bolt; the location will differ depending on the presence of filter.
- Use a new gasket.

### Tightening torque:

**T1: 6.4 N·m (0.7 kgf-m, 4.7 ft-lb)**

**T2: 29 N·m (3.0 kgf-m, 21.4 ft-lb)**

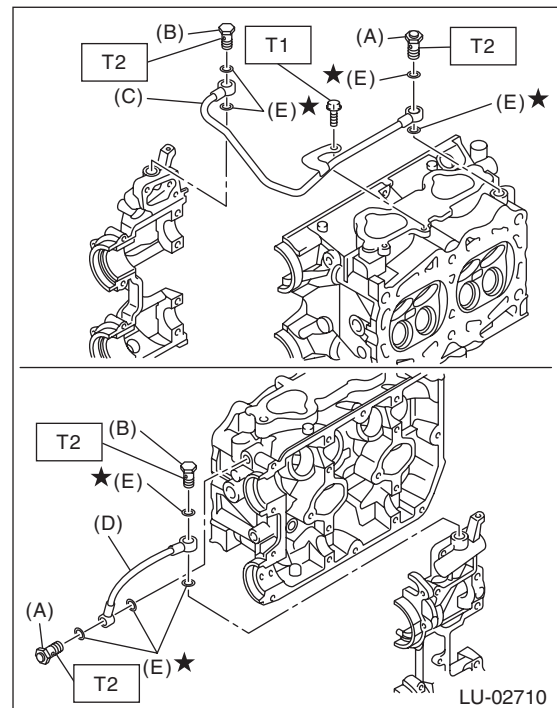

- (A) Union bolt with filter (with protrusion)
- (B) Union bolt without filter (without protrusion)
- (C) Oil pipe RH
- (D) Oil pipe LH
- (E) Gasket



# Oil Pipe

## LUBRICATION

3) Install the timing belt cover No. 2 LH.

**Tightening torque:**

**5 N·m (0.5 kgf·m, 3.7 ft·lb)**

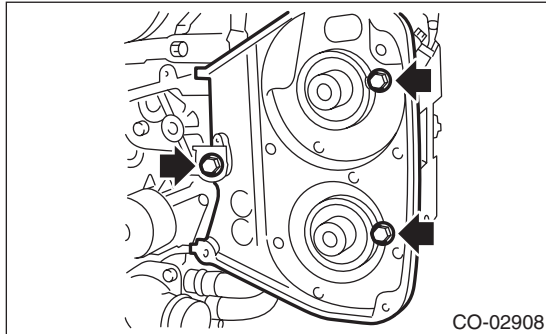

4) Install the cam sprocket LH. <Ref. to ME(STI)-59, INSTALLATION, Cam Sprocket.> <Ref. to ME(w/o STI)-58, INSTALLATION, Cam Sprocket.>

5) Install the timing belt. <Ref. to ME(STI)-53, TIMING BELT, INSTALLATION, Timing Belt.> <Ref. to ME(w/o STI)-52, TIMING BELT, INSTALLATION, Timing Belt.>

6) Install the timing belt cover. <Ref. to ME(STI)-49, INSTALLATION, Timing Belt Cover.> <Ref. to ME(w/o STI)-48, INSTALLATION, Timing Belt Cover.>

7) Install the crank pulley. <Ref. to ME(STI)-47, INSTALLATION, Crank Pulley.> <Ref. to ME(w/o STI)-46, INSTALLATION, Crank Pulley.>

8) Install the V-belts. <Ref. to ME(STI)-40, INSTALLATION, V-belt.> <Ref. to ME(w/o STI)-39, INSTALLATION, V-belt.>

9) Install the radiator main fan and the radiator sub fan. <Ref. to CO(STI)-23, INSTALLATION, Radiator Main Fan and Fan Motor.> <Ref. to CO(STI)-25, INSTALLATION, Radiator Sub Fan and Fan Motor.> <Ref. to CO(w/o STI)-23, INSTALLATION, Radiator Main Fan and Fan Motor.> <Ref. to CO(w/o STI)-25, INSTALLATION, Radiator Sub Fan and Fan Motor.>

10) Install the blow-by pipe and water pipe assembly. (Oil pipe RH only)

• STI model

**Tightening torque:**

**6.4 N·m (0.7 kgf·m, 4.7 ft·lb)**

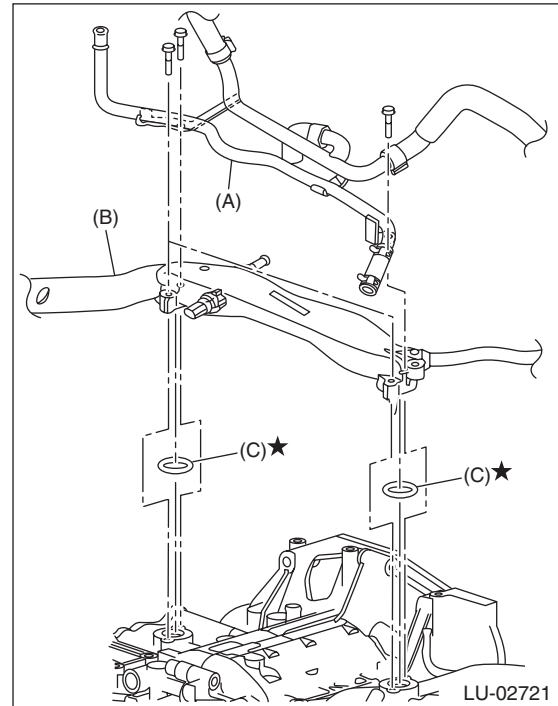

(A) Water tank pipe ASSY

(B) Water pipe ASSY

(C) O-ring

- Except for STI model

**Tightening torque:**

**6.5 N·m (0.7 kgf·m, 4.8 ft·lb)**

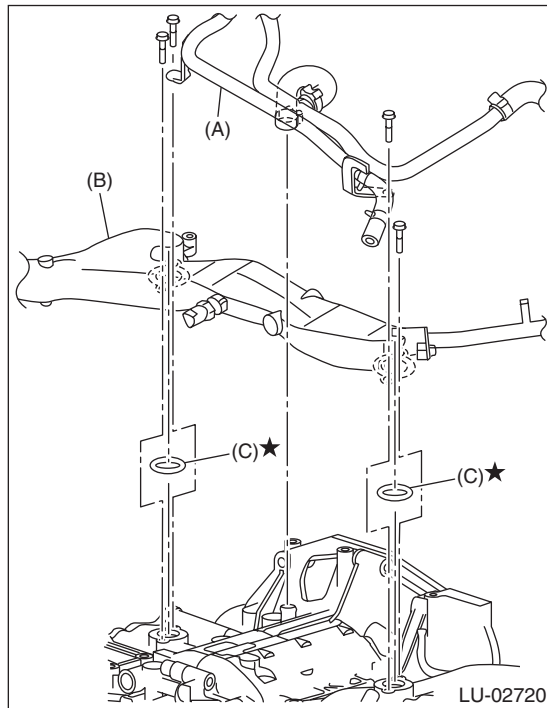

- (A) Water tank pipe ASSY
- (B) Water pipe ASSY
- (C) O-ring

11) Install the secondary air pump. (Oil pipe LH only) <Ref. to EC(STI)-27, INSTALLATION, Secondary Air Pump.> <Ref. to EC(w/o STI)-29, INSTALLATION, Secondary Air Pump.>

12) Install the intake manifold. <Ref. to FU(STI)-21, INSTALLATION, Intake Manifold.> <Ref. to FU(w/o STI)-22, INSTALLATION, Intake Manifold.>

13) Install the turbocharger oil pipe.

**Tightening torque:**

**T1: 6.4 N·m (0.7 kgf·m, 4.7 ft·lb)**

**T2: 29 N·m (3.0 kgf·m, 21.4 ft·lb)**

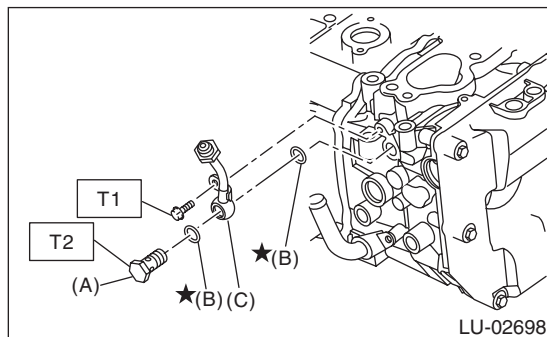

- (A) Union bolt without filter (without protrusion)
- (B) Gasket
- (C) Turbocharger oil pipe

14) Install the turbocharger stay.

**Tightening torque:**

**T1: 33 N·m (3.4 kgf·m, 24.3 ft·lb)**

**T2: 42.5 N·m (4.3 kgf·m, 31.3 ft·lb)**

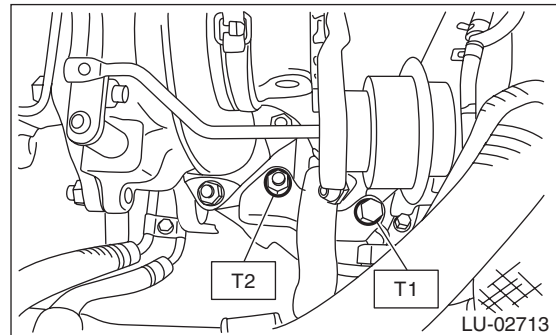

15) Temporarily tighten the bolts and flare nuts which secure the oil inlet pipe to the turbocharger.

**NOTE:**

Use a new gasket.

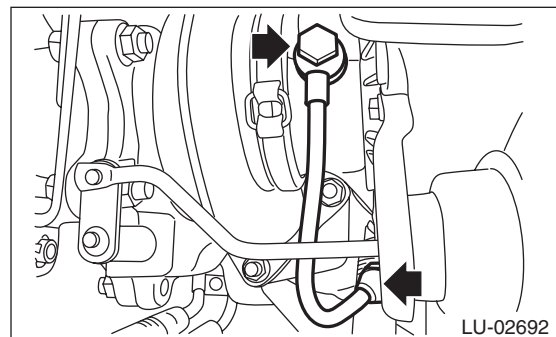



# Oil Pipe

## LUBRICATION

16) Tighten the union bolts and flare nuts which secure the oil inlet pipe to the turbocharger.

### CAUTION:

In order to prevent damaging the oil pipe on the cylinder head side, fix the section (a) shown in the figure when tightening the oil inlet pipe flare nut, and avoid the part from rotating together while tightening the nut.

### Tightening torque:

**T1: 16 N·m (1.6 kgf-m, 11.8 ft-lb)**

**T2: 20 N·m (2.0 kgf-m, 14.8 ft-lb)**

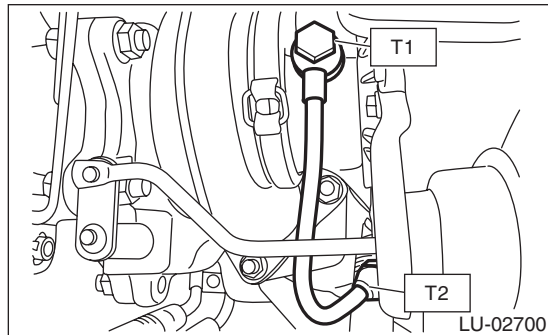
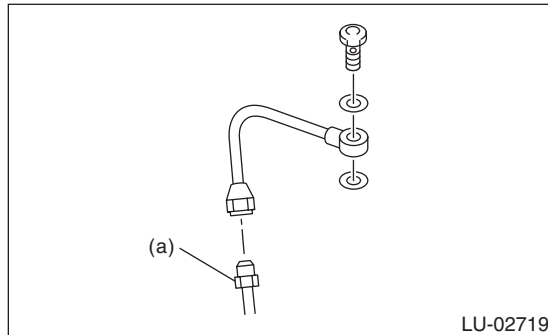

17) Attach the turbocharger upper cover.

### Tightening torque:

**7.5 N·m (0.8 kgf-m, 5.5 ft-lb)**

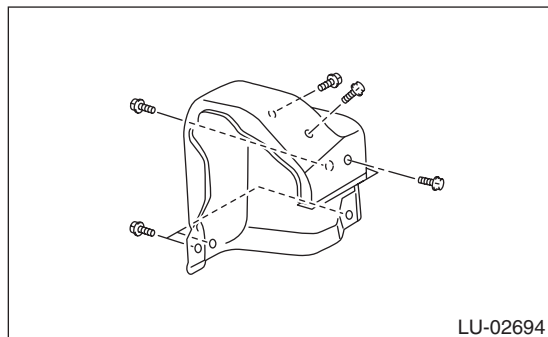

18) Install the intercooler. <Ref. to IN(STI)-13, INSTALLATION, Intercooler.> <Ref. to IN(w/o STI)-12, INSTALLATION, Intercooler.>

19) Connect the battery ground terminal.

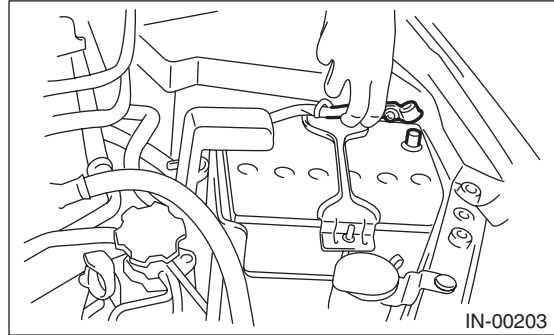

20) Fill engine coolant. <Ref. to CO(STI)-13, FILLING OF ENGINE COOLANT, REPLACEMENT, Engine Coolant.> <Ref. to CO(w/o STI)-13, FILLING OF ENGINE COOLANT, REPLACEMENT, Engine Coolant.>

## C: INSPECTION

### 1. INSPECTING UNION BOLT WITH FILTER

Check the filter part of union bolt for clogging or damage, and if defective, replace the union bolt with filter with the new part.

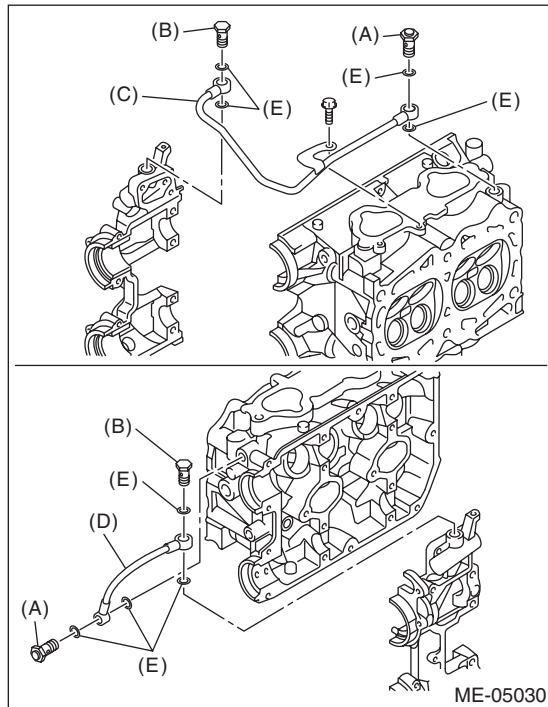

- (A) Union bolt with filter (with protrusion)
- (B) Union bolt without filter (without protrusion)
- (C) Oil pipe RH
- (D) Oil pipe LH
- (E) Gasket

### 2. OTHER INSPECTIONS

- 1) Check that the oil pipe and union bolt have no deformation, cracks and other damages.
- 2) Check that there are no oil leaks or oil oozing from the oil pipe attachment section.

# Engine Oil Filter

## LUBRICATION

### 9. Engine Oil Filter

#### A: REMOVAL

##### CAUTION:

If the engine oil is spilt over exhaust pipe or the under cover, wipe it off with cloth to avoid emitting smoke or causing a fire.

- 1) Lift up the vehicle.
- 2) Remove the under cover. <Ref. to EI-28, REMOVAL, Front Under Cover.>
- 3) Remove the oil filter.

- Oil filter (Black)

Remove using the ST.

ST 18332AA000 OIL FILTER WRENCH (OUTER DIAMETER: 68 MM (2.68 IN) FOR OIL FILTER)

- Oil filter (Blue)

Remove using a general tool (65/67 mm 14 Flutes).

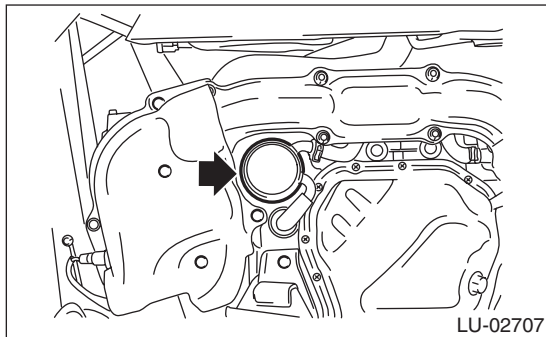

#### B: INSTALLATION

##### CAUTION:

Do not tighten excessively, or oil may leak.

- 1) Clean the oil filter installation surface on cylinder block or oil cooler.
- 2) Obtain a new oil filter and apply a thin coat of engine oil to the seal rubber.
- 3) Install the oil filter turning it by hand, being careful not to damage the seal rubber of the oil filter.
  - Tighten the oil filter (Black) with an outer diameter of 68 mm (2.68 in) (approx. 1 rotation) after the seal rubber of the oil filter comes in contact with the cylinder block or oil cooler. When using a torque wrench, tighten to 14 N·m (1.4 kgf-m, 10.3 ft-lb).
  - Tighten the oil filter (Blue) with an outer diameter of 67.4 mm (2.65 in) (approx. 7/8 rotation) after the seal rubber of the oil filter comes in contact with cylinder block or oil cooler. When using a torque wrench, tighten to 12 N·m (1.2 kgf-m, 8.9 ft-lb).
- 4) Install the under cover. <Ref. to EI-28, INSTALLATION, Front Under Cover.>
- 5) Lower the vehicle.
- 6) After installing, check the engine oil level and replenish it if necessary. <Ref. to LU(STI)-11, INSPECTION, Engine Oil.>

#### C: INSPECTION

- 1) After installing the oil filter, run the engine and check for oil leakage around seal rubber.

##### NOTE:

The filter element and filter case are permanently jointed; therefore, interior cleaning is not necessary.

- 2) Check the engine oil level. <Ref. to LU(STI)-11, INSPECTION, Engine Oil.>

## 10.Engine Lubrication System Trouble in General

### A: INSPECTION

Before performing diagnostics, make sure that the engine oil level is correct and no oil leakage exists.

Trouble	Possible cause	Corrective action
Warning light remains ON.	a. Oil pressure switch failure	
	<input type="radio"/> Cracked diaphragm or oil leakage within switch	Replace.
	<input type="radio"/> Broken spring or seized contacts	Replace.
	b. Low oil pressure	
	<input type="radio"/> Clogging of oil filter	Replace.
	<input type="radio"/> Malfunction of oil by-pass valve in oil filter	Replace.
	<input type="radio"/> Malfunction of oil relief valve in oil pump	Clean or replace.
	<input type="radio"/> Clogged oil passage	Clean.
	<input type="radio"/> Excessive tip clearance and side clearance of oil pump rotor	Replace.
	<input type="radio"/> Clogged oil strainer or broken pipe	Clean or replace.
	c. No oil pressure	
	<input type="radio"/> Insufficient engine oil (degradation, etc.)	Replace.
	<input type="radio"/> Broken pipe of oil strainer	Replace.
	<input type="radio"/> Stuck oil pump rotor	Replace.
Warning light does not illuminate.	a. Malfunction of combination meter	Replace.
	b. Poor contact of switch contact points	Replace.
	c. Disconnection of wiring	Repair.
Warning light flickers momentarily.	a. Defective terminal contact	Repair.
	b. Defective wiring harness	Repair.
	c. Oil pressure switch failure	
	<input type="radio"/> Cracked diaphragm or oil leakage within switch	Replace.
	<input type="radio"/> Broken spring or seized contacts	Replace.
	d. Low oil pressure	
	<input type="radio"/> Clogging of oil filter	Replace.
	<input type="radio"/> Malfunction of oil by-pass valve in oil filter	Replace.
	<input type="radio"/> Malfunction of oil relief valve in oil pump	Clean or replace.
	<input type="radio"/> Clogged oil passage	Clean.
<input type="radio"/> Excessive tip clearance and side clearance of oil pump rotor	Replace.	
<input type="radio"/> Clogged oil strainer or broken pipe	Clean or replace.	

# Engine Lubrication System Trouble in General

LUBRICATION

---

**LU(STI)-34**

Brought to you by Ebay Seller "SubaruManuals"

# SPEED CONTROL SYSTEMS

# *SP(STI)*

---

	<b>Page</b>
1. General Description .....	2
2. Accelerator Pedal .....	4

# General Description

## SPEED CONTROL SYSTEMS

### 1. General Description

#### A: SPECIFICATION

Accelerator pedal	Stroke	At pedal pad	50 — 59 mm (1.97 — 2.32 in)
-------------------	--------	--------------	-----------------------------

#### B: COMPONENT

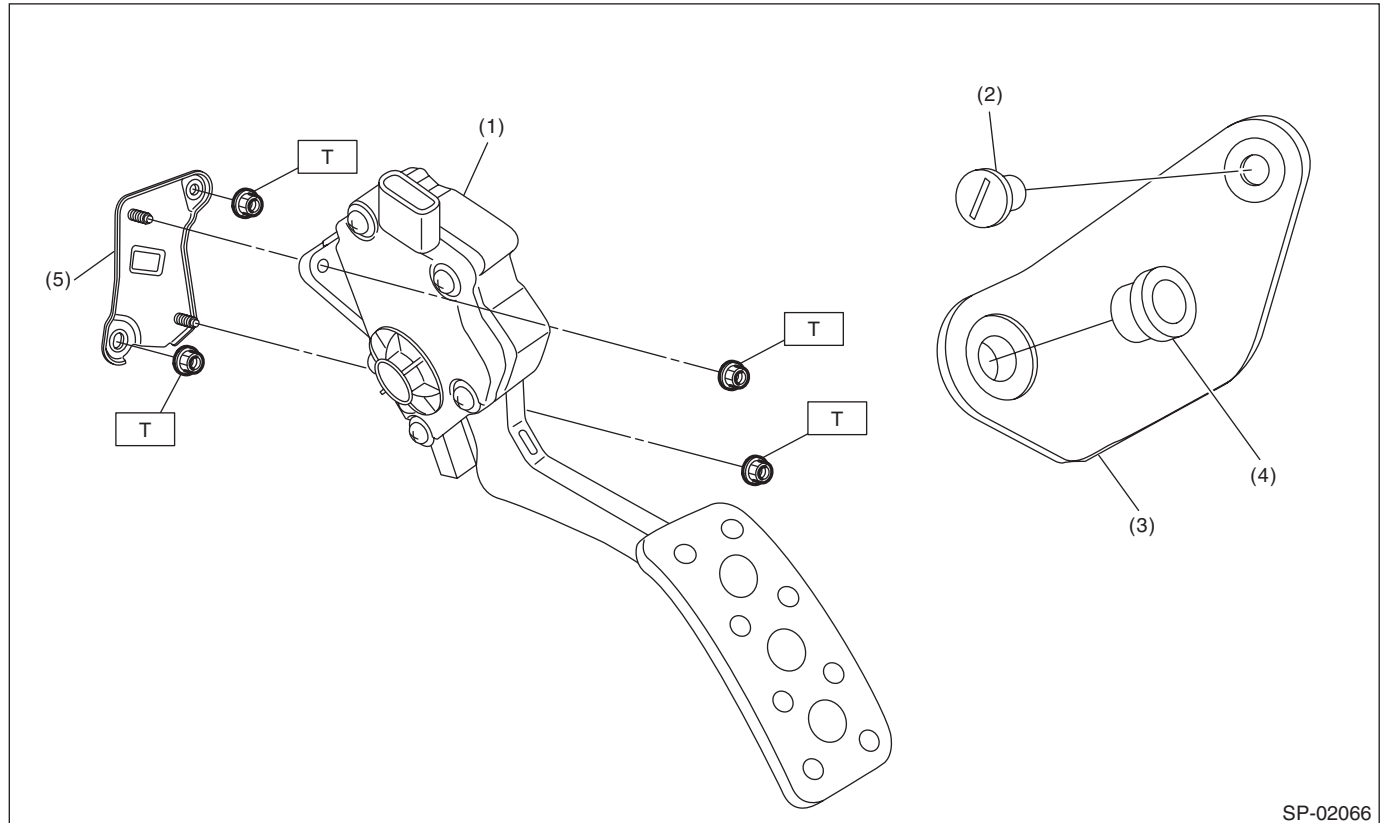

- |                            |                               |
|----------------------------|-------------------------------|
| (1) Accelerator pedal ASSY | (4) Accelerator stopper       |
| (2) Clip                   | (5) Accelerator pedal bracket |
| (3) Accelerator plate      |                               |

**Tightening torque: N·m (kgf·m, ft·lb)**  
**T: 18 (1.8, 13.3)**

#### C: CAUTION

- Wear appropriate work clothing, including a cap, protective goggles and protective shoes when performing any work.
- Remove contamination including dirt and corrosion before removal or installation.
- Keep the parts in order and protect them from dust and dirt.
- Before removal or installation, be sure to clarify the failure. Avoid unnecessary removal, installation, disassembly and replacement.
- Vehicle components are extremely hot after driving. Be wary of receiving burns from heated parts.
- Be sure to tighten fasteners including bolts and nuts to the specified torque.
- Place shop jacks or rigid racks at the specified points.
- Before disconnecting connectors of sensors or units, be sure to disconnect the ground cable from the battery.

## D: PREPARATION TOOL

### 1. SPECIAL TOOL

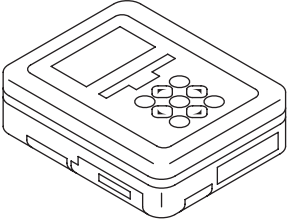
ILLUSTRATION	TOOL NUMBER	DESCRIPTION	REMARKS
 <p style="text-align: center;">ST1B022XU0</p>	1B022XU0	SUBARU SELECT MONITOR III KIT	Used for inspecting the accelerator pedal.

### 2. GENERAL TOOL

TOOL NAME	REMARKS
Circuit tester	Used for measuring voltage.



# Accelerator Pedal

## SPEED CONTROL SYSTEMS

### 2. Accelerator Pedal

#### A: REMOVAL

- 1) Disconnect the ground cable from battery.

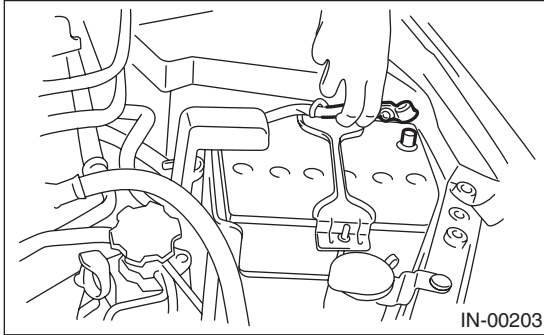

- 2) Disconnect the connector (A).
- 3) Remove the nut (B) securing accelerator pedal assembly, and remove the accelerator pedal assembly.

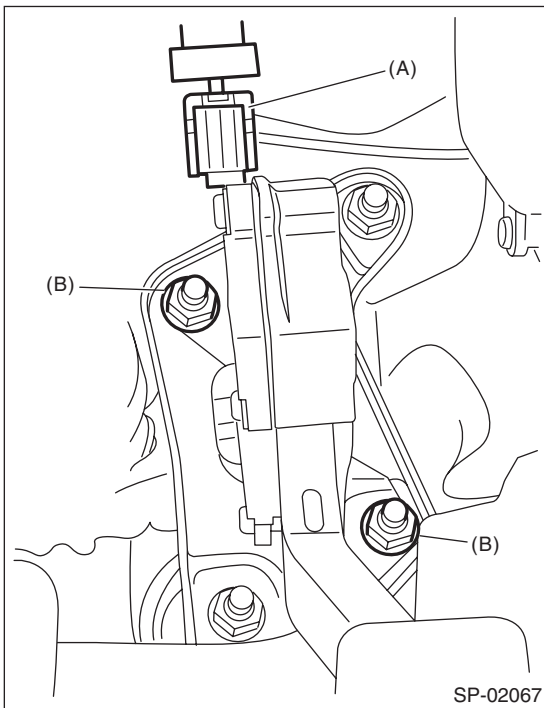

#### B: INSTALLATION

Install in the reverse order of removal.

#### Tightening torque:

**18 N·m (1.8 kgf·m, 13.3 ft·lb)**

#### C: DISASSEMBLY

NOTE:

The accelerator pedal cannot be disassembled.

#### D: INSPECTION

##### 1. CHECK ACCELERATOR PEDAL SENSOR AREA (METHOD WITH CIRCUIT TESTER)

- 1) Remove the lower inner trim of passenger's side. <Ref. to EI-57, REMOVAL, Lower Inner Trim.>
- 2) Turn over the floor mat of passenger's seat.
- 3) Remove the protect cover.

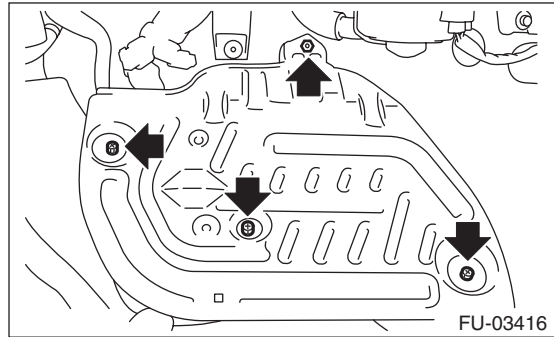

- 4) Remove the nuts and bolts which hold the ECM to the bracket.

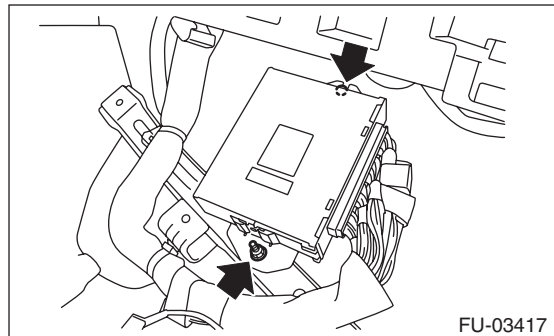

- 5) Turn the ignition switch to ON. (engine OFF)
- 6) Measure the voltage between ECM connector terminals.

- Main sensor side

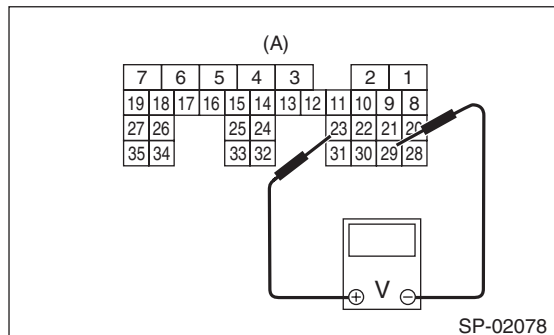

(A) To ECM connector

- Sub sensor side

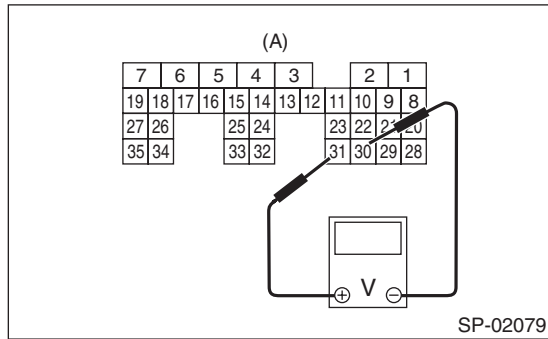

(A) To ECM connector

### 3. OTHER INSPECTIONS

- 1) Check that the accelerator pedal does not have deformation, cracks or damage.
- 2) Check for smooth operation when the accelerator pedal is depressed.
- 3) Check if the accelerator pedal returns to its original position smoothly when the pedal is released.

Accelerator pedal sensor	Accelerator pedal	Terminal No.	Standard
Main	Not depressed (Full closed)	23 (+) and 29 (-)	0.4 — 1.0 V
	Depressed (Full opened)		2.4 — 3.7 V
Sub	Not depressed (Full closed)	31 (+) and 30 (-)	0.3 — 1.1 V
	Depressed (Full opened)		2.3 — 3.8 V

7) After inspection, install the related parts in the reverse order of removal.

**Tightening torque:**

**7.5 N·m (0.8 kgf·m, 5.5 ft·lb)**

## 2. CHECK ACCELERATOR PEDAL SENSOR AREA (METHOD WITH SUBARU SELECT MONITOR)

- 1) Turn the ignition switch to ON. (engine OFF)
- 2) Read the accelerator pedal opening angle signal and voltage of accelerator pedal sensor using Subaru Select Monitor. <Ref. to EN(H4DOTC)(diag)-41, READ CURRENT DATA FOR ENGINE (NORMAL MODE), OPERATION, Subaru Select Monitor.>

Accelerator pedal sensor	Accelerator pedal opening angle signal	Standard
Main	0.0%	0.4 — 1.0 V
	100.0%	2.4 — 3.7 V
Sub	0.0%	0.3 — 1.1 V
	100.0%	2.3 — 3.8 V

# Accelerator Pedal

SPEED CONTROL SYSTEMS

---

**SP(STI)-6**

Brought to you by Ebay Seller "SubaruManuals"

# IGNITION

# *IG(STI)*

---

	<b>Page</b>
1. General Description .....	2
2. Spark Plug .....	4
3. Ignition Coil .....	7

# General Description

## IGNITION

### 1. General Description

#### A: SPECIFICATION

Item		Specifications
Ignition coil	Type	FK0368
	Ignition system	Independent ignition coil
	Manufacturer	Diamond Electric
Spark plug	Manufacturer and type	NGK: SILFR6A
	Thread size (diameter, pitch, length)	mm 14, 1.25, 26.5
	Spark plug gap	mm (in)   Standard 0.7 — 0.8 (0.028 — 0.031)
	Electrode	Iridium

#### B: COMPONENT

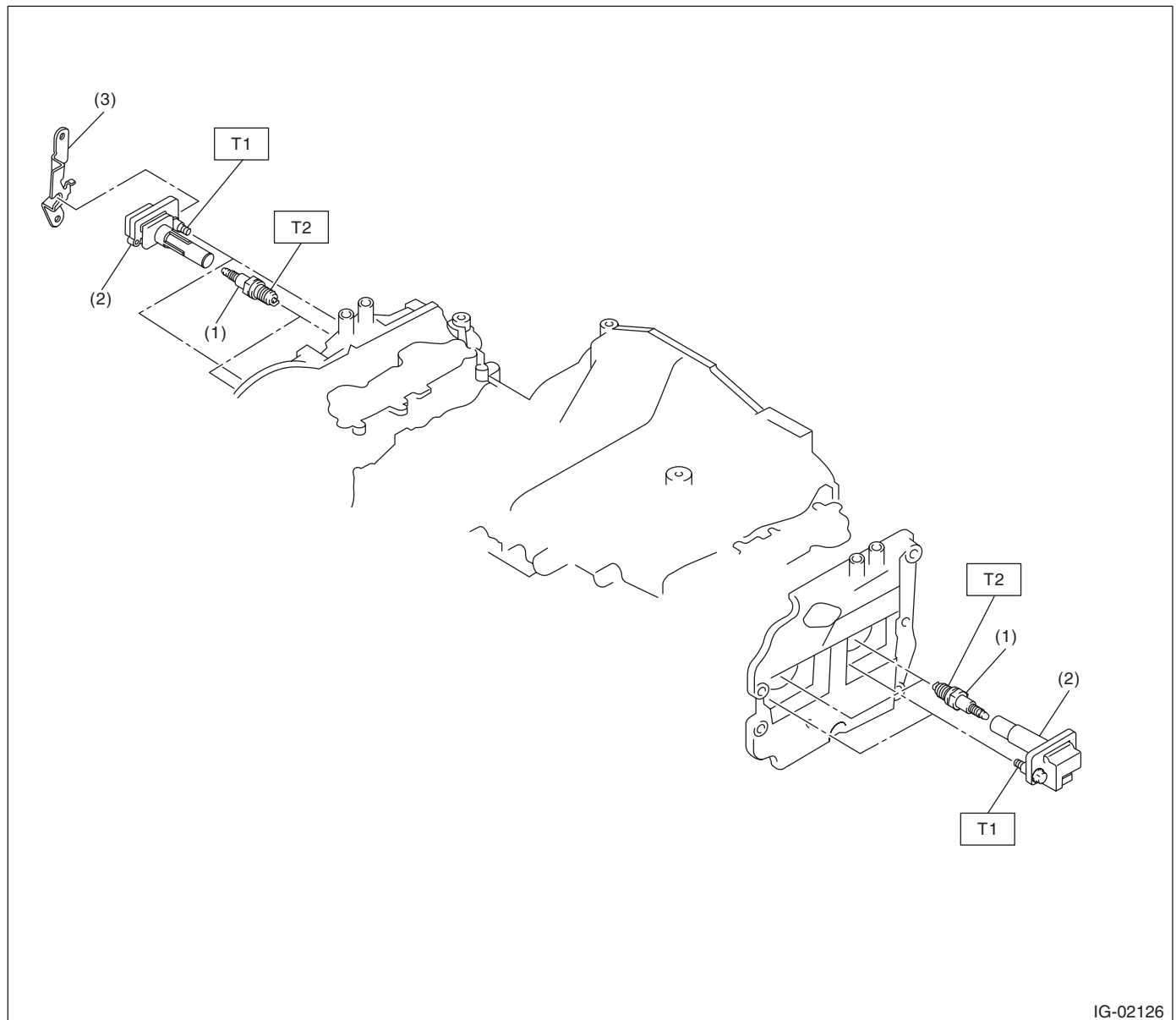

- (1) Spark plug
- (2) Ignition coil

- (3) Engine harness stay (#3 ignition coil side only)

**Tightening torque: N-m (kgf-m, ft-lb)**

**T1: 16 (1.6, 11.8)**

**T2: 21 (2.1, 15.5)**

**IG(STI)-2**

Brought to you by Ebay Seller "SubaruManuals"

### **C: CAUTION**

- Wear appropriate work clothing, including a cap, protective goggles and protective shoes when performing any work.
- Remove contamination including dirt and corrosion before removal, installation or disassembly.
- Keep the disassembled parts in order and protect them from dust and dirt.
- Before removal, installation or disassembly, be sure to clarify the failure. Avoid unnecessary removal, installation, disassembly and replacement.
- Vehicle components are extremely hot after driving. Be wary of receiving burns from heated parts.
- Be sure to tighten fasteners including bolts and nuts to the specified torque.
- Place shop jacks or rigid racks at the specified points.
- Before disconnecting connectors of sensors or units, be sure to disconnect the ground cable from the battery.

# Spark Plug

## IGNITION

## 2. Spark Plug

### A: REMOVAL

#### Spark plug:

Refer to "SPECIFICATION" for the spark plug. <Ref. to IG(STI)-2, SPECIFICATION, General Description.>

#### 1. RH SIDE

- 1) Disconnect the ground cable from battery.

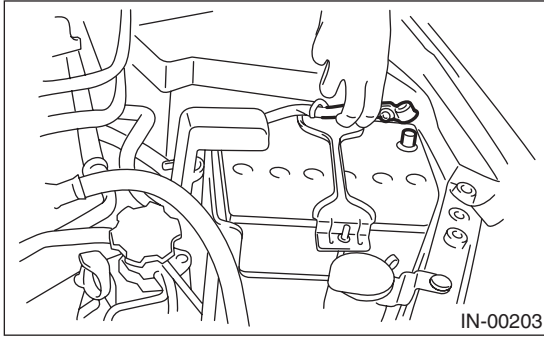

- 2) Remove the air cleaner case. <Ref. to IN(STI)-8, REMOVAL, Air Cleaner Case.>
- 3) Disconnect the connector from ignition coil.
- 4) Remove the ignition coil.

#### NOTE:

Turn #3 ignition coil by 180 degrees to remove it.

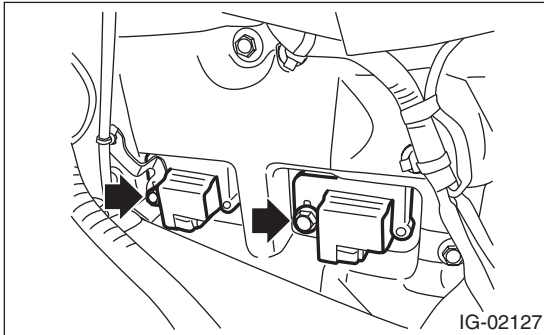

- 5) Remove the spark plug with a spark plug socket.

#### 2. LH SIDE

- 1) Remove the battery. <Ref. to SC(STI)-27, REMOVAL, Battery.>
- 2) Remove the secondary air pump. <Ref. to EC(STI)-27, REMOVAL, Secondary Air Pump.>

- 3) Remove the bolts that secure the air duct to the rocker cover LH, and lift the air duct.

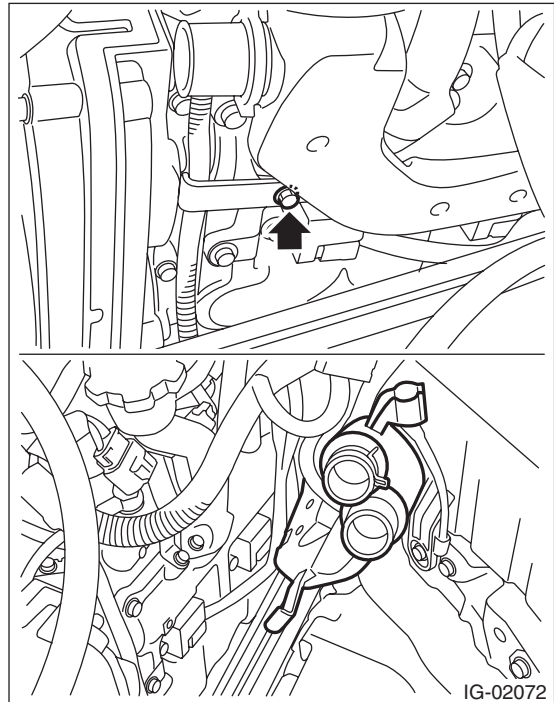

- 4) Disconnect the connector from ignition coil.
- 5) Remove the ignition coil.

#### NOTE:

Turn #4 ignition coil by 180° to remove it.

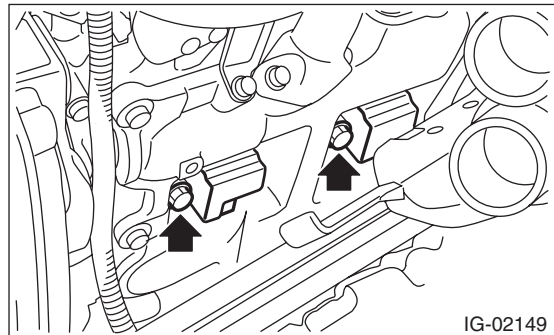

- 6) Remove the spark plug with a spark plug socket.

## B: INSTALLATION

### 1. RH SIDE

Install in the reverse order of removal.

**Tightening torque (Spark plug):**  
**21 N·m (2.1 kgf·m, 15.5 ft·lb)**

**Tightening torque (Ignition coil):**  
**16 N·m (1.6 kgf·m, 11.8 ft·lb)**

### 2. LH SIDE

Install in the reverse order of removal.

**Tightening torque (Spark plug):**  
**21 N·m (2.1 kgf·m, 15.5 ft·lb)**

**Tightening torque (Ignition coil):**  
**16 N·m (1.6 kgf·m, 11.8 ft·lb)**

**Tightening torque (Air duct):**  
**6.4 N·m (0.7 kgf·m, 4.7 ft·lb)**

## C: INSPECTION

1) Check the spark plug for abnormalities. If defective, replace the spark plug.

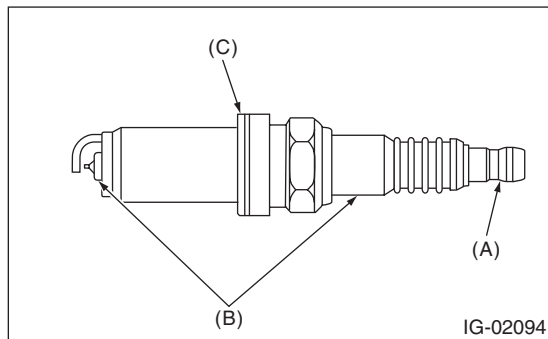

- (A) Terminal damage
- (B) Crack or damage in insulator
- (C) Damaged gasket

2) Check the spark plug electrode and condition of the insulator. If abnormal, check and repair the cause and replace the spark plug.

(1) Normal:

Brown to grayish-tan deposits and slight electrode wear indicate correct spark plug heat range.

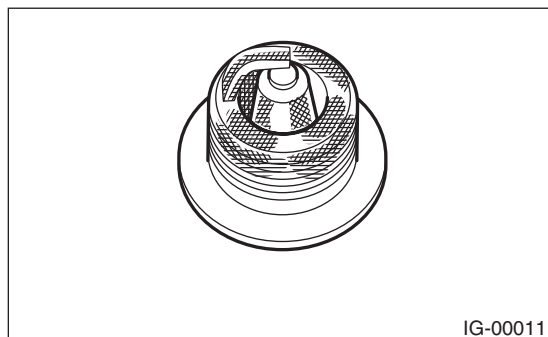

(2) Carbon fouled:

Dry fluffy carbon deposits on insulator and electrode are mostly caused by slow speed driving in the city, weak ignition, too rich fuel mixture, etc.

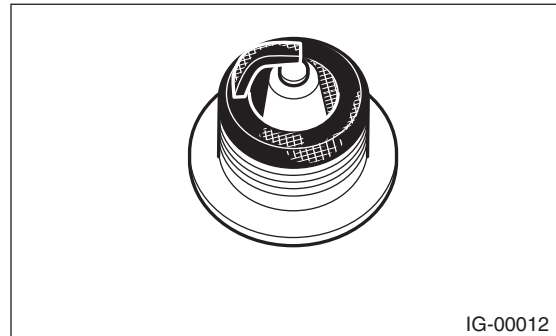

(3) Oil fouled:

Wet black deposits show oil entrance into combustion chamber through worn piston rings or increased clearance between valve guides and valve stems.

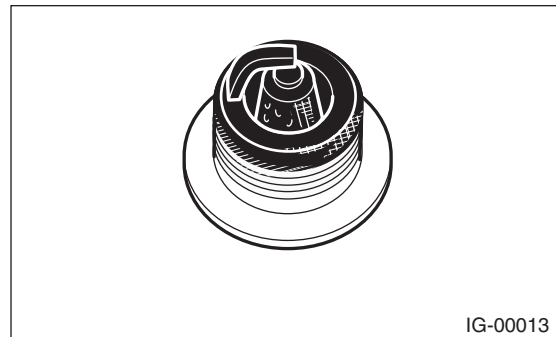

(4) Overheating:

A white or light gray insulator with black or brown spots and bluish burnt electrodes indicate engine overheating, wrong selection of fuel, or loose spark plugs.

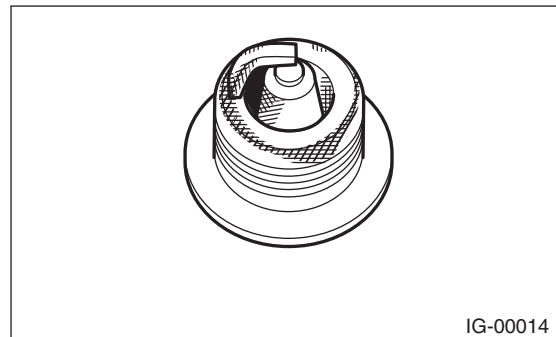



# Spark Plug

## IGNITION

---

3) Using a nylon brush, etc., clean and remove the carbon or oxide deposits from the spark plug. If deposits are too stubborn, replace the spark plugs. After cleaning the spark plugs, check the spark plug gap "L" using a gap gauge. If it is not within the standard, replace the spark plug.

### NOTE:

- Never use a plug cleaner.
- Do not use a metal brush as it may damage the electrode area.

### **Spark plug gap L:**

#### **Standard**

**0.7 — 0.8 mm (0.028 — 0.031 in)**

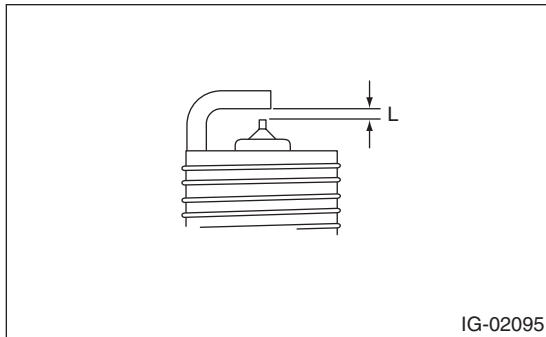

IG-02095

## 3. Ignition Coil

### A: REMOVAL

Direct ignition type is adopted. Refer to "Spark Plug" for removal procedure. <Ref. to IG(STI)-4, REMOVAL, Spark Plug.>

### B: INSTALLATION

Install in the reverse order of removal.

#### *Tightening torque:*

**16 N·m (1.6 kgf-m, 11.8 ft-lb)**

### C: INSPECTION

For inspection procedure, refer to "Diagnostics for Engine Starting Failure". <Ref. to EN(H4DOTC)(diag)-80, IGNITION CONTROL SYSTEM, Diagnostics for Engine Starting Failure.>

# Ignition Coil

IGNITION

---

**IG(STI)-8**

Brought to you by Ebay Seller "SubaruManuals"

# STARTING/CHARGING SYSTEMS

# SC(*STI*)

---

	<b>Page</b>
1. General Description .....	2
2. Starter .....	7
3. Generator .....	21
4. Battery .....	27

# General Description

## STARTING/CHARGING SYSTEMS

### 1. General Description

#### A: SPECIFICATION

Item		Specifications		
Vehicle model		6MT	5MT	
Starter	Type	Reduction type		
	Model	428000-5760	M000T30475	
	Manufacturer	DENSO	Mitsubishi Electric	
	Voltage and output	12 V — 1.0 kW		
	Direction of rotation	Counterclockwise (when observed from pinion)		
	Number of pinion teeth	9	8	
	Armature commutator runout	Standard	0.05 mm (0.0020 in)	0.05 mm (0.0020 in)
		Limit	0.10 mm (0.0039 in)	0.10 mm (0.0039 in)
	Armature depth of segment mold	Standard	0.5 mm (0.020 in)	0.5 mm (0.020 in)
		Brush length	Standard	12.3 mm (0.484 in)
	Brush length	Limit	7.0 mm (0.276 in)	7.0 mm (0.276 in)
		Brush spring force	Standard	15.9 — 19.5 N (1.62 — 1.99 kgf, 3.57 — 4.38 lbf)
	No-load characteristics		Limit	2.5 N (0.25 kgf, 0.56 lbf)
		Voltage	11 V	11 V
		Current	90 A or less	95 A or less
	Load characteristics	Rotating speed	2,860 rpm or more	2,500 rpm or more
		Voltage	8 V	7.5 V
		Current	280 A	300 A
		Torque	9.3 N·m (0.9 kgf·m, 6.9 ft·lb) or more	8.84 N·m (0.9 kgf·m, 6.5 ft·lb) or more
	Lock characteristics	Rotating speed	860 rpm or more	870 rpm or more
Voltage		4 V	4 V	
Current		515 A or less	680 A or less	
Generator	Torque	16 N·m (1.6 kgf·m, 11.8 ft·lb) or more	17 N·m (1.7 kgf·m, 12.5 ft·lb) or more	
		Type	Rotating-field three-phase type, voltage regulator built-in type, with load response control system	
	Model	A003TG6591A		
	Manufacturer	Mitsubishi Electric		
	Voltage and output	12 V — 110 A		
	Polarity on ground side	Negative		
	Direction of rotation	Clockwise (when observed from pulley side)		
	Stator connection	3-phase $\Delta$ type		
	Output current	1,500 rpm — 50 A or more		
		2,500 rpm — 91 A or more		
		5,000 rpm — 105 A or more		
	Regulated voltage	14.1 — 14.8 V [20°C (68°F)]		
	Rotor slip ring outer diameter	Standard	22.7 mm (0.894 in)	
Limit		22.1 mm (0.870 in)		
Brush length	Standard	18.5 mm (0.728 in)		
	Limit	5.0 mm (0.197 in)		
Battery	Type and capacity	12 V — 48 AH (55D23L)	12 V — 48 AH (55D23L)	

**SC(STI)-2**

Brought to you by Ebay Seller "SubaruManuals"

## B: COMPONENT

### 1. STARTER

- STI model

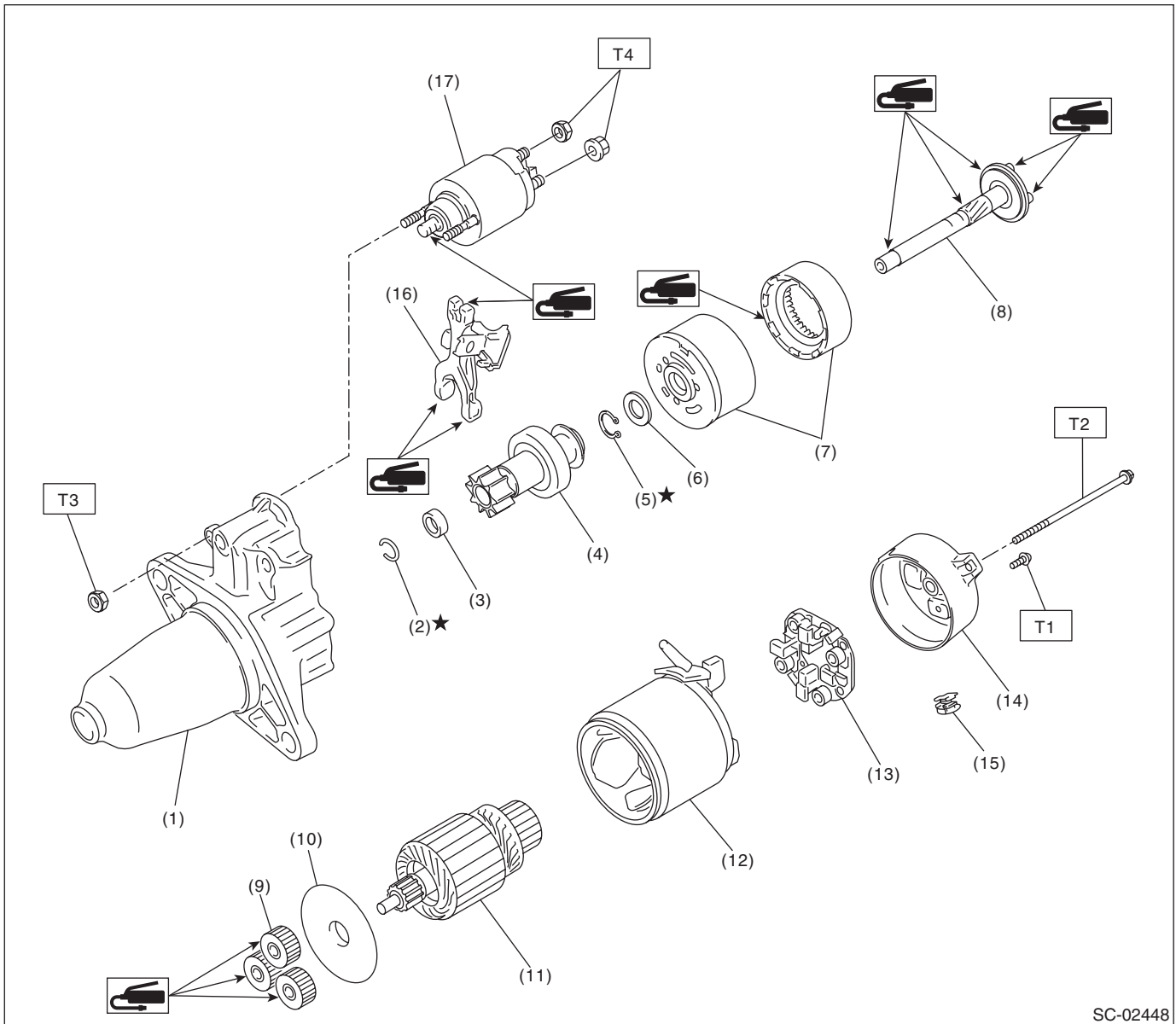

SC-02448

- |                          |                         |                         |
|--------------------------|-------------------------|-------------------------|
| (1) Starter housing ASSY | (9) Pinion gear         | (17) Magnet switch ASSY |
| (2) Snap ring            | (10) Starter plate      |                         |
| (3) Stopper              | (11) Armature           |                         |
| (4) Overrunning clutch   | (12) Yoke ASSY          |                         |
| (5) Snap ring            | (13) Brush holder ASSY  |                         |
| (6) Washer               | (14) Starter cover ASSY |                         |
| (7) Internal gear ASSY   | (15) Drain duct         |                         |
| (8) Shaft                | (16) Shift lever        |                         |

---

**Tightening torque: N-m (kgf-m, ft-lb)**

**T1: 1.4 (0.1, 1.0)**

**T2: 6 (0.6, 4.4)**

**T3: 7.5 (0.8, 5.5)**

**T4: 10 (1.0, 7.4)**

---

# General Description

## STARTING/CHARGING SYSTEMS

- Except for STI model

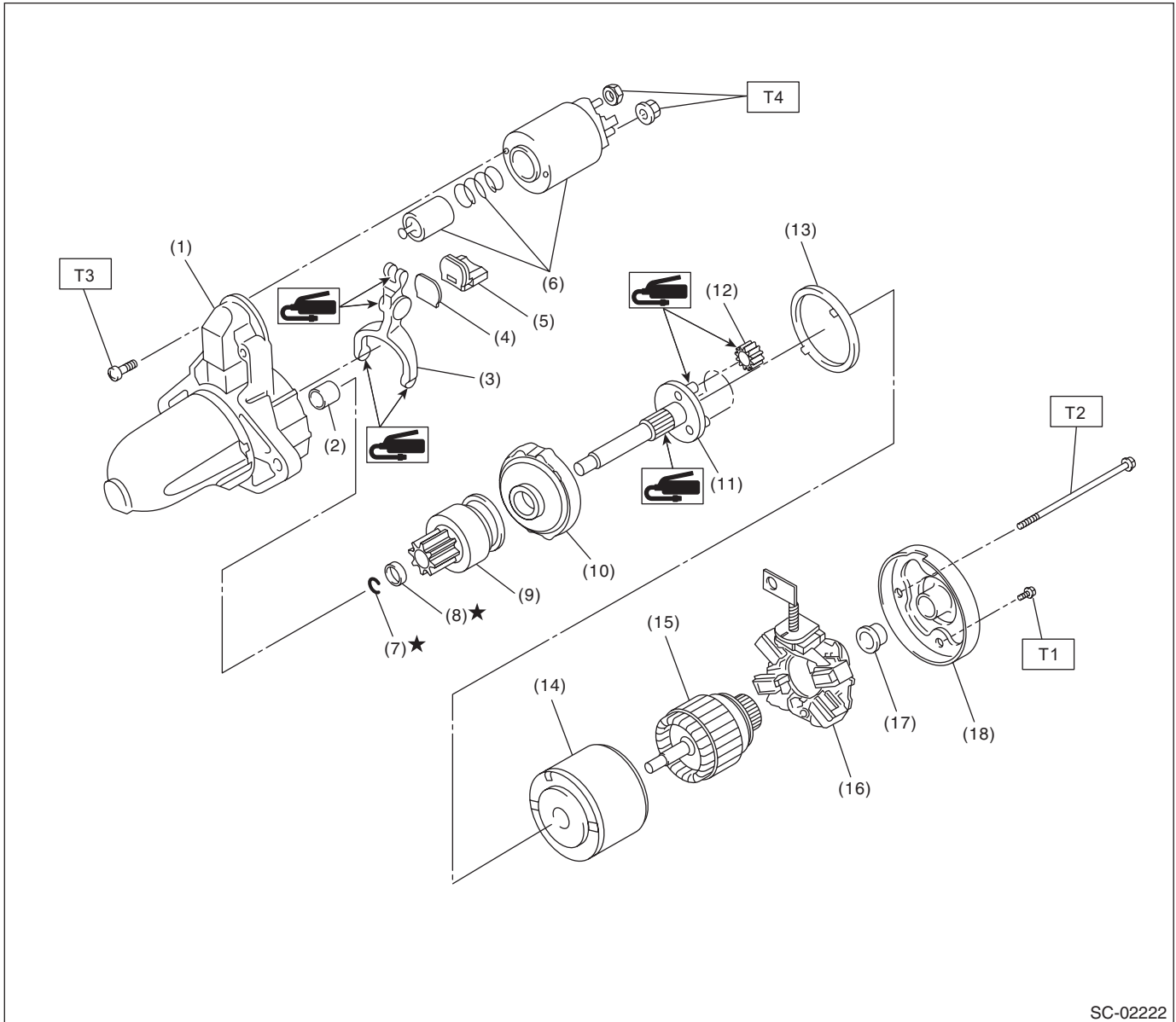

- |                          |                         |                         |
|--------------------------|-------------------------|-------------------------|
| (1) Starter housing ASSY | (9) Overrunning clutch  | (17) Sleeve bearing     |
| (2) Sleeve bearing       | (10) Internal gear ASSY | (18) Starter cover ASSY |
| (3) Shift lever          | (11) Shaft              |                         |
| (4) Plate                | (12) Pinion gear        |                         |
| (5) Seal rubber          | (13) Seal rubber        |                         |
| (6) Magnet switch ASSY   | (14) Yoke ASSY          |                         |
| (7) Snap ring            | (15) Armature ASSY      |                         |
| (8) Stopper              | (16) Brush holder ASSY  |                         |

---

**Tightening torque: N·m (kgf·m, ft·lb)**

**T1: 1.4 (0.1, 1.0)**

**T2: 6 (0.6, 4.4)**

**T3: 7.5 (0.8, 5.5)**

**T4: 10 (1.0, 7.4)**

---

**SC(STI)-4**

Brought to you by Ebay Seller "SubaruManuals"

# General Description

## 2. GENERATOR

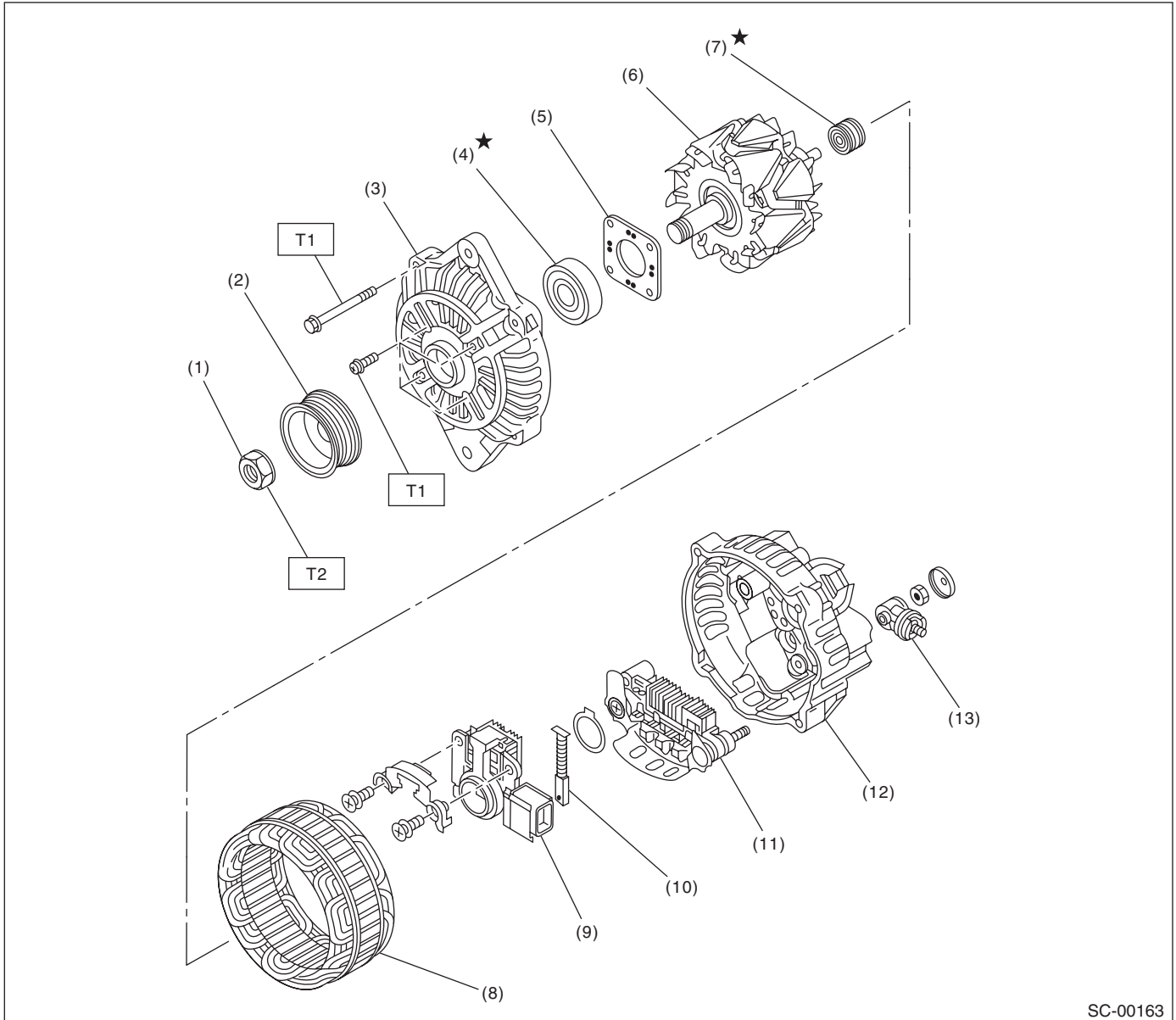

SC-00163

- |                      |                             |                |
|----------------------|-----------------------------|----------------|
| (1) Pulley nut       | (7) Bearing                 | (13) Terminals |
| (2) Pulley           | (8) Stator coil             |                |
| (3) Front cover      | (9) IC regulator with brush |                |
| (4) Ball bearing     | (10) Brush                  |                |
| (5) Bearing retainer | (11) Rectifier              |                |
| (6) Rotor            | (12) Rear cover             |                |

**Tightening torque: N·m (kgf·m, ft·lb)**

**T1: 4.7 (0.5, 3.5)**

**T2: 108 (11.0, 79.8)**

**SC(STI)-5**

Brought to you by Ebay Seller "SubaruManuals"



# General Description

## STARTING/CHARGING SYSTEMS

### 3. GENERATOR BRACKET

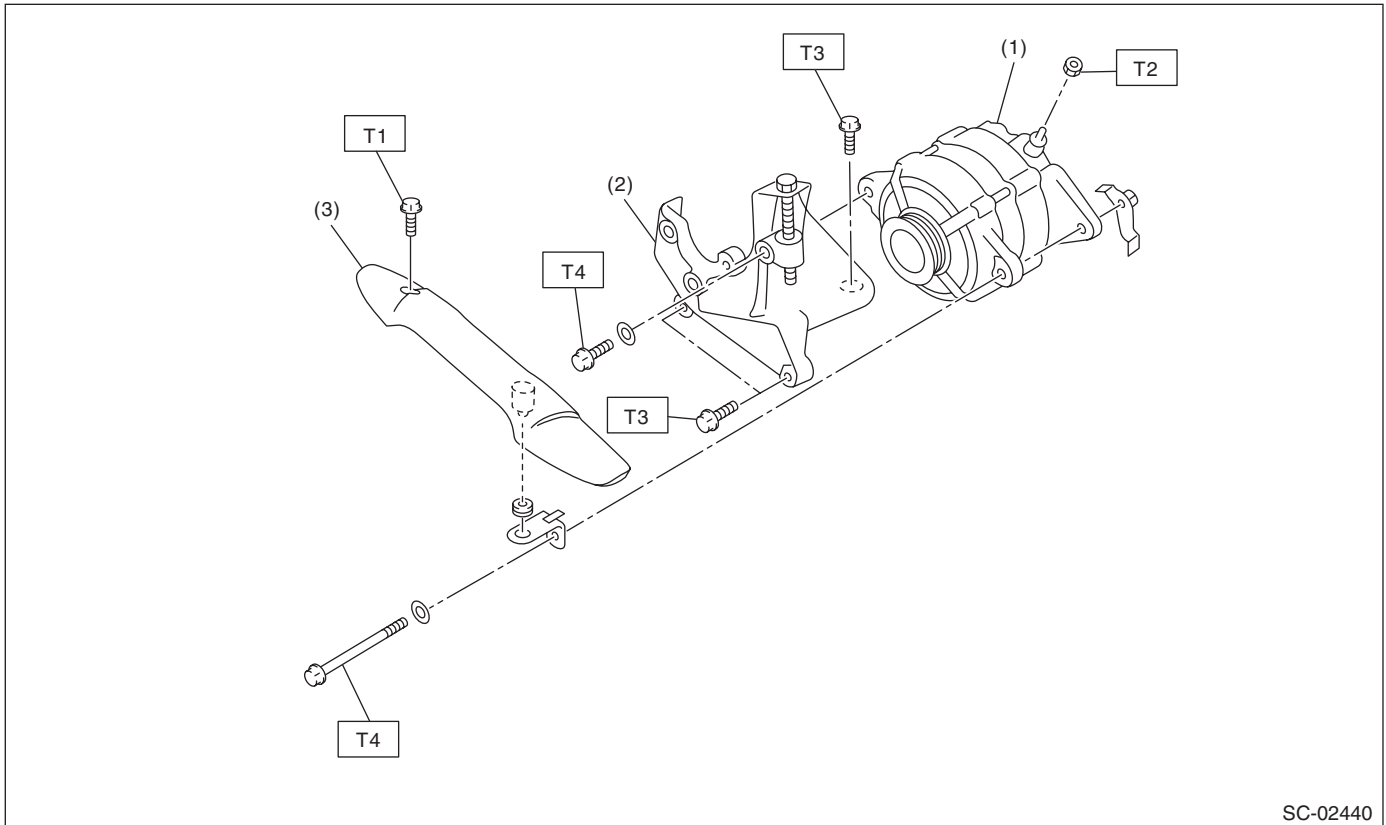

SC-02440

- (1) Generator  
 (2) Power steering pump bracket  
 (3) V-belt cover

**Tightening torque: N·m (kgf·m, ft·lb)**

- T1: 13 (1.3, 9.6)**  
**T2: 16 (1.6, 11.8)**  
**T3: 22 (2.2, 16.2)**  
**T4: 25 (2.5, 18.4)**

### C: CAUTION

- Wear appropriate work clothing, including a cap, protective goggles and protective shoes when performing any work.
- Remove contamination including dirt and corrosion before removal, installation or disassembly.
- Keep the disassembled parts in order and protect them from dust and dirt.
- Before removal, installation or disassembly, be sure to clarify the failure. Avoid unnecessary removal, installation, disassembly and replacement.
- Vehicle components are extremely hot after driving. Be wary of receiving burns from heated parts.
- Be sure to tighten fasteners including bolts and nuts to the specified torque.
- Place shop jacks or rigid racks at the specified points.
- Before disconnecting connectors of sensors or units, be sure to disconnect the ground cable from the battery.

### D: PREPARATION TOOL

#### 1. GENERAL TOOL

TOOL NAME	REMARKS
Circuit tester	Used for measuring resistance, voltage and current.

## 2. Starter

### A: REMOVAL

- 1) Disconnect the ground cable from battery.

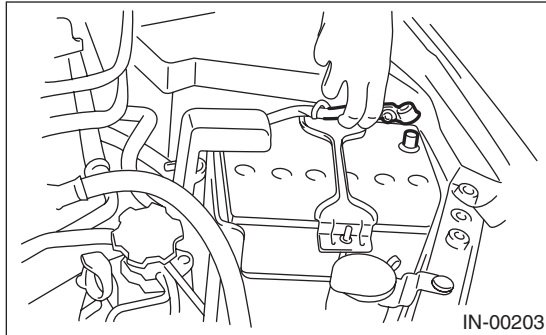

- 2) Remove the intercooler. <Ref. to IN(STI)-12, REMOVAL, Intercooler.> <Ref. to IN(w/o STI)-12, REMOVAL, Intercooler.>

- 3) Disconnect the connector (B) and terminal (A) from starter.

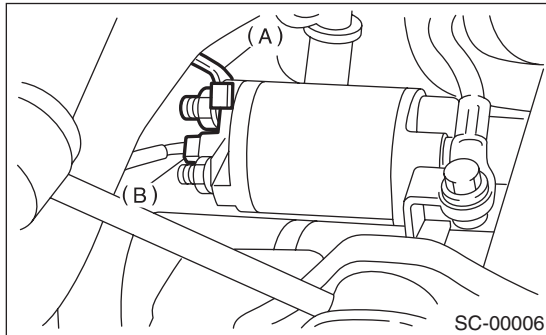

- 4) Remove the starter from transmission.

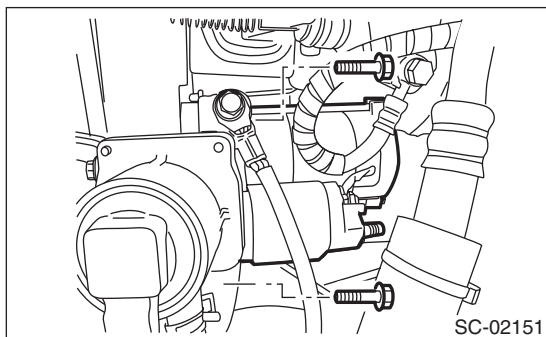

### B: INSTALLATION

Install in the reverse order of removal.

**Tightening torque:**

**50 N·m (5.1 kgf-m, 36.9 ft-lb)**

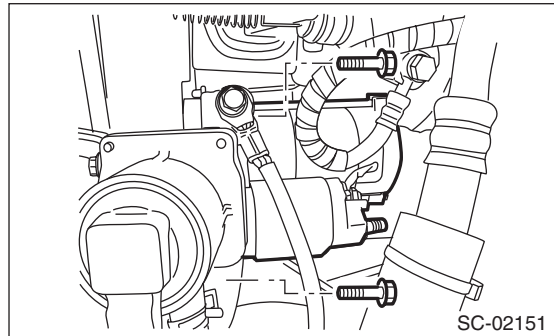

**Tightening torque:**

**10 N·m (1.0 kgf-m, 7.4 ft-lb)**

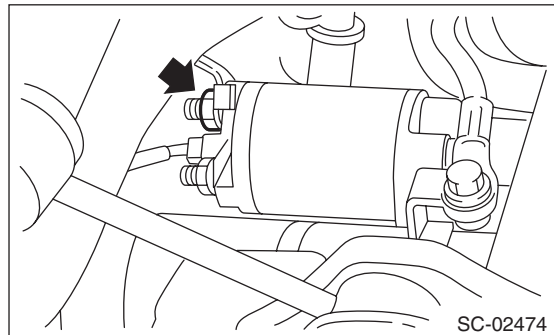

# Starter

## STARTING/CHARGING SYSTEMS

### C: DISASSEMBLY

#### 1. STI MODEL

1) Disconnect cable from terminal M (A) of the magnet switch assembly.

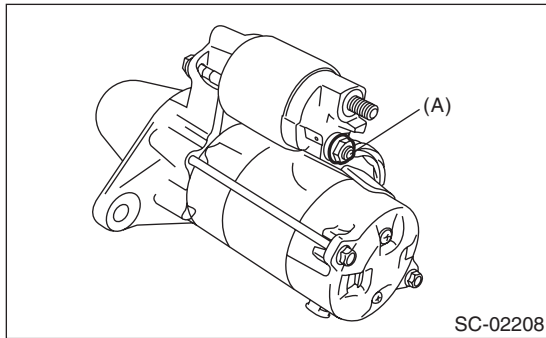

2) Remove the magnet switch assembly from the starter housing assembly.

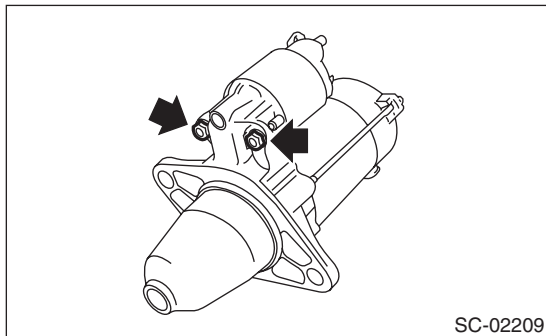

3) Remove through bolts (A) on both sides and the brush holder screws (B), and remove the starter cover assembly.

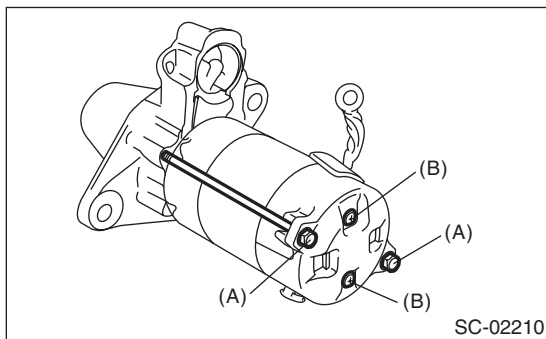

4) Remove the yoke assembly and brush holder assembly as a unit.

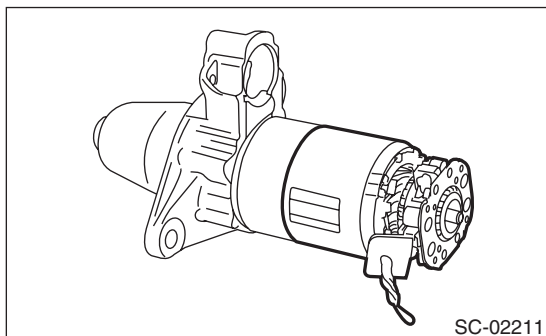

5) Remove the two brushes wired to the yoke assembly, and separate the yoke assembly and the brush holder assembly.

#### NOTE:

As shown in the figure, use a flat tip screwdriver, etc. to hold the brush spring and remove the brush.

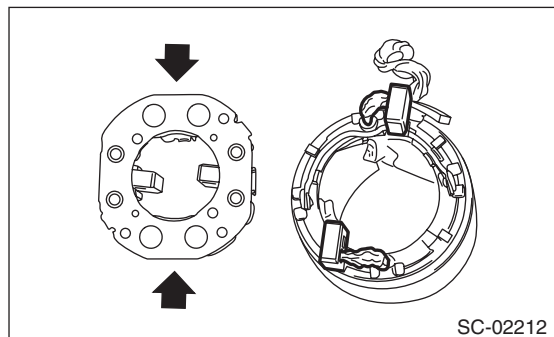
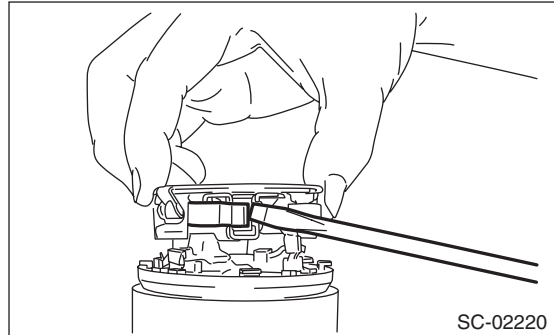

6) Remove the armature from the internal gear assembly.

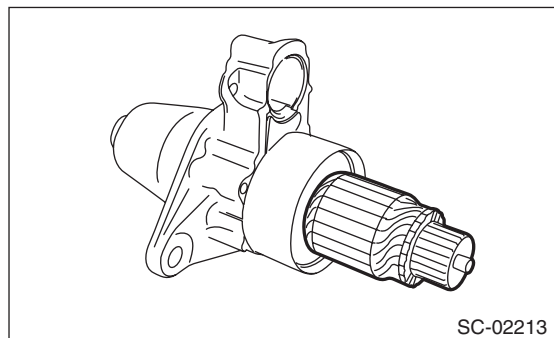

7) Remove the starter housing assembly (A) then remove the shift lever (B).

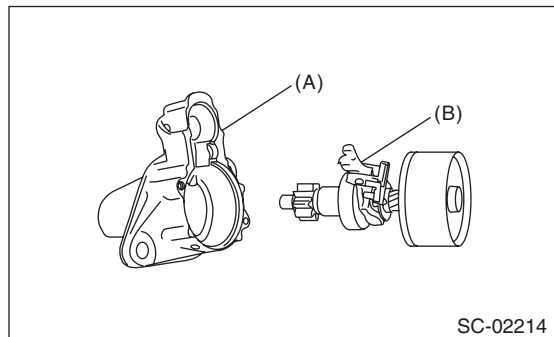

8) Use the following procedures to remove the overrunning clutch from the shaft.

(1) Use an appropriate tool (such as a fit socket wrench), and remove the stopper from snap ring by lightly tapping the stopper with a plastic hammer.

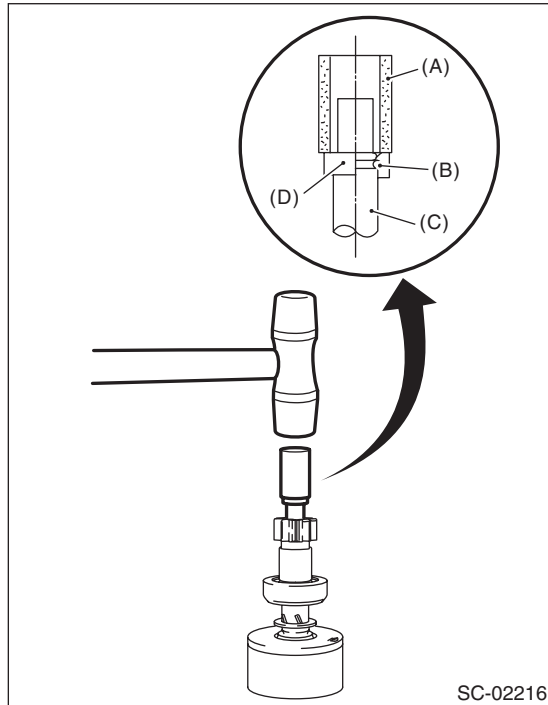

- (A) Appropriate tool
- (B) Snap ring
- (C) Shaft
- (D) Stopper

(2) Remove snap ring (A) from the shaft, and remove stopper (B).

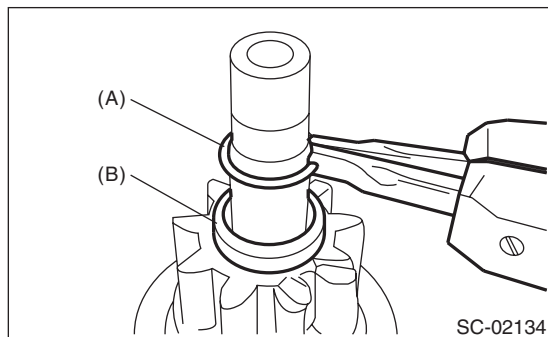

(3) Remove the overrunning clutch from the shaft.

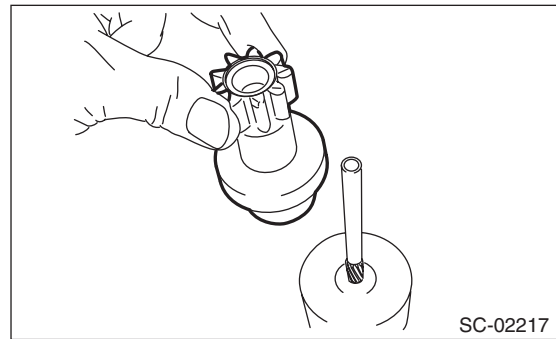

9) Use the following procedures to remove the shaft.

(1) Remove the starter plate, and remove the pinion gear.

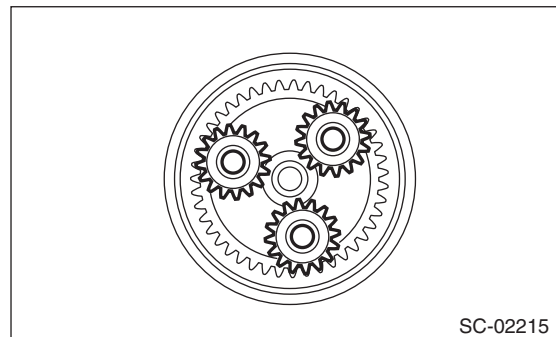

(2) Remove the snap ring from the shaft.

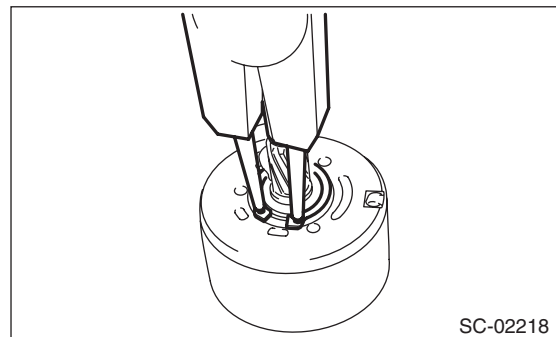

(3) Remove the shaft from the internal gear assembly.

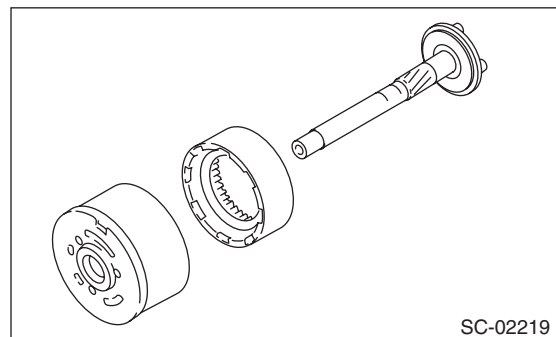

# Starter

## STARTING/CHARGING SYSTEMS

### 2. EXCEPT FOR STI MODEL

1) Disconnect the cable from the terminal M of the magnet switch assembly.

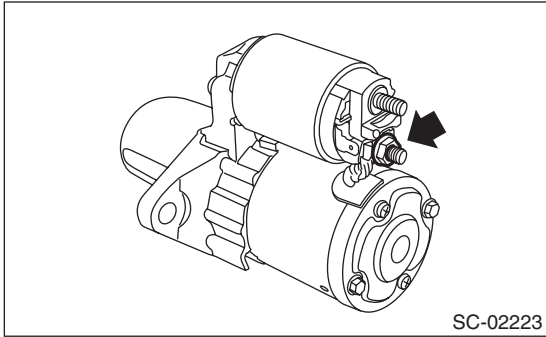

2) Remove the magnet switch assembly from the starter housing assembly.

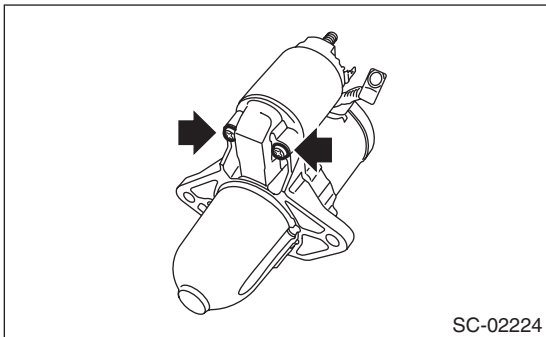

3) Remove screws (A) of the brush holder assembly, and through bolts (B) on both sides, and remove the starter cover assembly.

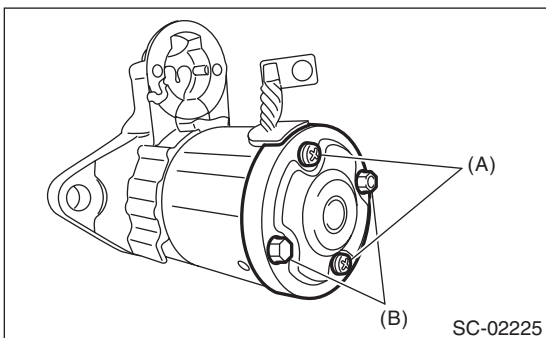

4) Remove the brush holder assembly from the armature assembly.

#### NOTE:

Hold the brush with your fingers so that the brush spring does not come flying out.

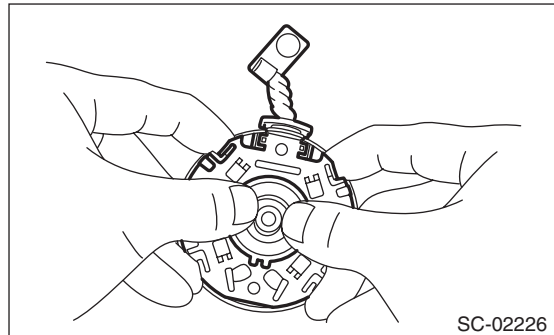

5) Remove the armature assembly and yoke assembly from the starter housing assembly together as a single unit.

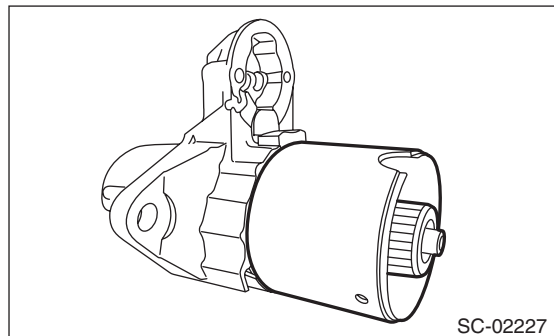

6) Separate the armature assembly and yoke assembly.

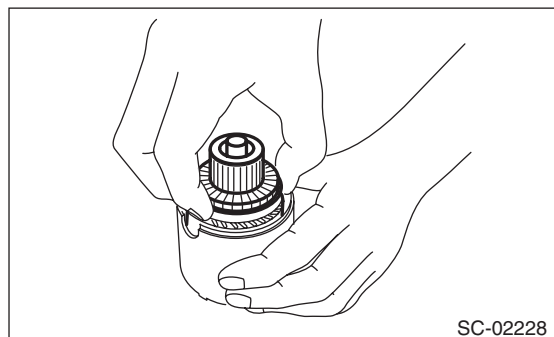

7) Remove the pinion gear from the internal gear assembly.

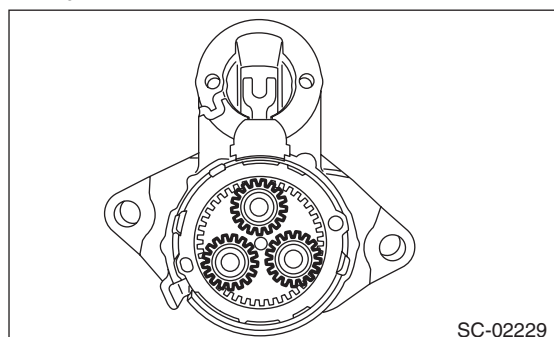

# Starter

## STARTING/CHARGING SYSTEMS

8) Remove seal rubber (A), plate (B), and seal rubber (C).

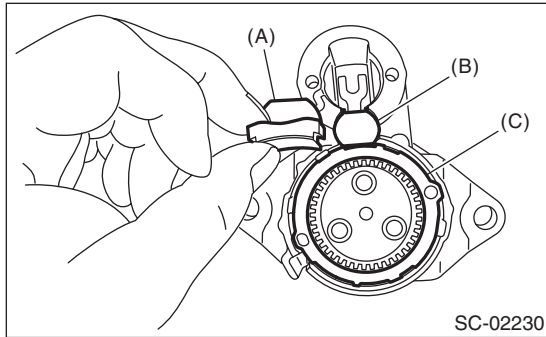

9) Lightly tap the starter housing assembly with a plastic hammer as shown in the figure, and remove the overrunning clutch, internal gear assembly, shaft and shift lever together as one unit.

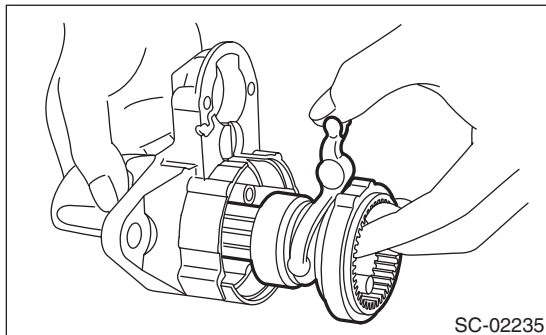
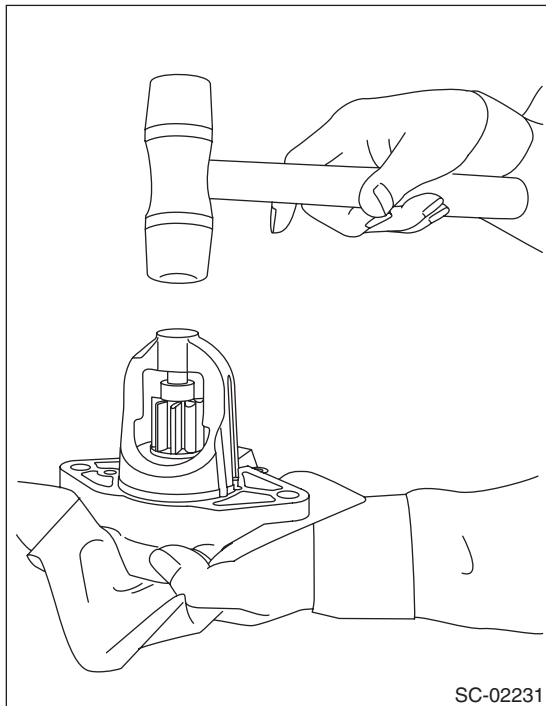

10) Use the following procedures to remove the overrunning clutch from the shaft.

(1) Use an appropriate tool (such as a fit socket wrench), and remove the stopper from snap ring by lightly tapping the stopper with a plastic hammer.

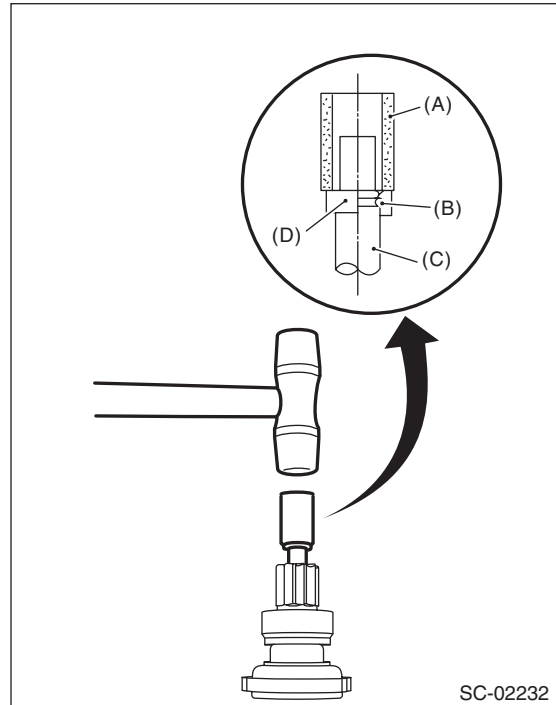

- (A) Appropriate tool
- (B) Snap ring
- (C) Shaft
- (D) Stopper

(2) Remove snap ring (A) from the shaft, and remove stopper (B).

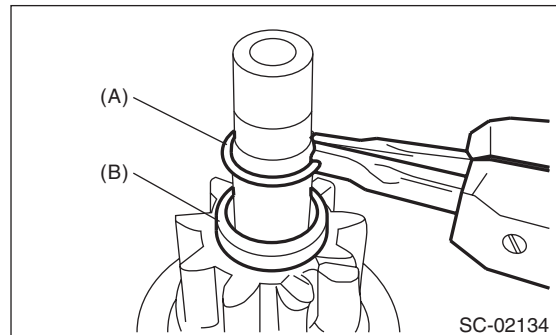

# Starter

## STARTING/CHARGING SYSTEMS

(3) Remove the overrunning clutch from the shaft.

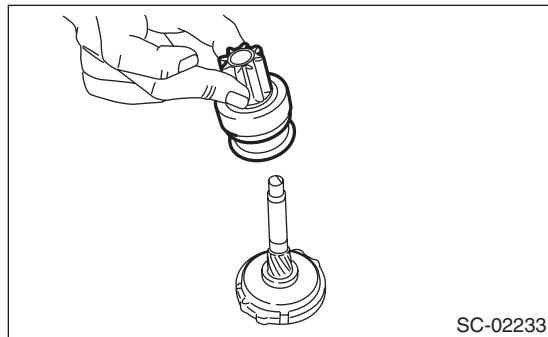

11) Separate the internal gear assembly and shaft.

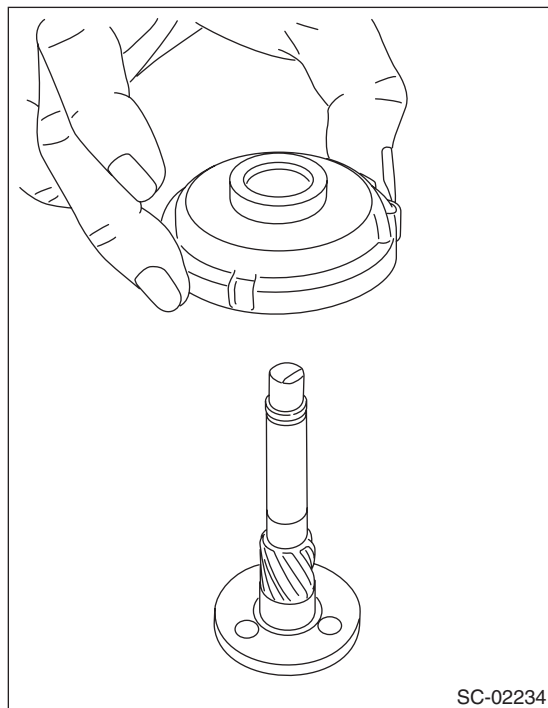

## D: ASSEMBLY

### 1. STI MODEL

1) Use the following procedures to install the shaft.

(1) Apply grease to the shaft sliding surfaces of the internal gear assembly.

**Grease:**

**DENSO HL50**

(2) Assemble the shaft to the internal gear assembly.

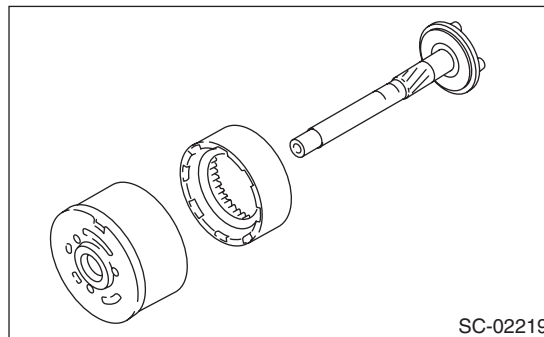

(3) Install the snap ring to shaft.

**NOTE:**

Use new snap rings.

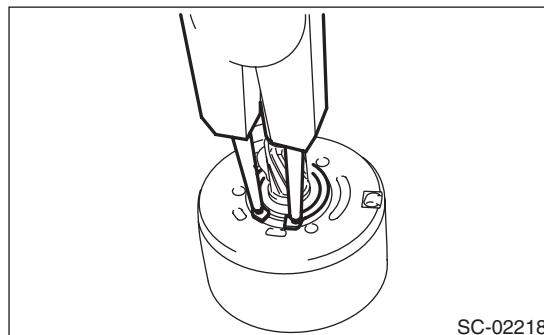

(4) Apply grease to the pinion gear attachment area.

**Grease:**

**DENSO HL50**

(5) Attach the pinion gear to the pin.

(6) Apply grease to the pinion gear, internal gear assembly, and on top of the shaft pin.

**NOTE:**

- Apply grease so that it contacts each gear.
- Be careful not to allow dirt to get in.



**Grease:**  
**DENSO HL50**

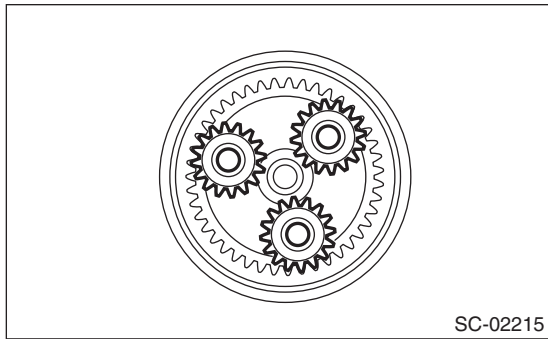

- (7) Install the starter plate.  
2) Assemble the overrunning clutch and shift lever (B) to the starter housing (A) as a unit.

**NOTE:**  
Apply grease to the contact portion of the shift lever.

**Grease:**  
**DENSO HL50**

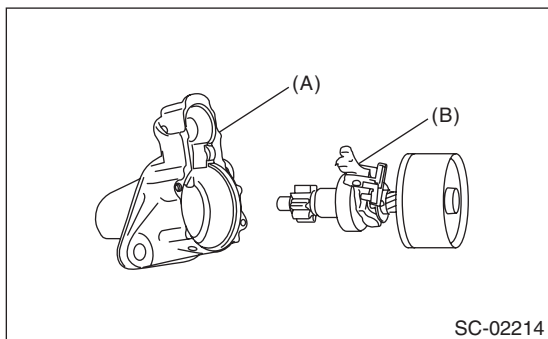

- 3) Assemble the overrunning clutch as follows:  
(1) Apply grease to the spline portion of the shaft.

**Grease:**  
**DENSO HL50**  
(2) Install the overrunning clutch to shaft.

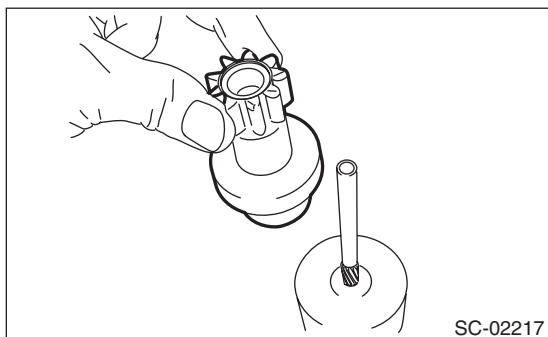

- (3) Pass stopper (B) through the shaft, and attach snap ring (A).

**NOTE:**  
Use new snap rings.

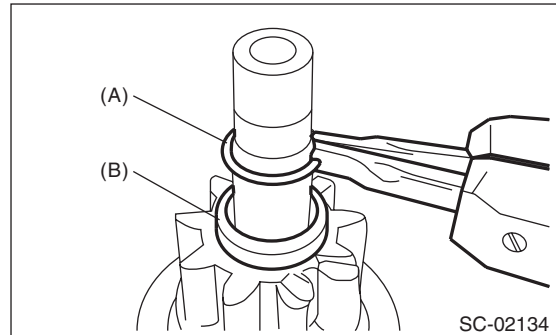

- (4) Using a press, pressure fit stopper (B) into snap ring (A).

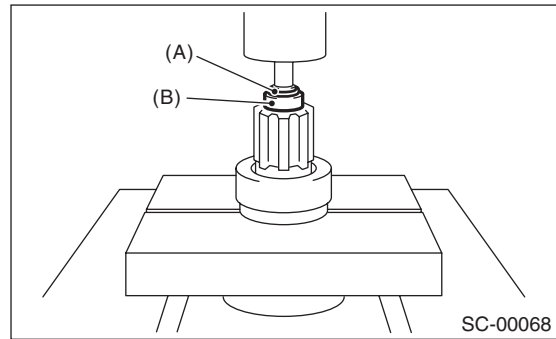

- 4) Install the armature to the internal gear assembly.

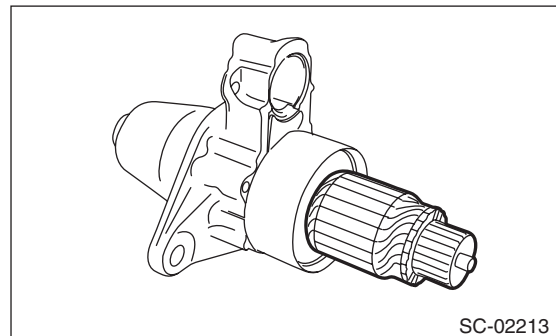



# Starter

## STARTING/CHARGING SYSTEMS

5) Attach the two brushes wired to the yoke assembly to the brush holder assembly to the brush holder assembly.

**NOTE:**

As shown in the figure, use a flat tip screwdriver, etc. to hold the brush spring and insert the brush while being careful not to damage the brush.

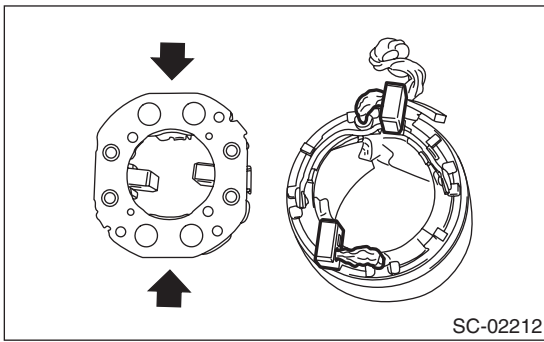
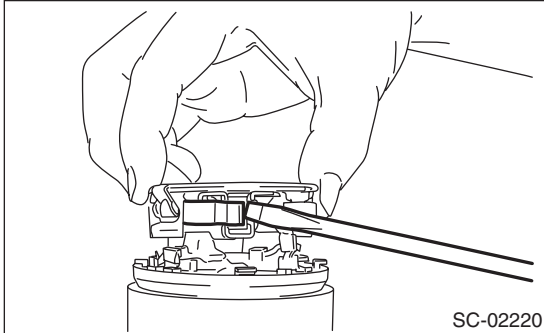

6) Install the yoke assembly and brush holder assembly as a single unit to the armature.

**NOTE:**

Spread the brush with your fingers, being careful not to damage the brush.

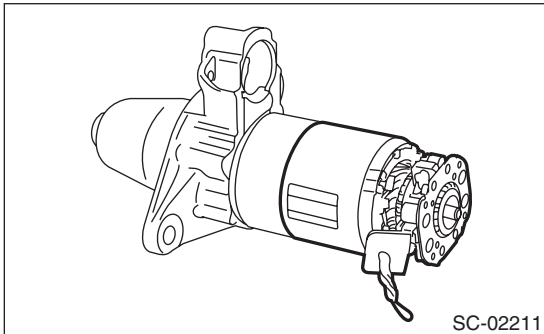

7) Install starter cover assembly to the brush holder assembly with screws (B).

**Tightening torque:**

**1.4 N·m (0.1 kgf·m, 1.0 ft·lb)**

8) Tighten the through bolts (A) on both sides.

**Tightening torque:**

**6 N·m (0.6 kgf·m, 4.4 ft·lb)**

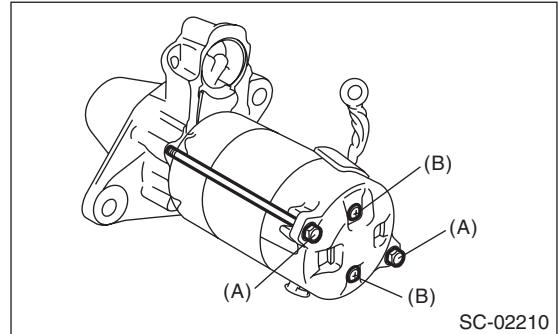

9) Attach the magnet switch assembly to the starter housing assembly.

**Tightening torque:**

**7.5 N·m (0.8 kgf·m, 5.5 ft·lb)**

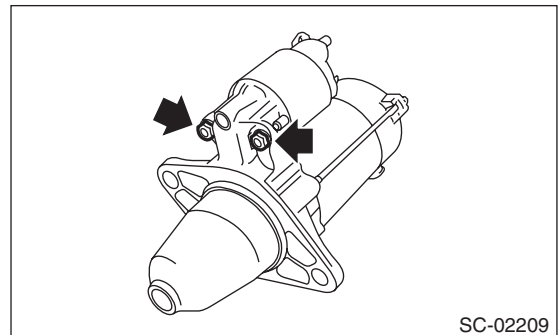

10) Connect terminal M (A) to magnet switch assembly.

**Tightening torque:**

**10 N·m (1.0 kgf·m, 7.4 ft·lb)**

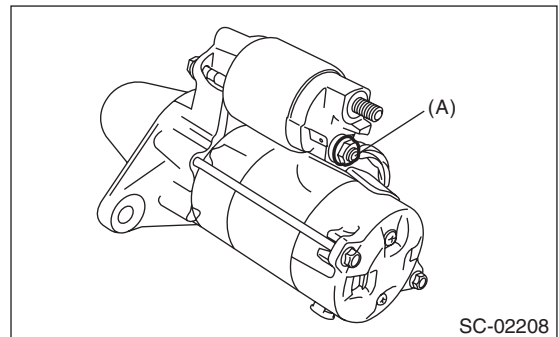

### 2. EXCEPT FOR STI MODEL

1) Apply grease to the shaft sliding surfaces of the internal gear assembly.

**Grease:**

**Multemp #6129 or equivalent**

2) Assemble the shaft to the internal gear assembly.

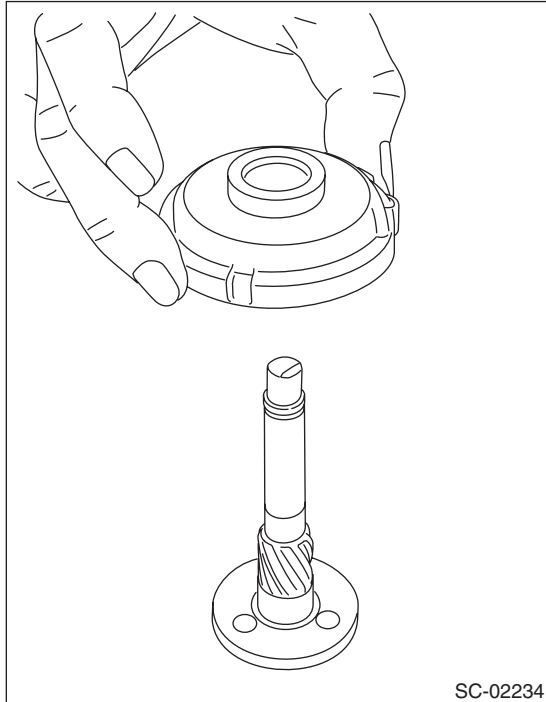

3) Assemble the overrunning clutch as follows:

(1) Apply grease to the spline portion of the shaft.

**Grease:**

**Multemp #6129 or equivalent**

(2) Install the overrunning clutch to shaft.

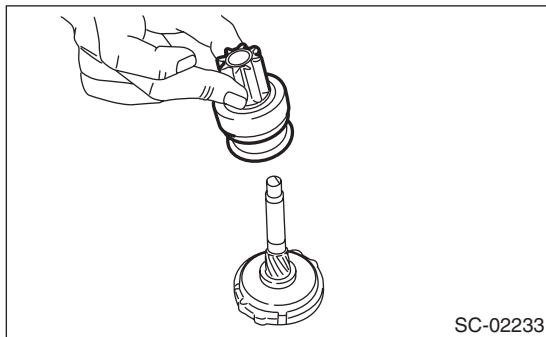

(3) Pass stopper (B) through the shaft assembly, and attach snap ring (A).

**NOTE:**

Use new stoppers and snap rings.

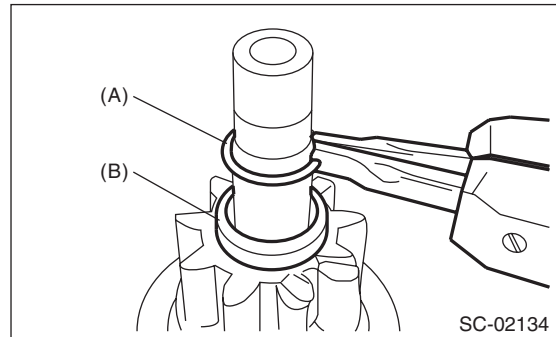

(4) Using a press, pressure fit stopper (B) into snap ring (A).

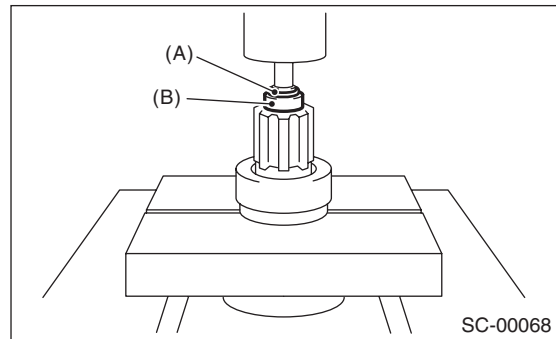

4) Assemble the overrunning clutch, internal gear assembly, shaft and shift lever as a single unit into the starter housing assembly.

**NOTE:**

Apply grease to the moving parts of the shift lever.

**Grease:**

**Multemp #6129 or equivalent**

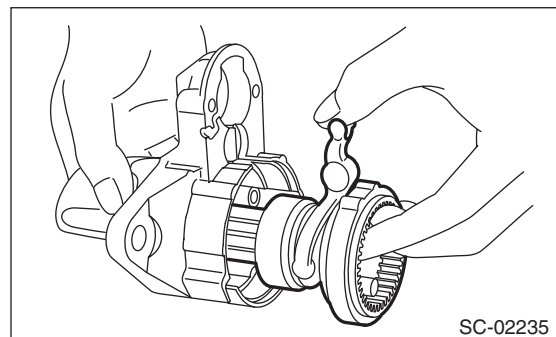

# Starter

## STARTING/CHARGING SYSTEMS

5) Apply grease to the inside of the internal gear assembly and pinion gear, and attach the pinion gear to the internal gear assembly.

**NOTE:**

- Apply grease evenly to the contact surfaces of each gear.
- Be careful that no debris becomes attached.

**Grease:**

**Molykote® AG650 or equivalent**

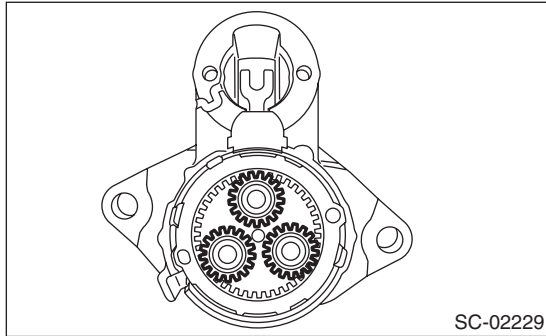

6) Install seal rubber (A), plate (B), and seal rubber (C).

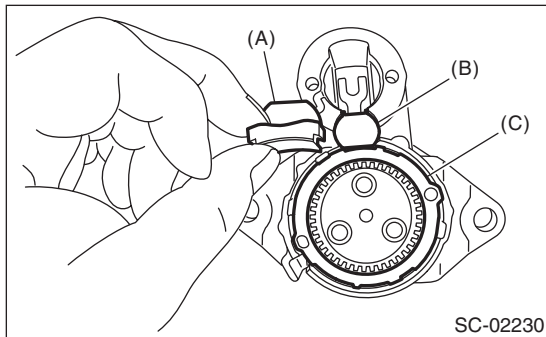

7) Assemble the armature assembly to the yoke assembly.

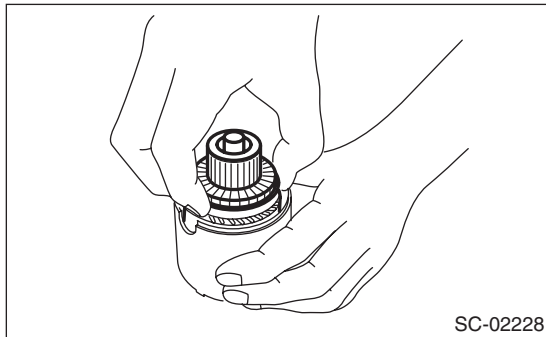

8) Attach the armature assembly and yoke assembly to the starter housing assembly together as a single unit.

**NOTE:**

As shown in the figure, match the protrusion of the yoke assembly to the cut out of the starter housing assembly.

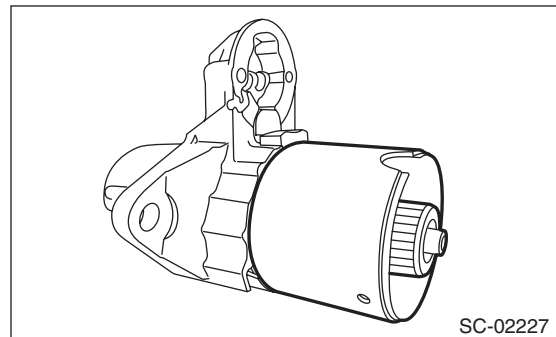
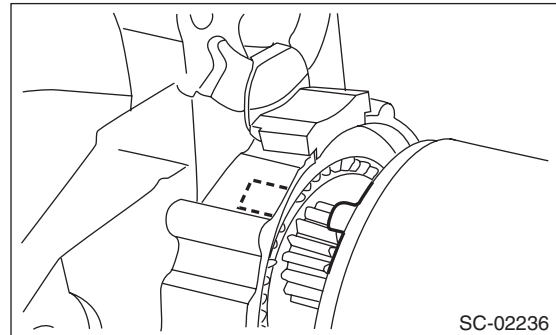

9) Use an appropriate tool (such as correctly sized socket wrenches) and attach the brush holder assembly to the armature assembly.

**NOTE:**

Be careful not to damage the brushes.

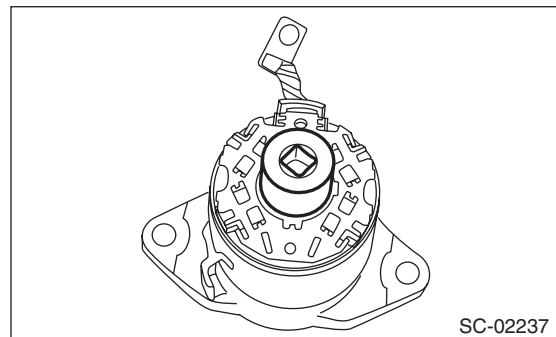

10) Secure starter cover assembly to the brush holder assembly with screws (A).

**Tightening torque:**

**1.4 N·m (0.1 kgf·m, 1.0 ft·lb)**

11) Install through bolts (B) on both sides.

**Tightening torque:**

**6 N·m (0.6 kgf·m, 4.4 ft·lb)**

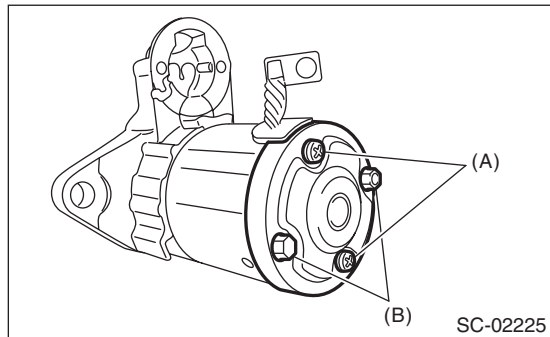

12) Attach the magnet switch assembly to the starter housing assembly.

**Tightening torque:**

**7.5 N·m (0.8 kgf·m, 5.5 ft·lb)**

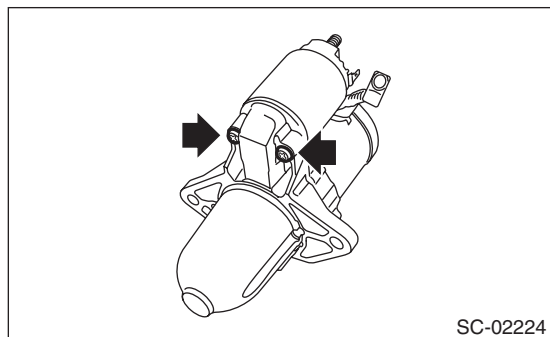

13) Attach the cable to the terminal M of the magnet switch assembly, and secure with nuts.

**Tightening torque:**

**10 N·m (1.0 kgf·m, 7.4 ft·lb)**

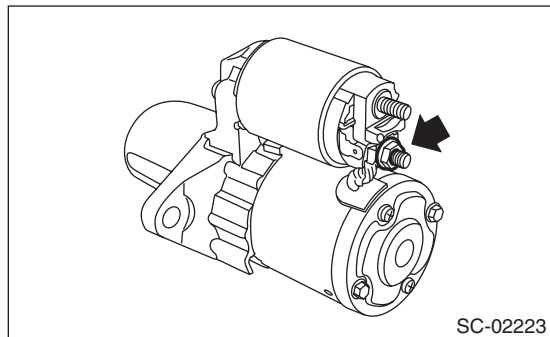

## E: INSPECTION

### 1. ARMATURE

1) Check the commutator for signs of seizure or stepped wear caused by roughness of the surface. If there is light wear, use sandpaper to repair.

2) Check for runout on the commutator. If excessive, replace the armature.

**Commutator runout:**

**Standard**

**0.05 mm (0.0020 in)**

**Limit**

**0.10 mm (0.0039 in)**

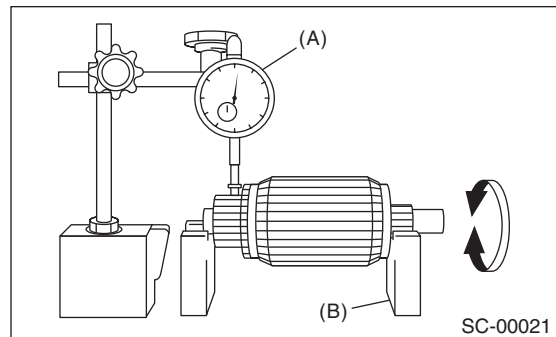

(A) Dial gauge

(B) V-block

3) Check the depth of the segment mold. If it is not within the standard, replace the armature.

**Depth of segment mold:**

**Standard**

**0.5 mm (0.020 in)**

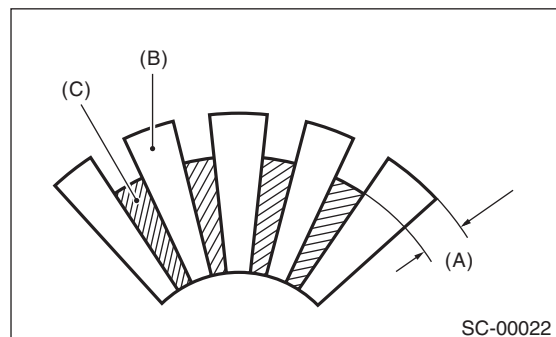

(A) Depth of mold

(B) Segment

(C) Mold

# Starter

## STARTING/CHARGING SYSTEMS

4) Place the armature on the growler tester to check for short circuits. While slowly turning the armature, support the steel sheet for the armature core. If the circuit of the armature is shorted, the steel sheet will vibrate, causing it to move towards the core. When the steel sheet has moved or vibrated, replace the armature.

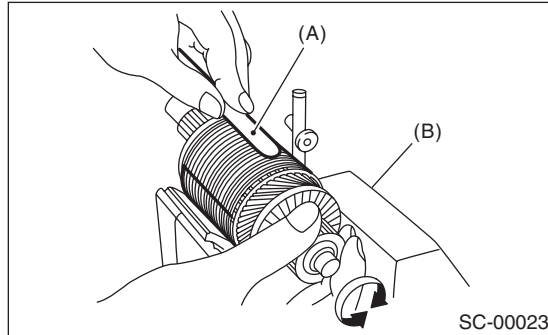

(A) Steel sheet  
(B) Growler tester

5) Use a circuit tester to touch the probe of one side to the commutator segment, and the other probe to the shaft. If there is continuity, replace the armature.

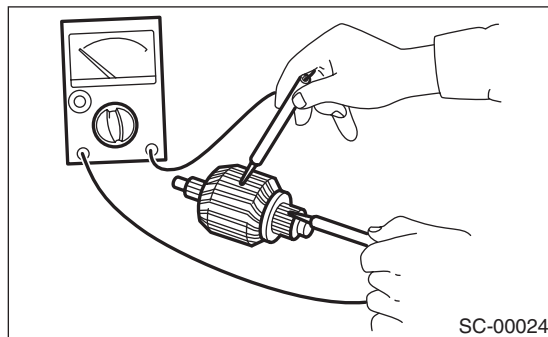

SC-00024

## 2. YOKE

Make sure that the pole is set at the predetermined position.

## 3. OVERRUNNING CLUTCH

Check that there is no wear or damage to the piston teeth. Replace the overrunning clutch if it is damaged.

Check that it rotates smoothly when rotated in the correct direction (counterclockwise) and does not return to the other direction. Replace the overrunning clutch if any fault is found.

### CAUTION:

To prevent spilling of grease, do not clean the overrunning clutch with oil.

## 4. BRUSH AND BRUSH HOLDER

1) Measure the length of the brush. Replace if it exceeds service limits or there is abnormal wear or cracks.

### Brush length:

#### Standard

12.3 mm (0.484 in)

#### Limit

7.0 mm (0.276 in)

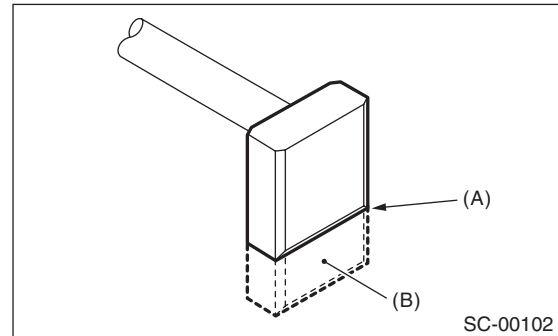

(A) Service limit line  
(B) Brush

2) Check that the brush moves smoothly in the brush holder.

3) Measure the brush spring force with a spring scale. Replace the brush holder if below the service limit.

### Brush spring force:

#### Standard

15.9 — 19.5 N (1.62 — 1.99 kgf, 3.57 — 4.38 lbf) (When new)

#### Limit

2.5 N (0.25 kgf, 0.56 lbf)

### 5. SWITCH ASSEMBLY

Using a circuit tester (set to "ohm"), check that there is continuity between terminals S and M, and between terminal S and ground.

Also check to be sure there is no continuity between M terminal and B.

#### **Resistance between switch assembly terminals:**

Terminals	Standard
S — M	1 $\Omega$ or less
S — Ground	1 $\Omega$ or less
M — B	1 M $\Omega$ or more

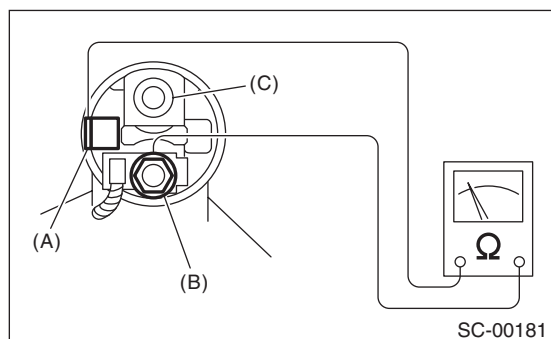

- (A) S terminal
- (B) M terminal
- (C) B terminal

### 6. SWITCH ASSEMBLY OPERATION

1) Using a lead wire, connect the terminal S of switch assembly to positive terminal of battery, and starter body to ground terminal of battery. The pinion should be forced endwise on shaft.

#### NOTE:

With the pinion forced endwise on shaft, starter motor can sometimes rotate because current flows, through pull-in coil, to motor. This is not a problem.

2) Disconnect the connector from terminal M. Then using a lead wire, connect the positive terminal of battery and terminal M, and ground terminal to starter body.

In this test set up, the pinion should return to its original position even when it is pulled out with a screwdriver.

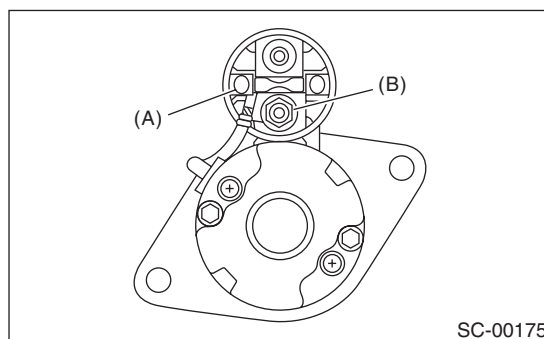

- (A) Terminal S
- (B) Terminal M

# Starter

## STARTING/CHARGING SYSTEMS

### 7. PERFORMANCE TEST

The starter should be submitted to performance tests whenever it has been overhauled, to assure its satisfactory performance when installed on the engine.

Three performance tests, no-load test, load test, and lock test, are presented here; however, if the load test and lock test cannot be performed, carry out at least the no-load test.

For these performance tests, use the circuit shown in figure.

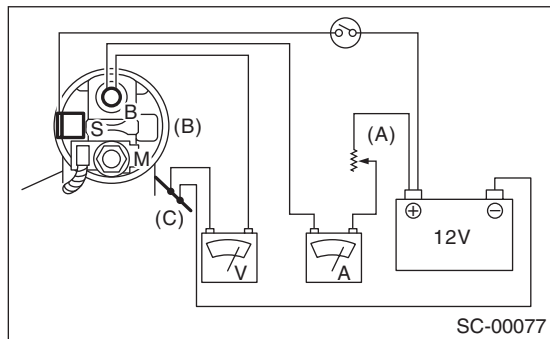

- (A) Variable resistance
- (B) Magnet switch
- (C) Starter body

1) Adjust the variable resistance with the switch on until the voltage is 11 V, and read the value displayed by the ammeter to measure starter speed. Compare these values with the standard.

#### No-load test (standard):

##### Voltage/Current

**6MT**

**Max. 11 V/90 A or less**

**5MT**

**Max. 11 V/95 A or less**

##### Rotating speed

**6MT**

**2,860 rpm or more**

**5MT**

**2,500 rpm or more**

2) Apply the specified braking torque to starter. The condition is normal if the current draw and starter speed are within standard.

#### Load test (standard):

##### Voltage/Load

**6MT**

**8 V/9.3 N·m (0.9 kgf-m, 6.9 ft-lb) or more**

**5MT**

**7.5 V/8.84 N·m (0.9 kgf-m, 6.5 ft-lb) or more**

##### Current/Speed

**6MT**

**280 A/860 rpm or more**

**5MT**

**300 A/870 rpm or more**

3) With the starter stalled, or not rotating, measure the torque developed and current draw when the voltage is adjusted to standard voltage.

#### Lock test (standard):

##### Voltage/Current

**6MT**

**4 V/515 A or less**

**5MT**

**4 V/680 A or less**

##### Torque

**6MT**

**16 N·m (1.6 kgf-m, 11.8 ft-lb) or more**

**5MT**

**17 N·m (1.7 kgf-m, 12.5 ft-lb) or more**

### 8. OTHER INSPECTIONS

Check that the starter does not have deformation, cracks and any other damage.



## 3. Generator

### A: REMOVAL

- 1) Disconnect the ground cable from battery.

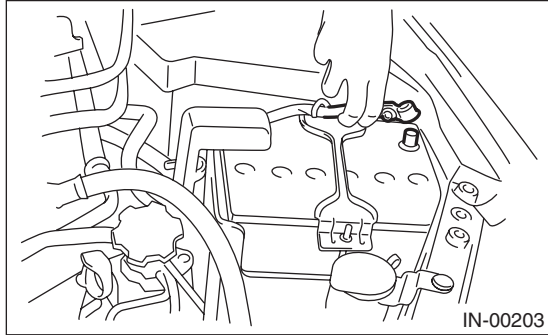

- 2) Remove the V-belt covers.

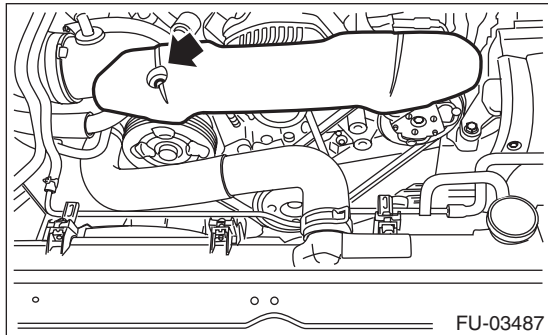

- 3) Disconnect the connector and terminal from generator.

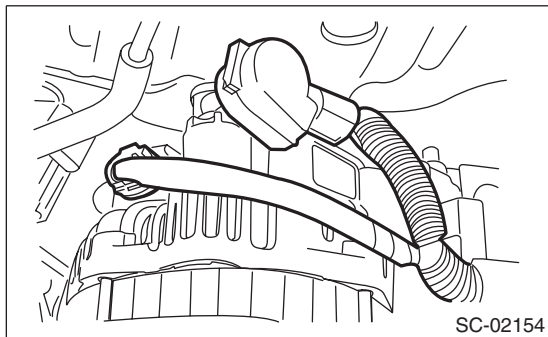

- 4) Remove the front side belts. <Ref. to ME(STI)-40, FRONT SIDE BELT, REMOVAL, V-belt.> <Ref. to ME(w/o STI)-39, FRONT SIDE BELT, REMOVAL, V-belt.>

- 5) Remove the bolts which install the generator onto bracket.

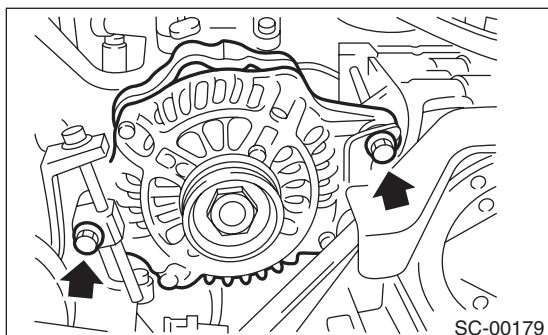

### B: INSTALLATION

Install in the reverse order of removal.

#### CAUTION:

Check and adjust the front side belt tension. <Ref. to ME(STI)-46, FRONT SIDE BELT, INSPECTION, V-belt.> <Ref. to ME(w/o STI)-45, FRONT SIDE BELT, INSPECTION, V-belt.>

#### Tightening torque:

25 N·m (2.5 kgf·m, 18.4 ft·lb)

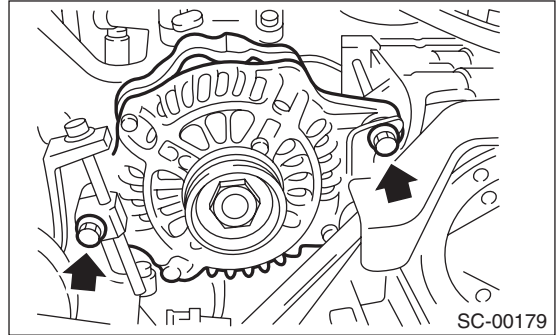

#### Tightening torque:

13 N·m (1.3 kgf·m, 9.6 ft·lb)

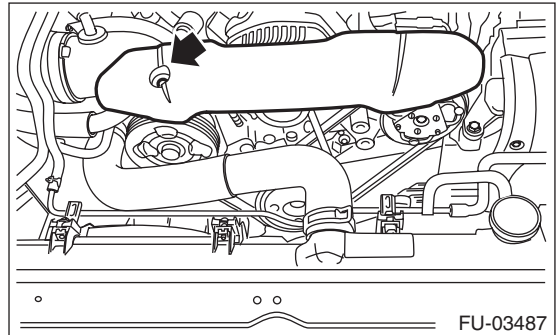

### C: DISASSEMBLY

- 1) Remove the four through-bolts.

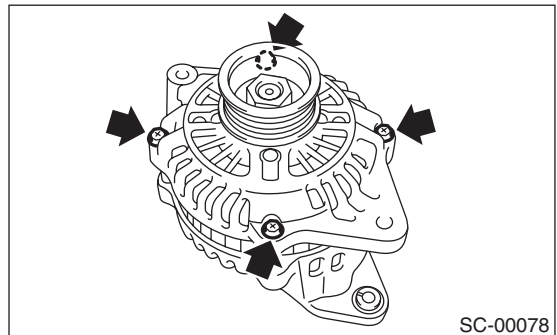



# Generator

## STARTING/CHARGING SYSTEMS

2) Use a drier to heat the rear cover (A) portion to 50°C (122°F).

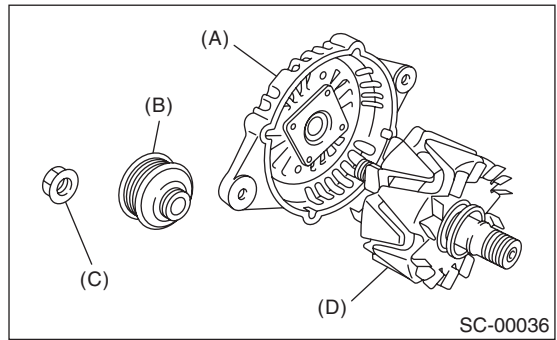
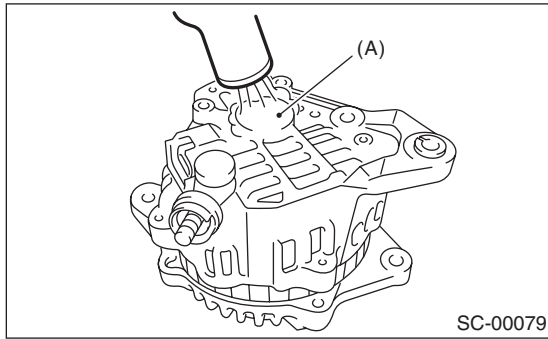

- (A) Front cover
- (B) Pulley
- (C) Pulley nut
- (D) Rotor

3) Insert the end of a flat tip screwdriver into the gap between stator core and front cover. Pry them apart to disassemble.

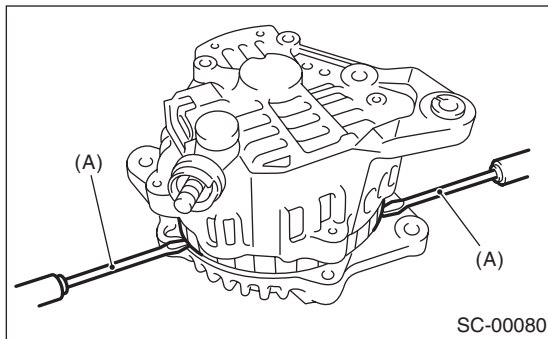

(A) Screwdriver

4) Using a vise, support the rotor and remove the pulley nut, and remove the rotor from the front cover.

### CAUTION:

When holding the rotor with a vise, place aluminum plates or wooden pieces on the vise jaws to prevent rotor from damage.

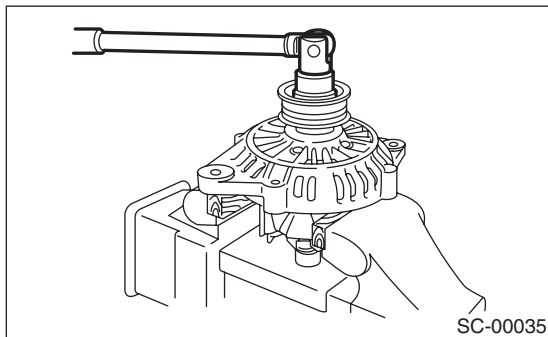

5) Use the following procedures to remove the ball bearings.

(1) Remove the bolt, and then detach the bearing retainer.

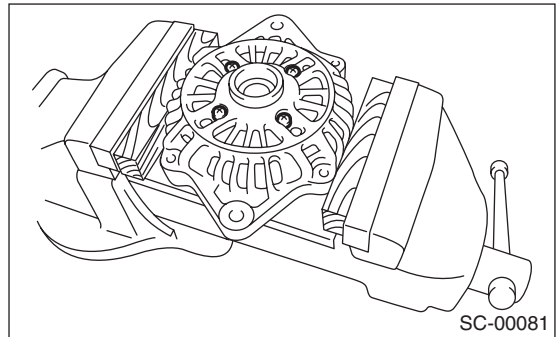

(2) Firmly attach an appropriate tool (such as a correct size socket wrench) to the bearing inner race.

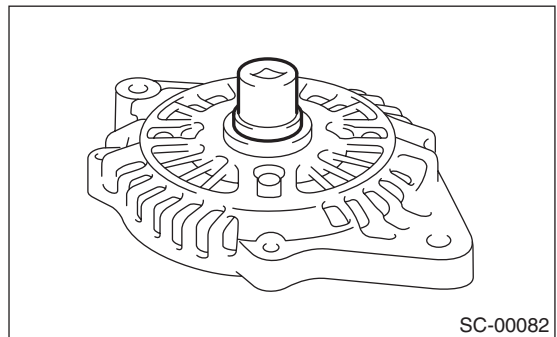

(3) Use the press to push the ball bearings out from the front cover.

6) Using the bearing puller, remove the bearings from the rotor.

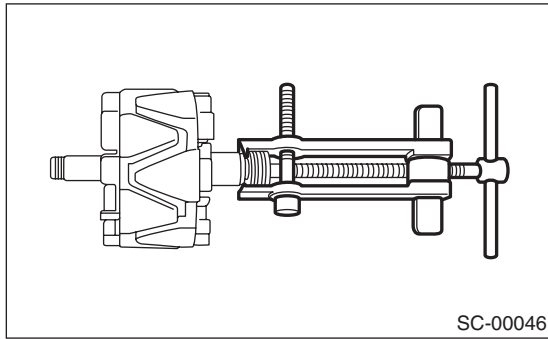

7) Disconnect the connection between the rectifier and stator coil, then remove the stator coil.

**CAUTION:**

The rectifier is easily damaged by heat. Do not allow a 180 — 270 W soldering iron to contact the terminals for 5 seconds or more at a time.

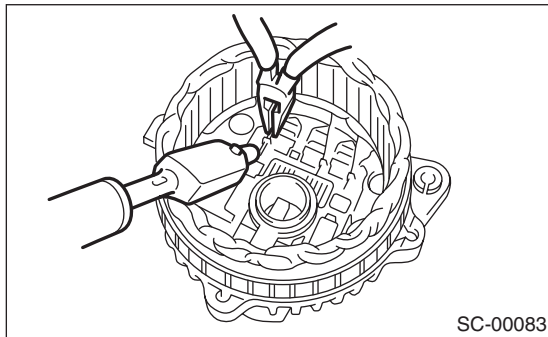

8) Use the following procedures to remove the IC regulator.

(1) Remove the screws which secure the IC regulator to the rear cover.

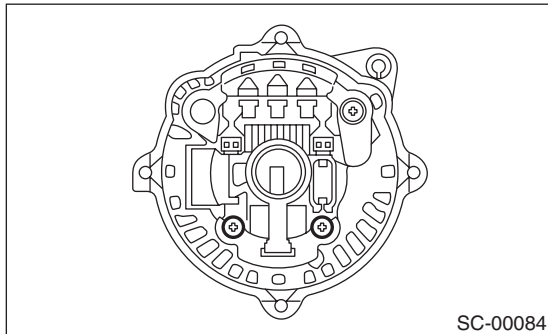

(2) Disconnect the connection between the IC regulator and rectifier, then remove the IC regulator.

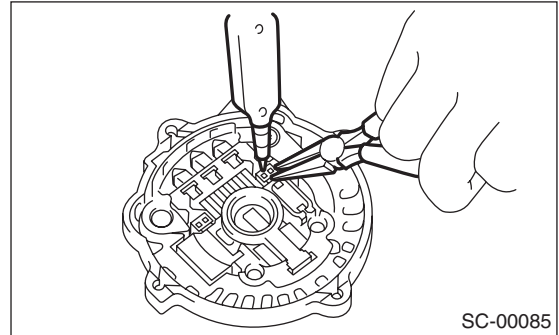

9) Use the following procedures to remove the brush.

(1) Remove the cover A.

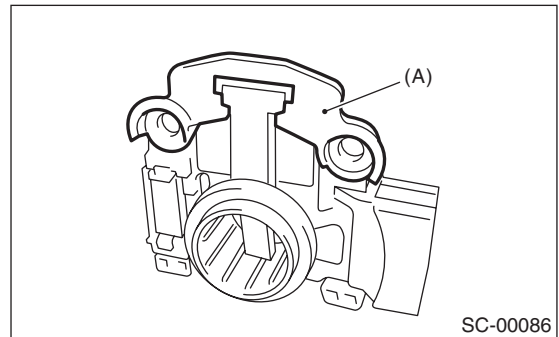

(A) Cover A

(2) Remove the cover B.

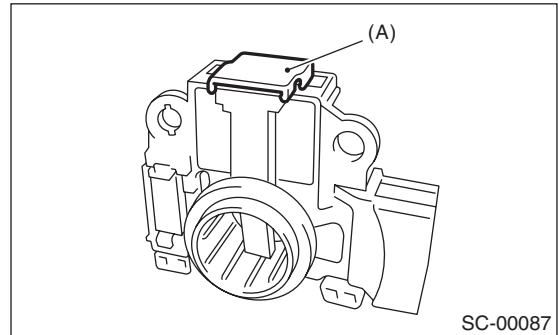

(A) Cover B

(3) Disconnect the connection and remove the brush.

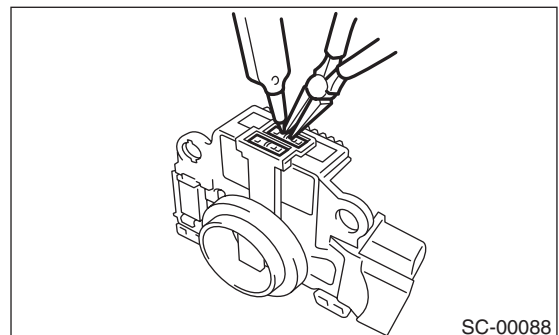

# Generator

## STARTING/CHARGING SYSTEMS

10) Remove the rectifier as follows.

(1) Remove the bolts which secure the rectifier.

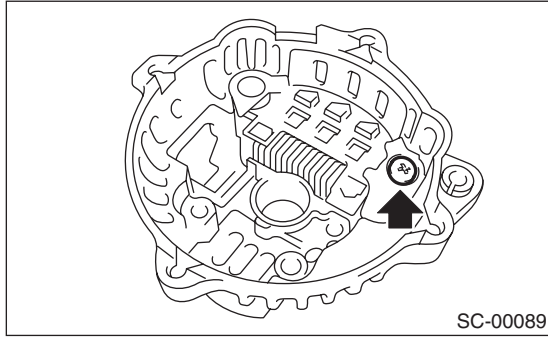

(2) Remove the cover on terminal B.

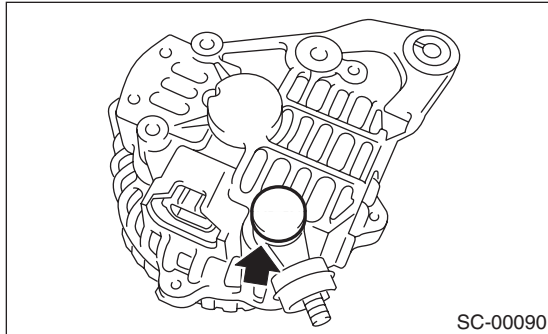

(3) Remove the nuts of terminal B, then remove the rectifier.

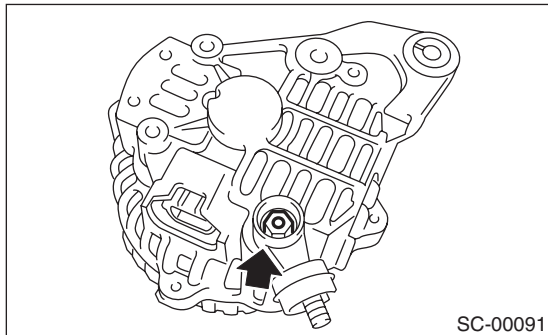

## D: ASSEMBLY

Assemble in the reverse order of disassembly.

### NOTE:

- Refer to component for tightening torque of each part. <Ref. to SC(STI)-5, GENERATOR, COMPONENT, General Description.>

- After assembling, manually turn the pulley to check that the rotor rotates smoothly.

1) Push of the brush

Before assembling the front and rear parts, press the brush down into the brush holder, then fix the brush in that position by inserting a [1 mm (0.08 in) dia., 40 — 50 mm (1.6 — 2.0 in) long] wire through the hole as shown in the figure.

### CAUTION:

After assembling, remove the wire.

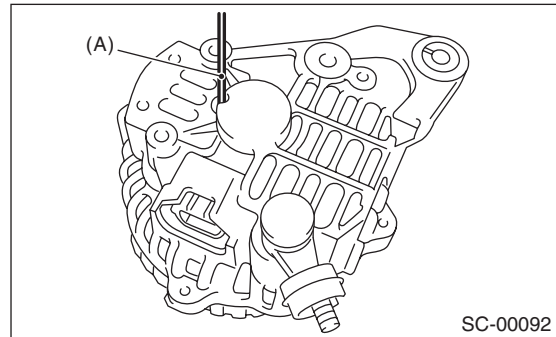

(A) Wire

2) Install the ball bearings.

(1) Set the ball bearings in the front cover, then securely install an appropriate tool (such as a socket wrench of proper size) to the bearing outer race.

(2) Using a press to press the ball bearings into the specified location.

(3) Install the bearing retainer.

3) Install the bearings.

### CAUTION:

Do not apply grease to the bearings. If there is any oil on the bearing box, remove it completely.

(1) Use a press to install the bearings to the rotor shaft.

(2) Heat the bearing box in rear cover at 50 to 60°C (122 to 140°F), and then press the bearing into rear cover.

**E: INSPECTION****1. DIODE****CAUTION:**

There is the possibility of damaging the diodes if a mega-tester (used to measure high voltages) or a similar measuring instrument is used. Never use a mega tester or equivalent for this test.

1) Check for continuity between the diode lead and positive side heat sink. If resistance is  $1\ \Omega$  or more only in the direction from the diode lead to the heat sink, replace the rectifier.

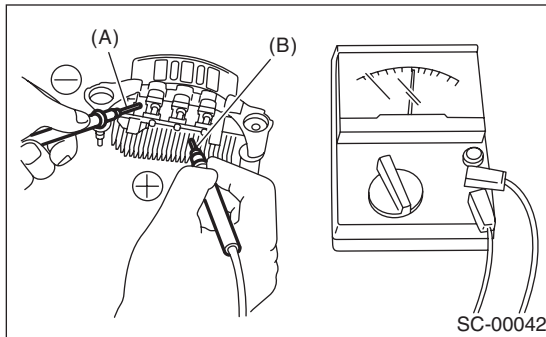

- (A) Diode lead  
(B) Heat sink (positive side)

2) Check for continuity between the negative side heat sink and diode lead. If resistance is  $1\ \Omega$  or more only in the direction from the heat sink to the diode lead, replace the rectifier.

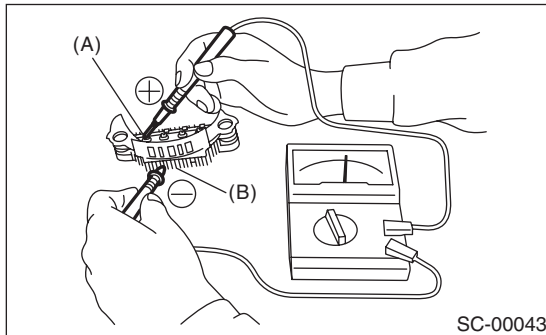

- (A) Diode lead  
(B) Heat sink (negative side)

**2. ROTOR**

1) Inspect the slip rings for contamination or any roughness on the sliding surface. Repair the slip ring surface using a lathe or sand paper.

2) Measure the slip ring outer diameter. Replace the rotor if the slip ring is worn.

**Slip ring outer diameter:****Standard**

**22.7 mm (0.894 in)**

**Limit**

**22.1 mm (0.870 in)**

3) Using a circuit tester, check the resistance between slip rings. If resistance exceeds the standard, replace the rotor.

**Standard:**

**Approx. 1.8 — 2.2  $\Omega$**

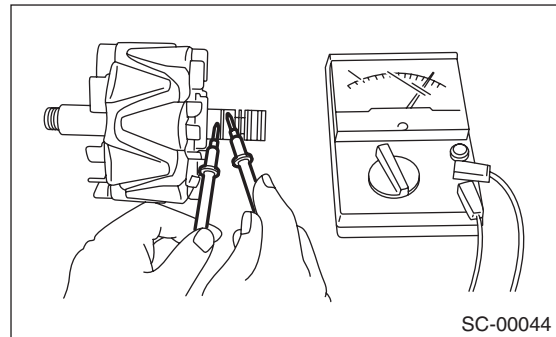

4) Check the continuity between slip ring and rotor core or shaft. If there is continuity, replace the rotor because the rotor coil is grounded.

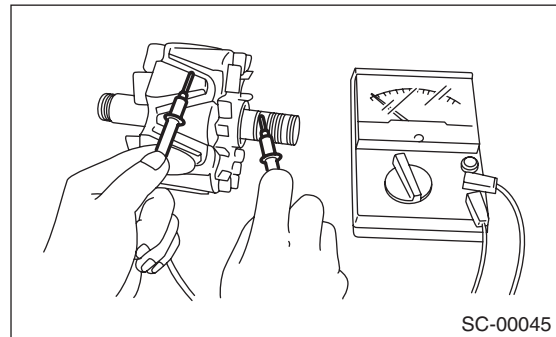

5) Check the bearings. If there is any noise, or the rotor does not rotate smoothly, replace the bearings.

# Generator

## STARTING/CHARGING SYSTEMS

### 3. STATOR COIL

1) Inspect continuity between the stator coil lead wire terminals. If the resistance is  $1\text{ M}\Omega$  or more, replace the stator coil.

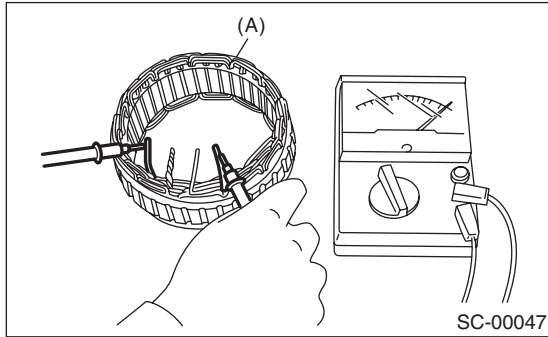

(A) Stator coil

2) Inspect the continuity between the stator coil stator core and lead wire terminals. If the resistance is  $1\ \Omega$  or less, replace the stator coil.

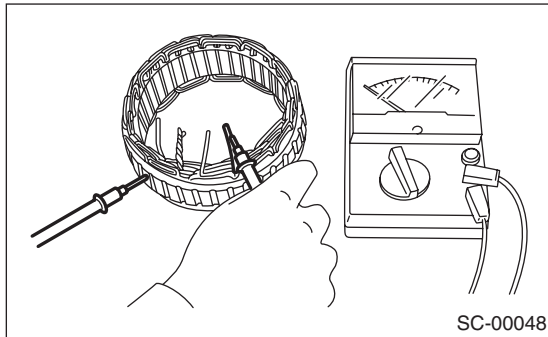

### 4. BRUSH

1) Measure the length of each brush. Replace the brush if wear exceeds service limits. There is a service limit mark (A) on each brush.

#### **Brush length:**

##### **Standard (1)**

**18.5 mm (0.728 in)**

##### **Limit (2)**

**5.0 mm (0.197 in)**

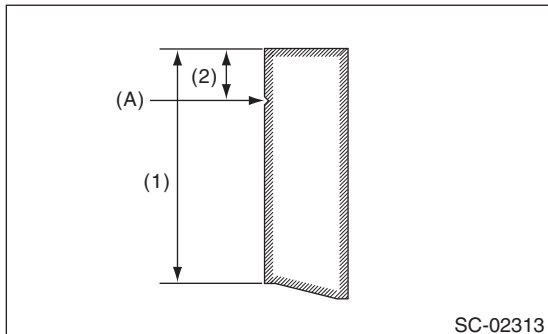

2) Using a spring pressure indicator, push the brush into the brush holder until its tip protrudes 2 mm (0.08 in). Then measure the pressure of brush spring. If the pressure is 2.648 N (270 g, 9.52 oz) or less, replace the brush spring with a new part. 4.609 — 5.786 N (470 — 590 g, 16.58 — 20.810 oz) pressure is required on the new spring.

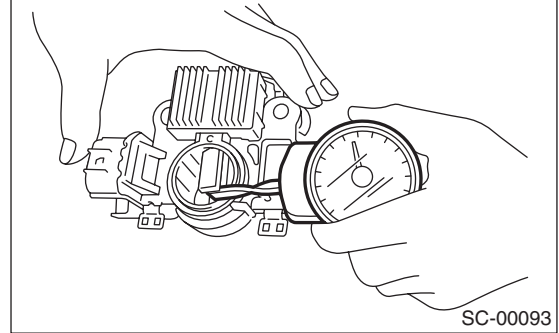

### 5. BALL BEARING

Check the ball bearings. Replace the ball bearings if there is resistance in the rotation, or if there is any abnormal noise.

### 6. OTHER INSPECTIONS

Check that the generator does not have deformation, cracks and any other damage.

## 4. Battery

### A: REMOVAL

- 1) Disconnect the positive (+) terminal after disconnecting the negative (-) terminal of battery.
- 2) Remove the harness clip of the negative terminal from the battery rod.
- 3) Remove the flange nut from battery rod and remove battery holder.

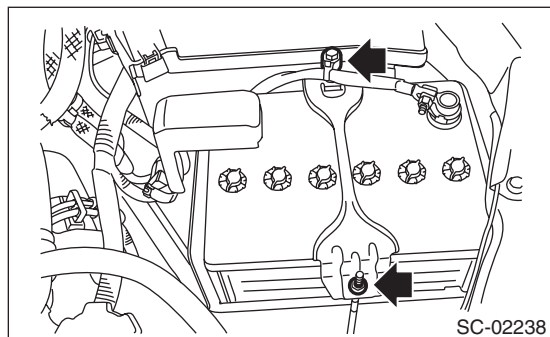

- 4) Remove the battery.

### B: INSTALLATION

Install in the reverse order of removal.

#### **Tightening torque:**

**3.5 N·m (0.4 kgf·m, 2.6 ft·lb)**

#### **NOTE:**

- Clean the battery cable terminals and apply grease to retard the formation of corrosion.
- Connect the positive (+) terminal, and then connect the negative (-) terminal of the battery.
- After the battery is installed, initial diagnosis of the electronic throttle control is performed. Wait for 10 seconds or more after turning the ignition switch to ON, and then start the engine.

### C: INSPECTION

#### **WARNING:**

- Electrolyte is corrosive acid, and has toxicity; be careful of handling the fluid.
- Make sure the electrode does not come into contact with skin, eyes or clothing. Especially at contact with eyes, flush with water for 15 minutes and get prompt medical attention.
- In addition, be careful not to let the electrode contact with the coated parts.
- Be careful when handling the batteries because they produce explosive gases.
- Be sure to keep battery away from any fire.
- For safety, in case an explosion does occur, wear eye protection or shield your eyes when working near any battery. In addition, never lean over the battery.
- Ventilate sufficiently when using or charging battery in enclosed space.
- Before starting work, remove rings, metal watch-bands, and other metal jewelry.
- Never allow metal tools to contact the positive battery terminal and anything connected to it while you are at the same time in contact with any other metallic portion of the vehicle.

#### **1. EXTERNAL PARTS**

Check the battery case, top cover, vent plugs, and terminal posts for dirt or cracks. If necessary, clean with water and wipe with a dry cloth.

Apply a thin coat of grease on the terminal posts to prevent corrosion.

#### **2. ELECTROLYTE LEVEL**

Check the electrolyte level in each cell. If the level is below MIN level, bring the level to MAX level by pouring distilled water into the battery cell. Do not fill beyond MAX level.



# Battery

## STARTING/CHARGING SYSTEMS

### 3. SPECIFIC GRAVITY OF ELECTROLYTE

1) Measure specific gravity of electrolyte using a hydrometer and a thermometer.

Specific gravity varies with temperature of electrolyte so that it must be corrected at 20°C (68°F) using the following calculation:

$$S_{20} = St + 0.0007 \times (t - 20)$$

*S<sub>20</sub>*: Specific gravity corrected at electrolyte temperature of 20°C (68°F)

*St*: Measured specific gravity

*t*: Measured temperature (°C)

**Judge whether or not the battery requires charging according to corrected specific gravity.**

**Standard specific gravity: 1.220 — 1.290 [at 20°C (68°F)]**

2) Measuring the specific gravity of the electrolyte in the battery will disclose the state of charge of the battery. The relation between specific gravity and state of charge is as shown in the figure.

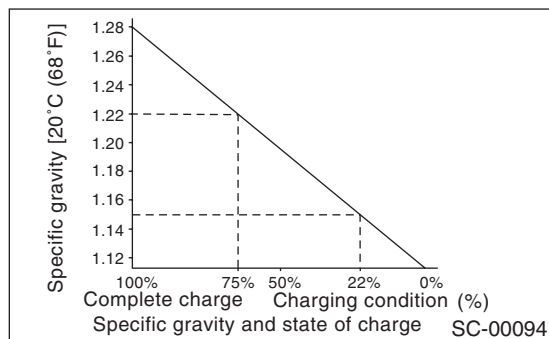

### D: MEASUREMENT

#### WARNING:

**Do not bring an open flame close to the battery when working.**

#### CAUTION:

- Prior to charging, corroded terminals should be cleaned with a brush and common caustic soda solution.
- Be careful since battery electrolyte overflows while charging the battery.
- Observe instructions when handling the battery charger.
- Before charging the battery on the vehicle, disconnect the battery ground terminal to prevent damage of generator diodes or other electrical units.

### 1. JUDGMENT OF BATTERY IN CHARGED CONDITION

1) Specific gravity of electrolyte should be held within the specific range of 1.250 — 1.290 for one hour or more.

2) Voltage per battery cell should be held at a specific value in a range of 2.5 — 2.8 V for one hour or more.

### 2. CHECK CONDITION OF CHARGE WITH HYDROMETER

Hydrometer indicator	State of charge	Corrective action
Green dot	65% or more	Load test
Dark dot	65% or less	Charge battery
Clear dot	Low electrolyte	Replace the battery.* (If cranking is difficult)

\* Check electrical system before replacement.

### 3. NORMAL CHARGING

Charge the battery at the current value specified by manufacturer or at approximately 1/10 of battery's ampere-hour rating.

### 4. QUICK CHARGING

#### CAUTION:

- Observe the items in "3. NORMAL CHARGING".
- Never use 10 A or more when charging the battery because it will shorten the battery life.

Quick charging is a method that the battery is charged in a short period of time with a relatively large current by using a quick charger.

Since a large current flow raises electrolyte temperature, the battery is subject to damage if the large current is used for prolonged time. For this reason, quick charging must be carried out within a current range that will not raise the electrolyte temperature to 40°C (104°F) or more.

Also the quick charging is a temporary mean to bring battery voltage up to some level, and battery should be charged slowly with low current as a rule.

**ENGINE 2 SECTION**

This service manual has been prepared to provide SUBARU service personnel with the necessary information and data for the correct maintenance and repair of SUBARU vehicles.

This manual includes the procedures for maintenance, disassembling, reassembling, inspection and adjustment of components and diagnostics for guidance of experienced mechanics.

Please peruse and utilize this manual fully to ensure complete repair work for satisfying our customers by keeping their vehicle in optimum condition. When replacement of parts during repair work is needed, be sure to use SUBARU genuine parts.

All information, illustration and specifications contained in this manual are based on the latest product information available at the time of publication approval.

**FUEL INJECTION (FUEL SYSTEMS) FU(w/o STI)**

**EMISSION CONTROL (AUX. EMISSION CONTROL DEVICES) EC(w/o STI)**

**INTAKE (INDUCTION) IN(w/o STI)**

**MECHANICAL ME(w/o STI)**

**EXHAUST EX(w/o STI)**

**COOLING CO(w/o STI)**

**LUBRICATION LU(w/o STI)**

**SPEED CONTROL SYSTEMS SP(w/o STI)**

**IGNITION IG(w/o STI)**

**STARTING/CHARGING SYSTEMS SC(w/o STI)**



# FUEL INJECTION (FUEL SYSTEMS)

# *FU(w/o STI)*

---

	<b>Page</b>
1. General Description .....	2
2. Throttle Body .....	15
3. Intake Manifold .....	18
4. Engine Coolant Temperature Sensor .....	35
5. Crankshaft Position Sensor .....	36
6. Camshaft Position Sensor .....	38
7. Knock Sensor .....	40
8. Throttle Position Sensor .....	42
9. Mass Air Flow and Intake Air Temperature Sensor .....	43
10. Manifold Absolute Pressure Sensor .....	44
11. Fuel Injector .....	46
12. Tumble Generator Valve Assembly .....	49
13. Tumble Generator Valve Actuator .....	50
14. Oil Flow Control Solenoid Valve .....	51
15. Wastegate Control Solenoid Valve .....	52
16. Front Oxygen (A/F) Sensor .....	54
17. Rear Oxygen Sensor .....	56
18. Engine Control Module (ECM) .....	58
19. Main Relay .....	59
20. Fuel Pump Relay .....	61
21. Electronic Throttle Control Relay .....	63
22. Fuel Pump Control Unit .....	65
23. Fuel .....	66
24. Fuel Tank .....	69
25. Fuel Filler Pipe .....	76
26. Fuel Pump .....	79
27. Fuel Level Sensor .....	81
28. Fuel Sub Level Sensor .....	82
29. Fuel Filter .....	84
30. Fuel Damper .....	88
31. Purge Damper .....	89
32. Fuel Delivery, Return and Evaporation Lines .....	90
33. Fuel System Trouble in General .....	96

# General Description

FUEL INJECTION (FUEL SYSTEMS)

---

## 1. General Description

### A: SPECIFICATION

Fuel tank	Capacity	64 ℓ (16.9 US gal, 14.1 Imp gal)
	Location	Under rear seat
Fuel pump	Type	Impeller
	Shutoff discharge pressure	550 — 850 kPa (5.61 — 8.67 kgf/cm <sup>2</sup> , 79.8 — 123.3 psi)
	Discharge rate	155 ℓ (40.9 US gal, 34.1 Imp gal)/h or more [12 V at 300 kPa (3.06 kgf/cm <sup>2</sup> , 43.5 psi)]
Fuel filter		In-tank type

### B: COMPONENT

#### 1. INTAKE MANIFOLD

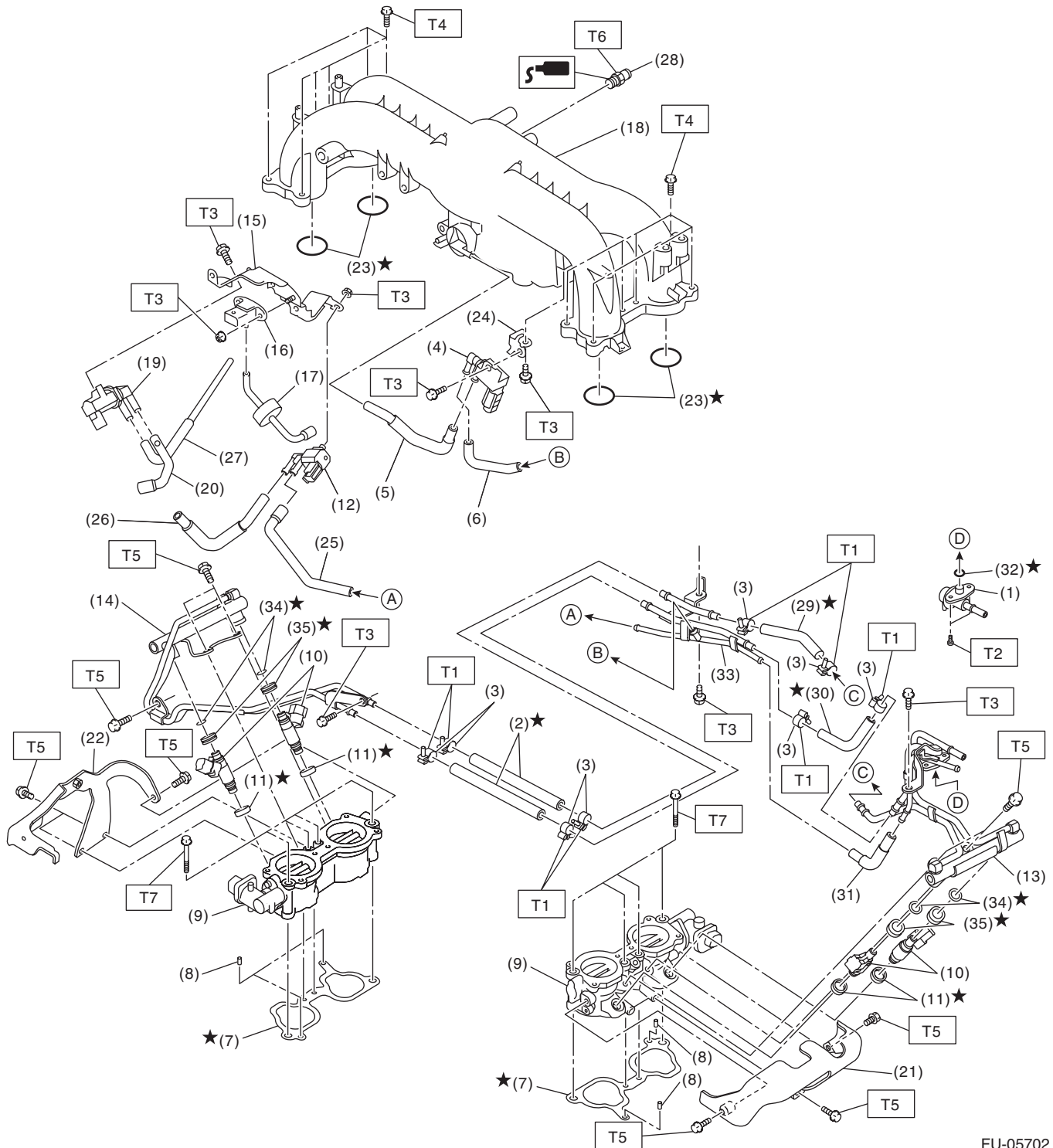

FU-05702

## General Description

### FUEL INJECTION (FUEL SYSTEMS)

---

(1) Pressure regulator	(16) Manifold absolute pressure sensor	(31) Vacuum hose
(2) Fuel hose A	(17) Filter	(32) O-ring
(3) Clamp	(18) Intake manifold	(33) Fuel pipe
(4) Purge control solenoid valve 1	(19) Wastegate control solenoid valve ASSY	(34) O-ring
(5) Vacuum hose D	(20) Vacuum hose	(35) Rubber
(6) Vacuum hose C	(21) Fuel pipe protector LH	
(7) Intake manifold gasket	(22) Fuel pipe protector RH	
(8) Guide pin	(23) O-ring	
(9) Tumble generator valve ASSY	(24) Solenoid valve bracket	
(10) Fuel injector	(25) Vacuum hose B	
(11) Seal ring	(26) Vacuum hose A	
(12) Purge control solenoid valve 2	(27) Air control hose	
(13) Fuel injector pipe LH	(28) Nipple	
(14) Fuel injector pipe RH	(29) Fuel hose B	
(15) Solenoid valve bracket	(30) Fuel hose C	

---

**Tightening torque:N-m (kgf-m, ft-lb)****T1: 1.25 (0.1, 0.9)****T2: 3.5 (0.4, 2.6)****T3: 6.4 (0.7, 4.7)****T4: 8.3 (0.8, 6.1)****T5: 19 (1.9, 14.0)****T6: 23 (2.3, 17.0)****T7: 25 (2.5, 18.4)**

---

## 2. AIR INTAKE SYSTEM

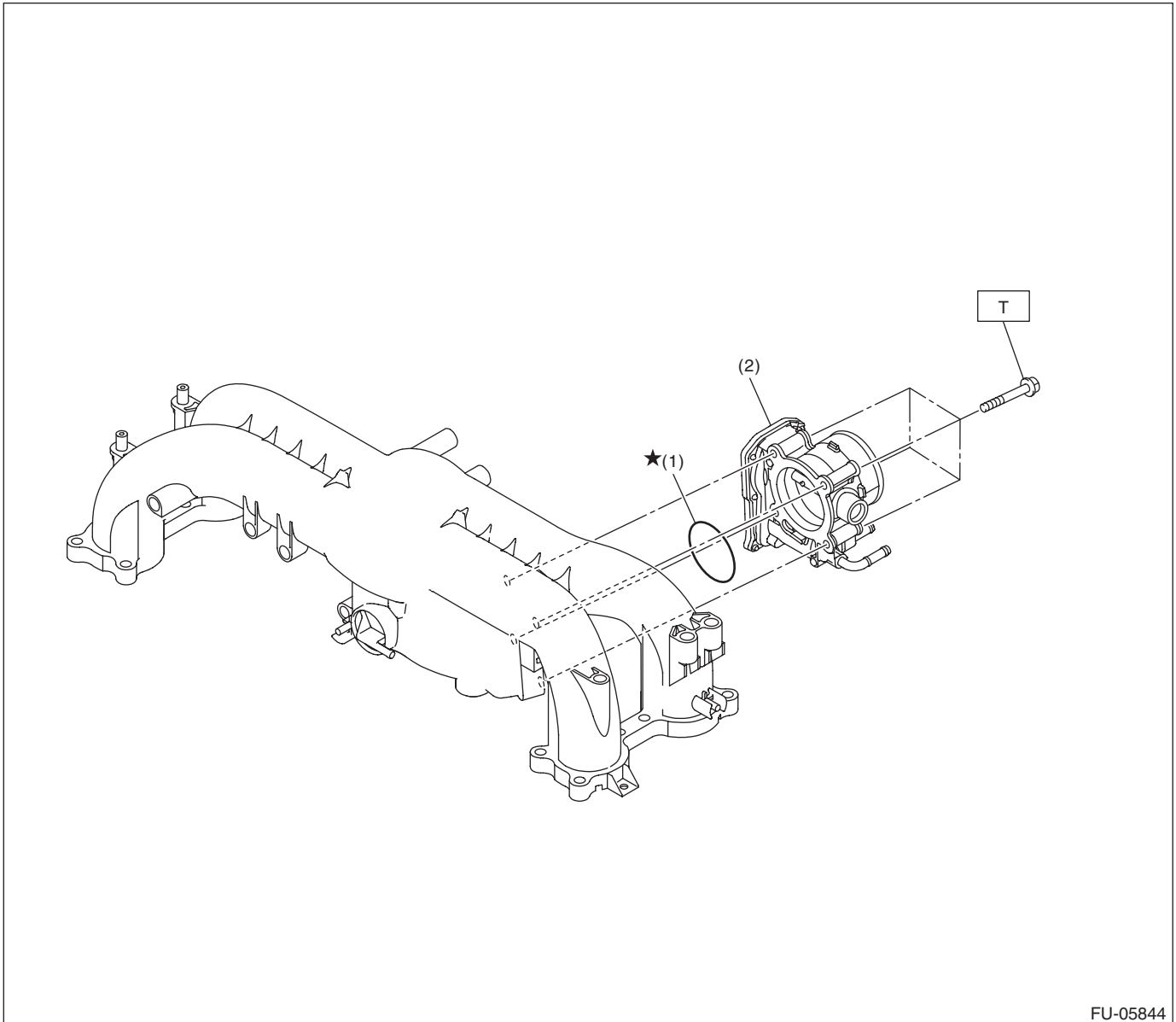

FU-05844

(1) O-ring

(2) Throttle body

**Tightening torque: N·m (kgf·m, ft·lb)**

**T: 8 (0.8, 5.9)**

# General Description

FUEL INJECTION (FUEL SYSTEMS)

## 3. CRANKSHAFT POSITION, CAMSHAFT POSITION AND KNOCK SENSORS

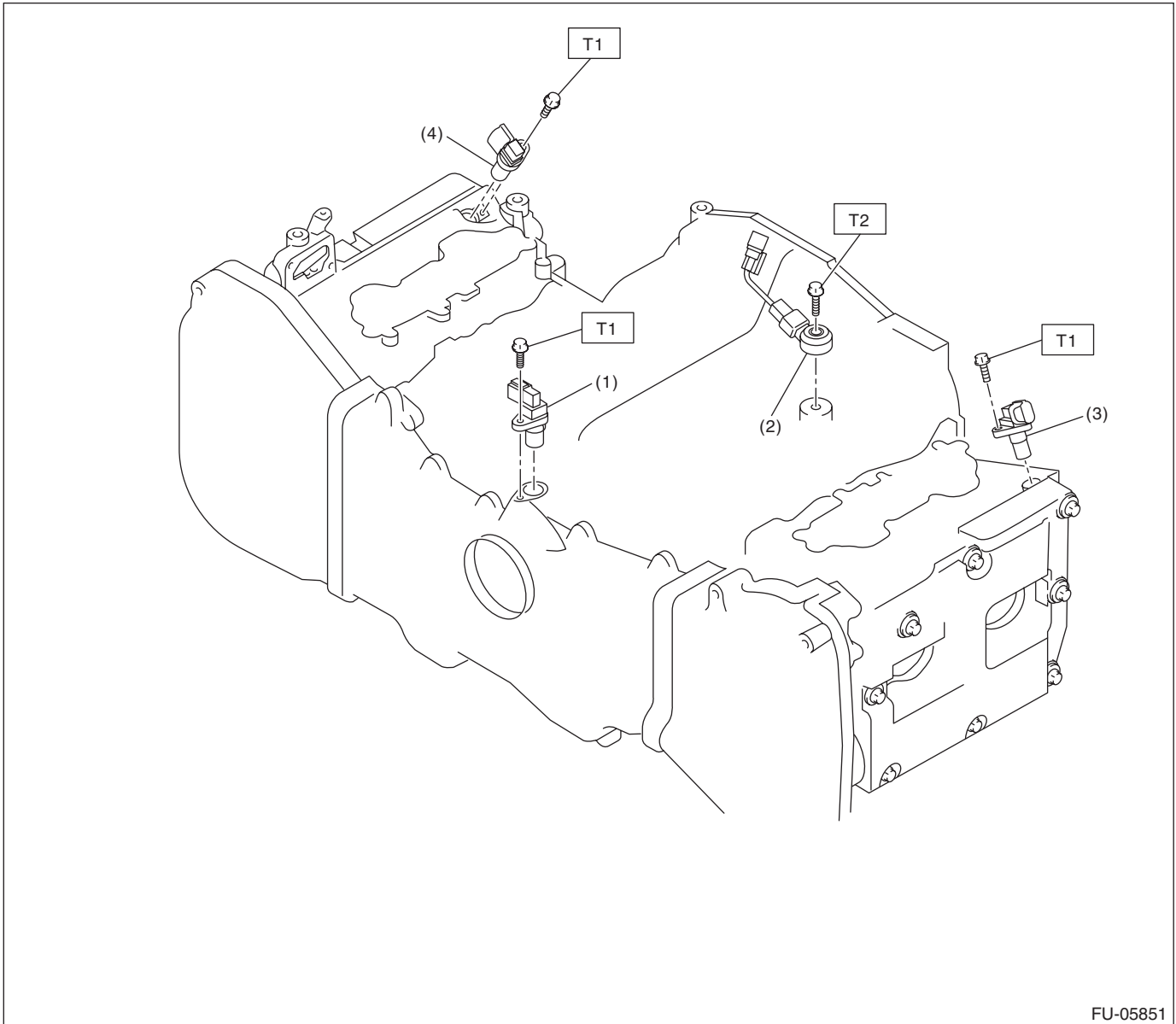

FU-05851

- (1) Crankshaft position sensor
- (2) Knock sensor

- (3) Camshaft position sensor LH
- (4) Camshaft position sensor RH

**Tightening torque: N·m (kgf-m, ft-lb)**

**T1: 6.4 (0.7, 4.7)**

**T2: 24 (2.4, 17.7)**

**FU(w/o STI)-6**

Brought to you by Ebay Seller "SubaruManuals"

# General Description

## 4. FUEL TANK

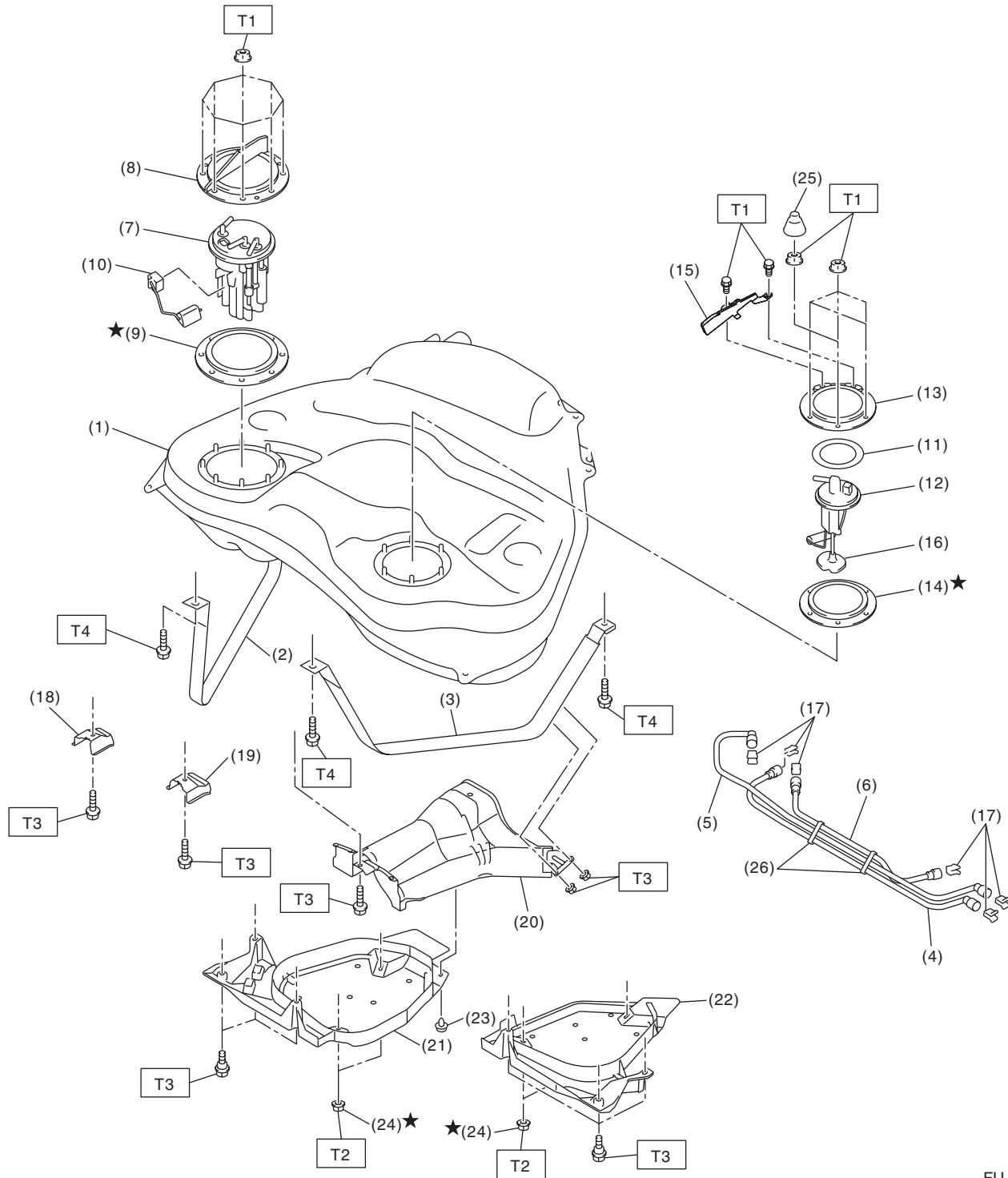

FU-06739

# General Description

## FUEL INJECTION (FUEL SYSTEMS)

---

(1) Fuel tank	(12) Fuel sub level sensor	(23) Clip
(2) Fuel tank band RH	(13) Fuel sub level sensor upper plate	(24) Self-locking nut
(3) Fuel tank band LH	(14) Fuel sub level sensor gasket	(25) Rubber cap
(4) Fuel delivery tube	(15) Fuel sub level sensor protector	(26) Tube clamp
(5) Fuel return tube	(16) Fuel sub level sensor filter	
(6) Jet pump tube	(17) Retainer	<hr/>
(7) Fuel pump ASSY	(18) Stopper RH	<b>Tightening torque:N-m (kgf-m, ft-lb)</b>
(8) Fuel pump upper plate	(19) Stopper LH	<b>T1: 4.4 (0.4, 3.2)</b>
(9) Fuel pump gasket	(20) Heat shield cover	<b>T2: 9 (0.9, 6.6)</b>
(10) Fuel level sensor	(21) Fuel tank protector RH	<b>T3: 18 (1.8, 13.3)</b>
(11) Fuel sub level sensor upper plate cushion	(22) Fuel tank protector LH	<b>T4: 33 (3.4, 24.3)</b>

---



# General Description

## 5. FUEL LINE

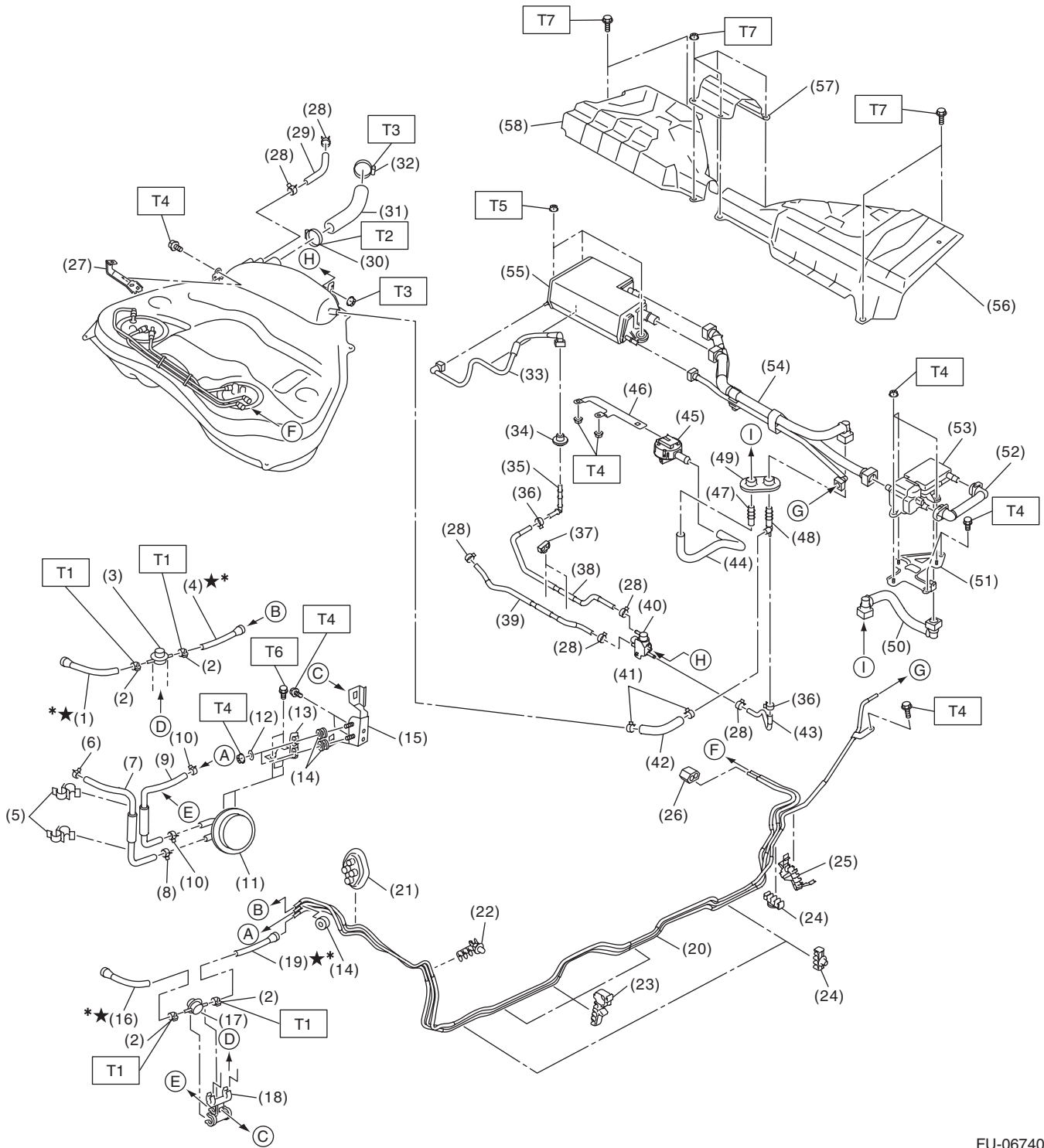

FU-06740

## General Description

### FUEL INJECTION (FUEL SYSTEMS)

---

(1) Fuel delivery hose A	(24) Pipe clamp	(47) Hose connector
(2) Clamp	(25) Pipe clamp	(48) Hose connector
(3) Fuel damper A	(26) Fuel pipe rear grommet	(49) Grommet
(4) Fuel delivery hose B	(27) Bracket	(50) Drain tube A
(5) Hose clamp	(28) Clip	(51) Leak check valve ASSY bracket
(6) Clip	(29) Evaporation hose C	(52) Drain tube B
(7) Evaporation hose A	(30) Clamp	(53) Leak check valve ASSY
(8) Clip	(31) Fuel filler hose	(54) Canister tube ASSY
(9) Evaporation hose B	(32) Clamp	(55) Canister
(10) Clip	(33) PCV drain tube	(56) Canister cover LH
(11) Purge damper	(34) Grommet	(57) Center canister cover
(12) Collar	(35) Hose connector	(58) Canister cover RH
(13) Purge damper bracket	(36) Clip	
(14) Bushing	(37) Hose clamp	<b><i>Tightening torque:N-m (kgf-m, ft-lb)</i></b>
(15) Damper bracket	(38) Evaporation hose D	<b><i>T1: 1.25 (0.1, 0.9)</i></b>
(16) Fuel return hose A	(39) Evaporation hose E	<b><i>T2: 2 (0.2, 1.5)</i></b>
(17) Fuel damper B	(40) Pressure control solenoid valve ASSY	<b><i>T3: 2.5 (0.3, 1.8)</i></b>
(18) Fuel damper holder	(41) Clip	<b><i>T4: 7.5 (0.8, 5.5)</i></b>
(19) Fuel return hose B	(42) Evaporation hose F	<b><i>T5: 8 (0.8, 5.9)</i></b>
(20) Fuel pipe ASSY	(43) Evaporation hose G	<b><i>T6: 13 (1.3, 9.6)</i></b>
(21) Fuel pipe front grommet	(44) Drain hose	<b><i>T7: 18 (1.8, 13.3)</i></b>
(22) Pipe clamp	(45) Drain separator	
(23) Pipe clamp	(46) Drain separator bracket	

\* It can be reused if the quick connector side is disconnected.

# General Description

FUEL INJECTION (FUEL SYSTEMS)

## 6. FUEL FILLER PIPE

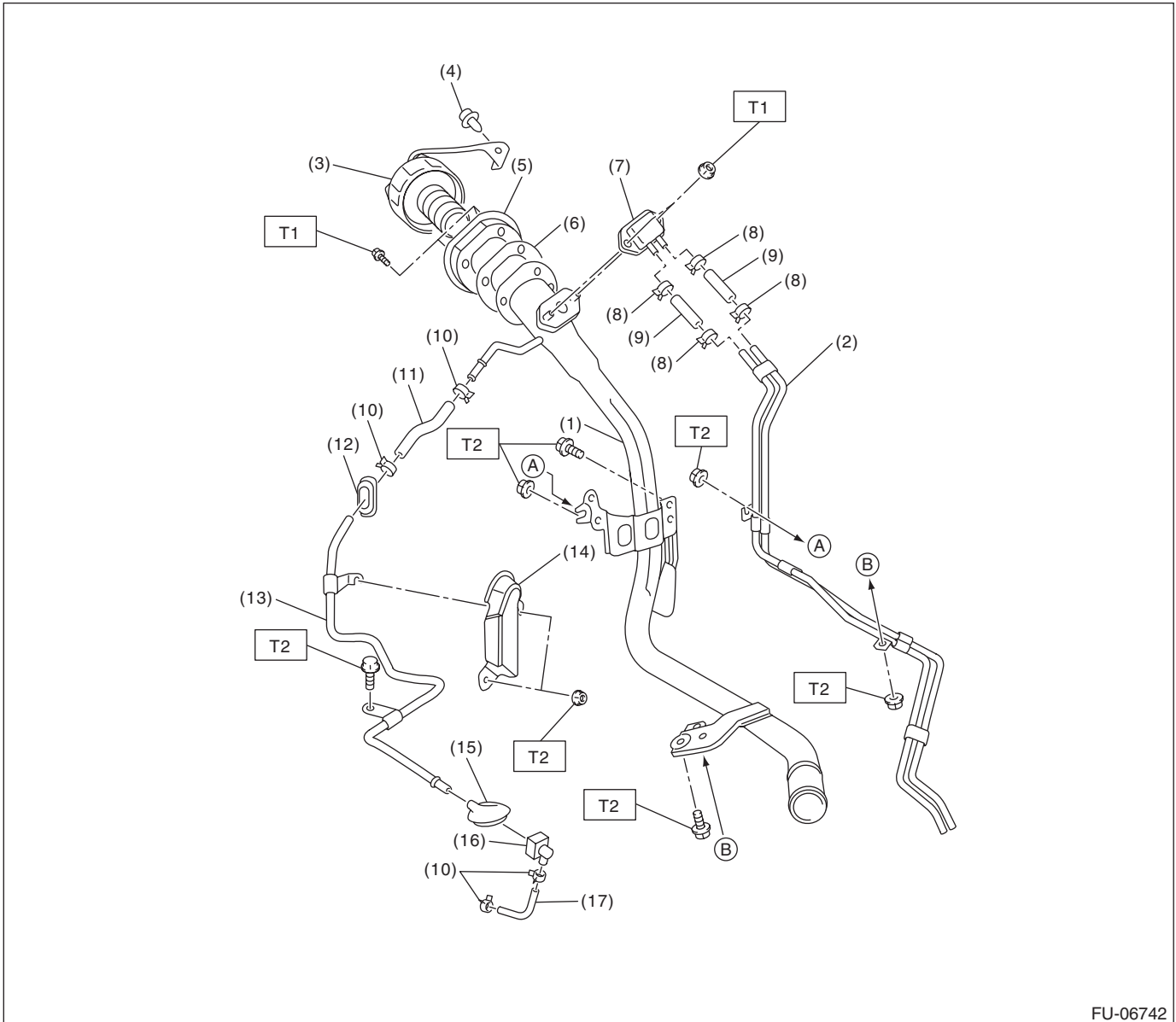

FU-06742

- |                        |                                 |                         |
|------------------------|---------------------------------|-------------------------|
| (1) Fuel filler pipe   | (8) Clip                        | (15) Grommet            |
| (2) Evaporation pipe A | (9) Evaporation hose A          | (16) Quick connector    |
| (3) Fuel filler cap    | (10) Clip                       | (17) Evaporation hose C |
| (4) Clip               | (11) Evaporation hose B         |                         |
| (5) Filler ring        | (12) Grommet                    |                         |
| (6) Filler pipe gasket | (13) Evaporation pipe B         |                         |
| (7) Shut valve         | (14) Evaporation pipe protector |                         |

**Tightening torque: N·m (kgf-m, ft-lb)**

**T1: 4.4 (0.4, 3.2)**

**T2: 7.5 (0.8, 5.5)**

**FU(w/o STI)-11**

Brought to you by Ebay Seller "SubaruManuals"

# General Description

## FUEL INJECTION (FUEL SYSTEMS)

### 7. FUEL PUMP

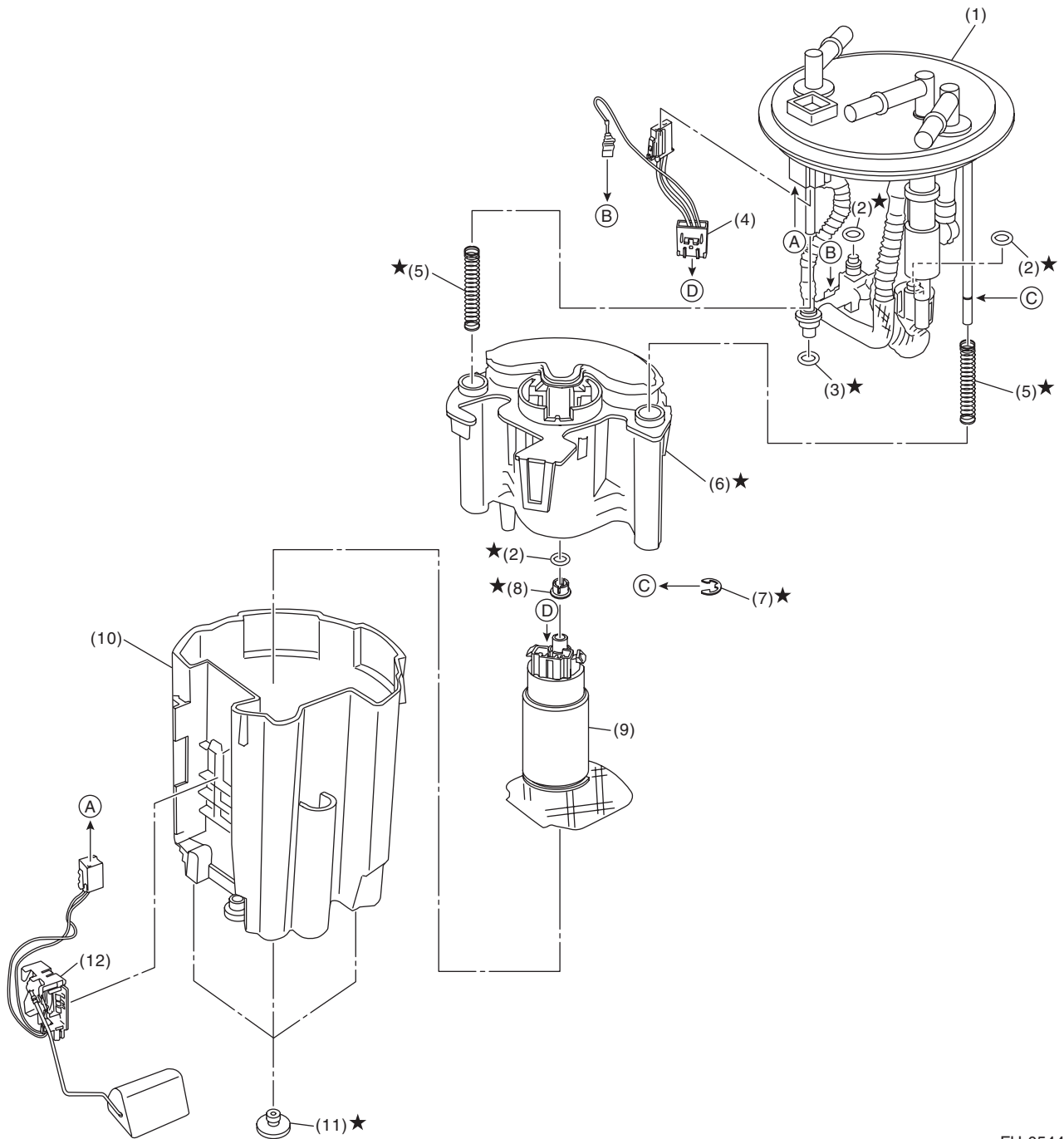

FU-05444

- |                           |                 |                        |
|---------------------------|-----------------|------------------------|
| (1) Sub tank bracket ASSY | (5) Spring      | (9) Pump ASSY          |
| (2) O-ring                | (6) Fuel filter | (10) Sub tank          |
| (3) O-ring                | (7) Clip        | (11) Cushion           |
| (4) Fuel pump harness     | (8) Spacer      | (12) Fuel level sensor |

# General Description

FUEL INJECTION (FUEL SYSTEMS)

## C: CAUTION

- Wear appropriate work clothing, including a cap, protective goggles and protective shoes when performing any work.
- Remove contamination including dirt and corrosion before removal, installation or disassembly.
- Keep the disassembled parts in order and protect them from dust and dirt.
- Before removal, installation or disassembly, be sure to clarify the failure. Avoid unnecessary removal, installation, disassembly and replacement.
- Vehicle components are extremely hot after driving. Be wary of receiving burns from heated parts.
- Be sure to tighten fasteners including bolts and nuts to the specified torque.
- Place shop jacks or rigid racks at the specified points.
- Before disconnecting connectors of sensors or units, be sure to disconnect the ground cable from battery.
- Place "NO OPEN FLAMES" signs near the working area.
- Prepare a container and cloth to prevent scattering of fuels when performing work where fuels can be spilled. If the oil spills, wipe it off immediately to prevent from penetrating into floor or flowing out for environmental protection.
- Follow all government and local regulations concerning disposal of refuse when disposing fuel.

## D: PREPARATION TOOL

### 1. SPECIAL TOOL

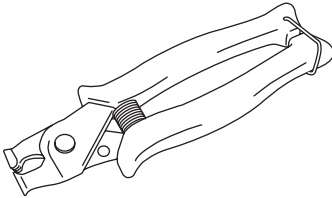
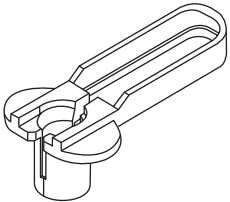
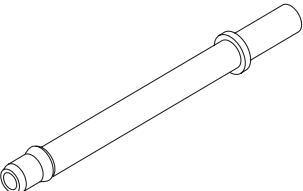
ILLUSTRATION	TOOL NUMBER	DESCRIPTION	REMARKS
 <p>ST18353AA000</p>	18353AA000	CLAMP PLIERS	<ul style="list-style-type: none"> <li>• Used for removing and installing the PCV hose.</li> <li>• This tool is made by the French company CAILLAU. (code) 54.0.000.205</li> </ul> To make it easier to obtain, it has been provided with a tool number.
 <p>ST18371AA000</p>	18371AA000	CONNECTOR REMOVER	Used for disconnecting the quick connector on the fuel return hose side of the engine compartment (intake manifold).
 <p>ST18471AA000</p>	18471AA000	FUEL PIPE ADAPTER	Used for draining fuel.

## General Description

### FUEL INJECTION (FUEL SYSTEMS)

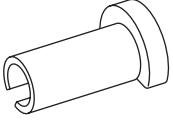
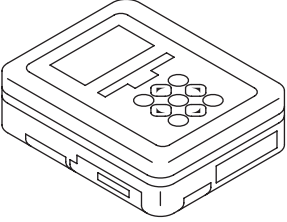
ILLUSTRATION	TOOL NUMBER	DESCRIPTION	REMARKS
  ST42099AE000	42099AE000	QUICK CONNecTOR RELEASE	Used for removing the quick connector.
  ST1B022XU0	1B022XU0	SUBARU SELECT MONITOR III KIT	Used for draining fuel and each inspection.

## 2. GENERAL TOOL

TOOL NAME	REMARKS
Circuit tester	Used for measuring resistance and voltage.
Oscilloscope	Used for inspecting the waveform of each sensor.

# Throttle Body

FUEL INJECTION (FUEL SYSTEMS)

## 2. Throttle Body

### A: REMOVAL

1) Disconnect the ground cable from battery.

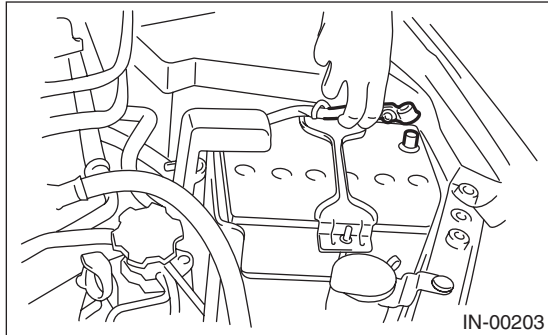

2) Lift up the vehicle.

3) Remove the under cover. <Ref. to EI-28, REMOVAL, Front Under Cover.>

4) Drain approximately 3.0 ℓ (3.2 US qt, 2.6 Imp qt) of coolant. <Ref. to CO(w/o STI)-13, DRAINING OF ENGINE COOLANT, REPLACEMENT, Engine Coolant.>

5) Remove the intercooler. <Ref. to IN(w/o STI)-12, REMOVAL, Intercooler.>

6) Disconnect the connectors from the throttle position sensor.

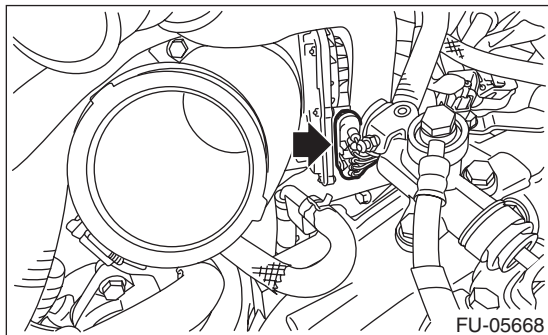

7) Remove the brake booster vacuum hose from the clip (A), and remove the bolts securing the air bypass pipe to the intake manifold.

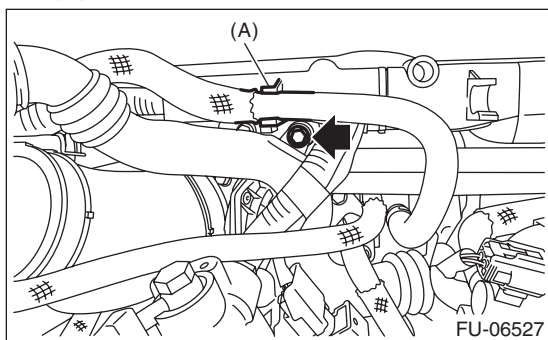

8) Remove the bolts securing the PCV pipe assembly to the intake manifold, and remove the intake duct from the throttle body.

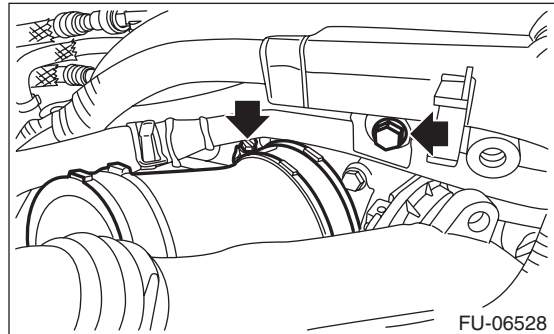

9) Disconnect the engine coolant hose from throttle body.

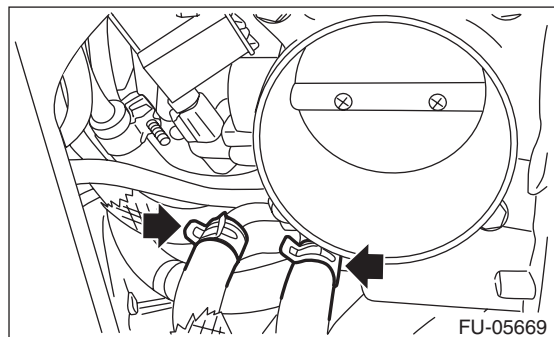

10) Remove the throttle body from the intake manifold.

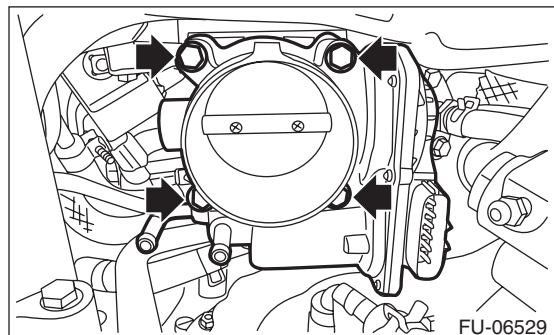

# Throttle Body

## FUEL INJECTION (FUEL SYSTEMS)

### B: INSTALLATION

Install in the reverse order of removal.

NOTE:

Use new O-rings.

**Tightening torque:**

**8 N·m (0.8 kgf-m, 5.9 ft-lb)**

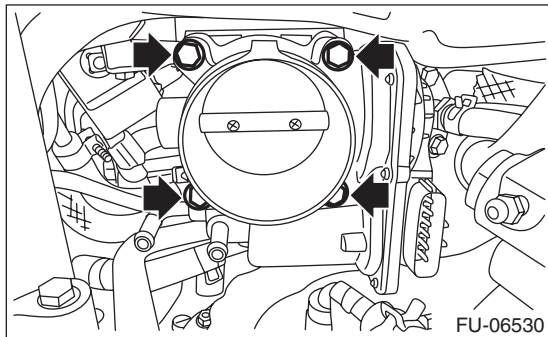

**Tightening torque:**

**T1: 3 N·m (0.3 kgf-m, 2.2 ft-lb)**

**T2: 6.4 N·m (0.7 kgf-m, 4.7 ft-lb)**

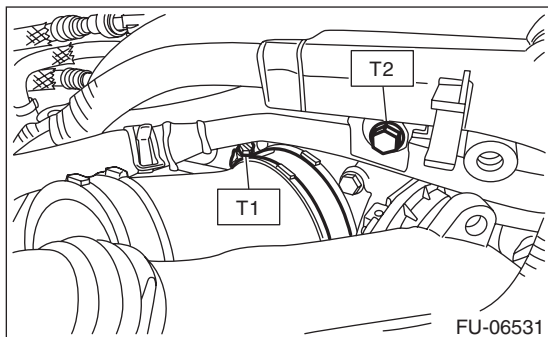

**Tightening torque:**

**6.4 N·m (0.7 kgf-m, 4.7 ft-lb)**

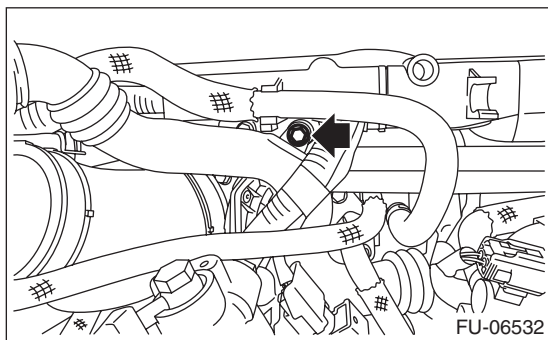

### C: INSPECTION

#### 1. THROTTLE SENSOR INSPECTION (METHOD WITH CIRCUIT TESTER)

- 1) Remove the lower inner trim of passenger's side. <Ref. to EI-57, REMOVAL, Lower Inner Trim.>
- 2) Turn over the floor mat of passenger's seat.
- 3) Remove the protect cover.

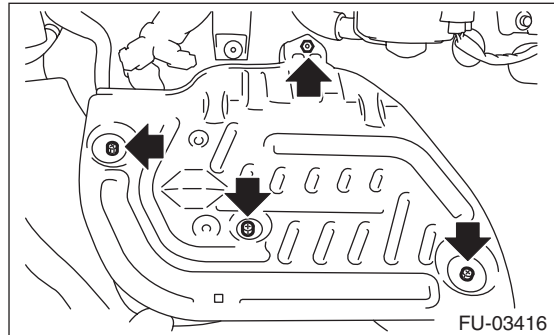

- 4) Remove the nuts and bolts which hold the ECM to the bracket.

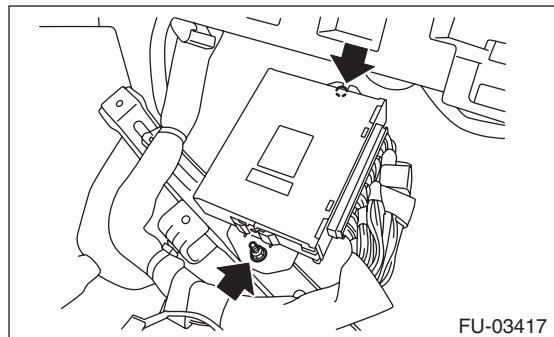

- 5) Turn the ignition switch to ON. (engine OFF)



6) Measure the voltage between ECM connector terminals.

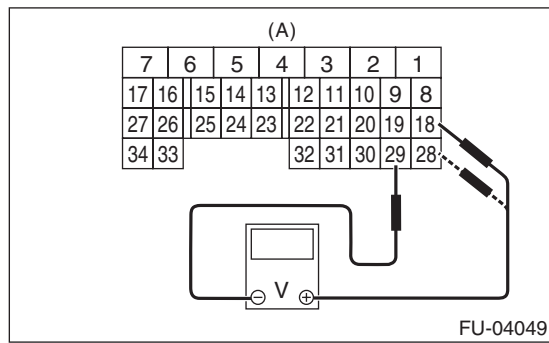

(A) To ECM connector

Throttle sensor	Accelerator pedal	Terminal No.	Standard
Main	Not depressed (Full closed)	18 (+) and 29 (-)	Approx. 0.6 V
	Depressed (Full opened)		Approx. 3.96 V
Sub	Not depressed (Full closed)	28 (+) and 29 (-)	Approx. 1.48 V
	Depressed (Full opened)		Approx. 4.17 V

7) After inspection, install the related parts in the reverse order of removal.

**Tightening torque:**

**7.5 N·m (0.8 kgf-m, 5.5 ft-lb)**

## 2. THROTTLE SENSOR INSPECTION (METHOD WITH SUBARU SELECT MONITOR)

- 1) Turn the ignition switch to ON. (engine OFF)
- 2) Read the throttle opening angle signal and voltage of throttle sensor using Subaru Select Monitor. <Ref. to EN(H4DOTC)(diag)-41, READ CURRENT DATA FOR ENGINE (NORMAL MODE), OPERATION, Subaru Select Monitor.>

Throttle sensor	Throttle opening angle signal	Standard
Main	0.0%	Approx. 0.6 V
	100.0%	Approx. 3.96 V
Sub	0.0%	Approx. 1.48 V
	100.0%	Approx. 4.17 V

## 3. OTHER INSPECTIONS

- 1) Check that the throttle body has no deformation, cracks or other damages.
- 2) Check that the engine coolant hose has no cracks, damage or loose part.

# Intake Manifold

## FUEL INJECTION (FUEL SYSTEMS)

### 3. Intake Manifold

#### A: REMOVAL

1) Remove the V-belt covers.

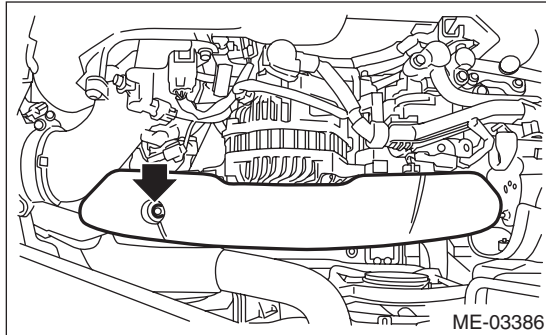

2) Collect the refrigerant from A/C system. <Ref. to AC-20, PROCEDURE, Refrigerant Recovery Procedure.>

3) Release the fuel pressure. <Ref. to FU(w/o STI)-66, RELEASING OF FUEL PRESSURE, PROCEDURE, Fuel.>

4) Disconnect the ground cable from battery.

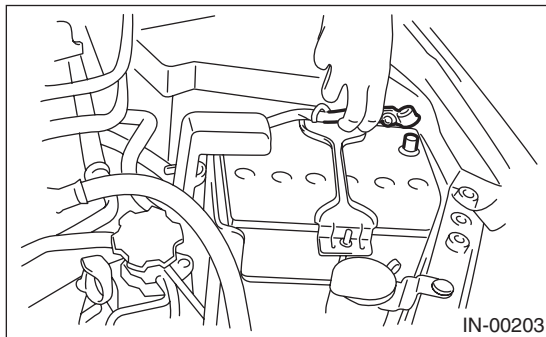

5) Open the fuel filler lid and remove the fuel filler cap.

6) Lift up the vehicle.

7) Remove the under cover. <Ref. to EI-28, REMOVAL, Front Under Cover.>

8) Drain approximately 3.0 ℓ (3.2 US qt, 2.6 Imp qt) of coolant. <Ref. to CO(w/o STI)-13, DRAINING OF ENGINE COOLANT, REPLACEMENT, Engine Coolant.>

9) Remove the air intake duct and air cleaner case. <Ref. to IN(w/o STI)-10, REMOVAL, Air Intake Duct.> <Ref. to IN(w/o STI)-8, REMOVAL, Air Cleaner Case.>

10) Remove the intercooler. <Ref. to IN(w/o STI)-12, REMOVAL, Intercooler.>

11) Remove the generator. <Ref. to SC(STI)-21, REMOVAL, Generator.>

12) Remove the coolant filler tank. <Ref. to CO(w/o STI)-28, REMOVAL, Coolant Filler Tank.>

13) Disconnect the A/C pressure hoses from A/C compressor. <Ref. to AC-40, REMOVAL, Hose and Pipe.>

14) Disconnect the brake booster vacuum hose.

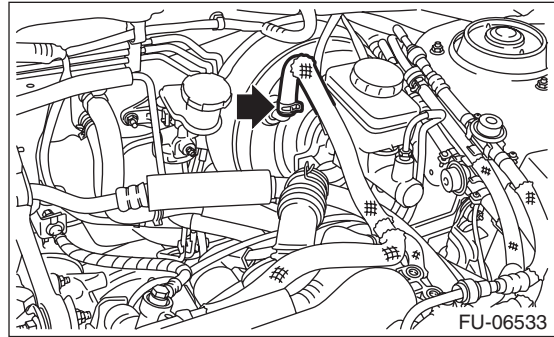

15) Remove the brake booster vacuum hose from the clip (A), and remove the bolts securing the air bypass pipe to the intake manifold.

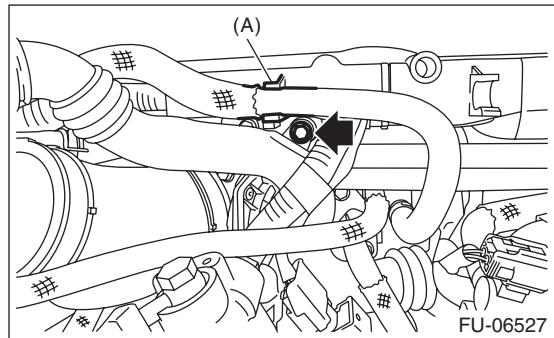

16) Remove the bolts securing the PCV pipe assembly to the intake manifold, and remove the intake duct from the throttle body.

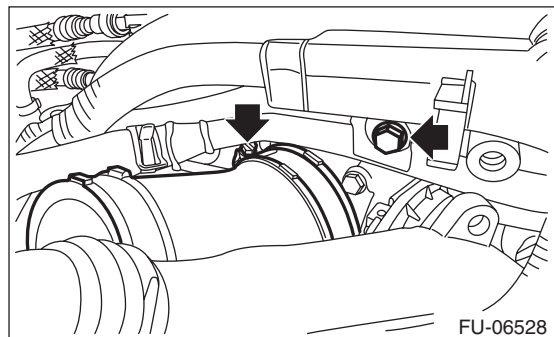

17) Disconnect the engine coolant hose from throttle body.

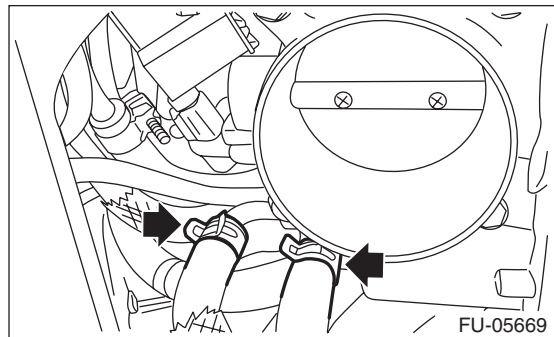

# Intake Manifold

## FUEL INJECTION (FUEL SYSTEMS)

18) Disconnect the vacuum hose from nipple.

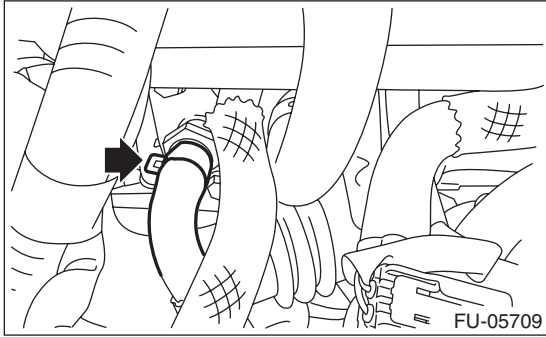

19) Disconnect the air control hose (A) from the waste gate actuator, and loosen the clamp which holds the intake duct to the turbocharger.

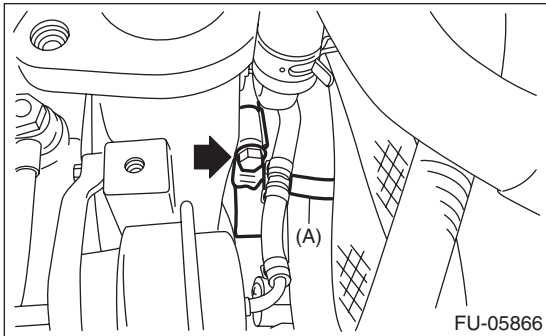

20) Disconnect the connector (A) from the PCV hose assembly A and the connector (B) from the knock sensor.

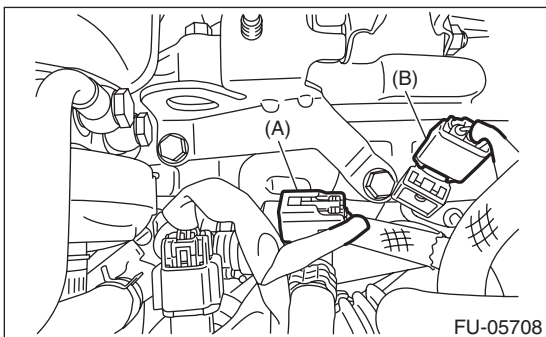

21) Disconnect the connector from the PCV hose assembly B and PCV hose assembly C.

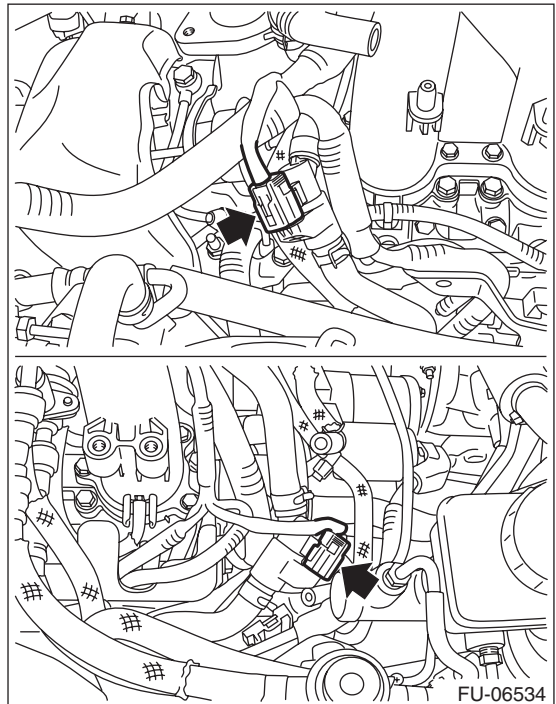

22) Disconnect the bulkhead harness connectors from the engine harness connectors.

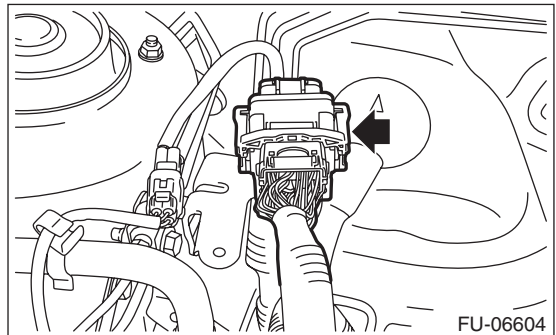

23) Remove the engine harness connector from the engine harness bracket.

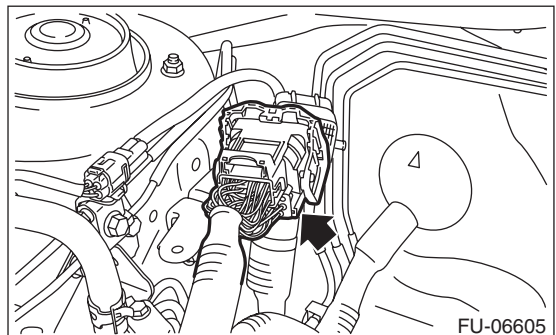

# Intake Manifold

## FUEL INJECTION (FUEL SYSTEMS)

24) Disconnect the connector (A) from the engine coolant temperature sensor, connector (B) from the oil pressure switch, and connector (C) from the crankshaft position sensor.

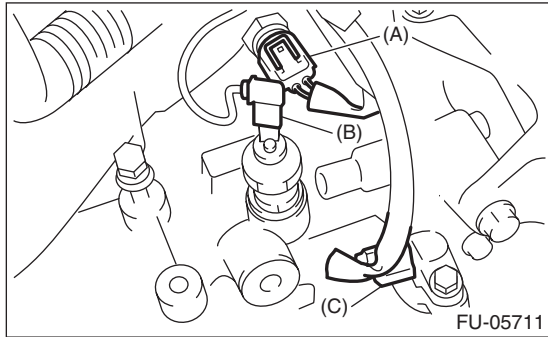

25) Disconnect the connector from power steering pump switch.

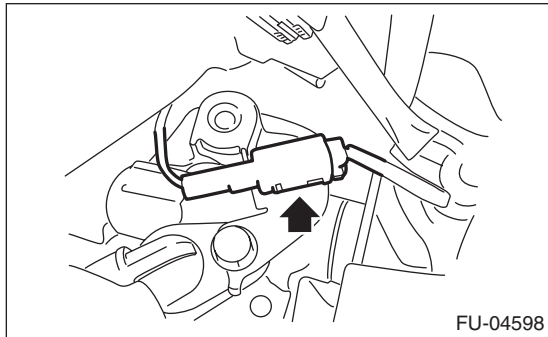

26) Disconnect the connector from the secondary air combination valve.

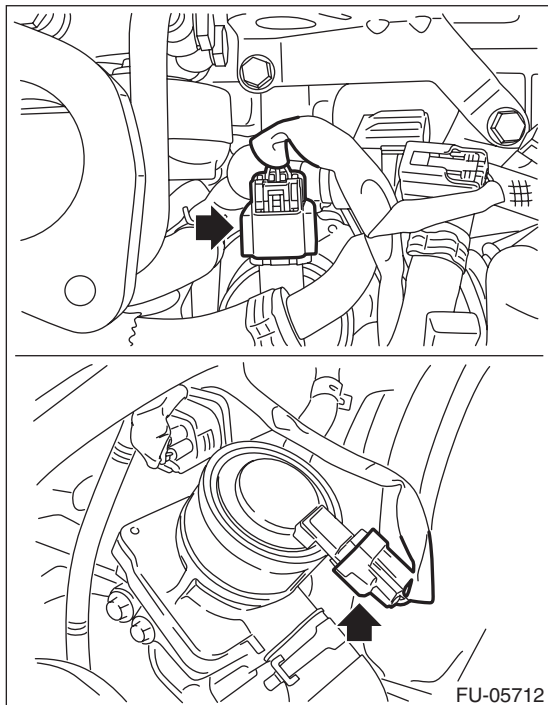

27) Disconnect the connector from camshaft position sensor.

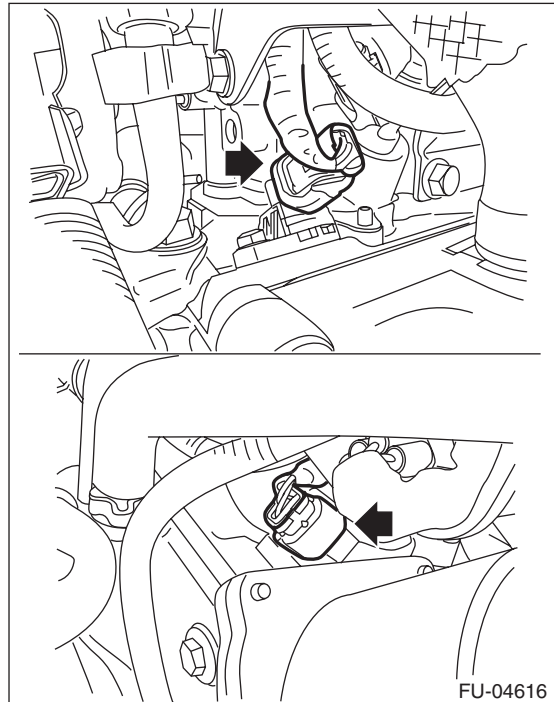

28) Disconnect the connector from the oil flow control solenoid valve.

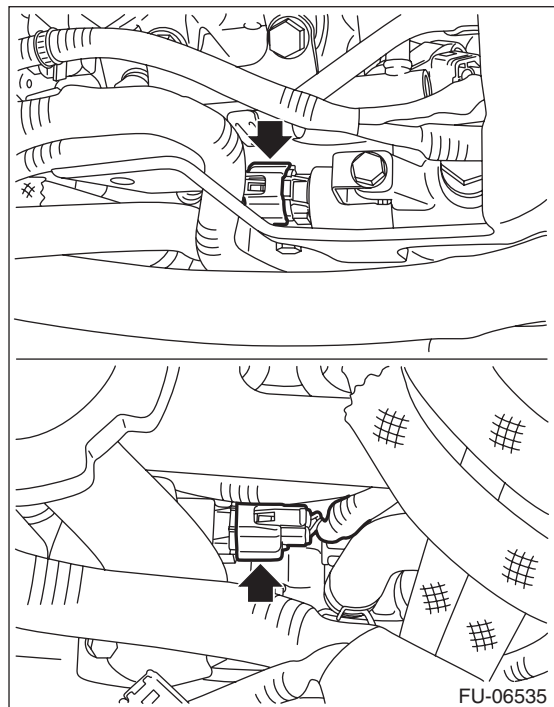

29) Lift up the vehicle.



# Intake Manifold

FUEL INJECTION (FUEL SYSTEMS)

30) Disconnect the connector from ignition coil.

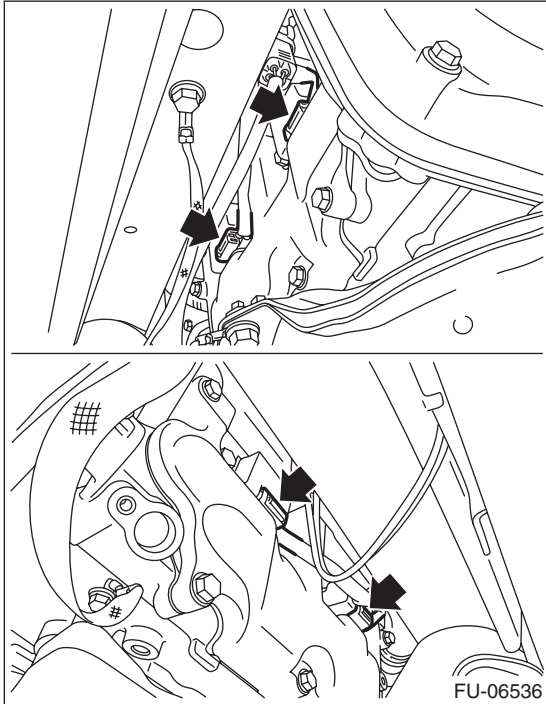

31) Lower the vehicle.

32) Disconnect the connector from the front oxygen (A/F) sensor, and remove the clip (A) and stay (B) which hold the engine harness to the rocker cover RH.

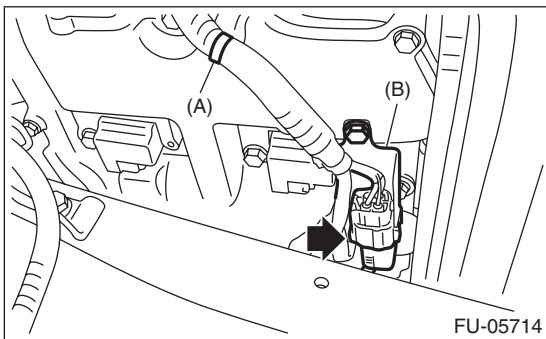

33) Attach ST to the fuel delivery pipe and push ST in the direction of arrow mark to disconnect the fuel delivery hose.

ST 42099AE000 QUICK CONNECTOR RELEASE

### CAUTION:

- Be careful not to spill fuel.
- Catch the fuel from hoses using a container or cloth.

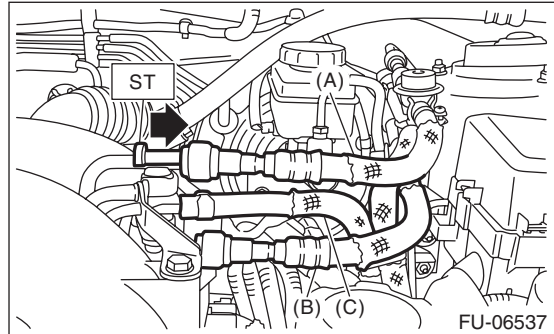

(A) Fuel delivery hose

(B) Fuel return hose

(C) Evaporation hose

34) Disconnect the fuel return hose using the ST.  
ST 18371AA000 CONNECTOR REMOVER

### CAUTION:

- Be careful not to spill fuel.
- Catch the fuel from hoses using a container or cloth.

(1) Attach ST to the fuel return pipe as shown in the figure.

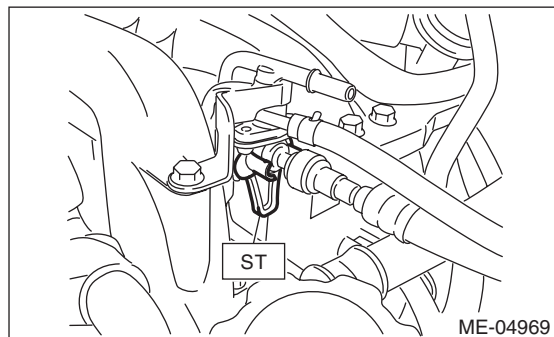

FU(w/o STI)-21

Brought to you by Ebay Seller "SubaruManuals"

# Intake Manifold

## FUEL INJECTION (FUEL SYSTEMS)

(2) Insert the front side of ST into the quick connector.

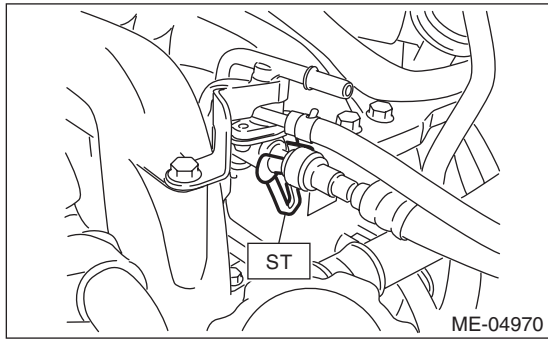

(3) Insert the back side of ST into the quick connector and push ST in the direction of arrow mark to disconnect the fuel return hose.

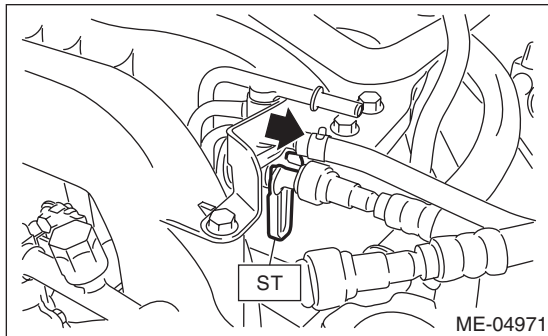

35) Remove the clip and disconnect the evaporation hose from the fuel pipe.

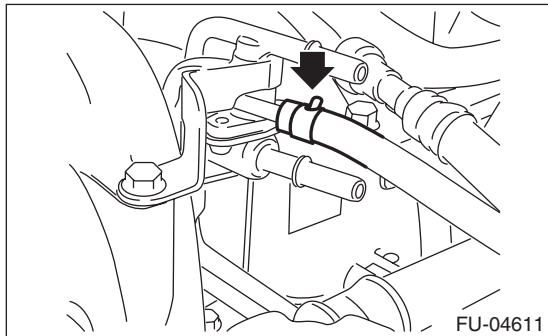

36) Remove the intake manifold from cylinder head.

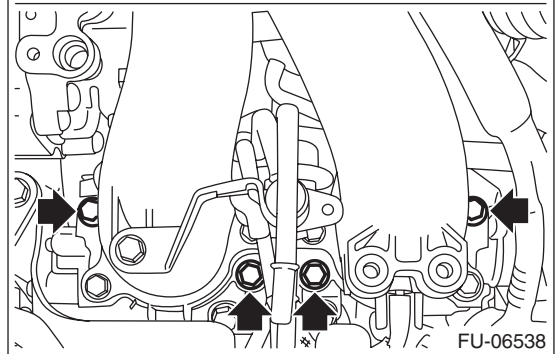
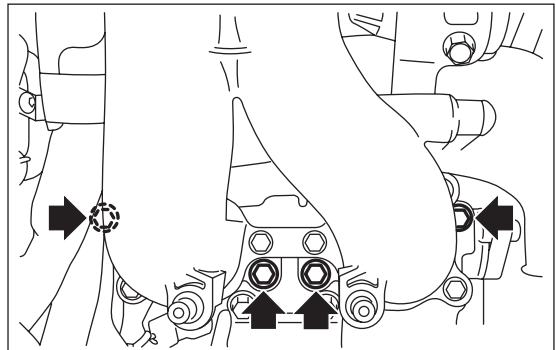

## B: INSTALLATION

1) Install the intake manifold onto cylinder heads.

NOTE:

Use a new gasket.

**Tightening torque:**

**25 N·m (2.5 kgf-m, 18.4 ft-lb)**

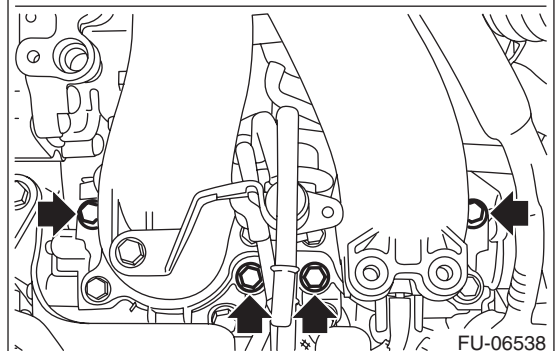
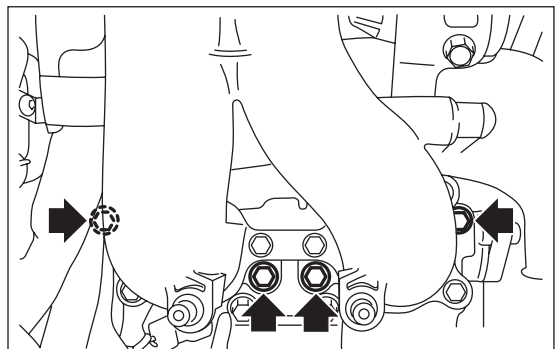

**FU(w/o STI)-22**

Brought to you by Ebay Seller "SubaruManuals"

# Intake Manifold

## FUEL INJECTION (FUEL SYSTEMS)

2) Connect the fuel delivery hose, fuel return hose, and evaporation hose.

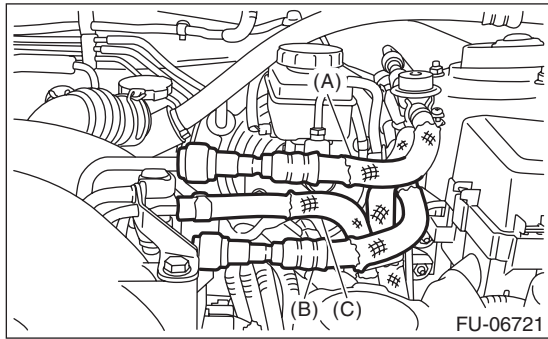

- (A) Fuel delivery hose
- (B) Fuel return hose
- (C) Evaporation hose

3) Connect the front oxygen (A/F) sensor connector, and secure the engine harness to the rocker cover RH with clip (A) and stay (B).

### **Tightening torque:**

**6.4 N·m (0.7 kgf·m, 4.7 ft·lb)**

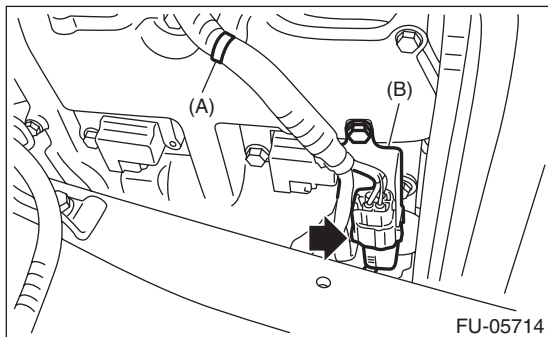

4) Lift up the vehicle.

5) Connect the connector to the ignition coil.

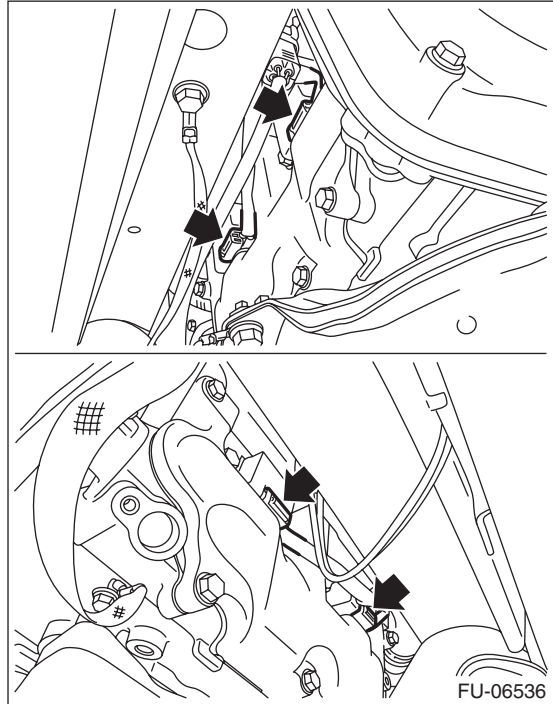

6) Lower the vehicle.

7) Connect the connector to oil flow control solenoid valve.

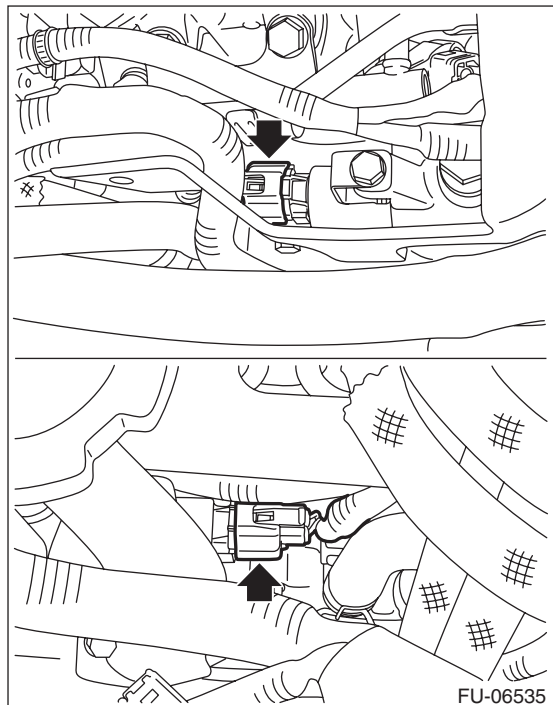

# Intake Manifold

## FUEL INJECTION (FUEL SYSTEMS)

8) Connect the connectors to camshaft position sensor.

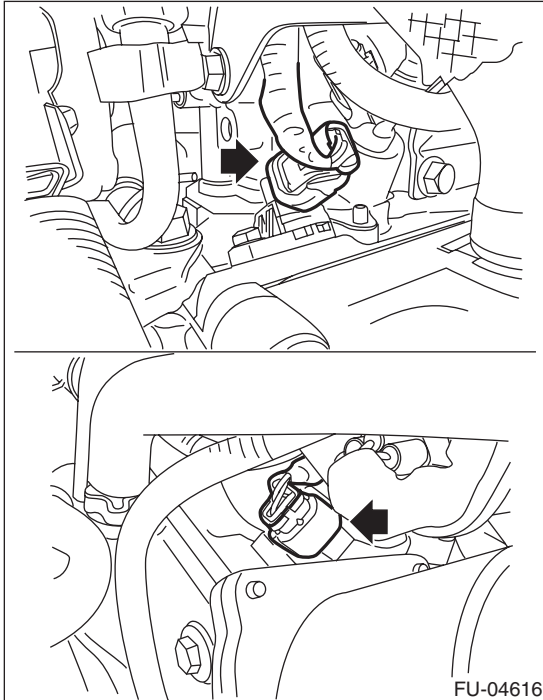

9) Connect the connector to the secondary air combination valve.

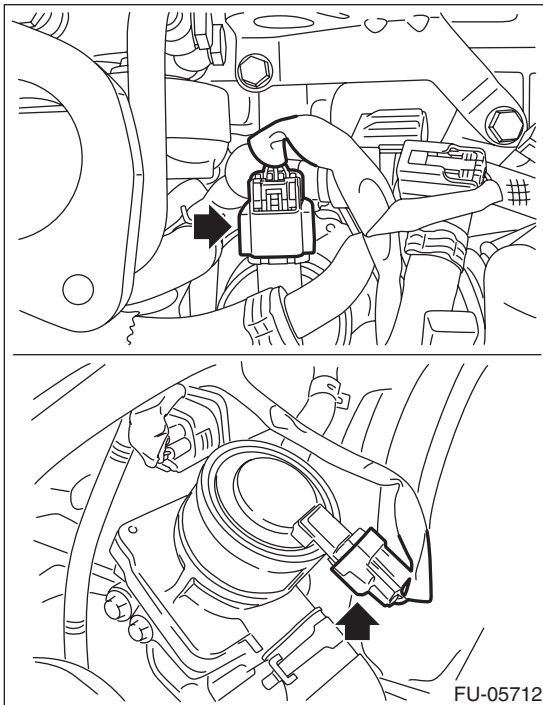

10) Connect the connector to the power steering pump switch.

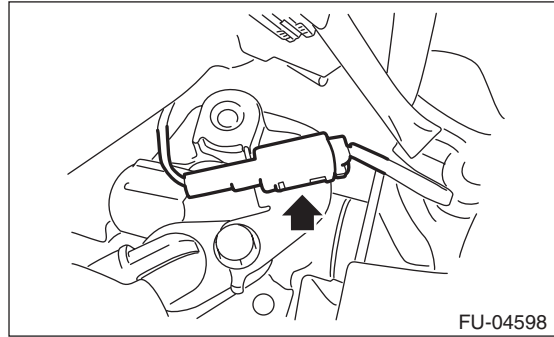

11) Connect the connector (A) to the engine coolant temperature sensor, connector (B) to the oil pressure switch, and the connector (C) to the crankshaft position sensor.

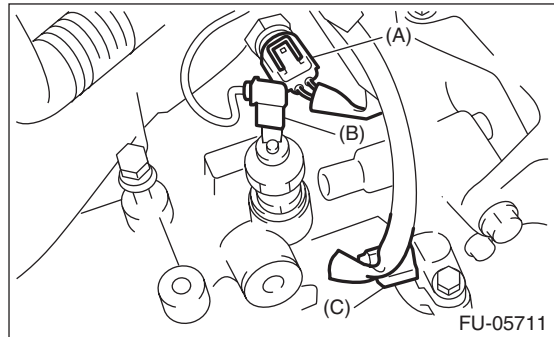

12) Install the engine harness connector to engine harness bracket, then connect the bulkhead harness connector to the engine harness connector.

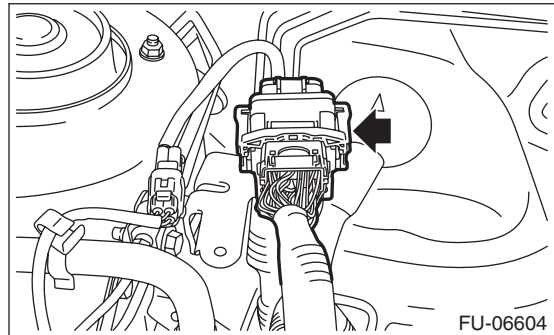



# Intake Manifold

## FUEL INJECTION (FUEL SYSTEMS)

13) Connect the connector to the PCV hose assembly B and PCV hose assembly C.

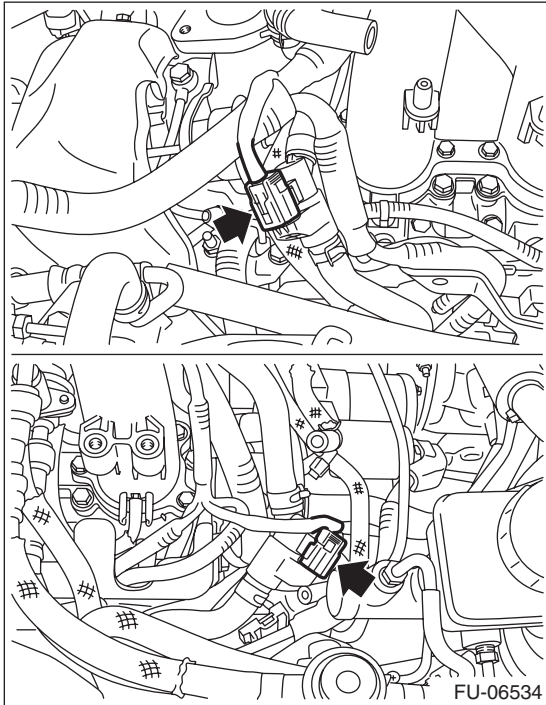

14) Connect the connector (A) to the PCV hose assembly A and the connector (B) to the knock sensor.

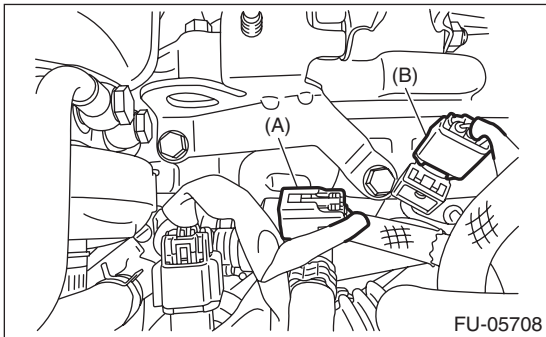

15) Connect the air control hose (A) to the wastegate actuator, and install the turbocharger to the intake duct.

**Tightening torque:**

**3 N·m (0.3 kgf-m, 2.2 ft-lb)**

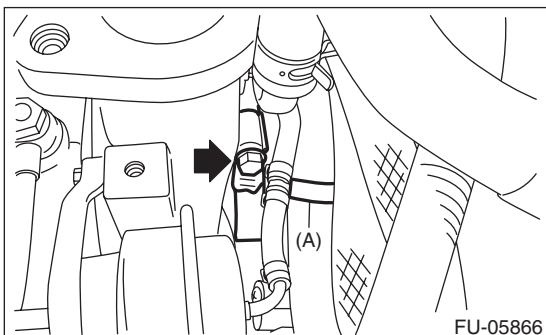

16) Connect the vacuum hose to the nipple.

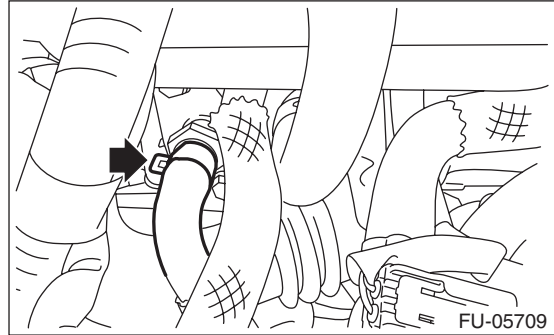

17) Connect the engine coolant hoses to throttle body.

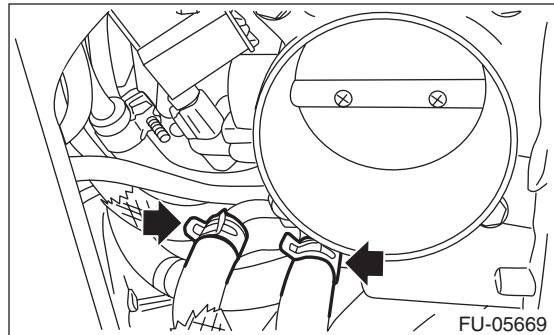

18) Install the intake duct to the throttle body, and install the bolts which secure the PCV pipe assembly to the intake manifold.

**Tightening torque:**

**T1: 3 N·m (0.3 kgf-m, 2.2 ft-lb)**

**T2: 6.4 N·m (0.7 kgf-m, 4.7 ft-lb)**

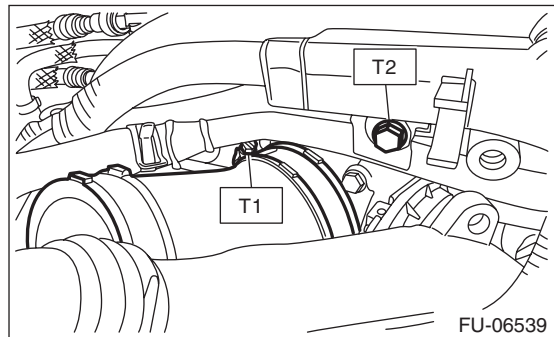

# Intake Manifold

## FUEL INJECTION (FUEL SYSTEMS)

19) Install the bolts which secure the air bypass pipe to the intake manifold, and install the brake booster vacuum hose to the clip (A).

### Tightening torque:

**6.4 N·m (0.7 kgf·m, 4.7 ft·lb)**

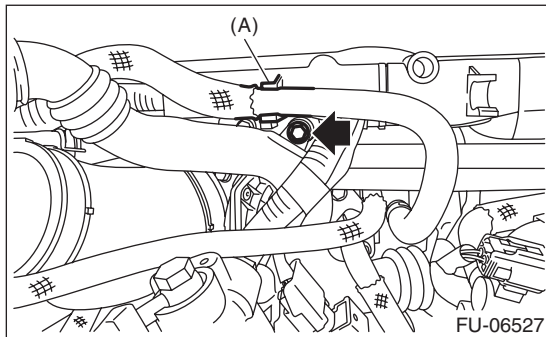

20) Connect the brake booster vacuum hose.

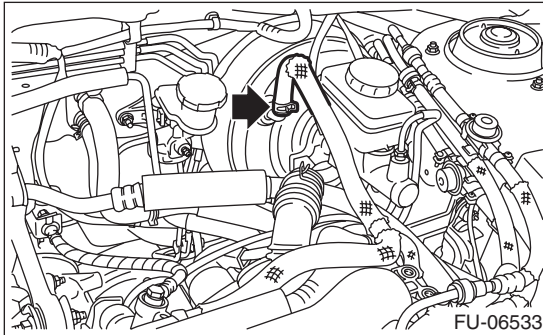

21) Install the A/C pressure hoses to A/C compressor. <Ref. to AC-40, INSTALLATION, Hose and Pipe.>

22) Install the coolant filler tank. <Ref. to CO(w/o STI)-28, INSTALLATION, Coolant Filler Tank.>

23) Install the generator. <Ref. to SC(STI)-21, INSTALLATION, Generator.>

24) Install the intercooler. <Ref. to IN(w/o STI)-12, INSTALLATION, Intercooler.>

25) Install the air intake duct and air cleaner case. <Ref. to IN(w/o STI)-8, INSTALLATION, Air Cleaner Case.> <Ref. to IN(w/o STI)-10, INSTALLATION, Air Intake Duct.>

26) Connect the battery ground terminal.

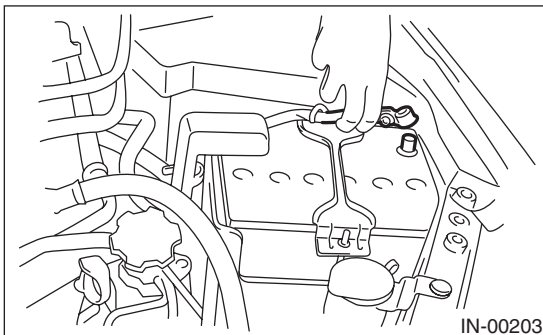

27) Lift up the vehicle.

28) Install the under cover. <Ref. to EI-28, INSTALLATION, Front Under Cover.>

29) Lower the vehicle.

30) Fill engine coolant. <Ref. to CO(w/o STI)-13, FILLING OF ENGINE COOLANT, REPLACEMENT, Engine Coolant.>

31) Charge the A/C system with refrigerant. <Ref. to AC-21, PROCEDURE, Refrigerant Charging Procedure.>

32) Install the V-belt cover.

### Tightening torque:

**13 N·m (1.3 kgf·m, 9.6 ft·lb)**

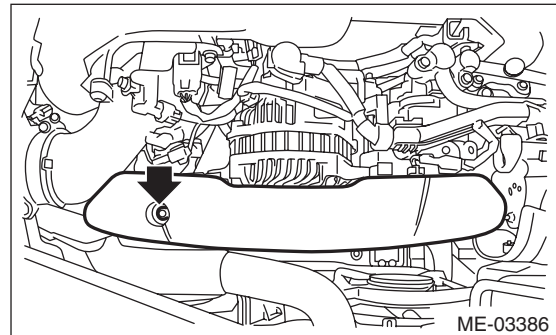

## C: DISASSEMBLY

1) Remove the fuel pipe protector RH from the intake manifold.

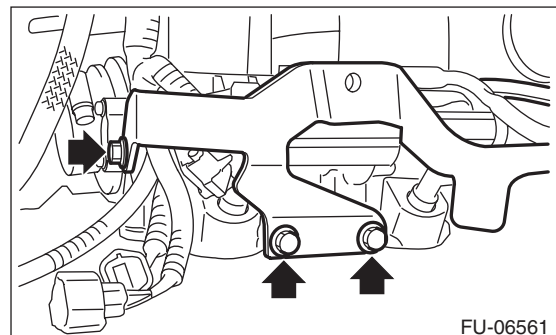

2) Remove the engine ground terminal from the fuel pipe protector LH and remove the fuel pipe protector LH from the intake manifold.

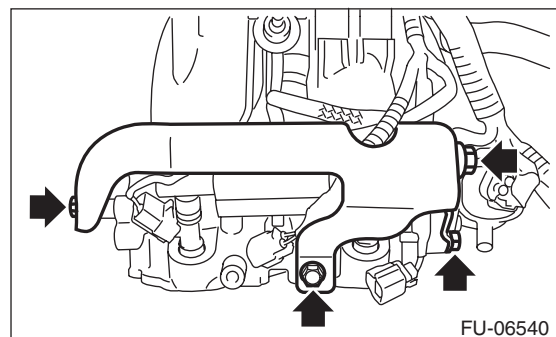

3) Disconnect the vacuum hose (A) from intake manifold.

**FU(w/o STI)-26**

Brought to you by Ebay Seller "SubaruManuals"

# Intake Manifold

## FUEL INJECTION (FUEL SYSTEMS)

4) Disconnect the vacuum hose (B) and the connector (C) from the fuel pipe, and remove the purge control solenoid valve 1 from the intake manifold.

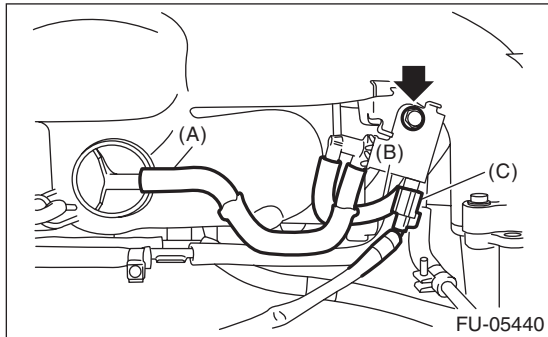

5) Disconnect the filter assembly.

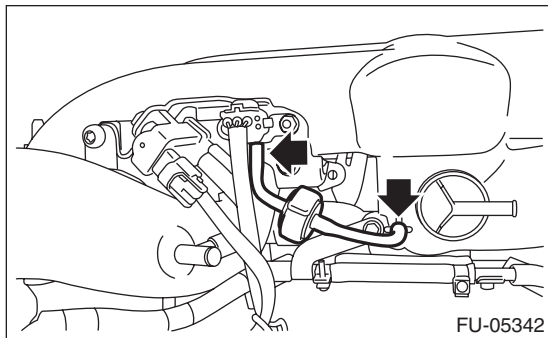

6) Disconnect the connector from the wastegate control solenoid valve and the manifold absolute pressure sensor, and remove the solenoid valve bracket assembly from the intake manifold.

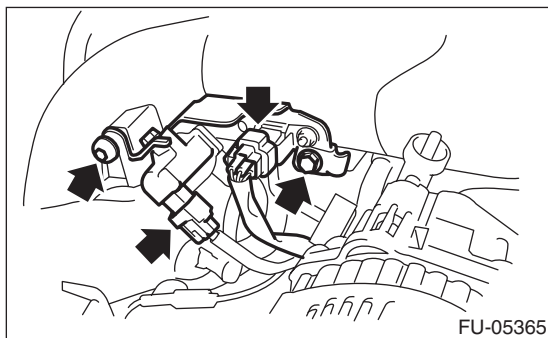

7) Disconnect the connector from the purge control solenoid valve 2, and disconnect the vacuum hose from the intake duct and the fuel pipe.

8) Disconnect the connectors from the throttle position sensor.

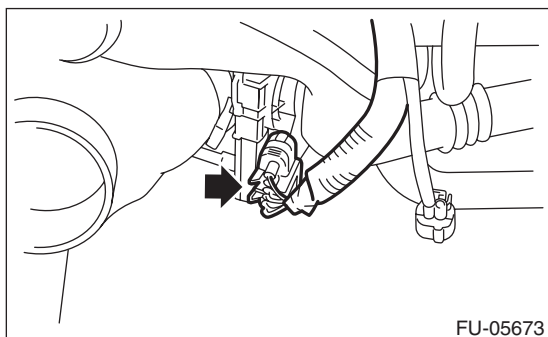

9) Remove the throttle body from the intake manifold.

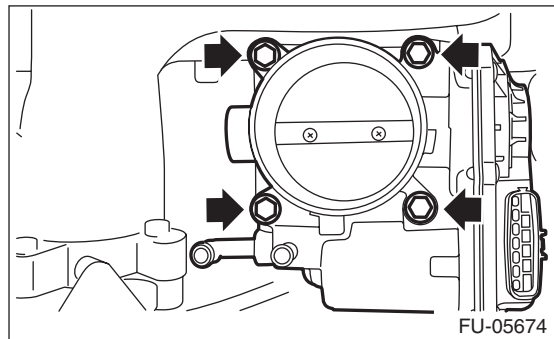

10) Disconnect the connector from the fuel injector and tumble generator valve assembly.

• RH side

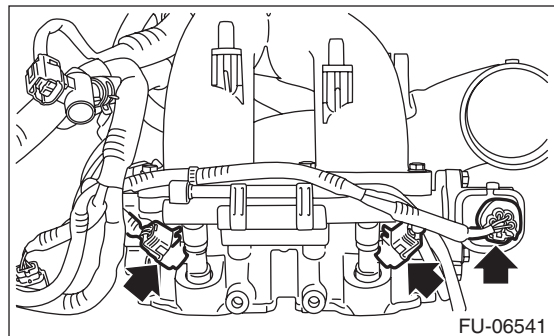

• LH side

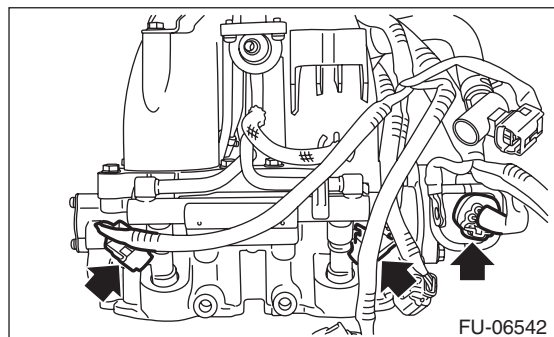

11) Remove the PCV pipe (A), harness assembly (B), intake duct (C), brake booster vacuum hose (D) and vacuum hose (E) from the intake manifold.

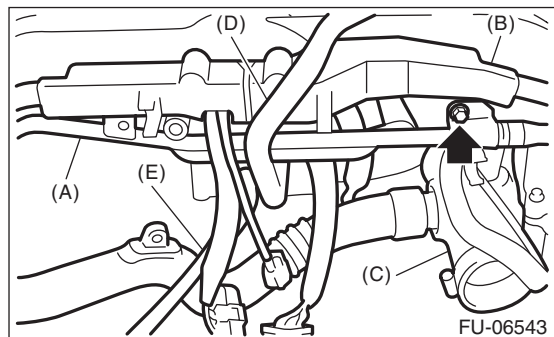

# Intake Manifold

## FUEL INJECTION (FUEL SYSTEMS)

12) Remove the bolt which secures the fuel injector pipe LH onto the intake manifold, and disconnect the pressure regulator vacuum hose from the intake manifold.

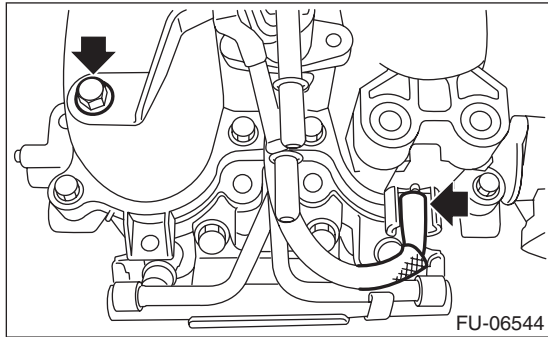

13) Remove the bolts which hold fuel injector pipe onto intake manifold.

- RH side

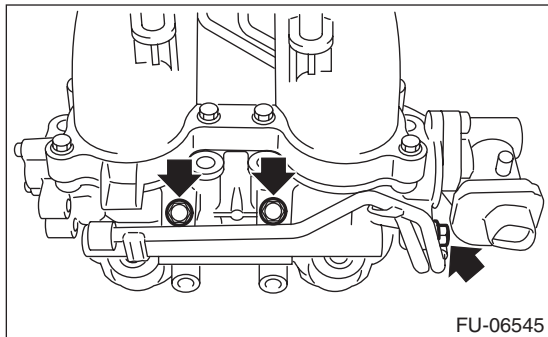

- LH side

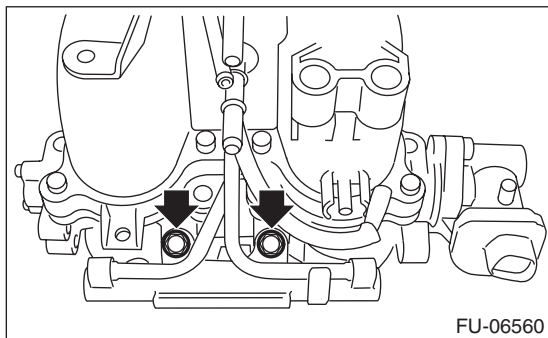

14) Remove the fuel injector.

- RH side

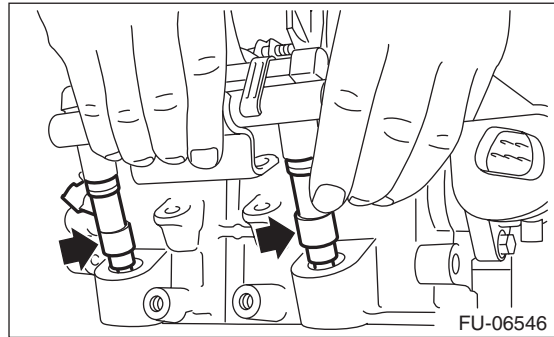

- LH side

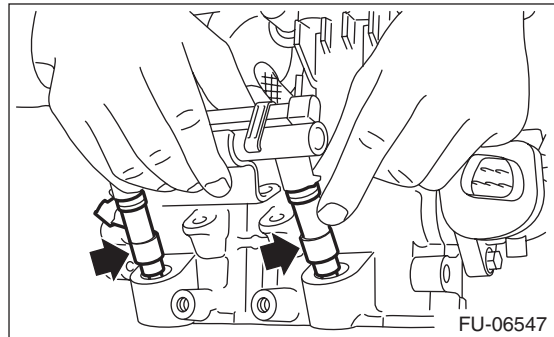

15) Remove the bolts which hold fuel pipe onto intake manifold.

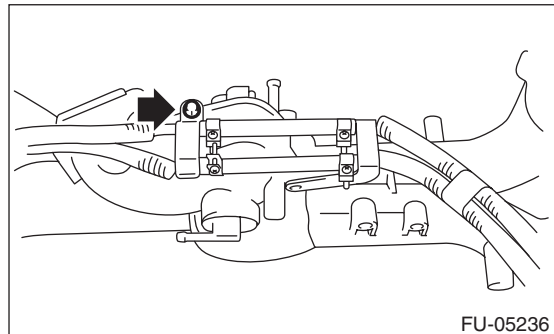

16) Remove the bolt which holds fuel injector pipe RH onto intake manifold.

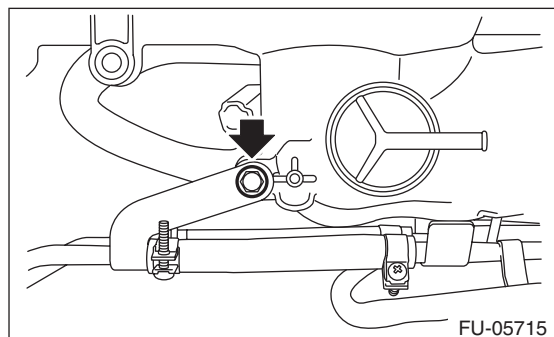



# Intake Manifold

FUEL INJECTION (FUEL SYSTEMS)

17) Loosen the clamp which holds the fuel hose to the fuel injector pipe RH and the fuel pipe, and then disconnect the pipe from the fuel hose.

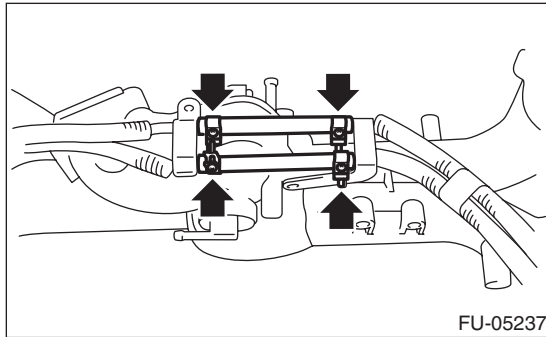

18) Remove the fuel injector pipe and the fuel pipe.  
19) Remove the tumble generator valve assembly from the intake manifold.

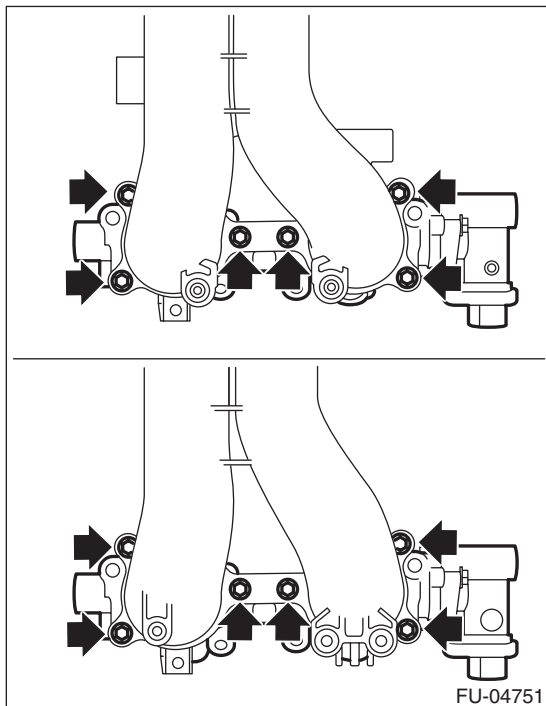

20) Remove the nipple from the intake manifold.

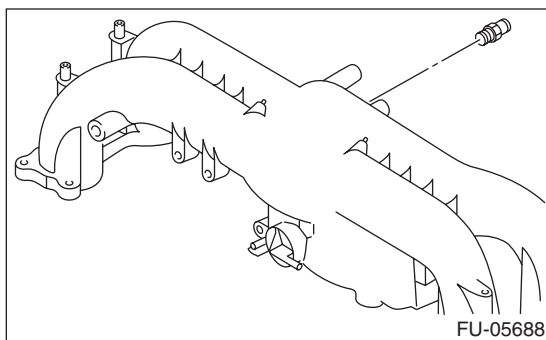

## D: ASSEMBLY

1) Apply liquid gasket to the nipple threads, and install the nipple to the intake manifold.

**Liquid gasket:**

**THREE BOND 1105 (Part No. 004403010) or equivalent**

**Tightening torque:**

**23 N-m (2.3 kgf-m, 17.0 ft-lb)**

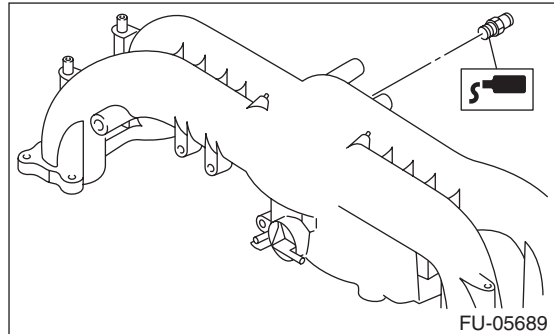

2) Install the tumble generator valve assembly onto intake manifold.

**NOTE:**

Use new O-rings.

**Tightening torque:**

**8.3 N-m (0.8 kgf-m, 6.1 ft-lb)**

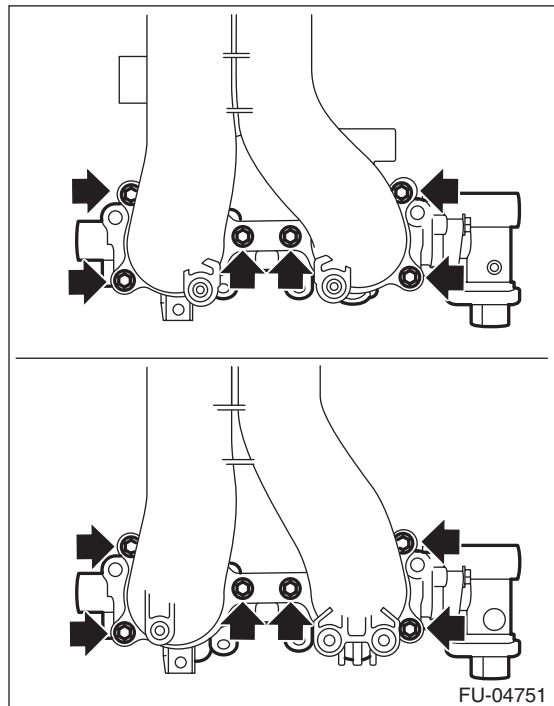

3) Install the fuel injector pipe.

**FU(w/o STI)-29**

Brought to you by Ebay Seller "SubaruManuals"

# Intake Manifold

## FUEL INJECTION (FUEL SYSTEMS)

4) Connect fuel hoses to the fuel injector pipe and the fuel pipe. <Ref. to FU(w/o STI)-94, CONNECTING FUEL DELIVERY HOSE, FUEL RETURN HOSE AND FUEL HOSE, INSTALLATION, Fuel Delivery, Return and Evaporation Lines.>

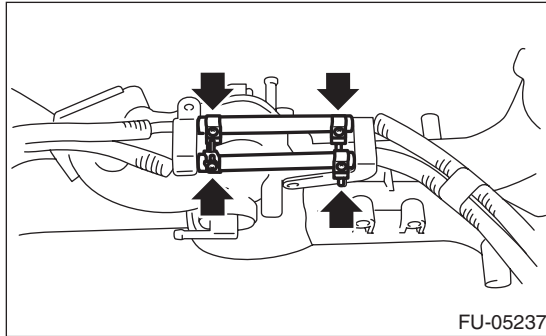

5) Secure the fuel injector pipe RH to intake manifold with bolt.

**Tightening torque:**

**6.4 N·m (0.7 kgf-m, 4.7 ft-lb)**

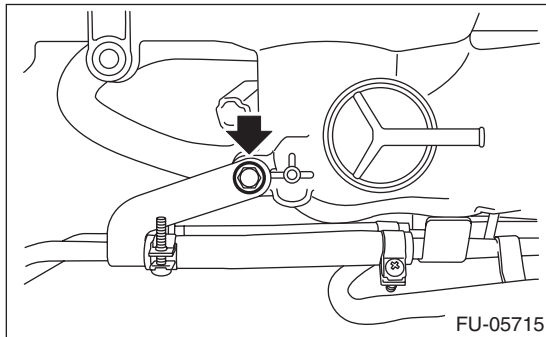

6) Secure the fuel pipe to intake manifold with bolts.

**Tightening torque:**

**6.4 N·m (0.7 kgf-m, 4.7 ft-lb)**

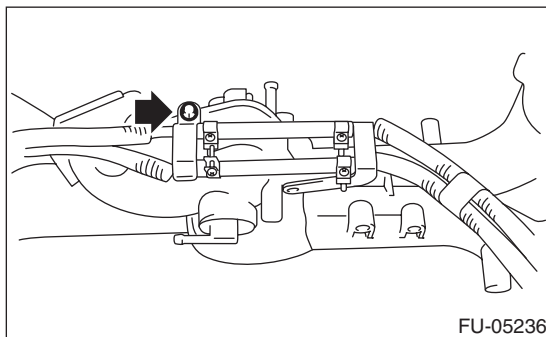

7) Install the fuel injector.

**NOTE:**

Use new O-rings, rubbers and seal rings.

- RH side

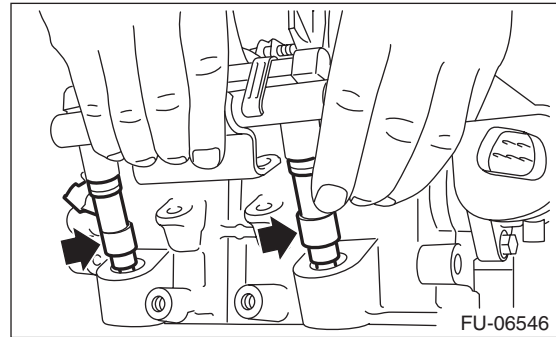

- LH side

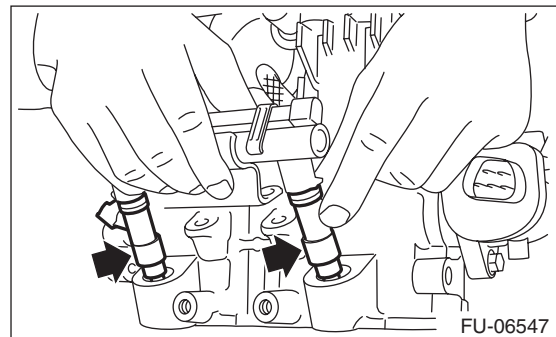

8) Secure the fuel injector pipe to intake manifold with bolts.

**Tightening torque:**

**19 N·m (1.9 kgf-m, 14.0 ft-lb)**

- RH side

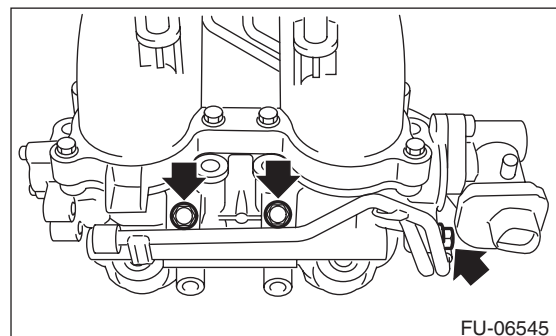

- LH side

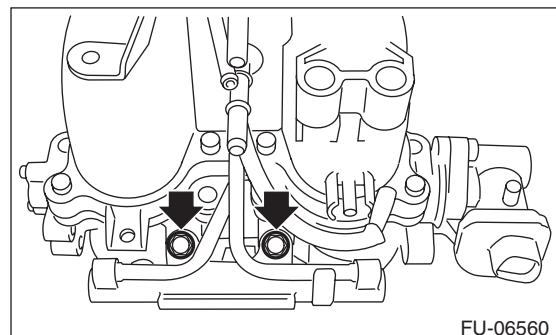

**FU(w/o STI)-30**

Brought to you by Ebay Seller "SubaruManuals"

# Intake Manifold

## FUEL INJECTION (FUEL SYSTEMS)

9) Secure the fuel injector pipe LH to intake manifold with bolt, and connect the pressure regulator vacuum hose to the intake manifold.

**Tightening torque:**

**6.4 N·m (0.7 kgf-m, 4.7 ft-lb)**

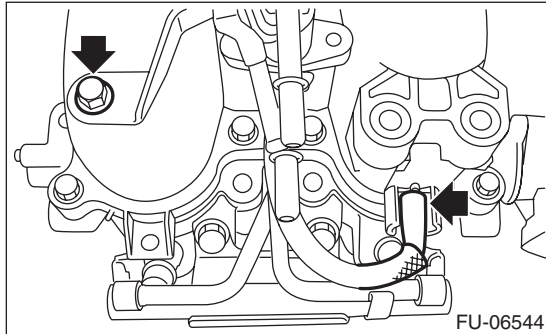

10) Install the PCV pipe (A), harness assembly (B), intake duct (C), brake booster vacuum hose (D) and vacuum hose (E) to the intake manifold.

**Tightening torque:**

**6.4 N·m (0.7 kgf-m, 4.7 ft-lb)**

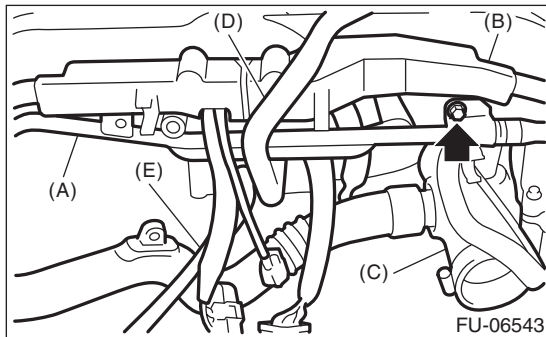

11) Connect the connector to the fuel injector and the tumble generator valve assembly.

- RH side

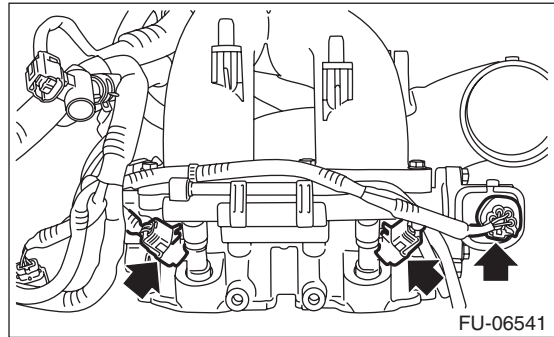

- LH side

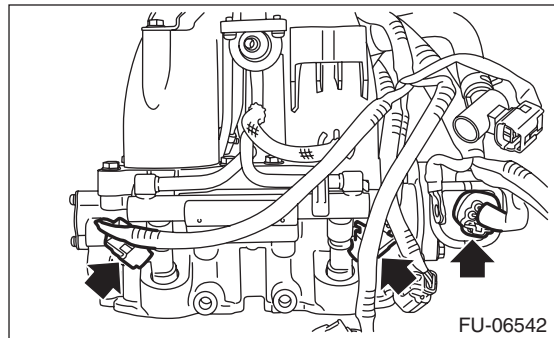

12) Install the throttle body to the intake manifold.

**NOTE:**

Use new O-rings.

**Tightening torque:**

**8 N·m (0.8 kgf-m, 5.9 ft-lb)**

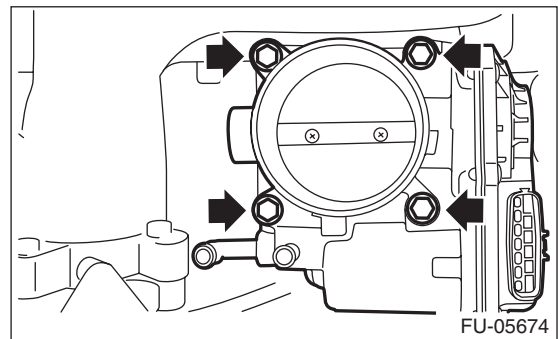

# Intake Manifold

## FUEL INJECTION (FUEL SYSTEMS)

13) Connect the connector to the throttle position sensor.

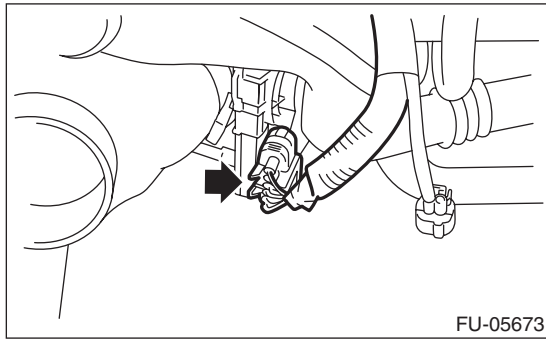

14) Connect the vacuum hose to the intake duct and the fuel pipe, then connect the connector to the purge control solenoid valve 2.

**NOTE:**

Connect the vacuum hose as shown in the figure.

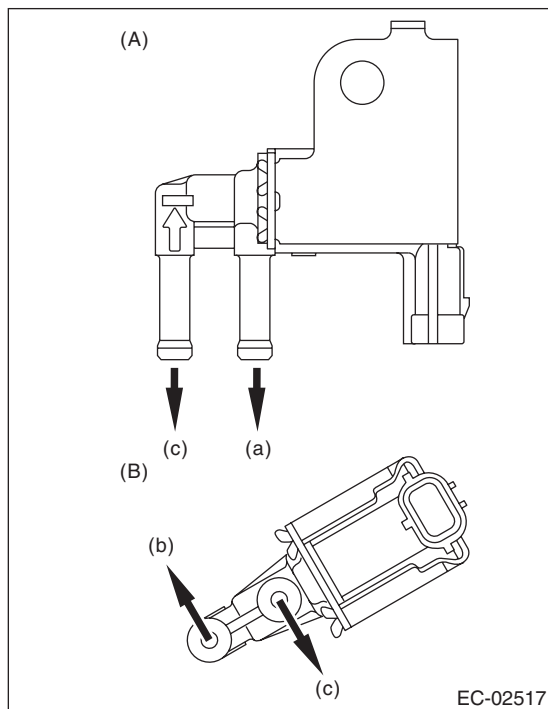

- (A) Purge control solenoid valve 1
- (B) Purge control solenoid valve 2
- (a) To intake manifold
- (b) To intake duct
- (c) To fuel pipe

15) Install the solenoid valve bracket assembly to the intake manifold, and connect the connector to the wastegate control solenoid valve and the manifold absolute pressure sensor.

**Tightening torque:**

**T1: 17 N·m (1.7 kgf-m, 12.5 ft-lb)**

**T2: 19 N·m (1.9 kgf-m, 14.0 ft-lb)**

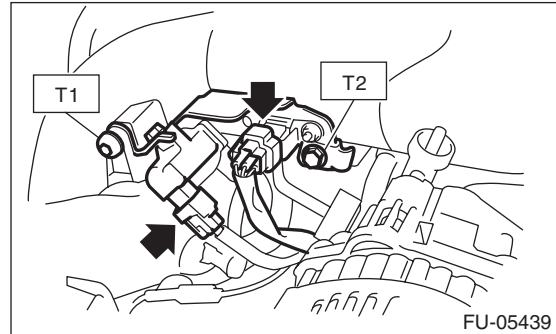

16) Connect the filter assembly.

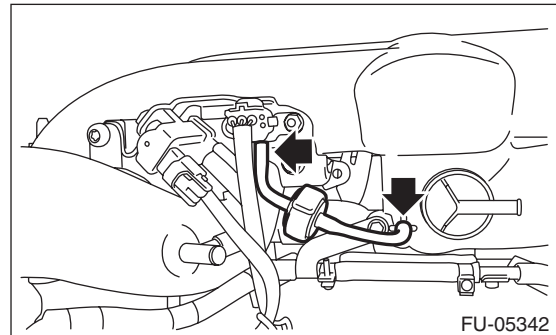



# Intake Manifold

## FUEL INJECTION (FUEL SYSTEMS)

17) Connect the vacuum hose and the connector the fuel pipe, and install the purge control solenoid valve 1 to the intake manifold.

**NOTE:**

Connect the vacuum hose as shown in the figure.

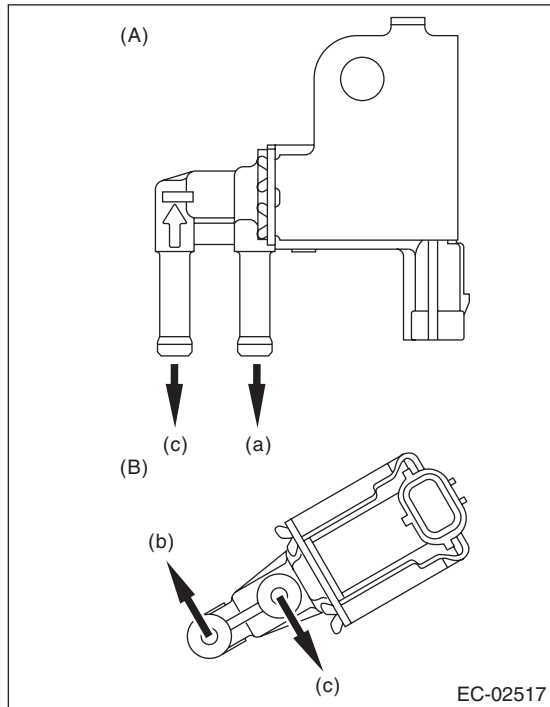

- (A) Purge control solenoid valve 1
- (B) Purge control solenoid valve 2
- (a) To intake manifold
- (b) To intake duct
- (c) To fuel pipe

18) Connect the vacuum hose to the intake manifold.

**NOTE:**

Connect the vacuum hose as shown in the figure.

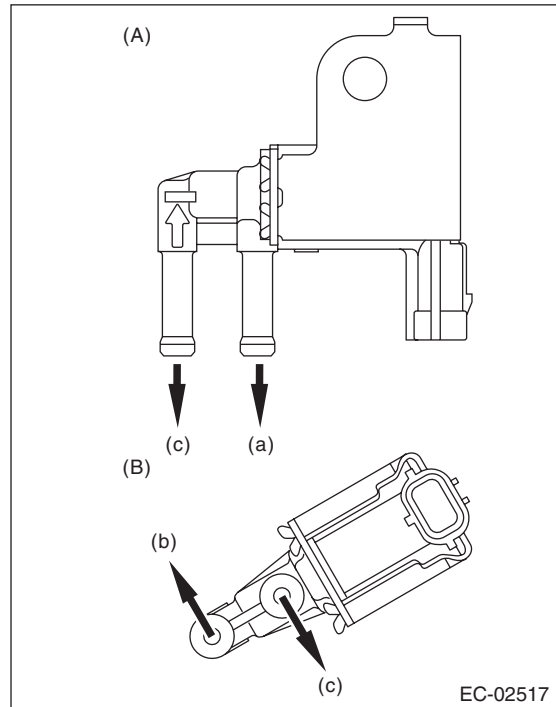

- (A) Purge control solenoid valve 1
- (B) Purge control solenoid valve 2
- (a) To intake manifold
- (b) To intake duct
- (c) To fuel pipe

**Tightening torque:**

**6.4 N·m (0.7 kgf-m, 4.7 ft-lb)**

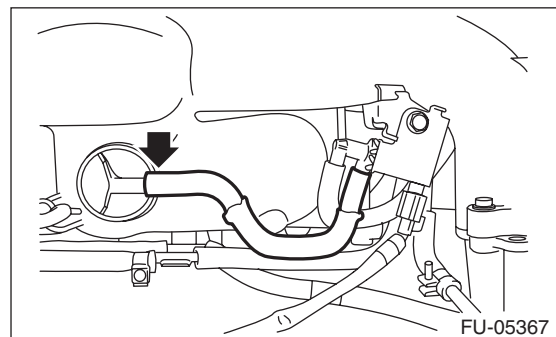
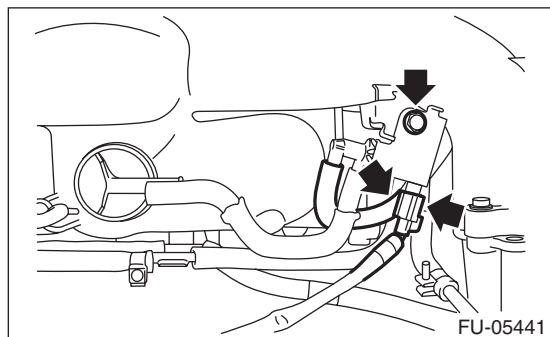

# Intake Manifold

## FUEL INJECTION (FUEL SYSTEMS)

---

19) Install the fuel pipe protector LH to the intake manifold, and install the engine ground terminal to the fuel pipe protector LH.

**Tightening torque:**

**19 N·m (1.9 kgf·m, 14.0 ft·lb)**

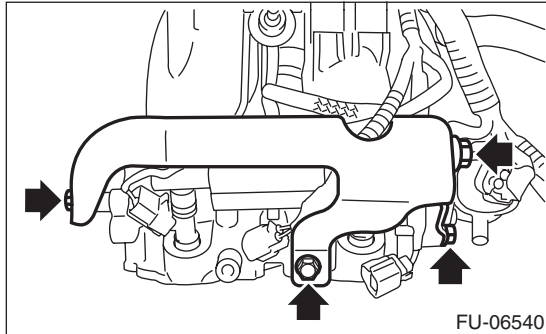

20) Install the fuel pipe protector RH to the intake manifold.

**Tightening torque:**

**19 N·m (1.9 kgf·m, 14.0 ft·lb)**

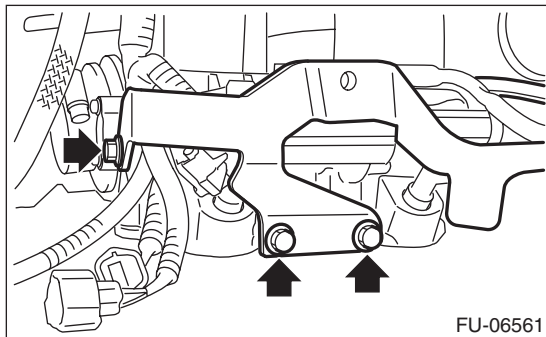

## E: INSPECTION

- 1) Check that the intake manifold and fuel pipe have no deformation, cracks and other damages.
- 2) Check that the hose has no cracks, damage or loose part.

# Engine Coolant Temperature Sensor

FUEL INJECTION (FUEL SYSTEMS)

## 4. Engine Coolant Temperature Sensor

### A: REMOVAL

1) Disconnect the ground cable from battery.

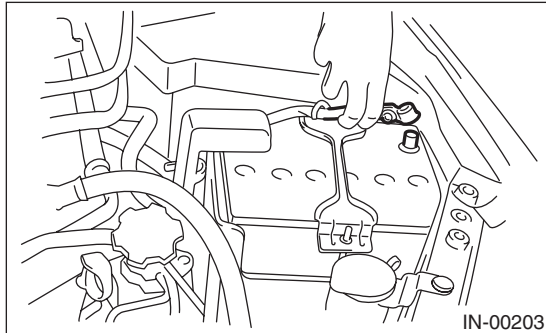

2) Remove the generator. <Ref. to SC(STI)-21, REMOVAL, Generator.>

3) Drain engine coolant. <Ref. to CO(w/o STI)-13, DRAINING OF ENGINE COOLANT, REPLACEMENT, Engine Coolant.>

4) Disconnect the connector (A) from the engine coolant temperature sensor, and remove the engine coolant temperature sensor.

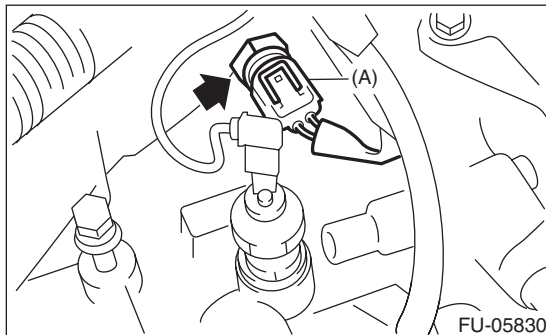

### B: INSTALLATION

Install in the reverse order of removal.

NOTE:

Use a new gasket.

**Tightening torque:**

**18 N·m (1.8 kgf·m, 13.3 ft·lb)**

### C: INSPECTION

1) Check that the engine coolant temperature sensor has no deformation, cracks or other damages.

2) Immerse the engine coolant temperature sensor and a thermometer in water.

**CAUTION:**

**Take care not to allow water to get into the engine coolant temperature sensor connector. Completely remove any water inside.**

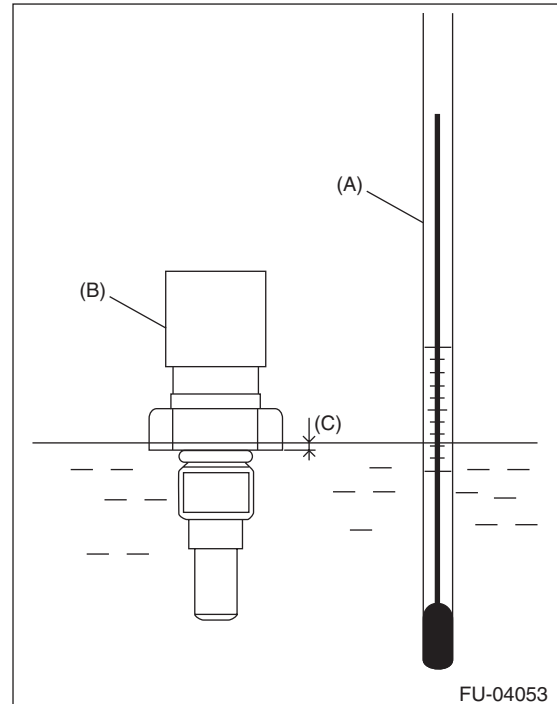

(A) Thermometer

(B) Engine coolant temperature sensor

(C) Hexagonal part height: to approx.  $\frac{1}{3}$

3) Raise water temperature gradually, measure the resistance between the engine coolant temperature sensor terminals when the temperature is 20°C (68°F) and 80°C (176°F).

NOTE:

Agitate the water for even temperature distribution.

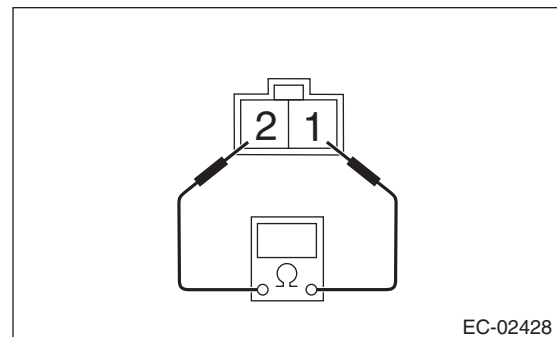

Water temperature	Terminal No.	Standard
20°C (68°F)	1 and 2	2.45±0.2 kΩ
80°C (176°F)		0.318±0.013 kΩ

**FU(w/o STI)-35**

Brought to you by Ebay Seller "SubaruManuals"

# Crankshaft Position Sensor

FUEL INJECTION (FUEL SYSTEMS)

## 5. Crankshaft Position Sensor

### A: REMOVAL

- 1) Remove the collector cover.
- 2) Disconnect the ground cable from battery.

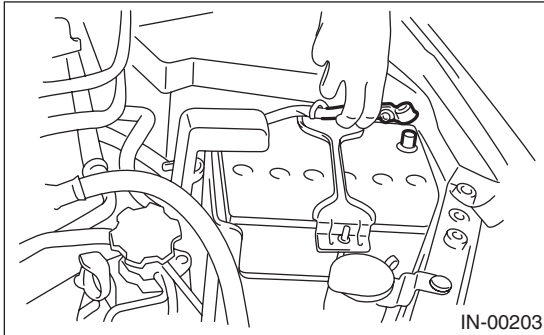

- 3) Remove the bolt which secures crankshaft position sensor to oil pump.

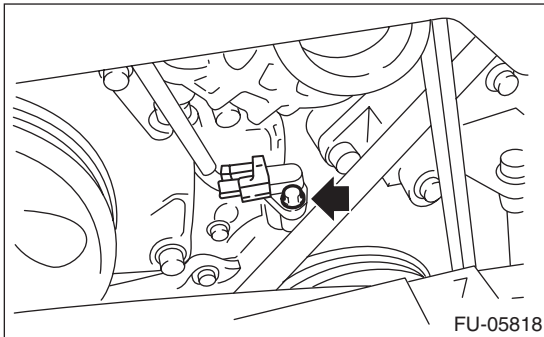

- 4) Remove the crankshaft position sensor, and disconnect the connector from the crankshaft position sensor.

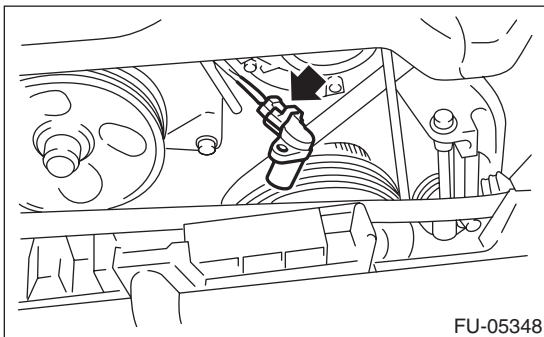

### B: INSTALLATION

Install in the reverse order of removal.

**Tightening torque:**

**6.4 N·m (0.7 kgf·m, 4.7 ft·lb)**

### C: INSPECTION

#### 1. CRANKSHAFT POSITION SENSOR (METHOD WITH CIRCUIT TESTER)

Measure the resistance between crankshaft position sensor terminals.

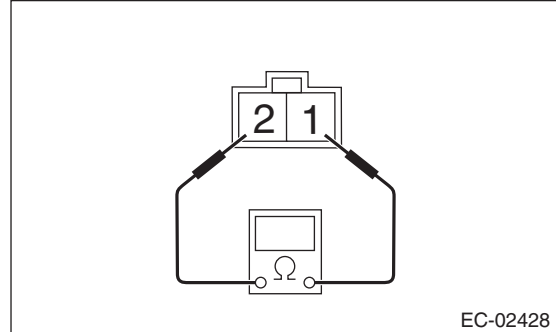

Terminal No.	Standard
1 and 2	2.04±0.204 kΩ

#### 2. CRANKSHAFT POSITION SENSOR (METHOD WITH OSCILLOSCOPE)

- 1) Prepare an oscilloscope.
- 2) Remove the lower inner trim of passenger's side. <Ref. to EI-57, REMOVAL, Lower Inner Trim.>
- 3) Turn over the floor mat of passenger's seat.
- 4) Remove the protect cover.

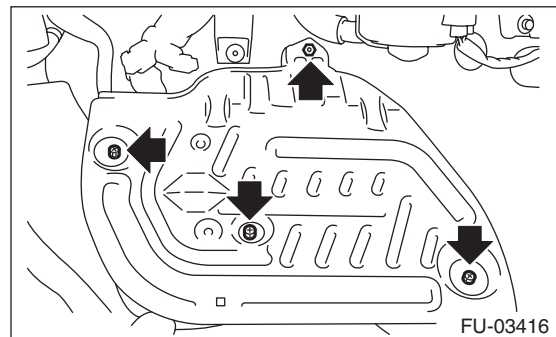

- 5) Remove the nuts and bolts which hold the ECM to the bracket.

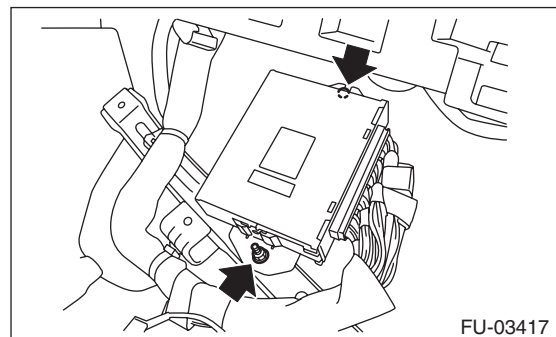

**FU(w/o STI)-36**

Brought to you by Ebay Seller "SubaruManuals"

# Crankshaft Position Sensor

6) Connect the probe to ECM connector.

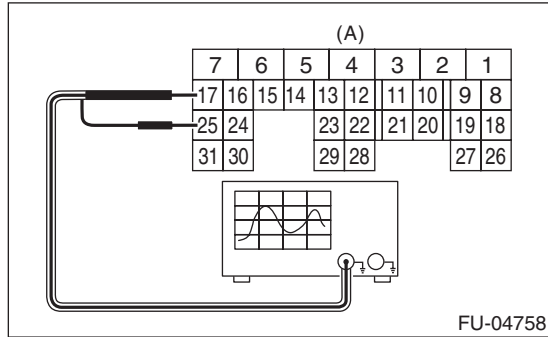

(A) To ECM connector

Terminal No.	Probe
17	+
25	-

7) Start the engine and let it idle.

8) Check the pattern is the same as the waveform and voltage shown below.

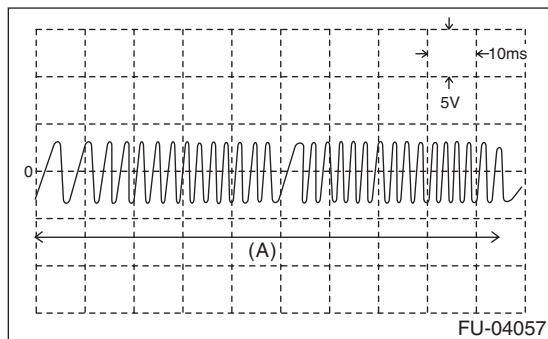

(A) One crankshaft rotation

9) After inspection, install the related parts in the reverse order of removal.

**Tightening torque:**

**7.5 N·m (0.8 kgf·m, 5.5 ft·lb)**

### 3. OTHER INSPECTIONS

Check that the crankshaft position sensor has no deformation, cracks or other damages.

# Camshaft Position Sensor

FUEL INJECTION (FUEL SYSTEMS)

## 6. Camshaft Position Sensor

### A: REMOVAL

#### 1. CAMSHAFT POSITION SENSOR RH

- 1) Disconnect the ground cable from battery.

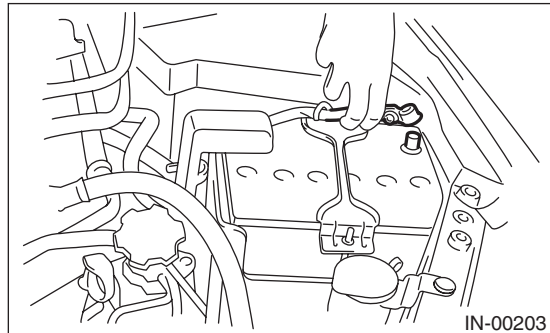

- 2) Disconnect the connector (A) from the camshaft position sensor RH, and remove the camshaft position sensor RH from the rear side of the cylinder head.

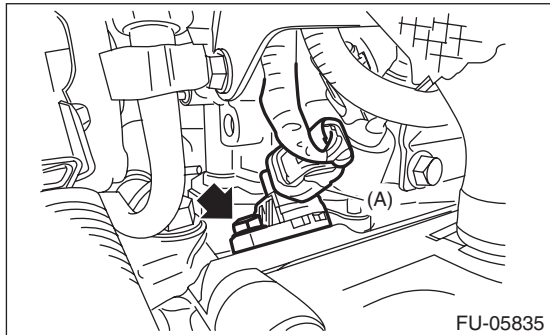

#### 2. CAMSHAFT POSITION SENSOR LH

- 1) Remove the collector cover.
- 2) Disconnect the ground cable from battery.

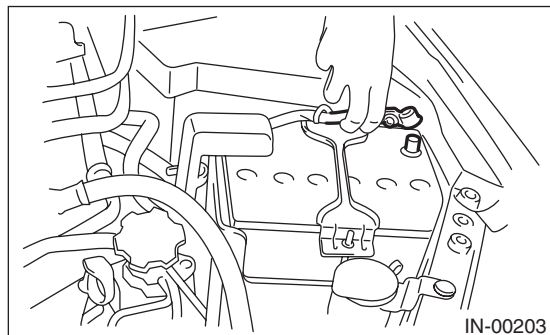

- 3) Remove the intake manifold. <Ref. to FU(w/o STI)-18, REMOVAL, Intake Manifold.>

- 4) Remove the camshaft position sensor LH.

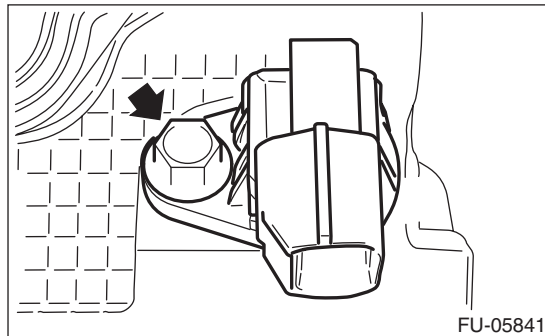

### B: INSTALLATION

Install in the reverse order of removal.

#### Tightening torque:

**6.4 N·m (0.7 kgf·m, 4.7 ft·lb)**

### C: INSPECTION

#### 1. CAMSHAFT POSITION SENSOR (METHOD WITH OSCILLOSCOPE)

- 1) Prepare an oscilloscope.
- 2) Remove the lower inner trim of passenger's side. <Ref. to EI-57, REMOVAL, Lower Inner Trim.>
- 3) Turn over the floor mat of passenger's seat.
- 4) Remove the protect cover.

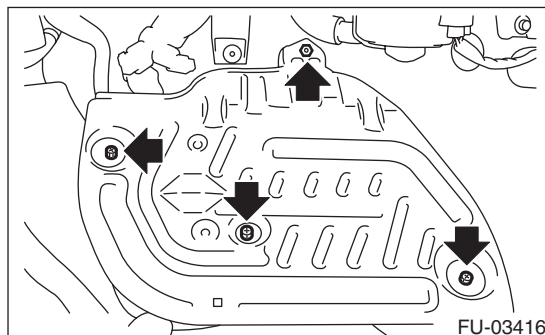

- 5) Remove the nuts and bolts which hold the ECM to the bracket.

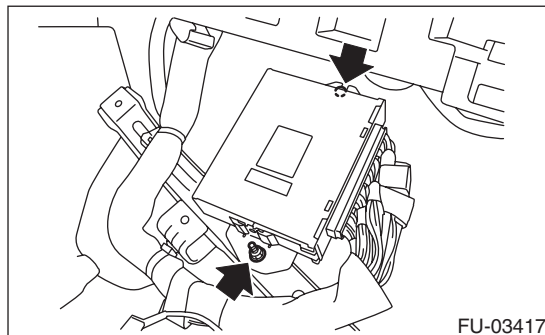

# Camshaft Position Sensor

6) Connect the probe to ECM connector.

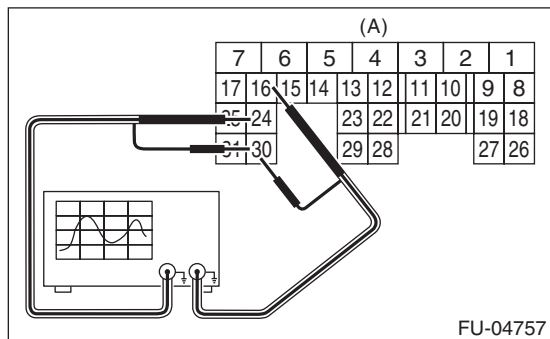

(A) To ECM connector

Camshaft position sensor	Terminal No.	Probe
RH	24	+
LH	16	+
RH and LH	30	-

7) Start the engine and let it idle.

8) Check the pattern is the same as the waveform and voltage shown below.

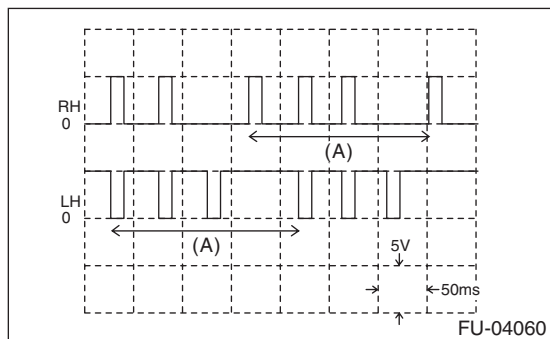

(A) One camshaft rotation

9) After inspection, install the related parts in the reverse order of removal.

**Tightening torque:**

**7.5 N·m (0.8 kgf-m, 5.5 ft-lb)**

## 2. OTHER INSPECTIONS

Check that the camshaft position sensor has no deformation, cracks or other damages.



# Knock Sensor

FUEL INJECTION (FUEL SYSTEMS)

## 7. Knock Sensor

### A: REMOVAL

- 1) Disconnect the ground cable from battery.

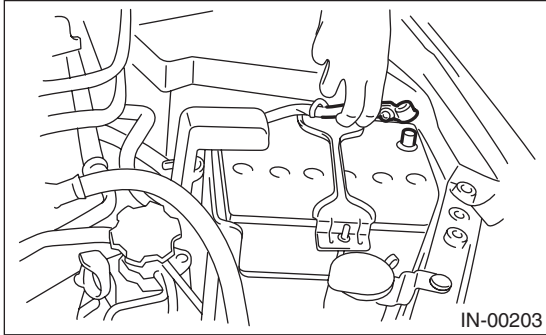

- 2) Remove the intercooler. <Ref. to IN(w/o STI)-12, REMOVAL, Intercooler.>
- 3) Disconnect the connector from the knock sensor.

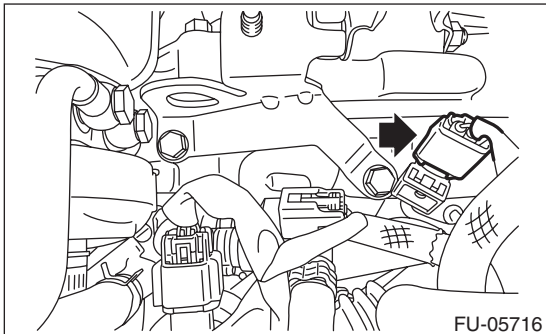

- 4) Remove the knock sensor from cylinder block.

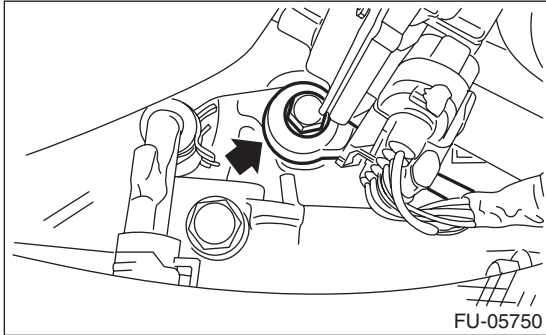

### B: INSTALLATION

- 1) Install the knock sensor to the cylinder block.

#### NOTE:

The portion of the knock sensor cord that is pulled out must be positioned at a 60° angle relative to the engine rear.

#### Tightening torque:

**24 N·m (2.4 kgf·m, 17.7 ft·lb)**

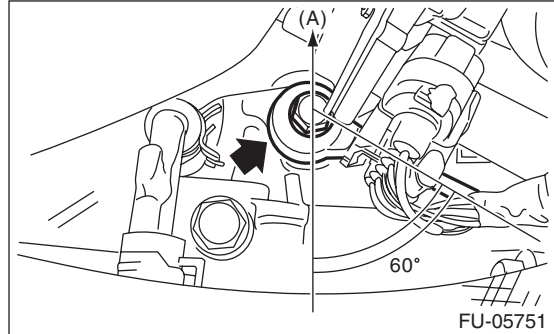

(A) Front side of vehicle

- 2) Connect the connector to the knock sensor.

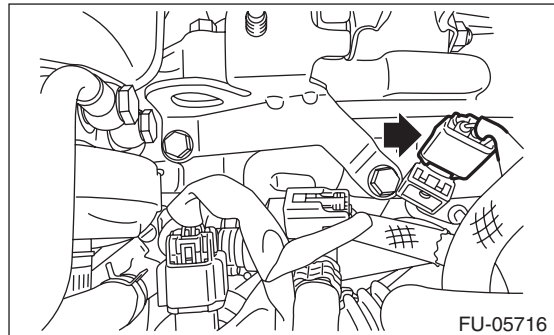

- 3) Install the intercooler. <Ref. to IN(w/o STI)-12, INSTALLATION, Intercooler.>

- 4) Connect the battery ground terminal.

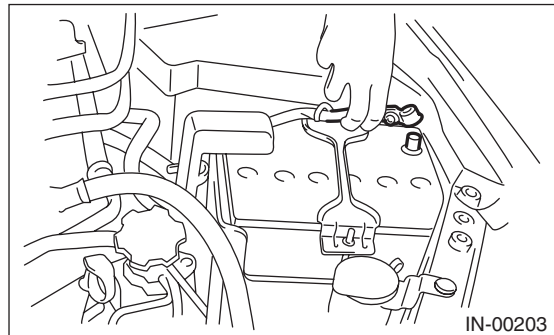

**FU(w/o STI)-40**

Brought to you by Ebay Seller "SubaruManuals"



## C: INSPECTION

- 1) Check that the knock sensor has no deformation, cracks or other damages.
- 2) Measure the resistance between knock sensor terminals.

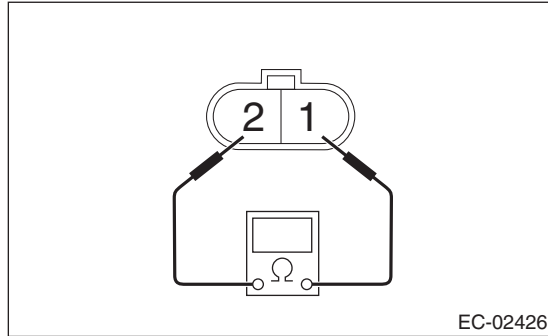

Terminal No.	Standard
1 and 2	560±28 kΩ

# Throttle Position Sensor

FUEL INJECTION (FUEL SYSTEMS)

---

## 8. Throttle Position Sensor

### A: SPECIFICATION

Throttle body is a non-disassembled part, so do not remove the throttle position sensor from throttle body.

Refer to "Throttle Body" for removal and installation procedure. <Ref. to FU(w/o STI)-15, REMOVAL, Throttle Body.> <Ref. to FU(w/o STI)-16, INSTALLATION, Throttle Body.>

# Mass Air Flow and Intake Air Temperature Sensor

FUEL INJECTION (FUEL SYSTEMS)

## 9. Mass Air Flow and Intake Air Temperature Sensor

### A: REMOVAL

1) Disconnect the ground cable from battery.

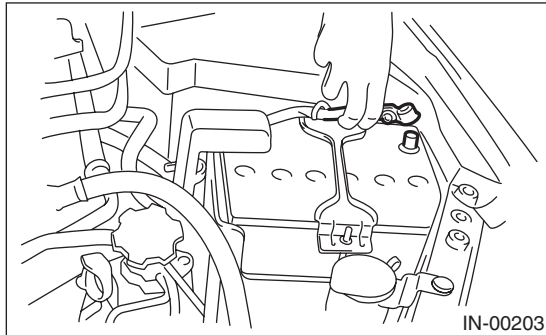

2) Disconnect the connector (A) from the mass air flow and intake air temperature sensor, and remove the mass air flow and intake air temperature sensor.

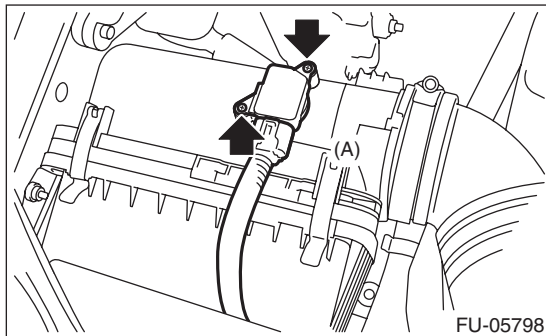

### B: INSTALLATION

Install in the reverse order of removal.

#### Tightening torque:

1 N·m (0.1 kgf·m, 0.7 ft·lb)

### C: INSPECTION

#### 1. CHECK THE MASS AIR FLOW SENSOR UNIT

1) Connect the battery positive terminal to terminal No. 3 and the battery ground terminal to terminal No. 4, the circuit tester positive terminal to terminal No. 5 and the circuit tester ground terminal to terminal No. 4.

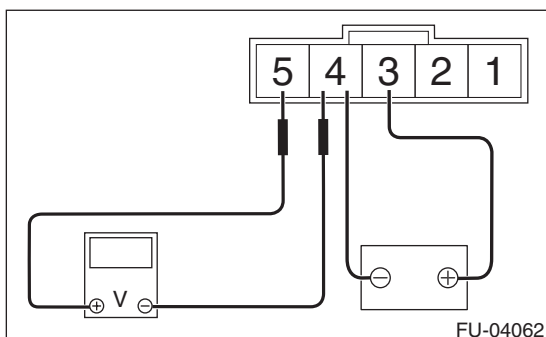

2) Check the voltage changes when air is blown to the mass air flow sensor unit in arrow direction.

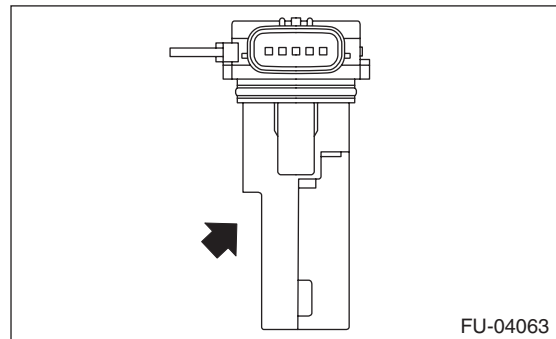

#### 2. CHECK THE INTAKE AIR TEMPERATURE SENSOR UNIT

Measure the resistance between intake air temperature sensor terminals.

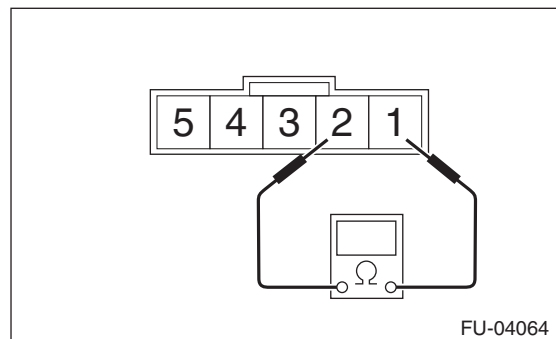

Temperature	Terminal No.	Standard
-20°C (-4°F)	1 and 2	16.0±2.4 kΩ
20°C (68°F)		2.45±0.24 kΩ
60°C (140°F)		0.580±0.087 kΩ

#### 3. OTHER INSPECTIONS

1) Check that the mass air flow and intake air temperature sensor has no deformation, cracks or other damages.

2) Check that the mass air flow and intake air temperature sensor has no dirt.

FU(w/o STI)-43

Brought to you by Ebay Seller "SubaruManuals"

# Manifold Absolute Pressure Sensor

FUEL INJECTION (FUEL SYSTEMS)

## 10. Manifold Absolute Pressure Sensor

### A: REMOVAL

- 1) Remove the collector cover.
- 2) Disconnect the ground cable from battery.

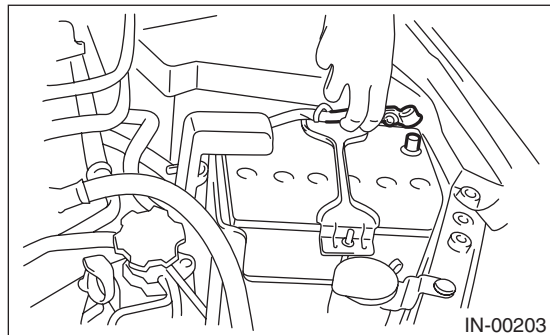

- 3) Disconnect the connector (A) from manifold absolute pressure sensor, and remove the filter assembly (B) from intake manifold.
- 4) Remove the manifold absolute pressure sensor from the solenoid valve bracket.

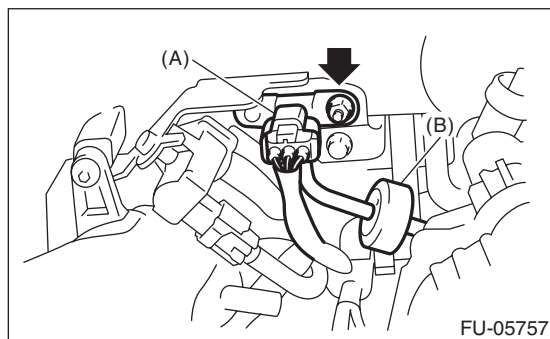

### B: INSTALLATION

Install in the reverse order of removal.

#### Tightening torque:

**6.4 N·m (0.7 kgf·m, 4.7 ft·lb)**

### C: INSPECTION

- 1) Check that the manifold absolute pressure sensor has no deformation, cracks or other damages.
- 2) Connect dry-cell battery positive terminal to terminal No. 3 and dry-cell battery ground terminal to terminal No. 1, circuit tester positive terminal to terminal No. 2 and the circuit tester negative terminal to terminal No. 1.

#### NOTE:

- Use new dry-cell batteries.
- Using circuit tester, check the voltage of a single dry-cell battery is 1.6 V or more. And also check the voltage of three batteries in series is between 4.8 V and 5.2 V.

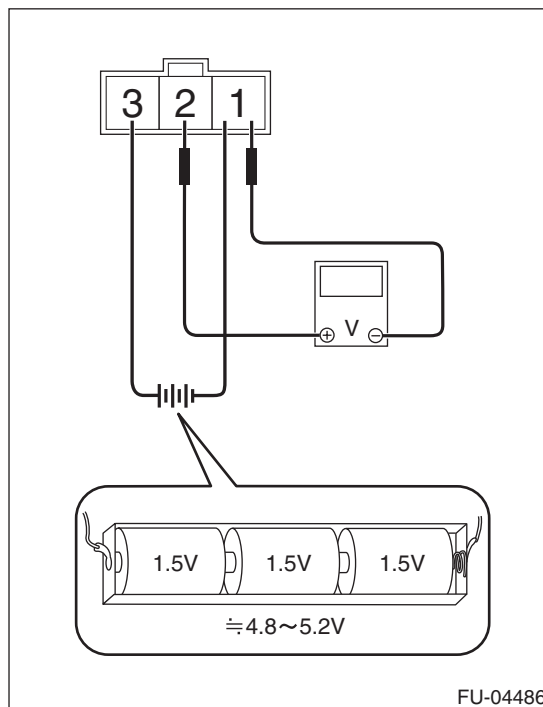

- 3) Check the voltage at a normal atmospheric pressure.

#### NOTE:

The atmospheric pressure at higher altitude is lower than normal. Therefore, the voltage is lower than the standard value.

Terminal No.	Standard
2 (+) and 1 (-)	Approx. 2.2 V (when 25°C (77°F))

**FU(w/o STI)-44**

Brought to you by Ebay Seller "SubaruManuals"

# Manifold Absolute Pressure Sensor

FUEL INJECTION (FUEL SYSTEMS)

4) Connect the Mighty Vac to the pressure port (A) of manifold absolute pressure sensor.

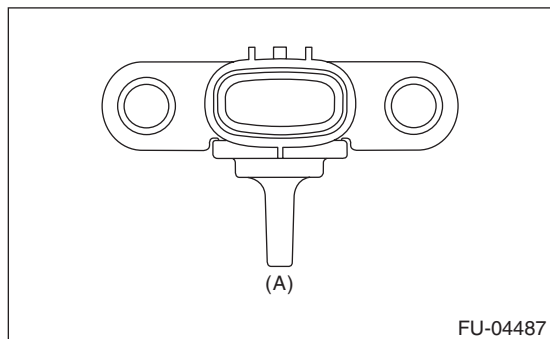

5) Check the voltage when generating vacuum and positive pressure using Mighty Vac.

### CAUTION:

**Do not apply vacuum of less than  $-88$  —  $200$  kPa ( $-0.9$  —  $2.04$  kgf/cm<sup>2</sup>,  $-12.8$  —  $29.0$  psi). Doing so may damage the manifold absolute pressure sensor.**

### NOTE:

When vacuum occurs at the pressure port of manifold absolute pressure sensor, the voltage will drop from the value as in step 3). When positive pressure occurs, on the other hand, the voltage will rise.

Pressure	Terminal No.	Standard
$-88$ kPa ( $-0.9$ kgf/cm <sup>2</sup> , $-12.8$ psi)	2 (+) and 1 (-)	Approx. 1.0 V (when 25°C (77°F))
152 kPa (1.55 kgf/cm <sup>2</sup> , 22.0 psi)		Approx. 4.5 V (when 25°C (77°F))

**FU(w/o STI)-45**

Brought to you by Ebay Seller "SubaruManuals"

# Fuel Injector

## FUEL INJECTION (FUEL SYSTEMS)

### 11. Fuel Injector

#### A: REMOVAL

##### 1. RH SIDE

1) Release the fuel pressure. <Ref. to FU(w/o STI)-66, RELEASING OF FUEL PRESSURE, PROCEDURE, Fuel.>

2) Disconnect the ground cable from battery.

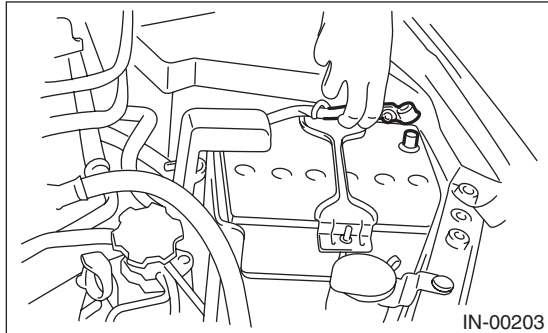

3) Open the fuel filler lid and remove the fuel filler cap.

4) Remove the intake manifold. <Ref. to FU(w/o STI)-18, REMOVAL, Intake Manifold.>

5) Remove the fuel pipe protector RH from the intake manifold.

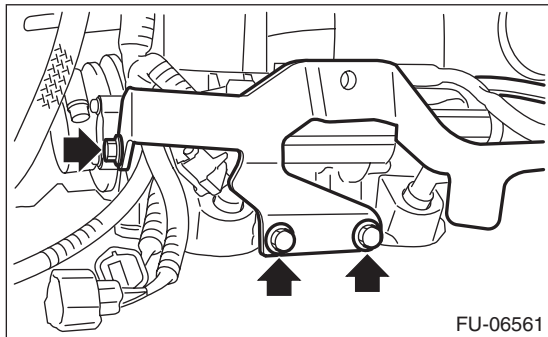

6) Disconnect the connector from fuel injector.

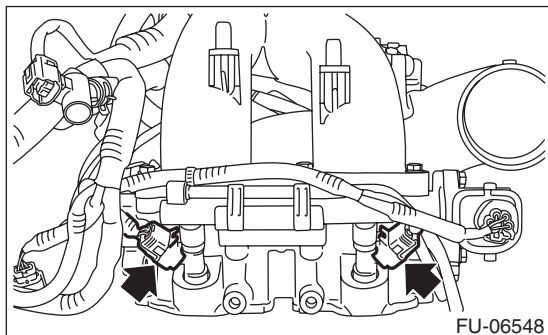

7) Remove the bolt which holds fuel injector pipe RH onto intake manifold.

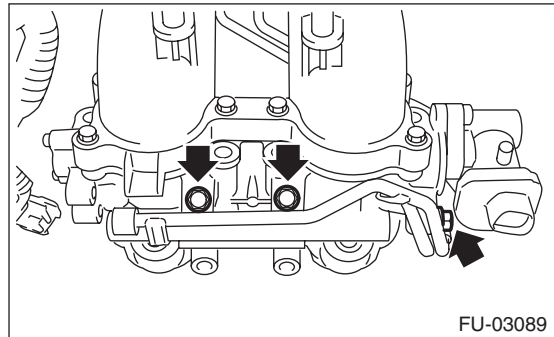

8) Remove the fuel injector.

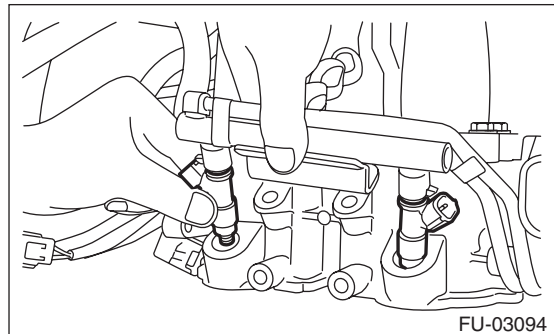

##### 2. LH SIDE

1) Release the fuel pressure. <Ref. to FU(w/o STI)-66, RELEASING OF FUEL PRESSURE, PROCEDURE, Fuel.>

2) Disconnect the ground cable from battery.

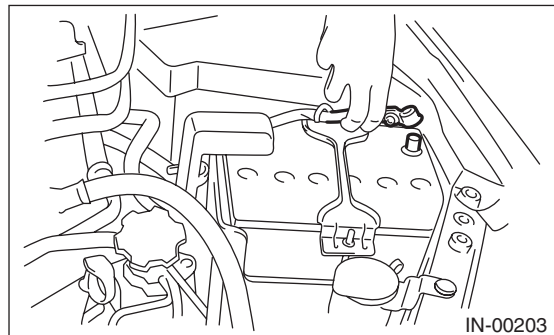

3) Open the fuel filler lid and remove the fuel filler cap.

4) Remove the intake manifold. <Ref. to FU(w/o STI)-18, REMOVAL, Intake Manifold.>

# Fuel Injector

## FUEL INJECTION (FUEL SYSTEMS)

5) Remove the engine ground terminal from the fuel pipe protector LH and remove the fuel pipe protector LH from the intake manifold.

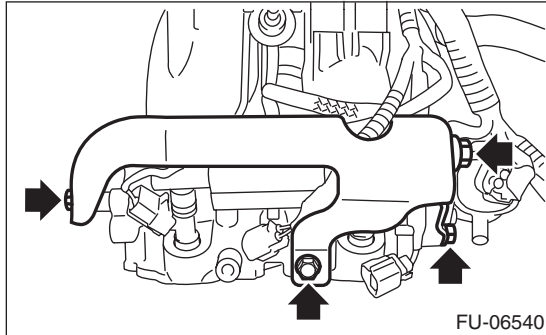

6) Disconnect the connector from fuel injector.

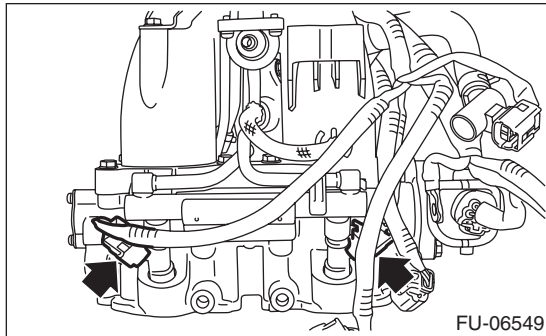

7) Remove the bolt which holds fuel injector pipe LH onto intake manifold.

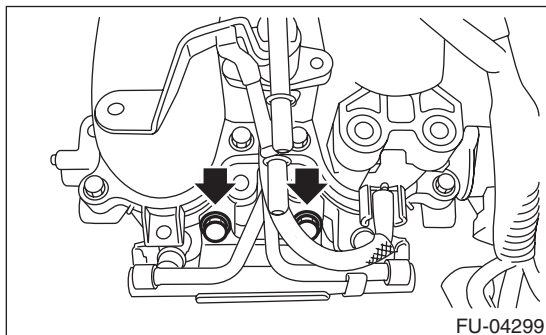
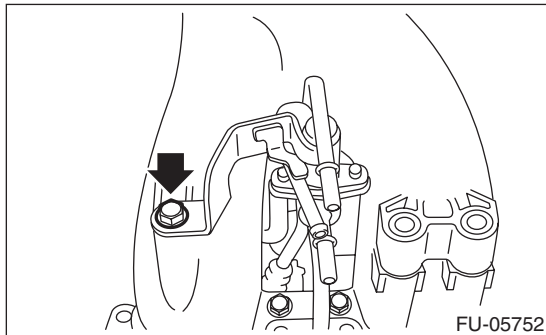

8) Remove the fuel injector.

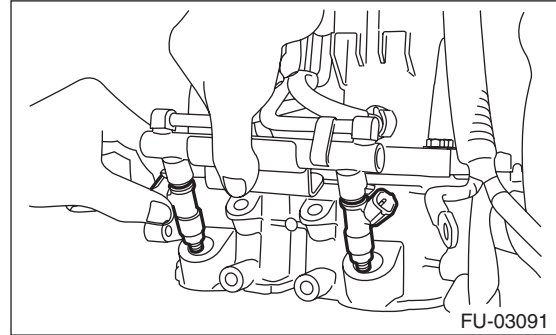

## B: INSTALLATION

### 1. RH SIDE

Install in the reverse order of removal.

NOTE:

Use new O-rings, rubbers and seal rings.

**Tightening torque:**

**19 N·m (1.9 kgf-m, 14.0 ft-lb)**

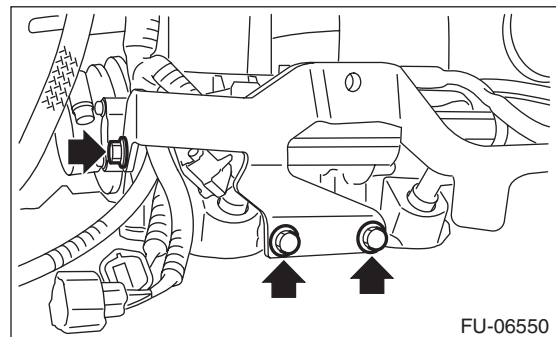
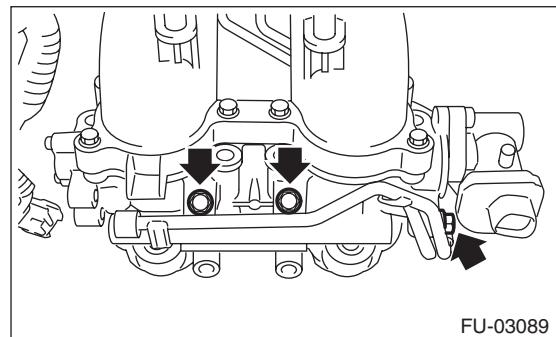

# Fuel Injector

## FUEL INJECTION (FUEL SYSTEMS)

### 2. LH SIDE

Install in the reverse order of removal.

NOTE:

Use new O-rings, rubbers and seal rings.

**Tightening torque:**

**6.4 N·m (0.7 kgf-m, 4.7 ft-lb)**

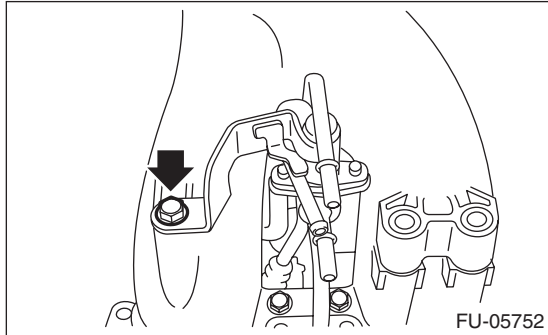

**Tightening torque:**

**19 N·m (1.9 kgf-m, 14.0 ft-lb)**

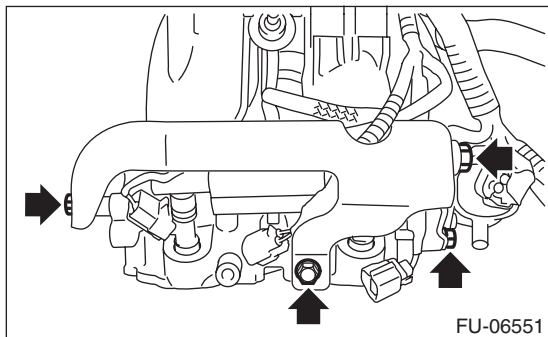
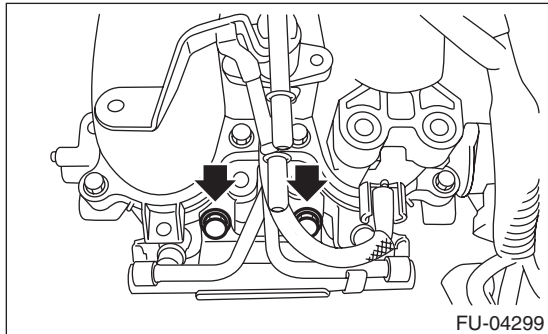

### C: INSPECTION

- 1) Check that the fuel injector has no deformation, cracks or other damages.
- 2) Measure the resistance between fuel injector terminals.

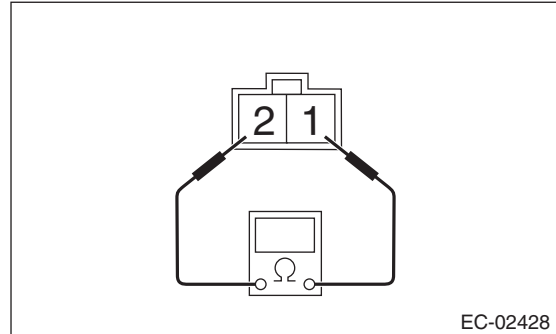

Terminal No.	Standard
1 and 2	Approx. 12.0 Ω (when 20°C (68°F))

**FU(w/o STI)-48**

Brought to you by Ebay Seller "SubaruManuals"



## 12. Tumble Generator Valve Assembly

### A: REMOVAL

- 1) Release the fuel pressure. <Ref. to FU(w/o STI)-66, RELEASING OF FUEL PRESSURE, PROCEDURE, Fuel.>
- 2) Disconnect the ground cable from battery.

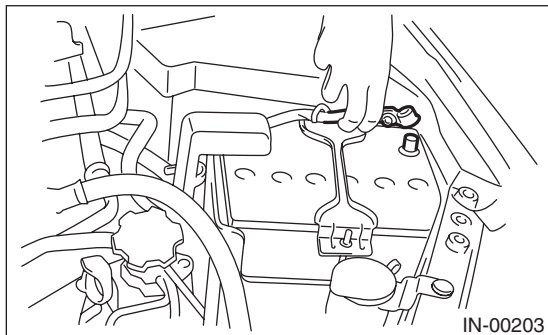

- 3) Open the fuel filler lid and remove the fuel filler cap.

- 4) Remove the intake manifold. <Ref. to FU(w/o STI)-18, REMOVAL, Intake Manifold.>

- 5) Disconnect the connector from the tumble generator valve assembly.

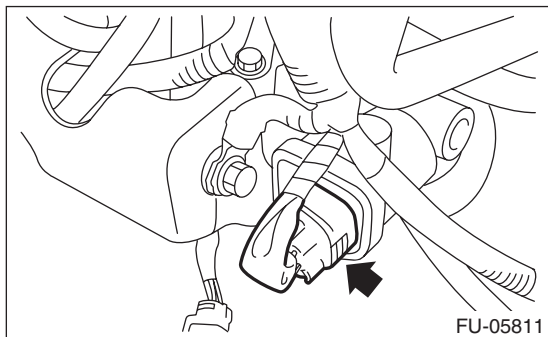

- 6) Remove the fuel injector. <Ref. to FU(w/o STI)-46, REMOVAL, Fuel Injector.>

- 7) Remove the tumble generator valve assembly from the intake manifold.

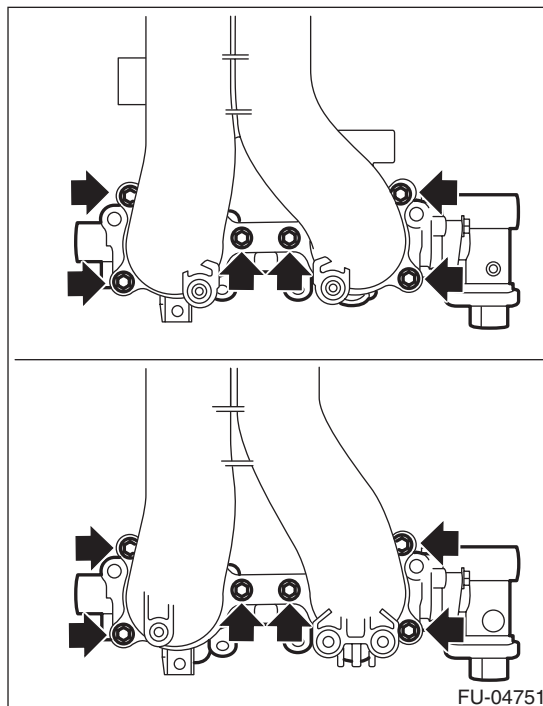

### B: INSTALLATION

Install in the reverse order of removal.

#### NOTE:

Use a new gasket.

#### **Tightening torque:**

**8.3 N·m (0.8 kgf·m, 6.1 ft·lb)**

### C: INSPECTION

- 1) Check that the tumble generator valve assembly has no deformation, cracks or other damages.
- 2) Check tumble generator valve for contamination or clogging.

# Tumble Generator Valve Actuator

FUEL INJECTION (FUEL SYSTEMS)

---

## 13. Tumble Generator Valve Actuator

### A: SPECIFICATION

The tumble generator valve assembly cannot be disassembled.

Refer to "Tumble Generator Valve Assembly" for removal and installation procedures. <Ref. to FU(w/o STI)-49, REMOVAL, Tumble Generator Valve Assembly.> <Ref. to FU(w/o STI)-49, INSTALLATION, Tumble Generator Valve Assembly.>

# Oil Flow Control Solenoid Valve

FUEL INJECTION (FUEL SYSTEMS)

## 14.Oil Flow Control Solenoid Valve

### A: REMOVAL

Oil flow control solenoid valve is a unit with front camshaft cap.

Refer to "Camshaft" for removal procedures. <Ref. to ME(w/o STI)-60, REMOVAL, Camshaft.>

### B: INSTALLATION

Refer to "Camshaft" for installation procedure. <Ref. to ME(w/o STI)-63, INSTALLATION, Camshaft.>

### C: DISASSEMBLY

1) Remove the two mounting bolts securing oil return cover, and remove the oil return cover and gasket.

2) Remove the bolt securing oil flow control solenoid valve, and remove the oil flow control solenoid valve.

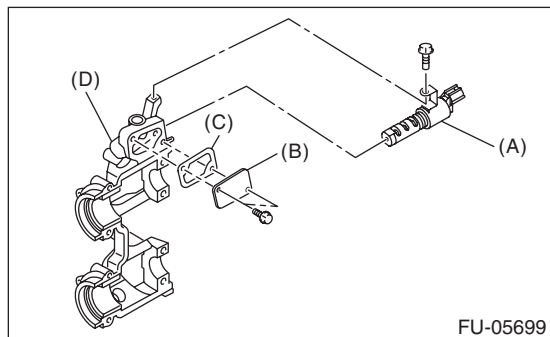

- (A) Oil flow control solenoid valve
- (B) Oil return cover
- (C) Gasket
- (D) Front camshaft cap

### D: ASSEMBLY

1) Install the oil flow control solenoid valve.

**Tightening torque:**

**6.4 N·m (0.7 kgf·m, 4.7 ft·lb)**

2) Apply liquid gasket to the two bolts securing oil return cover.

**Liquid gasket:**

**THREE BOND 1324 (Part No. 004403042) or equivalent**

3) Attach the oil return cover and gasket.

**NOTE:**

Use a new gasket.

**Tightening torque:**

**9 N·m (0.9 kgf·m, 6.6 ft·lb)**

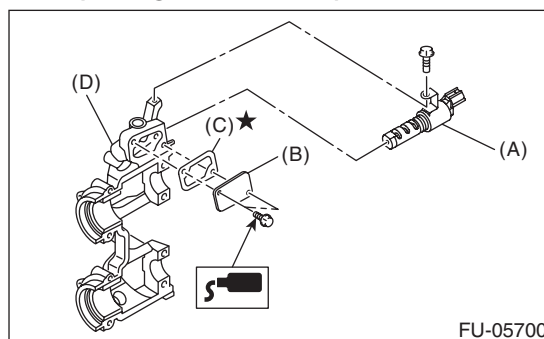

- (A) Oil flow control solenoid valve
- (B) Oil return cover
- (C) Gasket
- (D) Front camshaft cap

### E: INSPECTION

1) Check that the oil flow control solenoid valve has no deformation, cracks or other damages.

2) Measure the resistance between the oil flow control solenoid valve terminals.

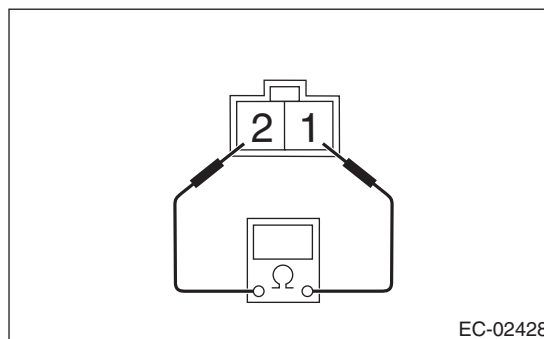

Terminal No.	Standard
1 and 2	7.4±0.5 Ω (when 20°C (68°F))

**FU(w/o STI)-51**

Brought to you by Ebay Seller "SubaruManuals"

# Wastegate Control Solenoid Valve

FUEL INJECTION (FUEL SYSTEMS)

## 15. Wastegate Control Solenoid Valve

### A: REMOVAL

- 1) Remove the collector cover.
- 2) Disconnect the ground cable from battery.

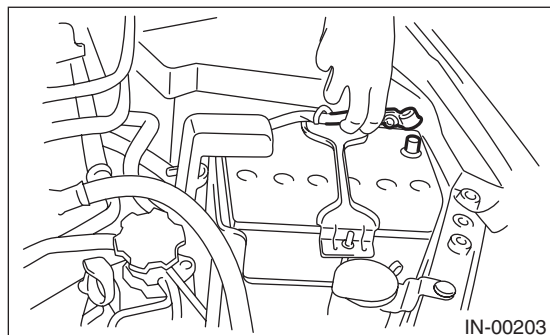

- 3) Disconnect the connector (A) from the wastegate control solenoid valve.
- 4) Disconnect the vacuum hose (B) and air control hose (C) from the wastegate control solenoid valve.
- 5) Remove the wastegate control solenoid valve from the bracket.

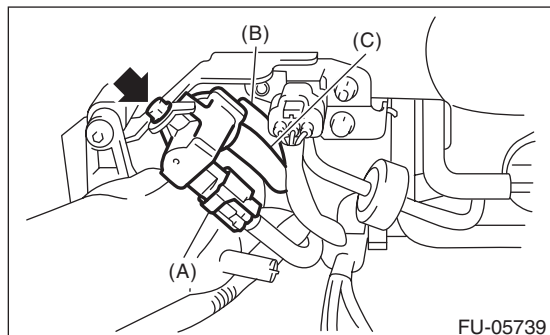

### B: INSTALLATION

Install in the reverse order of removal.

**Tightening torque:**

**6.4 N·m (0.7 kgf·m, 4.7 ft·lb)**

### C: INSPECTION

#### 1. WASTEGATE CONTROL SOLENOID VALVE

- 1) Check that the wastegate control solenoid valve has no deformation, cracks or other damages.
- 2) Check the resistance between the wastegate control solenoid valve terminals.

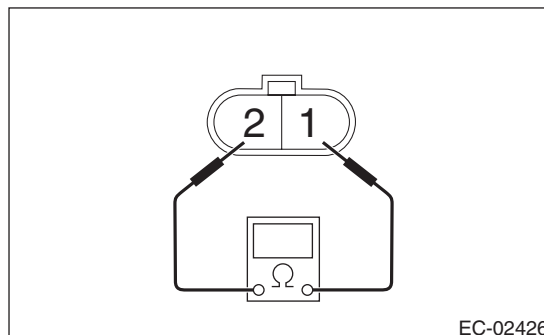

Terminal No.	Standard
1 and 2	28±2 Ω (when 20°C (68°F))

- 3) Check that air does not come out from (B) when air is blown into (A).

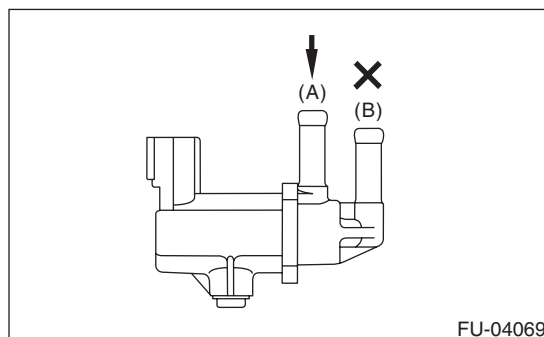

# Wastegate Control Solenoid Valve

FUEL INJECTION (FUEL SYSTEMS)

4) Connect the battery positive terminal to the terminal No. 1 and the battery negative terminal to the terminal No. 2. Check that air is discharged from (B), when supplying air to (A).

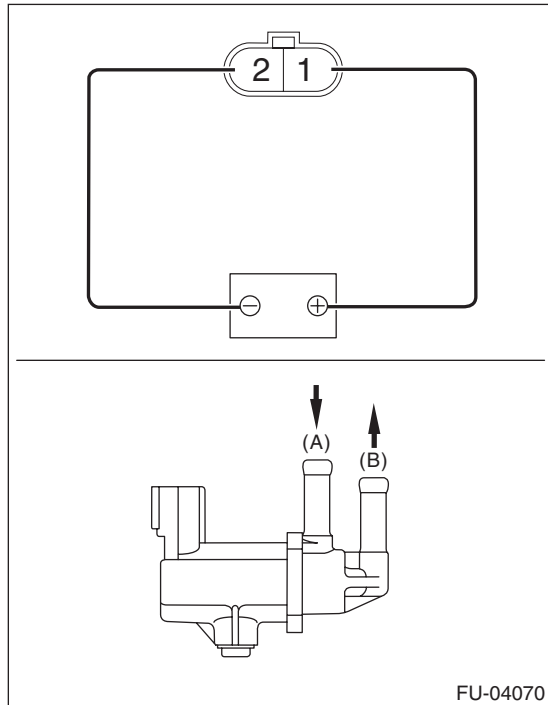

## 2. OTHER INSPECTIONS

Check that the vacuum hose and air control hose have no cracks, damage or loose part.

# Front Oxygen (A/F) Sensor

FUEL INJECTION (FUEL SYSTEMS)

## 16. Front Oxygen (A/F) Sensor

### A: REMOVAL

- 1) Disconnect the ground cable from battery.

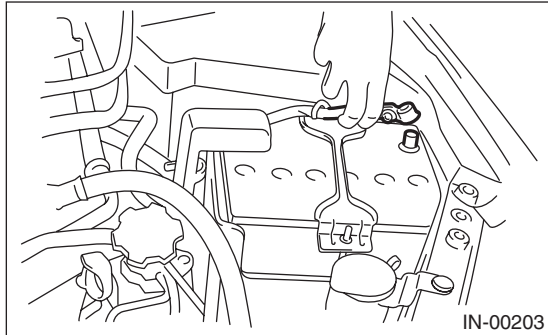

- 2) Remove the air intake duct (rear) and air cleaner case. <Ref. to IN(w/o STI)-10, REMOVAL, Air Intake Duct.> <Ref. to IN(w/o STI)-8, REMOVAL, Air Cleaner Case.>

- 3) Disconnect the connectors from front oxygen (A/F) sensor.



- 4) Lift up the vehicle.
- 5) Remove the under cover. <Ref. to EI-28, REMOVAL, Front Under Cover.>
- 6) Apply spray-type lubricant to the threaded portion of front oxygen (A/F) sensor, and leave it for one minute or more.
- 7) Remove the front oxygen (A/F) sensor.

### CAUTION:

**When removing the front oxygen (A/F) sensor, wait until exhaust pipe cools, otherwise it will damage the exhaust pipe.**

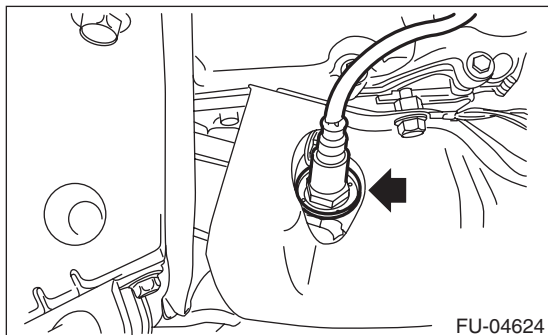

### B: INSTALLATION

#### CAUTION:

**If lubricant is spilled onto the exhaust pipe, wipe it off completely with cloth to avoid emission of smoke or causing a fire.**

- 1) Before installing front oxygen (A/F) sensor, apply anti-seize compound only to the threaded portion of front oxygen (A/F) sensor to make the next removal easier.

#### CAUTION:

**Never apply anti-seize compound to the protector of front oxygen (A/F) sensor.**

#### Anti-seize compound:

**NEVER-SEEZ NSN, JET LUBE SS-30 or equivalent**

- 2) Install the front oxygen (A/F) sensor.

#### Tightening torque:

**30 N·m (3.1 kgf·m, 22.1 ft·lb)**

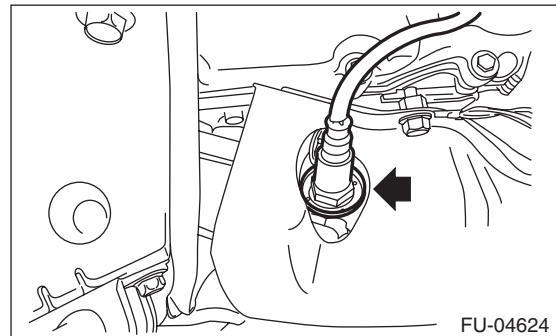

- 3) Install the under cover. <Ref. to EI-28, INSTALLATION, Front Under Cover.>
- 4) Lower the vehicle.
- 5) Connect the connector of front oxygen (A/F) sensor.



- 6) Install the air intake duct (rear) and air cleaner case. <Ref. to IN(w/o STI)-8, INSTALLATION, Air Cleaner Case.> <Ref. to IN(w/o STI)-10, INSTALLATION, Air Intake Duct.>

**FU(w/o STI)-54**

Brought to you by Ebay Seller "SubaruManuals"

# Front Oxygen (A/F) Sensor

FUEL INJECTION (FUEL SYSTEMS)

7) Connect the battery ground terminal.

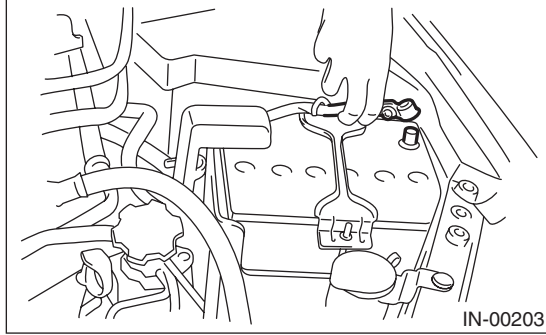

## C: INSPECTION

- 1) Check that the front oxygen (A/F) sensor has no deformation, cracks or other damages.
- 2) Measure the resistance between front oxygen (A/F) sensor terminals.

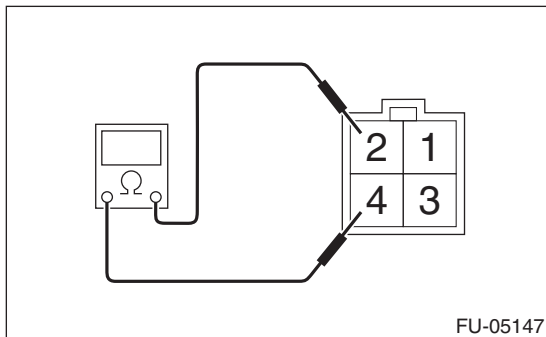

Terminal No.	Standard
2 and 4	$2.4 \pm 0.24 \Omega$ (when 20°C (68°F))

# Rear Oxygen Sensor

FUEL INJECTION (FUEL SYSTEMS)

## 17. Rear Oxygen Sensor

### A: REMOVAL

- 1) Disconnect the ground cable from battery.

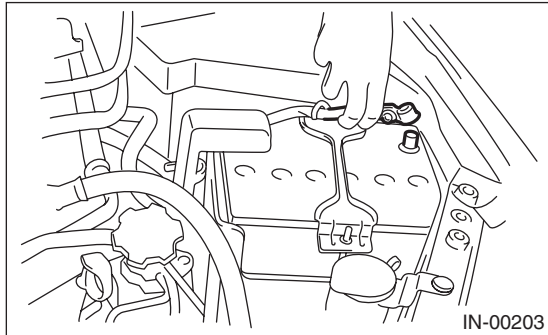

- 2) Lift up the vehicle.
- 3) Disconnect the connector from the rear oxygen sensor, and remove the clip (A) holding the rear oxygen sensor harness.

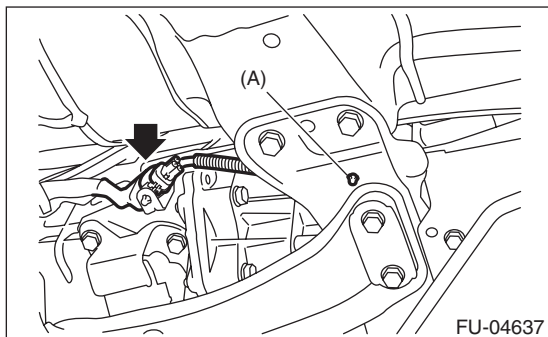

- 4) Apply spray-type lubricant to the threaded portion of rear oxygen sensor, and leave it for one minute or more.
- 5) Remove the rear oxygen sensor.

### CAUTION:

**When removing the rear oxygen sensor, wait until exhaust pipe cools, otherwise it will damage the exhaust pipe.**

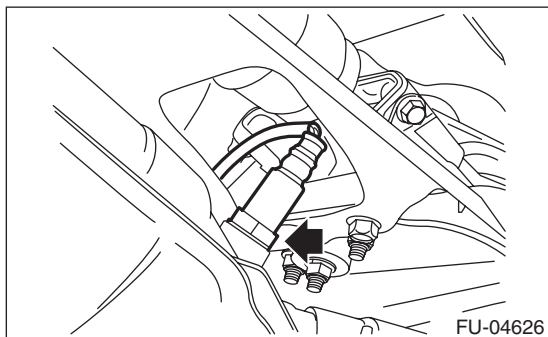

### B: INSTALLATION

#### CAUTION:

**If lubricant is spilled onto the exhaust pipe, wipe it off completely with cloth to avoid emission of smoke or causing a fire.**

- 1) Before installing rear oxygen sensor, apply the anti-seize compound only to the threaded portion of rear oxygen sensor to make the next removal easier.

#### CAUTION:

**Never apply anti-seize compound to the protector of rear oxygen sensor.**

#### Anti-seize compound:

**NEVER-SEEZ NSN, JET LUBE SS-30 or equivalent**

- 2) Install the rear oxygen sensor.

#### Tightening torque:

**21 N·m (2.1 kgf·m, 15.5 ft·lb)**

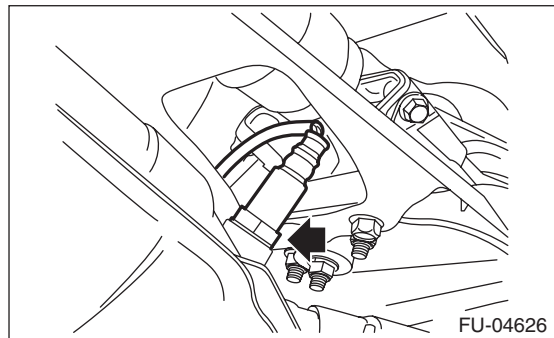

- 3) Connect the connector to the rear oxygen sensor, and hold the rear oxygen sensor harness with the clip (A).

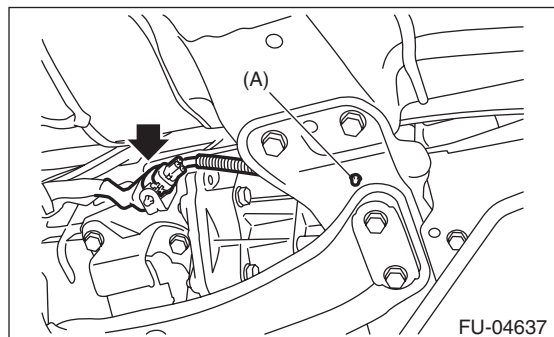

- 4) Lower the vehicle.

FU(w/o STI)-56

Brought to you by Ebay Seller "SubaruManuals"



# Rear Oxygen Sensor

5) Connect the battery ground terminal.

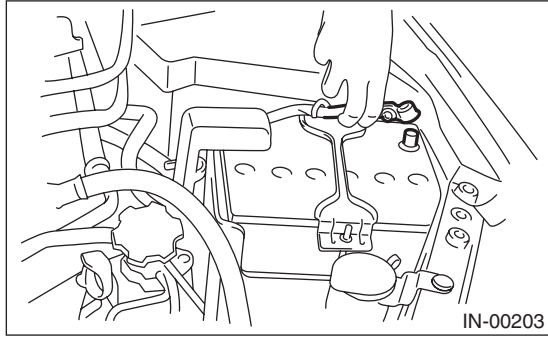

## C: INSPECTION

- 1) Check that the rear oxygen sensor has no deformation, cracks or other damages.
- 2) Measure the resistance between rear oxygen sensor terminals.

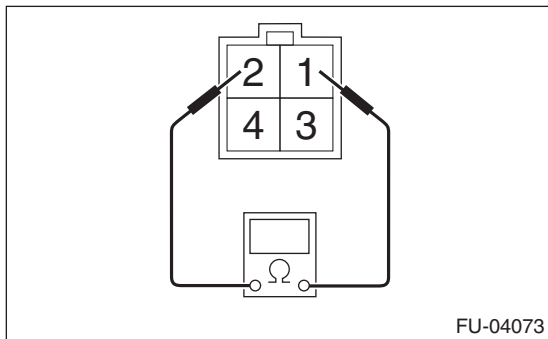

Terminal No.	Standard
1 and 2	$5.6^{+0.8}_{-0.6} \Omega$ (when 20°C (68°F))

# Engine Control Module (ECM)

## FUEL INJECTION (FUEL SYSTEMS)

### 18. Engine Control Module (ECM)

#### A: REMOVAL

1) Disconnect the ground cable from battery.

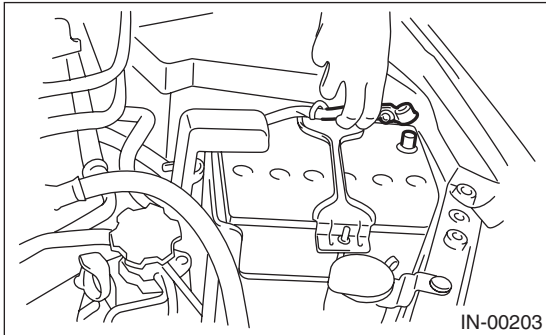

2) Remove the lower inner trim of passenger's side. <Ref. to EI-57, REMOVAL, Lower Inner Trim.>

3) Turn over the floor mat of passenger's seat.

4) Remove the protect cover.

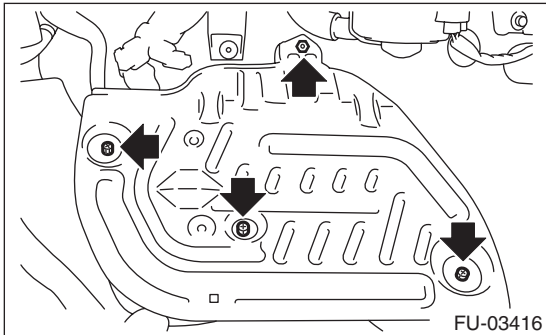

5) Remove the nuts and bolts which hold the ECM to the bracket.

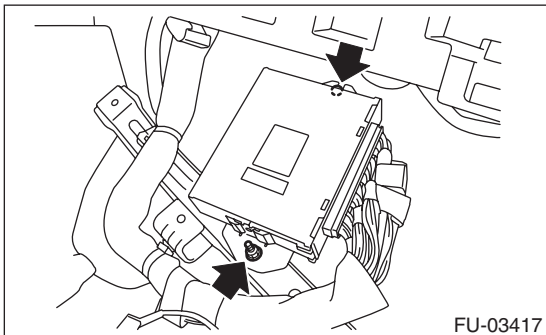

6) Disconnect the ECM connectors, and take out the ECM.

#### B: INSTALLATION

Install in the reverse order of removal.

#### CAUTION:

- When the ECM of model with immobilizer has been replaced, be sure to perform the registration of immobilizer system. (Refer to "PC application help for Subaru Select Monitor".)
- If replacing ECM or the bracket, replace both parts with new parts at a time.
- After installing the bracket to ECM, do not separate the bracket.
- If the bracket has been installed to ECM in the wrong direction, replace both parts to new parts.

#### NOTE:

When replacing the ECM, be careful not to use the wrong spec. ECM to avoid any damage on the fuel injection system.

#### Tightening torque:

*7.5 N·m (0.8 kgf·m, 5.5 ft·lb)*

#### C: INSPECTION

Check that the ECM has no deformation, cracks or other damages.

## 19.Main Relay

### A: REMOVAL

1) Disconnect the ground cable from battery.

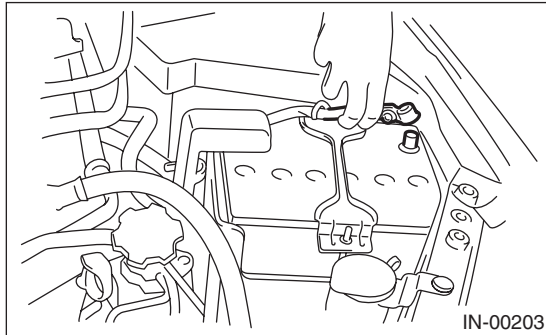

2) Remove the main relay from the relay block on the back side of the glove box.

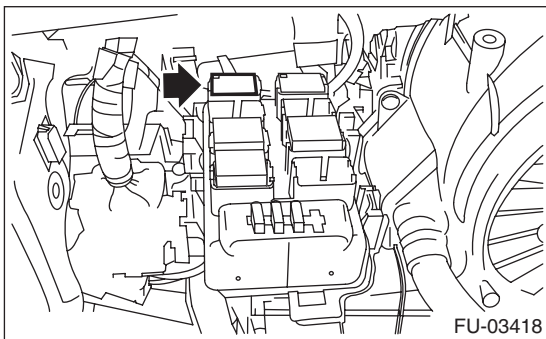

### B: INSTALLATION

Install in the reverse order of removal.

### C: INSPECTION

- 1) Check that the main relay has no deformation, cracks or other damages.
- 2) Measure the resistance between main relay terminals.

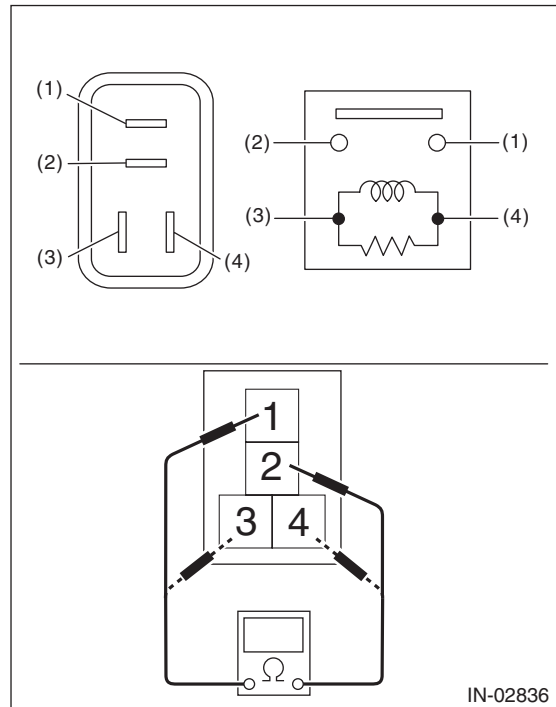

Terminal No.	Standard
1 and 2	1 MΩ or more
3 and 4	130.4 — 230.8 Ω (when 20°C (68°F))

# Main Relay

## FUEL INJECTION (FUEL SYSTEMS)

---

3) Connect battery positive terminal to terminal No. 3 and battery ground terminal to terminal No. 4, and measure the resistance between the main relay terminals.

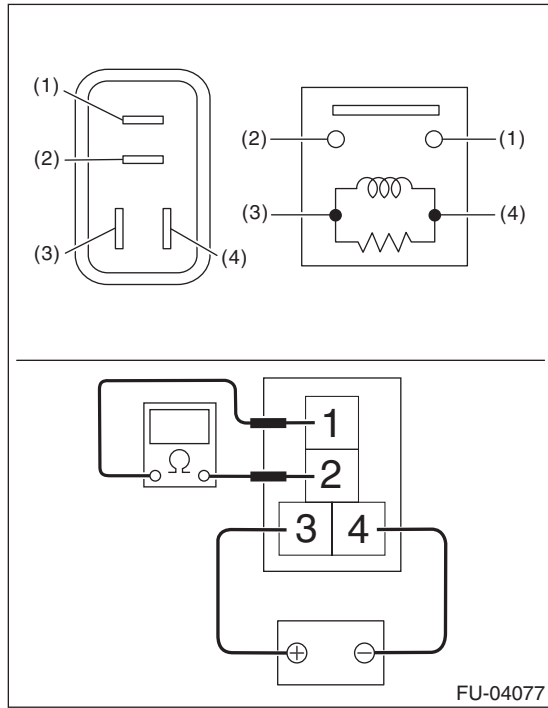

Terminal No.	Standard
1 and 2	Less than 1 $\Omega$

## 20. Fuel Pump Relay

### A: REMOVAL

1) Disconnect the ground cable from battery.

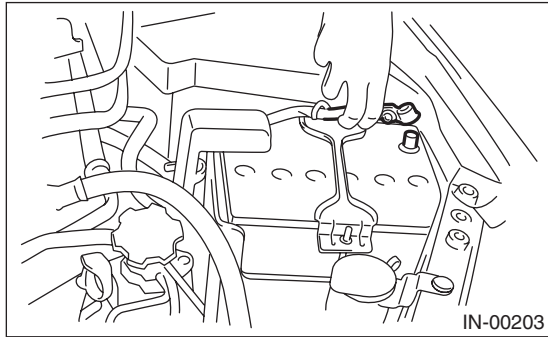

2) Remove the fuel pump relay from the relay block on the back side of the glove box.



### B: INSTALLATION

Install in the reverse order of removal.

### C: INSPECTION

- 1) Check that the fuel pump relay has no deformation, cracks or other damages.
- 2) Measure the resistance between fuel pump relay terminals.

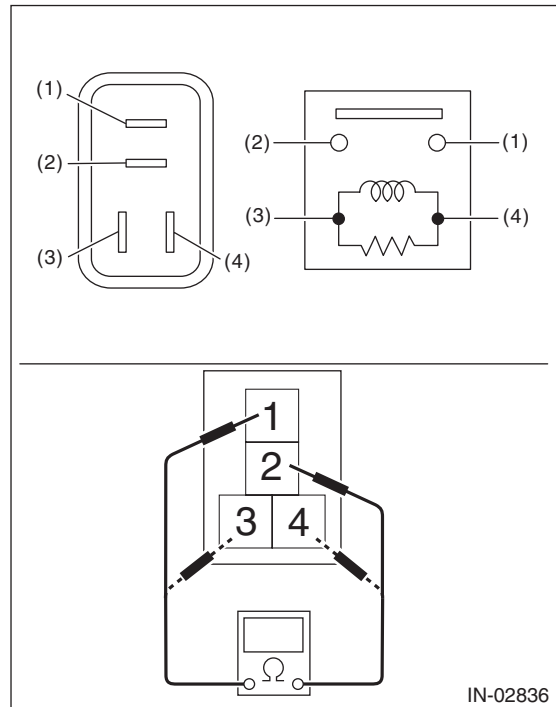

Terminal No.	Standard
1 and 2	1 MΩ or more
3 and 4	93.8 — 136.4 Ω (when 20°C (68°F))

# Fuel Pump Relay

## FUEL INJECTION (FUEL SYSTEMS)

3) Connect battery positive terminal to terminal No. 3 and battery ground terminal to terminal No. 4, and measure the resistance between the fuel pump relay terminals.

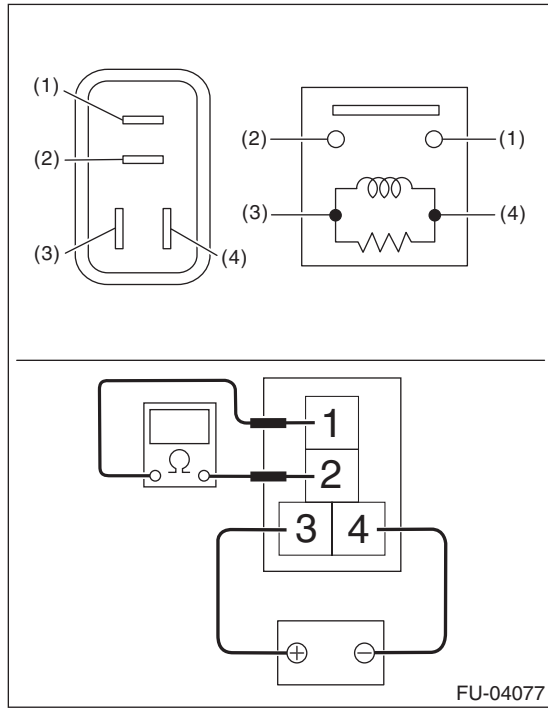

Terminal No.	Standard
1 and 2	Less than 1 $\Omega$

# Electronic Throttle Control Relay

FUEL INJECTION (FUEL SYSTEMS)

## 21. Electronic Throttle Control Relay

### A: REMOVAL

1) Disconnect the ground cable from battery.

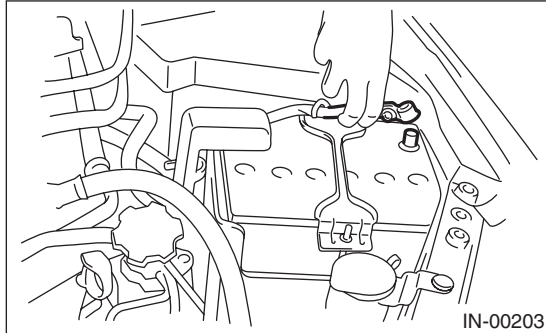

2) Remove the electronic throttle control relay from the relay block on the back side of the glove box.

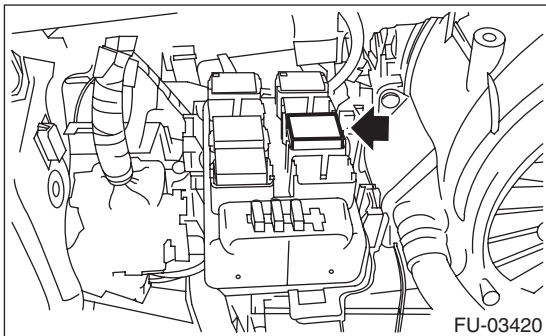

### B: INSTALLATION

Install in the reverse order of removal.

### C: INSPECTION

- 1) Check that the electronic throttle control relay has no deformation, cracks or other damages.
- 2) Measure the resistance between electronic throttle control relay terminals.

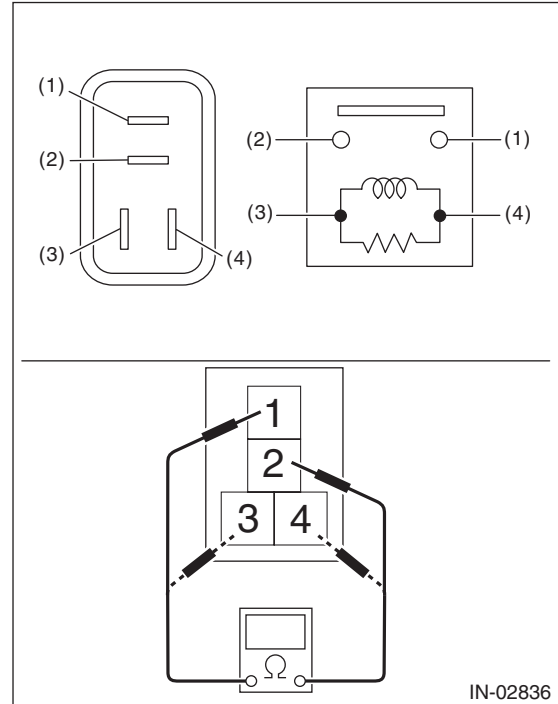

Terminal No.	Standard
1 and 2	1 M $\Omega$ or more
3 and 4	93.8 — 136.4 $\Omega$ (when 20°C (68°F))

# Electronic Throttle Control Relay

## FUEL INJECTION (FUEL SYSTEMS)

---

3) Connect battery positive terminal to terminal No. 3 and battery ground terminal to terminal No. 4, and measure the resistance between the electronic throttle control relay terminals.

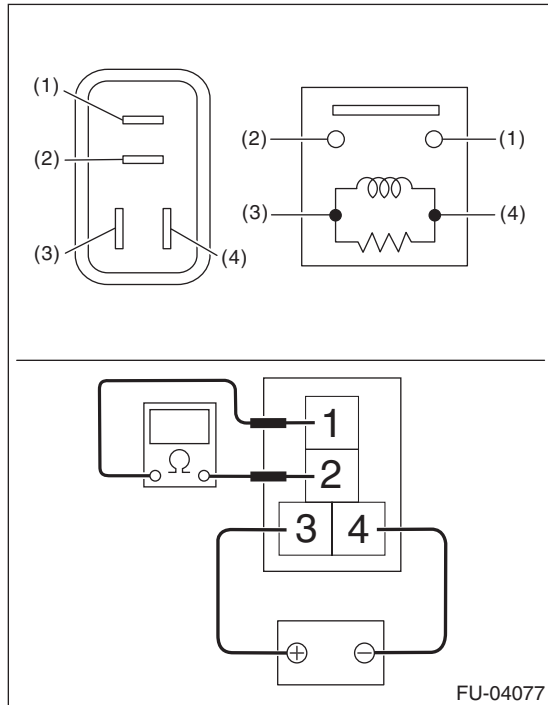

Terminal No.	Standard
1 and 2	Less than 1 $\Omega$



## 22. Fuel Pump Control Unit

### A: REMOVAL

1) Disconnect the ground cable from battery.

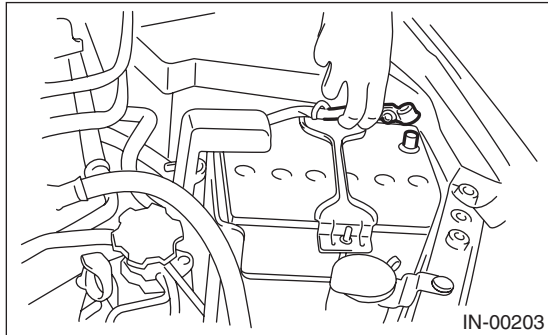

2) Remove the right side trunk side trim. (4 door model) <Ref. to EI-63, REMOVAL, Trunk Room Trim.>

3) Remove the right side rear quarter trim. (5 door model) <Ref. to EI-60, REMOVAL, Rear Quarter Trim.>

4) Disconnect the connector (A) from the fuel pump control unit, and remove the fuel pump control unit.

- 4 door model

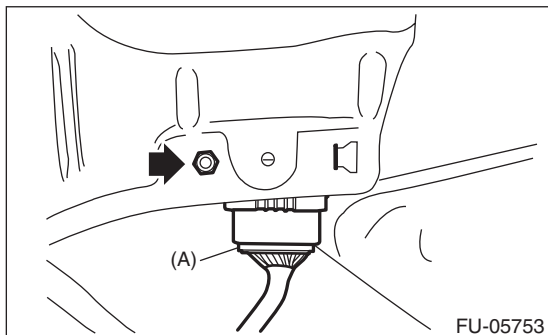

- 5 door model

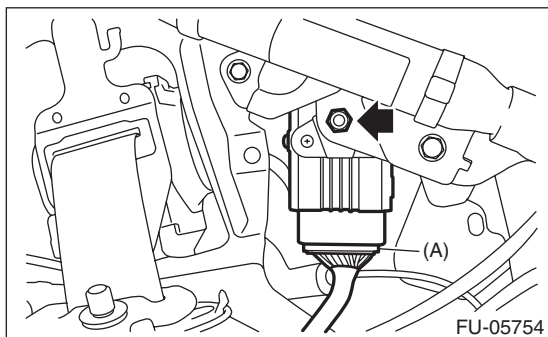

### B: INSTALLATION

Install in the reverse order of removal.

**Tightening torque:**

**5 N·m (0.5 kgf·m, 3.7 ft·lb)**

### C: INSPECTION

Check that the fuel pump control unit has no deformation, cracks or other damages.

### 23. Fuel

#### A: PROCEDURE

##### 1. RELEASING OF FUEL PRESSURE

**WARNING:**

Place "NO OPEN FLAMES" signs near the working area.

**CAUTION:**

**Be careful not to spill fuel.**

1) Remove the fuse of fuel pump from main fuse box.

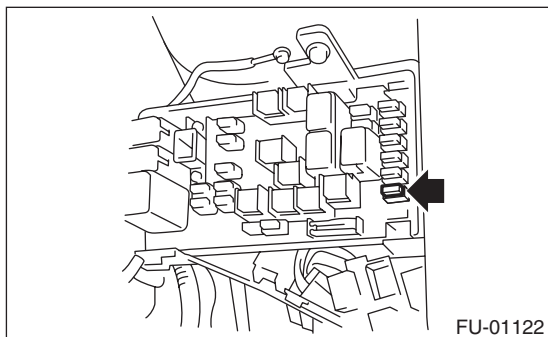

- 2) Start the engine and run it until it stalls.
- 3) After the engine stalls, crank it for five more seconds.
- 4) Turn the ignition switch to OFF.
- 5) Install the fuse of fuel pump to the main fuse box.

##### 2. DRAINING FUEL (WITH SUBARU SELECT MONITOR)

**WARNING:**

Place "NO OPEN FLAMES" signs near the working area.

**CAUTION:**

**Be careful not to spill fuel.**

**NOTE:**

- If the fuel pump cannot be driven, refer to the procedures for draining from the fuel filler hose. <Ref. to FU(w/o STI)-67, DRAINING FUEL (THROUGH THE FUEL FILLER HOSE), PROCEDURE, Fuel.>
- Be careful not to let the battery run-out.

- 1) Release the fuel pressure. <Ref. to FU(w/o STI)-66, RELEASING OF FUEL PRESSURE, PROCEDURE, Fuel.>

- 2) Attach ST to the fuel delivery pipe and push ST in the direction of arrow mark to disconnect the fuel delivery hose.

ST 42099AE000 QUICK CONNECTOR RELEASE

**CAUTION:**

- **Be careful not to spill fuel.**
- **Catch the fuel from hoses using a container or cloth.**

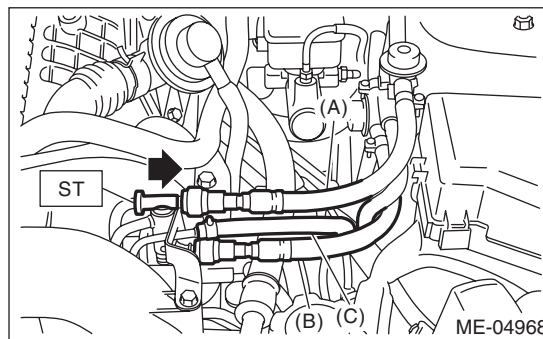

- (A) Fuel delivery hose
- (B) Fuel return hose
- (C) Evaporation hose

- 3) Connect ST to the fuel delivery hose.  
ST 18471AA000 FUEL PIPE ADAPTER
- 4) Connect the gasoline proof hose to ST and put the end of the hose in the container.
- 5) Drive the fuel pump and drain the fuel using Subaru Select Monitor. <Ref. to EN(H4DOTC)(diag)-64, FUEL PUMP CONTROL (ON/OFF DRIVE), OPERATION, System Operation Check Mode.>

**CAUTION:**

**Be careful not to spill fuel.**

6) Install the related parts in the reverse order after draining the fuel.

### 3. DRAINING FUEL (THROUGH THE FUEL FILLER HOSE)

- 4 door model

**WARNING:**

Place "NO OPEN FLAMES" signs near the working area.

**CAUTION:**

- Be careful not to spill fuel.
- Fuel may remain in the fuel filler pipe. Draining the fuel from the fuel filler pipe through the fill opening using the gasoline proof pump and the gasoline proof hose (ø10 or less) before the operation.

- 1) Lift up the vehicle.
- 2) Remove the rear exhaust pipe and muffler. <Ref. to EX(STI)-13, REMOVAL, Rear Exhaust Pipe.> <Ref. to EX(STI)-15, REMOVAL, Muffler.>
- 3) Remove the rear sub frame. <Ref. to RS-17, REMOVAL, Rear Sub Frame.>
- 4) Open the fuel filler lid and remove the fuel filler cap.
- 5) Drain the fuel from the fuel filler pipe through the filler opening using the gasoline proof pump and the gasoline proof hose (ø10 or less).
- 6) Disconnect the fuel filler hose from the fuel filler pipe assembly.

**CAUTION:**

- Be careful not to spill fuel.
- Catch the fuel from hoses using a container or cloth.

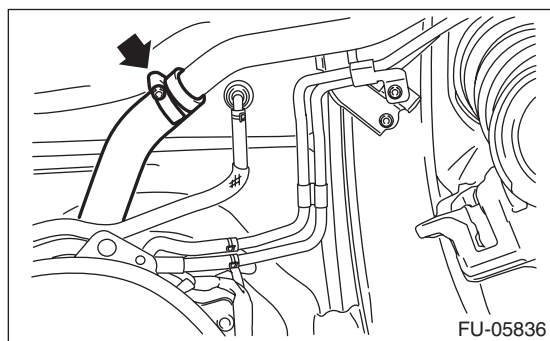

- 7) Set the container under the vehicle and insert the gasoline proof hose (ø10 or less) into the fuel filler hose to drain the fuel.

**CAUTION:**

Be careful not to spill fuel.

- 8) Install the related parts in the reverse order after draining the fuel.

**NOTE:**

Correctly insert the fuel filler hose to spool, and then install the clamp as shown in the figure.

**Tightening torque:**

**2.5 N·m (0.3 kgf-m, 1.8 ft-lb)**

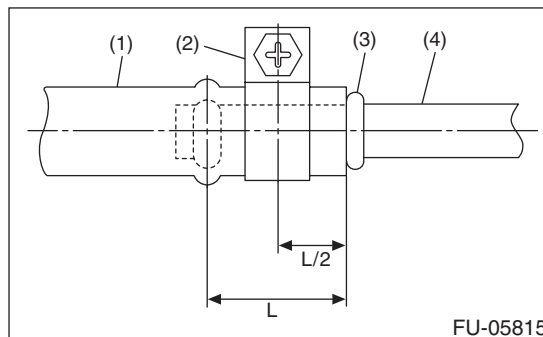

- (1) Fuel filler hose
- (2) Clamp
- (3) Spool
- (4) Fuel filler pipe

- 5 door model

**WARNING:**

Place "NO OPEN FLAMES" signs near the working area.

**CAUTION:**

- Be careful not to spill fuel.
- Fuel may remain in the fuel filler pipe. Draining the fuel from the fuel filler pipe through the fill opening using the gasoline proof pump and the gasoline proof hose (ø10 or less) before the operation.

- 1) Lift up the vehicle.
- 2) Remove the rear exhaust pipe and muffler. <Ref. to EX(STI)-13, REMOVAL, Rear Exhaust Pipe.> <Ref. to EX(STI)-15, REMOVAL, Muffler.>
- 3) Open the fuel filler lid and remove the fuel filler cap.
- 4) Drain the fuel from the fuel filler pipe through the filler opening using the gasoline proof pump and the gasoline proof hose (ø10 or less).

# Fuel

## FUEL INJECTION (FUEL SYSTEMS)

---

5) Disconnect the fuel filler hose from the fuel filler pipe assembly.

**CAUTION:**

- Be careful not to spill fuel.
- Catch the fuel from hoses using a container or cloth.

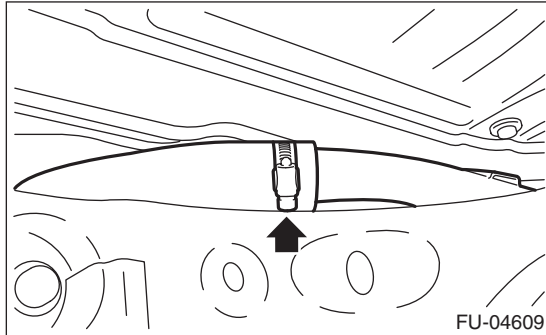

6) Set the container under the vehicle and insert the gasoline proof hose (ø10 or less) into the fuel filler hose to drain the fuel.

**CAUTION:**

**Be careful not to spill fuel.**

7) Install the related parts in the reverse order after draining the fuel.

**NOTE:**

Correctly insert the fuel filler hose to spool, and then install the clamp as shown in the figure.

**Tightening torque:**

**2.5 N·m (0.3 kgf·m, 1.8 ft·lb)**

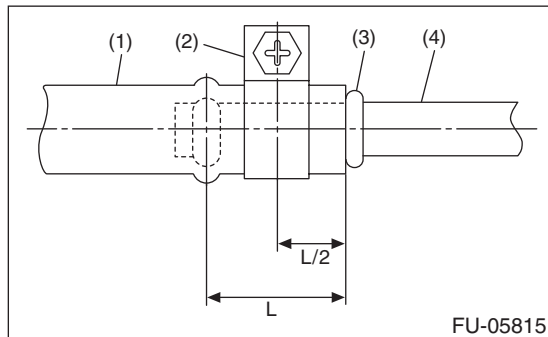

- (1) Fuel filler hose
- (2) Clamp
- (3) Spool
- (4) Fuel filler pipe

## 24. Fuel Tank

### A: REMOVAL

**WARNING:**

Place "NO OPEN FLAMES" signs near the working area.

**CAUTION:**

Be careful not to spill fuel.

1) Release the fuel pressure. <Ref. to FU(w/o STI)-66, RELEASING OF FUEL PRESSURE, PROCEDURE, Fuel.>

2) Drain fuel. <Ref. to FU(w/o STI)-66, DRAINING FUEL (WITH SUBARU SELECT MONITOR), PROCEDURE, Fuel.>

3) Disconnect the ground cable from battery.

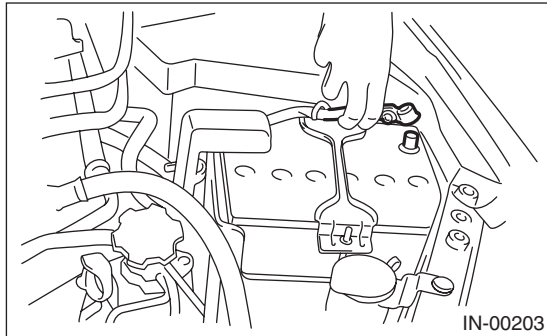

4) Remove the rear seat cushion. <Ref. to SE-13, REMOVAL, Rear Seat.>

5) Remove the service hole cover of fuel pump.

(1) Disconnect fuel pump connector (A), and remove clip (B).

(2) Remove the screw (C).

(3) Push the grommet (D) down and remove the service hole cover.

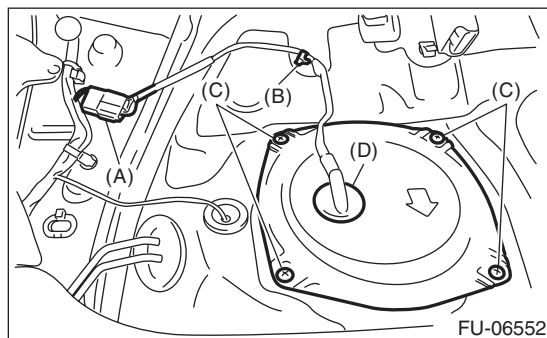

6) Remove the service hole cover of fuel sub level sensor.

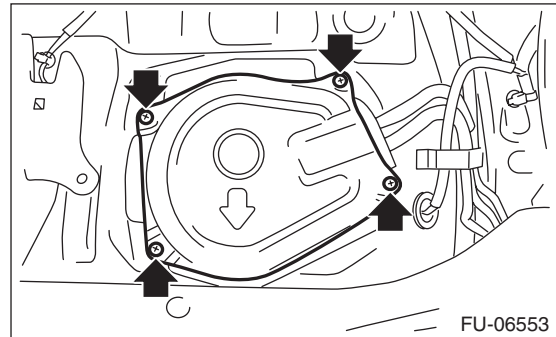

7) Disconnect the quick connector of fuel delivery tube (A) and fuel return tube (B). <Ref. to FU(w/o STI)-90, REMOVAL, Fuel Delivery, Return and Evaporation Lines.>

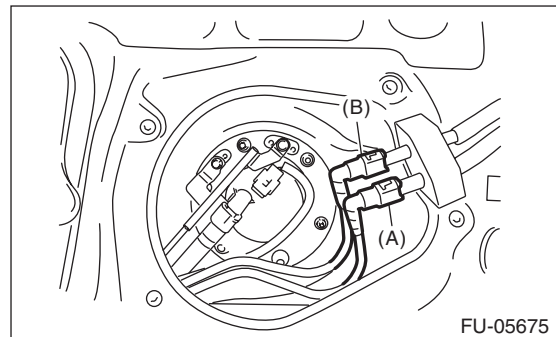

8) Remove the rear wheels.

9) Lift up the vehicle.

10) Remove the rear ABS wheel speed sensor from the rear housing.

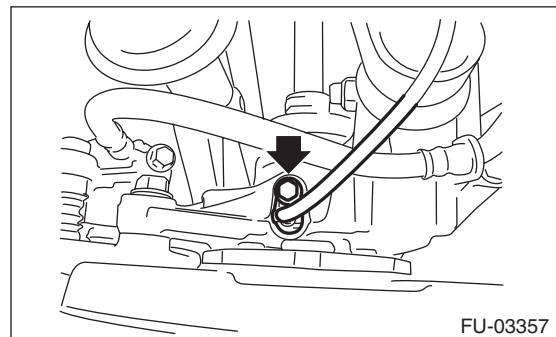

11) Remove the rear brake hose bracket from rear housing.

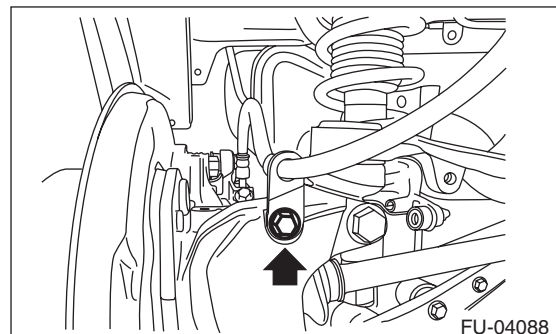

# Fuel Tank

## FUEL INJECTION (FUEL SYSTEMS)

12) Remove the rear disc brake assembly and tie it to the body side of the vehicle.

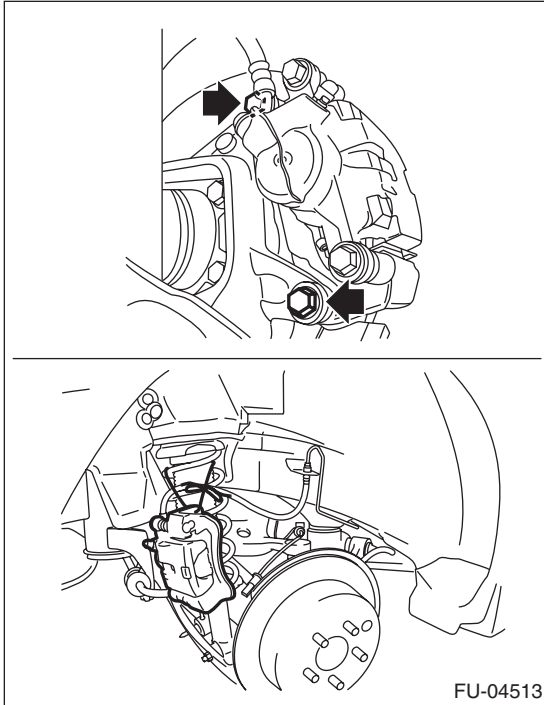

13) Remove the parking brake cable from parking brake assembly. <Ref. to PB-6, REMOVAL, Parking Brake Assembly (Rear Disc Brake).>

14) Remove the rear exhaust pipe and muffler. <Ref. to EX(STI)-13, REMOVAL, Rear Exhaust Pipe.> <Ref. to EX(STI)-15, REMOVAL, Muffler.>

15) Remove the propeller shaft. <Ref. to DS-11, REMOVAL, Propeller Shaft.>

16) Remove the heat shield cover and fuel tank protector.

17) Disconnect the connector from the rear ABS wheel speed sensor.

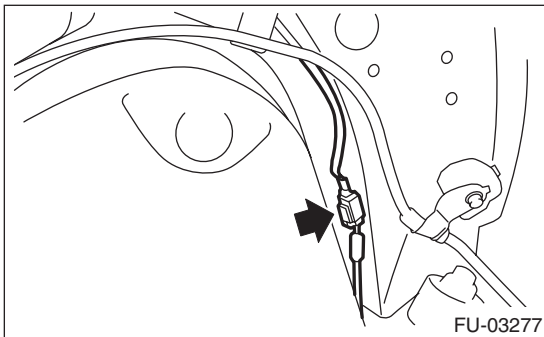

18) Remove the parking brake cable clamp from the body.

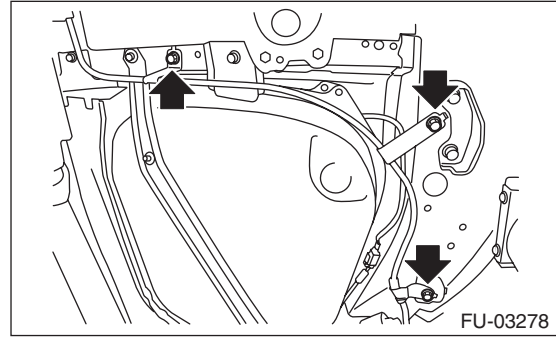

19) Remove the rear suspension assembly.

### WARNING:

**A helper is required to perform this work.**

(1) Support the rear differential with the transmission jack.

(2) Remove the bolt and nut which secures rear shock absorber to rear suspension arm.

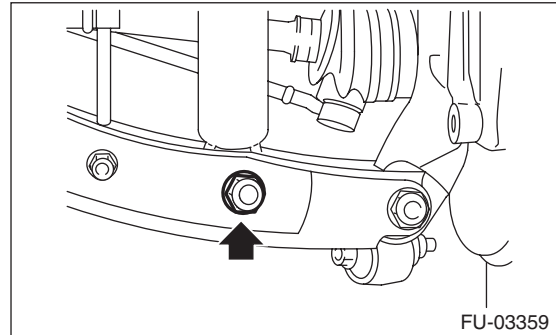

(3) Remove the bolts which secure the rear suspension assembly to the body.

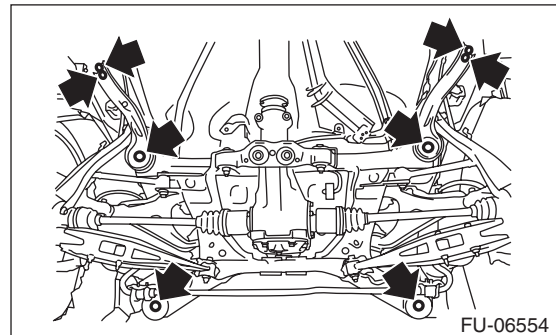

(4) Remove the rear suspension assembly.



# Fuel Tank

## FUEL INJECTION (FUEL SYSTEMS)

20) Disconnect the evaporation hose (B) from hose connector (A).

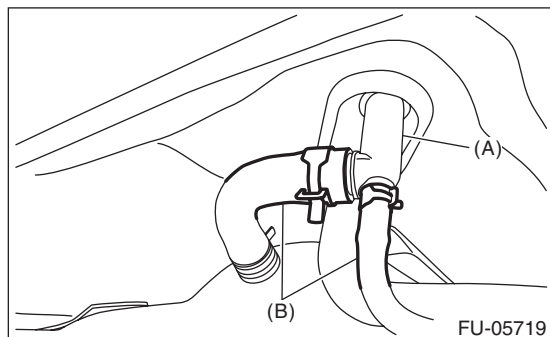

21) Disconnect the quick connector of the evaporation hose from the evaporation pipe.

### NOTE:

Disconnect the quick connector as shown in the figure.

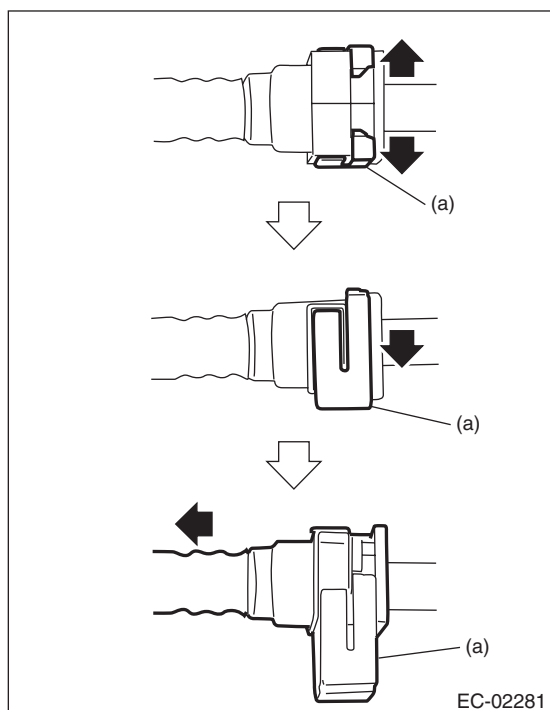

(a) Retainer

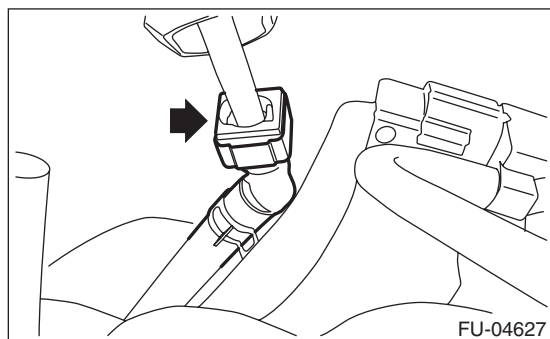

22) Disconnect the fuel filler hose (A) and evaporation hose (B).

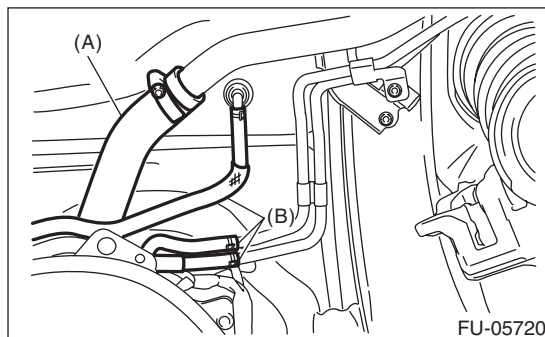

23) Support the fuel tank with a transmission jack, remove the fuel tank band, and remove the fuel tank from the vehicle.

### WARNING:

- A helper is required to perform this work.
- Fuel may remain in the fuel tank. This will cause the left and right sides to be unbalanced. Be careful not to drop the fuel tank.

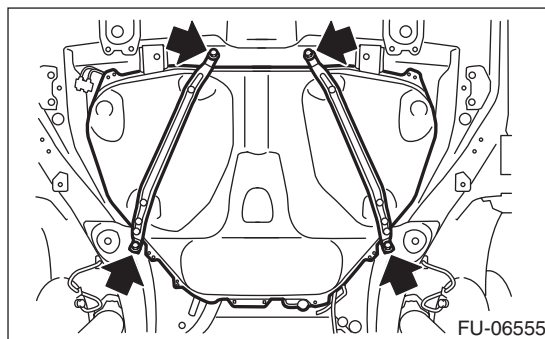

## B: INSTALLATION

1) Support the fuel tank with a transmission jack, set the fuel tank and the fuel tank band in place, and temporarily tighten the bolts of the fuel tank band.

### WARNING:

A helper is required to perform this work.

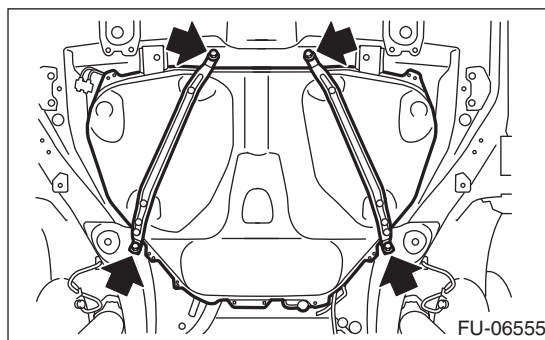

# Fuel Tank

## FUEL INJECTION (FUEL SYSTEMS)

2) Securely insert the fuel filler hose (A) and evaporation hose (B) until the hose end contacts the spool, then attach the clamp or clip as shown in the figure.

### Tightening torque:

**2.5 N·m (0.3 kgf-m, 1.8 ft-lb)**

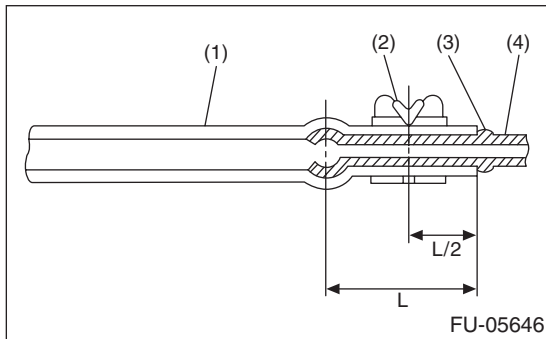
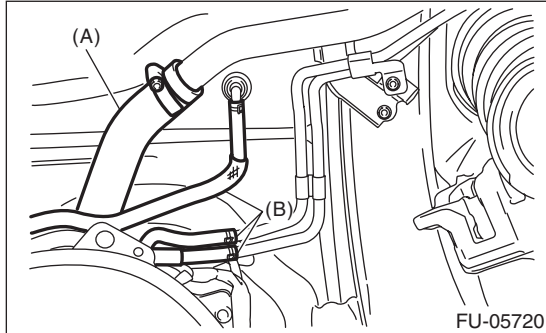

- (1) Hose
- (2) Clamp or clip
- (3) Spool
- (4) Pipe

3) Connect the quick connector of the evaporation hose to the evaporation pipe.

### CAUTION:

- Check that there is no damage or dust on the quick connector. If necessary, clean the seal surface of the pipe.
- When connecting the quick connector, securely insert the pipe all the way before locking the retainer.
- When it is difficult to lock the retainer, make sure that the pipe is securely inserted.
- Make sure that the quick connector is securely connected.

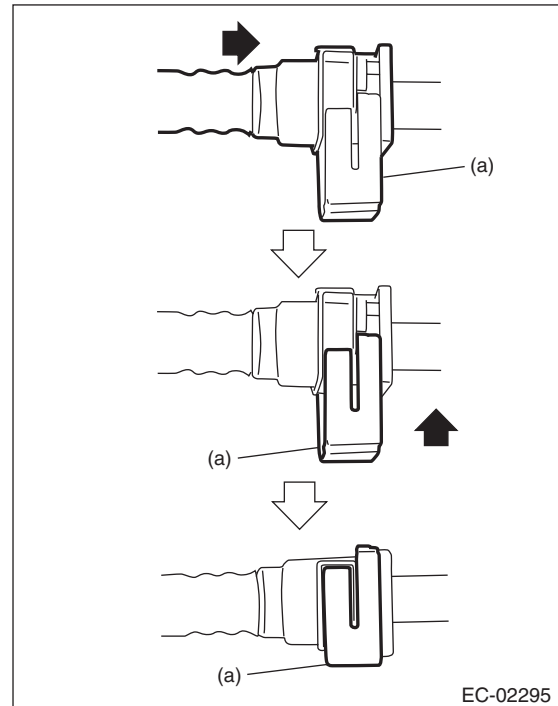

(a) Retainer

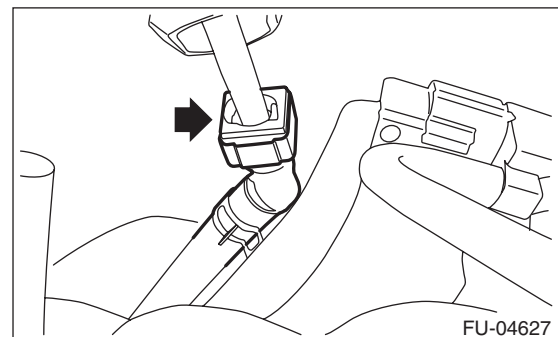



# Fuel Tank

FUEL INJECTION (FUEL SYSTEMS)

- 4) Connect the evaporation hose (B) to hose connector (A).

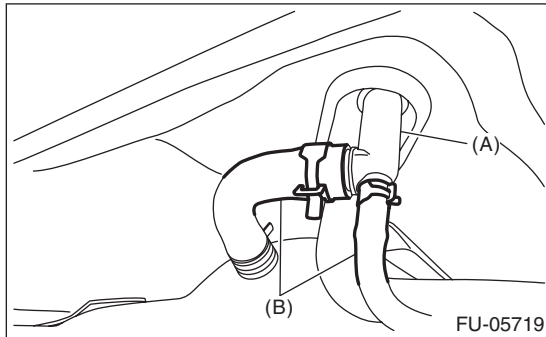

- 5) Tighten the bolts of the fuel tank band in the order shown in the figure.

**Tightening torque:**

**33 N·m (3.4 kgf-m, 24.3 ft-lb)**

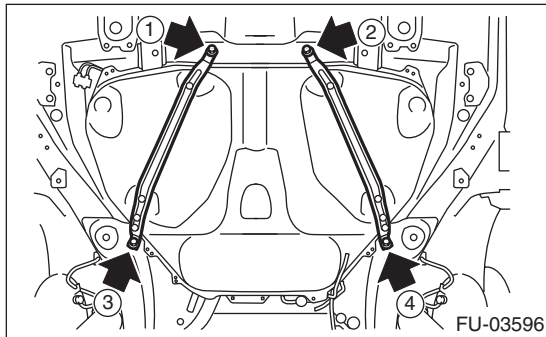

- 6) Install the rear suspension assembly.

**WARNING:**

**A helper is required to perform this work.**

- (1) Support the rear differential with the transmission jack.
- (2) Support the rear suspension assembly and install the rear suspension assembly to the body.

**Tightening torque:**

**T1: 70 N·m (7.1 kgf-m, 51.6 ft-lb)**

**T2: 145 N·m (14.8 kgf-m, 106.9 ft-lb)**

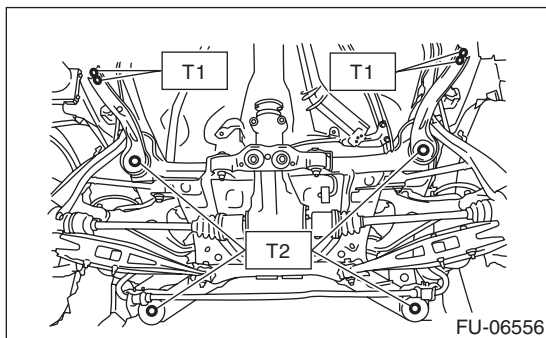

- (3) Install the rear shock absorber to the rear suspension arm.

**NOTE:**

Use a new self-locking nut.

**Tightening torque:**

**120 N·m (12.2 kgf-m, 88.5 ft-lb)**

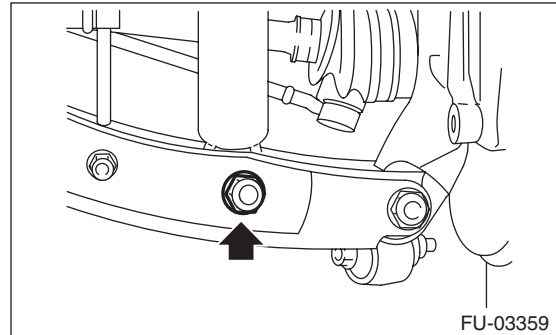

- 7) Install the parking brake cable clamp to the body.

**Tightening torque:**

**18 N·m (1.8 kgf-m, 13.3 ft-lb)**

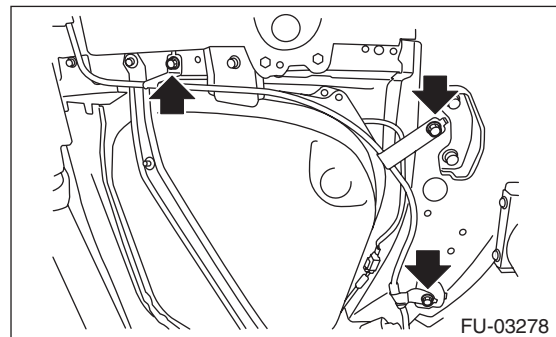

- 8) Connect the connector to the rear ABS wheel speed sensor.

**NOTE:**

Prevent the harness identification (line) from being twisted when installing. (RH: White line, LH: Yellow line)

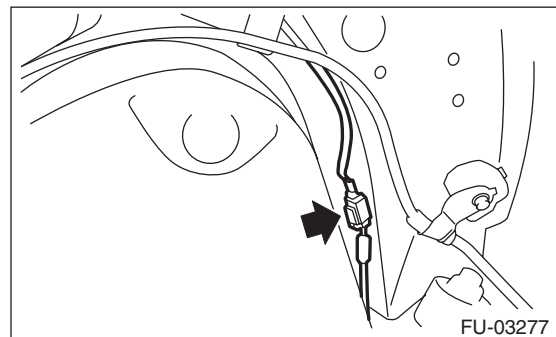

- 9) Install the heat shield cover.

**Tightening torque:**

**18 N·m (1.8 kgf-m, 13.3 ft-lb)**

**FU(w/o STI)-73**

Brought to you by Ebay Seller "SubaruManuals"

# Fuel Tank

## FUEL INJECTION (FUEL SYSTEMS)

10) Install the fuel tank protector.

### NOTE:

Use a new self-locking nut.

### Tightening torque:

**Nut: 9 N·m (0.9 kgf-m, 6.6 ft-lb)**

**Bolt: 18 N·m (1.8 kgf-m, 13.3 ft-lb)**

11) Install the propeller shaft. <Ref. to DS-12, INSTALLATION, Propeller Shaft.>

12) Install the rear exhaust pipe and muffler. <Ref. to EX(STI)-13, INSTALLATION, Rear Exhaust Pipe.> <Ref. to EX(STI)-15, INSTALLATION, Muffler.>

13) Lower the vehicle.

14) Connect the parking brake cable to the parking brake assembly. <Ref. to PB-7, INSTALLATION, Parking Brake Assembly (Rear Disc Brake).>

15) Install the rear disc brake assembly.

### Tightening torque:

**66 N·m (6.7 kgf-m, 48.7 ft-lb)**

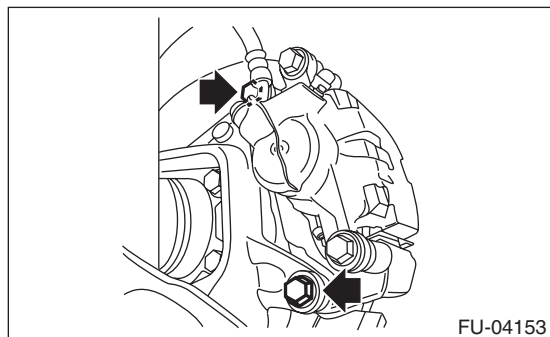

16) Install the rear brake hose bracket to the rear housing.

### Tightening torque:

**33 N·m (3.4 kgf-m, 24.3 ft-lb)**

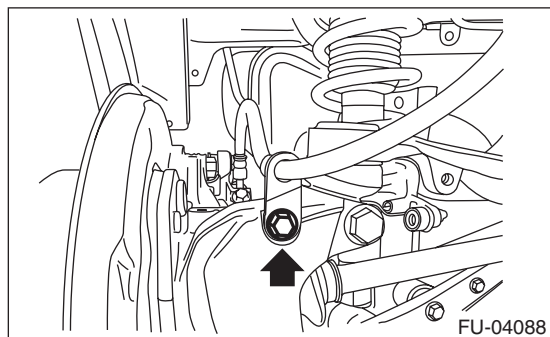

17) Attach the rear ABS wheel speed sensor to the rear housing.

### NOTE:

Prevent the harness identification (line) from being twisted when installing. (RH: White line, LH: Yellow line)

### Tightening torque:

**7.5 N·m (0.8 kgf-m, 5.5 ft-lb)**

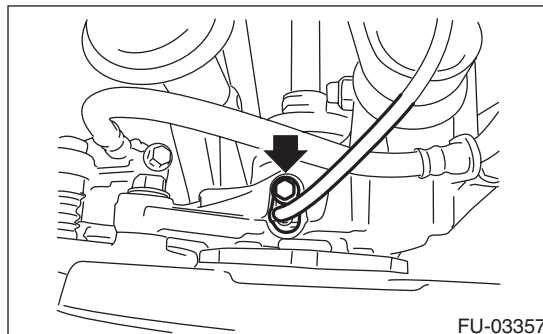

18) Install the rear wheels.

### Tightening torque:

**100 N·m (10.2 kgf-m, 73.8 ft-lb)**

19) Connect the quick connector of fuel delivery tube (A) and fuel return tube (B). <Ref. to FU(w/o STI)-93, INSTALLATION, Fuel Delivery, Return and Evaporation Lines.>

### NOTE:

When connecting, be careful not to reverse the delivery side and return side.

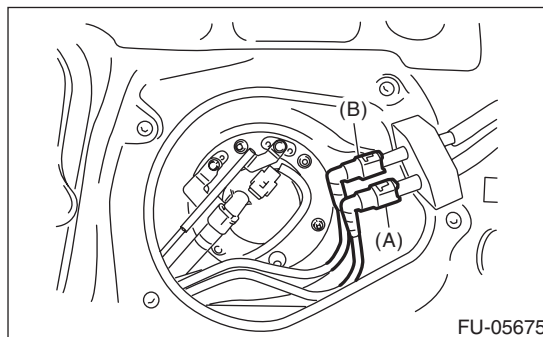

20) Install the service hole cover of fuel sub level sensor.

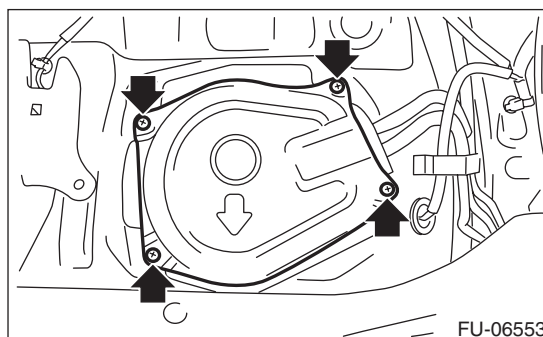

**FU(w/o STI)-74**

Brought to you by Ebay Seller "SubaruManuals"

21) Attach the service hole cover of the fuel pump, and attach the connector and clip.

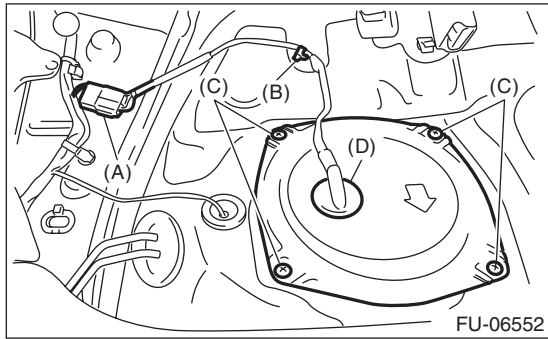

- (A) Connector
- (B) Clip
- (C) Screw
- (D) Grommet

22) Install the rear seat cushion. <Ref. to SE-14, INSTALLATION, Rear Seat.>

23) Connect the battery ground terminal.

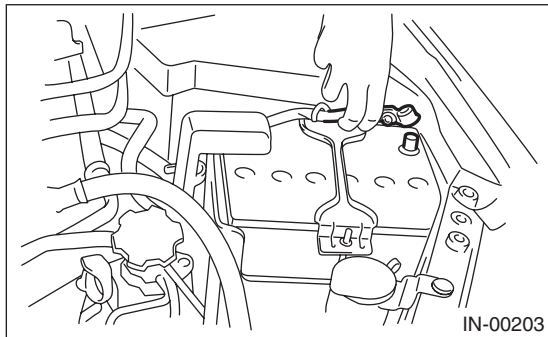

24) Inspect the wheel alignment and adjust if necessary.

### **C: INSPECTION**

- 1) Check that the fuel tank and fuel pipe have no deformation, cracks and other damages.
- 2) Check that the fuel hose has no cracks, damage or loose part.

# Fuel Filler Pipe

FUEL INJECTION (FUEL SYSTEMS)

## 25. Fuel Filler Pipe

### A: REMOVAL

#### WARNING:

Place "NO OPEN FLAMES" signs near the working area.

#### CAUTION:

Be careful not to spill fuel.

1) Release the fuel pressure. <Ref. to FU(w/o STI)-66, RELEASING OF FUEL PRESSURE, PROCEDURE, Fuel.>

2) Drain fuel. <Ref. to FU(w/o STI)-66, DRAINING FUEL (WITH SUBARU SELECT MONITOR), PROCEDURE, Fuel.>

3) Disconnect the ground cable from battery.

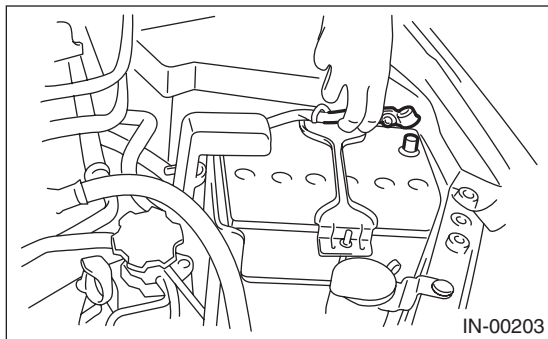

4) Open the fuel filler lid, and remove the filler cap.

5) Remove the screws which secure the fuel filler ring, and then remove the fuel filler ring.

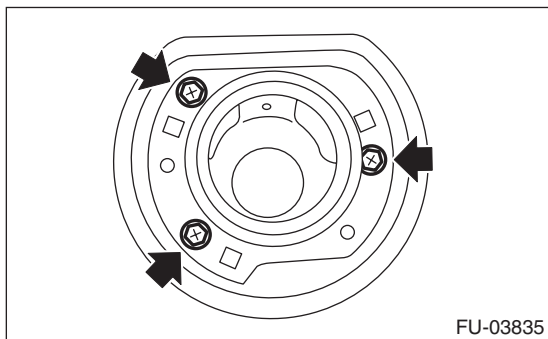

6) Remove the rear wheel RH.

7) Lift up the vehicle.

8) Remove the rear mud guard RH. <Ref. to EI-30, REAR MUD GUARD, REMOVAL, Mud Guard.>

9) Remove the rear sub frame. <Ref. to RS-17, REMOVAL, Rear Sub Frame.>

10) Remove the bolts and nuts which secure fuel filler pipe assembly onto the vehicle body.

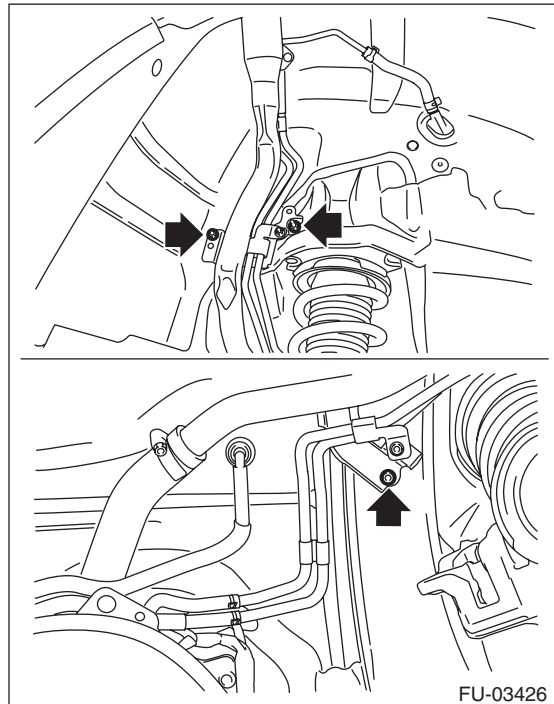

11) Disconnect the fuel filler hose (A) and evaporation hose (B) from the fuel filler pipe assembly.

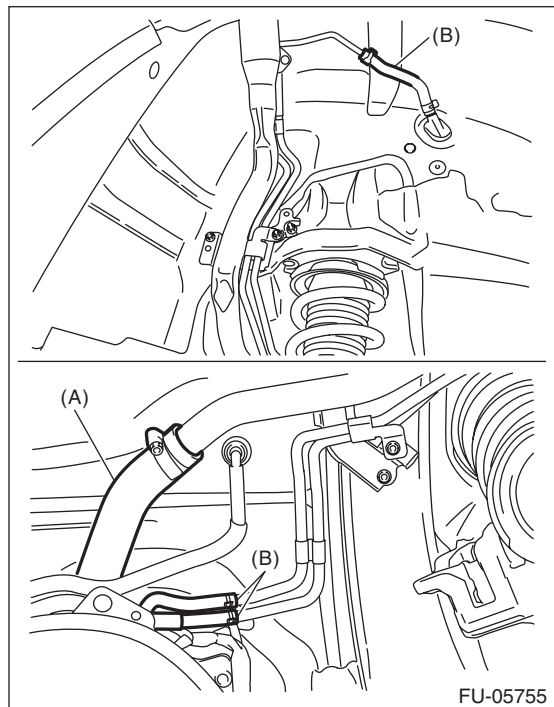

12) Remove the fuel filler pipe assembly from the underside of the vehicle.

FU(w/o STI)-76

Brought to you by Ebay Seller "SubaruManuals"

# Fuel Filler Pipe

FUEL INJECTION (FUEL SYSTEMS)

## B: INSTALLATION

- 1) Open the fuel filler lid.
- 2) Attach the fuel filler pipe gasket to the fuel filler pipe assembly, and insert the fuel filler pipe assembly from inside of the rear fender.
- 3) Install the fuel filler ring to the fuel filler pipe assembly.

### NOTE:

If the edges of rubber gasket are folded toward inside, straighten it with a flat tip screwdriver.

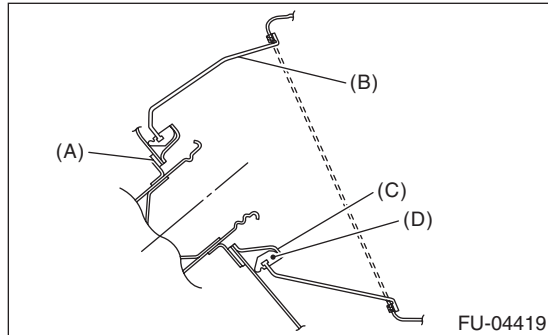

- (A) Fuel filler pipe gasket
- (B) Fuel saucer
- (C) Fuel filler ring
- (D) Rubber gasket

### Tightening torque:

**4.4 N·m (0.4 kgf-m, 3.2 ft-lb)**

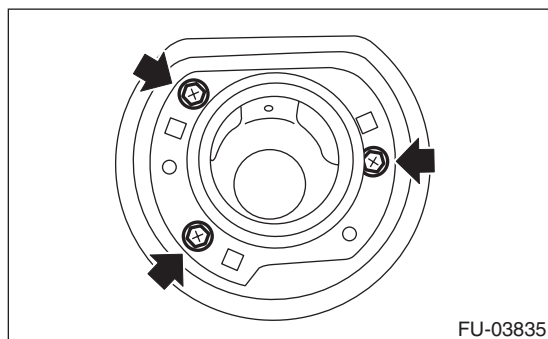

- 4) Securely insert the fuel filler hose (A) and evaporation hose (B) until the hose end contacts the spool, then attach the clamp or clip as shown in the figure.

### Tightening torque:

**2.5 N·m (0.3 kgf-m, 1.8 ft-lb)**

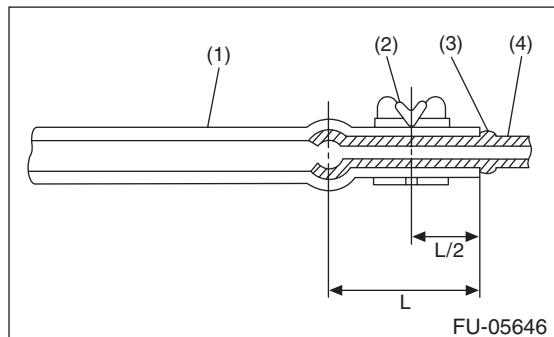
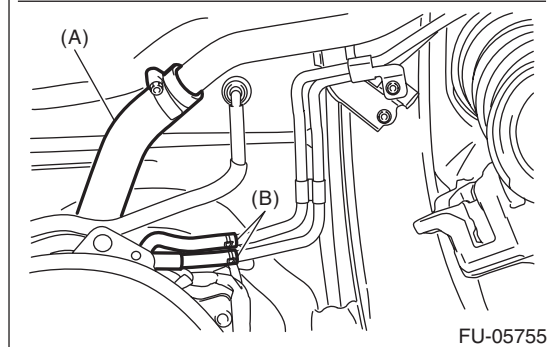
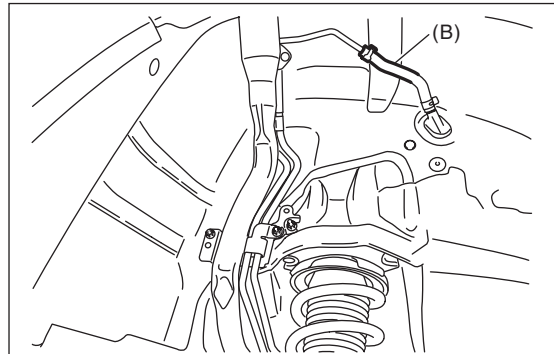

- (1) Hose
- (2) Clamp or clip
- (3) Spool
- (4) Pipe

FU(w/o STI)-77

Brought to you by Ebay Seller "SubaruManuals"

# Fuel Filler Pipe

## FUEL INJECTION (FUEL SYSTEMS)

5) Install the fuel filler pipe assembly to vehicle body.

### **Tightening torque:**

**7.5 N·m (0.8 kgf-m, 5.5 ft-lb)**

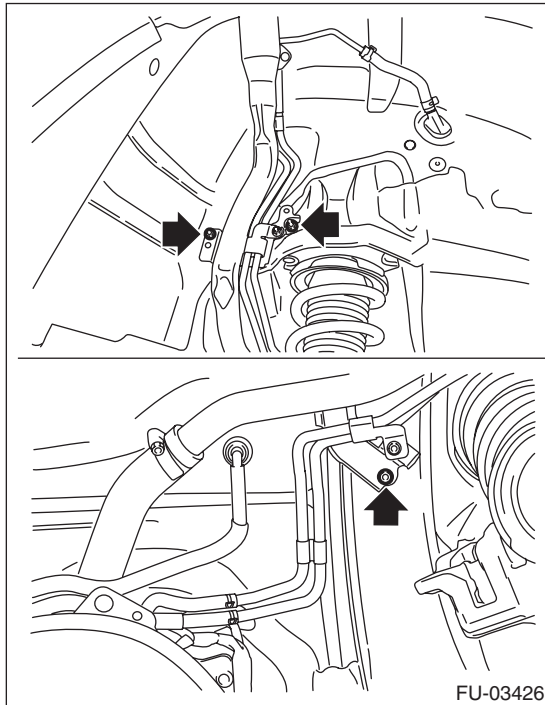

6) Install the rear sub frame. <Ref. to RS-18, INSTALLATION, Rear Sub Frame.>

7) Install the rear mud guard RH. <Ref. to EI-30, INSTALLATION, Mud Guard.>

8) Lower the vehicle.

9) Install the rear wheel RH.

### **Tightening torque:**

**100 N·m (10.2 kgf-m, 73.8 ft-lb)**

10) Connect the battery ground terminal.

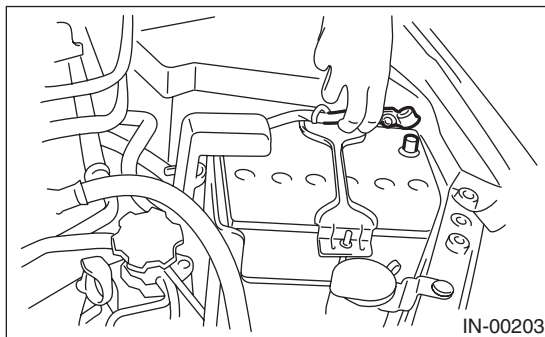

11) Inspect the wheel alignment and adjust if necessary.

## **C: DISASSEMBLY**

1) Remove the shut valve from the fuel filler pipe. <Ref. to EC(w/o STI)-19, REMOVAL, Shut Valve.>

2) Remove the evaporation pipe from the fuel filler pipe.

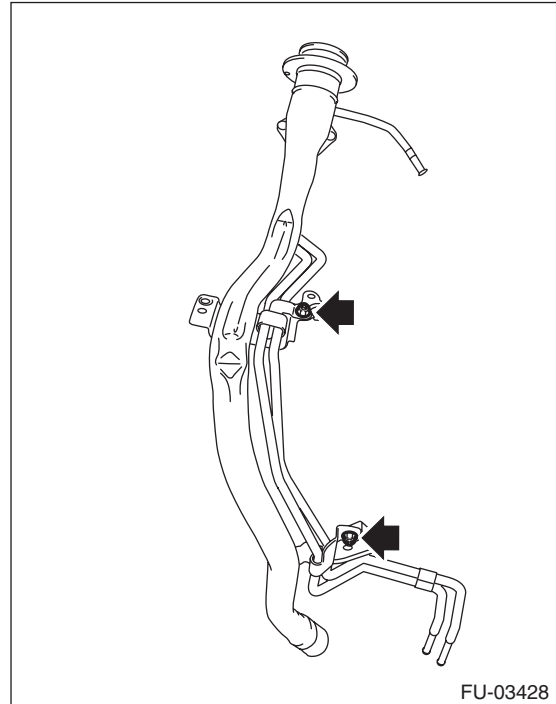

## **D: ASSEMBLY**

Assemble in the reverse order of disassembly.

### **Tightening torque:**

**7.5 N·m (0.8 kgf-m, 5.5 ft-lb)**

## **E: INSPECTION**

1) Check that the fuel filler pipe and evaporation pipe have no deformation, cracks or other damages.

2) Check that the hose has no cracks, damage or loose part.



## 26. Fuel Pump

### A: REMOVAL

**WARNING:**

Place "NO OPEN FLAMES" signs near the working area.

**CAUTION:**

- Be careful not to spill fuel.
- If the fuel gauge indicates that two thirds or more of the fuel is remaining, be sure to drain fuel before starting work to avoid the fuel to spill.

**NOTE:**

Fuel pump assembly consists of fuel pump, fuel filter and fuel level sensor.

- 1) Release the fuel pressure. <Ref. to FU(w/o STI)-66, RELEASING OF FUEL PRESSURE, PROCEDURE, Fuel.>
- 2) Drain fuel. <Ref. to FU(w/o STI)-66, DRAINING FUEL (WITH SUBARU SELECT MONITOR), PROCEDURE, Fuel.>
- 3) Disconnect the ground cable from battery.

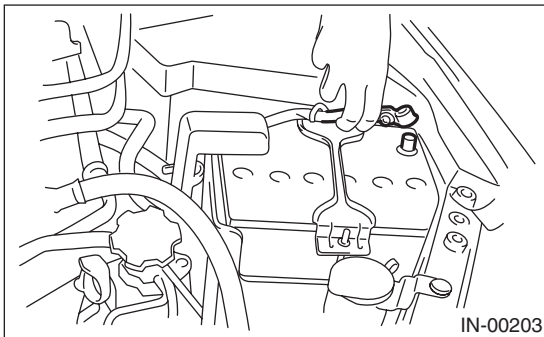

- 4) Remove the rear seat cushion. <Ref. to SE-13, REMOVAL, Rear Seat.>
- 5) Remove the service hole cover.
  - (1) Remove the screws (A).
  - (2) Push the grommet (B) down and remove service hole cover.

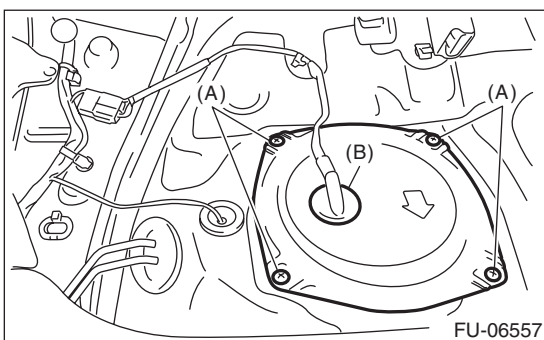

- 6) Disconnect the connector from fuel pump.

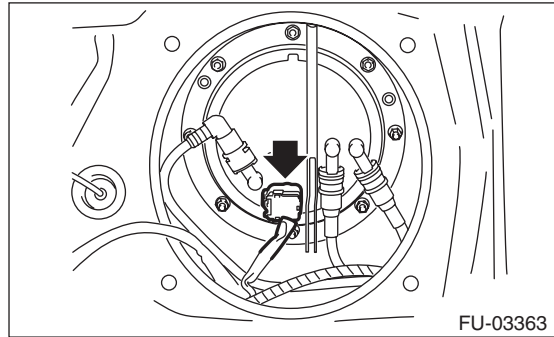

- 7) Disconnect the quick connectors of fuel delivery tube (A), fuel return tube (B), and jet pump tube (C). <Ref. to FU(w/o STI)-90, REMOVAL, Fuel Delivery, Return and Evaporation Lines.>

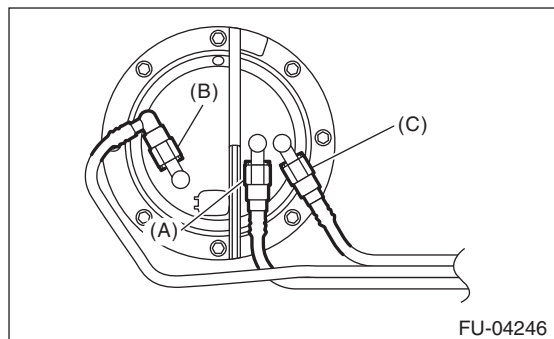

- 8) Remove the nuts which hold the fuel pump upper plate to the fuel tank.

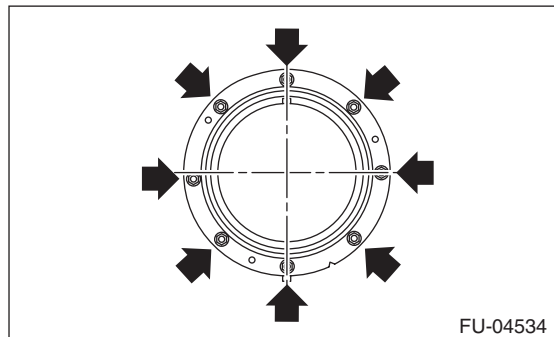

- 9) Remove the fuel pump assembly from the fuel tank.

# Fuel Pump

## FUEL INJECTION (FUEL SYSTEMS)

### B: INSTALLATION

Install in the reverse order of removal while being careful of the following.

- Make sure the sealing portion is free from fuel or foreign matter before installation.
- Align protrusion (A) of the gasket to the position shown in the figure.
- Insert the protrusion (B) of gasket to the fuel pump upper plate. (3 places)
- Align the protrusion (C) of fuel pump assembly with the cutout on the fuel pump upper plate.
- Tighten the nuts to the specified torque in the order as shown in the figure.

NOTE:

Use a new gasket.

**Tightening torque:**

**4.4 N·m (0.4 kgf·m, 3.2 ft·lb)**

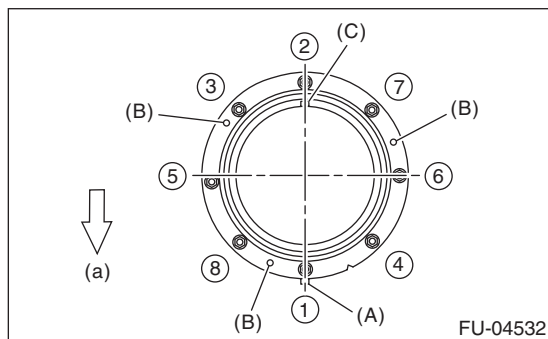

(a) Front side of vehicle

### C: INSPECTION

- 1) Check that the fuel pump has no deformation, cracks or other damages.
- 2) Connect the battery positive terminal to terminal No. 5 and the battery ground terminal to terminal No. 6, and inspect the fuel pump operation.

**WARNING:**

- **Wipe off fuel completely.**
- **Keep the battery as far apart from fuel pump as possible.**
- **Do not run the fuel pump for a long time under non-load condition.**

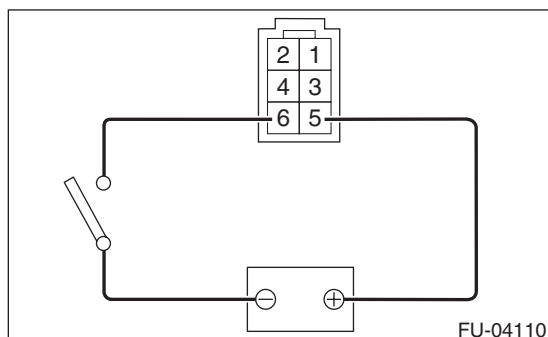

**FU(w/o STI)-80**

Brought to you by Ebay Seller "SubaruManuals"



## 27. Fuel Level Sensor

### A: REMOVAL

**WARNING:**

Place "NO OPEN FLAMES" signs near the working area.

**CAUTION:**

- Be careful not to spill fuel.
- If the fuel gauge indicates that two thirds or more of the fuel is remaining, be sure to drain fuel before starting work to avoid the fuel to spill.

**NOTE:**

The fuel level sensor is built in fuel pump assembly.

- 1) Remove the fuel pump assembly. <Ref. to FU(w/o STI)-79, REMOVAL, Fuel Pump.>
- 2) Disconnect the fuel level sensor connector.

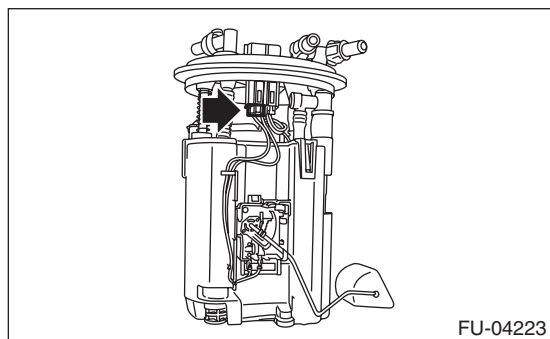

3) Slide the fuel level sensor in the direction of the arrow and remove the fuel level sensor by pressing the claw (A) of the fuel level sensor.

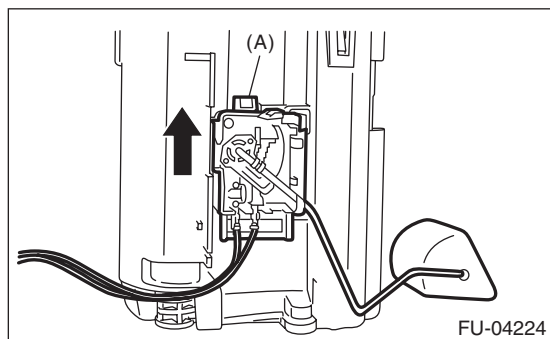

### B: INSTALLATION

Install in the reverse order of removal.

### C: INSPECTION

- 1) Check that the fuel level sensor has no damage.
- 2) Measure the fuel level sensor float position.

**NOTE:**

When inspecting the fuel level sensor, perform the work with the sensor installed to the fuel pump.

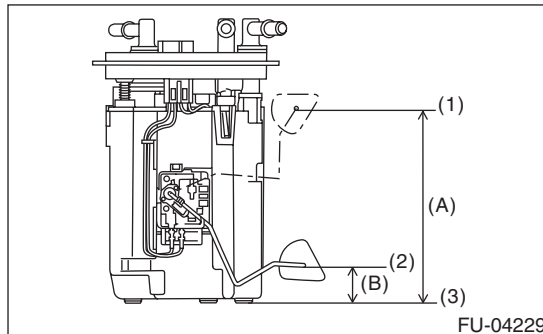

- (1) FULL
- (2) EMPTY
- (3) Fuel tank seating surface

Float position	Standard
FULL to Fuel tank seating surface (A)	135±4 mm (5.315±0.157 in)
EMPTY to Fuel tank seating surface (B)	23.7±4 mm (0.933±0.157 in)

3) Measure the resistance between fuel level sensor terminals.

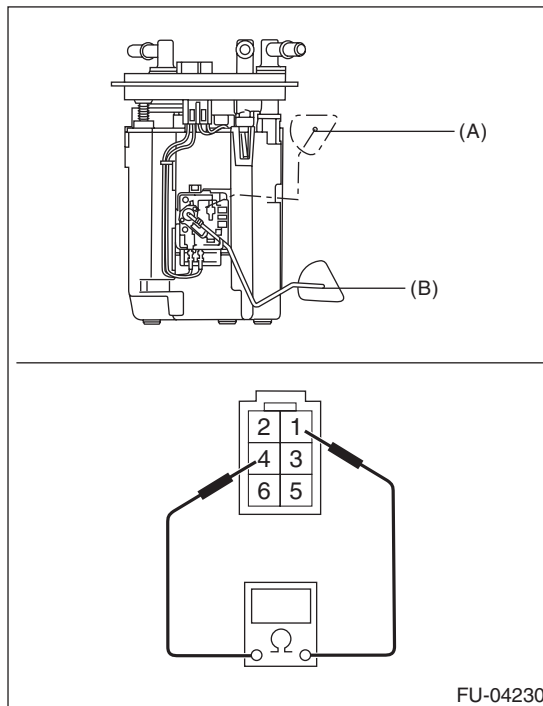

Float position	Terminal No.	Standard
FULL (A)	1 and 4	2.0±1.0 Ω
EMPTY (B)		31.9±1.0 Ω

# Fuel Sub Level Sensor

FUEL INJECTION (FUEL SYSTEMS)

## 28. Fuel Sub Level Sensor

### A: REMOVAL

#### WARNING:

Place "NO OPEN FLAMES" signs near the working area.

#### CAUTION:

- Be careful not to spill fuel.
- If the fuel gauge indicates that two thirds or more of the fuel is remaining, be sure to drain fuel before starting work to avoid the fuel to spill.

1) Release the fuel pressure. <Ref. to FU(w/o STI)-66, RELEASING OF FUEL PRESSURE, PROCEDURE, Fuel.>

2) Drain fuel. <Ref. to FU(w/o STI)-66, DRAINING FUEL (WITH SUBARU SELECT MONITOR), PROCEDURE, Fuel.>

3) Disconnect the ground cable from battery.

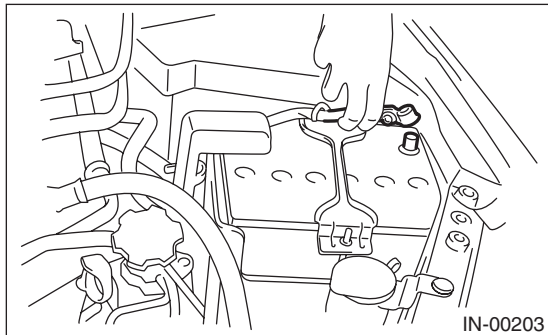

4) Remove the rear seat cushion. <Ref. to SE-13, REMOVAL, Rear Seat.>

5) Remove the service hole cover.

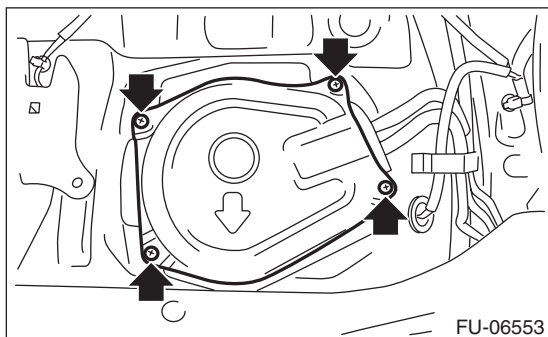

6) Disconnect the connector from the fuel sub level sensor.

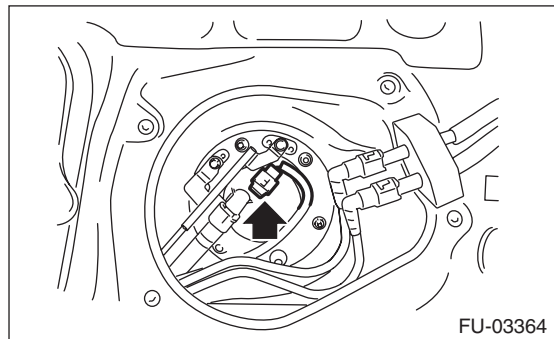

7) Disconnect the quick connectors of fuel delivery tube (A), fuel return tube (B), and jet pump tube (C). <Ref. to FU(w/o STI)-90, REMOVAL, Fuel Delivery, Return and Evaporation Lines.>

8) Remove the rubber cap (D) from the nut.

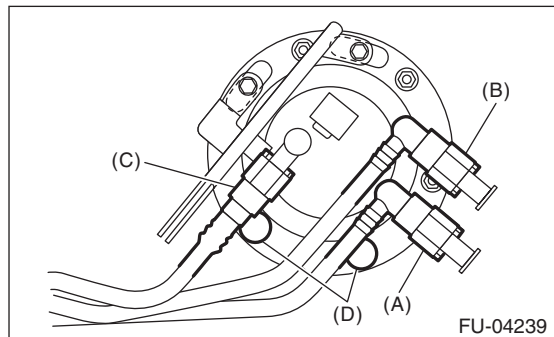

9) Remove the bolts and nuts which hold fuel sub level sensor protector and fuel sub level sensor upper plate to the fuel tank.

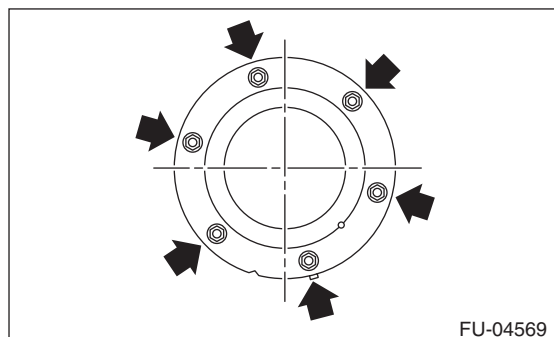
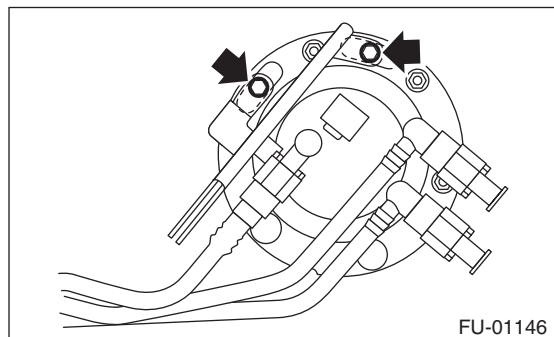

10) Remove the fuel sub level sensor from the fuel tank.

FU(w/o STI)-82

Brought to you by Ebay Seller "SubaruManuals"

# Fuel Sub Level Sensor

## B: INSTALLATION

Install in the reverse order of removal while being careful of the following.

- Make sure the sealing portion is free from fuel or foreign matter before installation.
- Align protrusion (A) of the gasket to the position shown in the figure.
- Align protrusion (B) of the fuel sub level sensor to the cutout in the fuel sub level sensor upper plate.
- Tighten the nuts and bolts to the specified torque in the order as shown in the figure.
- After tightening, install the rubber cap (C) at the position shown in the figure.

**NOTE:**

- Use a new gasket.
- Do not forget to install rubber cap (C).

**Tightening torque:**

**4.4 N·m (0.4 kgf·m, 3.2 ft·lb)**

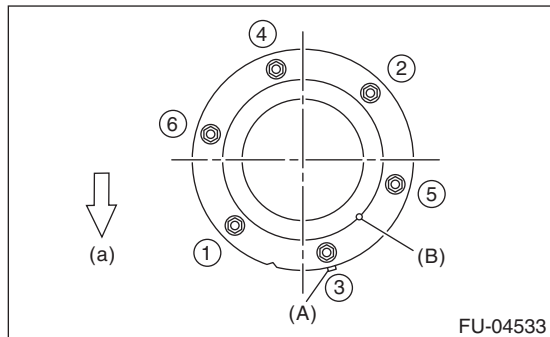

(a) Front side of vehicle

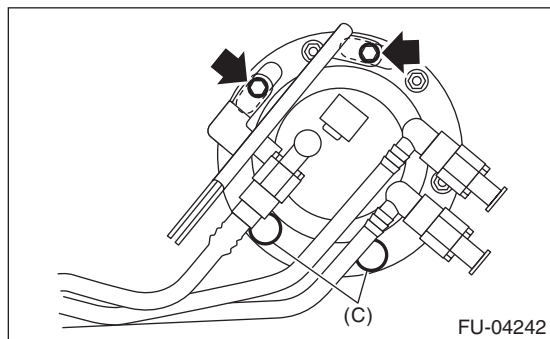

## C: INSPECTION

- 1) Check that the fuel sub level sensor has no damage.
- 2) Measure the fuel sub level sensor float position.

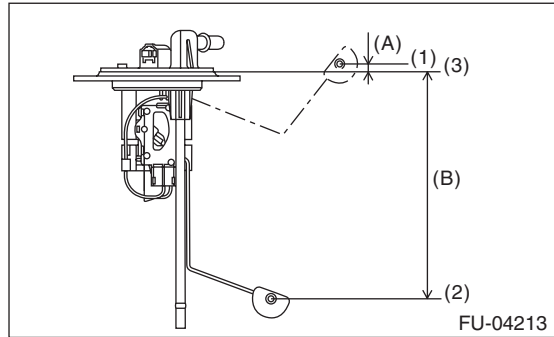

- (1) FULL
- (2) EMPTY
- (3) Datum points

Float position	Standard
FULL to Datum point (A)	5.31±3.5 mm (0.209±0.138 in)
EMPTY to Datum point (B)	160.6±3.5 mm (6.323±0.138 in)

- 3) Measure the resistance between fuel sub level sensor terminals.

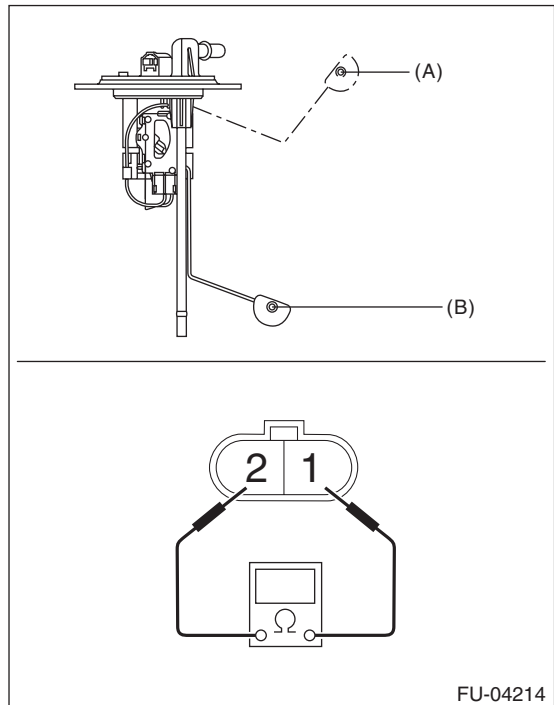

Float position	Terminal No.	Standard
FULL (A)	1 and 2	2.0 <sup>+0.5</sup> <sub>-1.0</sub> Ω
EMPTY (B)		62.1±1.0 Ω

# Fuel Filter

FUEL INJECTION (FUEL SYSTEMS)

## 29. Fuel Filter

### A: REMOVAL

#### WARNING:

Place "NO OPEN FLAMES" signs near the working area.

#### CAUTION:

- Be careful not to spill fuel.
- If the fuel gauge indicates that two thirds or more of the fuel is remaining, be sure to drain fuel before starting work to avoid the fuel to spill.
- Be careful not to drop or apply any impact to the fuel pump during work. This may deteriorate its performance.

#### NOTE:

The fuel filter is built in fuel pump assembly.

- 1) Remove the fuel pump assembly. <Ref. to FU(w/o STI)-79, REMOVAL, Fuel Pump.>
- 2) Remove the fuel level sensor. <Ref. to FU(w/o STI)-81, REMOVAL, Fuel Level Sensor.>
- 3) Disconnect the pump assembly connector from sub tank bracket assembly.

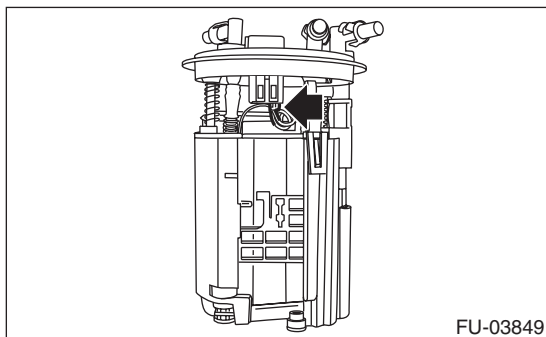

- 4) Cut off the tab holders connecting the sub tank bracket assembly and the sub tank in four locations, and separate the sub tank bracket assembly and the sub tank.

#### CAUTION:

Be careful not to damage the sub tank.

#### NOTE:

If the O-ring is remaining on the sub tank, remove.

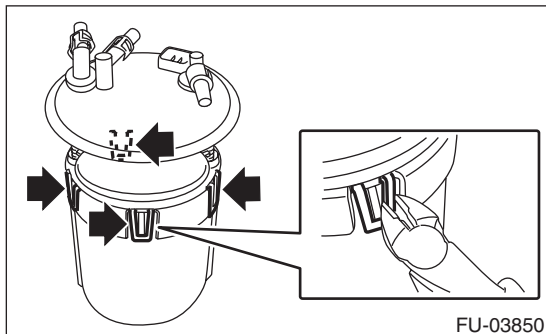

- 5) Disconnect two connectors of fuel delivery pipe from fuel filter assembly.

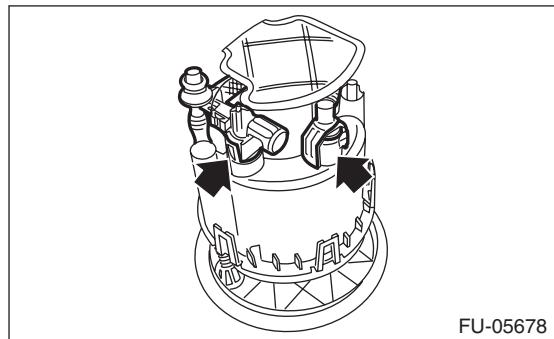

- 6) Push to compress the fuel filter assembly in the direction of the arrow, remove clip (A), and separate the sub tank bracket assembly and the fuel filter assembly.

#### CAUTION:

When separating the sub tank bracket assembly and the fuel filter assembly, be careful not to damage the ground wire.

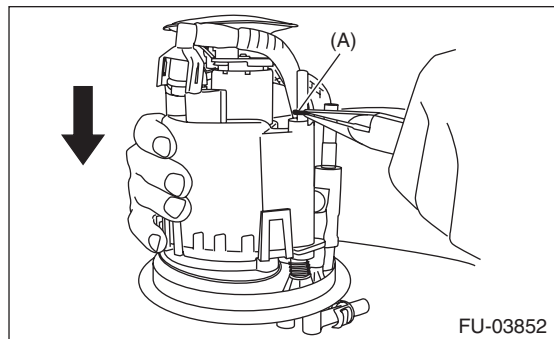

- 7) Disconnect the connector from the pump assembly.

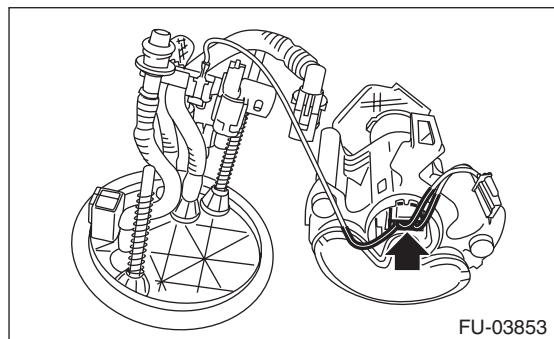

FU(w/o STI)-84

Brought to you by Ebay Seller "SubaruManuals"

8) Lift the two tab holders connecting the pump assembly to the fuel filter using a flat tip screwdriver (with a shaft diameter of approx. 3 mm (0.12 in)), etc., and separate the fuel filter and pump assembly.

### CAUTION:

- To prevent damaging the tabs of the pump assembly, wrap the tip of flat tip screwdriver (A), etc. with tape (B).

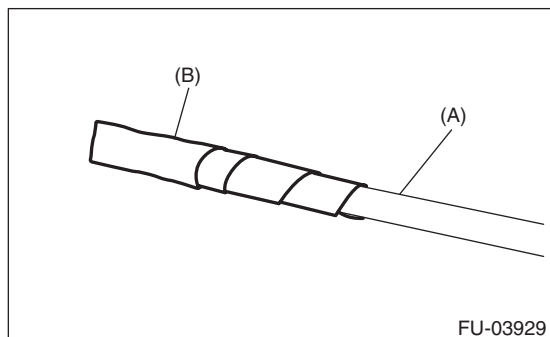

- Be careful not to drop or apply any impact to the pump assembly.

### NOTE:

If the spacer and O-ring is remaining on the pump assembly, remove these.

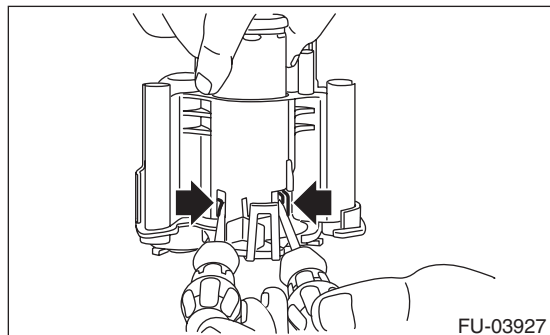

## B: INSTALLATION

1) Assemble O-ring (A) and spacer (B) to the pump assembly and attach the pump assembly to the fuel filter.

### NOTE:

- Use new O-rings (8 mm (0.31 in) inner diameter).
- Use a new spacer.
- Apply gasoline to the O-ring.
- Insert the pump assembly until a click is heard.

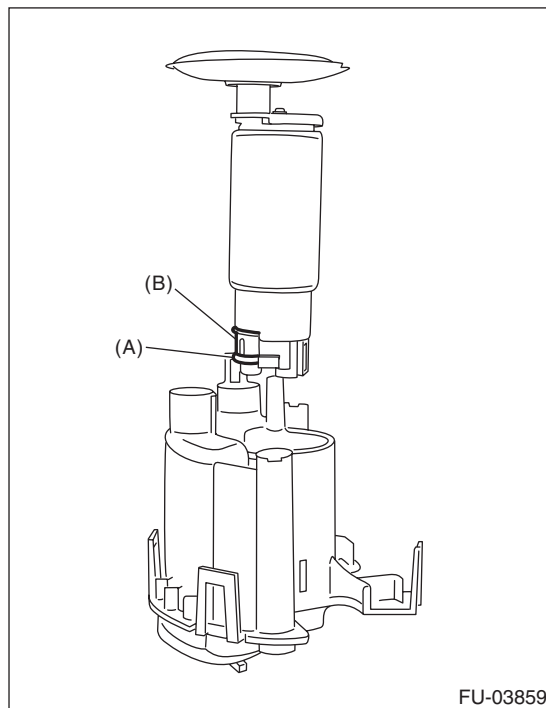

2) Connect the connector to the pump assembly.

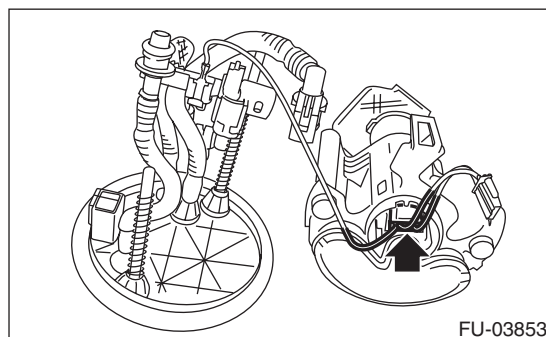

# Fuel Filter

## FUEL INJECTION (FUEL SYSTEMS)

3) Attach spring (A) to the metal rod of the sub tank bracket assembly, and assemble the fuel filter assembly.

**NOTE:**

Use a new spring.

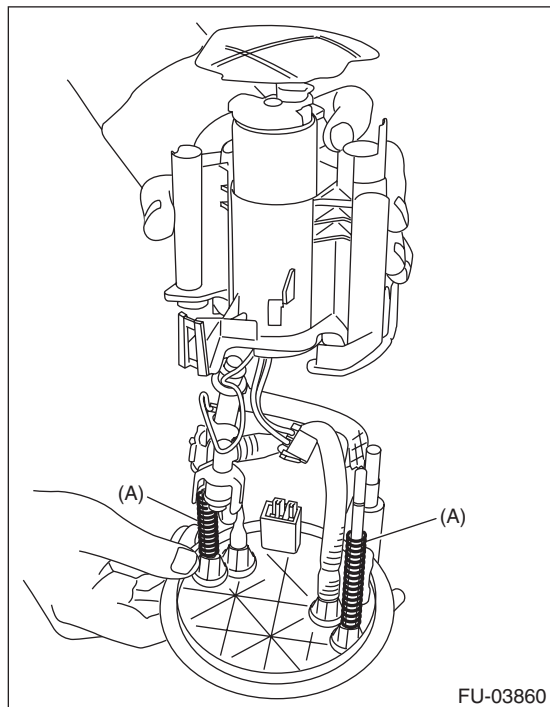

4) Push the fuel filter assembly in the direction of the arrow to compress, and attach clip (A).

**NOTE:**

Use a new clip.

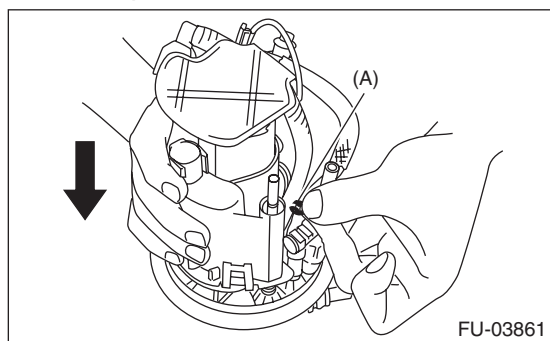

5) Connect the fuel piping connector to the fuel filter assembly.

**NOTE:**

- Use new O-rings.
- Apply gasoline to the O-ring.
- The O-rings of the black and white connectors are identified by a difference in diameter. Be careful not to confuse the two during assembly.

**O-ring inner diameter:**

**Black connector O-ring [Approx. 7 mm (0.28 in)]**

**White connector O-ring [Approx. 8 mm (0.31 in)]**

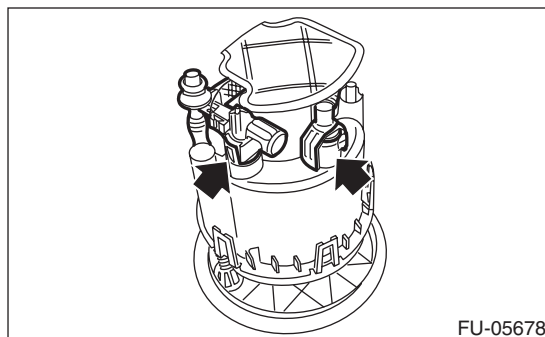

6) Attach the O-ring (A) to the fuel filter assembly, and attach the sub tank to the sub tank bracket assembly.

**NOTE:**

- Use new O-rings (8 mm (0.31 in) inner diameter).
- Apply gasoline to the O-ring.
- Insert the pump assembly until a "pop" is heard.

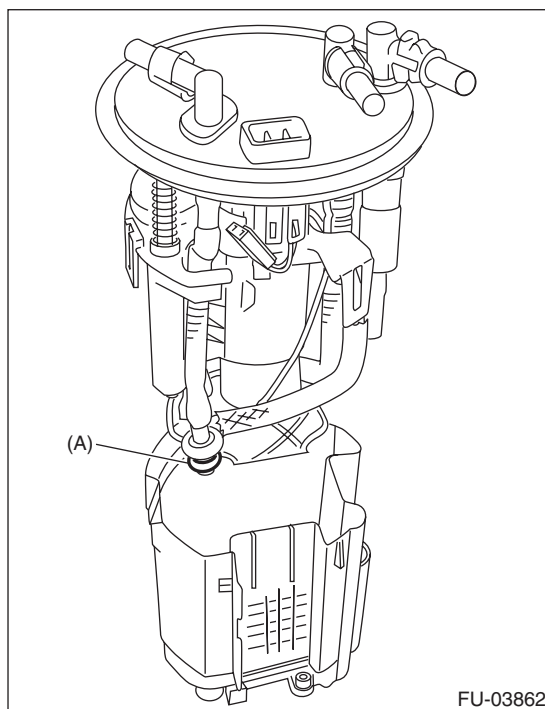

**FU(w/o STI)-86**

Brought to you by Ebay Seller "SubaruManuals"

7) Replace the cushion on the rear face of the sub tank with a new cushion.

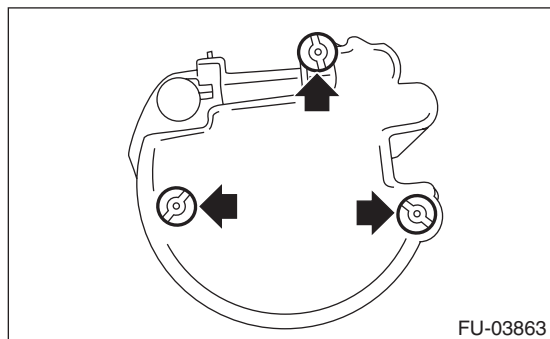

8) Connect the pump assembly connector to the sub tank bracket assembly.

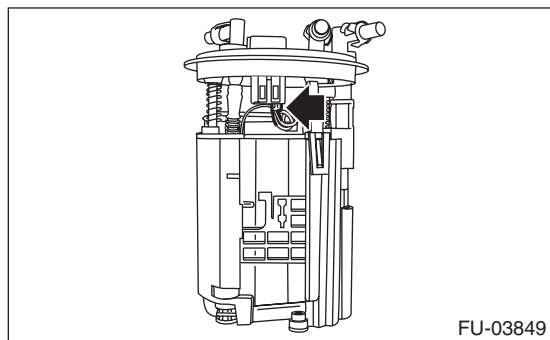

9) Install the fuel level sensor. <Ref. to FU(w/o STI)-81, INSTALLATION, Fuel Level Sensor.>

10) Inspect the fuel level sensor. <Ref. to FU(w/o STI)-81, INSPECTION, Fuel Level Sensor.>

11) Install the fuel pump assembly. <Ref. to FU(w/o STI)-80, INSTALLATION, Fuel Pump.>



# Fuel Damper

FUEL INJECTION (FUEL SYSTEMS)

---

## 30. Fuel Damper

### A: REMOVAL

#### WARNING:

Place "NO OPEN FLAMES" signs near the working area.

#### CAUTION:

- Be careful not to spill fuel.
- Catch the fuel from hoses using a container or cloth.

1) Release the fuel pressure. <Ref. to FU(w/o STI)-66, RELEASING OF FUEL PRESSURE, PROCEDURE, Fuel.>

2) Disconnect the fuel delivery hose (A) and fuel return hose (B) from the fuel damper, and remove the fuel damper.

#### NOTE:

Fuel dampers on delivery side and return side are different. Be careful not to confuse them.

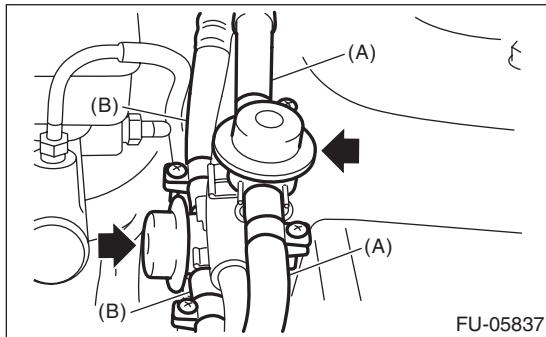

### B: INSTALLATION

Install in the reverse order of removal.

#### NOTE:

- Fuel dampers on delivery side and return side are different. Be careful not to confuse them.
- For the information about connecting the fuel delivery hose and fuel return hose, refer to "Fuel Delivery, Return and Evaporation Lines". <Ref. to FU(w/o STI)-94, CONNECTING FUEL DELIVERY HOSE, FUEL RETURN HOSE AND FUEL HOSE, INSTALLATION, Fuel Delivery, Return and Evaporation Lines.>



## 31.Purge Damper

### A: REMOVAL

#### WARNING:

Place "NO OPEN FLAMES" signs near the working area.

1) Remove the bolts which secure the purge damper to the purge damper bracket.

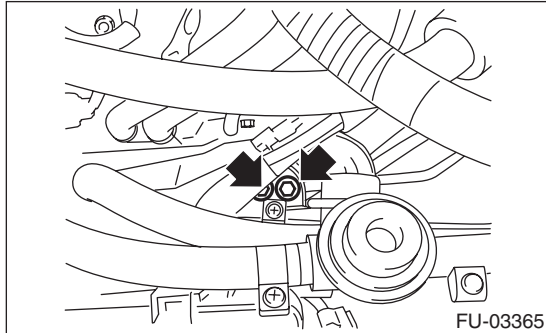

2) Disconnect the evaporation hose from the purge damper and remove the purge damper.

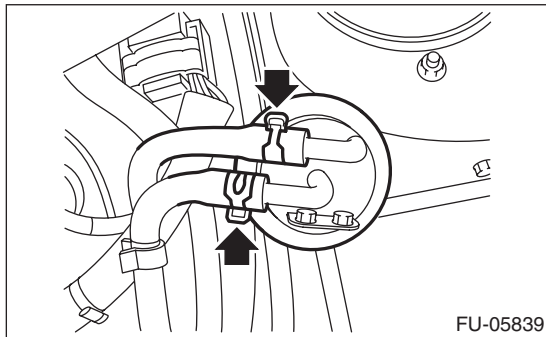

### B: INSTALLATION

Install in the reverse order of removal.

#### Tightening torque:

**13 N·m (1.3 kgf·m, 9.6 ft·lb)**

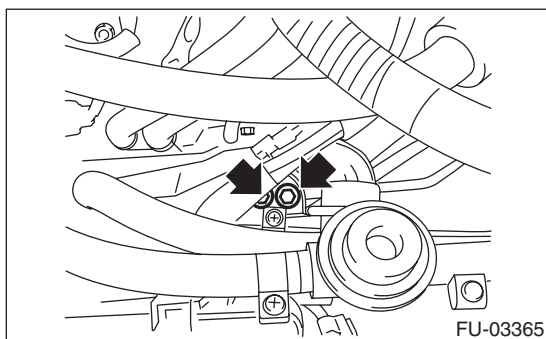

### C: INSPECTION

1) Check that the purge damper has no deformation, cracks or other damages.

2) Check that the evaporation hose has no cracks, damage or loose part.

# Fuel Delivery, Return and Evaporation Lines

FUEL INJECTION (FUEL SYSTEMS)

## 32. Fuel Delivery, Return and Evaporation Lines

### A: REMOVAL

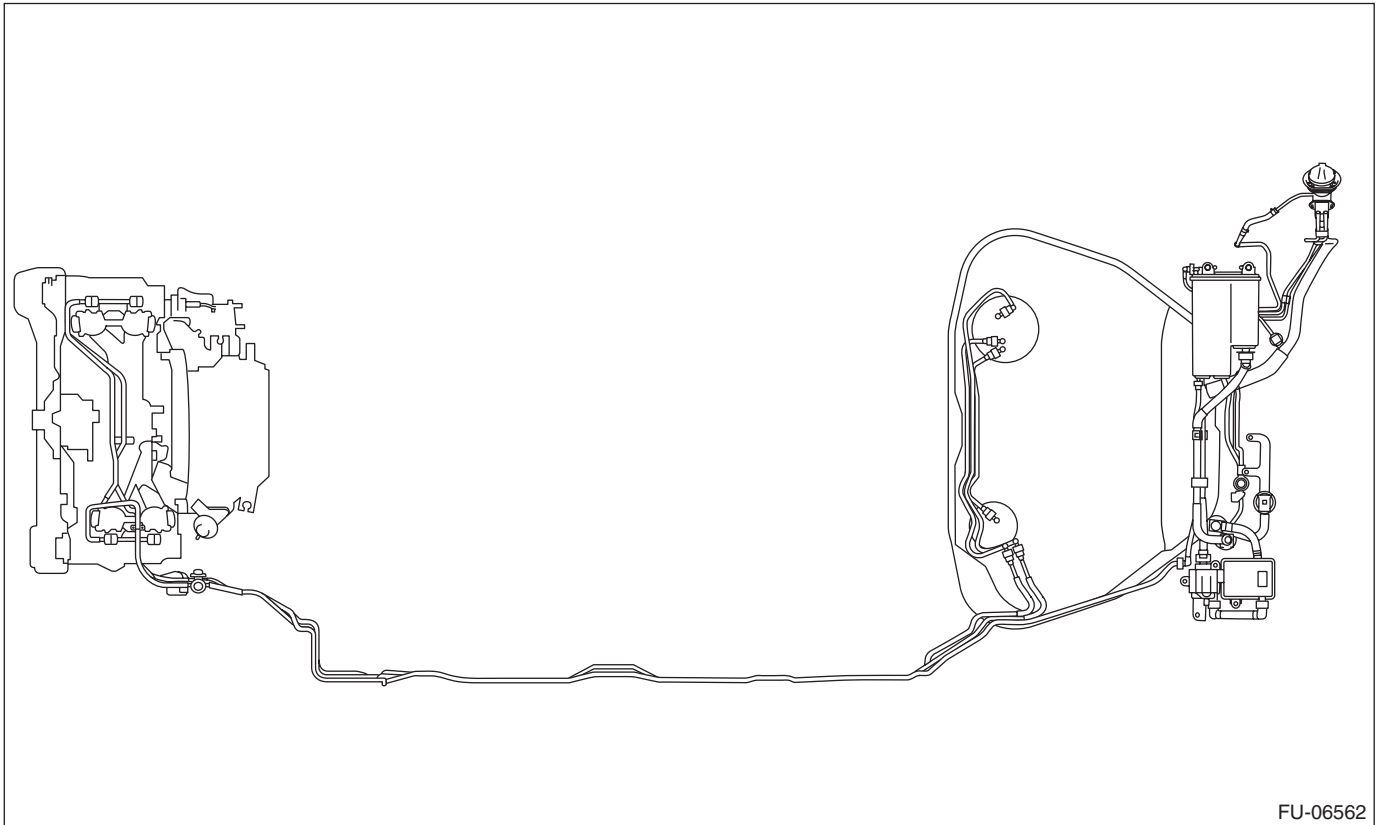

FU-06562

**FU(w/o STI)-90**

Brought to you by Ebay Seller "SubaruManuals"

# Fuel Delivery, Return and Evaporation Lines

FUEL INJECTION (FUEL SYSTEMS)

## WARNING:

Place "NO OPEN FLAMES" signs near the working area.

## CAUTION:

Be careful not to spill fuel.

1) Release the fuel pressure. <Ref. to FU(w/o STI)-66, RELEASING OF FUEL PRESSURE, PROCEDURE, Fuel.>

2) Open the fuel filler lid and remove the fuel filler cap.

3) Remove the floor mat. <Ref. to EI-71, REMOVAL, Floor Mat.>

4) In the engine compartment, disconnect the fuel delivery hoses, fuel return hoses and evaporation hoses.

## CAUTION:

- Be careful not to spill fuel.
- Catch the fuel from hoses using a container or cloth.

(1) Set the ST to the fuel pipe.

ST 42099AE000 QUICK CONNECTOR RELEASE

(2) Disconnect the quick connector of the fuel delivery hose and fuel return hose by pushing the ST in the direction of the arrow.

(3) Remove the clip and disconnect the evaporation hose from the fuel pipe.

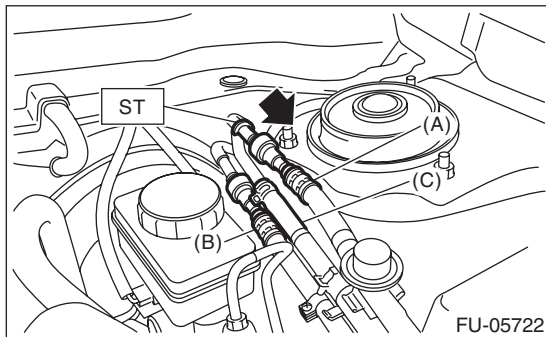

- (A) Fuel delivery hose
- (B) Fuel return hose
- (C) Evaporation hose

5) Remove the canister. <Ref. to EC(w/o STI)-7, REMOVAL, Canister.>

6) Remove the fuel tank. <Ref. to FU(w/o STI)-69, REMOVAL, Fuel Tank.>

7) Remove the fuel pipe assembly from vehicle.

8) Disconnect the quick connector, then disconnect the fuel delivery tube, fuel return tube and jet pump tube from the fuel tank.

- When using ST

1. Attach ST to the pipe and push ST in the direction of arrow mark to disconnect the quick connector.

ST 42099AE000 QUICK CONNECTOR RELEASE

## CAUTION:

- Be careful not to spill fuel.
- Catch the fuel from hoses using a container or cloth.
- To disconnect the connector, hold (C) shown in the figure and pull in axial direction.
- If the connector and pipe are sticking to each other, push and pull the connector with ST pushed, and then pull the connector after it starts moving freely.
- When disconnecting the connector, do not bend or twist the tube forcibly. If the tube is bent, replace with a new part.

## NOTE:

Clean the pipe and quick connector, if they are covered with dust.

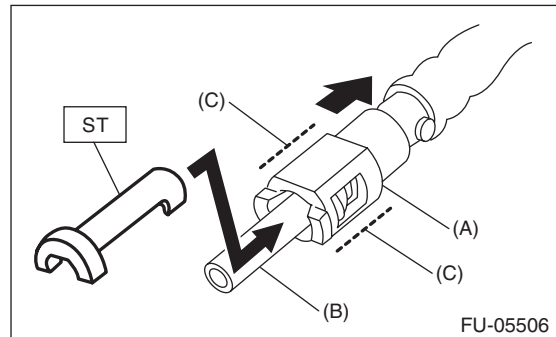

- (A) Quick connector
- (B) Pipe
- (C) Connector holding position

2. To prevent from damaging or entering foreign matter, wrap the pipes and quick connectors with plastic bag etc.

## CAUTION:

When reusing the retainer, do not disconnect the retainer from the connector.

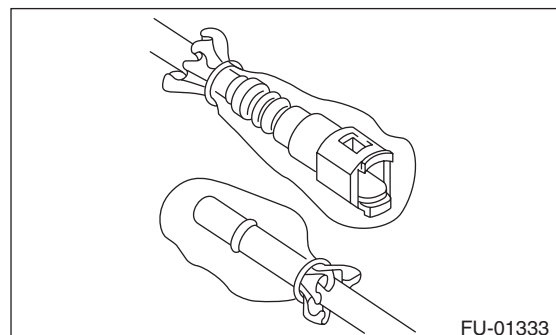

FU(w/o STI)-91

Brought to you by Ebay Seller "SubaruManuals"

# Fuel Delivery, Return and Evaporation Lines

## FUEL INJECTION (FUEL SYSTEMS)

- When not using ST

1. Push the retainer in the direction of the arrow, disconnect the quick connector from pipe.

### CAUTION:

- Be careful not to spill fuel.
- Catch the fuel from hoses using a container or cloth.
- To disconnect the connector, hold (D) shown in the figure and pull in axial direction.
- If the connector and pipe are sticking to each other, push and pull the connector with the retainer pushed in the direction of the arrow, and then pull the connector after it starts moving freely.
- When disconnecting the connector, do not bend or twist the tube forcibly. If the tube is bent, replace with a new part.

### NOTE:

Clean the pipe and quick connector, if they are covered with dust.

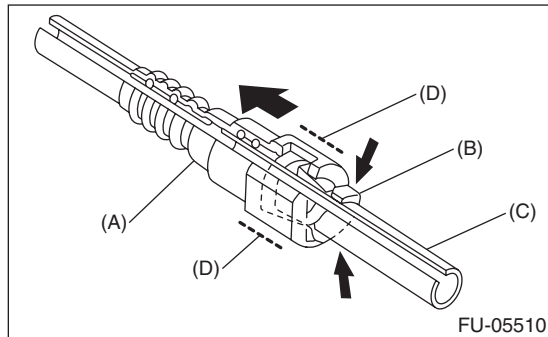

- (A) Quick connector
- (B) Retainer
- (C) Pipe
- (D) Connector holding position

2. To prevent from damaging or entering foreign matter, wrap the pipes and quick connectors with plastic bag etc.

### CAUTION:

When reusing the retainer, do not disconnect the retainer from the pipe.

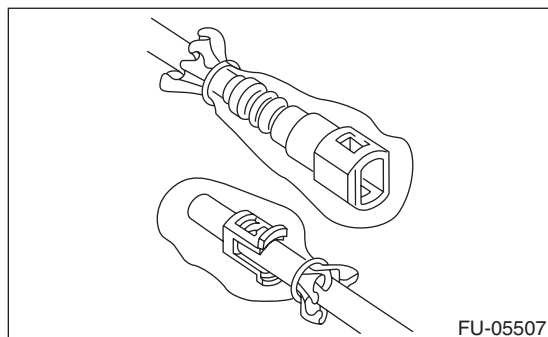

9) Remove the evaporation pipe.

(1) Remove the rear mud guard RH. <Ref. to EI-30, REMOVAL, Mud Guard.>

(2) Disconnect the evaporation hose.

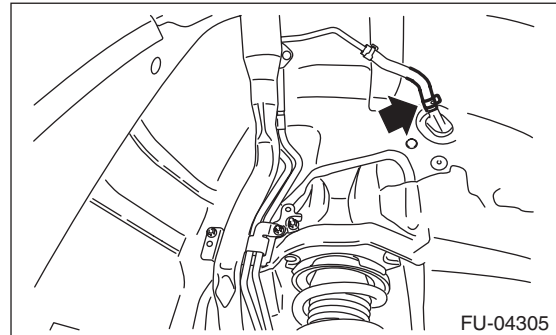

(3) Remove the right side rear quarter trim. <Ref. to EI-60, REMOVAL, Rear Quarter Trim.>

(4) Remove the evaporation pipe protector.

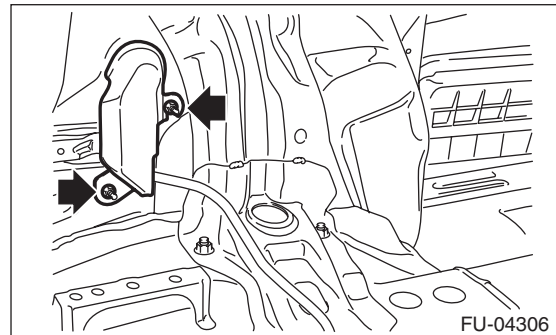

(5) Remove the evaporation pipe from vehicle.

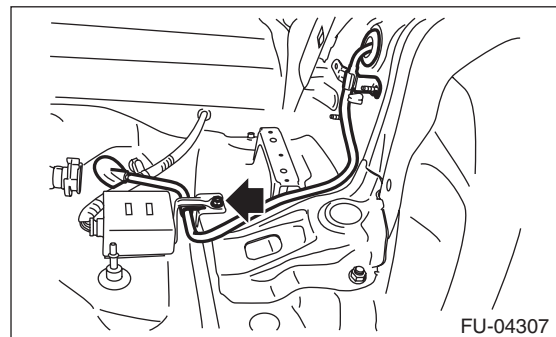

## B: INSTALLATION

Install in the reverse order of removal while being careful of the following.

### 1. EVAPORATION PIPE INSTALLATION

1) Install the evaporation pipe to the vehicle.

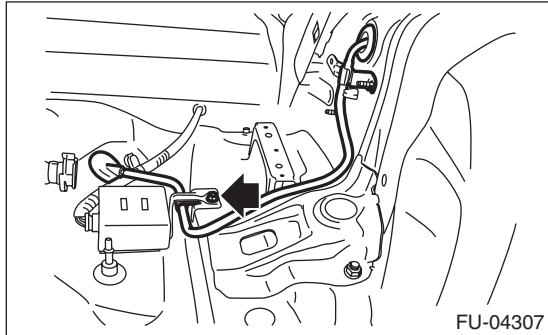

2) Install the evaporation pipe protector.

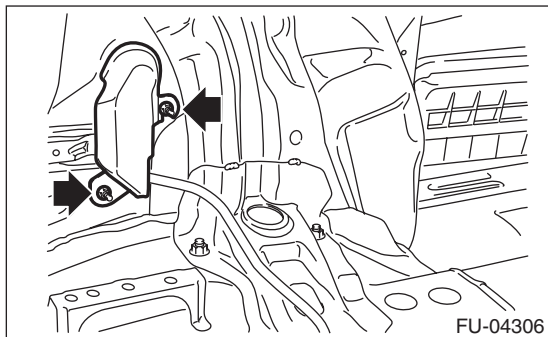

3) Install the right side rear quarter trim. <Ref. to EI-61, INSTALLATION, Rear Quarter Trim.>

4) Connect the evaporation hose.

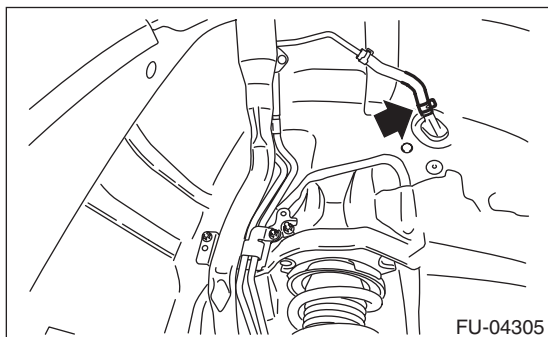

5) Install the rear mud guard RH. <Ref. to EI-30, INSTALLATION, Mud Guard.>

### 2. CONNECTING THE FUEL LINE QUICK CONNECTOR

#### CAUTION:

- Make sure there are no damage or dust on connections. If necessary, clean seal surface of pipe.

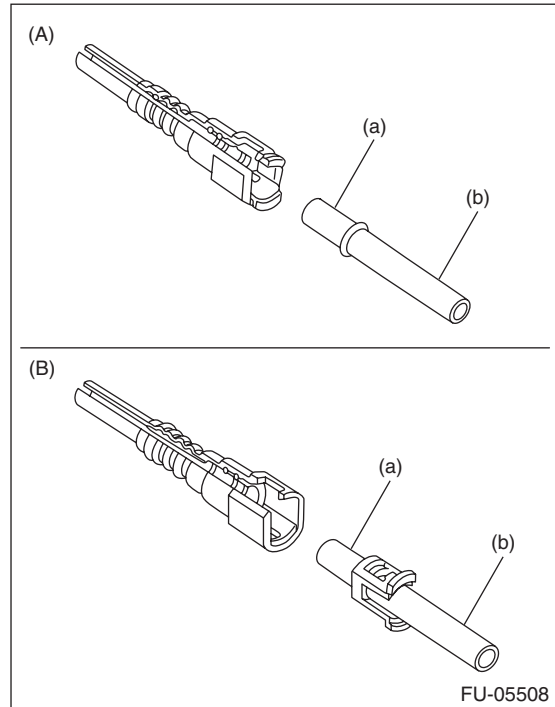

- (A) When removed using the ST  
 (B) When removed without using the ST  
 (a) Seal surface  
 (b) Pipe

- When reusing the retainer, make sure that neither scratches nor deformation exist on the retainer. If it is faulty, use a new part.

1) Connect the quick connector to pipe.

#### CAUTION:

- Make sure that the quick connector is securely connected.

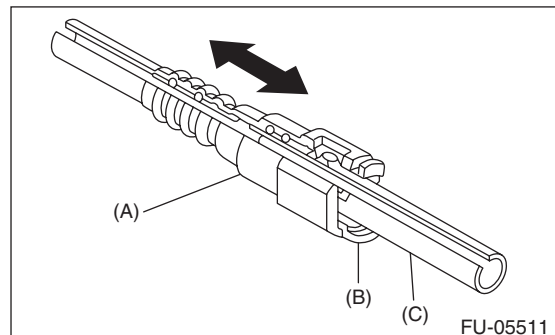

- (A) Quick connector  
 (B) Retainer  
 (C) Pipe

# Fuel Delivery, Return and Evaporation Lines

## FUEL INJECTION (FUEL SYSTEMS)

- Make sure the two retainer pawls are engaged in their mating positions in the quick connector.
- Be sure to inspect tubes and their connections for any leakage of fuel.
- To connect the connector, hold (d) shown in the figure and push in axial direction.
- When connecting the connector, do not bend or twist the tube forcibly. If the tube is bent, replace with a new part.

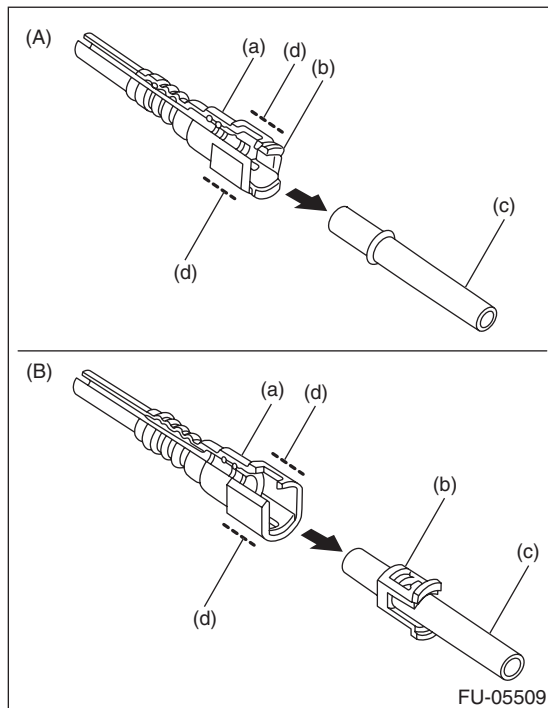

- (A) When removed using the ST  
(B) When removed without using the ST  
(a) Quick connector  
(b) Retainer  
(c) Pipe  
(d) Connector holding position

### 3. CONNECTING FUEL DELIVERY HOSE, FUEL RETURN HOSE AND FUEL HOSE

Connect the fuel delivery hose, fuel return hose, and fuel hose as shown in the figure.

#### CAUTION:

- If the connection portion has a spool or stopper, do not allow the end of the hose to bend or ride over by inserting the hose too deep.
- Be sure to inspect hoses and their connections for any leakage of fuel.

#### NOTE:

Use new fuel delivery hose, fuel return hose, and fuel hose.

#### Tightening torque:

$1.25 \text{ N}\cdot\text{m}$  (0.1 kgf-m, 0.9 ft-lb)

**L1:**  $2.5 \pm 1.5 \text{ mm}$  (0.098 ± 0.059 in)

**L2:**  $22.5 \pm 2.5 \text{ mm}$  (0.886 ± 0.098 in)

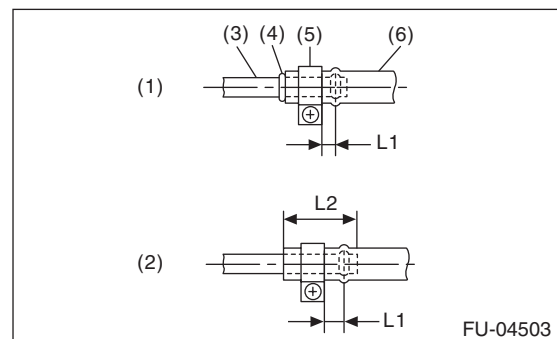

- (1) When there is a spool or bump  
(2) When there is no spool or bump  
(3) Pipe  
(4) Spool or bump  
(5) Clamp  
(6) Hose

## 4. EVAPORATION HOSE CONNECTION

Connect the evaporation hose to the pipe with an overlap of 15 to 20 mm (0.59 to 0.79 in).

**$L = 17.5 \pm 2.5 \text{ mm (0.689 \pm 0.098 in)}$**

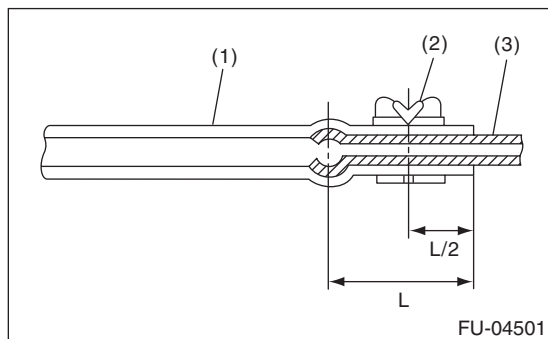

- (1) Hose
- (2) Clip
- (3) Pipe

## C: INSPECTION

- 1) Check that the fuel pipe has no deformation, cracks or other damages.
- 2) Check that the hose and tube have no cracks, damage or loose part.

# Fuel System Trouble in General

FUEL INJECTION (FUEL SYSTEMS)

## 33. Fuel System Trouble in General

### A: INSPECTION

Trouble	Possible cause	Corrective action
Insufficient fuel supply to fuel injector	a. Fuel pump does not operate.	
	○ Defective terminal contact	Inspect contact, especially ground, and tighten it securely.
	○ Trouble in electromagnetic or electronic circuit parts	Replace the faulty parts.
	b. Decline of fuel pump function	Replace the fuel pump.
	c. Clogged fuel filter	Replace the fuel filter. Clean or replace the fuel tank if necessary.
	d. Clogged or bent fuel line pipe, hose or tube	Clean, correct or replace the fuel line pipe, hose or tube.
	e. Air is mixed in fuel system.	Check the fuel line connections, correct or replace the defective part.
	f. Damaged diaphragm of pressure regulator	Replace the pressure regulator.
Leakage or blow out of fuel	a. Loose connections of fuel line pipe, hose or tube	Check the fuel line connections, correct or replace the defective part.
	b. Cracked fuel line pipe, hose or tube	Replace the fuel line pipe, hose or tube.
	c. Cracked fuel tank or defective welding part	Replace the fuel tank.
	d. Clogged or bent fuel line pipe, hose or tube	Clean, correct or replace the fuel line pipe, hose or tube.
Gasoline smell inside of compartment	a. Loose connections of fuel line pipe, hose or tube	Check the fuel line connections, correct or replace the defective part.
	b. Defective gasket of fuel saucer or fuel filler pipe assembly	Correct or replace the gasket.
	c. Defective canister	Replace the canister.
Defective fuel gauge	a. Defective operation of fuel level sensor	Replace the fuel level sensor.
	b. Defective operation of combination meter	Replace the combination meter.
Noise	a. Large operation noise or vibration of fuel pump	Replace the fuel pump.

#### NOTE:

- When the vehicle is left unattended for an extended period of time, water may accumulate in the fuel tank. Fill fuel fully to prevent the problem.
- In snow-covered areas, mountainous areas, skiing areas, etc. where ambient temperatures drop to 0°C (32°F) or less throughout the winter season, use a water removing agent in the fuel system to prevent freezing fuel system and accumulating water.
- When water is accumulated in fuel filter, fill the water removing agent in the fuel tank.
- Before using water removing agent, follow the cautions noted on the bottle.



# EMISSION CONTROL (AUX. EMISSION CONTROL DEVICES)

## *EC(w/o STI)*

---

	<b>Page</b>
1. General Description .....	2
2. Front Catalytic Converter .....	5
3. Rear Catalytic Converter .....	6
4. Canister .....	7
5. Purge Control Solenoid Valve .....	11
6. Fuel Level Sensor .....	15
7. Fuel Sub Level Sensor .....	16
8. Pressure Control Solenoid Valve Assembly .....	17
9. Drain Filter .....	18
10. Shut Valve .....	19
11. Leak Check Valve Assembly .....	20
12. Drain Separator .....	24
13. PCV Hose Assembly .....	25
14. PCV Valve .....	27
15. Secondary Air Pump .....	29
16. Secondary Air Combination Valve .....	30

# General Description

EMISSION CONTROL (AUX. EMISSION CONTROL DEVICES)

## 1. General Description

### A: COMPONENT

#### 1. SECONDARY AIR PUMP

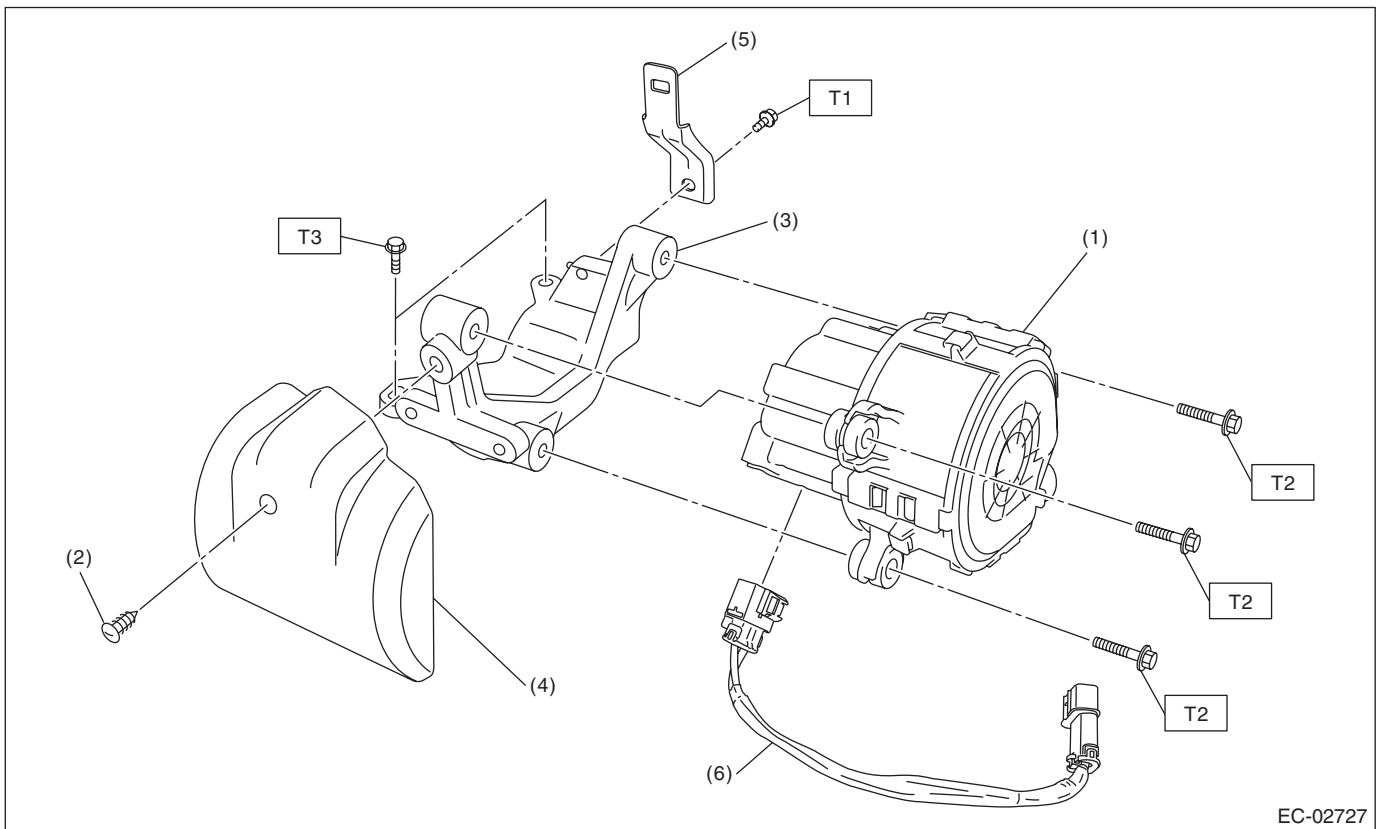

- |                                |                                |
|--------------------------------|--------------------------------|
| (1) Secondary air pump         | (4) Secondary air pump cover   |
| (2) Clip                       | (5) Harness stay               |
| (3) Secondary air pump bracket | (6) Secondary air pump harness |

**Tightening torque: N·m (kgf·m, ft·lb)**

**T1: 6.4 (0.7, 4.7)**

**T2: 9 (0.9, 6.6)**

**T3: 19 (1.9, 14.0)**

**EC(w/o STI)-2**

Brought to you by Ebay Seller "SubaruManuals"

# General Description

EMISSION CONTROL (AUX. EMISSION CONTROL DEVICES)

## 2. SECONDARY AIR COMBINATION VALVE

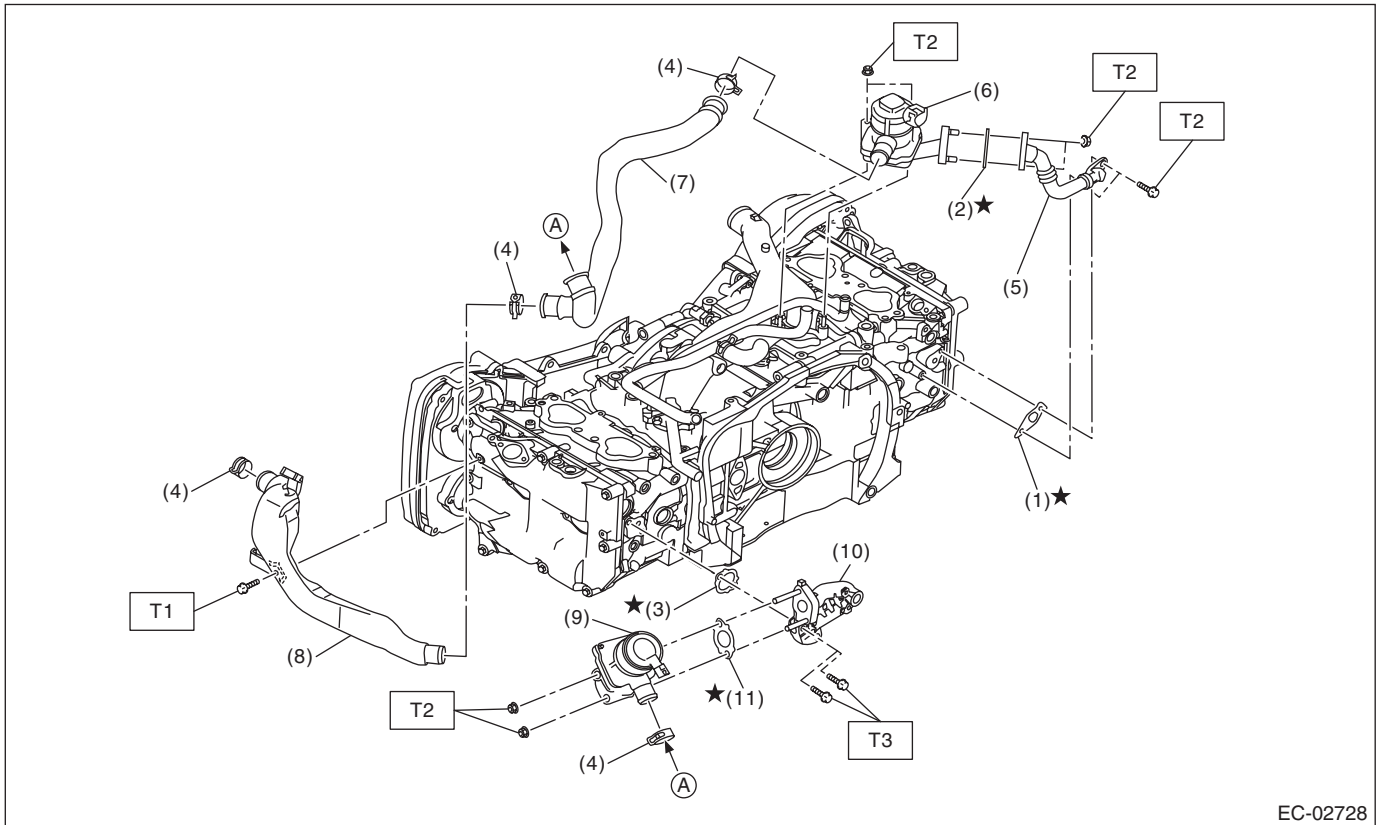

EC-02728

- |  |  |
|--|--|
| (1) Gasket                             | (7) Air duct A                         |
| (2) Gasket                             | (8) Air duct B                         |
| (3) Gasket                             | (9) Secondary air combination valve LH |
| (4) Clip                               | (10) Secondary air pipe LH             |
| (5) Secondary air pipe RH              | (11) Gasket                            |
| (6) Secondary air combination valve RH |  |

**Tightening torque: N·m (kgf·m, ft·lb)**

**T1: 6.4 (0.7, 4.7)**

**T2: 9 (0.9, 6.6)**

**T3: 19 (1.9, 14.0)**

### B: CAUTION

- Wear appropriate work clothing, including a cap, protective goggles and protective shoes when performing any work.
- Remove contamination including dirt and corrosion before removal, installation or disassembly.
- Keep the disassembled parts in order and protect them from dust and dirt.
- Before removal, installation or disassembly, be sure to clarify the failure. Avoid unnecessary removal, installation, disassembly and replacement.
- Vehicle components are extremely hot after driving. Be wary of receiving burns from heated parts.
- Be sure to tighten fasteners including bolts and nuts to the specified torque.
- Place shop jacks or rigid racks at the specified points.
- Before disconnecting connectors of sensors or units, be sure to disconnect the ground cable from battery.

**EC(w/o STI)-3**

Brought to you by Ebay Seller "SubaruManuals"

## General Description

EMISSION CONTROL (AUX. EMISSION CONTROL DEVICES)

### C: PREPARATION TOOL

#### 1. SPECIAL TOOL

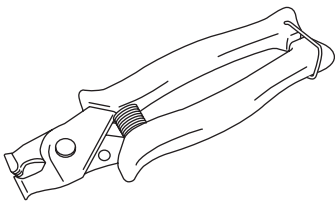
ILLUSTRATION	TOOL NUMBER	DESCRIPTION	REMARKS
 ST18353AA000	18353AA000	CLAMP PLIERS	<ul style="list-style-type: none"><li>• Used for removing and installing the PCV hose.</li><li>• This tool is made by the French company CAILLAU. (code) 54.0.000.205</li></ul> To make it easier to obtain, it has been provided with a tool number.

#### 2. GENERAL TOOL

TOOL NAME	REMARKS
Circuit tester	Used for measuring resistance and voltage.
Mighty Vac	Used for inspecting the fuel tank pressure sensor.

# Front Catalytic Converter

EMISSION CONTROL (AUX. EMISSION CONTROL DEVICES)

---

## 2. Front Catalytic Converter

### A: REMOVAL

The front catalytic converter is integrated into the center exhaust pipe (front). Refer to "Center Exhaust Pipe" for removal procedures. <Ref. to EX(STI)-8, REMOVAL, Center Exhaust Pipe.>

### B: INSTALLATION

The front catalytic converter is integrated into the center exhaust pipe (front). Refer to "Center Exhaust Pipe" for installation procedures. <Ref. to EX(STI)-9, INSTALLATION, Center Exhaust Pipe.>

### C: INSPECTION

- 1) Check the connections and welded parts for exhaust leaks.
- 2) Make sure there are no holes or rusting.

## Rear Catalytic Converter

EMISSION CONTROL (AUX. EMISSION CONTROL DEVICES)

---

### 3. Rear Catalytic Converter

#### A: REMOVAL

The rear catalytic converter is integrated into the center exhaust pipe (rear). Refer to "Center Exhaust Pipe" for removal procedures. <Ref. to EX(STI)-8, REMOVAL, Center Exhaust Pipe.>

#### B: INSTALLATION

The rear catalytic converter is integrated into the center exhaust pipe (rear). Refer to "Center Exhaust Pipe" for installation procedures. <Ref. to EX(STI)-9, INSTALLATION, Center Exhaust Pipe.>

#### C: INSPECTION

- 1) Check the connections and welded parts for exhaust leaks.
- 2) Make sure there are no holes or rusting.

# Canister

EMISSION CONTROL (AUX. EMISSION CONTROL DEVICES)

## 4. Canister

### A: REMOVAL

1) Disconnect the ground cable from battery.

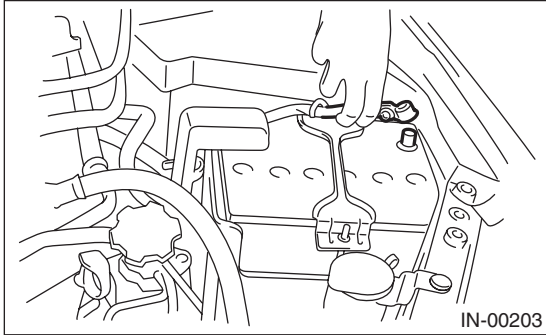

2) Open the trunk, and remove the trunk room mat. (4 door model)

3) Open the rear gate, and remove the luggage floor mat. (5 door model)

4) Tilt the rear seat backrest forward.

5) Remove the sub trunk box and spacers. (4 door model)

6) Remove the luggage floor box and spacers. (5 door model)

7) Remove the center canister cover.

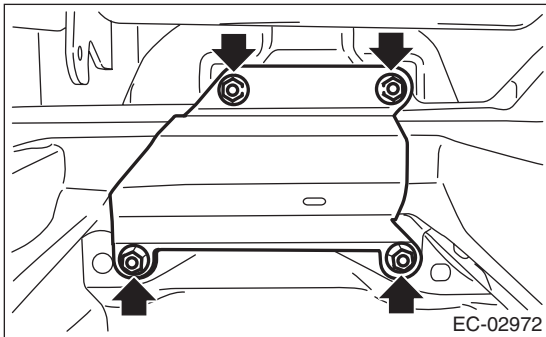

8) Remove the canister cover RH.

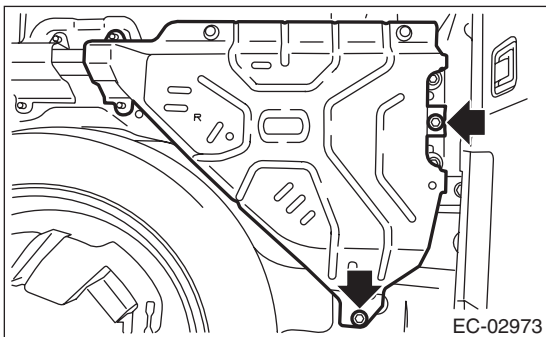

9) Disconnect the purge tube (A), vent tube (B), drain tube A (C) and PCV drain tube (D).

NOTE:

Disconnect the quick connector as shown in the figure.

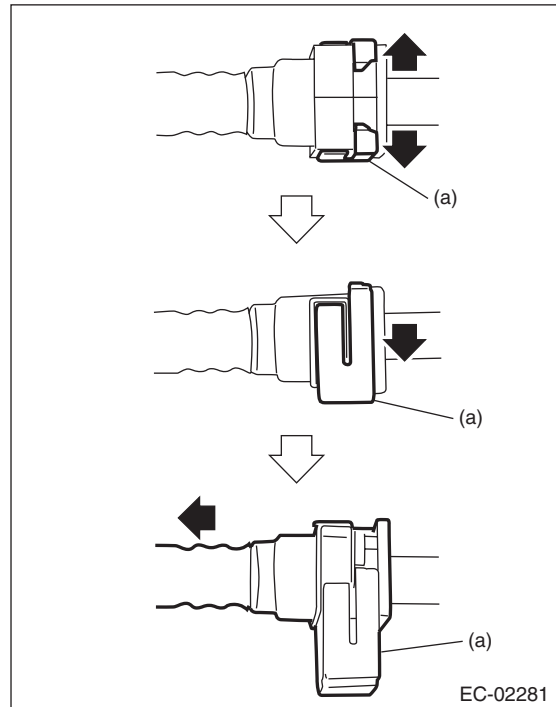

(a) Retainer

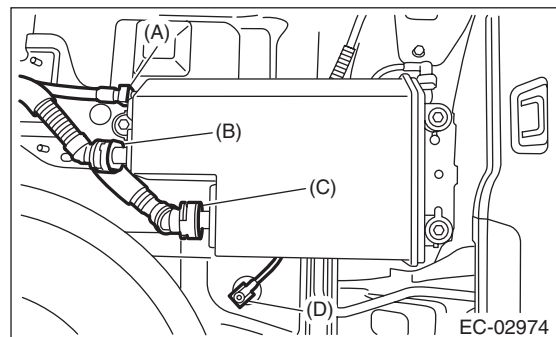

10) Remove the canister.

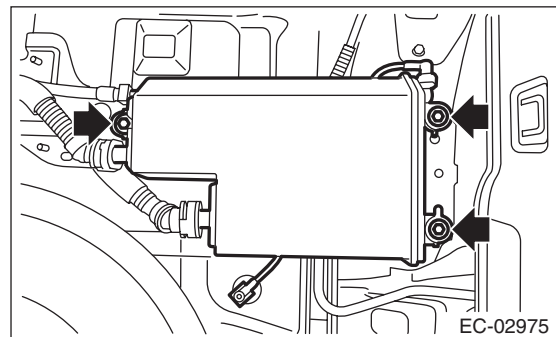

# Canister

## EMISSION CONTROL (AUX. EMISSION CONTROL DEVICES)

11) Remove the canister cover LH.

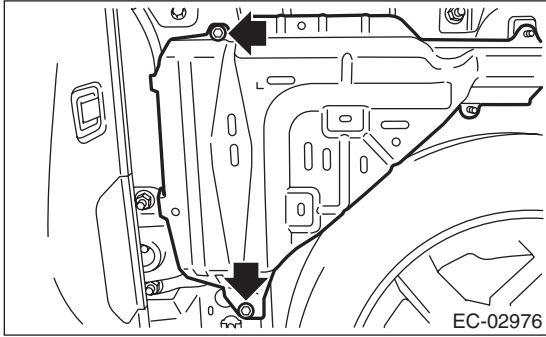

12) Disconnect drain tube A (A) and drain tube B (B).

### NOTE:

Disconnect the quick connector as shown in the figure.

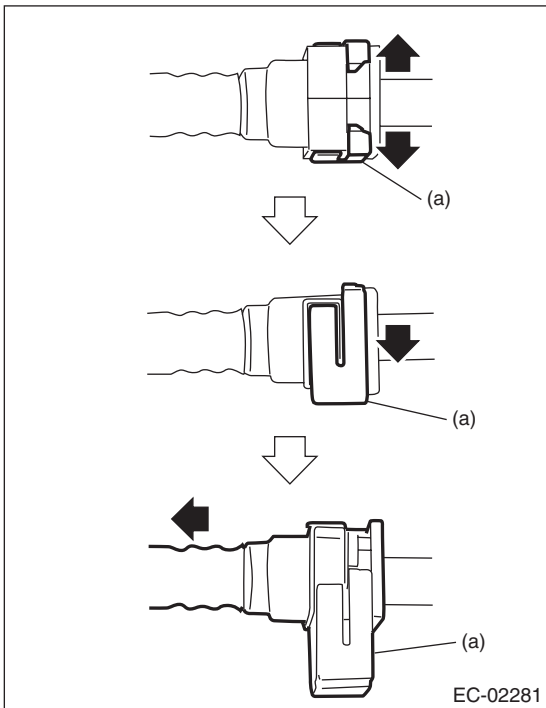

(a) Retainer

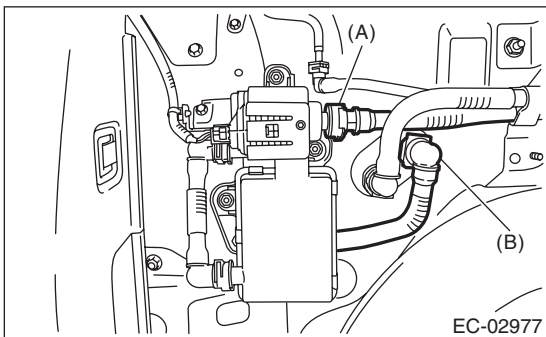

13) Disconnect the connector (A) from leak check valve assembly, and remove the leak check valve assembly.

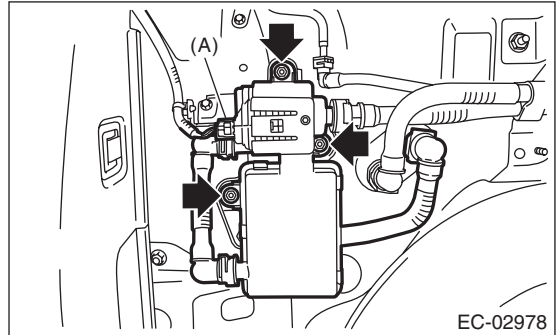

14) Remove the clip (A), which secures the leak check valve assembly harness, from the valve bracket, and remove the valve bracket.

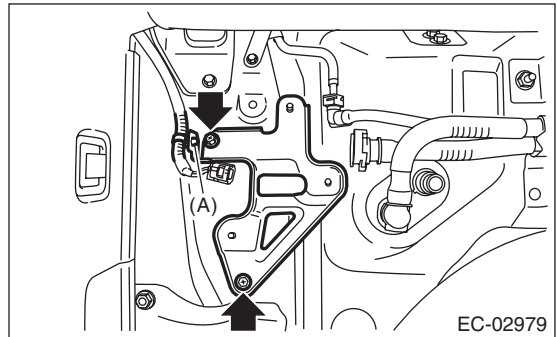



# Canister

EMISSION CONTROL (AUX. EMISSION CONTROL DEVICES)

15) Disconnect purge tube (A) and vent tube (B).

### NOTE:

Disconnect the quick connector as shown in the figure.

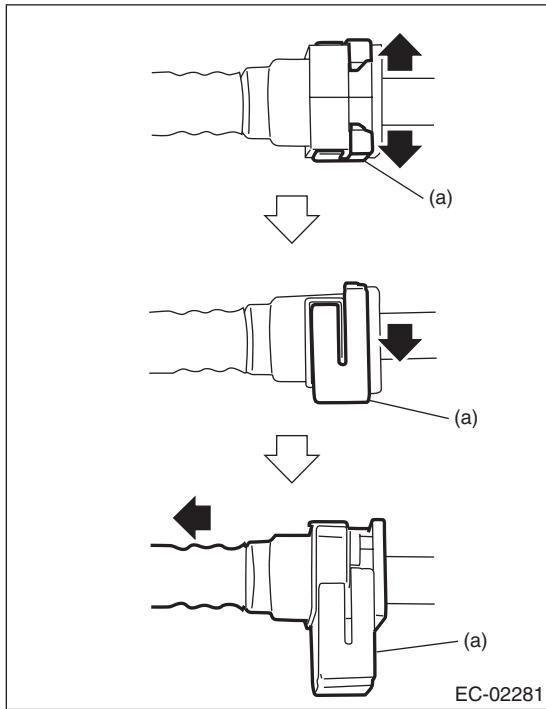

(a) Retainer

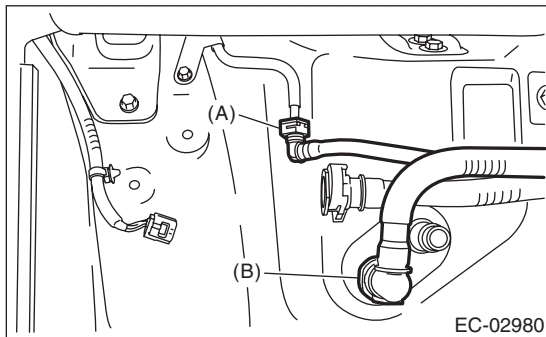

16) Remove purge tube (A), vent tube (B), and drain tube A (C).

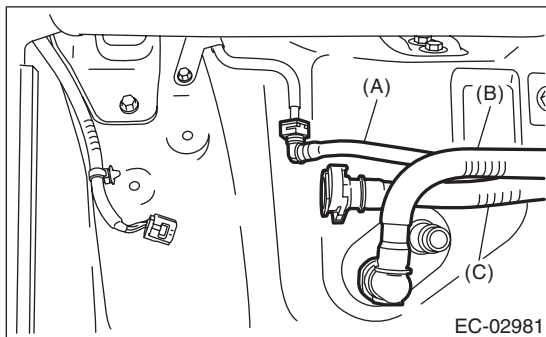

## B: INSTALLATION

Install in the reverse order of removal while being careful of the following.

- Connect the quick connector as shown in the figure.

### CAUTION:

- Check that there is no damage or dust on the quick connector. If necessary, clean the seal surface of the pipe.
- When connecting the quick connector, securely insert the pipe all the way before locking the retainer.
- When it is difficult to lock the retainer, make sure that the pipe is securely inserted.
- Make sure that the quick connector is securely connected.

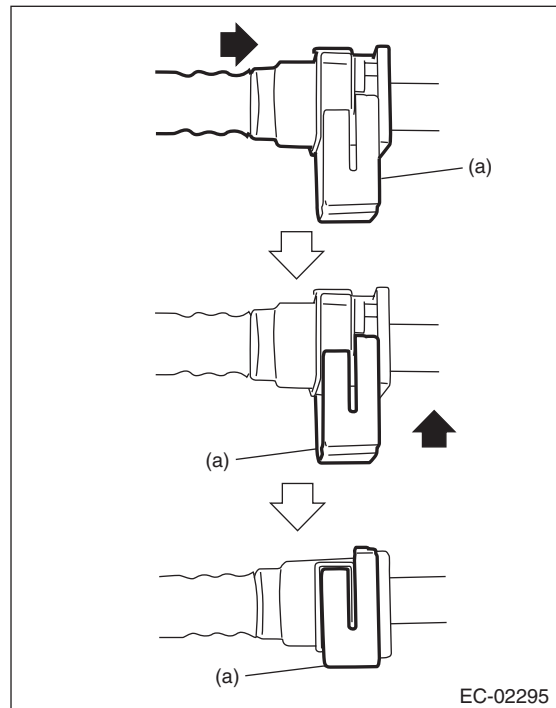

(a) Retainer

# Canister

EMISSION CONTROL (AUX. EMISSION CONTROL DEVICES)

**Tightening torque:**  
**7.5 N·m (0.8 kgf-m, 5.5 ft-lb)**

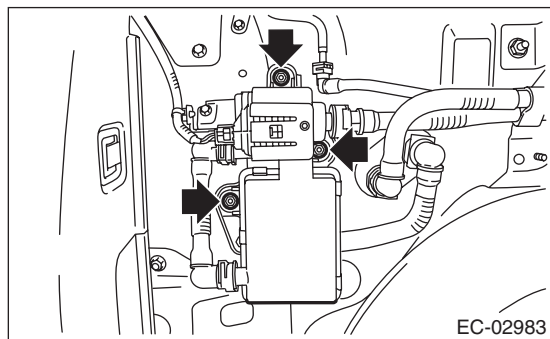
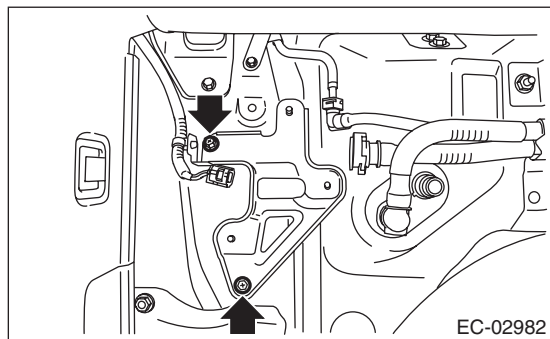

**Tightening torque:**  
**18 N·m (1.8 kgf-m, 13.3 ft-lb)**

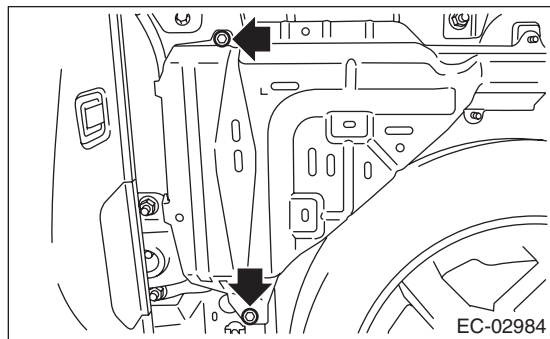

**Tightening torque:**  
**8 N·m (0.8 kgf-m, 5.9 ft-lb)**

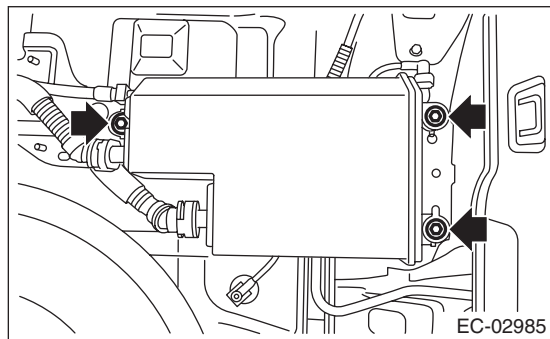

**Tightening torque:**  
**18 N·m (1.8 kgf-m, 13.3 ft-lb)**

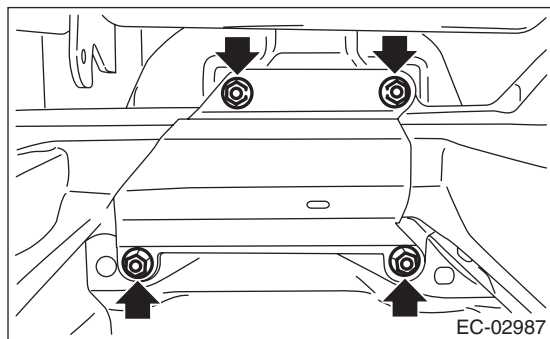
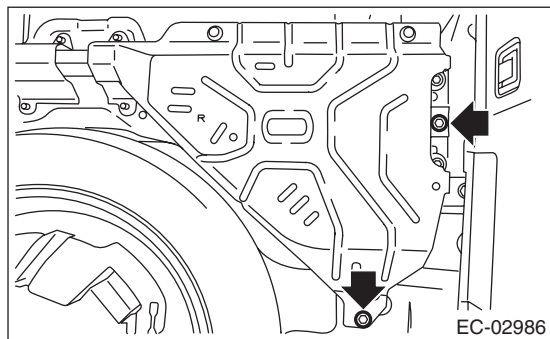

## C: INSPECTION

- 1) Check that the canister and leak check valve assembly have no deformation, cracks or other damages.
- 2) Check that the tube has no cracks, damage or loose part.

# Purge Control Solenoid Valve

EMISSION CONTROL (AUX. EMISSION CONTROL DEVICES)

## 5. Purge Control Solenoid Valve

### A: REMOVAL

#### 1. PURGE CONTROL SOLENOID VALVE 1

1) Disconnect the ground cable from battery.

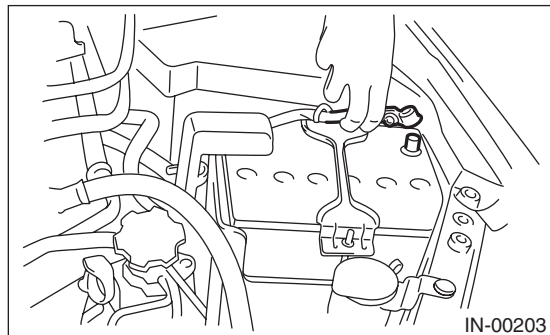

2) Remove the bolts which secure purge control solenoid valve 1 to the intake manifold, and disconnect the connector from the purge control solenoid valve 1.

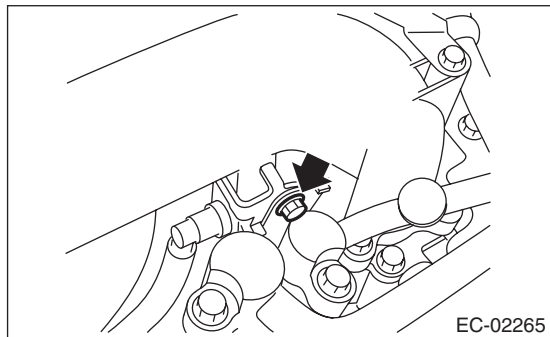

3) Disconnect the vacuum hose from purge control solenoid valve 1.

#### 2. PURGE CONTROL SOLENOID VALVE 2

1) Disconnect the ground cable from battery.

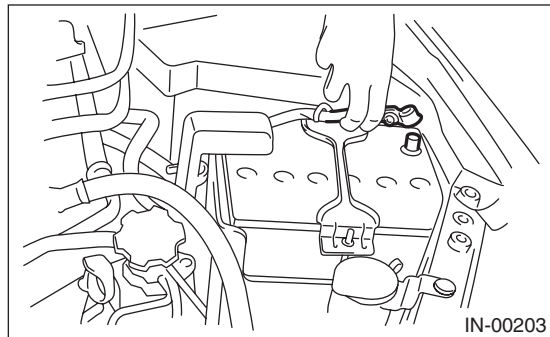

2) Remove the solenoid valve bracket assembly from the intake manifold.

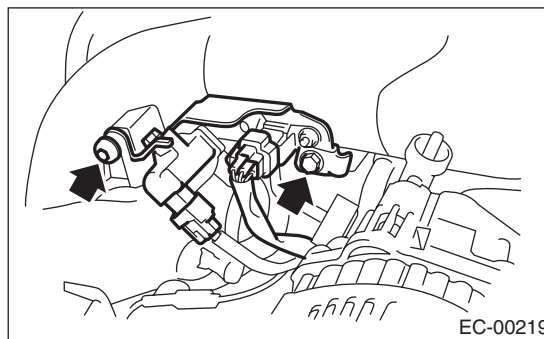

3) Disconnect the connector and the vacuum hose from purge control solenoid valve 2.

4) Remove the purge control solenoid valve 2 from the solenoid valve bracket assembly.

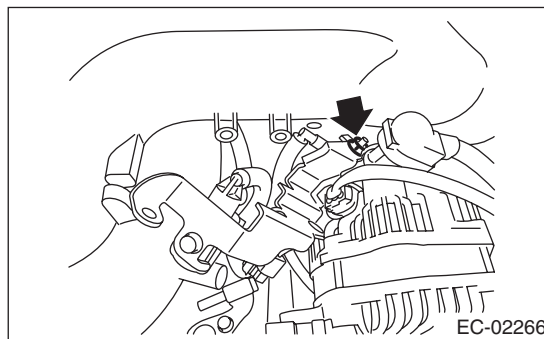

# Purge Control Solenoid Valve

EMISSION CONTROL (AUX. EMISSION CONTROL DEVICES)

## B: INSTALLATION

### 1. PURGE CONTROL SOLENOID VALVE 1

Install in the reverse order of removal.

NOTE:

Connect the vacuum hose as shown in the figure.

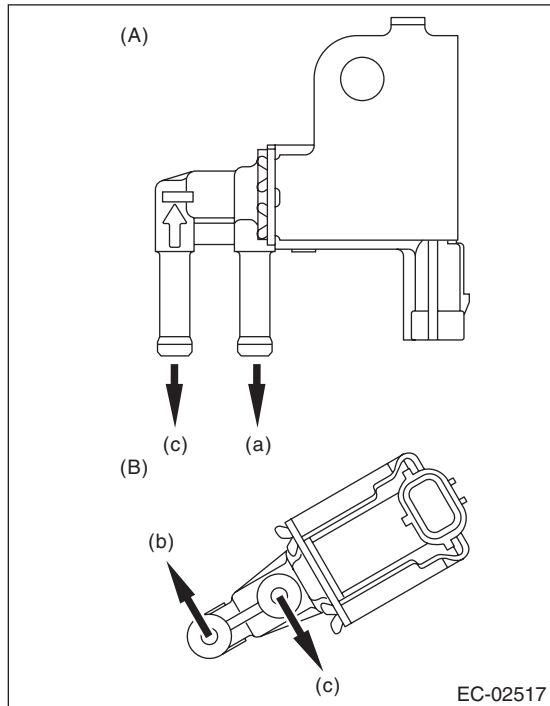

- (A) Purge control solenoid valve 1
- (B) Purge control solenoid valve 2
- (a) To intake manifold
- (b) To intake duct
- (c) To fuel pipe

**Tightening torque:**

**6.4 N·m (0.7 kgf·m, 4.7 ft·lb)**

### 2. PURGE CONTROL SOLENOID VALVE 2

Install in the reverse order of removal.

NOTE:

Connect the vacuum hose as shown in the figure.

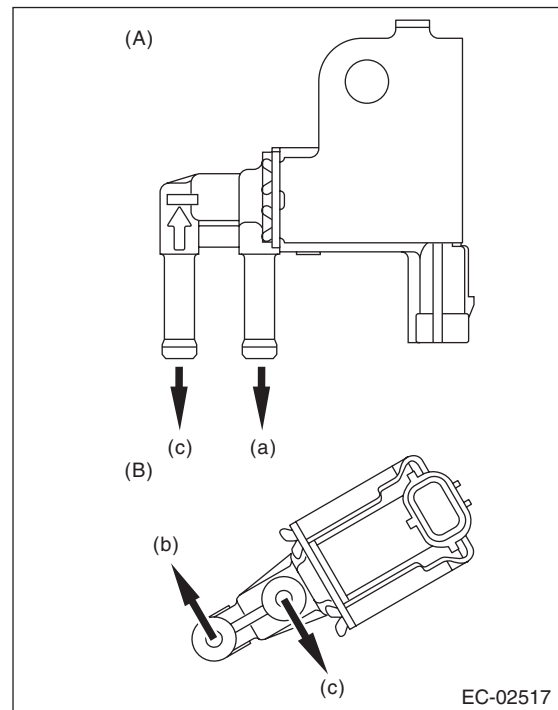

- (A) Purge control solenoid valve 1
- (B) Purge control solenoid valve 2
- (a) To intake manifold
- (b) To intake duct
- (c) To fuel pipe

**Tightening torque:**

**6.4 N·m (0.7 kgf·m, 4.7 ft·lb)**

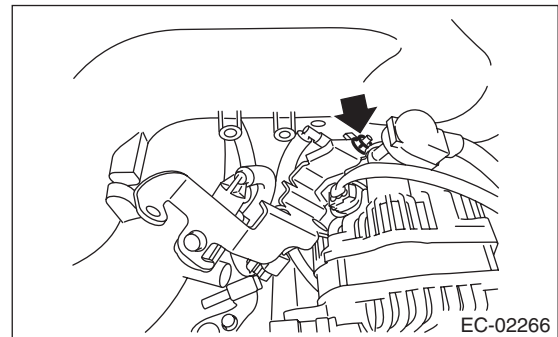

# Purge Control Solenoid Valve

EMISSION CONTROL (AUX. EMISSION CONTROL DEVICES)

## Tightening torque:

T1: 17 N·m (1.7 kgf·m, 12.5 ft·lb)

T2: 19 N·m (1.9 kgf·m, 14.0 ft·lb)

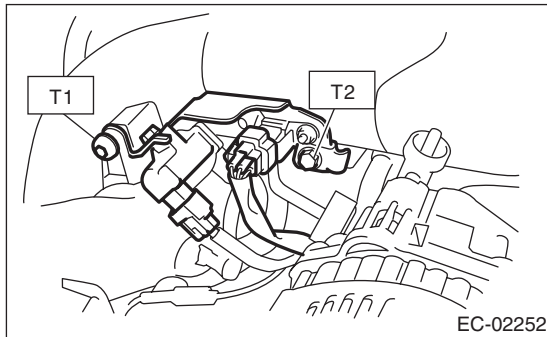

## C: INSPECTION

### 1. PURGE CONTROL SOLENOID VALVE

- 1) Check that the purge control solenoid valve has no deformation, cracks or other damages.
- 2) Measure the resistance between the purge control solenoid valve terminals.

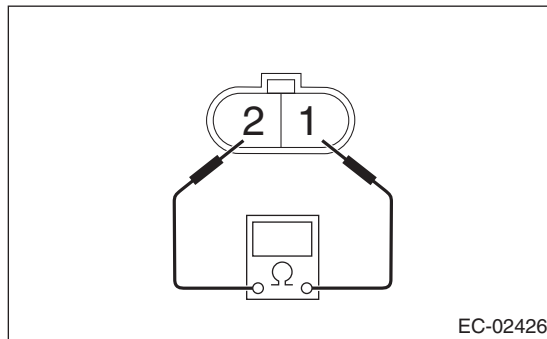

	Terminal No.	Standard
Purge control solenoid valve 1	1 and 2	32±2 Ω (when 20°C (68°F))
Purge control solenoid valve 2		24±3 Ω (when 20°C (68°F))

- 3) Check that air does not come out from (B) when air is blown into (A).

- Purge control solenoid valve 1

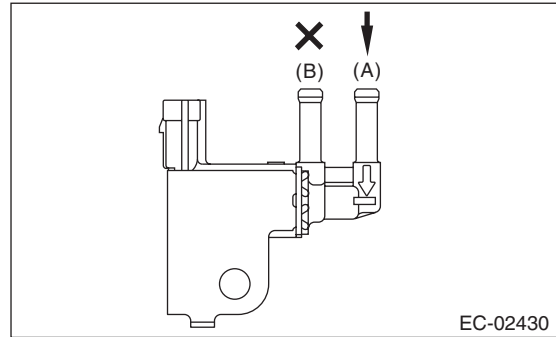

- Purge control solenoid valve 2

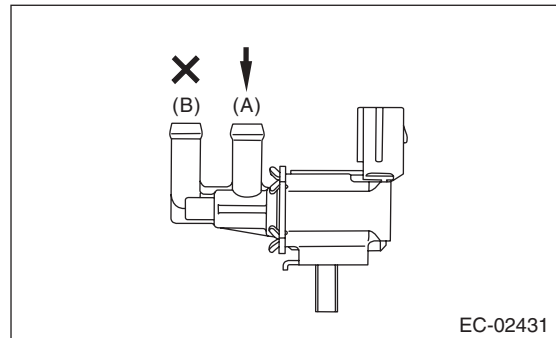

- 4) Connect the battery positive terminal to the terminal No. 1 and the battery negative terminal to the terminal No. 2. Check that air is discharged from (B), when supplying air to (A).

- Purge control solenoid valve 1

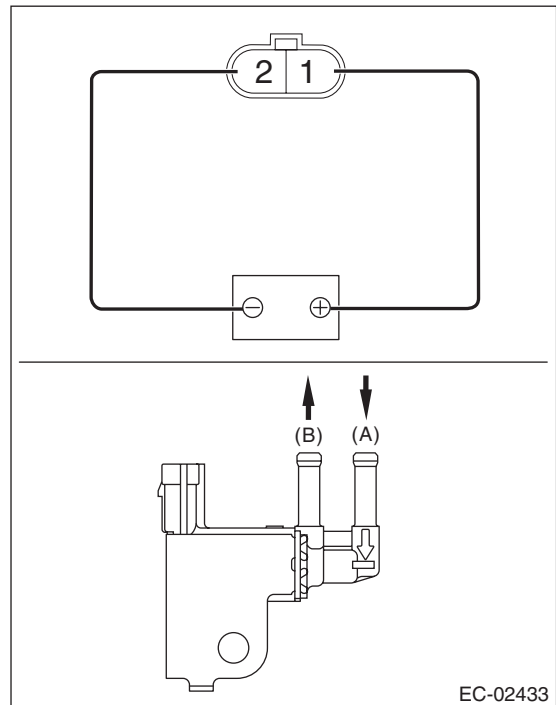

# Purge Control Solenoid Valve

EMISSION CONTROL (AUX. EMISSION CONTROL DEVICES)

---

- Purge control solenoid valve 2

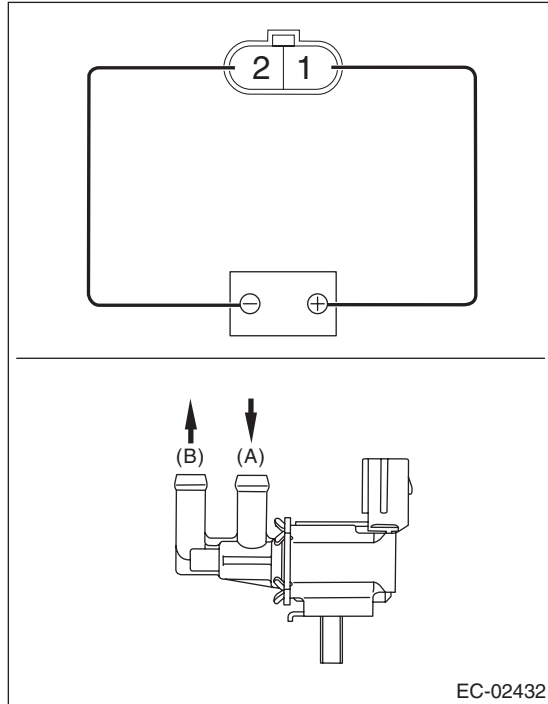

## 2. OTHER INSPECTIONS

Check the vacuum hose for cracks, damage or looseness.

# Fuel Level Sensor

EMISSION CONTROL (AUX. EMISSION CONTROL DEVICES)

---

## 6. Fuel Level Sensor

### A: REMOVAL

For removal procedures, refer to the "FU(w/o STI)" section. <Ref. to FU(w/o STI)-81, REMOVAL, Fuel Level Sensor.>

### B: INSTALLATION

For installation procedures, refer to the "FU(w/o STI)" section. <Ref. to FU(w/o STI)-81, INSTALLATION, Fuel Level Sensor.>

### C: INSPECTION

For inspection procedures, refer to the "FU(w/o STI)" section. <Ref. to FU(w/o STI)-81, INSPECTION, Fuel Level Sensor.>

## Fuel Sub Level Sensor

EMISSION CONTROL (AUX. EMISSION CONTROL DEVICES)

---

### 7. Fuel Sub Level Sensor

#### A: REMOVAL

For removal procedures, refer to the "FU(w/o STI)" section. <Ref. to FU(w/o STI)-82, REMOVAL, Fuel Sub Level Sensor.>

#### B: INSTALLATION

For installation procedures, refer to the "FU(w/o STI)" section. <Ref. to FU(w/o STI)-83, INSTALLATION, Fuel Sub Level Sensor.>

#### C: INSPECTION

For inspection procedures, refer to the "FU(w/o STI)" section. <Ref. to FU(w/o STI)-83, INSPECTION, Fuel Sub Level Sensor.>



# Pressure Control Solenoid Valve Assembly

EMISSION CONTROL (AUX. EMISSION CONTROL DEVICES)

## 8. Pressure Control Solenoid Valve Assembly

### A: REMOVAL

- 1) Disconnect the ground cable from battery.

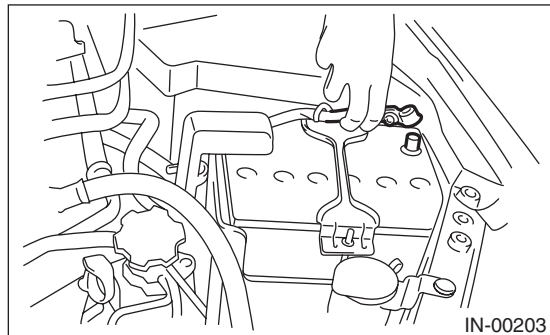

- 2) Lift up the vehicle.
- 3) Disconnect the connector (A) and evaporation hose (B) from the pressure control solenoid valve assembly.
- 4) Remove the nut (C) securing the bracket to the fuel tank and remove the pressure control solenoid valve assembly.

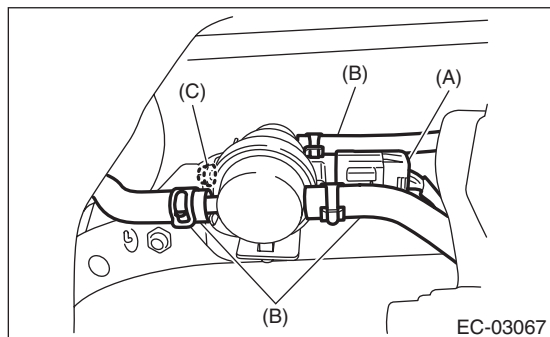

### B: INSTALLATION

Install in the reverse order of removal.

#### **Tightening torque:**

**2.5 N·m (0.3 kgf·m, 1.8 ft·lb)**

### C: INSPECTION

#### 1. PRESSURE CONTROL SOLENOID VALVE ASSEMBLY

- 1) Check that the pressure control solenoid valve assembly has no deformation, cracks or other damages.
- 2) Check the resistance between the pressure control solenoid valve assembly terminals.

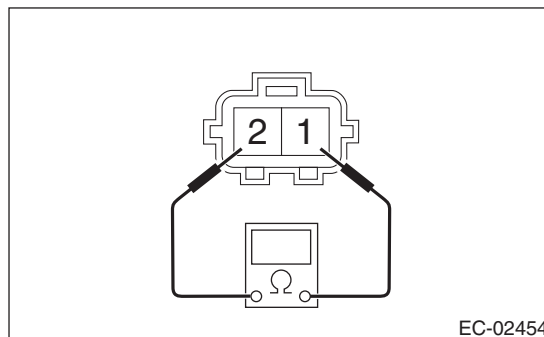

Terminal No.	Standard
1 and 2	20 — 30 Ω

#### 2. OTHER INSPECTIONS

Check that the evaporation hose has no cracks, damage or loose part.

## Drain Filter

EMISSION CONTROL (AUX. EMISSION CONTROL DEVICES)

---

### 9. Drain Filter

#### A: SPECIFICATION

The leak check valve assembly is a non-disassembled part. Do not remove the drain filter from the leak check valve assembly. Refer to "Canister" for removal and installation procedures. <Ref. to EC(w/o STI)-7, REMOVAL, Canister.> <Ref. to EC(w/o STI)-9, INSTALLATION, Canister.>

# Shut Valve

EMISSION CONTROL (AUX. EMISSION CONTROL DEVICES)

## 10.Shut Valve

### A: REMOVAL

#### WARNING:

Place "NO OPEN FLAMES" signs near the working area.

#### CAUTION:

Be careful not to spill fuel.

- 1) Remove the fuel filler pipe. <Ref. to FU(w/o STI)-76, REMOVAL, Fuel Filler Pipe.>
- 2) Disconnect the evaporation hose from the shut valve.

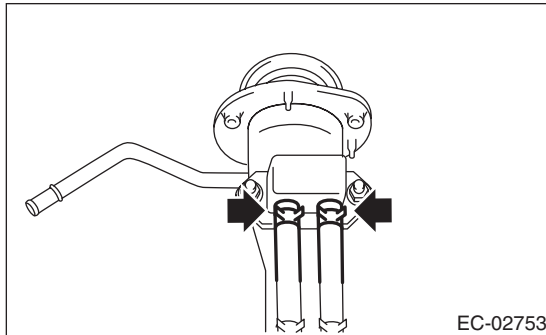

- 3) Remove the shut valve from the fuel filler pipe.

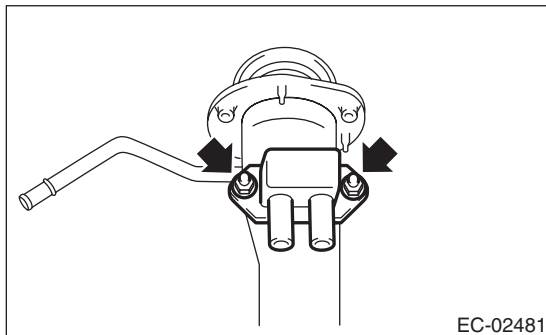

### B: INSTALLATION

Install in the reverse order of removal.

#### Tightening torque:

**4.5 N·m (0.5 kgf-m, 3.3 ft-lb)**

### C: INSPECTION

- 1) Check that the shut valve has no deformation, cracks or other damages.
- 2) Check that the evaporation hose has no cracks, damage or loose part.

# Leak Check Valve Assembly

EMISSION CONTROL (AUX. EMISSION CONTROL DEVICES)

## 11. Leak Check Valve Assembly

### A: REMOVAL

Refer to "Canister" for removal procedures. <Ref. to EC(w/o STI)-7, REMOVAL, Canister.>

### B: INSTALLATION

Refer to "Canister" for installation procedures. <Ref. to EC(w/o STI)-9, INSTALLATION, Canister.>

### C: DISASSEMBLY

Disconnect the drain tube from the leak check valve assembly.

#### NOTE:

Disconnect the quick connector as shown in the figure.

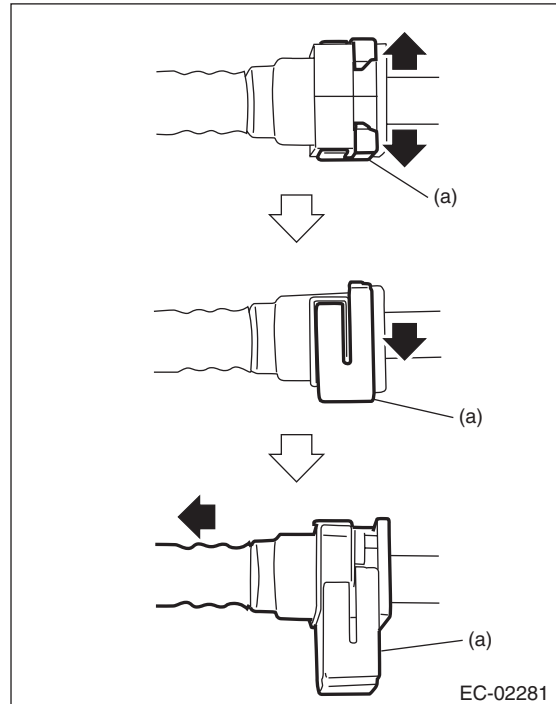

(a) Retainer

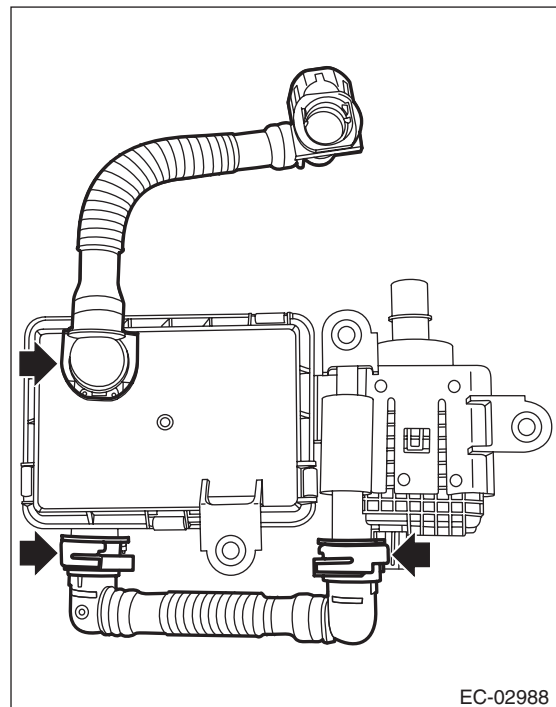

EC(w/o STI)-20

Brought to you by Ebay Seller "SubaruManuals"

# Leak Check Valve Assembly

EMISSION CONTROL (AUX. EMISSION CONTROL DEVICES)

## D: ASSEMBLY

Assemble the parts in the reverse order of disassembly while being careful of the following.

- Connect the quick connector as shown in the figure.

### CAUTION:

- Check that there is no damage or dust on the quick connector. If necessary, clean the seal surface of the pipe.
- When connecting the quick connector, securely insert the pipe all the way before locking the retainer.
- When it is difficult to lock the retainer, make sure that the pipe is securely inserted.
- Make sure that the quick connector is securely connected.

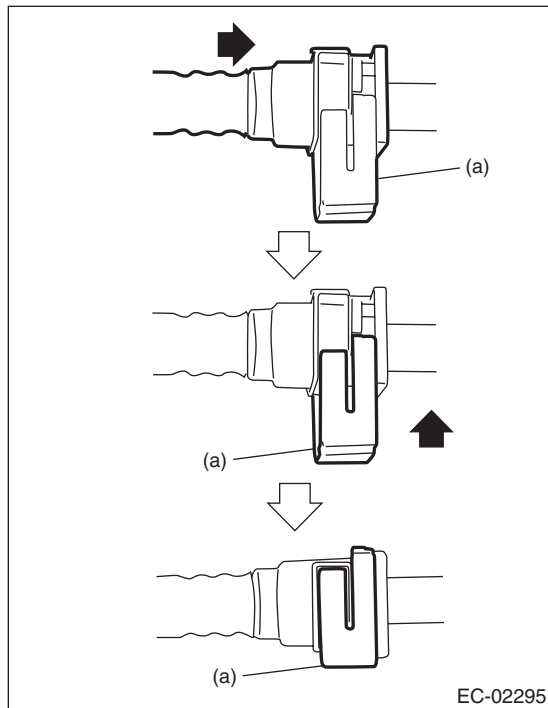

(a) Retainer

## E: INSPECTION

### 1. CHECK SWITCHING VALVE

- 1) Check the resistance between switching valve terminals.

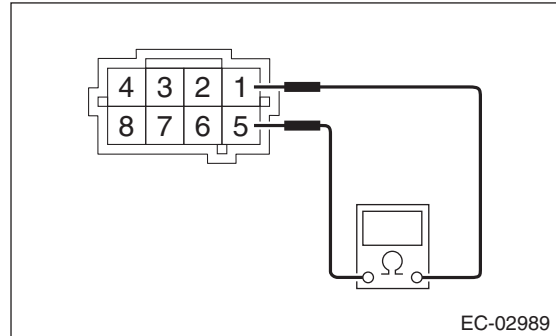

Terminal No.	Standard
1 and 5	$27^{+3}_{-2} \Omega$ (when 20°C (68°F))
	$31 \pm 4 \Omega$ (when 60°C (140°F))

- 2) Disconnect the drain tube from the leak check valve assembly.

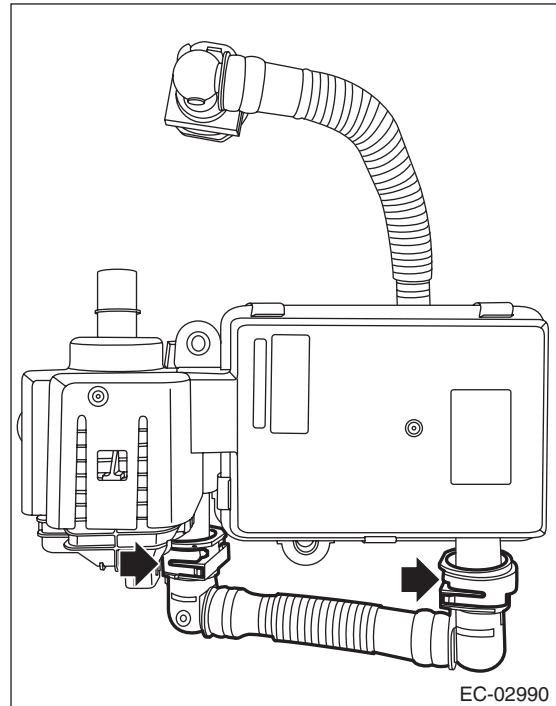

# Leak Check Valve Assembly

EMISSION CONTROL (AUX. EMISSION CONTROL DEVICES)

3) Check that air does not come out from (B) when air is blown into (A).

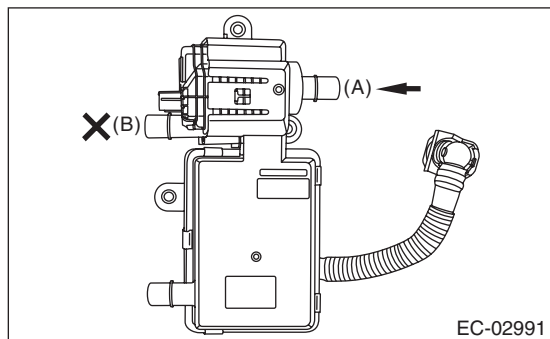

4) Connect the battery positive terminal to the terminal No. 5 and the battery negative terminal to the terminal No. 1. Check that air is discharged from (B), when supplying air to (A).

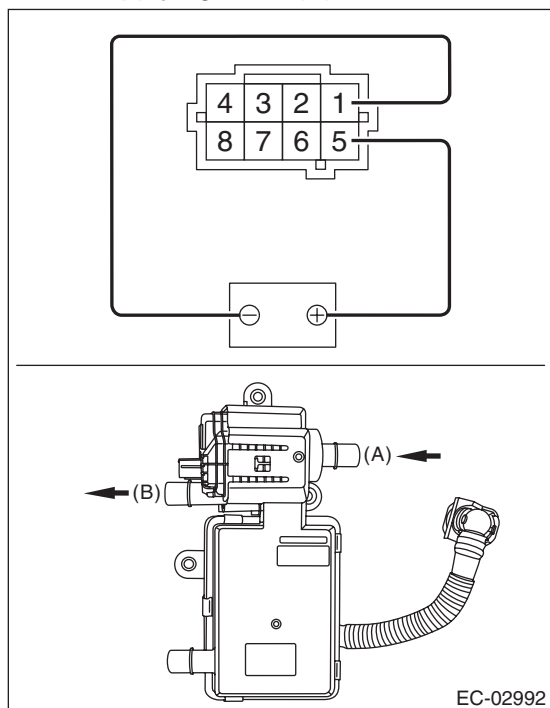

## 2. CHECK VACUUM PUMP

1) Connect the battery positive terminal to terminal No. 3 and the battery ground terminal to terminal No. 4, and inspect the vacuum pump operation.

### CAUTION:

Do not operate the vacuum pump for 5 minutes or more.

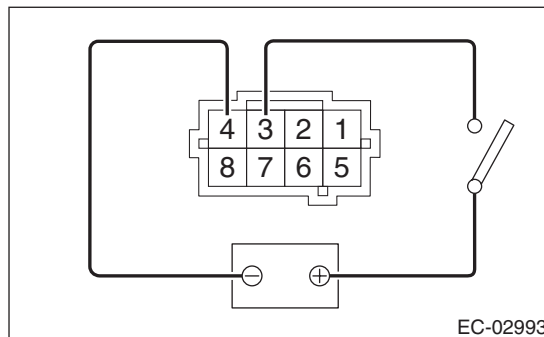

## 3. CHECK PRESSURE SENSOR

1) Connect dry-cell battery positive terminal to terminal No. 6 and dry-cell battery ground terminal to terminal No. 8, circuit tester positive terminal to terminal No. 7 and the circuit tester negative terminal to terminal No. 8.

### NOTE:

- Use new dry-cell batteries.
- Using circuit tester, check the voltage of a single dry-cell battery is 1.6 V or more. And also check the voltage of three batteries in series is between 4.8 V and 5.2 V.

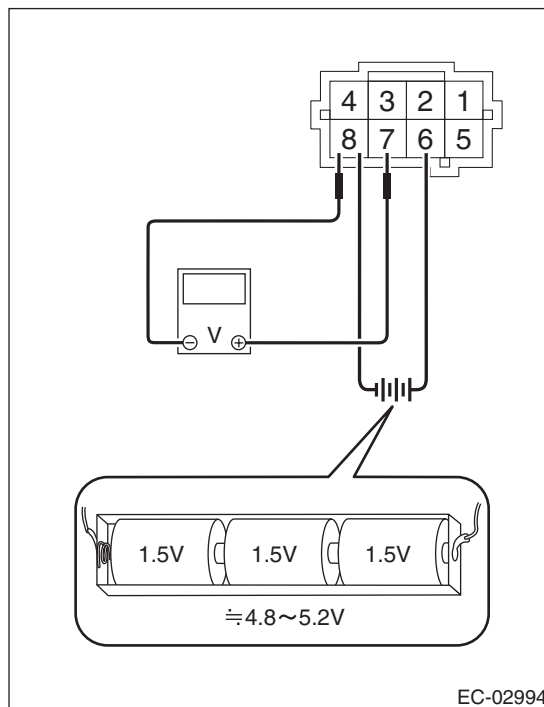

EC(w/o STI)-22

Brought to you by Ebay Seller "SubaruManuals"

# Leak Check Valve Assembly

EMISSION CONTROL (AUX. EMISSION CONTROL DEVICES)

2) Check the voltage at a normal atmospheric pressure.

## NOTE:

The atmospheric pressure at higher altitude is lower than normal. Therefore, the voltage is lower than the standard value.

Terminal No.	Standard
7 (+) and 8 (-)	Approx. 3.5 V (when 25°C (77°F))

3) Connect the battery positive terminal to terminal No. 3 and the battery ground terminal to terminal No. 4, and check that there is a voltage drop from the voltage measured in step 2) when the vacuum pump is operated.

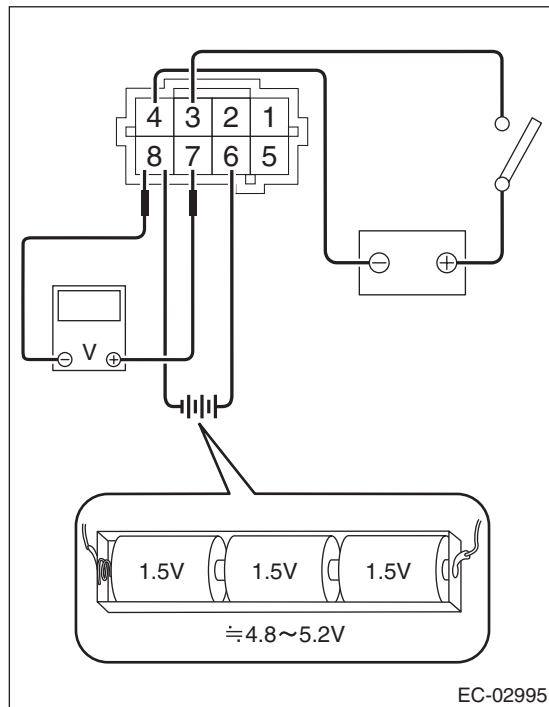

## 4. OTHER INSPECTIONS

Check that the drain tube has no cracks, damage or loose part.

# Drain Separator

EMISSION CONTROL (AUX. EMISSION CONTROL DEVICES)

## 12. Drain Separator

### A: REMOVAL

- 1) Lift up the vehicle.
- 2) Remove the rear differential. <Ref. to DI-22, REMOVAL, Rear Differential (T-type).>
- 3) Disconnect the drain hose from the connector.

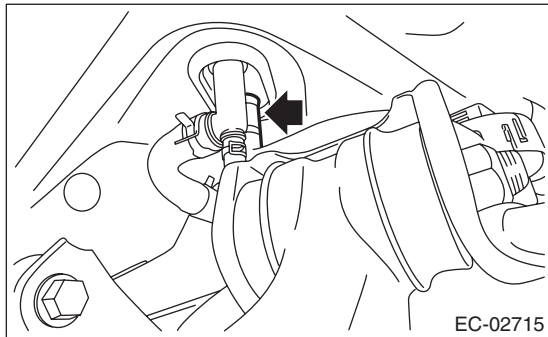

- 4) Remove the drain separator from the vehicle.

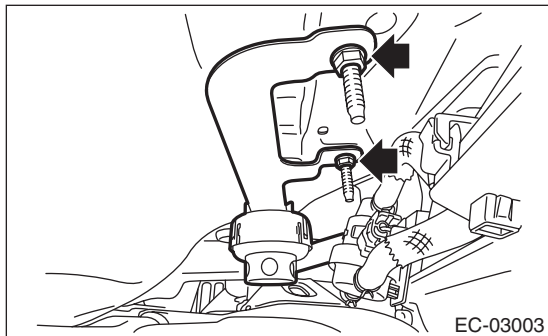

### B: INSTALLATION

Install in the reverse order of removal.

#### **Tightening torque:**

**7.5 N·m (0.8 kgf·m, 5.5 ft·lb)**

### C: DISASSEMBLY

- 1) Remove the drain hose from the drain separator.

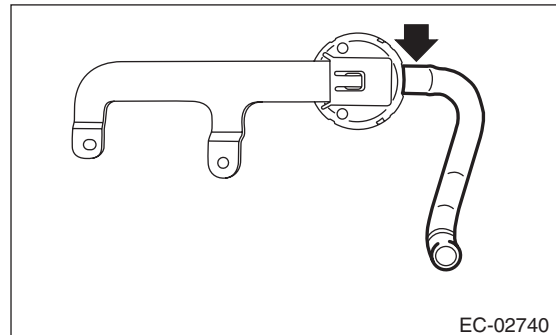

- 2) Lift up the claw (A) of the drain separator and slide the drain separator in the direction of the arrow to remove the drain separator.

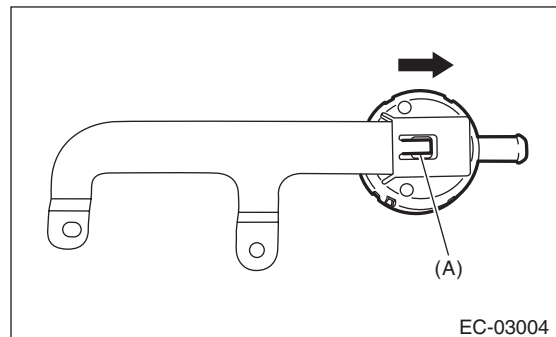

### D: ASSEMBLY

Assemble in the reverse order of disassembly.

### E: INSPECTION

- 1) Check that the drain separator and drain separator bracket have no deformation, crack, or other damage.
- 2) Check that the drain hose has no crack, damage, or looseness.
- 3) Check that no foreign substances are clogged in the drain separator.



# PCV Hose Assembly

EMISSION CONTROL (AUX. EMISSION CONTROL DEVICES)

## 13.PCV Hose Assembly

### A: REMOVAL

#### CAUTION:

**Do not remove unless the hose and the diagnostics connector are broken.**

1) Disconnect the connector (A) from the PCV hose assembly A, and remove the PCV hose assembly A from the rocker cover RH.

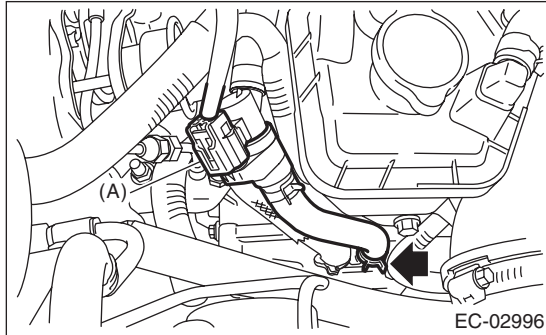

2) Disconnect the connector (A) from the PCV hose assembly B, and remove the PCV hose assembly B from the rocker cover LH.

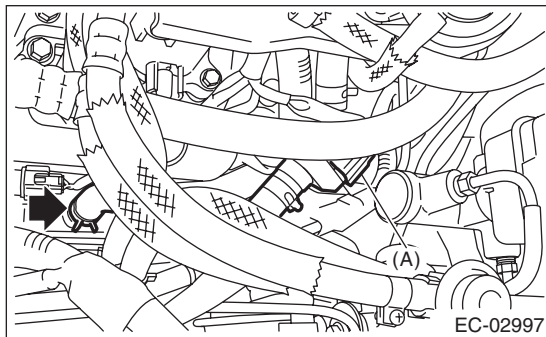

3) Remove the intake manifold. <Ref. to FU(w/o STI)-18, REMOVAL, Intake Manifold.>

4) Remove the turbocharger. <Ref. to IN(w/o STI)-14, REMOVAL, Turbocharger.>

5) Remove the intake duct. <Ref. to IN(w/o STI)-11, REMOVAL, Intake Duct.>

6) Remove the PCV hose assembly C from the intake duct and the cylinder block RH.

#### NOTE:

Pinch the clamp of the PCV hose assembly C by fitting the cut out in the ST with the protrusion on the clamp as shown in the figure, and unlock the clamp.

ST 18353AA000 CLAMP PLIERS

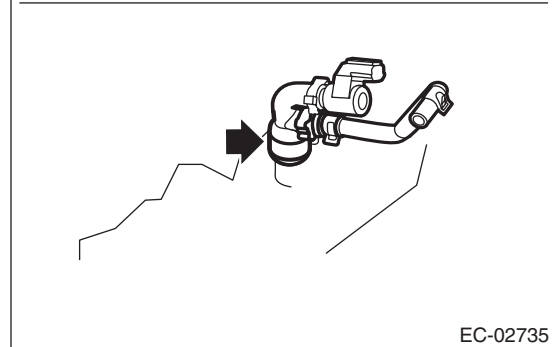
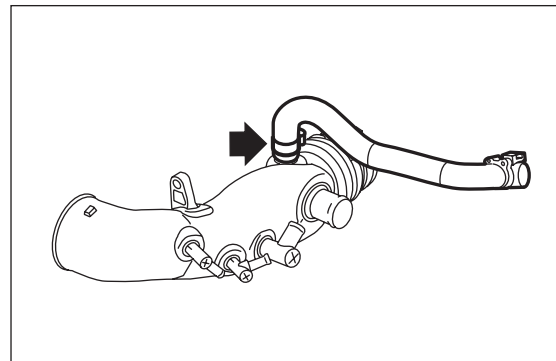
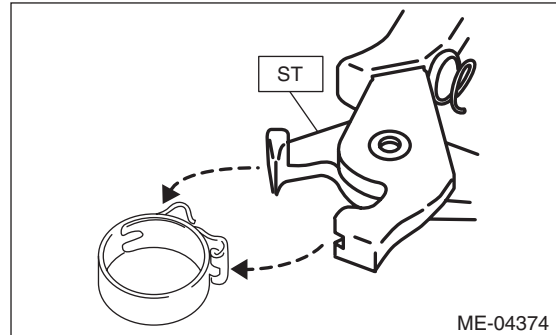

# PCV Hose Assembly

EMISSION CONTROL (AUX. EMISSION CONTROL DEVICES)

## B: INSTALLATION

1) Install the PCV hose assembly C to the intake duct and the cylinder block RH.

### NOTE:

Use a new clamp for the PCV hose assembly C, fit the cut out in the ST with the protrusion on the clamp as shown in the figure, and lock the clamp.

ST 18353AA000 CLAMP PLIERS

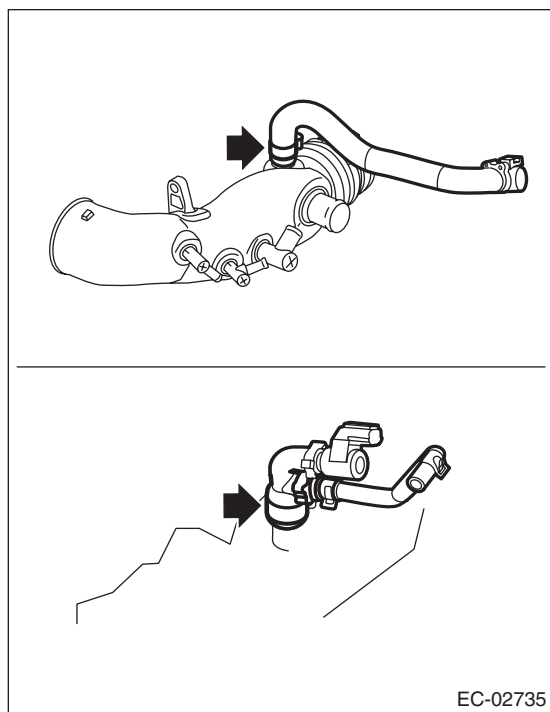
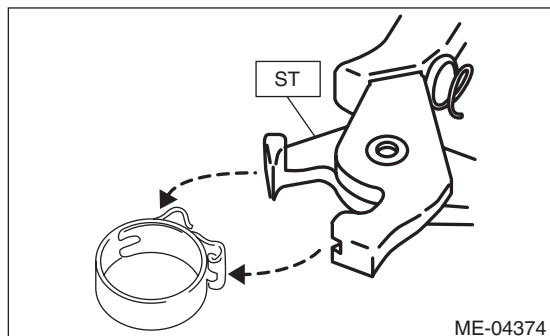

2) Install the intake duct. <Ref. to IN(w/o STI)-11, INSTALLATION, Intake Duct.>

3) Install the turbocharger. <Ref. to IN(w/o STI)-15, INSTALLATION, Turbocharger.>

4) Install the intake manifold. <Ref. to FU(w/o STI)-22, INSTALLATION, Intake Manifold.>

5) Install the PCV hose assembly B to the rocker cover LH, and connect the connector (A) to the PCV hose assembly B.

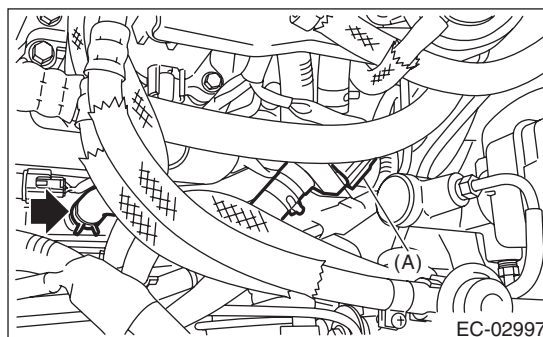

6) Install the PCV hose assembly A to the rocker cover RH, and connect the connector (A) to the PCV hose assembly A.

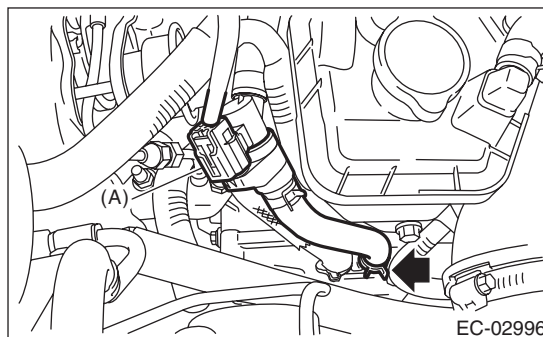

## C: INSPECTION

### 1. DIAGNOSIS CONNECTOR

1) Check that the diagnosis connector has no deformation, cracks and any other damage.

2) Check the resistance between the diagnosis connector terminals.

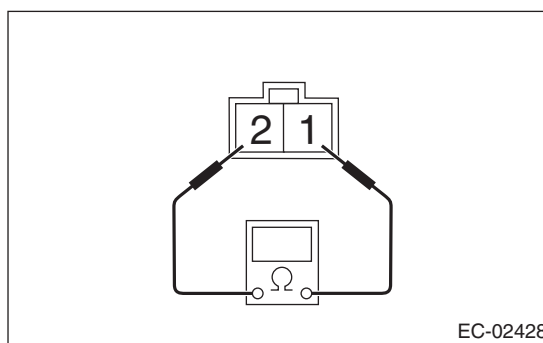

Terminal No.	Standard
1 and 2	Less than 1 $\Omega$

### 2. OTHER INSPECTIONS

1) Check that the PCV connector has no deformation, cracks or other damages.

2) Check that the hose has no cracks, damage or loose part.

EC(w/o STI)-26

Brought to you by Ebay Seller "SubaruManuals"

# PCV Valve

EMISSION CONTROL (AUX. EMISSION CONTROL DEVICES)

## 14.PCV Valve

### A: REMOVAL

#### CAUTION:

**Do not remove unless the PCV valve is broken.**

- 1) Remove the intake manifold. <Ref. to FU(w/o STI)-18, REMOVAL, Intake Manifold.>
- 2) Remove the secondary air combination valve RH. <Ref. to EC(w/o STI)-30, REMOVAL, Secondary Air Combination Valve.>
- 3) Disconnect the vacuum hose (A) from the PCV valve and remove the PCV valve from the PCV connector.

#### NOTE:

Pinch the clamp of the PCV connector by fitting the cut out in the ST with the protrusion on the clamp as shown in the figure, and unlock the clamp.

ST 18353AA000 CLAMP PLIERS

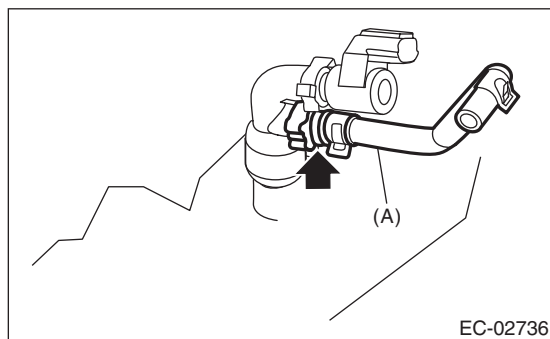
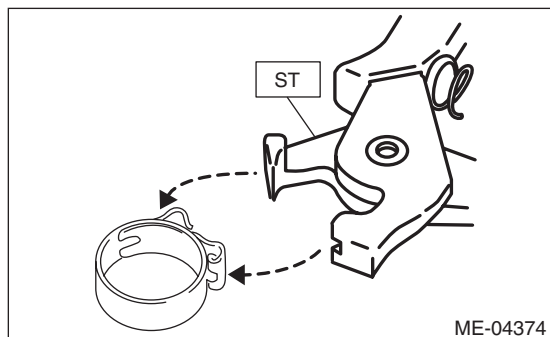

### B: INSTALLATION

- 1) Install the PCV valve to the PCV connector and connect the vacuum hose (A) to the PCV valve.

#### NOTE:

Use a new clamp for the PCV connector clamp, fit the cut out in the ST with the protrusion on the clamp as shown in the figure, and lock the clamp.

ST 18353AA000 CLAMP PLIERS

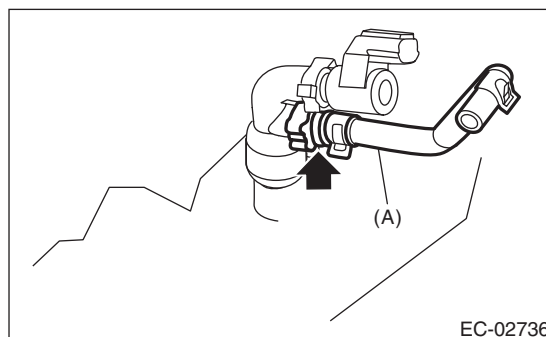
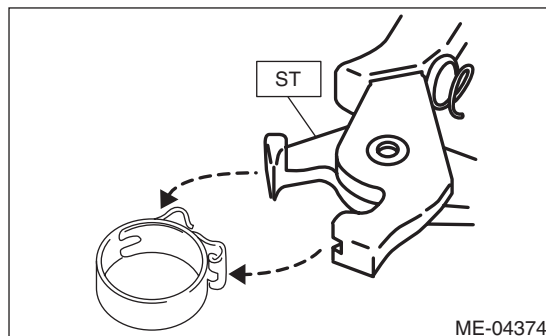

- 2) Install the secondary air combination valve RH. <Ref. to EC(w/o STI)-31, INSTALLATION, Secondary Air Combination Valve.>
- 3) Install the intake manifold. <Ref. to FU(w/o STI)-22, INSTALLATION, Intake Manifold.>
- 4) Install the collector cover.

EC(w/o STI)-27

Brought to you by Ebay Seller "SubaruManuals"

# PCV Valve

EMISSION CONTROL (AUX. EMISSION CONTROL DEVICES)

---

## C: INSPECTION

### 1. PCV VALVE

- 1) Check that the PCV valve has no deformation, cracks or other damages.
- 2) Check that air is discharged from (B) when air is blown into (A).

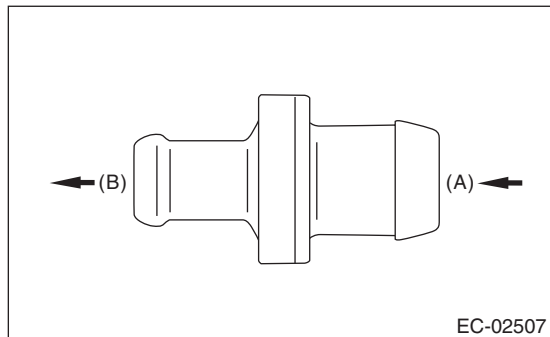

- 3) Check that air does not come out from (B) when air is blown into (A).

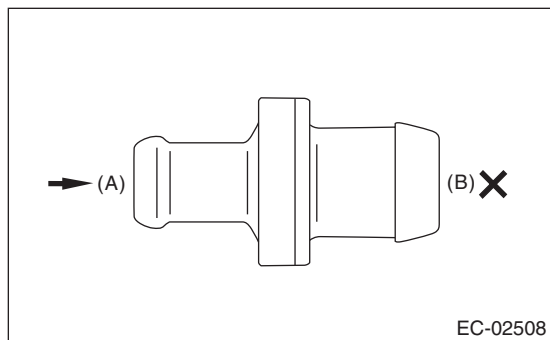

### 2. OTHER INSPECTIONS

Check the vacuum hose for cracks, damage or looseness.

# Secondary Air Pump

EMISSION CONTROL (AUX. EMISSION CONTROL DEVICES)

## 15. Secondary Air Pump

### A: REMOVAL

1) Disconnect the ground cable from battery.

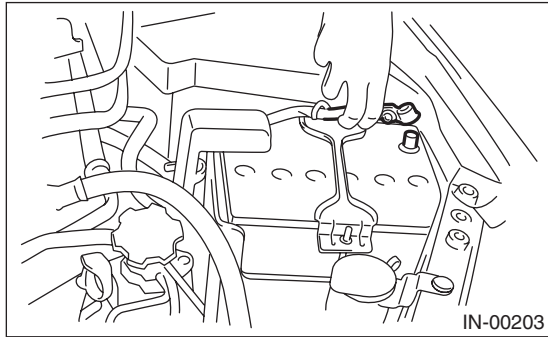

2) Remove the clip (A) which holds the harness on the harness stay and remove the bolt (B) which holds the secondary air pump on the vehicle.

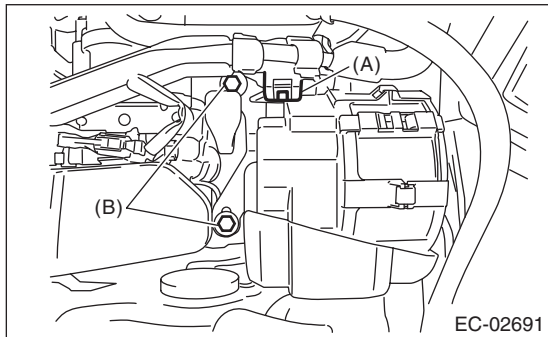

3) Disconnect the connector (A) and air duct (B) from secondary air pump and remove the secondary air pump.

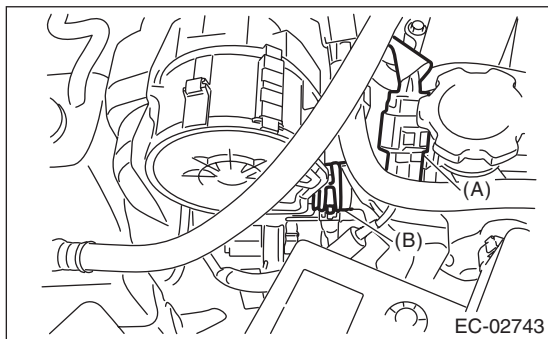

### B: INSTALLATION

Install in the reverse order of removal.

**Tightening torque:**

**19 N·m (1.9 kgf·m, 14.0 ft·lb)**

### C: INSPECTION

#### 1. SECONDARY AIR PUMP

1) Check that the secondary air pump has no deformation, cracks or other damages.

2) Connect battery positive terminal to the terminal No. 2 and battery negative terminal to the terminal No. 1, and inspect the secondary air pump operation.

#### CAUTION:

**Do not operate the secondary air pump continuously for 80 seconds or more.**

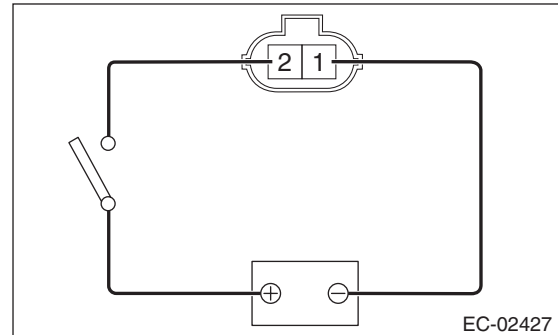

#### 2. OTHER INSPECTIONS

Check that the air duct has no cracks, damage or loose part.

# Secondary Air Combination Valve

EMISSION CONTROL (AUX. EMISSION CONTROL DEVICES)

## 16. Secondary Air Combination Valve

### A: REMOVAL

#### 1. SECONDARY AIR COMBINATION VALVE LH

1) Disconnect the ground cable from battery.

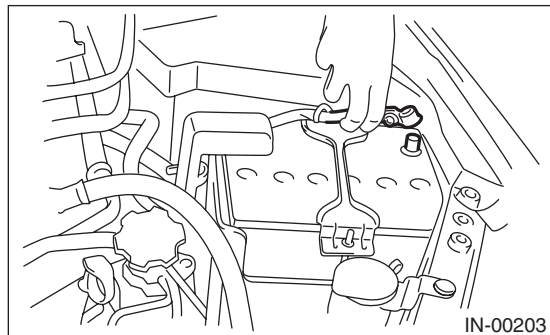

2) Remove the intercooler. <Ref. to IN(w/o STI)-12, REMOVAL, Intercooler.>

3) Disconnect the connector from the secondary air combination valve LH.

4) Disconnect the air duct A.

5) Remove the secondary air pipe LH.

6) Remove the secondary air combination valve LH.

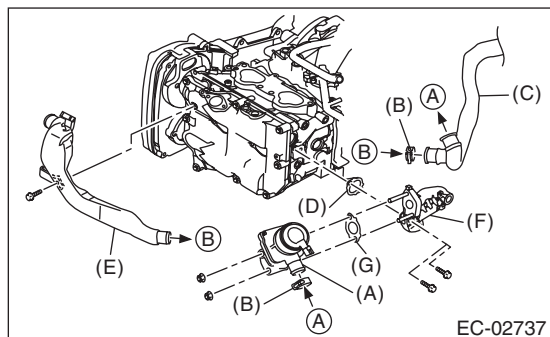

- (A) Secondary air combination valve LH
- (B) Clip
- (C) Air duct A
- (D) Gasket
- (E) Air duct B
- (F) Secondary air pipe LH
- (G) Gasket

#### 2. SECONDARY AIR COMBINATION VALVE RH

1) Disconnect the ground cable from battery.

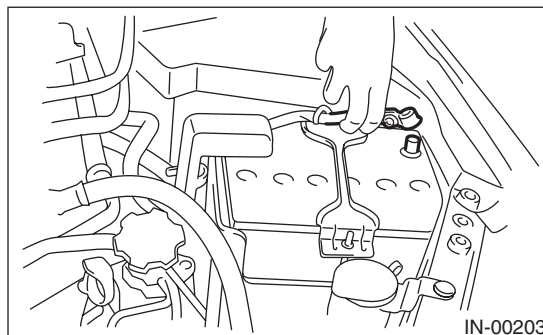

2) Remove the intercooler. <Ref. to IN(w/o STI)-12, REMOVAL, Intercooler.>

3) Remove the intake manifold. <Ref. to FU(w/o STI)-18, REMOVAL, Intake Manifold.>

4) Disconnect the air duct A.

5) Disconnect the secondary air pipe RH.

6) Remove the secondary air combination valve RH.

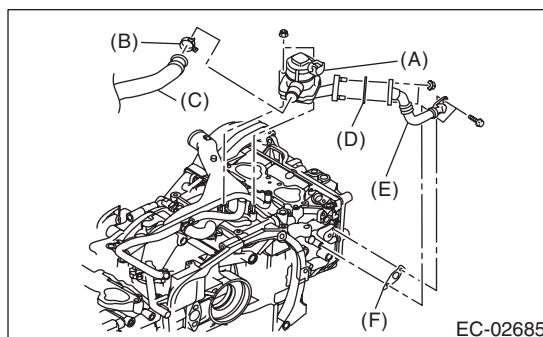

- (A) Secondary air combination valve RH
- (B) Clip
- (C) Air duct A
- (D) Gasket
- (E) Secondary air pipe RH
- (F) Gasket

# Secondary Air Combination Valve

EMISSION CONTROL (AUX. EMISSION CONTROL DEVICES)

## B: INSTALLATION

### 1. SECONDARY AIR COMBINATION VALVE LH

Install in the reverse order of removal.

NOTE:

Use a new gasket.

**Tightening torque:**

**T1: 6.4 N·m (0.7 kgf-m, 4.7 ft-lb)**

**T2: 9 N·m (0.9 kgf-m, 6.6 ft-lb)**

**T3: 19 N·m (1.9 kgf-m, 14.0 ft-lb)**

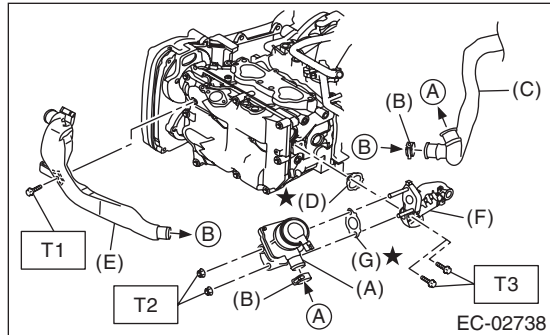

- (A) Secondary air combination valve LH
- (B) Clip
- (C) Air duct A
- (D) Gasket
- (E) Air duct B
- (F) Secondary air pipe LH
- (G) Gasket

### 2. SECONDARY AIR COMBINATION VALVE RH

Install in the reverse order of removal.

NOTE:

Use a new gasket.

**Tightening torque:**

**9 N·m (0.9 kgf-m, 6.6 ft-lb)**

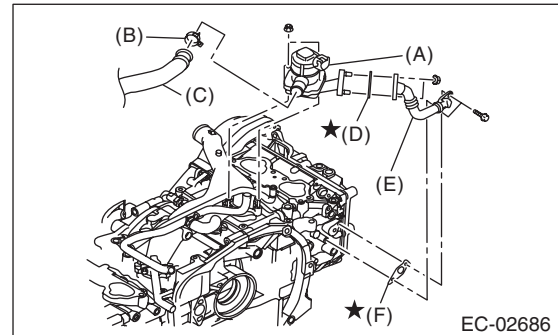

- (A) Secondary air combination valve RH
- (B) Clip
- (C) Air duct A
- (D) Gasket
- (E) Secondary air pipe RH
- (F) Gasket



# Secondary Air Combination Valve

EMISSION CONTROL (AUX. EMISSION CONTROL DEVICES)

## C: INSPECTION

### 1. SECONDARY AIR COMBINATION VALVE LH

- 1) Check that the secondary air combination valve LH has no deformation, cracks or other damages.
- 2) Check the resistance between the terminals of secondary air combination valve LH.

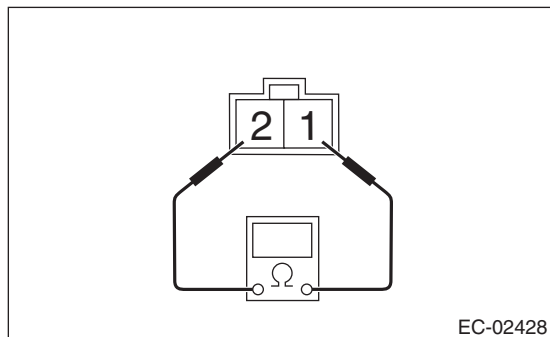

Terminal No.	Standard
1 and 2	$5.0 \pm 0.5 \Omega$ (when 20°C (68°F))

- 3) Check that air does not come out from (B) when air is blown into (A).

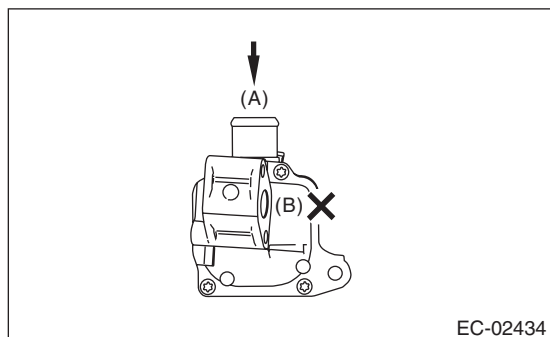

- 4) Connect the battery positive terminal to the terminal No. 2 and the battery negative terminal to the terminal No. 1. Check that air is discharged from (B), when supplying air to (A).

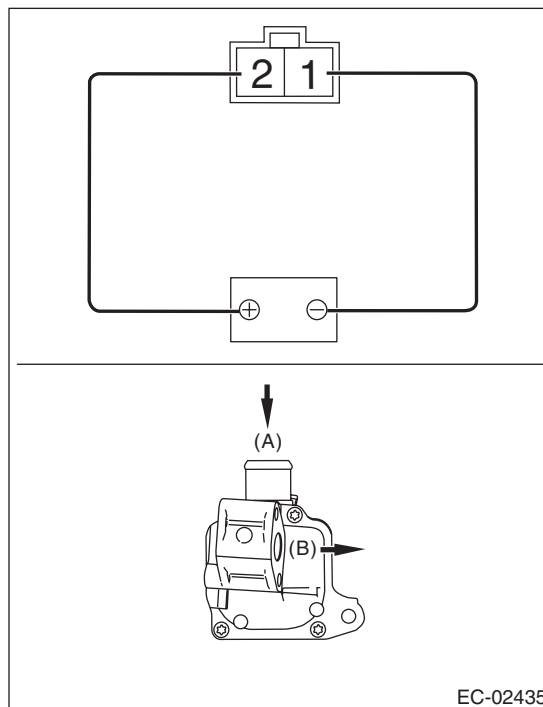

### 2. SECONDARY AIR COMBINATION VALVE RH

- 1) Check that the secondary air combination valve RH has no deformation, cracks or other damages.
- 2) Check the resistance between the terminals of secondary air combination valve RH.

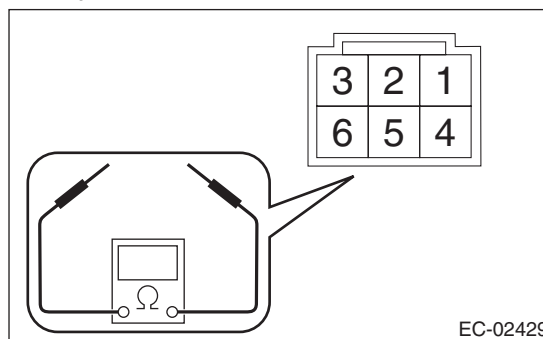

Terminal No.	Standard
4 and 6	$5.0 \pm 0.5 \Omega$ (when 20°C (68°F))
2 and 3	15 kΩ or less
1 and 2	4.5 kΩ or less



# Secondary Air Combination Valve

EMISSION CONTROL (AUX. EMISSION CONTROL DEVICES)

3) Check that air does not come out from (B) when air is blown into (A).

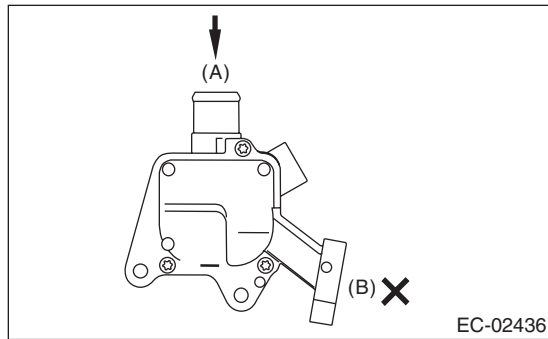

4) Connect the battery positive terminal to the terminal No. 6 and the battery negative terminal to the terminal No. 4. Check that air is discharged from (B), when supplying air to (A).

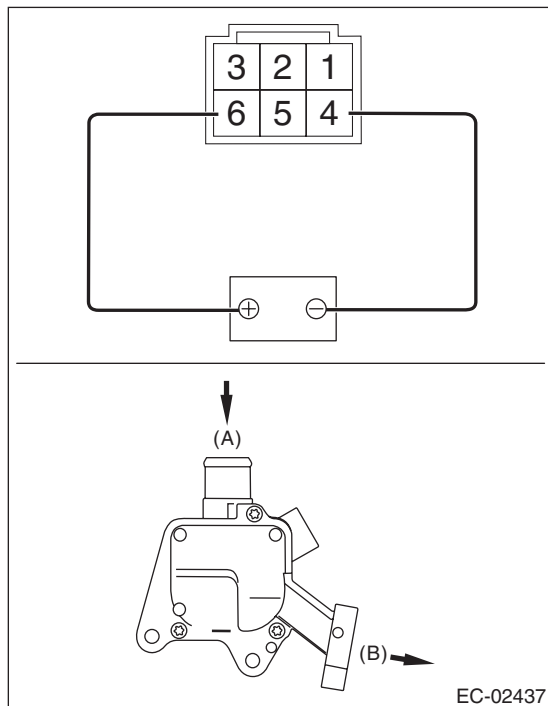

### 3. OTHER INSPECTIONS

- 1) Check that the secondary air pipe has no deformation, cracks or other damages.
- 2) Check that the air duct has no cracks, damage or loose part.

EC(w/o STI)-33

Brought to you by Ebay Seller "SubaruManuals"

# Secondary Air Combination Valve

EMISSION CONTROL (AUX. EMISSION CONTROL DEVICES)

---

**EC(w/o STI)-34**

Brought to you by Ebay Seller "SubaruManuals"

# INTAKE (INDUCTION)

# *IN(w/o STI)*

---

	<b>Page</b>
1. General Description .....	2
2. Air Cleaner Element .....	7
3. Air Cleaner Case .....	8
4. Air Intake Duct .....	10
5. Intake Duct .....	11
6. Intercooler .....	12
7. Turbocharger .....	14
8. Air By-pass Valve .....	18

# General Description

INTAKE (INDUCTION)

## 1. General Description

### A: COMPONENT

#### 1. AIR CLEANER

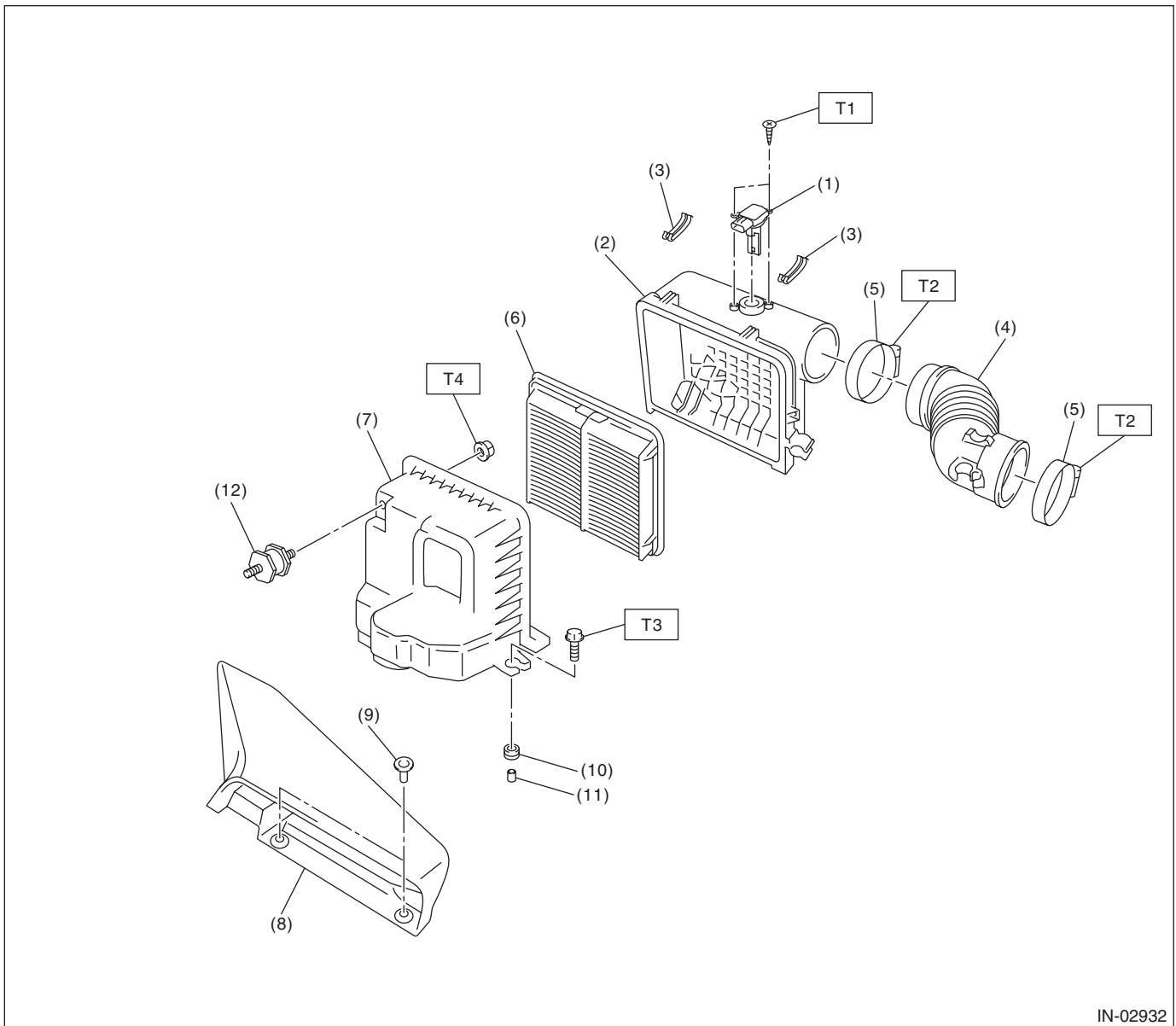

IN-02932

- |   |                              |
|---|------------------------------|
| (1) Mass air flow and intake air temperature sensor | (7) Air cleaner case (Front) |
| (2) Air cleaner case (Rear)                         | (8) Air intake duct          |
| (3) Clip  | (9) Clip                     |
| (4) Air intake boot                                 | (10) Cushion                 |
| (5) Clamp   | (11) Spacer                  |
| (6) Air cleaner element                             | (12) Cushion                 |

**Tightening torque: N-m (kgf-m, ft-lb)**

**T1: 1 (0.1, 0.7)**

**T2: 2.5 (0.3, 1.8)**

**T3: 6 (0.6, 4.4)**

**T4: 7.5 (0.8, 5.5)**

**IN(w/o STI)-2**

Brought to you by Ebay Seller "SubaruManuals"

### 2. INTAKE DUCT

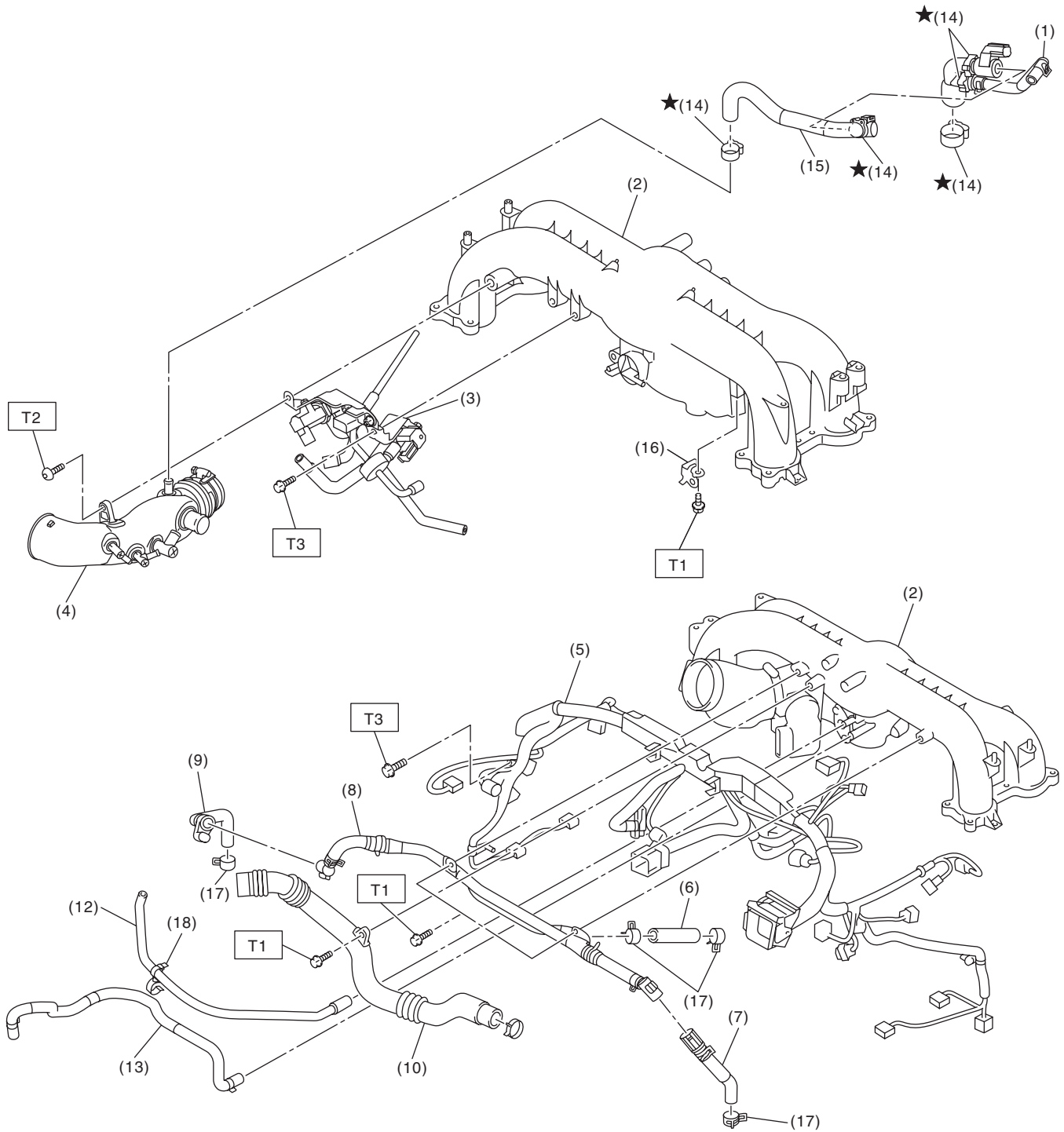

IN-03068

# General Description

## INTAKE (INDUCTION)

- |                                 |                                |           |
|---------------------------------|--------------------------------|-----------|
| (1) PCV hose ASSY A             | (9) PCV hose ASSY C            | (17) Clip |
| (2) Intake manifold             | (10) Air by-pass pipe          | (18) Clip |
| (3) Solenoid valve bracket ASSY | (11) Clip                      |           |
| (4) Intake duct                 | (12) Vacuum hose               |           |
| (5) Engine harness ASSY         | (13) Brake booster vacuum hose |           |
| (6) Vacuum hose                 | (14) Clamp                     |           |
| (7) PCV hose ASSY B             | (15) PCV hose ASSY D           |           |
| (8) PCV pipe ASSY               | (16) Solenoid valve bracket    |           |

**Tightening torque: N·m (kgf·m, ft·lb)**

**T1: 6.4 (0.7, 4.7)**

**T2: 17 (1.7, 12.5)**

**T3: 19 (1.9, 14.0)**

## 3. INTERCOOLER

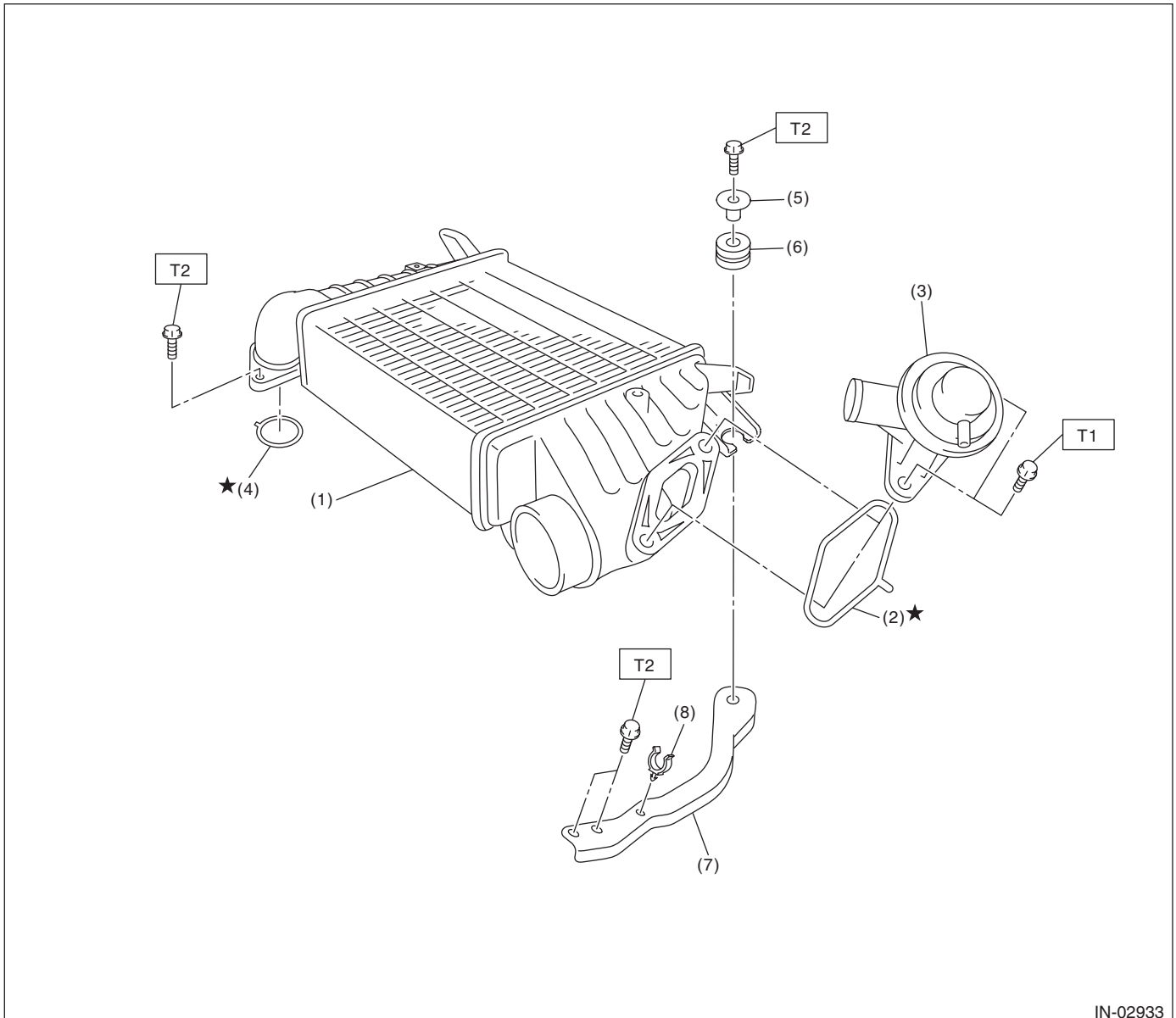

IN-02933

- |                       |                      |
|-----------------------|----------------------|
| (1) Intercooler       | (5) Spacer           |
| (2) O-ring            | (6) Cushion          |
| (3) Air by-pass valve | (7) Intercooler stay |
| (4) O-ring            | (8) Clip             |

**Tightening torque: N·m (kgf·m, ft·lb)**

**T1: 6.5 (0.7, 4.8)**

**T2: 16 (1.6, 11.8)**

**IN(w/o STI)-4**

Brought to you by Ebay Seller "SubaruManuals"

## 4. TURBOCHARGER

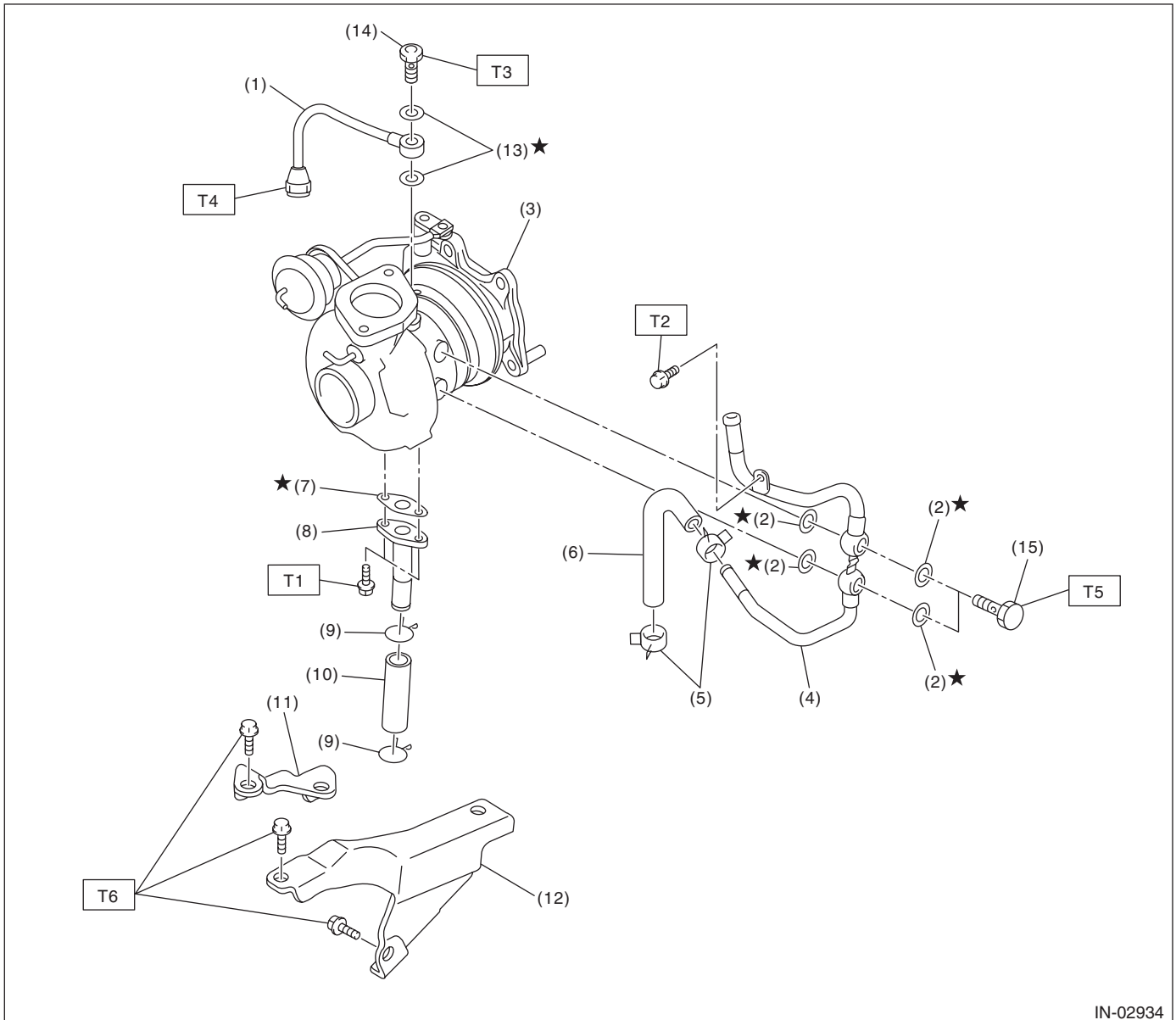

IN-02934

- |                         |                           |
|-------------------------|---------------------------|
| (1) Oil inlet pipe      | (9) Clip                  |
| (2) Gasket              | (10) Oil outlet hose      |
| (3) Turbocharger        | (11) Turbocharger stay RH |
| (4) Water pipe          | (12) Turbocharger stay LH |
| (5) Clip                | (13) Gasket               |
| (6) Engine coolant hose | (14) Union bolt A         |
| (7) Gasket              | (15) Union bolt B         |
| (8) Oil outlet pipe     |                           |

**Tightening torque: N·m (kgf·m, ft·lb)**

**T1: 4.9 (0.5, 3.6)**

**T2: 7.8 (0.8, 5.8)**

**T3: 16 (1.6, 11.8)**

**T4: 20 (2.0, 14.8)**

**T5: 23 (2.3, 17.0)**

**T6: 33 (3.4, 24.3)**

## General Description

INTAKE (INDUCTION)

---

### B: CAUTION

- Wear appropriate work clothing, including a cap, protective goggles and protective shoes when performing any work.
- Remove contamination including dirt and corrosion before removal, installation or disassembly.
- Keep the disassembled parts in order and protect them from dust and dirt.
- Before removal, installation or disassembly, be sure to clarify the failure. Avoid unnecessary removal, installation, disassembly and replacement.
- Vehicle components are extremely hot after driving. Be wary of receiving burns from heated parts.
- Be sure to tighten fasteners including bolts and nuts to the specified torque.
- Place shop jacks or rigid racks at the specified points.
- Before disconnecting connectors of sensors or units, be sure to disconnect the ground cable from battery.

### C: PREPARATION TOOL

#### 1. GENERAL TOOL

TOOL NAME	REMARKS
Mighty Vac	Used for checking waste gate actuator and air by-pass valve.

**IN(w/o STI)-6**

Brought to you by Ebay Seller "SubaruManuals"



## 2. Air Cleaner Element

### A: REMOVAL

- 1) Disconnect the ground cable from battery.

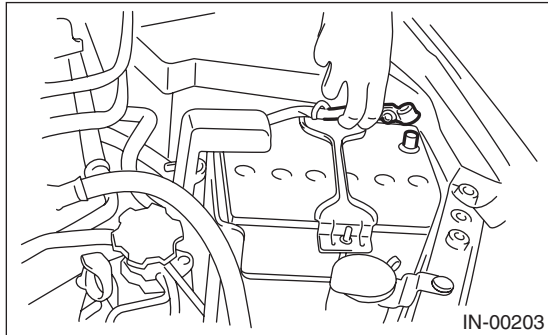

- 2) Remove the air intake duct. <Ref. to IN(w/o STI)-10, REMOVAL, Air Intake Duct.>

- 3) Disconnect the connector (A) from air flow and intake air temperature sensor.

- 4) Remove the clips (B) from the air cleaner case (front).

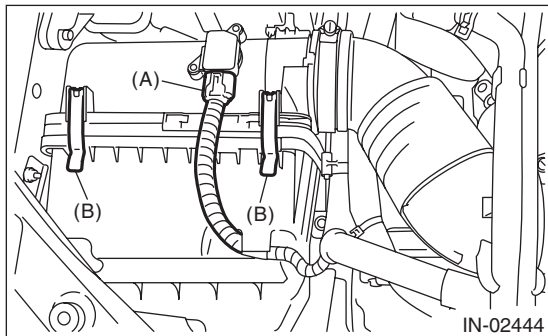

- 5) Open the air cleaner case, and remove the air cleaner element.

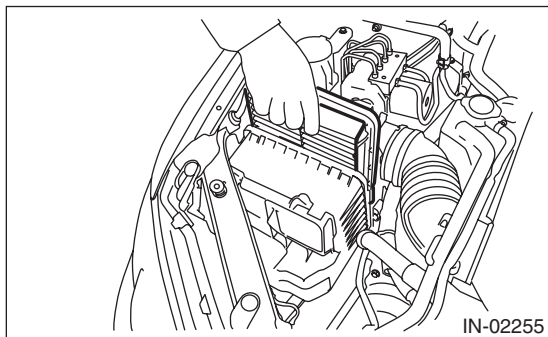

### B: INSTALLATION

Install in the reverse order of removal.

#### CAUTION:

Be sure to use **SUBARU** genuine air cleaner element depending on the engine type when replacing the air cleaner elements. Using other air cleaner element may affect the engine performance.

#### NOTE:

- Check that there are no foreign objects in the air cleaner case.
- If the protrusion of the air cleaner case (rear) is removed when removing the air cleaner element, align the protrusion of the air cleaner case (rear) to the hole on the air cleaner case (front) to install.

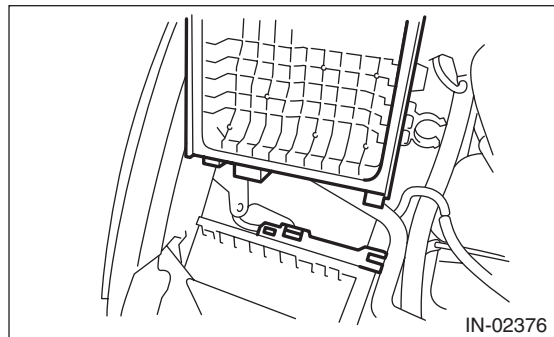

### C: INSPECTION

- 1) Check that the air cleaner element has no deformation, cracks or other damages.
- 2) Check the air cleaner element for excessive dirt.

# Air Cleaner Case

INTAKE (INDUCTION)

## 3. Air Cleaner Case

### A: REMOVAL

- 1) Disconnect the ground cable from battery.

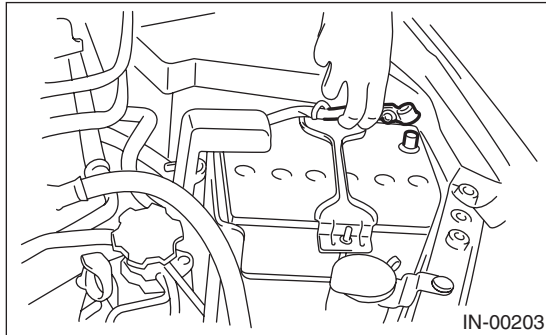

- 2) Remove the air intake duct. <Ref. to IN(w/o STI)-10, REMOVAL, Air Intake Duct.>
- 3) Disconnect the connector (A) from air flow and intake air temperature sensor.
- 4) Loosen the clamp (B) which holds the air intake boot.
- 5) Remove the clip (C) from the air cleaner case (front).

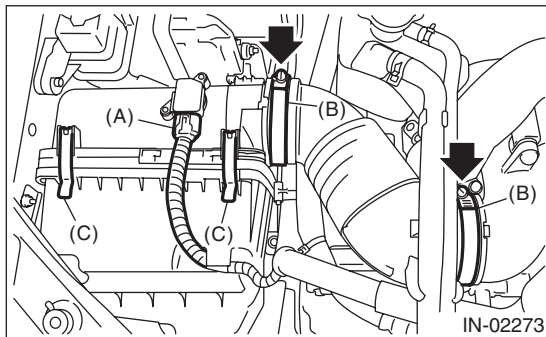

- 6) Remove the air cleaner case (rear) and air intake boot.
- 7) Remove the air cleaner element.
- 8) Remove bolts (A) and nuts (B) which secure the air cleaner case (front) to the body, and remove the air cleaner case (front).

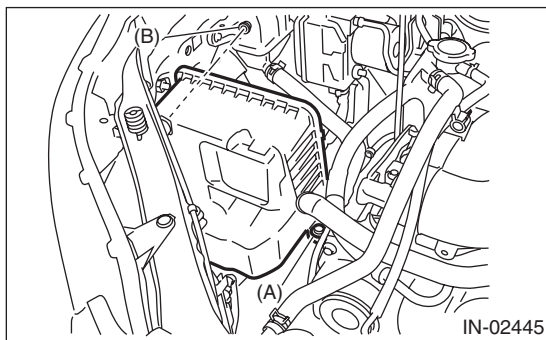

### B: INSTALLATION

- 1) Install the bolt (A) and nut (B) which secure the air cleaner case (front) to the body.

#### Tightening torque:

**Bolt (A)**

**6 N·m (0.6 kgf-m, 4.4 ft-lb)**

**Nut (B)**

**7.5 N·m (0.8 kgf-m, 5.5 ft-lb)**

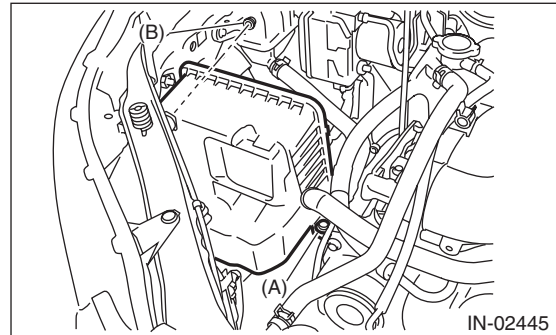

- 2) Install the air cleaner element.
- 3) Install the air cleaner case (rear) and air intake boot.

#### NOTE:

When installing the air cleaner case (rear), align the protrusion of the air cleaner case (rear) to the hole on the air cleaner case (front) to install.

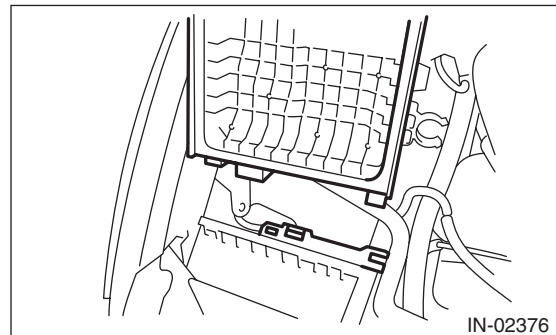

#### Tightening torque:

**2.5 N·m (0.3 kgf-m, 1.8 ft-lb)**

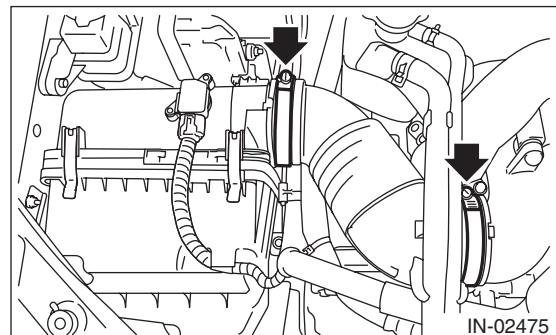

- 4) Install the clip (B) to the air cleaner case (front).

IN(w/o STI)-8

Brought to you by Ebay Seller "SubaruManuals"

- 5) Connect the connector (A) to the mass air flow and intake air temperature sensor.

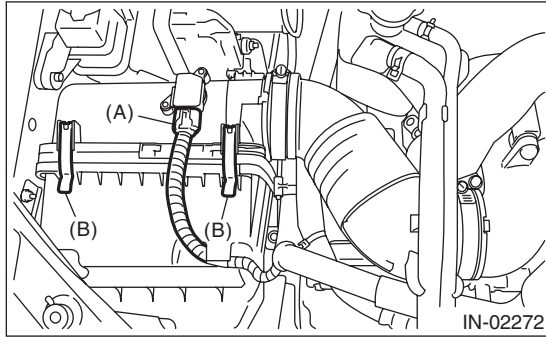

- 6) Install the air intake duct. <Ref. to IN(w/o STI)-10, INSTALLATION, Air Intake Duct.>  
7) Connect the battery ground terminal.

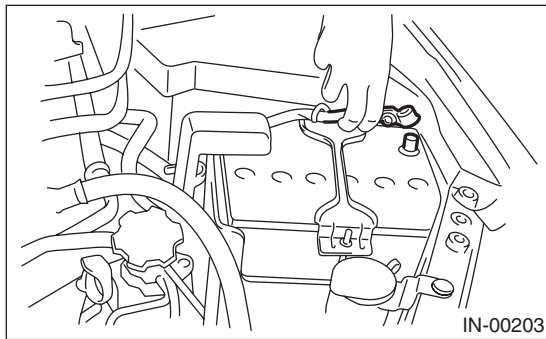

## C: INSPECTION

- 1) Check that the air cleaner case has no deformation, cracks or other damages.
- 2) Check that the air intake boot has no cracks, damage or loose part.

# Air Intake Duct

INTAKE (INDUCTION)

---

## 4. Air Intake Duct

### A: REMOVAL

Remove the clip which secures the air intake duct, and remove the air intake duct.

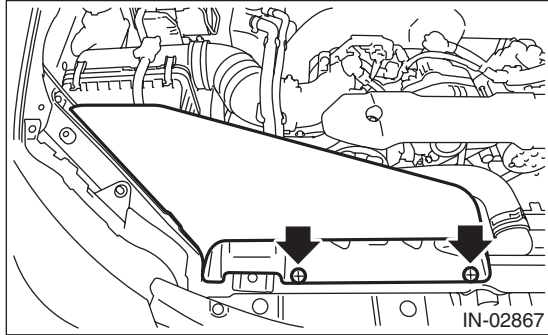

### B: INSTALLATION

Install in the reverse order of removal.

### C: INSPECTION

- 1) Check that the air intake duct has no deformation, cracks or other damages.
- 2) Inspect that no foreign objects are mixed in the air intake duct.

## 5. Intake Duct

### A: REMOVAL

- 1) Disconnect the ground cable from battery.

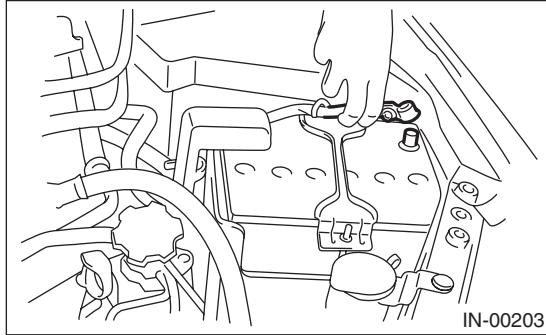

- 2) Remove the intake manifold. <Ref. to FU(w/o STI)-18, REMOVAL, Intake Manifold.>

- 3) Remove the sensor, engine harness and fuel pipe from the intake manifold. <Ref. to FU(w/o STI)-26, DISASSEMBLY, Intake Manifold.>

- 4) Remove the intake duct from intake manifold.

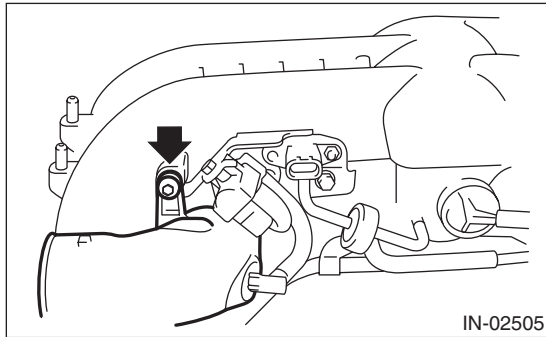

### B: INSTALLATION

Install in the reverse order of removal.

#### *Tightening torque:*

**17 N·m (1.7 kgf·m, 12.5 ft·lb)**

### C: INSPECTION

Check that the intake duct has no deformation, cracks or other damages.



# Intercooler

## INTAKE (INDUCTION)

### 6. Intercooler

#### A: REMOVAL

- 1) Disconnect the air by-pass pipe (A) and vacuum hose (B) from the air by-pass valve.
- 2) Loosen the clamp (C) which holds the intake duct to intercooler.

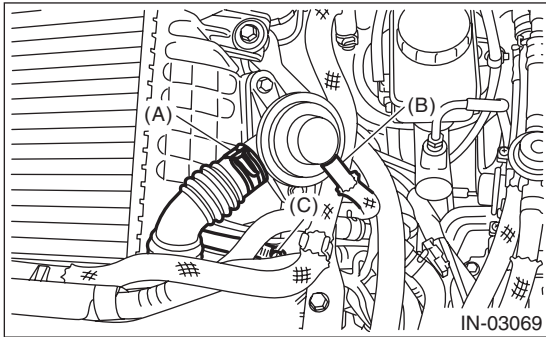

- 3) Remove the bolts which secure the intercooler to the turbocharger.

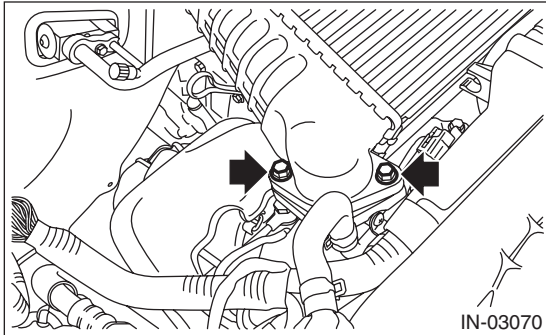

- 4) Remove the bolts which secure the intercooler to the intercooler stay, and remove the intercooler.

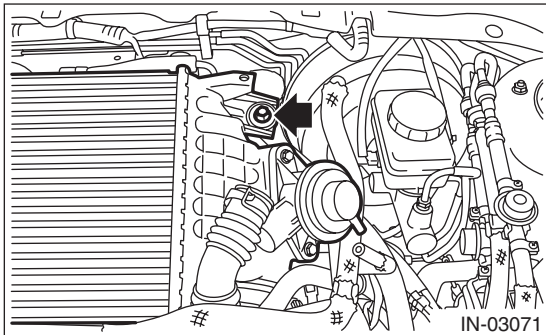

- 5) Remove the brake booster vacuum hose from the clip (A), and remove the intercooler stay.

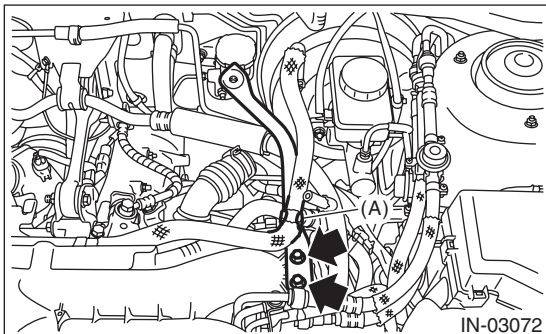

#### B: INSTALLATION

Install in the reverse order of removal.

#### NOTE:

- Use new O-rings.
- Be careful not to pinch the O-ring.

#### Tightening torque:

**16 N·m (1.6 kgf-m, 11.8 ft-lb)**

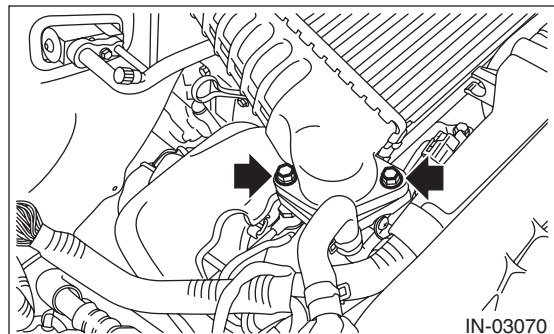
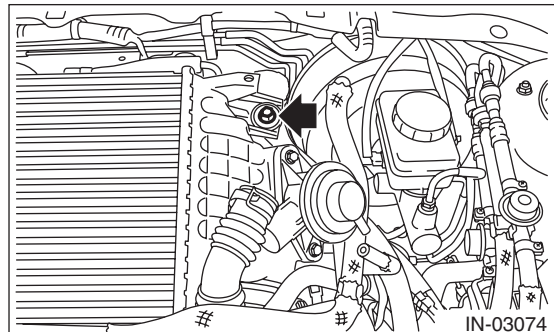
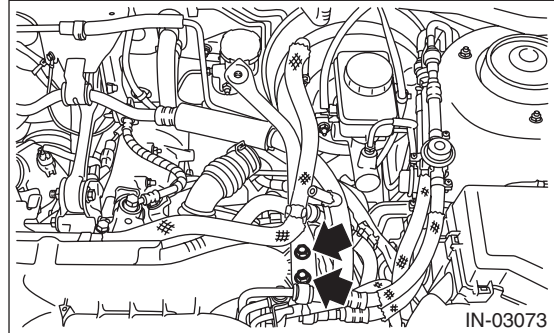

#### Tightening torque:

**3 N·m (0.3 kgf-m, 2.2 ft-lb)**

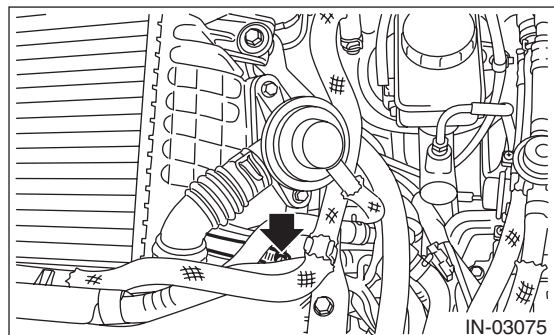

## C: DISASSEMBLY

1) Remove the air by-pass valve from intercooler.

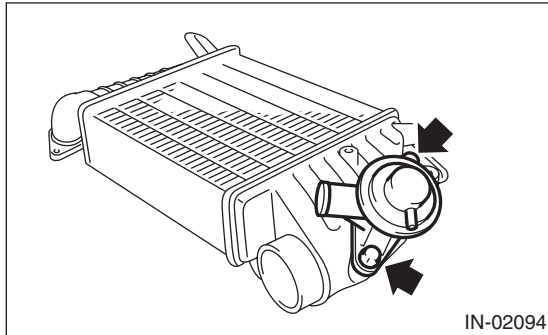

## D: ASSEMBLY

Assemble in the reverse order of disassembly.

NOTE:

- Use new O-rings.
- Be careful not to pinch the O-ring.

**Tightening torque:**

**6.5 N·m (0.7 kgf-m, 4.8 ft-lb)**

## E: INSPECTION

- 1) Check that the intercooler has no deformation, cracks or other damages.
- 2) Check that the vacuum hose, air by-pass pipe and intake duct have no cracks, damage or loose part.

# Turbocharger

## INTAKE (INDUCTION)

### 7. Turbocharger

#### A: REMOVAL

1) Disconnect the ground cable from battery.

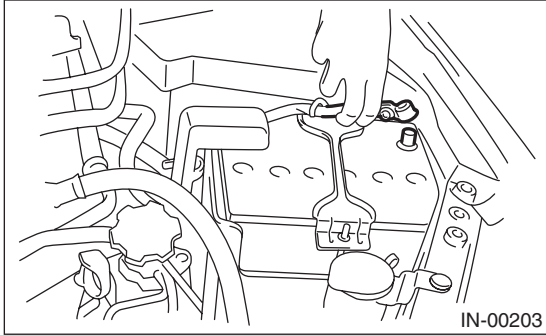

2) Lift up the vehicle.

3) Drain approximately 3.0 ℓ (3.2 US qt, 2.6 Imp qt) of coolant. <Ref. to CO(w/o STI)-13, DRAINING OF ENGINE COOLANT, REPLACEMENT, Engine Coolant.>

4) Lower the vehicle.

5) Remove the intercooler. <Ref. to IN(w/o STI)-12, REMOVAL, Intercooler.>

6) Remove the center exhaust pipe. <Ref. to EX(STI)-8, REMOVAL, Center Exhaust Pipe.>

7) Lower the vehicle.

8) Remove the joint pipe from the turbocharger.

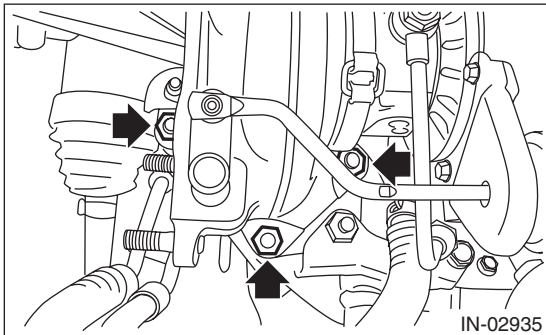

9) Disconnect the engine coolant hoses from coolant filler tank.

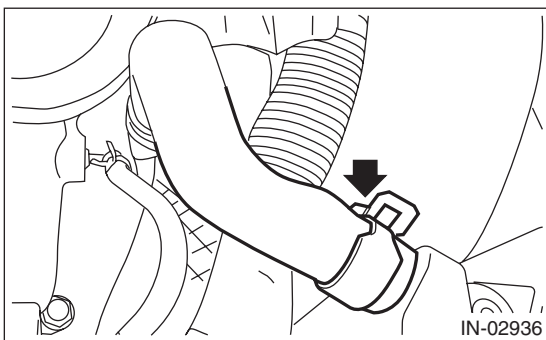

10) Disconnect the air control hose (A), and loosen the clamp holding the intake duct to the turbocharger.

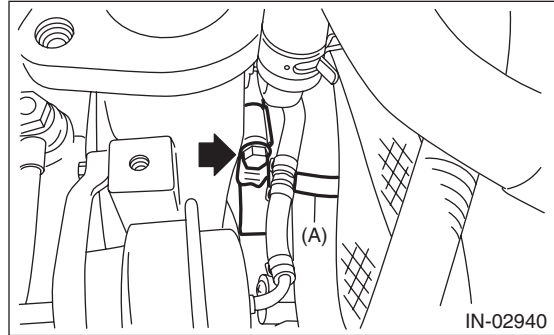

11) Remove the oil inlet pipe from the turbocharger.

#### CAUTION:

**In order to prevent damaging the oil pipe on the cylinder head side, fix the section (a) shown in the figure when loosening the oil inlet pipe flare nut, and avoid the part from rotating together while loosening the nut.**

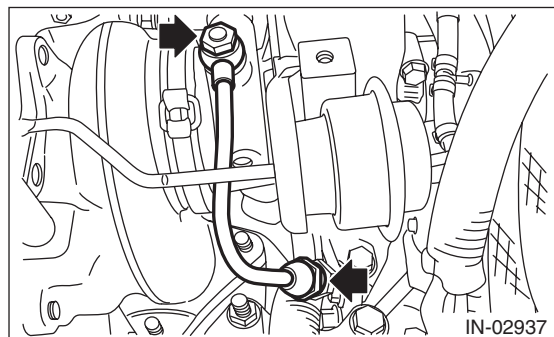
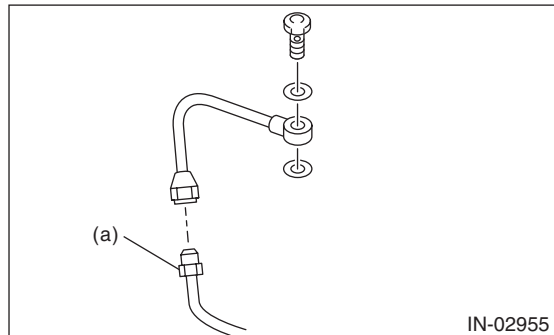

12) Disconnect the engine coolant hose from the water pipe.

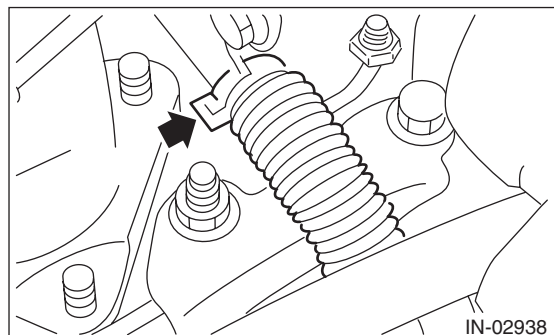



# Turbocharger

INTAKE (INDUCTION)

13) Disconnect the oil outlet hose from the oil outlet pipe, and remove the turbocharger.

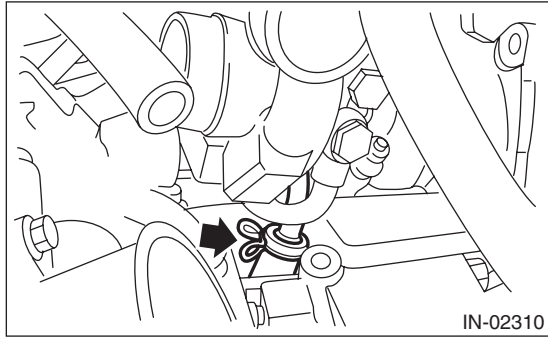

2) Connect the oil outlet hose to the oil outlet pipe.

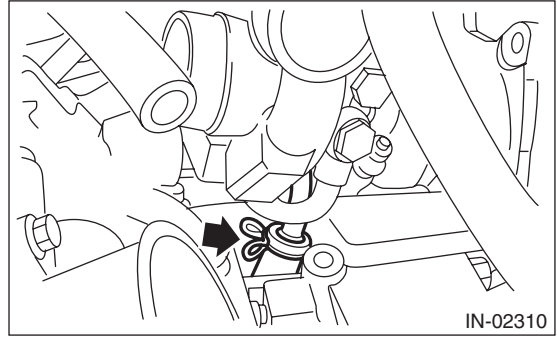

14) Remove the turbocharger stay.

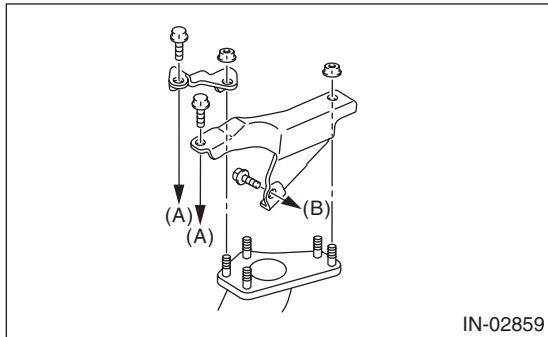

- (A) To cylinder head RH
- (B) To cylinder block RH

3) Connect the engine coolant hoses to the water pipe.

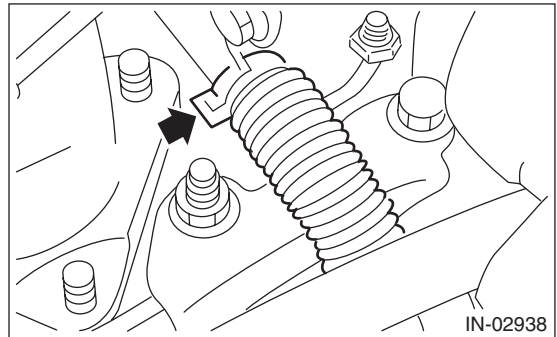

4) Temporarily tighten the union bolts and flare nuts which secure the oil inlet pipe to the turbocharger.

NOTE:  
Use a new gasket.

## B: INSTALLATION

1) Install the turbocharger stay.

**Tightening torque:**

**T1: 33 N·m (3.4 kgf-m, 24.3 ft-lb)**

**T2: 42.5 N·m (4.3 kgf-m, 31.3 ft-lb)**

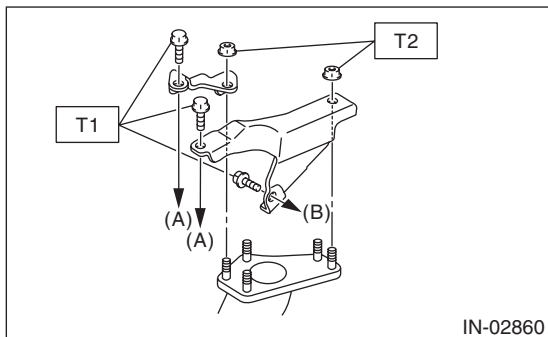

- (A) To cylinder head RH
- (B) To cylinder block RH

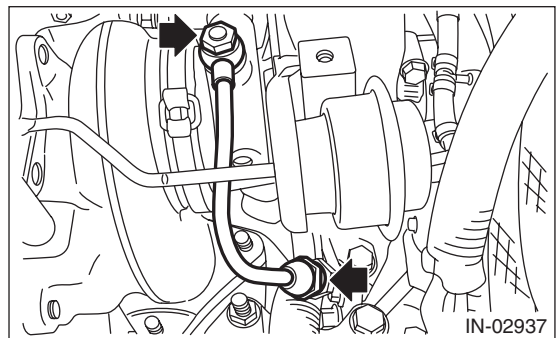

IN(w/o STI)-15

Brought to you by Ebay Seller "SubaruManuals"

# Turbocharger

## INTAKE (INDUCTION)

5) Tighten the union bolts and flare nuts which secure the oil inlet pipe to the turbocharger.

### CAUTION:

In order to prevent damaging the oil pipe on the cylinder head side, fix the section (a) shown in the figure when tightening the oil inlet pipe flare nut, and avoid the part from rotating together while tightening the nut.

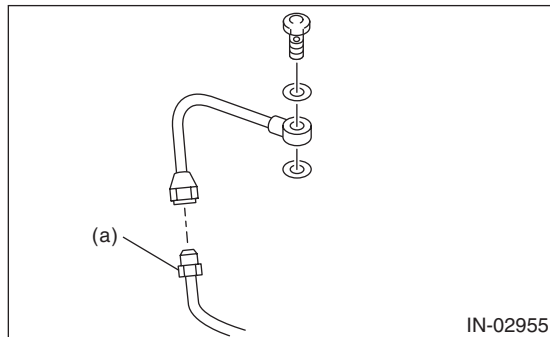

### Tightening torque:

**T1: 16 N·m (1.6 kgf-m, 11.8 ft-lb)**

**T2: 20 N·m (2.0 kgf-m, 14.8 ft-lb)**

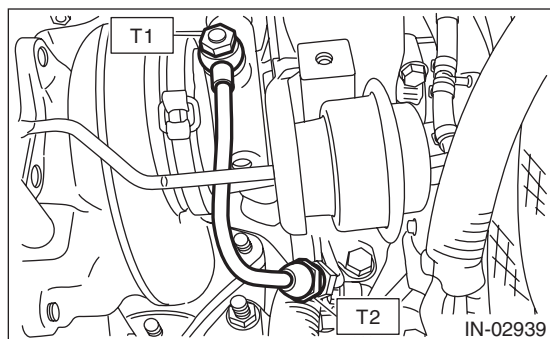

6) Connect the air control hose (A), and install the intake duct to the turbocharger.

### Tightening torque:

**3 N·m (0.3 kgf-m, 2.2 ft-lb)**

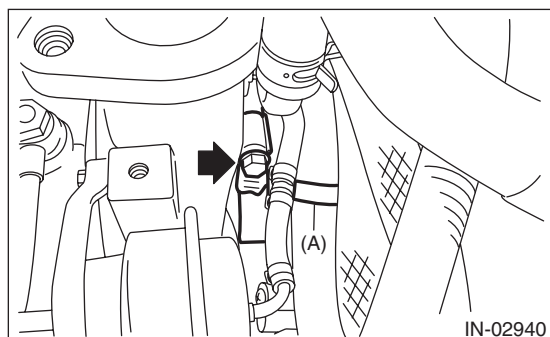

7) Connect the engine coolant hoses to the coolant filler tank.

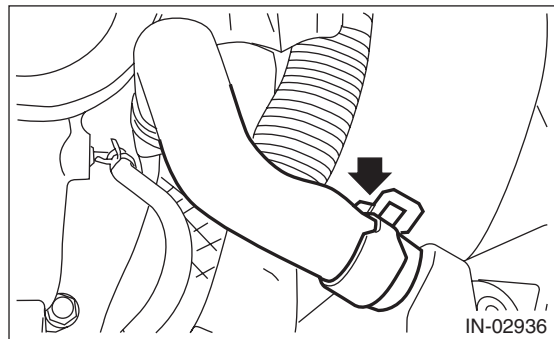

8) Install the joint pipe to turbocharger.

### NOTE:

Replace the gasket with a new part.

### Tightening torque:

**42.5 N·m (4.3 kgf-m, 31.3 ft-lb)**

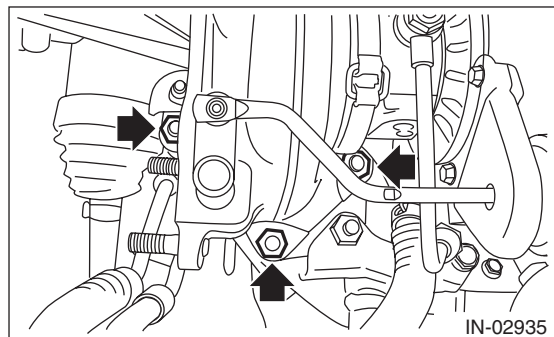

9) Lift up the vehicle.

10) Install the center exhaust pipe. <Ref. to EX(STI)-9, INSTALLATION, Center Exhaust Pipe.>

11) Lower the vehicle.

12) Install the intercooler. <Ref. to IN(w/o STI)-12, INSTALLATION, Intercooler.>

13) Connect the battery ground terminal.

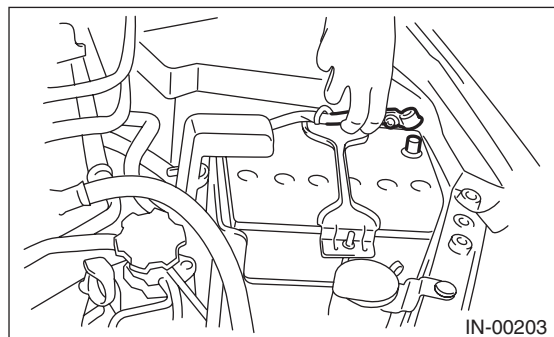

14) Fill engine coolant. <Ref. to CO(w/o STI)-13, FILLING OF ENGINE COOLANT, REPLACEMENT, Engine Coolant.>

## C: INSPECTION

### 1. WASTE GATE ACTUATOR

- 1) Remove the intercooler. <Ref. to IN(w/o STI)-12, REMOVAL, Intercooler.>
- 2) Remove the turbocharger upper cover.

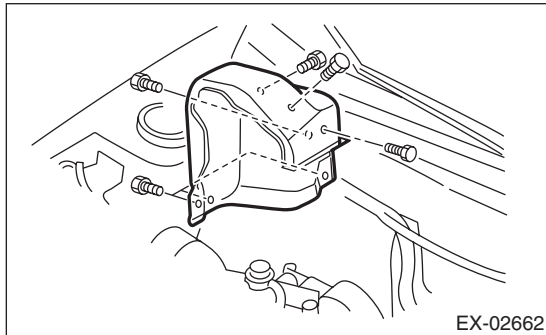

- 3) Remove the boost hose (B) from the waste gate actuator (A) of the turbocharger, and connect the Mighty Vac to the waste gate actuator (A).

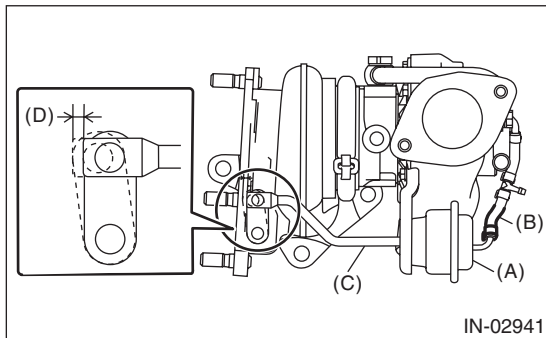

- (A) Waste gate actuator
- (B) Boost hose
- (C) Control rod
- (D) Control rod stroke

- 4) Pressurize slowly with the Mighty Vac, and measure the pressure when the control rod stroke (D) becomes 2 mm (0.08 in). If it is not within the standard, replace the turbocharger assembly.

#### CAUTION:

**Do not pressurize over 89.9 kPa (0.92 kgf/cm<sup>2</sup>, 13.0 psi) to prevent damaging the waste gate actuator.**

**Operating pressure (control rod stroke 2 mm (0.08 in)):**

#### Standard

**74.7 — 80.8 kPa (0.76 — 0.82 kgf/cm<sup>2</sup>, 10.8 — 11.7 psi)**

- 5) After inspection, install the related parts in the reverse order of removal.

#### Tightening torque:

**7.5 N·m (0.8 kgf·m, 5.5 ft·lb)**

### 2. OTHER INSPECTIONS

- 1) Check that the turbocharger and pipe have no deformation, cracks or other damages.
- 2) Check that the hose and intake duct have no cracks, damage or loose part.
- 3) Check that there are no oil leakage or water leakage from the pipe attachment section.

# Air By-pass Valve

INTAKE (INDUCTION)

## 8. Air By-pass Valve

### A: REMOVAL

Disconnect the air by-pass pipe (A) and vacuum hose (B) from the air by-pass valve, and remove the air by-pass valve from the intercooler.

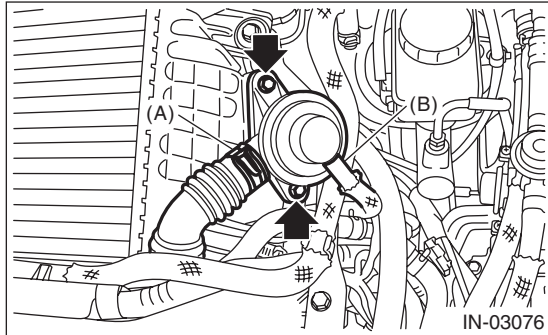

### B: INSTALLATION

Install in the reverse order of removal.

NOTE:

- Use new O-rings.
- Be careful not to pinch the O-ring.

**Tightening torque:**

**6.5 N·m (0.7 kgf·m, 4.8 ft·lb)**

### C: INSPECTION

#### 1. AIR BY-PASS VALVE

- 1) Check that the air by-pass valve has no deformation, cracks or other damages.
- 2) Connect the Mighty Vac to the nipple (A) of the air by-pass valve.

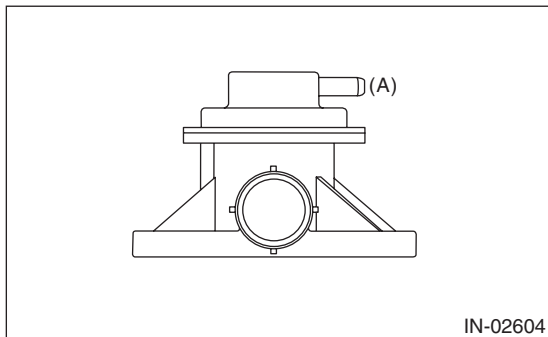

- 3) Using the Mighty Vac, generate the negative pressure to  $-93.3 \text{ kPa}$  ( $-0.95 \text{ kgf/cm}^2$ ,  $-13.5 \text{ psi}$ ). Check that the Mighty Vac gauge needle holds 10 seconds without falling by  $-92.6 \text{ kPa}$  ( $-0.94 \text{ kgf/cm}^2$ ,  $-13.4 \text{ psi}$ ).

- 4) Set a dial gauge to the end of valve rod of the air by-pass valve.

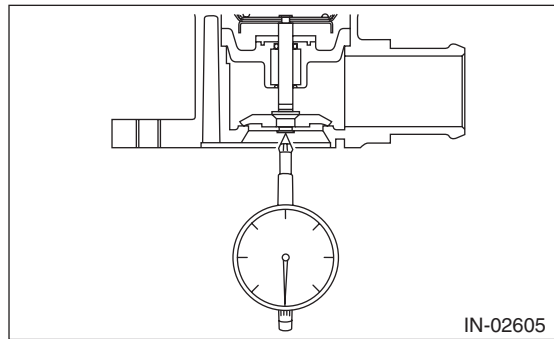

- 5) Using the Mighty Vac, generate the negative pressure, and check the pressure when dial gauge needle (valve stroke) shows 0.5 mm (0.02 in). If it is not within the standard, replace the air by-pass valve.

**Opening pressure (valve stroke 0.5 mm (0.02 in)):**

**Standard**

**$-53.3$  —  $-61.3 \text{ kPa}$  ( $-0.54$  —  $-0.63 \text{ kgf/cm}^2$ ,  
 $-7.73$  —  $-8.89 \text{ psi}$ )**

- 6) Generate the additional negative pressure from 5), and check the pressure when dial gauge needle (valve stroke) shows 7.5 mm (0.3 in). If it is not within the standard, replace the air by-pass valve.

**Full open pressure (valve stroke 7.5 mm (0.3 in)):**

**Standard**

**$-93.4$  —  $-108 \text{ kPa}$  ( $-0.95$  —  $-1.10 \text{ kgf/cm}^2$ ,  
 $-13.5$  —  $-15.7 \text{ psi}$ )**

#### 2. OTHER INSPECTIONS

Check that the vacuum hose and air by-pass pipe have no cracks, damage or loose part.

IN(w/o STI)-18

Brought to you by Ebay Seller "SubaruManuals"

# MECHANICAL

# *ME(w/o STI)*

---

	<b>Page</b>
1. General Description .....	2
2. Compression .....	20
3. Idle Speed .....	21
4. Ignition Timing .....	22
5. Intake Manifold Vacuum .....	23
6. Engine Oil Pressure .....	24
7. Fuel Pressure .....	25
8. Valve Clearance .....	26
9. Engine Assembly .....	30
10. Engine Mounting .....	37
11. Preparation for Overhaul .....	38
12. V-belt .....	39
13. Crank Pulley .....	46
14. Timing Belt Cover .....	48
15. Timing Belt .....	49
16. Cam Sprocket .....	58
17. Crank Sprocket .....	59
18. Camshaft .....	60
19. Cylinder Head .....	69
20. Cylinder Block .....	79
21. Intake and Exhaust Valve .....	102
22. Piston .....	103
23. Connecting Rod .....	104
24. Crankshaft .....	105
25. Engine Trouble in General .....	106
26. Engine Noise .....	112

# General Description

MECHANICAL

## 1. General Description

### A: SPECIFICATION

Engine	Model		2.5 L			
	Cylinder arrangement		Horizontally opposed, liquid cooled, 4-cylinder, 4-stroke gasoline engine			
	Valve system mechanism		Belt driven, double overhead camshaft, 4-valve/cylinder			
	Bore × Stroke		mm (in)	99.5 × 79.0 (3.92 × 3.11)		
	Displacement		cm <sup>3</sup> (cu in)	2,457 (149.94)		
	Compression ratio		8.4			
	Compression pressure (at 200 — 300 rpm)		kPa (kg/cm <sup>2</sup> , psi)	Standard	981 — 1,177 (10 — 12, 142 — 171)	
	Number of piston rings		Pressure ring: 2, Oil ring: 1			
	Intake valve timing		Open	Max. retard	ATDC 5°	
				Min. advance	BTDC 35°	
			Close	Max. retard	ABDC 65°	
				Min. advance	ABDC 25°	
	Exhaust valve timing		Open	BBDC 55°		
			Close	ATDC 5°		
	Valve clearance		Inspection value	mm (in)	Intake	0.20 <sup>+0.04</sup> <sub>-0.06</sub> (0.0079 <sup>+0.0016</sup> <sub>-0.0024</sub> )
				Exhaust	0.35±0.05 (0.0138±0.0020)	
			Adjustment value	Intake	0.20 <sup>+0.01</sup> <sub>-0.03</sub> (0.0079 <sup>+0.0004</sup> <sub>-0.0012</sub> )	
				Exhaust	0.35±0.02 (0.0138±0.0008)	
Idle speed (Gear shift lever is in neutral)		rpm	No load	Standard	700±100	
			A/C ON	Standard	750±100	
Ignition order				1 → 3 → 2 → 4		
Ignition timing		BTDC/rpm	Standard	12°±10°/700		

ME(w/o STI)-2

Brought to you by Ebay Seller "SubaruManuals"

# General Description

MECHANICAL

NOTE:

OS: Oversize    US: Undersize

Belt tension adjuster	Adjuster rod protrusion amount	mm (in)		5.2 — 6.2 (0.205 — 0.244)	
Camshaft	Bending limit	mm (in)		0.020 (0.00079)	
	Cam lobe height	mm (in)	Intake	Standard	46.55 — 46.65 (1.833 — 1.837)
			Exhaust	Standard	46.75 — 46.85 (1.841 — 1.844)
	Cam base circle diameter	mm (in)	Standard	37.0 (1.457)	
	Journal O.D.	mm (in)	Front	Standard	37.946 — 37.963 (1.4939 — 1.4946)
			Center, rear	Standard	29.946 — 29.963 (1.1790 — 1.1796)
	Oil clearance	mm (in)	Standard	0.037 — 0.072 (0.0015 — 0.0028)	
Thrust clearance	mm (in)	Standard	0.068 — 0.116 (0.0027 — 0.0047)		
Cylinder head	Warping limit (mating surface with cylinder block)	mm (in)		0.035 (0.0014)	
	Grinding limit	mm (in)		0.3 (0.012)	
	Standard height	mm (in)		127.5 (5.02)	
Valve seat	Seating angle between valve and valve seat			90°	
	Contacting width between valve and valve seat	mm (in)	Intake	Standard	0.6 — 1.4 (0.024 — 0.055)
			Exhaust	Standard	1.2 — 1.8 (0.047 — 0.071)
Valve guide	Clearance between the valve guide and valve stem	mm (in)	Intake	Standard	0.030 — 0.057 (0.0012 — 0.0022)
			Exhaust	Standard	0.040 — 0.067 (0.0016 — 0.0026)
	Inside diameter	mm (in)		6.000 — 6.012 (0.2362 — 0.2367)	
	Valve stem outer diameters	mm (in)	Intake		5.955 — 5.970 (0.2344 — 0.2350)
			Exhaust		5.945 — 5.960 (0.2341 — 0.2346)
Valve guide protrusion amount	mm (in)		15.8 — 16.2 (0.622 — 0.638)		
Valve	Head edge thickness	mm (in)	Intake	Standard	1.0 — 1.4 (0.039 — 0.055)
			Exhaust	Standard	1.3 — 1.7 (0.051 — 0.067)
	Overall length	mm (in)	Intake		104.4 (4.110)
			Exhaust		104.65 (4.1201)
Valve spring	Free length	mm (in)		47.32 (1.863)	
	Tension/spring height	N (kgf, lb)/mm (in)	Set		205 — 235 (20.9 — 24.0, 46.1 — 52.8)/36.0 (1.417)
			Lift		426 — 490 (43.4 — 50.0, 95.8 — 110)/26.50 (1.043)
	Squareness			2.5°, 2.1 mm (0.083 in) or less	
Valve lifter	Outer diameter	mm (in)	Standard	34.959 — 34.975 (1.3763 — 1.3770)	
	Valve lifter mating surface inner diameter	mm (in)	Standard	34.994 — 35.016 (1.3777 — 1.3786)	
	Valve lifter and valve lifter mating surface clearance	mm (in)	Standard	0.019 — 0.057 (0.0007 — 0.0022)	
Cylinder block	Warping limit (mating surface with cylinder head)	mm (in)		0.025 (0.0098)	
	Grinding limit	mm (in)		0.1 (0.004)	
	Standard height	mm (in)		201.0 (7.91)	
	Cylindricity	mm (in)	Limit	0.015 (0.0006)	
	Out-of-roundness	mm (in)	Limit	0.010 (0.0004)	
	Clearance between cylinder and piston at 20°C (68°F)	mm (in)	Standard	-0.010 — 0.010 (-0.00039 — 0.00039)	
	Cylinder inner diameter boring limit (diameter)	mm (in)		To 100.005 (3.9372)	

**ME(w/o STI)-3**

Brought to you by Ebay Seller "SubaruManuals"

# General Description

## MECHANICAL

Piston	Piston grade point		mm (in)	38.2 (1.50)	
	Outer diameter	mm (in)	Standard	A	99.505 — 99.515 (3.9175 — 3.9179)
				B	99.495 — 99.505 (3.9171 — 3.9175)
			0.25 (0.0098) OS		99.745 — 99.765 (3.9270 — 3.9278)
		0.50 (0.0197) OS		99.995 — 100.015 (3.9368 — 3.9376)	
Piston pin	Degree of fit			Piston pin must be fitted into position with thumb at 20°C (68°F).	
	Clearance between piston pin hole and piston pin		mm (in)	Standard	0.004 — 0.008 (0.0002 — 0.0003)
Piston ring	Piston ring gap	mm (in)	Top ring	Standard	0.20 — 0.25 (0.0079 — 0.0098)
			Second ring	Standard	0.37 — 0.52 (0.015 — 0.0203)
			Oil ring	Standard	0.20 — 0.50 (0.0079 — 0.0197)
	Clearance between piston ring and piston ring groove	mm (in)	Top ring	Standard	0.040 — 0.080 (0.0016 — 0.0031)
			Second ring	Standard	0.030 — 0.070 (0.0012 — 0.0028)
Connecting rod and connecting rod bearing	Bend or twist per 100 mm (3.94 in) in length		mm (in)	Limit	0.10 (0.0039)
	Thrust clearance		mm (in)	Standard	0.070 — 0.330 (0.0028 — 0.0130)
	Oil clearance		mm (in)	Standard	0.017 — 0.045 (0.0007 — 0.0018)
	Bearing size (Thickness at center)	mm (in)	Standard		1.490 — 1.506 (0.0587 — 0.0593)
			0.03 (0.0012) US		1.504 — 1.512 (0.0592 — 0.0595)
0.05 (0.0020) US			1.514 — 1.522 (0.0596 — 0.0599)		
0.25 (0.0098) US			1.614 — 1.622 (0.0635 — 0.0639)		
Bushings of small end	Clearance between piston pin and bushing		mm (in)	Standard	0 — 0.022 (0 — 0.0009)
	Bending limit			mm (in)	0.035 (0.0014)
Crankshaft and crankshaft bearing	Crank pin	Cylindricality	mm (in)	Limit	0.004 (0.0002)
		Out-of-roundness	mm (in)	Limit	0.003 (0.0001)
		Grinding limit (dia.)		mm (in)	To 51.750 (2.0374)
	Crank journal	Cylindricality	mm (in)	Limit	0.006 (0.0002)
		Out-of-roundness	mm (in)	Limit	0.005 (0.0002)
		Grinding limit (dia.)		mm (in)	To 59.758 (2.3527)
	Crank pin outer diameter	mm (in)	Standard		51.976 — 52.000 (2.0463 — 2.0472)
			0.03 (0.0012) US		51.954 — 51.970 (2.0454 — 2.0461)
			0.05 (0.0020) US		51.934 — 51.950 (2.0447 — 2.0453)
			0.25 (0.0098) US		51.734 — 51.750 (2.0368 — 2.0374)
	Crank journal outer diameter	mm (in)	Standard		59.984 — 60.008 (2.3616 — 2.3625)
			0.03 (0.0012) US		59.962 — 59.978 (2.3607 — 2.3613)
			0.05 (0.0020) US		59.942 — 59.958 (2.3599 — 2.3605)
			0.25 (0.0098) US		59.742 — 59.758 (2.3520 — 2.3527)
	Bearing size (Thickness at center)	#1, #3	Standard		1.998 — 2.015 (0.0787 — 0.0793)
0.03 (0.0012) US			2.017 — 2.020 (0.0794 — 0.0795)		
0.05 (0.0020) US			2.027 — 2.030 (0.0798 — 0.0799)		
0.25 (0.0098) US			2.127 — 2.130 (0.0837 — 0.0839)		
#2, #4, #5		Standard		2.000 — 2.017 (0.0787 — 0.0794)	
		0.03 (0.0012) US		2.019 — 2.022 (0.0795 — 0.0796)	
		0.05 (0.0020) US		2.029 — 2.032 (0.0799 — 0.0800)	
		0.25 (0.0098) US		2.129 — 2.132 (0.0838 — 0.0839)	
Thrust clearance		mm (in)	Standard	0.030 — 0.115 (0.0012 — 0.0045)	
Oil clearance		mm (in)	Standard	0.010 — 0.030 (0.0004 — 0.0012)	

**ME(w/o STI)-4**

Brought to you by Ebay Seller "SubaruManuals"



## B: COMPONENT

### 1. TIMING BELT

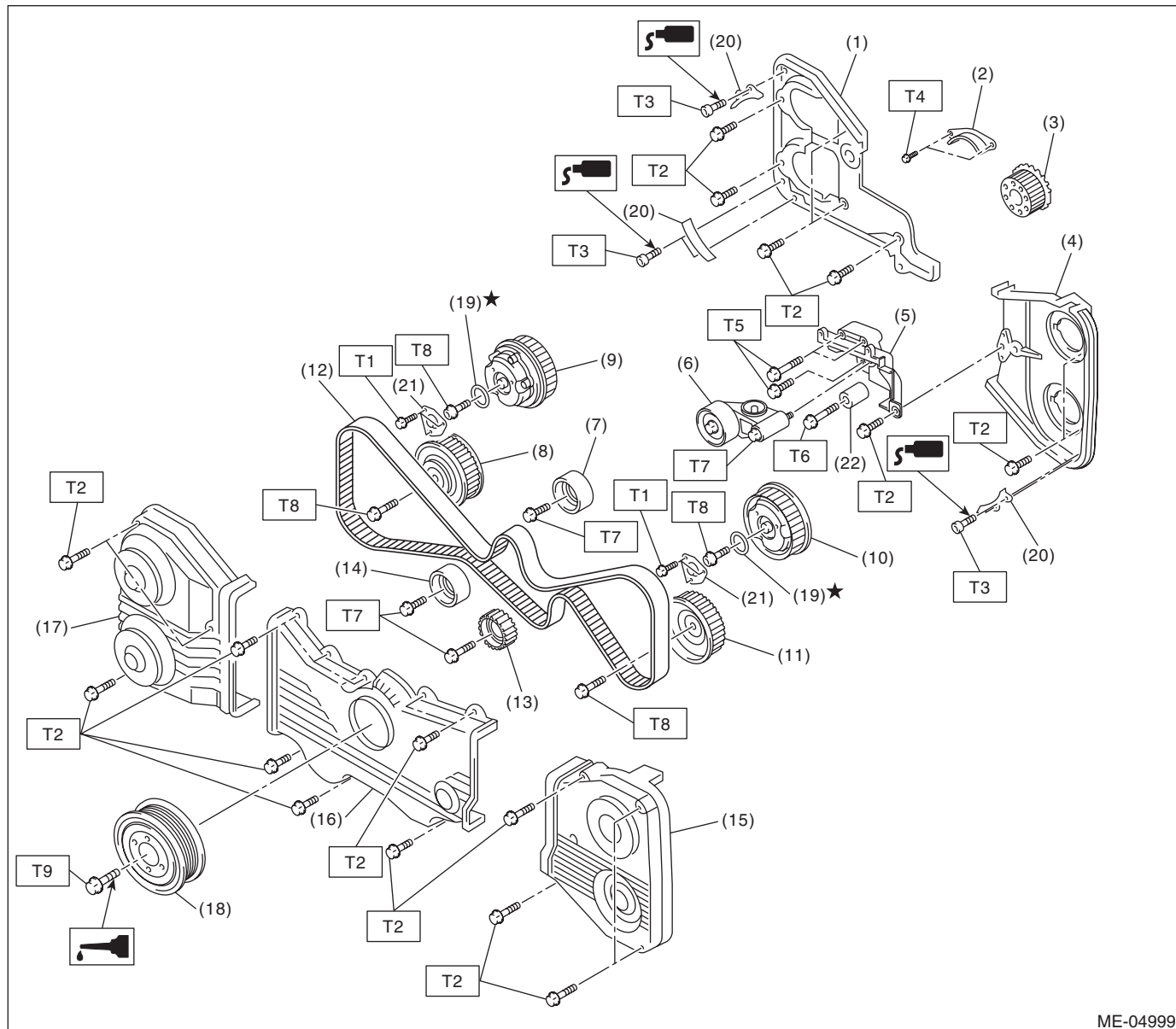

ME-04999

- |  |                           |
|--|---------------------------|
| (1) Timing belt cover No. 2 RH           | (12) Timing belt          |
| (2) Timing belt guide                    | (13) Belt idler No. 2     |
| (3) Crank sprocket                       | (14) Belt idler           |
| (4) Timing belt cover No. 2 LH           | (15) Timing belt cover LH |
| (5) Tensioner bracket                    | (16) Front belt cover     |
| (6) Automatic belt tension adjuster ASSY | (17) Timing belt cover RH |
| (7) Belt idler                           | (18) Crank pulley         |
| (8) Exhaust cam sprocket RH              | (19) O-ring               |
| (9) Intake cam sprocket RH               | (20) Timing belt guide    |
| (10) Intake cam sprocket LH              | (21) Actuator cover       |
| (11) Exhaust cam sprocket LH             | (22) Belt idler           |

**Tightening torque: N·m (kgf·m, ft·lb)**

**T1: 3.4 (0.3, 2.5)**

**T2: 5 (0.5, 3.7)**

**T3: 6.4 (0.7, 4.7)**

**T4: 9.75 (1.0, 7.2)**

**T5: 24.5 (2.5, 18.1)**

**T6: 25 (2.5, 18.4)**

**T7: 39 (4.0, 28.8)**

**T8: <Ref. to ME(w/o STI)-58, INSTALLATION, Cam Sprocket.>**

**T9: <Ref. to ME(w/o STI)-46, INSTALLATION, Crank Pulley.>**

**ME(w/o STI)-5**

Brought to you by Ebay Seller "SubaruManuals"

# General Description

MECHANICAL

## 2. CYLINDER HEAD AND CAMSHAFT

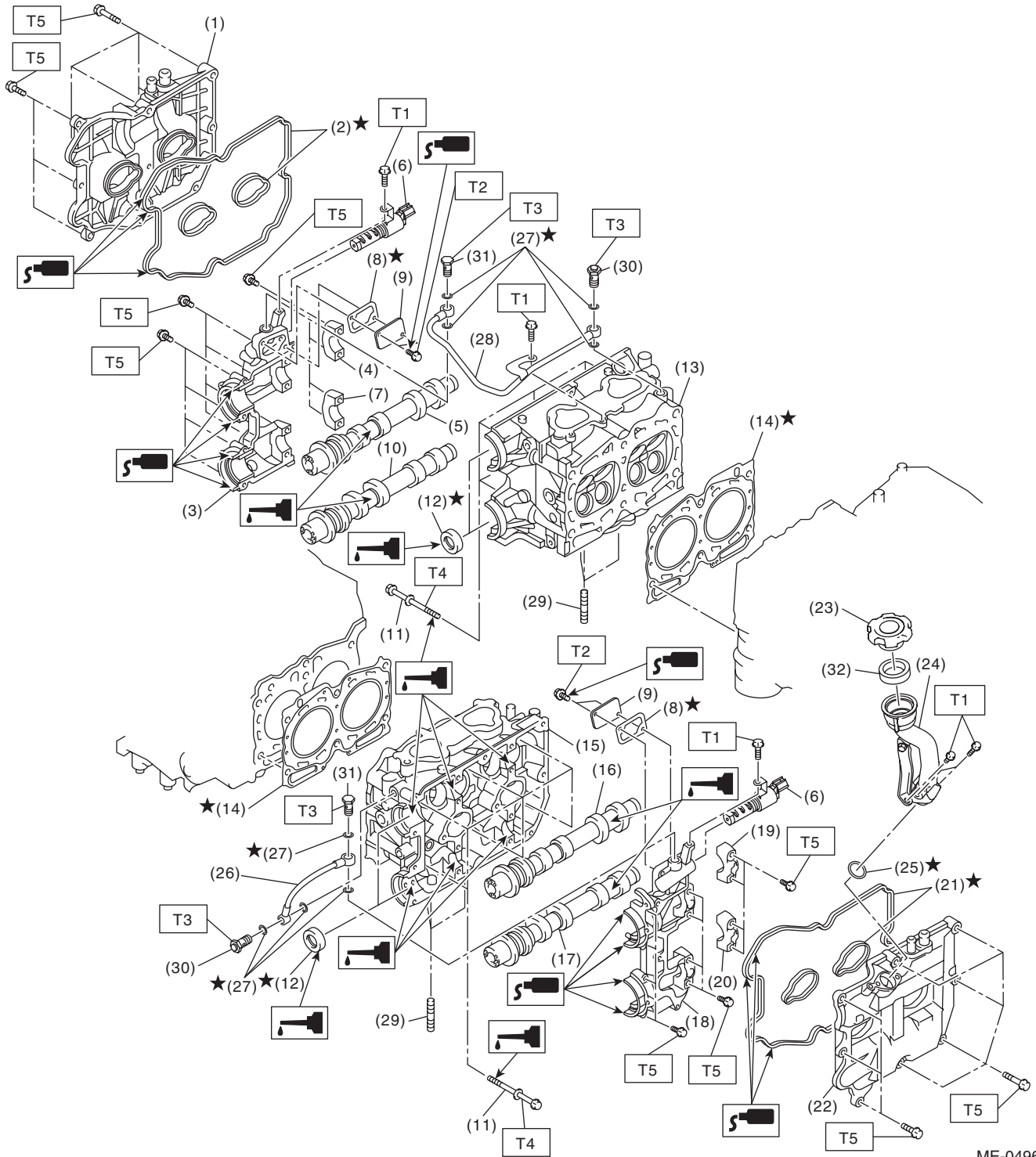

ME-04964

# General Description

MECHANICAL

---

(1) Rocker cover RH	(14) Cylinder head gasket	(27) Gasket
(2) Rocker cover gasket RH	(15) Cylinder head LH	(28) Oil pipe RH
(3) Front camshaft cap RH	(16) Intake camshaft LH	(29) Stud bolt
(4) Intake camshaft cap RH	(17) Exhaust camshaft LH	(30) Union bolt with filter (with protrusion)
(5) Intake camshaft RH	(18) Front camshaft cap LH	(31) Union bolt without filter (without protrusion)
(6) Oil flow control solenoid valve	(19) Intake camshaft cap LH	(32) Gasket
(7) Exhaust camshaft cap RH	(20) Exhaust camshaft cap LH	
(8) Gasket	(21) Rocker cover gasket LH	<hr/> <b>Tightening torque:N·m (kgf-m, ft-lb)</b>
(9) Oil return cover	(22) Rocker cover LH	<b>T1: 6.4 (0.7, 4.7)</b>
(10) Exhaust camshaft RH	(23) Oil filler cap	<b>T2: 9 (0.9, 6.6)</b>
(11) Cylinder head bolt	(24) Oil filler duct	<b>T3: 29 (3.0, 21.4)</b>
(12) Oil seal	(25) O-ring	<b>T4: &lt;Ref. to ME(w/o STI)-69, INSTALLATION, Cylinder Head.&gt;</b>
(13) Cylinder head RH	(26) Oil pipe LH	<b>T5: &lt;Ref. to ME(w/o STI)-63, INSTALLATION, Camshaft.&gt;</b>

---

**ME(w/o STI)-7**

Brought to you by Ebay Seller "SubaruManuals"

# General Description

MECHANICAL

## 3. CYLINDER HEAD AND VALVE ASSEMBLY

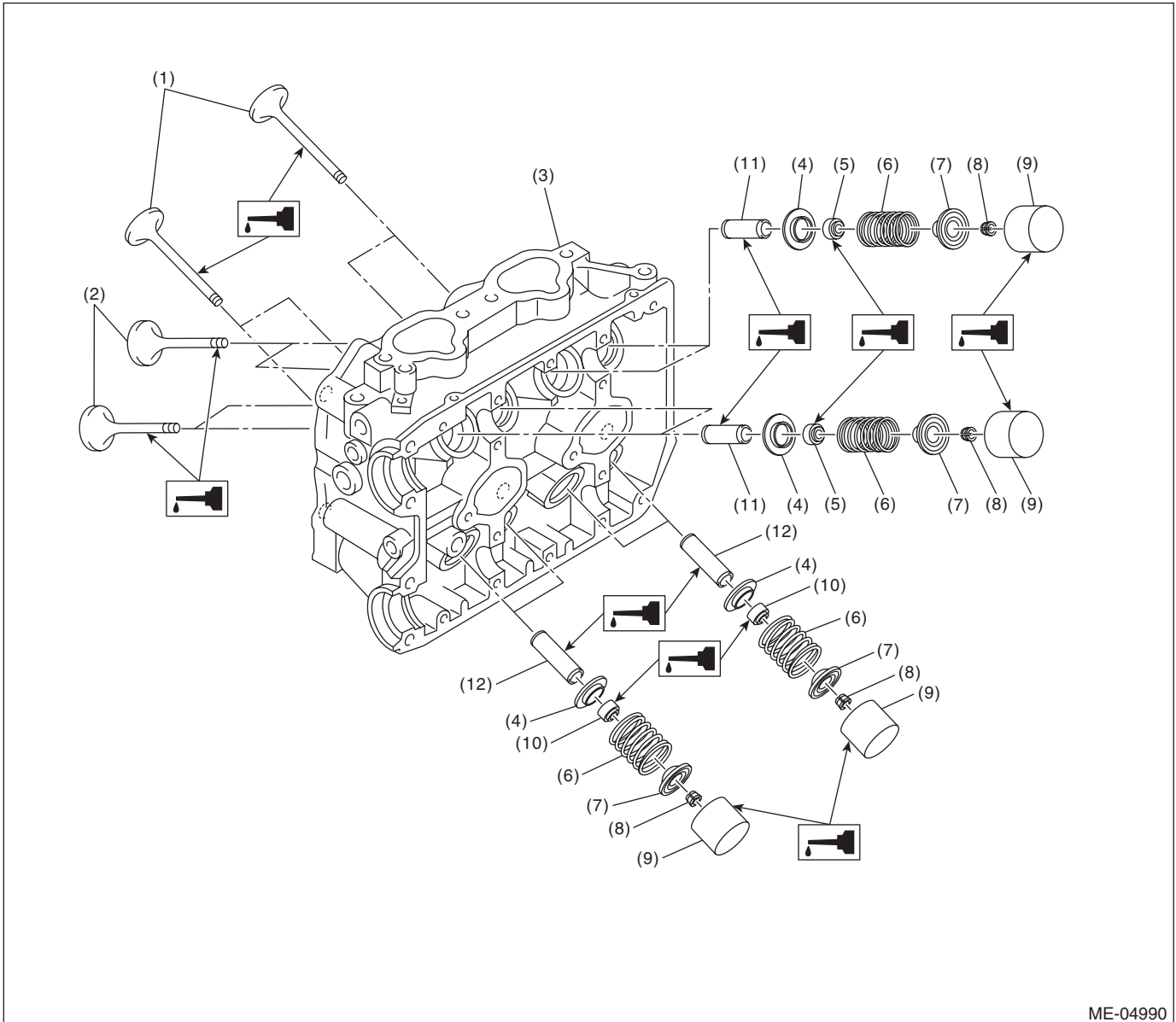

ME-04990

- |                       |                               |                             |
|-----------------------|-------------------------------|-----------------------------|
| (1) Exhaust valve     | (5) Intake valve oil seal     | (9) Valve lifter            |
| (2) Intake valve      | (6) Valve spring              | (10) Exhaust valve oil seal |
| (3) Cylinder head     | (7) Valve spring retainer     | (11) Intake valve guide     |
| (4) Valve spring seat | (8) Valve spring retainer key | (12) Exhaust valve guide    |

**ME(w/o STI)-8**

Brought to you by Ebay Seller "SubaruManuals"

## 4. CYLINDER BLOCK

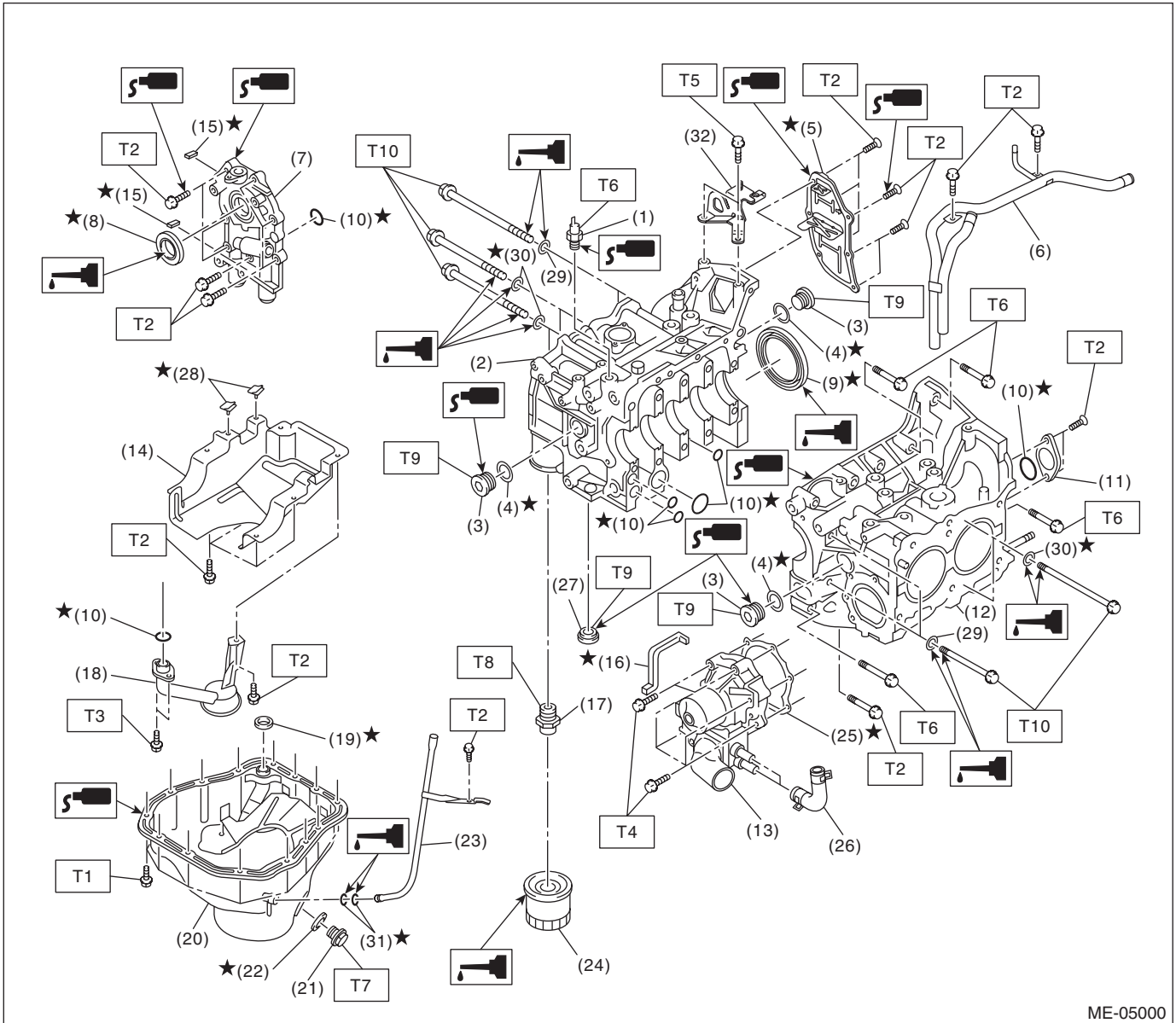

ME-05000

# General Description

## MECHANICAL

---

(1) Oil pressure switch	(16) Water pump sealing	(31) O-ring
(2) Cylinder block RH	(17) Oil filter connector	(32) Engine rear hanger
(3) Service hole plug	(18) Oil strainer	
(4) Gasket	(19) Gasket	
(5) Oil separator cover	(20) Oil pan	
(6) Water by-pass pipe	(21) Drain plug	
(7) Oil pump	(22) Drain plug gasket	
(8) Front oil seal	(23) Oil level gauge guide	
(9) Rear oil seal	(24) Oil filter	
(10) O-ring	(25) Gasket	
(11) Service hole cover	(26) Water pump hose	
(12) Cylinder block LH	(27) Plug	
(13) Water pump	(28) Seal	
(14) Baffle plate	(29) Washer	
(15) Oil pump seal	(30) Seal washer	

---

**Tightening torque:N·m (kgf-m, ft-lb)****T1: 5 (0.5, 3.7)****T2: 6.4 (0.7, 4.7)****T3: 10 (1.0, 7.2)****T4: First 12 (1.2, 8.9)  
Second 12 (1.2, 8.9)****T5: 16 (1.6, 11.8)****T6: 25 (2.5, 18.4)****T7: 44 (4.5, 32.5)****T8: 45 (4.6, 33.2)****T9: 70 (7.1, 51.6)****T10: <Ref. to ME(w/o STI)-83,  
INSTALLATION, Cylinder  
Block.>**

---

## 5. CRANKSHAFT AND PISTON

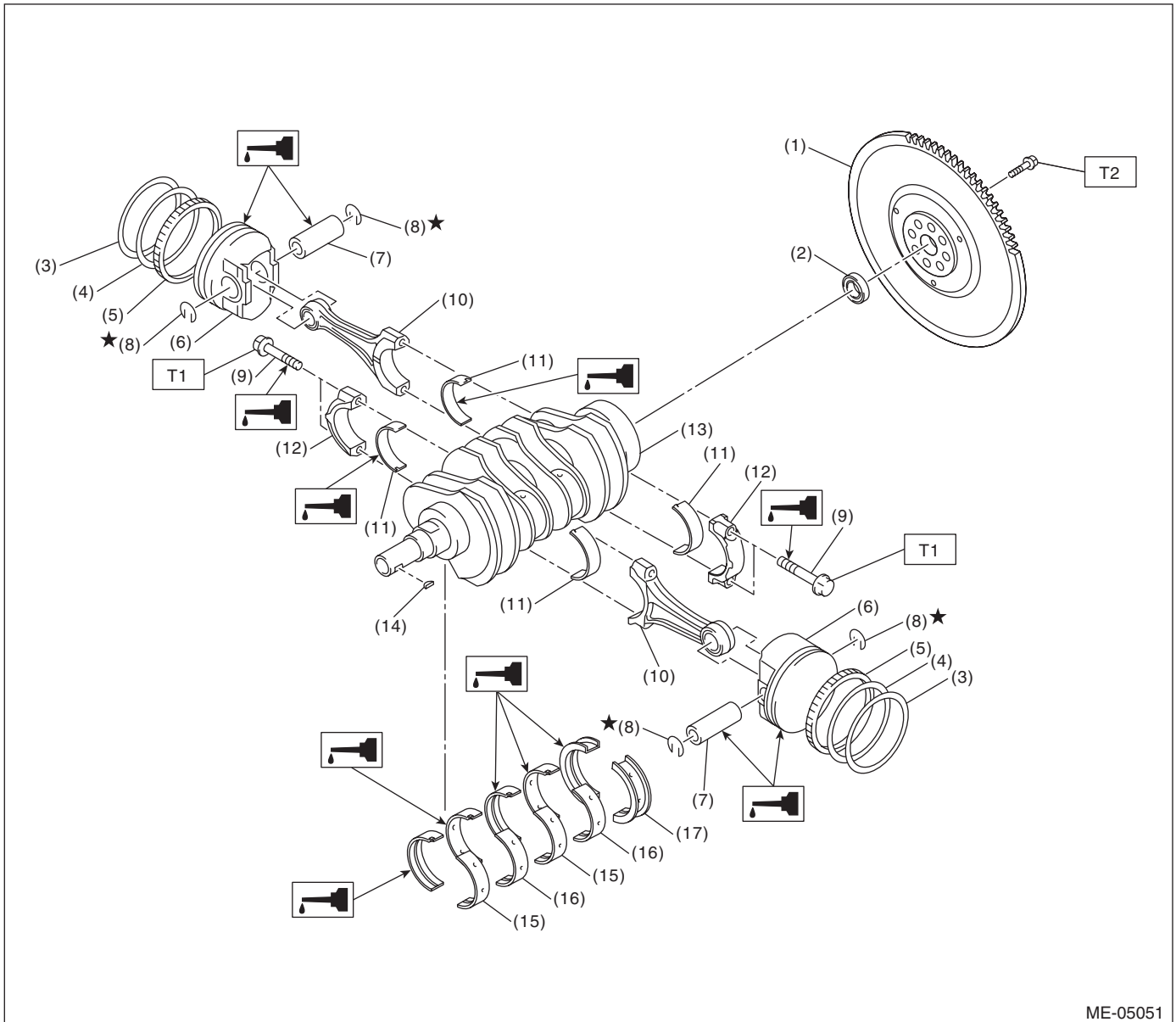

ME-05051

- |                  |                             |                                |
|------------------|-----------------------------|--------------------------------|
| (1) Flywheel     | (8) Snap ring               | (15) Crankshaft bearing #1, #3 |
| (2) Ball bearing | (9) Connecting rod bolt     | (16) Crankshaft bearing #2, #4 |
| (3) Top ring     | (10) Connecting rod         | (17) Crankshaft bearing #5     |
| (4) Second ring  | (11) Connecting rod bearing |                                |
| (5) Oil ring     | (12) Connecting rod cap     |                                |
| (6) Piston       | (13) Crankshaft             |                                |
| (7) Piston pin   | (14) Woodruff key           |                                |

**Tightening torque: N·m (kgf·m, ft·lb)**

**T1: 52 (5.3, 38.4)**

**T2: <Ref. to CL-14, INSTALLATION, Flywheel.>**

**ME(w/o STI)-11**

Brought to you by Ebay Seller "SubaruManuals"

# General Description

MECHANICAL

## 6. ENGINE MOUNTING

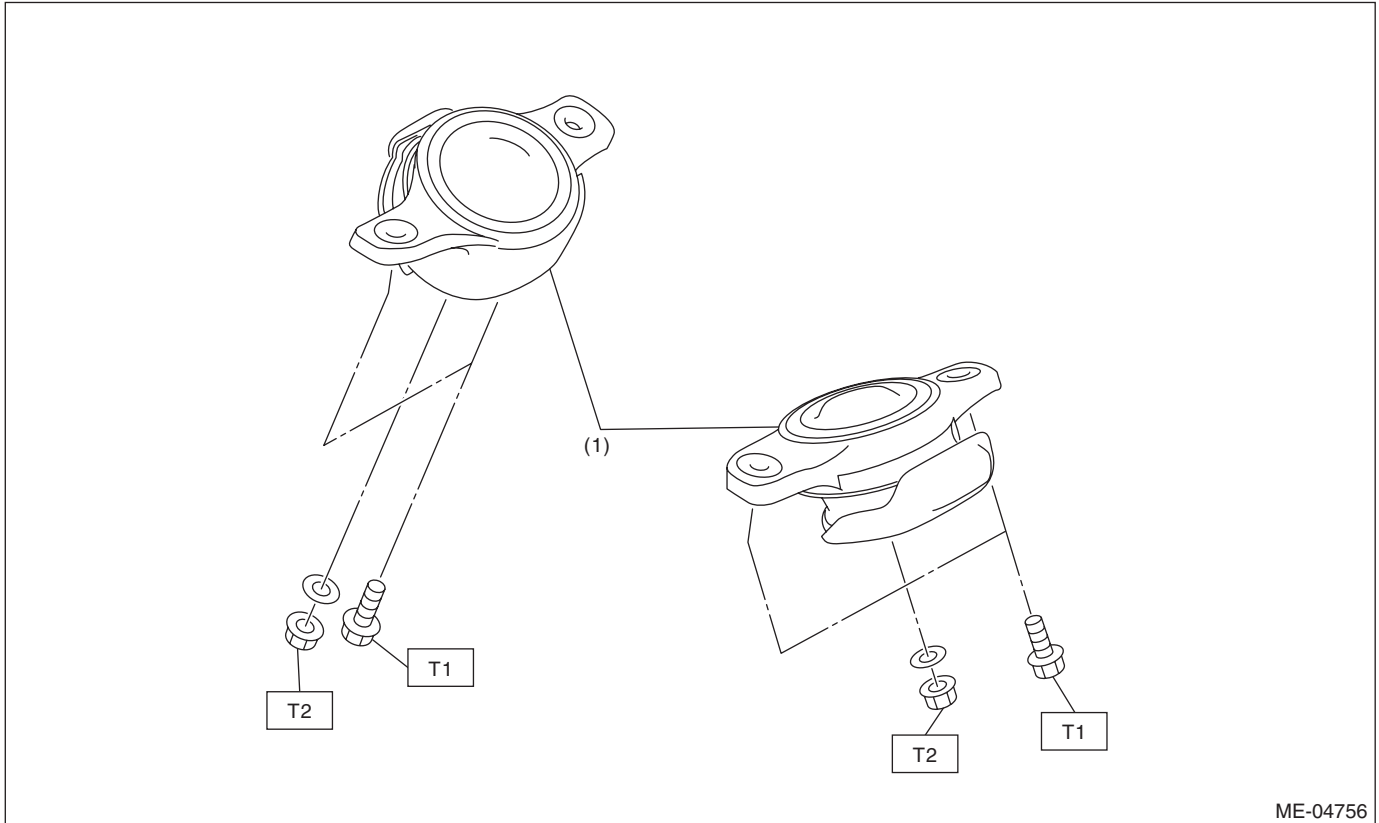

(1) Front cushion rubber

**Tightening torque: N·m (kgf-m, ft-lb)**

**T1: 35 (3.6, 25.8)**

**T2: 85 (8.7, 62.7)**



## C: CAUTION

- Wear appropriate work clothing, including a cap, protective goggles and protective shoes when performing any work.
- Remove contamination including dirt and corrosion before removal, installation or disassembly.
- Keep the disassembled parts in order and protect them from dust and dirt.
- Before removal, installation or disassembly, be sure to clarify the failure. Avoid unnecessary removal, installation, disassembly and replacement.
- Vehicle components are extremely hot after driving. Be wary of receiving burns from heated parts.
- Be sure to tighten fasteners including bolts and nuts to the specified torque.
- Place shop jacks or rigid racks at the specified points.
- Before disconnecting connectors of sensors or units, be sure to disconnect the ground cable from battery.
- All parts should be thoroughly cleaned, paying special attention to engine oil passages, pistons and bearings.
- Rotating parts and sliding parts such as piston, bearing and gear should be coated with oil prior to assembly.
- Be careful not to let oil, grease or coolant contact the timing belt, clutch disc and flywheel.
- All removed parts, if to be reused, should be re-installed in the original positions and directions.
- Bolts, nuts and washers should be replaced with new parts as required.
- Even if necessary inspections have been made in advance, proceed with assembly work while making rechecks.
- Remove or install the engine in an area where chain hoists, lifting devices, etc. are available for ready use.
- Be sure not to damage coated surfaces of body panels with tools, or not to stain seats and windows with coolant or oil. Place a cover over fender, as required, for protection.
- Prior to starting work, prepare the following:  
Service tools, clean cloth, containers to catch coolant and oil, wire ropes, chain hoist, transmission jacks, etc.
- Lift up or lower the vehicle when necessary. Make sure to support the correct positions.

# General Description

MECHANICAL

## D: PREPARATION TOOL

### 1. SPECIAL TOOL

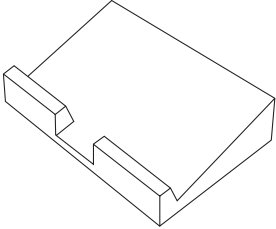
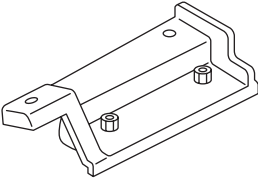
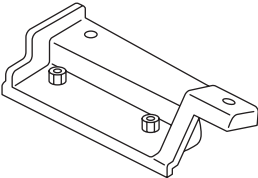
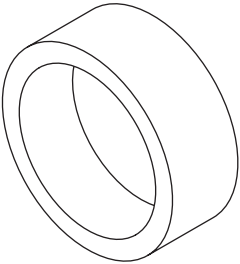
ILLUSTRATION	TOOL NUMBER	DESCRIPTION	REMARKS
 ST-498267600	498267600	CYLINDER HEAD TABLE	<ul style="list-style-type: none"><li>• Used for replacing valve guides.</li><li>• Used for removing and installing valve spring.</li></ul>
 ST-498457000	498457000	ENGINE STAND ADAPTER RH	Used together with ENGINE STAND (499817100).
 ST-498457100	498457100	ENGINE STAND ADAPTER LH	Used together with ENGINE STAND (499817100).
 ST-498747300	498747300	PISTON GUIDE	Used for installing the piston into the cylinder.

**ME(w/o STI)-14**

Brought to you by Ebay Seller "SubaruManuals"

# General Description

MECHANICAL

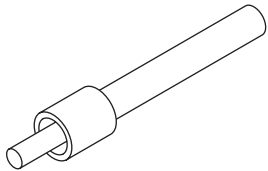
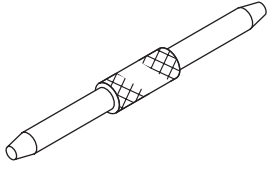
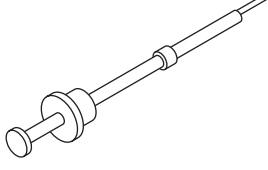
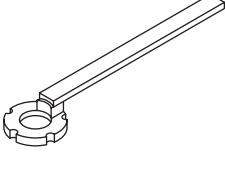
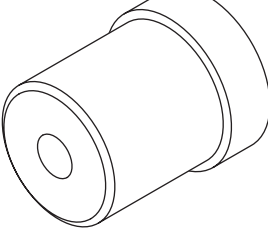
ILLUSTRATION	TOOL NUMBER	DESCRIPTION	REMARKS
 <p>ST-498857100</p>	498857100	VALVE OIL SEAL GUIDE	Used for press-fitting of intake valve guide oil seals and exhaust valve guide oil seals.
 <p>ST-499017100</p>	499017100	PISTON PIN GUIDE	Used for installing piston pin, piston and connecting rod.
 <p>ST-499097700</p>	499097700	PISTON PIN REMOVER ASSY	Used for removing piston pin.
 <p>ST-499207400</p>	499207400	CAM SPROCKET WRENCH	Used for removing and installing exhaust cam sprocket.
 <p>ST-499587100</p>	499587100	OIL SEAL INSTALLER	Used for installing oil pump oil seal.

**ME(w/o STI)-15**

Brought to you by Ebay Seller "SubaruManuals"

# General Description

## MECHANICAL

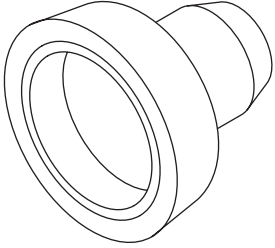
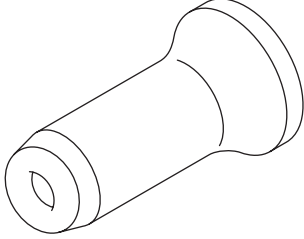
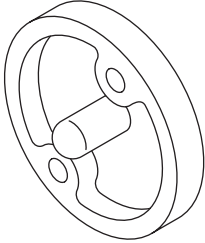
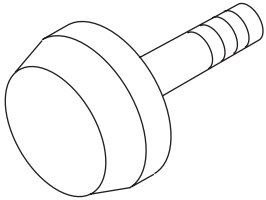
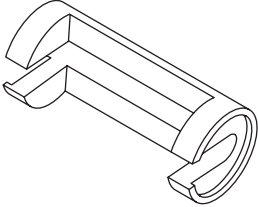
ILLUSTRATION	TOOL NUMBER	DESCRIPTION	REMARKS
 <p style="text-align: center;">ST-499587200</p>	499587200	CRANKSHAFT OIL SEAL INSTALLER	<ul style="list-style-type: none"> <li>• Used for installing crankshaft oil seal.</li> <li>• Used together with CRANKSHAFT OIL SEAL GUIDE (499597100).</li> </ul>
 <p style="text-align: center;">ST-499587600</p>	499587600	OIL SEAL INSTALLER	Used for installing the camshaft oil seal.
 <p style="text-align: center;">ST-499597100</p>	499597100	CRANKSHAFT OIL SEAL GUIDE	<ul style="list-style-type: none"> <li>• Used for installing crankshaft oil seal.</li> <li>• Used together with CRANKSHAFT OIL SEAL INSTALLER (499587200).</li> </ul>
 <p style="text-align: center;">ST-499597200</p>	499597200	OIL SEAL GUIDE	<ul style="list-style-type: none"> <li>• Used for installing the camshaft oil seal.</li> <li>• Used together with OIL SEAL INSTALLER (499587600).</li> </ul>
 <p style="text-align: center;">ST-499718000</p>	499718000	VALVE SPRING REMOVER	Used for removing and installing valve spring.

**ME(w/o STI)-16**

Brought to you by Ebay Seller "SubaruManuals"

# General Description

MECHANICAL

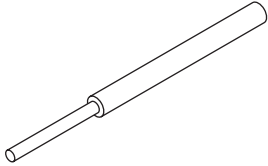
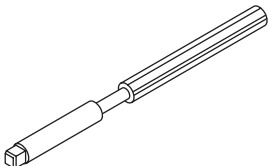
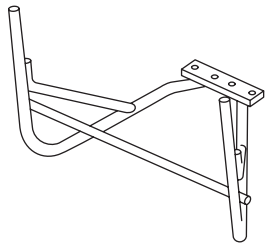
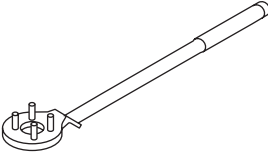
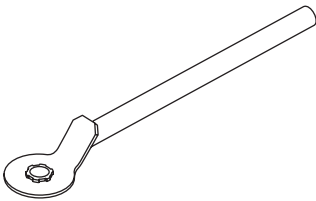
ILLUSTRATION	TOOL NUMBER	DESCRIPTION	REMARKS
 <p style="text-align: center;">ST-499767200</p>	499767200	VALVE GUIDE REMOVER	Used for removing valve guides.
 <p style="text-align: center;">ST-499767400</p>	499767400	VALVE GUIDE REAMER	Used for reaming valve guides.
 <p style="text-align: center;">ST-499817100</p>	499817100	ENGINE STAND	<ul style="list-style-type: none"> <li>• Used for disassembling and assembling engine.</li> <li>• Used together with ENGINE STAND ADAPTER RH (498457000) &amp; LH (498457100).</li> </ul>
 <p style="text-align: center;">ST-499977100</p>	499977100	CRANK PULLEY WRENCH	Used for removing and installing the crank pulley.
 <p style="text-align: center;">ST-499977500</p>	499977500	CAM SPROCKET WRENCH	Used for removing and installing intake cam sprocket.

**ME(w/o STI)-17**

Brought to you by Ebay Seller "SubaruManuals"

# General Description

## MECHANICAL

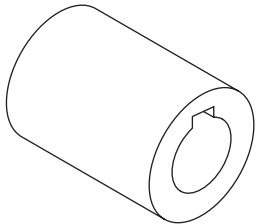
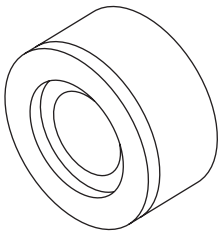
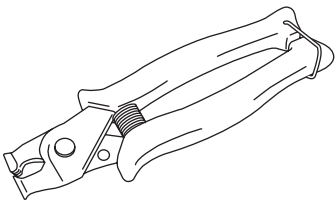
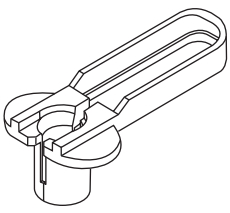
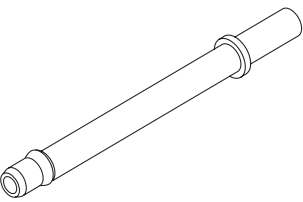
ILLUSTRATION	TOOL NUMBER	DESCRIPTION	REMARKS
 <p style="text-align: center;">ST-499987500</p>	499987500	CRANKSHAFT SOCKET	Used for rotating crankshaft.
 <p style="text-align: center;">ST18251AA020</p>	18251AA020	VALVE GUIDE ADJUSTER	Used for installing intake valve guides and exhaust valve guides.
 <p style="text-align: center;">ST18353AA000</p>	18353AA000	CLAMP PLIERS	<ul style="list-style-type: none"> <li>• Used for removing and installing the PCV hose.</li> <li>• This tool is made by the French company CAIL-LAU. (code) 54.0.000.205</li> </ul> To make it easier to obtain, it has been provided with a tool number.
 <p style="text-align: center;">ST18371AA000</p>	18371AA000	CONNECTOR REMOVER	Used for disconnecting the quick connector on the fuel return hose side of the engine compartment (intake manifold).
 <p style="text-align: center;">ST18471AA000</p>	18471AA000	FUEL PIPE ADAPTER	Used for inspecting the fuel pressure.

**ME(w/o STI)-18**

Brought to you by Ebay Seller "SubaruManuals"

# General Description

MECHANICAL

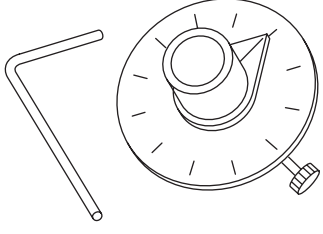
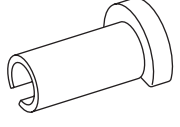
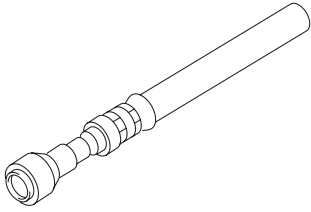
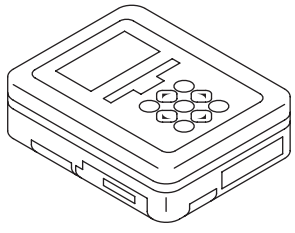
ILLUSTRATION	TOOL NUMBER	DESCRIPTION	REMARKS
 <p style="text-align: center;">ST18854AA000</p>	18854AA000	ANGLE GAUGE	Used for installing the crank pulley.
 <p style="text-align: center;">ST42099AE000</p>	42099AE000	QUICK CONNecTOR RELEASE	Used for removing the quick connector.
 <p style="text-align: center;">ST42075AG690</p>	42075AG690	FUEL HOSE	Used for inspecting the fuel pressure. NOTE: This is the SUBARU genuine part.
 <p style="text-align: center;">ST1B022XU0</p>	1B022XU0	SUBARU SELECT MONITOR III KIT	Used for various inspections.

## 2. GENERAL TOOL

TOOL NAME	REMARKS
Compression gauge	Used for measuring compression.
Timing light	Used for measuring ignition timing.
Vacuum gauge	Used for measuring intake manifold vacuum.
Oil pressure gauge	Used for measuring engine oil pressure.
Fuel pressure gauge	Used for measuring fuel pressure.

# Compression

MECHANICAL

## 2. Compression

### A: INSPECTION

#### CAUTION:

**After warming-up, engine becomes very hot. Be careful not to burn yourself during measurement.**

- 1) After warming-up the engine, turn the ignition switch to OFF.
- 2) Make sure that the battery is fully charged.
- 3) Remove the fuse of fuel pump from main fuse box.

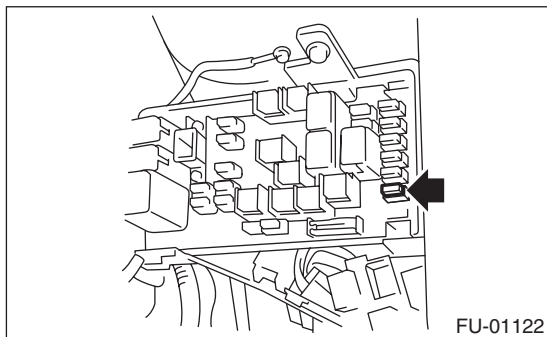

- 4) Start the engine and run it until it stalls.
- 5) After the engine stalls, crank it for five more seconds.
- 6) Turn the ignition switch to OFF.
- 7) Remove all spark plugs. <Ref. to IG(w/o STI)-4, REMOVAL, Spark Plug.>
- 8) Fully open the throttle valve.
- 9) Check the starter motor for satisfactory performance and operation.
- 10) Install the compression gauge to the spark plug hole.

#### NOTE:

When using a screw-in type compression gauge, the screw should be less than 18 mm (0.71 in) long.

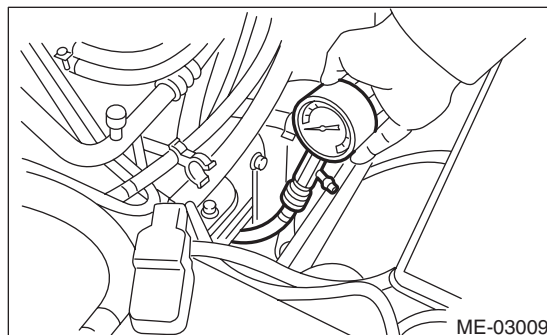

- 11) Crank the engine by starter motor and read the value when the needle of the compression gauge becomes stable.

#### NOTE:

- Perform at least two measurements per cylinder, and make sure that the values are correct.
- If the compression pressure is out of standard, check or adjust the pistons, valves and cylinders.

#### **Compression (fully open throttle):**

##### **Standard**

**981 — 1,177 kPa (10 — 12 kgf/cm<sup>2</sup>, 142 — 171 psi)**

##### **Difference between cylinders**

**49 kPa (0.5 kgf/cm<sup>2</sup>, 7 psi) or less**

- 12) After inspection, install the related parts in the reverse order of removal.

**ME(w/o STI)-20**

Brought to you by Ebay Seller "SubaruManuals"



### 3. Idle Speed

#### A: INSPECTION

1) Before checking the idle speed, check the following item:

(1) Check the air cleaner element is free from clogging, ignition timing is correct, spark plugs are in good condition, and hoses are connected properly.

(2) Check the malfunction indicator light does not illuminate.

2) Warm up the engine.

3) Read the engine idle speed using Subaru Select Monitor. <Ref. to EN(H4DOTC)(diag)-41, READ CURRENT DATA FOR ENGINE (NORMAL MODE), OPERATION, Subaru Select Monitor.>

#### NOTE:

- Idle speed cannot be adjusted manually, because the idle speed is automatically adjusted.
- If idle speed is out of standard, refer to the General Diagnosis Table under "Engine Control System". <Ref. to EN(H4DOTC)(diag)-2, Basic Diagnostic Procedure.>

(1) Check the idle speed when no-loaded. (Headlight, heater fan, rear defroster, radiator fan, A/C and etc. are OFF)

***Idle speed (No load and gear shift lever in neutral position):***

#### ***Standard***

***700±100 rpm***

(2) Check the idle speed when loaded. (Turn the A/C switch to "ON" and operate the compressor for at least one minute before measurement.)

***Idle speed (A/C ON and gear shift lever in neutral position):***

#### ***Standard***

***750±100 rpm***

# Ignition Timing

MECHANICAL

## 4. Ignition Timing

### A: INSPECTION

#### CAUTION:

After warming-up, engine becomes very hot. Be careful not to burn yourself at measurement.

#### 1. METHOD WITH SUBARU SELECT MONITOR

1) Before checking the ignition timing, check the following item:

- (1) Check the air cleaner element is free from clogging, spark plugs are in good condition, and hoses are connected properly.
- (2) Check the malfunction indicator light does not illuminate.

2) Warm up the engine.

3) Read the ignition timing using Subaru Select Monitor. <Ref. to EN(H4DOTC)(diag)-41, READ CURRENT DATA FOR ENGINE (NORMAL MODE), OPERATION, Subaru Select Monitor.>

#### NOTE:

If ignition timing is out of standard, check the ignition control system. Refer to "Engine Control System". <Ref. to EN(H4DOTC)(diag)-2, Basic Diagnostic Procedure.>

#### Ignition timing [BTDC/rpm]:

##### Standard

$12^{\circ} \pm 10^{\circ} / 700$

#### 2. METHOD WITH TIMING LIGHT

1) Before checking the ignition timing, check the following item:

- (1) Check the air cleaner element is free from clogging, spark plugs are in good condition, and hoses are connected properly.
- (2) Check the malfunction indicator light does not illuminate.

2) Warm up the engine.

3) Stop the engine, and turn the ignition switch to OFF.

4) Disconnect the ground cable from battery.

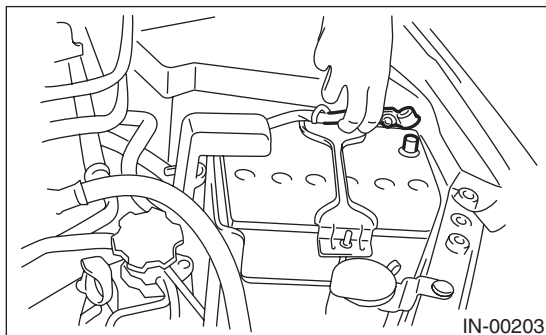

5) Remove the air intake duct. <Ref. to IN(w/o STI)-10, REMOVAL, Air Intake Duct.>

6) Remove the air cleaner case. <Ref. to IN(w/o STI)-8, REMOVAL, Air Cleaner Case.>

7) Connect the timing light to the power wire of #1 ignition coil.

8) Install the air cleaner case. <Ref. to IN(w/o STI)-8, INSTALLATION, Air Cleaner Case.>

9) Connect the battery ground terminal.

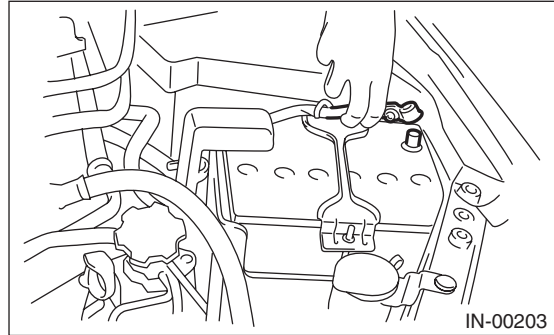

10) Start the engine, turn the timing light to the crank pulley, and check the ignition timing through the timing belt cover gauge.

#### NOTE:

If ignition timing is out of standard, check the ignition control system. Refer to "Engine Control System". <Ref. to EN(H4DOTC)(diag)-2, Basic Diagnostic Procedure.>

#### Ignition timing [BTDC/rpm]:

##### Standard

$12^{\circ} \pm 10^{\circ} / 700$

11) After inspection, install the related parts in the reverse order of removal.

ME(w/o STI)-22

Brought to you by Ebay Seller "SubaruManuals"

## 5. Intake Manifold Vacuum

### A: INSPECTION

- 1) Warm up the engine.
- 2) Remove the intercooler. <Ref. to IN(w/o STI)-12, REMOVAL, Intercooler.>
- 3) Disconnect the brake booster vacuum hose from the intake manifold, and attach the vacuum gauge.

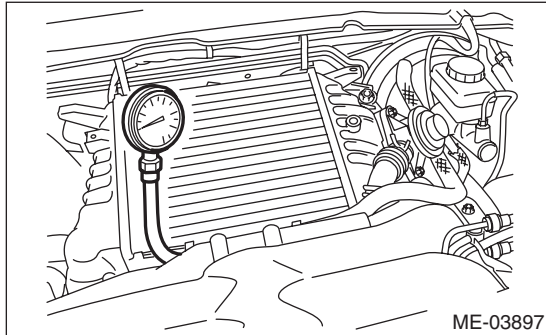

- 4) Install the intercooler. <Ref. to IN(w/o STI)-12, INSTALLATION, Intercooler.>
- 5) Keep the engine at idle speed and read the vacuum gauge indication.

**NOTE:**

Condition of engine inside can be diagnosed by observing the behavior of the vacuum gauge needle as described in table below.

**Intake manifold vacuum (at idling, A/C OFF):**

**Standard**

**-70.6 kPa (-530 mmHg, -20.85 inHg) or more**

- 6) After inspection, install the related parts in the reverse order of removal.

<b>Diagnosis of engine condition by inspection of intake manifold vacuum</b>	
Vacuum gauge needle behavior	Possible engine condition
1. Needle is steady but lower than standard value. This tendency becomes more evident as engine temperature rises.	Leakage around intake manifold gasket, disconnection or damage of vacuum hose
2. Needle intermittently drops to position lower than standard value.	Leakage around cylinder
3. Needle drops suddenly and intermittently from standard value.	Sticky valve
4. When engine speed is gradually increased, needle begins to vibrate rapidly at certain speed, and then vibration increases as engine speed increases.	Weak or broken valve springs
5. Needle vibrates above and below standard value in narrow range.	Defective ignition system

# Engine Oil Pressure

MECHANICAL

## 6. Engine Oil Pressure

### A: INSPECTION

1) Disconnect the ground cable from battery.

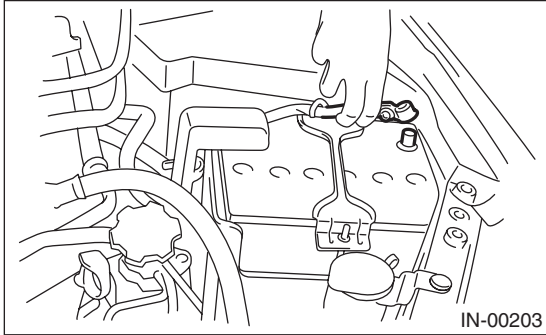

2) Remove the oil pressure switch. <Ref. to LU(STI)-22, REMOVAL, Oil Pressure Switch.>

3) Install the oil pressure gauge to cylinder block.

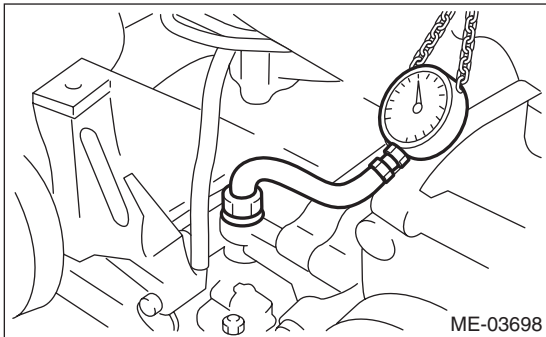

4) Connect the battery ground terminal.

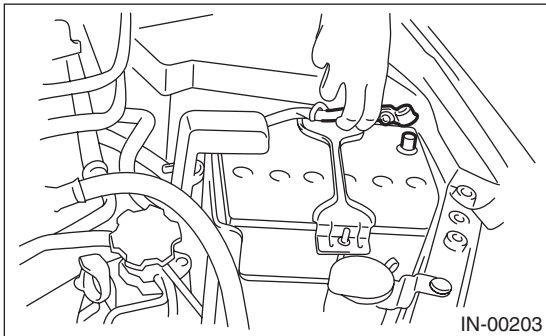

5) Start the engine, and check the oil pressure.

NOTE:

- Standard value is based on an engine oil temperature of 80°C (176°F).
- If the oil pressure is out of specification, check oil pump, oil filter and lubrication line. <Ref. to LU(STI)-33, INSPECTION, Engine Lubrication System Trouble in General.>
- If the oil pressure warning light is ON and oil pressure is within specification, check the oil pressure switch. <Ref. to LU(STI)-33, INSPECTION, Engine Lubrication System Trouble in General.>

**Engine oil pressure:**

**Standard**

**98 kPa (1.0 kgf/cm<sup>2</sup>, 14 psi) or more (at 600 rpm)**

**294 kPa (3.0 kgf/cm<sup>2</sup>, 43 psi) or more (at 5,000 rpm)**

6) After inspection, install the related parts in the reverse order of removal.

**ME(w/o STI)-24**

Brought to you by Ebay Seller "SubaruManuals"

## 7. Fuel Pressure

### A: INSPECTION

#### CAUTION:

- Before removing the fuel pressure gauge, release the fuel pressure.
- Be careful not to spill fuel.
- Catch the fuel from hoses using a container or cloth.

1) Release the fuel pressure. <Ref. to FU(w/o STI)-66, RELEASING OF FUEL PRESSURE, PROCEDURE, Fuel.>

2) Open the fuel filler lid and remove the fuel filler cap.

3) Disconnect the fuel delivery hose from the fuel delivery pipe, and connect the fuel pressure gauge.

#### CAUTION:

- Be careful not to spill fuel.
- Catch the fuel from hoses using a container or cloth.

(1) Attach ST to the fuel delivery pipe and push ST in the direction of arrow mark to disconnect the quick connector of the fuel delivery hose.

ST 42099AE000 QUICK CONNECTOR RELEASE

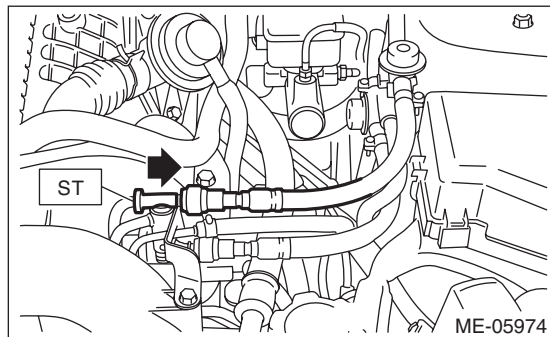

(2) Connect the fuel pressure gauge with ST1 and ST2.

#### NOTE:

ST1 is a SUBARU genuine part.

ST1 42075AG690 FUEL HOSE

ST2 18471AA000 FUEL PIPE ADAPTER

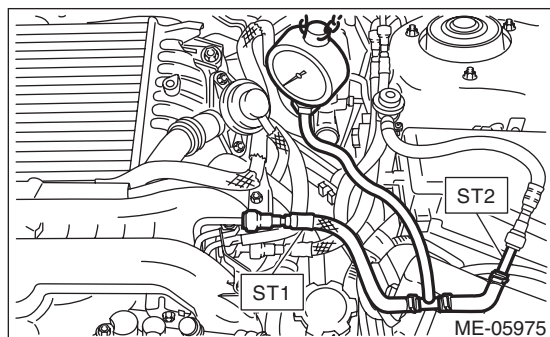

4) Start the engine.

5) Check the fuel pressure while disconnecting pressure regulator vacuum hose from intake manifold.

#### NOTE:

• The fuel pressure gauge registers 10 to 20 kPa (0.1 to 0.2 kgf/cm<sup>2</sup>, 1 to 3 psi) higher than standard values during high-altitude operations.

• If the fuel pressure is out of specification, check or replace the fuel pump, fuel line, pressure regulator and pressure regulator vacuum hose.

#### Fuel pressure:

##### Standard

**284 — 314 kPa (2.9 — 3.2 kgf/cm<sup>2</sup>, 41 — 46 psi)**

6) After connecting the vacuum hose to the pressure regulator, check the fuel pressure again.

#### NOTE:

• The fuel pressure gauge registers 10 to 20 kPa (0.1 to 0.2 kgf/cm<sup>2</sup>, 1 to 3 psi) higher than standard values during high-altitude operations.

• If the fuel pressure is out of specification, check or replace the fuel pump, fuel line, pressure regulator and pressure regulator vacuum hose.

#### Fuel pressure:

##### Standard

**230 — 260 kPa (2.4 — 2.7 kgf/cm<sup>2</sup>, 33 — 38 psi)**

7) After inspection, install the related parts in the reverse order of removal.

# Valve Clearance

MECHANICAL

## 8. Valve Clearance

### A: INSPECTION

- 1) Disconnect the ground cable from battery.

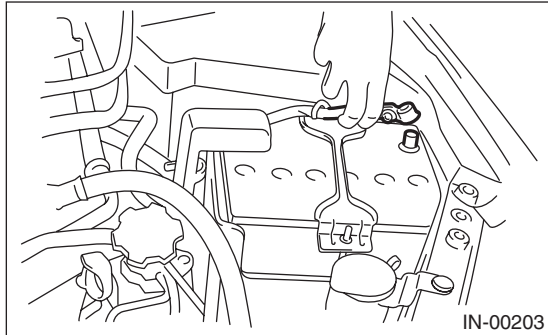

- 2) Remove the engine from vehicle. <Ref. to ME(w/o STI)-30, REMOVAL, Engine Assembly.>

- 3) Remove the timing belt cover RH. <Ref. to ME(w/o STI)-48, REMOVAL, Timing Belt Cover.>

- 4) When inspecting #1 and #3 cylinders  
(1) Remove the clip (A) and the stay (B) which hold the engine harness to the rocker cover RH.

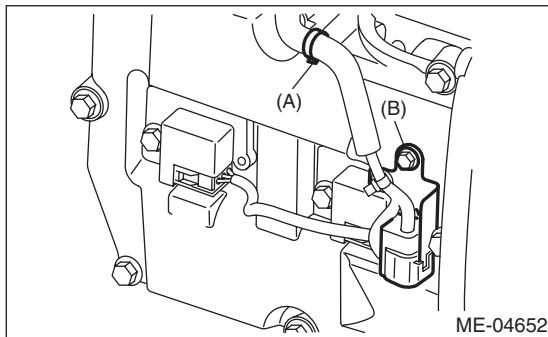

- (2) Remove the ignition coil. <Ref. to IG(w/o STI)-7, REMOVAL, Ignition Coil.>

- (3) Disconnect the PCV hose (A) and PCV hose assembly (B) from the rocker cover RH.

#### NOTE:

Pinch the clamp of the PCV hose (A) by fitting the cut out in the ST with the protrusion on the clamp as shown in the figure, and unlock the clamp.

ST 18353AA000 CLAMP PLIERS

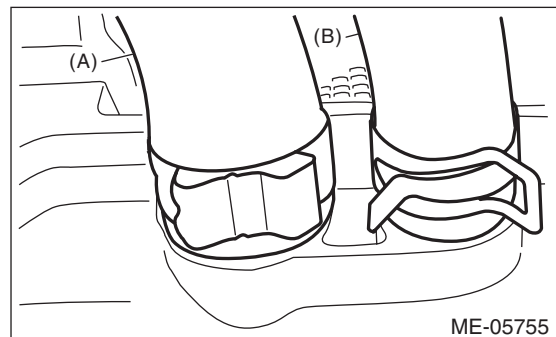
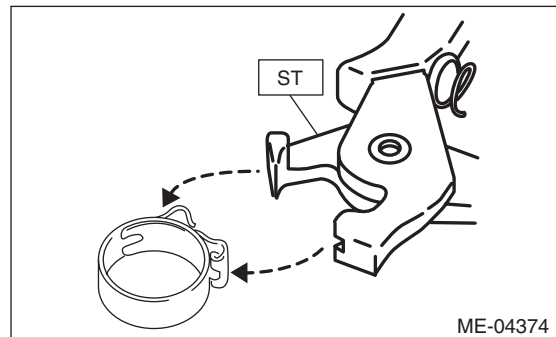

- (4) Remove the rocker cover RH.

- 5) When inspecting #2 and #4 cylinders

- (1) Remove the secondary air pump. <Ref. to EC(w/o STI)-29, REMOVAL, Secondary Air Pump.>

- (2) Remove the air duct B (B) from the rocker cover LH and the air duct A (A).

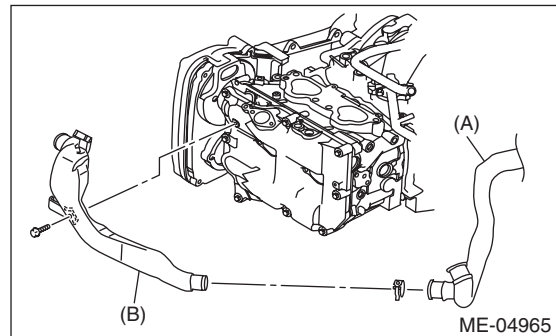

- (3) Remove the ignition coil. <Ref. to IG(w/o STI)-7, REMOVAL, Ignition Coil.>

ME(w/o STI)-26

Brought to you by Ebay Seller "SubaruManuals"

# Valve Clearance

MECHANICAL

(4) Disconnect the PCV hose (A) and PCV hose assembly (B) from the rocker cover LH.

**NOTE:**

Pinch the clamp of the PCV hose (A) by fitting the cut out in the ST with the protrusion on the clamp as shown in the figure, and unlock the clamp.

ST 18353AA000 CLAMP PLIERS

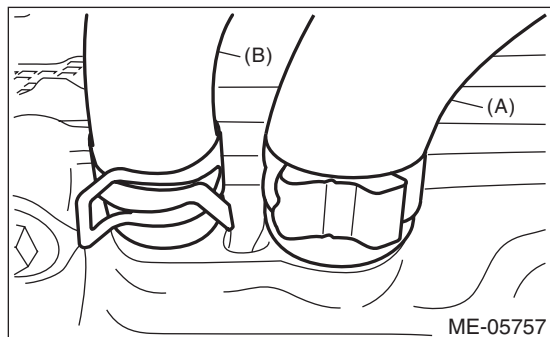
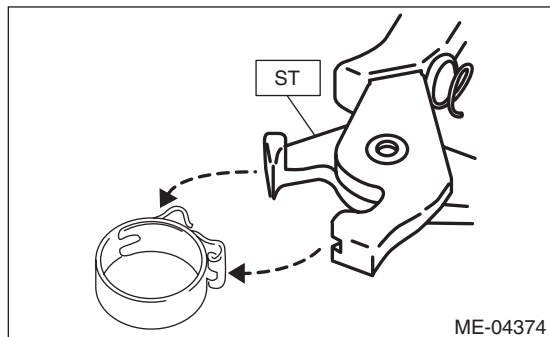

(5) Remove the rocker cover LH.

6) Turn the crank pulley clockwise until the round mark and arrow mark on the cam sprocket are set to position shown in the figure.

**NOTE:**

Turn the crank pulley using a socket wrench.

- Measurement of clearance of #1 cylinder intake valve and #3 cylinder exhaust valve

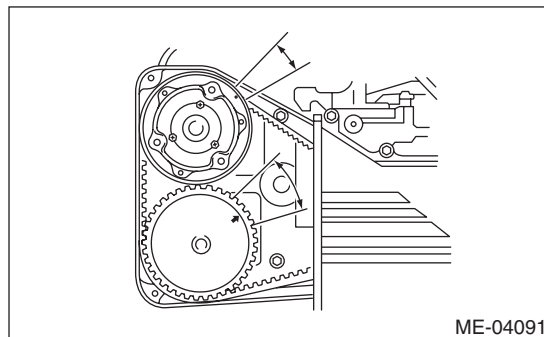

- Measurement of clearance of #2 cylinder exhaust valve and #3 cylinder intake valve

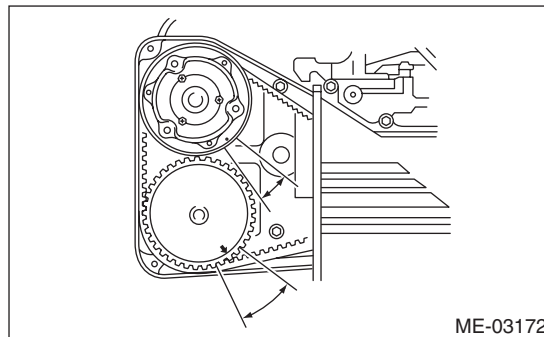

- Measurement of clearance of #2 cylinder intake valve and #4 cylinder exhaust valve

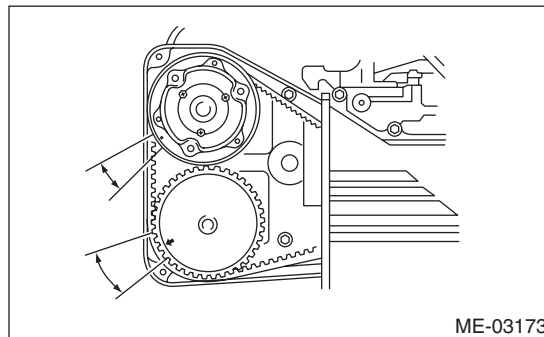

- Measurement of clearance of #1 cylinder exhaust valve and #4 cylinder intake valve

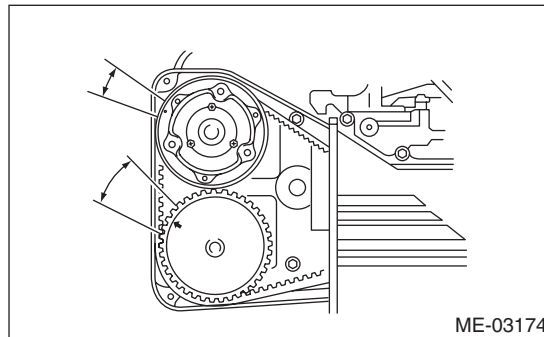

**ME(w/o STI)-27**

Brought to you by Ebay Seller "SubaruManuals"



# Valve Clearance

## MECHANICAL

7) Measure the clearance of intake valve and exhaust valve using thickness gauge (A).

### NOTE:

- Insert a thickness gauge in a direction as horizontal as possible with respect to the valve lifter.
- Lift up the vehicle, and then measure the exhaust valve clearances.
- If the measured value is not within the inspection value, take notes of the value in order to adjust the valve clearance later on.

### Valve clearance (inspection value):

#### Intake

$0.20^{+0.04}_{-0.06}$  mm ( $0.0079^{+0.0016}_{-0.0024}$  in)

#### Exhaust

$0.35 \pm 0.05$  mm ( $0.0138 \pm 0.0020$  in)

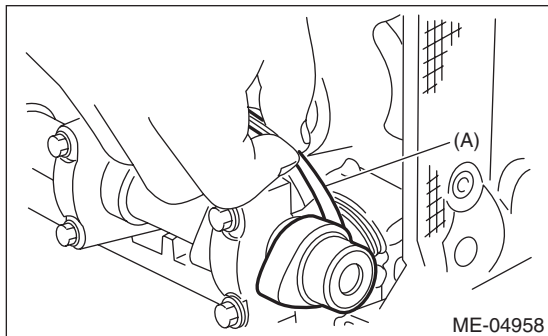

8) If necessary, adjust the valve clearance. <Ref. to ME(w/o STI)-29, ADJUSTMENT, Valve Clearance.>

9) After inspection, install the related parts in the reverse order of removal.

### NOTE:

- Refer to "Camshaft" when installing the rocker cover. <Ref. to ME(w/o STI)-63, INSTALLATION, Camshaft.>
- Use a new clamp for the PCV hose (A), fit the cut out in the ST with the protrusion on the clamp as shown in the figure, and lock the clamp.  
ST 18353AA000 CLAMP PLIERS

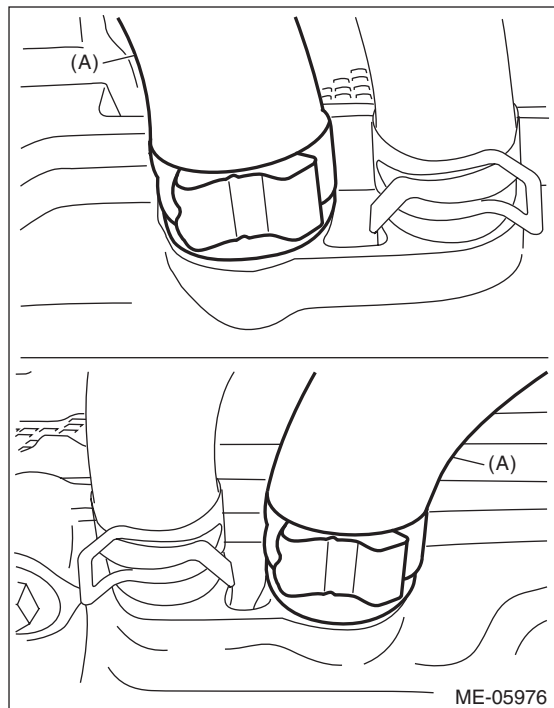
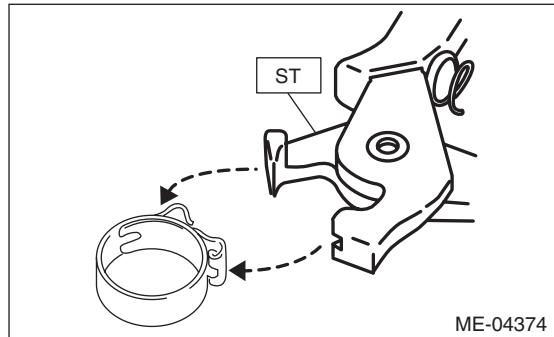



**Tightening torque:**  
**6.4 N·m (0.7 kgf-m, 4.7 ft-lb)**

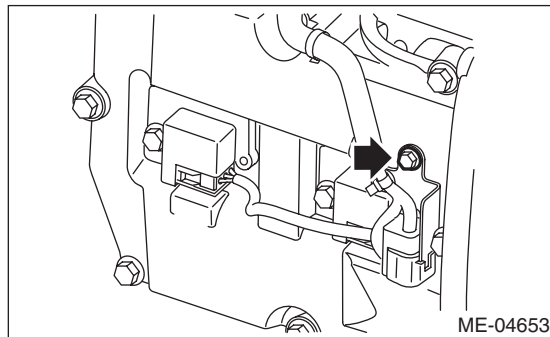
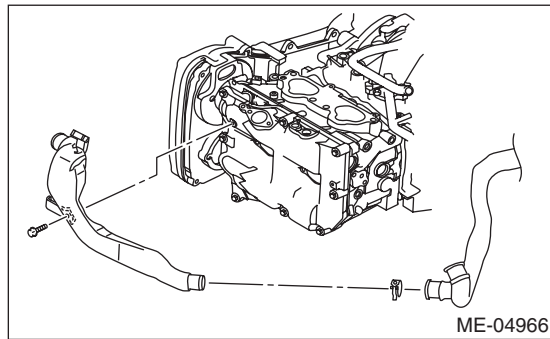

## B: ADJUSTMENT

1) Measure all the valve clearances. <Ref. to ME(w/o STI)-26, INSPECTION, Valve Clearance.>

**NOTE:**

Record the measured value of each valve clearance.

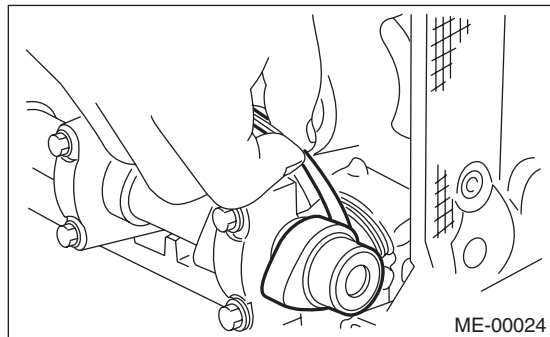

- 2) Remove the camshaft. <Ref. to ME(w/o STI)-60, REMOVAL, Camshaft.>
- 3) Remove the valve lifter.

4) Measure the thickness of valve lifter using micrometer.

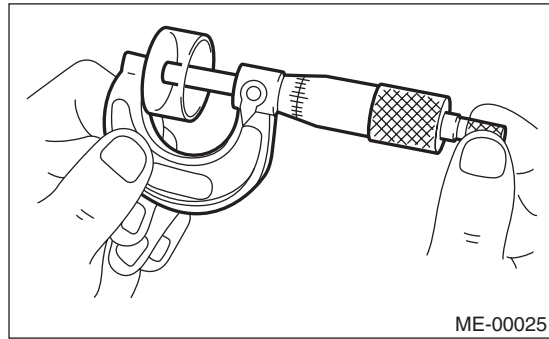

5) Select a valve lifter of suitable thickness using the measured valve clearance and valve lifter thickness, and install it.

**NOTE:**

Use a new valve lifter.

Unit: mm (in)
Intake valve: $S = (V + T) - 0.19 (0.0075)$
Exhaust valve: $S = (V + T) - 0.35 (0.0138)$
S: Valve lifter thickness required
V: Measured valve clearance
T: Valve lifter thickness to be used

6) Install the camshaft. <Ref. to ME(w/o STI)-63, INSTALLATION, Camshaft.>

7) Install the cam sprocket. <Ref. to ME(w/o STI)-58, INSTALLATION, Cam Sprocket.>

8) Install the timing belt. <Ref. to ME(w/o STI)-52, TIMING BELT, INSTALLATION, Timing Belt.>

9) Measure all valves for valve clearance again at this time. If the valve clearance is not within the adjustment value, repeat the procedure over again from step 2).

**Valve clearance (adjustment value):**

**Intake**

$$0.20^{+0.01} \text{ } _{-0.03} \text{ mm } (0.0079^{+0.0004} \text{ } _{-0.0012} \text{ in})$$

**Exhaust**

$$0.35 \pm 0.02 \text{ mm } (0.0138 \pm 0.0008 \text{ in})$$

10) After adjustment, install the related parts in the reverse order of removal.

# Engine Assembly

MECHANICAL

## 9. Engine Assembly

### A: REMOVAL

1) Change the bolt installation position from (A) to (B), then open the front hood completely.

**Tightening torque:**

**7.5 N·m (0.8 kgf-m, 5.5 ft-lb)**

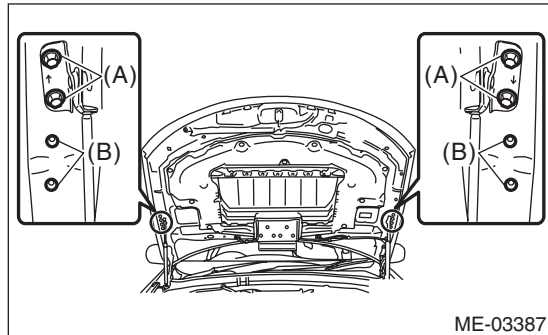

2) Remove the V-belt covers.

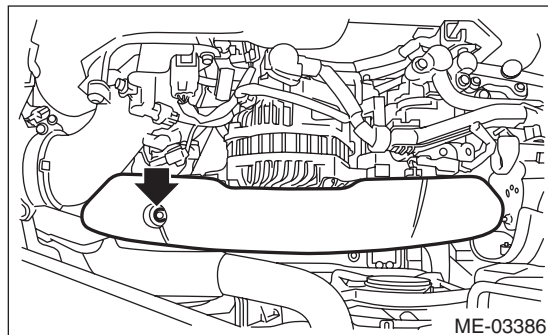

3) Collect the refrigerant from A/C system. <Ref. to AC-20, Refrigerant Recovery Procedure.>

4) Release the fuel pressure. <Ref. to FU(w/o STI)-66, RELEASING OF FUEL PRESSURE, PROCEDURE, Fuel.>

5) Remove the battery. <Ref. to SC(STI)-27, REMOVAL, Battery.>

6) Open the fuel filler lid and remove the fuel filler cap.

7) Remove the air intake duct and air cleaner case. <Ref. to IN(w/o STI)-10, REMOVAL, Air Intake Duct.> <Ref. to IN(w/o STI)-8, REMOVAL, Air Cleaner Case.>

8) Remove the intercooler. <Ref. to IN(w/o STI)-12, REMOVAL, Intercooler.>

9) Remove the radiator. <Ref. to CO(w/o STI)-19, REMOVAL, Radiator.>

10) Remove the coolant filler tank. <Ref. to CO(w/o STI)-28, REMOVAL, Coolant Filler Tank.>

11) Disconnect the bulkhead harness connectors from the engine harness connectors.

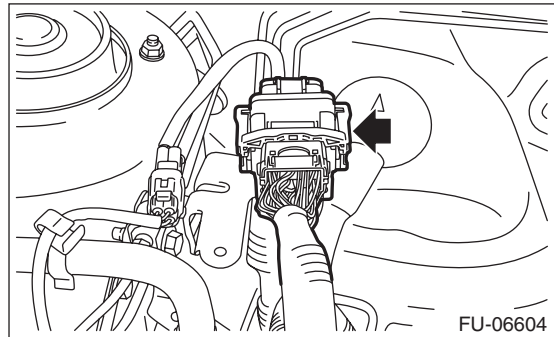

12) Remove the engine harness connector from the engine harness bracket.

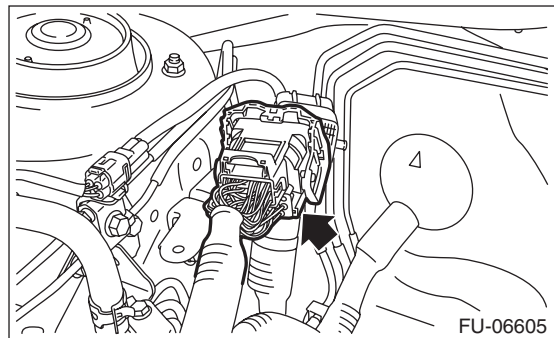

13) Disconnect the following connectors and terminals.

(1) Generator connector and terminal

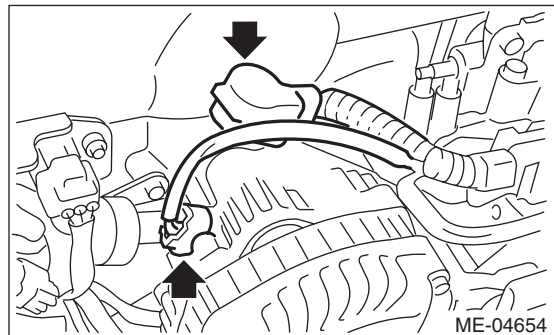

(2) Secondary air pump connector

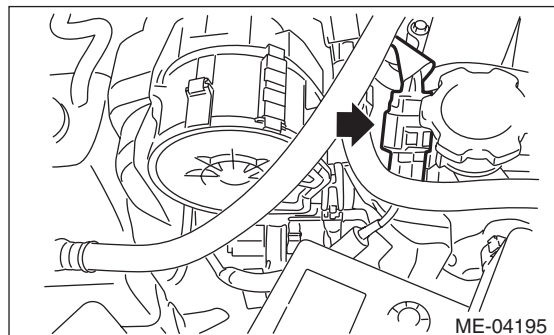

**ME(w/o STI)-30**

Brought to you by Ebay Seller "SubaruManuals"

- 14) Disconnect the connector (A) from the A/C compressor, and remove the clip (B) securing the generator cord.

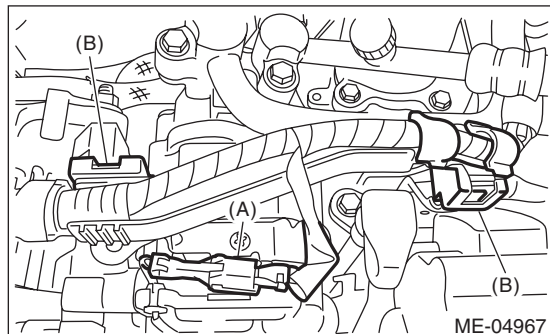

- 15) Disconnect the following hoses.  
 (1) A/C pressure hose <Ref. to AC-40, REMOVAL, Hose and Pipe.>  
 (2) Brake booster vacuum hose

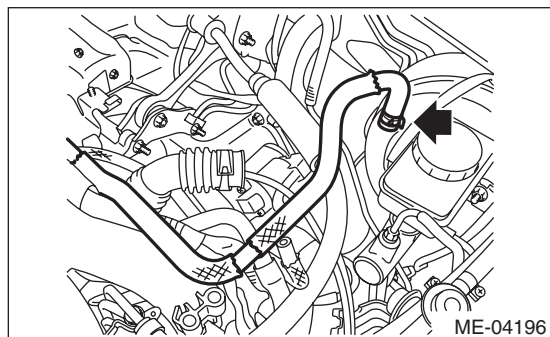

- (3) Heater inlet hose and heater outlet hose

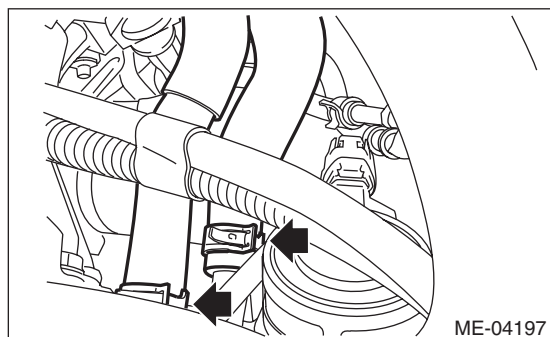

- 16) Remove the power steering pump.  
 (1) Remove the front side belts. <Ref. to ME(w/o STI)-39, FRONT SIDE BELT, REMOVAL, V-belt.>  
 (2) Disconnect the connector from power steering pump switch.

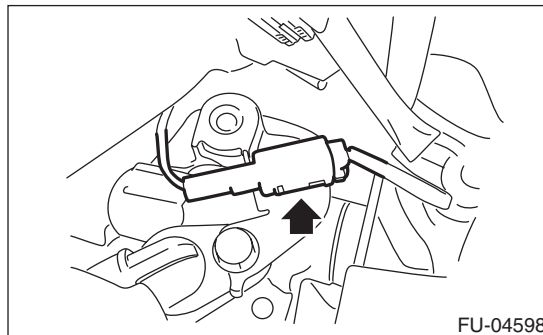

- (3) Remove the power steering pump from the engine.

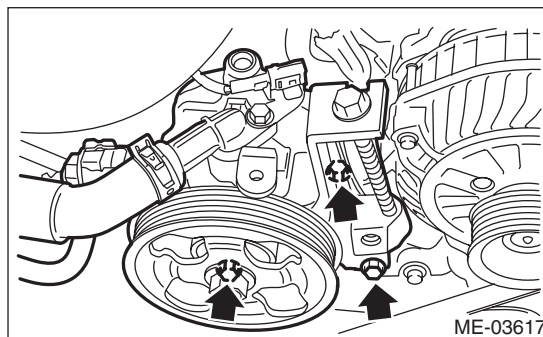

- (4) Place the power steering pump on the right side wheel apron.

- 17) Remove the center exhaust pipe. <Ref. to EX(STI)-8, REMOVAL, Center Exhaust Pipe.>  
 18) Remove the turbocharger. <Ref. to IN(w/o STI)-14, REMOVAL, Turbocharger.>  
 19) Remove the joint pipe and front exhaust pipe. <Ref. to EX(STI)-12, REMOVAL, Joint Pipe.> <Ref. to EX(STI)-6, REMOVAL, Front Exhaust Pipe.>  
 20) Disconnect the ground cable on the engine side.

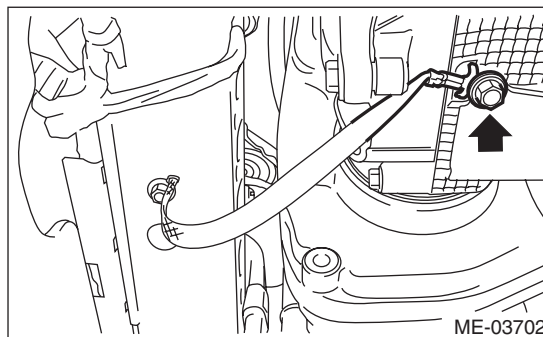

# Engine Assembly

## MECHANICAL

21) Remove the bolts and nuts which hold the lower side of transmission to the engine.

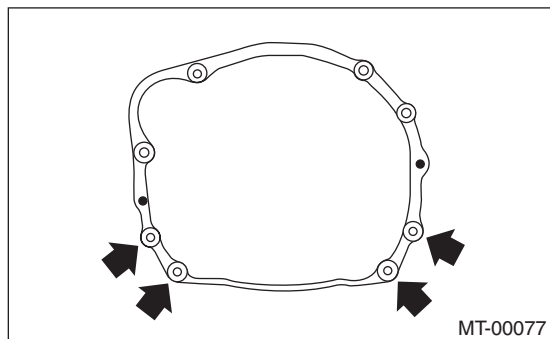

22) Remove the nuts which secure the engine mounting to the front crossmember.

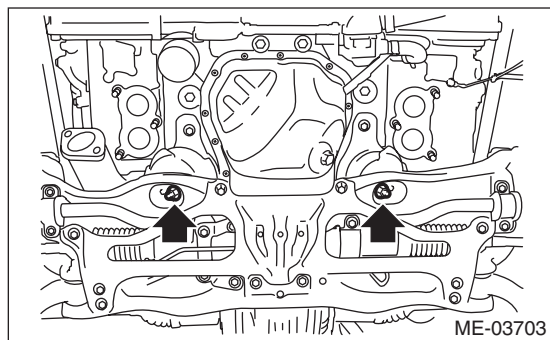

23) Lower the vehicle.

24) Remove the pitching stopper.

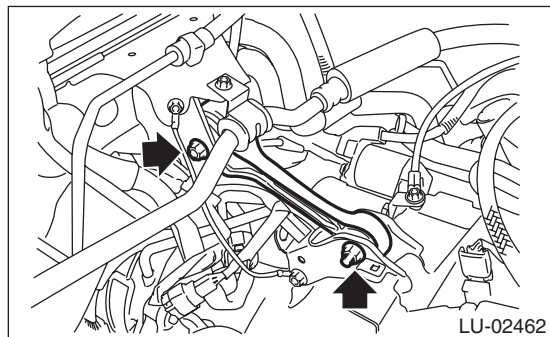

25) Attach ST to the fuel delivery pipe and push ST in the direction of arrow mark to disconnect the fuel delivery hose.

ST 42099AE000 QUICK CONNECTOR RELEASE

### CAUTION:

- Be careful not to spill fuel.
- Catch the fuel from hoses using a container or cloth.

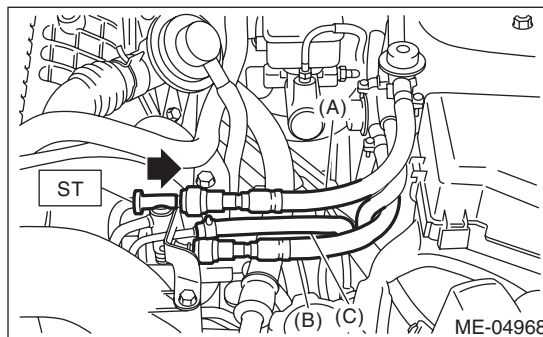

(A) Fuel delivery hose

(B) Fuel return hose

(C) Evaporation hose

26) Disconnect the fuel return hose using the ST.  
ST 18371AA000 CONNECTOR REMOVER

### CAUTION:

- Be careful not to spill fuel.
- Catch the fuel from hoses using a container or cloth.

(1) Attach ST to the fuel return pipe as shown in the figure.

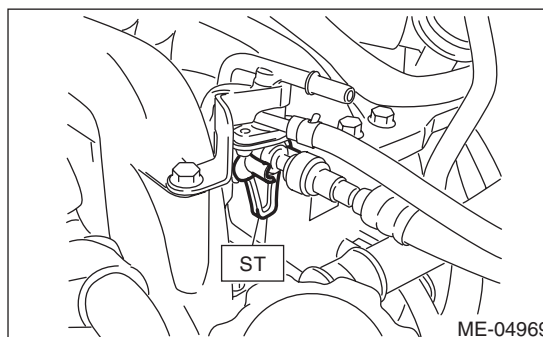



(2) Insert the front side of ST into the quick connector.

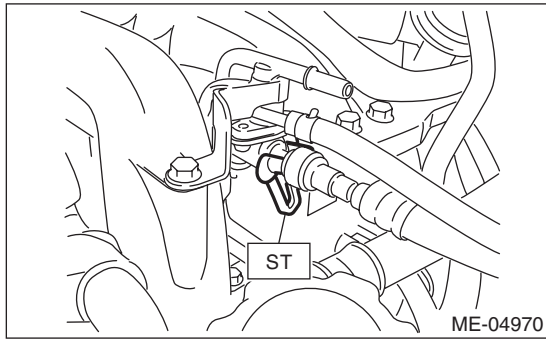

(3) Insert the back side of ST into the quick connector and push ST in the direction of arrow mark to disconnect the fuel return hose.

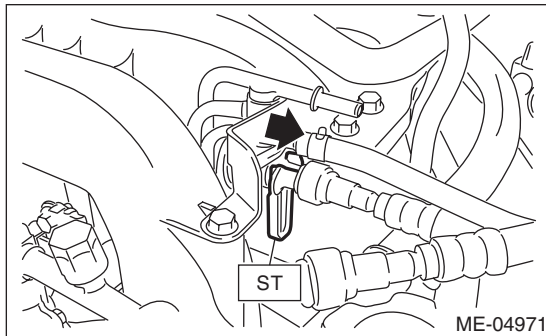

27) Remove the clip and disconnect the evaporation hose from the fuel pipe.

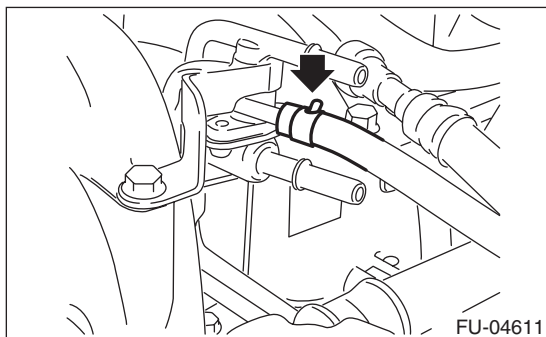

28) Support the engine with a lifting device and wire ropes.

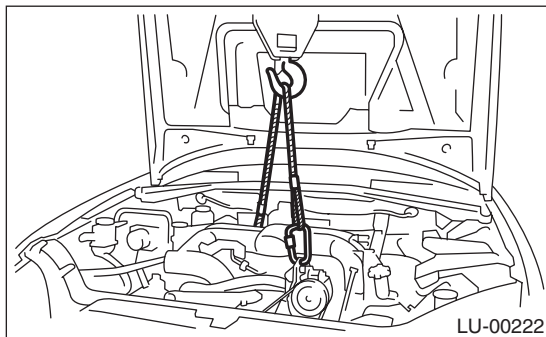

29) Support the transmission with a garage jack.

**CAUTION:**

Be sure to perform this procedure to prevent the transmission from lowering by its own weight.

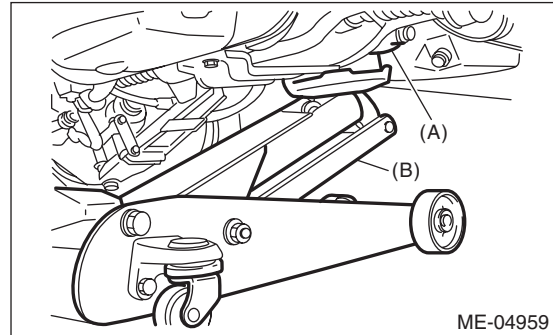

- (A) Transmission
- (B) Garage jack

30) Separation of engine and transmission

**CAUTION:**

Before removing the engine away from transmission, check to be sure no work has been overlooked.

- (1) Remove the starter. <Ref. to SC(STI)-7, REMOVAL, Starter.>
- (2) Remove the bolts which hold the upper side of the transmission to the engine.

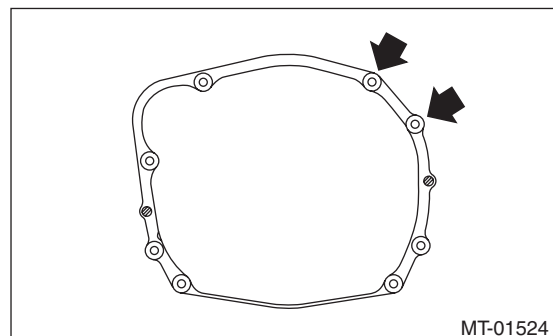

31) Remove the engine from the vehicle.

**NOTE:**

Be careful not to damage adjacent parts or body panels with crank pulley, oil level gauge, etc.

- (1) Slightly raise the engine.
- (2) Raise the transmission with garage jack.
- (3) Move the engine horizontally until main shaft is withdrawn from clutch cover.
- (4) Slowly move the engine away from engine compartment.

32) Remove the engine mounting from the engine.

# Engine Assembly

## MECHANICAL

### B: INSTALLATION

1) Install the engine mounting onto the engine.

**Tightening torque:**

**35 N·m (3.6 kgf·m, 25.8 ft-lb)**

2) Apply a small amount of grease to splines of main shaft.

**Grease:**

**NICHIMOLY N-130 or equivalent**

3) Position the engine in engine compartment and align it with transmission.

**NOTE:**

Be careful not to damage adjacent parts or body panels with crank pulley, oil level gauge, etc.

4) Tighten the bolts which hold upper side of transmission to engine.

**Tightening torque:**

**50 N·m (5.1 kgf·m, 36.9 ft-lb)**

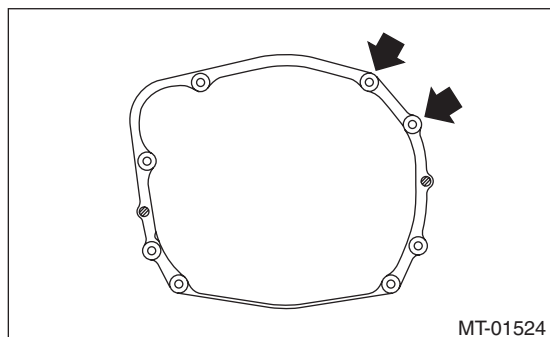

5) Remove the lifting device and wire ropes.

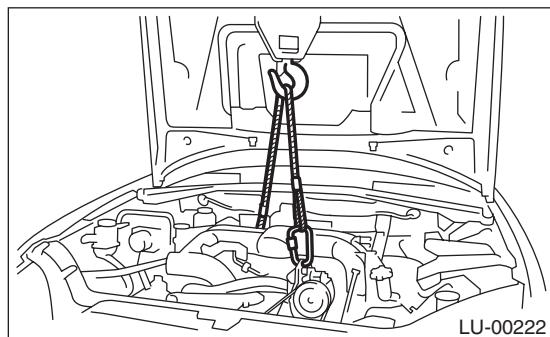

6) Remove the garage jack.

7) Install the pitching stopper.

**Tightening torque:**

**T1: 50 N·m (5.1 kgf·m, 36.9 ft-lb)**

**T2: 58 N·m (5.9 kgf·m, 42.8 ft-lb)**

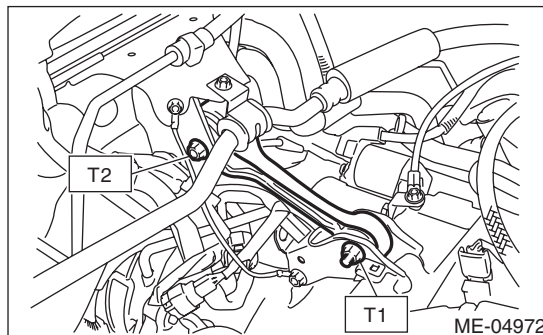

8) Install the starter. <Ref. to SC(STI)-7, INSTALLATION, Starter.>

9) Install the power steering pump.

(1) Install the power steering pump onto the engine.

**Tightening torque:**

**Refer to "COMPONENT" of "Power Steering" for the tightening torque. <Ref. to PS-3, COMPONENT, General Description.>**

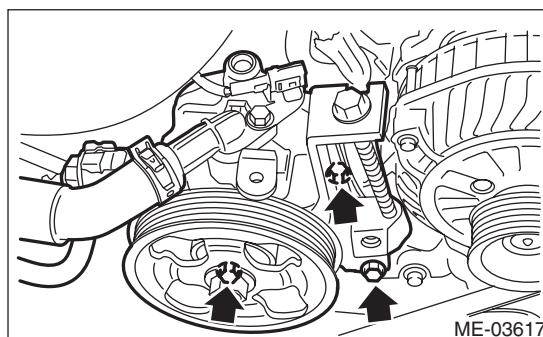

(2) Connect the connector to the power steering pump switch.

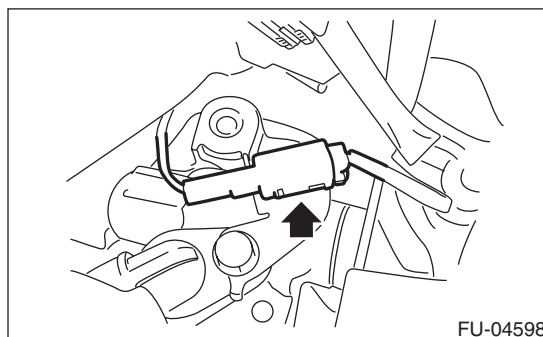

(3) Install the front side belt. <Ref. to ME(w/o STI)-39, FRONT SIDE BELT, INSTALLATION, V-belt.>

- 10) Lift up the vehicle.
- 11) Install the bolts and nuts which hold lower side of the transmission to engine.

**Tightening torque:**

**50 N·m (5.1 kgf-m, 36.9 ft-lb)**

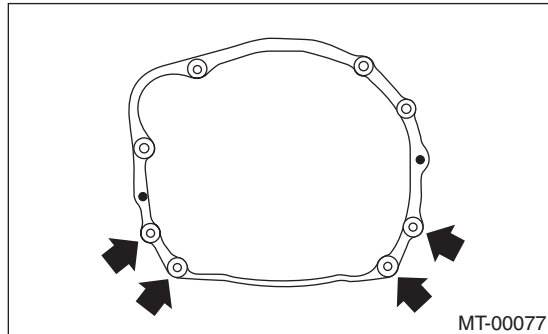

- 12) Install the nuts which hold the engine mounting to the crossmember.

**NOTE:**

Make sure that the engine mounting nuts (A) and locator (B) are securely installed.

**Tightening torque:**

**85 N·m (8.7 kgf-m, 62.7 ft-lb)**

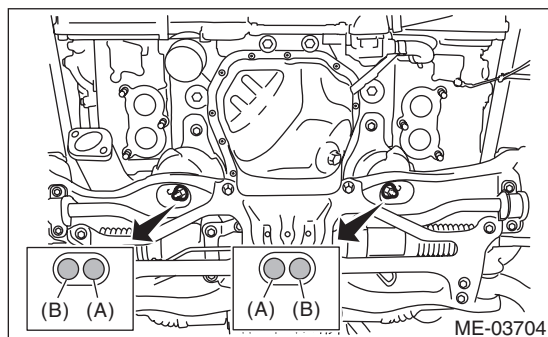

- 13) Connect the ground cable.

**Tightening torque:**

**7.5 N·m (0.8 kgf-m, 5.5 ft-lb)**

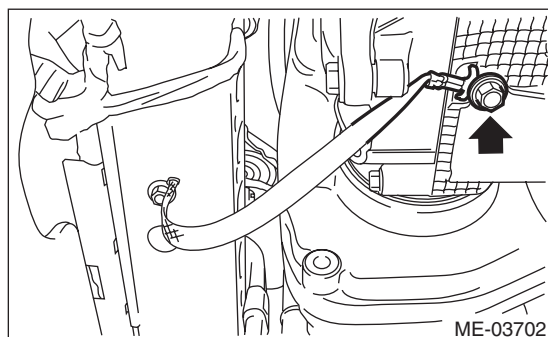

- 14) Install the joint pipe and front exhaust pipe. <Ref. to EX(STI)-6, INSTALLATION, Front Exhaust Pipe.> <Ref. to EX(STI)-12, INSTALLATION, Joint Pipe.>
- 15) Install the turbocharger. <Ref. to IN(w/o STI)-15, INSTALLATION, Turbocharger.>

- 16) Install the center exhaust pipe. <Ref. to EX(STI)-9, INSTALLATION, Center Exhaust Pipe.>

- 17) Connect the following hoses.

- (1) Fuel delivery hose, fuel return hose and evaporation hose
- (2) Heater inlet hose and heater outlet hose
- (3) Brake booster vacuum hose
- (4) A/C pressure hose <Ref. to AC-40, INSTALLATION, Hose and Pipe.>

- 18) Secure the generator cord using the clip (B) and connect the connector (A) to A/C compressor.

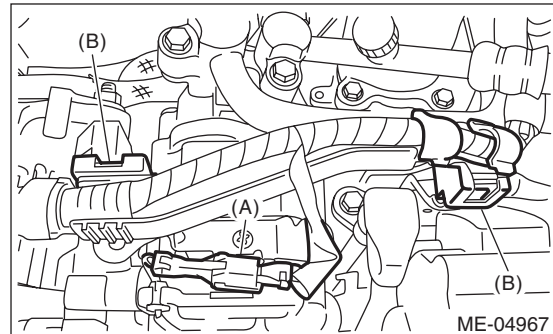

- 19) Connect the following connectors and terminals.

- (1) Generator connector and terminal

**Tightening torque:**

**15 N·m (1.5 kgf-m, 11.1 ft-lb)**

- (2) Secondary air pump connector

- 20) Install the engine harness connector to engine harness bracket, then connect the bulkhead harness connector to the engine harness connector.

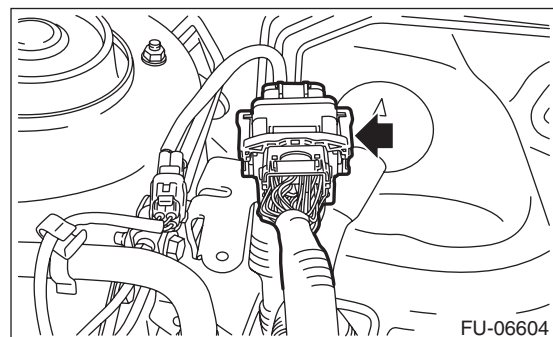

- 21) Install the intercooler. <Ref. to IN(w/o STI)-12, INSTALLATION, Intercooler.>
- 22) Install the radiator. <Ref. to CO(w/o STI)-20, INSTALLATION, Radiator.>
- 23) Install the coolant filler tank. <Ref. to CO(w/o STI)-28, INSTALLATION, Coolant Filler Tank.>
- 24) Install the air cleaner case and air intake duct. <Ref. to IN(w/o STI)-8, INSTALLATION, Air Cleaner Case.> <Ref. to IN(w/o STI)-10, INSTALLATION, Air Intake Duct.>
- 25) Install the battery. <Ref. to SC(STI)-27, INSTALLATION, Battery.>

# Engine Assembly

## MECHANICAL

26) Fill engine coolant. <Ref. to CO(w/o STI)-13, FILLING OF ENGINE COOLANT, REPLACEMENT, Engine Coolant.>

27) Charge the A/C system with refrigerant. <Ref. to AC-21, PROCEDURE, Refrigerant Charging Procedure.>

28) Install the V-belt cover.

### **Tightening torque:**

**13 N·m (1.3 kgf-m, 9.6 ft-lb)**

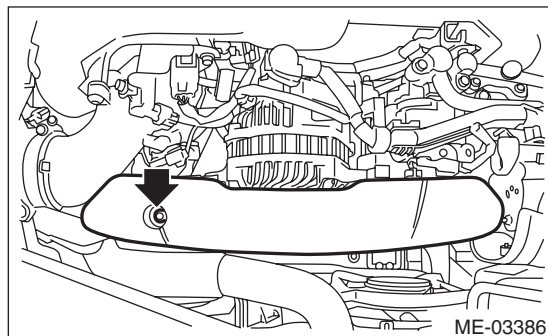

29) Change the bolt installation position from (B) to (A), then close the front hood.

### **Tightening torque:**

**7.5 N·m (0.8 kgf-m, 5.5 ft-lb)**

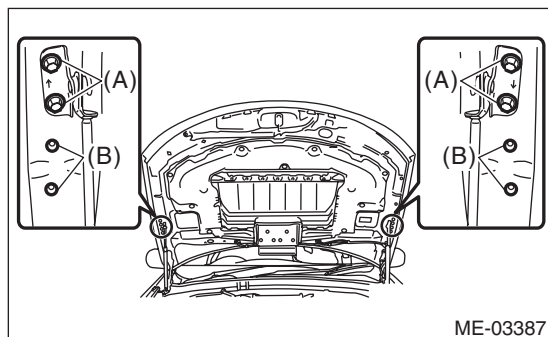

## **C: INSPECTION**

- 1) Check that pipes, hoses, connectors and clamps are installed firmly.
- 2) Check the engine coolant is at specified level.
- 3) Start the engine and check for exhaust gas, engine coolant, leaks of fuel, etc. Also check for noise and vibrations.



## 10.Engine Mounting

### A: REMOVAL

- 1) Remove the engine from the vehicle. <Ref. to ME(w/o STI)-30, REMOVAL, Engine Assembly.>
- 2) Remove the engine mounting from the engine.

### B: INSTALLATION

Install in the reverse order of removal.

#### *Tightening torque:*

***35 N·m (3.6 kgf-m, 25.8 ft-lb)***

### C: INSPECTION

Make sure that there are no cracks or other damages.

# Preparation for Overhaul

MECHANICAL

---

## 11. Preparation for Overhaul

### A: PROCEDURE

1) After removing the engine from vehicle body, attach the ST to the engine as shown in the figure.

ST1 498457000 ENGINE STAND ADAPTER  
RH

ST2 498457100 ENGINE STAND ADAPTER  
LH

ST3 499817100 ENGINE STAND

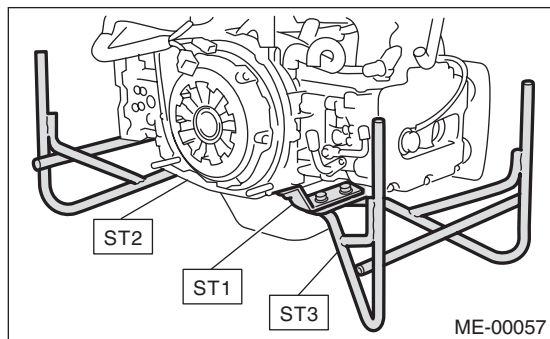

2) In this section the procedures described under each index are all connected and stated in order. The procedure for overhauling of the engine will be completed when you go through all steps in the process.

Therefore, in this section, to conduct the particular procedure within the flow of a section, you need to go back and conduct the procedure described previously in order to do that particular procedure.

## 12.V-belt

### A: REMOVAL

#### NOTE:

When replacing a single part, perform the work with the engine assembly installed to body.

#### 1. FRONT SIDE BELT

- 1) Remove the V-belt covers.

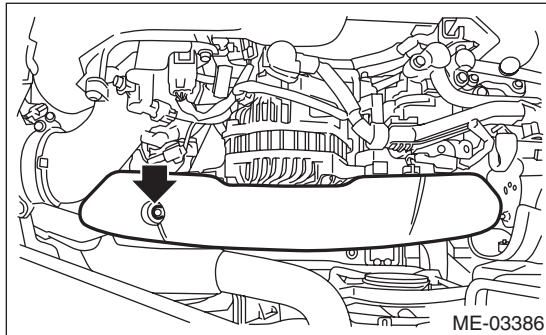

- 2) Remove the air intake duct. <Ref. to IN(w/o STI)-10, REMOVAL, Air Intake Duct.>
- 3) Loosen the bolt (A).
- 4) Loosen the slider bolt (B).
- 5) Remove the front side belt (C).

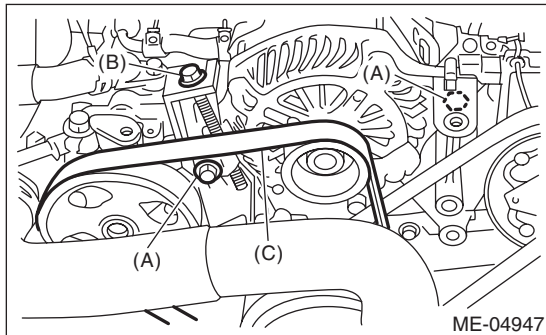

#### 2. REAR SIDE BELT

- 1) Remove the front side belts. <Ref. to ME(w/o STI)-39, FRONT SIDE BELT, REMOVAL, V-belt.>
- 2) Cut the rear side belt with a wire cutter, etc., and discard.

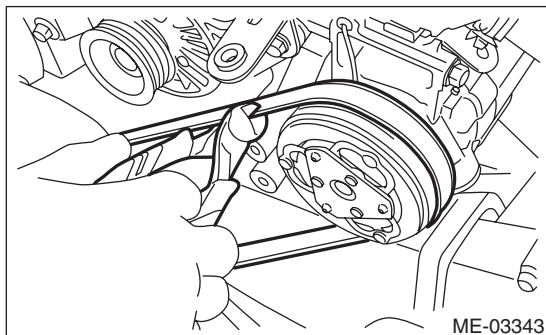

### B: INSTALLATION

#### 1. FRONT SIDE BELT

#### CAUTION:

- When reusing the front side belt, wipe off dust and water with cloth.
- Do not use the front side belt if there is any oil, grease or coolant on the belt.
- Be careful not to rub the belt end surface with bare hands; exposed core may cause injury.

- 1) Wipe off any dust, oil and water on the groove of each pulley with cloth.
- 2) Install the front side belt (C), and adjust the slider bolt (B) so as to obtain the specified belt tension. <Ref. to ME(w/o STI)-45, INSPECTION, V-belt.>
- 3) Tighten the bolt (A).
- 4) Tighten the slider bolt (B).

#### Tightening torque:

##### Bolt (A)

**25 N·m (2.5 kgf-m, 18.4 ft-lb)**

##### Slider bolt (B)

**8 N·m (0.8 kgf-m, 5.9 ft-lb)**

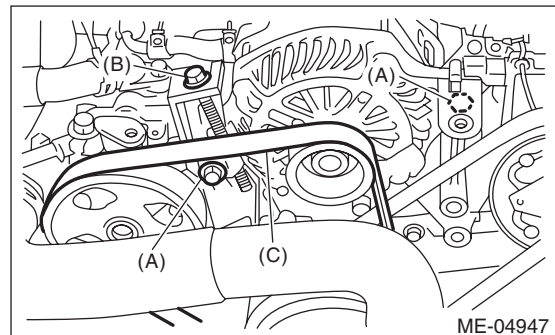

- 5) Install the air intake duct. <Ref. to IN(w/o STI)-10, INSTALLATION, Air Intake Duct.>
- 6) Install the V-belt cover.

#### Tightening torque:

**13 N·m (1.3 kgf-m, 9.6 ft-lb)**

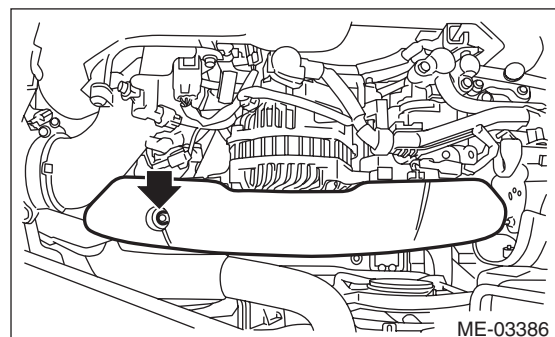

# V-belt

## MECHANICAL

### 2. REAR SIDE BELT

#### CAUTION:

- Do not re-use the rear side belt.
- Be careful not to let oil, grease or coolant contact a new rear side belt.
- Be careful not to rub the belt end surface with bare hands; exposed core may cause injury.
- To install the rear side belt, always use the provided tools (belt stopper, belt guide, belt guide holder, and bolt).

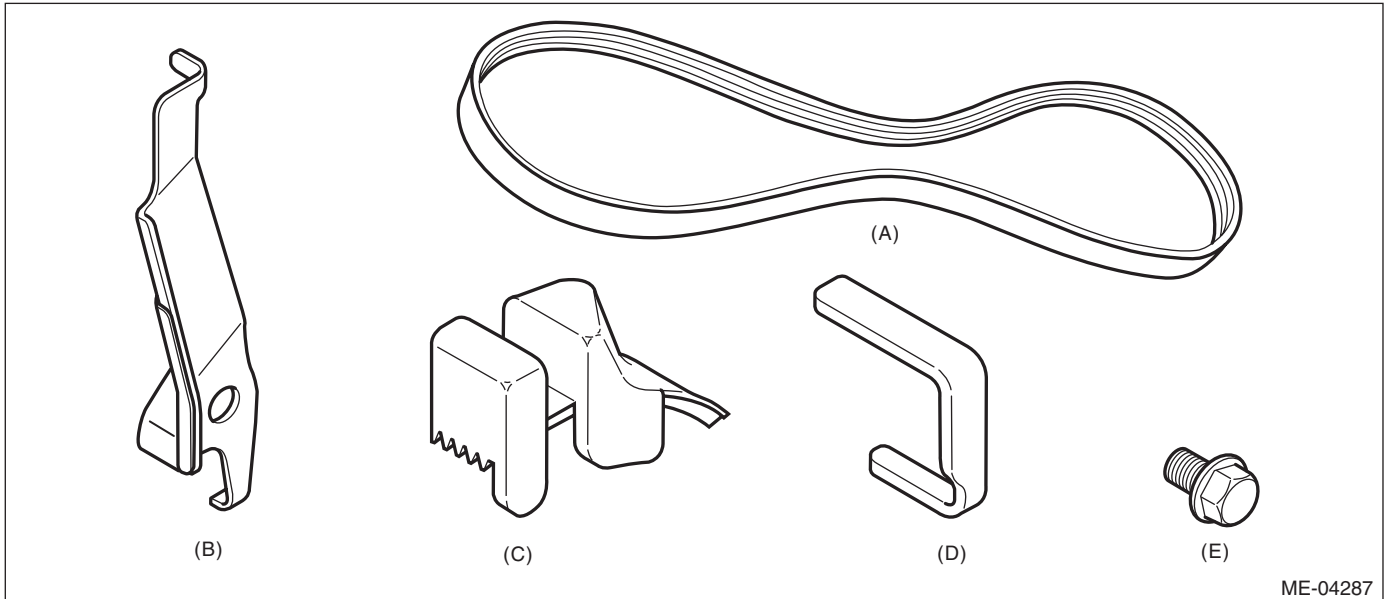

(A) Rear side belt

(C) Belt guide

(E) Bolt

(B) Belt stopper

(D) Belt guide holder

- 1) Wipe off any dust, oil and water on the groove of each pulley with cloth.
- 2) Wipe off any oil, water, dirt, and rust on the front of the crank pulley with cloth.
- 3) Slowly turn the crank pulley clockwise so that the service hole of the crank pulley comes around the top.

#### CAUTION:

**Do not turn the crank pulley counterclockwise.**

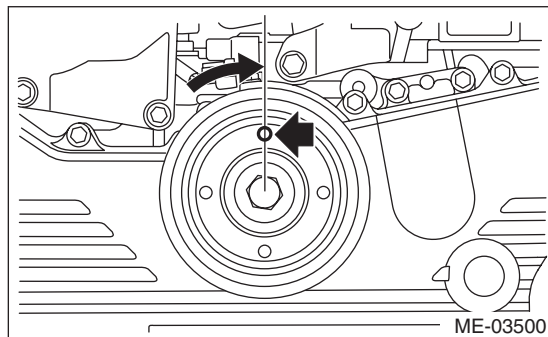

- 4) Hook a new rear side belt on the A/C compressor pulley.

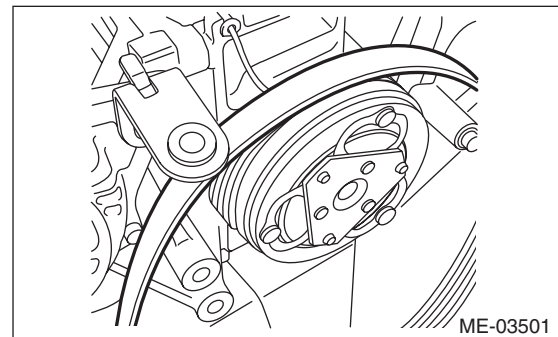

- 5) As shown in the figure, insert the claw of the belt stopper (A) to the lower hole (B) of the compressor bracket, then attach with bolt (C).

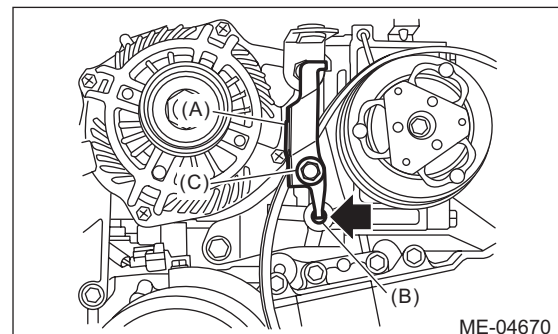

**ME(w/o STI)-40**

Brought to you by Ebay Seller "SubaruManuals"

6) Place the belt guide while aligning it with the belt line of the crank pulley on the front side belt side.

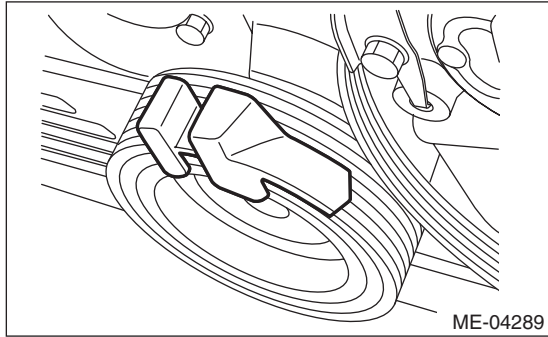

7) Insert the belt guide holder into the service hole of the crank pulley so that the belt guide comes in between.

**NOTE:**

Place the belt guide holder with the longer side up.

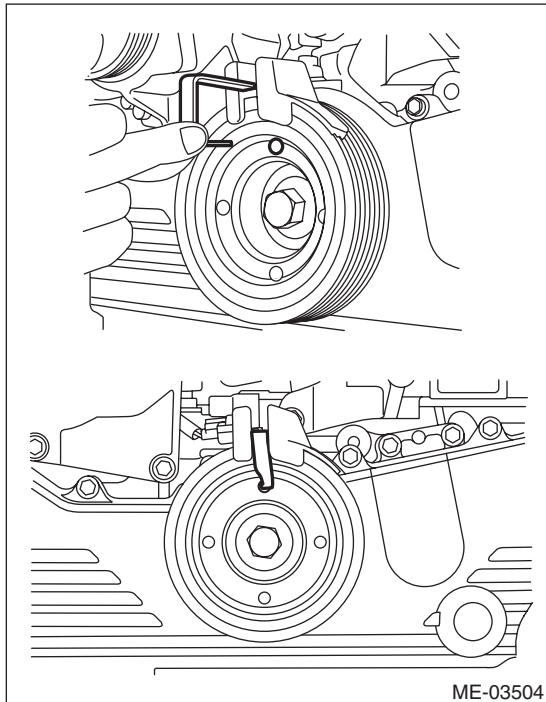

8) Slowly turn the crank pulley clockwise until the belt guide comes to approximately 45°.

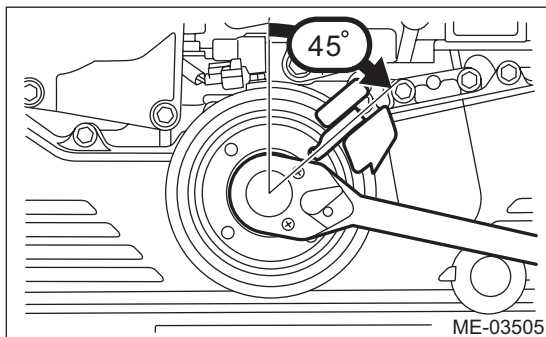

9) Place the rib surface of the rear side belt into the crank pulley groove, so that the rear side belt comes in between the belt guide holder.

**CAUTION:**

When it is difficult to place the rear side belt to the crank pulley groove, pull out the belt guide holder half way, then place the rear side belt into the groove so that it comes in between the belt guide holder.

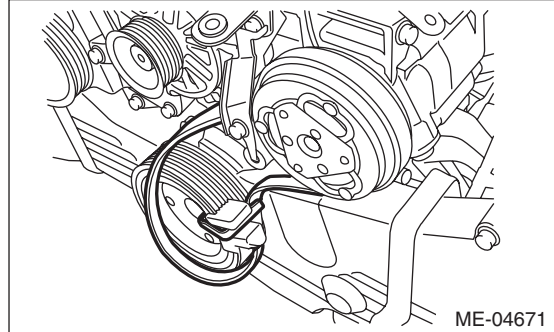

10) Place the tool through the loop of the rear side belt, and set on the crank pulley bolt.

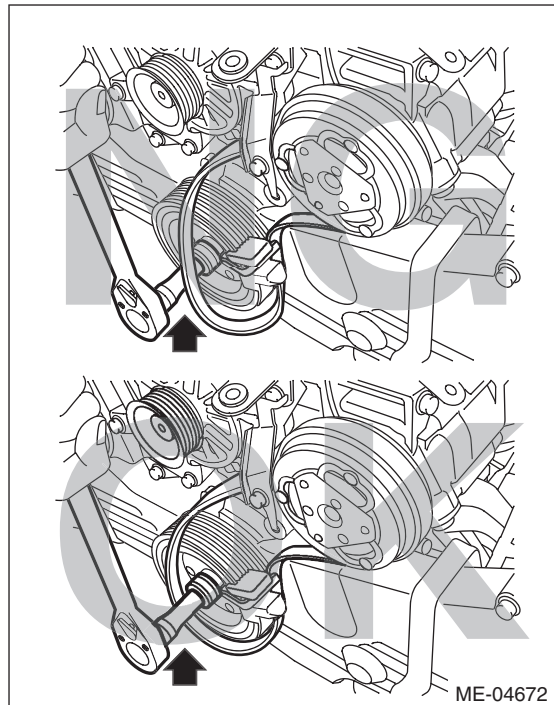

# V-belt

## MECHANICAL

11) While checking the following, slowly turn the crank pulley approximately 90° clockwise so that the belt guide comes to the position shown in the figure.

### CAUTION:

When turning the crank pulley, always make sure that the belt guide is not off from the crank pulley groove.

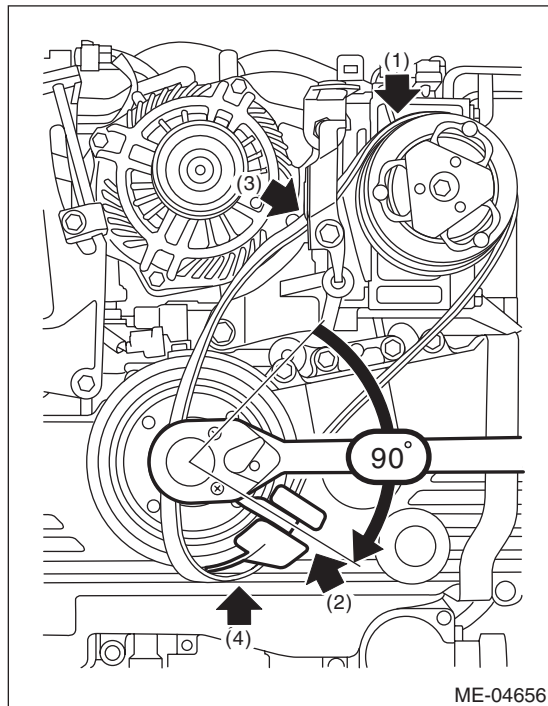

(1) The rib of the rear side belt is securely placed on the groove of the A/C compressor pulley.

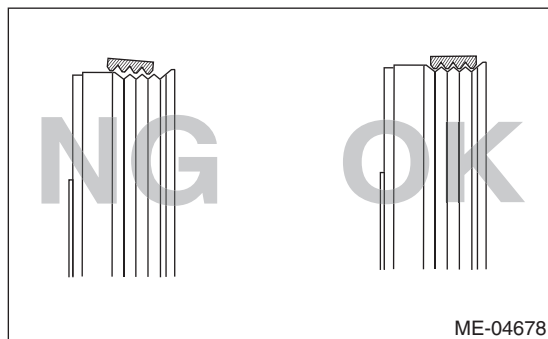

(2) The rib of the rear side belt is securely placed on the groove of the crank pulley.

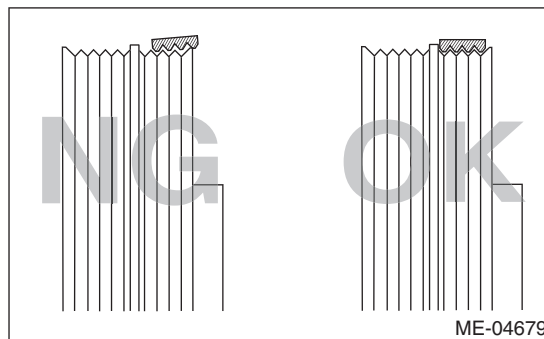

(3) The surface of the rear side belt is held by the belt stopper.

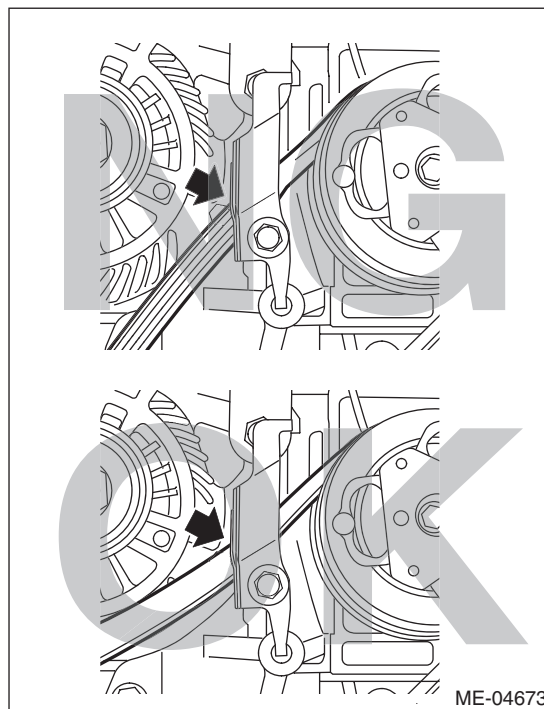

(4) The rear side belt is securely placed on the belt guide.

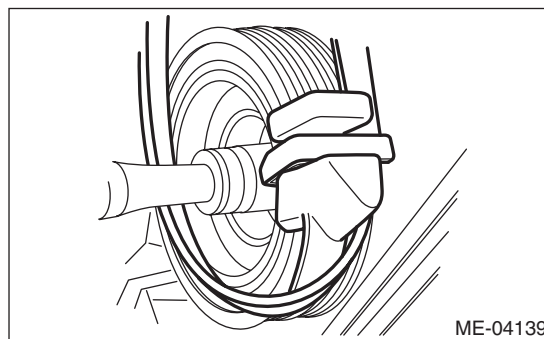



12) While checking the following, slowly turn the crank pulley approximately 90° clockwise so that the belt guide comes to the position shown in the figure.

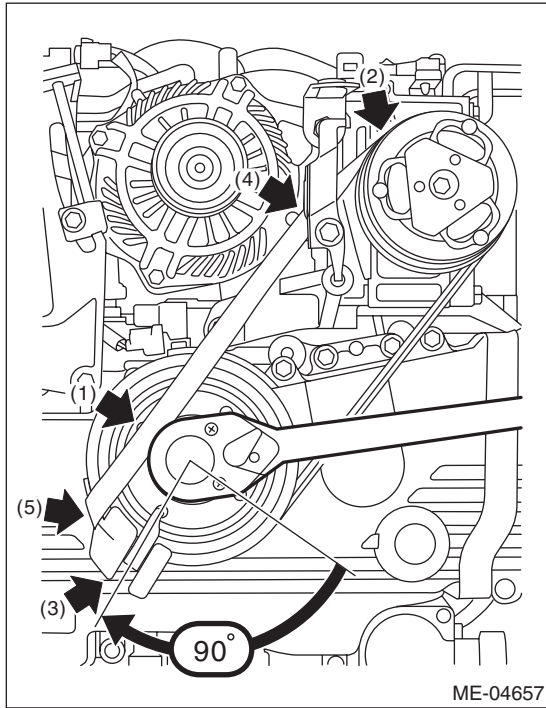

(1) The rear side belt is not twisted.

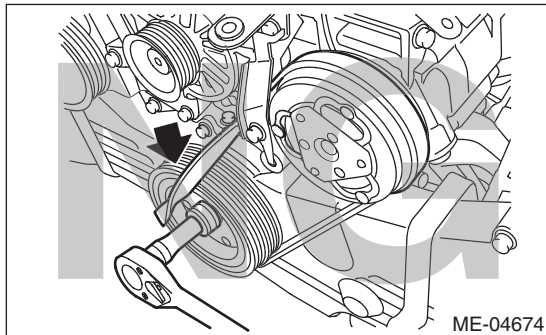

(2) The rib of the rear side belt is securely placed on the groove of the A/C compressor pulley.

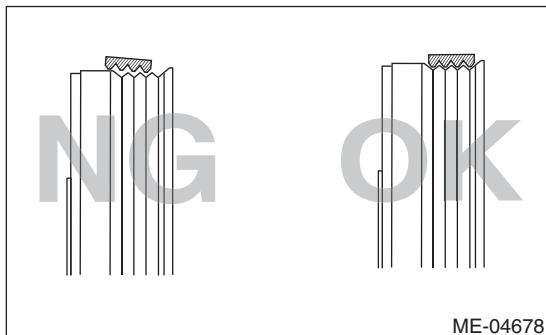

(3) The rib of the rear side belt is securely placed on the groove of the crank pulley.

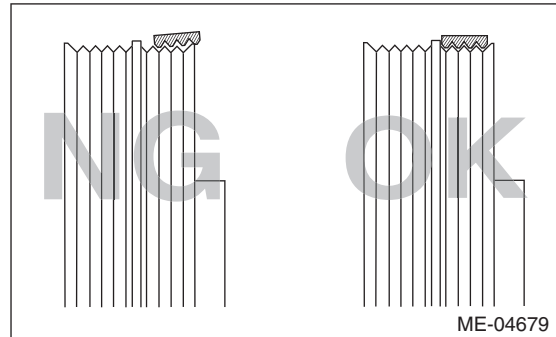

(4) The surface of the rear side belt is held by the belt stopper.

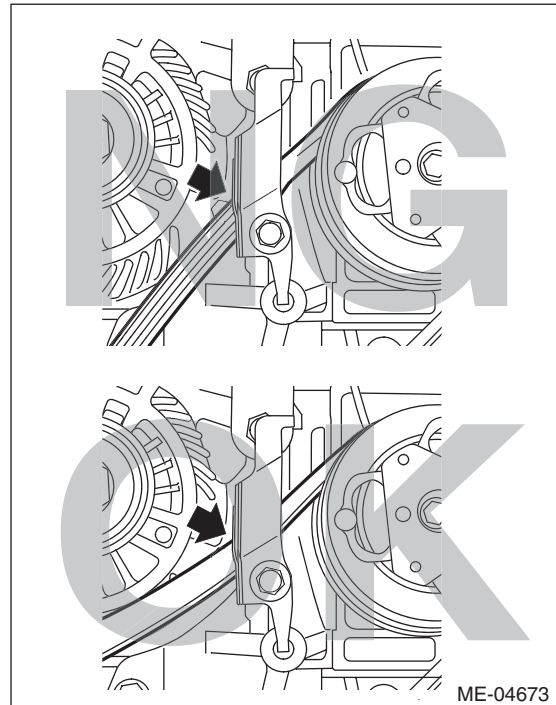

(5) The rear side belt is securely placed on the belt guide.

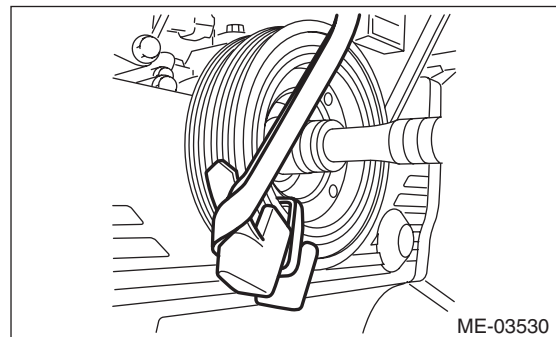

## V-belt

### MECHANICAL

13) Slowly turn the crank pulley clockwise, and install the rear side belt.

#### CAUTION:

Be careful that the total of procedures 8), 11), 12) and 13) does not exceed 330°; failure to do so may cause damage to the rear side belt and fall of the belt guide holder.

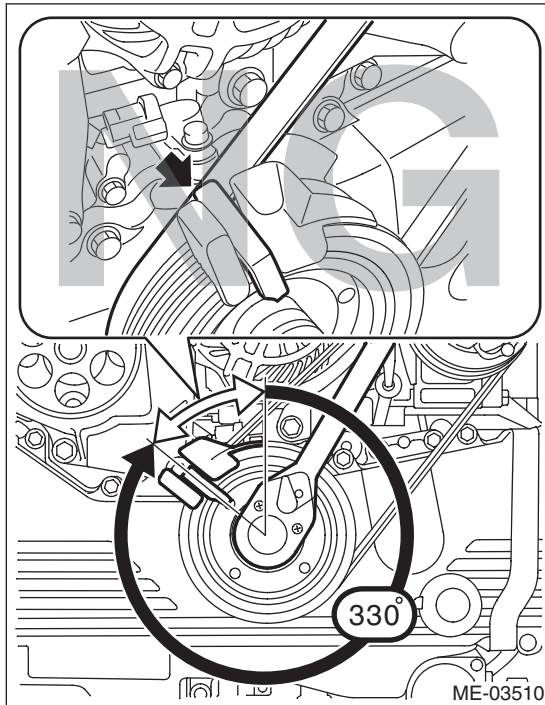

14) Remove the belt guide and belt guide holder from the crank pulley.

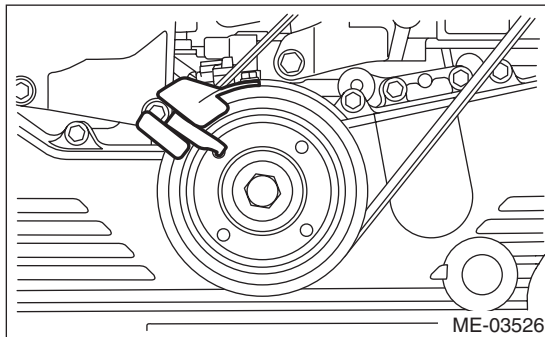

15) Remove the belt stopper from the compressor bracket.

#### CAUTION:

Always remove the belt stopper; failure to do so may cause smoke, fire, or belt cutting.

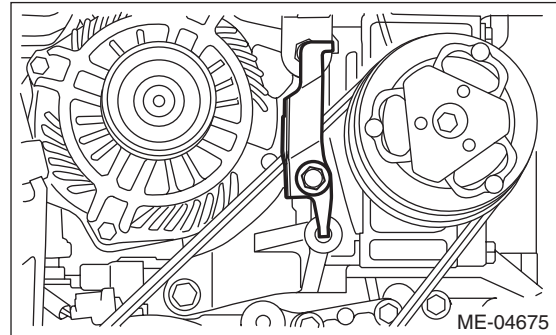

16) Make sure that the belt rib is securely installed on the groove of each pulley, then turn the crank pulley slowly, twice in the clockwise direction, to seat the rear side belt properly.

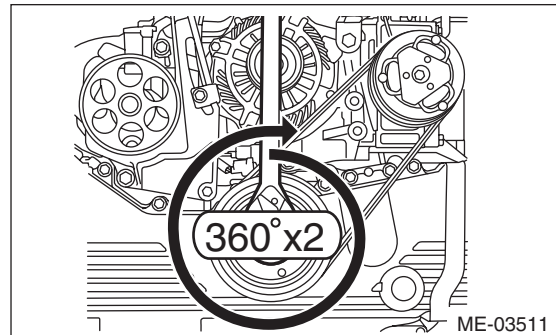

17) Discard the provided tools (belt stopper, belt guide, belt guide holder, and bolt) that are used.

18) Install the front side belt. <Ref. to ME(w/o STI)-39, FRONT SIDE BELT, INSTALLATION, V-belt.>



## C: INSPECTION

### 1. FRONT SIDE BELT

#### CAUTION:

Check and adjust the front side belt tension so that it is within the specified range. Using the belt with a tension out of the specified range may result in a fault such as the following:

- If the front side belt tension is higher, unexpected force is generated at the power steering oil pump, generator and crankshaft bearing, causing abnormal noise due to abnormal wear of the bearing.
- If the front side belt tension is lower, the front side belt and crank pulley slip, causing abnormally high temperature on the crank pulley due to frictional heat. If this condition repeatedly occurs, the front side belt may abnormally wear, causing abnormal noise, front side belt damage or crank pulley damage.

- 1) Replace the front side belt, if crack, fraying or wear is found.
- 2) Check the front side belt tension and adjust it if necessary by changing the generator installing position.

#### Front side belt tension (with belt tension gauge):

##### When installing new parts

640 — 780 N (65 — 80 kgf, 144 — 175 lbf)

##### At inspection

490 — 640 N (50 — 65 kgf, 110 — 144 lbf)

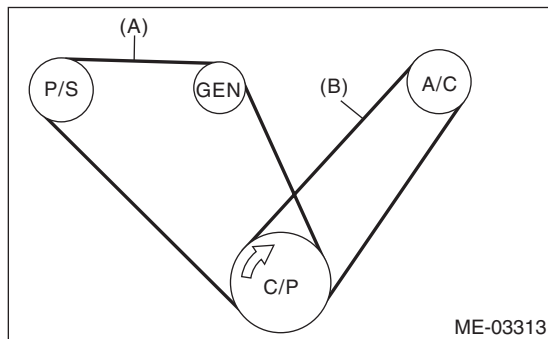

- (A) Front side belt
- (B) Rear side belt
- C/P Crank pulley
- GEN Generator pulley
- P/S Power steering oil pump pulley
- A/C A/C compressor pulley

#### Front side belt tension (without belt tension gauge):

##### When installing new parts

7 — 9 mm (0.276 — 0.354 in)

##### At inspection

9 — 11 mm (0.354 — 0.433 in)

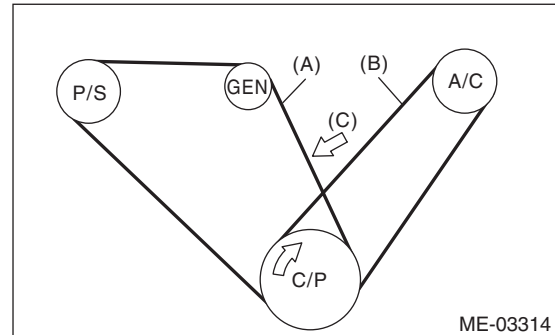

- (A) Front side belt
- (B) Rear side belt
- (C) 98 N (10 kgf, 22 lbf)
- C/P Crank pulley
- GEN Generator pulley
- P/S Power steering oil pump pulley
- A/C A/C compressor pulley

### 2. REAR SIDE BELT

Replace the rear side belt, if crack, fraying or wear is found, or noise is emitted.

#### NOTE:

For the rear side belt, a stretch type belt is used, and therefore, it is not necessary to check deflection nor tension.

# Crank Pulley

MECHANICAL

## 13. Crank Pulley

### A: REMOVAL

#### NOTE:

When replacing a single part, perform the work with the engine assembly installed to body.

1) Remove the V-belts. <Ref. to ME(w/o STI)-39, REMOVAL, V-belt.>

2) Use the ST to lock the crank pulley, and remove the crank pulley bolt.

ST 499977100 CRANK PULLEY WRENCH

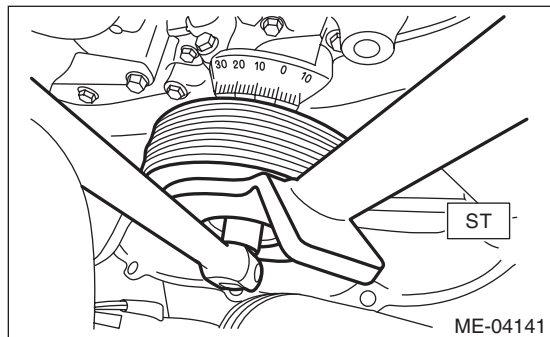

3) Remove the crank pulley.

### B: INSTALLATION

#### 1. METHOD WITHOUT ANGLE GAUGE

1) Clean the crankshaft thread using compressed air.

2) Install the crank pulley.

3) Apply engine oil to the crank pulley bolt seat and thread.

4) Tighten the crank pulley bolts.

(1) Use the ST to lock the crank pulley, and temporarily tighten the crank pulley bolt.

ST 499977100 CRANK PULLEY WRENCH

#### Tightening torque:

**47 N·m (4.8 kgf·m, 34.7 ft·lb)**

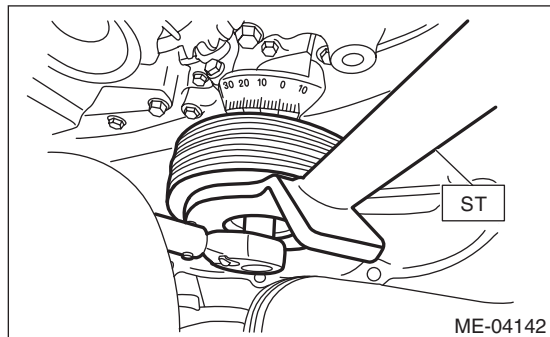

(2) Draw reference lines (A) and (B) using a marker to set the socket to the crank pulley bolt as shown in the figure.

#### NOTE:

Set the socket onto the crank pulley bolt so that reference lines (A) and (B) is visible.

ST 499977100 CRANK PULLEY WRENCH

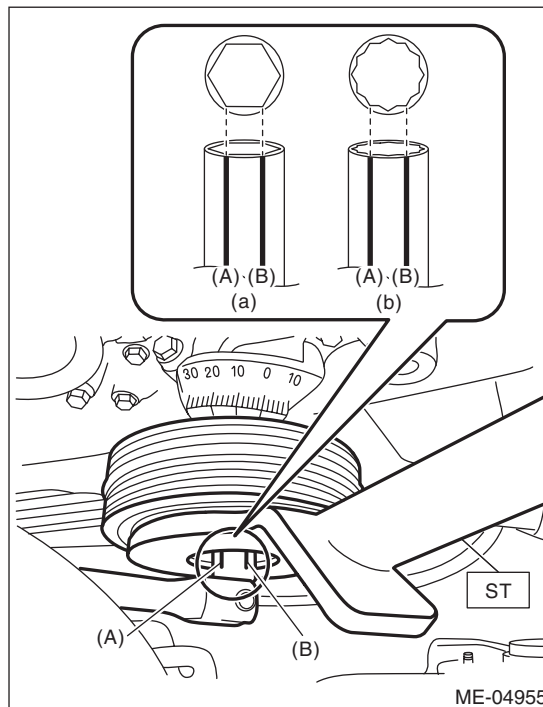

(a) When using 6-point socket

(b) When using 12-point socket

(3) Draw end line (C) on ST using a marker at the same position as reference line (B) drawn on the socket in step (2).

ST 499977100 CRANK PULLEY WRENCH

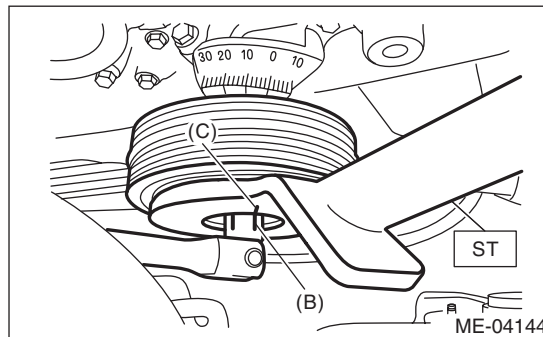

ME(w/o STI)-46

Brought to you by Ebay Seller "SubaruManuals"

(4) Use the ST to lock the crank pulley, and tighten the crank pulley bolt to the angle where reference line (A) and end line (C) are aligned.

**NOTE:**

It should be approx. 60° when reference line (A) and end line (C) are aligned.

ST 499977100 CRANK PULLEY WRENCH

**Tightening angle:**

**60°±5°**

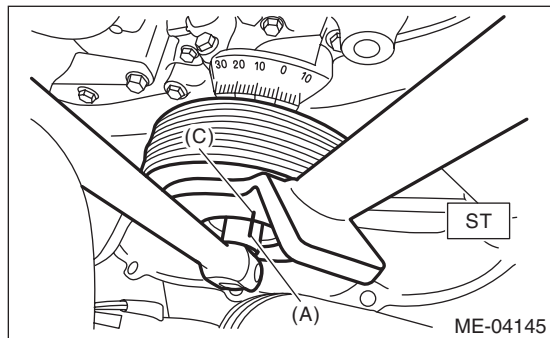

5) Install the V-belts. <Ref. to ME(w/o STI)-39, INSTALLATION, V-belt.>

**2. METHOD WITH ANGLE GAUGE**

- 1) Clean the crankshaft thread using compressed air.
- 2) Install the crank pulley.
- 3) Apply engine oil to the crank pulley bolt seat and thread.
- 4) Tighten the crank pulley bolts.

(1) Remove the radiator main fan motor assembly and radiator sub fan motor assembly. <Ref. to CO(w/o STI)-23, REMOVAL, Radiator Main Fan and Fan Motor.> <Ref. to CO(w/o STI)-25, REMOVAL, Radiator Sub Fan and Fan Motor.>

(2) Use the ST1 to lock the crank pulley, and temporarily tighten the crank pulley bolt.

ST1 499977100 CRANK PULLEY WRENCH

**Tightening torque:**

**47 N·m (4.8 kgf·m, 34.7 ft·lb)**

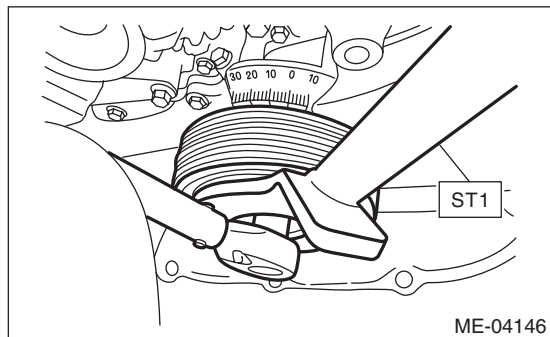

(3) Set the ST2, use the ST1 to lock the crank pulley, and tighten the crank pulley bolt to the specified angle.

**NOTE:**

Attach the magnet used for securing the ST2 (ANGLE GAUGE) to ST1.

ST1 499977100 CRANK PULLEY WRENCH

ST2 18854AA000 ANGLE GAUGE

**Tightening angle:**

**60°±5°**

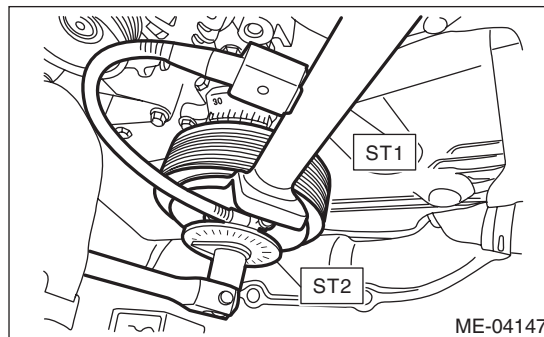

(4) Install the radiator main fan motor assembly and radiator sub fan motor assembly. <Ref. to CO(w/o STI)-23, INSTALLATION, Radiator Main Fan and Fan Motor.> <Ref. to CO(w/o STI)-25, INSTALLATION, Radiator Sub Fan and Fan Motor.>

5) Install the V-belts. <Ref. to ME(w/o STI)-39, INSTALLATION, V-belt.>

**C: INSPECTION**

- 1) Check that the crank pulley has no deformation, cracks or other damages.

# Timing Belt Cover

MECHANICAL

## 14. Timing Belt Cover

### A: REMOVAL

NOTE:

When replacing a single part, perform the work with the engine assembly installed to body.

- 1) Remove the secondary air pump. <Ref. to EC(w/o STI)-29, REMOVAL, Secondary Air Pump.>
- 2) Remove the crank pulley. <Ref. to ME(w/o STI)-46, REMOVAL, Crank Pulley.>
- 3) Remove the timing belt cover RH (A).
- 4) Remove the timing belt cover LH (B).
- 5) Remove the front timing belt cover (C).

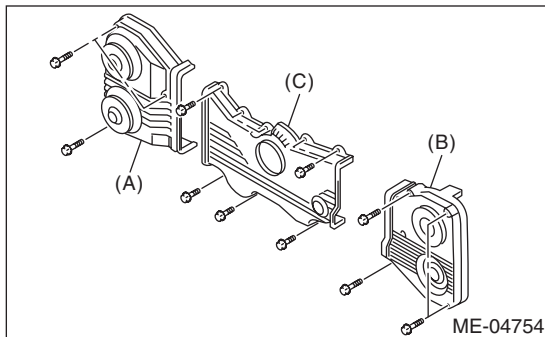

### B: INSTALLATION

- 1) Install the front timing belt cover (C).

**Tightening torque:**

**5 N·m (0.5 kgf·m, 3.7 ft·lb)**

- 2) Install the timing belt cover LH (B).

**Tightening torque:**

**5 N·m (0.5 kgf·m, 3.7 ft·lb)**

- 3) Install the timing belt cover RH (A).

**Tightening torque:**

**5 N·m (0.5 kgf·m, 3.7 ft·lb)**

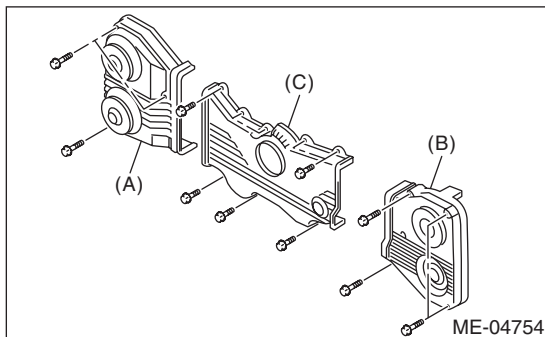

- 4) Install the crank pulley. <Ref. to ME(w/o STI)-46, INSTALLATION, Crank Pulley.>

- 5) Install the secondary air pump. <Ref. to EC(w/o STI)-29, INSTALLATION, Secondary Air Pump.>

### C: INSPECTION

Check the timing belt cover for damage.

**ME(w/o STI)-48**

Brought to you by Ebay Seller "SubaruManuals"

## 15. Timing Belt

### A: REMOVAL

**NOTE:**

- When replacing a single part, perform the work with the engine assembly installed to body.
- When performing the work with the engine installed to body, the following parts must also be removed/installed.
  - Radiator main fan motor assembly <Ref. to CO(w/o STI)-23, REMOVAL, Radiator Main Fan and Fan Motor.> <Ref. to CO(w/o STI)-23, INSTALLATION, Radiator Main Fan and Fan Motor.>
  - Radiator sub fan motor assembly <Ref. to CO(w/o STI)-25, REMOVAL, Radiator Sub Fan and Fan Motor.> <Ref. to CO(w/o STI)-25, INSTALLATION, Radiator Sub Fan and Fan Motor.>
- When performing the work with the engine installed to body, protect the radiator with cardboards or blankets.

### 1. TIMING BELT

- 1) Remove the crank pulley. <Ref. to ME(w/o STI)-46, REMOVAL, Crank Pulley.>
- 2) Remove the timing belt cover. <Ref. to ME(w/o STI)-48, REMOVAL, Timing Belt Cover.>

- 3) Remove the timing belt guide.

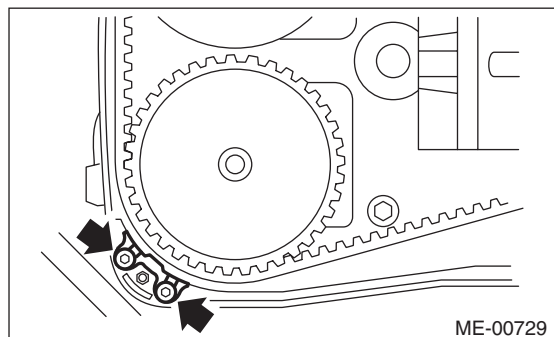
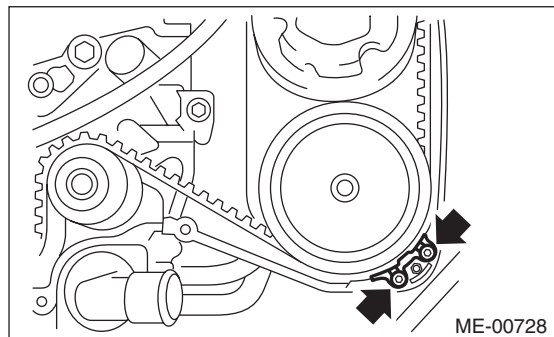
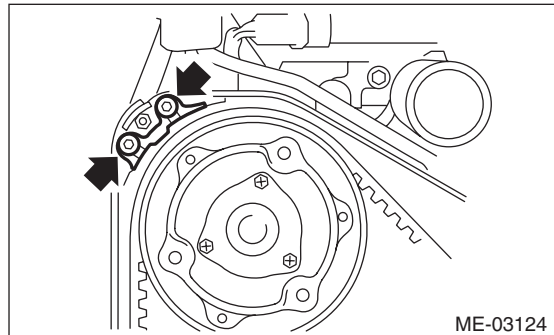
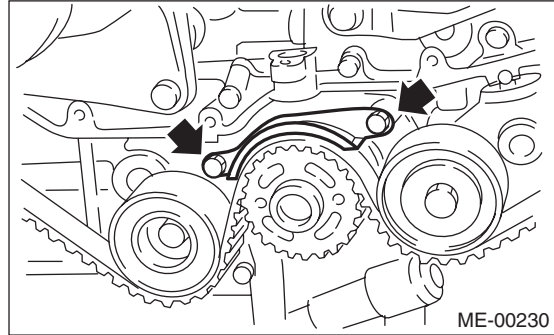

- 4) If the alignment mark or arrow mark (which indicates the direction of rotation) on timing belt fade away, put new marks before removing the timing belt as shown in procedures below.



# Timing Belt

## MECHANICAL

(1) Turn the crankshaft using ST, and align the alignment marks on crank sprocket, intake cam sprocket LH, exhaust cam sprocket LH, intake cam sprocket RH and exhaust cam sprocket RH with marks on oil pump and notches of timing belt cover.

ST 499987500 CRANKSHAFT SOCKET

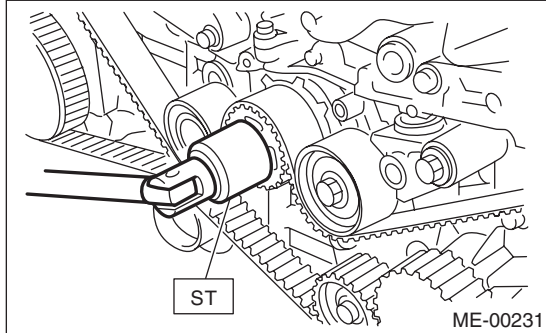

(2) Using white paint, put an alignment mark or an arrow mark on timing belts in relation to the crank sprocket and cam sprockets.

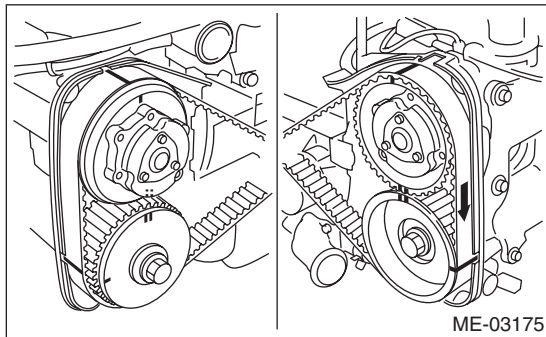
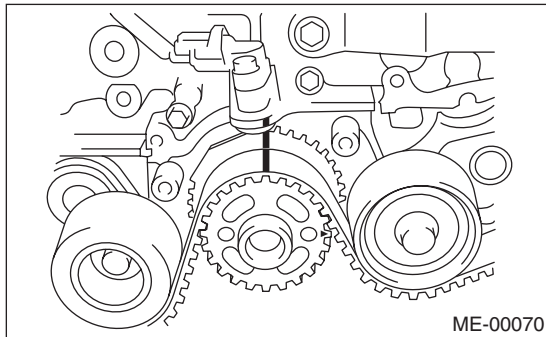

**Z<sub>1</sub>: 54.5 teeth**  
**Z<sub>2</sub>: 51 teeth**  
**Z<sub>3</sub>: 28 teeth**

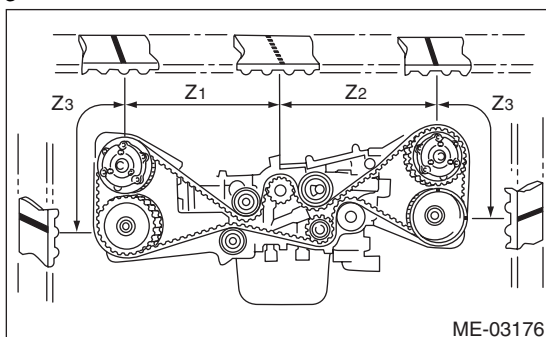

5) Remove the belt idler (A).

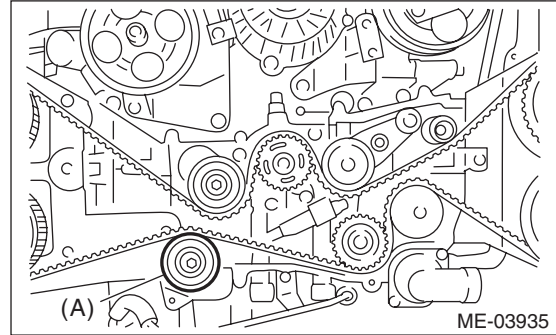

6) Remove the timing belt.

### CAUTION:

After the timing belt has been removed, never rotate the intake and exhaust sprocket. If the cam sprocket is rotated, the intake and exhaust valve heads strike together and valve stems are bent.

## 2. AUTOMATIC BELT TENSION ADJUSTER ASSEMBLY AND BELT IDLER

1) Remove the belt idler (A) and (B).

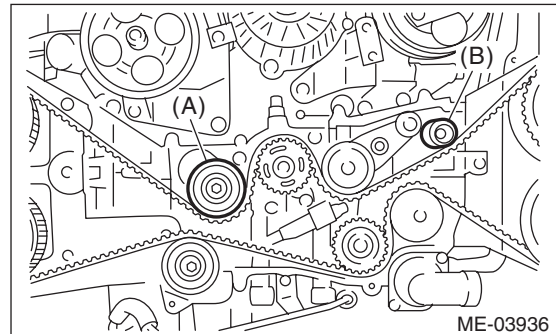

2) Remove the belt idler No. 2.

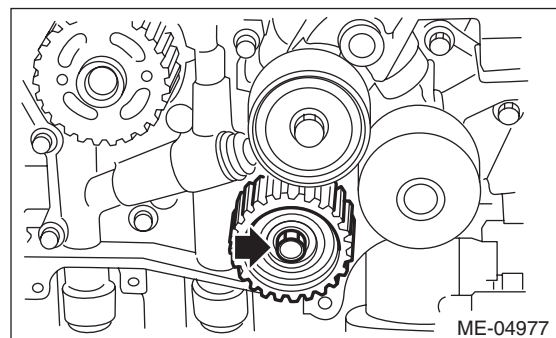

**ME(w/o STI)-50**

Brought to you by Ebay Seller "SubaruManuals"

3) Remove the automatic belt tension adjuster assembly.

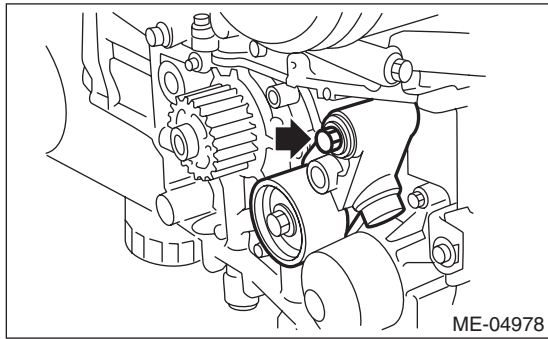

## B: INSTALLATION

### 1. AUTOMATIC BELT TENSION ADJUSTER ASSEMBLY AND BELT IDLER

1) Prepare for installation of the automatic belt tension adjuster assembly.

#### CAUTION:

- Always use a vertical type pressing tool to move the adjuster rod down.
- Do not use a lateral type vise.
- Push the adjuster rod vertically.
- Press-in the push adjuster rod gradually taking three minutes or more.
- Do not allow press pressure to exceed 9,807 N (1,000 kgf, 2,205 lb).
- Push in the adjuster rod to the end face of the cylinder. However, do not press the adjuster rod below the end face of the cylinder. Doing so may damage the cylinder.
- Do not release the press pressure until stopper pin is completely inserted.

(1) Attach the automatic belt tension adjuster assembly to vertical pressing tool.

(2) Slowly push in the adjuster rod with a pressure of 165 N (16.8 kgf, 37.1 lbf) or more until the adjuster rod is aligned with the stopper pin hole in the cylinder.

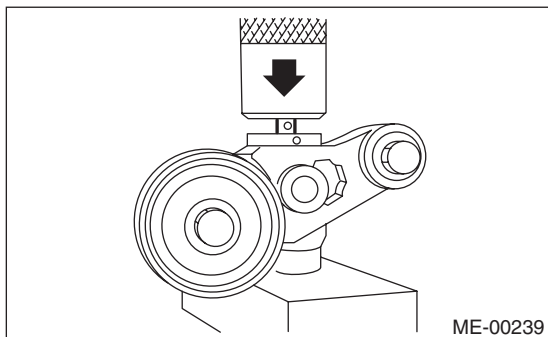

(3) With a 2 mm (0.08 in) dia. stopper pin or a 2 mm (nominal) dia. hex wrench inserted into the stopper pin hole in cylinder, secure the adjuster rod.

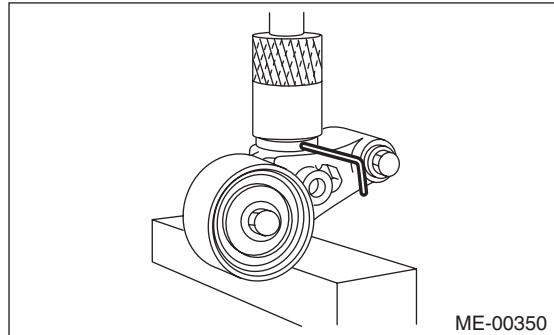

2) Install the automatic belt tension adjuster assembly.

#### Tightening torque:

**39 N·m (4.0 kgf·m, 28.8 ft·lb)**

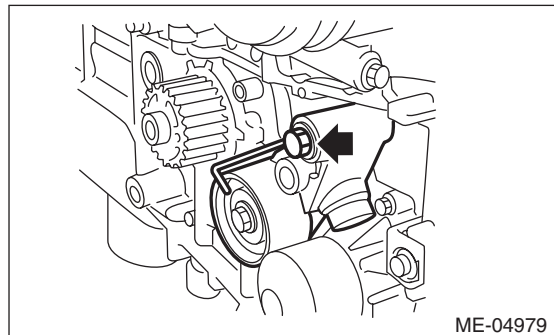

3) Install the belt idler No. 2.

#### Tightening torque:

**39 N·m (4.0 kgf·m, 28.8 ft·lb)**

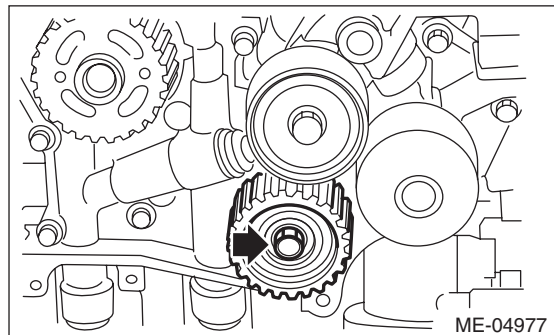

# Timing Belt

## MECHANICAL

4) Install the belt idlers.

**Tightening torque:**

**39 N·m (4.0 kgf·m, 28.8 ft·lb)**

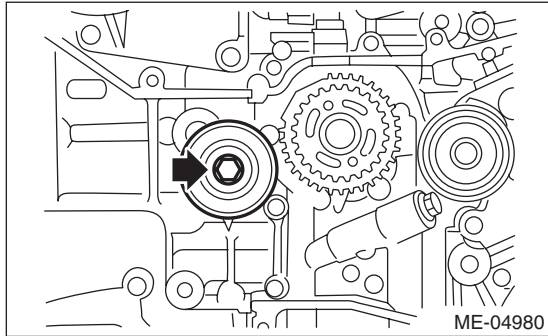

**Tightening torque:**

**25 N·m (2.5 kgf·m, 18.4 ft·lb)**

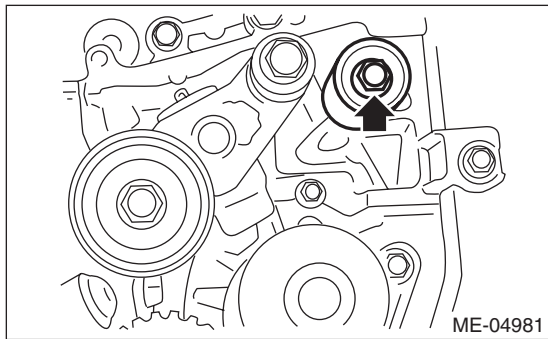

## 2. TIMING BELT

1) Prepare for installation of the automatic belt tension adjuster assembly. <Ref. to ME(w/o STI)-51, AUTOMATIC BELT TENSION ADJUSTER ASSEMBLY AND BELT IDLER, INSTALLATION, Timing Belt.>

2) Align the mark (B) on crank sprocket with the mark (A) on oil pump.

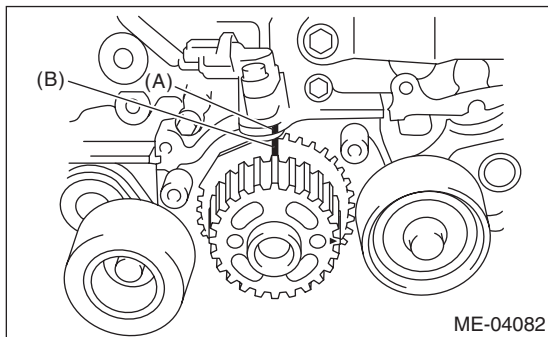

3) Align the single line mark (B) on the exhaust cam sprocket RH with notch (A) on the timing belt cover.

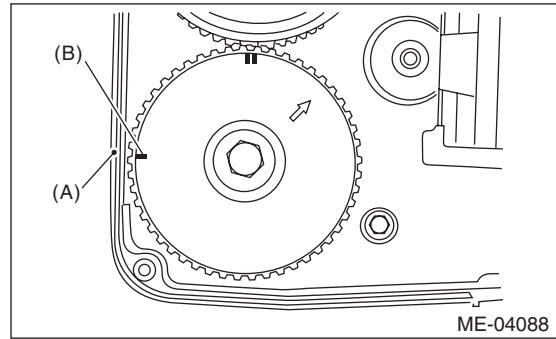

4) Align the single line mark (B) on the intake cam sprocket RH with notch (A) on the timing belt cover. Make sure that the double line marks (C) on intake cam sprocket and exhaust cam sprocket are aligned.

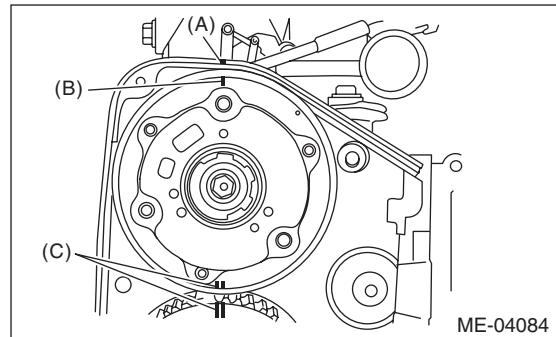

5) Align the single line mark (B) on exhaust cam sprocket LH with notch (A) on the timing belt cover by turning the sprocket counterclockwise (as viewed from front of engine).

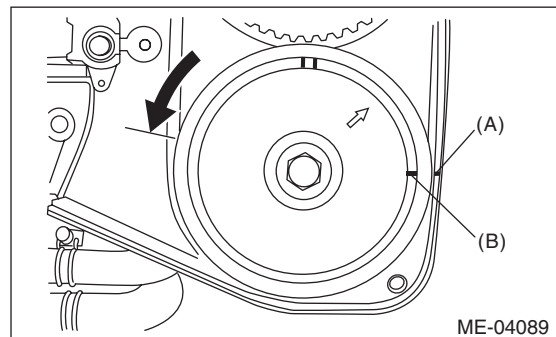



6) Align the single line mark (B) on intake cam sprocket LH with notch (A) on the timing belt cover by turning the sprocket clockwise (as viewed from front of engine). Make sure that the double line marks (C) on intake cam sprocket and exhaust cam sprocket are aligned.

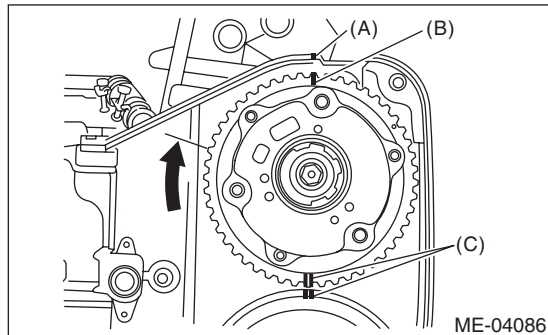

7) Make sure that the cam and crank sprockets are positioned properly.

**CAUTION:**

• Intake and exhaust camshafts for this DOHC engine can be independently rotated with the timing belts removed. As can be seen from the figure, if the intake and exhaust valves are lifted simultaneously, heads will interfere with each other, resulting in bent valves.

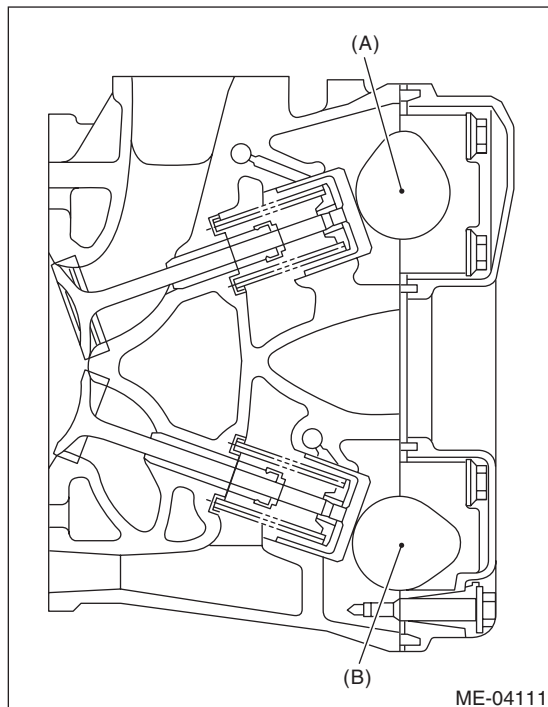

- (A) Intake camshaft
- (B) Exhaust camshaft

- When the timing belts are not installed, four camshafts are held at the “zero-lift” position, where all cams on camshafts are not pushing down on the intake and exhaust valves. (Under this condition, all valves remain unlifted.)
- When the camshafts are rotated to install the timing belts, #2 intake and #4 exhaust cam of camshaft LH are held, pushing their corresponding valves down. (Under this condition, these valves are held lifted.) Camshaft RH are held so that their cams do not push the valves down.
- Camshafts LH must be rotated from the zero-lift position to the position where the timing belt is to be installed with the smallest possible angle, in order to prevent mutual interference of intake and exhaust valve heads.
- Do not allow the camshafts to rotate in the direction shown in the upper figure. Doing this may cause both the intake and exhaust valves to lift simultaneously, resulting in mutual interference of valve heads.

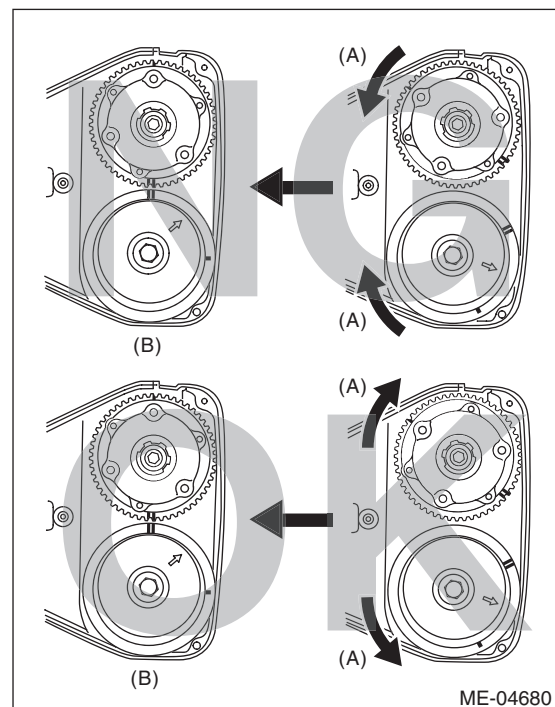

- (A) Direction of rotation
- (B) Timing belt installation position

# Timing Belt

## MECHANICAL

8) Align the alignment mark on the timing belt with marks on the sprockets in the alphabetical order shown in the figure. While aligning marks, position the timing belt properly, and install the timing belt.

### CAUTION:

- If the timing belt slips by 1 or more teeth, the valve and piston may hit each other.
- Make sure that the direction of belt rotation is correct.

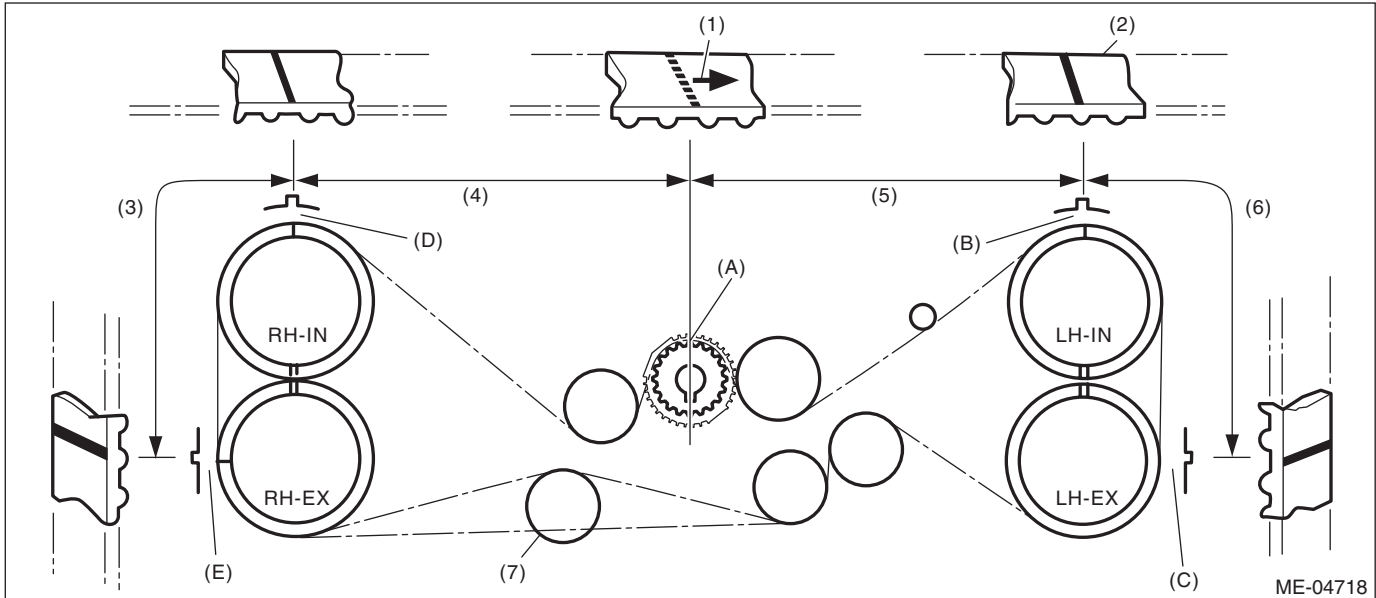

- |                 |                |                           |
|-----------------|----------------|---------------------------|
| (1) Arrow mark  | (4) 54.5 teeth | (6) 28 teeth              |
| (2) Timing belt | (5) 51 teeth   | (7) Install it in the end |
| (3) 28 teeth    |                |                           |

9) Install the belt idlers.

### Tightening torque:

**39 N·m (4.0 kgf·m, 28.8 ft·lb)**

### NOTE:

Make sure that the marks on the timing belt and sprockets are aligned.

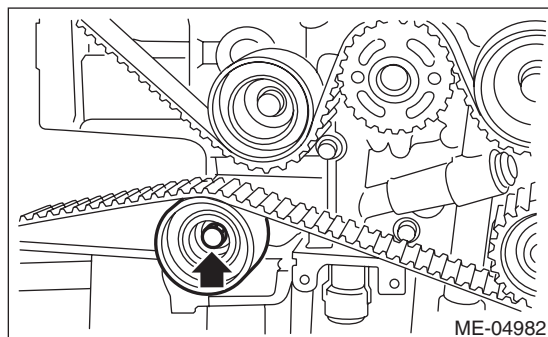

10) After ensuring that the marks on the timing belt and sprockets are aligned, remove the stopper pin from tensioner adjuster.

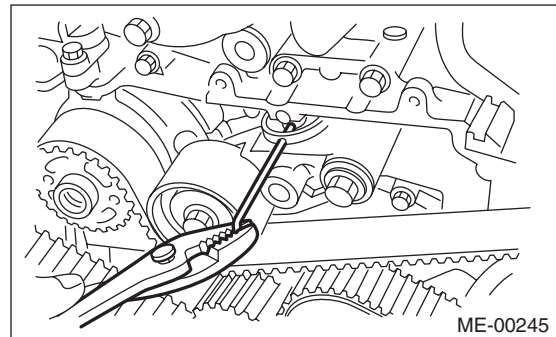

**ME(w/o STI)-54**

Brought to you by Ebay Seller "SubaruManuals"

11) Install the timing belt guide.

(1) Temporarily tighten the bolts securing the timing belt guide.

**NOTE:**

- Before installing the timing belt guide, clean the timing belt guide mounting bolt holes of the timing belt cover No. 2.
- Apply liquid gasket to the thread of the timing belt guide mounting bolt on the cam sprocket section. (when reusing bolts)

**Liquid gasket:**

**THREE BOND 1324 (Part No. 004403042)**

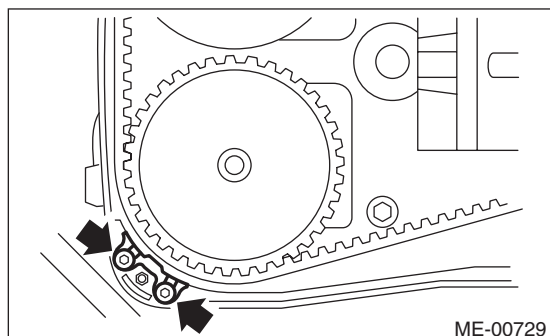
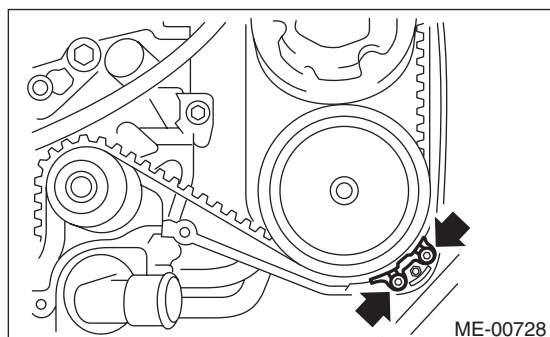
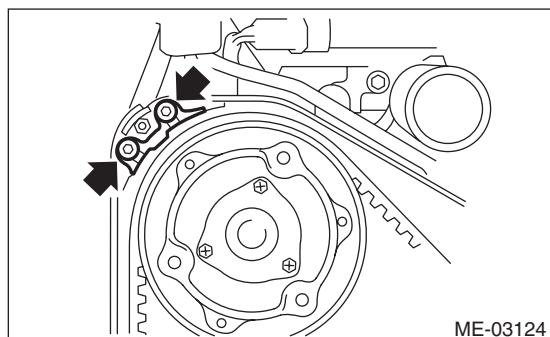
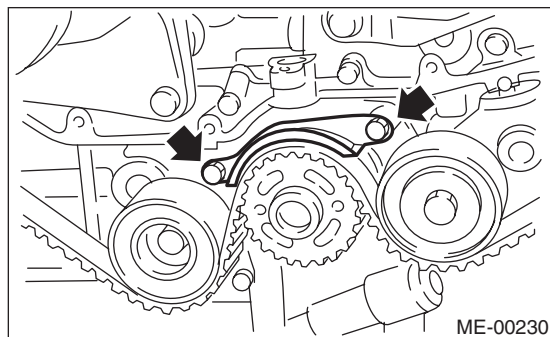

(2) Adjust the clearance between timing belt and timing belt guide using a thickness gauge and tighten.

**Clearance:**

**1.0±0.5 mm (0.039±0.020 in)**

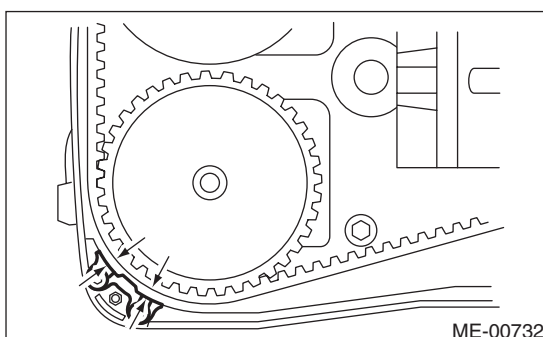
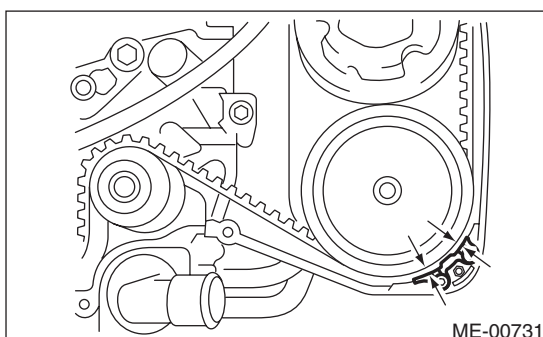
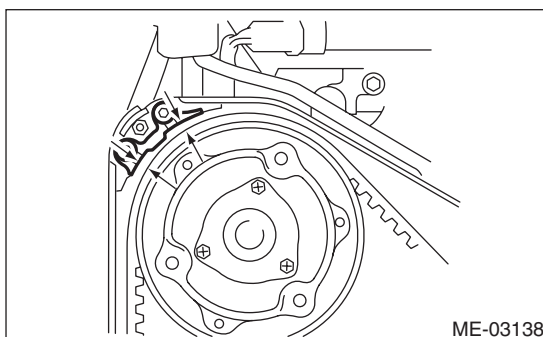
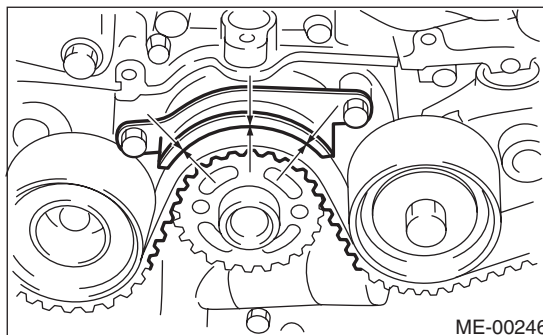

# Timing Belt

MECHANICAL

## Tightening torque:

**9.75 N·m (1.0 kgf·m, 7.2 ft·lb)**

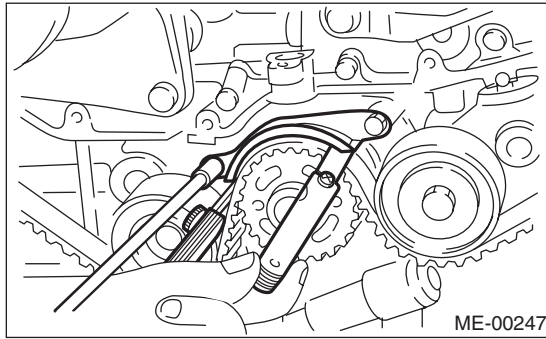

## Tightening torque:

**6.4 N·m (0.7 kgf·m, 4.7 ft·lb)**

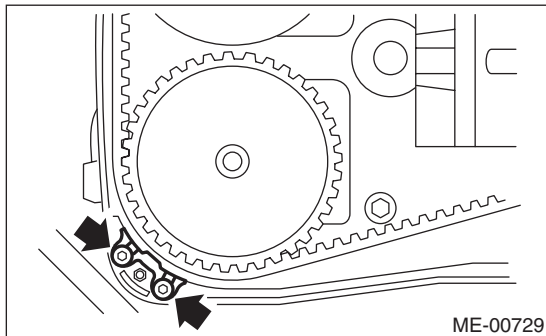
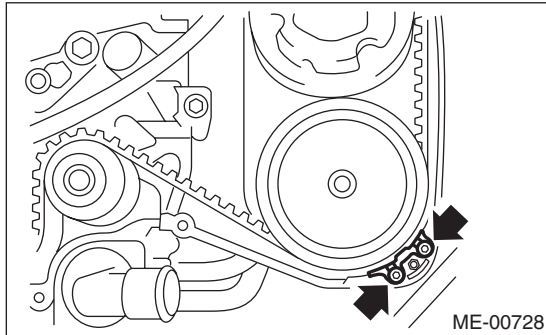
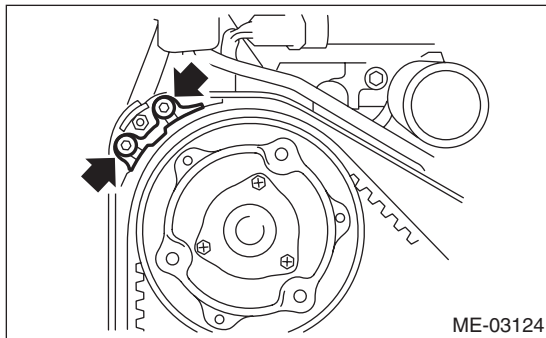

12) Install the timing belt cover. <Ref. to ME(w/o STI)-48, INSTALLATION, Timing Belt Cover.>

13) Install the crank pulley. <Ref. to ME(w/o STI)-46, INSTALLATION, Crank Pulley.>

## C: INSPECTION

### 1. TIMING BELT

- 1) Check the timing belt teeth for breaks, cracks or wear. If any fault is found, replace the timing belt.
- 2) Check the condition on the back surface of the timing belt. If cracks are found, replace the timing belt.

### CAUTION:

- Be careful not to let oil, grease or coolant contact the timing belt. Remove quickly and thoroughly if this happens.
- Do not bend the timing belt sharply.

### In radial diameter h:

**60 mm (2.36 in) or more**

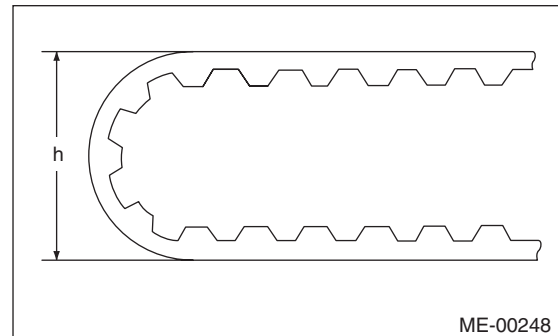

### 2. AUTOMATIC BELT TENSION ADJUST-ER

- 1) Visually check the oil seals for leaks, and rod ends for abnormal wear and scratches. If necessary, replace the automatic belt tension adjuster assembly.

### NOTE:

Slight traces of oil at the rod oil seal does not indicate a problem.

- 2) Check that the adjuster rod does not move when a pressure of 165 N (16.8 kgf, 37.1 lb) is applied to it. This is to check adjuster rod stiffness.
- 3) If the adjuster rod is not stiff and moves freely when applying 165 N (16.8 kgf, 37.1 lb), check it using the following procedures:

- (1) Slowly press the adjuster rod down to the end surface of cylinder. Repeat this operation two to three times.
- (2) With the adjuster rod moved all the way up, apply a pressure of 165 N (16.8 kgf, 37.1 lb) to it, and check the adjuster rod stiffness.
- (3) If the adjuster rod is not stiff and moves down, replace the automatic belt tension adjuster assembly with a new part.

**ME(w/o STI)-56**

Brought to you by Ebay Seller "SubaruManuals"

**CAUTION:**

- Always use a vertical type pressing tool to move the adjuster rod down.
- Do not use a lateral type vise.
- Push the adjuster rod vertically.
- Press-in the push adjuster rod gradually taking three minutes or more.
- Do not allow press pressure to exceed 9,807 N (1,000 kgf, 2,205 lb).
- Push in the adjuster rod to the end face of the cylinder. However, do not press the adjuster rod below the end face of the cylinder. Doing so may damage the cylinder.

4) Measure the amount of adjuster rod protrusion "L" from the end surface of the cylinder. If it is not within specifications, replace the automatic belt tension adjuster assembly with a new part.

**Protrusion amount of adjuster rod L:**

**5.2 — 6.2 mm (0.205 — 0.244 in)**

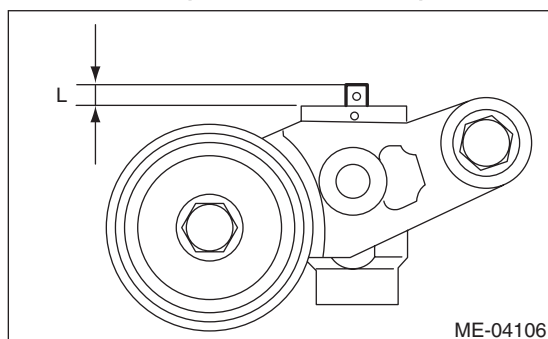

### 3. BELT TENSION PULLEY

- 1) Check the mating surfaces of timing belt and contact point of adjuster rod for abnormal wear or scratches. Replace the automatic belt tension adjuster assembly with a new part if faulty.
- 2) Check the belt tension pulley for smooth rotation. Replace the automatic belt tension adjuster assembly with a new part if abnormal noise or excessive play occurs.
- 3) Check the belt tension pulley for grease leakage.

### 4. BELT IDLER

- 1) Check the belt idler for smooth rotation. Replace if noise or excessive play occurs.
- 2) Check the outer contacting surfaces of idler pulley for abnormal wear and scratches.
- 3) Check the belt idler for grease leakage.



# Cam Sprocket

MECHANICAL

## 16. Cam Sprocket

### A: REMOVAL

#### NOTE:

When replacing a single part, perform the work with the engine assembly installed to body.

- 1) Remove the crank pulley. <Ref. to ME(w/o STI)-46, REMOVAL, Crank Pulley.>
- 2) Remove the timing belt cover. <Ref. to ME(w/o STI)-48, REMOVAL, Timing Belt Cover.>
- 3) Remove the timing belt. <Ref. to ME(w/o STI)-49, REMOVAL, Timing Belt.>
- 4) Remove the actuator cover from intake cam sprocket.
- 5) Use the ST to lock the cam sprocket, and remove the cam sprocket bolt.

ST 499207400 CAM SPROCKET WRENCH

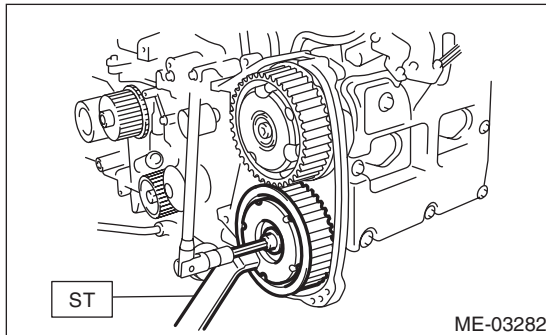

ST 499977500 CAM SPROCKET WRENCH

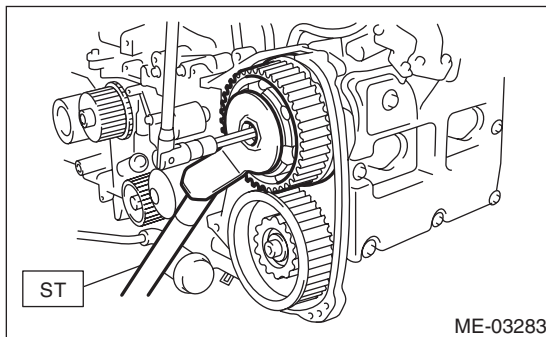

- 6) Remove the cam sprocket.

### B: INSTALLATION

- 1) Install the cam sprocket.
- 2) Use the ST to lock the cam sprocket, and install the cam sprocket bolt.

#### NOTE:

Do not confuse cam sprockets (LH) and (RH) during installation.

ST 499207400 CAM SPROCKET WRENCH

#### Tightening torque:

**Tighten to 30 N·m (3.1 kgf·m, 22.1 ft·lb) of torque, and then tighten further by 45°.**

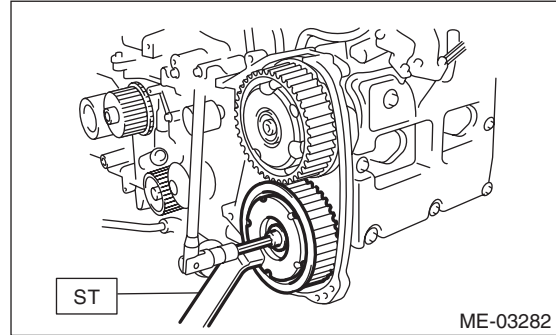

ST 499977500 CAM SPROCKET WRENCH

#### Tightening torque:

**Tighten to 30 N·m (3.1 kgf·m, 22.1 ft·lb) of torque, and then tighten further by 45°.**

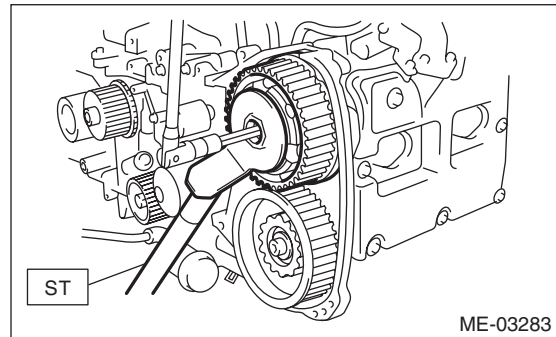

- 3) Install the actuator cover to intake cam sprocket.

#### NOTE:

Use new O-rings.

#### Tightening torque:

**3.4 N·m (0.3 kgf·m, 2.5 ft·lb)**

- 4) Install the timing belt. <Ref. to ME(w/o STI)-51, INSTALLATION, Timing Belt.>
- 5) Install the timing belt cover. <Ref. to ME(w/o STI)-48, INSTALLATION, Timing Belt Cover.>
- 6) Install the crank pulley. <Ref. to ME(w/o STI)-46, INSTALLATION, Crank Pulley.>

### C: INSPECTION

- 1) Check the cam sprocket teeth for abnormal wear and scratches.
- 2) Make sure there is no free play between cam sprocket and key.

ME(w/o STI)-58

Brought to you by Ebay Seller "SubaruManuals"

## 17. Crank Sprocket

### A: REMOVAL

#### NOTE:

When replacing a single part, perform the work with the engine assembly installed to body.

- 1) Remove the crank pulley. <Ref. to ME(w/o STI)-46, REMOVAL, Crank Pulley.>
- 2) Remove the timing belt cover. <Ref. to ME(w/o STI)-48, REMOVAL, Timing Belt Cover.>
- 3) Remove the timing belt. <Ref. to ME(w/o STI)-49, REMOVAL, Timing Belt.>
- 4) Remove the crank sprocket.

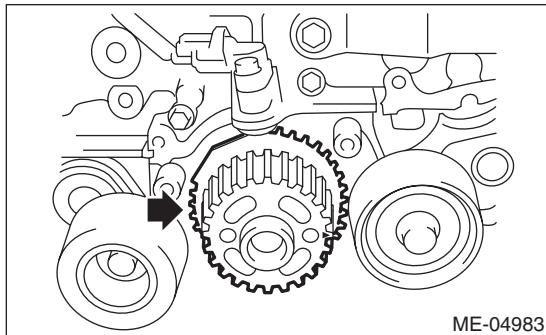

### B: INSTALLATION

- 1) Install the crank sprocket.

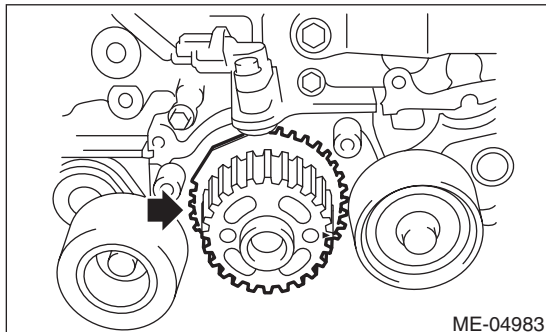

- 2) Install the timing belt. <Ref. to ME(w/o STI)-51, INSTALLATION, Timing Belt.>
- 3) Install the timing belt cover. <Ref. to ME(w/o STI)-48, INSTALLATION, Timing Belt Cover.>
- 4) Install the crank pulley. <Ref. to ME(w/o STI)-46, INSTALLATION, Crank Pulley.>

### C: INSPECTION

- 1) Check the crank sprocket teeth for abnormal wear and scratches.
- 2) Make sure there is no free play between crank sprocket and key.
- 3) Check the crank sprocket protrusion used for sensor for damage and contamination of foreign matter.

# Camshaft

MECHANICAL

## 18. Camshaft

### A: REMOVAL

- 1) Remove the engine from the vehicle. <Ref. to ME(w/o STI)-30, REMOVAL, Engine Assembly.>
- 2) Remove the rear side belt. <Ref. to ME(w/o STI)-39, REAR SIDE BELT, REMOVAL, V-belt.>
- 3) Remove the crank pulley. <Ref. to ME(w/o STI)-46, REMOVAL, Crank Pulley.>
- 4) Remove the timing belt cover. <Ref. to ME(w/o STI)-48, REMOVAL, Timing Belt Cover.>
- 5) Remove the timing belt. <Ref. to ME(w/o STI)-49, REMOVAL, Timing Belt.>
- 6) Remove the cam sprocket. <Ref. to ME(w/o STI)-58, REMOVAL, Cam Sprocket.>
- 7) Disconnect the connector from the oil flow control solenoid valve.

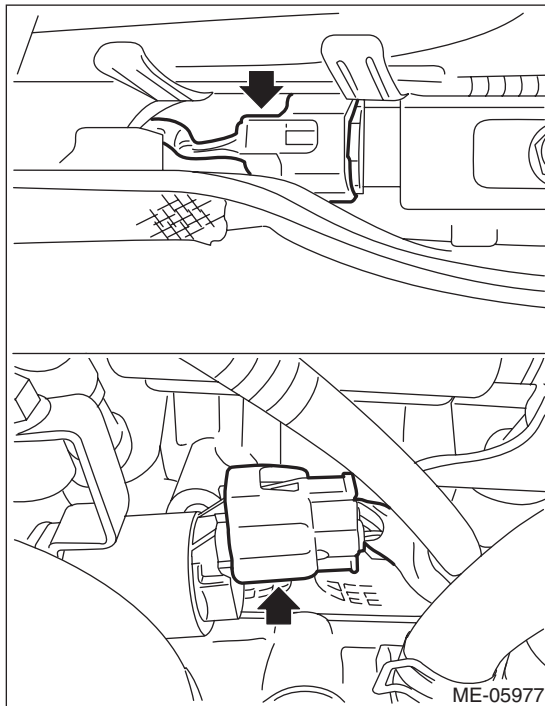

- 8) Remove the timing belt cover No. 2 RH (A) and timing belt cover No. 2 LH (B).

#### NOTE:

When removing the timing belt cover, be careful not to damage the seal rubber.

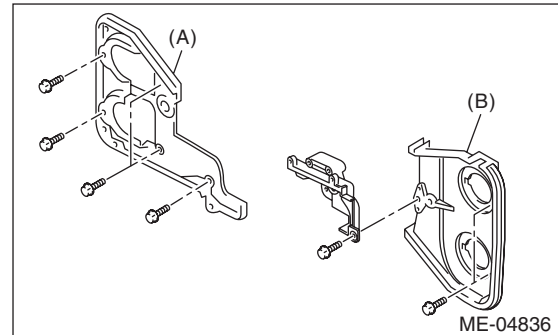

- 9) Remove the tensioner bracket.

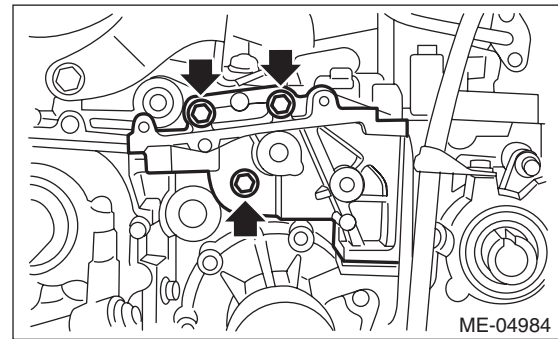

- 10) Remove the clip (A) and the stay (B) which hold the engine harness to the rocker cover RH.

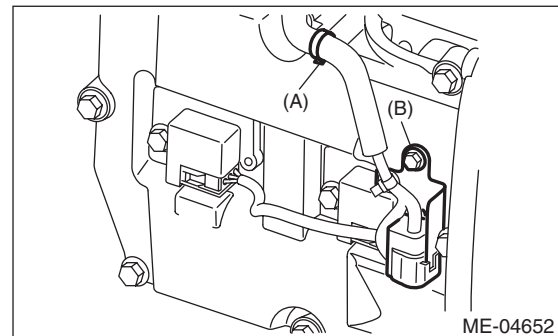

- 11) Remove the air duct B (B) from the rocker cover LH and the air duct A (A).

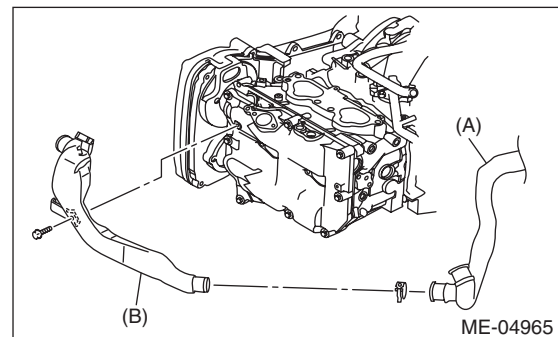

- 12) Remove the ignition coil. <Ref. to IG(w/o STI)-7, REMOVAL, Ignition Coil.>

ME(w/o STI)-60

Brought to you by Ebay Seller "SubaruManuals"



13) Disconnect the PCV hose (A) and PCV hose assembly (B) from the rocker cover.

**NOTE:**

Pinch the clamp of the PCV hose (A) by fitting the cut out in the ST with the protrusion on the clamp as shown in the figure, and unlock the clamp.

ST 18353AA000 CLAMP PLIERS

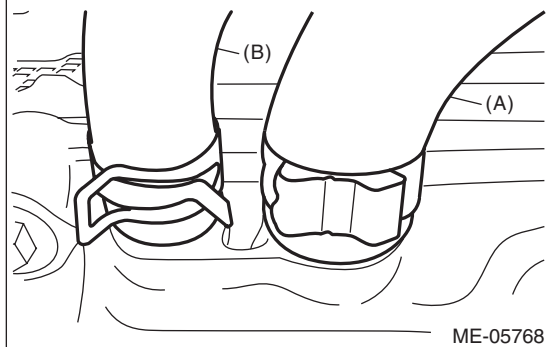
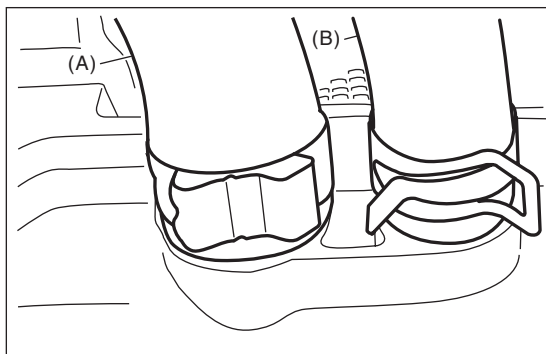
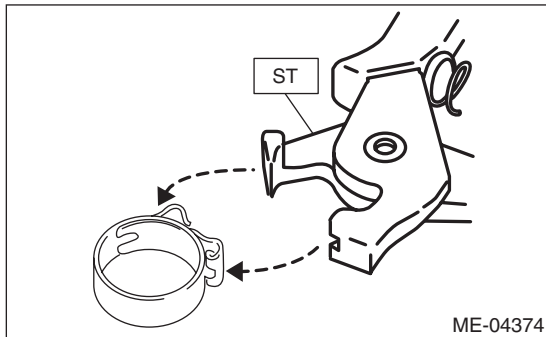

15) Remove the union bolt without filter (without protrusion) which secures the oil pipe to the front camshaft cap.

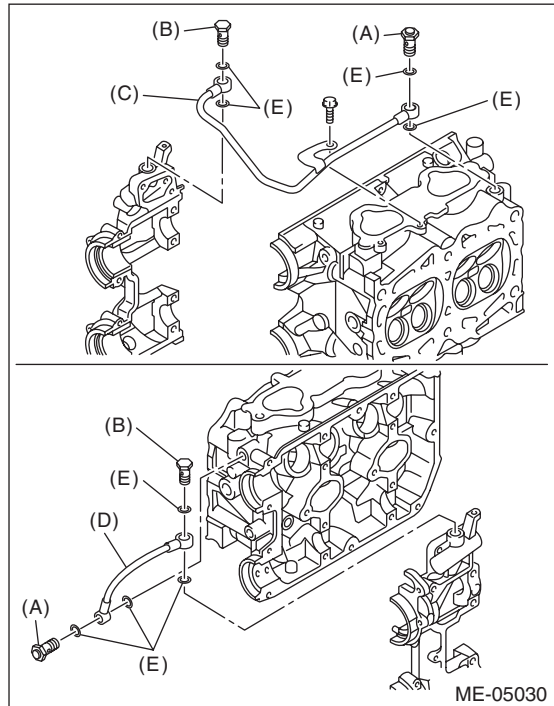

- (A) Union bolt with filter (with protrusion)
- (B) Union bolt without filter (without protrusion)
- (C) Oil pipe RH
- (D) Oil pipe LH
- (E) Gasket

14) Remove the rocker cover.

# Camshaft

## MECHANICAL

16) Loosen the upper side of the front camshaft cap and the intake camshaft cap bolts equally, a little at a time in alphabetical sequence shown in the figure.

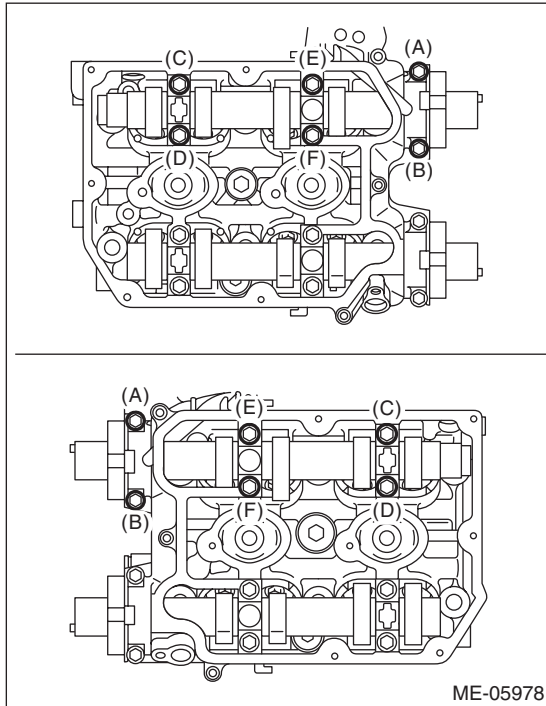

17) Loosen the lower side of the front camshaft cap and the exhaust camshaft cap bolts equally, a little at a time in alphabetical sequence shown in the figure.

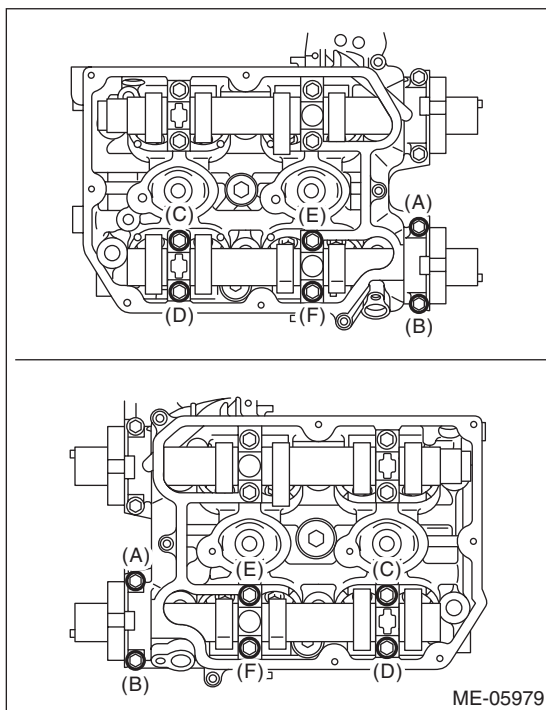

18) Remove the front camshaft cap.

19) Remove the intake camshaft caps and intake camshaft.

20) Remove the exhaust camshaft caps and exhaust camshaft.

### NOTE:

Arrange camshaft caps in order so that they can be installed in their original positions.

21) Remove the oil seal.

### CAUTION:

**Do not scratch the journal surface when removing the oil seal.**

## B: INSTALLATION

1) Install the camshaft.

Apply engine oil to the cylinder head at camshaft bearing installation location before installing the camshaft. Install the camshaft so that each valve is close to or in contact with base circle of the cam lobe.

NOTE:

- Set the camshaft to the position shown in the figure.
- When set at the position shown in the figure, it is not necessary to rotate the camshaft RH when installing the timing belt, but it is necessary to rotate the camshaft LH slightly.

**Intake camshaft LH:**

**Rotate 80° clockwise.**

**Exhaust camshaft LH:**

**Rotate 45° counterclockwise.**

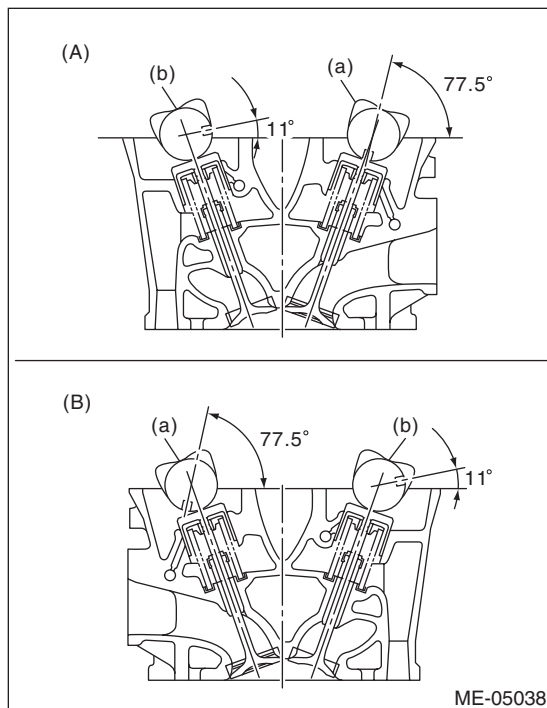

- (A) Cylinder head RH
- (B) Cylinder head LH
- (a) Intake camshaft
- (b) Exhaust camshaft

2) Install the camshaft cap.

(1) Apply small amount of liquid gasket to the mating surface of cap.

NOTE:

- Install within 5 min. after applying liquid gasket.
- Do not apply liquid gasket excessively. Applying excessively may cause excess gasket to come out and flow toward oil seal, resulting in oil leak.

**Liquid gasket:**

**THREE BOND 1217G (Part No. K0877Y0100) or equivalent**

**Liquid gasket applying diameter:**

**Mating surfaces other than ranges A and B**

**2±0.5 mm (0.0787±0.0197 in)**

**Mating surfaces of ranges A and B**

**3±1 mm (0.1181±0.0394 in)**

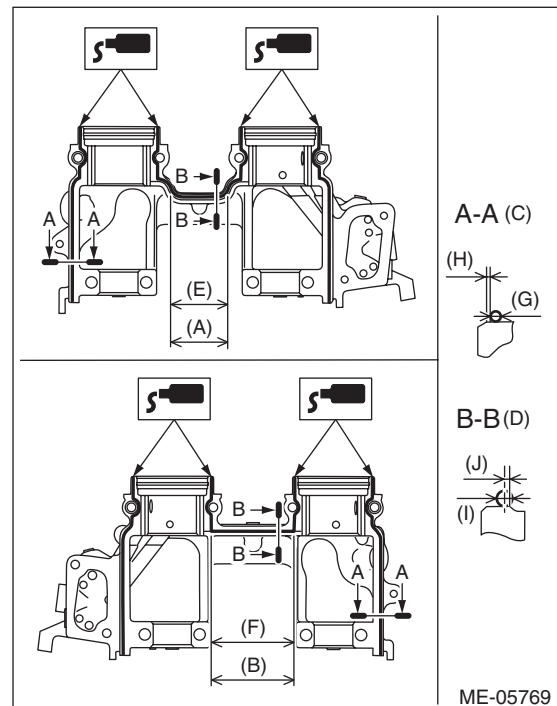

- (A) Range A
- (B) Range B
- (C) Liquid gasket applying position of mating surfaces of ranges other than A and B
- (D) Liquid gasket applying position of mating surfaces of ranges A and B
- (E) 44.8 mm (1.7638 in)
- (F) 65 mm (2.5591 in)
- (G)  $\phi 2 \pm 0.5$  mm (0.0787±0.0197 in)
- (H)  $0.5 \pm 0.5$  mm (0.0197±0.0197 in)
- (I)  $\phi 3 \pm 1$  mm (0.1181±0.0394 in)
- (J) 1 mm (0.0394 in) or less

(2) Apply a thin coat of engine oil to the cap journal surface, and install the camshaft cap to the camshaft.

# Camshaft

## MECHANICAL

(3) Gradually tighten the camshaft cap in at least two steps, in alphabetical order shown in the figure, and then tighten to the specified torque.

### Tightening torque:

**T1: 9.75 N·m (1.0 kgf-m, 7.2 ft-lb)**

**T2: 20 N·m (2.0 kgf-m, 14.8 ft-lb)**

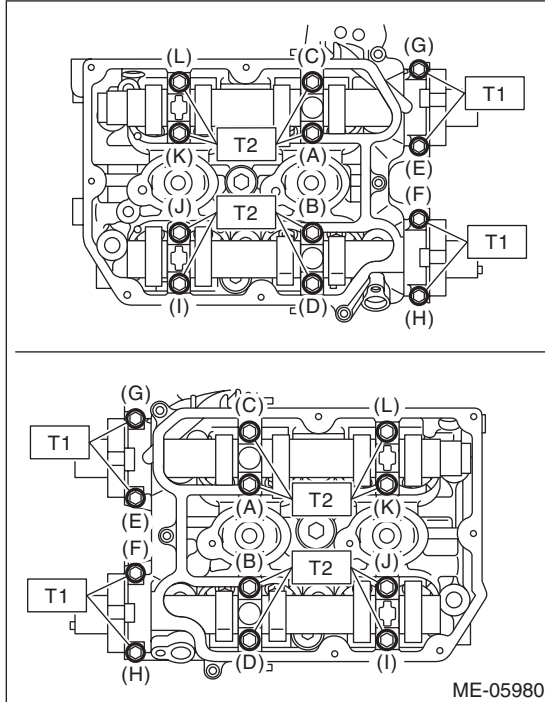

(4) After tightening the camshaft cap, ensure the camshaft rotates only slightly while holding it at base circle.

3) Apply a thin coat of engine oil to the periphery of the camshaft oil seal and oil seal lip, and install the oil seal on the camshaft using ST1 and ST2.

### NOTE:

Use a new oil seal.

ST1 499587600 OIL SEAL INSTALLER

ST2 499597200 OIL SEAL GUIDE

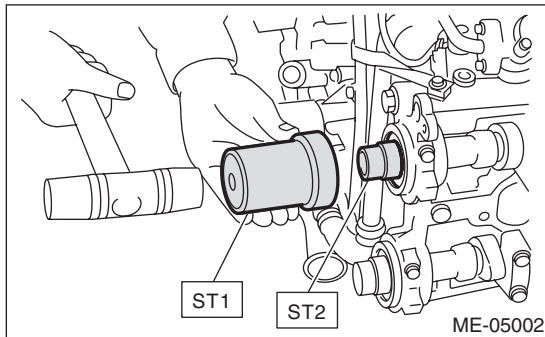

4) Install the oil pipe to the front camshaft cap using the union bolt without filter (without protrusion).

### NOTE:

Use a new gasket.

### Tightening torque:

**29 N·m (3.0 kgf-m, 21.4 ft-lb)**

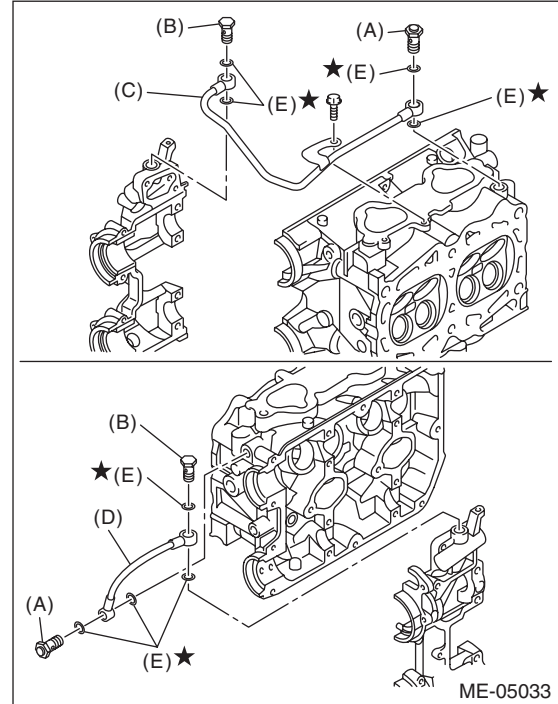

(A) Union bolt with filter (with protrusion)

(B) Union bolt without filter (without protrusion)

(C) Oil pipe RH

(D) Oil pipe LH

(E) Gasket

5) Install the tensioner bracket.

### Tightening torque:

**24.5 N·m (2.5 kgf-m, 18.1 ft-lb)**

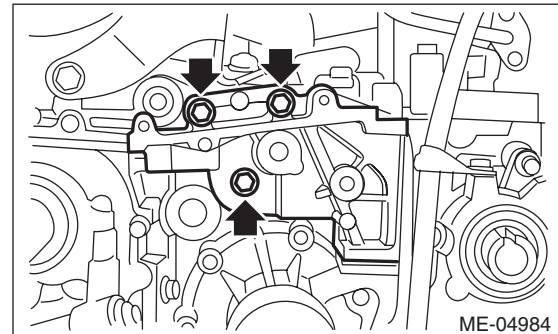

6) Install the timing belt cover No. 2 RH (A) and timing belt cover No. 2 LH (B).

**Tightening torque:**

**5 N·m (0.5 kgf·m, 3.7 ft·lb)**

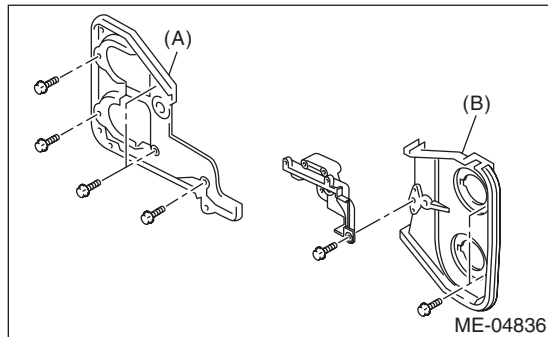

7) Install the cam sprocket. <Ref. to ME(w/o STI)-58, INSTALLATION, Cam Sprocket.>

8) Install the timing belt. <Ref. to ME(w/o STI)-51, INSTALLATION, Timing Belt.>

9) Adjust the valve clearance. <Ref. to ME(w/o STI)-29, ADJUSTMENT, Valve Clearance.>

10) Install the rocker cover.

(1) Install the rocker cover gasket to the rocker cover. (outer section and ignition coil section)

**NOTE:**

Use a new rocker cover gasket.

(2) Apply liquid gasket to the specified point of the cylinder head.

**NOTE:**

Install within 5 min. after applying liquid gasket.

**Liquid gasket:**

**THREE BOND 1217G (Part No. K0877Y0100) or equivalent**

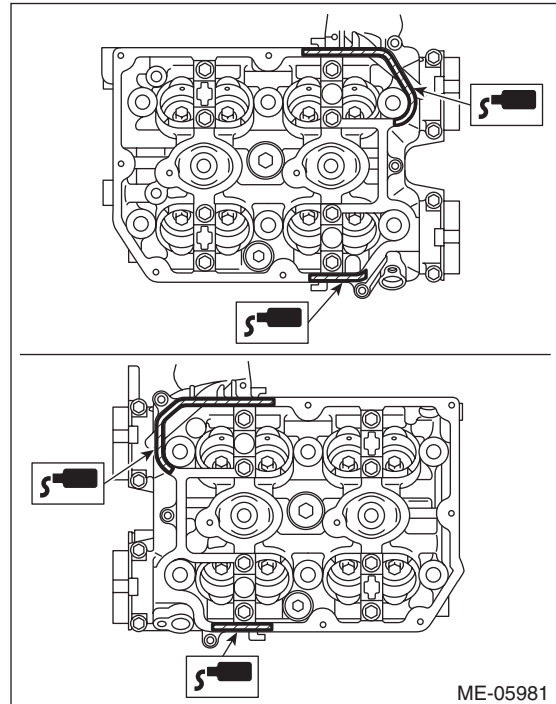

(3) Install the rocker cover onto cylinder heads. Ensure the gasket is properly positioned during installation.

(4) Temporarily tighten the rocker cover bolts in alphabetical order shown in the figure, and then tighten to specified torque in alphabetical order.

**Tightening torque:**

**6.4 N·m (0.7 kgf·m, 4.7 ft·lb)**

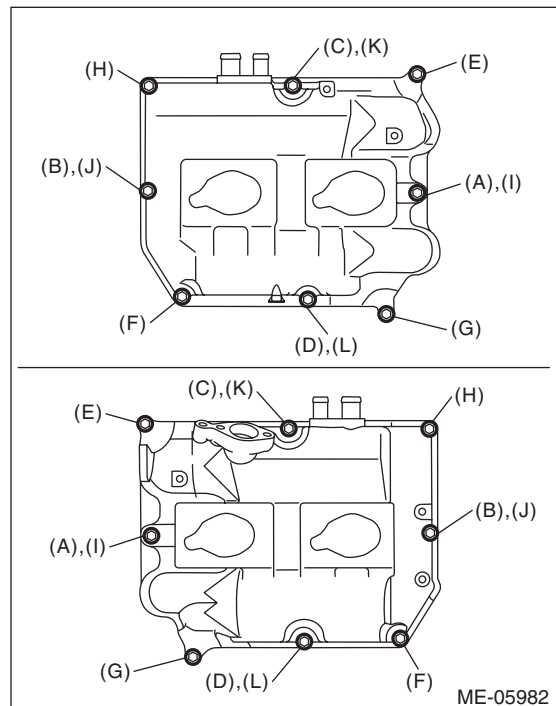

# Camshaft

## MECHANICAL

11) Connect the PCV hose (A) and PCV hose assembly (B) to the rocker cover.

### NOTE:

Use a new clamp for the PCV hose (A), fit the cut out in the ST with the protrusion on the clamp as shown in the figure, and lock the clamp.

ST 18353AA000 CLAMP PLIERS

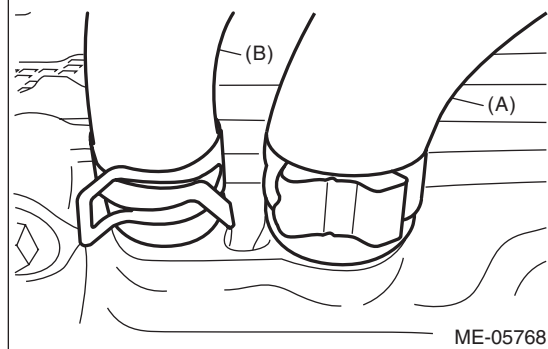
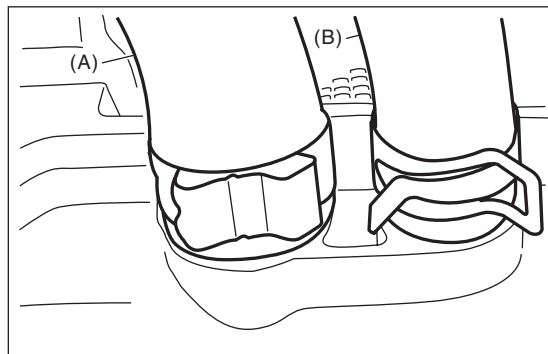
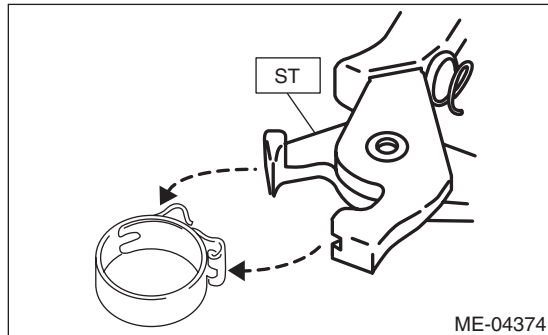

12) Connect the connector to oil flow control solenoid valve.

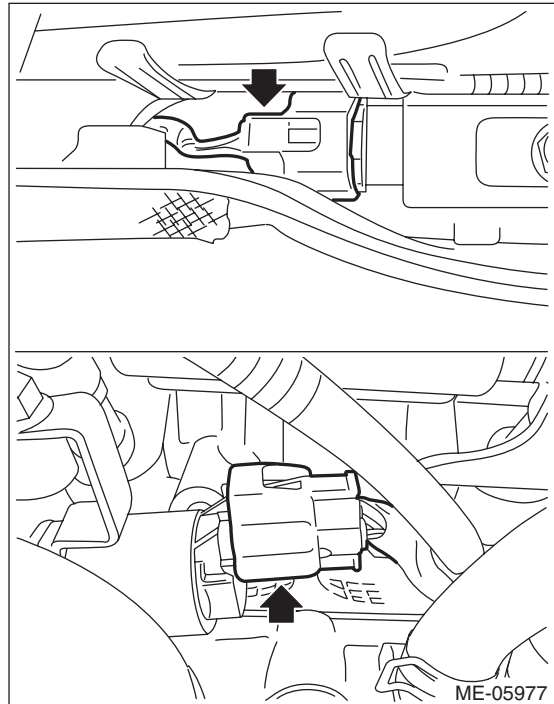

13) Install the ignition coil. <Ref. to IG(w/o STI)-7, INSTALLATION, Ignition Coil.>

14) Install the air duct B (B) to the rocker cover LH and the air duct A (A).

### Tightening torque:

**6.4 N·m (0.7 kgf·m, 4.7 ft·lb)**

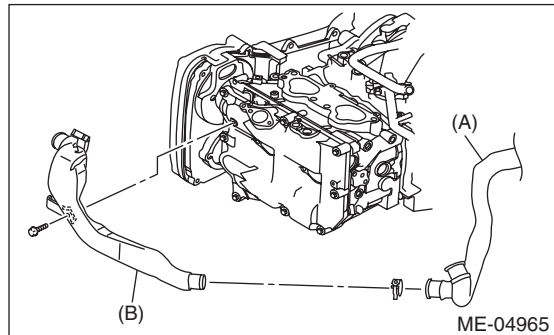

15) Securely install the engine harness with clip (A) and stay (B) to the rocker cover RH.

### Tightening torque:

**6.4 N·m (0.7 kgf·m, 4.7 ft·lb)**

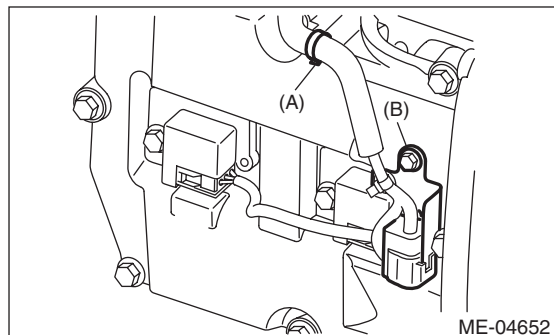

**ME(w/o STI)-66**

Brought to you by Ebay Seller "SubaruManuals"



- 16) Install the timing belt cover. <Ref. to ME(w/o STI)-48, INSTALLATION, Timing Belt Cover.>
- 17) Install the crank pulley. <Ref. to ME(w/o STI)-46, INSTALLATION, Crank Pulley.>
- 18) Install the rear side belt. <Ref. to ME(w/o STI)-40, REAR SIDE BELT, INSTALLATION, V-belt.>
- 19) Install the engine to the vehicle. <Ref. to ME(w/o STI)-34, INSTALLATION, Engine Assembly.>

## C: INSPECTION

1) Measure the bend, and repair or replace if necessary.

**Camshaft bend limit:**  
**0.020 mm (0.00079 in)**

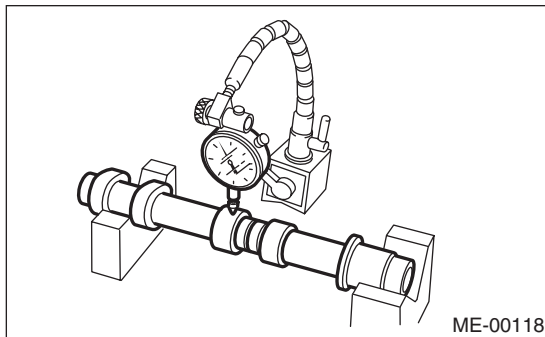

- 2) Check the journal for damage and wear. Replace if faulty.
- 3) Check the cutout portion used for camshaft sensor for damage. Replace if faulty.
- 4) Check the cam face condition, and remove the minor faults by grinding with oil stone. If offset wear occurs, replace it.
- 5) Measure the cam lobe height "H" and cam base circle diameter "A". If it exceeds the standard or offset wear occurs, replace it.

**Cam lobe height H:**

**Standard**

**Intake**

**46.55 — 46.65 mm (1.833 — 1.837 in)**

**Exhaust**

**46.75 — 46.85 mm (1.841 — 1.844 in)**

**Cam base circle diameter A:**

**Standard**

**37.0 mm (1.457 in)**

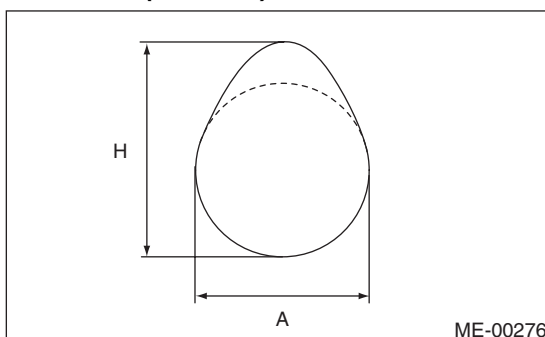

6) Measure the outside diameter of camshaft journal. If the journal diameter is not within specification, check the oil clearance.

	Camshaft journal	
	Front	Center, rear
Standard mm (in)	37.946 — 37.963 (1.4939 — 1.4946)	29.946 — 29.963 (1.1790 — 1.1796)

- 7) Measure the oil clearance of camshaft journal.
  - (1) Clean the camshaft cap and cylinder head camshaft journal.
  - (2) Place the camshaft on cylinder head. (Without installing the valve lifter)
  - (3) Place a plastigauge across each camshaft journals.
  - (4) Gradually tighten the camshaft cap in at least two steps, in alphabetical order shown in the figure, and then tighten to the specified torque. Do not turn the camshaft.

**Tightening torque:**

**T1: 9.75 N·m (1.0 kgf-m, 7.2 ft-lb)**

**T2: 20 N·m (2.0 kgf-m, 14.8 ft-lb)**

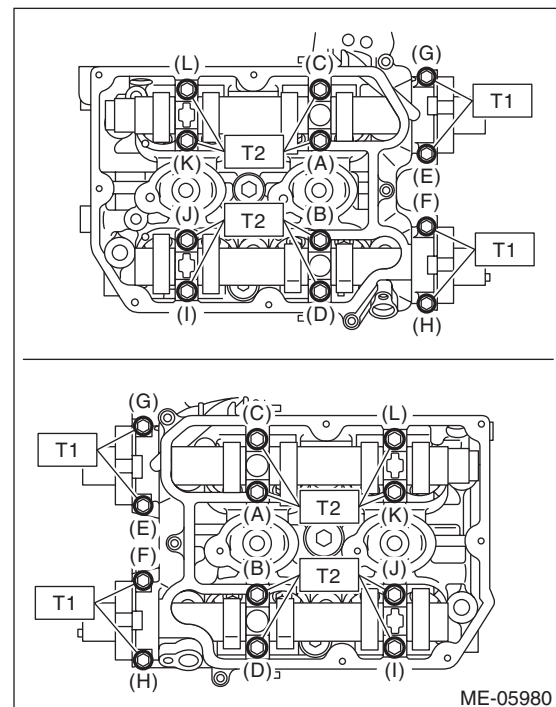

(5) Remove the camshaft cap.

# Camshaft

## MECHANICAL

(6) Measure the widest point of the plastigauge on each journal. If oil clearance exceeds the standard, replace the camshaft. If necessary, replace the camshaft caps and cylinder head as a set.

### **Camshaft oil clearance:**

#### **Standard**

**0.037 — 0.072 mm (0.0015 — 0.0028 in)**

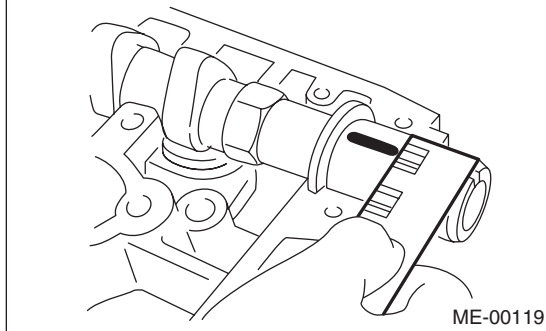

(7) Completely remove the plastigauge.

8) Measure the thrust clearance with setting the dial gauge at end surface of camshaft. If the thrust clearance is not within the standard or there is off-set wear, replace the camshaft caps and cylinder head as a set. If necessary replace the camshaft.

### **Camshaft thrust clearance:**

#### **Standard**

**0.068 — 0.116 mm (0.0027 — 0.0047 in)**

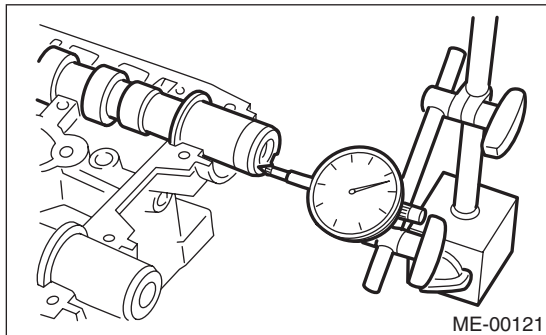



## 19. Cylinder Head

### A: REMOVAL

- 1) Remove the engine from the vehicle. <Ref. to ME(w/o STI)-30, REMOVAL, Engine Assembly.>
- 2) Remove the rear side belt. <Ref. to ME(w/o STI)-39, REAR SIDE BELT, REMOVAL, V-belt.>
- 3) Remove the intake manifold. <Ref. to FU(w/o STI)-18, REMOVAL, Intake Manifold.>
- 4) Remove the crank pulley. <Ref. to ME(w/o STI)-46, REMOVAL, Crank Pulley.>
- 5) Remove the timing belt cover. <Ref. to ME(w/o STI)-48, REMOVAL, Timing Belt Cover.>
- 6) Remove the timing belt. <Ref. to ME(w/o STI)-49, REMOVAL, Timing Belt.>
- 7) Remove the cam sprocket. <Ref. to ME(w/o STI)-58, REMOVAL, Cam Sprocket.>
- 8) Remove the secondary air combination valve. <Ref. to EC(w/o STI)-30, REMOVAL, Secondary Air Combination Valve.>
- 9) Remove the bolts which secure A/C compressor bracket to cylinder head.
- 10) Remove the oil pipe. <Ref. to LU(STI)-25, REMOVAL, Oil Pipe.>
- 11) Remove the camshaft. <Ref. to ME(w/o STI)-60, REMOVAL, Camshaft.>
- 12) Remove the oil level gauge guide. (LH side only)
- 13) Remove the cylinder head bolts in alphabetical order shown in the figure.

#### NOTE:

Leave the bolts (A) and (D) engaged by three or four threads to prevent the cylinder head from falling.

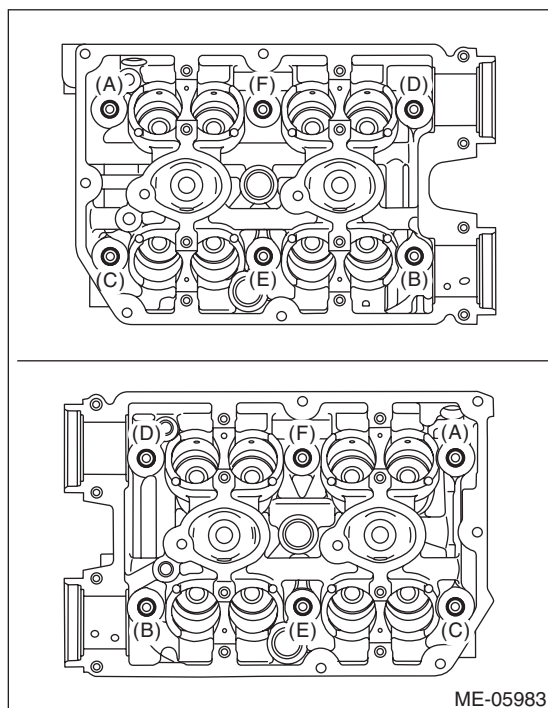

- 14) While tapping the cylinder head with a plastic hammer, separate it from cylinder block. Remove the bolts (A) and (D) to remove cylinder head.

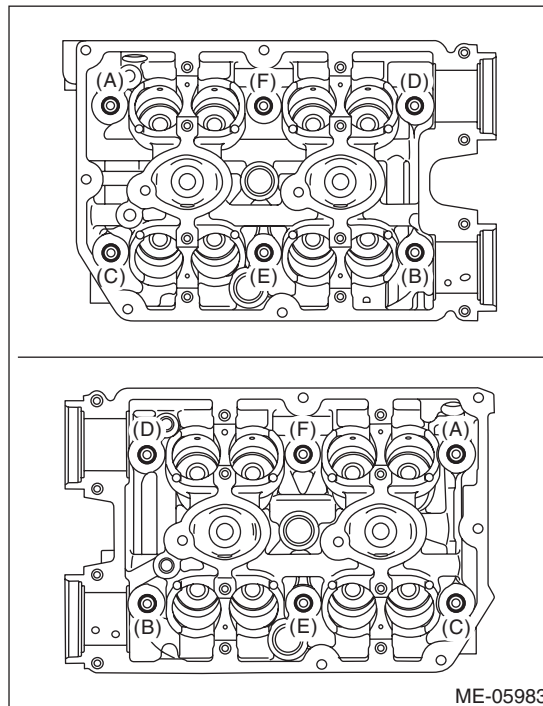

- 15) Remove the cylinder head gasket.

#### CAUTION:

**Be careful not to scratch the mating surface of cylinder head and cylinder block.**

### B: INSTALLATION

- 1) Install the cylinder head to the cylinder block.

#### CAUTION:

**Be careful not to scratch the mating surface of cylinder head and cylinder block.**

#### NOTE:

Use a new cylinder head gasket.

- (1) Clean the bolt threads and the bolt holes in the cylinder block

#### CAUTION:

**To avoid erroneous tightening of the bolts, clean out the bolt holes sufficiently by blowing with compressed air to eliminate engine coolant etc.**

- (2) Apply a sufficient coat of engine oil to the washer and bolt thread.
- (3) Tighten all bolts to 40 N·m (4.1 kgf-m, 29.5 ft-lb) in alphabetical order.

# Cylinder Head

## MECHANICAL

- (4) Retighten all bolts to 95 N·m (9.7 kgf-m, 70.1 ft-lb) in alphabetical order.

### CAUTION:

If the bolt makes stick-slip sound during tightening, repeat the procedure from step (1). In this case, the cylinder head gasket can be re-used.

- (5) Loosen all the bolts by 180° in the reverse order of installing, and loosen them further by 180°.
- (6) Tighten all bolts to 10 N·m (1.0 kgf-m, 7.4 ft-lb) in alphabetical order.
- (7) Retighten all bolts to 30 N·m (3.1 kgf-m, 22.1 ft-lb) in alphabetical order.
- (8) Retighten all bolts to 70 N·m (7.1 kgf-m, 51.6 ft-lb) in alphabetical order.
- (9) Retighten all bolts by 80 — 90° in alphabetical order.
- (10) Retighten all bolts by 40 — 45° in alphabetical order.

### CAUTION:

The tightening angle of the bolt should not exceed 45°.

- (11) Retighten bolts (A) and (B) by 40 — 45°.

### CAUTION:

Make sure the total "tightening angle" of steps (10) and (11) does not exceed 90°.

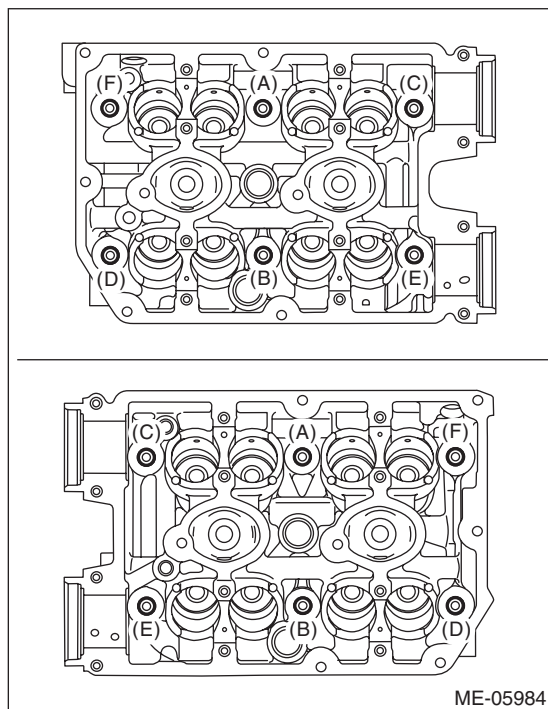

- 2) Install the oil level gauge guide. (LH side only)

### Tightening torque:

**6.4 N·m (0.7 kgf-m, 4.7 ft-lb)**

- 3) Install the camshaft. <Ref. to ME(w/o STI)-63, INSTALLATION, Camshaft.>

- 4) Install the oil pipe. <Ref. to LU(STI)-27, INSTALLATION, Oil Pipe.>

- 5) Install the A/C compressor bracket on cylinder head.

### Tightening torque:

**36 N·m (3.7 kgf-m, 26.6 ft-lb)**

- 6) Install the secondary air combination valve. <Ref. to EC(w/o STI)-31, INSTALLATION, Secondary Air Combination Valve.>

- 7) Install the cam sprocket. <Ref. to ME(w/o STI)-58, INSTALLATION, Cam Sprocket.>

- 8) Install the timing belt. <Ref. to ME(w/o STI)-51, INSTALLATION, Timing Belt.>

- 9) Adjust the valve clearance. <Ref. to ME(w/o STI)-29, ADJUSTMENT, Valve Clearance.>

- 10) Install the rocker cover.

- (1) Install the rocker cover gasket to the rocker cover. (outer section and ignition coil section)

### NOTE:

Use a new rocker cover gasket.

- (2) Apply liquid gasket to the specified point of the cylinder head.

### NOTE:

Install within 5 min. after applying liquid gasket.

### Liquid gasket:

**THREE BOND 1217G (Part No. K0877Y0100) or equivalent**

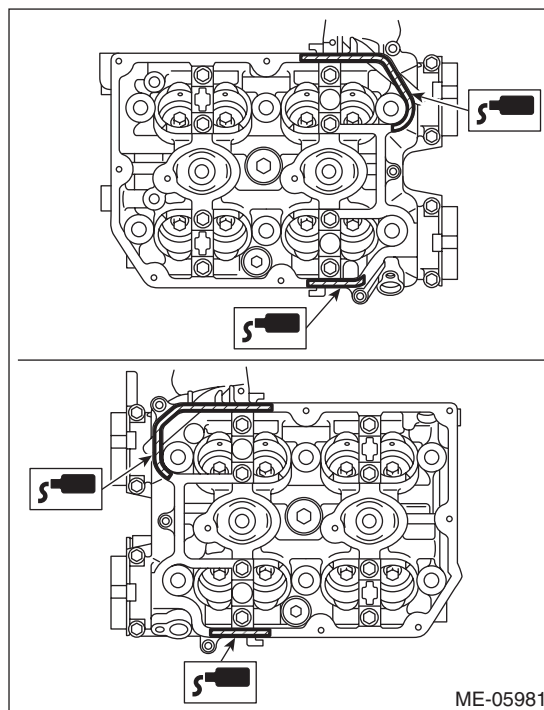

**ME(w/o STI)-70**

Brought to you by Ebay Seller "SubaruManuals"

# Cylinder Head

MECHANICAL

(3) Install the rocker cover onto cylinder heads. Ensure the gasket is properly positioned during installation.

(4) Temporarily tighten the rocker cover bolts in alphabetical order shown in the figure, and then tighten to specified torque in alphabetical order.

### Tightening torque:

**6.4 N·m (0.7 kgf·m, 4.7 ft·lb)**

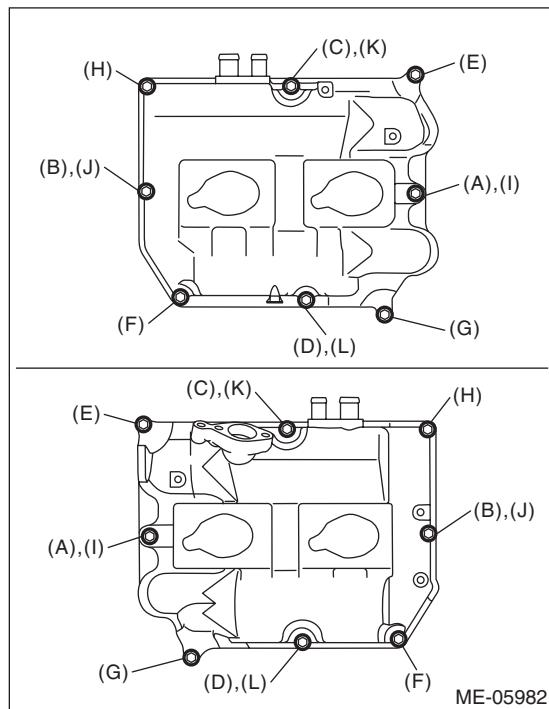

11) Connect the PCV hose (A) and PCV hose assembly (B) to the rocker cover.

### NOTE:

Use a new clamp for the PCV hose (A), fit the cut out in the ST with the protrusion on the clamp as shown in the figure, and lock the clamp.

ST 18353AA000 CLAMP PLIERS

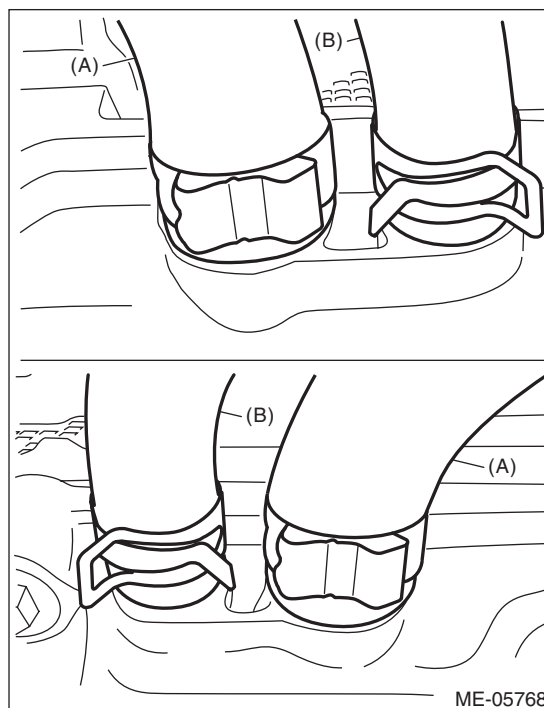
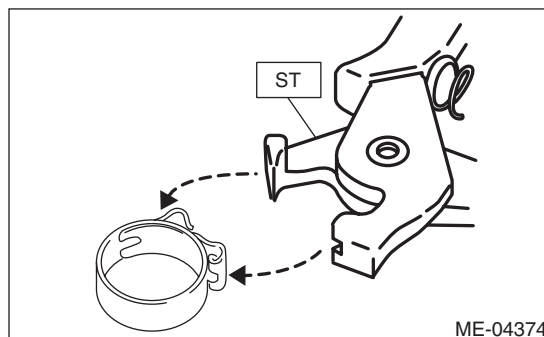

12) Install the timing belt cover. <Ref. to ME(w/o STI)-48, INSTALLATION, Timing Belt Cover.>

13) Install the crank pulley. <Ref. to ME(w/o STI)-46, INSTALLATION, Crank Pulley.>

14) Install the intake manifold. <Ref. to FU(w/o STI)-22, INSTALLATION, Intake Manifold.>

15) Install the rear side belt. <Ref. to ME(w/o STI)-40, REAR SIDE BELT, INSTALLATION, V-belt.>

16) Install the engine to the vehicle. <Ref. to ME(w/o STI)-34, INSTALLATION, Engine Assembly.>

**ME(w/o STI)-71**

Brought to you by Ebay Seller "SubaruManuals"

# Cylinder Head

MECHANICAL

---

## C: DISASSEMBLY

1) Remove the valve lifter.

2) Place the cylinder head on ST1.

ST1 498267600 CYLINDER HEAD TABLE

3) Using ST2, compress the valve spring and remove the valve spring retainer key. Remove each valve and valve spring.

ST2 499718000 VALVE SPRING REMOVER

NOTE:

- Mark each valve to prevent confusion.
- Pay careful attention not to damage the lips of intake valve oil seals and exhaust valve oil seals.
- Keep all the removed parts in order for re-installing in their original positions.
- For removal and installation procedures of the valve guide, intake valve oil seal and exhaust valve oil seal, refer to "INSPECTION". <Ref. to ME(w/o STI)-75, VALVE GUIDE, INSPECTION, Cylinder Head.> <Ref. to ME(w/o STI)-77, INTAKE AND EXHAUST VALVE OIL SEAL, INSPECTION, Cylinder Head.>

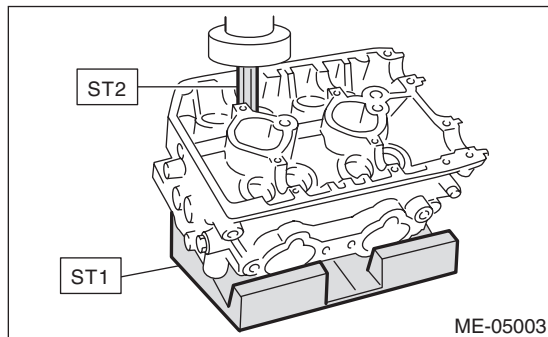

**ME(w/o STI)-72**

Brought to you by Ebay Seller "SubaruManuals"

## D: ASSEMBLY

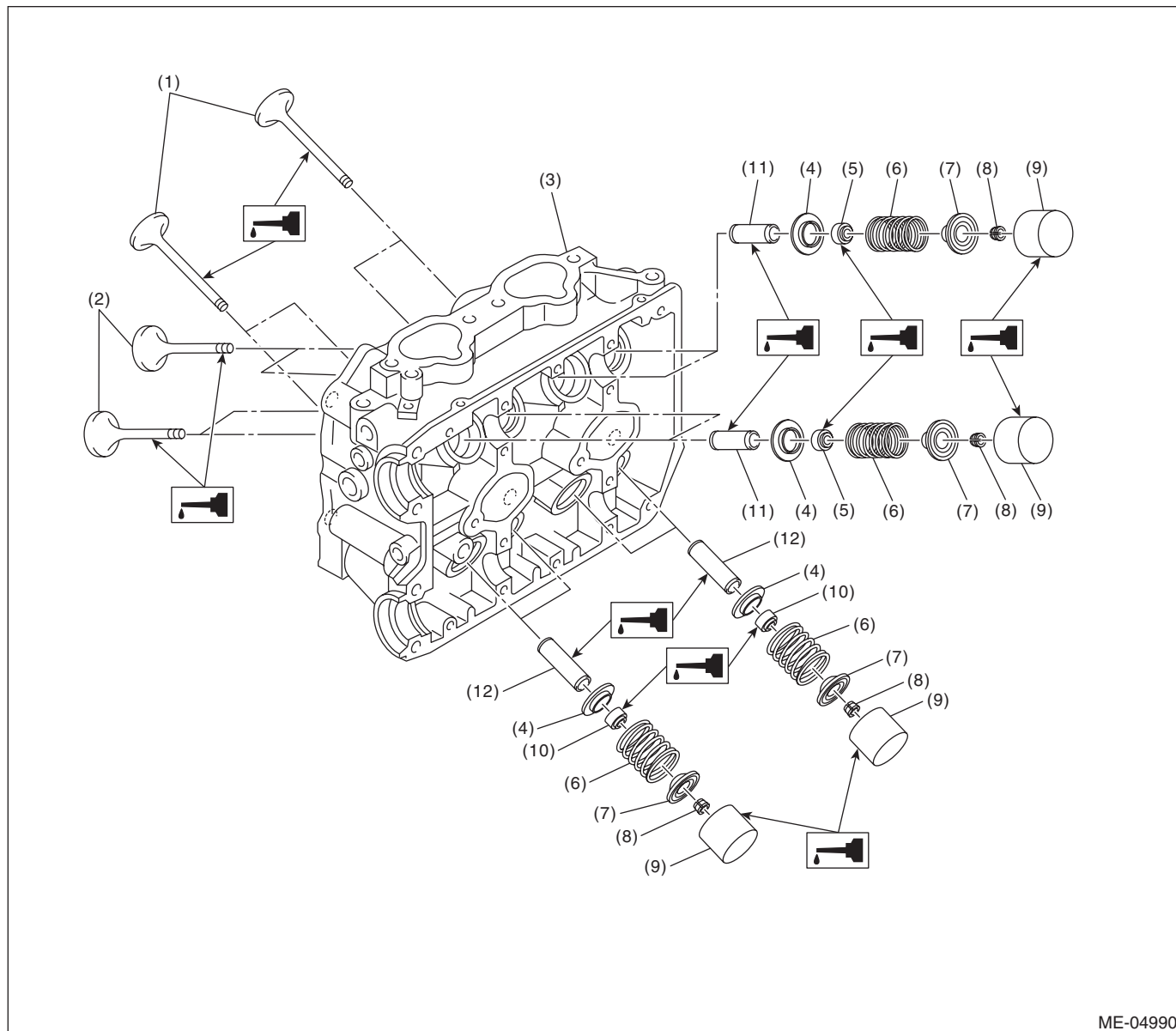

ME-04990

- |                       |                               |                             |
|-----------------------|-------------------------------|-----------------------------|
| (1) Exhaust valve     | (5) Intake valve oil seal     | (9) Valve lifter            |
| (2) Intake valve      | (6) Valve spring              | (10) Exhaust valve oil seal |
| (3) Cylinder head     | (7) Valve spring retainer     | (11) Intake valve guide     |
| (4) Valve spring seat | (8) Valve spring retainer key | (12) Exhaust valve guide    |

# Cylinder Head

## MECHANICAL

- 1) Install the valve spring and valve.
  - (1) Coat the valve stem of each valve with engine oil and insert the valve into valve guide.

### NOTE:

When inserting the valve into valve guide, use special care not to damage the oil seal lip.

- (2) Set the cylinder head on ST1.

ST1 498267600 CYLINDER HEAD TABLE

- (3) Install the valve spring and valve spring retainer.

### NOTE:

Be sure to install the valve spring with its close-coiled end facing the cylinder head side.

- (4) Set the ST2 on valve spring.

ST2 499718000 VALVE SPRING REMOVER

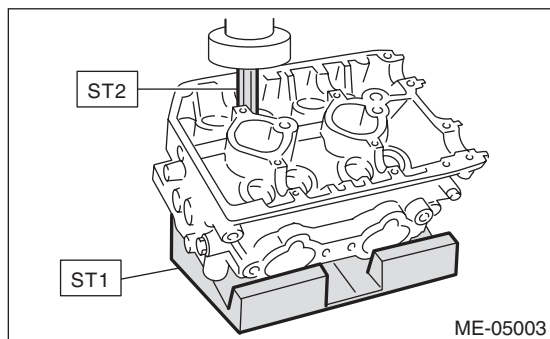

- (5) Compress the valve spring and fit the valve spring retainer key.

- (6) After installing, tap the valve spring retainers lightly with a plastic hammer for better seating.

- 2) Apply oil to the surface of valve lifter.
- 3) Install the valve lifter.

## E: INSPECTION

### 1. CYLINDER HEAD

1) Check for cracks or damage. Use liquid penetrant tester on the important sections to check for fissures. Check that there are no marks of gas leaking or water leaking on gasket installing surface.

2) Measure the warping of the cylinder head surface that mates with cylinder block using a straight edge (A) and thickness gauge (B).

If the warping exceeds the limit, correct the surface by grinding it with a surface grinder.

#### Warping limit:

**0.035 mm (0.0014 in)**

#### Grinding limit:

**0.3 mm (0.012 in)**

#### Standard height of cylinder head:

**127.5 mm (5.02 in)**

### NOTE:

Uneven torque for the cylinder head bolts can cause warpage. When reinstalling, pay special attention to the torque so as to tighten evenly.

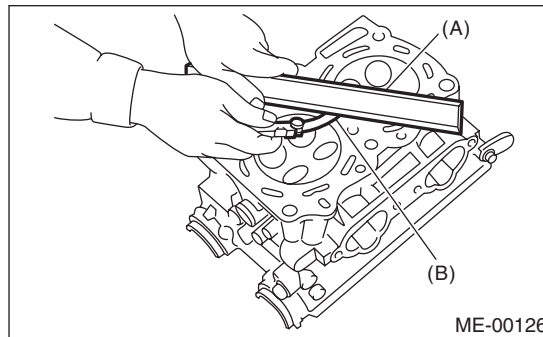

### 2. VALVE SEAT

Inspect the intake and exhaust valve seats, and correct the contact surfaces with a valve seat cutter if they are defective or when valve guides are replaced.

#### Contacting width *W* between valve and valve seat:

##### Standard

##### Intake

**0.6 — 1.4 mm (0.024 — 0.055 in)**

##### Exhaust

**1.2 — 1.8 mm (0.047 — 0.071 in)**

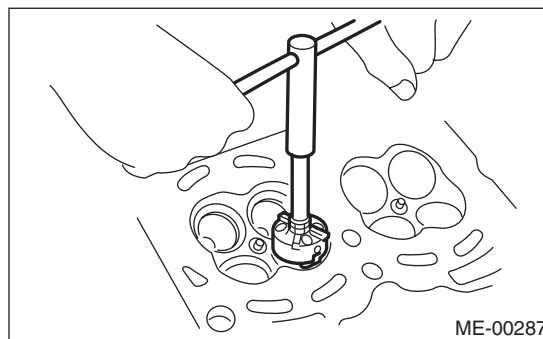
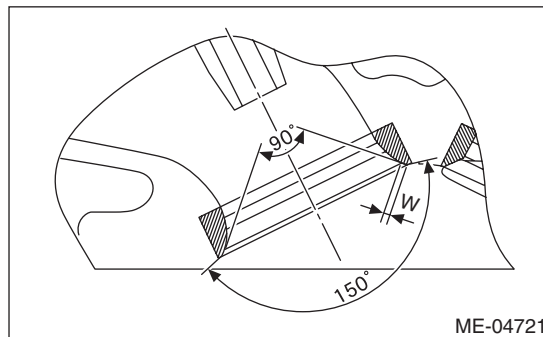



## 3. VALVE GUIDE

1) Check the clearance between valve guide and valve stem. The clearance can be checked by measuring respectively the outer diameter of valve stem with a micrometer and the inner diameter of valve guide with a caliper gauge.

**Clearance between the valve guide and valve stem:**

**Standard**

**Intake**

**0.030 — 0.057 mm (0.0012 — 0.0022 in)**

**Exhaust**

**0.040 — 0.067 mm (0.0016 — 0.0026 in)**

2) If the clearance between valve guide and valve stem exceeds the standard, replace the valve guide or valve itself, whichever shows the greater amount of wear or damage. See the following procedure for valve guide replacement.

**Valve guide inner diameter:**

**6.000 — 6.012 mm (0.2362 — 0.2367 in)**

**Valve stem outer diameters:**

**Intake**

**5.955 — 5.970 mm (0.2344 — 0.2350 in)**

**Exhaust**

**5.945 — 5.960 mm (0.2341 — 0.2346 in)**

(1) Place the cylinder head on ST1 with the combustion chamber upward so that valve guides fit the holes in ST1.

(2) Insert the ST2 into valve guide and press it down to remove the valve guide.

ST1 498267600 CYLINDER HEAD TABLE

ST2 499767200 VALVE GUIDE REMOVER

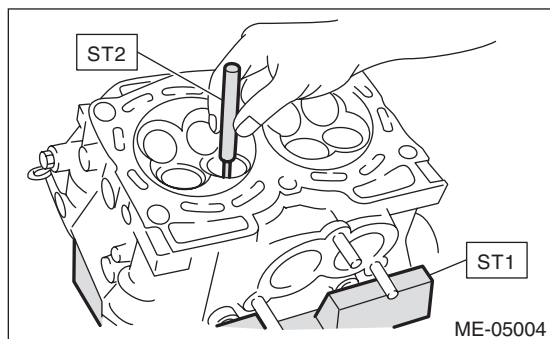

(3) Turn the cylinder head upside down and place the ST as shown in the figure.

ST 18251AA020 VALVE GUIDE ADJUSTER

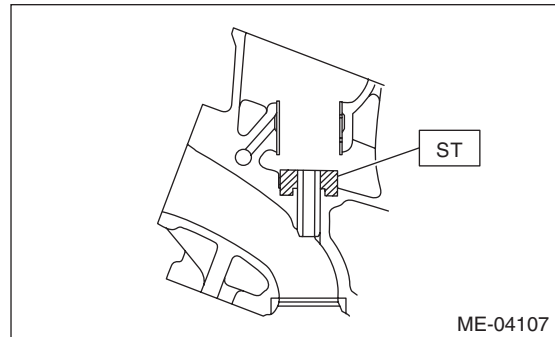

(4) Before installing a new valve guide, make sure that neither scratches nor damages exist on the inner surface of valve guide holes in cylinder head.

(5) Put a new valve guide, coated with sufficient oil, in the cylinder head, and insert the ST1 into valve guide. Press in until the valve guide upper end is flush with the upper surface of ST2.

ST1 499767200 VALVE GUIDE REMOVER

ST2 18251AA020 VALVE GUIDE ADJUSTER

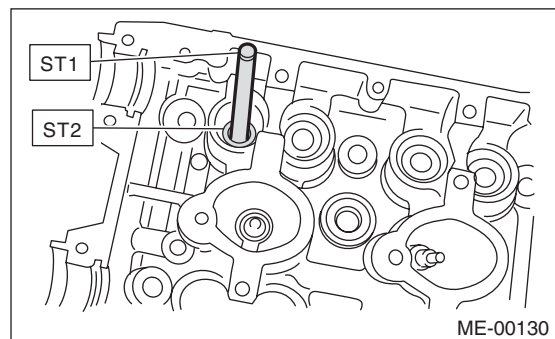

(6) Check the valve guide protrusion amount "L".

**Valve guide protrusion amount L:**

**15.8 — 16.2 mm (0.622 — 0.638 in)**

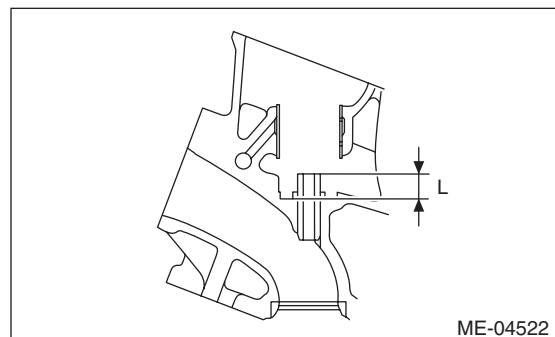

# Cylinder Head

## MECHANICAL

(7) Ream the inside of valve guide using ST. Put the ST in valve guide, and rotate the ST slowly clockwise while pushing it lightly. Bring the ST back while rotating it clockwise.

### NOTE:

- Apply engine oil to the ST when reaming.
- If the inner surface of valve guide is damaged, the edge of ST should be slightly ground with oil stone.
- If the inner surface of valve guide becomes lustrous and the ST does not chip, use a new ST or remedy the ST.

ST 499767400 VALVE GUIDE REAMER

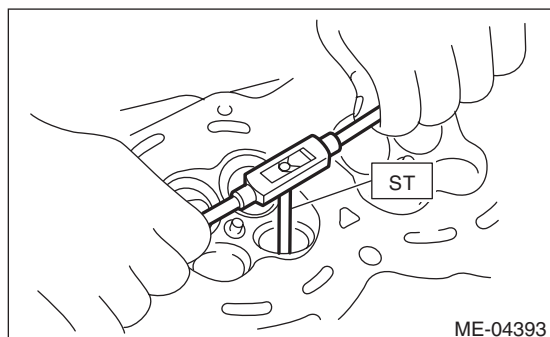

(8) After reaming, clean the valve guide to remove chips.

(9) Recheck the contact condition between valve and valve seat after replacing the valve guide.

## 4. INTAKE AND EXHAUST VALVE

1) Inspect the flange of valve and valve stem, and replace the valve with a new part if damaged, worn, deformed, or if dimension "H" in the figure is outside of the specified limit.

### Head edge thickness H:

#### Standard

##### Intake (A)

1.0 — 1.4 mm (0.039 — 0.055 in)

##### Exhaust (B)

1.3 — 1.7 mm (0.051 — 0.067 in)

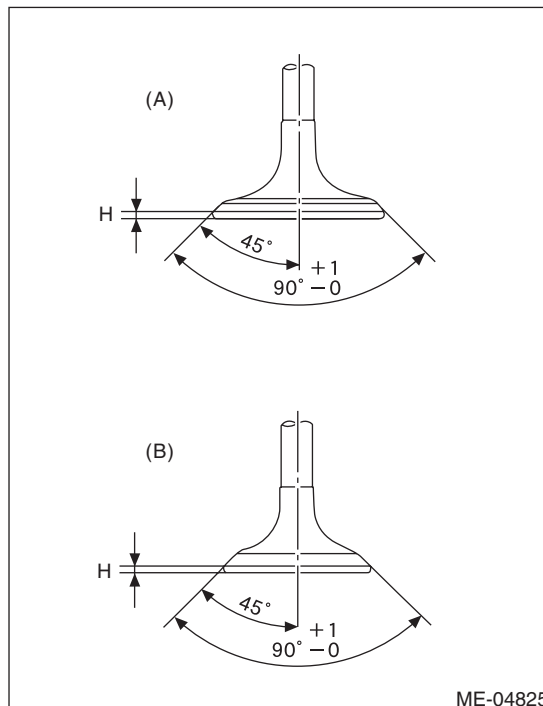

2) Put a small amount of grinding compound on the valve seat surface, and lap the valve and valve seat surface. Replace with a new valve oil seal after lapping.

### NOTE:

It is possible to differentiate between the intake valve and the exhaust valve by their overall length.

### Valve overall length:

#### Intake

104.4 mm (4.110 in)

#### Exhaust

104.65 mm (4.1201 in)



## 5. VALVE SPRING

1) Check the valve springs for damage, free length, and tension. Replace the valve spring if it is not within the standard value presented in the table.

2) To measure the squareness of the valve spring, stand the valve spring on a surface plate and measure its deflection at the top of the valve spring using a try square.

Free length	mm (in)	47.32 (1.863)
Tension/spring height N (kgf, lb)/mm (in)	Set	205 — 235 (20.9 — 24.0, 46.1 — 52.8)/36.0 (1.417)
	Lift	426 — 490 (43.4 — 50.0, 95.8 — 110)/26.50 (1.041)
Squareness	2.5°, 2.1 mm (0.083 in) or less	

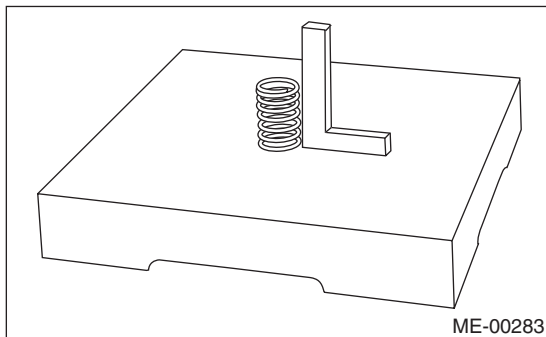

## 6. INTAKE AND EXHAUST VALVE OIL SEAL

1) For the following, replace the oil seal with a new part. See the procedure 2) and subsequent for replacement procedures.

- When the lip is damaged.
- When the spring is out of the specified position.
- When readjusting the surfaces of valve and valve seat.
- When replacing the valve guide.

2) Place the cylinder head on ST1, and use ST2 to press-fit the oil seal.

ST1 498267600 CYLINDER HEAD TABLE  
ST2 498857100 VALVE OIL SEAL GUIDE

### NOTE:

- Apply engine oil to oil seal before press-fitting.
- When press-fitting the oil seal, do not use a hammer to strike in.
- The intake valve oil seals and exhaust valve oil seals are distinguished by their colors.

### Color of rubber part:

**Intake [Gray]**

**Exhaust [Green]**

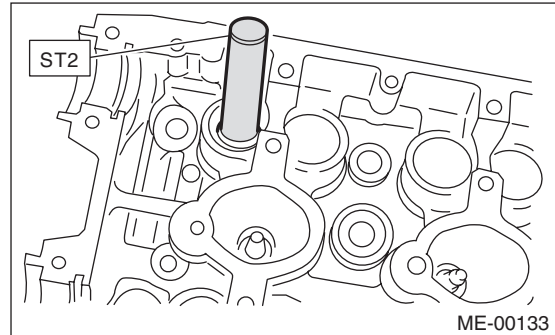

## 7. VALVE LIFTER

- 1) Check the valve lifter visually.
- 2) Measure the outer diameter of valve lifter.

### Outer diameter of valve lifter:

#### Standard

**34.959 — 34.975 mm (1.3763 — 1.3770 in)**

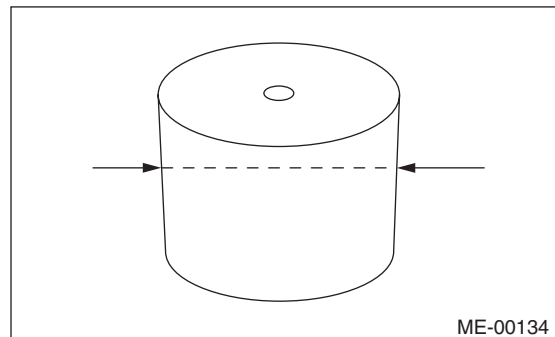

- 3) Measure the inner diameter of valve lifter mating surface on cylinder head.

### Valve lifter mating surface inner diameter:

#### Standard

**34.994 — 35.016 mm (1.3777 — 1.3786 in)**

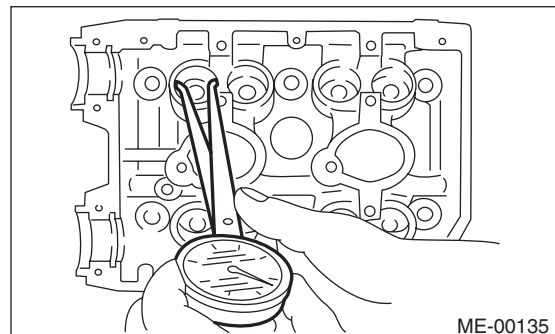

# Cylinder Head

## MECHANICAL

---

4) Check the clearance between valve lifter and valve lifter mating surface. The clearance can be checked by measuring the outer diameter of valve lifter and the inner diameter of valve lifter. If it exceeds the standard or offset wear occurs, replace the cylinder head.

***Valve lifter and valve lifter mating surface clearance:***

***Standard***

***0.019 — 0.057 mm (0.0007 — 0.0022 in)***

## 20. Cylinder Block

### A: REMOVAL

**NOTE:**

Before conducting this procedure, drain the engine oil completely.

- 1) Remove the engine from the vehicle. <Ref. to ME(w/o STI)-30, REMOVAL, Engine Assembly.>
- 2) Remove the rear side belt. <Ref. to ME(w/o STI)-39, REAR SIDE BELT, REMOVAL, V-belt.>
- 3) Remove the intake manifold. <Ref. to FU(w/o STI)-18, REMOVAL, Intake Manifold.>
- 4) Remove the crank pulley. <Ref. to ME(w/o STI)-46, REMOVAL, Crank Pulley.>
- 5) Remove the timing belt cover. <Ref. to ME(w/o STI)-48, REMOVAL, Timing Belt Cover.>
- 6) Remove the timing belt. <Ref. to ME(w/o STI)-49, REMOVAL, Timing Belt.>
- 7) Remove the cam sprocket. <Ref. to ME(w/o STI)-58, REMOVAL, Cam Sprocket.>
- 8) Remove the crank sprocket. <Ref. to ME(w/o STI)-59, REMOVAL, Crank Sprocket.>
- 9) Remove the generator and A/C compressor with their brackets.
- 10) Remove the camshaft. <Ref. to ME(w/o STI)-60, REMOVAL, Camshaft.>
- 11) Remove the cylinder head. <Ref. to ME(w/o STI)-69, REMOVAL, Cylinder Head.>
- 12) Remove the clutch disc and cover. <Ref. to CL-11, REMOVAL, Clutch Disc and Cover.>
- 13) Remove the flywheel. <Ref. to CL-14, REMOVAL, Flywheel.>
- 14) Remove the oil separator cover.
- 15) Remove the water by-pass pipe for heater.
- 16) Remove the oil filter. <Ref. to LU(STI)-32, REMOVAL, Engine Oil Filter.>
- 17) Remove the water pump. <Ref. to CO(w/o STI)-15, REMOVAL, Water Pump.>
- 18) Remove the bolts which secure oil pump to cylinder block.

**NOTE:**

When disassembling and checking the oil pump, loosen the relief valve plug before removing the oil pump.

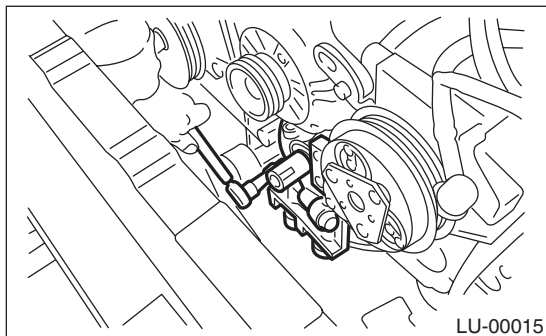

- 19) Remove the oil pump from cylinder block using a flat tip screwdriver.

**CAUTION:**

**Be careful not to scratch the mating surface of the cylinder block and oil pump.**

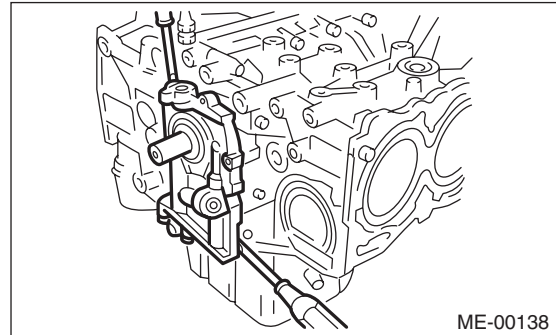

- 20) Remove the front oil seal from the oil pump.
- 21) Remove the oil pan.
  - (1) Set the part so that the cylinder block LH is on the upper side.
  - (2) Remove the bolts which secure oil pan to cylinder block.
  - (3) Insert an oil pan cutter blade between cylinder block-to-oil pan clearance and remove the oil pan.

**CAUTION:**

**Do not use a screwdriver or similar tools in place of oil pan cutter.**

- 22) Remove the oil strainer.
- 23) Remove the baffle plate.
- 24) Remove the water tank pipe assembly from the cylinder block RH.

# Cylinder Block

## MECHANICAL

### NOTE:

Pinch the clamp of the water tank pipe assembly by fitting the cut out in the ST with the protrusion on the clamp as shown in the figure, and unlock the clamp.

ST 18353AA000 CLAMP PLIERS

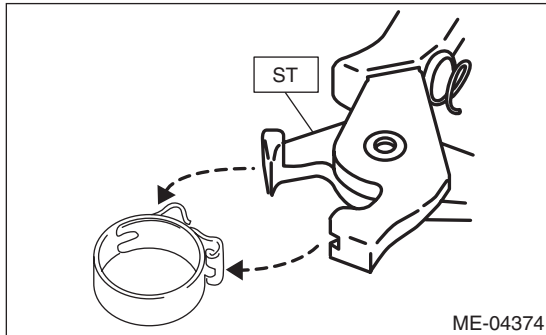

ME-04374

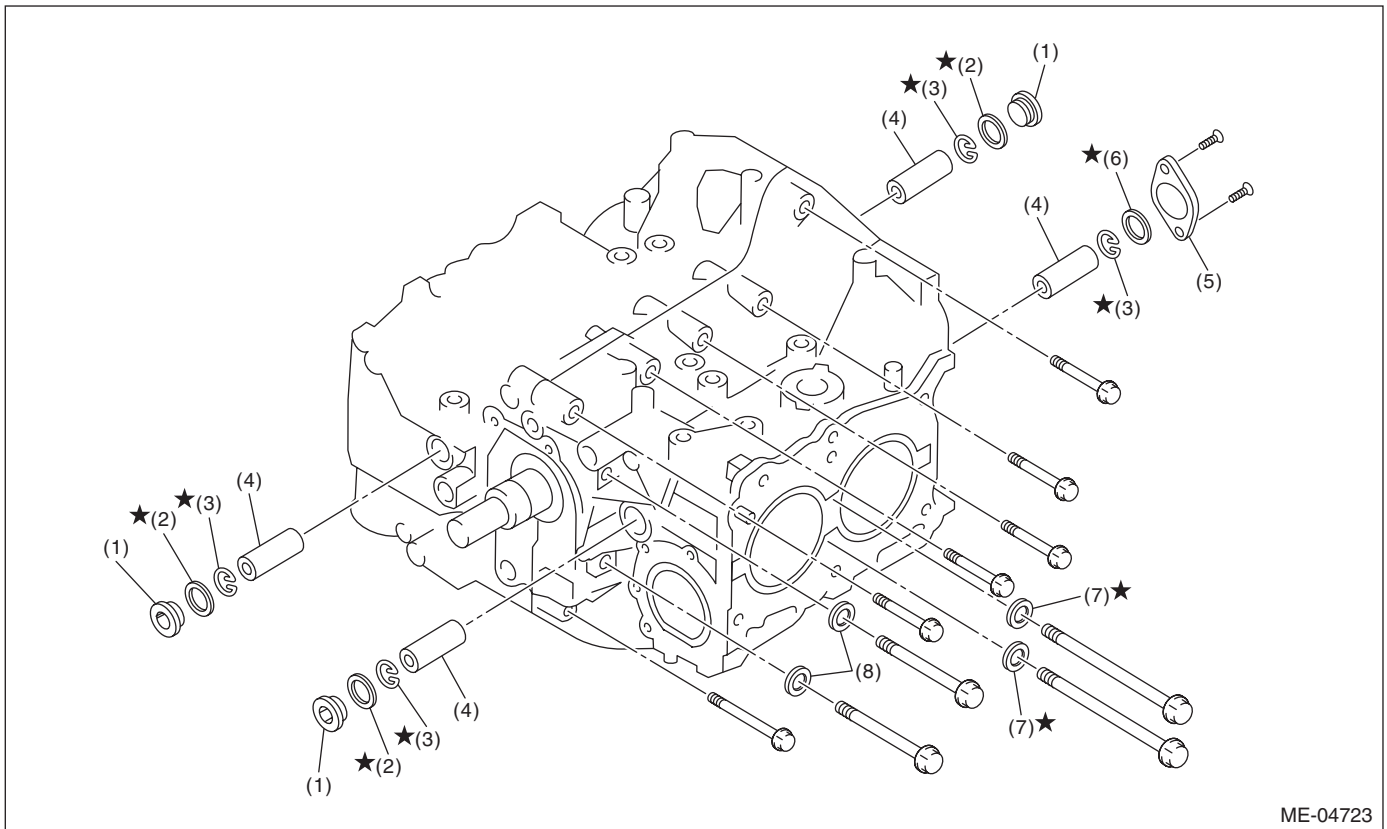

ME-04723

- (1) Service hole plug
- (2) Gasket
- (3) Snap ring

- (4) Piston pin
- (5) Service hole cover
- (6) O-ring

- (7) Seal washer
- (8) Washer

**ME(w/o STI)-80**

Brought to you by Ebay Seller "SubaruManuals"

# Cylinder Block

MECHANICAL

25) Remove the service hole plugs using a hexagon wrench [14 mm].

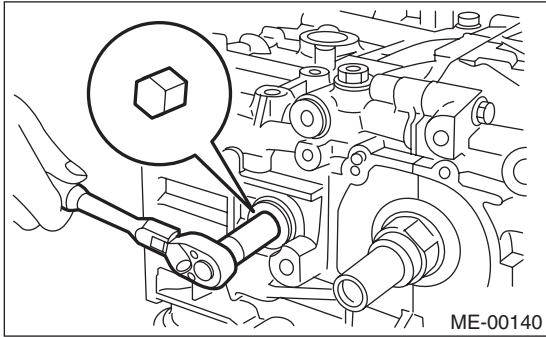

26) Remove the service hole cover.

27) Rotate the crankshaft to bring #1 and #2 pistons to bottom dead center position, then remove the piston snap ring through service hole of #1 and #2 cylinders.

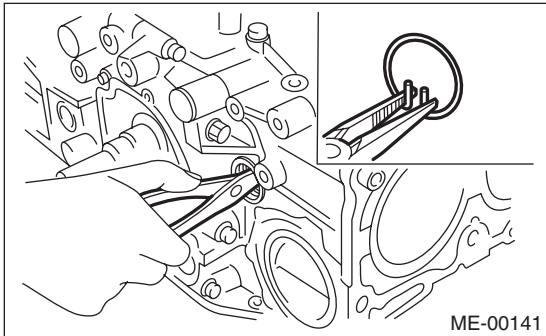

28) Draw out the piston pin from #1 and #2 pistons using ST.

ST 499097700 PISTON PIN REMOVER ASSY

## NOTE:

Be careful not to confuse the original combination of piston, piston pin and cylinder.

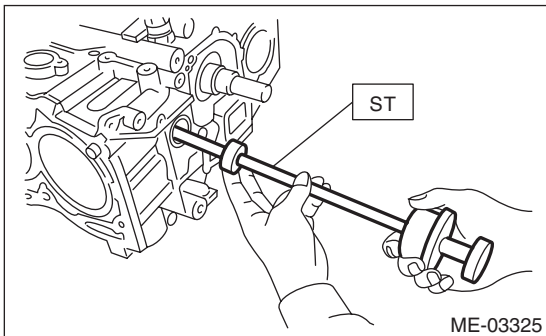

29) Similarly draw out the piston pins from #3 and #4 pistons.

30) Remove the cylinder block connecting bolt on the RH side.

31) Loosen the cylinder block connecting bolt on the LH side by 2 to 3 turns.

32) Set the part so that the cylinder block LH is on the upper side, and remove the cylinder block connecting bolt.

**ME(w/o STI)-81**

Brought to you by Ebay Seller "SubaruManuals"

# Cylinder Block

## MECHANICAL

33) Separate the cylinder block LH and RH.

### NOTE:

When separating the cylinder block, do not allow the connecting rod to fall or damage the cylinder block.

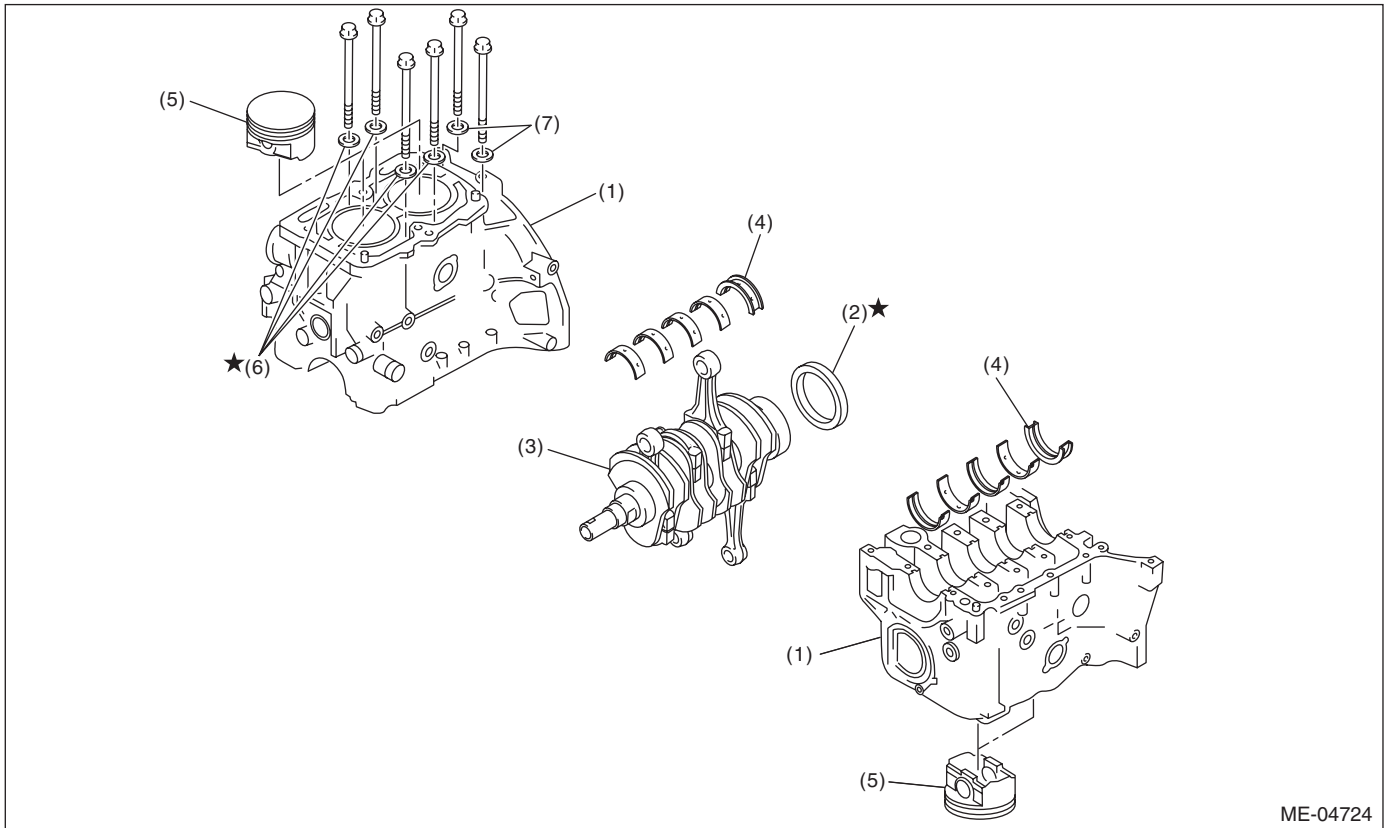

- |                    |                        |                 |
|--------------------|------------------------|-----------------|
| (1) Cylinder block | (4) Crankshaft bearing | (6) Seal washer |
| (2) Rear oil seal  | (5) Piston             | (7) Washer      |
| (3) Crankshaft     |                        |                 |

34) Remove the rear oil seal.

35) Remove the crankshaft together with connecting rod.

36) Remove the crankshaft bearings from cylinder block using a hammer handle.

### NOTE:

- Press the crankshaft bearing at the end opposite to locking lip to remove.
- Be careful not to confuse the crankshaft bearing combination.

37) Remove each piston from the cylinder block using a wooden bar or hammer handle.

### NOTE:

Be careful not to confuse the original combination of piston and cylinder.

## B: INSTALLATION

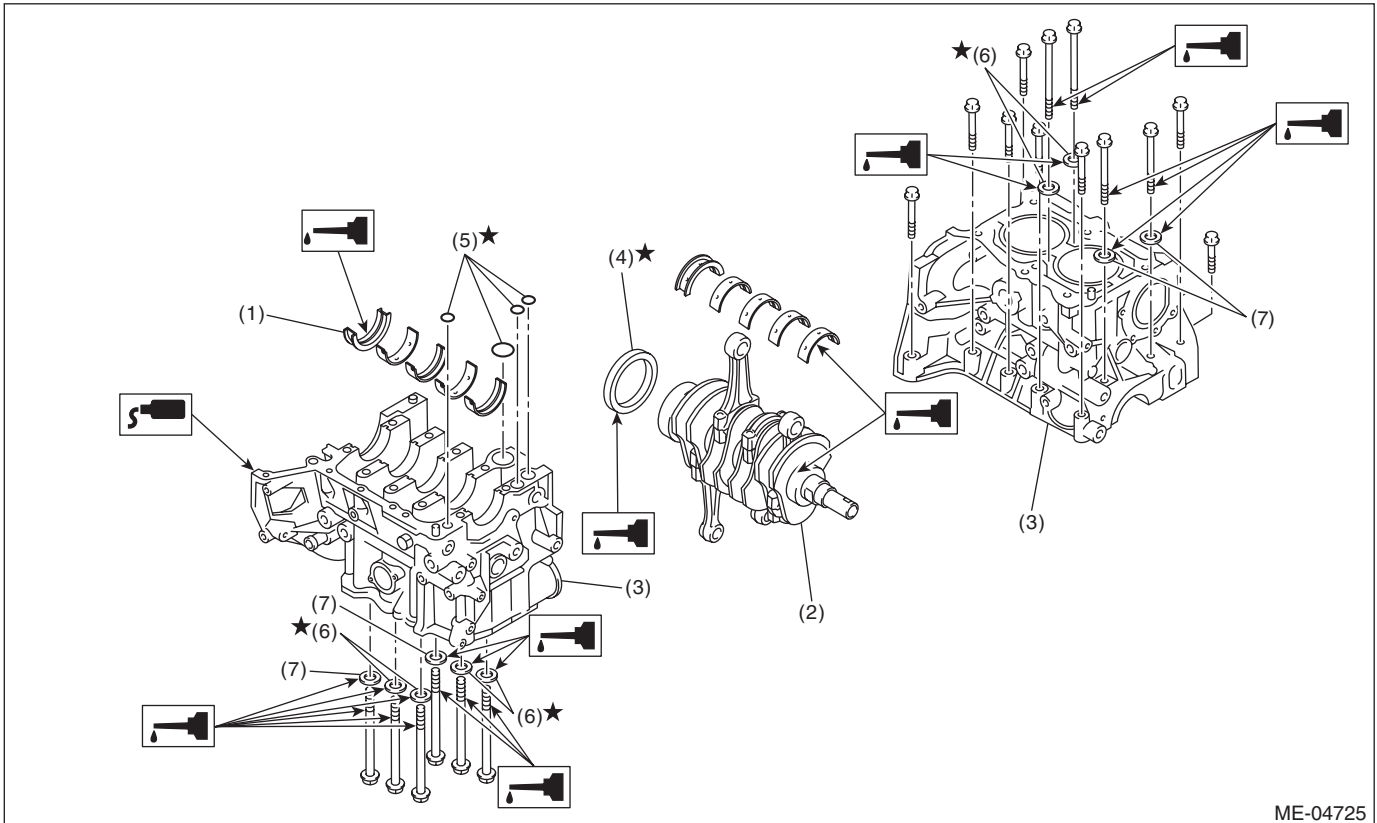

- |                        |                   |                 |
|------------------------|-------------------|-----------------|
| (1) Crankshaft bearing | (4) Rear oil seal | (6) Seal washer |
| (2) Crankshaft         | (5) O-ring        | (7) Washer      |
| (3) Cylinder block     |                   |                 |

1) Remove oil on the mating surface of cylinder block before installation. Apply a coat of engine oil to the bearing and crankshaft journal.

2) Position the crankshaft and O-ring on cylinder block RH.

**NOTE:**

Use new O-rings.

3) Apply liquid gasket to the mating surfaces of cylinder block RH, and position cylinder block LH.

**NOTE:**

- Install within 5 min. after applying liquid gasket.
- Do not allow liquid gasket to jut into O-ring grooves, oil passages, bearing grooves, etc.

**Liquid gasket:**

**THREE BOND 1217G (Part No. K0877Y0100) or equivalent**

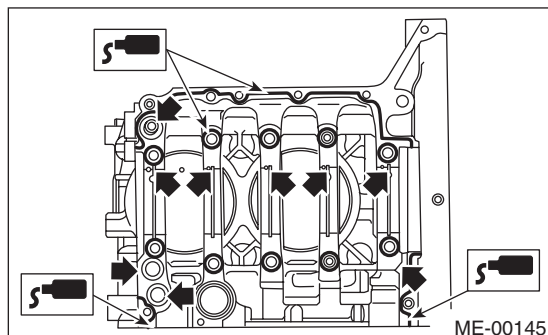



# Cylinder Block

## MECHANICAL

4) Apply a coat of engine oil to the washer and bolt thread.

### NOTE:

Use a new seal washer.

5) Tighten the 10 mm cylinder block connecting bolts on the LH side (A — D) in alphabetical order.

### Tightening torque:

**10 N·m (1.0 kgf·m, 7.4 ft·lb)**

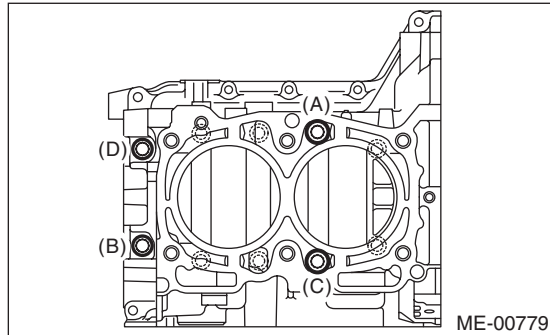

6) Tighten the 10 mm cylinder block connecting bolts on the RH side (E — J) in alphabetical order.

### Tightening torque:

**10 N·m (1.0 kgf·m, 7.4 ft·lb)**

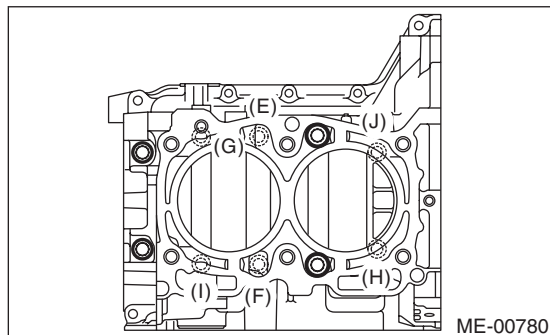

7) Tighten the LH side cylinder block connecting bolts (A — D) further in alphabetical order.

### Tightening torque:

**18 N·m (1.8 kgf·m, 13.3 ft·lb)**

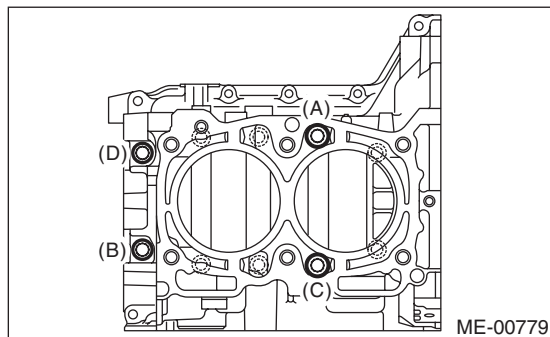

8) Tighten the RH side cylinder block connecting bolts (E — J) further in alphabetical order.

### Tightening torque:

**18 N·m (1.8 kgf·m, 13.3 ft·lb)**

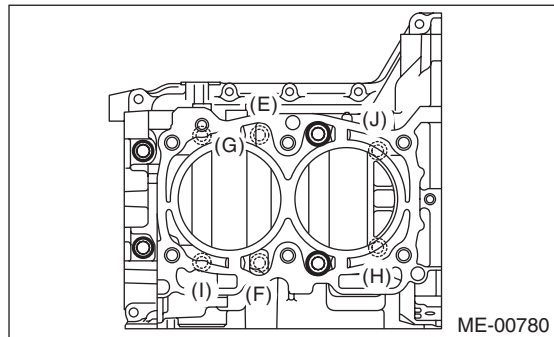

9) Tighten the LH side cylinder block connecting bolts (A — D) further in alphabetical order.

- (A), (C): Angle tightening

### Tightening angle:

**90°**

- (B), (D): Torque tightening

### Tightening torque:

**40 N·m (4.1 kgf·m, 29.5 ft·lb)**

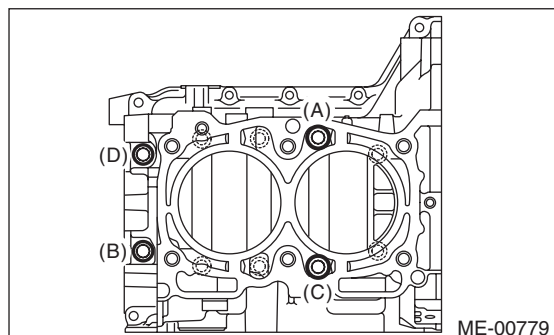

10) Tighten the RH side cylinder block connecting bolts (E — J) further in alphabetical order.

### Tightening angle:

**90°**

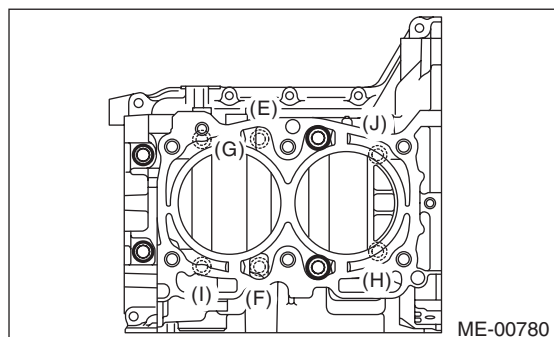



# Cylinder Block

MECHANICAL

11) Tighten the 8 mm and 6 mm cylinder block connecting bolts on the LH side (A — H) in alphabetical order.

**Tightening torque:**

(A) — (G): 25 N·m (2.5 kgf·m, 18.4 ft·lb)

(H): 6.4 N·m (0.7 kgf·m, 4.7 ft·lb)

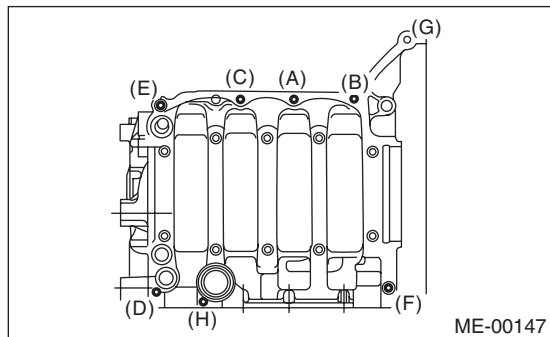

12) Apply a coat of engine oil to the oil seal inner periphery and outer periphery, and install the rear oil seal using ST1 and ST2.

**NOTE:**

Use a new rear oil seal.

ST1 499597100 CRANKSHAFT OIL SEAL GUIDE

ST2 499587200 CRANKSHAFT OIL SEAL INSTALLER

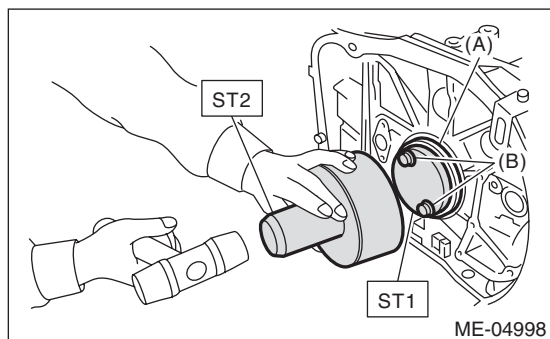

(A) Rear oil seal

(B) Flywheel attachment bolt

13) Position the top ring gap at (A) or (B) in the figure.

14) Position the second ring gap at 180° on the reverse side the top ring gap.

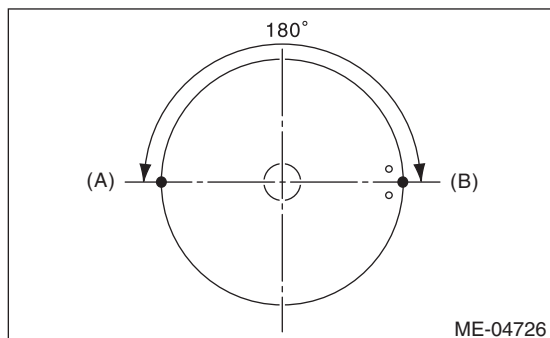

15) Position the upper rail gap at (C) in the figure.

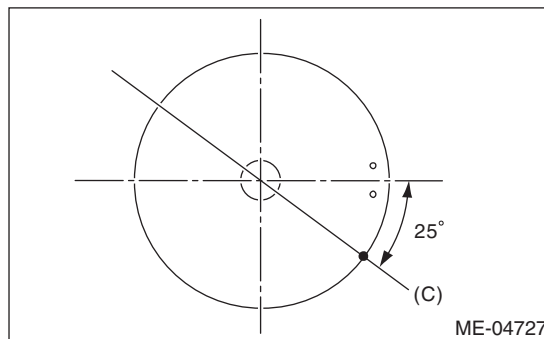

16) Align the upper rail spin stopper (E) to the side hole (D) on the piston.

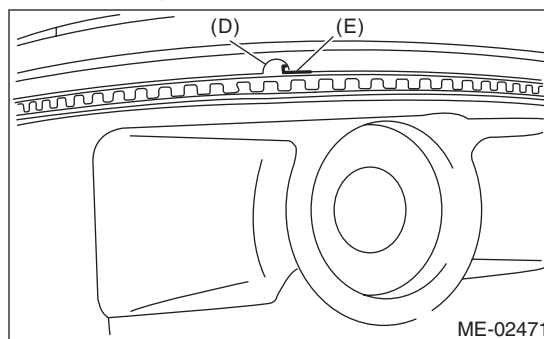

17) Position the expander gap at (F) in the figure on the 180° opposite direction of (C).

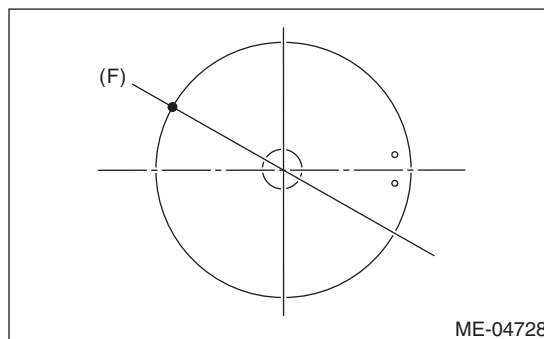

18) Set the lower rail gap at position (G), located 120° clockwise from (C) in the figure.

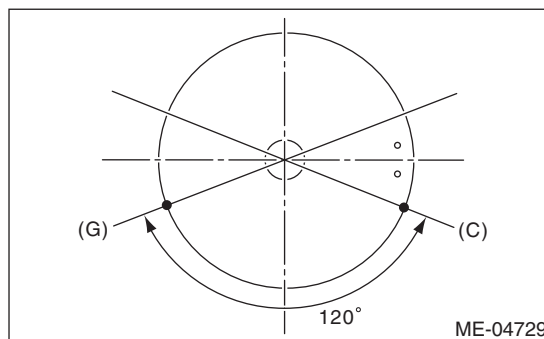

**NOTE:**

- Make sure ring gaps do not face the same direction.
- Make sure ring gaps are not within the piston skirt area.

**ME(w/o STI)-85**

Brought to you by Ebay Seller "SubaruManuals"

# Cylinder Block

## MECHANICAL

19) Install the snap ring.

Before positioning the piston on the cylinder block, attach the snap ring in the service hole of the cylinder block, and the piston hole on the opposite side.

### NOTE:

Use new snap rings.

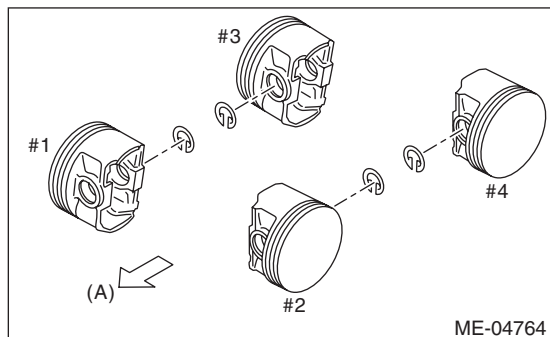

(A) Front side

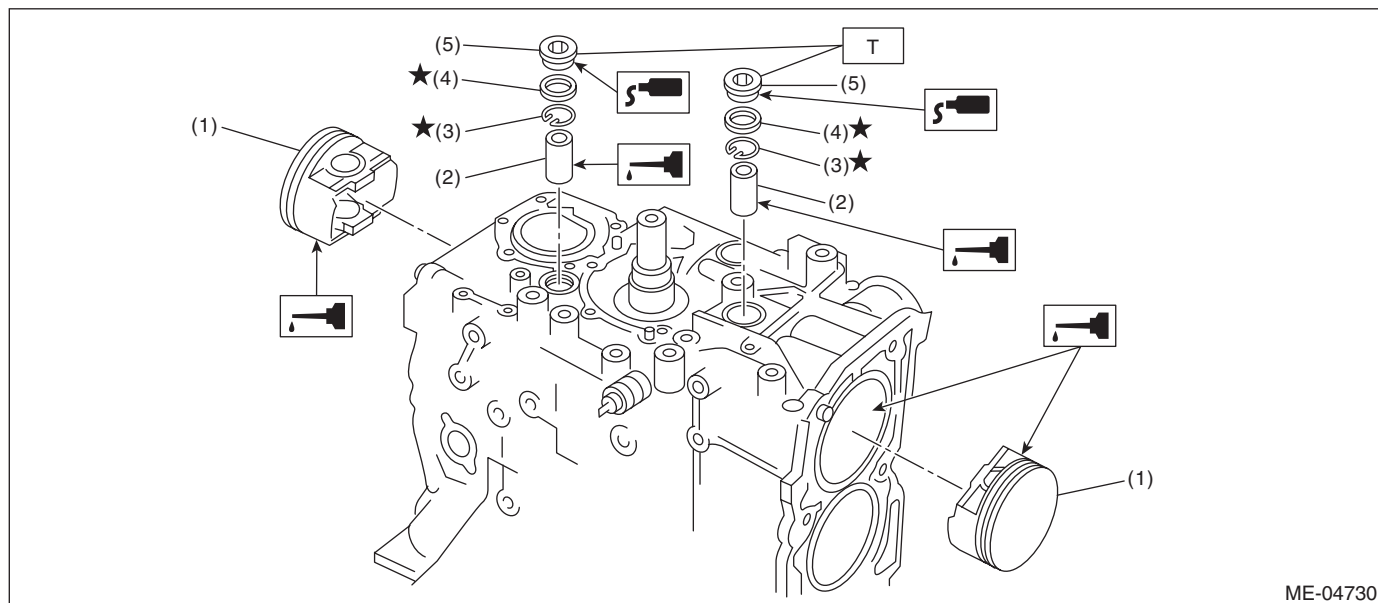

- |                |                       |
|----------------|-----------------------|
| (1) Piston     | (4) Gasket            |
| (2) Piston pin | (5) Service hole plug |
| (3) Snap ring  |                       |

**Tightening torque: N·m (kgf·m, ft·lb)**

**T: 70 (7.1, 51.6)**

**ME(w/o STI)-86**

Brought to you by Ebay Seller "SubaruManuals"

# Cylinder Block

MECHANICAL

20) Install the piston.

(1) Set the parts so that the #1 and #2 cylinders are on the upper side.

(2) Using the ST1, turn the crankshaft so that #1 and #2 connecting rods are set at bottom dead center.

ST1 499987500 CRANKSHAFT SOCKET

(3) Apply a coat of engine oil to the pistons and cylinders and insert pistons in their cylinders using ST2.

ST2 498747300 PISTON GUIDE

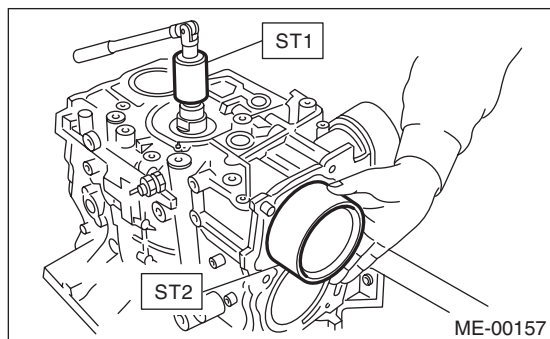

NOTE:

Face the piston front mark towards the front of the engine.

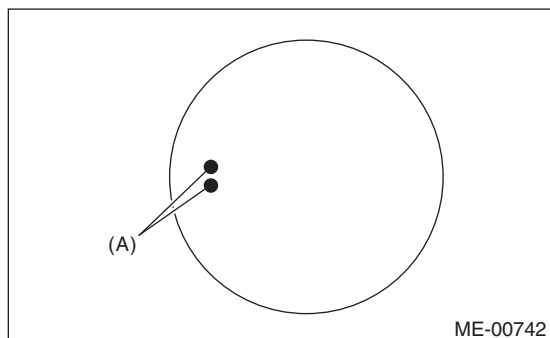

(A) Front mark

21) Install the piston pin.

(1) Apply a coat of engine oil to ST3.

(2) Insert ST3 into the service hole to align the piston pin hole and the connecting rod small end.

ST3 499017100 PISTON PIN GUIDE

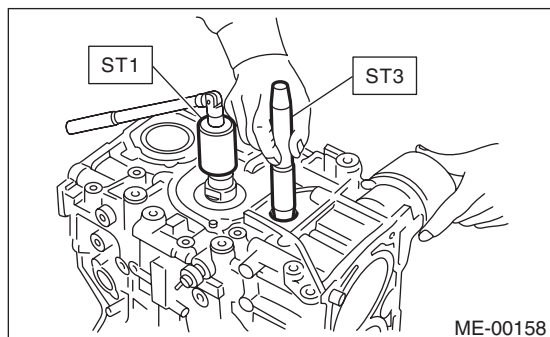

(3) Apply a thin coat of engine oil to piston pin, and insert the piston pin into piston and connecting rod through service hole.

(4) Install the snap ring.

NOTE:

Use new snap rings.

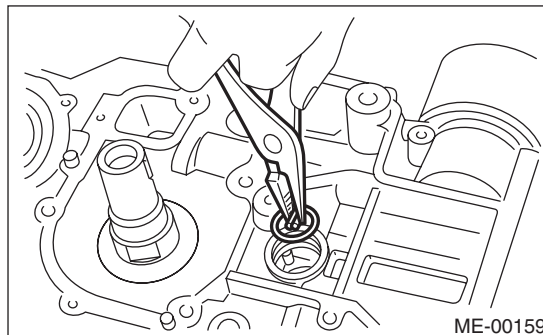

(5) Apply liquid gasket to the threaded portion of the service hole plug.

**Liquid gasket:**

**THREE BOND 1105 (Part No. 004403010) or equivalent**

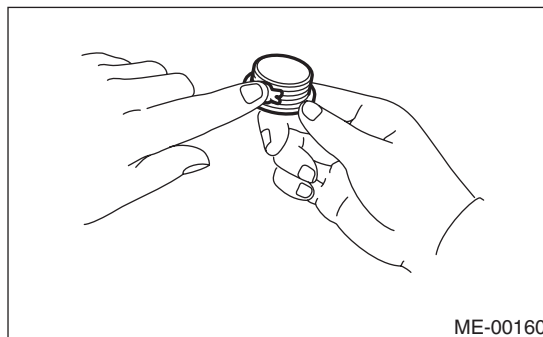

ME(w/o STI)-87

Brought to you by Ebay Seller "SubaruManuals"

# Cylinder Block

## MECHANICAL

(6) Install the service hole plug and gasket.

### NOTE:

Use a new gasket.

### Tightening torque:

**70 N·m (7.1 kgf·m, 51.6 ft·lb)**

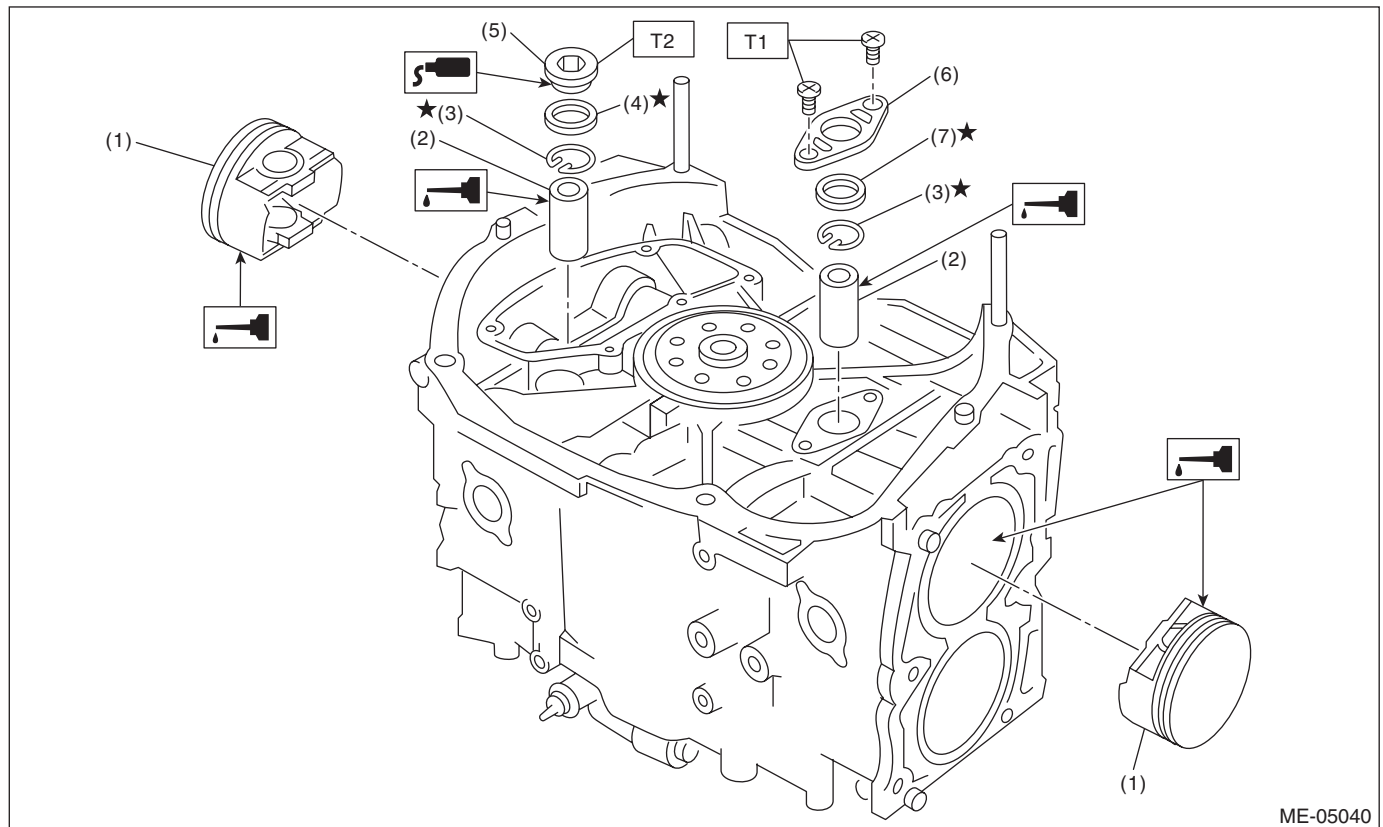
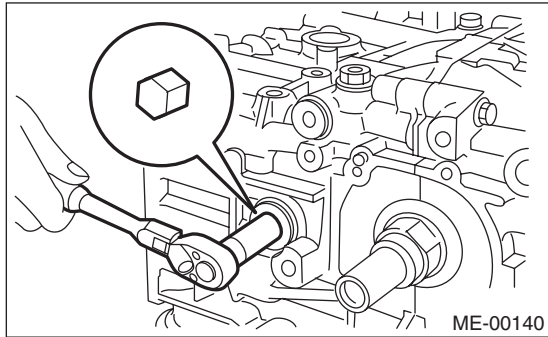

- |                |                        |
|----------------|------------------------|
| (1) Piston     | (5) Service hole plug  |
| (2) Piston pin | (6) Service hole cover |
| (3) Snap ring  | (7) O-ring             |
| (4) Gasket     |                        |

**Tightening torque: N·m (kgf·m, ft·lb)**

**T1: 6.4 (0.7, 4.7)**

**T2: 70 (7.1, 51.6)**

**ME(w/o STI)-88**

Brought to you by Ebay Seller "SubaruManuals"

# Cylinder Block

MECHANICAL

(7) Set the parts so that the #3 and #4 cylinders are on the upper side. Following the same procedures as used for #1 and #2 cylinders, install the pistons and piston pins.

(8) Install the service hole cover.

NOTE:

Use new O-rings.

**Tightening torque:**

**6.4 N·m (0.7 kgf-m, 4.7 ft-lb)**

22) Install the water tank pipe assembly onto the cylinder block RH.

NOTE:

Use a new clamp for the water tank pipe assembly clamp, fit the cut out in the ST with the protrusion on the clamp as shown in the figure, and lock the clamp.

ST 18353AA000 CLAMP PLIERS

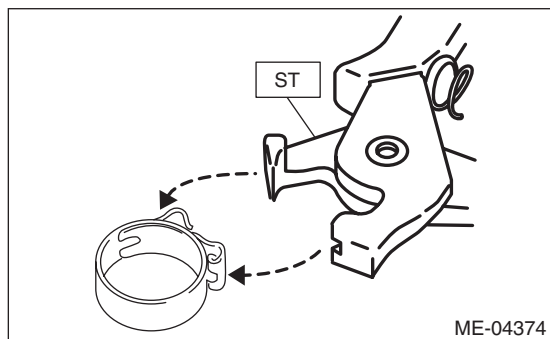

23) Install the baffle plate.

**Tightening torque:**

**6.4 N·m (0.7 kgf-m, 4.7 ft-lb)**

24) Install the oil strainer.

NOTE:

Use new O-rings.

**Tightening torque:**

**10 N·m (1.0 kgf-m, 7.2 ft-lb)**

25) Tighten the oil strainer stay together with the baffle plate.

**Tightening torque:**

**6.4 N·m (0.7 kgf-m, 4.7 ft-lb)**

26) Apply liquid gasket to the mating surfaces of oil pan, and install the oil pan.

NOTE:

Install within 5 min. after applying liquid gasket.

**Liquid gasket:**

**THREE BOND 1217G (Part No. K0877Y0100) or equivalent**

**Tightening torque:**

**5 N·m (0.5 kgf-m, 3.7 ft-lb)**

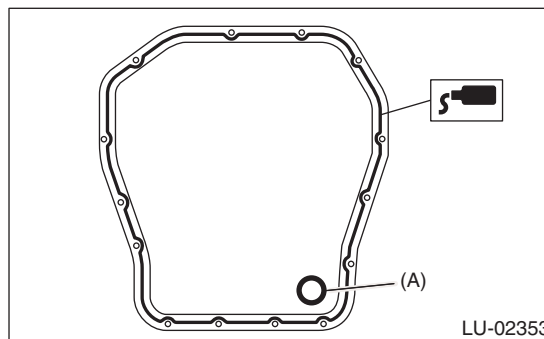

(A) Gasket

27) Apply liquid gasket to the mating surface of oil separator cover and the threaded portion of bolt (A) shown in the figure (when reusing the bolt), and then install the oil separator cover.

NOTE:

- Install within 5 min. after applying liquid gasket.
- Use new oil separator cover.

**Liquid gasket:**

**Mating surface**

**THREE BOND 1217G (Part No. K0877Y0100) or equivalent**

**Bolt thread (A) (when reusing the bolt)**

**THREE BOND 1324 (Part No. 004403042) or equivalent**

**Tightening torque:**

**6.4 N·m (0.7 kgf-m, 4.7 ft-lb)**

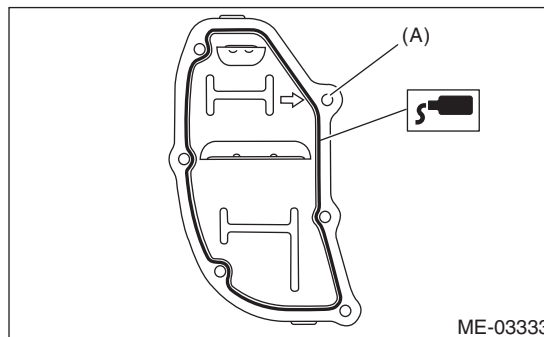

28) Install the flywheel. <Ref. to CL-14, INSTALLATION, Flywheel.>

29) Install the clutch disc and cover. <Ref. to CL-11, INSTALLATION, Clutch Disc and Cover.>

**ME(w/o STI)-89**

Brought to you by Ebay Seller "SubaruManuals"

# Cylinder Block

## MECHANICAL

30) Install the oil pump.

(1) Using the ST, install the front oil seal.  
ST 499587100 OIL SEAL INSTALLER

NOTE:

Use a new front oil seal.

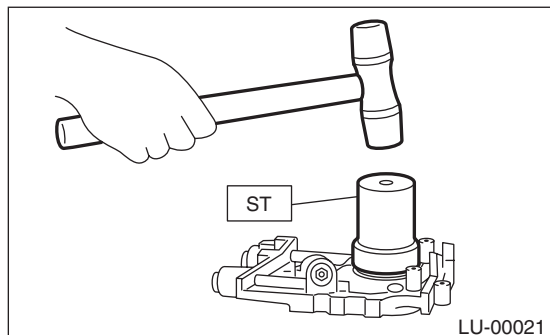

(2) Apply liquid gasket to the mating surfaces of oil pump.

NOTE:

Install within 5 min. after applying liquid gasket.

**Liquid gasket:**

**THREE BOND 1217G (Part No. K0877Y0100) or equivalent**

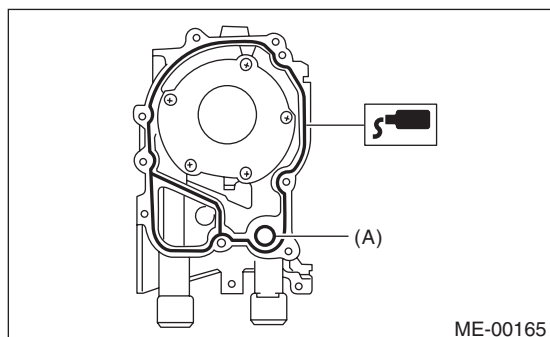

(A) O-ring

(3) Apply a thin coat of engine oil to the inside of front oil seal.

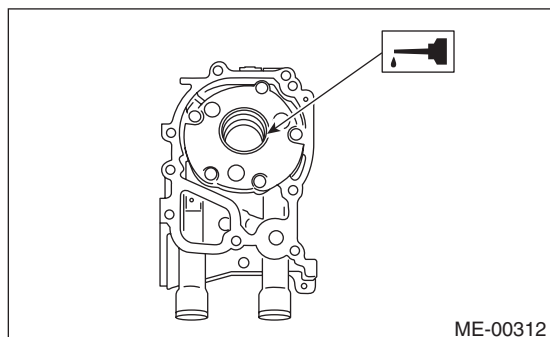

(4) Install the oil pump to cylinder block.

**CAUTION:**

- Be careful not to damage the front oil seal during installation.
- Make sure the front oil seal lip is not folded.

NOTE:

- Align the flat surface of oil pump's inner rotor with that of crankshaft before installation.
- Use new O-rings.
- Do not forget to assemble O-rings.
- (5) Apply liquid gasket to the three bolts thread shown in figure. (when reusing bolts)

**Liquid gasket:**

**THREE BOND 1324 (Part No. 004403042) or equivalent**

**Tightening torque:**

**6.4 N·m (0.7 kgf·m, 4.7 ft·lb)**

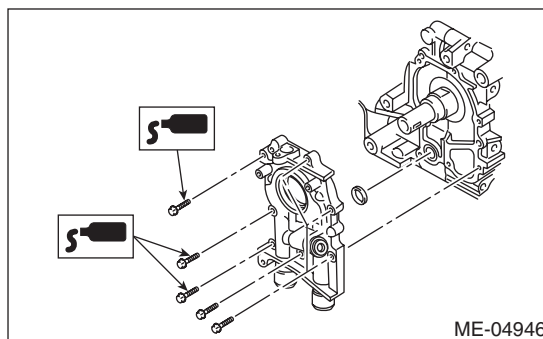

31) Install the water pump and gasket.

NOTE:

- When installing the water pump, tighten bolts in two stages in alphabetical order as shown in the figure.
- Use a new gasket.

**Tightening torque:**

**First:**

**12 N·m (1.2 kgf·m, 8.9 ft·lb)**

**Second:**

**12 N·m (1.2 kgf·m, 8.9 ft·lb)**

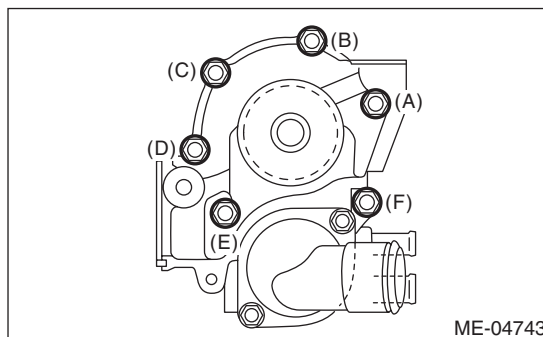

32) Install the water by-pass pipe for heater.

**Tightening torque:**

**6.4 N·m (0.7 kgf·m, 4.7 ft·lb)**

33) Install the oil filter. <Ref. to LU(STI)-32, INSTALLATION, Engine Oil Filter.>

34) Install the cylinder head. <Ref. to ME(w/o STI)-69, INSTALLATION, Cylinder Head.>

35) Install the camshaft. <Ref. to ME(w/o STI)-63, INSTALLATION, Camshaft.>

**ME(w/o STI)-90**

Brought to you by Ebay Seller "SubaruManuals"

36) Install the generator and A/C compressor with their brackets.

**Tightening torque:**

**36 N·m (3.7 kgf·m, 26.6 ft·lb)**

37) Install the crank sprocket. <Ref. to ME(w/o STI)-59, INSTALLATION, Crank Sprocket.>

38) Install the cam sprocket. <Ref. to ME(w/o STI)-58, INSTALLATION, Cam Sprocket.>

39) Install the timing belt. <Ref. to ME(w/o STI)-51, INSTALLATION, Timing Belt.>

40) Adjust the valve clearance. <Ref. to ME(w/o STI)-29, ADJUSTMENT, Valve Clearance.>

41) Install the rocker cover.

(1) Install the rocker cover gasket to the rocker cover. (outer section and ignition coil section)

**NOTE:**

Use a new rocker cover gasket.

(2) Apply liquid gasket to the specified point of the cylinder head.

**NOTE:**

Install within 5 min. after applying liquid gasket.

**Liquid gasket:**

**THREE BOND 1217G (Part No. K0877Y0100) or equivalent**

(3) Install the rocker cover onto cylinder heads. Ensure the gasket is properly positioned during installation.

(4) Temporarily tighten the rocker cover bolts in alphabetical order shown in the figure, and then tighten to specified torque in alphabetical order.

**Tightening torque:**

**6.4 N·m (0.7 kgf·m, 4.7 ft·lb)**

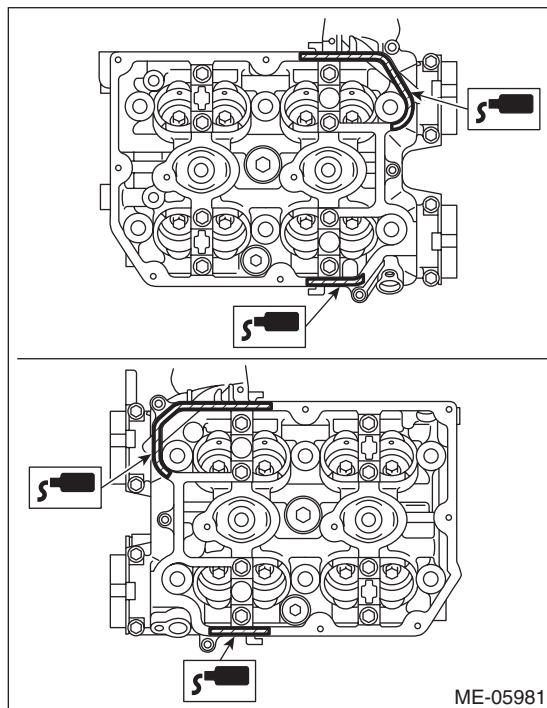
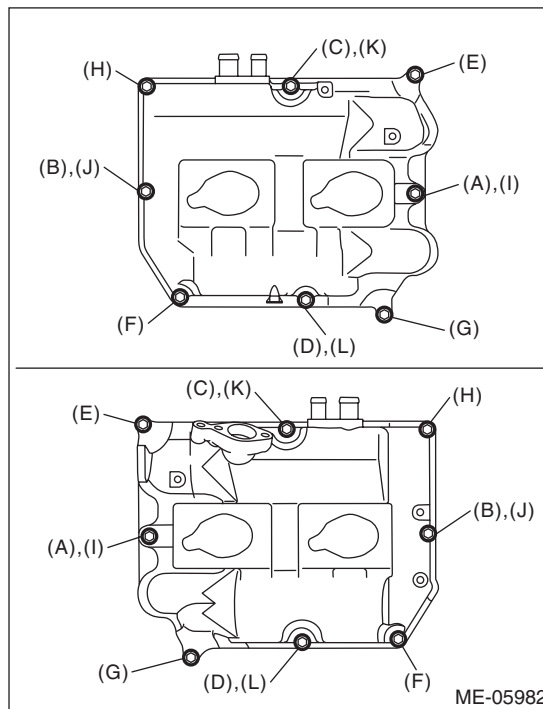



# Cylinder Block

## MECHANICAL

42) Connect the PCV hose (A) and PCV hose assembly (B) to the rocker cover.

### NOTE:

Use a new clamp for the PCV hose (A), fit the cut out in the ST with the protrusion on the clamp as shown in the figure, and lock the clamp.

ST 18353AA000 CLAMP PLIERS

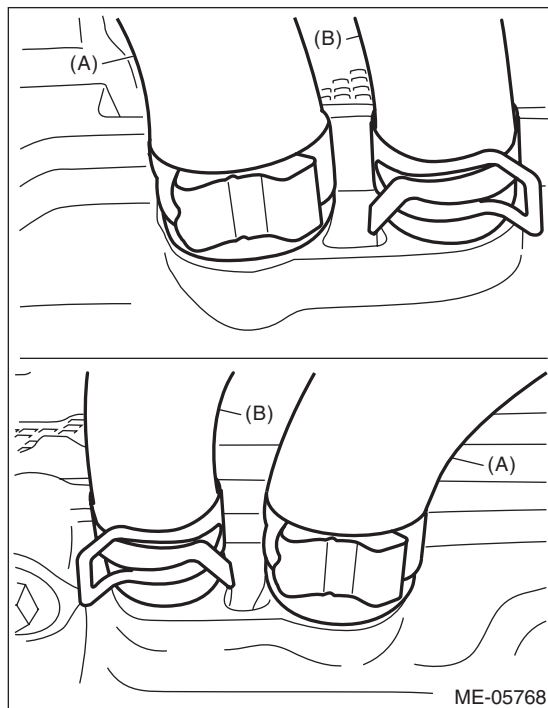
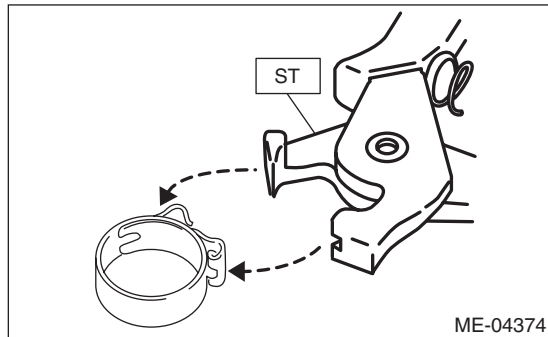

43) Install the timing belt cover. <Ref. to ME(w/o STI)-48, INSTALLATION, Timing Belt Cover.>

44) Install the crank pulley. <Ref. to ME(w/o STI)-46, INSTALLATION, Crank Pulley.>

45) Install the intake manifold. <Ref. to FU(w/o STI)-22, INSTALLATION, Intake Manifold.>

46) Install the rear side belt. <Ref. to ME(w/o STI)-40, REAR SIDE BELT, INSTALLATION, V-belt.>

47) Install the engine to the vehicle. <Ref. to ME(w/o STI)-34, INSTALLATION, Engine Assembly.>



## C: DISASSEMBLY

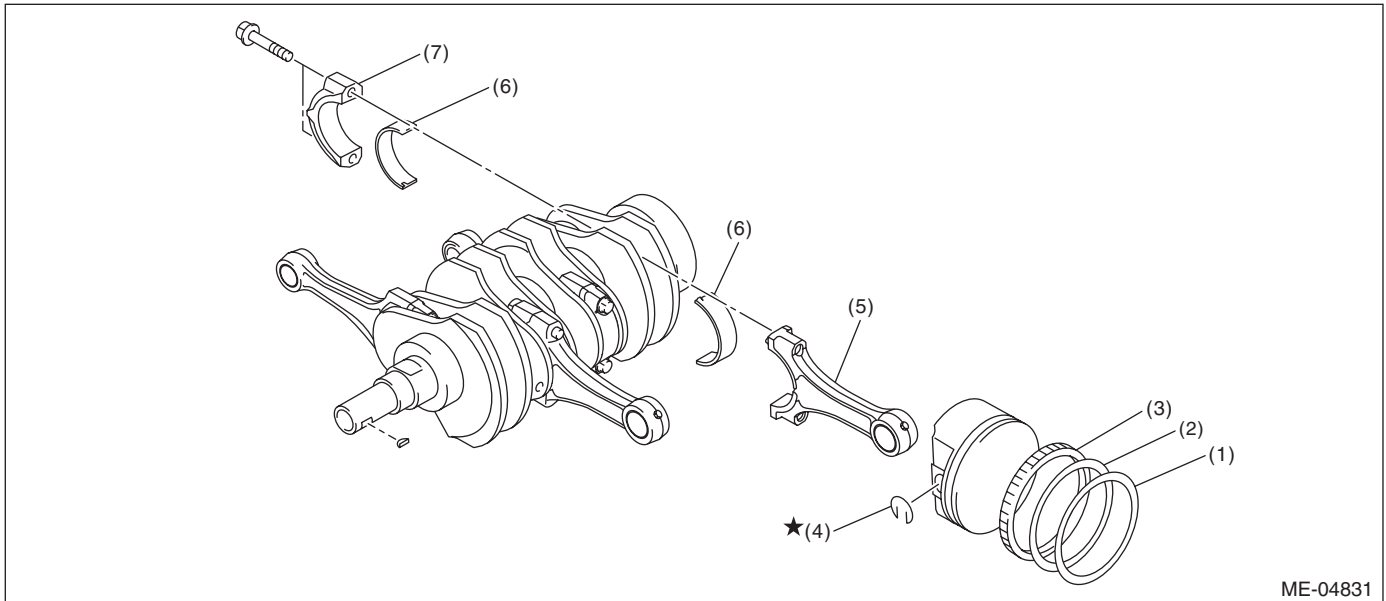

- |                 |                    |                            |
|-----------------|--------------------|----------------------------|
| (1) Top ring    | (4) Snap ring      | (6) Connecting rod bearing |
| (2) Second ring | (5) Connecting rod | (7) Connecting rod cap     |
| (3) Oil ring    |                    |                            |

- 1) Remove the connecting rod cap.
- 2) Remove the connecting rod bearing.

**NOTE:**

Keep the removed connecting rods, connecting rod caps and bearings in order so that they are kept in their original combinations/groups, and not mixed together.

3) Remove the piston rings using piston ring expander.

4) Remove the oil ring by hand.

**NOTE:**

Arrange the removed piston rings in proper order, to prevent confusion.

5) Remove the snap ring.

# Cylinder Block

MECHANICAL

## D: ASSEMBLY

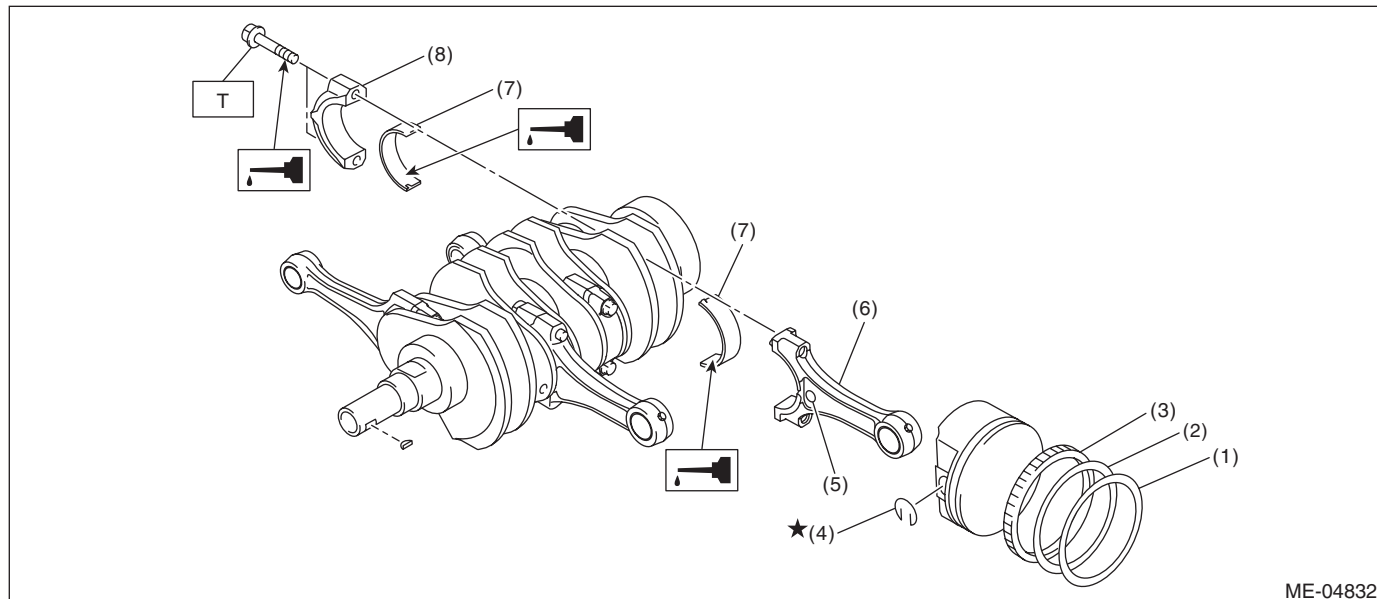

- |                 |                            |
|-----------------|----------------------------|
| (1) Top ring    | (5) Side mark              |
| (2) Second ring | (6) Connecting rod         |
| (3) Oil ring    | (7) Connecting rod bearing |
| (4) Snap ring   | (8) Connecting rod cap     |

**Tightening torque: N·m (kgf·m, ft·lb)**

**T: 52 (5.3, 38.4)**

- 1) Apply engine oil to the surface of the connecting rod bearings, and install the connecting rod bearings on connecting rods and connecting rod caps.
- 2) Position each connecting rod with the side with a side mark facing forward, and install it.
- 3) Attach the connecting rod cap and tighten it with connecting rod bolt. Make sure the arrow on connecting rod cap faces the front during installation.

### NOTE:

- Each connecting rod has its own mating cap. Make sure that they are assembled correctly by checking their matching number.
- When tightening the connecting rod bolts, apply oil on the threads.

### Tightening torque:

**52 N·m (5.3 kgf·m, 38.4 ft·lb)**

- 4) Install the oil ring upper rail, expander and lower rail by hand.
- 5) Install the second ring and top ring using piston ring expander.

### NOTE:

Assemble so that the piston ring mark "R" faces the top side of the piston.

**ME(w/o STI)-94**

Brought to you by Ebay Seller "SubaruManuals"

## E: INSPECTION

### 1. CYLINDER BLOCK

- 1) Check for cracks or damage. Use liquid penetrant tester on the important sections to check for fissures. Check that there are no marks of gas leaking or water leaking on gasket installing surface.
- 2) Check the oil passages for clogging.
- 3) Inspect the cylinder head surface that mates with cylinder block for warping by using a straight edge, and correct by grinding if necessary.

**Warping limit:**  
**0.025 mm (0.00098 in)**

**Grinding limit:**  
**0.1 mm (0.004 in)**

**Standard height of cylinder block:**  
**201.0 mm (7.91 in)**

### 2. CYLINDER AND PISTON

- 1) The cylinder bore size is stamped on the front upper face of the cylinder block.

**NOTE:**

- Measurement should be performed at a temperature of 20°C (68°F).
- Standard sized pistons are classified into two grades, "A" and "B". These grades should be used as guide lines in selecting a standard piston.

**Standard diameter:**  
**A: 99.505 — 99.515 mm (3.9175 — 3.9179 in)**  
**B: 99.495 — 99.505 mm (3.9171 — 3.9175 in)**

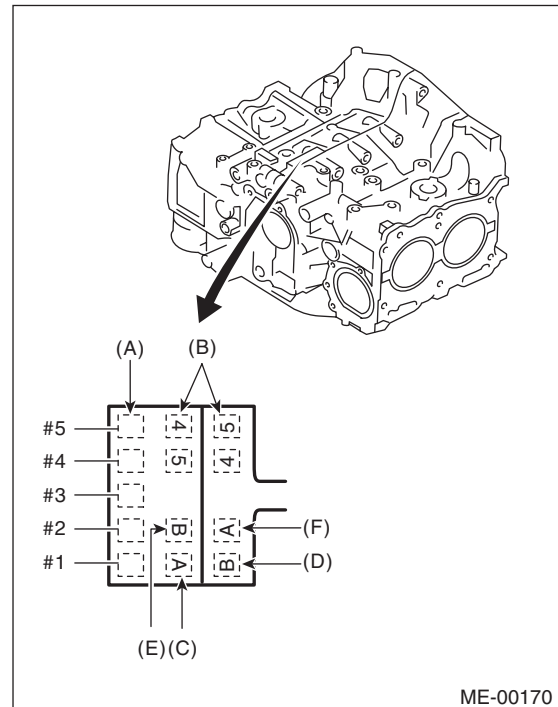

- (A) Main journal size mark
- (B) Cylinder block (RH) – (LH) combination mark
- (C) #1 cylinder bore size mark
- (D) #2 cylinder bore size mark
- (E) #3 cylinder bore size mark
- (F) #4 cylinder bore size mark

# Cylinder Block

## MECHANICAL

2) Measure inner diameter of each cylinder. Measure the inner diameter of each cylinder in both the thrust and piston pin directions at the heights as shown in the figure, using a cylinder bore gauge.

### NOTE:

Measurement should be performed at a temperature of 20°C (68°F).

### Cylindricity:

#### Limit

**0.015 mm (0.0006 in)**

### Out-of-roundness:

#### Limit

**0.010 mm (0.0004 in)**

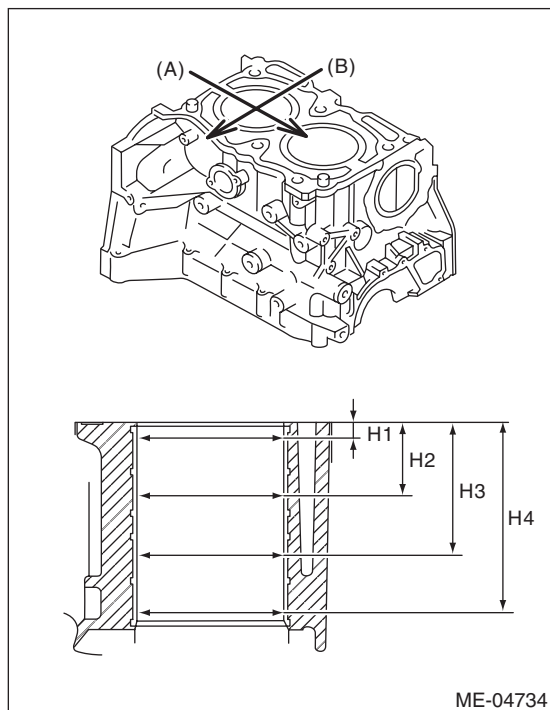

(A) Piston pin direction

(B) Thrust direction

H1: 10 mm (0.39 in)

H2: 45 mm (1.77 in)

H3: 80 mm (3.15 in)

H4: 115 mm (4.53 in)

3) When the piston is to be replaced due to general or cylinder wear, select a suitable sized piston by measuring the piston clearance.

4) Measure outer diameter of each piston.

Measure the outer diameter of each piston at the height as shown in the figure. (Thrust direction)

### NOTE:

Measurement should be performed at a temperature of 20°C (68°F).

### Piston grade point H:

**38.2 mm (1.50 in)**

### Piston outer diameter:

#### Standard

**A: 99.505 — 99.515 mm (3.9175 — 3.9179 in)**

**B: 99.495 — 99.505 mm (3.9171 — 3.9175 in)**

**0.25 mm (0.0098 in) oversize**

**99.745 — 99.765 mm (3.9270 — 3.9278 in)**

**0.50 mm (0.0197 in) oversize**

**99.995 — 100.015 mm (3.9368 — 3.9376 in)**

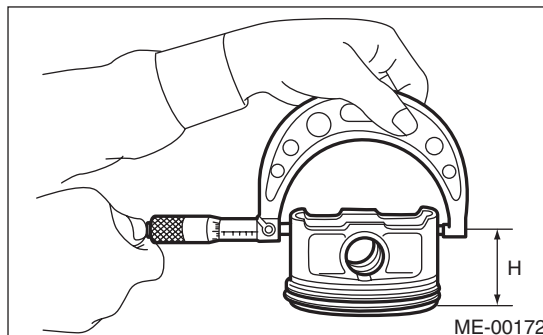

5) Calculate the clearance between cylinder and piston.

### NOTE:

Measurement should be performed at a temperature of 20°C (68°F).

### Clearance between cylinder and piston at 20°C (68°F):

#### Standard

**-0.010 — 0.010 mm (-0.00039 — 0.00039 in)**

6) Boring and honing

(1) If any of the measured value of cylindricity, out-of-roundness or cylinder-to-piston clearance is out of standard or if there is any damage on the cylinder wall, rebores it to replace with an oversize piston.

### CAUTION:

**When any of the cylinders needs reboring, all other cylinders must be bored at the same time, and replaced with oversize pistons.**

(2) If the cylinder inner diameter exceeds the limit after boring and honing, replace the cylinder block.

### NOTE:

Immediately after reboring, the cylinder diameter may differ from its real diameter due to temperature rise. Thus, when measuring the cylinder diameter, wait until it has cooled to room temperature.

### Cylinder inner diameter boring limit (diameter):

**To 100.005 mm (3.9372 in)**

### 3. PISTON AND PISTON PIN

- 1) Check the piston and piston pin for damage, cracks or wear. Replace if faulty.
- 2) Check the piston ring groove for wear or damage. Replace if faulty.
- 3) Make sure that the piston pin can be inserted into the piston pin hole with a thumb at 20°C (68°F). Replace if faulty.

**Clearance between piston pin hole and piston pin:**

**Standard**

**0.004 — 0.008 mm (0.0002 — 0.0003 in)**

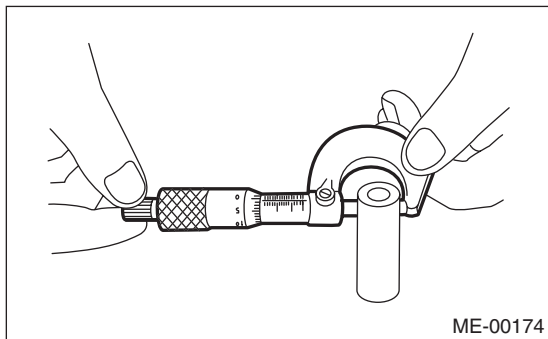
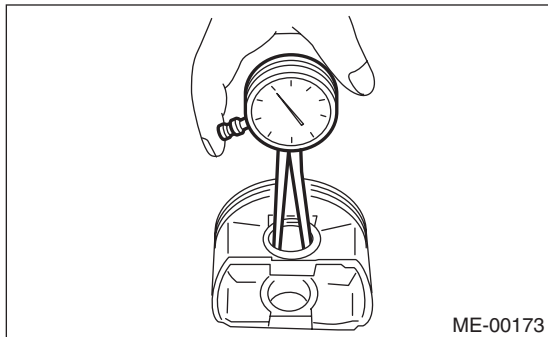

- 4) Check the snap ring installation groove (A) on the piston for burr. If necessary, remove burr from the groove so that the piston pin can lightly move.

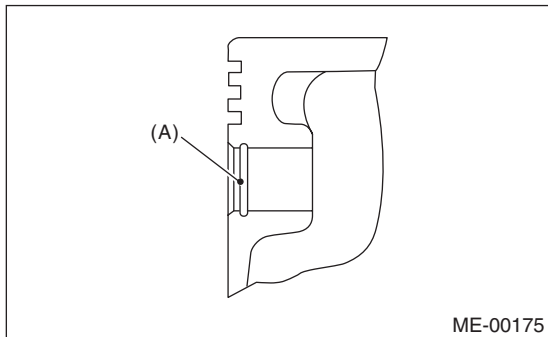

- 5) Check the snap ring for distortion, cracks and wear.

### 4. PISTON RING

- 1) If the piston ring is broken, damaged or worn, or if its tension is insufficient, or when the piston is replaced, replace the piston ring with a new part of the same size as piston.

**NOTE:**

- The top ring and second ring have the mark to determine the direction for installing. When installing the ring to piston, face marks to the top side.
- Oil ring consists of the upper rail, expander and lower rail. When installing oil ring on piston, be careful of the direction of each rail.

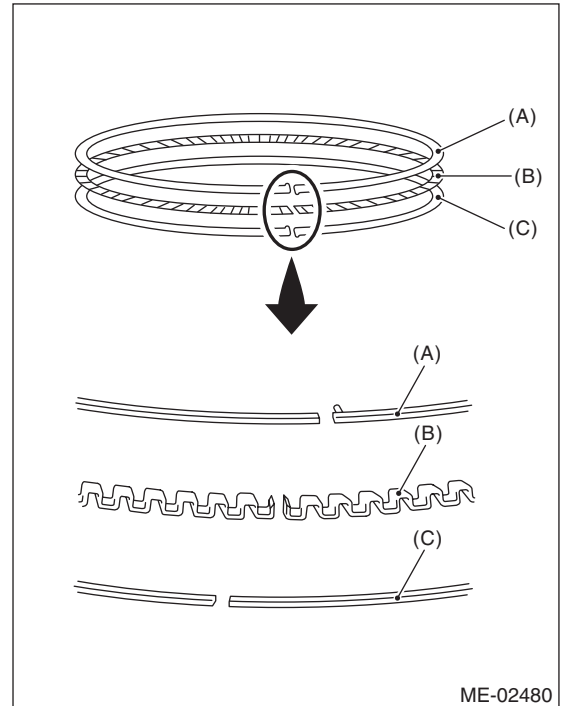

- (A) Upper rail
- (B) Expander
- (C) Lower rail

# Cylinder Block

## MECHANICAL

2) Using the piston, insert the piston ring and oil ring into the cylinder block so that they are perpendicular to the cylinder wall, and measure the piston ring gap using a thickness gauge.

		Standard mm (in)
Piston ring gap	Top ring	0.20 — 0.25 (0.0079 — 0.0098)
	Second ring	0.37 — 0.52 (0.015 — 0.020)
	Oil ring rail	0.20 — 0.50 (0.0079 — 0.0197)

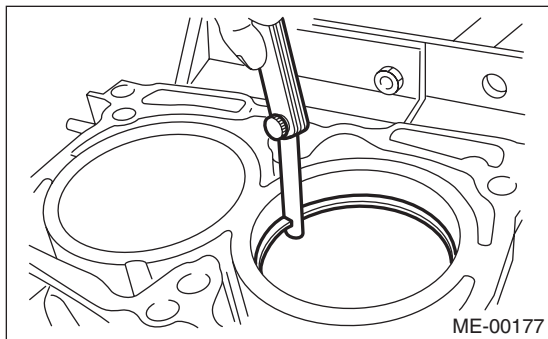

3) Fit the piston ring straight into the piston ring groove, then measure the clearance between piston ring and piston ring groove with a thickness gauge.

### NOTE:

Before measuring the clearance, clean the piston ring groove and piston ring.

		Standard mm (in)
Clearance between piston ring and piston ring groove	Top ring	0.040 — 0.080 (0.0016 — 0.0031)
	Second ring	0.030 — 0.070 (0.0012 — 0.0028)

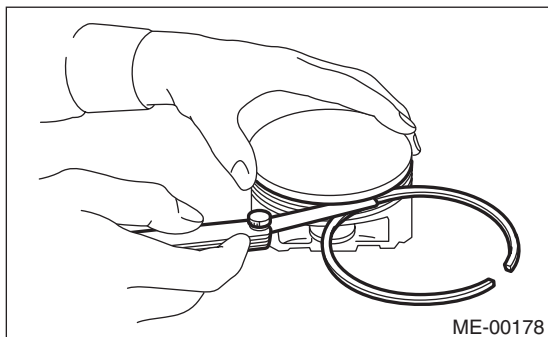

## 5. CONNECTING ROD

- 1) Replace the connecting rod, if the large or small end thrust surface is damaged.
- 2) Check for bend or twist using a connecting rod aligner. Replace the connecting rod if the bend or twist exceeds the limit.

**Limit of bend or twist per 100 mm (3.94 in) in length:**

**0.10 mm (0.0039 in)**

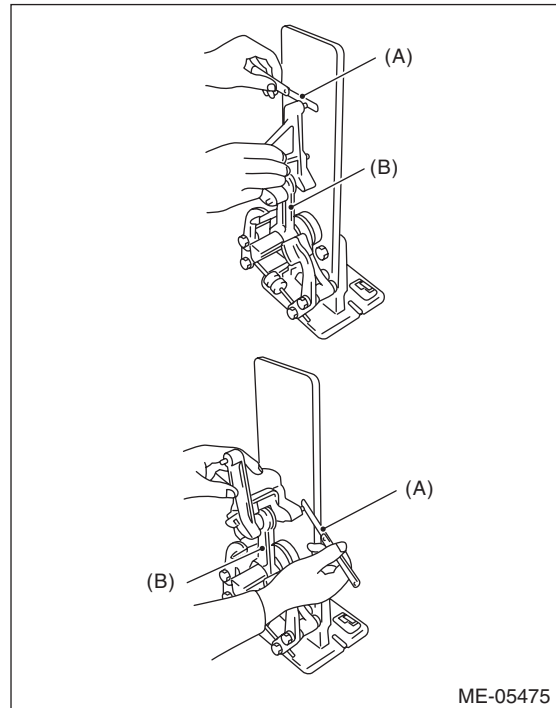

- (A) Thickness gauge  
(B) Connecting rod

3) Install the connecting rod with bearings attached to the crankshaft, and using a thickness gauge, measure the thrust clearance. If the thrust clearance exceeds the standard or uneven wear is found, replace the connecting rod.

**Connecting rod thrust clearance:**

**Standard**

**0.070 — 0.330 mm (0.0028 — 0.0130 in)**

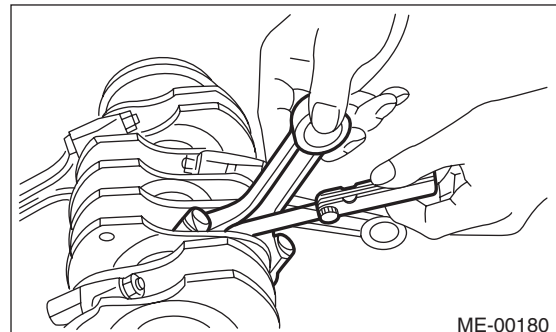

4) Inspect the connecting rod bearing for scar, peeling, seizure, melting, wear, etc.

5) Measure the oil clearance on each connecting rod bearing using plastigauge. If any oil clearance is not within the standard, replace the defective bearing with a new part of standard size or under-size as necessary.

**Connecting rod oil clearance:**

**Standard**

**0.017 — 0.045 mm (0.0007 — 0.0018 in)**

Unit: mm (in)		
Bearing	Bearing size (Thickness at center)	Outer diameter of crank pin
Standard	1.490 — 1.506 (0.0587 — 0.0593)	51.976 — 52.000 (2.0463 — 2.0472)
0.03 (0.0012) Undersize	1.504 — 1.512 (0.0592 — 0.0595)	51.954 — 51.970 (2.0454 — 2.0461)
0.05 (0.0020) Undersize	1.514 — 1.522 (0.0596 — 0.0599)	51.934 — 51.950 (2.0447 — 2.0453)
0.25 (0.0098) Undersize	1.614 — 1.622 (0.0635 — 0.0639)	51.734 — 51.750 (2.0368 — 2.0374)

6) Inspect the bushing at connecting rod small end, and replace the connecting rod if it is worn or damaged.

7) Measure the piston pin clearance at connecting rod small end. If the measured value is not within the standard, replace the connecting rod and piston pin as a set.

**Clearance between piston pin and bushing:**

**Standard**

**0 — 0.022 mm (0 — 0.0009 in)**

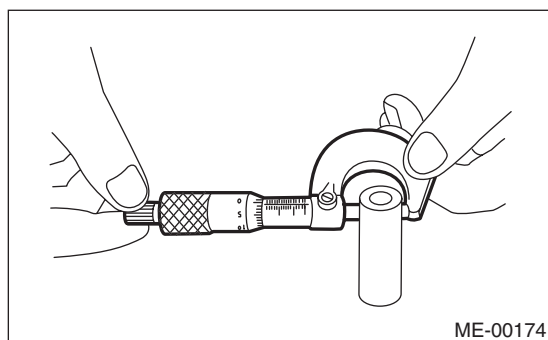
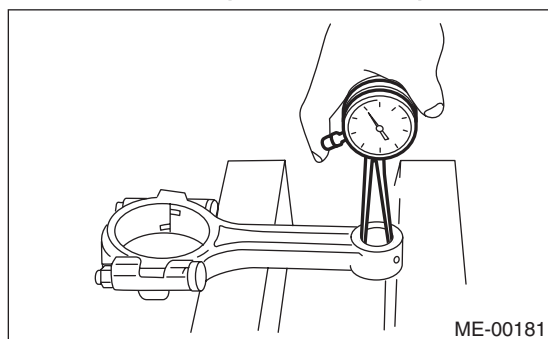

## 6. CRANKSHAFT AND CRANKSHAFT BEARING

1) Clean the crankshaft completely, and check it for cracks using liquid penetrant tester. If defective, replace the crankshaft.

2) Measure warping of the crankshaft. If it exceeds the limit, correct or replace it.

**NOTE:**

If a suitable V-block is not available, using just the #1 and #5 crankshaft bearings on cylinder block, position the crankshaft on cylinder block. Then, measure the crankshaft bend using a dial gauge.

**Crankshaft bend limit:**

**0.035 mm (0.0014 in)**

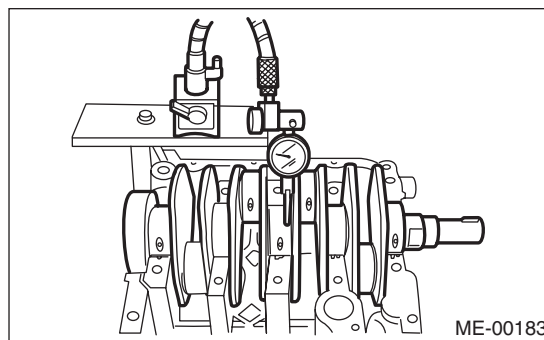

3) Inspect the crank journal and crank pin for wear. If they are not within the standard, replace the bearing with a suitable (undersize) one, and replace or grind to correct the crankshaft as necessary. When grinding the crank journal or crank pin, finish them to the specified dimensions according to the under-size bearing to be used.



# Cylinder Block

MECHANICAL

## Crank pin:

### Cylindricality

#### Limit

0.004 mm (0.0002 in)

### Out-of-roundness

#### Limit

0.003 mm (0.0001 in)

### Grinding limit (dia.)

To 51.750 mm (2.0374 in)

## Crank journal:

### Cylindricality

#### Limit

0.006 mm (0.0002 in)

### Out-of-roundness

#### Limit

0.005 mm (0.0002 in)

### Grinding limit (dia.)

To 59.758 mm (2.3527 in)

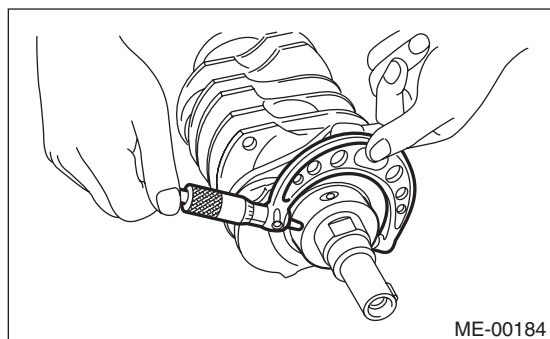

		Unit: mm (in)		
		Crank journal diameter		Crank pin outer diameter
		#1, #3	#2, #4, #5	
Standard	Journal O.D.	59.984 — 60.008 (2.3616 — 2.3625)	59.984 — 60.008 (2.3616 — 2.3625)	51.976 — 52.000 (2.0463 — 2.0472)
	Bearing size (Thickness at center)	1.998 — 2.015 (0.0787 — 0.0793)	2.000 — 2.017 (0.0787 — 0.0794)	1.490 — 1.506 (0.0587 — 0.0593)
0.03 (0.0012) Undersize	Journal O.D.	59.962 — 59.978 (2.3607 — 2.3613)	59.962 — 59.978 (2.3607 — 2.3613)	51.954 — 51.970 (2.0454 — 2.0461)
	Bearing size (Thickness at center)	2.017 — 2.020 (0.0794 — 0.0795)	2.019 — 2.022 (0.0795 — 0.0796)	1.504 — 1.512 (0.0592 — 0.0595)
0.05 (0.0020) Undersize	Journal O.D.	59.942 — 59.958 (2.3599 — 2.3605)	59.942 — 59.958 (2.3599 — 2.3605)	51.934 — 51.950 (2.0447 — 2.0453)
	Bearing size (Thickness at center)	2.027 — 2.030 (0.0798 — 0.0799)	2.029 — 2.032 (0.0799 — 0.0800)	1.514 — 1.522 (0.0596 — 0.0599)
0.25 (0.0098) Undersize	Journal O.D.	59.742 — 59.758 (2.3520 — 2.3527)	59.742 — 59.758 (2.3520 — 2.3527)	51.734 — 51.750 (2.0368 — 2.0374)
	Bearing size (Thickness at center)	2.127 — 2.130 (0.0837 — 0.0839)	2.129 — 2.132 (0.0838 — 0.0839)	1.614 — 1.622 (0.0635 — 0.0639)

ME(w/o STI)-100

Brought to you by Ebay Seller "SubaruManuals"



4) Use a thickness gauge to measure the thrust clearance of crankshaft at #5 crank journal bearing. If clearance exceeds the standard, replace the bearing.

**Crankshaft thrust clearance:**

**Standard**

**0.030 — 0.115 mm (0.0012 — 0.0045 in)**

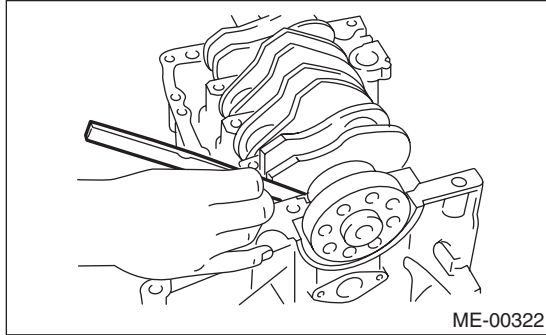

5) Inspect individual crankshaft bearings for signs of flaking, seizure, melting and wear.

6) Measure the oil clearance on each crankshaft bearing using plastigauge. If the measured value is out of standard, replace the defective bearing with an undersize one, and replace or grind to correct the crankshaft as necessary.

**Crankshaft oil clearance:**

**Standard**

**0.010 — 0.030 mm (0.0004 — 0.0012 in)**

## 21. Intake and Exhaust Valve

### A: SPECIFICATION

Refer to "Cylinder Head" for removal and installation procedures of the intake and exhaust valves.  
<Ref. to ME(w/o STI)-69, REMOVAL, Cylinder Head.> <Ref. to ME(w/o STI)-69, INSTALLATION, Cylinder Head.>

## 22.Piston

### A: SPECIFICATION

Refer to "Cylinder Block" for removal and installation procedures of pistons. <Ref. to ME(w/o STI)-79, REMOVAL, Cylinder Block.> <Ref. to ME(w/o STI)-83, INSTALLATION, Cylinder Block.>

## 23. Connecting Rod

### A: SPECIFICATION

Refer to "Cylinder Block" for removal and installation procedures of connecting rod.

<Ref. to ME(w/o STI)-79, REMOVAL, Cylinder Block.> <Ref. to ME(w/o STI)-83, INSTALLATION, Cylinder Block.>

## 24.Crankshaft

### A: SPECIFICATION

Refer to "Cylinder Block" for removal and installation procedures of the crankshaft. <Ref. to ME(w/o STI)-79, REMOVAL, Cylinder Block.> <Ref. to ME(w/o STI)-83, INSTALLATION, Cylinder Block.>

# Engine Trouble in General

MECHANICAL

## 25.Engine Trouble in General

### A: INSPECTION

NOTE:

The "RANK" shown in the chart shows the possibilities of the cause of trouble in order from "Very often" to "Rarely".

A — Very often

B — Sometimes

C — Rarely

Symptoms	Problem parts etc.	Possible cause	RANK
1. Engine does not start.			
1) Starter does not turn.	Starter	Defective battery-to-starter harness	B
		Defective starter switch	C
		Defective starter	B
	Battery	Improper connection of terminal	A
		Run-down battery	A
		Defective charging system	B
	Friction	Seizure of crankshaft and connecting rod bearing	C
		Seized camshaft	C
		Seized or stuck piston and cylinder	C
	Immobilizer system <Ref. to IM(diag)-2, Basic Diagnostic Procedure.>	A	
2) Initial combustion does not occur.	Starter	Defective starter	C
		Engine control system <Ref. to EN(H4DOTC)(diag)-2, Basic Diagnostic Procedure.>	A
	Fuel line	Defective fuel pump and relay	A
		Clogged fuel line	C
		Lack of fuel or insufficient fuel	B
	Timing belt	Degradation, etc.	B
		Defective timing	B
	Compression	Incorrect valve clearance	C
		Loosened spark plug or defective gasket	C
		Loosened cylinder head bolt or defective cylinder head gasket	C
		Improper valve sealing	C
		Defective valve stem	C
		Worn or broken valve spring	B
		Worn or stuck piston rings, cylinder and piston	C
Incorrect valve timing		B	
Improper engine oil (low viscosity)		B	

# Engine Trouble in General

MECHANICAL

Symptoms	Problem parts etc.	Possible cause	RANK
3) Initial combustion occurs.	Engine control system <Ref. to EN(H4DOTC)(diag)-2, Basic Diagnostic Procedure.>		A
	Intake system	Defective intake manifold gasket	B
		Defective throttle body gasket	B
	Fuel line	Defective fuel pump and relay	C
		Clogged fuel line	C
		Lack of fuel or insufficient fuel	B
	Timing belt	Degradation, etc.	B
		Defective timing	B
	Compression	Incorrect valve clearance	C
		Loosened spark plug or defective gasket	C
		Loosened cylinder head bolt or defective cylinder head gasket	C
		Improper valve sealing	C
		Defective valve stem	C
		Worn or broken valve spring	B
Worn or stuck piston rings, cylinder and piston		C	
Incorrect valve timing		B	
Improper engine oil (low viscosity)	B		
4) Engine stalls after initial combustion.	Engine control system <Ref. to EN(H4DOTC)(diag)-2, Basic Diagnostic Procedure.>		A
	Intake system	Loosened or cracked intake duct	B
		Loosened or cracked PCV hose	C
		Loosened or cracked vacuum hose	C
		Defective intake manifold gasket	B
		Defective throttle body gasket	B
		Dirty air cleaner element	C
	Fuel line	Clogged fuel line	C
		Lack of fuel or insufficient fuel	B
	Timing belt	Degradation, etc.	B
		Defective timing	B
	Compression	Incorrect valve clearance	C
		Loosened spark plug or defective gasket	C
		Loosened cylinder head bolt or defective cylinder head gasket	C
Improper valve sealing		C	
Defective valve stem		C	
Worn or broken valve spring		B	
Worn or stuck piston rings, cylinder and piston		C	
Incorrect valve timing		B	
Improper engine oil (low viscosity)	B		

# Engine Trouble in General

## MECHANICAL

Symptoms	Problem parts etc.	Possible cause	RANK
2. Rough idle and engine stall	Engine control system <Ref. to EN(H4DOTC)(diag)-2, Basic Diagnostic Procedure.>		A
	Intake system	Loosened or cracked intake duct	A
		Loosened or cracked PCV hose	A
		Loosened or cracked vacuum hose	A
		Defective intake manifold gasket	B
		Defective throttle body gasket	B
		Defective PCV valve	C
		Loosened oil filler cap	B
		Dirty air cleaner element	C
	Fuel line	Defective fuel pump and relay	C
		Clogged fuel line	C
		Lack of fuel or insufficient fuel	B
	Timing belt	Defective timing	C
	Compression	Incorrect valve clearance	B
		Loosened spark plug or defective gasket	B
		Loosened cylinder head bolt or defective cylinder head gasket	B
		Improper valve sealing	B
		Defective valve stem	C
		Worn or broken valve spring	B
		Worn or stuck piston rings, cylinder and piston	B
		Incorrect valve timing	A
	Improper engine oil (low viscosity)	B	
	Lubrication system	Incorrect oil pressure	B
Defective rocker cover gasket		C	
Cooling system	Over-heating	C	
Others	Evaporative emission control system malfunction	A	
	Stuck or damaged throttle valve	B	



# Engine Trouble in General

MECHANICAL

Symptoms	Problem parts etc.	Possible cause	RANK
3. Low output, hesitation and poor acceleration	Engine control system <Ref. to EN(H4DOTC)(diag)-2, Basic Diagnostic Procedure.>		A
	Intake system	Loosened or cracked intake duct	A
		Loosened or cracked PCV hose	A
		Loosened or cracked vacuum hose	B
		Defective intake manifold gasket	B
		Defective throttle body gasket	B
		Defective PCV valve	B
		Loosened oil filler cap	B
		Dirty air cleaner element	A
	Fuel line	Defective fuel pump and relay	B
		Clogged fuel line	B
		Lack of fuel or insufficient fuel	C
	Timing belt	Defective timing	B
	Compression	Incorrect valve clearance	B
		Loosened spark plug or defective gasket	B
		Loosened cylinder head bolt or defective cylinder head gasket	B
		Improper valve sealing	B
		Defective valve stem	C
		Worn or broken valve spring	B
		Worn or stuck piston rings, cylinder and piston	C
		Incorrect valve timing	A
	Improper engine oil (low viscosity)	B	
	Lubrication system	Incorrect oil pressure	B
Cooling system	Over-heating	C	
	Over-cooling	C	
Others	Evaporative emission control system malfunction	A	

# Engine Trouble in General

## MECHANICAL

Symptoms	Problem parts etc.	Possible cause	RANK
4. Surging	Engine control system <Ref. to EN(H4DOTC)(diag)-2, Basic Diagnostic Procedure.>		A
	Intake system	Loosened or cracked intake duct	A
		Loosened or cracked PCV hose	A
		Loosened or cracked vacuum hose	A
		Defective intake manifold gasket	B
		Defective throttle body gasket	B
		Defective PCV valve	B
		Loosened oil filler cap	B
		Dirty air cleaner element	B
	Fuel line	Defective fuel pump and relay	B
		Clogged fuel line	B
		Lack of fuel or insufficient fuel	C
	Timing belt	Defective timing	B
	Compression	Incorrect valve clearance	B
		Loosened spark plug or defective gasket	C
		Loosened cylinder head bolt or defective cylinder head gasket	C
		Improper valve sealing	C
		Defective valve stem	C
		Worn or broken valve spring	C
		Worn or stuck piston rings, cylinder and piston	C
Incorrect valve timing		A	
Improper engine oil (low viscosity)	B		
Cooling system	Over-heating	B	
Others	Evaporative emission control system malfunction	C	
5. Engine does not return to idle.	Engine control system <Ref. to EN(H4DOTC)(diag)-2, Basic Diagnostic Procedure.>		A
	Intake system	Loosened or cracked vacuum hose	A
	Others	Stuck or damaged throttle valve	A
6. Dieseling (Run-on)	Engine control system <Ref. to EN(H4DOTC)(diag)-2, Basic Diagnostic Procedure.>		A
	Cooling system	Over-heating	B
	Others	Evaporative emission control system malfunction	B
7. After burning in exhaust system	Engine control system <Ref. to EN(H4DOTC)(diag)-2, Basic Diagnostic Procedure.>		A
	Intake system	Loosened or cracked intake duct	C
		Loosened or cracked PCV hose	C
		Loosened or cracked vacuum hose	B
		Defective PCV valve	B
		Loosened oil filler cap	C
	Timing belt	Defective timing	B
	Compression	Incorrect valve clearance	B
		Loosened spark plug or defective gasket	C
		Loosened cylinder head bolt or defective cylinder head gasket	C
		Improper valve sealing	B
		Defective valve stem	C
		Worn or broken valve spring	C
		Worn or stuck piston rings, cylinder and piston	C
		Incorrect valve timing	A
	Lubrication system	Incorrect oil pressure	C
Cooling system	Over-cooling	C	
Others	Evaporative emission control system malfunction	C	

# Engine Trouble in General

MECHANICAL

Symptoms	Problem parts etc.	Possible cause	RANK
8. Knocking	Engine control system <Ref. to EN(H4DOTC)(diag)-2, Basic Diagnostic Procedure.>		A
	Intake system	Loosened oil filler cap	B
	Timing belt	Defective timing	B
	Compression	Incorrect valve clearance	C
		Incorrect valve timing	B
Cooling system	Over-heating	A	
9. Excessive engine oil consumption	Intake system	Loosened or cracked PCV hose	A
		Defective PCV valve	B
		Loosened oil filler cap	C
	Compression	Defective valve stem	A
		Worn or stuck piston rings, cylinder and piston	A
	Lubrication system	Loosened oil pump attaching bolts and defective gasket	B
		Defective oil filter gasket	B
		Defective crankshaft oil seal	B
		Defective rocker cover gasket	B
		Loosened oil drain plug or defective gasket	B
Loosened oil pan fitting bolts or defective oil pan	B		
10. Excessive fuel consumption	Engine control system <Ref. to EN(H4DOTC)(diag)-2, Basic Diagnostic Procedure.>		A
	Intake system	Dirty air cleaner element	A
	Timing belt	Defective timing	B
	Compression	Incorrect valve clearance	B
		Loosened spark plug or defective gasket	C
		Loosened cylinder head bolt or defective cylinder head gasket	C
		Improper valve sealing	B
		Defective valve stem	C
		Worn or broken valve spring	C
		Worn or stuck piston rings, cylinder and piston	B
		Incorrect valve timing	B
	Lubrication system	Incorrect oil pressure	C
	Cooling system	Over-cooling	C

# Engine Noise

MECHANICAL

## 26.Engine Noise

### A: INSPECTION

Type of sound	Condition	Possible cause
Regular clicking sound	Sound increases as engine speed increases.	<ul style="list-style-type: none"> <li>• Valve mechanism is defective.</li> <li>• Incorrect valve clearance</li> <li>• Worn camshaft</li> <li>• Broken valve spring</li> </ul>
Heavy and dull clank	Oil pressure is low.	<ul style="list-style-type: none"> <li>• Worn crankshaft main bearing</li> <li>• Worn connecting rod bearing (large end)</li> </ul>
	Oil pressure is normal.	<ul style="list-style-type: none"> <li>• Loosened flywheel mounting bolt</li> <li>• Damaged engine mounting</li> </ul>
High-pitched clank	Sound is noticeable when accelerating with an overload condition.	<ul style="list-style-type: none"> <li>• Ignition timing advanced</li> <li>• Accumulation of carbon inside combustion chamber</li> <li>• Wrong heat range of spark plug</li> <li>• Improper octane value gasoline</li> </ul>
Clank when engine speed is between 1,000 and 2,000 rpms.	Sound is reduced when the fuel injector connector of the noisy cylinder is disconnected.*	<ul style="list-style-type: none"> <li>• Worn crankshaft main bearing</li> <li>• Worn connecting rod bearing (large end)</li> </ul>
Knocking sound when engine is operating under idling speed and engine is warm	Sound is reduced when the fuel injector connector of the noisy cylinder is disconnected.*	<ul style="list-style-type: none"> <li>• Worn cylinder liner and piston ring</li> <li>• Broken or stuck piston ring</li> <li>• Worn piston pin and hole at piston end of connecting rod</li> </ul>
	Sound is not reduced if each fuel injector connector is disconnected in turn.*	<ul style="list-style-type: none"> <li>• Unusually worn valve lifter</li> <li>• Worn cam sprocket</li> <li>• Worn camshaft journal bore in cylinder head</li> </ul>
Squeaky sound	—	<ul style="list-style-type: none"> <li>• Insufficient generator lubrication</li> </ul>
Rubbing sound	—	<ul style="list-style-type: none"> <li>• Poor contact of generator brush and rotor</li> </ul>
Gear scream when starting engine	—	<ul style="list-style-type: none"> <li>• Defective ignition starter switch</li> <li>• Worn gear and starter pinion</li> </ul>
Sound like polishing glass with a dry cloth	—	<ul style="list-style-type: none"> <li>• Loose V-belt</li> <li>• Defective water pump shaft</li> </ul>
Hissing sound	—	<ul style="list-style-type: none"> <li>• Insufficient compression</li> <li>• Air leakage in air intake system, hose, connection or manifold</li> </ul>
Timing belt noise	—	<ul style="list-style-type: none"> <li>• Loose timing belt</li> <li>• Timing belt contacting with adjacent part</li> </ul>
Valve noise	—	<ul style="list-style-type: none"> <li>• Incorrect valve clearance</li> </ul>

\* When disconnecting the fuel injector connector, the malfunction indicator light illuminates and DTC is stored in ECM memory. Therefore, perform the Clear Memory Mode <Ref. to EN(H4DOTC)(diag)-62, OPERATION, Clear Memory Mode.> and Inspection Mode <Ref. to EN(H4DOTC)(diag)-48, PROCEDURE, Inspection Mode.> after connecting the fuel injector connector.

# EXHAUST

# *EX(w/o STI)*

---

	<b>Page</b>
1. General Description .....	2

# General Description

EXHAUST

---

## 1. General Description

### A: SPECIFICATION

Specifications for models other than STI model are included in the EX (STI) section. <Ref. to EX(STI)-2, General Description.>

# COOLING

# CO(w/o STI)

---

	<b>Page</b>
1. General Description .....	2
2. Radiator Fan System .....	7
3. Engine Coolant .....	13
4. Water Pump .....	15
5. Thermostat .....	17
6. Radiator .....	19
7. Radiator Cap .....	22
8. Radiator Main Fan and Fan Motor .....	23
9. Radiator Sub Fan and Fan Motor .....	25
10. Reservoir Tank .....	27
11. Coolant Filler Tank .....	28
12. Engine Cooling System Trouble in General .....	29

# General Description

## COOLING

### 1. General Description

#### A: SPECIFICATION

Cooling system				Electric fan + Forced engine coolant circulation system		
Total engine coolant capacity				ø (US qt, Imp qt)		
				Approx. 7.4 (7.8, 6.5)		
Water pump	Type		Centrifugal impeller type			
	Discharge performance	Discharge rate		ø (US gal, Imp gal)/min.		
		Pump speed — Discharge pressure		200 (52.8, 44.0)		
		Engine coolant temperature		6,000 rpm — 225.4 kPa (23.0 mAq)		
	Impeller diameter		mm (in)		80°C (176°F)	
	Number of impeller vanes				76 (2.99)	
	Pump pulley diameter		mm (in)		8	
	Clearance between impeller and pump case		mm (in) Standard		60 (2.36)	
				0.5 — 1.5 (0.020 — 0.059)		
Thermostat	Type		Wax pellet type			
	Starting temperature to open		76 — 80°C (169 — 176°F)			
	Fully opens		91°C (196°F)			
	Valve lift		mm (in)		9.0 (0.354) or more	
	Valve bore		mm (in)		35 (1.38)	
Radiator fan	Motor input	Main fan		W		
		Sub fan		W		
	Fan diameter / Blade	Main fan		318.5 mm (12.54 in)/9		
		Sub fan		318.5 mm (12.54 in)/11		
Radiator	Type		Down flow			
	Core dimensions		Width × Height × Thickness		mm (in)	
	Pressure range in which cap valve is open	Coolant filler tank side	kPa (kg/cm <sup>2</sup> , psi)		Standard	93 — 123 (0.95 — 1.25, 14 — 18)
					Limit	83 (0.85, 12)
		Radiator side	kPa (kg/cm <sup>2</sup> , psi)		Standard	-1.0 — -4.9 (-0.01 — -0.05, -0.1 — -0.7)
					Limit	122 — 152 (1.24 — 1.55, 18 — 22)
	Fins				112 (1.14, 16)	
				Corrugated fin type		
Reservoir tank	Capacity		ø (US qt, Imp qt)		0.45 (0.48, 0.40)	

	Recommended materials	Item number	Alternative
Coolant	SUBARU SUPER COOLANT (Concentrated type)	—	—
	SUBARU SUPER COOLANT (Diluted type)	K0670Y0001	
Water for dilution	Distilled water	—	Soft water or tap water
Cooling system protective agent	Cooling system conditioner	SOA345001	—



## B: COMPONENT

### 1. WATER PUMP

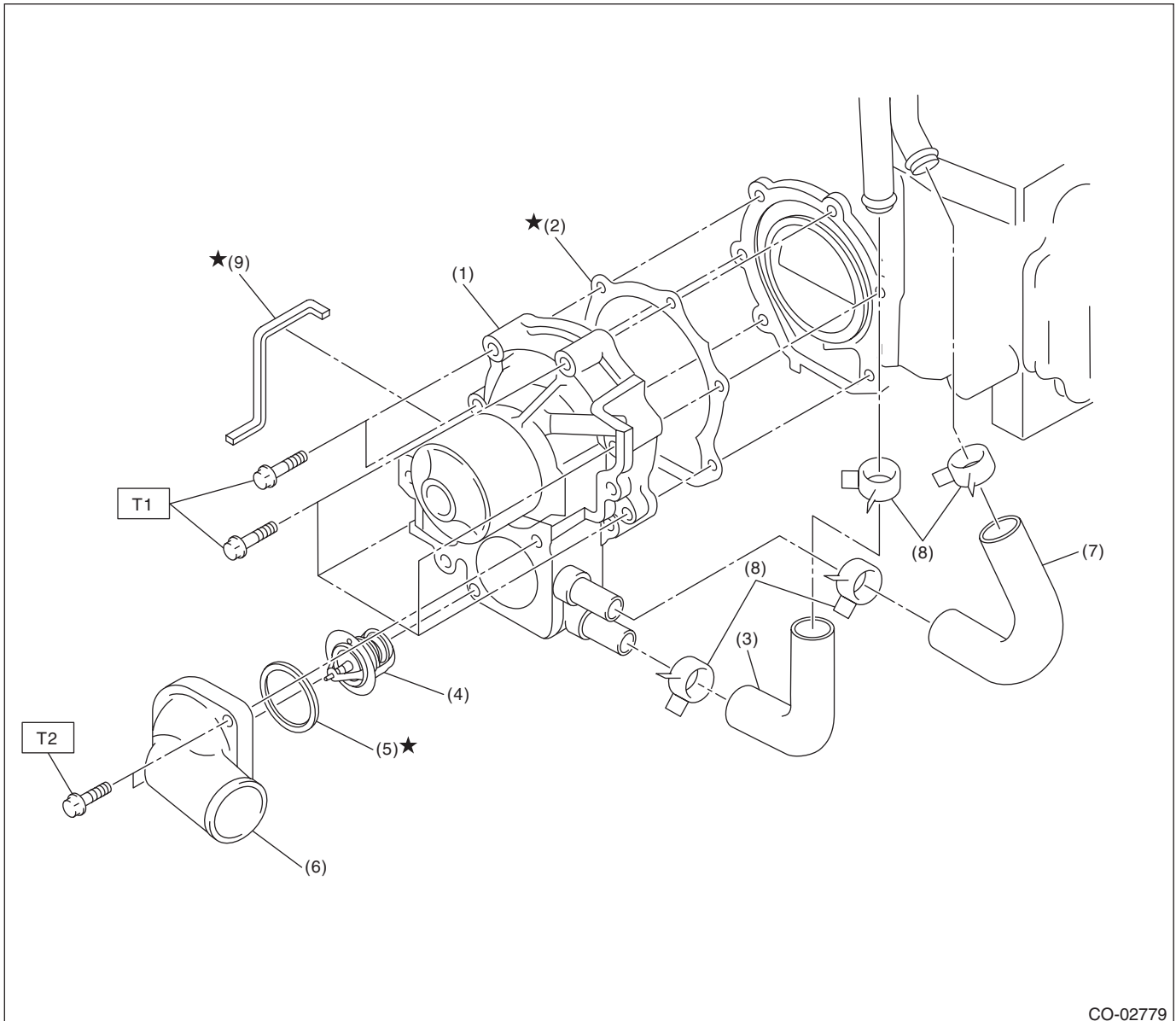

CO-02779

- |                         |                                 |
|-------------------------|---------------------------------|
| (1) Water pump ASSY     | (6) Thermostat cover            |
| (2) Gasket              | (7) Coolant filler by-pass hose |
| (3) Heater by-pass hose | (8) Clip                        |
| (4) Thermostat          | (9) Water pump sealing          |
| (5) Gasket              |                                 |

**Tightening torque: N·m (kgf·m, ft·lb)**

**T1: First 12 (1.2, 8.9)**

**Second 12 (1.2, 8.9)**

**T2: 12 (1.2, 8.9)**

# General Description

## COOLING

### 2. RADIATOR & RADIATOR FAN

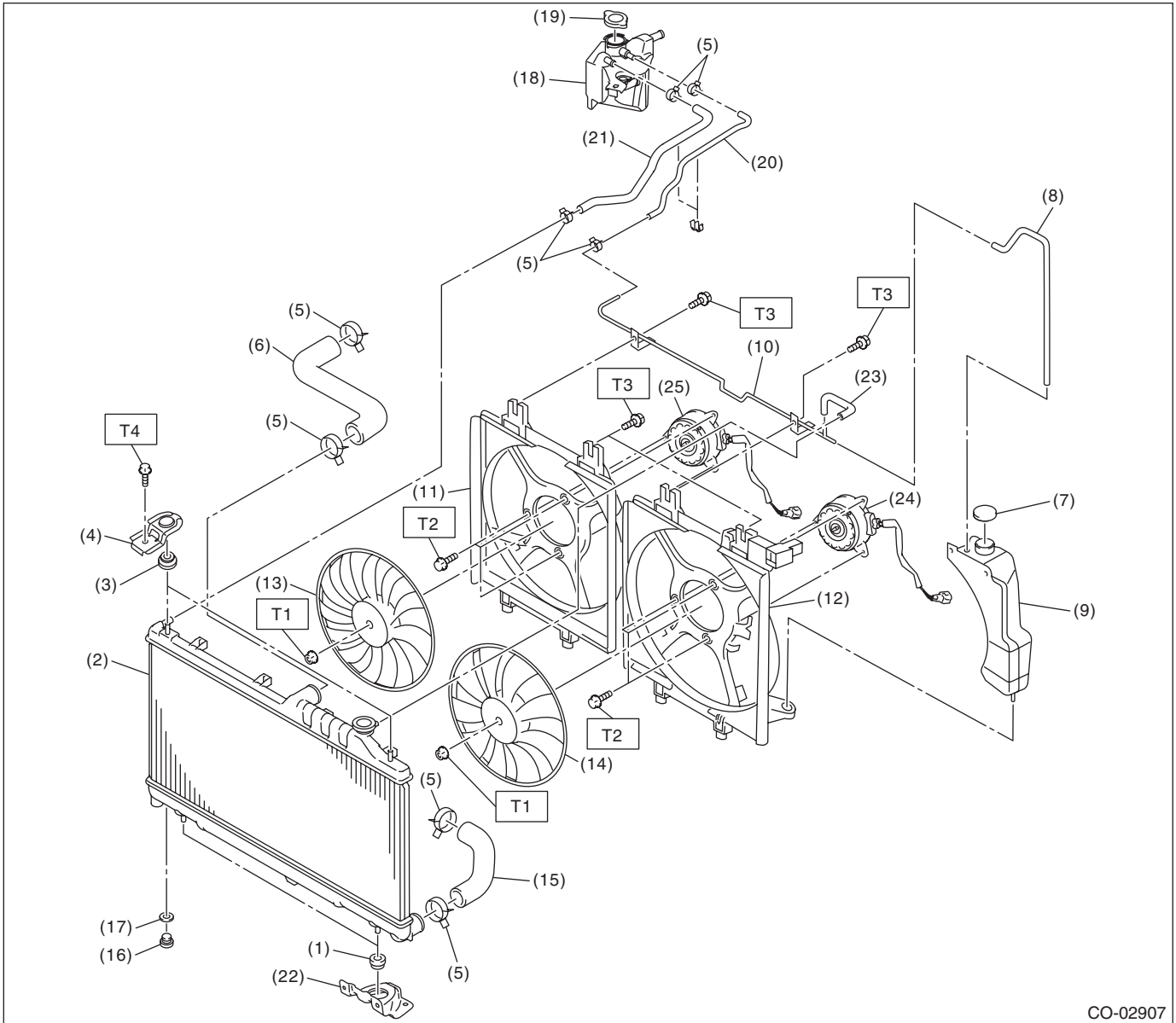

CO-02907

**CO(w/o STI)-4**

Brought to you by Ebay Seller "SubaruManuals"

# General Description

COOLING

(1) Radiator lower cushion	(12) Radiator main fan shroud	(23) Over flow hose B
(2) Radiator	(13) Radiator sub fan	(24) Main fan motor
(3) Radiator upper cushion	(14) Radiator main fan	(25) Sub fan motor
(4) Radiator upper bracket	(15) Radiator outlet hose	
(5) Clip	(16) Radiator drain plug	
(6) Radiator inlet hose	(17) O-ring	
(7) Engine coolant reservoir tank cap	(18) Coolant filler tank	
(8) Over flow hose A	(19) Radiator cap (Coolant filler tank cap)	
(9) Engine coolant reservoir tank	(20) Engine coolant hose A	
(10) Over flow pipe	(21) Engine coolant hose B	
(11) Radiator sub fan shroud	(22) Radiator lower bracket	

---

**Tightening torque: N·m (kgf-m, ft-lb)**

**T1: 3.4 (0.3, 2.5)**

**T2: 4.41 (0.45, 3.25)**

**T3: 7.5 (0.8, 5.5)**

---

**T4: 12 (1.2, 8.9)**

---

## C: CAUTION

- Wear appropriate work clothing, including a cap, protective goggles and protective shoes when performing any work.
- Remove contamination including dirt and corrosion before removal, installation or disassembly.
- Keep the disassembled parts in order and protect them from dust and dirt.
- Before removal, installation or disassembly, be sure to clarify the failure. Avoid unnecessary removal, installation, disassembly and replacement.
- Vehicle components are extremely hot after driving. Be wary of receiving burns from heated parts.
- Be sure to tighten fasteners including bolts and nuts to the specified torque.
- Place shop jacks or rigid racks at the specified points.
- Before disconnecting connectors of sensors or units, be sure to disconnect the ground cable from battery.
- Prepare a container and cloth to prevent scattering of engine coolant when performing work where engine coolant can be spilled. If the oil spills, wipe it off immediately to prevent from penetrating into floor or flowing out for environmental protection.
- Follow all government and local regulations concerning disposal of refuse when disposing engine coolant.

**CO(w/o STI)-5**

Brought to you by Ebay Seller "SubaruManuals"

# General Description

COOLING

## D: PREPARATION TOOL

### 1. SPECIAL TOOL

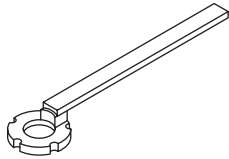
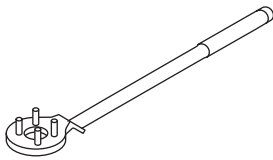
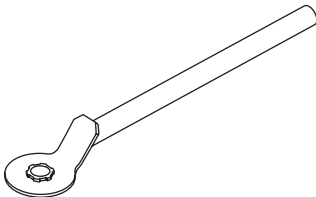
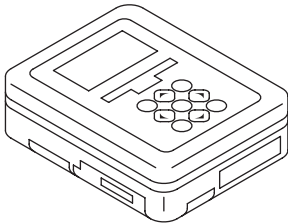
ILLUSTRATION	TOOL NUMBER	DESCRIPTION	REMARKS
 <p style="text-align: center;">ST-499207400</p>	499207400	CAM SPROCKET WRENCH	Used for removing and installing exhaust cam sprocket.
 <p style="text-align: center;">ST-499977100</p>	499977100	CRANK PULLEY WRENCH	Used for removing and installing the crank pulley.
 <p style="text-align: center;">ST-499977500</p>	499977500	CAM SPROCKET WRENCH	Used for removing and installing intake cam sprocket.
 <p style="text-align: center;">ST1B022XU0</p>	1B022XU0	SUBARU SELECT MONITOR III KIT	Used for troubleshooting the electrical system.

### 2. GENERAL TOOL

TOOL NAME	REMARKS
Circuit tester	Used for measuring resistance and voltage.
Radiator cap tester	Used for checking radiator and radiator cap.

**CO(w/o STI)-6**

Brought to you by Ebay Seller "SubaruManuals"

## 2. Radiator Fan System

### A: WIRING DIAGRAM

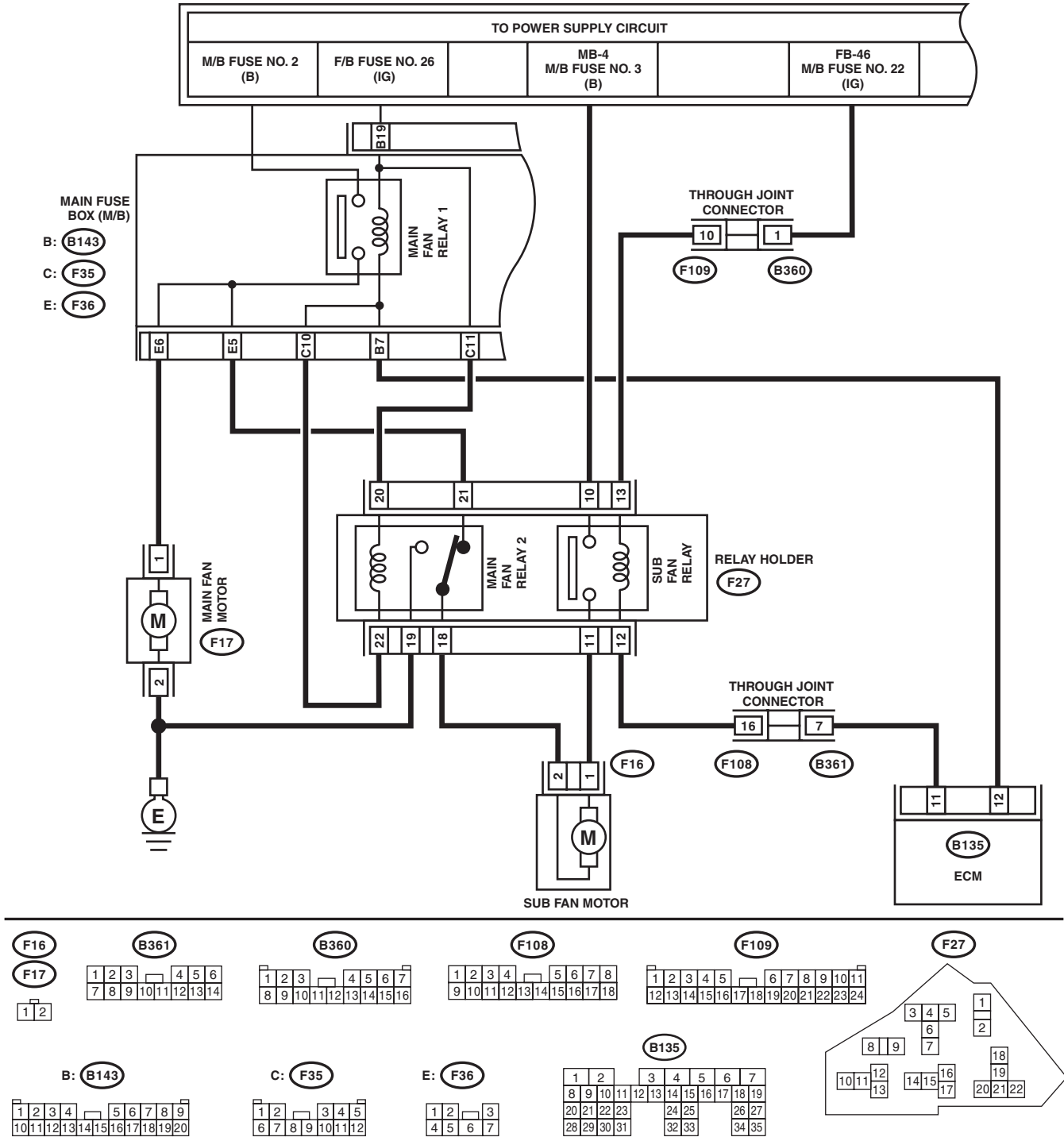

CO-02773

# Radiator Fan System

COOLING

## B: INSPECTION

### OPERATING CONDITION:

Vehicle speed	A/C compressor load	Engine coolant temperature		
		Increase: 94°C (201°F) or less Decrease: 91°C (196°F) or less	Increase: 95 — 96°C (203 — 205°F) Decrease: 92 — 94°C (198 — 201°F)	Increase: 97°C (207°F) or more Decrease: 95°C (203°F) or more
		Radiator fan operation	Radiator fan operation	Radiator fan operation
During acceleration: 19 km/h (12 MPH) or less During deceleration: 10 km/h (6 MPH) or less	OFF	OFF	Low-Speed	High-Speed
	Low	Low-Speed	Low-Speed	High-Speed
	High	High-Speed	High-Speed	High-Speed
During acceleration: 20 — 69 km/h (12 — 43 MPH) During deceleration: 11 — 64 km/h (7 — 40 MPH)	OFF	OFF	Low-Speed	High-Speed
	Low	High-Speed	High-Speed	High-Speed
	High	High-Speed	High-Speed	High-Speed
During acceleration: 70 — 105 km/h (43 — 65 MPH) During deceleration: 65 — 103 km/h (40 — 64 MPH)	OFF	OFF	Low-Speed	High-Speed
	Low	High-Speed	High-Speed	High-Speed
	High	High-Speed	High-Speed	High-Speed
During acceleration: 106 km/h (66 MPH) or more During deceleration: 104 km/h (65 MPH) or more	OFF	OFF	High-Speed	High-Speed
	Low	High-Speed	High-Speed	High-Speed
	High	High-Speed	High-Speed	High-Speed

CO(w/o STI)-8

Brought to you by Ebay Seller "SubaruManuals"

# Radiator Fan System

COOLING

## DIAGNOSIS:

Radiator main fan and radiator sub fans do not rotate under the above operating conditions.

Step	Check	Yes	No
<b>1</b> <b>CHECK OPERATION OF RADIATOR FAN.</b> 1) Connect the delivery (test) mode connector. 2) Turn the ignition switch to ON. 3) Perform the compulsory operation check for the radiator fan relay using Subaru Select Monitor. NOTE: • When performing a forced operation radiator fan relay check using the Subaru Select Monitor, the radiator main fan and radiator sub fan will repeat low speed revolution → high speed revolution → OFF in this order. • Subaru Select Monitor Refer to "Compulsory Valve Operation Check Mode" for detailed procedures. <Ref. to EN(H4DOTC)(diag)-63, Compulsory Valve Operation Check Mode.>	Do the radiator main fans and radiator sub fans rotate at low speed?	Go to step 2.	Go to step 3.
<b>2</b> <b>CHECK OPERATION OF RADIATOR FAN.</b> 1) Connect the delivery (test) mode connector. 2) Turn the ignition switch to ON. 3) Perform the compulsory operation check for the radiator fan relay using Subaru Select Monitor. NOTE: • When performing a forced operation radiator fan relay check using the Subaru Select Monitor, the radiator main fan and radiator sub fan will repeat low speed revolution → high speed revolution → OFF in this order. • Subaru Select Monitor Refer to "Compulsory Valve Operation Check Mode" for detailed procedures. <Ref. to EN(H4DOTC)(diag)-63, Compulsory Valve Operation Check Mode.>	Do the radiator main fans and radiator sub fans rotate at high speed?	Radiator main fan system is normal.	Go to step 27.
<b>3</b> <b>CHECK POWER SUPPLY TO SUB FAN RELAY.</b> 1) Turn the ignition switch to OFF. 2) Remove the sub fan relay from the relay holder. 3) Measure the voltage between sub fan relay connector and chassis ground. <b>Connector &amp; terminal</b> <b>(F27) No. 10 (+) — Chassis ground (-):</b>	Is the voltage 10 V or more?	Go to step 4.	Go to step 5.
<b>4</b> <b>CHECK POWER SUPPLY TO SUB FAN RELAY.</b> 1) Turn the ignition switch to ON. 2) Measure the voltage between sub fan relay connector and chassis ground. <b>Connector &amp; terminal</b> <b>(F27) No. 13 (+) — Chassis ground (-):</b>	Is the voltage 10 V or more?	Go to step 7.	Go to step 6.
<b>5</b> <b>CHECK FUSE.</b> 1) Turn the ignition switch to OFF. 2) Remove the fuse No. 3. 3) Check the condition of fuse.	Is the fuse blown out?	Replace the fuse.	Repair the power supply line.

# Radiator Fan System

## COOLING

Step	Check	Yes	No
<b>6 CHECK FUSE.</b> 1) Turn the ignition switch to OFF. 2) Remove the fuse No. 22. 3) Check the condition of fuse.	Is the fuse blown out?	Replace the fuse.	Repair the power supply line.
<b>7 CHECK SUB FAN RELAY.</b> 1) Turn the ignition switch to OFF. 2) Measure the resistance between sub fan relay terminals. <i>Terminals</i> <i>No. 10 — No. 11:</i>	Is the resistance 1 M $\Omega$ or more?	Go to step 8.	Replace the sub fan relay.
<b>8 CHECK SUB FAN RELAY.</b> 1) Connect the battery to terminals No. 12 and No. 13 of the sub fan relay. 2) Measure the resistance between sub fan relay terminals. <i>Terminals</i> <i>No. 10 — No. 11:</i>	Is the resistance less than 1 $\Omega$ ?	Go to step 9.	Replace the sub fan relay.
<b>9 CHECK HARNESS BETWEEN SUB FAN RELAY CONNECTOR AND SUB FAN MOTOR CONNECTOR.</b> 1) Disconnect the connector from the sub fan motor. 2) Measure the resistance of harness between sub fan relay connector and sub fan motor connector. <i>Connector &amp; terminal</i> <i>(F16) No. 1 — (F27) No. 11:</i>	Is the resistance less than 1 $\Omega$ ?	Go to step 10.	Repair the open circuit of harness between sub fan relay connector and sub fan motor connector.
<b>10 CHECK HARNESS BETWEEN SUB FAN MOTOR CONNECTOR AND MAIN FAN RELAY 2 CONNECTOR.</b> 1) Remove main fan relay 2 from the relay holder. 2) Measure the resistance of harness between sub fan motor connector and main fan relay 2 connector. <i>Connector &amp; terminal</i> <i>(F16) No. 2 — (F27) No. 18:</i>	Is the resistance less than 1 $\Omega$ ?	Go to step 11.	Repair the open circuit of the harness between sub fan motor connector and main fan relay 2 connector.
<b>11 CHECK FOR POOR CONTACT.</b> Check poor contact of sub fan motor connector.	Is there poor contact of the sub fan motor connector?	Repair the poor contact of sub fan motor connector.	Go to step 12.
<b>12 CHECK SUB FAN MOTOR.</b> Connect the battery positive (+) terminal to terminal No. 1 of the sub fan motor, and the ground (-) terminal to terminal No. 2.	Does the radiator sub fan rotate?	Go to step 13.	Replace the sub fan motor.
<b>13 CHECK MAIN FAN RELAY 2.</b> Measure the resistance between main fan relay 2 terminals. <i>Terminals</i> <i>No. 21 — No. 18:</i>	Is the resistance less than 1 $\Omega$ ?	Go to step 14.	Replace the main fan relay 2.
<b>14 CHECK HARNESS BETWEEN MAIN FAN RELAY 2 CONNECTOR AND MAIN FAN MOTOR CONNECTOR.</b> 1) Disconnect the connector from the main fan motor. 2) Measure the resistance of the harness between main fan relay 2 connector and main fan motor connector. <i>Connector &amp; terminal</i> <i>(F17) No. 1 — (F27) No. 21:</i>	Is the resistance less than 1 $\Omega$ ?	Go to step 15.	Repair the open circuit of the harness between main fan relay 2 connector and main fan motor connector.



# Radiator Fan System

COOLING

Step	Check	Yes	No
<b>15 CHECK MAIN FAN MOTOR AND GROUND CIRCUIT.</b> Measure the resistance between main fan motor connector and chassis ground. <i>Connector &amp; terminal</i> <i>(F17) No. 2 — Chassis ground:</i>	Is the resistance less than 5 $\Omega$ ?	Go to step 16.	Repair the open circuit of the harness between main fan motor connector and chassis ground.
<b>16 CHECK FOR POOR CONTACT.</b> Check poor contact of main fan motor connector.	Is there poor contact of the main fan motor connector?	Repair the poor contact of main fan motor connector.	Go to step 17.
<b>17 CHECK MAIN FAN MOTOR.</b> Connect the battery positive (+) terminal to terminal No. 1 of the main fan motor, and the ground (-) terminal to terminal No. 2.	Does the radiator main fan rotate?	Go to step 18.	Replace the main fan motor.
<b>18 CHECK HARNESS BETWEEN SUB FAN RELAY CONNECTOR AND ECM.</b> 1) Disconnect the connector from ECM. 2) Measure the resistance between the sub fan relay connector and ECM connector. <i>Connector &amp; terminal</i> <i>(B135) No. 11 — (F27) No. 12:</i>	Is the resistance less than 1 $\Omega$ ?	Go to step 19.	Repair the open circuit of harness between sub fan relay connector and ECM.
<b>19 CHECK FOR POOR CONTACT.</b> Check for poor contact of ECM connector.	Is there poor contact of ECM connector?	Repair the poor contact of ECM connector.	Check the DTC. Repair the trouble cause. <Ref. to EN(H4DOTC)(diag)-47, Read Diagnostic Trouble Code (DTC).>
<b>20 CHECK MAIN FAN RELAY 1.</b> 1) Turn the ignition switch to OFF. 2) Remove main fan relay 1 from the main fuse box. 3) Measure the resistance between terminals of main fan relay 1 switch.	Is the resistance 1 M $\Omega$ or more?	Go to step 21.	Replace the main fan relay 1.
<b>21 CHECK MAIN FAN RELAY 1.</b> 1) Connect the main fan relay 1 coil side terminal to the battery. 2) Measure the resistance between terminals of main fan relay 1 switch.	Is the resistance less than 1 $\Omega$ ?	Go to step 22.	Replace the main fan relay 1.
<b>22 CHECK HARNESS BETWEEN MAIN FAN RELAY 1 CONNECTOR AND MAIN FAN MOTOR CONNECTOR.</b> 1) Disconnect the connector from the main fan motor. 2) Measure the resistance of the harness between main fan relay 1 connector and main fan motor connector. <i>Connector &amp; terminal</i> <i>(F17) No. 1 — (F36) No. 6:</i>	Is the resistance less than 1 $\Omega$ ?	Go to step 23.	Repair the open circuit of the harness between main fan relay 1 connector and main fan motor connector.
<b>23 CHECK HARNESS BETWEEN MAIN FAN RELAY 1 CONNECTOR AND ECM.</b> 1) Disconnect the connector from ECM. 2) Measure the resistance between the main fan relay 1 connector and ECM connector. <i>Connector &amp; terminal</i> <i>(B135) No. 12 — (B143) No. 7:</i>	Is the resistance less than 1 $\Omega$ ?	Go to step 24.	Repair the open circuit of the harness between main fan relay 1 connector and ECM.

# Radiator Fan System

## COOLING

Step	Check	Yes	No
<b>24 CHECK HARNESS BETWEEN MAIN FAN RELAY 2 CONNECTOR AND ECM.</b> Measure the resistance between the main fan relay 2 connector and ECM connector. <b>Connector &amp; terminal</b> <b>(B135) No. 12 — (F27) No. 22:</b>	Is the resistance less than 1 $\Omega$ ?	Go to step 25.	Repair the open circuit of the harness between main fan relay 2 connector and ECM.
<b>25 CHECK FUSE.</b> 1) Turn the ignition switch to OFF. 2) Remove the fuse No. 2 and No. 26. 3) Check the condition of fuse.	Is the fuse blown out?	Replace the fuse.	Go to step 26.
<b>26 CHECK FOR POOR CONTACT.</b> Check for poor contact of ECM connector.	Is there poor contact of ECM connector?	Repair the poor contact of ECM connector.	Repair the power supply circuit to the main fuse box.
<b>27 CHECK OPERATION OF RADIATOR FAN.</b> If the both fans do not rotate at high speed in the condition of step 2, check whether the radiator sub fan is rotating.	Does the radiator sub fan rotate?	Go to step 20.	Go to step 28.
<b>28 CHECK GROUND CIRCUIT OF MAIN FAN RELAY 2.</b> 1) Remove main fan relay 2 from the relay holder. 2) Measure the resistance between main fan relay 2 connector and chassis ground. <b>Connector &amp; terminal</b> <b>(F27) No. 19 — Chassis ground:</b>	Is the resistance less than 1 $\Omega$ ?	Go to step 29.	Repair the open circuit of harness between main fan relay 2 connector and chassis ground.
<b>29 CHECK POWER SUPPLY TO MAIN FAN RELAY 2.</b> 1) Turn the ignition switch to ON. 2) Measure the voltage between main fan relay 2 connector and chassis ground. <b>Connector &amp; terminal</b> <b>(F27) No. 20 (+) — Chassis ground (-):</b>	Is the voltage 10 V or more?	Go to step 30.	Repair the power supply line.
<b>30 CHECK MAIN FAN RELAY 2.</b> 1) Turn the ignition switch to OFF. 2) Remove the main fan relay 2. 3) Measure the resistance between main fan relay 2 terminals. <b>Terminals</b> <b>No. 18 — No. 19:</b>	Is the resistance 1 M $\Omega$ or more?	Go to step 31.	Replace the main fan relay 2.
<b>31 CHECK MAIN FAN RELAY 2.</b> 1) Connect the battery to terminals No. 20 and No. 22 of the main fan relay 2. 2) Measure the resistance between main fan relay 2 terminals. <b>Terminals</b> <b>No. 18 — No. 19:</b>	Is the resistance less than 1 $\Omega$ ?	Go to step 23.	Replace the main fan relay 2.

## 3. Engine Coolant

### A: REPLACEMENT

#### 1. DRAINING OF ENGINE COOLANT

- 1) Lift up the vehicle.
- 2) Remove the under cover. <Ref. to EI-28, REMOVAL, Front Under Cover.>
- 3) Remove the drain plug to drain engine coolant into container.

**NOTE:**

Remove the coolant filler tank cap so that engine coolant will drain faster.

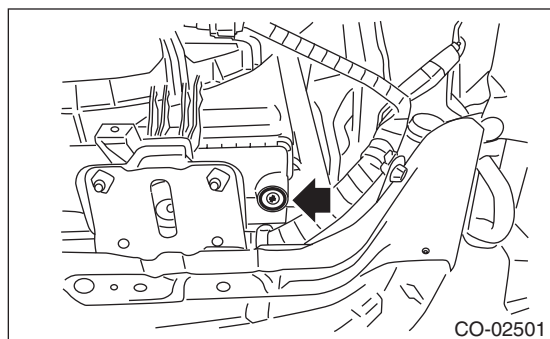

- 4) Install the drain plug.
- 5) Install the under cover. <Ref. to EI-28, INSTALLATION, Front Under Cover.>

#### 2. FILLING OF ENGINE COOLANT

- 1) Pour cooling system conditioner through the filler neck of coolant filler tank.

**Cooling system protective agent:**

Refer to "SPECIFICATION" for cooling system protective agent. <Ref. to CO(w/o STI)-2, SPECIFICATION, General Description.>

- 2) Fill the engine coolant into coolant filler tank up to the filler neck position.

**Recommended engine coolant:**

Refer to "SPECIFICATION" for recommended engine coolant. <Ref. to CO(w/o STI)-2, SPECIFICATION, General Description.>

**Engine coolant level:**

Refer to "SPECIFICATION" for engine coolant level. <Ref. to CO(w/o STI)-2, SPECIFICATION, General Description.>

**Engine coolant concentration:**

Refer to "ADJUSTMENT" for the recommended engine coolant concentration. <Ref. to CO(w/o STI)-14, ADJUSTMENT, Engine Coolant.>

**CAUTION:**

Do not confuse the cap of coolant filler tank and cap of radiator.

**NOTE:**

- When pouring the engine coolant, the radiator side cap must not be removed.
  - The SUBARU Super Coolant contains anti-freeze and anti-rust agents, and is especially made for Subaru engines with an aluminum cylinder block. Be sure to use SUBARU Super Coolant, since other coolant may cause corrosion.
- 3) Fill engine coolant into the reservoir tank up to "FULL" level.

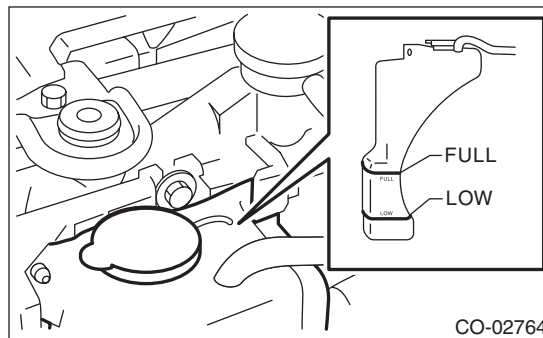

- 4) Close the coolant filler tank cap, and start the engine. Race 5 to 6 times at 3,000 rpm or less, then stop the engine. (Complete this operation within 40 seconds.)
- 5) Wait for one minute after the engine stops, then open the coolant filler tank cap. If the engine coolant level drops, add engine coolant into coolant filler tank up to the filler neck position.
- 6) Perform the procedures 4) and 5) again.
- 7) Install the coolant filler tank cap and reservoir tank cap properly.
- 8) Start the engine and operate the heater at maximum hot position and the blower speed setting to "LO".
- 9) Run the engine at 2,000 rpm or less until radiator fan starts and stops.

**NOTE:**

Be careful with the engine coolant temperature to prevent overheating.

- 10) Stop the engine and wait until the engine coolant temperature lowers to 30°C (86°F) or less.
- 11) Open the coolant filler tank cap. If the engine coolant level drops, add engine coolant into the coolant filler tank up to the filler neck position and the reservoir tank to "FULL" level.
- 12) Install the coolant filler tank cap and reservoir tank cap properly.
- 13) Set the heater setting to maximum hot position and the blower speed setting to "LO" and start the engine. Perform racing at 3,000 rpm or less. If the flowing sound is heard from the heater core, repeat the procedures from step 9).

# Engine Coolant

COOLING

---

## B: ADJUSTMENT

### 1. PROCEDURE TO ADJUST THE SUBARU SUPER COOLANT CONCENTRATION

#### CAUTION:

**Use the SUBARU Super Coolant with a 50 — 60% concentration in order to obtain maximum anti-freeze and anti-rust performance.**

To adjust the concentration of SUBARU Super Coolant according to temperature, find the proper SUBARU Super Coolant concentration in the table, and add dilution water to the SUBARU Super Coolant (concentrated type) until it reaches the proper dilution.

Relationship of SUBARU Super Coolant concentration and freezing temperature			
SUBARU Super Coolant concentration	50%	55%	60%
Freezing temperature	-36°C (-33°F)	-41°C (-42°F)	-50°C (-58°F)

#### ***Engine coolant and diluting water:***

***Refer to "SPECIFICATION" for recommended engine coolant and diluting water. <Ref. to CO(w/o STI)-2, SPECIFICATION, General Description.>***

## 4. Water Pump

### A: REMOVAL

- 1) Remove the radiator. <Ref. to CO(w/o STI)-19, REMOVAL, Radiator.>
- 2) Remove the V-belts. <Ref. to ME(w/o STI)-39, REMOVAL, V-belt.>
- 3) Remove the crank pulley. <Ref. to ME(w/o STI)-46, REMOVAL, Crank Pulley.>
- 4) Remove the timing belt cover. <Ref. to ME(w/o STI)-48, REMOVAL, Timing Belt Cover.>
- 5) Remove the timing belt. <Ref. to ME(w/o STI)-49, REMOVAL, Timing Belt.>
- 6) Remove the automatic belt tension adjuster (A).
- 7) Remove the belt idler (B).
- 8) Remove the belt idler No. 2 (C).

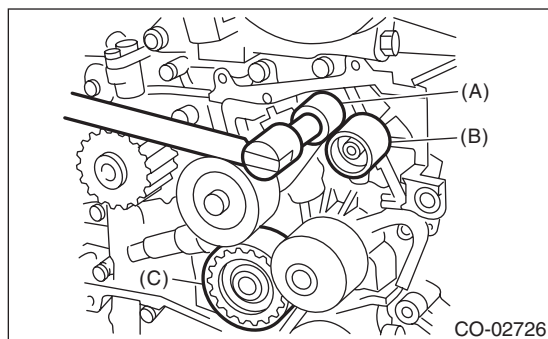

- 9) Remove the cam sprocket LH. <Ref. to ME(w/o STI)-58, REMOVAL, Cam Sprocket.>
- 10) Remove the belt cover No. 2 LH.

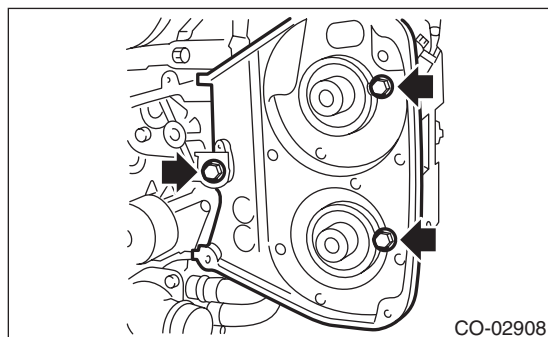

- 11) Remove the tensioner bracket.

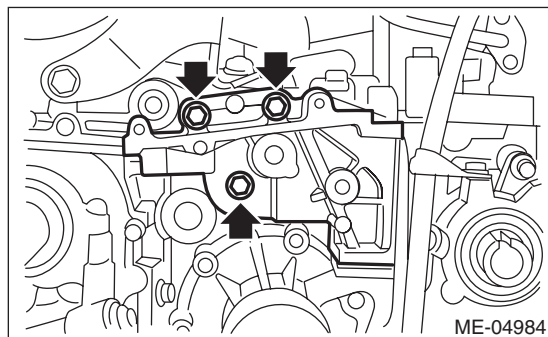

- 12) Disconnect the hose from water pump.

- 13) Remove the water pump.

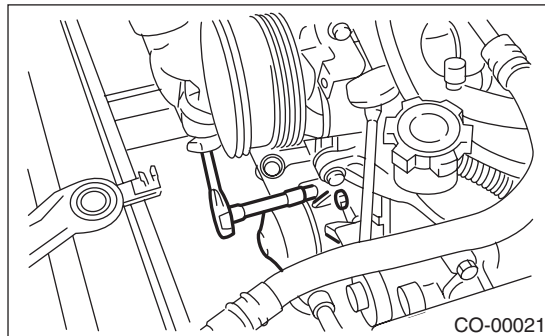

### B: INSTALLATION

- 1) Install the water pump onto cylinder block LH.

#### NOTE:

- Use a new gasket.
- When installing the water pump, tighten the bolts in two stages in alphabetical sequence as shown in figure.

#### Tightening torque:

##### First:

**12 N·m (1.2 kgf-m, 8.9 ft-lb)**

##### Second:

**12 N·m (1.2 kgf-m, 8.9 ft-lb)**

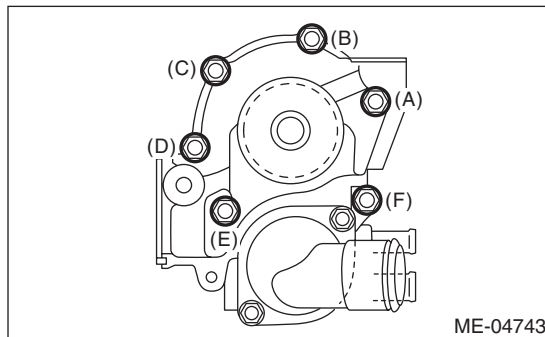

- 2) Install the hose to water pump.
- 3) Install the tensioner bracket.

#### Tightening torque:

**24.5 N·m (2.5 kgf-m, 18.1 ft-lb)**

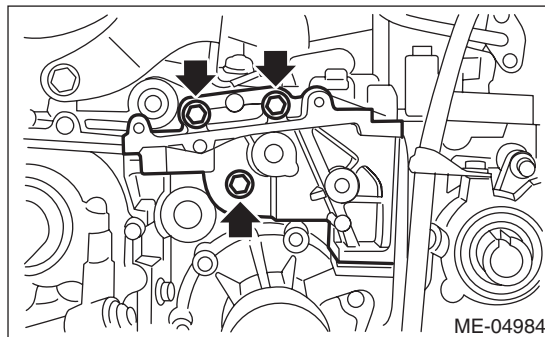

# Water Pump

## COOLING

4) Install the belt cover No. 2 LH.

**Tightening torque:**

**5 N·m (0.5 kgf·m, 3.7 ft·lb)**

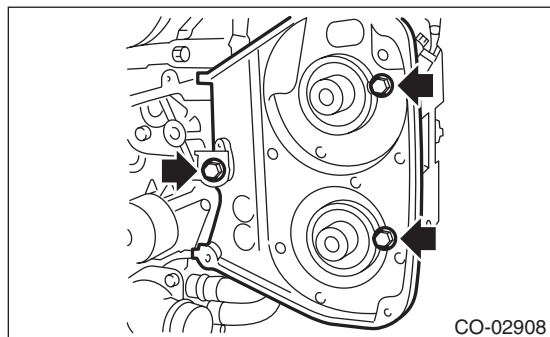

5) Install the cam sprocket LH. <Ref. to ME(w/o STI)-58, INSTALLATION, Cam Sprocket.>

6) Install the belt idler No. 2 (C).

**Tightening torque:**

**39 N·m (4.0 kgf·m, 28.8 ft·lb)**

7) Install the belt idler (B).

**Tightening torque:**

**25 N·m (2.5 kgf·m, 18.4 ft·lb)**

8) Install the automatic belt tension adjuster (A) with the tension rod held by a pin. <Ref. to ME(w/o STI)-51, AUTOMATIC BELT TENSION ADJUSTER ASSEMBLY AND BELT IDLER, INSTALLATION, Timing Belt.>

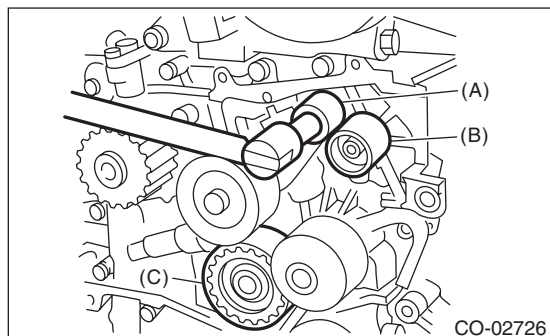

9) Install the timing belt. <Ref. to ME(w/o STI)-52, TIMING BELT, INSTALLATION, Timing Belt.>

10) Install the timing belt cover. <Ref. to ME(w/o STI)-48, INSTALLATION, Timing Belt Cover.>

11) Install the crank pulley. <Ref. to ME(w/o STI)-46, INSTALLATION, Crank Pulley.>

12) Install the V-belts. <Ref. to ME(w/o STI)-39, INSTALLATION, V-belt.>

13) Install the radiator. <Ref. to CO(w/o STI)-20, INSTALLATION, Radiator.>

## C: INSPECTION

- 1) Check the water pump bearing for smooth rotation.
- 2) Check the water pump pulley for abnormalities.
- 3) Make sure the impeller is not abnormally deformed or damaged.
- 4) Inspect the clearance between impeller and pump case.

**Clearance between impeller and pump case:**

**Standard**

**0.5 — 1.5 mm (0.020 — 0.059 in)**

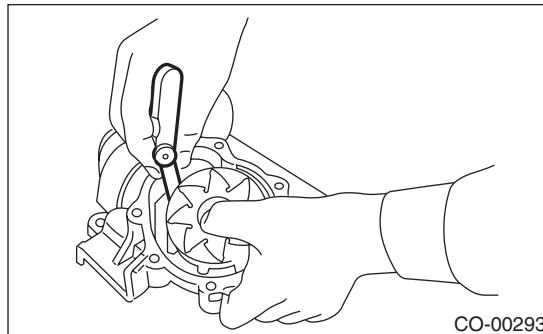

5) After water pump installation, check pulley shaft for engine coolant leaks or noise. If leaks or noise are noted, replace the water pump assembly.

## 5. Thermostat

### A: REMOVAL

- 1) Lift up the vehicle.
- 2) Remove the under cover. <Ref. to EI-28, REMOVAL, Front Under Cover.>
- 3) Drain engine coolant. <Ref. to CO(w/o STI)-13, DRAINING OF ENGINE COOLANT, REPLACEMENT, Engine Coolant.>
- 4) Disconnect the radiator outlet hose from thermostat cover.

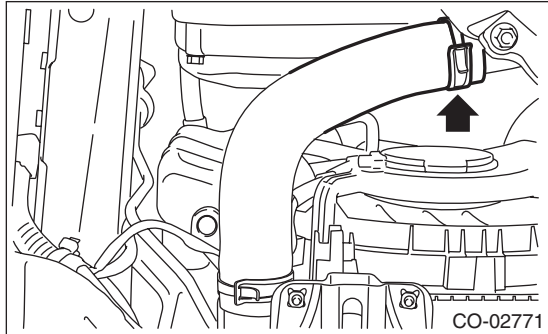

- 5) Remove the thermostat cover, and then remove the gasket and thermostat.

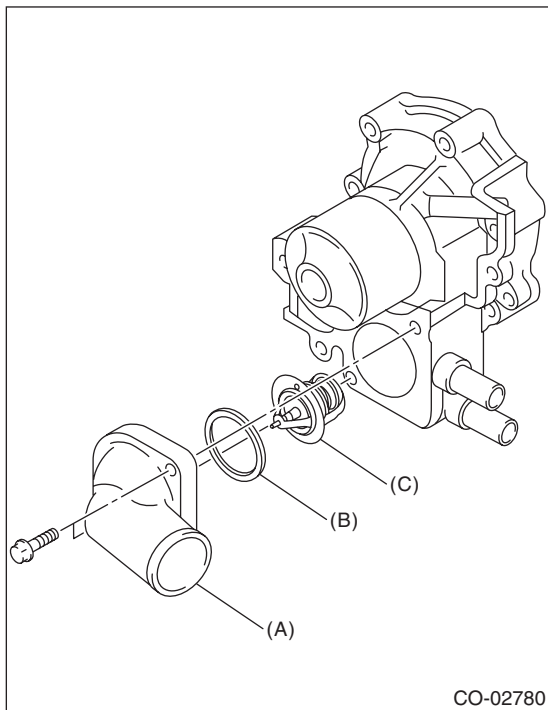

- (A) Thermostat cover
- (B) Gasket
- (C) Thermostat

### B: INSTALLATION

- 1) Install a gasket to thermostat.

NOTE:

Use a new gasket.

- 2) Install the thermostat and thermostat cover.

NOTE:

Install the parts with the jiggle pin facing upward.

**Tightening torque:**

**12 N·m (1.2 kgf·m, 8.9 ft·lb)**

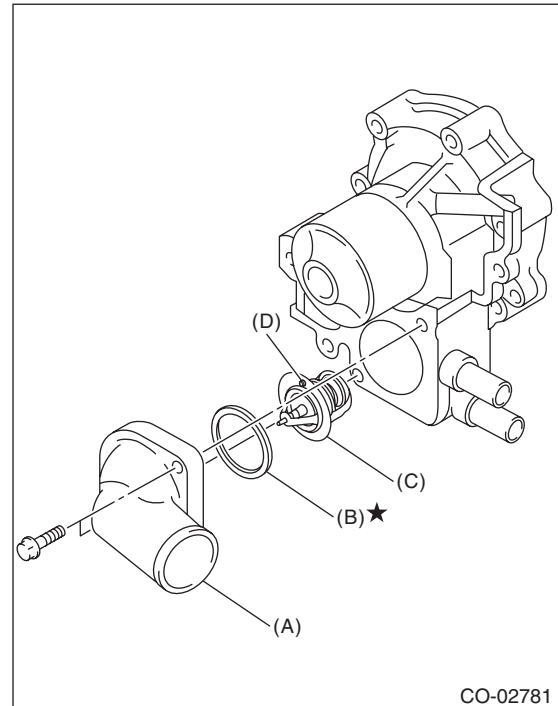

- (A) Thermostat cover
- (B) Gasket
- (C) Thermostat
- (D) Jiggle pin

- 3) Connect the radiator outlet hose to thermostat cover.
- 4) Install the under cover. <Ref. to EI-28, INSTALLATION, Front Under Cover.>
- 5) Lower the vehicle.
- 6) Fill engine coolant. <Ref. to CO(w/o STI)-13, FILLING OF ENGINE COOLANT, REPLACEMENT, Engine Coolant.>

# Thermostat

## COOLING

---

### C: INSPECTION

- 1) Check that the thermostat does not have deformation, cracks or damage.
- 2) Check that the thermostat valve closes completely at an ambient temperature.
- 3) Immerse the thermostat and a thermometer in water. Raise water temperature gradually, and check the temperature and valve lift when the valve begins to open and when the valve is fully opened. Replace the thermostat if faulty.

#### NOTE:

- During the test, agitate the water for even temperature distribution.
- Leave the thermostat in the boiling water for five minutes or more before measuring the valve lift.
- Hold the thermostat with a wire or the like to avoid contacting the container.

#### **Starting temperature to open:**

**76 — 80°C (169 — 176°F)**

#### **Full open temperature:**

**91°C (196°F)**

#### **Total valve lift:**

**9.0 mm (0.354 in) or more**

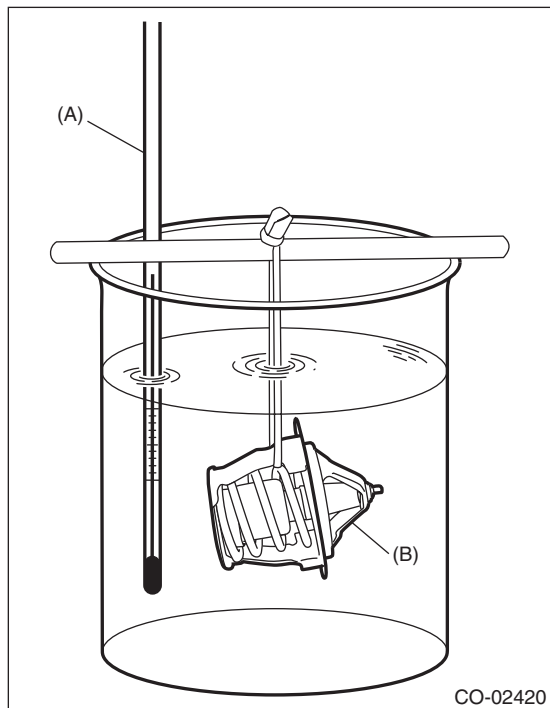

(A) Thermometer

(B) Thermostat



## 6. Radiator

### A: REMOVAL

#### CAUTION:

The radiator is pressurized when the engine and radiator are hot. Wait until engine and radiator cool down before working on the radiator.

1) Disconnect the ground cable from battery.

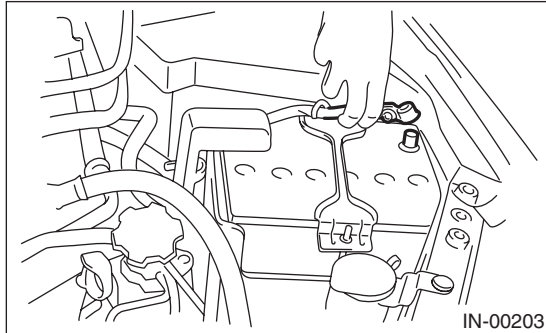

2) Lift up the vehicle.

3) Remove the under cover. <Ref. to EI-28, REMOVAL, Front Under Cover.>

4) Drain engine coolant. <Ref. to CO(w/o STI)-13, DRAINING OF ENGINE COOLANT, REPLACEMENT, Engine Coolant.>

5) Disconnect the connector (A) from the main fan motor and the connector (B) from the sub fan motor.

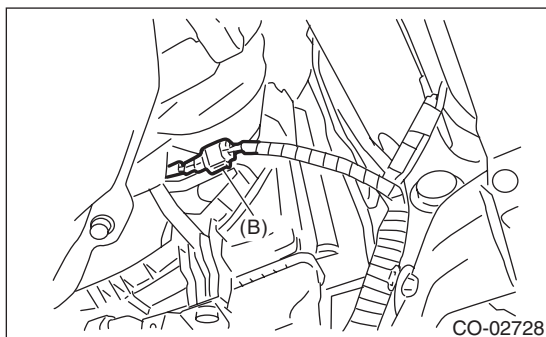
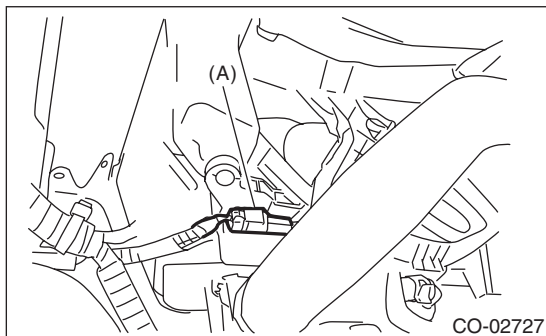

6) Disconnect the radiator outlet hose from thermostat cover.

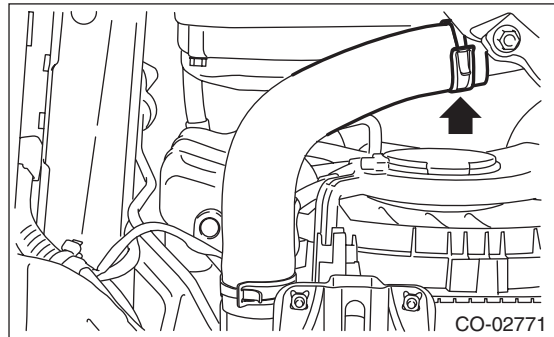

7) Lower the vehicle.

8) Remove the air intake duct. <Ref. to IN(w/o STI)-10, REMOVAL, Air Intake Duct.>

9) Remove the reservoir tank. <Ref. to CO(w/o STI)-27, REMOVAL, Reservoir Tank.>

10) Disconnect the radiator inlet hose from the radiator.

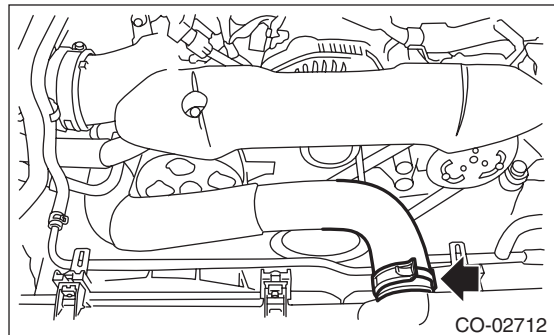

11) Disconnect the two engine coolant hoses from the radiator.

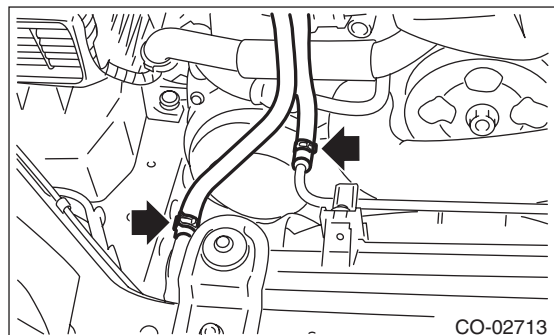

12) Remove the radiator upper brackets.

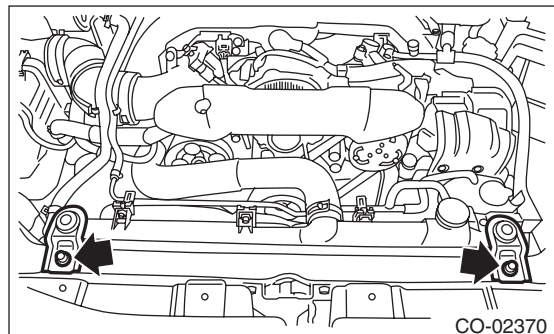

# Radiator

## COOLING

- 13) Move the radiator to the left while lifting it upward.
- 14) Lift the radiator up and remove the radiator from vehicle.
- 15) Remove the radiator lower cushion from the radiator lower bracket.

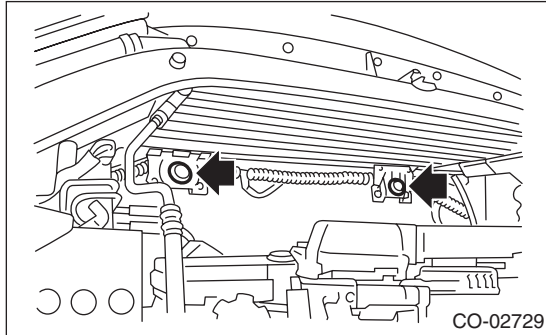

## B: INSTALLATION

- 1) Attach the radiator lower cushion to the radiator lower bracket.

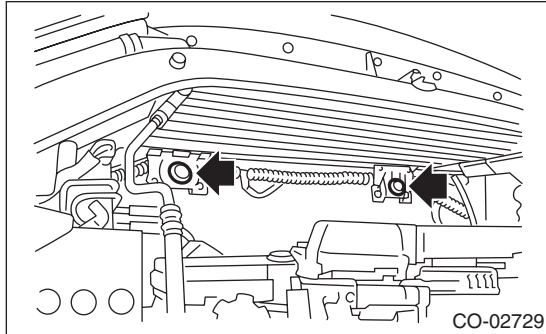

- 2) Install the radiator to vehicle.

### NOTE:

Make pins on the lower side of radiator be fitted into the radiator lower cushions.

- 3) Install the radiator upper brackets.

### Tightening torque:

**12 N·m (1.2 kgf·m, 8.9 ft·lb)**

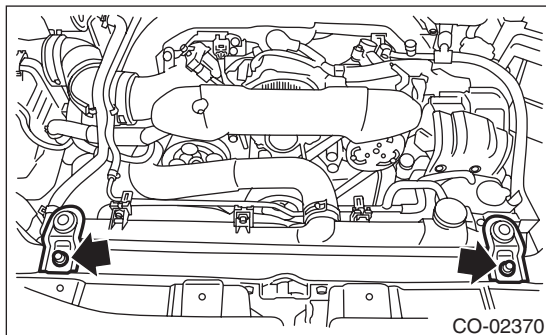

- 4) Connect the two engine coolant hoses to the radiator.

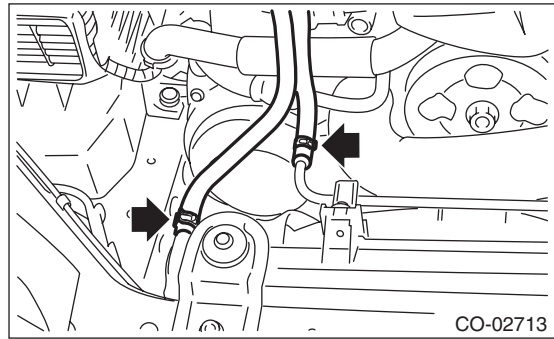

- 5) Connect the radiator inlet hose.

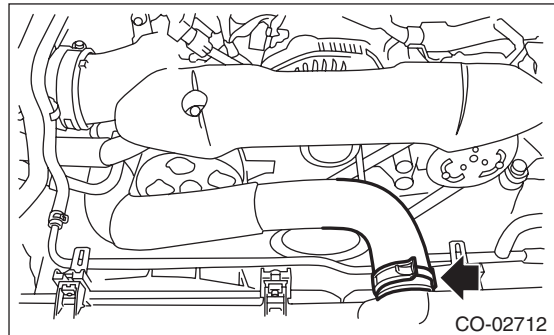

- 6) Install the reservoir tank. <Ref. to CO(w/o STI)-27, INSTALLATION, Reservoir Tank.>

- 7) Install the air intake duct. <Ref. to IN(w/o STI)-10, INSTALLATION, Air Intake Duct.>

- 8) Lift up the vehicle.

- 9) Connect the radiator outlet hose.

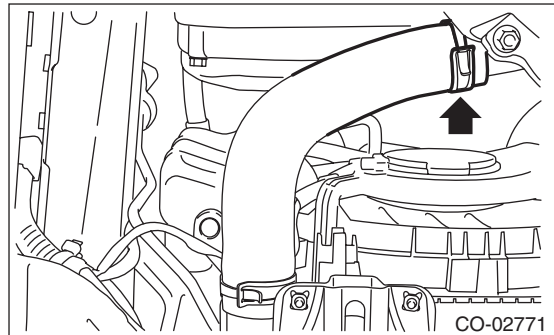

10) Connect the connector (A) to the main fan motor and the connector (B) to the sub fan motor connector.

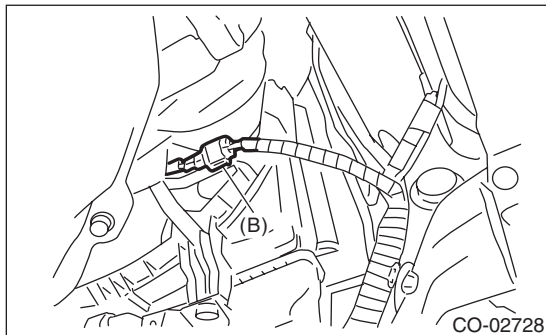
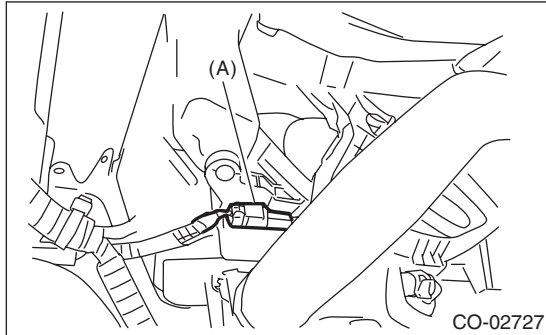

11) Install the under cover. <Ref. to EI-28, INSTALLATION, Front Under Cover.>

12) Lower the vehicle.

13) Connect the battery ground terminal.

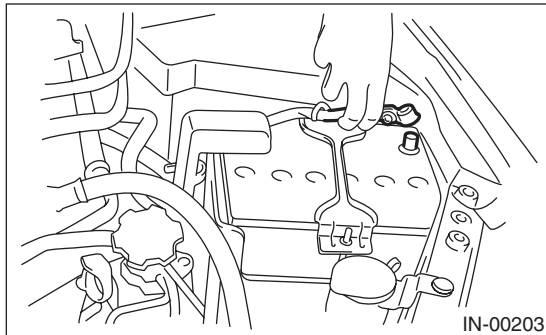

14) Fill engine coolant. <Ref. to CO(w/o STI)-13, FILLING OF ENGINE COOLANT, REPLACEMENT, Engine Coolant.>

## C: INSPECTION

- 1) Check that the radiator does not have deformation, cracks or damage.
- 2) Check that the hose has no cracks, damage or loose part.
- 3) Remove the coolant filler tank cap, fill the coolant filler tank with engine coolant, then install the radiator cap tester to the filler neck of coolant filler tank.

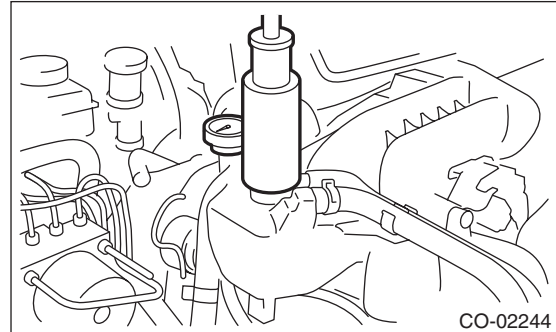

4) Apply a pressure of 122 kPa (1.2 kg/cm<sup>2</sup>, 18 psi) to the radiator and check the following points:

- Leakage from the radiator or its vicinity
- Leakage from the hose or its connections

### CAUTION:

- Inspection must be carried out at the side of coolant filler tank, not at the side of radiator.
- Engine should be turned off.
- Wipe engine coolant from check points in advance.
- Be careful not to deform the filler neck of the coolant filler tank when installing and removing the radiator cap tester.
- Be careful of engine coolant from spurting out when removing the radiator cap tester.

# Radiator Cap

COOLING

## 7. Radiator Cap

### A: INSPECTION

- 1) Check that the radiator cap does not have deformation, cracks or damage.
- 2) Attach the radiator cap tester to radiator cap.

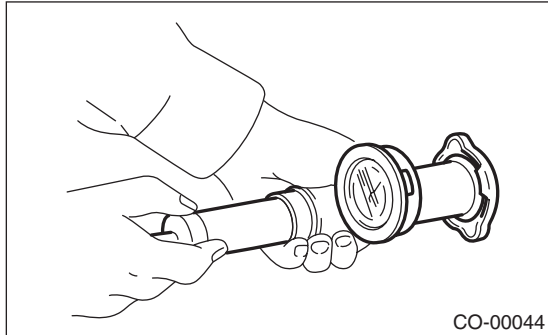

- 3) Increase pressure until the radiator cap tester gauge needle stops. Radiator cap is functioning properly if it holds the service limit pressure for 5 — 6 seconds. Replace the radiator cap if its valve opens at less than the service limit.

#### **Coolant filler tank side:**

##### **Standard**

**93 — 123 kPa (0.95 — 1.25 kg/cm<sup>2</sup>, 14 — 18 psi)**

##### **Limit**

**83 kPa (0.85 kg/cm<sup>2</sup>, 12 psi)**

#### **Radiator side:**

##### **Standard**

**122 — 152 kPa (1.24 — 1.55 kg/cm<sup>2</sup>, 18 — 22 psi)**

##### **Limit**

**112 kPa (1.14 kg/cm<sup>2</sup>, 16 psi)**

#### **CAUTION:**

- Be sure to remove foreign matter and rust from the cap in advance. Otherwise, results of pressure test will be incorrect.
- Do not confuse the cap of coolant filler tank and cap of radiator.

## 8. Radiator Main Fan and Fan Motor

### A: REMOVAL

- 1) Disconnect the ground cable from battery.

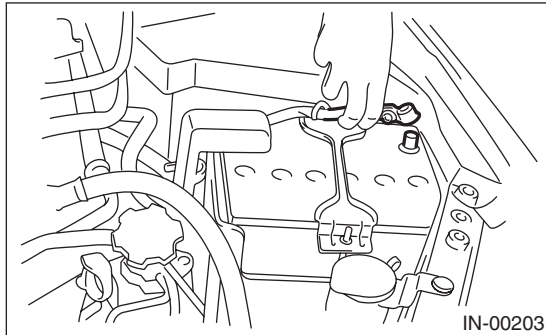

- 2) Lift up the vehicle.
- 3) Remove the under cover. <Ref. to EI-28, REMOVAL, Front Under Cover.>
- 4) Disconnect the connector from the main fan motor.

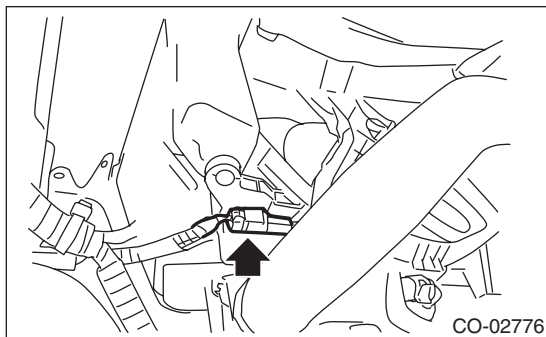

- 5) Lower the vehicle.
- 6) Remove the air intake duct. <Ref. to IN(w/o STI)-10, REMOVAL, Air Intake Duct.>
- 7) Remove the reservoir tank. <Ref. to CO(w/o STI)-27, REMOVAL, Reservoir Tank.>
- 8) Remove the bolts which secure the radiator main fan motor assembly and the over flow pipe.

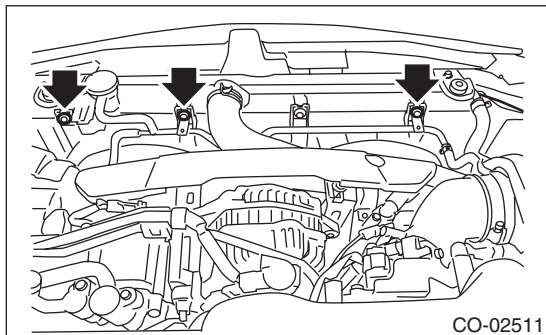

- 9) Remove the radiator main fan motor assembly from the upper side of the vehicle.

### B: INSTALLATION

Install in the reverse order of removal.

#### CAUTION:

Check if the radiator hose and the over flow hose are properly connected.

#### Tightening torque:

7.5 N·m (0.8 kgf·m, 5.5 ft·lb)

### C: DISASSEMBLY

- 1) Remove the clip which holds the main fan motor connector onto the radiator main fan shroud.
- 2) Disconnect the radiator main fan from the main fan motor.

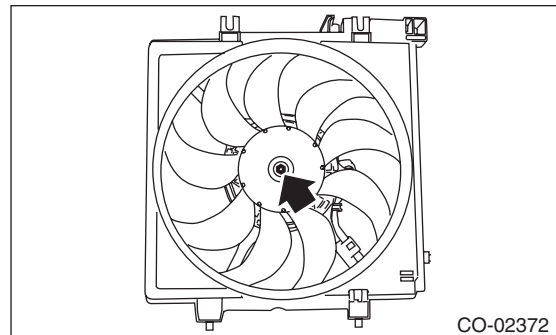

- 3) Disconnect the main fan motor from the radiator main fan shroud.

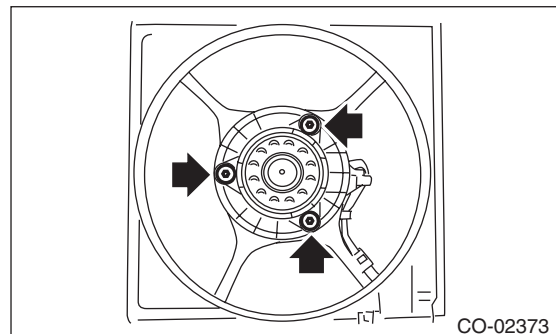

# Radiator Main Fan and Fan Motor

COOLING

---

## D: ASSEMBLY

Assemble in the reverse order of disassembly.

**Tightening torque:**

**4.41 N·m (0.45 kgf-m, 3.25 ft-lb)**

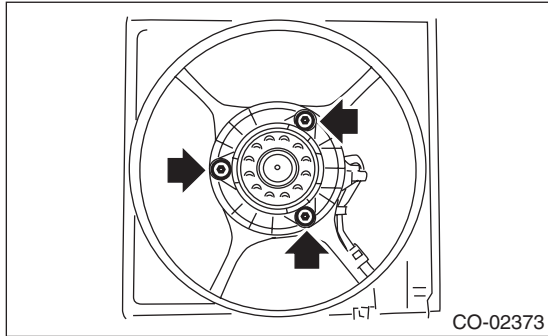

**Tightening torque:**

**3.4 N·m (0.3 kgf-m, 2.5 ft-lb)**

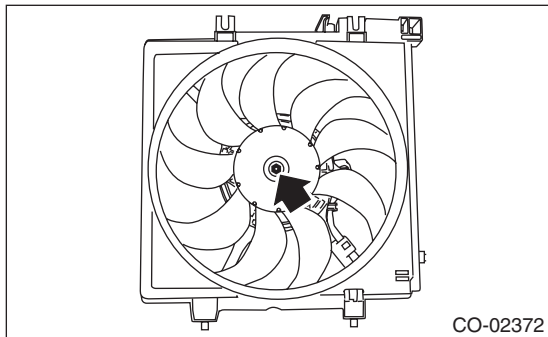

## E: INSPECTION

Check that the radiator main fan, radiator main fan shroud and main fan motor do not have deformation, cracks or damage.



## 9. Radiator Sub Fan and Fan Motor

### A: REMOVAL

- 1) Disconnect the ground cable from battery.

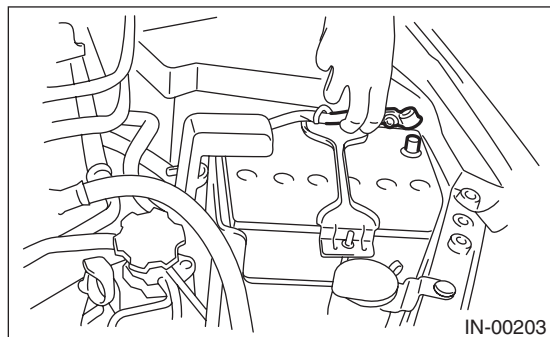

- 2) Lift up the vehicle.
- 3) Remove the under cover. <Ref. to EI-28, REMOVAL, Front Under Cover.>
- 4) Disconnect the connector from the sub fan motor.

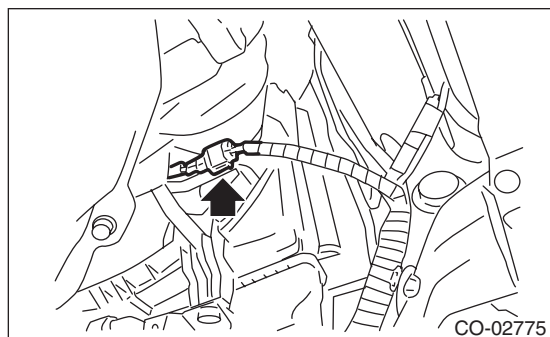

- 5) Lower the vehicle.
- 6) Remove the air intake duct. <Ref. to IN(w/o STI)-10, REMOVAL, Air Intake Duct.>
- 7) Remove the bolts which secure the radiator sub fan motor assembly and the over flow pipe.

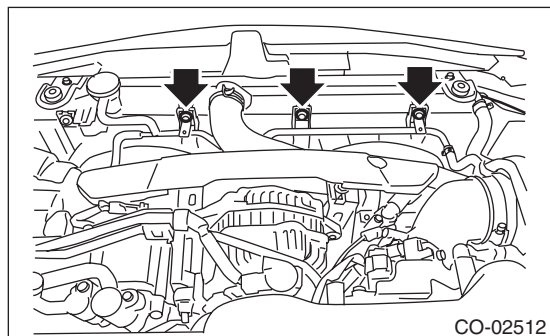

- 8) Raise the radiator sub fan motor assembly slightly, remove the pin at the lower part of the radiator sub fan motor assembly from the radiator hole, and remove the radiator sub fan motor assembly from the lower side of the vehicle.

### B: INSTALLATION

Install in the reverse order of removal.

#### CAUTION:

Check if the radiator hose and the over flow hose are properly connected.

#### Tightening torque:

7.5 N·m (0.8 kgf·m, 5.5 ft·lb)

### C: DISASSEMBLY

- 1) Remove the clip which holds the sub fan motor connector onto the radiator sub fan shroud.
- 2) Disconnect the radiator sub fan from the sub fan motor.

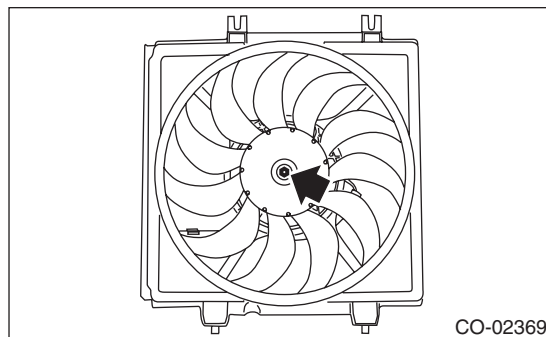

- 3) Disconnect the sub fan motor from the radiator sub fan shroud.

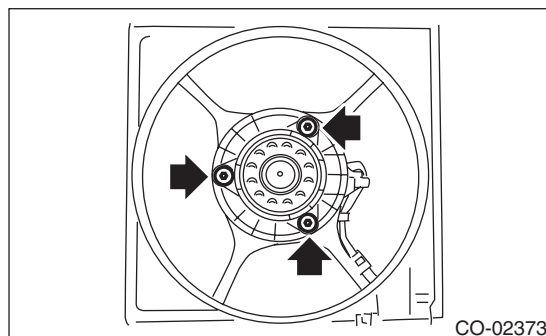

# Radiator Sub Fan and Fan Motor

COOLING

---

## D: ASSEMBLY

Assemble in the reverse order of disassembly.

**Tightening torque:**

**4.41 N·m (0.45 kgf-m, 3.25 ft-lb)**

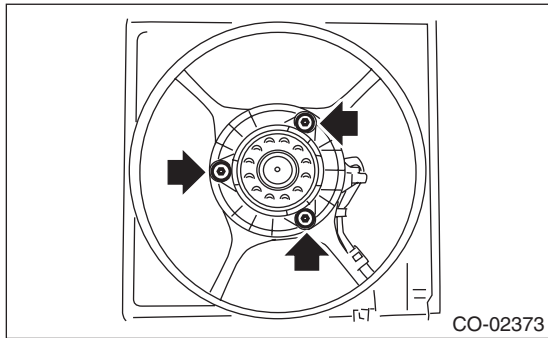

**Tightening torque:**

**3.4 N·m (0.3 kgf-m, 2.5 ft-lb)**

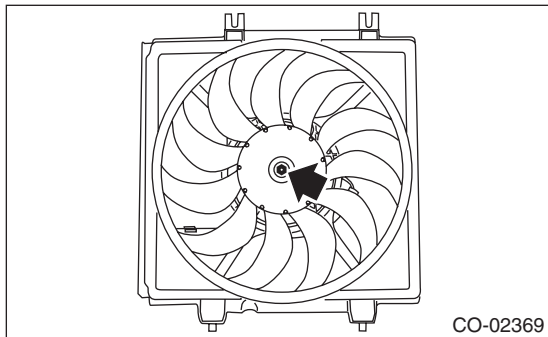

## E: INSPECTION

Check that the radiator sub fan, radiator sub fan shroud and sub fan motor do not have deformation, cracks or damage.



## 10. Reservoir Tank

### A: REMOVAL

- 1) Pull out the over flow hose (A).
- 2) Pull out the reservoir tank to the arrow direction while pushing the claw (B).

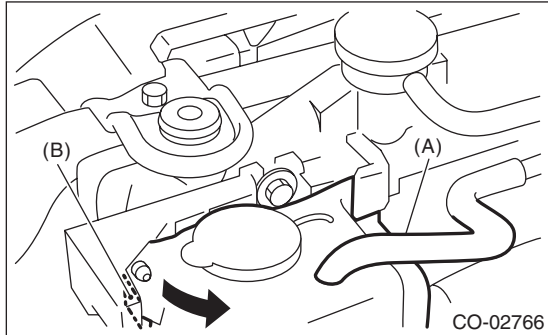

### B: INSTALLATION

Install in the reverse order of removal.

### C: INSPECTION

- 1) Check that the reservoir tank does not have deformation, cracks or damage.
- 2) Check the over flow hose for cracks or damage.
- 3) Make sure the engine coolant level is between "FULL" and "LOW".

## 11. Coolant Filler Tank

### A: REMOVAL

#### CAUTION:

The coolant filler tank is pressurized when the engine and radiator are hot. Wait until engine and radiator cool down before working on the coolant filler tank.

- 1) Drain approximately 3.0 ℓ (3.2 US qt, 2.6 Imp qt) of coolant. <Ref. to CO(w/o STI)-13, DRAINING OF ENGINE COOLANT, REPLACEMENT, Engine Coolant.>
- 2) Disconnect the engine coolant hoses from coolant filler tank.
- 3) Remove the bolts which secure the coolant filler tank.

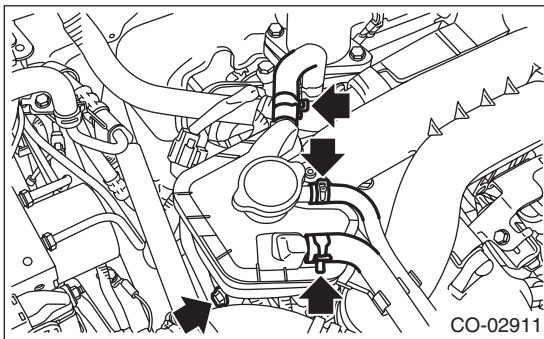

- 4) Disconnect the engine coolant hose which connects the under side of coolant filler tank, and remove the coolant filler tank.

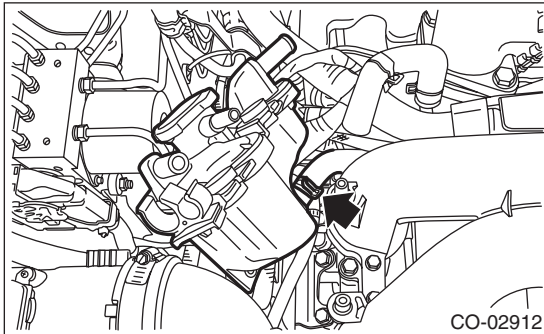

### B: INSTALLATION

Install in the reverse order of removal.

#### Tightening torque:

**16 N·m (1.6 kgf·m, 11.8 ft·lb)**

### C: INSPECTION

- 1) Check that the coolant filler tank does not have deformation, cracks or damage.
- 2) Check that the engine coolant hose has no cracks, damage or loose part.

## 12.Engine Cooling System Trouble in General

### A: INSPECTION

Trouble	Possible cause	Corrective action
Over-heating	a. Insufficient engine coolant	Replenish engine coolant, inspect for leakage, and repair it if necessary.
	b. Loose timing belt	Repair or replace timing belt tensioner.
	c. Oil on timing belt	Replace.
	d. Malfunction of thermostat	Replace.
	e. Malfunction of water pump	Replace.
	f. Clogged engine coolant passage	Clean.
	g. Improper ignition timing	Inspect and repair ignition control system. <Ref. to EN(H4DOTC)(diag)-2, PROCEDURE, Basic Diagnostic Procedure.>
	h. Clogged or leaking radiator	Clean, repair or replace.
	i. Defective radiator fan	Replace.
	j. Improper engine oil in engine coolant	Replace the engine coolant. If ineffective, check, repair or replace engine components.
	k. Air/fuel mixture ratio too lean	Inspect and repair the fuel injection system. <Ref. to EN(H4DOTC)(diag)-2, PROCEDURE, Basic Diagnostic Procedure.>
	l. Excessive back pressure in exhaust system	Clean or replace.
	m. Insufficient clearance between piston and cylinder	Adjust or replace.
	n. Slipping clutch	Repair or replace.
	o. Dragging brake	Adjust.
p. Defective radiator fan	Inspect the radiator fan relay, engine coolant temperature sensor or fan motor and replace them.	
Over-cooling	a. Ambient temperature extremely low	Partly cover radiator front area.
	b. Defective thermostat	Replace.
Engine coolant leaks	a. Loosened or damaged connecting units on hoses	Repair or replace.
	b. Leakage from water pump	Replace.
	c. Leakage from water pipe	Repair or replace.
	d. Leakage around cylinder head gasket	Retighten cylinder head bolts or replace cylinder head gasket.
	e. Damaged or cracked cylinder head and cylinder block	Repair or replace.
	f. Damaged or cracked thermostat cover	Repair or replace.
	g. Leakage from radiator	Repair or replace.
Noise	a. Timing belt problem	Replace.
	b. Defective radiator fan	Replace.
	c. Defective water pump bearing	Replace water pump.
	d. Defective water pump mechanical seal	Replace water pump.

# Engine Cooling System Trouble in General

COOLING

---

**CO(w/o STI)-30**

Brought to you by Ebay Seller "SubaruManuals"

# LUBRICATION

# *LU(w/o STI)*

---

	<b>Page</b>
1. General Description .....	2

# General Description

LUBRICATION

---

## 1. General Description

### A: SPECIFICATION

Specifications for models other than STI are included in the LU (STI) section. <Ref. to LU(STI)-2, General Description.>

# SPEED CONTROL SYSTEMS

# *SP(w/o STI)*

---

	Page
1. General Description .....	2

# General Description

SPEED CONTROL SYSTEMS

---

## 1. General Description

### A: SPECIFICATION

Specifications for models other than STI are the same as those for STI model. <Ref. to SP(STI)-2, General Description.>



# IGNITION

# *IG(w/o STI)*

---

	<b>Page</b>
1. General Description .....	2
2. Spark Plug .....	4
3. Ignition Coil .....	7

# General Description

IGNITION

---

## 1. General Description

### A: SPECIFICATION

Item			Specifications
Ignition coil	Type		FK0368
	Ignition system		Independent ignition coil
	Manufacturer		Diamond Electric
Spark plug	Manufacturer and type		NGK: SILFR6A
	Thread size (diameter, pitch, length) mm		14, 1.25, 26.5
	Spark plug gap	mm (in) Standard	0.7 — 0.8 (0.028 — 0.031)
	Electrode		Iridium

**IG(w/o STI)-2**

Brought to you by Ebay Seller "SubaruManuals"

## B: COMPONENT

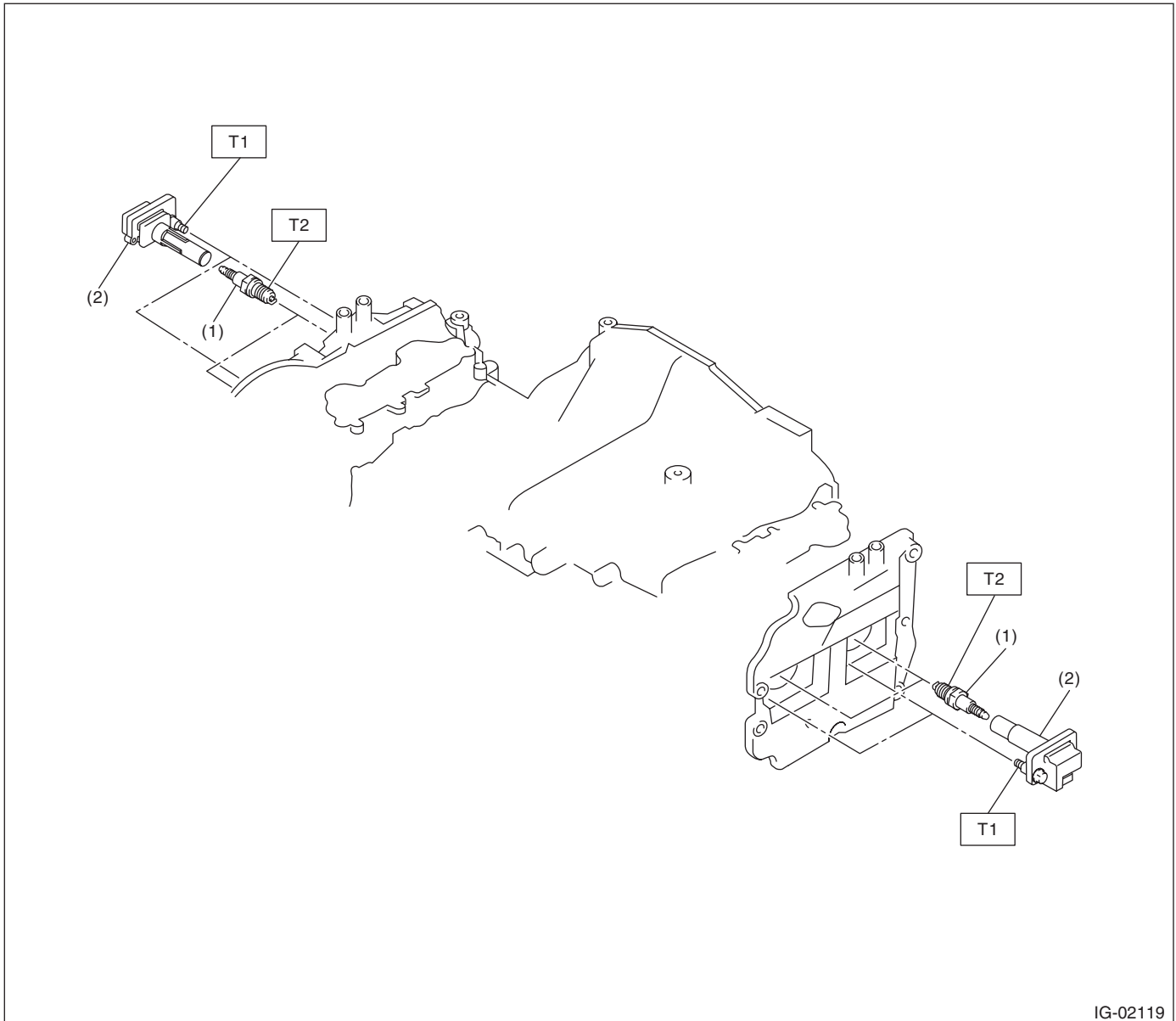

(1) Spark plug

(2) Ignition coil

**Tightening torque: N·m (kgf·m, ft·lb)**

**T1: 16 (1.6, 11.8)**

**T2: 21 (2.1, 15.5)**

## C: CAUTION

- Wear appropriate work clothing, including a cap, protective goggles and protective shoes when performing any work.
- Remove contamination including dirt and corrosion before removal, installation or disassembly.
- Keep the disassembled parts in order and protect them from dust and dirt.
- Before removal, installation or disassembly, be sure to clarify the failure. Avoid unnecessary removal, installation, disassembly and replacement.
- Vehicle components are extremely hot after driving. Be wary of receiving burns from heated parts.
- Be sure to tighten fasteners including bolts and nuts to the specified torque.
- Place shop jacks or rigid racks at the specified points.
- Before disconnecting connectors of sensors or units, be sure to disconnect the ground cable from battery.

**IG(w/o STI)-3**

Brought to you by Ebay Seller "SubaruManuals"

# Spark Plug

## IGNITION

## 2. Spark Plug

### A: REMOVAL

#### Spark plug:

Refer to "SPECIFICATION" for spark plug.  
<Ref. to IG(w/o STI)-2, SPECIFICATION, General Description.>

#### 1. RH SIDE

- 1) Disconnect the ground cable from battery.

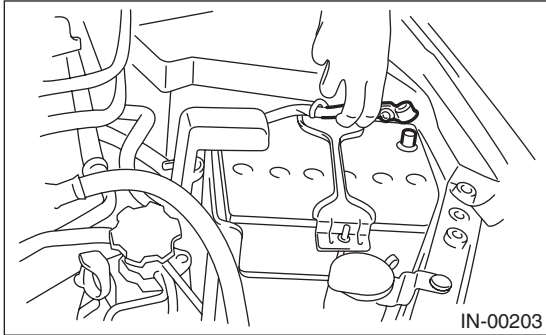

- 2) Remove the air cleaner case. <Ref. to IN(w/o STI)-8, REMOVAL, Air Cleaner Case.>
- 3) Disconnect the connector from ignition coil.
- 4) Remove the ignition coil.

#### NOTE:

Turn #3 ignition coil by 180° to remove it.

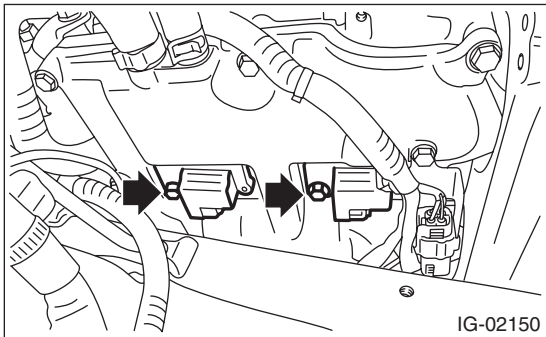

- 5) Remove the spark plug with a spark plug socket.

#### 2. LH SIDE

- 1) Remove the battery. <Ref. to SC(STI)-27, REMOVAL, Battery.>
- 2) Disconnect the air duct from the secondary air pump.

- 3) Remove the bolts that secure the air duct to the rocker cover LH, and lift the air duct.

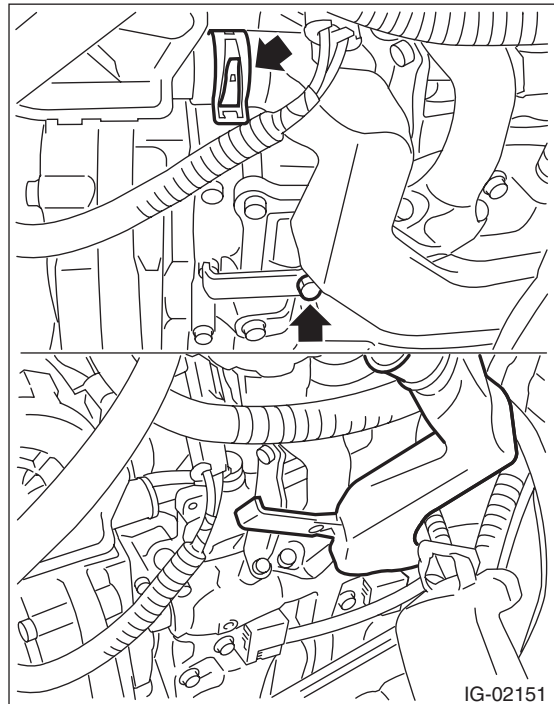

- 4) Disconnect the connector from ignition coil.
- 5) Remove the ignition coil.

#### NOTE:

Turn #4 ignition coil by 180° to remove it.

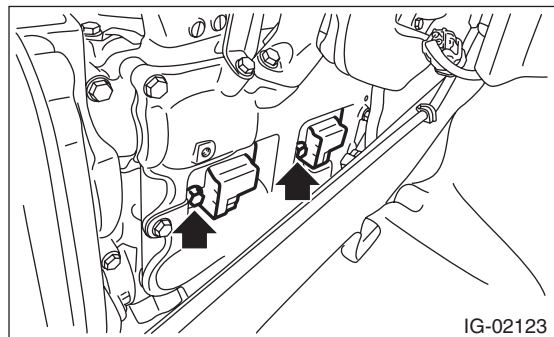

- 6) Remove the spark plug with a spark plug socket.

## B: INSTALLATION

### 1. RH SIDE

Install in the reverse order of removal.

**Tightening torque (Spark plug):**  
**21 N·m (2.1 kgf·m, 15.5 ft·lb)**

**Tightening torque (Ignition coil):**  
**16 N·m (1.6 kgf·m, 11.8 ft·lb)**

### 2. LH SIDE

Install in the reverse order of removal.

**Tightening torque (Spark plug):**  
**21 N·m (2.1 kgf·m, 15.5 ft·lb)**

**Tightening torque (Ignition coil):**  
**16 N·m (1.6 kgf·m, 11.8 ft·lb)**

**Tightening torque (Air duct):**  
**6.4 N·m (0.7 kgf·m, 4.7 ft·lb)**

## C: INSPECTION

1) Check the spark plug for abnormalities. If defective, replace the spark plug.

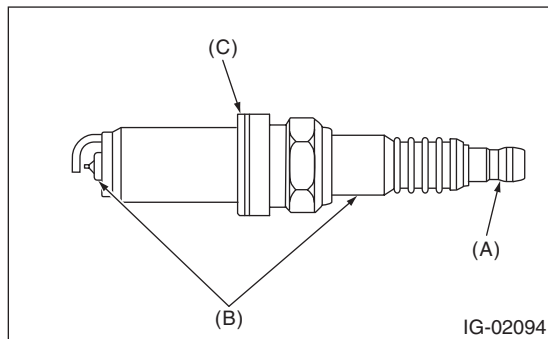

- (A) Terminal damage
- (B) Crack or damage in insulator
- (C) Damaged gasket

2) Check the spark plug electrode and condition of the insulator. If abnormal, check and repair the cause and replace the spark plug.

(1) Normal:

Brown to grayish-tan deposits and slight electrode wear indicate correct spark plug heat range.

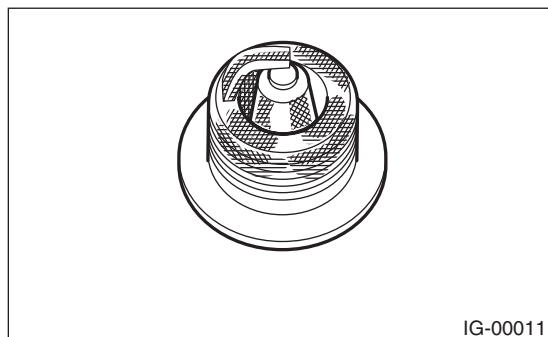

(2) Carbon fouled:

Dry fluffy carbon deposits on insulator and electrode are mostly caused by slow speed driving in the city, weak ignition, too rich fuel mixture, etc.

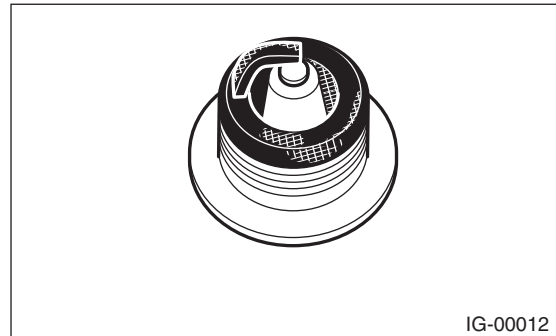

(3) Oil fouled:

Wet black deposits show oil entrance into combustion chamber through worn piston rings or increased clearance between valve guides and valve stems.

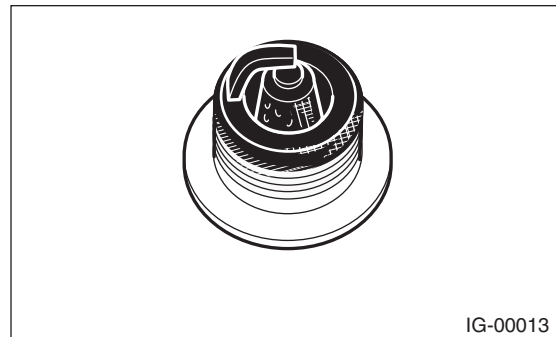

(4) Overheating:

A white or light gray insulator with black or brown spots and bluish burnt electrodes indicate engine overheating, wrong selection of fuel, or loose spark plugs.

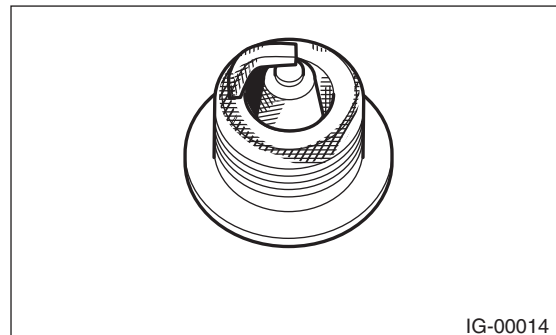

# Spark Plug

## IGNITION

---

3) Using a nylon brush, etc., clean and remove the carbon or oxide deposits from the spark plug. If deposits are too stubborn, replace the spark plugs. After cleaning the spark plugs, check the spark plug gap "L" using a gap gauge. If it is not within the standard, replace the spark plug.

### NOTE:

- Never use a plug cleaner.
- Do not use a metal brush as it may damage the electrode area.

### **Spark plug gap L:**

#### **Standard**

**0.7 — 0.8 mm (0.028 — 0.031 in)**

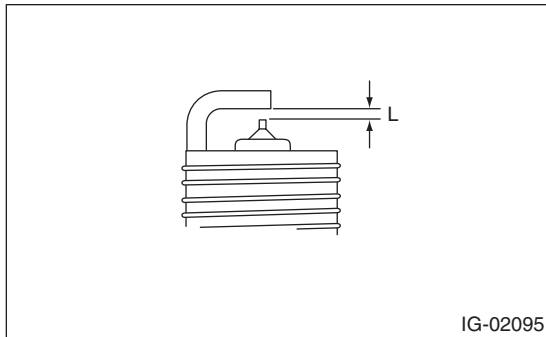

IG-02095

## 3. Ignition Coil

### A: REMOVAL

Direct ignition type is adopted. Refer to "Spark Plug" for removal procedure. <Ref. to IG(w/o STI)-4, REMOVAL, Spark Plug.>

### B: INSTALLATION

Install in the reverse order of removal.

#### *Tightening torque:*

**16 N·m (1.6 kgf-m, 11.8 ft-lb)**

### C: INSPECTION

For inspection procedure, refer to "Diagnostics for Engine Starting Failure". <Ref. to EN(H4DOTC)(diag)-80, IGNITION CONTROL SYSTEM, Diagnostics for Engine Starting Failure.>

# Ignition Coil

IGNITION

---

**IG(w/o STI)-8**

Brought to you by Ebay Seller "SubaruManuals"



# STARTING/CHARGING SYSTEMS

# *SC(w/o STI)*

---

	Page
1. General Description .....	2

# General Description

STARTING/CHARGING SYSTEMS

---

## 1. General Description

### A: SPECIFICATION

Specifications for models other than STI are included in the SC (STI) section. <Ref. to SC(STI)-2, General Description.>

**SC(w/o STI)-2**

Brought to you by Ebay Seller "SubaruManuals"

**ENGINE 3 SECTION**

**ENGINE (DIAGNOSTICS)**

**EN(H4DOTC)  
(diag)**

**GENERAL DESCRIPTION**

**GD(H4DOTC)**

This service manual has been prepared to provide SUBARU service personnel with the necessary information and data for the correct maintenance and repair of SUBARU vehicles.

This manual includes the procedures for maintenance, disassembling, reassembling, inspection and adjustment of components and diagnostics for guidance of experienced mechanics.

Please peruse and utilize this manual fully to ensure complete repair work for satisfying our customers by keeping their vehicle in optimum condition. When replacement of parts during repair work is needed, be sure to use SUBARU genuine parts.

All information, illustration and specifications contained in this manual are based on the latest product information available at the time of publication approval.

# ENGINE (DIAGNOSTICS)

# *EN(H4DOTC)(diag)*

---

	<b>Page</b>
1. Basic Diagnostic Procedure .....	2
2. Check List for Interview .....	4
3. General Description .....	6
4. Electrical Component Location .....	9
5. Engine Control Module (ECM) I/O Signal .....	23
6. Engine Condition Data .....	33
7. Data Link Connector .....	34
8. General Scan Tool .....	35
9. Subaru Select Monitor .....	40
10. Read Diagnostic Trouble Code (DTC) .....	47
11. Inspection Mode .....	48
12. Drive Cycle .....	54
13. Clear Memory Mode .....	62
14. Compulsory Valve Operation Check Mode .....	63
15. System Operation Check Mode .....	64
16. Malfunction Indicator Light .....	66
17. Diagnostics for Engine Starting Failure .....	73
18. Diagnostic Procedure for Subaru Select Monitor Communication .....	86
19. List of Diagnostic Trouble Code (DTC) .....	88
20. Diagnostic Procedure with Diagnostic Trouble Code (DTC) .....	96
21. Diagnostic Procedure without Diagnostic Trouble Code (DTC) .....	443
22. General Diagnostic Table .....	448

# Basic Diagnostic Procedure

ENGINE (DIAGNOSTICS)

## 1. Basic Diagnostic Procedure

### A: PROCEDURE

#### 1. ENGINE

	Step	Check	Yes	No
1	<p><b>CHECK ENGINE START FAILURE.</b></p> <p>1) Ask the customer when and how the trouble occurred using the interview check list. &lt;Ref. to EN(H4DOTC)(diag)-4, CHECK, Check List for Interview.&gt;</p> <p>2) Start the engine.</p>	Does the engine start?	Go to step 2.	Inspection using "Diagnostics for Engine Start Failure". <Ref. to EN(H4DOTC)(diag)-73, Diagnostics for Engine Starting Failure.>
2	<p><b>CHECK ILLUMINATION OF MALFUNCTION INDICATOR LIGHT.</b></p>	Does the malfunction indicator light illuminate?	Go to step 3.	Inspection using "General Diagnostic Table". <Ref. to EN(H4DOTC)(diag)-448, General Diagnostic Table.>
3	<p><b>CHECK COMMUNICATION STATUS.</b></p> <p>1) Turn the ignition switch to OFF.</p> <p>2) Connect the Subaru Select Monitor or general scan tool to the data link connector.</p> <p>3) Turn the ignition switch to ON, and run the Subaru Select Monitor or general scan tool.</p> <p>NOTE:</p> <ul style="list-style-type: none"> <li>Subaru Select Monitor</li> </ul> <p>For detailed procedures, refer to "Subaru Select Monitor". &lt;Ref. to EN(H4DOTC)(diag)-40, Subaru Select Monitor.&gt;</p> <ul style="list-style-type: none"> <li>General scan tool</li> </ul> <p>For detailed operation procedures, refer to the general scan tool operation manual.</p>	Does Subaru Select Monitor or general scan tool communicate with vehicle normally?	Go to step 4.	Inspection using "Diagnostics Procedure for Subaru Select Monitor Communication". <Ref. to EN(H4DOTC)(diag)-86, Diagnostic Procedure for Subaru Select Monitor Communication.>
4	<p><b>CHECK DTC.</b></p> <p>Read DTC using Subaru Select Monitor or general scan tool.</p> <p>NOTE:</p> <ul style="list-style-type: none"> <li>Subaru Select Monitor</li> </ul> <p>Refer to "Read Diagnostic Trouble Code" for detailed operation procedure. &lt;Ref. to EN(H4DOTC)(diag)-47, Read Diagnostic Trouble Code (DTC).&gt;</p> <ul style="list-style-type: none"> <li>General scan tool</li> </ul> <p>For detailed operation procedures, refer to the general scan tool operation manual.</p>	Is DTC displayed on Subaru Select Monitor or general scan tool?	Record the DTC. Repair the trouble cause. <Ref. to EN(H4DOTC)(diag)-88, List of Diagnostic Trouble Code (DTC).> Go to step 5.	Repair the related parts. NOTE: If DTC is not shown on display although the malfunction indicator light illuminates, perform the diagnosis of malfunction indicator light circuit or combination meter. <Ref. to EN(H4DOTC)(diag)-66, Malfunction Indicator Light.>

# Basic Diagnostic Procedure

ENGINE (DIAGNOSTICS)

Step	Check	Yes	No
<p><b>5</b></p> <p><b>CHECK FREEZE FRAME DATA.</b> Check the freeze frame data using the Subaru Select Monitor or general scan tool.</p> <p>NOTE:</p> <ul style="list-style-type: none"> <li>• Subaru Select Monitor</li> </ul> <p>For detailed procedures, refer to "Subaru Select Monitor". &lt;Ref. to EN(H4DOTC)(diag)-40, Subaru Select Monitor.&gt;</p> <ul style="list-style-type: none"> <li>• General scan tool</li> </ul> <p>For detailed operation procedures, refer to the general scan tool operation manual.</p>	<p>Is freeze frame data displayed on Subaru Select Monitor or general scan tool?</p>	<p>Record the freeze frame data. Repair the cause of fault, and go to the next step. Go to step <b>6</b>.</p>	<p>Go to step <b>6</b>.</p>
<p><b>6</b></p> <p><b>PERFORM DIAGNOSIS.</b></p> <p>1) Perform the Clear Memory Mode. &lt;Ref. to EN(H4DOTC)(diag)-62, Clear Memory Mode.&gt;</p> <p>2) Perform the Inspection Mode or Drive Cycle. &lt;Ref. to EN(H4DOTC)(diag)-48, Inspection Mode.&gt; &lt;Ref. to EN(H4DOTC)(diag)-54, Drive Cycle.&gt;</p>	<p>Is DTC displayed on Subaru Select Monitor or general scan tool?</p>	<p>Inspect using "Diagnostic Procedure with Diagnostic Trouble Code (DTC)". &lt;Ref. to EN(H4DOTC)(diag)-96, Diagnostic Procedure with Diagnostic Trouble Code (DTC).&gt;</p>	<p>Finish the diagnosis.</p>

## Check List for Interview

ENGINE (DIAGNOSTICS)

### 2. Check List for Interview

#### A: CHECK

##### 1. CHECK LIST NO. 1

Check the following item when problem has occurred.

NOTE:

Use copies of this page for interviewing customers.

Customer's name		Engine No.	
Date of purchase		Fuel type	
Date of repair		Odometer reading	km
V.I.N.			miles
Weather	<input type="checkbox"/> Fine <input type="checkbox"/> Cloudy <input type="checkbox"/> Rainy <input type="checkbox"/> Snowy <input type="checkbox"/> Various/Others:		
Ambient air temperature	°C (°F)		
	<input type="checkbox"/> Hot <input type="checkbox"/> Warm <input type="checkbox"/> Cool <input type="checkbox"/> Cold		
Place	<input type="checkbox"/> Highway <input type="checkbox"/> Suburbs <input type="checkbox"/> Inner city <input type="checkbox"/> Uphill <input type="checkbox"/> Downhill <input type="checkbox"/> Rough road <input type="checkbox"/> Others:		
Engine temperature	<input type="checkbox"/> Cold <input type="checkbox"/> Warming-up <input type="checkbox"/> After warming-up <input type="checkbox"/> Any temperature <input type="checkbox"/> Others:		
Engine speed	rpm		
Vehicle speed	km/h (MPH)		
Driving conditions	<input type="checkbox"/> Not affected <input type="checkbox"/> At starting <input type="checkbox"/> While idling <input type="checkbox"/> At racing <input type="checkbox"/> While accelerating <input type="checkbox"/> While cruising <input type="checkbox"/> While decelerating <input type="checkbox"/> While turning (RH/LH)		
Headlight	<input type="checkbox"/> ON/ <input type="checkbox"/> OFF	Rear defogger	<input type="checkbox"/> ON/ <input type="checkbox"/> OFF
Blower	<input type="checkbox"/> ON/ <input type="checkbox"/> OFF	Audio	<input type="checkbox"/> ON/ <input type="checkbox"/> OFF
A/C compressor	<input type="checkbox"/> ON/ <input type="checkbox"/> OFF	Rear entertainment system	<input type="checkbox"/> ON/ <input type="checkbox"/> OFF
Radiator fan	<input type="checkbox"/> ON/ <input type="checkbox"/> OFF	Car phone	<input type="checkbox"/> ON/ <input type="checkbox"/> OFF
Front wiper	<input type="checkbox"/> ON/ <input type="checkbox"/> OFF	Wireless device	<input type="checkbox"/> ON/ <input type="checkbox"/> OFF
Rear wiper	<input type="checkbox"/> ON/ <input type="checkbox"/> OFF		

# Check List for Interview

ENGINE (DIAGNOSTICS)

## 2. CHECK LIST NO. 2

Check the following item about the vehicle's state when the malfunction indicator light turns on.

NOTE:

Use copies of this page for interviewing customers.

a) Other warning lights or indicators illuminate: <input type="checkbox"/> Yes / <input type="checkbox"/> No
<input type="checkbox"/> Fuel level warning light <input type="checkbox"/> Charge warning light <input type="checkbox"/> Engine coolant temperature warning light <input type="checkbox"/> Oil pressure warning light <input type="checkbox"/> ATF temperature warning light or SPORT indicator light <input type="checkbox"/> Driver's control center differential indicator light <input type="checkbox"/> ABS warning light <input type="checkbox"/> VDC warning light <input type="checkbox"/> Cruise indicator light <input type="checkbox"/> SI-CRUISE warning light <input type="checkbox"/> Immobilizer indicator light <input type="checkbox"/> STEERING warning light <input type="checkbox"/> Electronic parking brake warning light <input type="checkbox"/> Glow indicator light <input type="checkbox"/> Sedimenter warning light <input type="checkbox"/> Others:
b) Fuel level
<ul style="list-style-type: none"><li>• Lack of fuel: <input type="checkbox"/> Yes / <input type="checkbox"/> No</li><li>• Indicator position of fuel gauge:</li><li>• Experienced running out of fuel: <input type="checkbox"/> Yes / <input type="checkbox"/> No</li></ul>
c) Intentional connecting or disconnecting of connectors or spark plug cords: <input type="checkbox"/> Yes / <input type="checkbox"/> No
<ul style="list-style-type: none"><li>• What:</li></ul>
d) Intentional connecting or disconnecting of hoses: <input type="checkbox"/> Yes / <input type="checkbox"/> No
<ul style="list-style-type: none"><li>• What:</li></ul>
e) Installing of other parts except genuine parts: <input type="checkbox"/> Yes / <input type="checkbox"/> No
<ul style="list-style-type: none"><li>• What:</li><li>• Where:</li></ul>
f) Occurrence of noise: <input type="checkbox"/> Yes / <input type="checkbox"/> No
<ul style="list-style-type: none"><li>• From where:</li><li>• What kind:</li></ul>
g) Occurrence of smell: <input type="checkbox"/> Yes / <input type="checkbox"/> No
<ul style="list-style-type: none"><li>• From where:</li><li>• What kind:</li></ul>
h) Intrusion of water into engine compartment or passenger compartment: <input type="checkbox"/> Yes / <input type="checkbox"/> No
i) Troubles occurred
<input type="checkbox"/> Engine does not start. <input type="checkbox"/> Engine stalls during idling. <input type="checkbox"/> Engine stalls while driving. <input type="checkbox"/> Engine speed decreases. <input type="checkbox"/> Engine speed does not decrease. <input type="checkbox"/> Rough idling <input type="checkbox"/> Poor acceleration <input type="checkbox"/> Back fire <input type="checkbox"/> After fire <input type="checkbox"/> Does not shift. <input type="checkbox"/> Excessive shift shock



## General Description

### ENGINE (DIAGNOSTICS)

## 3. General Description

### A: CAUTION

1) Airbag system wiring harness is routed near the ECM, main relay and fuel pump relay.

#### CAUTION:

- Do not use electrical test equipment on the airbag system circuits.
- Be careful not to damage the airbag system wiring harness when servicing the ECM, TCM, main relay and fuel pump relay.

2) Never connect the battery in reverse polarity. Doing so will damage the ECM instantly, and other parts will also be damaged.

3) Do not disconnect the battery terminals while the engine is running. A large counter electromotive force will be generated in the generator, and this voltage may damage electronic parts such as ECM etc.

4) Before disconnecting the connectors of each sensor and ECM, be sure to turn the ignition switch to OFF. Perform the Clear Memory Mode after connecting the connectors. <Ref. to EN(H4DOTC)(diag)-62, Clear Memory Mode.>

5) When measuring the voltage or resistance of individual sensor or all electrical control modules, use a tapered pin with a diameter of less than 0.6 mm (0.024 in). Do not insert the pin 4 mm (0.16 in) or more into the part.

#### CAUTION:

**When replacing the ECM, be careful not to use the wrong spec. ECM to avoid any damage on the fuel injection system.**

#### NOTE:

When replacing the ECM of the models with Immobilizer, immobilizer system must be registered. To do so, all ignition keys and ID cards need to be prepared. Refer to the "PC application help for Subaru Select Monitor".

6) Take care not to allow water to get into the connectors when servicing or washing the vehicle in rainy weather. Avoid exposure to water even if the connectors are waterproof.

7) Use ECM mounting stud bolts at the body side grounding point when measuring voltage and resistance inside the passenger compartment.

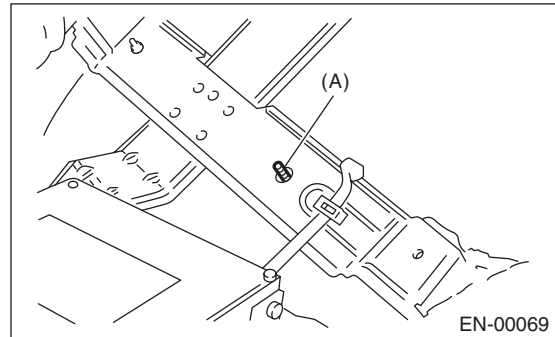

(A) Stud bolt

8) Use the engine ground terminal or engine assembly as the grounding point to chassis when measuring the voltage and resistance in engine compartment.

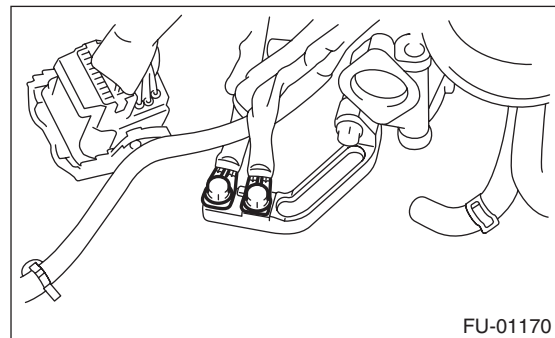

9) Every engine control system-related part is a precision part. Do not drop them.

10) Observe the following cautions when installing a radio in vehicle.

#### CAUTION:

- The antenna must be kept as far apart as possible from control module. (ECM is installed under the passenger's side floor mat.)
- The antenna feeder must be placed as far apart as possible from the ECM and engine control system harness.
- Carefully adjust the antenna for correct matching.
- When mounting a large power type radio, pay special attention to the three items mentioned above.
- Incorrect installation of the radio may affect the operation of ECM.

11) When disconnecting the fuel hose, release the fuel pressure. <Ref. to FU(STI)-67, RELEASING OF FUEL PRESSURE, PROCEDURE, Fuel.> <Ref. to FU(w/o STI)-66, RELEASING OF FUEL PRESSURE, PROCEDURE, Fuel.>

12) Warning lights may illuminate when performing driving test with jacked-up or lifted-up condition, but this is not a system malfunction. The reason for this is the speed difference between the front and rear wheels. When engine control system diagnosis is finished, perform the VDC memory clearance procedure of self-diagnosis function. <Ref. to VDC(diag)-27, Clear Memory Mode.>

## B: INSPECTION

Before performing diagnostics, check the following item which might affect engine problems.

### 1. BATTERY

1) Measure the battery voltage and specific gravity of the electrolyte.

**Standard voltage: 12 V**

**Specific gravity: 1.260 or more**

2) Check the condition of the main and other fuses, and harnesses and connectors. Also check for proper grounding.

### 2. ENGINE GROUND

Make sure that the engine ground terminal has no contamination, corrosion or looseness and is properly connected to the engine.

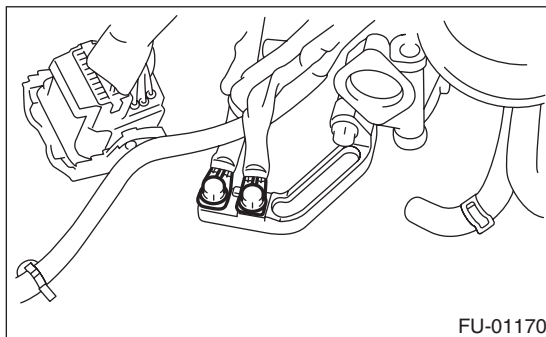

## C: NOTE

- The on-board diagnostic (OBD) system detects and indicates a fault in various inputs and outputs of the complex electronic control. Malfunction indicator light in the combination meter indicates occurrence of a fault or trouble.
  - Further, against such a failure of sensors as may disable the drive, the fail-safe function is provided to ensure the minimal drivability.
  - The OBD system incorporated with the vehicles within this type of engine complies with OBD-II regulations. The OBD system monitors the components and the system malfunction listed in "Engine Section" which affects on emissions.
  - When the system decides that a malfunction occurs, malfunction indicator light illuminates. At the same time of the malfunction indicator light illumination or blinking, a DTC and a freeze frame engine conditions are stored into on-board computer.
  - The OBD system stores freeze frame engine condition data (engine load, engine coolant temperature, fuel trim, engine speed and vehicle speed, etc.) into on-board computer when it detects a malfunction.
  - Freeze frame engine condition data are stored until the DTCs are cleared. However when such malfunctions as fuel trim fault and misfire are detected with the freeze frame engine condition data stored, they are rewritten into those related to the fuel trim fault and misfire.
  - When the malfunction does not occur again for three consecutive driving cycles\*, malfunction indicator light is turned off, but DTC remains at on-board computer.
- \*: One driving cycle means the period between the ignition switch ON and the ignition switch OFF after driving.
- When performing diagnosis, connect the Subaru Select Monitor or general scan tool to the vehicle.

# General Description

ENGINE (DIAGNOSTICS)

## D: PREPARATION TOOL

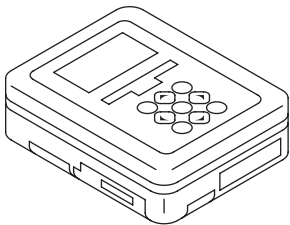
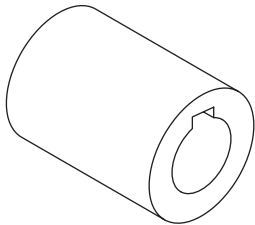
ILLUSTRATION	TOOL NUMBER	DESCRIPTION	REMARKS
 <p>ST1B022XU0</p>	1B022XU0	SUBARU SELECT MONITOR III KIT	Used for troubleshooting the electrical system.
 <p>ST-499987500</p>	499987500	CRANKSHAFT SOCKET	Used for rotating crankshaft.

## 4. Electrical Component Location

### A: LOCATION

#### 1. CONTROL MODULE

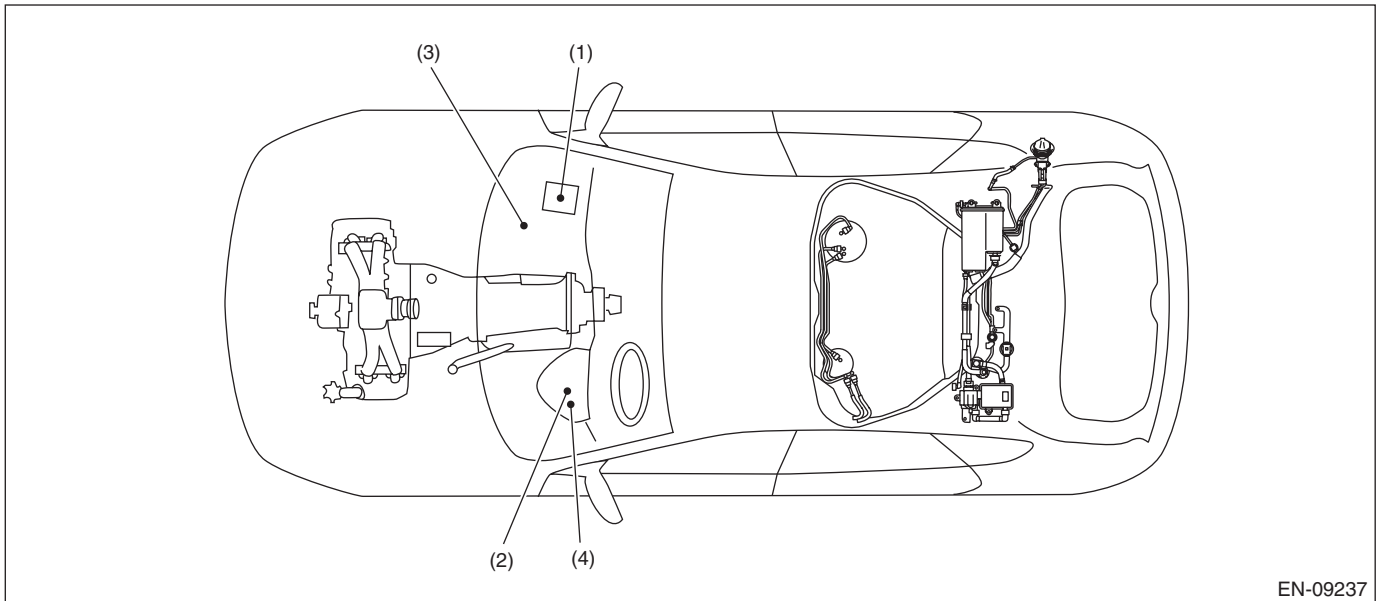

- (1) Engine control module (ECM)      (3) Delivery (test) mode connector      (4) Data link connector  
(2) Malfunction indicator light

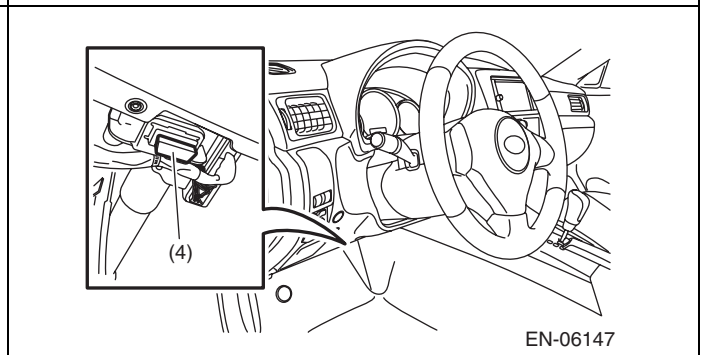
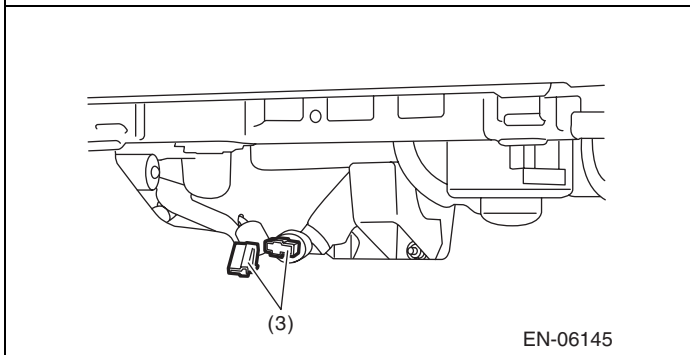
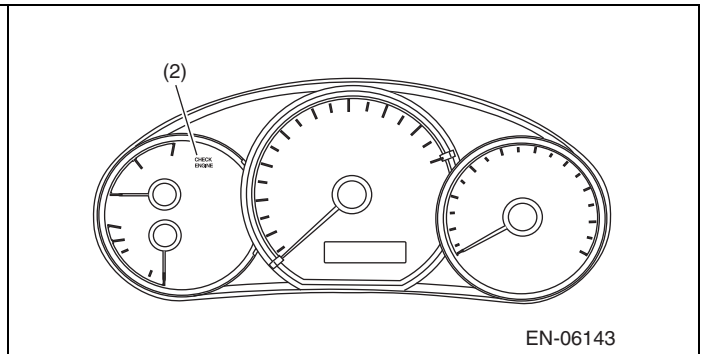
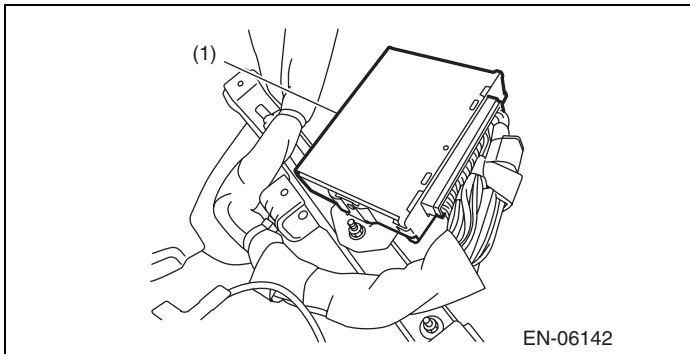

# Electrical Component Location

## ENGINE (DIAGNOSTICS)

### 2. SENSOR

- Models without SI-DRIVE

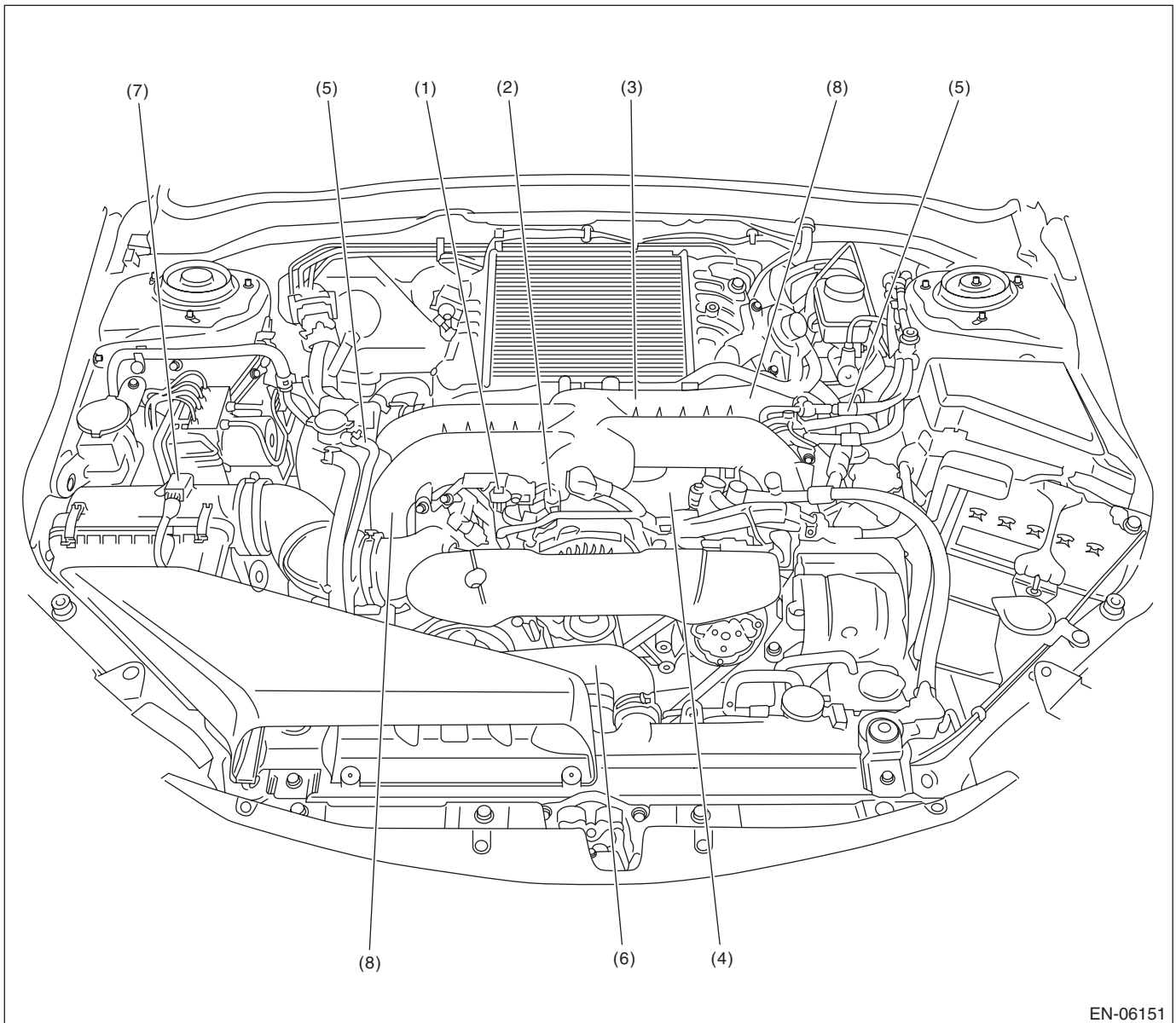

EN-06151

- |                                       |                                     |   |
|---------------------------------------|-------------------------------------|---|
| (1) Manifold absolute pressure sensor | (4) Knock sensor                    | (7) Mass air flow and intake air temperature sensor |
| (2) Engine coolant temperature sensor | (5) Intake camshaft position sensor | (8) Tumble generator valve ASSY                     |
| (3) Electronic throttle control       | (6) Crankshaft position sensor      |   |

EN(H4DOTC)(diag)-10

Brought to you by Ebay Seller "SubaruManuals"

# Electrical Component Location

ENGINE (DIAGNOSTICS)

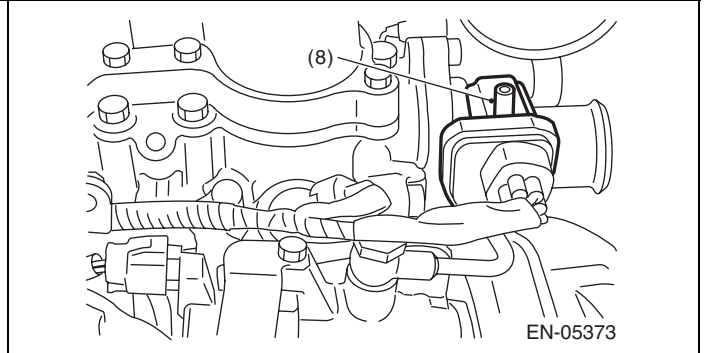
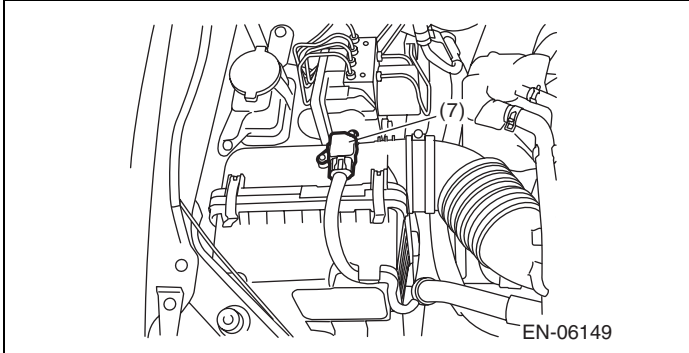
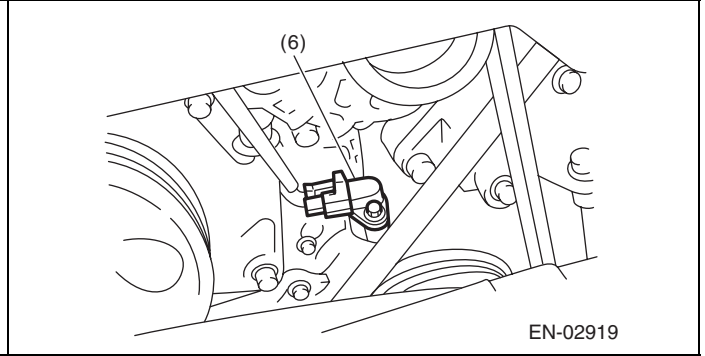
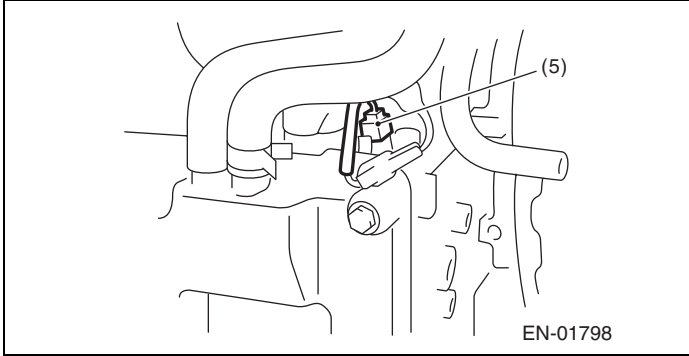
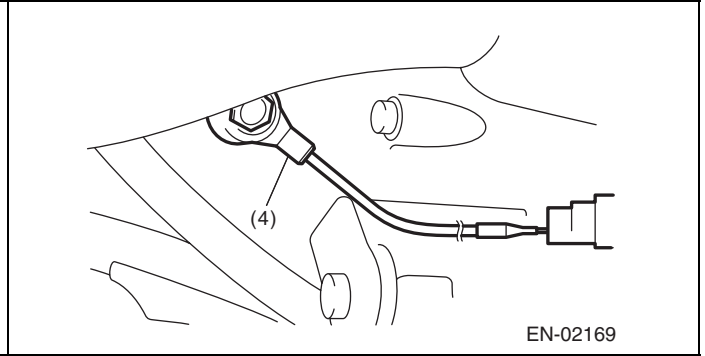
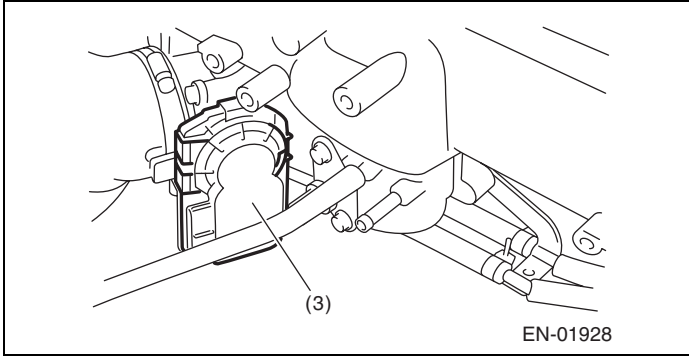
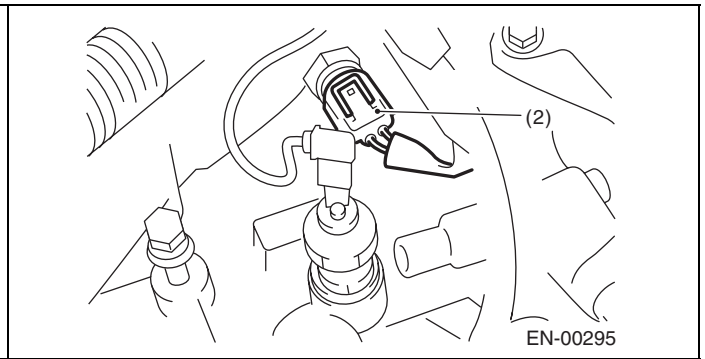
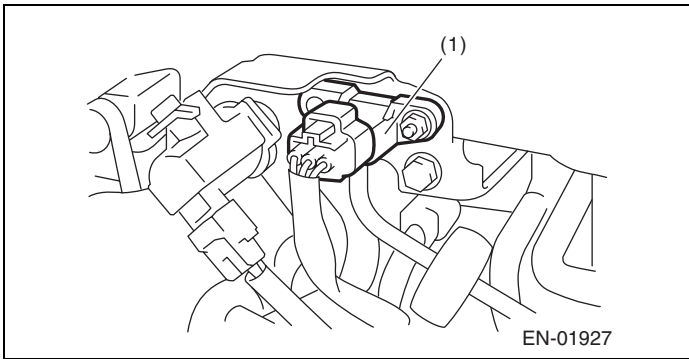



# Electrical Component Location

## ENGINE (DIAGNOSTICS)

- Models with SI-DRIVE

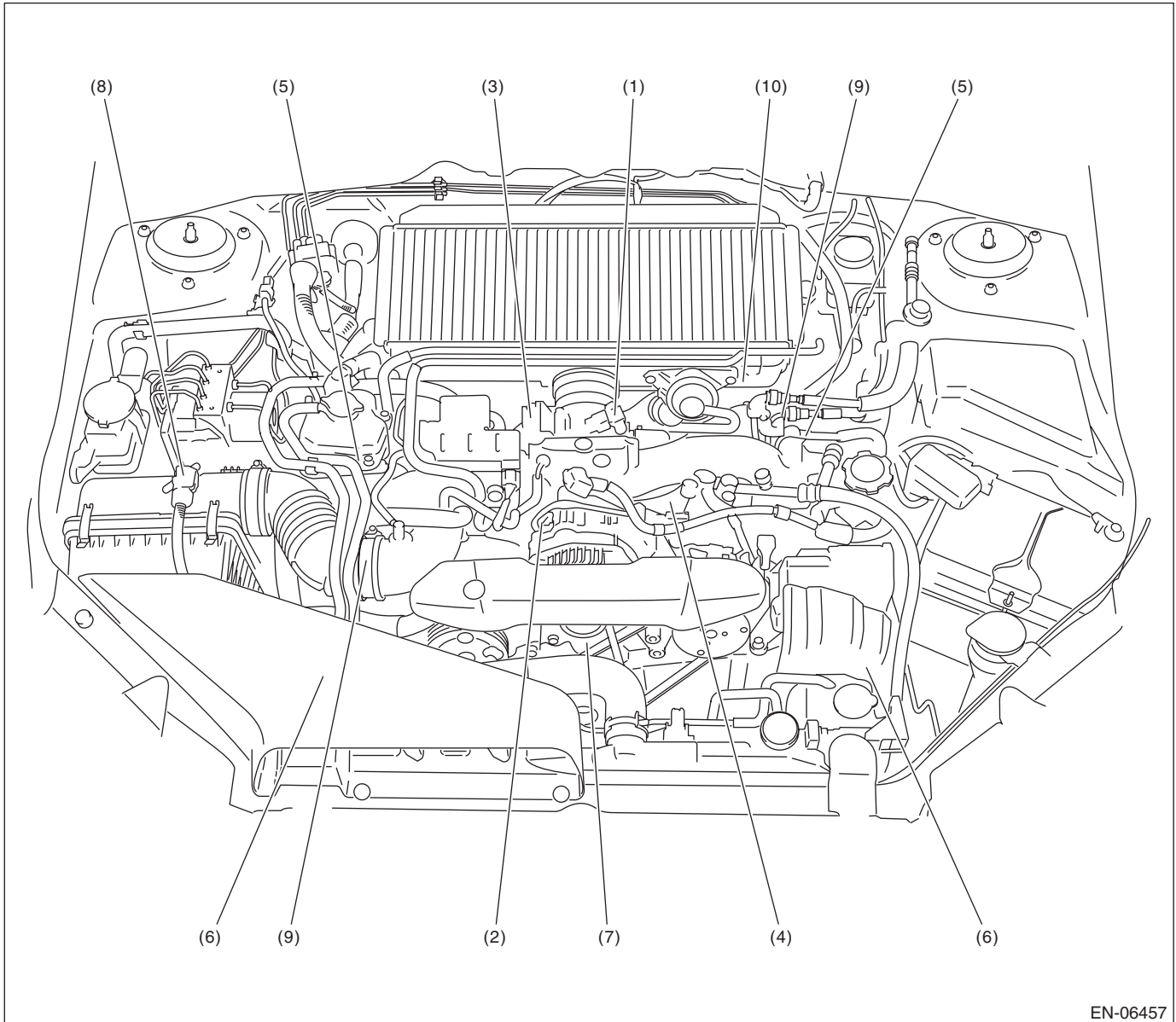

EN-06457

- |                                       |                                      |   |
|---------------------------------------|--------------------------------------|---|
| (1) Manifold absolute pressure sensor | (5) Intake camshaft position sensor  | (8) Mass air flow and intake air temperature sensor |
| (2) Engine coolant temperature sensor | (6) Exhaust camshaft position sensor | (9) Tumble generator valve ASSY                     |
| (3) Electronic throttle control       | (7) Crankshaft position sensor       | (10) Secondary air pipe pressure sensor             |
| (4) Knock sensor                      |                                      |   |

**EN(H4DOTC)(diag)-12**

Brought to you by Ebay Seller "SubaruManuals"

# Electrical Component Location

ENGINE (DIAGNOSTICS)

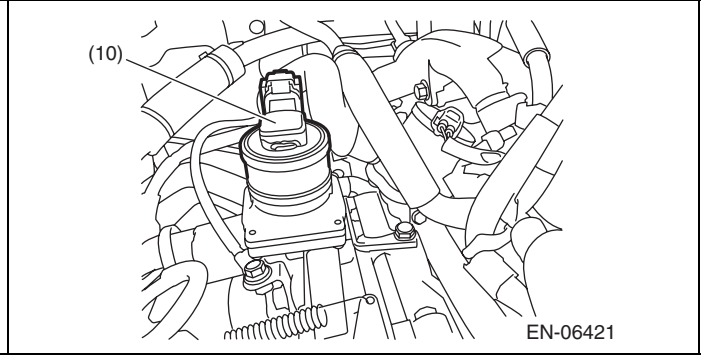
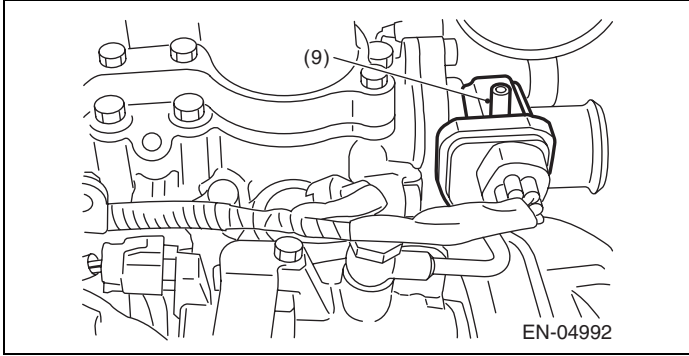
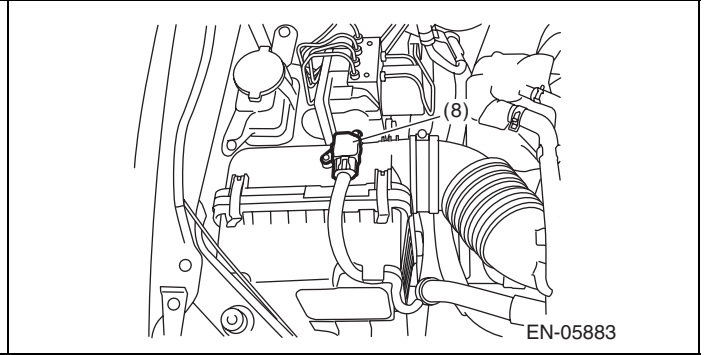
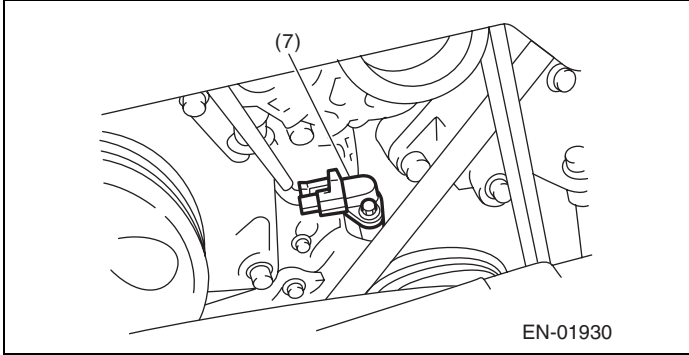
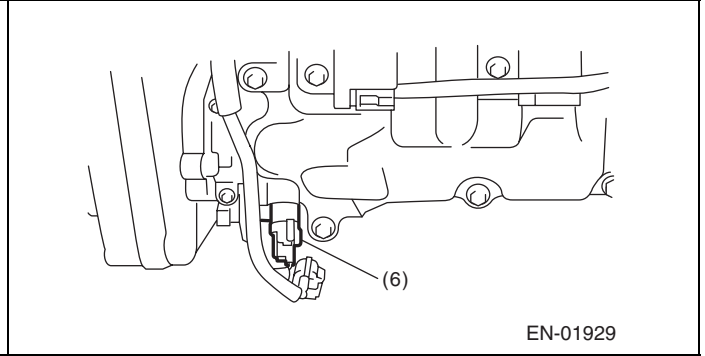
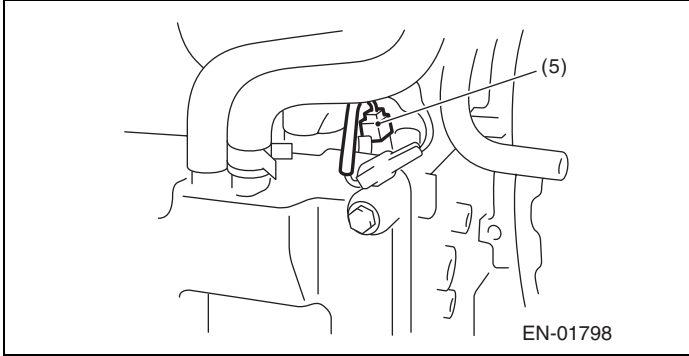
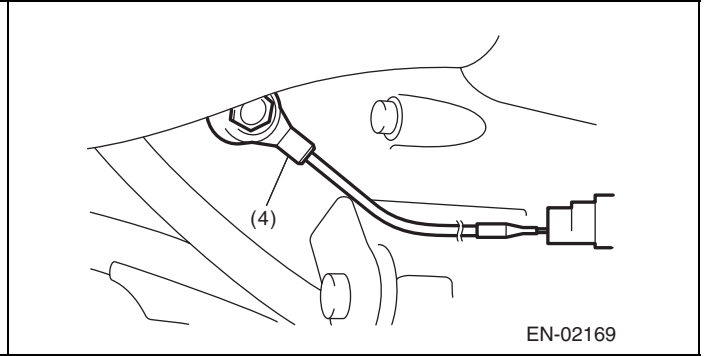
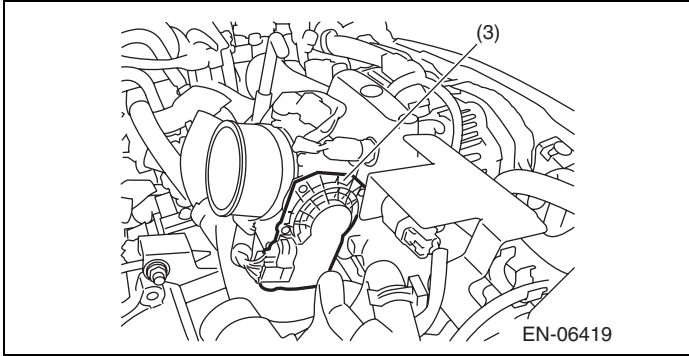
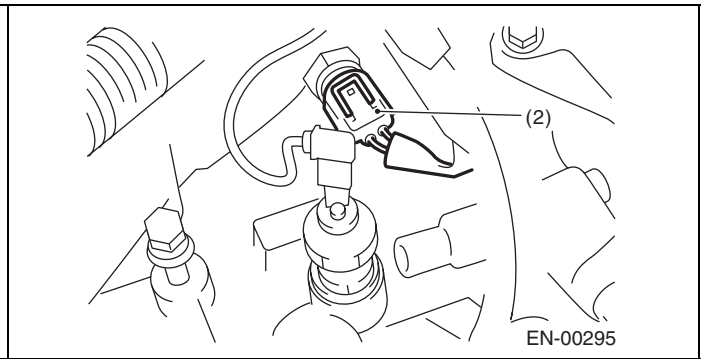
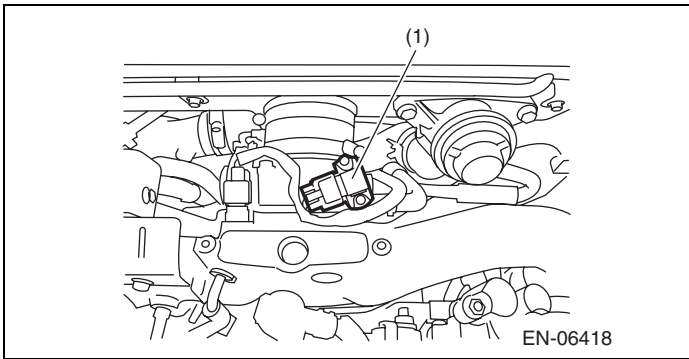



# Electrical Component Location

## ENGINE (DIAGNOSTICS)

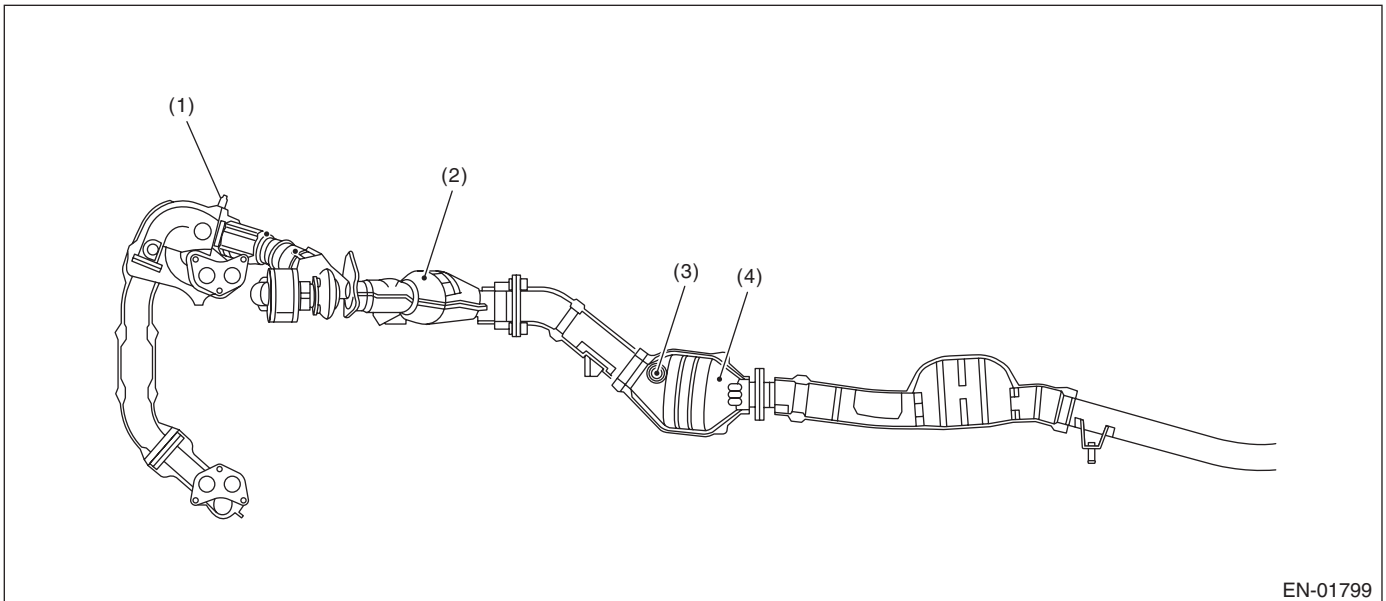

(1) Front oxygen (A/F) sensor  
(2) Front catalytic converter

(3) Rear oxygen sensor

(4) Rear catalytic converter

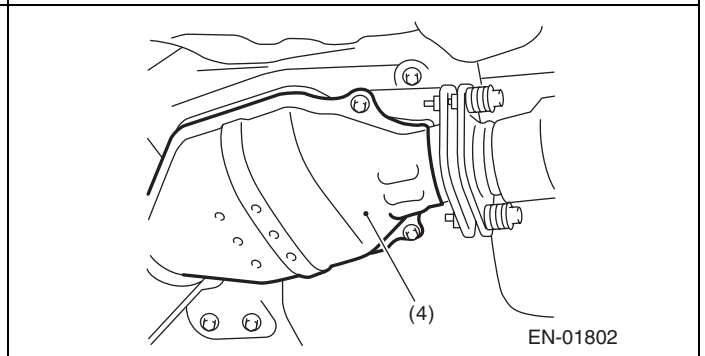
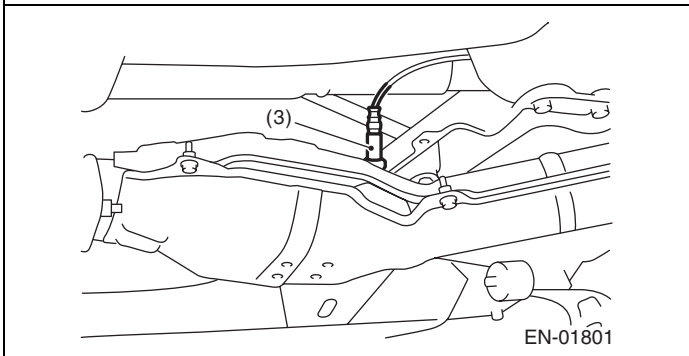
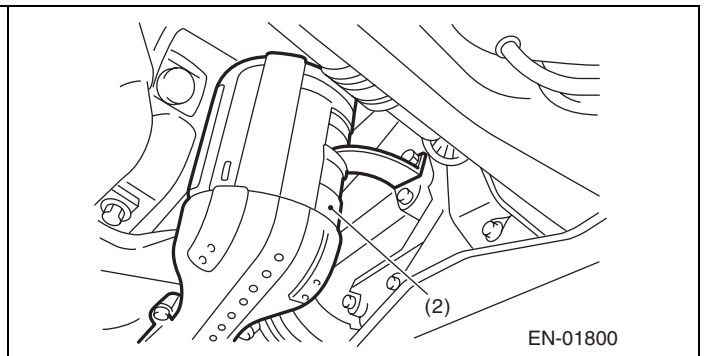
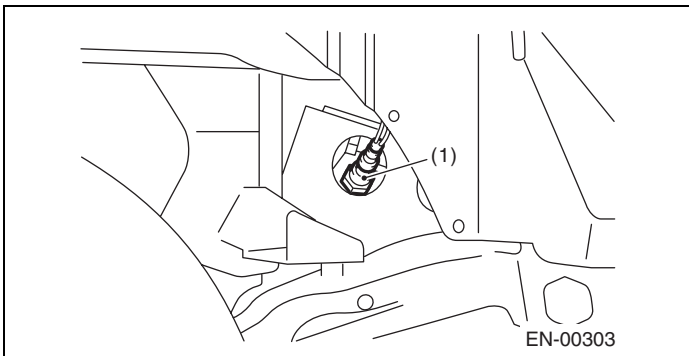

# Electrical Component Location

ENGINE (DIAGNOSTICS)

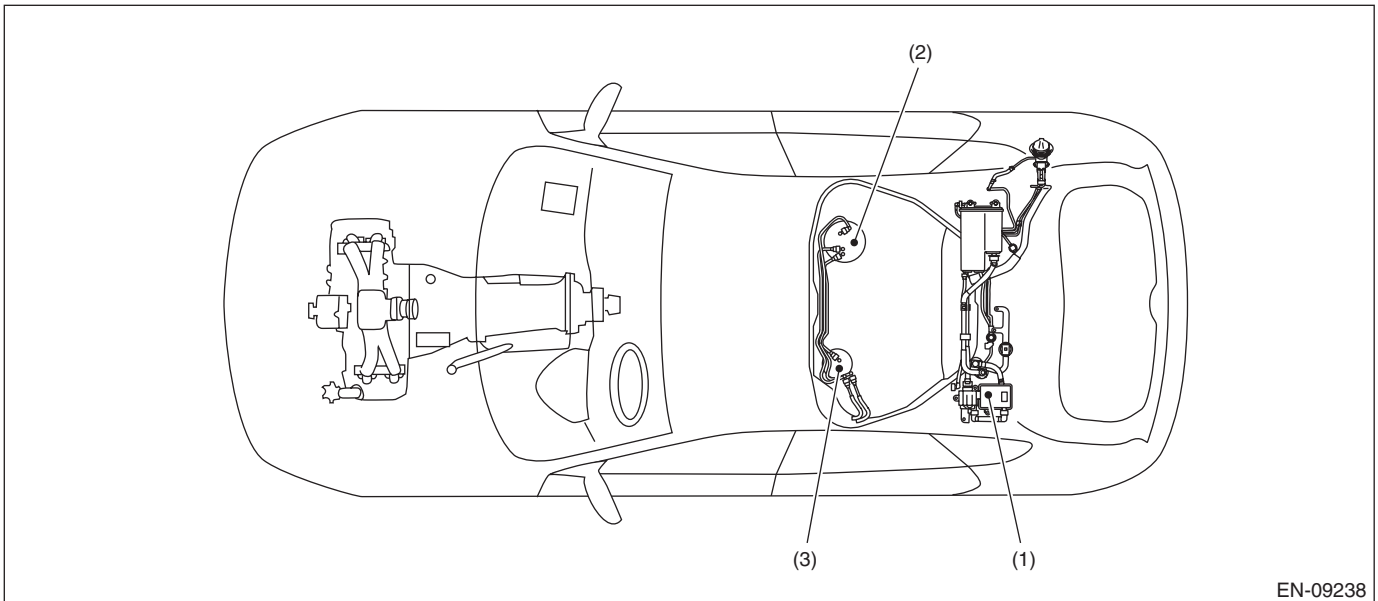

(1) Leak check valve ASSY (with built-in pressure sensor)

(2) Fuel level sensor

(3) Fuel sub level sensor

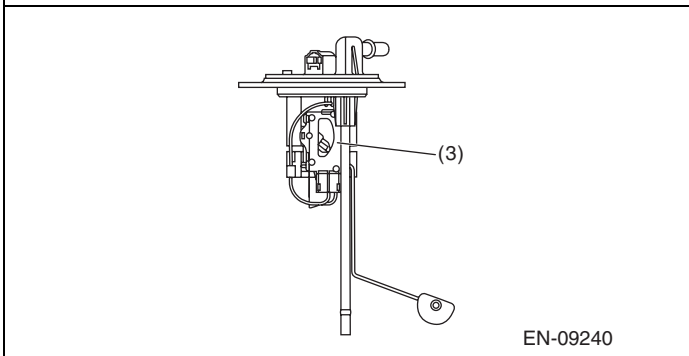
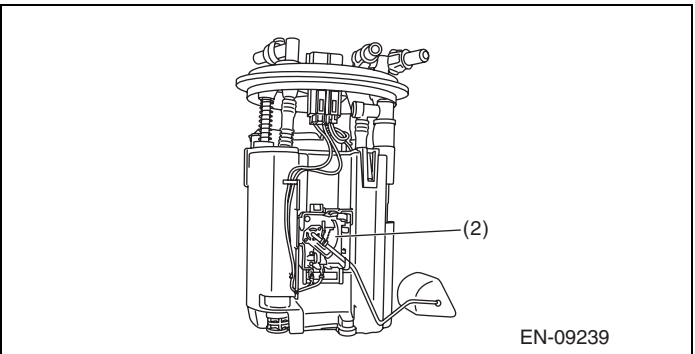
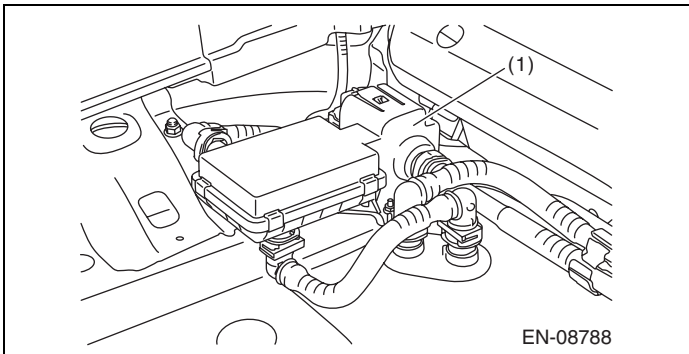

# Electrical Component Location

## ENGINE (DIAGNOSTICS)

### 3. SOLENOID VALVE, ACTUATOR, EMISSION CONTROL SYSTEM PARTS AND IGNITION SYSTEM PARTS

- Models without SI-DRIVE

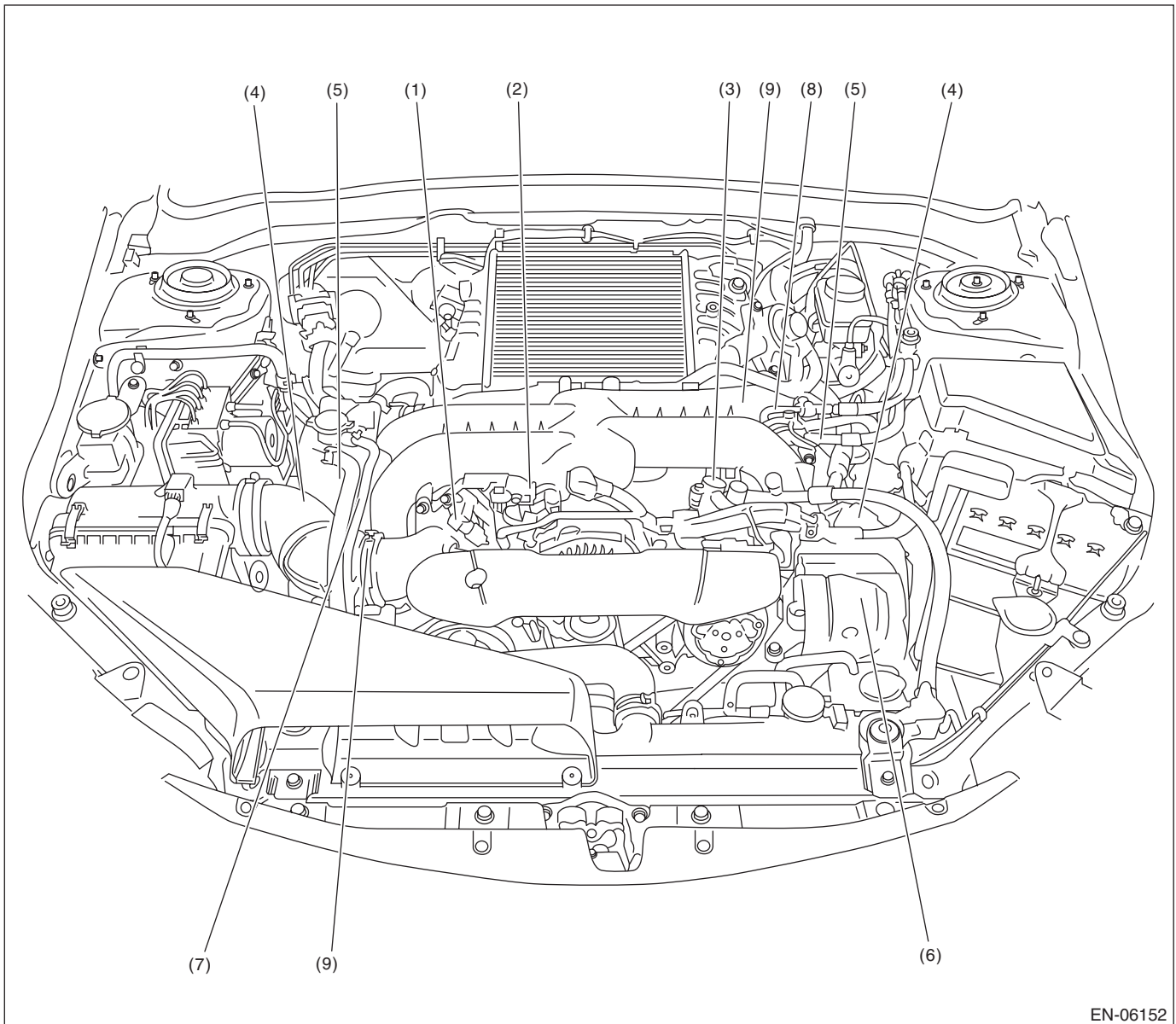

EN-06152

- |                                      |  |  |
|--------------------------------------|--|--|
| (1) Wastegate control solenoid valve | (4) Ignition coil                          | (7) Secondary air combination valve RH |
| (2) Purge control solenoid valve 2   | (5) Intake oil flow control solenoid valve | (8) Secondary air combination valve LH |
| (3) Purge control solenoid valve 1   | (6) Secondary air pump                     | (9) Tumble generator valve ASSY        |

# Electrical Component Location

ENGINE (DIAGNOSTICS)

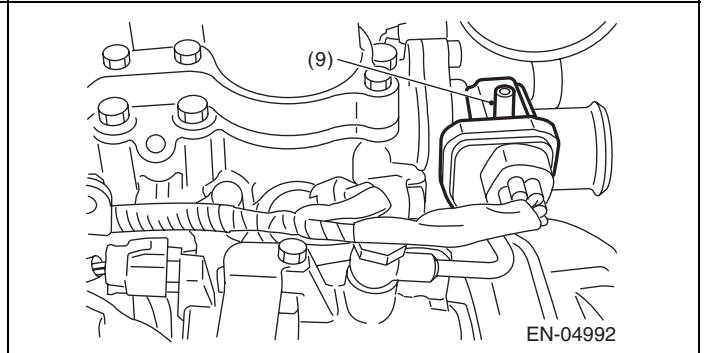
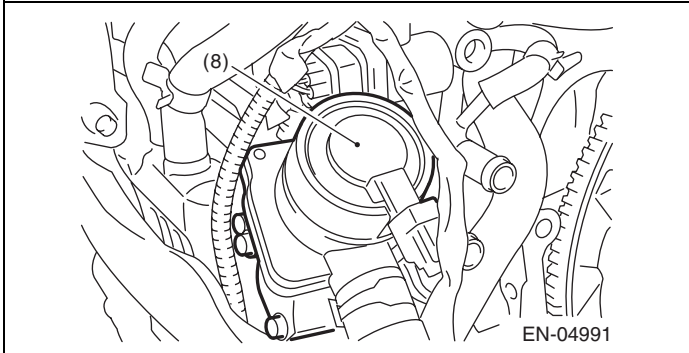
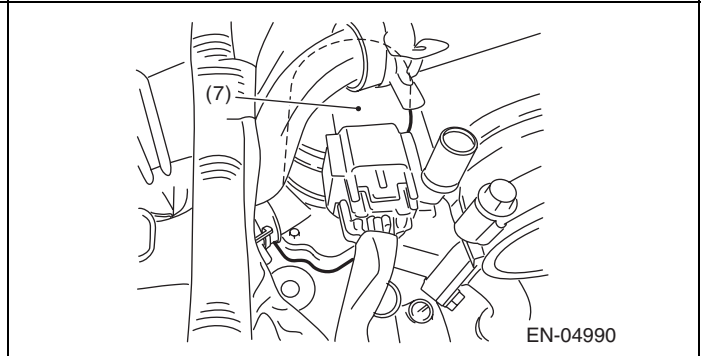
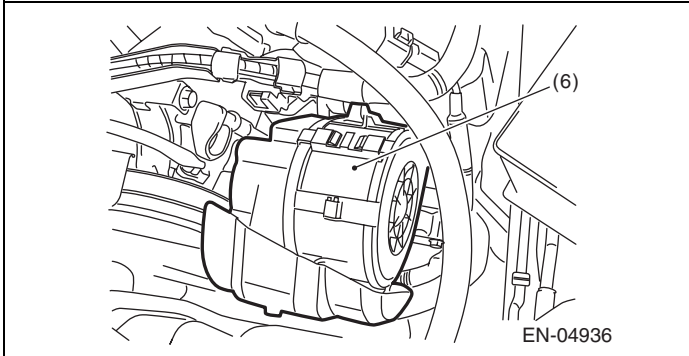
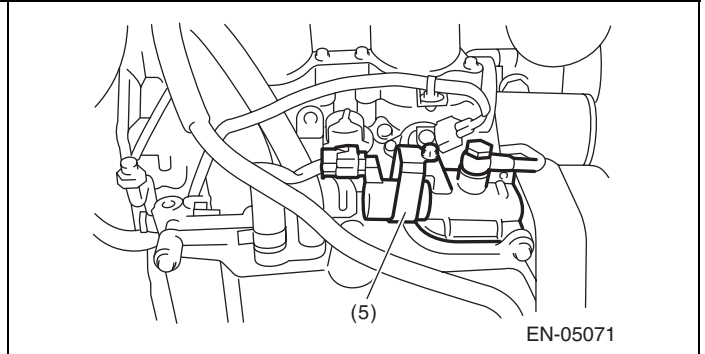
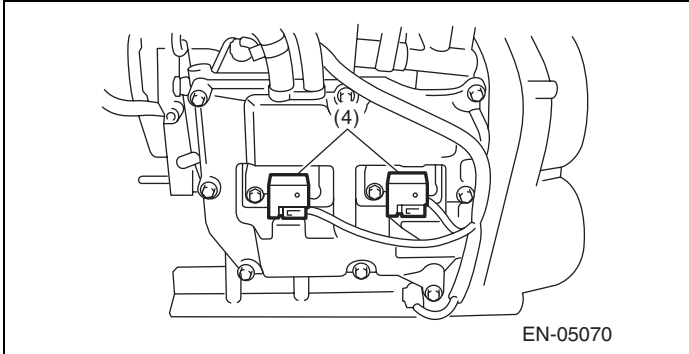
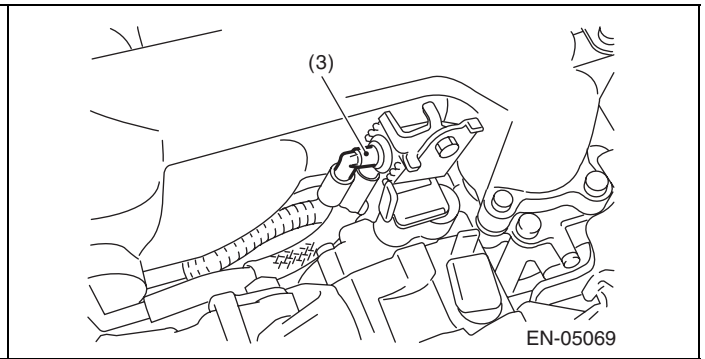
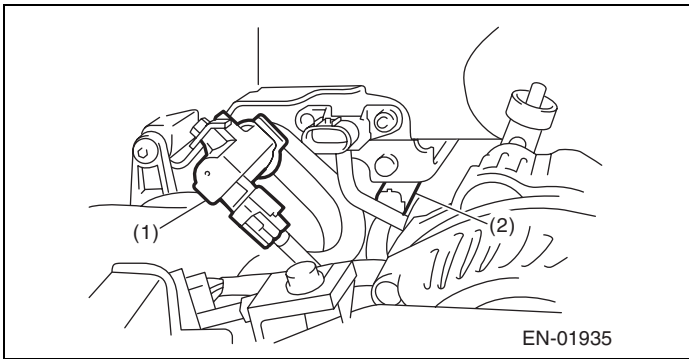

# Electrical Component Location

## ENGINE (DIAGNOSTICS)

- Models with SI-DRIVE

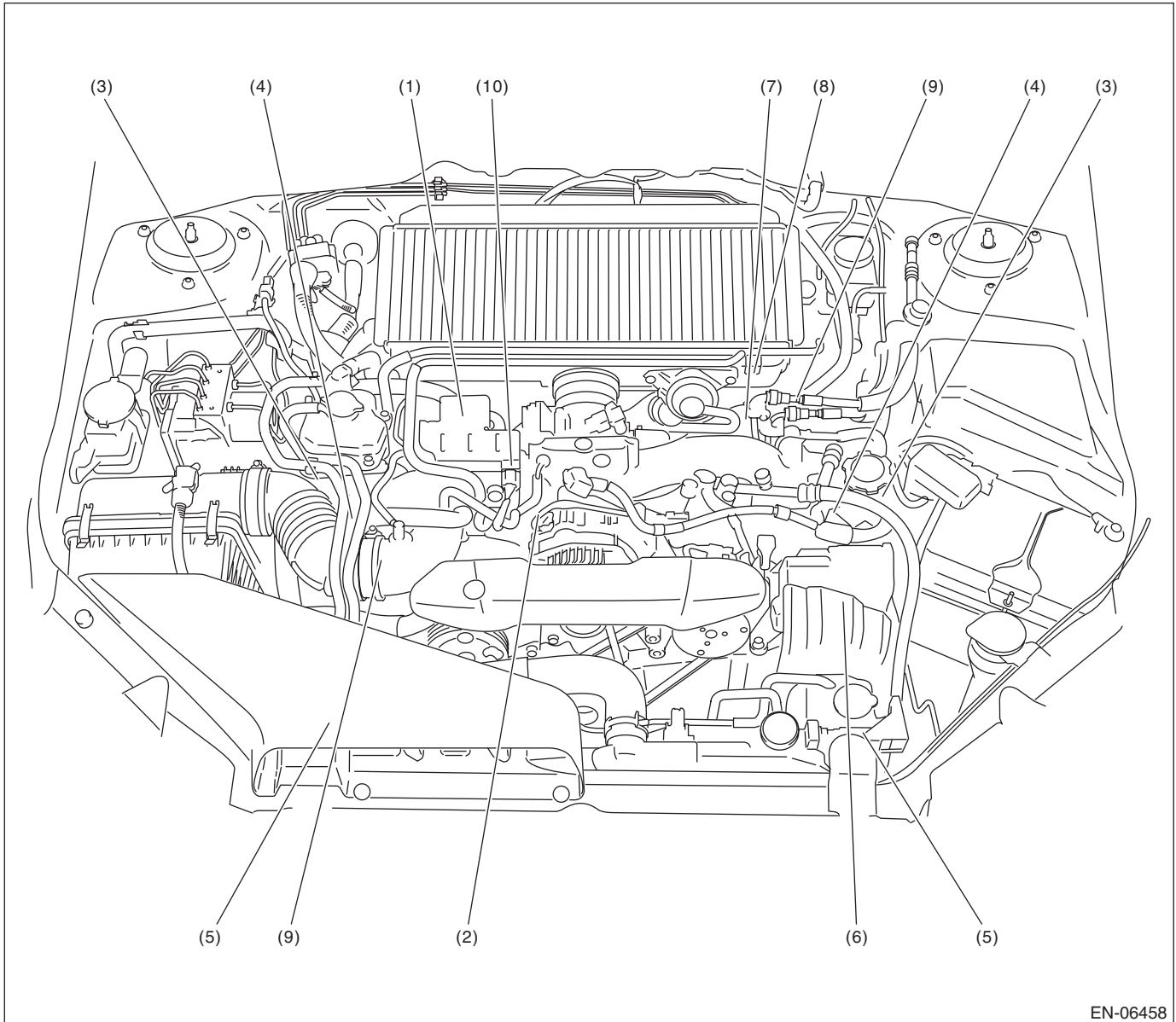

EN-06458

- |  |   |  |
|--|---|--|
| (1) Wastegate control solenoid valve       | (5) Exhaust oil flow control solenoid valve | (8) Secondary air combination valve LH |
| (2) Purge control solenoid valve 1         | (6) Secondary air pump                      | (9) Tumble generator valve ASSY        |
| (3) Ignition coil                          | (7) Secondary air combination valve RH      | (10) Purge control solenoid valve 2    |
| (4) Intake oil flow control solenoid valve |   |  |

**EN(H4DOTC)(diag)-18**

Brought to you by Ebay Seller "SubaruManuals"

# Electrical Component Location

ENGINE (DIAGNOSTICS)

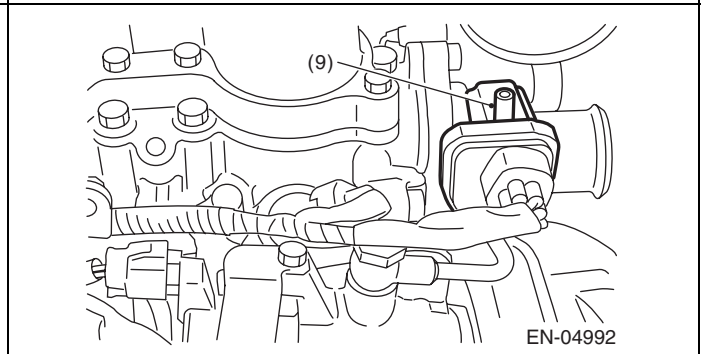
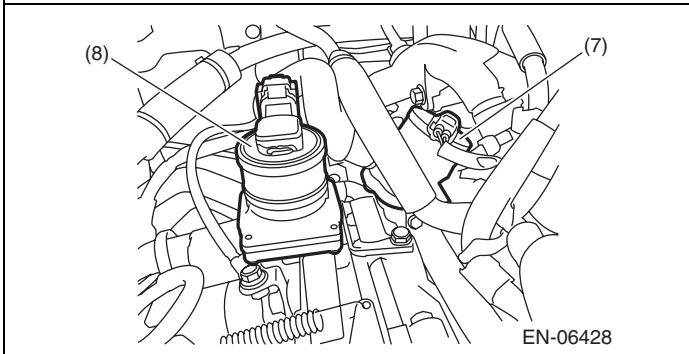
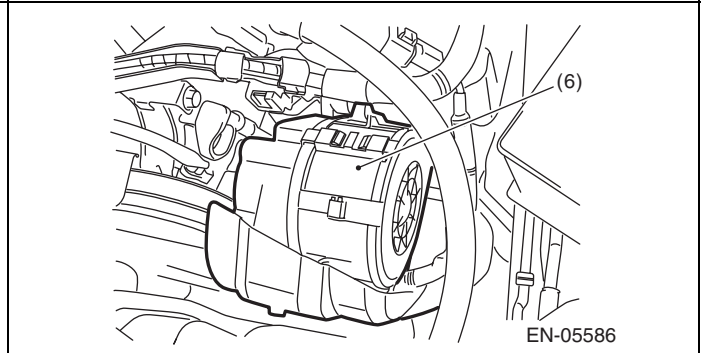
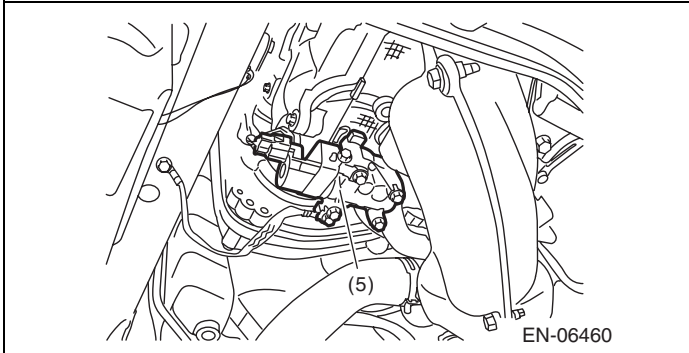
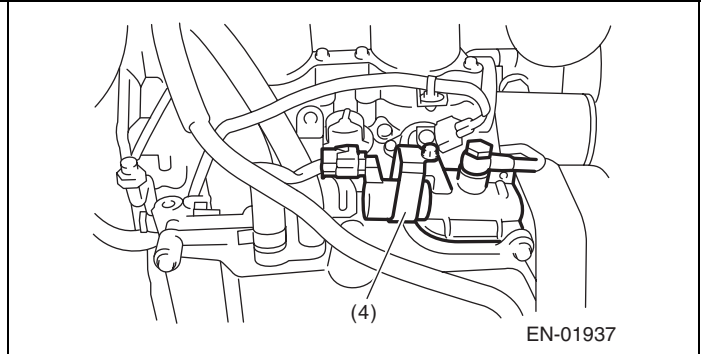
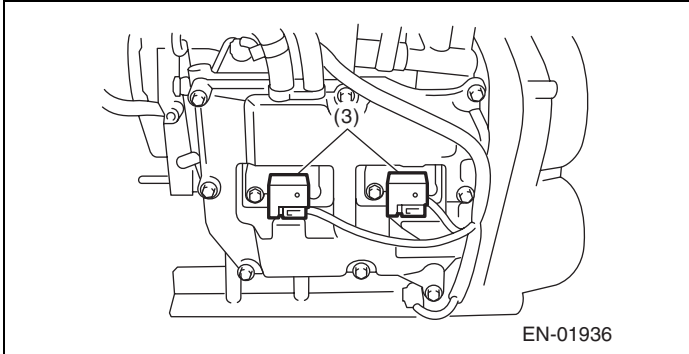
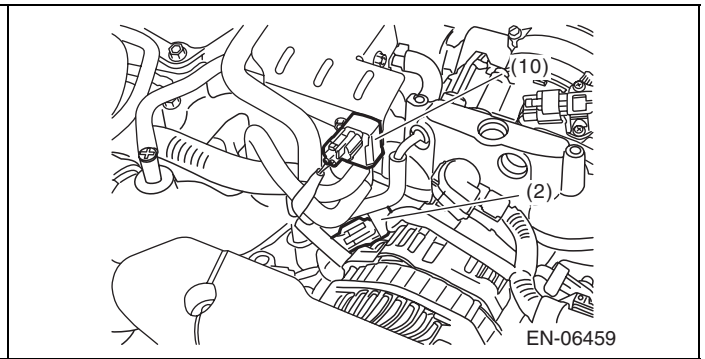
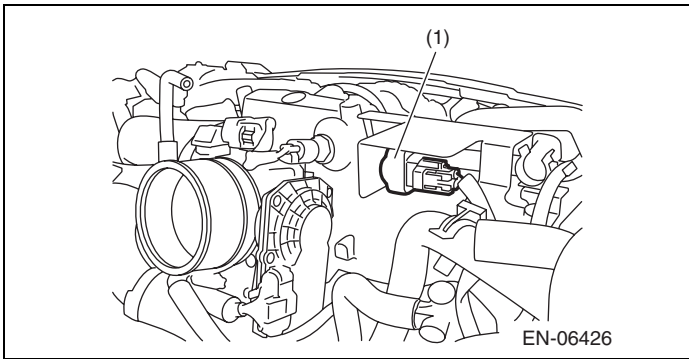



# Electrical Component Location

## ENGINE (DIAGNOSTICS)

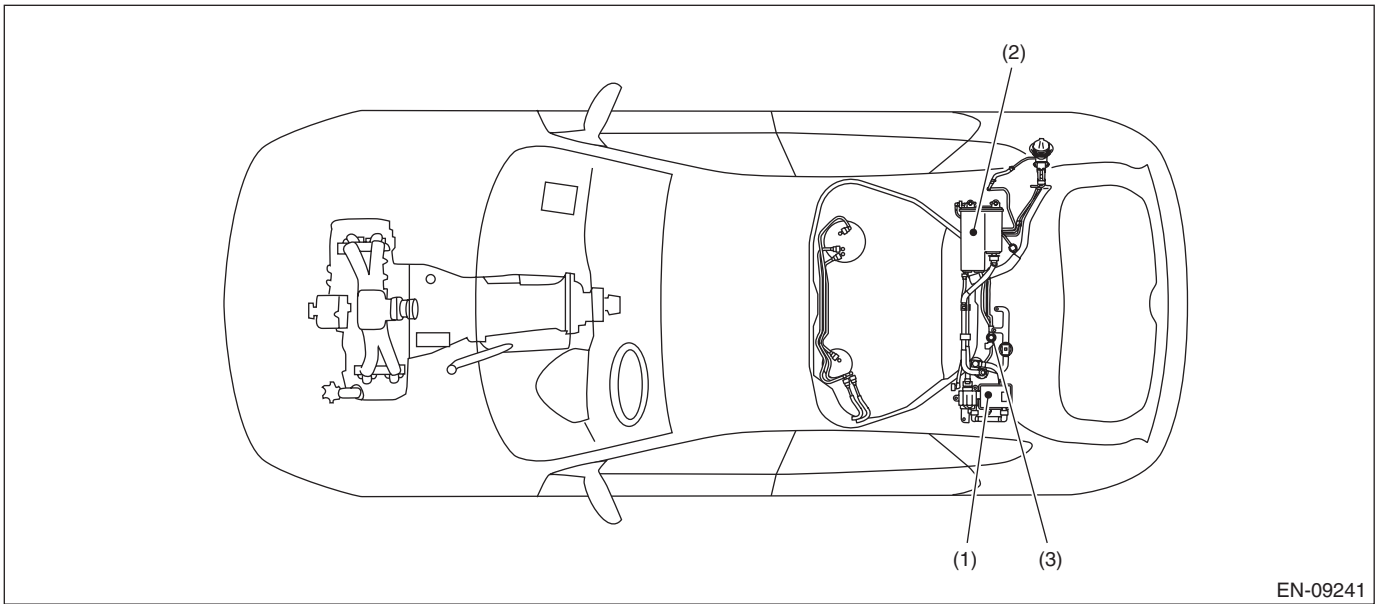

(1) Leak check valve ASSY

(2) Canister

(3) Pressure control solenoid valve ASSY

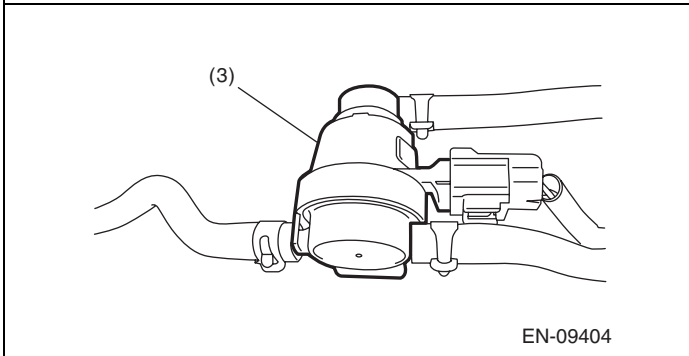
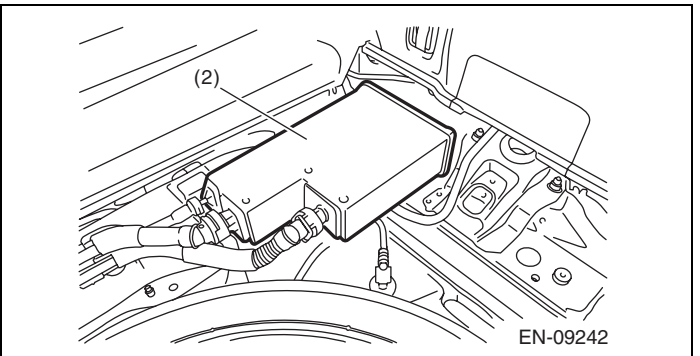
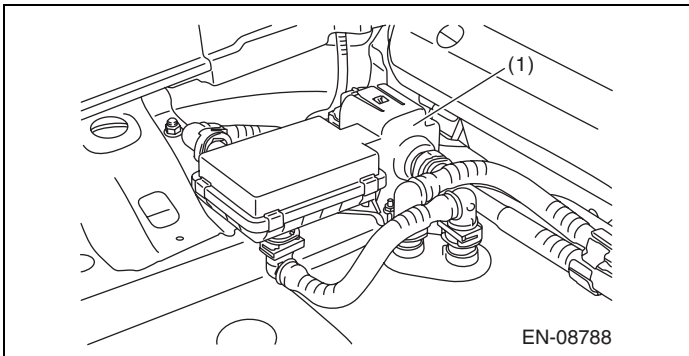

# Electrical Component Location

ENGINE (DIAGNOSTICS)

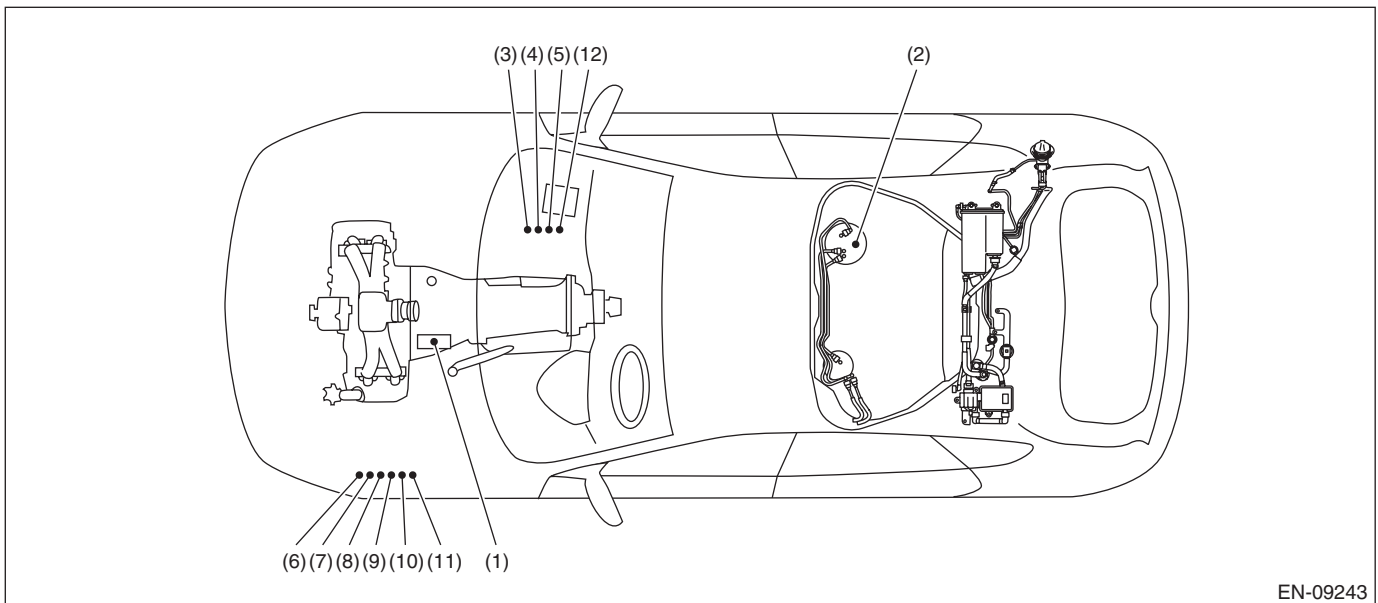

EN-09243

- |                     |                                       |  |
|---------------------|---------------------------------------|--|
| (1) Starter         | (5) Electronic throttle control relay | (9) Secondary air combination valve relay 1  |
| (2) Fuel pump       | (6) Radiator main fan relay 1         | (10) Secondary air combination valve relay 2 |
| (3) Main relay      | (7) Radiator sub fan relay            | (11) Secondary air pump relay                |
| (4) Fuel pump relay | (8) Radiator main fan relay 2         | (12) A/F, oxygen sensor relay                |

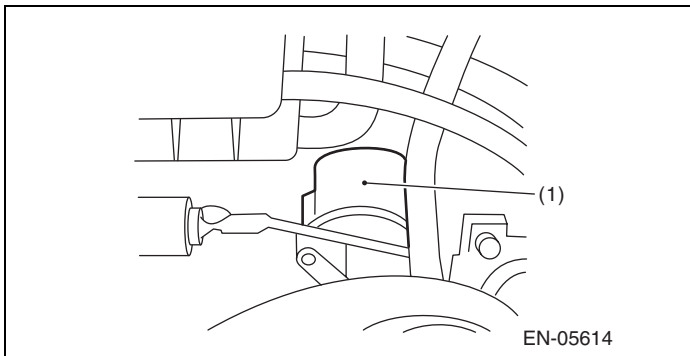

EN-05614

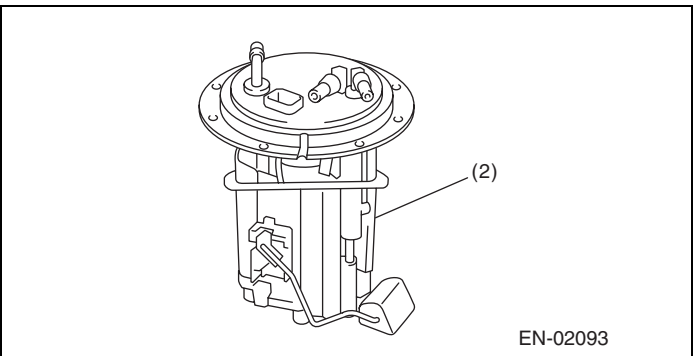

EN-02093

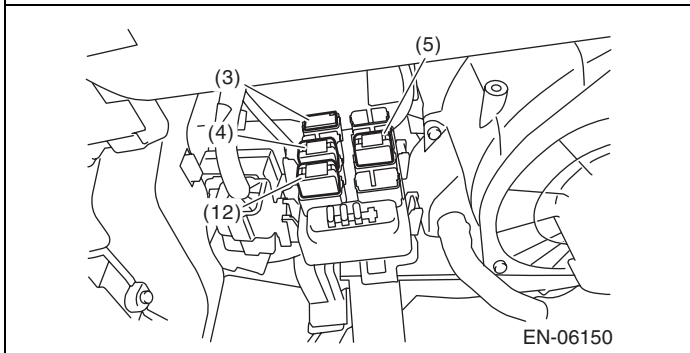

EN-06150

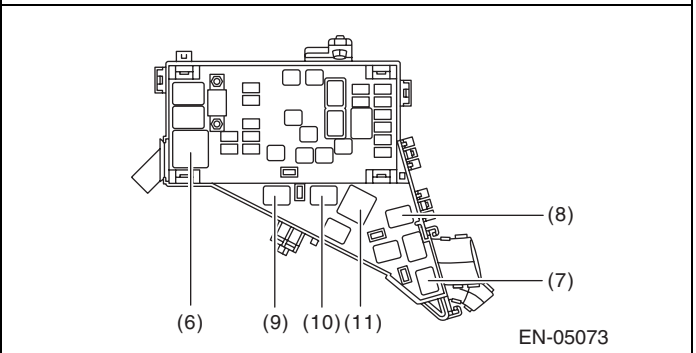

EN-05073



# Electrical Component Location

ENGINE (DIAGNOSTICS)

## 4. TRANSMISSION

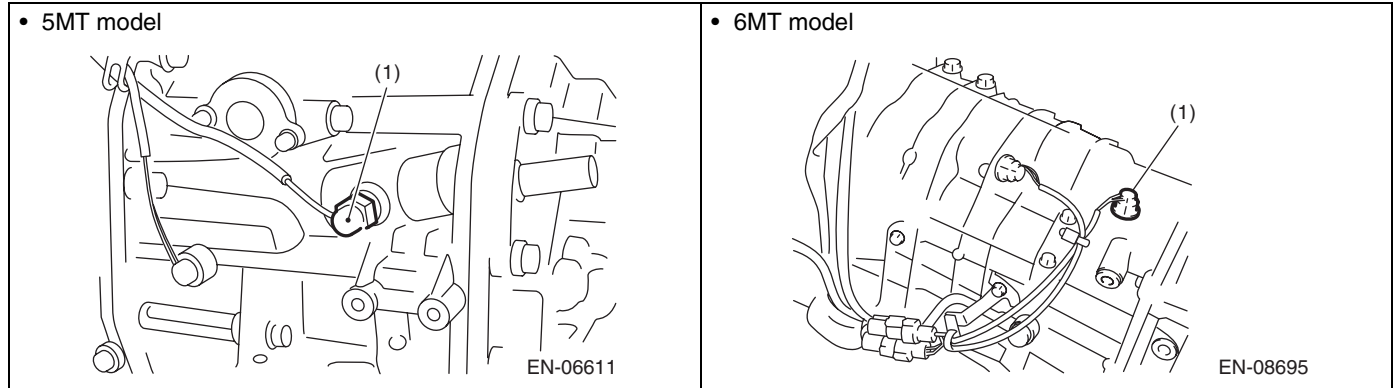

(1) Neutral position switch

## 5. Engine Control Module (ECM) I/O Signal

### A: ELECTRICAL SPECIFICATION

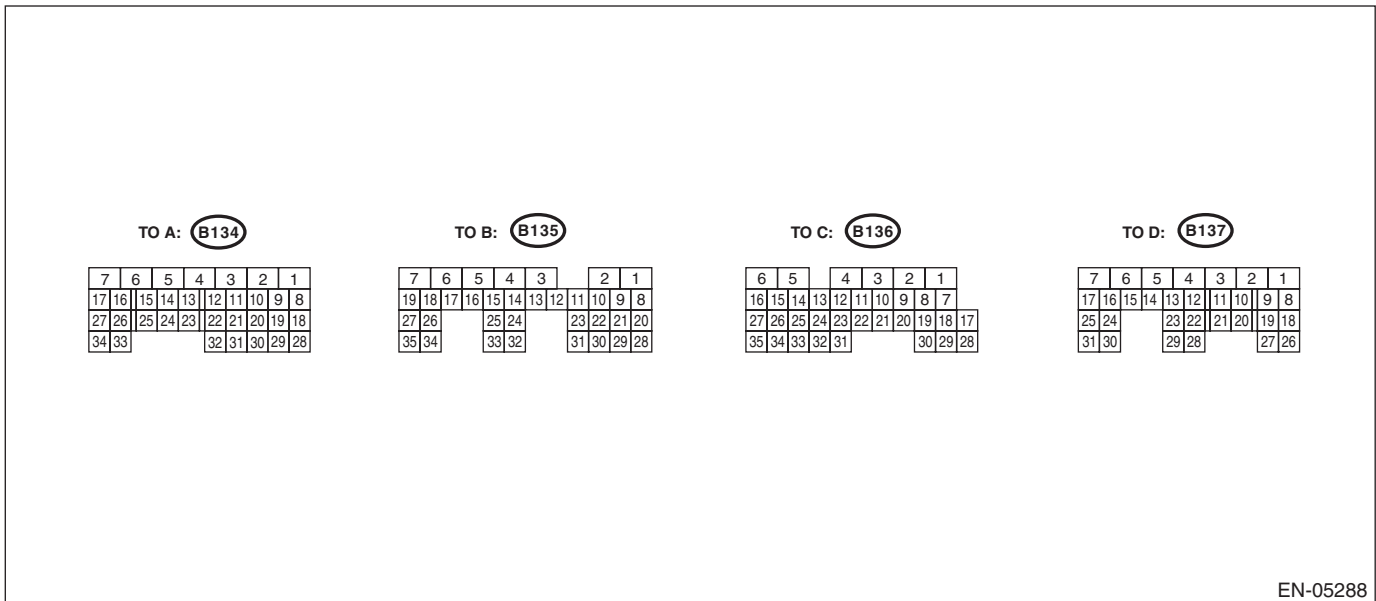

EN-05288

Contents	Connector No.	Terminal No.	Signal (V)		Note	
			Ignition SW ON (engine OFF)	Engine ON (idling)		
Crankshaft position sensor	Signal (+)	B137	17	0	-7 — +7	Waveform
	Signal (-)	B137	25	0	0	—
	Shield	B137	31	0	0	—
Front oxygen (A/F) sensor	Signal (+)	B136	19	2.8 — 3.2	2.8 — 3.2	—
	Signal (-)	B136	18	2.4 — 2.7	2.4 — 2.7	—
	Shield	B136	9	0	0	—
Rear oxygen sensor	Signal	B136	20	0	0 — 0.9	—
	Shield	B136	9	0	0	—
	Ground (sensor)	B135	30	0	0	—
Front oxygen (A/F) sensor heater	Signal 1	B136	6	—	—	Waveform
	Signal 2	B136	5	—	—	Waveform
Rear oxygen sensor heater signal	B135	6	0 — 13	12 — 14	Waveform	
Engine coolant temperature sensor	Signal	B137	22	1.0 — 1.4	1.0 — 1.4	After engine is warmed up.
	Ground (sensor)	B134	29	0	0	After engine is warmed up.
Air flow sensor	Signal	B136	22	—	0.3 — 4.5	—
	Shield	B136	10	0	0	—
	Ground	B136	11	0	0	—
Intake air temperature sensor signal	B136	31	0.3 — 4.6	0.3 — 4.6	—	
Wastegate control solenoid valve	B134	33	0 or 10 — 13	0 or 12 — 14	Waveform	
Starter switch	B136	16	0	0	Cranking: 8 — 14	
A/C switch	B136	29	ON: 10 — 13 OFF: 0	ON: 12 — 14 OFF: 0	—	
Ignition switch	B136	30	10 — 13	12 — 14	—	

# Engine Control Module (ECM) I/O Signal

## ENGINE (DIAGNOSTICS)

Contents	Connector No.	Terminal No.	Signal (V)		Note	
			Ignition SW ON (engine OFF)	Engine ON (idling)		
Neutral position switch	B136	35	ON: 0 OFF: 10 — 13	ON: 0 OFF: 12 — 14	—	
Delivery (test) mode connector	B136	34	10 — 13	13 — 14	When connected: 0	
Knock sensor	Signal	B137	2	2.8	2.8	—
	Shield	B137	8	0	0	—
Back-up power supply	B136	2	10 — 13	12 — 14	Ignition switch "OFF": 10 — 13	
Control module power supply	B136	1	10 — 13	12 — 14	—	
	B137	7	10 — 13	12 — 14	—	
Sensor power supply	B134	19	5	5	—	
Ignition control	#1	B134	21	0	0 or 5	Waveform
	#2	B134	22	0	0 or 5	Waveform
	#3	B134	31	0	0 or 5	Waveform
	#4	B134	32	0	0 or 5	Waveform
Fuel injector	#1	B134	10	10 — 13	1 — 14	Waveform
	#2	B134	11	10 — 13	1 — 14	Waveform
	#3	B134	12	10 — 13	1 — 14	Waveform
	#4	B134	13	10 — 13	1 — 14	Waveform
Fuel pump control unit	Control	B136	33	0 or 5	0 or 5	Waveform
	Diagnostic signal	B135	10	10 — 13	12 — 14	—
A/C relay control	B135	35	ON: 0.5 or less OFF: 10 — 13	ON: 0.5 or less OFF: 12 — 14	—	
Main fan relay control	B135	12	ON: 0.5 or less OFF: 10 — 13	ON: 0.5 or less OFF: 12 — 14	—	
Sub fan relay control	B135	11	ON: 0.5 or less OFF: 10 — 13	ON: 0.5 or less OFF: 12 — 14	—	
Engine speed output	B135	15	—	0 — 13 or more	Waveform	
Purge control solenoid valve 1	B137	6	ON: 1 or less OFF: 10 — 13	ON: 1 or less OFF: 12 — 14	Waveform	
Purge control solenoid valve 2	B137	15	ON: 1 or less OFF: 10 — 13	ON: 1 or less OFF: 12 — 14	Waveform	
Manifold absolute pressure sensor	Signal	B137	20	1.7 — 2.4	1.1 — 1.6	—
	Power supply	B134	19	5	5	
	Ground (sensor)	B134	29	0	0	
Power steering oil pressure switch	B137	28	10 — 13	ON: 0 OFF: 12 — 14	—	
SSM/GST communication line	B135	14	1 or less ↔ 4 or more	1 or less ↔ 4 or more	—	
Intake camshaft position sensor (LH)	B137	16	0 or 5	0 or 5	Waveform	
Intake camshaft position sensor (RH)	B137	24	0 or 5	0 or 5	Waveform	
Exhaust camshaft position sensor (LH)	B137	29	0	-7 — +7	Waveform	
Exhaust camshaft position sensor (RH)	B137	23	0	-7 — +7	Waveform	
Camshaft position sensor ground	B137	30	0	0	—	

# Engine Control Module (ECM) I/O Signal

ENGINE (DIAGNOSTICS)

Contents		Connector No.	Terminal No.	Signal (V)		Note
				Ignition SW ON (engine OFF)	Engine ON (idling)	
Electronic Throttle	Main	B134	18	Approx. 0.9 (After engine is warmed up.)	Approx. 0.6 — 0.7 (After engine is warmed up.)	Fully closed: Approx. 0.6 Fully open: Approx. 4.0
	Sub	B134	28	Approx. 1.7 (After engine is warmed up.)	Approx. 1.5 — 1.6 (After engine is warmed up.)	Fully closed: Approx. 1.5 Fully open: Approx. 4.2
	Power supply	B134	19	5	5	—
	Ground (sensor)	B134	29	0	0	—
Electronic throttle control motor (+)		B134	2	Duty waveform	Duty waveform	Drive frequency: 500 Hz
Electronic throttle control motor (-)		B134	1	Duty waveform	Duty waveform	Drive frequency: 500 Hz
Electronic throttle control motor power supply		B135	7	10 — 13	12 — 14	—
Electronic throttle control motor relay		B135	17	ON: 0 OFF: 10 — 13	ON: 0 OFF: 12 — 14	When ignition switch is turned to ON: ON
Intake oil flow control solenoid valve (LH)	Signal (+)	B134	17	ON: 10 — 13 OFF: 0	ON: 12 — 14 OFF: 0	—
	Signal (-)	B134	16	0	0	—
Intake oil flow control solenoid valve (RH)	Signal (+)	B134	34	ON: 10 — 13 OFF: 0	ON: 12 — 14 OFF: 0	—
	Signal (-)	B134	27	0	0	—
Exhaust oil flow control solenoid valve (LH)	Signal (+)	B134	5	ON: 10 — 13 OFF: 0	ON: 12 — 14 OFF: 0	—
	Signal (-)	B134	14	0	0	—
Exhaust oil flow control solenoid valve (RH)	Signal (+)	B134	7	ON: 10 — 13 OFF: 0	ON: 12 — 14 OFF: 0	—
	Signal (-)	B134	15	0	0	—
Accelerator pedal position sensor	Main sensor signal	B135	23	Fully closed: 1 Fully opened: 3.3	Fully closed: 1 Fully opened: 3.3	—
	Main power supply	B135	21	5	5	—
	Ground (main sensor)	B135	29	0	0	—
	Shield	B136	4	0	0	—
	Sub sensor signal	B135	31	Fully closed: 1 Fully opened: 3.3	Fully closed: 1 Fully opened: 3.3	—
	Sub power supply	B135	22	5	5	—
	Ground (sub sensor)	B135	30	0	0	—
Starter relay		B135	26	ON: 0 OFF: 10 — 13	ON: 0 OFF: 12 — 14	ON: cranking

# Engine Control Module (ECM) I/O Signal

## ENGINE (DIAGNOSTICS)

Contents	Connector No.	Terminal No.	Signal (V)		Note
			Ignition SW ON (engine OFF)	Engine ON (idling)	
A/C middle pressure switch	B136	7	ON: 0 OFF: 10 — 13	ON: 0 OFF: 12 — 14	—
Blower fan switch	B135	19	ON: 0 OFF: 10 — 13	ON: 0 OFF: 12 — 14	Manual A/C model
Clutch switch	B135	9	When clutch pedal is depressed: 0 When clutch pedal is released: 10 — 13	When clutch pedal is depressed: 0 When clutch pedal is released: 12 — 14	—
Brake switch 1	B136	15	When brake pedal is depressed: 0 When brake pedal is released: 10 — 13	When brake pedal is depressed: 0 When brake pedal is released: 12 — 14	—
Brake switch 2	B136	3	When brake pedal is depressed: 10 — 13 When brake pedal is released: 0	When brake pedal is depressed: 12 — 14 When brake pedal is released: 0	—
Cruise control command switch	B136	12	When operating nothing: 3.5 — 4.5 When operating RES/ACC: 2.5 — 3.5 When operating SET/COAST: 0.5 — 1.5 When operating CANCEL: 0 — 0.5	When operating nothing: 3.5 — 4.5 When operating RES/ACC: 2.5 — 3.5 When operating SET/COAST: 0.5 — 1.5 When operating CANCEL: 0 — 0.5	—
Cruise control main switch	B136	13	ON: 0 OFF: 5	ON: 0 OFF: 5	—
Fuel tank pressure sensor	B136	21	2.3 — 2.7	2.3 — 2.7	—
Pressure control solenoid valve assembly	B135	3	ON: 1 or less OFF: 10 — 13	ON: 1 or less OFF: 12 — 14	—
Immobilizer	Signal 1	B135	25	—	—
	Signal 2	B135	24	—	—
CAN communication (Hi)	B136	17	—	—	—
CAN communication (Lo)	B136	28	—	—	—
Blow-by leak diagnosis	B137	12	0	0	At the time of open circuit (fault): 5
Tumble generator valve position sensor signal (RH)	B137	11	Fully closed: 0.4 — 1.2 Fully opened: 2.8 — 4.6	Fully closed: 0.4 — 1.2 Fully opened: 2.8 — 4.6	—
Tumble generator valve position sensor signal (LH)	B137	10	Fully closed: 0.4 — 1.2 Fully opened: 2.8 — 4.6	Fully closed: 0.4 — 1.2 Fully opened: 2.8 — 4.6	—
Tumble generator valve (RH closed)	B134	26	0 or 10 — 13	0 or 12 — 14	—
Tumble generator valve (LH closed)	B134	24	0 or 10 — 13	0 or 12 — 14	—
Tumble generator valve (RH open)	B134	25	0 or 10 — 13	0 or 12 — 14	—
Tumble generator valve (LH open)	B134	23	0 or 10 — 13	0 or 12 — 14	—

# Engine Control Module (ECM) I/O Signal

ENGINE (DIAGNOSTICS)

Contents		Connector No.	Terminal No.	Signal (V)		Note
				Ignition SW ON (engine OFF)	Engine ON (idling)	
Secondary air pipe pressure sensor	Signal	B137	9	2.2 — 2.8	2.2 — 2.8	When secondary air is inducted: 3.2 — 4.9
	Power supply	B134	19	5.12	5.12	—
	Ground (sensor)	B134	29	0	0	—
Secondary air combination valve relay 1		B135	8	ON: 0 OFF: 10 — 13	ON: 0 OFF: 12 — 14	—
Secondary air combination valve relay 2		B135	20	ON: 0 OFF: 10 — 13	ON: 0 OFF: 12 — 14	—
Secondary air pump relay		B135	27	ON: 0 OFF: 10 — 13	ON: 0 OFF: 12 — 14	—
Self-shutoff control		B135	13	10 — 13	12 — 14	—
ELCM	Switching valve	B135	4	10 — 13	12 — 14	Operating: 0
	Pressure sensor	B136	21	1 — 4	1 — 4	When ignition switch is turned to ON: atmospheric pressure
	Vacuum pump	B137	27	10 — 13	12 — 14	Operating: 0
Ground (engine 1)		B134	6	0	0	—
Ground (engine 2)		B134	4	0	0	—
Ground (engine 3)		B134	3	0	0	—
Ground (engine 4)		B137	1	0	0	—
Ground (engine 5)		B137	3	0	0	—
Ground (body)		B136	4	0	0	—

### Input/output name:

- Crankshaft position sensor
- Intake camshaft position sensor RH
- Intake camshaft position sensor LH
- Exhaust camshaft position sensor RH
- Exhaust camshaft position sensor LH

### Measuring condition:

- After warming-up

# Engine Control Module (ECM) I/O Signal

## ENGINE (DIAGNOSTICS)

- At idling

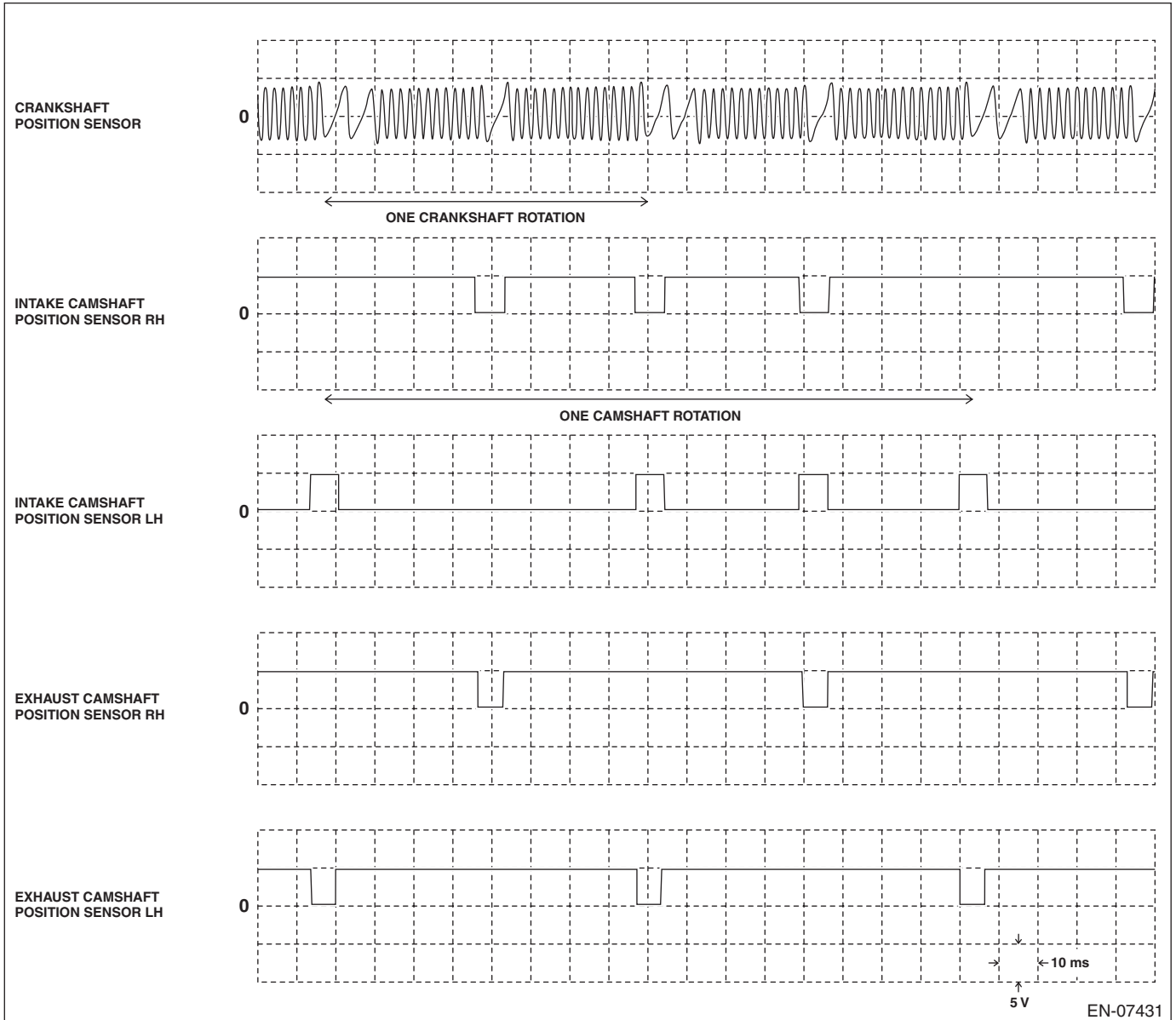

# Engine Control Module (ECM) I/O Signal

ENGINE (DIAGNOSTICS)

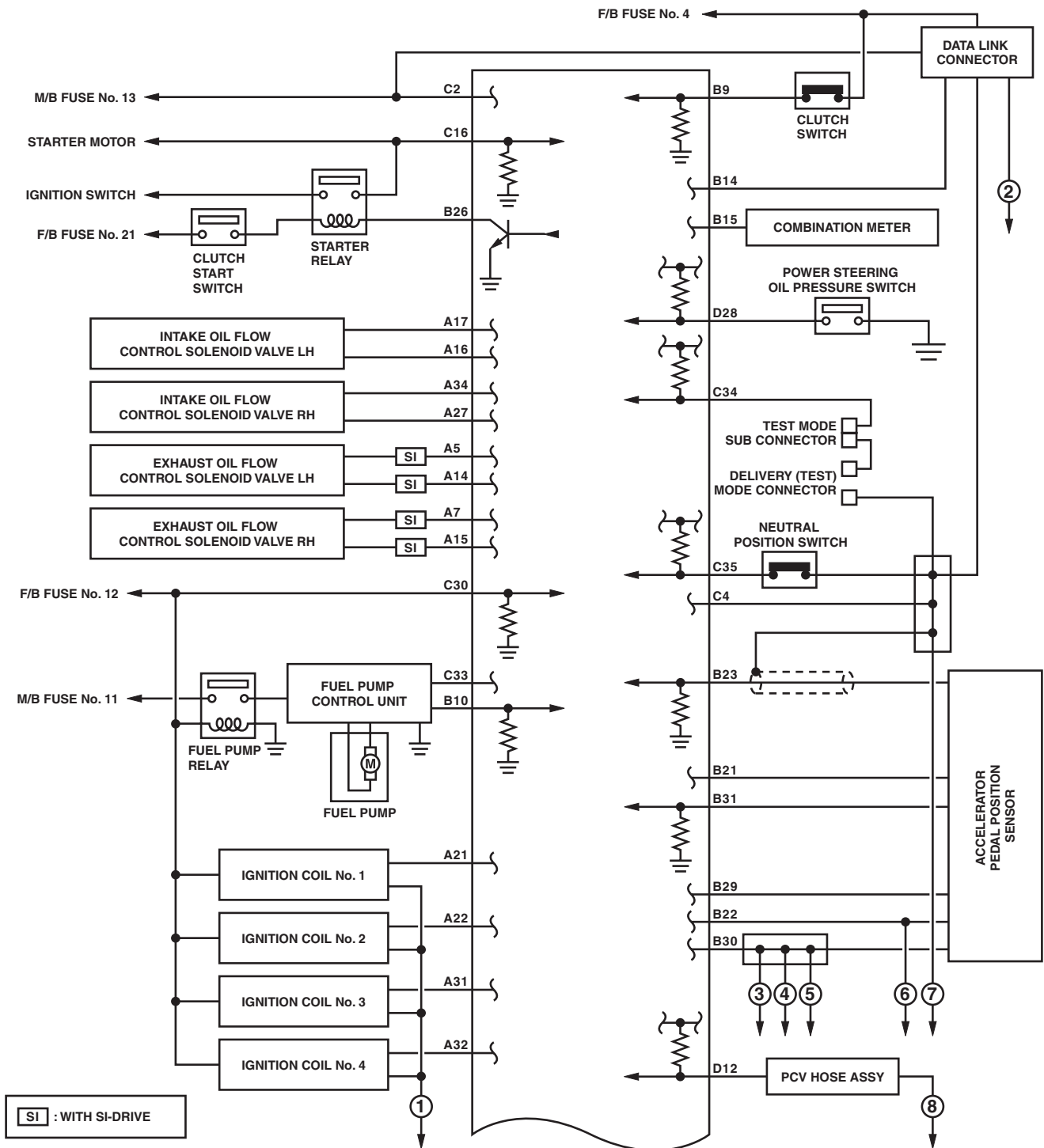

EN-09244

EN(H4DOTC)(diag)-29

Brought to you by Ebay Seller "SubaruManuals"



# Engine Control Module (ECM) I/O Signal

ENGINE (DIAGNOSTICS)

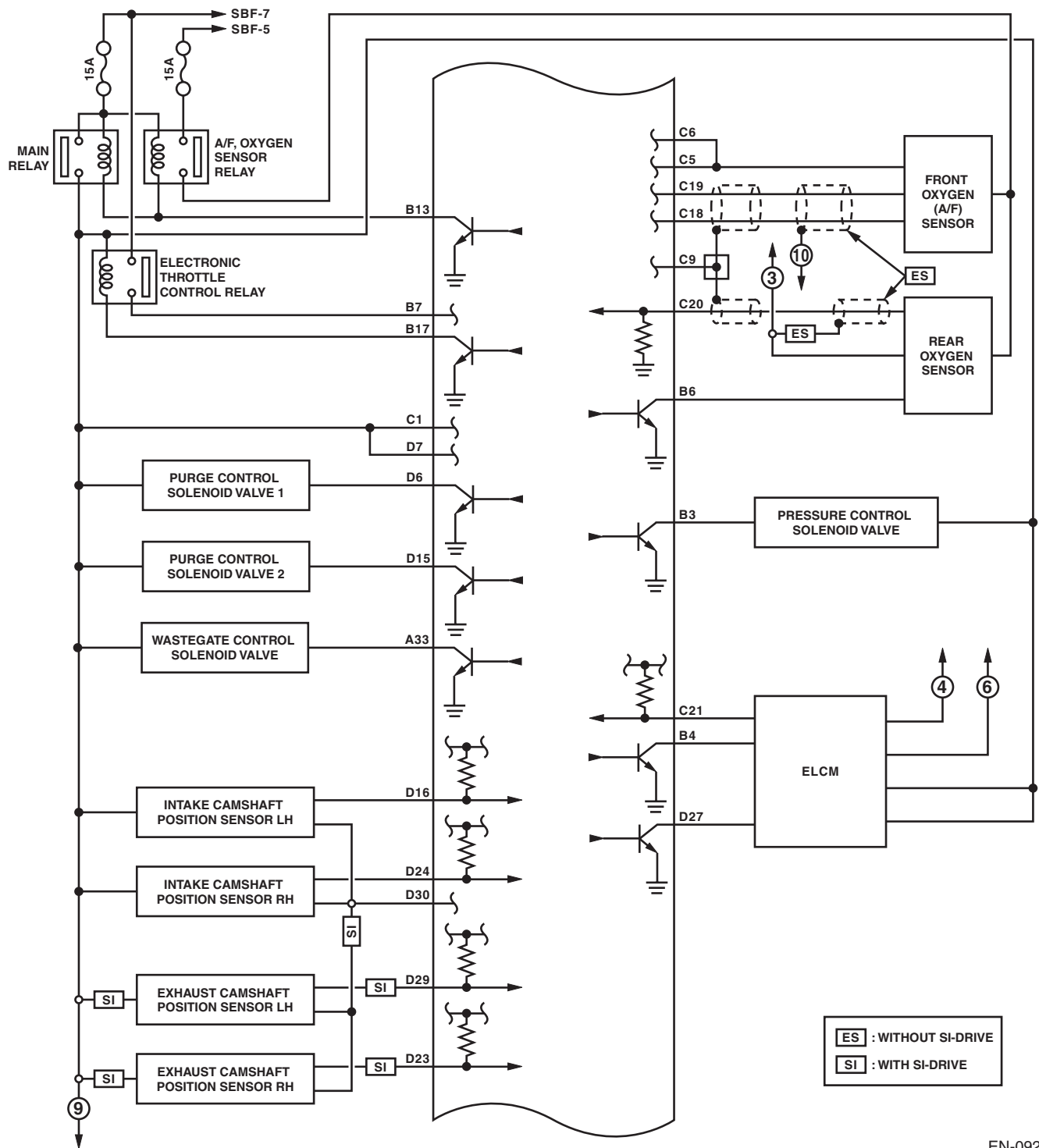

EN(H4DOTC)(diag)-30

Brought to you by Ebay Seller "SubaruManuals"

# Engine Control Module (ECM) I/O Signal

ENGINE (DIAGNOSTICS)

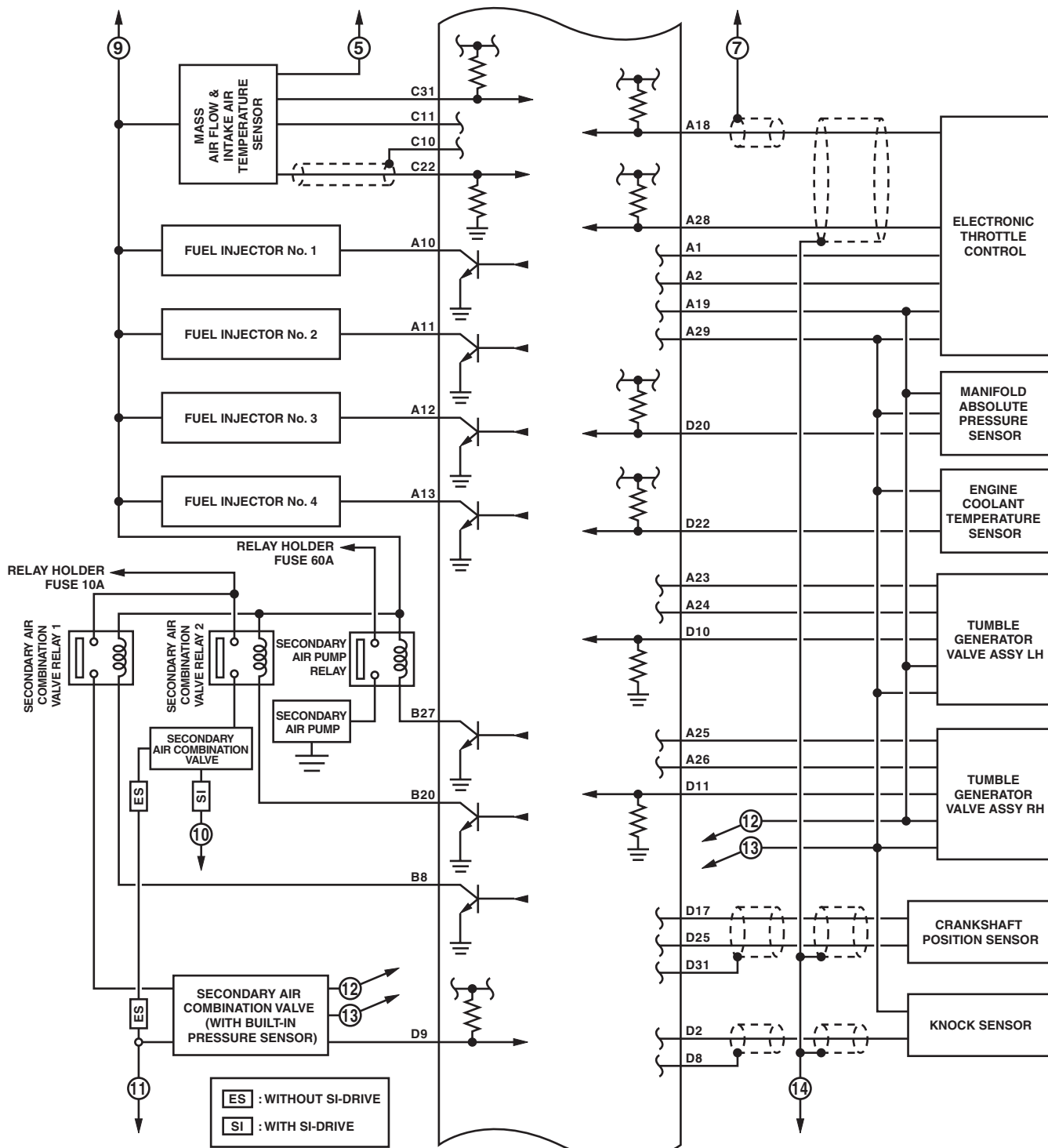

EN-09246

# Engine Control Module (ECM) I/O Signal

ENGINE (DIAGNOSTICS)

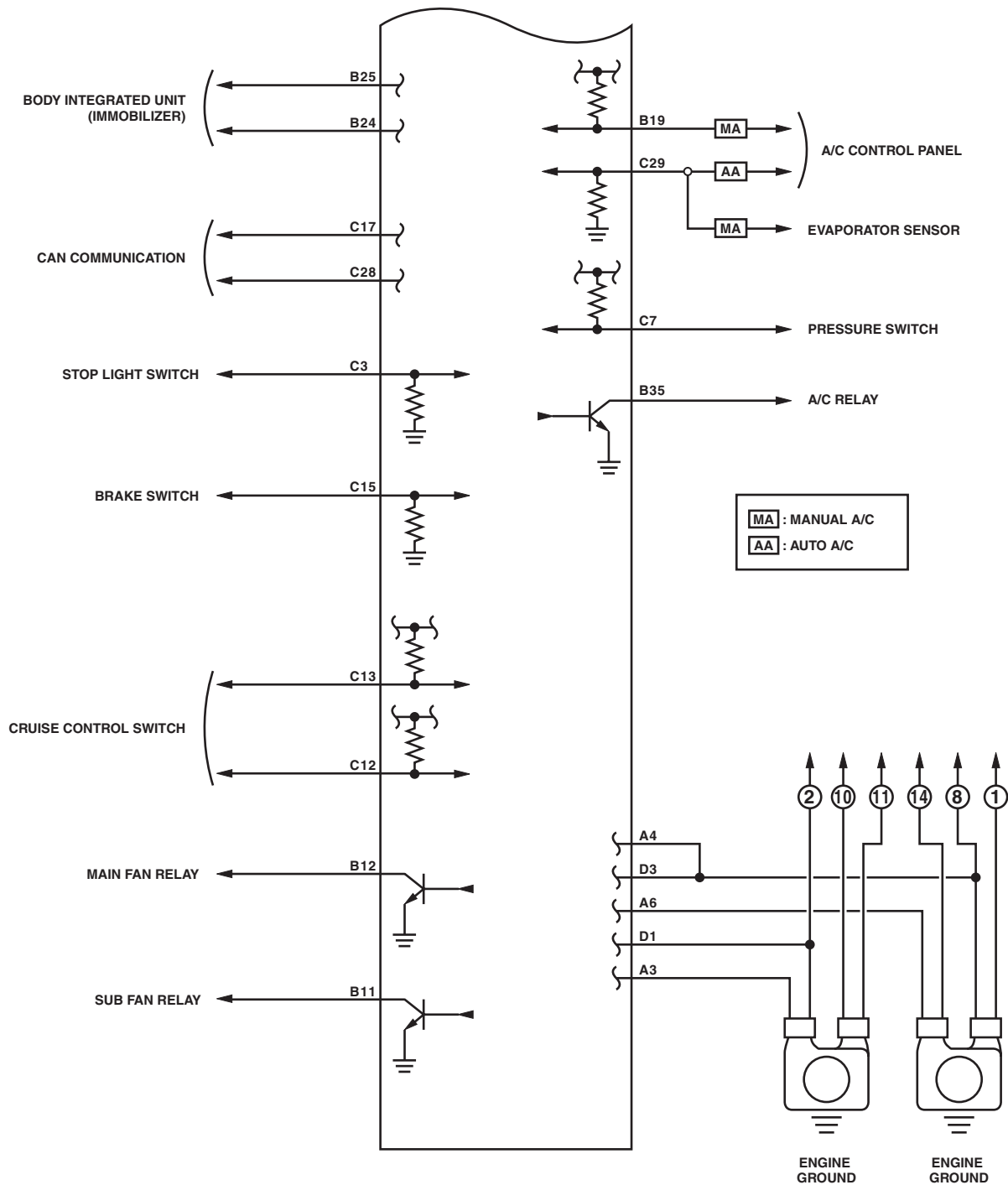

EN-09247

EN(H4DOTC)(diag)-32

Brought to you by Ebay Seller "SubaruManuals"

## 6. Engine Condition Data

### A: ELECTRICAL SPECIFICATION

Content	Specifications
Engine load	17.6 — 35.64 (%): Idling
	13.2 — 26.73 (%): 2,500 rpm racing

Measuring condition:

- After engine is warmed up.
- Place the shift lever in neutral position.
- Turn the A/C to OFF.
- Turn all the accessory switches to OFF.

# Data Link Connector

ENGINE (DIAGNOSTICS)

## 7. Data Link Connector

### A: NOTE

This connector is used for Subaru Select Monitor.

### CAUTION:

Do not connect any scan tools other than Subaru Select Monitor or general scan tool because the circuit for Subaru Select Monitor may be damaged.

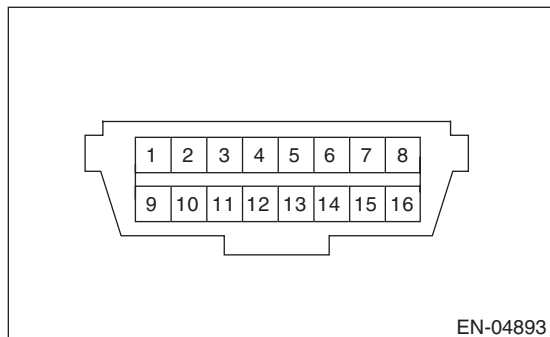

Terminal No.	Content	Terminal No.	Content
1	Blank	9	Blank
2	Blank	10	Blank
3	Blank	11	Blank
4	Ground	12	Blank
5	Ground	13	Blank
6	CAN communication (Hi)	14	CAN communication (Lo)
7	Subaru Select Monitor signal	15	Blank
8	Blank	16	Power supply

## 8. General Scan Tool

### A: OPERATION

#### 1. HOW TO USE GENERAL SCAN TOOL

- 1) Prepare a scan tool (general scan tool) required by SAE J1978.
- 2) Connect the general scan tool to data link connector located in the lower portion of the instrument panel (on the driver's side).

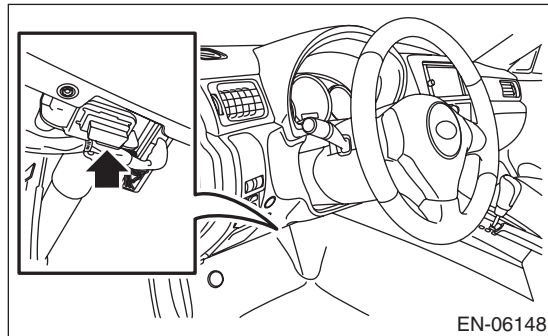

- 3) Using the general scan tool, call up each data. General scan tool functions consist of:

- (1) MODE \$01: Current powertrain diagnostic data
- (2) MODE \$02: Powertrain freeze frame data
- (3) MODE \$03: Emission-related powertrain DTC
- (4) MODE \$04: Clear/Reset emission-related diagnostic information
- (5) MODE \$06: Request on-board monitoring test results for intermittently monitored systems
- (6) MODE \$07: Request on-board monitoring test results for continuously monitored systems
- (7) MODE \$08: Request control for on-board system, test, and component
- (8) MODE \$09: Request vehicle information

- 4) Read out the data according to repair procedures. (For detailed operation procedure, refer to the general scan tool operation manual.)

#### NOTE:

For details concerning DTC, refer to "List of Diagnostic Trouble Code (DTC)". <Ref. to EN(H4DOTC)(diag)-88, List of Diagnostic Trouble Code (DTC).>

# General Scan Tool

## ENGINE (DIAGNOSTICS)

### 2. MODE \$01 (CURRENT POWERTRAIN DIAGNOSTIC DATA)

Refer to data denoting the current operating condition of analog input/output, digital input/output or the powertrain system.

A list of the support data and PID (Parameter Identification) codes are shown in the following table.

PID	Data	Unit of measure
\$01	Number of emission-related powertrain DTC, and malfunction indicator light status and diagnosis support information	—
\$03	Fuel system control status	—
\$04	Calculated engine load value	%
\$05	Engine coolant temperature	°C
\$06	Short term fuel trim	%
\$07	Long term fuel trim	%
\$0B	Intake manifold absolute pressure	kPa
\$0C	Engine speed	rpm
\$0D	Vehicle speed	MPH
\$0E	Ignition timing advance	°
\$0F	Intake air temperature	°C
\$10	Intake air amount	g/s
\$11	Throttle valve opening angle	%
\$12	Secondary air control status	—
\$13	Air fuel ratio sensor	—
\$15	Oxygen sensor output voltage and short term fuel trim associated with oxygen sensor	V and %
\$1C	Supporting OBD system	—
\$1F	Elapsed time after starting the engine	sec
\$21	Running distance after MIL turns on	miles
\$24	A/F value and A/F sensor output voltage	— and V
\$2E	Evaporative purge	%
\$2F	Fuel level	%
\$30	Number of warm ups after DTC clear	—
\$31	Travel distance after DTC clear	miles
\$33	Barometric pressure	kPa
\$34	A/F sensor $\lambda$ value, current	— and mA
\$3C	Catalyst temperature	°C
\$41	Diagnostic monitor of each drive cycle	—
\$42	ECM power voltage	V
\$43	Absolute load	%
\$44	A/F target lambda	—
\$45	Relative throttle opening angle	%
\$46	Ambient temperature	°C
\$47	Absolute throttle opening angle 2	%
\$49	Absolute accelerator opening angle 1	%
\$4A	Absolute accelerator opening angle 2	%
\$4C	Target throttle opening angle	%
\$4D	Engine operation time during MIL on	min
\$4E	Elapsed time after DTC clear	min
\$51	Fuel used	—
\$5A	Relative accelerator opening angle	%
\$65	Neutral status	—

**NOTE:**

Refer to general scan tool manufacturer's operation manual to access current powertrain diagnostic data (MODE \$01).

### 3. MODE \$02 (POWERTRAIN FREEZE FRAME DATA)

Refer to data denoting the operating condition when trouble is detected by on-board diagnosis system. A list of the support data and PID (Parameter Identification) codes are shown in the following table.

PID	Data	Unit of measure
\$02	DTC that caused the freeze frame data storage required by CARB	—
\$03	Fuel system control status	—
\$04	Calculated engine load value	%
\$05	Engine coolant temperature	°C
\$06	Short term fuel trim	%
\$07	Long term fuel trim	%
\$0B	Intake manifold absolute pressure	kPa
\$0C	Engine speed	rpm
\$0D	Vehicle speed	MPH
\$0E	Ignition timing advance	°
\$0F	Intake air temperature	°C
\$10	Intake air amount	g/s
\$11	Throttle valve opening angle	%
\$12	Secondary air control status	—
\$13	Air fuel ratio sensor	—
\$15	Rear oxygen sensor voltage, compensation value	V and %
\$1C	Supporting OBD system	—
\$1F	Elapsed time after starting the engine	sec
\$2E	Evaporative purge	%
\$2F	Fuel level	%
\$33	Barometric pressure	kPa
\$42	ECM power voltage	V
\$43	Absolute load	%
\$44	A/F target lambda	—
\$45	Relative throttle opening angle	%
\$46	Ambient temperature	°C
\$47	Absolute throttle opening angle 2	%
\$49	Absolute accelerator opening angle 1	%
\$4A	Absolute accelerator opening angle 2	%
\$4C	Target throttle opening angle	%
\$65	Neutral status	—

**NOTE:**

Refer to general scan tool manufacturer's operation manual to access freeze frame data (MODE \$02).

### 4. MODE \$03 (EMISSION-RELATED POWERTRAIN DTC)

Refer to "List of Diagnostic Trouble Code (DTC)" for information about data denoting emission-related powertrain DTC. <Ref. to EN(H4DOTC)(diag)-88, List of Diagnostic Trouble Code (DTC).>



# General Scan Tool

## ENGINE (DIAGNOSTICS)

### 5. MODE \$04 (CLEAR/RESET EMISSION-RELATED DIAGNOSTIC INFORMATION)

Refer to the mode used to clear or reset emission-related diagnostic information (OBD-II trouble diagnostic information).

#### NOTE:

- Refer to the manufacturer's operation manual for the general scan tool to clear the emission-related diagnostic information (MODE \$04).
- Initial diagnosis of electronic throttle control is performed after memory clearance. Wait for 10 seconds or more after turning the ignition switch to ON, and then start the engine.

### 6. MODE \$06

Refer to diagnostic value of troubleshooting and data of test limit indicated on the support data bit sequence table. A list of the support data is shown in the following table.

OBDMID	TID	SID	Diagnostic item	
\$01	\$84	\$1E	A/F sensor range failure (Bank 1 Sensor 1)	
	\$85	\$1E		
	\$86	\$20		
		\$91	\$20	A/F sensor response failure (Bank 1 Sensor 1)
		\$92	\$10	
		\$A3	\$20	
		\$A4	\$10	
		\$AC	\$10	
		\$AD	\$10	
		\$AE	\$10	
		\$AF	\$10	
		\$CD	\$20	
		\$CF	\$20	
\$02	\$07	\$0B	Oxygen sensor drop failure (Bank 1 Sensor 2)	
	\$08	\$0B		
	\$A5	\$0B		
		\$05	\$10	Oxygen sensor response failure (Bank 1 Sensor 2)
		\$06	\$10	
		\$D1	\$10	Oxygen sensor delay failure (Bank 1 Sensor 2)
		\$D2	\$01	
\$21	\$89	\$20	Catalyst deterioration diagnosis (Bank 1)	
\$35	\$8B	\$9D	VVT monitor (Bank 1)	
	\$8C	\$9D		
	\$8D	\$9D		
	\$8E	\$9D		
\$36	\$8B	\$9D	VVT monitor (Bank 2)	
	\$8C	\$9D		
	\$8D	\$9D		
	\$8E	\$9D		

# General Scan Tool

ENGINE (DIAGNOSTICS)

OBDMID	TID	SID	Diagnostic item
\$3C	\$96	\$FE	Evaporative emission control system (0.02 inch leak)
	\$C1	\$FE	
	\$C2	\$FE	
	\$C3	\$FE	
	\$C4	\$FE	
	\$C5	\$FE	
	\$C6	\$35	
	\$C7	\$FE	
	\$C8	\$FE	
	\$C9	\$FE	
\$CA	\$FE		
\$3D	\$98	\$FE	Evaporative emission control system (Purge flow)
\$41	\$9B	\$14	A/F sensor heater characteristics failure (Bank 1 Sensor 1)
\$42	\$A2	\$24	Oxygen sensor heater characteristics failure (Bank 1 Sensor 2)
\$71	\$9E	\$17	Secondary air system (all systems)
	\$9F	\$0B	
	\$A0	\$0B	
	\$B0	\$17	Secondary air system (relay 2 — combination valve 2)
	\$B1	\$0B	
	\$B2	\$0B	
	\$B3	\$0B	
	\$B4	\$0B	
	\$B5	\$0B	
	\$B6	\$31	
\$B7	\$31		
\$A1	\$0B	\$24	Misfire monitoring (All cylinders)
	\$0C	\$24	
\$A2	\$0B	\$24	Misfire monitoring (#1 cylinder)
	\$0C	\$24	
\$A3	\$0B	\$24	Misfire monitoring (#2 cylinder)
	\$0C	\$24	
\$A4	\$0B	\$24	Misfire monitoring (#3 cylinder)
	\$0C	\$24	
\$A5	\$0B	\$24	Misfire monitoring (#4 cylinder)
	\$0C	\$24	

## 7. MODE \$07

Refer to the data of DTC (pending code) for troubleshooting result about emission in the first time.

## 8. MODE \$08 (REQUEST CONTROL FOR ON-BOARD SYSTEM, TEST, AND COMPONENT)

Perform "Active Test" of the on-board system.

## 9. MODE \$09

Refer to the data of vehicle specification (V.I.N., calibration ID, etc.).

# Subaru Select Monitor

ENGINE (DIAGNOSTICS)

## 9. Subaru Select Monitor

### A: OPERATION

#### 1. HOW TO USE SUBARU SELECT MONITOR

1) Prepare the Subaru Select Monitor kit. <Ref. to EN(H4DOTC)(diag)-8, PREPARATION TOOL, General Description.>

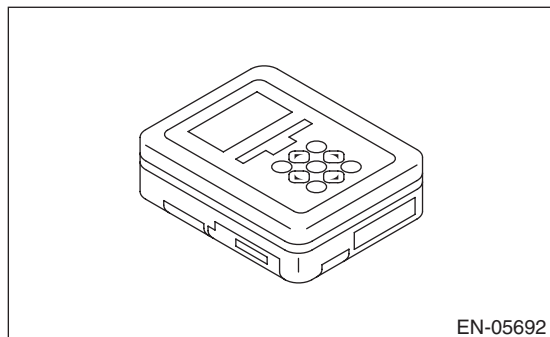

2) Prepare PC with Subaru Select Monitor installed.

3) Connect the USB cable to SDI (Subaru Diagnosis Interface) and USB port on the personal computer (dedicated port for the Subaru Select Monitor).

#### NOTE:

The dedicated port for the Subaru Select Monitor means the USB port which was used to install the Subaru Select Monitor.

4) Connect the diagnosis cable to SDI.

5) Connect SDI to data link connector located in the lower portion of the instrument panel (on the driver's side).

#### CAUTION:

**Do not connect the scan tools except for Subaru Select Monitor and general scan tool.**

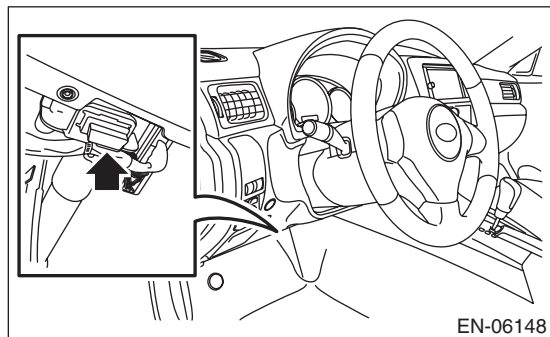

6) Start the PC.

7) Turn the ignition switch to ON (engine OFF) and run the "PC application for Subaru Select Monitor".

8) Call up DTC and data, then record them.

#### NOTE:

For detailed operation procedures, refer to "PC application help for Subaru Select Monitor".

**EN(H4DOTC)(diag)-40**

Brought to you by Ebay Seller "SubaruManuals"

## 2. READ CURRENT DATA FOR ENGINE (NORMAL MODE)

- 1) On «Main Menu» display, select {Each System Check}.
  - 2) On «System Selection Menu» display, select {Engine Control System}.
  - 3) Click the [OK] button after the information of engine type has been displayed.
  - 4) On «Engine Diagnosis» display, select {Current Data Display & Save}.
  - 5) On «Current Data Display & Save» display, select {Normal sampling}.
  - 6) Using the scroll key, scroll the display screen up or down until the desired data is shown.
- A list of the support data is shown in the following table.

Content	Display	Unit of measure	Note (at idling)
Engine load	Engine Load	%	21.0%
Engine coolant temperature signal	Coolant Temp.	°C or °F	80 — 100°C or 176 — 212°F
A/F correction #1	A/F Correction #1	%	-10 — +10%
A/F learning #1	A/F Learning #1	%	-15 — +15%
Intake manifold absolute pressure	Mani. Absolute Pressure	mmHg, kPa, inHg or psig	220 — 275 mmHg, 29.5 — 37 kPa, 8.7 — 10 inHg or 4.2 — 5.3 psig
Engine speed signal	Engine Speed	rpm	630 — 770 rpm (Agree with the tachometer indication)
Meter vehicle speed signal	Vehicle Speed	km/h or MPH	0 km/h or 0 MPH (at parking)
Ignition timing signal	Ignition Timing	deg	10 — 15 deg
Intake air temperature signal	Intake Air Temp.	°C or °F	20 — 50°C or 68 — 122°F
Intake air amount	Mass Air Flow	g/s or lb/m	2.1 — 3.1 g/s or 0.35 — 0.40 lb/m
Throttle opening angle signal	Throttle Opening Angle	%	2.0 — 2.4%
Rear oxygen sensor voltage	Rear O2 Sensor	V	0 — 1.0 V
Battery voltage	Battery Voltage	V	12 — 15 V
Mass air flow voltage	Air Flow Sensor Voltage	V	1.0 — 1.7 V
Injection 1 pulse width	Fuel Injection #1 Pulse	ms	1.2 — 2.2 ms
Atmospheric pressure	Atmosphere Pressure	mmHg, kPa, inHg or psig	—
Intake manifold relative pressure	Mani. Relative Pressure	mmHg, kPa, inHg or psig	Air intake absolute pressure — Atmospheric pressure
Learned ignition timing	Learned Ignition Timing	deg	0 deg
Acceleration opening angle signal	Accel. Opening Angle	%	0.0%
Primary supercharged pressure control signal	Primary Control	%	0.0%
Purge control solenoid duty ratio	CPC Valve Duty Ratio	%	0 — 25%
Tumble generator valve RH opening signal	TGV Position Sensor R	V	0.81 V
Tumble generator valve LH opening signal	TGV Position Sensor L	V	0.81 V
Fuel pump duty ratio	Fuel Pump Duty	%	30 — 40%
AVCS advance angle amount RH	VVT Adv. Ang. Amount R	deg	±5 deg
AVCS advance angle amount LH	VVT Adv. Ang. Amount L	deg	±5 deg
Oil flow control solenoid valve duty ratio RH	OCV Duty R	%	0 — 20%
Oil flow control solenoid valve duty ratio LH	OCV Duty L	%	0 — 20%
Oil flow control solenoid valve current RH	OCV Current R	mA	40 — 100 mA
Oil flow control solenoid valve current LH	OCV Current L	mA	40 — 100 mA
A/F sensor current value 1	A/F Sensor #1 Current	mA	-20 — 20 mA
A/F sensor resistance value 1	A/F Sensor #1 Resistance	Ω	27 — 35 mA
A/F sensor output lambda 1	A/F Sensor #1	—	1.0
A/F correction #3	A/F Correction #3	%	0.00%
A/F learning #3	A/F Learning #3	%	0.00%
SI drive mode (model with SI-DRIVE)	SI Drive mode	—	I, S or S#
Throttle motor duty	Throttle Motor Duty	%	-5%
Throttle motor voltage	Throttle Motor Voltage	V	12 — 15 V

# Subaru Select Monitor

## ENGINE (DIAGNOSTICS)

Content	Display	Unit of measure	Note (at idling)
Sub throttle sensor voltage	Sub-Throttle Sensor	V	1.5 V
Main throttle sensor voltage	Main-Throttle Sensor	V	0.6 V
Sub accelerator sensor voltage	Sub-Accelerator Sensor	V	1.1 V
Main acceleration sensor voltage	Main-Accelerator Sensor	V	1.0 V
Secondary air supply piping pressure signal	Sec. Air Piping Pressure	mmHg, kPa, inHg or psig	765 mmHg, 102 kPa, 30.1 inHg or 14.8 psig
Secondary airflow signal	Sec. Air Flow	g/s or lb/m	0.00 g/s or 0.00 lb/m
Memory vehicle speed	Memorized Cruise Speed	km/h or MPH	—
Fuel level sensor resistance	Fuel level resistance	$\Omega$	4 — 96 $\Omega$
Odometer	Odometer	km	—
Exhaust AVCS retard angle amount RH (model with SI-DRIVE)	Exh. VVT Retard Ang. R	deg	$\pm 5$ deg
Exhaust AVCS retard angle amount LH (model with SI-DRIVE)	Exh. VVT Retard Ang. L	deg	$\pm 5$ deg
Exhaust oil flow control solenoid valve duty ratio RH (model with SI-DRIVE)	Exh. OCV Duty R	%	0 — 20%
Exhaust oil flow control solenoid valve duty ratio LH (model with SI-DRIVE)	Exh. OCV Duty L	%	0 — 20%
Exhaust oil flow control solenoid valve current value RH (model with SI-DRIVE)	Exh. OCV Current R	mA	40 — 100 mA
Exhaust oil flow control solenoid valve current value LH (model with SI-DRIVE)	Exh. OCV Current L	mA	40 — 100 mA
#1 cylinder roughness monitor	Roughness Monitor #1	—	0
#2 cylinder roughness monitor	Roughness Monitor #2	—	0
#3 cylinder roughness monitor	Roughness Monitor #3	—	0
#4 cylinder roughness monitor	Roughness Monitor #4	—	0
Knock sensor correction	Knocking Correction	deg	0.0 deg
AT vehicle ID signal	AT Vehicle ID Signal	—	OFF
D-check require Flag	D-check Require Flag	—	OFF
Delivery (test) mode terminal	Delivery Mode Connector (Test Mode Connector)	—	OFF
Neutral position switch signal	Neutral Position Switch	—	ON
Soft idle switch signal	Idle Switch Signal	—	ON
Ignition switch signal	Ignition Switch	—	ON
Power steering switch signal	P/S Switch	—	OFF (when OFF)
Air conditioning switch signal	A/C Switch	—	OFF (when OFF)
Starter switch signal	Starter Switch	—	OFF
Rear oxygen monitor	Rear O2 Rich Signal	—	ON/OFF
Knocking signal	Knocking Signal	—	OFF
Crankshaft position sensor signal	Crankshaft Position Sig.	—	ON
Camshaft position sensor signal	Camshaft Position Sig.	—	ON
Rear defogger switch signal	Rear Defogger SW	—	OFF (when OFF)
Blower fan switch signal	Blower Fan SW	—	OFF (when OFF)
Light switch signal	Light Switch	—	OFF (when OFF)
A/C middle pressure switch signal	A/C Mid Pressure Switch	—	OFF (when OFF)
Air conditioner compressor relay output signal	A/C Compressor Signal	—	OFF (when OFF)
Radiator fan relay 1 signal	Radiator Fan Relay #1	—	OFF (when OFF)
Radiator fan relay 2 signal	Radiator Fan Relay #2	—	OFF (when OFF)
PCV hose assembly diagnosis signal	Blow-by leak Connector	—	ON
Pressure control solenoid valve assembly signal	PCV Solenoid Valve	—	OFF (when OFF)

EN(H4DOTC)(diag)-42

Brought to you by Ebay Seller "SubaruManuals"

# Subaru Select Monitor

ENGINE (DIAGNOSTICS)

Content	Display	Unit of measure	Note (at idling)
Tumble generator valve output signal	TGV Output	—	OFF
Tumble generator valve driving signal	TGV Drive	—	Close
Purge control solenoid valve 2 signal	CPC Solenoid 2	—	OFF (when OFF)
Vehicle dynamics control (VDC) torque down prohibition output	Ban of Torque Down	—	ON
Vehicle dynamics control (VDC) torque down demand	Request Torque Down VDC	—	OFF
ETC motor relay signal	ETC Motor Relay	—	ON
Clutch switch signal	Clutch Switch	—	OFF (when OFF)
Stop light switch signal	Stop Light Switch	—	OFF (when OFF)
SET/COAST switch signal	SET/COAST Switch	—	OFF (when OFF)
RES/ACC switch signal	RESUME/ACCEL Switch	—	OFF (when OFF)
Brake switch signal*	Brake Switch	—	OFF (when OFF)
Main switch signal	Main Switch	—	OFF (when OFF)
Secondary air combination valve relay 2 signal	Sec. Air Combi V Relay 2	—	OFF (when OFF)
Secondary air pump relay signal	Sec. Air Pump Relay	—	OFF (when OFF)
Secondary air combination valve relay 1 signal	Sec. Air Combi V Relay 1	—	OFF (when OFF)
Cruise control cancel switch signal	CC Cancel SW	—	OFF (when OFF)
Malfunction indicator light signal	MIL On Flag	—	OFF (when unlit)
ELCM switching valve drive signal	ELCM switching valve	—	Open
ELCM vacuum pump drive signal	ELCM pump	—	OFF

**NOTE:**

- For detailed operation procedures, refer to “PC application help for Subaru Select Monitor”.
- \*: For models without cruise control, the brake switch signal does not change.

### 3. READ CURRENT DATA FOR ENGINE (OBD MODE)

- 1) On «Main Menu» display, select {Each System Check}.
  - 2) On «System Selection Menu» display, select {Engine Control System}.
  - 3) Click the [OK] button after the information of engine type has been displayed.
  - 4) On «Engine Diagnosis» display, select {OBD System}.
  - 5) On «OBD Menu» display, select {Current Data Display & Save}.
  - 6) On «Current Data Display & Save» display, select {All data display}.
  - 7) Using the scroll key, scroll the display screen up or down until the desired data is shown.
- A list of the support data is shown in the following table.

Content	Display	Note (at idling)	Unit of measure
Number of diagnosis code	Number of DTCs	0	—
Condition of malfunction indicator light	MI(MIL)	OFF	—
Monitoring test of misfire	Misfire monitoring(Supp)	YES	—
Monitoring test of misfire	Misfire monitoring(Rdy)	YES	—
Monitoring test of fuel system	Fuel system monitoring(Supp)	YES	—
Monitoring test of fuel system	Fuel system monitoring(Rdy)	YES	—
Monitoring test of comprehensive component	Component monitoring(Supp)	YES	—
Monitoring test of comprehensive component	Component monitoring(Rdy)	YES	—
Test of catalyst	Catalyst Diagnosis(Supp)	YES	—
Test of catalyst	Catalyst Diagnosis(Rdy)	NO	—
Test of heating-type catalyst	Heated catalyst(Supp)	NO	—
Test of heating-type catalyst	Heated catalyst(Rdy)	N/A	—
Test of evaporative emission purge control system	Evaporative purge system(Supp)	YES	—

# Subaru Select Monitor

## ENGINE (DIAGNOSTICS)

Content	Display	Note (at idling)	Unit of measure
Test of evaporative emission purge control system	Evaporative purge system(Rdy)	NO	—
Secondary air system test	Secondary air system(Supp)	YES	—
Secondary air system test	Secondary air system(Rdy)	NO	—
Test of air conditioning system refrigerant	A/C system refrigerant(Supp)	NO	—
Test of air conditioning system refrigerant	A/C system refrigerant(Rdy)	N/A	—
Test of oxygen sensor	Oxygen sensor(Supp)	YES	—
Test of oxygen sensor	Oxygen sensor(Rdy)	NO	—
Test of oxygen sensor heater	O2 Heater Diagnosis(Supp)	YES	—
Test of oxygen sensor heater	O2 Heater Diagnosis(Rdy)	YES	—
Test of EGR system	EGR system(Supp)	NO	—
Test of EGR system	EGR system(Rdy)	N/A	—
Air fuel ratio control system for bank 1	Fuel system for Bank 1	Cl_normal	—
Engine load data	Calculated load value	19.2	%
Engine coolant temperature signal	Coolant Temp.	96	°C
Short term fuel trim by front oxygen (A/F) sensor (Bank 1)	Short term fuel trim B1	17.2	%
Long term fuel trim by front oxygen (A/F) sensor (Bank 1)	Long term fuel trim B1	5.5	%
Intake manifold absolute pressure signal	Mani. Absolute Pressure	248	mmHg
Engine speed signal	Engine Speed	846	rpm
Vehicle speed signal	Vehicle Speed	0	km/h
#1 Cylinder ignition timing	Ignition timing adv. #1	13.5	°
Intake air temperature signal	Intake Air Temp.	44	°C
Intake air amount	Mass Air Flow	3.6	g/s
Throttle position signal	Throttle Opening Angle	13	%
Secondary air control status	Secondary air system	Stop	—
Oxygen sensor (Bank 1 Sensor 2)	Oxygen sensor #12	0.1 — 0.7	V
A/F correction (Bank 1 Sensor 2)	Short term fuel trim #12	0.0	%
On-board diagnostic system	OBD System	OBD/OBD2	—
Front oxygen (A/F) sensor (Bank 1 Sensor 1)	Oxygen sensor #11	Supported	—
Oxygen sensor (Bank 1 Sensor 2)	Oxygen sensor #12	Supported	—
Elapsed time after engine start	Time Since Engine Start	—	sec
Travel distance after the malfunction indicator light illuminates	Lighted MI lamp history	—	km
A/F lambda signal (Bank 1 Sensor 1)	A/F Sensor #11	0.951	—
A/F sensor output signal (Bank 1 Sensor 1)	A/F Sensor #11	2.468	V
Evaporative purge	Evap Purge	0	%
Fuel level signal	Fuel Level	—	%
Number of warm ups after DTC clear	Number of warm-ups	—	—
Travel distance after DTC clear	Meter since DTC cleared	—	km
Atmospheric pressure signal	Atmosphere Pressure	Atmospheric pressure	mmHg
A/F lambda signal (Bank 1 Sensor 1)	A/F Sensor #11	0.957	—
A/F sensor output signal (Bank 1 Sensor 1)	A/F Sensor #11	-0.18	mA
Catalyst temperature #1	Catalyst Temperature #11	—	°C
Monitoring test of misfire	Misfire monitoring(Enable)	YES	—
Monitoring test of misfire	Misfire monitoring(Comp)	YES	—
Monitoring test of fuel system	Fuel system monitoring(Enable)	YES	—
Monitoring test of fuel system	Fuel system monitoring(Comp)	NO	—
Monitoring test of comprehensive component	Component monitoring(Enable)	NO	—
Monitoring test of comprehensive component	Component monitoring(Comp)	NO	—

# Subaru Select Monitor

ENGINE (DIAGNOSTICS)

Content	Display	Note (at idling)	Unit of measure
Test of catalyst	Catalyst Diagnosis(Enable)	YES	—
Test of catalyst	Catalyst Diagnosis(Comp)	NO	—
Test of heating-type catalyst	Heated catalyst(Enable)	N/A	—
Test of heating-type catalyst	Heated catalyst(Comp)	N/A	—
Test of evaporative emission purge control system	Evaporative purge system(Enable)	YES	—
Test of evaporative emission purge control system	Evaporative purge system(Comp)	NO	—
Secondary air system test	Secondary air system(Enable)	YES	—
Secondary air system test	Secondary air system(Comp)	NO	—
Test of air conditioning system refrigerant	A/C system refrigerant(Enable)	N/A	—
Test of air conditioning system refrigerant	A/C system refrigerant(Comp)	N/A	—
Test of oxygen sensor	Oxygen sensor(Enable)	YES	—
Test of oxygen sensor	Oxygen sensor(Comp)	NO	—
Test of oxygen sensor heater	O2 Heater Diagnosis(Enable)	YES	—
Test of oxygen sensor heater	O2 Heater Diagnosis(Comp)	YES	—
Test of EGR system	EGR system(Enable)	N/A	—
Test of EGR system	EGR system(Comp)	N/A	—
ECM power supply voltage	Control module voltage	13.848	V
Absolute load	Absolute Load Value	21	%
A/F target lambda	Target Equivalence Ratio	0.993	—
Relative throttle opening angle	Relative Throttle Pos.	2	%
Ambient temperature	Ambient Temperature	Ambient temperature	°C
Absolute throttle opening angle 2	Absolute Throttle Pos.#2	31	%
Absolute accelerator opening angle 1	Accelerator Pedal Pos.#1	13	%
Absolute accelerator opening angle 2	Accelerator Pedal Pos.#2	13	%
Target throttle opening angle	Target Throttle Opening Angle	0	%
Engine operating time while malfunction indicator light lit	Time while MIL lighted	—	min
Elapsed time after DTC clear	Time since DTC cleared	—	min
Type of fuel	Type of fuel	GAS	—
Relative acceleration opening angle	Relative Acceleration Pos.	0	%
Neutral condition	MT gear status	NEUT	—

**NOTE:**

For detailed operation procedures, refer to "PC application help for Subaru Select Monitor".



# Subaru Select Monitor

## ENGINE (DIAGNOSTICS)

### 4. READ FREEZE FRAME DATA FOR ENGINE (OBD MODE)

- 1) On «Main Menu» display, select {Each System Check}.
  - 2) On «System Selection Menu» display, select {Engine Control System}.
  - 3) Click the [OK] button after the information of engine type has been displayed.
  - 4) On «Engine Diagnosis» display, select {OBD System}.
  - 5) On «OBD Menu» display, select {Freeze Frame Data Display}.
- A list of the support data is shown in the following table.

Content	Display	Unit of measure
DTC of freeze frame data	Freeze frame data	—
Air fuel ratio control system for bank 1	Fuel system for Bank 1	—
Engine load data	Calculated load value	%
Engine coolant temperature signal	Coolant Temp.	°C or °F
Short term fuel trim by front oxygen (A/F) sensor (Bank 1)	Short term fuel trim B1	%
Long term fuel trim by front oxygen (A/F) sensor (Bank 1)	Long term fuel trim B1	%
Intake manifold absolute pressure signal	Mani. Absolute Pressure	mmHg, kPa, inHg or psi
Engine speed signal	Engine Speed	rpm
Vehicle speed signal	Vehicle Speed	km/h or MPH
Ignition timing adv. #1	Ignition timing adv. #1	°
Intake air temperature	Intake Air Temp.	°C
Amount of intake air	Mass Air Flow	g/s
Throttle valve angle	Throttle Opening Angle	%
Secondary air control status	Secondary air system	—
Oxygen sensor #12	Oxygen sensor #12	V
A/F correction #12	Short term fuel trim #12	%
OBD system	OBD System	—
Oxygen sensor #11	Oxygen sensor #11	—
Oxygen sensor #12	Oxygen sensor #12	—
Elapsed time after starting engine	Time Since Engine Start	sec
Evaporative purge	Evap Purge	%
Fuel level	Fuel Level	%
Atmospheric pressure	Atmosphere Pressure	mmHg, kPa, inHg or psig
ECM power supply voltage	Control module voltage	V
Absolute load	Absolute Load Value	%
A/F target lambda	Target Equivalence Ratio	—
Relative throttle opening angle	Relative Throttle Pos.	%
Ambient temperature	Ambient Temperature	°C or °F
Absolute throttle opening angle 2	Absolute Throttle Pos.#2	%
Absolute accelerator opening angle 1	Accelerator Pedal Pos.#1	%
Absolute accelerator opening angle 2	Accelerator Pedal Pos.#2	%
Target throttle opening angle	Target Throttle Opening Angle	%
Neutral condition	MT gear status	—

#### NOTE:

For detailed operation procedures, refer to “PC application help for Subaru Select Monitor”.

### 5. V.I.N REGISTRATION

- 1) On «Main Menu» display, select {Each System Check}.
- 2) On «System Selection Menu» display, select {Engine Control System}.
- 3) Click the [OK] button after the information of engine type has been displayed.
- 4) On the «Engine Diagnosis» display, select {Entry VIN}.
- 5) Perform the procedures shown on the display screen.

## 10. Read Diagnostic Trouble Code (DTC)

### A: OPERATION

#### 1. SUBARU SELECT MONITOR (NORMAL MODE)

- 1) On «Main Menu» display, select {Each System Check}.
- 2) On «System Selection Menu» display, select {Engine Control System}.
- 3) Click the [OK] button after the information of engine type has been displayed.
- 4) On «Engine Diagnosis» display, select {Diagnostic Code(s) Display}.
- 5) On «Diagnostic Code(s) Display» display, select {Temporary Diagnostic Code(s)} or {Memorized Diagnostic Code(s)}.

#### NOTE:

- For detailed operation procedures, refer to “PC application help for Subaru Select Monitor”.
- For details concerning DTC, refer to “List of Diagnostic Trouble Code (DTC)”. <Ref. to EN(H4DOTC)(diag)-88, List of Diagnostic Trouble Code (DTC).>

#### 2. SUBARU SELECT MONITOR (OBD MODE)

- 1) On «Main Menu» display, select {Each System Check}.
- 2) On «System Selection Menu» display, select {Engine Control System}.
- 3) Click the [OK] button after the information of engine type has been displayed.
- 4) On «Engine Diagnosis» display, select {OBD System}.
- 5) On «OBD Menu» display, select {Diagnostic Code(s) Display}.
- 6) Make sure DTC is shown on the screen.

#### NOTE:

- For detailed operation procedures, refer to “PC application help for Subaru Select Monitor”.
- For details concerning DTC, refer to “List of Diagnostic Trouble Code (DTC)”. <Ref. to EN(H4DOTC)(diag)-88, List of Diagnostic Trouble Code (DTC).>

#### 3. GENERAL SCAN TOOL

Refer to data denoting emission-related powertrain DTC.

For details concerning DTC, refer to “List of Diagnostic Trouble Code (DTC)”. <Ref. to EN(H4DOTC)(diag)-88, List of Diagnostic Trouble Code (DTC).>

#### NOTE:

Refer to general scan tool manufacturer’s instruction manual to access powertrain DTC (MODE \$03).

# Inspection Mode

ENGINE (DIAGNOSTICS)

## 11. Inspection Mode

### A: PROCEDURE

Perform the diagnosis shown in the following DTC table.

When performing the diagnosis not listed in "List of Diagnostic Trouble Code (DTC)", refer to the item on the drive cycle. <Ref. to EN(H4DOTC)(diag)-54, Drive Cycle.>

DTC	Item	Condition
P0011	Intake Camshaft Position - Timing Over-Advanced or System Performance (Bank 1)	—
P0014	Exhaust AVCS System 1 (Range/Performance)	—
P0016	Crankshaft Position - Camshaft Position Correlation (Bank1)	—
P0017	Crank and Cam Timing B System Failure (Bank 1)	—
P0018	Crankshaft Position - Camshaft Position Correlation (Bank2)	—
P0019	Crank and Cam Timing B System Failure (Bank 2)	—
P0021	Intake Camshaft Position - Timing Over-Advanced or System Performance (Bank 2)	—
P0024	Exhaust AVCS System 2 (Range/Performance)	—
P0031	HO2S Heater Control Circuit Low (Bank 1 Sensor 1)	—
P0032	HO2S Heater Control Circuit High (Bank 1 Sensor 1)	—
P0037	HO2S Heater Control Circuit Low (Bank 1 Sensor 2)	—
P0038	HO2S Heater Control Circuit High (Bank 1 Sensor 2)	—
P0102	Mass or Volume Air Flow Circuit Low Input	—
P0103	Mass or Volume Air Flow Circuit High Input	—
P0107	Manifold Absolute Pressure/Barometric Pressure Circuit Low Input	—
P0108	Manifold Absolute Pressure/Barometric Pressure Circuit High Input	—
P0112	Intake Air Temperature Sensor 1 Circuit Low	—
P0113	Intake Air Temperature Sensor 1 Circuit High	—
P0117	Engine Coolant Temperature Circuit Low	—
P0118	Engine Coolant Temperature Circuit High	—
P0122	Throttle/Pedal Position Sensor/Switch "A" Circuit Low	—
P0123	Throttle/Pedal Position Sensor/Switch "A" Circuit High	—
P0131	O2 Sensor Circuit Low Voltage (Bank 1 Sensor 1)	—
P0132	O2 Sensor Circuit High Voltage (Bank 1 Sensor 1)	—
P0137	O2 Sensor Circuit Low Voltage (Bank 1 Sensor 2)	—
P0138	O2 Sensor Circuit High Voltage (Bank 1 Sensor 2)	—
P0140	O2 Sensor Circuit No Activity Detected (Bank1 Sensor2)	—
P0201	Injector #1	—
P0202	Injector #2	—
P0203	Injector #3	—
P0204	Injector #4	—
P0222	Throttle/Pedal Position Sensor/Switch "B" Circuit Low	—
P0223	Throttle/Pedal Position Sensor/Switch "B" Circuit High	—
P0230	Fuel Pump Primary Circuit	—
P0245	Turbo/Super Charger Wastegate Solenoid "A" Low	—
P0327	Knock Sensor 1 Circuit Low (Bank 1 or Single Sensor)	—
P0328	Knock Sensor 1 Circuit High (Bank 1 or Single Sensor)	—
P0335	Crankshaft Position Sensor "A" Circuit	—
P0336	Crankshaft Position Sensor "A" Circuit Range/Performance	—
P0340	Camshaft Position Sensor "A" Circuit (Bank 1 or Single Sensor)	—
P0345	Camshaft Position Sensor "A" Circuit (Bank 2)	—
P0351	Ignition Coil A Primary/Secondary Circuit	—

EN(H4DOTC)(diag)-48

Brought to you by Ebay Seller "SubaruManuals"

# Inspection Mode

ENGINE (DIAGNOSTICS)

DTC	Item	Condition
P0352	Ignition Coil B Primary/Secondary Circuit	—
P0353	Ignition Coil C Primary/Secondary Circuit	—
P0354	Ignition Coil D Primary/Secondary Circuit	—
P0365	Camshaft Position Sensor "B" Circuit (Bank 1)	—
P0390	Camshaft Position Sensor "B" Circuit (Bank 2)	—
P0413	Secondary Air Injection System Switching Valve "A" Circuit Open	—
P0416	Secondary Air Injection System Switching Valve "B" Circuit Open	—
P0418	Secondary Air Injection System Control "A" Circuit Open	—
P0451	Evaporative Emission System Pressure Sensor/Switch Range/Performance	—
P0452	Evaporative Emission System Pressure Sensor/Switch Low	—
P0453	Evaporative Emission System Pressure Sensor/Switch High	—
P0458	Evaporative Emission System Purge Control Valve Circuit Low	—
P0462	Fuel Level Sensor "A" Circuit Low	—
P0463	Fuel Level Sensor "A" Circuit High	—
P0500	Vehicle Speed Sensor "A"	—
P0512	Starter Request Circuit	—
P0513	Incorrect Immobilizer Key	—
P0604	Internal Control Module Random Access Memory (RAM) Error	—
P0605	Internal Control Module Read Only Memory (ROM) Error	—
P0607	Throttle Control System Circuit Range/Performance	—
P0638	Throttle Actuator Control Range/Performance (Bank 1)	—
P0851	Park/Neutral Switch Input Circuit Low	—
P0852	Park/Neutral Switch Input Circuit High	—
P1152	O2 Sensor Circuit Range/Performance (Low) (Bank1 Sensor1)	—
P1153	O2 Sensor Circuit Range/Performance (High) (Bank1 Sensor1)	—
P1160	Return Spring Failure	—
P1400	Fuel Tank Pressure Control Solenoid Valve Circuit Low	—
P1410	Secondary Air Injection System Switching Valve Stuck Open	—
P1420	Fuel Tank Pressure Control Sol. Valve Circuit High	—
P1458	Canister Purge Control Solenoid Valve 2	—
P1459	Canister Purge Control Solenoid Valve 2	—
P1491	Positive Crankcase Ventilation (Blow-By) Function Problem	—
P1518	Starter Switch Circuit Low Input	—
P1560	Back-Up Voltage Circuit Malfunction	—
P1570	Antenna	—
P1571	Reference Code Incompatibility	—
P1572	IMM Circuit Failure (Except Antenna Circuit)	—
P1574	Key Communication Failure	—
P1576	EGI Control Module EEPROM	—
P1577	IMM Control Module EEPROM	—
P1578	Meter Failure	—
P2006	Intake Manifold Runner Control Stuck Closed (Bank 1)	—
P2007	Intake Manifold Runner Control Stuck Closed (Bank 2)	—
P2008	Intake Manifold Runner Control Circuit / Open (Bank 1)	—
P2009	Intake Manifold Runner Control Circuit Low (Bank 1)	—
P2011	Intake Manifold Runner Control Circuit / Open (Bank 2)	—
P2012	Intake Manifold Runner Control Circuit Low (Bank 2)	—
P2016	Intake Manifold Runner Position Sensor / Switch Circuit Low (Bank 1)	—
P2017	Intake Manifold Runner Position Sensor / Switch Circuit High (Bank 1)	—
P2021	Intake Manifold Runner Position Sensor / Switch Circuit Low (Bank 2)	—

**EN(H4DOTC)(diag)-49**

Brought to you by Ebay Seller "SubaruManuals"

## Inspection Mode

### ENGINE (DIAGNOSTICS)

DTC	Item	Condition
P2022	Intake Manifold Runner Position Sensor / Switch Circuit High (Bank 2)	—
P2088	Intake Camshaft Position Actuator Control Circuit Low (Bank 1)	—
P2089	Intake Camshaft Position Actuator Control Circuit High (Bank 1)	—
P2090	Exhaust Camshaft Position Actuator Control Circuit Low (Bank 1)	—
P2091	Exhaust Camshaft Position Actuator Control Circuit High (Bank 1)	—
P2092	Intake Camshaft Position Actuator Control Circuit Low (Bank 2)	—
P2093	Intake Camshaft Position Actuator Control Circuit High (Bank 2)	—
P2094	Exhaust Camshaft Position Actuator Control Circuit Low (Bank 2)	—
P2095	Exhaust Camshaft Position Actuator Control Circuit High (Bank 2)	—
P2101	Throttle Actuator Control Motor Circuit Range/Performance	—
P2102	Throttle Actuator Control Motor Circuit Low	—
P2103	Throttle Actuator Control Motor Circuit High	—
P2109	Throttle/Pedal Position Sensor "A" Minimum Stop Performance	—
P2122	Throttle/Pedal Position Sensor/Switch "D" Circuit Low Input	—
P2123	Throttle/Pedal Position Sensor/Switch "D" Circuit High Input	—
P2127	Throttle/Pedal Position Sensor/Switch "E" Circuit Low Input	—
P2128	Throttle/Pedal Position Sensor/Switch "E" Circuit High Input	—
P2135	Throttle/Pedal Position Sensor/Switch "A"/"B" Voltage Correlation	—
P2138	Throttle/Pedal Position Sensor/Switch "D"/"E" Voltage Correlation	—
P2401	Evaporative Emission System Leak Detection Pump Control Circuit Low	—
P2419	Evaporative Emission System Switching Valve Control Circuit Low	—
P2431	Secondary Air Injection System Air Flow /Pressure Sensor Circuit Range/Performance	—
P2432	Secondary Air Injection System Air Flow /Pressure Sensor Circuit Low	—
P2433	Secondary Air Injection System Air Flow /Pressure Sensor Circuit High	—
P2444	Secondary Air Injection System Pump Stuck On	—
U0073	CAN Failure, Bus 'Off' Detection	—
U0122	CAN (VDC) Data Not Loaded	—
U0140	CAN (BCU) Data Not Loaded	—
U0416	CAN (VDC) Data Abnormal	—
U0422	CAN (BCU) Data Abnormal	—

## 1. PREPARATION FOR THE INSPECTION MODE

- 1) Check that the battery voltage is 12 V or more and fuel remains approx. half [20 — 40 ℓ (5.3 — 10.6 US gal, 4.4 — 8.8 Imp gal)].
- 2) Lift up the vehicle using a garage jack and place it on rigid racks, or drive the vehicle onto free rollers.

### WARNING:

- Before lifting up the vehicle, ensure parking brake is applied.
- Do not use a pantograph jack in place of a rigid rack.
- Secure a rope or wire to the front or rear towing hooks to prevent the lateral runout of front wheels.
- Before rotating the wheels, make sure that there is no one in front of the vehicle. Besides while the wheels are rotating, make sure that no one approaches the vehicle front side.
- Make sure that there is nothing around the wheels. For AWD model, pay attention to all four wheels.
- While servicing, do not depress or release the clutch pedal or accelerator pedal quickly regardless of the engine speed. Quick operation may cause the vehicle to drop off the free roller.
- To prevent the vehicle from slipping due to vibration, do not place anything between rigid rack and the vehicle.

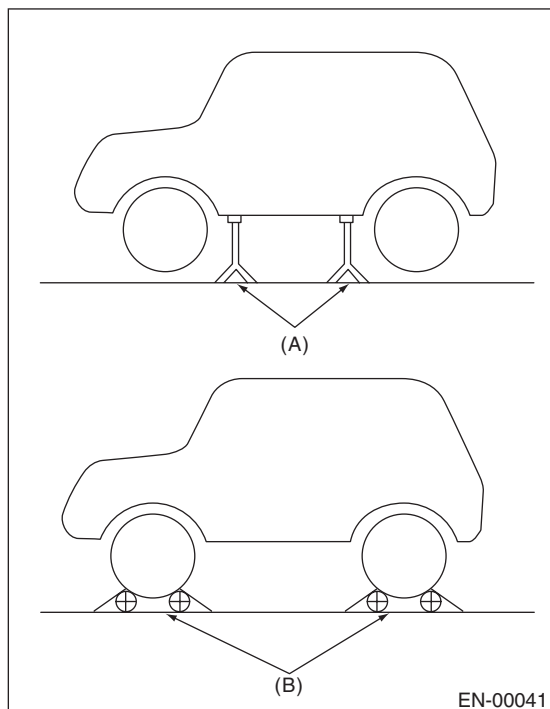

- (A) Rigid rack  
(B) Free roller

## 2. SUBARU SELECT MONITOR

- 1) Check that no DTC remains after clearing memory. <Ref. to EN(H4DOTC)(diag)-62, Clear Memory Mode.>
- 2) Warm up the engine.
- 3) Prepare the Subaru Select Monitor kit. <Ref. to EN(H4DOTC)(diag)-8, PREPARATION TOOL, General Description.>

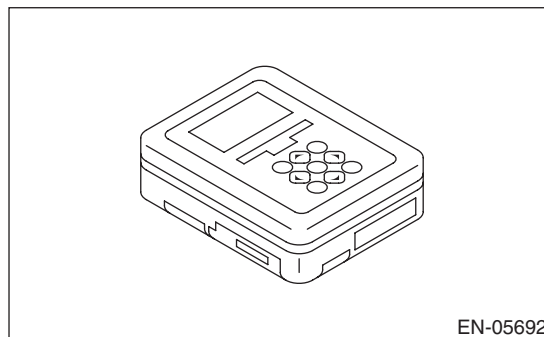

- 4) Prepare PC with Subaru Select Monitor installed.
- 5) Connect the USB cable to SDI (Subaru Diagnosis Interface) and USB port on the personal computer (dedicated port for the Subaru Select Monitor).

### NOTE:

The dedicated port for the Subaru Select Monitor means the USB port which was used to install the Subaru Select Monitor.

- 6) Connect the diagnosis cable to SDI.
- 7) Connect the delivery (test) mode connector (A) located under the glove box.

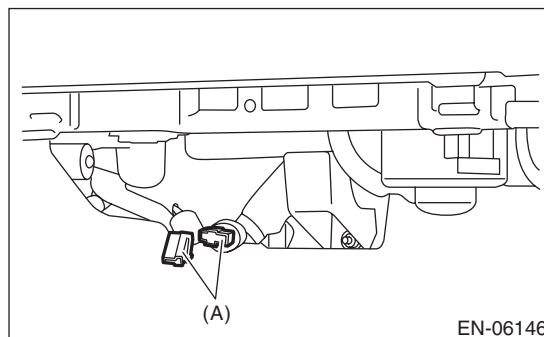

# Inspection Mode

## ENGINE (DIAGNOSTICS)

8) Connect SDI to data link connector located in the lower portion of the instrument panel (on the driver's side).

### CAUTION:

**Do not connect the scan tools except for Subaru Select Monitor and general scan tool.**

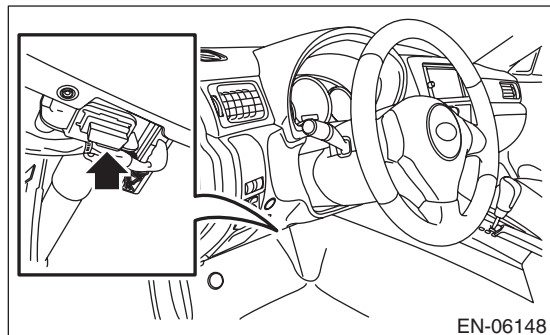

9) Start the PC.

10) Turn the ignition switch to ON (engine OFF) and run the "PC application for Subaru Select Monitor".

11) On «Main Menu» display, select {Each System Check}.

12) On «System Selection Menu» display, select {Engine Control System}.

13) Click the [OK] button after the information of engine type has been displayed.

14) On «Engine Diagnosis» display, select {Dealer Check Mode Procedure}.

15) When the "Perform Inspection (Dealer Check Mode ?)" is shown on the screen, click the [Next] button.

16) Perform subsequent procedures as instructed on the display screen.

- If trouble still remains in the memory, the corresponding DTC appears on the display screen.

### NOTE:

- For detailed operation procedures, refer to "PC application help for Subaru Select Monitor".
- For details concerning DTC, refer to "List of Diagnostic Trouble Code (DTC)".  
<Ref. to EN(H4DOTC)(diag)-88, List of Diagnostic Trouble Code (DTC).>
- Release the parking brake.
- The speed difference between front and rear wheels may illuminate the ABS warning light, but this does not indicate a malfunction. When engine control system diagnosis is finished, perform the VDC memory clearance procedure of self-diagnosis function. <Ref. to VDC(diag)-27, Clear Memory Mode.>

## 3. GENERAL SCAN TOOL

1) Check that no DTC remains after clearing memory. <Ref. to EN(H4DOTC)(diag)-62, Clear Memory Mode.>

2) Warm up the engine.

3) Connect the delivery (test) mode connector (A) located under the glove box.

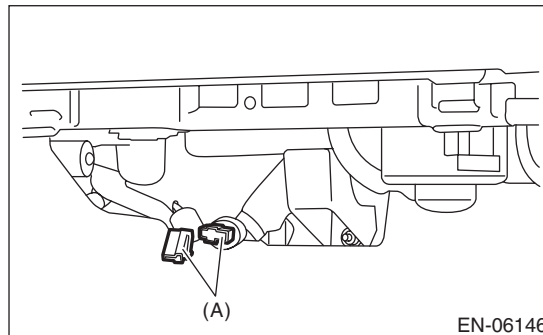

4) Connect the general scan tool to data link connector located in the lower portion of the instrument panel (on the driver's side).

### CAUTION:

**Do not connect the scan tools except for Subaru Select Monitor and general scan tool.**

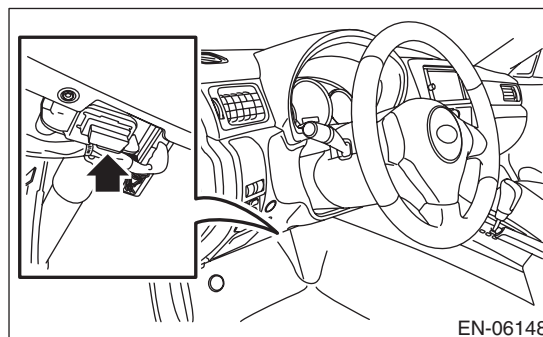

5) Start the engine.

### NOTE:

Depress the clutch pedal when starting engine.

6) Turn the neutral position switch to ON by operating shift lever.

7) Keep the engine speed in 2,500 — 3,000 rpm range for 40 seconds.

8) Place the shift lever in 1st gear and drive the vehicle at 5 to 10 km/h (3 to 6 MPH).

### NOTE:

- For AWD model, release the parking brake.
- The speed difference between front and rear wheels may illuminate the ABS warning light, but this does not indicate a malfunction. When engine control system diagnosis is finished, perform the VDC memory clearance procedure of self-diagnosis function. <Ref. to VDC(diag)-27, Clear Memory Mode.>

9) Using the general scan tool, check for DTC and record the result(s).

**NOTE:**

- For detailed operation procedures, refer to the general scan tool operation manual.
- For details concerning DTC, refer to "List of Diagnostic Trouble Code (DTC)".

<Ref. to EN(H4DOTC)(diag)-88, List of Diagnostic Trouble Code (DTC).>



# Drive Cycle

## ENGINE (DIAGNOSTICS)

### 12. Drive Cycle

#### A: PROCEDURE

It is necessary to perform the drive cycle listed below if DTC is not found in the Inspection Mode. It is possible to complete diagnosis of the DTC by performing the indicated drive cycle. After the repair for the DTC, perform a necessary drive cycle and make sure the function recovers and the DTC is recorded.

#### 1. PREPARATION FOR DRIVE CYCLE

- 1) Check that the battery voltage is 12 V or more and fuel remains approx. half [20 — 40 ℓ (5.3 — 10.6 US gal, 4.4 — 8.8 Imp gal)].
- 2) After performing the diagnostics and Clear Memory Mode, check that no DTC remains. <Ref. to EN(H4DOTC)(diag)-62, Clear Memory Mode.>
- 3) Check the delivery (test) mode connector is disconnected.

#### NOTE:

- Perform the drive cycle after warming up the engine except when the engine coolant temperature at engine start is specified.
- Perform the drive cycle twice if the DTC in the list is marked with \*. After completing the first drive cycle, stop the engine and perform second diagnosis in same condition.

#### 2. DRIVE CYCLE A

DTC	Item	Condition
*P0125	Insufficient Coolant Temperature for Closed Loop Fuel Control	«Coolant Temp.» at engine start: Less than 20°C (68°F)
*P0126	Insufficient Engine Coolant Temperature for Stable Operation	—
*P0128	Coolant Thermostat (Engine Coolant Temperature Below Thermostat Regulating Temperature)	—
*P0133	O2 Sensor Circuit Slow Response (Bank 1 Sensor 1)	—
*P0141	O2 Sensor Heater Circuit (Bank1 Sensor2)	—
*P0171	System Too Lean (Bank 1)	Complete diagnosis with drive cycle B or C as well.
*P0172	System Too Rich (Bank 1)	Complete diagnosis with drive cycle B or C as well.
*P0301	Cylinder 1 Misfire Detected	Complete diagnosis with drive cycle B or C as well.
*P0302	Cylinder 2 Misfire Detected	Complete diagnosis with drive cycle B or C as well.
*P0303	Cylinder 3 Misfire Detected	Complete diagnosis with drive cycle B or C as well.
*P0304	Cylinder 4 Misfire Detected	Complete diagnosis with drive cycle B or C as well.
*P0420	Catalyst System Efficiency Below Threshold (Bank 1)	—
*P0459	Evaporative Emission System Purge Control Valve Circuit High	—
*P2096	Post Catalyst Fuel Trim System Too Lean (Bank 1)	Complete diagnosis with drive cycle B or C as well.
*P2097	Post Catalyst Fuel Trim System Too Rich (Bank 1)	Complete diagnosis with drive cycle B or C as well.

#### Diagnostic procedure:

- 1) Drive for 20 minutes or more at a constant speed of 80 km/h (50 MPH) or more.
- 2) Stop the vehicle and idle for one minute.

# Drive Cycle

ENGINE (DIAGNOSTICS)

## 3. DRIVE CYCLE B

DTC	Item	Condition
*P0171	System Too Lean (Bank 1)	Complete diagnosis with drive cycle A or C as well.
*P0172	System Too Rich (Bank 1)	Complete diagnosis with drive cycle A or C as well.
*P0301	Cylinder 1 Misfire Detected	Complete diagnosis with drive cycle A or C as well.
*P0302	Cylinder 2 Misfire Detected	Complete diagnosis with drive cycle A or C as well.
*P0303	Cylinder 3 Misfire Detected	Complete diagnosis with drive cycle A or C as well.
*P0304	Cylinder 4 Misfire Detected	Complete diagnosis with drive cycle A or C as well.
*P0506	Idle Air Control System RPM Lower Than Expected	—
*P0507	Idle Air Control System RPM Higher Than Expected	—
*P2096	Post Catalyst Fuel Trim System Too Lean (Bank 1)	Complete diagnosis with drive cycle A or C as well.
*P2097	Post Catalyst Fuel Trim System Too Rich (Bank 1)	Complete diagnosis with drive cycle A or C as well.
*P219A	Bank 1 Air-Fuel Ratio Imbalance	Complete diagnosis with drive cycle C as well.

### Diagnostic procedure:

- 1) Drive at 10 km/h (6 MPH) or more.
- 2) Stop the vehicle and idle for ten minutes.

## 4. DRIVE CYCLE C

DTC	Item	Condition
*P0030	HO2S Heater Control Circuit (Bank 1 Sensor 1)	—
*P0068	MAP/MAF - Throttle Position Correlation	—
*P0101	Mass or Volume Air Flow Circuit Range/Performance	—
P0134	O2 Sensor Circuit No Activity Detected (Bank 1 Sensor 1)	—
*P013A	O2 Sensor Slow Response - Rich to Lean (Bank 1 Sensor 2)	—
*P013B	O2 Sensor Slow Response - Lean to Rich (Bank 1 Sensor 2)	—
*P013E	O2 Sensor Delayed Response - Rich to Lean (Bank 1 Sensor 2)	—
*P013F	O2 Sensor Delayed Response - Lean to Rich (Bank 1 Sensor 2)	—
*P0171	System Too Lean (Bank 1)	Complete diagnosis with drive cycle A or B as well.
*P0172	System Too Rich (Bank 1)	Complete diagnosis with drive cycle A or B as well.
P0244	Turbo/Super Charger Wastegate Solenoid "A" Range/Performance	—
P0246	Turbo/Super Charger Wastegate Solenoid "A" High	—
*P0301	Cylinder 1 Misfire Detected	Complete diagnosis with drive cycle A or B as well.
*P0302	Cylinder 2 Misfire Detected	Complete diagnosis with drive cycle A or B as well.
*P0303	Cylinder 3 Misfire Detected	Complete diagnosis with drive cycle A or B as well.
*P0304	Cylinder 4 Misfire Detected	Complete diagnosis with drive cycle A or B as well.
*P0441	Evaporative Emission Cont. Sys. Incorrect Purge Flow	—
*P1449	Evaporative Emission Cont. Sys. Air Filter Clog	—
P2004	Intake Manifold Runner Control Stuck Open (Bank 1)	—

# Drive Cycle

## ENGINE (DIAGNOSTICS)

DTC	Item	Condition
P2005	Intake Manifold Runner Control Stuck Open (Bank 2)	—
*P2096	Post Catalyst Fuel Trim System Too Lean (Bank 1)	Complete diagnosis with drive cycle A or B as well.
*P2097	Post Catalyst Fuel Trim System Too Rich (Bank 1)	Complete diagnosis with drive cycle A or B as well.
*P219A	Bank 1 Air-Fuel Ratio Imbalance	Complete diagnosis with drive cycle B as well.

### Diagnostic procedure:

Drive according to the drive pattern described below.

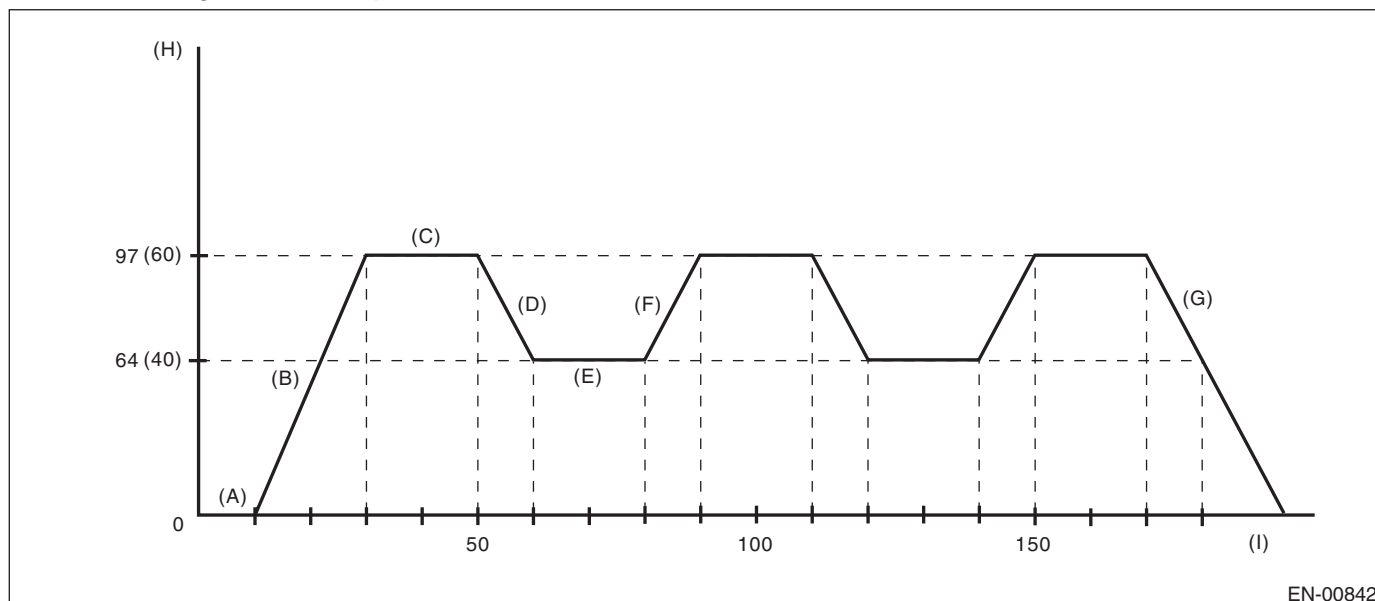

- |   |  |  |
|---|--|--|
| (A) Idle the engine for 10 seconds or more.                   | (D) Decelerate with fully closed throttle to 64 km/h (40 MPH) or less. | (G) Stop the vehicle with throttle fully closed. |
| (B) Accelerate to 97 km/h (60 MPH) or more within 20 seconds. | (E) Drive for 20 seconds or more at 64 km/h (40 MPH) or less.          | (H) Vehicle speed km/h (MPH)                     |
| (C) Drive for 20 seconds or more at 97 km/h (60 MPH) or more. | (F) Accelerate to 97 km/h (60 MPH) or more within 10 seconds.          | (I) Sec.   |

## 5. DRIVE CYCLE E

DTC	Item	Condition
*P0461	Fuel Level Sensor "A" Circuit Range/Performance	—

### Diagnostic procedure:

- 1) Make sure that the battery voltage is 10.9 V or more.
- 2) Perform the Clear Memory Mode. <Ref. to EN(H4DOTC)(diag)-62, Clear Memory Mode.>
- 3) Drive for approximately 30 ℓ (7.9 US gal, 6.6 Imp gal) of fuel.

#### NOTE:

- It is acceptable to drive the vehicle intermittently.
- Do not disconnect the battery terminals while diagnosing. (Data will be cleared by disconnecting the battery terminals.)

## 6. DRIVE CYCLE F

DTC	Item	Condition
*P0111	Intake Air Temperature Sensor 1 Circuit Range/Performance	—

### Diagnostic procedure:

- 1) Make sure that the engine coolant temperature is less than 30°C (86°F).
- 2) Drive according to the drive pattern described below.

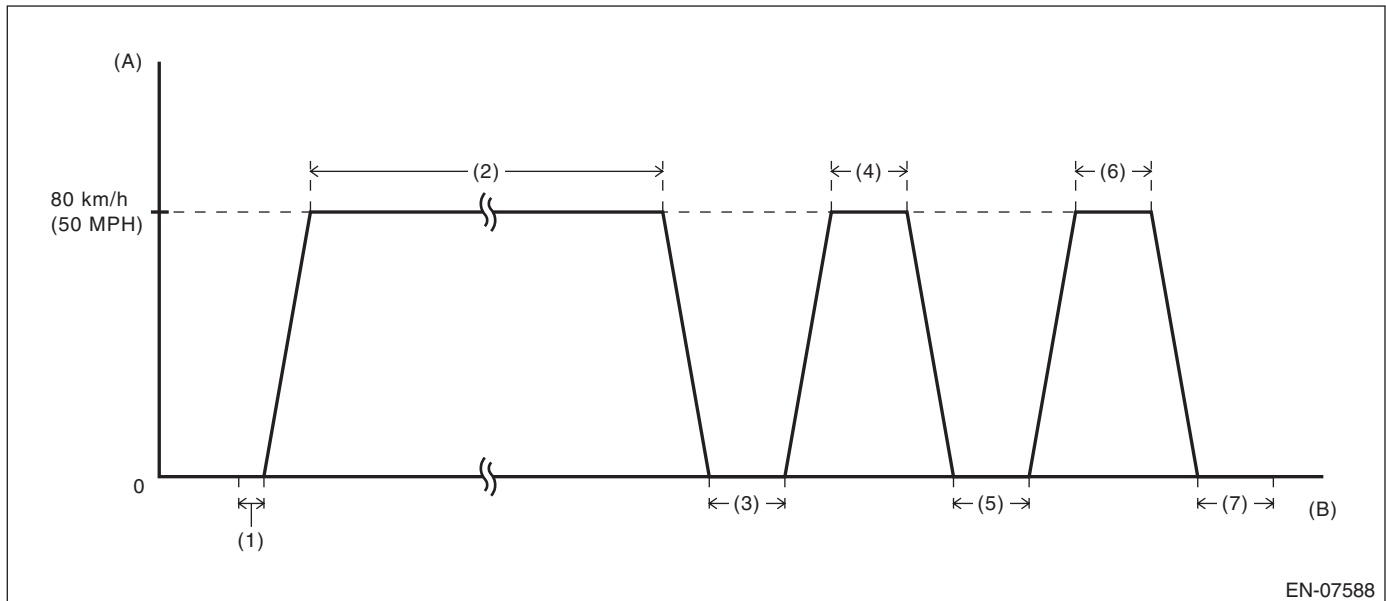

EN-07588

(A) Vehicle speed

(B) Elapsed time

- |  |   |   |
|--|---|---|
| <p>(1) Idle the engine for 10 seconds or more after engine start.</p> <p>(2) Drive for 8 minutes or more at a constant speed of 80 km/h (50 MPH) or more.</p> <p>(3) Stop the vehicle and idle for 30 seconds or more.</p> | <p>(4) Drive for 30 seconds or more at a constant speed of 80 km/h (50 MPH) or more.</p> <p>(5) Stop the vehicle and idle for 30 seconds or more.</p> | <p>(6) Drive for 30 seconds or more at a constant speed of 80 km/h (50 MPH) or more.</p> <p>(7) Stop the vehicle and idle for 30 seconds.</p> |
|--|---|---|

### NOTE:

- There is no given transition time between idling and cruising.
- Driving at constant speed only on a downhill causes smaller engine load and may result in failure to obtain a right diagnostic result.
- When the engine stops while performing drive cycle F, perform it again from the state of procedure 1).

# Drive Cycle

## ENGINE (DIAGNOSTICS)

### 7. DRIVE CYCLE G

DTC	Item	Condition
*P0410	Secondary Air Injection System	—
*P0411	Secondary Air Injection System Incorrect Flow Detected	—
P0414	Secondary Air Injection System Switching Valve "A" Circuit Shorted	—
P0417	Secondary Air Injection System Switching Valve "B" Circuit Shorted	—
P1418	Secondary Air Injection System Control "A" Circuit Shorted	—
*P2440	Secondary Air Injection System Switching Valve Stuck Open (Bank1)	—
*P2441	Secondary Air Injection System Switching Valve Stuck Closed (Bank1)	—
*P2442	Secondary Air Injection System Switching Valve Stuck Open (Bank2)	—
*P2443	Secondary Air Injection System Switching Valve Stuck Closed (Bank2)	—

#### Diagnostic procedure:

- 1) Disconnect the battery negative terminal, and reconnect after at least 10 seconds have passed.
- 2) Idle the engine until engine coolant temperature is 80°C (176°F).
- 3) Stop the engine to decrease the engine coolant temperature down to 40°C (104°F) or less.

#### NOTE:

Do not let engine coolant temperature drop to 5°C (41°F) or less.

- 4) Idle the engine until engine coolant temperature is 80°C (176°F).
- 5) Stop the engine to decrease the engine coolant temperature down to 40°C (104°F) or less.

#### NOTE:

Do not let engine coolant temperature drop to 5°C (41°F) or less.

- 6) Idle the engine.

### 8. DRIVE CYCLE H

DTC	Item	Condition
*P050A	Cold Start Idle Air Control System Performance	—
*P050B	Cold Start Ignition Timing Performance	—

#### Diagnostic procedure:

- 1) Perform the Clear Memory Mode. <Ref. to EN(H4DOTC)(diag)-62, Clear Memory Mode.>
- 2) With the ignition switch ON (engine OFF), read the engine coolant temperature, intake air temperature and fuel temperature. <Ref. to EN(H4DOTC)(diag)-41, READ CURRENT DATA FOR ENGINE (NORMAL MODE), OPERATION, Subaru Select Monitor.>
- 3) If the values from step 2) satisfy the following two conditions, idle the engine for one minute.

#### Condition:

$$|\text{Engine coolant temperature} - \text{Intake air temperature}| \leq 5^{\circ}\text{C} (9^{\circ}\text{F})$$

#### NOTE:

- If the conditions are not satisfied, turn the ignition switch to OFF and wait until the parameters are satisfied.
- Do not move the shift lever from neutral position during idling.

## 9. DRIVE CYCLE I

DTC	Item	Condition
*P0455	Evaporative Emission System Leak Detected (Large Leak)	«Coolant Temp.»: 5 — 45°C (41 — 113°F) «Intake Air Temp.»: 5 — 50°C (41 — 122°F)
*P0456	Evaporative Emission Control System Leak Detected (Very Small Leak)	
*P1451	Evaporative Emission Cont. Sys.	
*P2402	Evaporative Emission System Leak Detection Pump Control Circuit High	
*P2404	Evaporative Emission System Leak Detection Pump Sense Circuit Range/Performance	
*P2420	Evaporative Emission System Switching Valve Control Circuit High	

### CAUTION:

**Be careful of the state of the battery when performing the DRIVE CYCLE I consecutively. Performing the DRIVE CYCLE I consecutively without the engine running may cause a low battery voltage and battery discharge.**

### NOTE:

- If it is necessary to perform DRIVE CYCLE I consecutively, drive the vehicle under the following conditions to release accumulated evaporating gas. Performing the DRIVE CYCLE I consecutively without starting the engine causes a large amount of evaporating gas to accumulate in the canister, which hinders an accurate diagnosis.
  - After engine is warmed up
  - Drive for 10 minutes or more at a speed of 48 km/h (30 MPH) or more (duration of drive can be an accumulation)
- To obtain an accurate diagnostic result, perform the procedures according to the following points.
  - Do not refuel gas immediately before performing DRIVE CYCLE I. There will be a large amount of evaporating gas immediately after refuel, which may cause a less accurate diagnostic performance.
  - Do not shake the vehicle while performing DRIVE CYCLE I. Shaking the vehicle causes evaporating gas to increase inside the fuel tank, which may cause a less accurate diagnostic performance.
  - Do not perform any service operation including installation or removal of parts or connectors while performing DRIVE CYCLE I. Performing service operation could affect on the functions of related parts, which may cause a less accurate diagnostic performance.

1) Prepare the Subaru Select Monitor kit. <Ref. to EN(H4DOTC)(diag)-8, PREPARATION TOOL, General Description.>

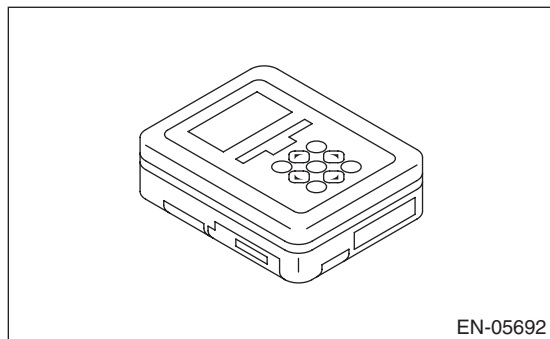

2) Prepare PC with Subaru Select Monitor installed.

3) Connect the USB cable to SDI (Subaru Diagnosis Interface) and USB port on the personal computer (dedicated port for the Subaru Select Monitor).

### NOTE:

The dedicated port for the Subaru Select Monitor means the USB port which was used to install the Subaru Select Monitor.

4) Connect the diagnosis cable to SDI.

# Drive Cycle

## ENGINE (DIAGNOSTICS)

5) Connect SDI to data link connector located in the lower portion of the instrument panel (on the driver's side).

### CAUTION:

**Do not connect the scan tools except for Subaru Select Monitor and general scan tool.**

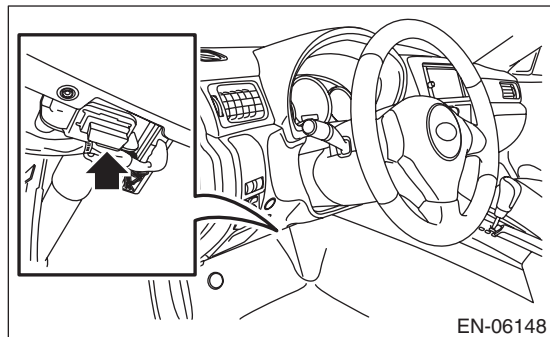

6) Start the PC.

7) Turn the ignition switch to ON (engine OFF) and run the "PC application for Subaru Select Monitor".

8) On «Main Menu» display, select {Each System Check}.

9) On «System Selection Menu» display, select {Engine Control System}.

10) Click the [OK] button after the information of engine type has been displayed.

11) On «Engine Diagnosis» display, select {OBD System}.

12) On «OBD Menu» display, select {Evaporative System Leak Test}.

13) On «Evaporative System Leak Test» display, select {Evaporative System Leak Test}.

14) On «Evaporative System Leak Test is running. Press Cancel to exit this function.» display, click the [OK] button to perform evaporative system leak test.

15) When «Conditions have been enabled to control this function. Turn the ignition switch off to terminate the test.» display appears, wait for 30 minutes without clicking the [OK] button.

### CAUTION:

**Do not leave the vehicle for an extended period of time after the test is complete. This may cause early deterioration of the battery or discharged battery.**

### NOTE:

- Clicking the [OK] button bring the «Evaporative System Leak Test» display back, although the test is continuing.
- The Subaru Select Monitor screen does not change after the evaporative system leak test is complete or when the test is aborted by turning off the ignition switch.
- If «Test conditions are not correct» display appears, check that the values in «Coolant Temp.» and «Intake Air Temp.» are within the specified range using Subaru Select Monitor. If the conditions are satisfied, make the necessary preparation for the drive cycle again. <Ref. to EN(H4DOTC)(diag)-54, PREPARATION FOR DRIVE CYCLE, PROCEDURE, Drive Cycle.>

16) After 30 minutes passed from the start of step 14), click the [OK] button to return to the «Evaporative System Leak Test» display.

17) Click buttons until the «OBD Menu» display appears, then select {Result of on-board monitor test}.

18) In the {Result of on-board monitor test}, check TID \$C1 — \$CA of MID \$3C.

### Result of on-board monitor test

Display	Details	Remarks
\$0000 is stored in all Val.	During the evaporative system leak test, the test conditions were not met and the test was canceled.	Once the test conditions are met, perform the test again.
All Val. are stored with values and OK is set to all the results.	Evaporative system leak test is completed correctly.	While the ignition switch is ON, read temporary codes using the Subaru Select Monitor.
Some results were no good.	The evaporative system leak test completed successfully but the results were faulty.	While the ignition switch is ON, read temporary codes using the Subaru Select Monitor.

# Drive Cycle

ENGINE (DIAGNOSTICS)

19) When the evaporative system leak test is completed correctly, read the temporary codes with the ignition switch turned to ON position. If the DTC is recorded, check the appropriate DTC. <Ref. to EN(H4DOTC)(diag)-47, OPERATION, Read Diagnostic Trouble Code (DTC).>

**NOTE:**

The temporary code will be cleared by turning ignition switch to OFF.

## 10.DRIVE CYCLE J

DTC	Item	Condition
P2610	ECM/PCM Internal Engine Off Timer Performance	—

1) Idle the engine for 15 minutes or more.

2) Turn the ignition switch to OFF.

3) After 6 hours passed from the start of step 2), read the temporary code using the Subaru Select Monitor. <Ref. to EN(H4DOTC)(diag)-47, OPERATION, Read Diagnostic Trouble Code (DTC).>



# Clear Memory Mode

ENGINE (DIAGNOSTICS)

---

## 13. Clear Memory Mode

### A: OPERATION

#### 1. SUBARU SELECT MONITOR (NORMAL MODE)

- 1) On «Main Menu» display, select {Each System Check}.
- 2) On «System Selection Menu» display, select {Engine Control System}.
- 3) Click the [OK] button after the information of engine type has been displayed.
- 4) On «Engine Diagnosis» display, select {Clear Memory}.
- 5) When the “Clear Memory?” is shown on the screen, click the [YES] button.
- 6) When “Done” and “Turn off the ignition switch.” are shown on the display screen, turn the ignition switch to OFF.

#### NOTE:

- Initial diagnosis of electronic throttle control is performed after memory clearance. Wait for 10 seconds or more after turning the ignition switch to ON, and then start the engine.
- For detailed operation procedures, refer to “PC application help for Subaru Select Monitor”.

#### 2. SUBARU SELECT MONITOR (OBD MODE)

- 1) On «Main Menu» display, select {Each System Check}.
- 2) On «System Selection Menu» display, select {Engine Control System}.
- 3) Click the [OK] button after the information of engine type has been displayed.
- 4) On «Engine Diagnosis» display, select {OBD System}.
- 5) On «OBD Menu» display, select {Clear Diagnostic Code(s)}.
- 6) When the “Clear Diagnostic Code?” is shown on the screen, click the [Yes] button.
- 7) When “Done” and “Turn off the ignition switch.” are shown on the display screen, turn the ignition switch to OFF.

#### NOTE:

- Initial diagnosis of electronic throttle control is performed after memory clearance. Wait for 10 seconds or more after turning the ignition switch to ON, and then start the engine.
- For detailed operation procedures, refer to “PC application help for Subaru Select Monitor”.

#### 3. GENERAL SCAN TOOL

For procedures clearing memory using the general scan tool, refer to the general scan tool operation manual.

#### NOTE:

Initial diagnosis of electronic throttle control is performed after memory clearance. Wait for 10 seconds or more after turning the ignition switch to ON, and then start the engine.

## 14. Compulsory Valve Operation Check Mode

### A: OPERATION

1) Prepare the Subaru Select Monitor kit. <Ref. to EN(H4DOTC)(diag)-8, PREPARATION TOOL, General Description.>

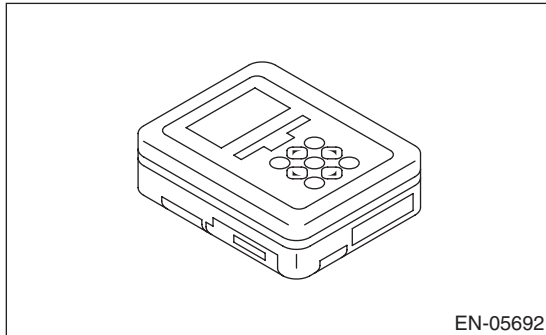

2) Prepare PC with Subaru Select Monitor installed.

3) Connect the USB cable to SDI (Subaru Diagnosis Interface) and USB port on the personal computer (dedicated port for the Subaru Select Monitor).

#### NOTE:

The dedicated port for the Subaru Select Monitor means the USB port which was used to install the Subaru Select Monitor.

4) Connect the diagnosis cable to SDI.

5) Connect the delivery (test) mode connector (A) located under the glove box.

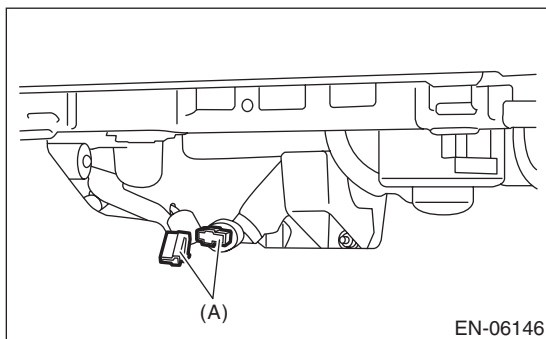

6) Connect SDI to data link connector located in the lower portion of the instrument panel (on the driver's side).

#### CAUTION:

**Do not connect the scan tools except for Subaru Select Monitor and general scan tool.**

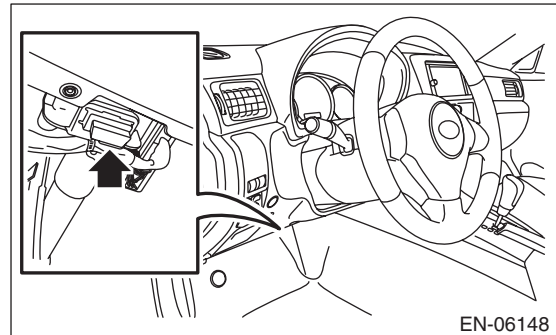

7) Start the PC.

8) Turn the ignition switch to ON (engine OFF) and run the "PC application for Subaru Select Monitor".

9) On «Main Menu» display, select {Each System Check}.

10) On «System Selection Menu» display, select {Engine Control System}.

11) Click the [OK] button after the information of engine type has been displayed.

12) On «Engine Diagnosis» display, select {System Operation Check Mode}.

13) On «System Operation Check Mode» display, select {Actuator ON/OFF Operation}.

14) Select the actuator to be forcibly driven on the «Actuator ON/OFF Operation» display screen and click the [Next] button.

15) Clicking the [Finished] button completes the compulsory drive mode of actuator. The display will then return to the «Actuator ON/OFF Operation» screen.

#### NOTE:

For detailed operation procedures, refer to "PC application help for Subaru Select Monitor".

# System Operation Check Mode

ENGINE (DIAGNOSTICS)

## 15. System Operation Check Mode

### A: OPERATION

1) Prepare the Subaru Select Monitor kit. <Ref. to EN(H4DOTC)(diag)-8, PREPARATION TOOL, General Description.>

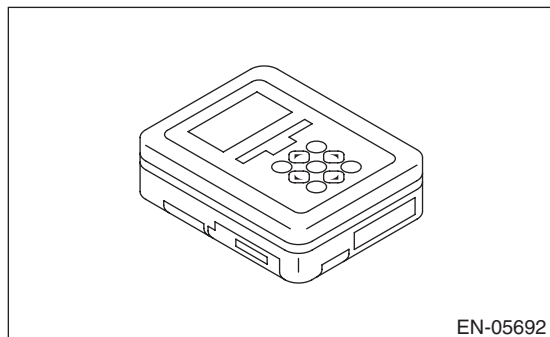

2) Prepare PC with Subaru Select Monitor installed.

3) Connect the USB cable to SDI (Subaru Diagnosis Interface) and USB port on the personal computer (dedicated port for the Subaru Select Monitor).

#### NOTE:

The dedicated port for the Subaru Select Monitor means the USB port which was used to install the Subaru Select Monitor.

4) Connect the diagnosis cable to SDI.

5) Connect SDI to data link connector located in the lower portion of the instrument panel (on the driver's side).

#### CAUTION:

Do not connect the scan tools except for Subaru Select Monitor and general scan tool.

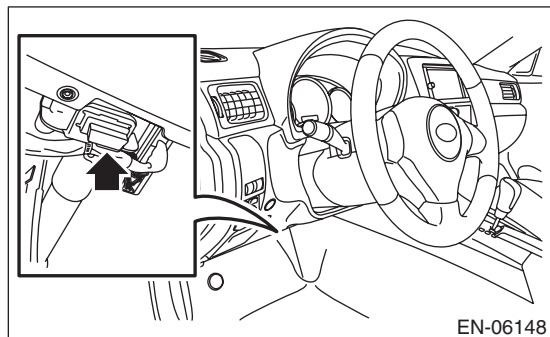

6) Start the PC.

7) Turn the ignition switch to ON (engine OFF) and run the "PC application for Subaru Select Monitor".

8) On «Main Menu» display, select {Each System Check}.

9) On «System Selection Menu» display, select {Engine Control System}.

10) Click the [OK] button after the information of engine type has been displayed.

11) On «Engine Diagnosis» display, select {System Operation Check Mode}.

12) The following items are displayed on the monitor.

Display
Actuator ON/OFF Operation
Immobilizer System
Fuel Pump Control
Fixed Idle Ignition Timing
Idle Speed Control
Injector Control

### 1. FUEL PUMP CONTROL (OFF DRIVE)

#### CAUTION:

After executing the system operation check mode, execute the Clear Memory Mode. <Ref. to EN(H4DOTC)(diag)-62, OPERATION, Clear Memory Mode.>

1) On «System Operation Check Mode» display, select {Fuel Pump Control}.

2) On «Fuel Pump Control» display, select {OFF Drive}.

3) On «Start the Engine» display, start the engine and click the [OK] button.

4) On «OFF Drive» display, click the [Execution] button and execute the OFF drive.

5) Click the [Cancel] button to stop the OFF drive.

6) Click the [Exit] button to end the OFF drive. The screen will return to the «Fuel Pump Control» screen.

#### NOTE:

For detailed operation procedures, refer to "PC application help for Subaru Select Monitor".

### 2. FUEL PUMP CONTROL (ON/OFF DRIVE)

#### CAUTION:

After executing the system operation check mode, execute the Clear Memory Mode. <Ref. to EN(H4DOTC)(diag)-62, OPERATION, Clear Memory Mode.>

1) On «System Operation Check Mode» display, select {Fuel Pump Control}.

2) On «Fuel Pump Control» display, select {ON/OFF Dr.}.

3) On «Turn Ignition Switch ON with Engine OFF» display, turn the ignition switch to ON and click the [OK] button.

4) On «ON/OFF Dr.» display, click the [Execution] button and execute the ON/OFF drive.

5) Click the [Cancel] button to stop the ON/OFF drive.

6) Click the [F12 Exit] button to end the ON/OFF drive. The screen will return to the «Fuel Pump Control» screen.

**NOTE:**

For detailed operation procedures, refer to “PC application help for Subaru Select Monitor”.

### 3. IDLING IGNITION TIMING FIXED

**CAUTION:**

**After executing the system operation check mode, execute the Clear Memory Mode. <Ref. to EN(H4DOTC)(diag)-62, OPERATION, Clear Memory Mode.>**

- 1) On «System Operation Check Mode» display, select {Fixed Idle Ignition Timing}.
- 2) On «Start the Engine» display, start the engine and click the [OK] button.
- 3) On «Fixed Idle Ignition Timing» display, click the [Execution] button and execute the idling ignition timing fixed.
- 4) Click the [Cancel] button to stop the idling ignition timing fixed.
- 5) Click the [F12 Exit] button to end the idle ignition timing fixed. The screen will return to the «System Operation Check Mode» screen.

**NOTE:**

For detailed operation procedures, refer to “PC application help for Subaru Select Monitor”.

### 4. IDLE SPEED CONTROL

**CAUTION:**

**After executing the system operation check mode, execute the Clear Memory Mode. <Ref. to EN(H4DOTC)(diag)-62, OPERATION, Clear Memory Mode.>**

- 1) On «System Operation Check Mode» display, select {Idle Speed Control}.
- 2) On «Start the Engine» display, start the engine and click the [OK] button.
- 3) In the «Idle Speed Control» display, click the [Δ] button or the [▽] button to change the setting values, then click the [OK] button.

Setting is possible in a range between 500 rpm — 2,000 rpm, in increments of 50 rpm. However, the engine speed that can actually be controlled will vary depending on the vehicle.

- 4) Click the [Cancel] button to stop the idle speed control.
- 5) Click the [F12 Exit] button to end the idle speed control. The screen will return to the «System Operation Check Mode» screen.

**NOTE:**

For detailed operation procedures, refer to “PC application help for Subaru Select Monitor”.

### 5. INJECTOR CONTROL (INJECTION STOP MODE)

**CAUTION:**

**After executing the system operation check mode, execute the Clear Memory Mode. <Ref. to EN(H4DOTC)(diag)-62, OPERATION, Clear Memory Mode.>**

- 1) On «System Operation Check Mode» display, select {Injector Control}.
- 2) On «Injector Control» display, select {Injection Stop Mode}.
- 3) On «Injection Stop Mode» display, select the fuel injector to be stopped.
- 4) On «Start the Engine» display, start the engine and click the [OK] button.
- 5) On «Fuel Injector #» display, click the [Execution] button and execute the injection stop mode.
- 6) Click the [Cancel] button to stop the injection stop mode.
- 7) Click the [F12 Exit] button to return the «Injection Stop Mode» display screen.
- 8) On the «Injection Stop Mode» display, click the [Return] button to end the «Injection Stop Mode». The screen will return to the «Injector Control» screen.

**NOTE:**

For detailed operation procedures, refer to “PC application help for Subaru Select Monitor”.

### 6. INJECTOR CONTROL. (INJECTION QUANTITY CONTROL)

**CAUTION:**

**After executing the system operation check mode, execute the Clear Memory Mode. <Ref. to EN(H4DOTC)(diag)-62, OPERATION, Clear Memory Mode.>**

- 1) On «System Operation Check Mode» display, select {Injector Control}.
- 2) On «Injector Control» display, select {Injection Quantity Control}.
- 3) On «Start the Engine» display, start the engine and click the [OK] button.
- 4) In the «Injection Quantity Control» display, click the [Δ] button or the [▽] button to change the setting values, then click the [OK] button. Setting is possible in a range between 0 — 20%, in increments of 1%.
- 5) Click the [Cancel] button to stop the injection quantity control.
- 6) Click the [F12 Exit] button to end the injection quantity control. The screen will return to the «Injector Control» screen.

**NOTE:**

For detailed operation procedures, refer to “PC application help for Subaru Select Monitor”.

# Malfunction Indicator Light

ENGINE (DIAGNOSTICS)

## 16. Malfunction Indicator Light

### A: PROCEDURE

1. Activation of malfunction indicator light. <Ref. to EN(H4DOTC)(diag)-66, ACTIVATION OF MALFUNCTION INDICATOR LIGHT, Malfunction Indicator Light.>
↓
2. Malfunction indicator light does not come on. <Ref. to EN(H4DOTC)(diag)-68, MALFUNCTION INDICATOR LIGHT DOES NOT COME ON, Malfunction Indicator Light.>
↓
3. Malfunction indicator light does not go off <Ref. to EN(H4DOTC)(diag)-68, MALFUNCTION INDICATOR LIGHT DOES NOT GO OFF, Malfunction Indicator Light.>
↓
4. Malfunction indicator light does not blink <Ref. to EN(H4DOTC)(diag)-69, MALFUNCTION INDICATOR LIGHT DOES NOT BLINK, Malfunction Indicator Light.>
↓
5. Malfunction indicator light remains blinking <Ref. to EN(H4DOTC)(diag)-71, MALFUNCTION INDICATOR LIGHT REMAINS BLINKING, Malfunction Indicator Light.>

### B: ACTIVATION OF MALFUNCTION INDICATOR LIGHT

1) When the ignition switch is turned to ON (engine OFF), the malfunction indicator light (A) in the combination meter illuminates.

#### NOTE:

If the malfunction indicator light does not illuminate, perform diagnostics of the malfunction indicator light circuit or the combination meter circuit. <Ref. to EN(H4DOTC)(diag)-68, MALFUNCTION INDICATOR LIGHT DOES NOT COME ON, Malfunction Indicator Light.>

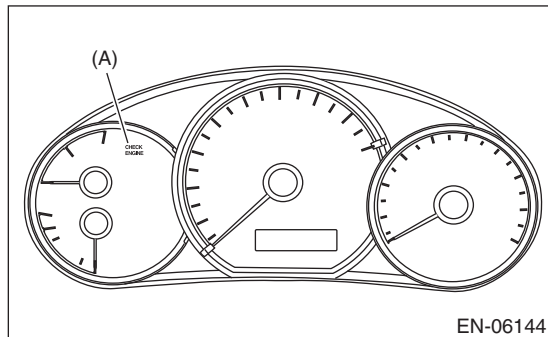

2) After starting the engine, the malfunction indicator light goes out. If it does not go off, any of the engine and emission control system has malfunction.

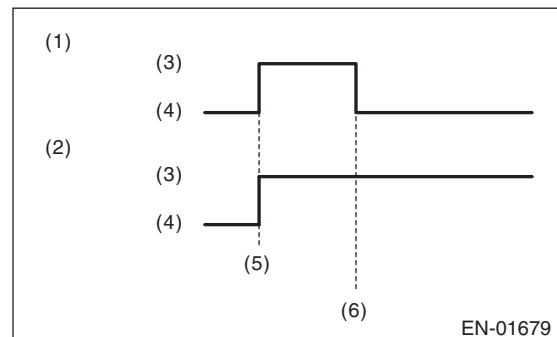

- (1) No DTC
- (2) Trouble occurs
- (3) ON
- (4) OFF
- (5) Ignition switch ON
- (6) Engine start

EN(H4DOTC)(diag)-66

Brought to you by Ebay Seller "SubaruManuals"

# Malfunction Indicator Light

ENGINE (DIAGNOSTICS)

3) If the diagnostic system detects a misfire which could damage the catalyst, the malfunction indicator light will blink at a cycle of 1 Hz.

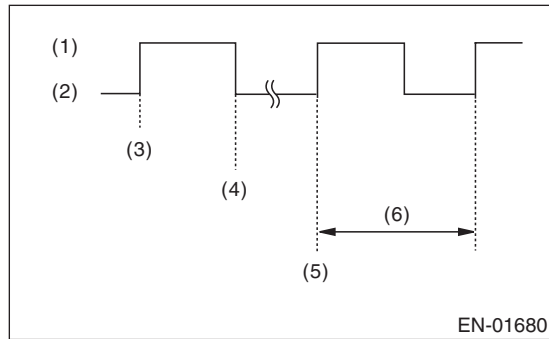

- (1) ON
- (2) OFF
- (3) Ignition switch ON
- (4) Engine start
- (5) Misfire start
- (6) 1 second

(3) Malfunction indicator light blinks at a cycle of 3 Hz after diagnosis if there is no trouble. Malfunction indicator light illuminates if faulty.

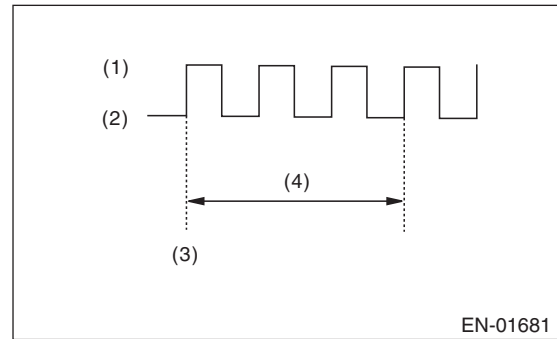

- (1) ON
- (2) OFF
- (3) Ignition switch ON
- (4) 1 second

4) Turn the ignition switch to OFF and connect the delivery (test) mode connector (A) located under the glove box.

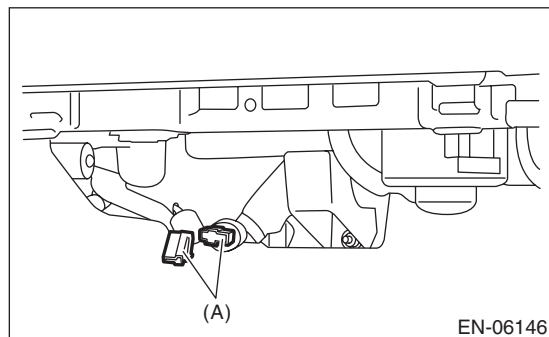

- (1) When the ignition switch is turned to ON (engine OFF), the malfunction indicator light illuminates.
- (2) After the engine starts, malfunction indicator light blinks in a cycle of 0.5 Hz. (During diagnosis)

# Malfunction Indicator Light

ENGINE (DIAGNOSTICS)

## C: MALFUNCTION INDICATOR LIGHT DOES NOT COME ON

### TROUBLE SYMPTOM:

When the ignition switch is turned to ON (engine OFF), malfunction indicator light does not illuminate.

Step	Check	Yes	No	
<b>1</b>	<b>CHECK DTC.</b>	Is DTC of LAN system displayed? <Ref. to LAN(diag)-29, OPERATION, Read Diagnostic Trouble Code (DTC).>	Check the appropriate DTC using the "List of Diagnostic Trouble Code (DTC)". <Ref. to LAN(diag)-33, List of Diagnostic Trouble Code (DTC).>	Replace the meter case assembly of combination meter. <Ref. to IDI-16, Combination Meter.>

## D: MALFUNCTION INDICATOR LIGHT DOES NOT GO OFF

### TROUBLE SYMPTOM:

Although malfunction indicator light comes on when the engine runs, DTC is not shown on the Subaru Select Monitor or general scan tool display.

Step	Check	Yes	No	
<b>1</b>	<b>CHECK DTC.</b>	Is DTC of engine or LAN system displayed? <Ref. to EN(H4DOTC)(diag)-47, OPERATION, Read Diagnostic Trouble Code (DTC).>	Check the appropriate DTC using the "List of Diagnostic Trouble Code (DTC)". <Ref. to EN(H4DOTC)(diag)-88, List of Diagnostic Trouble Code (DTC).> <Ref. to LAN(diag)-33, List of Diagnostic Trouble Code (DTC).>	Go to step 2.
<b>2</b>	<b>CHECK COMBINATION METER.</b> Perform the self-diagnosis for combination meter system. <Ref. to IDI-5, SELF-DIAGNOSIS, INSPECTION, Combination Meter System.>	Does the malfunction indicator light illuminate and go off normally?	Replace the ECM. <Ref. to FU(STI)-59, Engine Control Module (ECM).> <Ref. to FU(w/o STI)-58, Engine Control Module (ECM).>	Replace the meter case assembly of combination meter. <Ref. to IDI-16, Combination Meter.>

# Malfunction Indicator Light

## E: MALFUNCTION INDICATOR LIGHT DOES NOT BLINK

### DIAGNOSIS:

- The malfunction indicator light circuit is open or shorted.
- The delivery (test) mode connector circuit is open.

### TROUBLE SYMPTOM:

Malfunction indicator light does not blink during Inspection Mode.

### WIRING DIAGRAM:

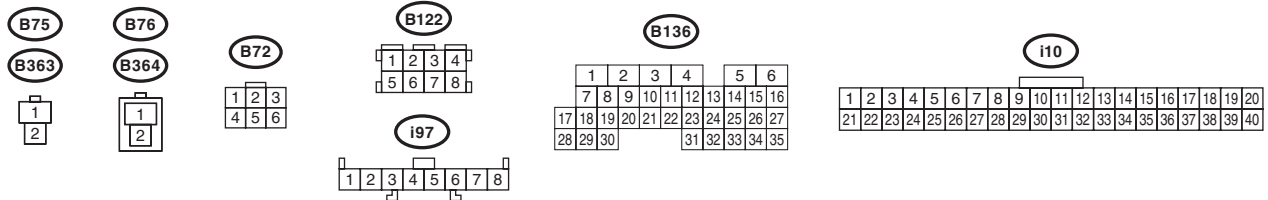
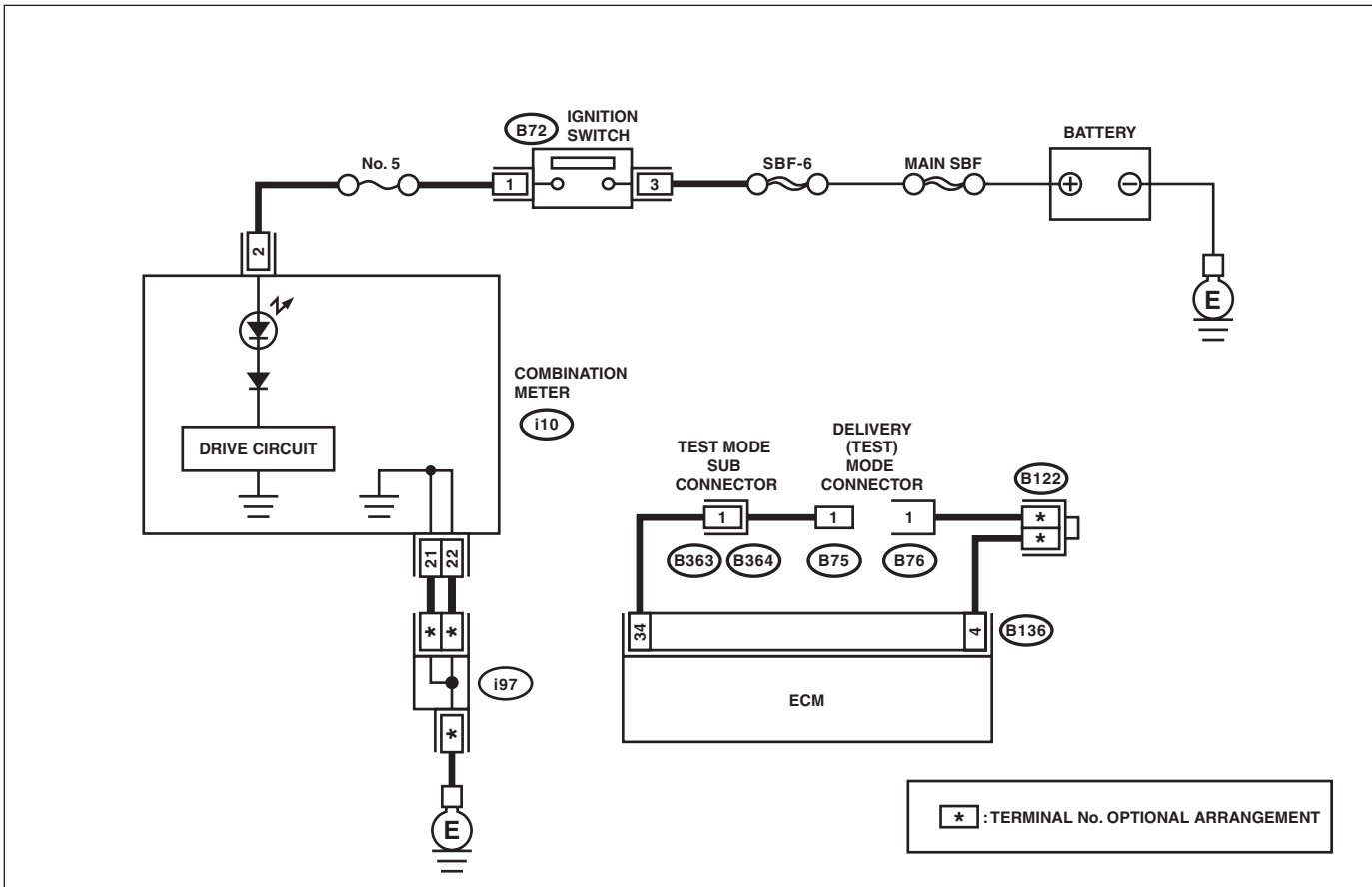



# Malfunction Indicator Light

## ENGINE (DIAGNOSTICS)

Step	Check	Yes	No
<b>1 CHECK STATUS OF MALFUNCTION INDICATOR LIGHT.</b> 1) Turn the ignition switch to OFF. 2) Check the delivery (test) mode connector is disconnected. 3) Turn the ignition switch to ON. (engine OFF)	Does the malfunction indicator light illuminate?	Go to step 2.	Repair the malfunction indicator light circuit. <Ref. to EN(H4DOTC)(diag)-68, MALFUNCTION INDICATOR LIGHT DOES NOT COME ON, Malfunction Indicator Light.>
<b>2 CHECK HARNESS BETWEEN ECM AND DELIVERY (TEST) MODE CONNECTOR.</b> 1) Turn the ignition switch to OFF. 2) Disconnect the connector from ECM. 3) Connect the delivery (test) mode connector. 4) Measure the resistance of harness between ECM connectors. <b>Connector &amp; terminal</b> <b>(B136) No. 34 — (B136) No. 4:</b>	Is the resistance less than 1 Ω?	Go to step 3.	Repair the harness and connector. NOTE: In this case, repair the following item: • Open circuit in harness between ECM connector • Poor contact of each connector between ECM connector
<b>3 CHECK FOR POOR CONTACT.</b> Check for poor contact of ECM connector.	Is there poor contact of ECM connector?	Repair the poor contact of ECM connector.	Replace the ECM. <Ref. to FU(STI)-59, Engine Control Module (ECM).> <Ref. to FU(w/o STI)-58, Engine Control Module (ECM).>

# Malfunction Indicator Light

ENGINE (DIAGNOSTICS)

## F: MALFUNCTION INDICATOR LIGHT REMAINS BLINKING

### DIAGNOSIS:

The delivery (test) mode connector circuit is short-circuited to ground.

### TROUBLE SYMPTOM:

Malfunction indicator light blinks when delivery (test) mode connector is not connected.

### WIRING DIAGRAM:

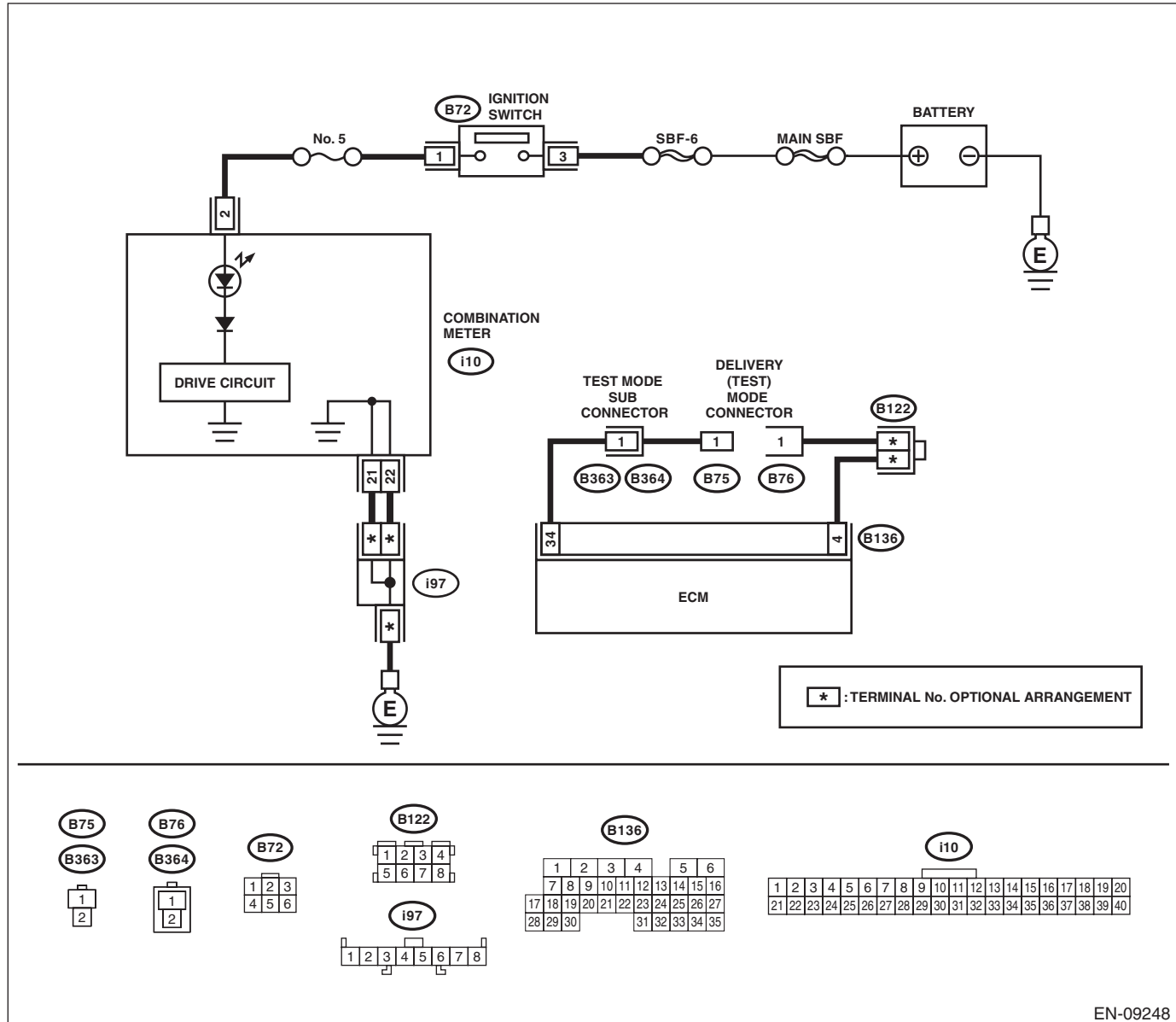

EN-09248

Step	Check	Yes	No
<b>1 CHECK DELIVERY (TEST) MODE CONNECTOR.</b> 1) Check the delivery (test) mode connector is disconnected. 2) Turn the ignition switch to ON.	Does the malfunction indicator light blink?	Go to step 2.	System is normal. NOTE: Malfunction indicator light blinks at a cycle of 3 Hz when delivery (test) mode connector is connected.

# Malfunction Indicator Light

## ENGINE (DIAGNOSTICS)

Step	Check	Yes	No
<b>2</b> <b>CHECK HARNESS BETWEEN ECM AND DELIVERY (TEST) MODE CONNECTOR.</b> 1) Turn the ignition switch to OFF. 2) Disconnect the connector from ECM. 3) Measure the resistance between ECM and chassis ground. <b>Connector &amp; terminal</b> <b>(B136) No. 34 — Chassis ground:</b>	Is the resistance 1 MΩ or more?	Replace the ECM. <Ref. to FU(STI)-59, Engine Control Module (ECM).> <Ref. to FU(w/o STI)-58, Engine Control Module (ECM).>	Repair the short circuit to ground in harness between ECM and delivery (test) mode connector.

## 17. Diagnostics for Engine Starting Failure

### A: PROCEDURE

1. Check of the fuel amount
↓
2. Inspection of starter motor circuit <Ref. to EN(H4DOTC)(diag)-74, STARTER MOTOR CIRCUIT, Diagnostics for Engine Starting Failure.>
↓
3. Inspection of ECM power supply and ground line <Ref. to EN(H4DOTC)(diag)-78, CHECK POWER SUPPLY AND GROUND LINE OF ENGINE CONTROL MODULE (ECM), Diagnostics for Engine Starting Failure.>
↓
4. Inspection of ignition control system <Ref. to EN(H4DOTC)(diag)-80, IGNITION CONTROL SYSTEM, Diagnostics for Engine Starting Failure.>
↓
5. Inspection of fuel pump circuit <Ref. to EN(H4DOTC)(diag)-83, FUEL PUMP CIRCUIT, Diagnostics for Engine Starting Failure.>
↓
6. Inspection of fuel injector circuit <Ref. to EN(H4DOTC)(diag)-84, FUEL INJECTOR CIRCUIT, Diagnostics for Engine Starting Failure.>

# Diagnostics for Engine Starting Failure

ENGINE (DIAGNOSTICS)

## B: STARTER MOTOR CIRCUIT

### CAUTION:

After servicing or replacing faulty parts, perform Clear Memory Mode <Ref. to EN(H4DOTC)(diag)-62, OPERATION, Clear Memory Mode.>, and Inspection Mode <Ref. to EN(H4DOTC)(diag)-48, PROCEDURE, Inspection Mode.>.

### WIRING DIAGRAM:

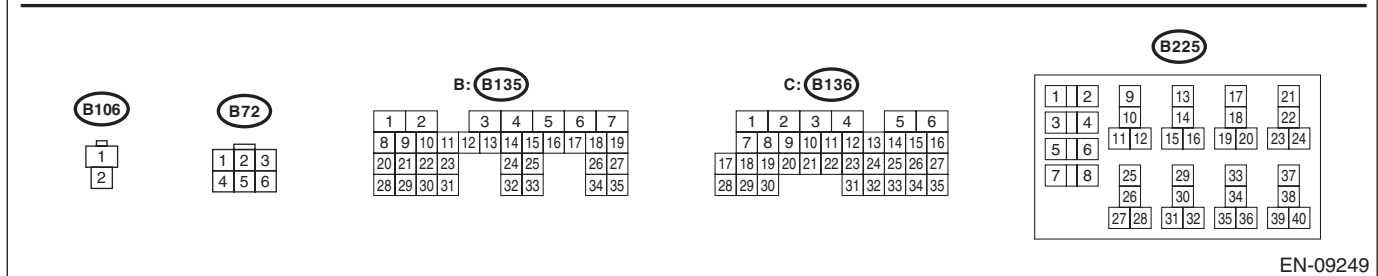
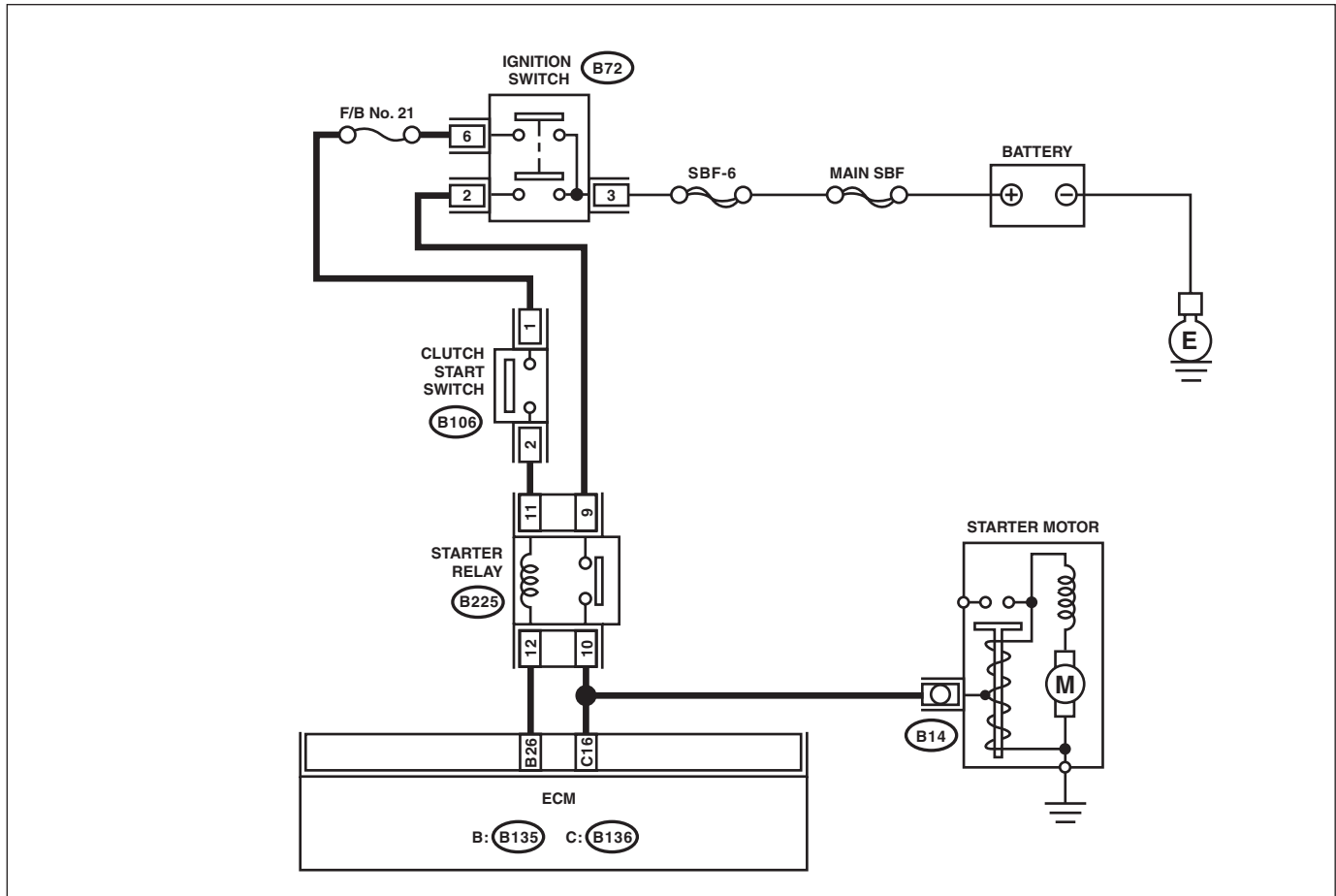

EN-09249

Step	Check	Yes	No
1	<b>CHECK BATTERY.</b> Check the battery voltage.	Go to step 2.	Charge or replace the battery.
2	<b>CHECK OPERATION OF STARTER MOTOR.</b>	Go to step 3.	Go to step 4.

EN(H4DOTC)(diag)-74

Brought to you by Ebay Seller "SubaruManuals"

# Diagnostics for Engine Starting Failure

ENGINE (DIAGNOSTICS)

Step	Check	Yes	No
<b>3</b> <b>CHECK DTC.</b>	Is DTC displayed? <Ref. to EN(H4DOTC)(diag)-47, OPERATION, Read Diagnostic Trouble Code (DTC).>	Check the appropriate DTC using the "List of Diagnostic Trouble Code (DTC)". <Ref. to EN(H4DOTC)(diag)-88, List of Diagnostic Trouble Code (DTC).>	The circuit has returned to a normal condition at this time. Reproduce the failure, and then perform the diagnosis again. NOTE: In this case, temporary poor contact of connector, temporary open or short circuit of harness may be the cause.
<b>4</b> <b>CHECK INPUT SIGNAL FOR STARTER MOTOR.</b> 1) Turn the ignition switch to OFF. 2) Disconnect the connector from starter motor. 3) Depress the clutch pedal. 4) Turn the ignition switch to START. 5) Measure the voltage between the starter motor connector and the engine ground. <i>Connector &amp; terminal</i> <i>(B14) No. 1 (+) — Engine ground (-):</i>	Is the voltage 10 V or more?	Check the starter motor. <Ref. to SC(STI)-7, Starter.>	Go to step 5.
<b>5</b> <b>CHECK INPUT SIGNAL FOR STARTER MOTOR.</b> 1) Depress the clutch pedal. 2) Turn the ignition switch to START. 3) Measure the voltage between starter relay connector and chassis ground. <i>Connector &amp; terminal</i> <i>(B225) No. 10 (+) — Chassis ground (-):</i>	Is the voltage 10 V or more?	Repair the open circuit of the harness between starter relay connector and starter motor.	Go to step 6.
<b>6</b> <b>CHECK HARNESS BETWEEN BATTERY AND IGNITION SWITCH CONNECTOR.</b> 1) Turn the ignition switch to OFF. 2) Disconnect the connector from ignition switch. 3) Measure the voltage between ignition switch connector and chassis ground. <i>Connector &amp; terminal</i> <i>(B72) No. 3 (+) — Chassis ground (-):</i>	Is the voltage 10 V or more?	Go to step 7.	Repair the power supply circuit.
<b>7</b> <b>CHECK IGNITION SWITCH.</b> Measure the resistance between ignition switch terminals after turning the ignition switch to START position. <i>Terminals</i> <i>No. 2 — No. 3:</i> <i>No. 6 — No. 3:</i>	Is the resistance less than 1 Ω?	Go to step 8.	Replace the ignition switch. <Ref. to SL-42, REPLACEMENT, Ignition Key Lock.>

# Diagnostics for Engine Starting Failure

## ENGINE (DIAGNOSTICS)

Step	Check	Yes	No
<b>8 CHECK INPUT VOLTAGE OF CLUTCH START SWITCH.</b> 1) Turn the ignition switch to OFF. 2) Disconnect the clutch start switch connector. 3) Connect the connector to ignition switch. 4) Turn the ignition switch to START. 5) Measure the voltage between the clutch start switch connector and chassis ground. <i><b>Connector &amp; terminal</b></i> <i><b>(B106) No. 1 (+) — Chassis ground (-):</b></i>	Is the voltage 10 V or more?	Go to step 9.	Check the following item and repair if necessary. <ul style="list-style-type: none"> <li>• Blown out of fuse (F/B No. 21)</li> <li>• Open or short circuit to ground in harness between ignition switch connector and clutch start switch connector</li> </ul>
<b>9 CHECK HARNESS BETWEEN STARTER RELAY CONNECTOR AND CLUTCH START SWITCH CONNECTOR.</b> 1) Turn the ignition switch to OFF. 2) Remove the starter relay. 3) Measure the resistance of harness between starter relay connector and clutch start switch connector. <i><b>Connector &amp; terminal</b></i> <i><b>(B225) No. 11 — (B106) No. 2:</b></i>	Is the resistance less than 1 $\Omega$ ?	Go to step 10.	Repair the open circuit in harness between starter relay connector and clutch start switch connector.
<b>10 CHECK INPUT VOLTAGE OF STARTER RELAY.</b> 1) Connect the connector to the clutch start switch. 2) Depress the clutch pedal. 3) Turn the ignition switch to START. 4) Measure the voltage between starter relay connector and chassis ground. <i><b>Connector &amp; terminal</b></i> <i><b>(B225) No. 11 (+) — Chassis ground (-):</b></i>	Is the voltage 10 V or more?	Go to step 11.	Replace the clutch start switch. <Ref. to CL-33, Clutch Switch.>
<b>11 CHECK INPUT VOLTAGE OF STARTER RELAY.</b> 1) Turn the ignition switch to START. 2) Measure the voltage between starter relay connector and chassis ground. <i><b>Connector &amp; terminal</b></i> <i><b>(B225) No. 9 (+) — Chassis ground (-):</b></i>	Is the voltage 10 V or more?	Go to step 12.	Repair the open circuit of harness between starter relay connector and ignition switch connector.
<b>12 CHECK STARTER RELAY.</b> 1) Connect the battery to starter relay terminals No. 11 and No. 12. 2) Measure the resistance between starter relay terminals. <i><b>Terminals</b></i> <i><b>No. 9 — No. 10:</b></i>	Is the resistance less than 1 $\Omega$ ?	Go to step 13.	Replace the starter relay.
<b>13 CHECK HARNESS BETWEEN ECM AND STARTER RELAY CONNECTOR.</b> 1) Turn the ignition switch to OFF. 2) Disconnect the connector from ECM. 3) Measure the resistance of harness between ECM and starter relay connector. <i><b>Connector &amp; terminal</b></i> <i><b>(B136) No. 16 — (B225) No. 10:</b></i>	Is the resistance less than 1 $\Omega$ ?	Go to step 14.	Repair the open circuit of harness between ECM and starter relay connector.

# Diagnostics for Engine Starting Failure

ENGINE (DIAGNOSTICS)

Step	Check	Yes	No
<b>14</b> <b>CHECK ECM INPUT VOLTAGE.</b> 1) Install the starter relay. 2) Depress the clutch pedal. 3) Turn the ignition switch to START. 4) Measure the voltage between ECM connector and chassis ground. <i><b>Connector &amp; terminal</b></i> <i><b>(B135) No. 26 (+) — Chassis ground (-):</b></i>	Is the voltage 10 V or more?	Check the ECM power supply and ground line. <Ref. to EN(H4DOTC)(diag)-78, CHECK POWER SUPPLY AND GROUND LINE OF ENGINE CONTROL MODULE (ECM), Diagnostics for Engine Starting Failure.>	Repair the open circuit of harness between ECM and starter relay connector.



# Diagnostics for Engine Starting Failure

ENGINE (DIAGNOSTICS)

## C: CHECK POWER SUPPLY AND GROUND LINE OF ENGINE CONTROL MODULE (ECM)

### CAUTION:

After servicing or replacing faulty parts, perform Clear Memory Mode <Ref. to EN(H4DOTC)(diag)-62, OPERATION, Clear Memory Mode.>, and Inspection Mode <Ref. to EN(H4DOTC)(diag)-48, PROCEDURE, Inspection Mode.>.

### WIRING DIAGRAM:

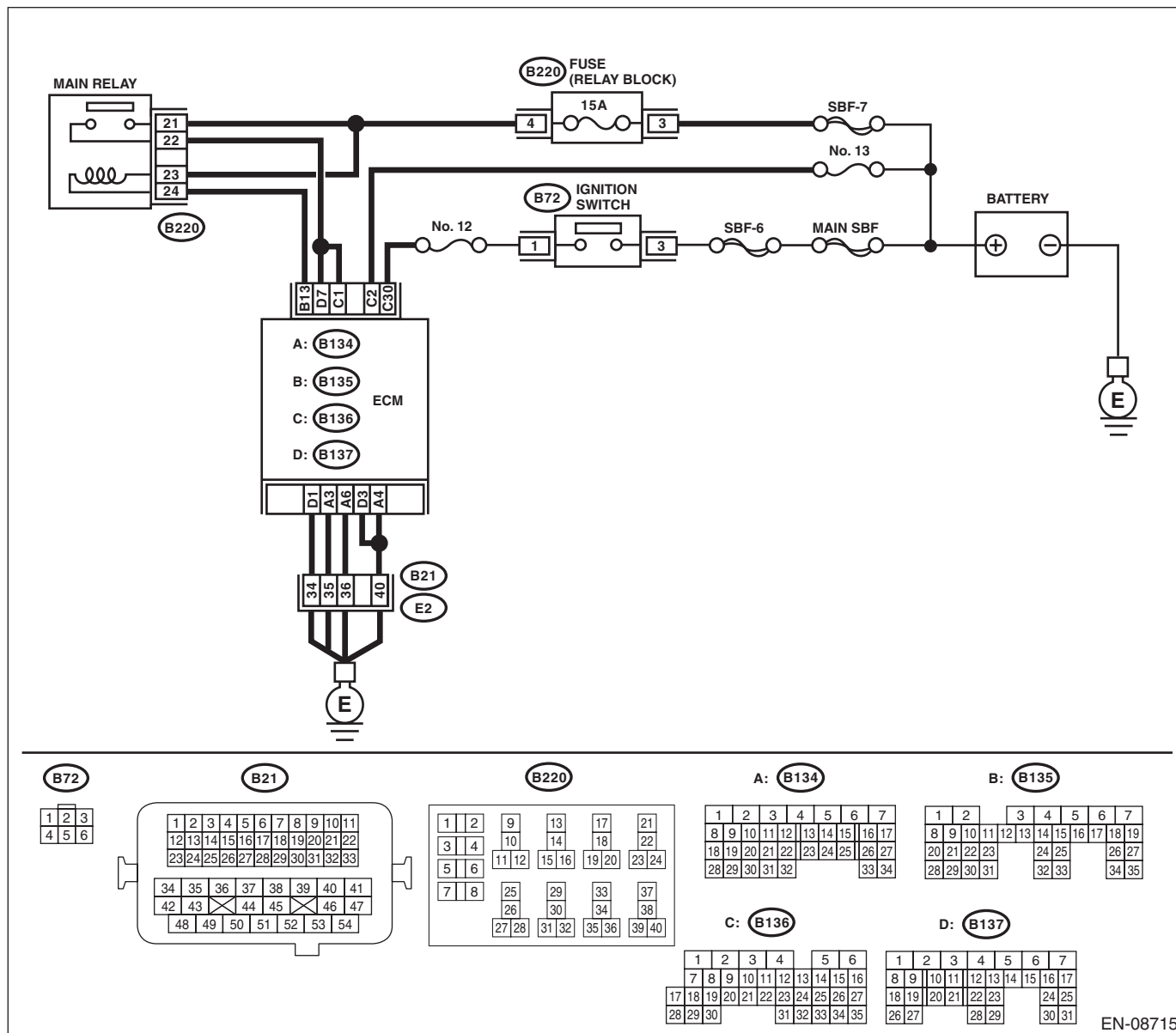

Step	Check	Yes	No
<b>1</b> <b>CHECK MAIN RELAY.</b> 1) Turn the ignition switch to OFF. 2) Remove the main relay. 3) Connect the battery to main relay terminals No. 23 and No. 24. 4) Measure the resistance between main relay terminals. <b>Terminals</b> <b>No. 21 — No. 22:</b>	Is the resistance less than 1 Ω?	Go to step 2.	Replace the main relay. <Ref. to FU(STI)-60, Main Relay.> <Ref. to FU(w/o STI)-59, Main Relay.>

# Diagnostics for Engine Starting Failure

ENGINE (DIAGNOSTICS)

Step	Check	Yes	No
<b>2 CHECK GROUND CIRCUIT FOR ECM.</b> 1) Disconnect the connector from ECM. 2) Measure the resistance of harness between ECM and chassis ground. <b>Connector &amp; terminal</b> <i>(B134) No. 3 — Chassis ground:</i> <i>(B134) No. 4 — Chassis ground:</i> <i>(B134) No. 6 — Chassis ground:</i> <i>(B137) No. 1 — Chassis ground:</i> <i>(B137) No. 3 — Chassis ground:</i>	Is the resistance less than 5 Ω?	Go to step 3.	Repair the harness and connector. NOTE: In this case, repair the following item: <ul style="list-style-type: none"> <li>• Open circuit of harness between ECM connector and engine ground</li> <li>• Poor contact of coupling connector</li> </ul>
<b>3 CHECK INPUT VOLTAGE OF ECM.</b> 1) Turn the ignition switch to ON. 2) Measure the voltage between ECM and chassis ground. <b>Connector &amp; terminal</b> <i>(B136) No. 2 (+) — Chassis ground (-):</i> <i>(B136) No. 30 (+) — Chassis ground (-):</i>	Is the voltage 10 V or more?	Go to step 4.	Repair the open or ground short circuit of harness of power supply circuit.
<b>4 CHECK INPUT VOLTAGE OF MAIN RELAY.</b> Measure the voltage between main relay connector and chassis ground. <b>Connector &amp; terminal</b> <i>(B220) No. 21 (+) — Chassis ground (-):</i> <i>(B220) No. 23 (+) — Chassis ground (-):</i>	Is the voltage 10 V or more?	Go to step 5.	Repair the open or ground short circuit of harness of power supply circuit.
<b>5 CHECK INPUT VOLTAGE OF ECM.</b> 1) Turn the ignition switch to OFF. 2) Install the main relay. 3) Turn the ignition switch to ON. 4) Measure the voltage between ECM and chassis ground. <b>Connector &amp; terminal</b> <i>(B135) No. 13 (+) — Chassis ground (-):</i>	Is the voltage 10 V or more?	Go to step 6.	Repair the open or ground short circuit of harness between ECM and main relay connector.
<b>6 CHECK INPUT VOLTAGE OF ECM.</b> 1) Turn the ignition switch to OFF. 2) Connect the connector to ECM. 3) Turn the ignition switch to ON. 4) Measure the voltage between ECM and chassis ground. <b>Connector &amp; terminal</b> <i>(B136) No. 1 (+) — Chassis ground (-):</i> <i>(B137) No. 7 (+) — Chassis ground (-):</i>	Is the voltage 10 V or more?	Check ignition control system. <Ref. to EN(H4DOTC)(diag)-80, IGNITION CONTROL SYSTEM, Diagnostics for Engine Starting Failure.>	Repair the harness and connector. NOTE: In this case, repair the following item: <ul style="list-style-type: none"> <li>• Open circuit in harness between ECM and main relay connector</li> <li>• Poor contact of main relay connector</li> <li>• Poor contact of ECM connector</li> </ul>

# Diagnostics for Engine Starting Failure

ENGINE (DIAGNOSTICS)

## D: IGNITION CONTROL SYSTEM

### CAUTION:

After servicing or replacing faulty parts, perform Clear Memory Mode <Ref. to EN(H4DOTC)(diag)-62, OPERATION, Clear Memory Mode.>, and Inspection Mode <Ref. to EN(H4DOTC)(diag)-48, PROCEDURE, Inspection Mode.>.

### WIRING DIAGRAM:

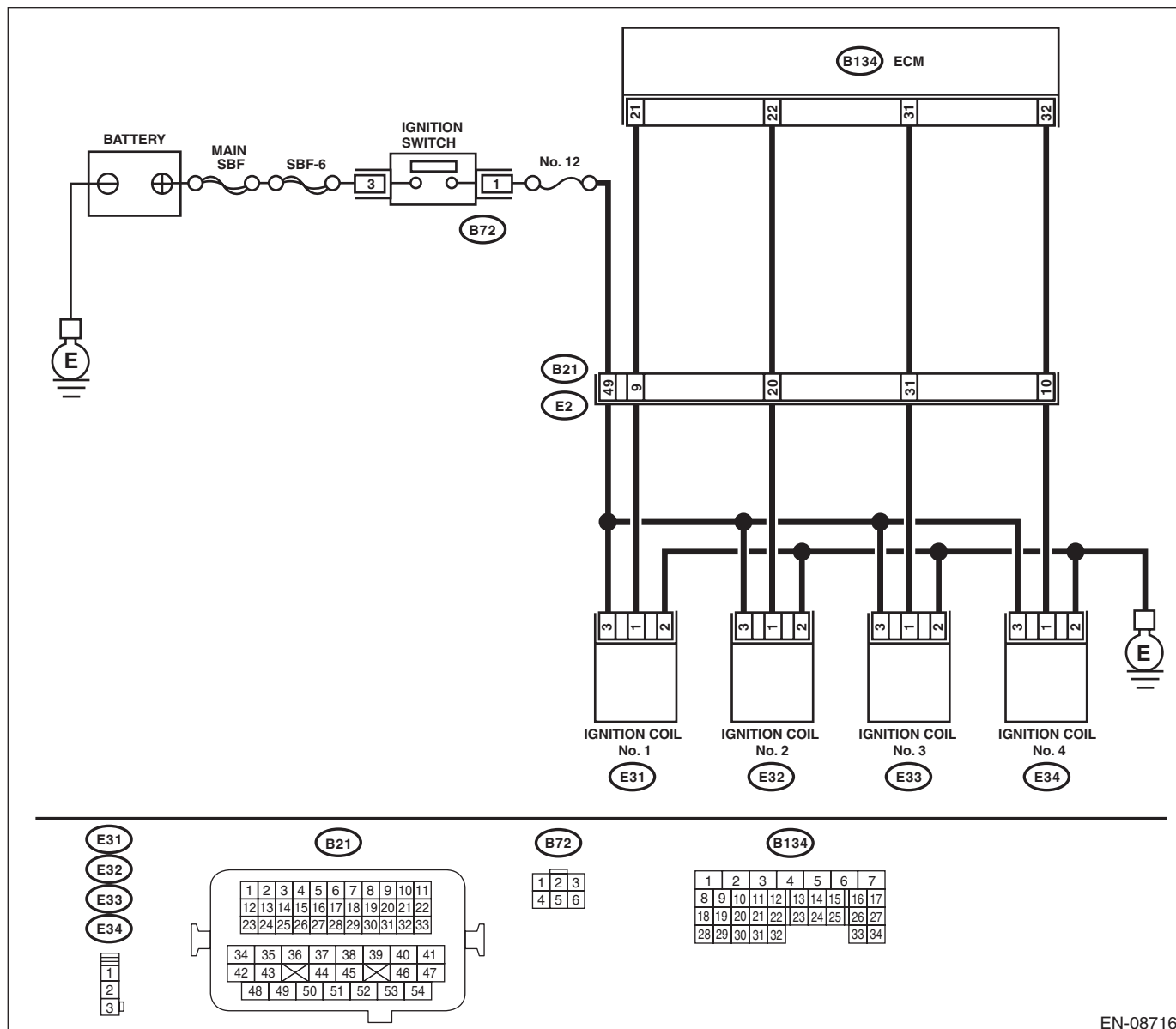

EN-08716

Step	Check	Yes	No	
1	<p><b>CHECK SPARK PLUG CONDITION.</b></p> <p>1) Remove the spark plug. &lt;Ref. to IG(STI)-4, REMOVAL, Spark Plug.&gt; &lt;Ref. to IG(w/o STI)-4, REMOVAL, Spark Plug.&gt;</p> <p>2) Check the spark plug condition. &lt;Ref. to IG(STI)-5, INSPECTION, Spark Plug.&gt; &lt;Ref. to IG(w/o STI)-5, INSPECTION, Spark Plug.&gt;</p>	Is the spark plug condition normal?	Go to step 2.	Replace the spark plug. <Ref. to IG(STI)-4, Spark Plug.> <Ref. to IG(w/o STI)-4, Spark Plug.>

EN(H4DOTC)(diag)-80

Brought to you by Ebay Seller "SubaruManuals"

# Diagnostics for Engine Starting Failure

ENGINE (DIAGNOSTICS)

Step	Check	Yes	No
<p><b>2 CHECK IGNITION SYSTEM FOR SPARKS.</b></p> <p>1) Connect the spark plug to ignition coil.                      2) Release the fuel pressure. &lt;Ref. to FU(STI)-67, RELEASING OF FUEL PRESSURE, PROCEDURE, Fuel.&gt; &lt;Ref. to FU(w/o STI)-66, RELEASING OF FUEL PRESSURE, PROCEDURE, Fuel.&gt;                      3) Contact the spark plug thread portion to engine.                      4) While opening the throttle valve fully, crank the engine to check that spark occurs at each cylinder.</p>	Does spark occur at each cylinder?	Check fuel pump system. <Ref. to EN(H4DOTC)(diag)-83, FUEL PUMP CIRCUIT, Diagnostics for Engine Starting Failure.>	Go to step 3.
<p><b>3 CHECK IGNITION COIL POWER SUPPLY CIRCUIT.</b></p> <p>1) Turn the ignition switch to OFF.                      2) Disconnect the connector from ignition coil.                      3) Turn the ignition switch to ON.                      4) Measure the power supply voltage between ignition coil connector and engine ground.</p> <p><b>Connector &amp; terminal</b>                      (E31) No. 3 (+) — Engine ground (-):                      (E32) No. 3 (+) — Engine ground (-):                      (E33) No. 3 (+) — Engine ground (-):                      (E34) No. 3 (+) — Engine ground (-):</p>	Is the voltage 10 V or more?	Go to step 4.	Repair the harness and connector. NOTE: In this case, repair the following item: • Open circuit or short circuit to ground in power supply circuit • Poor contact of coupling connector • Blown out of fuse
<p><b>4 CHECK HARNESS OF IGNITION COIL GROUND CIRCUIT.</b></p> <p>1) Turn the ignition switch to OFF.                      2) Measure the resistance between ignition coil connector and engine ground.</p> <p><b>Connector &amp; terminal</b>                      (E31) No. 2 — Engine ground:                      (E32) No. 2 — Engine ground:                      (E33) No. 2 — Engine ground:                      (E34) No. 2 — Engine ground:</p>	Is the resistance less than 1 Ω?	Go to step 5.	Repair the open circuit in harness between ignition coil connector and engine ground.
<p><b>5 CHECK HARNESS BETWEEN ECM AND IGNITION COIL CONNECTOR.</b></p> <p>1) Turn the ignition switch to OFF.                      2) Disconnect the connector from ECM and ignition coil.                      3) Measure the resistance of harness between ECM and ignition coil connector.</p> <p><b>Connector &amp; terminal</b>                      (B134) No. 21 — (E31) No. 1:                      (B134) No. 22 — (E32) No. 1:                      (B134) No. 31 — (E33) No. 1:                      (B134) No. 32 — (E34) No. 1:</p>	Is the resistance less than 1 Ω?	Go to step 6.	Repair the harness and connector. NOTE: In this case, repair the following item: • Open circuit of harness between ECM and ignition coil connector • Poor contact of coupling connector
<p><b>6 CHECK HARNESS BETWEEN ECM AND IGNITION COIL CONNECTOR.</b></p> <p>Measure the resistance of harness between ECM and engine ground.</p> <p><b>Connector &amp; terminal</b>                      (B134) No. 21 — Engine ground:                      (B134) No. 22 — Engine ground:                      (B134) No. 31 — Engine ground:                      (B134) No. 32 — Engine ground:</p>	Is the resistance 1 MΩ or more?	Go to step 7.	Repair the ground short circuit of harness between ECM and ignition coil connector.

# Diagnostics for Engine Starting Failure

## ENGINE (DIAGNOSTICS)

	Step	Check	Yes	No
7	<b>CHECK FOR POOR CONTACT.</b> Check for poor contact of ECM connector.	Is there poor contact of ECM connector?	Repair the poor contact of ECM connector.	Replace the ignition coil. <Ref. to IG(STI)-7, Ignition Coil.> <Ref. to IG(w/o STI)-7, Ignition Coil.>

# Diagnostics for Engine Starting Failure

ENGINE (DIAGNOSTICS)

## E: FUEL PUMP CIRCUIT

### CAUTION:

After servicing or replacing faulty parts, perform Clear Memory Mode <Ref. to EN(H4DOTC)(diag)-62, OPERATION, Clear Memory Mode.>, and Inspection Mode <Ref. to EN(H4DOTC)(diag)-48, PROCEDURE, Inspection Mode.>.

	Step	Check	Yes	No
1	<b>CHECK OPERATING SOUND OF FUEL PUMP.</b> Make sure that the fuel pump operates for two seconds when turning the ignition switch to ON. NOTE: Fuel pump operation can be executed using the Subaru Select Monitor. For the procedures, refer to "Compulsory Valve Operation Check Mode". <Ref. to EN(H4DOTC)(diag)-63, Compulsory Valve Operation Check Mode.>	Does the fuel pump emit operating sound?	Check the fuel injector circuit. <Ref. to EN(H4DOTC)(diag)-84, FUEL INJECTOR CIRCUIT, Diagnostics for Engine Starting Failure.>	Display the DTC. <Ref. to EN(H4DOTC)(diag)-47, OPERATION, Read Diagnostic Trouble Code (DTC).>

# Diagnostics for Engine Starting Failure

ENGINE (DIAGNOSTICS)

## F: FUEL INJECTOR CIRCUIT

### CAUTION:

- Check or repair only faulty parts.
- After servicing or replacing faulty parts, perform Clear Memory Mode <Ref. to EN(H4DOTC)(diag)-62, OPERATION, Clear Memory Mode.>, and Inspection Mode <Ref. to EN(H4DOTC)(diag)-48, PROCEDURE, Inspection Mode.>.

### WIRING DIAGRAM:

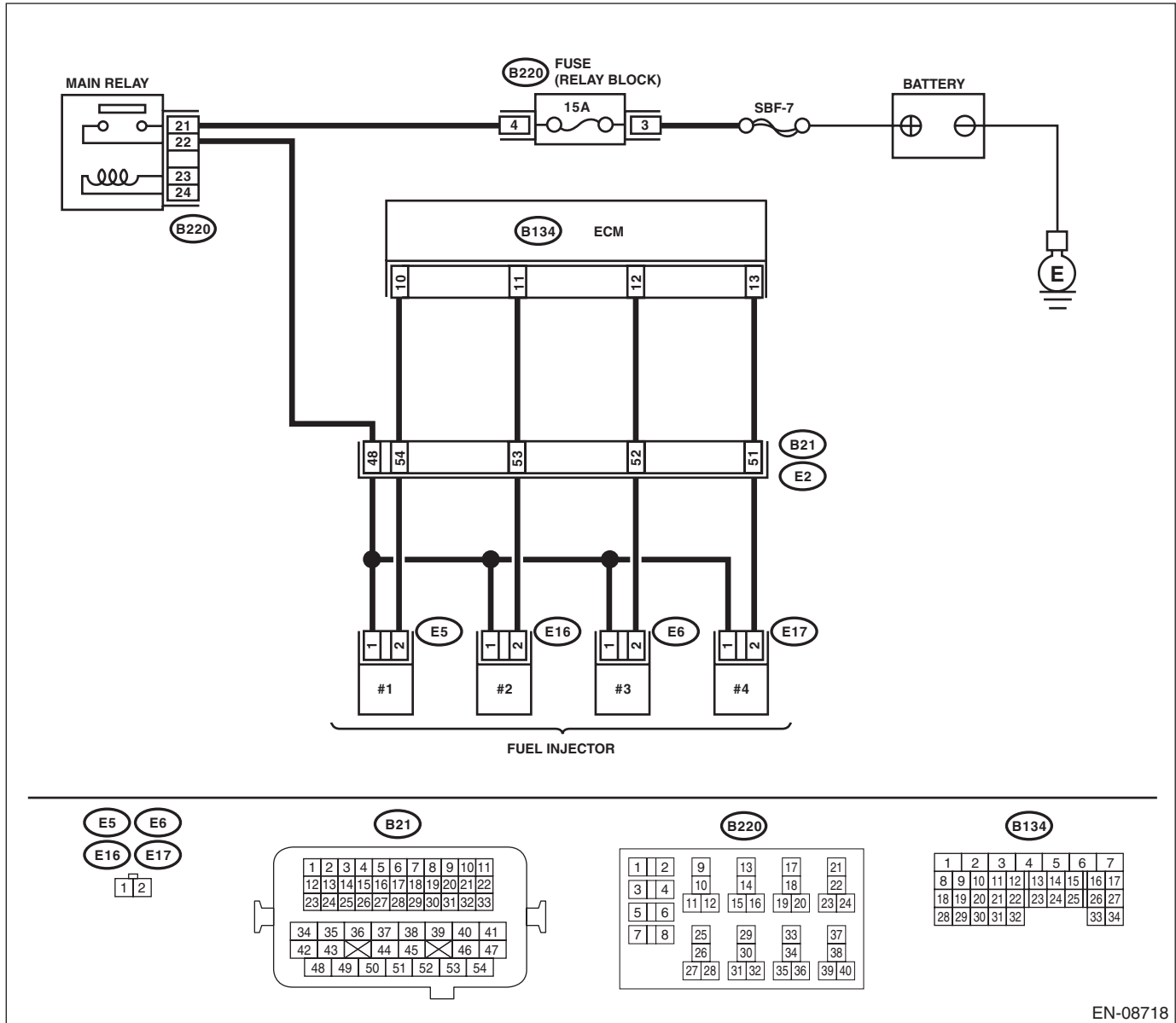

EN-08718

Step	Check	Yes	No	
1	<p><b>CHECK OPERATION OF EACH FUEL INJECTOR.</b></p> <p>While cranking the engine, check each fuel injector emits operating sound. Use a sound scope or attach a screwdriver to the injector for this check.</p>	<p>Does the fuel injector emit operating sound?</p>	<p>Check the fuel pressure. &lt;Ref. to ME(STI)-25, INSPECTION, Fuel Pressure.&gt; &lt;Ref. to ME(w/o STI)-25, INSPECTION, Fuel Pressure.&gt;</p>	<p>Go to step 2.</p>

# Diagnostics for Engine Starting Failure

ENGINE (DIAGNOSTICS)

Step	Check	Yes	No
<p><b>2</b></p> <p><b>CHECK POWER SUPPLY TO EACH FUEL INJECTOR.</b></p> <p>1) Turn the ignition switch to OFF.                      2) Disconnect the connector from fuel injector.                      3) Turn the ignition switch to ON.                      4) Measure the power supply voltage between fuel injector connector and the engine ground.</p> <p><b>Connector &amp; terminal</b></p> <p><b>#1 (E5) No. 1 (+) — Engine ground (-):</b>  <b>#2 (E16) No. 1 (+) — Engine ground (-):</b>  <b>#3 (E6) No. 1 (+) — Engine ground (-):</b>  <b>#4 (E17) No. 1 (+) — Engine ground (-):</b></p>	<p>Is the voltage 10 V or more?</p>	<p>Go to step 3.</p>	<p>Repair the harness and connector.</p> <p>NOTE:                      In this case, repair the following item:</p> <ul style="list-style-type: none"> <li>• Open circuit in harness between main relay connector and fuel injector connector</li> <li>• Poor contact of main relay connector</li> <li>• Poor contact of coupling connector</li> </ul>
<p><b>3</b></p> <p><b>CHECK HARNESS BETWEEN ECM AND FUEL INJECTOR CONNECTOR.</b></p> <p>1) Turn the ignition switch to OFF.                      2) Disconnect the connector from ECM.                      3) Measure the resistance of harness between ECM and fuel injector connector.</p> <p><b>Connector &amp; terminal</b></p> <p><b>#1 (B134) No. 10 — (E5) No. 2:</b>  <b>#2 (B134) No. 11 — (E16) No. 2:</b>  <b>#3 (B134) No. 12 — (E6) No. 2:</b>  <b>#4 (B134) No. 13 — (E17) No. 2:</b></p>	<p>Is the resistance less than 1 Ω?</p>	<p>Go to step 4.</p>	<p>Repair the harness and connector.</p> <p>NOTE:                      In this case, repair the following item:</p> <ul style="list-style-type: none"> <li>• Open circuit in harness between ECM and fuel injector connector</li> <li>• Poor contact of coupling connector</li> </ul>
<p><b>4</b></p> <p><b>CHECK HARNESS BETWEEN ECM AND FUEL INJECTOR CONNECTOR.</b></p> <p>Measure the resistance of harness between ECM and chassis ground.</p> <p><b>Connector &amp; terminal</b></p> <p><b>#1 (B134) No. 10 — Chassis ground:</b>  <b>#2 (B134) No. 11 — Chassis ground:</b>  <b>#3 (B134) No. 12 — Chassis ground:</b>  <b>#4 (B134) No. 13 — Chassis ground:</b></p>	<p>Is the resistance 1 MΩ or more?</p>	<p>Go to step 5.</p>	<p>Repair the short circuit to ground in harness between ECM and fuel injector connector.</p>
<p><b>5</b></p> <p><b>CHECK EACH FUEL INJECTOR.</b></p> <p>Measure the resistance between each fuel injector terminals.</p> <p><b>Terminals</b></p> <p><b>No. 1 — No. 2:</b></p>	<p>Is the resistance 5 — 20 Ω?</p>	<p>Go to step 6.</p>	<p>Replace the faulty fuel injector. &lt;Ref. to FU(STI)-45, Fuel Injector.&gt;                      &lt;Ref. to FU(w/o STI)-46, Fuel Injector.&gt;</p>
<p><b>6</b></p> <p><b>CHECK FOR POOR CONTACT.</b></p> <p>Check for poor contact of ECM connector.</p>	<p>Is there poor contact of ECM connector?</p>	<p>Repair the poor contact of ECM connector.</p>	<p>Inspection using “General Diagnostic Table”. &lt;Ref. to EN(H4DOTC)(diag)-448, INSPECTION, General Diagnostic Table.&gt;</p>



# Diagnostic Procedure for Subaru Select Monitor Communication

ENGINE (DIAGNOSTICS)

## 18. Diagnostic Procedure for Subaru Select Monitor Communication

### A: COMMUNICATION FOR INITIALIZING IMPOSSIBLE

#### DIAGNOSIS:

Open or short circuit in data link connector

#### TROUBLE SYMPTOM:

Subaru Select Monitor communication failure

#### WIRING DIAGRAM:

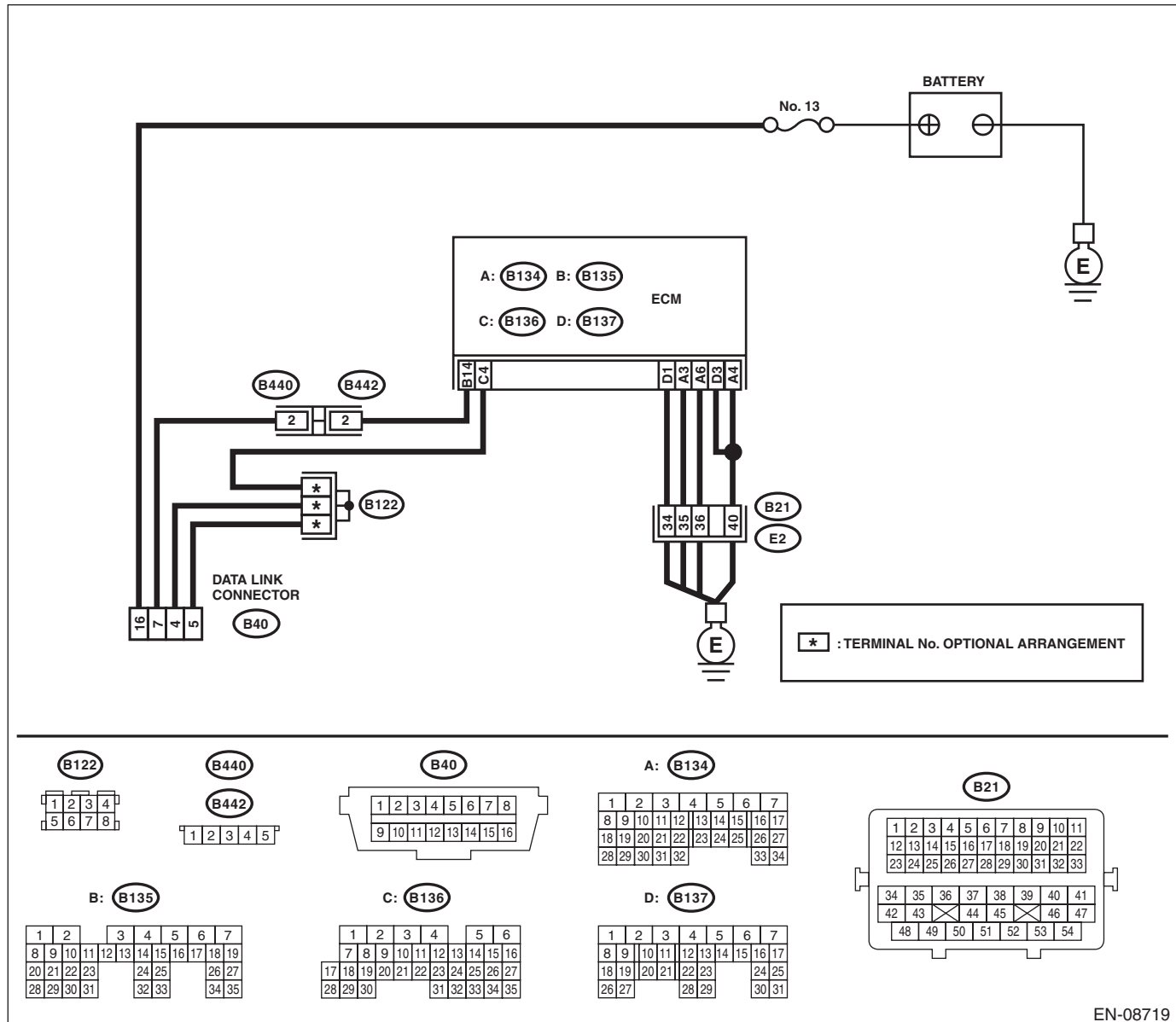

Step	Check	Yes	No
1	<b>CHECK POWER SUPPLY CIRCUIT.</b> Connect the SDI (Subaru Diagnosis Interface) or general scan tool to data link connector.	Go to step 4.	Go to step 2.

# Diagnostic Procedure for Subaru Select Monitor Communication

ENGINE (DIAGNOSTICS)

Step	Check	Yes	No
<p><b>2</b></p> <p><b>CHECK POWER SUPPLY CIRCUIT.</b> Measure the voltage between data link connector and chassis ground. <b>Connector &amp; terminal</b> <b>(B40) No. 16 (+) — Chassis ground (-):</b></p>	Is the voltage 10 V or more?	Go to step 3.	<p>Repair the power supply circuit.</p> <p>NOTE: In this case, repair the following item:</p> <ul style="list-style-type: none"> <li>• Open or ground short circuit of harness between battery and data link connector</li> <li>• Blown out of fuse (M/B No. 13)</li> </ul>
<p><b>3</b></p> <p><b>CHECK HARNESS BETWEEN DATA LINK CONNECTOR AND CHASSIS GROUND.</b> 1) Turn the ignition switch to OFF. 2) Measure the resistance of harness between data link connector and chassis ground. <b>Connector &amp; terminal</b> <b>(B40) No. 4 — Chassis ground:</b> <b>(B40) No. 5 — Chassis ground:</b></p>	Is the resistance less than 5 Ω?	Repair the poor contact of data link connector.	<p>Repair the harness and connector.</p> <p>NOTE: In this case, repair the following item:</p> <ul style="list-style-type: none"> <li>• Open circuit of harness between ECM and data link connector</li> <li>• Open circuit of harness between ECM and engine ground</li> <li>• Poor contact of ECM connector</li> <li>• Poor contact of coupling connector</li> </ul>
<p><b>4</b></p> <p><b>CHECK HARNESS BETWEEN ECM AND DATA LINK CONNECTOR.</b> 1) Disconnect the connectors from ECM, DCCD CM (6MT model only), VDC CM, airbag CM, impact sensor, TPMS &amp; keyless entry CM, and body integrated unit. <b>CAUTION:</b> <b>When disconnecting the connector from airbag CM, always follow the precautions on AB section. &lt;Ref. to AB-5, CAUTION, General Description.&gt;</b> 2) Measure the resistance of harness between ECM and data link connector. <b>Connector &amp; terminal</b> <b>(B135) No. 14 — (B40) No. 7:</b></p>	Is the resistance less than 1 Ω?	Go to step 5.	<p>Repair the harness and connector.</p> <p>NOTE: In this case, repair the following item:</p> <ul style="list-style-type: none"> <li>• Open circuit of harness between ECM and data link connector</li> <li>• Poor contact of coupling connector</li> </ul>
<p><b>5</b></p> <p><b>CHECK HARNESS BETWEEN ECM AND DATA LINK CONNECTOR.</b> Measure the resistance between data link connector and chassis ground. <b>Connector &amp; terminal</b> <b>(B40) No. 7 — Chassis ground:</b></p>	Is the resistance 1 MΩ or more?	Repair the poor contact of the ECM or data link connector.	<p>Repair the ground short circuit of harness between ECM and data link connector.</p>

## List of Diagnostic Trouble Code (DTC)

ENGINE (DIAGNOSTICS)

### 19. List of Diagnostic Trouble Code (DTC)

#### A: LIST

DTC	Item	Note
P0011	Intake Camshaft Position - Timing Over-Advanced or System Performance (Bank 1)	<Ref. to EN(H4DOTC)(diag)-96, DTC P0011 INTAKE CAMSHAFT POSITION - TIMING OVER-ADVANCED OR SYSTEM PERFORMANCE (BANK 1), Diagnostic Procedure with Diagnostic Trouble Code (DTC).>
P0014	Exhaust AVCS System 1 (Range/Performance)	<Ref. to EN(H4DOTC)(diag)-97, DTC P0014 EXHAUST AVCS SYSTEM 1 (RANGE/PERFORMANCE), Diagnostic Procedure with Diagnostic Trouble Code (DTC).>
P0016	Crankshaft Position - Camshaft Position Correlation (Bank1)	<Ref. to EN(H4DOTC)(diag)-98, DTC P0016 CRANKSHAFT POSITION - CAMSHAFT POSITION CORRELATION (BANK1), Diagnostic Procedure with Diagnostic Trouble Code (DTC).>
P0017	Crank and Cam Timing B System Failure (Bank 1)	<Ref. to EN(H4DOTC)(diag)-99, DTC P0017 CRANK AND CAM TIMING B SYSTEM FAILURE (BANK 1), Diagnostic Procedure with Diagnostic Trouble Code (DTC).>
P0018	Crankshaft Position - Camshaft Position Correlation (Bank2)	<Ref. to EN(H4DOTC)(diag)-100, DTC P0018 CRANKSHAFT POSITION - CAMSHAFT POSITION CORRELATION (BANK2), Diagnostic Procedure with Diagnostic Trouble Code (DTC).>
P0019	Crank and Cam Timing B System Failure (Bank 2)	<Ref. to EN(H4DOTC)(diag)-101, DTC P0019 CRANK AND CAM TIMING B SYSTEM FAILURE (BANK 2), Diagnostic Procedure with Diagnostic Trouble Code (DTC).>
P0021	Intake Camshaft Position - Timing Over-Advanced or System Performance (Bank 2)	<Ref. to EN(H4DOTC)(diag)-102, DTC P0021 INTAKE CAMSHAFT POSITION - TIMING OVER-ADVANCED OR SYSTEM PERFORMANCE (BANK 2), Diagnostic Procedure with Diagnostic Trouble Code (DTC).>
P0024	Exhaust AVCS System 2 (Range/Performance)	<Ref. to EN(H4DOTC)(diag)-103, DTC P0024 EXHAUST AVCS SYSTEM 2 (RANGE/PERFORMANCE), Diagnostic Procedure with Diagnostic Trouble Code (DTC).>
P0030	HO2S Heater Control Circuit (Bank 1 Sensor 1)	<Ref. to EN(H4DOTC)(diag)-104, DTC P0030 HO2S HEATER CONTROL CIRCUIT (BANK 1 SENSOR 1), Diagnostic Procedure with Diagnostic Trouble Code (DTC).>
P0031	HO2S Heater Control Circuit Low (Bank 1 Sensor 1)	<Ref. to EN(H4DOTC)(diag)-107, DTC P0031 HO2S HEATER CONTROL CIRCUIT LOW (BANK 1 SENSOR 1), Diagnostic Procedure with Diagnostic Trouble Code (DTC).>
P0032	HO2S Heater Control Circuit High (Bank 1 Sensor 1)	<Ref. to EN(H4DOTC)(diag)-110, DTC P0032 HO2S HEATER CONTROL CIRCUIT HIGH (BANK 1 SENSOR 1), Diagnostic Procedure with Diagnostic Trouble Code (DTC).>
P0037	HO2S Heater Control Circuit Low (Bank 1 Sensor 2)	<Ref. to EN(H4DOTC)(diag)-113, DTC P0037 HO2S HEATER CONTROL CIRCUIT LOW (BANK 1 SENSOR 2), Diagnostic Procedure with Diagnostic Trouble Code (DTC).>
P0038	HO2S Heater Control Circuit High (Bank 1 Sensor 2)	<Ref. to EN(H4DOTC)(diag)-116, DTC P0038 HO2S HEATER CONTROL CIRCUIT HIGH (BANK 1 SENSOR 2), Diagnostic Procedure with Diagnostic Trouble Code (DTC).>
P0068	MAP/MAF - Throttle Position Correlation	<Ref. to EN(H4DOTC)(diag)-119, DTC P0068 MAP/MAF - THROTTLE POSITION CORRELATION, Diagnostic Procedure with Diagnostic Trouble Code (DTC).>
P0101	Mass or Volume Air Flow Circuit Range/Performance	<Ref. to EN(H4DOTC)(diag)-120, DTC P0101 MASS OR VOLUME AIR FLOW CIRCUIT RANGE/PERFORMANCE, Diagnostic Procedure with Diagnostic Trouble Code (DTC).>
P0102	Mass or Volume Air Flow Circuit Low Input	<Ref. to EN(H4DOTC)(diag)-121, DTC P0102 MASS OR VOLUME AIR FLOW CIRCUIT LOW INPUT, Diagnostic Procedure with Diagnostic Trouble Code (DTC).>
P0103	Mass or Volume Air Flow Circuit High Input	<Ref. to EN(H4DOTC)(diag)-124, DTC P0103 MASS OR VOLUME AIR FLOW CIRCUIT HIGH INPUT, Diagnostic Procedure with Diagnostic Trouble Code (DTC).>
P0107	Manifold Absolute Pressure/Barometric Pressure Circuit Low Input	<Ref. to EN(H4DOTC)(diag)-126, DTC P0107 MANIFOLD ABSOLUTE PRESSURE/BAROMETRIC PRESSURE CIRCUIT LOW INPUT, Diagnostic Procedure with Diagnostic Trouble Code (DTC).>
P0108	Manifold Absolute Pressure/Barometric Pressure Circuit High Input	<Ref. to EN(H4DOTC)(diag)-129, DTC P0108 MANIFOLD ABSOLUTE PRESSURE/BAROMETRIC PRESSURE CIRCUIT HIGH INPUT, Diagnostic Procedure with Diagnostic Trouble Code (DTC).>
P0111	Intake Air Temperature Sensor 1 Circuit Range/Performance	<Ref. to EN(H4DOTC)(diag)-131, DTC P0111 INTAKE AIR TEMPERATURE SENSOR 1 CIRCUIT RANGE/PERFORMANCE, Diagnostic Procedure with Diagnostic Trouble Code (DTC).>
P0112	Intake Air Temperature Sensor 1 Circuit Low	<Ref. to EN(H4DOTC)(diag)-132, DTC P0112 INTAKE AIR TEMPERATURE SENSOR 1 CIRCUIT LOW, Diagnostic Procedure with Diagnostic Trouble Code (DTC).>

**EN(H4DOTC)(diag)-88**

Brought to you by Ebay Seller "SubaruManuals"

# List of Diagnostic Trouble Code (DTC)

ENGINE (DIAGNOSTICS)

DTC	Item	Note
P0113	Intake Air Temperature Sensor 1 Circuit High	<Ref. to EN(H4DOTC)(diag)-134, DTC P0113 INTAKE AIR TEMPERATURE SENSOR 1 CIRCUIT HIGH, Diagnostic Procedure with Diagnostic Trouble Code (DTC).>
P0117	Engine Coolant Temperature Circuit Low	<Ref. to EN(H4DOTC)(diag)-136, DTC P0117 ENGINE COOLANT TEMPERATURE CIRCUIT LOW, Diagnostic Procedure with Diagnostic Trouble Code (DTC).>
P0118	Engine Coolant Temperature Circuit High	<Ref. to EN(H4DOTC)(diag)-138, DTC P0118 ENGINE COOLANT TEMPERATURE CIRCUIT HIGH, Diagnostic Procedure with Diagnostic Trouble Code (DTC).>
P0122	Throttle/Pedal Position Sensor/Switch "A" Circuit Low	<Ref. to EN(H4DOTC)(diag)-140, DTC P0122 THROTTLE/PEDAL POSITION SENSOR/SWITCH "A" CIRCUIT LOW, Diagnostic Procedure with Diagnostic Trouble Code (DTC).>
P0123	Throttle/Pedal Position Sensor/Switch "A" Circuit High	<Ref. to EN(H4DOTC)(diag)-142, DTC P0123 THROTTLE/PEDAL POSITION SENSOR/SWITCH "A" CIRCUIT HIGH, Diagnostic Procedure with Diagnostic Trouble Code (DTC).>
P0125	Insufficient Coolant Temperature for Closed Loop Fuel Control	<Ref. to EN(H4DOTC)(diag)-144, DTC P0125 INSUFFICIENT COOLANT TEMPERATURE FOR CLOSED LOOP FUEL CONTROL, Diagnostic Procedure with Diagnostic Trouble Code (DTC).>
P0126	Insufficient Engine Coolant Temperature for Stable Operation	<Ref. to EN(H4DOTC)(diag)-145, DTC P0126 INSUFFICIENT ENGINE COOLANT TEMPERATURE FOR STABLE OPERATION, Diagnostic Procedure with Diagnostic Trouble Code (DTC).>
P0128	Coolant Thermostat (Engine Coolant Temperature Below Thermostat Regulating Temperature)	<Ref. to EN(H4DOTC)(diag)-146, DTC P0128 COOLANT THERMOSTAT (ENGINE COOLANT TEMPERATURE BELOW THERMOSTAT REGULATING TEMPERATURE), Diagnostic Procedure with Diagnostic Trouble Code (DTC).>
P0131	O2 Sensor Circuit Low Voltage (Bank 1 Sensor 1)	<Ref. to EN(H4DOTC)(diag)-147, DTC P0131 O2 SENSOR CIRCUIT LOW VOLTAGE (BANK 1 SENSOR 1), Diagnostic Procedure with Diagnostic Trouble Code (DTC).>
P0132	O2 Sensor Circuit High Voltage (Bank 1 Sensor 1)	<Ref. to EN(H4DOTC)(diag)-150, DTC P0132 O2 SENSOR CIRCUIT HIGH VOLTAGE (BANK 1 SENSOR 1), Diagnostic Procedure with Diagnostic Trouble Code (DTC).>
P0133	O2 Sensor Circuit Slow Response (Bank 1 Sensor 1)	<Ref. to EN(H4DOTC)(diag)-152, DTC P0133 O2 SENSOR CIRCUIT SLOW RESPONSE (BANK 1 SENSOR 1), Diagnostic Procedure with Diagnostic Trouble Code (DTC).>
P0134	O2 Sensor Circuit No Activity Detected (Bank 1 Sensor 1)	<Ref. to EN(H4DOTC)(diag)-153, DTC P0134 O2 SENSOR CIRCUIT NO ACTIVITY DETECTED (BANK 1 SENSOR 1), Diagnostic Procedure with Diagnostic Trouble Code (DTC).>
P0137	O2 Sensor Circuit Low Voltage (Bank 1 Sensor 2)	<Ref. to EN(H4DOTC)(diag)-156, DTC P0137 O2 SENSOR CIRCUIT LOW VOLTAGE (BANK 1 SENSOR 2), Diagnostic Procedure with Diagnostic Trouble Code (DTC).>
P0138	O2 Sensor Circuit High Voltage (Bank 1 Sensor 2)	<Ref. to EN(H4DOTC)(diag)-159, DTC P0138 O2 SENSOR CIRCUIT HIGH VOLTAGE (BANK 1 SENSOR 2), Diagnostic Procedure with Diagnostic Trouble Code (DTC).>
P013A	O2 Sensor Slow Response - Rich to Lean (Bank 1 Sensor 2)	<Ref. to EN(H4DOTC)(diag)-162, DTC P013A O2 SENSOR SLOW RESPONSE - RICH TO LEAN (BANK 1 SENSOR 2), Diagnostic Procedure with Diagnostic Trouble Code (DTC).>
P013B	O2 Sensor Slow Response - Lean to Rich (Bank 1 Sensor 2)	<Ref. to EN(H4DOTC)(diag)-164, DTC P013B O2 SENSOR SLOW RESPONSE - LEAN TO RICH (BANK 1 SENSOR 2), Diagnostic Procedure with Diagnostic Trouble Code (DTC).>
P013E	O2 Sensor Delayed Response - Rich to Lean (Bank 1 Sensor 2)	<Ref. to EN(H4DOTC)(diag)-164, DTC P013E O2 SENSOR DELAYED RESPONSE - RICH TO LEAN (BANK 1 SENSOR 2), Diagnostic Procedure with Diagnostic Trouble Code (DTC).>
P013F	O2 Sensor Delayed Response - Lean to Rich (Bank 1 Sensor 2)	<Ref. to EN(H4DOTC)(diag)-164, DTC P013F O2 SENSOR DELAYED RESPONSE - LEAN TO RICH (BANK 1 SENSOR 2), Diagnostic Procedure with Diagnostic Trouble Code (DTC).>
P0140	O2 Sensor Circuit No Activity Detected (Bank1 Sensor2)	<Ref. to EN(H4DOTC)(diag)-165, DTC P0140 O2 SENSOR CIRCUIT NO ACTIVITY DETECTED (BANK1 SENSOR2), Diagnostic Procedure with Diagnostic Trouble Code (DTC).>
P0141	O2 Sensor Heater Circuit (Bank1 Sensor2)	<Ref. to EN(H4DOTC)(diag)-168, DTC P0141 O2 SENSOR HEATER CIRCUIT (BANK1 SENSOR2), Diagnostic Procedure with Diagnostic Trouble Code (DTC).>
P0171	System Too Lean (Bank 1)	<Ref. to EN(H4DOTC)(diag)-168, DTC P0171 SYSTEM TOO LEAN (BANK 1), Diagnostic Procedure with Diagnostic Trouble Code (DTC).>
P0172	System Too Rich (Bank 1)	<Ref. to EN(H4DOTC)(diag)-169, DTC P0172 SYSTEM TOO RICH (BANK 1), Diagnostic Procedure with Diagnostic Trouble Code (DTC).>

**EN(H4DOTC)(diag)-89**

Brought to you by Ebay Seller "SubaruManuals"

## List of Diagnostic Trouble Code (DTC)

### ENGINE (DIAGNOSTICS)

DTC	Item	Note
P0201	Injector #1	<Ref. to EN(H4DOTC)(diag)-171, DTC P0201 INJECTOR #1, Diagnostic Procedure with Diagnostic Trouble Code (DTC).>
P0202	Injector #2	<Ref. to EN(H4DOTC)(diag)-173, DTC P0202 INJECTOR #2, Diagnostic Procedure with Diagnostic Trouble Code (DTC).>
P0203	Injector #3	<Ref. to EN(H4DOTC)(diag)-173, DTC P0203 INJECTOR #3, Diagnostic Procedure with Diagnostic Trouble Code (DTC).>
P0204	Injector #4	<Ref. to EN(H4DOTC)(diag)-173, DTC P0204 INJECTOR #4, Diagnostic Procedure with Diagnostic Trouble Code (DTC).>
P0222	Throttle/Pedal Position Sensor/Switch "B" Circuit Low	<Ref. to EN(H4DOTC)(diag)-174, DTC P0222 THROTTLE/PEDAL POSITION SENSOR/SWITCH "B" CIRCUIT LOW, Diagnostic Procedure with Diagnostic Trouble Code (DTC).>
P0223	Throttle/Pedal Position Sensor/Switch "B" Circuit High	<Ref. to EN(H4DOTC)(diag)-176, DTC P0223 THROTTLE/PEDAL POSITION SENSOR/SWITCH "B" CIRCUIT HIGH, Diagnostic Procedure with Diagnostic Trouble Code (DTC).>
P0230	Fuel Pump Primary Circuit	<Ref. to EN(H4DOTC)(diag)-178, DTC P0230 FUEL PUMP PRIMARY CIRCUIT, Diagnostic Procedure with Diagnostic Trouble Code (DTC).>
P0244	Turbo/Super Charger Wastegate Solenoid "A" Range/Performance	<Ref. to EN(H4DOTC)(diag)-181, DTC P0244 TURBO/SUPER CHARGER WASTEGATE SOLENOID "A" RANGE/PERFORMANCE, Diagnostic Procedure with Diagnostic Trouble Code (DTC).>
P0245	Turbo/Super Charger Wastegate Solenoid "A" Low	<Ref. to EN(H4DOTC)(diag)-182, DTC P0245 TURBO/SUPER CHARGER WASTEGATE SOLENOID "A" LOW, Diagnostic Procedure with Diagnostic Trouble Code (DTC).>
P0246	Turbo/Super Charger Wastegate Solenoid "A" High	<Ref. to EN(H4DOTC)(diag)-185, DTC P0246 TURBO/SUPER CHARGER WASTEGATE SOLENOID "A" HIGH, Diagnostic Procedure with Diagnostic Trouble Code (DTC).>
P0301	Cylinder 1 Misfire Detected	<Ref. to EN(H4DOTC)(diag)-186, DTC P0301 CYLINDER 1 MISFIRE DETECTED, Diagnostic Procedure with Diagnostic Trouble Code (DTC).>
P0302	Cylinder 2 Misfire Detected	<Ref. to EN(H4DOTC)(diag)-186, DTC P0302 CYLINDER 2 MISFIRE DETECTED, Diagnostic Procedure with Diagnostic Trouble Code (DTC).>
P0303	Cylinder 3 Misfire Detected	<Ref. to EN(H4DOTC)(diag)-186, DTC P0303 CYLINDER 3 MISFIRE DETECTED, Diagnostic Procedure with Diagnostic Trouble Code (DTC).>
P0304	Cylinder 4 Misfire Detected	<Ref. to EN(H4DOTC)(diag)-187, DTC P0304 CYLINDER 4 MISFIRE DETECTED, Diagnostic Procedure with Diagnostic Trouble Code (DTC).>
P0327	Knock Sensor 1 Circuit Low (Bank 1 or Single Sensor)	<Ref. to EN(H4DOTC)(diag)-192, DTC P0327 KNOCK SENSOR 1 CIRCUIT LOW (BANK 1 OR SINGLE SENSOR), Diagnostic Procedure with Diagnostic Trouble Code (DTC).>
P0328	Knock Sensor 1 Circuit High (Bank 1 or Single Sensor)	<Ref. to EN(H4DOTC)(diag)-194, DTC P0328 KNOCK SENSOR 1 CIRCUIT HIGH (BANK 1 OR SINGLE SENSOR), Diagnostic Procedure with Diagnostic Trouble Code (DTC).>
P0335	Crankshaft Position Sensor "A" Circuit	<Ref. to EN(H4DOTC)(diag)-196, DTC P0335 CRANKSHAFT POSITION SENSOR "A" CIRCUIT, Diagnostic Procedure with Diagnostic Trouble Code (DTC).>
P0336	Crankshaft Position Sensor "A" Circuit Range/Performance	<Ref. to EN(H4DOTC)(diag)-198, DTC P0336 CRANKSHAFT POSITION SENSOR "A" CIRCUIT RANGE/PERFORMANCE, Diagnostic Procedure with Diagnostic Trouble Code (DTC).>
P0340	Camshaft Position Sensor "A" Circuit (Bank 1 or Single Sensor)	<Ref. to EN(H4DOTC)(diag)-199, DTC P0340 CAMSHAFT POSITION SENSOR "A" CIRCUIT (BANK 1 OR SINGLE SENSOR), Diagnostic Procedure with Diagnostic Trouble Code (DTC).>
P0345	Camshaft Position Sensor "A" Circuit (Bank 2)	<Ref. to EN(H4DOTC)(diag)-201, DTC P0345 CAMSHAFT POSITION SENSOR "A" CIRCUIT (BANK 2), Diagnostic Procedure with Diagnostic Trouble Code (DTC).>
P0351	Ignition Coil A Primary/Secondary Circuit	<Ref. to EN(H4DOTC)(diag)-204, DTC P0351 IGNITION COIL A PRIMARY/SECONDARY CIRCUIT, Diagnostic Procedure with Diagnostic Trouble Code (DTC).>
P0352	Ignition Coil B Primary/Secondary Circuit	<Ref. to EN(H4DOTC)(diag)-206, DTC P0352 IGNITION COIL B PRIMARY/SECONDARY CIRCUIT, Diagnostic Procedure with Diagnostic Trouble Code (DTC).>
P0353	Ignition Coil C Primary/Secondary Circuit	<Ref. to EN(H4DOTC)(diag)-206, DTC P0353 IGNITION COIL C PRIMARY/SECONDARY CIRCUIT, Diagnostic Procedure with Diagnostic Trouble Code (DTC).>
P0354	Ignition Coil D Primary/Secondary Circuit	<Ref. to EN(H4DOTC)(diag)-206, DTC P0354 IGNITION COIL D PRIMARY/SECONDARY CIRCUIT, Diagnostic Procedure with Diagnostic Trouble Code (DTC).>

**EN(H4DOTC)(diag)-90**

Brought to you by Ebay Seller "SubaruManuals"

# List of Diagnostic Trouble Code (DTC)

ENGINE (DIAGNOSTICS)

DTC	Item	Note
P0365	Camshaft Position Sensor "B" Circuit (Bank 1)	<Ref. to EN(H4DOTC)(diag)-207, DTC P0365 CAMSHAFT POSITION SENSOR "B" CIRCUIT (BANK 1), Diagnostic Procedure with Diagnostic Trouble Code (DTC).>
P0390	Camshaft Position Sensor "B" Circuit (Bank 2)	<Ref. to EN(H4DOTC)(diag)-209, DTC P0390 CAMSHAFT POSITION SENSOR "B" CIRCUIT (BANK 2), Diagnostic Procedure with Diagnostic Trouble Code (DTC).>
P0410	Secondary Air Injection System	<Ref. to EN(H4DOTC)(diag)-211, DTC P0410 SECONDARY AIR INJECTION SYSTEM, Diagnostic Procedure with Diagnostic Trouble Code (DTC).>
P0411	Secondary Air Injection System Incorrect Flow Detected	<Ref. to EN(H4DOTC)(diag)-217, DTC P0411 SECONDARY AIR INJECTION SYSTEM INCORRECT FLOW DETECTED, Diagnostic Procedure with Diagnostic Trouble Code (DTC).>
P0413	Secondary Air Injection System Switching Valve "A" Circuit Open	<Ref. to EN(H4DOTC)(diag)-218, DTC P0413 SECONDARY AIR INJECTION SYSTEM SWITCHING VALVE "A" CIRCUIT OPEN, Diagnostic Procedure with Diagnostic Trouble Code (DTC).>
P0414	Secondary Air Injection System Switching Valve "A" Circuit Shorted	<Ref. to EN(H4DOTC)(diag)-222, DTC P0414 SECONDARY AIR INJECTION SYSTEM SWITCHING VALVE "A" CIRCUIT SHORTED, Diagnostic Procedure with Diagnostic Trouble Code (DTC).>
P0416	Secondary Air Injection System Switching Valve "B" Circuit Open	<Ref. to EN(H4DOTC)(diag)-226, DTC P0416 SECONDARY AIR INJECTION SYSTEM SWITCHING VALVE "B" CIRCUIT OPEN, Diagnostic Procedure with Diagnostic Trouble Code (DTC).>
P0417	Secondary Air Injection System Switching Valve "B" Circuit Shorted	<Ref. to EN(H4DOTC)(diag)-230, DTC P0417 SECONDARY AIR INJECTION SYSTEM SWITCHING VALVE "B" CIRCUIT SHORTED, Diagnostic Procedure with Diagnostic Trouble Code (DTC).>
P0418	Secondary Air Injection System Control "A" Circuit Open	<Ref. to EN(H4DOTC)(diag)-234, DTC P0418 SECONDARY AIR INJECTION SYSTEM CONTROL "A" CIRCUIT OPEN, Diagnostic Procedure with Diagnostic Trouble Code (DTC).>
P0420	Catalyst System Efficiency Below Threshold (Bank 1)	<Ref. to EN(H4DOTC)(diag)-238, DTC P0420 CATALYST SYSTEM EFFICIENCY BELOW THRESHOLD (BANK 1), Diagnostic Procedure with Diagnostic Trouble Code (DTC).>
P0441	Evaporative Emission Cont. Sys. Incorrect Purge Flow	<Ref. to EN(H4DOTC)(diag)-243, DTC P0441 EVAPORATIVE EMISSION CONT. SYS. INCORRECT PURGE FLOW, Diagnostic Procedure with Diagnostic Trouble Code (DTC).>
P0451	Evaporative Emission System Pressure Sensor/Switch Range/Performance	<Ref. to EN(H4DOTC)(diag)-244, DTC P0451 EVAPORATIVE EMISSION SYSTEM PRESSURE SENSOR/SWITCH RANGE/PERFORMANCE, Diagnostic Procedure with Diagnostic Trouble Code (DTC).>
P0452	Evaporative Emission System Pressure Sensor/Switch Low	<Ref. to EN(H4DOTC)(diag)-245, DTC P0452 EVAPORATIVE EMISSION SYSTEM PRESSURE SENSOR/SWITCH LOW, Diagnostic Procedure with Diagnostic Trouble Code (DTC).>
P0453	Evaporative Emission System Pressure Sensor/Switch High	<Ref. to EN(H4DOTC)(diag)-247, DTC P0453 EVAPORATIVE EMISSION SYSTEM PRESSURE SENSOR/SWITCH HIGH, Diagnostic Procedure with Diagnostic Trouble Code (DTC).>
P0455	Evaporative Emission System Leak Detected (Large Leak)	<Ref. to EN(H4DOTC)(diag)-249, DTC P0455 EVAPORATIVE EMISSION SYSTEM LEAK DETECTED (LARGE LEAK), Diagnostic Procedure with Diagnostic Trouble Code (DTC).>
P0456	Evaporative Emission Control System Leak Detected (Very Small Leak)	<Ref. to EN(H4DOTC)(diag)-250, DTC P0456 EVAPORATIVE EMISSION CONTROL SYSTEM LEAK DETECTED (VERY SMALL LEAK), Diagnostic Procedure with Diagnostic Trouble Code (DTC).>
P0458	Evaporative Emission System Purge Control Valve Circuit Low	<Ref. to EN(H4DOTC)(diag)-251, DTC P0458 EVAPORATIVE EMISSION SYSTEM PURGE CONTROL VALVE CIRCUIT LOW, Diagnostic Procedure with Diagnostic Trouble Code (DTC).>
P0459	Evaporative Emission System Purge Control Valve Circuit High	<Ref. to EN(H4DOTC)(diag)-254, DTC P0459 EVAPORATIVE EMISSION SYSTEM PURGE CONTROL VALVE CIRCUIT HIGH, Diagnostic Procedure with Diagnostic Trouble Code (DTC).>
P0461	Fuel Level Sensor "A" Circuit Range/Performance	<Ref. to EN(H4DOTC)(diag)-256, DTC P0461 FUEL LEVEL SENSOR "A" CIRCUIT RANGE/PERFORMANCE, Diagnostic Procedure with Diagnostic Trouble Code (DTC).>
P0462	Fuel Level Sensor "A" Circuit Low	<Ref. to EN(H4DOTC)(diag)-256, DTC P0462 FUEL LEVEL SENSOR "A" CIRCUIT LOW, Diagnostic Procedure with Diagnostic Trouble Code (DTC).>

**EN(H4DOTC)(diag)-91**

Brought to you by Ebay Seller "SubaruManuals"

## List of Diagnostic Trouble Code (DTC)

### ENGINE (DIAGNOSTICS)

DTC	Item	Note
P0463	Fuel Level Sensor "A" Circuit High	<Ref. to EN(H4DOTC)(diag)-257, DTC P0463 FUEL LEVEL SENSOR "A" CIRCUIT HIGH, Diagnostic Procedure with Diagnostic Trouble Code (DTC).>
P0500	Vehicle Speed Sensor "A"	<Ref. to EN(H4DOTC)(diag)-257, DTC P0500 VEHICLE SPEED SENSOR "A", Diagnostic Procedure with Diagnostic Trouble Code (DTC).>
P0506	Idle Air Control System RPM Lower Than Expected	<Ref. to EN(H4DOTC)(diag)-258, DTC P0506 IDLE AIR CONTROL SYSTEM RPM LOWER THAN EXPECTED, Diagnostic Procedure with Diagnostic Trouble Code (DTC).>
P0507	Idle Air Control System RPM Higher Than Expected	<Ref. to EN(H4DOTC)(diag)-259, DTC P0507 IDLE AIR CONTROL SYSTEM RPM HIGHER THAN EXPECTED, Diagnostic Procedure with Diagnostic Trouble Code (DTC).>
P050A	Cold Start Idle Air Control System Performance	<Ref. to EN(H4DOTC)(diag)-260, DTC P050A COLD START IDLE AIR CONTROL SYSTEM PERFORMANCE, Diagnostic Procedure with Diagnostic Trouble Code (DTC).>
P050B	Cold Start Ignition Timing Performance	<Ref. to EN(H4DOTC)(diag)-269, DTC P050B COLD START IGNITION TIMING PERFORMANCE, Diagnostic Procedure with Diagnostic Trouble Code (DTC).>
P0512	Starter Request Circuit	<Ref. to EN(H4DOTC)(diag)-270, DTC P0512 STARTER REQUEST CIRCUIT, Diagnostic Procedure with Diagnostic Trouble Code (DTC).>
P0513	Incorrect Immobilizer Key	<Ref. to IM(diag)-15, DTC P0513 INCORRECT IMMOBILIZER KEY, Diagnostic Procedure with Diagnostic Trouble Code (DTC).>
P0604	Internal Control Module Random Access Memory (RAM) Error	<Ref. to EN(H4DOTC)(diag)-272, DTC P0604 INTERNAL CONTROL MODULE RANDOM ACCESS MEMORY (RAM) ERROR, Diagnostic Procedure with Diagnostic Trouble Code (DTC).>
P0605	Internal Control Module Read Only Memory (ROM) Error	<Ref. to EN(H4DOTC)(diag)-272, DTC P0605 INTERNAL CONTROL MODULE READ ONLY MEMORY (ROM) ERROR, Diagnostic Procedure with Diagnostic Trouble Code (DTC).>
P0607	Throttle Control System Circuit Range/Performance	<Ref. to EN(H4DOTC)(diag)-273, DTC P0607 THROTTLE CONTROL SYSTEM CIRCUIT RANGE/PERFORMANCE, Diagnostic Procedure with Diagnostic Trouble Code (DTC).>
P0638	Throttle Actuator Control Range/Performance (Bank 1)	<Ref. to EN(H4DOTC)(diag)-274, DTC P0638 THROTTLE ACTUATOR CONTROL RANGE/PERFORMANCE (BANK 1), Diagnostic Procedure with Diagnostic Trouble Code (DTC).>
P0851	Neutral Switch Input Circuit Low (MT Model)	<Ref. to EN(H4DOTC)(diag)-275, DTC P0851 NEUTRAL SWITCH INPUT CIRCUIT LOW (MT MODEL), Diagnostic Procedure with Diagnostic Trouble Code (DTC).>
P0852	Neutral Switch Input Circuit High (MT Model)	<Ref. to EN(H4DOTC)(diag)-277, DTC P0852 NEUTRAL SWITCH INPUT CIRCUIT HIGH (MT MODEL), Diagnostic Procedure with Diagnostic Trouble Code (DTC).>
P1152	O2 Sensor Circuit Range/Performance (Low) (Bank1 Sensor1)	<Ref. to EN(H4DOTC)(diag)-279, DTC P1152 O2 SENSOR CIRCUIT RANGE/PERFORMANCE (LOW) (BANK1 SENSOR1), Diagnostic Procedure with Diagnostic Trouble Code (DTC).>
P1153	O2 Sensor Circuit Range/Performance (High) (Bank1 Sensor1)	<Ref. to EN(H4DOTC)(diag)-282, DTC P1153 O2 SENSOR CIRCUIT RANGE/PERFORMANCE (HIGH) (BANK1 SENSOR1), Diagnostic Procedure with Diagnostic Trouble Code (DTC).>
P1160	Return Spring Failure	<Ref. to EN(H4DOTC)(diag)-284, DTC P1160 RETURN SPRING FAILURE, Diagnostic Procedure with Diagnostic Trouble Code (DTC).>
P1400	Fuel Tank Pressure Control Solenoid Valve Circuit Low	<Ref. to EN(H4DOTC)(diag)-285, DTC P1400 FUEL TANK PRESSURE CONTROL SOLENOID VALVE CIRCUIT LOW, Diagnostic Procedure with Diagnostic Trouble Code (DTC).>
P1410	Secondary Air Injection System Switching Valve Stuck Open	<Ref. to EN(H4DOTC)(diag)-288, DTC P1410 SECONDARY AIR INJECTION SYSTEM SWITCHING VALVE STUCK OPEN, Diagnostic Procedure with Diagnostic Trouble Code (DTC).>
P1418	Secondary Air Injection System Control "A" Circuit Shorted	<Ref. to EN(H4DOTC)(diag)-289, DTC P1418 SECONDARY AIR INJECTION SYSTEM CONTROL "A" CIRCUIT SHORTED, Diagnostic Procedure with Diagnostic Trouble Code (DTC).>
P1420	Fuel Tank Pressure Control Sol. Valve Circuit High	<Ref. to EN(H4DOTC)(diag)-293, DTC P1420 FUEL TANK PRESSURE CONTROL SOL. VALVE CIRCUIT HIGH, Diagnostic Procedure with Diagnostic Trouble Code (DTC).>
P1449	Evaporative Emission Cont. Sys. Air Filter Clog	<Ref. to EN(H4DOTC)(diag)-295, DTC P1449 EVAPORATIVE EMISSION CONT. SYS. AIR FILTER CLOG, Diagnostic Procedure with Diagnostic Trouble Code (DTC).>
P1451	Evaporative Emission Cont. Sys.	<Ref. to EN(H4DOTC)(diag)-296, DTC P1451 EVAPORATIVE EMISSION CONT. SYS., Diagnostic Procedure with Diagnostic Trouble Code (DTC).>

**EN(H4DOTC)(diag)-92**

Brought to you by Ebay Seller "SubaruManuals"

# List of Diagnostic Trouble Code (DTC)

ENGINE (DIAGNOSTICS)

DTC	Item	Note
P1458	Canister Purge Control Solenoid Valve 2	<Ref. to EN(H4DOTC)(diag)-297, DTC P1458 CANISTER PURGE CONTROL SOLENOID VALVE 2, Diagnostic Procedure with Diagnostic Trouble Code (DTC).>
P1459	Canister Purge Control Solenoid Valve 2	<Ref. to EN(H4DOTC)(diag)-300, DTC P1459 CANISTER PURGE CONTROL SOLENOID VALVE 2, Diagnostic Procedure with Diagnostic Trouble Code (DTC).>
P1491	Positive Crankcase Ventilation (Blow-By) Function Problem	<Ref. to EN(H4DOTC)(diag)-302, DTC P1491 POSITIVE CRANKCASE VENTILATION (BLOW-BY) FUNCTION PROBLEM, Diagnostic Procedure with Diagnostic Trouble Code (DTC).>
P1518	Starter Switch Circuit Low Input	<Ref. to EN(H4DOTC)(diag)-304, DTC P1518 STARTER SWITCH CIRCUIT LOW INPUT, Diagnostic Procedure with Diagnostic Trouble Code (DTC).>
P1560	Back-Up Voltage Circuit Malfunction	<Ref. to EN(H4DOTC)(diag)-306, DTC P1560 BACK-UP VOLTAGE CIRCUIT MALFUNCTION, Diagnostic Procedure with Diagnostic Trouble Code (DTC).>
P1570	Antenna	<Ref. to IM(diag)-16, DTC P1570 ANTENNA, Diagnostic Procedure with Diagnostic Trouble Code (DTC).>
P1571	Reference Code Incompatibility	<Ref. to IM(diag)-18, DTC P1571 REFERENCE CODE INCOMPATIBILITY, Diagnostic Procedure with Diagnostic Trouble Code (DTC).>
P1572	IMM Circuit Failure (Except Antenna Circuit)	<Ref. to IM(diag)-19, DTC P1572 IMM CIRCUIT FAILURE (EXCEPT ANTENNA CIRCUIT), Diagnostic Procedure with Diagnostic Trouble Code (DTC).>
P1574	Key Communication Failure	<Ref. to IM(diag)-22, DTC P1574 KEY COMMUNICATION FAILURE, Diagnostic Procedure with Diagnostic Trouble Code (DTC).>
P1576	EGI Control Module EEPROM	<Ref. to IM(diag)-22, DTC P1576 EGI CONTROL MODULE EEPROM, Diagnostic Procedure with Diagnostic Trouble Code (DTC).>
P1577	IMM Control Module EEPROM	<Ref. to IM(diag)-23, DTC P1577 IMM CONTROL MODULE EEPROM, Diagnostic Procedure with Diagnostic Trouble Code (DTC).>
P1578	Meter Failure	<Ref. to IM(diag)-24, DTC P1578 METER FAILURE, Diagnostic Procedure with Diagnostic Trouble Code (DTC).>
P2004	Intake Manifold Runner Control Stuck Open (Bank 1)	<Ref. to EN(H4DOTC)(diag)-308, DTC P2004 INTAKE MANIFOLD RUNNER CONTROL STUCK OPEN (BANK 1), Diagnostic Procedure with Diagnostic Trouble Code (DTC).>
P2005	Intake Manifold Runner Control Stuck Open (Bank 2)	<Ref. to EN(H4DOTC)(diag)-309, DTC P2005 INTAKE MANIFOLD RUNNER CONTROL STUCK OPEN (BANK 2), Diagnostic Procedure with Diagnostic Trouble Code (DTC).>
P2006	Intake Manifold Runner Control Stuck Closed (Bank 1)	<Ref. to EN(H4DOTC)(diag)-310, DTC P2006 INTAKE MANIFOLD RUNNER CONTROL STUCK CLOSED (BANK 1), Diagnostic Procedure with Diagnostic Trouble Code (DTC).>
P2007	Intake Manifold Runner Control Stuck Closed (Bank 2)	<Ref. to EN(H4DOTC)(diag)-311, DTC P2007 INTAKE MANIFOLD RUNNER CONTROL STUCK CLOSED (BANK 2), Diagnostic Procedure with Diagnostic Trouble Code (DTC).>
P2008	Intake Manifold Runner Control Circuit / Open (Bank 1)	<Ref. to EN(H4DOTC)(diag)-312, DTC P2008 INTAKE MANIFOLD RUNNER CONTROL CIRCUIT / OPEN (BANK 1), Diagnostic Procedure with Diagnostic Trouble Code (DTC).>
P2009	Intake Manifold Runner Control Circuit Low (Bank 1)	<Ref. to EN(H4DOTC)(diag)-314, DTC P2009 INTAKE MANIFOLD RUNNER CONTROL CIRCUIT LOW (BANK 1), Diagnostic Procedure with Diagnostic Trouble Code (DTC).>
P2011	Intake Manifold Runner Control Circuit / Open (Bank 2)	<Ref. to EN(H4DOTC)(diag)-316, DTC P2011 INTAKE MANIFOLD RUNNER CONTROL CIRCUIT / OPEN (BANK 2), Diagnostic Procedure with Diagnostic Trouble Code (DTC).>
P2012	Intake Manifold Runner Control Circuit Low (Bank 2)	<Ref. to EN(H4DOTC)(diag)-318, DTC P2012 INTAKE MANIFOLD RUNNER CONTROL CIRCUIT LOW (BANK 2), Diagnostic Procedure with Diagnostic Trouble Code (DTC).>
P2016	Intake Manifold Runner Position Sensor / Switch Circuit Low (Bank 1)	<Ref. to EN(H4DOTC)(diag)-320, DTC P2016 INTAKE MANIFOLD RUNNER POSITION SENSOR / SWITCH CIRCUIT LOW (BANK 1), Diagnostic Procedure with Diagnostic Trouble Code (DTC).>
P2017	Intake Manifold Runner Position Sensor / Switch Circuit High (Bank 1)	<Ref. to EN(H4DOTC)(diag)-323, DTC P2017 INTAKE MANIFOLD RUNNER POSITION SENSOR / SWITCH CIRCUIT HIGH (BANK 1), Diagnostic Procedure with Diagnostic Trouble Code (DTC).>
P2021	Intake Manifold Runner Position Sensor / Switch Circuit Low (Bank 2)	<Ref. to EN(H4DOTC)(diag)-325, DTC P2021 INTAKE MANIFOLD RUNNER POSITION SENSOR / SWITCH CIRCUIT LOW (BANK 2), Diagnostic Procedure with Diagnostic Trouble Code (DTC).>
P2022	Intake Manifold Runner Position Sensor / Switch Circuit High (Bank 2)	<Ref. to EN(H4DOTC)(diag)-328, DTC P2022 INTAKE MANIFOLD RUNNER POSITION SENSOR / SWITCH CIRCUIT HIGH (BANK 2), Diagnostic Procedure with Diagnostic Trouble Code (DTC).>

**EN(H4DOTC)(diag)-93**

Brought to you by Ebay Seller "SubaruManuals"



## List of Diagnostic Trouble Code (DTC)

### ENGINE (DIAGNOSTICS)

DTC	Item	Note
P2088	Intake Camshaft Position Actuator Control Circuit Low (Bank 1)	<Ref. to EN(H4DOTC)(diag)-330, DTC P2088 INTAKE CAMSHAFT POSITION ACTUATOR CONTROL CIRCUIT LOW (BANK 1), Diagnostic Procedure with Diagnostic Trouble Code (DTC).>
P2089	Intake Camshaft Position Actuator Control Circuit High (Bank 1)	<Ref. to EN(H4DOTC)(diag)-332, DTC P2089 INTAKE CAMSHAFT POSITION ACTUATOR CONTROL CIRCUIT HIGH (BANK 1), Diagnostic Procedure with Diagnostic Trouble Code (DTC).>
P2090	Exhaust Camshaft Position Actuator Control Circuit Low (Bank 1)	<Ref. to EN(H4DOTC)(diag)-334, DTC P2090 EXHAUST CAMSHAFT POSITION ACTUATOR CONTROL CIRCUIT LOW (BANK 1), Diagnostic Procedure with Diagnostic Trouble Code (DTC).>
P2091	Exhaust Camshaft Position Actuator Control Circuit High (Bank 1)	<Ref. to EN(H4DOTC)(diag)-336, DTC P2091 EXHAUST CAMSHAFT POSITION ACTUATOR CONTROL CIRCUIT HIGH (BANK 1), Diagnostic Procedure with Diagnostic Trouble Code (DTC).>
P2092	Intake Camshaft Position Actuator Control Circuit Low (Bank 2)	<Ref. to EN(H4DOTC)(diag)-338, DTC P2092 INTAKE CAMSHAFT POSITION ACTUATOR CONTROL CIRCUIT LOW (BANK 2), Diagnostic Procedure with Diagnostic Trouble Code (DTC).>
P2093	Intake Camshaft Position Actuator Control Circuit High (Bank 2)	<Ref. to EN(H4DOTC)(diag)-340, DTC P2093 INTAKE CAMSHAFT POSITION ACTUATOR CONTROL CIRCUIT HIGH (BANK 2), Diagnostic Procedure with Diagnostic Trouble Code (DTC).>
P2094	Exhaust Camshaft Position Actuator Control Circuit Low (Bank 2)	<Ref. to EN(H4DOTC)(diag)-342, DTC P2094 EXHAUST CAMSHAFT POSITION ACTUATOR CONTROL CIRCUIT LOW (BANK 2), Diagnostic Procedure with Diagnostic Trouble Code (DTC).>
P2095	Exhaust Camshaft Position Actuator Control Circuit High (Bank 2)	<Ref. to EN(H4DOTC)(diag)-344, DTC P2095 EXHAUST CAMSHAFT POSITION ACTUATOR CONTROL CIRCUIT HIGH (BANK 2), Diagnostic Procedure with Diagnostic Trouble Code (DTC).>
P2096	Post Catalyst Fuel Trim System Too Lean (Bank 1)	<Ref. to EN(H4DOTC)(diag)-346, DTC P2096 POST CATALYST FUEL TRIM SYSTEM TOO LEAN (BANK 1), Diagnostic Procedure with Diagnostic Trouble Code (DTC).>
P2097	Post Catalyst Fuel Trim System Too Rich (Bank 1)	<Ref. to EN(H4DOTC)(diag)-355, DTC P2097 POST CATALYST FUEL TRIM SYSTEM TOO RICH (BANK 1), Diagnostic Procedure with Diagnostic Trouble Code (DTC).>
P2101	Throttle Actuator Control Motor Circuit Range/Performance	<Ref. to EN(H4DOTC)(diag)-364, DTC P2101 THROTTLE ACTUATOR CONTROL MOTOR CIRCUIT RANGE/PERFORMANCE, Diagnostic Procedure with Diagnostic Trouble Code (DTC).>
P2102	Throttle Actuator Control Motor Circuit Low	<Ref. to EN(H4DOTC)(diag)-369, DTC P2102 THROTTLE ACTUATOR CONTROL MOTOR CIRCUIT LOW, Diagnostic Procedure with Diagnostic Trouble Code (DTC).>
P2103	Throttle Actuator Control Motor Circuit High	<Ref. to EN(H4DOTC)(diag)-371, DTC P2103 THROTTLE ACTUATOR CONTROL MOTOR CIRCUIT HIGH, Diagnostic Procedure with Diagnostic Trouble Code (DTC).>
P2109	Throttle/Pedal Position Sensor "A" Minimum Stop Performance	<Ref. to EN(H4DOTC)(diag)-372, DTC P2109 THROTTLE/PEDAL POSITION SENSOR "A" MINIMUM STOP PERFORMANCE, Diagnostic Procedure with Diagnostic Trouble Code (DTC).>
P2122	Throttle/Pedal Position Sensor/Switch "D" Circuit Low Input	<Ref. to EN(H4DOTC)(diag)-373, DTC P2122 THROTTLE/PEDAL POSITION SENSOR/SWITCH "D" CIRCUIT LOW INPUT, Diagnostic Procedure with Diagnostic Trouble Code (DTC).>
P2123	Throttle/Pedal Position Sensor/Switch "D" Circuit High Input	<Ref. to EN(H4DOTC)(diag)-375, DTC P2123 THROTTLE/PEDAL POSITION SENSOR/SWITCH "D" CIRCUIT HIGH INPUT, Diagnostic Procedure with Diagnostic Trouble Code (DTC).>
P2127	Throttle/Pedal Position Sensor/Switch "E" Circuit Low Input	<Ref. to EN(H4DOTC)(diag)-377, DTC P2127 THROTTLE/PEDAL POSITION SENSOR/SWITCH "E" CIRCUIT LOW INPUT, Diagnostic Procedure with Diagnostic Trouble Code (DTC).>
P2128	Throttle/Pedal Position Sensor/Switch "E" Circuit High Input	<Ref. to EN(H4DOTC)(diag)-379, DTC P2128 THROTTLE/PEDAL POSITION SENSOR/SWITCH "E" CIRCUIT HIGH INPUT, Diagnostic Procedure with Diagnostic Trouble Code (DTC).>
P2135	Throttle/Pedal Position Sensor/Switch "A"/"B" Voltage Correlation	<Ref. to EN(H4DOTC)(diag)-381, DTC P2135 THROTTLE/PEDAL POSITION SENSOR/SWITCH "A"/"B" VOLTAGE CORRELATION, Diagnostic Procedure with Diagnostic Trouble Code (DTC).>
P2138	Throttle/Pedal Position Sensor/Switch "D"/"E" Voltage Correlation	<Ref. to EN(H4DOTC)(diag)-384, DTC P2138 THROTTLE/PEDAL POSITION SENSOR/SWITCH "D"/"E" VOLTAGE CORRELATION, Diagnostic Procedure with Diagnostic Trouble Code (DTC).>

**EN(H4DOTC)(diag)-94**

Brought to you by Ebay Seller "SubaruManuals"

# List of Diagnostic Trouble Code (DTC)

ENGINE (DIAGNOSTICS)

DTC	Item	Note
P219A	Bank 1 Air-Fuel Ratio Imbalance	<Ref. to EN(H4DOTC)(diag)-386, DTC P219A BANK 1 AIR-FUEL RATIO IMBALANCE, Diagnostic Procedure with Diagnostic Trouble Code (DTC).>
P2401	Evaporative Emission System Leak Detection Pump Control Circuit Low	<Ref. to EN(H4DOTC)(diag)-400, DTC P2401 EVAPORATIVE EMISSION SYSTEM LEAK DETECTION PUMP CONTROL CIRCUIT LOW, Diagnostic Procedure with Diagnostic Trouble Code (DTC).>
P2402	Evaporative Emission System Leak Detection Pump Control Circuit High	<Ref. to EN(H4DOTC)(diag)-403, DTC P2402 EVAPORATIVE EMISSION SYSTEM LEAK DETECTION PUMP CONTROL CIRCUIT HIGH, Diagnostic Procedure with Diagnostic Trouble Code (DTC).>
P2404	Evaporative Emission System Leak Detection Pump Sense Circuit Range/Performance	<Ref. to EN(H4DOTC)(diag)-405, DTC P2404 EVAPORATIVE EMISSION SYSTEM LEAK DETECTION PUMP SENSE CIRCUIT RANGE/PERFORMANCE, Diagnostic Procedure with Diagnostic Trouble Code (DTC).>
P2419	Evaporative Emission System Switching Valve Control Circuit Low	<Ref. to EN(H4DOTC)(diag)-409, DTC P2419 EVAPORATIVE EMISSION SYSTEM SWITCHING VALVE CONTROL CIRCUIT LOW, Diagnostic Procedure with Diagnostic Trouble Code (DTC).>
P2420	Evaporative Emission System Switching Valve Control Circuit High	<Ref. to EN(H4DOTC)(diag)-412, DTC P2420 EVAPORATIVE EMISSION SYSTEM SWITCHING VALVE CONTROL CIRCUIT HIGH, Diagnostic Procedure with Diagnostic Trouble Code (DTC).>
P2431	Secondary Air Injection System Air Flow /Pressure Sensor Circuit Range/Performance	<Ref. to EN(H4DOTC)(diag)-414, DTC P2431 SECONDARY AIR INJECTION SYSTEM AIR FLOW /PRESSURE SENSOR CIRCUIT RANGE/PERFORMANCE, Diagnostic Procedure with Diagnostic Trouble Code (DTC).>
P2432	Secondary Air Injection System Air Flow /Pressure Sensor Circuit Low	<Ref. to EN(H4DOTC)(diag)-415, DTC P2432 SECONDARY AIR INJECTION SYSTEM AIR FLOW /PRESSURE SENSOR CIRCUIT LOW, Diagnostic Procedure with Diagnostic Trouble Code (DTC).>
P2433	Secondary Air Injection System Air Flow /Pressure Sensor Circuit High	<Ref. to EN(H4DOTC)(diag)-420, DTC P2433 SECONDARY AIR INJECTION SYSTEM AIR FLOW /PRESSURE SENSOR CIRCUIT HIGH, Diagnostic Procedure with Diagnostic Trouble Code (DTC).>
P2440	Secondary Air Injection System Switching Valve Stuck Open (Bank1)	<Ref. to EN(H4DOTC)(diag)-424, DTC P2440 SECONDARY AIR INJECTION SYSTEM SWITCHING VALVE STUCK OPEN (BANK1), Diagnostic Procedure with Diagnostic Trouble Code (DTC).>
P2441	Secondary Air Injection System Switching Valve Stuck Closed (Bank1)	<Ref. to EN(H4DOTC)(diag)-430, DTC P2441 SECONDARY AIR INJECTION SYSTEM SWITCHING VALVE STUCK CLOSED (BANK1), Diagnostic Procedure with Diagnostic Trouble Code (DTC).>
P2442	Secondary Air Injection System Switching Valve Stuck Open (Bank2)	<Ref. to EN(H4DOTC)(diag)-431, DTC P2442 SECONDARY AIR INJECTION SYSTEM SWITCHING VALVE STUCK OPEN (BANK2), Diagnostic Procedure with Diagnostic Trouble Code (DTC).>
P2443	Secondary Air Injection System Switching Valve Stuck Closed (Bank2)	<Ref. to EN(H4DOTC)(diag)-437, DTC P2443 SECONDARY AIR INJECTION SYSTEM SWITCHING VALVE STUCK CLOSED (BANK2), Diagnostic Procedure with Diagnostic Trouble Code (DTC).>
P2444	Secondary Air Injection System Pump Stuck On	<Ref. to EN(H4DOTC)(diag)-438, DTC P2444 SECONDARY AIR INJECTION SYSTEM PUMP STUCK ON, Diagnostic Procedure with Diagnostic Trouble Code (DTC).>
P2610	ECM/PCM Internal Engine Off Timer Performance	<Ref. to EN(H4DOTC)(diag)-442, DTC P2610 ECM/PCM INTERNAL ENGINE OFF TIMER PERFORMANCE, Diagnostic Procedure with Diagnostic Trouble Code (DTC).>
U0073	CAN Failure, Bus 'Off' Detection	<Ref. to EN(H4DOTC)(diag)-442, DTC U0073 CAN FAILURE, BUS 'OFF' DETECTION, Diagnostic Procedure with Diagnostic Trouble Code (DTC).>
U0122	CAN (VDC) Data Not Loaded	<Ref. to EN(H4DOTC)(diag)-442, DTC U0122 CAN (VDC) DATA NOT LOADED, Diagnostic Procedure with Diagnostic Trouble Code (DTC).>
U0140	CAN (BCU) Data Not Loaded	<Ref. to EN(H4DOTC)(diag)-442, DTC U0140 CAN (BCU) DATA NOT LOADED, Diagnostic Procedure with Diagnostic Trouble Code (DTC).>
U0416	CAN (VDC) Data Abnormal	<Ref. to EN(H4DOTC)(diag)-442, DTC U0416 CAN (VDC) DATA ABNORMAL, Diagnostic Procedure with Diagnostic Trouble Code (DTC).>
U0422	CAN (BCU) Data Abnormal	<Ref. to EN(H4DOTC)(diag)-442, DTC U0422 CAN (BCU) DATA ABNORMAL, Diagnostic Procedure with Diagnostic Trouble Code (DTC).>

**EN(H4DOTC)(diag)-95**

Brought to you by Ebay Seller "SubaruManuals"

# Diagnostic Procedure with Diagnostic Trouble Code (DTC)

ENGINE (DIAGNOSTICS)

## 20. Diagnostic Procedure with Diagnostic Trouble Code (DTC)

### A: DTC P0011 INTAKE CAMSHAFT POSITION - TIMING OVER-ADVANCED OR SYSTEM PERFORMANCE (BANK 1)

#### DTC DETECTING CONDITION:

- Detected when two consecutive driving cycles with fault occur.
- GENERAL DESCRIPTION <Ref. to GD(H4DOTC)-11, DTC P0011 INTAKE CAMSHAFT POSITION - TIMING OVER-ADVANCED OR SYSTEM PERFORMANCE (BANK 1), Diagnostic Trouble Code (DTC) Detecting Criteria.>

#### TROUBLE SYMPTOM:

- Engine stalls.
- Improper idling

#### CAUTION:

**After servicing or replacing faulty parts, perform Clear Memory Mode <Ref. to EN(H4DOTC)(diag)-62, OPERATION, Clear Memory Mode.>, and Inspection Mode <Ref. to EN(H4DOTC)(diag)-48, PROCEDURE, Inspection Mode.>.**

Step	Check	Yes	No
<b>1</b> <b>CHECK CURRENT DATA.</b> 1) Start the engine and let it idle. 2) Read the value of «VVT Adv. Ang. Amount R» using the Subaru Select Monitor. NOTE: For detailed operation procedures, refer to "READ CURRENT DATA FOR ENGINE". <Ref. to EN(H4DOTC)(diag)-40, Subaru Select Monitor.>	Is the value of «VVT Adv. Ang. Amount R» approx. 0 deg?	Go to step 2.	Check the following item and repair or replace if necessary. <ul style="list-style-type: none"> <li>• Oil pipe (clog)</li> <li>• Oil flow control solenoid valve (clog or dirt of oil routing, setting of spring)</li> <li>• Intake camshaft (dirt, damage of camshaft)</li> </ul>
<b>2</b> <b>CHECK CURRENT DATA.</b> 1) Drive with acceleration and deceleration at 80 km/h (50 MPH) or less. NOTE: Drive to an extent that the duty output of oil flow control solenoid valve increases. 2) Read the values of «OCV Duty R» and «VVT Adv. Ang. Amount R» using the Subaru Select Monitor. NOTE: For detailed operation procedures, refer to "READ CURRENT DATA FOR ENGINE". <Ref. to EN(H4DOTC)(diag)-40, Subaru Select Monitor.>	When the value of «OCV Duty R» increases more than 10%, is the value of «VVT Adv. Ang. Amount R» approx. 0 deg?	Check the following item and repair or replace if necessary. <ul style="list-style-type: none"> <li>• Oil pipe (clog)</li> <li>• Oil flow control solenoid valve (clog or dirt of oil routing, setting of spring)</li> <li>• Intake camshaft (dirt, damage of camshaft)</li> </ul>	Perform the following procedures, and clean the oil routing. Replace the engine oil and idle the engine for 5 minutes, and then replace the oil filter and engine oil. <Ref. to LU(STI)-11, REPLACE- MENT, Engine Oil.> <Ref. to LU(STI)-32, Engine Oil Filter.>

# Diagnostic Procedure with Diagnostic Trouble Code (DTC)

ENGINE (DIAGNOSTICS)

## B: DTC P0014 EXHAUST AVCS SYSTEM 1 (RANGE/PERFORMANCE)

### DTC DETECTING CONDITION:

- Detected when two consecutive driving cycles with fault occur.
- GENERAL DESCRIPTION <Ref. to GD(H4DOTC)-13, DTC P0014 EXHAUST AVCS SYSTEM 1 (RANGE/PERFORMANCE), Diagnostic Trouble Code (DTC) Detecting Criteria.>

### TROUBLE SYMPTOM:

- Engine stalls.
- Improper idling

### CAUTION:

After servicing or replacing faulty parts, perform Clear Memory Mode <Ref. to EN(H4DOTC)(diag)-62, OPERATION, Clear Memory Mode.>, and Inspection Mode <Ref. to EN(H4DOTC)(diag)-48, PROCEDURE, Inspection Mode.>.

Step	Check	Yes	No
<b>1</b> <b>CHECK CURRENT DATA.</b> 1) Start the engine and let it idle. 2) Read the value of «Exh. VVT Retard Ang. R» using the Subaru Select Monitor.  NOTE: For detailed operation procedures, refer to "READ CURRENT DATA FOR ENGINE". <Ref. to EN(H4DOTC)(diag)-40, Subaru Select Monitor.>	Is the value of «Exh. VVT Retard Ang. R» approx. 0 deg?	Go to step 2.	Check the following item and repair or replace if necessary. <ul style="list-style-type: none"> <li>• Oil pipe (clog)</li> <li>• Oil flow control solenoid valve (clog or dirt of oil routing, setting of spring)</li> <li>• Exhaust camshaft (dirt, damage of camshaft)</li> </ul>
<b>2</b> <b>CHECK CURRENT DATA.</b> 1) Drive with acceleration and deceleration at 80 km/h (50 MPH) or less.  NOTE: Drive to an extent that the duty output of oil flow control solenoid valve increases. 2) Read the values of «Exh. OCV Duty R» and «Exh. VVT Retard Ang. R» using the Subaru Select Monitor.  NOTE: For detailed operation procedures, refer to "READ CURRENT DATA FOR ENGINE". <Ref. to EN(H4DOTC)(diag)-40, Subaru Select Monitor.>	When the value of «Exh. OCV Duty R» increases more than 10%, is the value of «Exh. VVT Retard Ang. R» approx. 0 deg?	Check the following item and repair or replace if necessary. <ul style="list-style-type: none"> <li>• Oil pipe (clog)</li> <li>• Oil flow control solenoid valve (clog or dirt of oil routing, setting of spring)</li> <li>• Exhaust camshaft (dirt, damage of camshaft)</li> </ul>	Perform the following procedures, and clean the oil routing.  Replace the engine oil and idle the engine for 5 minutes, and then replace the oil filter and engine oil. <Ref. to LU(STI)-11, REPLACEMENT, Engine Oil.> <Ref. to LU(STI)-32, Engine Oil Filter.>

# Diagnostic Procedure with Diagnostic Trouble Code (DTC)

ENGINE (DIAGNOSTICS)

## C: DTC P0016 CRANKSHAFT POSITION - CAMSHAFT POSITION CORRELATION (BANK1)

### DTC DETECTING CONDITION:

- Detected when two consecutive driving cycles with fault occur.
- GENERAL DESCRIPTION <Ref. to GD(H4DOTC)-15, DTC P0016 CRANKSHAFT POSITION - CAMSHAFT POSITION CORRELATION (BANK1), Diagnostic Trouble Code (DTC) Detecting Criteria.>

### TROUBLE SYMPTOM:

- Engine stalls.
- Improper idling

### CAUTION:

After servicing or replacing faulty parts, perform Clear Memory Mode <Ref. to EN(H4DOTC)(diag)-62, OPERATION, Clear Memory Mode.>, and Inspection Mode <Ref. to EN(H4DOTC)(diag)-48, PROCEDURE, Inspection Mode.>.

	Step	Check	Yes	No
1	<b>CHECK CURRENT DATA.</b> 1) Start the engine and let it idle. 2) Read the values of «VVT Adv. Ang. Amount R» and «OCV Duty R» using the Subaru Select Monitor.  NOTE: For detailed operation procedures, refer to "READ CURRENT DATA FOR ENGINE". <Ref. to EN(H4DOTC)(diag)-40, Subaru Select Monitor.>	Is the value of «VVT Adv. Ang. Amount R» approx. 0 deg, and the value of «OCV Duty R» approx. 10%?	Perform the following procedures, and clean the oil routing. Replace the engine oil and idle the engine for 5 minutes, and then replace the oil filter and engine oil. <Ref. to LU(STI)-11, REPLACE-MENT, Engine Oil.> <Ref. to LU(STI)-32, Engine Oil Filter.>	Check the following item and repair or replace if necessary. <ul style="list-style-type: none"><li>• Oil pipe (clog)</li><li>• Oil flow control solenoid valve (clog or dirt of oil routing, setting of spring)</li><li>• Intake camshaft (dirt, damage of camshaft)</li><li>• Timing belt (matching of timing mark)</li></ul>

# Diagnostic Procedure with Diagnostic Trouble Code (DTC)

ENGINE (DIAGNOSTICS)

## D: DTC P0017 CRANK AND CAM TIMING B SYSTEM FAILURE (BANK 1)

### DTC DETECTING CONDITION:

- Detected when two consecutive driving cycles with fault occur.
- GENERAL DESCRIPTION <Ref. to GD(H4DOTC)-17, DTC P0017 CRANK AND CAM TIMING B SYSTEM FAILURE (BANK 1), Diagnostic Trouble Code (DTC) Detecting Criteria.>

### TROUBLE SYMPTOM:

- Engine stalls.
- Improper idling

### CAUTION:

After servicing or replacing faulty parts, perform Clear Memory Mode <Ref. to EN(H4DOTC)(diag)-62, OPERATION, Clear Memory Mode.>, and Inspection Mode <Ref. to EN(H4DOTC)(diag)-48, PROCEDURE, Inspection Mode.>.

Step	Check	Yes	No
<b>1</b> <b>CHECK CURRENT DATA.</b> 1) Start the engine and let it idle. 2) Read the values of «Exh. VVT Retard Ang. R» and «Exh. OCV Duty R» using the Subaru Select Monitor.  NOTE: For detailed operation procedures, refer to "READ CURRENT DATA FOR ENGINE". <Ref. to EN(H4DOTC)(diag)-40, Subaru Select Monitor.>	Is the value of «Exh. VVT Retard Ang. R» approx. 0 deg, and the value of «Exh. OCV Duty R» approx. 10%?	Perform the following procedures, and clean the oil routing. Replace the engine oil and idle the engine for 5 minutes, and then replace the oil filter and engine oil. <Ref. to LU(STI)-11, REPLACE-MENT, Engine Oil.> <Ref. to LU(STI)-32, Engine Oil Filter.>	Check the following item and repair or replace if necessary. <ul style="list-style-type: none"><li>• Oil pipe (clog)</li><li>• Oil flow control solenoid valve (clog or dirt of oil routing, setting of spring)</li><li>• Exhaust camshaft (dirt, damage of camshaft)</li><li>• Timing belt (matching of timing mark)</li></ul>

# Diagnostic Procedure with Diagnostic Trouble Code (DTC)

ENGINE (DIAGNOSTICS)

## E: DTC P0018 CRANKSHAFT POSITION - CAMSHAFT POSITION CORRELATION (BANK2)

### DTC DETECTING CONDITION:

- Detected when two consecutive driving cycles with fault occur.
- GENERAL DESCRIPTION <Ref. to GD(H4DOTC)-19, DTC P0018 CRANKSHAFT POSITION - CAMSHAFT POSITION CORRELATION (BANK2), Diagnostic Trouble Code (DTC) Detecting Criteria.>

### TROUBLE SYMPTOM:

- Engine stalls.
- Improper idling

### CAUTION:

After servicing or replacing faulty parts, perform Clear Memory Mode <Ref. to EN(H4DOTC)(diag)-62, OPERATION, Clear Memory Mode.>, and Inspection Mode <Ref. to EN(H4DOTC)(diag)-48, PROCEDURE, Inspection Mode.>.

	Step	Check	Yes	No
1	<b>CHECK CURRENT DATA.</b> 1) Start the engine and let it idle. 2) Read the values of «VVT Adv. Ang. Amount L» and «OCV Duty L» using the Subaru Select Monitor.  NOTE: For detailed operation procedures, refer to "READ CURRENT DATA FOR ENGINE". <Ref. to EN(H4DOTC)(diag)-40, Subaru Select Monitor.>	Is the value of «VVT Adv. Ang. Amount L» approx. 0 deg, and the value of «OCV Duty L» approx. 10%?	Perform the following procedures, and clean the oil routing. Replace the engine oil and idle the engine for 5 minutes, and then replace the oil filter and engine oil. <Ref. to LU(STI)-11, REPLACEMENT, Engine Oil.> <Ref. to LU(STI)-32, Engine Oil Filter.>	Check the following item and repair or replace if necessary. <ul style="list-style-type: none"><li>• Oil pipe (clog)</li><li>• Oil flow control solenoid valve (clog or dirt of oil routing, setting of spring)</li><li>• Intake camshaft (dirt, damage of camshaft)</li><li>• Timing belt (matching of timing mark)</li></ul>

# Diagnostic Procedure with Diagnostic Trouble Code (DTC)

ENGINE (DIAGNOSTICS)

## F: DTC P0019 CRANK AND CAM TIMING B SYSTEM FAILURE (BANK 2)

### DTC DETECTING CONDITION:

- Detected when two consecutive driving cycles with fault occur.
- GENERAL DESCRIPTION <Ref. to GD(H4DOTC)-19, DTC P0019 CRANK AND CAM TIMING B SYSTEM FAILURE (BANK 2), Diagnostic Trouble Code (DTC) Detecting Criteria.>

### TROUBLE SYMPTOM:

- Engine stalls.
- Improper idling

### CAUTION:

After servicing or replacing faulty parts, perform Clear Memory Mode <Ref. to EN(H4DOTC)(diag)-62, OPERATION, Clear Memory Mode.>, and Inspection Mode <Ref. to EN(H4DOTC)(diag)-48, PROCEDURE, Inspection Mode.>.

Step	Check	Yes	No
<b>1</b> <b>CHECK CURRENT DATA.</b> 1) Start the engine and let it idle. 2) Read the values of «Exh. VVT Retard Ang. L» and «Exh. OCV Duty L» using the Subaru Select Monitor.  NOTE: For detailed operation procedures, refer to "READ CURRENT DATA FOR ENGINE". <Ref. to EN(H4DOTC)(diag)-40, Subaru Select Monitor.>	Is the value of «Exh. VVT Retard Ang. L» approx. 0 deg, and the value of «Exh. OCV Duty L» approx. 10%?	Perform the following procedures, and clean the oil routing. Replace the engine oil and idle the engine for 5 minutes, and then replace the oil filter and engine oil. <Ref. to LU(STI)-11, REPLACE-MENT, Engine Oil.> <Ref. to LU(STI)-32, Engine Oil Filter.>	Check the following item and repair or replace if necessary. <ul style="list-style-type: none"><li>• Oil pipe (clog)</li><li>• Oil flow control solenoid valve (clog or dirt of oil routing, setting of spring)</li><li>• Exhaust camshaft (dirt, damage of camshaft)</li><li>• Timing belt (matching of timing mark)</li></ul>



# Diagnostic Procedure with Diagnostic Trouble Code (DTC)

ENGINE (DIAGNOSTICS)

## G: DTC P0021 INTAKE CAMSHAFT POSITION - TIMING OVER-ADVANCED OR SYSTEM PERFORMANCE (BANK 2)

### DTC DETECTING CONDITION:

- Detected when two consecutive driving cycles with fault occur.
- GENERAL DESCRIPTION <Ref. to GD(H4DOTC)-19, DTC P0021 INTAKE CAMSHAFT POSITION - TIMING OVER-ADVANCED OR SYSTEM PERFORMANCE (BANK 2), Diagnostic Trouble Code (DTC) Detecting Criteria.>

### TROUBLE SYMPTOM:

- Engine stalls.
- Improper idling

### CAUTION:

After servicing or replacing faulty parts, perform Clear Memory Mode <Ref. to EN(H4DOTC)(diag)-62, OPERATION, Clear Memory Mode.>, and Inspection Mode <Ref. to EN(H4DOTC)(diag)-48, PROCEDURE, Inspection Mode.>.

	Step	Check	Yes	No
1	<p><b>CHECK CURRENT DATA.</b></p> <p>1) Start the engine and let it idle.</p> <p>2) Read the value of «VVT Adv. Ang. Amount L» using the Subaru Select Monitor.</p> <p>NOTE: For detailed operation procedures, refer to "READ CURRENT DATA FOR ENGINE". &lt;Ref. to EN(H4DOTC)(diag)-40, Subaru Select Monitor.&gt;</p>	Is the value of «VVT Adv. Ang. Amount L» approx. 0 deg?	Go to step 2.	<p>Check the following item and repair or replace if necessary.</p> <ul style="list-style-type: none"> <li>• Oil pipe (clog)</li> <li>• Oil flow control solenoid valve (clog or dirt of oil routing, setting of spring)</li> <li>• Intake camshaft (dirt, damage of camshaft)</li> </ul>
2	<p><b>CHECK CURRENT DATA.</b></p> <p>1) Drive with acceleration and deceleration at 80 km/h (50 MPH) or less.</p> <p>NOTE: Drive to an extent that the duty output of oil flow control solenoid valve increases.</p> <p>2) Read the values of «OCV Duty L» and «VVT Adv. Ang. Amount L» using the Subaru Select Monitor.</p> <p>NOTE: For detailed operation procedures, refer to "READ CURRENT DATA FOR ENGINE". &lt;Ref. to EN(H4DOTC)(diag)-40, Subaru Select Monitor.&gt;</p>	When the value of «OCV Duty L» increases more than 10%, is the value of «VVT Adv. Ang. Amount L» approx. 0 deg?	<p>Check the following item and repair or replace if necessary.</p> <ul style="list-style-type: none"> <li>• Oil pipe (clog)</li> <li>• Oil flow control solenoid valve (clog or dirt of oil routing, setting of spring)</li> <li>• Intake camshaft (dirt, damage of camshaft)</li> </ul>	<p>Perform the following procedures, and clean the oil routing.</p> <p>Replace the engine oil and idle the engine for 5 minutes, and then replace the oil filter and engine oil. &lt;Ref. to LU(STI)-11, REPLACEMENT, Engine Oil.&gt; &lt;Ref. to LU(STI)-32, Engine Oil Filter.&gt;</p>

# Diagnostic Procedure with Diagnostic Trouble Code (DTC)

ENGINE (DIAGNOSTICS)

## H: DTC P0024 EXHAUST AVCS SYSTEM 2 (RANGE/PERFORMANCE)

### DTC DETECTING CONDITION:

- Detected when two consecutive driving cycles with fault occur.
- GENERAL DESCRIPTION <Ref. to GD(H4DOTC)-19, DTC P0024 EXHAUST AVCS SYSTEM 2 (RANGE/PERFORMANCE), Diagnostic Trouble Code (DTC) Detecting Criteria.>

### TROUBLE SYMPTOM:

- Engine stalls.
- Improper idling

### CAUTION:

After servicing or replacing faulty parts, perform Clear Memory Mode <Ref. to EN(H4DOTC)(diag)-62, OPERATION, Clear Memory Mode.>, and Inspection Mode <Ref. to EN(H4DOTC)(diag)-48, PROCEDURE, Inspection Mode.>.

Step	Check	Yes	No
<b>1</b> <b>CHECK CURRENT DATA.</b> 1) Start the engine and let it idle. 2) Read the value of «Exh. VVT Retard Ang. L» using the Subaru Select Monitor.  NOTE: For detailed operation procedures, refer to "READ CURRENT DATA FOR ENGINE". <Ref. to EN(H4DOTC)(diag)-40, Subaru Select Monitor.>	Is the value of «Exh. VVT Retard Ang. L» approx. 0 deg?	Go to step 2.	Check the following item and repair or replace if necessary. <ul style="list-style-type: none"> <li>• Oil pipe (clog)</li> <li>• Oil flow control solenoid valve (clog or dirt of oil routing, setting of spring)</li> <li>• Exhaust camshaft (dirt, damage of camshaft)</li> </ul>
<b>2</b> <b>CHECK CURRENT DATA.</b> 1) Drive with acceleration and deceleration at 80 km/h (50 MPH) or less.  NOTE: Drive to an extent that the duty output of oil flow control solenoid valve increases. 2) Read the values of «Exh. OCV Duty L» and «Exh. VVT Retard Ang. L» using the Subaru Select Monitor.  NOTE: For detailed operation procedures, refer to "READ CURRENT DATA FOR ENGINE". <Ref. to EN(H4DOTC)(diag)-40, Subaru Select Monitor.>	When the value of «Exh. OCV Duty L» increases more than 10%, is the value of «Exh. VVT Retard Ang. L» approx. 0 deg?	Check the following item and repair or replace if necessary. <ul style="list-style-type: none"> <li>• Oil pipe (clog)</li> <li>• Oil flow control solenoid valve (clog or dirt of oil routing, setting of spring)</li> <li>• Exhaust camshaft (dirt, damage of camshaft)</li> </ul>	Perform the following procedures, and clean the oil routing. Replace the engine oil and idle the engine for 5 minutes, and then replace the oil filter and engine oil. <Ref. to LU(STI)-11, REPLACEMENT, Engine Oil.> <Ref. to LU(STI)-32, Engine Oil Filter.>

# Diagnostic Procedure with Diagnostic Trouble Code (DTC)

ENGINE (DIAGNOSTICS)

## I: DTC P0030 HO2S HEATER CONTROL CIRCUIT (BANK 1 SENSOR 1)

### DTC DETECTING CONDITION:

- Detected when two consecutive driving cycles with fault occur.
- GENERAL DESCRIPTION <Ref. to GD(H4DOTC)-20, DTC P0030 HO2S HEATER CONTROL CIRCUIT (BANK 1 SENSOR 1), Diagnostic Trouble Code (DTC) Detecting Criteria.>

### CAUTION:

After servicing or replacing faulty parts, perform Clear Memory Mode <Ref. to EN(H4DOTC)(diag)-62, OPERATION, Clear Memory Mode.>, and Inspection Mode <Ref. to EN(H4DOTC)(diag)-48, PROCEDURE, Inspection Mode.>.

### WIRING DIAGRAM:

- Models without SI-DRIVE

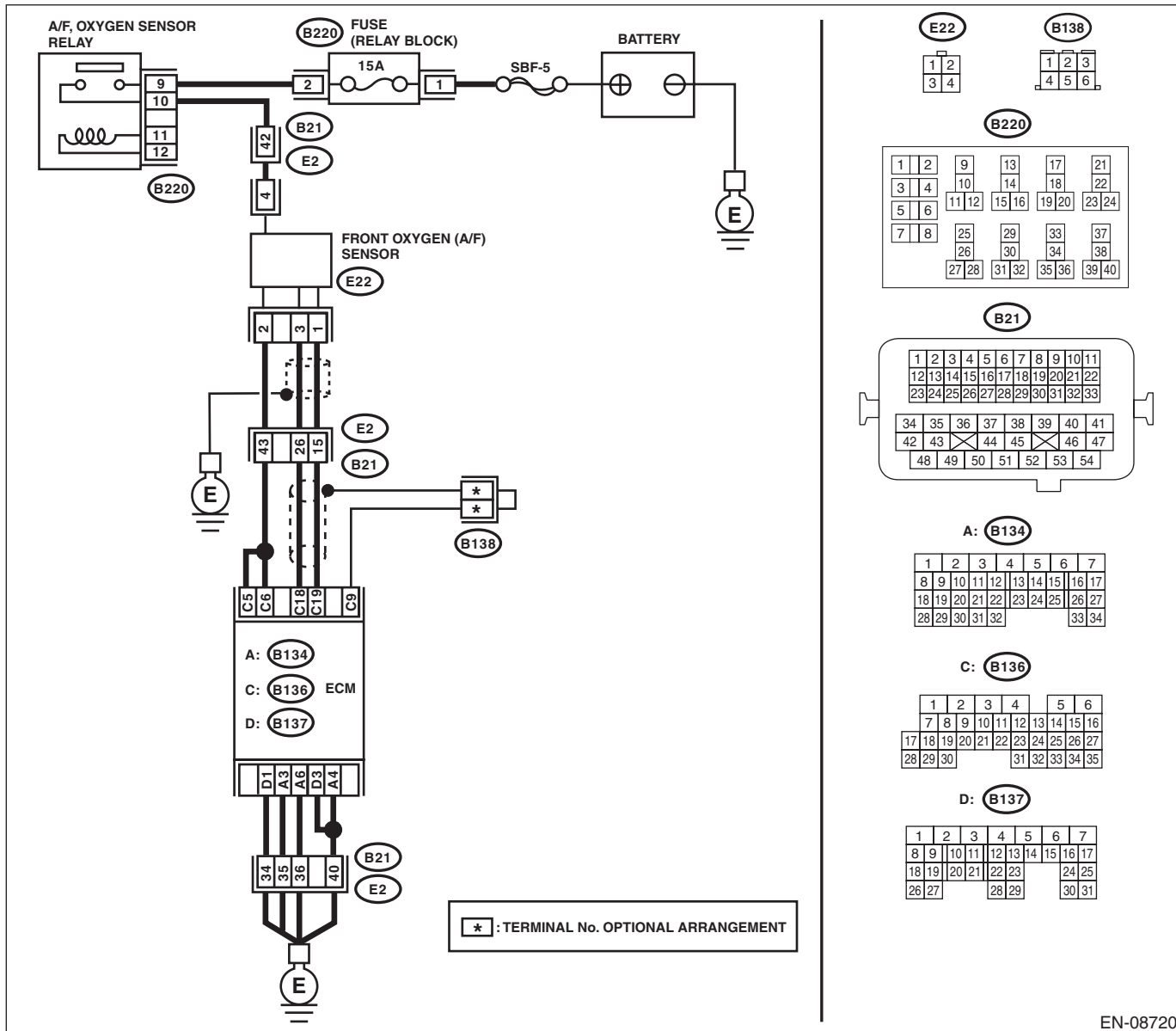

EN-08720

# Diagnostic Procedure with Diagnostic Trouble Code (DTC)

ENGINE (DIAGNOSTICS)

- Models with SI-DRIVE

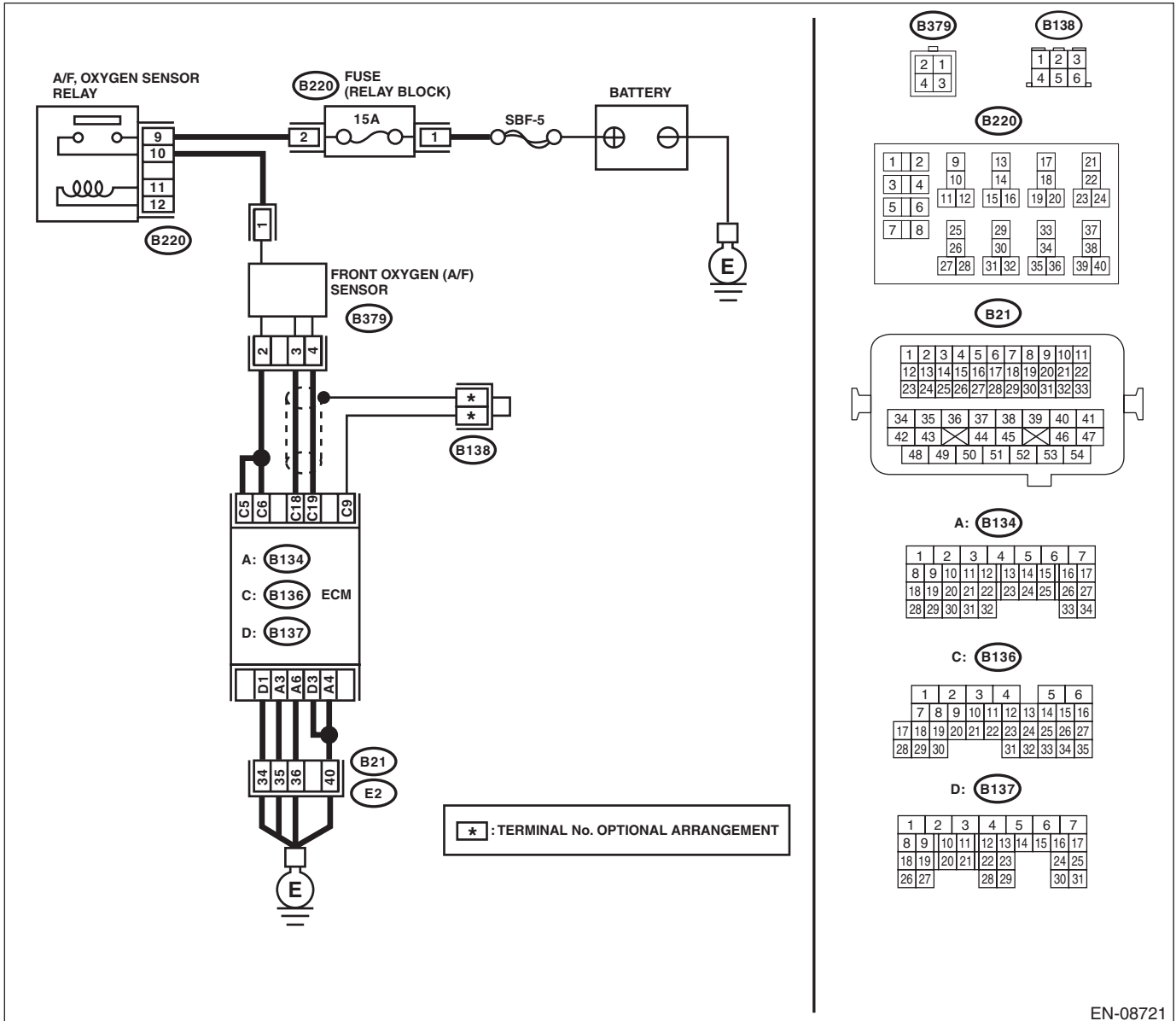

EN-08721

# Diagnostic Procedure with Diagnostic Trouble Code (DTC)

ENGINE (DIAGNOSTICS)

Step	Check	Yes	No
<p><b>1</b>      <b>CHECK HARNESS BETWEEN ECM AND FRONT OXYGEN (A/F) SENSOR CONNECTOR.</b></p> <p>1) Start and warm up the engine.                  2) Turn the ignition switch to OFF.                  3) Disconnect the connectors from ECM and front oxygen (A/F) sensor.                  4) Measure the resistance of harness between ECM and front oxygen (A/F) sensor connector.</p> <p><b>Connector &amp; terminal</b>  <b>Models without SI-DRIVE</b>                  (B136) No. 6 — (E22) No. 2:                  (B136) No. 5 — (E22) No. 2:                  (B136) No. 19 — (E22) No. 1:                  (B136) No. 18 — (E22) No. 3:  <b>Models with SI-DRIVE</b>                  (B136) No. 6 — (B379) No. 2:                  (B136) No. 5 — (B379) No. 2:                  (B136) No. 19 — (B379) No. 4:                  (B136) No. 18 — (B379) No. 3:</p>	<p>Is the resistance less than 1 Ω?</p>	<p>Go to step 2.</p>	<p>Repair the open circuit of harness between ECM and front oxygen (A/F) sensor connector.</p>
<p><b>2</b>      <b>CHECK FRONT OXYGEN (A/F) SENSOR.</b>                  Measure the resistance between front oxygen (A/F) sensor terminals.</p> <p><b>Terminals</b>  <b>Models without SI-DRIVE</b>                  No. 4 — No. 2:  <b>Models with SI-DRIVE</b>                  No. 2 — No. 1:</p>	<p>Is the resistance less than 2 — 3 Ω?</p>	<p>Go to step 3.</p>	<p>Replace the front oxygen (A/F) sensor. &lt;Ref. to FU(STI)-54, Front Oxygen (A/F) Sensor.&gt; &lt;Ref. to FU(w/o STI)-54, Front Oxygen (A/F) Sensor.&gt;</p>
<p><b>3</b>      <b>CHECK FOR POOR CONTACT.</b>                  Check for poor contact of ECM and front oxygen (A/F) sensor connector.</p>	<p>Is there poor contact of ECM or front oxygen (A/F) sensor connector?</p>	<p>Repair the poor contact of ECM or front oxygen (A/F) sensor connector.</p>	<p>Replace the front oxygen (A/F) sensor. &lt;Ref. to FU(STI)-54, Front Oxygen (A/F) Sensor.&gt; &lt;Ref. to FU(w/o STI)-54, Front Oxygen (A/F) Sensor.&gt;</p>

# Diagnostic Procedure with Diagnostic Trouble Code (DTC)

ENGINE (DIAGNOSTICS)

## J: DTC P0031 HO2S HEATER CONTROL CIRCUIT LOW (BANK 1 SENSOR 1)

### DTC DETECTING CONDITION:

- Immediately at fault recognition
- GENERAL DESCRIPTION <Ref. to GD(H4DOTC)-22, DTC P0031 HO2S HEATER CONTROL CIRCUIT LOW (BANK 1 SENSOR 1), Diagnostic Trouble Code (DTC) Detecting Criteria.>

### CAUTION:

After servicing or replacing faulty parts, perform Clear Memory Mode <Ref. to EN(H4DOTC)(diag)-62, OPERATION, Clear Memory Mode.>, and Inspection Mode <Ref. to EN(H4DOTC)(diag)-48, PROCEDURE, Inspection Mode.>.

### WIRING DIAGRAM:

- Models without SI-DRIVE

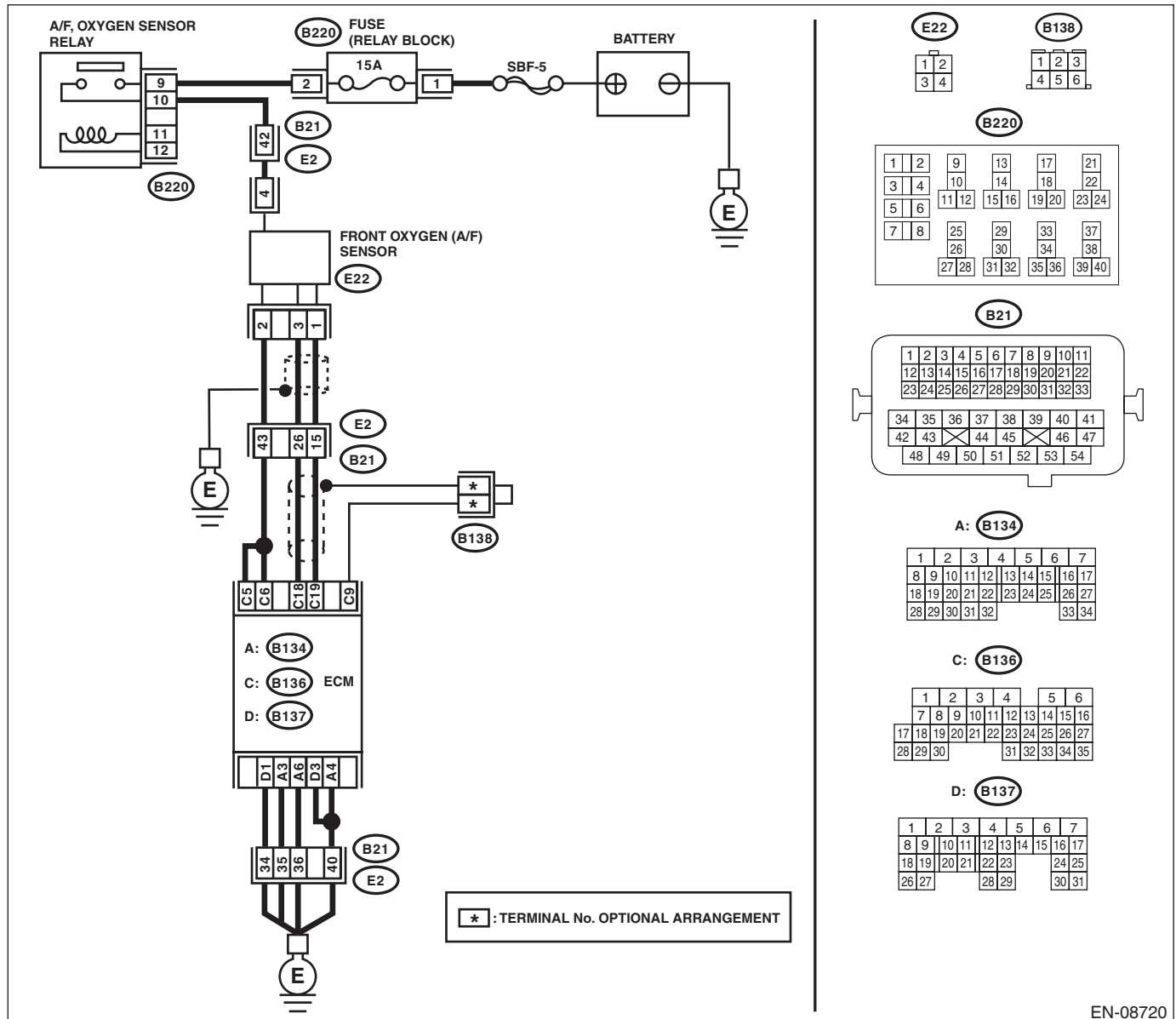

EN-08720

# Diagnostic Procedure with Diagnostic Trouble Code (DTC)

## ENGINE (DIAGNOSTICS)

- Models with SI-DRIVE

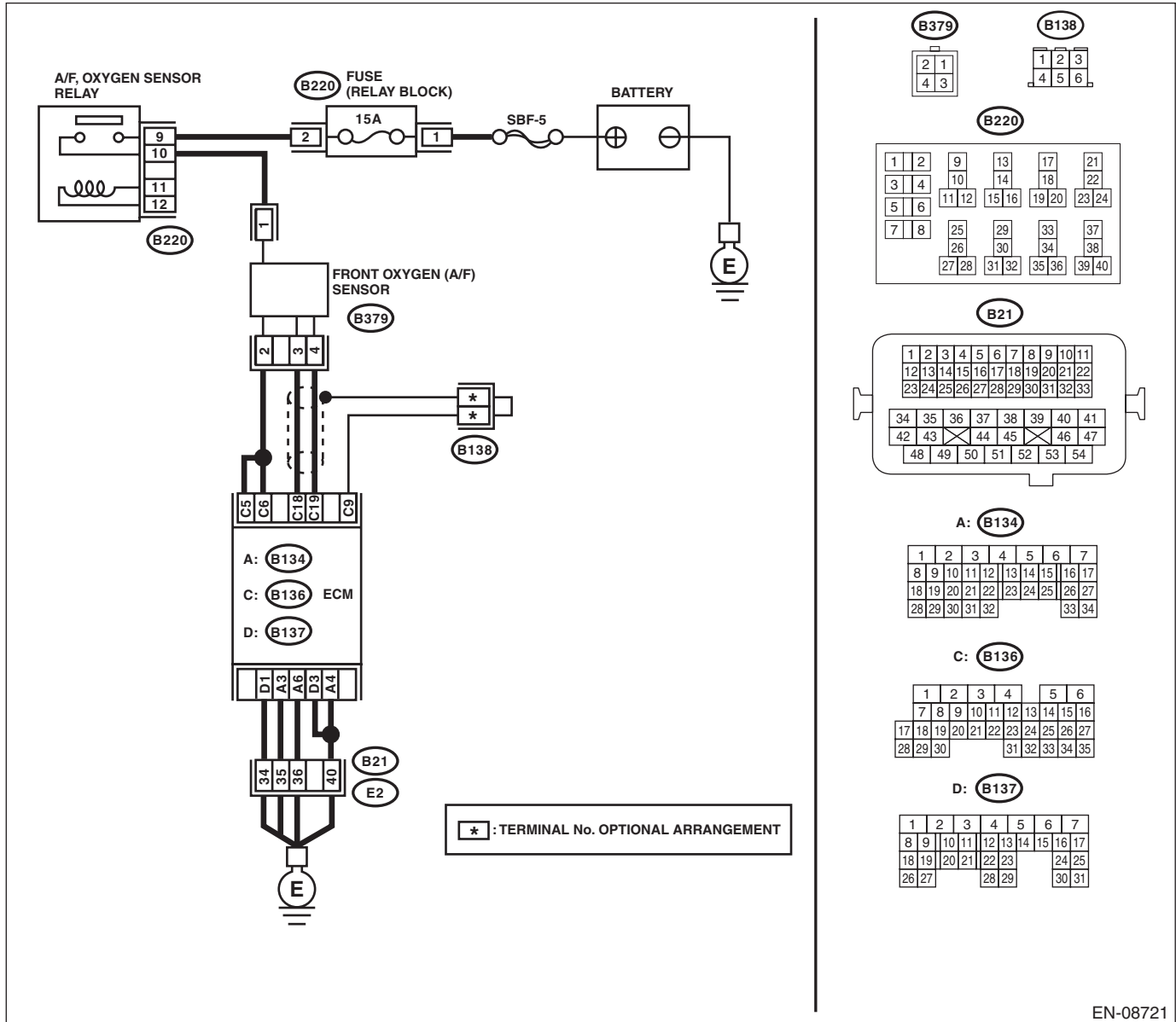

EN-08721

Step	Check	Yes	No
<p><b>1</b></p> <p><b>CHECK POWER SUPPLY TO FRONT OXYGEN (A/F) SENSOR.</b></p> <p>1) Turn the ignition switch to OFF.</p> <p>2) Disconnect the connectors from front oxygen (A/F) sensor.</p> <p>3) Turn the ignition switch to ON.</p> <p>4) Measure the voltage between front oxygen (A/F) sensor connector and engine ground.</p> <p><b>Connector &amp; terminal</b></p> <p><b>Models without SI-DRIVE</b> (E22) No. 4 (+) — Engine ground (-):</p> <p><b>Models with SI-DRIVE</b> (B379) No. 1 (+) — Engine ground (-):</p>	<p>Is the voltage 10 V or more?</p>	<p>Go to step 2.</p>	<p>Repair the power supply line.</p> <p><b>NOTE:</b> In this case, repair the following item:</p> <ul style="list-style-type: none"> <li>Open circuit in harness between A/F, oxygen sensor relay and front oxygen (A/F) sensor connector</li> <li>Poor contact of A/F, oxygen sensor relay connector</li> <li>Malfunction of A/F, oxygen sensor relay</li> </ul>

# Diagnostic Procedure with Diagnostic Trouble Code (DTC)

ENGINE (DIAGNOSTICS)

Step	Check	Yes	No
<p><b>2</b>      <b>CHECK HARNESS BETWEEN ECM AND FRONT OXYGEN (A/F) SENSOR CONNECTOR.</b>                      1) Turn the ignition switch to OFF.                      2) Disconnect the connector from ECM.                      3) Measure the resistance between ECM and front oxygen (A/F) sensor connector.  <b>Connector &amp; terminal</b>  <b>Models without SI-DRIVE</b>                      (B136) No. 6 — (E22) No. 2:                      (B136) No. 5 — (E22) No. 2:  <b>Models with SI-DRIVE</b>                      (B136) No. 6 — (B379) No. 2:                      (B136) No. 5 — (B379) No. 2:</p>	<p>Is the resistance less than 1 Ω?</p>	<p>Go to step 3.</p>	<p>Repair the open circuit of harness between ECM and front oxygen (A/F) sensor connector.</p>
<p><b>3</b>      <b>CHECK GROUND CIRCUIT FOR ECM.</b>                      Measure the resistance of harness between ECM and chassis ground.  <b>Connector &amp; terminal</b>                      (B134) No. 3 — Chassis ground:                      (B134) No. 4 — Chassis ground:                      (B134) No. 6 — Chassis ground:                      (B137) No. 1 — Chassis ground:                      (B137) No. 3 — Chassis ground:</p>	<p>Is the resistance less than 5 Ω?</p>	<p>Go to step 4.</p>	<p>Repair the harness and connector.                      NOTE:                      In this case, repair the following item:                      • Open circuit of harness between ECM and engine ground                      • Poor contact of coupling connector</p>
<p><b>4</b>      <b>CHECK FRONT OXYGEN (A/F) SENSOR.</b>                      Measure the resistance between front oxygen (A/F) sensor terminals.  <b>Terminals</b>  <b>Models without SI-DRIVE</b>                      No. 4 — No. 2:  <b>Models with SI-DRIVE</b>                      No. 2 — No. 1:</p>	<p>Is the resistance 2 — 3 Ω?</p>	<p>Repair the poor contact of ECM connector.</p>	<p>Replace the front oxygen (A/F) sensor. &lt;Ref. to FU(STI)-54, Front Oxygen (A/F) Sensor.&gt; &lt;Ref. to FU(w/o STI)-54, Front Oxygen (A/F) Sensor.&gt;</p>



# Diagnostic Procedure with Diagnostic Trouble Code (DTC)

ENGINE (DIAGNOSTICS)

## K: DTC P0032 HO2S HEATER CONTROL CIRCUIT HIGH (BANK 1 SENSOR 1)

### DTC DETECTING CONDITION:

- Immediately at fault recognition
- GENERAL DESCRIPTION <Ref. to GD(H4DOTC)-24, DTC P0032 HO2S HEATER CONTROL CIRCUIT HIGH (BANK 1 SENSOR 1), Diagnostic Trouble Code (DTC) Detecting Criteria.>

### CAUTION:

After servicing or replacing faulty parts, perform Clear Memory Mode <Ref. to EN(H4DOTC)(diag)-62, OPERATION, Clear Memory Mode.>, and Inspection Mode <Ref. to EN(H4DOTC)(diag)-48, PROCEDURE, Inspection Mode.>.

### WIRING DIAGRAM:

- Models without SI-DRIVE

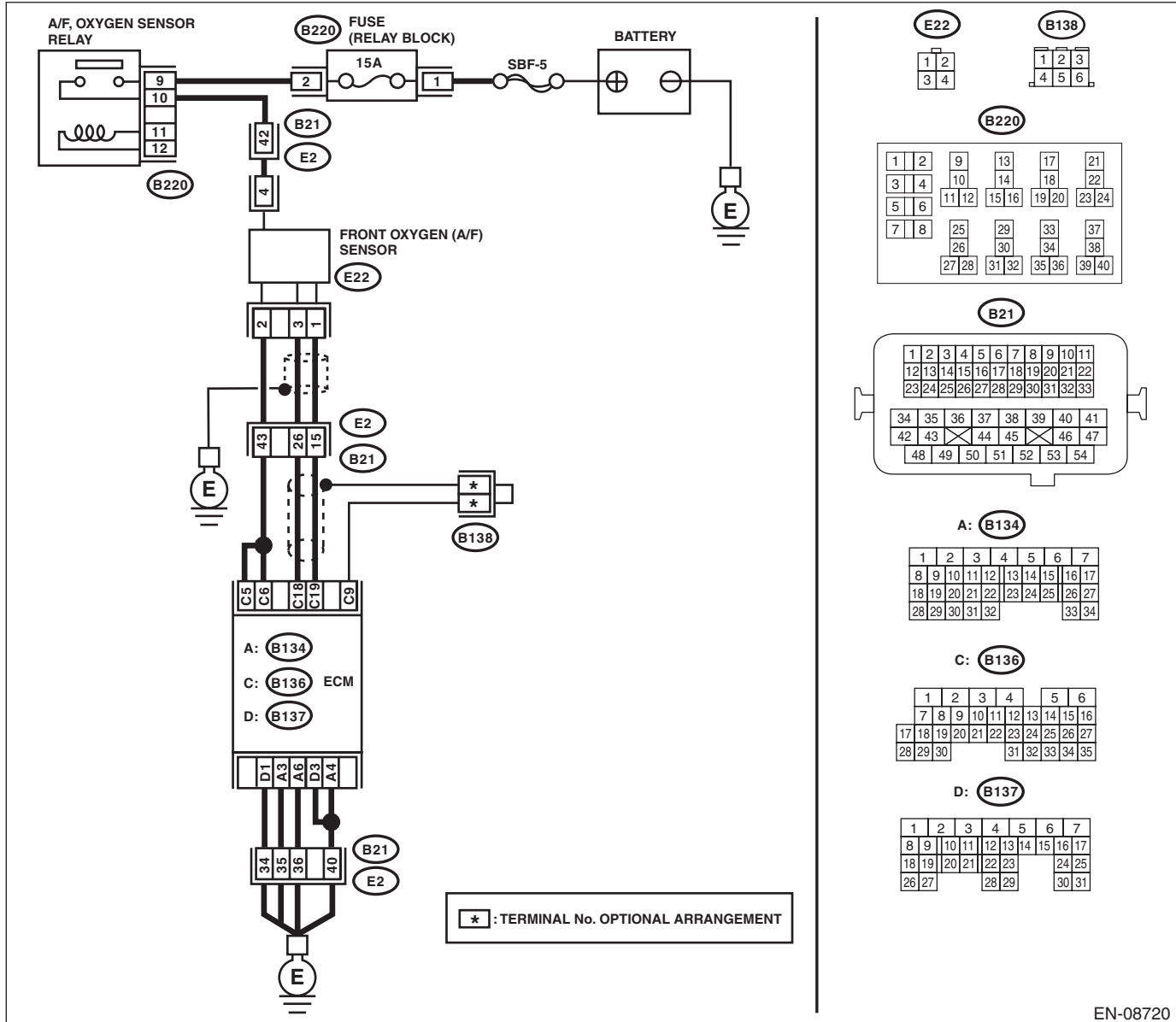

# Diagnostic Procedure with Diagnostic Trouble Code (DTC)

ENGINE (DIAGNOSTICS)

- Models with SI-DRIVE

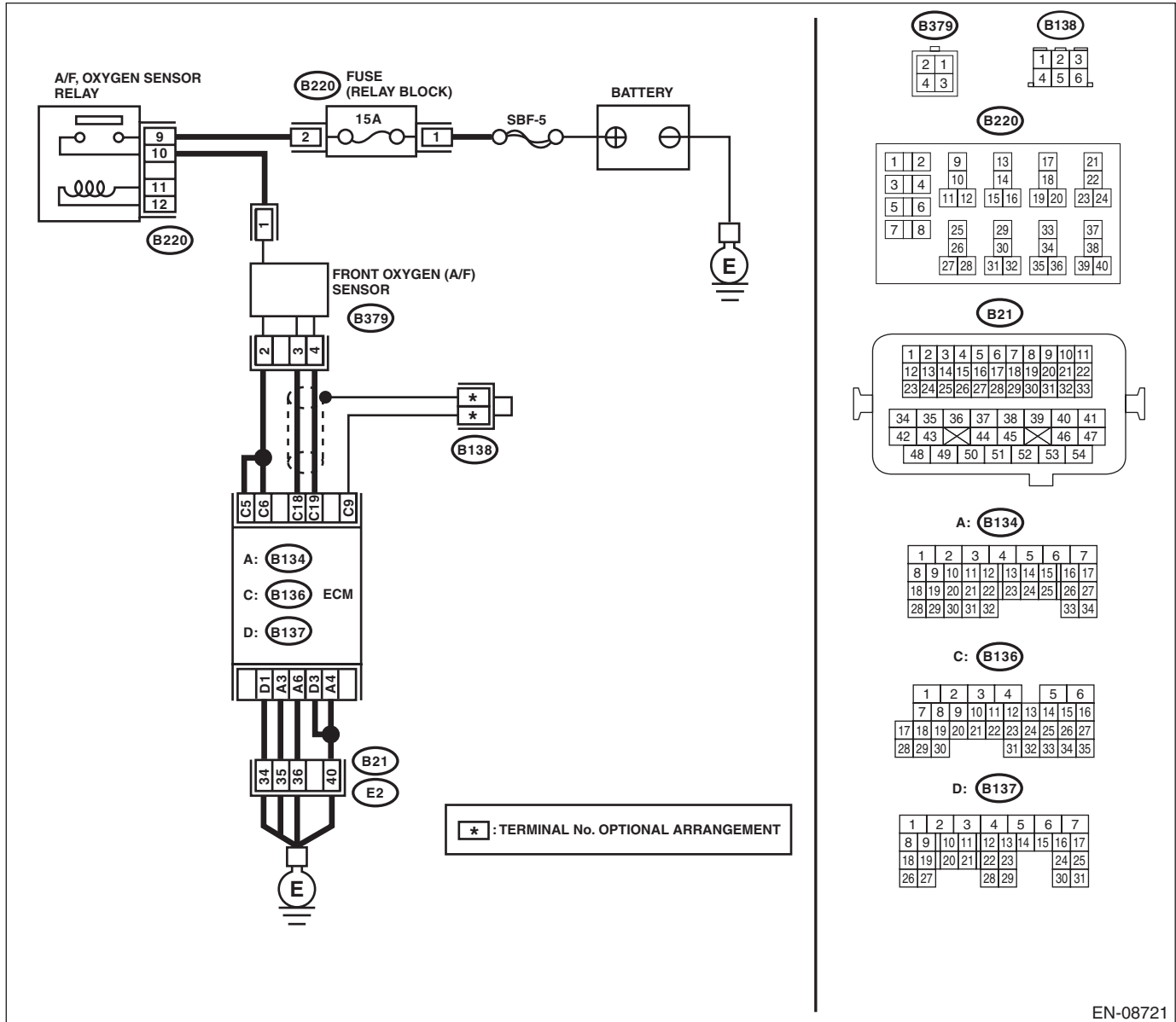

EN-08721

Step	Check	Yes	No
<b>1</b> <b>CHECK HARNESS BETWEEN ECM AND FRONT OXYGEN (A/F) SENSOR CONNECTOR.</b> 1) Turn the ignition switch to OFF. 2) Measure the voltage between ECM and chassis ground. <b>Connector &amp; terminal</b> (B136) No. 6 (+) — Chassis ground (-): (B136) No. 5 (+) — Chassis ground (-):	Is the voltage 10 V or more?	Repair the short circuit to power in the harness between ECM and front oxygen (A/F) sensor connector.	Go to step 2.

## Diagnostic Procedure with Diagnostic Trouble Code (DTC)

### ENGINE (DIAGNOSTICS)

Step	Check	Yes	No
<b>2</b> <b>CHECK GROUND CIRCUIT FOR ECM.</b> 1) Disconnect the connector from ECM. 2) Measure the resistance between ECM and chassis ground. <b>Connector &amp; terminal</b> <b>(B134) No. 3 — Chassis ground:</b> <b>(B134) No. 4 — Chassis ground:</b> <b>(B134) No. 6 — Chassis ground:</b> <b>(B137) No. 1 — Chassis ground:</b> <b>(B137) No. 3 — Chassis ground:</b>	Is the resistance less than 5 $\Omega$ ?	Repair the poor contact of ECM connector.	Repair the harness and connector. <b>NOTE:</b> In this case, repair the following item: <ul style="list-style-type: none"><li>• Open circuit of harness between ECM and engine ground</li><li>• Poor contact of coupling connector</li></ul>

# Diagnostic Procedure with Diagnostic Trouble Code (DTC)

ENGINE (DIAGNOSTICS)

## L: DTC P0037 HO2S HEATER CONTROL CIRCUIT LOW (BANK 1 SENSOR 2)

### DTC DETECTING CONDITION:

- Detected when two consecutive driving cycles with fault occur.
- GENERAL DESCRIPTION <Ref. to GD(H4DOTC)-26, DTC P0037 HO2S HEATER CONTROL CIRCUIT LOW (BANK 1 SENSOR 2), Diagnostic Trouble Code (DTC) Detecting Criteria.>

### CAUTION:

After servicing or replacing faulty parts, perform Clear Memory Mode <Ref. to EN(H4DOTC)(diag)-62, OPERATION, Clear Memory Mode.>, and Inspection Mode <Ref. to EN(H4DOTC)(diag)-48, PROCEDURE, Inspection Mode.>.

### WIRING DIAGRAM:

- Models without SI-DRIVE

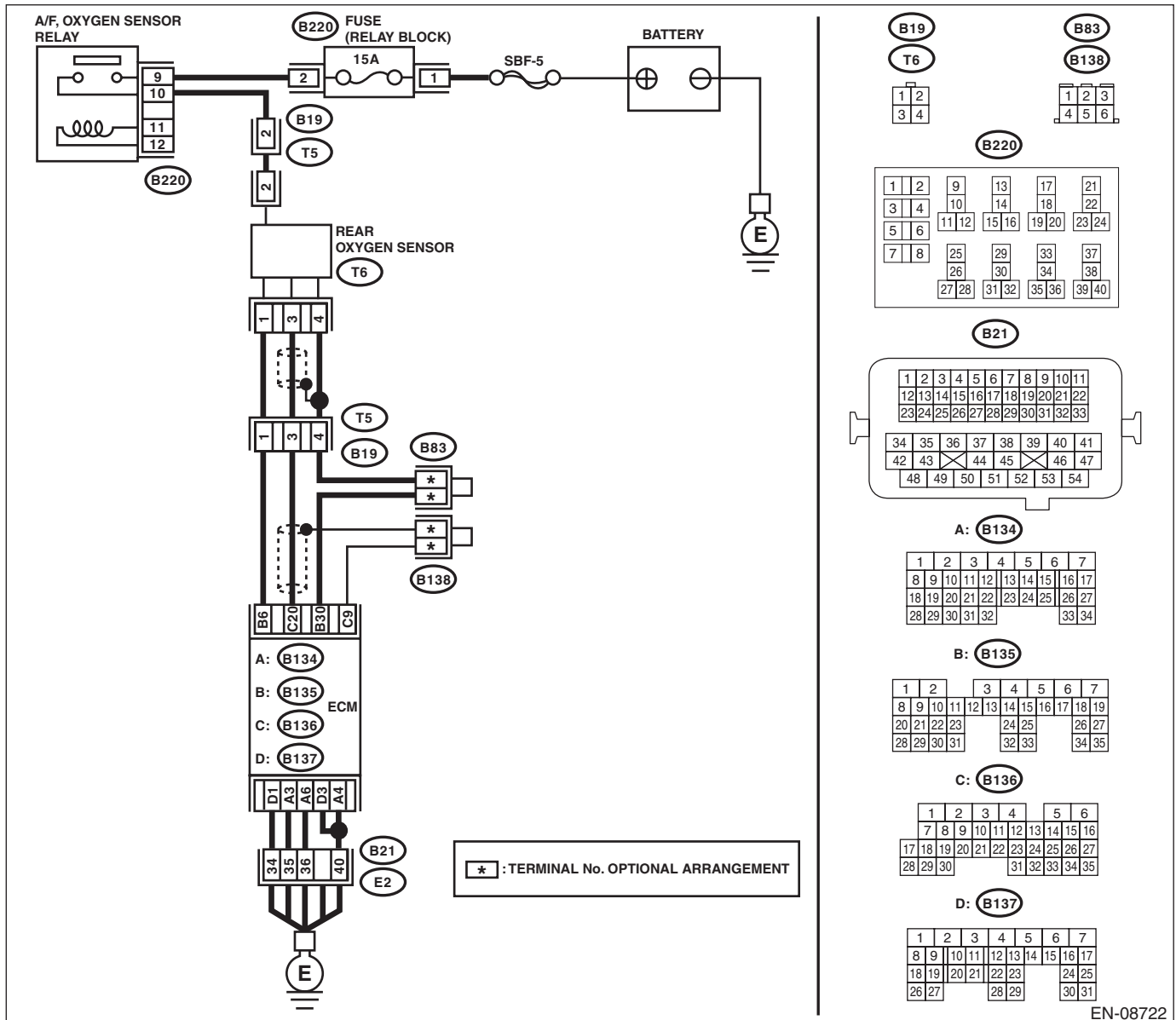

EN-08722

# Diagnostic Procedure with Diagnostic Trouble Code (DTC)

## ENGINE (DIAGNOSTICS)

- Models with SI-DRIVE

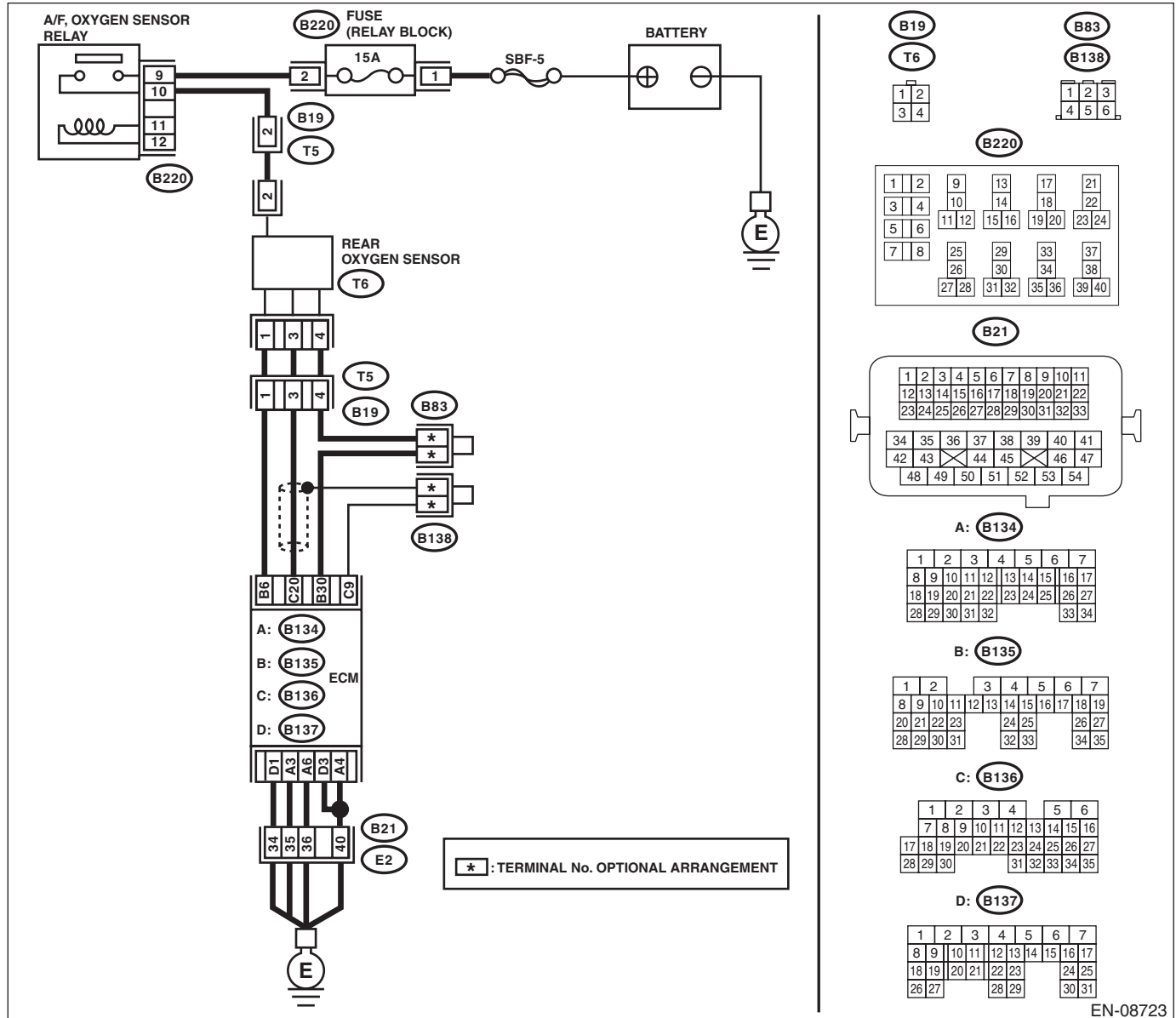

EN-08723

# Diagnostic Procedure with Diagnostic Trouble Code (DTC)

ENGINE (DIAGNOSTICS)

Step	Check	Yes	No
<p><b>1</b>      <b>CHECK POWER SUPPLY TO REAR OXYGEN SENSOR.</b>                      1) Turn the ignition switch to OFF.                      2) Disconnect the connector from rear oxygen sensor.                      3) Turn the ignition switch to ON.                      4) Measure the voltage between rear oxygen sensor connector and engine ground.  <b>Connector &amp; terminal</b>  <b>(T6) No. 2 (+) — Engine ground (-):</b></p>	Is the voltage 10 V or more?	Go to step 2.	Repair the power supply line. NOTE: In this case, repair the following item: • Open circuit in harness between A/F, oxygen sensor relay and rear oxygen sensor connector • Poor contact of A/F, oxygen sensor relay connector • Poor contact of coupling connector • Malfunction of A/F, oxygen sensor relay
<p><b>2</b>      <b>CHECK HARNESS BETWEEN ECM AND REAR OXYGEN SENSOR CONNECTOR.</b>                      1) Turn the ignition switch to OFF.                      2) Disconnect the connector from ECM.                      3) Measure the resistance between the ECM and rear oxygen sensor connector.  <b>Connector &amp; terminal</b>  <b>(B135) No. 6 — (T6) No. 1:</b></p>	Is the resistance less than 1 $\Omega$ ?	Go to step 3.	Repair the harness and connector. NOTE: In this case, repair the following item: • Open circuit in harness between ECM and rear oxygen sensor connector • Poor contact of coupling connector
<p><b>3</b>      <b>CHECK GROUND CIRCUIT FOR ECM.</b>                      Measure the resistance of harness between ECM and chassis ground.  <b>Connector &amp; terminal</b>  <b>(B134) No. 3 — Chassis ground:</b>  <b>(B134) No. 4 — Chassis ground:</b>  <b>(B134) No. 6 — Chassis ground:</b>  <b>(B137) No. 1 — Chassis ground:</b>  <b>(B137) No. 3 — Chassis ground:</b></p>	Is the resistance less than 5 $\Omega$ ?	Go to step 4.	Repair the harness and connector. NOTE: In this case, repair the following item: • Open circuit of harness between ECM and engine ground • Poor contact of ECM connector • Poor contact of coupling connector
<p><b>4</b>      <b>CHECK REAR OXYGEN SENSOR.</b>                      Measure the resistance between rear oxygen sensor terminals.  <b>Terminals</b>  <b>No. 1 — No. 2:</b></p>	Is the resistance 5 — 7 $\Omega$ ?	Repair the poor contact of ECM connector.	Replace the rear oxygen sensor. <Ref. to FU(STI)-56, Rear Oxygen Sensor.> <Ref. to FU(w/o STI)-56, Rear Oxygen Sensor.>

# Diagnostic Procedure with Diagnostic Trouble Code (DTC)

ENGINE (DIAGNOSTICS)

## M: DTC P0038 HO2S HEATER CONTROL CIRCUIT HIGH (BANK 1 SENSOR 2)

### DTC DETECTING CONDITION:

- Detected when two consecutive driving cycles with fault occur.
- GENERAL DESCRIPTION <Ref. to GD(H4DOTC)-28, DTC P0038 HO2S HEATER CONTROL CIRCUIT HIGH (BANK 1 SENSOR 2), Diagnostic Trouble Code (DTC) Detecting Criteria.>

### CAUTION:

After servicing or replacing faulty parts, perform Clear Memory Mode <Ref. to EN(H4DOTC)(diag)-62, OPERATION, Clear Memory Mode.>, and Inspection Mode <Ref. to EN(H4DOTC)(diag)-48, PROCEDURE, Inspection Mode.>.

### WIRING DIAGRAM:

- Models without SI-DRIVE

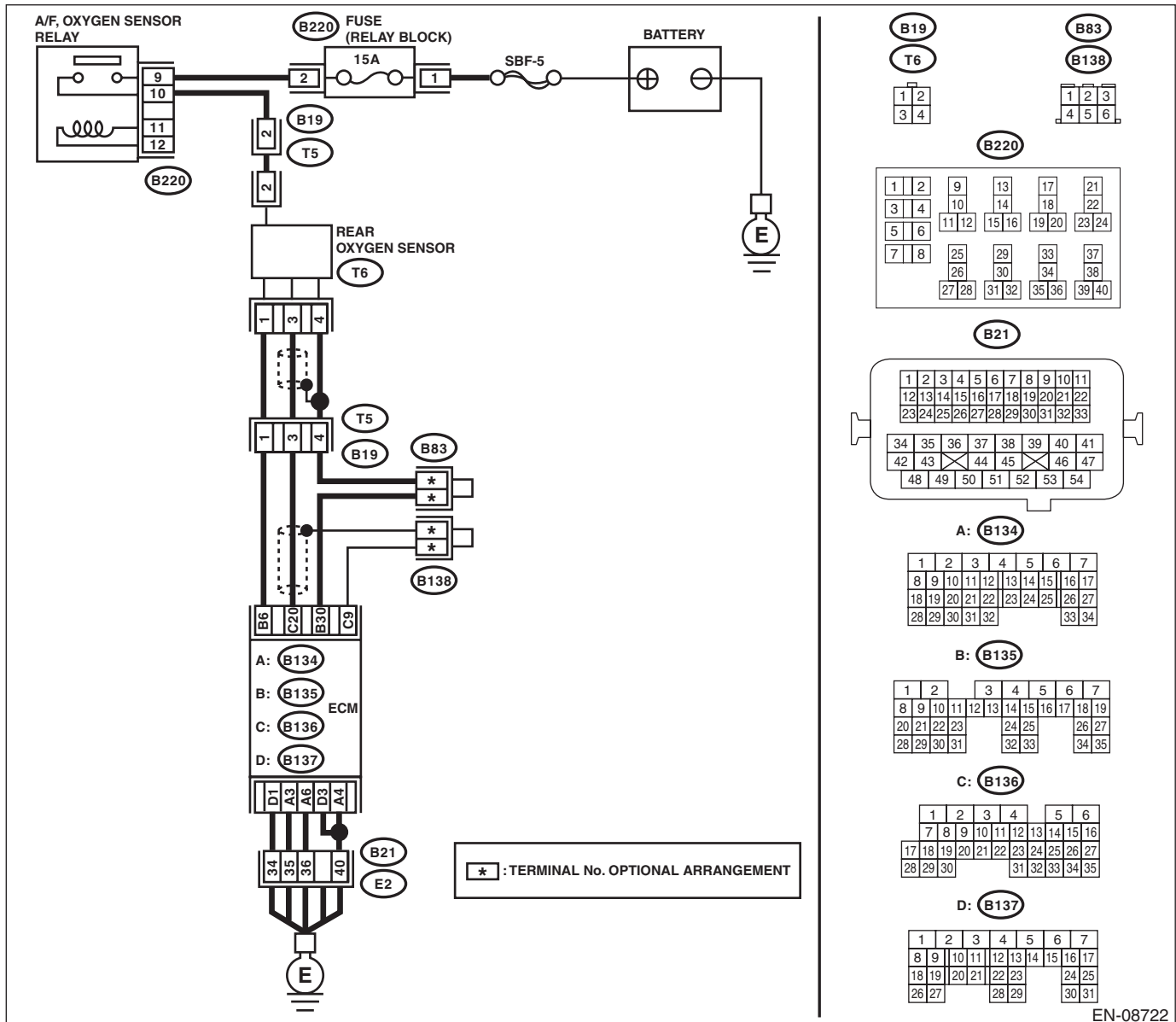

# Diagnostic Procedure with Diagnostic Trouble Code (DTC)

ENGINE (DIAGNOSTICS)

- Models with SI-DRIVE

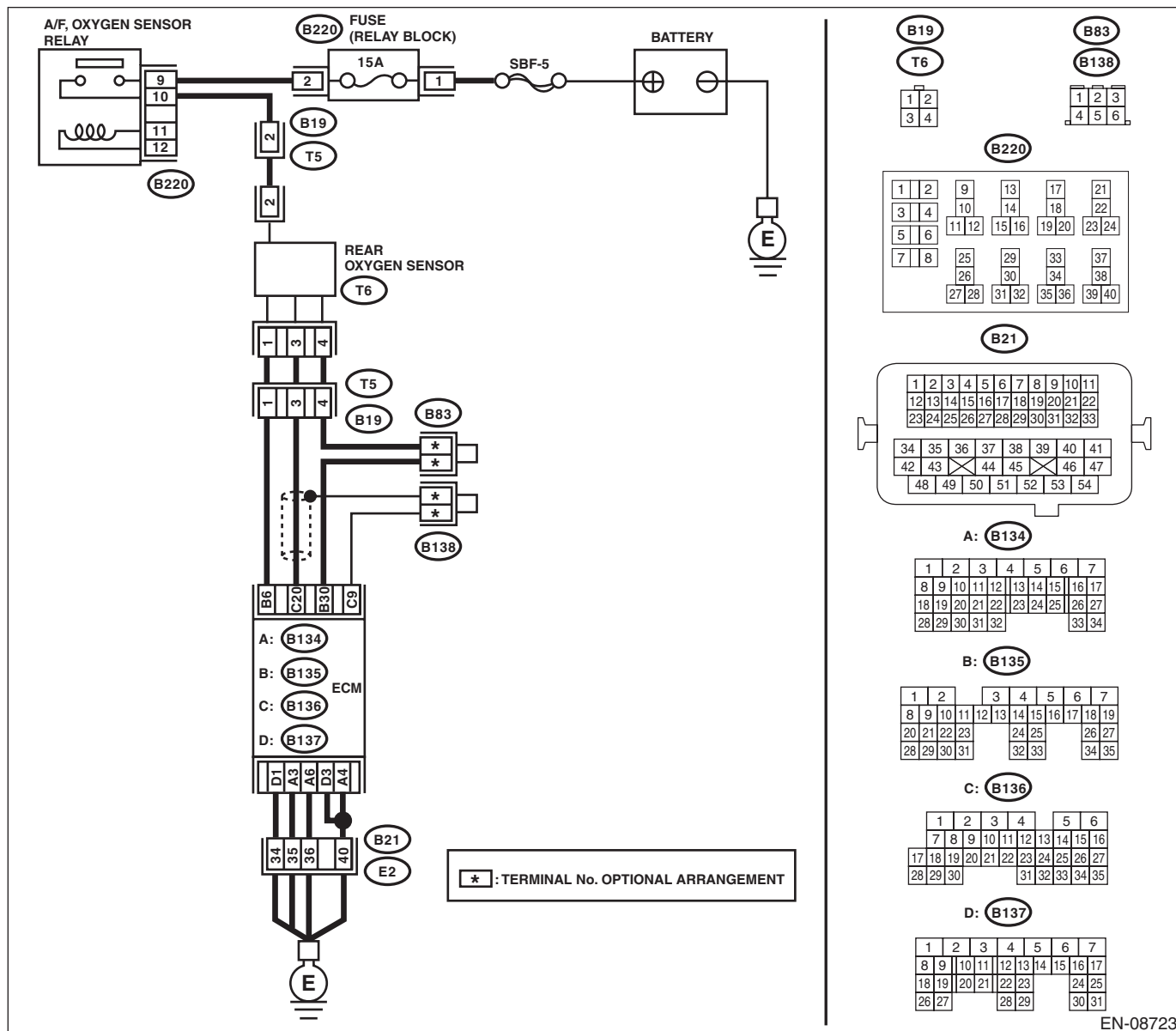

EN-08723

Step	Check	Yes	No
<b>1</b> <b>CHECK HARNESS BETWEEN ECM AND REAR OXYGEN SENSOR CONNECTOR.</b> 1) Turn the ignition switch to OFF. 2) Measure the voltage between ECM and chassis ground. <b>Connector &amp; terminal</b> <b>(B135) No. 6 (+) — Chassis ground (-):</b>	Is the voltage 10 V or more?	Repair the short circuit to power in the harness between ECM and rear oxygen sensor connector.	Go to step 2.



## Diagnostic Procedure with Diagnostic Trouble Code (DTC)

### ENGINE (DIAGNOSTICS)

Step	Check	Yes	No
<b>2</b> <b>CHECK GROUND CIRCUIT FOR ECM.</b> 1) Disconnect the connector from ECM. 2) Measure the resistance between ECM and chassis ground. <b>Connector &amp; terminal</b> <b>(B134) No. 3 — Chassis ground:</b> <b>(B134) No. 4 — Chassis ground:</b> <b>(B134) No. 6 — Chassis ground:</b> <b>(B137) No. 1 — Chassis ground:</b> <b>(B137) No. 3 — Chassis ground:</b>	Is the resistance less than 5 $\Omega$ ?	Repair the poor contact of ECM connector.	Repair the harness and connector. <b>NOTE:</b> In this case, repair the following item: <ul style="list-style-type: none"><li>• Open circuit of harness between ECM and engine ground</li><li>• Poor contact of coupling connector</li></ul>

# Diagnostic Procedure with Diagnostic Trouble Code (DTC)

ENGINE (DIAGNOSTICS)

## N: DTC P0068 MAP/MAF - THROTTLE POSITION CORRELATION

### DTC DETECTING CONDITION:

- Detected when two consecutive driving cycles with fault occur.
- GENERAL DESCRIPTION <Ref. to GD(H4DOTC)-30, DTC P0068 MAP/MAF - THROTTLE POSITION CORRELATION, Diagnostic Trouble Code (DTC) Detecting Criteria.>

### CAUTION:

**After servicing or replacing faulty parts, perform Clear Memory Mode <Ref. to EN(H4DOTC)(diag)-62, OPERATION, Clear Memory Mode.>, and Inspection Mode <Ref. to EN(H4DOTC)(diag)-48, PROCEDURE, Inspection Mode.>.**

Step	Check	Yes	No
1 <b>CHECK AIR INTAKE SYSTEM.</b>	Are there holes, loose bolts or disconnection of hose on air intake system?	Repair the air intake system.	Go to step 2.
2 <b>CHECK MANIFOLD ABSOLUTE PRESSURE SENSOR.</b> 1) Start the engine and warm up engine until coolant temperature is higher than 75°C (167°F). 2) Place the shift lever in neutral position. 3) Turn the A/C switch to OFF. 4) Turn all the accessory switches to OFF. 5) Read the value of «Mani. Absolute Pressure» using the Subaru Select Monitor or a general scan tool.  NOTE: • Subaru Select Monitor For detailed operation procedures, refer to "READ CURRENT DATA FOR ENGINE". <Ref. to EN(H4DOTC)(diag)-40, Subaru Select Monitor.> • General scan tool For detailed operation procedures, refer to the "General Scan Tool Instruction Manual".	Is the value in «Mani. Absolute Pressure» 73.3 — 106.6 kPa (550 — 800 mmHg, 21.65 — 31.50 inHg) when the ignition is turned ON, and 20.0 — 46.7 kPa (150 — 350 mmHg, 5.91 — 13.78 inHg) during idling?	Go to step 3.	Replace the manifold absolute pressure sensor. <Ref. to FU(STI)-43, Manifold Absolute Pressure Sensor.> <Ref. to FU(w/o STI)-44, Manifold Absolute Pressure Sensor.>
3 <b>CHECK THROTTLE OPENING ANGLE.</b> Using the Subaru Select Monitor or a general scan tool, read the value in «Throttle Opening Angle».  NOTE: • Subaru Select Monitor For detailed operation procedures, refer to "READ CURRENT DATA FOR ENGINE". <Ref. to EN(H4DOTC)(diag)-40, Subaru Select Monitor.> • General scan tool For detailed operation procedures, refer to the "General Scan Tool Instruction Manual".	Is the value in «Throttle Opening Angle» with the throttle fully closed less than 5%?	Go to step 4.	Replace the electronic throttle control. <Ref. to FU(STI)-15, Throttle Body.> <Ref. to FU(w/o STI)-15, Throttle Body.>
4 <b>CHECK THROTTLE OPENING ANGLE.</b>	Is the value in «Throttle Opening Angle» with the throttle fully open 85% or more?	Replace the manifold absolute pressure sensor. <Ref. to FU(STI)-43, Manifold Absolute Pressure Sensor.> <Ref. to FU(w/o STI)-44, Manifold Absolute Pressure Sensor.>	Replace the electronic throttle control. <Ref. to FU(STI)-15, Throttle Body.> <Ref. to FU(w/o STI)-15, Throttle Body.>

# Diagnostic Procedure with Diagnostic Trouble Code (DTC)

ENGINE (DIAGNOSTICS)

## O: DTC P0101 MASS OR VOLUME AIR FLOW CIRCUIT RANGE/PERFORMANCE

### DTC DETECTING CONDITION:

- Detected when two consecutive driving cycles with fault occur.
- GENERAL DESCRIPTION <Ref. to GD(H4DOTC)-32, DTC P0101 MASS OR VOLUME AIR FLOW CIRCUIT RANGE/PERFORMANCE, Diagnostic Trouble Code (DTC) Detecting Criteria.>

### TROUBLE SYMPTOM:

- Improper idling
- Engine stalls.
- Poor driving performance

### CAUTION:

After servicing or replacing faulty parts, perform Clear Memory Mode <Ref. to EN(H4DOTC)(diag)-62, OPERATION, Clear Memory Mode.>, and Inspection Mode <Ref. to EN(H4DOTC)(diag)-48, PROCEDURE, Inspection Mode.>.

Step	Check	Yes	No
1 CHECK FOR ANY OTHER DTC ON DISPLAY.	Is any other DTC displayed?	Check the appropriate DTC using the "List of Diagnostic Trouble Code (DTC)". <Ref. to EN(H4DOTC)(diag)-88, List of Diagnostic Trouble Code (DTC).>	Replace the mass air flow and intake air temperature sensor. <Ref. to FU(STI)-42, Mass Air Flow and Intake Air Temperature Sensor.> <Ref. to FU(w/o STI)-43, Mass Air Flow and Intake Air Temperature Sensor.>

# Diagnostic Procedure with Diagnostic Trouble Code (DTC)

ENGINE (DIAGNOSTICS)

## P: DTC P0102 MASS OR VOLUME AIR FLOW CIRCUIT LOW INPUT

### DTC DETECTING CONDITION:

- Immediately at fault recognition
- GENERAL DESCRIPTION <Ref. to GD(H4DOTC)-34, DTC P0102 MASS OR VOLUME AIR FLOW CIRCUIT LOW INPUT, Diagnostic Trouble Code (DTC) Detecting Criteria.>

### TROUBLE SYMPTOM:

- Improper idling
- Engine stalls.
- Poor driving performance

### CAUTION:

After servicing or replacing faulty parts, perform Clear Memory Mode <Ref. to EN(H4DOTC)(diag)-62, OPERATION, Clear Memory Mode.>, and Inspection Mode <Ref. to EN(H4DOTC)(diag)-48, PROCEDURE, Inspection Mode.>.

### WIRING DIAGRAM:

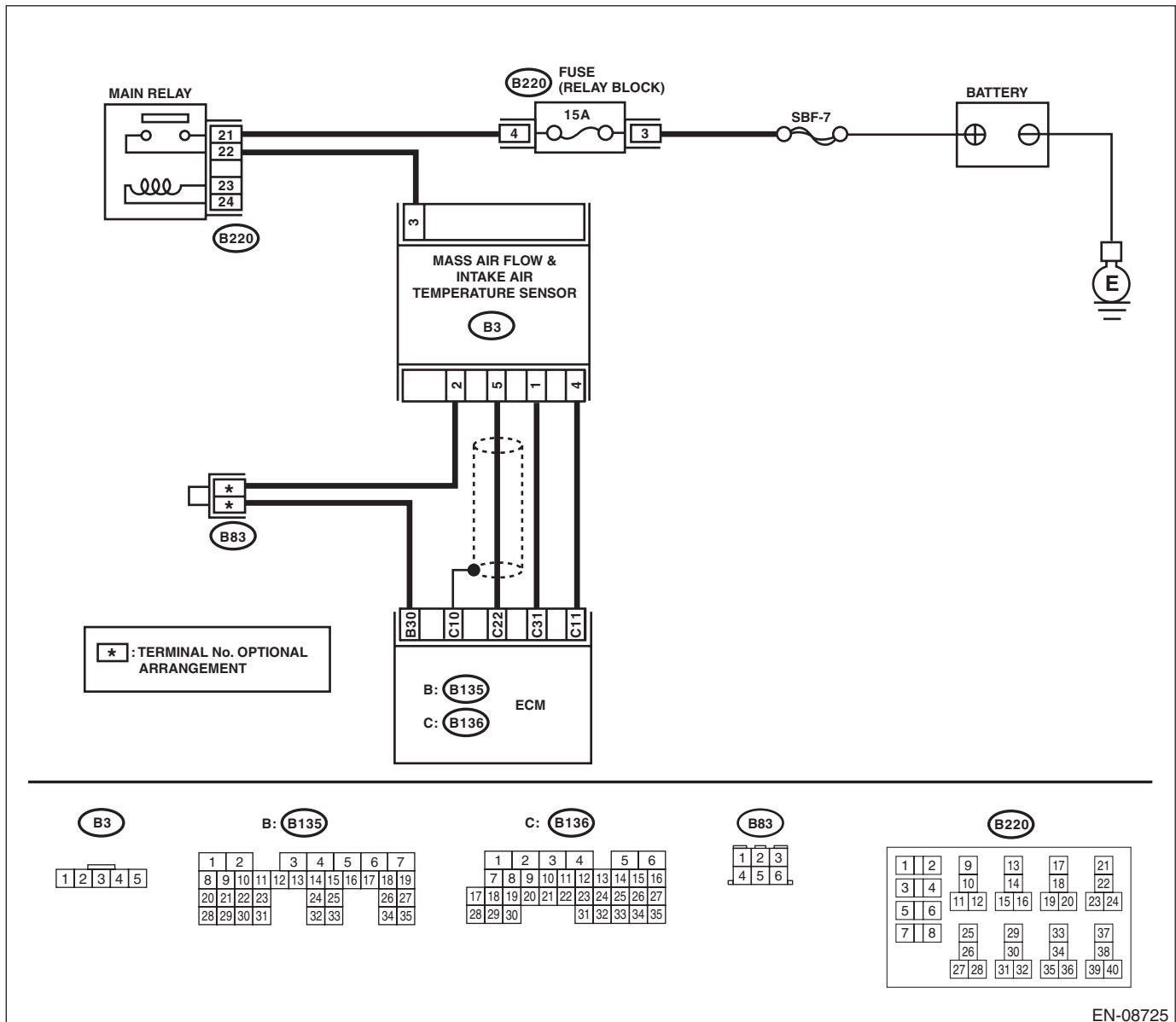

EN-08725

# Diagnostic Procedure with Diagnostic Trouble Code (DTC)

ENGINE (DIAGNOSTICS)

Step	Check	Yes	No
<p><b>1</b></p> <p><b>CHECK CURRENT DATA.</b></p> <p>1) Start the engine.</p> <p>2) Read the value of «Air Flow Sensor Voltage» using Subaru Select Monitor.</p> <p>NOTE: For detailed operation procedures, refer to "READ CURRENT DATA FOR ENGINE". &lt;Ref. to EN(H4DOTC)(diag)-40, Subaru Select Monitor.&gt;</p>	<p>Is the value of «Air Flow Sensor Voltage» less than 0.2 V?</p>	<p>Go to step 2.</p>	<p>Even if DTC is detected, the circuit has returned to a normal condition at this time. Reproduce the failure, and then perform the diagnosis again.</p> <p>NOTE: In this case, temporary poor contact of connector, temporary open or short circuit of harness may be the cause.</p>
<p><b>2</b></p> <p><b>CHECK POWER SUPPLY OF MASS AIR FLOW AND INTAKE AIR TEMPERATURE SENSOR.</b></p> <p>1) Turn the ignition switch to OFF.</p> <p>2) Disconnect the connectors from the mass air flow and intake air temperature sensor.</p> <p>3) Turn the ignition switch to ON.</p> <p>4) Measure the voltage between mass air flow and intake air temperature sensor connector and engine ground.</p> <p><b>Connector &amp; terminal</b> <b>(B3) No. 3 (+) — Engine ground (-):</b></p>	<p>Is the voltage 10 V or more?</p>	<p>Go to step 3.</p>	<p>Repair the harness and connector.</p> <p>NOTE: In this case, repair the following item:</p> <ul style="list-style-type: none"> <li>• Open circuit in harness between main relay connector and mass air flow and intake air temperature sensor connector</li> <li>• Poor contact of main relay connector</li> </ul>
<p><b>3</b></p> <p><b>CHECK HARNESS BETWEEN ECM AND MASS AIR FLOW AND INTAKE AIR TEMPERATURE SENSOR CONNECTOR.</b></p> <p>1) Turn the ignition switch to OFF.</p> <p>2) Disconnect the connector from ECM.</p> <p>3) Measure the resistance of harness between ECM and the mass air flow and intake air temperature sensor connector.</p> <p><b>Connector &amp; terminal</b> <b>(B136) No. 22 — (B3) No. 5:</b></p>	<p>Is the resistance less than 1 Ω?</p>	<p>Go to step 4.</p>	<p>Repair the open circuit in harness between ECM and the mass air flow and intake air temperature sensor connector.</p>
<p><b>4</b></p> <p><b>CHECK HARNESS BETWEEN ECM AND MASS AIR FLOW AND INTAKE AIR TEMPERATURE SENSOR CONNECTOR.</b></p> <p>Measure the resistance between ECM and chassis ground.</p> <p><b>Connector &amp; terminal</b> <b>(B136) No. 22 — Chassis ground:</b></p>	<p>Is the resistance 1 MΩ or more?</p>	<p>Go to step 5.</p>	<p>Repair the short circuit to ground in harness between ECM and mass air flow and intake air temperature sensor connector.</p>

# Diagnostic Procedure with Diagnostic Trouble Code (DTC)

ENGINE (DIAGNOSTICS)

Step	Check	Yes	No
5 <b>CHECK FOR POOR CONTACT.</b> Check for poor contact of ECM and mass air flow and intake air temperature sensor connector.	Is there poor contact of ECM or mass air flow and intake air temperature sensor connector?	Repair the poor contact of ECM or mass air flow and intake air temperature sensor connector.	Replace the mass air flow and intake air temperature sensor. <Ref. to FU(STI)-42, Mass Air Flow and Intake Air Temperature Sensor.> <Ref. to FU(w/o STI)-43, Mass Air Flow and Intake Air Temperature Sensor.>

# Diagnostic Procedure with Diagnostic Trouble Code (DTC)

ENGINE (DIAGNOSTICS)

## Q: DTC P0103 MASS OR VOLUME AIR FLOW CIRCUIT HIGH INPUT

### DTC DETECTING CONDITION:

- Immediately at fault recognition
- GENERAL DESCRIPTION <Ref. to GD(H4DOTC)-36, DTC P0103 MASS OR VOLUME AIR FLOW CIRCUIT HIGH INPUT, Diagnostic Trouble Code (DTC) Detecting Criteria.>

### TROUBLE SYMPTOM:

- Improper idling
- Engine stalls.
- Poor driving performance

### CAUTION:

After servicing or replacing faulty parts, perform Clear Memory Mode <Ref. to EN(H4DOTC)(diag)-62, OPERATION, Clear Memory Mode.>, and Inspection Mode <Ref. to EN(H4DOTC)(diag)-48, PROCEDURE, Inspection Mode.>.

### WIRING DIAGRAM:

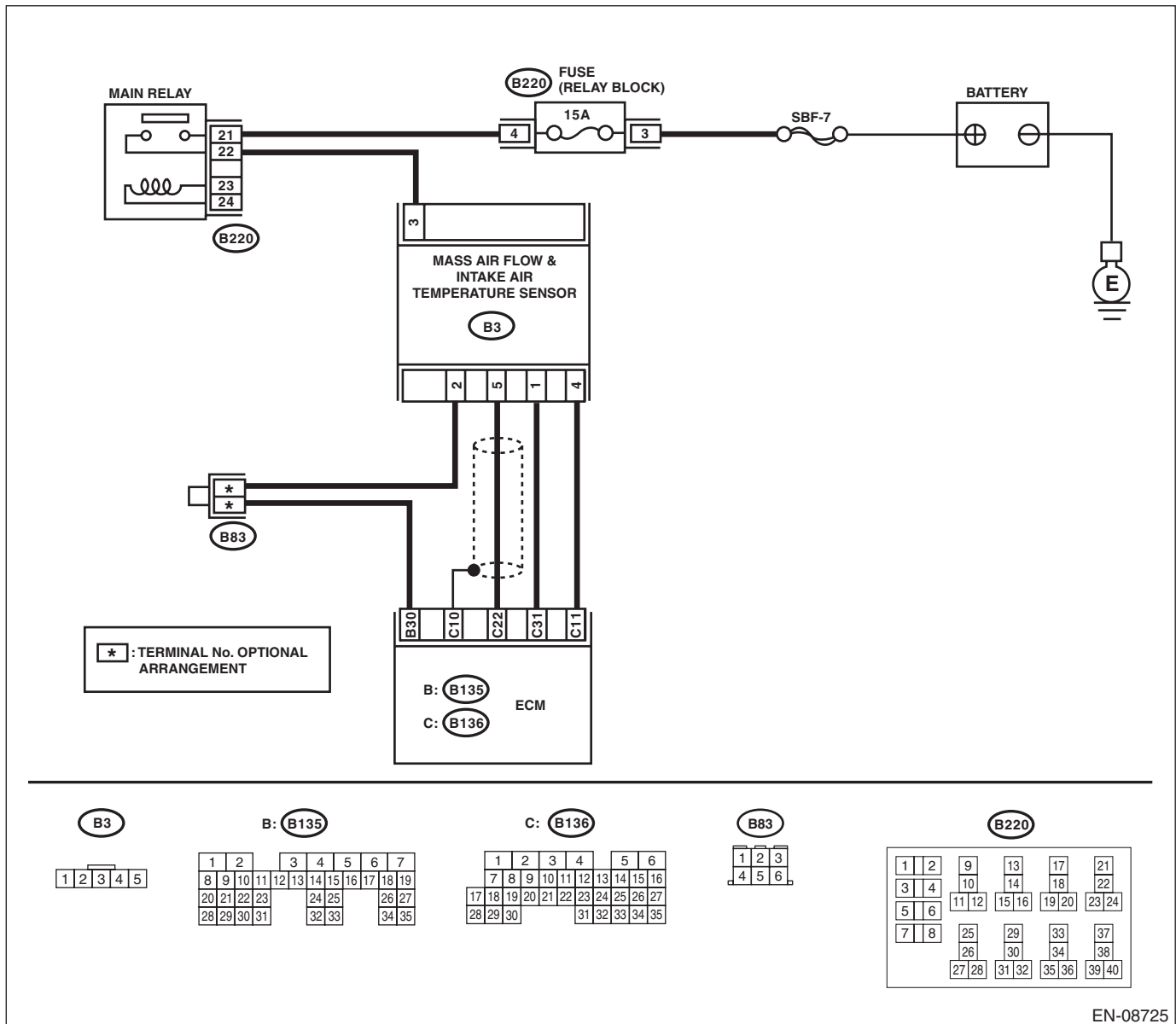

EN-08725

# Diagnostic Procedure with Diagnostic Trouble Code (DTC)

ENGINE (DIAGNOSTICS)

Step	Check	Yes	No
<p><b>1</b></p> <p><b>CHECK CURRENT DATA.</b></p> <p>1) Start the engine.</p> <p>2) Read the value of «Air Flow Sensor Voltage» using Subaru Select Monitor.</p> <p>NOTE: For detailed operation procedures, refer to "READ CURRENT DATA FOR ENGINE". &lt;Ref. to EN(H4DOTC)(diag)-40, Subaru Select Monitor.&gt;</p>	<p>Is the value of «Air Flow Sensor Voltage» 5 V or more?</p>	<p>Go to step 2.</p>	<p>Even if DTC is detected, the circuit has returned to a normal condition at this time. Reproduce the failure, and then perform the diagnosis again.</p> <p>NOTE: In this case, temporary poor contact of connector, temporary open or short circuit of harness may be the cause.</p>
<p><b>2</b></p> <p><b>CHECK HARNESS BETWEEN ECM AND MASS AIR FLOW AND INTAKE AIR TEMPERATURE SENSOR CONNECTOR.</b></p> <p>1) Turn the ignition switch to OFF.</p> <p>2) Disconnect the connectors from the mass air flow and intake air temperature sensor.</p> <p>3) Start the engine.</p> <p>4) Read the value of «Air Flow Sensor Voltage» using Subaru Select Monitor.</p> <p>NOTE: For detailed operation procedures, refer to "READ CURRENT DATA FOR ENGINE". &lt;Ref. to EN(H4DOTC)(diag)-40, Subaru Select Monitor.&gt;</p>	<p>Is the value of «Air Flow Sensor Voltage» 5 V or more?</p>	<p>Repair the short circuit of harness to power supply between ECM and mass air flow and intake air temperature sensor connector.</p>	<p>Go to step 3.</p>
<p><b>3</b></p> <p><b>CHECK HARNESS BETWEEN ECM AND MASS AIR FLOW AND INTAKE AIR TEMPERATURE SENSOR CONNECTOR.</b></p> <p>1) Turn the ignition switch to OFF.</p> <p>2) Measure the resistance of harness between mass air flow and intake air temperature sensor connector and engine ground.</p> <p><b>Connector &amp; terminal</b> <b>(B3) No. 4 — Engine ground:</b></p>	<p>Is the resistance less than 5 Ω?</p>	<p>Go to step 4.</p>	<p>Repair the harness and connector.</p> <p>NOTE: In this case, repair the following item:</p> <ul style="list-style-type: none"> <li>• Open circuit in harness between ECM and mass air flow and intake air temperature sensor connector</li> <li>• Poor contact of ECM connector</li> </ul>
<p><b>4</b></p> <p><b>CHECK FOR POOR CONTACT.</b></p> <p>Check for poor contact of mass air flow and intake air temperature sensor connector.</p>	<p>Is there poor contact of mass air flow and intake air temperature sensor connector?</p>	<p>Repair the poor contact of mass air flow and intake air temperature sensor connector.</p>	<p>Replace the mass air flow and intake air temperature sensor. &lt;Ref. to FU(STI)-42, Mass Air Flow and Intake Air Temperature Sensor.&gt; &lt;Ref. to FU(w/o STI)-43, Mass Air Flow and Intake Air Temperature Sensor.&gt;</p>



# Diagnostic Procedure with Diagnostic Trouble Code (DTC)

ENGINE (DIAGNOSTICS)

## R: DTC P0107 MANIFOLD ABSOLUTE PRESSURE/BAROMETRIC PRESSURE CIRCUIT LOW INPUT

### DTC DETECTING CONDITION:

- Immediately at fault recognition
- GENERAL DESCRIPTION <Ref. to GD(H4DOTC)-38, DTC P0107 MANIFOLD ABSOLUTE PRESSURE/BAROMETRIC PRESSURE CIRCUIT LOW INPUT, Diagnostic Trouble Code (DTC) Detecting Criteria.>

### CAUTION:

After servicing or replacing faulty parts, perform Clear Memory Mode <Ref. to EN(H4DOTC)(diag)-62, OPERATION, Clear Memory Mode.>, and Inspection Mode <Ref. to EN(H4DOTC)(diag)-48, PROCEDURE, Inspection Mode.>.

### WIRING DIAGRAM:

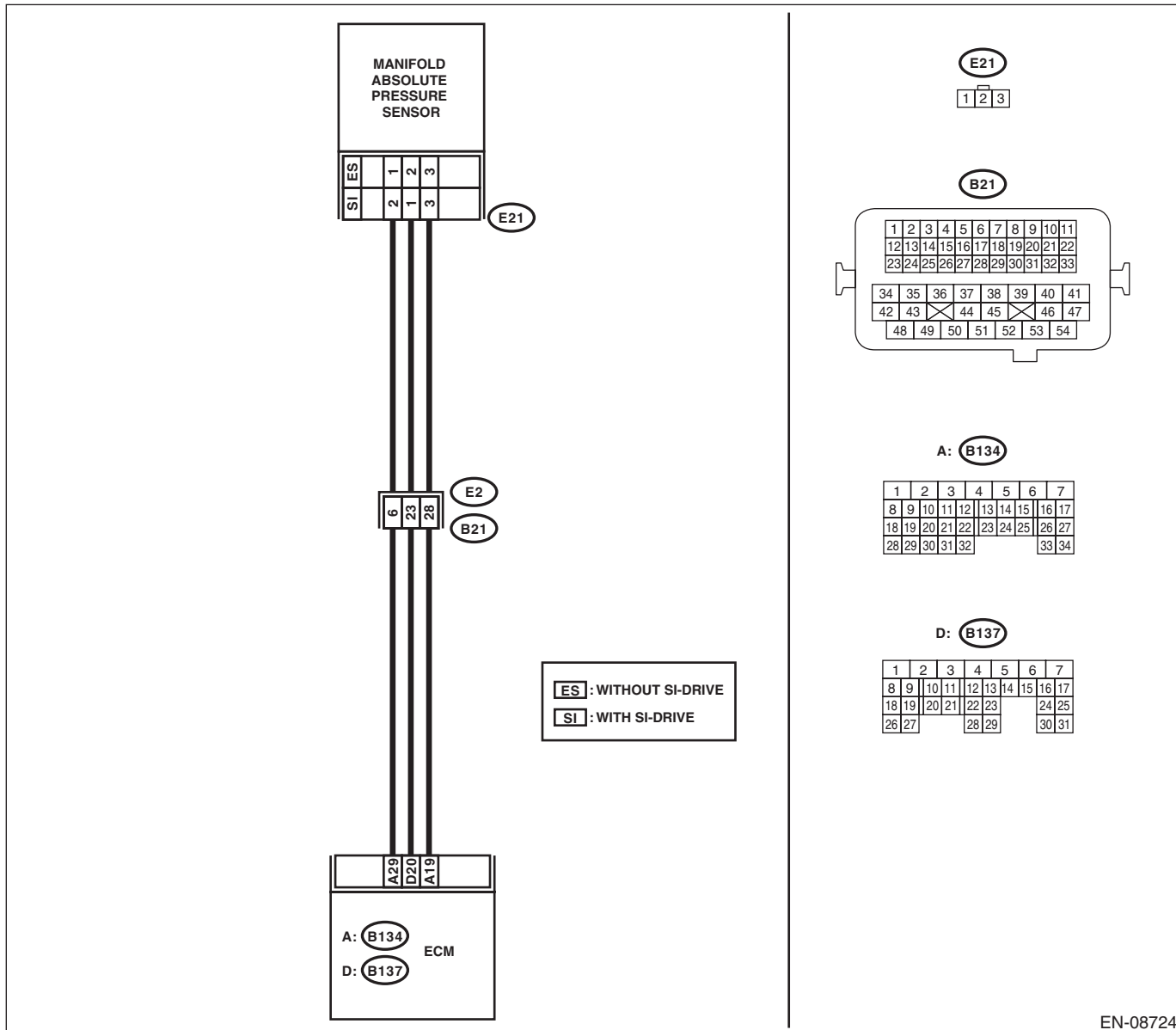

EN-08724

# Diagnostic Procedure with Diagnostic Trouble Code (DTC)

ENGINE (DIAGNOSTICS)

	Step	Check	Yes	No
1	<p><b>CHECK CURRENT DATA.</b></p> <p>1) Start the engine.</p> <p>2) Read the value of «Mani. Absolute Pressure» using the Subaru Select Monitor or a general scan tool.</p> <p>NOTE:</p> <ul style="list-style-type: none"> <li>• Subaru Select Monitor</li> </ul> <p>For detailed operation procedures, refer to "READ CURRENT DATA FOR ENGINE". &lt;Ref. to EN(H4DOTC)(diag)-40, Subaru Select Monitor.&gt;</p> <ul style="list-style-type: none"> <li>• General scan tool</li> </ul> <p>For detailed operation procedures, refer to the general scan tool operation manual.</p>	<p>Is the value of «Mani. Absolute Pressure» less than 13.3 kPa (100 mmHg, 3.94 inHg)?</p>	<p>Go to step 2.</p>	<p>Even if DTC is detected, the circuit has returned to a normal condition at this time. Reproduce the failure, and then perform the diagnosis again.</p> <p>NOTE:</p> <p>In this case, temporary poor contact of connector, temporary open or short circuit of harness may be the cause.</p>
2	<p><b>CHECK POWER SUPPLY OF MANIFOLD ABSOLUTE PRESSURE SENSOR.</b></p> <p>1) Turn the ignition switch to OFF.</p> <p>2) Disconnect the connector from manifold absolute pressure sensor.</p> <p>3) Turn the ignition switch to ON.</p> <p>4) Measure the voltage between manifold absolute pressure sensor connector and engine ground.</p> <p><b>Connector &amp; terminal</b> <b>(E21) No. 3 (+) — Engine ground (-):</b></p>	<p>Is the voltage 4.5 V or more?</p>	<p>Go to step 3.</p>	<p>Repair the harness and connector.</p> <p>NOTE:</p> <p>In this case, repair the following item:</p> <ul style="list-style-type: none"> <li>• Open circuit of harness between ECM and manifold absolute pressure sensor connector.</li> <li>• Poor contact of ECM connector</li> <li>• Poor contact of coupling connector</li> </ul>
3	<p><b>CHECK HARNESS BETWEEN ECM AND MANIFOLD ABSOLUTE PRESSURE SENSOR CONNECTOR.</b></p> <p>1) Turn the ignition switch to OFF.</p> <p>2) Disconnect the connector from ECM.</p> <p>3) Measure the resistance of harness between ECM and manifold absolute pressure sensor connector.</p> <p><b>Connector &amp; terminal</b> <b>Models without SI-DRIVE</b> <b>(B137) No. 20 — (E21) No. 2:</b> <b>Models with SI-DRIVE</b> <b>(B137) No. 20 — (E21) No. 1:</b></p>	<p>Is the resistance less than 1 Ω?</p>	<p>Go to step 4.</p>	<p>Repair the harness and connector.</p> <p>NOTE:</p> <p>In this case, repair the following item:</p> <ul style="list-style-type: none"> <li>• Open circuit of harness between ECM and manifold absolute pressure sensor connector.</li> <li>• Poor contact of coupling connector</li> </ul>
4	<p><b>CHECK HARNESS BETWEEN ECM AND MANIFOLD ABSOLUTE PRESSURE SENSOR CONNECTOR.</b></p> <p>Measure the resistance between ECM and chassis ground.</p> <p><b>Connector &amp; terminal</b> <b>(B137) No. 20 — Chassis ground:</b></p>	<p>Is the resistance 1 MΩ or more?</p>	<p>Go to step 5.</p>	<p>Repair ground short circuit of harness between ECM and manifold absolute pressure sensor connector.</p>

# Diagnostic Procedure with Diagnostic Trouble Code (DTC)

ENGINE (DIAGNOSTICS)

Step	Check	Yes	No
<b>5</b> <b>CHECK FOR POOR CONTACT.</b> Check for poor contact of ECM and manifold absolute pressure sensor connector.	Is there poor contact of ECM or manifold absolute pressure sensor connector?	Repair the poor contact of ECM or manifold absolute pressure sensor connector.	Replace the manifold absolute pressure sensor. <Ref. to FU(STI)-43, Manifold Absolute Pressure Sensor.> <Ref. to FU(w/o STI)-44, Manifold Absolute Pressure Sensor.>

# Diagnostic Procedure with Diagnostic Trouble Code (DTC)

ENGINE (DIAGNOSTICS)

## S: DTC P0108 MANIFOLD ABSOLUTE PRESSURE/BAROMETRIC PRESSURE CIRCUIT HIGH INPUT

### DTC DETECTING CONDITION:

- Immediately at fault recognition
- GENERAL DESCRIPTION <Ref. to GD(H4DOTC)-40, DTC P0108 MANIFOLD ABSOLUTE PRESSURE/BAROMETRIC PRESSURE CIRCUIT HIGH INPUT, Diagnostic Trouble Code (DTC) Detecting Criteria.>

### CAUTION:

After servicing or replacing faulty parts, perform Clear Memory Mode <Ref. to EN(H4DOTC)(diag)-62, OPERATION, Clear Memory Mode.>, and Inspection Mode <Ref. to EN(H4DOTC)(diag)-48, PROCEDURE, Inspection Mode.>.

### WIRING DIAGRAM:

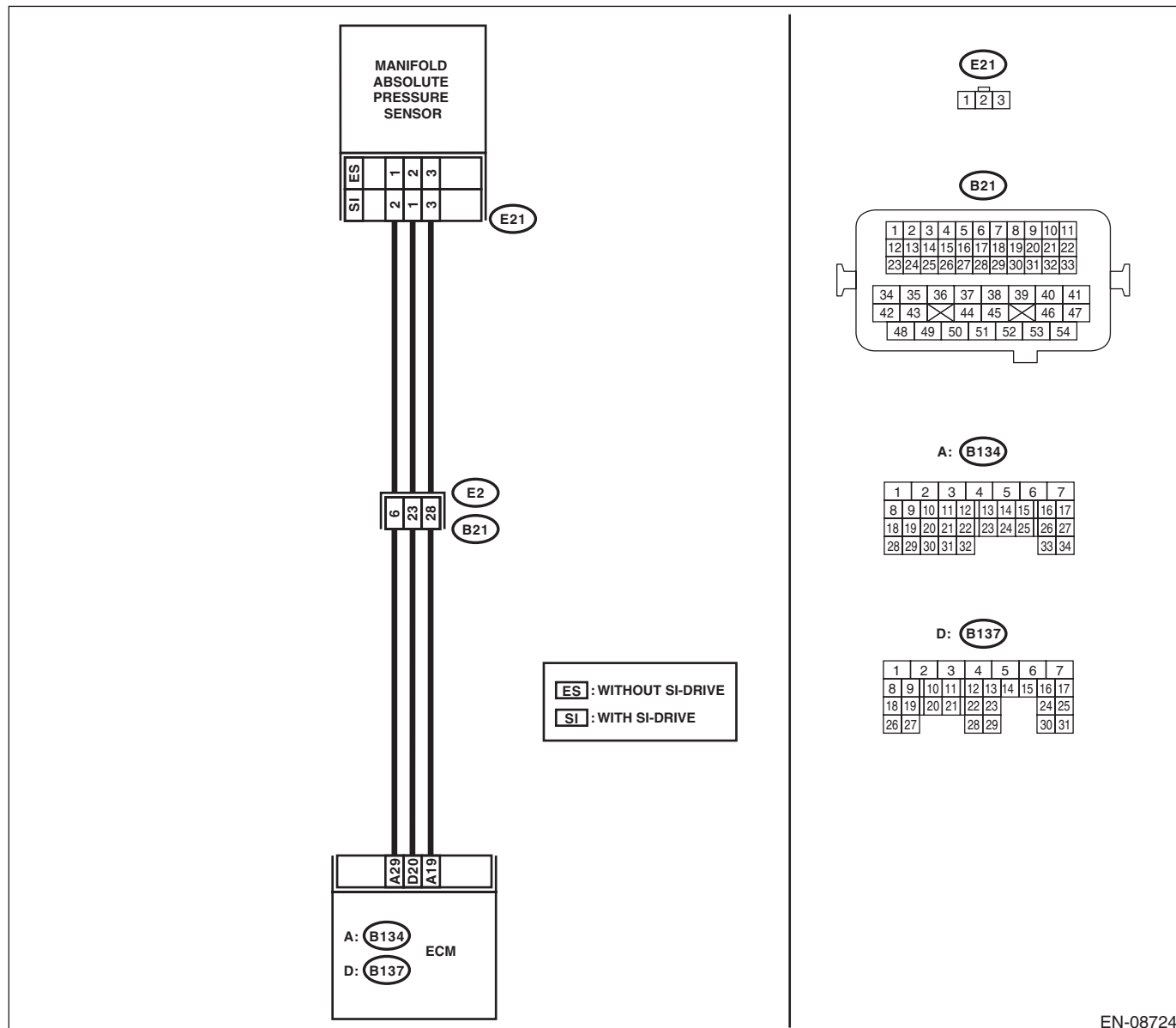

EN-08724

# Diagnostic Procedure with Diagnostic Trouble Code (DTC)

## ENGINE (DIAGNOSTICS)

Step	Check	Yes	No
<p><b>1 CHECK CURRENT DATA.</b></p> <p>1) Start the engine.</p> <p>2) Read the value of «Mani. Absolute Pressure» using the Subaru Select Monitor or a general scan tool.</p> <p>NOTE:</p> <ul style="list-style-type: none"> <li>• Subaru Select Monitor</li> </ul> <p>For detailed operation procedures, refer to "READ CURRENT DATA FOR ENGINE". &lt;Ref. to EN(H4DOTC)(diag)-40, Subaru Select Monitor.&gt;</p> <ul style="list-style-type: none"> <li>• General scan tool</li> </ul> <p>For detailed operation procedures, refer to the general scan tool operation manual.</p>	<p>Is the value of «Mani. Absolute Pressure» 119.5 kPa (896.5 mmHg, 35.29 inHg) or more?</p>	<p>Go to step 2.</p>	<p>Even if DTC is detected, the circuit has returned to a normal condition at this time. Reproduce the failure, and then perform the diagnosis again.</p> <p>NOTE:</p> <p>In this case, temporary poor contact of connector, temporary open or short circuit of harness may be the cause.</p>
<p><b>2 CHECK HARNESS BETWEEN ECM AND MANIFOLD ABSOLUTE PRESSURE SENSOR CONNECTOR.</b></p> <p>1) Turn the ignition switch to OFF.</p> <p>2) Disconnect the connector from manifold absolute pressure sensor.</p> <p>3) Start the engine.</p> <p>4) Read the value of «Mani. Absolute Pressure» using the Subaru Select Monitor or a general scan tool.</p> <p>NOTE:</p> <ul style="list-style-type: none"> <li>• Subaru Select Monitor</li> </ul> <p>For detailed operation procedures, refer to "READ CURRENT DATA FOR ENGINE". &lt;Ref. to EN(H4DOTC)(diag)-40, Subaru Select Monitor.&gt;</p> <ul style="list-style-type: none"> <li>• General scan tool</li> </ul> <p>For detailed operation procedures, refer to the general scan tool operation manual.</p>	<p>Is the value of «Mani. Absolute Pressure» 119.5 kPa (896.5 mmHg, 35.29 inHg) or more?</p>	<p>Repair the short circuit to power in harness between ECM and manifold absolute pressure sensor connector.</p>	<p>Go to step 3.</p>
<p><b>3 CHECK HARNESS BETWEEN ECM AND MANIFOLD ABSOLUTE PRESSURE SENSOR CONNECTOR.</b></p> <p>1) Turn the ignition switch to OFF.</p> <p>2) Measure the resistance of harness between manifold absolute pressure sensor connector and engine ground.</p> <p><b>Connector &amp; terminal</b></p> <p><b>Models without SI-DRIVE</b></p> <p><b>(E21) No. 1 — Engine ground:</b></p> <p><b>Models with SI-DRIVE</b></p> <p><b>(E21) No. 2 — Engine ground:</b></p>	<p>Is the resistance less than 5 Ω?</p>	<p>Go to step 4.</p>	<p>Repair the harness and connector.</p> <p>NOTE:</p> <p>In this case, repair the following item:</p> <ul style="list-style-type: none"> <li>• Open circuit of harness between ECM and manifold absolute pressure sensor connector.</li> <li>• Poor contact of ECM connector</li> <li>• Poor contact of coupling connector</li> </ul>
<p><b>4 CHECK FOR POOR CONTACT.</b></p> <p>Check for poor contact of manifold absolute pressure sensor connector.</p>	<p>Is there poor contact of manifold absolute pressure sensor connector?</p>	<p>Repair the poor contact of manifold absolute pressure sensor connector.</p>	<p>Replace the manifold absolute pressure sensor. &lt;Ref. to FU(STI)-43, Manifold Absolute Pressure Sensor.&gt; &lt;Ref. to FU(w/o STI)-44, Manifold Absolute Pressure Sensor.&gt;</p>

# Diagnostic Procedure with Diagnostic Trouble Code (DTC)

ENGINE (DIAGNOSTICS)

## T: DTC P0111 INTAKE AIR TEMPERATURE SENSOR 1 CIRCUIT RANGE/PERFORMANCE

### DTC DETECTING CONDITION:

- Detected when two consecutive driving cycles with fault occur.
- GENERAL DESCRIPTION <Ref. to GD(H4DOTC)-42, DTC P0111 INTAKE AIR TEMPERATURE SENSOR 1 CIRCUIT RANGE/PERFORMANCE, Diagnostic Trouble Code (DTC) Detecting Criteria.>

### TROUBLE SYMPTOM:

- Improper idling
- Poor driving performance

### CAUTION:

After servicing or replacing faulty parts, perform Clear Memory Mode <Ref. to EN(H4DOTC)(diag)-62, OPERATION, Clear Memory Mode.>, and Inspection Mode <Ref. to EN(H4DOTC)(diag)-48, PROCEDURE, Inspection Mode.>.

	Step	Check	Yes	No
1	<p><b>CHECK ENGINE COOLANT TEMPERATURE.</b></p> <p>1) Start the engine and warm up completely. 2) Read the value of «Coolant Temp.» using the Subaru Select Monitor or a general scan tool.</p> <p>NOTE:</p> <ul style="list-style-type: none"><li>• Subaru Select Monitor</li></ul> <p>For detailed operation procedures, refer to "READ CURRENT DATA FOR ENGINE". &lt;Ref. to EN(H4DOTC)(diag)-40, Subaru Select Monitor.&gt;</p> <ul style="list-style-type: none"><li>• General scan tool</li></ul> <p>For detailed operation procedures, refer to the general scan tool operation manual.</p>	<p>Is the value of «Coolant Temp.» 75°C (167°F) or more?</p>	<p>Replace the mass air flow and intake air temperature sensor. &lt;Ref. to FU(STI)-42, Mass Air Flow and Intake Air Temperature Sensor.&gt; &lt;Ref. to FU(w/o STI)-43, Mass Air Flow and Intake Air Temperature Sensor.&gt;</p>	<p>Check for DTC P0125. &lt;Ref. to EN(H4DOTC)(diag)-144, DTC P0125 INSUFFICIENT COOLANT TEMPERATURE FOR CLOSED LOOP FUEL CONTROL, Diagnostic Procedure with Diagnostic Trouble Code (DTC).&gt;</p>

# Diagnostic Procedure with Diagnostic Trouble Code (DTC)

ENGINE (DIAGNOSTICS)

## U: DTC P0112 INTAKE AIR TEMPERATURE SENSOR 1 CIRCUIT LOW

### DTC DETECTING CONDITION:

- Immediately at fault recognition
- GENERAL DESCRIPTION <Ref. to GD(H4DOTC)-45, DTC P0112 INTAKE AIR TEMPERATURE SENSOR 1 CIRCUIT LOW, Diagnostic Trouble Code (DTC) Detecting Criteria.>

### TROUBLE SYMPTOM:

- Improper idling
- Poor driving performance

### CAUTION:

After servicing or replacing faulty parts, perform Clear Memory Mode <Ref. to EN(H4DOTC)(diag)-62, OPERATION, Clear Memory Mode.>, and Inspection Mode <Ref. to EN(H4DOTC)(diag)-48, PROCEDURE, Inspection Mode.>.

### WIRING DIAGRAM:

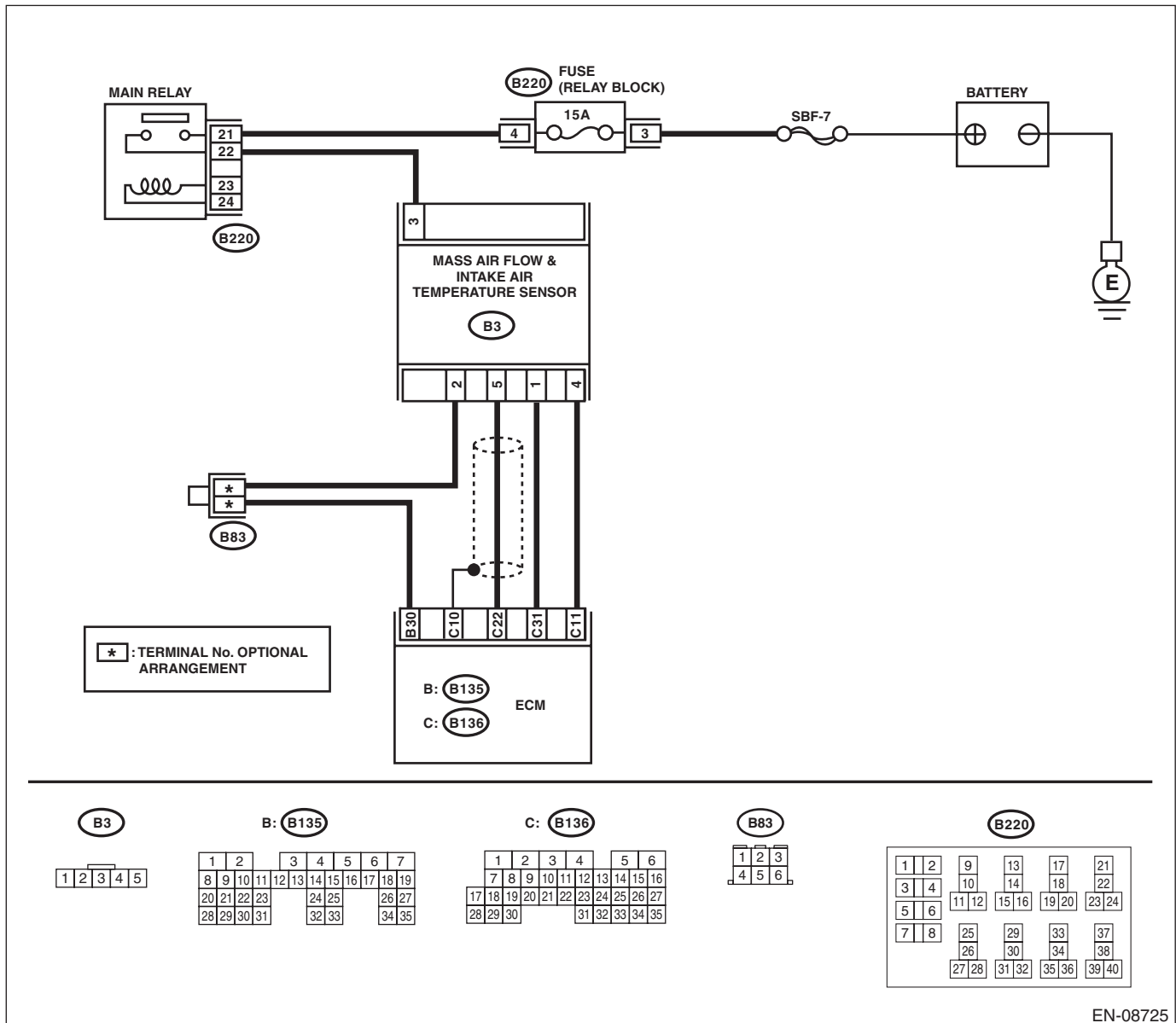

EN-08725

# Diagnostic Procedure with Diagnostic Trouble Code (DTC)

ENGINE (DIAGNOSTICS)

Step	Check	Yes	No
<p><b>1</b></p> <p><b>CHECK CURRENT DATA.</b></p> <p>1) Start the engine.</p> <p>2) Read the value of «Intake Air Temp.» using the Subaru Select Monitor or a general scan tool.</p> <p>NOTE:</p> <ul style="list-style-type: none"> <li>• Subaru Select Monitor</li> </ul> <p>For detailed operation procedures, refer to "READ CURRENT DATA FOR ENGINE". &lt;Ref. to EN(H4DOTC)(diag)-40, Subaru Select Monitor.&gt;</p> <ul style="list-style-type: none"> <li>• General scan tool</li> </ul> <p>For detailed operation procedures, refer to the general scan tool operation manual.</p>	<p>Is the value of «Intake Air Temp.» 120°C (248°F) or more?</p>	<p>Go to step 2.</p>	<p>Even if DTC is detected, the circuit has returned to a normal condition at this time. Reproduce the failure, and then perform the diagnosis again.</p> <p>NOTE:</p> <p>In this case, temporary poor contact of connector, temporary open or short circuit of harness may be the cause.</p>
<p><b>2</b></p> <p><b>CHECK HARNESS BETWEEN ECM AND MASS AIR FLOW AND INTAKE AIR TEMPERATURE SENSOR CONNECTOR.</b></p> <p>1) Turn the ignition switch to OFF.</p> <p>2) Disconnect the connector from ECM and the mass air flow and intake air temperature sensor.</p> <p>3) Measure the resistance between ECM and chassis ground.</p> <p><b>Connector &amp; terminal</b> <b>(B136) No. 31 — Chassis ground:</b></p>	<p>Is the resistance 1 MΩ or more?</p>	<p>Replace the mass air flow and intake air temperature sensor. &lt;Ref. to FU(STI)-42, Mass Air Flow and Intake Air Temperature Sensor.&gt; &lt;Ref. to FU(w/o STI)-43, Mass Air Flow and Intake Air Temperature Sensor.&gt;</p>	<p>Repair the short circuit to ground in harness between ECM and mass air flow and intake air temperature sensor connector.</p>



# Diagnostic Procedure with Diagnostic Trouble Code (DTC)

ENGINE (DIAGNOSTICS)

## V: DTC P0113 INTAKE AIR TEMPERATURE SENSOR 1 CIRCUIT HIGH

### DTC DETECTING CONDITION:

- Immediately at fault recognition
- GENERAL DESCRIPTION <Ref. to GD(H4DOTC)-47, DTC P0113 INTAKE AIR TEMPERATURE SENSOR 1 CIRCUIT HIGH, Diagnostic Trouble Code (DTC) Detecting Criteria.>

### TROUBLE SYMPTOM:

- Improper idling
- Poor driving performance

### CAUTION:

After servicing or replacing faulty parts, perform Clear Memory Mode <Ref. to EN(H4DOTC)(diag)-62, OPERATION, Clear Memory Mode.>, and Inspection Mode <Ref. to EN(H4DOTC)(diag)-48, PROCEDURE, Inspection Mode.>.

### WIRING DIAGRAM:

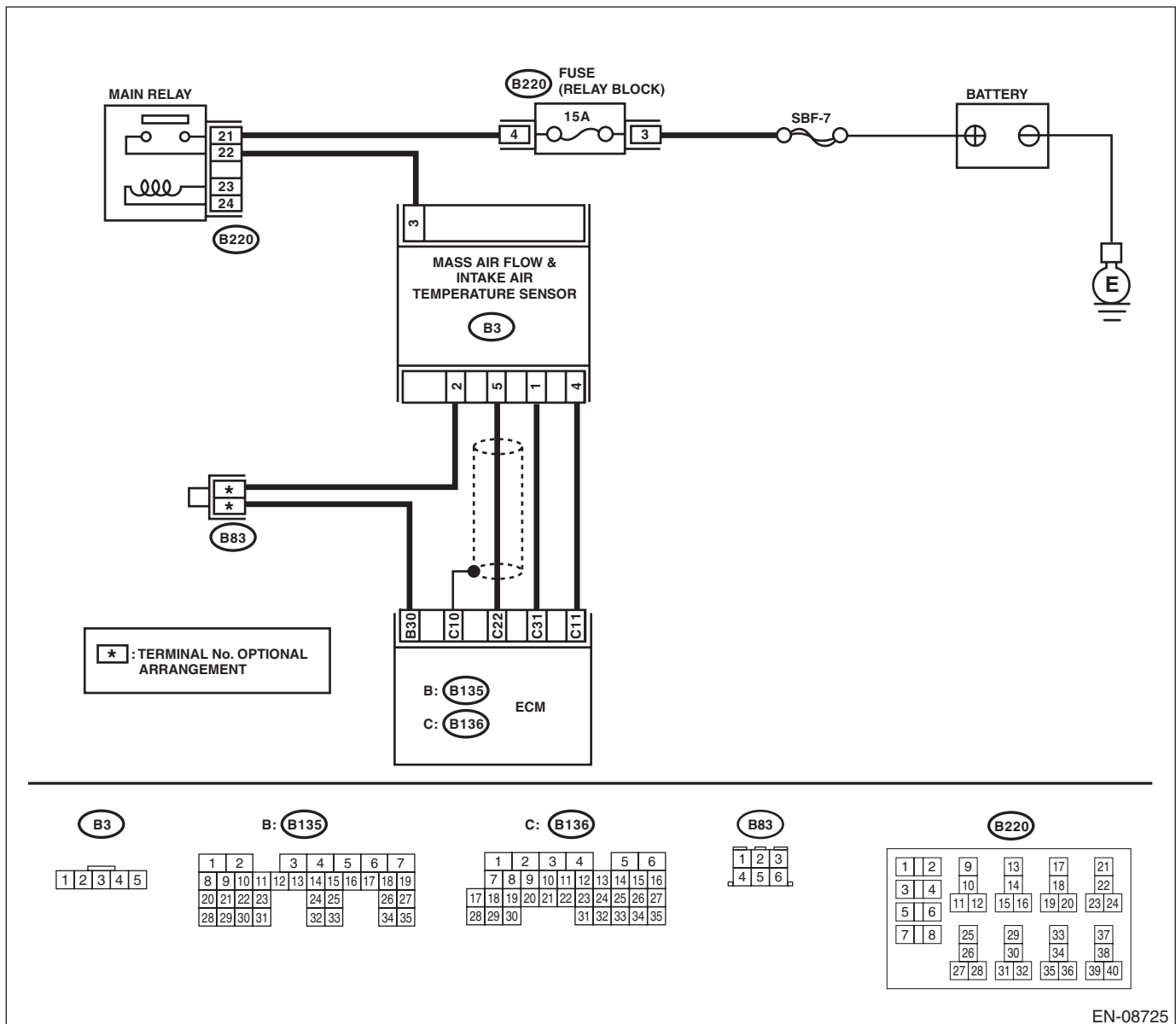

EN-08725

# Diagnostic Procedure with Diagnostic Trouble Code (DTC)

ENGINE (DIAGNOSTICS)

	Step	Check	Yes	No
1	<p><b>CHECK CURRENT DATA.</b></p> <p>1) Start the engine.</p> <p>2) Read the value of «Intake Air Temp.» using the Subaru Select Monitor or a general scan tool.</p> <p>NOTE:</p> <ul style="list-style-type: none"> <li>• Subaru Select Monitor</li> </ul> <p>For detailed operation procedures, refer to "READ CURRENT DATA FOR ENGINE". &lt;Ref. to EN(H4DOTC)(diag)-40, Subaru Select Monitor.&gt;</p> <ul style="list-style-type: none"> <li>• General scan tool</li> </ul> <p>For detailed operation procedures, refer to the general scan tool operation manual.</p>	<p>Is the value of «Intake Air Temp.» less than <math>-40^{\circ}\text{C}</math> (<math>-40^{\circ}\text{F}</math>)?</p>	<p>Go to step 2.</p>	<p>Even if DTC is detected, the circuit has returned to a normal condition at this time. Reproduce the failure, and then perform the diagnosis again.</p> <p>NOTE:</p> <p>In this case, temporary poor contact of connector, temporary open or short circuit of harness may be the cause.</p>
2	<p><b>CHECK FOR POOR CONTACT.</b></p> <p>Check for poor contact of ECM and mass air flow and intake air temperature sensor connector.</p>	<p>Is there poor contact of ECM or mass air flow and intake air temperature sensor connector?</p>	<p>Repair the poor contact of ECM or mass air flow and intake air temperature sensor connector.</p>	<p>Go to step 3.</p>
3	<p><b>CHECK HARNESS BETWEEN ECM AND MASS AIR FLOW AND INTAKE AIR TEMPERATURE SENSOR CONNECTOR.</b></p> <p>1) Turn the ignition switch to OFF.</p> <p>2) Disconnect the connector from ECM and the mass air flow and intake air temperature sensor.</p> <p>3) Measure the resistance of harness between ECM and the mass air flow and intake air temperature sensor connector.</p> <p><b>Connector &amp; terminal</b></p> <p><b>(B136) No. 31 — (B3) No. 1:</b></p> <p><b>(B135) No. 30 — (B3) No. 2:</b></p>	<p>Is the resistance less than <math>1\ \Omega</math>?</p>	<p>Go to step 4.</p>	<p>Repair the harness and connector.</p> <p>NOTE:</p> <p>In this case, repair the following item:</p> <ul style="list-style-type: none"> <li>• Open circuit in harness between ECM and mass air flow and intake air temperature sensor connector</li> <li>• Poor contact of joint connector</li> </ul>
4	<p><b>CHECK HARNESS BETWEEN ECM AND MASS AIR FLOW AND INTAKE AIR TEMPERATURE SENSOR CONNECTOR.</b></p> <p>1) Connect all connectors.</p> <p>2) Turn the ignition switch to ON.</p> <p>3) Measure the voltage between ECM and chassis ground.</p> <p><b>Connector &amp; terminal</b></p> <p><b>(B136) No. 31 (+) — Chassis ground (-):</b></p>	<p>Is the voltage 5 V or more?</p>	<p>Repair the short circuit of harness to power supply between ECM and mass air flow and intake air temperature sensor connector.</p>	<p>Replace the mass air flow and intake air temperature sensor. &lt;Ref. to FU(STI)-42, Mass Air Flow and Intake Air Temperature Sensor.&gt; &lt;Ref. to FU(w/o STI)-43, Mass Air Flow and Intake Air Temperature Sensor.&gt;</p>

# Diagnostic Procedure with Diagnostic Trouble Code (DTC)

ENGINE (DIAGNOSTICS)

## W: DTC P0117 ENGINE COOLANT TEMPERATURE CIRCUIT LOW

### DTC DETECTING CONDITION:

- Immediately at fault recognition
- GENERAL DESCRIPTION <Ref. to GD(H4DOTC)-49, DTC P0117 ENGINE COOLANT TEMPERATURE CIRCUIT LOW, Diagnostic Trouble Code (DTC) Detecting Criteria.>

### TROUBLE SYMPTOM:

- Hard to start
- Improper idling
- Poor driving performance

### CAUTION:

After servicing or replacing faulty parts, perform Clear Memory Mode <Ref. to EN(H4DOTC)(diag)-62, OPERATION, Clear Memory Mode.>, and Inspection Mode <Ref. to EN(H4DOTC)(diag)-48, PROCEDURE, Inspection Mode.>.

### WIRING DIAGRAM:

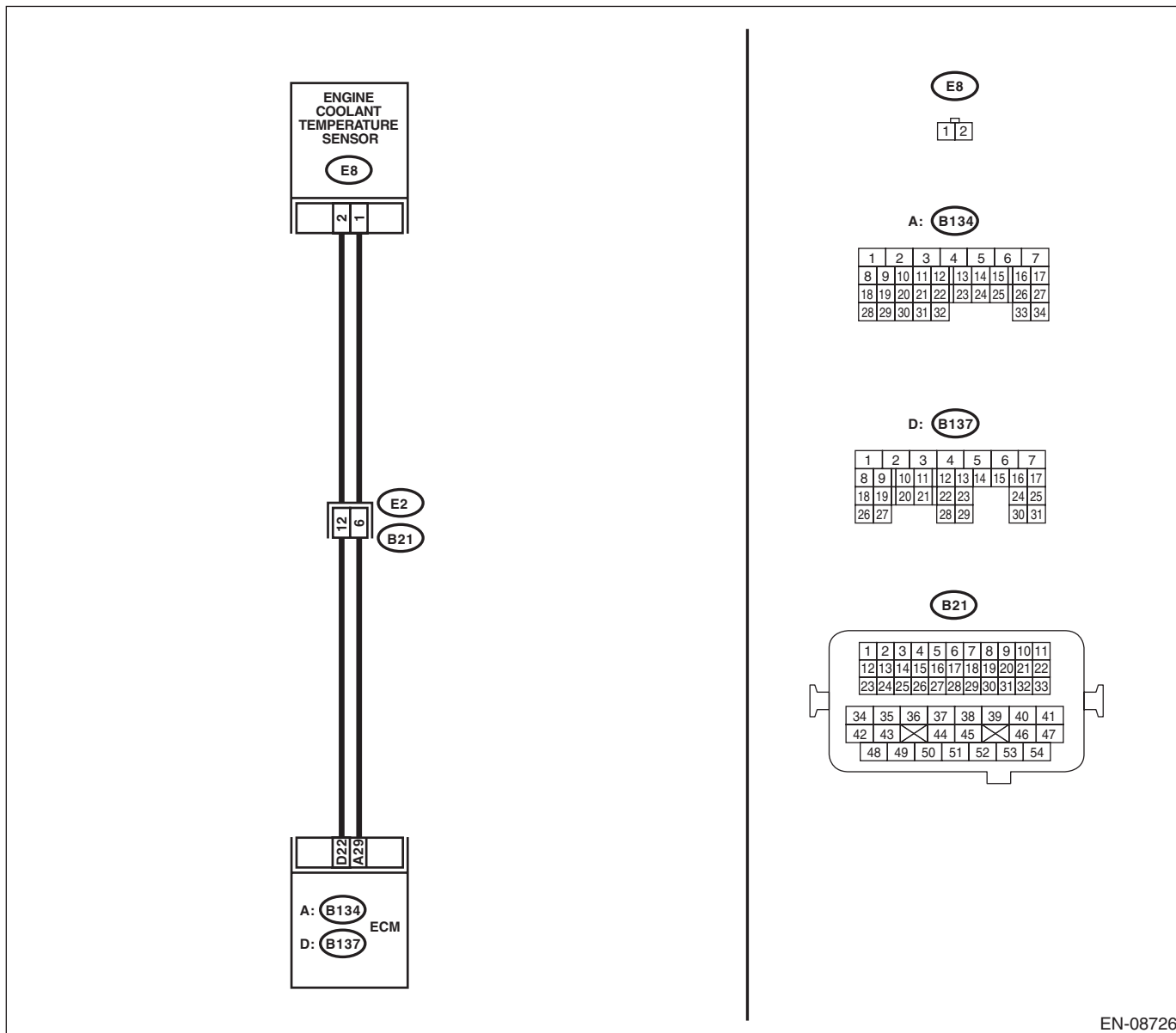

EN-08726

# Diagnostic Procedure with Diagnostic Trouble Code (DTC)

ENGINE (DIAGNOSTICS)

	Step	Check	Yes	No
1	<p><b>CHECK CURRENT DATA.</b></p> <p>1) Start the engine.</p> <p>2) Read the value of «Coolant Temp.» using the Subaru Select Monitor or a general scan tool.</p> <p>NOTE:</p> <ul style="list-style-type: none"> <li>Subaru Select Monitor</li> </ul> <p>For detailed operation procedures, refer to "READ CURRENT DATA FOR ENGINE". &lt;Ref. to EN(H4DOTC)(diag)-40, Subaru Select Monitor.&gt;</p> <ul style="list-style-type: none"> <li>General scan tool</li> </ul> <p>For detailed operation procedures, refer to the general scan tool operation manual.</p>	<p>Is the value of «Coolant Temp.» 150°C (302°F) or more?</p>	<p>Go to step 2.</p>	<p>Even if DTC is detected, the circuit has returned to a normal condition at this time. Reproduce the failure, and then perform the diagnosis again.</p> <p>NOTE:</p> <p>In this case, temporary poor contact of connector, temporary open or short circuit of harness may be the cause.</p>
2	<p><b>CHECK HARNESS BETWEEN ECM AND ENGINE COOLANT TEMPERATURE SENSOR CONNECTOR.</b></p> <p>1) Turn the ignition switch to OFF.</p> <p>2) Disconnect the connectors from ECM and engine coolant temperature sensor.</p> <p>3) Measure the resistance between ECM and chassis ground.</p> <p><b>Connector &amp; terminal</b> <b>(B137) No. 22 — Chassis ground:</b></p>	<p>Is the resistance 1 MΩ or more?</p>	<p>Replace the engine coolant temperature sensor. &lt;Ref. to FU(STI)-34, Engine Coolant Temperature Sensor.&gt; &lt;Ref. to FU(w/o STI)-35, Engine Coolant Temperature Sensor.&gt;</p>	<p>Repair short circuit in harness to ground between ECM and engine coolant temperature sensor connector.</p>

# Diagnostic Procedure with Diagnostic Trouble Code (DTC)

ENGINE (DIAGNOSTICS)

## X: DTC P0118 ENGINE COOLANT TEMPERATURE CIRCUIT HIGH

### DTC DETECTING CONDITION:

- Immediately at fault recognition
- GENERAL DESCRIPTION <Ref. to GD(H4DOTC)-51, DTC P0118 ENGINE COOLANT TEMPERATURE CIRCUIT HIGH, Diagnostic Trouble Code (DTC) Detecting Criteria.>

### TROUBLE SYMPTOM:

- Hard to start
- Improper idling
- Poor driving performance

### CAUTION:

After servicing or replacing faulty parts, perform Clear Memory Mode <Ref. to EN(H4DOTC)(diag)-62, OPERATION, Clear Memory Mode.>, and Inspection Mode <Ref. to EN(H4DOTC)(diag)-48, PROCEDURE, Inspection Mode.>.

### WIRING DIAGRAM:

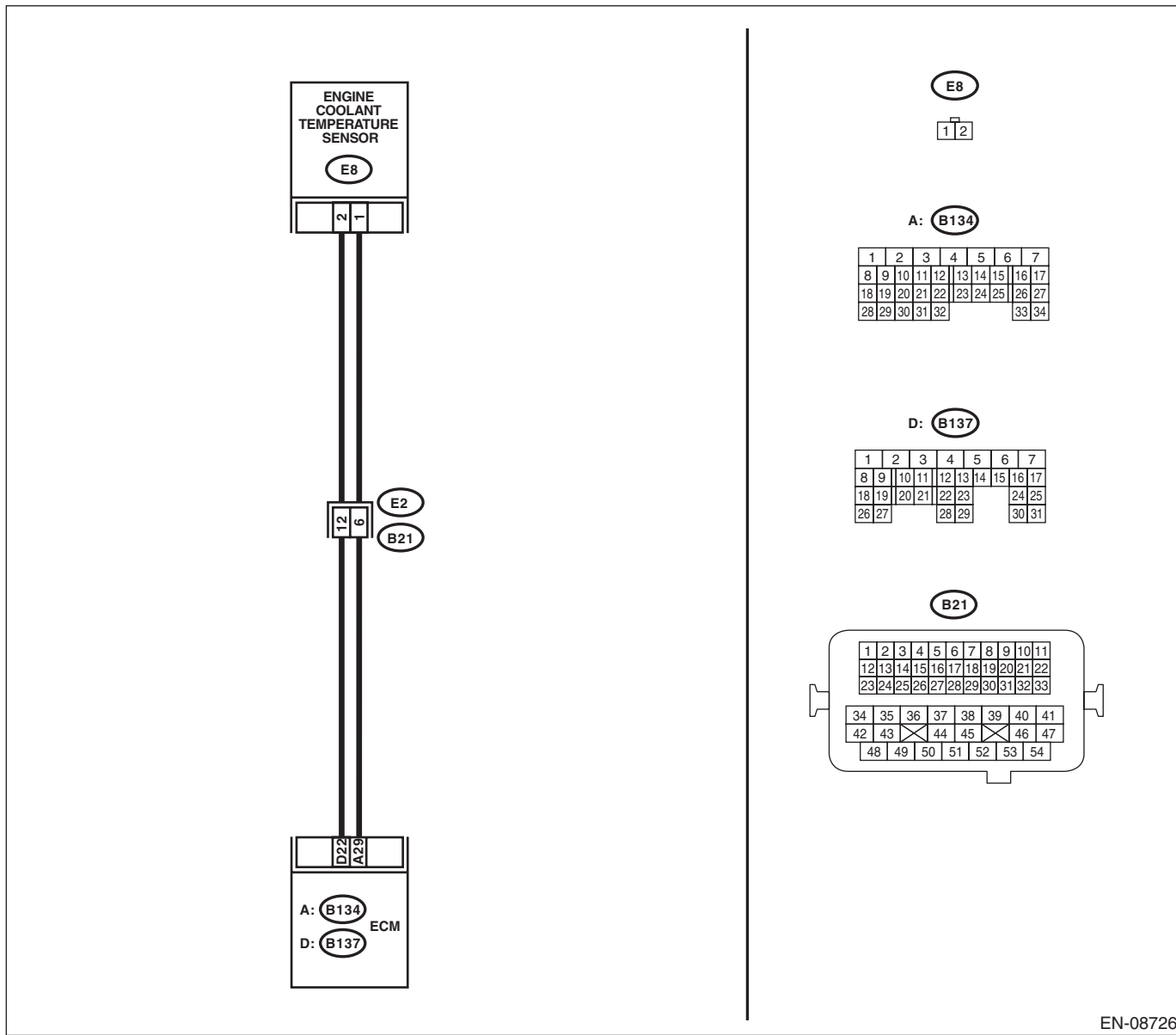

EN-08726

# Diagnostic Procedure with Diagnostic Trouble Code (DTC)

ENGINE (DIAGNOSTICS)

Step	Check	Yes	No
<p><b>1</b>      <b>CHECK CURRENT DATA.</b>                      1) Start the engine.                      2) Read the value of «Coolant Temp.» using the Subaru Select Monitor or a general scan tool.                      NOTE:                      • Subaru Select Monitor                      For detailed operation procedures, refer to "READ CURRENT DATA FOR ENGINE". &lt;Ref. to EN(H4DOTC)(diag)-40, Subaru Select Monitor.&gt;                      • General scan tool                      For detailed operation procedures, refer to the general scan tool operation manual.</p>	<p>Is the value of «Coolant Temp.» less than -40°C (-40°F)?</p>	<p>Go to step 2.</p>	<p>Even if DTC is detected, the circuit has returned to a normal condition at this time. Reproduce the failure, and then perform the diagnosis again.                      NOTE:                      In this case, temporary poor contact of connector, temporary open or short circuit of harness may be the cause.</p>
<p><b>2</b>      <b>CHECK FOR POOR CONTACT.</b>                      Check for poor contact of ECM and engine coolant temperature sensor connector.</p>	<p>Is there poor contact of ECM or engine coolant temperature sensor connector?</p>	<p>Repair the poor contact of ECM or engine coolant temperature sensor connector.</p>	<p>Go to step 3.</p>
<p><b>3</b>      <b>CHECK HARNESS BETWEEN ECM AND ENGINE COOLANT TEMPERATURE SENSOR CONNECTOR.</b>                      1) Turn the ignition switch to OFF.                      2) Disconnect the connectors from ECM and engine coolant temperature sensor.                      3) Measure the resistance of harness between ECM and engine coolant temperature sensor connector.  <i>Connector &amp; terminal</i>  <i>(B137) No. 22 — (E8) No. 2:</i>  <i>(B134) No. 29 — (E8) No. 1:</i></p>	<p>Is the resistance less than 1 Ω?</p>	<p>Go to step 4.</p>	<p>Repair the harness and connector.                      NOTE:                      In this case, repair the following item:                      • Open circuit in harness between ECM and engine coolant temperature sensor connector                      • Poor contact of coupling connector</p>
<p><b>4</b>      <b>CHECK HARNESS BETWEEN ECM AND ENGINE COOLANT TEMPERATURE SENSOR CONNECTOR.</b>                      1) Connect all connectors.                      2) Turn the ignition switch to ON.                      3) Measure the voltage between ECM and chassis ground.  <i>Connector &amp; terminal</i>  <i>(B137) No. 22 (+) — Chassis ground (-):</i></p>	<p>Is the voltage 5 V or more?</p>	<p>Repair the short circuit to power in harness between ECM and engine coolant temperature sensor connector.</p>	<p>Replace the engine coolant temperature sensor. &lt;Ref. to FU(STI)-34, Engine Coolant Temperature Sensor.&gt; &lt;Ref. to FU(w/o STI)-35, Engine Coolant Temperature Sensor.&gt;</p>

# Diagnostic Procedure with Diagnostic Trouble Code (DTC)

ENGINE (DIAGNOSTICS)

## Y: DTC P0122 THROTTLE/PEDAL POSITION SENSOR/SWITCH "A" CIRCUIT LOW

### DTC DETECTING CONDITION:

- Immediately at fault recognition
- GENERAL DESCRIPTION <Ref. to GD(H4DOTC)-53, DTC P0122 THROTTLE/PEDAL POSITION SENSOR/SWITCH "A" CIRCUIT LOW, Diagnostic Trouble Code (DTC) Detecting Criteria.>

### TROUBLE SYMPTOM:

- Improper idling
- Engine stalls.
- Poor driving performance

### CAUTION:

After servicing or replacing faulty parts, perform Clear Memory Mode <Ref. to EN(H4DOTC)(diag)-62, OPERATION, Clear Memory Mode.>, and Inspection Mode <Ref. to EN(H4DOTC)(diag)-48, PROCEDURE, Inspection Mode.>.

### WIRING DIAGRAM:

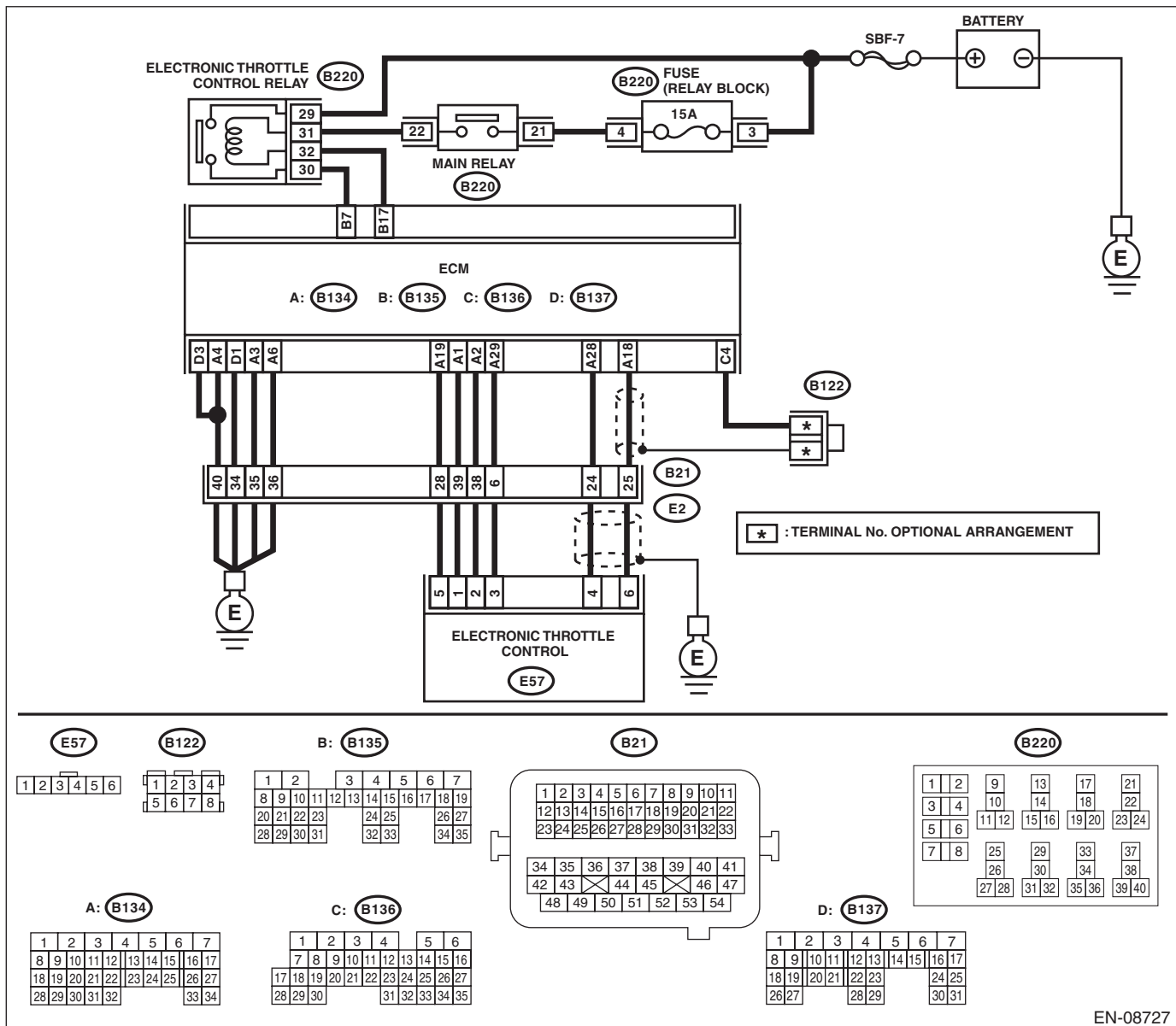

# Diagnostic Procedure with Diagnostic Trouble Code (DTC)

ENGINE (DIAGNOSTICS)

	Step	Check	Yes	No
1	<p><b>CHECK HARNESS BETWEEN ECM AND ELECTRONIC THROTTLE CONTROL CONNECTOR.</b></p> <p>1) Turn the ignition switch to OFF. 2) Disconnect the connectors from ECM and electronic throttle control. 3) Measure the resistance between ECM and chassis ground.</p> <p><b>Connector &amp; terminal</b> <b>(B134) No. 19 — Chassis ground:</b> <b>(B134) No. 18 — Chassis ground:</b> <b>(B134) No. 18 — (B136) No. 4:</b></p>	Is the resistance 1 MΩ or more?	Go to step 2.	Repair the short circuit to ground in harness between ECM and electronic throttle control connector.
2	<p><b>CHECK SHORT CIRCUIT INSIDE THE ECM.</b></p> <p>1) Connect the connector to ECM. 2) Measure the resistance between electronic throttle control connector and engine ground.</p> <p><b>Connector &amp; terminal</b> <b>(E57) No. 6 — Engine ground:</b></p>	Is the resistance 1 MΩ or more?	Replace the electronic throttle control. <Ref. to FU(STI)-15, Throttle Body.> <Ref. to FU(w/o STI)-15, Throttle Body.>	Repair the short circuit to ground in harness between ECM and electronic throttle control connector. Replace the ECM if defective. <Ref. to FU(STI)-59, Engine Control Module (ECM).> <Ref. to FU(w/o STI)-58, Engine Control Module (ECM).>



# Diagnostic Procedure with Diagnostic Trouble Code (DTC)

ENGINE (DIAGNOSTICS)

## Z: DTC P0123 THROTTLE/PEDAL POSITION SENSOR/SWITCH "A" CIRCUIT HIGH

### DTC DETECTING CONDITION:

- Immediately at fault recognition
- GENERAL DESCRIPTION <Ref. to GD(H4DOTC)-55, DTC P0123 THROTTLE/PEDAL POSITION SENSOR/SWITCH "A" CIRCUIT HIGH, Diagnostic Trouble Code (DTC) Detecting Criteria.>

### TROUBLE SYMPTOM:

- Improper idling
- Engine stalls.
- Poor driving performance

### CAUTION:

After servicing or replacing faulty parts, perform Clear Memory Mode <Ref. to EN(H4DOTC)(diag)-62, OPERATION, Clear Memory Mode.>, and Inspection Mode <Ref. to EN(H4DOTC)(diag)-48, PROCEDURE, Inspection Mode.>.

### WIRING DIAGRAM:

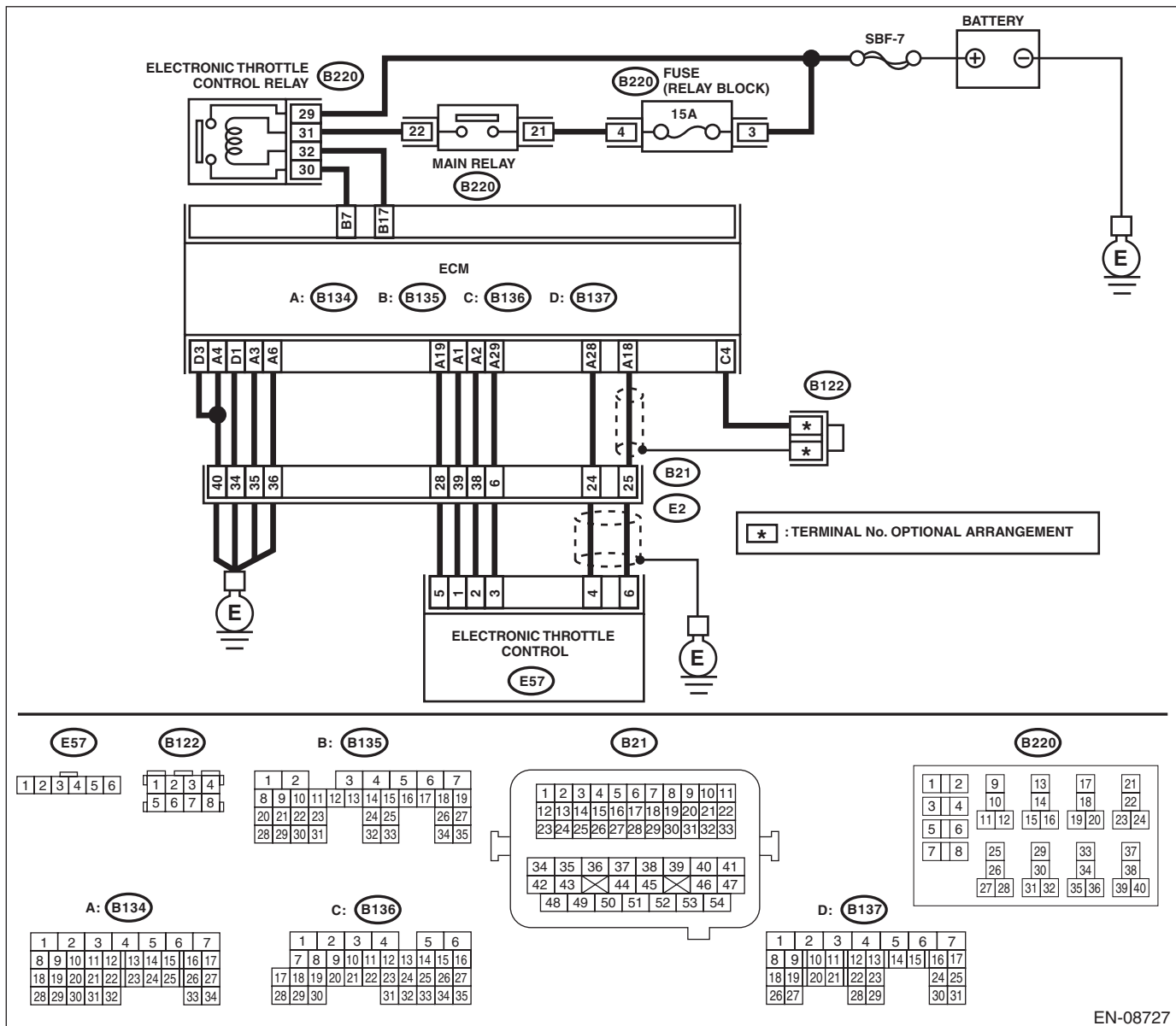

EN-08727

# Diagnostic Procedure with Diagnostic Trouble Code (DTC)

ENGINE (DIAGNOSTICS)

Step	Check	Yes	No
<p><b>1</b>     <b>CHECK HARNESS BETWEEN ECM AND ELECTRONIC THROTTLE CONTROL CONNECTOR.</b></p> <p>1) Turn the ignition switch to OFF.                      2) Disconnect the connectors from ECM and electronic throttle control.                      3) Measure the resistance of harness between ECM and electronic throttle control connector.</p> <p><b>Connector &amp; terminal</b>                      (B134) No. 18 — (E57) No. 6:                      (B134) No. 29 — (E57) No. 3:</p>	Is the resistance less than 1 Ω?	Go to step 2.	Repair the harness and connector.  NOTE: In this case, repair the following item: • Open circuit in harness between ECM and electronic throttle control connector • Poor contact of coupling connector
<p><b>2</b>     <b>CHECK HARNESS BETWEEN ECM AND ELECTRONIC THROTTLE CONTROL CONNECTOR.</b></p> <p>1) Connect the connector to ECM.                      2) Measure the resistance between electronic throttle control connector and engine ground.</p> <p><b>Connector &amp; terminal</b>                      (E57) No. 3 — Engine ground:</p>	Is the resistance less than 5 Ω?	Go to step 3.	Repair the harness and connector.  NOTE: In this case, repair the following item: • Open circuit of harness between ECM and engine ground • Poor contact of ECM connector • Poor contact of coupling connector
<p><b>3</b>     <b>CHECK HARNESS BETWEEN ECM AND ELECTRONIC THROTTLE CONTROL CONNECTOR.</b></p> <p>1) Turn the ignition switch to ON.                      2) Measure the voltage between electronic throttle control connector and engine ground.</p> <p><b>Connector &amp; terminal</b>                      (E57) No. 6 (+) — Engine ground (-):</p>	Is the voltage 5 V or more?	Repair the short circuit to power in harness between ECM and electronic throttle control connector.	Go to step 4.
<p><b>4</b>     <b>CHECK HARNESS BETWEEN ECM AND ELECTRONIC THROTTLE CONTROL CONNECTOR.</b></p> <p>1) Turn the ignition switch to OFF.                      2) Disconnect the connector from ECM.                      3) Measure the resistance between ECM connectors.</p> <p><b>Connector &amp; terminal</b>                      (B134) No. 19 — (B134) No. 18:</p>	Is the resistance 1 MΩ or more?	Repair the poor contact of electronic throttle control connector. Replace the electronic throttle control if defective. <Ref. to FU(STI)-15, Throttle Body.> <Ref. to FU(w/o STI)-15, Throttle Body.>	Repair the short circuit to power in harness between ECM and electronic throttle control connector.

# Diagnostic Procedure with Diagnostic Trouble Code (DTC)

ENGINE (DIAGNOSTICS)

## AA:DTC P0125 INSUFFICIENT COOLANT TEMPERATURE FOR CLOSED LOOP FUEL CONTROL

### DTC DETECTING CONDITION:

- Detected when two consecutive driving cycles with fault occur.
- GENERAL DESCRIPTION <Ref. to GD(H4DOTC)-57, DTC P0125 INSUFFICIENT COOLANT TEMPERATURE FOR CLOSED LOOP FUEL CONTROL, Diagnostic Trouble Code (DTC) Detecting Criteria.>

### TROUBLE SYMPTOM:

Engine does not return to idle.

### CAUTION:

After servicing or replacing faulty parts, perform Clear Memory Mode <Ref. to EN(H4DOTC)(diag)-62, OPERATION, Clear Memory Mode.>, and Inspection Mode <Ref. to EN(H4DOTC)(diag)-48, PROCEDURE, Inspection Mode.>.

Step	Check	Yes	No
1 <b>CHECK TIRE SIZE.</b>	Is the tire size as specified and the same size as three other wheels?	Go to step 2.	Replace the tire.
2 <b>CHECK ENGINE COOLANT.</b> Check the following items: <ul style="list-style-type: none"><li>• Amount of engine coolant</li><li>• Engine coolant freeze</li><li>• Contamination of engine coolant</li></ul>	Is the engine coolant normal?	Go to step 3.	Fill or replace the engine coolant. <Ref. to CO(STI)-13, Engine Coolant.> <Ref. to CO(w/o STI)-13, Engine Coolant.>
3 <b>CHECK THERMOSTAT.</b>	Does the thermostat remain opened?	Replace the thermostat. <Ref. to CO(STI)-17, Thermostat.> <Ref. to CO(w/o STI)-17, Thermostat.>	Replace the engine coolant temperature sensor. <Ref. to FU(STI)-34, Engine Coolant Temperature Sensor.> <Ref. to FU(w/o STI)-35, Engine Coolant Temperature Sensor.>

# Diagnostic Procedure with Diagnostic Trouble Code (DTC)

ENGINE (DIAGNOSTICS)

## AB:DTC P0126 INSUFFICIENT ENGINE COOLANT TEMPERATURE FOR STABLE OPERATION

### DTC DETECTING CONDITION:

- Detected when two consecutive driving cycles with fault occur.
- GENERAL DESCRIPTION <Ref. to GD(H4DOTC)-59, DTC P0126 INSUFFICIENT ENGINE COOLANT TEMPERATURE FOR STABLE OPERATION, Diagnostic Trouble Code (DTC) Detecting Criteria.>

### TROUBLE SYMPTOM:

- Hard to start
- Improper idling
- Poor driving performance

### CAUTION:

After servicing or replacing faulty parts, perform Clear Memory Mode <Ref. to EN(H4DOTC)(diag)-62, OPERATION, Clear Memory Mode.>, and Inspection Mode <Ref. to EN(H4DOTC)(diag)-48, PROCEDURE, Inspection Mode.>.

Step	Check	Yes	No
1 <b>CHECK FOR ANY OTHER DTC ON DISPLAY.</b>	Is any other DTC displayed?	Check the appropriate DTC using the "List of Diagnostic Trouble Code (DTC)". <Ref. to EN(H4DOTC)(diag)-88, List of Diagnostic Trouble Code (DTC).>	Go to step 2.
2 <b>CHECK ENGINE COOLANT TEMPERATURE SENSOR.</b> 1) Disconnect the connectors from the engine coolant temperature sensor. 2) Measure the resistance between engine coolant temperature sensor terminals when the engine coolant is cold and after warmed up. <b>Terminals</b> <b>No. 1 — No. 2:</b>	Is the resistance of engine coolant temperature sensor different between when engine coolant is cold and after warmed up?	Repair the poor contact of ECM connector.	Replace the engine coolant temperature sensor. <Ref. to FU(STI)-34, Engine Coolant Temperature Sensor.> <Ref. to FU(w/o STI)-35, Engine Coolant Temperature Sensor.>

# Diagnostic Procedure with Diagnostic Trouble Code (DTC)

ENGINE (DIAGNOSTICS)

## AC:DTC P0128 COOLANT THERMOSTAT (ENGINE COOLANT TEMPERATURE BELOW THERMOSTAT REGULATING TEMPERATURE)

### DTC DETECTING CONDITION:

- Detected when two consecutive driving cycles with fault occur.
- GENERAL DESCRIPTION <Ref. to GD(H4DOTC)-61, DTC P0128 COOLANT THERMOSTAT (ENGINE COOLANT TEMPERATURE BELOW THERMOSTAT REGULATING TEMPERATURE), Diagnostic Trouble Code (DTC) Detecting Criteria.>

### TROUBLE SYMPTOM:

Thermostat remains open.

### CAUTION:

After servicing or replacing faulty parts, perform Clear Memory Mode <Ref. to EN(H4DOTC)(diag)-62, OPERATION, Clear Memory Mode.>, and Inspection Mode <Ref. to EN(H4DOTC)(diag)-48, PROCEDURE, Inspection Mode.>.

Step	Check	Yes	No
1 <b>CHECK FOR ANY OTHER DTC ON DISPLAY.</b>	Is any other DTC displayed?	Check the appropriate DTC using the "List of Diagnostic Trouble Code (DTC)". <Ref. to EN(H4DOTC)(diag)-88, List of Diagnostic Trouble Code (DTC).>	Go to step 2.
2 <b>CHECK ENGINE COOLANT.</b>	Is the engine coolant amount normal?	Go to step 3.	Refill the engine coolant. <Ref. to CO(STI)-13, Engine Coolant.> <Ref. to CO(w/o STI)-13, Engine Coolant.>
3 <b>CHECK RADIATOR FAN.</b> 1) Start the engine. 2) Check the radiator fan operation.	Does the radiator fan continuously rotate for 3 minutes or more during idling?	Repair radiator fan circuit. <Ref. to CO(STI)-23, Radiator Main Fan and Fan Motor.> <Ref. to CO(w/o STI)-23, Radiator Main Fan and Fan Motor.> <Ref. to CO(STI)-25, Radiator Sub Fan and Fan Motor.> <Ref. to CO(w/o STI)-25, Radiator Sub Fan and Fan Motor.>	Replace the thermostat. <Ref. to CO(STI)-17, Thermostat.> <Ref. to CO(w/o STI)-17, Thermostat.>

# Diagnostic Procedure with Diagnostic Trouble Code (DTC)

ENGINE (DIAGNOSTICS)

## AD:DTC P0131 O2 SENSOR CIRCUIT LOW VOLTAGE (BANK 1 SENSOR 1)

### DTC DETECTING CONDITION:

- Immediately at fault recognition
- GENERAL DESCRIPTION <Ref. to GD(H4DOTC)-65, DTC P0131 O2 SENSOR CIRCUIT LOW VOLTAGE (BANK 1 SENSOR 1), Diagnostic Trouble Code (DTC) Detecting Criteria.>

### CAUTION:

After servicing or replacing faulty parts, perform Clear Memory Mode <Ref. to EN(H4DOTC)(diag)-62, OPERATION, Clear Memory Mode.>, and Inspection Mode <Ref. to EN(H4DOTC)(diag)-48, PROCEDURE, Inspection Mode.>.

### WIRING DIAGRAM:

- Models without SI-DRIVE

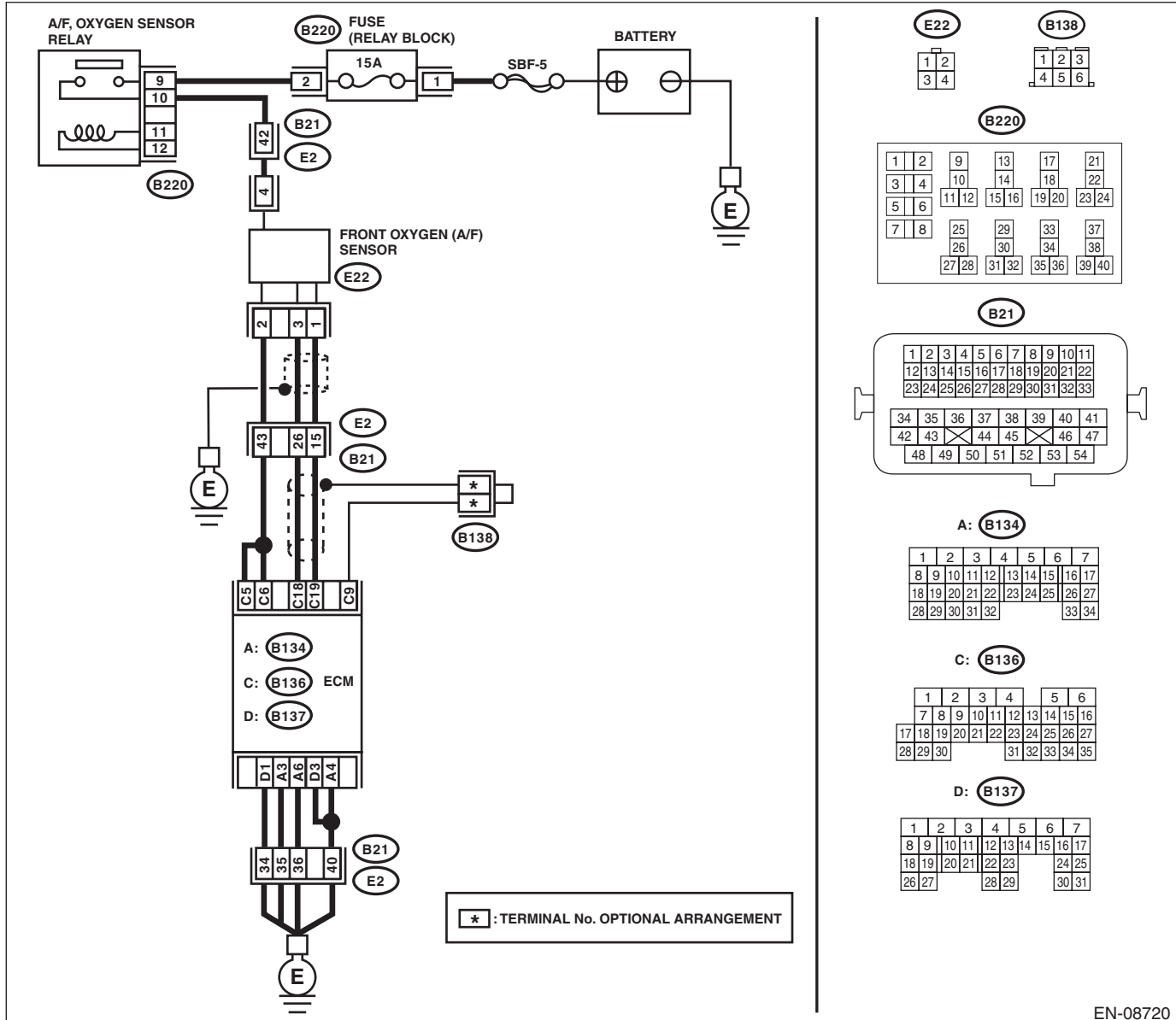

EN-08720

# Diagnostic Procedure with Diagnostic Trouble Code (DTC)

## ENGINE (DIAGNOSTICS)

- Models with SI-DRIVE

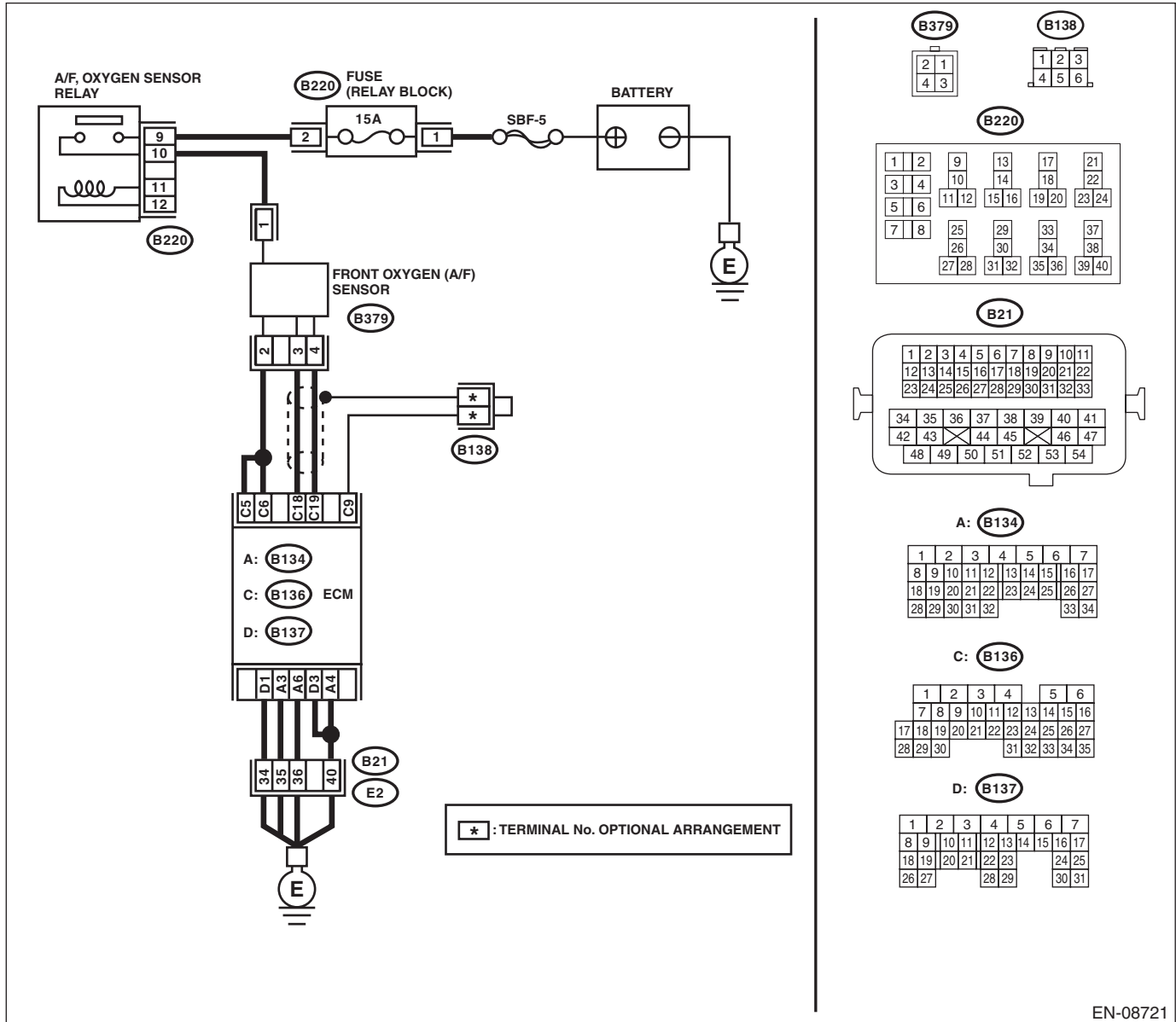

EN-08721

Step	Check	Yes	No
1	<b>CHECK FRONT OXYGEN (A/F) SENSOR CONNECTOR AND COUPLING CONNECTOR.</b>	Has water entered the connector?	Completely remove any water inside.
2	<b>CHECK HARNESS BETWEEN ECM AND FRONT OXYGEN (A/F) SENSOR CONNECTOR.</b> 1) Turn the ignition switch to OFF. 2) Disconnect the connectors from ECM and front oxygen (A/F) sensor connector. 3) Measure the resistance between ECM and chassis ground. <b>Connector &amp; terminal</b> <b>(B136) No. 19 — Chassis ground:</b> <b>(B136) No. 18 — Chassis ground:</b>	Is the resistance 1 MΩ or more?	Go to step 3.
			Repair the ground short circuit of harness between ECM and front oxygen (A/F) sensor connector.

# Diagnostic Procedure with Diagnostic Trouble Code (DTC)

ENGINE (DIAGNOSTICS)

Step	Check	Yes	No
<b>3</b> <b>CHECK FOR POOR CONTACT.</b> Check for poor contact of the front oxygen (A/F) sensor connector.	Is there poor contact of front oxygen (A/F) sensor connector?	Repair the poor contact of front oxygen (A/F) sensor connector.	Replace the front oxygen (A/F) sensor. <Ref. to FU(STI)-54, Front Oxygen (A/F) Sensor.> <Ref. to FU(w/o STI)-54, Front Oxygen (A/F) Sensor.>



# Diagnostic Procedure with Diagnostic Trouble Code (DTC)

ENGINE (DIAGNOSTICS)

## AE:DTC P0132 O2 SENSOR CIRCUIT HIGH VOLTAGE (BANK 1 SENSOR 1)

### DTC DETECTING CONDITION:

- Immediately at fault recognition
- GENERAL DESCRIPTION <Ref. to GD(H4DOTC)-67, DTC P0132 O2 SENSOR CIRCUIT HIGH VOLTAGE (BANK 1 SENSOR 1), Diagnostic Trouble Code (DTC) Detecting Criteria.>

### CAUTION:

After servicing or replacing faulty parts, perform Clear Memory Mode <Ref. to EN(H4DOTC)(diag)-62, OPERATION, Clear Memory Mode.>, and Inspection Mode <Ref. to EN(H4DOTC)(diag)-48, PROCEDURE, Inspection Mode.>.

### WIRING DIAGRAM:

- Models without SI-DRIVE

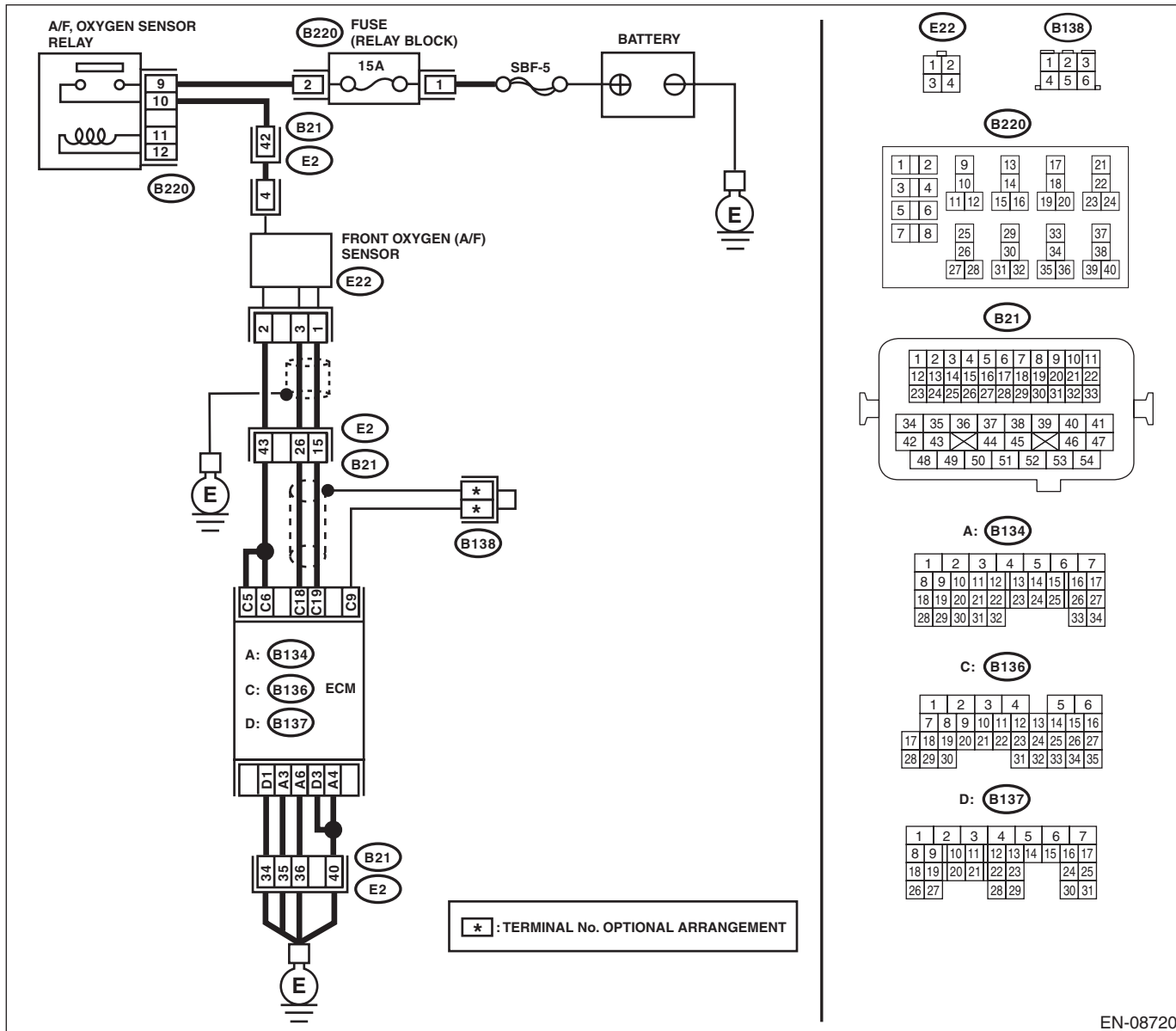

EN-08720

# Diagnostic Procedure with Diagnostic Trouble Code (DTC)

ENGINE (DIAGNOSTICS)

- Models with SI-DRIVE

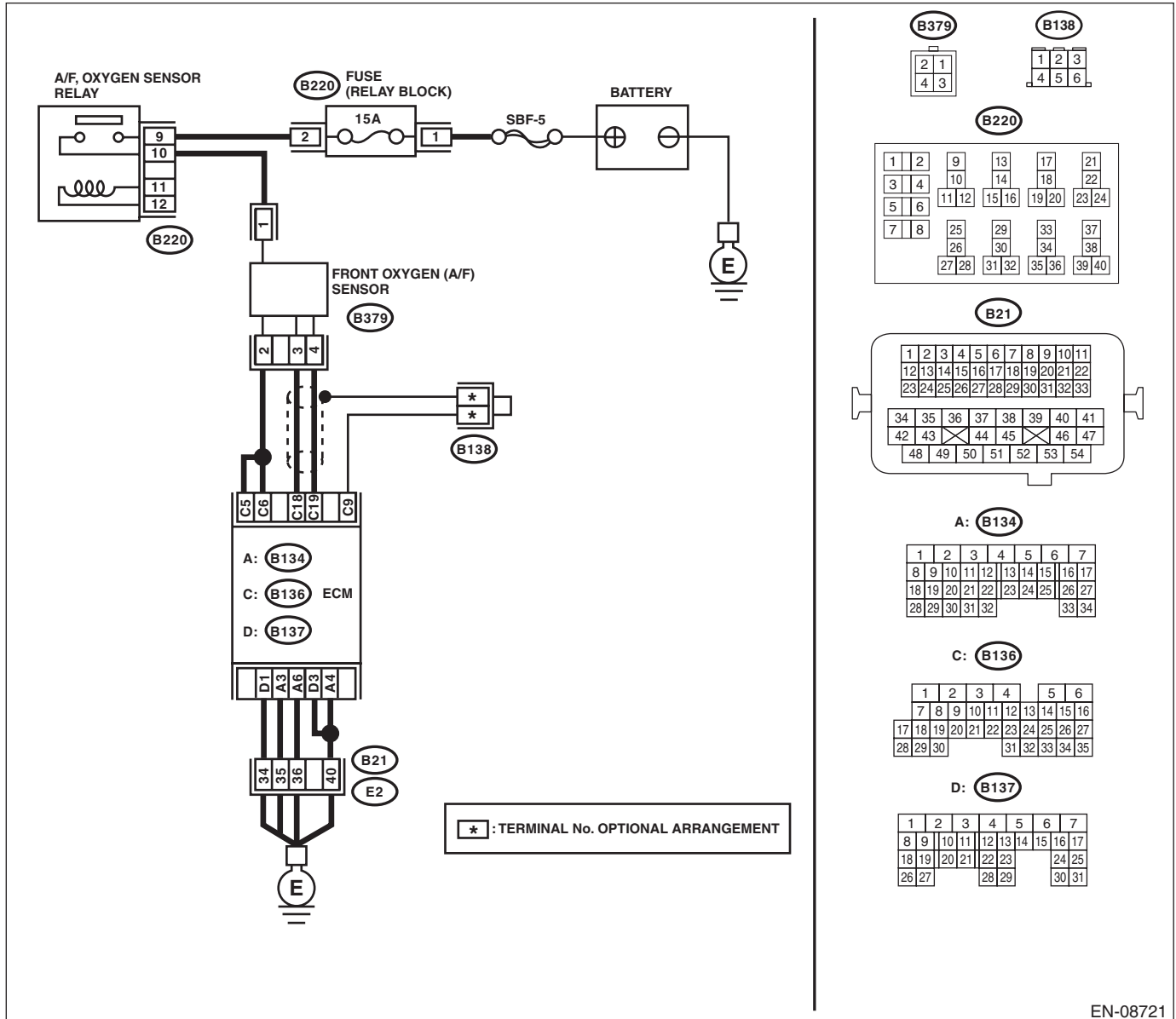

EN-08721

Step	Check	Yes	No
1	<b>CHECK FRONT OXYGEN (A/F) SENSOR CONNECTOR AND COUPLING CONNECTOR.</b>	Completely remove any water inside.	Go to step 2.
2	<b>CHECK HARNESS BETWEEN ECM AND FRONT OXYGEN (A/F) SENSOR CONNECTOR.</b> 1) Turn the ignition switch to OFF. 2) Disconnect the connectors from front oxygen (A/F) sensor. 3) Turn the ignition switch to ON. 4) Measure the voltage between ECM and chassis ground. <b>Connector &amp; terminal</b> <b>(B136) No. 19 (+) — Chassis ground (-):</b> <b>(B136) No. 18 (+) — Chassis ground (-):</b>	Repair the short circuit to power in the harness between ECM and front oxygen (A/F) sensor connector.	Replace the front oxygen (A/F) sensor. <Ref. to FU(STI)-54, Front Oxygen (A/F) Sensor.> <Ref. to FU(w/o STI)-54, Front Oxygen (A/F) Sensor.>

# Diagnostic Procedure with Diagnostic Trouble Code (DTC)

ENGINE (DIAGNOSTICS)

## AF:DTC P0133 O2 SENSOR CIRCUIT SLOW RESPONSE (BANK 1 SENSOR 1)

### DTC DETECTING CONDITION:

- Detected when two consecutive driving cycles with fault occur.
- GENERAL DESCRIPTION <Ref. to GD(H4DOTC)-69, DTC P0133 O2 SENSOR CIRCUIT SLOW RESPONSE (BANK 1 SENSOR 1), Diagnostic Trouble Code (DTC) Detecting Criteria.>

### CAUTION:

After servicing or replacing faulty parts, perform Clear Memory Mode <Ref. to EN(H4DOTC)(diag)-62, OPERATION, Clear Memory Mode.>, and Inspection Mode <Ref. to EN(H4DOTC)(diag)-48, PROCEDURE, Inspection Mode.>.

Step	Check	Yes	No
1 <b>CHECK EXHAUST SYSTEM.</b> NOTE: Check the following items. <ul style="list-style-type: none"><li>• Loose installation of front portion of exhaust pipe onto cylinder heads</li><li>• Loose connection between front exhaust pipe and front catalytic converter</li><li>• Damage of exhaust pipe resulting in a hole</li></ul>	Is there any fault in exhaust system?	Repair the exhaust system.	Replace the front oxygen (A/F) sensor. <Ref. to FU(STI)-54, Front Oxygen (A/F) Sensor.> <Ref. to FU(w/o STI)-54, Front Oxygen (A/F) Sensor.>

# Diagnostic Procedure with Diagnostic Trouble Code (DTC)

ENGINE (DIAGNOSTICS)

## AG:DTC P0134 O2 SENSOR CIRCUIT NO ACTIVITY DETECTED (BANK 1 SENSOR 1)

### DTC DETECTING CONDITION:

- Immediately at fault recognition
- GENERAL DESCRIPTION <Ref. to GD(H4DOTC)-72, DTC P0134 O2 SENSOR CIRCUIT NO ACTIVITY DETECTED (BANK 1 SENSOR 1), Diagnostic Trouble Code (DTC) Detecting Criteria.>

### CAUTION:

After servicing or replacing faulty parts, perform Clear Memory Mode <Ref. to EN(H4DOTC)(diag)-62, OPERATION, Clear Memory Mode.>, and Inspection Mode <Ref. to EN(H4DOTC)(diag)-48, PROCEDURE, Inspection Mode.>.

### WIRING DIAGRAM:

- Models without SI-DRIVE

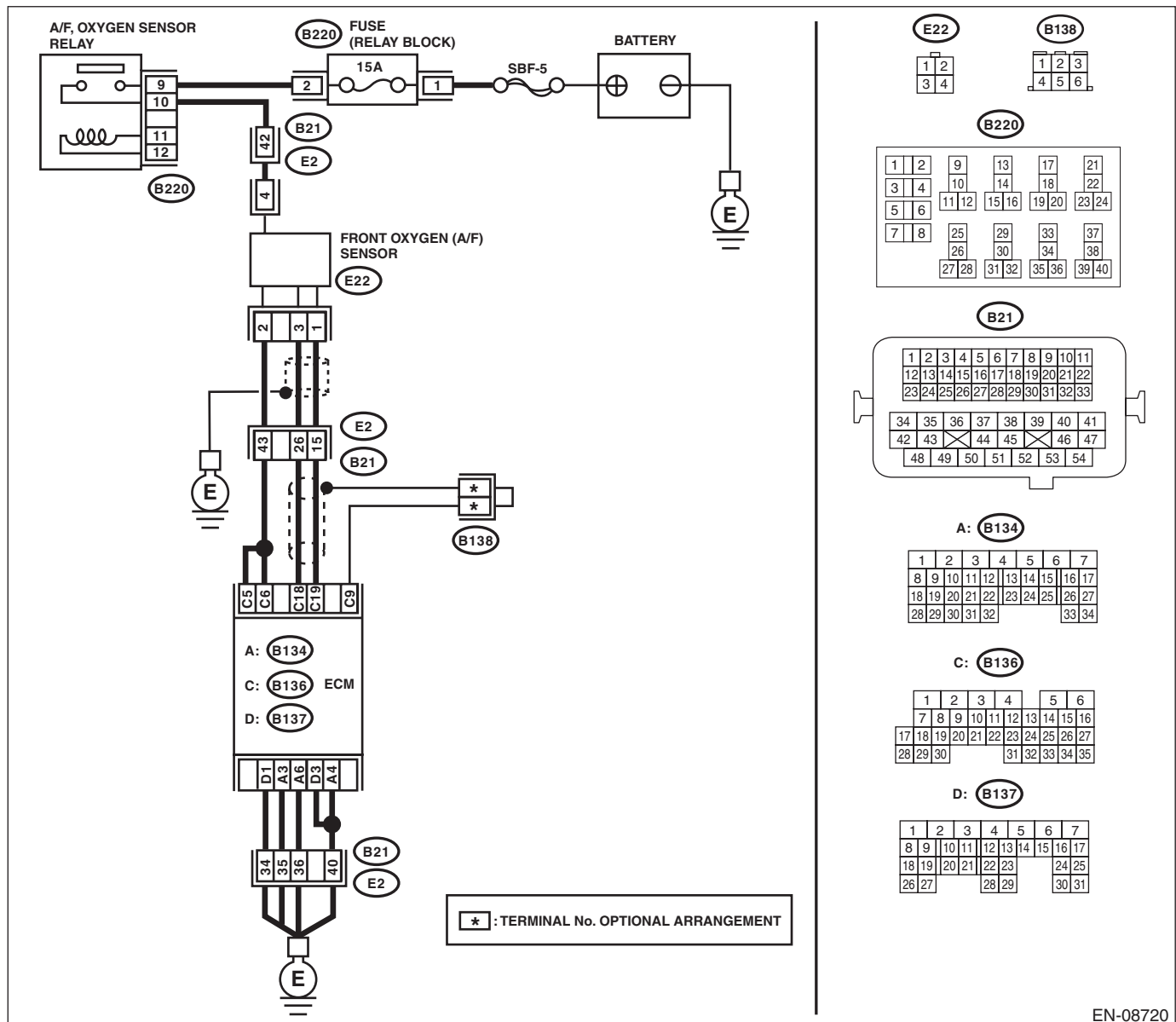

EN-08720

# Diagnostic Procedure with Diagnostic Trouble Code (DTC)

## ENGINE (DIAGNOSTICS)

- Models with SI-DRIVE

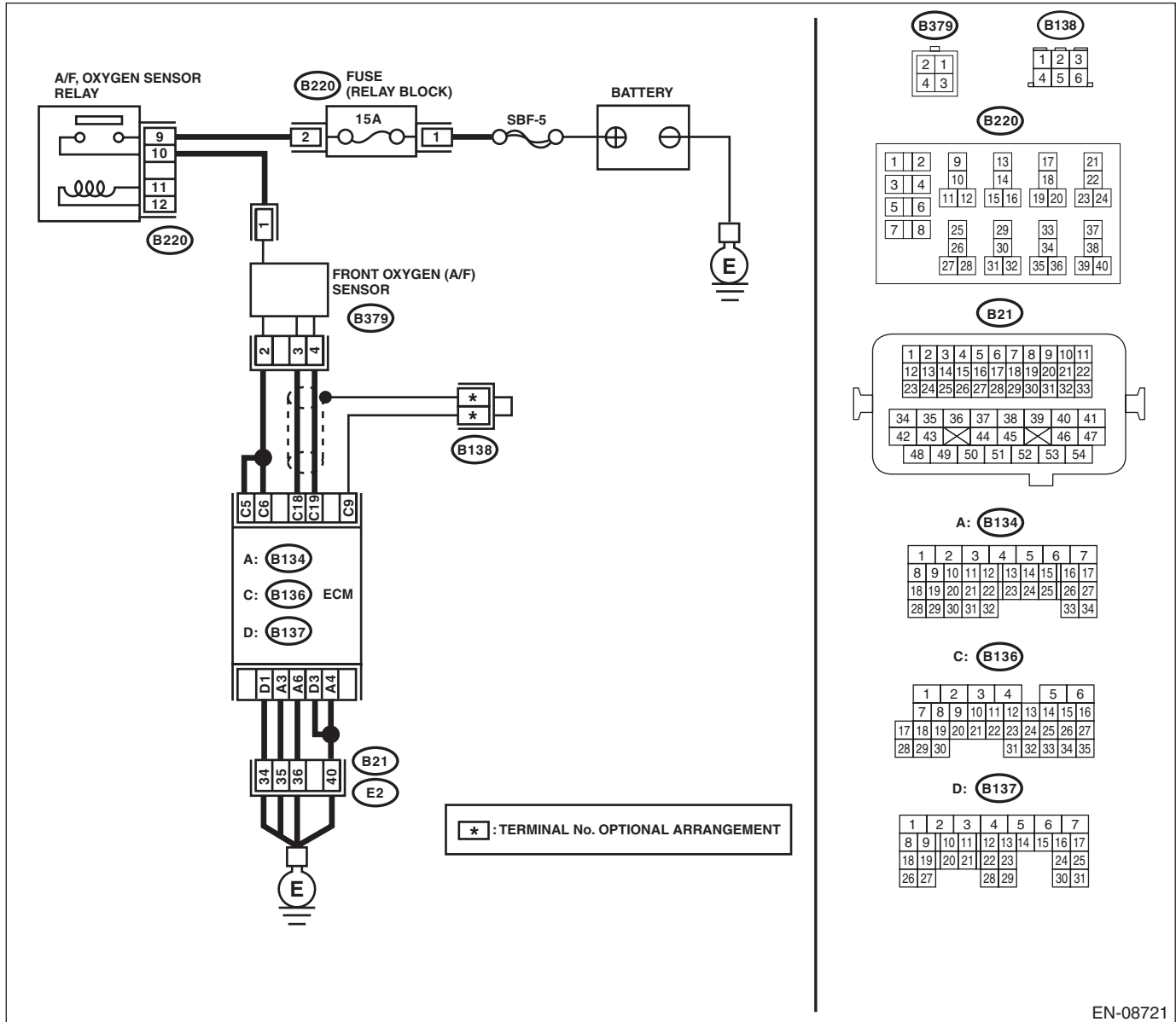

EN-08721

Step	Check	Yes	No
<p><b>1</b></p> <p><b>CHECK HARNESS BETWEEN ECM AND FRONT OXYGEN (A/F) SENSOR CONNECTOR.</b></p> <p>1) Turn the ignition switch to OFF.</p> <p>2) Disconnect the connectors from ECM and front oxygen (A/F) sensor connector.</p> <p>3) Measure the resistance of harness between ECM and front oxygen (A/F) sensor connector.</p> <p><b>Connector &amp; terminal</b></p> <p><b>Models without SI-DRIVE</b></p> <p>(B136) No. 19 — (E22) No. 1:</p> <p>(B136) No. 18 — (E22) No. 3:</p> <p><b>Models with SI-DRIVE</b></p> <p>(B136) No. 19 — (B379) No. 4:</p> <p>(B136) No. 18 — (B379) No. 3:</p>	<p>Is the resistance less than 1 Ω?</p>	<p>Go to step 2.</p>	<p>Repair the open circuit of harness between ECM and front oxygen (A/F) sensor connector.</p>

# Diagnostic Procedure with Diagnostic Trouble Code (DTC)

ENGINE (DIAGNOSTICS)

Step	Check	Yes	No
<b>2</b> <b>CHECK FOR POOR CONTACT.</b> Check for poor contact of ECM and front oxygen (A/F) sensor connector.	Is there poor contact of ECM or front oxygen (A/F) sensor connector?	Repair the poor contact of ECM or front oxygen (A/F) sensor connector.	Replace the front oxygen (A/F) sensor. <Ref. to FU(STI)-54, Front Oxygen (A/F) Sensor.> <Ref. to FU(w/o STI)-54, Front Oxygen (A/F) Sensor.>

# Diagnostic Procedure with Diagnostic Trouble Code (DTC)

ENGINE (DIAGNOSTICS)

## AH:DTC P0137 O2 SENSOR CIRCUIT LOW VOLTAGE (BANK 1 SENSOR 2)

### DTC DETECTING CONDITION:

- Detected when two consecutive driving cycles with fault occur.
- GENERAL DESCRIPTION <Ref. to GD(H4DOTC)-74, DTC P0137 O2 SENSOR CIRCUIT LOW VOLTAGE (BANK 1 SENSOR 2), Diagnostic Trouble Code (DTC) Detecting Criteria.>

### CAUTION:

After servicing or replacing faulty parts, perform Clear Memory Mode <Ref. to EN(H4DOTC)(diag)-62, OPERATION, Clear Memory Mode.>, and Inspection Mode <Ref. to EN(H4DOTC)(diag)-48, PROCEDURE, Inspection Mode.>.

### WIRING DIAGRAM:

- Models without SI-DRIVE

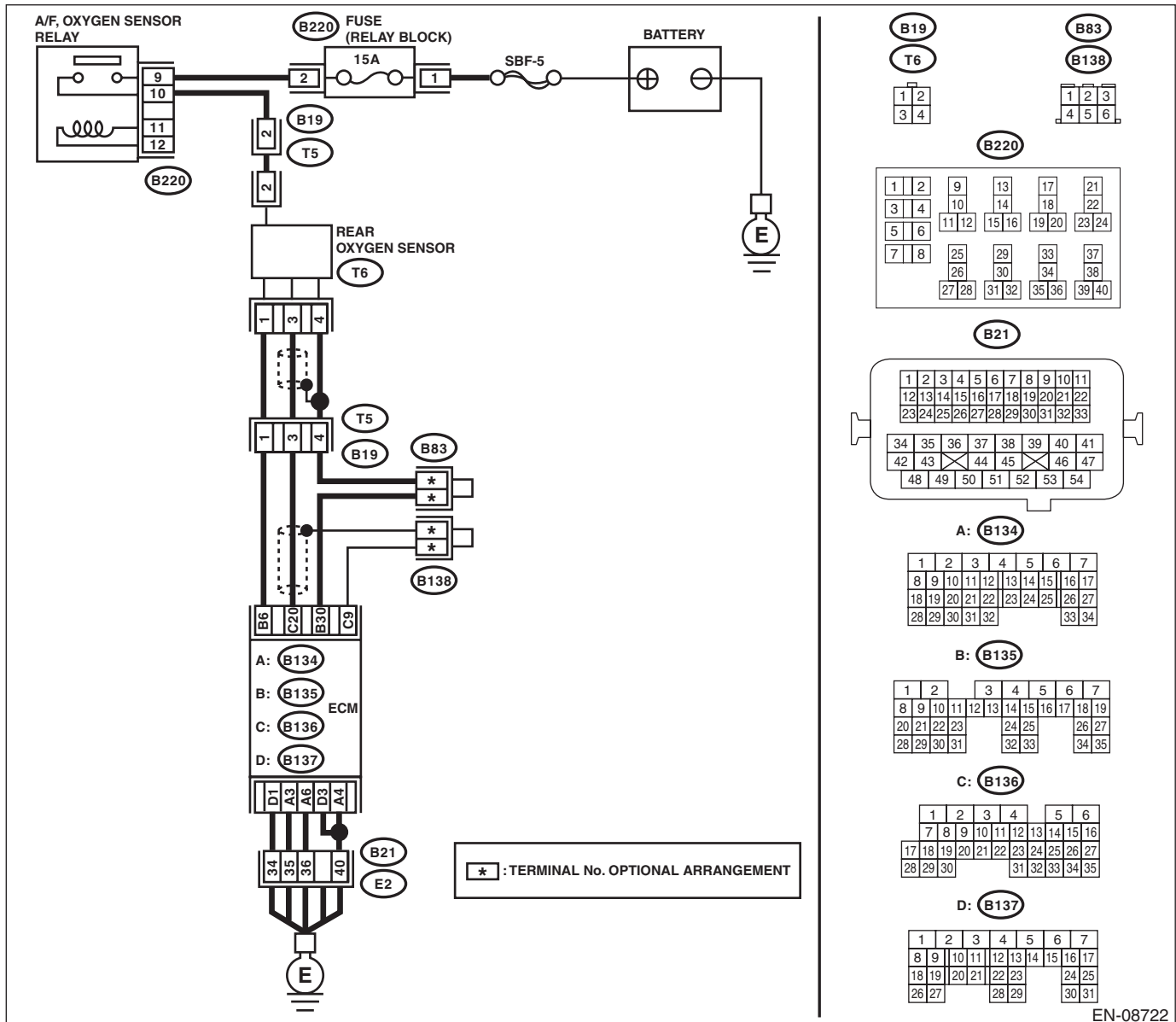

EN-08722

# Diagnostic Procedure with Diagnostic Trouble Code (DTC)

ENGINE (DIAGNOSTICS)

- Models with SI-DRIVE

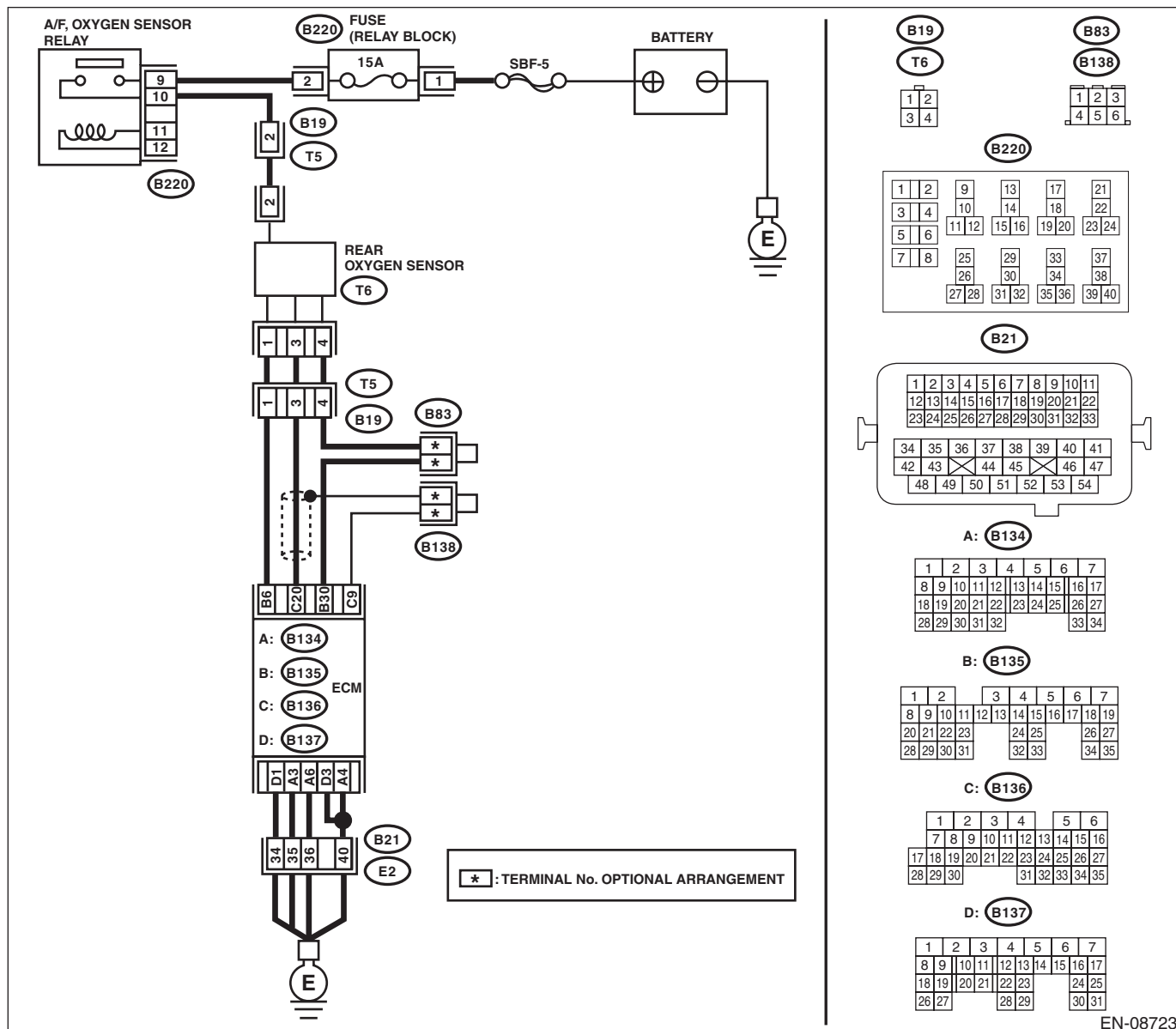

EN-08723

Step	Check	Yes	No
<p><b>1</b></p> <p><b>CHECK REAR OXYGEN SENSOR DATA.</b></p> <p>1) Warm up the engine until engine coolant temperature is higher than 75°C (167°F), and keep the engine speed at 3,000 rpm. (2 minutes maximum)</p> <p>2) Read the value of «Rear O2 Sensor» using the Subaru Select Monitor or a general scan tool.</p> <p>NOTE:</p> <ul style="list-style-type: none"> <li>Subaru Select Monitor</li> </ul> <p>For detailed operation procedures, refer to "READ CURRENT DATA FOR ENGINE". &lt;Ref. to EN(H4DOTC)(diag)-40, Subaru Select Monitor.&gt;</p> <ul style="list-style-type: none"> <li>General scan tool</li> </ul> <p>For detailed operation procedures, refer to the general scan tool operation manual.</p>	<p>Is the value of «Rear O2 Sensor» 0.490 V or more?</p>	<p>Go to step 5.</p>	<p>Go to step 2.</p>



## Diagnostic Procedure with Diagnostic Trouble Code (DTC)

ENGINE (DIAGNOSTICS)

Step	Check	Yes	No
<b>2</b> <b>CHECK REAR OXYGEN SENSOR CONNECTOR AND COUPLING CONNECTOR.</b>	Has water entered the connector?	Completely remove any water inside.	Go to step 3.
<b>3</b> <b>CHECK HARNESS BETWEEN ECM AND REAR OXYGEN SENSOR CONNECTOR.</b> 1) Turn the ignition switch to OFF. 2) Disconnect the connector from ECM and rear oxygen sensor. 3) Measure the resistance of harness between ECM and rear oxygen sensor connector. <b>Connector &amp; terminal</b> <b>(B136) No. 20 — (T6) No. 3:</b> <b>(B135) No. 30 — (T6) No. 4:</b>	Is the resistance less than 1 $\Omega$ ?	Go to step 4.	Repair the harness and connector. <b>NOTE:</b> In this case, repair the following item: • Open circuit in harness between ECM and rear oxygen sensor connector • Poor contact of coupling connector
<b>4</b> <b>CHECK HARNESS BETWEEN ECM AND REAR OXYGEN SENSOR CONNECTOR.</b> 1) Connect the connector to ECM. 2) Turn the ignition switch to ON. 3) Measure the voltage between rear oxygen sensor connector and chassis ground. <b>Connector &amp; terminal</b> <b>(T6) No. 3 (+) — Chassis ground (-):</b>	Is the voltage 0.2 — 0.5 V?	Replace the rear oxygen sensor. <Ref. to FU(STI)-56, Rear Oxygen Sensor.> <Ref. to FU(w/o STI)-56, Rear Oxygen Sensor.>	Repair the harness and connector. <b>NOTE:</b> In this case, repair the following item: • Open circuit in harness between ECM and rear oxygen sensor connector • Poor contact of ECM connector • Poor contact of coupling connector
<b>5</b> <b>CHECK EXHAUST SYSTEM.</b> Check exhaust system parts. <b>NOTE:</b> Check the following items. • Looseness and improper fitting of exhaust system parts • Damage (crack, hole etc.) of parts • Loose part and improper installation between front oxygen (A/F) sensor and rear oxygen sensor	Is there any fault in exhaust system?	Repair or replace faulty parts.	Replace the rear oxygen sensor. <Ref. to FU(STI)-56, Rear Oxygen Sensor.> <Ref. to FU(w/o STI)-56, Rear Oxygen Sensor.>

# Diagnostic Procedure with Diagnostic Trouble Code (DTC)

ENGINE (DIAGNOSTICS)

## AI: DTC P0138 O2 SENSOR CIRCUIT HIGH VOLTAGE (BANK 1 SENSOR 2)

### DTC DETECTING CONDITION:

- Detected when two consecutive driving cycles with fault occur.
- GENERAL DESCRIPTION <Ref. to GD(H4DOTC)-76, DTC P0138 O2 SENSOR CIRCUIT HIGH VOLTAGE (BANK 1 SENSOR 2), Diagnostic Trouble Code (DTC) Detecting Criteria.>

### CAUTION:

After servicing or replacing faulty parts, perform Clear Memory Mode <Ref. to EN(H4DOTC)(diag)-62, OPERATION, Clear Memory Mode.>, and Inspection Mode <Ref. to EN(H4DOTC)(diag)-48, PROCEDURE, Inspection Mode.>.

### WIRING DIAGRAM:

- Models without SI-DRIVE

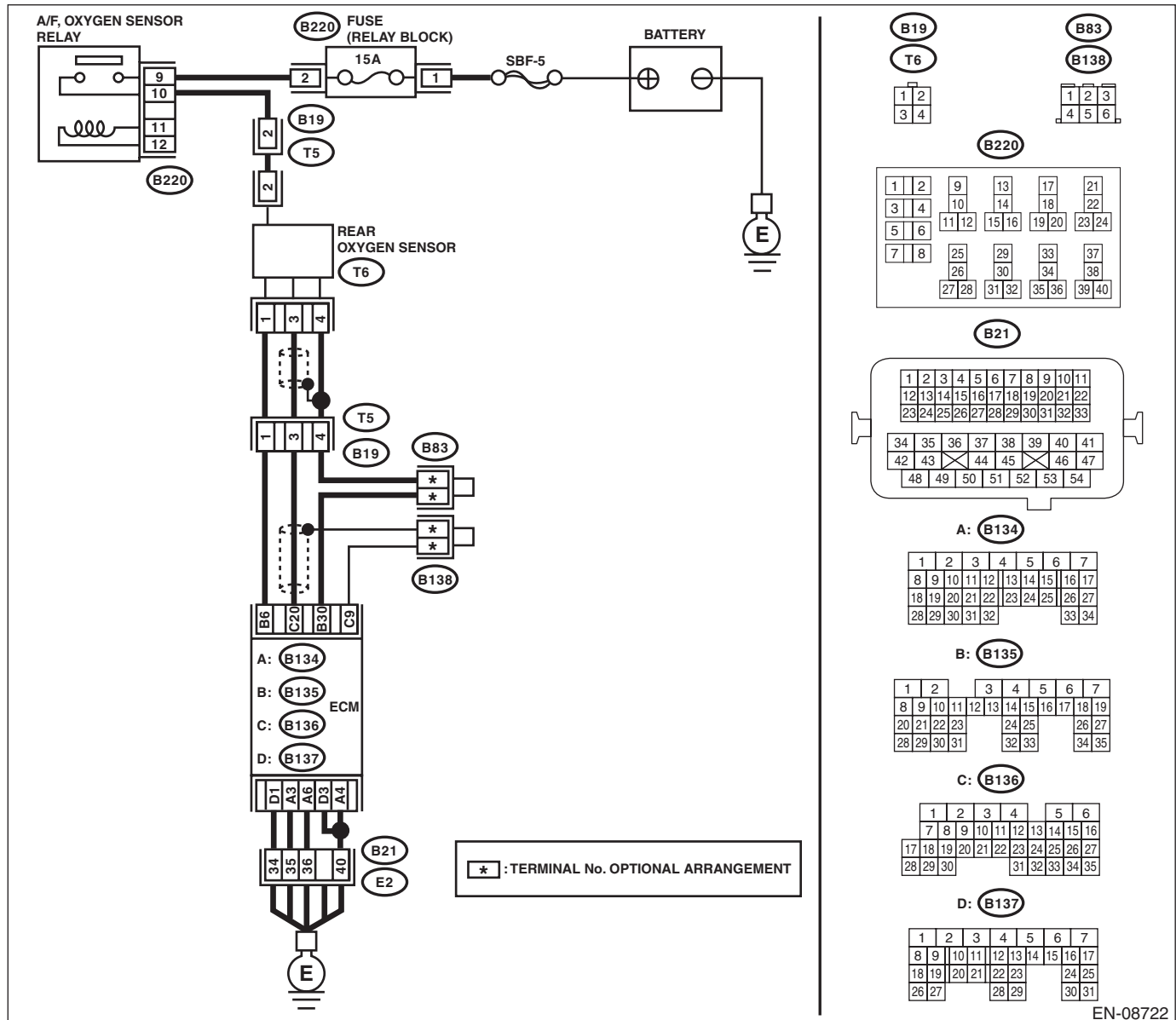

# Diagnostic Procedure with Diagnostic Trouble Code (DTC)

## ENGINE (DIAGNOSTICS)

- Models with SI-DRIVE

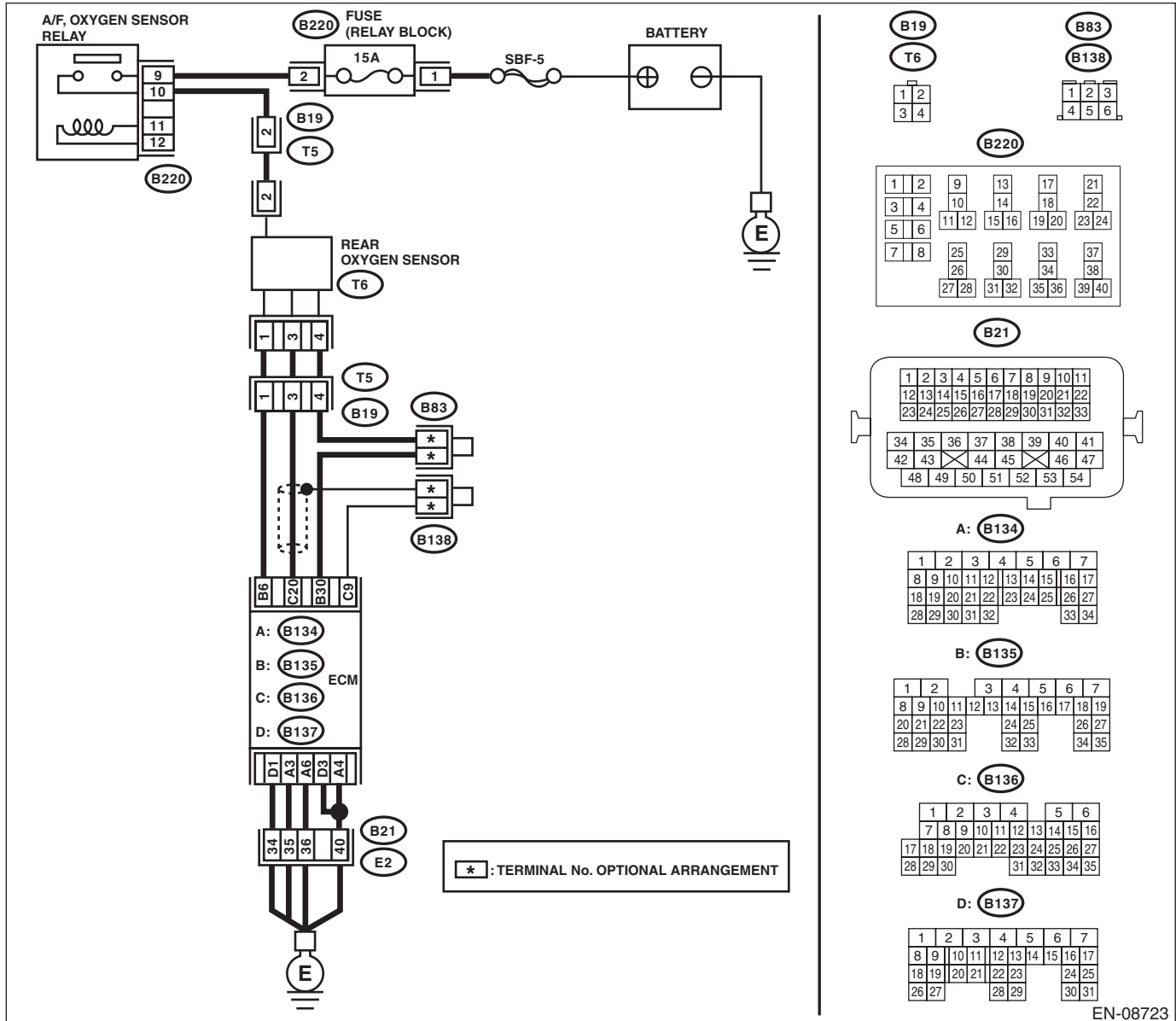

EN-08723

Step	Check	Yes	No
<b>1 CHECK REAR OXYGEN SENSOR DATA.</b> 1) Warm up the engine until engine coolant temperature is higher than 75°C (167°F), and rapidly reduce the engine speed from 3,000 rpm. 2) Read the value of «Rear O2 Sensor» using the Subaru Select Monitor or a general scan tool. NOTE: • Subaru Select Monitor For detailed operation procedures, refer to "READ CURRENT DATA FOR ENGINE". <Ref. to EN(H4DOTC)(diag)-40, Subaru Select Monitor.> • General scan tool For detailed operation procedures, refer to the general scan tool operation manual.	Is the value of «Rear O2 Sensor» 0.250 V or less?	Go to step 5.	Go to step 2.

# Diagnostic Procedure with Diagnostic Trouble Code (DTC)

ENGINE (DIAGNOSTICS)

Step	Check	Yes	No
2	<b>CHECK REAR OXYGEN SENSOR CONNECTOR AND COUPLING CONNECTOR.</b>	Has water entered the connector?	Completely remove any water inside.
3	<b>CHECK HARNESS BETWEEN ECM AND REAR OXYGEN SENSOR CONNECTOR.</b> 1) Turn the ignition switch to OFF. 2) Disconnect the connector from ECM and rear oxygen sensor. 3) Measure the resistance of harness between ECM and rear oxygen sensor connector. <b>Connector &amp; terminal</b> <b>(B136) No. 20 — (T6) No. 3:</b> <b>(B135) No. 30 — (T6) No. 4:</b>	Is the resistance less than 1 $\Omega$ ?	Go to step 4.  Repair the harness and connector. <b>NOTE:</b> In this case, repair the following item: • Open circuit in harness between ECM and rear oxygen sensor connector • Poor contact of coupling connector
4	<b>CHECK HARNESS BETWEEN ECM AND REAR OXYGEN SENSOR CONNECTOR.</b> 1) Connect the connector to ECM. 2) Turn the ignition switch to ON. 3) Measure the voltage between rear oxygen sensor connector and chassis ground. <b>Connector &amp; terminal</b> <b>(T6) No. 3 (+) — Chassis ground (-):</b>	Is the voltage 0.2 — 0.5 V?	Replace the rear oxygen sensor. <Ref. to FU(STI)-56, Rear Oxygen Sensor.> <Ref. to FU(w/o STI)-56, Rear Oxygen Sensor.>  Repair the harness and connector. <b>NOTE:</b> In this case, repair the following item: • Open circuit in harness between ECM and rear oxygen sensor connector • Poor contact of ECM connector • Poor contact of coupling connector
5	<b>CHECK EXHAUST SYSTEM.</b> Check exhaust system parts. <b>NOTE:</b> Check the following items. • Looseness and improper fitting of exhaust system parts • Damage (crack, hole etc.) of parts • Loose part and improper installation between front oxygen (A/F) sensor and rear oxygen sensor	Is there any fault in exhaust system?	Repair or replace faulty parts.  Replace the rear oxygen sensor. <Ref. to FU(STI)-56, Rear Oxygen Sensor.> <Ref. to FU(w/o STI)-56, Rear Oxygen Sensor.>

# Diagnostic Procedure with Diagnostic Trouble Code (DTC)

ENGINE (DIAGNOSTICS)

## AJ:DTC P013A O2 SENSOR SLOW RESPONSE - RICH TO LEAN (BANK 1 SENSOR 2)

### DTC DETECTING CONDITION:

- Detected when two consecutive driving cycles with fault occur.
- GENERAL DESCRIPTION <Ref. to GD(H4DOTC)-77, DTC P013A O2 SENSOR SLOW RESPONSE - RICH TO LEAN (BANK 1 SENSOR 2), Diagnostic Trouble Code (DTC) Detecting Criteria.>

### CAUTION:

After servicing or replacing faulty parts, perform Clear Memory Mode <Ref. to EN(H4DOTC)(diag)-62, OPERATION, Clear Memory Mode.>, and Inspection Mode <Ref. to EN(H4DOTC)(diag)-48, PROCEDURE, Inspection Mode.>.

### WIRING DIAGRAM:

- Models without SI-DRIVE

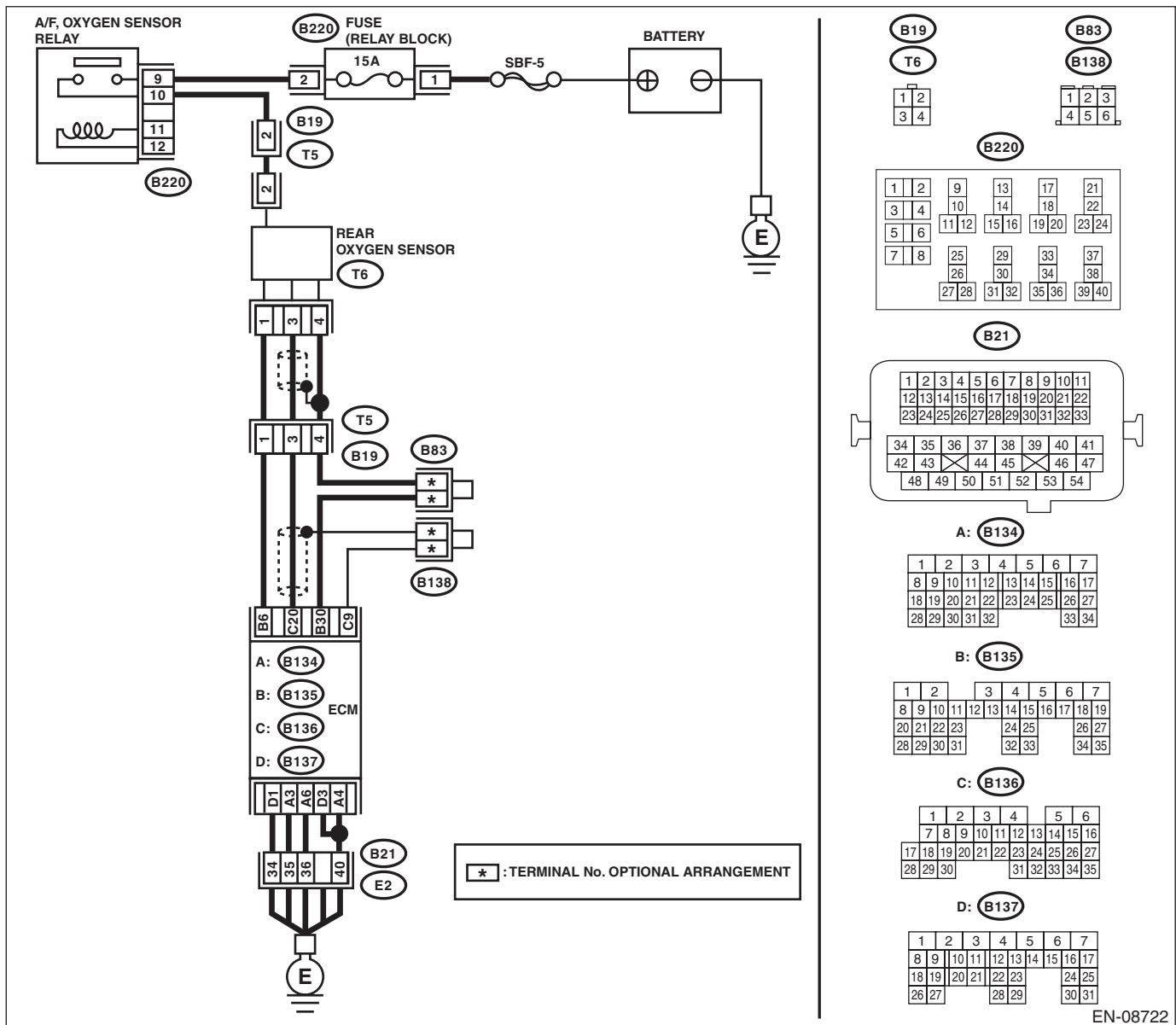

EN-08722

# Diagnostic Procedure with Diagnostic Trouble Code (DTC)

ENGINE (DIAGNOSTICS)

- Models with SI-DRIVE

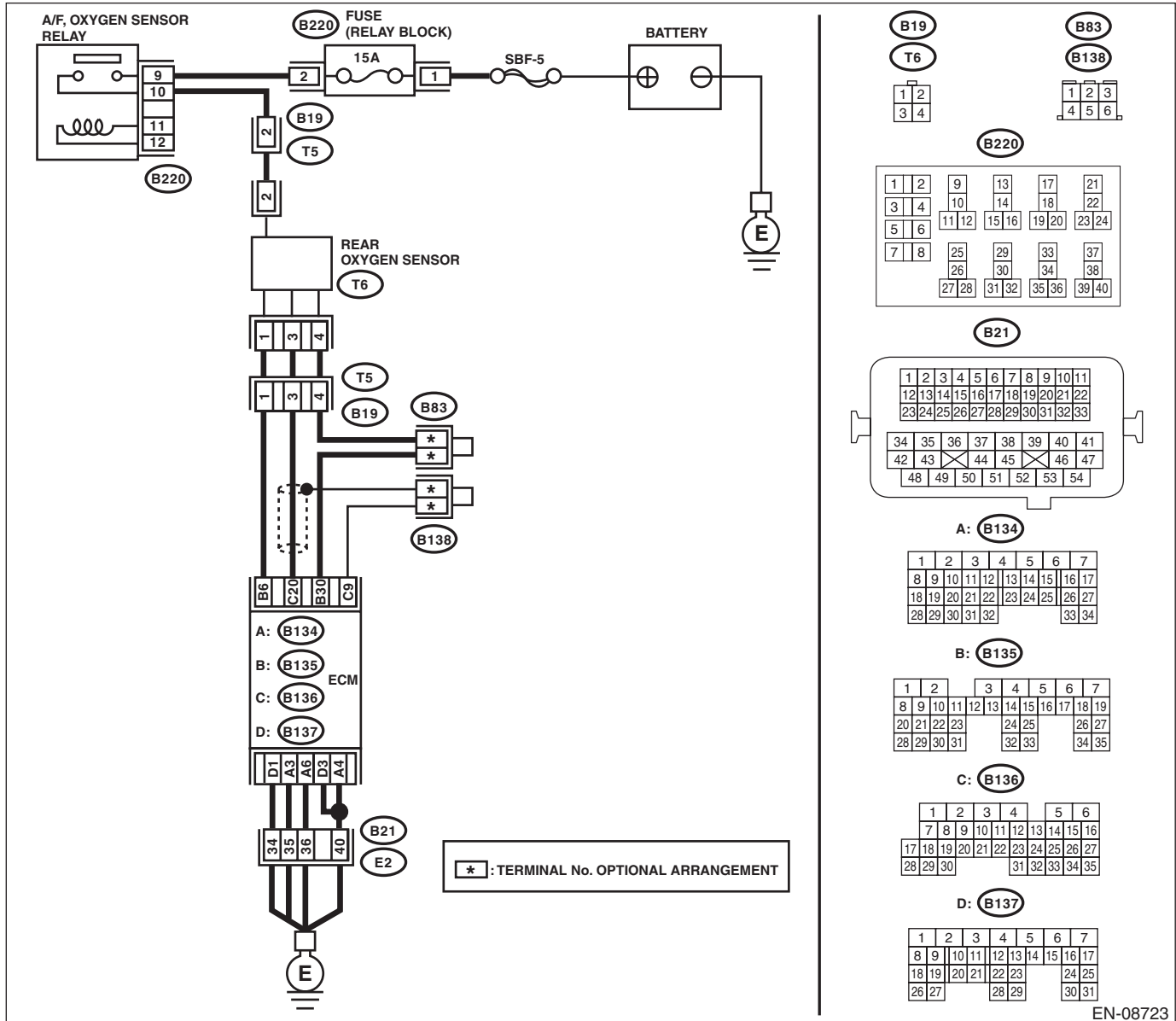

EN-08723

Step	Check	Yes	No
<b>1</b> <b>CHECK HARNESS BETWEEN ECM AND REAR OXYGEN SENSOR CONNECTOR.</b> 1) Turn the ignition switch to OFF. 2) Disconnect the connector from ECM and rear oxygen sensor. 3) Measure the resistance of harness between ECM and rear oxygen sensor connector. <b>Connector &amp; terminal</b> <b>(B136) No. 20 — (T6) No. 3:</b>	Is the resistance less than 1 Ω?	Go to step 2.	Repair the harness and connector. <b>NOTE:</b> In this case, repair the following item: • Open circuit in harness between ECM and rear oxygen sensor connector • Poor contact of coupling connector

# Diagnostic Procedure with Diagnostic Trouble Code (DTC)

ENGINE (DIAGNOSTICS)

Step	Check	Yes	No
<b>2</b> <b>CHECK HARNESS BETWEEN ECM AND REAR OXYGEN SENSOR CONNECTOR.</b> Measure the resistance between rear oxygen sensor connector and chassis ground. <b>Connector &amp; terminal</b> <b>(T6) No. 3 — Chassis ground:</b>	Is the resistance 1 M $\Omega$ or more?	Go to step 3.	Repair the ground short circuit of harness between ECM and rear oxygen sensor connector.
<b>3</b> <b>CHECK REAR OXYGEN SENSOR.</b> Measure the resistance between rear oxygen sensor terminals. <b>Terminals</b> <b>No. 3 — No. 4</b>	Is the resistance less than 1 $\Omega$ ?	Replace the rear oxygen sensor. <Ref. to FU(STI)-56, Rear Oxygen Sensor.> <Ref. to FU(w/o STI)-56, Rear Oxygen Sensor.>	Even if DTC is detected, the circuit has returned to a normal condition at this time. Reproduce the failure, and then perform the diagnosis again.  NOTE: In this case, temporary poor contact of connector, temporary open or short circuit of harness may be the cause.

## AK:DTC P013B O2 SENSOR SLOW RESPONSE - LEAN TO RICH (BANK 1 SENSOR 2)

NOTE:

For the diagnostic procedure, refer to DTC P013A. <Ref. to EN(H4DOTC)(diag)-162, DTC P013A O2 SENSOR SLOW RESPONSE - RICH TO LEAN (BANK 1 SENSOR 2), Diagnostic Procedure with Diagnostic Trouble Code (DTC).>

## AL:DTC P013E O2 SENSOR DELAYED RESPONSE - RICH TO LEAN (BANK 1 SENSOR 2)

NOTE:

For the diagnostic procedure, refer to DTC P013A. <Ref. to EN(H4DOTC)(diag)-162, DTC P013A O2 SENSOR SLOW RESPONSE - RICH TO LEAN (BANK 1 SENSOR 2), Diagnostic Procedure with Diagnostic Trouble Code (DTC).>

## AM:DTC P013F O2 SENSOR DELAYED RESPONSE - LEAN TO RICH (BANK 1 SENSOR 2)

NOTE:

For the diagnostic procedure, refer to DTC P013A. <Ref. to EN(H4DOTC)(diag)-162, DTC P013A O2 SENSOR SLOW RESPONSE - RICH TO LEAN (BANK 1 SENSOR 2), Diagnostic Procedure with Diagnostic Trouble Code (DTC).>

# Diagnostic Procedure with Diagnostic Trouble Code (DTC)

ENGINE (DIAGNOSTICS)

## AN:DTC P0140 O2 SENSOR CIRCUIT NO ACTIVITY DETECTED (BANK1 SENSOR2)

### DTC DETECTING CONDITION:

- Detected when two consecutive driving cycles with fault occur.
- GENERAL DESCRIPTION <Ref. to GD(H4DOTC)-85, DTC P0140 O2 SENSOR CIRCUIT NO ACTIVITY DETECTED (BANK1 SENSOR2), Diagnostic Trouble Code (DTC) Detecting Criteria.>

### CAUTION:

After servicing or replacing faulty parts, perform Clear Memory Mode <Ref. to EN(H4DOTC)(diag)-62, OPERATION, Clear Memory Mode.>, and Inspection Mode <Ref. to EN(H4DOTC)(diag)-48, PROCEDURE, Inspection Mode.>.

### WIRING DIAGRAM:

- Models without SI-DRIVE

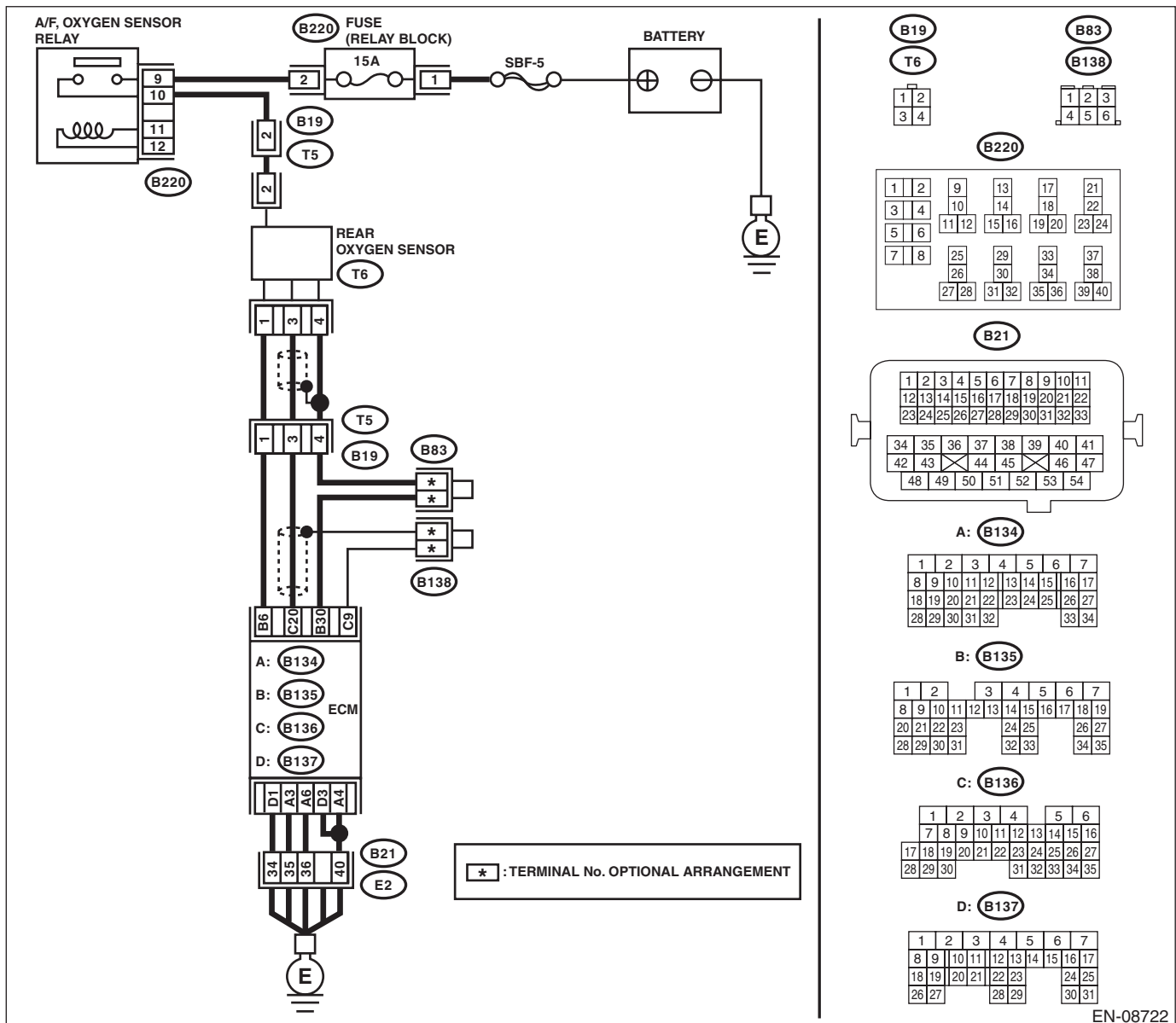

EN-08722



# Diagnostic Procedure with Diagnostic Trouble Code (DTC)

## ENGINE (DIAGNOSTICS)

- Models with SI-DRIVE

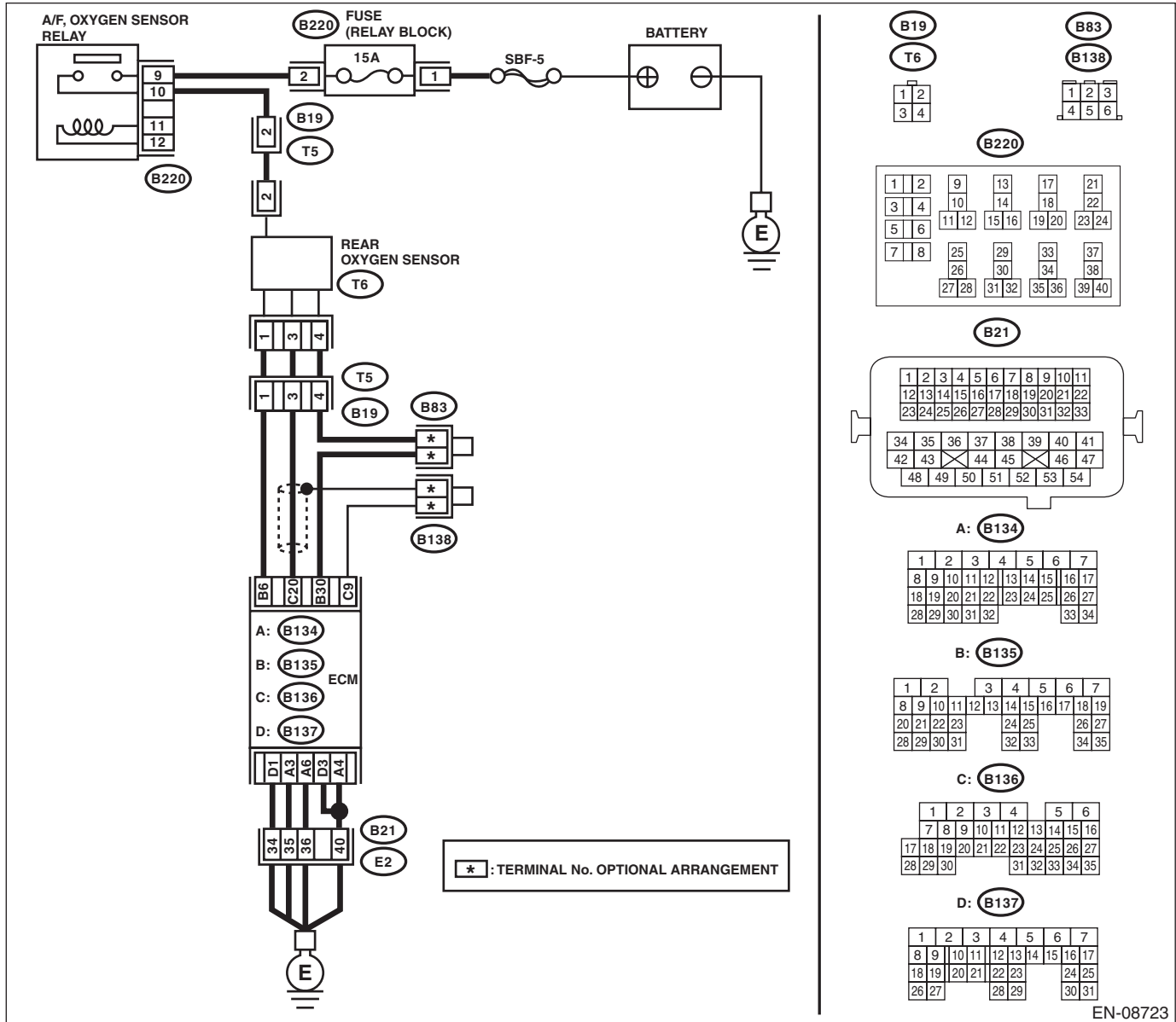

EN-08723

Step	Check	Yes	No
<p><b>1</b></p> <p><b>CHECK REAR OXYGEN SENSOR DATA.</b></p> <p>1) Warm up the engine until engine coolant temperature is higher than 75°C (167°F), and keep the engine speed at 3,000 rpm. (2 minutes maximum)</p> <p>2) Read the value of «Rear O2 Sensor» using the Subaru Select Monitor or a general scan tool.</p> <p>NOTE:</p> <ul style="list-style-type: none"> <li>Subaru Select Monitor</li> </ul> <p>For detailed operation procedures, refer to "READ CURRENT DATA FOR ENGINE". &lt;Ref. to EN(H4DOTC)(diag)-40, Subaru Select Monitor.&gt;</p> <ul style="list-style-type: none"> <li>General scan tool</li> </ul> <p>For detailed operation procedures, refer to the general scan tool operation manual.</p>	<p>Is the value of «Rear O2 Sensor» 0.490 V or more?</p>	<p>Go to step 6.</p>	<p>Go to step 2.</p>

# Diagnostic Procedure with Diagnostic Trouble Code (DTC)

ENGINE (DIAGNOSTICS)

Step	Check	Yes	No
<p><b>2 CHECK REAR OXYGEN SENSOR DATA.</b></p> <p>1) Warm up the engine until engine coolant temperature is higher than 75°C (167°F), and rapidly reduce the engine speed from 3,000 rpm.</p> <p>2) Read the value of «Rear O2 Sensor» using the Subaru Select Monitor or a general scan tool.</p> <p>NOTE:</p> <ul style="list-style-type: none"> <li>Subaru Select Monitor</li> </ul> <p>For detailed operation procedures, refer to "READ CURRENT DATA FOR ENGINE". &lt;Ref. to EN(H4DOTC)(diag)-40, Subaru Select Monitor.&gt;</p> <ul style="list-style-type: none"> <li>General scan tool</li> </ul> <p>For detailed operation procedures, refer to the general scan tool operation manual.</p>	<p>Is the value of «Rear O2 Sensor» 0.250 V or less?</p>	<p>Go to step 6.</p>	<p>Go to step 3.</p>
<p><b>3 CHECK REAR OXYGEN SENSOR CONNECTOR AND COUPLING CONNECTOR.</b></p>	<p>Has water entered the connector?</p>	<p>Completely remove any water inside.</p>	<p>Go to step 4.</p>
<p><b>4 CHECK HARNESS BETWEEN ECM AND REAR OXYGEN SENSOR CONNECTOR.</b></p> <p>1) Turn the ignition switch to OFF.</p> <p>2) Disconnect the connector from ECM and rear oxygen sensor.</p> <p>3) Measure the resistance of harness between ECM and rear oxygen sensor connector.</p> <p><b>Connector &amp; terminal</b></p> <p><b>(B136) No. 20 — (T6) No. 3:</b></p> <p><b>(B135) No. 30 — (T6) No. 4:</b></p>	<p>Is the resistance less than 1 Ω?</p>	<p>Go to step 5.</p>	<p>Repair the harness and connector.</p> <p>NOTE:</p> <p>In this case, repair the following item:</p> <ul style="list-style-type: none"> <li>Open circuit in harness between ECM and rear oxygen sensor connector</li> <li>Poor contact of coupling connector</li> </ul>
<p><b>5 CHECK HARNESS BETWEEN ECM AND REAR OXYGEN SENSOR CONNECTOR.</b></p> <p>1) Connect the connector to ECM.</p> <p>2) Turn the ignition switch to ON.</p> <p>3) Measure the voltage between rear oxygen sensor connector and chassis ground.</p> <p><b>Connector &amp; terminal</b></p> <p><b>(T6) No. 3 (+) — Chassis ground (-):</b></p>	<p>Is the voltage 0.2 — 0.5 V?</p>	<p>Replace the rear oxygen sensor.</p> <p>&lt;Ref. to FU(STI)-56, Rear Oxygen Sensor.&gt; &lt;Ref. to FU(w/o STI)-56, Rear Oxygen Sensor.&gt;</p>	<p>Repair the harness and connector.</p> <p>NOTE:</p> <p>In this case, repair the following item:</p> <ul style="list-style-type: none"> <li>Open circuit in harness between ECM and rear oxygen sensor connector</li> <li>Poor contact of ECM connector</li> <li>Poor contact of coupling connector</li> </ul>
<p><b>6 CHECK EXHAUST SYSTEM.</b></p> <p>Check exhaust system parts.</p> <p>NOTE:</p> <p>Check the following items.</p> <ul style="list-style-type: none"> <li>Looseness and improper fitting of exhaust system parts</li> <li>Damage (crack, hole etc.) of parts</li> <li>Loose part and improper installation between front oxygen (A/F) sensor and rear oxygen sensor</li> </ul>	<p>Is there any fault in exhaust system?</p>	<p>Repair or replace faulty parts.</p>	<p>Replace the rear oxygen sensor.</p> <p>&lt;Ref. to FU(STI)-56, Rear Oxygen Sensor.&gt; &lt;Ref. to FU(w/o STI)-56, Rear Oxygen Sensor.&gt;</p>

## Diagnostic Procedure with Diagnostic Trouble Code (DTC)

ENGINE (DIAGNOSTICS)

---

### **AO:DTC P0141 O2 SENSOR HEATER CIRCUIT (BANK1 SENSOR2)**

For the diagnostic procedure, refer to DTC P0037. <Ref. to EN(H4DOTC)(diag)-113, DTC P0037 HO2S HEATER CONTROL CIRCUIT LOW (BANK 1 SENSOR 2), Diagnostic Procedure with Diagnostic Trouble Code (DTC).>

### **AP:DTC P0171 SYSTEM TOO LEAN (BANK 1)**

For the diagnostic procedure, refer to DTC P0172. <Ref. to EN(H4DOTC)(diag)-169, DTC P0172 SYSTEM TOO RICH (BANK 1), Diagnostic Procedure with Diagnostic Trouble Code (DTC).>

# Diagnostic Procedure with Diagnostic Trouble Code (DTC)

ENGINE (DIAGNOSTICS)

## AQ:DTC P0172 SYSTEM TOO RICH (BANK 1)

### DTC DETECTING CONDITION:

- Detected when two consecutive driving cycles with fault occur.
- GENERAL DESCRIPTION <Ref. to GD(H4DOTC)-91, DTC P0172 SYSTEM TOO RICH (BANK 1), Diagnostic Trouble Code (DTC) Detecting Criteria.>

### TROUBLE SYMPTOM:

- Improper idling
- Engine stalls.
- Poor driving performance

### CAUTION:

After servicing or replacing faulty parts, perform Clear Memory Mode <Ref. to EN(H4DOTC)(diag)-62, OPERATION, Clear Memory Mode.>, and Inspection Mode <Ref. to EN(H4DOTC)(diag)-48, PROCEDURE, Inspection Mode.>.

Step	Check	Yes	No
1	<b>CHECK EXHAUST SYSTEM.</b>	Are there holes or loose bolts on exhaust system?	Repair the exhaust system. Go to step 2.
2	<b>CHECK AIR INTAKE SYSTEM.</b>	Are there holes, loose bolts or disconnection of hose on air intake system?	Repair the air intake system. Go to step 3.
3	<b>CHECK FUEL PRESSURE.</b> <b>WARNING:</b> Place "NO OPEN FLAMES" signs near the working area. <b>CAUTION:</b> Be careful not to spill fuel. Measure the fuel pressure while disconnecting pressure regulator vacuum hose from intake manifold. <Ref. to ME(STI)-25, INSPECTION, Fuel Pressure.> <Ref. to ME(w/o STI)-25, INSPECTION, Fuel Pressure.> <b>CAUTION:</b> Release fuel pressure before removing the fuel pressure gauge. NOTE: If fuel pressure does not increase, squeeze the fuel return hose 2 to 3 times, then measure fuel pressure again.	Is the measured value 284 — 314 kPa (2.9 — 3.2 kg/cm <sup>2</sup> , 41 — 46 psi)?	Go to step 4. Repair the following item. Fuel pressure is too high: • Clogged fuel return line or bent hose Fuel pressure is too low: • Improper fuel pump discharge • Clogged fuel supply line
4	<b>CHECK FUEL PRESSURE.</b> After connecting the pressure regulator vacuum hose, measure fuel pressure. <Ref. to ME(STI)-25, INSPECTION, Fuel Pressure.> <Ref. to ME(w/o STI)-25, INSPECTION, Fuel Pressure.> <b>CAUTION:</b> Release fuel pressure before removing the fuel pressure gauge. NOTE: • If fuel pressure does not increase, squeeze fuel return hose 2 to 3 times, then measure fuel pressure again. • If the measured value at this step is out of specification, check or replace pressure regulator and pressure regulator vacuum hose.	Is the measured value 230 — 260 kPa (2.35 — 2.65 kg/cm <sup>2</sup> , 33 — 38 psi)?	Go to step 5. Repair the following item. Fuel pressure is too high: • Faulty pressure regulator • Clogged fuel return line or bent hose Fuel pressure is too low: • Faulty pressure regulator • Improper fuel pump discharge • Clogged fuel supply line

# Diagnostic Procedure with Diagnostic Trouble Code (DTC)

## ENGINE (DIAGNOSTICS)

Step	Check	Yes	No
<p><b>5 CHECK ENGINE COOLANT TEMPERATURE SENSOR.</b></p> <p>1) Start the engine and warm up completely.</p> <p>2) Read the value of «Coolant Temp.» using the Subaru Select Monitor or a general scan tool.</p> <p>NOTE:</p> <ul style="list-style-type: none"> <li>• Subaru Select Monitor</li> </ul> <p>For detailed operation procedures, refer to "READ CURRENT DATA FOR ENGINE". &lt;Ref. to EN(H4DOTC)(diag)-40, Subaru Select Monitor.&gt;</p> <ul style="list-style-type: none"> <li>• General scan tool</li> </ul> <p>For detailed operation procedures, refer to the general scan tool operation manual.</p>	<p>Is the value of «Coolant Temp.» 75°C (167°F) or more?</p>	<p>Go to step 6.</p>	<p>Replace the engine coolant temperature sensor. &lt;Ref. to FU(STI)-34, Engine Coolant Temperature Sensor.&gt; &lt;Ref. to FU(w/o STI)-35, Engine Coolant Temperature Sensor.&gt;</p>
<p><b>6 CHECK MASS AIR FLOW AND INTAKE AIR TEMPERATURE SENSOR.</b></p> <p>1) Start the engine and warm up engine until coolant temperature is higher than 75°C (167°F).</p> <p>2) Place the shift lever in neutral position.</p> <p>3) Turn the A/C switch to OFF.</p> <p>4) Turn all the accessory switches to OFF.</p> <p>5) Read the value of «Mass Air Flow» using the Subaru Select Monitor or a general scan tool.</p> <p>NOTE:</p> <ul style="list-style-type: none"> <li>• Subaru Select Monitor</li> </ul> <p>For detailed operation procedures, refer to "READ CURRENT DATA FOR ENGINE". &lt;Ref. to EN(H4DOTC)(diag)-40, Subaru Select Monitor.&gt;</p> <ul style="list-style-type: none"> <li>• General scan tool</li> </ul> <p>For detailed operation procedures, refer to the general scan tool operation manual.</p>	<p>Is the value of «Mass Air Flow» 2.0 — 5.0 g/s (0.26 — 0.66 lb/m)?</p>	<p>Go to step 7.</p>	<p>Replace the mass air flow and intake air temperature sensor. &lt;Ref. to FU(STI)-42, Mass Air Flow and Intake Air Temperature Sensor.&gt; &lt;Ref. to FU(w/o STI)-43, Mass Air Flow and Intake Air Temperature Sensor.&gt;</p>
<p><b>7 CHECK MASS AIR FLOW AND INTAKE AIR TEMPERATURE SENSOR.</b></p> <p>1) Start the engine and warm up engine until coolant temperature is higher than 75°C (167°F).</p> <p>2) Place the shift lever in neutral position.</p> <p>3) Turn the A/C switch to OFF.</p> <p>4) Turn all the accessory switches to OFF.</p> <p>5) Open the front hood.</p> <p>6) Measure the ambient temperature.</p> <p>7) Read the value of «Intake Air Temp.» using the Subaru Select Monitor or a general scan tool.</p> <p>NOTE:</p> <ul style="list-style-type: none"> <li>• Subaru Select Monitor</li> </ul> <p>For detailed operation procedures, refer to "READ CURRENT DATA FOR ENGINE". &lt;Ref. to EN(H4DOTC)(diag)-40, Subaru Select Monitor.&gt;</p> <ul style="list-style-type: none"> <li>• General scan tool</li> </ul> <p>For detailed operation procedures, refer to the general scan tool operation manual.</p>	<p>Subtract ambient temperature from «Intake Air Temp.». Is the obtained value -10 — 50°C (-18 — 90°F)?</p>	<p>Repair the poor contact of ECM connector.</p>	<p>Check the mass air flow and intake air temperature sensor. &lt;Ref. to FU(STI)-42, Mass Air Flow and Intake Air Temperature Sensor.&gt; &lt;Ref. to FU(w/o STI)-43, Mass Air Flow and Intake Air Temperature Sensor.&gt;</p>

# Diagnostic Procedure with Diagnostic Trouble Code (DTC)

ENGINE (DIAGNOSTICS)

## AR:DTC P0201 INJECTOR #1

### DTC DETECTING CONDITION:

- Immediately at fault recognition
- GENERAL DESCRIPTION <Ref. to GD(H4DOTC)-93, DTC P0201 INJECTOR #1, Diagnostic Trouble Code (DTC) Detecting Criteria.>

### TROUBLE SYMPTOM:

- Improper idling
- Poor driving performance

### CAUTION:

After servicing or replacing faulty parts, perform Clear Memory Mode <Ref. to EN(H4DOTC)(diag)-62, OPERATION, Clear Memory Mode.>, and Inspection Mode <Ref. to EN(H4DOTC)(diag)-48, PROCEDURE, Inspection Mode.>.

### WIRING DIAGRAM:

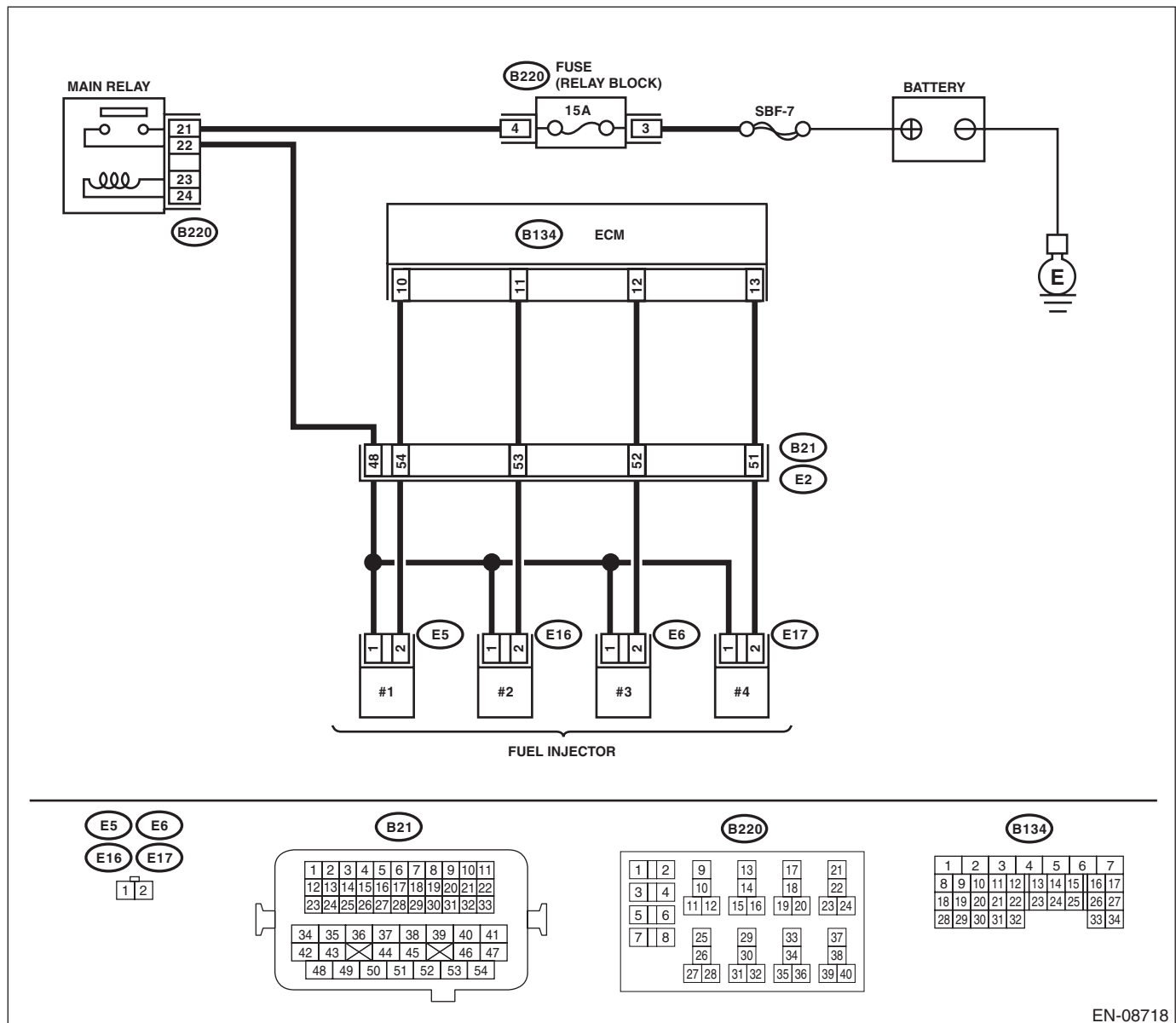

EN-08718

# Diagnostic Procedure with Diagnostic Trouble Code (DTC)

ENGINE (DIAGNOSTICS)

Step	Check	Yes	No
<p><b>1 CHECK POWER SUPPLY TO FUEL INJECTOR.</b></p> <p>1) Turn the ignition switch to OFF.                      2) Disconnect the connector from fuel injector.                      3) Turn the ignition switch to ON.                      4) Measure the voltage between fuel injector connector and the engine ground.</p> <p><b>Connector &amp; terminal</b>  <b>DTC P0201; (E5) No. 1 (+) — Engine ground (-):</b>  <b>DTC P0202; (E16) No. 1 (+) — Engine ground (-):</b>  <b>DTC P0203; (E6) No. 1 (+) — Engine ground (-):</b>  <b>DTC P0204; (E17) No. 1 (+) — Engine ground (-):</b></p>	Is the voltage 10 V or more?	Go to step 2.	Repair the harness and connector.  NOTE: In this case, repair the following item: • Open circuit in harness between main relay and fuel injector connector • Poor contact of main relay connector • Poor contact of coupling connector
<p><b>2 CHECK HARNESS BETWEEN ECM AND FUEL INJECTOR CONNECTOR.</b></p> <p>1) Turn the ignition switch to OFF.                      2) Disconnect the connector from ECM.                      3) Measure the resistance between fuel injector connector and engine ground.</p> <p><b>Connector &amp; terminal</b>  <b>DTC P0201; (E5) No. 2 — Engine ground:</b>  <b>DTC P0202; (E16) No. 2 — Engine ground:</b>  <b>DTC P0203; (E6) No. 2 — Engine ground:</b>  <b>DTC P0204; (E17) No. 2 — Engine ground:</b></p>	Is the resistance 1 M $\Omega$ or more?	Go to step 3.	Repair the short circuit to ground in harness between ECM connector and fuel injector connector.
<p><b>3 CHECK HARNESS BETWEEN ECM AND FUEL INJECTOR CONNECTOR.</b></p> <p>Measure the resistance of harness between ECM connector and fuel injector connector.</p> <p><b>Connector &amp; terminal</b>  <b>DTC P0201; (B134) No. 10 — (E5) No. 2:</b>  <b>DTC P0202; (B134) No. 11 — (E16) No. 2:</b>  <b>DTC P0203; (B134) No. 12 — (E6) No. 2:</b>  <b>DTC P0204; (B134) No. 13 — (E17) No. 2:</b></p>	Is the resistance less than 1 $\Omega$ ?	Go to step 4.	Repair the harness and connector.  NOTE: In this case, repair the following item: • Open circuit in harness between ECM connector and fuel injector connector • Poor contact of coupling connector
<p><b>4 CHECK FUEL INJECTOR.</b></p> <p>Measure the resistance between fuel injector terminals on the corresponding cylinder.</p> <p><b>Terminals</b>  <b>No. 1 — No. 2:</b></p>	Is the resistance 5 — 20 $\Omega$ ?	Go to step 5.	Replace the fuel injector. <Ref. to FU(STI)-45, Fuel Injector.> <Ref. to FU(w/o STI)-46, Fuel Injector.>
<p><b>5 CHECK FOR POOR CONTACT.</b></p> <p>Check for poor contact of ECM connector.</p>	Is there poor contact of ECM connector?	Repair the poor contact of ECM connector.	Go to step 6.

# Diagnostic Procedure with Diagnostic Trouble Code (DTC)

ENGINE (DIAGNOSTICS)

Step	Check	Yes	No
<b>6</b> <b>CHECK FUEL INJECTOR OPERATION.</b> 1) Connect all connectors. 2) Start the engine. 3) Check if the corresponding fuel injector emits operating sound.  NOTE: Use a sound scope to check the operating sound.	Does the fuel injector emit operating sound?	Even if DTC is detected, the circuit has returned to a normal condition at this time. Reproduce the failure, and then perform the diagnosis again.  NOTE: In this case, temporary poor contact of connector, temporary open or short circuit of harness may be the cause.	Repair the poor contact of fuel injector connector.

## AS:DTC P0202 INJECTOR #2

NOTE:

For the diagnostic procedure, refer to DTC P0201. <Ref. to EN(H4DOTC)(diag)-171, DTC P0201 INJECTOR #1, Diagnostic Procedure with Diagnostic Trouble Code (DTC).>

## AT:DTC P0203 INJECTOR #3

NOTE:

For the diagnostic procedure, refer to DTC P0201. <Ref. to EN(H4DOTC)(diag)-171, DTC P0201 INJECTOR #1, Diagnostic Procedure with Diagnostic Trouble Code (DTC).>

## AU:DTC P0204 INJECTOR #4

NOTE:

For the diagnostic procedure, refer to DTC P0201. <Ref. to EN(H4DOTC)(diag)-171, DTC P0201 INJECTOR #1, Diagnostic Procedure with Diagnostic Trouble Code (DTC).>



# Diagnostic Procedure with Diagnostic Trouble Code (DTC)

ENGINE (DIAGNOSTICS)

## AV:DTC P0222 THROTTLE/PEDAL POSITION SENSOR/SWITCH "B" CIRCUIT LOW

### DTC DETECTING CONDITION:

- Immediately at fault recognition
- GENERAL DESCRIPTION <Ref. to GD(H4DOTC)-95, DTC P0222 THROTTLE/PEDAL POSITION SENSOR/SWITCH "B" CIRCUIT LOW, Diagnostic Trouble Code (DTC) Detecting Criteria.>

### TROUBLE SYMPTOM:

- Improper idling
- Poor driving performance
- Engine stalls.

### CAUTION:

After servicing or replacing faulty parts, perform Clear Memory Mode <Ref. to EN(H4DOTC)(diag)-62, OPERATION, Clear Memory Mode.>, and Inspection Mode <Ref. to EN(H4DOTC)(diag)-48, PROCEDURE, Inspection Mode.>.

### WIRING DIAGRAM:

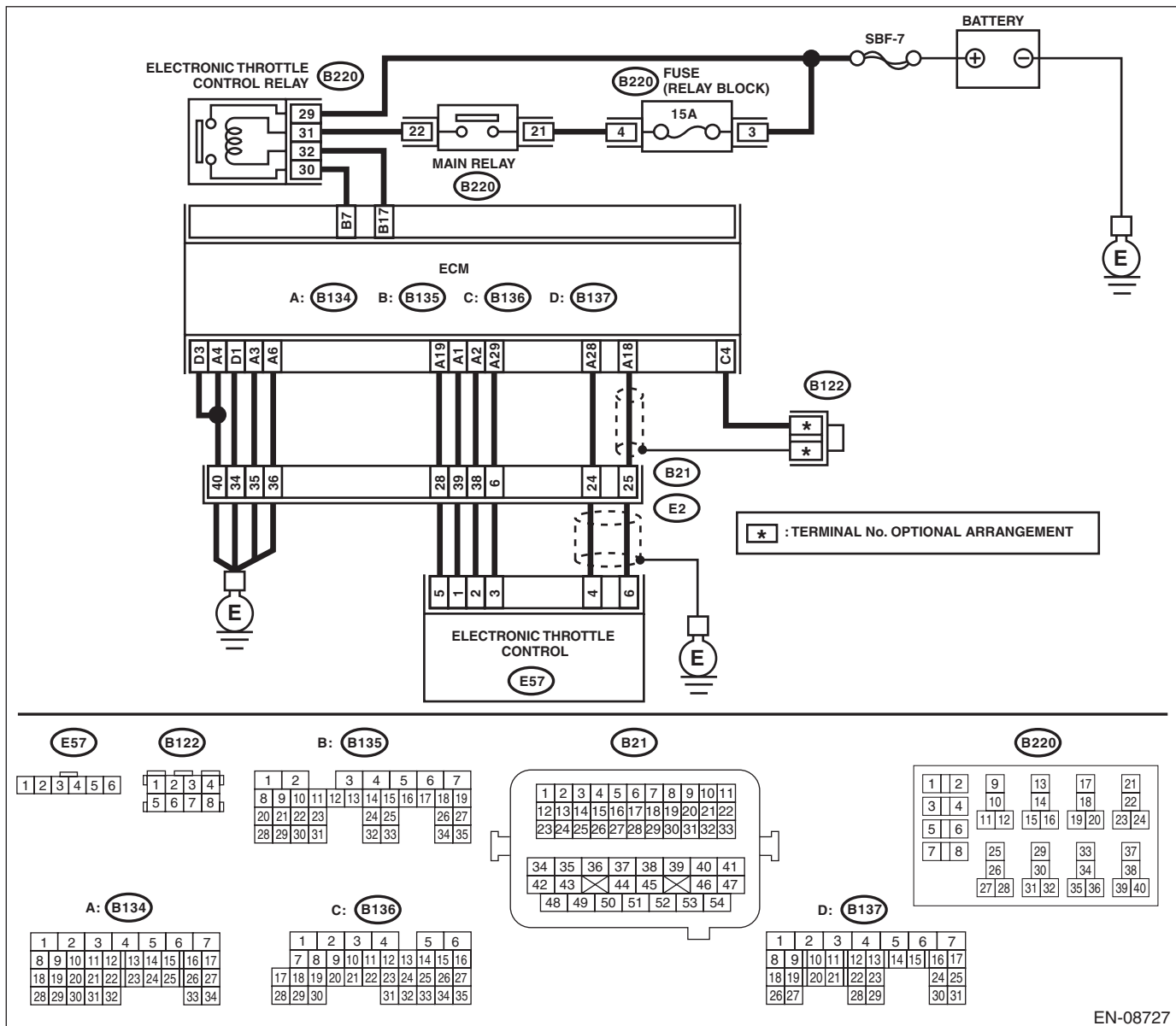

EN-08727

# Diagnostic Procedure with Diagnostic Trouble Code (DTC)

ENGINE (DIAGNOSTICS)

	Step	Check	Yes	No
1	<p><b>CHECK HARNESS BETWEEN ECM AND ELECTRONIC THROTTLE CONTROL CONNECTOR.</b></p> <p>1) Turn the ignition switch to OFF.</p> <p>2) Disconnect the connectors from ECM and electronic throttle control.</p> <p>3) Measure the resistance between ECM and chassis ground.</p> <p><b>Connector &amp; terminal</b>  <b>(B134) No. 19 — Chassis ground:</b>  <b>(B134) No. 28 — Chassis ground:</b></p>	Is the resistance 1 MΩ or more?	Go to step 2.	Repair the short circuit to ground in harness between ECM and electronic throttle control connector.
2	<p><b>CHECK SHORT CIRCUIT INSIDE THE ECM.</b></p> <p>1) Connect the connector to ECM.</p> <p>2) Measure the resistance between electronic throttle control connector and engine ground.</p> <p><b>Connector &amp; terminal</b>  <b>(E57) No. 4 — Engine ground:</b></p>	Is the resistance 1 MΩ or more?	Replace the electronic throttle control. <Ref. to FU(STI)-15, Throttle Body.> <Ref. to FU(w/o STI)-15, Throttle Body.>	Repair the short circuit to ground in harness between ECM and electronic throttle control connector. Replace the ECM if defective. <Ref. to FU(STI)-59, Engine Control Module (ECM).> <Ref. to FU(w/o STI)-58, Engine Control Module (ECM).>

# Diagnostic Procedure with Diagnostic Trouble Code (DTC)

ENGINE (DIAGNOSTICS)

## AW:DTC P0223 THROTTLE/PEDAL POSITION SENSOR/SWITCH "B" CIRCUIT HIGH

### DTC DETECTING CONDITION:

- Immediately at fault recognition
- GENERAL DESCRIPTION <Ref. to GD(H4DOTC)-97, DTC P0223 THROTTLE/PEDAL POSITION SENSOR/SWITCH "B" CIRCUIT HIGH, Diagnostic Trouble Code (DTC) Detecting Criteria.>

### TROUBLE SYMPTOM:

- Improper idling
- Poor driving performance
- Engine stalls.

### CAUTION:

After servicing or replacing faulty parts, perform Clear Memory Mode <Ref. to EN(H4DOTC)(diag)-62, OPERATION, Clear Memory Mode.>, and Inspection Mode <Ref. to EN(H4DOTC)(diag)-48, PROCEDURE, Inspection Mode.>.

### WIRING DIAGRAM:

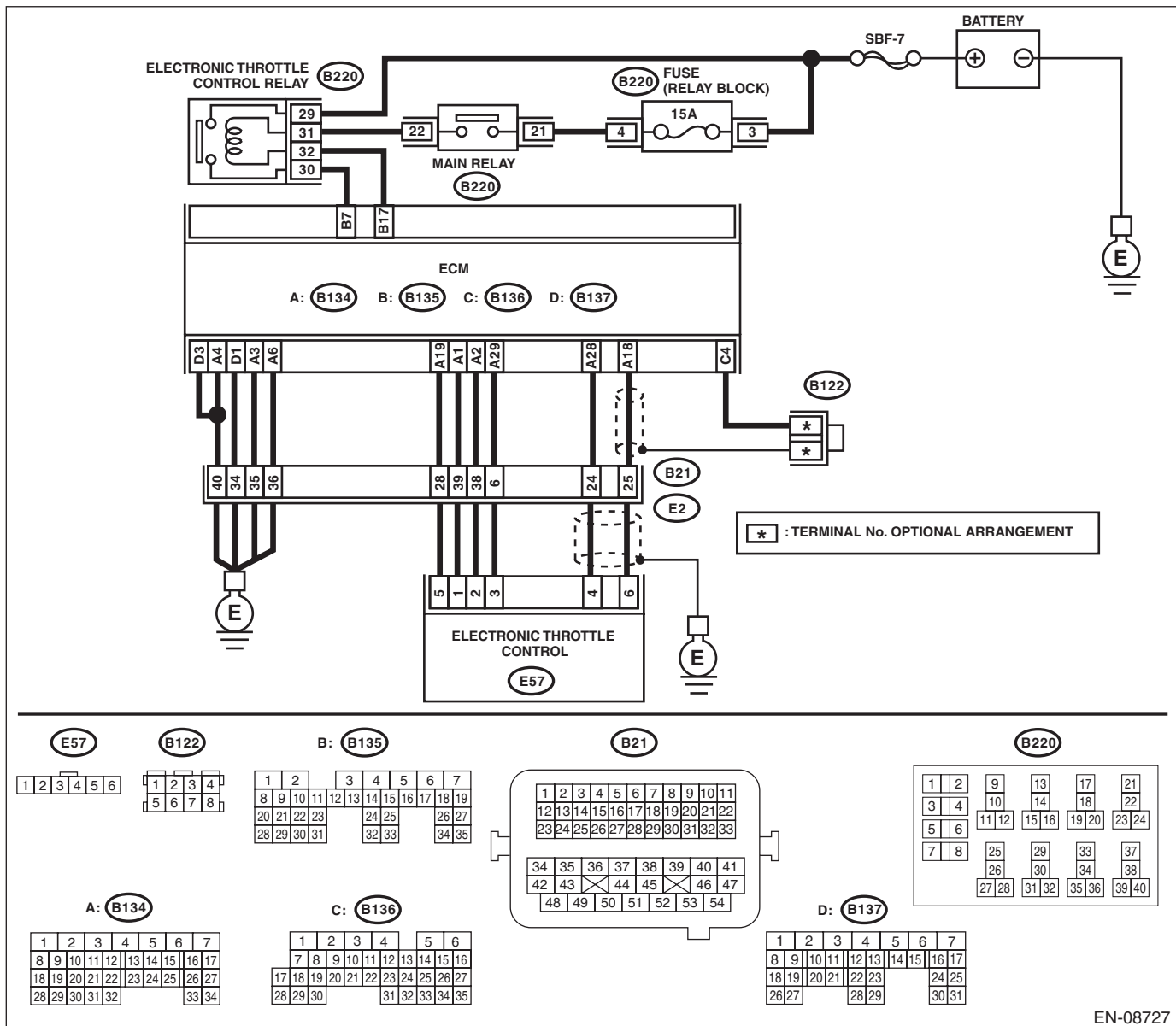

EN-08727

# Diagnostic Procedure with Diagnostic Trouble Code (DTC)

ENGINE (DIAGNOSTICS)

Step	Check	Yes	No
<p><b>1 CHECK HARNESS BETWEEN ECM AND ELECTRONIC THROTTLE CONTROL CONNECTOR.</b></p> <p>1) Turn the ignition switch to OFF. 2) Disconnect the connectors from ECM and electronic throttle control. 3) Measure the resistance of harness between ECM and electronic throttle control connector.</p> <p><b>Connector &amp; terminal</b> <b>(B134) No. 28 — (E57) No. 4:</b> <b>(B134) No. 29 — (E57) No. 3:</b></p>	<p>Is the resistance less than 1 <math>\Omega</math>?</p>	<p>Go to step 2.</p>	<p>Repair the harness and connector.</p> <p>NOTE: In this case, repair the following item:</p> <ul style="list-style-type: none"> <li>• Open circuit in harness between ECM and electronic throttle control connector</li> <li>• Poor contact of coupling connector</li> </ul>
<p><b>2 CHECK HARNESS BETWEEN ECM AND ELECTRONIC THROTTLE CONTROL CONNECTOR.</b></p> <p>1) Connect the connector to ECM. 2) Measure the resistance between electronic throttle control connector and engine ground.</p> <p><b>Connector &amp; terminal</b> <b>(E57) No. 3 — Engine ground:</b></p>	<p>Is the resistance less than 5 <math>\Omega</math>?</p>	<p>Go to step 3.</p>	<p>Repair the harness and connector.</p> <p>NOTE: In this case, repair the following item:</p> <ul style="list-style-type: none"> <li>• Open circuit of harness between ECM and engine ground</li> <li>• Poor contact of ECM connector</li> <li>• Poor contact of coupling connector</li> </ul>
<p><b>3 CHECK HARNESS BETWEEN ECM AND ELECTRONIC THROTTLE CONTROL CONNECTOR.</b></p> <p>1) Turn the ignition switch to ON. 2) Measure the voltage between electronic throttle control connector and engine ground.</p> <p><b>Connector &amp; terminal</b> <b>(E57) No. 4 (+) — Engine ground (-):</b></p>	<p>Is the voltage 5 V or more?</p>	<p>Repair the short circuit to power in harness between ECM and electronic throttle control connector.</p>	<p>Go to step 4.</p>
<p><b>4 CHECK HARNESS BETWEEN ECM AND ELECTRONIC THROTTLE CONTROL CONNECTOR.</b></p> <p>1) Turn the ignition switch to OFF. 2) Disconnect the connector from ECM. 3) Measure the resistance between ECM connectors.</p> <p><b>Connector &amp; terminal</b> <b>(B134) No. 19 — (B134) No. 28:</b></p>	<p>Is the resistance 1 M<math>\Omega</math> or more?</p>	<p>Repair the poor contact of electronic throttle control connector. Replace the electronic throttle control if defective. &lt;Ref. to FU(STI)-15, Throttle Body.&gt; &lt;Ref. to FU(w/o STI)-15, Throttle Body.&gt;</p>	<p>Repair the short circuit to power in harness between ECM and electronic throttle control connector.</p>

# Diagnostic Procedure with Diagnostic Trouble Code (DTC)

ENGINE (DIAGNOSTICS)

## AX:DTC P0230 FUEL PUMP PRIMARY CIRCUIT

### DTC DETECTING CONDITION:

- Detected when two consecutive driving cycles with fault occur.
- GENERAL DESCRIPTION <Ref. to GD(H4DOTC)-99, DTC P0230 FUEL PUMP PRIMARY CIRCUIT, Diagnostic Trouble Code (DTC) Detecting Criteria.>

### CAUTION:

After servicing or replacing faulty parts, perform Clear Memory Mode <Ref. to EN(H4DOTC)(diag)-62, OPERATION, Clear Memory Mode.>, and Inspection Mode <Ref. to EN(H4DOTC)(diag)-48, PROCEDURE, Inspection Mode.>.

### WIRING DIAGRAM:

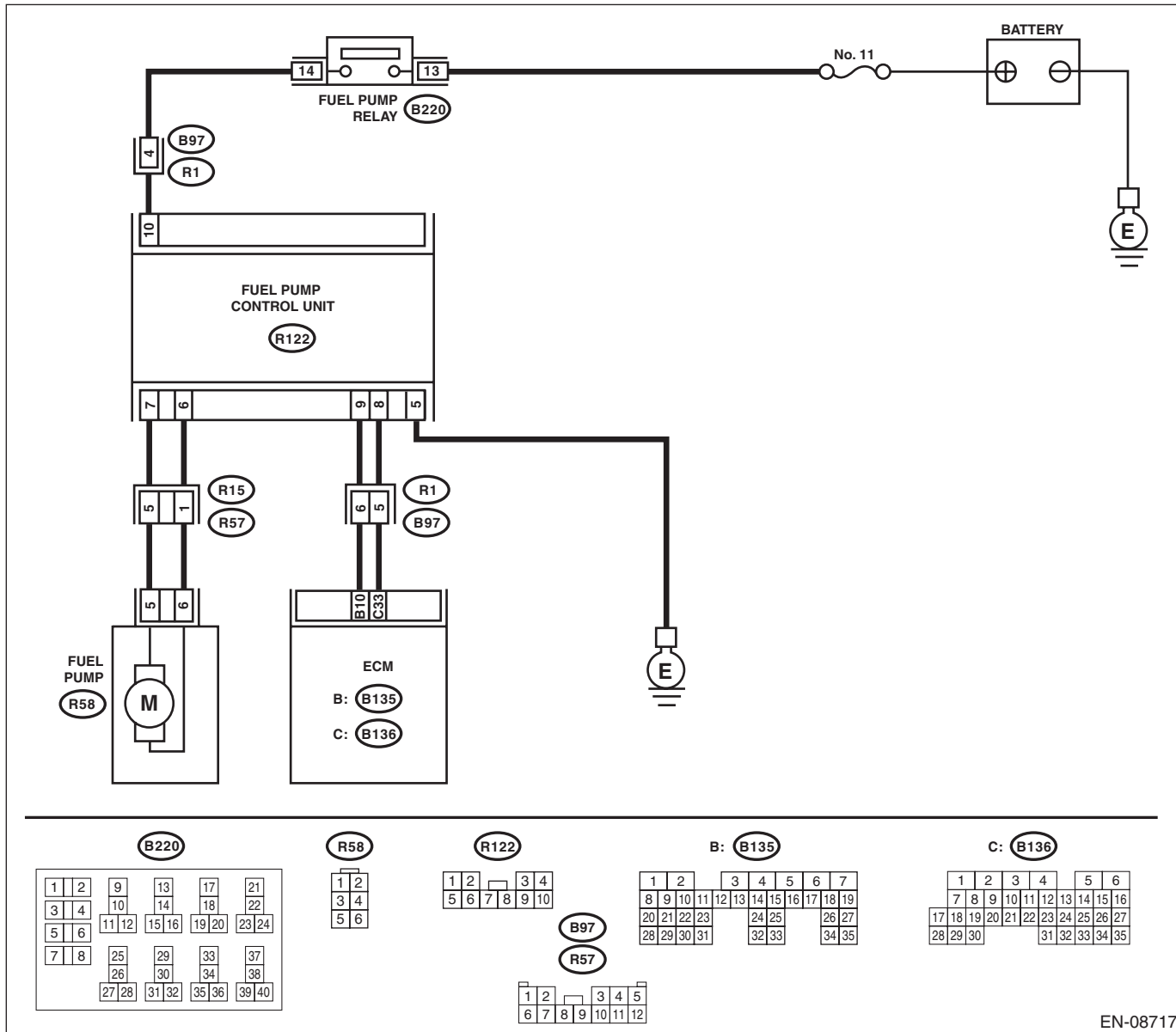

EN-08717

# Diagnostic Procedure with Diagnostic Trouble Code (DTC)

ENGINE (DIAGNOSTICS)

Step	Check	Yes	No
<p><b>1 CHECK POWER SUPPLY CIRCUIT TO FUEL PUMP CONTROL UNIT.</b></p> <p>1) Turn the ignition switch to OFF.                      2) Disconnect the connector from fuel pump control unit.                      3) Turn the ignition switch to ON.                      4) Measure the voltage between fuel pump control unit connector and chassis ground.</p> <p><b>Connector &amp; terminal</b>  <b>(R122) No. 10 (+) — Chassis ground (-):</b></p>	<p>Is the voltage 10 V or more?</p>	<p>Go to step 2.</p>	<p>Repair the power supply circuit.</p> <p>NOTE:                      In this case, repair the following item:</p> <ul style="list-style-type: none"> <li>• Open circuit or short circuit to ground in harness between fuel pump relay connector and fuel pump control unit connector</li> <li>• Poor contact of fuel pump relay connector</li> <li>• Poor contact of coupling connector</li> </ul>
<p><b>2 CHECK GROUND CIRCUIT OF FUEL PUMP CONTROL UNIT.</b></p> <p>1) Turn the ignition switch to OFF.                      2) Measure the resistance of harness between fuel pump control unit connector and chassis ground.</p> <p><b>Connector &amp; terminal</b>  <b>(R122) No. 5 — Chassis ground:</b></p>	<p>Is the resistance less than 5 Ω?</p>	<p>Go to step 3.</p>	<p>Repair the open circuit in harness between fuel pump control unit connector and chassis ground.</p>
<p><b>3 CHECK HARNESS BETWEEN FUEL PUMP CONTROL UNIT AND FUEL PUMP CONNECTOR.</b></p> <p>1) Disconnect the connector from fuel pump.                      2) Measure the resistance of harness between fuel pump control unit and fuel pump connector.</p> <p><b>Connector &amp; terminal</b>  <b>(R122) No. 7 — (R58) No. 5:</b>  <b>(R122) No. 6 — (R58) No. 6:</b></p>	<p>Is the resistance less than 1 Ω?</p>	<p>Go to step 4.</p>	<p>Repair the harness and connector.</p> <p>NOTE:                      In this case, repair the following item:</p> <ul style="list-style-type: none"> <li>• Open circuit in harness between fuel pump control unit connector and fuel pump connector</li> <li>• Poor contact of coupling connector</li> </ul>
<p><b>4 CHECK HARNESS BETWEEN FUEL PUMP CONTROL UNIT AND FUEL PUMP CONNECTOR.</b></p> <p>Measure the resistance between fuel pump control unit connector and chassis ground.</p> <p><b>Connector &amp; terminal</b>  <b>(R122) No. 7 — Chassis ground:</b>  <b>(R122) No. 6 — Chassis ground:</b></p>	<p>Is the resistance 1 MΩ or more?</p>	<p>Go to step 5.</p>	<p>Repair the short circuit to ground in harness between fuel pump control unit connector and fuel pump connector.</p>
<p><b>5 CHECK HARNESS BETWEEN ECM AND FUEL PUMP CONTROL UNIT CONNECTOR.</b></p> <p>1) Disconnect the connector from ECM.                      2) Measure the resistance of harness between ECM and fuel pump control unit connector.</p> <p><b>Connector &amp; terminal</b>  <b>(B135) No. 10 — (R122) No. 9:</b>  <b>(B136) No. 33 — (R122) No. 8:</b></p>	<p>Is the resistance less than 1 Ω?</p>	<p>Go to step 6.</p>	<p>Repair the harness and connector.</p> <p>NOTE:                      In this case, repair the following item:</p> <ul style="list-style-type: none"> <li>• Open circuit in harness between ECM and fuel pump control unit connector</li> <li>• Poor contact of coupling connector</li> </ul>

## Diagnostic Procedure with Diagnostic Trouble Code (DTC)

### ENGINE (DIAGNOSTICS)

Step	Check	Yes	No
<b>6</b> <b>CHECK HARNESS BETWEEN ECM AND FUEL PUMP CONTROL UNIT CONNECTOR.</b> Measure the resistance between fuel pump control unit connector and chassis ground. <i>Connector &amp; terminal</i> <i>(R122) No. 9 — Chassis ground:</i> <i>(R122) No. 8 — Chassis ground:</i>	Is the resistance 1 MΩ or more?	Go to step 7.	Repair the short circuit to ground in harness between ECM and fuel pump control unit connector.
<b>7</b> <b>CHECK FOR POOR CONTACT.</b> Check for poor contact of ECM and fuel pump control unit connector.	Is there poor contact of ECM or fuel pump control unit connector?	Repair the poor contact of ECM or fuel pump control unit connector.	Go to step 8.
<b>8</b> <b>CHECK EXPERIENCE OF RUNNING OUT OF FUEL.</b>	Has the vehicle experienced running out of fuel?	Finish the diagnosis. NOTE: DTC may be recorded as a result of fuel pump idling while running out of fuel.	Replace the fuel pump control unit. <Ref. to FU(STI)-66, Fuel Pump Control Unit.> <Ref. to FU(w/o STI)-65, Fuel Pump Control Unit.>

# Diagnostic Procedure with Diagnostic Trouble Code (DTC)

ENGINE (DIAGNOSTICS)

## AY:DTC P0244 TURBO/SUPER CHARGER WASTEGATE SOLENOID "A" RANGE/PERFORMANCE

### DTC DETECTING CONDITION:

- Immediately at fault recognition
- GENERAL DESCRIPTION <Ref. to GD(H4DOTC)-101, DTC P0244 TURBO/SUPER CHARGER WASTEGATE SOLENOID "A" RANGE/PERFORMANCE, Diagnostic Trouble Code (DTC) Detecting Criteria.>

### TROUBLE SYMPTOM:

Poor driving performance

### CAUTION:

After servicing or replacing faulty parts, perform Clear Memory Mode <Ref. to EN(H4DOTC)(diag)-62, OPERATION, Clear Memory Mode.>, and Inspection Mode <Ref. to EN(H4DOTC)(diag)-48, PROCEDURE, Inspection Mode.>.

Step	Check	Yes	No
1 <b>CHECK FOR ANY OTHER DTC ON DISPLAY.</b>	Is any other DTC displayed?	Check the appropriate DTC using the "List of Diagnostic Trouble Code (DTC)". <Ref. to EN(H4DOTC)(diag)-88, List of Diagnostic Trouble Code (DTC).>	Go to step 2.
2 <b>CHECK WASTEGATE ACTUATOR PIPING AND WASTEGATE CONTROL SOLENOID VALVE PIPING.</b>	Are there any damage or disconnection of hose in wastegate actuator piping or wastegate control solenoid valve piping?	Connect the wastegate actuator pipe or wastegate control solenoid valve pipe properly. If defective, replace the hose.	Replace the wastegate control solenoid valve. <Ref. to FU(STI)-52, Wastegate Control Solenoid Valve.> <Ref. to FU(w/o STI)-52, Wastegate Control Solenoid Valve.>



# Diagnostic Procedure with Diagnostic Trouble Code (DTC)

ENGINE (DIAGNOSTICS)

## AZ:DTC P0245 TURBO/SUPER CHARGER WASTEGATE SOLENOID "A" LOW

### DTC DETECTING CONDITION:

- Immediately at fault recognition
- GENERAL DESCRIPTION <Ref. to GD(H4DOTC)-103, DTC P0245 TURBO/SUPER CHARGER WASTEGATE SOLENOID "A" LOW, Diagnostic Trouble Code (DTC) Detecting Criteria.>

### TROUBLE SYMPTOM:

Poor driving performance

### CAUTION:

After servicing or replacing faulty parts, perform Clear Memory Mode <Ref. to EN(H4DOTC)(diag)-62, OPERATION, Clear Memory Mode.>, and Inspection Mode <Ref. to EN(H4DOTC)(diag)-48, PROCEDURE, Inspection Mode.>.

### WIRING DIAGRAM:

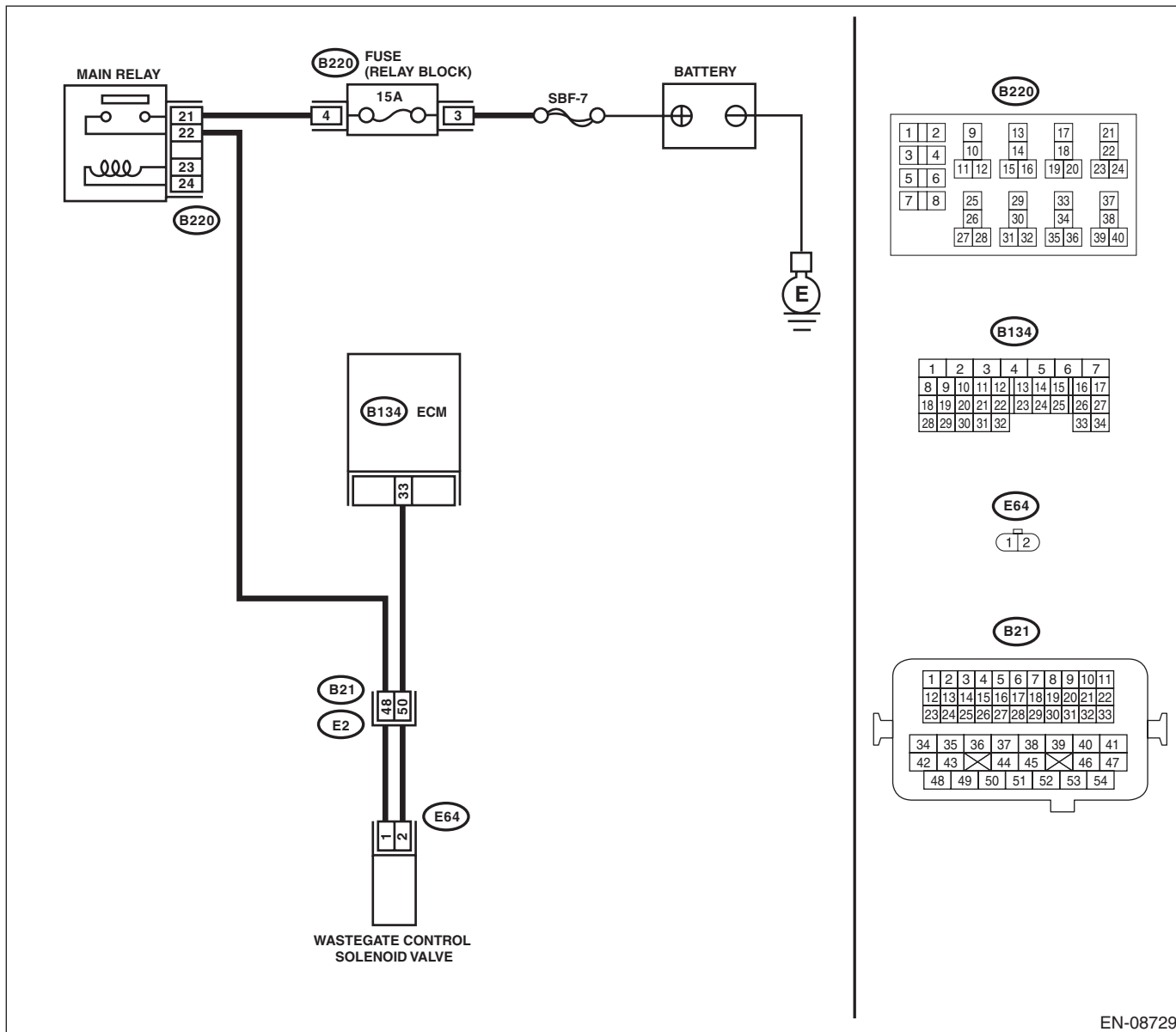

EN-08729

# Diagnostic Procedure with Diagnostic Trouble Code (DTC)

ENGINE (DIAGNOSTICS)

	Step	Check	Yes	No
1	<p><b>CHECK OUTPUT SIGNAL OF ECM.</b>                      1) Turn the ignition switch to ON.                      2) Measure the voltage between ECM and chassis ground.  <b>Connector &amp; terminal</b>  <b>(B134) No. 33 (+) — Chassis ground (-):</b></p>	Is the voltage 10 V or more?	Go to step 2.	Go to step 3.
2	<p><b>CHECK FOR POOR CONTACT.</b>                      Check for poor contact of ECM connector.</p>	Is there poor contact of ECM connector?	Repair the poor contact of ECM connector.	Even if DTC is detected, the circuit has returned to a normal condition at this time. Reproduce the failure, and then perform the diagnosis again. NOTE: In this case, temporary open or short circuit of harness or temporary poor contact of connector may be the cause.
3	<p><b>CHECK POWER SUPPLY TO WASTEGATE CONTROL SOLENOID VALVE.</b>                      Measure the voltage between wastegate control solenoid valve connector and engine ground.  <b>Connector &amp; terminal</b>  <b>(E64) No. 1 (+) — Engine ground (-):</b></p>	Is the voltage 10 V or more?	Go to step 4.	Repair the power supply circuit.
4	<p><b>CHECK HARNESS BETWEEN ECM AND WASTEGATE CONTROL SOLENOID VALVE CONNECTOR.</b>                      1) Turn the ignition switch to OFF.                      2) Disconnect the connectors from ECM and wastegate control solenoid valve.                      3) Measure the resistance between wastegate control solenoid valve connector and engine ground.  <b>Connector &amp; terminal</b>  <b>(E64) No. 2 — Engine ground:</b></p>	Is the resistance 1 M $\Omega$ or more?	Go to step 5.	Repair ground short circuit of harness between ECM and wastegate control solenoid valve connector.
5	<p><b>CHECK HARNESS BETWEEN ECM AND WASTEGATE CONTROL SOLENOID VALVE CONNECTOR.</b>                      Measure the resistance of harness between ECM and wastegate control solenoid valve connector.  <b>Connector &amp; terminal</b>  <b>(B134) No. 33 — (E64) No. 2:</b></p>	Is the resistance less than 1 $\Omega$ ?	Go to step 6.	Repair the harness and connector. NOTE: In this case, repair the following item: <ul style="list-style-type: none"> <li>• Open circuit of harness between ECM and wastegate control solenoid valve connector</li> <li>• Poor contact of coupling connector</li> </ul>

# Diagnostic Procedure with Diagnostic Trouble Code (DTC)

ENGINE (DIAGNOSTICS)

Step	Check	Yes	No
<b>6</b> <b>CHECK WASTEGATE CONTROL SOLENOID VALVE.</b> 1) Remove the wastegate control solenoid valve. 2) Measure the resistance between wastegate control solenoid valve terminals. <b>Terminals</b> <b>No. 1 — No. 2:</b>	Is the resistance 10 — 100 Ω?	Repair poor contact of wastegate control solenoid valve connector.	Replace the wastegate control solenoid valve. <Ref. to FU(STI)-52, Wastegate Control Solenoid Valve.> <Ref. to FU(w/o STI)-52, Wastegate Control Solenoid Valve.>

# Diagnostic Procedure with Diagnostic Trouble Code (DTC)

ENGINE (DIAGNOSTICS)

## BA:DTC P0246 TURBO/SUPER CHARGER WASTEGATE SOLENOID "A" HIGH

### DTC DETECTING CONDITION:

- Immediately at fault recognition
- GENERAL DESCRIPTION <Ref. to GD(H4DOTC)-105, DTC P0246 TURBO/SUPER CHARGER WASTEGATE SOLENOID "A" HIGH, Diagnostic Trouble Code (DTC) Detecting Criteria.>

### TROUBLE SYMPTOM:

Poor driving performance

### CAUTION:

After servicing or replacing faulty parts, perform Clear Memory Mode <Ref. to EN(H4DOTC)(diag)-62, OPERATION, Clear Memory Mode.>, and Inspection Mode <Ref. to EN(H4DOTC)(diag)-48, PROCEDURE, Inspection Mode.>.

### WIRING DIAGRAM:

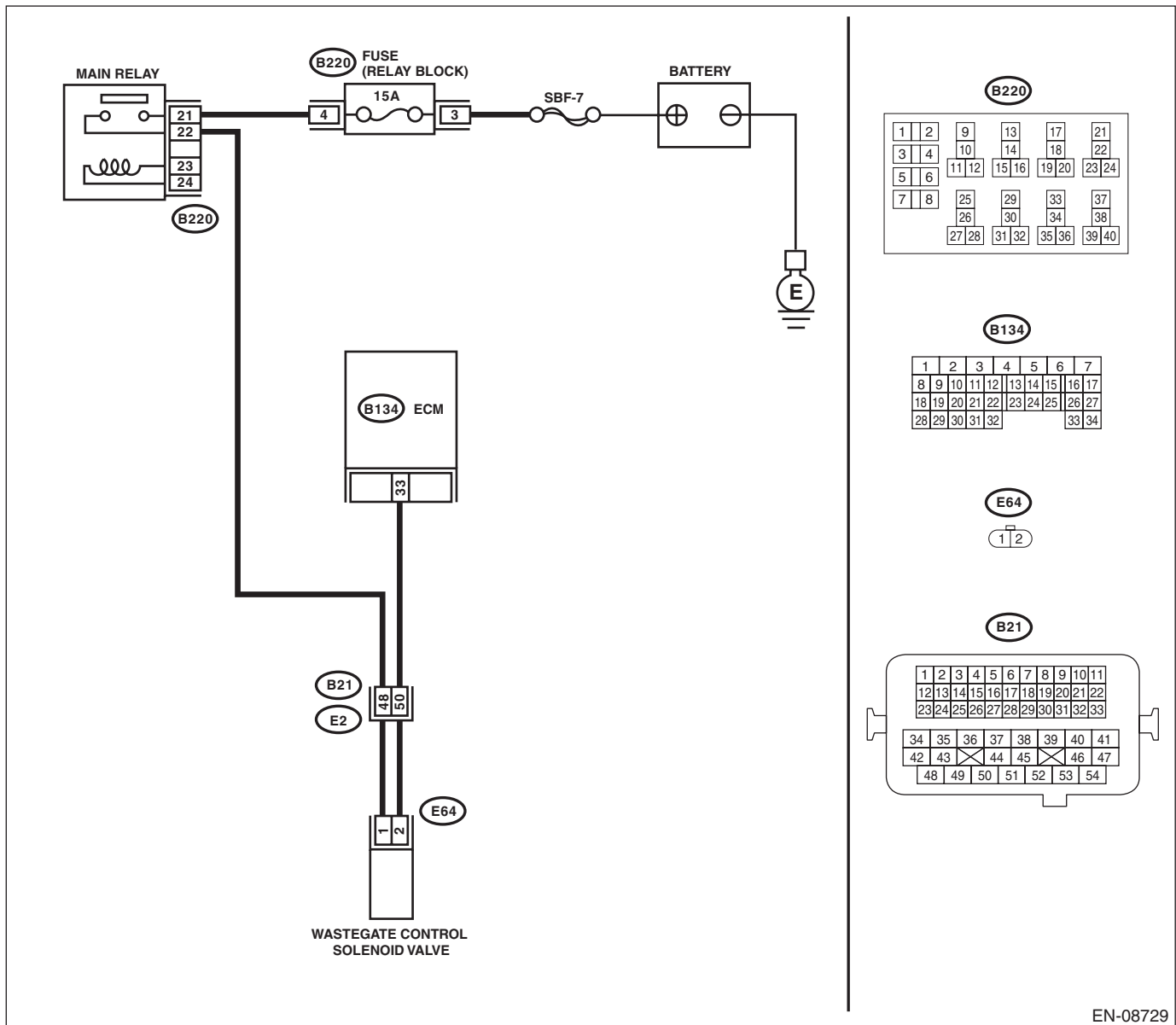

EN-08729

# Diagnostic Procedure with Diagnostic Trouble Code (DTC)

## ENGINE (DIAGNOSTICS)

Step	Check	Yes	No
<b>1</b> <b>CHECK HARNESS BETWEEN ECM AND WASTEGATE CONTROL SOLENOID VALVE CONNECTOR.</b> 1) Turn the ignition switch to OFF. 2) Disconnect the connectors from ECM and wastegate control solenoid valve. 3) Turn the ignition switch to ON. 4) Measure the voltage between ECM and chassis ground. <b>Connector &amp; terminal</b> <b>(B134) No. 33 (+) — Chassis ground (-):</b>	Is the voltage 10 V or more?	Repair short circuit to power in the harness between ECM and wastegate control solenoid valve connector.	Go to step 2.
<b>2</b> <b>CHECK WASTEGATE CONTROL SOLENOID VALVE.</b> 1) Turn the ignition switch to OFF. 2) Measure the resistance between wastegate control solenoid valve terminals. <b>Terminals</b> <b>No. 1 — No. 2:</b>	Is the resistance less than 1 $\Omega$ ?	Replace the wastegate control solenoid valve. <Ref. to FU(STI)-52, Wastegate Control Solenoid Valve.> <Ref. to FU(w/o STI)-52, Wastegate Control Solenoid Valve.>	Repair the poor contact of ECM connector.

### BB:DTC P0301 CYLINDER 1 MISFIRE DETECTED

#### NOTE:

For the diagnostic procedure, refer to DTC P0304. <Ref. to EN(H4DOTC)(diag)-187, DTC P0304 CYLINDER 4 MISFIRE DETECTED, Diagnostic Procedure with Diagnostic Trouble Code (DTC).>

### BC:DTC P0302 CYLINDER 2 MISFIRE DETECTED

#### NOTE:

For the diagnostic procedure, refer to DTC P0304. <Ref. to EN(H4DOTC)(diag)-187, DTC P0304 CYLINDER 4 MISFIRE DETECTED, Diagnostic Procedure with Diagnostic Trouble Code (DTC).>

### BD:DTC P0303 CYLINDER 3 MISFIRE DETECTED

#### NOTE:

For the diagnostic procedure, refer to DTC P0304. <Ref. to EN(H4DOTC)(diag)-187, DTC P0304 CYLINDER 4 MISFIRE DETECTED, Diagnostic Procedure with Diagnostic Trouble Code (DTC).>

# Diagnostic Procedure with Diagnostic Trouble Code (DTC)

ENGINE (DIAGNOSTICS)

## BE:DTC P0304 CYLINDER 4 MISFIRE DETECTED

### DTC DETECTING CONDITION:

- Detected when two consecutive driving cycles with fault occur.
- Immediately at fault recognition (A misfire which could damage catalyst occurs.)
- GENERAL DESCRIPTION <Ref. to GD(H4DOTC)-116, DTC P0304 CYLINDER 4 MISFIRE DETECTED, Diagnostic Trouble Code (DTC) Detecting Criteria.>

### TROUBLE SYMPTOM:

- Engine stalls.
- Improper idling
- Rough driving

### CAUTION:

After servicing or replacing faulty parts, perform Clear Memory Mode <Ref. to EN(H4DOTC)(diag)-62, OPERATION, Clear Memory Mode.>, and Inspection Mode <Ref. to EN(H4DOTC)(diag)-48, PROCEDURE, Inspection Mode.>.

### WIRING DIAGRAM:

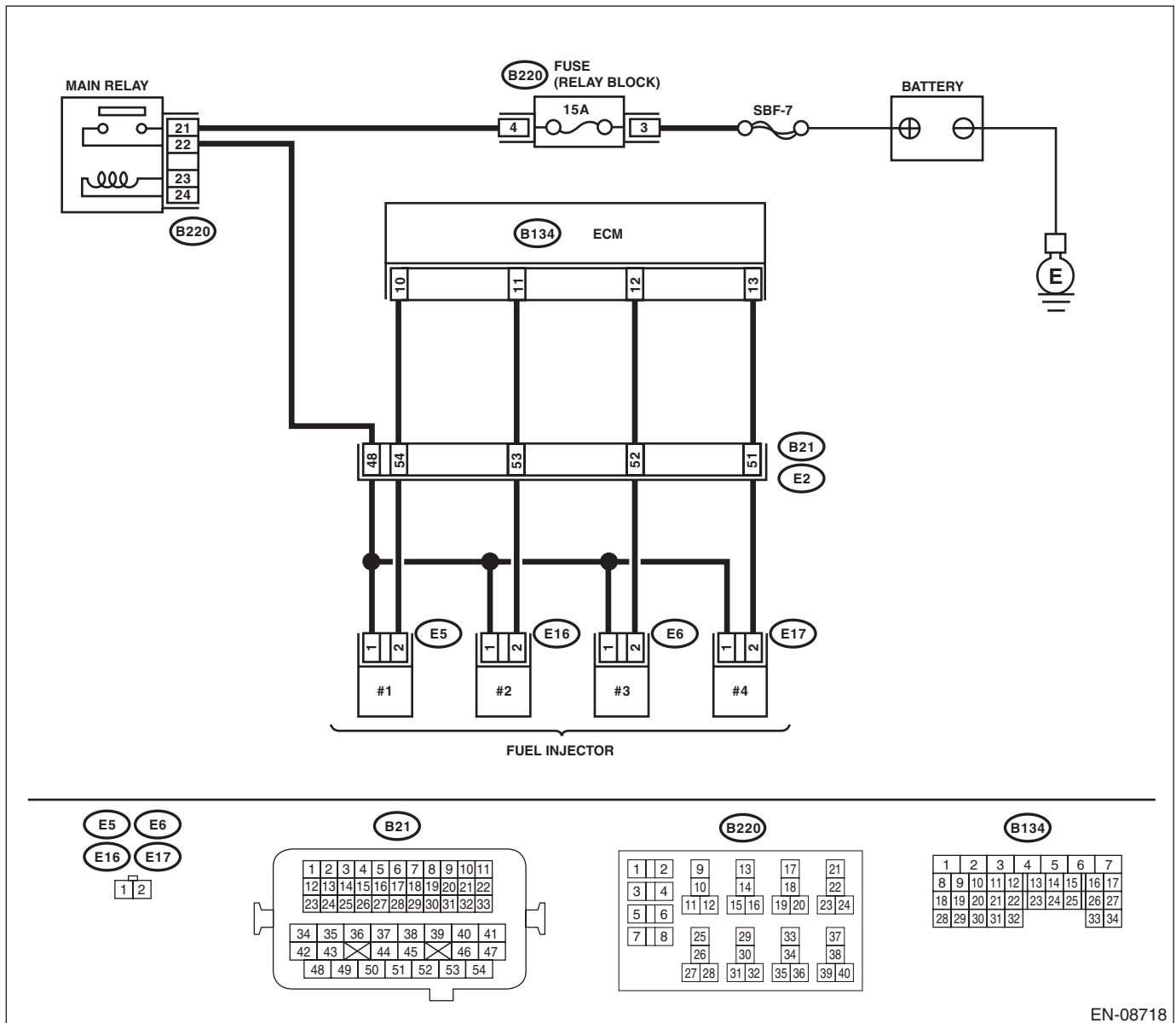

EN-08718

# Diagnostic Procedure with Diagnostic Trouble Code (DTC)

## ENGINE (DIAGNOSTICS)

Step	Check	Yes	No
<b>1 CHECK OUTPUT SIGNAL OF ECM.</b> 1) Turn the ignition switch to ON. 2) Measure the voltage between ECM and chassis ground on faulty cylinders. <b>Connector &amp; terminal</b> <i>#1 (B134) No. 10 (+) — Chassis ground (-):</i> <i>#2 (B134) No. 11 (+) — Chassis ground (-):</i> <i>#3 (B134) No. 12 (+) — Chassis ground (-):</i> <i>#4 (B134) No. 13 (+) — Chassis ground (-):</i>	Is the voltage 10 V or more?	Go to step 6.	Go to step 2.
<b>2 CHECK HARNESS BETWEEN ECM AND FUEL INJECTOR CONNECTOR.</b> 1) Turn the ignition switch to OFF. 2) Disconnect the connector from fuel injector on faulty cylinders. 3) Measure the resistance between fuel injector connector and engine ground on faulty cylinders. <b>Connector &amp; terminal</b> <i>#1 (E5) No. 2 — Engine ground:</i> <i>#2 (E16) No. 2 — Engine ground:</i> <i>#3 (E6) No. 2 — Engine ground:</i> <i>#4 (E17) No. 2 — Engine ground:</i>	Is the resistance 1 M $\Omega$ or more?	Go to step 3.	Repair the short circuit to ground in harness between ECM and fuel injector connector.
<b>3 CHECK HARNESS BETWEEN ECM AND FUEL INJECTOR CONNECTOR.</b> Measure the resistance of harness between ECM and fuel injector connector on faulty cylinders. <b>Connector &amp; terminal</b> <i>#1 (B134) No. 10 — (E5) No. 2:</i> <i>#2 (B134) No. 11 — (E16) No. 2:</i> <i>#3 (B134) No. 12 — (E6) No. 2:</i> <i>#4 (B134) No. 13 — (E17) No. 2:</i>	Is the resistance less than 1 $\Omega$ ?	Go to step 4.	Repair the harness and connector. NOTE: In this case, repair the following item: <ul style="list-style-type: none"> <li>• Open circuit in harness between ECM and fuel injector connector</li> <li>• Poor contact of coupling connector</li> </ul>
<b>4 CHECK FUEL INJECTOR.</b> Measure the resistance between fuel injector terminals on faulty cylinder. <b>Terminals</b> <i>No. 1 — No. 2:</i>	Is the resistance 5 — 20 $\Omega$ ?	Go to step 5.	Replace the faulty fuel injector. <Ref. to FU(STI)-45, Fuel Injector.> <Ref. to FU(w/o STI)-46, Fuel Injector.>
<b>5 CHECK POWER SUPPLY LINE.</b> 1) Turn the ignition switch to ON. 2) Measure the voltage between fuel injector connector of faulty cylinders and engine ground. <b>Connector &amp; terminal</b> <i>#1 (E5) No. 1 (+) — Engine ground (-):</i> <i>#2 (E16) No. 1 (+) — Engine ground (-):</i> <i>#3 (E6) No. 1 (+) — Engine ground (-):</i> <i>#4 (E17) No. 1 (+) — Engine ground (-):</i>	Is the voltage 10 V or more?	Repair the poor contact of all connectors in fuel injector circuit.	Repair the harness and connector. NOTE: In this case, repair the following item: <ul style="list-style-type: none"> <li>• Open circuit in harness between the main relay connector and fuel injector connector on faulty cylinders</li> <li>• Poor contact of coupling connector</li> <li>• Poor contact of main relay connector</li> </ul>

# Diagnostic Procedure with Diagnostic Trouble Code (DTC)

ENGINE (DIAGNOSTICS)

Step	Check	Yes	No
<b>6 CHECK HARNESS BETWEEN ECM AND FUEL INJECTOR CONNECTOR.</b> 1) Turn the ignition switch to OFF. 2) Disconnect the connector from fuel injector on faulty cylinders. 3) Turn the ignition switch to ON. 4) Measure the voltage between ECM and chassis ground on faulty cylinders. <b>Connector &amp; terminal</b> <b>#1 (B134) No. 10 (+) — Chassis ground (-):</b> <b>#2 (B134) No. 11 (+) — Chassis ground (-):</b> <b>#3 (B134) No. 12 (+) — Chassis ground (-):</b> <b>#4 (B134) No. 13 (+) — Chassis ground (-):</b>	Is the voltage 10 V or more?	Repair the short circuit to power in harness between ECM and fuel injector connector.	Go to step 7.
<b>7 CHECK FUEL INJECTOR.</b> 1) Turn the ignition switch to OFF. 2) Measure the resistance between fuel injector terminals on faulty cylinder. <b>Terminals</b> <b>No. 1 — No. 2:</b>	Is the resistance 5 — 20 Ω?	Go to step 8.	Replace the faulty fuel injector. <Ref. to FU(STI)-45, Fuel Injector.> <Ref. to FU(w/o STI)-46, Fuel Injector.>
<b>8 CHECK INSTALLATION OF CAMSHAFT POSITION SENSOR/CRANKSHAFT POSITION SENSOR.</b>	Is the camshaft position sensor or crankshaft position sensor loosely installed?	Tighten the camshaft position sensor or crankshaft position sensor. <Ref. to FU(STI)-37, Camshaft Position Sensor.> <Ref. to FU(STI)-35, Crankshaft Position Sensor.> <Ref. to FU(w/o STI)-38, Camshaft Position Sensor.> <Ref. to FU(w/o STI)-36, Crankshaft Position Sensor.>	Go to step 9.
<b>9 CHECK CRANK SPROCKET.</b> Remove the timing belt cover.	Is the crank sprocket rusted or does it have broken teeth?	Replace the crank sprocket. <Ref. to ME(STI)-60, Crank Sprocket.> <Ref. to ME(w/o STI)-59, Crank Sprocket.>	Go to step 10.
<b>10 CHECK INSTALLATION CONDITION OF TIMING BELT.</b> Turn the crankshaft, and align alignment mark on crank sprocket with alignment mark on cylinder block. ST 499987500                      CRANKSHAFT SOCKET	Is the timing belt dislocated from its proper position?	Repair the installation condition of timing belt. <Ref. to ME(STI)-50, Timing Belt.> <Ref. to ME(w/o STI)-49, Timing Belt.>	Go to step 11.
<b>11 CHECK FUEL LEVEL.</b>	Is the fuel meter indication higher than the "Lower" level?	Go to step 12.	Refill the fuel so that the fuel meter indication is higher than the "Lower" level, and proceed to the next step. Go to step 12.



# Diagnostic Procedure with Diagnostic Trouble Code (DTC)

## ENGINE (DIAGNOSTICS)

Step	Check	Yes	No
<b>12 CHECK STATUS OF MALFUNCTION INDICATOR LIGHT.</b> 1) Clear the memory using the Subaru Select Monitor or general scan tool. <Ref. to EN(H4DOTC)(diag)-62, Clear Memory Mode.> 2) Start the engine, and drive the vehicle 10 minutes or more.	Does the malfunction indicator light illuminate or blink?	Go to step 14.	Go to step 13.
<b>13 CHECK CAUSE OF MISFIRE.</b>	Was the cause of misfire identified when the engine is running?	Finish diagnostics operation, if the engine has no abnormality.	Repair the poor contact of connector. NOTE: In this case, repair the following item: <ul style="list-style-type: none"> <li>• Poor contact of ignition coil connector</li> <li>• Poor contact of fuel injector connector on faulty cylinders</li> <li>• Poor contact of ECM connector</li> <li>• Poor contact of coupling connector</li> </ul>
<b>14 CHECK AIR INTAKE SYSTEM.</b>	Is there any fault in air intake system?	Repair the air intake system. NOTE: Check the following items. <ul style="list-style-type: none"> <li>• Are there air leaks or air suction caused by loose or dislocated nuts and bolts?</li> <li>• Are there cracks or any disconnection of hoses?</li> </ul>	Go to step 15.
<b>15 CHECK MISFIRE SYMPTOM.</b> 1) Turn the ignition switch to ON. 2) Check for DTC. <Ref. to EN(H4DOTC)(diag)-47, Read Diagnostic Trouble Code (DTC).>	Does the Subaru Select Monitor or general scan tool indicate only one DTC?	Go to step 18.	Go to step 16.
<b>16 CHECK DTC.</b>	Is DTC P0301 and P0303 displayed on the Subaru Select Monitor or general scan tool?	Go to step 19.	Go to step 17.
<b>17 CHECK DTC.</b>	Is DTC P0302 and P0304 displayed on the Subaru Select Monitor or general scan tool?	Go to step 20.	Go to step 21.
<b>18 ONLY ONE CYLINDER.</b>	Is there any fault in the cylinder?	Repair or replace faulty parts. NOTE: Check the following items. <ul style="list-style-type: none"> <li>• Spark plug</li> <li>• Ignition coil</li> <li>• Fuel injector</li> <li>• Compression ratio</li> </ul>	Go to DTC P0171. <Ref. to EN(H4DOTC)(diag)-168, DTC P0171 SYSTEM TOO LEAN (BANK 1), Diagnostic Procedure with Diagnostic Trouble Code (DTC).>

# Diagnostic Procedure with Diagnostic Trouble Code (DTC)

ENGINE (DIAGNOSTICS)

Step	Check	Yes	No
19 <b>GROUP OF #1 AND #3 CYLINDERS.</b>	Are there any faults in #1 and #3 cylinders?	Repair or replace faulty parts. NOTE: Check the following items. • Spark plug • Ignition coil • Fuel injector • Compression ratio • Skipping timing belt teeth	Go to DTC P0171. <Ref. to EN(H4DOTC)(diag)-168, DTC P0171 SYSTEM TOO LEAN (BANK 1), Diagnostic Procedure with Diagnostic Trouble Code (DTC).>
20 <b>GROUP OF #2 AND #4 CYLINDERS.</b>	Are there any faults in #2 and #4 cylinders?	Repair or replace faulty parts. NOTE: Check the following items. • Spark plug • Ignition coil • Fuel injector • Compression ratio • Skipping timing belt teeth	Go to DTC P0171. <Ref. to EN(H4DOTC)(diag)-168, DTC P0171 SYSTEM TOO LEAN (BANK 1), Diagnostic Procedure with Diagnostic Trouble Code (DTC).>
21 <b>CYLINDER AT RANDOM.</b>	Is the engine idle rough?	Go to DTC P0171. <Ref. to EN(H4DOTC)(diag)-168, DTC P0171 SYSTEM TOO LEAN (BANK 1), Diagnostic Procedure with Diagnostic Trouble Code (DTC).>	Repair or replace faulty parts. NOTE: Check the following items. • Spark plug • Ignition coil • Fuel injector • Compression ratio

# Diagnostic Procedure with Diagnostic Trouble Code (DTC)

ENGINE (DIAGNOSTICS)

## BF:DTC P0327 KNOCK SENSOR 1 CIRCUIT LOW (BANK 1 OR SINGLE SENSOR)

### DTC DETECTING CONDITION:

- Immediately at fault recognition
- GENERAL DESCRIPTION <Ref. to GD(H4DOTC)-117, DTC P0327 KNOCK SENSOR 1 CIRCUIT LOW (BANK 1 OR SINGLE SENSOR), Diagnostic Trouble Code (DTC) Detecting Criteria.>

### TROUBLE SYMPTOM:

- Poor driving performance
- Knocking occurs.

### CAUTION:

After servicing or replacing faulty parts, perform Clear Memory Mode <Ref. to EN(H4DOTC)(diag)-62, OPERATION, Clear Memory Mode.>, and Inspection Mode <Ref. to EN(H4DOTC)(diag)-48, PROCEDURE, Inspection Mode.>.

### WIRING DIAGRAM:

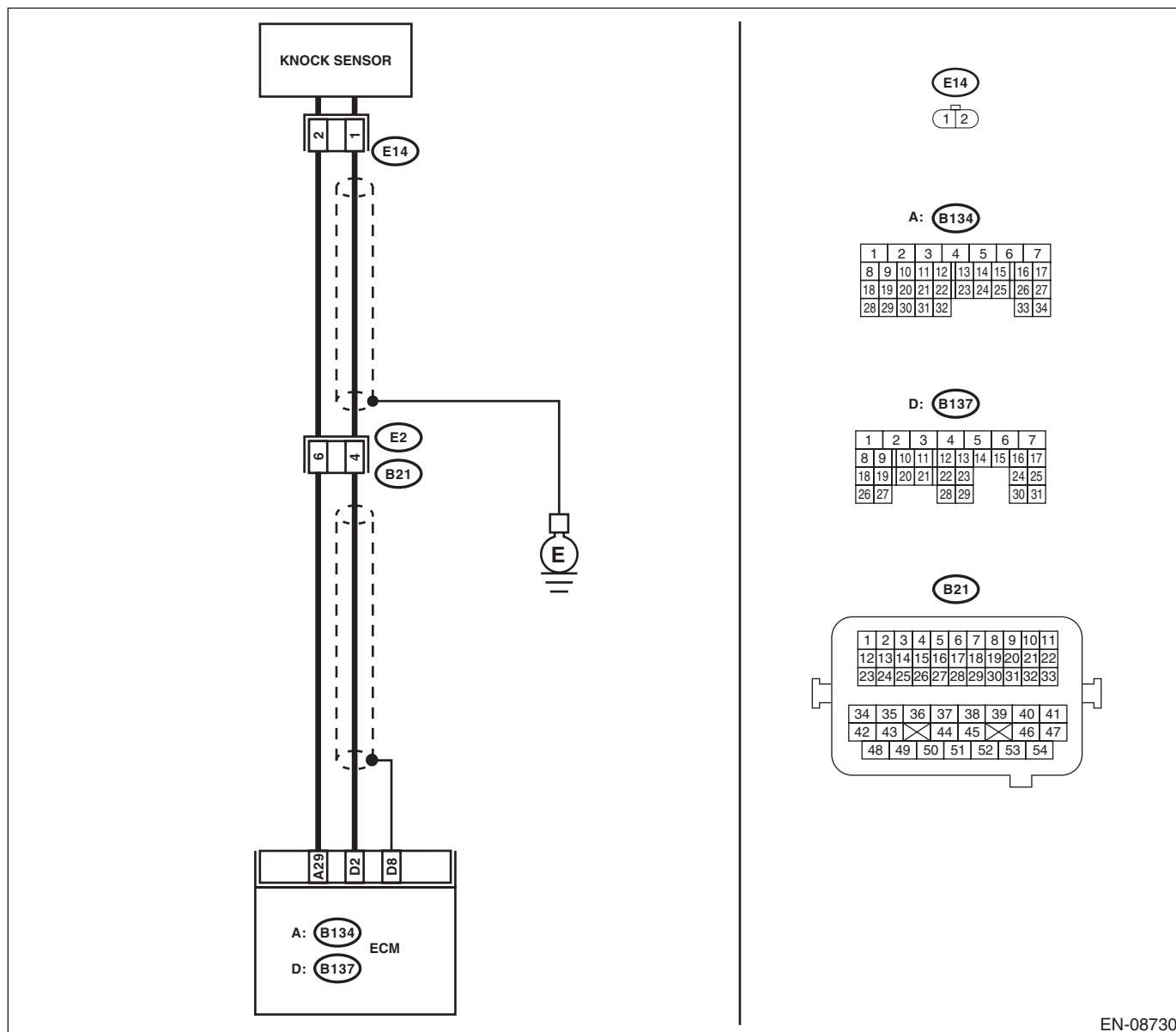

EN-08730

# Diagnostic Procedure with Diagnostic Trouble Code (DTC)

ENGINE (DIAGNOSTICS)

Step	Check	Yes	No
<b>1 CHECK HARNESS BETWEEN ECM AND KNOCK SENSOR CONNECTOR.</b> 1) Turn the ignition switch to OFF. 2) Disconnect the connector from ECM. 3) Measure the resistance between ECM connectors. <i>Connector &amp; terminal (B137) No. 2 — (B134) No. 29:</i>	Is the resistance 600 kΩ or more?	Go to step 2.	Repair the poor contact of ECM connector.
<b>2 CHECK KNOCK SENSOR.</b> 1) Disconnect the connector from the knock sensor. 2) Measure the resistance between knock sensor terminals. <i>Terminals No. 1 — No. 2:</i>	Is the resistance 600 kΩ or more?	Replace the knock sensor. <Ref. to FU(STI)-40, Knock Sensor.> <Ref. to FU(w/o STI)-40, Knock Sensor.>	Repair the harness and connector. NOTE: In this case, repair the following item: <ul style="list-style-type: none"> <li>• Open circuit in harness between ECM and knock sensor connector</li> <li>• Poor contact of knock sensor connector</li> <li>• Poor contact of coupling connector</li> </ul>

# Diagnostic Procedure with Diagnostic Trouble Code (DTC)

ENGINE (DIAGNOSTICS)

## BG:DTC P0328 KNOCK SENSOR 1 CIRCUIT HIGH (BANK 1 OR SINGLE SENSOR)

### DTC DETECTING CONDITION:

- Immediately at fault recognition
- GENERAL DESCRIPTION <Ref. to GD(H4DOTC)-119, DTC P0328 KNOCK SENSOR 1 CIRCUIT HIGH (BANK 1 OR SINGLE SENSOR), Diagnostic Trouble Code (DTC) Detecting Criteria.>

### TROUBLE SYMPTOM:

- Poor driving performance
- Knocking occurs.

### CAUTION:

After servicing or replacing faulty parts, perform Clear Memory Mode <Ref. to EN(H4DOTC)(diag)-62, OPERATION, Clear Memory Mode.>, and Inspection Mode <Ref. to EN(H4DOTC)(diag)-48, PROCEDURE, Inspection Mode.>.

### WIRING DIAGRAM:

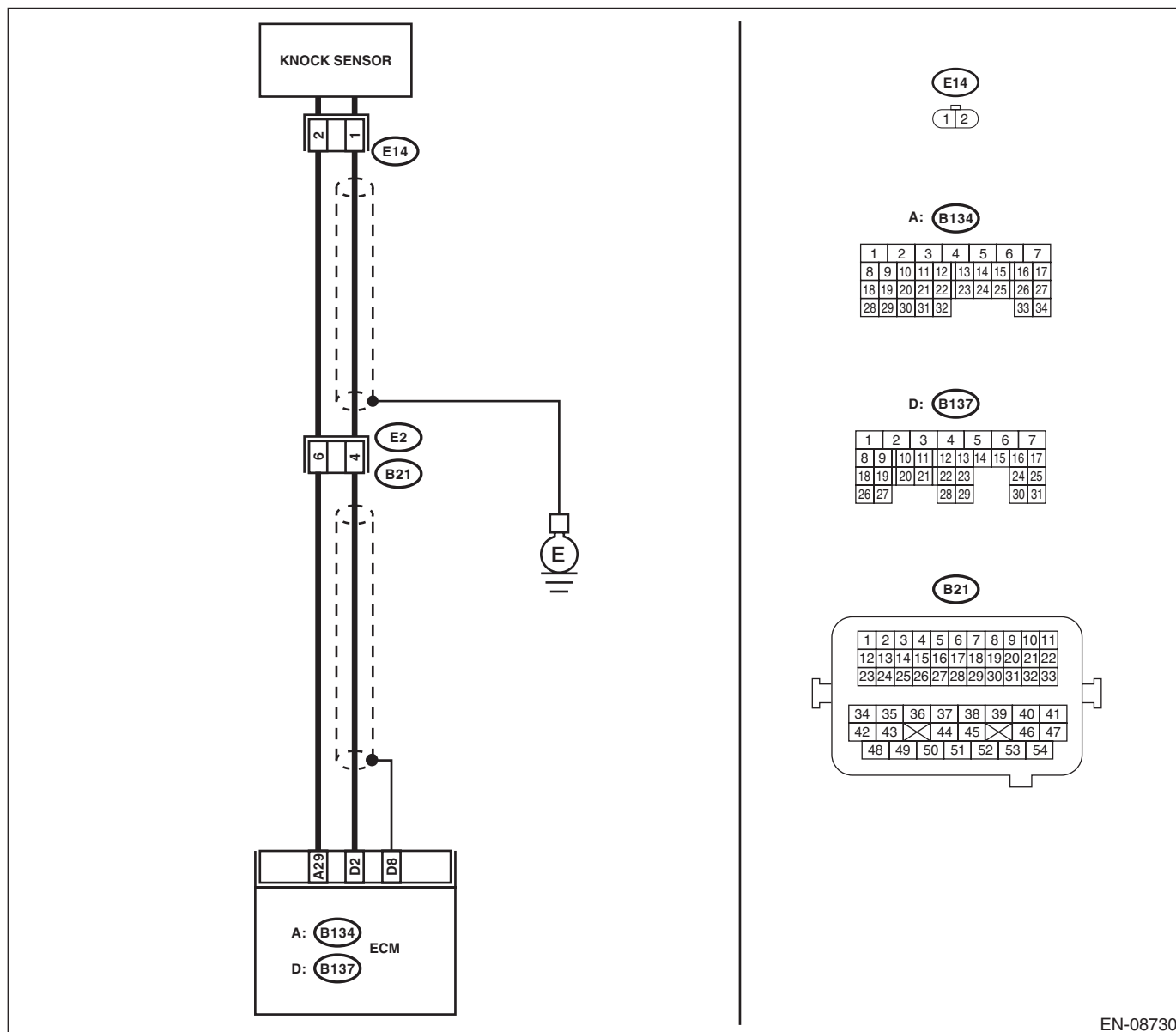

EN-08730

# Diagnostic Procedure with Diagnostic Trouble Code (DTC)

ENGINE (DIAGNOSTICS)

Step	Check	Yes	No
<p><b>1 CHECK HARNESS BETWEEN ECM AND KNOCK SENSOR CONNECTOR.</b></p> <p>1) Turn the ignition switch to OFF. 2) Disconnect the connector from ECM. 3) Measure the resistance between ECM connectors.</p> <p><b>Connector &amp; terminal</b> <b>(B137) No. 2 — (B134) No. 29:</b></p>	<p>Is the resistance less than 500 kΩ?</p>	<p>Go to step 2.</p>	<p>Go to step 3.</p>
<p><b>2 CHECK KNOCK SENSOR.</b></p> <p>1) Disconnect the connector from the knock sensor. 2) Measure the resistance between knock sensor connectors.</p> <p><b>Terminals</b> <b>No. 1 — No. 2:</b></p>	<p>Is the resistance less than 500 kΩ?</p>	<p>Replace the knock sensor. &lt;Ref. to FU(STI)-40, Knock Sensor.&gt; &lt;Ref. to FU(w/o STI)-40, Knock Sensor.&gt;</p>	<p>Repair the short circuit to ground in harness between ECM and knock sensor connector.</p> <p><b>NOTE:</b> The harness between both connectors are shielded. Remove the shield and repair the short circuit of harness.</p>
<p><b>3 CHECK INPUT SIGNAL OF ECM.</b></p> <p>1) Connect the connector to ECM. 2) Turn the ignition switch to ON. 3) Measure the voltage between ECM and chassis ground.</p> <p><b>Connector &amp; terminal</b> <b>(B137) No. 2 (+) — Chassis ground (-):</b></p>	<p>Is the voltage 2 V or more?</p>	<p>Even if DTC is detected, the circuit has returned to a normal condition at this time. Reproduce the failure, and then perform the diagnosis again.</p> <p><b>NOTE:</b> In this case, temporary poor contact of connector, temporary open or short circuit of harness may be the cause.</p>	<p>Repair the poor contact of ECM connector.</p>

# Diagnostic Procedure with Diagnostic Trouble Code (DTC)

ENGINE (DIAGNOSTICS)

## BH:DTC P0335 CRANKSHAFT POSITION SENSOR "A" CIRCUIT

### DTC DETECTING CONDITION:

- Immediately at fault recognition
- GENERAL DESCRIPTION <Ref. to GD(H4DOTC)-121, DTC P0335 CRANKSHAFT POSITION SENSOR "A" CIRCUIT, Diagnostic Trouble Code (DTC) Detecting Criteria.>

### TROUBLE SYMPTOM:

- Engine stalls.
- Failure of engine to start

### CAUTION:

After servicing or replacing faulty parts, perform Clear Memory Mode <Ref. to EN(H4DOTC)(diag)-62, OPERATION, Clear Memory Mode.>, and Inspection Mode <Ref. to EN(H4DOTC)(diag)-48, PROCEDURE, Inspection Mode.>.

### WIRING DIAGRAM:

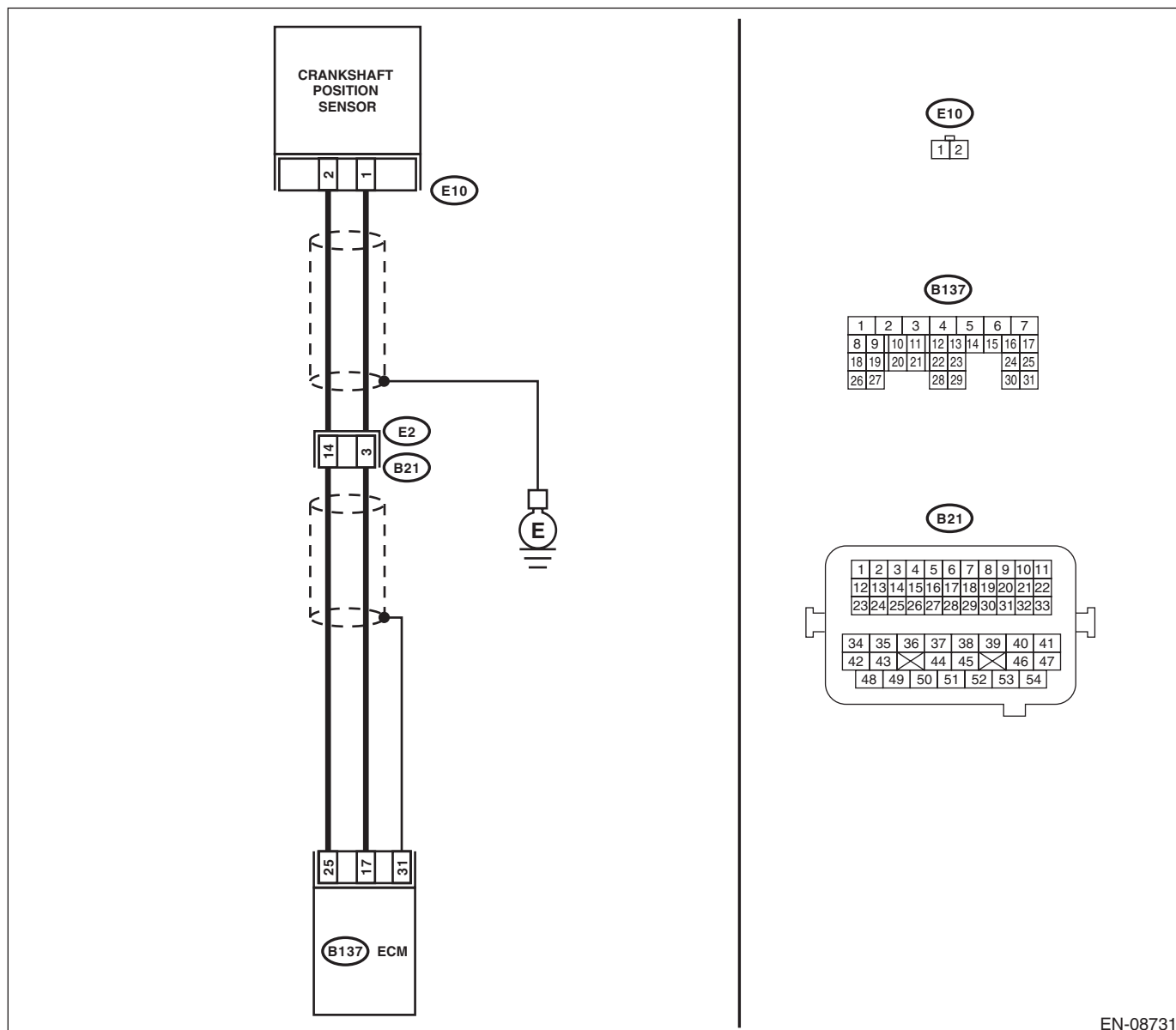

EN-08731

# Diagnostic Procedure with Diagnostic Trouble Code (DTC)

ENGINE (DIAGNOSTICS)

Step	Check	Yes	No
<b>1</b> <b>CHECK CONDITION OF CRANKSHAFT POSITION SENSOR.</b>	Is the crankshaft position sensor installation bolt tightened securely?	Go to step 2.	Tighten the crankshaft position sensor installation bolt securely. <Ref. to FU(STI)-35, Crankshaft Position Sensor.> <Ref. to FU(w/o STI)-36, Crankshaft Position Sensor.>
<b>2</b> <b>CHECK CRANKSHAFT POSITION SENSOR.</b> 1) Turn the ignition switch to OFF. 2) Remove the crankshaft position sensor. 3) Measure the resistance between terminals of crankshaft position sensor. <b>Terminals</b> <b>No. 1 — No. 2:</b>	Is the resistance between 1 and 4 k $\Omega$ ?	Go to step 3.	Replace the crankshaft position sensor. <Ref. to FU(STI)-35, Crankshaft Position Sensor.> <Ref. to FU(w/o STI)-36, Crankshaft Position Sensor.>
<b>3</b> <b>CHECK HARNESS BETWEEN ECM AND CRANKSHAFT POSITION SENSOR CONNECTOR.</b> 1) Disconnect the connector from ECM. 2) Measure the resistance of harness between ECM and crankshaft position sensor connector. <b>Connector &amp; terminal</b> <b>(B137) No. 17 — (E10) No. 1:</b> <b>(B137) No. 25 — (E10) No. 2:</b>	Is the resistance less than 1 $\Omega$ ?	Repair the poor contact of ECM and crankshaft position sensor connector.	Repair the harness and connector. NOTE: In this case, repair the following item: <ul style="list-style-type: none"> <li>• Open circuit in harness between ECM and crankshaft position sensor connector</li> <li>• Poor contact of coupling connector</li> </ul>



# Diagnostic Procedure with Diagnostic Trouble Code (DTC)

ENGINE (DIAGNOSTICS)

## BI: DTC P0336 CRANKSHAFT POSITION SENSOR “A” CIRCUIT RANGE/PERFORMANCE

### DTC DETECTING CONDITION:

- Detected when two consecutive driving cycles with fault occur.
- GENERAL DESCRIPTION <Ref. to GD(H4DOTC)-123, DTC P0336 CRANKSHAFT POSITION SENSOR “A” CIRCUIT RANGE/PERFORMANCE, Diagnostic Trouble Code (DTC) Detecting Criteria.>

### TROUBLE SYMPTOM:

- Engine stalls.
- Failure of engine to start

### CAUTION:

After servicing or replacing faulty parts, perform Clear Memory Mode <Ref. to EN(H4DOTC)(diag)-62, OPERATION, Clear Memory Mode.>, and Inspection Mode <Ref. to EN(H4DOTC)(diag)-48, PROCEDURE, Inspection Mode.>.

	Step	Check	Yes	No
1	<b>CHECK CONDITION OF CRANKSHAFT POSITION SENSOR.</b> Turn the ignition switch to OFF.	Is the crankshaft position sensor installation bolt tightened securely?	Go to step 2.	Tighten the crankshaft position sensor installation bolt securely. <Ref. to FU(STI)-35, Crankshaft Position Sensor.> <Ref. to FU(w/o STI)-36, Crankshaft Position Sensor.>
2	<b>CHECK CRANK SPROCKET.</b> Remove the timing belt cover.	Are crank sprocket teeth cracked or damaged?	Replace the crank sprocket. <Ref. to ME(STI)-60, Crank Sprocket.> <Ref. to ME(w/o STI)-59, Crank Sprocket.>	Go to step 3.
3	<b>CHECK INSTALLATION CONDITION OF TIMING BELT.</b> Turn the crankshaft, and align alignment mark on crank sprocket with alignment mark on cylinder block. ST 499987500                      CRANKSHAFT SOCKET	Is the timing belt dislocated from its proper position?	Repair the installation condition of timing belt. <Ref. to ME(STI)-50, Timing Belt.> <Ref. to ME(w/o STI)-49, Timing Belt.>	Replace the crankshaft position sensor. <Ref. to FU(STI)-35, Crankshaft Position Sensor.> <Ref. to FU(w/o STI)-36, Crankshaft Position Sensor.>

# Diagnostic Procedure with Diagnostic Trouble Code (DTC)

ENGINE (DIAGNOSTICS)

## BJ:DTC P0340 CAMSHAFT POSITION SENSOR "A" CIRCUIT (BANK 1 OR SINGLE SENSOR)

### DTC DETECTING CONDITION:

- Immediately at fault recognition
- GENERAL DESCRIPTION <Ref. to GD(H4DOTC)-125, DTC P0340 CAMSHAFT POSITION SENSOR "A" CIRCUIT (BANK 1 OR SINGLE SENSOR), Diagnostic Trouble Code (DTC) Detecting Criteria.>

### TROUBLE SYMPTOM:

- Engine stalls.
- Failure of engine to start

### CAUTION:

After servicing or replacing faulty parts, perform Clear Memory Mode <Ref. to EN(H4DOTC)(diag)-62, OPERATION, Clear Memory Mode.>, and Inspection Mode <Ref. to EN(H4DOTC)(diag)-48, PROCEDURE, Inspection Mode.>.

### WIRING DIAGRAM:

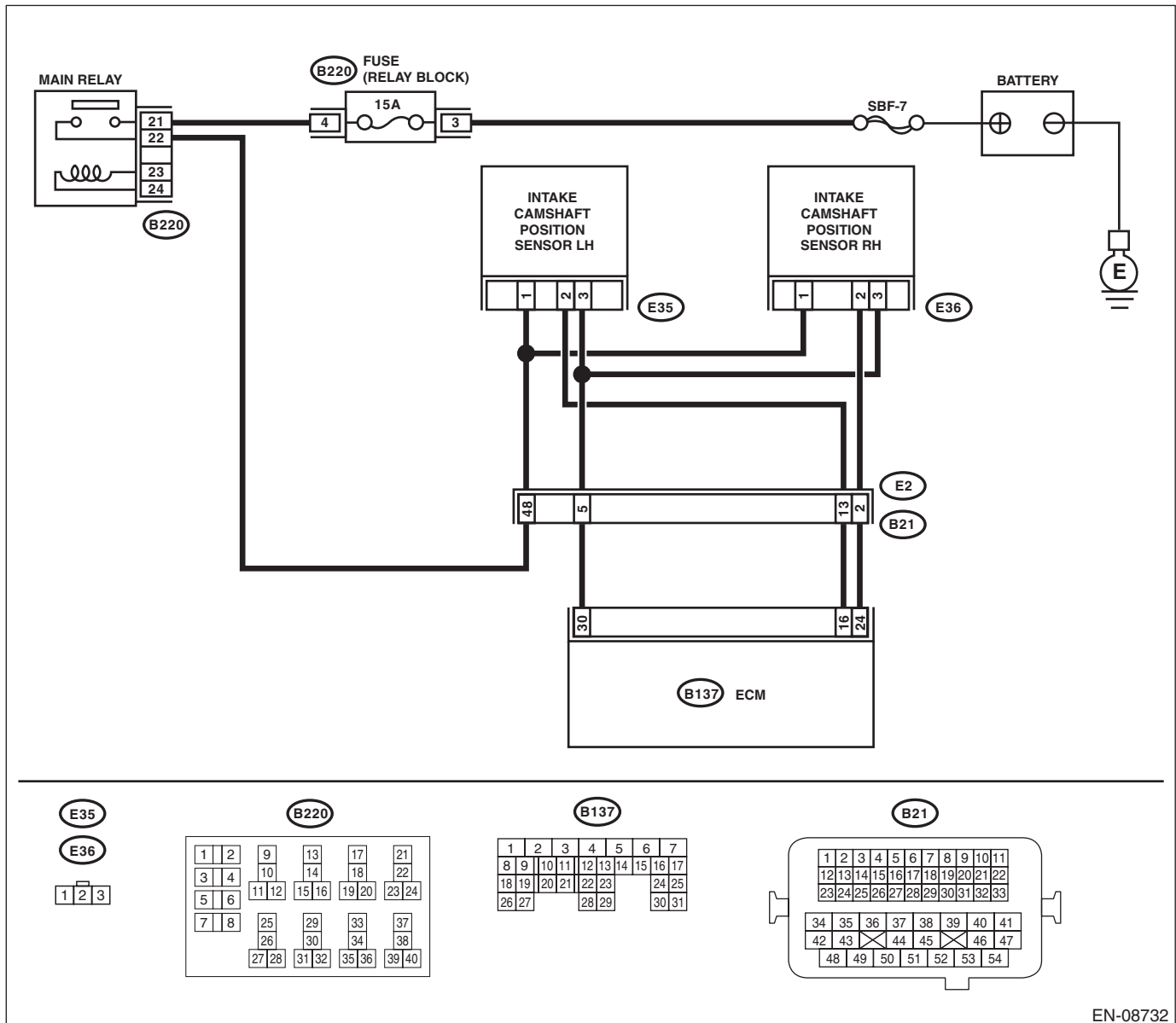

EN-08732

# Diagnostic Procedure with Diagnostic Trouble Code (DTC)

## ENGINE (DIAGNOSTICS)

Step	Check	Yes	No
<b>1 CHECK POWER SUPPLY OF CAMSHAFT POSITION SENSOR.</b> 1) Turn the ignition switch to OFF. 2) Disconnect the connector from camshaft position sensor. 3) Turn the ignition switch to ON. 4) Measure the voltage between camshaft position sensor connector and engine ground. <b>Connector &amp; terminal</b> <b>(E36) No. 1 (+) — Engine ground (-):</b>	Is the voltage 10 V or more?	Go to step 2.	Repair the harness and connector.  NOTE: In this case, repair the following item: • Open circuit or short circuit to ground in harness between main relay connector and camshaft position sensor connector • Poor contact of coupling connector
<b>2 CHECK HARNESS BETWEEN ECM AND CAMSHAFT POSITION SENSOR CONNECTOR.</b> 1) Turn the ignition switch to OFF. 2) Disconnect the connector from ECM. 3) Measure the resistance between ECM and camshaft position sensor connector. <b>Connector &amp; terminal</b> <b>(B137) No. 24 — (E36) No. 2:</b> <b>(B137) No. 30 — (E36) No. 3:</b>	Is the resistance less than 1 $\Omega$ ?	Go to step 3.	Repair the harness and connector.  NOTE: In this case, repair the following item: • Open circuit in harness between ECM and camshaft position sensor connector • Poor contact of coupling connector
<b>3 CHECK HARNESS BETWEEN ECM AND CAMSHAFT POSITION SENSOR CONNECTOR.</b> Measure the resistance between camshaft position sensor connector and engine ground. <b>Connector &amp; terminal</b> <b>(E36) No. 2 — Engine ground:</b>	Is the resistance 1 M $\Omega$ or more?	Go to step 4.	Repair short circuit to ground in harness between ECM and camshaft position sensor connector.
<b>4 CHECK HARNESS BETWEEN ECM AND CAMSHAFT POSITION SENSOR CONNECTOR.</b> Measure the voltage between camshaft position sensor connector and engine ground. <b>Connector &amp; terminal</b> <b>(E36) No. 2 (+) — Engine ground (-):</b>	Is the voltage 5 V or more?	Repair the short circuit to power in the harness between ECM and camshaft position sensor connector.	Go to step 5.
<b>5 CHECK CONDITION OF CAMSHAFT POSITION SENSOR.</b>	Is the camshaft position sensor installation bolt tightened securely?	Go to step 6.	Tighten the camshaft position sensor installation bolt securely. <Ref. to FU(STI)-37, Camshaft Position Sensor.> <Ref. to FU(w/o STI)-38, Camshaft Position Sensor.>
<b>6 CHECK CAMSHAFT POSITION SENSOR.</b> Check the waveform of the camshaft position sensor. <Ref. to EN(H4DOTC)(diag)-23, Engine Control Module (ECM) I/O Signal.>	Is there any abnormality in waveform?	Replace the camshaft position sensor. <Ref. to FU(STI)-37, Camshaft Position Sensor.> <Ref. to FU(w/o STI)-38, Camshaft Position Sensor.>	Repair the following item. • Poor contact of ECM connector • Poor contact of camshaft position sensor connector • Poor contact of coupling connector

# Diagnostic Procedure with Diagnostic Trouble Code (DTC)

ENGINE (DIAGNOSTICS)

## BK:DTC P0345 CAMSHAFT POSITION SENSOR "A" CIRCUIT (BANK 2)

### DTC DETECTING CONDITION:

- Immediately at fault recognition
- GENERAL DESCRIPTION <Ref. to GD(H4DOTC)-126, DTC P0345 CAMSHAFT POSITION SENSOR "A" CIRCUIT (BANK 2), Diagnostic Trouble Code (DTC) Detecting Criteria.>

### TROUBLE SYMPTOM:

- Engine stalls.
- Failure of engine to start

### CAUTION:

After servicing or replacing faulty parts, perform Clear Memory Mode <Ref. to EN(H4DOTC)(diag)-62, OPERATION, Clear Memory Mode.>, and Inspection Mode <Ref. to EN(H4DOTC)(diag)-48, PROCEDURE, Inspection Mode.>.

### WIRING DIAGRAM:

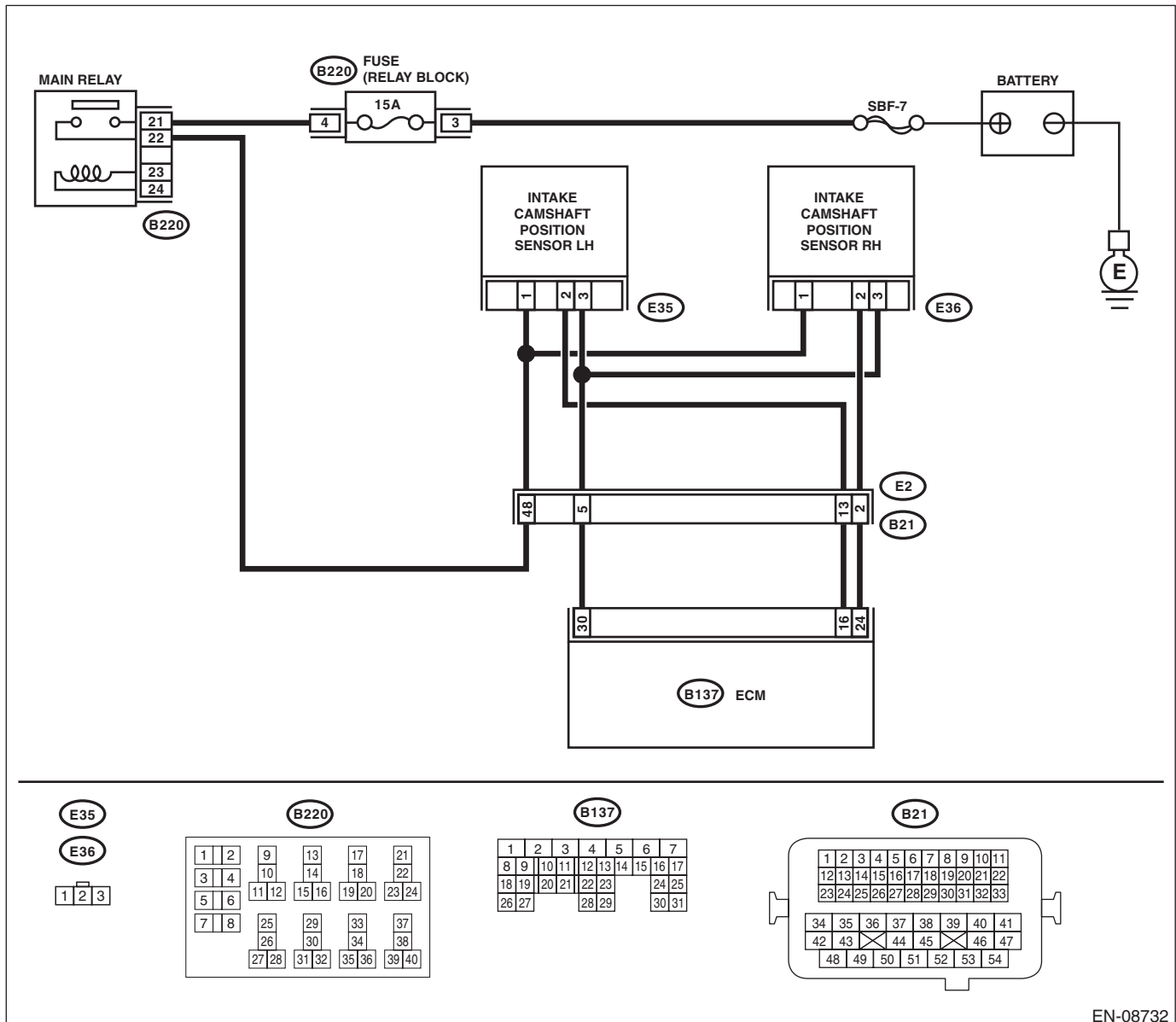

EN-08732

# Diagnostic Procedure with Diagnostic Trouble Code (DTC)

ENGINE (DIAGNOSTICS)

Step	Check	Yes	No
<p><b>1 CHECK POWER SUPPLY OF CAMSHAFT POSITION SENSOR.</b></p> <p>1) Turn the ignition switch to OFF.                      2) Disconnect the connector from camshaft position sensor.                      3) Turn the ignition switch to ON.                      4) Measure the voltage between camshaft position sensor connector and engine ground.</p> <p><b>Connector &amp; terminal</b>  <b>(E35) No. 1 (+) — Engine ground (-):</b></p>	Is the voltage 10 V or more?	Go to step 2.	Repair the harness and connector.  NOTE: In this case, repair the following item: • Open circuit or short circuit to ground in harness between main relay connector and camshaft position sensor connector • Poor contact of coupling connector
<p><b>2 CHECK HARNESS BETWEEN ECM AND CAMSHAFT POSITION SENSOR CONNECTOR.</b></p> <p>1) Turn the ignition switch to OFF.                      2) Disconnect the connector from ECM.                      3) Measure the resistance between ECM and camshaft position sensor connector.</p> <p><b>Connector &amp; terminal</b>  <b>(B137) No. 16 — (E35) No. 2:</b>  <b>(B137) No. 22 — (E35) No. 3:</b></p>	Is the resistance less than 1 Ω?	Go to step 3.	Repair the harness and connector.  NOTE: In this case, repair the following item: • Open circuit in harness between ECM connector and camshaft position sensor connector • Poor contact of coupling connector
<p><b>3 CHECK HARNESS BETWEEN ECM AND CAMSHAFT POSITION SENSOR CONNECTOR.</b></p> <p>Measure the resistance between camshaft position sensor connector and engine ground.</p> <p><b>Connector &amp; terminal</b>  <b>(E35) No. 2 — Engine ground:</b></p>	Is the resistance 1 MΩ or more?	Go to step 4.	Repair short circuit to ground in harness between ECM and camshaft position sensor connector.
<p><b>4 CHECK HARNESS BETWEEN ECM AND CAMSHAFT POSITION SENSOR CONNECTOR.</b></p> <p>Measure the voltage between camshaft position sensor connector and engine ground.</p> <p><b>Connector &amp; terminal</b>  <b>(E35) No. 2 (+) — Engine ground (-):</b></p>	Is the voltage 5 V or more?	Repair the short circuit to power in the harness between ECM and camshaft position sensor connector.	Go to step 5.
<p><b>5 CHECK CONDITION OF CAMSHAFT POSITION SENSOR.</b></p>	Is the camshaft position sensor installation bolt tightened securely?	Go to step 6.	Tighten the camshaft position sensor installation bolt securely. <Ref. to FU(STI)-37, Camshaft Position Sensor.> <Ref. to FU(w/o STI)-38, Camshaft Position Sensor.>

# Diagnostic Procedure with Diagnostic Trouble Code (DTC)

ENGINE (DIAGNOSTICS)

Step	Check	Yes	No
<b>6</b> <b>CHECK CAMSHAFT POSITION SENSOR.</b> Check the waveform of the camshaft position sensor. <Ref. to EN(H4DOTC)(diag)-23, Engine Control Module (ECM) I/O Signal.>	Is there any abnormality in waveform?	Replace the camshaft position sensor. <Ref. to FU(STI)-37, Camshaft Position Sensor.> <Ref. to FU(w/o STI)-38, Camshaft Position Sensor.>	Repair the following item. <ul style="list-style-type: none"><li>• Poor contact of ECM connector</li><li>• Poor contact of camshaft position sensor connector</li><li>• Poor contact of coupling connector</li></ul>

# Diagnostic Procedure with Diagnostic Trouble Code (DTC)

ENGINE (DIAGNOSTICS)

## BL:DTC P0351 IGNITION COIL A PRIMARY/SECONDARY CIRCUIT

### DTC DETECTING CONDITION:

- Immediately at fault recognition
- GENERAL DESCRIPTION <Ref. to GD(H4DOTC)-127, DTC P0351 IGNITION COIL A PRIMARY/SECONDARY CIRCUIT, Diagnostic Trouble Code (DTC) Detecting Criteria.>

### TROUBLE SYMPTOM:

- Improper idling
- Poor driving performance

### CAUTION:

After servicing or replacing faulty parts, perform Clear Memory Mode <Ref. to EN(H4DOTC)(diag)-62, OPERATION, Clear Memory Mode.>, and Inspection Mode <Ref. to EN(H4DOTC)(diag)-48, PROCEDURE, Inspection Mode.>.

### WIRING DIAGRAM:

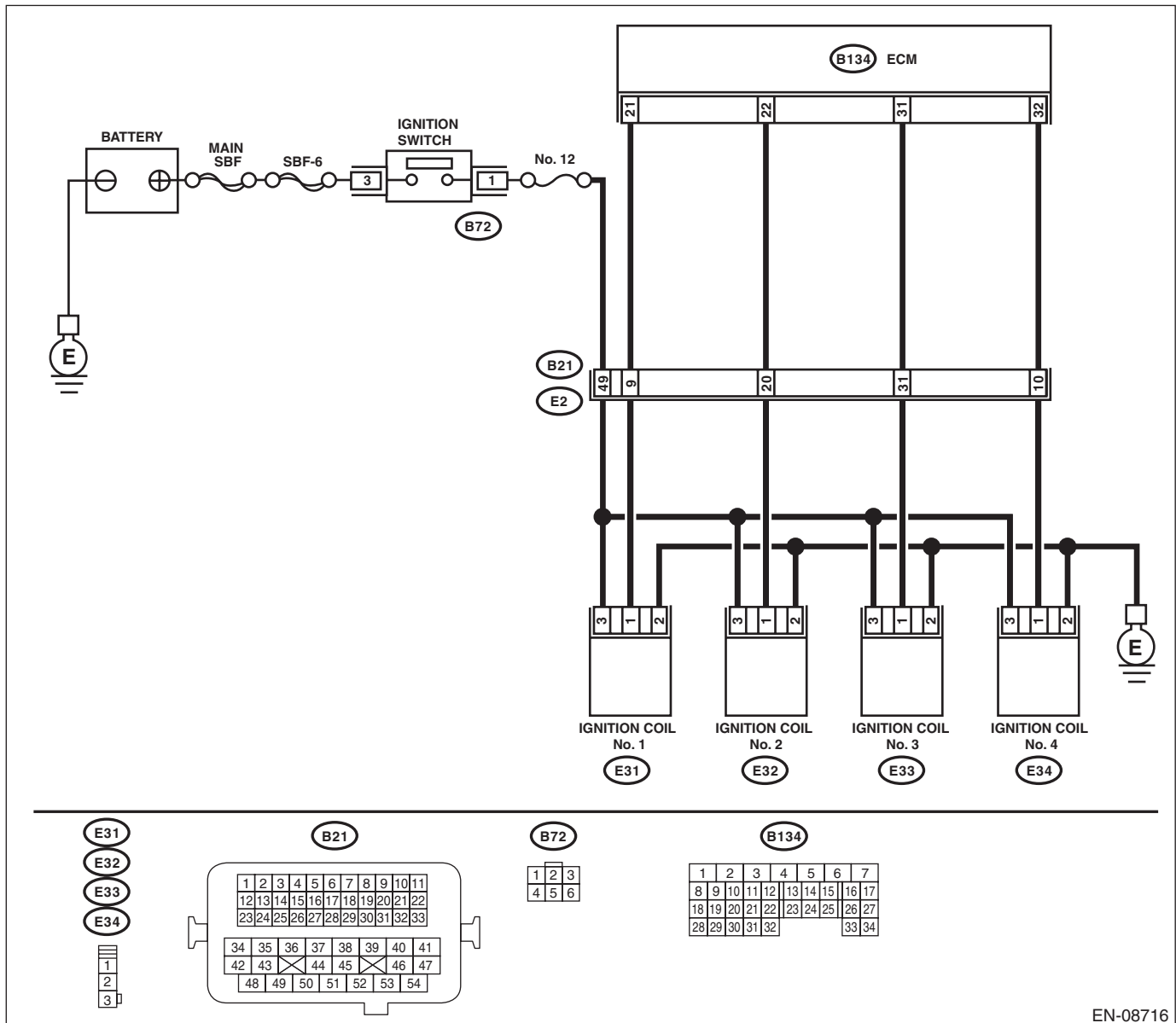

EN-08716

# Diagnostic Procedure with Diagnostic Trouble Code (DTC)

ENGINE (DIAGNOSTICS)

Step	Check	Yes	No
<p><b>1 CHECK IGNITION COIL POWER SUPPLY CIRCUIT.</b></p> <p>1) Turn the ignition switch to OFF. 2) Disconnect the connector from ignition coil. 3) Turn the ignition switch to ON. 4) Measure the voltage between ignition coil connector and engine ground.</p> <p><b>Connector &amp; terminal</b> <b>DTC P0351; (E31) No. 3 (+) — Engine ground (-):</b> <b>DTC P0352; (E32) No. 3 (+) — Engine ground (-):</b> <b>DTC P0353; (E33) No. 3 (+) — Engine ground (-):</b> <b>DTC P0354; (E34) No. 3 (+) — Engine ground (-):</b></p>	Is the voltage 10 V or more?	Go to step 2.	Repair the harness and connector.  NOTE: In this case, repair the following item: • Open circuit or short circuit to ground in harness of power supply circuit • Blown out of fuse • Poor contact of coupling connector
<p><b>2 CHECK HARNESS OF IGNITION COIL GROUND CIRCUIT.</b></p> <p>1) Turn the ignition switch to OFF. 2) Measure the resistance of harness between ignition coil connector and engine ground.</p> <p><b>Connector &amp; terminal</b> <b>DTC P0351; (E31) No. 2 — Engine ground:</b> <b>DTC P0352; (E32) No. 2 — Engine ground:</b> <b>DTC P0353; (E33) No. 2 — Engine ground:</b> <b>DTC P0354; (E34) No. 2 — Engine ground:</b></p>	Is the resistance less than 5 Ω?	Go to step 3.	Repair the open circuit in harness between ignition coil connector and engine grounding terminal.
<p><b>3 CHECK HARNESS BETWEEN ECM AND IGNITION COIL CONNECTOR.</b></p> <p>1) Disconnect the connector from ECM. 2) Measure the resistance between ignition coil connector and engine ground.</p> <p><b>Connector &amp; terminal</b> <b>DTC P0351; (E31) No. 1 — Engine ground:</b> <b>DTC P0352; (E32) No. 1 — Engine ground:</b> <b>DTC P0353; (E33) No. 1 — Engine ground:</b> <b>DTC P0354; (E34) No. 1 — Engine ground:</b></p>	Is the resistance 1 MΩ or more?	Go to step 4.	Repair the ground short circuit of harness between ECM connector and ignition coil connector.
<p><b>4 CHECK HARNESS BETWEEN ECM AND IGNITION COIL CONNECTOR.</b></p> <p>Measure the resistance of harness between ECM connector and ignition coil connector.</p> <p><b>Connector &amp; terminal</b> <b>DTC P0351; (B134) No. 21 — (E31) No. 1:</b> <b>DTC P0352; (B134) No. 22 — (E32) No. 1:</b> <b>DTC P0353; (B134) No. 31 — (E33) No. 1:</b> <b>DTC P0354; (B134) No. 32 — (E34) No. 1:</b></p>	Is the resistance less than 1 Ω?	Go to step 5.	Repair the harness and connector.  NOTE: In this case, repair the following item: • Open circuit of harness between ECM connector and the ignition coil connector • Poor contact of coupling connector
<p><b>5 CHECK FOR POOR CONTACT.</b></p> <p>Check for poor contact of ECM connector.</p>	Is there poor contact of ECM connector?	Repair the poor contact of ECM connector.	Go to step 6.
<p><b>6 CHECK SPARK PLUG CONDITION.</b></p> <p>1) Remove the spark plug of the corresponding cylinder. &lt;Ref. to IG(STI)-4, REMOVAL, Spark Plug.&gt; &lt;Ref. to IG(w/o STI)-4, REMOVAL, Spark Plug.&gt; 2) Check the spark plug condition. &lt;Ref. to IG(STI)-5, INSPECTION, Spark Plug.&gt; &lt;Ref. to IG(w/o STI)-5, INSPECTION, Spark Plug.&gt;</p>	Is the spark plug condition normal?	Replace the ignition coil. <Ref. to IG(STI)-7, Ignition Coil.> <Ref. to IG(w/o STI)-7, Ignition Coil.>	Replace the spark plug. <Ref. to IG(STI)-4, Spark Plug.> <Ref. to IG(w/o STI)-4, Spark Plug.>



## Diagnostic Procedure with Diagnostic Trouble Code (DTC)

ENGINE (DIAGNOSTICS)

---

### **BM:DTC P0352 IGNITION COIL B PRIMARY/SECONDARY CIRCUIT**

NOTE:

For the diagnostic procedure, refer to DTC P0351. <Ref. to EN(H4DOTC)(diag)-204, DTC P0351 IGNITION COIL A PRIMARY/SECONDARY CIRCUIT, Diagnostic Procedure with Diagnostic Trouble Code (DTC).>

### **BN:DTC P0353 IGNITION COIL C PRIMARY/SECONDARY CIRCUIT**

NOTE:

For the diagnostic procedure, refer to DTC P0351. <Ref. to EN(H4DOTC)(diag)-204, DTC P0351 IGNITION COIL A PRIMARY/SECONDARY CIRCUIT, Diagnostic Procedure with Diagnostic Trouble Code (DTC).>

### **BO:DTC P0354 IGNITION COIL D PRIMARY/SECONDARY CIRCUIT**

NOTE:

For the diagnostic procedure, refer to DTC P0351. <Ref. to EN(H4DOTC)(diag)-204, DTC P0351 IGNITION COIL A PRIMARY/SECONDARY CIRCUIT, Diagnostic Procedure with Diagnostic Trouble Code (DTC).>

# Diagnostic Procedure with Diagnostic Trouble Code (DTC)

ENGINE (DIAGNOSTICS)

## BP:DTC P0365 CAMSHAFT POSITION SENSOR "B" CIRCUIT (BANK 1)

### DTC DETECTING CONDITION:

- Immediately at fault recognition
- GENERAL DESCRIPTION <Ref. to GD(H4DOTC)-129, DTC P0365 CAMSHAFT POSITION SENSOR "B" CIRCUIT (BANK 1), Diagnostic Trouble Code (DTC) Detecting Criteria.>

### TROUBLE SYMPTOM:

- Engine stalls.
- Failure of engine to start

### CAUTION:

After servicing or replacing faulty parts, perform Clear Memory Mode <Ref. to EN(H4DOTC)(diag)-62, OPERATION, Clear Memory Mode.>, and Inspection Mode <Ref. to EN(H4DOTC)(diag)-48, PROCEDURE, Inspection Mode.>.

### WIRING DIAGRAM:

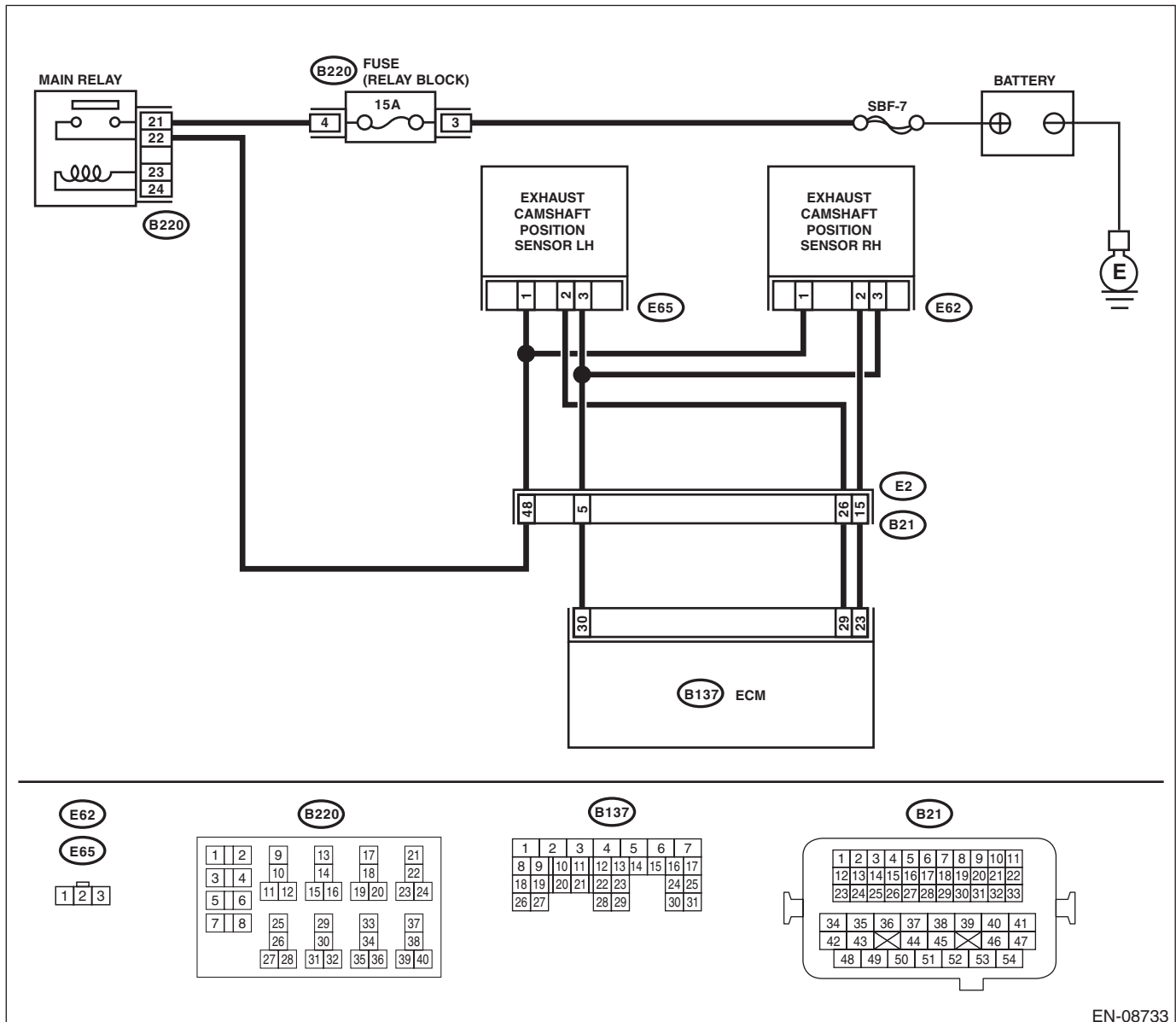

EN-08733

# Diagnostic Procedure with Diagnostic Trouble Code (DTC)

ENGINE (DIAGNOSTICS)

Step	Check	Yes	No
<p><b>1 CHECK POWER SUPPLY OF CAMSHAFT POSITION SENSOR.</b>                      1) Turn the ignition switch to OFF.                      2) Disconnect the connector from camshaft position sensor.                      3) Turn the ignition switch to ON.                      4) Measure the voltage between camshaft position sensor connector and engine ground.  <b>Connector &amp; terminal</b>  <b>(E62) No. 1 (+) — Engine ground (-):</b></p>	Is the voltage 10 V or more?	Go to step 2.	Repair the harness and connector.  NOTE: In this case, repair the following item: • Open circuit or short circuit to ground in harness between main relay connector and camshaft position sensor connector • Poor contact of coupling connector
<p><b>2 CHECK HARNESS BETWEEN ECM AND CAMSHAFT POSITION SENSOR CONNECTOR.</b>                      1) Turn the ignition switch to OFF.                      2) Disconnect the connector from ECM.                      3) Measure the resistance between ECM and camshaft position sensor connector.  <b>Connector &amp; terminal</b>  <b>(B137) No. 23 — (E62) No. 2:</b>  <b>(B137) No. 30 — (E62) No. 3:</b></p>	Is the resistance less than 1 Ω?	Go to step 3.	Repair the harness and connector.  NOTE: In this case, repair the following item: • Open circuit in harness between ECM and camshaft position sensor connector • Poor contact of coupling connector
<p><b>3 CHECK HARNESS BETWEEN ECM AND CAMSHAFT POSITION SENSOR CONNECTOR.</b>                      Measure the resistance between camshaft position sensor connector and engine ground.  <b>Connector &amp; terminal</b>  <b>(E62) No. 2 — Engine ground:</b></p>	Is the resistance 1 MΩ or more?	Go to step 4.	Repair short circuit to ground in harness between ECM and camshaft position sensor connector.
<p><b>4 CHECK HARNESS BETWEEN ECM AND CAMSHAFT POSITION SENSOR CONNECTOR.</b>                      Measure the voltage between camshaft position sensor connector and engine ground.  <b>Connector &amp; terminal</b>  <b>(E62) No. 2 (+) — Engine ground (-):</b></p>	Is the voltage 5 V or more?	Repair the short circuit to power in the harness between ECM and camshaft position sensor connector.	Go to step 5.
<p><b>5 CHECK CONDITION OF CAMSHAFT POSITION SENSOR.</b></p>	Is the camshaft position sensor installation bolt tightened securely?	Go to step 6.	Tighten the camshaft position sensor installation bolt securely. <Ref. to FU(STI)-37, Camshaft Position Sensor.>
<p><b>6 CHECK CAMSHAFT POSITION SENSOR.</b>                      Check the waveform of the camshaft position sensor. &lt;Ref. to EN(H4DOTC)(diag)-23, Engine Control Module (ECM) I/O Signal.&gt;</p>	Is there any abnormality in waveform?	Replace the camshaft position sensor. <Ref. to FU(STI)-37, Camshaft Position Sensor.>	Repair the following item. • Poor contact of ECM connector • Poor contact of camshaft position sensor connector • Poor contact of coupling connector

# Diagnostic Procedure with Diagnostic Trouble Code (DTC)

ENGINE (DIAGNOSTICS)

## BQ:DTC P0390 CAMSHAFT POSITION SENSOR "B" CIRCUIT (BANK 2)

### DTC DETECTING CONDITION:

- Immediately at fault recognition
- GENERAL DESCRIPTION <Ref. to GD(H4DOTC)-129, DTC P0390 CAMSHAFT POSITION SENSOR "B" CIRCUIT (BANK 2), Diagnostic Trouble Code (DTC) Detecting Criteria.>

### TROUBLE SYMPTOM:

- Engine stalls.
- Failure of engine to start

### CAUTION:

After servicing or replacing faulty parts, perform Clear Memory Mode <Ref. to EN(H4DOTC)(diag)-62, OPERATION, Clear Memory Mode.>, and Inspection Mode <Ref. to EN(H4DOTC)(diag)-48, PROCEDURE, Inspection Mode.>.

### WIRING DIAGRAM:

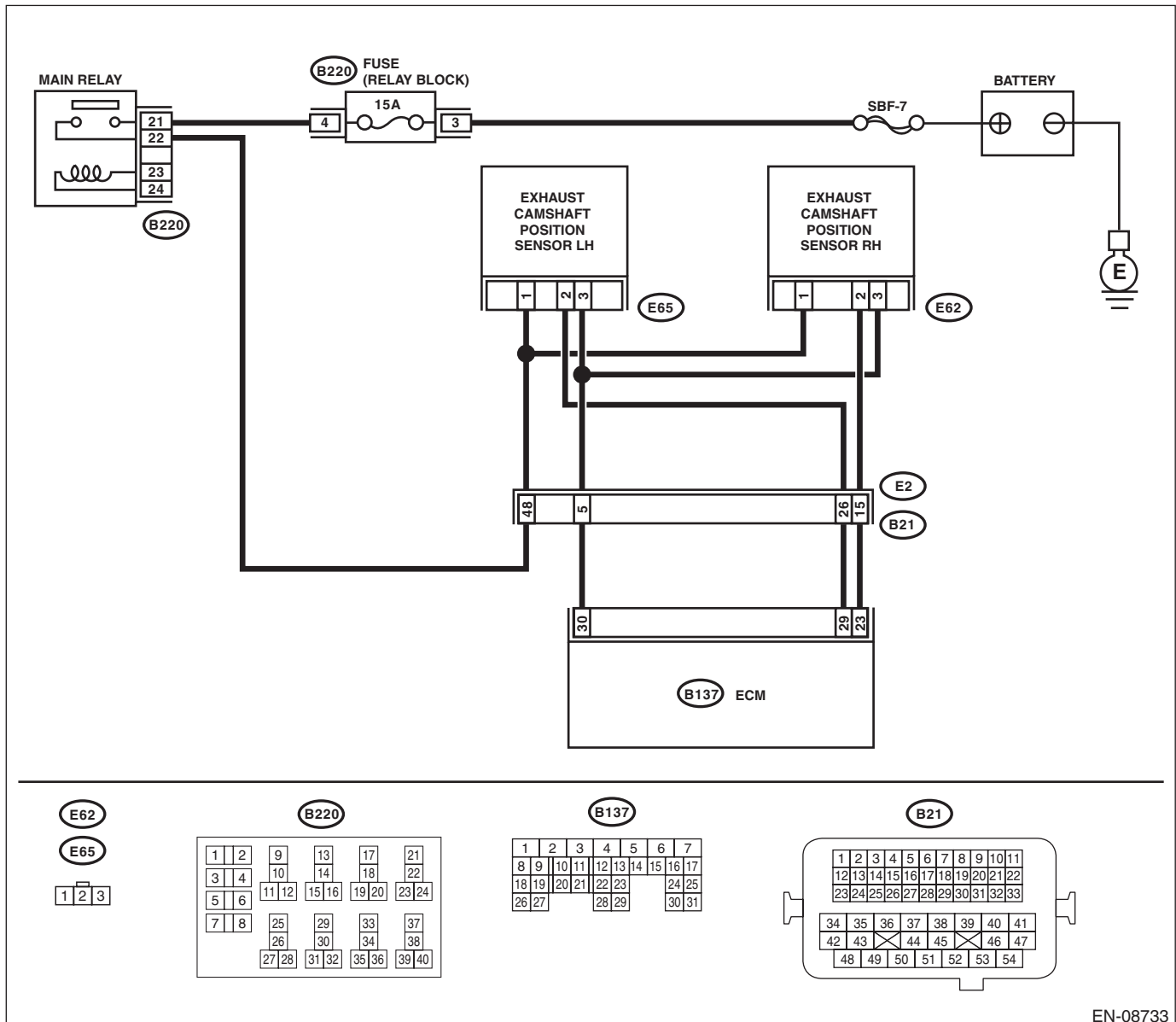

EN-08733

# Diagnostic Procedure with Diagnostic Trouble Code (DTC)

ENGINE (DIAGNOSTICS)

Step	Check	Yes	No
<p><b>1 CHECK POWER SUPPLY OF CAMSHAFT POSITION SENSOR.</b>                      1) Turn the ignition switch to OFF.                      2) Disconnect the connector from camshaft position sensor.                      3) Turn the ignition switch to ON.                      4) Measure the voltage between camshaft position sensor connector and engine ground.  <b>Connector &amp; terminal</b>  <b>(E65) No. 1 (+) — Engine ground (-):</b></p>	Is the voltage 10 V or more?	Go to step 2.	Repair the harness and connector.  NOTE: In this case, repair the following item: <ul style="list-style-type: none"> <li>• Open circuit or short circuit to ground in harness between main relay connector and camshaft position sensor connector</li> <li>• Poor contact of coupling connector</li> </ul>
<p><b>2 CHECK HARNESS BETWEEN ECM AND CAMSHAFT POSITION SENSOR CONNECTOR.</b>                      1) Turn the ignition switch to OFF.                      2) Disconnect the connector from ECM.                      3) Measure the resistance between ECM and camshaft position sensor connector.  <b>Connector &amp; terminal</b>  <b>(B137) No. 29 — (E65) No. 2:</b>  <b>(B137) No. 30 — (E65) No. 3:</b></p>	Is the resistance less than 1 Ω?	Go to step 3.	Repair the harness and connector.  NOTE: In this case, repair the following item: <ul style="list-style-type: none"> <li>• Open circuit in harness between ECM and camshaft position sensor connector</li> <li>• Poor contact of coupling connector</li> </ul>
<p><b>3 CHECK HARNESS BETWEEN ECM AND CAMSHAFT POSITION SENSOR CONNECTOR.</b>                      Measure the resistance between camshaft position sensor connector and engine ground.  <b>Connector &amp; terminal</b>  <b>(E65) No. 2 — Engine ground:</b></p>	Is the resistance 1 MΩ or more?	Go to step 4.	Repair short circuit to ground in harness between ECM and camshaft position sensor connector.
<p><b>4 CHECK HARNESS BETWEEN ECM AND CAMSHAFT POSITION SENSOR CONNECTOR.</b>                      Measure the voltage between camshaft position sensor connector and engine ground.  <b>Connector &amp; terminal</b>  <b>(E65) No. 2 (+) — Engine ground (-):</b></p>	Is the voltage 5 V or more?	Repair the short circuit to power in the harness between ECM and camshaft position sensor connector.	Go to step 5.
<p><b>5 CHECK CONDITION OF CAMSHAFT POSITION SENSOR.</b></p>	Is the camshaft position sensor installation bolt tightened securely?	Go to step 6.	Tighten the camshaft position sensor installation bolt securely. <Ref. to FU(STI)-37, Camshaft Position Sensor.>
<p><b>6 CHECK CAMSHAFT POSITION SENSOR.</b>                      Check the waveform of the camshaft position sensor. &lt;Ref. to EN(H4DOTC)(diag)-23, Engine Control Module (ECM) I/O Signal.&gt;</p>	Is there any abnormality in waveform?	Replace the camshaft position sensor. <Ref. to FU(STI)-37, Camshaft Position Sensor.>	Repair the following item. <ul style="list-style-type: none"> <li>• Poor contact of ECM connector</li> <li>• Poor contact of camshaft position sensor connector</li> <li>• Poor contact of coupling connector</li> </ul>

## **BR:DTC P0410 SECONDARY AIR INJECTION SYSTEM**

### **DTC DETECTING CONDITION:**

- Detected when two consecutive driving cycles with fault occur.
- GENERAL DESCRIPTION <Ref. to GD(H4DOTC)-130, DTC P0410 SECONDARY AIR INJECTION SYSTEM, Diagnostic Trouble Code (DTC) Detecting Criteria.>

### **CAUTION:**

**After servicing or replacing faulty parts, perform Clear Memory Mode <Ref. to EN(H4DOTC)(diag)-62, OPERATION, Clear Memory Mode.>, and Inspection Mode <Ref. to EN(H4DOTC)(diag)-48, PROCEDURE, Inspection Mode.>.**

# Diagnostic Procedure with Diagnostic Trouble Code (DTC)

ENGINE (DIAGNOSTICS)

## WIRING DIAGRAM:

- Models without SI-DRIVE

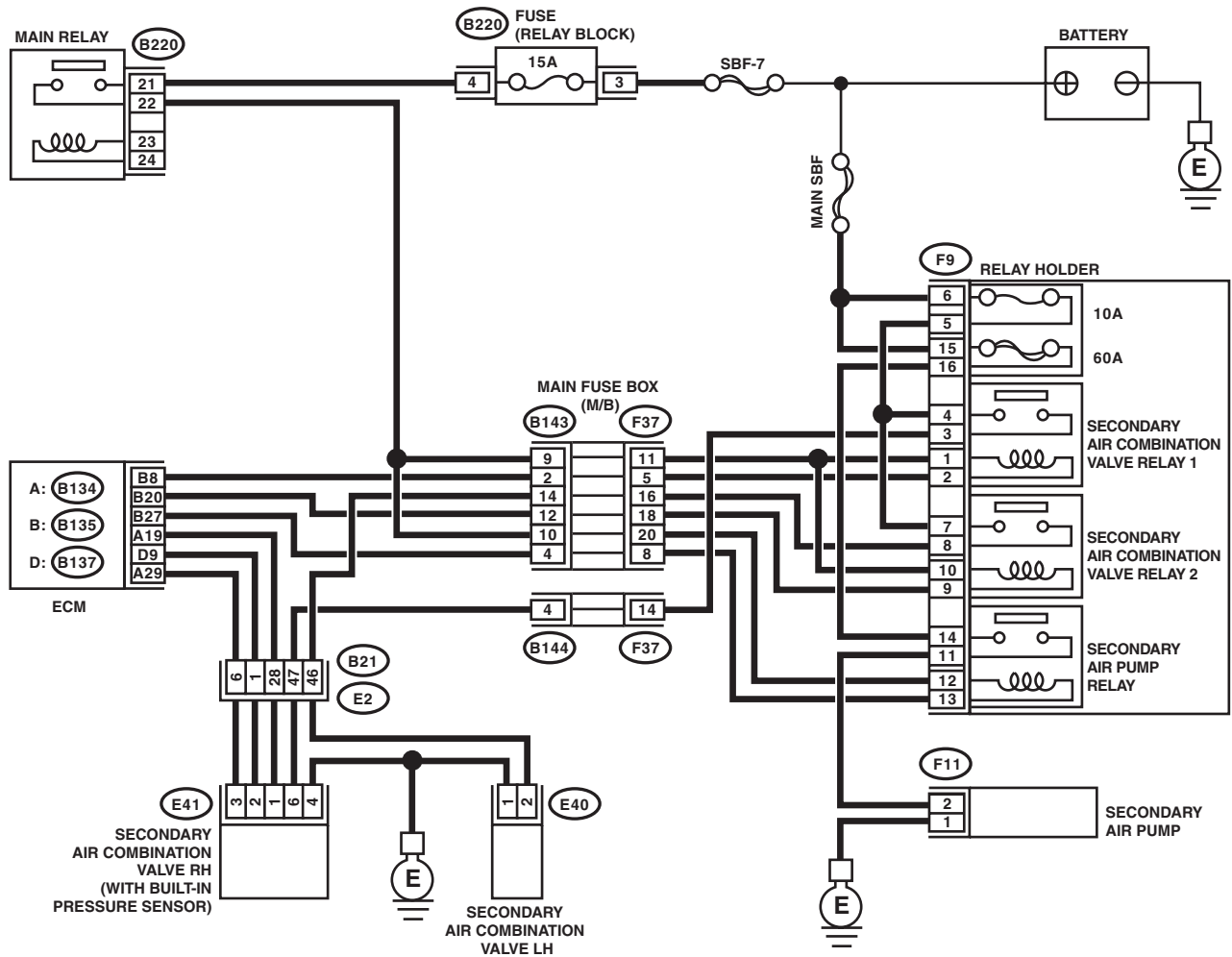

A: B134

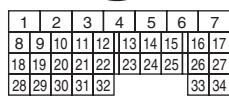

B: B135

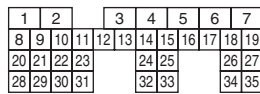

B220

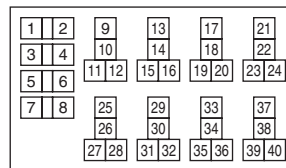

B21

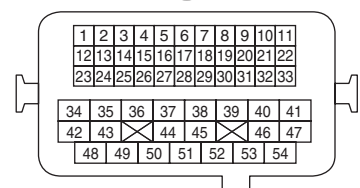

D: B137

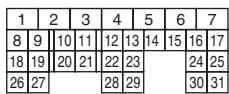

F9

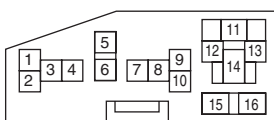

F37

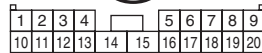

B143

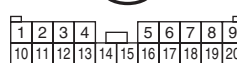

F11



E40



E41



B144

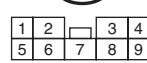

EN-08734

# Diagnostic Procedure with Diagnostic Trouble Code (DTC)

ENGINE (DIAGNOSTICS)

- Models with SI-DRIVE

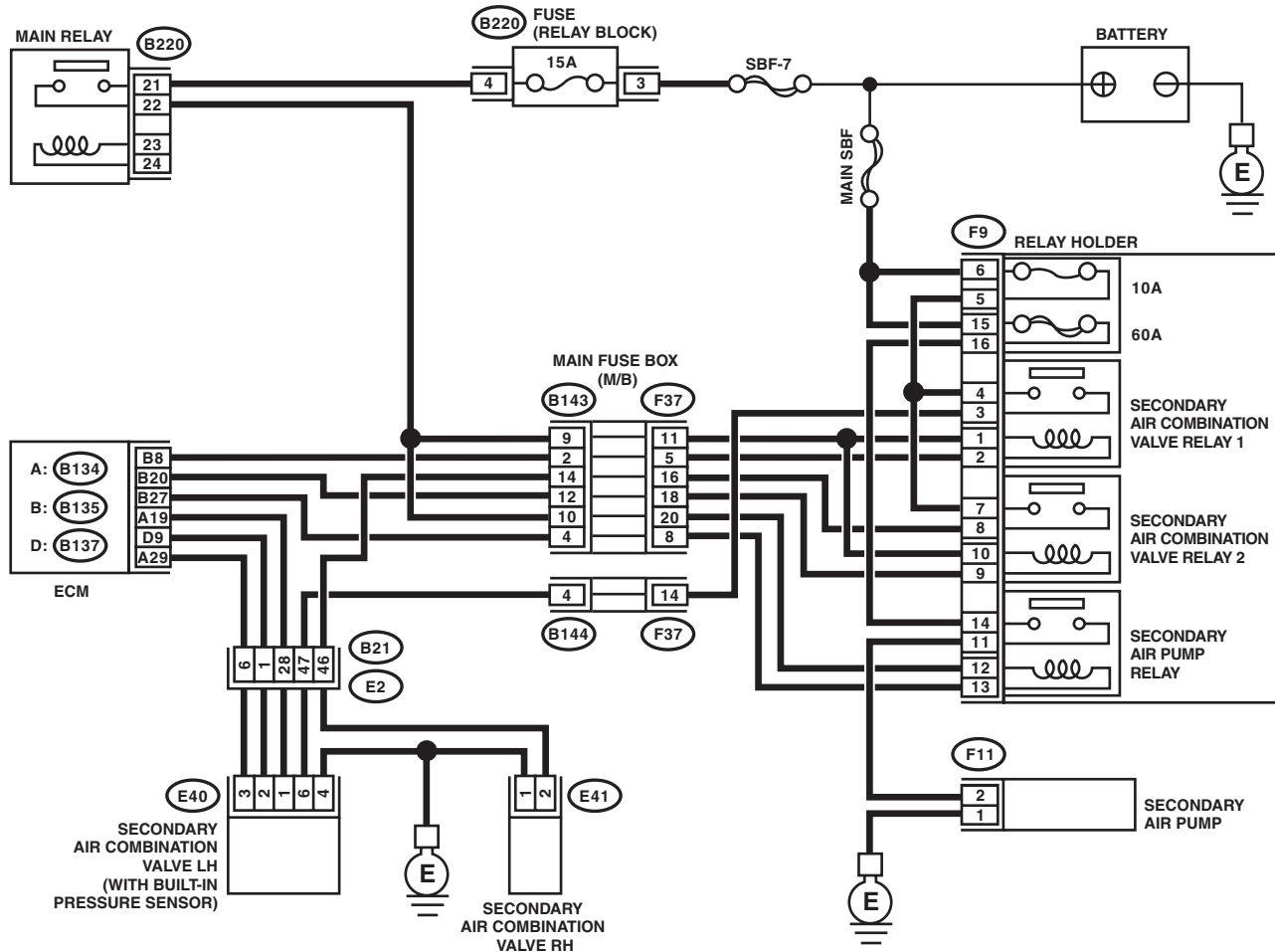

A: (B134)

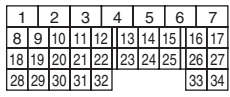

B: (B135)

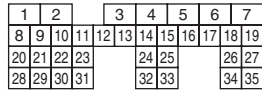

(B220)

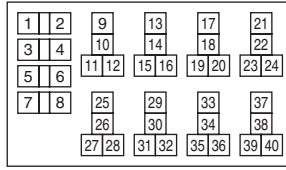

(B21)

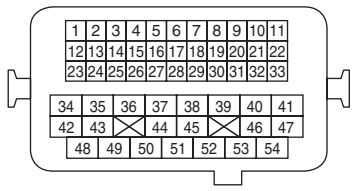

D: (B137)

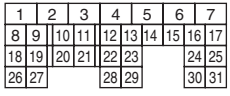

(F9)

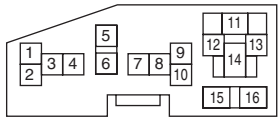

(F37)

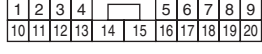

(B143)

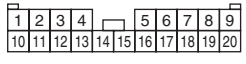

(F11)



(E41)



(E40)



(B144)

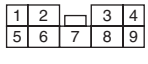

EN-08735

Step	Check	Yes	No
1	<b>CHECK SECONDARY AIR PUMP FUSE.</b> Check if the secondary air pump fuse (60 A) is blown out.	Go to step 2.	Go to step 3.



## Diagnostic Procedure with Diagnostic Trouble Code (DTC)

### ENGINE (DIAGNOSTICS)

Step	Check	Yes	No
<p><b>2</b></p> <p><b>CHECK HARNESS BETWEEN FUSE BOX AND SECONDARY AIR PUMP CONNECTOR.</b></p> <p>1) Remove the secondary air pump fuse from the fuse box.</p> <p>2) Disconnect the secondary air pump connector.</p> <p>3) Measure the resistance between the secondary air pump fuse and secondary air pump connector, and chassis ground.</p> <p><b>Connector &amp; terminal</b>  <b>(F9) No. 16 — Chassis ground:</b>  <b>(F11) No. 2 — Chassis ground:</b></p>	<p>Is the resistance 1 MΩ or more?</p>	<p>Replace the fuse with a new part, and connect the secondary air pump connector. Go to step 3.</p>	<p>Repair ground short of the harness between the fuse box and the secondary air pump connector.</p>
<p><b>3</b></p> <p><b>CHECK SECONDARY AIR PUMP OPERATION.</b></p> <p>1) Connect the delivery (test) mode connector.</p> <p>2) Turn the ignition switch to ON.</p> <p>3) Perform the Clear Memory Mode.</p> <p>4) Perform operation check for the secondary air pump using the Subaru Select Monitor.</p> <p>NOTE:</p> <ul style="list-style-type: none"> <li>• Subaru Select Monitor</li> </ul> <p>For detailed operation procedure, refer to "Clear Memory Mode" &lt;Ref. to EN(H4DOTC)(diag)-62, Clear Memory Mode.&gt; and "Compulsory Valve Operation Check Mode" &lt;Ref. to EN(H4DOTC)(diag)-63, Compulsory Valve Operation Check Mode.&gt;.</p> <ul style="list-style-type: none"> <li>• The compulsory operation using the Subaru Select Monitor is performed only for 5 seconds in order to protect the secondary air pump. When operating again, perform the Clear Memory Mode.</li> </ul>	<p>Does the secondary air pump operate?</p>	<p>Go to step 4.</p>	<p>Go to step 5.</p>
<p><b>4</b></p> <p><b>CHECK DUCT BETWEEN SECONDARY AIR PUMP AND COMBINATION VALVE.</b></p> <p>Check the duct between secondary air pump and combination valve.</p>	<p>Is there damage, clog or disconnection of the duct?</p>	<p>Replace, clean or connect the duct.</p>	<p>Replace the secondary air combination valve LH (models with SI-DRIVE) or RH (models without SI-DRIVE). &lt;Ref. to EC(STI)-29, Secondary Air Combination Valve.&gt; &lt;Ref. to EC(w/o STI)-30, Secondary Air Combination Valve.&gt;</p>

# Diagnostic Procedure with Diagnostic Trouble Code (DTC)

ENGINE (DIAGNOSTICS)

Step	Check	Yes	No
<p><b>5 CHECK POWER SUPPLY TO SECONDARY AIR PUMP.</b></p> <p>1) Perform the Clear Memory Mode.                      2) Turn the ignition switch to OFF.                      3) Disconnect the secondary air pump connector.                      4) In the condition of step 3, measure the voltage between the secondary air pump connector and the chassis ground.</p> <p>NOTE:                      For detailed procedures, refer to "Clear Memory Mode". &lt;Ref. to EN(H4DOTC)(diag)-62, Clear Memory Mode.&gt;</p> <p><b>Connector &amp; terminal</b>  <b>(F11) No. 2 (+) — Chassis ground (-):</b></p>	Is the voltage 10 V or more?	Replace the secondary air pump. <Ref. to EC(STI)-27, Secondary Air Pump.> <Ref. to EC(w/o STI)-29, Secondary Air Pump.>	Go to step 6.
<p><b>6 CHECK HARNESS BETWEEN SECONDARY AIR PUMP RELAY AND SECONDARY AIR PUMP CONNECTOR.</b></p> <p>1) Turn the ignition switch to OFF.                      2) Remove the secondary air pump relay.                      3) Measure the resistance of harness between secondary air pump relay connector and secondary air pump connector.</p> <p><b>Connector &amp; terminal</b>  <b>(F9) No. 11 — (F11) No. 2:</b></p>	Is the resistance less than 1 $\Omega$ ?	Go to step 7.	Repair the open circuit in harness between secondary air pump relay connector and secondary air pump connector.
<p><b>7 CHECK HARNESS BETWEEN SECONDARY AIR PUMP CONNECTOR AND CHASSIS GROUND.</b></p> <p>Measure the resistance of the harness between secondary air pump connector and chassis ground.</p> <p><b>Connector &amp; terminal</b>  <b>(F11) No. 1 — Chassis ground:</b></p>	Is the resistance less than 5 $\Omega$ ?	Go to step 8.	Repair the open circuit of the harness between secondary air pump connector and chassis ground.
<p><b>8 CHECK SECONDARY AIR PUMP RELAY.</b></p> <p>1) Connect the battery to terminals No. 12 and No. 13 of the secondary air pump relay.                      2) Measure the resistance between secondary air pump relay terminals.</p> <p><b>Terminals</b>  <b>No. 14 — No. 11:</b></p>	Is the resistance less than 1 $\Omega$ ?	Go to step 9.	Replace the secondary air pump relay. <Ref. to EN(H4DOTC)(diag)-9, Electrical Component Location.>
<p><b>9 CHECK SECONDARY AIR PUMP RELAY POWER SUPPLY.</b></p> <p>1) Turn the ignition switch to ON.                      2) Measure the voltage between the secondary air pump relay connector and chassis ground.</p> <p><b>Connector &amp; terminal</b>  <b>(F9) No. 14 (+) — Chassis ground (-):</b>  <b>(F9) No. 12 (+) — Chassis ground (-):</b></p>	Is the voltage 10 V or more?	Go to step 10.	Repair the open or ground short circuit of power supply circuit.

# Diagnostic Procedure with Diagnostic Trouble Code (DTC)

ENGINE (DIAGNOSTICS)

Step	Check	Yes	No
<p><b>10</b>    <b>CHECK HARNESS BETWEEN ECM AND SECONDARY AIR PUMP RELAY CONNECTOR.</b></p> <p>1) Turn the ignition switch to OFF. 2) Disconnect the ECM connector. 3) Measure the resistance of harness between ECM and secondary air pump relay connector.</p> <p><b>Connector &amp; terminal</b> <b>(B135) No. 27 — (F9) No. 13:</b></p>	<p>Is the resistance less than 1 <math>\Omega</math>?</p>	<p>Repair the poor contact of ECM connector.</p>	<p>Repair the harness and connector.</p> <p>NOTE: In this case, repair the following item:</p> <ul style="list-style-type: none"><li>• Open circuit in harness between ECM connector and secondary air pump relay connector</li><li>• Poor contact of coupling connector</li></ul>

# Diagnostic Procedure with Diagnostic Trouble Code (DTC)

ENGINE (DIAGNOSTICS)

## BS:DTC P0411 SECONDARY AIR INJECTION SYSTEM INCORRECT FLOW DETECTED

### DTC DETECTING CONDITION:

- Detected when two consecutive driving cycles with fault occur.
- GENERAL DESCRIPTION <Ref. to GD(H4DOTC)-137, DTC P0411 SECONDARY AIR INJECTION SYSTEM INCORRECT FLOW DETECTED, Diagnostic Trouble Code (DTC) Detecting Criteria.>

### CAUTION:

After servicing or replacing faulty parts, perform Clear Memory Mode <Ref. to EN(H4DOTC)(diag)-62, OPERATION, Clear Memory Mode.>, and Inspection Mode <Ref. to EN(H4DOTC)(diag)-48, PROCEDURE, Inspection Mode.>.

	Step	Check	Yes	No
1	<b>CHECK SECONDARY AIR COMBINATION VALVE.</b> Check the pipe between the secondary air combination valve and cylinder head.	Is there damage or disconnection of the pipe?	Replace the pipe between secondary air combination valve and cylinder head. <Ref. to EC(STI)-29, Secondary Air Combination Valve.> <Ref. to EC(w/o STI)-30, Secondary Air Combination Valve.>	Go to step 2.
2	<b>CHECK SECONDARY AIR COMBINATION VALVE.</b> Race the engine at 2,000 rpm to check whether or not the exhaust leak is heard.	Is there any exhaust leak?	Replace the pipe between secondary air combination valve and cylinder head. <Ref. to EC(STI)-29, Secondary Air Combination Valve.> <Ref. to EC(w/o STI)-30, Secondary Air Combination Valve.>	Repair the poor contact of ECM connector.

## Diagnostic Procedure with Diagnostic Trouble Code (DTC)

ENGINE (DIAGNOSTICS)

---

### **BT:DTC P0413 SECONDARY AIR INJECTION SYSTEM SWITCHING VALVE "A" CIRCUIT OPEN**

#### **DTC DETECTING CONDITION:**

- Immediately at fault recognition
- GENERAL DESCRIPTION <Ref. to GD(H4DOTC)-138, DTC P0413 SECONDARY AIR INJECTION SYSTEM SWITCHING VALVE "A" CIRCUIT OPEN, Diagnostic Trouble Code (DTC) Detecting Criteria.>

#### **CAUTION:**

**After servicing or replacing faulty parts, perform Clear Memory Mode <Ref. to EN(H4DOTC)(diag)-62, OPERATION, Clear Memory Mode.>, and Inspection Mode <Ref. to EN(H4DOTC)(diag)-48, PROCEDURE, Inspection Mode.>.**

# Diagnostic Procedure with Diagnostic Trouble Code (DTC)

ENGINE (DIAGNOSTICS)

## WIRING DIAGRAM:

- Models without SI-DRIVE

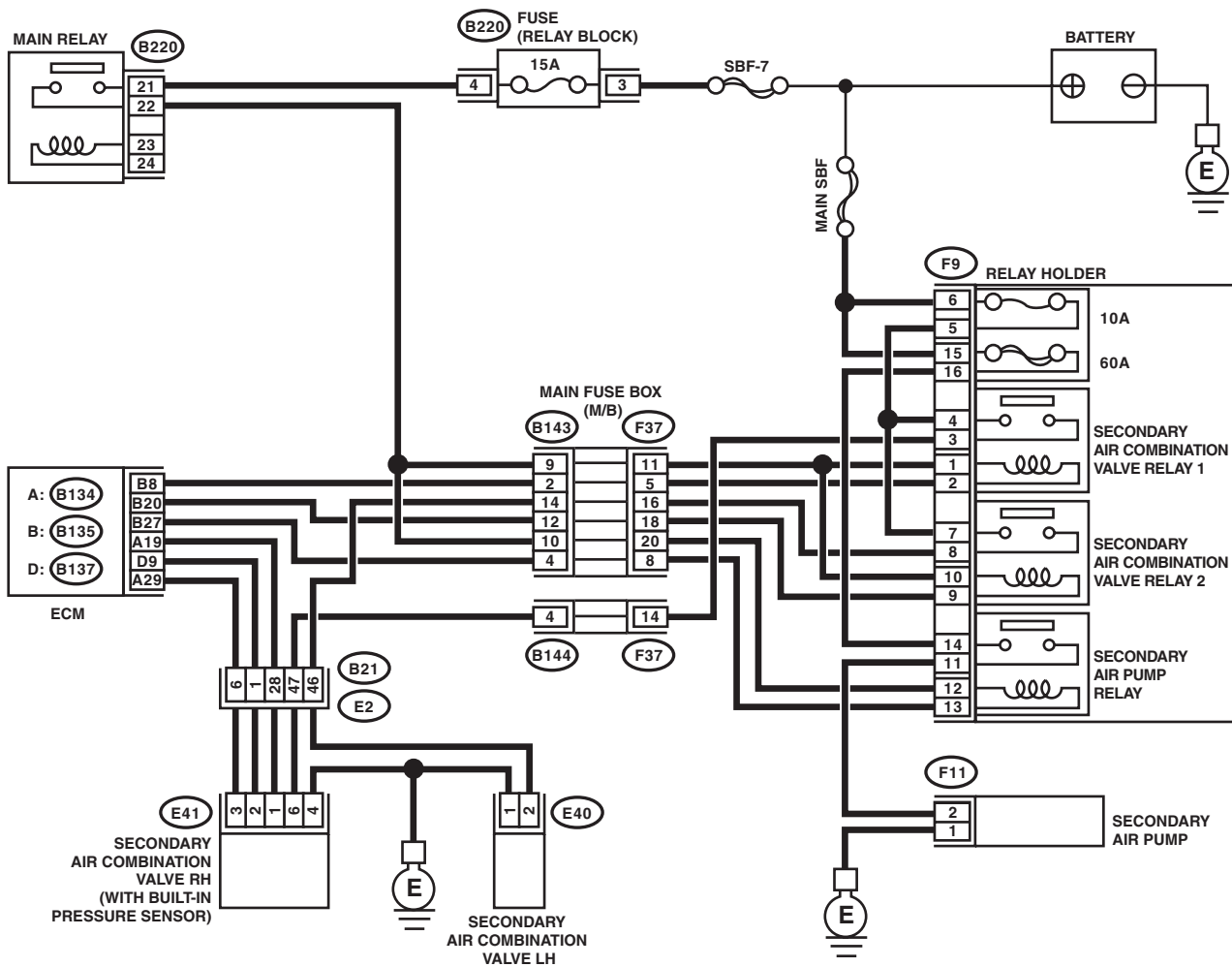

A: (B134)



B: (B135)



(B220)

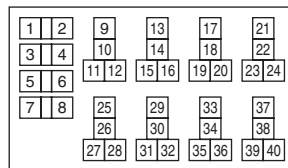

(B21)

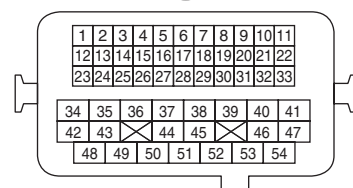

D: (B137)

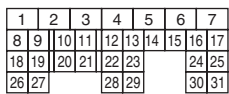

(F9)

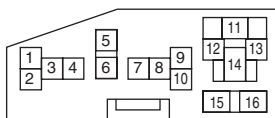

(F37)

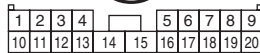

(B143)



(F11)



(E40)



(E41)



(B144)

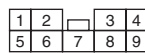

EN-08734

# Diagnostic Procedure with Diagnostic Trouble Code (DTC)

## ENGINE (DIAGNOSTICS)

- Models with SI-DRIVE

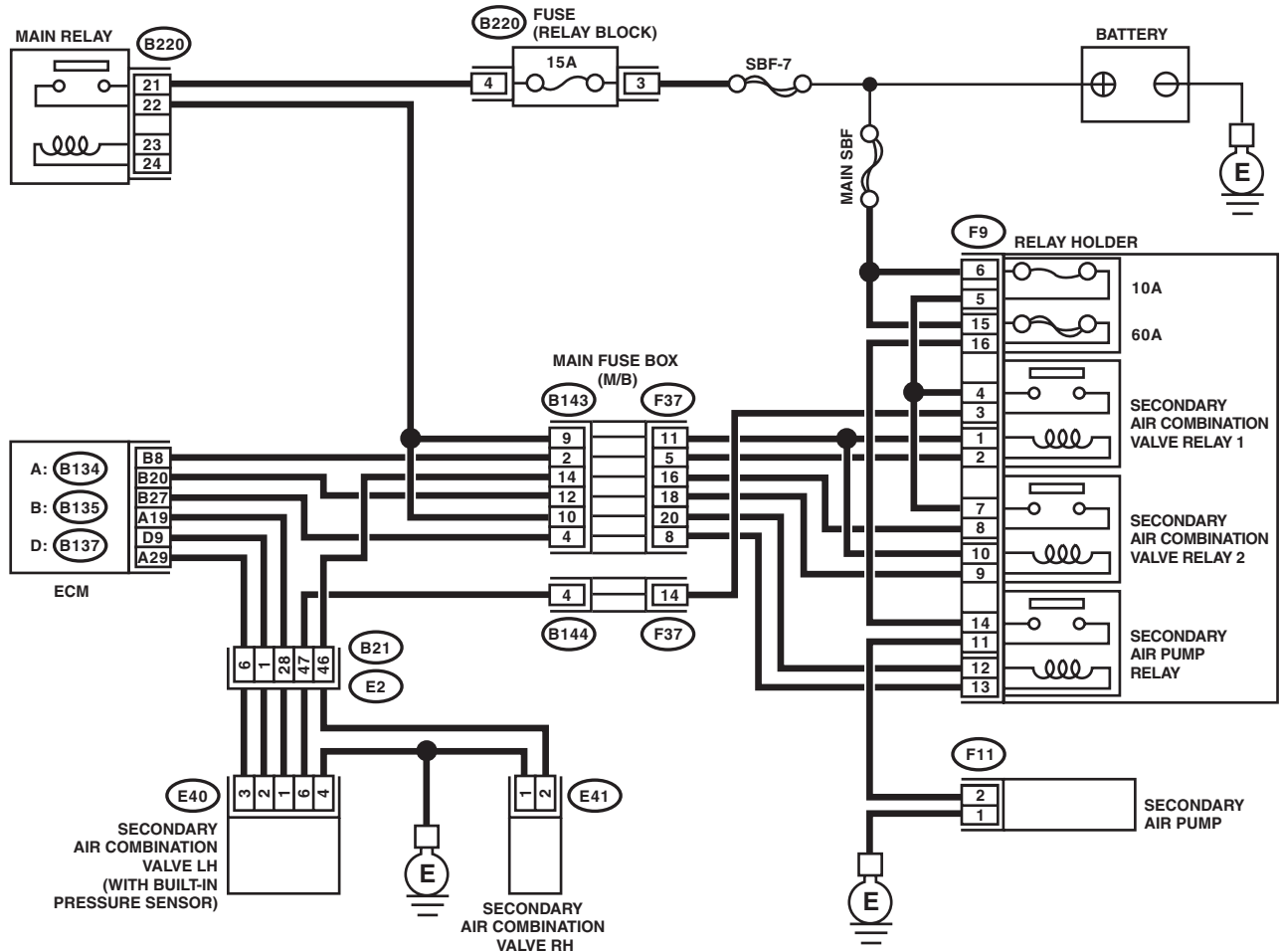

A: B134

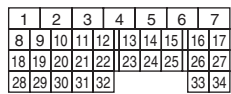

D: B137

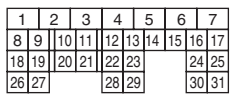

B: B135

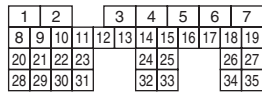

B220

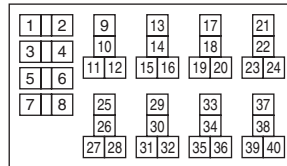

B21

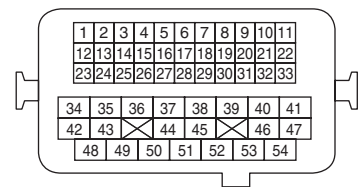

F9

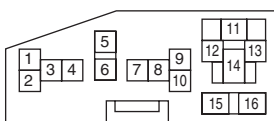

F37

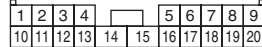

B143

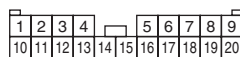

F11



E41



E40



B144

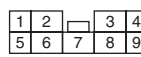

EN-08735

# Diagnostic Procedure with Diagnostic Trouble Code (DTC)

ENGINE (DIAGNOSTICS)

	Step	Check	Yes	No
1	<p><b>CHECK HARNESS BETWEEN ECM AND SECONDARY AIR COMBINATION VALVE RELAY 1 CONNECTOR.</b></p> <p>1) Turn the ignition switch to OFF.                      2) Disconnect the connector from ECM.                      3) Remove the secondary air combination valve relay 1.                      4) Measure the resistance of harness between ECM and secondary air combination valve relay 1 connector.</p> <p><b>Connector &amp; terminal</b>  <b>(B135) No. 8 — (F9) No. 2:</b></p>	Is the resistance less than 1 Ω?	Go to step 2.	<p>Repair the harness and connector.</p> <p>NOTE:                      In this case, repair the following item:</p> <ul style="list-style-type: none"> <li>• Open circuit in harness between ECM and secondary air combination valve relay 1 connector</li> <li>• Poor contact of coupling connector</li> </ul>
2	<p><b>CHECK HARNESS BETWEEN ECM AND SECONDARY AIR COMBINATION VALVE RELAY 1 CONNECTOR.</b></p> <p>Measure the resistance between ECM and chassis ground.</p> <p><b>Connector &amp; terminal</b>  <b>(B135) No. 8 — Chassis ground:</b></p>	Is the resistance 1 MΩ or more?	<p>Even if DTC is detected, the circuit has returned to a normal condition at this time. Reproduce the failure, and then perform the diagnosis again.</p> <p>NOTE:                      In this case, temporary poor contact of connector, temporary open or short circuit of harness may be the cause.</p>	Repair the short circuit to ground in harness between ECM and secondary air combination valve relay 1 connector.



## Diagnostic Procedure with Diagnostic Trouble Code (DTC)

ENGINE (DIAGNOSTICS)

---

### **BU:DTC P0414 SECONDARY AIR INJECTION SYSTEM SWITCHING VALVE "A" CIRCUIT SHORTED**

#### **DTC DETECTING CONDITION:**

- Immediately at fault recognition
- GENERAL DESCRIPTION <Ref. to GD(H4DOTC)-139, DTC P0414 SECONDARY AIR INJECTION SYSTEM SWITCHING VALVE "A" CIRCUIT SHORTED, Diagnostic Trouble Code (DTC) Detecting Criteria.>

#### **CAUTION:**

**After servicing or replacing faulty parts, perform Clear Memory Mode <Ref. to EN(H4DOTC)(diag)-62, OPERATION, Clear Memory Mode.>, and Inspection Mode <Ref. to EN(H4DOTC)(diag)-48, PROCEDURE, Inspection Mode.>.**

# Diagnostic Procedure with Diagnostic Trouble Code (DTC)

ENGINE (DIAGNOSTICS)

## WIRING DIAGRAM:

- Models without SI-DRIVE

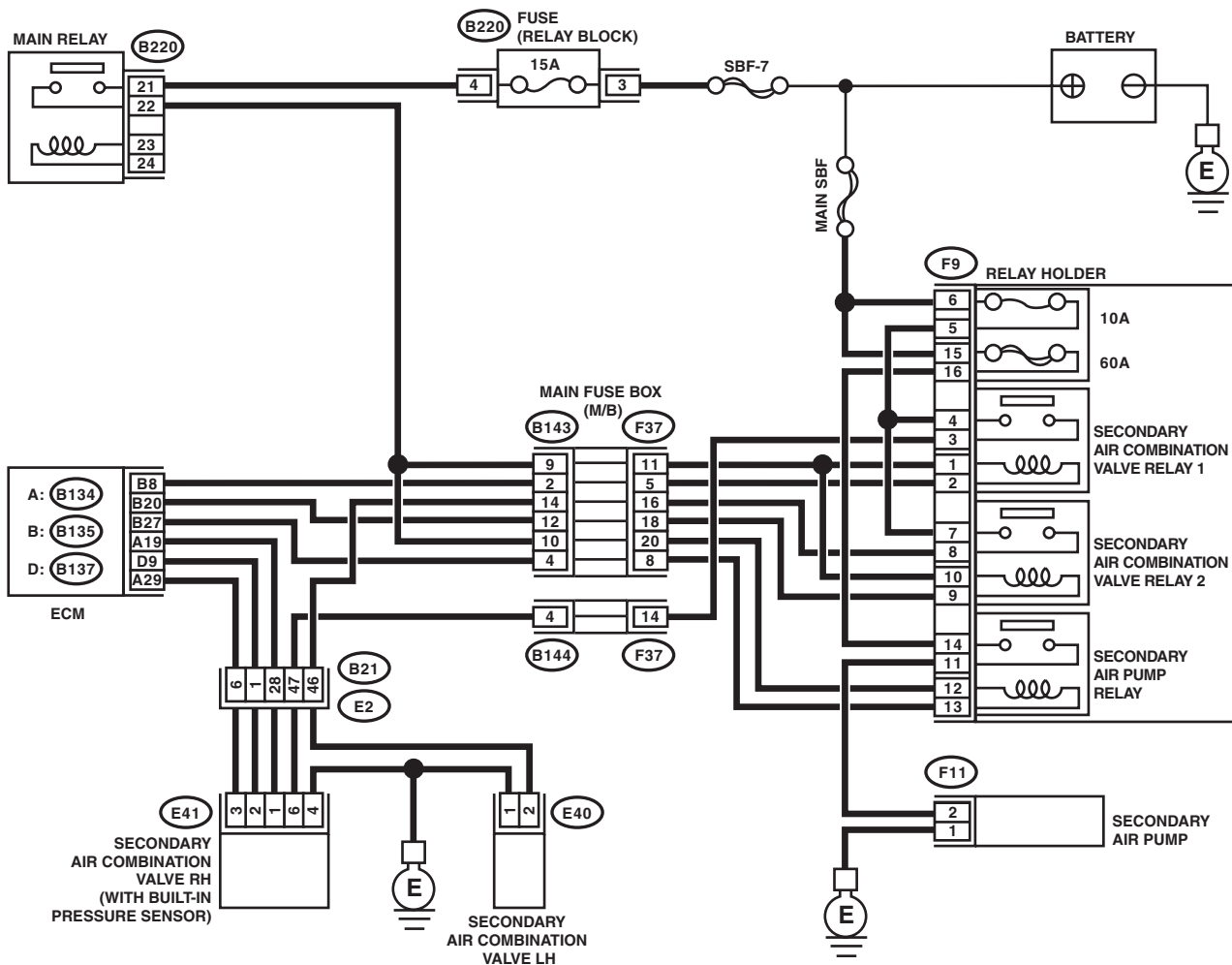

A: B134



B: B135



B220

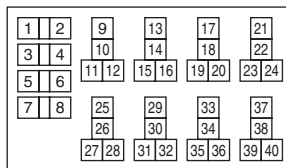

B21

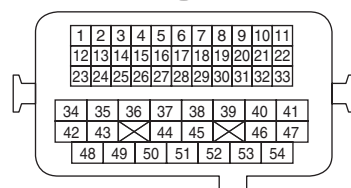

D: B137

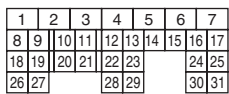

F9

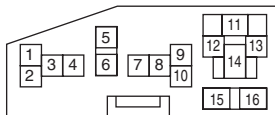

F37

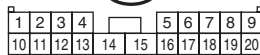

B143



F11



E40



E41



B144

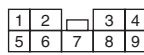

EN-08734

# Diagnostic Procedure with Diagnostic Trouble Code (DTC)

## ENGINE (DIAGNOSTICS)

- Models with SI-DRIVE

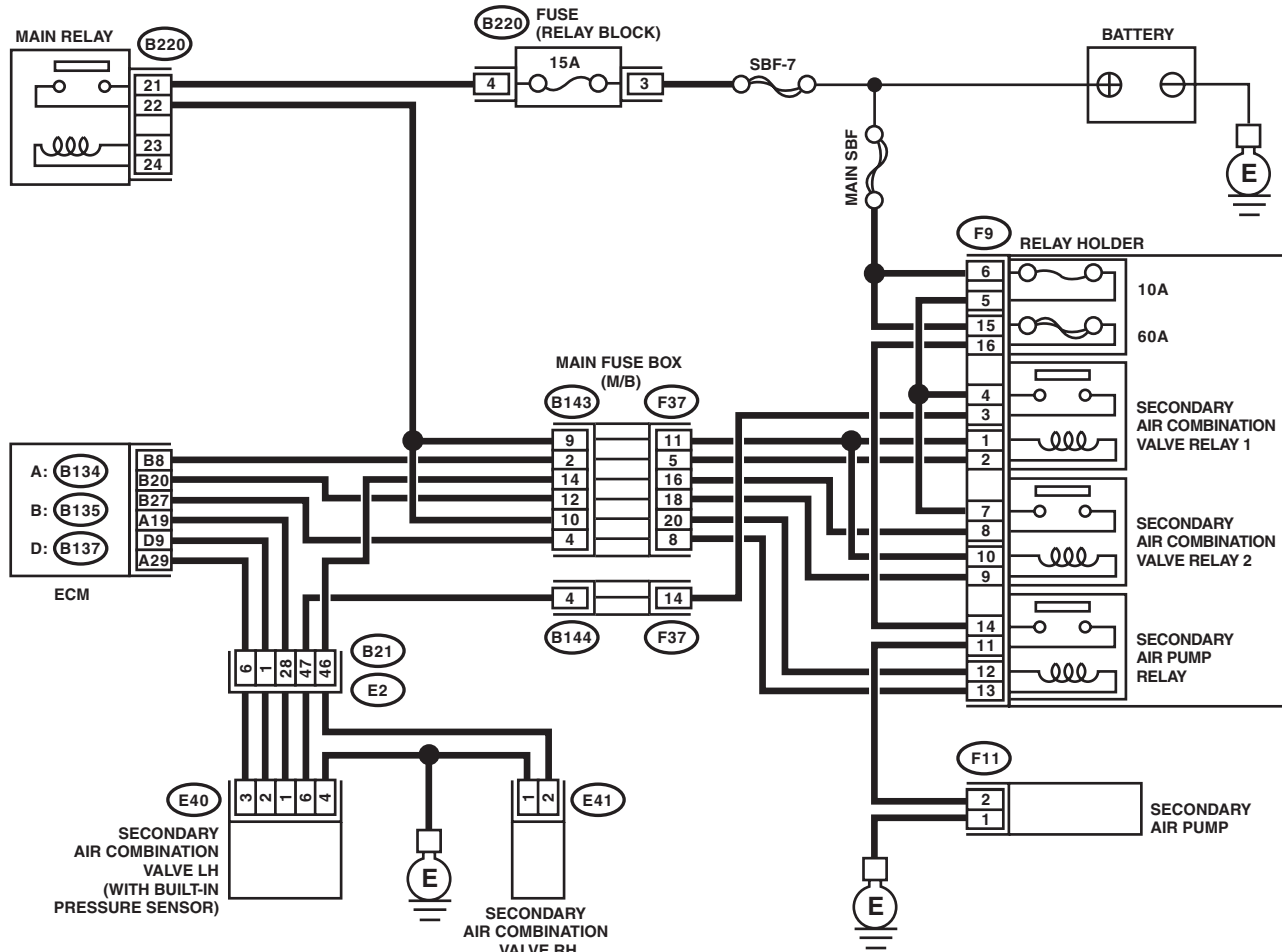

A: B134

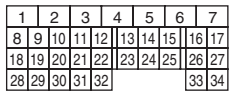

B: B135

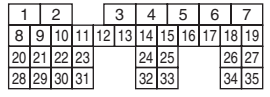

B220

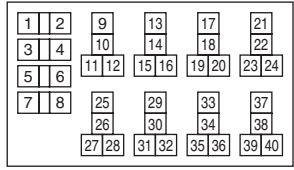

B21

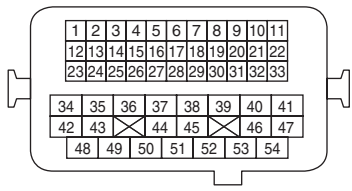

D: B137

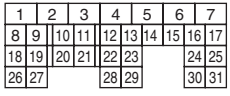

F9

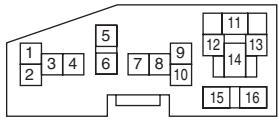

F37

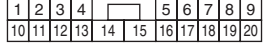

B143

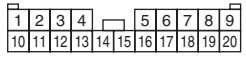

F11



E41



E40



B144

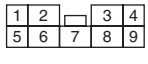

EN-08735

# Diagnostic Procedure with Diagnostic Trouble Code (DTC)

ENGINE (DIAGNOSTICS)

	Step	Check	Yes	No
1	<b>CHECK HARNESS BETWEEN ECM AND SECONDARY AIR COMBINATION VALVE RELAY 1 CONNECTOR.</b> 1) Turn the ignition switch to OFF. 2) Disconnect the connector from ECM. 3) Remove the secondary air combination valve relay 1. 4) Measure the voltage between ECM and chassis ground. <b>Connector &amp; terminal</b> <b>(B135) No. 8 (+) — Chassis ground (-):</b>	Is the voltage 10 V or more?	Repair the short circuit to power in harness between ECM and secondary air combination valve relay 1 connector.	Repair the poor contact of ECM connector.

## Diagnostic Procedure with Diagnostic Trouble Code (DTC)

ENGINE (DIAGNOSTICS)

---

### **BV:DTC P0416 SECONDARY AIR INJECTION SYSTEM SWITCHING VALVE "B" CIRCUIT OPEN**

#### **DTC DETECTING CONDITION:**

- Immediately at fault recognition
- GENERAL DESCRIPTION <Ref. to GD(H4DOTC)-140, DTC P0416 SECONDARY AIR INJECTION SYSTEM SWITCHING VALVE "B" CIRCUIT OPEN, Diagnostic Trouble Code (DTC) Detecting Criteria.>

#### **CAUTION:**

**After servicing or replacing faulty parts, perform Clear Memory Mode <Ref. to EN(H4DOTC)(diag)-62, OPERATION, Clear Memory Mode.>, and Inspection Mode <Ref. to EN(H4DOTC)(diag)-48, PROCEDURE, Inspection Mode.>.**

# Diagnostic Procedure with Diagnostic Trouble Code (DTC)

ENGINE (DIAGNOSTICS)

## WIRING DIAGRAM:

- Models without SI-DRIVE

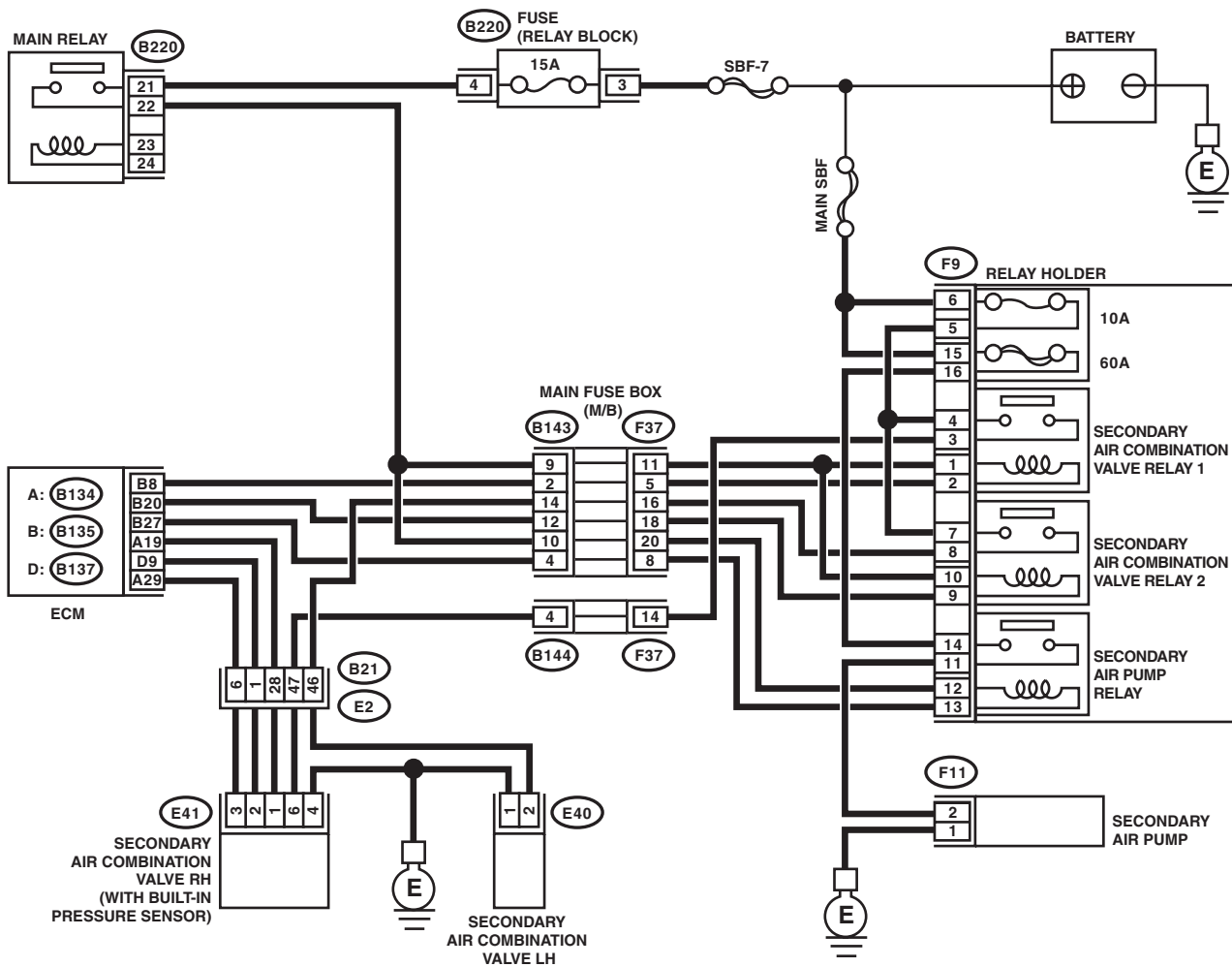

A: B134



B: B135



B220

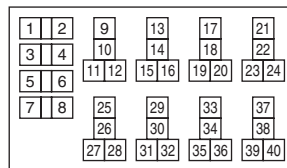

B21

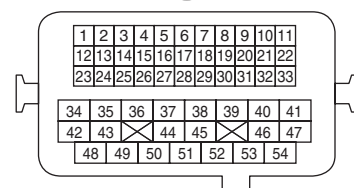

D: B137

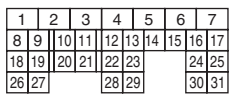

F9

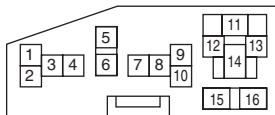

F37

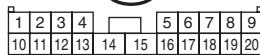

B143



F11



E40



E41



B144

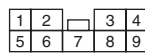

EN-08734

# Diagnostic Procedure with Diagnostic Trouble Code (DTC)

## ENGINE (DIAGNOSTICS)

- Models with SI-DRIVE

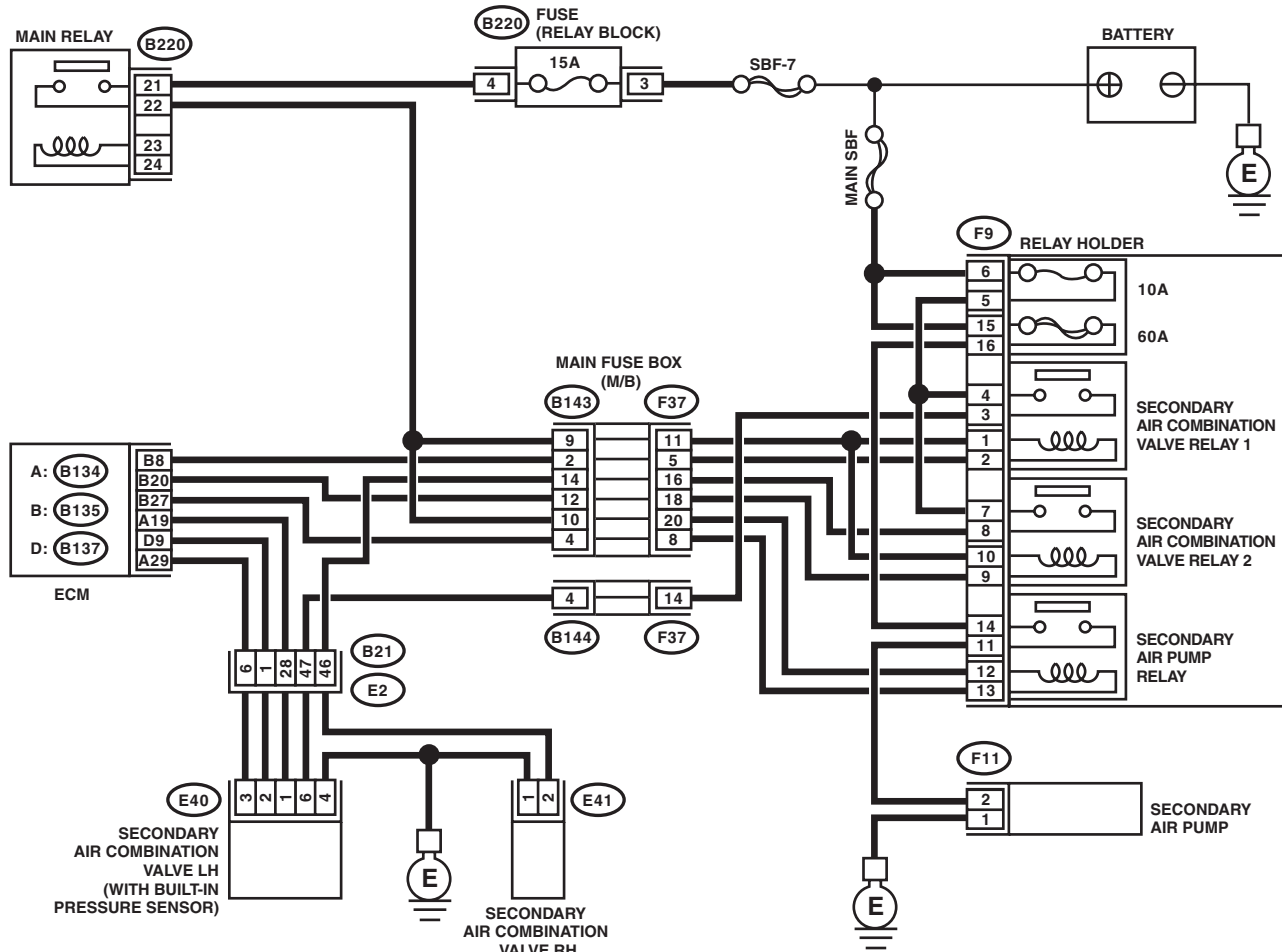

A: **B134**

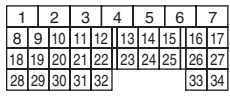

B: **B135**

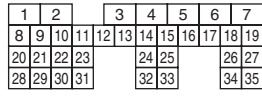

**B220**

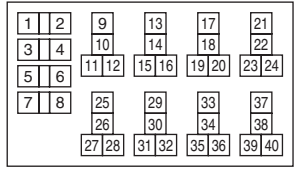

**B21**

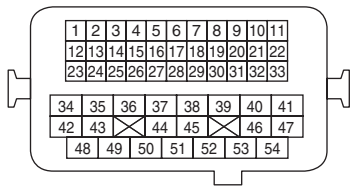

D: **B137**

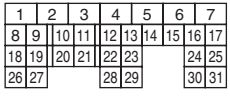

**F9**

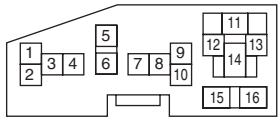

**F37**

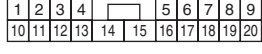

**B143**

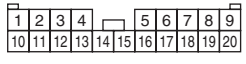

**F11**



**E41**



**E40**



**B144**

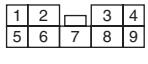

EN-08735

# Diagnostic Procedure with Diagnostic Trouble Code (DTC)

ENGINE (DIAGNOSTICS)

Step	Check	Yes	No
<p><b>1</b></p> <p><b>CHECK HARNESS BETWEEN ECM AND SECONDARY AIR COMBINATION VALVE RELAY 2 CONNECTOR.</b></p> <p>1) Turn the ignition switch to OFF.                      2) Disconnect the connector from ECM.                      3) Remove the secondary air combination valve relay 2.                      4) Measure the resistance of harness between ECM and secondary air combination valve relay 2 connector.</p> <p><b>Connector &amp; terminal</b>  <b>(B135) No. 20 — (F9) No. 9:</b></p>	<p>Is the resistance less than 1 Ω?</p>	<p>Go to step 2.</p>	<p>Repair the harness and connector.</p> <p>NOTE:                      In this case, repair the following item:</p> <ul style="list-style-type: none"> <li>• Open circuit in harness between ECM and secondary air combination valve relay 2 connector</li> <li>• Poor contact of coupling connector</li> </ul>
<p><b>2</b></p> <p><b>CHECK HARNESS BETWEEN ECM AND SECONDARY AIR COMBINATION VALVE RELAY 2 CONNECTOR.</b></p> <p>Measure the resistance between ECM and chassis ground.</p> <p><b>Connector &amp; terminal</b>  <b>(B135) No. 20 — Chassis ground:</b></p>	<p>Is the resistance 1 MΩ or more?</p>	<p>Even if DTC is detected, the circuit has returned to a normal condition at this time. Reproduce the failure, and then perform the diagnosis again.</p> <p>NOTE:                      In this case, temporary poor contact of connector, temporary open or short circuit of harness may be the cause.</p>	<p>Repair the short circuit to ground in harness between ECM and secondary air combination valve relay 2 connector.</p>



## Diagnostic Procedure with Diagnostic Trouble Code (DTC)

ENGINE (DIAGNOSTICS)

---

### **BW:DTC P0417 SECONDARY AIR INJECTION SYSTEM SWITCHING VALVE "B" CIRCUIT SHORTED**

#### **DTC DETECTING CONDITION:**

- Immediately at fault recognition
- GENERAL DESCRIPTION <Ref. to GD(H4DOTC)-140, DTC P0417 SECONDARY AIR INJECTION SYSTEM SWITCHING VALVE "B" CIRCUIT SHORTED, Diagnostic Trouble Code (DTC) Detecting Criteria.>

#### **CAUTION:**

**After servicing or replacing faulty parts, perform Clear Memory Mode <Ref. to EN(H4DOTC)(diag)-62, OPERATION, Clear Memory Mode.>, and Inspection Mode <Ref. to EN(H4DOTC)(diag)-48, PROCEDURE, Inspection Mode.>.**

# Diagnostic Procedure with Diagnostic Trouble Code (DTC)

ENGINE (DIAGNOSTICS)

## WIRING DIAGRAM:

- Models without SI-DRIVE

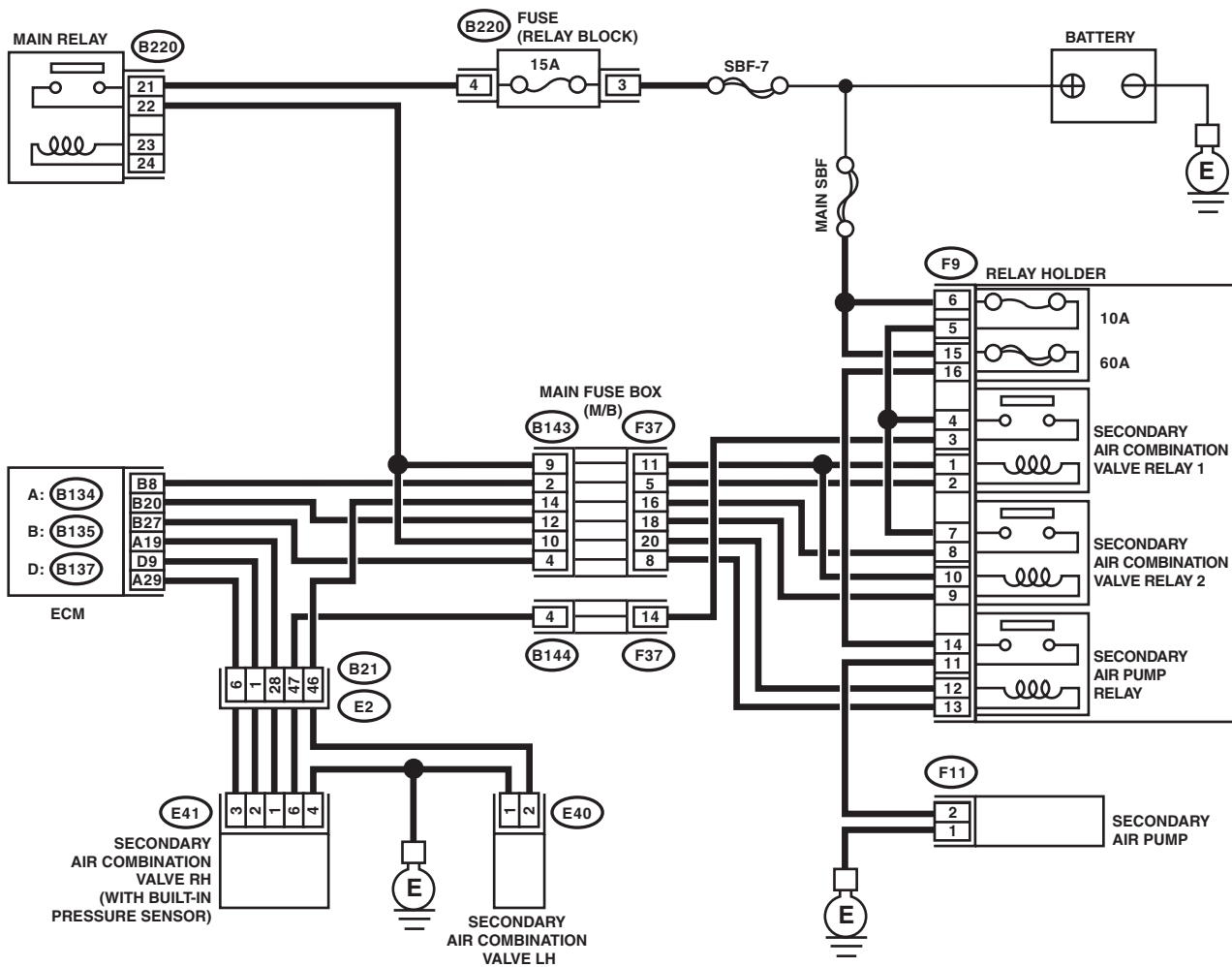

A: (B134)



B: (B135)



(B220)

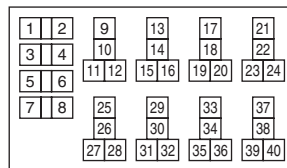

(B21)

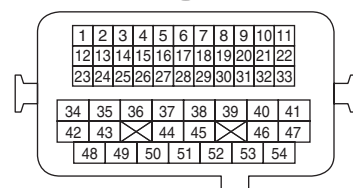

D: (B137)

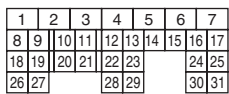

(F9)

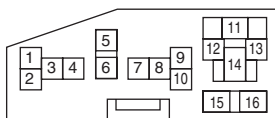

(F37)

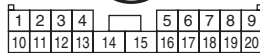

(B143)



(F11)



(E40)



(E41)



(B144)

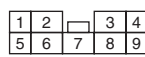

EN-08734

# Diagnostic Procedure with Diagnostic Trouble Code (DTC)

## ENGINE (DIAGNOSTICS)

- Models with SI-DRIVE

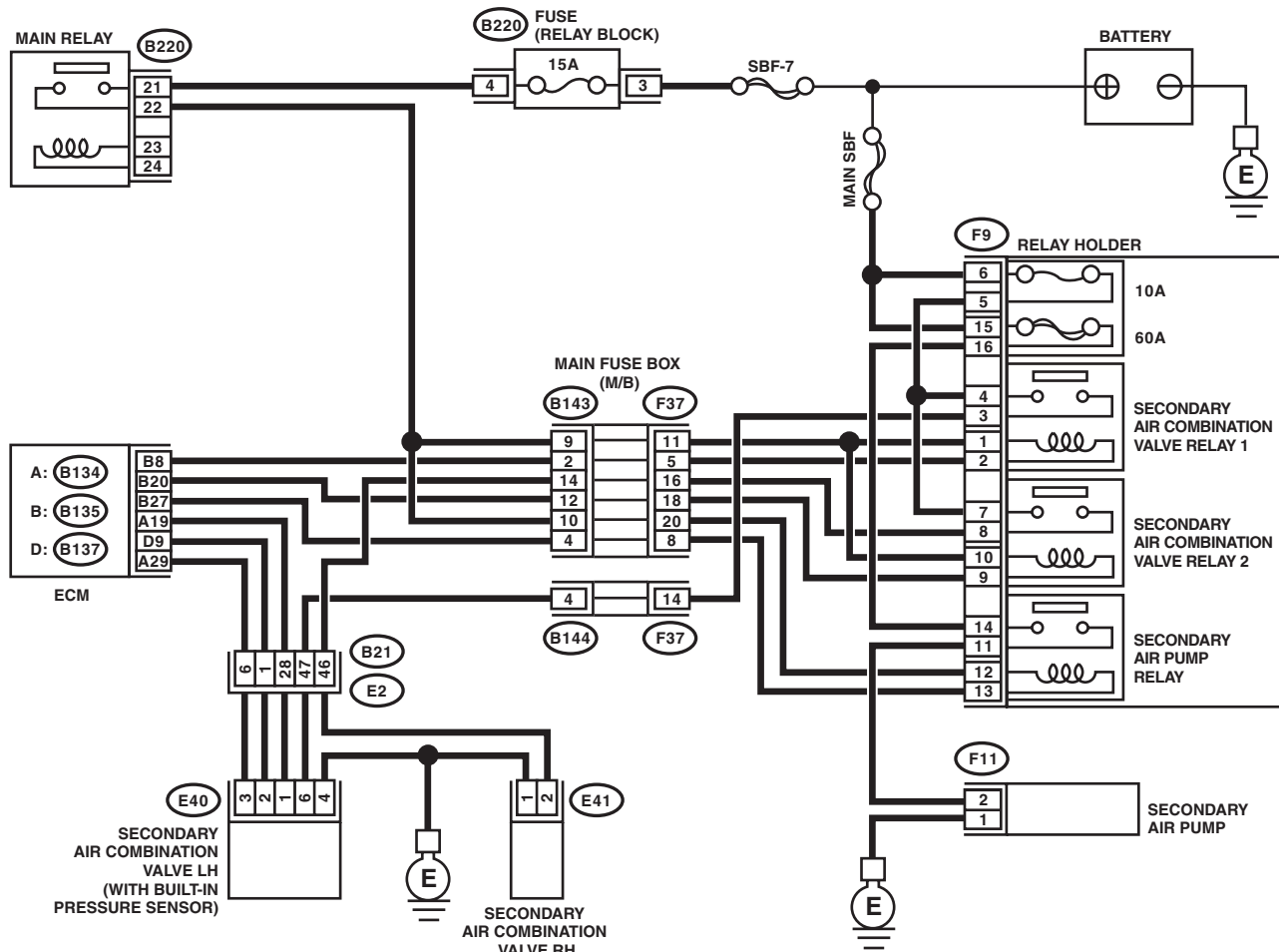

A: B134

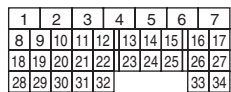

D: B137

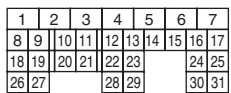

B: B135

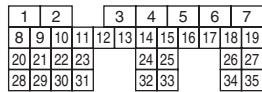

B220

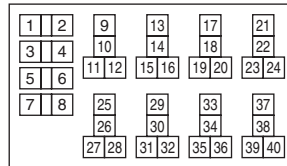

B21

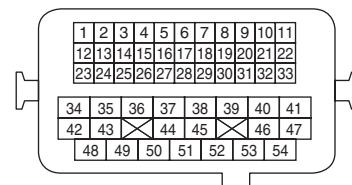

F9

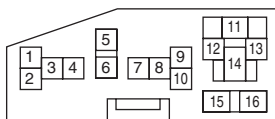

F37

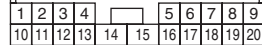

B143

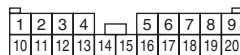

F11



E41



E40



B144

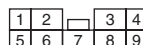

EN-08735

# Diagnostic Procedure with Diagnostic Trouble Code (DTC)

ENGINE (DIAGNOSTICS)

	Step	Check	Yes	No
1	<b>CHECK HARNESS BETWEEN ECM AND SECONDARY AIR COMBINATION VALVE RELAY 2 CONNECTOR.</b> 1) Turn the ignition switch to OFF. 2) Disconnect the connector from ECM. 3) Remove the secondary air combination valve relay 2. 4) Measure the voltage between ECM and chassis ground. <b>Connector &amp; terminal</b> <b>(B135) No. 20 (+) — Chassis ground (-):</b>	Is the voltage 10 V or more?	Repair the short circuit to power in harness between ECM and secondary air combination valve relay 2 connector.	Repair the poor contact of ECM connector.

## Diagnostic Procedure with Diagnostic Trouble Code (DTC)

ENGINE (DIAGNOSTICS)

---

### **BX:DTC P0418 SECONDARY AIR INJECTION SYSTEM CONTROL "A" CIRCUIT OPEN**

#### **DTC DETECTING CONDITION:**

- Immediately at fault recognition
- GENERAL DESCRIPTION <Ref. to GD(H4DOTC)-141, DTC P0418 SECONDARY AIR INJECTION SYSTEM CONTROL "A" CIRCUIT OPEN, Diagnostic Trouble Code (DTC) Detecting Criteria.>

#### **CAUTION:**

**After servicing or replacing faulty parts, perform Clear Memory Mode <Ref. to EN(H4DOTC)(diag)-62, OPERATION, Clear Memory Mode.>, and Inspection Mode <Ref. to EN(H4DOTC)(diag)-48, PROCEDURE, Inspection Mode.>.**

# Diagnostic Procedure with Diagnostic Trouble Code (DTC)

ENGINE (DIAGNOSTICS)

## WIRING DIAGRAM:

- Models without SI-DRIVE

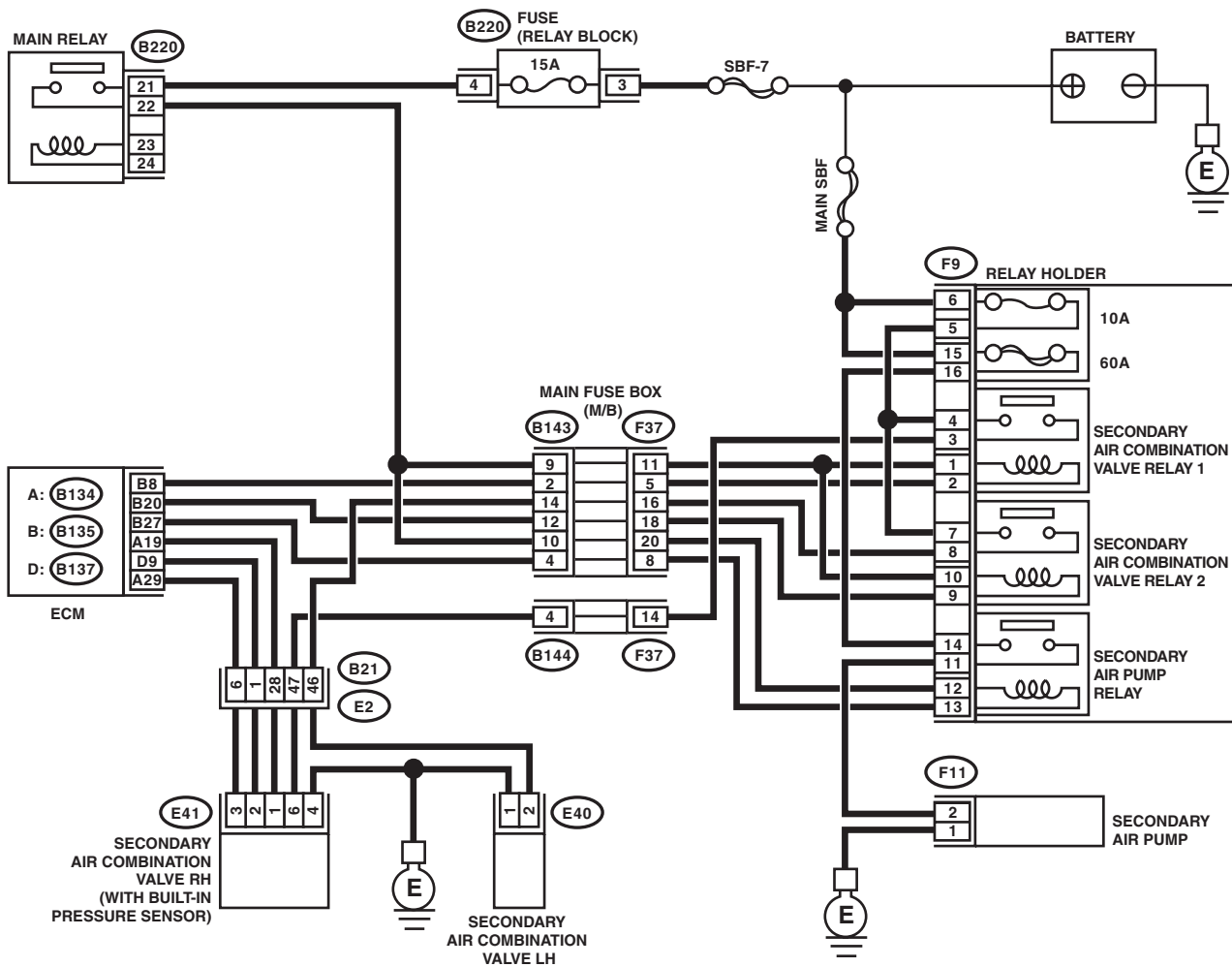

A: (B134)



B: (B135)



(B220)

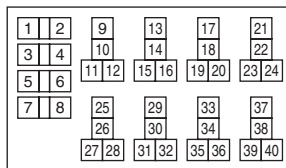

(B21)

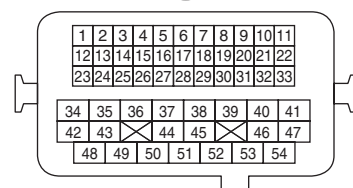

D: (B137)

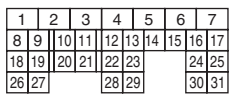

(F9)

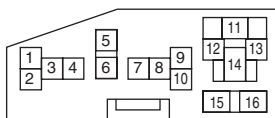

(F37)

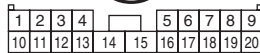

(B143)



(F11)



(E40)



(E41)



(B144)

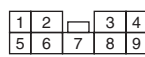

EN-08734

# Diagnostic Procedure with Diagnostic Trouble Code (DTC)

## ENGINE (DIAGNOSTICS)

- Models with SI-DRIVE

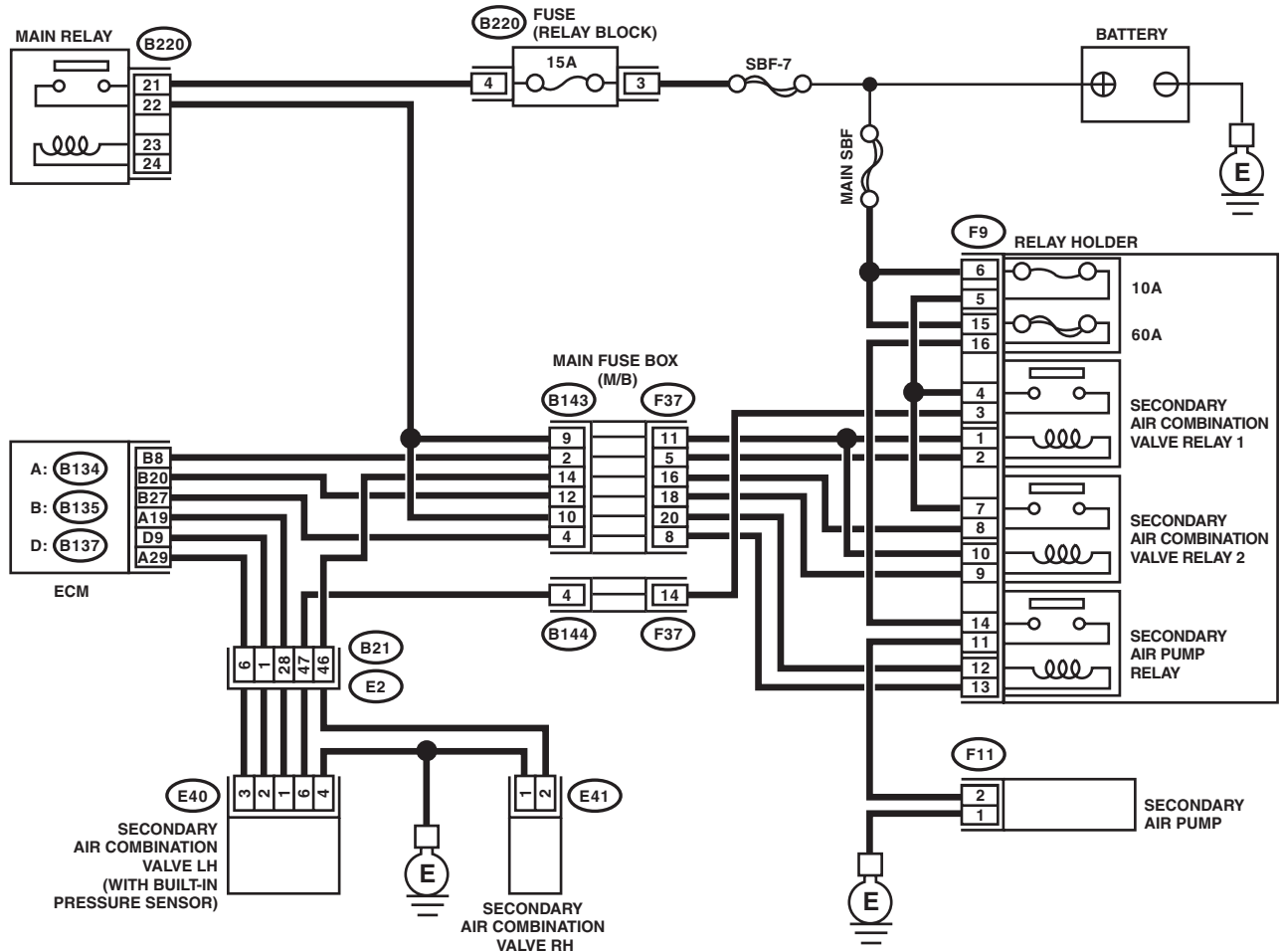

A: B134

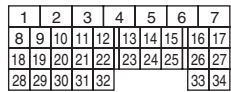

D: B137

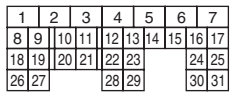

B: B135

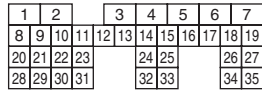

B220

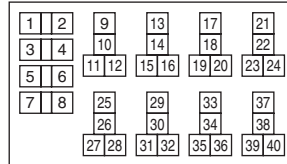

B21

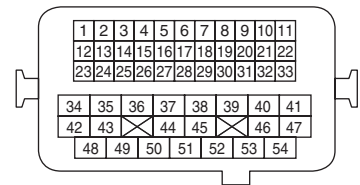

F9

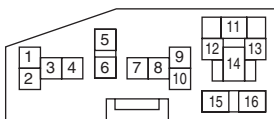

F37

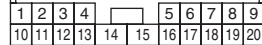

B143

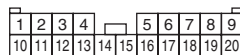

F11



E41



E40



B144

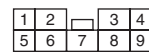

EN-08735

# Diagnostic Procedure with Diagnostic Trouble Code (DTC)

ENGINE (DIAGNOSTICS)

Step	Check	Yes	No
<p><b>1</b></p> <p><b>CHECK HARNESS BETWEEN ECM AND SECONDARY AIR PUMP RELAY CONNECTOR.</b></p> <p>1) Turn the ignition switch to OFF.                      2) Disconnect the connector from ECM.                      3) Remove the secondary air pump relay.                      4) Measure the resistance of harness between ECM and secondary air pump relay connector.</p> <p><b>Connector &amp; terminal</b>  <b>(B135) No. 27 — (F9) No. 13:</b></p>	<p>Is the resistance less than 1 Ω?</p>	<p>Go to step 2.</p>	<p>Repair the harness and connector.</p> <p>NOTE:                      In this case, repair the following item:</p> <ul style="list-style-type: none"> <li>• Open circuit in harness between ECM and secondary air pump relay connector</li> <li>• Poor contact of coupling connector</li> </ul>
<p><b>2</b></p> <p><b>CHECK HARNESS BETWEEN ECM AND SECONDARY AIR PUMP RELAY CONNECTOR.</b></p> <p>Measure the resistance between ECM and chassis ground.</p> <p><b>Connector &amp; terminal</b>  <b>(B135) No. 27 — Chassis ground:</b></p>	<p>Is the resistance 1 MΩ or more?</p>	<p>Even if DTC is detected, the circuit has returned to a normal condition at this time. Reproduce the failure, and then perform the diagnosis again.</p> <p>NOTE:                      In this case, temporary poor contact of connector, temporary open or short circuit of harness may be the cause.</p>	<p>Repair the short circuit to ground in harness between ECM and secondary air pump relay connector.</p>



# Diagnostic Procedure with Diagnostic Trouble Code (DTC)

ENGINE (DIAGNOSTICS)

## BY:DTC P0420 CATALYST SYSTEM EFFICIENCY BELOW THRESHOLD (BANK 1)

### DTC DETECTING CONDITION:

- Detected when two consecutive driving cycles with fault occur.
- GENERAL DESCRIPTION <Ref. to GD(H4DOTC)-142, DTC P0420 CATALYST SYSTEM EFFICIENCY BELOW THRESHOLD (BANK 1), Diagnostic Trouble Code (DTC) Detecting Criteria.>

### TROUBLE SYMPTOM:

- Engine stalls.
- Idle mixture is out of specifications.

### CAUTION:

After servicing or replacing faulty parts, perform Clear Memory Mode <Ref. to EN(H4DOTC)(diag)-62, OPERATION, Clear Memory Mode.>, and Inspection Mode <Ref. to EN(H4DOTC)(diag)-48, PROCEDURE, Inspection Mode.>.

### WIRING DIAGRAM:

- Models without SI-DRIVE

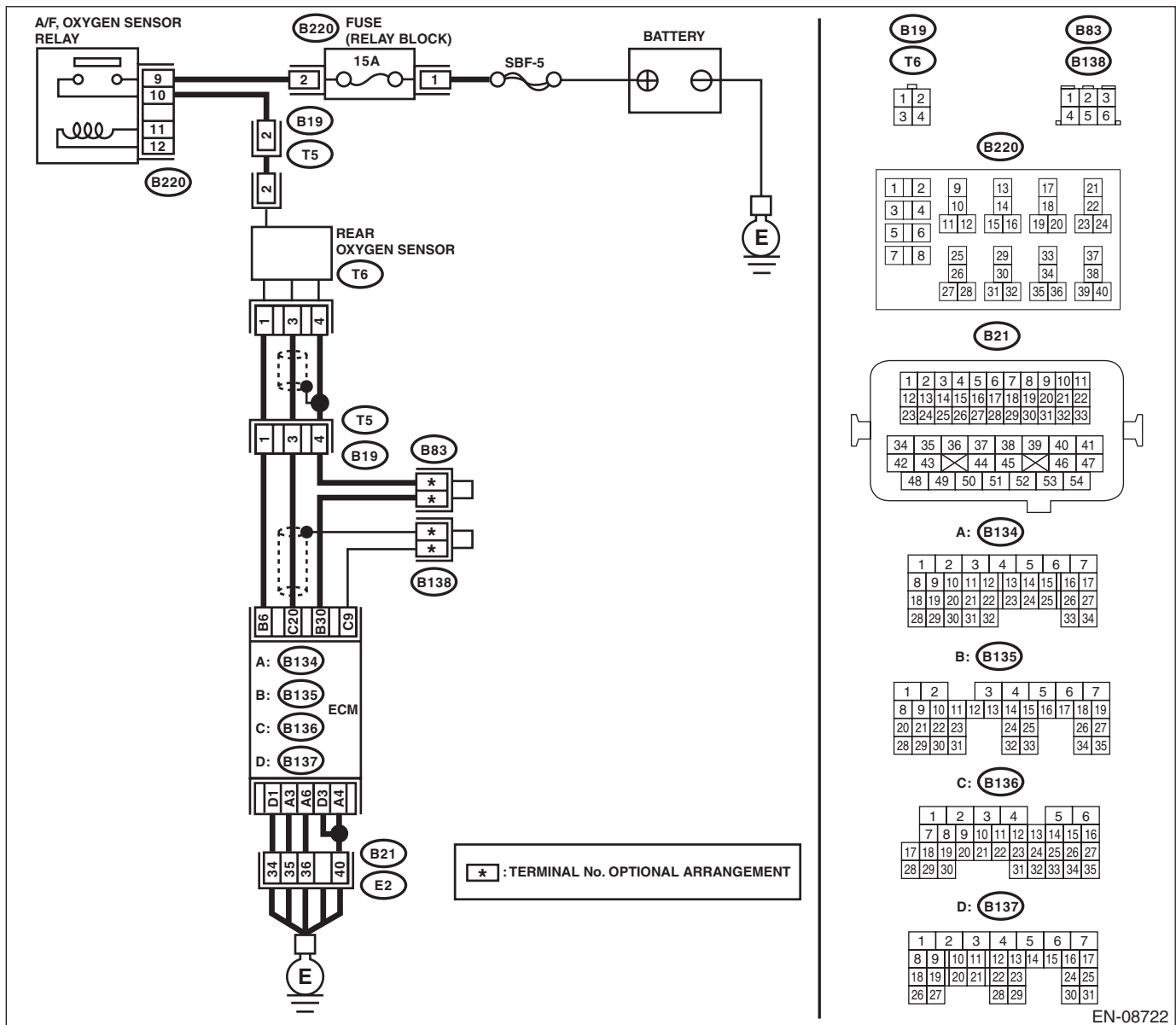

EN-08722

# Diagnostic Procedure with Diagnostic Trouble Code (DTC)

ENGINE (DIAGNOSTICS)

- Models with SI-DRIVE

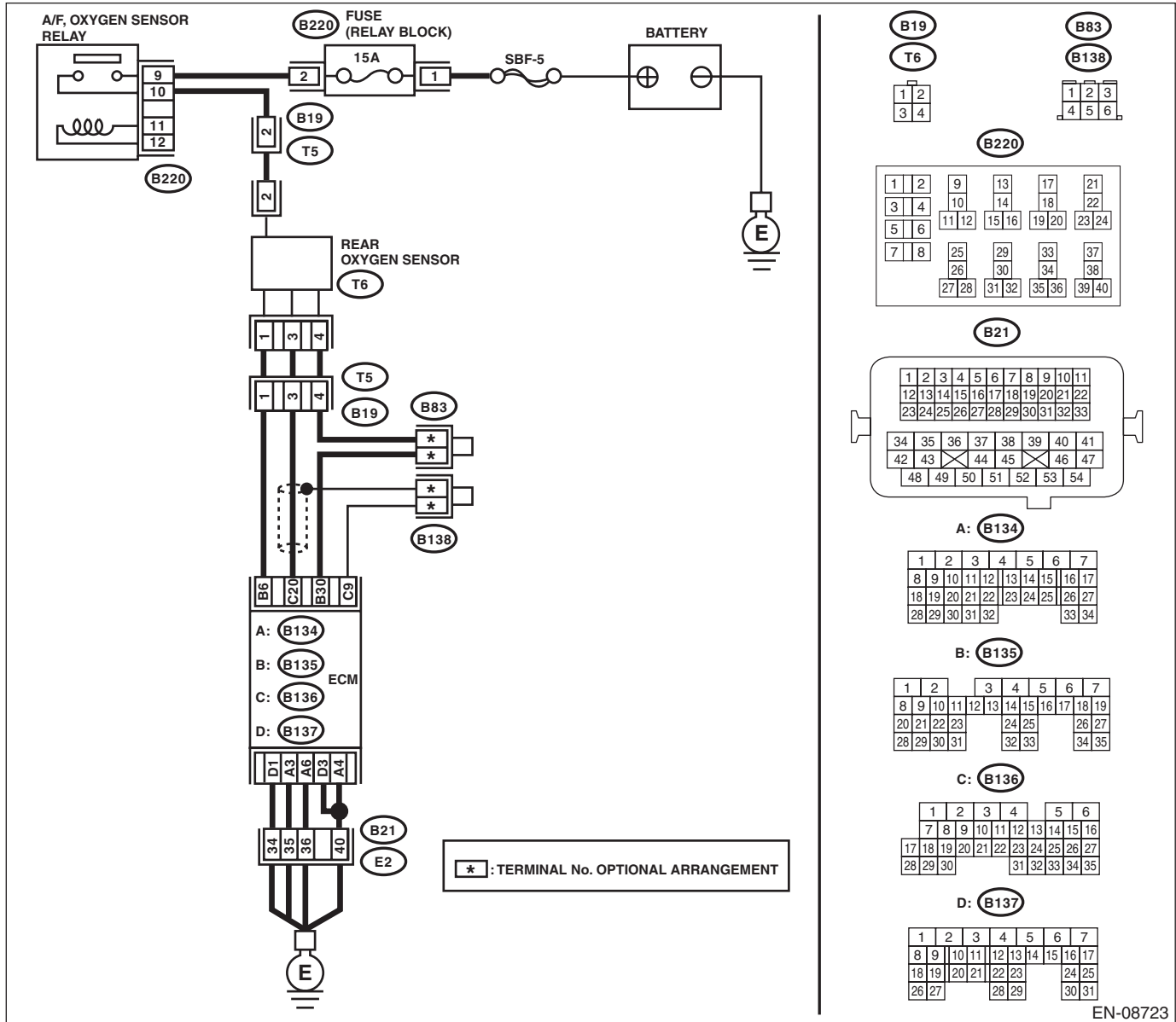

EN-08723

Step	Check	Yes	No
<p><b>1</b></p> <p><b>CHECK EXHAUST SYSTEM.</b>                      Check for gas leaks or air suction caused by loose or dislocated nuts and bolts, and open hole at exhaust pipes.                      NOTE:                      Check the following positions.</p> <ul style="list-style-type: none"> <li>Between cylinder head and front exhaust pipe</li> <li>Between front exhaust pipe and front catalytic converter</li> <li>Between front catalytic converter and rear catalytic converter</li> <li>Loose or improperly attached front oxygen (A/F) sensor or rear oxygen sensor</li> </ul>	<p>Is there any fault in exhaust system?</p>	<p>Repair or replace the exhaust system. &lt;Ref. to EX(STI)-2, General Description.&gt;</p>	<p>Go to step 2.</p>

# Diagnostic Procedure with Diagnostic Trouble Code (DTC)

## ENGINE (DIAGNOSTICS)

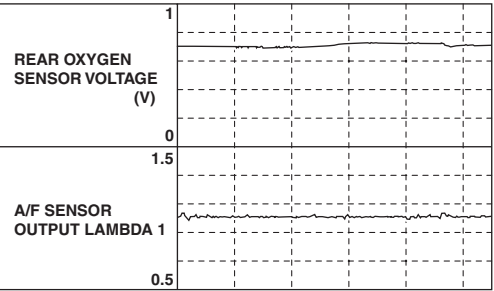
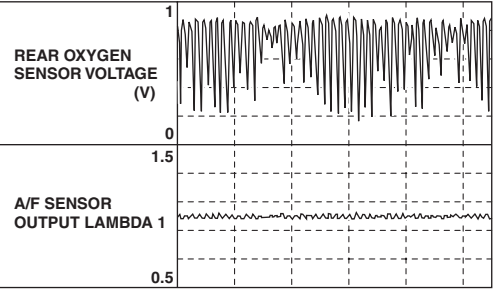
Step	Check	Yes	No
<p><b>2</b>     <b>CHECK WAVEFORM DATA ON THE SUBARU SELECT MONITOR (WHILE DRIVING).</b></p> <p>1) Drive at a constant speed between 80 — 112 km/h (50 — 70 MPH).</p> <p>2) After 5 minutes have elapsed in the condition of step 1), use the Subaru Select Monitor while still driving to read the waveform data.</p> <ul style="list-style-type: none"> <li>• At normal condition</li> </ul>  <p style="text-align: right;">EN-06666</p> <ul style="list-style-type: none"> <li>• At abnormal condition (numerous inversion)</li> </ul>  <p style="text-align: right;">EN-06667</p>	<p>Is a normal waveform displayed?</p>	<p>Even if DTC is detected, the circuit has returned to a normal condition at this time. Reproduce the failure, and then perform the diagnosis again.</p> <p><b>NOTE:</b> In this case, temporary poor contact of connector, temporary open or short circuit of harness may be the cause.</p>	<p>Go to step 3.</p>

# Diagnostic Procedure with Diagnostic Trouble Code (DTC)

ENGINE (DIAGNOSTICS)

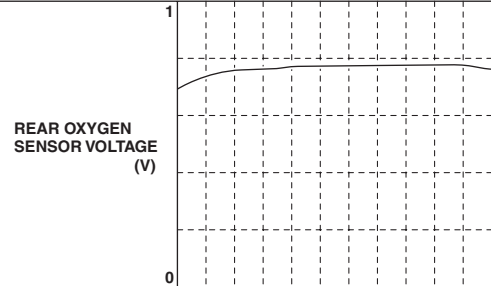
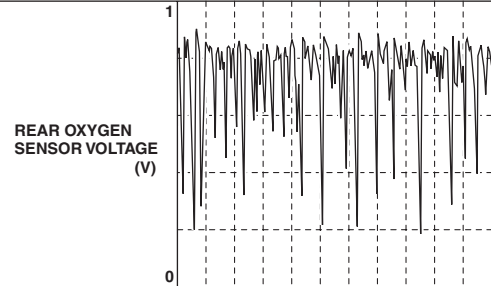
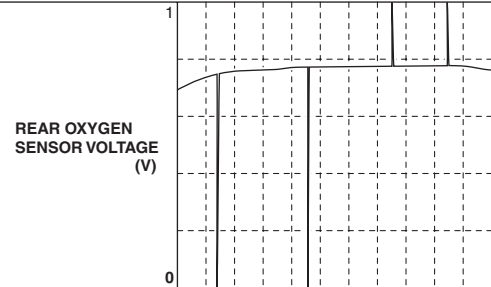
Step	Check	Yes	No
<p><b>3 CHECK WAVEFORM DATA ON THE SUBARU SELECT MONITOR (WHILE IDLING).</b></p> <p>1) Run the engine at idle. 2) In the condition of step 1), use the Subaru Select Monitor to read the waveform data.</p> <ul style="list-style-type: none"> <li>At normal condition</li> </ul>  <p>10 sec/div EN-06668</p> <ul style="list-style-type: none"> <li>At abnormal condition 1 (numerous inversion)</li> </ul>  <p>10 sec/div EN-06669</p> <ul style="list-style-type: none"> <li>At abnormal condition 2 (noise input)</li> </ul>  <p>10 sec/div EN-06670</p>	<p>Is a normal waveform displayed?</p>	<p>Go to step 4.</p>	<ul style="list-style-type: none"> <li>The waveform is displayed at abnormal condition 1: Go to step 4.</li> <li>The waveform is displayed at abnormal condition 2: Go to step 5.</li> </ul>
<p><b>4 CHECK CATALYTIC CONVERTER.</b></p>	<p>Is the catalytic converter damaged?</p>	<p>Replace the catalytic converter. &lt;Ref. to EC(STI)-5, Front Catalytic Converter.&gt; &lt;Ref. to EC(w/o STI)-5, Front Catalytic Converter.&gt;</p>	<p>Go to step 5.</p>
<p><b>5 CHECK REAR OXYGEN SENSOR CONNECTOR AND COUPLING CONNECTOR.</b></p>	<p>Has water entered the connector?</p>	<p>Completely remove any water inside.</p>	<p>Go to step 6.</p>

# Diagnostic Procedure with Diagnostic Trouble Code (DTC)

## ENGINE (DIAGNOSTICS)

Step	Check	Yes	No
<b>6 CHECK HARNESS BETWEEN ECM AND REAR OXYGEN SENSOR CONNECTOR.</b> 1) Turn the ignition switch to OFF. 2) Disconnect the connector from ECM and rear oxygen sensor. 3) Measure the resistance of harness between ECM and rear oxygen sensor connector. <b>Connector &amp; terminal</b> <b>(B136) No. 20 — (T6) No. 3:</b> <b>(B135) No. 30 — (T6) No. 4:</b>	Is the resistance less than 1 $\Omega$ ?	Go to step 7.	Repair the harness and connector. NOTE: Repair the following locations. • Open circuit in harness between ECM and rear oxygen sensor connector • Poor contact of coupling connector
<b>7 CHECK HARNESS BETWEEN ECM AND REAR OXYGEN SENSOR CONNECTOR.</b> 1) Connect the connector to ECM. 2) Turn the ignition switch to ON. 3) Measure the voltage between rear oxygen sensor connector and chassis ground. <b>Connector &amp; terminal</b> <b>(T6) No. 3 (+) — Chassis ground (-):</b>	Is the voltage 0.2 — 0.5 V?	Go to step 8.	Repair the harness and connector. NOTE: Repair the following locations. • Open circuit in harness between ECM and rear oxygen sensor connector • Poor contact of ECM connector • Poor contact of coupling connector
<b>8 CHECK REAR OXYGEN SENSOR SHIELD.</b> 1) Turn the ignition switch to OFF. 2) Expose the rear oxygen sensor connector body side harness sensor shield. 3) Measure the resistance between sensor shield and chassis ground.	Is the resistance less than 1 $\Omega$ ?	Replace the rear oxygen sensor. <Ref. to FU(STI)-56, Rear Oxygen Sensor.> <Ref. to FU(w/o STI)-56, Rear Oxygen Sensor.>	Repair the open circuit of rear oxygen sensor harness.

# Diagnostic Procedure with Diagnostic Trouble Code (DTC)

ENGINE (DIAGNOSTICS)

## BZ:DTC P0441 EVAPORATIVE EMISSION CONT. SYS. INCORRECT PURGE FLOW

### DTC DETECTING CONDITION:

- Detected when two consecutive driving cycles with fault occur.
- GENERAL DESCRIPTION <Ref. to GD(H4DOTC)-145, DTC P0441 EVAPORATIVE EMISSION CONT. SYS. INCORRECT PURGE FLOW, Diagnostic Trouble Code (DTC) Detecting Criteria.>

### TROUBLE SYMPTOM:

Improper idling

### CAUTION:

After servicing or replacing faulty parts, perform Clear Memory Mode <Ref. to EN(H4DOTC)(diag)-62, OPERATION, Clear Memory Mode.>, and Inspection Mode <Ref. to EN(H4DOTC)(diag)-48, PROCEDURE, Inspection Mode.>.

Step	Check	Yes	No
<b>1</b> <b>CHECK FOR ANY OTHER DTC ON DISPLAY.</b>	Is any other DTC displayed?	Check the appropriate DTC using the "List of Diagnostic Trouble Code (DTC)". <Ref. to EN(H4DOTC)(diag)-88, List of Diagnostic Trouble Code (DTC).>	Go to step 2.
<b>2</b> <b>CHECK PURGE CONTROL SOLENOID VALVE.</b> Operate the purge control solenoid valve using the Subaru Select Monitor. NOTE: Refer to "Compulsory Valve Operation Check Mode" for more operation procedures. <Ref. to EN(H4DOTC)(diag)-63, Compulsory Valve Operation Check Mode.>	Does the purge control solenoid valve operate?	Go to step 3.	Replace the purge control solenoid valve. <Ref. to EC(STI)-11, Purge Control Solenoid Valve.> <Ref. to EC(w/o STI)-11, Purge Control Solenoid Valve.>
<b>3</b> <b>CHECK EVAPORATIVE EMISSION CONTROL SYSTEM LINE.</b> 1) Turn the ignition switch to OFF. 2) Check the delivery (test) mode connector is disconnected.	Are there holes, cracks, clogging, or disconnection, misconnection of hoses or pipes in evaporative emission control system?	Repair or replace the hoses or pipes.	Repair the poor contact of ECM connector.

# Diagnostic Procedure with Diagnostic Trouble Code (DTC)

ENGINE (DIAGNOSTICS)

## CA:DTC P0451 EVAPORATIVE EMISSION SYSTEM PRESSURE SENSOR/ SWITCH RANGE/PERFORMANCE

### DTC DETECTING CONDITION:

- Detected when two consecutive driving cycles with fault occur.
- GENERAL DESCRIPTION <Ref. to GD(H4DOTC)-148, DTC P0451 EVAPORATIVE EMISSION SYSTEM PRESSURE SENSOR/SWITCH RANGE/PERFORMANCE, Diagnostic Trouble Code (DTC) Detecting Criteria.>

### CAUTION:

After servicing or replacing faulty parts, perform Clear Memory Mode <Ref. to EN(H4DOTC)(diag)-62, OPERATION, Clear Memory Mode.>, and Inspection Mode <Ref. to EN(H4DOTC)(diag)-48, PROCEDURE, Inspection Mode.>.

Step	Check	Yes	No
1 <b>CHECK FOR ANY OTHER DTC ON DISPLAY.</b>	Is any other DTC displayed?	Check the appropriate DTC using the "List of Diagnostic Trouble Code (DTC)". <Ref. to EN(H4DOTC)(diag)-88, List of Diagnostic Trouble Code (DTC).>	Go to step 2.
2 <b>CHECK CURRENT DATA.</b> 1) Turn the ignition switch to ON (engine OFF). 2) Using the Subaru Select Monitor or general scan tool, read the value in «Atmosphere Pressure» and «Mani. Absolute Pressure», and compare them with the actual atmospheric pressure. <b>NOTE:</b> • Subaru Select Monitor For detailed operation procedures, refer to "READ CURRENT DATA FOR ENGINE". <Ref. to EN(H4DOTC)(diag)-40, Subaru Select Monitor.> • General scan tool For detailed operation procedures, refer to the general scan tool operation manual. • To read the actual atmospheric pressure, connect the Subaru Select Monitor or general scan tool to the other known good vehicle.	Is the difference with the actual atmospheric pressure 27 kPa (200 mmHg, 7.9 inHg) or more?	Replace the parts that showed deviations from the actual atmospheric pressure. • If deviations are found in value for «Atmosphere Pressure»: Replace the leak check valve assembly. <Ref. to EC(STI)-19, Leak Check Valve Assembly.> <Ref. to EC(w/o STI)-20, Leak Check Valve Assembly.> • If deviations are found in value for «Mani. Absolute Pressure»: Replace the manifold pressure sensor. <Ref. to FU(STI)-43, Manifold Absolute Pressure Sensor.> <Ref. to FU(w/o STI)-44, Manifold Absolute Pressure Sensor.>	Even if DTC is detected, the circuit has returned to a normal condition at this time. Reproduce the failure, and then perform the diagnosis again. <b>NOTE:</b> In this case, temporary poor contact of connector, temporary open or short circuit of harness may be the cause.

# Diagnostic Procedure with Diagnostic Trouble Code (DTC)

ENGINE (DIAGNOSTICS)

## CB:DTC P0452 EVAPORATIVE EMISSION SYSTEM PRESSURE SENSOR/ SWITCH LOW

### DTC DETECTING CONDITION:

- Immediately at fault recognition
- GENERAL DESCRIPTION <Ref. to GD(H4DOTC)-150, DTC P0452 EVAPORATIVE EMISSION SYSTEM PRESSURE SENSOR/SWITCH LOW, Diagnostic Trouble Code (DTC) Detecting Criteria.>

### CAUTION:

After servicing or replacing faulty parts, perform Clear Memory Mode <Ref. to EN(H4DOTC)(diag)-62, OPERATION, Clear Memory Mode.>, and Inspection Mode <Ref. to EN(H4DOTC)(diag)-48, PROCEDURE, Inspection Mode.>.

### WIRING DIAGRAM:

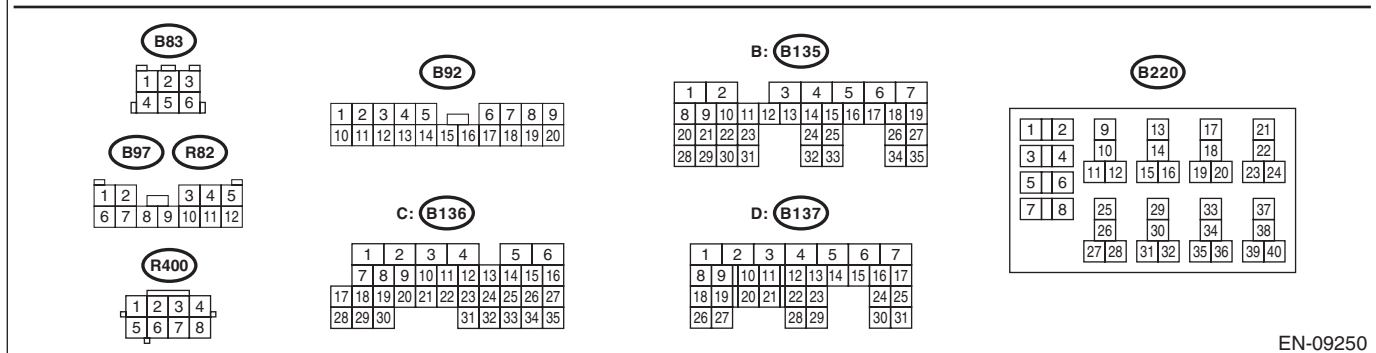
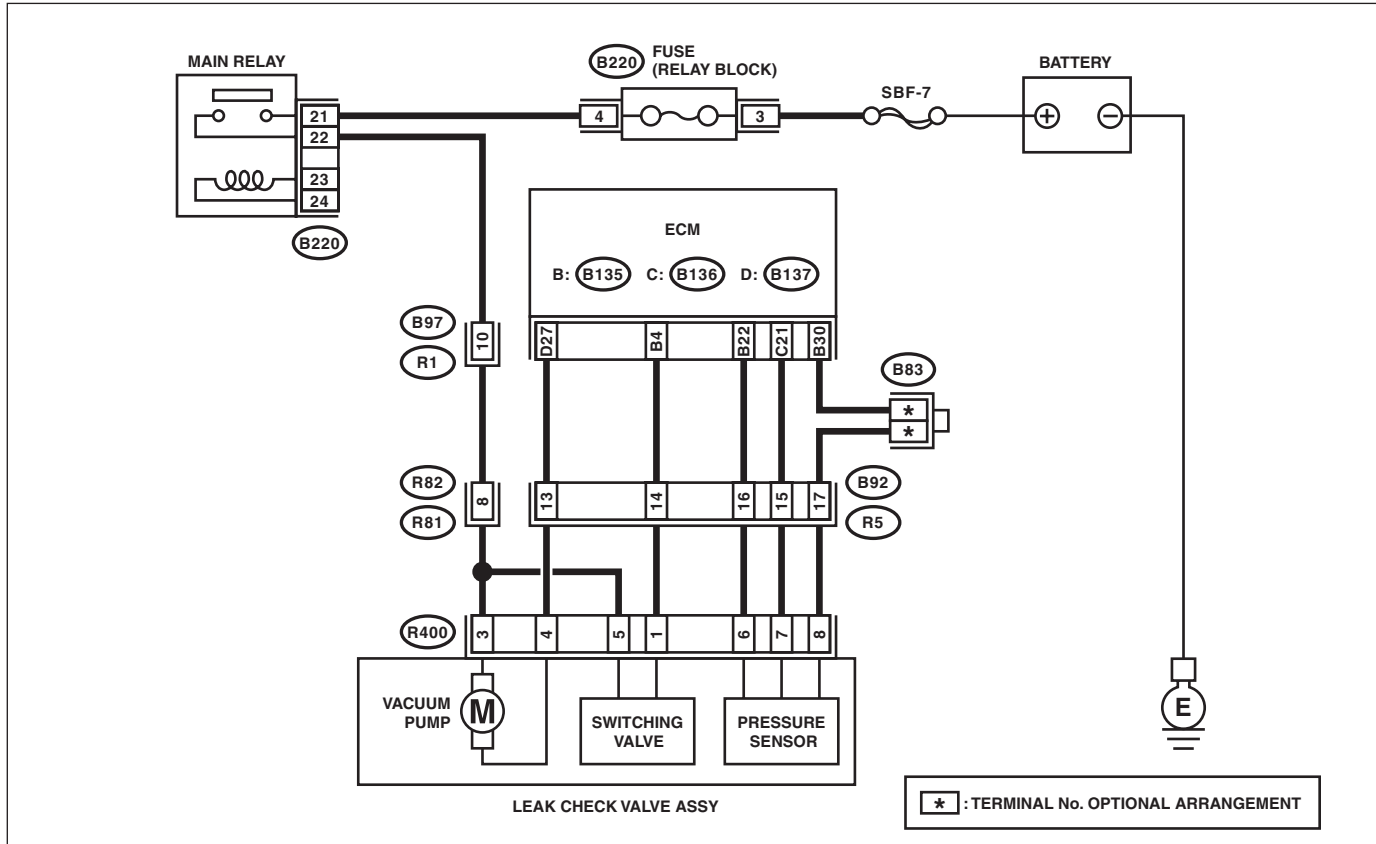

EN-09250



# Diagnostic Procedure with Diagnostic Trouble Code (DTC)

## ENGINE (DIAGNOSTICS)

	Step	Check	Yes	No
1	<p><b>CHECK CURRENT DATA.</b></p> <p>1) Turn the ignition switch to ON.</p> <p>2) Read the value of «Atmosphere Pressure» using the Subaru Select Monitor or a general scan tool.</p> <p>NOTE:</p> <ul style="list-style-type: none"> <li>Subaru Select Monitor</li> </ul> <p>For detailed operation procedures, refer to "READ CURRENT DATA FOR ENGINE". &lt;Ref. to EN(H4DOTC)(diag)-40, Subaru Select Monitor.&gt;</p> <ul style="list-style-type: none"> <li>General scan tool</li> </ul> <p>For detailed operation procedures, refer to the general scan tool operation manual.</p>	Is the value in «Atmosphere Pressure» 34 kPa (255 mmHg, 10 inHg) or less?	Go to step 2.	<p>Even if DTC is detected, the circuit has returned to a normal condition at this time. Reproduce the failure, and then perform the diagnosis again.</p> <p>NOTE:</p> <p>In this case, temporary poor contact of connector, temporary open or short circuit of harness may be the cause.</p>
2	<p><b>CHECK POWER SUPPLY OF LEAK CHECK VALVE ASSEMBLY.</b></p> <p>1) Turn the ignition switch to OFF.</p> <p>2) Disconnect the connector from the leak check valve assembly.</p> <p>3) Turn the ignition switch to ON.</p> <p>4) Measure the voltage between the leak check valve assembly connector and chassis ground.</p> <p><b>Connector &amp; terminal</b> <b>(R400) No. 6 (+) — Chassis ground (-):</b></p>	Is the voltage 4.5 V or more?	Go to step 3.	<p>Repair the harness and connector.</p> <p>NOTE:</p> <p>In this case, repair the following item:</p> <ul style="list-style-type: none"> <li>Open circuit in harness between ECM and the leak check valve assembly connector</li> <li>Poor contact of ECM connector</li> <li>Poor contact of coupling connector</li> </ul>
3	<p><b>CHECK HARNESS BETWEEN ECM AND LEAK CHECK VALVE ASSEMBLY CONNECTOR.</b></p> <p>1) Turn the ignition switch to OFF.</p> <p>2) Disconnect the connector from ECM.</p> <p>3) Measure the resistance between ECM and chassis ground.</p> <p><b>Connector &amp; terminal</b> <b>(B136) No. 21 — Chassis ground:</b></p>	Is the resistance 1 MΩ or more?	Go to step 4.	Repair the short circuit to ground in harness between ECM and leak check valve assembly connector.
4	<p><b>CHECK FOR POOR CONTACT.</b></p> <p>Check for poor contact of leak check valve assembly connector.</p>	Is there poor contact in the leak check valve assembly connector?	Repair the poor contact in the leak check valve assembly connector.	Replace the leak check valve assembly. <Ref. to EC(STI)-19, Leak Check Valve Assembly.> <Ref. to EC(w/o STI)-20, Leak Check Valve Assembly.>

# Diagnostic Procedure with Diagnostic Trouble Code (DTC)

ENGINE (DIAGNOSTICS)

## CC:DTC P0453 EVAPORATIVE EMISSION SYSTEM PRESSURE SENSOR/ SWITCH HIGH

### DTC DETECTING CONDITION:

- Immediately at fault recognition
- GENERAL DESCRIPTION <Ref. to GD(H4DOTC)-152, DTC P0453 EVAPORATIVE EMISSION SYSTEM PRESSURE SENSOR/SWITCH HIGH, Diagnostic Trouble Code (DTC) Detecting Criteria.>

### CAUTION:

After servicing or replacing faulty parts, perform Clear Memory Mode <Ref. to EN(H4DOTC)(diag)-62, OPERATION, Clear Memory Mode.>, and Inspection Mode <Ref. to EN(H4DOTC)(diag)-48, PROCEDURE, Inspection Mode.>.

### WIRING DIAGRAM:

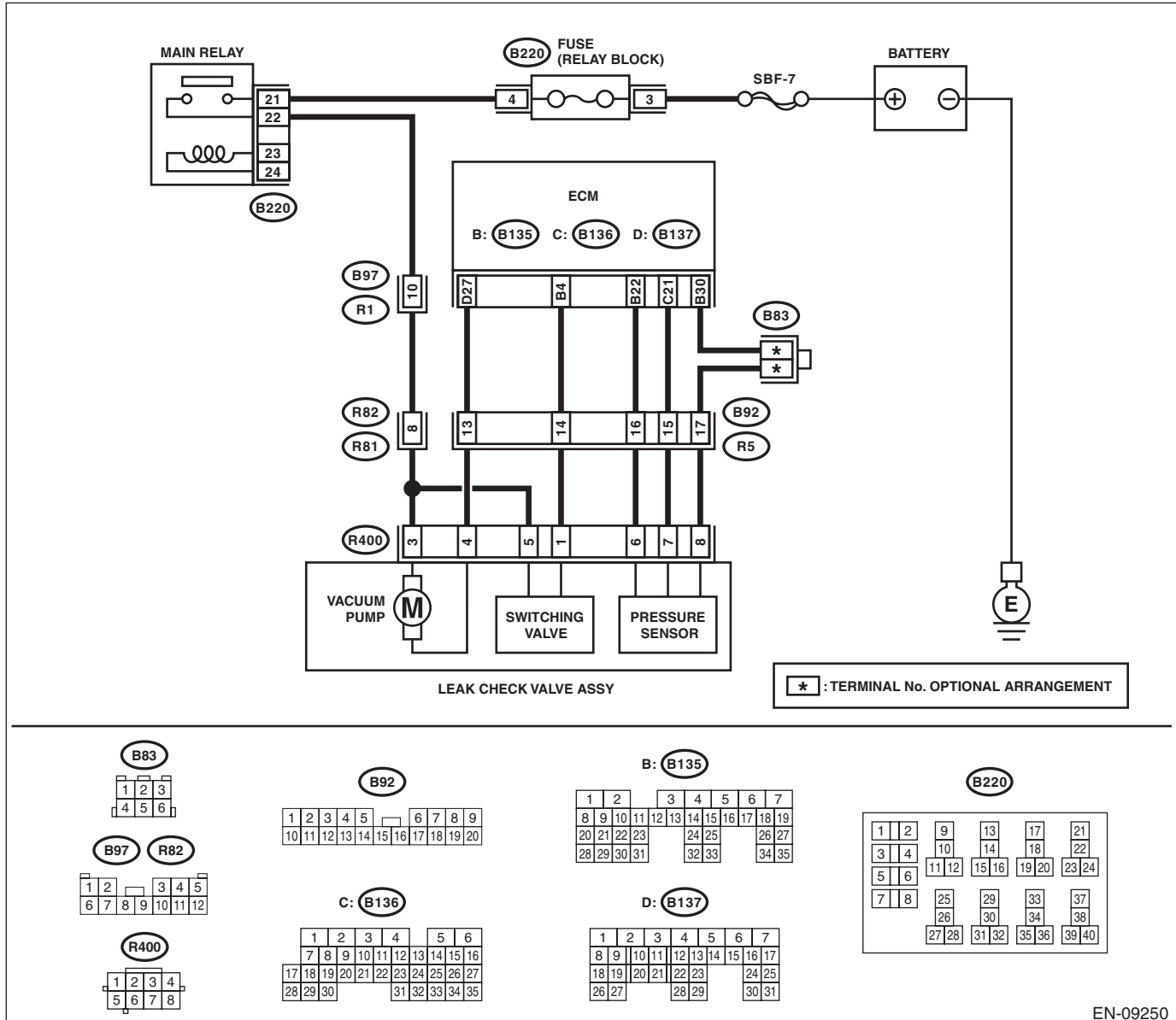

EN-09250

# Diagnostic Procedure with Diagnostic Trouble Code (DTC)

## ENGINE (DIAGNOSTICS)

Step	Check	Yes	No
<p><b>1 CHECK CURRENT DATA.</b></p> <p>1) Turn the ignition switch to ON.</p> <p>2) Read the value of «Atmosphere Pressure» using the Subaru Select Monitor or a general scan tool.</p> <p>NOTE:</p> <ul style="list-style-type: none"> <li>• Subaru Select Monitor</li> </ul> <p>For detailed operation procedures, refer to "READ CURRENT DATA FOR ENGINE". &lt;Ref. to EN(H4DOTC)(diag)-40, Subaru Select Monitor.&gt;</p> <ul style="list-style-type: none"> <li>• General scan tool</li> </ul> <p>For detailed operation procedures, refer to the general scan tool operation manual.</p>	<p>Is the value in «Atmosphere Pressure» 125 kPa (938 mmHg, 36.9 inHg) or more?</p>	<p>Go to step 2.</p>	<p>Even if DTC is detected, the circuit has returned to a normal condition at this time. Reproduce the failure, and then perform the diagnosis again.</p> <p>NOTE:</p> <p>In this case, temporary poor contact of connector, temporary open or short circuit of harness may be the cause.</p>
<p><b>2 CHECK HARNESS BETWEEN ECM AND LEAK CHECK VALVE ASSEMBLY CONNECTOR.</b></p> <p>1) Turn the ignition switch to OFF.</p> <p>2) Disconnect the connector from ECM and the leak check valve assembly.</p> <p>3) Measure the resistance of harness between ECM and the leak check valve assembly connector.</p> <p><b>Connector &amp; terminal</b></p> <p><b>(B136) No. 21 — (R400) No. 7:</b></p> <p><b>(B135) No. 30 — (R400) No. 8:</b></p>	<p>Is the resistance less than 1 Ω?</p>	<p>Go to step 3.</p>	<p>Repair the harness and connector.</p> <p>NOTE:</p> <p>In this case, repair the following item:</p> <ul style="list-style-type: none"> <li>• Open circuit in harness between ECM and the leak check valve assembly connector</li> <li>• Poor contact of coupling connector</li> <li>• Poor contact of joint connector</li> </ul>
<p><b>3 CHECK FOR POOR CONTACT.</b></p> <p>Check for poor contact of ECM and the leak check valve assembly connector.</p>	<p>Is there poor contact in ECM and the leak check valve assembly connector?</p>	<p>Repair the poor contact of ECM and the leak check valve assembly connector.</p>	<p>Go to step 4.</p>
<p><b>4 CHECK LEAK CHECK VALVE ASSEMBLY.</b></p> <p>Check the pressure sensor of the leak check valve assembly. &lt;Ref. to EC(STI)-21, CHECK PRESSURE SENSOR, INSPECTION, Leak Check Valve Assembly.&gt; &lt;Ref. to EC(w/o STI)-22, CHECK PRESSURE SENSOR, INSPECTION, Leak Check Valve Assembly.&gt;</p>	<p>Is the pressure sensor of the leak check valve assembly OK?</p>	<p>Repair the short circuit to power in harness between ECM and leak check valve assembly connector.</p>	<p>Replace the leak check valve assembly. &lt;Ref. to EC(STI)-19, Leak Check Valve Assembly.&gt; &lt;Ref. to EC(w/o STI)-20, Leak Check Valve Assembly.&gt;</p>

# Diagnostic Procedure with Diagnostic Trouble Code (DTC)

ENGINE (DIAGNOSTICS)

## CD:DTC P0455 EVAPORATIVE EMISSION SYSTEM LEAK DETECTED (LARGE LEAK)

### DTC DETECTING CONDITION:

- Detected when two consecutive driving cycles with fault occur.
- GENERAL DESCRIPTION <Ref. to GD(H4DOTC)-154, DTC P0455 EVAPORATIVE EMISSION SYSTEM LEAK DETECTED (LARGE LEAK), Diagnostic Trouble Code (DTC) Detecting Criteria.>

### TROUBLE SYMPTOM:

- Fuel odor
- There is a hole of more than 1.0 mm (0.04 in) dia. in evaporation system or fuel tank.
- Fuel filler cap loose or lost

### CAUTION:

After servicing or replacing faulty parts, perform Clear Memory Mode <Ref. to EN(H4DOTC)(diag)-62, OPERATION, Clear Memory Mode.>, and Inspection Mode <Ref. to EN(H4DOTC)(diag)-48, PROCEDURE, Inspection Mode.>.

	Step	Check	Yes	No
1	<b>CHECK FUEL FILLER CAP.</b> 1) Turn the ignition switch to OFF. 2) Check the fuel filler cap.  NOTE: The DTC is stored in memory if fuel filler cap is or was loose or if the cap chain has caught while tightening.	Is the fuel filler cap tightened securely?	Go to step 2.	Tighten fuel filler cap securely.
2	<b>CHECK FUEL FILLER CAP.</b>	Is the fuel filler cap genuine?	Go to step 3.	Replace with a genuine fuel filler cap.
3	<b>CHECK FUEL FILLER PIPE GASKET.</b>	Is there any damage to the seal between fuel filler cap and fuel filler pipe?	Repair or replace the fuel filler cap and fuel filler pipe. <Ref. to FU(STI)-77, Fuel Filler Pipe.> <Ref. to FU(w/o STI)-76, Fuel Filler Pipe.>	Go to step 4.
4	<b>CHECK PURGE CONTROL SOLENOID VALVE.</b> Check air-tightness of the purge control solenoid valve. <Ref. to EC(STI)-12, INSPECTION, Purge Control Solenoid Valve.> <Ref. to EC(w/o STI)-13, INSPECTION, Purge Control Solenoid Valve.>	Is the purge control solenoid valve OK?	Go to step 5.	Replace the purge control solenoid valve. <Ref. to EC(STI)-11, Purge Control Solenoid Valve.> <Ref. to EC(w/o STI)-11, Purge Control Solenoid Valve.>
5	<b>CHECK EVAPORATIVE EMISSION CONTROL SYSTEM LINE.</b>	Are there holes on the evaporation line?	Repair or replace the evaporation line. <Ref. to FU(STI)-93, Fuel Delivery, Return and Evaporation Lines.> <Ref. to FU(w/o STI)-90, Fuel Delivery, Return and Evaporation Lines.>	Go to step 6.

## Diagnostic Procedure with Diagnostic Trouble Code (DTC)

ENGINE (DIAGNOSTICS)

Step	Check	Yes	No	
6	<b>CHECK CANISTER.</b>	Are there holes on the canister?	Replace the canister. <Ref. to EC(STI)-7, Canister.> <Ref. to EC(w/o STI)-7, Canister.>	Go to step 7.
7	<b>CHECK LEAK CHECK VALVE ASSEMBLY.</b>	Are there damage or holes on the leak check valve assembly?	Replace the leak check valve assembly. <Ref. to EC(STI)-19, Leak Check Valve Assembly.> <Ref. to EC(w/o STI)-20, Leak Check Valve Assembly.>	Go to step 8.
8	<b>CHECK FUEL TANK.</b> Remove the fuel tank. <Ref. to FU(STI)-70, Fuel Tank.> <Ref. to FU(w/o STI)-69, Fuel Tank.>	Are there damage or holes on the fuel tank?	Repair or replace the fuel tank. <Ref. to FU(STI)-70, Fuel Tank.> <Ref. to FU(w/o STI)-69, Fuel Tank.>	Go to step 9.
9	<b>CHECK ANY OTHER MECHANICAL TROUBLE IN EVAPORATIVE EMISSION CONTROL SYSTEM.</b>	Are there holes, cracks, clogging, or disconnection, misconnection of hoses or pipes in evaporative emission control system?	Repair or replace the hoses or pipes.	Repair the poor contact of ECM connector.

### CE:DTC P0456 EVAPORATIVE EMISSION CONTROL SYSTEM LEAK DETECTED (VERY SMALL LEAK)

**NOTE:**

For the diagnostic procedure, refer to DTC P0455. <Ref. to EN(H4DOTC)(diag)-249, DTC P0455 EVAPORATIVE EMISSION SYSTEM LEAK DETECTED (LARGE LEAK), Diagnostic Procedure with Diagnostic Trouble Code (DTC).>

# Diagnostic Procedure with Diagnostic Trouble Code (DTC)

ENGINE (DIAGNOSTICS)

## CF:DTC P0458 EVAPORATIVE EMISSION SYSTEM PURGE CONTROL VALVE CIRCUIT LOW

### DTC DETECTING CONDITION:

- Detected when two consecutive driving cycles with fault occur.
- GENERAL DESCRIPTION <Ref. to GD(H4DOTC)-162, DTC P0458 EVAPORATIVE EMISSION SYSTEM PURGE CONTROL VALVE CIRCUIT LOW, Diagnostic Trouble Code (DTC) Detecting Criteria.>

### TROUBLE SYMPTOM:

Improper idling

### CAUTION:

After servicing or replacing faulty parts, perform Clear Memory Mode <Ref. to EN(H4DOTC)(diag)-62, OPERATION, Clear Memory Mode.>, and Inspection Mode <Ref. to EN(H4DOTC)(diag)-48, PROCEDURE, Inspection Mode.>.

### WIRING DIAGRAM:

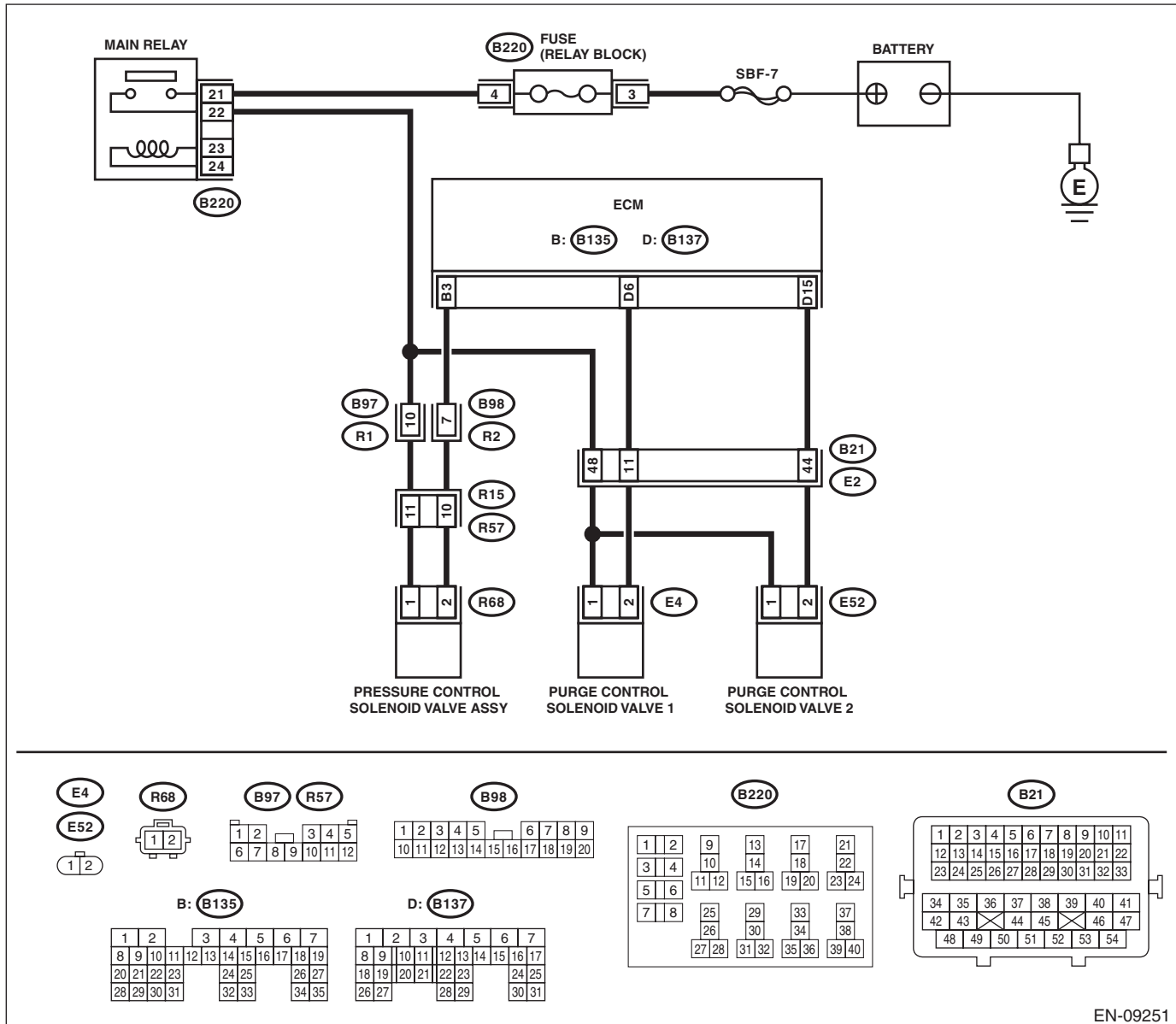

EN-09251

# Diagnostic Procedure with Diagnostic Trouble Code (DTC)

## ENGINE (DIAGNOSTICS)

Step	Check	Yes	No
<b>1 CHECK OUTPUT SIGNAL OF ECM.</b> 1) Turn the ignition switch to ON. 2) Measure the voltage between ECM and chassis ground. <i>Connector &amp; terminal</i> <i>(B137) No. 6 (+) — Chassis ground (-):</i>	Is the voltage 10 V or more?	Go to step 2.	Go to step 3.
<b>2 CHECK FOR POOR CONTACT.</b> Check for poor contact of ECM connector.	Is there poor contact of ECM connector?	Repair the poor contact of ECM connector.	Even if DTC is detected, the circuit has returned to a normal condition at this time. Reproduce the failure, and then perform the diagnosis again. NOTE: In this case, temporary open or short circuit of harness or temporary poor contact of connector may be the cause.
<b>3 CHECK POWER SUPPLY TO PURGE CONTROL SOLENOID VALVE CONNECTOR.</b> Measure the voltage between purge control solenoid valve connector and engine ground. <i>Connector &amp; terminal</i> <i>(E4) No. 1 (+) — Engine ground (-):</i>	Is the voltage 10 V or more?	Go to step 4.	Repair the power supply circuit.
<b>4 CHECK HARNESS BETWEEN ECM AND PURGE CONTROL SOLENOID VALVE CONNECTOR.</b> 1) Turn the ignition switch to OFF. 2) Disconnect the connectors from ECM and purge control solenoid valve. 3) Measure the resistance between the purge control solenoid valve connector and engine ground. <i>Connector &amp; terminal</i> <i>(E4) No. 2 — Engine ground:</i>	Is the resistance 1 M $\Omega$ or more?	Go to step 5.	Repair the ground short circuit of harness between ECM and purge control solenoid valve connector.
<b>5 CHECK HARNESS BETWEEN ECM AND PURGE CONTROL SOLENOID VALVE CONNECTOR.</b> Measure the resistance of harness between ECM and purge control solenoid valve connector. <i>Connector &amp; terminal</i> <i>(B137) No. 6 — (E4) No. 2:</i>	Is the resistance less than 1 $\Omega$ ?	Go to step 6.	Repair the harness and connector. NOTE: In this case, repair the following item: <ul style="list-style-type: none"> <li>• Open circuit in harness between ECM and purge control solenoid valve connector</li> <li>• Poor contact of coupling connector</li> </ul>

# Diagnostic Procedure with Diagnostic Trouble Code (DTC)

ENGINE (DIAGNOSTICS)

Step	Check	Yes	No
<b>6</b> <b>CHECK PURGE CONTROL SOLENOID VALVE.</b> 1) Remove the purge control solenoid valve. 2) Measure the resistance between purge control solenoid valve terminals. <b>Terminals</b> <b>No. 1 — No. 2:</b>	Is the resistance 10 — 100 $\Omega$ ?	Repair the poor contact of purge control solenoid valve connector.	Replace the purge control solenoid valve. <Ref. to EC(STI)-11, Purge Control Solenoid Valve.> <Ref. to EC(w/o STI)-11, Purge Control Solenoid Valve.>



# Diagnostic Procedure with Diagnostic Trouble Code (DTC)

ENGINE (DIAGNOSTICS)

## CG:DTC P0459 EVAPORATIVE EMISSION SYSTEM PURGE CONTROL VALVE CIRCUIT HIGH

### DTC DETECTING CONDITION:

- Detected when two consecutive driving cycles with fault occur.
- GENERAL DESCRIPTION <Ref. to GD(H4DOTC)-164, DTC P0459 EVAPORATIVE EMISSION SYSTEM PURGE CONTROL VALVE CIRCUIT HIGH, Diagnostic Trouble Code (DTC) Detecting Criteria.>

### TROUBLE SYMPTOM:

Improper idling

### CAUTION:

After servicing or replacing faulty parts, perform Clear Memory Mode <Ref. to EN(H4DOTC)(diag)-62, OPERATION, Clear Memory Mode.>, and Inspection Mode <Ref. to EN(H4DOTC)(diag)-48, PROCEDURE, Inspection Mode.>.

### WIRING DIAGRAM:

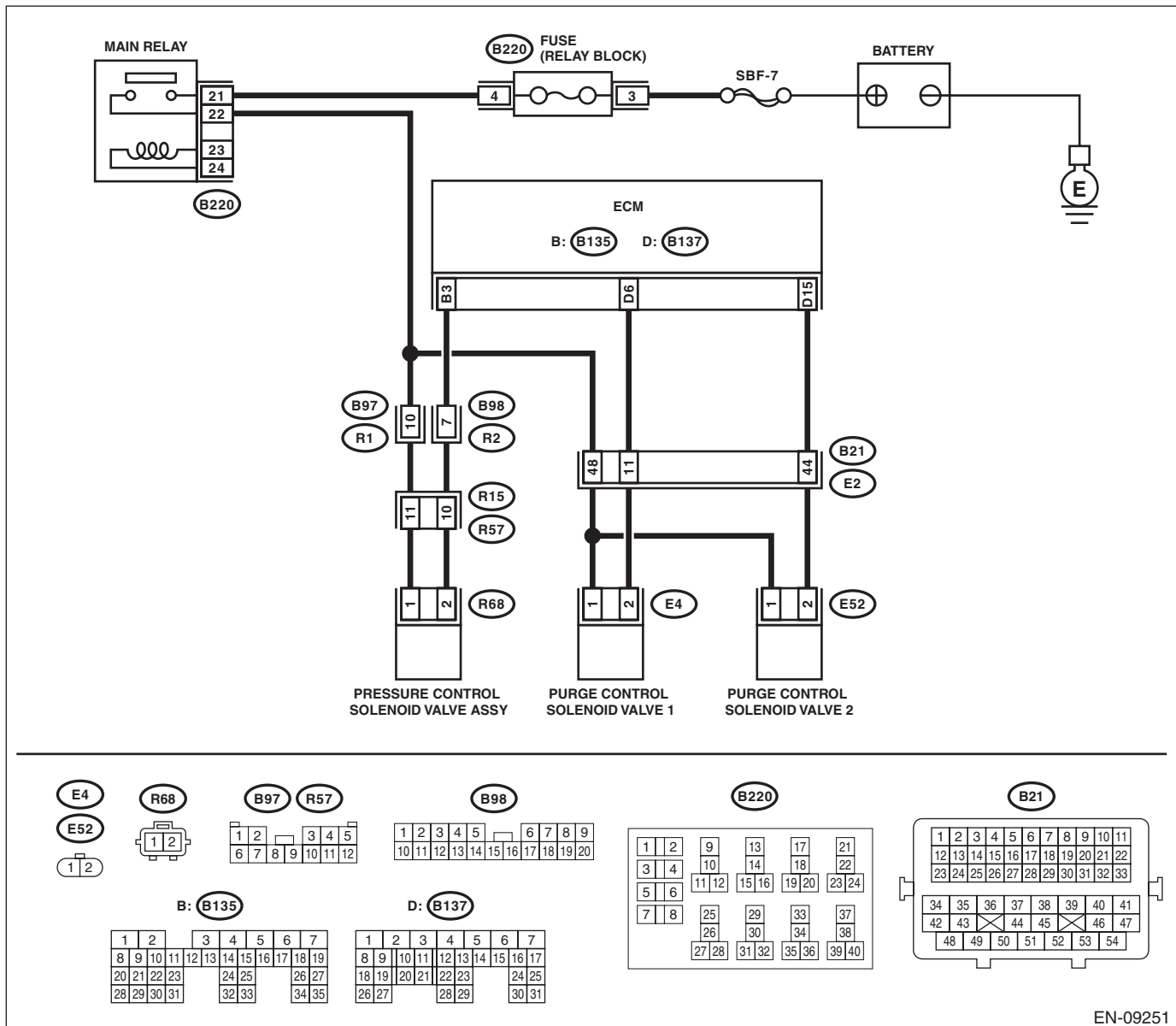

EN-09251

# Diagnostic Procedure with Diagnostic Trouble Code (DTC)

ENGINE (DIAGNOSTICS)

	Step	Check	Yes	No
1	<b>CHECK HARNESS BETWEEN ECM AND PURGE CONTROL SOLENOID VALVE CONNECTOR.</b> 1) Turn the ignition switch to OFF. 2) Disconnect the connectors from ECM and purge control solenoid valve. 3) Turn the ignition switch to ON. 4) Measure the voltage between ECM and chassis ground. <b>Connector &amp; terminal</b> <b>(B137) No. 6 (+) — Chassis ground (-):</b>	Is the voltage 10 V or more?	Repair the short circuit to power in the harness between ECM and purge control solenoid valve connector.	Go to step 2.
2	<b>CHECK PURGE CONTROL SOLENOID VALVE.</b> 1) Turn the ignition switch to OFF. 2) Measure the resistance between purge control solenoid valve terminals. <b>Terminals</b> <b>No. 1 — No. 2:</b>	Is the resistance less than 1 $\Omega$ ?	Replace the purge control solenoid valve. <Ref. to EC(STI)-11, Purge Control Solenoid Valve.> <Ref. to EC(w/o STI)-11, Purge Control Solenoid Valve.>	Repair the poor contact of ECM connector.

# Diagnostic Procedure with Diagnostic Trouble Code (DTC)

ENGINE (DIAGNOSTICS)

## CH:DTC P0461 FUEL LEVEL SENSOR "A" CIRCUIT RANGE/PERFORMANCE

### DTC DETECTING CONDITION:

- Detected when two consecutive driving cycles with fault occur.
- GENERAL DESCRIPTION <Ref. to GD(H4DOTC)-166, DTC P0461 FUEL LEVEL SENSOR "A" CIRCUIT RANGE/PERFORMANCE, Diagnostic Trouble Code (DTC) Detecting Criteria.>

### CAUTION:

After servicing or replacing faulty parts, perform Clear Memory Mode <Ref. to EN(H4DOTC)(diag)-62, OPERATION, Clear Memory Mode.>, and Inspection Mode <Ref. to EN(H4DOTC)(diag)-48, PROCEDURE, Inspection Mode.>.

Step	Check	Yes	No
1 CHECK FOR ANY OTHER DTC ON DISPLAY.	Is any other DTC displayed?	Check the appropriate DTC using the "List of Diagnostic Trouble Code (DTC)". <Ref. to EN(H4DOTC)(diag)-88, List of Diagnostic Trouble Code (DTC).>	Replace the fuel level sensor and fuel sub level sensor. <Ref. to FU(STI)-82, Fuel Level Sensor.> <Ref. to FU(STI)-83, Fuel Sub Level Sensor.> <Ref. to FU(w/o STI)-81, Fuel Level Sensor.> <Ref. to FU(w/o STI)-82, Fuel Sub Level Sensor.>

## CI: DTC P0462 FUEL LEVEL SENSOR "A" CIRCUIT LOW

### NOTE:

For the diagnostic procedure, refer to DTC P0463. <Ref. to EN(H4DOTC)(diag)-257, DTC P0463 FUEL LEVEL SENSOR "A" CIRCUIT HIGH, Diagnostic Procedure with Diagnostic Trouble Code (DTC).>

# Diagnostic Procedure with Diagnostic Trouble Code (DTC)

ENGINE (DIAGNOSTICS)

## CJ:DTC P0463 FUEL LEVEL SENSOR "A" CIRCUIT HIGH

### DTC DETECTING CONDITION:

- Detected when two consecutive driving cycles with fault occur.
- GENERAL DESCRIPTION <Ref. to GD(H4DOTC)-170, DTC P0463 FUEL LEVEL SENSOR "A" CIRCUIT HIGH, Diagnostic Trouble Code (DTC) Detecting Criteria.>

### CAUTION:

After servicing or replacing faulty parts, perform Clear Memory Mode <Ref. to EN(H4DOTC)(diag)-62, OPERATION, Clear Memory Mode.>, and Inspection Mode <Ref. to EN(H4DOTC)(diag)-48, PROCEDURE, Inspection Mode.>.

Step	Check	Yes	No
1 <b>CHECK FOR ANY OTHER DTC ON DISPLAY.</b>	Is DTC P0462 or P0463 displayed on the Subaru Select Monitor?	Check the combination meter. <Ref. to IDI-9, CHECK FUEL LEVEL SENSOR, INSPECTION, Combination Meter System.>	Even if DTC is detected, the circuit has returned to a normal condition at this time. Reproduce the failure, and then perform the diagnosis again.  NOTE: In this case, temporary poor contact of connector, temporary open or short circuit of harness may be the cause.

## CK:DTC P0500 VEHICLE SPEED SENSOR "A"

### DTC DETECTING CONDITION:

- Immediately at fault recognition
- GENERAL DESCRIPTION <Ref. to GD(H4DOTC)-172, DTC P0500 VEHICLE SPEED SENSOR "A", Diagnostic Trouble Code (DTC) Detecting Criteria.>

### CAUTION:

After servicing or replacing faulty parts, perform Clear Memory Mode <Ref. to EN(H4DOTC)(diag)-62, OPERATION, Clear Memory Mode.>, and Inspection Mode <Ref. to EN(H4DOTC)(diag)-48, PROCEDURE, Inspection Mode.>.

Step	Check	Yes	No
1 <b>CHECK DTC OF VDC.</b> Check DTC of VDC.	Is DTC of VDC displayed?	Perform the diagnosis according to DTC. <Ref. to VDC(diag)-48, List of Diagnostic Trouble Code (DTC).>	Repair the poor contact of ECM connector.

# Diagnostic Procedure with Diagnostic Trouble Code (DTC)

ENGINE (DIAGNOSTICS)

## CL:DTC P0506 IDLE AIR CONTROL SYSTEM RPM LOWER THAN EXPECTED

### DTC DETECTING CONDITION:

- Detected when two consecutive driving cycles with fault occur.
- GENERAL DESCRIPTION <Ref. to GD(H4DOTC)-173, DTC P0506 IDLE AIR CONTROL SYSTEM RPM LOWER THAN EXPECTED, Diagnostic Trouble Code (DTC) Detecting Criteria.>

### TROUBLE SYMPTOM:

- Hard to start the engine.
- Engine does not start.
- Improper idling
- Engine stalls.

### CAUTION:

After servicing or replacing faulty parts, perform Clear Memory Mode <Ref. to EN(H4DOTC)(diag)-62, OPERATION, Clear Memory Mode.>, and Inspection Mode <Ref. to EN(H4DOTC)(diag)-48, PROCEDURE, Inspection Mode.>.

Step	Check	Yes	No
<b>1</b> <b>CHECK FOR ANY OTHER DTC ON DISPLAY.</b>	Is any other DTC displayed?	Check the appropriate DTC using the "List of Diagnostic Trouble Code (DTC)". <Ref. to EN(H4DOTC)(diag)-88, List of Diagnostic Trouble Code (DTC).>	Go to step 2.
<b>2</b> <b>CHECK AIR CLEANER ELEMENT.</b> 1) Turn the ignition switch to OFF. 2) Check the air cleaner element.	Is there excessive clogging on air cleaner element?	Replace the air cleaner element. <Ref. to IN(STI)-7, Air Cleaner Element.> <Ref. to IN(w/o STI)-7, Air Cleaner Element.>	Go to step 3.
<b>3</b> <b>CHECK ELECTRONIC THROTTLE CONTROL.</b> 1) Remove the electronic throttle control. <Ref. to FU(STI)-15, REMOVAL, Throttle Body.> <Ref. to FU(w/o STI)-15, REMOVAL, Throttle Body.> 2) Check the electronic throttle control.	Are foreign matter found inside electronic throttle control?	Remove foreign matter from electronic throttle control.	Perform the diagnosis of DTC P2101. <Ref. to EN(H4DOTC)(diag)-364, DTC P2101 THROTTLE ACTUATOR CONTROL MOTOR CIRCUIT RANGE/PERFORMANCE, Diagnostic Procedure with Diagnostic Trouble Code (DTC).>

# Diagnostic Procedure with Diagnostic Trouble Code (DTC)

ENGINE (DIAGNOSTICS)

## CM:DTC P0507 IDLE AIR CONTROL SYSTEM RPM HIGHER THAN EXPECTED

### DTC DETECTING CONDITION:

- Detected when two consecutive driving cycles with fault occur.
- GENERAL DESCRIPTION <Ref. to GD(H4DOTC)-174, DTC P0507 IDLE AIR CONTROL SYSTEM RPM HIGHER THAN EXPECTED, Diagnostic Trouble Code (DTC) Detecting Criteria.>

### TROUBLE SYMPTOM:

Engine keeps running at higher speed than specified idle speed.

### CAUTION:

After servicing or replacing faulty parts, perform Clear Memory Mode <Ref. to EN(H4DOTC)(diag)-62, OPERATION, Clear Memory Mode.>, and Inspection Mode <Ref. to EN(H4DOTC)(diag)-48, PROCEDURE, Inspection Mode.>.

Step	Check	Yes	No
1 <b>CHECK FOR ANY OTHER DTC ON DISPLAY.</b>	Is any other DTC displayed?	Check the appropriate DTC using the "List of Diagnostic Trouble Code (DTC)". <Ref. to EN(H4DOTC)(diag)-88, List of Diagnostic Trouble Code (DTC).>	Go to step 2.
2 <b>CHECK AIR INTAKE SYSTEM.</b> 1) Start and idle the engine. 2) Check the following items. <ul style="list-style-type: none"><li>• Loose installation of intake manifold and throttle body</li><li>• Cracks of intake manifold gasket and throttle body gasket</li><li>• Disconnection of vacuum hoses</li></ul>	Is there any fault in air intake system?	Repair air suction and leaks.	Go to step 3.
3 <b>CHECK ELECTRONIC THROTTLE CONTROL.</b> 1) Turn the ignition switch to OFF. 2) Remove the electronic throttle control. <Ref. to FU(STI)-15, REMOVAL, Throttle Body.> <Ref. to FU(w/o STI)-15, REMOVAL, Throttle Body.> 3) Check the electronic throttle control.	Are foreign matter found inside electronic throttle control?	Remove foreign matter from electronic throttle control.	Perform the diagnosis of DTC P2101. <Ref. to EN(H4DOTC)(diag)-364, DTC P2101 THROTTLE ACTUATOR CONTROL MOTOR CIRCUIT RANGE/PERFORMANCE, Diagnostic Procedure with Diagnostic Trouble Code (DTC).>

# Diagnostic Procedure with Diagnostic Trouble Code (DTC)

ENGINE (DIAGNOSTICS)

## CN:DTC P050A COLD START IDLE AIR CONTROL SYSTEM PERFORMANCE

### DTC DETECTING CONDITION:

- Detected when two consecutive driving cycles with fault occur.
- GENERAL DESCRIPTION <Ref. to GD(H4DOTC)-175, DTC P050A COLD START IDLE AIR CONTROL SYSTEM PERFORMANCE, Diagnostic Trouble Code (DTC) Detecting Criteria.>

### TROUBLE SYMPTOM:

- Engine keeps running at higher speed than specified idle speed.
- Engine keeps running at a lower speed than the specified idle speed.
- Engine stalls.

### CAUTION:

After servicing or replacing faulty parts, perform Clear Memory Mode <Ref. to EN(H4DOTC)(diag)-62, OPERATION, Clear Memory Mode.>, and Inspection Mode <Ref. to EN(H4DOTC)(diag)-48, PROCEDURE, Inspection Mode.>.

### WIRING DIAGRAM:

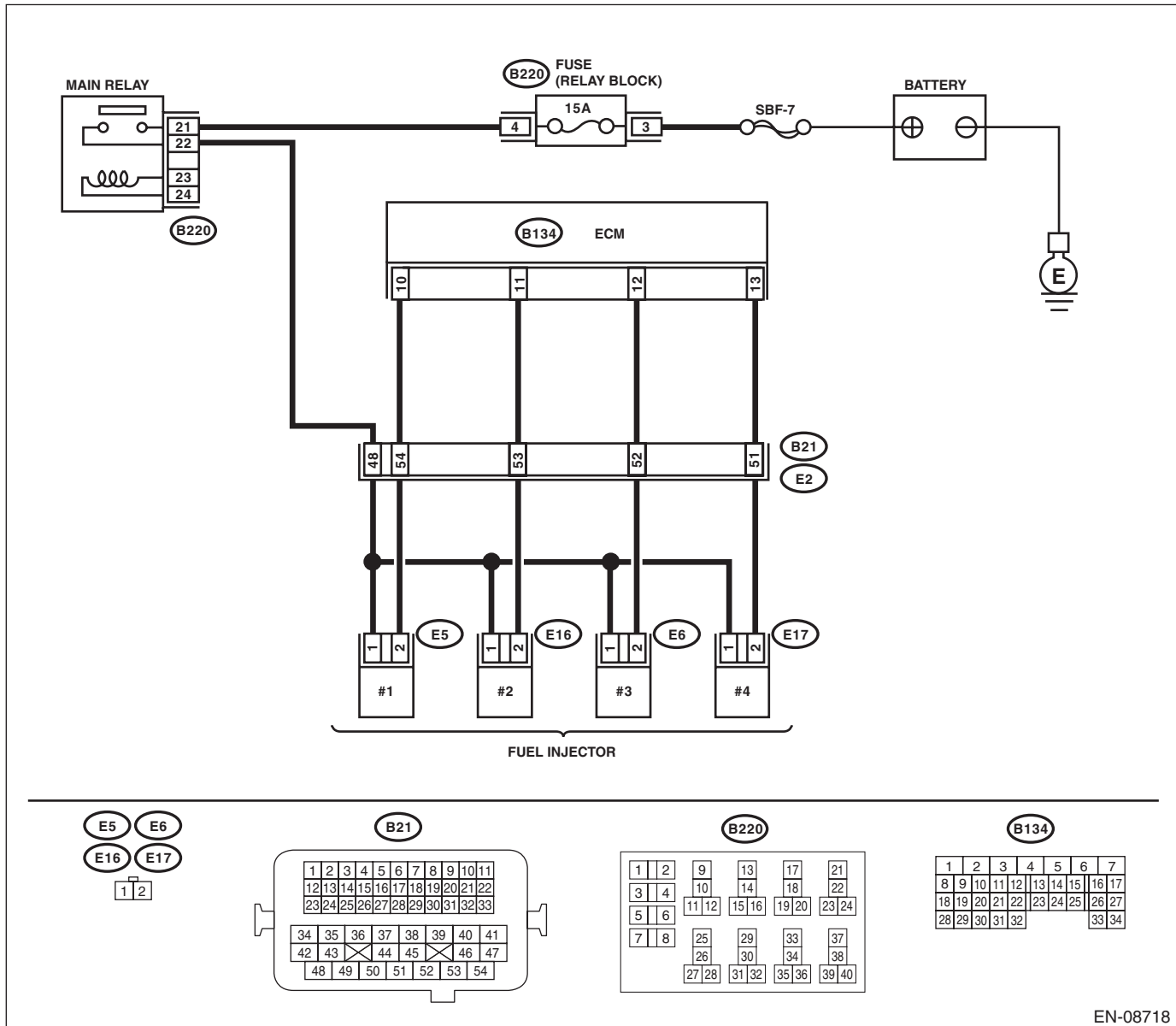

EN-08718

# Diagnostic Procedure with Diagnostic Trouble Code (DTC)

ENGINE (DIAGNOSTICS)

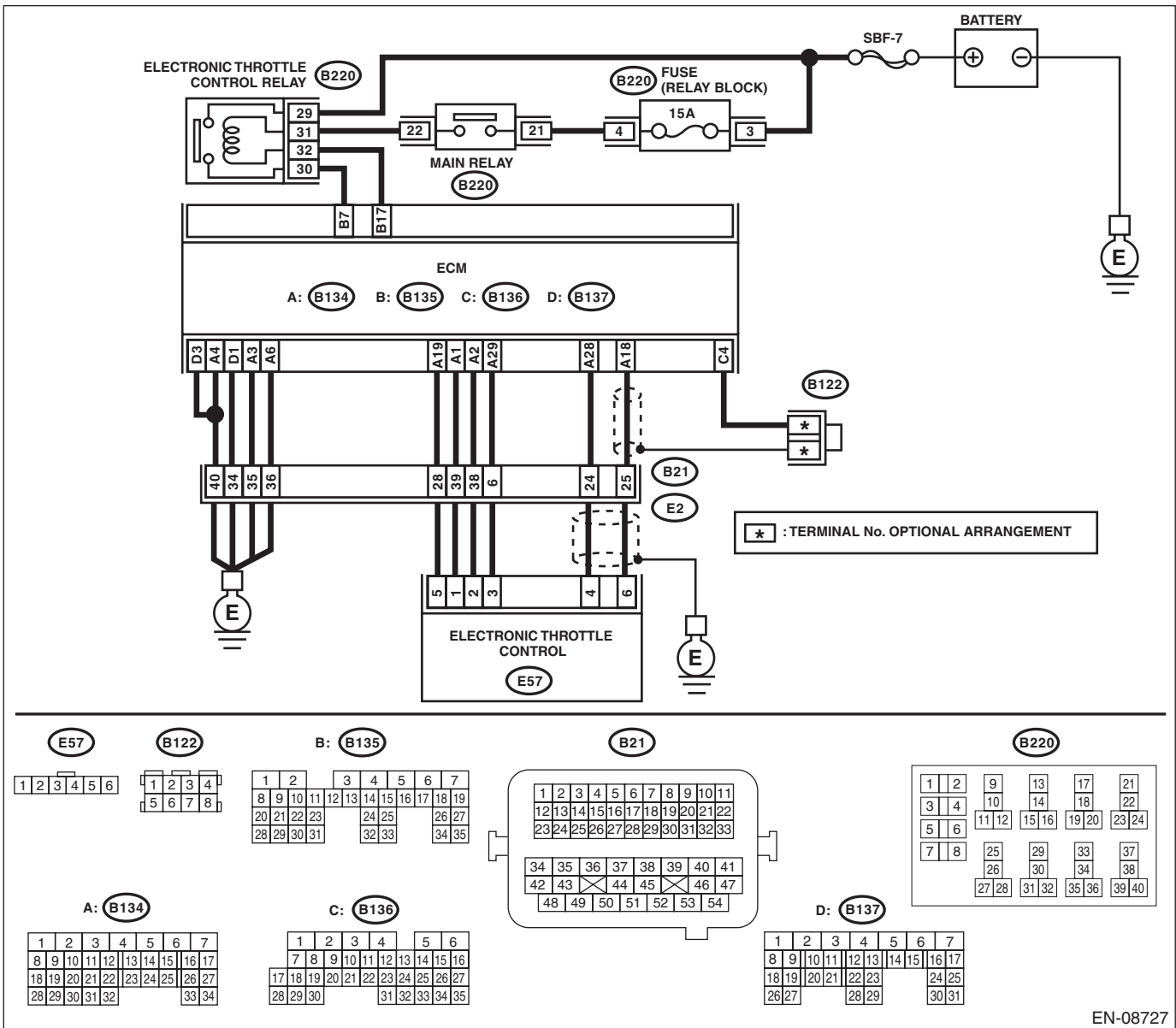

Step	Check	Yes	No
<b>1</b>	<b>CHECK FOR ANY OTHER DTC ON DISPLAY.</b> Is any other DTC displayed?	Check the appropriate DTC using the "List of Diagnostic Trouble Code (DTC)". <Ref. to EN(H4DOTC)(diag)-88, List of Diagnostic Trouble Code (DTC).>	Go to step 2.
<b>2</b>	<b>CHECK ENGINE OIL.</b> Is there a proper amount of engine oil?	Go to step 3.	Replace engine oil. <Ref. to LU(STI)-11, REPLACEMENT, Engine Oil.>
<b>3</b>	<b>CHECK EXHAUST SYSTEM.</b> Are there holes or loose bolts on exhaust system?	Repair the exhaust system.	Go to step 4.



# Diagnostic Procedure with Diagnostic Trouble Code (DTC)

## ENGINE (DIAGNOSTICS)

Step	Check	Yes	No	
4	<b>CHECK AIR INTAKE SYSTEM.</b>	Are there holes, loose bolts or disconnection of hose on air intake system?	Repair the air intake system.	Go to step 5.
5	<b>CHECK FUEL PRESSURE.</b> <b>WARNING:</b> Place "NO OPEN FLAMES" signs near the working area. <b>CAUTION:</b> Be careful not to spill fuel. Measure the fuel pressure while disconnecting pressure regulator vacuum hose from intake manifold. <Ref. to ME(STI)-25, INSPECTION, Fuel Pressure.> <Ref. to ME(w/o STI)-25, INSPECTION, Fuel Pressure.> <b>CAUTION:</b> Release fuel pressure before removing the fuel pressure gauge. NOTE: If fuel pressure does not increase, squeeze the fuel return hose 2 to 3 times, then measure fuel pressure again.	Is the measured value 284 — 314 kPa (2.9 — 3.2 kg/cm <sup>2</sup> , 41 — 46 psi)?	Go to step 6.	Repair the following item. Fuel pressure is too high: • Clogged fuel return line or bent hose Fuel pressure is too low: • Improper fuel pump discharge • Clogged fuel supply line
6	<b>CHECK FUEL PRESSURE.</b> After connecting the pressure regulator vacuum hose, measure fuel pressure. <Ref. to ME(STI)-25, INSPECTION, Fuel Pressure.> <Ref. to ME(w/o STI)-25, INSPECTION, Fuel Pressure.> <b>CAUTION:</b> Release fuel pressure before removing the fuel pressure gauge. NOTE: • If fuel pressure does not increase, squeeze fuel return hose 2 to 3 times, then measure fuel pressure again. • If the measured value at this step is out of specification, check or replace pressure regulator and pressure regulator vacuum hose.	Is the measured value 230 — 260 kPa (2.35 — 2.65 kg/cm <sup>2</sup> , 33 — 38 psi)?	Go to step 7.	Repair the following item. Fuel pressure is too high: • Faulty pressure regulator • Clogged fuel return line or bent hose Fuel pressure is too low: • Faulty pressure regulator • Improper fuel pump discharge • Clogged fuel supply line
7	<b>CHECK ENGINE COOLANT TEMPERATURE SENSOR.</b> 1) Start the engine and warm up completely. 2) Read the value of «Coolant Temp.» using the Subaru Select Monitor or a general scan tool. NOTE: • Subaru Select Monitor For detailed operation procedures, refer to "READ CURRENT DATA FOR ENGINE". <Ref. to EN(H4DOTC)(diag)-40, Subaru Select Monitor.> • General scan tool For detailed operation procedures, refer to the general scan tool operation manual.	Is the value of «Coolant Temp.» 75°C (167°F) or more?	Go to step 8.	Replace the engine coolant temperature sensor. <Ref. to FU(STI)-34, Engine Coolant Temperature Sensor.> <Ref. to FU(w/o STI)-35, Engine Coolant Temperature Sensor.>

# Diagnostic Procedure with Diagnostic Trouble Code (DTC)

ENGINE (DIAGNOSTICS)

Step	Check	Yes	No
<p><b>8</b>      <b>CHECK MASS AIR FLOW AND INTAKE AIR TEMPERATURE SENSOR.</b></p> <p>1) Start the engine and warm up engine until coolant temperature is higher than 75°C (167°F).</p> <p>2) Place the shift lever in neutral position.</p> <p>3) Turn the A/C switch to OFF.</p> <p>4) Turn all the accessory switches to OFF.</p> <p>5) Read the value of «Mass Air Flow» using the Subaru Select Monitor or a general scan tool.</p> <p>NOTE:</p> <ul style="list-style-type: none"> <li>• Subaru Select Monitor</li> </ul> <p>For detailed operation procedures, refer to "READ CURRENT DATA FOR ENGINE". &lt;Ref. to EN(H4DOTC)(diag)-40, Subaru Select Monitor.&gt;</p> <ul style="list-style-type: none"> <li>• General scan tool</li> </ul> <p>For detailed operation procedures, refer to the general scan tool operation manual.</p>	<p>Is the value of «Mass Air Flow» 2.0 — 5.0 g/s (0.26 — 0.66 lb/m)?</p>	<p>Go to step 9.</p>	<p>Replace the mass air flow and intake air temperature sensor. &lt;Ref. to FU(STI)-42, Mass Air Flow and Intake Air Temperature Sensor.&gt; &lt;Ref. to FU(w/o STI)-43, Mass Air Flow and Intake Air Temperature Sensor.&gt;</p>
<p><b>9</b>      <b>CHECK MASS AIR FLOW AND INTAKE AIR TEMPERATURE SENSOR.</b></p> <p>1) Start the engine and warm up engine until coolant temperature is higher than 75°C (167°F).</p> <p>2) Place the shift lever in neutral position.</p> <p>3) Turn the A/C switch to OFF.</p> <p>4) Turn all the accessory switches to OFF.</p> <p>5) Open the front hood.</p> <p>6) Measure the ambient temperature.</p> <p>7) Read the value of «Intake Air Temp.» using the Subaru Select Monitor or a general scan tool.</p> <p>NOTE:</p> <ul style="list-style-type: none"> <li>• Subaru Select Monitor</li> </ul> <p>For detailed operation procedures, refer to "READ CURRENT DATA FOR ENGINE". &lt;Ref. to EN(H4DOTC)(diag)-40, Subaru Select Monitor.&gt;</p> <ul style="list-style-type: none"> <li>• General scan tool</li> </ul> <p>For detailed operation procedures, refer to the general scan tool operation manual.</p>	<p>Subtract ambient temperature from «Intake Air Temp.». Is the obtained value -10 — 50°C (-18 — 90°F)?</p>	<p>Go to step 10.</p>	<p>Check the mass air flow and intake air temperature sensor. &lt;Ref. to FU(STI)-42, Mass Air Flow and Intake Air Temperature Sensor.&gt; &lt;Ref. to FU(w/o STI)-43, Mass Air Flow and Intake Air Temperature Sensor.&gt;</p>
<p><b>10</b>      <b>CHECK OUTPUT SIGNAL OF ECM.</b></p> <p>1) Turn the ignition switch to ON.</p> <p>2) Measure the voltage between ECM and chassis ground on faulty cylinders.</p> <p><b>Connector &amp; terminal</b></p> <p><b>#1 (B134) No. 10 (+) — Chassis ground (-):</b></p> <p><b>#2 (B134) No. 11 (+) — Chassis ground (-):</b></p> <p><b>#3 (B134) No. 12 (+) — Chassis ground (-):</b></p> <p><b>#4 (B134) No. 13 (+) — Chassis ground (-):</b></p>	<p>Is the voltage 10 V or more?</p>	<p>Go to step 15.</p>	<p>Go to step 11.</p>

# Diagnostic Procedure with Diagnostic Trouble Code (DTC)

## ENGINE (DIAGNOSTICS)

Step	Check	Yes	No
<b>11 CHECK HARNESS BETWEEN ECM AND FUEL INJECTOR CONNECTOR.</b> 1) Turn the ignition switch to OFF. 2) Disconnect the connector from fuel injector on faulty cylinders. 3) Measure the resistance between fuel injector connector and engine ground on faulty cylinders.  <b>Connector &amp; terminal</b> <b>#1 (E5) No. 2 — Engine ground:</b> <b>#2 (E16) No. 2 — Engine ground:</b> <b>#3 (E6) No. 2 — Engine ground:</b> <b>#4 (E17) No. 2 — Engine ground:</b>	Is the resistance 1 M $\Omega$ or more?	Go to step 12.	Repair the short circuit to ground in harness between ECM and fuel injector connector.
<b>12 CHECK HARNESS BETWEEN ECM AND FUEL INJECTOR CONNECTOR.</b> Measure the resistance of harness between ECM and fuel injector connector on faulty cylinders.  <b>Connector &amp; terminal</b> <b>#1 (B134) No. 10 — (E5) No. 2:</b> <b>#2 (B134) No. 11 — (E16) No. 2:</b> <b>#3 (B134) No. 12 — (E6) No. 2:</b> <b>#4 (B134) No. 13 — (E17) No. 2:</b>	Is the resistance less than 1 $\Omega$ ?	Go to step 13.	Repair the harness and connector.  NOTE: In this case, repair the following item: • Open circuit in harness between ECM and fuel injector connector • Poor contact of coupling connector
<b>13 CHECK FUEL INJECTOR.</b> Measure the resistance between fuel injector terminals on faulty cylinder.  <b>Terminals</b> <b>No. 1 — No. 2:</b>	Is the resistance 5 — 20 $\Omega$ ?	Go to step 14.	Replace the faulty fuel injector. <Ref. to FU(STI)-45, Fuel Injector.> <Ref. to FU(w/o STI)-46, Fuel Injector.>
<b>14 CHECK POWER SUPPLY LINE.</b> 1) Turn the ignition switch to ON. 2) Measure the voltage between fuel injector and engine ground on faulty cylinders.  <b>Connector &amp; terminal</b> <b>#1 (E5) No. 1 (+) — Engine ground (-):</b> <b>#2 (E16) No. 1 (+) — Engine ground (-):</b> <b>#3 (E6) No. 1 (+) — Engine ground (-):</b> <b>#4 (E17) No. 1 (+) — Engine ground (-):</b>	Is the voltage 10 V or more?	Repair the poor contact of all connectors in fuel injector circuit.	Repair the harness and connector.  NOTE: In this case, repair the following item: • Open circuit in harness between the main relay connector and fuel injector connector on faulty cylinders • Poor contact of coupling connector • Poor contact of main relay connector
<b>15 CHECK HARNESS BETWEEN ECM AND FUEL INJECTOR CONNECTOR.</b> 1) Turn the ignition switch to OFF. 2) Disconnect the connector from fuel injector on faulty cylinders. 3) Turn the ignition switch to ON. 4) Measure the voltage between ECM and chassis ground on faulty cylinders.  <b>Connector &amp; terminal</b> <b>#1 (B134) No. 10 (+) — Chassis ground (-):</b> <b>#2 (B134) No. 11 (+) — Chassis ground (-):</b> <b>#3 (B134) No. 12 (+) — Chassis ground (-):</b> <b>#4 (B134) No. 13 (+) — Chassis ground (-):</b>	Is the voltage 10 V or more?	Repair the short circuit to power in harness between ECM and fuel injector connector.	Go to step 16.

# Diagnostic Procedure with Diagnostic Trouble Code (DTC)

ENGINE (DIAGNOSTICS)

Step	Check	Yes	No
<b>16 CHECK FUEL INJECTOR.</b> 1) Turn the ignition switch to OFF. 2) Measure the resistance between fuel injector terminals on faulty cylinder. <b>Terminals</b> <b>No. 1 — No. 2:</b>	Is the resistance 5 — 20 Ω?	Go to step 17.	Replace the faulty fuel injector. <Ref. to FU(STI)-45, Fuel Injector.> <Ref. to FU(w/o STI)-46, Fuel Injector.>
<b>17 CHECK INSTALLATION OF CAMSHAFT POSITION SENSOR/CRANKSHAFT POSITION SENSOR.</b>	Is the camshaft position sensor or crankshaft position sensor loosely installed?	Tighten the camshaft position sensor or crankshaft position sensor. <Ref. to FU(STI)-37, Camshaft Position Sensor.> <Ref. to FU(STI)-35, Crankshaft Position Sensor.> <Ref. to FU(w/o STI)-38, Camshaft Position Sensor.> <Ref. to FU(w/o STI)-36, Crankshaft Position Sensor.>	Go to step 18.
<b>18 CHECK CRANK SPROCKET.</b> Remove the timing belt cover. <Ref. to ME(STI)-49, REMOVAL, Timing Belt Cover.> <Ref. to ME(w/o STI)-48, REMOVAL, Timing Belt Cover.>	Is the crank sprocket rusted or does it have broken teeth?	Replace the crank sprocket. <Ref. to ME(STI)-60, Crank Sprocket.> <Ref. to ME(w/o STI)-59, Crank Sprocket.>	Go to step 19.
<b>19 CHECK INSTALLATION CONDITION OF TIMING BELT.</b> Turn the crankshaft, and align alignment mark on crank sprocket with alignment mark on cylinder block. ST 499987500                      CRANKSHAFT SOCKET	Is the timing belt dislocated from its proper position?	Repair the installation condition of timing belt. <Ref. to ME(STI)-50, Timing Belt.> <Ref. to ME(w/o STI)-49, Timing Belt.>	Go to step 20.
<b>20 CHECK ELECTRONIC THROTTLE CONTROL RELAY.</b> 1) Turn the ignition switch to OFF. 2) Remove the electronic throttle control relay. 3) Connect the battery to terminals No. 31 and No. 32 of electronic throttle control relay. 4) Measure the resistance between electronic throttle control relay terminals. <b>Terminals</b> <b>No. 29 — No. 30:</b>	Is the resistance less than 1 Ω?	Go to step 21.	Replace the electronic throttle control relay. <Ref. to FU(STI)-64, Electronic Throttle Control Relay.> <Ref. to FU(w/o STI)-63, Electronic Throttle Control Relay.>
<b>21 CHECK POWER SUPPLY OF ELECTRONIC THROTTLE CONTROL RELAY.</b> Measure the voltage between electronic throttle control relay connector and chassis ground. <b>Connector &amp; terminal</b> <b>(B220) No. 29 (+) — Chassis ground (-):</b>	Is the voltage 10 V or more?	Go to step 22.	Repair the open or ground short circuit of power supply circuit.

# Diagnostic Procedure with Diagnostic Trouble Code (DTC)

## ENGINE (DIAGNOSTICS)

Step	Check	Yes	No
<b>22 CHECK HARNESS BETWEEN ECM AND ELECTRONIC THROTTLE CONTROL RELAY CONNECTOR.</b> 1) Disconnect the connector from ECM. 2) Turn the ignition switch to ON. 3) Measure the voltage between electronic throttle control relay connector and chassis ground. <i>Connector &amp; terminal</i> <i>(B220) No. 32 (+) — Chassis ground (-):</i>	Is the voltage 10 V or more?	Repair the short circuit to power in the harness between ECM and electronic throttle control relay connector.	Go to step 23.
<b>23 CHECK HARNESS BETWEEN ECM AND ELECTRONIC THROTTLE CONTROL RELAY CONNECTOR.</b> 1) Turn the ignition switch to OFF. 2) Measure the resistance between electronic throttle control relay connector and chassis ground. <i>Connector &amp; terminal</i> <i>(B220) No. 32 — Chassis ground:</i> <i>(B220) No. 30 — Chassis ground:</i>	Is the resistance 1 M $\Omega$ or more?	Go to step 24.	Repair the short circuit in harness to ground between ECM and electronic throttle control relay connector.
<b>24 CHECK HARNESS BETWEEN ECM AND ELECTRONIC THROTTLE CONTROL RELAY CONNECTOR.</b> Measure the resistance between ECM and electronic throttle control relay connector. <i>Connector &amp; terminal</i> <i>(B135) No. 17 — (B220) No. 32:</i> <i>(B135) No. 7 — (B220) No. 30:</i>	Is the resistance less than 1 $\Omega$ ?	Go to step 25.	Repair the open circuit in harness between ECM and electronic throttle control relay connector.
<b>25 CHECK HARNESS BETWEEN ECM AND ELECTRONIC THROTTLE CONTROL CONNECTOR.</b> 1) Turn the ignition switch to OFF. 2) Disconnect the connectors from ECM and electronic throttle control. 3) Measure the resistance between ECM and chassis ground. <i>Connector &amp; terminal</i> <i>(B134) No. 19 — Chassis ground:</i> <i>(B134) No. 18 — Chassis ground:</i> <i>(B134) No. 18 — (B136) No. 4:</i> <i>(B134) No. 28 — Chassis ground:</i>	Is the resistance 1 M $\Omega$ or more?	Go to step 26.	Repair the short circuit to ground in harness between ECM and electronic throttle control connector.
<b>26 CHECK SHORT CIRCUIT INSIDE THE ECM.</b> 1) Connect the connector to ECM. 2) Measure the resistance between electronic throttle control connector and engine ground. <i>Connector &amp; terminal</i> <i>(B57) No. 6 — Engine ground:</i> <i>(B57) No. 4 — Engine ground:</i>	Is the resistance 1 M $\Omega$ or more?	Go to step 27.	Repair the short circuit to ground in harness between ECM and electronic throttle control connector. Replace the ECM if defective. <Ref. to FU(STI)-59, Engine Control Module (ECM).> <Ref. to FU(w/o STI)-58, Engine Control Module (ECM).>

# Diagnostic Procedure with Diagnostic Trouble Code (DTC)

ENGINE (DIAGNOSTICS)

Step	Check	Yes	No
<p><b>27</b>     <b>CHECK HARNESS BETWEEN ECM AND ELECTRONIC THROTTLE CONTROL CONNECTOR.</b></p> <p>1) Disconnect the connector from ECM. 2) Measure the resistance of harness between ECM and electronic throttle control connector.</p> <p><b>Connector &amp; terminal</b> <b>(B134) No. 18 — (E57) No. 6:</b> <b>(B134) No. 28 — (E57) No. 4:</b> <b>(B134) No. 29 — (E57) No. 3:</b></p>	Is the resistance less than 1 $\Omega$ ?	Go to step 28.	<p>Repair the harness and connector.</p> <p>NOTE: In this case, repair the following item:</p> <ul style="list-style-type: none"> <li>• Open circuit in harness between ECM and electronic throttle control connector</li> <li>• Poor contact of coupling connector</li> </ul>
<p><b>28</b>     <b>CHECK HARNESS BETWEEN ECM AND ELECTRONIC THROTTLE CONTROL CONNECTOR.</b></p> <p>1) Connect the connector to ECM. 2) Measure the resistance between electronic throttle control connector and engine ground.</p> <p><b>Connector &amp; terminal</b> <b>(E57) No. 3 — Engine ground:</b></p>	Is the resistance less than 5 $\Omega$ ?	Go to step 29.	<p>Repair the harness and connector.</p> <p>NOTE: In this case, repair the following item:</p> <ul style="list-style-type: none"> <li>• Open circuit of harness between ECM and engine ground</li> <li>• Poor contact of ECM connector</li> <li>• Poor contact of coupling connector</li> </ul>
<p><b>29</b>     <b>CHECK HARNESS BETWEEN ECM AND ELECTRONIC THROTTLE CONTROL CONNECTOR.</b></p> <p>1) Turn the ignition switch to ON. 2) Measure the voltage between electronic throttle control connector and engine ground.</p> <p><b>Connector &amp; terminal</b> <b>(E57) No. 6 (+) — Engine ground (-):</b> <b>(E57) No. 4 (+) — Engine ground (-):</b></p>	Is the voltage 5 V or more?	Repair the short circuit to power in harness between ECM and electronic throttle control connector.	Go to step 30.
<p><b>30</b>     <b>CHECK HARNESS BETWEEN ECM AND ELECTRONIC THROTTLE CONTROL CONNECTOR.</b></p> <p>1) Turn the ignition switch to OFF. 2) Disconnect the connector from ECM. 3) Measure the resistance between ECM connectors.</p> <p><b>Connector &amp; terminal</b> <b>(B134) No. 19 — (B134) No. 18:</b> <b>(B134) No. 19 — (B134) No. 28:</b></p>	Is the resistance 1 M $\Omega$ or more?	Go to step 31.	Repair the short circuit to power in harness between ECM and electronic throttle control connector.
<p><b>31</b>     <b>CHECK SENSOR OUTPUT.</b></p> <p>1) Connect all connectors. 2) Turn the ignition switch to ON. 3) Read the value of «Main-Throttle Sensor» using Subaru Select Monitor.</p> <p>NOTE: For detailed operation procedures, refer to "READ CURRENT DATA FOR ENGINE". &lt;Ref. to EN(H4DOTC)(diag)-40, Subaru Select Monitor.&gt;</p>	Is the value of «Main-Throttle Sensor» 0.81 — 0.87 V?	Go to step 32.	<p>Repair the poor contact of electronic throttle control connector.</p> <p>Replace the electronic throttle control if defective.</p> <p>&lt;Ref. to FU(STI)-15, Throttle Body.&gt; &lt;Ref. to FU(w/o STI)-15, Throttle Body.&gt;</p>

# Diagnostic Procedure with Diagnostic Trouble Code (DTC)

## ENGINE (DIAGNOSTICS)

Step	Check	Yes	No
<b>32 CHECK SENSOR OUTPUT.</b> Read the value of «Sub-Throttle Sensor» using Subaru Select Monitor. NOTE: For detailed operation procedures, refer to "READ CURRENT DATA FOR ENGINE". <Ref. to EN(H4DOTC)(diag)-40, Subaru Select Monitor.>	Is the value of «Sub-Throttle Sensor» 1.64 — 1.70 V?	Go to step <b>33</b> .	Repair the poor contact of electronic throttle control connector. Replace the electronic throttle control if defective. <Ref. to FU(STI)-15, Throttle Body.> <Ref. to FU(w/o STI)-15, Throttle Body.>
<b>33 CHECK HARNESS BETWEEN ECM AND ELECTRONIC THROTTLE CONTROL MOTOR.</b> 1) Turn the ignition switch to OFF. 2) Disconnect the connectors from ECM and electronic throttle control. 3) Measure the resistance between ECM and electronic throttle control connector. <b>Connector &amp; terminal</b> <b>(B134) No. 2 — (E57) No. 2:</b> <b>(B134) No. 1 — (E57) No. 1:</b>	Is the resistance less than 1 Ω?	Go to step <b>34</b> .	Repair the harness and connector. NOTE: In this case, repair the following item: • Open circuit in harness between ECM and electronic throttle control connector • Poor contact of coupling connector
<b>34 CHECK HARNESS BETWEEN ECM AND ELECTRONIC THROTTLE CONTROL MOTOR.</b> 1) Connect the connector to ECM. 2) Turn the ignition switch to ON. 3) Measure the voltage between electronic throttle control connector and engine ground. <b>Connector &amp; terminal</b> <b>(E57) No. 2 (+) — Engine ground (-):</b> <b>(E57) No. 1 (+) — Engine ground (-):</b>	Is the voltage 5 V or more?	Repair the short circuit to power in harness between ECM and electronic throttle control connector.	Go to step <b>35</b> .
<b>35 CHECK HARNESS BETWEEN ECM AND ELECTRONIC THROTTLE CONTROL MOTOR.</b> 1) Turn the ignition switch to OFF. 2) Disconnect the connector from ECM. 3) Measure the resistance between electronic throttle control connector and engine ground. <b>Connector &amp; terminal</b> <b>(E57) No. 2 — Engine ground:</b> <b>(E57) No. 1 — Engine ground:</b>	Is the resistance 1 MΩ or more?	Go to step <b>36</b> .	Repair the short circuit to ground in harness between ECM and electronic throttle control connector.
<b>36 CHECK ELECTRONIC THROTTLE CONTROL MOTOR HARNESS.</b> Measure the resistance between electronic throttle control connectors. <b>Connector &amp; terminal</b> <b>(E57) No. 2 — (E57) No. 1:</b>	Is the resistance 1 MΩ or more?	Go to step <b>37</b> .	Repair the short circuit of harness between ECM and electronic throttle control connector.

# Diagnostic Procedure with Diagnostic Trouble Code (DTC)

ENGINE (DIAGNOSTICS)

Step	Check	Yes	No
<b>37</b> <b>CHECK ELECTRONIC THROTTLE CONTROL GROUND CIRCUIT.</b> Measure the resistance between ECM and chassis ground. <i>Connector &amp; terminal</i> <i>(B134) No. 3 — Chassis ground:</i> <i>(B134) No. 4 — Chassis ground:</i> <i>(B134) No. 6 — Chassis ground:</i> <i>(B137) No. 1 — Chassis ground:</i> <i>(B137) No. 3 — Chassis ground:</i>	Is the resistance less than 5 $\Omega$ ?	Go to step <b>38</b> .	Repair the harness and connector. NOTE: In this case, repair the following item: <ul style="list-style-type: none"> <li>• Open circuit of harness between ECM and engine ground</li> <li>• Poor contact of coupling connector</li> </ul>
<b>38</b> <b>CHECK ELECTRONIC THROTTLE CONTROL.</b> Measure the resistance between electronic throttle control terminals. <i>Terminals</i> <i>No. 1 — No. 2:</i>	Is the resistance 50 $\Omega$ or less?	Go to step <b>39</b> .	Replace the electronic throttle control. <Ref. to FU(STI)-15, Throttle Body.> <Ref. to FU(w/o STI)-15, Throttle Body.>
<b>39</b> <b>CHECK ELECTRONIC THROTTLE CONTROL.</b> Move the throttle valve to the fully open and fully closed positions with fingers. Check that the valve returns to the specified position when releasing fingers.	Does the valve return to the specified position? Standard value: 3 mm (0.12 in) from fully closed position	Repair the poor contact of ECM connector.	Replace the electronic throttle control. <Ref. to FU(STI)-15, Throttle Body.> <Ref. to FU(w/o STI)-15, Throttle Body.>

## CO:DTC P050B COLD START IGNITION TIMING PERFORMANCE

### NOTE:

For the diagnostic procedure, refer to DTC P050A. <Ref. to EN(H4DOTC)(diag)-260, DTC P050A COLD START IDLE AIR CONTROL SYSTEM PERFORMANCE, Diagnostic Procedure with Diagnostic Trouble Code (DTC).>



# Diagnostic Procedure with Diagnostic Trouble Code (DTC)

ENGINE (DIAGNOSTICS)

## CP:DTC P0512 STARTER REQUEST CIRCUIT

### DTC DETECTING CONDITION:

- Detected when two consecutive driving cycles with fault occur.
- GENERAL DESCRIPTION <Ref. to GD(H4DOTC)-180, DTC P0512 STARTER REQUEST CIRCUIT, Diagnostic Trouble Code (DTC) Detecting Criteria.>

### TROUBLE SYMPTOM:

Failure of engine to start

### CAUTION:

After servicing or replacing faulty parts, perform Clear Memory Mode <Ref. to EN(H4DOTC)(diag)-62, OPERATION, Clear Memory Mode.>, and Inspection Mode <Ref. to EN(H4DOTC)(diag)-48, PROCEDURE, Inspection Mode.>.

### WIRING DIAGRAM:

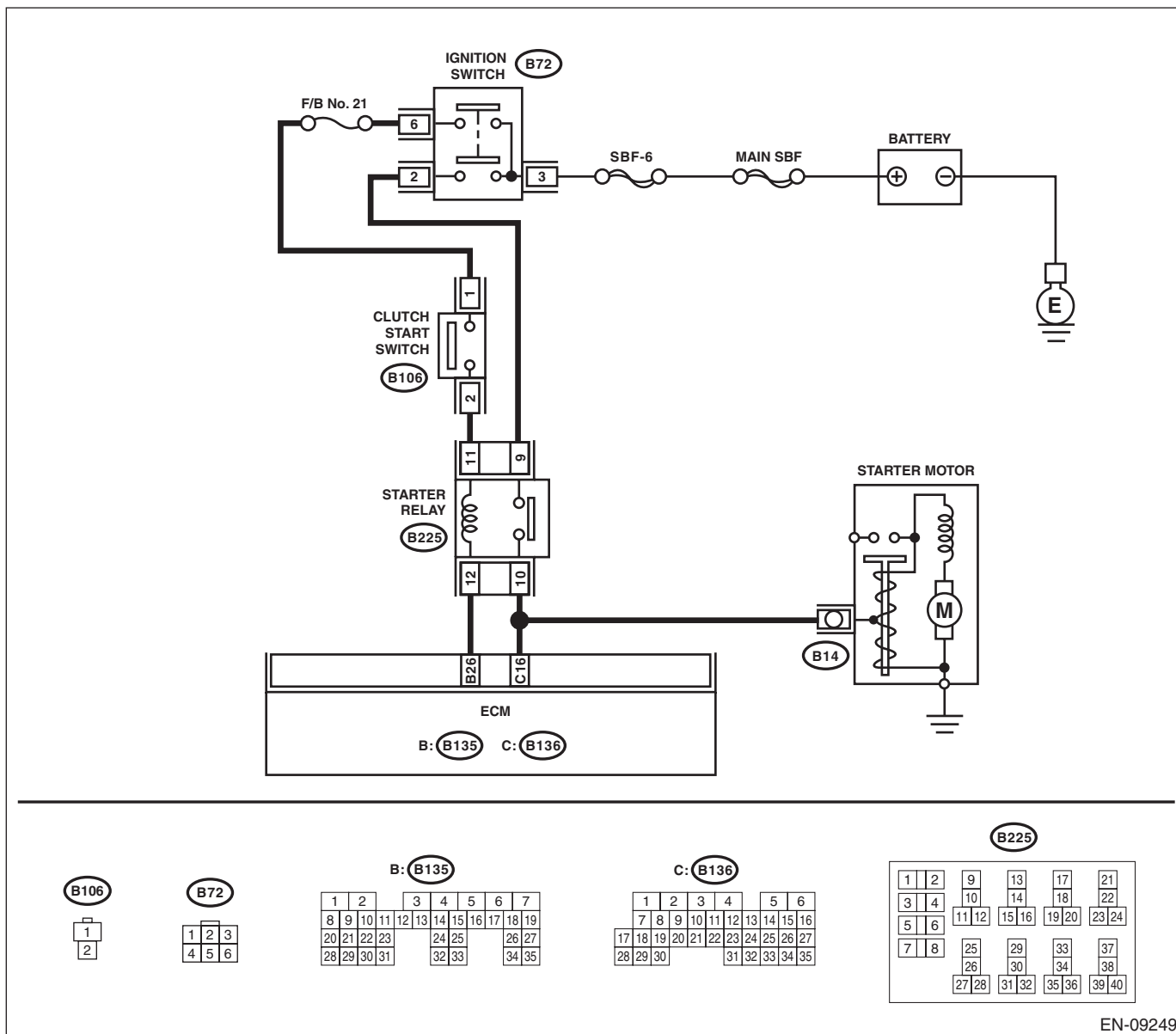

EN-09249

# Diagnostic Procedure with Diagnostic Trouble Code (DTC)

ENGINE (DIAGNOSTICS)

Step	Check	Yes	No
<b>1</b> <b>CHECK FOR ANY OTHER DTC ON DISPLAY.</b>	Is any other DTC displayed?	Check the appropriate DTC using the "List of Diagnostic Trouble Code (DTC)". <Ref. to EN(H4DOTC)(diag)-88, List of Diagnostic Trouble Code (DTC).>	Go to step 2.
<b>2</b> <b>CHECK HARNESS BETWEEN ECM AND IGNITION SWITCH CONNECTOR.</b> 1) Turn the ignition switch to OFF. 2) Disconnect the connector from ECM. 3) Turn the ignition switch to ON. 4) Measure the voltage between ECM and chassis ground. <b>Connector &amp; terminal</b> <b>(B136) No. 16 (+) — Chassis ground (-):</b>	Is the voltage 10 V or more?	Repair the short circuit to power in harness between ECM and ignition switch connector.	Repair the poor contact of ECM connector.

# Diagnostic Procedure with Diagnostic Trouble Code (DTC)

ENGINE (DIAGNOSTICS)

## CQ:DTC P0604 INTERNAL CONTROL MODULE RANDOM ACCESS MEMORY (RAM) ERROR

### DTC DETECTING CONDITION:

- Immediately at fault recognition
- GENERAL DESCRIPTION <Ref. to GD(H4DOTC)-182, DTC P0604 INTERNAL CONTROL MODULE RANDOM ACCESS MEMORY (RAM) ERROR, Diagnostic Trouble Code (DTC) Detecting Criteria.>

### TROUBLE SYMPTOM:

- Engine does not start.
- Engine stalls.

### CAUTION:

After servicing or replacing faulty parts, perform Clear Memory Mode <Ref. to EN(H4DOTC)(diag)-62, OPERATION, Clear Memory Mode.>, and Inspection Mode <Ref. to EN(H4DOTC)(diag)-48, PROCEDURE, Inspection Mode.>.

Step	Check	Yes	No
1 CHECK FOR ANY OTHER DTC ON DISPLAY.	Is any other DTC displayed?	Check the appropriate DTC using the "List of Diagnostic Trouble Code (DTC)". <Ref. to EN(H4DOTC)(diag)-88, List of Diagnostic Trouble Code (DTC).>	Even if DTC is detected, the circuit has returned to a normal condition at this time. Reproduce the failure, and then perform the diagnosis again.  NOTE: In this case, temporary poor contact of connector, temporary open or short circuit of harness may be the cause.

## CR:DTC P0605 INTERNAL CONTROL MODULE READ ONLY MEMORY (ROM) ERROR

### NOTE:

For the diagnostic procedure, refer to DTC P0607. <Ref. to EN(H4DOTC)(diag)-273, DTC P0607 THROTTLE CONTROL SYSTEM CIRCUIT RANGE/PERFORMANCE, Diagnostic Procedure with Diagnostic Trouble Code (DTC).>

# Diagnostic Procedure with Diagnostic Trouble Code (DTC)

ENGINE (DIAGNOSTICS)

## CS:DTC P0607 THROTTLE CONTROL SYSTEM CIRCUIT RANGE/PERFORMANCE

### DTC DETECTING CONDITION:

- Immediately at fault recognition
- GENERAL DESCRIPTION <Ref. to GD(H4DOTC)-184, DTC P0607 THROTTLE CONTROL SYSTEM CIRCUIT RANGE/PERFORMANCE, Diagnostic Trouble Code (DTC) Detecting Criteria.>

### TROUBLE SYMPTOM:

- Improper idling
- Poor driving performance

### CAUTION:

After servicing or replacing faulty parts, perform Clear Memory Mode <Ref. to EN(H4DOTC)(diag)-62, OPERATION, Clear Memory Mode.>, and Inspection Mode <Ref. to EN(H4DOTC)(diag)-48, PROCEDURE, Inspection Mode.>.

### WIRING DIAGRAM:

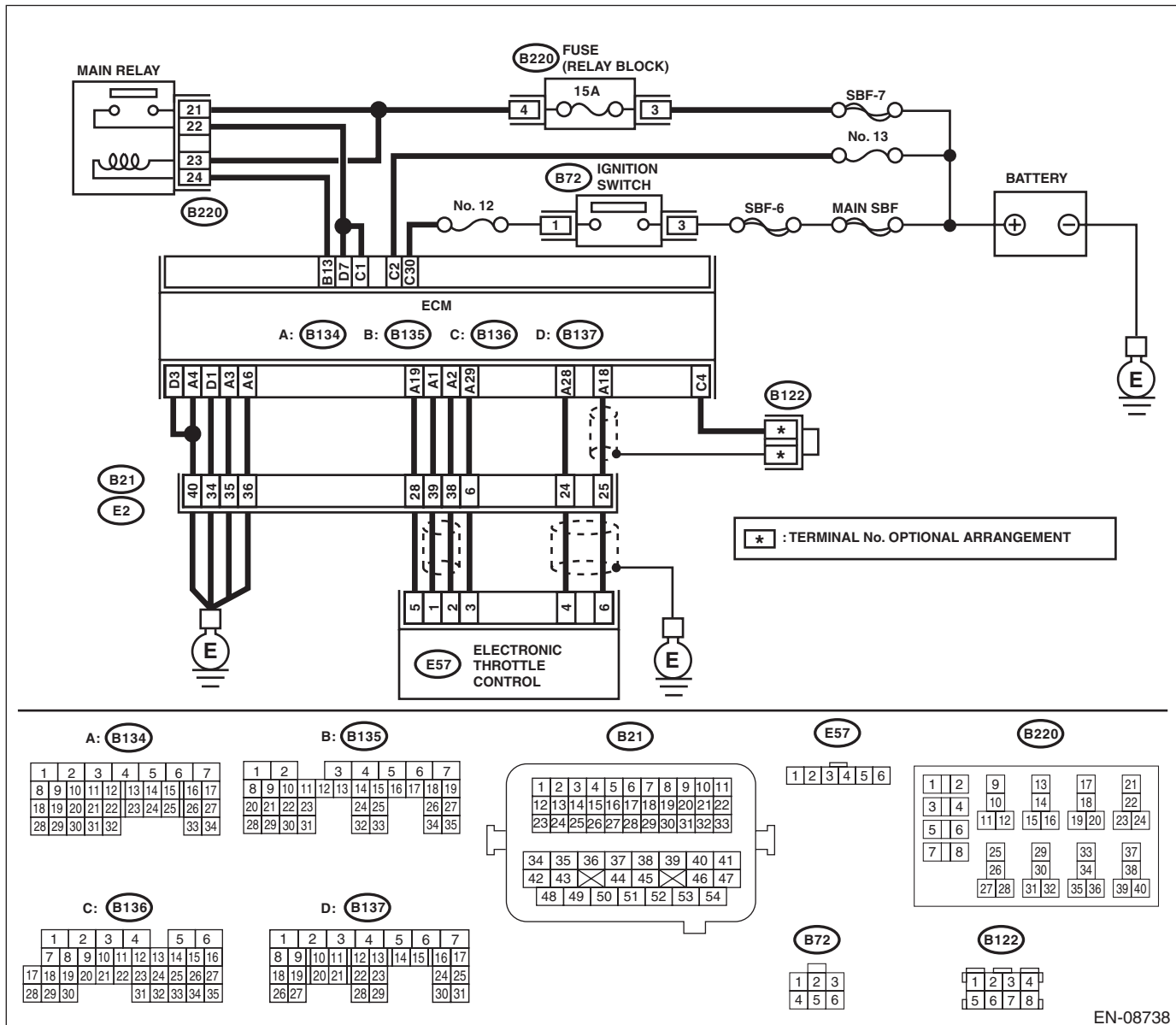

# Diagnostic Procedure with Diagnostic Trouble Code (DTC)

## ENGINE (DIAGNOSTICS)

Step	Check	Yes	No
<b>1 CHECK INPUT VOLTAGE OF ECM.</b> 1) Turn the ignition switch to ON. 2) Measure the voltage between ECM and chassis ground. <b>Connector &amp; terminal</b> (B136) No. 1 (+) — Chassis ground (-): (B137) No. 7 (+) — Chassis ground (-):	Is the voltage 10 — 13 V?	Go to step 2.	Repair the open or ground short circuit of power supply circuit.
<b>2 CHECK INPUT VOLTAGE OF ECM.</b> 1) Start the engine. 2) Measure the voltage between ECM and chassis ground. <b>Connector &amp; terminal</b> (B136) No. 1 (+) — Chassis ground (-): (B137) No. 7 (+) — Chassis ground (-):	Is the voltage 13 — 15 V?	Go to step 3.	Repair the open or ground short circuit of power supply circuit.
<b>3 CHECK HARNESS BETWEEN ECM AND ELECTRONIC THROTTLE CONTROL CONNECTOR.</b> 1) Turn the ignition switch to OFF. 2) Disconnect the connectors from ECM and electronic throttle control. 3) Measure the resistance of harness between ECM and electronic throttle control connector. <b>Connector &amp; terminal</b> (B134) No. 19 — (E57) No. 5: (B134) No. 29 — (E57) No. 3:	Is the resistance less than 1 $\Omega$ ?	Go to step 4.	Repair the harness and connector. NOTE: In this case, repair the following item: • Open circuit in harness between ECM and electronic throttle control connector • Poor contact of coupling connector
<b>4 CHECK ECM GROUND HARNESS.</b> 1) Connect all connectors. 2) Turn the ignition switch to ON. 3) Measure the voltage between ECM and chassis ground. <b>Connector &amp; terminal</b> (B134) No. 3 — Chassis ground: (B134) No. 4 — Chassis ground: (B134) No. 6 — Chassis ground: (B137) No. 1 — Chassis ground: (B137) No. 3 — Chassis ground:	Is the voltage less than 1 V?	Repair the poor contact of ECM connector.	Repair the harness and connector. NOTE: In this case, repair the following item: • Open circuit in ground circuit • Further tightening of the engine ground terminal • Poor contact of ECM connector • Poor contact of coupling connector

## CT:DTC P0638 THROTTLE ACTUATOR CONTROL RANGE/PERFORMANCE (BANK 1)

### NOTE:

For the diagnostic procedure, refer to DTC P2101. <Ref. to EN(H4DOTC)(diag)-364, DTC P2101 THROTTLE ACTUATOR CONTROL MOTOR CIRCUIT RANGE/PERFORMANCE, Diagnostic Procedure with Diagnostic Trouble Code (DTC).>

# Diagnostic Procedure with Diagnostic Trouble Code (DTC)

ENGINE (DIAGNOSTICS)

## CU:DTC P0851 NEUTRAL SWITCH INPUT CIRCUIT LOW (MT MODEL)

### DTC DETECTING CONDITION:

- Detected when two consecutive driving cycles with fault occur.
- GENERAL DESCRIPTION <Ref. to GD(H4DOTC)-189, DTC P0851 NEUTRAL SWITCH INPUT CIRCUIT LOW (MT MODEL), Diagnostic Trouble Code (DTC) Detecting Criteria.>

### TROUBLE SYMPTOM:

Improper idling

### CAUTION:

After servicing or replacing faulty parts, perform Clear Memory Mode <Ref. to EN(H4DOTC)(diag)-62, OPERATION, Clear Memory Mode.>, and Inspection Mode <Ref. to EN(H4DOTC)(diag)-48, PROCEDURE, Inspection Mode.>.

### WIRING DIAGRAM:

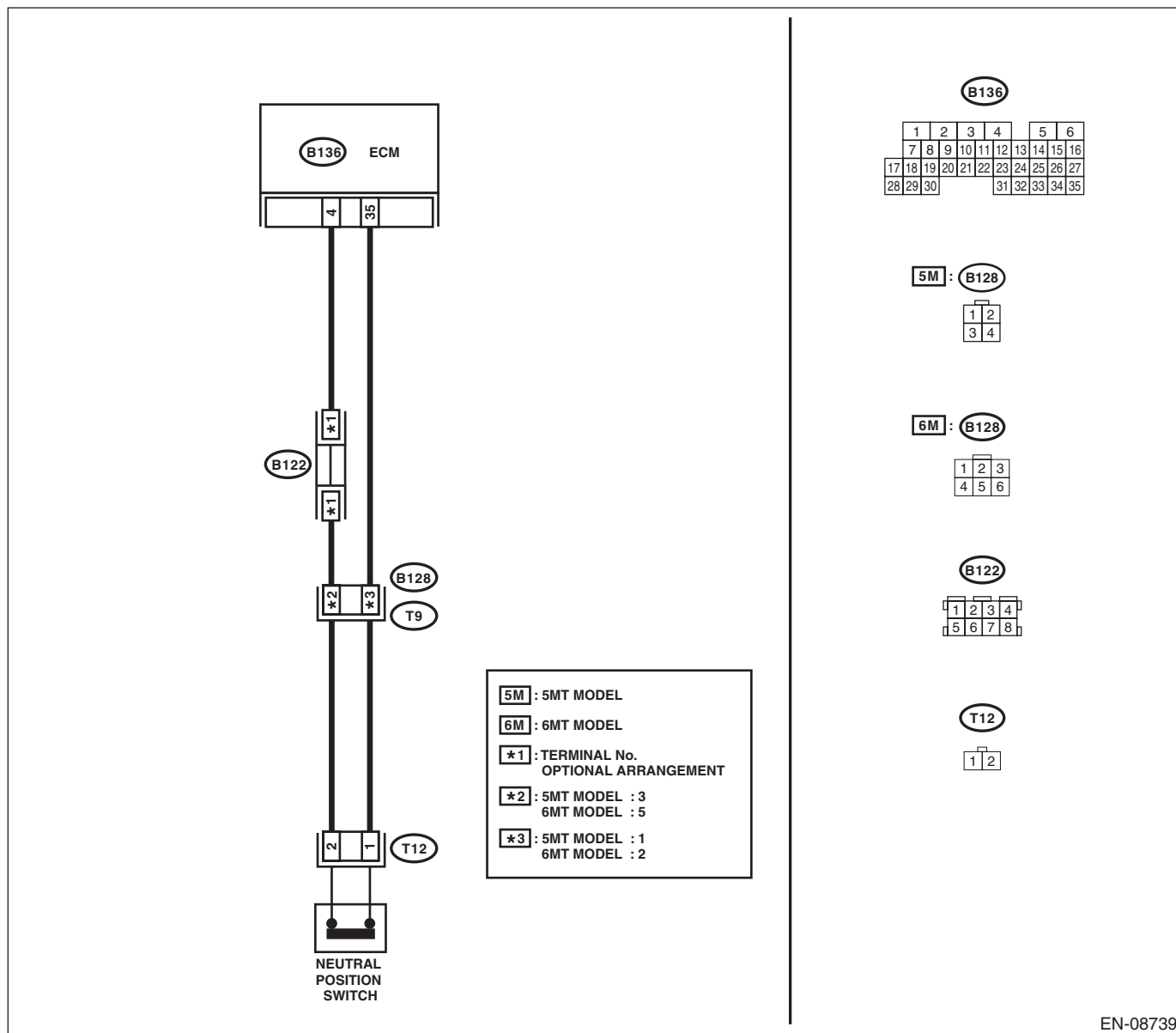

EN-08739

# Diagnostic Procedure with Diagnostic Trouble Code (DTC)

## ENGINE (DIAGNOSTICS)

Step	Check	Yes	No
<b>1</b> <b>CHECK INPUT SIGNAL OF ECM.</b> 1) Turn the ignition switch to ON. 2) Place the shift lever in a position other than neutral. 3) Measure the voltage between ECM and chassis ground. <b>Connector &amp; terminal</b> <b>(B136) No. 35 (+) — Chassis ground (-):</b>	Is the voltage 10 V or more?	Repair the poor contact of ECM connector.	Go to step 2.
<b>2</b> <b>CHECK HARNESS BETWEEN ECM AND NEUTRAL POSITION SWITCH CONNECTOR.</b> 1) Turn the ignition switch to OFF. 2) Disconnect the connectors from ECM and neutral position switch. 3) Measure the resistance between ECM and chassis ground. <b>Connector &amp; terminal</b> <b>(B136) No. 35 — Chassis ground:</b>	Is the resistance 1 MΩ or more?	Replace the neutral position switch. <Ref. to 5MT-33, Switches and Harness.> <Ref. to 6MT-42, Neutral Position Switch.>	Repair the short circuit to ground harness between ECM and neutral position switch connector.

# Diagnostic Procedure with Diagnostic Trouble Code (DTC)

ENGINE (DIAGNOSTICS)

## CV:DTC P0852 NEUTRAL SWITCH INPUT CIRCUIT HIGH (MT MODEL)

### DTC DETECTING CONDITION:

- Detected when two consecutive driving cycles with fault occur.
- GENERAL DESCRIPTION <Ref. to GD(H4DOTC)-190, DTC P0852 NEUTRAL SWITCH INPUT CIRCUIT HIGH (MT MODEL), Diagnostic Trouble Code (DTC) Detecting Criteria.>

### TROUBLE SYMPTOM:

Improper idling

### CAUTION:

After servicing or replacing faulty parts, perform Clear Memory Mode <Ref. to EN(H4DOTC)(diag)-62, OPERATION, Clear Memory Mode.>, and Inspection Mode <Ref. to EN(H4DOTC)(diag)-48, PROCEDURE, Inspection Mode.>.

### WIRING DIAGRAM:

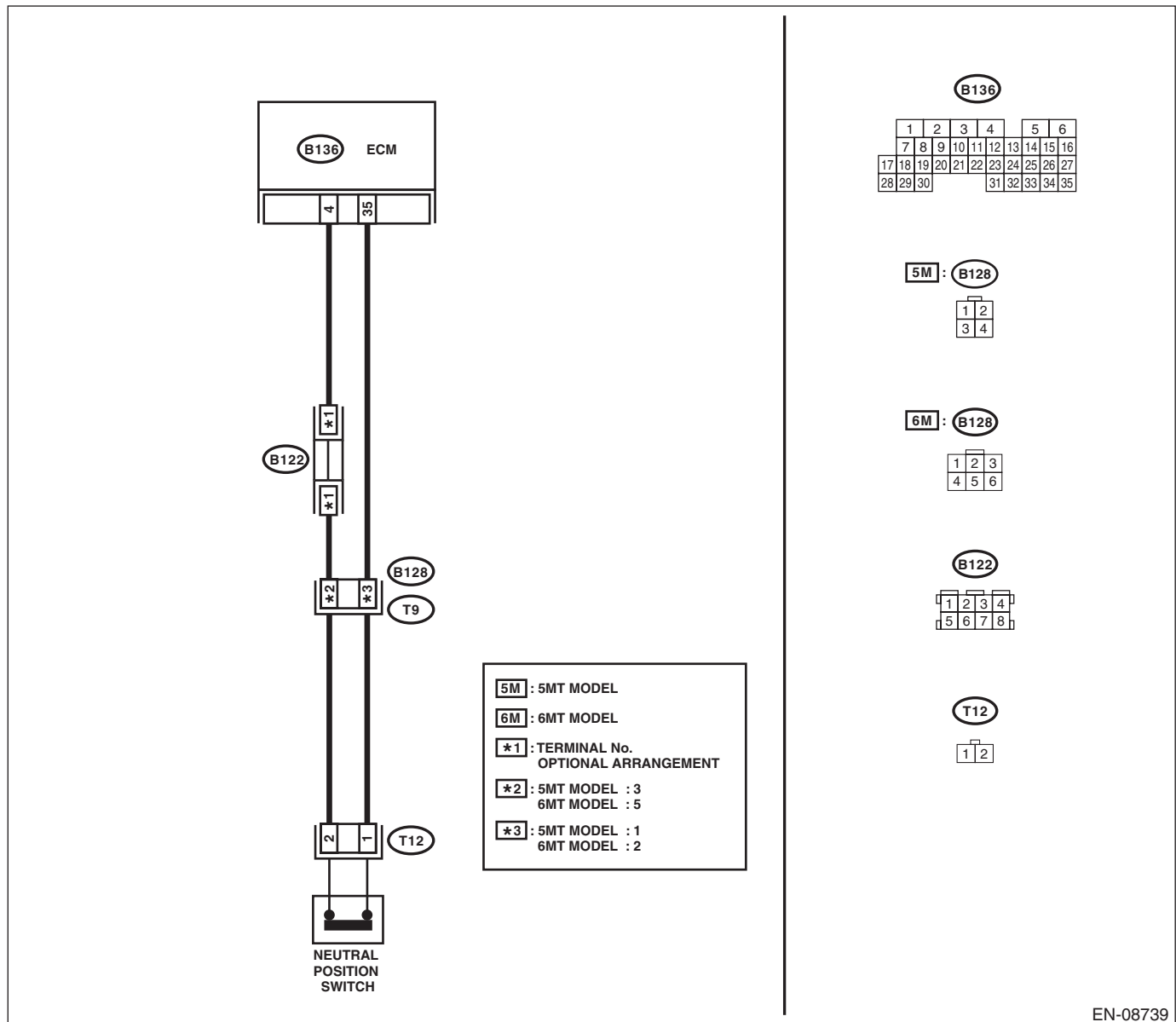

EN-08739



# Diagnostic Procedure with Diagnostic Trouble Code (DTC)

## ENGINE (DIAGNOSTICS)

Step	Check	Yes	No
<b>1</b> <b>CHECK INPUT SIGNAL OF ECM.</b> 1) Turn the ignition switch to ON. 2) Place the shift lever in neutral. 3) Measure the voltage between ECM and chassis ground. <b>Connector &amp; terminal</b> <b>(B136) No. 35 (+) — Chassis ground (-):</b>	Is the voltage less than 1 V?	Repair the poor contact of ECM connector. Replace the ECM if defective. <Ref. to FU(STI)-59, Engine Control Module (ECM).> <Ref. to FU(w/o STI)-58, Engine Control Module (ECM).>	Go to step 2.
<b>2</b> <b>CHECK HARNESS BETWEEN ECM AND NEUTRAL POSITION SWITCH CONNECTOR.</b> 1) Turn the ignition switch to OFF. 2) Disconnect the connectors from ECM and transmission harness connector (T9). 3) Measure the resistance of harness between ECM and transmission harness connector. <b>Connector &amp; terminal</b> <b>5MT model</b> <b>(B136) No. 35 — (B128) No. 1:</b> <b>6MT model</b> <b>(B136) No. 35 — (B128) No. 2:</b>	Is the resistance less than 1 $\Omega$ ?	Go to step 3.	Repair the open circuit in harness between ECM and transmission harness connector.
<b>3</b> <b>CHECK HARNESS BETWEEN ECM AND NEUTRAL POSITION SWITCH CONNECTOR.</b> Measure the resistance of harness between ECM and transmission harness connector. <b>Connector &amp; terminal</b> <b>5MT model</b> <b>(B128) No. 3 — (B136) No. 4:</b> <b>6MT model</b> <b>(B128) No. 5 — (B136) No. 4:</b>	Is the resistance less than 5 $\Omega$ ?	Go to step 4.	Repair the harness and connector. NOTE: In this case, repair the following item: • Open circuit in harness between ECM and transmission harness connector • Poor contact of coupling connector
<b>4</b> <b>CHECK NEUTRAL POSITION SWITCH.</b> 1) Place the shift lever in neutral. 2) Measure the resistance between transmission harness connector terminals. <b>Connector &amp; terminal</b> <b>5MT model</b> <b>(T9) No. 1 — No. 3:</b> <b>6MT model</b> <b>(T9) No. 2 — No. 5:</b>	Is the resistance less than 1 $\Omega$ ?	Repair the poor contact of transmission harness connector.	Repair the open circuit of transmission harness, or replace the neutral position switch. <Ref. to 5MT-33, Switches and Harness.> <Ref. to 6MT-42, Neutral Position Switch.>

# Diagnostic Procedure with Diagnostic Trouble Code (DTC)

ENGINE (DIAGNOSTICS)

## CW:DTC P1152 O2 SENSOR CIRCUIT RANGE/PERFORMANCE (LOW) (BANK1 SENSOR1)

### DTC DETECTING CONDITION:

- Detected when two consecutive driving cycles with fault occur.
- GENERAL DESCRIPTION <Ref. to GD(H4DOTC)-191, DTC P1152 O2 SENSOR CIRCUIT RANGE/PERFORMANCE (LOW) (BANK1 SENSOR1), Diagnostic Trouble Code (DTC) Detecting Criteria.>

### CAUTION:

After servicing or replacing faulty parts, perform Clear Memory Mode <Ref. to EN(H4DOTC)(diag)-62, OPERATION, Clear Memory Mode.>, and Inspection Mode <Ref. to EN(H4DOTC)(diag)-48, PROCEDURE, Inspection Mode.>.

### WIRING DIAGRAM:

- Models without SI-DRIVE

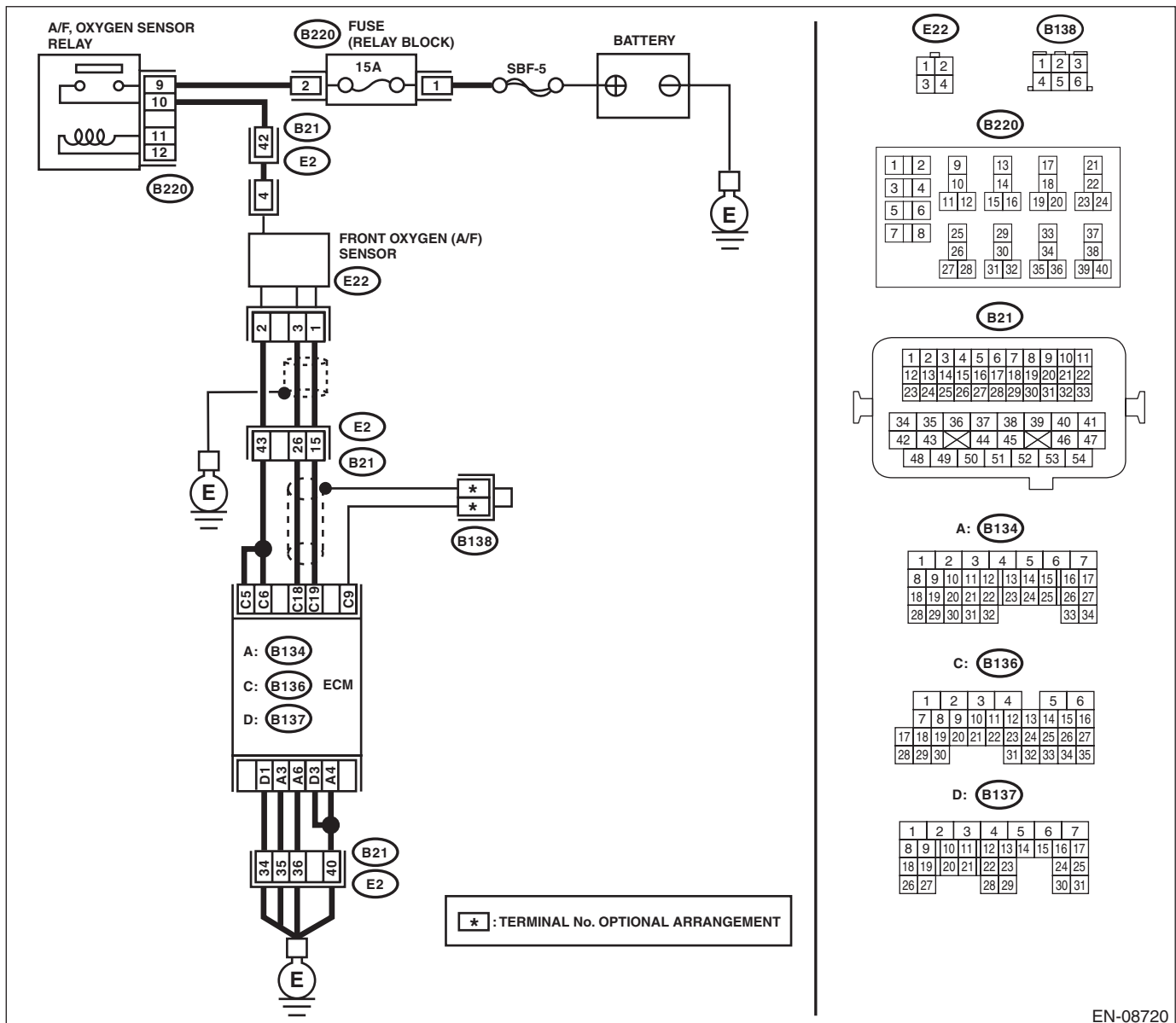

EN-08720

# Diagnostic Procedure with Diagnostic Trouble Code (DTC)

## ENGINE (DIAGNOSTICS)

- Models with SI-DRIVE

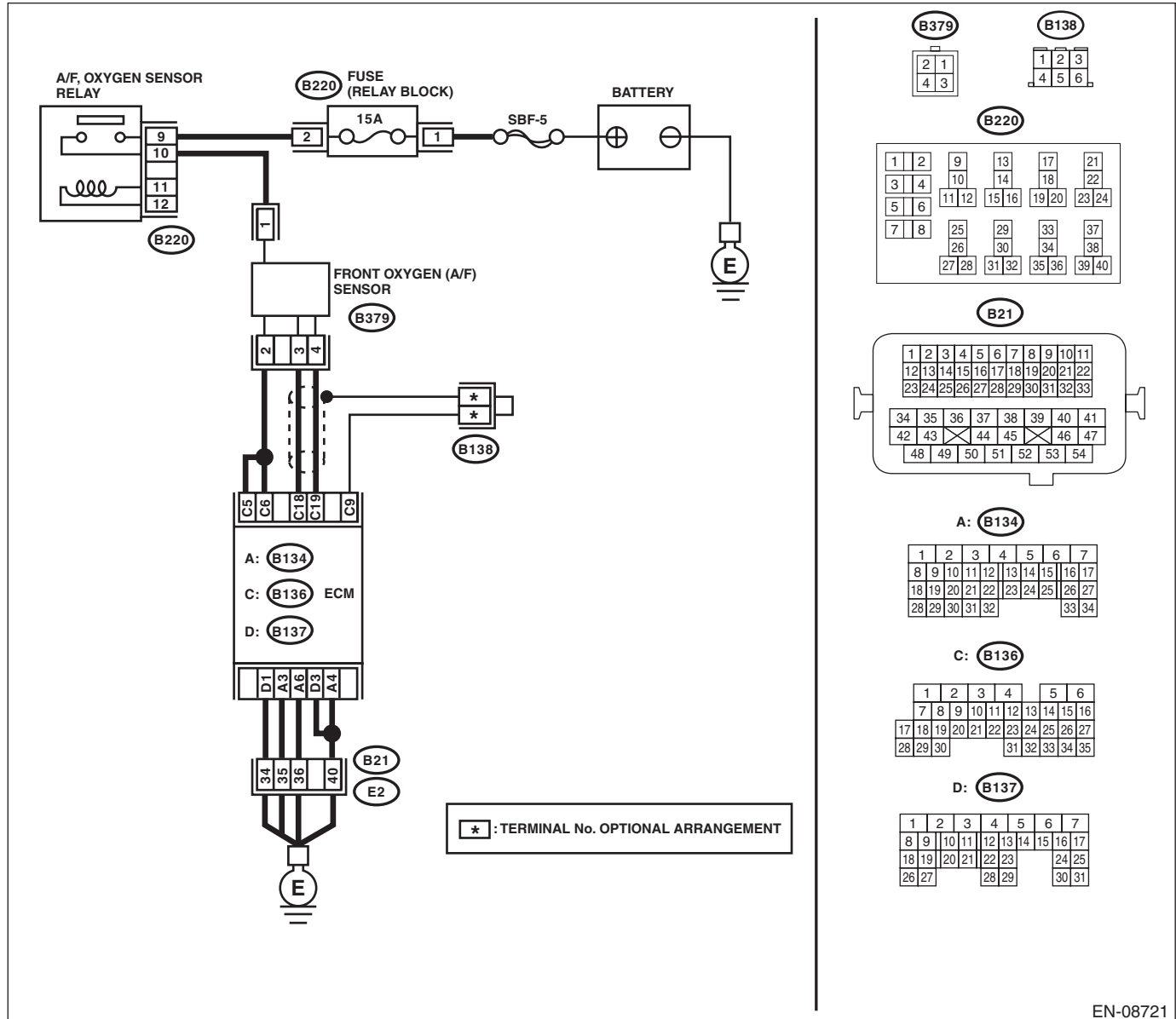

EN-08721

Step	Check	Yes	No
1	<b>CHECK FRONT OXYGEN (A/F) SENSOR CONNECTOR AND COUPLING CONNECTOR.</b>	Completely remove any water inside.	Go to step 2.
2	<b>CHECK HARNESS BETWEEN ECM AND FRONT OXYGEN (A/F) SENSOR CONNECTOR.</b> 1) Turn the ignition switch to OFF. 2) Disconnect the connectors from ECM and front oxygen (A/F) sensor. 3) Measure the resistance of harness between ECM and front oxygen (A/F) sensor connector. <b>Connector &amp; terminal</b> <b>Models without SI-DRIVE</b> (B136) No. 19 — (E22) No. 1: (B136) No. 18 — (E22) No. 3: <b>Models with SI-DRIVE</b> (B136) No. 19 — (B379) No. 4: (B136) No. 18 — (B379) No. 3:	Is the resistance less than 1 Ω?  Go to step 3.	Repair the open circuit of harness between ECM and front oxygen (A/F) sensor connector.

# Diagnostic Procedure with Diagnostic Trouble Code (DTC)

ENGINE (DIAGNOSTICS)

	Step	Check	Yes	No
3	<b>CHECK FOR POOR CONTACT.</b> Check for poor contact of the front oxygen (A/F) sensor connector.	Is there poor contact of front oxygen (A/F) sensor connector?	Repair the poor contact of front oxygen (A/F) sensor connector.	Replace the front oxygen (A/F) sensor. <Ref. to FU(STI)-54, Front Oxygen (A/F) Sensor.> <Ref. to FU(w/o STI)-54, Front Oxygen (A/F) Sensor.>

# Diagnostic Procedure with Diagnostic Trouble Code (DTC)

ENGINE (DIAGNOSTICS)

## CX:DTC P1153 O2 SENSOR CIRCUIT RANGE/PERFORMANCE (HIGH) (BANK1 SENSOR1)

### DTC DETECTING CONDITION:

- Detected when two consecutive driving cycles with fault occur.
- GENERAL DESCRIPTION <Ref. to GD(H4DOTC)-193, DTC P1153 O2 SENSOR CIRCUIT RANGE/PERFORMANCE (HIGH) (BANK1 SENSOR1), Diagnostic Trouble Code (DTC) Detecting Criteria.>

### CAUTION:

After servicing or replacing faulty parts, perform Clear Memory Mode <Ref. to EN(H4DOTC)(diag)-62, OPERATION, Clear Memory Mode.>, and Inspection Mode <Ref. to EN(H4DOTC)(diag)-48, PROCEDURE, Inspection Mode.>.

### WIRING DIAGRAM:

- Models without SI-DRIVE

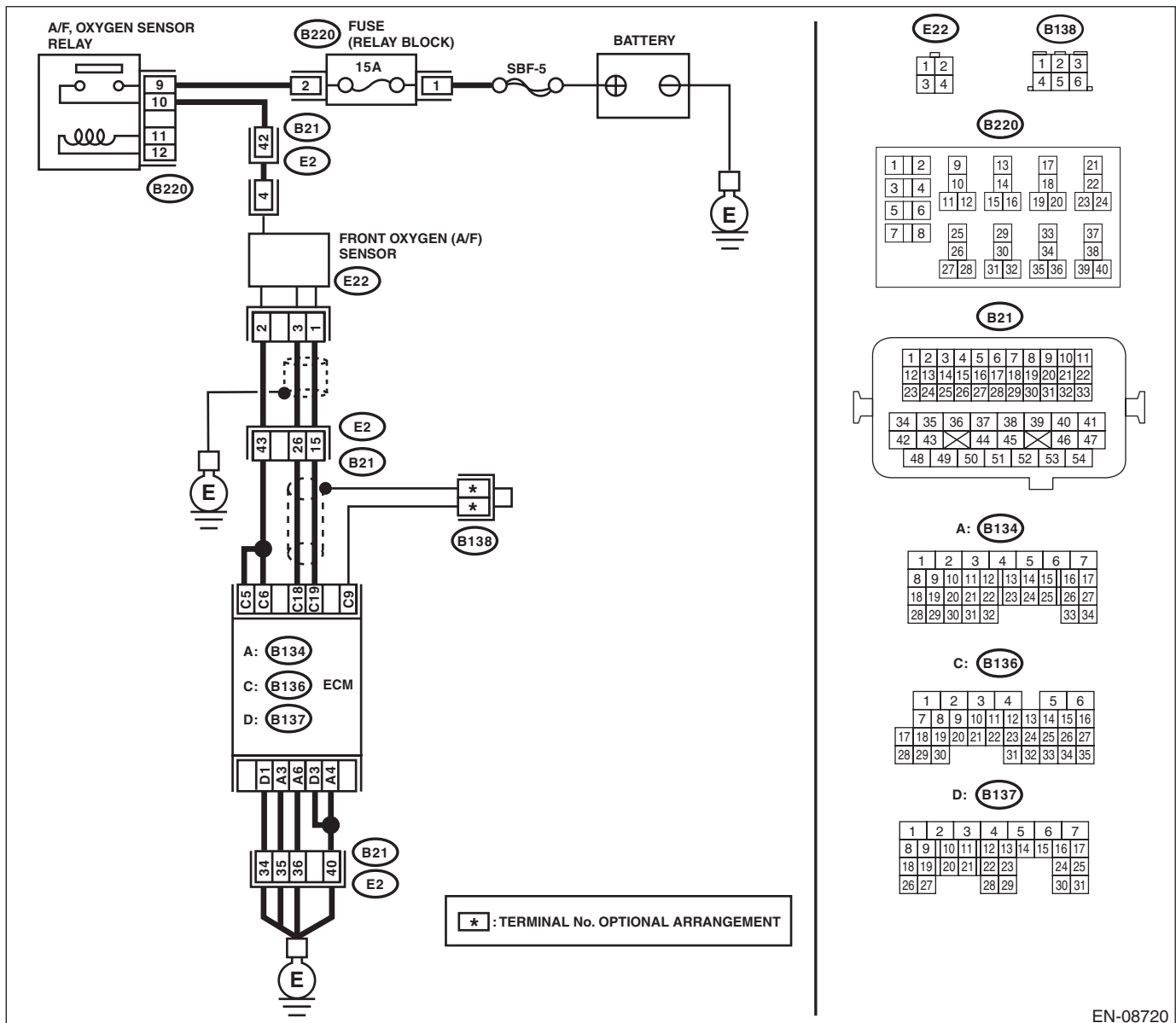

EN-08720

# Diagnostic Procedure with Diagnostic Trouble Code (DTC)

ENGINE (DIAGNOSTICS)

- Models with SI-DRIVE

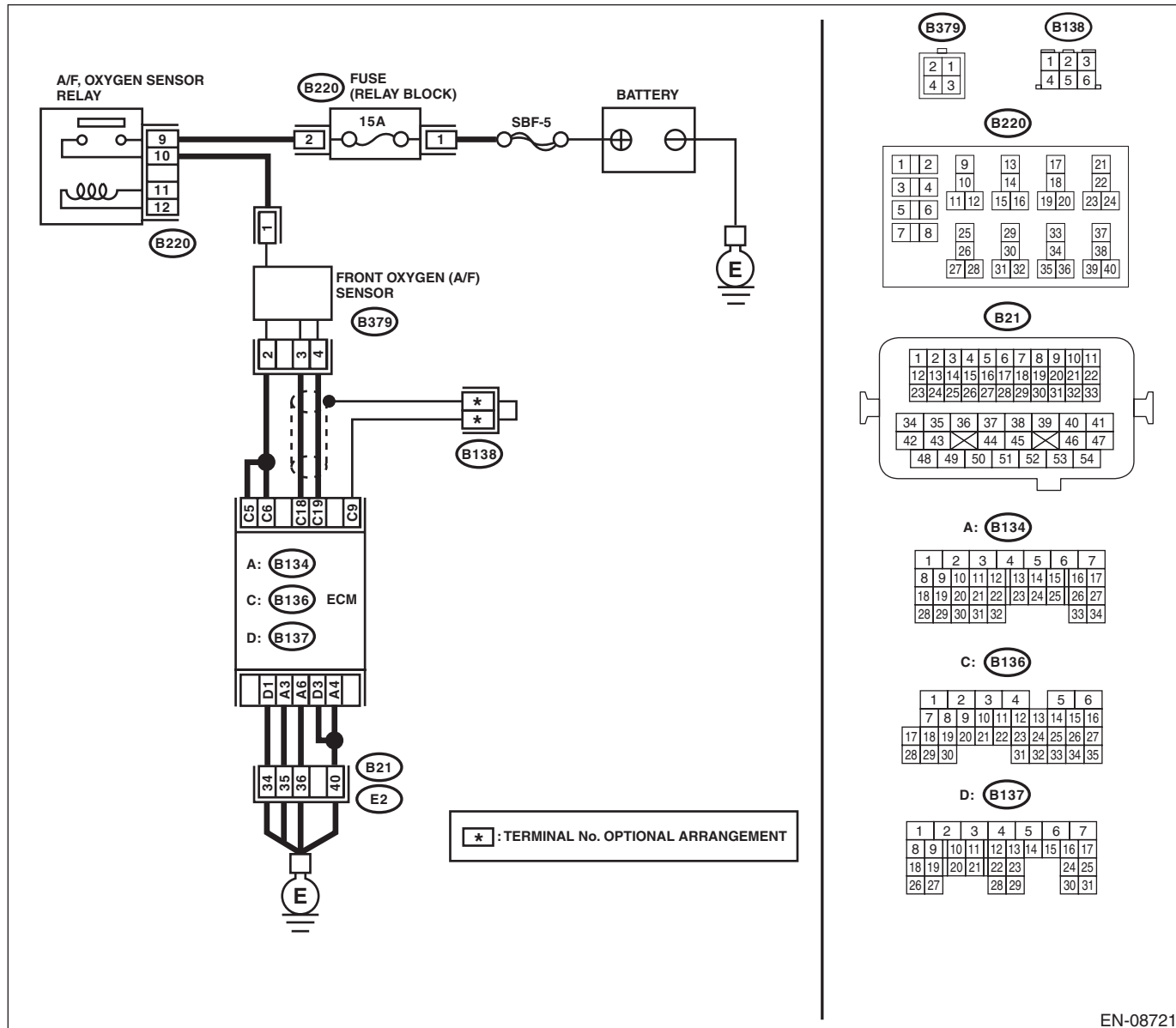

EN-08721

Step	Check	Yes	No
1	<b>CHECK FRONT OXYGEN (A/F) SENSOR CONNECTOR AND COUPLING CONNECTOR.</b>	Completely remove any water inside.	Go to step 2.
2	<b>CHECK HARNESS BETWEEN ECM AND FRONT OXYGEN (A/F) SENSOR CONNECTOR.</b> 1) Turn the ignition switch to OFF. 2) Disconnect the connector from ECM. 3) Measure the resistance between ECM and chassis ground. <b>Connector &amp; terminal</b> <b>(B136) No. 19 — Chassis ground:</b> <b>(B136) No. 18 — Chassis ground:</b>	Go to step 3.	Repair the ground short circuit of harness between ECM and front oxygen (A/F) sensor connector.

## Diagnostic Procedure with Diagnostic Trouble Code (DTC)

### ENGINE (DIAGNOSTICS)

Step	Check	Yes	No
<b>3</b> <b>CHECK OUTPUT SIGNAL FOR ECM.</b> 1) Connect the connector to ECM. 2) Turn the ignition switch to ON. 3) Measure the voltage between ECM and chassis ground. <i><b>Connector &amp; terminal</b></i> <i><b>(B136) No. 19 (+) — Chassis ground (-):</b></i>	Is the voltage 4.5 V or more?	Go to step 5.	Go to step 4.
<b>4</b> <b>CHECK OUTPUT SIGNAL FOR ECM.</b> Measure the voltage between ECM and chassis ground. <i><b>Connector &amp; terminal</b></i> <i><b>(B136) No. 18 (+) — Chassis ground (-):</b></i>	Is the voltage 4.95 V or more?	Go to step 5.	Replace the front oxygen (A/F) sensor. <Ref. to FU(STI)-54, Front Oxygen (A/F) Sensor.> <Ref. to FU(w/o STI)-54, Front Oxygen (A/F) Sensor.>
<b>5</b> <b>CHECK OUTPUT SIGNAL FOR ECM.</b> Measure the voltage between ECM and chassis ground. <i><b>Connector &amp; terminal</b></i> <i><b>(B136) No. 19 (+) — Chassis ground (-):</b></i> <i><b>(B136) No. 18 (+) — Chassis ground (-):</b></i>	Is the voltage 8 V or more?	Repair the short circuit to power in the harness between ECM and front oxygen (A/F) sensor connector. After repair, replace the ECM. <Ref. to FU(STI)-59, Engine Control Module (ECM).> <Ref. to FU(w/o STI)-58, Engine Control Module (ECM).>	Repair the poor contact of ECM connector.

### CY:DTC P1160 RETURN SPRING FAILURE

**NOTE:**

For the diagnostic procedure, refer to DTC P2101. <Ref. to EN(H4DOTC)(diag)-364, DTC P2101 THROTTLE ACTUATOR CONTROL MOTOR CIRCUIT RANGE/PERFORMANCE, Diagnostic Procedure with Diagnostic Trouble Code (DTC).>

# Diagnostic Procedure with Diagnostic Trouble Code (DTC)

ENGINE (DIAGNOSTICS)

## CZ:DTC P1400 FUEL TANK PRESSURE CONTROL SOLENOID VALVE CIRCUIT LOW

### DTC DETECTING CONDITION:

- Detected when two consecutive driving cycles with fault occur.
- GENERAL DESCRIPTION <Ref. to GD(H4DOTC)-197, DTC P1400 FUEL TANK PRESSURE CONTROL SOLENOID VALVE CIRCUIT LOW, Diagnostic Trouble Code (DTC) Detecting Criteria.>

### CAUTION:

After servicing or replacing faulty parts, perform Clear Memory Mode <Ref. to EN(H4DOTC)(diag)-62, OPERATION, Clear Memory Mode.>, and Inspection Mode <Ref. to EN(H4DOTC)(diag)-48, PROCEDURE, Inspection Mode.>.

### WIRING DIAGRAM:

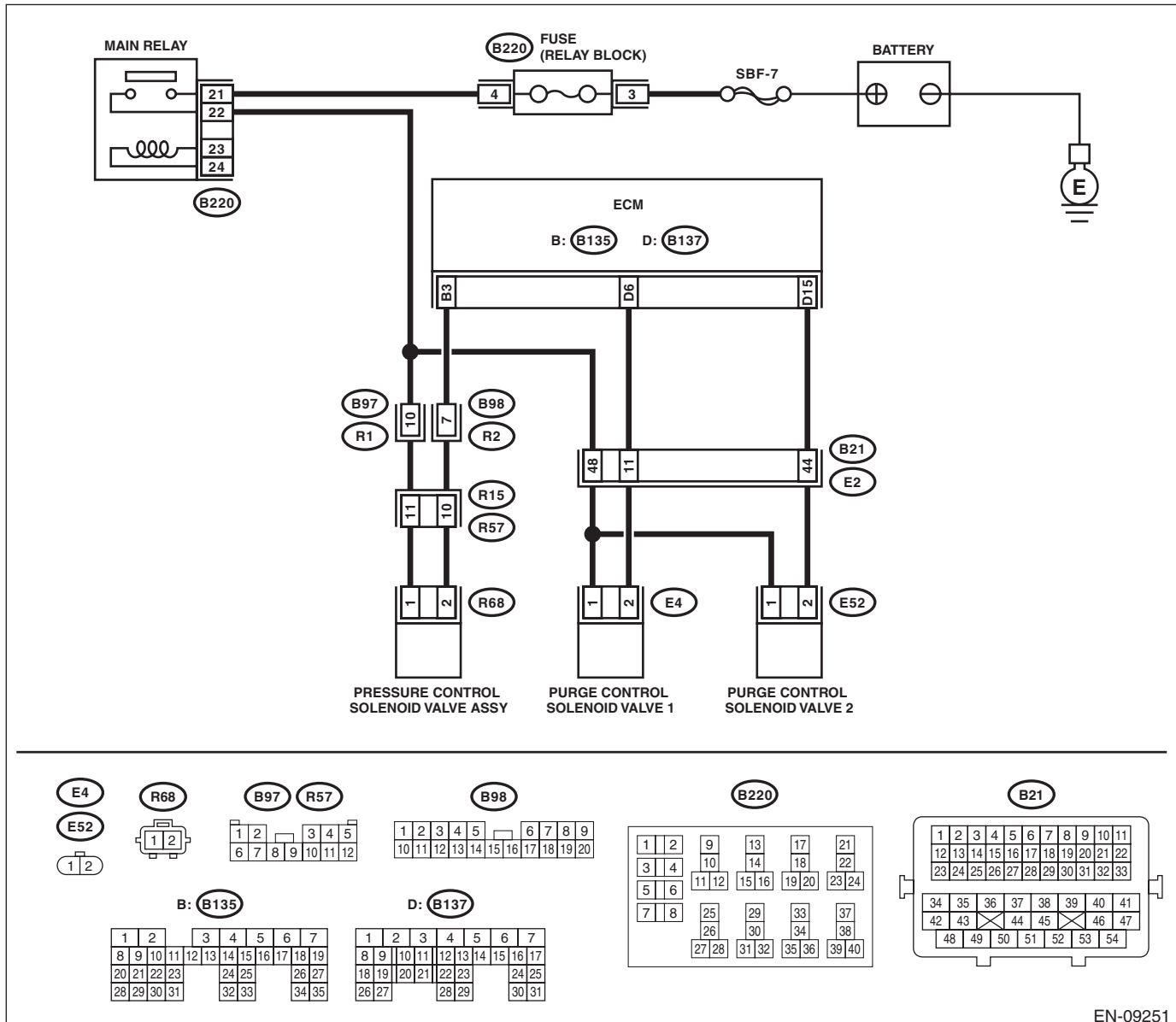

EN-09251



# Diagnostic Procedure with Diagnostic Trouble Code (DTC)

## ENGINE (DIAGNOSTICS)

	Step	Check	Yes	No
1	<p><b>CHECK OUTPUT SIGNAL OF ECM.</b>                      1) Turn the ignition switch to ON.                      2) Measure the voltage between ECM and chassis ground.  <b>Connector &amp; terminal</b>  <b>(B135) No. 3 (+) — Chassis ground (-):</b></p>	Is the voltage 10 V or more?	Go to step 2.	Go to step 3.
2	<p><b>CHECK FOR POOR CONTACT.</b>                      Check for poor contact of ECM connector.</p>	Is there poor contact of ECM connector?	Repair the poor contact of ECM connector.	Even if DTC is detected, the circuit has returned to a normal condition at this time. Reproduce the failure, and then perform the diagnosis again. <b>NOTE:</b> In this case, temporary open or short circuit of harness or temporary poor contact of connector may be the cause.
3	<p><b>CHECK POWER SUPPLY TO PRESSURE CONTROL SOLENOID VALVE ASSEMBLY.</b>                      Measure the voltage between the pressure control solenoid valve assembly and chassis ground.  <b>Connector &amp; terminal</b>  <b>(R68) No. 1 (+) — Chassis ground (-):</b></p>	Is the voltage 10 V or more?	Go to step 4.	Repair the power supply circuit.
4	<p><b>CHECK HARNESS BETWEEN ECM AND PRESSURE CONTROL SOLENOID VALVE ASSEMBLY CONNECTOR.</b>                      1) Turn the ignition switch to OFF.                      2) Disconnect the connectors from the ECM and pressure control solenoid valve assembly.                      3) Measure the resistance between the pressure control solenoid valve assembly connector and chassis ground.  <b>Connector &amp; terminal</b>  <b>(R68) No. 2 — Chassis ground:</b></p>	Is the resistance 1 M $\Omega$ or more?	Go to step 5.	Repair the harness between ECM and pressure control solenoid valve assembly connector for short-circuit to ground.
5	<p><b>CHECK HARNESS BETWEEN ECM AND PRESSURE CONTROL SOLENOID VALVE ASSEMBLY CONNECTOR.</b>                      Measure the resistance of harness between ECM and pressure control solenoid valve assembly connector.  <b>Connector &amp; terminal</b>  <b>(B135) No. 3 — (R68) No. 2:</b></p>	Is the resistance less than 1 $\Omega$ ?	Go to step 6.	Repair the harness and connector. <b>NOTE:</b> In this case, repair the following item: <ul style="list-style-type: none"> <li>• Open circuit in the wiring harness between ECM and pressure control solenoid valve assembly connector</li> <li>• Poor contact of coupling connector</li> </ul>

# Diagnostic Procedure with Diagnostic Trouble Code (DTC)

ENGINE (DIAGNOSTICS)

Step	Check	Yes	No
<b>6</b> <b>CHECK PRESSURE CONTROL SOLENOID VALVE ASSEMBLY.</b> Measure the resistance between terminals of pressure control solenoid valve assembly. <b>Terminals</b> <b>No. 1 — No. 2:</b>	Is the resistance 10 — 100 $\Omega$ ?	Repair the pressure control solenoid valve assembly connector for poor contact.	Replace the pressure control solenoid valve assembly. <Ref. to EC(STI)-16, Pressure Control Solenoid Valve Assembly.> <Ref. to EC(w/o STI)-17, Pressure Control Solenoid Valve Assembly.>

# Diagnostic Procedure with Diagnostic Trouble Code (DTC)

ENGINE (DIAGNOSTICS)

## DA:DTC P1410 SECONDARY AIR INJECTION SYSTEM SWITCHING VALVE STUCK OPEN

### DTC DETECTING CONDITION:

- Immediately at fault recognition
- GENERAL DESCRIPTION <Ref. to GD(H4DOTC)-199, DTC P1410 SECONDARY AIR INJECTION SYSTEM SWITCHING VALVE STUCK OPEN, Diagnostic Trouble Code (DTC) Detecting Criteria.>

### CAUTION:

After servicing or replacing faulty parts, perform Clear Memory Mode <Ref. to EN(H4DOTC)(diag)-62, OPERATION, Clear Memory Mode.>, and Inspection Mode <Ref. to EN(H4DOTC)(diag)-48, PROCEDURE, Inspection Mode.>.

	Step	Check	Yes	No
1	<b>CHECK SECONDARY AIR COMBINATION VALVE.</b> 1) Remove the secondary air combination valve. <Ref. to EC(STI)-29, Secondary Air Combination Valve.> <Ref. to EC(w/o STI)-30, Secondary Air Combination Valve.> 2) Blow in air from the secondary air combination valve air inlet, and check whether there are leaks at the pipe connections.	Are there air leaks from the pipe connections?	Replace the secondary air combination valve on the side with the air leak. <Ref. to EC(STI)-29, Secondary Air Combination Valve.> <Ref. to EC(w/o STI)-30, Secondary Air Combination Valve.>	Perform the diagnostic procedure of DTC P2440. <Ref. to EN(H4DOTC)(diag)-424, DTC P2440 SECONDARY AIR INJECTION SYSTEM SWITCHING VALVE STUCK OPEN (BANK1), Diagnostic Procedure with Diagnostic Trouble Code (DTC).>

# Diagnostic Procedure with Diagnostic Trouble Code (DTC)

ENGINE (DIAGNOSTICS)

---

## **DB:DTC P1418 SECONDARY AIR INJECTION SYSTEM CONTROL "A" CIRCUIT SHORTED**

### **DTC DETECTING CONDITION:**

- Immediately at fault recognition
- GENERAL DESCRIPTION <Ref. to GD(H4DOTC)-201, DTC P1418 SECONDARY AIR INJECTION SYSTEM CONTROL "A" CIRCUIT SHORTED, Diagnostic Trouble Code (DTC) Detecting Criteria.>

### **CAUTION:**

**After servicing or replacing faulty parts, perform Clear Memory Mode <Ref. to EN(H4DOTC)(diag)-62, OPERATION, Clear Memory Mode.>, and Inspection Mode <Ref. to EN(H4DOTC)(diag)-48, PROCEDURE, Inspection Mode.>.**

# Diagnostic Procedure with Diagnostic Trouble Code (DTC)

ENGINE (DIAGNOSTICS)

## WIRING DIAGRAM:

- Models without SI-DRIVE

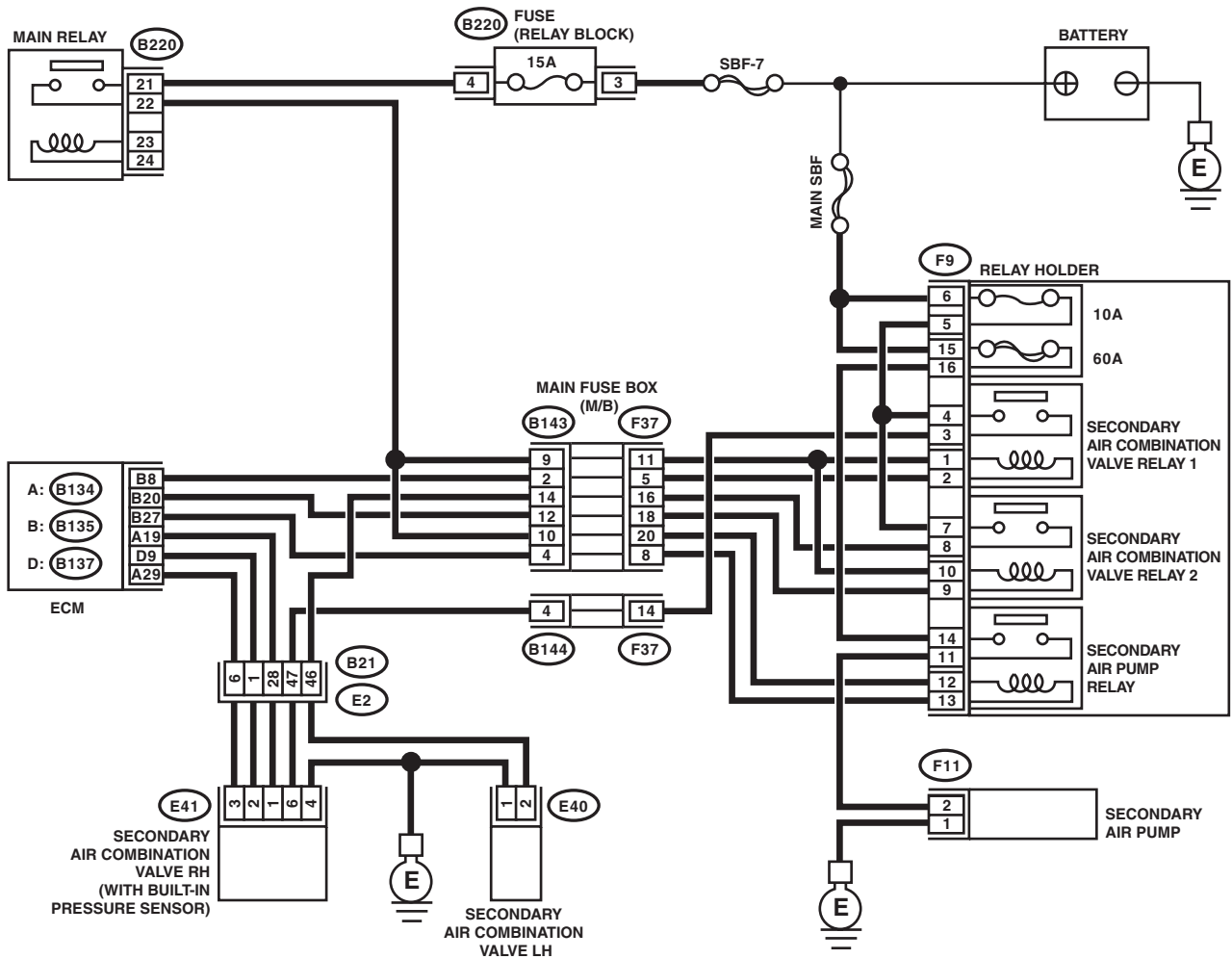

A: (B134)

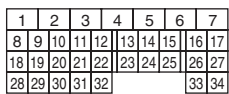

B: (B135)

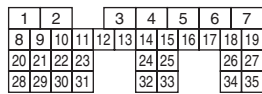

(B220)

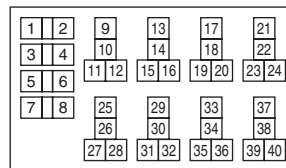

(B21)

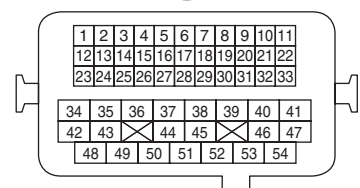

D: (B137)

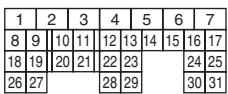

(F9)

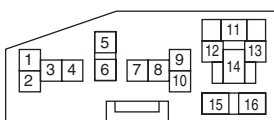

(F37)

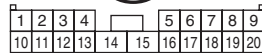

(B143)



(F11)



(E40)



(E41)



(B144)

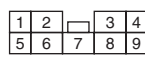

EN-08734

# Diagnostic Procedure with Diagnostic Trouble Code (DTC)

ENGINE (DIAGNOSTICS)

- Models with SI-DRIVE

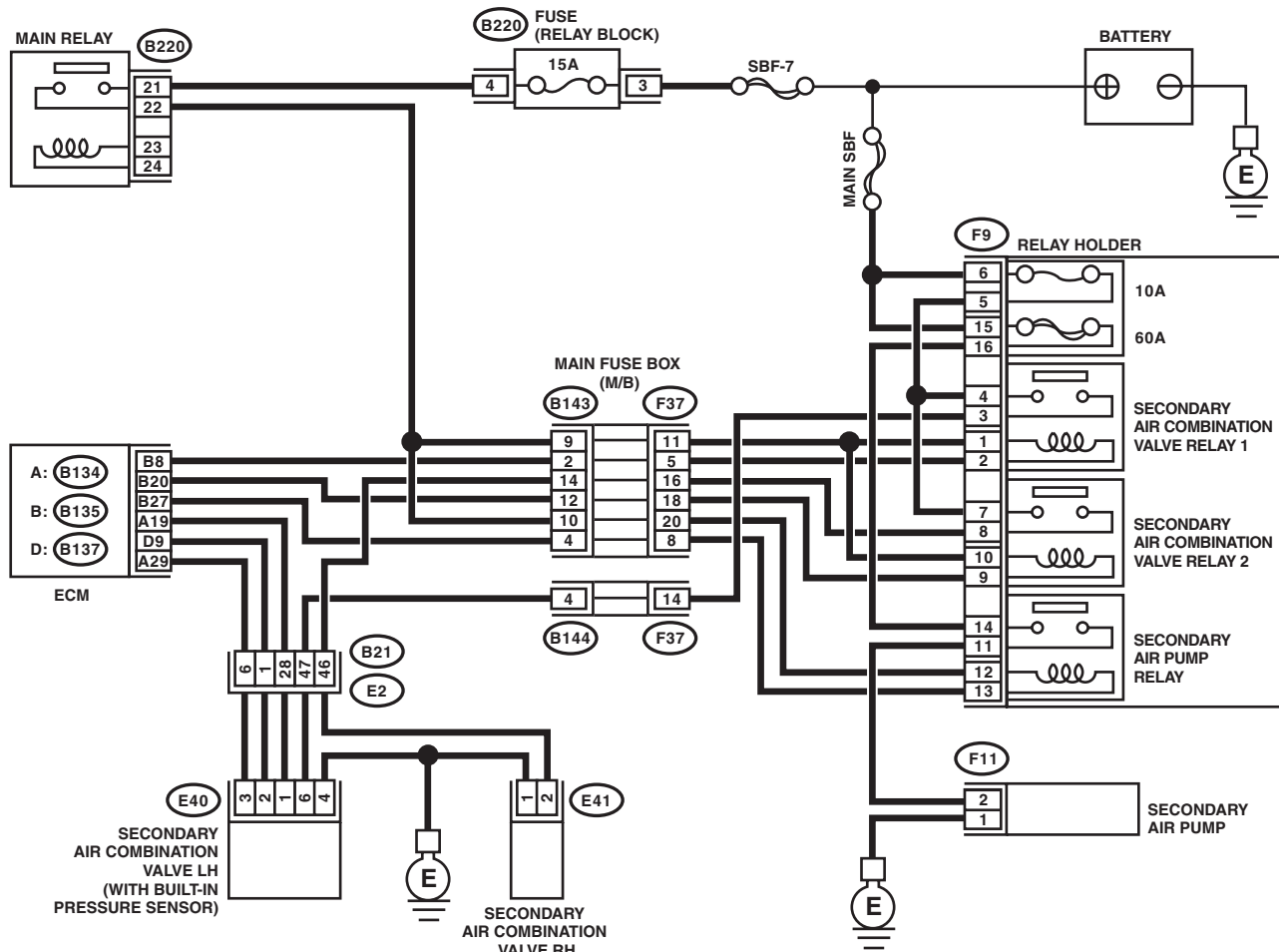

A: B134

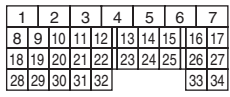

B: B135

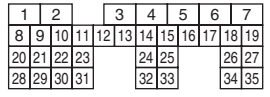

B220

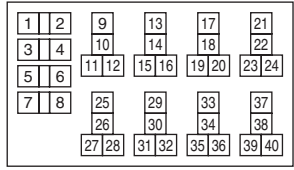

B21

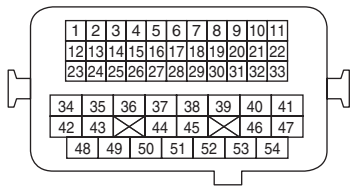

D: B137

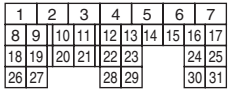

F9

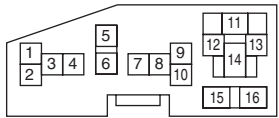

F37

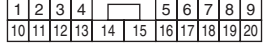

B143

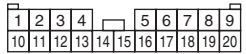

F11



E41



E40



B144



EN-08735

# Diagnostic Procedure with Diagnostic Trouble Code (DTC)

ENGINE (DIAGNOSTICS)

Step	Check	Yes	No
<p><b>1</b>    <b>CHECK HARNESS BETWEEN ECM AND SECONDARY AIR PUMP RELAY CONNECTOR.</b></p> <p>1) Turn the ignition switch to OFF. 2) Disconnect the connector from ECM. 3) Remove the secondary air pump relay. 4) Measure the voltage between ECM and chassis ground.</p> <p><b>Connector &amp; terminal</b> <b>(B135) No. 27 (+) — Chassis ground (-):</b></p>	<p>Is the voltage 10 V or more?</p>	<p>Repair the short circuit to power in the harness between ECM and secondary air pump relay connector.</p>	<p>Even if DTC is detected, the circuit has returned to a normal condition at this time. Reproduce the failure, and then perform the diagnosis again.</p> <p><b>NOTE:</b> In this case, temporary poor contact of connector, temporary open or short circuit of harness may be the cause.</p>

# Diagnostic Procedure with Diagnostic Trouble Code (DTC)

ENGINE (DIAGNOSTICS)

## DC:DTC P1420 FUEL TANK PRESSURE CONTROL SOL. VALVE CIRCUIT HIGH

### DTC DETECTING CONDITION:

- Detected when two consecutive driving cycles with fault occur.
- GENERAL DESCRIPTION <Ref. to GD(H4DOTC)-202, DTC P1420 FUEL TANK PRESSURE CONTROL SOL. VALVE CIRCUIT HIGH, Diagnostic Trouble Code (DTC) Detecting Criteria.>

### CAUTION:

After servicing or replacing faulty parts, perform Clear Memory Mode <Ref. to EN(H4DOTC)(diag)-62, OPERATION, Clear Memory Mode.>, and Inspection Mode <Ref. to EN(H4DOTC)(diag)-48, PROCEDURE, Inspection Mode.>.

### WIRING DIAGRAM:

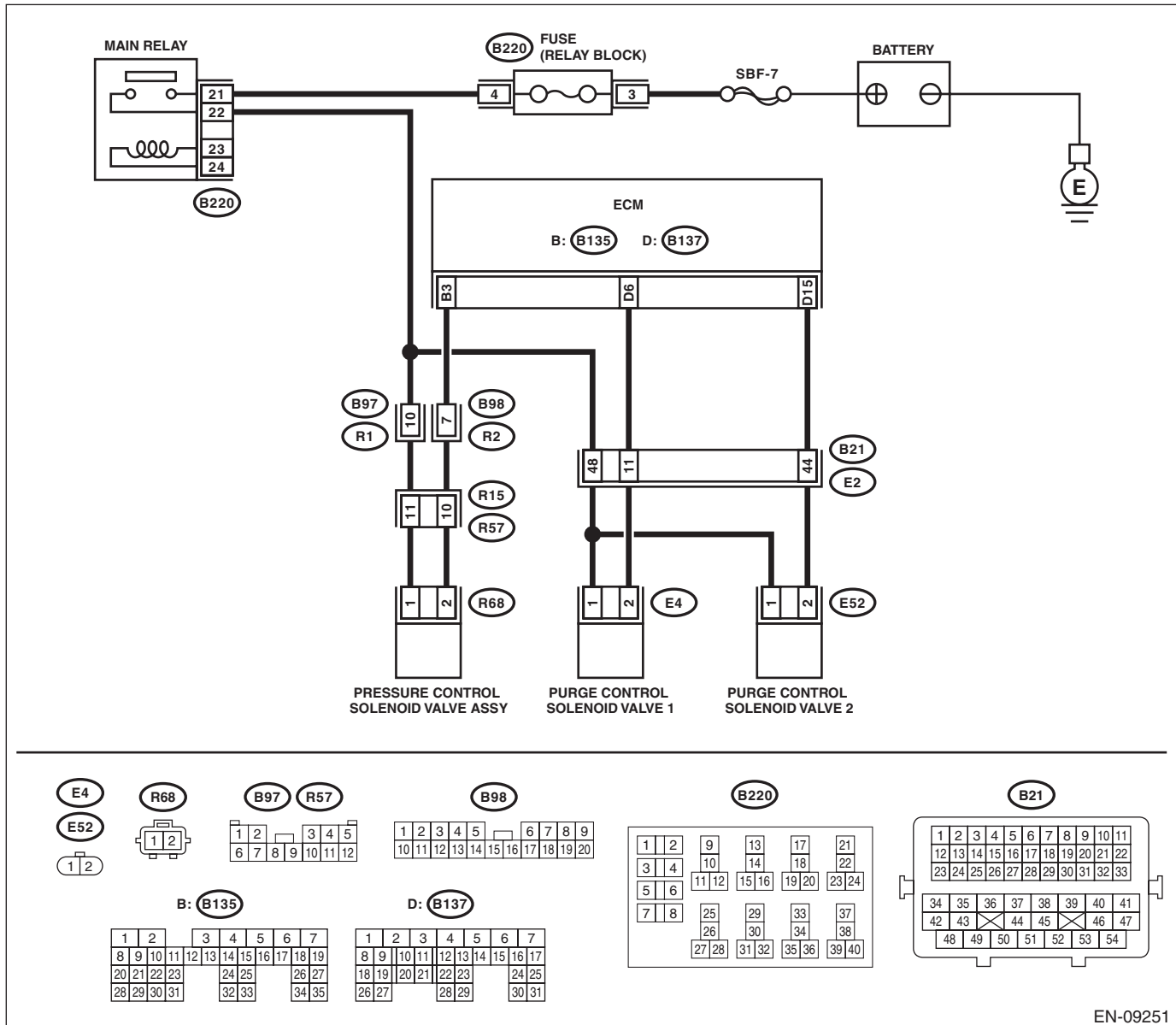

EN-09251



# Diagnostic Procedure with Diagnostic Trouble Code (DTC)

ENGINE (DIAGNOSTICS)

Step	Check	Yes	No
<p><b>1</b></p> <p><b>CHECK HARNESS BETWEEN ECM AND PRESSURE CONTROL SOLENOID VALVE ASSEMBLY CONNECTOR.</b></p> <p>1) Turn the ignition switch to OFF.                      2) Disconnect the connectors from the ECM and pressure control solenoid valve assembly.                      3) Turn the ignition switch to ON.                      4) Measure the voltage between ECM and chassis ground.</p> <p><b>Connector &amp; terminal</b>  <b>(B135) No. 3 (+) — Chassis ground (-):</b></p>	<p>Is the voltage 10 V or more?</p>	<p>Repair the harness between ECM and pressure control solenoid valve assembly connector for short-circuit to power supply.</p>	<p>Go to step 2.</p>
<p><b>2</b></p> <p><b>CHECK PRESSURE CONTROL SOLENOID VALVE ASSEMBLY.</b></p> <p>1) Turn the ignition switch to OFF.                      2) Measure the resistance between terminals of pressure control solenoid valve assembly.</p> <p><b>Terminals</b>  <b>No. 1 — No. 2:</b></p>	<p>Is the resistance less than 1 <math>\Omega</math>?</p>	<p>Replace the pressure control solenoid valve assembly. &lt;Ref. to EC(STI)-16, Pressure Control Solenoid Valve Assembly.&gt; &lt;Ref. to EC(w/o STI)-17, Pressure Control Solenoid Valve Assembly.&gt;</p>	<p>Repair the poor contact of ECM connector.</p>

# Diagnostic Procedure with Diagnostic Trouble Code (DTC)

ENGINE (DIAGNOSTICS)

## DD:DTC P1449 EVAPORATIVE EMISSION CONT. SYS. AIR FILTER CLOG

### DTC DETECTING CONDITION:

- Detected when two consecutive driving cycles with fault occur.
- GENERAL DESCRIPTION <Ref. to GD(H4DOTC)-204, DTC P1449 EVAPORATIVE EMISSION CONT. SYS. AIR FILTER CLOG, Diagnostic Trouble Code (DTC) Detecting Criteria.>

### CAUTION:

After servicing or replacing faulty parts, perform Clear Memory Mode <Ref. to EN(H4DOTC)(diag)-62, OPERATION, Clear Memory Mode.>, and Inspection Mode <Ref. to EN(H4DOTC)(diag)-48, PROCEDURE, Inspection Mode.>.

Step	Check	Yes	No
1 <b>CHECK FOR ANY OTHER DTC ON DISPLAY.</b>	Is any other DTC displayed?	Check the appropriate DTC using the "List of Diagnostic Trouble Code (DTC)". <Ref. to EN(H4DOTC)(diag)-88, List of Diagnostic Trouble Code (DTC).>	Go to step 2.
2 <b>CHECK DRAIN TUBE OF LEAK CHECK VALVE ASSEMBLY.</b>	Is the drain tube of leak check valve assembly clogged?	Replace the drain tube of leak check valve assembly. <Ref. to EC(STI)-19, Leak Check Valve Assembly.> <Ref. to EC(w/o STI)-20, Leak Check Valve Assembly.>	Go to step 3.
3 <b>CHECK HOSES BETWEEN LEAK CHECK VALVE ASSEMBLY AND DRAIN SEPARATOR.</b>	Are the hoses between the leak check valve assembly and drain separator clogged?	Replace the leak check valve assembly and drain separator. <Ref. to EC(STI)-7, Canister.> <Ref. to EC(w/o STI)-7, Canister.> <Ref. to EC(STI)-23, Drain Separator.> <Ref. to EC(w/o STI)-24, Drain Separator.>	Go to step 4.
4 <b>CHECK DRAIN SEPARATOR.</b>	Is the drain separator clogged?	Replace the drain separator. <Ref. to EC(STI)-23, Drain Separator.> <Ref. to EC(w/o STI)-24, Drain Separator.>	Replace the leak check valve assembly. <Ref. to EC(STI)-19, Leak Check Valve Assembly.> <Ref. to EC(w/o STI)-20, Leak Check Valve Assembly.>

# Diagnostic Procedure with Diagnostic Trouble Code (DTC)

ENGINE (DIAGNOSTICS)

## DE:DTC P1451 EVAPORATIVE EMISSION CONT. SYS.

### DTC DETECTING CONDITION:

- Detected when two consecutive driving cycles with fault occur.
- GENERAL DESCRIPTION <Ref. to GD(H4DOTC)-206, DTC P1451 EVAPORATIVE EMISSION CONT. SYS., Diagnostic Trouble Code (DTC) Detecting Criteria.>

### CAUTION:

After servicing or replacing faulty parts, perform Clear Memory Mode <Ref. to EN(H4DOTC)(diag)-62, OPERATION, Clear Memory Mode.>, and Inspection Mode <Ref. to EN(H4DOTC)(diag)-48, PROCEDURE, Inspection Mode.>.

Step	Check	Yes	No
1 <b>CHECK DRAIN TUBE BETWEEN CANISTER AND LEAK CHECK VALVE ASSEMBLY.</b>	Is the drain tube between canister and leak check valve assembly clogged?	Replace the drain tube between the canister and leak check valve assembly. <Ref. to EC(STI)-7, Canister.> <Ref. to EC(w/o STI)-7, Canister.>	Go to step 2.
2 <b>CHECK HOSES BETWEEN CANISTER AND FUEL TANK.</b>	Are the hoses between the canister and fuel tank clogged?	Replace the hoses between the canister and fuel tank. <Ref. to EC(STI)-7, Canister.> <Ref. to EC(w/o STI)-7, Canister.> <Ref. to FU(STI)-70, Fuel Tank.> <Ref. to FU(w/o STI)-69, Fuel Tank.>	Replace the canister. <Ref. to EC(STI)-7, Canister.> <Ref. to EC(w/o STI)-7, Canister.> After the operation is complete, go to the next step. Go to step 3.
3 <b>CHECK EVAPORATIVE EMISSION CONTROL SYSTEM.</b> Perform drive cycle I. <Ref. to EN(H4DOTC)(diag)-58, DRIVE CYCLE H, PROCEDURE, Drive Cycle.>	Is DTC P1451 displayed on the display?	Replace the leak check valve assembly. <Ref. to EC(STI)-19, Leak Check Valve Assembly.> <Ref. to EC(w/o STI)-20, Leak Check Valve Assembly.>	End.

# Diagnostic Procedure with Diagnostic Trouble Code (DTC)

ENGINE (DIAGNOSTICS)

## DF:DTC P1458 CANISTER PURGE CONTROL SOLENOID VALVE 2

### DTC DETECTING CONDITION:

- Detected when two consecutive driving cycles with fault occur.
- GENERAL DESCRIPTION <Ref. to GD(H4DOTC)-207, DTC P1458 CANISTER PURGE CONTROL SOLENOID VALVE 2, Diagnostic Trouble Code (DTC) Detecting Criteria.>

### TROUBLE SYMPTOM:

Improper idling

### CAUTION:

After servicing or replacing faulty parts, perform Clear Memory Mode <Ref. to EN(H4DOTC)(diag)-62, OPERATION, Clear Memory Mode.>, and Inspection Mode <Ref. to EN(H4DOTC)(diag)-48, PROCEDURE, Inspection Mode.>.

### WIRING DIAGRAM:

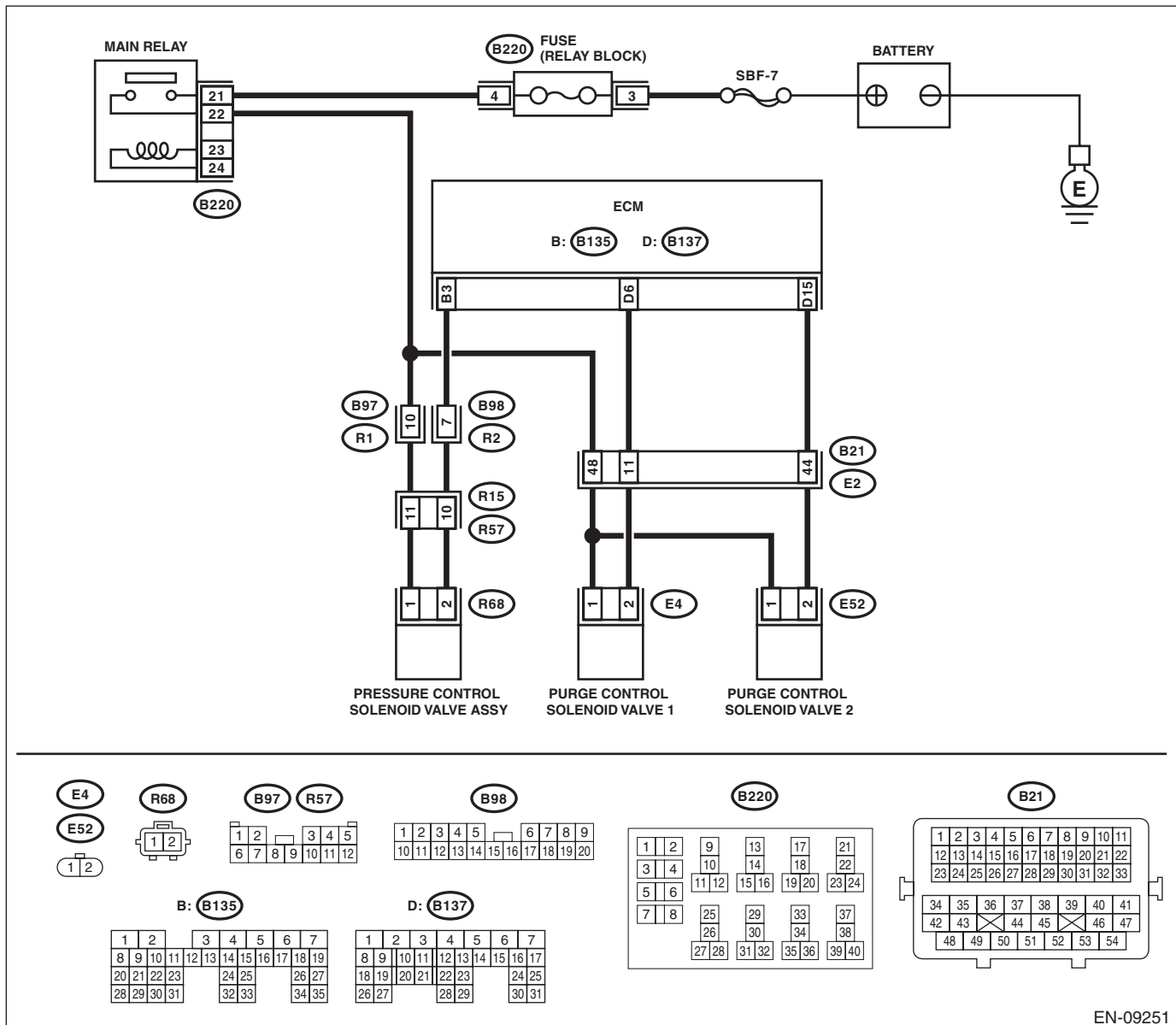

EN-09251

# Diagnostic Procedure with Diagnostic Trouble Code (DTC)

## ENGINE (DIAGNOSTICS)

Step	Check	Yes	No
<b>1 CHECK OUTPUT SIGNAL OF ECM.</b> 1) Turn the ignition switch to ON. 2) Measure the voltage between ECM and chassis ground. <b>Connector &amp; terminal</b> <b>(B137) No. 15 (+) — Chassis ground (-):</b>	Is the voltage 10 V or more?	Go to step 2.	Go to step 3.
<b>2 CHECK FOR POOR CONTACT.</b> Check for poor contact of ECM connector.	Is there poor contact of ECM connector?	Repair the poor contact of ECM connector.	Even if DTC is detected, the circuit has returned to a normal condition at this time. Reproduce the failure, and then perform the diagnosis again. <b>NOTE:</b> In this case, temporary open or short circuit of harness or temporary poor contact of connector may be the cause.
<b>3 CHECK POWER SUPPLY TO PURGE CONTROL SOLENOID VALVE 2 CONNECTOR.</b> Measure the voltage between purge control solenoid valve 2 connector and engine ground. <b>Connector &amp; terminal</b> <b>(E52) No. 1 (+) — Engine ground (-):</b>	Is the voltage 10 V or more?	Go to step 4.	Repair the power supply circuit.
<b>4 CHECK HARNESS BETWEEN ECM AND PURGE CONTROL SOLENOID VALVE 2 CONNECTOR.</b> 1) Turn the ignition switch to OFF. 2) Disconnect the connectors from ECM and purge control solenoid valve 2. 3) Measure the resistance between the purge control solenoid valve 2 connector and engine ground. <b>Connector &amp; terminal</b> <b>(E52) No. 2 — Engine ground:</b>	Is the resistance 1 M $\Omega$ or more?	Go to step 5.	Repair the ground short circuit of harness between ECM and purge control solenoid valve 2 connector.
<b>5 CHECK HARNESS BETWEEN ECM AND PURGE CONTROL SOLENOID VALVE 2 CONNECTOR.</b> Measure the resistance of harness between ECM and purge control solenoid valve 2 connector. <b>Connector &amp; terminal</b> <b>(B137) No. 15 — (E52) No. 2:</b>	Is the resistance less than 1 $\Omega$ ?	Go to step 6.	Repair the harness and connector. <b>NOTE:</b> In this case, repair the following item: <ul style="list-style-type: none"> <li>• Open circuit of harness between ECM and purge control solenoid valve 2 connector</li> <li>• Poor contact of coupling connector</li> </ul>

# Diagnostic Procedure with Diagnostic Trouble Code (DTC)

ENGINE (DIAGNOSTICS)

Step	Check	Yes	No
<b>6</b> <b>CHECK PURGE CONTROL SOLENOID VALVE 2.</b> 1) Remove the purge control solenoid valve 2. 2) Measure the resistance between purge control solenoid valve 2 terminals. <b>Terminals</b> <b>No. 1 — No. 2:</b>	Is the resistance 10 — 100 $\Omega$ ?	Repair the poor contact of the purge control solenoid valve 2 connector.	Replace the purge control solenoid valve 2. <Ref. to EC(STI)-11, Purge Control Solenoid Valve.> <Ref. to EC(w/o STI)-11, Purge Control Solenoid Valve.>

# Diagnostic Procedure with Diagnostic Trouble Code (DTC)

ENGINE (DIAGNOSTICS)

## DG:DTC P1459 CANISTER PURGE CONTROL SOLENOID VALVE 2

### DTC DETECTING CONDITION:

- Detected when two consecutive driving cycles with fault occur.
- GENERAL DESCRIPTION <Ref. to GD(H4DOTC)-208, DTC P1459 CANISTER PURGE CONTROL SOLENOID VALVE 2, Diagnostic Trouble Code (DTC) Detecting Criteria.>

### TROUBLE SYMPTOM:

Improper idling

### CAUTION:

After servicing or replacing faulty parts, perform Clear Memory Mode <Ref. to EN(H4DOTC)(diag)-62, OPERATION, Clear Memory Mode.>, and Inspection Mode <Ref. to EN(H4DOTC)(diag)-48, PROCEDURE, Inspection Mode.>.

### WIRING DIAGRAM:

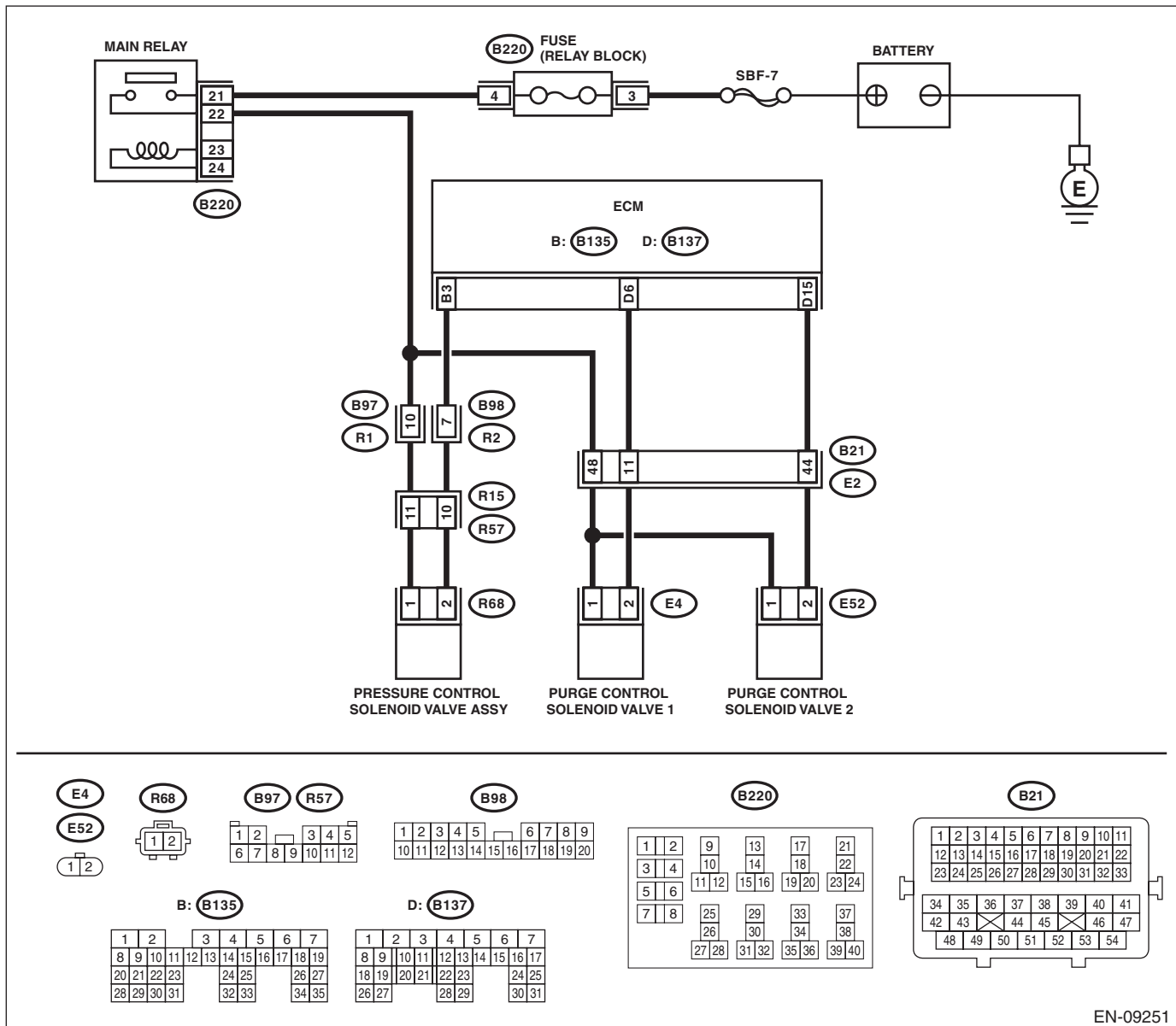

EN-09251

# Diagnostic Procedure with Diagnostic Trouble Code (DTC)

ENGINE (DIAGNOSTICS)

	Step	Check	Yes	No
1	<b>CHECK HARNESS BETWEEN ECM AND PURGE CONTROL SOLENOID VALVE 2 CONNECTOR.</b> 1) Turn the ignition switch to OFF. 2) Disconnect the connectors from ECM and purge control solenoid valve 2. 3) Turn the ignition switch to ON. 4) Measure the voltage between ECM and chassis ground. <b>Connector &amp; terminal</b> <b>(B137) No. 15 (+) — Chassis ground (-):</b>	Is the voltage 10 V or more?	Repair the short to power in the harness between ECM and purge control solenoid valve 2 connector.	Go to step 2.
2	<b>CHECK PURGE CONTROL SOLENOID VALVE 2.</b> 1) Turn the ignition switch to OFF. 2) Measure the resistance between purge control solenoid valve 2 terminals. <b>Terminals</b> <b>No. 1 — No. 2:</b>	Is the resistance less than 1 $\Omega$ ?	Replace the purge control solenoid valve 2. <Ref. to EC(STI)-11, Purge Control Solenoid Valve.> <Ref. to EC(w/o STI)-11, Purge Control Solenoid Valve.>	Repair the poor contact of ECM connector.



# Diagnostic Procedure with Diagnostic Trouble Code (DTC)

ENGINE (DIAGNOSTICS)

## DH:DTC P1491 POSITIVE CRANKCASE VENTILATION (BLOW-BY) FUNCTION PROBLEM

### DTC DETECTING CONDITION:

- Immediately at fault recognition
- GENERAL DESCRIPTION <Ref. to GD(H4DOTC)-209, DTC P1491 POSITIVE CRANKCASE VENTILATION (BLOW-BY) FUNCTION PROBLEM, Diagnostic Trouble Code (DTC) Detecting Criteria.>

### TROUBLE SYMPTOM:

Improper idling

### CAUTION:

After servicing or replacing faulty parts, perform Clear Memory Mode <Ref. to EN(H4DOTC)(diag)-62, OPERATION, Clear Memory Mode.>, and Inspection Mode <Ref. to EN(H4DOTC)(diag)-48, PROCEDURE, Inspection Mode.>.

### WIRING DIAGRAM:

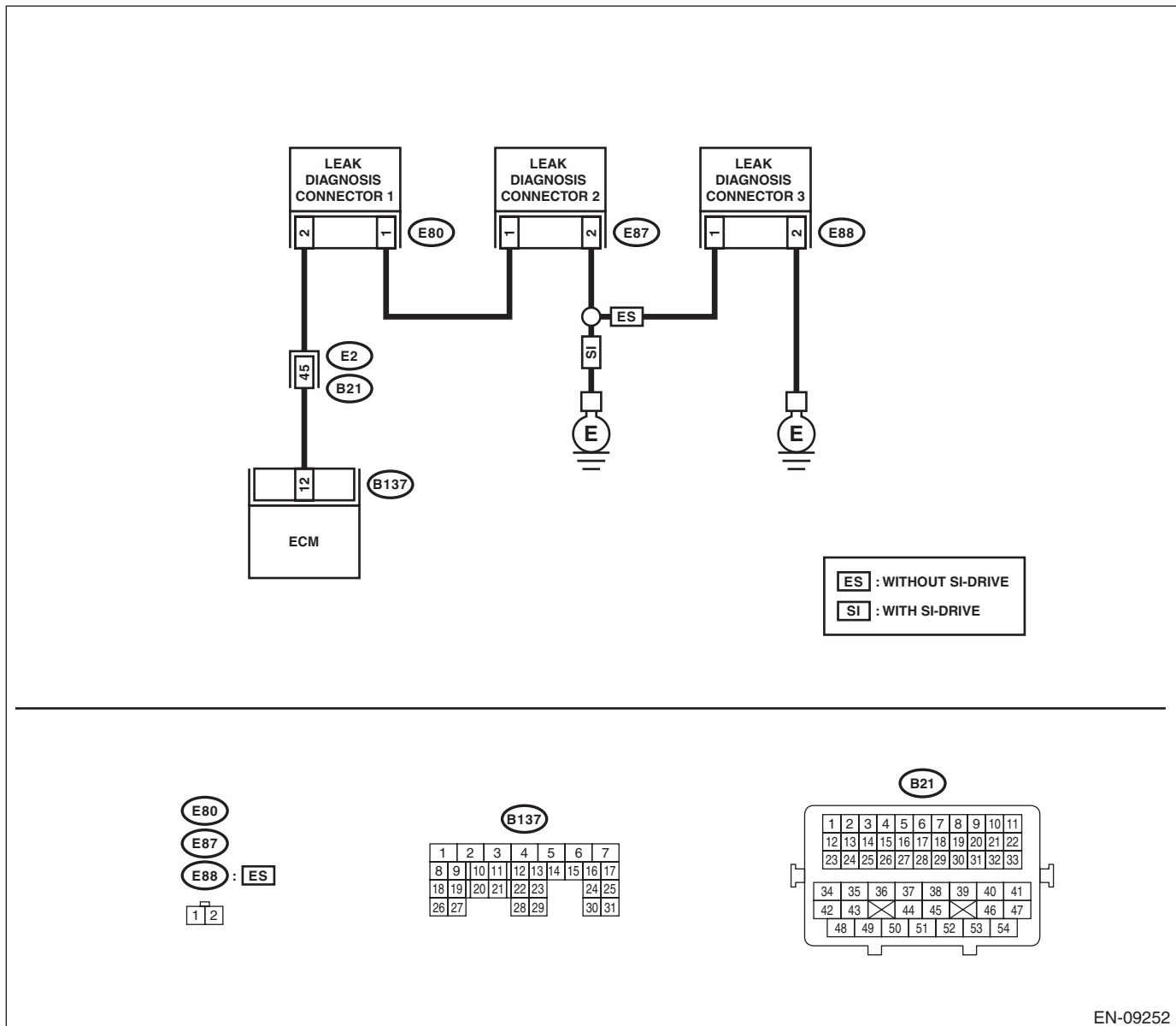

EN-09252

Step	Check	Yes	No	
1	<b>CHECK BLOW-BY HOSE.</b> Check the blow-by hose condition.	Is there any disconnection or crack in blow-by hose?	Repair or replace the blow-by hose.	Go to step 2.

# Diagnostic Procedure with Diagnostic Trouble Code (DTC)

ENGINE (DIAGNOSTICS)

Step	Check	Yes	No
<p><b>2</b></p> <p><b>CHECK HARNESS BETWEEN ECM AND PCV HOSE ASSEMBLY CONNECTOR.</b>                      1) Turn the ignition switch to OFF.                      2) Disconnect the connectors from the ECM and PCV hose assembly.                      3) Measure the resistance of harness between ECM and PCV hose assembly connector.  <i>Connector &amp; terminal</i>  <i>(B137) No. 12 — (E80) No. 2:</i></p>	Is the resistance less than 1 Ω?	Go to step 3.	Repair the harness and connector. NOTE: In this case, repair the following item: • Open circuit in harness between ECM and PCV hose assembly connector • Poor contact of coupling connector
<p><b>3</b></p> <p><b>CHECK HARNESS BETWEEN ECM AND PCV HOSE ASSEMBLY CONNECTOR.</b>                      Measure the resistance between PCV hose assembly connector and chassis ground.  <i>Connector &amp; terminal</i>  <i>(B137) No. 12 — Chassis ground:</i></p>	Is the resistance 1 MΩ or more?	Go to step 4.	Repair the short circuit to ground in harness between ECM and PCV hose assembly connector.
<p><b>4</b></p> <p><b>CHECK HARNESS BETWEEN LEAK DIAGNOSIS CONNECTORS.</b>                      Measure the resistance of harness between leak diagnosis connectors.  <i>Connector &amp; terminal</i>  <i>Models without SI-DRIVE</i>  <i>(B80) No. 1 — (B87) No. 1:</i>  <i>(B87) No. 2 — (B88) No. 1:</i>  <i>Models with SI-DRIVE</i>  <i>(B80) No. 1 — (B87) No. 1:</i></p>	Is the resistance less than 1 Ω?	Go to step 5.	Repair the open circuit in the wiring harness between leak diagnosis connectors.
<p><b>5</b></p> <p><b>CHECK GROUND CIRCUIT OF PCV HOSE ASSEMBLY.</b>                      Measure the resistance of harness between PCV hose assembly connector and engine ground.  <i>Connector &amp; terminal</i>  <i>Models without SI-DRIVE</i>  <i>(B88) No. 2 — Engine ground:</i>  <i>Models with SI-DRIVE</i>  <i>(B87) No. 2 — Engine ground:</i></p>	Is the resistance less than 5 Ω?	Go to step 6.	Repair the open circuit in harness between PCV hose assembly connector and engine ground.
<p><b>6</b></p> <p><b>CHECK PCV HOSE ASSEMBLY.</b>                      Measure the resistance between terminals of each leak diagnosis connector.  <i>Terminals</i>  <i>No. 1 — No. 2:</i></p>	Is the resistance less than 1 Ω at all measurement?	Repair the poor contact of ECM and PCV hose assembly connector.	Replace the PCV hose assembly. <Ref. to EC(STI)-24, PCV Hose Assembly.> <Ref. to EC(w/o STI)-25, PCV Hose Assembly.>

# Diagnostic Procedure with Diagnostic Trouble Code (DTC)

ENGINE (DIAGNOSTICS)

## DI: DTC P1518 STARTER SWITCH CIRCUIT LOW INPUT

### DTC DETECTING CONDITION:

- Immediately at fault recognition
- GENERAL DESCRIPTION <Ref. to GD(H4DOTC)-211, DTC P1518 STARTER SWITCH CIRCUIT LOW INPUT, Diagnostic Trouble Code (DTC) Detecting Criteria.>

### TROUBLE SYMPTOM:

Failure of engine to start

### CAUTION:

After servicing or replacing faulty parts, perform Clear Memory Mode <Ref. to EN(H4DOTC)(diag)-62, OPERATION, Clear Memory Mode.>, and Inspection Mode <Ref. to EN(H4DOTC)(diag)-48, PROCEDURE, Inspection Mode.>.

### WIRING DIAGRAM:

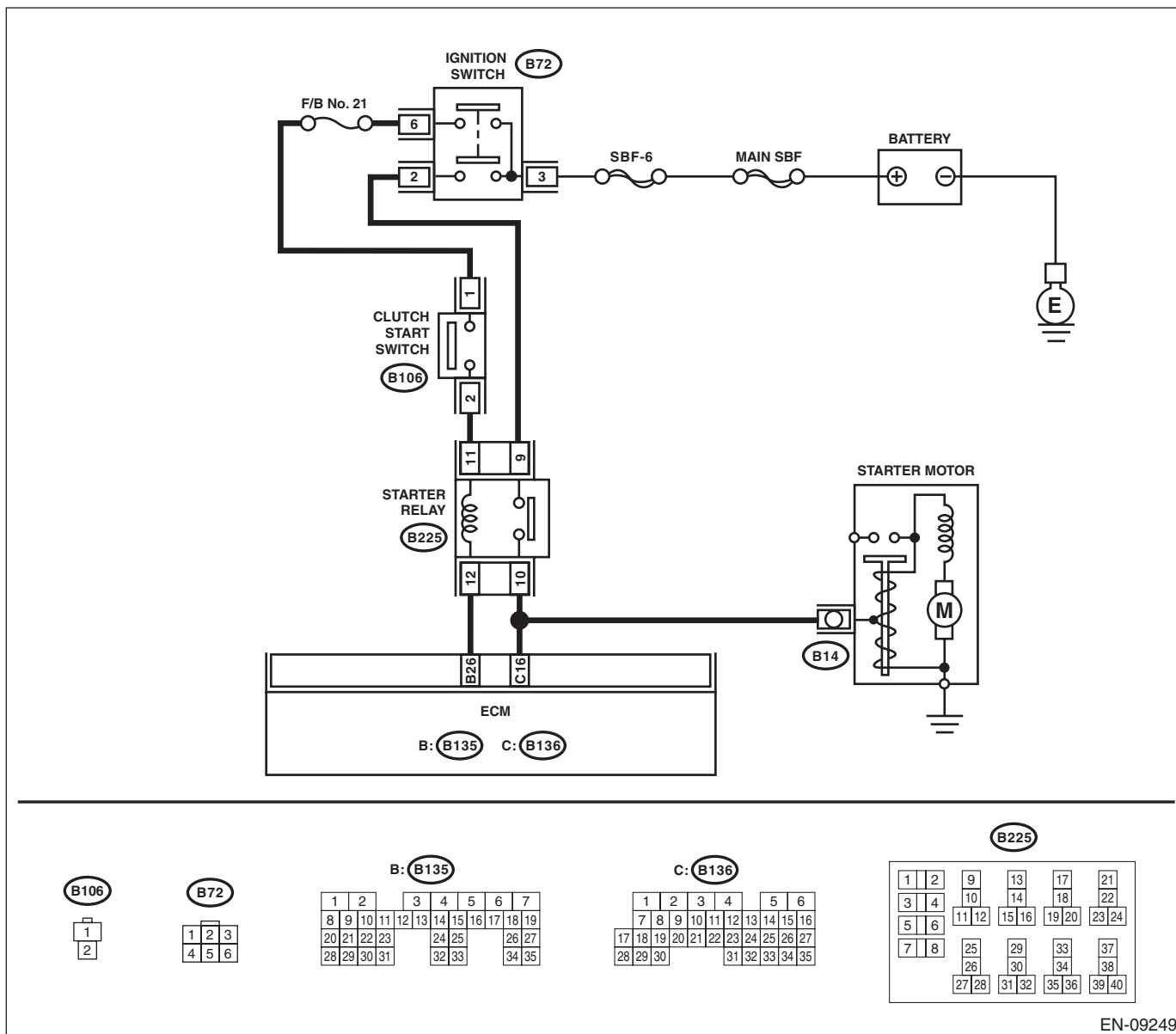

EN-09249

# Diagnostic Procedure with Diagnostic Trouble Code (DTC)

ENGINE (DIAGNOSTICS)

	Step	Check	Yes	No
1	<b>CHECK FOR ANY OTHER DTC ON DISPLAY.</b>	Is any other DTC displayed?	Check DTC using "List of Diagnostic Trouble Code (DTC)". <Ref. to EN(H4DOTC)(diag)-88, List of Diagnostic Trouble Code (DTC).>	Go to step 2.
2	<b>CHECK HARNESS BETWEEN ECM AND STARTER RELAY CONNECTOR.</b> 1) Turn the ignition switch to OFF. 2) Disconnect the connectors from ECM and starter motor. 3) Remove the starter relay. 4) Measure the resistance of harness between ECM and starter relay connector. <b>Connector &amp; terminal</b> <b>(B136) No. 16 — (B225) No. 10:</b>	Is the resistance less than 1 Ω?	Go to step 3.	Repair the open circuit of harness between ECM and starter relay connector.
3	<b>CHECK HARNESS BETWEEN ECM AND STARTER RELAY CONNECTOR.</b> Measure the resistance between ECM and chassis ground. <b>Connector &amp; terminal</b> <b>(B136) No. 16 — Chassis ground:</b>	Is the resistance 1 MΩ or more?	Repair the poor contact of ECM connector.	Repair the short circuit to ground in harness between ECM and starter relay connector.

# Diagnostic Procedure with Diagnostic Trouble Code (DTC)

ENGINE (DIAGNOSTICS)

## DJ:DTC P1560 BACK-UP VOLTAGE CIRCUIT MALFUNCTION

### DTC DETECTING CONDITION:

- Immediately at fault recognition
- GENERAL DESCRIPTION <Ref. to GD(H4DOTC)-212, DTC P1560 BACK-UP VOLTAGE CIRCUIT MALFUNCTION, Diagnostic Trouble Code (DTC) Detecting Criteria.>

### CAUTION:

After servicing or replacing faulty parts, perform Clear Memory Mode <Ref. to EN(H4DOTC)(diag)-62, OPERATION, Clear Memory Mode.>, and Inspection Mode <Ref. to EN(H4DOTC)(diag)-48, PROCEDURE, Inspection Mode.>.

### WIRING DIAGRAM:

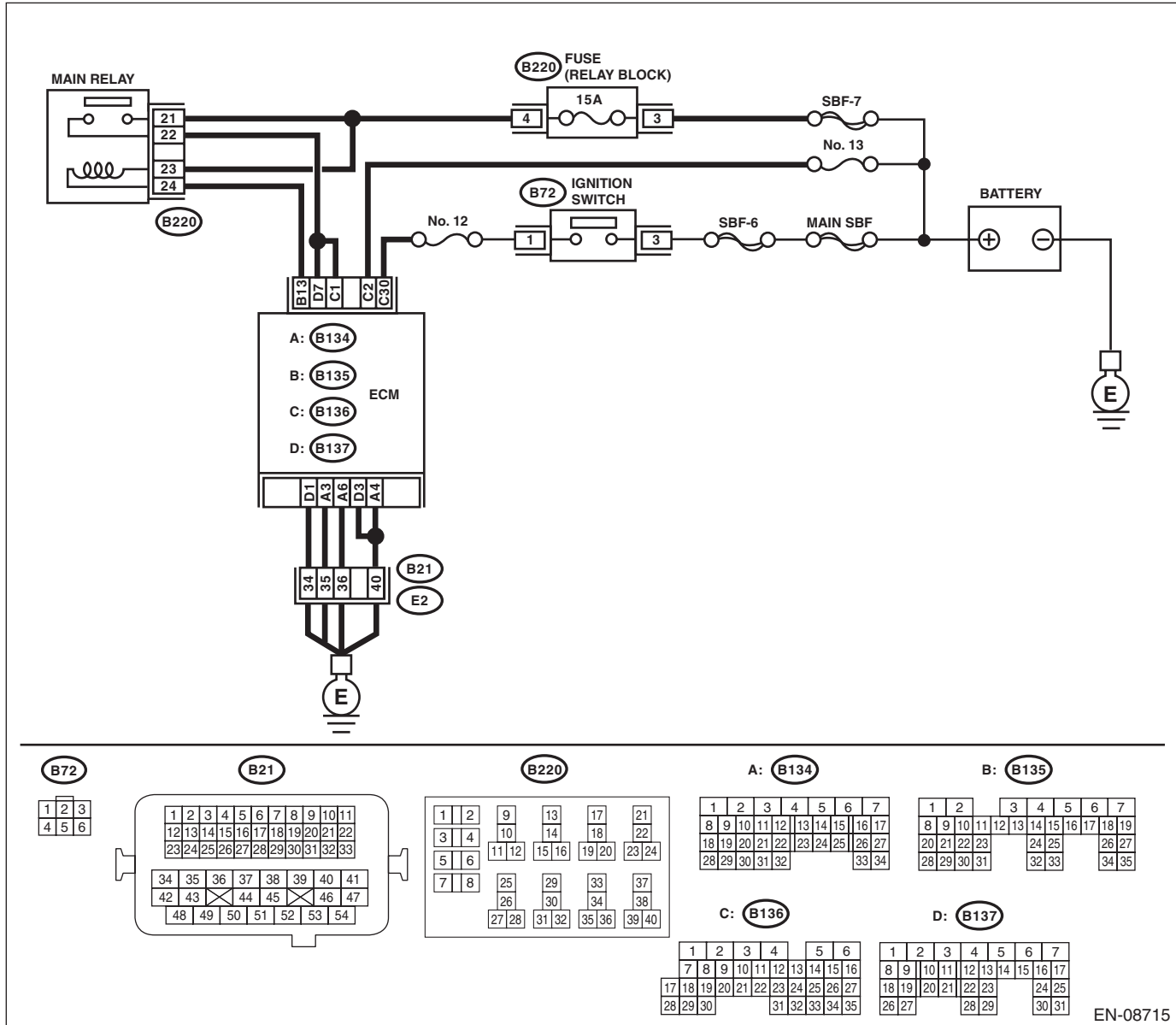

EN-08715

Step	Check	Yes	No
<b>1</b> <b>CHECK INPUT SIGNAL OF ECM.</b> 1) Turn the ignition switch to OFF. 2) Measure the voltage between ECM and chassis ground. <i>Connector &amp; terminal</i> <i>(B136) No. 2 (+) — Chassis ground (-):</i>	Is the voltage 10 V or more?	Repair the poor contact of ECM connector.	Go to step 2.

# Diagnostic Procedure with Diagnostic Trouble Code (DTC)

ENGINE (DIAGNOSTICS)

Step	Check	Yes	No
<b>2</b> <b>CHECK HARNESS BETWEEN ECM AND MAIN FUSE BOX CONNECTOR.</b> 1) Disconnect the connector from ECM. 2) Measure the resistance between ECM and chassis ground. <b>Connector &amp; terminal</b> <b>(B136) No. 2 — Chassis ground:</b>	Is the resistance 1 M $\Omega$ or more?	Go to step 3.	Repair the ground short circuit of harness between ECM and battery terminal.
<b>3</b> <b>CHECK FUSE NO. 13.</b>	Is the fuse blown out?	Replace the fuse.	Repair the harness and connector. NOTE: In this case, repair the following item: <ul style="list-style-type: none"><li>• Open circuit in harness between ECM and battery</li><li>• Poor contact of ECM connector</li><li>• Poor contact of battery terminal</li></ul>

# Diagnostic Procedure with Diagnostic Trouble Code (DTC)

ENGINE (DIAGNOSTICS)

## DK:DTC P2004 INTAKE MANIFOLD RUNNER CONTROL STUCK OPEN (BANK 1)

### DTC DETECTING CONDITION:

- Immediately at fault recognition
- GENERAL DESCRIPTION <Ref. to GD(H4DOTC)-214, DTC P2004 INTAKE MANIFOLD RUNNER CONTROL STUCK OPEN (BANK 1), Diagnostic Trouble Code (DTC) Detecting Criteria.>

### CAUTION:

After servicing or replacing faulty parts, perform Clear Memory Mode <Ref. to EN(H4DOTC)(diag)-62, OPERATION, Clear Memory Mode.>, and Inspection Mode <Ref. to EN(H4DOTC)(diag)-48, PROCEDURE, Inspection Mode.>.

Step	Check	Yes	No
<b>1</b> <b>CHECK FOR ANY OTHER DTC ON DISPLAY.</b>	Is any other DTC displayed?	Check the appropriate DTC using the "List of Diagnostic Trouble Code (DTC)". <Ref. to EN(H4DOTC)(diag)-88, List of Diagnostic Trouble Code (DTC).>	Go to step 2.
<b>2</b> <b>CHECK TUMBLE GENERATOR VALVE RH.</b> 1) Remove the tumble generator valve assembly RH. 2) Check the tumble generator valve body.	Is there any dirt or clogging with foreign objects in the tumble generator valve?	Clean the tumble generator valve.	Replace the tumble generator valve assembly RH. <Ref. to FU(STI)-48, Tumble Generator Valve Assembly.> <Ref. to FU(w/o STI)-49, Tumble Generator Valve Assembly.>

# Diagnostic Procedure with Diagnostic Trouble Code (DTC)

ENGINE (DIAGNOSTICS)

## DL:DTC P2005 INTAKE MANIFOLD RUNNER CONTROL STUCK OPEN (BANK 2)

### DTC DETECTING CONDITION:

- Immediately at fault recognition
- GENERAL DESCRIPTION <Ref. to GD(H4DOTC)-215, DTC P2005 INTAKE MANIFOLD RUNNER CONTROL STUCK OPEN (BANK 2), Diagnostic Trouble Code (DTC) Detecting Criteria.>

### CAUTION:

After servicing or replacing faulty parts, perform Clear Memory Mode <Ref. to EN(H4DOTC)(diag)-62, OPERATION, Clear Memory Mode.>, and Inspection Mode <Ref. to EN(H4DOTC)(diag)-48, PROCEDURE, Inspection Mode.>.

Step	Check	Yes	No
<b>1</b> <b>CHECK FOR ANY OTHER DTC ON DISPLAY.</b>	Is any other DTC displayed?	Check the appropriate DTC using the "List of Diagnostic Trouble Code (DTC)". <Ref. to EN(H4DOTC)(diag)-88, List of Diagnostic Trouble Code (DTC).>	Go to step 2.
<b>2</b> <b>CHECK TUMBLE GENERATOR VALVE LH.</b> 1) Remove the tumble generator valve assembly LH. 2) Check the tumble generator valve body.	Is there any dirt or clogging with foreign objects in the tumble generator valve?	Clean the tumble generator valve.	Replace the tumble generator valve assembly LH. <Ref. to FU(STI)-48, Tumble Generator Valve Assembly.> <Ref. to FU(w/o STI)-49, Tumble Generator Valve Assembly.>



# Diagnostic Procedure with Diagnostic Trouble Code (DTC)

ENGINE (DIAGNOSTICS)

## DM:DTC P2006 INTAKE MANIFOLD RUNNER CONTROL STUCK CLOSED (BANK 1)

### DTC DETECTING CONDITION:

- Immediately at fault recognition
- GENERAL DESCRIPTION <Ref. to GD(H4DOTC)-216, DTC P2006 INTAKE MANIFOLD RUNNER CONTROL STUCK CLOSED (BANK 1), Diagnostic Trouble Code (DTC) Detecting Criteria.>

### CAUTION:

After servicing or replacing faulty parts, perform Clear Memory Mode <Ref. to EN(H4DOTC)(diag)-62, OPERATION, Clear Memory Mode.>, and Inspection Mode <Ref. to EN(H4DOTC)(diag)-48, PROCEDURE, Inspection Mode.>.

Step	Check	Yes	No
1 <b>CHECK FOR ANY OTHER DTC ON DISPLAY.</b>	Is any other DTC displayed?	Check the appropriate DTC using the "List of Diagnostic Trouble Code (DTC)". <Ref. to EN(H4DOTC)(diag)-88, List of Diagnostic Trouble Code (DTC).>	Go to step 2.
2 <b>CHECK TUMBLE GENERATOR VALVE RH.</b> 1) Remove the tumble generator valve assembly RH. 2) Check the tumble generator valve body.	Is there any dirt or clogging with foreign objects in the tumble generator valve?	Clean the tumble generator valve.	Replace the tumble generator valve assembly RH. <Ref. to FU(STI)-48, Tumble Generator Valve Assembly.> <Ref. to FU(w/o STI)-49, Tumble Generator Valve Assembly.>

# Diagnostic Procedure with Diagnostic Trouble Code (DTC)

ENGINE (DIAGNOSTICS)

## DN:DTC P2007 INTAKE MANIFOLD RUNNER CONTROL STUCK CLOSED (BANK 2)

### DTC DETECTING CONDITION:

- Immediately at fault recognition
- GENERAL DESCRIPTION <Ref. to GD(H4DOTC)-217, DTC P2007 INTAKE MANIFOLD RUNNER CONTROL STUCK CLOSED (BANK 2), Diagnostic Trouble Code (DTC) Detecting Criteria.>

### CAUTION:

After servicing or replacing faulty parts, perform Clear Memory Mode <Ref. to EN(H4DOTC)(diag)-62, OPERATION, Clear Memory Mode.>, and Inspection Mode <Ref. to EN(H4DOTC)(diag)-48, PROCEDURE, Inspection Mode.>.

Step	Check	Yes	No
1 <b>CHECK FOR ANY OTHER DTC ON DISPLAY.</b>	Is any other DTC displayed?	Check the appropriate DTC using the "List of Diagnostic Trouble Code (DTC)". <Ref. to EN(H4DOTC)(diag)-88, List of Diagnostic Trouble Code (DTC).>	Go to step 2.
2 <b>CHECK TUMBLE GENERATOR VALVE LH.</b> 1) Remove the tumble generator valve assembly LH. 2) Check the tumble generator valve body.	Is there any dirt or clogging with foreign objects in the tumble generator valve?	Clean the tumble generator valve.	Replace the tumble generator valve assembly LH. <Ref. to FU(STI)-48, Tumble Generator Valve Assembly.> <Ref. to FU(w/o STI)-49, Tumble Generator Valve Assembly.>

# Diagnostic Procedure with Diagnostic Trouble Code (DTC)

ENGINE (DIAGNOSTICS)

## DO:DTC P2008 INTAKE MANIFOLD RUNNER CONTROL CIRCUIT / OPEN (BANK 1)

### DTC DETECTING CONDITION:

- Immediately at fault recognition
- GENERAL DESCRIPTION <Ref. to GD(H4DOTC)-218, DTC P2008 INTAKE MANIFOLD RUNNER CONTROL CIRCUIT / OPEN (BANK 1), Diagnostic Trouble Code (DTC) Detecting Criteria.>

### CAUTION:

After servicing or replacing faulty parts, perform Clear Memory Mode <Ref. to EN(H4DOTC)(diag)-62, OPERATION, Clear Memory Mode.>, and Inspection Mode <Ref. to EN(H4DOTC)(diag)-48, PROCEDURE, Inspection Mode.>.

### WIRING DIAGRAM:

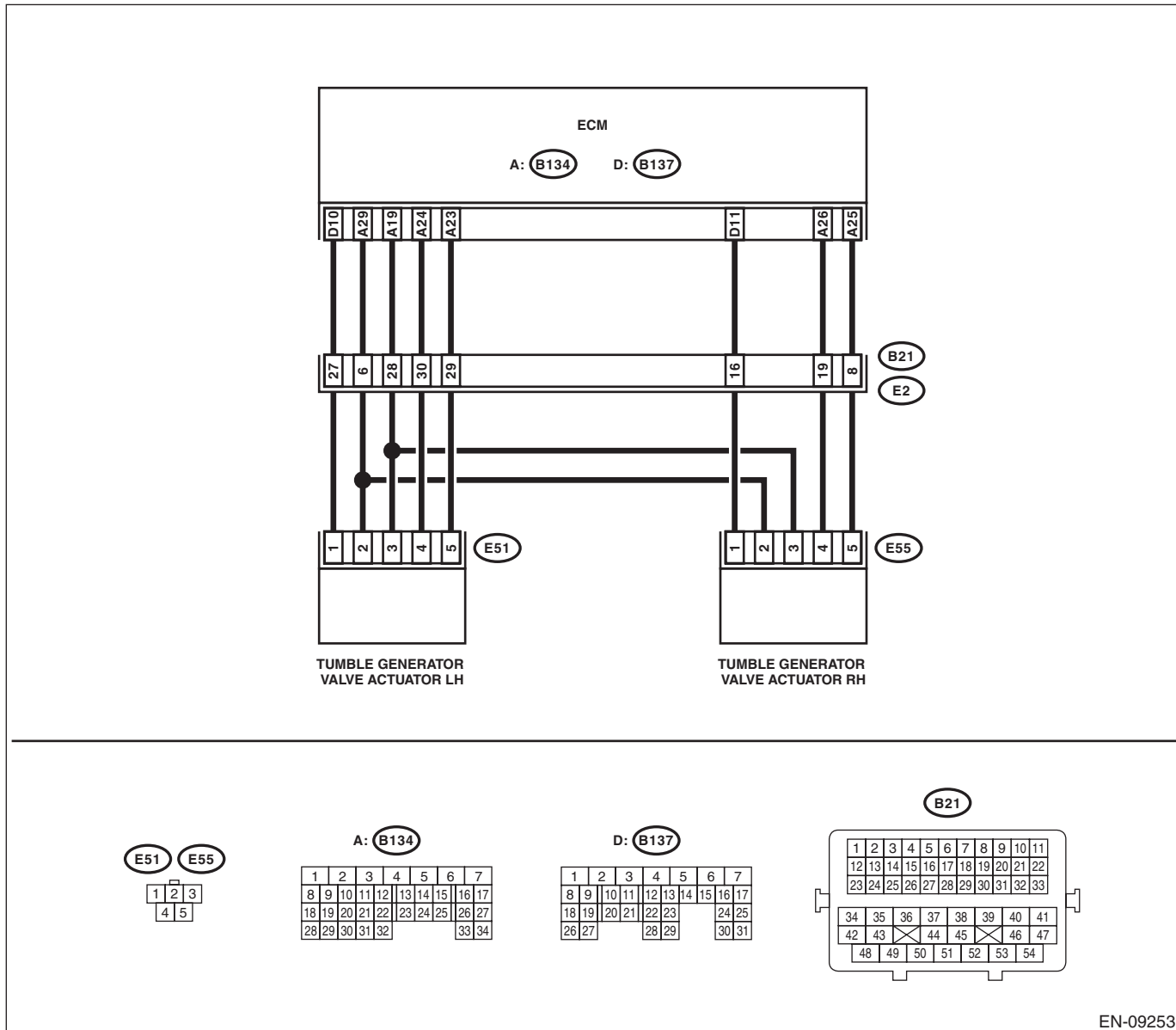

EN-09253

# Diagnostic Procedure with Diagnostic Trouble Code (DTC)

ENGINE (DIAGNOSTICS)

Step	Check	Yes	No
<b>1</b> <b>CHECK HARNESS BETWEEN ECM AND TUMBLE GENERATOR VALVE ASSEMBLY RH CONNECTOR.</b> 1) Turn the ignition switch to OFF. 2) Disconnect the connectors from the ECM and tumble generator valve assembly RH. 3) Measure the resistance of harness between ECM and tumble generator valve assembly RH. <b>Connector &amp; terminal</b> <b>(B134) No. 25 — (E55) No. 5:</b> <b>(B134) No. 26 — (E55) No. 4:</b>	Is the resistance less than 1 Ω?	Go to step 2.	Repair the harness and connector. NOTE: In this case, repair the following item: • Open circuit in harness between ECM and tumble generator valve assembly RH connector • Poor contact of coupling connector
<b>2</b> <b>CHECK HARNESS BETWEEN ECM AND TUMBLE GENERATOR VALVE ASSEMBLY RH CONNECTOR.</b> Measure the resistance between ECM and chassis ground. <b>Connector &amp; terminal</b> <b>(B134) No. 25 — Chassis ground:</b> <b>(B134) No. 26 — Chassis ground:</b>	Is the resistance 1 MΩ or more?	Go to step 3.	Repair the short circuit to ground in harness between ECM and tumble generator valve assembly RH connector.
<b>3</b> <b>CHECK FOR POOR CONTACT.</b> Check for poor contact of tumble generator valve assembly RH connector.	Is there poor contact of the tumble generator valve assembly RH connector?	Repair the poor contact of tumble generator valve assembly RH connector.	Replace the tumble generator valve assembly RH. <Ref. to FU(STI)-48, Tumble Generator Valve Assembly.> <Ref. to FU(w/o STI)-49, Tumble Generator Valve Assembly.>

# Diagnostic Procedure with Diagnostic Trouble Code (DTC)

ENGINE (DIAGNOSTICS)

## DP:DTC P2009 INTAKE MANIFOLD RUNNER CONTROL CIRCUIT LOW (BANK 1)

### DTC DETECTING CONDITION:

- Immediately at fault recognition
- GENERAL DESCRIPTION <Ref. to GD(H4DOTC)-220, DTC P2009 INTAKE MANIFOLD RUNNER CONTROL CIRCUIT LOW (BANK 1), Diagnostic Trouble Code (DTC) Detecting Criteria.>

### CAUTION:

After servicing or replacing faulty parts, perform Clear Memory Mode <Ref. to EN(H4DOTC)(diag)-62, OPERATION, Clear Memory Mode.>, and Inspection Mode <Ref. to EN(H4DOTC)(diag)-48, PROCEDURE, Inspection Mode.>.

### WIRING DIAGRAM:

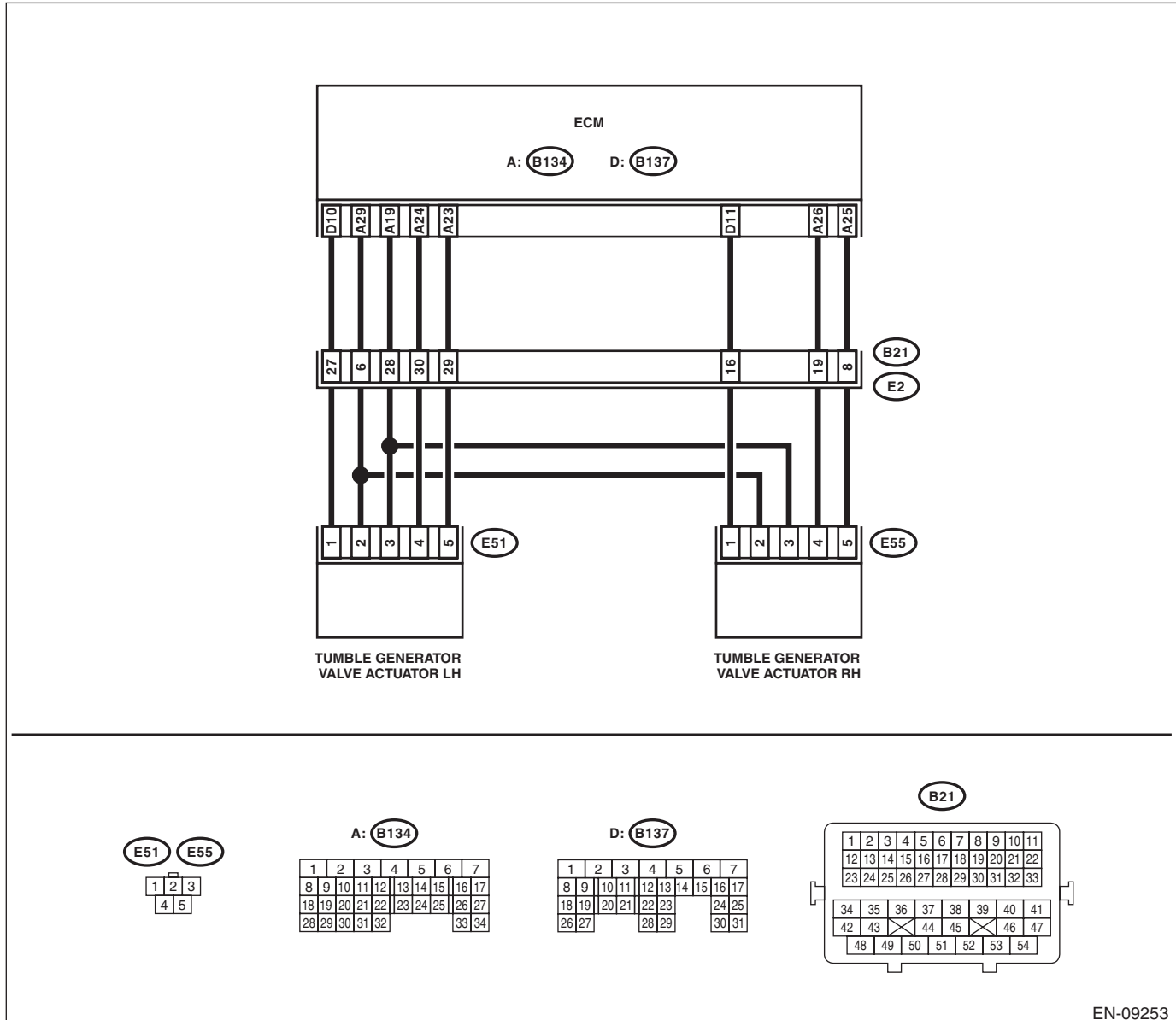

EN-09253

# Diagnostic Procedure with Diagnostic Trouble Code (DTC)

ENGINE (DIAGNOSTICS)

Step	Check	Yes	No
<p><b>1</b>    <b>CHECK HARNESS BETWEEN ECM AND TUMBLE GENERATOR VALVE ASSEMBLY RH CONNECTOR.</b></p> <p>1) Turn the ignition switch to OFF. 2) Disconnect the connector from ECM. 3) Measure the voltage between ECM and chassis ground.</p> <p><b>Connector &amp; terminal</b> <b>(B134) No. 25 (+) — Chassis ground (-):</b> <b>(B134) No. 26 (+) — Chassis ground (-):</b></p>	<p>Is the voltage 5 V or more?</p>	<p>Repair the short circuit to power in harness between ECM and tumble generator valve assembly RH connector.</p>	<p>Replace the tumble generator valve assembly RH. &lt;Ref. to FU(STI)-48, Tumble Generator Valve Assembly.&gt; &lt;Ref. to FU(w/o STI)-49, Tumble Generator Valve Assembly.&gt;</p>

# Diagnostic Procedure with Diagnostic Trouble Code (DTC)

ENGINE (DIAGNOSTICS)

## DQ:DTC P2011 INTAKE MANIFOLD RUNNER CONTROL CIRCUIT / OPEN (BANK 2)

### DTC DETECTING CONDITION:

- Immediately at fault recognition
- GENERAL DESCRIPTION <Ref. to GD(H4DOTC)-221, DTC P2011 INTAKE MANIFOLD RUNNER CONTROL CIRCUIT / OPEN (BANK 2), Diagnostic Trouble Code (DTC) Detecting Criteria.>

### CAUTION:

After servicing or replacing faulty parts, perform Clear Memory Mode <Ref. to EN(H4DOTC)(diag)-62, OPERATION, Clear Memory Mode.>, and Inspection Mode <Ref. to EN(H4DOTC)(diag)-48, PROCEDURE, Inspection Mode.>.

### WIRING DIAGRAM:

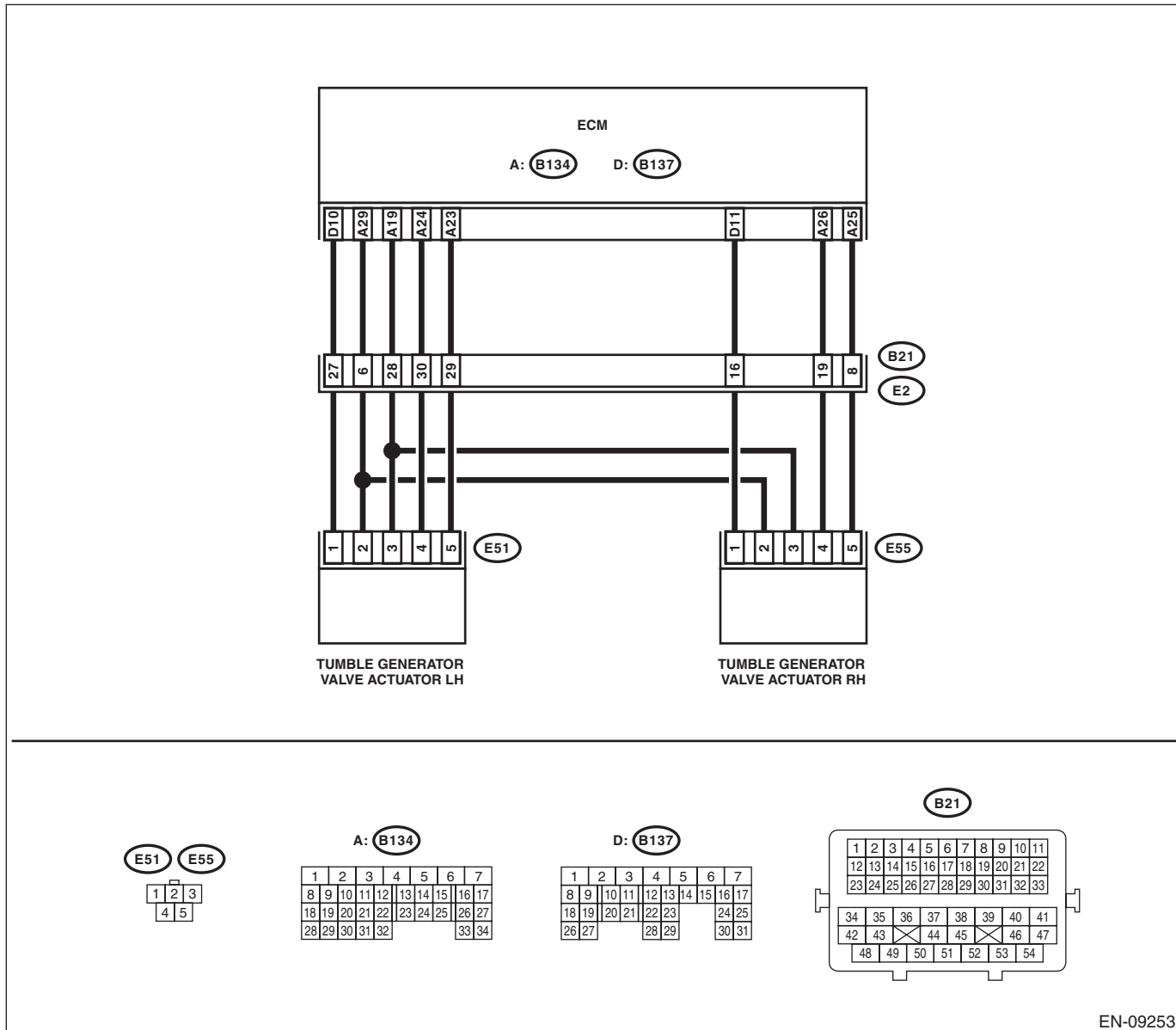

EN-09253

# Diagnostic Procedure with Diagnostic Trouble Code (DTC)

ENGINE (DIAGNOSTICS)

Step	Check	Yes	No
<b>1</b> <b>CHECK HARNESS BETWEEN ECM AND TUMBLE GENERATOR VALVE ASSEMBLY LH CONNECTOR.</b> 1) Turn the ignition switch to OFF. 2) Disconnect the connectors from ECM and tumble generator valve assembly LH. 3) Measure the resistance of harness between ECM and tumble generator valve assembly LH. <b>Connector &amp; terminal</b> <b>(B134) No. 23 — (E51) No. 5:</b> <b>(B134) No. 24 — (E51) No. 4:</b>	Is the resistance less than 1 Ω?	Go to step 2.	Repair the harness and connector. NOTE: In this case, repair the following item: • Open circuit in harness between ECM and tumble generator valve assembly LH connector • Poor contact of coupling connector
<b>2</b> <b>CHECK HARNESS BETWEEN ECM AND TUMBLE GENERATOR VALVE ASSEMBLY LH CONNECTOR.</b> Measure the resistance between ECM and chassis ground. <b>Connector &amp; terminal</b> <b>(B134) No. 23 — Chassis ground:</b> <b>(B134) No. 24 — Chassis ground:</b>	Is the resistance 1 MΩ or more?	Go to step 3.	Repair the short circuit to ground in harness between ECM and tumble generator valve assembly LH connector.
<b>3</b> <b>CHECK FOR POOR CONTACT.</b> Check for poor contact of tumble generator valve assembly LH connector.	Is there poor contact of the tumble generator valve assembly LH connector?	Repair the poor contact of tumble generator valve assembly LH connector.	Replace the tumble generator valve assembly LH. <Ref. to FU(STI)-48, Tumble Generator Valve Assembly.> <Ref. to FU(w/o STI)-49, Tumble Generator Valve Assembly.>



# Diagnostic Procedure with Diagnostic Trouble Code (DTC)

ENGINE (DIAGNOSTICS)

## DR:DTC P2012 INTAKE MANIFOLD RUNNER CONTROL CIRCUIT LOW (BANK 2)

### DTC DETECTING CONDITION:

- Immediately at fault recognition
- GENERAL DESCRIPTION <Ref. to GD(H4DOTC)-223, DTC P2012 INTAKE MANIFOLD RUNNER CONTROL CIRCUIT LOW (BANK 2), Diagnostic Trouble Code (DTC) Detecting Criteria.>

### CAUTION:

After servicing or replacing faulty parts, perform Clear Memory Mode <Ref. to EN(H4DOTC)(diag)-62, OPERATION, Clear Memory Mode.>, and Inspection Mode <Ref. to EN(H4DOTC)(diag)-48, PROCEDURE, Inspection Mode.>.

### WIRING DIAGRAM:

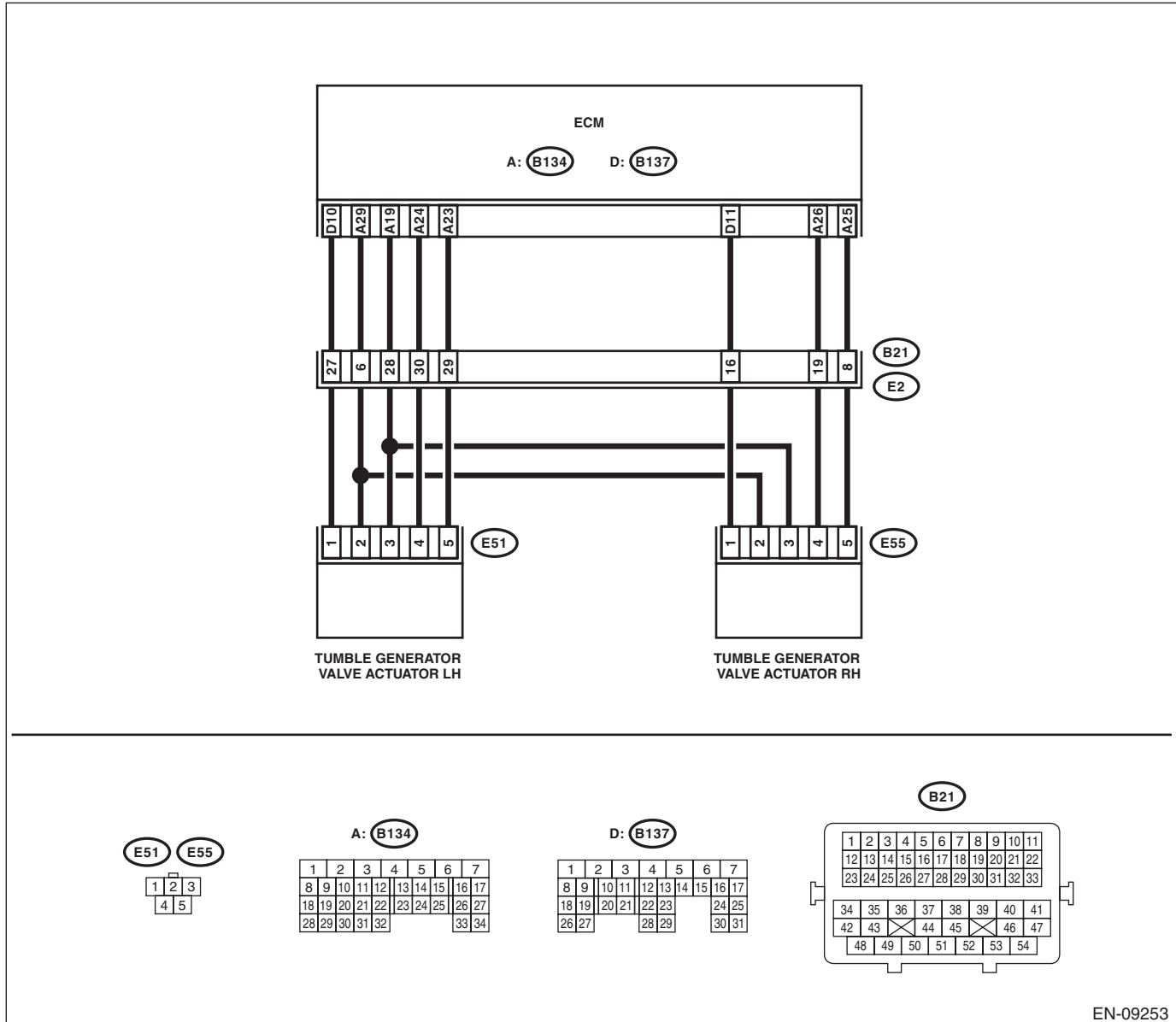

EN-09253

# Diagnostic Procedure with Diagnostic Trouble Code (DTC)

ENGINE (DIAGNOSTICS)

Step	Check	Yes	No
<p><b>1</b>    <b>CHECK HARNESS BETWEEN ECM AND TUMBLE GENERATOR VALVE ASSEMBLY LH CONNECTOR.</b></p> <p>1) Turn the ignition switch to OFF. 2) Disconnect the connector from ECM. 3) Measure the voltage between ECM and chassis ground.</p> <p><b>Connector &amp; terminal</b> <b>(B134) No. 23 (+) — Chassis ground (-):</b> <b>(B134) No. 24 (+) — Chassis ground (-):</b></p>	<p>Is the voltage 5 V or more?</p>	<p>Repair the short circuit to power in harness between ECM and tumble generator valve assembly LH connector.</p>	<p>Replace the tumble generator valve assembly LH. &lt;Ref. to FU(STI)-48, Tumble Generator Valve Assembly.&gt; &lt;Ref. to FU(w/o STI)-49, Tumble Generator Valve Assembly.&gt;</p>

# Diagnostic Procedure with Diagnostic Trouble Code (DTC)

ENGINE (DIAGNOSTICS)

## DS:DTC P2016 INTAKE MANIFOLD RUNNER POSITION SENSOR / SWITCH CIRCUIT LOW (BANK 1)

### DTC DETECTING CONDITION:

- Immediately at fault recognition
- GENERAL DESCRIPTION <Ref. to GD(H4DOTC)-224, DTC P2016 INTAKE MANIFOLD RUNNER POSITION SENSOR / SWITCH CIRCUIT LOW (BANK 1), Diagnostic Trouble Code (DTC) Detecting Criteria.>

### TROUBLE SYMPTOM:

- Improper idling
- Engine stalls.
- Poor driving performance

### CAUTION:

After servicing or replacing faulty parts, perform Clear Memory Mode <Ref. to EN(H4DOTC)(diag)-62, OPERATION, Clear Memory Mode.>, and Inspection Mode <Ref. to EN(H4DOTC)(diag)-48, PROCEDURE, Inspection Mode.>.

### WIRING DIAGRAM:

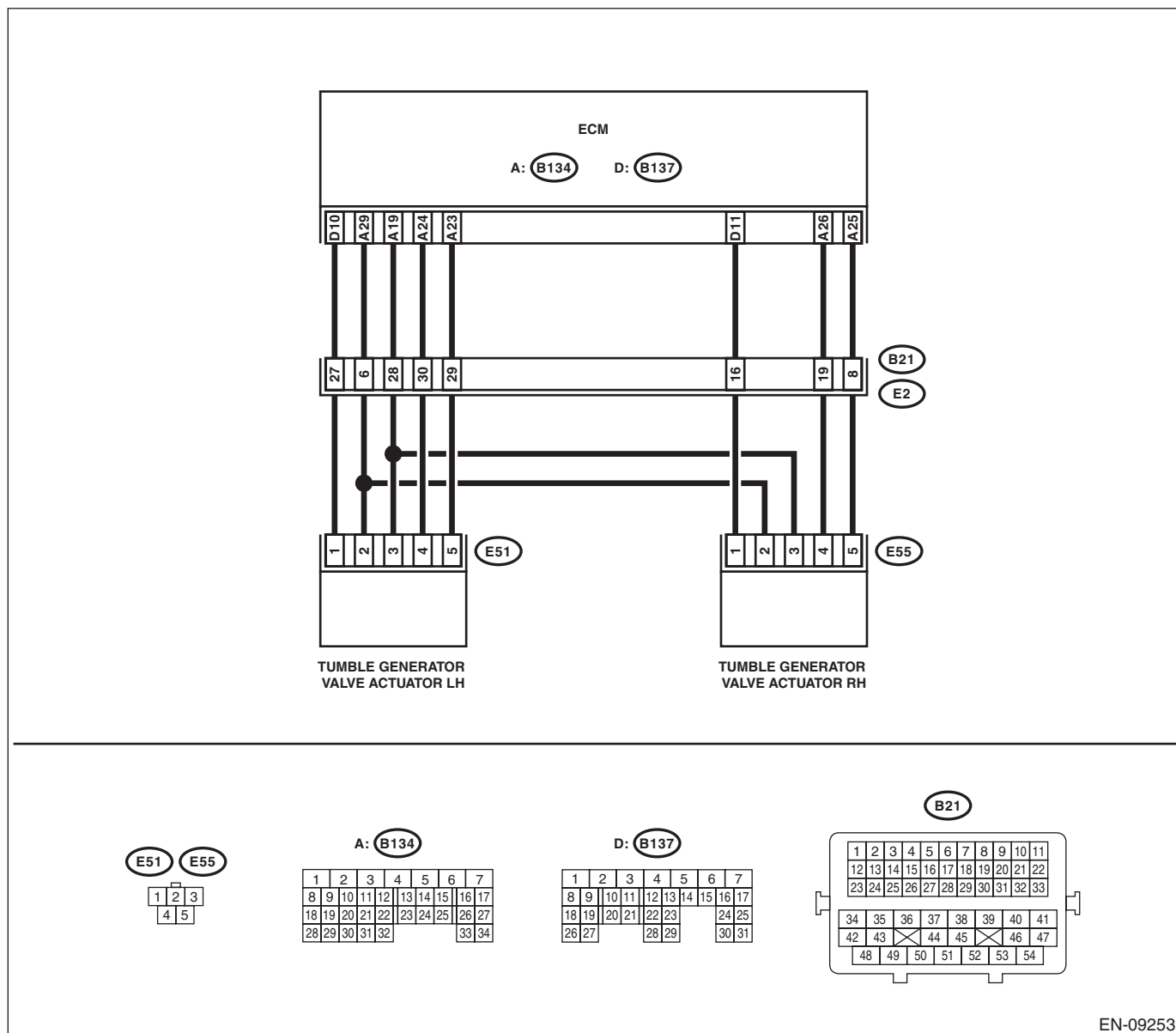

EN-09253

# Diagnostic Procedure with Diagnostic Trouble Code (DTC)

ENGINE (DIAGNOSTICS)

	Step	Check	Yes	No
1	<p><b>CHECK CURRENT DATA.</b></p> <p>1) Start the engine.</p> <p>2) Read the value of «TGV Position Sensor R» using the Subaru Select Monitor.</p> <p>NOTE: For detailed operation procedures, refer to "READ CURRENT DATA FOR ENGINE". &lt;Ref. to EN(H4DOTC)(diag)-40, Subaru Select Monitor.&gt;</p>	Is the value of «TGV Position Sensor R» less than 0.2 V?	Go to step 2.	<p>Even if DTC is detected, the circuit has returned to a normal condition at this time. Reproduce the failure, and then perform the diagnosis again.</p> <p>NOTE: In this case, temporary poor contact of connector, temporary open or short circuit of harness may be the cause.</p>
2	<p><b>CHECK POWER SUPPLY OF TUMBLE GENERATOR VALVE ASSEMBLY RH.</b></p> <p>1) Turn the ignition switch to OFF.</p> <p>2) Disconnect the connector from tumble generator valve assembly RH.</p> <p>3) Turn the ignition switch to ON.</p> <p>4) Measure the voltage between tumble generator valve assembly RH connector and engine ground.</p> <p><b>Connector &amp; terminal</b> <b>(E55) No. 3 (+) — Engine ground (-):</b></p>	Is the voltage 4.5 V or more?	Go to step 3.	<p>Repair the harness and connector.</p> <p>NOTE: In this case, repair the following item:</p> <ul style="list-style-type: none"> <li>• Open circuit in harness between ECM and tumble generator valve assembly RH connector</li> <li>• Poor contact of ECM connector</li> <li>• Poor contact of coupling connector</li> </ul>
3	<p><b>CHECK HARNESS BETWEEN ECM AND TUMBLE GENERATOR VALVE ASSEMBLY RH CONNECTOR.</b></p> <p>1) Turn the ignition switch to OFF.</p> <p>2) Disconnect the connector from ECM.</p> <p>3) Measure the resistance of harness between ECM and tumble generator valve assembly RH.</p> <p><b>Connector &amp; terminal</b> <b>(B137) No. 11 — (E55) No. 1:</b></p>	Is the resistance less than 1 Ω?	Go to step 4.	<p>Repair the harness and connector.</p> <p>NOTE: In this case, repair the following item:</p> <ul style="list-style-type: none"> <li>• Open circuit in harness between ECM and tumble generator valve assembly RH connector</li> <li>• Poor contact of coupling connector</li> </ul>
4	<p><b>CHECK HARNESS BETWEEN ECM AND TUMBLE GENERATOR VALVE ASSEMBLY RH CONNECTOR.</b></p> <p>Measure the resistance between ECM and chassis ground.</p> <p><b>Connector &amp; terminal</b> <b>(B137) No. 11 — Chassis ground:</b></p>	Is the resistance 1 MΩ or more?	Go to step 5.	Repair the short circuit to ground in harness between ECM and tumble generator valve assembly RH connector.

# Diagnostic Procedure with Diagnostic Trouble Code (DTC)

ENGINE (DIAGNOSTICS)

Step	Check	Yes	No
<b>5</b> <b>CHECK FOR POOR CONTACT.</b> Check for poor contact of ECM and tumble generator valve assembly RH connector.	Is there poor contact of ECM or the tumble generator valve assembly RH connector?	Repair the poor contact of ECM or tumble generator valve assembly RH connector.	Replace the tumble generator valve assembly RH. <Ref. to FU(STI)-48, Tumble Generator Valve Assembly.> <Ref. to FU(w/o STI)-49, Tumble Generator Valve Assembly.>

# Diagnostic Procedure with Diagnostic Trouble Code (DTC)

ENGINE (DIAGNOSTICS)

## DT:DTC P2017 INTAKE MANIFOLD RUNNER POSITION SENSOR / SWITCH CIRCUIT HIGH (BANK 1)

### DTC DETECTING CONDITION:

- Immediately at fault recognition
- GENERAL DESCRIPTION <Ref. to GD(H4DOTC)-226, DTC P2017 INTAKE MANIFOLD RUNNER POSITION SENSOR / SWITCH CIRCUIT HIGH (BANK 1), Diagnostic Trouble Code (DTC) Detecting Criteria.>

### TROUBLE SYMPTOM:

- Improper idling
- Engine stalls.
- Poor driving performance

### CAUTION:

After servicing or replacing faulty parts, perform Clear Memory Mode <Ref. to EN(H4DOTC)(diag)-62, OPERATION, Clear Memory Mode.>, and Inspection Mode <Ref. to EN(H4DOTC)(diag)-48, PROCEDURE, Inspection Mode.>.

### WIRING DIAGRAM:

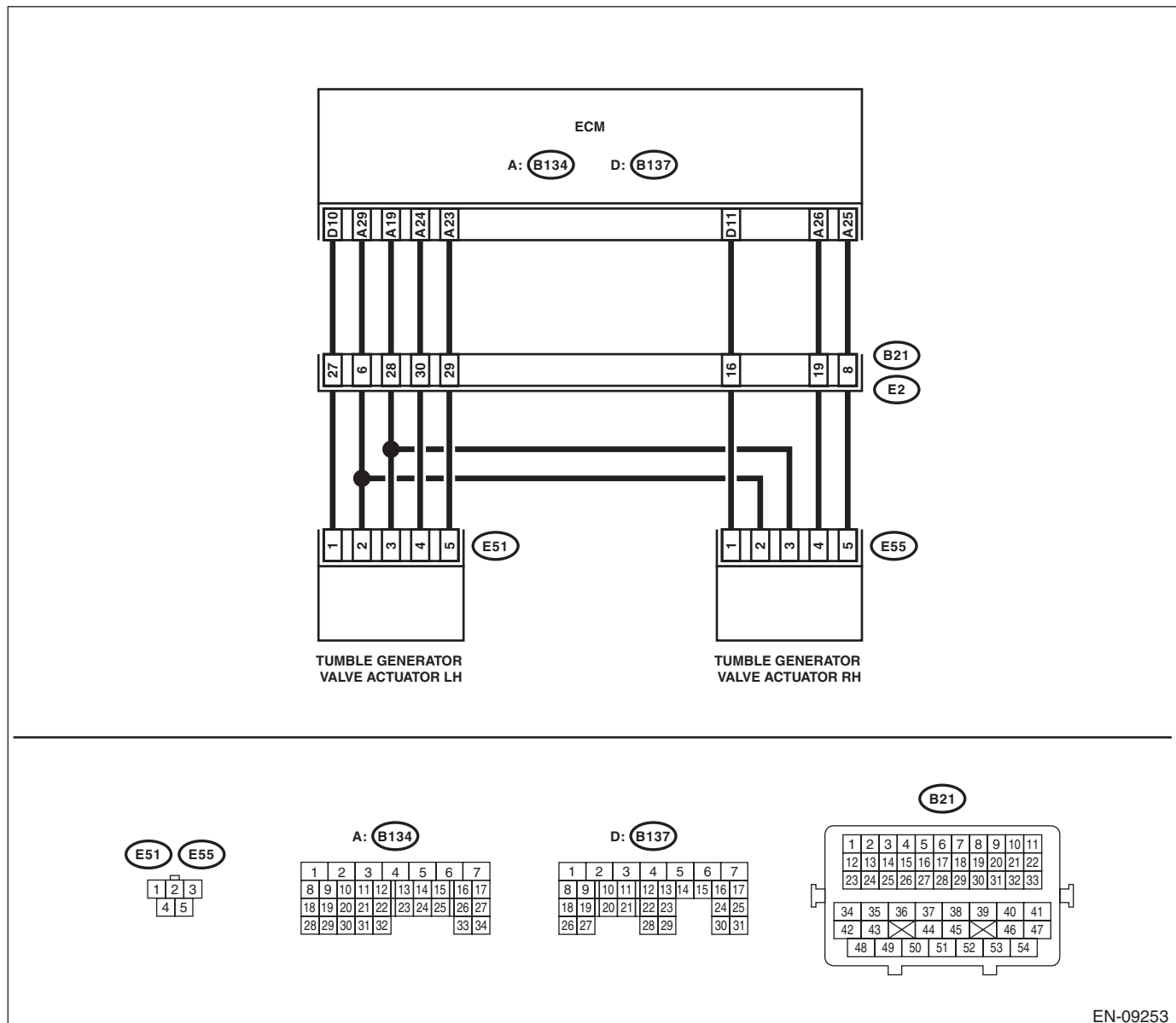

EN-09253

# Diagnostic Procedure with Diagnostic Trouble Code (DTC)

ENGINE (DIAGNOSTICS)

Step	Check	Yes	No
<p><b>1</b></p> <p><b>CHECK CURRENT DATA.</b></p> <p>1) Start the engine.</p> <p>2) Read the value of «TGV Position Sensor R» using the Subaru Select Monitor.</p> <p>NOTE: For detailed operation procedures, refer to "READ CURRENT DATA FOR ENGINE". &lt;Ref. to EN(H4DOTC)(diag)-40, Subaru Select Monitor.&gt;</p>	<p>Is the value of «TGV Position Sensor R» 5 V or more?</p>	<p>Go to step 2.</p>	<p>Even if DTC is detected, the circuit has returned to a normal condition at this time. Reproduce the failure, and then perform the diagnosis again.</p> <p>NOTE: In this case, temporary poor contact of connector, temporary open or short circuit of harness may be the cause.</p>
<p><b>2</b></p> <p><b>CHECK HARNESS BETWEEN ECM AND TUMBLE GENERATOR VALVE ASSEMBLY RH CONNECTOR.</b></p> <p>1) Turn the ignition switch to OFF.</p> <p>2) Disconnect the connector from tumble generator valve assembly RH.</p> <p>3) Start the engine.</p> <p>4) Read the value of «TGV Position Sensor R» using the Subaru Select Monitor.</p> <p>NOTE: For detailed operation procedures, refer to "READ CURRENT DATA FOR ENGINE". &lt;Ref. to EN(H4DOTC)(diag)-40, Subaru Select Monitor.&gt;</p>	<p>Is the value of «TGV Position Sensor R» 5 V or more?</p>	<p>Repair the short circuit to power in harness between ECM and tumble generator valve assembly RH connector.</p>	<p>Go to step 3.</p>
<p><b>3</b></p> <p><b>CHECK HARNESS BETWEEN ECM AND TUMBLE GENERATOR VALVE ASSEMBLY RH CONNECTOR.</b></p> <p>1) Turn the ignition switch to OFF.</p> <p>2) Measure the resistance of harness between tumble generator valve assembly RH connector and engine ground.</p> <p><b>Connector &amp; terminal</b> <b>(E55) No. 2 — Engine ground:</b></p>	<p>Is the resistance less than 5 Ω?</p>	<p>Go to step 4.</p>	<p>Repair the harness and connector.</p> <p>NOTE: In this case, repair the following item:</p> <ul style="list-style-type: none"> <li>• Open circuit in harness between ECM and tumble generator valve assembly RH connector</li> <li>• Poor contact of ECM connector</li> <li>• Poor contact of coupling connector</li> </ul>
<p><b>4</b></p> <p><b>CHECK FOR POOR CONTACT.</b></p> <p>Check for poor contact of tumble generator valve assembly RH connector.</p>	<p>Is there poor contact of the tumble generator valve assembly RH connector?</p>	<p>Repair the poor contact of tumble generator valve assembly RH connector.</p>	<p>Replace the tumble generator valve assembly RH.</p> <p>&lt;Ref. to FU(STI)-48, Tumble Generator Valve Assembly.&gt; &lt;Ref. to FU(w/o STI)-49, Tumble Generator Valve Assembly.&gt;</p>

# Diagnostic Procedure with Diagnostic Trouble Code (DTC)

ENGINE (DIAGNOSTICS)

## DU:DTC P2021 INTAKE MANIFOLD RUNNER POSITION SENSOR / SWITCH CIRCUIT LOW (BANK 2)

### DTC DETECTING CONDITION:

- Immediately at fault recognition
- GENERAL DESCRIPTION <Ref. to GD(H4DOTC)-228, DTC P2021 INTAKE MANIFOLD RUNNER POSITION SENSOR / SWITCH CIRCUIT LOW (BANK 2), Diagnostic Trouble Code (DTC) Detecting Criteria.>

### TROUBLE SYMPTOM:

- Improper idling
- Engine stalls.
- Poor driving performance

### CAUTION:

After servicing or replacing faulty parts, perform Clear Memory Mode <Ref. to EN(H4DOTC)(diag)-62, OPERATION, Clear Memory Mode.>, and Inspection Mode <Ref. to EN(H4DOTC)(diag)-48, PROCEDURE, Inspection Mode.>.

### WIRING DIAGRAM:

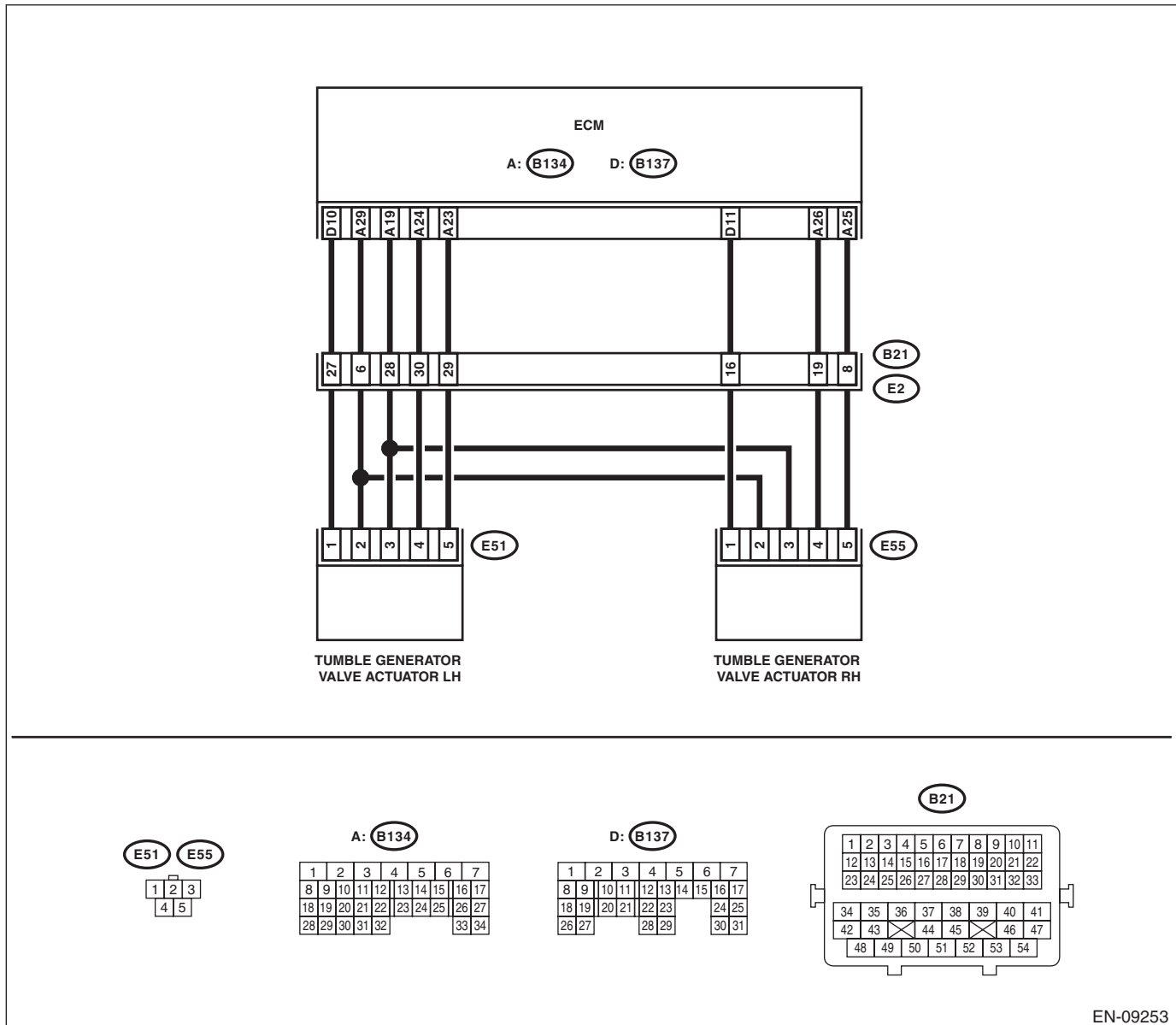

EN-09253



# Diagnostic Procedure with Diagnostic Trouble Code (DTC)

ENGINE (DIAGNOSTICS)

Step	Check	Yes	No
<p><b>1</b></p> <p><b>CHECK CURRENT DATA.</b>                      1) Start the engine.                      2) Read the value of «TGV Position Sensor L» using the Subaru Select Monitor.</p> <p>NOTE:                      For detailed operation procedures, refer to "READ CURRENT DATA FOR ENGINE". &lt;Ref. to EN(H4DOTC)(diag)-40, Subaru Select Monitor.&gt;</p>	<p>Is the value of «TGV Position Sensor L» less than 0.2 V?</p>	<p>Go to step 2.</p>	<p>Even if DTC is detected, the circuit has returned to a normal condition at this time. Reproduce the failure, and then perform the diagnosis again.</p> <p>NOTE:                      In this case, temporary poor contact of connector, temporary open or short circuit of harness may be the cause.</p>
<p><b>2</b></p> <p><b>CHECK POWER SUPPLY OF TUMBLE GENERATOR VALVE ASSEMBLY LH.</b>                      1) Turn the ignition switch to OFF.                      2) Disconnect the connector from tumble generator valve assembly LH.                      3) Turn the ignition switch to ON.                      4) Measure the voltage between tumble generator valve assembly LH connector and engine ground.</p> <p><b>Connector &amp; terminal</b>  <b>(E51) No. 3 (+) — Engine ground (-):</b></p>	<p>Is the voltage 4.5 V or more?</p>	<p>Go to step 3.</p>	<p>Repair the harness and connector.</p> <p>NOTE:                      In this case, repair the following item:</p> <ul style="list-style-type: none"> <li>• Open circuit in harness between ECM and tumble generator valve assembly LH connector</li> <li>• Poor contact of ECM connector</li> <li>• Poor contact of coupling connector</li> </ul>
<p><b>3</b></p> <p><b>CHECK HARNESS BETWEEN ECM AND TUMBLE GENERATOR VALVE ASSEMBLY LH CONNECTOR.</b>                      1) Turn the ignition switch to OFF.                      2) Disconnect the connector from ECM.                      3) Measure the resistance of harness between ECM and tumble generator valve assembly LH.</p> <p><b>Connector &amp; terminal</b>  <b>(B137) No. 10 — (E51) No. 1:</b></p>	<p>Is the resistance less than 1 Ω?</p>	<p>Go to step 4.</p>	<p>Repair the harness and connector.</p> <p>NOTE:                      In this case, repair the following item:</p> <ul style="list-style-type: none"> <li>• Open circuit in harness between ECM and tumble generator valve assembly LH connector</li> <li>• Poor contact of coupling connector</li> </ul>
<p><b>4</b></p> <p><b>CHECK HARNESS BETWEEN ECM AND TUMBLE GENERATOR VALVE ASSEMBLY LH CONNECTOR.</b>                      Measure the resistance between ECM and chassis ground.</p> <p><b>Connector &amp; terminal</b>  <b>(B137) No. 10 — Chassis ground:</b></p>	<p>Is the resistance 1 MΩ or more?</p>	<p>Go to step 5.</p>	<p>Repair the short circuit to ground in harness between ECM and tumble generator valve assembly LH connector.</p>

# Diagnostic Procedure with Diagnostic Trouble Code (DTC)

ENGINE (DIAGNOSTICS)

Step	Check	Yes	No
<b>5</b> <b>CHECK FOR POOR CONTACT.</b> Check for poor contact of ECM and tumble generator valve assembly LH connector.	Is there poor contact of ECM or the tumble generator valve assembly LH connector?	Repair the poor contact of ECM or tumble generator valve assembly LH connector.	Replace the tumble generator valve assembly LH. <Ref. to FU(STI)-48, Tumble Generator Valve Assembly.> <Ref. to FU(w/o STI)-49, Tumble Generator Valve Assembly.>

# Diagnostic Procedure with Diagnostic Trouble Code (DTC)

ENGINE (DIAGNOSTICS)

## DV:DTC P2022 INTAKE MANIFOLD RUNNER POSITION SENSOR / SWITCH CIRCUIT HIGH (BANK 2)

### DTC DETECTING CONDITION:

- Immediately at fault recognition
- GENERAL DESCRIPTION <Ref. to GD(H4DOTC)-230, DTC P2022 INTAKE MANIFOLD RUNNER POSITION SENSOR / SWITCH CIRCUIT HIGH (BANK 2), Diagnostic Trouble Code (DTC) Detecting Criteria.>

### TROUBLE SYMPTOM:

- Improper idling
- Engine stalls.
- Poor driving performance

### CAUTION:

After servicing or replacing faulty parts, perform Clear Memory Mode <Ref. to EN(H4DOTC)(diag)-62, OPERATION, Clear Memory Mode.>, and Inspection Mode <Ref. to EN(H4DOTC)(diag)-48, PROCEDURE, Inspection Mode.>.

### WIRING DIAGRAM:

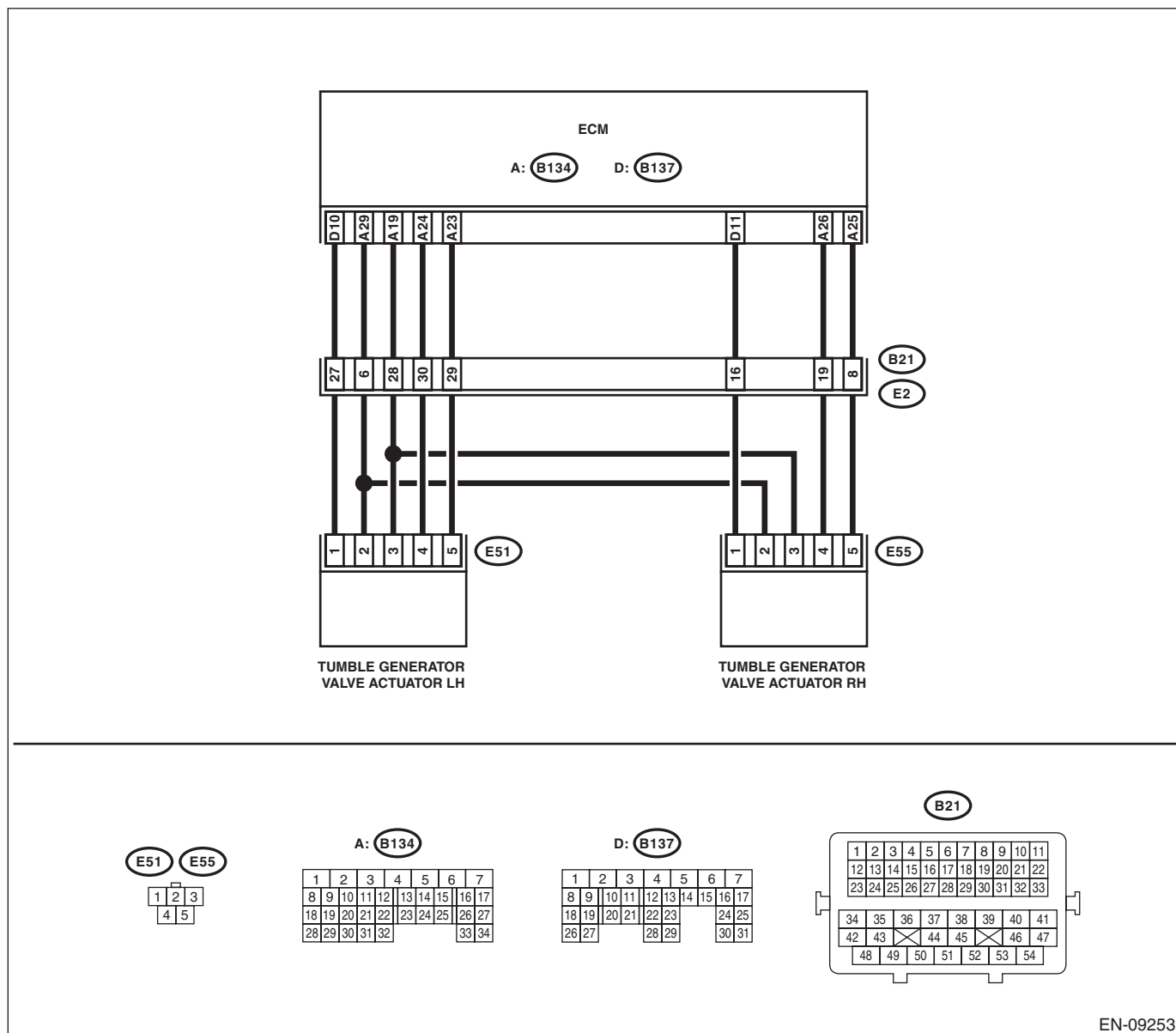

EN-09253

# Diagnostic Procedure with Diagnostic Trouble Code (DTC)

ENGINE (DIAGNOSTICS)

	Step	Check	Yes	No
1	<p><b>CHECK CURRENT DATA.</b></p> <p>1) Start the engine.</p> <p>2) Read the value of «TGV Position Sensor L» using the Subaru Select Monitor.</p> <p>NOTE: For detailed operation procedures, refer to "READ CURRENT DATA FOR ENGINE". &lt;Ref. to EN(H4DOTC)(diag)-40, Subaru Select Monitor.&gt;</p>	Is the value of «TGV Position Sensor L» 5 V or more?	Go to step 2.	<p>Even if DTC is detected, the circuit has returned to a normal condition at this time. Reproduce the failure, and then perform the diagnosis again.</p> <p>NOTE: In this case, temporary poor contact of connector, temporary open or short circuit of harness may be the cause.</p>
2	<p><b>CHECK HARNESS BETWEEN ECM AND TUMBLE GENERATOR VALVE ASSEMBLY LH CONNECTOR.</b></p> <p>1) Turn the ignition switch to OFF.</p> <p>2) Disconnect the connector from tumble generator valve assembly LH.</p> <p>3) Start the engine.</p> <p>4) Read the value of «TGV Position Sensor L» using the Subaru Select Monitor.</p> <p>NOTE: For detailed operation procedures, refer to "READ CURRENT DATA FOR ENGINE". &lt;Ref. to EN(H4DOTC)(diag)-40, Subaru Select Monitor.&gt;</p>	Is the value of «TGV Position Sensor L» 5 V or more?	Repair the short circuit to power in harness between ECM and tumble generator valve assembly LH connector.	Go to step 3.
3	<p><b>CHECK HARNESS BETWEEN ECM AND TUMBLE GENERATOR VALVE ASSEMBLY LH CONNECTOR.</b></p> <p>1) Turn the ignition switch to OFF.</p> <p>2) Measure the resistance of harness between tumble generator valve assembly LH connector and engine ground.</p> <p><b>Connector &amp; terminal</b> <b>(E51) No. 2 — Engine ground:</b></p>	Is the resistance less than 5 Ω?	Go to step 4.	<p>Repair the harness and connector.</p> <p>NOTE: In this case, repair the following item:</p> <ul style="list-style-type: none"> <li>• Open circuit in harness between ECM and tumble generator valve assembly LH connector</li> <li>• Poor contact of ECM connector</li> <li>• Poor contact of coupling connector</li> </ul>
4	<p><b>CHECK FOR POOR CONTACT.</b></p> <p>Check for poor contact of tumble generator valve assembly LH connector.</p>	Is there poor contact of the tumble generator valve assembly LH connector?	Repair the poor contact of tumble generator valve assembly LH connector.	<p>Replace the tumble generator valve assembly LH.</p> <p>&lt;Ref. to FU(STI)-48, Tumble Generator Valve Assembly.&gt; &lt;Ref. to FU(w/o STI)-49, Tumble Generator Valve Assembly.&gt;</p>

# Diagnostic Procedure with Diagnostic Trouble Code (DTC)

ENGINE (DIAGNOSTICS)

## DW:DTC P2088 INTAKE CAMSHAFT POSITION ACTUATOR CONTROL CIRCUIT LOW (BANK 1)

### DTC DETECTING CONDITION:

- Immediately at fault recognition
- GENERAL DESCRIPTION <Ref. to GD(H4DOTC)-232, DTC P2088 INTAKE CAMSHAFT POSITION ACTUATOR CONTROL CIRCUIT LOW (BANK 1), Diagnostic Trouble Code (DTC) Detecting Criteria.>

### TROUBLE SYMPTOM:

Improper idling

### CAUTION:

After servicing or replacing faulty parts, perform Clear Memory Mode <Ref. to EN(H4DOTC)(diag)-62, OPERATION, Clear Memory Mode.>, and Inspection Mode <Ref. to EN(H4DOTC)(diag)-48, PROCEDURE, Inspection Mode.>.

### WIRING DIAGRAM:

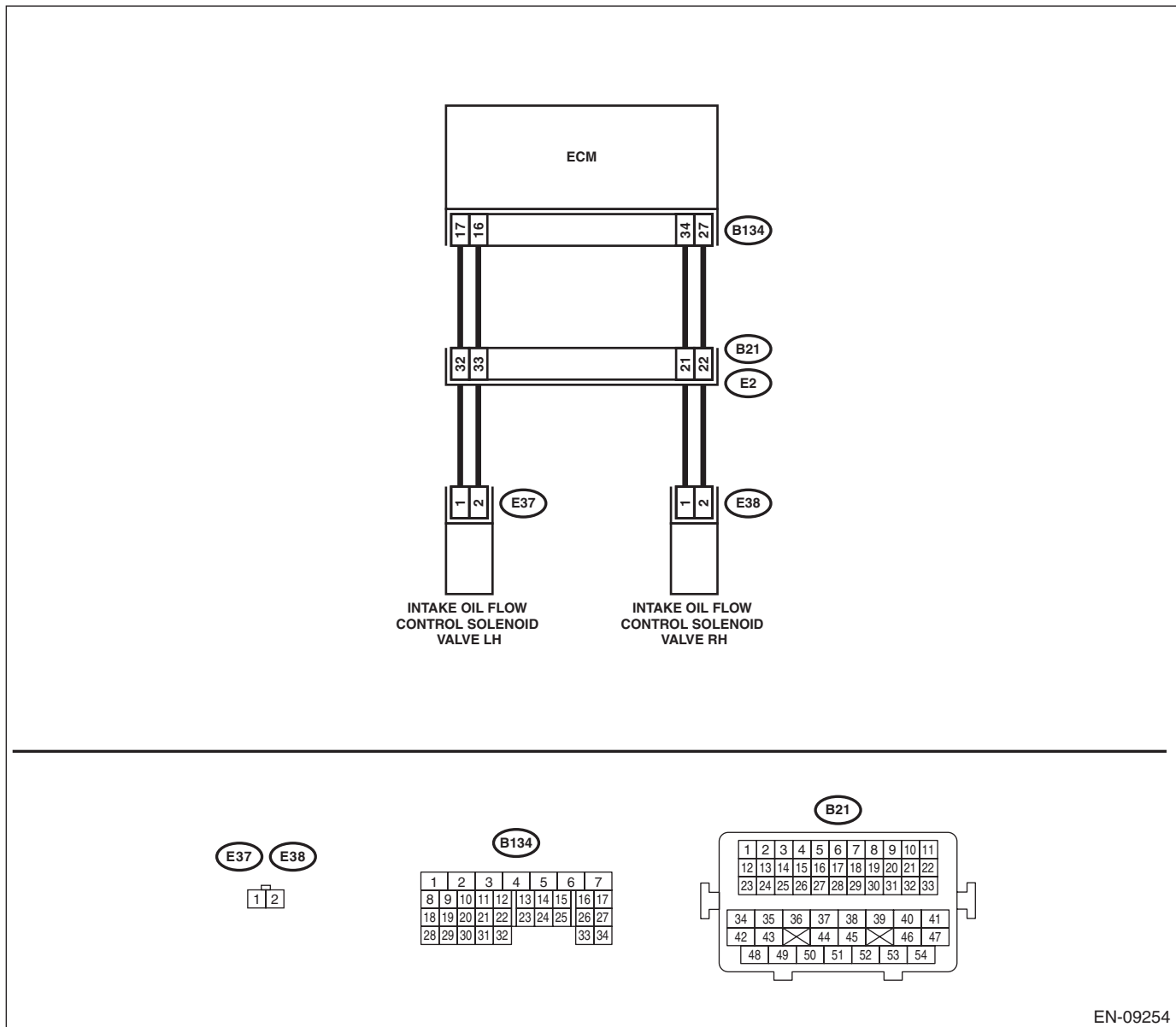

EN-09254

# Diagnostic Procedure with Diagnostic Trouble Code (DTC)

ENGINE (DIAGNOSTICS)

Step	Check	Yes	No
<b>1 CHECK HARNESS BETWEEN ECM AND OIL FLOW CONTROL SOLENOID VALVE RH CONNECTOR.</b> 1) Turn the ignition switch to OFF. 2) Disconnect the connectors from ECM and oil flow control solenoid valve RH. 3) Measure the resistance of harness between ECM and oil flow control solenoid valve RH connector. <b>Connector &amp; terminal</b> <b>(B134) No. 34 — (E38) No. 1:</b> <b>(B134) No. 27 — (E38) No. 2:</b>	Is the resistance less than 1 Ω?	Go to step 2.	Repair the harness and connector.  NOTE: In this case, repair the following item: • Open circuit in harness between ECM and oil flow control solenoid valve RH connector • Poor contact of coupling connector
<b>2 CHECK HARNESS BETWEEN ECM AND OIL FLOW CONTROL SOLENOID VALVE RH CONNECTOR.</b> Measure the resistance between ECM and chassis ground. <b>Connector &amp; terminal</b> <b>(B134) No. 34 — Chassis ground:</b> <b>(B134) No. 27 — Chassis ground:</b>	Is the resistance 1 MΩ or more?	Go to step 3.	Repair the short circuit to ground in harness between ECM and oil flow control solenoid valve RH connector.
<b>3 CHECK OIL FLOW CONTROL SOLENOID VALVE.</b> Measure the resistance between oil flow control solenoid valve terminals. <b>Terminals</b> <b>No. 1 — No. 2:</b>	Is the resistance 6 — 12 Ω?	Repair the poor contact of ECM and oil flow control solenoid valve RH connector RH.	Replace the oil flow control solenoid valve RH. <Ref. to ME(STI)-61, Camshaft.> <Ref. to ME(w/o STI)-60, Camshaft.>

# Diagnostic Procedure with Diagnostic Trouble Code (DTC)

ENGINE (DIAGNOSTICS)

## DX:DTC P2089 INTAKE CAMSHAFT POSITION ACTUATOR CONTROL CIRCUIT HIGH (BANK 1)

### DTC DETECTING CONDITION:

- Immediately at fault recognition
- GENERAL DESCRIPTION <Ref. to GD(H4DOTC)-233, DTC P2089 INTAKE CAMSHAFT POSITION ACTUATOR CONTROL CIRCUIT HIGH (BANK 1), Diagnostic Trouble Code (DTC) Detecting Criteria.>

### TROUBLE SYMPTOM:

Improper idling

### CAUTION:

After servicing or replacing faulty parts, perform Clear Memory Mode <Ref. to EN(H4DOTC)(diag)-62, OPERATION, Clear Memory Mode.>, and Inspection Mode <Ref. to EN(H4DOTC)(diag)-48, PROCEDURE, Inspection Mode.>.

### WIRING DIAGRAM:

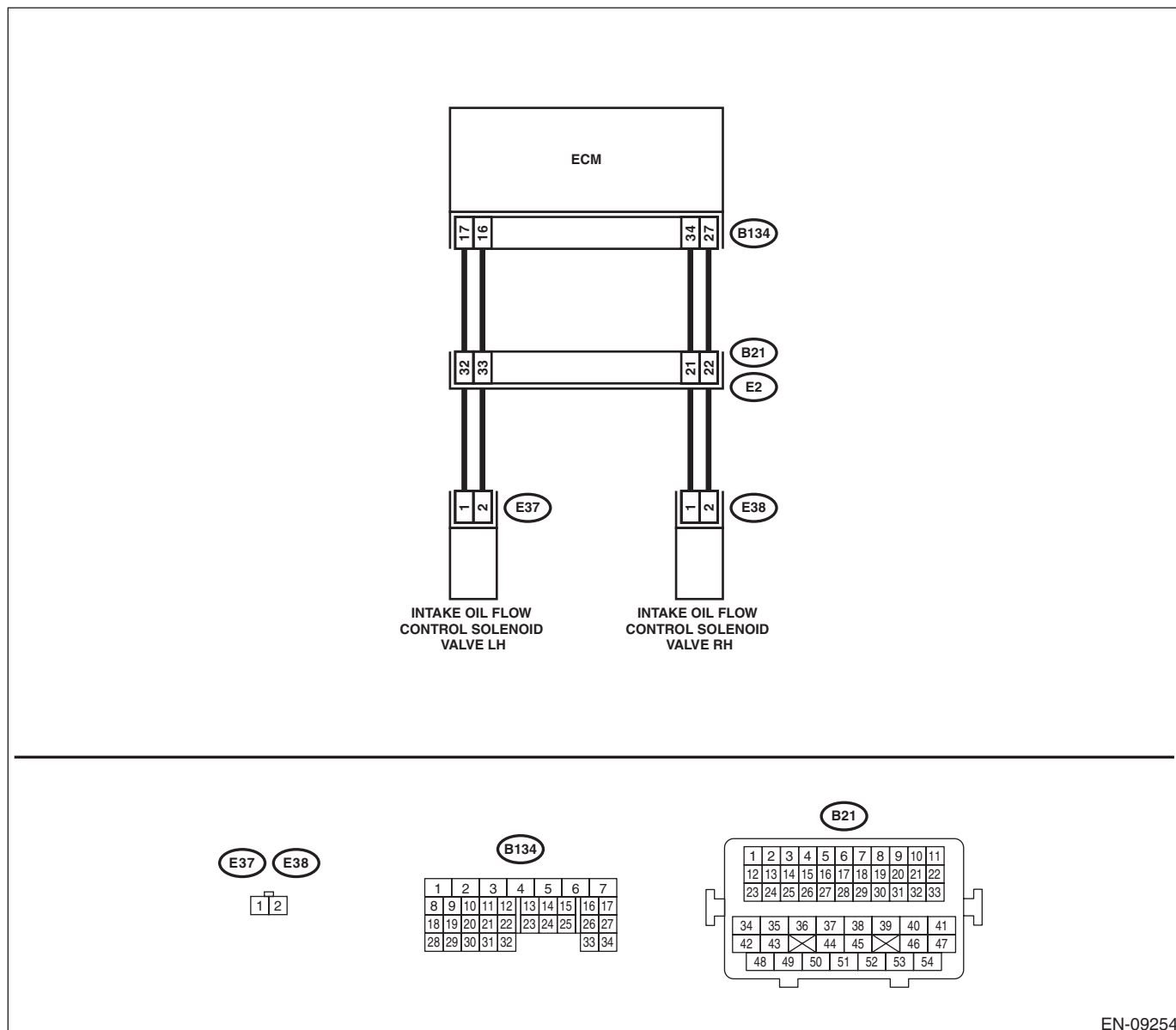

EN-09254

# Diagnostic Procedure with Diagnostic Trouble Code (DTC)

ENGINE (DIAGNOSTICS)

Step	Check	Yes	No
<p><b>1</b>    <b>CHECK HARNESS BETWEEN ECM AND OIL FLOW CONTROL SOLENOID VALVE RH CONNECTOR.</b>            1) Turn the ignition switch to OFF.            2) Disconnect the connectors from ECM and oil flow control solenoid valve RH.            3) Measure the voltage between ECM and chassis ground.  <b>Connector &amp; terminal</b>  <b>(B134) No. 34 (+) — Chassis ground (-):</b>  <b>(B134) No. 27 (+) — Chassis ground (-):</b></p>	<p>Is the voltage less than 1 V?</p>	<p>Go to step 2.</p>	<p>Repair the short circuit to power supply in harness between ECM and oil flow control solenoid valve RH connector.</p>
<p><b>2</b>    <b>CHECK HARNESS BETWEEN ECM AND OIL FLOW CONTROL SOLENOID VALVE RH CONNECTOR.</b>            Measure the resistance of harness between ECM and oil flow control solenoid valve RH connector.  <b>Connector &amp; terminal</b>  <b>(B134) No. 34 — (E38) No. 1:</b>  <b>(B134) No. 27 — (E38) No. 2:</b></p>	<p>Is the resistance less than 1 Ω?</p>	<p>Go to step 3.</p>	<p>Repair the harness and connector.  <b>NOTE:</b>            In this case, repair the following item:            • Open circuit in harness between ECM and oil flow control solenoid valve RH connector            • Poor contact of coupling connector</p>
<p><b>3</b>    <b>CHECK OIL FLOW CONTROL SOLENOID VALVE.</b>            Measure the resistance between oil flow control solenoid valve terminals.  <b>Terminals</b>  <b>No. 1 — No. 2:</b></p>	<p>Is the resistance 6 — 12 Ω?</p>	<p>Repair the poor contact of ECM and oil flow control solenoid valve RH connector RH.</p>	<p>Replace the oil flow control solenoid valve RH.            &lt;Ref. to ME(STI)-61, Camshaft.&gt;            &lt;Ref. to ME(w/o STI)-60, Camshaft.&gt;</p>



# Diagnostic Procedure with Diagnostic Trouble Code (DTC)

ENGINE (DIAGNOSTICS)

## DY:DTC P2090 EXHAUST CAMSHAFT POSITION ACTUATOR CONTROL CIRCUIT LOW (BANK 1)

### DTC DETECTING CONDITION:

- Immediately at fault recognition
- GENERAL DESCRIPTION <Ref. to GD(H4DOTC)-234, DTC P2090 EXHAUST CAMSHAFT POSITION ACTUATOR CONTROL CIRCUIT LOW (BANK 1), Diagnostic Trouble Code (DTC) Detecting Criteria.>

### TROUBLE SYMPTOM:

Improper idling

### CAUTION:

After servicing or replacing faulty parts, perform Clear Memory Mode <Ref. to EN(H4DOTC)(diag)-62, OPERATION, Clear Memory Mode.>, and Inspection Mode <Ref. to EN(H4DOTC)(diag)-48, PROCEDURE, Inspection Mode.>.

### WIRING DIAGRAM:

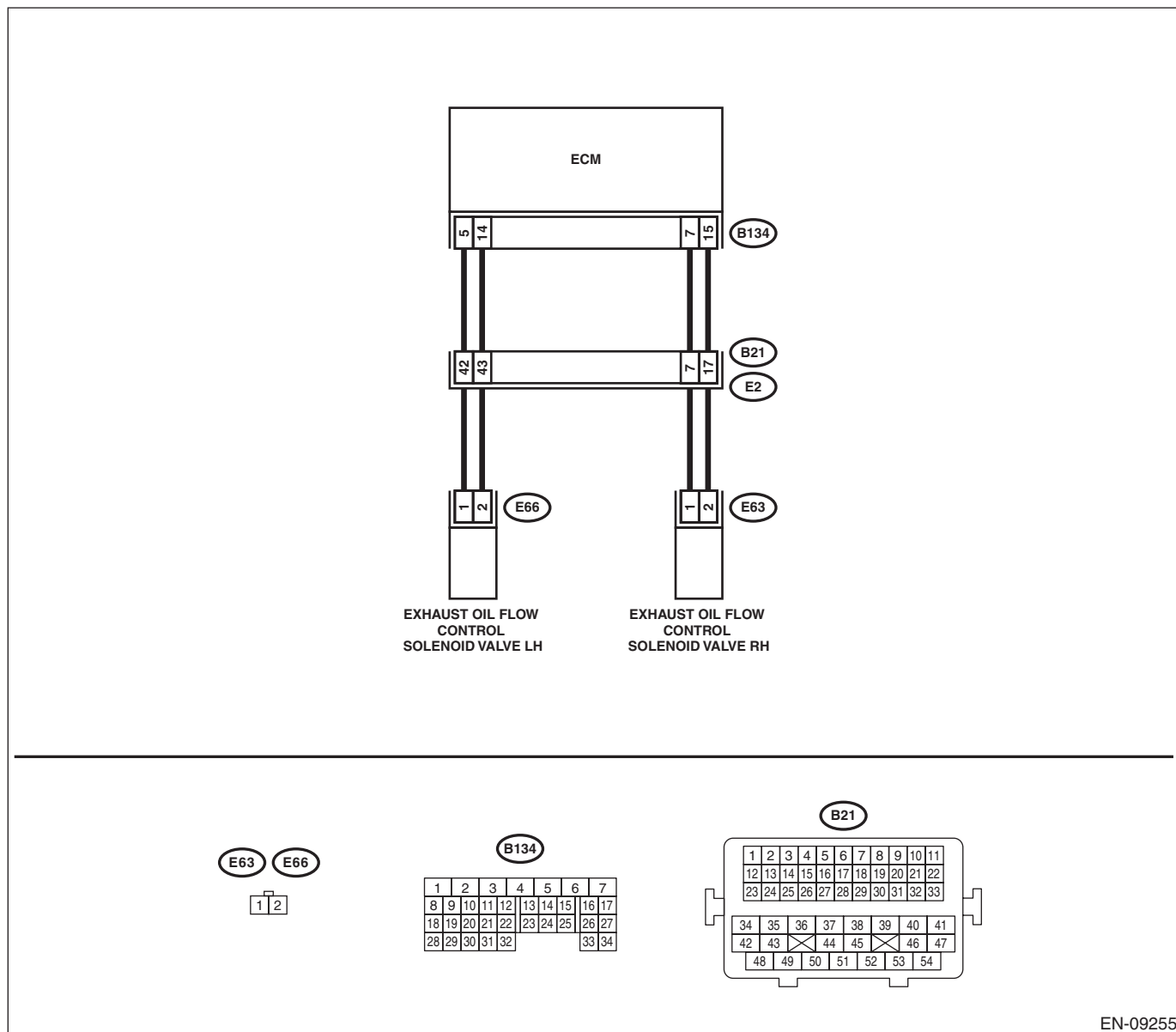

EN-09255

# Diagnostic Procedure with Diagnostic Trouble Code (DTC)

ENGINE (DIAGNOSTICS)

	Step	Check	Yes	No
1	<p><b>CHECK HARNESS BETWEEN ECM AND OIL FLOW CONTROL SOLENOID VALVE RH CONNECTOR.</b></p> <p>1) Turn the ignition switch to OFF.                      2) Disconnect the connectors from ECM and oil flow control solenoid valve RH.                      3) Measure the resistance of harness between ECM and oil flow control solenoid valve RH connector.</p> <p><b>Connector &amp; terminal</b>                      (B134) No. 7 — (E63) No. 1:                      (B134) No. 15 — (E63) No. 2:</p>	Is the resistance less than 1 Ω?	Go to step 2.	<p>Repair the harness and connector.</p> <p>NOTE:                      In this case, repair the following item:</p> <ul style="list-style-type: none"> <li>• Open circuit in harness between ECM and oil flow control solenoid valve RH connector</li> <li>• Poor contact of coupling connector</li> </ul>
2	<p><b>CHECK HARNESS BETWEEN ECM AND OIL FLOW CONTROL SOLENOID VALVE RH CONNECTOR.</b></p> <p>Measure the resistance between ECM and chassis ground.</p> <p><b>Connector &amp; terminal</b>                      (B134) No. 7 — Chassis ground:                      (B134) No. 15 — Chassis ground:</p>	Is the resistance 1 MΩ or more?	Go to step 3.	Repair the short circuit to ground in harness between ECM and oil flow control solenoid valve RH connector.
3	<p><b>CHECK OIL FLOW CONTROL SOLENOID VALVE.</b></p> <p>Measure the resistance between oil flow control solenoid valve terminals.</p> <p><b>Terminals</b>                      No. 1 — No. 2:</p>	Is the resistance 6 — 12 Ω?	Repair the poor contact of ECM and oil flow control solenoid valve RH connector RH.	Replace the oil flow control solenoid valve RH. <Ref. to FU(STI)-50, Oil Flow Control Solenoid Valve.>

# Diagnostic Procedure with Diagnostic Trouble Code (DTC)

ENGINE (DIAGNOSTICS)

## DZ:DTC P2091 EXHAUST CAMSHAFT POSITION ACTUATOR CONTROL CIRCUIT HIGH (BANK 1)

### DTC DETECTING CONDITION:

- Immediately at fault recognition
- GENERAL DESCRIPTION <Ref. to GD(H4DOTC)-235, DTC P2091 EXHAUST CAMSHAFT POSITION ACTUATOR CONTROL CIRCUIT HIGH (BANK 1), Diagnostic Trouble Code (DTC) Detecting Criteria.>

### TROUBLE SYMPTOM:

Improper idling

### CAUTION:

After servicing or replacing faulty parts, perform Clear Memory Mode <Ref. to EN(H4DOTC)(diag)-62, OPERATION, Clear Memory Mode.>, and Inspection Mode <Ref. to EN(H4DOTC)(diag)-48, PROCEDURE, Inspection Mode.>.

### WIRING DIAGRAM:

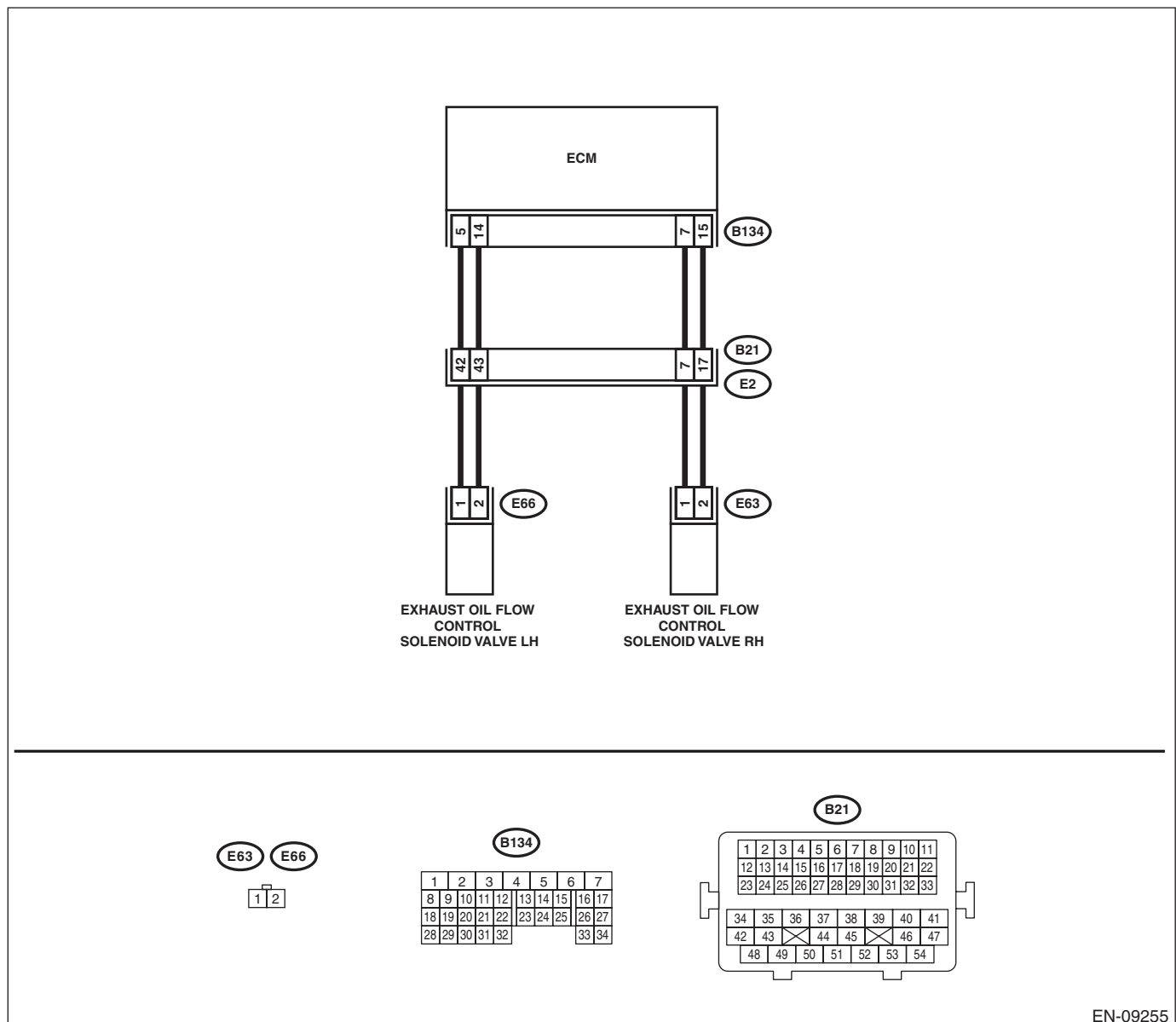

EN-09255

# Diagnostic Procedure with Diagnostic Trouble Code (DTC)

ENGINE (DIAGNOSTICS)

Step	Check	Yes	No
<p><b>1</b>     <b>CHECK HARNESS BETWEEN ECM AND OIL FLOW CONTROL SOLENOID VALVE RH CONNECTOR.</b>            1) Turn the ignition switch to OFF.            2) Disconnect the connectors from ECM and oil flow control solenoid valve RH.            3) Measure the voltage between ECM and chassis ground.  <b>Connector &amp; terminal</b>  <b>(B134) No. 7 (+) — Chassis ground (-):</b>  <b>(B134) No. 15 (+) — Chassis ground (-):</b></p>	<p>Is the voltage less than 1 V?</p>	<p>Go to step 2.</p>	<p>Repair the short circuit to power supply in harness between ECM and oil flow control solenoid valve RH connector.</p>
<p><b>2</b>     <b>CHECK HARNESS BETWEEN ECM AND OIL FLOW CONTROL SOLENOID VALVE RH CONNECTOR.</b>            Measure the resistance of harness between ECM and oil flow control solenoid valve RH connector.  <b>Connector &amp; terminal</b>  <b>(B134) No. 7 — (E63) No. 1:</b>  <b>(B134) No. 15 — (E63) No. 2:</b></p>	<p>Is the resistance less than 1 Ω?</p>	<p>Go to step 3.</p>	<p>Repair the harness and connector.  <b>NOTE:</b>            In this case, repair the following item:            • Open circuit in harness between ECM and oil flow control solenoid valve RH connector            • Poor contact of coupling connector</p>
<p><b>3</b>     <b>CHECK OIL FLOW CONTROL SOLENOID VALVE.</b>            Measure the resistance between oil flow control solenoid valve terminals.  <b>Terminals</b>  <b>No. 1 — No. 2:</b></p>	<p>Is the resistance 6 — 12 Ω?</p>	<p>Repair the poor contact of ECM and oil flow control solenoid valve RH connector RH.</p>	<p>Replace the oil flow control solenoid valve RH.            &lt;Ref. to FU(STI)-50, Oil Flow Control Solenoid Valve.&gt;</p>

# Diagnostic Procedure with Diagnostic Trouble Code (DTC)

ENGINE (DIAGNOSTICS)

## EA:DTC P2092 INTAKE CAMSHAFT POSITION ACTUATOR CONTROL CIRCUIT LOW (BANK 2)

### DTC DETECTING CONDITION:

- Immediately at fault recognition
- GENERAL DESCRIPTION <Ref. to GD(H4DOTC)-236, DTC P2092 INTAKE CAMSHAFT POSITION ACTUATOR CONTROL CIRCUIT LOW (BANK 2), Diagnostic Trouble Code (DTC) Detecting Criteria.>

### TROUBLE SYMPTOM:

Improper idling

### CAUTION:

After servicing or replacing faulty parts, perform Clear Memory Mode <Ref. to EN(H4DOTC)(diag)-62, OPERATION, Clear Memory Mode.>, and Inspection Mode <Ref. to EN(H4DOTC)(diag)-48, PROCEDURE, Inspection Mode.>.

### WIRING DIAGRAM:

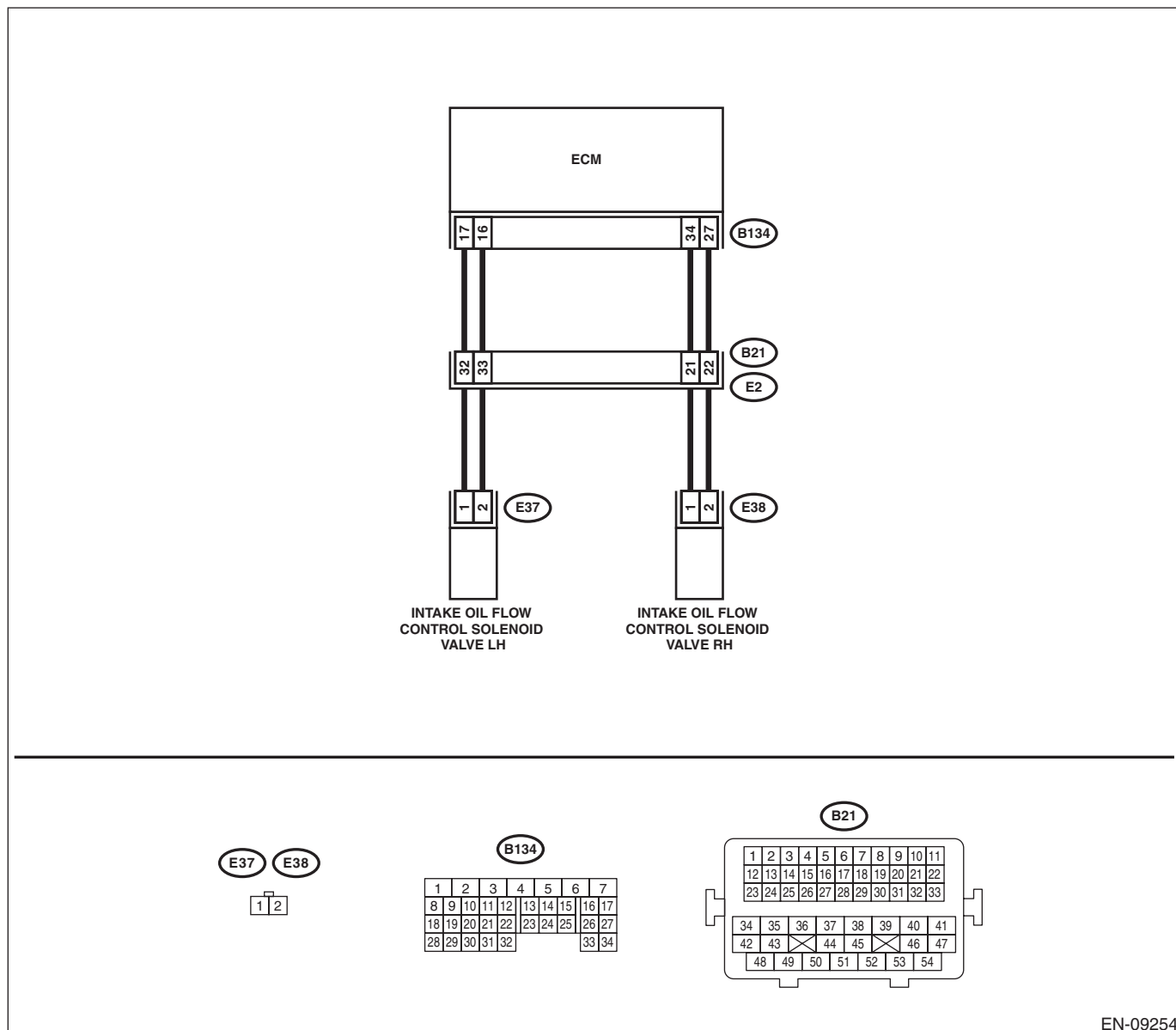

EN-09254

# Diagnostic Procedure with Diagnostic Trouble Code (DTC)

ENGINE (DIAGNOSTICS)

	Step	Check	Yes	No
1	<p><b>CHECK HARNESS BETWEEN ECM AND OIL FLOW CONTROL SOLENOID VALVE LH CONNECTOR.</b></p> <p>1) Turn the ignition switch to OFF. 2) Disconnect the connectors from ECM and oil flow control solenoid valve LH. 3) Measure the resistance of harness between ECM and oil flow control solenoid valve LH connector.</p> <p><b>Connector &amp; terminal</b> <b>(B134) No. 17 — (E37) No. 1:</b> <b>(B134) No. 16 — (E37) No. 2:</b></p>	Is the resistance less than 1 Ω?	Go to step 2.	<p>Repair the harness and connector.</p> <p>NOTE: In this case, repair the following item:</p> <ul style="list-style-type: none"> <li>• Open circuit in harness between ECM and oil flow control solenoid valve LH connector</li> <li>• Poor contact of coupling connector</li> </ul>
2	<p><b>CHECK HARNESS BETWEEN ECM AND OIL FLOW CONTROL SOLENOID VALVE LH CONNECTOR.</b></p> <p>Measure the resistance between ECM and chassis ground.</p> <p><b>Connector &amp; terminal</b> <b>(B134) No. 17 — Chassis ground:</b> <b>(B134) No. 16 — Chassis ground:</b></p>	Is the resistance 1 MΩ or more?	Go to step 3.	Repair the short circuit to ground in harness between ECM and oil flow control solenoid valve LH connector.
3	<p><b>CHECK OIL FLOW CONTROL SOLENOID VALVE.</b></p> <p>Measure the resistance between oil flow control solenoid valve terminals.</p> <p><b>Terminals</b> <b>No. 1 — No. 2:</b></p>	Is the resistance 6 — 12 Ω?	Repair the poor contact of ECM and oil flow control solenoid valve LH connector.	<p>Replace the oil flow control solenoid valve LH.</p> <p>&lt;Ref. to ME(STI)-61, Camshaft.&gt; &lt;Ref. to ME(w/o STI)-60, Camshaft.&gt;</p>

# Diagnostic Procedure with Diagnostic Trouble Code (DTC)

ENGINE (DIAGNOSTICS)

## EB:DTC P2093 INTAKE CAMSHAFT POSITION ACTUATOR CONTROL CIRCUIT HIGH (BANK 2)

### DTC DETECTING CONDITION:

- Immediately at fault recognition
- GENERAL DESCRIPTION <Ref. to GD(H4DOTC)-236, DTC P2093 INTAKE CAMSHAFT POSITION ACTUATOR CONTROL CIRCUIT HIGH (BANK 2), Diagnostic Trouble Code (DTC) Detecting Criteria.>

### TROUBLE SYMPTOM:

Improper idling

### CAUTION:

After servicing or replacing faulty parts, perform Clear Memory Mode <Ref. to EN(H4DOTC)(diag)-62, OPERATION, Clear Memory Mode.>, and Inspection Mode <Ref. to EN(H4DOTC)(diag)-48, PROCEDURE, Inspection Mode.>.

### WIRING DIAGRAM:

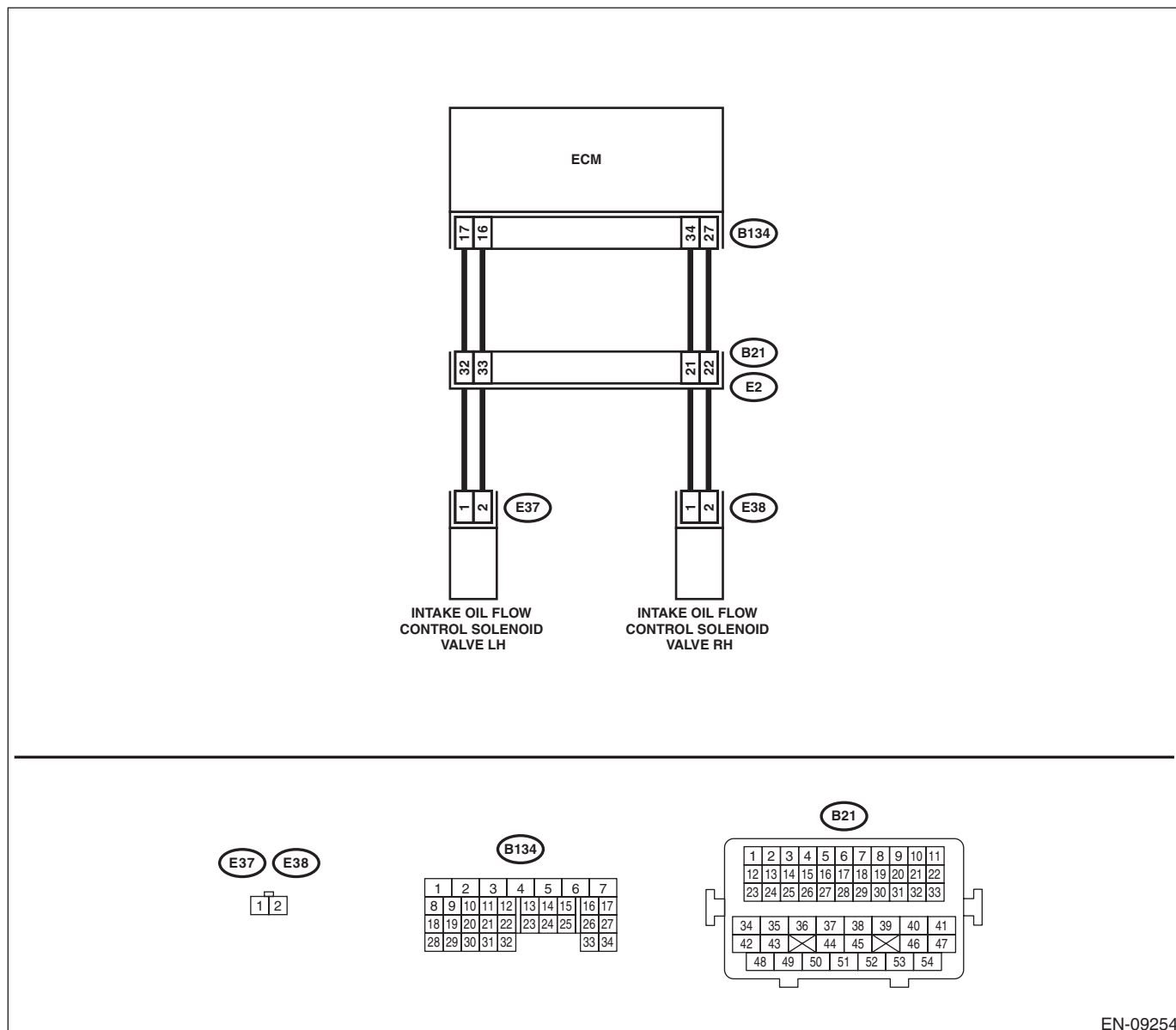

EN-09254

# Diagnostic Procedure with Diagnostic Trouble Code (DTC)

ENGINE (DIAGNOSTICS)

Step	Check	Yes	No
<p><b>1</b>    <b>CHECK HARNESS BETWEEN ECM AND OIL FLOW CONTROL SOLENOID VALVE LH CONNECTOR.</b>            1) Turn the ignition switch to OFF.            2) Disconnect the connectors from ECM and oil flow control solenoid valve LH.            3) Measure the voltage between ECM and chassis ground.  <b>Connector &amp; terminal</b>  <b>(B134) No. 17 (+) — Chassis ground (-):</b>  <b>(B134) No. 16 (+) — Chassis ground (-):</b></p>	<p>Is the voltage less than 1 V?</p>	<p>Go to step 2.</p>	<p>Repair the short circuit to power supply in harness between ECM and oil flow control solenoid valve LH connector.</p>
<p><b>2</b>    <b>CHECK HARNESS BETWEEN ECM AND OIL FLOW CONTROL SOLENOID VALVE LH CONNECTOR.</b>            Measure the resistance of harness between ECM and oil flow control solenoid valve LH connector.  <b>Connector &amp; terminal</b>  <b>(B134) No. 17 — (E37) No. 1:</b>  <b>(B134) No. 16 — (E37) No. 2:</b></p>	<p>Is the resistance less than 1 Ω?</p>	<p>Go to step 3.</p>	<p>Repair the harness and connector.  <b>NOTE:</b>            In this case, repair the following item:            • Open circuit in harness between ECM and oil flow control solenoid valve LH connector            • Poor contact of coupling connector</p>
<p><b>3</b>    <b>CHECK OIL FLOW CONTROL SOLENOID VALVE.</b>            Measure the resistance between oil flow control solenoid valve terminals.  <b>Terminals</b>  <b>No. 1 — No. 2:</b></p>	<p>Is the resistance 6 — 12 Ω?</p>	<p>Repair the poor contact of ECM and oil flow control solenoid valve LH connector.</p>	<p>Replace the oil flow control solenoid valve LH.            &lt;Ref. to ME(STI)-61, Camshaft.&gt;            &lt;Ref. to ME(w/o STI)-60, Camshaft.&gt;</p>



# Diagnostic Procedure with Diagnostic Trouble Code (DTC)

ENGINE (DIAGNOSTICS)

## EC:DTC P2094 EXHAUST CAMSHAFT POSITION ACTUATOR CONTROL CIRCUIT LOW (BANK 2)

### DTC DETECTING CONDITION:

- Immediately at fault recognition
- GENERAL DESCRIPTION <Ref. to GD(H4DOTC)-236, DTC P2094 EXHAUST CAMSHAFT POSITION ACTUATOR CONTROL CIRCUIT LOW (BANK 2), Diagnostic Trouble Code (DTC) Detecting Criteria.>

### TROUBLE SYMPTOM:

Improper idling

### CAUTION:

After servicing or replacing faulty parts, perform Clear Memory Mode <Ref. to EN(H4DOTC)(diag)-62, OPERATION, Clear Memory Mode.>, and Inspection Mode <Ref. to EN(H4DOTC)(diag)-48, PROCEDURE, Inspection Mode.>.

### WIRING DIAGRAM:

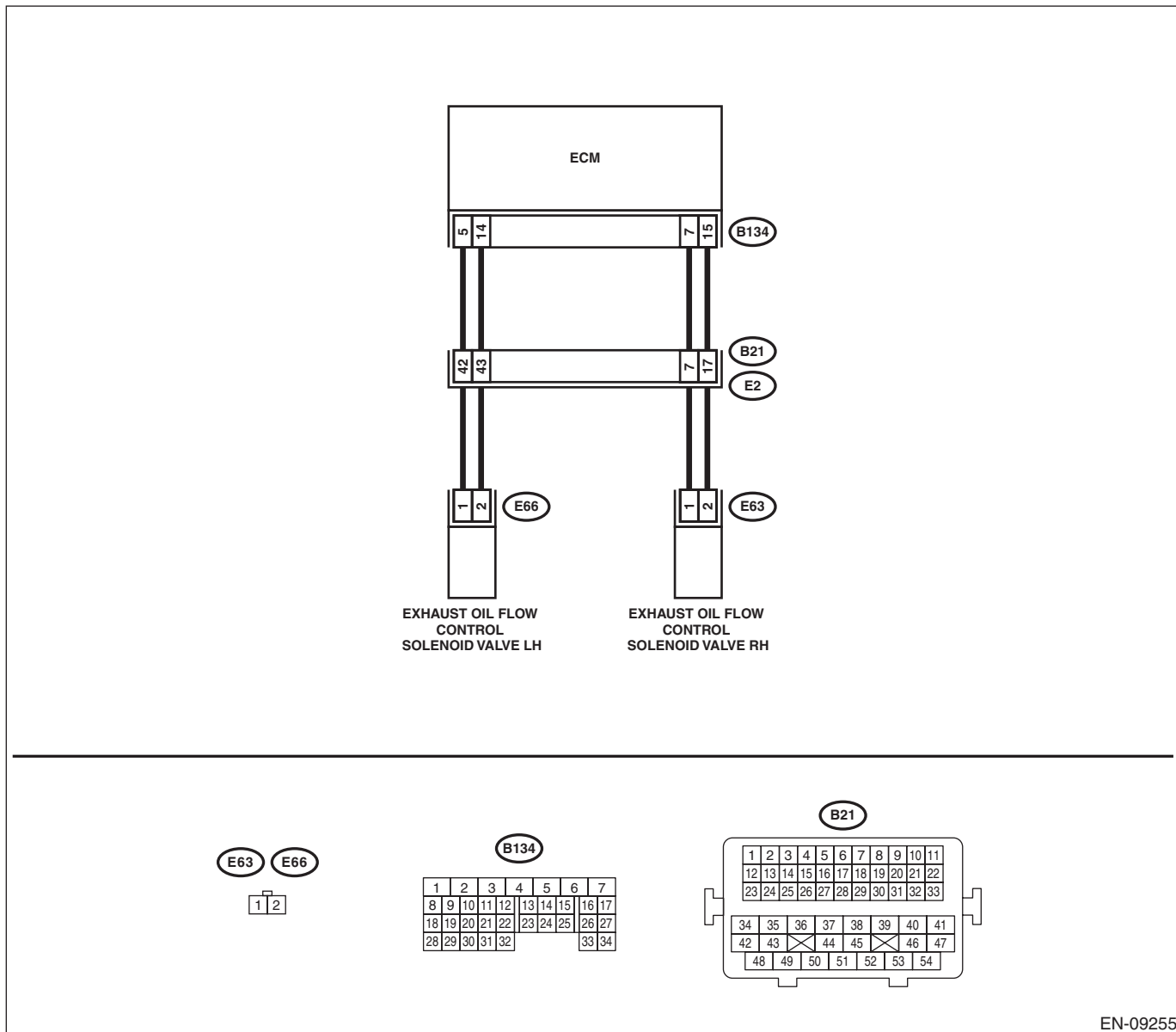

EN-09255

# Diagnostic Procedure with Diagnostic Trouble Code (DTC)

ENGINE (DIAGNOSTICS)

	Step	Check	Yes	No
1	<p><b>CHECK HARNESS BETWEEN ECM AND OIL FLOW CONTROL SOLENOID VALVE LH CONNECTOR.</b></p> <p>1) Turn the ignition switch to OFF.                      2) Disconnect the connectors from ECM and oil flow control solenoid valve LH.                      3) Measure the resistance of harness between ECM and oil flow control solenoid valve LH connector.</p> <p><b>Connector &amp; terminal</b>                      (B134) No. 5 — (E66) No. 1:                      (B134) No. 14 — (E66) No. 2:</p>	Is the resistance less than 1 Ω?	Go to step 2.	<p>Repair the harness and connector.</p> <p>NOTE:                      In this case, repair the following item:</p> <ul style="list-style-type: none"> <li>• Open circuit in harness between ECM and oil flow control solenoid valve LH connector</li> <li>• Poor contact of coupling connector</li> </ul>
2	<p><b>CHECK HARNESS BETWEEN ECM AND OIL FLOW CONTROL SOLENOID VALVE LH CONNECTOR.</b></p> <p>Measure the resistance between ECM and chassis ground.</p> <p><b>Connector &amp; terminal</b>                      (B134) No. 5 — Chassis ground:                      (B134) No. 14 — Chassis ground:</p>	Is the resistance 1 MΩ or more?	Go to step 3.	<p>Repair the short circuit to ground in harness between ECM and oil flow control solenoid valve LH connector.</p>
3	<p><b>CHECK OIL FLOW CONTROL SOLENOID VALVE.</b></p> <p>Measure the resistance between oil flow control solenoid valve terminals.</p> <p><b>Terminals</b>                      No. 1 — No. 2:</p>	Is the resistance 6 — 12 Ω?	Repair the poor contact of ECM and oil flow control solenoid valve LH connector.	<p>Replace the oil flow control solenoid valve LH.</p> <p>&lt;Ref. to FU(STI)-50, Oil Flow Control Solenoid Valve.&gt;</p>

# Diagnostic Procedure with Diagnostic Trouble Code (DTC)

ENGINE (DIAGNOSTICS)

## ED:DTC P2095 EXHAUST CAMSHAFT POSITION ACTUATOR CONTROL CIRCUIT HIGH (BANK 2)

### DTC DETECTING CONDITION:

- Immediately at fault recognition
- GENERAL DESCRIPTION <Ref. to GD(H4DOTC)-236, DTC P2095 EXHAUST CAMSHAFT POSITION ACTUATOR CONTROL CIRCUIT HIGH (BANK 2), Diagnostic Trouble Code (DTC) Detecting Criteria.>

### TROUBLE SYMPTOM:

Improper idling

### CAUTION:

After servicing or replacing faulty parts, perform Clear Memory Mode <Ref. to EN(H4DOTC)(diag)-62, OPERATION, Clear Memory Mode.>, and Inspection Mode <Ref. to EN(H4DOTC)(diag)-48, PROCEDURE, Inspection Mode.>.

### WIRING DIAGRAM:

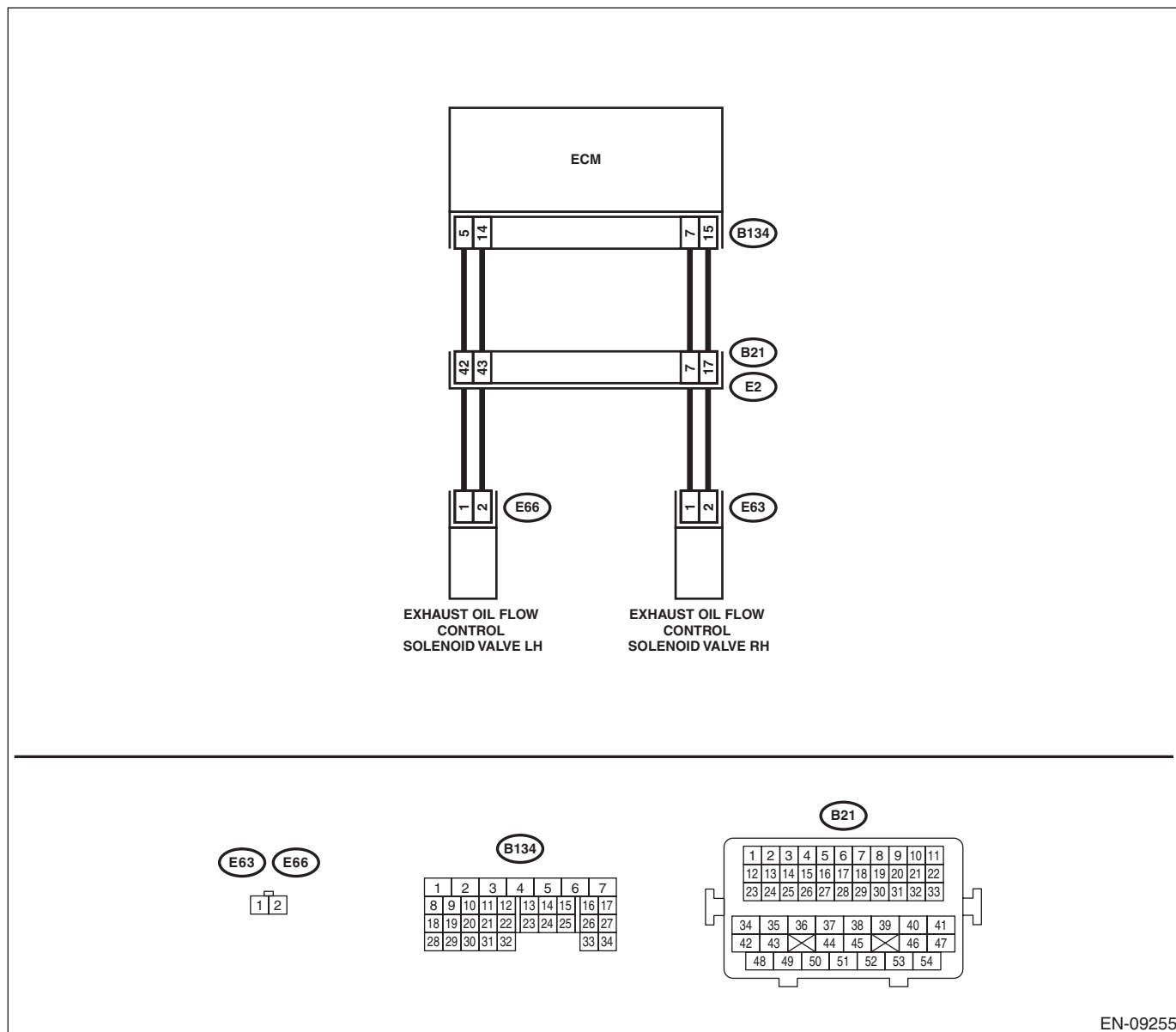

EN-09255

# Diagnostic Procedure with Diagnostic Trouble Code (DTC)

ENGINE (DIAGNOSTICS)

Step	Check	Yes	No
<p><b>1</b>     <b>CHECK HARNESS BETWEEN ECM AND OIL FLOW CONTROL SOLENOID VALVE LH CONNECTOR.</b>            1) Turn the ignition switch to OFF.            2) Disconnect the connectors from ECM and oil flow control solenoid valve LH.            3) Measure the voltage between ECM and chassis ground.  <b>Connector &amp; terminal</b>  <b>(B134) No. 5 (+) — Chassis ground (-):</b>  <b>(B134) No. 14 (+) — Chassis ground (-):</b></p>	<p>Is the voltage less than 1 V?</p>	<p>Go to step 2.</p>	<p>Repair the short circuit to power supply in harness between ECM and oil flow control solenoid valve LH connector.</p>
<p><b>2</b>     <b>CHECK HARNESS BETWEEN ECM AND OIL FLOW CONTROL SOLENOID VALVE LH CONNECTOR.</b>            Measure the resistance of harness between ECM and oil flow control solenoid valve LH connector.  <b>Connector &amp; terminal</b>  <b>(B134) No. 5 — (E66) No. 1:</b>  <b>(B134) No. 14 — (E66) No. 2:</b></p>	<p>Is the resistance less than 1 Ω?</p>	<p>Go to step 3.</p>	<p>Repair the harness and connector.  <b>NOTE:</b>            In this case, repair the following item:            • Open circuit in harness between ECM and oil flow control solenoid valve LH connector            • Poor contact of coupling connector</p>
<p><b>3</b>     <b>CHECK OIL FLOW CONTROL SOLENOID VALVE.</b>            Measure the resistance between oil flow control solenoid valve terminals.  <b>Terminals</b>  <b>No. 1 — No. 2:</b></p>	<p>Is the resistance 6 — 12 Ω?</p>	<p>Repair the poor contact of ECM and oil flow control solenoid valve LH connector.</p>	<p>Replace the oil flow control solenoid valve LH.            &lt;Ref. to FU(STI)-50, Oil Flow Control Solenoid Valve.&gt;</p>

# Diagnostic Procedure with Diagnostic Trouble Code (DTC)

ENGINE (DIAGNOSTICS)

## EE:DTC P2096 POST CATALYST FUEL TRIM SYSTEM TOO LEAN (BANK 1)

### DTC DETECTING CONDITION:

- Detected when two consecutive driving cycles with fault occur.
- GENERAL DESCRIPTION <Ref. to GD(H4DOTC)-237, DTC P2096 POST CATALYST FUEL TRIM SYSTEM TOO LEAN (BANK 1), Diagnostic Trouble Code (DTC) Detecting Criteria.>

### CAUTION:

After servicing or replacing faulty parts, perform Clear Memory Mode <Ref. to EN(H4DOTC)(diag)-62, OPERATION, Clear Memory Mode.>, and Inspection Mode <Ref. to EN(H4DOTC)(diag)-48, PROCEDURE, Inspection Mode.>.

### WIRING DIAGRAM:

- Models without SI-DRIVE

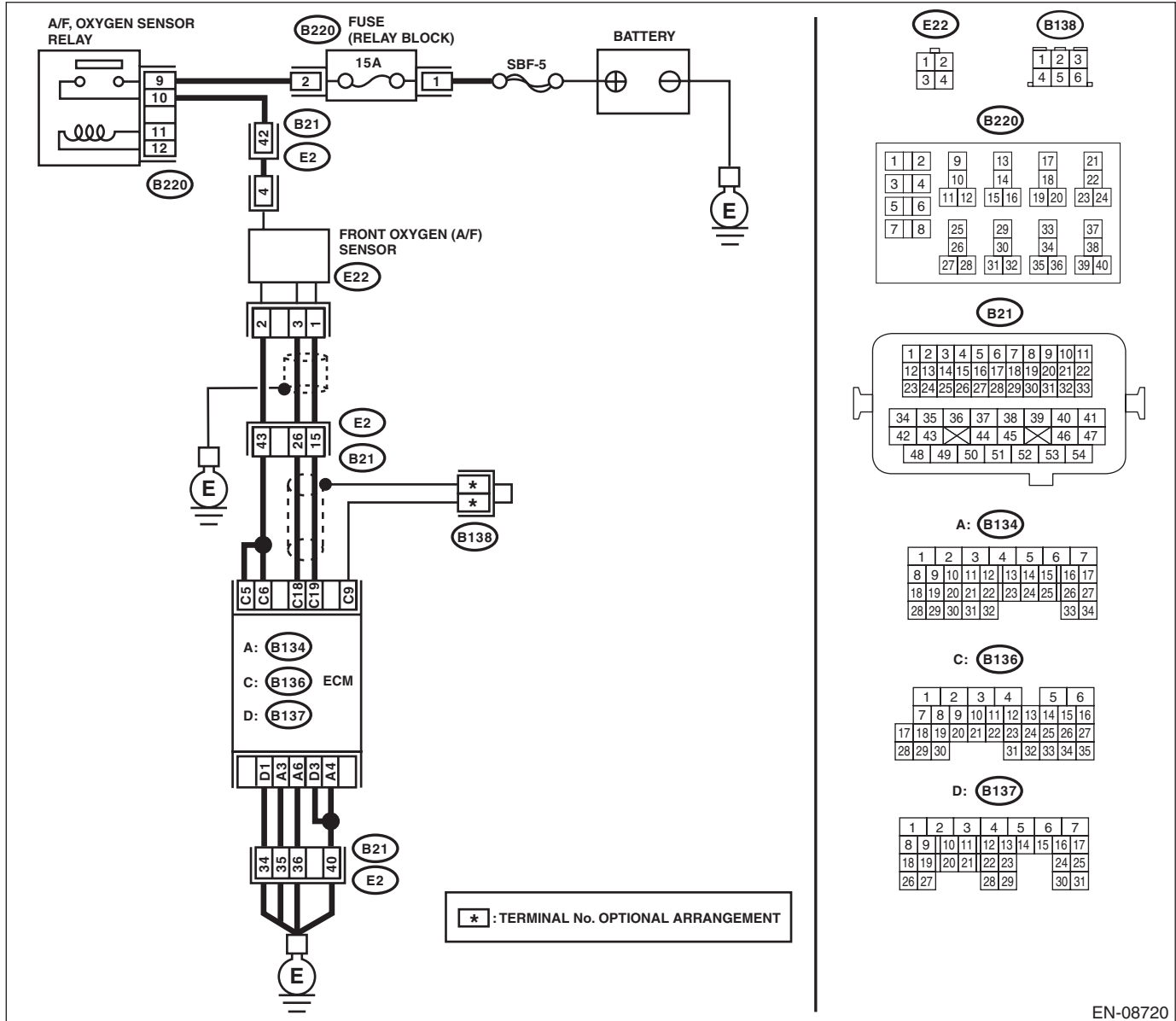

EN-08720

# Diagnostic Procedure with Diagnostic Trouble Code (DTC)

ENGINE (DIAGNOSTICS)

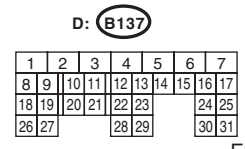
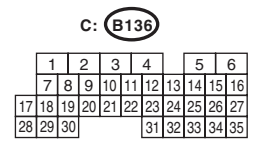
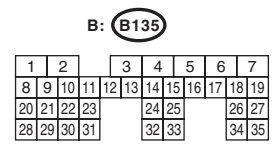
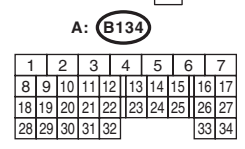
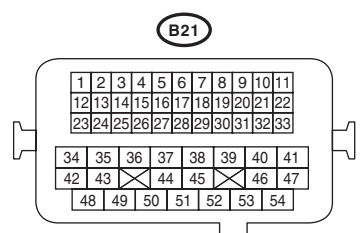
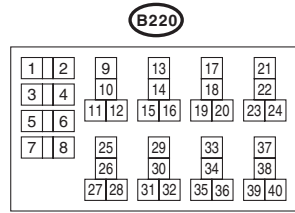
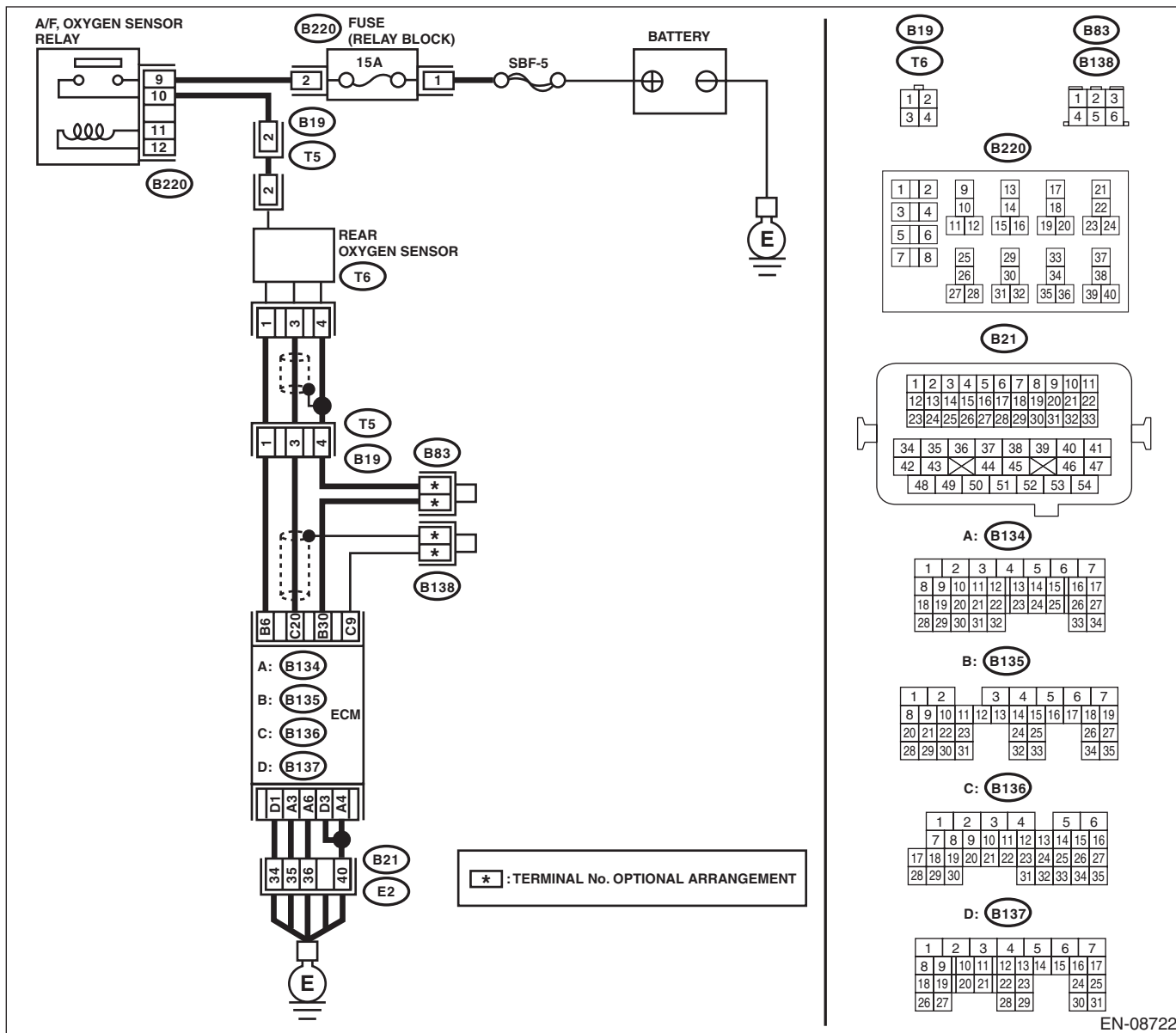

EN-08722

# Diagnostic Procedure with Diagnostic Trouble Code (DTC)

## ENGINE (DIAGNOSTICS)

- Models with SI-DRIVE

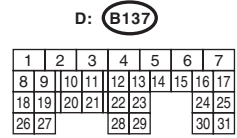
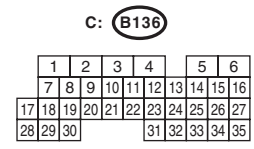
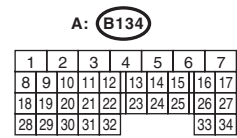
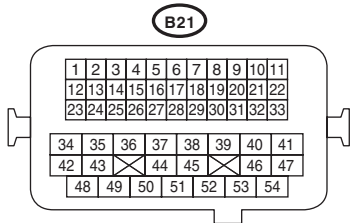
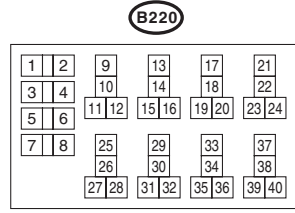
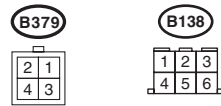
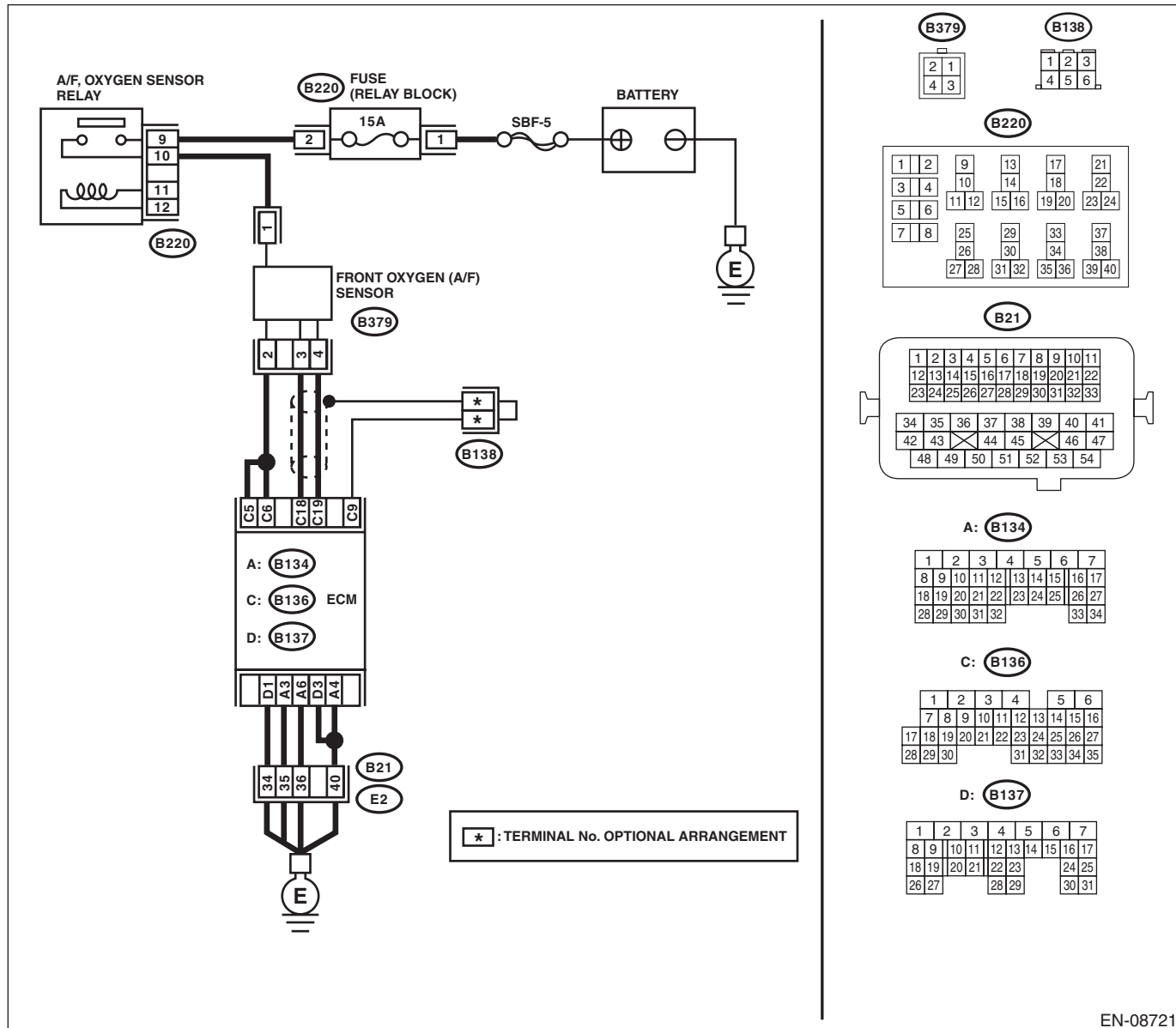

EN-08721

# Diagnostic Procedure with Diagnostic Trouble Code (DTC)

ENGINE (DIAGNOSTICS)

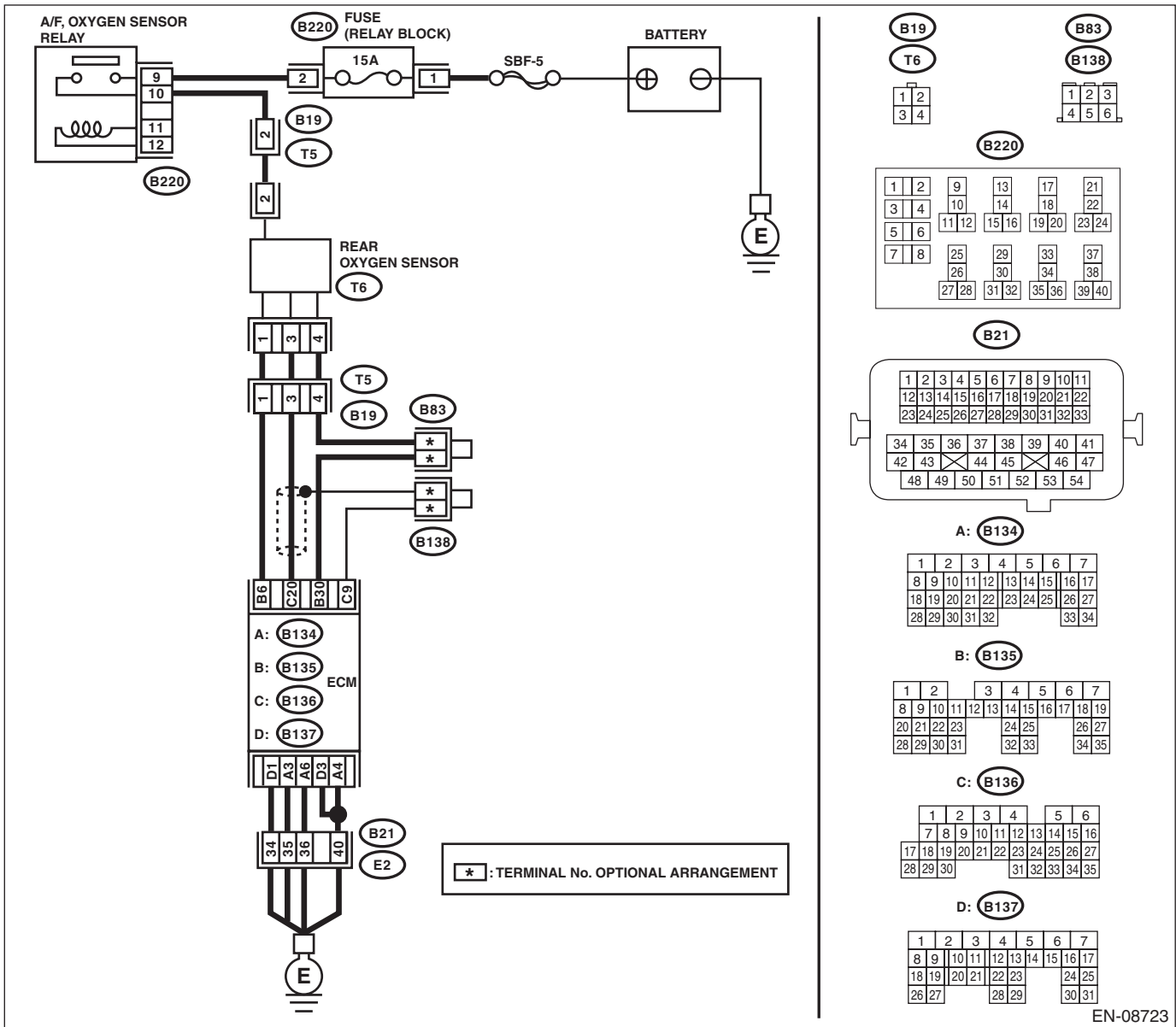

EN-08723

Step	Check	Yes	No
1	<b>CHECK FOR ANY OTHER DTC ON DISPLAY.</b> Is any other DTC displayed?	Check DTC using "List of Diagnostic Trouble Code (DTC)". <Ref. to EN(H4DOTC)(diag)-88, List of Diagnostic Trouble Code (DTC).>	Go to step 2.
2	<b>CHECK FRONT OXYGEN (A/F) SENSOR CONNECTOR AND COUPLING CONNECTOR.</b> Has water entered the connector?	Completely remove any water inside.	Go to step 3.



# Diagnostic Procedure with Diagnostic Trouble Code (DTC)

## ENGINE (DIAGNOSTICS)

Step	Check	Yes	No
<b>3</b> <b>CHECK HARNESS BETWEEN ECM AND FRONT OXYGEN (A/F) SENSOR CONNECTOR.</b> 1) Turn the ignition switch to OFF. 2) Disconnect the connectors from ECM and front oxygen (A/F) sensor. 3) Measure the resistance of harness between ECM and front oxygen (A/F) sensor connector. <b>Connector &amp; terminal</b> <b>Models without SI-DRIVE</b> (B136) No. 19 — (E22) No. 1: (B136) No. 18 — (E22) No. 3: <b>Models with SI-DRIVE</b> (B136) No. 19 — (B379) No. 4: (B136) No. 18 — (B379) No. 3:	Is the resistance less than 1 $\Omega$ ?	Go to step 4.	Repair the harness and connector. NOTE: In this case, repair the following item: <ul style="list-style-type: none"> <li>• Open circuit in harness between ECM and front oxygen (A/F) sensor connector</li> <li>• Poor contact of front oxygen (A/F) sensor connector</li> <li>• Poor contact of ECM connector</li> <li>• Poor contact of coupling connector</li> </ul>
<b>4</b> <b>CHECK HARNESS BETWEEN ECM AND FRONT OXYGEN (A/F) SENSOR CONNECTOR.</b> Measure the resistance between ECM and chassis ground. <b>Connector &amp; terminal</b> (B136) No. 19 — Chassis ground: (B136) No. 18 — Chassis ground:	Is the resistance 1 M $\Omega$ or more?	Go to step 5.	Repair the ground short circuit of harness between ECM and front oxygen (A/F) sensor connector.
<b>5</b> <b>CHECK OUTPUT SIGNAL FOR ECM.</b> 1) Connect the connector to ECM. 2) Turn the ignition switch to ON. 3) Measure the voltage between front oxygen (A/F) sensor connector and chassis ground. <b>Connector &amp; terminal</b> <b>Models without SI-DRIVE</b> (E22) No. 1 (+) — Chassis ground (-): <b>Models with SI-DRIVE</b> (B379) No. 4 (+) — Chassis ground (-):	Is the voltage 4.5 V or more?	Go to step 7.	Go to step 6.
<b>6</b> <b>CHECK OUTPUT SIGNAL FOR ECM.</b> Measure the voltage between front oxygen (A/F) sensor connector and chassis ground. <b>Connector &amp; terminal</b> <b>Models without SI-DRIVE</b> (E22) No. 3 (+) — Chassis ground (-): <b>Models with SI-DRIVE</b> (B379) No. 3 (+) — Chassis ground (-):	Is the voltage 4.95 V or more?	Go to step 7.	Go to step 8.
<b>7</b> <b>CHECK OUTPUT SIGNAL FOR ECM.</b> Measure the voltage between front oxygen (A/F) sensor connector and chassis ground. <b>Connector &amp; terminal</b> <b>Models without SI-DRIVE</b> (E22) No. 3 (+) — Chassis ground (-): (E22) No. 1 (+) — Chassis ground (-): <b>Models with SI-DRIVE</b> (B379) No. 3 (+) — Chassis ground (-): (B379) No. 4 (+) — Chassis ground (-):	Is the voltage 8 V or more?	Repair the short circuit to power in the harness between ECM and front oxygen (A/F) sensor connector. After repair, replace the ECM. <Ref. to FU(STI)-59, Engine Control Module (ECM).> <Ref. to FU(w/o STI)-58, Engine Control Module (ECM).>	Repair the poor contact of ECM connector.
<b>8</b> <b>CHECK EXHAUST SYSTEM.</b>	Are there holes or loose bolts on exhaust system?	Repair the exhaust system.	Go to step 9.

# Diagnostic Procedure with Diagnostic Trouble Code (DTC)

ENGINE (DIAGNOSTICS)

Step	Check	Yes	No
9 <b>CHECK AIR INTAKE SYSTEM.</b>	Are there holes, loose bolts or disconnection of hose on air intake system?	Repair the air intake system.	Go to step 10.
10 <b>CHECK FUEL PRESSURE.</b> <b>WARNING:</b> Place "NO OPEN FLAMES" signs near the working area. <b>CAUTION:</b> Be careful not to spill fuel. 1) Connect the front oxygen (A/F) sensor connector. 2) Measure the fuel pressure while disconnecting pressure regulator vacuum hose from intake manifold. <Ref. to ME(STI)-25, INSPECTION, Fuel Pressure.> <Ref. to ME(w/o STI)-25, INSPECTION, Fuel Pressure.> <b>CAUTION:</b> Release fuel pressure before removing the fuel pressure gauge. NOTE: If fuel pressure does not increase, squeeze the fuel return hose 2 to 3 times, then measure fuel pressure again.	Is the measured value 284 — 314 kPa (2.9 — 3.2 kgf/cm <sup>2</sup> , 41 — 46 psi)?	Go to step 11.	Repair the following item. Fuel pressure is too high: • Clogged fuel return line or bent hose Fuel pressure is too low: • Improper fuel pump discharge • Clogged fuel supply line
11 <b>CHECK FUEL PRESSURE.</b> After connecting the pressure regulator vacuum hose, measure fuel pressure. <Ref. to ME(STI)-25, INSPECTION, Fuel Pressure.> <Ref. to ME(w/o STI)-25, INSPECTION, Fuel Pressure.> <b>CAUTION:</b> Release fuel pressure before removing the fuel pressure gauge. NOTE: • If fuel pressure does not increase, squeeze fuel return hose 2 to 3 times, then measure fuel pressure again. • If the measured value at this step is out of specification, check or replace pressure regulator and pressure regulator vacuum hose.	Is the measured value 230 — 260 kPa (2.35 — 2.65 kgf/cm <sup>2</sup> , 33 — 38 psi)?	Go to step 12.	Repair the following item. Fuel pressure is too high: • Faulty pressure regulator • Clogged fuel return line or bent hose Fuel pressure is too low: • Faulty pressure regulator • Improper fuel pump discharge • Clogged fuel supply line
12 <b>CHECK ENGINE COOLANT TEMPERATURE SENSOR.</b> 1) Start the engine and warm up completely. 2) Read the value of «Coolant Temp.» using the Subaru Select Monitor or a general scan tool. NOTE: • Subaru Select Monitor For detailed operation procedures, refer to "READ CURRENT DATA FOR ENGINE". <Ref. to EN(H4DOTC)(diag)-40, Subaru Select Monitor.> • General scan tool For detailed operation procedures, refer to the general scan tool operation manual.	Is the value of «Coolant Temp.» 75°C (167°F) or more?	Go to step 13.	Replace the engine coolant temperature sensor. <Ref. to FU(STI)-34, Engine Coolant Temperature Sensor.> <Ref. to FU(w/o STI)-35, Engine Coolant Temperature Sensor.>

# Diagnostic Procedure with Diagnostic Trouble Code (DTC)

## ENGINE (DIAGNOSTICS)

Step	Check	Yes	No
<p><b>13 CHECK MASS AIR FLOW AND INTAKE AIR TEMPERATURE SENSOR.</b></p> <p>1) Start the engine and warm up engine until coolant temperature is higher than 75°C (167°F).</p> <p>2) Place the shift lever in neutral position.</p> <p>3) Turn the A/C switch to OFF.</p> <p>4) Turn all the accessory switches to OFF.</p> <p>5) Read the value of «Mass Air Flow» using the Subaru Select Monitor or a general scan tool.</p> <p>NOTE:</p> <ul style="list-style-type: none"> <li>• Subaru Select Monitor</li> </ul> <p>For detailed operation procedures, refer to "READ CURRENT DATA FOR ENGINE". &lt;Ref. to EN(H4DOTC)(diag)-40, Subaru Select Monitor.&gt;</p> <ul style="list-style-type: none"> <li>• General scan tool</li> </ul> <p>For detailed operation procedures, refer to the general scan tool operation manual.</p>	<p>Is the value of «Mass Air Flow» 2.0 — 5.0 g/s (0.26 — 0.66 lb/m)?</p>	Go to step 14.	<p>Replace the mass air flow and intake air temperature sensor. &lt;Ref. to FU(STI)-42, Mass Air Flow and Intake Air Temperature Sensor.&gt; &lt;Ref. to FU(w/o STI)-43, Mass Air Flow and Intake Air Temperature Sensor.&gt;</p>
<p><b>14 CHECK MASS AIR FLOW AND INTAKE AIR TEMPERATURE SENSOR.</b></p> <p>1) Start the engine and warm up engine until coolant temperature is higher than 75°C (167°F).</p> <p>2) Place the shift lever in neutral position.</p> <p>3) Turn the A/C switch to OFF.</p> <p>4) Turn all the accessory switches to OFF.</p> <p>5) Open the front hood.</p> <p>6) Measure the ambient temperature.</p> <p>7) Read the value of «Intake Air Temp.» using the Subaru Select Monitor or a general scan tool.</p> <p>NOTE:</p> <ul style="list-style-type: none"> <li>• Subaru Select Monitor</li> </ul> <p>For detailed operation procedures, refer to "READ CURRENT DATA FOR ENGINE". &lt;Ref. to EN(H4DOTC)(diag)-40, Subaru Select Monitor.&gt;</p> <ul style="list-style-type: none"> <li>• General scan tool</li> </ul> <p>For detailed operation procedures, refer to the general scan tool operation manual.</p>	<p>Subtract ambient temperature from «Intake Air Temp.». Is the obtained value -10 — 50°C (-18 — 90°F)?</p>	Go to step 15.	<p>Check the mass air flow and intake air temperature sensor. &lt;Ref. to FU(STI)-42, Mass Air Flow and Intake Air Temperature Sensor.&gt; &lt;Ref. to FU(w/o STI)-43, Mass Air Flow and Intake Air Temperature Sensor.&gt;</p>
<p><b>15 CHECK REAR OXYGEN SENSOR DATA.</b></p> <p>1) Warm up the engine until engine coolant temperature is higher than 75°C (167°F), and keep the engine speed at 3,000 rpm. (2 minutes maximum)</p> <p>2) Read the value of «Rear O2 Sensor» using the Subaru Select Monitor or a general scan tool.</p> <p>NOTE:</p> <ul style="list-style-type: none"> <li>• Depress the clutch pedal.</li> <li>• Subaru Select Monitor</li> </ul> <p>For detailed operation procedures, refer to "READ CURRENT DATA FOR ENGINE". &lt;Ref. to EN(H4DOTC)(diag)-40, Subaru Select Monitor.&gt;</p> <ul style="list-style-type: none"> <li>• General scan tool</li> </ul> <p>For detailed operation procedures, refer to the general scan tool operation manual.</p>	<p>Is the value of «Rear O2 Sensor» 0.490 V or more?</p>	Go to step 16.	Go to step 17.

# Diagnostic Procedure with Diagnostic Trouble Code (DTC)

ENGINE (DIAGNOSTICS)

Step	Check	Yes	No
<p><b>16 CHECK REAR OXYGEN SENSOR DATA.</b></p> <p>1) Warm up the engine until engine coolant temperature is higher than 75°C (167°F), and rapidly reduce the engine speed from 3,000 rpm.</p> <p>2) Read the value of «Rear O2 Sensor» using the Subaru Select Monitor or a general scan tool.</p> <p>NOTE:</p> <ul style="list-style-type: none"> <li>• Depress the clutch pedal.</li> <li>• Subaru Select Monitor</li> </ul> <p>For detailed operation procedures, refer to "READ CURRENT DATA FOR ENGINE". &lt;Ref. to EN(H4DOTC)(diag)-40, Subaru Select Monitor.&gt;</p> <ul style="list-style-type: none"> <li>• General scan tool</li> </ul> <p>For detailed operation procedures, refer to the general scan tool operation manual.</p>	<p>Is the value of «Rear O2 Sensor» 0.250 V or less?</p>	<p>Go to step 18.</p>	<p>Go to step 17.</p>
<p><b>17 CHECK REAR OXYGEN SENSOR CONNECTOR AND COUPLING CONNECTOR.</b></p>	<p>Has water entered the connector?</p>	<p>Completely remove any water inside.</p>	<p>Go to step 19.</p>
<p><b>18 CHECK FRONT OXYGEN (A/F) SENSOR USING REAR OXYGEN SENSOR SIGNAL.</b></p> <p>1) Warm up the engine until engine coolant temperature is higher than 75°C (167°F), then keep the engine idling for 5 minutes or more.</p> <p>2) Read the value of «Rear O2 Sensor» using the Subaru Select Monitor or a general scan tool.</p> <p>NOTE:</p> <ul style="list-style-type: none"> <li>• Subaru Select Monitor</li> </ul> <p>For detailed operation procedures, refer to "READ CURRENT DATA FOR ENGINE". &lt;Ref. to EN(H4DOTC)(diag)-40, Subaru Select Monitor.&gt;</p> <ul style="list-style-type: none"> <li>• General scan tool</li> </ul> <p>For detailed operation procedures, refer to the general scan tool operation manual.</p>	<p>Is the value in «Rear O2 Sensor» kept at 0.250 V or less for 5 minutes or more?</p>	<p>Replace the front oxygen (A/F) sensor. &lt;Ref. to FU(STI)-54, Front Oxygen (A/F) Sensor.&gt; &lt;Ref. to FU(w/o STI)-54, Front Oxygen (A/F) Sensor.&gt;</p>	<p>Go to step 19.</p>
<p><b>19 CHECK HARNESS BETWEEN ECM AND REAR OXYGEN SENSOR CONNECTOR.</b></p> <p>1) Turn the ignition switch to OFF.</p> <p>2) Disconnect the connector from ECM and rear oxygen sensor.</p> <p>3) Measure the resistance of harness between ECM and rear oxygen sensor connector.</p> <p><b>Connector &amp; terminal</b></p> <p><b>(B136) No. 20 — (T6) No. 3:</b></p> <p><b>(B135) No. 30 — (T6) No. 4:</b></p>	<p>Is the resistance less than 1 Ω?</p>	<p>Go to step 20.</p>	<p>Repair the harness and connector.</p> <p>NOTE:</p> <p>In this case, repair the following item:</p> <ul style="list-style-type: none"> <li>• Open circuit in harness between ECM and rear oxygen sensor connector</li> <li>• Poor contact of coupling connector</li> </ul>

# Diagnostic Procedure with Diagnostic Trouble Code (DTC)

## ENGINE (DIAGNOSTICS)

Step	Check	Yes	No
<b>20</b> <b>CHECK HARNESS BETWEEN ECM AND REAR OXYGEN SENSOR CONNECTOR.</b> 1) Connect the connector to ECM. 2) Turn the ignition switch to ON. 3) Measure the voltage between rear oxygen sensor connector and chassis ground. <b>Connector &amp; terminal</b> <b>(T6) No. 3 (+) — Chassis ground (-):</b>	Is the voltage 0.2 — 0.5 V?	Replace the rear oxygen sensor. <Ref. to FU(STI)-56, Rear Oxygen Sensor.> <Ref. to FU(w/o STI)-56, Rear Oxygen Sensor.>	Repair the harness and connector. <b>NOTE:</b> In this case, repair the following item: • Open circuit in harness between ECM and rear oxygen sensor connector • Poor contact of ECM connector • Poor contact of coupling connector

# Diagnostic Procedure with Diagnostic Trouble Code (DTC)

ENGINE (DIAGNOSTICS)

## EF:DTC P2097 POST CATALYST FUEL TRIM SYSTEM TOO RICH (BANK 1)

### DTC DETECTING CONDITION:

- Detected when two consecutive driving cycles with fault occur.
- GENERAL DESCRIPTION <Ref. to GD(H4DOTC)-239, DTC P2097 POST CATALYST FUEL TRIM SYSTEM TOO RICH (BANK 1), Diagnostic Trouble Code (DTC) Detecting Criteria.>

### CAUTION:

After servicing or replacing faulty parts, perform Clear Memory Mode <Ref. to EN(H4DOTC)(diag)-62, OPERATION, Clear Memory Mode.>, and Inspection Mode <Ref. to EN(H4DOTC)(diag)-48, PROCEDURE, Inspection Mode.>.

### WIRING DIAGRAM:

- Models without SI-DRIVE

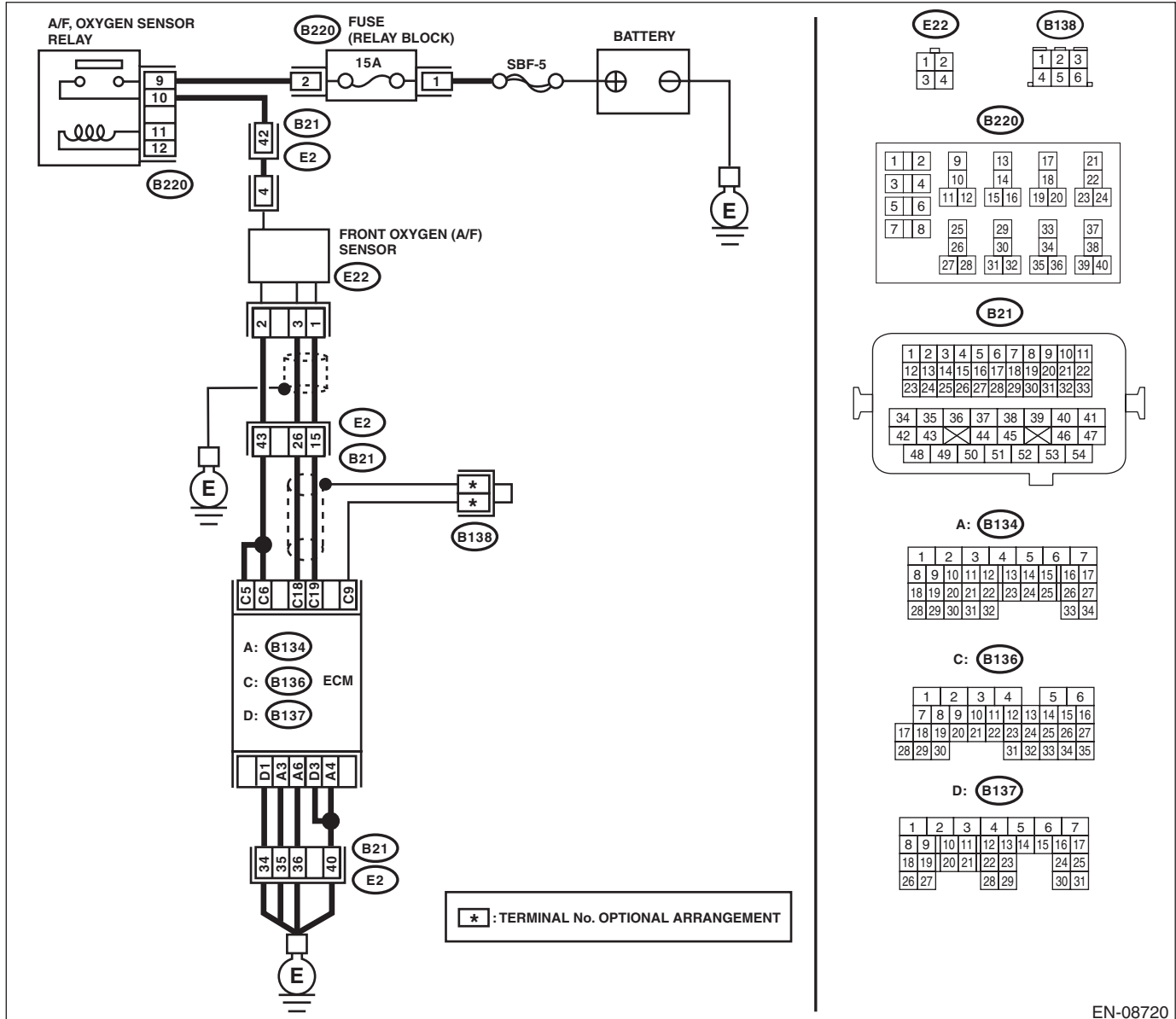

# Diagnostic Procedure with Diagnostic Trouble Code (DTC)

## ENGINE (DIAGNOSTICS)

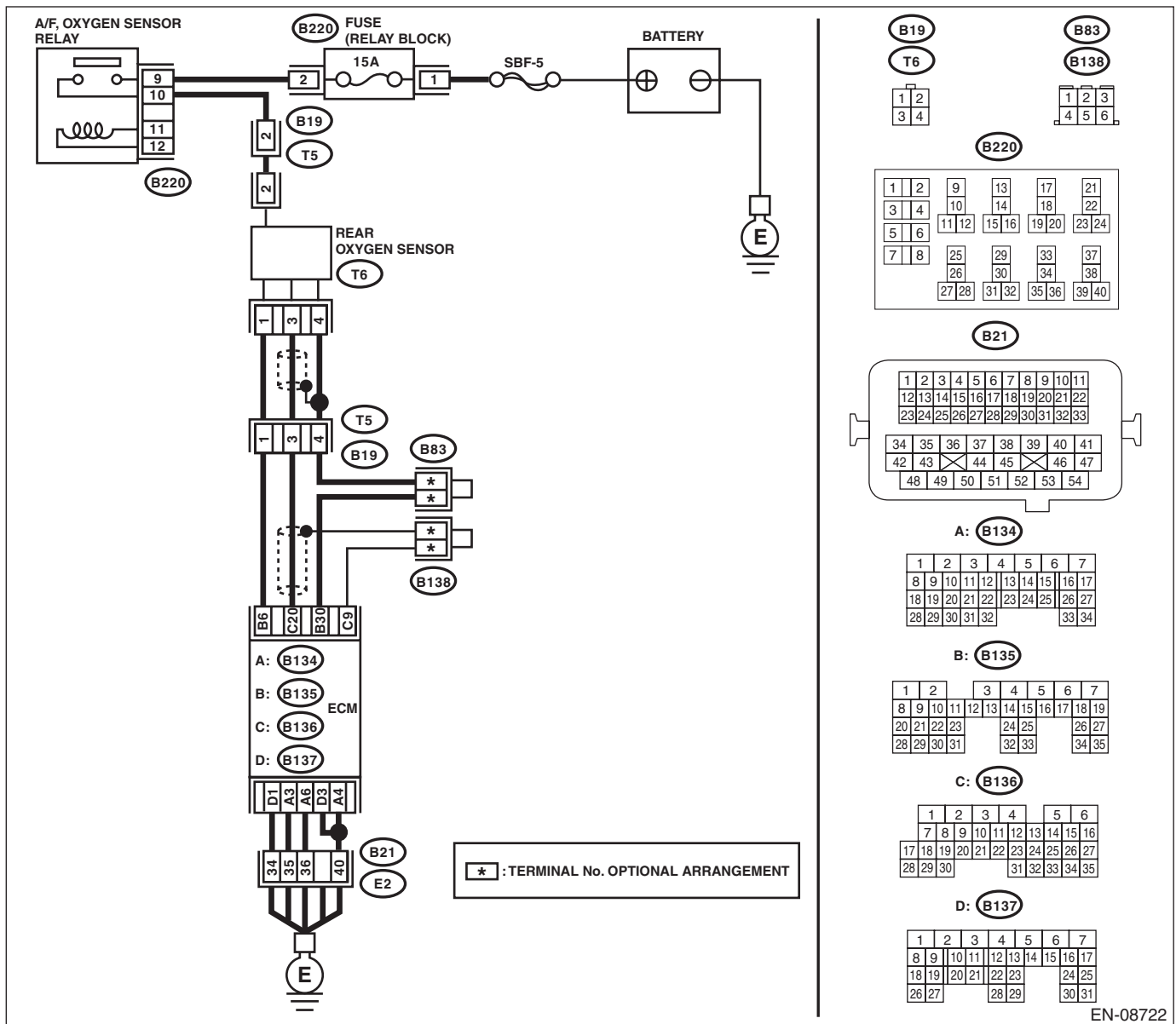

EN-08722

# Diagnostic Procedure with Diagnostic Trouble Code (DTC)

ENGINE (DIAGNOSTICS)

- Models with SI-DRIVE

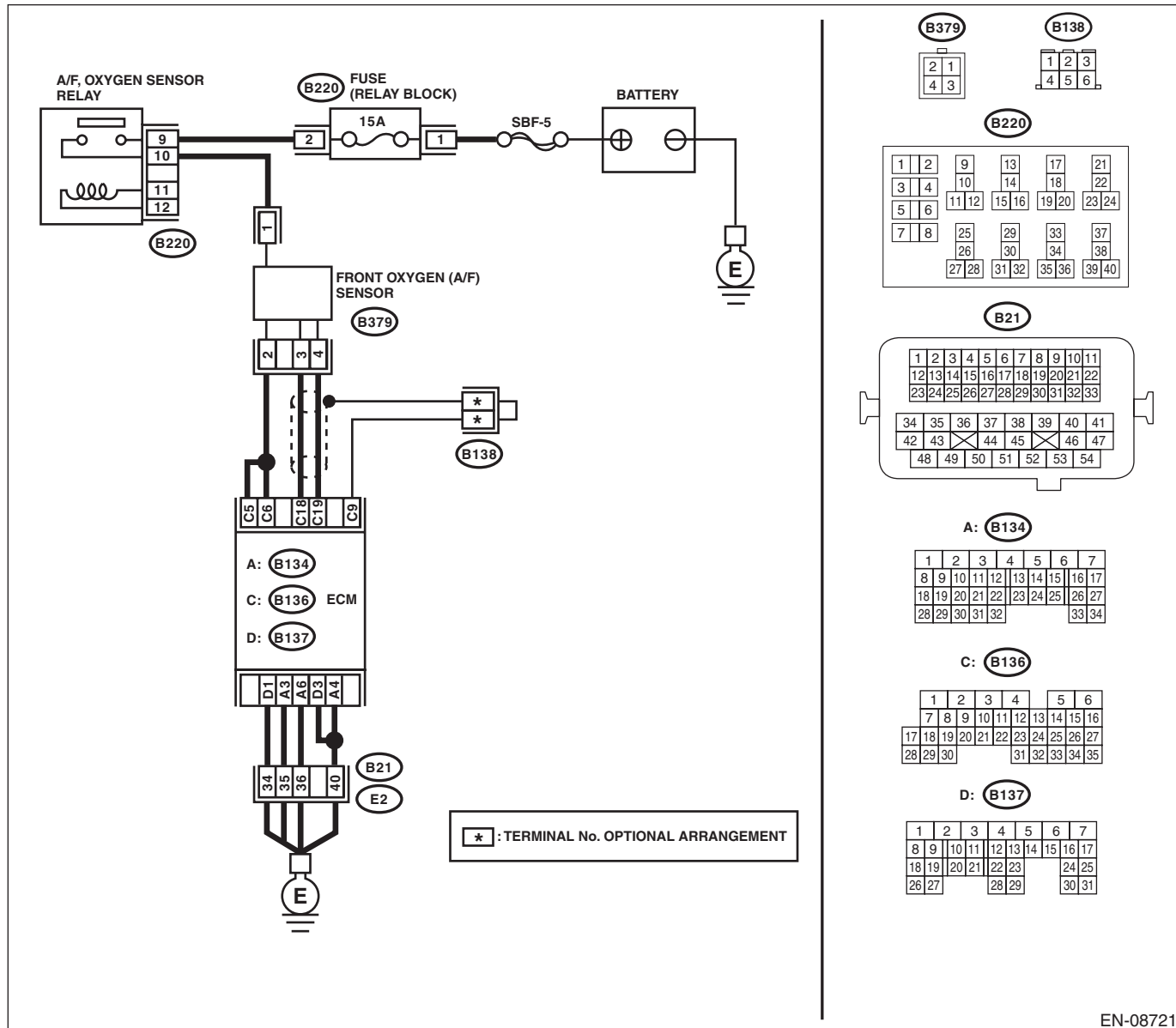

EN-08721



# Diagnostic Procedure with Diagnostic Trouble Code (DTC)

## ENGINE (DIAGNOSTICS)

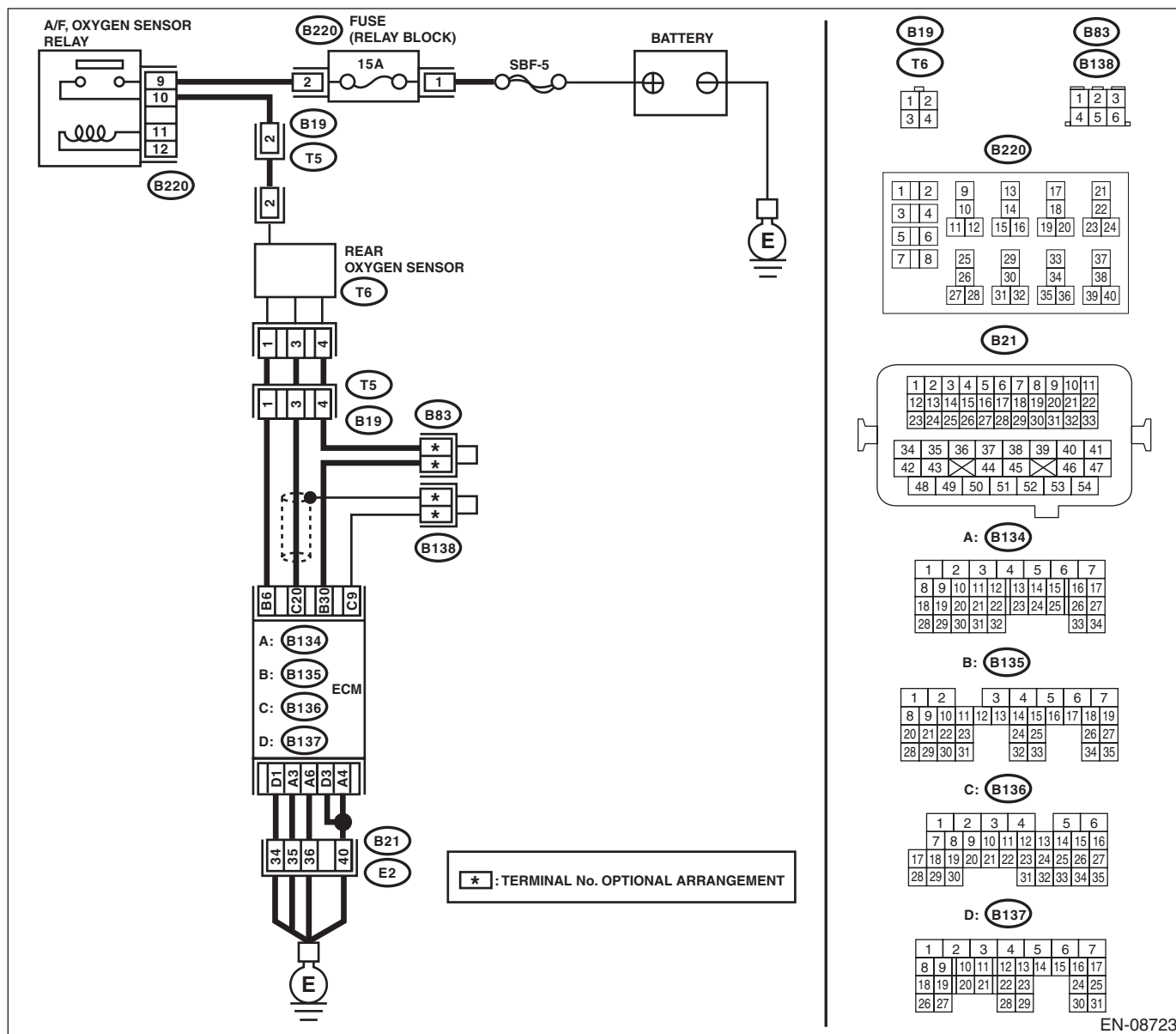

EN-08723

Step	Check	Yes	No
1	<b>CHECK FOR ANY OTHER DTC ON DISPLAY.</b> Is any other DTC displayed?	Check DTC using "List of Diagnostic Trouble Code (DTC)". <Ref. to EN(H4DOTC)(diag)-88, List of Diagnostic Trouble Code (DTC).>	Go to step 2.
2	<b>CHECK FRONT OXYGEN (A/F) SENSOR CONNECTOR AND COUPLING CONNECTOR.</b> Has water entered the connector?	Completely remove any water inside.	Go to step 3.

# Diagnostic Procedure with Diagnostic Trouble Code (DTC)

ENGINE (DIAGNOSTICS)

Step	Check	Yes	No
<p><b>3</b></p> <p><b>CHECK HARNESS BETWEEN ECM AND FRONT OXYGEN (A/F) SENSOR CONNECTOR.</b></p> <p>1) Turn the ignition switch to OFF. 2) Disconnect the connectors from ECM and front oxygen (A/F) sensor. 3) Measure the resistance of harness between ECM and front oxygen (A/F) sensor connector.</p> <p><b>Connector &amp; terminal</b> <b>Models without SI-DRIVE</b> (B136) No. 19 — (E22) No. 1: (B136) No. 18 — (E22) No. 3: <b>Models with SI-DRIVE</b> (B136) No. 19 — (B379) No. 4: (B136) No. 18 — (B379) No. 3:</p>	Is the resistance less than 1 Ω?	Go to step 4.	Repair the open circuit of harness between ECM and front oxygen (A/F) sensor connector.
<p><b>4</b></p> <p><b>CHECK HARNESS BETWEEN ECM AND FRONT OXYGEN (A/F) SENSOR CONNECTOR.</b></p> <p>Measure the resistance between ECM and chassis ground.</p> <p><b>Connector &amp; terminal</b> (B136) No. 19 — Chassis ground: (B136) No. 18 — Chassis ground:</p>	Is the resistance 1 MΩ or more?	Go to step 5.	Repair the ground short circuit of harness between ECM and front oxygen (A/F) sensor connector.
<p><b>5</b></p> <p><b>CHECK OUTPUT SIGNAL FOR ECM.</b></p> <p>1) Connect the connector to ECM. 2) Turn the ignition switch to ON. 3) Measure the voltage between front oxygen (A/F) sensor connector and chassis ground.</p> <p><b>Connector &amp; terminal</b> <b>Models without SI-DRIVE</b> (E22) No. 1 (+) — Chassis ground (-): <b>Models with SI-DRIVE</b> (B379) No. 4 (+) — Chassis ground (-):</p>	Is the voltage 4.5 V or more?	Go to step 7.	Go to step 6.
<p><b>6</b></p> <p><b>CHECK OUTPUT SIGNAL FOR ECM.</b></p> <p>Measure the voltage between front oxygen (A/F) sensor connector and chassis ground.</p> <p><b>Connector &amp; terminal</b> <b>Models without SI-DRIVE</b> (E22) No. 3 (+) — Chassis ground (-): <b>Models with SI-DRIVE</b> (B379) No. 3 (+) — Chassis ground (-):</p>	Is the voltage 4.95 V or more?	Go to step 7.	Go to step 8.
<p><b>7</b></p> <p><b>CHECK OUTPUT SIGNAL FOR ECM.</b></p> <p>Measure the voltage between front oxygen (A/F) sensor connector and chassis ground.</p> <p><b>Connector &amp; terminal</b> <b>Models without SI-DRIVE</b> (E22) No. 3 (+) — Chassis ground (-): (E22) No. 1 (+) — Chassis ground (-): <b>Models with SI-DRIVE</b> (B379) No. 3 (+) — Chassis ground (-): (B379) No. 4 (+) — Chassis ground (-):</p>	Is the voltage 8 V or more?	Repair the short circuit to power in the harness between ECM and front oxygen (A/F) sensor connector. After repair, replace the ECM. <Ref. to FU(STI)-59, Engine Control Module (ECM).> <Ref. to FU(w/o STI)-58, Engine Control Module (ECM).>	Repair the poor contact of ECM connector.
<p><b>8</b></p> <p><b>CHECK EXHAUST SYSTEM.</b></p>	Are there holes or loose bolts on exhaust system?	Repair the exhaust system.	Go to step 9.

# Diagnostic Procedure with Diagnostic Trouble Code (DTC)

## ENGINE (DIAGNOSTICS)

Step	Check	Yes	No
<b>9</b> <b>CHECK AIR INTAKE SYSTEM.</b>	Are there holes, loose bolts or disconnection of hose on air intake system?	Repair the air intake system.	Go to step 10.
<b>10</b> <b>CHECK FUEL PRESSURE.</b> <b>WARNING:</b> Place "NO OPEN FLAMES" signs near the working area. <b>CAUTION:</b> Be careful not to spill fuel. 1) Connect the front oxygen (A/F) sensor connector. 2) Measure the fuel pressure while disconnecting pressure regulator vacuum hose from intake manifold. <Ref. to ME(STI)-25, INSPECTION, Fuel Pressure.> <Ref. to ME(w/o STI)-25, INSPECTION, Fuel Pressure.> <b>CAUTION:</b> Release fuel pressure before removing the fuel pressure gauge. NOTE: If fuel pressure does not increase, squeeze the fuel return hose 2 to 3 times, then measure fuel pressure again.	Is the measured value 284 — 314 kPa (2.9 — 3.2 kgf/cm <sup>2</sup> , 41 — 46 psi)?	Go to step 11.	Repair the following item. Fuel pressure is too high: • Clogged fuel return line or bent hose Fuel pressure is too low: • Improper fuel pump discharge • Clogged fuel supply line
<b>11</b> <b>CHECK FUEL PRESSURE.</b> After connecting the pressure regulator vacuum hose, measure fuel pressure. <Ref. to ME(STI)-25, INSPECTION, Fuel Pressure.> <Ref. to ME(w/o STI)-25, INSPECTION, Fuel Pressure.> <b>CAUTION:</b> Release fuel pressure before removing the fuel pressure gauge. NOTE: • If fuel pressure does not increase, squeeze fuel return hose 2 to 3 times, then measure fuel pressure again. • If the measured value at this step is out of specification, check or replace pressure regulator and pressure regulator vacuum hose.	Is the measured value 230 — 260 kPa (2.35 — 2.65 kgf/cm <sup>2</sup> , 33 — 38 psi)?	Go to step 12.	Repair the following item. Fuel pressure is too high: • Faulty pressure regulator • Clogged fuel return line or bent hose Fuel pressure is too low: • Faulty pressure regulator • Improper fuel pump discharge • Clogged fuel supply line
<b>12</b> <b>CHECK ENGINE COOLANT TEMPERATURE SENSOR.</b> 1) Start the engine and warm up completely. 2) Read the value of «Coolant Temp.» using the Subaru Select Monitor or a general scan tool. NOTE: • Subaru Select Monitor For detailed operation procedures, refer to "READ CURRENT DATA FOR ENGINE". <Ref. to EN(H4DOTC)(diag)-40, Subaru Select Monitor.> • General scan tool For detailed operation procedures, refer to the general scan tool operation manual.	Is the value of «Coolant Temp.» 75°C (167°F) or more?	Go to step 13.	Replace the engine coolant temperature sensor. <Ref. to FU(STI)-34, Engine Coolant Temperature Sensor.> <Ref. to FU(w/o STI)-35, Engine Coolant Temperature Sensor.>

# Diagnostic Procedure with Diagnostic Trouble Code (DTC)

ENGINE (DIAGNOSTICS)

Step	Check	Yes	No
<p><b>13 CHECK MASS AIR FLOW AND INTAKE AIR TEMPERATURE SENSOR.</b></p> <p>1) Start the engine and warm up engine until coolant temperature is higher than 75°C (167°F).</p> <p>2) Place the shift lever in neutral position.</p> <p>3) Turn the A/C switch to OFF.</p> <p>4) Turn all the accessory switches to OFF.</p> <p>5) Read the value of «Mass Air Flow» using the Subaru Select Monitor or a general scan tool.</p> <p>NOTE:</p> <ul style="list-style-type: none"> <li>• Subaru Select Monitor</li> </ul> <p>For detailed operation procedures, refer to "READ CURRENT DATA FOR ENGINE". &lt;Ref. to EN(H4DOTC)(diag)-40, Subaru Select Monitor.&gt;</p> <ul style="list-style-type: none"> <li>• General scan tool</li> </ul> <p>For detailed operation procedures, refer to the general scan tool operation manual.</p>	<p>Is the value of «Mass Air Flow» 2.0 — 5.0 g/s (0.26 — 0.66 lb/m)?</p>	<p>Go to step 14.</p>	<p>Replace the mass air flow and intake air temperature sensor. &lt;Ref. to FU(STI)-42, Mass Air Flow and Intake Air Temperature Sensor.&gt; &lt;Ref. to FU(w/o STI)-43, Mass Air Flow and Intake Air Temperature Sensor.&gt;</p>
<p><b>14 CHECK MASS AIR FLOW AND INTAKE AIR TEMPERATURE SENSOR.</b></p> <p>1) Start the engine and warm up engine until coolant temperature is higher than 75°C (167°F).</p> <p>2) Place the shift lever in neutral position.</p> <p>3) Turn the A/C switch to OFF.</p> <p>4) Turn all the accessory switches to OFF.</p> <p>5) Open the front hood.</p> <p>6) Measure the ambient temperature.</p> <p>7) Read the value of «Intake Air Temp.» using the Subaru Select Monitor or a general scan tool.</p> <p>NOTE:</p> <ul style="list-style-type: none"> <li>• Subaru Select Monitor</li> </ul> <p>For detailed operation procedures, refer to "READ CURRENT DATA FOR ENGINE". &lt;Ref. to EN(H4DOTC)(diag)-40, Subaru Select Monitor.&gt;</p> <ul style="list-style-type: none"> <li>• General scan tool</li> </ul> <p>For detailed operation procedures, refer to the general scan tool operation manual.</p>	<p>Subtract ambient temperature from «Intake Air Temp.». Is the obtained value -10 — 50°C (-18 — 90°F)?</p>	<p>Go to step 15.</p>	<p>Check the mass air flow and intake air temperature sensor. &lt;Ref. to FU(STI)-42, Mass Air Flow and Intake Air Temperature Sensor.&gt; &lt;Ref. to FU(w/o STI)-43, Mass Air Flow and Intake Air Temperature Sensor.&gt;</p>
<p><b>15 CHECK REAR OXYGEN SENSOR DATA.</b></p> <p>1) Warm up the engine until engine coolant temperature is higher than 75°C (167°F), and keep the engine speed at 3,000 rpm. (2 minutes maximum)</p> <p>2) Read the value of «Rear O2 Sensor» using the Subaru Select Monitor or a general scan tool.</p> <p>NOTE:</p> <ul style="list-style-type: none"> <li>• Depress the clutch pedal.</li> <li>• Subaru Select Monitor</li> </ul> <p>For detailed operation procedures, refer to "READ CURRENT DATA FOR ENGINE". &lt;Ref. to EN(H4DOTC)(diag)-40, Subaru Select Monitor.&gt;</p> <ul style="list-style-type: none"> <li>• General scan tool</li> </ul> <p>For detailed operation procedures, refer to the general scan tool operation manual.</p>	<p>Is the value of «Rear O2 Sensor» 0.490 V or more?</p>	<p>Go to step 16.</p>	<p>Go to step 17.</p>

**EN(H4DOTC)(diag)-361**

Brought to you by Ebay Seller "SubaruManuals"

# Diagnostic Procedure with Diagnostic Trouble Code (DTC)

## ENGINE (DIAGNOSTICS)

Step	Check	Yes	No
<p><b>16 CHECK REAR OXYGEN SENSOR DATA.</b></p> <p>1) Warm up the engine until engine coolant temperature is higher than 75°C (167°F), and rapidly reduce the engine speed from 3,000 rpm.</p> <p>2) Read the value of «Rear O2 Sensor» using the Subaru Select Monitor or a general scan tool.</p> <p>NOTE:</p> <ul style="list-style-type: none"> <li>• Depress the clutch pedal.</li> <li>• Subaru Select Monitor</li> </ul> <p>For detailed operation procedures, refer to "READ CURRENT DATA FOR ENGINE". &lt;Ref. to EN(H4DOTC)(diag)-40, Subaru Select Monitor.&gt;</p> <ul style="list-style-type: none"> <li>• General scan tool</li> </ul> <p>For detailed operation procedures, refer to the general scan tool operation manual.</p>	<p>Is the value of «Rear O2 Sensor» 0.250 V or less?</p>	<p>Go to step 18.</p>	<p>Go to step 17.</p>
<p><b>17 CHECK REAR OXYGEN SENSOR CONNECTOR AND COUPLING CONNECTOR.</b></p>	<p>Has water entered the connector?</p>	<p>Completely remove any water inside.</p>	<p>Go to step 19.</p>
<p><b>18 CHECK FRONT OXYGEN (A/F) SENSOR USING REAR OXYGEN SENSOR SIGNAL.</b></p> <p>1) Warm up the engine until engine coolant temperature is higher than 75°C (167°F), then keep the engine idling for 5 minutes or more.</p> <p>2) Read the value of «Rear O2 Sensor» using the Subaru Select Monitor or a general scan tool.</p> <p>NOTE:</p> <ul style="list-style-type: none"> <li>• Subaru Select Monitor</li> </ul> <p>For detailed operation procedures, refer to "READ CURRENT DATA FOR ENGINE". &lt;Ref. to EN(H4DOTC)(diag)-40, Subaru Select Monitor.&gt;</p> <ul style="list-style-type: none"> <li>• General scan tool</li> </ul> <p>For detailed operation procedures, refer to the general scan tool operation manual.</p>	<p>Is the value in «Rear O2 Sensor» kept at 0.8 V or more for 5 minutes or more?</p>	<p>Replace the front oxygen (A/F) sensor. &lt;Ref. to FU(STI)-54, Front Oxygen (A/F) Sensor.&gt; &lt;Ref. to FU(w/o STI)-54, Front Oxygen (A/F) Sensor.&gt;</p>	<p>Go to step 19.</p>
<p><b>19 CHECK HARNESS BETWEEN ECM AND REAR OXYGEN SENSOR CONNECTOR.</b></p> <p>1) Turn the ignition switch to OFF.</p> <p>2) Disconnect the connector from ECM and rear oxygen sensor.</p> <p>3) Measure the resistance of harness between ECM and rear oxygen sensor connector.</p> <p><b>Connector &amp; terminal</b></p> <p><b>(B136) No. 20 — (T6) No. 3:</b></p> <p><b>(B135) No. 30 — (T6) No. 4:</b></p>	<p>Is the resistance less than 1 Ω?</p>	<p>Go to step 20.</p>	<p>Repair the harness and connector.</p> <p>NOTE:</p> <p>In this case, repair the following item:</p> <ul style="list-style-type: none"> <li>• Open circuit in harness between ECM and rear oxygen sensor connector</li> <li>• Poor contact of coupling connector</li> </ul>

# Diagnostic Procedure with Diagnostic Trouble Code (DTC)

ENGINE (DIAGNOSTICS)

Step	Check	Yes	No
<p><b>20</b>     <b>CHECK HARNESS BETWEEN ECM AND REAR OXYGEN SENSOR CONNECTOR.</b> 1) Connect the connector to ECM. 2) Turn the ignition switch to ON. 3) Measure the voltage between rear oxygen sensor connector and chassis ground. <b>Connector &amp; terminal</b> <b>(T6) No. 3 (+) — Chassis ground (-):</b></p>	<p>Is the voltage 0.2 — 0.5 V?</p>	<p>Replace the rear oxygen sensor. &lt;Ref. to FU(STI)-56, Rear Oxygen Sensor.&gt; &lt;Ref. to FU(w/o STI)-56, Rear Oxygen Sensor.&gt;</p>	<p>Repair the harness and connector. <b>NOTE:</b> In this case, repair the following item: • Open circuit in harness between ECM and rear oxygen sensor connector • Poor contact of ECM connector • Poor contact of coupling connector</p>

# Diagnostic Procedure with Diagnostic Trouble Code (DTC)

ENGINE (DIAGNOSTICS)

## EG:DTC P2101 THROTTLE ACTUATOR CONTROL MOTOR CIRCUIT RANGE/ PERFORMANCE

### DTC DETECTING CONDITION:

- Immediately at fault recognition
- GENERAL DESCRIPTION <Ref. to GD(H4DOTC)-241, DTC P2101 THROTTLE ACTUATOR CONTROL MOTOR CIRCUIT RANGE/PERFORMANCE, Diagnostic Trouble Code (DTC) Detecting Criteria.>

### TROUBLE SYMPTOM:

- Improper idling
- Poor driving performance
- Engine stalls.

### CAUTION:

After servicing or replacing faulty parts, perform Clear Memory Mode <Ref. to EN(H4DOTC)(diag)-62, OPERATION, Clear Memory Mode.>, and Inspection Mode <Ref. to EN(H4DOTC)(diag)-48, PROCEDURE, Inspection Mode.>.

### WIRING DIAGRAM:

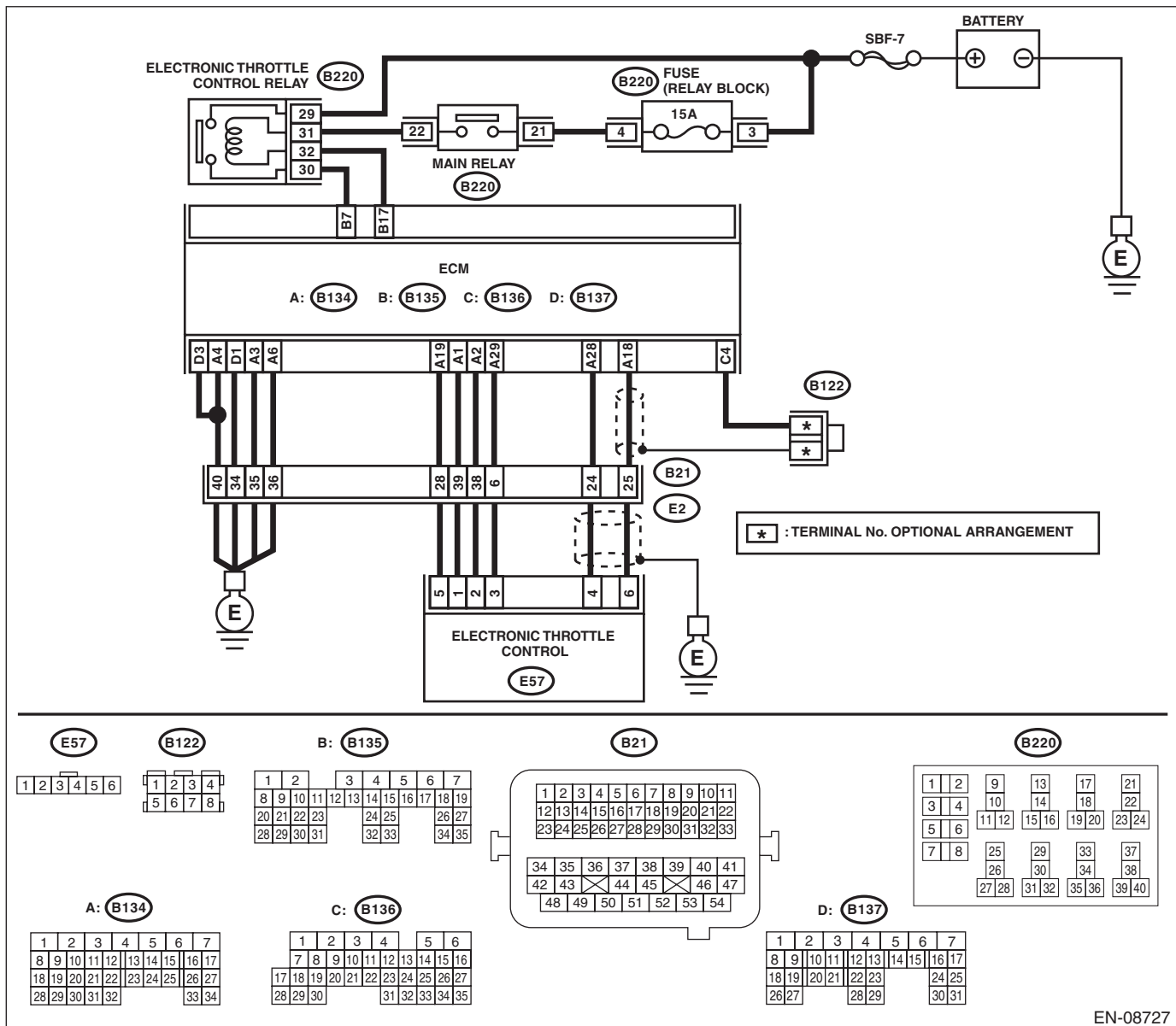

EN-08727

# Diagnostic Procedure with Diagnostic Trouble Code (DTC)

ENGINE (DIAGNOSTICS)

Step	Check	Yes	No
<p><b>1 CHECK ELECTRONIC THROTTLE CONTROL RELAY.</b></p> <p>1) Turn the ignition switch to OFF.                      2) Remove the electronic throttle control relay.                      3) Connect the battery to terminals No. 31 and No. 32 of electronic throttle control relay.                      4) Measure the resistance between electronic throttle control relay terminals.</p> <p><b>Terminals</b>  <b>No. 29 — No. 30:</b></p>	Is the resistance less than 1 Ω?	Go to step 2.	Replace the electronic throttle control relay. <Ref. to FU(STI)-64, Electronic Throttle Control Relay.> <Ref. to FU(w/o STI)-63, Electronic Throttle Control Relay.>
<p><b>2 CHECK POWER SUPPLY OF ELECTRONIC THROTTLE CONTROL RELAY.</b></p> <p>Measure the voltage between electronic throttle control relay connector and chassis ground.</p> <p><b>Connector &amp; terminal</b>  <b>(B220) No. 29 (+) — Chassis ground (-):</b></p>	Is the voltage 10 V or more?	Go to step 3.	Repair the open or ground short circuit of power supply circuit.
<p><b>3 CHECK HARNESS BETWEEN ECM AND ELECTRONIC THROTTLE CONTROL RELAY CONNECTOR.</b></p> <p>1) Disconnect the connector from ECM.                      2) Turn the ignition switch to ON.                      3) Measure the voltage between electronic throttle control relay connector and chassis ground.</p> <p><b>Connector &amp; terminal</b>  <b>(B220) No. 32 (+) — Chassis ground (-):</b></p>	Is the voltage 10 V or more?	Repair the short circuit to power in the harness between ECM and electronic throttle control relay connector.	Go to step 4.
<p><b>4 CHECK HARNESS BETWEEN ECM AND ELECTRONIC THROTTLE CONTROL RELAY CONNECTOR.</b></p> <p>1) Turn the ignition switch to OFF.                      2) Measure the resistance between electronic throttle control relay connector and chassis ground.</p> <p><b>Connector &amp; terminal</b>  <b>(B220) No. 32 — Chassis ground:</b>  <b>(B220) No. 30 — Chassis ground:</b></p>	Is the resistance 1 MΩ or more?	Go to step 5.	Repair the short circuit in harness to ground between ECM and electronic throttle control relay connector.
<p><b>5 CHECK HARNESS BETWEEN ECM AND ELECTRONIC THROTTLE CONTROL RELAY CONNECTOR.</b></p> <p>Measure the resistance between ECM and electronic throttle control relay connector.</p> <p><b>Connector &amp; terminal</b>  <b>(B135) No. 17 — (B220) No. 32:</b>  <b>(B135) No. 7 — (B220) No. 30:</b></p>	Is the resistance less than 1 Ω?	Go to step 6.	Repair the open circuit in harness between ECM and electronic throttle control relay connector.
<p><b>6 CHECK HARNESS BETWEEN ECM AND ELECTRONIC THROTTLE CONTROL CONNECTOR.</b></p> <p>1) Turn the ignition switch to OFF.                      2) Disconnect the connectors from electronic throttle control.                      3) Measure the resistance between ECM and chassis ground.</p> <p><b>Connector &amp; terminal</b>  <b>(B134) No. 19 — Chassis ground:</b>  <b>(B134) No. 18 — Chassis ground:</b>  <b>(B134) No. 18 — (B136) No. 4:</b>  <b>(B134) No. 28 — Chassis ground:</b></p>	Is the resistance 1 MΩ or more?	Go to step 7.	Repair the short circuit to ground in harness between ECM and electronic throttle control connector.



# Diagnostic Procedure with Diagnostic Trouble Code (DTC)

## ENGINE (DIAGNOSTICS)

Step	Check	Yes	No
<p><b>7</b></p> <p><b>CHECK SHORT CIRCUIT INSIDE THE ECM.</b></p> <p>1) Connect the connector to ECM. 2) Measure the resistance between electronic throttle control connector and engine ground.</p> <p><b>Connector &amp; terminal</b> <b>(E57) No. 6 — Engine ground:</b> <b>(E57) No. 4 — Engine ground:</b></p>	<p>Is the resistance 1 M<math>\Omega</math> or more?</p>	<p>Go to step 8.</p>	<p>Repair the short circuit to ground in harness between ECM and electronic throttle control connector. Replace the ECM if defective. &lt;Ref. to FU(STI)-59, Engine Control Module (ECM).&gt; &lt;Ref. to FU(w/o STI)-58, Engine Control Module (ECM).&gt;</p>
<p><b>8</b></p> <p><b>CHECK HARNESS BETWEEN ECM AND ELECTRONIC THROTTLE CONTROL CONNECTOR.</b></p> <p>1) Disconnect the connector from ECM. 2) Measure the resistance of harness between ECM and electronic throttle control connector.</p> <p><b>Connector &amp; terminal</b> <b>(B134) No. 18 — (E57) No. 6:</b> <b>(B134) No. 28 — (E57) No. 4:</b> <b>(B134) No. 29 — (E57) No. 3:</b></p>	<p>Is the resistance less than 1 <math>\Omega</math>?</p>	<p>Go to step 9.</p>	<p>Repair the harness and connector.</p> <p><b>NOTE:</b> In this case, repair the following item:</p> <ul style="list-style-type: none"> <li>• Open circuit in harness between ECM and electronic throttle control connector</li> <li>• Poor contact of coupling connector</li> </ul>
<p><b>9</b></p> <p><b>CHECK HARNESS BETWEEN ECM AND ELECTRONIC THROTTLE CONTROL CONNECTOR.</b></p> <p>1) Connect the connector to ECM. 2) Measure the resistance between electronic throttle control connector and engine ground.</p> <p><b>Connector &amp; terminal</b> <b>(E57) No. 3 — Engine ground:</b></p>	<p>Is the resistance less than 5 <math>\Omega</math>?</p>	<p>Go to step 10.</p>	<p>Repair the harness and connector.</p> <p><b>NOTE:</b> In this case, repair the following item:</p> <ul style="list-style-type: none"> <li>• Open circuit of harness between ECM and engine ground</li> <li>• Poor contact of ECM connector</li> <li>• Poor contact of coupling connector</li> </ul>
<p><b>10</b></p> <p><b>CHECK HARNESS BETWEEN ECM AND ELECTRONIC THROTTLE CONTROL CONNECTOR.</b></p> <p>1) Turn the ignition switch to ON. 2) Measure the voltage between electronic throttle control connector and engine ground.</p> <p><b>Connector &amp; terminal</b> <b>(E57) No. 6 (+) — Engine ground (-):</b> <b>(E57) No. 4 (+) — Engine ground (-):</b></p>	<p>Is the voltage 5 V or more?</p>	<p>Repair the short circuit to power in harness between ECM and electronic throttle control connector.</p>	<p>Go to step 11.</p>
<p><b>11</b></p> <p><b>CHECK HARNESS BETWEEN ECM AND ELECTRONIC THROTTLE CONTROL CONNECTOR.</b></p> <p>1) Turn the ignition switch to OFF. 2) Disconnect the connector from ECM. 3) Measure the resistance between ECM connectors.</p> <p><b>Connector &amp; terminal</b> <b>(B134) No. 19 — (B134) No. 18:</b> <b>(B134) No. 19 — (B134) No. 28:</b></p>	<p>Is the resistance 1 M<math>\Omega</math> or more?</p>	<p>Go to step 12.</p>	<p>Repair the short circuit to power in harness between ECM and electronic throttle control connector.</p>

# Diagnostic Procedure with Diagnostic Trouble Code (DTC)

ENGINE (DIAGNOSTICS)

Step	Check	Yes	No
<p><b>12 CHECK SENSOR OUTPUT.</b></p> <p>1) Connect all connectors. 2) Turn the ignition switch to ON. 3) Read the value of «Main-Throttle Sensor» using Subaru Select Monitor.</p> <p>NOTE: For detailed operation procedures, refer to "READ CURRENT DATA FOR ENGINE". &lt;Ref. to EN(H4DOTC)(diag)-40, Subaru Select Monitor.&gt;</p>	Is the value of «Main-Throttle Sensor» 0.81 — 0.87 V?	Go to step 13.	Repair the poor contact of electronic throttle control connector. Replace the electronic throttle control if defective. <Ref. to FU(STI)-15, Throttle Body.> <Ref. to FU(w/o STI)-15, Throttle Body.>
<p><b>13 CHECK SENSOR OUTPUT.</b></p> <p>Read the value of «Sub-Throttle Sensor» using Subaru Select Monitor.</p> <p>NOTE: For detailed operation procedures, refer to "READ CURRENT DATA FOR ENGINE". &lt;Ref. to EN(H4DOTC)(diag)-40, Subaru Select Monitor.&gt;</p>	Is the value of «Sub-Throttle Sensor» 1.64 — 1.70 V?	Go to step 14.	Repair the poor contact of electronic throttle control connector. Replace the electronic throttle control if defective. <Ref. to FU(STI)-15, Throttle Body.> <Ref. to FU(w/o STI)-15, Throttle Body.>
<p><b>14 CHECK HARNESS BETWEEN ECM AND ELECTRONIC THROTTLE CONTROL MOTOR.</b></p> <p>1) Turn the ignition switch to OFF. 2) Disconnect the connectors from ECM and electronic throttle control. 3) Measure the resistance between ECM and electronic throttle control connector.</p> <p><b>Connector &amp; terminal</b> <b>(B134) No. 2 — (E57) No. 2:</b> <b>(B134) No. 1 — (E57) No. 1:</b></p>	Is the resistance less than 1 Ω?	Go to step 15.	Repair the harness and connector. NOTE: In this case, repair the following item: • Open circuit in harness between ECM and electronic throttle control connector • Poor contact of coupling connector
<p><b>15 CHECK HARNESS BETWEEN ECM AND ELECTRONIC THROTTLE CONTROL MOTOR.</b></p> <p>1) Connect the connector to ECM. 2) Turn the ignition switch to ON. 3) Measure the voltage between electronic throttle control connector and engine ground.</p> <p><b>Connector &amp; terminal</b> <b>(E57) No. 2 (+) — Engine ground (-):</b> <b>(E57) No. 1 (+) — Engine ground (-):</b></p>	Is the voltage 5 V or more?	Repair the short circuit to power in harness between ECM and electronic throttle control connector.	Go to step 16.
<p><b>16 CHECK HARNESS BETWEEN ECM AND ELECTRONIC THROTTLE CONTROL MOTOR.</b></p> <p>1) Turn the ignition switch to OFF. 2) Disconnect the connector from ECM. 3) Measure the resistance between electronic throttle control connector and engine ground.</p> <p><b>Connector &amp; terminal</b> <b>(E57) No. 2 — Engine ground:</b> <b>(E57) No. 1 — Engine ground:</b></p>	Is the resistance 1 MΩ or more?	Go to step 17.	Repair the short circuit to ground in harness between ECM and electronic throttle control connector.

# Diagnostic Procedure with Diagnostic Trouble Code (DTC)

## ENGINE (DIAGNOSTICS)

Step	Check	Yes	No
<b>17</b> <b>CHECK ELECTRONIC THROTTLE CONTROL MOTOR HARNESS.</b> Measure the resistance between electronic throttle control connectors. <i>Connector &amp; terminal</i> <i>(E57) No. 2 — (E57) No. 1:</i>	Is the resistance 1 M $\Omega$ or more?	Go to step 18.	Repair the short circuit of harness between ECM and electronic throttle control connector.
<b>18</b> <b>CHECK ELECTRONIC THROTTLE CONTROL GROUND CIRCUIT.</b> Measure the resistance between ECM and chassis ground. <i>Connector &amp; terminal</i> <i>(B134) No. 3 — Chassis ground:</i> <i>(B134) No. 4 — Chassis ground:</i> <i>(B134) No. 6 — Chassis ground:</i> <i>(B137) No. 1 — Chassis ground:</i> <i>(B137) No. 3 — Chassis ground:</i>	Is the resistance less than 5 $\Omega$ ?	Go to step 19.	Repair the harness and connector. NOTE: In this case, repair the following item: • Open circuit of harness between ECM and engine ground • Poor contact of coupling connector
<b>19</b> <b>CHECK ELECTRONIC THROTTLE CONTROL.</b> Measure the resistance between electronic throttle control terminals. <i>Terminals</i> <i>No. 2 — No. 1:</i>	Is the resistance 50 $\Omega$ or less?	Go to step 20.	Replace the electronic throttle control. <Ref. to FU(STI)-15, Throttle Body.> <Ref. to FU(w/o STI)-15, Throttle Body.>
<b>20</b> <b>CHECK ELECTRONIC THROTTLE CONTROL.</b> Move the throttle valve to the fully open and fully closed positions with fingers. Check that the valve returns to the specified position when releasing fingers.	Does the valve return to the specified position? Standard value: 3 mm (0.12 in) from fully closed position	Repair the poor contact of ECM connector.	Replace the electronic throttle control. <Ref. to FU(STI)-15, Throttle Body.> <Ref. to FU(w/o STI)-15, Throttle Body.>

# Diagnostic Procedure with Diagnostic Trouble Code (DTC)

ENGINE (DIAGNOSTICS)

## EH:DTC P2102 THROTTLE ACTUATOR CONTROL MOTOR CIRCUIT LOW

### DTC DETECTING CONDITION:

- Immediately at fault recognition
- GENERAL DESCRIPTION <Ref. to GD(H4DOTC)-243, DTC P2102 THROTTLE ACTUATOR CONTROL MOTOR CIRCUIT LOW, Diagnostic Trouble Code (DTC) Detecting Criteria.>

### TROUBLE SYMPTOM:

- Improper idling
- Poor driving performance
- Engine stalls.

### CAUTION:

After servicing or replacing faulty parts, perform Clear Memory Mode <Ref. to EN(H4DOTC)(diag)-62, OPERATION, Clear Memory Mode.>, and Inspection Mode <Ref. to EN(H4DOTC)(diag)-48, PROCEDURE, Inspection Mode.>.

### WIRING DIAGRAM:

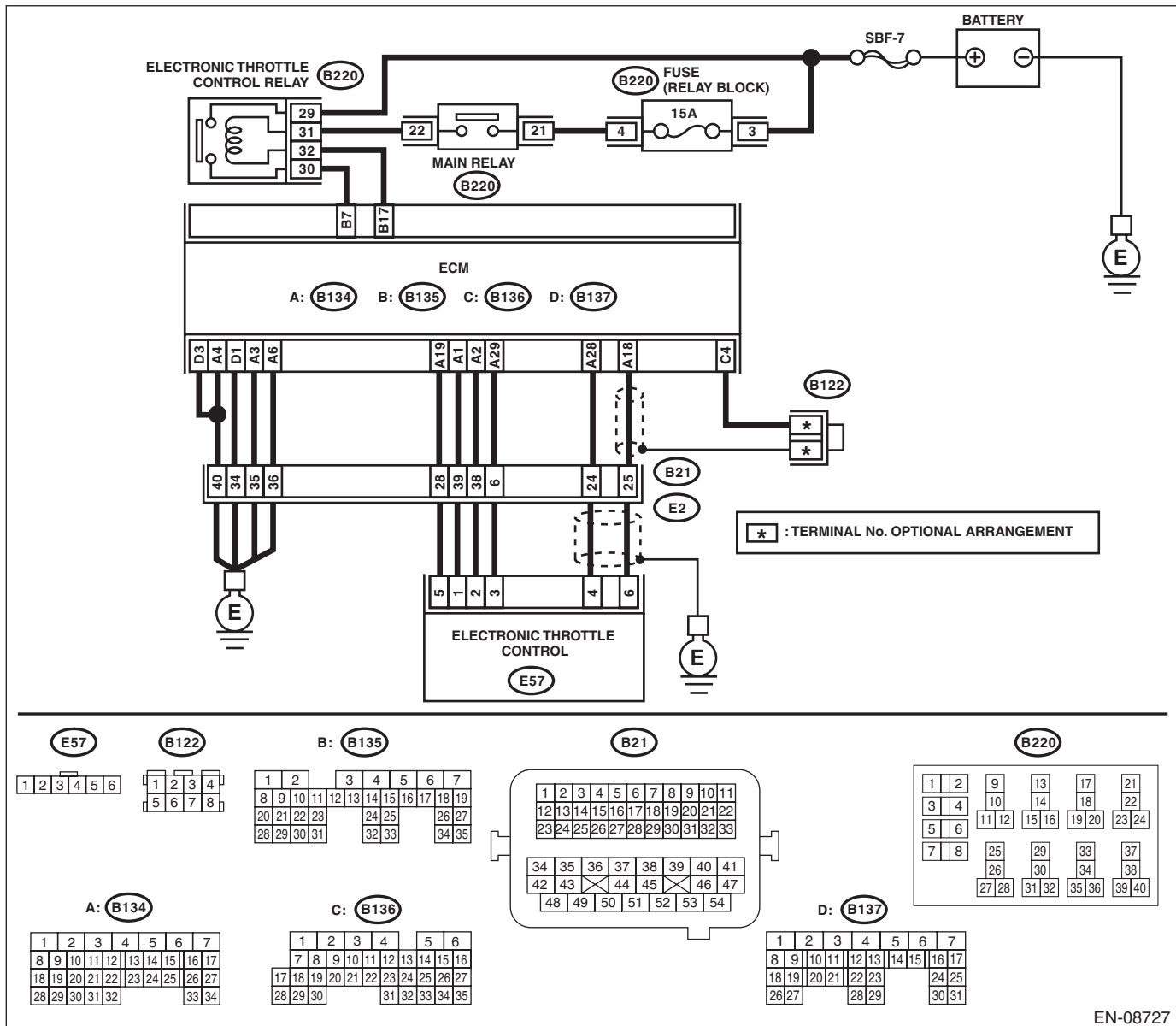

EN-08727

# Diagnostic Procedure with Diagnostic Trouble Code (DTC)

## ENGINE (DIAGNOSTICS)

	Step	Check	Yes	No
1	<p><b>CHECK ELECTRONIC THROTTLE CONTROL RELAY.</b></p> <p>1) Turn the ignition switch to OFF.                      2) Remove the electronic throttle control relay.                      3) Connect the battery to terminals No. 31 and No. 32 of electronic throttle control relay.                      4) Measure the resistance between electronic throttle control relay terminals.</p> <p><b>Terminals</b>  <b>No. 29 — No. 30:</b></p>	Is the resistance less than 1 Ω?	Go to step 2.	Replace the electronic throttle control relay. <Ref. to FU(STI)-64, Electronic Throttle Control Relay.> <Ref. to FU(w/o STI)-63, Electronic Throttle Control Relay.>
2	<p><b>CHECK POWER SUPPLY OF ELECTRONIC THROTTLE CONTROL RELAY.</b></p> <p>Measure the voltage between electronic throttle control relay connector and chassis ground.</p> <p><b>Connector &amp; terminal</b>  <b>(B220) No. 29 (+) — Chassis ground (-):</b></p>	Is the voltage 10 V or more?	Go to step 3.	Repair the open or ground short circuit of power supply circuit.
3	<p><b>CHECK HARNESS BETWEEN ECM AND ELECTRONIC THROTTLE CONTROL RELAY CONNECTOR.</b></p> <p>1) Disconnect the connector from ECM.                      2) Turn the ignition switch to ON.                      3) Measure the voltage between electronic throttle control relay connector and chassis ground.</p> <p><b>Connector &amp; terminal</b>  <b>(B220) No. 32 (+) — Chassis ground (-):</b></p>	Is the voltage 10 V or more?	Repair the short circuit to power in the harness between ECM and electronic throttle control relay connector.	Go to step 4.
4	<p><b>CHECK HARNESS BETWEEN ECM AND ELECTRONIC THROTTLE CONTROL RELAY CONNECTOR.</b></p> <p>1) Turn the ignition switch to OFF.                      2) Measure the resistance between electronic throttle control relay connector and chassis ground.</p> <p><b>Connector &amp; terminal</b>  <b>(B220) No. 32 — Chassis ground:</b>  <b>(B220) No. 30 — Chassis ground:</b></p>	Is the resistance 1 MΩ or more?	Go to step 5.	Repair the short circuit in harness to ground between ECM and electronic throttle control relay connector.
5	<p><b>CHECK HARNESS BETWEEN ECM AND ELECTRONIC THROTTLE CONTROL RELAY CONNECTOR.</b></p> <p>Measure the resistance between ECM and electronic throttle control relay connector.</p> <p><b>Connector &amp; terminal</b>  <b>(B135) No. 17 — (B220) No. 32:</b>  <b>(B135) No. 7 — (B220) No. 30:</b></p>	Is the resistance less than 1 Ω?	Repair the poor contact of ECM connector.	Repair the open circuit in harness between ECM and electronic throttle control relay connector.

# Diagnostic Procedure with Diagnostic Trouble Code (DTC)

ENGINE (DIAGNOSTICS)

## EI: DTC P2103 THROTTLE ACTUATOR CONTROL MOTOR CIRCUIT HIGH

### DTC DETECTING CONDITION:

- Immediately at fault recognition
- GENERAL DESCRIPTION <Ref. to GD(H4DOTC)-245, DTC P2103 THROTTLE ACTUATOR CONTROL MOTOR CIRCUIT HIGH, Diagnostic Trouble Code (DTC) Detecting Criteria.>

### CAUTION:

After servicing or replacing faulty parts, perform Clear Memory Mode <Ref. to EN(H4DOTC)(diag)-62, OPERATION, Clear Memory Mode.>, and Inspection Mode <Ref. to EN(H4DOTC)(diag)-48, PROCEDURE, Inspection Mode.>.

### WIRING DIAGRAM:

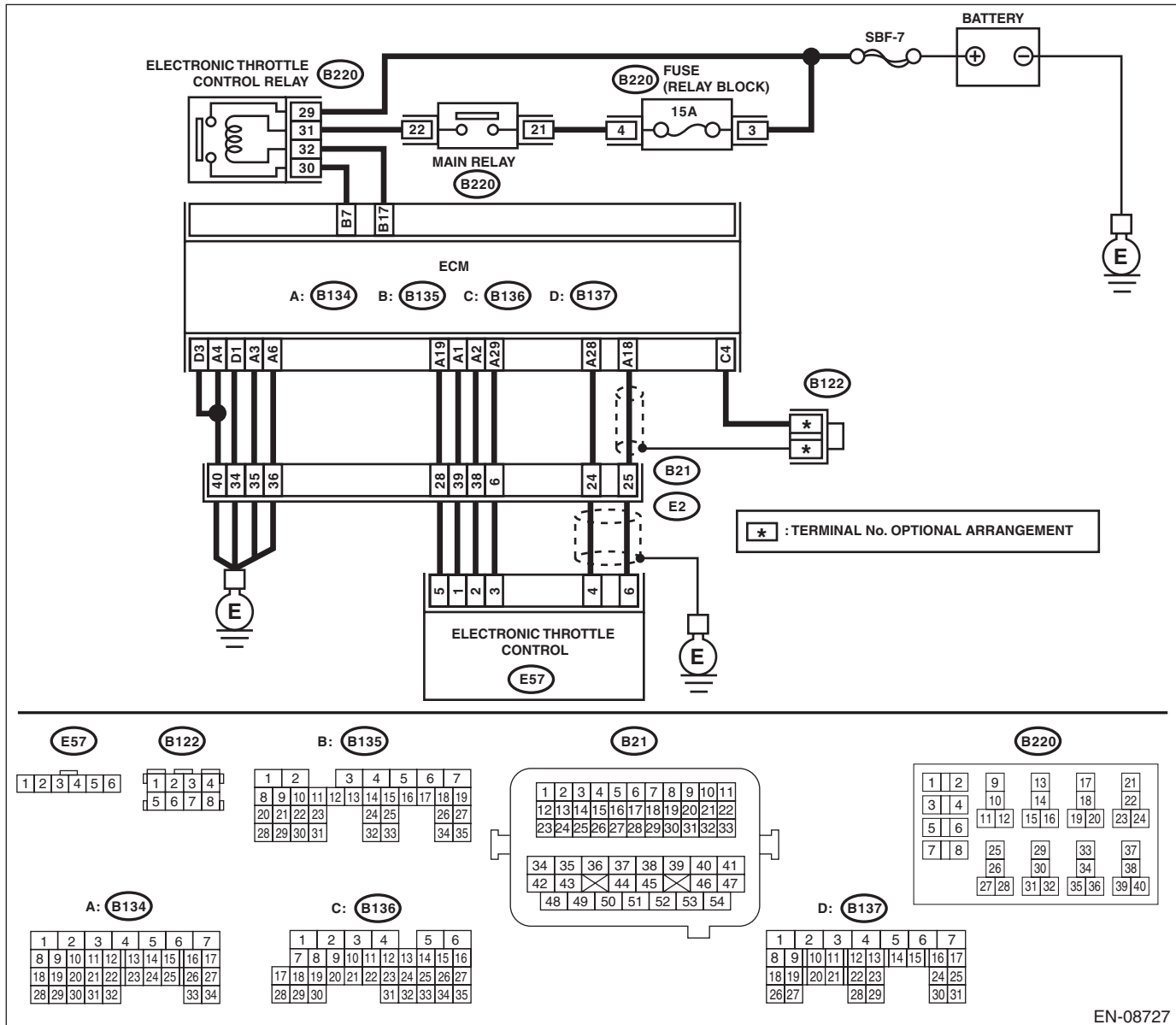

EN-08727

# Diagnostic Procedure with Diagnostic Trouble Code (DTC)

## ENGINE (DIAGNOSTICS)

Step	Check	Yes	No
<b>1 CHECK ELECTRONIC THROTTLE CONTROL RELAY.</b> 1) Turn the ignition switch to OFF. 2) Remove the electronic throttle control relay. 3) Measure the resistance between electronic throttle control relay terminals. <b>Terminals</b> <b>No. 29 — No. 30:</b>	Is the resistance 1 MΩ or more?	Go to step 2.	Replace the electronic throttle control relay. <Ref. to FU(STI)-64, Electronic Throttle Control Relay.> <Ref. to FU(w/o STI)-63, Electronic Throttle Control Relay.>
<b>2 CHECK SHORT CIRCUIT OF ELECTRONIC THROTTLE CONTROL RELAY POWER SUPPLY.</b> 1) Turn the ignition switch to ON. 2) Measure the voltage between electronic throttle control relay connector and chassis ground. <b>Connector &amp; terminal</b> <b>(B220) No. 30 (+) — Chassis ground (-):</b>	Is the voltage 10 V or more?	Repair the short circuit to power in the harness between ECM and electronic throttle control relay connector.	Go to step 3.
<b>3 CHECK HARNESS BETWEEN ECM AND ELECTRONIC THROTTLE CONTROL RELAY CONNECTOR.</b> 1) Turn the ignition switch to OFF. 2) Disconnect the connector from ECM. 3) Measure the resistance between ECM and chassis ground. <b>Connector &amp; terminal</b> <b>(B135) No. 17 — Chassis ground:</b>	Is the resistance 1 MΩ or more?	Repair the poor contact of ECM connector.	Repair the short circuit in harness to ground between ECM and electronic throttle control relay connector.

## EJ: DTC P2109 THROTTLE/PEDAL POSITION SENSOR "A" MINIMUM STOP PERFORMANCE

### NOTE:

For the diagnostic procedure, refer to DTC P2101. <Ref. to EN(H4DOTC)(diag)-364, DTC P2101 THROTTLE ACTUATOR CONTROL MOTOR CIRCUIT RANGE/PERFORMANCE, Diagnostic Procedure with Diagnostic Trouble Code (DTC).>

# Diagnostic Procedure with Diagnostic Trouble Code (DTC)

ENGINE (DIAGNOSTICS)

## EK:DTC P2122 THROTTLE/PEDAL POSITION SENSOR/SWITCH "D" CIRCUIT LOW INPUT

### DTC DETECTING CONDITION:

- Immediately at fault recognition
- GENERAL DESCRIPTION <Ref. to GD(H4DOTC)-249, DTC P2122 THROTTLE/PEDAL POSITION SENSOR/SWITCH "D" CIRCUIT LOW INPUT, Diagnostic Trouble Code (DTC) Detecting Criteria.>

### TROUBLE SYMPTOM:

- Improper idling
- Poor driving performance

### CAUTION:

After servicing or replacing faulty parts, perform Clear Memory Mode <Ref. to EN(H4DOTC)(diag)-62, OPERATION, Clear Memory Mode.>, and Inspection Mode <Ref. to EN(H4DOTC)(diag)-48, PROCEDURE, Inspection Mode.>.

### WIRING DIAGRAM:

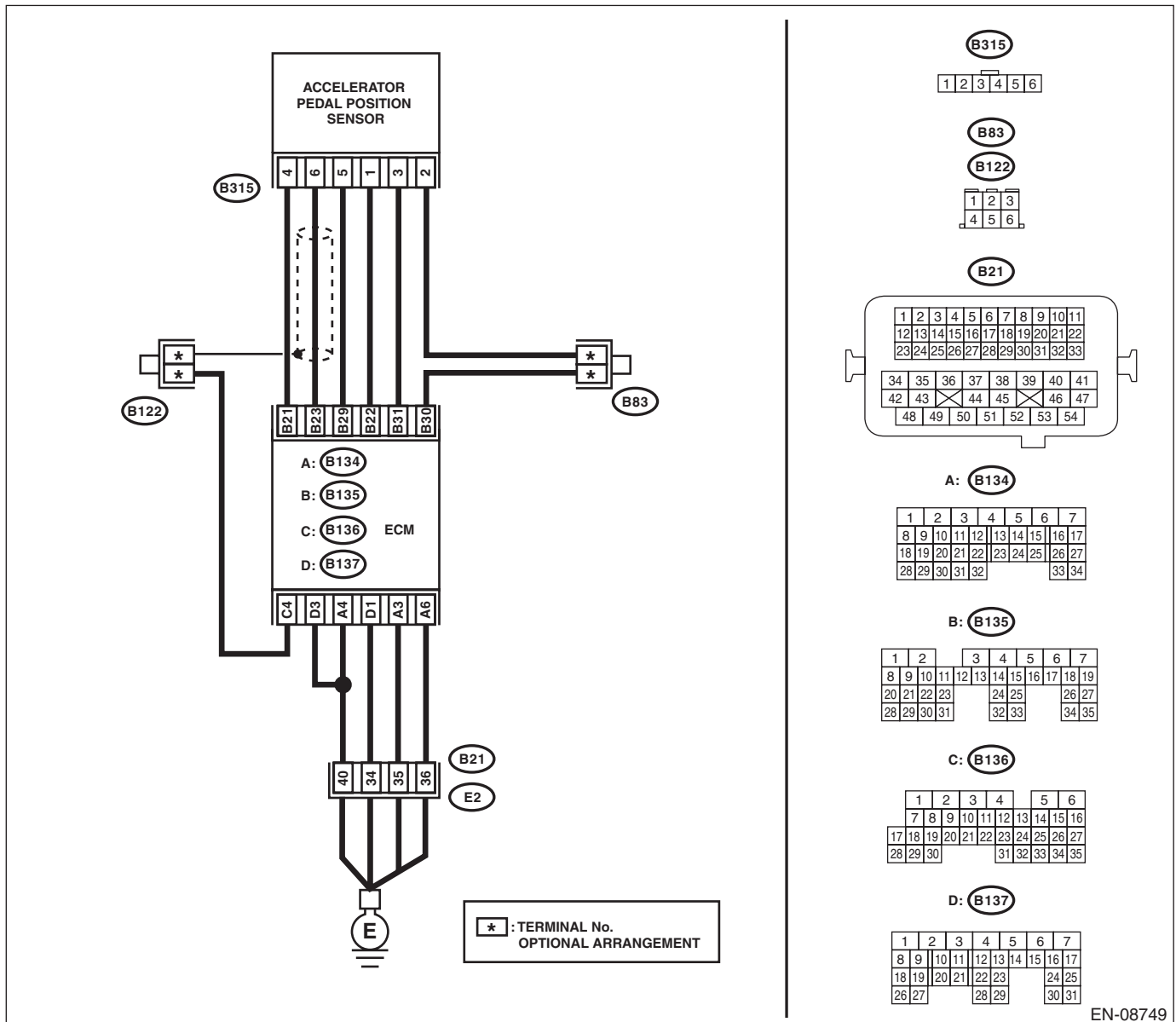

EN-08749



# Diagnostic Procedure with Diagnostic Trouble Code (DTC)

ENGINE (DIAGNOSTICS)

Step	Check	Yes	No
<p><b>1</b></p> <p><b>CHECK HARNESS BETWEEN ECM AND ACCELERATOR PEDAL POSITION SENSOR CONNECTOR.</b></p> <p>1) Turn the ignition switch to OFF.                      2) Disconnect the connectors from ECM and accelerator pedal position sensor.                      3) Measure the resistance between ECM and chassis ground.</p> <p><b>Connector &amp; terminal</b>  <b>(B135) No. 21 — Chassis ground:</b>  <b>(B135) No. 23 — Chassis ground:</b>  <b>(B135) No. 23 — (B136) No. 4:</b></p>	<p>Is the resistance 1 MΩ or more?</p>	<p>Go to step 2.</p>	<p>Repair the short circuit to ground in harness between ECM and accelerator pedal position sensor connector.</p>
<p><b>2</b></p> <p><b>CHECK SHORT CIRCUIT INSIDE THE ECM.</b></p> <p>1) Connect the connector to ECM.                      2) Measure the resistance between accelerator pedal position sensor connector and chassis ground.</p> <p><b>Connector &amp; terminal</b>  <b>(B315) No. 6 — Chassis ground:</b></p>	<p>Is the resistance 1 MΩ or more?</p>	<p>Replace the accelerator pedal. &lt;Ref. to SP(STI)-4, Accelerator Pedal.&gt;</p>	<p>Repair the short circuit to ground in harness between ECM and accelerator pedal position sensor connector. Replace the ECM if defective. &lt;Ref. to FU(STI)-59, Engine Control Module (ECM).&gt; &lt;Ref. to FU(w/o STI)-58, Engine Control Module (ECM).&gt;</p>

# Diagnostic Procedure with Diagnostic Trouble Code (DTC)

ENGINE (DIAGNOSTICS)

## EL:DTC P2123 THROTTLE/PEDAL POSITION SENSOR/SWITCH "D" CIRCUIT HIGH INPUT

### DTC DETECTING CONDITION:

- Immediately at fault recognition
- GENERAL DESCRIPTION <Ref. to GD(H4DOTC)-251, DTC P2123 THROTTLE/PEDAL POSITION SENSOR/SWITCH "D" CIRCUIT HIGH INPUT, Diagnostic Trouble Code (DTC) Detecting Criteria.>

### TROUBLE SYMPTOM:

- Improper idling
- Poor driving performance

### CAUTION:

After servicing or replacing faulty parts, perform Clear Memory Mode <Ref. to EN(H4DOTC)(diag)-62, OPERATION, Clear Memory Mode.>, and Inspection Mode <Ref. to EN(H4DOTC)(diag)-48, PROCEDURE, Inspection Mode.>.

### WIRING DIAGRAM:

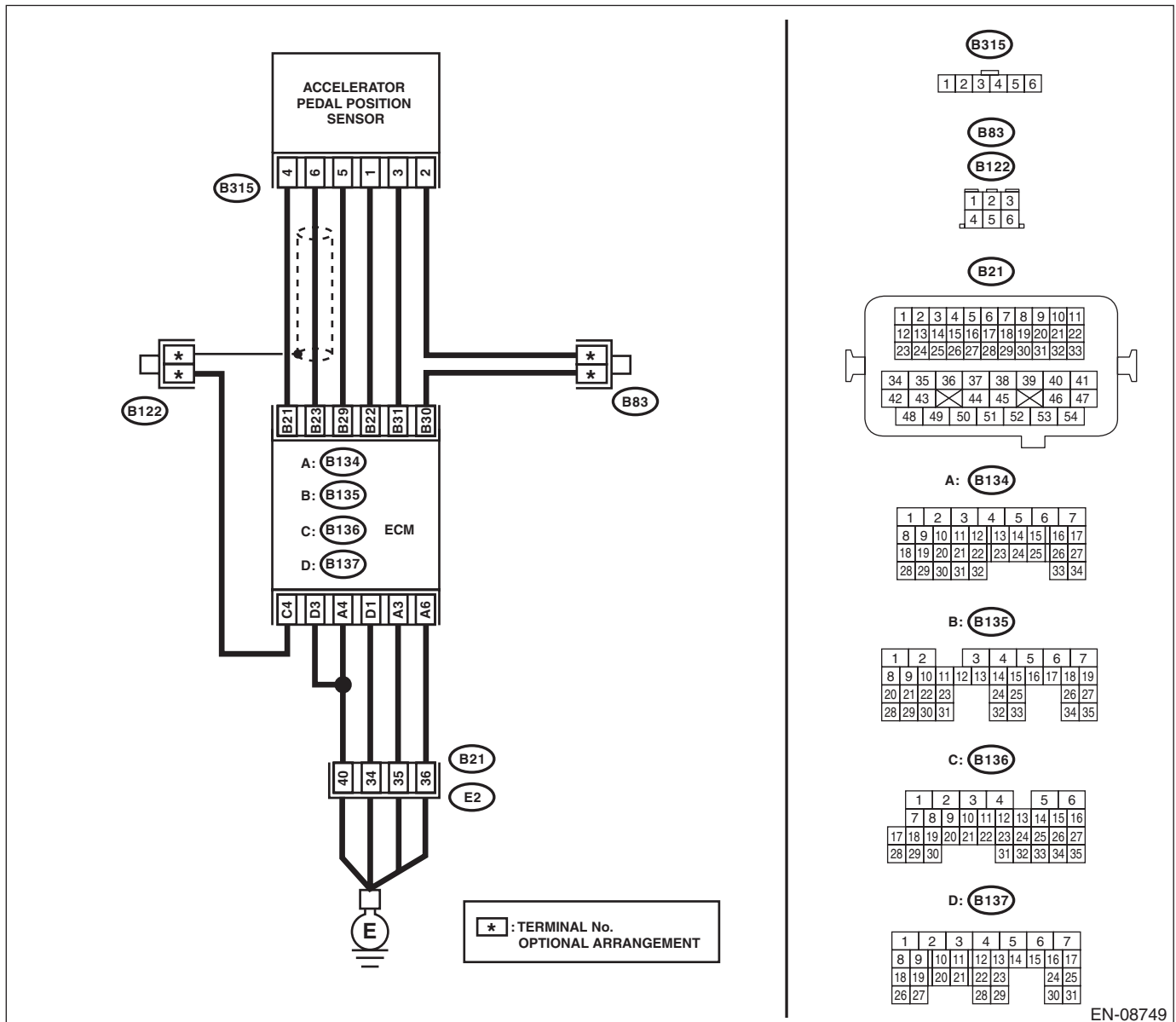

EN-08749

# Diagnostic Procedure with Diagnostic Trouble Code (DTC)

ENGINE (DIAGNOSTICS)

Step	Check	Yes	No
<p><b>1</b>    <b>CHECK HARNESS BETWEEN ECM AND ACCELERATOR PEDAL POSITION SENSOR CONNECTOR.</b></p> <p>1) Turn the ignition switch to OFF. 2) Disconnect the connectors from ECM and accelerator pedal position sensor. 3) Measure the resistance of harness between ECM and accelerator pedal position sensor connector.</p> <p><b>Connector &amp; terminal</b> <b>(B135) No. 23 — (B315) No. 6:</b> <b>(B135) No. 29 — (B315) No. 5:</b></p>	<p>Is the resistance less than 1 Ω?</p>	<p>Go to step 2.</p>	<p>Repair the open circuit in harness between ECM and accelerator pedal position sensor connector.</p>
<p><b>2</b>    <b>CHECK HARNESS BETWEEN ECM AND ACCELERATOR PEDAL POSITION SENSOR CONNECTOR.</b></p> <p>1) Connect the connector to ECM. 2) Measure the resistance between accelerator pedal position sensor connector and chassis ground.</p> <p><b>Connector &amp; terminal</b> <b>(B315) No. 5 — Chassis ground:</b></p>	<p>Is the resistance less than 5 Ω?</p>	<p>Go to step 3.</p>	<p>Repair the harness and connector.</p> <p>NOTE: In this case, repair the following item:</p> <ul style="list-style-type: none"> <li>• Open circuit of harness between ECM and engine ground</li> <li>• Poor contact of ECM connector</li> <li>• Poor contact of coupling connector</li> </ul>
<p><b>3</b>    <b>CHECK HARNESS BETWEEN ECM AND ACCELERATOR PEDAL POSITION SENSOR CONNECTOR.</b></p> <p>1) Turn the ignition switch to ON. 2) Measure the voltage between accelerator pedal position sensor connector and chassis ground.</p> <p><b>Connector &amp; terminal</b> <b>(B315) No. 6 (+) — Chassis ground (-):</b></p>	<p>Is the voltage 5 V or more?</p>	<p>Repair the short circuit to power supply in the harness between the ECM and accelerator pedal position sensor connector.</p>	<p>Go to step 4.</p>
<p><b>4</b>    <b>CHECK HARNESS BETWEEN ECM AND ACCELERATOR PEDAL POSITION SENSOR CONNECTOR.</b></p> <p>1) Turn the ignition switch to OFF. 2) Disconnect the connector from ECM. 3) Measure the resistance between ECM connectors.</p> <p><b>Connector &amp; terminal</b> <b>(B135) No. 21 — (B135) No. 23:</b></p>	<p>Is the resistance 1 MΩ or more?</p>	<p>Repair the poor contact of accelerator pedal position sensor connector. Replace the accelerator pedal if defective. &lt;Ref. to SP(STI)-4, Accelerator Pedal.&gt;</p>	<p>Repair the short circuit to power supply in the harness between the ECM and accelerator pedal position sensor connector.</p>

# Diagnostic Procedure with Diagnostic Trouble Code (DTC)

ENGINE (DIAGNOSTICS)

## EM:DTC P2127 THROTTLE/PEDAL POSITION SENSOR/SWITCH "E" CIRCUIT LOW INPUT

### DTC DETECTING CONDITION:

- Immediately at fault recognition
- GENERAL DESCRIPTION <Ref. to GD(H4DOTC)-253, DTC P2127 THROTTLE/PEDAL POSITION SENSOR/SWITCH "E" CIRCUIT LOW INPUT, Diagnostic Trouble Code (DTC) Detecting Criteria.>

### TROUBLE SYMPTOM:

- Improper idling
- Poor driving performance

### CAUTION:

After servicing or replacing faulty parts, perform Clear Memory Mode <Ref. to EN(H4DOTC)(diag)-62, OPERATION, Clear Memory Mode.>, and Inspection Mode <Ref. to EN(H4DOTC)(diag)-48, PROCEDURE, Inspection Mode.>.

### WIRING DIAGRAM:

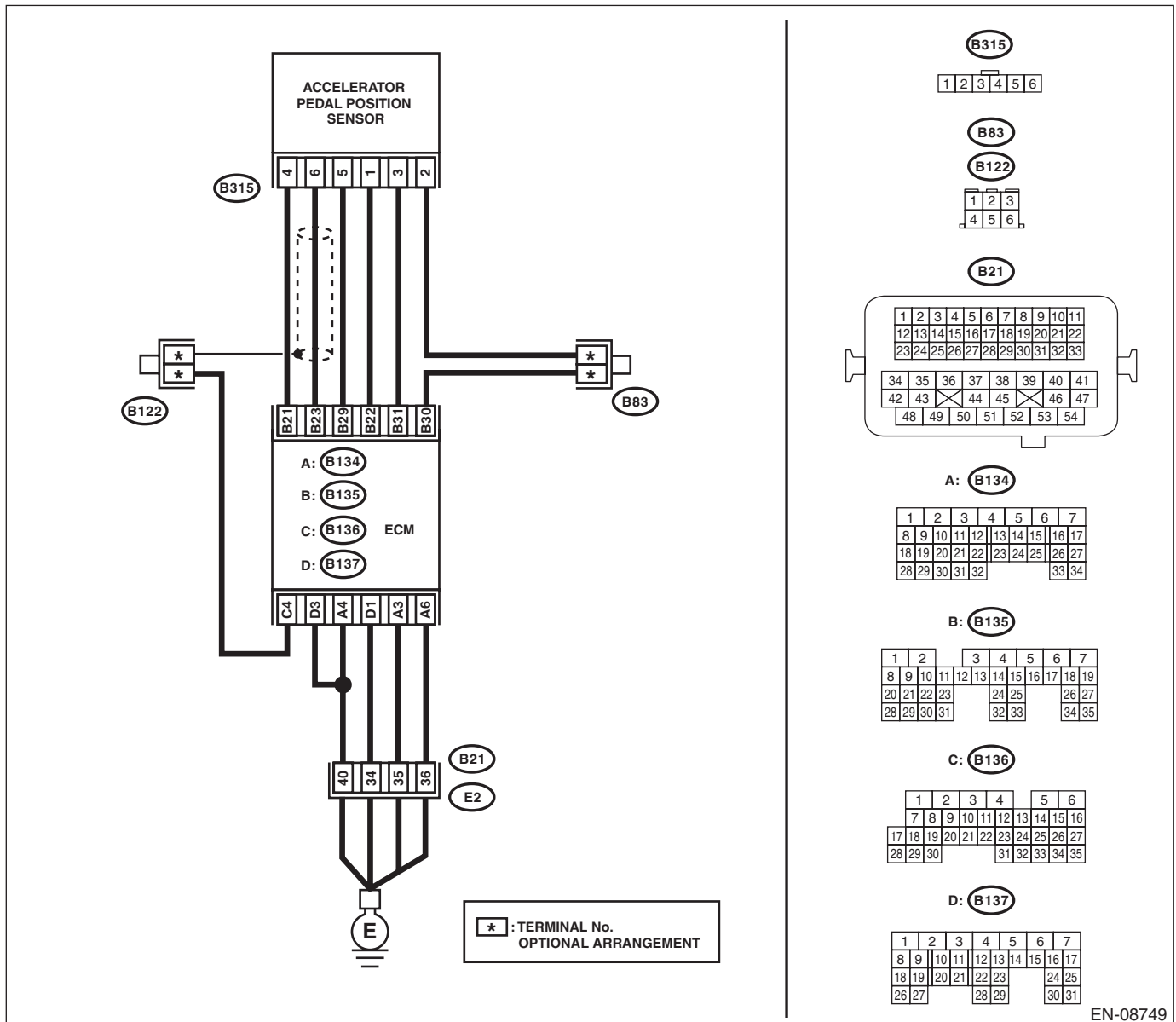

EN-08749

# Diagnostic Procedure with Diagnostic Trouble Code (DTC)

ENGINE (DIAGNOSTICS)

Step	Check	Yes	No
<p><b>1</b></p> <p><b>CHECK HARNESS BETWEEN ECM AND ACCELERATOR PEDAL POSITION SENSOR CONNECTOR.</b></p> <p>1) Turn the ignition switch to OFF.                  2) Disconnect the connectors from ECM and accelerator pedal position sensor.                  3) Measure the resistance between ECM and chassis ground.</p> <p><b>Connector &amp; terminal</b>  <b>(B135) No. 22 — Chassis ground:</b>  <b>(B135) No. 31 — Chassis ground:</b></p>	<p>Is the resistance 1 MΩ or more?</p>	<p>Go to step 2.</p>	<p>Repair the short circuit to ground in harness between ECM and accelerator pedal position sensor connector.</p>
<p><b>2</b></p> <p><b>CHECK SHORT CIRCUIT INSIDE THE ECM.</b></p> <p>1) Connect the connector to ECM.                  2) Measure the resistance between accelerator pedal position sensor connector and chassis ground.</p> <p><b>Connector &amp; terminal</b>  <b>(B315) No. 3 — Chassis ground:</b></p>	<p>Is the resistance 1 MΩ or more?</p>	<p>Replace the accelerator pedal. &lt;Ref. to SP(STI)-4, Accelerator Pedal.&gt;</p>	<p>Repair the short circuit to ground in harness between ECM and accelerator pedal position sensor connector. Replace the ECM if defective. &lt;Ref. to FU(STI)-59, Engine Control Module (ECM).&gt; &lt;Ref. to FU(w/o STI)-58, Engine Control Module (ECM).&gt;</p>

# Diagnostic Procedure with Diagnostic Trouble Code (DTC)

ENGINE (DIAGNOSTICS)

## EN:DTC P2128 THROTTLE/PEDAL POSITION SENSOR/SWITCH "E" CIRCUIT HIGH INPUT

### DTC DETECTING CONDITION:

- Immediately at fault recognition
- GENERAL DESCRIPTION <Ref. to GD(H4DOTC)-255, DTC P2128 THROTTLE/PEDAL POSITION SENSOR/SWITCH "E" CIRCUIT HIGH INPUT, Diagnostic Trouble Code (DTC) Detecting Criteria.>

### TROUBLE SYMPTOM:

- Improper idling
- Poor driving performance

### CAUTION:

After servicing or replacing faulty parts, perform Clear Memory Mode <Ref. to EN(H4DOTC)(diag)-62, OPERATION, Clear Memory Mode.>, and Inspection Mode <Ref. to EN(H4DOTC)(diag)-48, PROCEDURE, Inspection Mode.>.

### WIRING DIAGRAM:

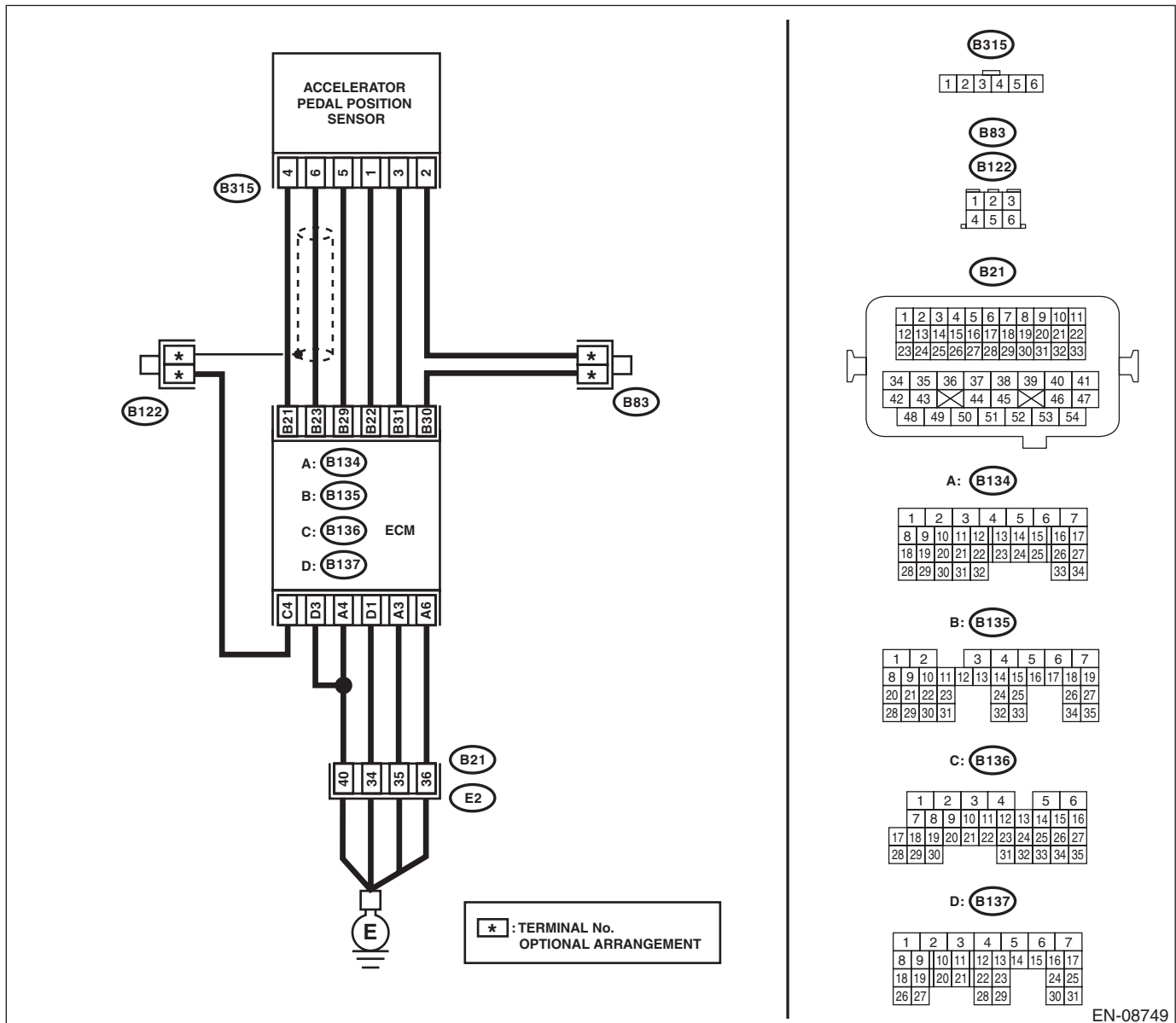

EN-08749

# Diagnostic Procedure with Diagnostic Trouble Code (DTC)

## ENGINE (DIAGNOSTICS)

Step	Check	Yes	No
<p><b>1</b>    <b>CHECK HARNESS BETWEEN ECM AND ACCELERATOR PEDAL POSITION SENSOR CONNECTOR.</b></p> <p>1) Turn the ignition switch to OFF. 2) Disconnect the connectors from ECM and accelerator pedal position sensor. 3) Measure the resistance of harness between ECM and accelerator pedal position sensor connector.</p> <p><b>Connector &amp; terminal</b> <b>(B135) No. 31 — (B315) No. 3:</b> <b>(B135) No. 30 — (B315) No. 2:</b></p>	Is the resistance less than 1 Ω?	Go to step 2.	Repair the harness and connector.  <b>NOTE:</b> In this case, repair the following item: <ul style="list-style-type: none"> <li>• Open circuit in harness between ECM and accelerator pedal position sensor connector</li> <li>• Poor contact of joint connector</li> </ul>
<p><b>2</b>    <b>CHECK HARNESS BETWEEN ECM AND ACCELERATOR PEDAL POSITION SENSOR CONNECTOR.</b></p> <p>1) Connect the connector to ECM. 2) Measure the resistance between accelerator pedal position sensor connector and chassis ground.</p> <p><b>Connector &amp; terminal</b> <b>(B315) No. 2 — Chassis ground:</b></p>	Is the resistance less than 1 Ω?	Go to step 3.	Repair the harness and connector.  <b>NOTE:</b> In this case, repair the following item: <ul style="list-style-type: none"> <li>• Open circuit of harness between ECM and engine ground</li> <li>• Poor contact of ECM connector</li> <li>• Poor contact of coupling connector</li> </ul>
<p><b>3</b>    <b>CHECK HARNESS BETWEEN ECM AND ACCELERATOR PEDAL POSITION SENSOR CONNECTOR.</b></p> <p>1) Turn the ignition switch to ON. 2) Measure the voltage between accelerator pedal position sensor connector and chassis ground.</p> <p><b>Connector &amp; terminal</b> <b>(B315) No. 3 (+) — Chassis ground (-):</b></p>	Is the voltage 5 V or more?	Repair the short circuit to power supply in the harness between the ECM and accelerator pedal position sensor connector.	Go to step 4.
<p><b>4</b>    <b>CHECK HARNESS BETWEEN ECM AND ACCELERATOR PEDAL POSITION SENSOR CONNECTOR.</b></p> <p>1) Turn the ignition switch to OFF. 2) Disconnect the connector from ECM. 3) Measure the resistance between ECM connectors.</p> <p><b>Connector &amp; terminal</b> <b>(B135) No. 22 — (B135) No. 31:</b></p>	Is the resistance 1 MΩ or more?	Repair the poor contact of accelerator pedal position sensor connector. Replace the accelerator pedal if defective. <Ref. to SP(STI)-4, Accelerator Pedal.>	Repair the short circuit to power supply in the harness between the ECM and accelerator pedal position sensor connector.

# Diagnostic Procedure with Diagnostic Trouble Code (DTC)

ENGINE (DIAGNOSTICS)

## EO:DTC P2135 THROTTLE/PEDAL POSITION SENSOR/SWITCH "A"/"B" VOLTAGE CORRELATION

### DTC DETECTING CONDITION:

- Immediately at fault recognition
- GENERAL DESCRIPTION <Ref. to GD(H4DOTC)-257, DTC P2135 THROTTLE/PEDAL POSITION SENSOR/SWITCH "A"/"B" VOLTAGE CORRELATION, Diagnostic Trouble Code (DTC) Detecting Criteria.>

### TROUBLE SYMPTOM:

- Improper idling
- Poor driving performance

### CAUTION:

After servicing or replacing faulty parts, perform Clear Memory Mode <Ref. to EN(H4DOTC)(diag)-62, OPERATION, Clear Memory Mode.>, and Inspection Mode <Ref. to EN(H4DOTC)(diag)-48, PROCEDURE, Inspection Mode.>.

### WIRING DIAGRAM:

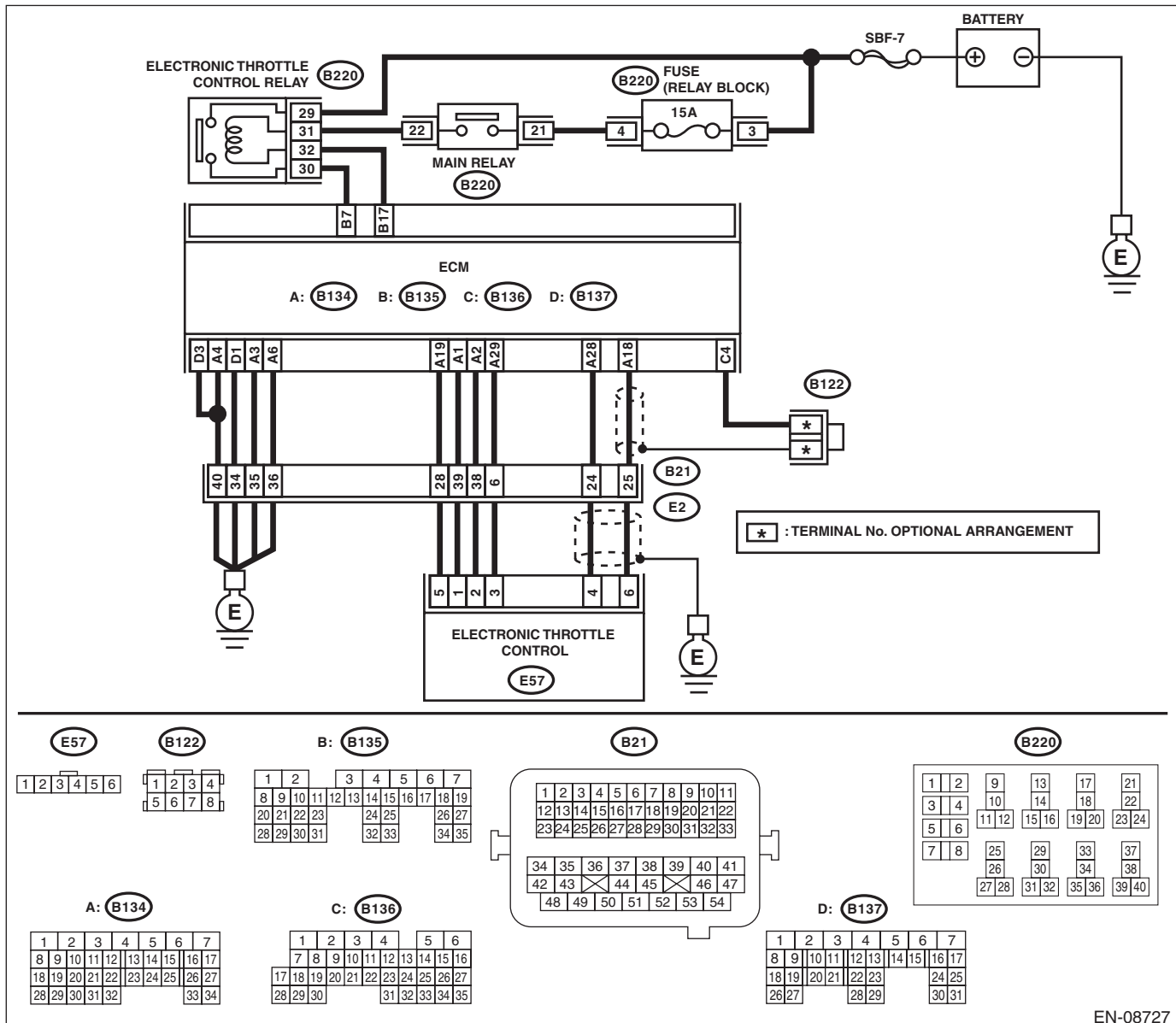

EN-08727



# Diagnostic Procedure with Diagnostic Trouble Code (DTC)

## ENGINE (DIAGNOSTICS)

Step	Check	Yes	No
<p><b>1</b>      <b>CHECK HARNESS BETWEEN ECM AND ELECTRONIC THROTTLE CONTROL CONNECTOR.</b></p> <p>1) Turn the ignition switch to OFF. 2) Disconnect the connectors from ECM and electronic throttle control. 3) Measure the resistance between ECM and chassis ground.</p> <p><b>Connector &amp; terminal</b> <b>(B134) No. 19 — Chassis ground:</b> <b>(B134) No. 18 — Chassis ground:</b> <b>(B134) No. 18 — (B136) No. 4:</b> <b>(B134) No. 28 — Chassis ground:</b></p>	Is the resistance 1 M $\Omega$ or more?	Go to step 2.	Repair the short circuit to ground in harness between ECM and electronic throttle control connector.
<p><b>2</b>      <b>CHECK SHORT CIRCUIT INSIDE THE ECM.</b></p> <p>1) Connect the connector to ECM. 2) Measure the resistance between electronic throttle control connector and engine ground.</p> <p><b>Connector &amp; terminal</b> <b>(E57) No. 6 — Engine ground:</b> <b>(E57) No. 4 — Engine ground:</b></p>	Is the resistance 1 M $\Omega$ or more?	Go to step 3.	Repair the short circuit to ground in harness between ECM and electronic throttle control connector. Replace the ECM if defective. <Ref. to FU(STI)-59, Engine Control Module (ECM).> <Ref. to FU(w/o STI)-58, Engine Control Module (ECM).>
<p><b>3</b>      <b>CHECK HARNESS BETWEEN ECM AND ELECTRONIC THROTTLE CONTROL CONNECTOR.</b></p> <p>1) Disconnect the connector from ECM. 2) Measure the resistance of harness between ECM and electronic throttle control connector.</p> <p><b>Connector &amp; terminal</b> <b>(B134) No. 18 — (E57) No. 6:</b> <b>(B134) No. 28 — (E57) No. 4:</b> <b>(B134) No. 29 — (E57) No. 3:</b></p>	Is the resistance less than 1 $\Omega$ ?	Go to step 4.	Repair the harness and connector. NOTE: In this case, repair the following item: • Open circuit in harness between ECM and electronic throttle control connector • Poor contact of coupling connector
<p><b>4</b>      <b>CHECK HARNESS BETWEEN ECM AND ELECTRONIC THROTTLE CONTROL CONNECTOR.</b></p> <p>1) Connect the connector to ECM. 2) Measure the resistance between electronic throttle control connector and engine ground.</p> <p><b>Connector &amp; terminal</b> <b>(E57) No. 3 — Engine ground:</b></p>	Is the resistance less than 5 $\Omega$ ?	Go to step 5.	Repair the harness and connector. NOTE: In this case, repair the following item: • Open circuit of harness between ECM and engine ground • Poor contact of ECM connector • Poor contact of coupling connector

# Diagnostic Procedure with Diagnostic Trouble Code (DTC)

ENGINE (DIAGNOSTICS)

Step	Check	Yes	No
<p><b>5</b></p> <p><b>CHECK HARNESS BETWEEN ECM AND ELECTRONIC THROTTLE CONTROL CONNECTOR.</b></p> <p>1) Turn the ignition switch to ON. 2) Measure the voltage between electronic throttle control connector and engine ground.</p> <p><b>Connector &amp; terminal</b> <b>(E57) No. 6 (+) — Engine ground (-):</b> <b>(E57) No. 4 (+) — Engine ground (-):</b></p>	<p>Is the voltage 5 V or more?</p>	<p>Repair the short circuit to power in harness between ECM and electronic throttle control connector.</p>	<p>Go to step 6.</p>
<p><b>6</b></p> <p><b>CHECK HARNESS BETWEEN ECM AND ELECTRONIC THROTTLE CONTROL CONNECTOR.</b></p> <p>1) Turn the ignition switch to OFF. 2) Disconnect the connector from ECM. 3) Measure the resistance between ECM connectors.</p> <p><b>Connector &amp; terminal</b> <b>(B134) No. 19 — (B134) No. 18:</b> <b>(B134) No. 19 — (B134) No. 28:</b></p>	<p>Is the resistance 1 M<math>\Omega</math> or more?</p>	<p>Repair the poor contact of electronic throttle control connector. Replace the electronic throttle control if defective. &lt;Ref. to FU(STI)-15, Throttle Body.&gt; &lt;Ref. to FU(w/o STI)-15, Throttle Body.&gt;</p>	<p>Repair the short circuit to power in harness between ECM and electronic throttle control connector.</p>

# Diagnostic Procedure with Diagnostic Trouble Code (DTC)

ENGINE (DIAGNOSTICS)

## EP:DTC P2138 THROTTLE/PEDAL POSITION SENSOR/SWITCH "D"/"E" VOLTAGE CORRELATION

### DTC DETECTING CONDITION:

- Immediately at fault recognition
- GENERAL DESCRIPTION <Ref. to GD(H4DOTC)-259, DTC P2138 THROTTLE/PEDAL POSITION SENSOR/SWITCH "D"/"E" VOLTAGE CORRELATION, Diagnostic Trouble Code (DTC) Detecting Criteria.>

### TROUBLE SYMPTOM:

- Improper idling
- Poor driving performance

### CAUTION:

After servicing or replacing faulty parts, perform Clear Memory Mode <Ref. to EN(H4DOTC)(diag)-62, OPERATION, Clear Memory Mode.>, and Inspection Mode <Ref. to EN(H4DOTC)(diag)-48, PROCEDURE, Inspection Mode.>.

### WIRING DIAGRAM:

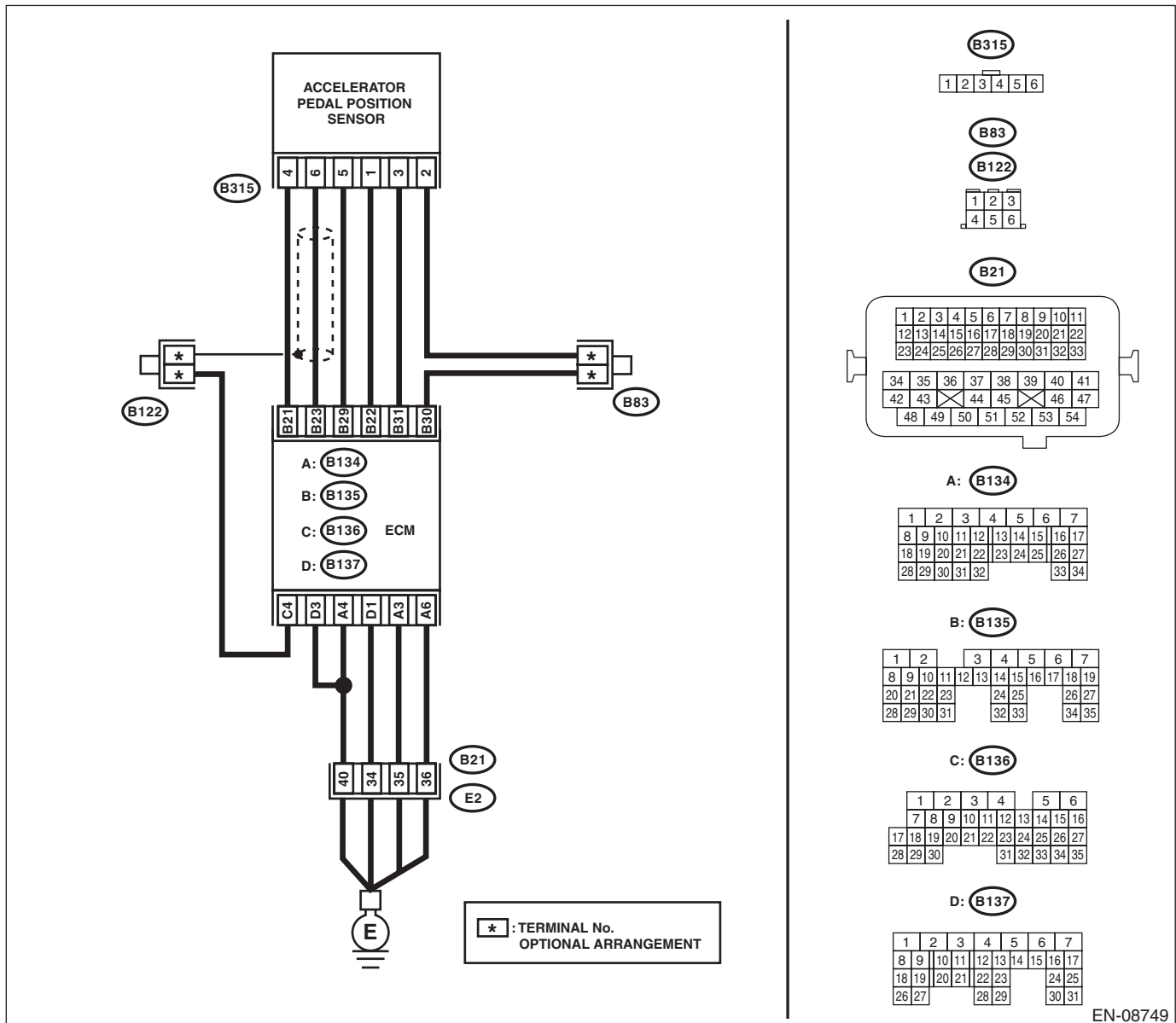

EN-08749

# Diagnostic Procedure with Diagnostic Trouble Code (DTC)

ENGINE (DIAGNOSTICS)

	Step	Check	Yes	No
1	<p><b>CHECK ACCELERATOR PEDAL POSITION SENSOR OUTPUT.</b></p> <p>1) Turn the ignition switch to ON. 2) Measure the voltage between ECM and chassis ground.</p> <p><b>Connector &amp; terminal</b> <b>Main accelerator pedal position sensor signal</b> <b>(B135) No. 23 (+) — Chassis ground (-):</b> <b>Sub accelerator pedal position sensor signal</b> <b>(B135) No. 31 (+) — Chassis ground (-):</b></p>	<p>Is the difference in measured values for the main accelerator pedal position sensor signal and the sub accelerator pedal position sensor signal 0 V?</p>	<p>Go to step 3.</p>	<p>Go to step 2.</p>
2	<p><b>CHECK ACCELERATOR PEDAL POSITION SENSOR OUTPUT.</b></p> <p>1) Measure the voltage between accelerator pedal position sensor connector and chassis ground.</p> <p><b>Connector &amp; terminal</b> <b>(B315) No. 6 (+) — Chassis ground (-):</b> <b>(B315) No. 3 (+) — Chassis ground (-):</b></p>	<p>Is the difference in measured values for the main accelerator pedal position sensor signal and the sub accelerator pedal position sensor signal 0 V?</p>	<p>Replace the accelerator pedal. &lt;Ref. to SP(STI)-4, Accelerator Pedal.&gt;</p>	<p>Repair the harness and connector. <b>NOTE:</b> In this case, repair the following item: • Open circuit in harness between ECM and accelerator pedal position sensor connector • Short circuit to ground in harness between ECM and accelerator pedal position sensor connector</p>
3	<p><b>CHECK HARNESS BETWEEN ECM AND ACCELERATOR PEDAL POSITION SENSOR CONNECTOR.</b></p> <p>Measure the resistance of harness between accelerator pedal position sensor connector and chassis ground.</p> <p><b>Connector &amp; terminal</b> <b>(B315) No. 5 — Chassis ground:</b> <b>(B315) No. 2 — Chassis ground:</b></p>	<p>Is the resistance less than 5 Ω?</p>	<p>Repair the poor contact of ECM connector.</p>	<p>Repair the harness and connector. <b>NOTE:</b> In this case, repair the following item: • Open circuit in harness between ECM and accelerator pedal position sensor connector • Open circuit of harness between ECM and engine ground • Poor contact of ECM connector • Poor contact of coupling connector</p>

# Diagnostic Procedure with Diagnostic Trouble Code (DTC)

ENGINE (DIAGNOSTICS)

## EQ:DTC P219A BANK 1 AIR-FUEL RATIO IMBALANCE

### DTC DETECTING CONDITION:

- Detected when two consecutive driving cycles with fault occur.
- GENERAL DESCRIPTION <Ref. to GD(H4DOTC)-261, DTC P219A BANK 1 AIR-FUEL RATIO IMBALANCE, Diagnostic Trouble Code (DTC) Detecting Criteria.>

### TROUBLE SYMPTOM:

- Engine stalls.
- Improper idling

### CAUTION:

After servicing or replacing faulty parts, perform Clear Memory Mode <Ref. to EN(H4DOTC)(diag)-62, OPERATION, Clear Memory Mode.>, and Inspection Mode <Ref. to EN(H4DOTC)(diag)-48, PROCEDURE, Inspection Mode.>.

### WIRING DIAGRAM:

- Models without SI-DRIVE

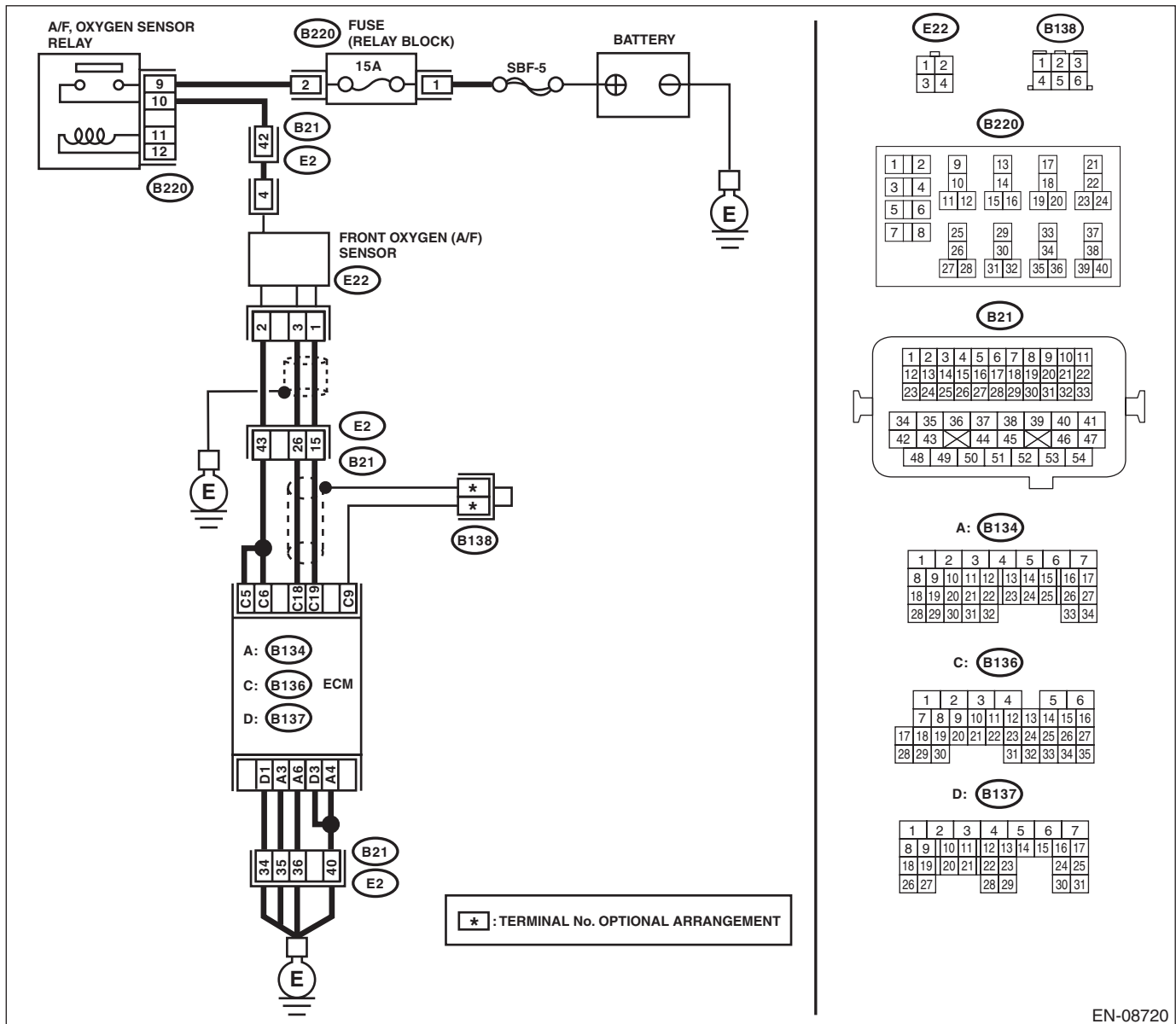

EN-08720

# Diagnostic Procedure with Diagnostic Trouble Code (DTC)

ENGINE (DIAGNOSTICS)

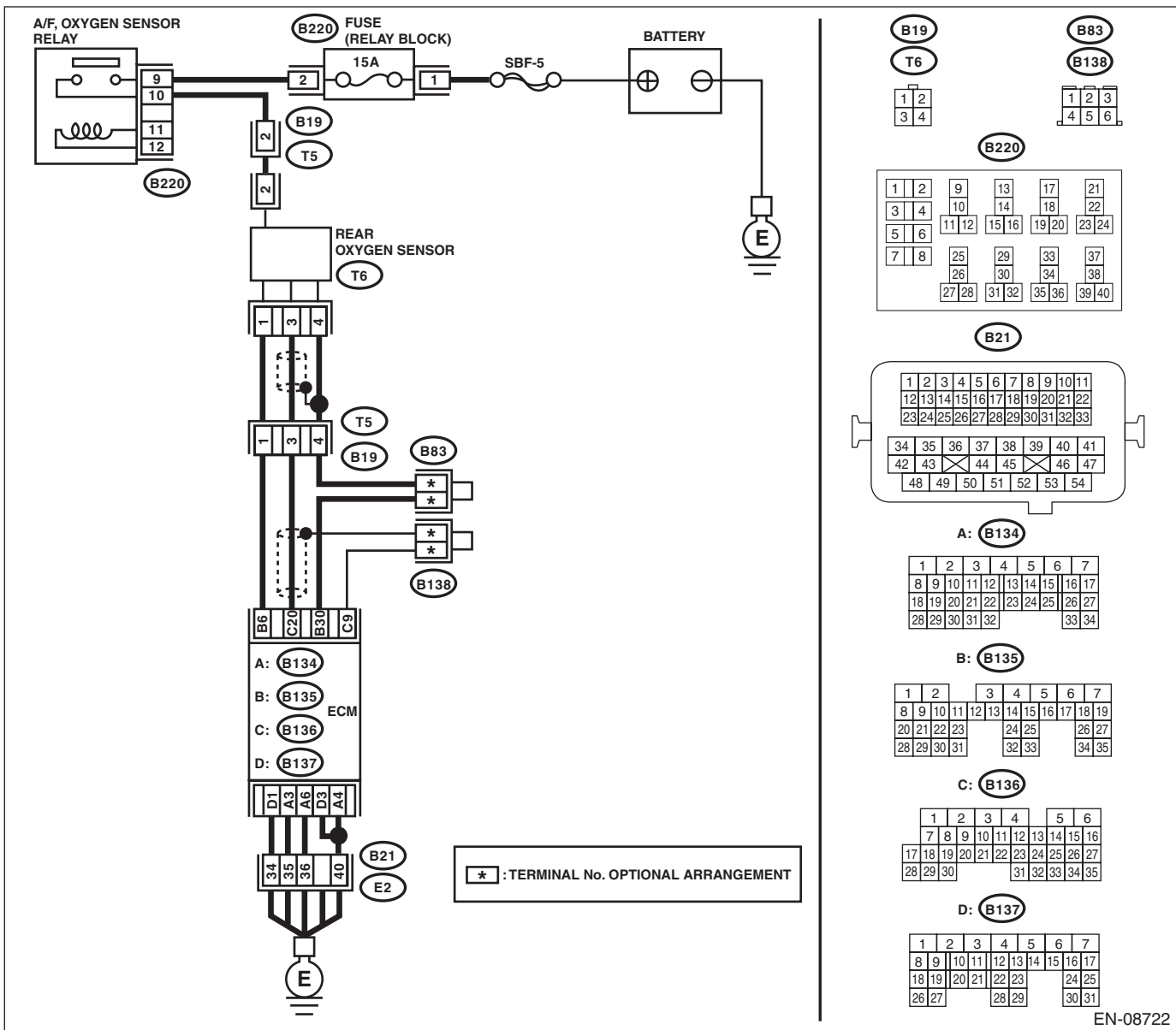

EN-08722

# Diagnostic Procedure with Diagnostic Trouble Code (DTC)

ENGINE (DIAGNOSTICS)

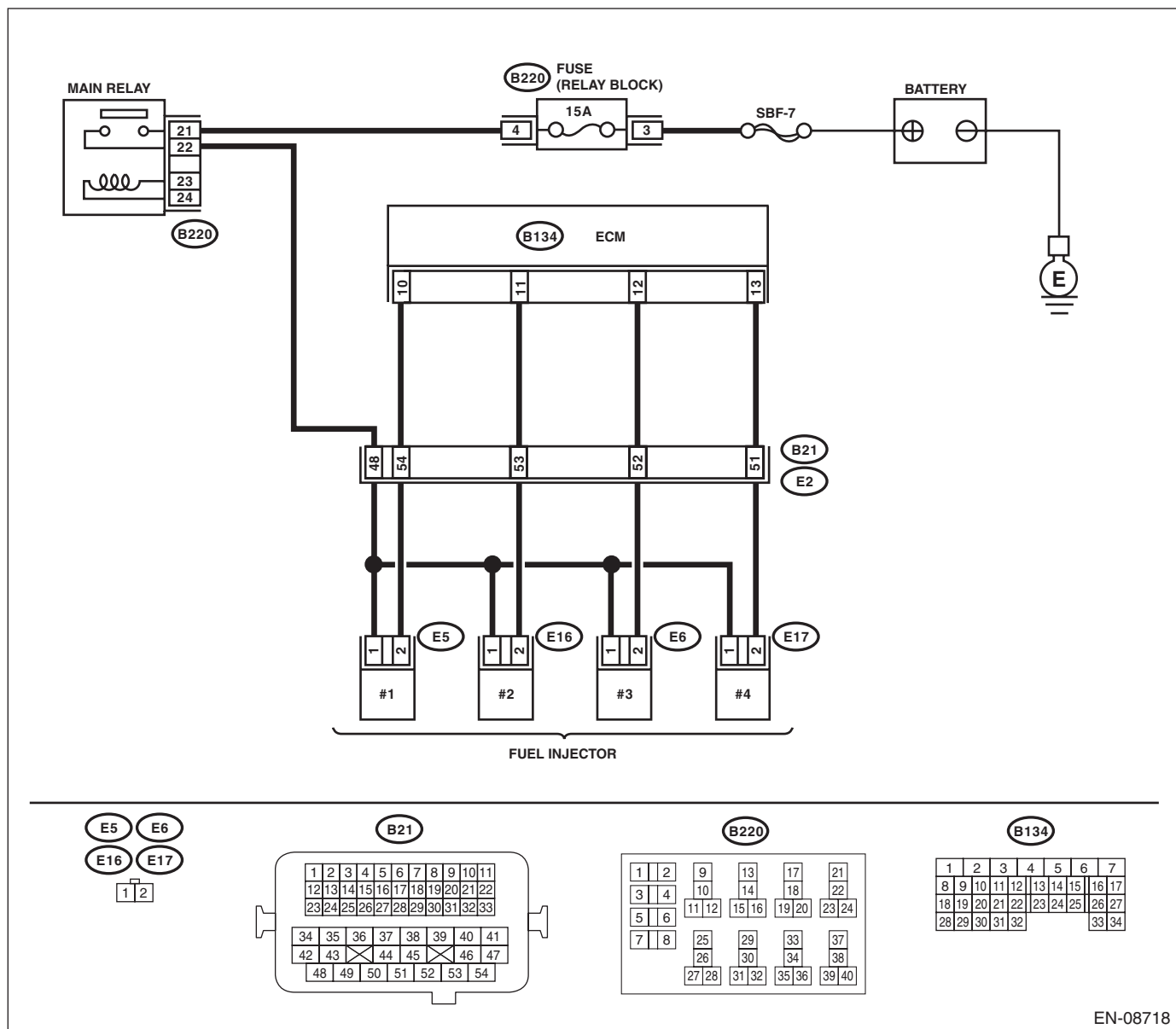

EN-08718

# Diagnostic Procedure with Diagnostic Trouble Code (DTC)

## ENGINE (DIAGNOSTICS)

- Models with SI-DRIVE

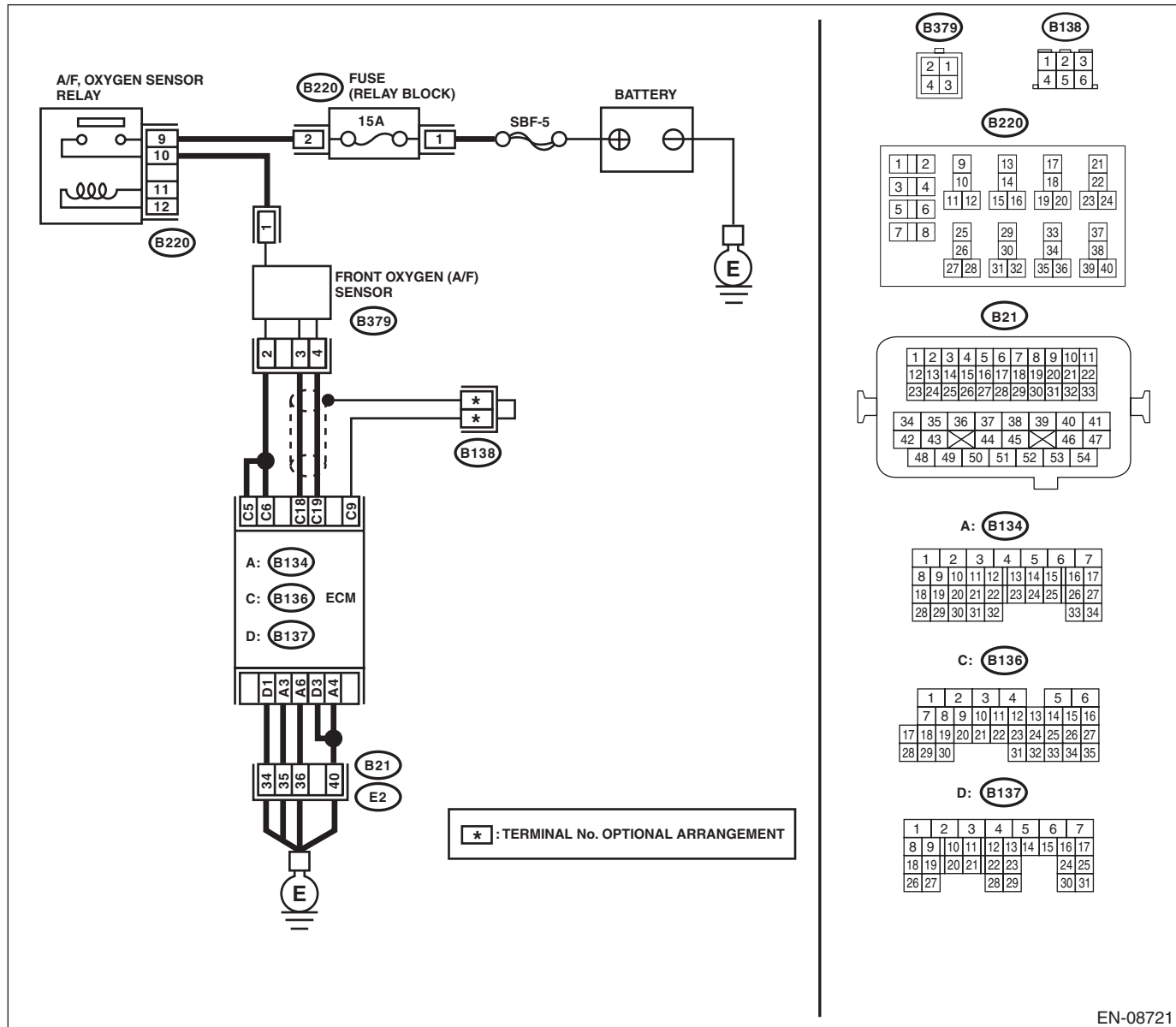

EN-08721



# Diagnostic Procedure with Diagnostic Trouble Code (DTC)

## ENGINE (DIAGNOSTICS)

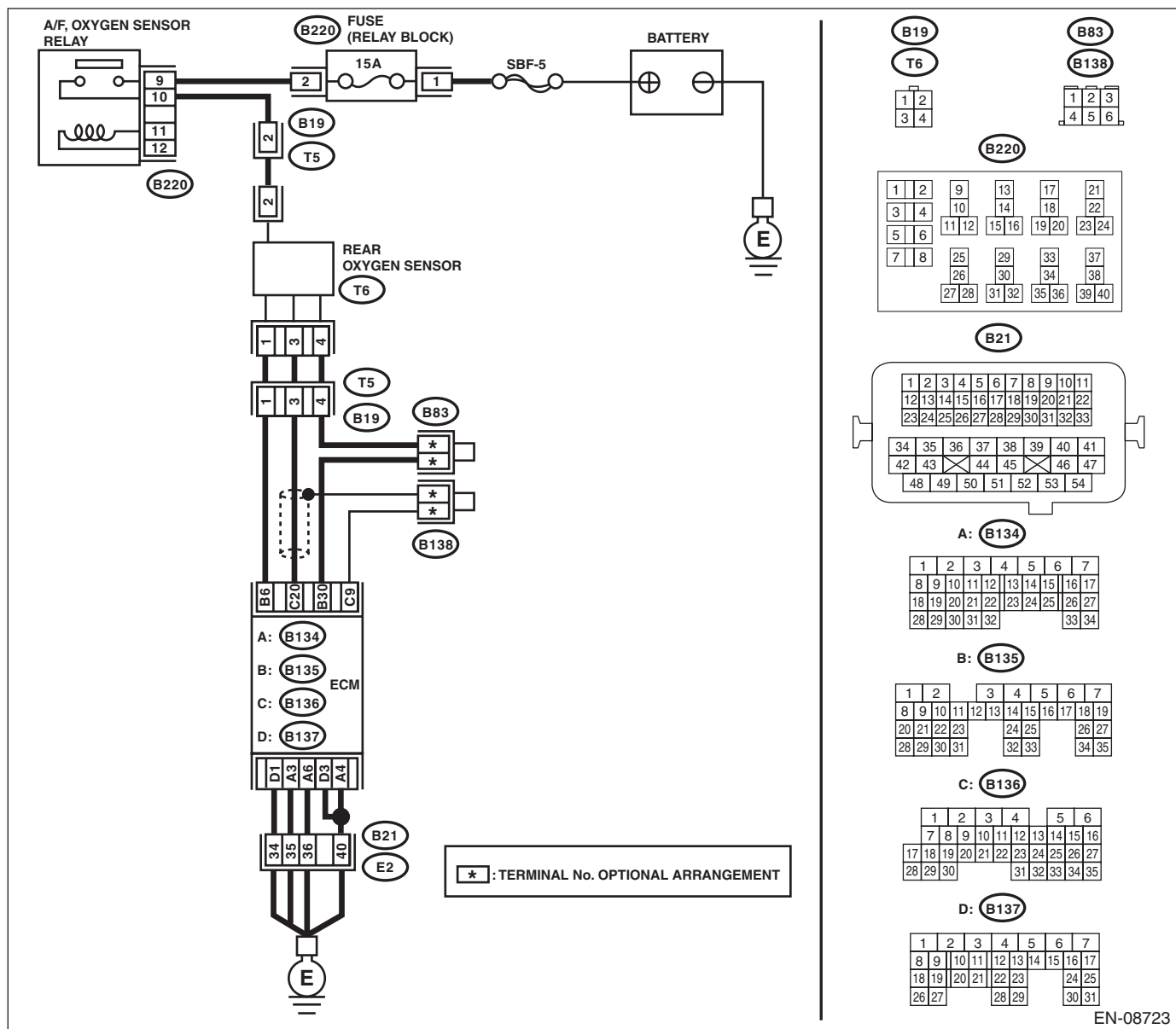

EN-08723

# Diagnostic Procedure with Diagnostic Trouble Code (DTC)

ENGINE (DIAGNOSTICS)

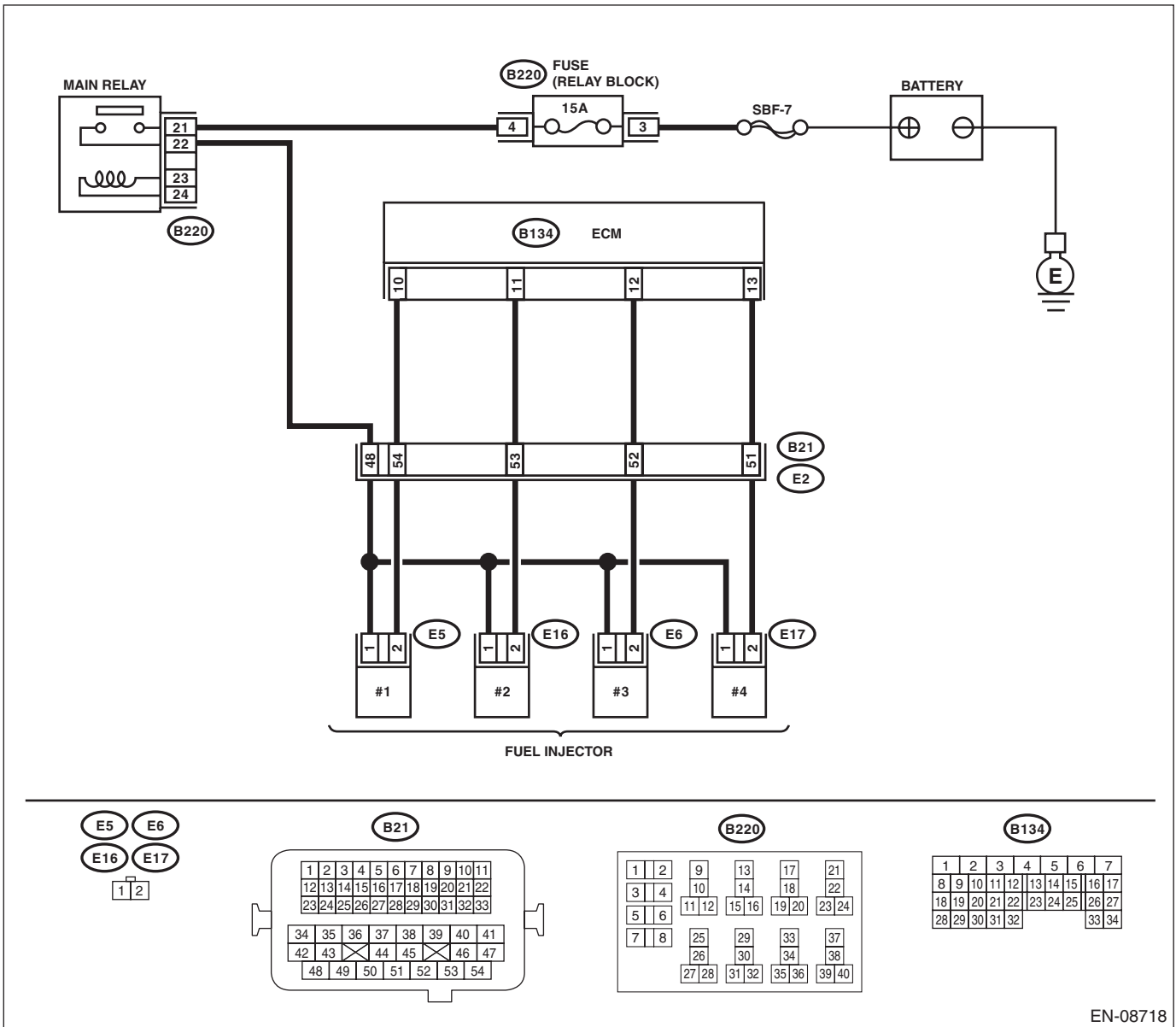

EN-08718

Step	Check	Yes	No
1	<b>CHECK FRONT OXYGEN (A/F) SENSOR CONNECTOR AND COUPLING CONNECTOR.</b> Has water entered the connector?	Completely remove any water inside.	Go to step 2.
2	<b>CHECK HARNESS BETWEEN ECM AND FRONT OXYGEN (A/F) SENSOR CONNECTOR.</b> 1) Turn the ignition switch to OFF. 2) Disconnect the connectors from ECM and front oxygen (A/F) sensor. 3) Measure the resistance of harness between ECM and front oxygen (A/F) sensor connector. <b>Connector &amp; terminal</b> <b>Models without SI-DRIVE</b> (B136) No. 19 — (E22) No. 1: (B136) No. 18 — (E22) No. 3: <b>Models with SI-DRIVE</b> (B136) No. 19 — (B379) No. 4: (B136) No. 18 — (B379) No. 3:	Is the resistance less than 1 Ω? Go to step 3.	Repair the harness and connector. <b>NOTE:</b> In this case, repair the following item: • Open circuit in harness between ECM and front oxygen (A/F) sensor connector • Poor contact of coupling connector

# Diagnostic Procedure with Diagnostic Trouble Code (DTC)

## ENGINE (DIAGNOSTICS)

Step	Check	Yes	No
<b>3 CHECK HARNESS BETWEEN ECM AND FRONT OXYGEN (A/F) SENSOR CONNECTOR.</b> Measure the resistance between ECM and chassis ground. <i><b>Connector &amp; terminal</b></i> <i><b>(B136) No. 19 — Chassis ground:</b></i> <i><b>(B136) No. 18 — Chassis ground:</b></i>	Is the resistance 1 MΩ or more?	Go to step 4.	Repair the ground short circuit of harness between ECM and front oxygen (A/F) sensor connector.
<b>4 CHECK OUTPUT SIGNAL FOR ECM.</b> 1) Connect the connector to ECM. 2) Turn the ignition switch to ON. 3) Measure the voltage between front oxygen (A/F) sensor connector and chassis ground. <i><b>Connector &amp; terminal</b></i> <i><b>Models without SI-DRIVE</b></i> <i><b>(E22) No. 1 (+) — Chassis ground (-):</b></i> <i><b>Models with SI-DRIVE</b></i> <i><b>(B379) No. 4 (+) — Chassis ground (-):</b></i>	Is the voltage 4.5 V or more?	Go to step 6.	Go to step 5.
<b>5 CHECK OUTPUT SIGNAL FOR ECM.</b> Measure the voltage between front oxygen (A/F) sensor connector and chassis ground. <i><b>Connector &amp; terminal</b></i> <i><b>Models without SI-DRIVE</b></i> <i><b>(E22) No. 3 (+) — Chassis ground (-):</b></i> <i><b>Models with SI-DRIVE</b></i> <i><b>(B379) No. 3 (+) — Chassis ground (-):</b></i>	Is the voltage 4.95 V or more?	Go to step 6.	Go to step 7.
<b>6 CHECK OUTPUT SIGNAL FOR ECM.</b> Measure the voltage between front oxygen (A/F) sensor connector and chassis ground. <i><b>Connector &amp; terminal</b></i> <i><b>Models without SI-DRIVE</b></i> <i><b>(E22) No. 3 (+) — Chassis ground (-):</b></i> <i><b>(E22) No. 1 (+) — Chassis ground (-):</b></i> <i><b>Models with SI-DRIVE</b></i> <i><b>(B379) No. 3 (+) — Chassis ground (-):</b></i> <i><b>(B379) No. 4 (+) — Chassis ground (-):</b></i>	Is the voltage 8 V or more?	Repair the short circuit to power in the harness between ECM and front oxygen (A/F) sensor connector. After repair, replace the ECM. <Ref. to FU(STI)-59, Engine Control Module (ECM).> <Ref. to FU(w/o STI)-58, Engine Control Module (ECM).>	Repair the poor contact of ECM connector.
<b>7 CHECK EXHAUST SYSTEM.</b>	Are there holes or loose bolts on exhaust system?	Repair the exhaust system.	Go to step 8.
<b>8 CHECK AIR INTAKE SYSTEM.</b>	Are there holes, loose bolts or disconnection of hose on air intake system?	Repair the air intake system.	Go to step 9.

# Diagnostic Procedure with Diagnostic Trouble Code (DTC)

ENGINE (DIAGNOSTICS)

Step	Check	Yes	No
<p><b>9</b></p> <p><b>CHECK FUEL PRESSURE.</b></p> <p><b>WARNING:</b> Place “NO OPEN FLAMES” signs near the working area.</p> <p><b>CAUTION:</b> Be careful not to spill fuel.</p> <p>1) Connect the front oxygen (A/F) sensor connector.</p> <p>2) Measure the fuel pressure while disconnecting pressure regulator vacuum hose from intake manifold. &lt;Ref. to ME(STI)-25, INSPECTION, Fuel Pressure.&gt; &lt;Ref. to ME(w/o STI)-25, INSPECTION, Fuel Pressure.&gt;</p> <p><b>CAUTION:</b> Release fuel pressure before removing the fuel pressure gauge.</p> <p>NOTE: If fuel pressure does not increase, squeeze the fuel return hose 2 to 3 times, then measure fuel pressure again.</p>	<p>Is the measured value 284 — 314 kPa (2.9 — 3.2 kg/cm<sup>2</sup>, 41 — 46 psi)?</p>	<p>Go to step 10.</p>	<p>Repair the following item.</p> <p>Fuel pressure is too high:</p> <ul style="list-style-type: none"> <li>• Clogged fuel line or bent hose</li> </ul> <p>Fuel pressure is too low:</p> <ul style="list-style-type: none"> <li>• Improper fuel pump discharge</li> <li>• Clogged fuel supply line</li> </ul>
<p><b>10</b></p> <p><b>CHECK FUEL PRESSURE.</b></p> <p>After connecting the pressure regulator vacuum hose, measure fuel pressure. &lt;Ref. to ME(STI)-25, INSPECTION, Fuel Pressure.&gt; &lt;Ref. to ME(w/o STI)-25, INSPECTION, Fuel Pressure.&gt;</p> <p><b>CAUTION:</b> Release fuel pressure before removing the fuel pressure gauge.</p> <p>NOTE:</p> <ul style="list-style-type: none"> <li>• If fuel pressure does not increase, squeeze fuel return hose 2 to 3 times, then measure fuel pressure again.</li> <li>• If the measured value at this step is out of specification, check or replace pressure regulator vacuum hose.</li> </ul>	<p>Is the measured value 230 — 260 kPa (2.35 — 2.65 kg/cm<sup>2</sup>, 33 — 38 psi)?</p>	<p>Go to step 11.</p>	<p>Repair the following item.</p> <p>Fuel pressure is too high:</p> <ul style="list-style-type: none"> <li>• Faulty pressure regulator</li> <li>• Clogged fuel return line or bent hose</li> </ul> <p>Fuel pressure is too low:</p> <ul style="list-style-type: none"> <li>• Faulty pressure regulator</li> <li>• Improper fuel pump discharge</li> <li>• Clogged fuel supply line</li> </ul>
<p><b>11</b></p> <p><b>CHECK ENGINE COOLANT TEMPERATURE SENSOR.</b></p> <p>1) Start the engine and warm up completely.</p> <p>2) Read the value of «Coolant Temp.» using the Subaru Select Monitor or a general scan tool.</p> <p>NOTE:</p> <ul style="list-style-type: none"> <li>• Subaru Select Monitor</li> </ul> <p>For detailed operation procedures, refer to “READ CURRENT DATA FOR ENGINE”. &lt;Ref. to EN(H4DOTC)(diag)-40, Subaru Select Monitor.&gt;</p> <ul style="list-style-type: none"> <li>• General scan tool</li> </ul> <p>For detailed operation procedures, refer to the general scan tool operation manual.</p>	<p>Is the value of «Coolant Temp.» 75°C (167°F) or more?</p>	<p>Go to step 12.</p>	<p>Replace the engine coolant temperature sensor. &lt;Ref. to FU(STI)-34, Engine Coolant Temperature Sensor.&gt; &lt;Ref. to FU(w/o STI)-35, Engine Coolant Temperature Sensor.&gt;</p>

# Diagnostic Procedure with Diagnostic Trouble Code (DTC)

## ENGINE (DIAGNOSTICS)

Step	Check	Yes	No
<p><b>12 CHECK MASS AIR FLOW AND INTAKE AIR TEMPERATURE SENSOR.</b></p> <p>1) Start the engine and warm up engine until coolant temperature is higher than 75°C (167°F).</p> <p>2) Place the shift lever in neutral position.</p> <p>3) Turn the A/C switch to OFF.</p> <p>4) Turn all the accessory switches to OFF.</p> <p>5) Read the value of «Mass Air Flow» using the Subaru Select Monitor or a general scan tool.</p> <p>NOTE:</p> <ul style="list-style-type: none"> <li>• Subaru Select Monitor</li> </ul> <p>For detailed operation procedures, refer to "READ CURRENT DATA FOR ENGINE". &lt;Ref. to EN(H4DOTC)(diag)-40, Subaru Select Monitor.&gt;</p> <ul style="list-style-type: none"> <li>• General scan tool</li> </ul> <p>For detailed operation procedures, refer to the general scan tool operation manual.</p>	<p>Is the value of «Mass Air Flow» 2.0 — 5.0 g/s (0.26 — 0.66 lb/m)?</p>	Go to step 13.	<p>Replace the mass air flow and intake air temperature sensor. &lt;Ref. to FU(STI)-42, Mass Air Flow and Intake Air Temperature Sensor.&gt; &lt;Ref. to FU(w/o STI)-43, Mass Air Flow and Intake Air Temperature Sensor.&gt;</p>
<p><b>13 CHECK MASS AIR FLOW AND INTAKE AIR TEMPERATURE SENSOR.</b></p> <p>1) Start the engine and warm up engine until coolant temperature is higher than 75°C (167°F).</p> <p>2) Place the shift lever in neutral position.</p> <p>3) Turn the A/C switch to OFF.</p> <p>4) Turn all the accessory switches to OFF.</p> <p>5) Open the front hood.</p> <p>6) Measure the ambient temperature.</p> <p>7) Read the value of «Intake Air Temp.» using the Subaru Select Monitor or a general scan tool.</p> <p>NOTE:</p> <ul style="list-style-type: none"> <li>• Subaru Select Monitor</li> </ul> <p>For detailed operation procedures, refer to "READ CURRENT DATA FOR ENGINE". &lt;Ref. to EN(H4DOTC)(diag)-40, Subaru Select Monitor.&gt;</p> <ul style="list-style-type: none"> <li>• General scan tool</li> </ul> <p>For detailed operation procedures, refer to the general scan tool operation manual.</p>	<p>Subtract ambient temperature from «Intake Air Temp.». Is the obtained value -10 — 50°C (-18 — 90°F)?</p>	Go to step 14.	<p>Check the mass air flow and intake air temperature sensor. &lt;Ref. to FU(STI)-42, Mass Air Flow and Intake Air Temperature Sensor.&gt; &lt;Ref. to FU(w/o STI)-43, Mass Air Flow and Intake Air Temperature Sensor.&gt;</p>
<p><b>14 CHECK REAR OXYGEN SENSOR DATA.</b></p> <p>1) Warm up the engine until engine coolant temperature is higher than 75°C (167°F), and keep the engine speed at 3,000 rpm. (2 minutes maximum)</p> <p>2) Read the value of «Rear O2 Sensor» using the Subaru Select Monitor or a general scan tool.</p> <p>NOTE:</p> <ul style="list-style-type: none"> <li>• Depress the clutch pedal.</li> <li>• Subaru Select Monitor</li> </ul> <p>For detailed operation procedures, refer to "READ CURRENT DATA FOR ENGINE". &lt;Ref. to EN(H4DOTC)(diag)-40, Subaru Select Monitor.&gt;</p> <ul style="list-style-type: none"> <li>• General scan tool</li> </ul> <p>For detailed operation procedures, refer to the general scan tool operation manual.</p>	<p>Is the value of «Rear O2 Sensor» 0.490 V or more?</p>	Go to step 15.	Go to step 16.

# Diagnostic Procedure with Diagnostic Trouble Code (DTC)

ENGINE (DIAGNOSTICS)

Step	Check	Yes	No
<p><b>15 CHECK REAR OXYGEN SENSOR DATA.</b></p> <p>1) Warm up the engine until engine coolant temperature is higher than 75°C (167°F), and rapidly reduce the engine speed from 3,000 rpm.</p> <p>2) Read the value of «Rear O2 Sensor» using the Subaru Select Monitor or a general scan tool.</p> <p>NOTE:</p> <ul style="list-style-type: none"> <li>• Depress the clutch pedal.</li> <li>• Subaru Select Monitor</li> </ul> <p>For detailed operation procedures, refer to "READ CURRENT DATA FOR ENGINE". &lt;Ref. to EN(H4DOTC)(diag)-40, Subaru Select Monitor.&gt;</p> <ul style="list-style-type: none"> <li>• General scan tool</li> </ul> <p>For detailed operation procedures, refer to the general scan tool operation manual.</p>	<p>Is the value of «Rear O2 Sensor» 0.250 V or less?</p>	<p>Go to step 17.</p>	<p>Go to step 16.</p>
<p><b>16 CHECK REAR OXYGEN SENSOR CONNECTOR AND COUPLING CONNECTOR.</b></p>	<p>Has water entered the connector?</p>	<p>Completely remove any water inside.</p>	<p>Go to step 18.</p>
<p><b>17 CHECK FRONT OXYGEN (A/F) SENSOR USING REAR OXYGEN SENSOR SIGNAL.</b></p> <p>1) Warm up the engine until engine coolant temperature is higher than 75°C (167°F), then keep the engine idling for 5 minutes or more.</p> <p>2) Read the value of «Rear O2 Sensor» using the Subaru Select Monitor or a general scan tool.</p> <p>NOTE:</p> <ul style="list-style-type: none"> <li>• Subaru Select Monitor</li> </ul> <p>For detailed operation procedures, refer to "READ CURRENT DATA FOR ENGINE". &lt;Ref. to EN(H4DOTC)(diag)-40, Subaru Select Monitor.&gt;</p> <ul style="list-style-type: none"> <li>• General scan tool</li> </ul> <p>For detailed operation procedures, refer to the general scan tool operation manual.</p>	<p>Is the value in «Rear O2 Sensor» kept at 0.250 V or less for 5 minutes or more?</p>	<p>Replace the front oxygen (A/F) sensor. &lt;Ref. to FU(STI)-54, Front Oxygen (A/F) Sensor.&gt; &lt;Ref. to FU(w/o STI)-54, Front Oxygen (A/F) Sensor.&gt;</p>	<p>Go to step 18.</p>
<p><b>18 CHECK HARNESS BETWEEN ECM AND REAR OXYGEN SENSOR CONNECTOR.</b></p> <p>1) Turn the ignition switch to OFF.</p> <p>2) Disconnect the connector from ECM and rear oxygen sensor.</p> <p>3) Measure the resistance of harness between ECM and rear oxygen sensor connector.</p> <p><b>Connector &amp; terminal</b>  <b>(B136) No. 20 — (T6) No. 3:</b>  <b>(B135) No. 30 — (T6) No. 4:</b></p>	<p>Is the resistance less than 1 Ω?</p>	<p>Go to step 19.</p>	<p>Repair the harness and connector.</p> <p>NOTE:</p> <p>In this case, repair the following item:</p> <ul style="list-style-type: none"> <li>• Open circuit in harness between ECM and rear oxygen sensor connector</li> <li>• Poor contact of coupling connector</li> </ul>
<p><b>19 CHECK HARNESS BETWEEN ECM AND REAR OXYGEN SENSOR CONNECTOR.</b></p> <p>1) Connect the connector to ECM.</p> <p>2) Turn the ignition switch to ON.</p> <p>3) Measure the voltage between rear oxygen sensor connector and chassis ground.</p> <p><b>Connector &amp; terminal</b>  <b>(T6) No. 3 (+) — Chassis ground (-):</b></p>	<p>Is the voltage 0.2 — 0.5 V?</p>	<p>Replace the rear oxygen sensor. &lt;Ref. to FU(STI)-56, Rear Oxygen Sensor.&gt; &lt;Ref. to FU(w/o STI)-56, Rear Oxygen Sensor.&gt;</p>	<p>Go to step 20.</p>

# Diagnostic Procedure with Diagnostic Trouble Code (DTC)

## ENGINE (DIAGNOSTICS)

Step	Check	Yes	No
<b>20 CHECK OUTPUT SIGNAL OF ECM.</b> 1) Turn the ignition switch to ON. 2) Measure the voltage between ECM and chassis ground on faulty cylinders. <b>Connector &amp; terminal</b> <i>#1 (B134) No. 10 (+) — Chassis ground (-);</i> <i>#2 (B134) No. 11 (+) — Chassis ground (-);</i> <i>#3 (B134) No. 12 (+) — Chassis ground (-);</i> <i>#4 (B134) No. 13 (+) — Chassis ground (-);</i>	Is the voltage 10 V or more?	Go to step 25.	Go to step 21.
<b>21 CHECK HARNESS BETWEEN ECM AND FUEL INJECTOR CONNECTOR.</b> 1) Turn the ignition switch to OFF. 2) Disconnect the connector from fuel injector on faulty cylinders. 3) Measure the resistance between fuel injector connector and engine ground on faulty cylinders. <b>Connector &amp; terminal</b> <i>#1 (E5) No. 2 — Engine ground;</i> <i>#2 (E16) No. 2 — Engine ground;</i> <i>#3 (E6) No. 2 — Engine ground;</i> <i>#4 (E17) No. 2 — Engine ground;</i>	Is the resistance 1 M $\Omega$ or more?	Go to step 22.	Repair the short circuit to ground in harness between ECM and fuel injector connector.
<b>22 CHECK HARNESS BETWEEN ECM AND FUEL INJECTOR CONNECTOR.</b> Measure the resistance of harness between ECM and fuel injector connector on faulty cylinders. <b>Connector &amp; terminal</b> <i>#1 (B134) No. 10 — (E5) No. 2;</i> <i>#2 (B134) No. 11 — (E16) No. 2;</i> <i>#3 (B134) No. 12 — (E6) No. 2;</i> <i>#4 (B134) No. 13 — (E17) No. 2;</i>	Is the resistance less than 1 $\Omega$ ?	Go to step 23.	Repair the harness and connector. NOTE: In this case, repair the following item: <ul style="list-style-type: none"> <li>• Open circuit in harness between ECM and fuel injector connector</li> <li>• Poor contact of coupling connector</li> </ul>
<b>23 CHECK FUEL INJECTOR.</b> Measure the resistance between fuel injector terminals on faulty cylinder. <b>Terminals</b> <i>No. 1 — No. 2:</i>	Is the resistance 5 — 20 $\Omega$ ?	Go to step 24.	Replace the faulty fuel injector. <Ref. to FU(STI)-45, Fuel Injector.> <Ref. to FU(w/o STI)-46, Fuel Injector.>
<b>24 CHECK POWER SUPPLY LINE.</b> 1) Turn the ignition switch to ON. 2) Measure the voltage between fuel injector connector of faulty cylinders and engine ground. <b>Connector &amp; terminal</b> <i>#1 (E5) No. 1 (+) — Engine ground (-);</i> <i>#2 (E16) No. 1 (+) — Engine ground (-);</i> <i>#3 (E6) No. 1 (+) — Engine ground (-);</i> <i>#4 (E17) No. 1 (+) — Engine ground (-);</i>	Is the voltage 10 V or more?	Repair the poor contact of all connectors in fuel injector circuit.	Repair the harness and connector. NOTE: In this case, repair the following item: <ul style="list-style-type: none"> <li>• Open circuit in harness between the main relay and fuel injector connector on faulty cylinders</li> <li>• Poor contact of coupling connector</li> <li>• Poor contact of main relay connector</li> </ul>

# Diagnostic Procedure with Diagnostic Trouble Code (DTC)

ENGINE (DIAGNOSTICS)

Step	Check	Yes	No
<b>25 CHECK HARNESS BETWEEN ECM AND FUEL INJECTOR CONNECTOR.</b> 1) Turn the ignition switch to OFF. 2) Disconnect the connector from fuel injector on faulty cylinders. 3) Turn the ignition switch to ON. 4) Measure the voltage between ECM and chassis ground on faulty cylinders. <b>Connector &amp; terminal</b> #1 (B134) No. 10 (+) — Chassis ground (-): #2 (B134) No. 11 (+) — Chassis ground (-): #3 (B134) No. 12 (+) — Chassis ground (-): #4 (B134) No. 13 (+) — Chassis ground (-):	Is the voltage 10 V or more?	Repair the short circuit to power in harness between ECM and fuel injector connector.	Go to step 26.
<b>26 CHECK FUEL INJECTOR.</b> 1) Turn the ignition switch to OFF. 2) Measure the resistance between fuel injector terminals on faulty cylinder. <b>Terminals</b> No. 1 — No. 2:	Is the resistance 5 — 20 Ω?	Go to step 27.	Replace the faulty fuel injector. <Ref. to FU(STI)-45, Fuel Injector.> <Ref. to FU(w/o STI)-46, Fuel Injector.>
<b>27 CHECK INSTALLATION CONDITION OF CAMSHAFT POSITION SENSOR/CRANKSHAFT POSITION SENSOR.</b>	Is the camshaft position sensor or crankshaft position sensor loosely installed?	Tighten the camshaft position sensor or crankshaft position sensor. <Ref. to FU(STI)-37, Camshaft Position Sensor.> <Ref. to FU(STI)-35, Crankshaft Position Sensor.> <Ref. to FU(w/o STI)-38, Camshaft Position Sensor.> <Ref. to FU(w/o STI)-36, Crankshaft Position Sensor.>	Go to step 28.
<b>28 CHECK CRANK SPROCKET.</b> Remove the timing belt cover. <Ref. to ME(STI)-49, REMOVAL, Timing Belt Cover.> <Ref. to ME(w/o STI)-48, REMOVAL, Timing Belt Cover.>	Is the crank sprocket rusted or does it have broken teeth?	Replace the crank sprocket. <Ref. to ME(STI)-60, Crank Sprocket.> <Ref. to ME(w/o STI)-59, Crank Sprocket.>	Go to step 29.
<b>29 CHECK INSTALLATION CONDITION OF TIMING BELT.</b> Turn the crankshaft using ST, and align the alignment mark on crank sprocket with alignment mark on cylinder block. ST 499987500                      CRANKSHAFT SOCKET	Is the timing belt dislocated from its proper position?	Repair the installation condition of timing belt. <Ref. to ME(STI)-50, Timing Belt.> <Ref. to ME(w/o STI)-49, Timing Belt.>	Go to step 30.
<b>30 CHECK FUEL LEVEL.</b>	Is the fuel meter indication higher than the "Lower" level?	Go to step 31.	Refill the fuel so that the fuel meter indication is higher than the "Lower" level, and proceed to the next step. Go to step 31.



# Diagnostic Procedure with Diagnostic Trouble Code (DTC)

## ENGINE (DIAGNOSTICS)

Step	Check	Yes	No
<b>31 CHECK STATUS OF MALFUNCTION INDICATOR LIGHT.</b> 1) Clear the memory using the Subaru Select Monitor or general scan tool. <Ref. to EN(H4DOTC)(diag)-62, Clear Memory Mode.> 2) Start the engine, and drive the vehicle 10 minutes or more.	Does the malfunction indicator light illuminate or blink?	Go to step <b>33</b> .	Go to step <b>32</b> .
<b>32 CHECK CAUSE OF MISFIRE.</b>	Was the cause of misfire identified when the engine is running?	Finish diagnostics operation, if the engine has no abnormality.	Repair the poor contact of connector. NOTE: In this case, repair the following item: <ul style="list-style-type: none"> <li>• Poor contact of ignition coil connector</li> <li>• Poor contact of fuel injector connector on faulty cylinders</li> <li>• Poor contact of ECM connector</li> <li>• Poor contact of coupling connector</li> </ul>
<b>33 CHECK AIR INTAKE SYSTEM.</b>	Is there any fault in air intake system?	Repair the air intake system. NOTE: Check the following items. <ul style="list-style-type: none"> <li>• Are there air leaks or air suction caused by loose or dislocated nuts and bolts?</li> <li>• Are there cracks or any disconnection of hoses?</li> </ul>	Go to step <b>34</b> .
<b>34 CHECK MISFIRE SYMPTOM.</b> 1) Turn the ignition switch to ON. 2) Check for DTC. <Ref. to EN(H4DOTC)(diag)-47, Read Diagnostic Trouble Code (DTC).>	Does the Subaru Select Monitor or general scan tool indicate only one DTC?	Go to step <b>37</b> .	Go to step <b>35</b> .
<b>35 CHECK DTC.</b>	Is DTC P0301 and P0303 displayed on the Subaru Select Monitor or general scan tool?	Go to step <b>38</b> .	Go to step <b>36</b> .
<b>36 CHECK DTC.</b>	Is DTC P0302 and P0304 displayed on the Subaru Select Monitor or general scan tool?	Go to step <b>39</b> .	Go to step <b>40</b> .
<b>37 ONLY ONE CYLINDER.</b>	Is there any fault in the cylinder?	Repair or replace faulty parts. NOTE: Check the following items. <ul style="list-style-type: none"> <li>• Spark plug</li> <li>• Ignition coil</li> <li>• Fuel injector</li> <li>• Compression ratio</li> </ul>	Go to DTC P0171. <Ref. to EN(H4DOTC)(diag)-168, DTC P0171 SYSTEM TOO LEAN (BANK 1), Diagnostic Procedure with Diagnostic Trouble Code (DTC).>

# Diagnostic Procedure with Diagnostic Trouble Code (DTC)

ENGINE (DIAGNOSTICS)

Step	Check	Yes	No
<b>38</b> <b>GROUP OF #1 AND #3 CYLINDERS.</b>	Are there any faults in #1 and #3 cylinders?	Repair or replace faulty parts. NOTE: Check the following items. • Spark plug • Ignition coil • Fuel injector • Compression ratio • Skipping timing belt teeth	Go to DTC P0171. <Ref. to EN(H4DOTC)(diag)-168, DTC P0171 SYSTEM TOO LEAN (BANK 1), Diagnostic Procedure with Diagnostic Trouble Code (DTC).>
<b>39</b> <b>GROUP OF #2 AND #4 CYLINDERS.</b>	Are there any faults in #2 and #4 cylinders?	Repair or replace faulty parts. NOTE: Check the following items. • Spark plug • Ignition coil • Fuel injector • Compression ratio • Skipping timing belt teeth	Go to DTC P0171. <Ref. to EN(H4DOTC)(diag)-168, DTC P0171 SYSTEM TOO LEAN (BANK 1), Diagnostic Procedure with Diagnostic Trouble Code (DTC).>
<b>40</b> <b>CYLINDER AT RANDOM.</b>	Is the engine idle rough?	Go to DTC P0171. <Ref. to EN(H4DOTC)(diag)-168, DTC P0171 SYSTEM TOO LEAN (BANK 1), Diagnostic Procedure with Diagnostic Trouble Code (DTC).>	Repair or replace faulty parts. NOTE: Check the following items. • Spark plug • Ignition coil • Fuel injector • Compression ratio

# Diagnostic Procedure with Diagnostic Trouble Code (DTC)

ENGINE (DIAGNOSTICS)

## ER:DTC P2401 EVAPORATIVE EMISSION SYSTEM LEAK DETECTION PUMP CONTROL CIRCUIT LOW

### DTC DETECTING CONDITION:

- Immediately at fault recognition
- GENERAL DESCRIPTION <Ref. to GD(H4DOTC)-264, DTC P2401 EVAPORATIVE EMISSION SYSTEM LEAK DETECTION PUMP CONTROL CIRCUIT LOW, Diagnostic Trouble Code (DTC) Detecting Criteria.>

### CAUTION:

After servicing or replacing faulty parts, perform Clear Memory Mode <Ref. to EN(H4DOTC)(diag)-62, OPERATION, Clear Memory Mode.>, and Inspection Mode <Ref. to EN(H4DOTC)(diag)-48, PROCEDURE, Inspection Mode.>.

### WIRING DIAGRAM:

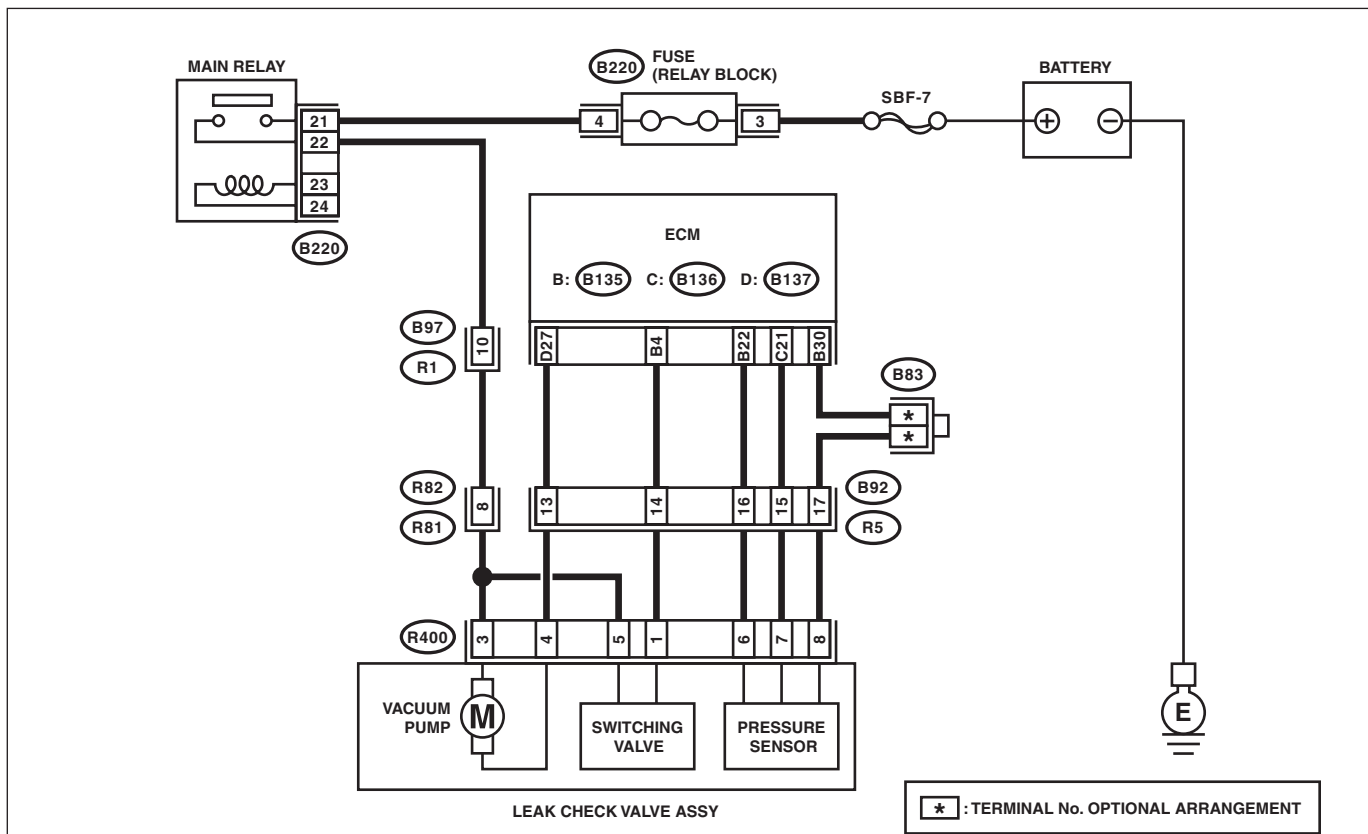

\* : TERMINAL No. OPTIONAL ARRANGEMENT

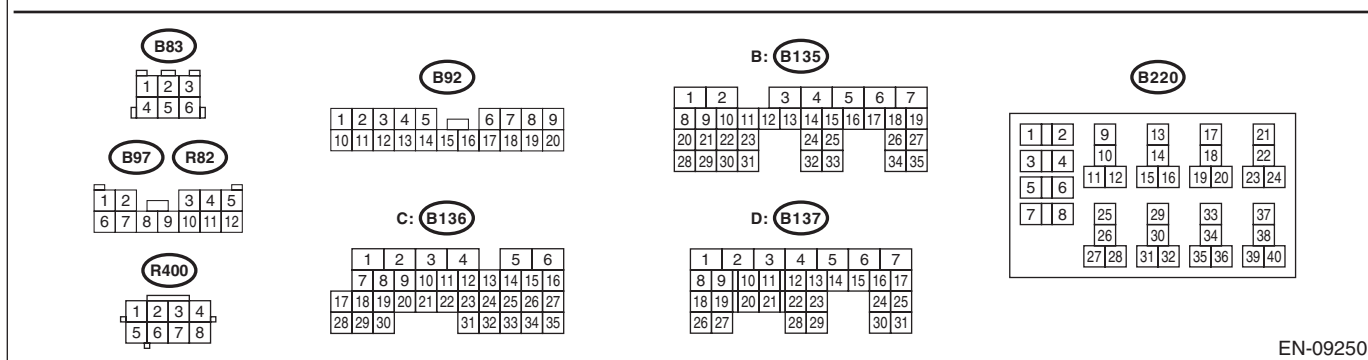

EN-09250

# Diagnostic Procedure with Diagnostic Trouble Code (DTC)

ENGINE (DIAGNOSTICS)

Step	Check	Yes	No
<p><b>1</b></p> <p><b>CHECK HARNESS BETWEEN ECM AND LEAK CHECK VALVE ASSEMBLY CONNECTOR.</b></p> <p>1) Turn the ignition switch to ON. 2) Measure the voltage between ECM and chassis ground.</p> <p><b>Connector &amp; terminal</b> <b>(B137) No. 27 (+) — Chassis ground (-):</b></p>	Is the voltage 10 V or more?	Go to step 2.	Go to step 3.
<p><b>2</b></p> <p><b>CHECK FOR POOR CONTACT.</b></p> <p>Check for poor contact of ECM connector.</p>	Is there poor contact of ECM connector?	Repair the poor contact of ECM connector.	Even if DTC is detected, the circuit has returned to a normal condition at this time. Reproduce the failure, and then perform the diagnosis again.  NOTE: In this case, temporary open or short circuit of harness or temporary poor contact of connector may be the cause.
<p><b>3</b></p> <p><b>CHECK POWER SUPPLY TO LEAK CHECK VALVE ASSEMBLY.</b></p> <p>Measure the voltage between the leak check valve assembly connector and engine ground.</p> <p><b>Connector &amp; terminal</b> <b>(R400) No. 3 (+) — Engine ground (-):</b></p>	Is the voltage 10 V or more?	Go to step 4.	Repair the power supply circuit.
<p><b>4</b></p> <p><b>CHECK HARNESS BETWEEN ECM AND LEAK CHECK VALVE ASSEMBLY CONNECTOR.</b></p> <p>1) Turn the ignition switch to OFF. 2) Disconnect the connector from ECM and the leak check valve assembly. 3) Measure the resistance between leak check valve assembly and chassis ground.</p> <p><b>Connector &amp; terminal</b> <b>(R400) No. 4 — Chassis ground:</b></p>	Is the resistance 1 M $\Omega$ or more?	Go to step 5.	Repair the short circuit to ground in harness between ECM and leak check valve assembly connector.
<p><b>5</b></p> <p><b>CHECK HARNESS BETWEEN ECM AND LEAK CHECK VALVE ASSEMBLY CONNECTOR.</b></p> <p>Measure the resistance of harness between ECM and the leak check valve assembly connector.</p> <p><b>Connector &amp; terminal</b> <b>(B137) No. 27 — (R400) No. 4:</b></p>	Is the resistance less than 1 $\Omega$ ?	Go to step 6.	Repair the harness and connector.  NOTE: In this case, repair the following item: • Open circuit in harness between ECM and the leak check valve assembly connector • Poor contact of coupling connector

# Diagnostic Procedure with Diagnostic Trouble Code (DTC)

ENGINE (DIAGNOSTICS)

Step	Check	Yes	No
<b>6</b> <b>CHECK LEAK CHECK VALVE ASSEMBLY.</b> Check the vacuum pump of the leak check valve assembly. <Ref. to EC(STI)-21, CHECK VACUUM PUMP, INSPECTION, Leak Check Valve Assembly.> <Ref. to EC(w/o STI)-22, CHECK VACUUM PUMP, INSPECTION, Leak Check Valve Assembly.>	Is the vacuum pump of the leak check valve assembly OK?	Repair the poor contact in the leak check valve assembly connector.	Replace the leak check valve assembly. <Ref. to EC(STI)-19, Leak Check Valve Assembly.> <Ref. to EC(w/o STI)-20, Leak Check Valve Assembly.>

# Diagnostic Procedure with Diagnostic Trouble Code (DTC)

ENGINE (DIAGNOSTICS)

## ES:DTC P2402 EVAPORATIVE EMISSION SYSTEM LEAK DETECTION PUMP CONTROL CIRCUIT HIGH

### DTC DETECTING CONDITION:

- Immediately at fault recognition
- GENERAL DESCRIPTION <Ref. to GD(H4DOTC)-266, DTC P2402 EVAPORATIVE EMISSION SYSTEM LEAK DETECTION PUMP CONTROL CIRCUIT HIGH, Diagnostic Trouble Code (DTC) Detecting Criteria.>

### CAUTION:

After servicing or replacing faulty parts, perform Clear Memory Mode <Ref. to EN(H4DOTC)(diag)-62, OPERATION, Clear Memory Mode.>, and Inspection Mode <Ref. to EN(H4DOTC)(diag)-48, PROCEDURE, Inspection Mode.>.

### WIRING DIAGRAM:

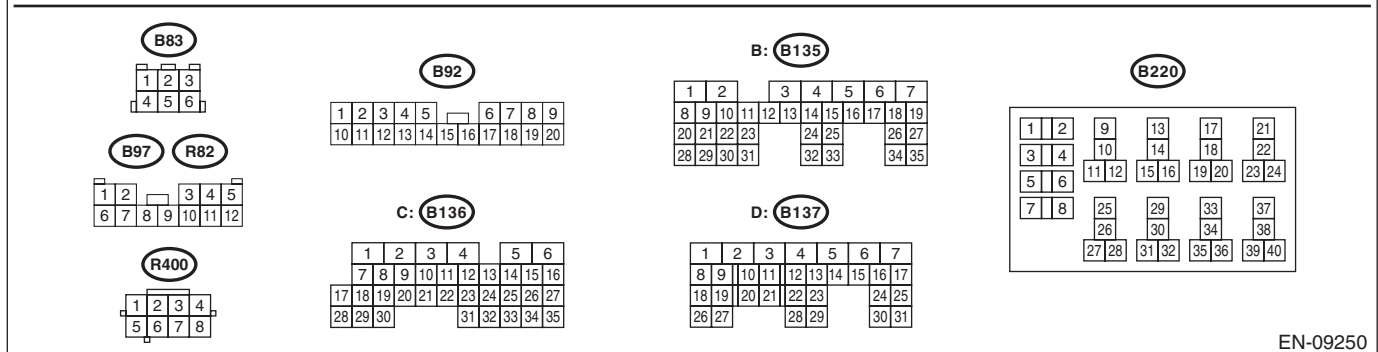
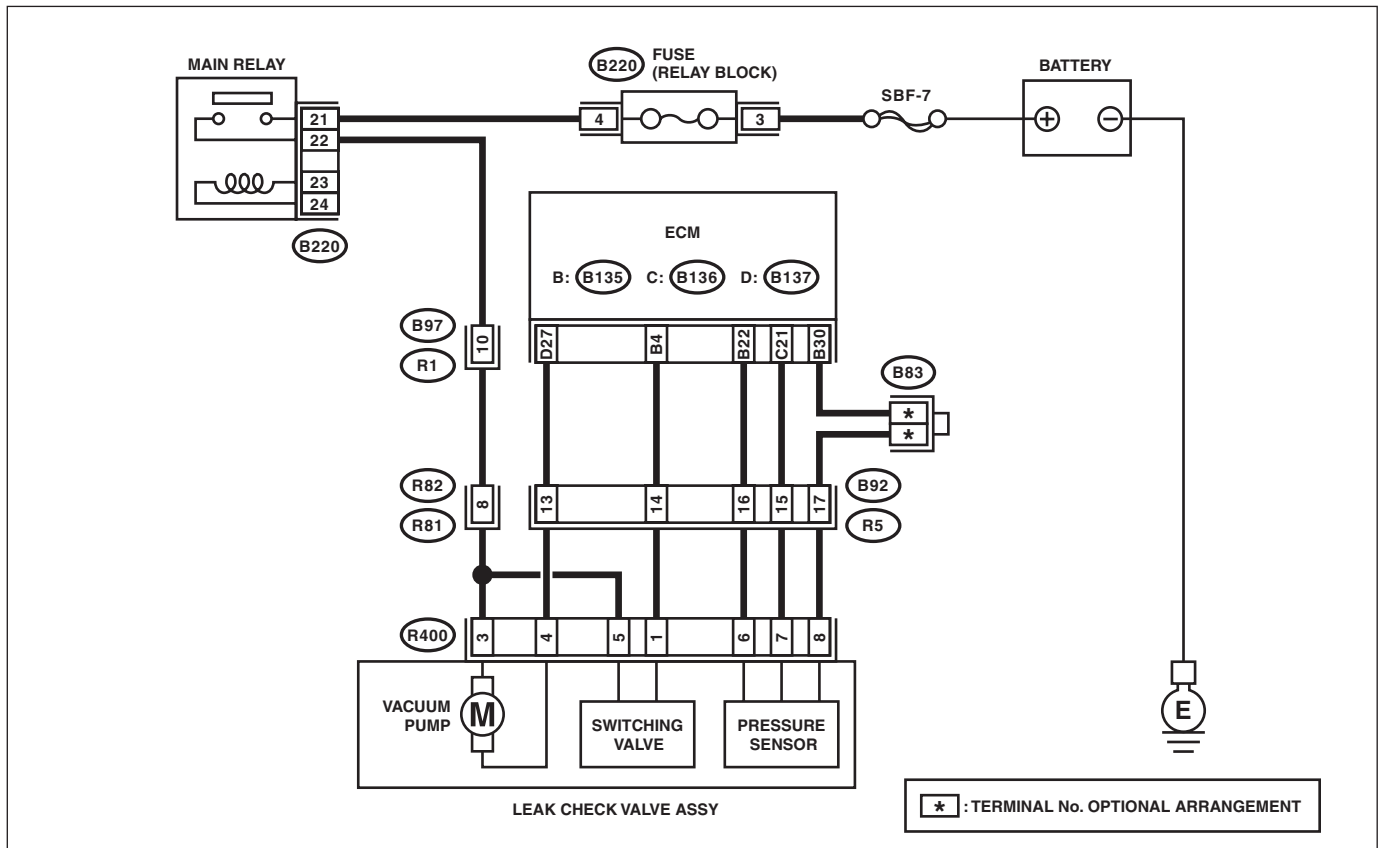

EN-09250

# Diagnostic Procedure with Diagnostic Trouble Code (DTC)

ENGINE (DIAGNOSTICS)

Step	Check	Yes	No
<p><b>1</b>    <b>CHECK HARNESS BETWEEN ECM AND LEAK CHECK VALVE ASSEMBLY CONNECTOR.</b></p> <p>1) Turn the ignition switch to OFF.                  2) Disconnect the connector from the leak check valve assembly.                  3) Turn the ignition switch to ON.                  4) Measure the voltage between leak check valve assembly and chassis ground.</p> <p><b>Connector &amp; terminal</b>  <b>(R400) No. 4 (+) — Chassis ground (-):</b></p>	<p>Is the voltage 10 V or more?</p>	<p>Repair the short circuit to power in harness between ECM and leak check valve assembly connector.</p>	<p>Go to step 2.</p>
<p><b>2</b>    <b>CHECK LEAK CHECK VALVE ASSEMBLY.</b></p> <p>1) Turn the ignition switch to OFF.                  2) Check the vacuum pump of the leak check valve assembly. &lt;Ref. to EC(STI)-21, CHECK VACUUM PUMP, INSPECTION, Leak Check Valve Assembly.&gt; &lt;Ref. to EC(w/o STI)-22, CHECK VACUUM PUMP, INSPECTION, Leak Check Valve Assembly.&gt;</p>	<p>Is the vacuum pump of the leak check valve assembly OK?</p>	<p>Repair the poor contact in the leak check valve assembly connector.</p>	<p>Replace the leak check valve assembly. &lt;Ref. to EC(STI)-19, Leak Check Valve Assembly.&gt; &lt;Ref. to EC(w/o STI)-20, Leak Check Valve Assembly.&gt;</p>

# Diagnostic Procedure with Diagnostic Trouble Code (DTC)

ENGINE (DIAGNOSTICS)

## ET:DTC P2404 EVAPORATIVE EMISSION SYSTEM LEAK DETECTION PUMP SENSE CIRCUIT RANGE/PERFORMANCE

### DTC DETECTING CONDITION:

- Detected when two consecutive driving cycles with fault occur.
- GENERAL DESCRIPTION <Ref. to GD(H4DOTC)-267, DTC P2404 EVAPORATIVE EMISSION SYSTEM LEAK DETECTION PUMP SENSE CIRCUIT RANGE/PERFORMANCE, Diagnostic Trouble Code (DTC) Detecting Criteria.>

### CAUTION:

After servicing or replacing faulty parts, perform Clear Memory Mode <Ref. to EN(H4DOTC)(diag)-62, OPERATION, Clear Memory Mode.>, and Inspection Mode <Ref. to EN(H4DOTC)(diag)-48, PROCEDURE, Inspection Mode.>.

### WIRING DIAGRAM:

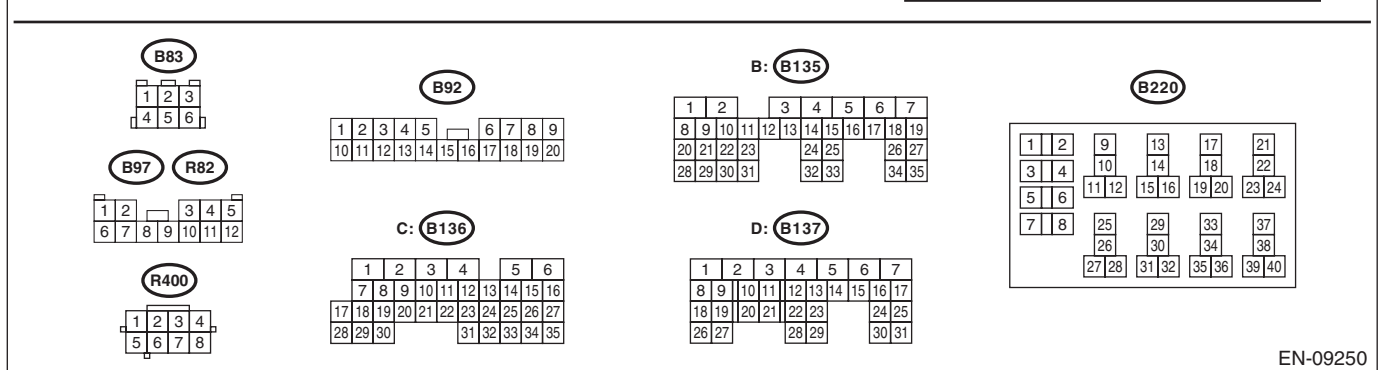
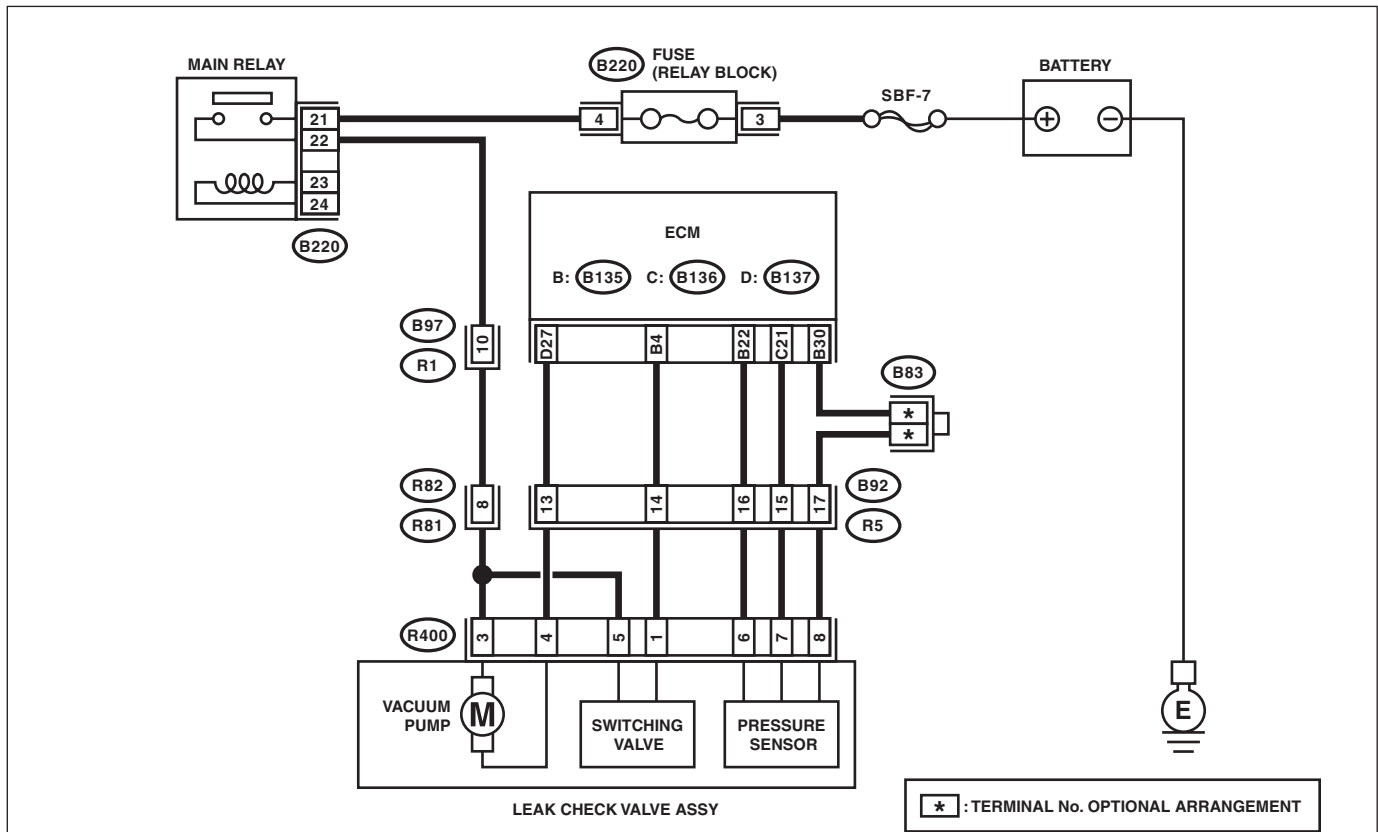

EN-09250



# Diagnostic Procedure with Diagnostic Trouble Code (DTC)

ENGINE (DIAGNOSTICS)

Step	Check	Yes	No
<b>1</b> <b>CHECK FOR ANY OTHER DTC ON DISPLAY.</b>	Is any other DTC displayed?	Check the appropriate DTC using the "List of Diagnostic Trouble Code (DTC)". <Ref. to EN(H4DOTC)(diag)-88, List of Diagnostic Trouble Code (DTC).>	Go to step 2.
<b>2</b> <b>CHECK ELCM PUMP.</b> Operate the ELCM pump using the Subaru Select Monitor.  NOTE: Refer to "Compulsory Valve Operation Check Mode" for more operation procedures. <Ref. to EN(H4DOTC)(diag)-63, Compulsory Valve Operation Check Mode.>	Does the ELCM pump operate?	Go to step 6.	Go to step 3.
<b>3</b> <b>CHECK POWER SUPPLY OF LEAK CHECK VALVE ASSEMBLY.</b> 1) Turn the ignition switch to OFF. 2) Disconnect the connector from the leak check valve assembly. 3) Turn the ignition switch to ON. 4) Measure the voltage between the leak check valve assembly connector and chassis ground.  <b>Connector &amp; terminal</b> <b>(R400) No. 3 (+) — Chassis ground (-):</b>	Is the voltage 10 V or more?	Go to step 4.	Repair the harness and connector.  NOTE: In this case, repair the following item: • Open circuit in harness between the main relay and the leak check valve assembly connector • Poor contact of main relay connector • Poor contact of coupling connector
<b>4</b> <b>CHECK HARNESS BETWEEN ECM AND LEAK CHECK VALVE ASSEMBLY CONNECTOR.</b> 1) Turn the ignition switch to OFF. 2) Disconnect the connector from ECM. 3) Measure the resistance of harness between ECM and the leak check valve assembly connector.  <b>Connector &amp; terminal</b> <b>(B137) No. 27 — (R400) No. 4:</b>	Is the resistance less than 1 Ω?	Go to step 5.	Repair the harness and connector.  NOTE: In this case, repair the following item: • Open circuit in harness between ECM and the leak check valve assembly connector • Poor contact of coupling connector
<b>5</b> <b>CHECK HARNESS BETWEEN ECM AND LEAK CHECK VALVE ASSEMBLY CONNECTOR.</b> 1) Measure the resistance of harness between ECM and chassis ground.  <b>Connector &amp; terminal</b> <b>(B137) No. 27 — Chassis ground:</b>	Is the resistance 1 MΩ or more?	Replace the leak check valve assembly. <Ref. to EC(STI)-19, Leak Check Valve Assembly.> <Ref. to EC(w/o STI)-20, Leak Check Valve Assembly.>	Repair the short circuit to ground in harness between ECM and leak check valve assembly connector.

# Diagnostic Procedure with Diagnostic Trouble Code (DTC)

ENGINE (DIAGNOSTICS)

Step	Check	Yes	No
<p><b>6</b></p> <p><b>CHECK ELCM SWITCHING VALVE.</b> Operate the ELCM switching valve using the Subaru Select Monitor.</p> <p>NOTE: Refer to "Compulsory Valve Operation Check Mode" for more operation procedures. &lt;Ref. to EN(H4DOTC)(diag)-63, Compulsory Valve Operation Check Mode.&gt;</p>	Does the ELCM switching valve operate?	Go to step 10.	Go to step 7.
<p><b>7</b></p> <p><b>CHECK POWER SUPPLY OF LEAK CHECK VALVE ASSEMBLY.</b> 1) Turn the ignition switch to OFF. 2) Disconnect the connector from the leak check valve assembly. 3) Turn the ignition switch to ON. 4) Measure the voltage between the leak check valve assembly connector and chassis ground.</p> <p><b>Connector &amp; terminal</b> <b>(R400) No. 5 (+) — Chassis ground (-):</b></p>	Is the voltage 10 V or more?	Go to step 8.	Repair the harness and connector. NOTE: In this case, repair the following item: • Open circuit in harness between the main relay and the leak check valve assembly connector • Poor contact of main relay connector • Poor contact of coupling connector
<p><b>8</b></p> <p><b>CHECK HARNESS BETWEEN ECM AND LEAK CHECK VALVE ASSEMBLY CONNECTOR.</b> 1) Turn the ignition switch to OFF. 2) Disconnect the connector from ECM. 3) Measure the resistance of harness between ECM and the leak check valve assembly connector.</p> <p><b>Connector &amp; terminal</b> <b>(B135) No. 4 — (R400) No. 1:</b></p>	Is the resistance less than 1 Ω?	Go to step 9.	Repair the harness and connector. NOTE: In this case, repair the following item: • Open circuit in harness between ECM and the leak check valve assembly connector • Poor contact of coupling connector
<p><b>9</b></p> <p><b>CHECK HARNESS BETWEEN ECM AND LEAK CHECK VALVE ASSEMBLY CONNECTOR.</b> 1) Measure the resistance of harness between ECM and chassis ground.</p> <p><b>Connector &amp; terminal</b> <b>(B135) No. 4 — Chassis ground:</b></p>	Is the resistance 1 MΩ or more?	Replace the leak check valve assembly. <Ref. to EC(STI)-19, Leak Check Valve Assembly.> <Ref. to EC(w/o STI)-20, Leak Check Valve Assembly.>	Repair the short circuit to ground in harness between ECM and leak check valve assembly connector.

# Diagnostic Procedure with Diagnostic Trouble Code (DTC)

ENGINE (DIAGNOSTICS)

Step	Check	Yes	No
<p><b>10</b>      <b>CHECK EVAPORATIVE EMISSION CONTROL SYSTEM.</b> Perform drive cycle I. &lt;Ref. to EN(H4DOTC)(diag)-58, DRIVE CYCLE H, PROCEDURE, Drive Cycle.&gt;</p>	<p>Is DTC P2404 displayed on the display?</p>	<p>Replace the leak check valve assembly. &lt;Ref. to EC(STI)-19, Leak Check Valve Assembly.&gt; &lt;Ref. to EC(w/o STI)-20, Leak Check Valve Assembly.&gt;</p>	<p>Even if DTC is detected, the circuit has returned to a normal condition at this time. Reproduce the failure, and then perform the diagnosis again. <b>NOTE:</b> In this case, temporary poor contact of connector, temporary open or short circuit of harness may be the cause.</p>

## EU:DTC P2419 EVAPORATIVE EMISSION SYSTEM SWITCHING VALVE CONTROL CIRCUIT LOW

### DTC DETECTING CONDITION:

- Immediately at fault recognition
- GENERAL DESCRIPTION <Ref. to GD(H4DOTC)-268, DTC P2419 EVAPORATIVE EMISSION SYSTEM SWITCHING VALVE CONTROL CIRCUIT LOW, Diagnostic Trouble Code (DTC) Detecting Criteria.>

### CAUTION:

**After servicing or replacing faulty parts, perform Clear Memory Mode <Ref. to EN(H4DOTC)(diag)-62, OPERATION, Clear Memory Mode.>, and Inspection Mode <Ref. to EN(H4DOTC)(diag)-48, PROCEDURE, Inspection Mode.>.**

### WIRING DIAGRAM:

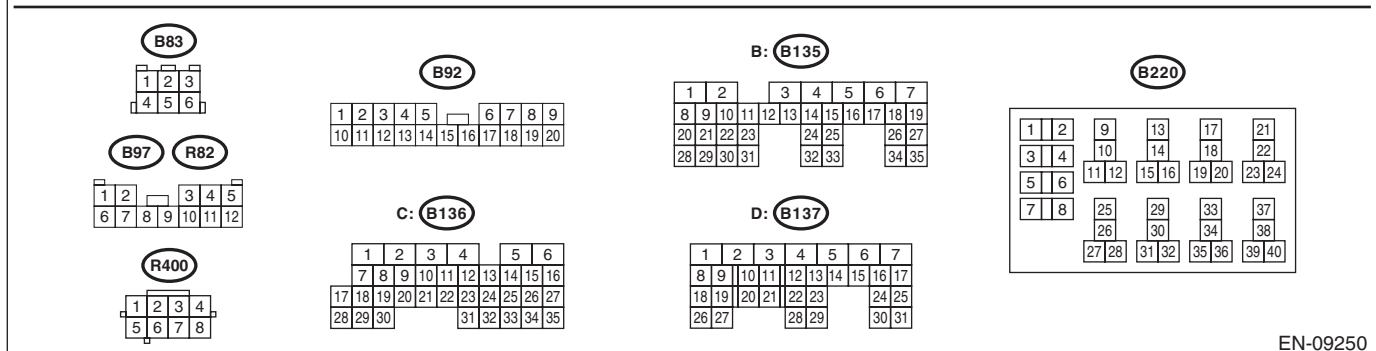
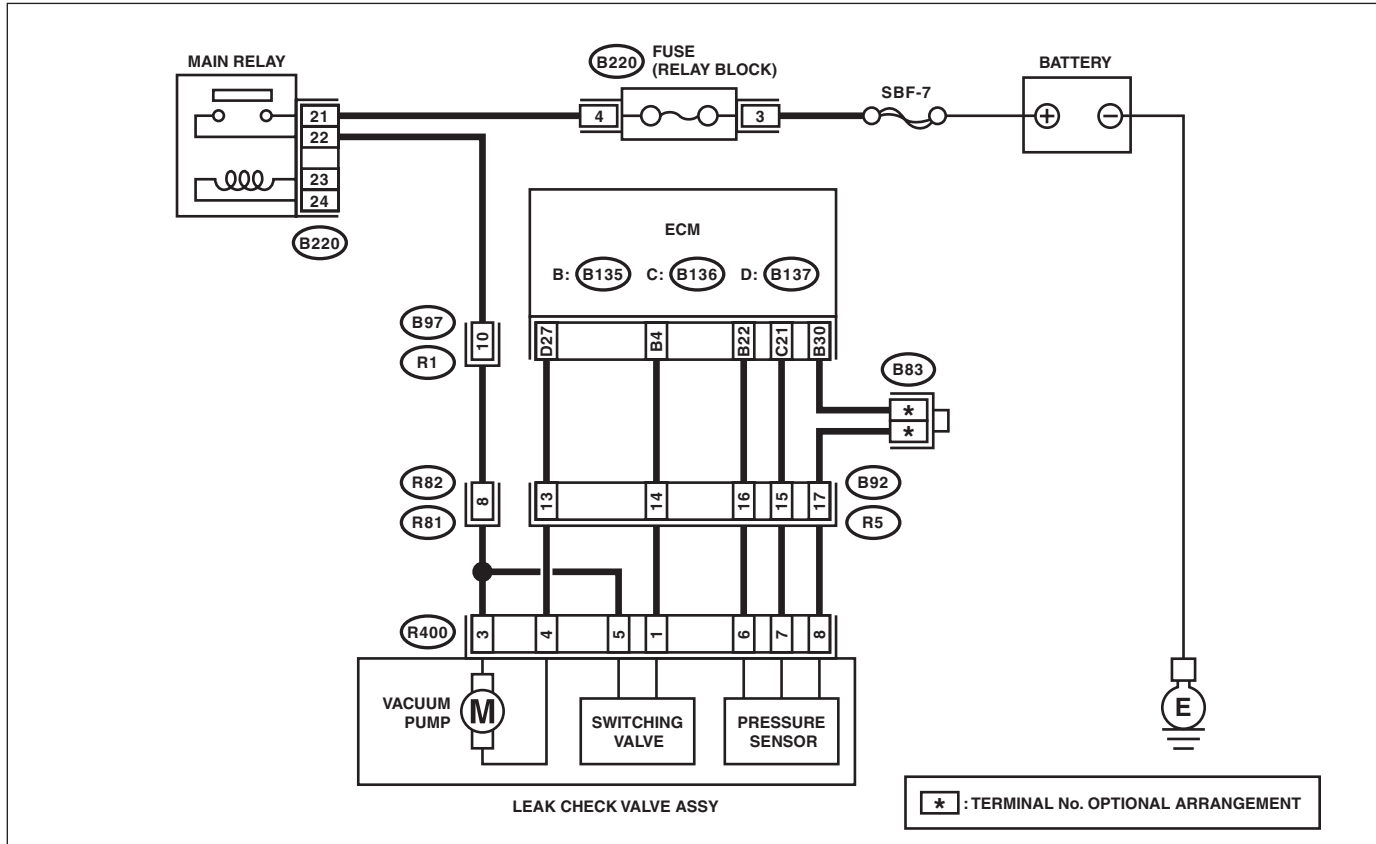

# Diagnostic Procedure with Diagnostic Trouble Code (DTC)

ENGINE (DIAGNOSTICS)

Step	Check	Yes	No
<p><b>1</b></p> <p><b>CHECK HARNESS BETWEEN ECM AND LEAK CHECK VALVE ASSEMBLY CONNECTOR.</b></p> <p>1) Turn the ignition switch to ON. 2) Measure the voltage between ECM and chassis ground.</p> <p><b>Connector &amp; terminal</b> <b>(B135) No. 4 (+) — Chassis ground (-):</b></p>	Is the voltage 10 V or more?	Go to step 2.	Go to step 3.
<p><b>2</b></p> <p><b>CHECK FOR POOR CONTACT.</b></p> <p>Check for poor contact of ECM connector.</p>	Is there poor contact of ECM connector?	Repair the poor contact of ECM connector.	<p>Even if DTC is detected, the circuit has returned to a normal condition at this time. Reproduce the failure, and then perform the diagnosis again.</p> <p><b>NOTE:</b> In this case, temporary open or short circuit of harness or temporary poor contact of connector may be the cause.</p>
<p><b>3</b></p> <p><b>CHECK POWER SUPPLY TO LEAK CHECK VALVE ASSEMBLY.</b></p> <p>Measure the voltage between the leak check valve assembly connector and engine ground.</p> <p><b>Connector &amp; terminal</b> <b>(R400) No. 5 (+) — Engine ground (-):</b></p>	Is the voltage 10 V or more?	Go to step 4.	Repair the power supply circuit.
<p><b>4</b></p> <p><b>CHECK HARNESS BETWEEN ECM AND LEAK CHECK VALVE ASSEMBLY CONNECTOR.</b></p> <p>1) Turn the ignition switch to OFF. 2) Disconnect the connector from ECM and the leak check valve assembly. 3) Measure the resistance between leak check valve assembly and chassis ground.</p> <p><b>Connector &amp; terminal</b> <b>(R400) No. 1 — Chassis ground:</b></p>	Is the resistance 1 M $\Omega$ or more?	Go to step 5.	Repair the short circuit to ground in harness between ECM and leak check valve assembly connector.
<p><b>5</b></p> <p><b>CHECK HARNESS BETWEEN ECM AND LEAK CHECK VALVE ASSEMBLY CONNECTOR.</b></p> <p>Measure the resistance of harness between ECM and the leak check valve assembly connector.</p> <p><b>Connector &amp; terminal</b> <b>(B135) No. 4 — (R400) No. 1:</b></p>	Is the resistance less than 1 $\Omega$ ?	Go to step 6.	<p>Repair the harness and connector.</p> <p><b>NOTE:</b> In this case, repair the following item:</p> <ul style="list-style-type: none"> <li>• Open circuit in harness between ECM and the leak check valve assembly connector</li> <li>• Poor contact of coupling connector</li> </ul>

# Diagnostic Procedure with Diagnostic Trouble Code (DTC)

ENGINE (DIAGNOSTICS)

Step	Check	Yes	No
<b>6</b> <b>CHECK LEAK CHECK VALVE ASSEMBLY.</b> Check the switching valve of the leak check valve assembly. <Ref. to EC(STI)-20, CHECK SWITCHING VALVE, INSPECTION, Leak Check Valve Assembly.> <Ref. to EC(w/o STI)-21, CHECK SWITCHING VALVE, INSPECTION, Leak Check Valve Assembly.>	Is the switching valve of the leak check valve assembly OK?	Repair the poor contact in the leak check valve assembly connector.	Replace the leak check valve assembly. <Ref. to EC(STI)-19, Leak Check Valve Assembly.> <Ref. to EC(w/o STI)-20, Leak Check Valve Assembly.>

# Diagnostic Procedure with Diagnostic Trouble Code (DTC)

ENGINE (DIAGNOSTICS)

## EV:DTC P2420 EVAPORATIVE EMISSION SYSTEM SWITCHING VALVE CONTROL CIRCUIT HIGH

### DTC DETECTING CONDITION:

- Immediately at fault recognition
- GENERAL DESCRIPTION <Ref. to GD(H4DOTC)-270, DTC P2420 EVAPORATIVE EMISSION SYSTEM SWITCHING VALVE CONTROL CIRCUIT HIGH, Diagnostic Trouble Code (DTC) Detecting Criteria.>

### CAUTION:

After servicing or replacing faulty parts, perform Clear Memory Mode <Ref. to EN(H4DOTC)(diag)-62, OPERATION, Clear Memory Mode.>, and Inspection Mode <Ref. to EN(H4DOTC)(diag)-48, PROCEDURE, Inspection Mode.>.

### WIRING DIAGRAM:

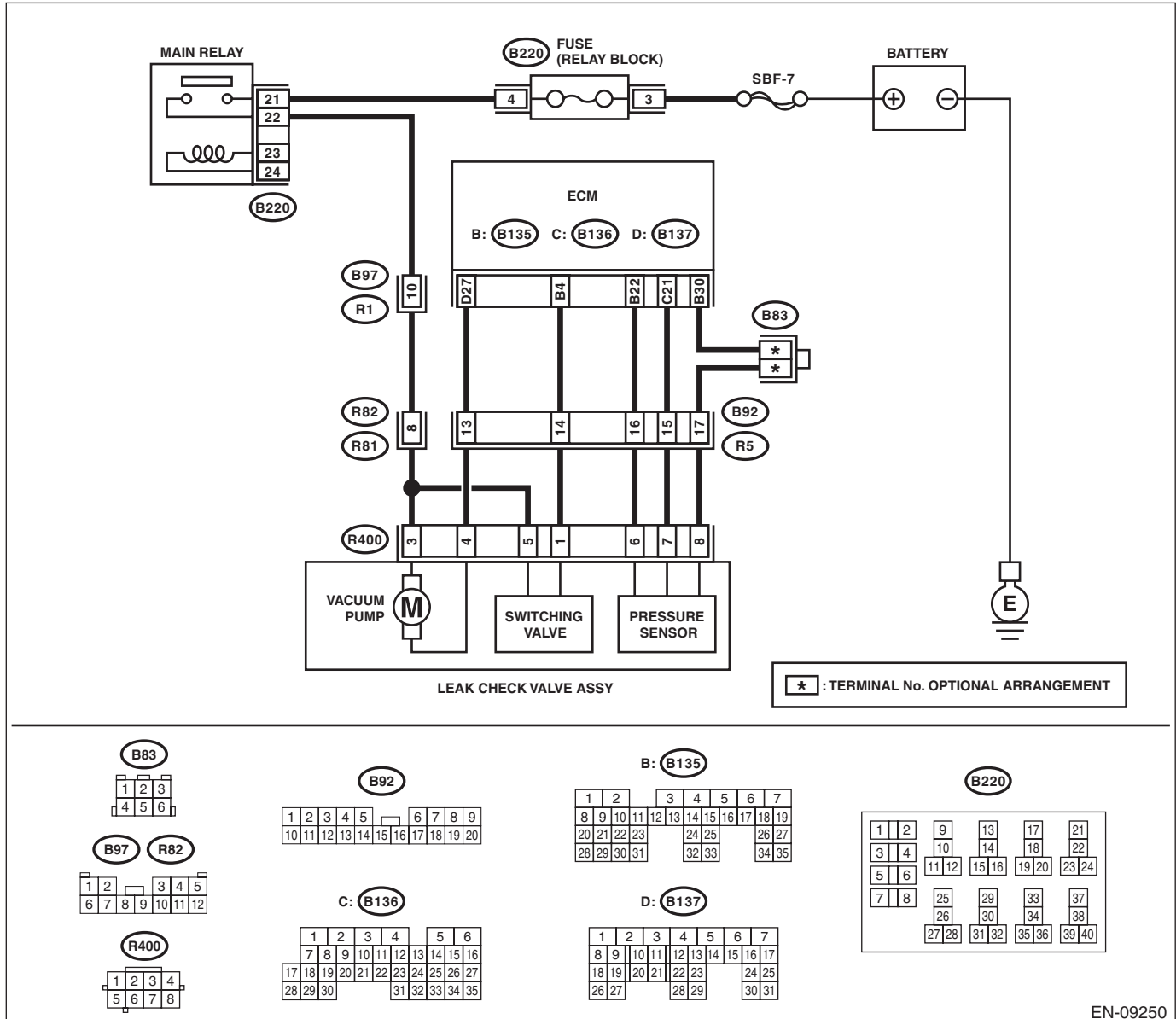

EN-09250

# Diagnostic Procedure with Diagnostic Trouble Code (DTC)

ENGINE (DIAGNOSTICS)

Step	Check	Yes	No
<p><b>1</b>    <b>CHECK HARNESS BETWEEN ECM AND LEAK CHECK VALVE ASSEMBLY CONNECTOR.</b></p> <p>1) Turn the ignition switch to OFF.                  2) Disconnect the connector from the leak check valve assembly.                  3) Turn the ignition switch to ON.                  4) Measure the voltage between leak check valve assembly and chassis ground.</p> <p><b>Connector &amp; terminal</b>  <b>(R400) No. 1 (+) — Chassis ground (-):</b></p>	<p>Is the voltage 10 V or more?</p>	<p>Repair the short circuit to power in harness between ECM and leak check valve assembly connector.</p>	<p>Go to step 2.</p>
<p><b>2</b>    <b>CHECK LEAK CHECK VALVE ASSEMBLY.</b></p> <p>1) Turn the ignition switch to OFF.                  2) Check the switching valve of the leak check valve assembly. &lt;Ref. to EC(STI)-20, CHECK SWITCHING VALVE, INSPECTION, Leak Check Valve Assembly.&gt; &lt;Ref. to EC(w/o STI)-21, CHECK SWITCHING VALVE, INSPECTION, Leak Check Valve Assembly.&gt;</p>	<p>Is the switching valve of the leak check valve assembly OK?</p>	<p>Repair the poor contact in the leak check valve assembly connector.</p>	<p>Replace the leak check valve assembly. &lt;Ref. to EC(STI)-19, Leak Check Valve Assembly.&gt; &lt;Ref. to EC(w/o STI)-20, Leak Check Valve Assembly.&gt;</p>



# Diagnostic Procedure with Diagnostic Trouble Code (DTC)

ENGINE (DIAGNOSTICS)

## EW:DTC P2431 SECONDARY AIR INJECTION SYSTEM AIR FLOW /PRESSURE SENSOR CIRCUIT RANGE/PERFORMANCE

### DTC DETECTING CONDITION:

- Detected when two consecutive driving cycles with fault occur.
- GENERAL DESCRIPTION <Ref. to GD(H4DOTC)-272, DTC P2431 SECONDARY AIR INJECTION SYSTEM AIR FLOW /PRESSURE SENSOR CIRCUIT RANGE/PERFORMANCE, Diagnostic Trouble Code (DTC) Detecting Criteria.>

### CAUTION:

After servicing or replacing faulty parts, perform Clear Memory Mode <Ref. to EN(H4DOTC)(diag)-62, OPERATION, Clear Memory Mode.>, and Inspection Mode <Ref. to EN(H4DOTC)(diag)-48, PROCEDURE, Inspection Mode.>.

Step	Check	Yes	No
1 <b>CHECK FOR ANY OTHER DTC ON DISPLAY.</b>	Is any other DTC displayed?	Check the appropriate DTC using the "List of Diagnostic Trouble Code (DTC)". <Ref. to EN(H4DOTC)(diag)-88, List of Diagnostic Trouble Code (DTC).>	Go to step 2.
2 <b>CHECK CURRENT DATA.</b> 1) Turn the ignition switch to ON (engine OFF). 2) Using the Subaru Select Monitor, read the values in «Sec. Air Piping Pressure», «Mani. Absolute Pressure» and «Atmosphere Pressure», and compare them with actual atmospheric pressure.  NOTE: For detailed operation procedures, refer to "READ CURRENT DATA FOR ENGINE". <Ref. to EN(H4DOTC)(diag)-40, Subaru Select Monitor.>	Does the displayed value differ from the actual atmospheric pressure by 200 mmHg (27 kPa, 8 inHg, 3.9 psig) or more?	Replace the secondary air combination valve (with built-in pressure sensor). <Ref. to EC(STI)-29, Secondary Air Combination Valve.> <Ref. to EC(w/o STI)-30, Secondary Air Combination Valve.>	Even if DTC is detected, the circuit has returned to a normal condition at this time. Reproduce the failure, and then perform the diagnosis again.  NOTE: In this case, temporary poor contact of connector, temporary open or short circuit of harness may be the cause.

## **EX:DTC P2432 SECONDARY AIR INJECTION SYSTEM AIR FLOW /PRESSURE SENSOR CIRCUIT LOW**

### **DTC DETECTING CONDITION:**

- Immediately at fault recognition
- GENERAL DESCRIPTION <Ref. to GD(H4DOTC)-273, DTC P2432 SECONDARY AIR INJECTION SYSTEM AIR FLOW /PRESSURE SENSOR CIRCUIT LOW, Diagnostic Trouble Code (DTC) Detecting Criteria.>

### **CAUTION:**

**After servicing or replacing faulty parts, perform Clear Memory Mode <Ref. to EN(H4DOTC)(diag)-62, OPERATION, Clear Memory Mode.>, and Inspection Mode <Ref. to EN(H4DOTC)(diag)-48, PROCEDURE, Inspection Mode.>.**

# Diagnostic Procedure with Diagnostic Trouble Code (DTC)

ENGINE (DIAGNOSTICS)

## WIRING DIAGRAM:

- Models without SI-DRIVE

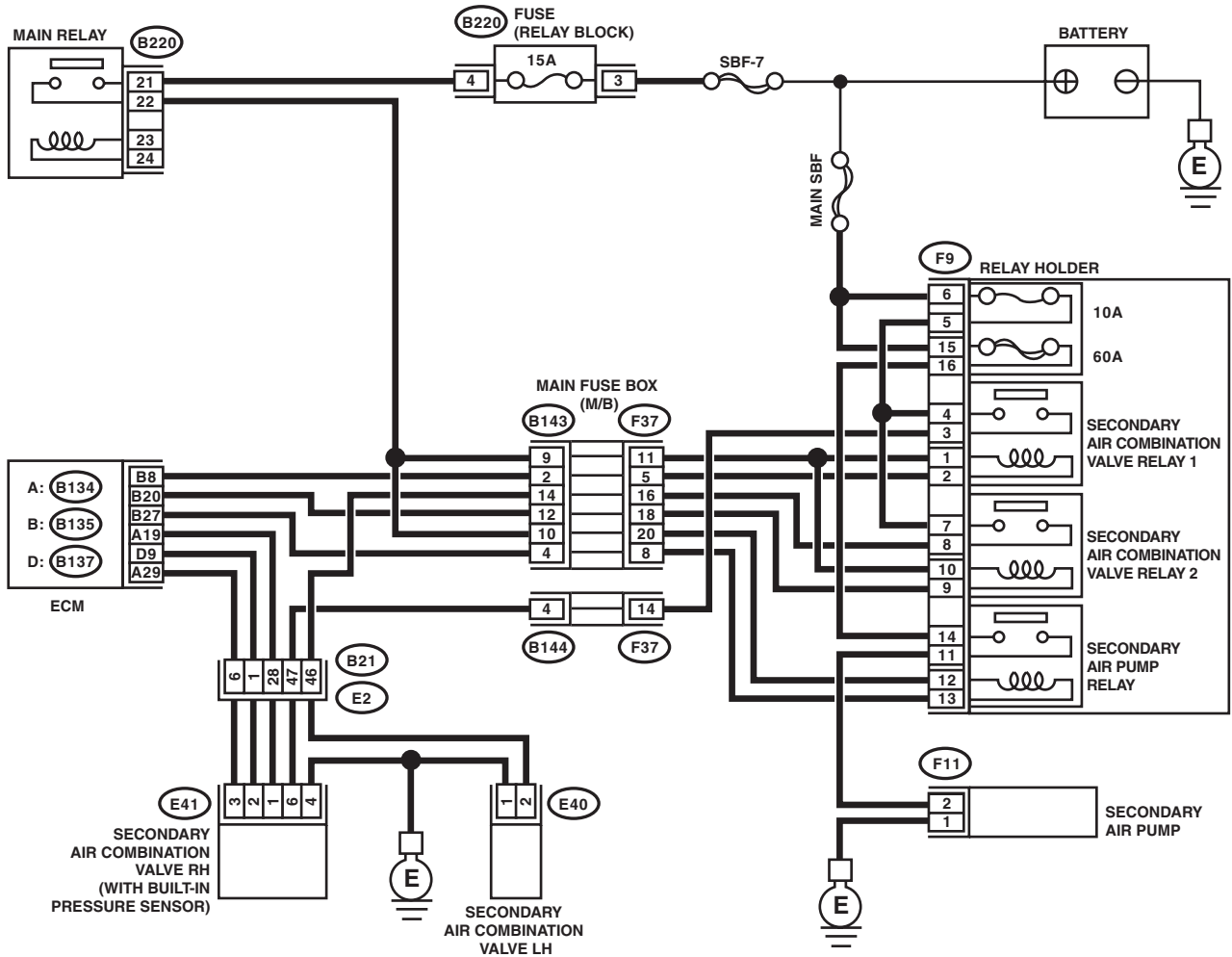

A: (B134)

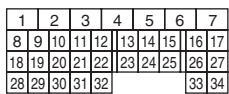

B: (B135)

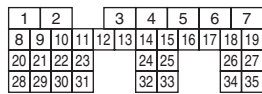

(B220)

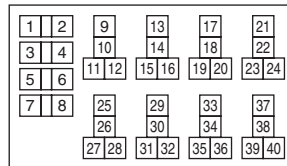

(B21)

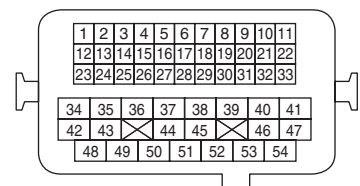

D: (B137)

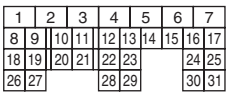

(F9)

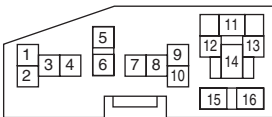

(F37)

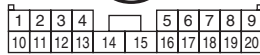

(B143)



(F11)



(E40)



(E41)



(B144)

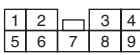

EN-08734

# Diagnostic Procedure with Diagnostic Trouble Code (DTC)

ENGINE (DIAGNOSTICS)

- Models with SI-DRIVE

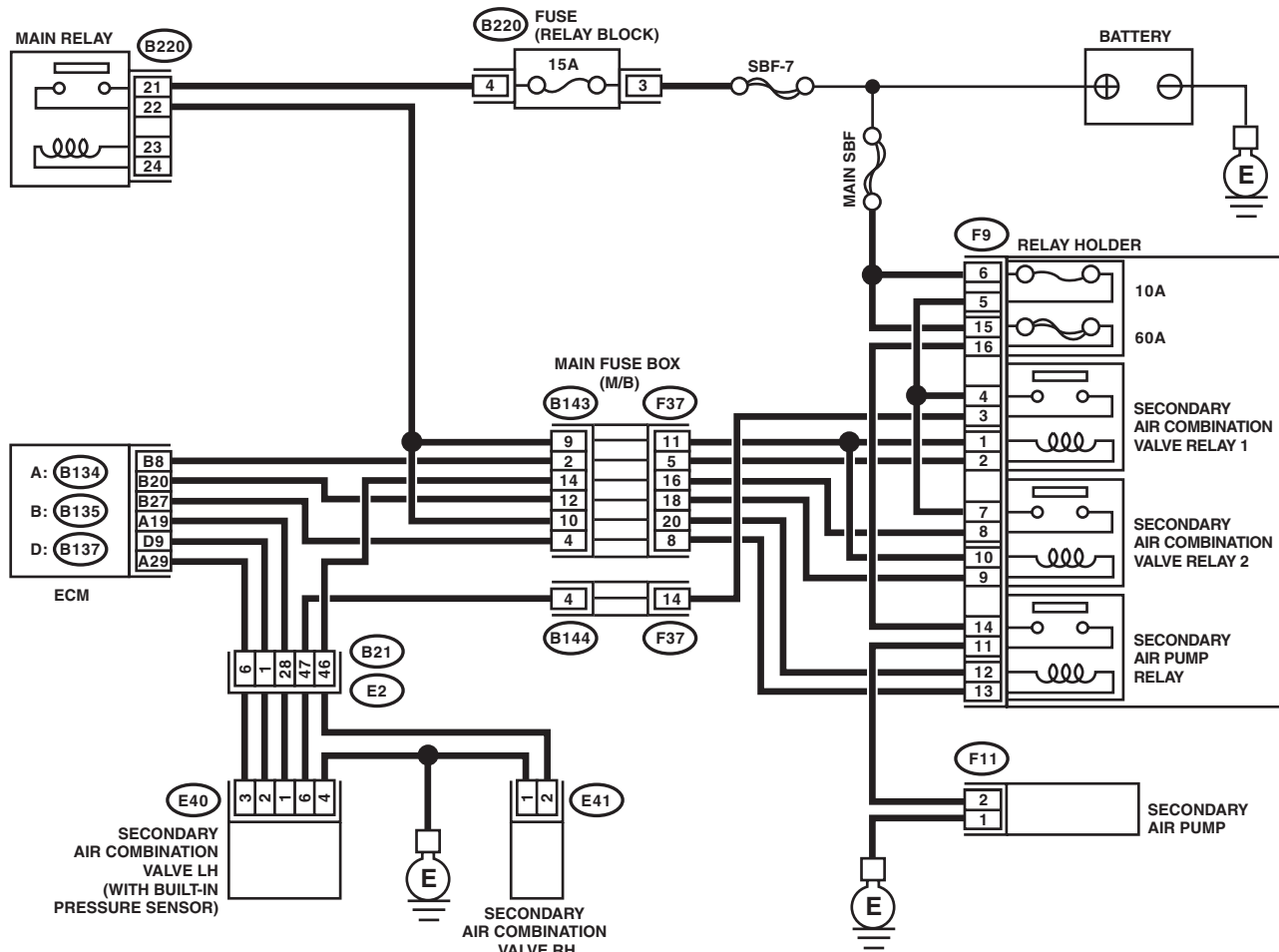

A: **B134**

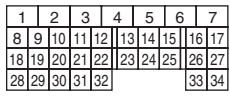

B: **B135**

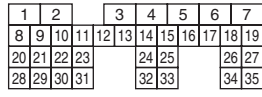

**B220**

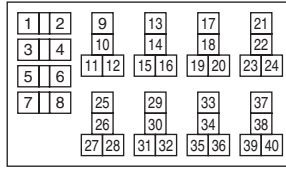

**B21**

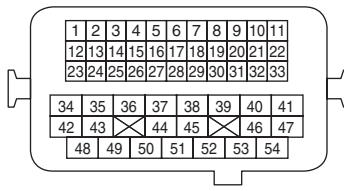

D: **B137**

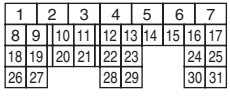

**F9**

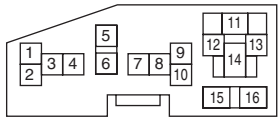

**F37**

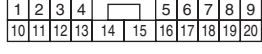

**B143**

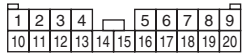

**F11**



**E41**



**E40**



**B144**

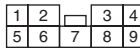

EN-08735

# Diagnostic Procedure with Diagnostic Trouble Code (DTC)

ENGINE (DIAGNOSTICS)

	Step	Check	Yes	No
1	<p><b>CHECK CURRENT DATA.</b></p> <ol style="list-style-type: none"> <li>Turn the ignition switch to ON.</li> <li>Read the value of «Sec. Air Piping Pressure» using Subaru Select Monitor.</li> </ol> <p>NOTE: For detailed operation procedures, refer to "READ CURRENT DATA FOR ENGINE". &lt;Ref. to EN(H4DOTC)(diag)-40, Subaru Select Monitor.&gt;</p>	Is the value of «Sec. Air Piping Pressure» less than 53.3 kPa (400 mmHg, 15.8 inHg)?	Go to step 2.	<p>Even if DTC is detected, the circuit has returned to a normal condition at this time. Reproduce the failure, and then perform the diagnosis again.</p> <p>NOTE: In this case, temporary poor contact of connector, temporary open or short circuit of harness may be the cause.</p>
2	<p><b>CHECK POWER SUPPLY OF SECONDARY AIR COMBINATION VALVE.</b></p> <ol style="list-style-type: none"> <li>Turn the ignition switch to OFF.</li> <li>Disconnect the connectors from secondary air combination valve RH (models without SI-DRIVE) or LH (models with SI-DRIVE).</li> <li>Turn the ignition switch to ON.</li> <li>Measure the voltage between the secondary air combination valve RH or LH connector and chassis ground.</li> </ol> <p><b>Connector &amp; terminal</b> <b>Models without SI-DRIVE</b> (E41) No. 1 (+) — Chassis ground (-): <b>Models with SI-DRIVE</b> (E40) No. 1 (+) — Chassis ground (-):</p>	Is the voltage 4.5 V or more?	Go to step 3.	<p>Repair the harness and connector.</p> <p>NOTE: In this case, repair the following item:</p> <ul style="list-style-type: none"> <li>Open circuit in harness between ECM and secondary air combination valve RH or LH connector</li> <li>Poor contact of ECM connector</li> <li>Poor contact of coupling connector</li> </ul>
3	<p><b>CHECK HARNESS BETWEEN ECM AND SECONDARY AIR COMBINATION VALVE CONNECTOR.</b></p> <ol style="list-style-type: none"> <li>Turn the ignition switch to OFF.</li> <li>Disconnect the connector from ECM.</li> <li>Measure the resistance of the harness between ECM and secondary air combination valve RH or LH connector.</li> </ol> <p><b>Connector &amp; terminal</b> <b>Models without SI-DRIVE</b> (B137) No. 9 — (E41) No. 2: <b>Models with SI-DRIVE</b> (B137) No. 9 — (E40) No. 2:</p>	Is the resistance less than 1 Ω?	Go to step 4.	<p>Repair the harness and connector.</p> <p>NOTE: In this case, repair the following item:</p> <ul style="list-style-type: none"> <li>Open circuit in harness between ECM and secondary air combination valve RH or LH connector</li> <li>Poor contact of coupling connector</li> </ul>
4	<p><b>CHECK HARNESS BETWEEN ECM AND SECONDARY AIR COMBINATION VALVE CONNECTOR.</b></p> <p>Measure the resistance between ECM and chassis ground.</p> <p><b>Connector &amp; terminal</b> (B137) No. 9 — Chassis ground:</p>	Is the resistance 1 MΩ or more?	Go to step 5.	<p>Repair the ground short circuit in harness between ECM and secondary air combination valve RH or LH connector.</p>

# Diagnostic Procedure with Diagnostic Trouble Code (DTC)

ENGINE (DIAGNOSTICS)

Step	Check	Yes	No
<b>5</b> <b>CHECK FOR POOR CONTACT.</b> Check for poor contact of the ECM and secondary air combination valve RH or LH connector.	Is there poor contact of ECM or secondary air combination valve RH or LH connector?	Repair the poor contact of the ECM or secondary air combination valve RH or LH connector.	Replace the secondary air combination valve RH or LH. <Ref. to EC(STI)-29, Secondary Air Combination Valve.> <Ref. to EC(w/o STI)-30, Secondary Air Combination Valve.>

## Diagnostic Procedure with Diagnostic Trouble Code (DTC)

ENGINE (DIAGNOSTICS)

---

### **EY:DTC P2433 SECONDARY AIR INJECTION SYSTEM AIR FLOW /PRESSURE SENSOR CIRCUIT HIGH**

#### **DTC DETECTING CONDITION:**

- Immediately at fault recognition
- GENERAL DESCRIPTION <Ref. to GD(H4DOTC)-274, DTC P2433 SECONDARY AIR INJECTION SYSTEM AIR FLOW /PRESSURE SENSOR CIRCUIT HIGH, Diagnostic Trouble Code (DTC) Detecting Criteria.>

#### **CAUTION:**

**After servicing or replacing faulty parts, perform Clear Memory Mode <Ref. to EN(H4DOTC)(diag)-62, OPERATION, Clear Memory Mode.>, and Inspection Mode <Ref. to EN(H4DOTC)(diag)-48, PROCEDURE, Inspection Mode.>.**

# Diagnostic Procedure with Diagnostic Trouble Code (DTC)

ENGINE (DIAGNOSTICS)

## WIRING DIAGRAM:

- Models without SI-DRIVE

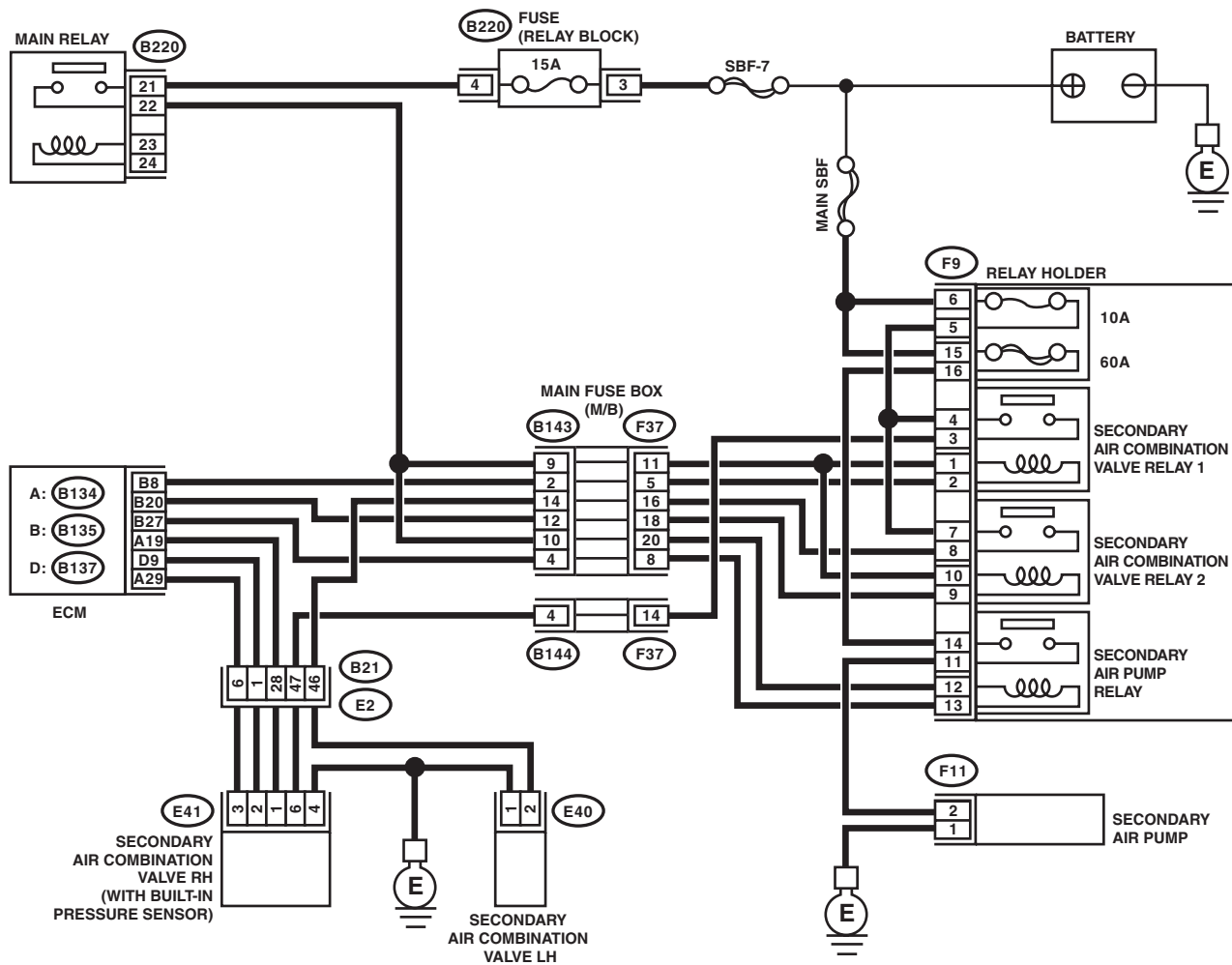

A: B134



B: B135



B220

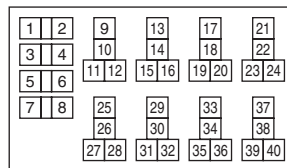

B21

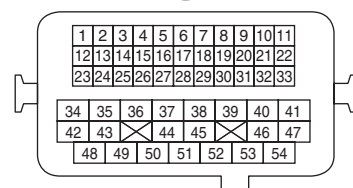

D: B137

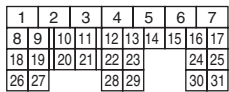

F9

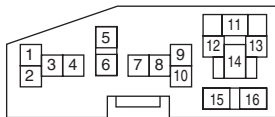

F37

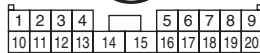

B143



F11



E40



E41



B144

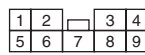

EN-08734



# Diagnostic Procedure with Diagnostic Trouble Code (DTC)

## ENGINE (DIAGNOSTICS)

- Models with SI-DRIVE

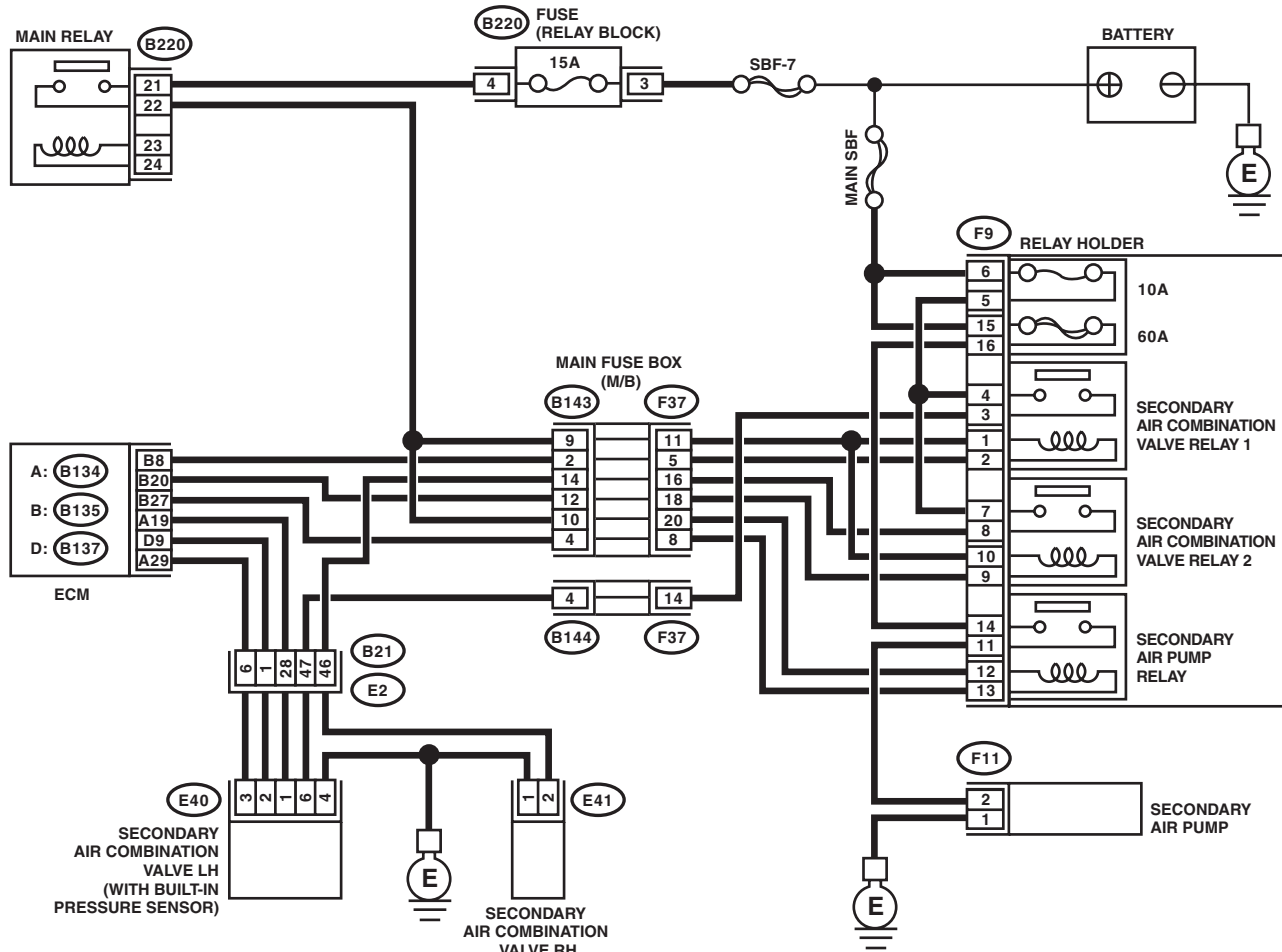

A: B134

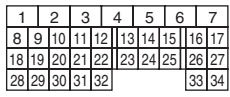

B: B135

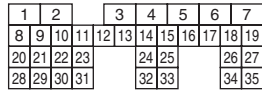

B220

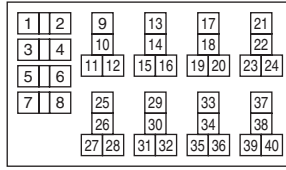

B21

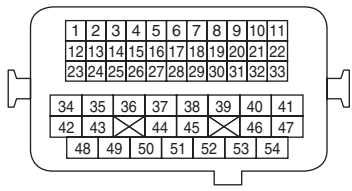

D: B137

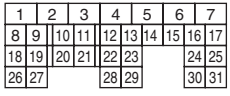

F9

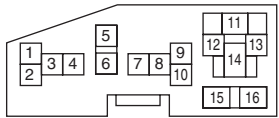

F37

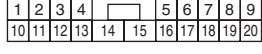

B143

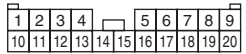

F11



E41



E40



B144

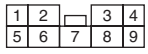

EN-08735

# Diagnostic Procedure with Diagnostic Trouble Code (DTC)

ENGINE (DIAGNOSTICS)

	Step	Check	Yes	No
1	<p><b>CHECK CURRENT DATA.</b></p> <p>1) Turn the ignition switch to ON.</p> <p>2) Read the value of «Sec. Air Piping Pressure» using Subaru Select Monitor.</p> <p>NOTE: For detailed operation procedures, refer to "READ CURRENT DATA FOR ENGINE". &lt;Ref. to EN(H4DOTC)(diag)-40, Subaru Select Monitor.&gt;</p>	Is the value of «Sec. Air Piping Pressure» 133.3 kPa (1000 mmHg, 39.4 inHg) or more?	Go to step 2.	<p>Even if DTC is detected, the circuit has returned to a normal condition at this time. Reproduce the failure, and then perform the diagnosis again.</p> <p>NOTE: In this case, temporary poor contact of connector, temporary open or short circuit of harness may be the cause.</p>
2	<p><b>CHECK HARNESS BETWEEN ECM AND SECONDARY AIR COMBINATION VALVE CONNECTOR.</b></p> <p>1) Turn the ignition switch to OFF.</p> <p>2) Disconnect the connectors from secondary air combination valve RH (models without SI-DRIVE) or LH (models with SI-DRIVE).</p> <p>3) Turn the ignition switch to ON.</p> <p>4) Read the value of «Sec. Air Piping Pressure» using Subaru Select Monitor.</p> <p>NOTE: For detailed operation procedures, refer to "READ CURRENT DATA FOR ENGINE". &lt;Ref. to EN(H4DOTC)(diag)-40, Subaru Select Monitor.&gt;</p>	Is the value of «Sec. Air Piping Pressure» 133.3 kPa (1000 mmHg, 39.4 inHg) or more?	Repair the short circuit to power supply in the harness between ECM and secondary air combination valve RH or LH connectors.	Go to step 3.
3	<p><b>CHECK HARNESS BETWEEN ECM AND SECONDARY AIR COMBINATION VALVE CONNECTOR.</b></p> <p>1) Turn the ignition switch to OFF.</p> <p>2) Measure the resistance of the harness between secondary air combination valve RH or LH connector and engine ground.</p> <p><b>Connector &amp; terminal</b></p> <p><b>Models without SI-DRIVE</b> (E41) No. 3 — Engine ground:</p> <p><b>Models with SI-DRIVE</b> (E40) No. 3 — Engine ground:</p>	Is the resistance less than 5 Ω?	Go to step 4.	<p>Repair the harness and connector.</p> <p>NOTE: In this case, repair the following item:</p> <ul style="list-style-type: none"> <li>• Open circuit in harness between ECM and secondary air combination valve RH or LH connector</li> <li>• Poor contact of ECM connector</li> <li>• Poor contact of coupling connector</li> </ul>
4	<p><b>CHECK FOR POOR CONTACT.</b></p> <p>Check for poor contact of the secondary air combination valve RH or LH connector.</p>	Is there poor contact of the secondary air combination valve RH or LH connector?	Repair the poor contact of secondary air combination valve RH or LH connector.	Replace the secondary air combination valve RH or LH. <Ref. to EC(STI)-29, Secondary Air Combination Valve.> <Ref. to EC(w/o STI)-30, Secondary Air Combination Valve.>

## Diagnostic Procedure with Diagnostic Trouble Code (DTC)

ENGINE (DIAGNOSTICS)

---

### **EZ:DTC P2440 SECONDARY AIR INJECTION SYSTEM SWITCHING VALVE STUCK OPEN (BANK1)**

#### **DTC DETECTING CONDITION:**

- Detected when two consecutive driving cycles with fault occur.
- GENERAL DESCRIPTION <Ref. to GD(H4DOTC)-275, DTC P2440 SECONDARY AIR INJECTION SYSTEM SWITCHING VALVE STUCK OPEN (BANK1), Diagnostic Trouble Code (DTC) Detecting Criteria.>

#### **CAUTION:**

**After servicing or replacing faulty parts, perform Clear Memory Mode <Ref. to EN(H4DOTC)(diag)-62, OPERATION, Clear Memory Mode.>, and Inspection Mode <Ref. to EN(H4DOTC)(diag)-48, PROCEDURE, Inspection Mode.>.**

# Diagnostic Procedure with Diagnostic Trouble Code (DTC)

ENGINE (DIAGNOSTICS)

## WIRING DIAGRAM:

- Models without SI-DRIVE

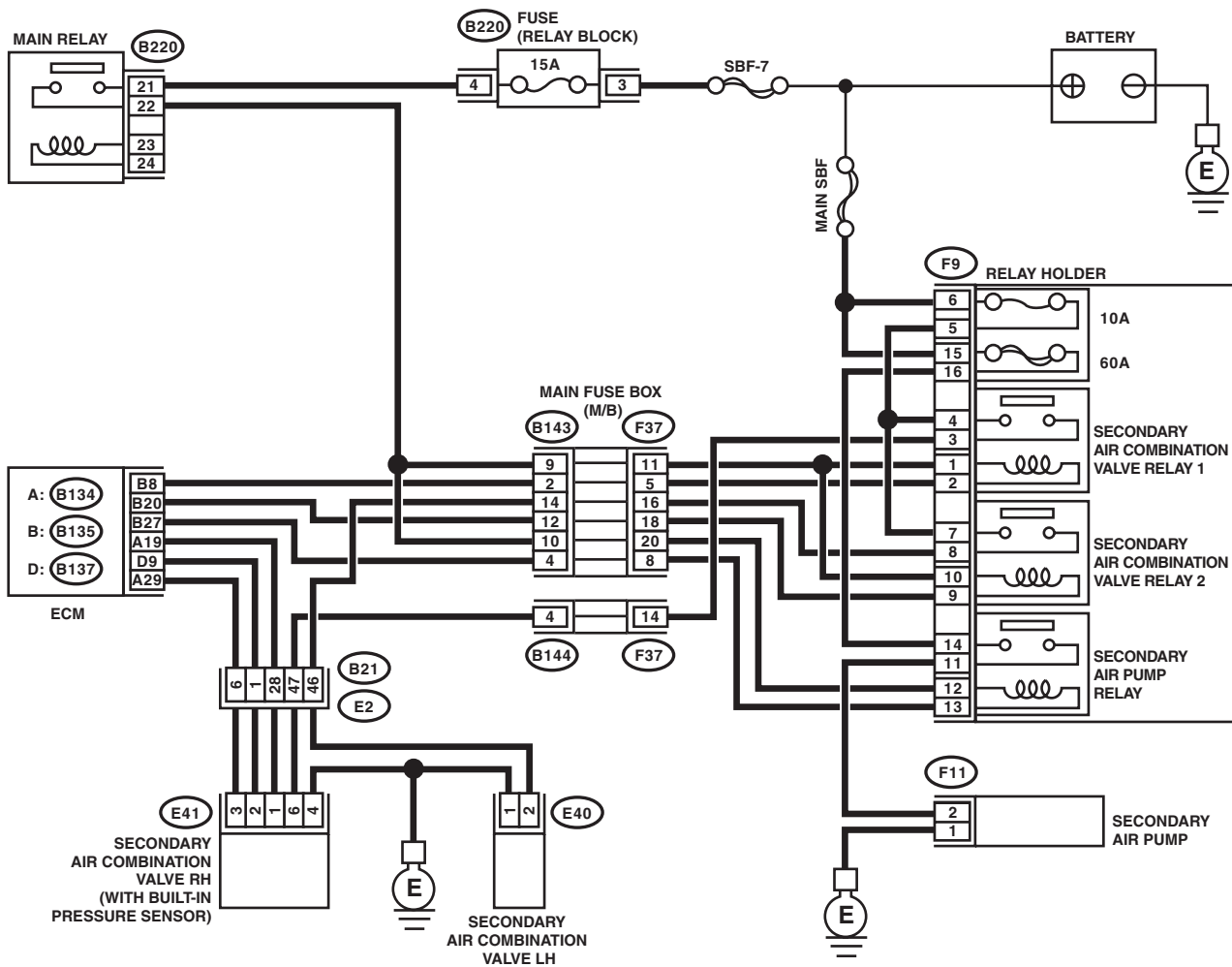

A: B134



B: B135



B220

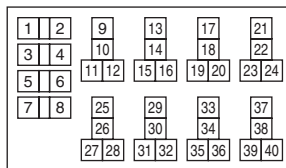

B21

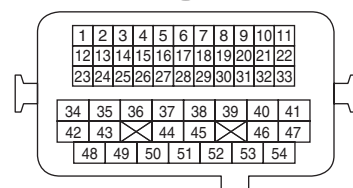

D: B137

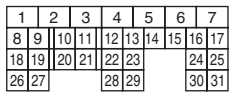

F9

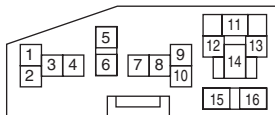

F37

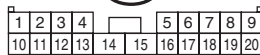

B143



F11



E40



E41



B144

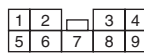

EN-08734

# Diagnostic Procedure with Diagnostic Trouble Code (DTC)

## ENGINE (DIAGNOSTICS)

- Models with SI-DRIVE

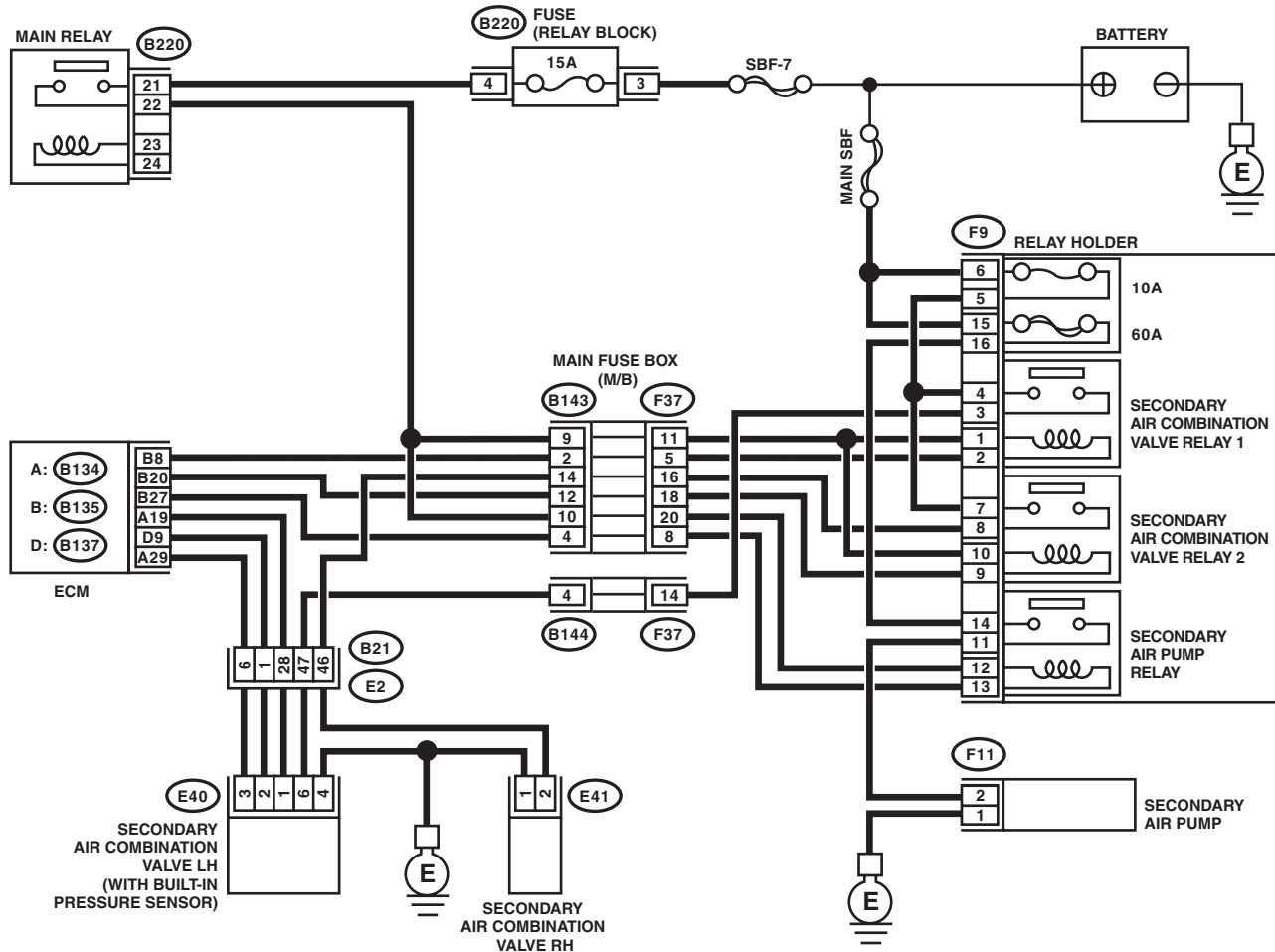

A: (B134)

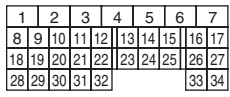

B: (B135)

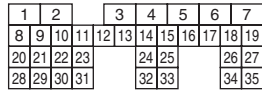

(B220)

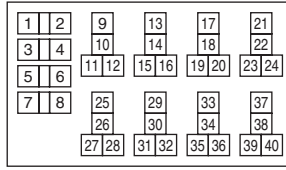

(B21)

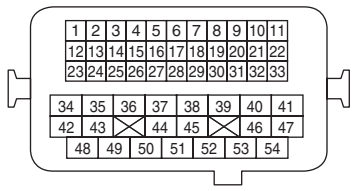

D: (B137)

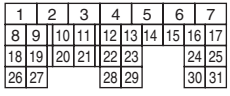

(F9)

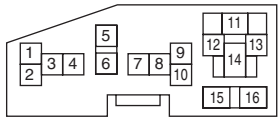

(F37)

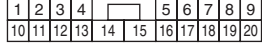

(B143)

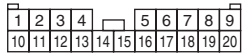

(F11)



(E41)



(E40)



(B144)

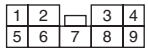

EN-08735

Step	Check	Yes	No
1	<b>CHECK SECONDARY AIR COMBINATION VALVE FUSE.</b> Check if the secondary air combination valve fuse (10 A) is blown out.	Go to step 2.	Go to step 3.

# Diagnostic Procedure with Diagnostic Trouble Code (DTC)

ENGINE (DIAGNOSTICS)

Step	Check	Yes	No
<p><b>2 CHECK HARNESS BETWEEN FUSE BOX AND SECONDARY AIR COMBINATION VALVE RH CONNECTOR.</b></p> <p>1) Remove the secondary air combination valve fuse (10 A) from the fuse box.</p> <p>2) Disconnect the connector from the secondary air combination valve RH.</p> <p>3) Measure the resistance between the secondary air combination valve fuse and secondary air combination valve RH connector, and chassis ground.</p> <p><b>Connector &amp; terminal</b>  <b>Models without SI-DRIVE</b>  <b>(F9) No. 5 — Chassis ground:</b>  <b>(E41) No. 6 — Chassis ground:</b>  <b>Models with SI-DRIVE</b>  <b>(F9) No. 5 — Chassis ground:</b>  <b>(E41) No. 2 — Chassis ground:</b></p>	<p>Is the resistance 1 MΩ or more?</p>	<p>Replace the fuse with a new part, and connect the secondary air combination valve RH connector.                      Go to step 3.</p>	<p>Repair the short circuit to ground in harness between the fuse box and the secondary air combination valve RH connector.</p>
<p><b>3 CHECK SECONDARY AIR COMBINATION VALVE RH OPERATION.</b></p> <p>1) Connect the delivery (test) mode connector.</p> <p>2) Turn the ignition switch to ON.</p> <p>3) Perform operation check for the secondary air combination valve RH using the Subaru Select Monitor.</p> <p>NOTE:                      Refer to "Compulsory Valve Operation Check Mode" for more operation procedures. &lt;Ref. to EN(H4DOTC)(diag)-63, Compulsory Valve Operation Check Mode.&gt;</p>	<p>Does the secondary air combination valve RH repeatedly switch to ON and OFF?</p>	<p>Go to step 4.</p>	<p>Go to step 6.</p>
<p><b>4 CHECK DUCT BETWEEN SECONDARY AIR PUMP AND SECONDARY AIR COMBINATION VALVE RH.</b></p> <p>Check the duct between the secondary air pump and secondary air combination valve RH.</p>	<p>Is there damage, clog or disconnection of the duct?</p>	<p>Replace, clean or connect the duct.</p>	<p>Go to step 5.</p>
<p><b>5 CHECK PIPE BETWEEN SECONDARY AIR COMBINATION VALVE RH AND CYLINDER HEAD.</b></p> <p>Check the pipe between the secondary air combination valve RH and cylinder head.</p>	<p>Is there damage, clog or disconnection of the pipe?</p>	<p>Replace, clean or connect the pipe.</p>	<p>Even if DTC is detected, the circuit has returned to a normal condition at this time. Reproduce the failure, and then perform the diagnosis again.</p> <p>NOTE:                      In this case, temporary poor contact of connector, temporary open or short circuit of harness may be the cause.</p>

# Diagnostic Procedure with Diagnostic Trouble Code (DTC)

## ENGINE (DIAGNOSTICS)

Step	Check	Yes	No
<p><b>6 CHECK POWER SUPPLY TO SECONDARY AIR COMBINATION VALVE RH.</b></p> <p>1) Disconnect the connector from the secondary air combination valve RH.</p> <p>2) In the condition of step 3, measure the voltage between secondary air combination valve RH connector and chassis ground.</p> <p><b>Connector &amp; terminal</b>  <b>Models without SI-DRIVE</b>  <b>(E41) No. 6 (+) — Chassis ground (-):</b>  <b>Models with SI-DRIVE</b>  <b>(E41) No. 2 (+) — Chassis ground (-):</b></p>	Does the voltage repeatedly change between 10 V and 0 V?	Replace the secondary air combination valve RH. <Ref. to EC(STI)-29, Secondary Air Combination Valve.> <Ref. to EC(w/o STI)-30, Secondary Air Combination Valve.>	Go to step 7.
<p><b>7 CHECK HARNESS BETWEEN SECONDARY AIR COMBINATION VALVE RH AND CHASSIS GROUND.</b></p> <p>Measure the resistance between the secondary air combination valve RH connector and chassis ground.</p> <p><b>Connector &amp; terminal</b>  <b>Models without SI-DRIVE</b>  <b>(E41) No. 4 — Chassis ground:</b>  <b>Models with SI-DRIVE</b>  <b>(E41) No. 1 — Chassis ground:</b></p>	Is the resistance less than 5 $\Omega$ ?	<ul style="list-style-type: none"> <li>• Models without SI-DRIVE: Go to step 8.</li> <li>• Models with SI-DRIVE: Go to step 14.</li> </ul>	Repair the open circuit in harness between secondary air combination valve RH connector and chassis ground.
<p><b>8 CHECK HARNESS BETWEEN SECONDARY AIR COMBINATION VALVE RELAY 1 AND SECONDARY AIR COMBINATION VALVE RH CONNECTOR.</b></p> <p>1) Turn the ignition switch to OFF.</p> <p>2) Remove the secondary air combination valve relay 1 from the relay box.</p> <p>3) Measure the resistance of the harness between secondary air combination valve relay 1 connector and secondary air combination valve RH connector.</p> <p><b>Connector &amp; terminal</b>  <b>(F9) No. 3 — (E41) No. 6:</b></p>	Is the resistance less than 1 $\Omega$ ?	Go to step 9.	Repair the open circuit in harness between secondary air combination valve relay 1 and secondary air combination valve RH connector.
<p><b>9 CHECK SECONDARY AIR COMBINATION VALVE RELAY 1.</b></p> <p>1) Connect the battery to terminals No. 1 and No. 2 of the secondary air combination valve relay 1.</p> <p>2) Measure the resistance between the secondary air combination valve relay 1 terminals.</p> <p><b>Terminals</b>  <b>No. 3 — No. 4:</b></p>	Is the resistance less than 1 $\Omega$ ?	Go to step 10.	Replace the secondary air combination valve relay 1. <Ref. to EN(H4DOTC)(diag)-9, Electrical Component Location.>
<p><b>10 CHECK SECONDARY AIR COMBINATION VALVE RELAY 1.</b></p> <p>Measure the resistance between the secondary air combination valve relay 1 terminals with the battery disconnected.</p> <p><b>Terminals</b>  <b>No. 3 — No. 4:</b></p>	Is the resistance 1 M $\Omega$ or more?	Go to step 11.	Replace the secondary air combination valve relay 1. <Ref. to EN(H4DOTC)(diag)-9, Electrical Component Location.>

# Diagnostic Procedure with Diagnostic Trouble Code (DTC)

ENGINE (DIAGNOSTICS)

Step	Check	Yes	No
<b>11 CHECK SECONDARY AIR COMBINATION VALVE RELAY 1 POWER SUPPLY.</b> 1) Turn the ignition switch to ON. 2) Measure the voltage between the secondary air combination valve relay 1 connector and chassis ground. <b>Connector &amp; terminal</b> <b>(F9) No. 4 (+) — Chassis ground (-):</b> <b>(F9) No. 1 (+) — Chassis ground (-):</b>	Is the voltage 10 V or more?	Go to step 12.	Repair the open or ground short circuit of power supply circuit.
<b>12 CHECK HARNESS BETWEEN ECM AND SECONDARY AIR COMBINATION VALVE RELAY 1 CONNECTOR.</b> 1) Turn the ignition switch to OFF. 2) Disconnect the ECM connector. 3) Measure the resistance of harness between ECM and secondary air combination valve relay 1 connector. <b>Connector &amp; terminal</b> <b>(B135) No. 8 — (F9) No. 2:</b>	Is the resistance less than 1 $\Omega$ ?	Go to step 13.	Repair the harness and connector. NOTE: In this case, repair the following item: • Open circuit in harness between ECM and secondary air combination valve relay 1 connector • Poor contact of coupling connector
<b>13 CHECK HARNESS BETWEEN ECM AND SECONDARY AIR COMBINATION VALVE RELAY 1 CONNECTOR.</b> Measure the resistance between the secondary air combination valve relay 1 connector and chassis ground. <b>Connector &amp; terminal</b> <b>(F9) No. 2 — Chassis ground:</b>	Is the resistance 1 M $\Omega$ or more?	Repair the poor contact of ECM connector.	Repair the short circuit to ground in harness between ECM and secondary air combination valve relay 1 connector.
<b>14 CHECK HARNESS BETWEEN SECONDARY AIR COMBINATION VALVE RELAY 2 AND SECONDARY AIR COMBINATION VALVE RH CONNECTOR.</b> 1) Turn the ignition switch to OFF. 2) Remove the secondary air combination valve relay 2 from the relay box. 3) Measure the resistance of the harness between secondary air combination valve relay 2 connector and secondary air combination valve RH connector. <b>Connector &amp; terminal</b> <b>(F9) No. 8 — (E41) No. 2:</b>	Is the resistance less than 1 $\Omega$ ?	Go to step 15.	Repair the open circuit in harness between secondary air combination valve relay 2 and secondary air combination valve RH connector.
<b>15 CHECK SECONDARY AIR COMBINATION VALVE RELAY 2.</b> 1) Connect the battery to terminals No. 9 and No. 10 of the secondary air combination valve relay 2. 2) Measure the resistance between the secondary air combination valve relay 2 terminals. <b>Terminals</b> <b>No. 7 — No. 8:</b>	Is the resistance less than 1 $\Omega$ ?	Go to step 16.	Replace the secondary air combination valve relay 2. <Ref. to EN(H4DOTC)(diag)-9, Electrical Component Location.>
<b>16 CHECK SECONDARY AIR COMBINATION VALVE RELAY 2.</b> Measure the resistance between the secondary air combination valve relay 2 terminals with the battery disconnected. <b>Terminals</b> <b>No. 7 — No. 8:</b>	Is the resistance 1 M $\Omega$ or more?	Go to step 17.	Replace the secondary air combination valve relay 2. <Ref. to EN(H4DOTC)(diag)-9, Electrical Component Location.>

EN(H4DOTC)(diag)-429

Brought to you by Ebay Seller "SubaruManuals"



## Diagnostic Procedure with Diagnostic Trouble Code (DTC)

### ENGINE (DIAGNOSTICS)

Step	Check	Yes	No
<b>17 CHECK SECONDARY AIR COMBINATION VALVE RELAY 2 POWER SUPPLY.</b> 1) Turn the ignition switch to ON. 2) Measure the voltage between the secondary air combination valve relay 2 connector and chassis ground. <i>Connector &amp; terminal</i> <i>(F9) No. 7 (+) — Chassis ground (-):</i> <i>(F9) No. 10 (+) — Chassis ground (-):</i>	Is the voltage 10 V or more?	Go to step 18.	Repair the open or ground short circuit of power supply circuit.
<b>18 CHECK HARNESS BETWEEN ECM AND SECONDARY AIR COMBINATION VALVE RELAY 2 CONNECTOR.</b> 1) Turn the ignition switch to OFF. 2) Disconnect the ECM connector. 3) Measure the resistance of harness between ECM and secondary air combination valve relay 2 connector. <i>Connector &amp; terminal</i> <i>(B135) No. 20 — (F9) No. 9:</i>	Is the resistance less than 1 $\Omega$ ?	Go to step 19.	Repair the harness and connector. NOTE: In this case, repair the following item: • Open circuit in harness between ECM and secondary air combination valve relay 2 connector • Poor contact of coupling connector
<b>19 CHECK HARNESS BETWEEN ECM AND SECONDARY AIR COMBINATION VALVE RELAY 2 CONNECTOR.</b> Measure the resistance between the secondary air combination valve relay 2 connector and chassis ground. <i>Connector &amp; terminal</i> <i>(F9) No. 9 — Chassis ground:</i>	Is the resistance 1 M $\Omega$ or more?	Repair the poor contact of ECM connector.	Repair the short circuit to ground in harness between ECM and secondary air combination valve relay 2 connector.

### FA:DTC P2441 SECONDARY AIR INJECTION SYSTEM SWITCHING VALVE STUCK CLOSED (BANK1)

**NOTE:**

For the diagnostic procedure, refer to DTC P2440. <Ref. to EN(H4DOTC)(diag)-424, DTC P2440 SECONDARY AIR INJECTION SYSTEM SWITCHING VALVE STUCK OPEN (BANK1), Diagnostic Procedure with Diagnostic Trouble Code (DTC).>

## **FB:DTC P2442 SECONDARY AIR INJECTION SYSTEM SWITCHING VALVE STUCK OPEN (BANK2)**

### **DTC DETECTING CONDITION:**

- Detected when two consecutive driving cycles with fault occur.
- GENERAL DESCRIPTION <Ref. to GD(H4DOTC)-275, DTC P2442 SECONDARY AIR INJECTION SYSTEM SWITCHING VALVE STUCK OPEN (BANK2), Diagnostic Trouble Code (DTC) Detecting Criteria.>

### **CAUTION:**

**After servicing or replacing faulty parts, perform Clear Memory Mode <Ref. to EN(H4DOTC)(diag)-62, OPERATION, Clear Memory Mode.>, and Inspection Mode <Ref. to EN(H4DOTC)(diag)-48, PROCEDURE, Inspection Mode.>.**

# Diagnostic Procedure with Diagnostic Trouble Code (DTC)

ENGINE (DIAGNOSTICS)

## WIRING DIAGRAM:

- Models without SI-DRIVE

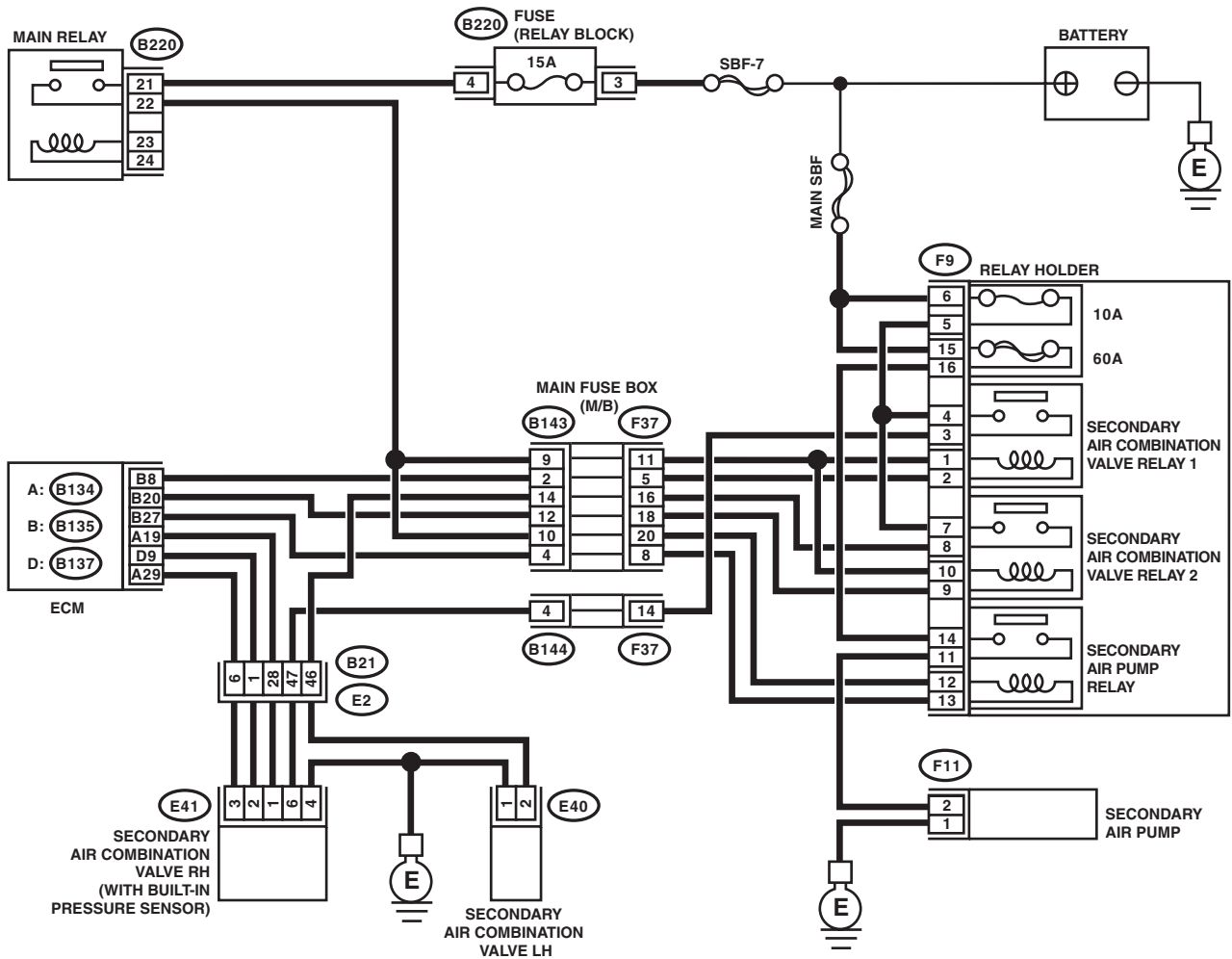

A: B134

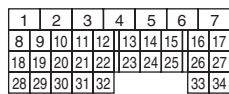

B: B135

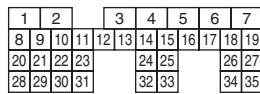

B220

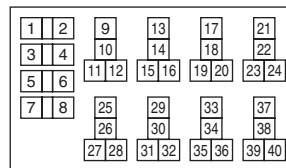

B21

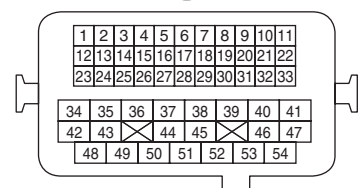

D: B137

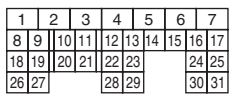

F9

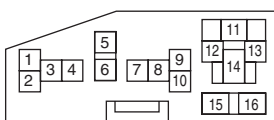

F37

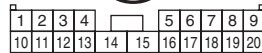

B143



F11



E40



E41



B144

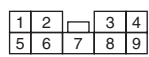

EN-08734

# Diagnostic Procedure with Diagnostic Trouble Code (DTC)

ENGINE (DIAGNOSTICS)

- Models with SI-DRIVE

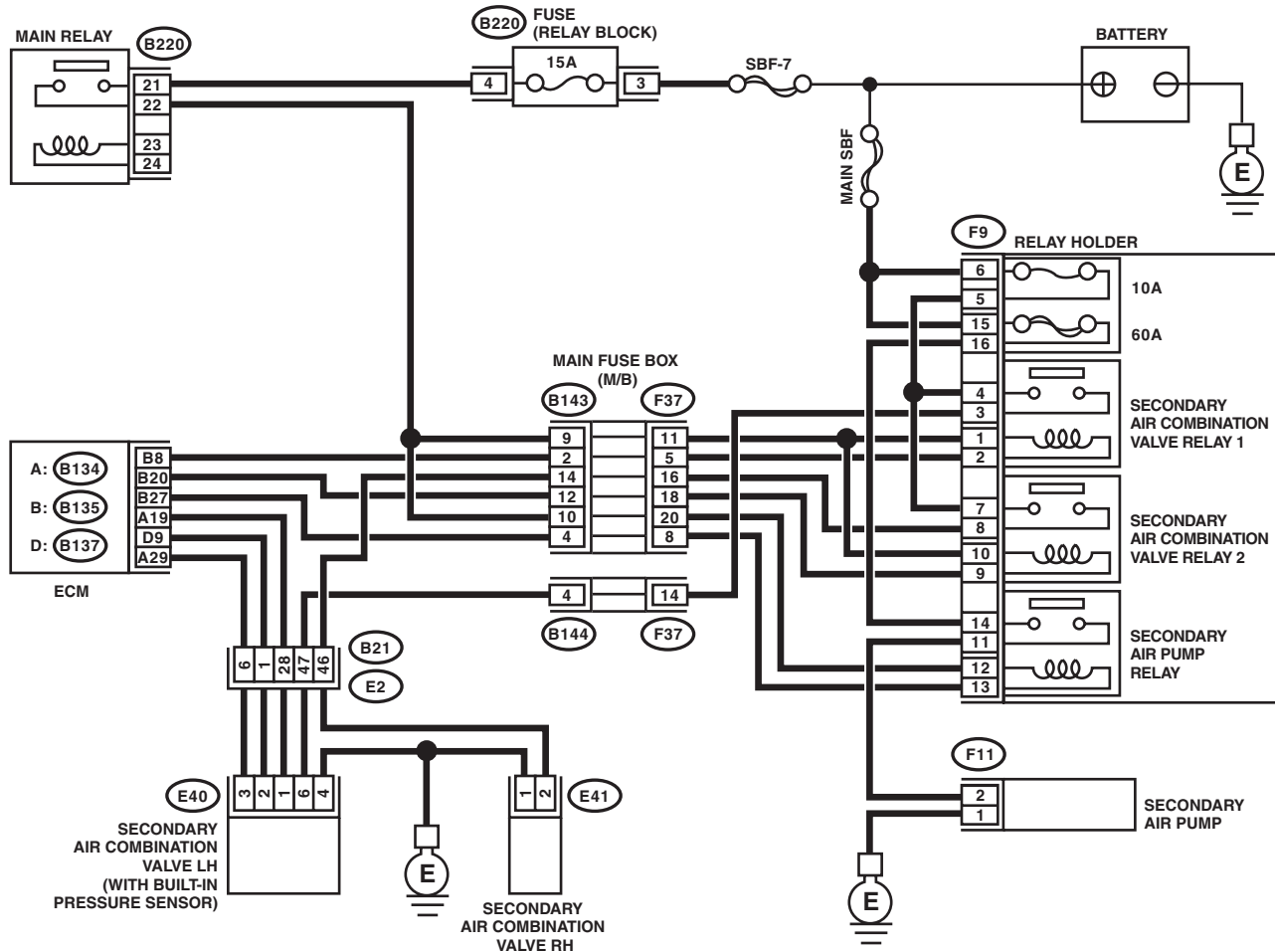

A: (B134)

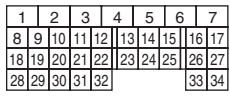

B: (B135)

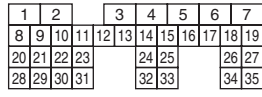

(B220)

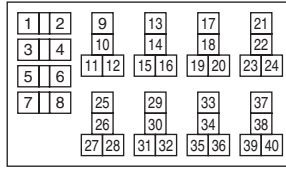

(B21)

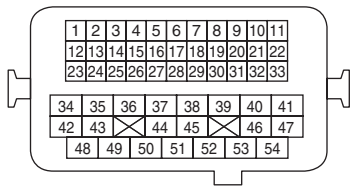

D: (B137)

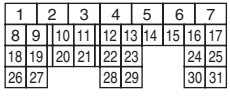

(F9)

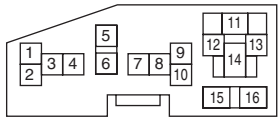

(F37)

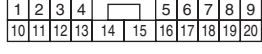

(B143)

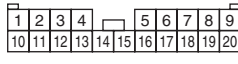

(F11)



(E41)



(E40)



(B144)

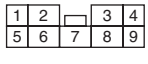

EN-08735

Step	Check	Yes	No
1	<b>CHECK SECONDARY AIR COMBINATION VALVE FUSE.</b> Check if the secondary air combination valve fuse (10 A) is blown out.	Go to step 2.	Go to step 3.

# Diagnostic Procedure with Diagnostic Trouble Code (DTC)

## ENGINE (DIAGNOSTICS)

Step	Check	Yes	No
<p><b>2</b></p> <p><b>CHECK HARNESS BETWEEN FUSE BOX AND SECONDARY AIR COMBINATION VALVE LH CONNECTOR.</b></p> <p>1) Remove the secondary air combination valve fuse (10 A) from the fuse box.</p> <p>2) Disconnect the connector from the secondary air combination valve LH.</p> <p>3) Measure the resistance between the secondary air combination valve fuse and secondary air combination valve LH connector, and chassis ground.</p> <p><b>Connector &amp; terminal</b>  <b>Models without SI-DRIVE</b>  <b>(F9) No. 5 — Chassis ground:</b>  <b>(E40) No. 2 — Chassis ground:</b>  <b>Models with SI-DRIVE</b>  <b>(F9) No. 5 — Chassis ground:</b>  <b>(E40) No. 6 — Chassis ground:</b></p>	<p>Is the resistance 1 MΩ or more?</p>	<p>Replace the fuse with a new part, and connect the secondary air combination valve LH connector.</p> <p>Go to step 3.</p>	<p>Repair the ground short circuit of harness between the fuse box and the secondary air combination valve LH connector.</p>
<p><b>3</b></p> <p><b>CHECK SECONDARY AIR COMBINATION VALVE LH OPERATION.</b></p> <p>1) Connect the delivery (test) mode connector.</p> <p>2) Turn the ignition switch to ON.</p> <p>3) Perform operation check for the secondary air combination valve LH using the Subaru Select Monitor.</p> <p>NOTE: Refer to "Compulsory Valve Operation Check Mode" for more operation procedures. &lt;Ref. to EN(H4DOTC)(diag)-63, Compulsory Valve Operation Check Mode.&gt;</p>	<p>Does the secondary air combination valve LH repeatedly switch to ON and OFF?</p>	<p>Go to step 4.</p>	<p>Go to step 6.</p>
<p><b>4</b></p> <p><b>CHECK DUCT BETWEEN SECONDARY AIR PUMP AND SECONDARY AIR COMBINATION VALVE LH.</b></p> <p>Check the duct between the secondary air pump and secondary air combination valve LH.</p>	<p>Is there damage, clog or disconnection of the duct?</p>	<p>Replace, clean or connect the duct.</p>	<p>Go to step 5.</p>
<p><b>5</b></p> <p><b>CHECK PIPE BETWEEN SECONDARY AIR COMBINATION VALVE LH AND CYLINDER HEAD.</b></p> <p>Check the pipe between the secondary air combination valve LH and cylinder head.</p>	<p>Is there damage, clog or disconnection of the pipe?</p>	<p>Replace, clean or connect the pipe.</p>	<p>Even if DTC is detected, the circuit has returned to a normal condition at this time. Reproduce the failure, and then perform the diagnosis again.</p> <p>NOTE: In this case, temporary poor contact of connector, temporary open or short circuit of harness may be the cause.</p>

# Diagnostic Procedure with Diagnostic Trouble Code (DTC)

ENGINE (DIAGNOSTICS)

Step	Check	Yes	No
<p><b>6</b></p> <p><b>CHECK POWER SUPPLY TO SECONDARY AIR COMBINATION VALVE LH.</b></p> <p>1) Disconnect the connector from the secondary air combination valve LH.</p> <p>2) In the condition of step 3, measure the voltage between secondary air combination valve LH connector and chassis ground.</p> <p><b>Connector &amp; terminal</b>  <b>Models without SI-DRIVE</b>  <b>(E40) No. 2 (+) — Chassis ground (-):</b>  <b>Models with SI-DRIVE</b>  <b>(E40) No. 6 (+) — Chassis ground (-):</b></p>	Does the voltage repeatedly change between 10 V and 0 V?	Replace the secondary air combination valve LH. <Ref. to EC(STI)-29, Secondary Air Combination Valve.> <Ref. to EC(w/o STI)-30, Secondary Air Combination Valve.>	Go to step 7.
<p><b>7</b></p> <p><b>CHECK HARNESS BETWEEN SECONDARY AIR COMBINATION VALVE LH AND CHASSIS GROUND.</b></p> <p>Measure the resistance between the secondary air combination valve LH connector and chassis ground.</p> <p><b>Connector &amp; terminal</b>  <b>Models without SI-DRIVE</b>  <b>(E40) No. 1 — Chassis ground:</b>  <b>Models with SI-DRIVE</b>  <b>(E40) No. 4 — Chassis ground:</b></p>	Is the resistance less than 5 Ω?	<ul style="list-style-type: none"> <li>• Models without SI-DRIVE: Go to step 8.</li> <li>• Models with SI-DRIVE: Go to step 14.</li> </ul>	Repair the open circuit in harness between secondary air combination valve LH connector and chassis ground.
<p><b>8</b></p> <p><b>CHECK HARNESS BETWEEN SECONDARY AIR COMBINATION VALVE RELAY 2 AND SECONDARY AIR COMBINATION VALVE LH CONNECTOR.</b></p> <p>1) Turn the ignition switch to OFF.</p> <p>2) Remove the secondary air combination valve relay 2 from the relay box.</p> <p>3) Measure the resistance of the harness between the secondary air combination valve relay 2 and secondary air combination valve LH connector.</p> <p><b>Connector &amp; terminal</b>  <b>(F9) No. 8 — (E40) No. 2:</b></p>	Is the resistance less than 1 Ω?	Go to step 9.	Repair the harness and connector. <b>NOTE:</b> In this case, repair the following item: <ul style="list-style-type: none"> <li>• Open circuit in harness between secondary air combination valve relay 2 connector and secondary air combination valve LH connector</li> <li>• Poor contact of coupling connector</li> </ul>
<p><b>9</b></p> <p><b>CHECK SECONDARY AIR COMBINATION VALVE RELAY 2.</b></p> <p>1) Connect the battery to terminals No. 10 and No. 9 of the secondary air combination valve relay 2.</p> <p>2) Measure the resistance between the secondary air combination valve relay 2 terminals.</p> <p><b>Terminals</b>  <b>No. 7 — No. 8:</b></p>	Is the resistance less than 1 Ω?	Go to step 10.	Replace the secondary air combination valve relay 2. <Ref. to EN(H4DOTC)(diag)-9, Electrical Component Location.>
<p><b>10</b></p> <p><b>CHECK SECONDARY AIR COMBINATION VALVE RELAY 2.</b></p> <p>Measure the resistance between the secondary air combination valve relay 2 terminals with the battery disconnected.</p> <p><b>Terminals</b>  <b>No. 7 — No. 8:</b></p>	Is the resistance 1 MΩ or more?	Go to step 11.	Replace the secondary air combination valve relay 2. <Ref. to EN(H4DOTC)(diag)-9, Electrical Component Location.>

# Diagnostic Procedure with Diagnostic Trouble Code (DTC)

## ENGINE (DIAGNOSTICS)

Step	Check	Yes	No
<b>11 CHECK SECONDARY AIR COMBINATION VALVE RELAY 2 POWER SUPPLY.</b> 1) Turn the ignition switch to ON. 2) Measure the voltage between the secondary air combination valve relay 2 connector and chassis ground. <b>Connector &amp; terminal</b> <b>(F9) No. 7 (+) — Chassis ground (-):</b> <b>(F9) No. 10 (+) — Chassis ground (-):</b>	Is the voltage 10 V or more?	Go to step 12.	Repair the open or ground short circuit of power supply circuit.
<b>12 CHECK HARNESS BETWEEN ECM AND SECONDARY AIR COMBINATION VALVE RELAY 2 CONNECTOR.</b> 1) Turn the ignition switch to OFF. 2) Disconnect the ECM connector. 3) Measure the resistance of harness between ECM and secondary air combination valve relay 2 connector. <b>Connector &amp; terminal</b> <b>(B135) No. 20 — (F9) No. 9:</b>	Is the resistance less than 1 $\Omega$ ?	Go to step 13.	Repair the harness and connector. NOTE: In this case, repair the following item: • Open circuit in harness between ECM and secondary air combination valve relay 2 connector • Poor contact of coupling connector
<b>13 CHECK HARNESS BETWEEN ECM AND SECONDARY AIR COMBINATION VALVE RELAY 2 CONNECTOR.</b> Measure the resistance between the secondary air combination valve relay 2 connector and chassis ground. <b>Connector &amp; terminal</b> <b>(F9) No. 9 — Chassis ground:</b>	Is the resistance 1 M $\Omega$ or more?	Repair the poor contact of ECM connector.	Repair the short circuit to ground in harness between ECM and secondary air combination valve relay 2 connector.
<b>14 CHECK HARNESS BETWEEN SECONDARY AIR COMBINATION VALVE RELAY 1 AND SECONDARY AIR COMBINATION VALVE LH CONNECTOR.</b> 1) Turn the ignition switch to OFF. 2) Remove the secondary air combination valve relay 1 from the relay box. 3) Measure the resistance of the harness between the secondary air combination valve relay 1 and secondary air combination valve LH connector. <b>Connector &amp; terminal</b> <b>(F9) No. 3 — (E40) No. 6:</b>	Is the resistance less than 1 $\Omega$ ?	Go to step 15.	Repair the harness and connector. NOTE: In this case, repair the following item: • Open circuit in harness between secondary air combination valve relay 1 connector and secondary air combination valve LH connector • Poor contact of coupling connector
<b>15 CHECK SECONDARY AIR COMBINATION VALVE RELAY 1.</b> 1) Connect the battery to terminals No. 1 and No. 2 of the secondary air combination valve relay 1. 2) Measure the resistance between the secondary air combination valve relay 1 terminals. <b>Terminals</b> <b>No. 3 — No. 4:</b>	Is the resistance less than 1 $\Omega$ ?	Go to step 16.	Replace the secondary air combination valve relay 1. <Ref. to EN(H4DOTC)(diag)-9, Electrical Component Location.>

# Diagnostic Procedure with Diagnostic Trouble Code (DTC)

ENGINE (DIAGNOSTICS)

Step	Check	Yes	No
<b>16 CHECK SECONDARY AIR COMBINATION VALVE RELAY 1.</b> Measure the resistance between the secondary air combination valve relay 1 terminals with the battery disconnected. <i>Terminals</i> <i>No. 3 — No. 4:</i>	Is the resistance 1 M $\Omega$ or more?	Go to step 17.	Replace the secondary air combination valve relay 1. <Ref. to EN(H4DOTC)(diag)-9, Electrical Component Location.>
<b>17 CHECK SECONDARY AIR COMBINATION VALVE RELAY 1 POWER SUPPLY.</b> 1) Turn the ignition switch to ON. 2) Measure the voltage between the secondary air combination valve relay 1 connector and chassis ground. <i>Connector &amp; terminal</i> <i>(F9) No. 4 (+) — Chassis ground (-):</i> <i>(F9) No. 1 (+) — Chassis ground (-):</i>	Is the voltage 10 V or more?	Go to step 18.	Repair the open or ground short circuit of power supply circuit.
<b>18 CHECK HARNESS BETWEEN ECM AND SECONDARY AIR COMBINATION VALVE RELAY 1 CONNECTOR.</b> 1) Turn the ignition switch to OFF. 2) Disconnect the ECM connector. 3) Measure the resistance of harness between ECM and secondary air combination valve relay 1 connector. <i>Connector &amp; terminal</i> <i>(B135) No. 8 — (F9) No. 2:</i>	Is the resistance less than 1 $\Omega$ ?	Go to step 19.	Repair the harness and connector. NOTE: In this case, repair the following item: • Open circuit in harness between ECM and secondary air combination valve relay 1 connector • Poor contact of coupling connector
<b>19 CHECK HARNESS BETWEEN ECM AND SECONDARY AIR COMBINATION VALVE RELAY 1 CONNECTOR.</b> Measure the resistance between the secondary air combination valve relay 1 connector and chassis ground. <i>Connector &amp; terminal</i> <i>(F9) No. 2 — Chassis ground:</i>	Is the resistance 1 M $\Omega$ or more?	Repair the poor contact of ECM connector.	Repair the short circuit to ground in harness between ECM and secondary air combination valve relay 1 connector.

## FC:DTC P2443 SECONDARY AIR INJECTION SYSTEM SWITCHING VALVE STUCK CLOSED (BANK2)

### NOTE:

For the diagnostic procedure, refer to DTC P2442. <Ref. to EN(H4DOTC)(diag)-431, DTC P2442 SECONDARY AIR INJECTION SYSTEM SWITCHING VALVE STUCK OPEN (BANK2), Diagnostic Procedure with Diagnostic Trouble Code (DTC).>



## Diagnostic Procedure with Diagnostic Trouble Code (DTC)

ENGINE (DIAGNOSTICS)

---

### **FD:DTC P2444 SECONDARY AIR INJECTION SYSTEM PUMP STUCK ON**

#### **DTC DETECTING CONDITION:**

- Immediately at fault recognition
- GENERAL DESCRIPTION <Ref. to GD(H4DOTC)-276, DTC P2444 SECONDARY AIR INJECTION SYSTEM PUMP STUCK ON, Diagnostic Trouble Code (DTC) Detecting Criteria.>

#### **CAUTION:**

**After servicing or replacing faulty parts, perform Clear Memory Mode <Ref. to EN(H4DOTC)(diag)-62, OPERATION, Clear Memory Mode.>, and Inspection Mode <Ref. to EN(H4DOTC)(diag)-48, PROCEDURE, Inspection Mode.>.**

# Diagnostic Procedure with Diagnostic Trouble Code (DTC)

ENGINE (DIAGNOSTICS)

## WIRING DIAGRAM:

- Models without SI-DRIVE

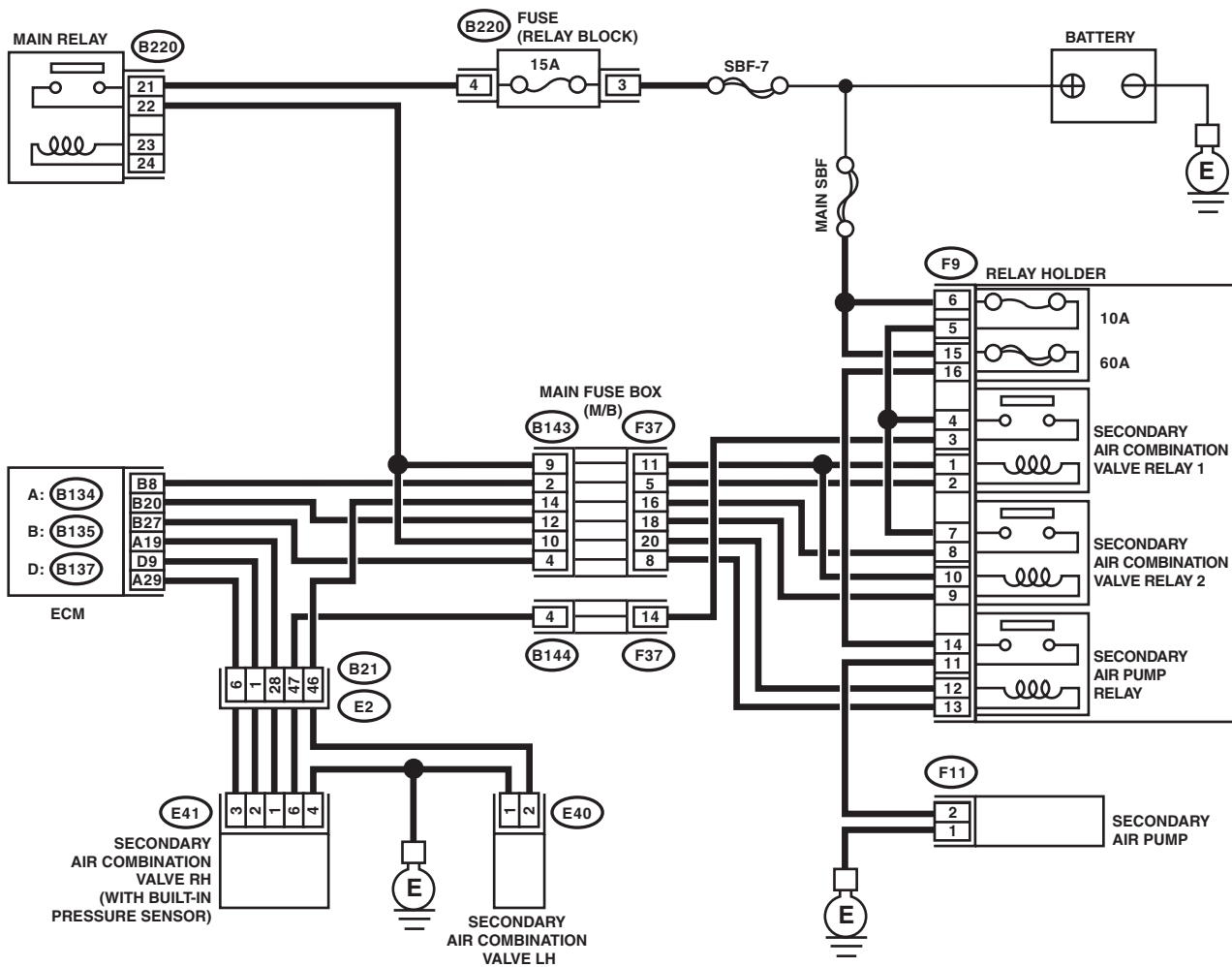

A: B134



B: B135



B220

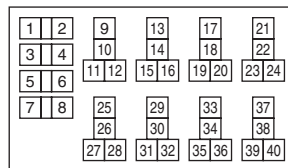

B21

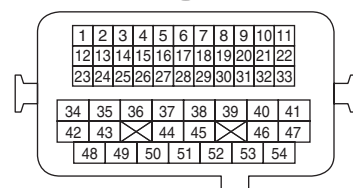

D: B137

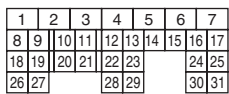

F9

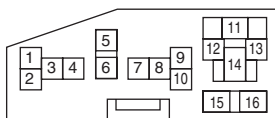

F37

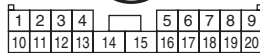

B143



F11



E40



E41



B144

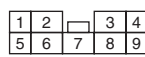

EN-08734

# Diagnostic Procedure with Diagnostic Trouble Code (DTC)

## ENGINE (DIAGNOSTICS)

- Models with SI-DRIVE

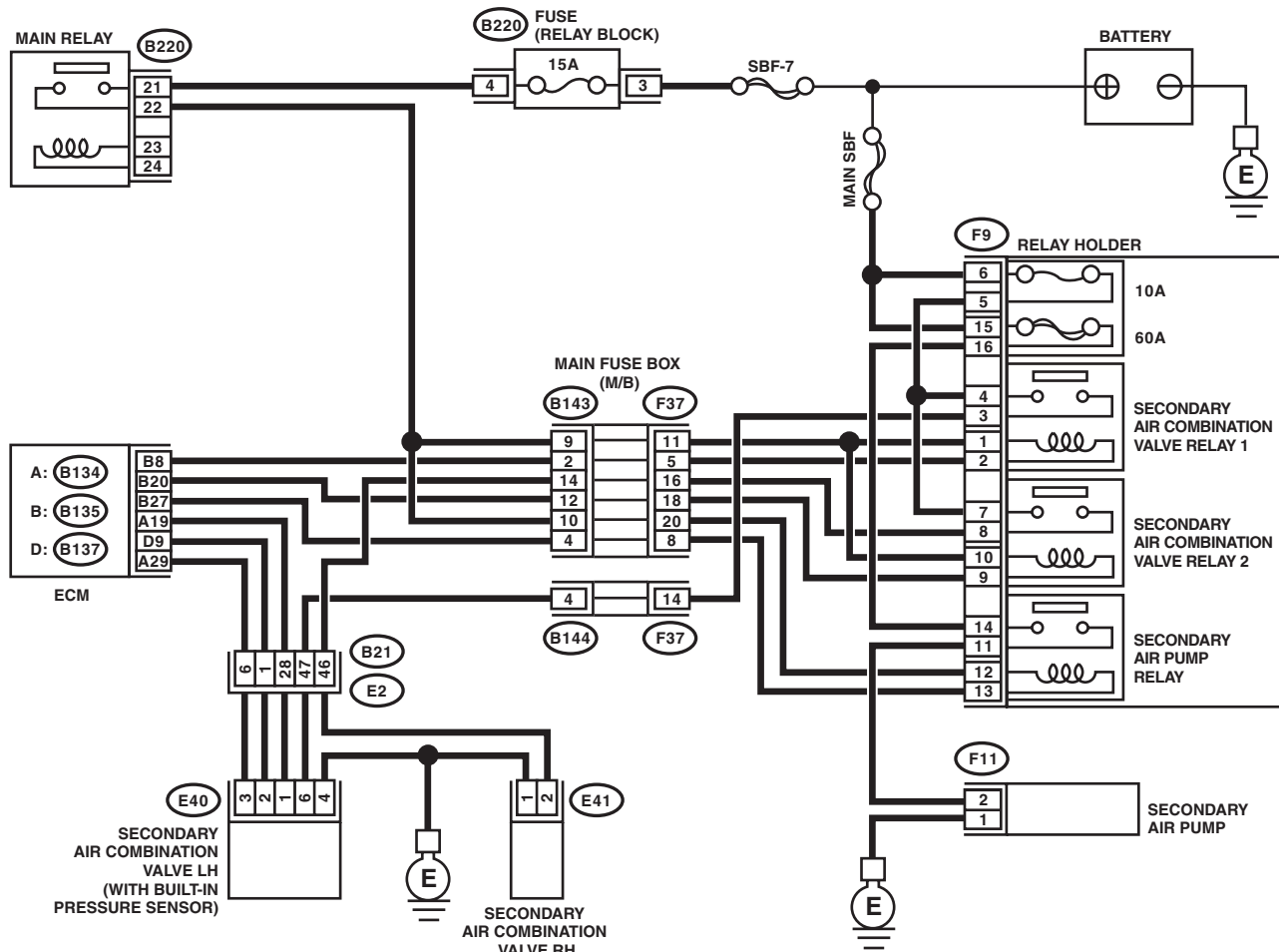

A: B134

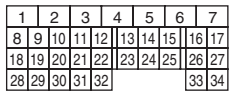

D: B137

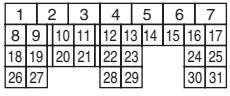

B: B135

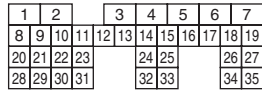

B220

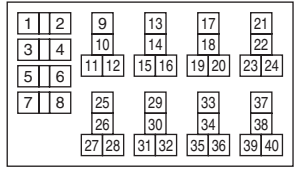

B21

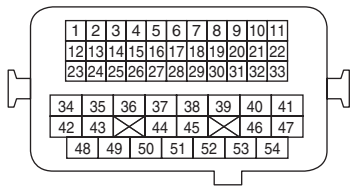

F9

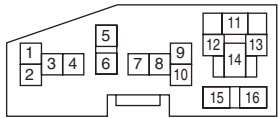

F37

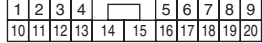

B143

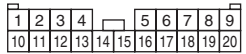

F11



E41



E40



B144

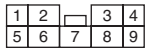

# Diagnostic Procedure with Diagnostic Trouble Code (DTC)

ENGINE (DIAGNOSTICS)

	Step	Check	Yes	No
1	<p><b>CHECK SECONDARY AIR PIPING PRESSURE.</b></p> <p>1) Turn the ignition switch to ON.</p> <p>2) Using the Subaru Select Monitor, read the value of «Sec. Air Piping Pressure», and compare with the actual atmospheric pressure.</p> <p>NOTE: For detailed operation procedures, refer to "READ CURRENT DATA FOR ENGINE". &lt;Ref. to EN(H4DOTC)(diag)-40, Subaru Select Monitor.&gt;</p>	Is the difference between «Sec. Air Piping Pressure» and atmospheric pressure 50 mmHg (6.7 kPa, 2.0 inHg, 0.97 psig) or more?	Go to step 2.	<p>Even if DTC is detected, the circuit has returned to a normal condition at this time. Reproduce the failure, and then perform the diagnosis again.</p> <p>NOTE: In this case, temporary poor contact of connector, temporary open or short circuit of harness may be the cause.</p>
2	<p><b>CHECK SECONDARY AIR PUMP.</b></p> <p>1) Start the engine and warm up engine until coolant temperature is higher than 75°C (167°F).</p> <p>2) Check whether the secondary air pump is operating.</p>	Is the secondary air pump operating?	Go to step 3.	<p>Replace the secondary air combination valve RH (models without SI-DRIVE) or LH (models with SI-DRIVE). &lt;Ref. to EC(STI)-29, Secondary Air Combination Valve.&gt;</p> <p>&lt;Ref. to EC(w/o STI)-30, Secondary Air Combination Valve.&gt;</p>
3	<p><b>CHECK HARNESS BETWEEN ECM AND SECONDARY AIR PUMP RELAY CONNECTOR.</b></p> <p>1) Turn the ignition switch to OFF.</p> <p>2) Remove the secondary air pump relay from the relay box.</p> <p>3) Measure the resistance between the secondary air pump relay connector and engine ground terminals.</p> <p><b>Connector &amp; terminal</b> <b>(F9) No. 13 — Engine ground:</b></p>	Is the resistance 1 MΩ or more?	Go to step 4.	Repair the short circuit to ground in harness between ECM and secondary air pump relay connector.
4	<p><b>CHECK SECONDARY AIR PUMP RELAY.</b></p> <p>Measure the resistance between the secondary air pump relay terminals.</p> <p><b>Terminals</b> <b>No. 14 — No. 11:</b></p>	Is the resistance 1 MΩ or more?	Repair the short circuit to power in the harness between secondary air pump relay and secondary air pump connector.	Replace the secondary air pump relay. <Ref. to EN(H4DOTC)(diag)-9, Electrical Component Location.>

# Diagnostic Procedure with Diagnostic Trouble Code (DTC)

ENGINE (DIAGNOSTICS)

## FE:DTC P2610 ECM/PCM INTERNAL ENGINE OFF TIMER PERFORMANCE

### DTC DETECTING CONDITION:

- Detected when two consecutive driving cycles with fault occur.
- GENERAL DESCRIPTION <Ref. to GD(H4DOTC)-277, DTC P2610 ECM/PCM INTERNAL ENGINE OFF TIMER PERFORMANCE, Diagnostic Trouble Code (DTC) Detecting Criteria.>

### CAUTION:

After servicing or replacing faulty parts, perform Clear Memory Mode <Ref. to EN(H4DOTC)(diag)-62, OPERATION, Clear Memory Mode.>, and Inspection Mode <Ref. to EN(H4DOTC)(diag)-48, PROCEDURE, Inspection Mode.>.

Step	Check	Yes	No
1 CHECK FOR ANY OTHER DTC ON DISPLAY.	Is any other DTC displayed?	Check DTC using "List of Diagnostic Trouble Code (DTC)". <Ref. to EN(H4DOTC)(diag)-88, List of Diagnostic Trouble Code (DTC).>	Replace the ECM. <Ref. to FU(STI)-59, Engine Control Module (ECM).> <Ref. to FU(w/o STI)-58, Engine Control Module (ECM).> NOTE: The soak timer IC is built into the ECM.

## FF:DTC U0073 CAN FAILURE, BUS 'OFF' DETECTION

### NOTE:

For the diagnostic procedure, refer to LAN section. <Ref. to LAN(diag)-2, Basic Diagnostic Procedure.>

## FG:DTC U0122 CAN (VDC) DATA NOT LOADED

### NOTE:

For the diagnostic procedure, refer to LAN section. <Ref. to LAN(diag)-2, Basic Diagnostic Procedure.>

## FH:DTC U0140 CAN (BCU) DATA NOT LOADED

### NOTE:

For the diagnostic procedure, refer to LAN section. <Ref. to LAN(diag)-2, Basic Diagnostic Procedure.>

## FI: DTC U0416 CAN (VDC) DATA ABNORMAL

### NOTE:

For the diagnostic procedure, refer to LAN section. <Ref. to LAN(diag)-2, Basic Diagnostic Procedure.>

## FJ: DTC U0422 CAN (BCU) DATA ABNORMAL

### NOTE:

For the diagnostic procedure, refer to LAN section. <Ref. to LAN(diag)-2, Basic Diagnostic Procedure.>

## 21. Diagnostic Procedure without Diagnostic Trouble Code (DTC)

### A: CHECK SI-DRIVE (SUBARU INTELLIGENT DRIVE) SYSTEM

#### DIAGNOSIS:

SI-DRIVE mode does not switch.

#### CAUTION:

Note that SI-DRIVE system operates the following controls when it switches the modes.

1. Switches to S (SPORT) when turning the engine ON after turning the engine OFF in S# (SPORT sharp) mode.
2. Returns to the mode last selected when turning the engine ON after turning the engine OFF in S (SPORT) or I (Intelligent) mode.
3. Switches to S (SPORT) when the malfunction indicator light illuminates while the engine is running. In this case, Cannot switch to S# (SPORT sharp) or I (Intelligent) mode.
4. Cannot switch to S# (SPORT sharp), when engine coolant temperature tells that overheating may occur. Switches to S (SPORT) while driving in S# (SPORT sharp) mode.

# Diagnostic Procedure without Diagnostic Trouble Code (DTC)

ENGINE (DIAGNOSTICS)

## 1. SI-DRIVE MODE INDICATION DOES NOT CHANGE AND MODES DO NOT SWITCH AFTER SWITCHING SI-DRIVE MODES

WIRING DIAGRAM:

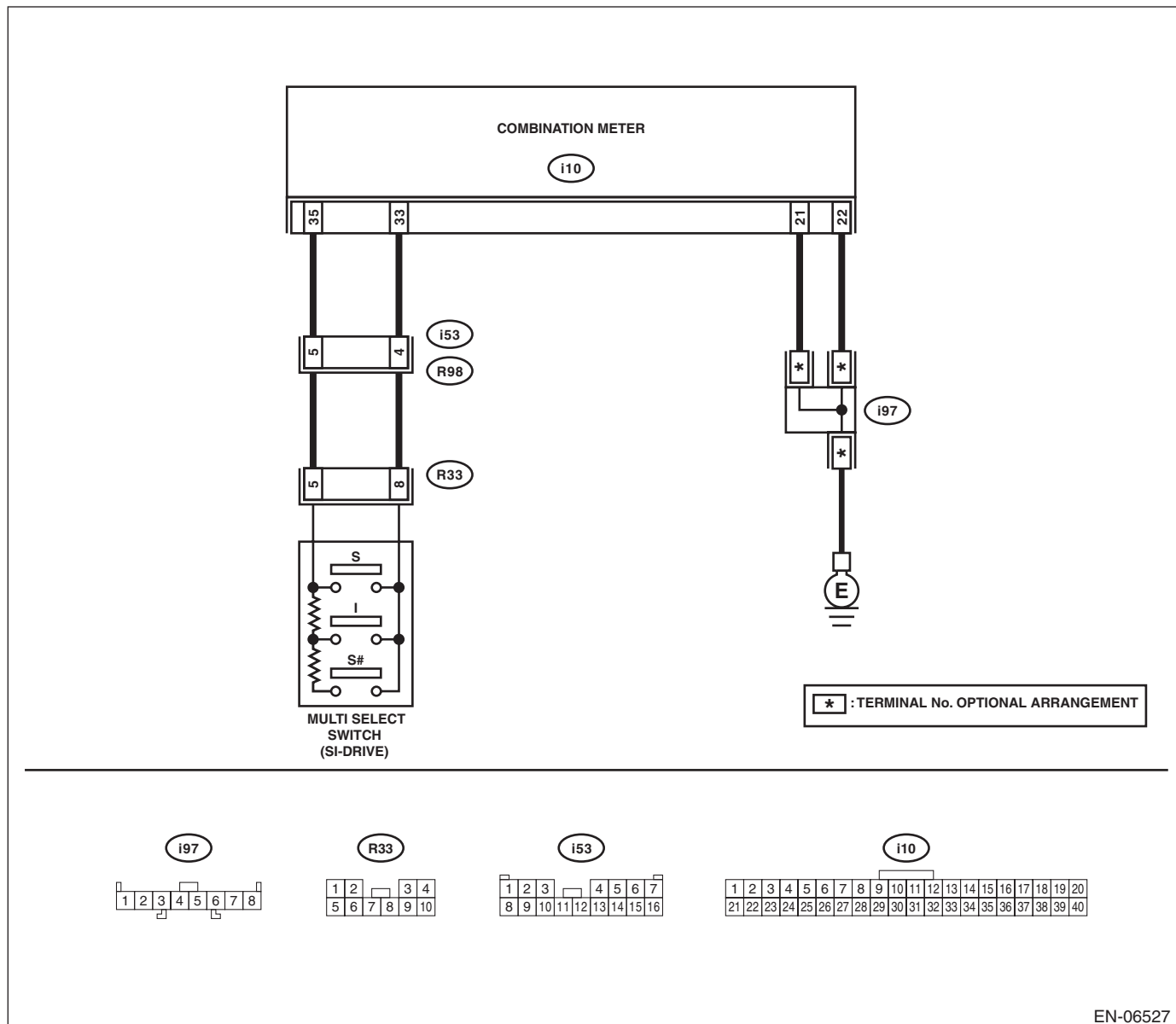

Step	Check	Yes	No
<p><b>1</b></p> <p><b>CHECK SI-DRIVE SELECTOR.</b></p> <p>1) Turn the ignition switch to OFF.</p> <p>2) Disconnect the connector from the combination meter.</p> <p>3) Measure the resistance between connectors when the SI-DRIVE selector is operated.</p> <p><b>Connector &amp; terminal</b> <b>(i10) No. 33 — (i10) No. 35:</b></p>	<p>Does the resistance change as below?</p> <p>S#: 3.48 — 3.85 kΩ</p> <p>I: 0.95 — 1.05 kΩ</p> <p>S: less than 1 Ω</p>	<p>Go to step 4.</p>	<p>Go to step 2.</p>

# Diagnostic Procedure without Diagnostic Trouble Code (DTC)

ENGINE (DIAGNOSTICS)

Step	Check	Yes	No
<p><b>2</b></p> <p><b>CHECK HARNESS BETWEEN COMBINATION METER AND MULTI-SELECT SWITCH CONNECTOR.</b></p> <p>1) Disconnect the connector from multi-select switch.</p> <p>2) Measure the resistance of harness between combination meter and multi-select switch connector.</p> <p><b>Connector &amp; terminal</b>  <i>(i10) No. 33 — (R33) No. 8:</i>  <i>(i10) No. 35 — (R33) No. 5:</i></p>	Is the resistance less than 1 $\Omega$ ?	Go to step 3.	<p>Repair the harness and connector.</p> <p><b>NOTE:</b>                      In this case, repair the following item:</p> <ul style="list-style-type: none"> <li>• Open circuit in harness between combination meter and multi-select switch connector</li> <li>• Poor contact of coupling connector</li> </ul>
<p><b>3</b></p> <p><b>CHECK HARNESS BETWEEN COMBINATION METER AND MULTI-SELECT SWITCH CONNECTOR.</b></p> <p>Measure the resistance between multi-select switch connector and chassis ground.</p> <p><b>Connector &amp; terminal</b>  <i>(R33) No. 8 — Chassis ground:</i>  <i>(R33) No. 5 — Chassis ground:</i></p>	Is the resistance 1 M $\Omega$ or more?	Repair the poor contact of multi-select switch connector. Replace the multi-select switch if defective. <Ref. to FU(STI)-58, SI-DRIVE (SUBARU Intelligent Drive) Selector.>	Repair the ground short circuit in harness between combination meter and multi-select switch connector.
<p><b>4</b></p> <p><b>CHECK HARNESS BETWEEN COMBINATION METER AND CHASSIS GROUND.</b></p> <p>Measure the resistance of harness between combination meter and chassis ground.</p> <p><b>Connector &amp; terminal</b>  <i>(i10) No. 21 — Chassis ground:</i>  <i>(i10) No. 22 — Chassis ground:</i></p>	Is the resistance less than 5 $\Omega$ ?	Go to step 5.	<p>Repair the harness and connector.</p> <p><b>NOTE:</b>                      In this case, repair the following item:</p> <ul style="list-style-type: none"> <li>• Open circuit in harness between combination meter and chassis ground</li> <li>• Poor contact of coupling connector</li> </ul>
<p><b>5</b></p> <p><b>RECHECK FAULT.</b></p> <p>1) Connect all connectors.</p> <p>2) Switch SI-DRIVE modes.</p>	Is there any fault?	Repair the poor contact of combination meter connector. Replace the combination meter if defective. <Ref. to IDI-16, Combination Meter.>	<p>The circuit has returned to a normal condition at this time. Reproduce the failure, and then perform the diagnosis again.</p> <p><b>NOTE:</b>                      In this case, temporary poor contact of connector, temporary open or short circuit of harness may be the cause.</p>



## Diagnostic Procedure without Diagnostic Trouble Code (DTC)

ENGINE (DIAGNOSTICS)

### 2. "S" BLINKS ON SI-DRIVE MODE DISPLAY IN THE COMBINATION METER APPROX. 5 SECONDS AFTER SWITCHING SI-DRIVE MODES

Step	Check	Yes	No
<b>1</b> <b>CHECK DTC.</b>	Is DTC displayed?	Check the appropriate DTC using the "List of Diagnostic Trouble Code (DTC)" concerning the respective units.	Go to step 2.
<b>2</b> <b>CHECK COMBINATION METER AND CLOCK DISPLAY.</b> Check for abnormal indication other than "S" blinking. Examples: <ul style="list-style-type: none"> <li>• Malfunction indicator light illuminates.</li> <li>• "Err" is displayed on fuel efficiency display part.</li> <li>• Engine coolant temperature gauge does not move.</li> </ul>	Is there any abnormal indication other than "S" blinking?	For the diagnostic procedure, refer to LAN section. <Ref. to LAN(diag)-2, Basic Diagnostic Procedure.>	Go to step 3.
<b>3</b> <b>CHECK COMBINATION METER, ECM AND BODY INTEGRATED UNIT.</b>	Are the part numbers of combination meter, ECM and body integrated unit correct?	Replace the combination meter. <Ref. to IDI-16, Combination Meter.>	Replace the combination meter, ECM or body integrated unit with parts of proper part number. <Ref. to IDI-16, Combination Meter.> <Ref. to FU(STI)-59, Engine Control Module (ECM).> or <Ref. to SL-48, Body Integrated Unit.>

# Diagnostic Procedure without Diagnostic Trouble Code (DTC)

ENGINE (DIAGNOSTICS)

## 3. "S#", "I" OR "S" BLINKS ON SI-DRIVE MODE DISPLAY IN THE COMBINATION METER AFTER SWITCHING SI-DRIVE MODES

NOTE:

In this case, there is a fault other than in SI-DRIVE system.

Step	Check	Yes	No
<b>1</b> <b>CHECK MALFUNCTION INDICATOR LIGHT.</b> 1) Start the engine. 2) Check if malfunction indicator light illuminates.	Does the malfunction indicator light illuminate?	Read the DTC using Subaru Select Monitor and check the indicated DTC. <Ref. to EN(H4DOTC)(diag)-88, List of Diagnostic Trouble Code (DTC).>	Go to step 2.
<b>2</b> <b>CHECK ENGINE COOLANT TEMPERATURE GAUGE.</b> 1) Turn the ignition switch to ON. 2) Check the engine coolant temperature gauge.	Does it indicate overheating?	Inspect for the cause of overheating and repair.	Go to step 3.
<b>3</b> <b>CHECK COMBINATION METER INDICATION.</b> 1) Turn the ignition switch to ON. 2) Switch SI-DRIVE modes. 3) Check the SI-DRIVE mode display in the combination meter.	Does "S#", "I" or "S" of the SI-DRIVE mode blink in combination meter?	Replace the combination meter. <Ref. to IDI-16, Combination Meter.>	Perform test driving to check the malfunction indicator light and engine coolant temperature gauge. Complete the diagnosis if they are normal.

# General Diagnostic Table

ENGINE (DIAGNOSTICS)

## 22. General Diagnostic Table

### A: INSPECTION

#### 1. ENGINE

NOTE:

Malfunction of parts other than those listed is also possible. <Ref. to ME(STI)-106, Engine Trouble in General.> <Ref. to ME(w/o STI)-106, Engine Trouble in General.>

Symptoms	Faulty parts
1. Engine stalls during idling.	1) Electronic throttle control 2) Manifold absolute pressure sensor 3) Mass air flow and intake air temperature sensor 4) Ignition parts (*1) 5) Engine coolant temperature sensor (*2) 6) Crankshaft position sensor (*3) 7) Camshaft position sensor (*3) 8) Fuel injection parts (*4)
2. Rough idling	1) Electronic throttle control 2) Manifold absolute pressure sensor 3) Mass air flow and intake air temperature sensor 4) Engine coolant temperature sensor (*2) 5) Ignition parts (*1) 6) Air intake system (*5) 7) Fuel injection parts (*4) 8) Crankshaft position sensor (*3) 9) Camshaft position sensor (*3) 10) Oxygen sensor 11) Fuel pump and fuel pump relay
3. Engine does not return to idle.	1) Electronic throttle control 2) Engine coolant temperature sensor 3) Manifold absolute pressure sensor 4) Mass air flow and intake air temperature sensor 5) Accelerator pedal position sensor
4. Poor acceleration	1) Manifold absolute pressure sensor 2) Mass air flow and intake air temperature sensor 3) Electronic throttle control 4) Fuel injection parts (*4) 5) Fuel pump and fuel pump relay 6) Engine coolant temperature sensor (*2) 7) Crankshaft position sensor (*3) 8) Camshaft position sensor (*3) 9) A/C switch and A/C relay 10) Engine torque control signal circuit 11) Ignition parts (*1) 12) Accelerator pedal position sensor
5. Engine stalls, hesitates, or sputters at acceleration.	1) Manifold absolute pressure sensor 2) Mass air flow and intake air temperature sensor 3) Engine coolant temperature sensor (*2) 4) Crankshaft position sensor (*3) 5) Camshaft position sensor (*3) 6) Purge control solenoid valve 7) Fuel injection parts (*4) 8) Fuel pump and fuel pump relay 9) Electronic throttle control

# General Diagnostic Table

ENGINE (DIAGNOSTICS)

Symptoms	Faulty parts
6. Surging	1) Manifold absolute pressure sensor 2) Mass air flow and intake air temperature sensor 3) Engine coolant temperature sensor (*2) 4) Crankshaft position sensor (*3) 5) Camshaft position sensor (*3) 6) Fuel injection parts (*4) 7) Electronic throttle control 8) Fuel pump and fuel pump relay
7. Spark knock	1) Manifold absolute pressure sensor 2) Mass air flow and intake air temperature sensor 3) Engine coolant temperature sensor 4) Knock sensor 5) Fuel injection parts (*4) 6) Fuel pump and fuel pump relay
8. After burning in exhaust system	1) Manifold absolute pressure sensor 2) Mass air flow and intake air temperature sensor 3) Engine coolant temperature sensor (*2) 4) Fuel injection parts (*4) 5) Fuel pump and fuel pump relay

\*1: Check ignition coil and spark plug.

\*2: Indicate the symptom occurring only in cold temperatures.

\*3: Ensure secure installation.

\*4: Check fuel injector, fuel pressure regulator and fuel filter.

\*5: Inspect for air leak in air intake system.

# General Diagnostic Table

ENGINE (DIAGNOSTICS)

---

**EN(H4DOTC)(diag)-450**

Brought to you by Ebay Seller "SubaruManuals"

# GENERAL DESCRIPTION

# *GD(H4DOTC)*

---

	<b>Page</b>
1. List of Diagnostic Trouble Code (DTC) .....	2
2. Diagnostic Trouble Code (DTC) Detecting Criteria .....	11

# List of Diagnostic Trouble Code (DTC)

## GENERAL DESCRIPTION

### 1. List of Diagnostic Trouble Code (DTC)

#### A: LIST

DTC	Item	Index
P0011	Intake Camshaft Position - Timing Over-Advanced or System Performance (Bank 1)	<Ref. to GD(H4DOTC)-11, DTC P0011 INTAKE CAMSHAFT POSITION - TIMING OVER-ADVANCED OR SYSTEM PERFORMANCE (BANK 1), Diagnostic Trouble Code (DTC) Detecting Criteria.>
P0014	Exhaust AVCS System 1 (Range/Performance)	<Ref. to GD(H4DOTC)-13, DTC P0014 EXHAUST AVCS SYSTEM 1 (RANGE/PERFORMANCE), Diagnostic Trouble Code (DTC) Detecting Criteria.>
P0016	Crankshaft Position - Camshaft Position Correlation (Bank1)	<Ref. to GD(H4DOTC)-15, DTC P0016 CRANKSHAFT POSITION - CAMSHAFT POSITION CORRELATION (BANK1), Diagnostic Trouble Code (DTC) Detecting Criteria.>
P0017	Crank and Cam Timing B System Failure (Bank 1)	<Ref. to GD(H4DOTC)-17, DTC P0017 CRANK AND CAM TIMING B SYSTEM FAILURE (BANK 1), Diagnostic Trouble Code (DTC) Detecting Criteria.>
P0018	Crankshaft Position - Camshaft Position Correlation (Bank2)	<Ref. to GD(H4DOTC)-19, DTC P0018 CRANKSHAFT POSITION - CAMSHAFT POSITION CORRELATION (BANK2), Diagnostic Trouble Code (DTC) Detecting Criteria.>
P0019	Crank and Cam Timing B System Failure (Bank 2)	<Ref. to GD(H4DOTC)-19, DTC P0019 CRANK AND CAM TIMING B SYSTEM FAILURE (BANK 2), Diagnostic Trouble Code (DTC) Detecting Criteria.>
P0021	Intake Camshaft Position - Timing Over-Advanced or System Performance (Bank 2)	<Ref. to GD(H4DOTC)-19, DTC P0021 INTAKE CAMSHAFT POSITION - TIMING OVER-ADVANCED OR SYSTEM PERFORMANCE (BANK 2), Diagnostic Trouble Code (DTC) Detecting Criteria.>
P0024	Exhaust AVCS System 2 (Range/Performance)	<Ref. to GD(H4DOTC)-19, DTC P0024 EXHAUST AVCS SYSTEM 2 (RANGE/PERFORMANCE), Diagnostic Trouble Code (DTC) Detecting Criteria.>
P0030	HO2S Heater Control Circuit (Bank 1 Sensor 1)	<Ref. to GD(H4DOTC)-20, DTC P0030 HO2S HEATER CONTROL CIRCUIT (BANK 1 SENSOR 1), Diagnostic Trouble Code (DTC) Detecting Criteria.>
P0031	HO2S Heater Control Circuit Low (Bank 1 Sensor 1)	<Ref. to GD(H4DOTC)-22, DTC P0031 HO2S HEATER CONTROL CIRCUIT LOW (BANK 1 SENSOR 1), Diagnostic Trouble Code (DTC) Detecting Criteria.>
P0032	HO2S Heater Control Circuit High (Bank 1 Sensor 1)	<Ref. to GD(H4DOTC)-24, DTC P0032 HO2S HEATER CONTROL CIRCUIT HIGH (BANK 1 SENSOR 1), Diagnostic Trouble Code (DTC) Detecting Criteria.>
P0037	HO2S Heater Control Circuit Low (Bank 1 Sensor 2)	<Ref. to GD(H4DOTC)-26, DTC P0037 HO2S HEATER CONTROL CIRCUIT LOW (BANK 1 SENSOR 2), Diagnostic Trouble Code (DTC) Detecting Criteria.>
P0038	HO2S Heater Control Circuit High (Bank 1 Sensor 2)	<Ref. to GD(H4DOTC)-28, DTC P0038 HO2S HEATER CONTROL CIRCUIT HIGH (BANK 1 SENSOR 2), Diagnostic Trouble Code (DTC) Detecting Criteria.>
P0068	MAP/MAF - Throttle Position Correlation	<Ref. to GD(H4DOTC)-30, DTC P0068 MAP/MAF - THROTTLE POSITION CORRELATION, Diagnostic Trouble Code (DTC) Detecting Criteria.>
P0101	Mass or Volume Air Flow Circuit Range/Performance	<Ref. to GD(H4DOTC)-32, DTC P0101 MASS OR VOLUME AIR FLOW CIRCUIT RANGE/PERFORMANCE, Diagnostic Trouble Code (DTC) Detecting Criteria.>
P0102	Mass or Volume Air Flow Circuit Low Input	<Ref. to GD(H4DOTC)-34, DTC P0102 MASS OR VOLUME AIR FLOW CIRCUIT LOW INPUT, Diagnostic Trouble Code (DTC) Detecting Criteria.>
P0103	Mass or Volume Air Flow Circuit High Input	<Ref. to GD(H4DOTC)-36, DTC P0103 MASS OR VOLUME AIR FLOW CIRCUIT HIGH INPUT, Diagnostic Trouble Code (DTC) Detecting Criteria.>
P0107	Manifold Absolute Pressure/Barometric Pressure Circuit Low Input	<Ref. to GD(H4DOTC)-38, DTC P0107 MANIFOLD ABSOLUTE PRESSURE/BAROMETRIC PRESSURE CIRCUIT LOW INPUT, Diagnostic Trouble Code (DTC) Detecting Criteria.>
P0108	Manifold Absolute Pressure/Barometric Pressure Circuit High Input	<Ref. to GD(H4DOTC)-40, DTC P0108 MANIFOLD ABSOLUTE PRESSURE/BAROMETRIC PRESSURE CIRCUIT HIGH INPUT, Diagnostic Trouble Code (DTC) Detecting Criteria.>

**GD(H4DOTC)-2**

Brought to you by Ebay Seller "SubaruManuals"

# List of Diagnostic Trouble Code (DTC)

GENERAL DESCRIPTION

DTC	Item	Index
P0111	Intake Air Temperature Sensor 1 Circuit Range/Performance	<Ref. to GD(H4DOTC)-42, DTC P0111 INTAKE AIR TEMPERATURE SENSOR 1 CIRCUIT RANGE/PERFORMANCE, Diagnostic Trouble Code (DTC) Detecting Criteria.>
P0112	Intake Air Temperature Sensor 1 Circuit Low	<Ref. to GD(H4DOTC)-45, DTC P0112 INTAKE AIR TEMPERATURE SENSOR 1 CIRCUIT LOW, Diagnostic Trouble Code (DTC) Detecting Criteria.>
P0113	Intake Air Temperature Sensor 1 Circuit High	<Ref. to GD(H4DOTC)-47, DTC P0113 INTAKE AIR TEMPERATURE SENSOR 1 CIRCUIT HIGH, Diagnostic Trouble Code (DTC) Detecting Criteria.>
P0117	Engine Coolant Temperature Circuit Low	<Ref. to GD(H4DOTC)-49, DTC P0117 ENGINE COOLANT TEMPERATURE CIRCUIT LOW, Diagnostic Trouble Code (DTC) Detecting Criteria.>
P0118	Engine Coolant Temperature Circuit High	<Ref. to GD(H4DOTC)-51, DTC P0118 ENGINE COOLANT TEMPERATURE CIRCUIT HIGH, Diagnostic Trouble Code (DTC) Detecting Criteria.>
P0122	Throttle/Pedal Position Sensor/Switch "A" Circuit Low	<Ref. to GD(H4DOTC)-53, DTC P0122 THROTTLE/PEDAL POSITION SENSOR/SWITCH "A" CIRCUIT LOW, Diagnostic Trouble Code (DTC) Detecting Criteria.>
P0123	Throttle/Pedal Position Sensor/Switch "A" Circuit High	<Ref. to GD(H4DOTC)-55, DTC P0123 THROTTLE/PEDAL POSITION SENSOR/SWITCH "A" CIRCUIT HIGH, Diagnostic Trouble Code (DTC) Detecting Criteria.>
P0125	Insufficient Coolant Temperature for Closed Loop Fuel Control	<Ref. to GD(H4DOTC)-57, DTC P0125 INSUFFICIENT COOLANT TEMPERATURE FOR CLOSED LOOP FUEL CONTROL, Diagnostic Trouble Code (DTC) Detecting Criteria.>
P0126	Insufficient Engine Coolant Temperature for Stable Operation	<Ref. to GD(H4DOTC)-59, DTC P0126 INSUFFICIENT ENGINE COOLANT TEMPERATURE FOR STABLE OPERATION, Diagnostic Trouble Code (DTC) Detecting Criteria.>
P0128	Coolant Thermostat (Engine Coolant Temperature Below Thermostat Regulating Temperature)	<Ref. to GD(H4DOTC)-61, DTC P0128 COOLANT THERMOSTAT (ENGINE COOLANT TEMPERATURE BELOW THERMOSTAT REGULATING TEMPERATURE), Diagnostic Trouble Code (DTC) Detecting Criteria.>
P0131	O2 Sensor Circuit Low Voltage (Bank 1 Sensor 1)	<Ref. to GD(H4DOTC)-65, DTC P0131 O2 SENSOR CIRCUIT LOW VOLTAGE (BANK 1 SENSOR 1), Diagnostic Trouble Code (DTC) Detecting Criteria.>
P0132	O2 Sensor Circuit High Voltage (Bank 1 Sensor 1)	<Ref. to GD(H4DOTC)-67, DTC P0132 O2 SENSOR CIRCUIT HIGH VOLTAGE (BANK 1 SENSOR 1), Diagnostic Trouble Code (DTC) Detecting Criteria.>
P0133	O2 Sensor Circuit Slow Response (Bank 1 Sensor 1)	<Ref. to GD(H4DOTC)-69, DTC P0133 O2 SENSOR CIRCUIT SLOW RESPONSE (BANK 1 SENSOR 1), Diagnostic Trouble Code (DTC) Detecting Criteria.>
P0134	O2 Sensor Circuit No Activity Detected (Bank 1 Sensor 1)	<Ref. to GD(H4DOTC)-72, DTC P0134 O2 SENSOR CIRCUIT NO ACTIVITY DETECTED (BANK 1 SENSOR 1), Diagnostic Trouble Code (DTC) Detecting Criteria.>
P0137	O2 Sensor Circuit Low Voltage (Bank 1 Sensor 2)	<Ref. to GD(H4DOTC)-74, DTC P0137 O2 SENSOR CIRCUIT LOW VOLTAGE (BANK 1 SENSOR 2), Diagnostic Trouble Code (DTC) Detecting Criteria.>
P0138	O2 Sensor Circuit High Voltage (Bank 1 Sensor 2)	<Ref. to GD(H4DOTC)-76, DTC P0138 O2 SENSOR CIRCUIT HIGH VOLTAGE (BANK 1 SENSOR 2), Diagnostic Trouble Code (DTC) Detecting Criteria.>
P013A	O2 Sensor Slow Response - Rich to Lean (Bank 1 Sensor 2)	<Ref. to GD(H4DOTC)-77, DTC P013A O2 SENSOR SLOW RESPONSE - RICH TO LEAN (BANK 1 SENSOR 2), Diagnostic Trouble Code (DTC) Detecting Criteria.>
P013B	O2 Sensor Slow Response - Lean to Rich (Bank 1 Sensor 2)	<Ref. to GD(H4DOTC)-79, DTC P013B O2 SENSOR SLOW RESPONSE - LEAN TO RICH (BANK 1 SENSOR 2), Diagnostic Trouble Code (DTC) Detecting Criteria.>
P013E	O2 Sensor Delayed Response - Rich to Lean (Bank 1 Sensor 2)	<Ref. to GD(H4DOTC)-81, DTC P013E O2 SENSOR DELAYED RESPONSE - RICH TO LEAN (BANK 1 SENSOR 2), Diagnostic Trouble Code (DTC) Detecting Criteria.>
P013F	O2 Sensor Delayed Response - Lean to Rich (Bank 1 Sensor 2)	<Ref. to GD(H4DOTC)-83, DTC P013F O2 SENSOR DELAYED RESPONSE - LEAN TO RICH (BANK 1 SENSOR 2), Diagnostic Trouble Code (DTC) Detecting Criteria.>

**GD(H4DOTC)-3**

Brought to you by Ebay Seller "SubaruManuals"



## List of Diagnostic Trouble Code (DTC)

### GENERAL DESCRIPTION

DTC	Item	Index
P0140	O2 Sensor Circuit No Activity Detected (Bank1 Sensor2)	<Ref. to GD(H4DOTC)-85, DTC P0140 O2 SENSOR CIRCUIT NO ACTIVITY DETECTED (BANK1 SENSOR2), Diagnostic Trouble Code (DTC) Detecting Criteria.>
P0141	O2 Sensor Heater Circuit (Bank1 Sensor2)	<Ref. to GD(H4DOTC)-87, DTC P0141 O2 SENSOR HEATER CIRCUIT (BANK1 SENSOR2), Diagnostic Trouble Code (DTC) Detecting Criteria.>
P0171	System Too Lean (Bank 1)	<Ref. to GD(H4DOTC)-89, DTC P0171 SYSTEM TOO LEAN (BANK 1), Diagnostic Trouble Code (DTC) Detecting Criteria.>
P0172	System Too Rich (Bank 1)	<Ref. to GD(H4DOTC)-91, DTC P0172 SYSTEM TOO RICH (BANK 1), Diagnostic Trouble Code (DTC) Detecting Criteria.>
P0201	Injector #1	<Ref. to GD(H4DOTC)-93, DTC P0201 INJECTOR #1, Diagnostic Trouble Code (DTC) Detecting Criteria.>
P0202	Injector #2	<Ref. to GD(H4DOTC)-94, DTC P0202 INJECTOR #2, Diagnostic Trouble Code (DTC) Detecting Criteria.>
P0203	Injector #3	<Ref. to GD(H4DOTC)-94, DTC P0203 INJECTOR #3, Diagnostic Trouble Code (DTC) Detecting Criteria.>
P0204	Injector #4	<Ref. to GD(H4DOTC)-94, DTC P0204 INJECTOR #4, Diagnostic Trouble Code (DTC) Detecting Criteria.>
P0222	Throttle/Pedal Position Sensor/Switch "B" Circuit Low	<Ref. to GD(H4DOTC)-95, DTC P0222 THROTTLE/PEDAL POSITION SENSOR/SWITCH "B" CIRCUIT LOW, Diagnostic Trouble Code (DTC) Detecting Criteria.>
P0223	Throttle/Pedal Position Sensor/Switch "B" Circuit High	<Ref. to GD(H4DOTC)-97, DTC P0223 THROTTLE/PEDAL POSITION SENSOR/SWITCH "B" CIRCUIT HIGH, Diagnostic Trouble Code (DTC) Detecting Criteria.>
P0230	Fuel Pump Primary Circuit	<Ref. to GD(H4DOTC)-99, DTC P0230 FUEL PUMP PRIMARY CIRCUIT, Diagnostic Trouble Code (DTC) Detecting Criteria.>
P0244	Turbo/Super Charger Wastegate Solenoid "A" Range/Performance	<Ref. to GD(H4DOTC)-101, DTC P0244 TURBO/SUPER CHARGER WASTEGATE SOLENOID "A" RANGE/PERFORMANCE, Diagnostic Trouble Code (DTC) Detecting Criteria.>
P0245	Turbo/Super Charger Wastegate Solenoid "A" Low	<Ref. to GD(H4DOTC)-103, DTC P0245 TURBO/SUPER CHARGER WASTEGATE SOLENOID "A" LOW, Diagnostic Trouble Code (DTC) Detecting Criteria.>
P0246	Turbo/Super Charger Wastegate Solenoid "A" High	<Ref. to GD(H4DOTC)-105, DTC P0246 TURBO/SUPER CHARGER WASTEGATE SOLENOID "A" HIGH, Diagnostic Trouble Code (DTC) Detecting Criteria.>
P0301	Cylinder 1 Misfire Detected	<Ref. to GD(H4DOTC)-107, DTC P0301 CYLINDER 1 MISFIRE DETECTED, Diagnostic Trouble Code (DTC) Detecting Criteria.>
P0302	Cylinder 2 Misfire Detected	<Ref. to GD(H4DOTC)-116, DTC P0302 CYLINDER 2 MISFIRE DETECTED, Diagnostic Trouble Code (DTC) Detecting Criteria.>
P0303	Cylinder 3 Misfire Detected	<Ref. to GD(H4DOTC)-116, DTC P0303 CYLINDER 3 MISFIRE DETECTED, Diagnostic Trouble Code (DTC) Detecting Criteria.>
P0304	Cylinder 4 Misfire Detected	<Ref. to GD(H4DOTC)-116, DTC P0304 CYLINDER 4 MISFIRE DETECTED, Diagnostic Trouble Code (DTC) Detecting Criteria.>
P0327	Knock Sensor 1 Circuit Low (Bank 1 or Single Sensor)	<Ref. to GD(H4DOTC)-117, DTC P0327 KNOCK SENSOR 1 CIRCUIT LOW (BANK 1 OR SINGLE SENSOR), Diagnostic Trouble Code (DTC) Detecting Criteria.>
P0328	Knock Sensor 1 Circuit High (Bank 1 or Single Sensor)	<Ref. to GD(H4DOTC)-119, DTC P0328 KNOCK SENSOR 1 CIRCUIT HIGH (BANK 1 OR SINGLE SENSOR), Diagnostic Trouble Code (DTC) Detecting Criteria.>
P0335	Crankshaft Position Sensor "A" Circuit	<Ref. to GD(H4DOTC)-121, DTC P0335 CRANKSHAFT POSITION SENSOR "A" CIRCUIT, Diagnostic Trouble Code (DTC) Detecting Criteria.>
P0336	Crankshaft Position Sensor "A" Circuit Range/Performance	<Ref. to GD(H4DOTC)-123, DTC P0336 CRANKSHAFT POSITION SENSOR "A" CIRCUIT RANGE/PERFORMANCE, Diagnostic Trouble Code (DTC) Detecting Criteria.>
P0340	Camshaft Position Sensor "A" Circuit (Bank 1 or Single Sensor)	<Ref. to GD(H4DOTC)-125, DTC P0340 CAMSHAFT POSITION SENSOR "A" CIRCUIT (BANK 1 OR SINGLE SENSOR), Diagnostic Trouble Code (DTC) Detecting Criteria.>

**GD(H4DOTC)-4**

Brought to you by Ebay Seller "SubaruManuals"

# List of Diagnostic Trouble Code (DTC)

GENERAL DESCRIPTION

DTC	Item	Index
P0345	Camshaft Position Sensor "A" Circuit (Bank 2)	<Ref. to GD(H4DOTC)-126, DTC P0345 CAMSHAFT POSITION SENSOR "A" CIRCUIT (BANK 2), Diagnostic Trouble Code (DTC) Detecting Criteria.>
P0351	Ignition Coil A Primary/Secondary Circuit	<Ref. to GD(H4DOTC)-127, DTC P0351 IGNITION COIL A PRIMARY/SECONDARY CIRCUIT, Diagnostic Trouble Code (DTC) Detecting Criteria.>
P0352	Ignition Coil B Primary/Secondary Circuit	<Ref. to GD(H4DOTC)-128, DTC P0352 IGNITION COIL B PRIMARY/SECONDARY CIRCUIT, Diagnostic Trouble Code (DTC) Detecting Criteria.>
P0353	Ignition Coil C Primary/Secondary Circuit	<Ref. to GD(H4DOTC)-128, DTC P0353 IGNITION COIL C PRIMARY/SECONDARY CIRCUIT, Diagnostic Trouble Code (DTC) Detecting Criteria.>
P0354	Ignition Coil D Primary/Secondary Circuit	<Ref. to GD(H4DOTC)-128, DTC P0354 IGNITION COIL D PRIMARY/SECONDARY CIRCUIT, Diagnostic Trouble Code (DTC) Detecting Criteria.>
P0365	Camshaft Position Sensor "B" Circuit (Bank 1)	<Ref. to GD(H4DOTC)-129, DTC P0365 CAMSHAFT POSITION SENSOR "B" CIRCUIT (BANK 1), Diagnostic Trouble Code (DTC) Detecting Criteria.>
P0390	Camshaft Position Sensor "B" Circuit (Bank 2)	<Ref. to GD(H4DOTC)-129, DTC P0390 CAMSHAFT POSITION SENSOR "B" CIRCUIT (BANK 2), Diagnostic Trouble Code (DTC) Detecting Criteria.>
P0410	Secondary Air Injection System	<Ref. to GD(H4DOTC)-130, DTC P0410 SECONDARY AIR INJECTION SYSTEM, Diagnostic Trouble Code (DTC) Detecting Criteria.>
P0411	Secondary Air Injection System Incorrect Flow Detected	<Ref. to GD(H4DOTC)-137, DTC P0411 SECONDARY AIR INJECTION SYSTEM INCORRECT FLOW DETECTED, Diagnostic Trouble Code (DTC) Detecting Criteria.>
P0413	Secondary Air Injection System Switching Valve "A" Circuit Open	<Ref. to GD(H4DOTC)-138, DTC P0413 SECONDARY AIR INJECTION SYSTEM SWITCHING VALVE "A" CIRCUIT OPEN, Diagnostic Trouble Code (DTC) Detecting Criteria.>
P0414	Secondary Air Injection System Switching Valve "A" Circuit Shorted	<Ref. to GD(H4DOTC)-139, DTC P0414 SECONDARY AIR INJECTION SYSTEM SWITCHING VALVE "A" CIRCUIT SHORTED, Diagnostic Trouble Code (DTC) Detecting Criteria.>
P0416	Secondary Air Injection System Switching Valve "B" Circuit Open	<Ref. to GD(H4DOTC)-140, DTC P0416 SECONDARY AIR INJECTION SYSTEM SWITCHING VALVE "B" CIRCUIT OPEN, Diagnostic Trouble Code (DTC) Detecting Criteria.>
P0417	Secondary Air Injection System Switching Valve "B" Circuit Shorted	<Ref. to GD(H4DOTC)-140, DTC P0417 SECONDARY AIR INJECTION SYSTEM SWITCHING VALVE "B" CIRCUIT SHORTED, Diagnostic Trouble Code (DTC) Detecting Criteria.>
P0418	Secondary Air Injection System Control "A" Circuit Open	<Ref. to GD(H4DOTC)-141, DTC P0418 SECONDARY AIR INJECTION SYSTEM CONTROL "A" CIRCUIT OPEN, Diagnostic Trouble Code (DTC) Detecting Criteria.>
P0420	Catalyst System Efficiency Below Threshold (Bank 1)	<Ref. to GD(H4DOTC)-142, DTC P0420 CATALYST SYSTEM EFFICIENCY BELOW THRESHOLD (BANK 1), Diagnostic Trouble Code (DTC) Detecting Criteria.>
P0441	Evaporative Emission Cont. Sys. Incorrect Purge Flow	<Ref. to GD(H4DOTC)-145, DTC P0441 EVAPORATIVE EMISSION CONT. SYS. INCORRECT PURGE FLOW, Diagnostic Trouble Code (DTC) Detecting Criteria.>
P0451	Evaporative Emission System Pressure Sensor/Switch Range/Performance	<Ref. to GD(H4DOTC)-148, DTC P0451 EVAPORATIVE EMISSION SYSTEM PRESSURE SENSOR/SWITCH RANGE/PERFORMANCE, Diagnostic Trouble Code (DTC) Detecting Criteria.>
P0452	Evaporative Emission System Pressure Sensor/Switch Low	<Ref. to GD(H4DOTC)-150, DTC P0452 EVAPORATIVE EMISSION SYSTEM PRESSURE SENSOR/SWITCH LOW, Diagnostic Trouble Code (DTC) Detecting Criteria.>
P0453	Evaporative Emission System Pressure Sensor/Switch High	<Ref. to GD(H4DOTC)-152, DTC P0453 EVAPORATIVE EMISSION SYSTEM PRESSURE SENSOR/SWITCH HIGH, Diagnostic Trouble Code (DTC) Detecting Criteria.>
P0455	Evaporative Emission System Leak Detected (Large Leak)	<Ref. to GD(H4DOTC)-154, DTC P0455 EVAPORATIVE EMISSION SYSTEM LEAK DETECTED (LARGE LEAK), Diagnostic Trouble Code (DTC) Detecting Criteria.>
P0456	Evaporative Emission Control System Leak Detected (Very Small Leak)	<Ref. to GD(H4DOTC)-161, DTC P0456 EVAPORATIVE EMISSION CONTROL SYSTEM LEAK DETECTED (VERY SMALL LEAK), Diagnostic Trouble Code (DTC) Detecting Criteria.>

**GD(H4DOTC)-5**

Brought to you by Ebay Seller "SubaruManuals"

## List of Diagnostic Trouble Code (DTC)

### GENERAL DESCRIPTION

DTC	Item	Index
P0458	Evaporative Emission System Purge Control Valve Circuit Low	<Ref. to GD(H4DOTC)-162, DTC P0458 EVAPORATIVE EMISSION SYSTEM PURGE CONTROL VALVE CIRCUIT LOW, Diagnostic Trouble Code (DTC) Detecting Criteria.>
P0459	Evaporative Emission System Purge Control Valve Circuit High	<Ref. to GD(H4DOTC)-164, DTC P0459 EVAPORATIVE EMISSION SYSTEM PURGE CONTROL VALVE CIRCUIT HIGH, Diagnostic Trouble Code (DTC) Detecting Criteria.>
P0461	Fuel Level Sensor "A" Circuit Range/Performance	<Ref. to GD(H4DOTC)-166, DTC P0461 FUEL LEVEL SENSOR "A" CIRCUIT RANGE/PERFORMANCE, Diagnostic Trouble Code (DTC) Detecting Criteria.>
P0462	Fuel Level Sensor "A" Circuit Low	<Ref. to GD(H4DOTC)-168, DTC P0462 FUEL LEVEL SENSOR "A" CIRCUIT LOW, Diagnostic Trouble Code (DTC) Detecting Criteria.>
P0463	Fuel Level Sensor "A" Circuit High	<Ref. to GD(H4DOTC)-170, DTC P0463 FUEL LEVEL SENSOR "A" CIRCUIT HIGH, Diagnostic Trouble Code (DTC) Detecting Criteria.>
P0500	Vehicle Speed Sensor "A"	<Ref. to GD(H4DOTC)-172, DTC P0500 VEHICLE SPEED SENSOR "A", Diagnostic Trouble Code (DTC) Detecting Criteria.>
P0506	Idle Air Control System RPM Lower Than Expected	<Ref. to GD(H4DOTC)-173, DTC P0506 IDLE AIR CONTROL SYSTEM RPM LOWER THAN EXPECTED, Diagnostic Trouble Code (DTC) Detecting Criteria.>
P0507	Idle Air Control System RPM Higher Than Expected	<Ref. to GD(H4DOTC)-174, DTC P0507 IDLE AIR CONTROL SYSTEM RPM HIGHER THAN EXPECTED, Diagnostic Trouble Code (DTC) Detecting Criteria.>
P050A	Cold Start Idle Air Control System Performance	<Ref. to GD(H4DOTC)-175, DTC P050A COLD START IDLE AIR CONTROL SYSTEM PERFORMANCE, Diagnostic Trouble Code (DTC) Detecting Criteria.>
P050B	Cold Start Ignition Timing Performance	<Ref. to GD(H4DOTC)-179, DTC P050B COLD START IGNITION TIMING PERFORMANCE, Diagnostic Trouble Code (DTC) Detecting Criteria.>
P0512	Starter Request Circuit	<Ref. to GD(H4DOTC)-180, DTC P0512 STARTER REQUEST CIRCUIT, Diagnostic Trouble Code (DTC) Detecting Criteria.>
P0513	Incorrect Immobilizer Key	<Ref. to GD(H4DOTC)-181, DTC P0513 INCORRECT IMMOBILIZER KEY, Diagnostic Trouble Code (DTC) Detecting Criteria.>
P0604	Internal Control Module Random Access Memory (RAM) Error	<Ref. to GD(H4DOTC)-182, DTC P0604 INTERNAL CONTROL MODULE RANDOM ACCESS MEMORY (RAM) ERROR, Diagnostic Trouble Code (DTC) Detecting Criteria.>
P0605	Internal Control Module Read Only Memory (ROM) Error	<Ref. to GD(H4DOTC)-183, DTC P0605 INTERNAL CONTROL MODULE READ ONLY MEMORY (ROM) ERROR, Diagnostic Trouble Code (DTC) Detecting Criteria.>
P0607	Throttle Control System Circuit Range/Performance	<Ref. to GD(H4DOTC)-184, DTC P0607 THROTTLE CONTROL SYSTEM CIRCUIT RANGE/PERFORMANCE, Diagnostic Trouble Code (DTC) Detecting Criteria.>
P0638	Throttle Actuator Control Range/Performance (Bank 1)	<Ref. to GD(H4DOTC)-186, DTC P0638 THROTTLE ACTUATOR CONTROL RANGE/PERFORMANCE (BANK 1), Diagnostic Trouble Code (DTC) Detecting Criteria.>
P0851	Neutral Switch Input Circuit Low (MT Model)	<Ref. to GD(H4DOTC)-189, DTC P0851 NEUTRAL SWITCH INPUT CIRCUIT LOW (MT MODEL), Diagnostic Trouble Code (DTC) Detecting Criteria.>
P0852	Neutral Switch Input Circuit High (MT Model)	<Ref. to GD(H4DOTC)-190, DTC P0852 NEUTRAL SWITCH INPUT CIRCUIT HIGH (MT MODEL), Diagnostic Trouble Code (DTC) Detecting Criteria.>
P1152	O2 Sensor Circuit Range/Performance (Low) (Bank1 Sensor1)	<Ref. to GD(H4DOTC)-191, DTC P1152 O2 SENSOR CIRCUIT RANGE/PERFORMANCE (LOW) (BANK1 SENSOR1), Diagnostic Trouble Code (DTC) Detecting Criteria.>
P1153	O2 Sensor Circuit Range/Performance (High) (Bank1 Sensor1)	<Ref. to GD(H4DOTC)-193, DTC P1153 O2 SENSOR CIRCUIT RANGE/PERFORMANCE (HIGH) (BANK1 SENSOR1), Diagnostic Trouble Code (DTC) Detecting Criteria.>
P1160	Return Spring Failure	<Ref. to GD(H4DOTC)-195, DTC P1160 RETURN SPRING FAILURE, Diagnostic Trouble Code (DTC) Detecting Criteria.>

**GD(H4DOTC)-6**

Brought to you by Ebay Seller "SubaruManuals"

# List of Diagnostic Trouble Code (DTC)

GENERAL DESCRIPTION

DTC	Item	Index
P1400	Fuel Tank Pressure Control Solenoid Valve Circuit Low	<Ref. to GD(H4DOTC)-197, DTC P1400 FUEL TANK PRESSURE CONTROL SOLENOID VALVE CIRCUIT LOW, Diagnostic Trouble Code (DTC) Detecting Criteria.>
P1410	Secondary Air Injection System Switching Valve Stuck Open	<Ref. to GD(H4DOTC)-199, DTC P1410 SECONDARY AIR INJECTION SYSTEM SWITCHING VALVE STUCK OPEN, Diagnostic Trouble Code (DTC) Detecting Criteria.>
P1418	Secondary Air Injection System Control "A" Circuit Shorted	<Ref. to GD(H4DOTC)-201, DTC P1418 SECONDARY AIR INJECTION SYSTEM CONTROL "A" CIRCUIT SHORTED, Diagnostic Trouble Code (DTC) Detecting Criteria.>
P1420	Fuel Tank Pressure Control Sol. Valve Circuit High	<Ref. to GD(H4DOTC)-202, DTC P1420 FUEL TANK PRESSURE CONTROL SOL. VALVE CIRCUIT HIGH, Diagnostic Trouble Code (DTC) Detecting Criteria.>
P1449	Evaporative Emission Cont. Sys. Air Filter Clog	<Ref. to GD(H4DOTC)-204, DTC P1449 EVAPORATIVE EMISSION CONT. SYS. AIR FILTER CLOG, Diagnostic Trouble Code (DTC) Detecting Criteria.>
P1451	Evaporative Emission Cont. Sys.	<Ref. to GD(H4DOTC)-206, DTC P1451 EVAPORATIVE EMISSION CONT. SYS., Diagnostic Trouble Code (DTC) Detecting Criteria.>
P1458	Canister Purge Control Solenoid Valve 2	<Ref. to GD(H4DOTC)-207, DTC P1458 CANISTER PURGE CONTROL SOLENOID VALVE 2, Diagnostic Trouble Code (DTC) Detecting Criteria.>
P1459	Canister Purge Control Solenoid Valve 2	<Ref. to GD(H4DOTC)-208, DTC P1459 CANISTER PURGE CONTROL SOLENOID VALVE 2, Diagnostic Trouble Code (DTC) Detecting Criteria.>
P1491	Positive Crankcase Ventilation (Blow-By) Function Problem	<Ref. to GD(H4DOTC)-209, DTC P1491 POSITIVE CRANKCASE VENTILATION (BLOW-BY) FUNCTION PROBLEM, Diagnostic Trouble Code (DTC) Detecting Criteria.>
P1518	Starter Switch Circuit Low Input	<Ref. to GD(H4DOTC)-211, DTC P1518 STARTER SWITCH CIRCUIT LOW INPUT, Diagnostic Trouble Code (DTC) Detecting Criteria.>
P1560	Back-Up Voltage Circuit Malfunction	<Ref. to GD(H4DOTC)-212, DTC P1560 BACK-UP VOLTAGE CIRCUIT MALFUNCTION, Diagnostic Trouble Code (DTC) Detecting Criteria.>
P1570	Antenna	<Ref. to GD(H4DOTC)-213, DTC P1570 ANTENNA, Diagnostic Trouble Code (DTC) Detecting Criteria.>
P1571	Reference Code Incompatibility	<Ref. to GD(H4DOTC)-213, DTC P1571 REFERENCE CODE INCOMPATIBILITY, Diagnostic Trouble Code (DTC) Detecting Criteria.>
P1572	IMM Circuit Failure (Except Antenna Circuit)	<Ref. to GD(H4DOTC)-213, DTC P1572 IMM CIRCUIT FAILURE (EXCEPT ANTENNA CIRCUIT), Diagnostic Trouble Code (DTC) Detecting Criteria.>
P1574	Key Communication Failure	<Ref. to GD(H4DOTC)-213, DTC P1574 KEY COMMUNICATION FAILURE, Diagnostic Trouble Code (DTC) Detecting Criteria.>
P1576	EGI Control Module EEPROM	<Ref. to GD(H4DOTC)-213, DTC P1576 EGI CONTROL MODULE EEPROM, Diagnostic Trouble Code (DTC) Detecting Criteria.>
P1577	IMM Control Module EEPROM	<Ref. to GD(H4DOTC)-213, DTC P1577 IMM CONTROL MODULE EEPROM, Diagnostic Trouble Code (DTC) Detecting Criteria.>
P1578	Meter Failure	<Ref. to GD(H4DOTC)-213, DTC P1578 METER FAILURE, Diagnostic Trouble Code (DTC) Detecting Criteria.>
P2004	Intake Manifold Runner Control Stuck Open (Bank 1)	<Ref. to GD(H4DOTC)-214, DTC P2004 INTAKE MANIFOLD RUNNER CONTROL STUCK OPEN (BANK 1), Diagnostic Trouble Code (DTC) Detecting Criteria.>
P2005	Intake Manifold Runner Control Stuck Open (Bank 2)	<Ref. to GD(H4DOTC)-215, DTC P2005 INTAKE MANIFOLD RUNNER CONTROL STUCK OPEN (BANK 2), Diagnostic Trouble Code (DTC) Detecting Criteria.>
P2006	Intake Manifold Runner Control Stuck Closed (Bank 1)	<Ref. to GD(H4DOTC)-216, DTC P2006 INTAKE MANIFOLD RUNNER CONTROL STUCK CLOSED (BANK 1), Diagnostic Trouble Code (DTC) Detecting Criteria.>
P2007	Intake Manifold Runner Control Stuck Closed (Bank 2)	<Ref. to GD(H4DOTC)-217, DTC P2007 INTAKE MANIFOLD RUNNER CONTROL STUCK CLOSED (BANK 2), Diagnostic Trouble Code (DTC) Detecting Criteria.>

**GD(H4DOTC)-7**

Brought to you by Ebay Seller "SubaruManuals"

## List of Diagnostic Trouble Code (DTC)

### GENERAL DESCRIPTION

DTC	Item	Index
P2008	Intake Manifold Runner Control Circuit / Open (Bank 1)	<Ref. to GD(H4DOTC)-218, DTC P2008 INTAKE MANIFOLD RUNNER CONTROL CIRCUIT / OPEN (BANK 1), Diagnostic Trouble Code (DTC) Detecting Criteria.>
P2009	Intake Manifold Runner Control Circuit Low (Bank 1)	<Ref. to GD(H4DOTC)-220, DTC P2009 INTAKE MANIFOLD RUNNER CONTROL CIRCUIT LOW (BANK 1), Diagnostic Trouble Code (DTC) Detecting Criteria.>
P2011	Intake Manifold Runner Control Circuit / Open (Bank 2)	<Ref. to GD(H4DOTC)-221, DTC P2011 INTAKE MANIFOLD RUNNER CONTROL CIRCUIT / OPEN (BANK 2), Diagnostic Trouble Code (DTC) Detecting Criteria.>
P2012	Intake Manifold Runner Control Circuit Low (Bank 2)	<Ref. to GD(H4DOTC)-223, DTC P2012 INTAKE MANIFOLD RUNNER CONTROL CIRCUIT LOW (BANK 2), Diagnostic Trouble Code (DTC) Detecting Criteria.>
P2016	Intake Manifold Runner Position Sensor / Switch Circuit Low (Bank 1)	<Ref. to GD(H4DOTC)-224, DTC P2016 INTAKE MANIFOLD RUNNER POSITION SENSOR / SWITCH CIRCUIT LOW (BANK 1), Diagnostic Trouble Code (DTC) Detecting Criteria.>
P2017	Intake Manifold Runner Position Sensor / Switch Circuit High (Bank 1)	<Ref. to GD(H4DOTC)-226, DTC P2017 INTAKE MANIFOLD RUNNER POSITION SENSOR / SWITCH CIRCUIT HIGH (BANK 1), Diagnostic Trouble Code (DTC) Detecting Criteria.>
P2021	Intake Manifold Runner Position Sensor / Switch Circuit Low (Bank 2)	<Ref. to GD(H4DOTC)-228, DTC P2021 INTAKE MANIFOLD RUNNER POSITION SENSOR / SWITCH CIRCUIT LOW (BANK 2), Diagnostic Trouble Code (DTC) Detecting Criteria.>
P2022	Intake Manifold Runner Position Sensor / Switch Circuit High (Bank 2)	<Ref. to GD(H4DOTC)-230, DTC P2022 INTAKE MANIFOLD RUNNER POSITION SENSOR / SWITCH CIRCUIT HIGH (BANK 2), Diagnostic Trouble Code (DTC) Detecting Criteria.>
P2088	Intake Camshaft Position Actuator Control Circuit Low (Bank 1)	<Ref. to GD(H4DOTC)-232, DTC P2088 INTAKE CAMSHAFT POSITION ACTUATOR CONTROL CIRCUIT LOW (BANK 1), Diagnostic Trouble Code (DTC) Detecting Criteria.>
P2089	Intake Camshaft Position Actuator Control Circuit High (Bank 1)	<Ref. to GD(H4DOTC)-233, DTC P2089 INTAKE CAMSHAFT POSITION ACTUATOR CONTROL CIRCUIT HIGH (BANK 1), Diagnostic Trouble Code (DTC) Detecting Criteria.>
P2090	Exhaust Camshaft Position Actuator Control Circuit Low (Bank 1)	<Ref. to GD(H4DOTC)-234, DTC P2090 EXHAUST CAMSHAFT POSITION ACTUATOR CONTROL CIRCUIT LOW (BANK 1), Diagnostic Trouble Code (DTC) Detecting Criteria.>
P2091	Exhaust Camshaft Position Actuator Control Circuit High (Bank 1)	<Ref. to GD(H4DOTC)-235, DTC P2091 EXHAUST CAMSHAFT POSITION ACTUATOR CONTROL CIRCUIT HIGH (BANK 1), Diagnostic Trouble Code (DTC) Detecting Criteria.>
P2092	Intake Camshaft Position Actuator Control Circuit Low (Bank 2)	<Ref. to GD(H4DOTC)-236, DTC P2092 INTAKE CAMSHAFT POSITION ACTUATOR CONTROL CIRCUIT LOW (BANK 2), Diagnostic Trouble Code (DTC) Detecting Criteria.>
P2093	Intake Camshaft Position Actuator Control Circuit High (Bank 2)	<Ref. to GD(H4DOTC)-236, DTC P2093 INTAKE CAMSHAFT POSITION ACTUATOR CONTROL CIRCUIT HIGH (BANK 2), Diagnostic Trouble Code (DTC) Detecting Criteria.>
P2094	Exhaust Camshaft Position Actuator Control Circuit Low (Bank 2)	<Ref. to GD(H4DOTC)-236, DTC P2094 EXHAUST CAMSHAFT POSITION ACTUATOR CONTROL CIRCUIT LOW (BANK 2), Diagnostic Trouble Code (DTC) Detecting Criteria.>
P2095	Exhaust Camshaft Position Actuator Control Circuit High (Bank 2)	<Ref. to GD(H4DOTC)-236, DTC P2095 EXHAUST CAMSHAFT POSITION ACTUATOR CONTROL CIRCUIT HIGH (BANK 2), Diagnostic Trouble Code (DTC) Detecting Criteria.>
P2096	Post Catalyst Fuel Trim System Too Lean (Bank 1)	<Ref. to GD(H4DOTC)-237, DTC P2096 POST CATALYST FUEL TRIM SYSTEM TOO LEAN (BANK 1), Diagnostic Trouble Code (DTC) Detecting Criteria.>
P2097	Post Catalyst Fuel Trim System Too Rich (Bank 1)	<Ref. to GD(H4DOTC)-239, DTC P2097 POST CATALYST FUEL TRIM SYSTEM TOO RICH (BANK 1), Diagnostic Trouble Code (DTC) Detecting Criteria.>
P2101	Throttle Actuator Control Motor Circuit Range/Performance	<Ref. to GD(H4DOTC)-241, DTC P2101 THROTTLE ACTUATOR CONTROL MOTOR CIRCUIT RANGE/PERFORMANCE, Diagnostic Trouble Code (DTC) Detecting Criteria.>

**GD(H4DOTC)-8**

Brought to you by Ebay Seller "SubaruManuals"

# List of Diagnostic Trouble Code (DTC)

GENERAL DESCRIPTION

DTC	Item	Index
P2102	Throttle Actuator Control Motor Circuit Low	<Ref. to GD(H4DOTC)-243, DTC P2102 THROTTLE ACTUATOR CONTROL MOTOR CIRCUIT LOW, Diagnostic Trouble Code (DTC) Detecting Criteria.>
P2103	Throttle Actuator Control Motor Circuit High	<Ref. to GD(H4DOTC)-245, DTC P2103 THROTTLE ACTUATOR CONTROL MOTOR CIRCUIT HIGH, Diagnostic Trouble Code (DTC) Detecting Criteria.>
P2109	Throttle/Pedal Position Sensor "A" Minimum Stop Performance	<Ref. to GD(H4DOTC)-247, DTC P2109 THROTTLE/PEDAL POSITION SENSOR "A" MINIMUM STOP PERFORMANCE, Diagnostic Trouble Code (DTC) Detecting Criteria.>
P2122	Throttle/Pedal Position Sensor/Switch "D" Circuit Low Input	<Ref. to GD(H4DOTC)-249, DTC P2122 THROTTLE/PEDAL POSITION SENSOR/SWITCH "D" CIRCUIT LOW INPUT, Diagnostic Trouble Code (DTC) Detecting Criteria.>
P2123	Throttle/Pedal Position Sensor/Switch "D" Circuit High Input	<Ref. to GD(H4DOTC)-251, DTC P2123 THROTTLE/PEDAL POSITION SENSOR/SWITCH "D" CIRCUIT HIGH INPUT, Diagnostic Trouble Code (DTC) Detecting Criteria.>
P2127	Throttle/Pedal Position Sensor/Switch "E" Circuit Low Input	<Ref. to GD(H4DOTC)-253, DTC P2127 THROTTLE/PEDAL POSITION SENSOR/SWITCH "E" CIRCUIT LOW INPUT, Diagnostic Trouble Code (DTC) Detecting Criteria.>
P2128	Throttle/Pedal Position Sensor/Switch "E" Circuit High Input	<Ref. to GD(H4DOTC)-255, DTC P2128 THROTTLE/PEDAL POSITION SENSOR/SWITCH "E" CIRCUIT HIGH INPUT, Diagnostic Trouble Code (DTC) Detecting Criteria.>
P2135	Throttle/Pedal Position Sensor/Switch "A"/"B" Voltage Correlation	<Ref. to GD(H4DOTC)-257, DTC P2135 THROTTLE/PEDAL POSITION SENSOR/SWITCH "A"/"B" VOLTAGE CORRELATION, Diagnostic Trouble Code (DTC) Detecting Criteria.>
P2138	Throttle/Pedal Position Sensor/Switch "D"/"E" Voltage Correlation	<Ref. to GD(H4DOTC)-259, DTC P2138 THROTTLE/PEDAL POSITION SENSOR/SWITCH "D"/"E" VOLTAGE CORRELATION, Diagnostic Trouble Code (DTC) Detecting Criteria.>
P219A	Bank 1 Air-Fuel Ratio Imbalance	<Ref. to GD(H4DOTC)-261, DTC P219A BANK 1 AIR-FUEL RATIO IMBALANCE, Diagnostic Trouble Code (DTC) Detecting Criteria.>
P2401	Evaporative Emission System Leak Detection Pump Control Circuit Low	<Ref. to GD(H4DOTC)-264, DTC P2401 EVAPORATIVE EMISSION SYSTEM LEAK DETECTION PUMP CONTROL CIRCUIT LOW, Diagnostic Trouble Code (DTC) Detecting Criteria.>
P2402	Evaporative Emission System Leak Detection Pump Control Circuit High	<Ref. to GD(H4DOTC)-266, DTC P2402 EVAPORATIVE EMISSION SYSTEM LEAK DETECTION PUMP CONTROL CIRCUIT HIGH, Diagnostic Trouble Code (DTC) Detecting Criteria.>
P2404	Evaporative Emission System Leak Detection Pump Sense Circuit Range/Performance	<Ref. to GD(H4DOTC)-267, DTC P2404 EVAPORATIVE EMISSION SYSTEM LEAK DETECTION PUMP SENSE CIRCUIT RANGE/PERFORMANCE, Diagnostic Trouble Code (DTC) Detecting Criteria.>
P2419	Evaporative Emission System Switching Valve Control Circuit Low	<Ref. to GD(H4DOTC)-268, DTC P2419 EVAPORATIVE EMISSION SYSTEM SWITCHING VALVE CONTROL CIRCUIT LOW, Diagnostic Trouble Code (DTC) Detecting Criteria.>
P2420	Evaporative Emission System Switching Valve Control Circuit High	<Ref. to GD(H4DOTC)-270, DTC P2420 EVAPORATIVE EMISSION SYSTEM SWITCHING VALVE CONTROL CIRCUIT HIGH, Diagnostic Trouble Code (DTC) Detecting Criteria.>
P2431	Secondary Air Injection System Air Flow /Pressure Sensor Circuit Range/Performance	<Ref. to GD(H4DOTC)-272, DTC P2431 SECONDARY AIR INJECTION SYSTEM AIR FLOW /PRESSURE SENSOR CIRCUIT RANGE/PERFORMANCE, Diagnostic Trouble Code (DTC) Detecting Criteria.>
P2432	Secondary Air Injection System Air Flow /Pressure Sensor Circuit Low	<Ref. to GD(H4DOTC)-273, DTC P2432 SECONDARY AIR INJECTION SYSTEM AIR FLOW /PRESSURE SENSOR CIRCUIT LOW, Diagnostic Trouble Code (DTC) Detecting Criteria.>
P2433	Secondary Air Injection System Air Flow /Pressure Sensor Circuit High	<Ref. to GD(H4DOTC)-274, DTC P2433 SECONDARY AIR INJECTION SYSTEM AIR FLOW /PRESSURE SENSOR CIRCUIT HIGH, Diagnostic Trouble Code (DTC) Detecting Criteria.>
P2440	Secondary Air Injection System Switching Valve Stuck Open (Bank1)	<Ref. to GD(H4DOTC)-275, DTC P2440 SECONDARY AIR INJECTION SYSTEM SWITCHING VALVE STUCK OPEN (BANK1), Diagnostic Trouble Code (DTC) Detecting Criteria.>

**GD(H4DOTC)-9**

Brought to you by Ebay Seller "SubaruManuals"

## List of Diagnostic Trouble Code (DTC)

### GENERAL DESCRIPTION

DTC	Item	Index
P2441	Secondary Air Injection System Switching Valve Stuck Closed (Bank1)	<Ref. to GD(H4DOTC)-275, DTC P2441 SECONDARY AIR INJECTION SYSTEM SWITCHING VALVE STUCK CLOSED (BANK1), Diagnostic Trouble Code (DTC) Detecting Criteria.>
P2442	Secondary Air Injection System Switching Valve Stuck Open (Bank2)	<Ref. to GD(H4DOTC)-275, DTC P2442 SECONDARY AIR INJECTION SYSTEM SWITCHING VALVE STUCK OPEN (BANK2), Diagnostic Trouble Code (DTC) Detecting Criteria.>
P2443	Secondary Air Injection System Switching Valve Stuck Closed (Bank2)	<Ref. to GD(H4DOTC)-275, DTC P2443 SECONDARY AIR INJECTION SYSTEM SWITCHING VALVE STUCK CLOSED (BANK2), Diagnostic Trouble Code (DTC) Detecting Criteria.>
P2444	Secondary Air Injection System Pump Stuck On	<Ref. to GD(H4DOTC)-276, DTC P2444 SECONDARY AIR INJECTION SYSTEM PUMP STUCK ON, Diagnostic Trouble Code (DTC) Detecting Criteria.>
P2610	ECM/PCM Internal Engine Off Timer Performance	<Ref. to GD(H4DOTC)-277, DTC P2610 ECM/PCM INTERNAL ENGINE OFF TIMER PERFORMANCE, Diagnostic Trouble Code (DTC) Detecting Criteria.>
U0073	CAN Failure, Bus 'Off' Detection	<Ref. to GD(H4DOTC)-285, DTC U0073 CAN FAILURE, BUS 'OFF' DETECTION, Diagnostic Trouble Code (DTC) Detecting Criteria.>
U0122	CAN (VDC) Data Not Loaded	<Ref. to GD(H4DOTC)-286, DTC U0122 CAN (VDC) DATA NOT LOADED, Diagnostic Trouble Code (DTC) Detecting Criteria.>
U0140	CAN (BCU) Data Not Loaded	<Ref. to GD(H4DOTC)-286, DTC U0140 CAN (BCU) DATA NOT LOADED, Diagnostic Trouble Code (DTC) Detecting Criteria.>
U0416	CAN (VDC) Data Abnormal	<Ref. to GD(H4DOTC)-287, DTC U0416 CAN (VDC) DATA ABNORMAL, Diagnostic Trouble Code (DTC) Detecting Criteria.>
U0422	CAN (BCU) Data Abnormal	<Ref. to GD(H4DOTC)-287, DTC U0422 CAN (BCU) DATA ABNORMAL, Diagnostic Trouble Code (DTC) Detecting Criteria.>

## 2. Diagnostic Trouble Code (DTC) Detecting Criteria

### A: DTC P0011 INTAKE CAMSHAFT POSITION - TIMING OVER-ADVANCED OR SYSTEM PERFORMANCE (BANK 1)

#### 1. OUTLINE OF DIAGNOSIS

Detect the AVCS system malfunction.

Judge NG when the amount of AVCS actual timing advance does not approach to the amount of AVCS target timing advance.

#### 2. COMPONENT DESCRIPTION

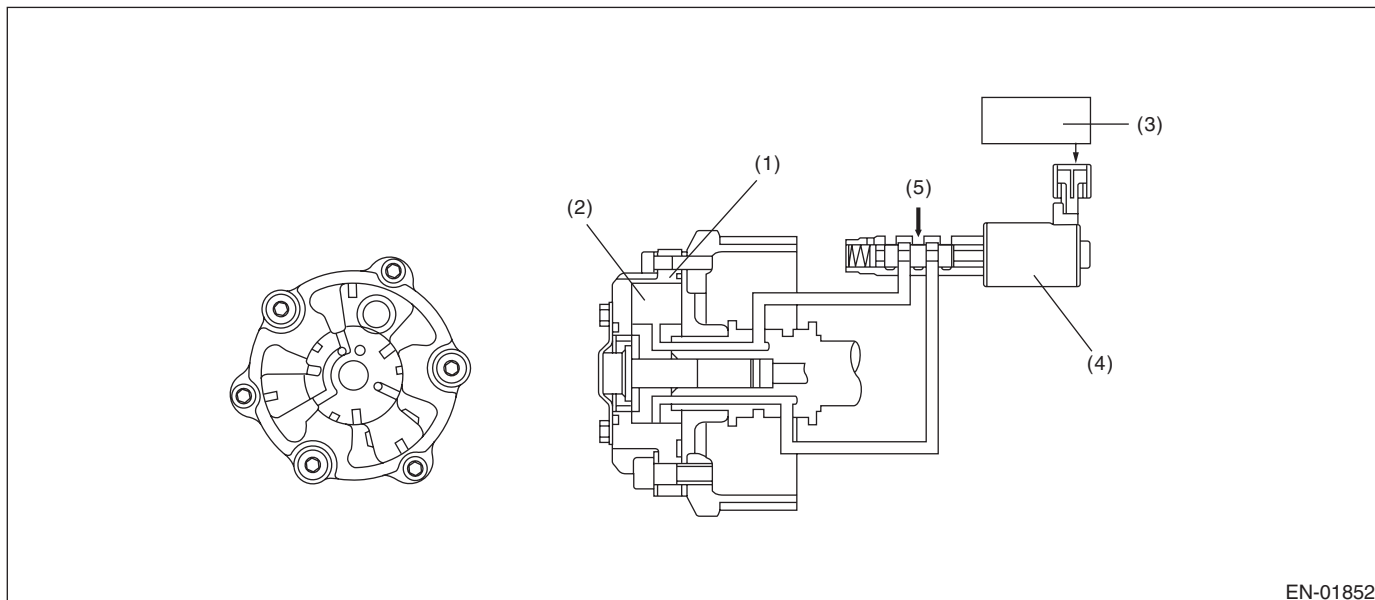

EN-01852

- |                            |                                     |                  |
|----------------------------|-------------------------------------|------------------|
| (1) AVCS timing controller | (3) Engine control module (ECM)     | (5) Oil pressure |
| (2) Vane                   | (4) Oil flow control solenoid valve |                  |

#### 3. ENABLE CONDITIONS

Secondary Parameters	Enable Conditions
Time of establishing all secondary parameter conditions	≥ 3000 ms
Battery voltage	≥ 10.9 V
Engine speed	≥ 1300 rpm (models without SI-DRIVE) ≥ 1500 rpm (models with SI-DRIVE)
Engine coolant temperature	≥ 60 °C (140 °F)
AVCS control	Operation
Target timing advance change amount (per 64 ms)	< 1.07 °CA

#### 4. GENERAL DRIVING CYCLE

Perform the diagnosis continuously after warming up when the engine speed increases and AVCS operates.



# Diagnostic Trouble Code (DTC) Detecting Criteria

## GENERAL DESCRIPTION

### 5. DIAGNOSTIC METHOD

- 1) When the conditions during which the differences of AVCS target timing advance amount and AVCS actual timing advance amount is large continues for certain amount of time.
- 2) When the differences of target timing advance amount and actual timing advance amount is calculated during AVCS control, and the difference per predetermined time is the specified value or larger.

#### • Abnormality Judgment

Judge as NG when the following conditions are established within the predetermined time.

#### Judgment Value

##### Models without SI-DRIVE

Malfuction Criteria	Threshold Value
$\Sigma(\text{Target position} - \text{Actual position})$	> 5300 °CA (Bank 1) > 5300 °CA (Bank 2)
or	
$\Sigma(\text{Target position} - \text{Actual position})$	< -5300 °CA (Bank 1) < -5300 °CA (Bank 2)

**Time Needed for Diagnosis:** 20000 ms

##### Models with SI-DRIVE

Malfuction Criteria	Threshold Value
$\Sigma(\text{Target position} - \text{Actual position})$	> 8000 °CA (Bank 1) > 8000 °CA (Bank 2)
or	
$\Sigma(\text{Target position} - \text{Actual position})$	< -8000 °CA (Bank 1) < -8000 °CA (Bank 2)

**Time Needed for Diagnosis:** 30000 ms

**Malfuction Indicator Light Illumination:** Illuminates when malfuction occurs in 2 continuous driving cycles.

#### • Normality Judgment

Judge as OK and clear the NG if the following conditions are established within the predetermined time.

#### Judgment Value

##### Models without SI-DRIVE

Malfuction Criteria	Threshold Value
$\Sigma(\text{Target position} - \text{Actual position})$	$\leq 5300$ °CA (Bank 1) $\leq 5300$ °CA (Bank 2) and $\geq -5300$ °CA (Bank 1) $\geq -5300$ °CA (Bank 2)

**Time Needed for Diagnosis:** 20000 ms

##### Models with SI-DRIVE

Malfuction Criteria	Threshold Value
$\Sigma(\text{Target position} - \text{Actual position})$	$\leq 8000$ °CA (Bank 1) $\leq 8000$ °CA (Bank 2) and $\geq -8000$ °CA (Bank 1) $\geq -8000$ °CA (Bank 2)

**Time Needed for Diagnosis:** 30000 ms

## B: DTC P0014 EXHAUST AVCS SYSTEM 1 (RANGE/PERFORMANCE)

### 1. OUTLINE OF DIAGNOSIS

Detect the exhaust AVCS system malfunction.

Judge NG when the amount of exhaust AVCS actual timing advance does not approach the amount of exhaust AVCS target timing advance.

### 2. COMPONENT DESCRIPTION

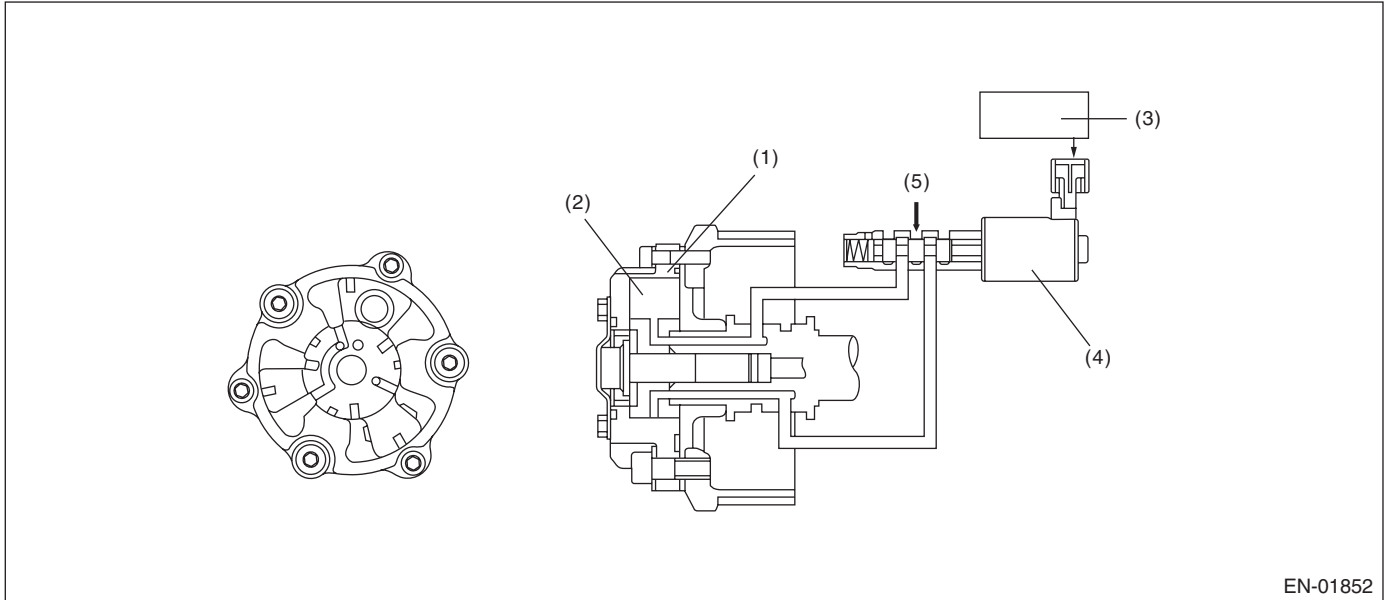

EN-01852

- |                                    |                                     |                  |
|------------------------------------|-------------------------------------|------------------|
| (1) Exhaust AVCS timing controller | (3) Engine control module (ECM)     | (5) Oil pressure |
| (2) Vane                           | (4) Oil flow control solenoid valve |                  |

### 3. ENABLE CONDITIONS

Secondary Parameters	Enable Conditions
Time of establishing all secondary parameter conditions	≥ 3000 ms
Battery voltage	≥ 10.9 V
Engine speed	≥ 1500 rpm
Engine coolant temperature	≥ 60 °C (140 °F)
Exhaust AVCS control	Operation
Target timing advance change amount (per 64 ms)	< 1.07 °CA

### 4. GENERAL DRIVING CYCLE

Perform the diagnosis continuously after warming up when the engine speed increases and exhaust AVCS operates.

# Diagnostic Trouble Code (DTC) Detecting Criteria

## GENERAL DESCRIPTION

---

### 5. DIAGNOSTIC METHOD

- 1) When the conditions during which the differences of exhaust AVCS target timing advance amount and exhaust AVCS actual timing advance amount is large continues for certain amount of time.
- 2) When the differences of target timing advance amount and actual timing advance amount is calculated during exhaust AVCS control, and the difference per predetermined time is the specified value or larger.

#### • Abnormality Judgment

Judge as NG when the following conditions are established within the predetermined time.

#### Judgment Value

Malfunction Criteria	Threshold Value
$\Sigma(\text{Target position} - \text{Actual position})$	> 8000 °CA (Bank 1) > 8000 °CA (Bank 2)
or	
$\Sigma(\text{Target position} - \text{Actual position})$	< -8000 °CA (Bank 1) < -8000 °CA (Bank 2)

#### Time Needed for Diagnosis:

30000 ms

**Malfunction Indicator Light Illumination:** Illuminates when malfunction occurs in 2 continuous driving cycles.

#### • Normality Judgment

Judge as OK and clear the NG if the following conditions are established within the predetermined time.

#### Judgment Value

Malfunction Criteria	Threshold Value
$\Sigma(\text{Target position} - \text{Actual position})$	$\leq 8000$ °CA (Bank 1) $\leq 8000$ °CA (Bank 2) and $\geq -8000$ °CA (Bank 1) $\geq -8000$ °CA (Bank 2)

**Time Needed for Diagnosis:** 30000 ms

# Diagnostic Trouble Code (DTC) Detecting Criteria

GENERAL DESCRIPTION

## C: DTC P0016 CRANKSHAFT POSITION - CAMSHAFT POSITION CORRELATION (BANK1)

### 1. OUTLINE OF DIAGNOSIS

Detect the AVCS system malfunction.

Judge as NG when standard timing advance amount is far from learning angle.

### 2. COMPONENT DESCRIPTION

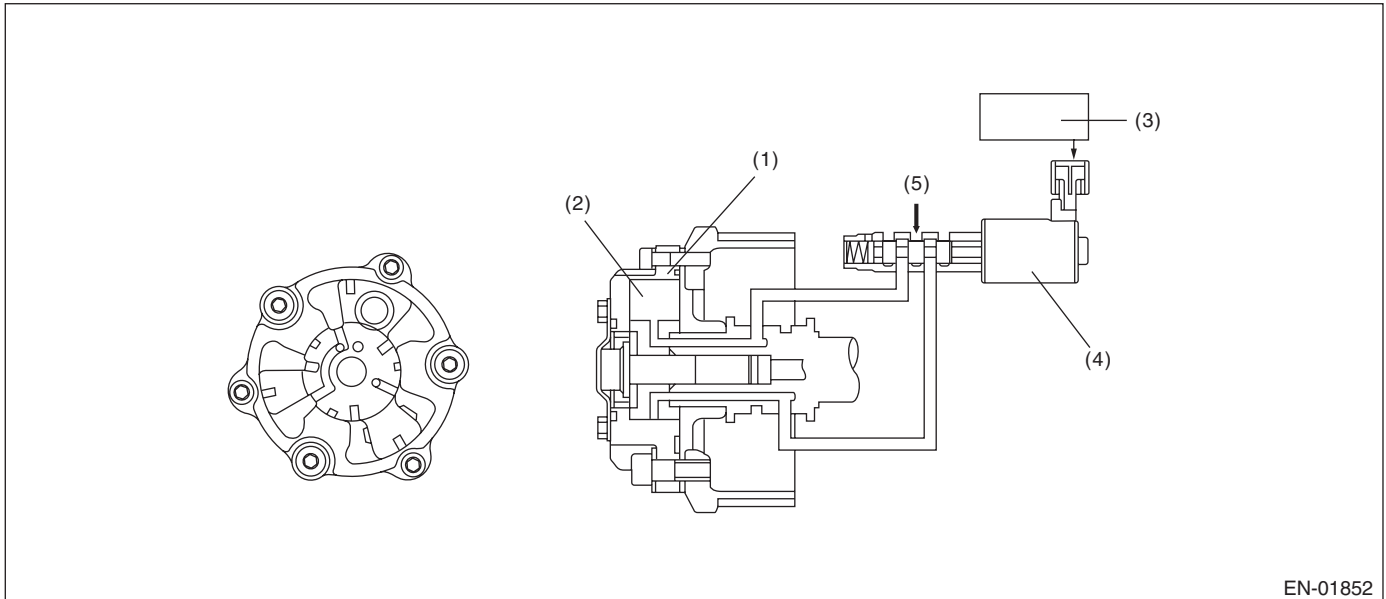

EN-01852

(1) AVCS timing controller

(3) Engine control module (ECM)

(5) Oil pressure

(2) Vane

(4) Oil flow control solenoid valve

### 3. ENABLE CONDITIONS

Secondary Parameters	Enable Conditions
Battery voltage	$\geq 10.9$ V
Engine speed (models without SI-DRIVE)	$\geq 600$ rpm and $< 1000$ rpm
Engine speed (models with SI-DRIVE)	$\geq 600$ rpm and $< 975$ rpm
Engine coolant temperature	$\geq 70$ °C (158 °F)
AVCS control	Not in operation
Target timing advance	0°CA

### 4. GENERAL DRIVING CYCLE

Perform the diagnosis continuously after starting engine and while AVCS is not operating.

# Diagnostic Trouble Code (DTC) Detecting Criteria

## GENERAL DESCRIPTION

---

### 5. DIAGNOSTIC METHOD

Judge as NG when the absolute value of the difference between cam signal input position and learning value is out of specification.

#### • Abnormality Judgment

If the duration of time while the following conditions are met is longer than the time indicated, judge as NG.

#### Judgment Value

Malfunction Criteria	Threshold Value
Crankshaft position when camshaft position sensor signal is input – Learning value	> 8.5 °CA

**Time Needed for Diagnosis:** 20000 ms

**Malfunction Indicator Light Illumination:** Illuminates when malfunction occurs in 2 continuous driving cycles.

#### NOTE:

Initial standard learning value is the value of crank angle initially input at the production plant. And then it will be updated every time normal judgment has been completed. Learning value will not be updated if NG judgment occurs because timing belt or chain derails suddenly in process or because wrong assembly occurs during servicing.

#### • Normality Judgment

Judge as OK and clear the NG if the continuous time while the following conditions are established is more than the predetermined time.

#### Judgment Value

Malfunction Criteria	Threshold Value
Crankshaft position when camshaft position sensor signal is input – Learning value	≤ 8.5 °CA

**Time Needed for Diagnosis:** Less than 1 second

## D: DTC P0017 CRANK AND CAM TIMING B SYSTEM FAILURE (BANK 1)

### 1. OUTLINE OF DIAGNOSIS

Detect the exhaust AVCS system malfunction.

Judge as NG when standard timing advance amount is far from learning angle.

### 2. COMPONENT DESCRIPTION

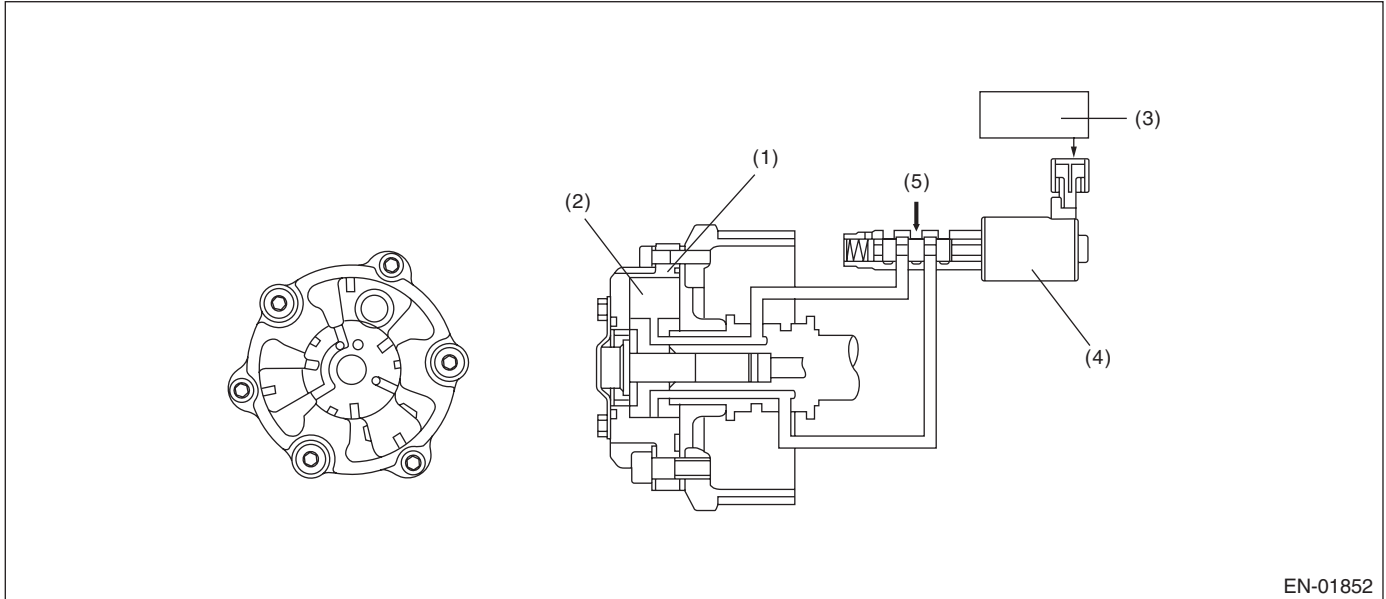

EN-01852

- |                                    |                                     |                  |
|------------------------------------|-------------------------------------|------------------|
| (1) Exhaust AVCS timing controller | (3) Engine control module (ECM)     | (5) Oil pressure |
| (2) Vane                           | (4) Oil flow control solenoid valve |                  |

### 3. ENABLE CONDITIONS

Secondary Parameters	Enable Conditions
Battery voltage	≥ 10.9 V
Engine speed	≥ 600 rpm and < 975 rpm
Engine coolant temperature	≥ 70 °C (158 °F)
Exhaust AVCS control	Not in operation
Target timing advance	0°CA

### 4. GENERAL DRIVING CYCLE

Perform the diagnosis continuously while the exhaust AVCS is not operating after warming up.

# Diagnostic Trouble Code (DTC) Detecting Criteria

## GENERAL DESCRIPTION

---

### 5. DIAGNOSTIC METHOD

Judge as NG when the absolute value of the difference between cam signal input position and learning value is out of specification.

#### • Abnormality Judgment

If the duration of time while the following conditions are met is longer than the time indicated, judge as NG.

#### Judgment Value

Malfunction Criteria	Threshold Value
Crankshaft position when camshaft position sensor signal is input – Learning value	> 8.5 °CA

**Time Needed for Diagnosis:** 20000 ms

**Malfunction Indicator Light Illumination:** Illuminates when malfunction occurs in 2 continuous driving cycles.

#### NOTE:

Initial standard learning value is the value of crank angle initially input at the production plant. And then it will be updated every time normal judgment has been completed. Learning value will not be updated if NG judgment occurs because timing belt or chain derails suddenly in process or because wrong assembly occurs during servicing.

#### • Normality Judgment

Judge as OK and clear the NG if the continuous time while the following conditions are established is more than the predetermined time.

#### Judgment Value

Malfunction Criteria	Threshold Value
Crankshaft position when camshaft position sensor signal is input – Learning value	≤ 8.5 °CA

**Time Needed for Diagnosis:** Less than 1 second

# Diagnostic Trouble Code (DTC) Detecting Criteria

GENERAL DESCRIPTION

## **E: DTC P0018 CRANKSHAFT POSITION - CAMSHAFT POSITION CORRELATION (BANK2)**

### **1. OUTLINE OF DIAGNOSIS**

#### **NOTE:**

For the detection standard, refer to DTC P0016. <Ref. to GD(H4DOTC)-15, DTC P0016 CRANKSHAFT POSITION - CAMSHAFT POSITION CORRELATION (BANK1), Diagnostic Trouble Code (DTC) Detecting Criteria.>

## **F: DTC P0019 CRANK AND CAM TIMING B SYSTEM FAILURE (BANK 2)**

### **1. OUTLINE OF DIAGNOSIS**

#### **NOTE:**

For the detection standard, refer to DTC P0017. <Ref. to GD(H4DOTC)-17, DTC P0017 CRANK AND CAM TIMING B SYSTEM FAILURE (BANK 1), Diagnostic Trouble Code (DTC) Detecting Criteria.>

## **G: DTC P0021 INTAKE CAMSHAFT POSITION - TIMING OVER-ADVANCED OR SYSTEM PERFORMANCE (BANK 2)**

### **1. OUTLINE OF DIAGNOSIS**

#### **NOTE:**

For the detection standard, refer to DTC P0011. <Ref. to GD(H4DOTC)-11, DTC P0011 INTAKE CAMSHAFT POSITION - TIMING OVER-ADVANCED OR SYSTEM PERFORMANCE (BANK 1), Diagnostic Trouble Code (DTC) Detecting Criteria.>

## **H: DTC P0024 EXHAUST AVCS SYSTEM 2 (RANGE/PERFORMANCE)**

### **1. OUTLINE OF DIAGNOSIS**

#### **NOTE:**

For the detection standard, refer to DTC P0014. <Ref. to GD(H4DOTC)-13, DTC P0014 EXHAUST AVCS SYSTEM 1 (RANGE/PERFORMANCE), Diagnostic Trouble Code (DTC) Detecting Criteria.>



# Diagnostic Trouble Code (DTC) Detecting Criteria

## GENERAL DESCRIPTION

### I: DTC P0030 HO2S HEATER CONTROL CIRCUIT (BANK 1 SENSOR 1)

#### 1. OUTLINE OF DIAGNOSIS

Detect functional errors of the front oxygen (A/F) sensor heater.

Judge as NG when it is determined that the front oxygen (A/F) sensor impedance is large when looking at engine status such as deceleration fuel cut.

#### 2. COMPONENT DESCRIPTION

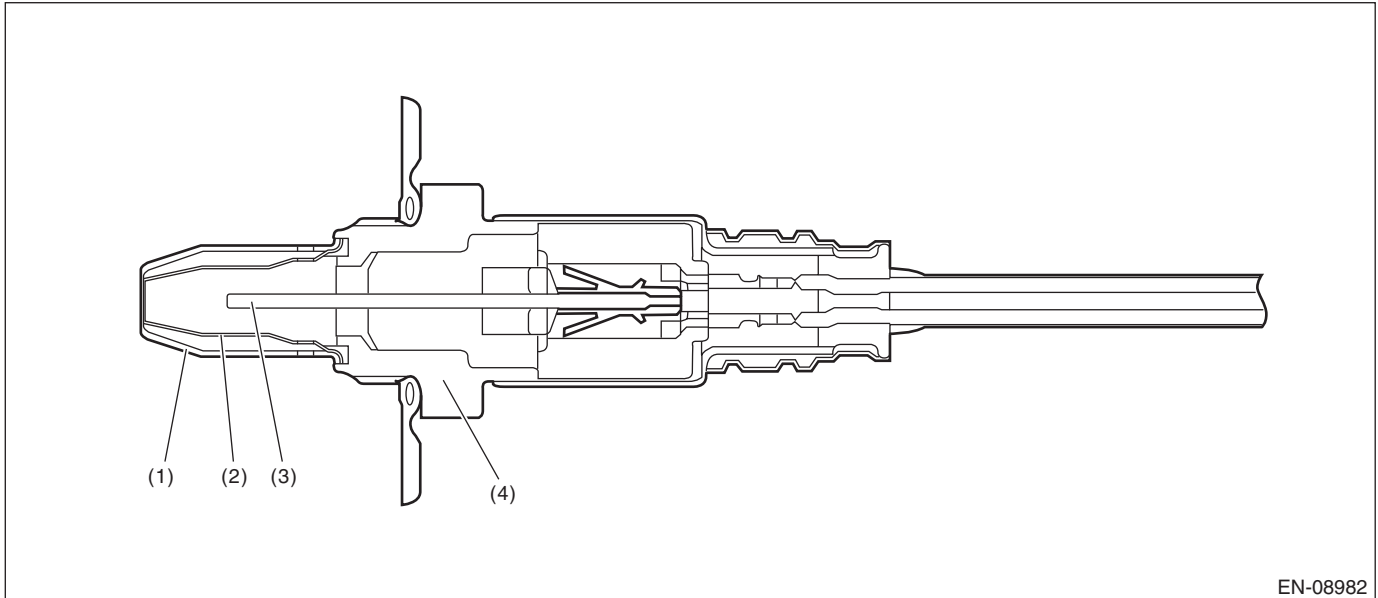

EN-08982

(1) Element cover (outer)

(3) Sensor element

(4) Sensor housing

(2) Element cover (inner)

#### 3. ENABLE CONDITIONS

Secondary Parameters	Enable Conditions
Condition established time	$\geq 42000$ ms
Battery voltage	$\geq 10.9$ V
Heater current	Permitted
A/F sensor heater final control	Main energization status
After fuel cut	$\geq 20000$ ms

#### 4. GENERAL DRIVING CYCLE

Perform the diagnosis continuously after 42000 ms or more have passed since the engine started.

# Diagnostic Trouble Code (DTC) Detecting Criteria

GENERAL DESCRIPTION

## 5. DIAGNOSTIC METHOD

### • Abnormality Judgment

If the duration of time while the following conditions are met is longer than the time indicated, judge as NG.

#### Judgment Value

Malfunction Criteria	Threshold Value
Front oxygen (A/F) sensor impedance	> 50 $\Omega$

**Time Needed for Diagnosis:** 10000 ms

**Malfunction Indicator Light Illumination:** Illuminates when malfunction occurs in 2 continuous driving cycles.

### • Normality Judgment

Judge as OK and clear the NG if the continuous time while the following conditions are established is more than the predetermined time.

#### Judgment Value

Malfunction Criteria	Threshold Value
Front oxygen (A/F) sensor impedance	$\leq$ 50 $\Omega$

**Time Needed for Diagnosis:** 10000 ms

# Diagnostic Trouble Code (DTC) Detecting Criteria

## GENERAL DESCRIPTION

### J: DTC P0031 HO2S HEATER CONTROL CIRCUIT LOW (BANK 1 SENSOR 1)

#### 1. OUTLINE OF DIAGNOSIS

Detect front oxygen (A/F) sensor heater open or short circuit.

The front oxygen (A/F) sensor heater performs duty control, and the output terminal voltage at ON is 0 V, and the output terminal voltage at OFF is the battery voltage.

Judge as NG when the terminal voltage remains Low.

#### 2. COMPONENT DESCRIPTION

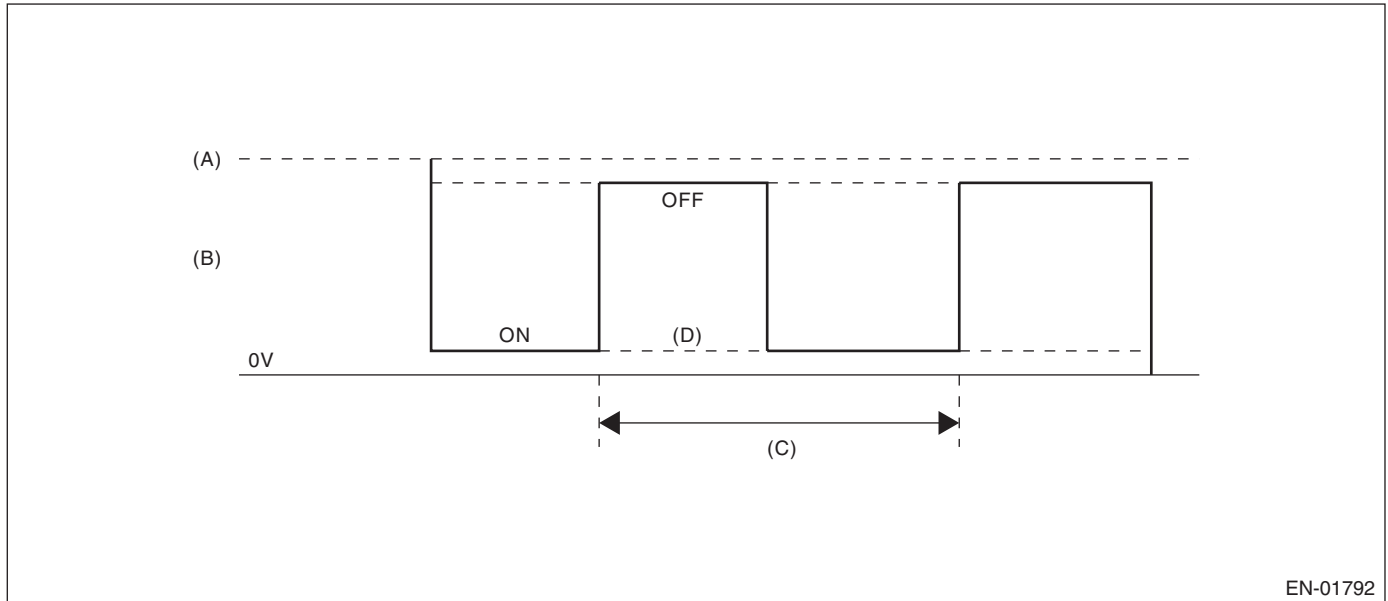

(A) Battery voltage

(B) Front oxygen (A/F) sensor heater  
output voltage

(C) 128 ms

(D) Low error

#### 3. ENABLE CONDITIONS

Secondary Parameters	Enable Conditions
Battery voltage	$\geq 10.9 \text{ V}$

#### 4. GENERAL DRIVING CYCLE

Always perform the diagnosis continuously.

# Diagnostic Trouble Code (DTC) Detecting Criteria

GENERAL DESCRIPTION

## 5. DIAGNOSTIC METHOD

### • Abnormality Judgment

If the duration of time while the following conditions are met is longer than the time indicated, judge as NG.

#### Judgment Value

Malfunction Criteria	Threshold Value
Output voltage level	Low
Front oxygen (A/F) sensor heater control duty	< 87.5 %

**Time Needed for Diagnosis:** 4 ms × 250 time(s)

**Malfunction Indicator Light Illumination:** Illuminates as soon as a malfunction occurs.

### • Normality Judgment

Judge as OK and clear the NG if the continuous time while the following conditions are established is more than the predetermined time.

#### Judgment Value

Malfunction Criteria	Threshold Value
Output voltage level	High

**Time Needed for Diagnosis:** Less than 1 second

# Diagnostic Trouble Code (DTC) Detecting Criteria

## GENERAL DESCRIPTION

### K: DTC P0032 HO2S HEATER CONTROL CIRCUIT HIGH (BANK 1 SENSOR 1)

#### 1. OUTLINE OF DIAGNOSIS

Detect front oxygen (A/F) sensor heater open or short circuit.

The front oxygen (A/F) sensor heater performs duty control, and the output terminal voltage at ON is 0 V, and the output terminal voltage at OFF is the battery voltage.

Judge as NG when the terminal voltage remains High.

#### 2. COMPONENT DESCRIPTION

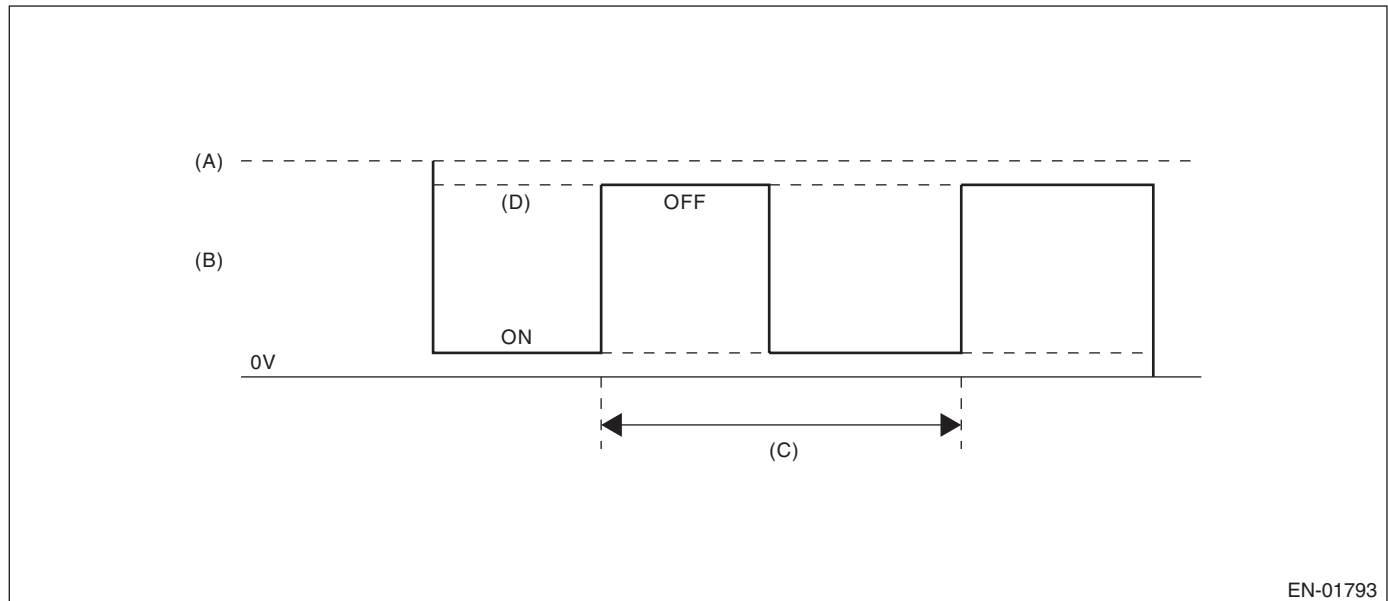

EN-01793

(A) Battery voltage

(B) Front oxygen (A/F) sensor heater  
output voltage

(C) 128 ms

(D) High error

#### 3. ENABLE CONDITIONS

Secondary Parameters	Enable Conditions
Battery voltage	$\geq 10.9$ V

#### 4. GENERAL DRIVING CYCLE

Always perform the diagnosis continuously.

# Diagnostic Trouble Code (DTC) Detecting Criteria

GENERAL DESCRIPTION

## 5. DIAGNOSTIC METHOD

### • Abnormality Judgment

If the duration of time while the following conditions are met is longer than the time indicated, judge as NG.

#### Judgment Value

Malfunction Criteria	Threshold Value
Output voltage level	High
Front oxygen (A/F) sensor heater control duty	≥ 12.5 %

**Time Needed for Diagnosis:** 4 ms × 500 time(s)

**Malfunction Indicator Light Illumination:** Illuminates as soon as a malfunction occurs.

### • Normality Judgment

Judge as OK and clear the NG if the continuous time while the following conditions are established is more than the predetermined time.

#### Judgment Value

Malfunction Criteria	Threshold Value
Output voltage level	Low

**Time Needed for Diagnosis:** Less than 1 second

# Diagnostic Trouble Code (DTC) Detecting Criteria

## GENERAL DESCRIPTION

### L: DTC P0037 HO2S HEATER CONTROL CIRCUIT LOW (BANK 1 SENSOR 2)

#### 1. OUTLINE OF DIAGNOSIS

Detect the rear oxygen sensor heater open or short circuit.

The rear oxygen sensor heater performs duty control, and the output terminal voltage at ON is 0 V, and the output terminal voltage at OFF is the battery voltage.

Judge as NG when the terminal voltage remains Low.

#### 2. COMPONENT DESCRIPTION

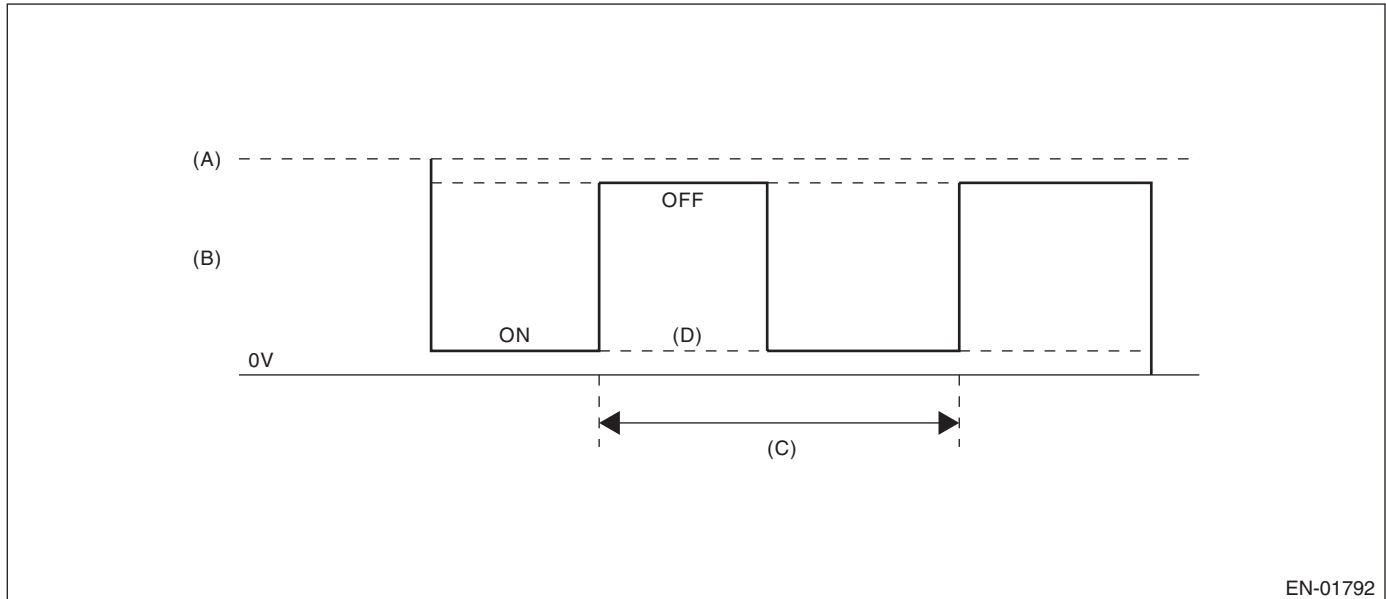

(A) Battery voltage

(B) Output voltage of the rear oxygen sensor heater

(C) 256 ms (cycles)

(D) Low error

#### 3. ENABLE CONDITIONS

Secondary Parameters	Enable Conditions
Battery voltage	$\geq 10.9 \text{ V}$
Elapsed time after engine starting	$\geq 1 \text{ second}$
Engine speed	$< 8000 \text{ rpm}$

#### 4. GENERAL DRIVING CYCLE

After starting the engine, perform the diagnosis continuously when engine is low speed.

# Diagnostic Trouble Code (DTC) Detecting Criteria

GENERAL DESCRIPTION

## 5. DIAGNOSTIC METHOD

### • Abnormality Judgment

If the duration of time while the following conditions are met is longer than the time indicated, judge as NG.

#### Judgment Value

Malfunction Criteria	Threshold Value
Output voltage level	Low
Rear oxygen sensor heater control duty	< 75 %

**Time Needed for Diagnosis:** 8 ms × 1250 time(s)

**Malfunction Indicator Light Illumination:** Illuminates when malfunction occurs in 2 continuous driving cycles.

### • Normality Judgment

Judge as OK and clear the NG if the continuous time while the following conditions are established is more than the predetermined time.

#### Judgment Value

Malfunction Criteria	Threshold Value
Output voltage level	High

**Time Needed for Diagnosis:** Less than 1 second



# Diagnostic Trouble Code (DTC) Detecting Criteria

## GENERAL DESCRIPTION

### M: DTC P0038 HO2S HEATER CONTROL CIRCUIT HIGH (BANK 1 SENSOR 2)

#### 1. OUTLINE OF DIAGNOSIS

Detect the rear oxygen sensor heater open or short circuit.

The rear oxygen sensor heater performs duty control, and the output terminal voltage at ON is 0 V, and the output terminal voltage at OFF is the battery voltage.

Judge as NG when the terminal voltage remains High.

#### 2. COMPONENT DESCRIPTION

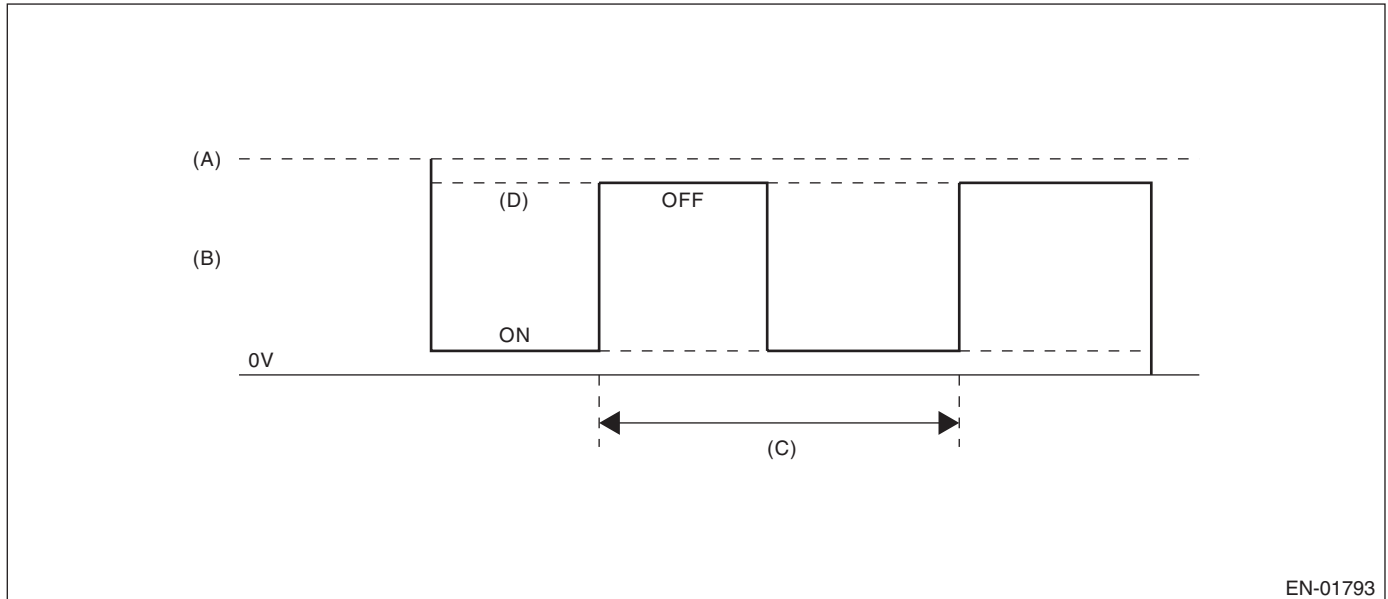

EN-01793

(A) Battery voltage

(B) Output voltage of the rear oxygen sensor heater

(C) 256 ms (cycles)

(D) High error

#### 3. ENABLE CONDITIONS

Secondary Parameters	Enable Conditions
Battery voltage	$\geq 10.9$ V
Elapsed time after engine starting	$\geq 1$ second
Engine speed	$< 8000$ rpm

#### 4. GENERAL DRIVING CYCLE

After starting the engine, perform the diagnosis continuously when engine is low speed.

# Diagnostic Trouble Code (DTC) Detecting Criteria

GENERAL DESCRIPTION

## 5. DIAGNOSTIC METHOD

### • Abnormality Judgment

If the duration of time while the following conditions are met is longer than the time indicated, judge as NG.

#### Judgment Value

Malfunction Criteria	Threshold Value
Output voltage level	High
Rear oxygen sensor heater control duty	≥ 25 %

**Time Needed for Diagnosis:** 8 ms × 320 time(s)

**Malfunction Indicator Light Illumination:** Illuminates when malfunction occurs in 2 continuous driving cycles.

### • Normality Judgment

Judge as OK and clear the NG if the continuous time while the following conditions are established is more than the predetermined time.

#### Judgment Value

Malfunction Criteria	Threshold Value
Output voltage level	Low

**Time Needed for Diagnosis:** Less than 1 second

# Diagnostic Trouble Code (DTC) Detecting Criteria

## GENERAL DESCRIPTION

### N: DTC P0068 MAP/MAF - THROTTLE POSITION CORRELATION

#### 1. OUTLINE OF DIAGNOSIS

Detect problems in the intake manifold pressure sensor output properties.

Judge as NG when the intake air pressure AD value is Low whereas it seemed to be High from the viewpoint of engine condition, or when it is High whereas it seemed to be Low from the engine condition.

#### 2. COMPONENT DESCRIPTION

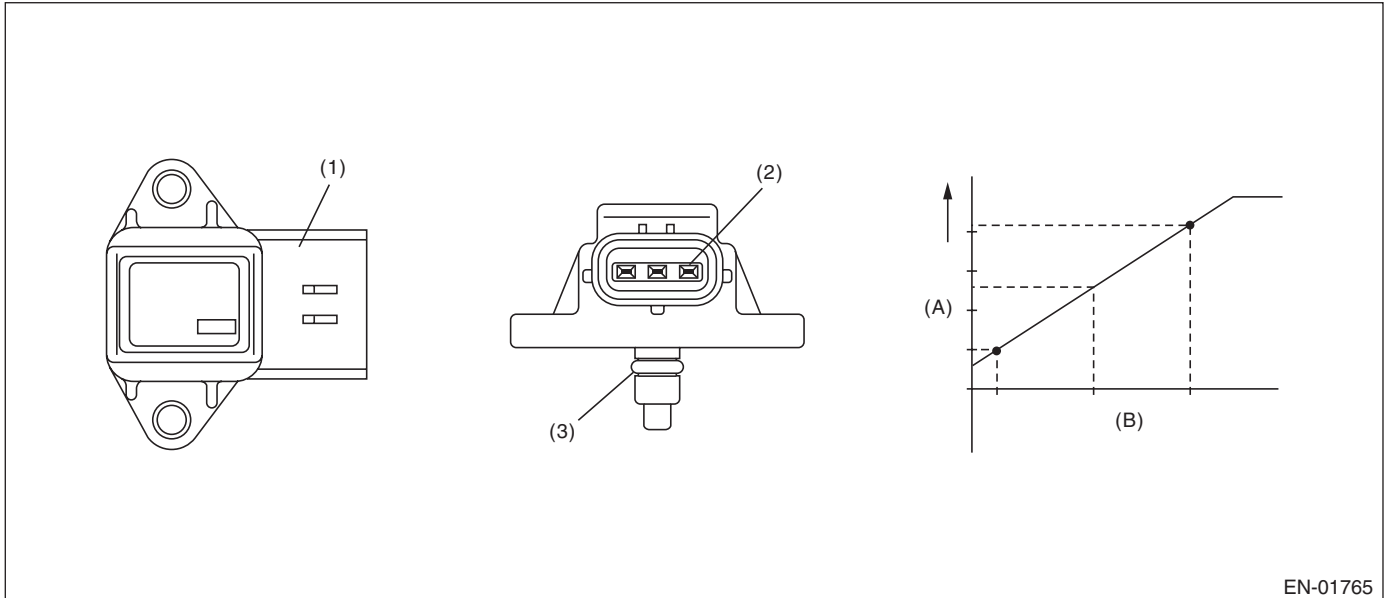

EN-01765

(A) Output voltage

(B) Absolute pressure

(1) Connector

(2) Terminals

(3) O-ring

#### 3. ENABLE CONDITIONS

Secondary Parameters	Enable Conditions
Engine coolant temperature	$\geq 70\text{ }^{\circ}\text{C}$ (158 $^{\circ}\text{F}$ )

#### 4. GENERAL DRIVING CYCLE

Perform the diagnosis continuously after idling.

# Diagnostic Trouble Code (DTC) Detecting Criteria

GENERAL DESCRIPTION

## 5. DIAGNOSTIC METHOD

### • Abnormality Judgment

Judge as NG when Low side or High side becomes NG.

If the duration of time while the following conditions are met is longer than the time indicated, judge as NG.

### Judgment Value

Malfunction Criteria	Threshold Value
<b>Low</b>	
Engine speed	< 2500 rpm
Throttle position	$\geq 10^\circ$
Output voltage	< 1 V (Models without SI-DRIVE) < 0.764 V (Models with SI-DRIVE)
Engine load	> 1.356 g/rev (0.05 oz/rev)
<b>High</b>	
Engine speed	600 rpm — 900 rpm
Throttle position	< $2.75^\circ$
Output voltage	$\geq 2.36$ V (Models without SI-DRIVE) $\geq 2.126$ V (Models with SI-DRIVE)
Engine load	< 0.4 g/rev (0.01 oz/rev)

### Time Needed for Diagnosis:

Low side: 5000 ms

High side: 5000 ms

**Malfunction Indicator Light Illumination:** Illuminates when malfunction occurs in 2 continuous driving cycles.

### • Normality Judgment

Judge as OK and clear the NG when both Low side and High side become OK.

If the duration of time while the following conditions are met is longer than the time indicated, judge as OK.

### Judgment Value

Malfunction Criteria	Threshold Value
<b>Low</b>	
Engine speed	< 2500 rpm
Throttle position	$\geq 10^\circ$
Output voltage	$\geq 1$ V (Models without SI-DRIVE) $\geq 0.764$ V (Models with SI-DRIVE)
Engine load	> 1.356 g/rev (0.05 oz/rev)
<b>High</b>	
Engine speed	600 rpm — 900 rpm
Throttle position	< $2.75^\circ$
Output voltage	< 2.36 V (Models without SI-DRIVE) < 2.126 V (Models with SI-DRIVE)
Engine load	< 0.4 g/rev (0.01 oz/rev)

### Time Needed for Diagnosis:

Low side: Less than 1 second

High side: Less than 1 second

# Diagnostic Trouble Code (DTC) Detecting Criteria

## GENERAL DESCRIPTION

### O: DTC P0101 MASS OR VOLUME AIR FLOW CIRCUIT RANGE/PERFORMANCE

#### 1. OUTLINE OF DIAGNOSIS

Detect the malfunction of air flow sensor output properties.

Judge as a low side NG when the air flow voltage indicates a small value regardless of running in a state where the air flow voltage increases. Judge as a high side NG when the air flow voltage indicates a large value regardless of running in a state where the air flow voltage decreases. Judge air flow sensor property NG when the Low side or High side becomes NG.

#### 2. COMPONENT DESCRIPTION

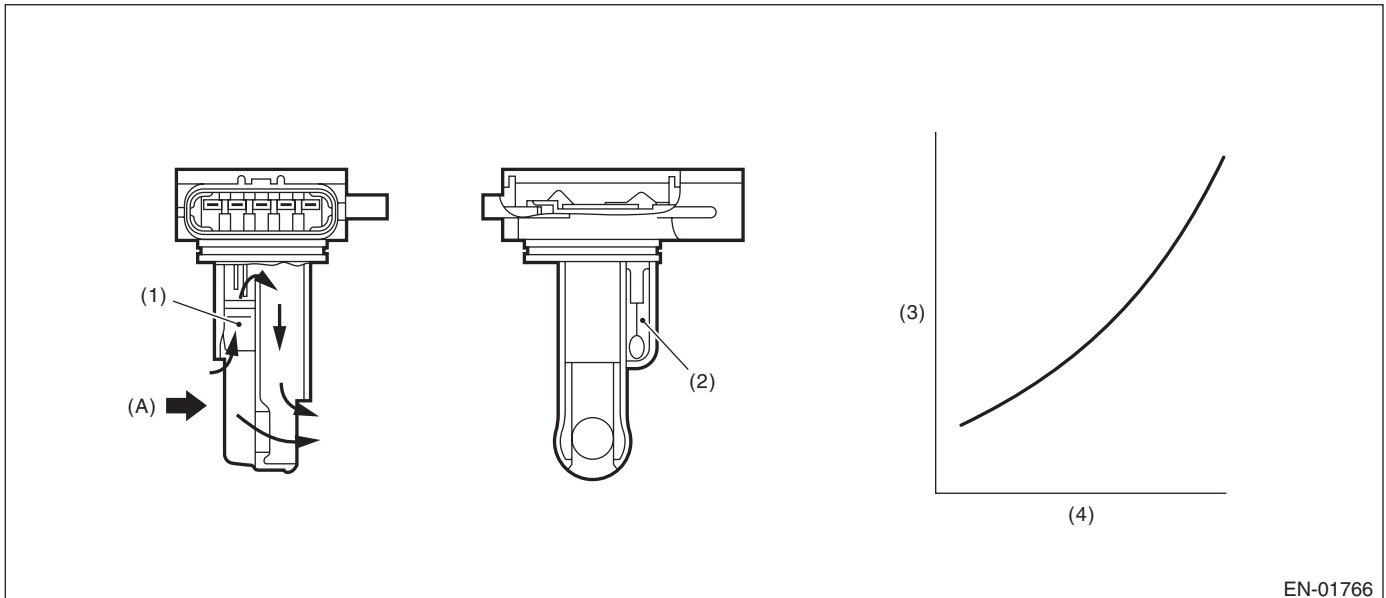

EN-01766

(A) Air

(1) Air flow sensor

(3) Voltage (V)

(4) Amount of intake air (kg (lb)/s)

(2) Intake air temperature sensor

#### 3. ENABLE CONDITIONS

Secondary Parameters	Enable Conditions
Engine coolant temperature	$\geq 70\text{ }^{\circ}\text{C}$ (158 $^{\circ}\text{F}$ )

#### 4. GENERAL DRIVING CYCLE

Perform the diagnosis continuously after idling.

# Diagnostic Trouble Code (DTC) Detecting Criteria

GENERAL DESCRIPTION

## 5. DIAGNOSTIC METHOD

### • Abnormality Judgment

Judge as NG when Low side or High side becomes NG.

If the duration of time while the following conditions are met is longer than the time indicated, judge as NG.

### Judgment Value

Malfunction Criteria	Threshold Value
<b>Low</b>	
Output voltage	< 1.5 V
Engine speed	≥ 2500 rpm
Throttle opening angle	≥ 15 °
Intake manifold pressure	≥ 53.3 kPa (400 mmHg, 15.7 inHg)
<b>High (1)</b>	
Output voltage	≥ 1.95 V
Engine speed	600 rpm — 900 rpm
Throttle opening angle	< 4.1 °
Intake manifold pressure	< 52.7 kPa (395 mmHg, 15.6 inHg)
<b>High (2)</b>	
Output voltage	≥ 1.70 V
Engine speed	600 rpm — 900 rpm
Throttle opening angle	< 4.1 °
Intake manifold pressure	< 52.7 kPa (395 mmHg, 15.6 inHg)
Fuel system diagnosis	Rich side malfunction

### Time Needed for Diagnosis:

Low: 5000 ms

High: 5000 ms

**Malfunction Indicator Light Illumination:** Illuminates when malfunction occurs in 2 continuous driving cycles.

### • Normality Judgment

Judge as OK and clear the NG when both Low side and High side become OK.

Judge as OK and clear the NG if the continuous time while the following conditions are established is more than the predetermined time.

### Judgment Value

Malfunction Criteria	Threshold Value
<b>Low</b>	
Output voltage	≥ 1.5 V
Engine speed	≥ 2500 rpm
Throttle opening angle	≥ 15 °
Intake manifold pressure	≥ 53.3 kPa (400 mmHg, 15.7 inHg)
<b>High</b>	
Output voltage	< 1.95 V
Engine speed	600 rpm — 900 rpm
Throttle opening angle	< 4.1 °
Intake manifold pressure	< 52.7 kPa (395 mmHg, 15.6 inHg)
Fuel system diagnosis	Rich side normal

### Time Needed for Diagnosis:

Low: Less than 1 second

High: Less than 1 second

# Diagnostic Trouble Code (DTC) Detecting Criteria

## GENERAL DESCRIPTION

### P: DTC P0102 MASS OR VOLUME AIR FLOW CIRCUIT LOW INPUT

#### 1. OUTLINE OF DIAGNOSIS

Detect open or short circuits of the air flow sensor.  
Judge as NG if out of specification.

#### 2. COMPONENT DESCRIPTION

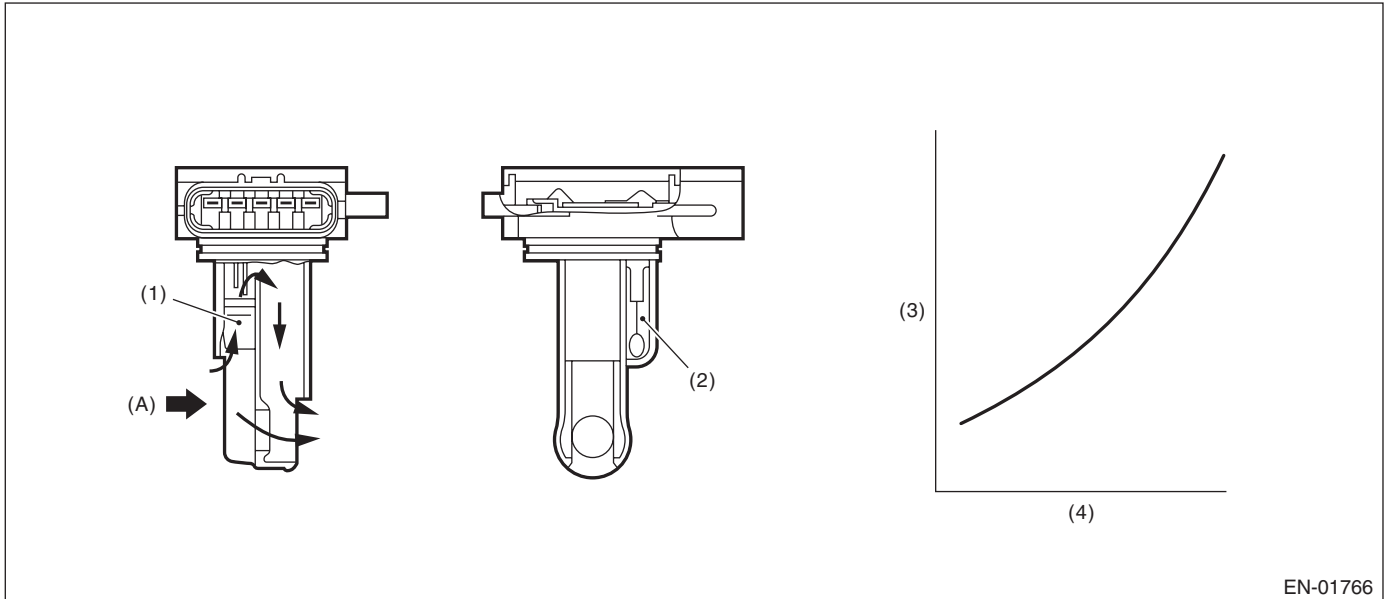

EN-01766

(A) Air

(1) Air flow sensor

(3) Voltage (V)

(4) Amount of intake air (kg (lb)/s)

(2) Intake air temperature sensor

#### 3. ENABLE CONDITIONS

Secondary Parameters	Enable Conditions
None	

#### 4. GENERAL DRIVING CYCLE

Always perform the diagnosis continuously.

# Diagnostic Trouble Code (DTC) Detecting Criteria

GENERAL DESCRIPTION

---

## 5. DIAGNOSTIC METHOD

### • Abnormality Judgment

If the duration of time while the following conditions are met is longer than the time indicated, judge as NG.

#### Judgment Value

Malfunction Criteria	Threshold Value
Output voltage	$\leq 0.22$ V

**Time Needed for Diagnosis:** 500 ms

**Malfunction Indicator Light Illumination:** Illuminates as soon as a malfunction occurs.

### • Normality Judgment

Judge as OK and clear the NG if the continuous time while the following conditions are established is more than the predetermined time.

#### Judgment Value

Malfunction Criteria	Threshold Value
Output voltage	$> 0.22$ V

**Time Needed for Diagnosis:** Less than 1 second



# Diagnostic Trouble Code (DTC) Detecting Criteria

## GENERAL DESCRIPTION

### Q: DTC P0103 MASS OR VOLUME AIR FLOW CIRCUIT HIGH INPUT

#### 1. OUTLINE OF DIAGNOSIS

Detect open or short circuits of the air flow sensor.  
Judge as NG if out of specification.

#### 2. COMPONENT DESCRIPTION

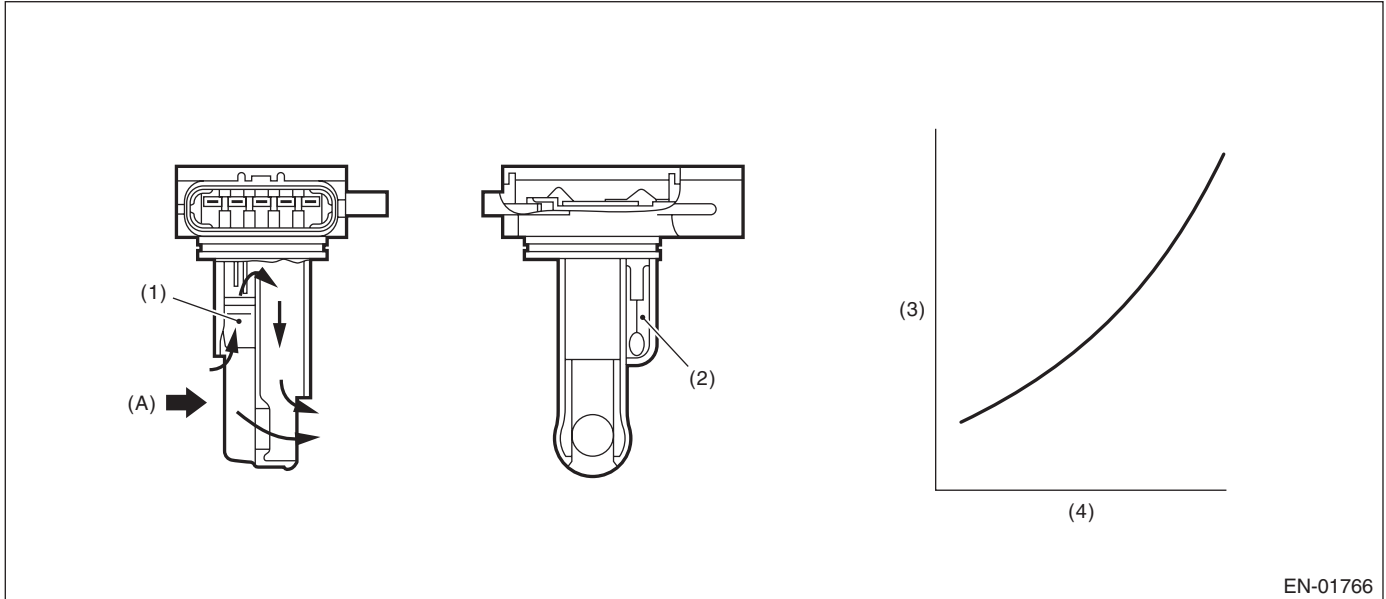

(A) Air

(1) Air flow sensor

(3) Voltage (V)

(4) Amount of intake air (kg (lb)/s)

(2) Intake air temperature sensor

#### 3. ENABLE CONDITIONS

Secondary Parameters	Enable Conditions
None	

#### 4. GENERAL DRIVING CYCLE

Always perform the diagnosis continuously.

# Diagnostic Trouble Code (DTC) Detecting Criteria

GENERAL DESCRIPTION

## 5. DIAGNOSTIC METHOD

### • Abnormality Judgment

If the duration of time while the following conditions are met is longer than the time indicated, judge as NG.

#### Judgment Value

Malfunction Criteria	Threshold Value
Output voltage	$\geq 4.952$ V

**Time Needed for Diagnosis:** 500 ms

**Malfunction Indicator Light Illumination:** Illuminates as soon as a malfunction occurs.

### • Normality Judgment

Judge as OK and clear the NG if the continuous time while the following conditions are established is more than the predetermined time.

#### Judgment Value

Malfunction Criteria	Threshold Value
Output voltage	$< 4.952$ V

**Time Needed for Diagnosis:** Less than 1 second

# Diagnostic Trouble Code (DTC) Detecting Criteria

## GENERAL DESCRIPTION

### R: DTC P0107 MANIFOLD ABSOLUTE PRESSURE/BAROMETRIC PRESSURE CIRCUIT LOW INPUT

#### 1. OUTLINE OF DIAGNOSIS

Detect the open or short circuit of intake manifold pressure sensor.  
Judge as NG if out of specification.

#### 2. COMPONENT DESCRIPTION

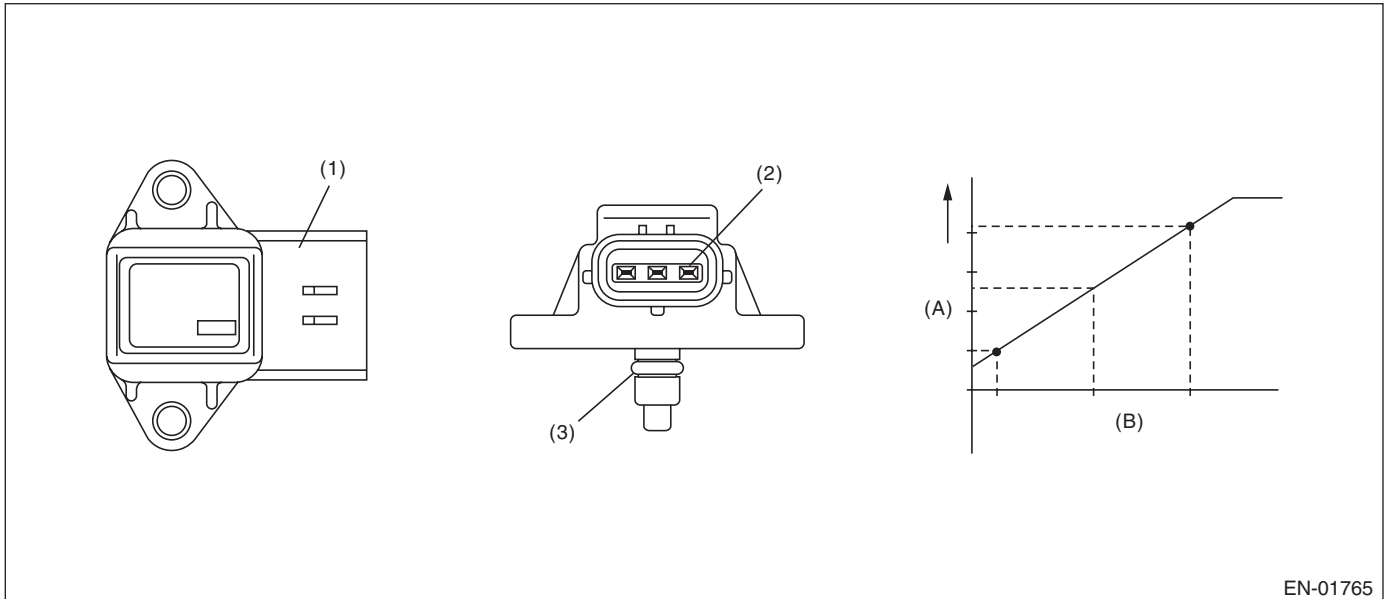

(A) Output voltage

(B) Absolute pressure

(1) Connector

(2) Terminals

(3) O-ring

#### 3. ENABLE CONDITIONS

Secondary Parameters	Enable Conditions
None	

#### 4. GENERAL DRIVING CYCLE

Always perform the diagnosis continuously.

# Diagnostic Trouble Code (DTC) Detecting Criteria

GENERAL DESCRIPTION

## 5. DIAGNOSTIC METHOD

### • Abnormality Judgment

If the duration of time while the following conditions are met is longer than the time indicated, judge as NG.

#### Judgment Value

Malfunction Criteria	Threshold Value
Output voltage	≤ 0.822 V (Models without SI-DRIVE) ≤ 0.581 V (Models with SI-DRIVE)

**Time Needed for Diagnosis:** 500 ms

**Malfunction Indicator Light Illumination:** Illuminates as soon as a malfunction occurs.

### • Normality Judgment

Judge as OK and clear the NG if the continuous time while the following conditions are established is more than the predetermined time.

#### Judgment Value

Malfunction Criteria	Threshold Value
Output voltage	> 0.822 V (Models without SI-DRIVE) > 0.581 V (Models with SI-DRIVE)

**Time Needed for Diagnosis:** Less than 1 second

# Diagnostic Trouble Code (DTC) Detecting Criteria

## GENERAL DESCRIPTION

### S: DTC P0108 MANIFOLD ABSOLUTE PRESSURE/BAROMETRIC PRESSURE CIRCUIT HIGH INPUT

#### 1. OUTLINE OF DIAGNOSIS

Detect the open or short circuit of intake manifold pressure sensor.  
Judge as NG if out of specification.

#### 2. COMPONENT DESCRIPTION

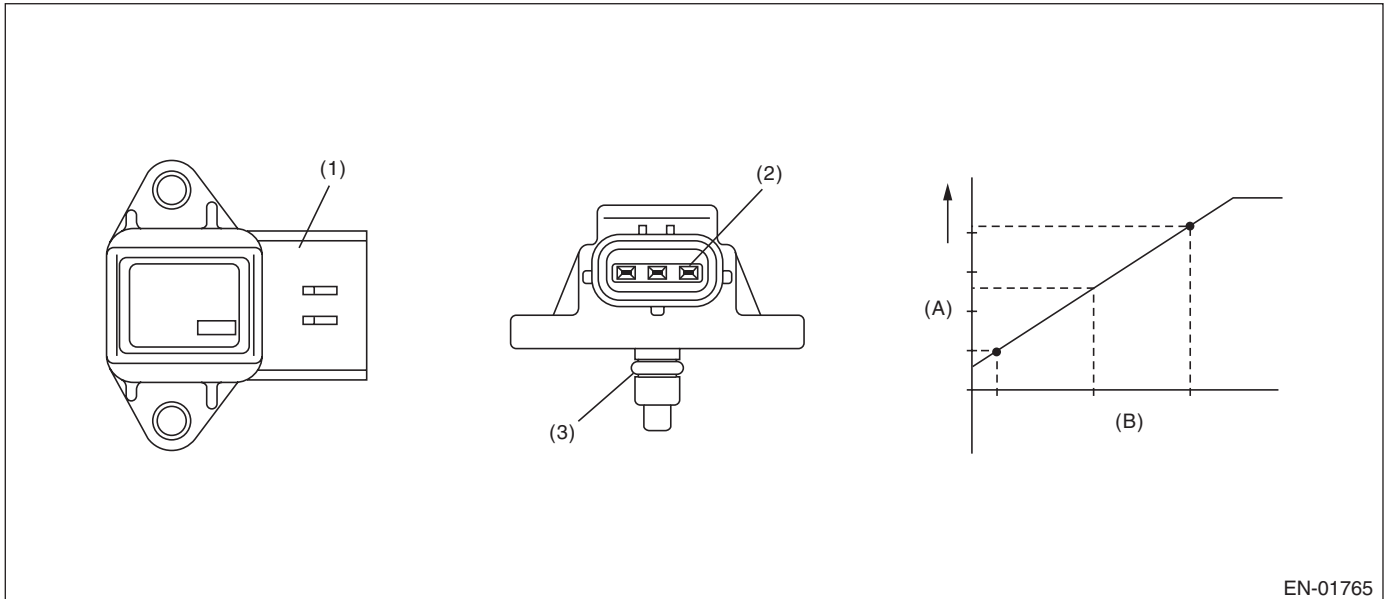

EN-01765

(A) Output voltage

(B) Absolute pressure

(1) Connector

(2) Terminals

(3) O-ring

#### 3. ENABLE CONDITIONS

Secondary Parameters	Enable Conditions
None	

#### 4. GENERAL DRIVING CYCLE

Always perform the diagnosis continuously.

# Diagnostic Trouble Code (DTC) Detecting Criteria

GENERAL DESCRIPTION

## 5. DIAGNOSTIC METHOD

### • Abnormality Judgment

If the duration of time while the following conditions are met is longer than the time indicated, judge as NG.

#### Judgment Value

Malfunction Criteria	Threshold Value
Output voltage	$\geq 4.474$ V (models without SI-DRIVE) $\geq 4.681$ V (models with SI-DRIVE)

**Time Needed for Diagnosis:** 500 ms

**Malfunction Indicator Light Illumination:** Illuminates as soon as a malfunction occurs.

### • Normality Judgment

Judge as OK and clear the NG if the continuous time while the following conditions are established is more than the predetermined time.

#### Judgment Value

Malfunction Criteria	Threshold Value
Output voltage	$< 4.474$ V (models without SI-DRIVE) $< 4.681$ V (models with SI-DRIVE)

**Time Needed for Diagnosis:** Less than 1 second

# Diagnostic Trouble Code (DTC) Detecting Criteria

## GENERAL DESCRIPTION

### T: DTC P0111 INTAKE AIR TEMPERATURE SENSOR 1 CIRCUIT RANGE/PERFORMANCE

#### 1. OUTLINE OF DIAGNOSIS

Detect the malfunction of intake air temperature sensor output property.

Judge as NG when the intake air temperature is not varied whereas it seemed to be varied from the viewpoint of engine condition.

#### 2. COMPONENT DESCRIPTION

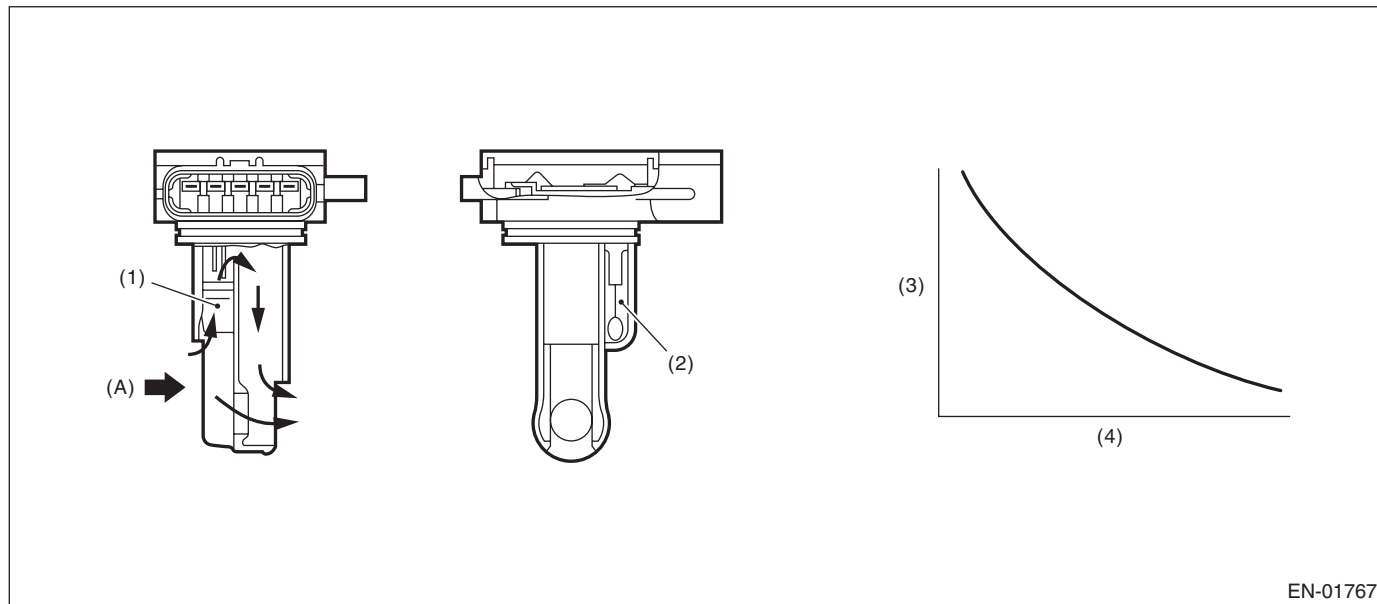

EN-01767

(A) Air

(1) Air flow sensor

(3) Resistance value ( $\Omega$ )

(4) Intake air temperature °C (°F)

(2) Intake air temperature sensor

# Diagnostic Trouble Code (DTC) Detecting Criteria

GENERAL DESCRIPTION

## 3. ENABLE CONDITIONS

Secondary Parameters	Enable Conditions
Engine coolant temperature at engine starting	< 35 °C (95 °F)
Battery voltage	≥ 10.9 V
Continuous time when the vehicle speed is less than 140 km/h (87 MPH)	≥ 610 s
Engine coolant temperature	≥ 70 °C (158 °F)
Intake air amount sum value	≥ Value of Map 1
Number of experiences under conditions below	≥ 3 time(s)
• Continuous time when vehicle speed is less than 4 km/h (2.5 MPH)	≥ Value from Map 2
• Continuous time when vehicle speed is 40 km/h (24.9 MPH) or more	≥ 15 s
and	
Establishing time of 1, 2	≥ 15 s
1. Intake air amount	≥ 15 g/s (0.53 oz/s)
2. Vehicle speed	≥ 4 km/h (2.5 MPH)

### Map 1 (Models without SI-DRIVE)

Engine coolant temperature °C (°F)	-20 (-4)	-10 (14)	0 (32)	10 (50)	20 (68)
Intake air amount sum value (g (oz))	76000 (2680.52)	10192 (359.47)	9028 (318.42)	7864 (277.36)	5800 (204.57)

### Map 1 (Models with SI-DRIVE)

Engine coolant temperature °C (°F)	-20 (-4)	-10 (14)	0 (32)	10 (50)	20 (68)
Intake air amount sum value (g (oz))	76000 (2680.52)	10192 (359.47)	9028 (318.42)	7864 (277.36)	6320 (222.91)

### Map 2

Engine coolant temperature °C (°F)	-20 (-4)	-10 (14)	5 (41)	20 (68)
Continuous time (s) when vehicle speed is less than 4 km/h (2.5 MPH)	250	40	32	24

## 4. GENERAL DRIVING CYCLE

Perform the diagnosis when the vehicle speed condition is met after warming up from a cold condition.



# Diagnostic Trouble Code (DTC) Detecting Criteria

## GENERAL DESCRIPTION

---

### 5. DIAGNOSTIC METHOD

#### • Abnormality Judgment

Judge as NG when the following conditions are established.

#### Judgment Value

Malfunction Criteria	Threshold Value
Output voltage difference between Max. and Min.	< 0.02 V (Equivalent to approximately 0.5°C (0.9°F) near 25°C)

**Time Needed for Diagnosis:** Less than 1 second

**Malfunction Indicator Light Illumination:** Illuminates when malfunction occurs in 2 continuous driving cycles.

#### • Normality Judgment

Judge as OK and clear the NG if the following conditions are established.

#### Judgment Value

Malfunction Criteria	Threshold Value
Output voltage difference between Max. and Min.	≥ 0.02 V

**Time Needed for Diagnosis:** Less than 1 second

# Diagnostic Trouble Code (DTC) Detecting Criteria

GENERAL DESCRIPTION

## U: DTC P0112 INTAKE AIR TEMPERATURE SENSOR 1 CIRCUIT LOW

### 1. OUTLINE OF DIAGNOSIS

Detect open or short circuit of the intake air temperature sensor.  
Judge as NG if out of specification.

### 2. COMPONENT DESCRIPTION

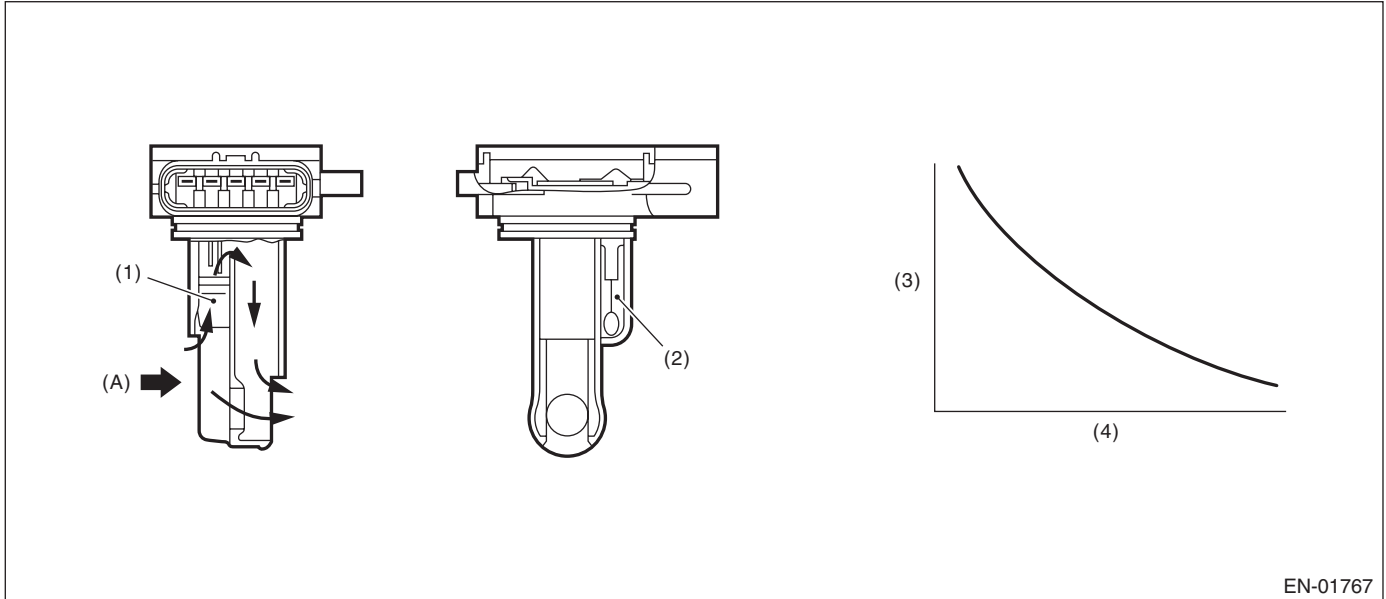

EN-01767

(A) Air

(1) Air flow sensor

(3) Resistance value ( $\Omega$ )

(4) Intake air temperature °C (°F)

(2) Intake air temperature sensor

### 3. ENABLE CONDITIONS

Secondary Parameters	Enable Conditions
None	

### 4. GENERAL DRIVING CYCLE

Always perform the diagnosis continuously.

# Diagnostic Trouble Code (DTC) Detecting Criteria

## GENERAL DESCRIPTION

---

### 5. DIAGNOSTIC METHOD

#### • Abnormality Judgment

If the duration of time while the following conditions are met is longer than the time indicated, judge as NG.

#### Judgment Value

Malfunction Criteria	Threshold Value
Output voltage	< 0.395 V

**Time Needed for Diagnosis:** 500 ms

**Malfunction Indicator Light Illumination:** Illuminates as soon as a malfunction occurs.

#### • Normality Judgment

Judge as OK and clear the NG if the continuous time while the following conditions are established is more than the predetermined time.

#### Judgment Value

Malfunction Criteria	Threshold Value
Output voltage	$\geq$ 0.395 V

**Time Needed for Diagnosis:** Less than 1 second

# Diagnostic Trouble Code (DTC) Detecting Criteria

GENERAL DESCRIPTION

## V: DTC P0113 INTAKE AIR TEMPERATURE SENSOR 1 CIRCUIT HIGH

### 1. OUTLINE OF DIAGNOSIS

Detect open or short circuit of the intake air temperature sensor.  
Judge as NG if out of specification.

### 2. COMPONENT DESCRIPTION

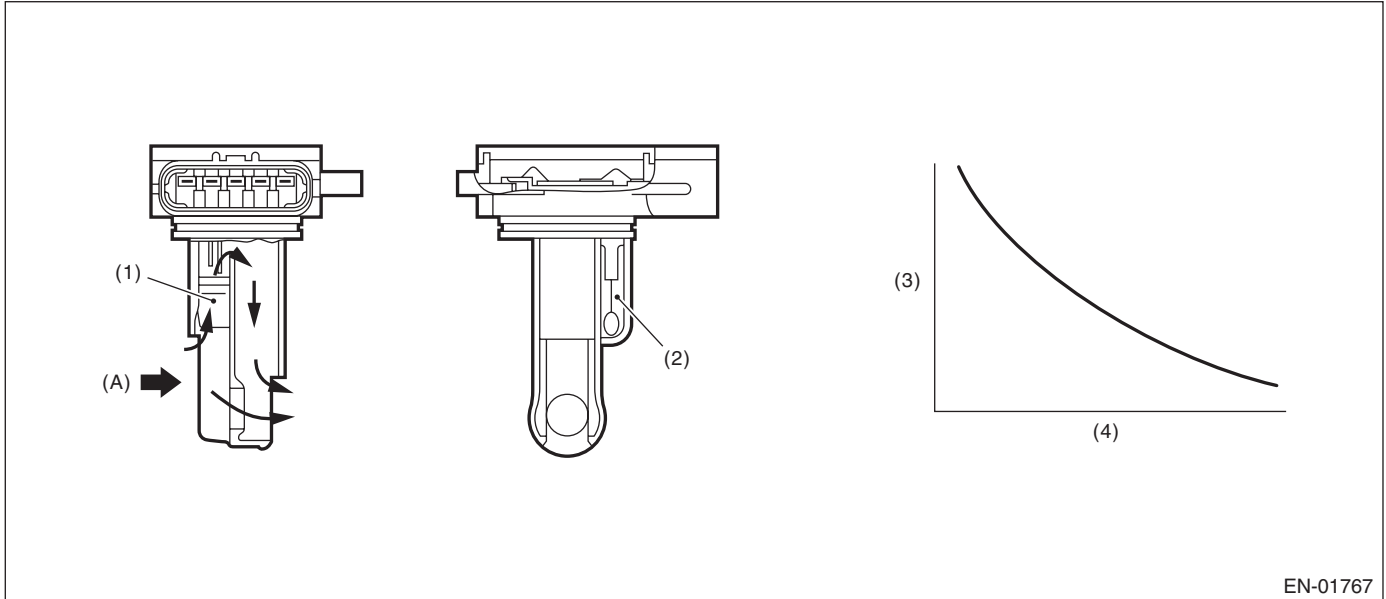

EN-01767

(A) Air

(1) Air flow sensor

(3) Resistance value ( $\Omega$ )

(4) Intake air temperature °C (°F)

(2) Intake air temperature sensor

### 3. ENABLE CONDITIONS

Secondary Parameters	Enable Conditions
None	

### 4. GENERAL DRIVING CYCLE

Always perform the diagnosis continuously.

# Diagnostic Trouble Code (DTC) Detecting Criteria

## GENERAL DESCRIPTION

---

### 5. DIAGNOSTIC METHOD

#### • Abnormality Judgment

If the duration of time while the following conditions are met is longer than the time indicated, judge as NG.

#### Judgment Value

Malfunction Criteria	Threshold Value
Output voltage	$\geq 4.712$ V

**Time Needed for Diagnosis:** 500 ms

**Malfunction Indicator Light Illumination:** Illuminates as soon as a malfunction occurs.

#### • Normality Judgment

Judge as OK and clear the NG if the continuous time while the following conditions are established is more than the predetermined time.

#### Judgment Value

Malfunction Criteria	Threshold Value
Output voltage	$< 4.712$ V

**Time Needed for Diagnosis:** Less than 1 second

# Diagnostic Trouble Code (DTC) Detecting Criteria

GENERAL DESCRIPTION

## W: DTC P0117 ENGINE COOLANT TEMPERATURE CIRCUIT LOW

### 1. OUTLINE OF DIAGNOSIS

Detect the open or short circuit of the engine coolant temperature sensor.  
Judge as NG if out of specification.

### 2. COMPONENT DESCRIPTION

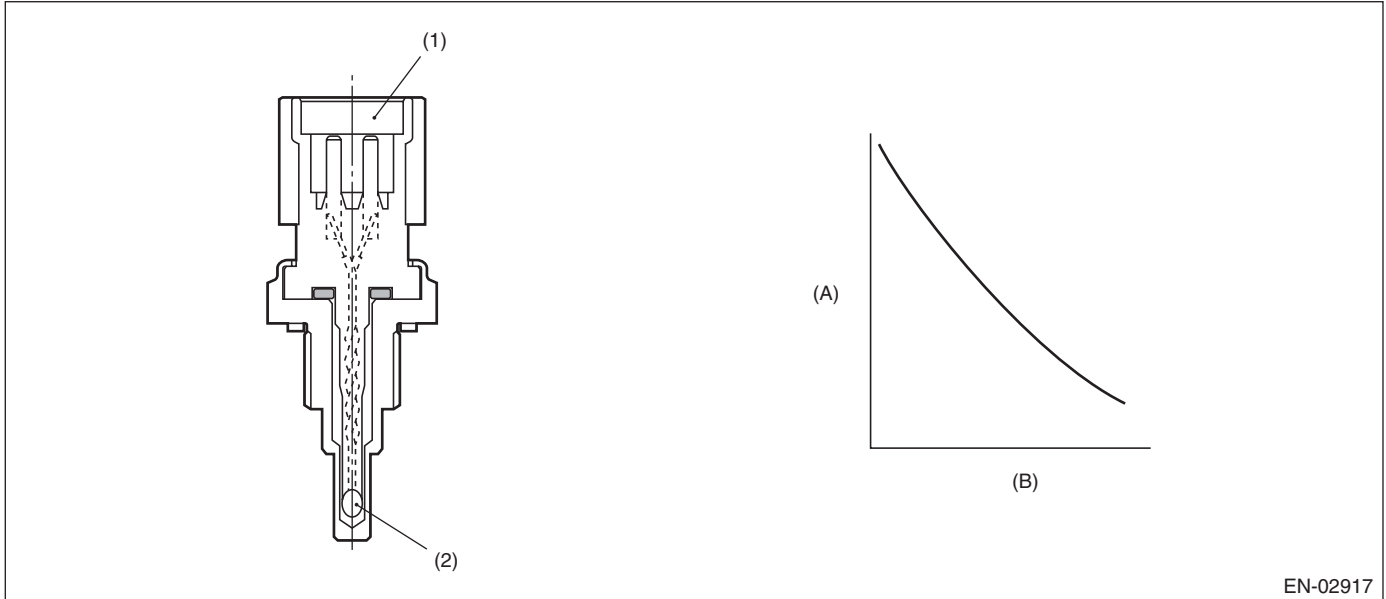

(A) Resistance value (k $\Omega$ )

(B) Temperature °C (°F)

(1) Connector

(2) Thermistor element

### 3. ENABLE CONDITIONS

Secondary Parameters	Enable Conditions
None	

### 4. GENERAL DRIVING CYCLE

Always perform the diagnosis continuously.

# Diagnostic Trouble Code (DTC) Detecting Criteria

## GENERAL DESCRIPTION

---

### 5. DIAGNOSTIC METHOD

#### • Abnormality Judgment

If the duration of time while the following conditions are met is longer than the time indicated, judge as NG.

#### Judgment Value

Malfunction Criteria	Threshold Value
Output voltage	< 0.464 V

**Time Needed for Diagnosis:** 500 ms

**Malfunction Indicator Light Illumination:** Illuminates as soon as a malfunction occurs.

#### • Normality Judgment

Judge as OK and clear the NG if the continuous time while the following conditions are established is more than the predetermined time.

#### Judgment Value

Malfunction Criteria	Threshold Value
Output voltage	$\geq 0.464$ V

**Time Needed for Diagnosis:** Less than 1 second

# Diagnostic Trouble Code (DTC) Detecting Criteria

GENERAL DESCRIPTION

## X: DTC P0118 ENGINE COOLANT TEMPERATURE CIRCUIT HIGH

### 1. OUTLINE OF DIAGNOSIS

Detect the open or short circuit of the engine coolant temperature sensor.  
Judge as NG if out of specification.

### 2. COMPONENT DESCRIPTION

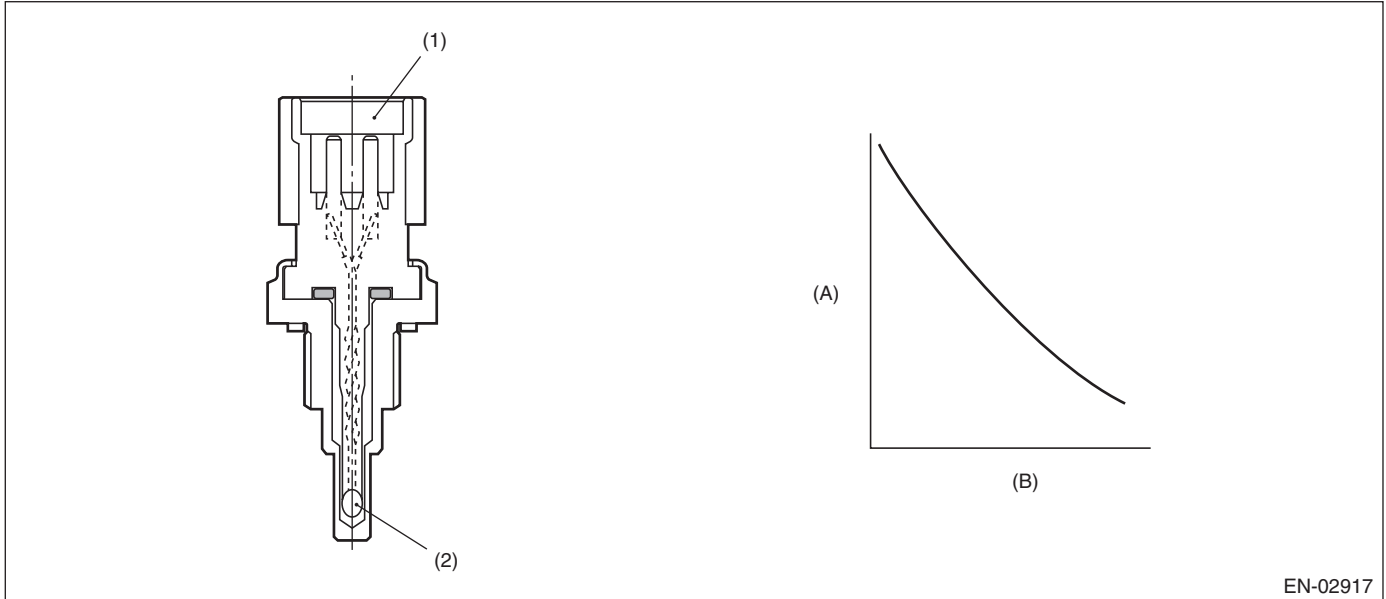

EN-02917

(A) Resistance value (k $\Omega$ )

(B) Temperature °C (°F)

(1) Connector

(2) Thermistor element

### 3. ENABLE CONDITIONS

Secondary Parameters	Enable Conditions
None	

### 4. GENERAL DRIVING CYCLE

Always perform the diagnosis continuously.



# Diagnostic Trouble Code (DTC) Detecting Criteria

## GENERAL DESCRIPTION

---

### 5. DIAGNOSTIC METHOD

#### • Abnormality Judgment

If the duration of time while the following conditions are met is longer than the time indicated, judge as NG.

#### Judgment Value

Malfunction Criteria	Threshold Value
Output voltage	$\geq 4.702$ V

**Time Needed for Diagnosis:** 500 ms

**Malfunction Indicator Light Illumination:** Illuminates as soon as a malfunction occurs.

#### • Normality Judgment

Judge as OK and clear the NG if the continuous time while the following conditions are established is more than the predetermined time.

#### Judgment Value

Malfunction Criteria	Threshold Value
Output voltage	$< 4.702$ V

**Time Needed for Diagnosis:** Less than 1 second

# Diagnostic Trouble Code (DTC) Detecting Criteria

GENERAL DESCRIPTION

## Y: DTC P0122 THROTTLE/PEDAL POSITION SENSOR/SWITCH "A" CIRCUIT LOW

### 1. OUTLINE OF DIAGNOSIS

Detect the open or short circuit of throttle position sensor 1.  
Judge as NG if out of specification.

### 2. COMPONENT DESCRIPTION

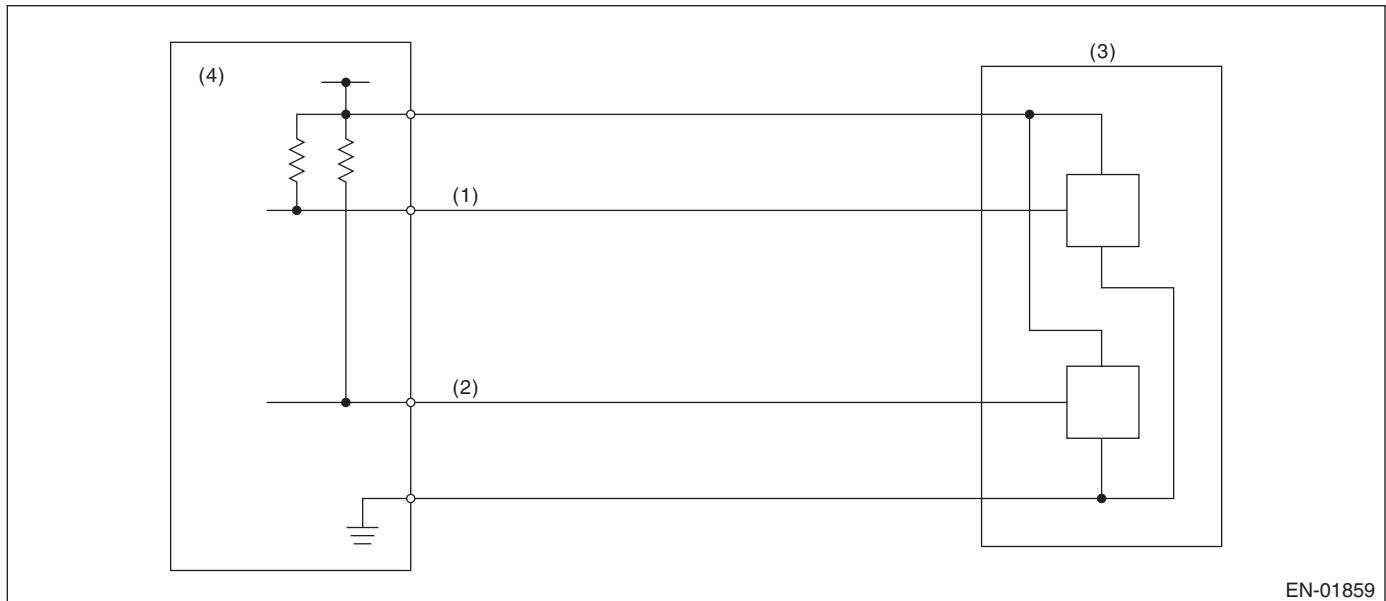

(1) Throttle position sensor 1 signal  
(2) Throttle position sensor 2 signal

(3) Throttle position sensor

(4) Engine control module (ECM)

### 3. ENABLE CONDITIONS

Secondary Parameters	Enable Conditions
Ignition switch	ON
Battery voltage	$\geq 6\text{ V}$

### 4. GENERAL DRIVING CYCLE

Always perform the diagnosis continuously.

# Diagnostic Trouble Code (DTC) Detecting Criteria

## GENERAL DESCRIPTION

---

### 5. DIAGNOSTIC METHOD

#### • Abnormality Judgment

If the duration of time while the following conditions are met is longer than the time indicated, judge as NG.

#### Judgment Value

Malfunction Criteria	Threshold Value
Sensor 1 input voltage	$\leq 0.23$ V

**Time Needed for Diagnosis:** 24 ms

**Malfunction Indicator Light Illumination:** Illuminates as soon as a malfunction occurs.

#### • Normality Judgment

Judge as OK and clear the NG if the continuous time while the following conditions are established is more than the predetermined time.

#### Judgment Value

Malfunction Criteria	Threshold Value
Sensor 1 input voltage	$> 0.23$ V

**Time Needed for Diagnosis:** 24 ms

# Diagnostic Trouble Code (DTC) Detecting Criteria

GENERAL DESCRIPTION

## Z: DTC P0123 THROTTLE/PEDAL POSITION SENSOR/SWITCH "A" CIRCUIT HIGH

### 1. OUTLINE OF DIAGNOSIS

Detect the open or short circuit of throttle position sensor 1.  
Judge as NG if out of specification.

### 2. COMPONENT DESCRIPTION

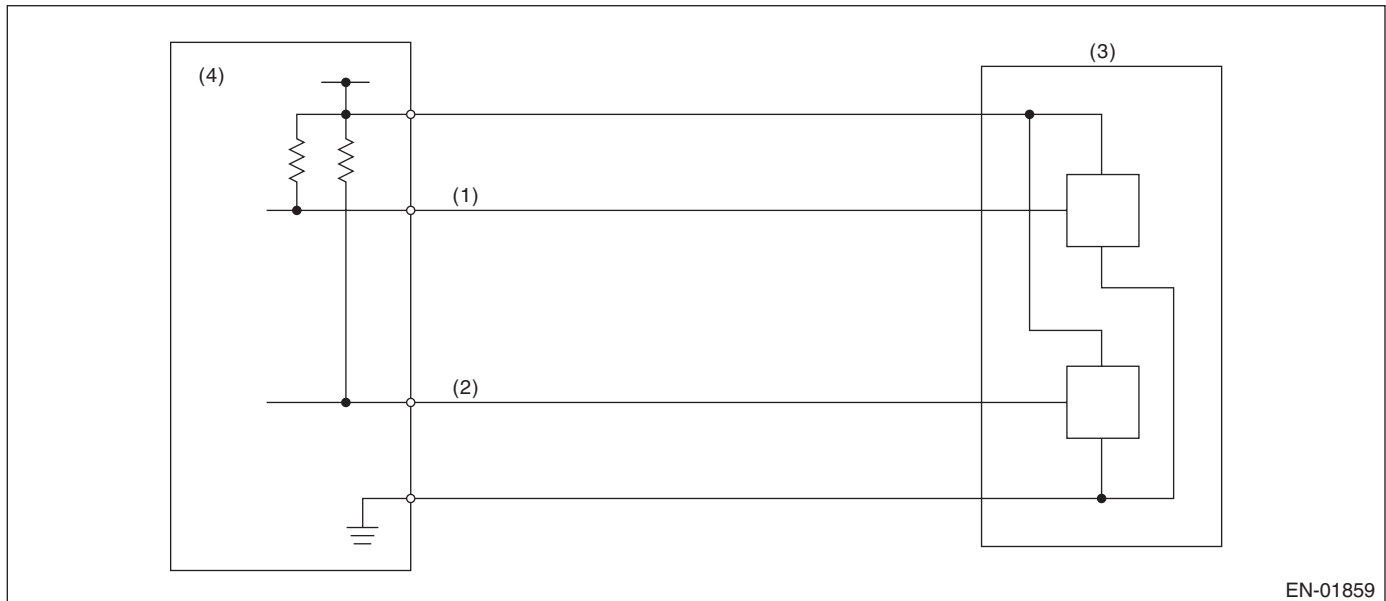

(1) Throttle position sensor 1 signal  
(2) Throttle position sensor 2 signal

(3) Throttle position sensor

(4) Engine control module (ECM)

### 3. ENABLE CONDITIONS

Secondary Parameters	Enable Conditions
Ignition switch	ON
Battery voltage	$\geq 6\text{ V}$

### 4. GENERAL DRIVING CYCLE

Always perform the diagnosis continuously.

# Diagnostic Trouble Code (DTC) Detecting Criteria

## GENERAL DESCRIPTION

---

### 5. DIAGNOSTIC METHOD

#### • Abnormality Judgment

If the duration of time while the following conditions are met is longer than the time indicated, judge as NG.

#### Judgment Value

Malfunction Criteria	Threshold Value
Sensor 1 input voltage	$\geq 4.858$ V

**Time Needed for Diagnosis:** 24 ms

**Malfunction Indicator Light Illumination:** Illuminates as soon as a malfunction occurs.

#### • Normality Judgment

Judge as OK and clear the NG if the continuous time while the following conditions are established is more than the predetermined time.

#### Judgment Value

Malfunction Criteria	Threshold Value
Sensor 1 input voltage	$< 4.858$ V

**Time Needed for Diagnosis:** 24 ms

# Diagnostic Trouble Code (DTC) Detecting Criteria

GENERAL DESCRIPTION

## AA:DTC P0125 INSUFFICIENT COOLANT TEMPERATURE FOR CLOSED LOOP FUEL CONTROL

### 1. OUTLINE OF DIAGNOSIS

Detect the malfunction of engine coolant temperature output property.

Judge as NG when the engine coolant temperature does not rise in driving conditions where it should.

### 2. COMPONENT DESCRIPTION

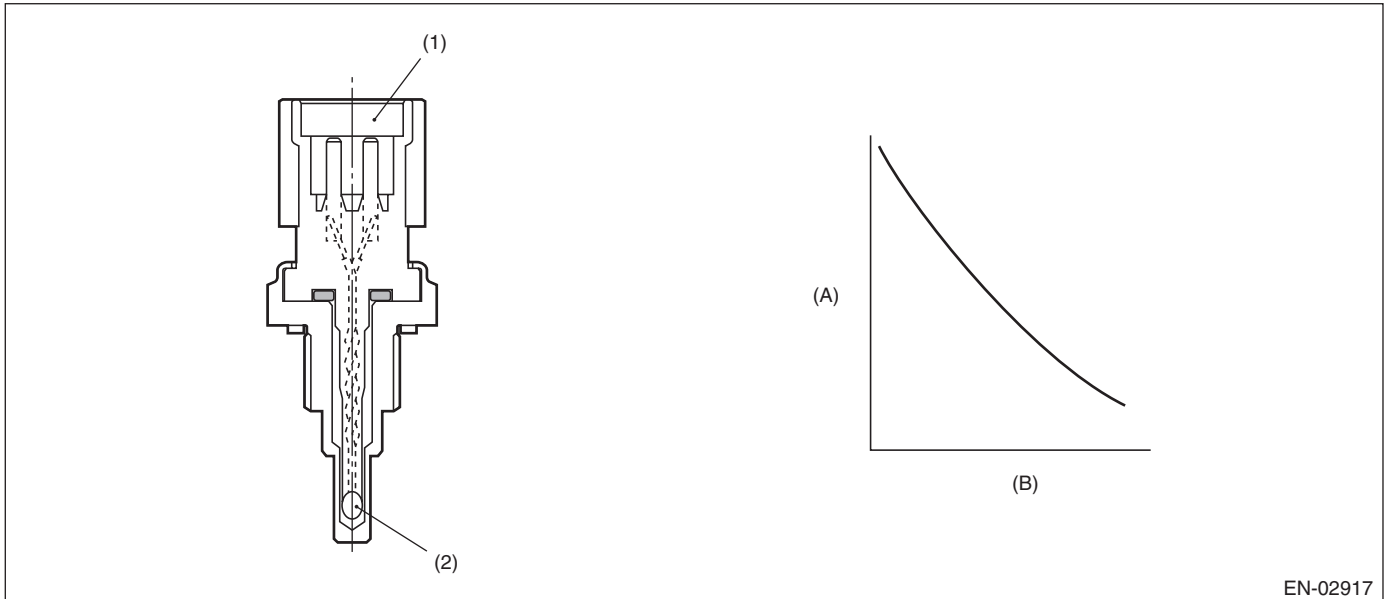

EN-02917

(A) Resistance value (k $\Omega$ )

(B) Temperature °C (°F)

(1) Connector

(2) Thermistor element

### 3. ENABLE CONDITIONS

Secondary Parameters	Enable Conditions
Engine speed	$\geq$ Value from Map
Battery voltage	$\geq 10.9$ V

#### Map

Engine coolant temperature °C (°F)	-40 (-40)	-30 (-22)	-20 (-4)	-10 (14)	0 (32)	10 (50)	20 (68)	30 (86)
Engine speed rpm	500	500	500	500	500	500	500	500

Engine coolant temperature °C (°F)	40 (104)	50 (122)	60 (140)	70 (158)	80 (176)	90 (194)	100 (212)	110 (230)
Engine speed rpm	500	500	500	500	500	500	500	500

### 4. GENERAL DRIVING CYCLE

Perform the diagnosis only once after engine start.

# Diagnostic Trouble Code (DTC) Detecting Criteria

## GENERAL DESCRIPTION

### 5. DIAGNOSTIC METHOD

#### • Abnormality Judgment

Judge as NG if the criteria below are met.

#### Judgment Value

Malfunction Criteria	Threshold Value
Engine coolant temperature	< 20 °C (68 °F)
Timer for diagnosis after engine start	≥ Judgment value of timer after engine start

Timer for diagnosis after engine start

a. Timer stop at fuel cut

b. During the driving conditions except a) above, timer counts up as follows.

64 ms + TWCNT ms (when at 64 ms)

TWCNT is defined as follows,

TWCNT = 0 at idle switch ON,

TWCNT show on the following table at idle switch OFF.

		Vehicle speed km/h (MPH)							
		0 (0)	8 (5)	16 (9.9)	24 (14.9)	32 (19.9)	40 (24.9)	48 (29.8)	56 (34.8)
Temperature °C (°F)	-20 (-4)	0 ms	37.136 ms	74.272 ms	111.41 ms	126.66 ms	141.91 ms	163.59 ms	185.26 ms
	-10 (14)	0 ms	27.391 ms	54.782 ms	82.173 ms	99.65 ms	117.13 ms	135.96 ms	154.8 ms
	0 (32)	0 ms	17.646 ms	35.292 ms	52.938 ms	72.64 ms	92.341 ms	108.34 ms	124.33 ms
	10 (50)	0 ms	7.9012 ms	15.802 ms	23.704 ms	45.63 ms	67.556 ms	80.711 ms	93.867 ms
	20 (68)	0 ms	7.9012 ms	15.802 ms	23.704 ms	45.63 ms	67.556 ms	80.711 ms	93.867 ms

Judgment value of timer after engine starting

$$t = 451056 \text{ ms} - 25870 \text{ ms} \times T_i$$

$T_i$  : The lowest coolant temperature after engine start

**Time Needed for Diagnosis:** Less than 1 second

**Malfunction Indicator Light Illumination:** Illuminates when malfunction occurs in 2 continuous driving cycles.

#### • Normality Judgment

Judge as OK and clear the NG when the malfunction criteria below are met.

#### Judgment Value

Malfunction Criteria	Threshold Value
Engine coolant temperature	≥ 20 °C (68 °F)

**Time Needed for Diagnosis:** Less than 1 second

# Diagnostic Trouble Code (DTC) Detecting Criteria

GENERAL DESCRIPTION

## AB:DTC P0126 INSUFFICIENT ENGINE COOLANT TEMPERATURE FOR STABLE OPERATION

### 1. OUTLINE OF DIAGNOSIS

Detect the malfunction of the engine coolant temperature sensor characteristics.

When the ignition is ON after the specified period of soaking time has elapsed, compare the engine coolant temperature with intake air temperature. Judge as NG if the difference between two temperatures is larger than the predetermined value and the engine coolant temperature becomes the specified value or more.

### 2. COMPONENT DESCRIPTION

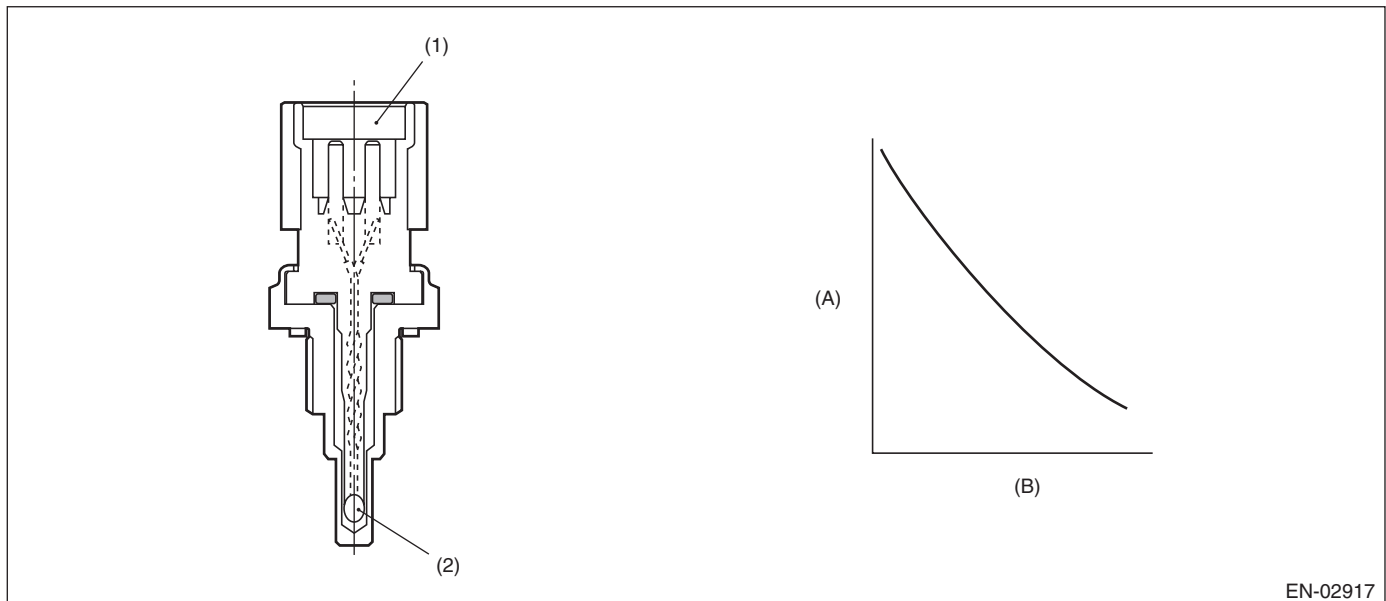

EN-02917

- (A) Resistance value (k $\Omega$ )                      (B) Temperature °C (°F)
- (1) Connector    (2) Thermistor element

### 3. ENABLE CONDITIONS

Secondary Parameters	Enable Conditions
Battery voltage	$\geq 10.9$ V
Soaking time	$\geq 21600$ s
Engine coolant temperature at the last engine stop	$\geq$ Value from Map

#### Map (Models without SI-DRIVE)

Estimate ambient temperature °C (°F)	-7 (19.4)	8 (46.4)	10 (50)	25 (77)
Engine coolant temperature at the last engine stop °C (°F)	75 (167)	75 (167)	75 (167)	75 (167)

#### Map (Models with SI-DRIVE)

Estimate ambient temperature °C (°F)	-7 (19.4)	8 (46.4)	10 (50)	25 (77)
Engine coolant temperature at the last engine stop °C (°F)	77.5 (171.5)	77.5 (171.5)	77.5 (171.5)	77.5 (171.5)

### 4. GENERAL DRIVING CYCLE

Perform the diagnosis only once after starting the engine.

**GD(H4DOTC)-59**

Brought to you by Ebay Seller "SubaruManuals"



# Diagnostic Trouble Code (DTC) Detecting Criteria

## GENERAL DESCRIPTION

---

### 5. DIAGNOSTIC METHOD

#### • Abnormality Judgment

If the duration of time while the following conditions are met is longer than the time indicated, judge as NG.

#### Judgment Value

Malfunction Criteria	Threshold Value
All of the following conditions are established.	
Engine coolant temperature – intake air temperature	> 15°C (27°F)
Engine coolant temperature	> 40 °C (104 °F)

**Time Needed for Diagnosis:** 512 ms

**Malfunction Indicator Light Illumination:** Illuminates when malfunction occurs in 2 continuous driving cycles.

#### • Normality Judgment

Judge as OK and clear the NG if the continuous time while the following conditions are established is more than the predetermined time.

#### Judgment Value

Malfunction Criteria	Threshold Value
When any one of the followings is established.	
Engine coolant temperature – intake air temperature	≤ 15°C (27°F)
Engine coolant temperature	≤ 40 °C (104 °F)

**Time Needed for Diagnosis:** Less than 1 second

## AC:DTC P0128 COOLANT THERMOSTAT (ENGINE COOLANT TEMPERATURE BELOW THERMOSTAT REGULATING TEMPERATURE)

### 1. OUTLINE OF DIAGNOSIS

Detect malfunctions of the thermostat function.

Judge as NG when any one of the following conditions is established.

- When the actual engine coolant temperature does not reach the maximum temperature necessary to perform other OBDII diagnosis and  $\Sigma$  (Estimated engine coolant temperature – actual engine coolant temperature) exceeded the predetermined value. (Judgment 1)
- When the actual engine coolant temperature does not reach the range within  $-11^{\circ}\text{C}$  ( $-19.8^{\circ}\text{F}$ ) from the regulated temperature and  $\Sigma$  (Estimated engine coolant temperature – actual engine coolant temperature) exceeded the predetermined value. (Judgment 2)
- When the difference between the estimated coolant temperature and the actual engine coolant temperature exceeds the predetermined value, and  $\Sigma$  (Estimated engine coolant temperature – actual engine coolant temperature) exceeded the predetermined value. (Judgment 3)

### 2. COMPONENT DESCRIPTION

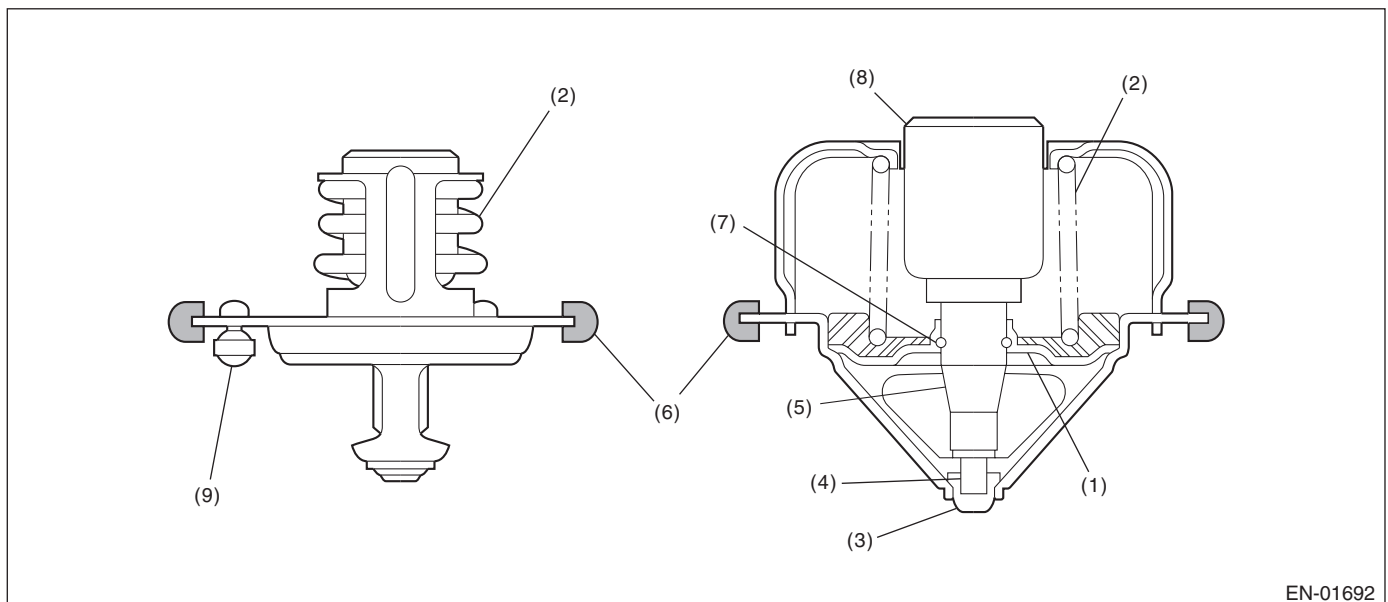

EN-01692

- |             |                 |                  |
|-------------|-----------------|------------------|
| (1) Valve   | (4) Piston      | (7) Stop ring    |
| (2) Spring  | (5) Guide       | (8) Wax element  |
| (3) Stopper | (6) Rubber seal | (9) Jiggle valve |

# Diagnostic Trouble Code (DTC) Detecting Criteria

## GENERAL DESCRIPTION

### 3. ENABLE CONDITIONS

Secondary Parameters	Enable Conditions
<Judgment 1>	
Battery voltage	≥ 10.9 V
Estimate ambient temperature	≥ -7 °C (19.4 °F)
Vehicle speed	≥ 30 km/h (18.6 MPH)
Estimated coolant temperature	≥ Value of Map 1
<Judgment 2>	
Battery voltage	≥ 10.9 V
Estimate ambient temperature	≥ -7 °C (19.4 °F)
Vehicle speed	≥ 30 km/h (18.6 MPH)
Estimated coolant temperature	≥ Value from Map 2
<Judgment 3>	
Battery voltage	≥ 10.9 V
Estimate ambient temperature	≥ -7 °C (19.4 °F)
Vehicle speed	≥ 30 km/h (18.6 MPH)
Estimated coolant temperature	≥ Value from Map 3

#### Map 1

Engine coolant temperature at engine starting °C (°F)	-7 (19.4)	8 (46.4)	10 (50)	25 (77)
Estimated coolant temperature °C (°F)	70 (158)	70 (158)	70 (158)	70 (158)

#### Map 2 (Models without SI-DRIVE)

Engine coolant temperature at engine starting °C (°F)	-7 (19.4)	8 (46.4)	10 (50)	25 (77)
Estimated coolant temperature °C (°F)	75 (167)	75 (167)	75 (167)	75 (167)

#### Map 2 (Models with SI-DRIVE)

Engine coolant temperature at engine starting °C (°F)	-7 (19.4)	8 (46.4)	10 (50)	25 (77)
Estimated coolant temperature °C (°F)	77.5 (171.5)	77.5 (171.5)	77.5 (171.5)	77.5 (171.5)

#### Map 3 (Models without SI-DRIVE)

Engine coolant temperature at engine starting °C (°F)	-7 (19.4)	10 (50)	25 (77)	27 (80.6)
Estimated coolant temperature °C (°F)	58.1 (136.6)	66.6 (151.9)	74.2 (165.6)	75 (167)

#### Map 3 (Models with SI-DRIVE)

Engine coolant temperature at engine starting °C (°F)	-7 (19.4)	10 (50)	25 (77)	46 (114.8)
Estimated coolant temperature °C (°F)	59.8 (139.6)	65.5 (149.9)	70.5 (158.9)	77.5 (171.5)

### 4. GENERAL DRIVING CYCLE

Perform the diagnosis only once after starting the engine.

# Diagnostic Trouble Code (DTC) Detecting Criteria

GENERAL DESCRIPTION

## 5. DIAGNOSTIC METHOD

### • Abnormality Judgment

If the duration of time while the following conditions are met is longer than the time indicated, judge as NG.

#### Judgment Value

Malfunction Criteria	Threshold Value
When any one of the followings is established.	
<Judgment 1>	
Actual engine coolant temperature and $\Sigma$ (Estimated engine coolant temperature – actual engine coolant temperature)	< Value of Map 4  > Value of Map 5
<Judgment 2>	
Actual engine coolant temperature and $\Sigma$ (Estimated engine coolant temperature – actual engine coolant temperature)	< Regulated temperature – Value of Map 6  > Value of Map 7
<Judgment 3>	
Estimated engine coolant temperature – actual engine coolant temperature and $\Sigma$ (Estimated engine coolant temperature – actual engine coolant temperature)	> Value of Map 8  > Value of Map 9

#### Map 4

Estimate ambient temperature °C (°F)	-7 (19.4)	8 (46.4)	10 (50)	25 (77)
Threshold Value °C (°F)	70 (158)	70 (158)	70 (158)	70 (158)

#### Map 5

Engine coolant temperature at engine starting °C (°F)	-7 (19.4)	0 (32)	8 (46.4)	10 (50)	25 (77)	35 (95)
Threshold Value °C (°F)	1731.6 (3116.9)	1731.6 (3116.9)	1731.6 (3116.9)	1731.6 (3116.9)	1731.6 (3116.9)	1000 (1800)

#### Map 6

Estimate ambient temperature °C (°F)	-7 (19.4)	8 (46.4)	10 (50)	25 (77)
Threshold Value °C (°F)	11.1 (20)	11.1 (20)	11.1 (20)	11.1 (20)

#### Map 7

Engine coolant temperature at engine starting °C (°F)	-7 (19.4)	0 (32)	8 (46.4)	10 (50)	25 (77)	30 (86)	35 (95)
Threshold Value °C (°F)	1731.6 (3116.9)	1731.6 (3116.9)	1731.6 (3116.9)	1731.6 (3116.9)	1731.6 (3116.9)	1731.6 (3116.9)	1200 (2160)

# Diagnostic Trouble Code (DTC) Detecting Criteria

## GENERAL DESCRIPTION

### Map 8

Estimate ambient temperature °C (°F)	-7 (19.4)	8 (46.4)	10 (50)	25 (77)
Threshold Value °C (°F)	11.1 (20)	11.1 (20)	11.1 (20)	11.1 (20)

### Map 9

Engine coolant temperature at engine starting °C (°F)	-7 (19.4)	8 (46.4)	10 (50)	25 (77)
Threshold Value °C (°F)	1731.6 (3116.9)	1731.6 (3116.9)	1731.6 (3116.9)	1731.6 (3116.9)

**Time Needed for Diagnosis:** 300 — 700 seconds

**Malfunction Indicator Light Illumination:** Illuminates when malfunction occurs in 2 continuous driving cycles.

#### • Normality Judgment

Judge as OK and clear the NG if the continuous time while the following conditions are established is more than the predetermined time.

#### Judgment Value

Malfunction Criteria	Threshold Value
All of the following conditions are established.	
<Judgment 1>	
Actual engine coolant temperature and $\Sigma$ (Estimated engine coolant temperature – actual engine coolant temperature)	$\geq$ Value of Map 4  $\leq$ Value of Map 5
<Judgment 2>	
Actual engine coolant temperature and $\Sigma$ (Estimated engine coolant temperature – actual engine coolant temperature)	$\geq$ Regulated temperature – Value of Map 6  $\leq$ Value of Map 7
<Judgment 3>	
Estimated engine coolant temperature – actual engine coolant temperature and $\Sigma$ (Estimated engine coolant temperature – actual engine coolant temperature) and Actual engine coolant temperature	$\leq$ Value of Map 8  $\leq$ Value of Map 9  $\geq$ Regulated temperature – Value of Map 10

### Map 10

Estimate ambient temperature °C (°F)	-7 (19.4)	8 (46.4)	10 (50)	25 (77)
Threshold Value °C (°F)	11.1 (20)	11.1 (20)	11.1 (20)	11.1 (20)

**Time Needed for Diagnosis:** 300 — 700 seconds

# Diagnostic Trouble Code (DTC) Detecting Criteria

GENERAL DESCRIPTION

## AD:DTC P0131 O2 SENSOR CIRCUIT LOW VOLTAGE (BANK 1 SENSOR 1)

### 1. OUTLINE OF DIAGNOSIS

Detect the open or short circuit of sensor.

Judge as NG, when the element voltage is out of the specified range.

### 2. COMPONENT DESCRIPTION

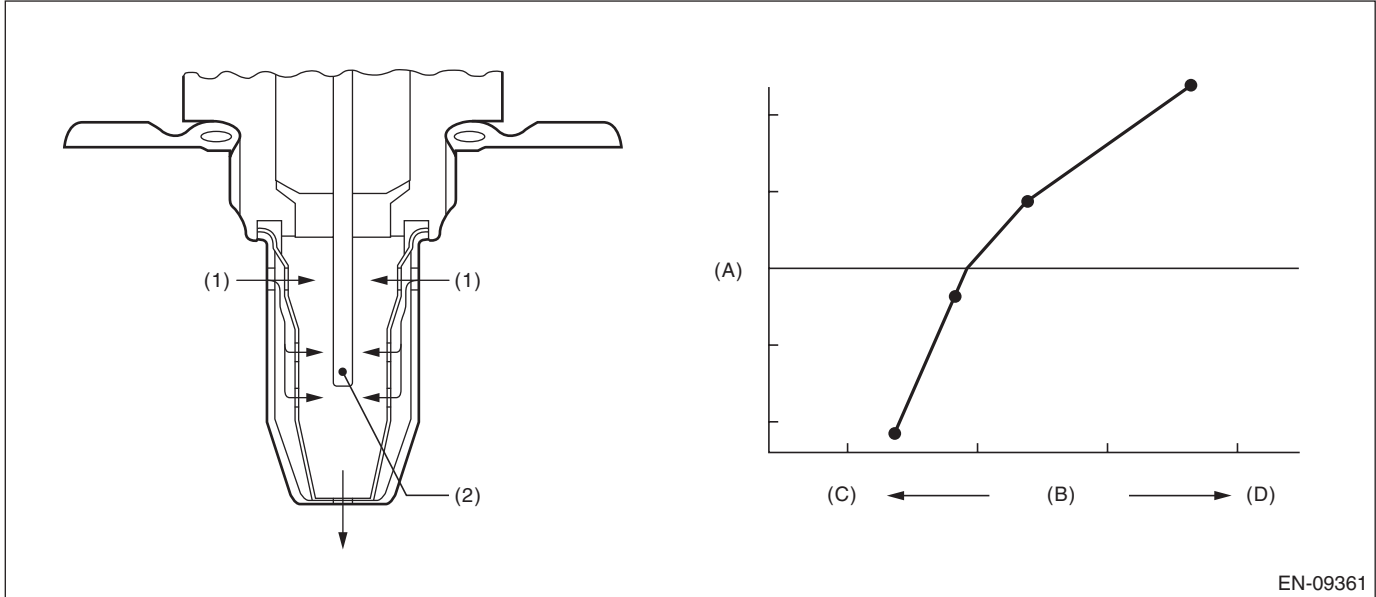

(A) Electromotive force

(B) Air fuel ratio

(C) Lean

(D) Rich

(1) Exhaust gas

(2)  $ZrO_2$

### 3. ENABLE CONDITIONS

Secondary Parameters	Enable Conditions
Battery voltage	$\geq 10.9$ V

### 4. GENERAL DRIVING CYCLE

Always perform the diagnosis continuously.

# Diagnostic Trouble Code (DTC) Detecting Criteria

## GENERAL DESCRIPTION

---

### 5. DIAGNOSTIC METHOD

#### • Abnormality Judgment

If the duration of time while the following conditions are met is longer than the time indicated, judge as NG.

#### Judgment Value

Malfunction Criteria	Threshold Value
Input voltage (+) or Input voltage (-) or  Input voltage (+) – Input voltage (-)	< 1.128 V  < 0.23 V  < 0.644 V

#### Time Needed for Diagnosis:

Input voltage (+): 1000 ms

Input voltage (-): 1000 ms

|Input voltage (+) – Input voltage (-)|: 1000 ms

**Malfunction Indicator Light Illumination:** Illuminates as soon as a malfunction occurs.

#### • Normality Judgment

Judge as OK and clear the NG if the continuous time while the following conditions are established is more than the predetermined time.

#### Judgment Value

Malfunction Criteria	Threshold Value
Input voltage (+) Input voltage (-)  Input voltage (+) – Input voltage (-)	$\geq 1.128$ V $\geq 0.23$ V $\geq 0.644$ V

**Time Needed for Diagnosis:** Less than 1 second

# Diagnostic Trouble Code (DTC) Detecting Criteria

GENERAL DESCRIPTION

## AE:DTC P0132 O2 SENSOR CIRCUIT HIGH VOLTAGE (BANK 1 SENSOR 1)

### 1. OUTLINE OF DIAGNOSIS

Detect the open or short circuit of sensor.

Judge as NG, when the element voltage is out of the specified range.

### 2. COMPONENT DESCRIPTION

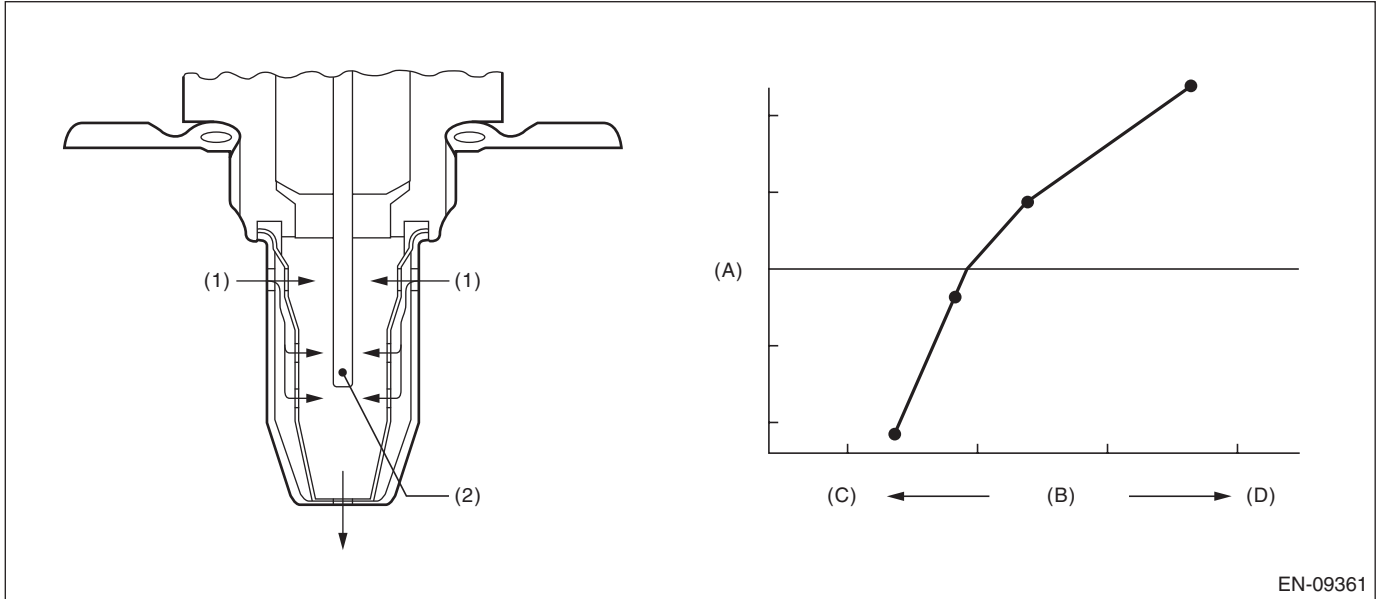

EN-09361

(A) Electromotive force

(B) Air fuel ratio

(C) Lean

(D) Rich

(1) Exhaust gas

(2)  $ZrO_2$

### 3. ENABLE CONDITIONS

Secondary Parameters	Enable Conditions
Battery voltage	$\geq 10.9$ V

### 4. GENERAL DRIVING CYCLE

Always perform the diagnosis continuously.



# Diagnostic Trouble Code (DTC) Detecting Criteria

## GENERAL DESCRIPTION

---

### 5. DIAGNOSTIC METHOD

#### • Abnormality Judgment

If the duration of time while the following conditions are met is longer than the time indicated, judge as NG.

#### Judgment Value

Malfunction Criteria	Threshold Value
Input voltage (+) or Input voltage (-)	> 3.589 V  > 3.541 V

#### Time Needed for Diagnosis:

Input voltage (+): 1000 ms

Input voltage (-): 1000 ms

**Malfunction Indicator Light Illumination:** Illuminates as soon as a malfunction occurs.

#### • Normality Judgment

Judge as OK and clear the NG if the continuous time while the following conditions are established is more than the predetermined time.

#### Judgment Value

Malfunction Criteria	Threshold Value
Input voltage (+) Input voltage (-)	$\leq 3.589$ V $\leq 3.541$ V

**Time Needed for Diagnosis:** Less than 1 second

# Diagnostic Trouble Code (DTC) Detecting Criteria

GENERAL DESCRIPTION

## AF:DTC P0133 O2 SENSOR CIRCUIT SLOW RESPONSE (BANK 1 SENSOR 1)

### 1. OUTLINE OF DIAGNOSIS

Detect the slow response of front oxygen (A/F) sensor.

Front oxygen (A/F) sensor cover has some ventilation holes for exhaust gas. Clogged ventilation holes are diagnosed.

When the holes are clogged, the A/F output variation becomes slow comparing with the actual A/F variation because oxygen which reaches the zirconia layer is insufficient. Therefore, if the sensor cover holes are clogged, the rich to lean judgment in the ECM is delayed when the actual change from rich to lean occurs. Judge as NG when the actual movement in comparison to the ECM control amount is slow.

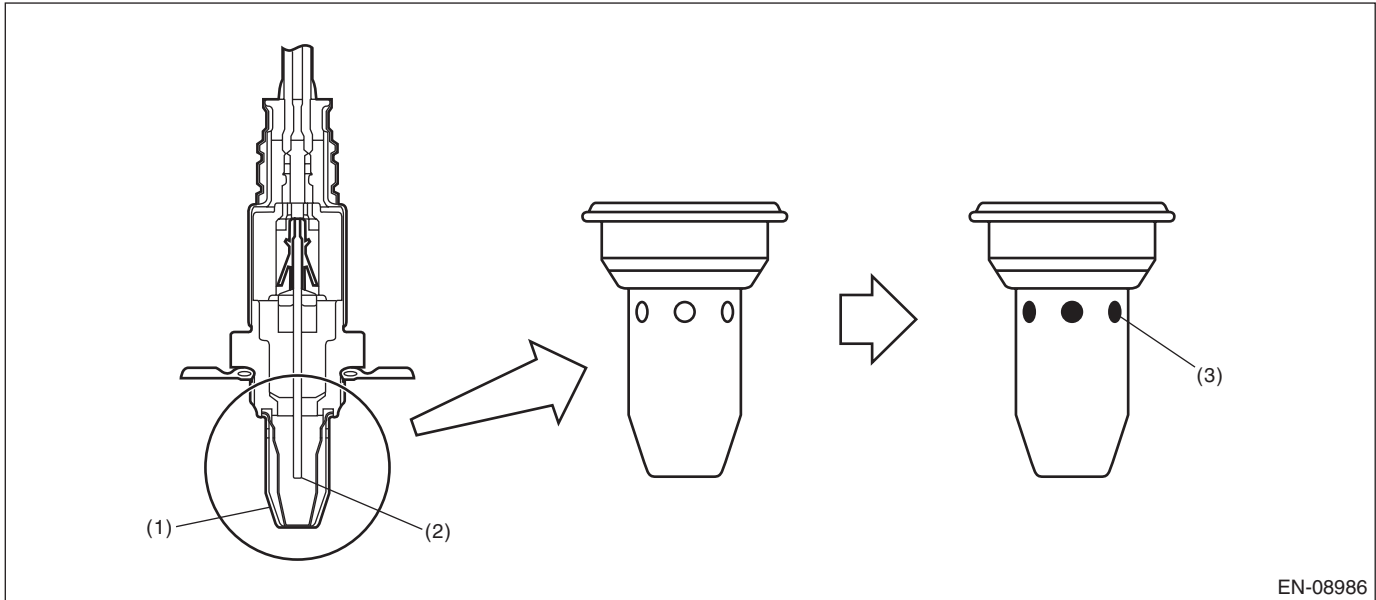

EN-08986

(1) Cover

(2) Zirconia

(3) Clogging

### 2. COMPONENT DESCRIPTION

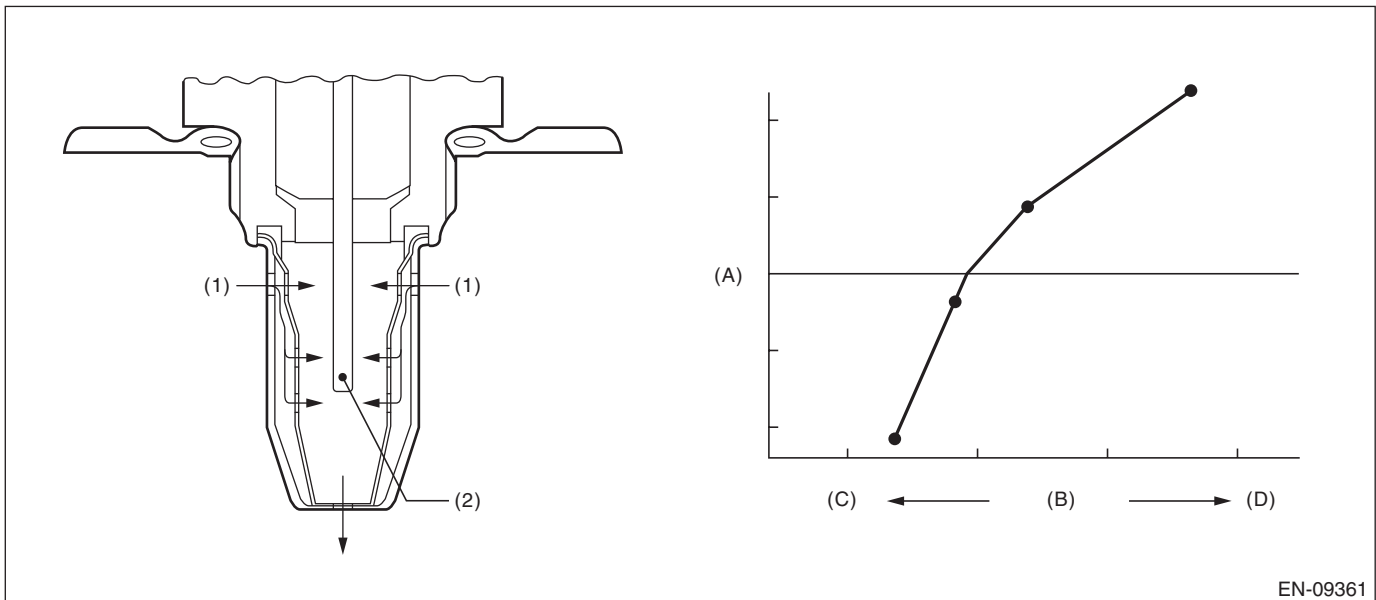

EN-09361

(A) Electromotive force

(B) Air fuel ratio

(C) Lean

(D) Rich

(1) Exhaust gas

(2) ZrO<sub>2</sub>

GD(H4DOTC)-69

Brought to you by Ebay Seller "SubaruManuals"

# Diagnostic Trouble Code (DTC) Detecting Criteria

## GENERAL DESCRIPTION

### 3. ENABLE CONDITIONS

Secondary Parameters	Enable Conditions
Time needed for all secondary parameters to be in enable conditions	$\geq 1024$ ms
Battery voltage	$\geq 10.9$ V
Atmospheric pressure	$> 75$ kPa (563 mmHg, 22.2 inHg)
Closed loop control with main feedback	Operation
Front oxygen (A/F) sensor impedance	$0 \Omega$ — $50 \Omega$
Elapsed time after starting the engine	$\geq 120000$ ms
Engine coolant temperature	$\geq 70$ °C (158 °F)
Engine speed	1000 rpm — 10000 rpm
Vehicle speed	10 km/h — 200 km/h (6.2 MPH — 124.3 MPH)
Amount of intake air	10 g/s — 31 g/s (0.35 oz/s — 1.09 oz/s)
Engine load	$< 0.02$ g/rev (0 oz/rev)
Learning value of EVAP conc. during purge	$< 0.2$
Total time of operating canister purge	$\geq 19.9$ s

### 4. GENERAL DRIVING CYCLE

Perform diagnosis only once at a constant speed of 10 km/h — 200 km/h (6.2 MPH — 124.3 MPH) 120000 ms seconds or more after starting the engine.

### 5. DIAGNOSTIC METHOD

Calculate  $faf$  difference every  $32 \text{ ms} \times 4$ , and the  $\lambda$  value difference. Calculate the diagnostic value after calculating 820 time(s).

#### • Abnormality Judgment

If the duration of time while the following conditions are met is longer than the time indicated, judge as NG.

#### Judgment Value

Malfunction Criteria	Threshold Value
$\text{para}fca = \text{td}2faf/\text{td}2lmd$ where, $\text{td}2faf(N) = \text{td}2faf(n-1) +  \text{d}2faf(n) $ $\text{td}2lmd(N) = \text{td}2lmd(n-1) +  \text{d}2lmd(n) $ add up to $32 \text{ ms} \times 4 \times 820$ time(s). $\text{d}2faf(n) = (faf(n) - faf(n-1)) - (faf(n-1) - faf(n-2))$ $\text{d}2lmd(n) = (lmd(n) - lmd(n-1)) - (lmd(n-1) - lmd(n-2))$ faf = main feedback compensation coefficient every 128 milliseconds lmd = output lambda every 128 milliseconds	$> 0.267$

**Time Needed for Diagnosis:**  $32 \text{ ms} \times 4 \times 820$  time(s)

**Malfunction Indicator Light Illumination:** Illuminates when malfunction occurs in 2 continuous driving cycles.

# Diagnostic Trouble Code (DTC) Detecting Criteria

GENERAL DESCRIPTION

## • Normality Judgment

Judge as OK and clear the NG if the continuous time while the following conditions are established is more than the predetermined time.

### Judgment Value

Malfunction Criteria	Threshold Value
$para_{fca} = td_{2faf}/td_{2lmd}$ where, $td_{2faf}(N) = td_{2faf}(n-1) +  d_{2faf}(n) $ $td_{2lmd}(N) = td_{2lmd}(n-1) +  d_{2lmd}(n) $ add up to $32 \text{ ms} \times 4 \times 820 \text{ time(s)}$ . $d_{2faf}(n) = (faf(n) - faf(n-1)) - (faf(n-1) - faf(n-2))$ $d_{2lmd}(n) = (lmd(n) - lmd(n-1)) - (lmd(n-1) - lmd(n-2))$ faf = main feedback compensation coefficient every 128 milliseconds lmd = output lambda every 128 milliseconds	$\leq 0.267$

**Time Needed for Diagnosis:**  $32 \text{ ms} \times 4 \times 820 \text{ time(s)}$

# Diagnostic Trouble Code (DTC) Detecting Criteria

## GENERAL DESCRIPTION

### AG:DTC P0134 O2 SENSOR CIRCUIT NO ACTIVITY DETECTED (BANK 1 SENSOR 1)

#### 1. OUTLINE OF DIAGNOSIS

Detect open circuits of the sensor.

Judge as NG when the impedance of the element is large.

#### 2. COMPONENT DESCRIPTION

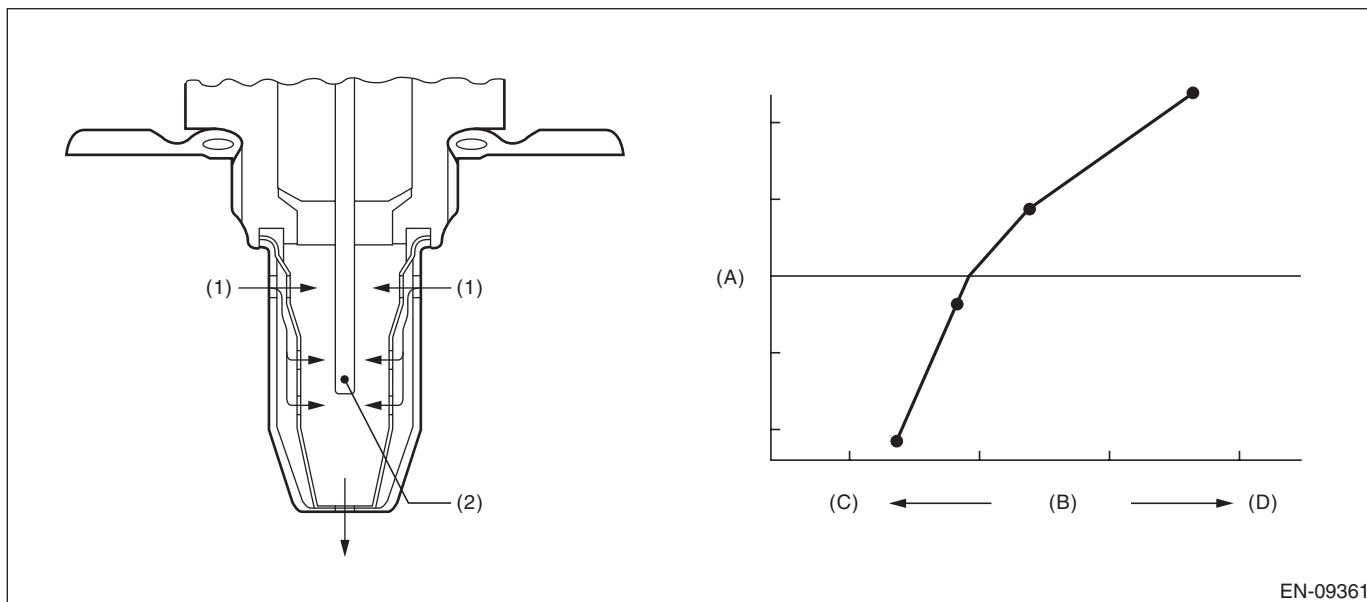

EN-09361

(A) Electromotive force

(B) Air fuel ratio

(C) Lean

(D) Rich

(1) Exhaust gas

(2) ZrO<sub>2</sub>

#### 3. ENABLE CONDITIONS

Secondary Parameters	Enable Conditions
None	

#### 4. GENERAL DRIVING CYCLE

Always perform the diagnosis continuously.

# Diagnostic Trouble Code (DTC) Detecting Criteria

GENERAL DESCRIPTION

## 5. DIAGNOSTIC METHOD

### • Abnormality Judgment

If the duration of time while the following conditions are met is longer than the time indicated, judge as NG.

#### Judgment Value

Malfunction Criteria	Threshold Value
Battery voltage	$\geq 10.9$ V
Time of heater control duty at 70 % or more	$\geq 36000$ ms
Front oxygen (A/F) sensor impedance.	$> 500$ $\Omega$

**Time Needed for Diagnosis:** 5000 ms

**Malfunction Indicator Light Illumination:** Illuminates as soon as a malfunction occurs.

### • Normality Judgment

Judge as OK and clear the NG if the continuous time while the following conditions are established is more than the predetermined time.

#### Judgment Value

Malfunction Criteria	Threshold Value
Battery voltage	$\geq 10.9$ V
Front oxygen (A/F) sensor impedance.	$\leq 500$ $\Omega$

**Time Needed for Diagnosis:** Less than 1 second

# Diagnostic Trouble Code (DTC) Detecting Criteria

## GENERAL DESCRIPTION

### AH:DTC P0137 O2 SENSOR CIRCUIT LOW VOLTAGE (BANK 1 SENSOR 2)

#### 1. OUTLINE OF DIAGNOSIS

Detect continuity NG of the oxygen sensor. If the oxygen sensor voltage reading is not within the probable range considering the operating conditions, judge as NG.

#### 2. COMPONENT DESCRIPTION

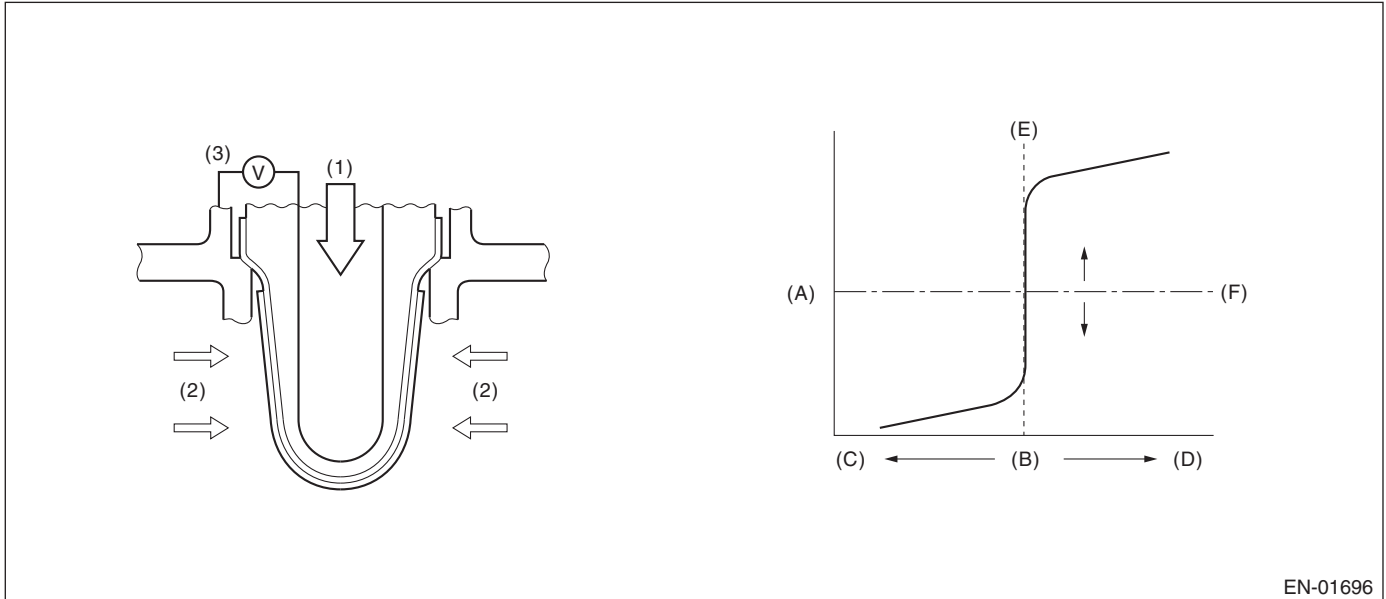

EN-01696

(A) Electromotive force

(B) Air fuel ratio

(C) Rich

(D) Lean

(E) Theoretical air fuel ratio

(F) Comparative voltage

(1) Atmosphere

(2) Exhaust gas

(3) Electromotive force

# Diagnostic Trouble Code (DTC) Detecting Criteria

GENERAL DESCRIPTION

## 3. ENABLE CONDITIONS

### Used for abnormality judgment

Secondary Parameters	Enable Conditions
<b>High</b> Secondary air system Closed loop control at the oxygen sensor Misfire detection every 200 rotations Front oxygen (A/F) sensor compensation coefficient Battery voltage Engine coolant temperature	Not in operation In operation < 65535 time(s) Not in limit value ≥ 10.9 V ≥ 70 °C (158 °F)
<b>Low (1)</b> Secondary air system Closed loop control at the oxygen sensor Misfire detection every 200 rotations Front oxygen (A/F) sensor compensation coefficient Battery voltage Engine coolant temperature Amount of intake air	Not in operation In operation < 65535 time(s) Not in limit value ≥ 10.9 V ≥ 70 °C (158 °F) ≥ 10 g/s (0.35 oz/s)
<b>Low (2)</b> Secondary air system Closed loop control at the oxygen sensor Misfire detection every 200 rotations Front oxygen (A/F) sensor compensation coefficient Battery voltage Engine coolant temperature Amount of intake air Current continuation time of the rear oxygen sensor heater	Not in operation In operation < 65535 time(s) Not in limit value ≥ 10.9 V ≥ 70 °C (158 °F) < 10 g/s (0.35 oz/s) ≥ 25000 ms
<b>Low (3)</b> Secondary air system Closed loop control at the oxygen sensor Misfire detection every 200 rotations Front oxygen (A/F) sensor compensation coefficient Battery voltage Engine coolant temperature Amount of intake air Current continuation time of the rear oxygen sensor heater Fuel cut	Not in operation In operation < 65535 time(s) Not in limit value ≥ 10.9 V ≥ 70 °C (158 °F) < 10 g/s (0.35 oz/s) ≥ 25000 ms Experienced

### Used for normality judgment

Secondary Parameters	Enable Conditions
Secondary air system Closed loop control at the oxygen sensor Misfire detection every 200 rotations Front oxygen (A/F) sensor compensation coefficient Battery voltage Engine coolant temperature	Not in operation In operation < 65535 time(s) Not in limit value ≥ 10.9 V ≥ 70 °C (158 °F)

## 4. GENERAL DRIVING CYCLE

After starting the engine, continuously perform the diagnosis with the same engine condition.

**GD(H4DOTC)-75**

Brought to you by Ebay Seller "SubaruManuals"



# Diagnostic Trouble Code (DTC) Detecting Criteria

## GENERAL DESCRIPTION

---

### 5. DIAGNOSTIC METHOD

#### • Abnormality Judgment

If the duration of time while the following conditions are met is longer than the time indicated, judge as NG.

#### Judgment Value

Malfunction Criteria	Threshold Value	DTC
<b>High</b> Sensor output voltage	> 1.2 V	P0138
<b>Low</b> Sensor output voltage	< 0.03 V	P0137

#### Time Needed for Diagnosis:

- High: 2500 ms
- Low (1): 20000 ms
- Low (2): 150000 ms
- Low (3): Value from Map

#### Map

Fuel cut time (s)	0	2000	10000
Time Needed for Diagnosis (s)	150000	150000	150000

**Malfunction Indicator Light Illumination:** Illuminates when malfunction occurs in 2 continuous driving cycles.

#### • Normality Judgment

Judge as OK and clear the NG if the continuous time while the following conditions are established is more than the predetermined time.

#### Judgment Value

Malfunction Criteria	Threshold Value	DTC
<b>High</b> Sensor output voltage	$\leq 1.2$ V	P0138
<b>Low</b> Sensor output voltage	$\geq 0.03$ V	P0137

#### Time Needed for Diagnosis:

- High: Less than 1 second
- Low (1): Less than 1 second
- Low (2): Less than 1 second
- Low (3): Less than 1 second

## AI: DTC P0138 O2 SENSOR CIRCUIT HIGH VOLTAGE (BANK 1 SENSOR 2)

### 1. OUTLINE OF DIAGNOSIS

#### NOTE:

For the detection standard, refer to DTC P0137. <Ref. to GD(H4DOTC)-74, DTC P0137 O2 SENSOR CIRCUIT LOW VOLTAGE (BANK 1 SENSOR 2), Diagnostic Trouble Code (DTC) Detecting Criteria.>

# Diagnostic Trouble Code (DTC) Detecting Criteria

GENERAL DESCRIPTION

## AJ:DTC P013A O2 SENSOR SLOW RESPONSE - RICH TO LEAN (BANK 1 SENSOR 2)

### 1. OUTLINE OF DIAGNOSIS

Detect the slow response of rich → lean for rear oxygen sensor output.

When the deceleration fuel cut has occurred, detect the trouble by calculating the time when the rear oxygen sensor output passes through the predetermined range of voltages.

Judge as NG when the response time is larger than the threshold value.

### 2. COMPONENT DESCRIPTION

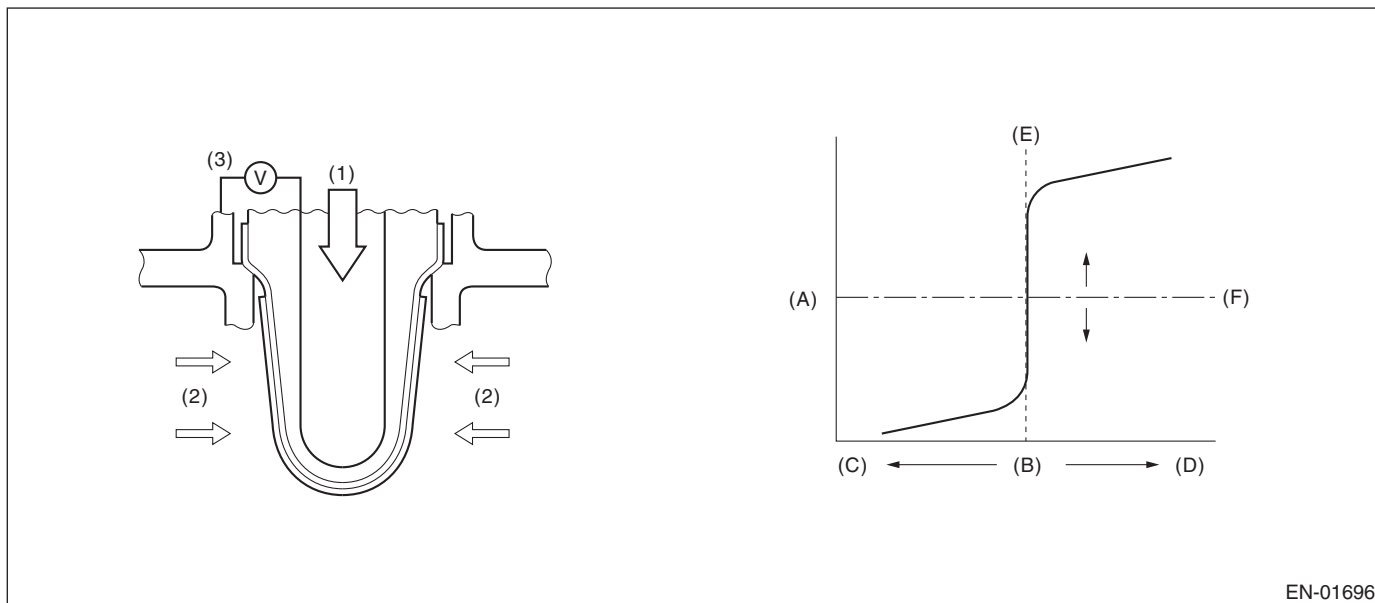

EN-01696

- |                         |                                |                         |
|-------------------------|--------------------------------|-------------------------|
| (A) Electromotive force | (B) Air fuel ratio             | (C) Rich                |
| (D) Lean                | (E) Theoretical air fuel ratio | (F) Comparative voltage |
| (1) Atmosphere          | (2) Exhaust gas                | (3) Electromotive force |

### 3. ENABLE CONDITIONS

Secondary Parameters	Enable Conditions
Battery voltage	> 10.9 V
Rear oxygen sensor closed loop control	Operation
Current calculation time of the rear oxygen sensor heater after starting	≥ 180000 ms
Engine speed when fuel cut starts	≥ 1600 rpm (Models without SI-DRIVE) ≥ 1700 rpm (Models with SI-DRIVE)
Rear oxygen sensor voltage when fuel cut starts	≥ 0.55 V
Fuel cut time	≥ 5000 ms
Engine coolant temperature when fuel cut starts	≥ 70 °C (158 °F)
Estimated temperature of rear oxygen sensor element when fuel cut starts	≥ 450 °C (842 °F)

### 4. GENERAL DRIVING CYCLE

Perform diagnosis once during deceleration fuel cut from a constant and high speed driving, when rear oxygen sensor is warmed up sufficiently.

# Diagnostic Trouble Code (DTC) Detecting Criteria

## GENERAL DESCRIPTION

### 5. DIAGNOSTIC METHOD

Detect the trouble by calculating the response time of the rear oxygen sensor during fuel cut.

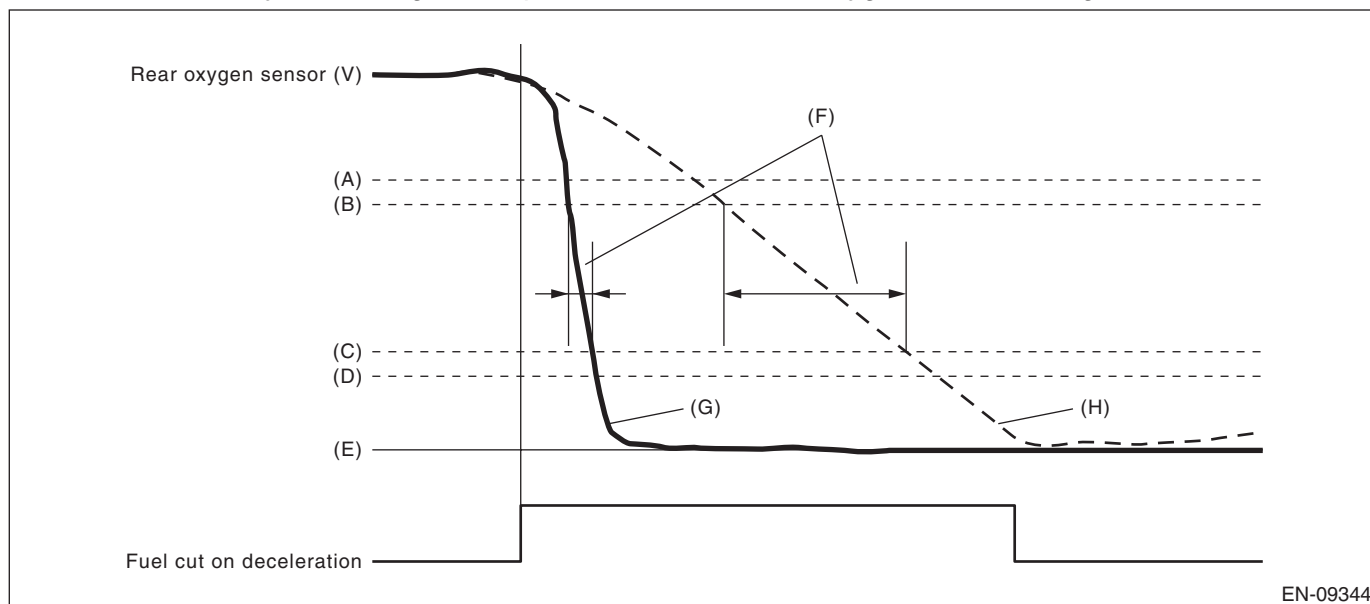

EN-09344

(A) 0.55 V	(B) 0.50 V	(C) 0.20 V
(D) 0.15 V	(E) 0 V	(F) Diagnostic parameter
(G) Normal	(H) Malfunction	

#### • Abnormality Judgment

Judge as NG when the following conditions are established.

#### Judgment Value

Malfunction Criteria	Threshold Value
Time when rear oxygen sensor voltage changed from 0.5 V to 0.2 V.	> 837 ms

**Time Needed for Diagnosis:** 10 seconds

**Malfunction Indicator Light Illumination:** Illuminates when malfunction occurs in 2 continuous driving cycles.

#### • Normality Judgment

Judge as OK and clear the NG if the following conditions are established.

#### Judgment Value

Malfunction Criteria	Threshold Value
Time when rear oxygen sensor voltage changed from 0.5 V to 0.2 V.	≤ 837 ms

**Time Needed for Diagnosis:** 10 seconds

# Diagnostic Trouble Code (DTC) Detecting Criteria

GENERAL DESCRIPTION

## AK:DTC P013B O2 SENSOR SLOW RESPONSE - LEAN TO RICH (BANK 1 SENSOR 2)

### 1. OUTLINE OF DIAGNOSIS

Detect the slow response of lean → rich for rear oxygen sensor output.

After the deceleration fuel cut has occurred, detect the trouble by calculating the time when the rear oxygen sensor output passes through the predetermined range of voltages.

Judge as NG when the response time is larger than the threshold value.

### 2. COMPONENT DESCRIPTION

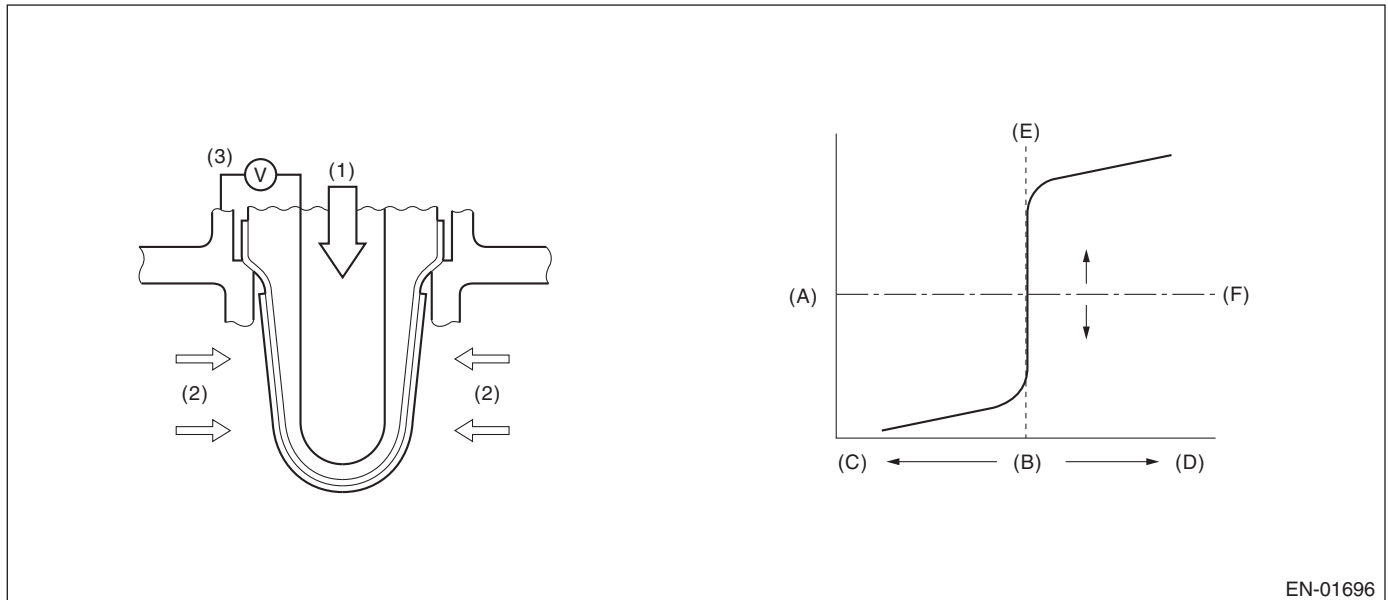

EN-01696

(A) Electromotive force

(B) Air fuel ratio

(C) Rich

(D) Lean

(E) Theoretical air fuel ratio

(F) Comparative voltage

(1) Atmosphere

(2) Exhaust gas

(3) Electromotive force

### 3. ENABLE CONDITIONS

Secondary Parameters	Enable Conditions
Battery voltage	> 10.9 V
Rear oxygen sensor closed loop control	Operation
Fuel cut time	≥ 5000 ms

### 4. GENERAL DRIVING CYCLE

Perform diagnosis only once after recovering from a deceleration fuel cut continued for more than predetermined time.

# Diagnostic Trouble Code (DTC) Detecting Criteria

## GENERAL DESCRIPTION

### 5. DIAGNOSTIC METHOD

Detect the trouble by calculating the response time of the rear oxygen sensor after fuel cut.

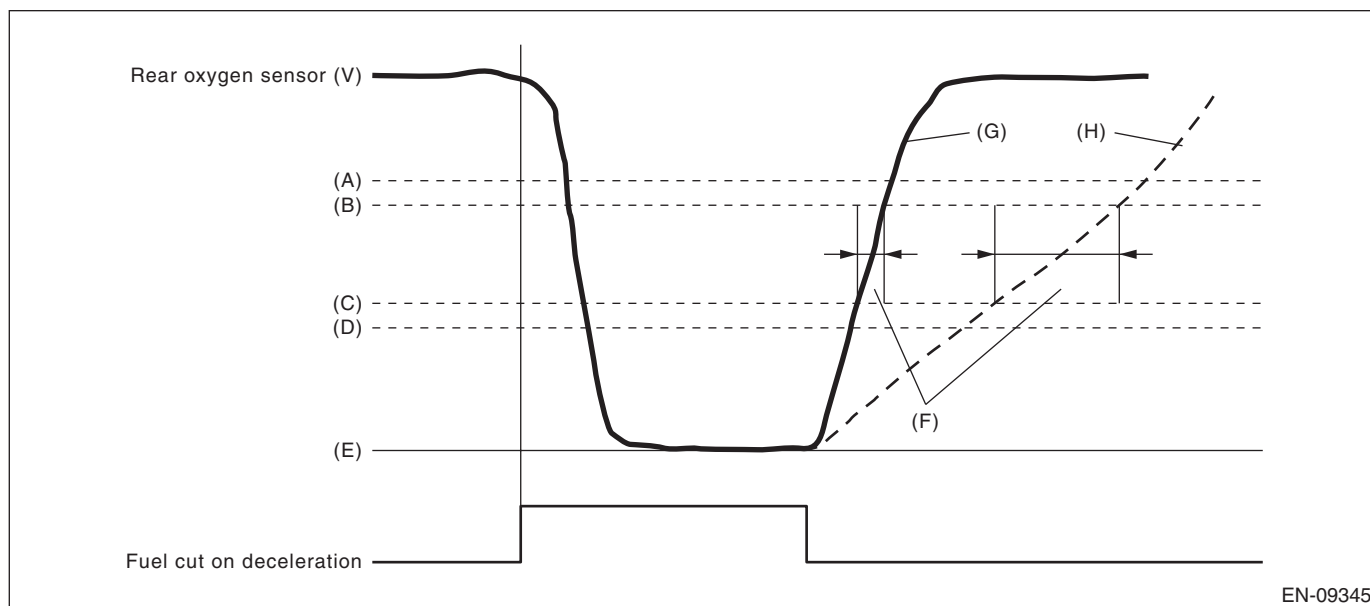

EN-09345

- |            |                 |                          |
|------------|-----------------|--------------------------|
| (A) 0.55 V | (B) 0.50 V      | (C) 0.30 V               |
| (D) 0.25 V | (E) 0 V         | (F) Diagnostic parameter |
| (G) Normal | (H) Malfunction |                          |

#### • Abnormality Judgment

Judge as NG when the following conditions are established.

#### Judgment Value

Malfunction Criteria	Threshold Value
Time when rear oxygen sensor voltage changed from 0.3 V to 0.5 V.	> 4000 ms

**Time Needed for Diagnosis:** 10 seconds

**Malfunction Indicator Light Illumination:** Illuminates when malfunction occurs in 2 continuous driving cycles.

#### • Normality Judgment

Judge as OK and clear the NG if the following conditions are established.

#### Judgment Value

Malfunction Criteria	Threshold Value
Time when rear oxygen sensor voltage changed from 0.3 V to 0.5 V.	≤ 4000 ms

**Time Needed for Diagnosis:** 10 seconds

## AL:DTC P013E O2 SENSOR DELAYED RESPONSE - RICH TO LEAN (BANK 1 SENSOR 2)

### 1. OUTLINE OF DIAGNOSIS

Detect the delayed response of rear oxygen sensor output for rich → lean.

After the deceleration fuel cut has started, detect the trouble by calculating the time when the rear oxygen sensor output decreases to the predetermined voltages.

Judge as NG when the response time is larger than the threshold value.

### 2. COMPONENT DESCRIPTION

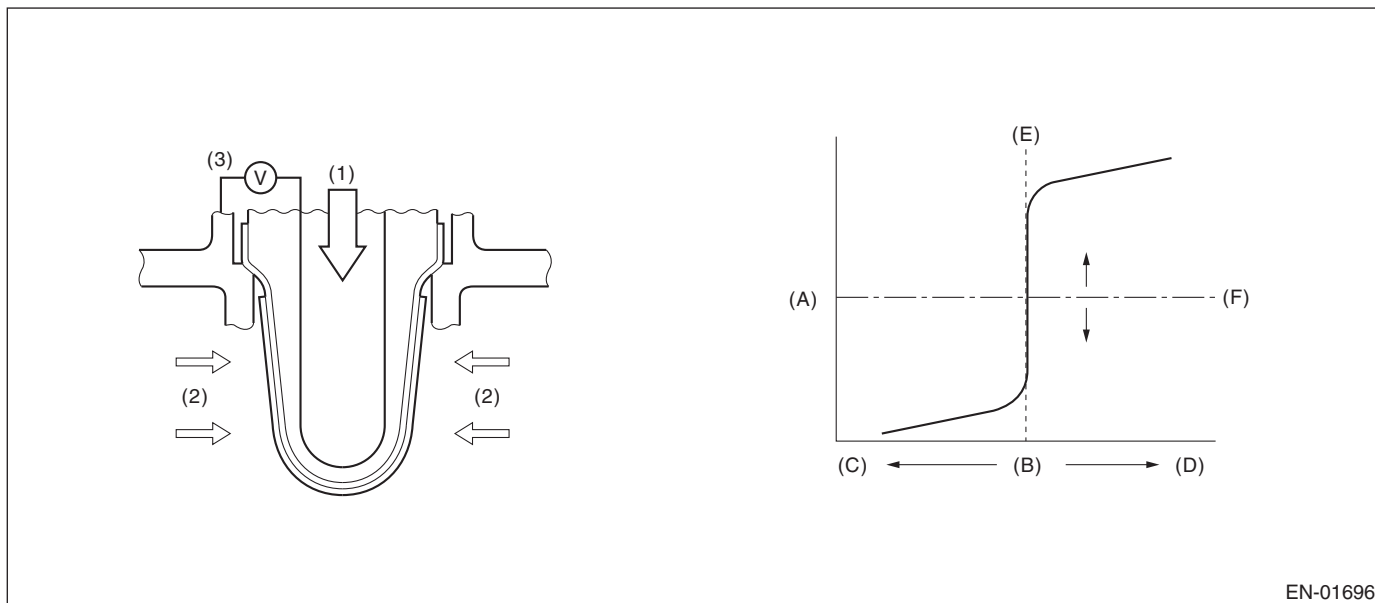

EN-01696

- |                         |                                |                         |
|-------------------------|--------------------------------|-------------------------|
| (A) Electromotive force | (B) Air fuel ratio             | (C) Rich                |
| (D) Lean                | (E) Theoretical air fuel ratio | (F) Comparative voltage |
| (1) Atmosphere          | (2) Exhaust gas                | (3) Electromotive force |

### 3. ENABLE CONDITIONS

Secondary Parameters	Enable Conditions
Battery voltage	> 10.9 V
Rear oxygen sensor closed loop control	Operation
Engine speed when fuel cut starts	≥ 1600 rpm (Models without SI-DRIVE) ≥ 1700 rpm (Models with SI-DRIVE)
Rear oxygen sensor voltage when fuel cut starts	≥ 0.55 V
Fuel cut time	≥ 5000 ms
Engine coolant temperature when fuel cut starts	≥ 70 °C (158 °F)
Estimated temperature of rear oxygen sensor element when fuel cut starts	≥ 450 °C (842 °F)

### 4. GENERAL DRIVING CYCLE

Perform diagnosis once during deceleration fuel cut from a constant and high speed driving, when rear oxygen sensor is warmed up sufficiently.

# Diagnostic Trouble Code (DTC) Detecting Criteria

## GENERAL DESCRIPTION

### 5. DIAGNOSTIC METHOD

Detect the trouble by calculating the time from the beginning of the fuel cut to the beginning of the rear oxygen sensor voltage starting to drop.

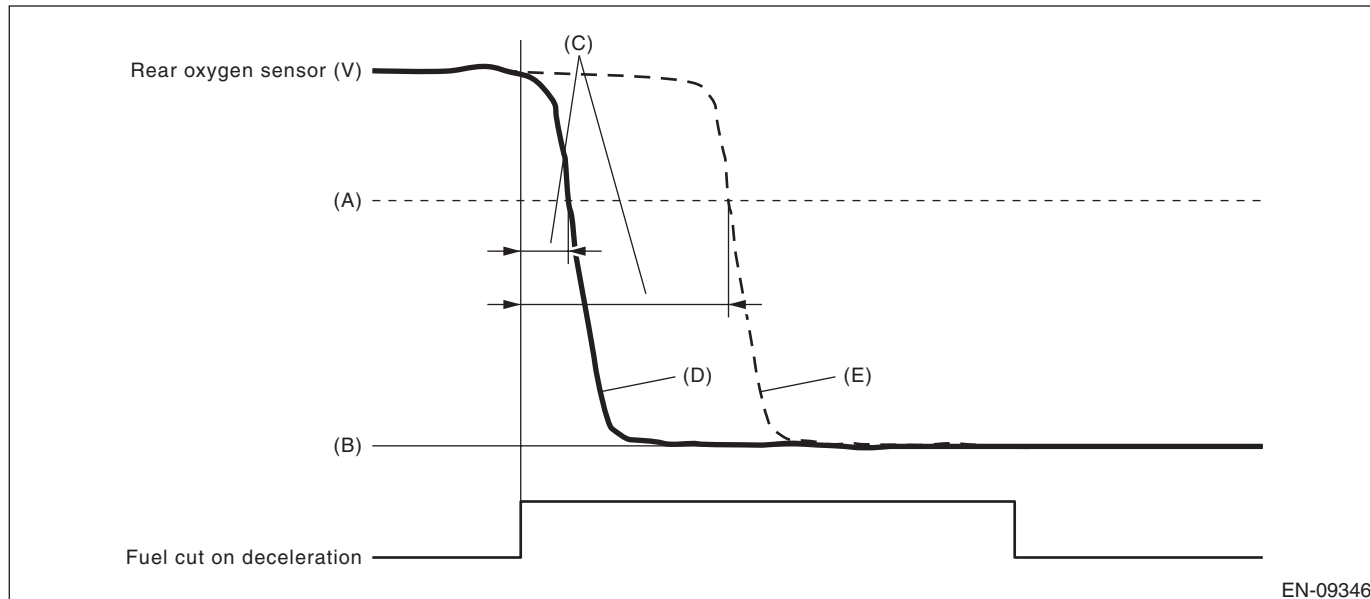

EN-09346

(A) 0.5 V

(B) 0 V

(C) Diagnostic parameter

(D) Normal

(E) Malfunction

#### • Abnormality Judgment

Judge as NG when the following conditions are established.

#### Judgment Value

Malfunction Criteria	Threshold Value
Time when rear oxygen sensor voltage changed to 0.5 V after the fuel cut started.	> 4000 ms

**Time Needed for Diagnosis:** 10 seconds

**Malfunction Indicator Light Illumination:** Illuminates when malfunction occurs in 2 continuous driving cycles.

#### • Normality Judgment

Judge as OK and clear the NG if the following conditions are established.

#### Judgment Value

Malfunction Criteria	Threshold Value
Time when rear oxygen sensor voltage changed to 0.5 V after the fuel cut started.	$\leq$ 4000 ms

**Time Needed for Diagnosis:** 10 seconds

## AM:DTC P013F O2 SENSOR DELAYED RESPONSE - LEAN TO RICH (BANK 1 SENSOR 2)

### 1. OUTLINE OF DIAGNOSIS

Detect the delayed response of rear oxygen sensor output for lean → rich.

After the deceleration fuel cut has completed, detect the trouble by calculating the time when the rear oxygen sensor output increases to the predetermined voltages.

Judge as NG when the response time is larger than the threshold value.

### 2. COMPONENT DESCRIPTION

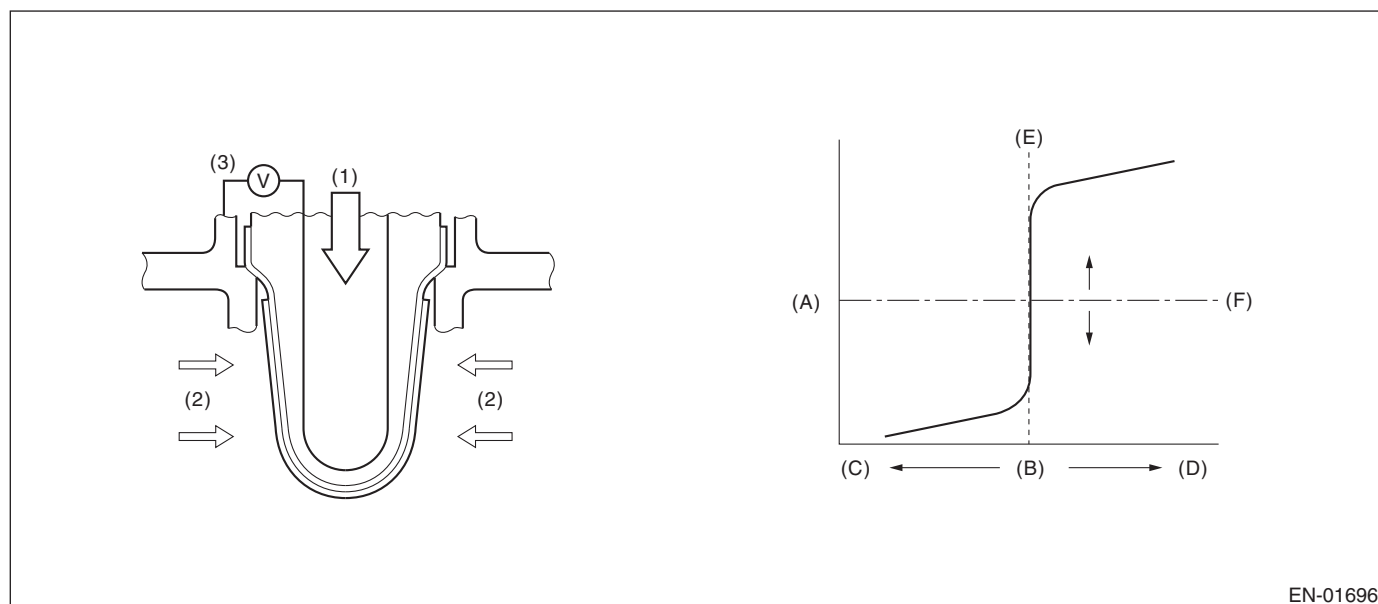

EN-01696

- |                         |                                |                         |
|-------------------------|--------------------------------|-------------------------|
| (A) Electromotive force | (B) Air fuel ratio             | (C) Rich                |
| (D) Lean                | (E) Theoretical air fuel ratio | (F) Comparative voltage |
| (1) Atmosphere          | (2) Exhaust gas                | (3) Electromotive force |

### 3. ENABLE CONDITIONS

Secondary Parameters	Enable Conditions
Battery voltage	> 10.9 V
Rear oxygen sensor closed loop control	Operation
Engine speed	≥ 500 rpm
Rear oxygen sensor voltage when fuel cut has completed	< 0.15 V
Fuel cut time	≥ 5000 ms
Engine coolant temperature when fuel cut has completed	≥ 70 °C (158 °F)
Estimated element temperature of rear oxygen sensor when fuel cut has completed	≥ 450 °C (842 °F)

### 4. GENERAL DRIVING CYCLE

Perform diagnosis only once when recovering from the deceleration fuel cut continued for more than predetermined time with the rear oxygen sensor warmed up sufficiently.



# Diagnostic Trouble Code (DTC) Detecting Criteria

## GENERAL DESCRIPTION

### 5. DIAGNOSTIC METHOD

Detect the trouble by calculating the time from the completion of the fuel cut to the beginning of the rear oxygen sensor voltage starting to rise.

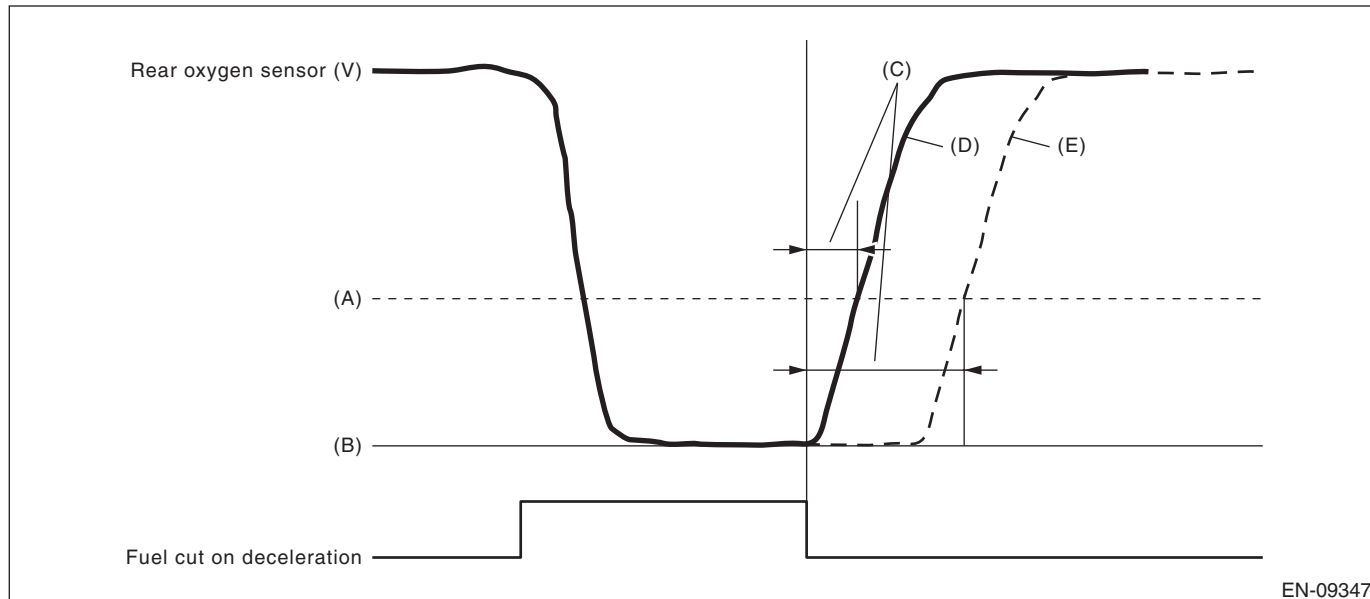

EN-09347

(A) 0.3 V

(B) 0 V

(C) Diagnostic parameter

(D) Normal

(E) Malfunction

#### • Abnormality Judgment

Judge as NG when the following conditions are established.

#### Judgment Value

Malfunction Criteria	Threshold Value
The number of times that the rear oxygen sensor voltage changed to 0.3 V after the fuel cut has completed (time counter)	> 3750 time(s)

**Time Needed for Diagnosis:** 10 seconds

**Malfunction Indicator Light Illumination:** Illuminates when malfunction occurs in 2 continuous driving cycles.

#### • Normality Judgment

Judge as OK and clear the NG if the following conditions are established.

#### Judgment Value

Malfunction Criteria	Threshold Value
The number of times that the rear oxygen sensor voltage changed to 0.3 V after the fuel cut has completed (time counter)	$\leq$ 3750 time(s)

**Time Needed for Diagnosis:** 10 seconds

# Diagnostic Trouble Code (DTC) Detecting Criteria

GENERAL DESCRIPTION

## AN:DTC P0140 O2 SENSOR CIRCUIT NO ACTIVITY DETECTED (BANK1 SENSOR2)

### 1. OUTLINE OF DIAGNOSIS

Detect the rear oxygen sensor open or short circuit. Judge as NG when the rear oxygen sensor voltage can be determined to be abnormal considering conditions such as intake air amount, engine coolant temperature, main feedback control and deceleration fuel cut.

### 2. COMPONENT DESCRIPTION

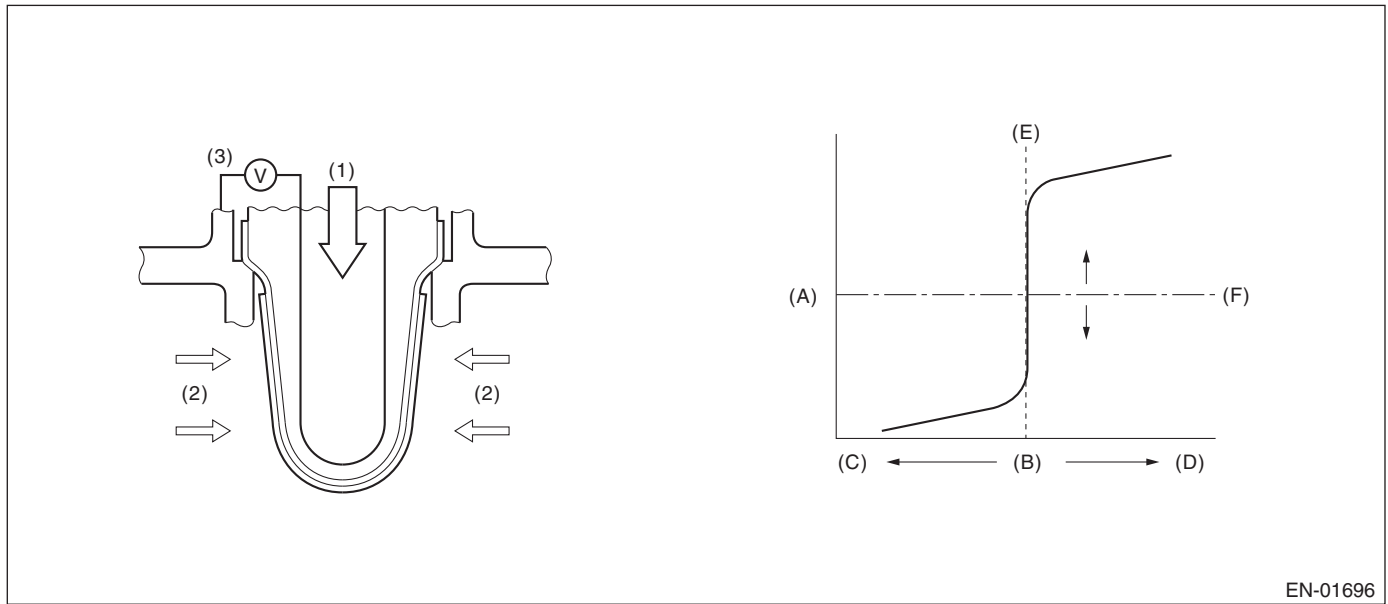

EN-01696

- |                         |                                |                         |
|-------------------------|--------------------------------|-------------------------|
| (A) Electromotive force | (B) Air fuel ratio             | (C) Rich                |
| (D) Lean                | (E) Theoretical air fuel ratio | (F) Comparative voltage |
| (1) Atmosphere          | (2) Exhaust gas                | (3) Electromotive force |

### 3. ENABLE CONDITION (USED ONLY FOR MALFUNCTION JUDGMENT)

Secondary Parameters	Enable Conditions
Closed loop control at the rear oxygen sensor	In operation
Target output voltage of rear oxygen sensor	$\geq 0.55 \text{ V} + 0.05 \text{ V}$
Amount of intake air	$\geq 10 \text{ g/s (0.35 oz/s)}$
Engine coolant temperature	$\geq 70 \text{ }^\circ\text{C (158 }^\circ\text{F)}$
Misfire detection every 200 rotations	$< 65535 \text{ time(s)}$
Front oxygen (A/F) sensor compensation coefficient	Not in limit value
Battery voltage	$\geq 10.9 \text{ V}$
Deceleration fuel cut of 5000 ms or more.	Experienced

### 4. GENERAL DRIVING CYCLE

Perform the diagnosis once after starting the engine.

# Diagnostic Trouble Code (DTC) Detecting Criteria

## GENERAL DESCRIPTION

---

### 5. DIAGNOSTIC METHOD

#### • Abnormality Judgment

If the duration of time while the following conditions are met is longer than the time indicated, judge as NG.

#### Judgment Value

Malfunction Criteria	Threshold Value
Minimum output voltage or Maximum output voltage	> 0.15 V  < 0.55 V

**Time Needed for Diagnosis:** 200000 ms

**Malfunction Indicator Light Illumination:** Illuminates when malfunction occurs in 2 continuous driving cycles.

#### • Normality Judgment

Judge as OK and clear the NG if the following conditions are established.

#### Judgment Value

Malfunction Criteria	Threshold Value
Diagnosis of the rear oxygen sensor voltage low side	Incomplete
Minimum output voltage	$\leq 0.15$ V
Maximum output voltage	$\geq 0.55$ V

**Time Needed for Diagnosis:** Less than 1 second

## AO:DTC P0141 O2 SENSOR HEATER CIRCUIT (BANK1 SENSOR2)

### 1. OUTLINE OF DIAGNOSIS

Detect malfunction of the rear oxygen sensor heater.

Judge as NG if it is determined that the rear oxygen sensor impedance is large by observing the engine conditions.

### 2. COMPONENT DESCRIPTION

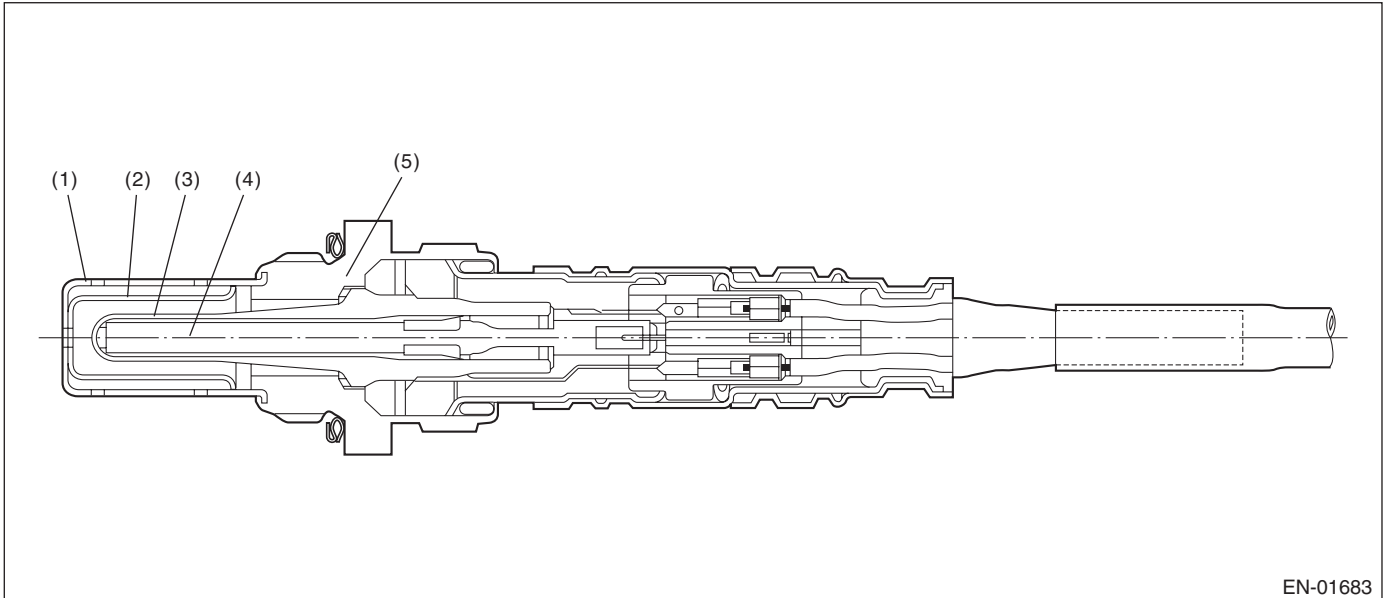

EN-01683

- |                           |                    |                    |
|---------------------------|--------------------|--------------------|
| (1) Element cover (outer) | (3) Sensor element | (5) Sensor housing |
| (2) Element cover (inner) | (4) Ceramic heater |                    |

### 3. ENABLE CONDITIONS

Secondary Parameters	Enable Conditions
Battery voltage	$\geq 10.9 \text{ V}$
Elapsed time after starting the engine	$\geq 1000 \text{ ms}$
Engine coolant temperature	$\geq 70 \text{ }^\circ\text{C}$ (158 $^\circ\text{F}$ )
A/F sensor element impedance	$\leq 50 \ \Omega$
A/F sensor heater control duty	$\leq 75 \%$
Rear oxygen sensor heater control duty	$< 30 \%$

### 4. GENERAL DRIVING CYCLE

Perform the diagnosis continuously after 1000 ms seconds or more have passed since the engine started.

# Diagnostic Trouble Code (DTC) Detecting Criteria

## GENERAL DESCRIPTION

---

### 5. DIAGNOSTIC METHOD

#### • Abnormality Judgment

If the duration of time while the following conditions are met is longer than the time indicated, judge as NG.

#### Judgment Value

Malfunction Criteria	Threshold Value
Output terminal for heater characteristics failure detection	Low

**Time Needed for Diagnosis:** 4 ms × 2500 time(s)

**Malfunction Indicator Light Illumination:** Illuminates when malfunction occurs in 2 continuous driving cycles.

#### • Normality Judgment

Judge as OK and clear the NG if the continuous time while the following conditions are established is more than the predetermined time.

#### Judgment Value

Malfunction Criteria	Threshold Value
Output terminal for heater characteristics failure detection	High

**Time Needed for Diagnosis:** 4 ms × 2500 time(s)

# Diagnostic Trouble Code (DTC) Detecting Criteria

GENERAL DESCRIPTION

## AP:DTC P0171 SYSTEM TOO LEAN (BANK 1)

### 1. OUTLINE OF DIAGNOSIS

Detect fuel system malfunction by the amount of main feedback control.

#### Diagnostic method

Fuel system is diagnosed by comparing the target air fuel ratio calculated by ECM with the actual air fuel ratio measured by sensor.

### 2. ENABLE CONDITIONS

Secondary Parameters	Enable Conditions
A/F main learning system	In operation
Engine coolant temperature	$\geq 70\text{ }^{\circ}\text{C}$ (158 °F)
Engine load change	$< 0.02\text{ g/rev}$ (0 oz/rev)
Engine load	$\geq$ Value of Map 1

#### Map1 (models without SI-DRIVE)

Engine speed (rpm)	Idling	800	1200	1600	2000	2400	2800	3200	3600	4000	4400
Measured value (g (oz)/rev)	na	0.228 (0.01)	0.22 (0.01)	0.22 (0.01)	0.22 (0.01)	0.228 (0.01)	0.23 (0.01)	0.234 (0.01)	0.242 (0.01)	0.25 (0.01)	0.25 (0.01)

#### Map1 (models with SI-DRIVE)

Engine speed (rpm)	Idling	800	1200	1600	2000	2400	2800	3200	3600	4000	4400
Measured value (g (oz)/rev)	na	0.274 (0.01)	0.245 (0.01)	0.239 (0.01)	0.224 (0.01)	0.233 (0.01)	0.259 (0.01)	0.257 (0.01)	0.254 (0.01)	0.256 (0.01)	0.274 (0.01)

### 3. GENERAL DRIVING CYCLE

Perform the diagnosis continuously at idling or at a constant speed after warming up the engine.

# Diagnostic Trouble Code (DTC) Detecting Criteria

## GENERAL DESCRIPTION

---

### 4. DIAGNOSTIC METHOD

#### • Abnormality Judgment

Compare the diagnostic value (fsobd) with the threshold value, and if a condition meeting the malfunction criteria below continues for 10 s × 5 time(s) or more, judge that there is a fault in the fuel system.

#### Judgment Value

Malfunction Criteria	Threshold Value
$fsobd = (sglmd - tglmda) + faf + flaf$ In this case: sglmd = measured lambda tglmda = target lambda faf = main feedback compensation coefficient (every 64 milliseconds) flaf = main feedback learning compensation coefficient	≥ Value from Map 2

#### Map 2

Amount of air (g (oz)/s)	0 (0)	2.34375 (0.08)	4.6875 (0.17)	7.03125 (0.25)	9.375 (0.33)	11.71875 (0.41)	14.0625 (0.5)
fsobdL1 (%)	1.4	1.4	1.368623	1.319185	1.26975	1.265	1.265

**Time Needed for Diagnosis:** 10 s × 5 time(s)

**Malfunction Indicator Light Illumination:** Illuminates when malfunction occurs in 2 continuous driving cycles.

#### • Normality Judgment

Judge as OK and clear the NG if the continuous time while the following conditions are established is more than the predetermined time.

#### Judgment Value

Malfunction Criteria	Threshold Value
$fsobd = (sglmd - tglmda) + faf + flaf$	< 1.15

**Time Needed for Diagnosis:** 10 s

# Diagnostic Trouble Code (DTC) Detecting Criteria

GENERAL DESCRIPTION

## AQ:DTC P0172 SYSTEM TOO RICH (BANK 1)

### 1. OUTLINE OF DIAGNOSIS

Detect fuel system malfunction by the amount of main feedback control.

#### Diagnostic method

Fuel system is diagnosed by comparing the target air fuel ratio calculated by ECM with the actual air fuel ratio measured by sensor.

### 2. ENABLE CONDITIONS

Secondary Parameters	Enable Conditions
A/F main learning system	In operation
Engine coolant temperature	≥ 70 °C (158 °F)
Engine load change	≤ 0.02 g/rev (0 oz/rev)
Learning value of EVAP conc.	< 0.2
Cumulative time of canister purge after engine start	≥ 20 s
Continuous period after canister purge starting	≥ 5000 ms
Engine load	≥ Value of Map 1

#### Map1 (models without SI-DRIVE)

Engine speed (rpm)	Idling	800	1200	1600	2000	2400	2800	3200	3600	4000	4400
Measured value (g (oz)/rev)	na	0.228 (0.01)	0.22 (0.01)	0.22 (0.01)	0.22 (0.01)	0.228 (0.01)	0.23 (0.01)	0.234 (0.01)	0.242 (0.01)	0.25 (0.01)	0.25 (0.01)

#### Map1 (models with SI-DRIVE)

Engine speed (rpm)	Idling	800	1200	1600	2000	2400	2800	3200	3600	4000	4400
Measured value (g (oz)/rev)	na	0.274 (0.01)	0.245 (0.01)	0.239 (0.01)	0.224 (0.01)	0.233 (0.01)	0.259 (0.01)	0.257 (0.01)	0.254 (0.01)	0.256 (0.01)	0.274 (0.01)

### 3. GENERAL DRIVING CYCLE

Perform the diagnosis continuously at idling or at a constant speed after warming up the engine.

### 4. DIAGNOSTIC METHOD

#### • Abnormality Judgment

Compare the diagnostic value (fsobd) with the threshold value, and if a condition meeting the malfunction criteria below continues for 10 s × 5 time(s) or more, judge that there is a fault in the fuel system.

#### Judgment Value

Malfunction Criteria	Threshold Value
$fsobd = (sglmd - tglmda) + faf + flaf$ In this case: sglmd = measured lambda tglmda = target lambda faf = main feedback compensation coefficient (every 64 milliseconds) flaf = main feedback learning compensation coefficient	< Value of Map 2

#### Map 2

Amount of air (g (oz)/s)	0 (0)	2.34375 (0.08)	4.6875 (0.17)	7.03125 (0.25)	9.375 (0.33)	11.7187 5 (0.41)	14.0625 (0.5)
fsobdL1 (%)	0.6	0.6	0.63137	0.68082	0.71025	0.72525	0.73025

**Time Needed for Diagnosis:** 10 s × 5 time(s)

**Malfunction Indicator Light Illumination:** Illuminates when malfunction occurs in 2 continuous driving cycles.



# Diagnostic Trouble Code (DTC) Detecting Criteria

## GENERAL DESCRIPTION

---

### • Normality Judgment

Judge as OK if the status that the criteria below are met continues for 10 seconds.

### Judgment Value

Malfunction Criteria	Threshold Value
$fsobd = (sglmd - tglmda) + faf + flaf$	$\geq 0.85$

**Time Needed for Diagnosis:** 10 s

# Diagnostic Trouble Code (DTC) Detecting Criteria

GENERAL DESCRIPTION

## AR:DTC P0201 INJECTOR #1

### 1. OUTLINE OF DIAGNOSIS

Based on the self-diagnostic result of the injector driving IC, judge the injector driving circuit as normal or abnormal.

Injector driving IC detects the status of "fuel remains injected" or "fuel is not injected" as a malfunction.

### 2. ENABLE CONDITIONS

Secondary Parameters	Enable Conditions
Battery voltage	≥ 10.9 V
Elapsed time after starting the engine	> 1 s
Engine speed	> 500 rpm
Injection time	≥ 1000 μs and < 120000000/engine speed – 1000 μs
Injection status	Not during fuel cut and Not during asynchronous injection controlled by crankshaft position sensor

### 3. GENERAL DRIVING CYCLE

Always perform the diagnosis continuously.

### 4. DIAGNOSTIC METHOD

#### • Abnormality Judgment

Judge as NG when the following conditions are established.

#### Judgment Value

Malfunction Criteria	Threshold Value
Injector driving IC information	Malfunction

**Time Needed for Diagnosis:** 2500 ms

**Malfunction Indicator Light Illumination:** Illuminates as soon as a malfunction occurs.

#### • Normality Judgment

Judge as OK and clear the NG if the following conditions are established.

#### Judgment Value

Malfunction Criteria	Threshold Value
Injector driving IC information	Normal

**Time Needed for Diagnosis:** Less than 1 second

# Diagnostic Trouble Code (DTC) Detecting Criteria

## GENERAL DESCRIPTION

---

### **AS:DTC P0202 INJECTOR #2**

#### **1. OUTLINE OF DIAGNOSIS**

**NOTE:**

For the detection standard, refer to DTC P0201. <Ref. to GD(H4DOTC)-93, DTC P0201 INJECTOR #1, Diagnostic Trouble Code (DTC) Detecting Criteria.>

### **AT:DTC P0203 INJECTOR #3**

#### **1. OUTLINE OF DIAGNOSIS**

**NOTE:**

For the detection standard, refer to DTC P0201. <Ref. to GD(H4DOTC)-93, DTC P0201 INJECTOR #1, Diagnostic Trouble Code (DTC) Detecting Criteria.>

### **AU:DTC P0204 INJECTOR #4**

#### **1. OUTLINE OF DIAGNOSIS**

**NOTE:**

For the detection standard, refer to DTC P0201. <Ref. to GD(H4DOTC)-93, DTC P0201 INJECTOR #1, Diagnostic Trouble Code (DTC) Detecting Criteria.>

# Diagnostic Trouble Code (DTC) Detecting Criteria

GENERAL DESCRIPTION

## AV:DTC P0222 THROTTLE/PEDAL POSITION SENSOR/SWITCH "B" CIRCUIT LOW

### 1. OUTLINE OF DIAGNOSIS

Detect the open or short circuit of throttle position sensor 2.  
Judge as NG if out of specification.

### 2. COMPONENT DESCRIPTION

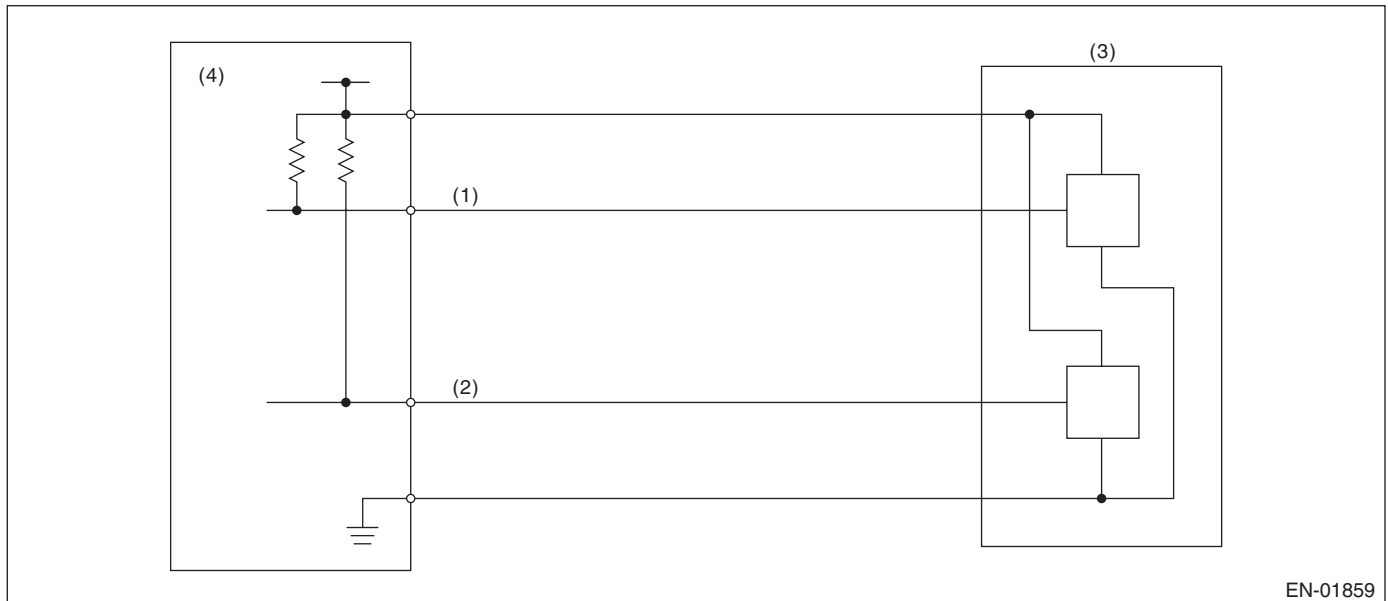

(1) Throttle position sensor 1 signal  
(2) Throttle position sensor 2 signal

(3) Throttle position sensor

(4) Engine control module (ECM)

### 3. ENABLE CONDITIONS

Secondary Parameters	Enable Conditions
Ignition switch	ON
Battery voltage	$\geq 6\text{ V}$

### 4. GENERAL DRIVING CYCLE

Always perform the diagnosis continuously.

# Diagnostic Trouble Code (DTC) Detecting Criteria

## GENERAL DESCRIPTION

---

### 5. DIAGNOSTIC METHOD

#### • Abnormality Judgment

If the duration of time while the following conditions are met is longer than the time indicated, judge as NG.

#### Judgment Value

Malfunction Criteria	Threshold Value
Sensor 2 input voltage	$\leq 1.07 \text{ V}$

**Time Needed for Diagnosis:** 24 ms

**Malfunction Indicator Light Illumination:** Illuminates as soon as a malfunction occurs.

#### • Normality Judgment

Judge as OK and clear the NG if the continuous time while the following conditions are established is more than the predetermined time.

#### Judgment Value

Malfunction Criteria	Threshold Value
Sensor 2 input voltage	$> 1.07 \text{ V}$

**Time Needed for Diagnosis:** 24 ms

# Diagnostic Trouble Code (DTC) Detecting Criteria

GENERAL DESCRIPTION

## AW:DTC P0223 THROTTLE/PEDAL POSITION SENSOR/SWITCH "B" CIRCUIT HIGH

### 1. OUTLINE OF DIAGNOSIS

Detect the open or short circuit of throttle position sensor 2.  
Judge as NG if out of specification.

### 2. COMPONENT DESCRIPTION

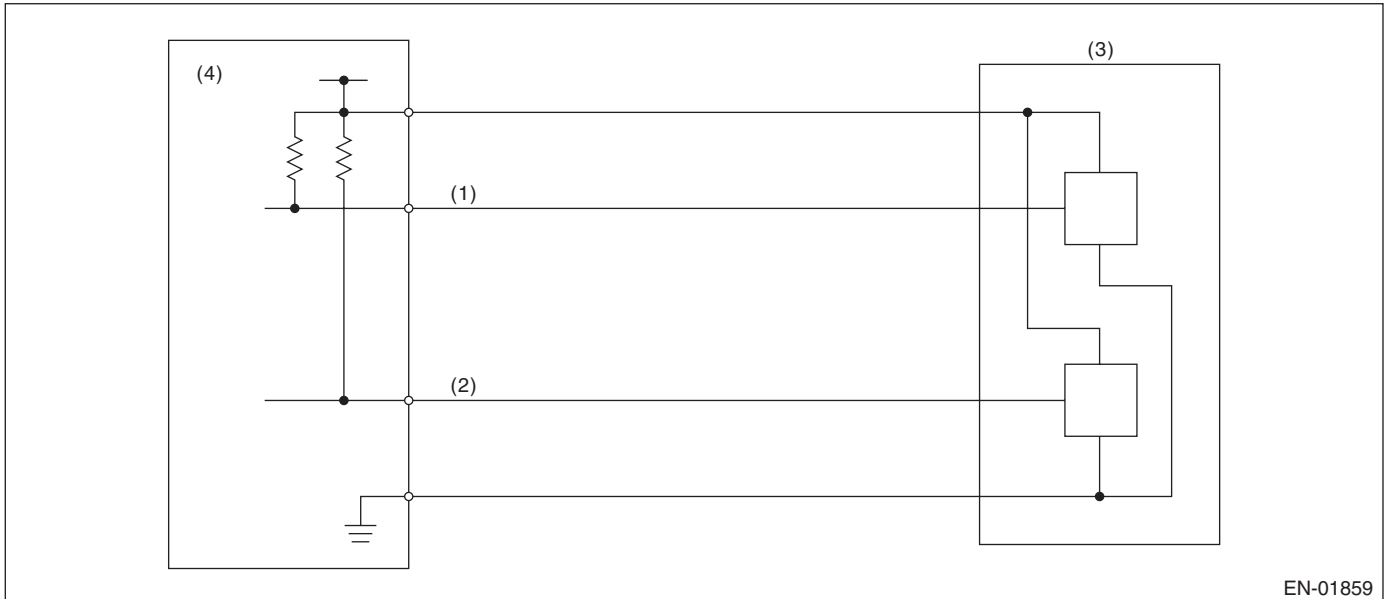

(1) Throttle position sensor 1 signal  
(2) Throttle position sensor 2 signal

(3) Throttle position sensor

(4) Engine control module (ECM)

### 3. ENABLE CONDITIONS

Secondary Parameters	Enable Conditions
Ignition switch	ON
Battery voltage	$\geq 6\text{ V}$

### 4. GENERAL DRIVING CYCLE

Always perform the diagnosis continuously.

# Diagnostic Trouble Code (DTC) Detecting Criteria

## GENERAL DESCRIPTION

---

### 5. DIAGNOSTIC METHOD

#### • Abnormality Judgment

If the duration of time while the following conditions are met is longer than the time indicated, judge as NG.

#### Judgment Value

Malfunction Criteria	Threshold Value
Sensor 2 input voltage	$\geq 4.858$ V

**Time Needed for Diagnosis:** 24 ms

**Malfunction Indicator Light Illumination:** Illuminates as soon as a malfunction occurs.

#### • Normality Judgment

Judge as OK and clear the NG if the continuous time while the following conditions are established is more than the predetermined time.

#### Judgment Value

Malfunction Criteria	Threshold Value
Sensor 2 input voltage	$< 4.858$ V

**Time Needed for Diagnosis:** 24 ms

# Diagnostic Trouble Code (DTC) Detecting Criteria

GENERAL DESCRIPTION

## AX:DTC P0230 FUEL PUMP PRIMARY CIRCUIT

### 1. OUTLINE OF DIAGNOSIS

Detect the malfunction of fuel pump control unit.

Judge as NG when the NG signal is sent through a diagnostic line coming from the fuel pump control unit. Fuel pump control unit detects the open or short circuit malfunction for each line, and then sends NG signals if one of them is found NG.

### 2. COMPONENT DESCRIPTION

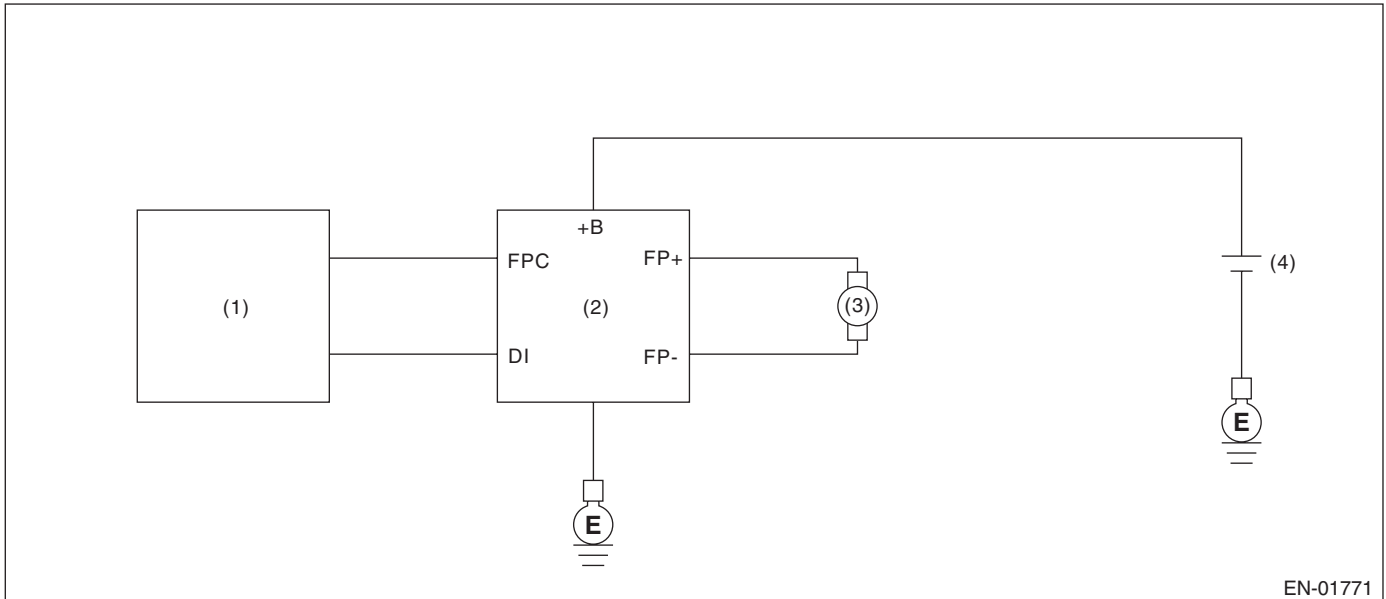

(1) Engine control module (ECM)

(3) Fuel pump

(4) Battery

(2) Fuel pump control unit

### 3. ENABLE CONDITIONS

Secondary Parameters	Enable Conditions
None	

### 4. GENERAL DRIVING CYCLE

Always perform the diagnosis continuously.



# Diagnostic Trouble Code (DTC) Detecting Criteria

## GENERAL DESCRIPTION

---

### 5. DIAGNOSTIC METHOD

#### • Abnormality Judgment

If the duration of time while the following conditions are met is longer than the time indicated, judge as NG.

#### Judgment Value

Malfunction Criteria	Threshold Value
Battery voltage	$\geq 8$ V
Elapsed time after starting the engine	$\geq 180000$ ms
Fuel pump control	ON
Fuel pump control unit output diagnosis signal	Low
Fuel level	$\geq 10$ ℓ (2.64 US gal, 2.2 Imp gal)

**Time Needed for Diagnosis:** 2500 ms

**Malfunction Indicator Light Illumination:** Illuminates when malfunction occurs in 2 continuous driving cycles.

#### • Normality Judgment

Judge as OK and clear the NG if the continuous time while the following conditions are established is more than the predetermined time.

#### Judgment Value

Malfunction Criteria	Threshold Value
Battery voltage	$\geq 8$ V
Elapsed time after starting the engine	$\geq 180000$ ms
Fuel pump control	ON
Fuel pump control unit output diagnosis signal	High
Fuel level	$\geq 10$ ℓ (2.64 US gal, 2.2 Imp gal)

**Time Needed for Diagnosis:** Less than 1 second

# Diagnostic Trouble Code (DTC) Detecting Criteria

GENERAL DESCRIPTION

## AY:DTC P0244 TURBO/SUPER CHARGER WASTEGATE SOLENOID "A" RANGE/PERFORMANCE

### 1. OUTLINE OF DIAGNOSIS

Detect the malfunction of wastegate control solenoid valve function.  
Judge as NG when becoming high wastegate pressure.

### 2. COMPONENT DESCRIPTION

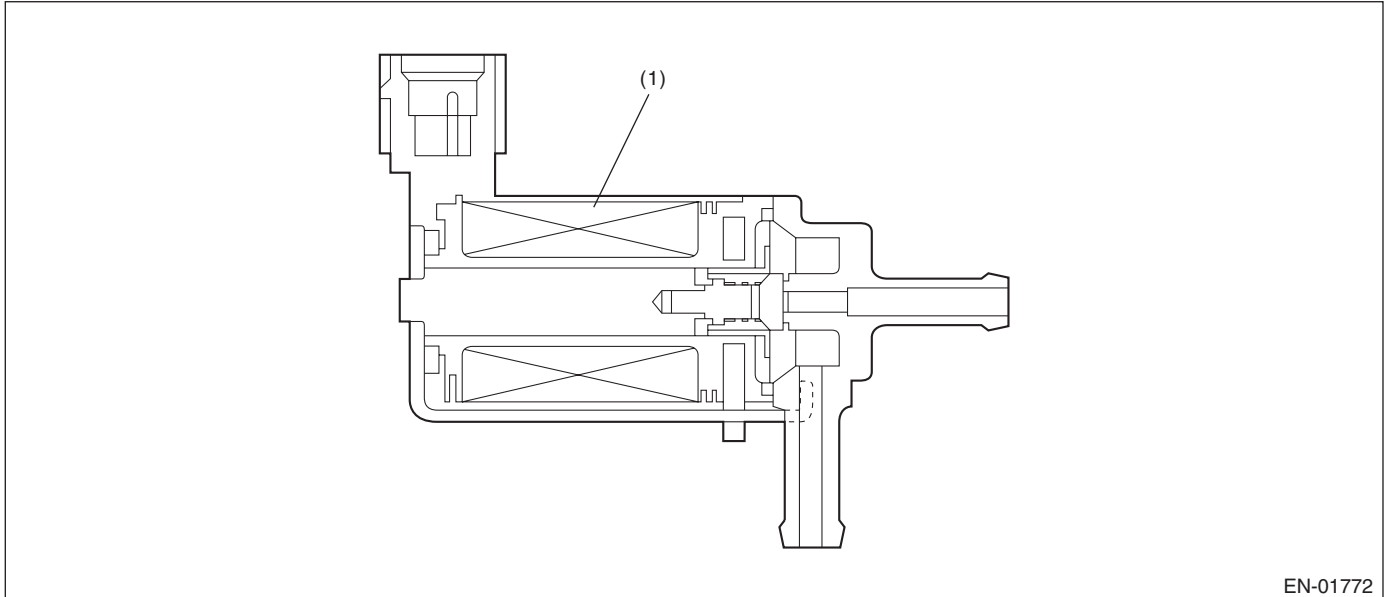

EN-01772

(1) Coil

### 3. ENABLE CONDITIONS

Secondary Parameters	Enable Conditions
None	

### 4. GENERAL DRIVING CYCLE

Always perform the diagnosis continuously.

# Diagnostic Trouble Code (DTC) Detecting Criteria

## GENERAL DESCRIPTION

### 5. DIAGNOSTIC METHOD

#### • Abnormality Judgment

If the duration of time while the following conditions are met is longer than the time indicated, judge as NG.

#### Judgment Value

Malfunction Criteria	Threshold Value
Intake manifold pressure	≥ Value from Map

#### Map (models without SI-DRIVE)

		Barometric pressure (kPa (mmHg, inHg))					
		58.7 (440, 17.3)	77.3 (580, 22.8)	89.3 (670, 26.4)	96 (720, 28.3)	98.6 (740, 29.1)	101.3 (760, 29.9)
Engine speed (rpm)	1000	109.5 (822, 32.3)	127.4 (956, 37.6)	138.6 (1040, 40.9)	138.6 (1040, 40.9)	138.6 (1040, 40.9)	138.6 (1040, 40.9)
	2000	139.1 (1044, 41.1)	163.4 (1226, 48.3)	178.6 (1340, 52.8)	178.6 (1340, 52.8)	178.6 (1340, 52.8)	178.6 (1340, 52.8)
	2400	169.7 (1273, 50.1)	200.6 (1505, 59.3)	219.9 (1650, 65)	219.9 (1650, 65)	219.9 (1650, 65)	219.9 (1650, 65)
	4000	169.7 (1273, 50.1)	200.6 (1505, 59.3)	219.9 (1650, 65)	219.9 (1650, 65)	219.9 (1650, 65)	219.9 (1650, 65)
	5000	144.1 (1081, 42.6)	173 (1298, 51.1)	193.9 (1454, 57.3)	200.7 (1506, 59.3)	217.9 (1635, 64.4)	217.9 (1635, 64.4)
	6000	138.6 (1040, 40.9)	166.6 (1250, 49.2)	187.2 (1404, 55.3)	194.6 (1460, 57.5)	213.3 (1600, 63)	213.3 (1600, 63)

kPa (mmHg, inHg)

#### Map (models with SI-DRIVE)

		Barometric pressure (kPa (mmHg, inHg))					
		59.3 (445, 17.5)	68.6 (515, 20.3)	78 (585, 23)	92 (690, 27.2)	96 (720, 28.3)	98.6 (740, 29.1)
Engine speed (rpm)	1000	124.4 (934, 36.8)	135.3 (1015, 40)	135.3 (1015, 40)	135.3 (1015, 40)	135.3 (1015, 40)	135.3 (1015, 40)
	2000	169.4 (1271, 50)	185.3 (1390, 54.7)	185.3 (1390, 54.7)	185.3 (1390, 54.7)	185.3 (1390, 54.7)	185.3 (1390, 54.7)
	3000	158.2 (1187, 46.7)	214.6 (1610, 63.4)	214.6 (1610, 63.4)	214.6 (1610, 63.4)	214.6 (1610, 63.4)	214.6 (1610, 63.4)
	4000	155.8 (1169, 46)	195.5 (1467, 57.7)	205.4 (1541, 60.7)	225.3 (1690, 66.5)	225.3 (1690, 66.5)	225.3 (1690, 66.5)
	5000	145.8 (1094, 43.1)	169.7 (1273, 50.1)	185.6 (1392, 54.8)	215.3 (1616, 63.6)	225.3 (1690, 66.5)	225.3 (1690, 66.5)
	6000	117.8 (884, 34.8)	156.3 (1173, 46.2)	168.5 (1264, 49.8)	205 (1538, 60.5)	215.1 (1614, 63.5)	229.3 (1720, 67.7)

kPa (mmHg, inHg)

**Time Needed for Diagnosis:** 2000 ms

**Malfunction Indicator Light Illumination:** Illuminates as soon as a malfunction occurs.

#### • Normality Judgment

Judge as OK and clear the NG if the continuous time while the following conditions are established is more than the predetermined time.

#### Judgment Value

Malfunction Criteria	Threshold Value
Intake manifold pressure	<Map Value of Map – 22.4 kPa (168 mmHg, 6.6 inHg) (models without SI-DRIVE) <Map Value of Map – 20 kPa (150 mmHg, 5.9 inHg) (models with SI-DRIVE)

**Time Needed for Diagnosis:** Less than 1 second

**GD(H4DOTC)-102**

Brought to you by Ebay Seller "SubaruManuals"

# Diagnostic Trouble Code (DTC) Detecting Criteria

GENERAL DESCRIPTION

## AZ:DTC P0245 TURBO/SUPER CHARGER WASTEGATE SOLENOID "A" LOW

### 1. OUTLINE OF DIAGNOSIS

Detect open or short circuit of the wastegate control solenoid valve.

Judge as NG when the terminal output voltage remains Low during outputting the duty signal.

### 2. COMPONENT DESCRIPTION

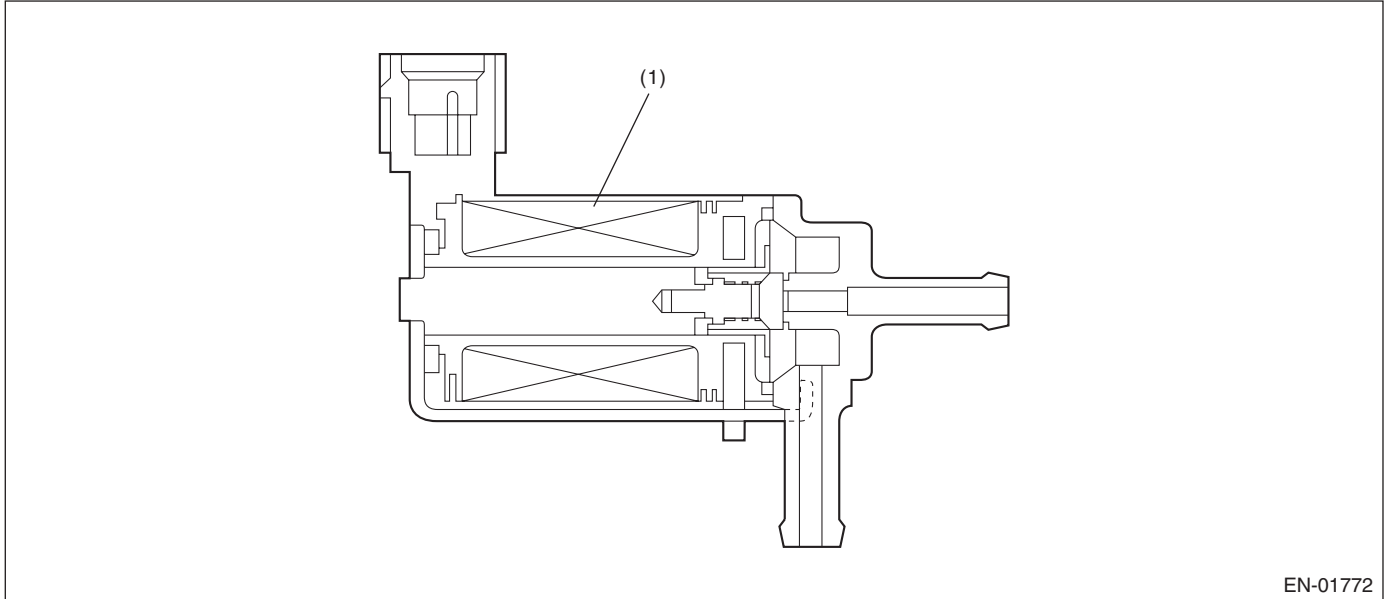

(1) Coil

### 3. ENABLE CONDITIONS

Secondary Parameters	Enable Conditions
Battery voltage	$\geq 10.9 \text{ V}$
Elapsed time after starting the engine	$\geq 1 \text{ second}$

### 4. GENERAL DRIVING CYCLE

Perform the diagnosis continuously after starting the engine.

# Diagnostic Trouble Code (DTC) Detecting Criteria

## GENERAL DESCRIPTION

---

### 5. DIAGNOSTIC METHOD

#### Abnormality Judgment

If the duration of time while the following conditions are met is longer than the time indicated, judge as NG.

#### Judgment Value

Malfunction Criteria	Threshold Value
Terminal output voltage	Low
Duty ratio of wastegate control	< 75%

**Time Needed for Diagnosis:** 640 ms

**Malfunction Indicator Light Illumination:** Illuminates as soon as a malfunction occurs.

#### Normality Judgment

Judge as OK and clear the NG if the continuous time while the following conditions are established is more than the predetermined time.

#### Judgment Value

Malfunction Criteria	Threshold Value
Terminal output voltage	High

**Time Needed for Diagnosis:** Less than 1 second

# Diagnostic Trouble Code (DTC) Detecting Criteria

GENERAL DESCRIPTION

## BA:DTC P0246 TURBO/SUPER CHARGER WASTEGATE SOLENOID "A" HIGH

### 1. OUTLINE OF DIAGNOSIS

Detect open or short circuit of the wastegate control solenoid valve.

Judge as NG when the terminal output voltage remains Low or High during outputting the duty signal.

### 2. COMPONENT DESCRIPTION

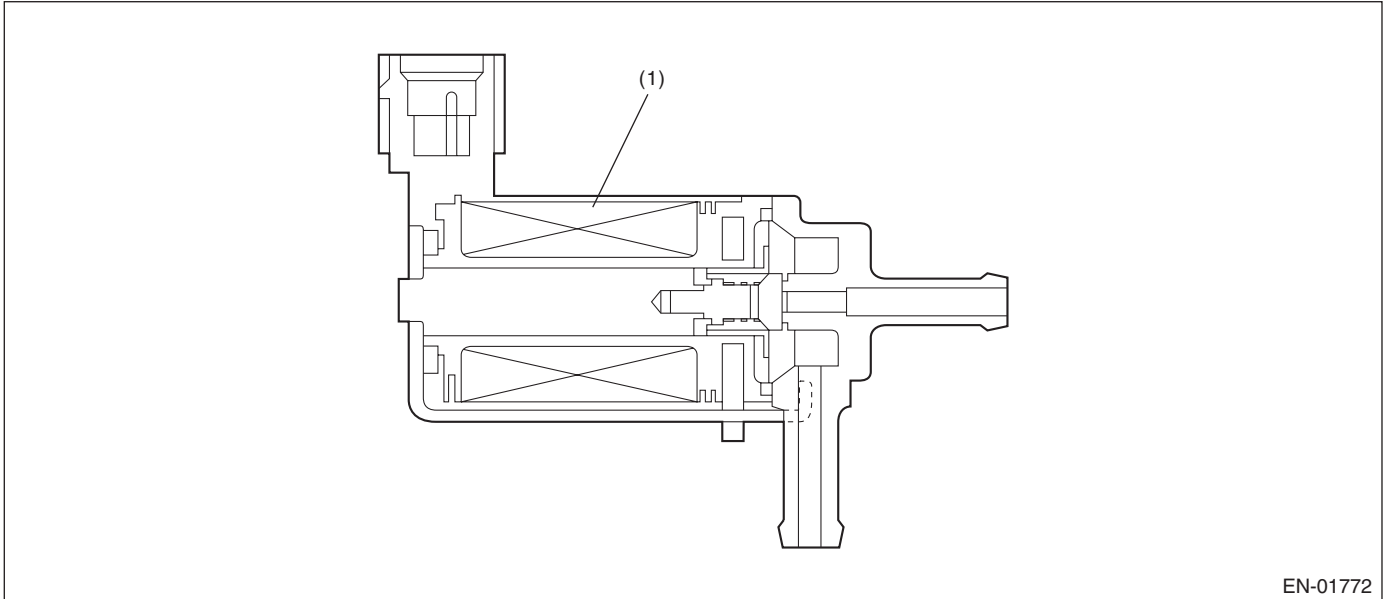

(1) Coil

### 3. ENABLE CONDITIONS

Secondary Parameters	Enable Conditions
Battery voltage	$\geq 10.9 \text{ V}$
Elapsed time after starting the engine	$\geq 1 \text{ second}$

### 4. GENERAL DRIVING CYCLE

Perform the diagnosis continuously after starting the engine.

# Diagnostic Trouble Code (DTC) Detecting Criteria

## GENERAL DESCRIPTION

---

### 5. DIAGNOSTIC METHOD

#### Abnormality Judgment

If the duration of time while the following conditions are met is longer than the time indicated, judge as NG.

#### Judgment Value

Malfunction Criteria	Threshold Value
Terminal output voltage	High
Duty ratio of wastegate control	≥ 25%

**Time Needed for Diagnosis:** 640 ms

**Malfunction Indicator Light Illumination:** Illuminates as soon as a malfunction occurs.

#### Normality Judgment

Judge as OK and clear the NG if the continuous time while the following conditions are established is more than the predetermined time.

#### Judgment Value

Malfunction Criteria	Threshold Value
Terminal output voltage	Low

**Time Needed for Diagnosis:** Less than 1 second

# Diagnostic Trouble Code (DTC) Detecting Criteria

GENERAL DESCRIPTION

## BB:DTC P0301 CYLINDER 1 MISFIRE DETECTED

### 1. OUTLINE OF DIAGNOSIS

Detect the presence of misfire occurrence. (Revolution fluctuation method)

Monitoring Misfire which influences exhaust deterioration (1.5 times of FTP) and catalyst damage is made obligatory by the law. Misfire affecting these two has two patterns below. :

- Intermittent misfire (The same cylinder misfires in random, or different cylinders misfire in random.): FTP 1.5 times misfire
- Every time misfire (The same cylinder misfires every time.): FTP 1.5 times misfire, Catalyst damage misfire

The following detecting methods are adopted for these detection.

1) Intermittent misfire: FTP 1.5 times misfire

- 180° Interval Difference Method
- 360° Interval Difference Method (whole range)
- 720° Interval Difference Method (3,000 rpm or more)

2) Misfire every time: FTP 1.5 times misfire, Catalyst damage misfire

- 360° Interval Difference Method

### 2. ENABLE CONDITIONS

Secondary Parameters	Enable Conditions
All secondary parameters enable conditions	≥ 1024 ms
Intake manifold pressure change at 180°CA	< Value of Map 1
Throttle position change during 16 milliseconds	< 14 °
Fuel shut-off function	Not in operation
Fuel level	≥ 9.6 ℓ (2.54 US gal, 2.11 Imp gal)
Vehicle dynamic control or AT torque control	Not in operation
Evaporative system leak check	Not in operation
Engine speed	550 rpm — 6700 rpm
Intake manifold pressure	≥ Value from Map 2
Battery voltage	≥ 8 V
Fuel parameter determination	Not extremely low volatility
Elapsed time after starting the engine	≥ 0 ms
Engine speed change during 32 milliseconds	< 1000 rpm

#### Map 1 (Models without SI-DRIVE)

rpm	750	1000	1500	2000	2500	3000	3500	4000
kPa (mmHg, inHg)	13.3 (100, 3.9)	13.3 (100, 3.9)	13.3 (100, 3.9)	13.3 (100, 3.9)	13.3 (100, 3.9)	13.3 (100, 3.9)	13.3 (100, 3.9)	13.3 (100, 3.9)

rpm	4500	5000	5500	6000	6500	6700
kPa (mmHg, inHg)	13.3 (100, 3.9)	13.3 (100, 3.9)	13.3 (100, 3.9)	13.3 (100, 3.9)	13.3 (100, 3.9)	13.3 (100, 3.9)



# Diagnostic Trouble Code (DTC) Detecting Criteria

## GENERAL DESCRIPTION

### Map 1 (Models with SI-DRIVE)

rpm	700	1000	1500	2000	2500	3000	3500	4000
kPa (mmHg, inHg)	13.3 (100, 3.9)	13.3 (100, 3.9)	13.3 (100, 3.9)	13.3 (100, 3.9)	13.3 (100, 3.9)	13.3 (100, 3.9)	13.3 (100, 3.9)	13.3 (100, 3.9)

rpm	4500	5000	5500	6000	6500	6700
kPa (mmHg, inHg)	13.3 (100, 3.9)	13.3 (100, 3.9)	13.3 (100, 3.9)	13.3 (100, 3.9)	13.3 (100, 3.9)	13.3 (100, 3.9)

### Map 2 (Models without SI-DRIVE)

- Normal ignition

		Barometric pressure (kPa (mmHg, inHg))						
		66.7 (500.0 , 19.7)	76.6 (575.0 , 22.6)	80 (600.0 , 23.6)	84 (630.0 , 24.8)	86.6 (650.0 , 25.6)	92 (690.0 , 27.2)	100.2 (752.0 , 29.6)
Engine speed (rpm)	700	23 (172.4 , 6.8)	23 (172.4 , 6.8)	23.7 (177.5 , 7)	25.4 (190.2 , 7.5)	26.7 (200.2 , 7.9)	26.5 (198.6 , 7.8)	27.9 (208.9 , 8.2)
	1000	20.4 (152.8 , 6)	20.4 (152.8 , 6)	20.8 (156.0 , 6.1)	22.7 (170.1 , 6.7)	23.2 (174.4 , 6.9)	23.9 (179.4 , 7.1)	25.1 (188.4 , 7.4)
	1500	20.7 (155.4 , 6.1)	20.7 (155.4 , 6.1)	21.5 (161.1 , 6.3)	22.6 (169.4 , 6.7)	23.3 (175.0 , 6.9)	24.4 (183.2 , 7.2)	25.8 (193.7 , 7.6)
	2000	20.1 (150.9 , 5.9)	20.1 (150.9 , 5.9)	20.9 (156.7 , 6.2)	22 (165.3 , 6.5)	22.8 (170.8 , 6.7)	23.6 (177.2 , 7)	24.8 (186.1 , 7.3)
	2500	20.2 (151.3 , 6)	20.2 (151.3 , 6)	20.9 (156.5 , 6.2)	21.9 (164.4 , 6.5)	22.5 (168.8 , 6.6)	23.2 (174.3 , 6.9)	24.4 (183.1 , 7.2)
	3000	21.4 (160.9 , 6.3)	21.4 (160.9 , 6.3)	20.7 (155.6 , 6.1)	21.9 (164.1 , 6.5)	22.6 (169.2 , 6.7)	23.6 (177.3 , 7)	24.3 (182.2 , 7.2)
	3500	25.1 (188.3 , 7.4)	25.1 (188.3 , 7.4)	25.8 (193.4 , 7.6)	27.1 (203.5 , 8)	27.8 (208.4 , 8.2)	29.2 (218.8 , 8.6)	29.3 (220.2 , 8.7)
	4000	25.7 (192.8 , 7.6)	25.7 (192.8 , 7.6)	26.5 (199.0 , 7.8)	28 (210.2 , 8.3)	28.9 (216.7 , 8.5)	29.4 (220.6 , 8.7)	29.5 (221.2 , 8.7)
	4500	25.8 (193.3 , 7.6)	25.8 (193.3 , 7.6)	26.3 (197.1 , 7.8)	27.5 (206.2 , 8.1)	28.7 (215.3 , 8.5)	29.1 (218.3 , 8.6)	29.2 (219.3 , 8.6)
	5000	30 (225.3 , 8.9)	30 (225.3 , 8.9)	30.6 (229.6 , 9)	31.3 (234.5 , 9.2)	32.1 (240.7 , 9.5)	33 (247.4 , 9.7)	33.2 (248.8 , 9.8)
	5500	33.8 (253.2 , 10)	33.8 (253.2 , 10)	34.2 (256.8 , 10.1)	35.5 (266.4 , 10.5)	36.2 (271.9 , 10.7)	37.2 (279.1 , 11)	37.2 (278.9 , 11)
	6000	37.9 (284.4 , 11.2)	37.9 (284.4 , 11.2)	38.2 (286.8 , 11.3)	39.3 (294.5 , 11.6)	40.2 (301.3 , 11.9)	40.8 (306.3 , 12.1)	41.6 (312.0 , 12.3)
	6500	42.6 (319.8 , 12.6)	42.6 (319.8 , 12.6)	43.4 (325.4 , 12.8)	44.5 (333.6 , 13.1)	45.5 (341.2 , 13.4)	47 (352.8 , 13.9)	47.2 (354.0 , 13.9)
6700	43.4 (325.2 , 12.8)	43.4 (325.2 , 12.8)	44.1 (330.8 , 13)	45.2 (339.0 , 13.3)	46.2 (346.6 , 13.6)	47.7 (358.2 , 14.1)	47.9 (359.4 , 14.1)	

kPa (mmHg, inHg)

# Diagnostic Trouble Code (DTC) Detecting Criteria

GENERAL DESCRIPTION

- Idling ignition

		Barometric pressure (kPa (mmHg, inHg))						
		66.7 (500.0 , 19.7)	76.6 (575.0 , 22.6)	80 (600.0 , 23.6)	84 (630.0 , 24.8)	86.6 (650.0 , 25.6)	92 (690.0 , 27.2)	100.2 (752.0 , 29.6)
Engine speed (rpm)	700	23 (172.4 , 6.8)	23 (172.4 , 6.8)	23.7 (177.5 , 7)	25.4 (190.2 , 7.5)	26.7 (200.2 , 7.9)	26.5 (198.6 , 7.8)	27.9 (208.9 , 8.2)
	1000	22.3 (167.3 , 6.6)	22.3 (167.3 , 6.6)	23 (172.6 , 6.8)	24.5 (184.2 , 7.3)	25.7 (192.8 , 7.6)	26.8 (201.0 , 7.9)	27 (202.3 , 8)
	1500	22.3 (167.6 , 6.6)	22.3 (167.6 , 6.6)	24.2 (181.9 , 7.2)	24.8 (185.7 , 7.3)	26.2 (196.7 , 7.7)	26.7 (200.0 , 7.9)	28.2 (211.8 , 8.3)
	2000	22 (164.8 , 6.5)	22 (164.8 , 6.5)	22.8 (170.9 , 6.7)	23.7 (177.8 , 7)	24.6 (184.7 , 7.3)	25.5 (191.6 , 7.5)	26.5 (198.4 , 7.8)
	2500	21.2 (158.9 , 6.3)	21.2 (158.9 , 6.3)	21.9 (164.3 , 6.5)	22.9 (171.7 , 6.8)	23.6 (177.2 , 7)	25.5 (191.6 , 7.5)	25.4 (190.3 , 7.5)
	3000	20.9 (156.4 , 6.2)	20.9 (156.4 , 6.2)	26.3 (197.6 , 7.8)	22.6 (169.7 , 6.7)	27.5 (206.2 , 8.1)	24.4 (183.1 , 7.2)	25.3 (189.5 , 7.5)
	3500	30 (225.3 , 8.9)	30 (225.3 , 8.9)	30.9 (231.8 , 9.1)	32 (240.4 , 9.5)	32.8 (246.0 , 9.7)	33.7 (252.5 , 9.9)	33.8 (253.7 , 10)
	4000	30.7 (230.0 , 9.1)	30.7 (230.0 , 9.1)	31.1 (233.6 , 9.2)	32.3 (242.7 , 9.6)	33.9 (254.5 , 10)	34.7 (260.6 , 10.3)	33.9 (254.4 , 10)
	4500	28.4 (213.4 , 8.4)	28.4 (213.4 , 8.4)	29 (217.2 , 8.6)	29.7 (222.9 , 8.8)	31.7 (237.5 , 9.3)	32.2 (241.8 , 9.5)	31.2 (234.1 , 9.2)
	5000	34.4 (257.9 , 10.2)	34.4 (257.9 , 10.2)	34.4 (257.7 , 10.1)	34.9 (261.8 , 10.3)	35.7 (268.1 , 10.6)	36.4 (272.8 , 10.7)	37 (277.6 , 10.9)
	5500	38.2 (286.5 , 11.3)	38.2 (286.5 , 11.3)	38.6 (289.8 , 11.4)	39.8 (298.3 , 11.7)	40.7 (305.1 , 12)	41.4 (310.8 , 12.2)	41.1 (308.3 , 12.1)
	6000	40.7 (305.0 , 12)	40.7 (305.0 , 12)	41.1 (308.6 , 12.2)	42.2 (316.8 , 12.5)	44.2 (331.3 , 13)	44.3 (332.3 , 13.1)	44.2 (331.3 , 13)
	6500	46.3 (347.3 , 13.7)	46.3 (347.3 , 13.7)	46.6 (349.9 , 13.8)	47.8 (358.4 , 14.1)	48.9 (366.5 , 14.4)	49.7 (372.9 , 14.7)	50.4 (377.9 , 14.9)
	6700	47 (352.7 , 13.9)	47 (352.7 , 13.9)	47.4 (355.3 , 14)	48.5 (363.8 , 14.3)	49.6 (371.9 , 14.6)	50.4 (378.3 , 14.9)	51.1 (383.3 , 15.1)

kPa (mmHg, inHg)

# Diagnostic Trouble Code (DTC) Detecting Criteria

## GENERAL DESCRIPTION

### Map 2 (Models with SI-DRIVE)

- Normal ignition

		Barometric pressure (kPa (mmHg, inHg))						
		66.7 (500, 19.7)	76.6 (575, 22.6)	80 (600, 23.6)	84 (630, 24.8)	86.6 (650, 25.6)	92 (690, 27.2)	100.2 (752, 29.6)
Engine speed (rpm)	700	26.7 (200.0, 7.9)	26.7 (200.0, 7.9)	27.3 (205.0, 8.1)	28.4 (213.0, 8.4)	29.3 (220.0, 8.7)	29.9 (224.0, 8.8)	28.8 (216.0, 8.5)
	1000	23.9 (179.0, 7)	23.9 (179.0, 7)	24.9 (187.0, 7.4)	25.5 (191.0, 7.5)	25.9 (194.0, 7.6)	27.5 (206.0, 8.1)	28.6 (214.7, 8.5)
	1500	22.4 (168.0, 6.6)	22.4 (168.0, 6.6)	23.3 (175.0, 6.9)	24.1 (181.0, 7.1)	24.7 (185.0, 7.3)	24.8 (186.0, 7.3)	24.9 (186.9, 7.4)
	2000	23.2 (174.0, 6.9)	23.2 (174.0, 6.9)	24 (180.0, 7.1)	25.5 (191.0, 7.5)	26.1 (196.0, 7.7)	25.6 (192.0, 7.6)	25.3 (189.5, 7.5)
	2500	23.9 (179.0, 7)	23.9 (179.0, 7)	24.5 (184.0, 7.2)	25.5 (191.0, 7.5)	26 (195.0, 7.7)	25.5 (191.0, 7.5)	25.1 (188.6, 7.4)
	3000	24.7 (185.0, 7.3)	24.7 (185.0, 7.3)	25.3 (190.0, 7.5)	25.6 (192.0, 7.6)	26.1 (196.0, 7.7)	25.9 (194.0, 7.6)	25.8 (193.3, 7.6)
	3500	29.1 (218.5, 8.6)	29.1 (218.5, 8.6)	29.8 (223.5, 8.8)	29.9 (224.5, 8.8)	31.3 (234.5, 9.2)	31.5 (236.0, 9.3)	29.5 (221.5, 8.7)
	4000	29.2 (219.0, 8.6)	29.2 (219.0, 8.6)	29.9 (224.0, 8.8)	30.5 (229.0, 9)	30.8 (231.0, 9.1)	31.7 (238.0, 9.4)	32.3 (242.2, 9.5)
	4500	29.3 (219.5, 8.6)	29.3 (219.5, 8.6)	30.3 (227.5, 9)	30.9 (231.5, 9.1)	31.4 (235.5, 9.3)	32.1 (241.0, 9.5)	32.6 (244.2, 9.6)
	5000	30.4 (228.1, 9)	30.4 (228.1, 9)	30.7 (230.1, 9.1)	31.7 (238.1, 9.4)	32.1 (241.1, 9.5)	32.7 (245.0, 9.6)	33.1 (248.0, 9.8)
	5500	33.4 (250.6, 9.9)	33.4 (250.6, 9.9)	34.2 (256.6, 10.1)	34.9 (261.6, 10.3)	35.1 (263.6, 10.4)	35.7 (268.0, 10.6)	36.1 (271.0, 10.7)
	6000	37.5 (281.1, 11.1)	37.5 (281.1, 11.1)	38 (285.1, 11.2)	38.8 (291.1, 11.5)	39.1 (293.1, 11.5)	40.3 (302.0, 11.9)	40.9 (306.9, 12.1)
	6500	42.6 (319.6, 12.6)	42.6 (319.6, 12.6)	43.3 (324.6, 12.8)	43.9 (329.6, 13)	43.8 (328.6, 12.9)	44.9 (337.0, 13.3)	45.6 (341.7, 13.5)
6700	43.3 (325, 12.8)	43.3 (325, 12.8)	44 (330, 13)	44.7 (335, 13.2)	44.5 (334, 13.1)	45.6 (342, 13.5)	46.3 (347.1442749, 13.7)	

kPa (mmHg, inHg)

# Diagnostic Trouble Code (DTC) Detecting Criteria

GENERAL DESCRIPTION

- Idling ignition

		Barometric pressure (kPa (mmHg, inHg))						
		66.7 (500, 19.7)	76.6 (575, 22.6)	80 (600, 23.6)	84 (630, 24.8)	86.6 (650, 25.6)	92 (690, 27.2)	100.2 (752, 29.6)
Engine speed (rpm)	700	26.7 (200.0, 7.9)	26.7 (200.0, 7.9)	27.3 (205.0, 8.1)	28.4 (213.0, 8.4)	29.3 (220.0, 8.7)	29.9 (224.0, 8.8)	28.8 (216.0, 8.5)
	1000	25.1 (188.0, 7.4)	25.1 (188.0, 7.4)	26 (195.0, 7.7)	26.9 (202.0, 8)	28 (210.0, 8.3)	28.7 (215.0, 8.5)	30.4 (228.1, 9)
	1500	22.9 (172.0, 6.8)	22.9 (172.0, 6.8)	23.3 (175.0, 6.9)	23.9 (179.0, 7)	24.7 (185.0, 7.3)	24.9 (187.0, 7.4)	26.7 (200.6, 7.9)
	2000	23.2 (174.0, 6.9)	23.2 (174.0, 6.9)	23.7 (178.0, 7)	24.4 (183.0, 7.2)	25.1 (188.0, 7.4)	25.3 (190.0, 7.5)	27.8 (208.5, 8.2)
	2500	23.2 (174.0, 6.9)	23.2 (174.0, 6.9)	23.7 (178.0, 7)	24.5 (184.0, 7.2)	24.8 (186.0, 7.3)	25.3 (190.0, 7.5)	26.6 (199.7, 7.9)
	3000	24.3 (182.0, 7.2)	24.3 (182.0, 7.2)	24.9 (187.0, 7.4)	25.9 (194.0, 7.6)	25.9 (194.0, 7.6)	26.1 (196.0, 7.7)	26.6 (199.7, 7.9)
	3500	31.7 (237.5, 9.4)	31.7 (237.5, 9.4)	31.4 (235.5, 9.3)	32.6 (244.5, 9.6)	33.1 (248.5, 9.8)	34.6 (259.5, 10.2)	35.2 (264.0, 10.4)
	4000	32.1 (241.0, 9.5)	32.1 (241.0, 9.5)	32.3 (242.0, 9.5)	33.2 (249.0, 9.8)	33.7 (253.0, 10)	34.9 (262.0, 10.3)	36 (270.0, 10.6)
	4500	32.1 (240.5, 9.5)	32.1 (240.5, 9.5)	32.1 (240.5, 9.5)	33 (247.5, 9.7)	33.9 (254.5, 10)	35.5 (266.5, 10.5)	35.3 (265.1, 10.4)
	5000	35.5 (266.1, 10.5)	35.5 (266.1, 10.5)	34.4 (258.1, 10.2)	35.3 (265.1, 10.4)	35.7 (268.1, 10.6)	37.3 (280.1, 11)	37.2 (279.2, 11)
	5500	38.1 (285.6, 11.2)	38.1 (285.6, 11.2)	37.5 (281.6, 11.1)	38.5 (288.6, 11.4)	39.5 (296.6, 11.7)	40.3 (302.6, 11.9)	40.7 (305.2, 12)
	6000	41.6 (312.1, 12.3)	41.6 (312.1, 12.3)	41.5 (311.1, 12.2)	42.8 (321.1, 12.6)	43.5 (326.1, 12.8)	45.6 (342.1, 13.5)	45.4 (340.3, 13.4)
	6500	48.6 (364.6, 14.4)	48.6 (364.6, 14.4)	49.3 (369.6, 14.6)	48.6 (364.6, 14.4)	49.4 (370.6, 14.6)	49.4 (370.6, 14.6)	53.4 (400.7, 15.8)
6700	49.3 (370, 14.6)	49.3 (370, 14.6)	50 (375, 14.8)	49.3 (370, 14.6)	50.1 (376, 14.8)	50.1 (376, 14.8)	54.1 (406.1514536, 16)	

kPa (mmHg, inHg)

### 3. GENERAL DRIVING CYCLE

- If conditions are met, it is possible to detect the misfires from idling to high engine speed. However, in case any engine load or breakage occurs, perform with the engine at idle.
- Perform the diagnosis continuously.

# Diagnostic Trouble Code (DTC) Detecting Criteria

## GENERAL DESCRIPTION

### 4. DIAGNOSTIC METHOD

When a misfire occurs, the engine speed will decrease and the crankshaft position speed will change. Calculate the interval difference value (diagnostic value) from crankshaft position speed by the following formula, and judge whether a misfire is occurring or not comparing the calculated result with judgment value. Count the number of misfires, if the misfire ratio is higher during 1000 revs. or 200 revs., judge corresponding cylinders as NG.

Diagnostic value calculation (Calculate from angle speed) →	Misfire detection every single ignition (Compare diagnostic value with judgment value) →	NG judgment (Misfire occurrence judgment required by the law) (Compare number of misfire with judgment value)
	<ul style="list-style-type: none"> <li>• 180° Interval Difference Method</li> <li>• 360° Interval Difference Method</li> <li>• 720° Interval Difference Method</li> </ul>	<ul style="list-style-type: none"> <li>• FTP 1.5 times misfire NG judgment</li> <li>• Catalyst damage misfire NG judgment</li> </ul>

As shown in the following figure, pick a cylinder as the standard and name it omg 0. And the former crankshaft position speed is named omg 1, the second former crankshaft position speed is named omg 2, the third is named omg 3, etc.

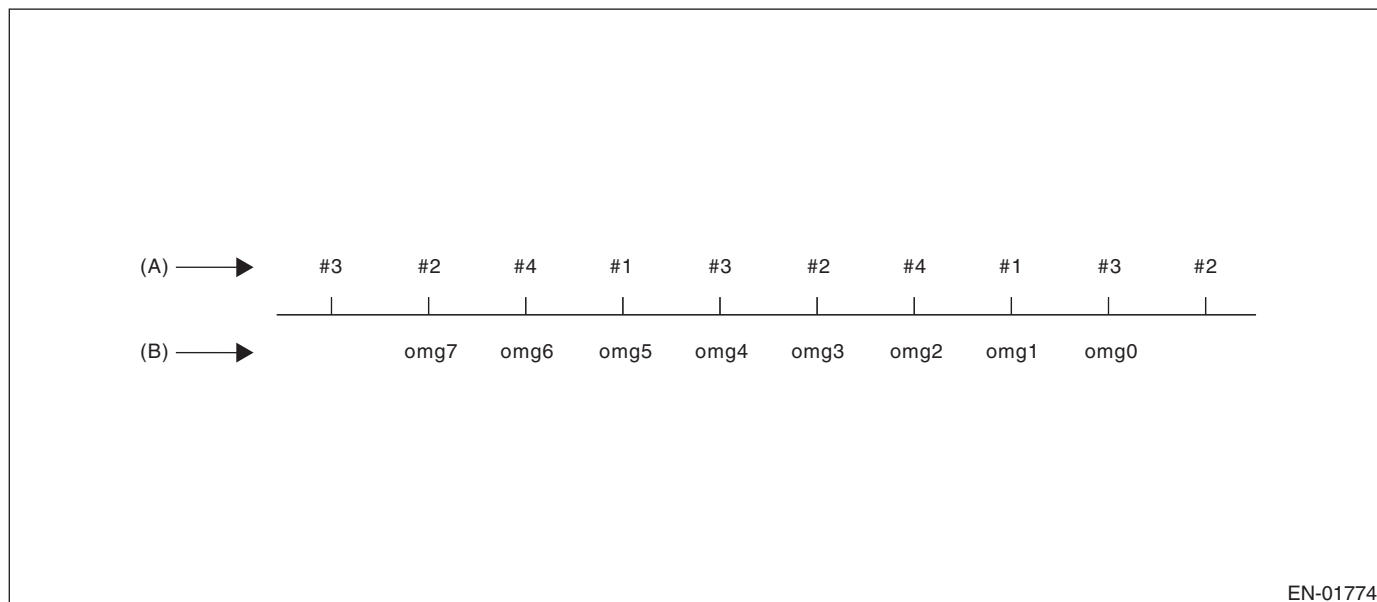

(A) Ignition order

(B) Crankshaft position speed

# Diagnostic Trouble Code (DTC) Detecting Criteria

GENERAL DESCRIPTION

## 180° Interval Difference Method

Diagnostic value	$\text{domg } 180 = (\text{omg } 1 - \text{omg } 0) - (\text{omg } 5 - \text{omg } 1)/4$
------------------	--

Judge as a misfire in the following cases.

- $\text{domg } 180 > \text{judgment value of positive side}$
- $\text{domg } 180 \leq \text{judgment value of negative side}$   
(Diagnostic value before 180° CA)

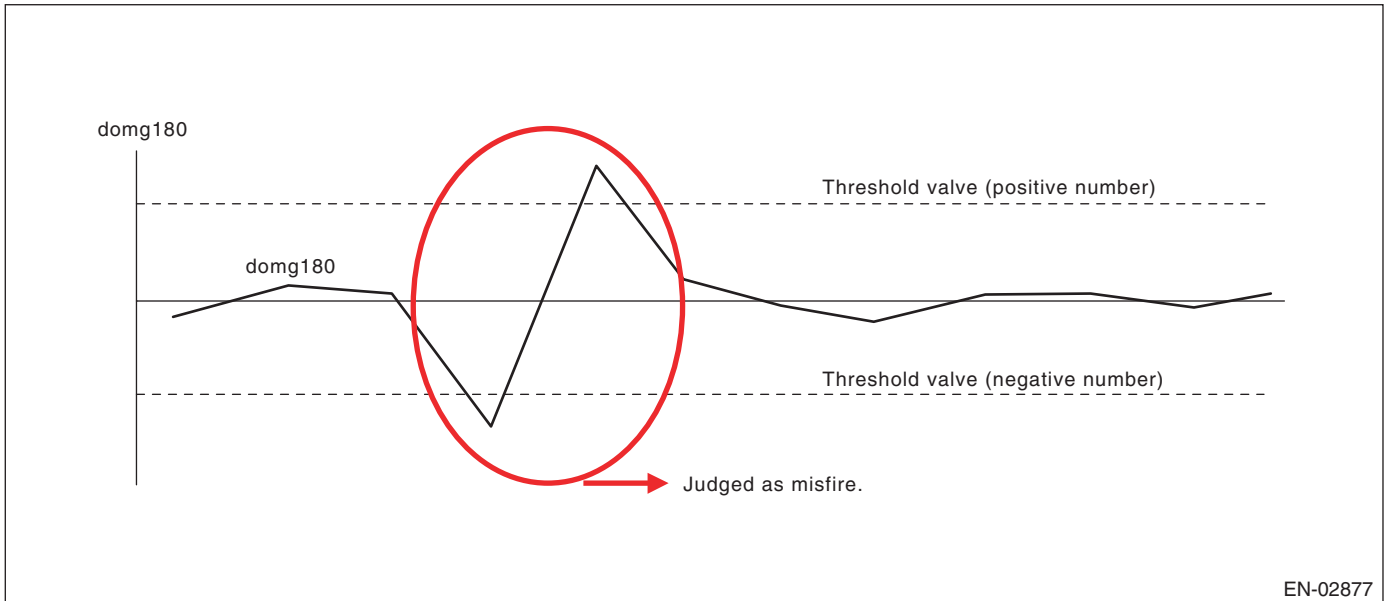

## 360° Interval Difference Method

Diagnostic value	$\text{domg } 360 = (\text{omg } 1 - \text{omg } 0) - (\text{omg } 3 - \text{omg } 2)$
------------------	--

Misfire judgment	$\text{domg } 360 > \text{Judgment value} \rightarrow \text{Judge as misfire}$
------------------	--

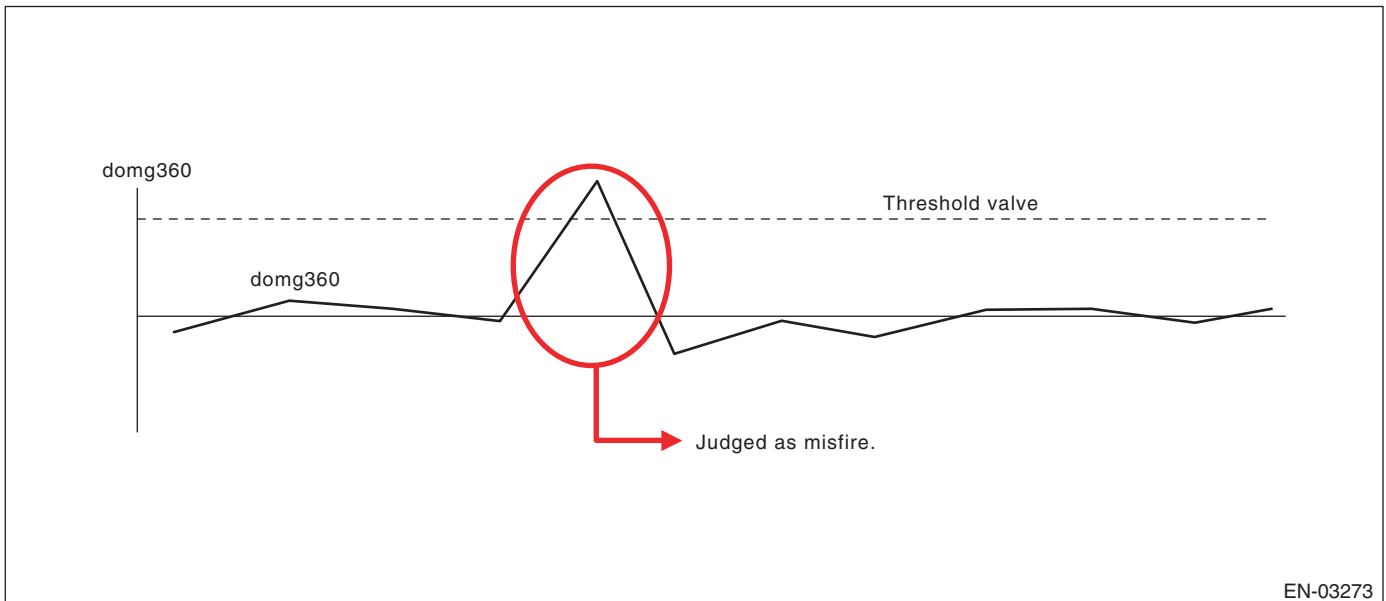

# Diagnostic Trouble Code (DTC) Detecting Criteria

## GENERAL DESCRIPTION

### 720° Interval Difference Method

Diagnostic value	$\text{domg 720} = (\text{omg 1} - \text{omg 0}) - (\text{omg 5} - \text{omg 4})$
Misfire judgment	$\text{domg 720} > \text{Judgment value} \rightarrow \text{Judge as misfire}$

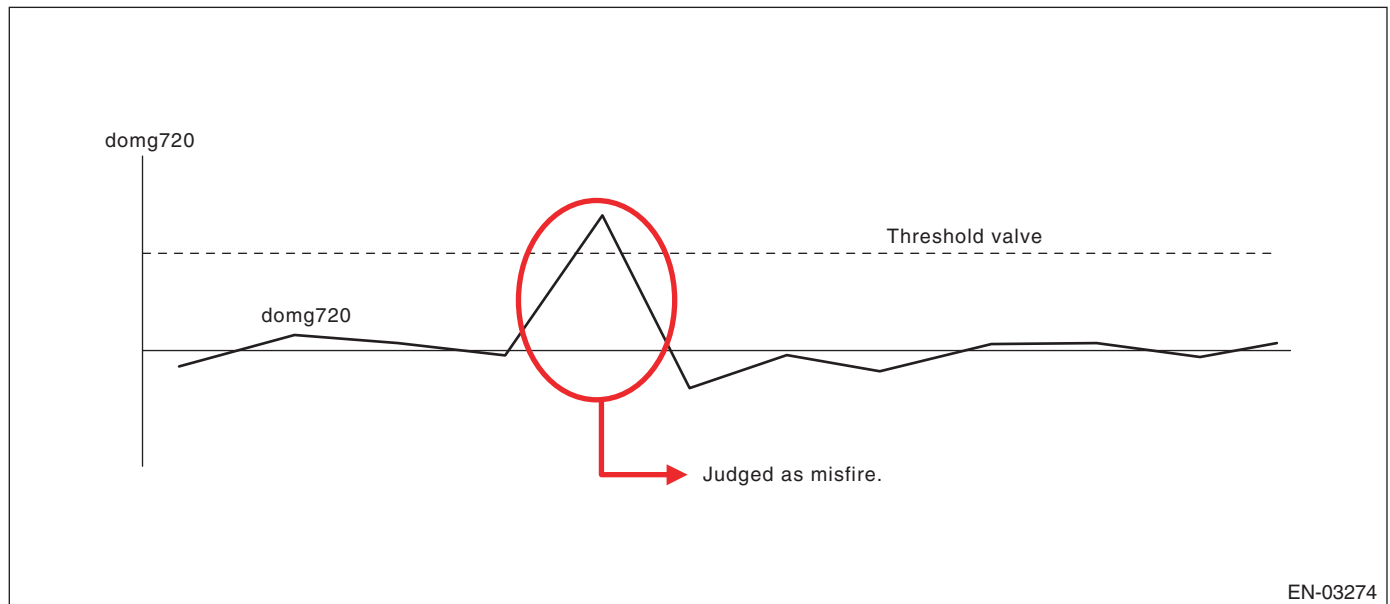

- FTP 1.5 times misfire (Misfire occurrence level which influences exhaust gas)

- Abnormality Judgment

**Judgment Value (Judge that malfunction occurs when the misfire ratio is high in 1000 engine revs.)**

Malfunction Criteria	Threshold Value
FTP emission diagnostic value	$\geq 17 \times 100/2000\%$ in 1000 revs.

**Time Needed for Diagnosis:** 1000 engine revs.

**Malfunction Indicator Light Illumination:** Illuminates when malfunction occurs in 2 continuous driving cycles.

- Normality Judgment

**Judgment Value**

Malfunction Criteria	Threshold Value
FTP emission diagnostic value	$< 17 \times 100/2000\%$ in 1000 revs.

**Time Needed for Diagnosis:** 1000 engine revs.

# Diagnostic Trouble Code (DTC) Detecting Criteria

GENERAL DESCRIPTION

- Catalyst damage misfire (Misfire occurrence level damaging catalyst)
- Abnormality Judgment

## Judgment Value

Malfunction Criteria	Threshold Value
Catalyst damage misfire diagnostic value	≥ Value from Map 3

## Map 3 (Models without SI-DRIVE)

		Intake air (g(oz)/rev)									
		0.2 (0.01)	0.4 (0.01)	0.6 (0.02)	0.8 (0.03)	1 (0.04)	1.2 (0.04)	1.4 (0.05)	1.6 (0.06)	1.8 (0.06)	2 (0.07)
Engine speed (rpm)	700	100	100	100	100	100	90	90	90	90	90
	1000	100	100	100	100	92	85	85	85	85	85
	1500	100	100	100	90	85	85	85	72	72	72
	2000	100	90	90	73	58	43	40	36	32	20
	2500	100	87	57	45	39	36	34	32	30	20
	3000	100	87	58	39	36	36	32	30	28	20
	3500	98	74	43	27	23	22	20	20	20	20
	4000	69	61	40	27	22	20	20	20	20	20
	4500	60	55	34	25	20	20	20	20	20	20
	5000	55	55	34	23	20	20	20	20	20	20
	5500	54	54	33	22	20	20	20	20	20	20
	6000	52	52	32	21	20	20	20	20	20	20
	6500	50	50	30	20	20	20	20	20	20	20
6700	50	50	30	20	20	20	20	20	20	20	

## Map 3 (Models with SI-DRIVE)

		Intake air (g(oz)/rev)									
		0.2 (0.01)	0.4 (0.01)	0.6 (0.02)	0.8 (0.03)	1 (0.04)	1.2 (0.04)	1.4 (0.05)	1.6 (0.06)	1.8 (0.06)	2 (0.07)
Engine speed (rpm)	700	148	128	116	106	100	90	90	90	90	90
	1000	148	128	114	104	92	85	85	85	85	85
	1500	140	118	102	90	85	85	85	72	72	72
	2000	128	90	90	73	58	43	40	36	32	20
	2500	116	87	57	45	39	36	34	32	30	20
	3000	108	87	58	39	36	36	32	30	28	20
	3500	74	74	43	27	23	22	20	20	20	20
	4000	61	61	40	27	22	20	20	20	20	20
	4500	55	55	34	25	20	20	20	20	20	20
	5000	55	55	34	23	20	20	20	20	20	20
	5500	54	54	33	22	20	20	20	20	20	20
	6000	52	52	32	21	20	20	20	20	20	20
	6500	50	50	30	20	20	20	20	20	20	20
6700	50	50	30	20	20	20	20	20	20	20	

**Time Needed for Diagnosis:** 200 engine revs.

**Malfunction Indicator Light Illumination:** Illuminates as soon as a malfunction occurs.

- Normality Judgment

## Judgment Value

Malfunction Criteria	Threshold Value
Catalyst damage misfire diagnostic value	< Value of Map 3

**Time Needed for Diagnosis:** 200 engine revs.

**GD(H4DOTC)-115**

Brought to you by Ebay Seller "SubaruManuals"



## Diagnostic Trouble Code (DTC) Detecting Criteria

### GENERAL DESCRIPTION

---

#### **BC:DTC P0302 CYLINDER 2 MISFIRE DETECTED**

##### **1. OUTLINE OF DIAGNOSIS**

###### NOTE:

For the detection standard, refer to DTC P0301. <Ref. to GD(H4DOTC)-107, DTC P0301 CYLINDER 1 MISFIRE DETECTED, Diagnostic Trouble Code (DTC) Detecting Criteria.>

#### **BD:DTC P0303 CYLINDER 3 MISFIRE DETECTED**

##### **1. OUTLINE OF DIAGNOSIS**

###### NOTE:

For the detection standard, refer to DTC P0301. <Ref. to GD(H4DOTC)-107, DTC P0301 CYLINDER 1 MISFIRE DETECTED, Diagnostic Trouble Code (DTC) Detecting Criteria.>

#### **BE:DTC P0304 CYLINDER 4 MISFIRE DETECTED**

##### **1. OUTLINE OF DIAGNOSIS**

###### NOTE:

For the detection standard, refer to DTC P0301. <Ref. to GD(H4DOTC)-107, DTC P0301 CYLINDER 1 MISFIRE DETECTED, Diagnostic Trouble Code (DTC) Detecting Criteria.>

# Diagnostic Trouble Code (DTC) Detecting Criteria

GENERAL DESCRIPTION

## BF:DTC P0327 KNOCK SENSOR 1 CIRCUIT LOW (BANK 1 OR SINGLE SENSOR)

### 1. OUTLINE OF DIAGNOSIS

Detect the open or short circuit of knock sensor.  
Judge as NG if out of specification.

### 2. COMPONENT DESCRIPTION

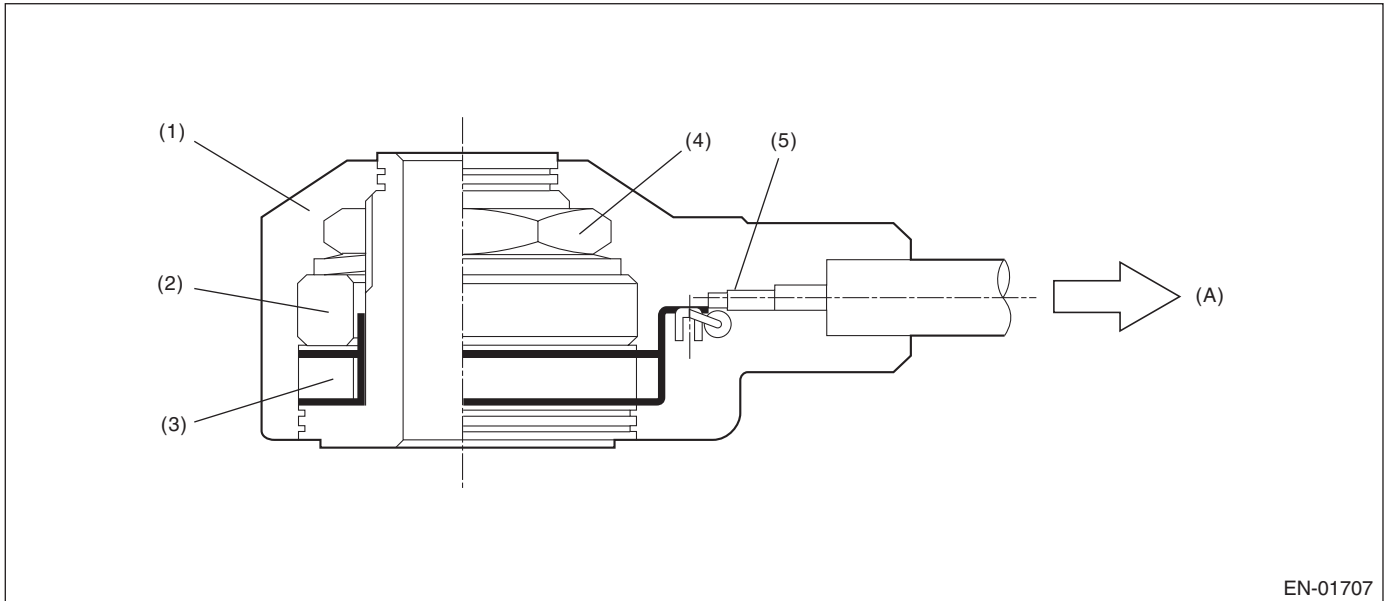

(A) To knock sensor harness

(1) Case

(3) Piezoelectric element

(5) Resistance

(2) Weight

(4) Nut

### 3. ENABLE CONDITIONS

Secondary Parameters	Enable Conditions
None	

### 4. GENERAL DRIVING CYCLE

Always perform the diagnosis continuously.

# Diagnostic Trouble Code (DTC) Detecting Criteria

## GENERAL DESCRIPTION

---

### 5. DIAGNOSTIC METHOD

#### • Abnormality Judgment

If the duration of time while the following conditions are met is longer than the time indicated, judge as NG.

#### Judgment Value

Malfunction Criteria	Threshold Value
Output voltage	< 0.243 V

**Time Needed for Diagnosis:** 1000 ms

**Malfunction Indicator Light Illumination:** Illuminates as soon as a malfunction occurs.

#### • Normality Judgment

Judge as OK and clear the NG if the continuous time while the following conditions are established is more than the predetermined time.

#### Judgment Value

Malfunction Criteria	Threshold Value
Output voltage	$\geq 0.243$ V

**Time Needed for Diagnosis:** Less than 1 second

# Diagnostic Trouble Code (DTC) Detecting Criteria

GENERAL DESCRIPTION

## BG:DTC P0328 KNOCK SENSOR 1 CIRCUIT HIGH (BANK 1 OR SINGLE SENSOR)

### 1. OUTLINE OF DIAGNOSIS

Detect the open or short circuit of knock sensor.  
Judge as NG if out of specification.

### 2. COMPONENT DESCRIPTION

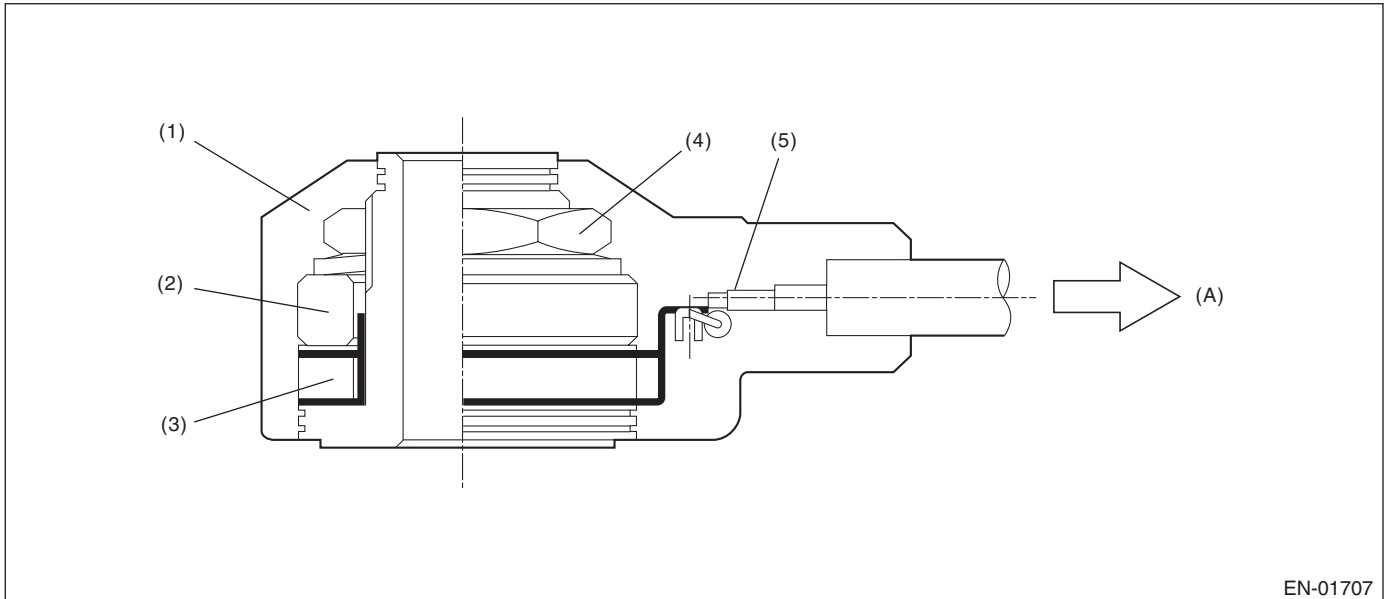

(A) To knock sensor harness

(1) Case

(3) Piezoelectric element

(5) Resistance

(2) Weight

(4) Nut

### 3. ENABLE CONDITIONS

Secondary Parameters	Enable Conditions
None	

### 4. GENERAL DRIVING CYCLE

Always perform the diagnosis continuously.

# Diagnostic Trouble Code (DTC) Detecting Criteria

## GENERAL DESCRIPTION

---

### 5. DIAGNOSTIC METHOD

#### • Abnormality Judgment

If the duration of time while the following conditions are met is longer than the time indicated, judge as NG.

#### Judgment Value

Malfunction Criteria	Threshold Value
Output voltage	$\geq 4.709$ V

**Time Needed for Diagnosis:** 1000 ms

**Malfunction Indicator Light Illumination:** Illuminates as soon as a malfunction occurs.

#### • Normality Judgment

Judge as OK and clear the NG if the continuous time while the following conditions are established is more than the predetermined time.

#### Judgment Value

Malfunction Criteria	Threshold Value
Output voltage	$< 4.709$ V

**Time Needed for Diagnosis:** Less than 1 second

# Diagnostic Trouble Code (DTC) Detecting Criteria

GENERAL DESCRIPTION

## BH:DTC P0335 CRANKSHAFT POSITION SENSOR "A" CIRCUIT

### 1. OUTLINE OF DIAGNOSIS

Detect the open or short circuit of the crankshaft position sensor.

Judge as NG when the crank signal is not input even though the starter was rotated.

### 2. COMPONENT DESCRIPTION

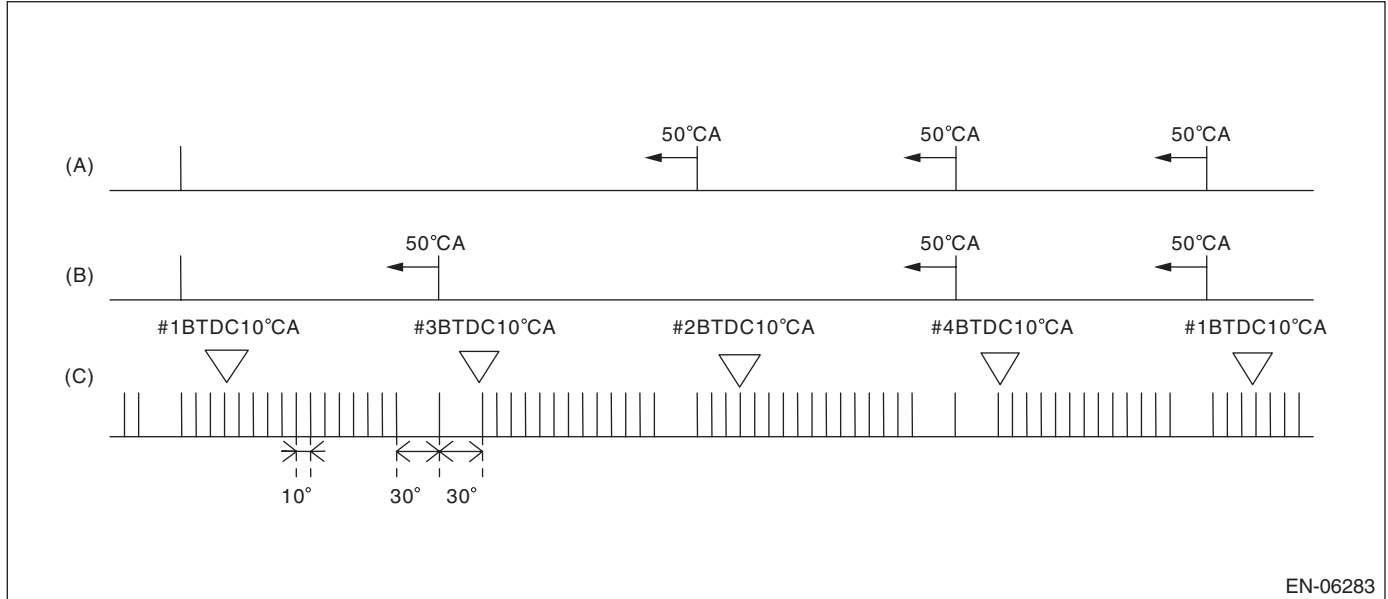

(A) Camshaft signal (RH)

(B) Camshaft signal (LH)

(C) Crankshaft signal

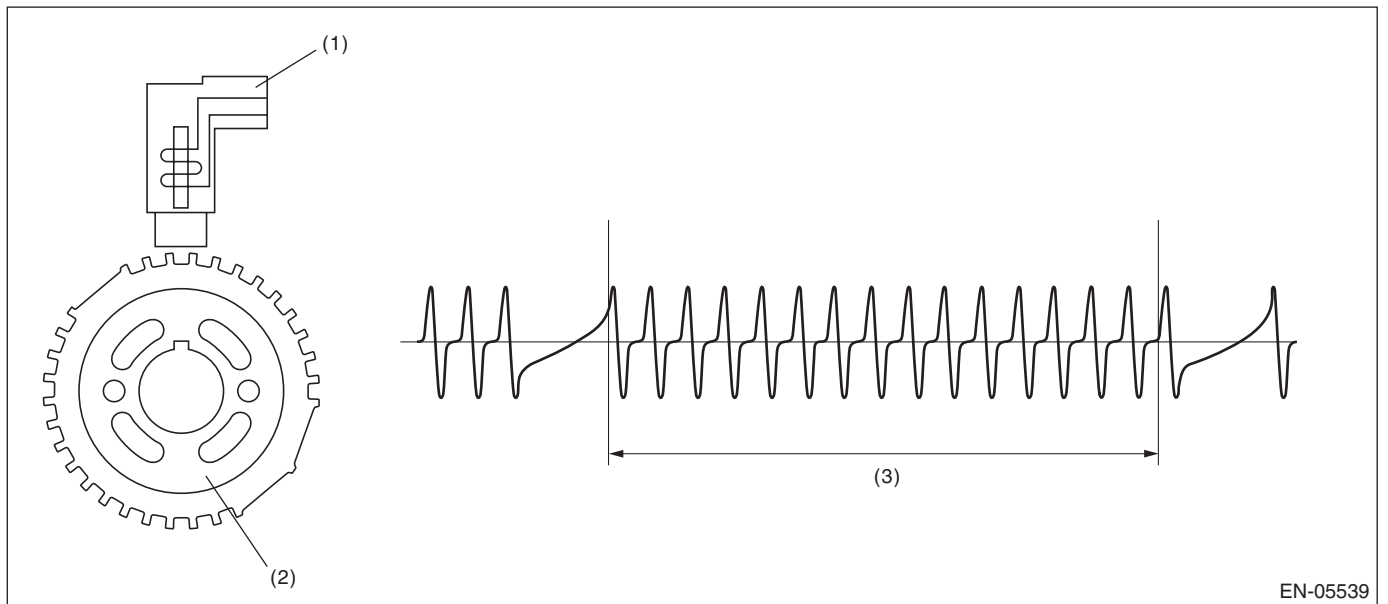

(1) Crankshaft position sensor

(2) Crank sprocket

(3) Crankshaft half-turn

### 3. ENABLE CONDITIONS

Secondary Parameters	Enable Conditions
None	

### 4. GENERAL DRIVING CYCLE

Always perform the diagnosis continuously.

GD(H4DOTC)-121

Brought to you by Ebay Seller "SubaruManuals"

# Diagnostic Trouble Code (DTC) Detecting Criteria

## GENERAL DESCRIPTION

---

### 5. DIAGNOSTIC METHOD

#### • Abnormality Judgment

If the duration of time while the following conditions are met is longer than the time indicated, judge as NG.

#### Judgment Value

Malfunction Criteria	Threshold Value
Starter switch	ON
Crankshaft position sensor signal	Not detected
Battery voltage	$\geq 8\text{ V}$

**Time Needed for Diagnosis:** 3000 ms

**Malfunction Indicator Light Illumination:** Illuminates as soon as a malfunction occurs.

#### • Normality Judgment

Judge as OK and clear the NG if the continuous time while the following conditions are established is more than the predetermined time.

#### Judgment Value

Malfunction Criteria	Threshold Value
Crankshaft position sensor signal	Input exists
Battery voltage	$\geq 8\text{ V}$

**Time Needed for Diagnosis:** Less than 1 second

# Diagnostic Trouble Code (DTC) Detecting Criteria

GENERAL DESCRIPTION

## BI: DTC P0336 CRANKSHAFT POSITION SENSOR "A" CIRCUIT RANGE/PERFORMANCE

### 1. OUTLINE OF DIAGNOSIS

Detect for faults in crankshaft position sensor output properties.

Judge as NG when there is a problem in the number of crankshaft signals for every revolution.

### 2. COMPONENT DESCRIPTION

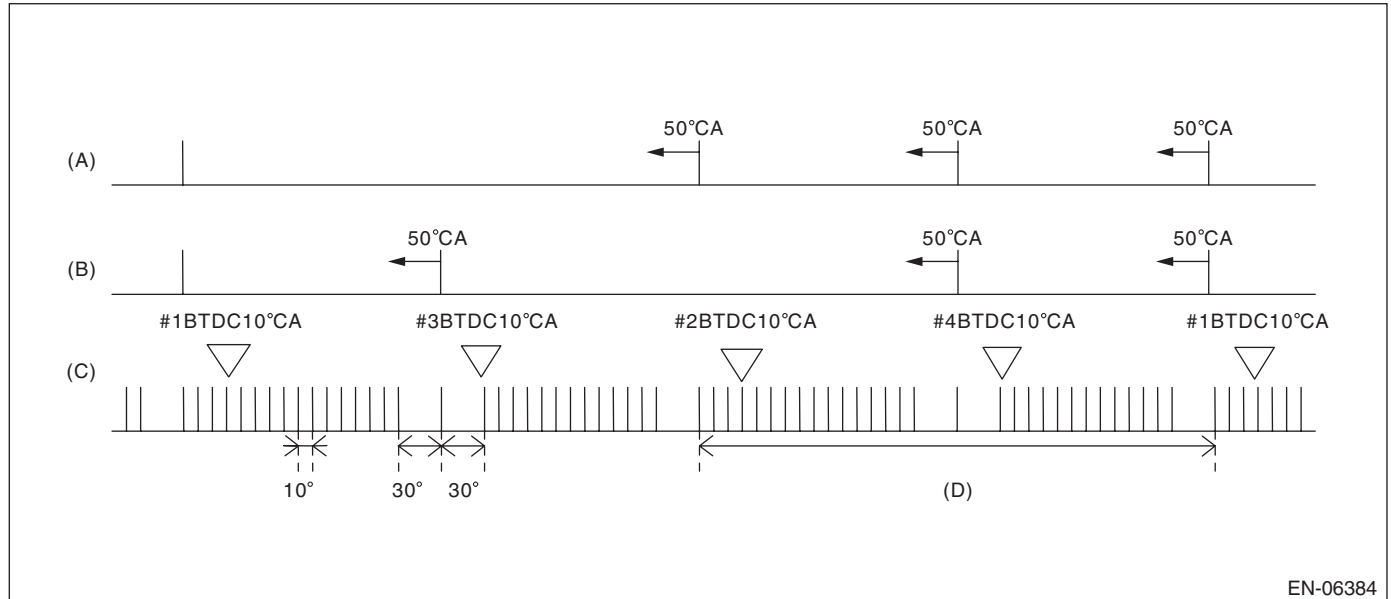

EN-06384

- (A) Camshaft signal (RH)                      (B) Camshaft signal (LH)                      (C) Crankshaft signal  
(D) Number of crankshaft signals = 30 is normal

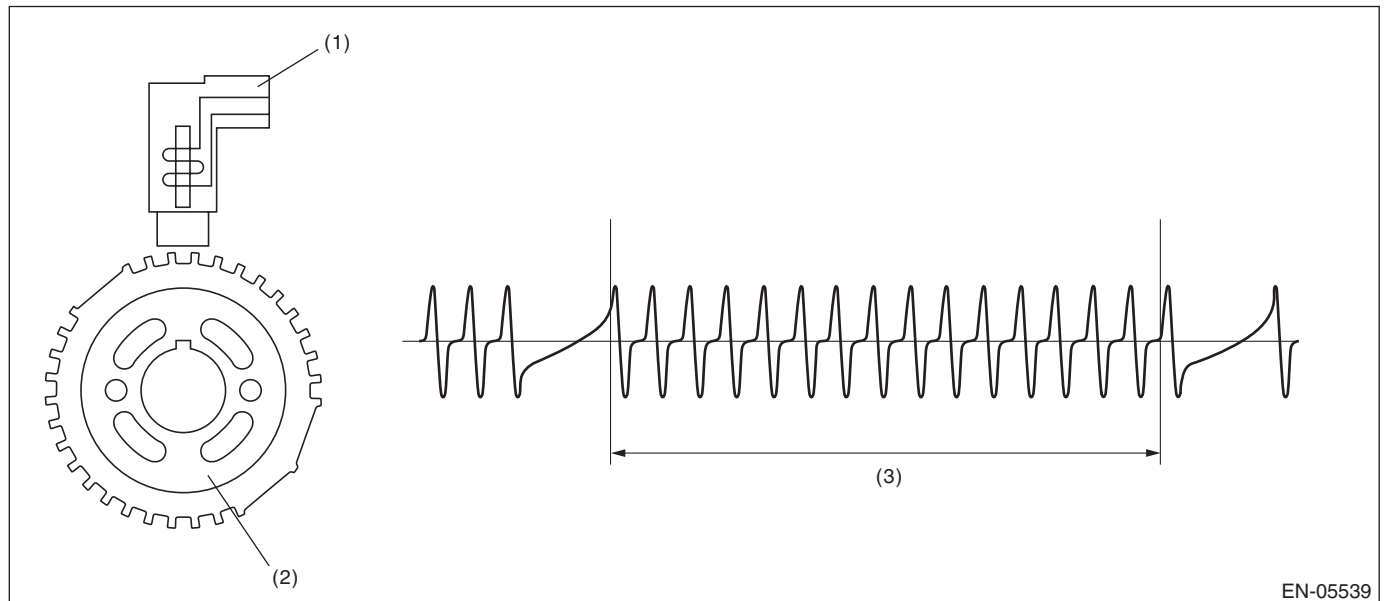

EN-05539

- (1) Crankshaft position sensor                      (2) Crank sprocket                      (3) Crankshaft half-turn



# Diagnostic Trouble Code (DTC) Detecting Criteria

## GENERAL DESCRIPTION

---

### 3. ENABLE CONDITIONS

Secondary Parameters	Enable Conditions
Battery voltage	$\geq 8$ V
Engine speed	$< 3000$ rpm

### 4. GENERAL DRIVING CYCLE

Perform the diagnosis continuously under 3000 rpm engine speed.

### 5. DIAGNOSTIC METHOD

#### • Abnormality Judgment

Judge as NG when the following conditions are established.

#### Judgment Value

Malfunction Criteria	Threshold Value
Cylinder number identification	Completed
Amount of crank sensor signal during 1 rev.	Not = 30

**Time Needed for Diagnosis:** 10 engine revs.

**Malfunction Indicator Light Illumination:** Illuminates when malfunction occurs in 2 continuous driving cycles.

#### • Normality Judgment

Judge as OK and clear the NG if the continuous time while the following conditions are established is more than the predetermined time.

#### Judgment Value

Malfunction Criteria	Threshold Value
Cylinder number identification	Completed
Amount of crank sensor signal during 1 rev.	= 30

**Time Needed for Diagnosis:** Less than 1 second

# Diagnostic Trouble Code (DTC) Detecting Criteria

GENERAL DESCRIPTION

## BJ:DTC P0340 CAMSHAFT POSITION SENSOR "A" CIRCUIT (BANK 1 OR SINGLE SENSOR)

### 1. OUTLINE OF DIAGNOSIS

Detect the open or short circuit of the camshaft position sensor.

Judge as NG when the number of camshaft signals remains abnormal.

### 2. COMPONENT DESCRIPTION

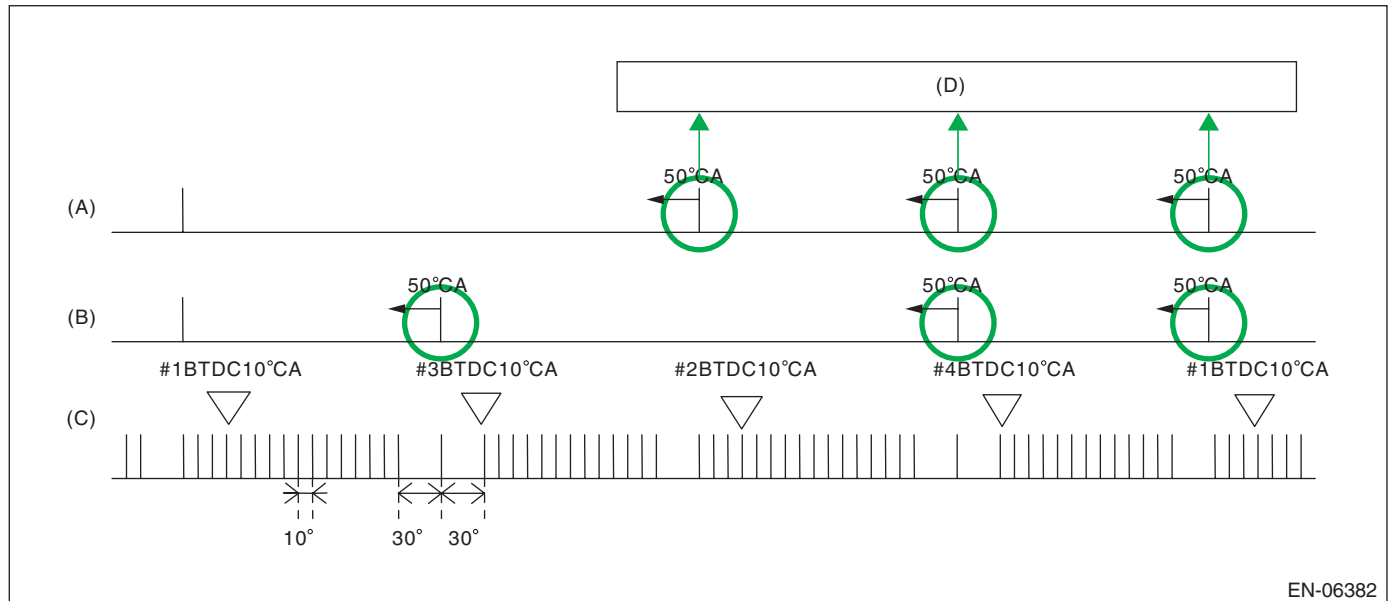

EN-06382

(A) Camshaft signal (RH)

(B) Camshaft signal (LH)

(C) Crankshaft signal

(D) Number of camshaft position signals = When normal, there will be 3 cam signals for every 2 engine revolutions.

### 3. ENABLE CONDITIONS

Secondary Parameters	Enable Conditions
Battery voltage	$\geq 8\text{ V}$

### 4. GENERAL DRIVING CYCLE

Always perform the diagnosis continuously.

# Diagnostic Trouble Code (DTC) Detecting Criteria

## GENERAL DESCRIPTION

---

### 5. DIAGNOSTIC METHOD

#### • Abnormality Judgment 1

Judge as NG when the status where the number of camshaft position sensor signal in two engine revolutions is less than 3 time(s).

#### Judgment Value

Malfunction Criteria	Threshold Value
Amount of camshaft sensor signal during 2 revs.	< 3 time(s)

**Time Needed for Diagnosis:** Engine two revolutions × 4 time(s)

**Malfunction Indicator Light Illumination:** Illuminates as soon as a malfunction occurs.

#### • Normality Judgment 1

Judge as OK and clear the NG when the malfunction criteria below are met.

#### Judgment Value

Malfunction Criteria	Threshold Value
Camshaft position sensor signal	≥ 3 time(s)

**Time Needed for Diagnosis:** Two engine revs.

#### • Abnormality Judgment 2

If the duration of time while the following conditions are met is longer than the time indicated, judge as NG.

#### Judgment Value

Malfunction Criteria	Threshold Value
Starter	ON
Camshaft position sensor signal	No input

**Time Needed for Diagnosis:** 3000 ms

#### • Normality Judgment 2

Judge as OK and clear the NG if the continuous time while the following conditions are established is more than the predetermined time.

#### Judgment Value

Malfunction Criteria	Threshold Value
Camshaft position sensor signal	Input exists

**Time Needed for Diagnosis:** Less than 1 second

## BK:DTC P0345 CAMSHAFT POSITION SENSOR "A" CIRCUIT (BANK 2)

### 1. OUTLINE OF DIAGNOSIS

#### NOTE:

For the detection standard, refer to DTC P0340. <Ref. to GD(H4DOTC)-125, DTC P0340 CAMSHAFT POSITION SENSOR "A" CIRCUIT (BANK 1 OR SINGLE SENSOR), Diagnostic Trouble Code (DTC) Detecting Criteria.>

# Diagnostic Trouble Code (DTC) Detecting Criteria

GENERAL DESCRIPTION

## BL:DTC P0351 IGNITION COIL A PRIMARY/SECONDARY CIRCUIT

### 1. OUTLINE OF DIAGNOSIS

Based on the self-diagnostic result of the ignition coil driving IC, judge the ignition coil driving circuit as normal or abnormal.

The ignition coil driving IC detects "no ignition" status as a malfunction.

### 2. ENABLE CONDITIONS

Secondary Parameters	Enable Conditions
Battery voltage	$\geq 10.9 \text{ V}$
Elapsed time after starting the engine	$> 1 \text{ s}$
Engine speed	$> 500 \text{ rpm}$
Ignition energization time	$> 2000 \mu\text{s}$
Ignition status	Not during ignition cut

### 3. GENERAL DRIVING CYCLE

Always perform the diagnosis continuously.

### 4. DIAGNOSTIC METHOD

#### • Abnormality Judgment

Judge as NG when the following conditions are established.

#### Judgment Value

Malfunction Criteria	Threshold Value
Ignition driving IC information	Malfunction

**Time Needed for Diagnosis:** 2500 ms

**Malfunction Indicator Light Illumination:** Illuminates as soon as a malfunction occurs.

#### • Normality Judgment

Judge as OK and clear the NG if the following conditions are established.

#### Judgment Value

Malfunction Criteria	Threshold Value
Ignition driving IC information	Normal

**Time Needed for Diagnosis:** Less than 1 second

## Diagnostic Trouble Code (DTC) Detecting Criteria

### GENERAL DESCRIPTION

---

#### **BM:DTC P0352 IGNITION COIL B PRIMARY/SECONDARY CIRCUIT**

##### **1. OUTLINE OF DIAGNOSIS**

###### NOTE:

For the detection standard, refer to DTC P0351. <Ref. to GD(H4DOTC)-127, DTC P0351 IGNITION COIL A PRIMARY/SECONDARY CIRCUIT, Diagnostic Trouble Code (DTC) Detecting Criteria.>

#### **BN:DTC P0353 IGNITION COIL C PRIMARY/SECONDARY CIRCUIT**

##### **1. OUTLINE OF DIAGNOSIS**

###### NOTE:

For the detection standard, refer to DTC P0351. <Ref. to GD(H4DOTC)-127, DTC P0351 IGNITION COIL A PRIMARY/SECONDARY CIRCUIT, Diagnostic Trouble Code (DTC) Detecting Criteria.>

#### **BO:DTC P0354 IGNITION COIL D PRIMARY/SECONDARY CIRCUIT**

##### **1. OUTLINE OF DIAGNOSIS**

###### NOTE:

For the detection standard, refer to DTC P0351. <Ref. to GD(H4DOTC)-127, DTC P0351 IGNITION COIL A PRIMARY/SECONDARY CIRCUIT, Diagnostic Trouble Code (DTC) Detecting Criteria.>

# Diagnostic Trouble Code (DTC) Detecting Criteria

GENERAL DESCRIPTION

## BP:DTC P0365 CAMSHAFT POSITION SENSOR "B" CIRCUIT (BANK 1)

### 1. OUTLINE OF DIAGNOSIS

Detect the open or short circuit of the camshaft position sensor.  
Judge as NG when the number of camshaft signals remains abnormal.

### 2. ENABLE CONDITIONS

Secondary Parameters	Enable Conditions
Battery voltage	$\geq 8\text{ V}$

### 3. GENERAL DRIVING CYCLE

Always perform the diagnosis continuously.

### 4. DIAGNOSTIC METHOD

#### • Abnormality Judgment

Judge as NG when the status where the number of camshaft position sensor signal in two engine revolutions is less than 2 time(s).

#### Judgment Value

Malfunction Criteria	Threshold Value
Amount of camshaft sensor signal during 2 revs.	$< 2\text{ time(s)}$

**Time Needed for Diagnosis:** Engine two revolutions  $\times$  4 time(s)

**Malfunction Indicator Light Illumination:** Illuminates as soon as a malfunction occurs.

#### • Normality Judgment

Judge as OK and clear the NG when the malfunction criteria below are met.

#### Judgment Value

Malfunction Criteria	Threshold Value
Camshaft position sensor signal	$\geq 2\text{ time(s)}$

**Time Needed for Diagnosis:** Two engine revs.

## BQ:DTC P0390 CAMSHAFT POSITION SENSOR "B" CIRCUIT (BANK 2)

### 1. OUTLINE OF DIAGNOSIS

NOTE:

For the detection standard, refer to DTC P0365. <Ref. to GD(H4DOTC)-129, DTC P0365 CAMSHAFT POSITION SENSOR "B" CIRCUIT (BANK 1), Diagnostic Trouble Code (DTC) Detecting Criteria.>

# Diagnostic Trouble Code (DTC) Detecting Criteria

## GENERAL DESCRIPTION

### BR:DTC P0410 SECONDARY AIR INJECTION SYSTEM

#### 1. OUTLINE OF DIAGNOSIS

Detect NG judging from secondary air delivery pipe pressure, pulse of secondary air delivery pipe pressure and secondary air pipe airflow amount.

#### 2. ENABLE CONDITIONS

Secondary Parameters	Enable Conditions
<b>Pump supply pressure check</b> Estimate ambient temperature Battery voltage Atmospheric pressure Engine Amount of intake air Secondary air pump Combination valve	$\geq 4.4$ °C $\geq 10.9$ V $\geq 75$ kPa (563 mmHg, 22.2 inHg) In operation $\geq 2$ g/s (0.07 oz/s) Operating Bank open (Except with both banks closed)
<b>Combination valve both closed pulse diagnosis</b> Estimate ambient temperature Battery voltage Atmospheric pressure Engine Engine load After fuel cut	$\geq 4.4$ °C $\geq 10.9$ V $\geq 75$ kPa (563 mmHg, 22.2 inHg) In operation $\geq 0.2$ g/rev (0.01 oz/rev) $\geq 1000$ ms
<b>Combination valve changeover pressure diagnosis</b> Estimate ambient temperature Battery voltage Atmospheric pressure Engine Amount of intake air Engine speed After fuel cut	$\geq 4.4$ °C $\geq 10.9$ V $\geq 75$ kPa (563 mmHg, 22.2 inHg) In operation $> 2$ g/s (0.07 oz/s) and $< 25$ g/s (0.88 oz/s) $< 4000$ rpm $\geq 1000$ ms
<b>Overflow diagnosis</b> Estimate ambient temperature Battery voltage Atmospheric pressure Engine	$\geq 4.4$ °C $\geq 10.9$ V $\geq 75$ kPa (563 mmHg, 22.2 inHg) In operation

#### 3. GENERAL DRIVING CYCLE

Perform diagnosis during secondary air pump operation

# Diagnostic Trouble Code (DTC) Detecting Criteria

GENERAL DESCRIPTION

## 4. DIAGNOSTIC METHOD

Measure secondary air delivery pipe pressure, pulse of secondary air delivery pipe pressure and secondary air pipe airflow amount.

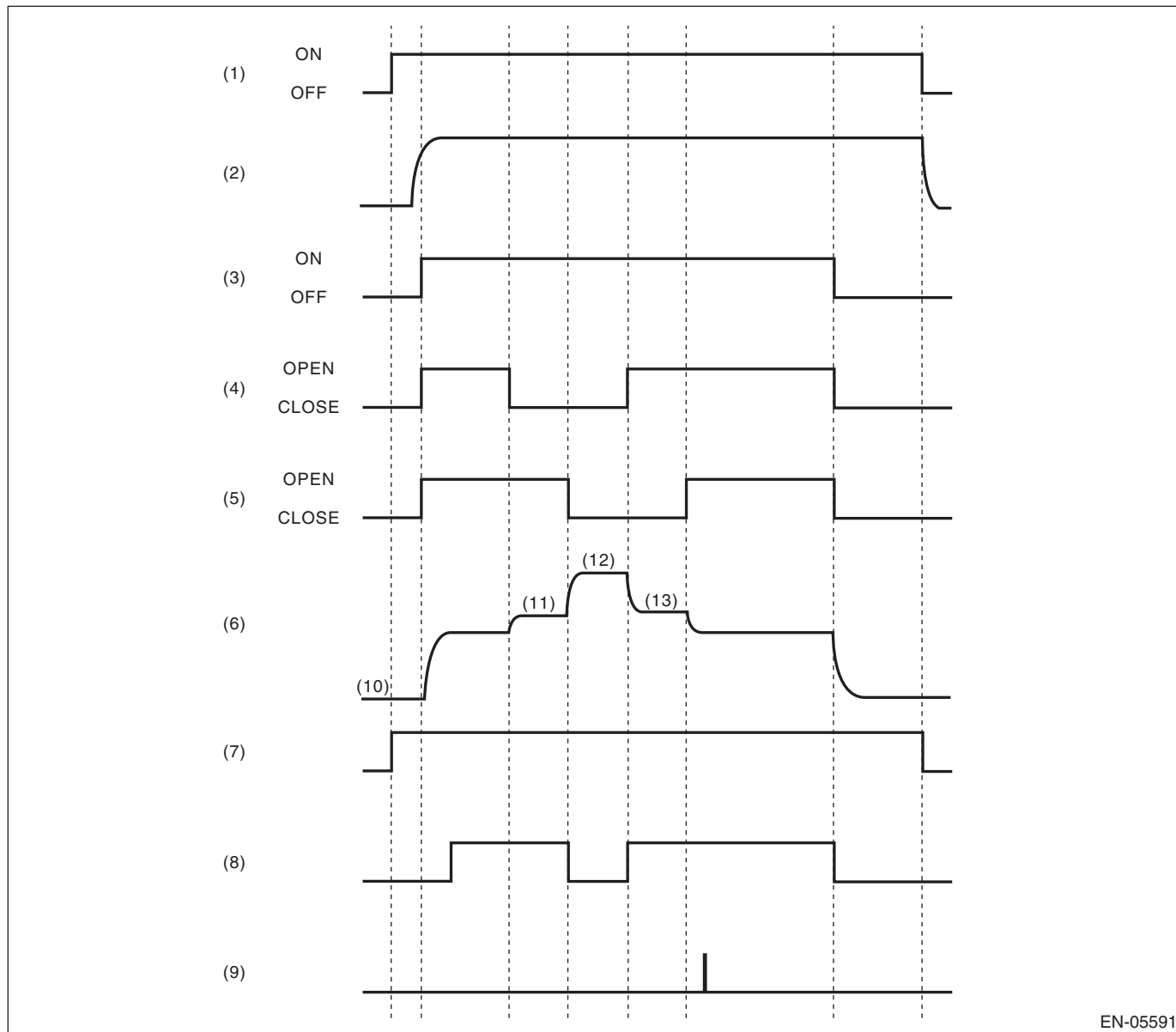

EN-05591

- |   |  |   |
|---|--|---|
| (1) IG                                  | (6) Secondary air delivery pipe pressure (psi) | (10) Barometric pressure (Pas) measurement before secondary air control |
| (2) Ne                                  | (7) Diagnosis enable condition                 | (11) Right bank all closed pressure (P0R) measurement                   |
| (3) Secondary air pump operating status | (8) Pump supply pressure check (judgment)      | (12) Both banks all closed pressure (P0RL) measurement                  |
| (4) E-COMB valve (right hand) status    | (9) Flow amount check (judgment)               | (13) Left bank all closed pressure (P0L) measurement                    |
| (5) E-COMB valve (left hand) status     |  |   |



# Diagnostic Trouble Code (DTC) Detecting Criteria

## GENERAL DESCRIPTION

### Pump supply pressure check

Perform the system function diagnosis with how much the pressure rises when the secondary air pump is turned from OFF to ON.

Judge as NG if delivery pipe pressure does not rise though it should when the secondary air pump turns OFF → ON.

- **Abnormality Judgment**

If the duration of time while the following conditions are met is longer than the time indicated, judge as NG.

#### Judgment Value

Malfunction Criteria	Threshold Value	DTC
Secondary air supply pipe pressure (after barometric pressure compensation)	< 0.9 kPa (7 mmHg, 0.3 inHg)	P0410

**Time Needed for Diagnosis:** 2000 ms + 2800 ms

**Malfunction Indicator Light Illumination:** Illuminates when malfunction occurs in 2 continuous driving cycles.

- **Normality Judgment**

Judge as OK and clear the NG if the continuous time while the following conditions are established is more than the predetermined time.

#### Judgment Value

Malfunction Criteria	Threshold Value	DTC
Secondary air supply pipe pressure (after barometric pressure compensation)	≥ 0.9 kPa (7 mmHg, 0.3 inHg)	P0410

**Time Needed for Diagnosis:** 2000 ms + 2800 ms

### Combination valve both closed pulse diagnosis

Perform open stuck diagnosis of both combination valves using delivery pipe pressure pulse when both combination valves are closed. Determine which side of valves is stuck open by comparing secondary air flow amount when RH combination valve is closed with that when LH combination valve is closed.

Calculate voltage pulse of the pump delivery pipe pressure when both combination valves are closed. The calculation should be small because there is no pulse from supply pipe pressure with both combination valves closed. When the calculation is large, determine that either of the combination valves is stuck open. Determine which side of valves is stuck open by comparing secondary air flow amount when the RH combination valve is closed with that when the LH combination valve is closed. Air flow amount is larger on the open stuck valve.

- **Abnormality Judgment**

If the duration of time while the following conditions are met is longer than the time indicated, judge as NG.

#### Judgment Value

Malfunction Criteria	Threshold Value	DTC
Pulse calculation value when both combination valves are closed Air flow amount when the right bank is closed (value from Map 4)	> Value of Map 3 ≥ Air flow amount when the left bank is closed (value from Map 5)	P2440
Pulse calculation value when both combination valves are closed Air flow amount when the left bank is closed (value from Map 5)	> Value of Map 3 > Air flow amount when the right bank is closed (value from Map 4)	P2442

**Time Needed for Diagnosis:** 4000 ms + 992 ms + 992 ms + 992 ms

**Malfunction Indicator Light Illumination:** Illuminates when malfunction occurs in 2 continuous driving cycles.

# Diagnostic Trouble Code (DTC) Detecting Criteria

GENERAL DESCRIPTION

## • Normality Judgment

Judge as OK and clear the NG if the continuous time while the following conditions are established is more than the predetermined time.

### Judgment Value

Malfunction Criteria	Threshold Value	DTC
Pulse calculation value when both combination valves are closed	≤ Value of Map 3	P2440, P2442

**Time Needed for Diagnosis:** 4000 ms + 992 ms + 992 ms + 992 ms

## Combination valve changeover pressure diagnosis

Perform the RH combination valve stuck closed diagnosis with the variation of delivery pipe pressure when the RH combination valve turns closed → open.

Delivery pipe pressure should vary when the RH combination valve turns closed → open. When the variation is small, determine that the RH combination valve is stuck closed.

## • Abnormality Judgment

If the duration of time while the following conditions are met is longer than the time indicated, judge as NG.

### Judgment Value

Malfunction Criteria	Threshold Value	DTC
Pressure variation value when the RH combination valve is switched	< Value of Map 6	P2441

**Time Needed for Diagnosis:** 4000 ms + 992 ms + 992 ms + 992 ms

**Malfunction Indicator Light Illumination:** Illuminates when malfunction occurs in 2 continuous driving cycles.

## • Normality Judgment

Judge as OK and clear the NG if the continuous time while the following conditions are established is more than the predetermined time.

### Judgment Value

Malfunction Criteria	Threshold Value	DTC
Pressure variation value when the RH combination valve is switched	≥ Value of Map 6	P2441

**Time Needed for Diagnosis:** 4000 ms + 992 ms + 992 ms + 992 ms

Perform the LH combination valve stuck closed diagnosis with the variation of delivery pipe pressure when the LH combination valve turns open → closed.

Delivery pipe pressure should vary when the LH combination valve turns open → closed. When the variation is small, determine that the LH combination valve is stuck closed.

## • Abnormality Judgment

If the duration of time while the following conditions are met is longer than the time indicated, judge as NG.

### Judgment Value

Malfunction Criteria	Threshold Value	DTC
Pressure variation value when the LH combination valve is switched	< Value of Map 7	P2443

**Time Needed for Diagnosis:** 4000 ms + 992 ms + 992 ms + 992 ms

**Malfunction Indicator Light Illumination:** Illuminates when malfunction occurs in 2 continuous driving cycles.

# Diagnostic Trouble Code (DTC) Detecting Criteria

## GENERAL DESCRIPTION

### • Normality Judgment

Judge as OK and clear the NG if the continuous time while the following conditions are established is more than the predetermined time.

### Judgment Value

Malfunction Criteria	Threshold Value	DTC
Pressure variation value when the LH combination valve is switched	≥ Value of Map 7	P2443

**Time Needed for Diagnosis:** 4000 ms + 992 ms + 992 ms + 992 ms

### Overflow diagnosis

Perform secondary air system flow abnormality diagnosis using both sides of combination valves secondary air amount when both are closed.

Judge as secondary air system flow abnormality either if there is excessive secondary air flow amount with the RH combination valve closed, or if there is excessive secondary air flow amount with the LH combination valve closed.

### • Abnormality Judgment

If the duration of time while the following conditions are met is longer than the time indicated, judge as NG.

### Judgment Value

Malfunction Criteria	Threshold Value	DTC
Air flow amount when the right bank is closed (value from Map 4) or Air flow amount when the left bank is closed (value from Map 5)	> Value of Map 8  > Value of Map 9	P0411
Voltage at P0RL measurement – Voltage at P0R measurement Voltage at P0RL measurement – Voltage at P0L measurement	≤ 4 V ≤ 4 V	

P0RL: Both banks all closed pressure

P0R: Right bank all closed pressure

P0L: Left bank all closed pressure

**Time Needed for Diagnosis:** 4000 ms + 992 ms + 992 ms + 992 ms

**Malfunction Indicator Light Illumination:** Illuminates when malfunction occurs in 2 continuous driving cycles.

### • Normality Judgment

Judge as OK and clear the NG if the continuous time while the following conditions are established is more than the predetermined time.

### Judgment Value

Malfunction Criteria	Threshold Value	DTC
Air flow amount when the right bank is closed (value from Map 4) or Air flow amount when the left bank is closed (value from Map 5)	≤ Value of Map 8  ≤ Value of Map 9	P0411
Voltage at P0RL measurement – Voltage at P0R measurement Voltage at P0RL measurement – Voltage at P0L measurement	≤ 4 V ≤ 4 V	

P0RL: Both banks all closed pressure

P0R: Right bank all closed pressure

P0L: Left bank all closed pressure

**Time Needed for Diagnosis:** 4000 ms + 992 ms + 992 ms + 992 ms

### Map 3 (Models without SI-DRIVE)

Intake air (g (oz)/rev)	0.1 (0)	0.25 (0.01)	0.3 (0.01)	1 (0.04)
Threshold value (V)	13	13	3.25	3.25

# Diagnostic Trouble Code (DTC) Detecting Criteria

GENERAL DESCRIPTION

## Map 3 (Models with SI-DRIVE)

Intake air (g (oz)/rev)	0.1 (0)	0.25 (0.01)	0.3 (0.01)	1 (0.04)
Threshold value (V)	100	100	4.5	4.5

## Map 4

Secondary air pressure in the pipe when both comb. valve is closing kPa (mmHg, inHg)																
Secondary air pressure in the pipe when LH comb. valve is closing kPa (mmHg, inHg)	69.3 (520, 20.5)	74.6 (560, 22)	80 (600, 23.6)	85.3 (640, 25.2)	90.6 (680, 26.8)	96 (720, 28.3)	101.3 (760, 29.9)	106.6 (800, 31.5)	112 (840, 33.1)	117.3 (880, 34.6)	122.6 (920, 36.2)	128 (960, 37.8)	133.3 (1000, 39.4)	138.6 (1040, 40.9)	144 (1080, 42.5)	149.3 (1120, 44.1)
69.3 (520, 20.5)	0	200	400	600	800	1000	1200	1400	1600	1800	2000	2200	2400	2400	2400	2400
74.6 (560, 22)	-200	0	200	400	600	800	1000	1200	1400	1600	1800	2000	2200	2400	2400	2400
80 (600, 23.6)	-400	-200	0	200	400	600	800	1000	1200	1400	1600	1800	2000	2200	2400	2400
85.3 (640, 25.2)	-600	-400	-200	0	200	400	600	800	1000	1200	1400	1600	1800	2000	2200	2400
90.6 (680, 26.8)	-800	-600	-400	-200	0	200	400	600	800	1000	1200	1400	1600	1800	2000	2200
96 (720, 28.3)	-1000	-800	-600	-400	-200	0	200	400	600	800	1000	1200	1400	1600	1800	2000
101.3 (760, 29.9)	-1200	-1000	-800	-600	-400	-200	0	200	400	600	800	1000	1200	1400	1600	1800
106.6 (800, 31.5)	-1400	-1200	-1000	-800	-600	-400	-200	0	200	400	600	800	1000	1200	1400	1600
112 (840, 33.1)	-1600	-1400	-1200	-1000	-800	-600	-400	-200	0	200	400	600	800	1000	1200	1400
117.3 (880, 34.6)	-1800	-1600	-1400	-1200	-1000	-800	-600	-400	-200	0	200	400	600	800	1000	1200
122.6 (920, 36.2)	-2000	-1800	-1600	-1400	-1200	-1000	-800	-600	-400	-200	0	200	400	600	800	1000
128 (960, 37.8)	-2200	-2000	-1800	-1600	-1400	-1200	-1000	-800	-600	-400	-200	0	200	400	600	800
133.3 (1000, 39.4)	-2400	-2200	-2000	-1800	-1600	-1400	-1200	-1000	-800	-600	-400	-200	0	200	400	600
138.6 (1040, 40.9)	-2400	-2400	-2200	-2000	-1800	-1600	-1400	-1200	-1000	-800	-600	-400	-200	0	200	400
144 (1080, 42.5)	-2400	-2400	-2400	-2200	-2000	-1800	-1600	-1400	-1200	-1000	-800	-600	-400	-200	0	200
149.3 (1120, 44.1)	-2400	-2400	-2400	-2400	-2200	-2000	-1800	-1600	-1400	-1200	-1000	-800	-600	-400	-200	0

(L/min)

**GD(H4DOTC)-135**

Brought to you by Ebay Seller "SubaruManuals"

# Diagnostic Trouble Code (DTC) Detecting Criteria

## GENERAL DESCRIPTION

### Map 5

Secondary air pressure in the pipe when both comb. valve is closing kPa (mmHg, inHg) Secondary air pressure in the pipe when RH comb. valve is closing kPa (mmHg, inHg)	69.3 (520, 20.5)	74.6 (560, 22)	80 (600, 23.6)	85.3 (640, 25.2)	90.6 (680, 26.8)	96 (720, 28.3)	101.3 (760, 29.9)	106.6 (800, 31.5)	112 (840, 33.1)	117.3 (880, 34.6)	122.6 (920, 36.2)	128 (960, 37.8)	133.3 (1000, 39.4)	138.6 (1040, 40.9)	144 (1080, 42.5)	149.3 (1120, 44.1)
69.3 (520, 20.5)	0	200	400	600	800	1000	1200	1400	1600	1800	2000	2200	2400	2400	2400	2400
74.6 (560, 22)	-200	0	200	400	600	800	1000	1200	1400	1600	1800	2000	2200	2400	2400	2400
80 (600, 23.6)	-400	-200	0	200	400	600	800	1000	1200	1400	1600	1800	2000	2200	2400	2400
85.3 (640, 25.2)	-600	-400	-200	0	200	400	600	800	1000	1200	1400	1600	1800	2000	2200	2400
90.6 (680, 26.8)	-800	-600	-400	-200	0	200	400	600	800	1000	1200	1400	1600	1800	2000	2200
96 (720, 28.3)	-1000	-800	-600	-400	-200	0	200	400	600	800	1000	1200	1400	1600	1800	2000
101.3 (760, 29.9)	-1200	-1000	-800	-600	-400	-200	0	200	400	600	800	1000	1200	1400	1600	1800
106.6 (800, 31.5)	-1400	-1200	-1000	-800	-600	-400	-200	0	200	400	600	800	1000	1200	1400	1600
112 (840, 33.1)	-1600	-1400	-1200	-1000	-800	-600	-400	-200	0	200	400	600	800	1000	1200	1400
117.3 (880, 34.6)	-1800	-1600	-1400	-1200	-1000	-800	-600	-400	-200	0	200	400	600	800	1000	1200
122.6 (920, 36.2)	-2000	-1800	-1600	-1400	-1200	-1000	-800	-600	-400	-200	0	200	400	600	800	1000
128 (960, 37.8)	-2200	-2000	-1800	-1600	-1400	-1200	-1000	-800	-600	-400	-200	0	200	400	600	800
133.3 (1000, 39.4)	-2400	-2200	-2000	-1800	-1600	-1400	-1200	-1000	-800	-600	-400	-200	0	200	400	600
138.6 (1040, 40.9)	-2400	-2400	-2200	-2000	-1800	-1600	-1400	-1200	-1000	-800	-600	-400	-200	0	200	400
144 (1080, 42.5)	-2400	-2400	-2400	-2200	-2000	-1800	-1600	-1400	-1200	-1000	-800	-600	-400	-200	0	200
149.3 (1120, 44.1)	-2400	-2400	-2400	-2400	-2200	-2000	-1800	-1600	-1400	-1200	-1000	-800	-600	-400	-200	0
(L/min)																

# Diagnostic Trouble Code (DTC) Detecting Criteria

GENERAL DESCRIPTION

## Map 6

Amount of intake air when RH comb. valve switches (g (oz)/s) Battery voltage when RH comb. valve switches (V)	10 (0.35)	15 (0.53)	20 (0.71)	25 (0.88)	26 (0.92)
11	0.025	0.025	0.025	0.005	0
12	0.035	0.035	0.035	0.015	0
13	0.05	0.05	0.05	0.025	0
14	0.05	0.05	0.05	0.025	0
					(V)

## Map 7

Amount of intake air when LH comb. valve switches (g (oz)/s) Battery voltage when LH comb. valve switches (V)	10 (0.35)	15 (0.53)	20 (0.71)	25 (0.88)	26 (0.92)
11	0.025	0.025	0.025	0.005	0
12	0.035	0.035	0.035	0.015	0
13	0.05	0.05	0.05	0.025	0
14	0.05	0.05	0.05	0.025	0
					(V)

## Map 8

Amount of intake air when P0R is measuring (g (oz)/s) Battery voltage when P0R measuring (V)	2 (0.07)	25 (0.88)
11.5	345	345
12.5	345	345
13.5	345	345
14.5	390	390
15.5	420	420
		(L/min)

## Map 9

Amount of intake air when P0L is measuring (g (oz)/s) Battery voltage when P0L measuring (V)	2 (0.07)	25 (0.88)
11.5	345	345
12.5	345	345
13.5	345	345
14.5	390	390
15.5	420	420
		(L/min)

## BS:DTC P0411 SECONDARY AIR INJECTION SYSTEM INCORRECT FLOW DETECTED

### 1. OUTLINE OF DIAGNOSIS

#### NOTE:

For the detection standard, refer to DTC P0410. <Ref. to GD(H4DOTC)-130, DTC P0410 SECONDARY AIR INJECTION SYSTEM, Diagnostic Trouble Code (DTC) Detecting Criteria.>

# Diagnostic Trouble Code (DTC) Detecting Criteria

## GENERAL DESCRIPTION

### BT:DTC P0413 SECONDARY AIR INJECTION SYSTEM SWITCHING VALVE "A" CIRCUIT OPEN

#### 1. OUTLINE OF DIAGNOSIS

Judge as NG when the ECM output level differs from the actual terminal level.

#### 2. ENABLE CONDITIONS

Secondary Parameters	Enable Conditions
None	

#### 3. GENERAL DRIVING CYCLE

Always perform the diagnosis continuously.

#### 4. DIAGNOSTIC METHOD

##### • Abnormality Judgment

If the duration of time while the following conditions are met is longer than the time indicated, judge as NG.

##### Judgment Value

Malfunction Criteria	Threshold Value
Battery voltage	$\geq 10.9$ V
Ignition	ON
Terminal output voltage when ECM outputs OFF signal	LOW

**Time Needed for Diagnosis:** 2500 ms

**Malfunction Indicator Light Illumination:** Illuminates as soon as a malfunction occurs.

##### • Normality Judgment

Judge as OK and clear the NG if the continuous time while the following conditions are established is more than the predetermined time.

##### Judgment Value

Malfunction Criteria	Threshold Value
Battery voltage	$\geq 10.9$ V
Ignition	ON
Terminal output voltage when ECM outputs OFF signal	HIGH

**Time Needed for Diagnosis:** Less than 1 second

# Diagnostic Trouble Code (DTC) Detecting Criteria

GENERAL DESCRIPTION

## BU:DTC P0414 SECONDARY AIR INJECTION SYSTEM SWITCHING VALVE "A" CIRCUIT SHORTED

### 1. OUTLINE OF DIAGNOSIS

Judge as NG when the ECM output level differs from the actual terminal level.

### 2. ENABLE CONDITIONS

Secondary Parameters	Enable Conditions
None	

### 3. GENERAL DRIVING CYCLE

Always perform the diagnosis continuously.

### 4. DIAGNOSTIC METHOD

#### • Abnormality Judgment

If the duration of time while the following conditions are met is longer than the time indicated, judge as NG.

#### Judgment Value

Malfunction Criteria	Threshold Value
Battery voltage	$\geq 10.9$ V
Ignition	ON
Terminal output voltage when ECM outputs ON signal	HIGH

**Time Needed for Diagnosis:** 2500 ms

**Malfunction Indicator Light Illumination:** Illuminates as soon as a malfunction occurs.

#### • Normality Judgment

Judge as OK and clear the NG if the continuous time while the following conditions are established is more than the predetermined time.

#### Judgment Value

Malfunction Criteria	Threshold Value
Battery voltage	$\geq 10.9$ V
Ignition	ON
Terminal output voltage when ECM outputs ON signal	LOW

**Time Needed for Diagnosis:** Less than 1 second



## Diagnostic Trouble Code (DTC) Detecting Criteria

### GENERAL DESCRIPTION

---

#### **BV:DTC P0416 SECONDARY AIR INJECTION SYSTEM SWITCHING VALVE "B" CIRCUIT OPEN**

##### **1. OUTLINE OF DIAGNOSIS**

###### NOTE:

For the detection standard, refer to DTC P0413. <Ref. to GD(H4DOTC)-138, DTC P0413 SECONDARY AIR INJECTION SYSTEM SWITCHING VALVE "A" CIRCUIT OPEN, Diagnostic Trouble Code (DTC) Detecting Criteria.>

#### **BW:DTC P0417 SECONDARY AIR INJECTION SYSTEM SWITCHING VALVE "B" CIRCUIT SHORTED**

##### **1. OUTLINE OF DIAGNOSIS**

###### NOTE:

For the detection standard, refer to DTC P0414. <Ref. to GD(H4DOTC)-139, DTC P0414 SECONDARY AIR INJECTION SYSTEM SWITCHING VALVE "A" CIRCUIT SHORTED, Diagnostic Trouble Code (DTC) Detecting Criteria.>

# Diagnostic Trouble Code (DTC) Detecting Criteria

GENERAL DESCRIPTION

## BX:DTC P0418 SECONDARY AIR INJECTION SYSTEM CONTROL "A" CIRCUIT OPEN

### 1. OUTLINE OF DIAGNOSIS

Judge as NG when the ECM output level differs from the actual terminal level.

### 2. ENABLE CONDITIONS

Secondary Parameters	Enable Conditions
None	

### 3. GENERAL DRIVING CYCLE

Always perform the diagnosis continuously.

### 4. DIAGNOSTIC METHOD

#### • Abnormality Judgment

If the duration of time while the following conditions are met is longer than the time indicated, judge as NG.

#### Judgment Value

Malfunction Criteria	Threshold Value
Battery voltage	$\geq 10.9$ V
Ignition	ON
Terminal output voltage when ECM outputs OFF signal	LOW

**Time Needed for Diagnosis:** 2500 ms

**Malfunction Indicator Light Illumination:** Illuminates as soon as a malfunction occurs.

#### • Normality Judgment

Judge as OK and clear the NG if the continuous time while the following conditions are established is more than the predetermined time.

#### Judgment Value

Malfunction Criteria	Threshold Value
Battery voltage	$\geq 10.9$ V
Ignition	ON
Terminal output voltage when ECM outputs OFF signal	HIGH

**Time Needed for Diagnosis:** Less than 1 second

# Diagnostic Trouble Code (DTC) Detecting Criteria

## GENERAL DESCRIPTION

### BY:DTC P0420 CATALYST SYSTEM EFFICIENCY BELOW THRESHOLD (BANK 1)

#### 1. OUTLINE OF DIAGNOSIS

Detect the deterioration of the catalytic function.

Though the front oxygen sensor output would change slowly with a new catalyst, the sensor output with a deteriorated catalyst becomes high and the inversion time is shortened.

For this reason, the catalyst diagnosis is carried out by monitoring the front oxygen sensor output and comparing it with the front oxygen (A/F) sensor output.

#### 2. COMPONENT DESCRIPTION

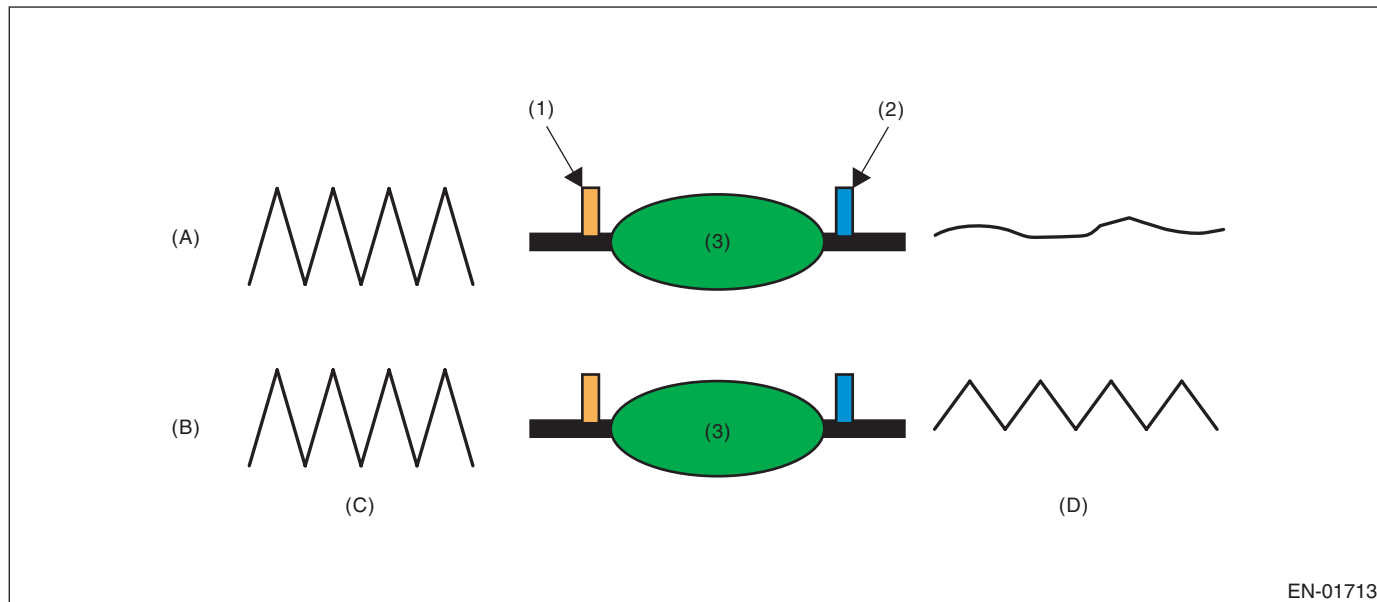

(A) Normal

(B) Deterioration

(C) Output waveform from the front oxygen (A/F) sensor

(D) Output waveform from the front oxygen sensor

(1) Front oxygen (A/F) sensor

(2) Front oxygen sensor

(3) Catalytic converter

EN-01713

# Diagnostic Trouble Code (DTC) Detecting Criteria

GENERAL DESCRIPTION

## 3. ENABLE CONDITIONS

Secondary Parameters	Enable Conditions
Battery voltage	≥ 10.9 V
Atmospheric pressure	≥ 75 kPa (563 mmHg, 22.2 inHg)
Engine coolant temperature	≥ 68.5 °C (155.3 °F) (models without SI-DRIVE) ≥ 70 °C (158 °F) (models with SI-DRIVE)
Estimated catalyst temperature	≥ 460 °C (860 °F) (models without SI-DRIVE) ≥ 490 °C (914 °F) (models with SI-DRIVE)
Misfire detection every 200 rotations	< 65535 time(s)
Learning value of evaporation gas density	< 0.2
Sub feedback	In operation
Evaporative system diagnosis	Not in operation
Time of difference (< 0.10) between actual lambda and target lambda	≥ 1000 ms
Vehicle speed	> 60 km/h (37.3 MPH)
Amount of intake air	≥ 10 g/s (0.35 oz/s) and < 50 g/s (1.76 oz/s)
Engine load change every 0.5 engine revs.	< 0.02 g/rev (0 oz/rev)
Rear oxygen output change from 660 mV or less to 660 mV or more	Experienced after fuel cut
Elapsed time after starting the engine	≥ Value from Map
Purge execution calculated time	≥ 5 s

### Map (models without SI-DRIVE)

Engine coolant temperature °C (°F)	-30 (-22)	-20 (-4)	-10 (14)	0 (32)	10 (50)	20 (68)
Elapsed time after starting the engine s	470	430	390	350	310	213

### Map (models with SI-DRIVE)

Engine coolant temperature °C (°F)	-30 (-22)	-20 (-4)	-10 (14)	0 (32)	10 (50)	20 (68)
Elapsed time after starting the engine s	470	430	390	350	310	230

## 4. GENERAL DRIVING CYCLE

Perform the diagnosis only once at a constant speed of 60 km/h (37.3 MPH) or higher.

# Diagnostic Trouble Code (DTC) Detecting Criteria

## GENERAL DESCRIPTION

---

### 5. DIAGNOSTIC METHOD

After the enable conditions have been established, calculate the front oxygen (A/F) sensor lambda value deviation sum value ( $\sum |(sglmd_n - sglmd_{n-1})|$ ), and rear oxygen sensor output voltage deviation sum value ( $\sum |(ro2sad_n - ro2sad_{n-1})|$ ) in every  $32 \text{ ms} \times 4$  times. If the front oxygen (A/F) sensor lambda value deviation sum value ( $\sum |(sglmd_n - sglmd_{n-1})|$ ) is the predetermined value or more, calculate the diagnostic value.

#### • Abnormality Judgment

If the duration of time while the following conditions are met is within the time indicated, judge as NG.

#### Judgment Value

Malfunction Criteria	Threshold Value
$\sum  (ro2sad_n - ro2sad_{n-1})  / \sum  (sglmd_n - sglmd_{n-1}) $	> 7.94 (Models without SI-DRIVE) > 8 (Models with SI-DRIVE)

**Time Needed for Diagnosis:** 30 — 55 seconds

**Malfunction Indicator Light Illumination:** Illuminates when malfunction occurs in 2 continuous driving cycles.

#### • Normality Judgment

Judge as OK and clear the NG if the continuous time while the following conditions are established is within the predetermined time.

#### Judgment Value

Malfunction Criteria	Threshold Value
$\sum  (ro2sad_n - ro2sad_{n-1})  / \sum  (sglmd_n - sglmd_{n-1}) $	$\leq 7.94$ (Models without SI-DRIVE) $\leq 8$ (Models with SI-DRIVE)

**Time Needed for Diagnosis:** 30 — 55 seconds

# Diagnostic Trouble Code (DTC) Detecting Criteria

GENERAL DESCRIPTION

## BZ:DTC P0441 EVAPORATIVE EMISSION CONT. SYS. INCORRECT PURGE FLOW

### 1. OUTLINE OF DIAGNOSIS

Detect the malfunction of purge flow by the change of ELCM pressure sensor output value before/after purge introduction.

### 2. ENABLE CONDITIONS

Secondary Parameters	Enable Conditions
<Common conditions>	
Battery voltage	≥ 10.9 V
Atmospheric pressure	> 75 kPa (563 mmHg, 22.2 inHg)
<First diagnosis>	
Learning value of EVAP conc. during purge	< 0.2
Total time of canister purge operation	≥ 120 s
<Second diagnosis>	
Time after cancel of second diagnosis	≥ 60000 ms
Total time of canister purge operation	≥ 120 s
Intake manifold pressure (absolute pressure)	> 13.3 kPa (100 mmHg, 3.9 inHg)
Engine speed	≥ 1050 rpm
Intake manifold pressure (relative pressure)	< 13.3 kPa (100 mmHg, 3.9 inHg)
Vehicle speed	≥ 30 km/h (18.6 MPH)
Closed air/fuel ratio control	In operation
Air fuel ratio	> 0.76 and < 1.25
Main feedback compensation coefficient	> 0.9
Learning value of EVAP conc. during purge	< 0.2

### 3. GENERAL DRIVING CYCLE

Perform the diagnosis only once after engine start.

# Diagnostic Trouble Code (DTC) Detecting Criteria

## GENERAL DESCRIPTION

### 4. DIAGNOSTIC METHOD

#### First diagnosis

Pressure decreases when the purge is introduced compared with when the purge is not performed. By using this, judge if the purge is correctly performed. If there is no pressure decrease, go to the second diagnosis.

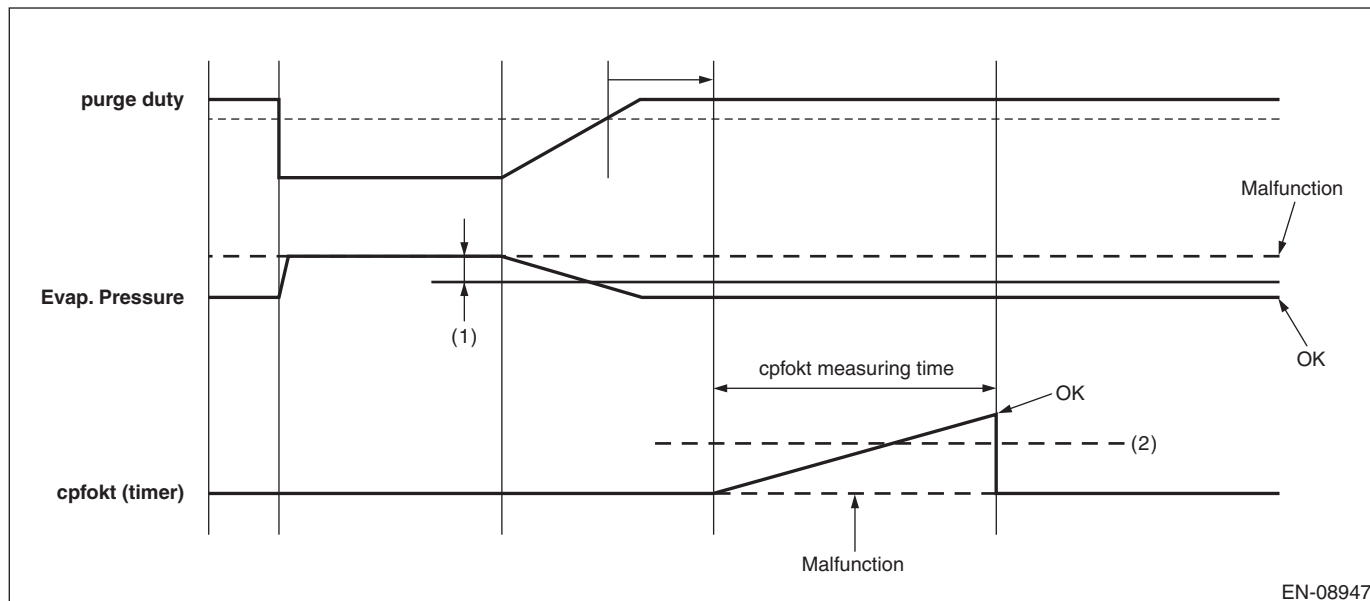

(1) 0.0045 V

(2) 2000 ms

#### • Abnormality Judgment

Judge as NG when the following conditions are established.

#### Judgment Value

Malfunction Criteria	Threshold Value
ELCM pressure sensor output voltage when purge is not performed – ELCM pressure sensor output voltage when purge is performed	> 0.0045 V
The accumulated time while the above conditions are met: cpfokt	< 2000 ms

**Time Needed for Diagnosis:** 26 seconds

#### • Normality Judgment

Judge as OK and clear the NG if the following conditions are established.

#### Judgment Value

Malfunction Criteria	Threshold Value
ELCM pressure sensor output voltage when purge is not performed – ELCM pressure sensor output voltage when purge is performed	> 0.0045 V
The accumulated time while the above conditions are met: cpfokt	≥ 2000 ms

**Time Needed for Diagnosis:** 26 seconds

#### Second diagnosis

# Diagnostic Trouble Code (DTC) Detecting Criteria

GENERAL DESCRIPTION

Close the ELCM switching valve, and close the fuel tank completely, and perform the forced purging. If pressure change amount is 0.7 kPa (5 mmHg, 0.2 inHg) or less, judge as malfunction of purge flow.

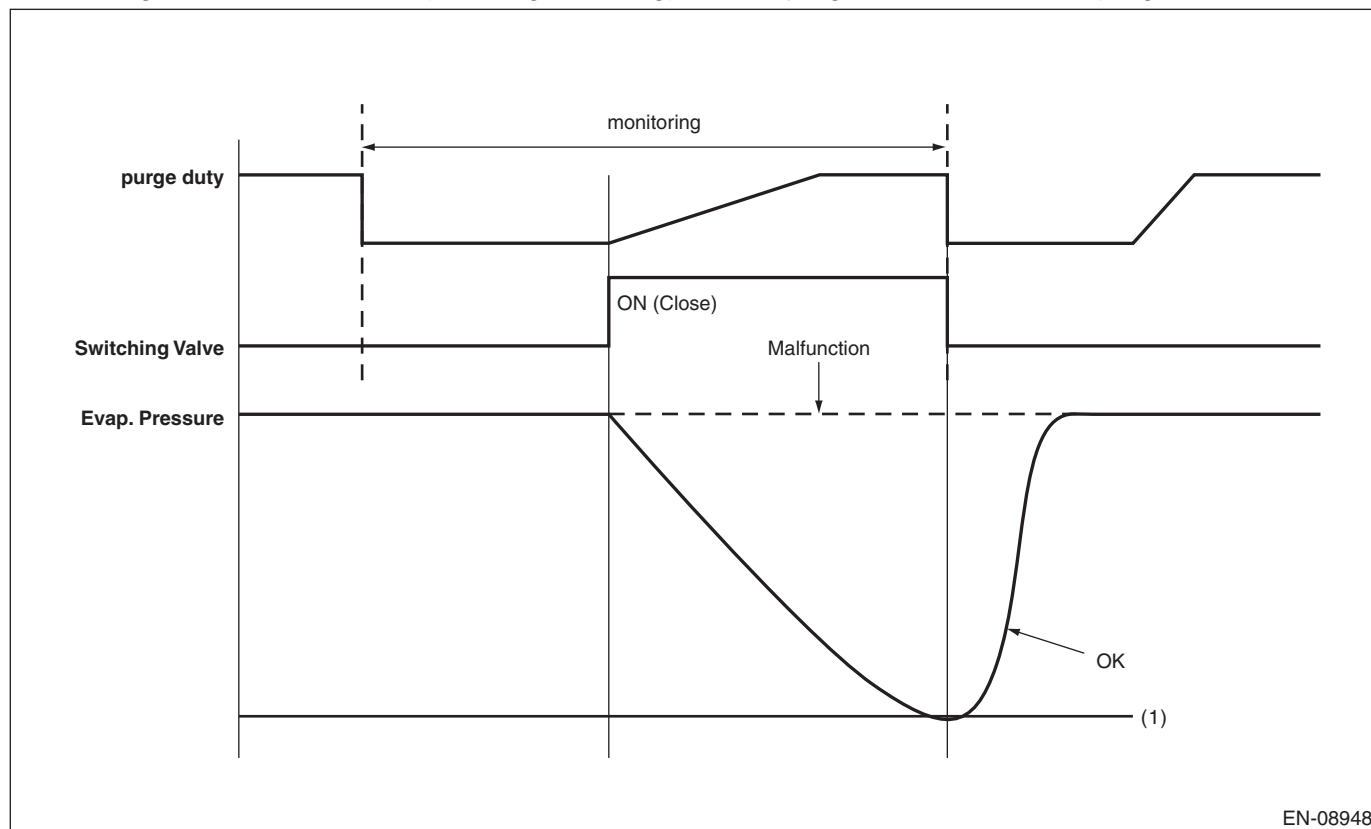

EN-08948

(1) 0.7 kPa (5 mmHg, 0.2 inHg)

## • Abnormality Judgment

Judge as NG when the following conditions are established.

### Judgment Value

Malfunction Criteria	Threshold Value
ELCM pressure sensor output voltage when purge is not performed – ELCM pressure sensor output voltage when purge is performed	< 0.7 kPa (5 mmHg, 0.2 inHg)
Time of negative pressure introduction	≥ 30000 ms

**Time Needed for Diagnosis:** 21 seconds

**Malfunction Indicator Light Illumination:** Illuminates when malfunction occurs in 2 continuous driving cycles.

## • Normality Judgment

Judge as OK and clear the NG if the following conditions are established.

### Judgment Value

Malfunction Criteria	Threshold Value
ELCM pressure sensor output voltage when purge is not performed – ELCM pressure sensor output voltage when purge is performed	≥ 0.7 kPa (5 mmHg, 0.2 inHg)

**Time Needed for Diagnosis:** Less than 21 second



# Diagnostic Trouble Code (DTC) Detecting Criteria

## GENERAL DESCRIPTION

### CA:DTC P0451 EVAPORATIVE EMISSION SYSTEM PRESSURE SENSOR/ SWITCH RANGE/PERFORMANCE

#### 1. OUTLINE OF DIAGNOSIS

Detect the malfunction of ELCM pressure sensor output properties.

Judge as NG when the ELCM pressure sensor output value is largely different from the intake manifold pressure when the ignition switch is ON.

#### 2. COMPONENT DESCRIPTION

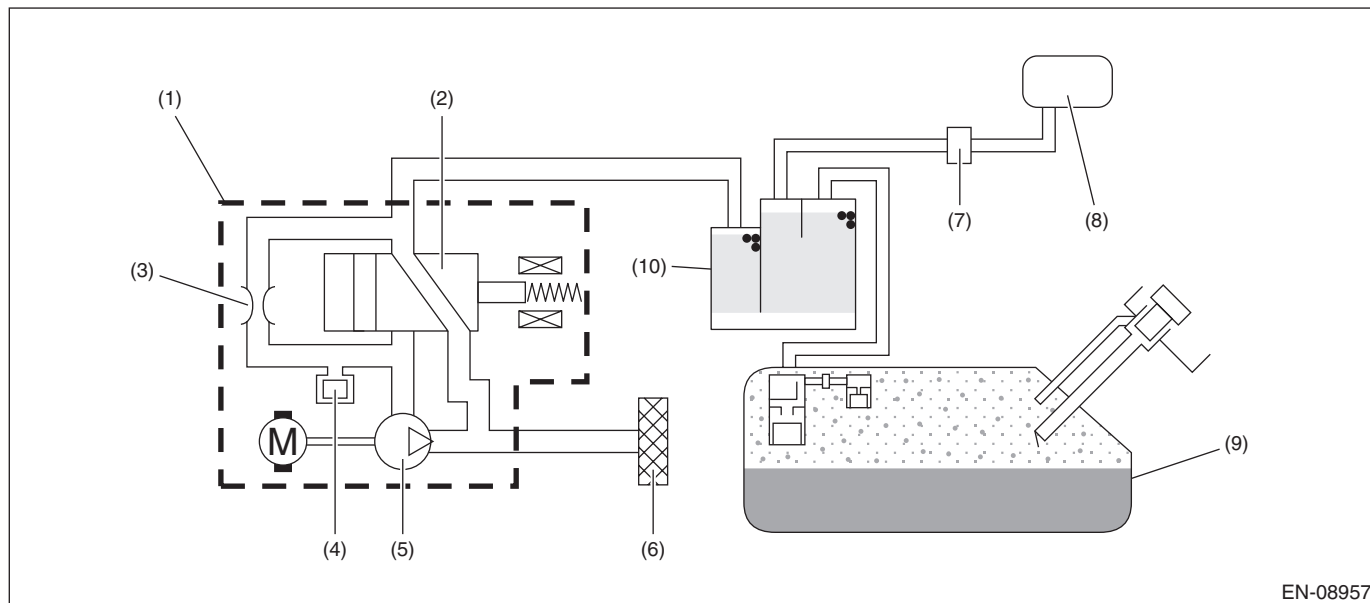

- |   |                                  |               |
|---|----------------------------------|---------------|
| (1) ELCM                                  | (5) Vacuum pump                  | (9) Fuel tank |
| (2) Switching valve                       | (6) Drain filter                 | (10) Canister |
| (3) Reference orifice (0.02 inch orifice) | (7) Purge control solenoid valve |               |
| (4) Pressure sensor                       | (8) Intake manifold              |               |

#### 3. ENABLE CONDITIONS

Secondary Parameters	Enable Conditions
Ignition switch	ON
Engine speed	< 300 rpm
Vehicle speed	< 1 km/h (0.621 MPH)
Soaking time	≥ 60 s
Variation value of intake manifold pressure (absolute pressure) since ignition switch is turned to ON	< 1.332 kPa (9.99 mmHg, 0.39 inHg)
ELCM vacuum pump	Not in operation
ELCM switching valve	Open
Purge control	Not in operation

#### 4. GENERAL DRIVING CYCLE

Perform the diagnosis once at ignition ON.

# Diagnostic Trouble Code (DTC) Detecting Criteria

GENERAL DESCRIPTION

## 5. DIAGNOSTIC METHOD

### • Abnormality Judgment

If the duration of time while the following conditions are met is longer than the time indicated, judge as NG.

#### Judgment Value

Malfunction Criteria	Threshold Value
ELCM pressure sensor output value – intake manifold pressure (absolute pressure) when ignition switch is ON	> 4.226 kPa (31.7 mmHg, 1.25 inHg)

**Time Needed for Diagnosis:** 328 ms

**Malfunction Indicator Light Illumination:** Illuminates when malfunction occurs in 2 continuous driving cycles.

### • Normality Judgment

Judge as OK and clear the NG if the continuous time while the following conditions are established is more than the predetermined time.

#### Judgment Value

Malfunction Criteria	Threshold Value
ELCM pressure sensor output value – intake manifold pressure (absolute pressure) when ignition switch is ON	≤ 4.226 kPa (31.7 mmHg, 1.25 inHg)

**Time Needed for Diagnosis:** 262 ms

# Diagnostic Trouble Code (DTC) Detecting Criteria

## GENERAL DESCRIPTION

### CB:DTC P0452 EVAPORATIVE EMISSION SYSTEM PRESSURE SENSOR/ SWITCH LOW

#### 1. OUTLINE OF DIAGNOSIS

Detect the open or short circuit of the ELCM pressure sensor.

Judge as NG if out of specification.

#### 2. COMPONENT DESCRIPTION

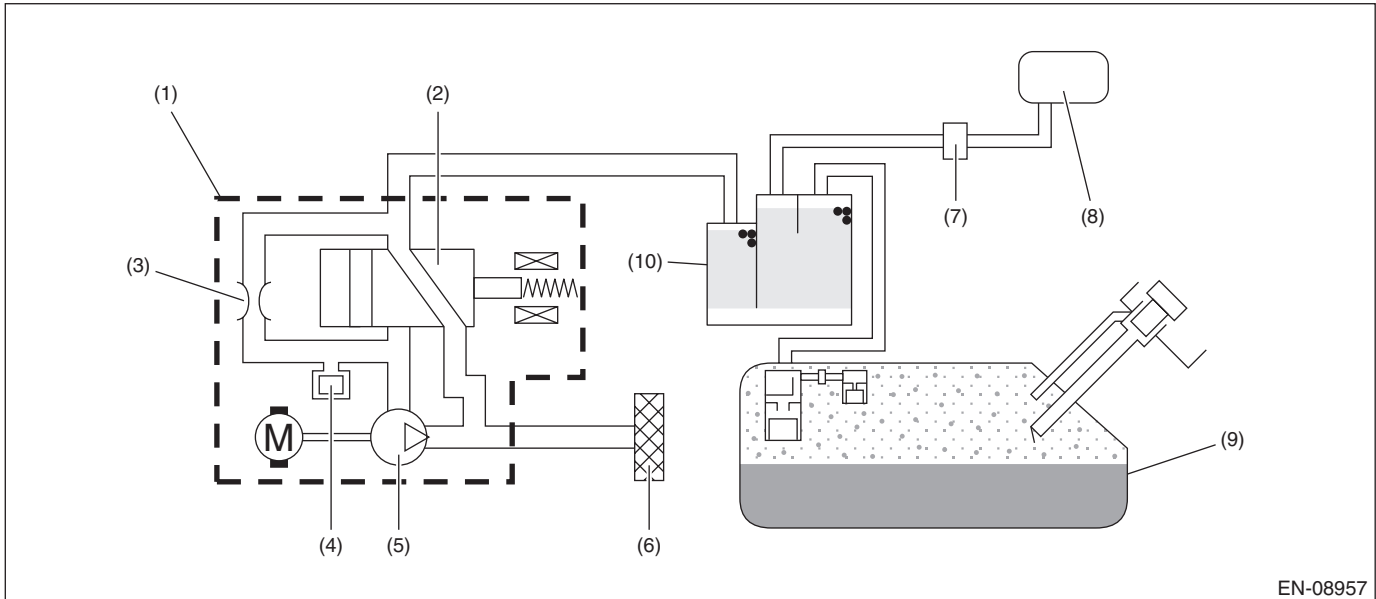

EN-08957

- |   |                                  |               |
|---|----------------------------------|---------------|
| (1) ELCM                                  | (5) Vacuum pump                  | (9) Fuel tank |
| (2) Switching valve                       | (6) Drain filter                 | (10) Canister |
| (3) Reference orifice (0.02 inch orifice) | (7) Purge control solenoid valve |               |
| (4) Pressure sensor                       | (8) Intake manifold              |               |

#### 3. ENABLE CONDITIONS

Secondary Parameters	Enable Conditions
None	

#### 4. GENERAL DRIVING CYCLE

Always perform the diagnosis continuously.

#### 5. DIAGNOSTIC METHOD

##### • Abnormality Judgment

If the duration of time while the following conditions are met is longer than the time indicated, judge as NG.

##### Judgment Value

Malfunction Criteria	Threshold Value
Output voltage	< 0.973 V

**Time Needed for Diagnosis:** 1000 ms

**Malfunction Indicator Light Illumination:** Illuminates as soon as a malfunction occurs.

# Diagnostic Trouble Code (DTC) Detecting Criteria

GENERAL DESCRIPTION

---

## • Normality Judgment

Judge as OK and clear the NG if the continuous time while the following conditions are established is more than the predetermined time.

### Judgment Value

Malfunction Criteria	Threshold Value
Output voltage	$\geq 0.973$ V

**Time Needed for Diagnosis:** Less than 1 second

# Diagnostic Trouble Code (DTC) Detecting Criteria

## GENERAL DESCRIPTION

### CC:DTC P0453 EVAPORATIVE EMISSION SYSTEM PRESSURE SENSOR/ SWITCH HIGH

#### 1. OUTLINE OF DIAGNOSIS

Detect the open or short circuit of the ELCM pressure sensor.  
Judge as NG if out of specification.

#### 2. COMPONENT DESCRIPTION

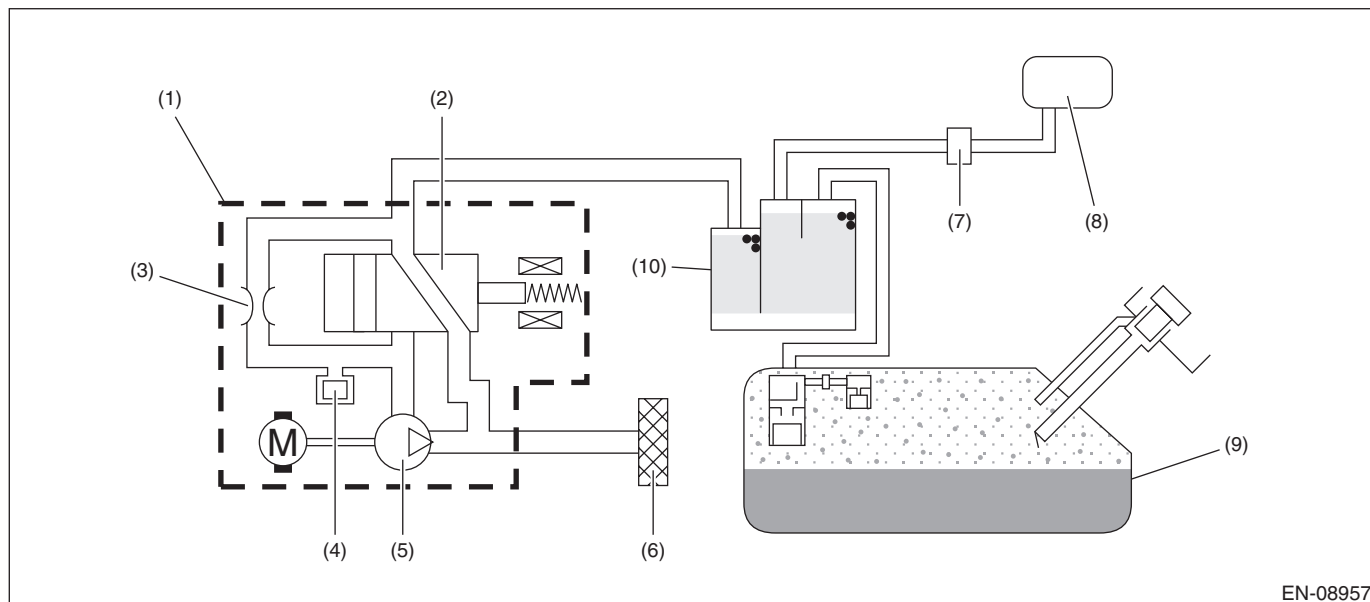

EN-08957

- |   |                                  |               |
|---|----------------------------------|---------------|
| (1) ELCM                                  | (5) Vacuum pump                  | (9) Fuel tank |
| (2) Switching valve                       | (6) Drain filter                 | (10) Canister |
| (3) Reference orifice (0.02 inch orifice) | (7) Purge control solenoid valve |               |
| (4) Pressure sensor                       | (8) Intake manifold              |               |

#### 3. ENABLE CONDITIONS

Secondary Parameters	Enable Conditions
None	

#### 4. GENERAL DRIVING CYCLE

Always perform the diagnosis continuously.

#### 5. DIAGNOSTIC METHOD

##### • Abnormality Judgment

If the duration of time while the following conditions are met is longer than the time indicated, judge as NG.

##### Judgment Value

Malfunction Criteria	Threshold Value
Output voltage	$\geq 4.095$ V

**Time Needed for Diagnosis:** 1000 ms

**Malfunction Indicator Light Illumination:** Illuminates as soon as a malfunction occurs.

# Diagnostic Trouble Code (DTC) Detecting Criteria

GENERAL DESCRIPTION

---

- **Normality Judgment**

Judge as OK and clear the NG if the continuous time while the following conditions are established is more than the predetermined time.

**Judgment Value**

Malfunction Criteria	Threshold Value
Output voltage	< 4.095 V

**Time Needed for Diagnosis:** Less than 1 second

# Diagnostic Trouble Code (DTC) Detecting Criteria

## GENERAL DESCRIPTION

### CD:DTC P0455 EVAPORATIVE EMISSION SYSTEM LEAK DETECTED (LARGE LEAK)

#### 1. OUTLINE OF DIAGNOSIS

This diagnosis judges whether the ELCM operation is normal or not, and whether the evaporative emission system has leak and clogging or not.

To purge the canister, after driving of 10 minutes or more, perform the five hours soaking after ignition switch OFF in order to stabilize the evaporative gas status. After five hours passed, ECM is activated by soaking timer, and the leak check is started.

Judges whether the ELCM operation is normal or not, by measuring the reference pressure status via reference orifice (0.02 inch orifice). Judge as malfunction if the reference pressure is out of specified range. Then, judge whether there is a leak or not, by comparing the pressure (leak pressure) when the reference pressure and the evaporative emission system are in negative pressure condition. Judge as system leak in the evaporative emission system if the leak pressure is higher than reference pressure. Judge as clogging of pipe if the leak pressure becomes lower than the reference pressure within the specified amount of time.

0.02 inch leak and 0.04 inch leak can be distinguished by measuring the leak pressure.

The diagnosis results are stored inside ECM until the engine is started again.

Diagnostic item	
ELCM system (ELCM body)	Vacuum pump stuck Switching valve stuck to open Switching valve stuck to close Reference orifice flow large Reference orifice flow small
Leak check	Large leak <ul style="list-style-type: none"> <li>• 0.04 inch leak</li> <li>• Fuel cap loose</li> <li>• Fuel cap off</li> <li>• System malfunction</li> </ul>
	Very small leak <ul style="list-style-type: none"> <li>• 0.02 inch leak</li> </ul>
Clogging of pipe	—

#### OUTLINE OF DIAGNOSIS

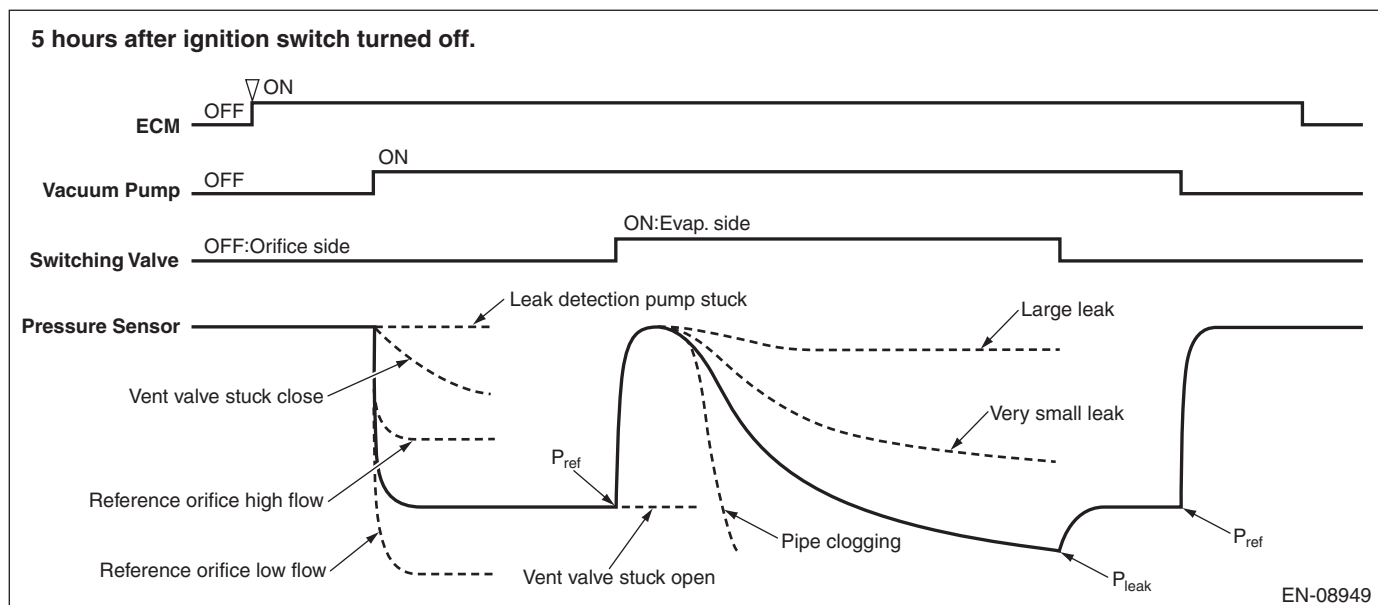

# Diagnostic Trouble Code (DTC) Detecting Criteria

GENERAL DESCRIPTION

## 2. COMPONENT DESCRIPTION

ELCM consists of the pressure sensor, the reference orifice (diameter of 0.02 inch), the vacuum pump which introduces the negative pressure into evaporative emission system, and the switching valve which switches the passage to introduce the negative pressure.

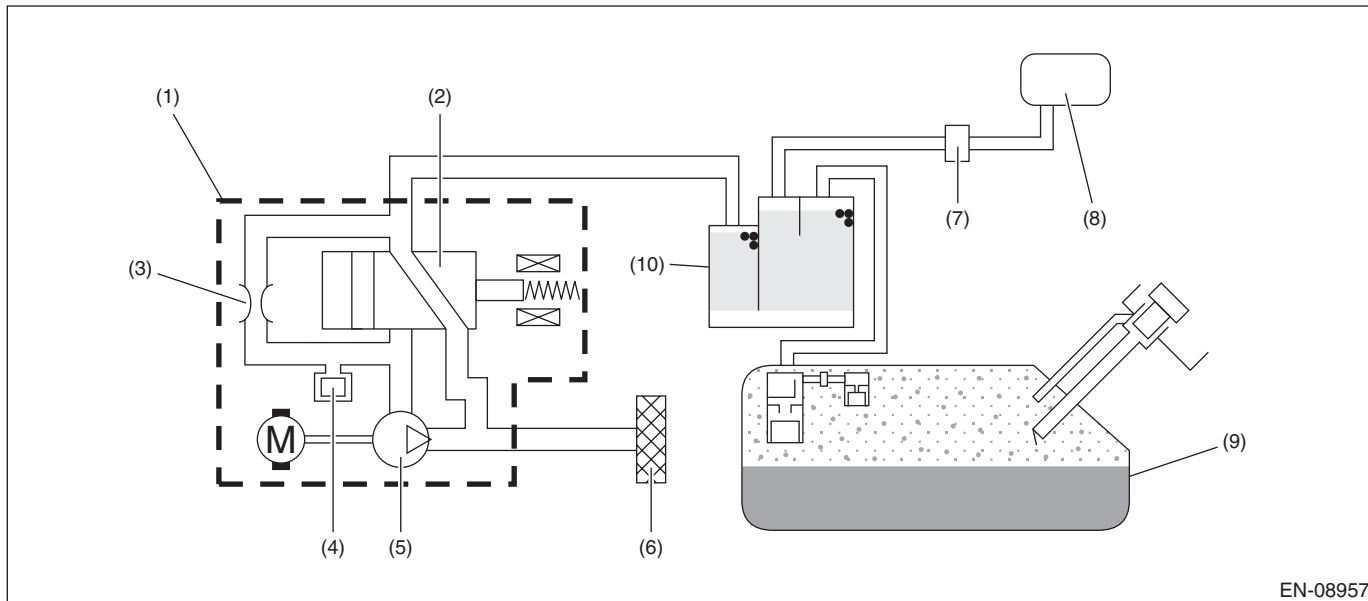

EN-08957

- |   |                                  |               |
|---|----------------------------------|---------------|
| (1) ELCM                                  | (5) Vacuum pump                  | (9) Fuel tank |
| (2) Switching valve                       | (6) Drain filter                 | (10) Canister |
| (3) Reference orifice (0.02 inch orifice) | (7) Purge control solenoid valve |               |
| (4) Pressure sensor                       | (8) Intake manifold              |               |

## 3. ENABLE CONDITIONS

Secondary Parameters	Enable Conditions
Activation of soaking timer	Completed
Battery voltage	≥ 10.9 V
Ignition switch	OFF
Engine coolant temperature	≥ 4.4 °C (39.9 °F) and < 45 °C (113 °F)
Intake air temperature	≥ 4.4 °C (39.9 °F) and < 200 °C (392 °F)
Atmospheric pressure	≥ 75 kPa (563 mmHg, 22.2 inHg) and < 110 kPa (825 mmHg, 32.5 inHg)
Fuel level	< 100 ℓ (26.42 US gal, 22 Imp gal)
EVAP conc. learning during previous driving cycle	Done
Learning value of EVAP conc. during previous driving cycle	≤ 0.2
Accumulated purge amount during previous driving cycle	≥ Value of Map 1
Soaking timer IC diagnosis	Completed*

\*: Engine running time of 600 s or more is required during previous driving cycle



# Diagnostic Trouble Code (DTC) Detecting Criteria

## GENERAL DESCRIPTION

---

### Map 1

Engine coolant temperature °C (°F)	0 (32)	30 (86)	45 (113)
Accumulated purge amount during previous driving cycle g (oz)	500 (17.64)	500 (17.64)	8000 (282.16)

### 4. GENERAL DRIVING CYCLE

Perform the diagnosis only once when five hours has passed after ignition switch is OFF.

# Diagnostic Trouble Code (DTC) Detecting Criteria

GENERAL DESCRIPTION

## 5. DIAGNOSTIC METHOD

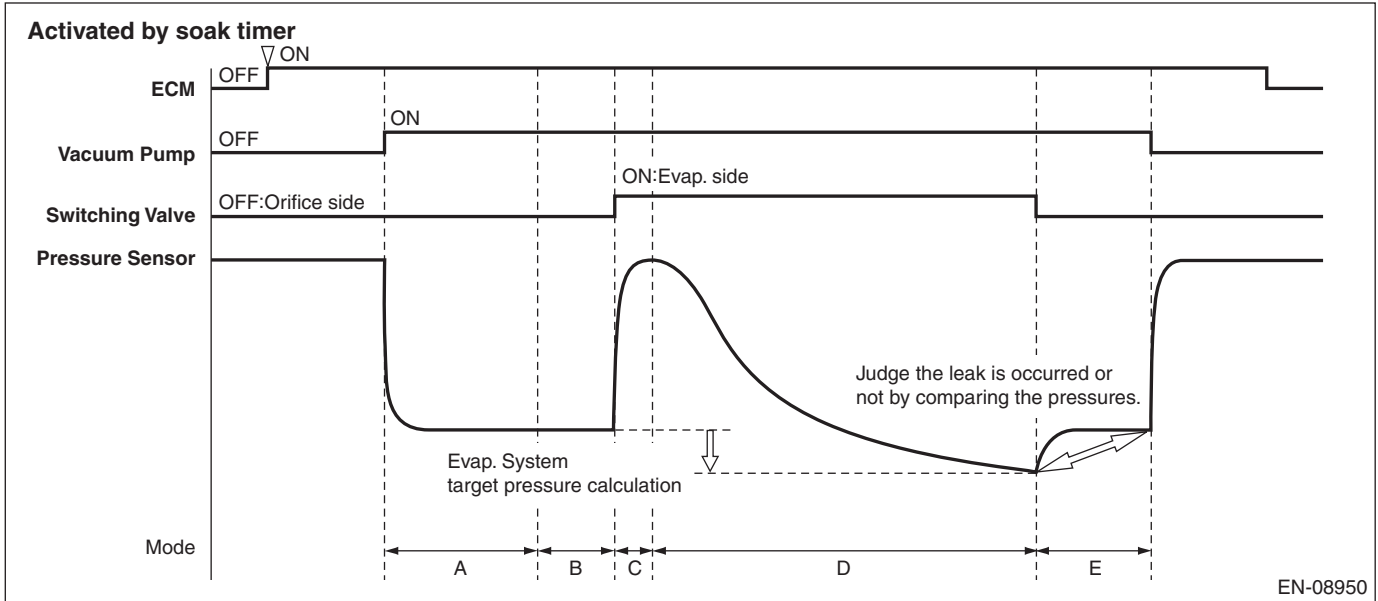

Mode	Explanation of Mode	Diagnosis Period
A	Vacuum pump operation confirmation and characteristics stability	7 s or less & 300 s
B	Measurement of reference pressure for setting the target negative pressure	40 s or less
C	Switching valve operation confirmation	12 s or less
D	Clogging of pipe diagnosis and leak pressure measurement	900 s or less
E	Reference pressure measurement for judgment	40 s or less

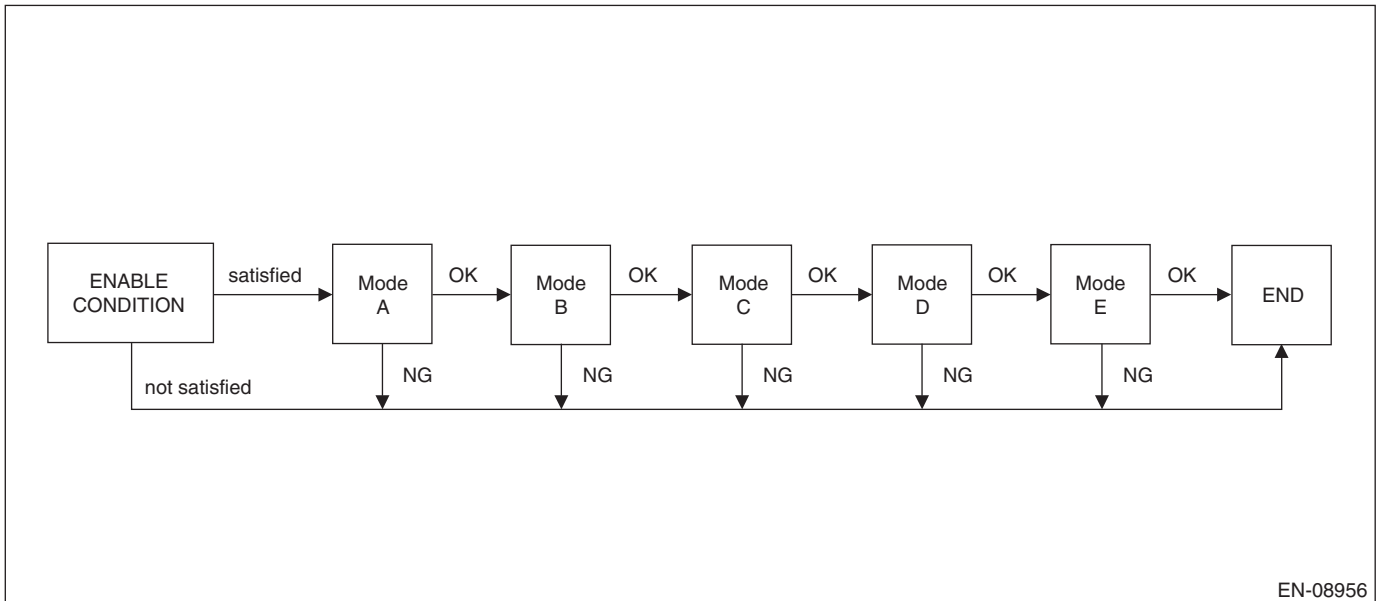

# Diagnostic Trouble Code (DTC) Detecting Criteria

## GENERAL DESCRIPTION

### Mode A (Vacuum pump operation confirmation and characteristics stability)

Purpose: Detect the vacuum pump operation trouble.

Judge as NG when the following conditions are established.

Judge as OK if the following conditions are not established, and warm up for five minutes to stabilize the vacuum pump characteristics.

#### Judgment Value

Malfunction Criteria	Threshold Value	DTC
Elapsed time after mode change	≥ 6976 ms	P2404
Pressure sensor output value	> -0.2 kPa (-1.68 mmHg, -0.1 inHg)	

### Mode B (Measurement of reference pressure for setting the target negative pressure)

1. Purpose: Judge the reference pressure stability.

Judge as NG when the following conditions are established.

#### Judgment Value

Malfunction Criteria	Threshold Value	DTC
Elapsed time after mode change	≥ 40 s	P2404
Pressure sensor maximum output value – Pressure sensor minimum output value	> 0.3 kPa (2.355 mmHg, 0.1 inHg)	

2. Purpose: Judge whether the reference pressure is within the normal range, and detect the vacuum pump and orifice malfunctions.

Judge as NG when the following conditions are established.

#### Judgment Value

Malfunction Criteria	Threshold Value	DTC
Reference pressure for setting the target negative pressure	< Value of Map 2 or > Value of Map 3	P2404

### Map 2

Atmospheric pressure kPa (mmHg, inHg)	70 (525, 20.7)	80 (600, 23.6)	90 (675, 26.6)	100 (750, 29.5)
Reference pressure for setting the target negative pressure kPa (mmHg, inHg)	-4 (-29.79, -1.2)	-4.1 (-30.593, -1.2)	-4.2 (-31.395, -1.2)	-4.3 (-32.19, -1.3)

### Map 3

Atmospheric pressure kPa (mmHg, inHg)	70 (525, 20.7)	80 (600, 23.6)	90 (675, 26.6)	100 (750, 29.5)
Reference pressure for setting the target negative pressure kPa (mmHg, inHg)	-0.9 (-7.065, -0.3)	-1 (-7.86, -0.3)	-1.2 (-8.663, -0.3)	-1.3 (-9.465, -0.4)

### Mode C (Switching valve operation confirmation)

Purpose: Measure the pressure increase when switching valve is changed from open to close, and detect the stuck to open/close malfunctions of the switching valve.

Judge as NG when the following conditions are established.

#### Judgment Value

Malfunction Criteria	Threshold Value	DTC
Elapsed time after mode change	≥ 12000 ms	P2404
Pressure sensor output value – Reference pressure for setting the target negative pressure	< 0.2 kPa (1.68 mmHg, 0.1 inHg)	

# Diagnostic Trouble Code (DTC) Detecting Criteria

GENERAL DESCRIPTION

## Mode D (Clogging of pipe diagnosis and leak pressure measurement)

### 1. Clogging of pipe

Purpose: Measure the time required for the evaporative emission system to reach the target negative pressure by the vacuum pump, and detect the clogging of pipe trouble.

Judge as clogging of pipe malfunction if the evaporative emission system reaches to the target negative pressure within the specified time.

### Judgment Value

Malfunction Criteria	Threshold Value	DTC
Time required to reach to the target negative pressure When any one of the followings is established.	< 30000 ms	P1451
• Reference pressure for setting the target negative pressure – Pressure sensor output value	≥ Value of Map 4	
• Pressure sensor output value	< –5 kPa (–37.298 mmHg, –1.5 inHg)	

### Map 4

Time of negative pressure introduction ms	0	100000	200000	300000	400000	500000	600000	700000	800000	900000	1000000	1100000	1200000
Reference pressure for setting the target negative pressure – Pressure sensor output value kPa (mmHg, inHg)	0.9 (7.058, 0.3)	0.9 (7.058, 0.3)	0.9 (7.058, 0.3)	0.9 (7.058, 0.3)	0.9 (7.058, 0.3)	0.9 (7.058, 0.3)	0.9 (7.058, 0.3)	0.9 (7.058, 0.3)	0.9 (7.058, 0.3)	0.9 (7.058, 0.3)	0.9 (7.058, 0.3)	0.9 (7.058, 0.3)	0.9 (7.058, 0.3)

### 2. Leak pressure measurement

Purpose: Measure the pressure (leak pressure) when the evaporative emission system becomes the negative pressure by the vacuum pump.

Store the pressure as a leak pressure while the following conditions are met.

### Judgment Value

Conditions for storing the leak pressure	Threshold Value
When any one of the followings is established.	
• Reference pressure for setting the target negative pressure – Pressure sensor output value	≥ Value of Map 4
• Pressure sensor output value	< –5 kPa (–37.298 mmHg, –1.5 inHg)
• Time of negative pressure introduction	≥ 900000 ms

# Diagnostic Trouble Code (DTC) Detecting Criteria

## GENERAL DESCRIPTION

### Mode E (Measurement of reference pressure for judgment)

1. Purpose: Judge the reference pressure stability.  
Judge as NG when the following conditions are established.

#### Judgment Value

Malfunction Criteria	Threshold Value	DTC
Elapsed time after mode change  Pressure sensor maximum output value – Pressure sensor minimum output value	≥ 40 s > 0.3 kPa (2.355 mmHg, 0.1 inHg)	P2404

2. Purpose: Judge whether the reference pressure is within the normal range, and detect the vacuum pump and orifice malfunctions. Judge the vacuum pump performance stability.  
Judge as NG when the following conditions are established.

#### Judgment Value

Malfunction Criteria	Threshold Value	DTC
When any one of the followings is established. • Reference pressure for judgment  • Reference pressure for setting the target negative pressure – Reference pressure for judgment	< Value of Map 5 or > Value of Map 6  > 0.9 kPa (7.058 mmHg, 0.3 inHg)	P2404

### Map 5

Atmospheric pressure kPa (mmHg, inHg)	70 (525, 20.7)	80 (600, 23.6)	90 (675, 26.6)	100 (750, 29.5)
Reference pressure for judgment kPa (mmHg, inHg)	–4.5 (–34.02, –1.3)	–4.6 (–34.815, –1.4)	–4.7 (–35.618, –1.4)	–4.9 (–36.42, –1.4)

### Map 6

Atmospheric pressure kPa (mmHg, inHg)	70 (525, 20.7)	80 (600, 23.6)	90 (675, 26.6)	100 (750, 29.5)
Reference pressure for judgment kPa (mmHg, inHg)	–0.8 (–6.18, –0.2)	–0.9 (–6.983, –0.3)	–1 (–7.785, –0.3)	–1.1 (–8.58, –0.3)

3. Purpose: Judge the presence of evaporative emission system leak.  
Judge as NG when the following conditions are established.

#### Judgment Value

Malfunction Criteria	Threshold Value	DTC
<Large leak (0.04 inch)> Leak pressure  $l_{leakjdg} = (\text{Reference pressure for judgment}) \times 0.377 - (-0.341)$	> Reference pressure for judgment and ≥ $l_{leakjdg}$	P0455
<Very small leak (0.02 inch)> Leak pressure	> Reference pressure for judgment and < $l_{leakjdg}$	P0456

**Time Needed for Diagnosis:** Approx. 23 min

#### • Abnormality Judgment

At next engine start, confirm whether the enable conditions are satisfied even though refueling has been done during soaking, and determine the malfunction.

**Malfunction Indicator Light Illumination:** Illuminates when malfunction occurs in 2 continuous driving cycles.

# Diagnostic Trouble Code (DTC) Detecting Criteria

GENERAL DESCRIPTION

## • Normality Judgment

At next engine start, confirm whether the enable conditions are satisfied even though refueling has been done during soaking, then, if the following conditions are established, judge as OK and clear the NG.

### Judgment Value

Malfunction Criteria	Threshold Value	DTC
NG flag	Not set	P0455 P0456 P1451 P2404

## CE:DTC P0456 EVAPORATIVE EMISSION CONTROL SYSTEM LEAK DETECTED (VERY SMALL LEAK)

### 1. OUTLINE OF DIAGNOSIS

#### NOTE:

For the detection standard, refer to DTC P0455. <Ref. to GD(H4DOTC)-154, DTC P0455 EVAPORATIVE EMISSION SYSTEM LEAK DETECTED (LARGE LEAK), Diagnostic Trouble Code (DTC) Detecting Criteria.>

# Diagnostic Trouble Code (DTC) Detecting Criteria

## GENERAL DESCRIPTION

### CF:DTC P0458 EVAPORATIVE EMISSION SYSTEM PURGE CONTROL VALVE CIRCUIT LOW

#### 1. OUTLINE OF DIAGNOSIS

Detect open or short circuit of the purge control solenoid valve.

Judge as NG when the ECM output level differs from the actual terminal level.

#### 2. COMPONENT DESCRIPTION

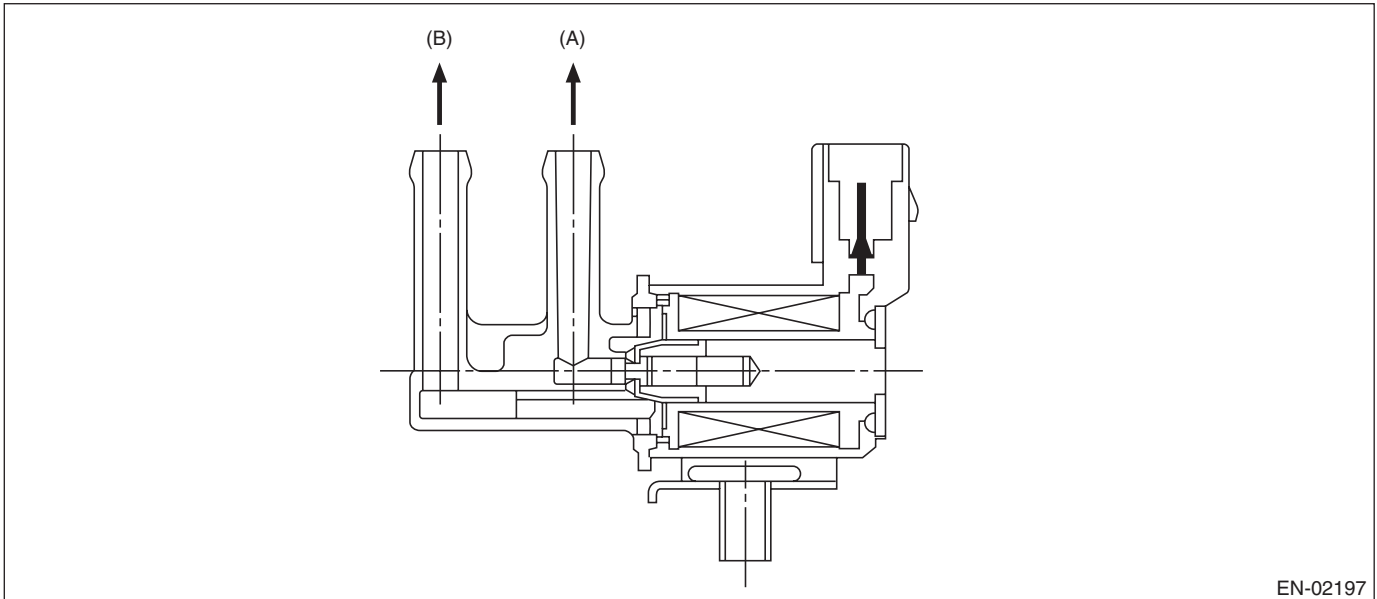

EN-02197

(A) To canister

(B) To intake manifold

#### 3. ENABLE CONDITIONS

Secondary Parameters	Enable Conditions
Battery voltage	$\geq 10.9 \text{ V}$
Elapsed time after starting the engine	$\geq 1 \text{ second}$

#### 4. GENERAL DRIVING CYCLE

Always perform the diagnosis after starting the engine.

# Diagnostic Trouble Code (DTC) Detecting Criteria

GENERAL DESCRIPTION

## 5. DIAGNOSTIC METHOD

### • Abnormality Judgment

If the duration of time while the following conditions are met is longer than the time indicated, judge as NG.

#### Judgment Value

Malfunction Criteria	Threshold Value
Duty ratio of "ON"	< 0.75
Terminal output voltage	Low

**Time Needed for Diagnosis:** 2500 ms

**Malfunction Indicator Light Illumination:** Illuminates when malfunction occurs in 2 continuous driving cycles.

### • Normality Judgment

Judge as OK and clear the NG if the continuous time while the following conditions are established is more than the predetermined time.

#### Judgment Value

Malfunction Criteria	Threshold Value
Terminal output voltage	High

**Time Needed for Diagnosis:** Less than 1 second



# Diagnostic Trouble Code (DTC) Detecting Criteria

## GENERAL DESCRIPTION

### CG:DTC P0459 EVAPORATIVE EMISSION SYSTEM PURGE CONTROL VALVE CIRCUIT HIGH

#### 1. OUTLINE OF DIAGNOSIS

Detect open or short circuit of the purge control solenoid valve.

Judge as NG when the ECM output level differs from the actual terminal level.

#### 2. COMPONENT DESCRIPTION

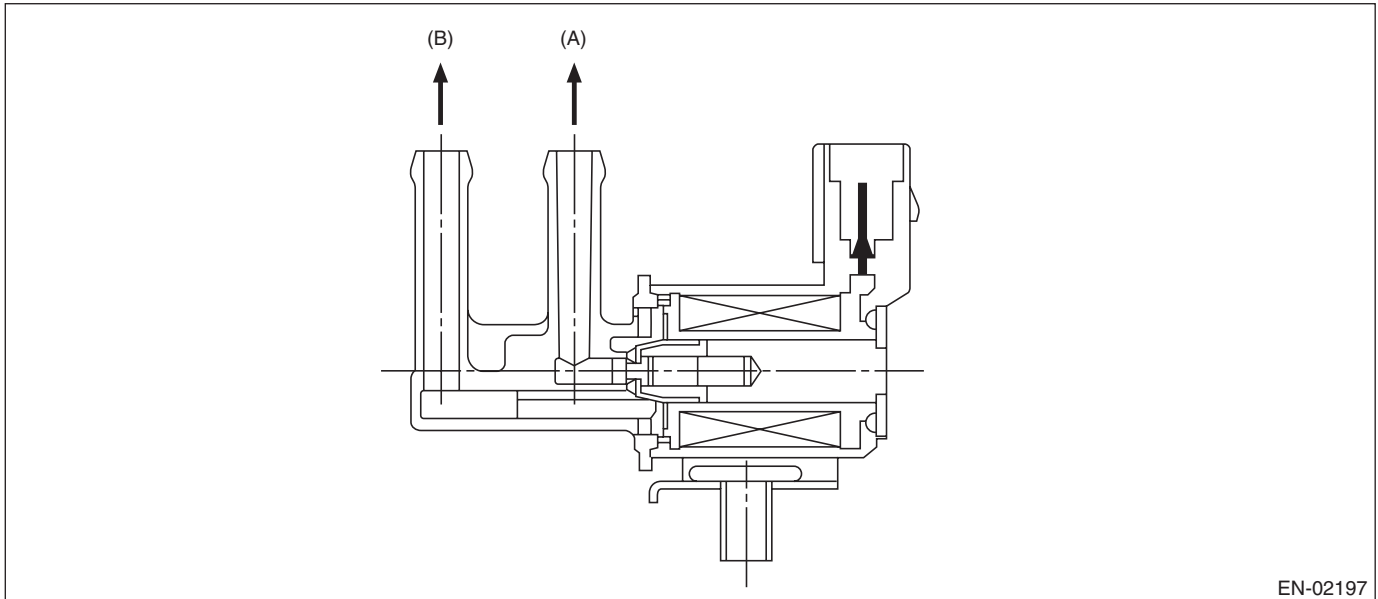

(A) To canister

(B) To intake manifold

#### 3. ENABLE CONDITIONS

Secondary Parameters	Enable Conditions
Battery voltage	$\geq 10.9 \text{ V}$
Elapsed time after starting the engine	$\geq 1 \text{ second}$

#### 4. GENERAL DRIVING CYCLE

Always perform the diagnosis after starting the engine.

# Diagnostic Trouble Code (DTC) Detecting Criteria

GENERAL DESCRIPTION

## 5. DIAGNOSTIC METHOD

### • Abnormality Judgment

If the duration of time while the following conditions are met is longer than the time indicated, judge as NG.

#### Judgment Value

Malfunction Criteria	Threshold Value
Duty ratio of "ON"	$\geq 0.25$
Terminal output voltage	High

**Time Needed for Diagnosis:** 2500 ms

**Malfunction Indicator Light Illumination:** Illuminates when malfunction occurs in 2 continuous driving cycles.

### • Normality Judgment

Judge as OK and clear the NG if the continuous time while the following conditions are established is more than the predetermined time.

#### Judgment Value

Malfunction Criteria	Threshold Value
Terminal output voltage	Low

**Time Needed for Diagnosis:** Less than 1 second

# Diagnostic Trouble Code (DTC) Detecting Criteria

## GENERAL DESCRIPTION

### CH:DTC P0461 FUEL LEVEL SENSOR "A" CIRCUIT RANGE/PERFORMANCE

#### 1. OUTLINE OF DIAGNOSIS

Detect malfunctions of the fuel level sensor output property.

If the fuel level does not vary in a particular driving condition / engine condition where it should, judge as NG.

#### 2. COMPONENT DESCRIPTION

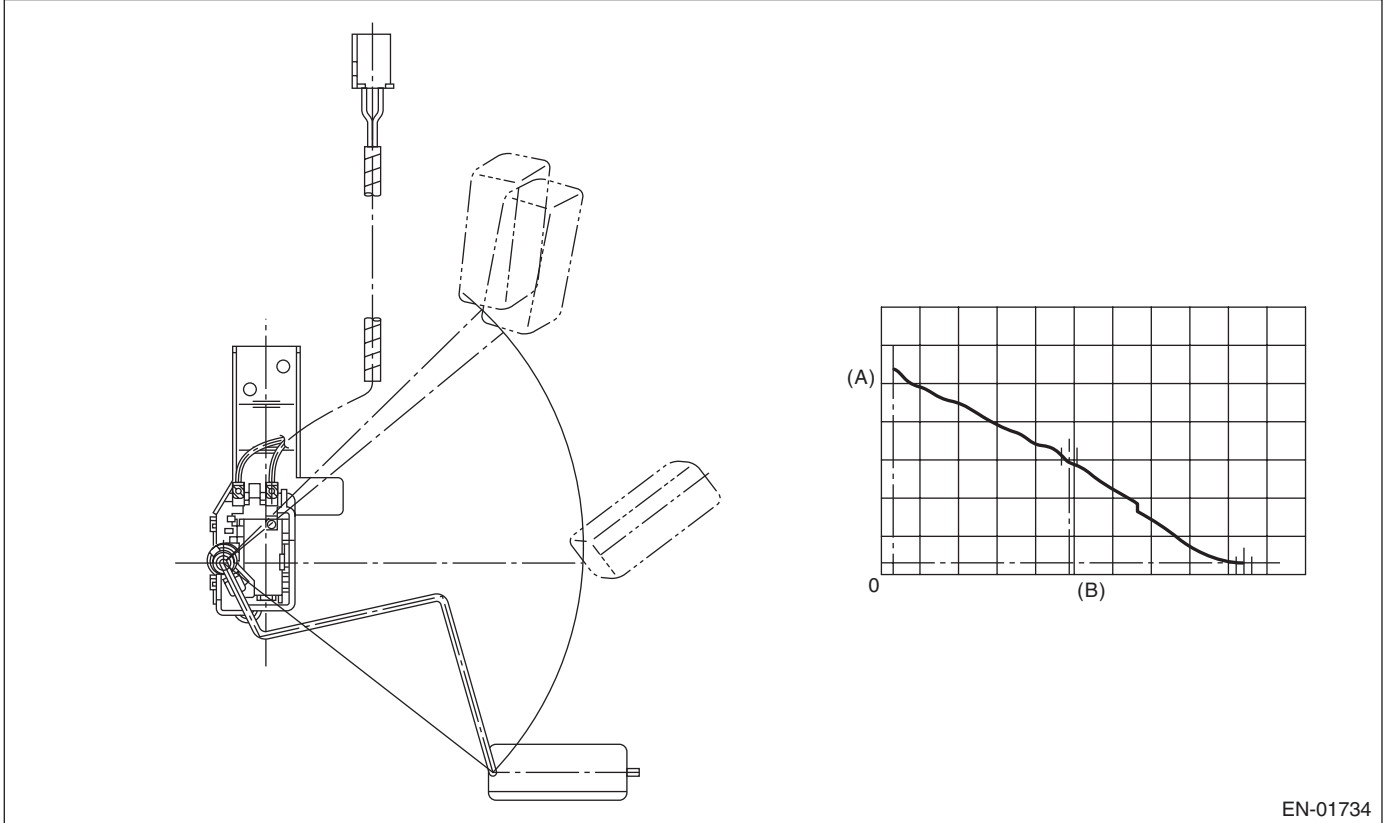

EN-01734

(A) Fuel level

(B) Resistance

#### 3. ENABLE CONDITIONS

Secondary Parameters	Enable Conditions
None	

#### 4. GENERAL DRIVING CYCLE

Always perform the diagnosis continuously.

# Diagnostic Trouble Code (DTC) Detecting Criteria

GENERAL DESCRIPTION

## 5. DIAGNOSTIC METHOD

### • Abnormality Judgment

Judge as NG when the following conditions are established.

#### Judgment Value

Malfunction Criteria	Threshold Value
Accumulated amount of intake air	≥ 165375 g (5832.78 oz)
Max. – min. values of fuel level output	< 2.6 ℓ (0.69 US gal, 0.57 Imp gal)
Battery voltage	≥ 10.9 V
Engine speed	< 10000 rpm
Elapsed time after starting the engine	≥ 5000 ms

**Time Needed for Diagnosis:** Less than 1 second

**Malfunction Indicator Light Illumination:** Illuminates when malfunction occurs in 2 continuous driving cycles.

### • Normality Judgment

Judge as OK and clear the NG if the following conditions are established.

#### Judgment Value

Malfunction Criteria	Threshold Value
Accumulated amount of intake air	≥ 165375 g (5832.78 oz)
Max. – min. values of fuel level output	≥ 2.6 ℓ (0.69 US gal, 0.57 Imp gal)
Battery voltage	≥ 10.9 V
Engine speed	< 10000 rpm
Elapsed time after starting the engine	≥ 5000 ms

**Time Needed for Diagnosis:** Less than 1 second

# Diagnostic Trouble Code (DTC) Detecting Criteria

## GENERAL DESCRIPTION

### CI: DTC P0462 FUEL LEVEL SENSOR "A" CIRCUIT LOW

#### 1. OUTLINE OF DIAGNOSIS

Detect the open or short circuit of fuel level sensor. Judge as NG if out of specification.

#### 2. COMPONENT DESCRIPTION

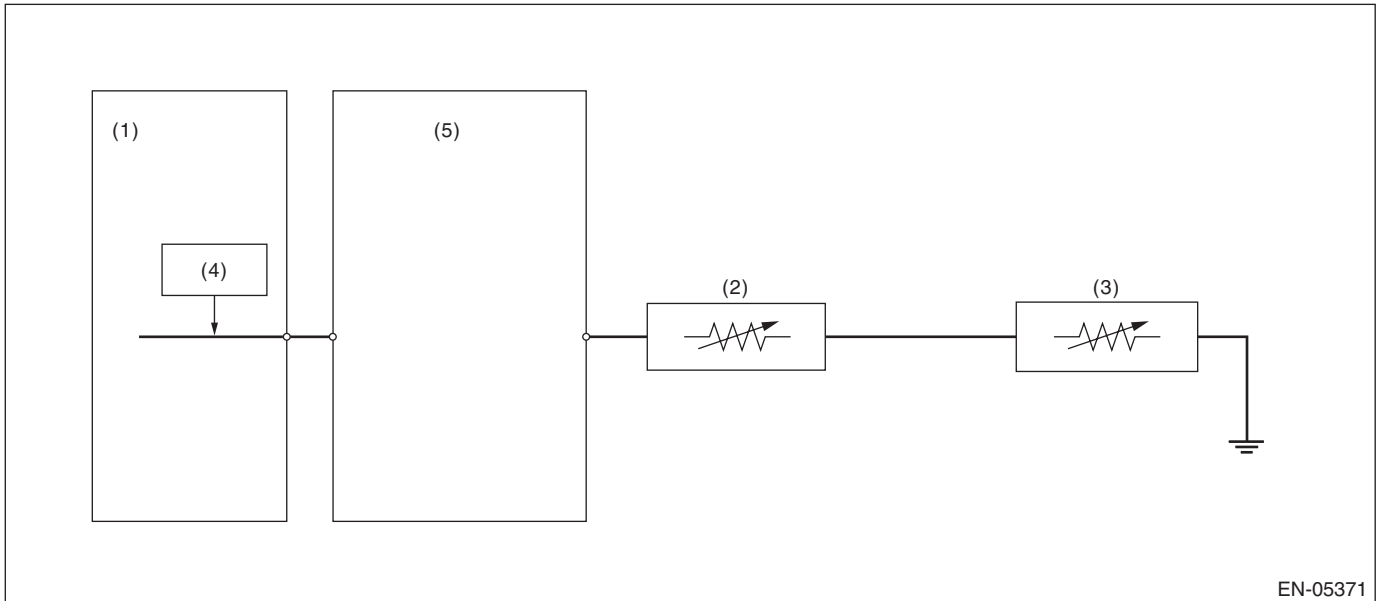

(1) Engine control module (ECM)

(3) Fuel sub level sensor

(5) Body integrated unit

(2) Fuel level sensor

(4) Detecting circuit

#### 3. ENABLE CONDITIONS

Secondary Parameters	Enable Conditions
None	

#### 4. GENERAL DRIVING CYCLE

Always perform the diagnosis continuously.

# Diagnostic Trouble Code (DTC) Detecting Criteria

GENERAL DESCRIPTION

## 5. DIAGNOSTIC METHOD

### • Abnormality Judgment

If the duration of time while the following conditions are met is longer than the time indicated, judge as NG.

#### Judgment Value

Malfunction Criteria	Threshold Value
Battery voltage	$\geq 10.9$ V
Elapsed time after starting the engine	$\geq 3000$ ms
Output voltage	$< 0.173$ V

**Time Needed for Diagnosis:** 2500 ms

**Malfunction Indicator Light Illumination:** Illuminates when malfunction occurs in 2 continuous driving cycles.

### • Normality Judgment

Judge as OK and clear the NG if the continuous time while the following conditions are established is more than the predetermined time.

#### Judgment Value

Malfunction Criteria	Threshold Value
Battery voltage	$\geq 10.9$ V
Elapsed time after starting the engine	$\geq 3000$ ms
Output voltage	$\geq 0.173$ V

**Time Needed for Diagnosis:** Less than 1 second

# Diagnostic Trouble Code (DTC) Detecting Criteria

## GENERAL DESCRIPTION

### CJ:DTC P0463 FUEL LEVEL SENSOR "A" CIRCUIT HIGH

#### 1. OUTLINE OF DIAGNOSIS

Detect the open or short circuit of fuel level sensor. Judge as NG if out of specification.

#### 2. COMPONENT DESCRIPTION

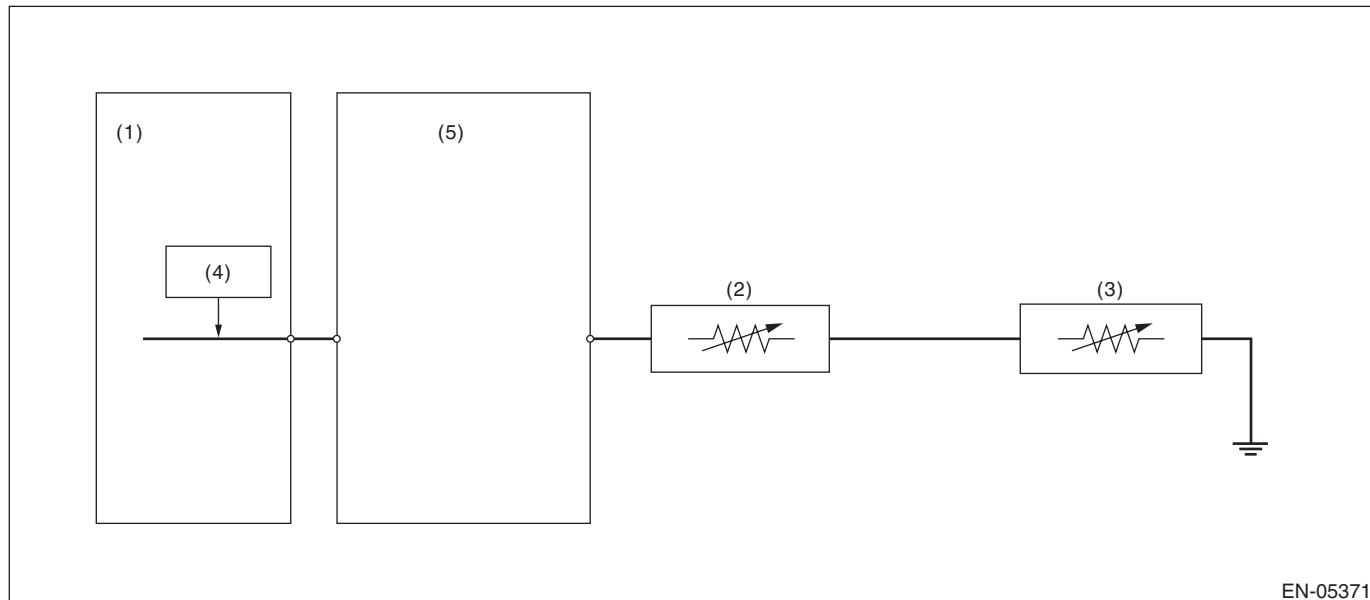

(1) Engine control module (ECM)

(3) Fuel sub level sensor

(5) Body integrated unit

(2) Fuel level sensor

(4) Detecting circuit

#### 3. ENABLE CONDITIONS

Secondary Parameters	Enable Conditions
None	

#### 4. GENERAL DRIVING CYCLE

Always perform the diagnosis continuously.

# Diagnostic Trouble Code (DTC) Detecting Criteria

GENERAL DESCRIPTION

## 5. DIAGNOSTIC METHOD

### • Abnormality Judgment

If the duration of time while the following conditions are met is longer than the time indicated, judge as NG.

#### Judgment Value

Malfunction Criteria	Threshold Value
Battery voltage	$\geq 10.9$ V
Elapsed time after starting the engine	$\geq 3000$ ms
Output voltage	$\geq 7.212$ V

**Time Needed for Diagnosis:** 1000 ms

**Malfunction Indicator Light Illumination:** Illuminates when malfunction occurs in 2 continuous driving cycles.

### • Normality Judgment

Judge as OK and clear the NG if the continuous time while the following conditions are established is more than the predetermined time.

#### Judgment Value

Malfunction Criteria	Threshold Value
Battery voltage	$\geq 10.9$ V
Elapsed time after starting the engine	$\geq 3000$ ms
Output voltage	$< 7.212$ V

**Time Needed for Diagnosis:** Less than 1 second



# Diagnostic Trouble Code (DTC) Detecting Criteria

## GENERAL DESCRIPTION

### CK:DTC P0500 VEHICLE SPEED SENSOR "A"

#### 1. OUTLINE OF DIAGNOSIS

Judge as NG when outside of the judgment value.

Judge NG when the received data from ABSCM&H/U is abnormal vehicle speed, and the vehicle speed data is impossible.

#### 2. COMPONENT DESCRIPTION

Vehicle speed signals are taken in to the ABS control module and hydraulic control unit, and normal/erroneous data of the ABS wheel speed sensor is received by CAN communication from the ABS control module and hydraulic control unit.

#### 3. ENABLE CONDITIONS

Secondary Parameters	Enable Conditions
Battery voltage	≥ 10.9 V
Elapsed time after engine starting	≥ 2000 ms

#### 4. GENERAL DRIVING CYCLE

Always perform diagnosis more than 2000 ms after starting the engine.

#### 5. DIAGNOSTIC METHOD

##### • Abnormality Judgment

If the duration of time while the following conditions are met is longer than the time indicated, judge as NG.

##### Judgment Value

Malfunction Criteria	Threshold Value
Front ABS wheel speed sensor status	Malfunction
Either of the following is established	
Front left wheel speed	≥ 300 km/h (186.4 MPH)
Front right wheel speed	≥ 300 km/h (186.4 MPH)

**Time Needed for Diagnosis:** 512 ms

**Malfunction Indicator Light Illumination:** Illuminates as soon as a malfunction occurs.

##### • Normality Judgment

Judge as OK and clear the NG if the continuous time while the following conditions are established is more than the predetermined time.

##### Judgment Value

Malfunction Criteria	Threshold Value
Front left wheel speed	> 0 km/h (0 MPH) and < 300 km/h (186.4 MPH)
Front right wheel speed	> 0 km/h (0 MPH) and < 300 km/h (186.4 MPH)

**Time Needed for Diagnosis:** 512 ms

# Diagnostic Trouble Code (DTC) Detecting Criteria

GENERAL DESCRIPTION

## CL:DTC P0506 IDLE AIR CONTROL SYSTEM RPM LOWER THAN EXPECTED

### 1. OUTLINE OF DIAGNOSIS

Detect the malfunction that actual engine speed is not close to target engine speed during idling. Judge as NG when actual engine speed is not close to target engine speed during idling.

### 2. ENABLE CONDITIONS

Secondary Parameters	Enable Conditions
Engine coolant temperature	≥ 70 °C (158 °F)
Battery voltage	≥ 10.9 V
Atmospheric pressure	≥ 75 kPa (563 mmHg, 22.2 inHg)
Fuel level	≥ 9.6 ℓ (2.54 US gal, 2.11 Imp gal)
Elapsed time after starting the engine	≥ 10.49 s
Feedback of ISC	In operation
Lambda value (left and right)	≥ 0.9 and < 1.1
After switching air conditioner to ON/OFF	≥ 5.1 s
After intake manifold pressure changes by 4 kPa (30 mmHg, 1.2 inHg) or more.	> 5.1 s
Elapsed time after switching neutral position switch to ON/OFF	> 5.1 s
Vehicle speed	0 km/h (0 MPH)

### 3. GENERAL DRIVING CYCLE

Perform the diagnosis continuously at idling after warming up engine.

### 4. DIAGNOSTIC METHOD

#### • Abnormality Judgment

If the duration of time while the following conditions are met is longer than the time indicated, judge as NG.

#### Judgment Value

Malfunction Criteria	Threshold Value
Actual engine speed – Targeted engine speed	< –100 rpm
Feedback compensation for ISC	Max.

**Time Needed for Diagnosis:** 10 s × 3 time(s)

**Malfunction Indicator Light Illumination:** Illuminates when malfunction occurs in 2 continuous driving cycles.

#### • Normality Judgment

Judge as OK and clear the NG if the continuous time while the following conditions are established is more than the predetermined time.

#### Judgment Value

Malfunction Criteria	Threshold Value
Actual engine speed – Targeted engine speed	≥ –100 rpm

**Time Needed for Diagnosis:** 10 s

# Diagnostic Trouble Code (DTC) Detecting Criteria

## GENERAL DESCRIPTION

### CM:DTC P0507 IDLE AIR CONTROL SYSTEM RPM HIGHER THAN EXPECTED

#### 1. OUTLINE OF DIAGNOSIS

Detect the malfunction that actual engine speed is not close to target engine speed during idling. Judge as NG when actual engine speed is not close to target engine speed during idling.

#### 2. ENABLE CONDITIONS

Secondary Parameters	Enable Conditions
Engine coolant temperature	≥ 70 °C (158 °F)
Battery voltage	≥ 10.9 V
Atmospheric pressure	≥ 75 kPa (563 mmHg, 22.2 inHg)
Fuel level	≥ 9.6 ℓ (2.54 US gal, 2.11 Imp gal)
Elapsed time after starting the engine	≥ 10.49 s
Feedback of ISC	In operation
Lambda value (left and right)	≥ 0.9 and < 1.1
After switching air conditioner to ON/OFF	≥ 5.1 s
After intake manifold pressure changes by 4 kPa (30 mmHg, 1.2 inHg) or more.	> 5.1 s
Elapsed time after switching neutral position switch to ON/OFF	> 5.1 s
Vehicle speed	0 km/h (0 MPH)

#### 3. GENERAL DRIVING CYCLE

Perform the diagnosis continuously at idling after warming up engine.

#### 4. DIAGNOSTIC METHOD

##### • Abnormality Judgment

If the duration of time while the following conditions are met is longer than the time indicated, judge as NG.

##### Judgment Value

Malfunction Criteria	Threshold Value
Actual engine speed – Targeted engine speed	≥ 200 rpm
Feedback compensation for ISC	Min.

**Time Needed for Diagnosis:** 10 s × 3 time(s)

**Malfunction Indicator Light Illumination:** Illuminates when malfunction occurs in 2 continuous driving cycles.

##### • Normality Judgment

Judge as OK and clear the NG if the continuous time while the following conditions are established is more than the predetermined time.

##### Judgment Value

Malfunction Criteria	Threshold Value
Actual engine speed – Targeted engine speed	< 200 rpm

**Time Needed for Diagnosis:** 10 s

# Diagnostic Trouble Code (DTC) Detecting Criteria

GENERAL DESCRIPTION

---

## CN:DTC P050A COLD START IDLE AIR CONTROL SYSTEM PERFORMANCE

### 1. OUTLINE OF DIAGNOSIS

- **When cold, the abnormality in the control of target engine speed increase is detected. (P050A)**

Judge as NG if the exhaust gas temperature diagnosis or idle speed diagnosis is NG.

- Exhaust gas temperature diagnosis

Judge as NG when the estimated exhausted gas temperature in 14 seconds after the cold start is below the specified value.

- Idle speed diagnosis

Judge as NG when actual engine speed is not close to target engine speed at cold start.

- **Detect malfunctions of the catalyst advanced idling retard angle control. (P050B)**

Judge as NG when ECM is not controlling the angle properly during catalyst advanced idling retard angle control.

- Final ignition timing diagnosis

Judge as NG when actual retard amount is under the specified value at cold start.

# Diagnostic Trouble Code (DTC) Detecting Criteria

## GENERAL DESCRIPTION

### 2. ENABLE CONDITIONS

Secondary Parameters	Enable Conditions
<Exhaust gas temperature diagnosis>	
Atmospheric pressure	≥ 75 kPa (563 mmHg, 22.2 inHg)
Battery voltage	> 10.9 V
Engine condition	In operation
Vehicle speed	≤ 2 km/h (1.2 MPH)
Elapsed time after gear position change (P ↔ D or N ↔ D)	≥ 3000 ms
ISC feedback	In operation
Throttle opening angle	< 0.37 °
Fuel property	Not extremely low volatility
Target retard amount	≥ 5 °CA
<Idle speed diagnosis>	
Atmospheric pressure	≥ 75 kPa (563 mmHg, 22.2 inHg)
Battery voltage	> 10.9 V
Engine condition	In operation
Vehicle speed	≤ 2 km/h (1.2 MPH)
Engine coolant temperature	≤ 60 °C (140 °F)
Intake air amount sum value	≤ Value of Map 1
Elapsed time after gear position change (P ↔ D or N ↔ D)	≥ 3000 ms
Throttle opening angle	< 0.37 °
Fuel property	Not extremely low volatility
Elapsed time after starting the engine	≥ 2000 ms
<Final ignition timing diagnosis>	
Atmospheric pressure	≥ 75 kPa (563 mmHg, 22.2 inHg)
Battery voltage	> 10.9 V
Engine condition	In operation
Vehicle speed	≤ 2 km/h (1.2 MPH)
Engine coolant temperature	≤ 60 °C (140 °F)
Intake air amount sum value	≤ Value of Map 2
Elapsed time after gear position change (P ↔ D or N ↔ D)	≥ 3000 ms
Throttle opening angle	< 0.37 °
Fuel property	Not extremely low volatility
Target retard amount	≥ Value from Map 3

#### Map 1 (Models without SI-DRIVE)

Engine coolant temperature at engine starting °C (°F)	-40 (-40)	-30 (-22)	-20 (-4)	-10 (14)	0 (32)	10 (50)	20 (68)	30 (86)
Intake air amount sum value g (oz)	1240 (43.73)	1170 (41.27)	1100 (38.8)	1040 (36.68)	980 (34.56)	570 (20.1)	280 (9.88)	265 (9.35)

Engine coolant temperature at engine starting °C (°F)	40 (104)	50 (122)	60 (140)	70 (158)	80 (176)	90 (194)	100 (212)	110 (230)
Intake air amount sum value g (oz)	250 (8.82)	210 (7.41)	210 (7.41)	210 (7.41)	210 (7.41)	210 (7.41)	210 (7.41)	210 (7.41)

# Diagnostic Trouble Code (DTC) Detecting Criteria

GENERAL DESCRIPTION

## Map 1 (Models with SI-DRIVE)

Engine coolant temperature at engine starting °C (°F)	-40 (-40)	-30 (-22)	-20 (-4)	-10 (14)	0 (32)	10 (50)	20 (68)	30 (86)
Intake air amount sum value g (oz)	950 (33.51)	925 (32.62)	900 (31.74)	870 (30.68)	840 (29.63)	620 (21.87)	420 (14.81)	310 (10.93)

Engine coolant temperature at engine starting °C (°F)	40 (104)	50 (122)	60 (140)	70 (158)	80 (176)	90 (194)	100 (212)	110 (230)
Intake air amount sum value g (oz)	260 (9.17)	210 (7.41)	170 (6)	170 (6)	170 (6)	170 (6)	170 (6)	170 (6)

## Map 2 (Models without SI-DRIVE)

Engine coolant temperature at engine starting °C (°F)	-40 (-40)	-30 (-22)	-20 (-4)	-10 (14)	0 (32)	10 (50)	20 (68)	30 (86)
Intake air amount sum value g (oz)	1240 (43.73)	1170 (41.27)	1100 (38.8)	1040 (36.68)	980 (34.56)	570 (20.1)	280 (9.88)	265 (9.35)

Engine coolant temperature at engine starting °C (°F)	40 (104)	50 (122)	60 (140)	70 (158)	80 (176)	90 (194)	100 (212)	110 (230)
Intake air amount sum value g (oz)	250 (8.82)	210 (7.41)	210 (7.41)	210 (7.41)	210 (7.41)	210 (7.41)	210 (7.41)	210 (7.41)

## Map 2 (Models with SI-DRIVE)

Engine coolant temperature at engine starting °C (°F)	-40 (-40)	-30 (-22)	-20 (-4)	-10 (14)	0 (32)	10 (50)	20 (68)	30 (86)
Intake air amount sum value g (oz)	950 (33.51)	925 (32.62)	900 (31.74)	870 (30.68)	840 (29.63)	620 (21.87)	420 (14.81)	310 (10.93)

Engine coolant temperature at engine starting °C (°F)	40 (104)	50 (122)	60 (140)	70 (158)	80 (176)	90 (194)	100 (212)	110 (230)
Intake air amount sum value g (oz)	260 (9.17)	210 (7.41)	170 (6)	170 (6)	170 (6)	170 (6)	170 (6)	170 (6)

## Map 3

Engine coolant temperature	-40 °C (-40 °F)	-30 °C (-22 °F)	-20 °C (-4 °F)	-10 °C (14 °F)	0 °C (32 °F)	10 °C (50 °F)	20 °C (68 °F)	30 °C (86 °F)	40 °C (104 °F)	50 °C (122 °F)	60 °C (140 °F)
Target retard amount	6 °CA	6 °CA	6 °CA	6 °CA	6 °CA	6 °CA	6 °CA	6 °CA	6 °CA	6 °CA	6 °CA

### 3. GENERAL DRIVING CYCLE

Perform the diagnosis at cold start.

# Diagnostic Trouble Code (DTC) Detecting Criteria

## GENERAL DESCRIPTION

### 4. DIAGNOSTIC METHOD

#### • Exhaust gas temperature diagnosis

##### Abnormality Judgment

Calculate the estimated exhaust gas temperature when the diagnostic enable condition is established. Judge as NG when the following conditions are established.

##### Judgment Value

Malfunction Criteria	Threshold Value
Estimated exhaust gas temperature	< Value of Map 4

##### Map 4 (Models without SI-DRIVE)

Engine coolant temperature at engine starting	-40 °C (-40 °F)	-30 °C (-22 °F)	-20 °C (-4 °F)	-10 °C (14 °F)	0 °C (32 °F)	10 °C (50 °F)	20 °C (68 °F)	30 °C (86 °F)	40 °C (104 °F)	45 °C (113 °F)
Threshold Value	200 °C (392 °F)	200 °C (392 °F)	200 °C (392 °F)	200 °C (392 °F)	80 °C (176 °F)	83 °C (181.4 °F)	81 °C (177.8 °F)	75 °C (167 °F)	74 °C (165.2 °F)	71 °C (159.8 °F)

##### Map 4 (Models with SI-DRIVE)

Engine coolant temperature at engine starting	-40 °C (-40 °F)	-30 °C (-22 °F)	-20 °C (-4 °F)	-10 °C (14 °F)	0 °C (32 °F)	10 °C (50 °F)	20 °C (68 °F)	30 °C (86 °F)	40 °C (104 °F)	45 °C (113 °F)
Threshold Value	200 °C (392 °F)	200 °C (392 °F)	200 °C (392 °F)	200 °C (392 °F)	80 °C (176 °F)	78 °C (172.4 °F)	79 °C (174.2 °F)	82 °C (179.6 °F)	79 °C (174.2 °F)	75 °C (167 °F)

**Time Needed for Diagnosis:** 14 seconds

**Malfunction Indicator Light Illumination:** Illuminates when malfunction occurs in 2 continuous driving cycles.

##### Normality Judgment

Judge as OK and clear the NG if the following conditions are established.

##### Judgment Value

Malfunction Criteria	Threshold Value
Estimated exhaust gas temperature	≥ Value of Map 4

**Time Needed for Diagnosis:** Less than 1 second

#### • Idle speed diagnosis

##### Abnormality Judgment

Judge as NG when the following conditions are established.

##### Judgment Value

Malfunction Criteria	Threshold Value
Actual engine speed – Target engine speed	< – 125 rpm

**Time Needed for Diagnosis:** 5000 ms

**Malfunction Indicator Light Illumination:** Illuminates when malfunction occurs in 2 continuous driving cycles.

##### Normality Judgment

Judge as OK and clear the NG if the following conditions are established.

##### Judgment Value

Malfunction Criteria	Threshold Value
Actual engine speed – Target engine speed	≥ – 125 rpm

**Time Needed for Diagnosis:** 5000 ms

# Diagnostic Trouble Code (DTC) Detecting Criteria

GENERAL DESCRIPTION

## • Final ignition timing diagnosis

### Abnormality Judgment

Judge as NG when the following conditions are established.

### Judgment Value

Malfunction Criteria	Threshold Value
Final ignition timing – ignition timing during CSERS* *: Ignition timing during CSERS (Cold Start Emission Reduction Strategy) = Base ignition timing – retard amount	> Value of Map 5

### Map 5

Engine coolant temperature	–40 °C (–40 °F)	–30 °C (–22 °F)	–20 °C (–4 °F)	–10 °C (14 °F)	0 °C (32 °F)	10 °C (50 °F)	20 °C (68 °F)	30 °C (86 °F)	40 °C (104 °F)	50 °C (122 °F)	60 °C (140 °F)
Threshold Value	6 °CA	6 °CA	6 °CA	6 °CA	6 °CA	6 °CA	6 °CA	6 °CA	6 °CA	6 °CA	6 °CA

**Time Needed for Diagnosis:** 5000 ms

**Malfunction Indicator Light Illumination:** Illuminates when malfunction occurs in 2 continuous driving cycles.

### Normality Judgment

Judge as OK and clear the NG if the following conditions are established.

### Judgment Value

Malfunction Criteria	Threshold Value
Final ignition timing – ignition timing during CSERS* *: Ignition timing during CSERS (Cold Start Emission Reduction Strategy) = Base ignition timing – retard amount	≤ Value of Map 5

**Time Needed for Diagnosis:** 5000 ms

## CO:DTC P050B COLD START IGNITION TIMING PERFORMANCE

### 1. OUTLINE OF DIAGNOSIS

#### NOTE:

For the detection standard, refer to DTC P050A. <Ref. to GD(H4DOTC)-175, DTC P050A COLD START IDLE AIR CONTROL SYSTEM PERFORMANCE, Diagnostic Trouble Code (DTC) Detecting Criteria.>



# Diagnostic Trouble Code (DTC) Detecting Criteria

## GENERAL DESCRIPTION

---

### CP:DTC P0512 STARTER REQUEST CIRCUIT

#### 1. OUTLINE OF DIAGNOSIS

Detect the open or short circuit of starter SW.

Judge as ON NG when the starter SW signal remains ON.

#### 2. ENABLE CONDITIONS

Secondary Parameters	Enable Conditions
None	

#### 3. GENERAL DRIVING CYCLE

Always perform the diagnosis continuously.

#### 4. DIAGNOSTIC METHOD

##### • Abnormality Judgment

If the duration of time while the following conditions are met is longer than the time indicated, judge as NG.

##### Judgment Value

Malfunction Criteria	Threshold Value
Engine condition	After engine starting
Starter OFF signal	Not detected
Battery voltage	$\geq 8\text{ V}$

**Time Needed for Diagnosis:** 30000 ms

**Malfunction Indicator Light Illumination:** Illuminates when malfunction occurs in 2 continuous driving cycles.

##### • Normality Judgment

Judge as OK and clear the NG if the continuous time while the following conditions are established is more than the predetermined time.

##### Judgment Value

Malfunction Criteria	Threshold Value
Starter OFF signal	Detected
Battery voltage	$\geq 8\text{ V}$

**Time Needed for Diagnosis:** Less than 1 second

# Diagnostic Trouble Code (DTC) Detecting Criteria

GENERAL DESCRIPTION

## CQ:DTC P0513 INCORRECT IMMOBILIZER KEY

### 1. OUTLINE OF DIAGNOSIS

DTC	Item	OUTLINE OF DIAGNOSIS
P0513	Incorrect Immobilizer Key	Incorrect immobilizer key (Use of unregistered key in body integrated unit)
P1570	Antenna	Faulty antenna
P1571	Reference Code Incompatibility	Reference code incompatibility between body integrated unit and ECM
P1572	IMM Circuit Failure (Except Antenna Circuit)	Communication failure between body integrated unit and ECM
P1574	Key Communication Failure	Failure of body integrated unit to verify key (transponder) ID code or transponder failure
P1576	EGI Control Module EEPROM	ECM malfunctioning
P1577	IMM Control Module EEPROM	Body integrated unit malfunctioning
P1578	Meter Failure	Reference code incompatibility between combination meter and body integrated unit

### 2. ENABLE CONDITIONS

When starting the engine.

### 3. GENERAL DRIVING CYCLE

Perform the diagnosis only after starting the engine.

### 4. DIAGNOSTIC METHOD

Judge as NG when the conditions for the outline of the diagnosis of the top are established.

# Diagnostic Trouble Code (DTC) Detecting Criteria

## GENERAL DESCRIPTION

---

### CR:DTC P0604 INTERNAL CONTROL MODULE RANDOM ACCESS MEMORY (RAM) ERROR

#### 1. OUTLINE OF DIAGNOSIS

Detect the malfunction of microcomputer (RAM).

When there is a problem in the main CPU normal RAM, or the sub CPU normal RAM, judge as NG. Judge as OK when both are operating properly.

If it is possible to write data to the whole area of RAM in the initial routine, and is possible to read the same data, it is judged as OK, and if not, NG.

#### 2. ENABLE CONDITIONS

Secondary Parameters	Enable Conditions
None	

Diagnosis with the initial routine.

#### 3. GENERAL DRIVING CYCLE

Perform the diagnosis as soon as the ignition switch is turned to ON.

#### 4. DIAGNOSTIC METHOD

##### • Abnormality Judgment

Judge as NG when the following conditions are established.

##### Judgment Value

Malfunction Criteria	Threshold Value
Write the specified value into the RAM.	The written value cannot be read.

**Time Needed for Diagnosis:** Less than 1 second

**Malfunction Indicator Light Illumination:** Illuminates as soon as a malfunction occurs.

##### • Normality Judgment

Judge as OK and clear the NG if the following conditions are established.

##### Judgment Value

Malfunction Criteria	Threshold Value
Write the specified value into the RAM.	The written value can be read.

**Time Needed for Diagnosis:** Less than 1 second

# Diagnostic Trouble Code (DTC) Detecting Criteria

GENERAL DESCRIPTION

## CS:DTC P0605 INTERNAL CONTROL MODULE READ ONLY MEMORY (ROM) ERROR

### 1. OUTLINE OF DIAGNOSIS

Judge as NG when SUM value of ROM is outside the standard value.

### 2. ENABLE CONDITIONS

Secondary Parameters	Enable Conditions
Ignition switch	ON

### 3. GENERAL DRIVING CYCLE

Always perform the diagnosis continuously.

### 4. DIAGNOSTIC METHOD

#### Abnormality Judgment

Judge as NG if the criteria below are met.

#### Judgment Value

Malfunction Criteria	Threshold Value
SUM value of ROM	Standard

**Time Needed for Diagnosis:** Undetermined

**Malfunction Indicator Light Illumination:** Illuminates as soon as a malfunction occurs.

# Diagnostic Trouble Code (DTC) Detecting Criteria

## GENERAL DESCRIPTION

### CT:DTC P0607 THROTTLE CONTROL SYSTEM CIRCUIT RANGE/PERFORMANCE

#### 1. OUTLINE OF DIAGNOSIS

Judge as NG when any one of the followings is established.

- (1) If the monitoring IC operation is abnormal (monitoring IC malfunction).
- (2) If the input amplifier circuit of throttle position sensor 1 is abnormal (quadruple amplification problem).
- (3) If the CPU operation is abnormal (instruction/flow check).
- (4) If the A/D converter operation is abnormal (ADC malfunction).
- (5) If the EEPROM operation is abnormal (EEPROM malfunction).
- (6) If the output IC operation is abnormal (output driver malfunction).

#### 2. COMPONENT DESCRIPTION

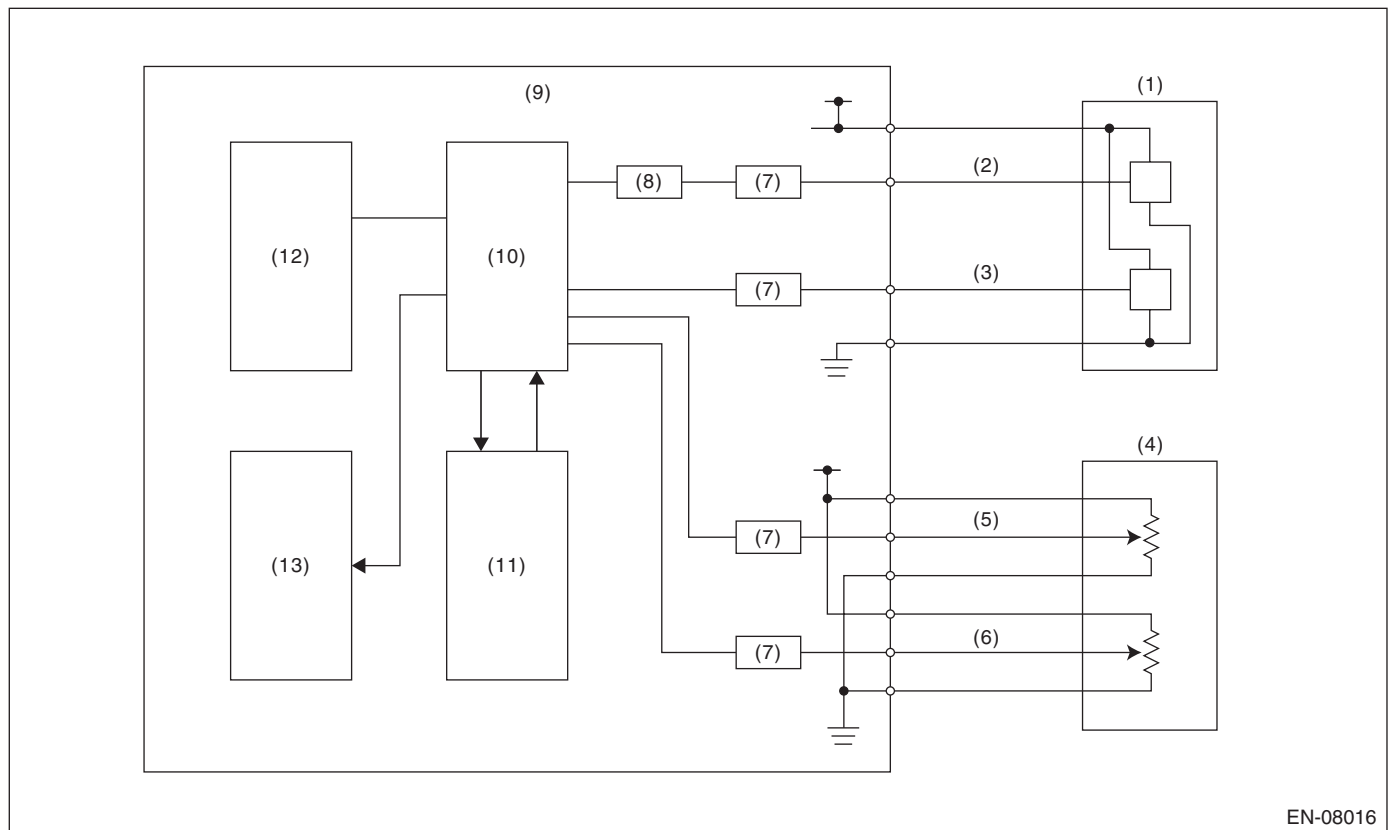

EN-08016

- |   |   |                    |
|---|---|--------------------|
| (1) Throttle position sensor            | (6) Accelerator pedal position sensor 2 | (10) CPU           |
| (2) Throttle position sensor 1          | (7) I/F circuit                         | (11) Monitoring IC |
| (3) Throttle position sensor 2          | (8) Amplifier circuit                   | (12) EEPROM        |
| (4) Accelerator pedal position sensor   | (9) Engine control module (ECM)         | (13) Output IC     |
| (5) Accelerator pedal position sensor 1 |   |                    |

# Diagnostic Trouble Code (DTC) Detecting Criteria

GENERAL DESCRIPTION

## 3. ENABLE CONDITIONS

Secondary Parameters	Enable Conditions
(1) Battery voltage	$\geq 6\text{ V}$
(2) Ignition switch	ON
(2) Battery voltage	$\geq 6\text{ V}$
(3) Ignition switch	ON
(3) ETC control	Permission
(4) Ignition switch	ON
(4) Battery voltage	$\geq 6\text{ V}$
(5) Starter switch	OFF
(5) Battery voltage	$> 6\text{ V}$
(6) Ignition switch	ON
(6) Battery voltage	$\geq 10.9\text{ V}$

## 4. GENERAL DRIVING CYCLE

Always perform the diagnosis continuously.

## 5. DIAGNOSTIC METHOD

Judge as OK and clear the NG when the malfunction criteria below are met.

### Judgment Value

Malfunction Criteria	Threshold Value
(1) Monitoring IC operation	The result and expected value match.
(2)   Throttle position sensor 1 opening angle – (Throttle position sensor 1 opening angle after passing amplifier/4)	$< 3^\circ$
(3) Main CPU calculation result	The result and expected value match.
(4)   standard voltage – read voltage value	$< 0.078125\text{ V}$
(5) EEPROM writing	Writing completed
(6) Communication between output ICs	Possible to communicate

### Time Needed for Diagnosis:

- (1): 200 ms
- (2): 24 ms
- (3): 192 ms
- (4): 200 ms
- (5): 48 ms
- (6): 2500 ms

**Malfunction Indicator Light Illumination:** Illuminates as soon as a malfunction occurs.

# Diagnostic Trouble Code (DTC) Detecting Criteria

## GENERAL DESCRIPTION

### CU:DTC P0638 THROTTLE ACTUATOR CONTROL RANGE/PERFORMANCE (BANK 1)

#### 1. OUTLINE OF DIAGNOSIS

Judge as NG when the target opening angle and actual opening angle is mismatched or the current to motor is the specified duty or more for specified time continuously.

#### 2. COMPONENT DESCRIPTION

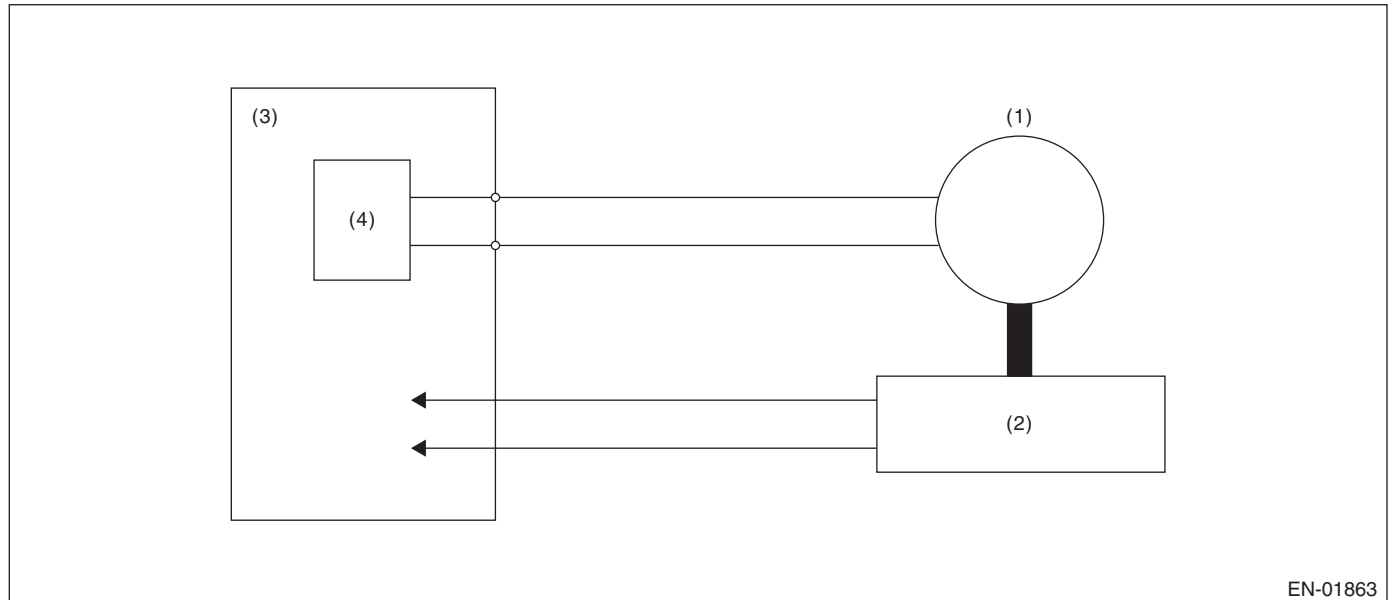

- (1) Motor  
(2) Throttle position sensor  
(3) Engine control module (ECM)  
(4) Drive circuit

#### 3. ENABLE CONDITIONS

Secondary Parameters	Enable Conditions
Ignition switch	ON
Normal operation of electronic throttle control	ON

#### 4. GENERAL DRIVING CYCLE

Always perform the diagnosis continuously when the electronic throttle control is operating.

#### 5. DIAGNOSTIC METHOD

Judge as OK and clear the NG when the malfunction criteria below are met.

##### Judgment Value

Malfunction Criteria	Threshold Value
Difference between target opening angle and actual opening angle	Within OK range of <b>Details of Judgment value</b>
Output duty to drive circuit	< 95 %

##### Time Needed for Diagnosis:

- Difference between target opening angle and actual opening angle:
  - NG judgment: See **Details of Judgment time**
  - OK judgment: 2000 ms
- Output duty to drive circuit: 2000 ms

# Diagnostic Trouble Code (DTC) Detecting Criteria

GENERAL DESCRIPTION

## Details of Judgment Value Models without SI-DRIVE

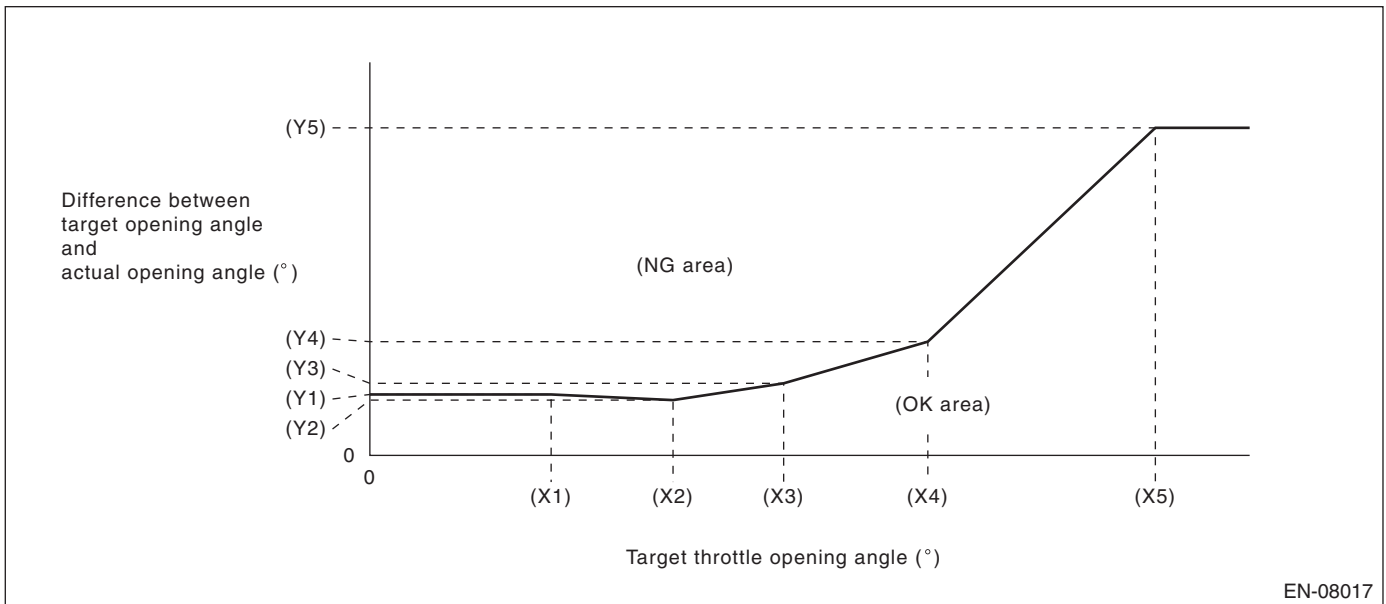

(X1) 6.915 °	(X2) 11.565 °	(X3) 15.785 °
(X4) 21.285 °	(X5) 29.965 °	
(Y1) 4.65 °	(Y2) 4.22 °	(Y3) 5.5 °
(Y4) 8.68 °	(Y5) 25 °	

## Models with SI-DRIVE

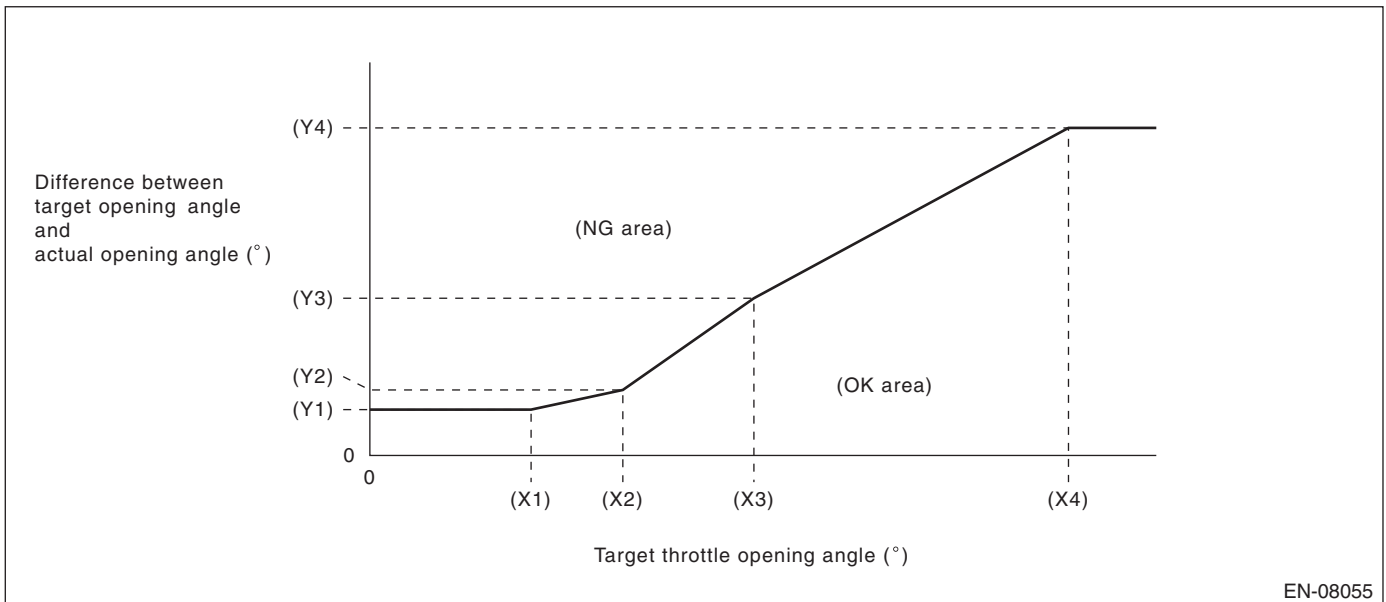

(X1) 6.15 °	(X2) 9.65 °	(X3) 14.65 °
(X4) 26.65 °		
(Y1) 3.5 °	(Y2) 5 °	(Y3) 12 °
(Y4) 25 °		



# Diagnostic Trouble Code (DTC) Detecting Criteria

## GENERAL DESCRIPTION

### Details of Judgment time Models without SI-DRIVE

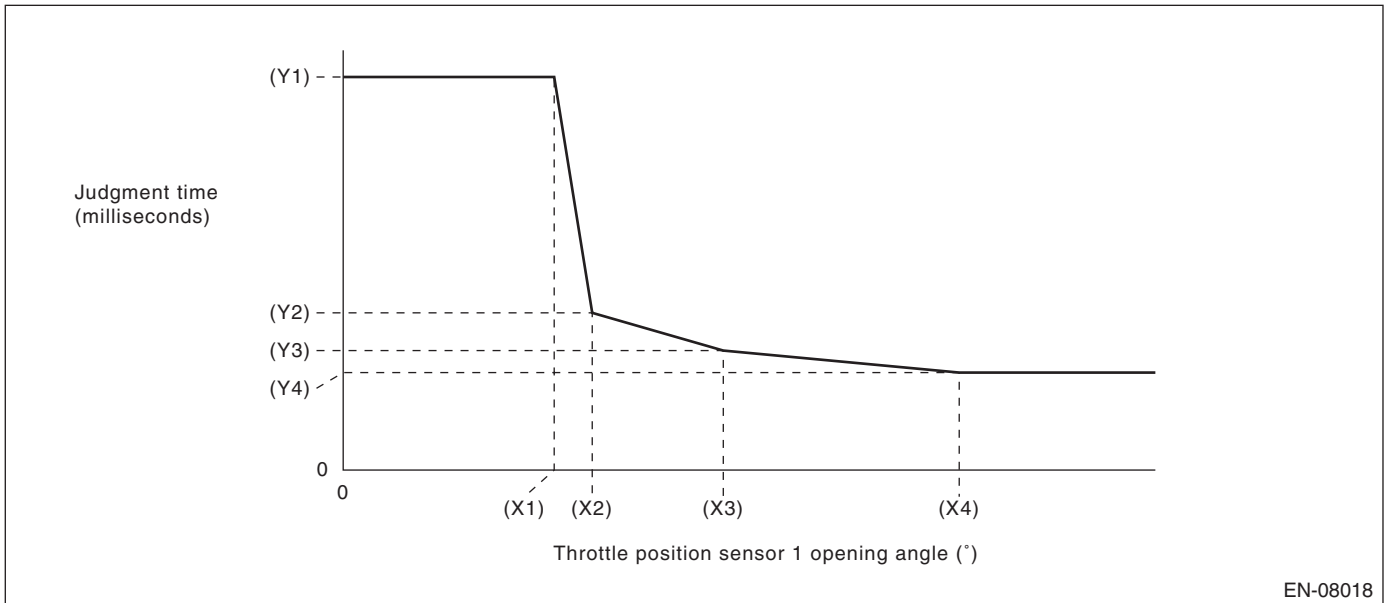

EN-08018

(X1) 8.049999237 °

(X2) 9.5 °

(X3) 14.5 °

(X4) 23.5 °

(Y1) 1000 ms

(Y2) 400 ms

(Y3) 304 ms

(Y4) 248 ms

### Models with SI-DRIVE

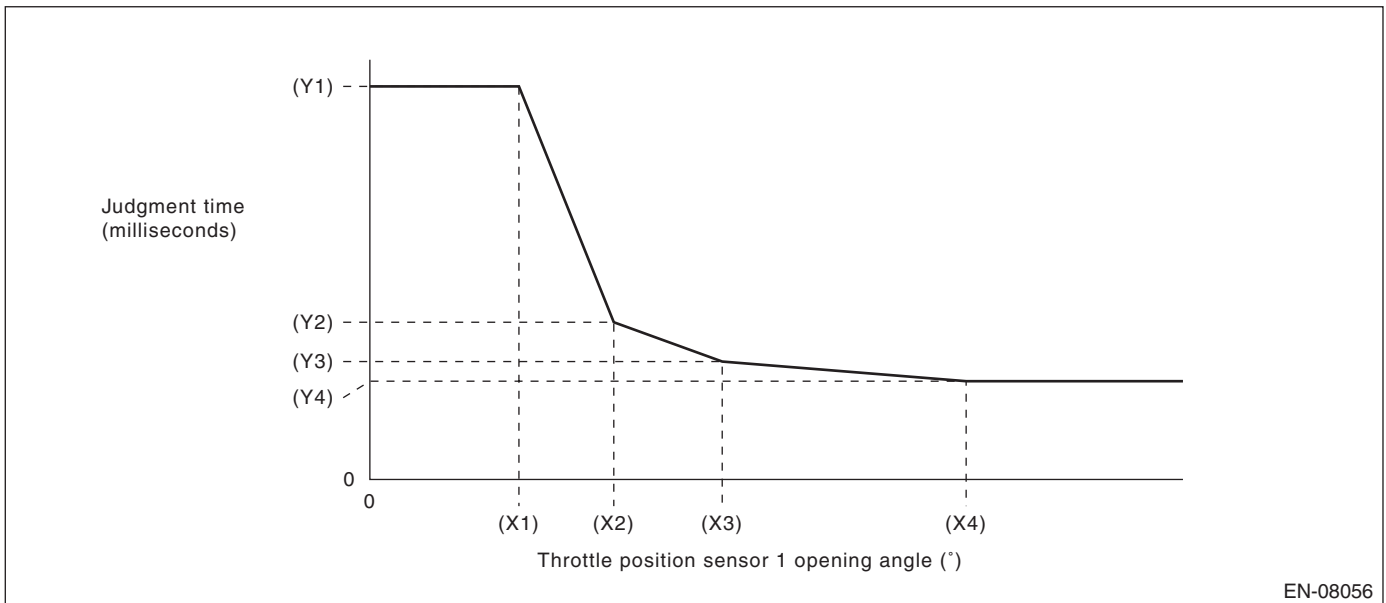

EN-08056

(X1) 5.5 °

(X2) 9 °

(X3) 13 °

(X4) 22 °

(Y1) 1000 ms

(Y2) 400 ms

(Y3) 300 ms

(Y4) 250 ms

#### NOTE:

Judgment time when actual opening angle  $\leq$  target opening angle is always 1000 milliseconds.

**Malfunction Indicator Light Illumination:** Illuminates as soon as a malfunction occurs.

**GD(H4DOTC)-188**

Brought to you by Ebay Seller "SubaruManuals"

# Diagnostic Trouble Code (DTC) Detecting Criteria

GENERAL DESCRIPTION

## CV:DTC P0851 NEUTRAL SWITCH INPUT CIRCUIT LOW (MT MODEL)

### 1. OUTLINE OF DIAGNOSIS

Detect the open or short circuit of neutral SW.

Judge as NG when there is no change in the neutral SW even if the driving shift was applied. (There is neutral SW ON/OFF inversion from the vehicle speed and engine speed.)

### 2. ENABLE CONDITIONS

Secondary Parameters	Enable Conditions
Battery voltage	$\geq 10.9$ V
Starter relay	OFF

### 3. GENERAL DRIVING CYCLE

Perform the diagnosis continuously in 2 seconds after starting the engine.

### 4. DIAGNOSTIC METHOD

#### • Abnormality Judgment

Judge NG when the malfunction criteria below are completed determined times or more after the neutral SW change.

#### Judgment Value

Malfunction Criteria	Threshold Value
Neutral switch signal (while changing from a to b below) Driving condition change a) Engine speed 600 rpm — 900 rpm & Vehicle speed = 0 km/h (0 MPH) b) Engine speed 1600 rpm — 2550 rpm & Vehicle speed $\geq 64$ km/h (39.8 MPH)	LOW (ON) continues. From a) to b)

**Time Needed for Diagnosis:** 3 time(s)

**Malfunction Indicator Light Illumination:** Illuminates when malfunction occurs in 2 continuous driving cycles.

#### • Normality Judgment

Judge as OK and clear NG when there is change in the neutral SW.

#### Judgment Value

Malfunction Criteria	Threshold Value
Neutral switch signal (while changing from a to b below) Driving condition change a) Engine speed 600 rpm — 900 rpm & Vehicle speed = 0 km/h (0 MPH) b) Engine speed 1600 rpm — 2550 rpm & Vehicle speed $\geq 64$ km/h (39.8 MPH)	Changes to HIGH (OFF). From a) to b)

**Time Needed for Diagnosis:** Less than 1 second

# Diagnostic Trouble Code (DTC) Detecting Criteria

## GENERAL DESCRIPTION

### CW:DTC P0852 NEUTRAL SWITCH INPUT CIRCUIT HIGH (MT MODEL)

#### 1. OUTLINE OF DIAGNOSIS

Detect the open or short circuit of neutral SW.

Judge as NG when there is no change in the neutral SW even if the driving shift was applied. (There is neutral SW ON/OFF inversion from the vehicle speed and engine speed.)

#### 2. ENABLE CONDITIONS

Secondary Parameters	Enable Conditions
Battery voltage	$\geq 10.9$ V
Starter relay	OFF

#### 3. GENERAL DRIVING CYCLE

Perform the diagnosis continuously in 2 seconds after starting the engine.

#### 4. DIAGNOSTIC METHOD

##### • Abnormality Judgment

Judge NG when the malfunction criteria below are completed determined times or more after the neutral SW change.

##### Judgment Value

Malfunction Criteria	Threshold Value
Neutral switch signal (while changing from a to b below) Driving condition change a) Engine speed 600 rpm — 900 rpm & Vehicle speed = 0 km/h (0 MPH) b) Engine speed 1600 rpm — 2550 rpm & Vehicle speed $\geq 64$ km/h (39.8 MPH)	HIGH (OFF) continues. From a) to b)

**Time Needed for Diagnosis:** 3 time(s)

**Malfunction Indicator Light Illumination:** Illuminates when malfunction occurs in 2 continuous driving cycles.

##### • Normality Judgment

Judge as OK and clear NG when there is change in the neutral SW.

##### Judgment Value

Malfunction Criteria	Threshold Value
Neutral switch signal (while changing from a to b below) Driving condition change a) Engine speed 600 rpm — 900 rpm & Vehicle speed = 0 km/h (0 MPH) b) Engine speed 1600 rpm — 2550 rpm & Vehicle speed $\geq 64$ km/h (39.8 MPH)	Changes to LOW (ON). From a) to b)

**Time Needed for Diagnosis:** Less than 1 second

# Diagnostic Trouble Code (DTC) Detecting Criteria

GENERAL DESCRIPTION

## CX:DTC P1152 O2 SENSOR CIRCUIT RANGE/PERFORMANCE (LOW) (BANK1 SENSOR1)

### 1. OUTLINE OF DIAGNOSIS

Detect that  $\lambda$  value remains low.

Judge as NG when lambda value is abnormal in accordance with  $\lambda$  value of front oxygen (A/F) sensor and running conditions such as vehicle speed, amount of intake air, engine coolant temperature, sub feedback control, etc.

$\lambda$  value = Actual air fuel ratio/Theoretical air fuel ratio

$\lambda > 1$ : Lean

$\lambda < 1$ : Rich

### 2. COMPONENT DESCRIPTION

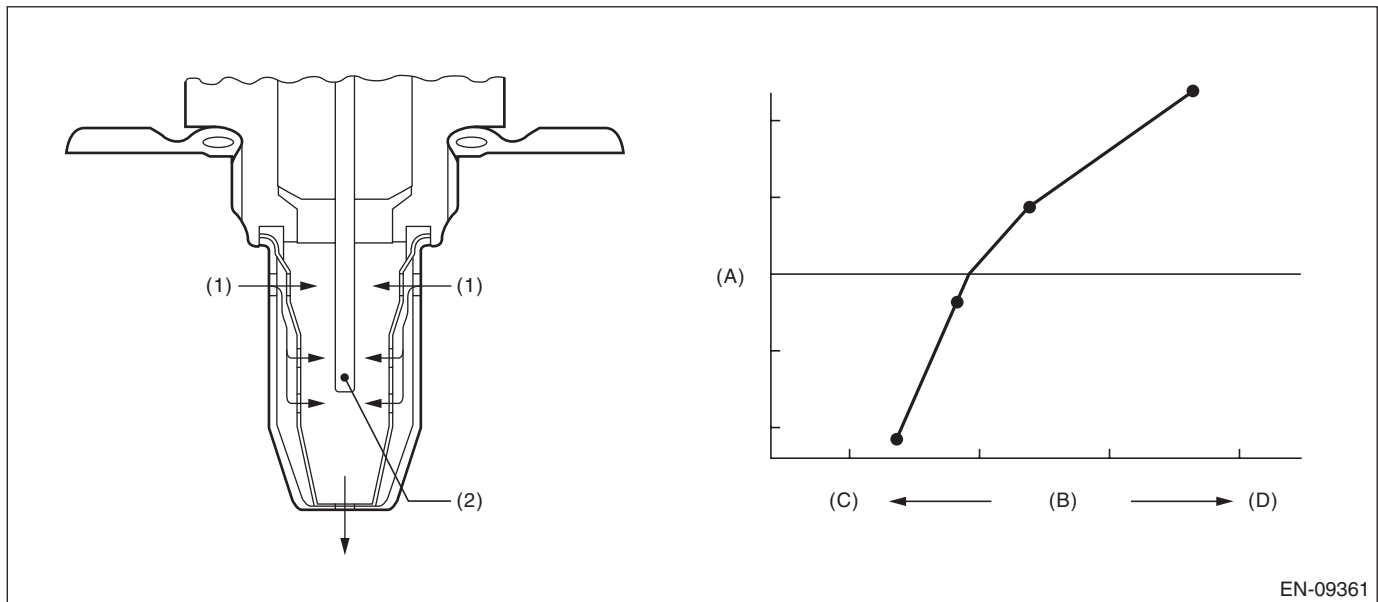

EN-09361

(A) Electromotive force

(B) Air fuel ratio

(C) Lean

(D) Rich

(1) Exhaust gas

(2) ZrO<sub>2</sub>

# Diagnostic Trouble Code (DTC) Detecting Criteria

## GENERAL DESCRIPTION

### 3. ENABLE CONDITIONS

Secondary Parameters	Enable Conditions
Time needed for all secondary parameters to be in enable conditions	$\geq 4096$ ms
Battery voltage	$\geq 10.9$ V
Atmospheric pressure	$\geq 75$ kPa (563 mmHg, 22.2 inHg)
Rear oxygen sensor sub feedback	Execution
Rear oxygen sensor output voltage – Feedback target voltage or Rear oxygen sensor sub feedback compensation coefficient or Rear oxygen sensor sub feedback compensation coefficient	$-0.2$ V — $0.1$ V On Min. On Max.
Elapsed time after starting the engine	$\geq 60000$ ms
Engine coolant temperature	$\geq 70$ °C (158 °F)
Vehicle speed	$\geq 20$ km/h (12.4 MPH)
Amount of intake air	$\geq 6$ g/s (0.21 oz/s)
Load change at 180°CA	$< 0.02$ g/rev (0 oz/rev)
Front oxygen (A/F) sensor impedance	$0 \Omega$ — $50 \Omega$
Learning value of evaporation gas density	$< 0.2$
Total time of operating canister purge	$\geq 19.9$ s
Targeted lambda value load compensation coefficient	$-1$ — $1$

### 4. GENERAL DRIVING CYCLE

Perform diagnosis continuously at a constant speed of 20 km/h (12.4 MPH) or more after 60000 ms have passed since the engine started.

### 5. DIAGNOSTIC METHOD

#### • Abnormality Judgment

If the duration of time while the following conditions are met is longer than the time indicated, judge as NG.

#### Judgment Value

Malfunction Criteria	Threshold Value
$\lambda$ value	$< 0.85$

**Time Needed for Diagnosis:** 10000 ms

**Malfunction Indicator Light Illumination:** Illuminates when malfunction occurs in 2 continuous driving cycles.

#### • Normality Judgment

Judge as OK and clear the NG if the continuous time while the following conditions are established is more than the predetermined time.

#### Judgment Value

Malfunction Criteria	Threshold Value
$\lambda$ value	$\geq 0.85$

**Time Needed for Diagnosis:** Less than 1 second

# Diagnostic Trouble Code (DTC) Detecting Criteria

GENERAL DESCRIPTION

## CY:DTC P1153 O2 SENSOR CIRCUIT RANGE/PERFORMANCE (HIGH) (BANK1 SENSOR1)

### 1. OUTLINE OF DIAGNOSIS

Detect that  $\lambda$  value remains high.

Judge as NG when lambda value is abnormal in accordance with  $\lambda$  value of front oxygen (A/F) sensor and running conditions such as vehicle speed, amount of intake air, engine coolant temperature, sub feedback control, etc.

$\lambda$  value = Actual air fuel ratio/Theoretical air fuel ratio  
 $\lambda > 1$ : Lean  
 $\lambda < 1$ : Rich

### 2. COMPONENT DESCRIPTION

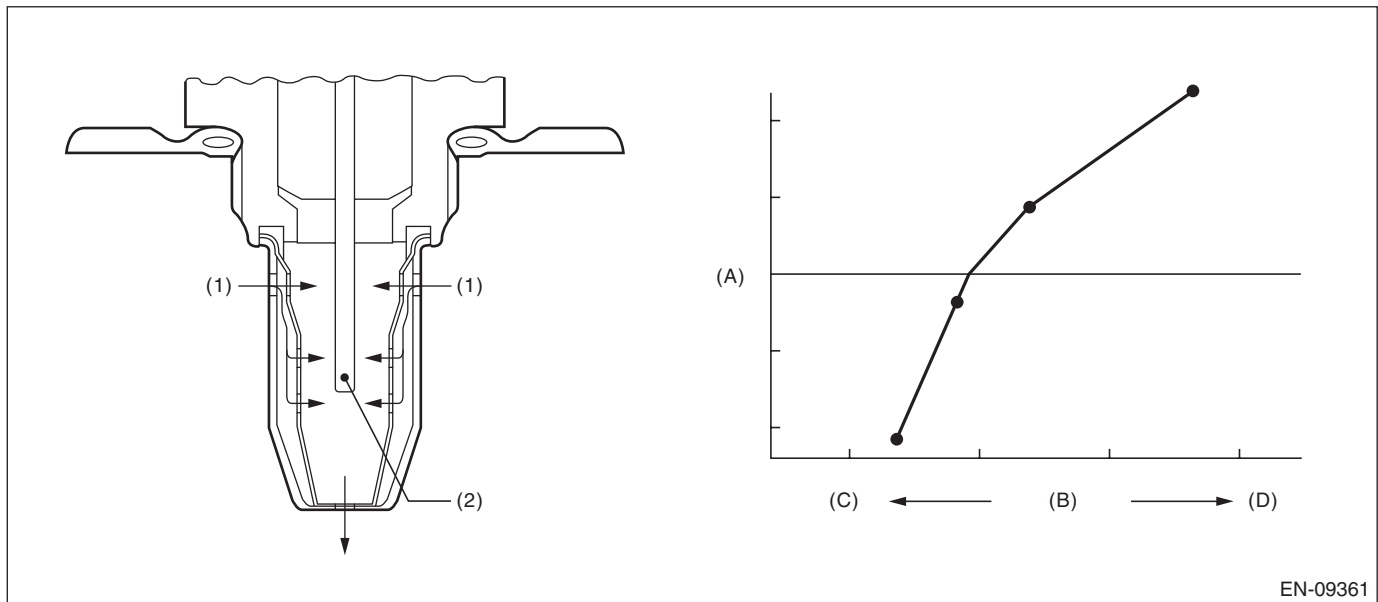

EN-09361

(A) Electromotive force

(B) Air fuel ratio

(C) Lean

(D) Rich

(1) Exhaust gas

(2) ZrO<sub>2</sub>

# Diagnostic Trouble Code (DTC) Detecting Criteria

## GENERAL DESCRIPTION

### 3. ENABLE CONDITIONS

Secondary Parameters	Enable Conditions
Time needed for all secondary parameters to be in enable conditions	$\geq 4096$ ms
Battery voltage	$\geq 10.9$ V
Atmospheric pressure	$\geq 75$ kPa (563 mmHg, 22.2 inHg)
Rear oxygen sensor sub feedback	Execution
Rear oxygen sensor output voltage – Feedback target voltage or	$-0.2$ V — $0.1$ V
Rear oxygen sensor sub feedback compensation coefficient or	On Min.
Rear oxygen sensor sub feedback compensation coefficient	On Max.
Elapsed time after starting the engine	$\geq 60000$ ms
Engine coolant temperature	$\geq 70$ °C (158 °F)
Vehicle speed	$\geq 20$ km/h (12.4 MPH)
Amount of intake air	$\geq 6$ g/s (0.21 oz/s)
Load change at 180°CA	$< 0.02$ g/rev (0 oz/rev)
Front oxygen (A/F) sensor impedance	$0 \Omega$ — $50 \Omega$
Learning value of evaporation gas density	$< 0.2$
Total time of operating canister purge	$\geq 19.9$ s
Targeted lambda value load compensation coefficient	$-1$ — $1$

### 4. GENERAL DRIVING CYCLE

Perform diagnosis continuously at a constant speed of 20 km/h (12.4 MPH) or more after 60000 ms have passed since the engine started.

### 5. DIAGNOSTIC METHOD

#### • Abnormality Judgment

If the duration of time while the following conditions are met is longer than the time indicated, judge as NG.

#### Judgment Value

Malfunction Criteria	Threshold Value
$\lambda$ value	$> 1.15$

**Time Needed for Diagnosis:** 10000 ms

**Malfunction Indicator Light Illumination:** Illuminates when malfunction occurs in 2 continuous driving cycles.

#### • Normality Judgment

Judge as OK and clear the NG if the continuous time while the following conditions are established is more than the predetermined time.

#### Judgment Value

Malfunction Criteria	Threshold Value
$\lambda$ value	$\leq 1.15$

**Time Needed for Diagnosis:** Less than 1 second

## CZ:DTC P1160 RETURN SPRING FAILURE

### 1. OUTLINE OF DIAGNOSIS

Judge as NG when the valve is opened more than the default opening angle, but does not move to the close direction with the motor power stopped.

### 2. COMPONENT DESCRIPTION

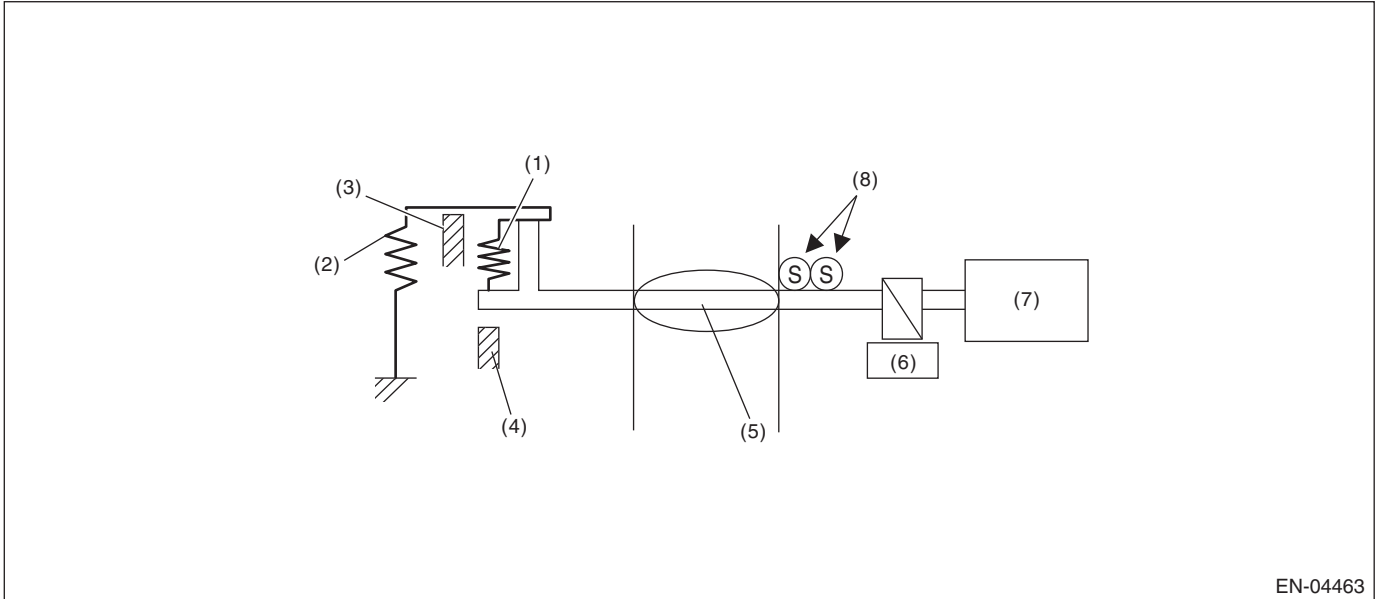

- |                          |                         |   |
|--------------------------|-------------------------|---|
| (1) Opener spring        | (4) Full closed stopper | (7) DC motor                              |
| (2) Return spring        | (5) Throttle valve      | (8) Main and sub throttle position sensor |
| (3) Intermediate stopper | (6) Gear                |   |

### 3. ENABLE CONDITIONS

Secondary Parameters	Enable Conditions
Battery voltage	≥ 6 V
Throttle position sensor	Normal

### 4. GENERAL DRIVING CYCLE

- Ignition switch ON → OFF
- Ignition switch OFF → ON (Only after clearing memory)



# Diagnostic Trouble Code (DTC) Detecting Criteria

## GENERAL DESCRIPTION

---

### 5. DIAGNOSTIC METHOD

#### • Abnormality Judgment

Judge as NG when the following conditions are established.

#### Judgment Value

Malfunction Criteria	Threshold Value
Opening variation after continuity is set to OFF	$< 2^\circ$

**Time Needed for Diagnosis:** 24 ms

**Malfunction Indicator Light Illumination:** Illuminates as soon as a malfunction occurs.

#### • Normality Judgment

Judge as OK and clear the NG if the following conditions are established.

#### Judgment Value

Malfunction Criteria	Threshold Value
Opening variation after continuity is set to OFF	$\geq 2^\circ$

**Time Needed for Diagnosis:** 3400 ms

# Diagnostic Trouble Code (DTC) Detecting Criteria

GENERAL DESCRIPTION

## DA:DTC P1400 FUEL TANK PRESSURE CONTROL SOLENOID VALVE CIRCUIT LOW

### 1. OUTLINE OF DIAGNOSIS

Detect the open/short circuit of pressure control solenoid valve.

Judge as NG when ECM output level is different from actual terminal level.

### 2. COMPONENT DESCRIPTION

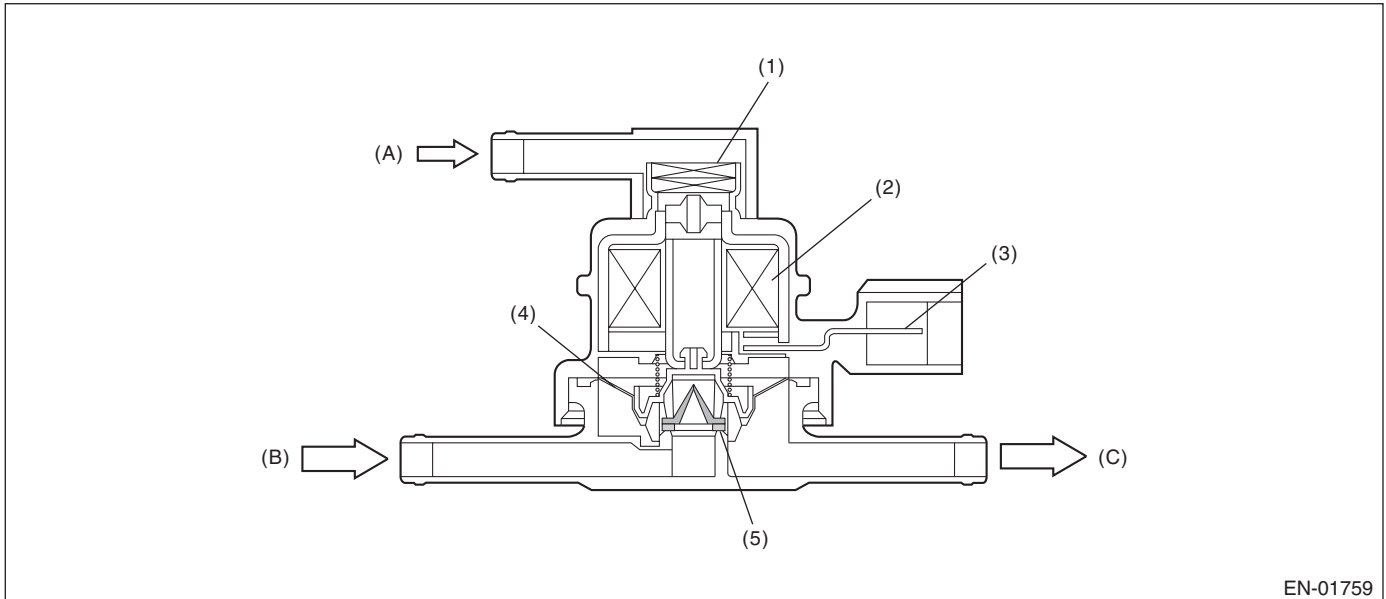

(A) Atmospheric pressure

(B) Shut-off valve

(C) To fuel tank

(1) Filter

(3) Connector terminal

(5) Valve

(2) Coil

(4) Diaphragm

### 3. ENABLE CONDITIONS

Secondary Parameters	Enable Conditions
None	

### 4. GENERAL DRIVING CYCLE

Always perform the diagnosis after starting the engine.

# Diagnostic Trouble Code (DTC) Detecting Criteria

## GENERAL DESCRIPTION

---

### 5. DIAGNOSTIC METHOD

#### • Abnormality Judgment

If the duration of time while the following conditions are met is longer than the time indicated, judge as NG.

#### Judgment Value

Malfunction Criteria	Threshold Value
Battery voltage	$\geq 10.9$ V
Elapsed time after starting the engine	$\geq 1$ s
Terminal output voltage when ECM outputs OFF signal	Low

**Time Needed for Diagnosis:** 2500 ms

**Malfunction Indicator Light Illumination:** Illuminates when malfunction occurs in 2 continuous driving cycles.

#### • Normality Judgment

Judge as OK and clear the NG if the continuous time while the following conditions are established is more than the predetermined time.

#### Judgment Value

Malfunction Criteria	Threshold Value
Battery voltage	$\geq 10.9$ V
Elapsed time after starting the engine	$\geq 1$ s
Terminal output voltage when ECM outputs OFF signal	High

**Time Needed for Diagnosis:** Less than 1 second

# Diagnostic Trouble Code (DTC) Detecting Criteria

GENERAL DESCRIPTION

## DB:DTC P1410 SECONDARY AIR INJECTION SYSTEM SWITCHING VALVE STUCK OPEN

### 1. OUTLINE OF DIAGNOSIS

Always detect abnormality that both combination valve electromagnetic valve and the reed valve are open failure.

Calculate the integrated value of Max./Min. value and output voltage deviation of the secondary air delivery pipe pressure sensor output voltage in a given time after engine start. Judge as NG if the integrated value and the difference between Max. and Min. values are large.

### 2. ENABLE CONDITIONS

Secondary Parameters	Enable Conditions
Engine speed	≥ 500 rpm and < 10000 rpm
Elapsed time after starting the engine	≥ 9000 ms
After secondary air system stops	≥ 9000 ms
Amount of intake air	≥ 2 g/s (0.07 oz/s) and < 400 g/s (14.11 oz/s)
Battery voltage	≥ 10.9 V
Engine load	> 0 g/rev
After fuel cut	≥ 1000 ms

### 3. GENERAL DRIVING CYCLE

Perform continuous diagnosis when air flow amount is large during the secondary air pump stop after engine start.

# Diagnostic Trouble Code (DTC) Detecting Criteria

## GENERAL DESCRIPTION

---

### 4. DIAGNOSTIC METHOD

When both combination valve electromagnetic valve and the reed valve are open failure, the failure appears as pulses in the secondary air delivery pipe pressure sensor output. Detect abnormality by capturing these pulses using the following method.

#### • Abnormality Judgment

Calculate Max./Min. value of the secondary air delivery pipe pressure sensor output voltage and the sum of the output voltage deviation for the given time. Compare the difference between Max. and Min. values with threshold value and also compare the sum value with the threshold value. If both values exceed the threshold value, count up NG counter and then judge as NG if the counter reaches the given times.

#### Judgment Value

Malfunction Criteria	Threshold Value
Pipe inner pressure difference between Max. and Min.	> 0.05 V
Sum of the pipe inner pressure variation value every 4 milliseconds	> 5 V
Barometric pressure variation value	< 26.7 kPa (200 mmHg, 7.9 inHg)

**Time Needed for Diagnosis:** 2000 ms × 20 time(s)

**Malfunction Indicator Light Illumination:** Illuminates as soon as a malfunction occurs.

#### • Normality Judgment

Judge as OK and clear NG if neither exceeds the threshold value, or if either of the two exceeds the threshold value.

#### Judgment Value

Malfunction Criteria	Threshold Value
Pipe inner pressure difference between Max. and Min.	≤ 0.05 V
Sum of the pipe inner pressure variation value every 4 milliseconds	≤ 5 V

**Time Needed for Diagnosis:** 2000 ms

# Diagnostic Trouble Code (DTC) Detecting Criteria

GENERAL DESCRIPTION

## DC:DTC P1418 SECONDARY AIR INJECTION SYSTEM CONTROL "A" CIRCUIT SHORTED

### 1. OUTLINE OF DIAGNOSIS

Judge as NG when the ECM output level differs from the actual terminal level.

### 2. ENABLE CONDITIONS

Secondary Parameters	Enable Conditions
None	

### 3. GENERAL DRIVING CYCLE

Always perform the diagnosis continuously.

### 4. DIAGNOSTIC METHOD

#### • Abnormality Judgment

If the duration of time while the following conditions are met is longer than the time indicated, judge as NG.

#### Judgment Value

Malfunction Criteria	Threshold Value
Battery voltage	$\geq 10.9$ V
Ignition	ON
Terminal output voltage when ECM outputs ON signal	HIGH

**Time Needed for Diagnosis:** 2500 ms

**Malfunction Indicator Light Illumination:** Illuminates as soon as a malfunction occurs.

#### • Normality Judgment

Judge as OK and clear the NG if the continuous time while the following conditions are established is more than the predetermined time.

#### Judgment Value

Malfunction Criteria	Threshold Value
Battery voltage	$\geq 10.9$ V
Ignition	ON
Terminal output voltage when ECM outputs ON signal	LOW

**Time Needed for Diagnosis:** Less than 1 second

# Diagnostic Trouble Code (DTC) Detecting Criteria

## GENERAL DESCRIPTION

### DD:DTC P1420 FUEL TANK PRESSURE CONTROL SOL. VALVE CIRCUIT HIGH

#### 1. OUTLINE OF DIAGNOSIS

Detect the open/short circuit of pressure control solenoid valve.

Judge as NG when ECM output level is different from actual terminal level.

#### 2. COMPONENT DESCRIPTION

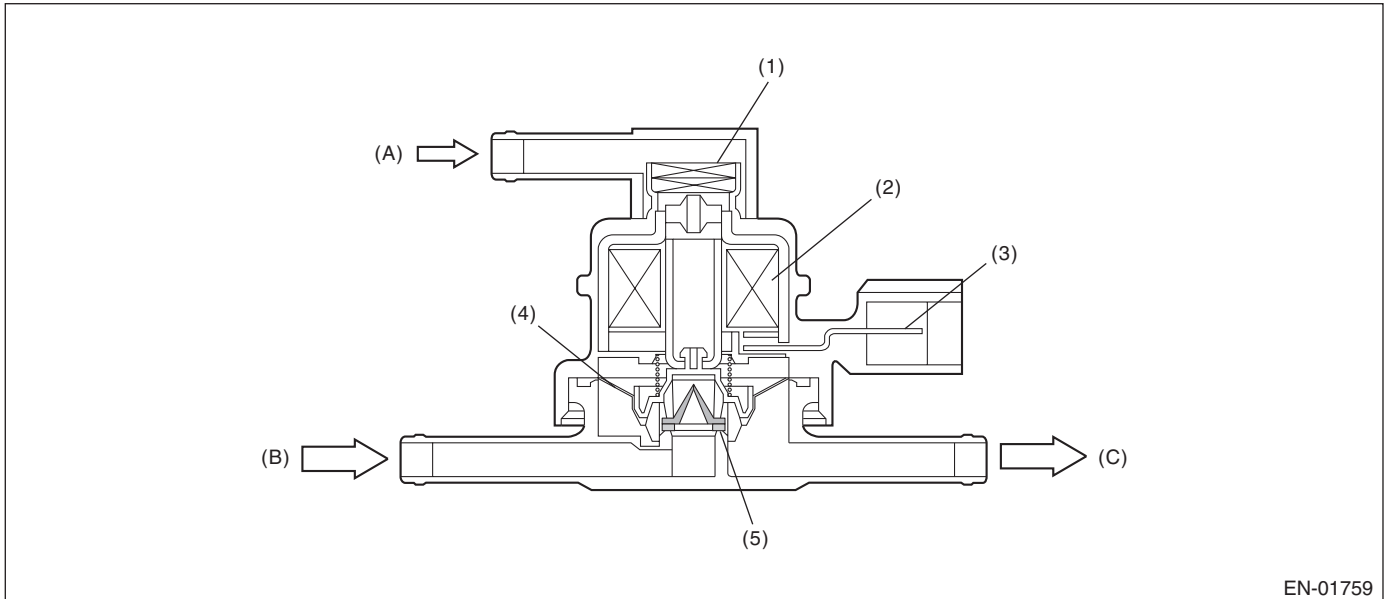

(A) Atmospheric pressure

(B) Shut-off valve

(C) To fuel tank

(1) Filter

(3) Connector terminal

(5) Valve

(2) Coil

(4) Diaphragm

#### 3. ENABLE CONDITIONS

Secondary Parameters	Enable Conditions
None	

#### 4. GENERAL DRIVING CYCLE

Always perform the diagnosis after starting the engine.

# Diagnostic Trouble Code (DTC) Detecting Criteria

GENERAL DESCRIPTION

## 5. DIAGNOSTIC METHOD

### • Abnormality Judgment

If the duration of time while the following conditions are met is longer than the time indicated, judge as NG.

#### Judgment Value

Malfunction Criteria	Threshold Value
Battery voltage	$\geq 10.9$ V
Elapsed time after starting the engine	$\geq 1$ s
Terminal output voltage when ECM outputs ON signal	High

**Time Needed for Diagnosis:** 2500 ms

**Malfunction Indicator Light Illumination:** Illuminates when malfunction occurs in 2 continuous driving cycles.

### • Normality Judgment

Judge as OK and clear the NG if the continuous time while the following conditions are established is more than the predetermined time.

#### Judgment Value

Malfunction Criteria	Threshold Value
Battery voltage	$\geq 10.9$ V
Elapsed time after starting the engine	$\geq 1$ s
Terminal output voltage when ECM outputs ON signal	Low

**Time Needed for Diagnosis:** Less than 1 second



# Diagnostic Trouble Code (DTC) Detecting Criteria

## GENERAL DESCRIPTION

### DE:DTC P1449 EVAPORATIVE EMISSION CONT. SYS. AIR FILTER CLOG

#### 1. OUTLINE OF DIAGNOSIS

Detect the drain filter clogging by the pressure change during purge introduction.

Judge as drain filter clogging malfunction if the pressure in the evaporative emission system piping suddenly decreases by the purging.

#### 2. COMPONENT DESCRIPTION

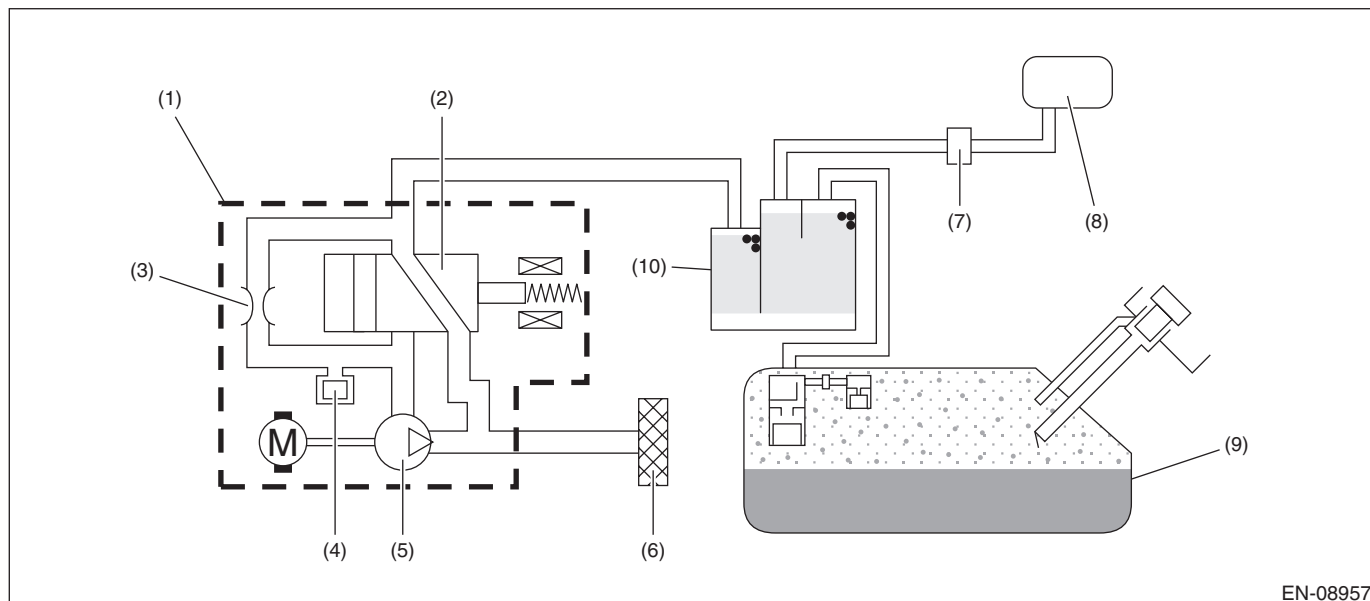

EN-08957

- |   |                                  |               |
|---|----------------------------------|---------------|
| (1) ELCM                                  | (5) Vacuum pump                  | (9) Fuel tank |
| (2) Switching valve                       | (6) Drain filter                 | (10) Canister |
| (3) Reference orifice (0.02 inch orifice) | (7) Purge control solenoid valve |               |
| (4) Pressure sensor                       | (8) Intake manifold              |               |

#### 3. ENABLE CONDITIONS

Secondary Parameters	Enable Conditions
Battery voltage	$\geq 10.9 \text{ V}$
Elapsed time after starting the engine	$\geq 20000 \text{ ms}$
Continuous time of $ \text{Pressure sensor output value} - \text{Pressure sensor output value 64 ms ago}  \leq 0.7 \text{ kPa}$ (5 mmHg, 0.2 inHg)	$\geq 5120 \text{ ms} + 13000 \text{ ms}$
Establishing time for following conditions	$\geq 10000 \text{ ms}$
• ELCM vacuum pump	Not in operation
• ELCM switching valve	Open

#### 4. GENERAL DRIVING CYCLE

Perform the diagnosis continuously when purging is performed after 20000 ms have passed since the engine started.

## 5. DIAGNOSTIC METHOD

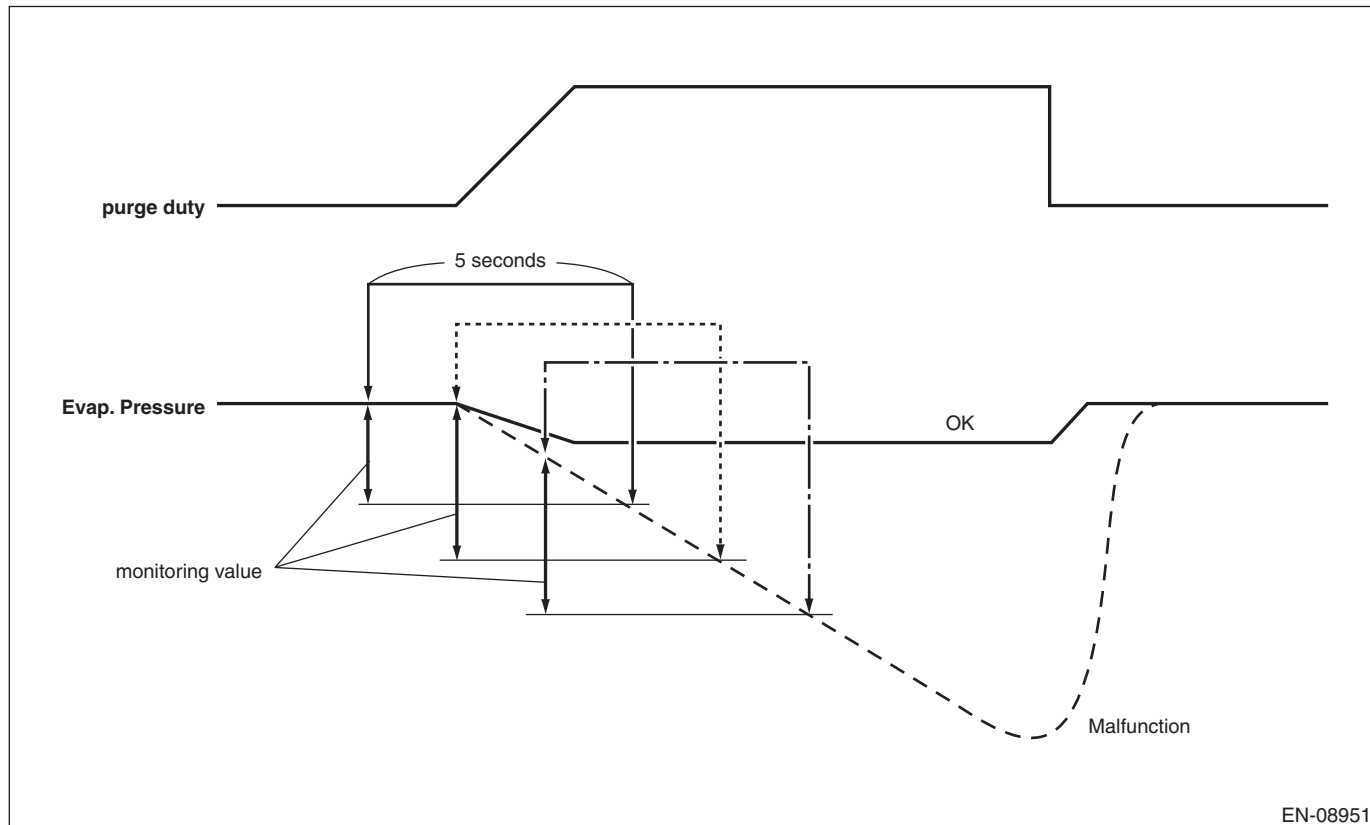

Calculate the difference between the ELCM pressure sensor output value as of 5 seconds ago and the current one, and if the value is greater than judgment value, detect and judge as filter clogging trouble.

### • Abnormality Judgment

Judge as NG when the following conditions are established.

#### Judgment Value

Malfunction Criteria	Threshold Value
Pressure sensor output value as of 5 seconds ago – Current pressure sensor output value	> Value from Map
Number of above conditions established	> 2 time(s)

#### Map

Vehicle speed km/h (MPH)	0 (0)	20 (12.4)	40 (24.9)	60 (37.3)	80 (49.7)	100 (62.1)	120 (74.6)	300 (186.4)
Pressure sensor output value as of 5 seconds ago – Current pressure sensor output value  kPa (mmHg, inHg)	0.8 (5.864, 0.2)	0.8 (5.864, 0.2)	0.9 (6.757, 0.3)	1 (7.649, 0.3)	1 (7.649, 0.3)	1 (7.649, 0.3)	1 (7.649, 0.3)	1.6 (11.647, 0.5)

**Time Needed for Diagnosis:** Approx. 5 seconds

**Malfunction Indicator Light Illumination:** Illuminates when malfunction occurs in 2 continuous driving cycles.

# Diagnostic Trouble Code (DTC) Detecting Criteria

## GENERAL DESCRIPTION

---

### • Normality Judgment

Judge as OK and clear the NG if the following conditions are established.

### Judgment Value

Malfunction Criteria	Threshold Value
Pressure sensor output value as of 5 seconds ago – Current pressure sensor output value	≤ Value from Map

## DF:DTC P1451 EVAPORATIVE EMISSION CONT. SYS.

### 1. OUTLINE OF DIAGNOSIS

#### NOTE:

For the detection standard, refer to DTC P0455. <Ref. to GD(H4DOTC)-154, DTC P0455 EVAPORATIVE EMISSION SYSTEM LEAK DETECTED (LARGE LEAK), Diagnostic Trouble Code (DTC) Detecting Criteria.>

# Diagnostic Trouble Code (DTC) Detecting Criteria

GENERAL DESCRIPTION

## DG:DTC P1458 CANISTER PURGE CONTROL SOLENOID VALVE 2

### 1. OUTLINE OF DIAGNOSIS

Detect open or short circuit of the purge control solenoid valve 2.

Judge as NG when the ECM output level differs from the actual terminal level.

### 2. ENABLE CONDITIONS

Secondary Parameters	Enable Conditions
None	

### 3. GENERAL DRIVING CYCLE

Always perform the diagnosis continuously.

### 4. DIAGNOSTIC METHOD

#### • Abnormality Judgment

If the duration of time while the following conditions are met is longer than the time indicated, judge as NG.

#### Judgment Value

Malfunction Criteria	Threshold Value
Battery voltage	$\geq 10.9$ V
Elapsed time after starting the engine	$\geq 1$ s
Terminal output voltage when ECM outputs OFF signal	Low

**Time Needed for Diagnosis:** 2500 ms

**Malfunction Indicator Light Illumination:** Illuminates when malfunction occurs in 2 continuous driving cycles.

#### • Normality Judgment

Judge as OK and clear the NG if the continuous time while the following conditions are established is more than the predetermined time.

#### Judgment Value

Malfunction Criteria	Threshold Value
Battery voltage	$\geq 10.9$ V
Elapsed time after starting the engine	$\geq 1$ s
Terminal output voltage when ECM outputs OFF signal	High

**Time Needed for Diagnosis:** Less than 1 second

# Diagnostic Trouble Code (DTC) Detecting Criteria

## GENERAL DESCRIPTION

---

### DH:DTC P1459 CANISTER PURGE CONTROL SOLENOID VALVE 2

#### 1. OUTLINE OF DIAGNOSIS

Detect open or short circuit of the purge control solenoid valve 2.

Judge as NG when the ECM output level differs from the actual terminal level.

#### 2. ENABLE CONDITIONS

Secondary Parameters	Enable Conditions
None	

#### 3. GENERAL DRIVING CYCLE

Always perform the diagnosis continuously.

#### 4. DIAGNOSTIC METHOD

##### • Abnormality Judgment

If the duration of time while the following conditions are met is longer than the time indicated, judge as NG.

##### Judgment Value

Malfunction Criteria	Threshold Value
Battery voltage	≥ 10.9 V
Elapsed time after starting the engine	≥ 1 s
Terminal output voltage when ECM outputs ON signal	High

**Time Needed for Diagnosis:** 2500 ms

**Malfunction Indicator Light Illumination:** Illuminates when malfunction occurs in 2 continuous driving cycles.

##### • Normality Judgment

Judge as OK and clear the NG if the continuous time while the following conditions are established is more than the predetermined time.

##### Judgment Value

Malfunction Criteria	Threshold Value
Battery voltage	≥ 10.9 V
Elapsed time after starting the engine	≥ 1 s
Terminal output voltage when ECM outputs ON signal	Low

**Time Needed for Diagnosis:** Less than 1 second

# Diagnostic Trouble Code (DTC) Detecting Criteria

GENERAL DESCRIPTION

## DI: DTC P1491 POSITIVE CRANKCASE VENTILATION (BLOW-BY) FUNCTION PROBLEM

### 1. OUTLINE OF DIAGNOSIS

Detect the blow-by hose disconnection abnormality.  
Judge as NG when the diagnosis terminal voltage is high.

### 2. COMPONENT DESCRIPTION

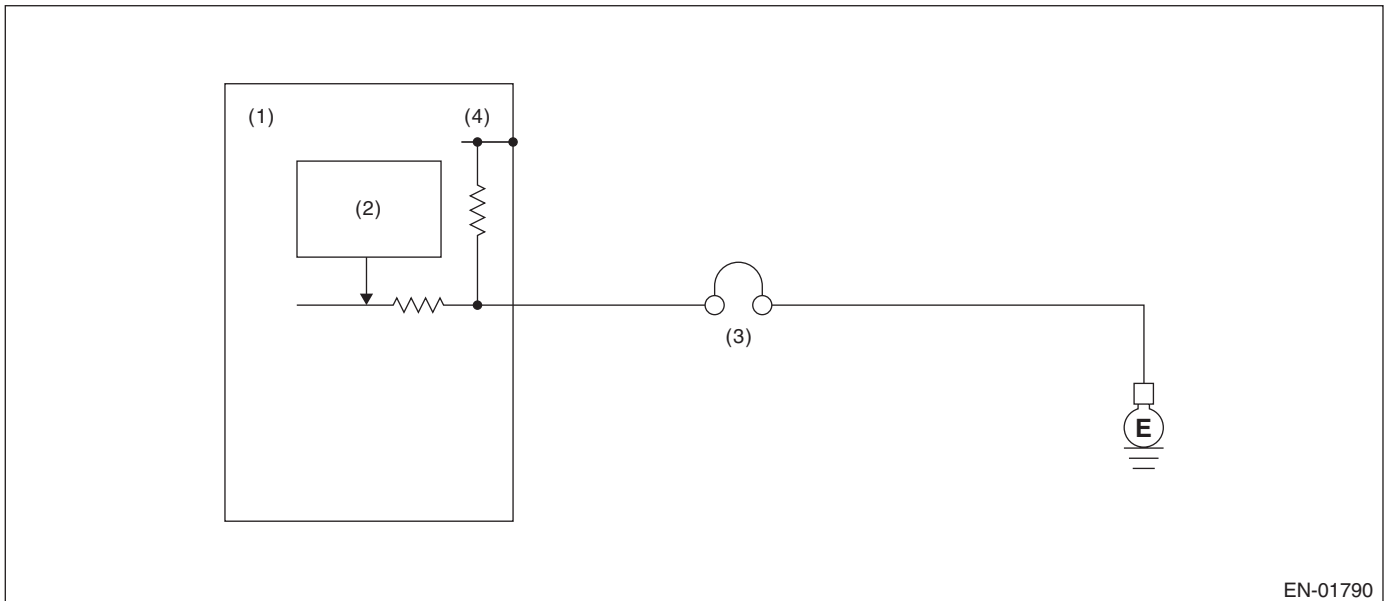

EN-01790

- (1) Engine control module (ECM)      (3) PCV diagnosis connector      (4) 5 V  
(2) Detecting circuit

### 3. ENABLE CONDITIONS

Secondary Parameters	Enable Conditions
None	

### 4. GENERAL DRIVING CYCLE

Always perform the diagnosis continuously.

# Diagnostic Trouble Code (DTC) Detecting Criteria

## GENERAL DESCRIPTION

---

### 5. DIAGNOSTIC METHOD

#### • Abnormality Judgment

If the duration of time while the following conditions are met is longer than the time indicated, judge as NG.

#### Judgment Value

Malfunction Criteria	Threshold Value
Battery voltage	$\geq 10.9$ V
Engine condition	After engine starting
Positive crankcase ventilation diagnosis voltage	High

**Time Needed for Diagnosis:** 2500 ms

**Malfunction Indicator Light Illumination:** Illuminates as soon as a malfunction occurs.

#### • Normality Judgment

Judge as OK and clear the NG if the continuous time while the following conditions are established is more than the predetermined time.

#### Judgment Value

Malfunction Criteria	Threshold Value
Battery voltage	$\geq 10.9$ V
Engine condition	After engine starting
Positive crankcase ventilation diagnosis voltage	Low

**Time Needed for Diagnosis:** Less than 1 second

# Diagnostic Trouble Code (DTC) Detecting Criteria

GENERAL DESCRIPTION

## DJ:DTC P1518 STARTER SWITCH CIRCUIT LOW INPUT

### 1. OUTLINE OF DIAGNOSIS

Detect the open or short circuit of starter SW.

If the status becomes post engine start although the starter has not been turned to ON, judge as OFF NG.

### 2. ENABLE CONDITIONS

Secondary Parameters	Enable Conditions
None	

### 3. GENERAL DRIVING CYCLE

Always perform the diagnosis continuously.

### 4. DIAGNOSTIC METHOD

#### • Abnormality Judgment

Judge as OFF NG when the following conditions are established.

#### Judgment Value

Malfunction Criteria	Threshold Value
Vehicle speed	< 1 km/h (0.6 MPH)
Starter ON signal	Not detected
Engine condition	Change from pre-start to post-start
Battery voltage	≥ 8 V

**Time Needed for Diagnosis:** Less than 1 second

**Malfunction Indicator Light Illumination:** Illuminates when malfunction occurs in 2 continuous driving cycles.

#### • Normality Judgment

Judge as OFF OK and clear the NG if the following conditions are established.

#### Judgment Value

Malfunction Criteria	Threshold Value
Starter ON	Experienced
Starter ON diagnosis	No diagnosis experience
Battery voltage	≥ 8 V

**Time Needed for Diagnosis:** Less than 1 second



# Diagnostic Trouble Code (DTC) Detecting Criteria

## GENERAL DESCRIPTION

---

### DK:DTC P1560 BACK-UP VOLTAGE CIRCUIT MALFUNCTION

#### 1. OUTLINE OF DIAGNOSIS

Detect the open/short circuit of back-up power supply circuit.  
Judge as NG when the backup power voltage is low.

#### 2. ENABLE CONDITIONS

Secondary Parameters	Enable Conditions
None	

#### 3. GENERAL DRIVING CYCLE

Always perform the diagnosis continuously.

#### 4. DIAGNOSTIC METHOD

##### • Abnormality Judgment

If the duration of time while the following conditions are met is longer than the time indicated, judge as NG.

##### Judgment Value

Malfunction Criteria	Threshold Value
Voltage of back-up power supply	Low
Battery voltage	$\geq 10.9$ V
Engine condition	After engine starting

**Time Needed for Diagnosis:** 2500 ms

**Malfunction Indicator Light Illumination:** Illuminates as soon as a malfunction occurs.

##### • Normality Judgment

Judge as OK and clear the NG if the continuous time while the following conditions are established is more than the predetermined time.

##### Judgment Value

Malfunction Criteria	Threshold Value
Voltage of back-up power supply	High
Battery voltage	$\geq 10.9$ V
Engine condition	After engine starting

**Time Needed for Diagnosis:** Less than 1 second

# Diagnostic Trouble Code (DTC) Detecting Criteria

GENERAL DESCRIPTION

---

## **DL:DTC P1570 ANTENNA**

### **1. OUTLINE OF DIAGNOSIS**

NOTE:

For the detection standard, refer to DTC P0513. <Ref. to GD(H4DOTC)-181, DTC P0513 INCORRECT IM-MOBILIZER KEY, Diagnostic Trouble Code (DTC) Detecting Criteria.>

## **DM:DTC P1571 REFERENCE CODE INCOMPATIBILITY**

### **1. OUTLINE OF DIAGNOSIS**

NOTE:

For the detection standard, refer to DTC P0513. <Ref. to GD(H4DOTC)-181, DTC P0513 INCORRECT IM-MOBILIZER KEY, Diagnostic Trouble Code (DTC) Detecting Criteria.>

## **DN:DTC P1572 IMM CIRCUIT FAILURE (EXCEPT ANTENNA CIRCUIT)**

### **1. OUTLINE OF DIAGNOSIS**

NOTE:

For the detection standard, refer to DTC P0513. <Ref. to GD(H4DOTC)-181, DTC P0513 INCORRECT IM-MOBILIZER KEY, Diagnostic Trouble Code (DTC) Detecting Criteria.>

## **DO:DTC P1574 KEY COMMUNICATION FAILURE**

### **1. OUTLINE OF DIAGNOSIS**

NOTE:

For the detection standard, refer to DTC P0513. <Ref. to GD(H4DOTC)-181, DTC P0513 INCORRECT IM-MOBILIZER KEY, Diagnostic Trouble Code (DTC) Detecting Criteria.>

## **DP:DTC P1576 EGI CONTROL MODULE EEPROM**

### **1. OUTLINE OF DIAGNOSIS**

NOTE:

For the detection standard, refer to DTC P0513. <Ref. to GD(H4DOTC)-181, DTC P0513 INCORRECT IM-MOBILIZER KEY, Diagnostic Trouble Code (DTC) Detecting Criteria.>

## **DQ:DTC P1577 IMM CONTROL MODULE EEPROM**

### **1. OUTLINE OF DIAGNOSIS**

NOTE:

For the detection standard, refer to DTC P0513. <Ref. to GD(H4DOTC)-181, DTC P0513 INCORRECT IM-MOBILIZER KEY, Diagnostic Trouble Code (DTC) Detecting Criteria.>

## **DR:DTC P1578 METER FAILURE**

### **1. OUTLINE OF DIAGNOSIS**

NOTE:

For the detection standard, refer to DTC P0513. <Ref. to GD(H4DOTC)-181, DTC P0513 INCORRECT IM-MOBILIZER KEY, Diagnostic Trouble Code (DTC) Detecting Criteria.>

# Diagnostic Trouble Code (DTC) Detecting Criteria

## GENERAL DESCRIPTION

---

### DS:DTC P2004 INTAKE MANIFOLD RUNNER CONTROL STUCK OPEN (BANK 1)

#### 1. OUTLINE OF DIAGNOSIS

Detect the malfunction of tumble generator valve motor function.

Judge open fixing malfunction when the opening degree is large even after finishing the tumble generator valve closing driving.

#### 2. ENABLE CONDITIONS

Secondary Parameters	Enable Conditions
Battery voltage	$\geq 10.9 \text{ V}$
Engine coolant temperature	$\geq -30 \text{ }^\circ\text{C}$ ( $-22 \text{ }^\circ\text{F}$ )
Ambient air temperature	$\geq -30 \text{ }^\circ\text{C}$ ( $-22 \text{ }^\circ\text{F}$ )

#### 3. GENERAL DRIVING CYCLE

Always perform the diagnosis continuously.

#### 4. DIAGNOSTIC METHOD

##### • Abnormality Judgment

If the duration of time while the following conditions are met is longer than the time indicated, judge as NG.

##### Judgment Value

Malfunction Criteria	Threshold Value
Tumble generator valve opening	$\geq 64.3 \text{ }^\circ$
Tumble generator valve "close" signal output	$\geq 3200 \text{ ms}$

**Time Needed for Diagnosis:** 3000 ms

**Malfunction Indicator Light Illumination:** Illuminates as soon as a malfunction occurs.

##### • Normality Judgment

Judge as OK and clear the NG if the continuous time while the following conditions are established is more than the predetermined time.

##### Judgment Value

Malfunction Criteria	Threshold Value
Tumble generator valve opening	$< 64.3 \text{ }^\circ$
Tumble generator valve "close" signal output	$\geq 3200 \text{ ms}$

**Time Needed for Diagnosis:** Less than 1 second

# Diagnostic Trouble Code (DTC) Detecting Criteria

GENERAL DESCRIPTION

## DT:DTC P2005 INTAKE MANIFOLD RUNNER CONTROL STUCK OPEN (BANK 2)

### 1. OUTLINE OF DIAGNOSIS

Detect the malfunction of tumble generator valve motor function.

Judge open fixing malfunction when the opening degree is large even after finishing the tumble generator valve closing driving.

### 2. ENABLE CONDITIONS

Secondary Parameters	Enable Conditions
Battery voltage	$\geq 10.9 \text{ V}$
Engine coolant temperature	$\geq -30 \text{ }^{\circ}\text{C}$ ( $-22 \text{ }^{\circ}\text{F}$ )
Ambient air temperature	$\geq -30 \text{ }^{\circ}\text{C}$ ( $-22 \text{ }^{\circ}\text{F}$ )

### 3. GENERAL DRIVING CYCLE

Always perform the diagnosis continuously.

### 4. DIAGNOSTIC METHOD

#### • Abnormality Judgment

If the duration of time while the following conditions are met is longer than the time indicated, judge as NG.

#### Judgment Value

Malfunction Criteria	Threshold Value
Tumble generator valve opening	$\geq 64.3 \text{ }^{\circ}$
Tumble generator valve "close" signal output	$\geq 3200 \text{ ms}$

**Time Needed for Diagnosis:** 3000 ms

**Malfunction Indicator Light Illumination:** Illuminates as soon as a malfunction occurs.

#### • Normality Judgment

Judge as OK and clear the NG if the continuous time while the following conditions are established is more than the predetermined time.

#### Judgment Value

Malfunction Criteria	Threshold Value
Tumble generator valve opening	$< 64.3 \text{ }^{\circ}$
Tumble generator valve "close" signal output	$\geq 3200 \text{ ms}$

**Time Needed for Diagnosis:** Less than 1 second

# Diagnostic Trouble Code (DTC) Detecting Criteria

## GENERAL DESCRIPTION

---

### DU:DTC P2006 INTAKE MANIFOLD RUNNER CONTROL STUCK CLOSED (BANK 1)

#### 1. OUTLINE OF DIAGNOSIS

Detect the malfunction of tumble generator valve motor function.

Judge close fixing malfunction when the opening degree is small even after finishing the tumble generator valve open driving.

#### 2. ENABLE CONDITIONS

Secondary Parameters	Enable Conditions
Battery voltage	$\geq 10.9$ V
Engine coolant temperature	$\geq -30$ °C ( $-22$ °F)
Ambient air temperature	$\geq -30$ °C ( $-22$ °F)

#### 3. GENERAL DRIVING CYCLE

Always perform the diagnosis continuously.

#### 4. DIAGNOSTIC METHOD

##### • Abnormality Judgment

If the duration of time while the following conditions are met is longer than the time indicated, judge as NG.

##### Judgment Value

Malfunction Criteria	Threshold Value
Tumble generator valve opening	$< 64.3$ °
Tumble generator valve "open" signal output	$\geq 4600$ ms

**Time Needed for Diagnosis:** 3000 ms

**Malfunction Indicator Light Illumination:** Illuminates as soon as a malfunction occurs.

##### • Normality Judgment

Judge as OK and clear the NG if the continuous time while the following conditions are established is more than the predetermined time.

##### Judgment Value

Malfunction Criteria	Threshold Value
Tumble generator valve opening	$\geq 64.3$ °
Tumble generator valve "open" signal output	$\geq 4600$ ms

**Time Needed for Diagnosis:** Less than 1 second

# Diagnostic Trouble Code (DTC) Detecting Criteria

GENERAL DESCRIPTION

## DV:DTC P2007 INTAKE MANIFOLD RUNNER CONTROL STUCK CLOSED (BANK 2)

### 1. OUTLINE OF DIAGNOSIS

Detect the malfunction of tumble generator valve motor function.

Judge close fixing malfunction when the opening degree is small even after finishing the tumble generator valve open driving.

### 2. ENABLE CONDITIONS

Secondary Parameters	Enable Conditions
Battery voltage	$\geq 10.9$ V
Engine coolant temperature	$\geq -30$ °C ( $-22$ °F)
Ambient air temperature	$\geq -30$ °C ( $-22$ °F)

### 3. GENERAL DRIVING CYCLE

Always perform the diagnosis continuously.

### 4. DIAGNOSTIC METHOD

#### • Abnormality Judgment

If the duration of time while the following conditions are met is longer than the time indicated, judge as NG.

#### Judgment Value

Malfunction Criteria	Threshold Value
Tumble generator valve opening	$< 64.3$ °
Tumble generator valve "open" signal output	$\geq 4600$ ms

**Time Needed for Diagnosis:** 3000 ms

**Malfunction Indicator Light Illumination:** Illuminates as soon as a malfunction occurs.

#### • Normality Judgment

Judge as OK and clear the NG if the continuous time while the following conditions are established is more than the predetermined time.

#### Judgment Value

Malfunction Criteria	Threshold Value
Tumble generator valve opening	$\geq 64.3$ °
Tumble generator valve "open" signal output	$\geq 4600$ ms

**Time Needed for Diagnosis:** Less than 1 second

# Diagnostic Trouble Code (DTC) Detecting Criteria

## GENERAL DESCRIPTION

### DW:DTC P2008 INTAKE MANIFOLD RUNNER CONTROL CIRCUIT / OPEN (BANK 1)

#### 1. OUTLINE OF DIAGNOSIS

Detect the open or short circuit of tumble generator valve motor.

Judge as NG when the open signal is sent from IC after tumble generator valve driving IC diagnosis.

#### 2. COMPONENT DESCRIPTION

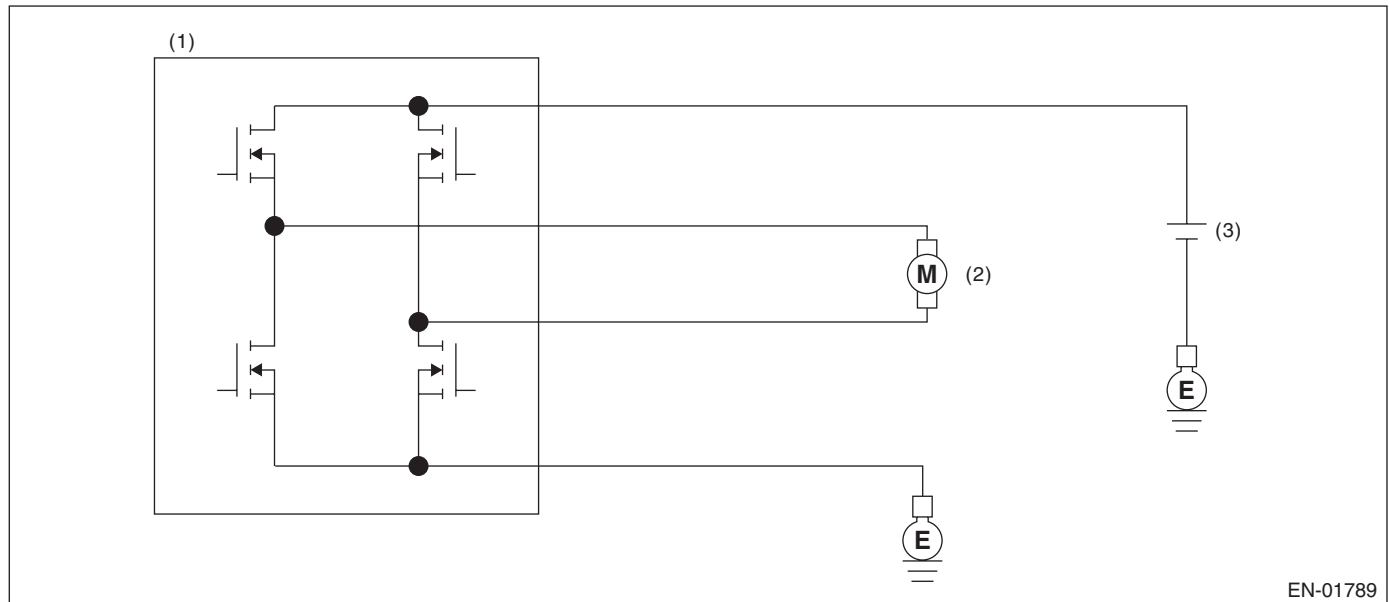

EN-01789

(1) Engine control module (ECM)

(2) Tumble generator valve

(3) Battery

#### 3. ENABLE CONDITIONS

Secondary Parameters	Enable Conditions
Battery voltage	$\geq 10.9 \text{ V}$

#### 4. GENERAL DRIVING CYCLE

Always perform the diagnosis continuously.

# Diagnostic Trouble Code (DTC) Detecting Criteria

GENERAL DESCRIPTION

## 5. DIAGNOSTIC METHOD

### • Abnormality Judgment

At the main IC, check the sent signal at each timing which occurs immediately after the tumble generator valve output is set to ON → OFF, and judge open NG when the open NG signal is sent  $96 \text{ ms} \times 20 \text{ time(s)}$  in a row.

### Judgment Value

Malfunction Criteria	Threshold Value
Open NG signal input	Low

**Time Needed for Diagnosis:**  $96 \text{ ms} \times 20 \text{ time(s)}$

**Malfunction Indicator Light Illumination:** Illuminates as soon as a malfunction occurs.

### • Normality Judgment

Judge as OK and clear the NG when the OK signal is sent.

### Judgment Value

Malfunction Criteria	Threshold Value
Open NG signal input	High

**Time Needed for Diagnosis:** Less than 1 second



# Diagnostic Trouble Code (DTC) Detecting Criteria

## GENERAL DESCRIPTION

### DX:DTC P2009 INTAKE MANIFOLD RUNNER CONTROL CIRCUIT LOW (BANK 1)

#### 1. OUTLINE OF DIAGNOSIS

Detect the open or short circuit of tumble generator valve motor.

Judge as NG when the overcurrent signal is sent from IC after tumble generator valve driving IC diagnosis.

#### 2. COMPONENT DESCRIPTION

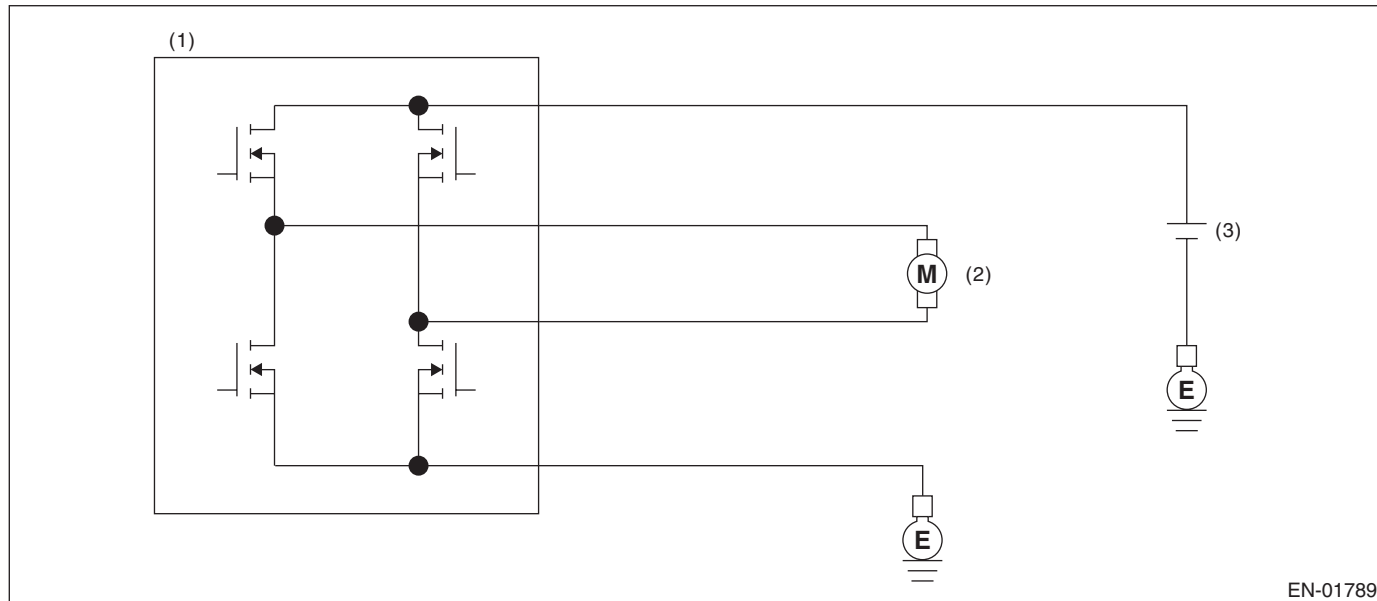

(1) Engine control module (ECM)

(2) Tumble generator valve

(3) Battery

EN-01789

#### 3. ENABLE CONDITIONS

Secondary Parameters	Enable Conditions
Battery voltage	$\geq 10.9$ V

#### 4. GENERAL DRIVING CYCLE

Always perform the diagnosis continuously.

#### 5. DIAGNOSTIC METHOD

##### • Abnormality Judgment

At the main IC, check the sent signal at each timing which occurs just before the tumble generator valve output is set to ON → OFF, and judge open NG when the open NG signal is sent 96 ms × 10 time(s) in a row.

##### Judgment Value

Malfunction Criteria	Threshold Value
Overcurrent NG signal input	Low

**Time Needed for Diagnosis:** 96 ms × 10 time(s)

**Malfunction Indicator Light Illumination:** Illuminates as soon as a malfunction occurs.

##### • Normality Judgment

Judge as OK and clear the NG when the OK signal is sent.

##### Judgment Value

Malfunction Criteria	Threshold Value
Overcurrent NG signal input	High

**Time Needed for Diagnosis:** Less than 1 second

# Diagnostic Trouble Code (DTC) Detecting Criteria

GENERAL DESCRIPTION

## DY:DTC P2011 INTAKE MANIFOLD RUNNER CONTROL CIRCUIT / OPEN (BANK 2)

### 1. OUTLINE OF DIAGNOSIS

Detect the open or short circuit of tumble generator valve motor.

Judge as NG when the open signal is sent from IC after tumble generator valve driving IC diagnosis.

### 2. COMPONENT DESCRIPTION

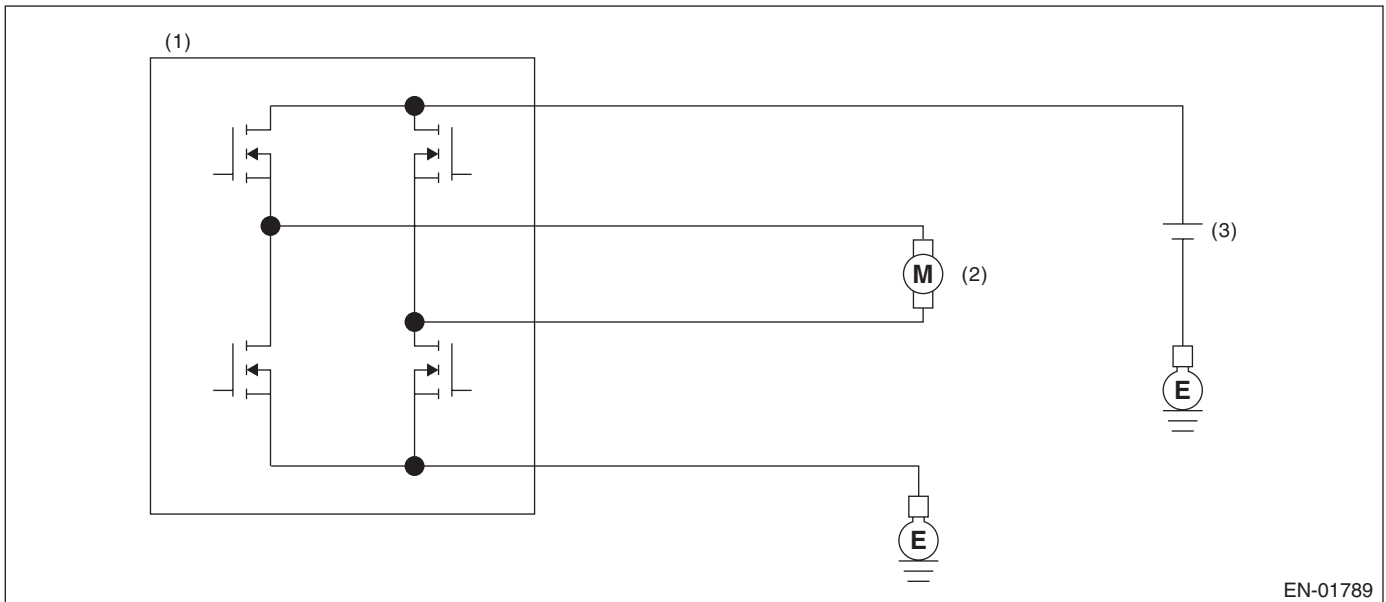

EN-01789

(1) Engine control module (ECM)

(2) Tumble generator valve

(3) Battery

### 3. ENABLE CONDITIONS

Secondary Parameters	Enable Conditions
Battery voltage	$\geq 10.9$ V

### 4. GENERAL DRIVING CYCLE

Always perform the diagnosis continuously.

# Diagnostic Trouble Code (DTC) Detecting Criteria

## GENERAL DESCRIPTION

---

### 5. DIAGNOSTIC METHOD

#### • Abnormality Judgment

At the main IC, check the sent signal at each timing which occurs immediately after the tumble generator valve output is set to ON → OFF, and judge open NG when the open NG signal is sent  $96 \text{ ms} \times 20 \text{ time(s)}$  in a row.

#### Judgment Value

Malfunction Criteria	Threshold Value
Open NG signal input	Low

**Time Needed for Diagnosis:**  $96 \text{ ms} \times 20 \text{ time(s)}$

**Malfunction Indicator Light Illumination:** Illuminates as soon as a malfunction occurs.

#### • Normality Judgment

Judge as OK and clear the NG when the OK signal is sent.

#### Judgment Value

Malfunction Criteria	Threshold Value
Open NG signal input	High

**Time Needed for Diagnosis:** Less than 1 second

# Diagnostic Trouble Code (DTC) Detecting Criteria

GENERAL DESCRIPTION

## DZ:DTC P2012 INTAKE MANIFOLD RUNNER CONTROL CIRCUIT LOW (BANK 2)

### 1. OUTLINE OF DIAGNOSIS

Detect the open or short circuit of tumble generator valve motor.

Judge as NG when the overcurrent signal is sent from IC after tumble generator valve driving IC diagnosis.

### 2. COMPONENT DESCRIPTION

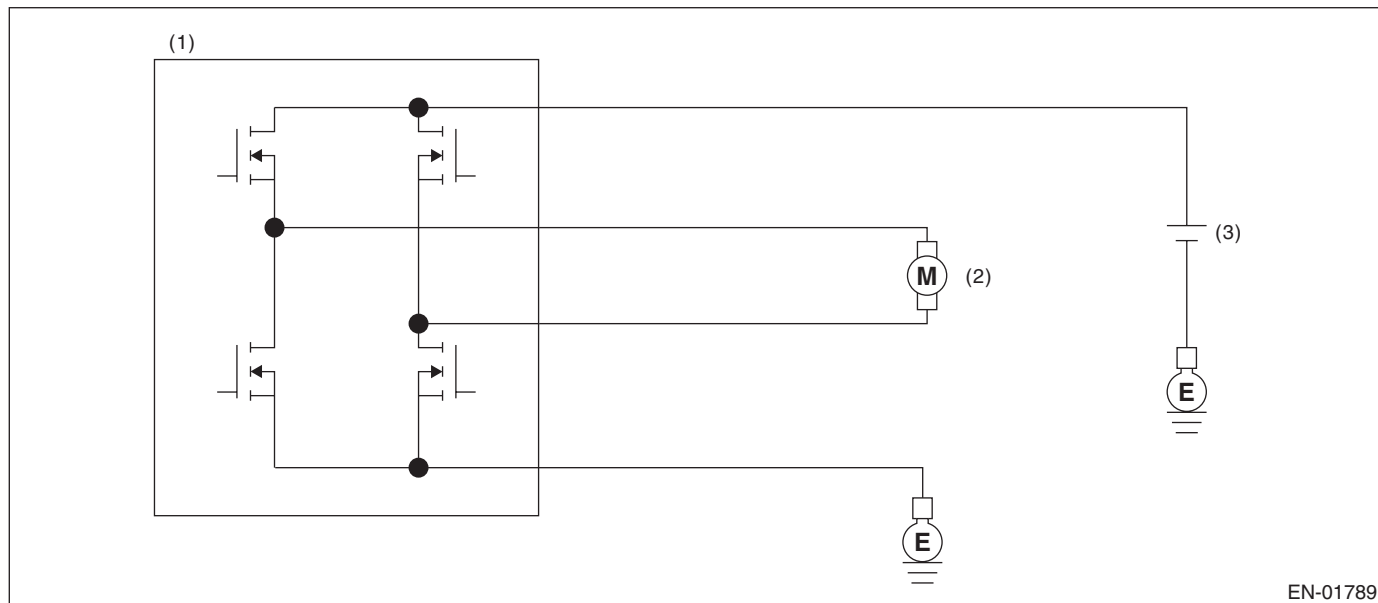

(1) Engine control module (ECM)

(2) Tumble generator valve

(3) Battery

EN-01789

### 3. ENABLE CONDITIONS

Secondary Parameters	Enable Conditions
Battery voltage	$\geq 10.9$ V

### 4. GENERAL DRIVING CYCLE

Always perform the diagnosis continuously.

### 5. DIAGNOSTIC METHOD

#### • Abnormality Judgment

At the main IC, check the sent signal at each timing which occurs just before the tumble generator valve output is set to ON → OFF, and judge open NG when the open NG signal is sent 96 ms × 10 time(s) in a row.

#### Judgment Value

Malfunction Criteria	Threshold Value
Overcurrent NG signal input	Low

**Time Needed for Diagnosis:** 96 ms × 10 time(s)

**Malfunction Indicator Light Illumination:** Illuminates as soon as a malfunction occurs.

#### • Normality Judgment

Judge as OK and clear the NG when the OK signal is sent.

#### Judgment Value

Malfunction Criteria	Threshold Value
Overcurrent NG signal input	High

**Time Needed for Diagnosis:** Less than 1 second

# Diagnostic Trouble Code (DTC) Detecting Criteria

## GENERAL DESCRIPTION

### EA:DTC P2016 INTAKE MANIFOLD RUNNER POSITION SENSOR / SWITCH CIRCUIT LOW (BANK 1)

#### 1. OUTLINE OF DIAGNOSIS

Detect open or short circuit of tumble generator valve position sensor.  
Judge as NG if out of specification.

#### 2. COMPONENT DESCRIPTION

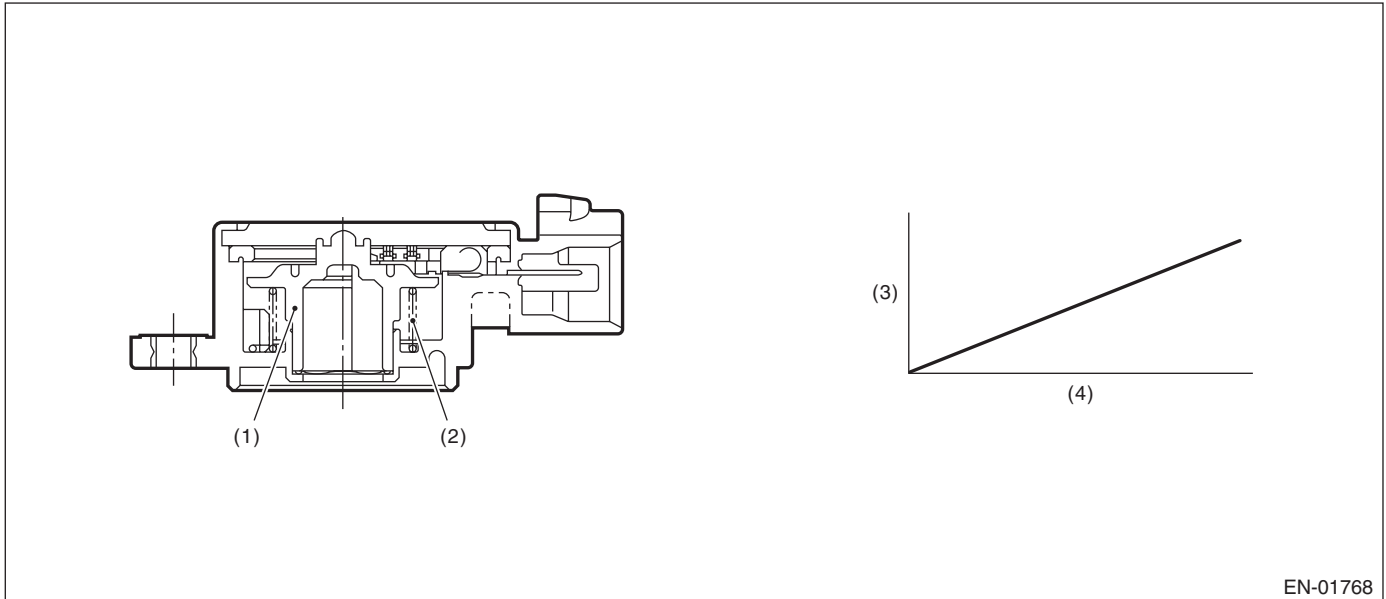

EN-01768

(1) Rotor

(3) Voltage (V)

(4) Tumble generator valve opening  
(°)

(2) Return spring

#### 3. ENABLE CONDITIONS

Secondary Parameters	Enable Conditions
None	

#### 4. GENERAL DRIVING CYCLE

Always perform the diagnosis continuously.

# Diagnostic Trouble Code (DTC) Detecting Criteria

GENERAL DESCRIPTION

## 5. DIAGNOSTIC METHOD

### • Abnormality Judgment

If the duration of time while the following conditions are met is longer than the time indicated, judge as NG.

#### Judgment Value

Malfunction Criteria	Threshold Value
Output voltage	< 0.264 V

**Time Needed for Diagnosis:** 500 ms

**Malfunction Indicator Light Illumination:** Illuminates as soon as a malfunction occurs.

### • Normality Judgment

Judge as OK and clear the NG if the continuous time while the following conditions are established is more than the predetermined time.

#### Judgment Value

Malfunction Criteria	Threshold Value
Output voltage	$\geq 0.264$ V

**Time Needed for Diagnosis:** Less than 1 second

# Diagnostic Trouble Code (DTC) Detecting Criteria

## GENERAL DESCRIPTION

### EB:DTC P2017 INTAKE MANIFOLD RUNNER POSITION SENSOR / SWITCH CIRCUIT HIGH (BANK 1)

#### 1. OUTLINE OF DIAGNOSIS

Detect open or short circuit of tumble generator valve position sensor.  
Judge as NG if out of specification.

#### 2. COMPONENT DESCRIPTION

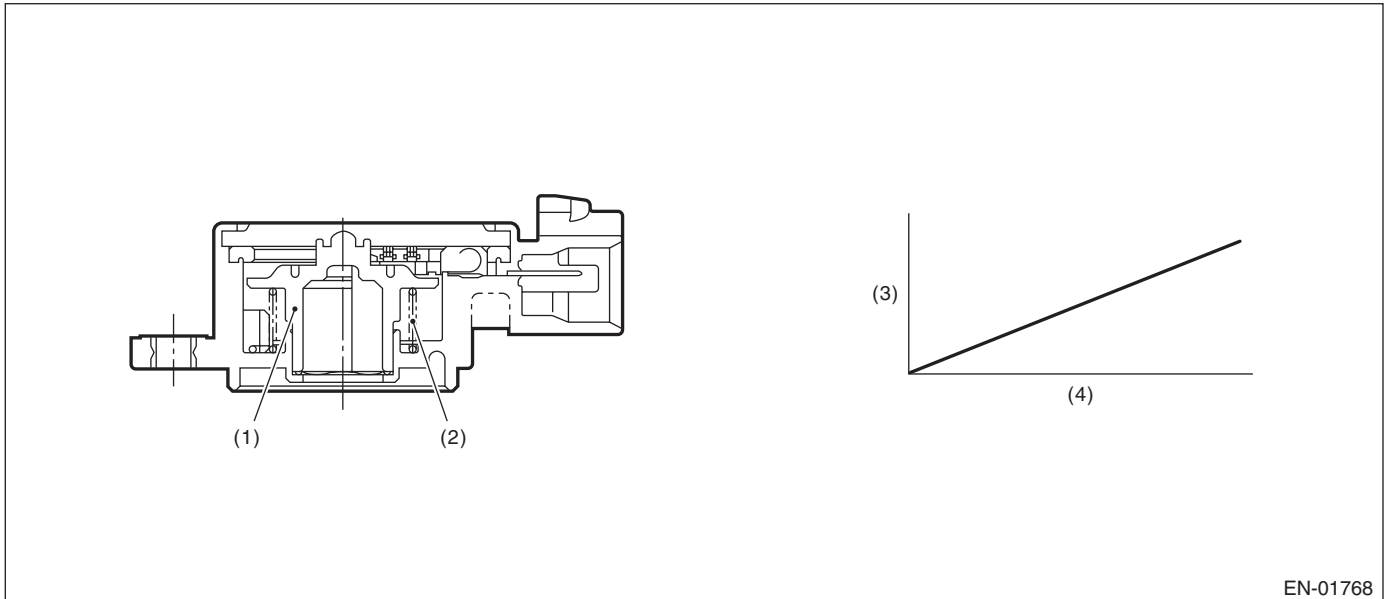

EN-01768

(1) Rotor

(3) Voltage (V)

(4) Tumble generator valve opening  
(°)

(2) Return spring

#### 3. ENABLE CONDITIONS

Secondary Parameters	Enable Conditions
None	

#### 4. GENERAL DRIVING CYCLE

Always perform the diagnosis continuously.

# Diagnostic Trouble Code (DTC) Detecting Criteria

GENERAL DESCRIPTION

## 5. DIAGNOSTIC METHOD

### • Abnormality Judgment

If the duration of time while the following conditions are met is longer than the time indicated, judge as NG.

#### Judgment Value

Malfunction Criteria	Threshold Value
Output voltage	$\geq 4.783$ V

**Time Needed for Diagnosis:** 500 ms

**Malfunction Indicator Light Illumination:** Illuminates as soon as a malfunction occurs.

### • Normality Judgment

Judge as OK and clear the NG if the continuous time while the following conditions are established is more than the predetermined time.

#### Judgment Value

Malfunction Criteria	Threshold Value
Output voltage	$< 4.783$ V

**Time Needed for Diagnosis:** Less than 1 second



# Diagnostic Trouble Code (DTC) Detecting Criteria

## GENERAL DESCRIPTION

### EC:DTC P2021 INTAKE MANIFOLD RUNNER POSITION SENSOR / SWITCH CIRCUIT LOW (BANK 2)

#### 1. OUTLINE OF DIAGNOSIS

Detect open or short circuit of tumble generator valve position sensor.

Judge as NG if out of specification.

#### 2. COMPONENT DESCRIPTION

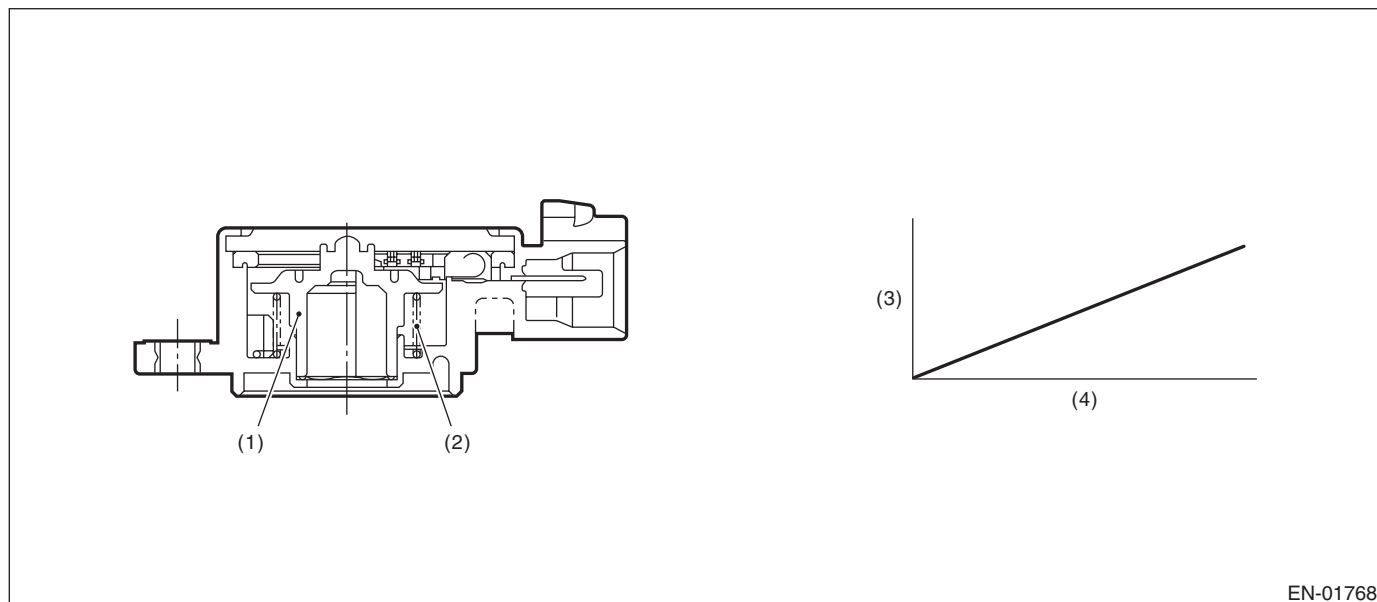

(1) Rotor

(3) Voltage (V)

(4) Tumble generator valve opening  
(°)

(2) Return spring

#### 3. ENABLE CONDITIONS

Secondary Parameters	Enable Conditions
None	

#### 4. GENERAL DRIVING CYCLE

Always perform the diagnosis continuously.

# Diagnostic Trouble Code (DTC) Detecting Criteria

GENERAL DESCRIPTION

## 5. DIAGNOSTIC METHOD

### • Abnormality Judgment

If the duration of time while the following conditions are met is longer than the time indicated, judge as NG.

#### Judgment Value

Malfunction Criteria	Threshold Value
Output voltage	< 0.264 V

**Time Needed for Diagnosis:** 500 ms

**Malfunction Indicator Light Illumination:** Illuminates as soon as a malfunction occurs.

### • Normality Judgment

Judge as OK and clear the NG if the continuous time while the following conditions are established is more than the predetermined time.

#### Judgment Value

Malfunction Criteria	Threshold Value
Output voltage	$\geq 0.264$ V

**Time Needed for Diagnosis:** Less than 1 second

# Diagnostic Trouble Code (DTC) Detecting Criteria

## GENERAL DESCRIPTION

### ED:DTC P2022 INTAKE MANIFOLD RUNNER POSITION SENSOR / SWITCH CIRCUIT HIGH (BANK 2)

#### 1. OUTLINE OF DIAGNOSIS

Detect open or short circuit of tumble generator valve position sensor.  
Judge as NG if out of specification.

#### 2. COMPONENT DESCRIPTION

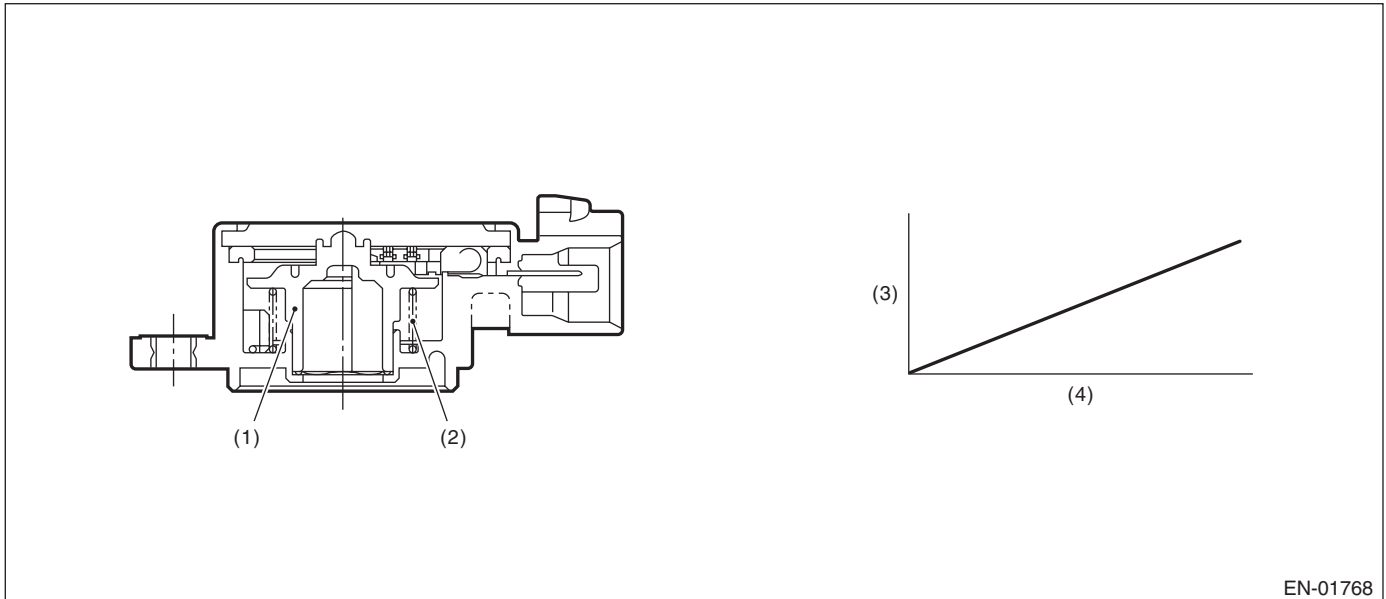

EN-01768

(1) Rotor

(3) Voltage (V)

(4) Tumble generator valve opening  
(°)

(2) Return spring

#### 3. ENABLE CONDITIONS

Secondary Parameters	Enable Conditions
None	

#### 4. GENERAL DRIVING CYCLE

Always perform the diagnosis continuously.

# Diagnostic Trouble Code (DTC) Detecting Criteria

GENERAL DESCRIPTION

## 5. DIAGNOSTIC METHOD

### • Abnormality Judgment

If the duration of time while the following conditions are met is longer than the time indicated, judge as NG.

#### Judgment Value

Malfunction Criteria	Threshold Value
Output voltage	$\geq 4.783$ V

**Time Needed for Diagnosis:** 500 ms

**Malfunction Indicator Light Illumination:** Illuminates as soon as a malfunction occurs.

### • Normality Judgment

Judge as OK and clear the NG if the continuous time while the following conditions are established is more than the predetermined time.

#### Judgment Value

Malfunction Criteria	Threshold Value
Output voltage	$< 4.783$ V

**Time Needed for Diagnosis:** Less than 1 second

# Diagnostic Trouble Code (DTC) Detecting Criteria

## GENERAL DESCRIPTION

### EE:DTC P2088 INTAKE CAMSHAFT POSITION ACTUATOR CONTROL CIRCUIT LOW (BANK 1)

#### 1. OUTLINE OF DIAGNOSIS

Detect open or short circuit of the oil flow control solenoid valve.  
Judge as NG when the current is small even though the duty signal is large.

#### 2. ENABLE CONDITIONS

Secondary Parameters	Enable Conditions
None	

#### 3. GENERAL DRIVING CYCLE

Always perform the diagnosis continuously.

#### 4. DIAGNOSTIC METHOD

##### • Abnormality Judgment

If the duration of time while the following conditions are met is longer than the time indicated, judge as NG.

##### Judgment Value

Malfunction Criteria	Threshold Value
Battery voltage	$\geq 10.9 \text{ V}$
Oil flow control solenoid valve control duty	$\geq 99.61 \%$
Oil control solenoid valve control present current	$< 0.306 \text{ A}$

**Time Needed for Diagnosis:** 2000 ms

**Malfunction Indicator Light Illumination:** Illuminates as soon as a malfunction occurs.

##### • Normality Judgment

Judge as OK and clear the NG if the continuous time while the following conditions are established is more than the predetermined time.

##### Judgment Value

Malfunction Criteria	Threshold Value
Battery voltage	$\geq 10.9 \text{ V}$
Target current value of the oil flow control solenoid valve	$\geq 0.14 \text{ A}$
Target current value of the oil flow control solenoid valve – oil flow control solenoid valve control current value	$< 0.08 \text{ A}$

**Time Needed for Diagnosis:** 2000 ms

# Diagnostic Trouble Code (DTC) Detecting Criteria

GENERAL DESCRIPTION

## EF:DTC P2089 INTAKE CAMSHAFT POSITION ACTUATOR CONTROL CIRCUIT HIGH (BANK 1)

### 1. OUTLINE OF DIAGNOSIS

Detect open or short circuit of oil flow control solenoid valve.

Judge as NG when the current is large even though the duty signal is small.

### 2. ENABLE CONDITIONS

Secondary Parameters	Enable Conditions
None	

### 3. GENERAL DRIVING CYCLE

Always perform the diagnosis continuously.

### 4. DIAGNOSTIC METHOD

#### • Abnormality Judgment

If the duration of time while the following conditions are met is longer than the time indicated, judge as NG.

#### Judgment Value

Malfunction Criteria	Threshold Value
Battery voltage	$\geq 10.9$ V
Oil flow control solenoid valve control duty	$< 0.39$ %
Oil control solenoid valve control present current	$\geq 0.306$ A

**Time Needed for Diagnosis:** 2000 ms

**Malfunction Indicator Light Illumination:** Illuminates as soon as a malfunction occurs.

#### • Normality Judgment

Judge as OK and clear the NG if the continuous time while the following conditions are established is more than the predetermined time.

#### Judgment Value

Malfunction Criteria	Threshold Value
Battery voltage	$\geq 10.9$ V
Target current value of the oil flow control solenoid valve – oil flow control solenoid valve control current value	$< 0.08$ A

**Time Needed for Diagnosis:** 2000 ms

# Diagnostic Trouble Code (DTC) Detecting Criteria

## GENERAL DESCRIPTION

---

### EG:DTC P2090 EXHAUST CAMSHAFT POSITION ACTUATOR CONTROL CIRCUIT LOW (BANK 1)

#### 1. OUTLINE OF DIAGNOSIS

Detect open or short circuit of the oil flow control solenoid valve.  
Judge as NG when the current is small even though the duty signal is large.

#### 2. ENABLE CONDITIONS

Secondary Parameters	Enable Conditions
None	

#### 3. GENERAL DRIVING CYCLE

Always perform the diagnosis continuously.

#### 4. DIAGNOSTIC METHOD

##### • Abnormality Judgment

If the duration of time while the following conditions are met is longer than the time indicated, judge as NG.

##### Judgment Value

Malfunction Criteria	Threshold Value
Battery voltage	$\geq 10.9$ V
Oil flow control solenoid valve control duty	$\geq 99.61$ %
Oil control solenoid valve control present current	$< 0.306$ A

**Time Needed for Diagnosis:** 2000 ms

**Malfunction Indicator Light Illumination:** Illuminates as soon as a malfunction occurs.

##### • Normality Judgment

Judge as OK and clear the NG if the continuous time while the following conditions are established is more than the predetermined time.

##### Judgment Value

Malfunction Criteria	Threshold Value
Battery voltage	$\geq 10.9$ V
Target current value of the oil flow control solenoid valve	$\geq 0.14$ A
Target current value of the oil flow control solenoid valve – oil flow control solenoid valve control current value	$< 0.08$ A

**Time Needed for Diagnosis:** 2000 ms

# Diagnostic Trouble Code (DTC) Detecting Criteria

GENERAL DESCRIPTION

## EH:DTC P2091 EXHAUST CAMSHAFT POSITION ACTUATOR CONTROL CIRCUIT HIGH (BANK 1)

### 1. OUTLINE OF DIAGNOSIS

Detect open or short circuit of oil flow control solenoid valve.

Judge as NG when the current is large even though the duty signal is small.

### 2. ENABLE CONDITIONS

Secondary Parameters	Enable Conditions
None	

### 3. GENERAL DRIVING CYCLE

Always perform the diagnosis continuously.

### 4. DIAGNOSTIC METHOD

#### • Abnormality Judgment

If the duration of time while the following conditions are met is longer than the time indicated, judge as NG.

#### Judgment Value

Malfunction Criteria	Threshold Value
Battery voltage	$\geq 10.9$ V
Oil flow control solenoid valve control duty	$< 0.39$ %
Oil control solenoid valve control present current	$\geq 0.306$ A

**Time Needed for Diagnosis:** 2000 ms

**Malfunction Indicator Light Illumination:** Illuminates as soon as a malfunction occurs.

#### • Normality Judgment

Judge as OK and clear the NG if the continuous time while the following conditions are established is more than the predetermined time.

#### Judgment Value

Malfunction Criteria	Threshold Value
Battery voltage	$\geq 10.9$ V
Target current value of the oil flow control solenoid valve – oil flow control solenoid valve control current value	$< 0.08$ A

**Time Needed for Diagnosis:** 2000 ms



## Diagnostic Trouble Code (DTC) Detecting Criteria

### GENERAL DESCRIPTION

---

#### **EI: DTC P2092 INTAKE CAMSHAFT POSITION ACTUATOR CONTROL CIRCUIT LOW (BANK 2)**

##### **1. OUTLINE OF DIAGNOSIS**

###### NOTE:

For the detection standard, refer to DTC P2088. <Ref. to GD(H4DOTC)-232, DTC P2088 INTAKE CAMSHAFT POSITION ACTUATOR CONTROL CIRCUIT LOW (BANK 1), Diagnostic Trouble Code (DTC) Detecting Criteria.>

#### **EJ: DTC P2093 INTAKE CAMSHAFT POSITION ACTUATOR CONTROL CIRCUIT HIGH (BANK 2)**

##### **1. OUTLINE OF DIAGNOSIS**

###### NOTE:

For the detection standard, refer to DTC P2089. <Ref. to GD(H4DOTC)-233, DTC P2089 INTAKE CAMSHAFT POSITION ACTUATOR CONTROL CIRCUIT HIGH (BANK 1), Diagnostic Trouble Code (DTC) Detecting Criteria.>

#### **EK: DTC P2094 EXHAUST CAMSHAFT POSITION ACTUATOR CONTROL CIRCUIT LOW (BANK 2)**

##### **1. OUTLINE OF DIAGNOSIS**

###### NOTE:

For the detection standard, refer to DTC P2090. <Ref. to GD(H4DOTC)-234, DTC P2090 EXHAUST CAMSHAFT POSITION ACTUATOR CONTROL CIRCUIT LOW (BANK 1), Diagnostic Trouble Code (DTC) Detecting Criteria.>

#### **EL: DTC P2095 EXHAUST CAMSHAFT POSITION ACTUATOR CONTROL CIRCUIT HIGH (BANK 2)**

##### **1. OUTLINE OF DIAGNOSIS**

###### NOTE:

For the detection standard, refer to DTC P2091. <Ref. to GD(H4DOTC)-235, DTC P2091 EXHAUST CAMSHAFT POSITION ACTUATOR CONTROL CIRCUIT HIGH (BANK 1), Diagnostic Trouble Code (DTC) Detecting Criteria.>

# Diagnostic Trouble Code (DTC) Detecting Criteria

GENERAL DESCRIPTION

## EM:DTC P2096 POST CATALYST FUEL TRIM SYSTEM TOO LEAN (BANK 1)

### 1. OUTLINE OF DIAGNOSIS

Detect the malfunction of fuel system from the size of the sub feedback learning value.  
Control the sub feedback learning and judge as NG when the learning value is in the lean zone.

### 2. COMPONENT DESCRIPTION

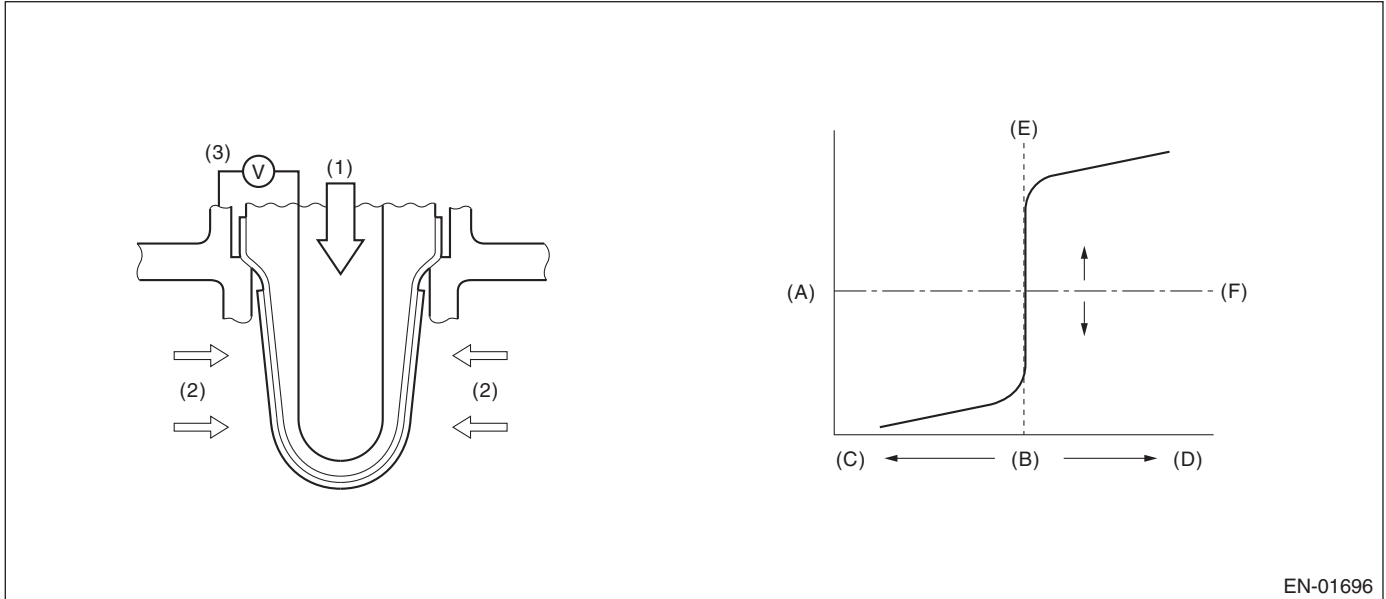

EN-01696

- |                         |                                |                         |
|-------------------------|--------------------------------|-------------------------|
| (A) Electromotive force | (B) Air fuel ratio             | (C) Rich                |
| (D) Lean                | (E) Theoretical air fuel ratio | (F) Comparative voltage |
| (1) Atmosphere          | (2) Exhaust gas                | (3) Electromotive force |

### 3. ENABLE CONDITIONS

Secondary Parameters	Enable Conditions
Conditions for carrying out the sub feedback learning	Completed
Continuous time when all conditions are established.	$\geq 1$ s

### 4. GENERAL DRIVING CYCLE

Perform the diagnosis continuously when the vehicle is idling or running at a constant speed of 80 km/h (50 MPH) or more.

# Diagnostic Trouble Code (DTC) Detecting Criteria

## GENERAL DESCRIPTION

---

### 5. DIAGNOSTIC METHOD

#### • Abnormality Judgment

If the duration of time while the following conditions are met is longer than the time indicated, judge as NG.

#### Judgment Value

Malfunction Criteria	Threshold Value
Sub feedback learning value	< -0.024 (Models without SI-DRIVE) < -0.025 (Models with SI-DRIVE)

**Time Needed for Diagnosis:** 1 s × 1 time(s)

**Malfunction Indicator Light Illumination:** Illuminates when malfunction occurs in 2 continuous driving cycles.

#### • Normality Judgment

Judge as OK and clear the NG if the continuous time while the following conditions are established is more than the predetermined time.

#### Judgment Value

Malfunction Criteria	Threshold Value
Sub feedback learning value	≥ -0.024 + 0.004 (Models without SI-DRIVE) ≥ -0.025 + 0 (Models with SI-DRIVE)

**Time Needed for Diagnosis:** 1 s

# Diagnostic Trouble Code (DTC) Detecting Criteria

GENERAL DESCRIPTION

## EN:DTC P2097 POST CATALYST FUEL TRIM SYSTEM TOO RICH (BANK 1)

### 1. OUTLINE OF DIAGNOSIS

Detect the malfunction of fuel system from the size of the sub feedback learning value.

Sub feedback learning is being performed. When the learning value goes to the rich side, judge as NG.

### 2. COMPONENT DESCRIPTION

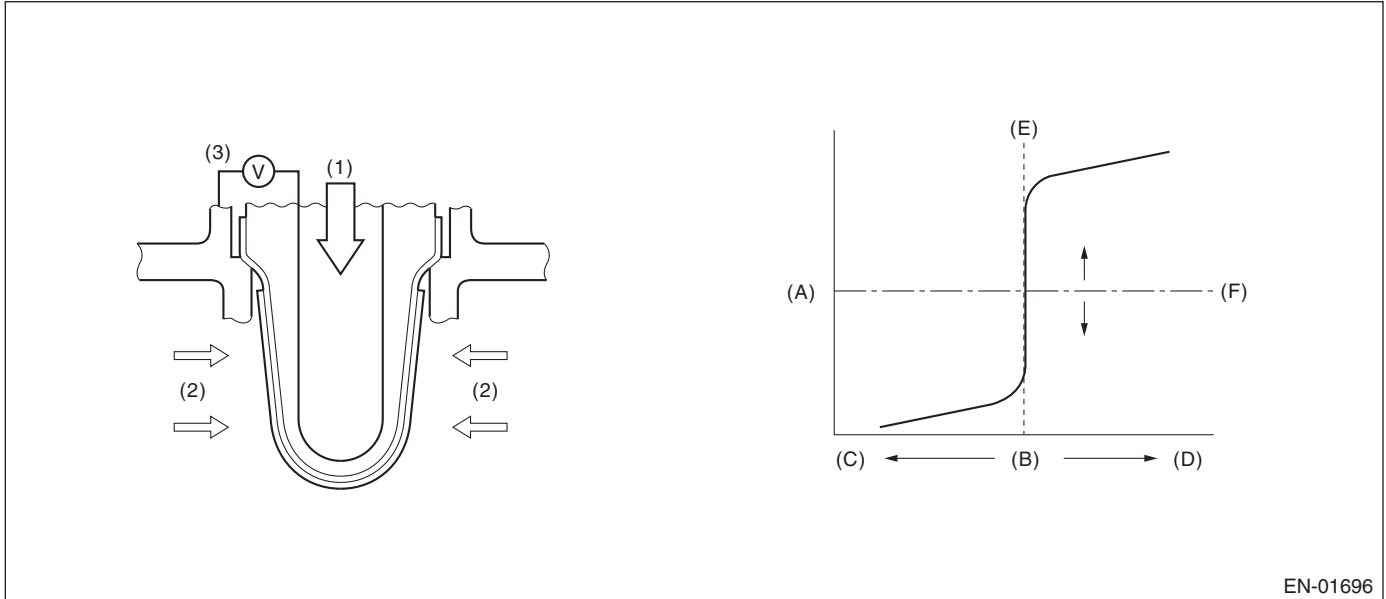

EN-01696

(A) Electromotive force

(B) Air fuel ratio

(C) Rich

(D) Lean

(E) Theoretical air fuel ratio

(F) Comparative voltage

(1) Atmosphere

(2) Exhaust gas

(3) Electromotive force

### 3. ENABLE CONDITIONS

Secondary Parameters	Enable Conditions
Conditions for carrying out the sub feedback learning	Completed
Continuous time when all conditions are established.	$\geq 1$ s

### 4. GENERAL DRIVING CYCLE

Perform the diagnosis continuously when the vehicle is idling or running at a constant speed of 80 km/h (50 MPH) or more.

# Diagnostic Trouble Code (DTC) Detecting Criteria

## GENERAL DESCRIPTION

---

### 5. DIAGNOSTIC METHOD

#### • Abnormality Judgment

If the duration of time while the following conditions are met is longer than the time indicated, judge as NG.

#### Judgment Value

Malfunction Criteria	Threshold Value
Sub feedback learning value	$\geq 0.028$ (Models without SI-DRIVE) $\geq 0.036$ (Models with SI-DRIVE)

**Time Needed for Diagnosis:** 1 s × 1 time(s)

**Malfunction Indicator Light Illumination:** Illuminates when malfunction occurs in 2 continuous driving cycles.

#### • Normality Judgment

Judge as OK and clear the NG if the continuous time while the following conditions are established is more than the predetermined time.

#### Judgment Value

Malfunction Criteria	Threshold Value
Sub feedback learning value	$< 0.028 + -0.01$ (Models without SI-DRIVE) $< 0.036 + -0.004$ (Models with SI-DRIVE)

**Time Needed for Diagnosis:** 1 s

## EO:DTC P2101 THROTTLE ACTUATOR CONTROL MOTOR CIRCUIT RANGE/ PERFORMANCE

### 1. OUTLINE OF DIAGNOSIS

Judge as NG when the motor current becomes large or drive circuit is heated.

### 2. COMPONENT DESCRIPTION

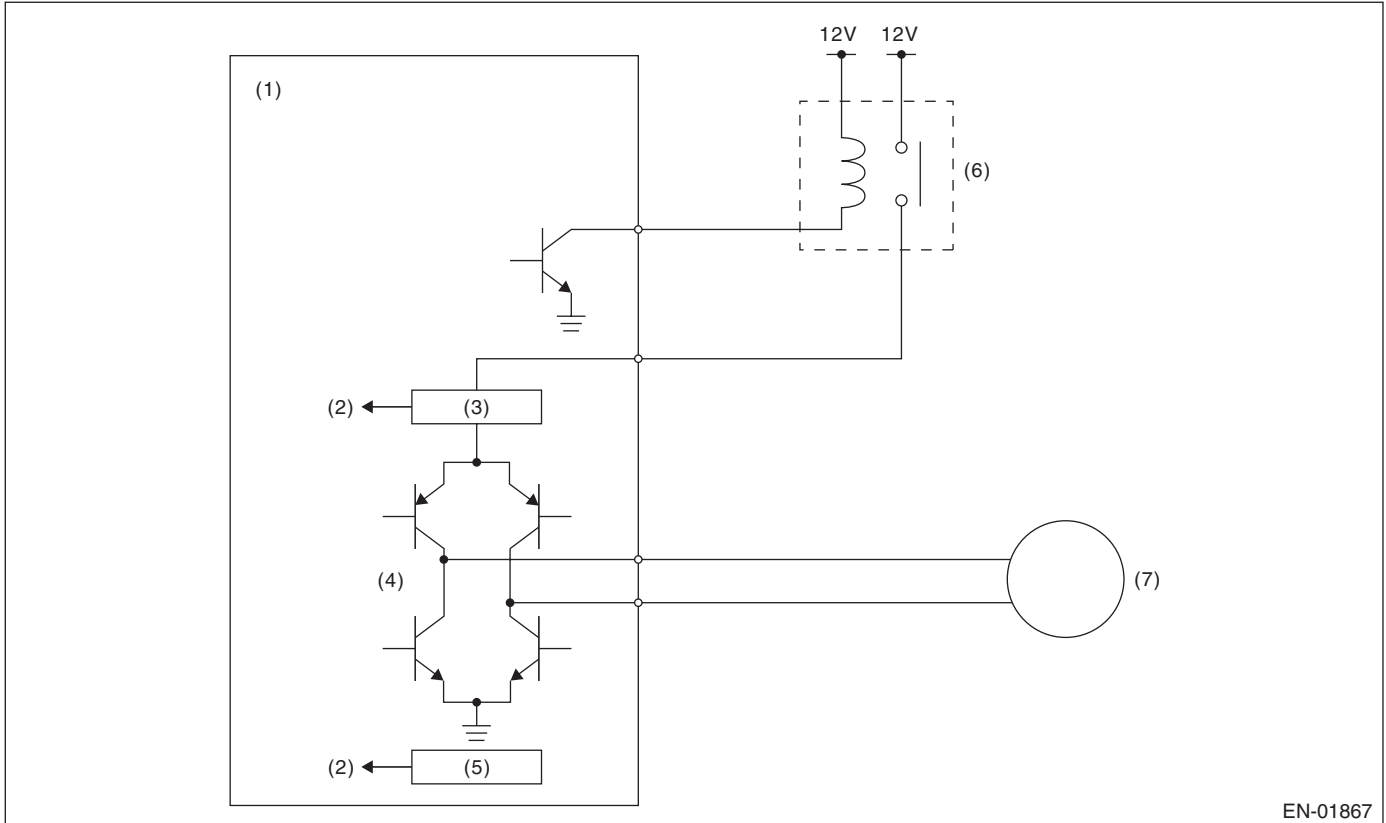

EN-01867

- |                                   |                                   |                                       |
|-----------------------------------|-----------------------------------|---------------------------------------|
| (1) Engine control module (ECM)   | (4) Drive circuit                 | (6) Electronic throttle control relay |
| (2) Detecting circuit             | (5) Temperature detection circuit | (7) Motor                             |
| (3) Overcurrent detection circuit |                                   |                                       |

### 3. ENABLE CONDITIONS

Secondary Parameters	Enable Conditions
Under control of electronic throttle control	ON
CPU communication line sub → main normal judgment	Normal

### 4. GENERAL DRIVING CYCLE

Always perform the diagnosis continuously.

# Diagnostic Trouble Code (DTC) Detecting Criteria

## GENERAL DESCRIPTION

---

### 5. DIAGNOSTIC METHOD

#### • Abnormality Judgment

If the duration of time while the following conditions are met is longer than the time indicated, judge as NG.

#### Judgment Value

Malfunction Criteria	Threshold Value
Motor current or Drive circuit inner temperature	> 8 A  > 175°C (347°F)

**Time Needed for Diagnosis:** 512 ms

**Malfunction Indicator Light Illumination:** Illuminates as soon as a malfunction occurs.

#### • Normality Judgment

Judge as OK and clear the NG if the continuous time while the following conditions are established is more than the predetermined time.

#### Judgment Value

Malfunction Criteria	Threshold Value
Motor current Drive circuit inner temperature	≤ 8 A ≤ 175°C (347°F)

**Time Needed for Diagnosis:** 2000 ms

# Diagnostic Trouble Code (DTC) Detecting Criteria

GENERAL DESCRIPTION

## EP:DTC P2102 THROTTLE ACTUATOR CONTROL MOTOR CIRCUIT LOW

### 1. OUTLINE OF DIAGNOSIS

Judge as NG when the electronic throttle control power is not supplied even when ECM sets the electric control throttle relay to ON.

### 2. COMPONENT DESCRIPTION

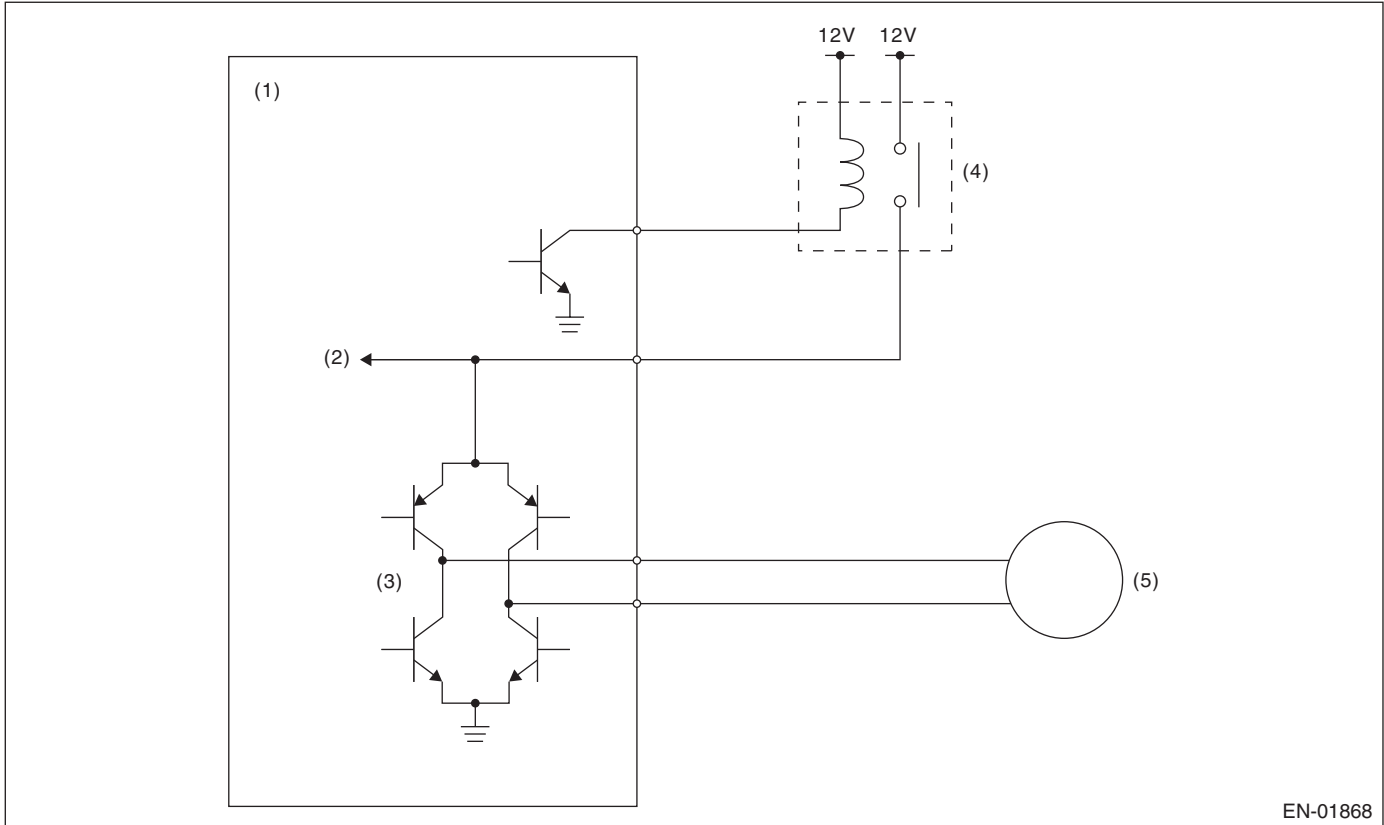

EN-01868

- (1) Engine control module (ECM)      (3) Drive circuit      (5) Motor  
(2) Voltage detection circuit      (4) Electronic throttle control relay

### 3. ENABLE CONDITIONS

Secondary Parameters	Enable Conditions
Battery voltage	$\geq 11 \text{ V}$
Electronic throttle control relay output	ON

### 4. GENERAL DRIVING CYCLE

Always perform the diagnosis continuously.



# Diagnostic Trouble Code (DTC) Detecting Criteria

## GENERAL DESCRIPTION

---

### 5. DIAGNOSTIC METHOD

#### • Abnormality Judgment

If the duration of time while the following conditions are met is longer than the time indicated, judge as NG.

#### Judgment Value

Malfunction Criteria	Threshold Value
Motor power voltage	$\leq 5\text{ V}$

**Time Needed for Diagnosis:** 352 ms

**Malfunction Indicator Light Illumination:** Illuminates as soon as a malfunction occurs.

#### • Normality Judgment

Judge as OK and clear the NG if the continuous time while the following conditions are established is more than the predetermined time.

#### Judgment Value

Malfunction Criteria	Threshold Value
Motor power voltage	$> 5\text{ V}$

**Time Needed for Diagnosis:** 2000 ms

# Diagnostic Trouble Code (DTC) Detecting Criteria

GENERAL DESCRIPTION

## EQ:DTC P2103 THROTTLE ACTUATOR CONTROL MOTOR CIRCUIT HIGH

### 1. OUTLINE OF DIAGNOSIS

Judge as NG when the electronic throttle control power is supplied even when ECM sets the electronic throttle control relay to OFF.

### 2. COMPONENT DESCRIPTION

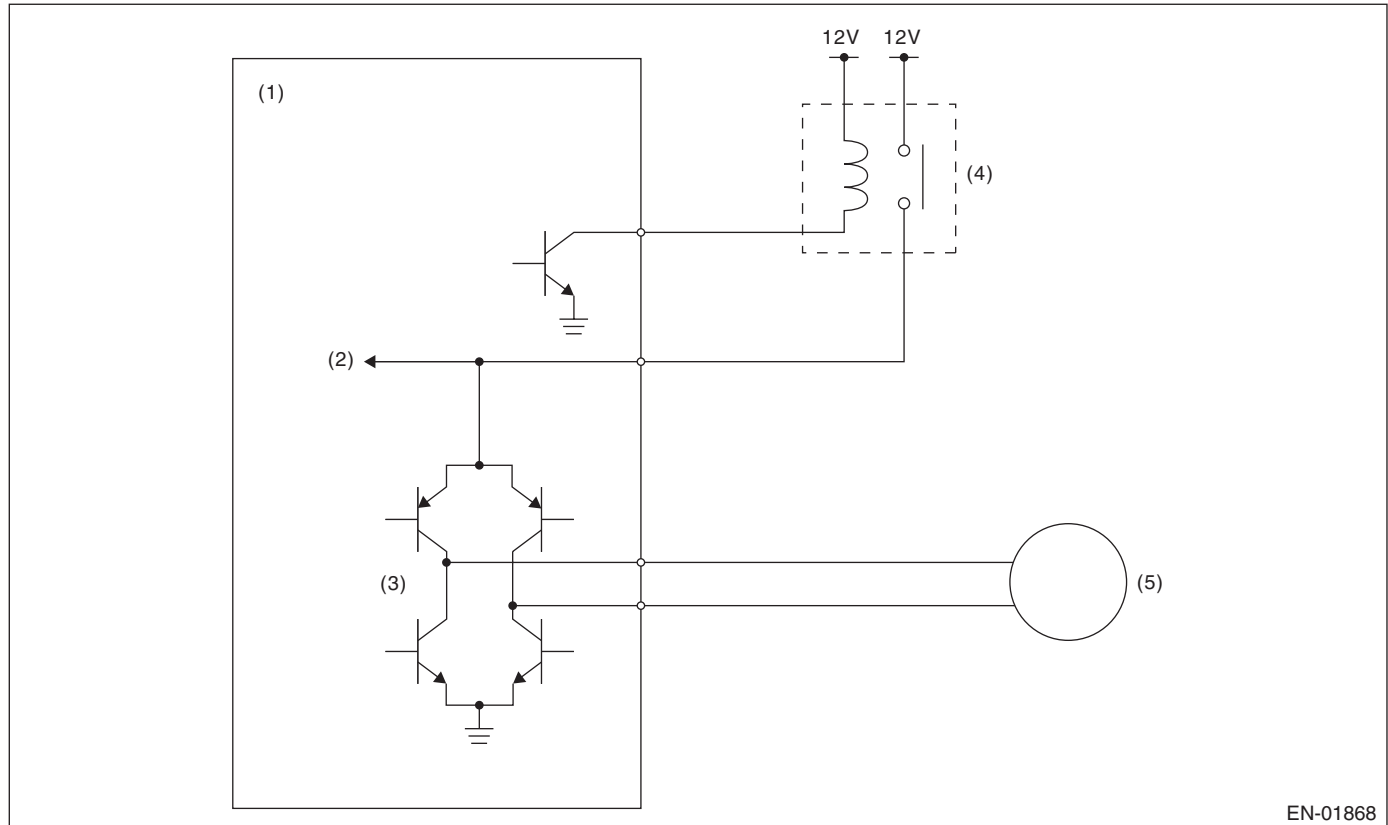

(1) Engine control module (ECM)

(3) Drive circuit

(5) Motor

(2) Voltage detection circuit

(4) Electronic throttle control relay

### 3. ENABLE CONDITIONS

Secondary Parameters	Enable Conditions
Battery voltage	$\geq 6\text{ V}$
Electronic throttle control relay output	OFF

### 4. GENERAL DRIVING CYCLE

- When ignition switch ON → OFF
- Ignition switch OFF → ON (Only after clearing memory)

# Diagnostic Trouble Code (DTC) Detecting Criteria

## GENERAL DESCRIPTION

---

### 5. DIAGNOSTIC METHOD

#### • Abnormality Judgment

If the duration of time while the following conditions are met is longer than the time indicated, judge as NG.

#### Judgment Value

Malfunction Criteria	Threshold Value
Motor power voltage	$\geq 5\text{ V}$

**Time Needed for Diagnosis:** 600 ms

**Malfunction Indicator Light Illumination:** Illuminates as soon as a malfunction occurs.

#### • Normality Judgment

Judge as OK and clear the NG if the continuous time while the following conditions are established is more than the predetermined time.

#### Judgment Value

Malfunction Criteria	Threshold Value
Motor power voltage	$< 5\text{ V}$

**Time Needed for Diagnosis:** 400 ms

# Diagnostic Trouble Code (DTC) Detecting Criteria

GENERAL DESCRIPTION

## ER:DTC P2109 THROTTLE/PEDAL POSITION SENSOR "A" MINIMUM STOP PERFORMANCE

### 1. OUTLINE OF DIAGNOSIS

Judge as NG when full close point learning cannot conducted or abnormal value is detected.

### 2. COMPONENT DESCRIPTION

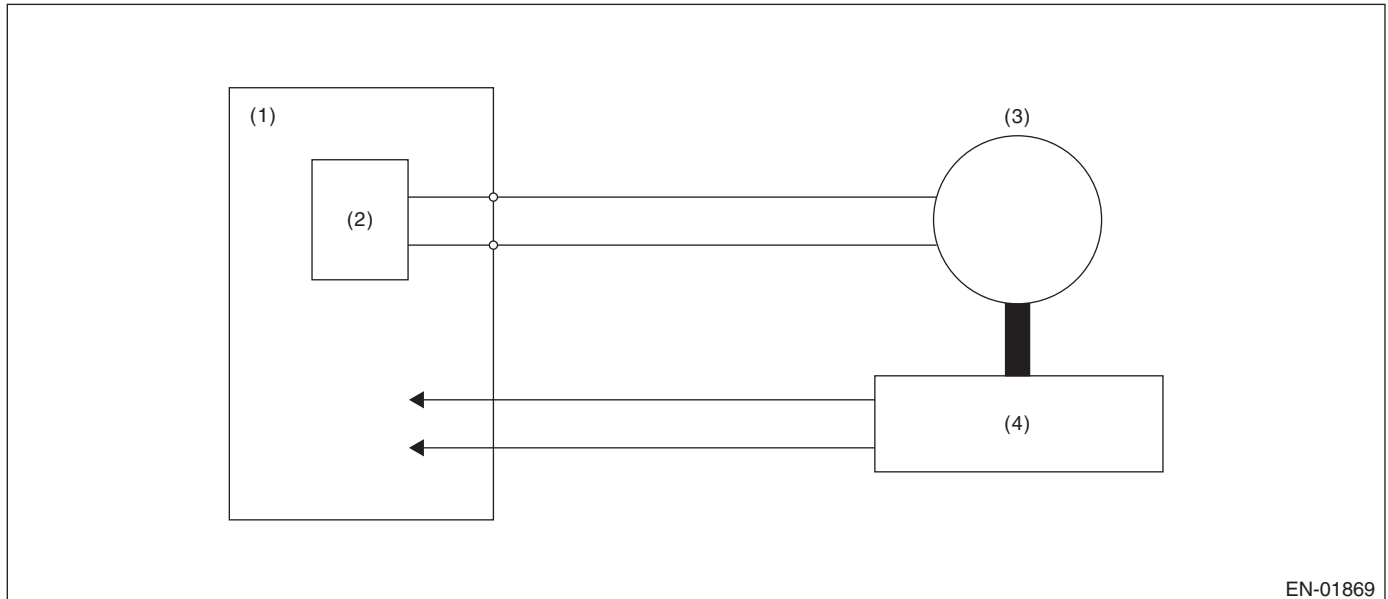

EN-01869

(1) Engine control module (ECM)

(3) Motor

(4) Throttle position sensor

(2) Drive circuit

### 3. ENABLE CONDITIONS

Secondary Parameters	Enable Conditions
Ignition switch	ON → OFF
Ignition switch (only after clear memory)	OFF → ON

### 4. GENERAL DRIVING CYCLE

Perform the diagnosis at full closed point learning.

# Diagnostic Trouble Code (DTC) Detecting Criteria

## GENERAL DESCRIPTION

---

### 5. DIAGNOSTIC METHOD

#### • Abnormality Judgment

If the duration of time while the following conditions are met is longer than the time indicated, judge as NG.

#### Judgment Value

Malfunction Criteria	Threshold Value
Throttle sensor opening angle at full close point learning	< 9.884 ° or > 20.116 °
or	
Throttle opening angle when the ignition switch is ON – Throttle minimum stop position	< 0.887 ° (models without SI-DRIVE) < 1.637 ° (models with SI-DRIVE)

**Time Needed for Diagnosis:** 8 ms — 80 ms

**Malfunction Indicator Light Illumination:** Illuminates as soon as a malfunction occurs.

#### • Normality Judgment

Judge as OK and clear the NG if the continuous time while the following conditions are established is more than the predetermined time.

#### Judgment Value

Malfunction Criteria	Threshold Value
Throttle sensor opening angle at full close point learning	≥ 9.884 ° and ≤ 20.116 °
Throttle opening angle when the ignition switch is ON – Throttle minimum stop position	≥ 0.887 ° (models without SI-DRIVE) ≥ 1.637 ° (models with SI-DRIVE)

**Time Needed for Diagnosis:** 8 ms

# Diagnostic Trouble Code (DTC) Detecting Criteria

GENERAL DESCRIPTION

## ES:DTC P2122 THROTTLE/PEDAL POSITION SENSOR/SWITCH "D" CIRCUIT LOW INPUT

### 1. OUTLINE OF DIAGNOSIS

Detect the open or short circuit of accelerator pedal position sensor 1.  
Judge as NG if out of specification.

### 2. COMPONENT DESCRIPTION

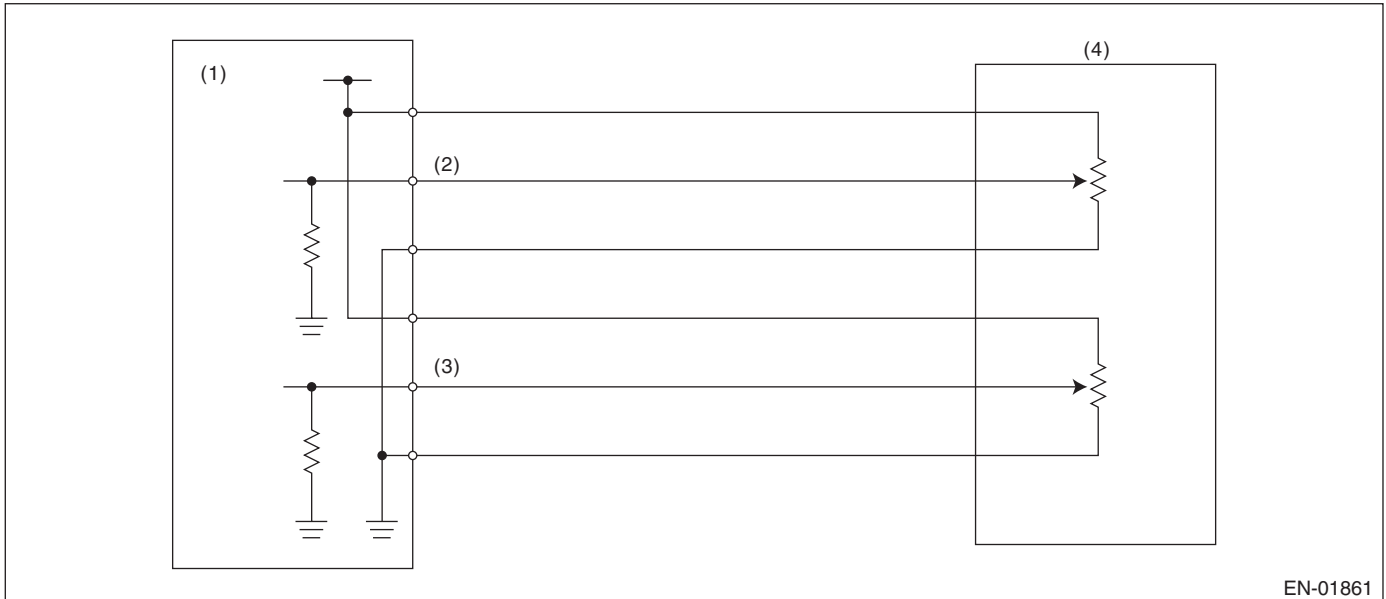

- (1) Engine control module (ECM)      (3) Accelerator pedal position sensor 2 signal      (4) Accelerator pedal position sensor
- (2) Accelerator pedal position sensor 1 signal

### 3. ENABLE CONDITIONS

Secondary Parameters	Enable Conditions
Ignition switch	ON
Battery voltage	$\geq 6 \text{ V}$

### 4. GENERAL DRIVING CYCLE

Always perform the diagnosis continuously.

# Diagnostic Trouble Code (DTC) Detecting Criteria

## GENERAL DESCRIPTION

---

### 5. DIAGNOSTIC METHOD

#### • Abnormality Judgment

If the duration of time while the following conditions are met is longer than the time indicated, judge as NG.

#### Judgment Value

Malfunction Criteria	Threshold Value
Sensor 1 input voltage	< 0.295 V

**Time Needed for Diagnosis:** 100 ms

**Malfunction Indicator Light Illumination:** Illuminates as soon as a malfunction occurs.

#### • Normality Judgment

Judge as OK and clear the NG if the continuous time while the following conditions are established is more than the predetermined time.

#### Judgment Value

Malfunction Criteria	Threshold Value
Sensor 1 input voltage	$\geq 0.295$ V

**Time Needed for Diagnosis:** 100 ms

# Diagnostic Trouble Code (DTC) Detecting Criteria

GENERAL DESCRIPTION

## ET:DTC P2123 THROTTLE/PEDAL POSITION SENSOR/SWITCH "D" CIRCUIT HIGH INPUT

### 1. OUTLINE OF DIAGNOSIS

Detect the open or short circuit of accelerator pedal position sensor 1.  
Judge as NG if out of specification.

### 2. COMPONENT DESCRIPTION

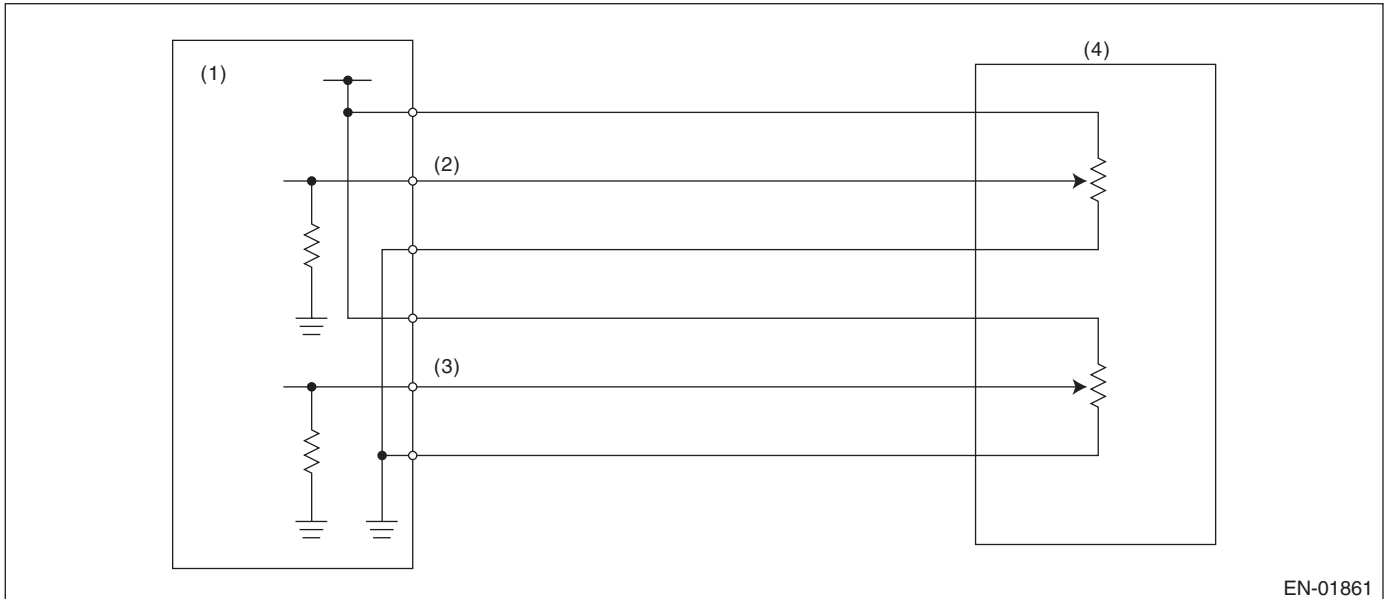

- (1) Engine control module (ECM)      (3) Accelerator pedal position sensor 2 signal      (4) Accelerator pedal position sensor 2 signal
- (2) Accelerator pedal position sensor 1 signal

### 3. ENABLE CONDITIONS

Secondary Parameters	Enable Conditions
Ignition switch	ON
Battery voltage	$\geq 6 \text{ V}$

### 4. GENERAL DRIVING CYCLE

Always perform the diagnosis continuously.



# Diagnostic Trouble Code (DTC) Detecting Criteria

## GENERAL DESCRIPTION

---

### 5. DIAGNOSTIC METHOD

#### • Abnormality Judgment

If the duration of time while the following conditions are met is longer than the time indicated, judge as NG.

#### Judgment Value

Malfunction Criteria	Threshold Value
Sensor 1 input voltage	$\geq 4.783$ V

**Time Needed for Diagnosis:** 32 ms

**Malfunction Indicator Light Illumination:** Illuminates as soon as a malfunction occurs.

#### • Normality Judgment

Judge as OK and clear the NG if the continuous time while the following conditions are established is more than the predetermined time.

#### Judgment Value

Malfunction Criteria	Threshold Value
Sensor 1 input voltage	$< 4.783$ V

**Time Needed for Diagnosis:** 32 ms

# Diagnostic Trouble Code (DTC) Detecting Criteria

GENERAL DESCRIPTION

## EU:DTC P2127 THROTTLE/PEDAL POSITION SENSOR/SWITCH "E" CIRCUIT LOW INPUT

### 1. OUTLINE OF DIAGNOSIS

Detect the open or short circuit of accelerator pedal position sensor 2.

Judge as NG if out of specification.

### 2. COMPONENT DESCRIPTION

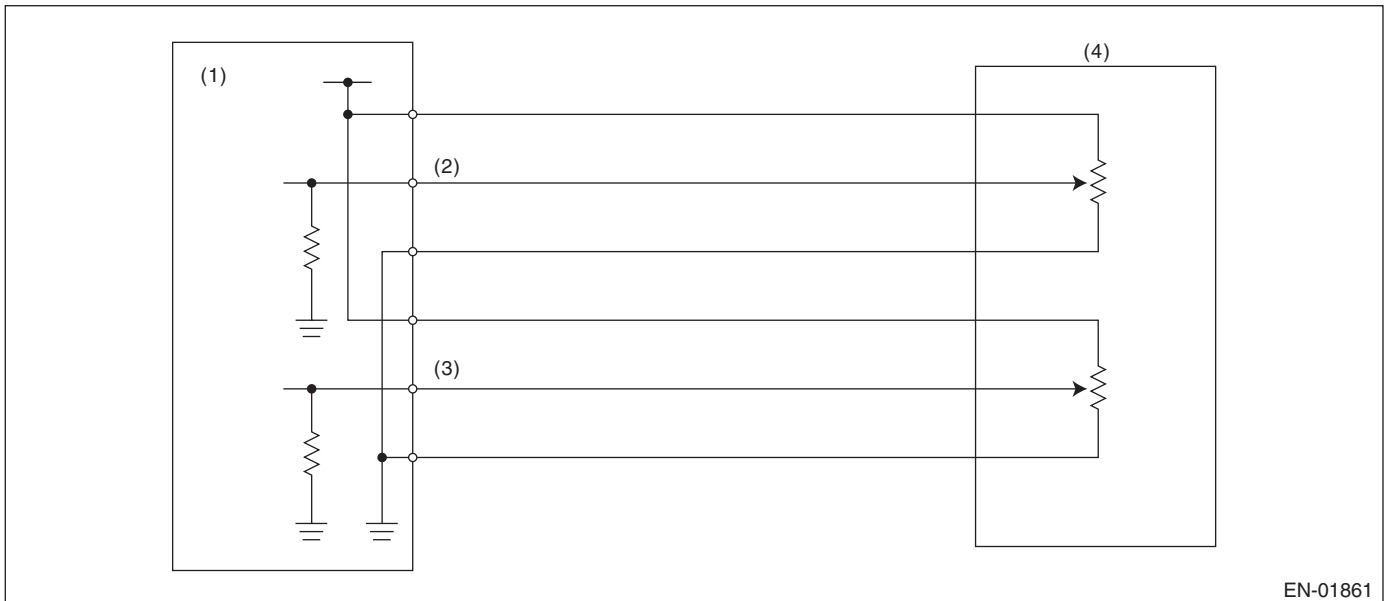

EN-01861

- (1) Engine control module (ECM)      (3) Accelerator pedal position sensor 2 signal      (4) Accelerator pedal position sensor 2 signal
- (2) Accelerator pedal position sensor 1 signal

### 3. ENABLE CONDITIONS

Secondary Parameters	Enable Conditions
Ignition switch	ON
Battery voltage	$\geq 6 \text{ V}$

### 4. GENERAL DRIVING CYCLE

Always perform the diagnosis continuously.

# Diagnostic Trouble Code (DTC) Detecting Criteria

## GENERAL DESCRIPTION

---

### 5. DIAGNOSTIC METHOD

#### • Abnormality Judgment

If the duration of time while the following conditions are met is longer than the time indicated, judge as NG.

#### Judgment Value

Malfunction Criteria	Threshold Value
Sensor 2 input voltage	< 0.295 V

**Time Needed for Diagnosis:** 100 ms

**Malfunction Indicator Light Illumination:** Illuminates as soon as a malfunction occurs.

#### • Normality Judgment

Judge as OK and clear the NG if the continuous time while the following conditions are established is more than the predetermined time.

#### Judgment Value

Malfunction Criteria	Threshold Value
Sensor 2 input voltage	$\geq 0.295$ V

**Time Needed for Diagnosis:** 100 ms

# Diagnostic Trouble Code (DTC) Detecting Criteria

GENERAL DESCRIPTION

## EV:DTC P2128 THROTTLE/PEDAL POSITION SENSOR/SWITCH "E" CIRCUIT HIGH INPUT

### 1. OUTLINE OF DIAGNOSIS

Detect the open or short circuit of accelerator pedal position sensor 2.  
Judge as NG if out of specification.

### 2. COMPONENT DESCRIPTION

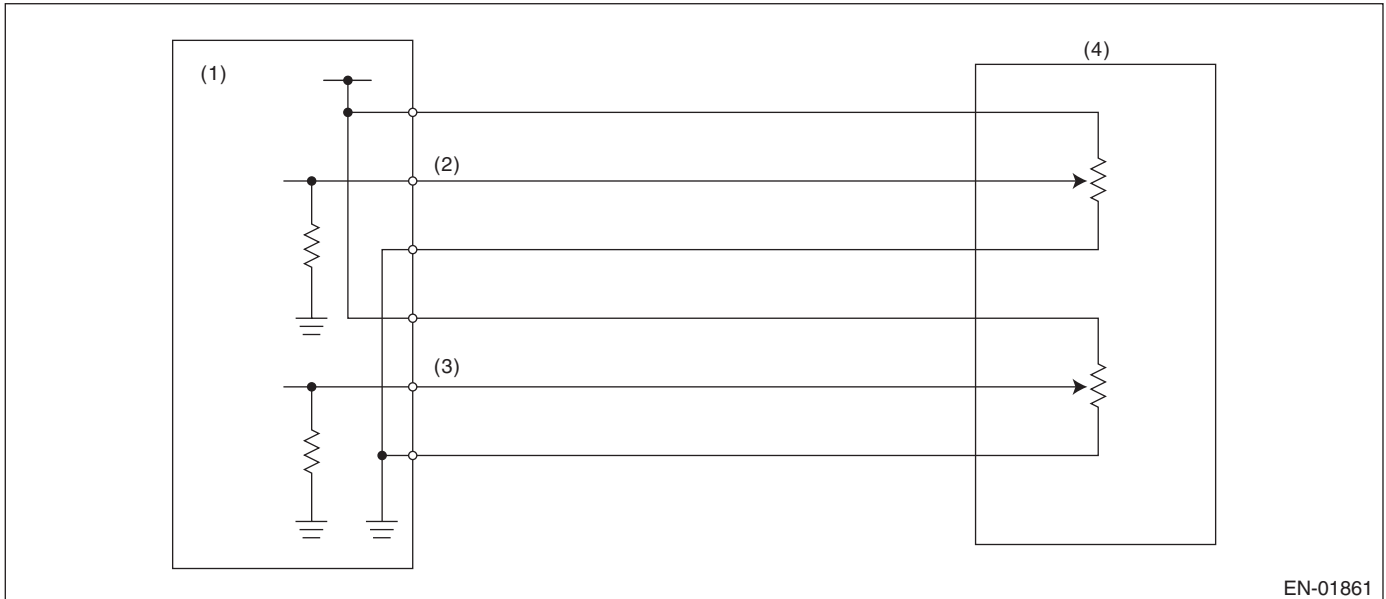

- (1) Engine control module (ECM)      (3) Accelerator pedal position sensor 2 signal      (4) Accelerator pedal position sensor 2 signal
- (2) Accelerator pedal position sensor 1 signal

### 3. ENABLE CONDITIONS

Secondary Parameters	Enable Conditions
Ignition switch	ON
Battery voltage	$\geq 6 \text{ V}$

### 4. GENERAL DRIVING CYCLE

Always perform the diagnosis continuously.

# Diagnostic Trouble Code (DTC) Detecting Criteria

## GENERAL DESCRIPTION

---

### 5. DIAGNOSTIC METHOD

#### • Abnormality Judgment

If the duration of time while the following conditions are met is longer than the time indicated, judge as NG.

#### Judgment Value

Malfunction Criteria	Threshold Value
Sensor 2 input voltage	$\geq 4.783$ V

**Time Needed for Diagnosis:** 100 ms

**Malfunction Indicator Light Illumination:** Illuminates as soon as a malfunction occurs.

#### • Normality Judgment

Judge as OK and clear the NG if the continuous time while the following conditions are established is more than the predetermined time.

#### Judgment Value

Malfunction Criteria	Threshold Value
Sensor 2 input voltage	$< 4.783$ V

**Time Needed for Diagnosis:** 100 ms

# Diagnostic Trouble Code (DTC) Detecting Criteria

GENERAL DESCRIPTION

## EW:DTC P2135 THROTTLE/PEDAL POSITION SENSOR/SWITCH "A"/"B" VOLTAGE CORRELATION

### 1. OUTLINE OF DIAGNOSIS

Judge as NG when the signal level of throttle position sensor 1 is different from the throttle position sensor 2.

### 2. COMPONENT DESCRIPTION

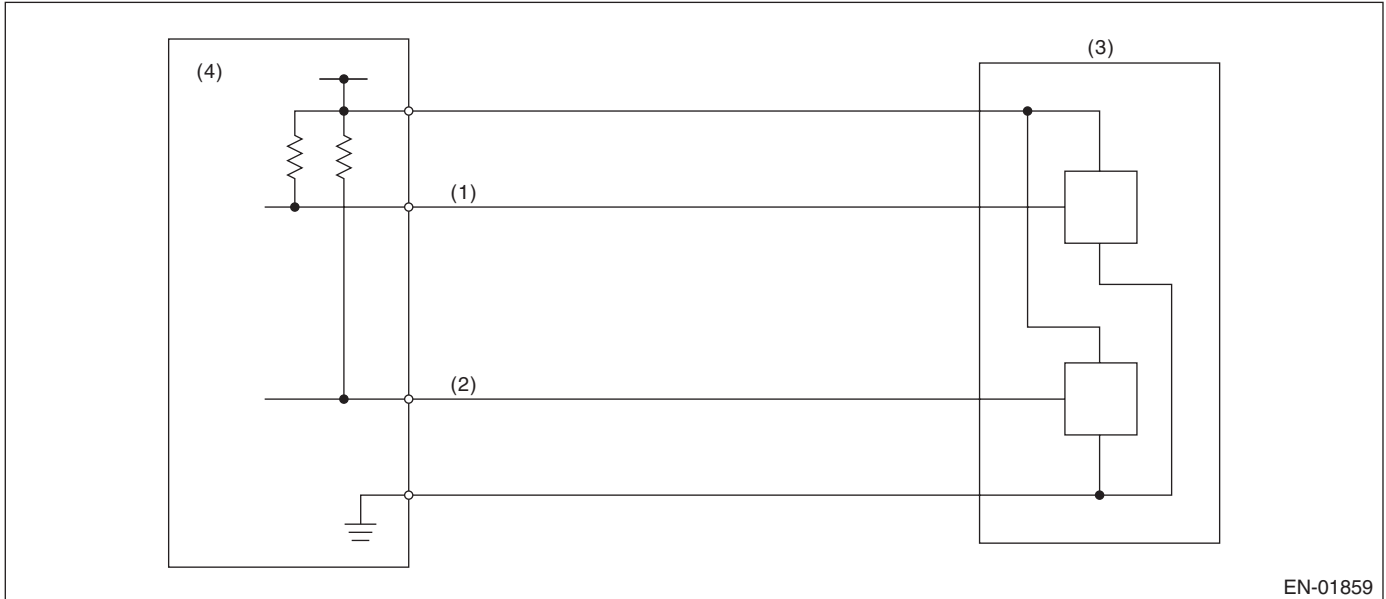

(1) Throttle position sensor 1 signal  
(2) Throttle position sensor 2 signal

(3) Throttle position sensor

(4) Engine control module (ECM)

### 3. ENABLE CONDITIONS

Secondary Parameters	Enable Conditions
Ignition switch	ON
Battery voltage	$\geq 6\text{ V}$

### 4. GENERAL DRIVING CYCLE

Always perform the diagnosis continuously.

# Diagnostic Trouble Code (DTC) Detecting Criteria

## GENERAL DESCRIPTION

### 5. DIAGNOSTIC METHOD

#### • Abnormality Judgment

If the duration of time while the following conditions are met is longer than the time indicated, judge as NG.

#### Judgment Value

Malfunction Criteria	Threshold Value
Signal difference between two sensors	Within NG range of <b>Details of Judgment value</b>

#### Details of Judgment Value

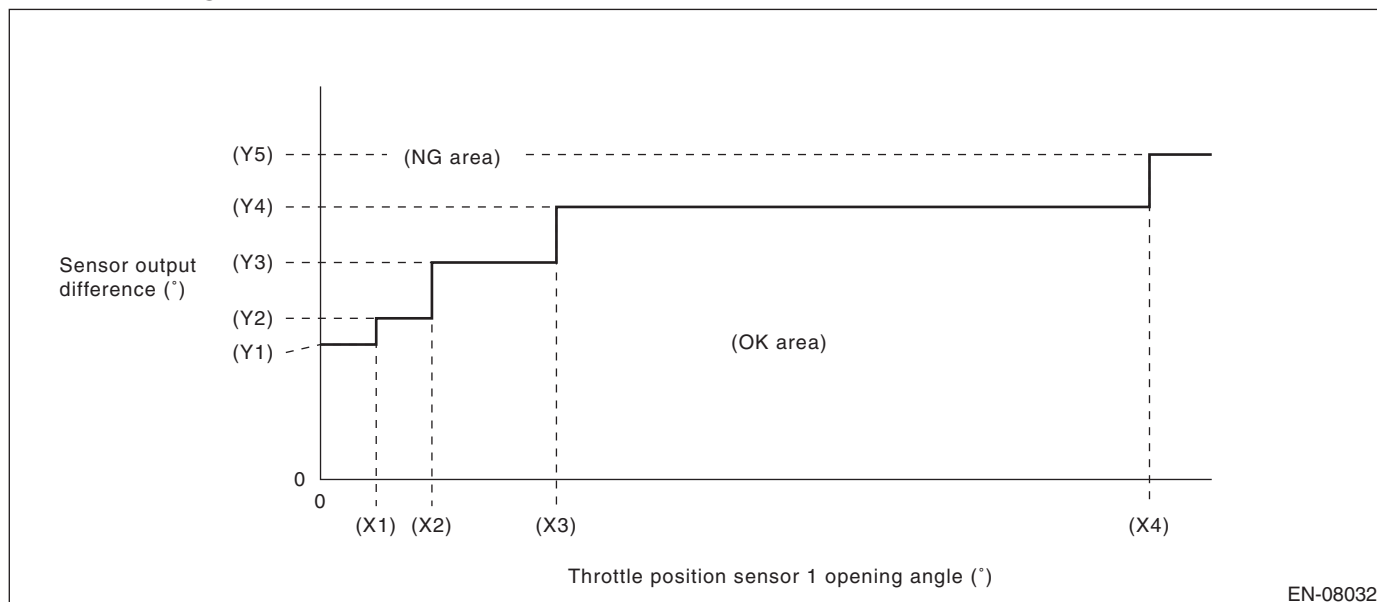

EN-08032

(X1) 2.125 °  
(X4) 31.625 °

(X2) 4.25 °

(X3) 9 °

(Y1) 5.15 °  
(Y4) 10.4 °

(Y2) 6.15 °  
(Y5) 12.4 °

(Y3) 8.28 °

**Time Needed for Diagnosis:** 212 ms

**Malfunction Indicator Light Illumination:** Illuminates as soon as a malfunction occurs.

#### • Normality Judgment

Judge as OK and clear the NG if the continuous time while the following conditions are established is more than the predetermined time.

#### Judgment Value

Malfunction Criteria	Threshold Value
Signal difference between two sensors	Within OK range of <b>Details of Judgment value</b>

**Time Needed for Diagnosis:** 24 ms

# Diagnostic Trouble Code (DTC) Detecting Criteria

GENERAL DESCRIPTION

## EX:DTC P2138 THROTTLE/PEDAL POSITION SENSOR/SWITCH "D"/"E" VOLTAGE CORRELATION

### 1. OUTLINE OF DIAGNOSIS

Judge as NG when the signal level of accelerator pedal position sensor 1 is different from the accelerator pedal position sensor 2.

### 2. COMPONENT DESCRIPTION

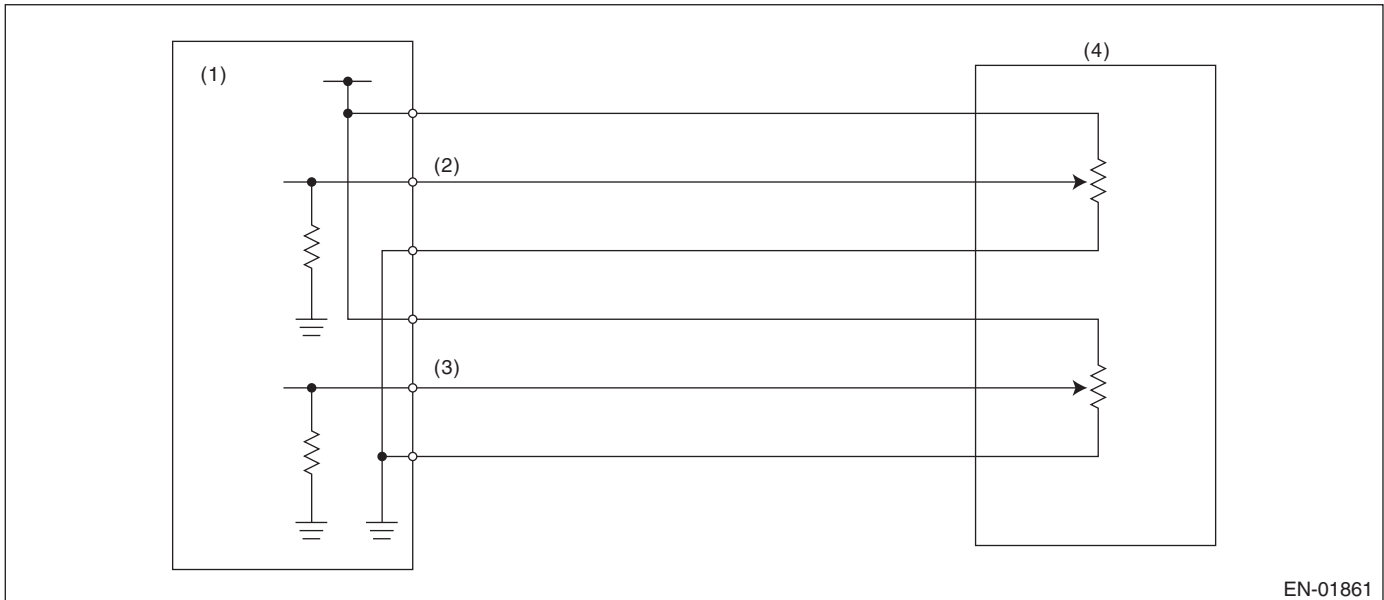

EN-01861

- (1) Engine control module (ECM)      (3) Accelerator pedal position sensor 2 signal      (4) Accelerator pedal position sensor 2 signal
- (2) Accelerator pedal position sensor 1 signal

### 3. ENABLE CONDITIONS

Secondary Parameters	Enable Conditions
Ignition switch	ON
Battery voltage	$\geq 6$ V

### 4. GENERAL DRIVING CYCLE

Always perform the diagnosis continuously.



# Diagnostic Trouble Code (DTC) Detecting Criteria

## GENERAL DESCRIPTION

### 5. DIAGNOSTIC METHOD

#### • Abnormality Judgment

If the duration of time while the following conditions are met is longer than the time indicated, judge as NG.

#### Judgment Value

Malfunction Criteria	Threshold Value
Signal difference between two sensors	Within NG range of <b>Details of Judgment value</b>

#### Details of Judgment Value

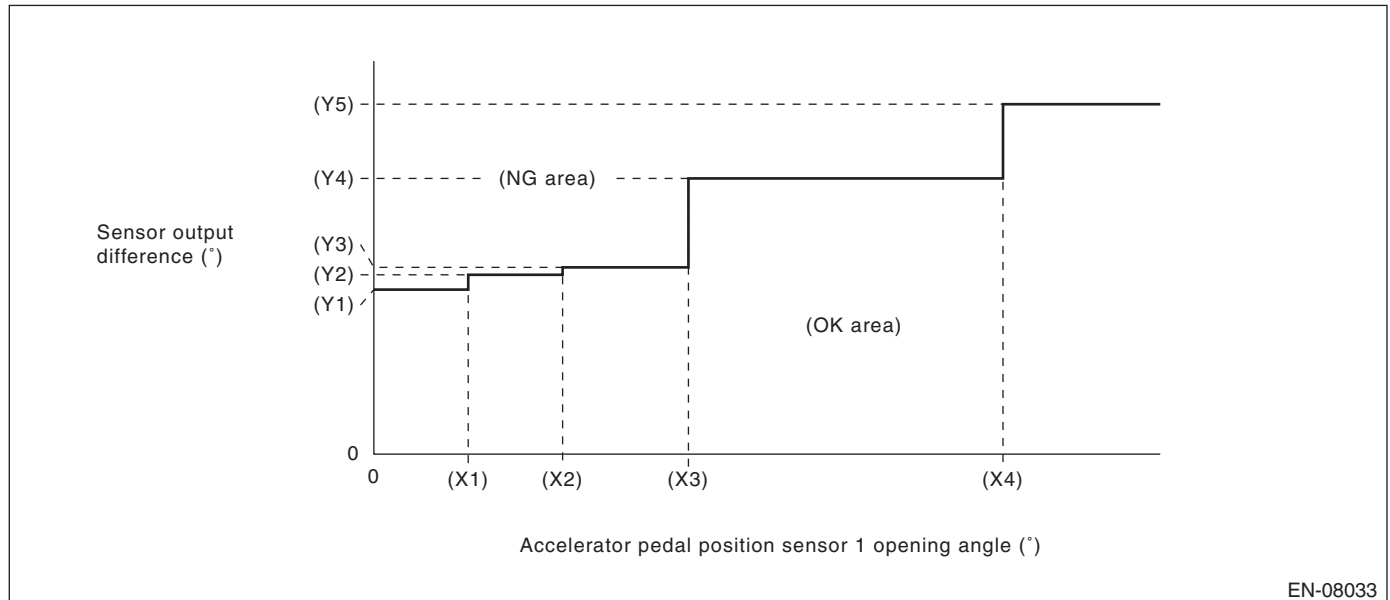

EN-08033

(X1) 0.6 °  
(X4) 4 °

(X2) 1.2 °

(X3) 2 °

(Y1) 1.465 °  
(Y4) 2.455 °

(Y2) 1.597 °  
(Y5) 3.116 °

(Y3) 1.663 °

**Time Needed for Diagnosis:** 116 ms

**Malfunction Indicator Light Illumination:** Illuminates as soon as a malfunction occurs.

#### • Normality Judgment

Judge as OK and clear the NG if the continuous time while the following conditions are established is more than the predetermined time.

#### Judgment Value

Malfunction Criteria	Threshold Value
Signal difference between two sensors	Within OK range of <b>Details of Judgment value</b>

**Time Needed for Diagnosis:** 116 ms

# Diagnostic Trouble Code (DTC) Detecting Criteria

GENERAL DESCRIPTION

## EY:DTC P219A BANK 1 AIR-FUEL RATIO IMBALANCE

### 1. OUTLINE OF DIAGNOSIS

Detect malfunction of air fuel ratio deviation between cylinders from main feedback learning value, sub feedback learning value and engine speed variation.

### 2. ENABLE CONDITIONS

Secondary Parameters	Enable Conditions
Battery voltage	> 10.9 V
Atmospheric pressure	> 75 kPa (563 mmHg, 22.2 inHg)
A/F main learning system	In operation
Engine speed	> 550 rpm
Engine coolant temperature	> 70 °C (158 °F)
Intake air temperature	< 70 °C (158 °F)
Engine load	> Value of Map 1
Engine load change	< 0.02 g/rev (0 oz/rev)
Evaporative system leak check	Not in operation
Cumulative time of canister purge after engine start	≥ 20 s
Learning value of EVAP conc.	< 0.2
Vehicle dynamic control or AT torque control	Not in operation
Intake manifold pressure change at 180°C	< Value of Map 2
Throttle position change during 16 milliseconds	< 14 °
Fuel shut-off function	Not in operation

#### Map 1 (Models without SI-DRIVE)

Engine speed (rpm)	Idling	800	1200	1600	2000	2400	2800	3200	3600	4000	4400
Measured value (g (oz)/rev)	na	0.228 (0.01)	0.22 (0.01)	0.22 (0.01)	0.22 (0.01)	0.228 (0.01)	0.23 (0.01)	0.234 (0.01)	0.242 (0.01)	0.25 (0.01)	0.25 (0.01)

#### Map 1 (Models with SI-DRIVE)

Engine speed (rpm)	Idling	800	1200	1600	2000	2400	2800	3200	3600	4000	4400
Measured value (g (oz)/rev)	na	0.274 (0.01)	0.245 (0.01)	0.239 (0.01)	0.224 (0.01)	0.233 (0.01)	0.259 (0.01)	0.257 (0.01)	0.254 (0.01)	0.256 (0.01)	0.274 (0.01)

#### Map 2 (Models without SI-DRIVE)

rpm	750	1000	1500	2000	2500	3000	3500	4000
kPa (mmHg, inHg)	13.3 (100, 3.9)	13.3 (100, 3.9)	13.3 (100, 3.9)	13.3 (100, 3.9)	13.3 (100, 3.9)	13.3 (100, 3.9)	13.3 (100, 3.9)	13.3 (100, 3.9)

rpm	4500	5000	5500	6000	6500	6700
kPa (mmHg, inHg)	13.3 (100, 3.9)	13.3 (100, 3.9)	13.3 (100, 3.9)	13.3 (100, 3.9)	13.3 (100, 3.9)	13.3 (100, 3.9)

#### Map 2 (Models with SI-DRIVE)

rpm	700	1000	1500	2000	2500	3000	3500	4000
kPa (mmHg, inHg)	13.3 (100, 3.9)	13.3 (100, 3.9)	13.3 (100, 3.9)	13.3 (100, 3.9)	13.3 (100, 3.9)	13.3 (100, 3.9)	13.3 (100, 3.9)	13.3 (100, 3.9)

rpm	4500	5000	5500	6000	6500	6700
kPa (mmHg, inHg)	13.3 (100, 3.9)	13.3 (100, 3.9)	13.3 (100, 3.9)	13.3 (100, 3.9)	13.3 (100, 3.9)	13.3 (100, 3.9)

# Diagnostic Trouble Code (DTC) Detecting Criteria

## GENERAL DESCRIPTION

### 3. GENERAL DRIVING CYCLE

Always perform the diagnosis continuously.

### 4. DIAGNOSTIC METHOD

#### • Abnormality Judgment

Judge as NG when the following conditions are established.

#### Judgment Value

#### Models without SI-DRIVE

Malfunction Criteria	Threshold Value
<b>Rich</b> Main feedback learning value Sub feedback learning value When any one of the followings is established. <ul style="list-style-type: none"><li>• Any one of the rich side misfire counters for each cylinder when in idling</li><li>• Total of the rich side misfire counters for each cylinder when in idling</li><li>• Any one of the rich side misfire counters for each cylinder when not in idling</li><li>• Total of the rich side misfire counters for each cylinder when not in idling</li></ul>	< -0.16 < -0.0124 > 8 time(s) > 8 time(s) > 18 time(s) > 18 time(s)
<b>Lean</b> Main feedback learning value Sub feedback learning value When any one of the followings is established. <ul style="list-style-type: none"><li>• Any one of the lean side misfire counters for each cylinder when in idling</li><li>• Total of the lean side misfire counters for each cylinder when in idling</li><li>• Any one of the lean side misfire counters for each cylinder when not in idling</li><li>• Total of the lean side misfire counters for each cylinder when not in idling</li></ul>	> 0.075 < 0 > 113 time(s) > 65535 time(s) > 127 time(s) > 65535 time(s)

#### Models with SI-DRIVE

Malfunction Criteria	Threshold Value
<b>Rich</b> Main feedback learning value Sub feedback learning value When any one of the followings is established. <ul style="list-style-type: none"><li>• Any one of the rich side misfire counters for each cylinder when in idling</li><li>• Total of the rich side misfire counters for each cylinder when in idling</li><li>• Any one of the rich side misfire counters for each cylinder when not in idling</li><li>• Total of the rich side misfire counters for each cylinder when not in idling</li></ul>	< -0.14 < -0.017 > 9 time(s) > 9 time(s) > 20 time(s) > 20 time(s)
<b>Lean</b> Main feedback learning value Sub feedback learning value When any one of the followings is established. <ul style="list-style-type: none"><li>• Any one of the lean side misfire counters for each cylinder when in idling</li><li>• Total of the lean side misfire counters for each cylinder when in idling</li><li>• Any one of the lean side misfire counters for each cylinder when not in idling</li><li>• Total of the lean side misfire counters for each cylinder when not in idling</li></ul>	> 0 < 0 > 177 time(s) > 65535 time(s) > 192 time(s) > 65535 time(s)

**Time Needed for Diagnosis:** 1000 engine revs.

**Malfunction Indicator Light Illumination:** Illuminates when malfunction occurs in 2 continuous driving cycles.

#### • Normality Judgment

Judge as OK and clear the NG if the following conditions are established.

# Diagnostic Trouble Code (DTC) Detecting Criteria

GENERAL DESCRIPTION

## Judgment Value

### Models without SI-DRIVE

Malfunction Criteria	Threshold Value
<b>Rich</b> Main feedback learning value or Sub feedback learning value or All of the following conditions are established. <ul style="list-style-type: none"> <li>Any one of the rich side misfire counters for each cylinder when in idling</li> <li>Total of the rich side misfire counters for each cylinder when in idling</li> <li>Any one of the rich side misfire counters for each cylinder when not in idling</li> <li>Total of the rich side misfire counters for each cylinder when not in idling</li> </ul>	$\geq -0.16$  $\geq -0.0124$  $\leq 8 \text{ time(s)}$ $\leq 8 \text{ time(s)}$ $\leq 18 \text{ time(s)}$ $\leq 18 \text{ time(s)}$
<b>Lean</b> Main feedback learning value or Sub feedback learning value or All of the following conditions are established. <ul style="list-style-type: none"> <li>Any one of the lean side misfire counters for each cylinder when in idling</li> <li>Total of the lean side misfire counters for each cylinder when in idling</li> <li>Any one of the lean side misfire counters for each cylinder when not in idling</li> <li>Total of the lean side misfire counters for each cylinder when not in idling</li> </ul>	$\leq 0.075$  $\geq 0$  $\leq 113 \text{ time(s)}$ $\leq 65535 \text{ time(s)}$ $\leq 127 \text{ time(s)}$ $\leq 65535 \text{ time(s)}$

### Models with SI-DRIVE

Malfunction Criteria	Threshold Value
<b>Rich</b> Main feedback learning value or Sub feedback learning value or All of the following conditions are established. <ul style="list-style-type: none"> <li>Any one of the rich side misfire counters for each cylinder when in idling</li> <li>Total of the rich side misfire counters for each cylinder when in idling</li> <li>Any one of the rich side misfire counters for each cylinder when not in idling</li> <li>Total of the rich side misfire counters for each cylinder when not in idling</li> </ul>	$\geq -0.14$  $\geq -0.017$  $\leq 9 \text{ time(s)}$ $\leq 9 \text{ time(s)}$ $\leq 20 \text{ time(s)}$ $\leq 20 \text{ time(s)}$
<b>Lean</b> Main feedback learning value or Sub feedback learning value or All of the following conditions are established. <ul style="list-style-type: none"> <li>Any one of the lean side misfire counters for each cylinder when in idling</li> <li>Total of the lean side misfire counters for each cylinder when in idling</li> <li>Any one of the lean side misfire counters for each cylinder when not in idling</li> <li>Total of the lean side misfire counters for each cylinder when not in idling</li> </ul>	$\leq 0$  $\geq 0$  $\leq 177 \text{ time(s)}$ $\leq 65535 \text{ time(s)}$ $\leq 192 \text{ time(s)}$ $\leq 65535 \text{ time(s)}$

**Time Needed for Diagnosis:** 1000 engine revs.

# Diagnostic Trouble Code (DTC) Detecting Criteria

## GENERAL DESCRIPTION

### EZ:DTC P2401 EVAPORATIVE EMISSION SYSTEM LEAK DETECTION PUMP CONTROL CIRCUIT LOW

#### 1. OUTLINE OF DIAGNOSIS

Detect the open or short circuit of the ELCM vacuum pump.  
Judge as NG if out of specification.

#### 2. COMPONENT DESCRIPTION

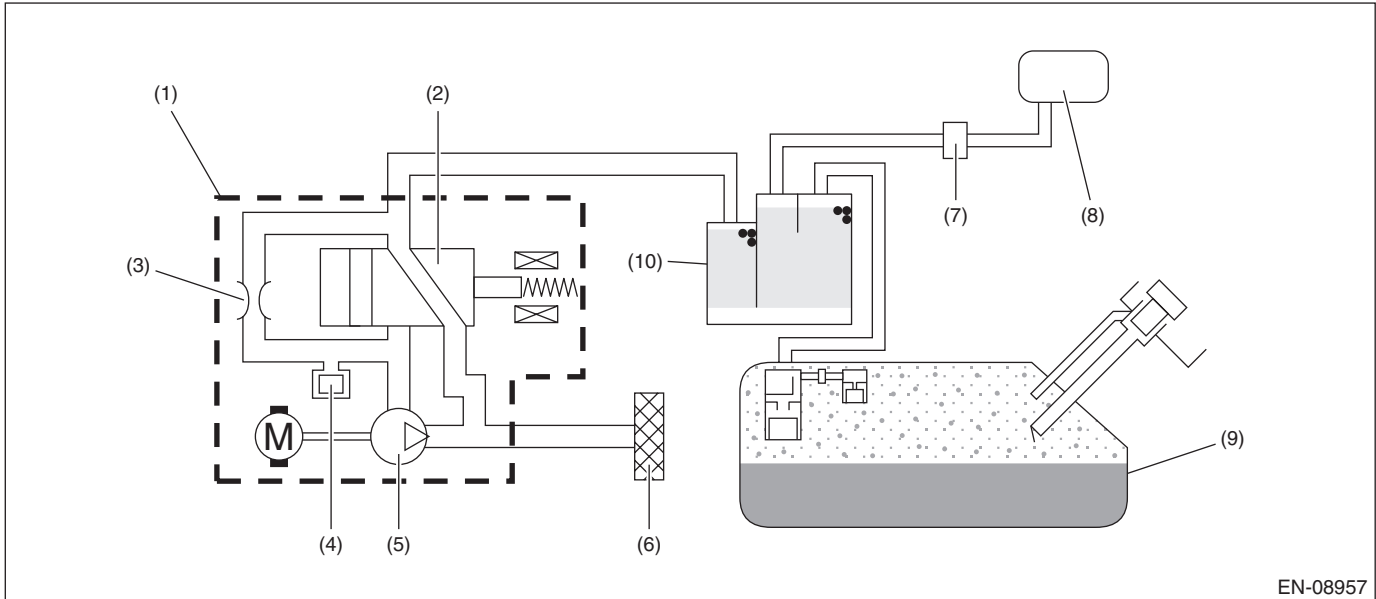

- |   |                                  |               |
|---|----------------------------------|---------------|
| (1) ELCM                                  | (5) Vacuum pump                  | (9) Fuel tank |
| (2) Switching valve                       | (6) Drain filter                 | (10) Canister |
| (3) Reference orifice (0.02 inch orifice) | (7) Purge control solenoid valve |               |
| (4) Pressure sensor                       | (8) Intake manifold              |               |

#### 3. ENABLE CONDITIONS

Secondary Parameters	Enable Conditions
None	

#### 4. GENERAL DRIVING CYCLE

Always perform the diagnosis continuously.

# Diagnostic Trouble Code (DTC) Detecting Criteria

GENERAL DESCRIPTION

## 5. DIAGNOSTIC METHOD

### • Abnormality Judgment

If the duration of time while the following conditions are met is longer than the time indicated, judge as NG.

#### Judgment Value

Malfunction Criteria	Threshold Value
Battery voltage	$\geq 10.9$
Terminal output voltage when ECM outputs OFF signal	Low

**Time Needed for Diagnosis:** 2500 ms

**Malfunction Indicator Light Illumination:** Illuminates as soon as a malfunction occurs.

### • Normality Judgment

Judge as OK and clear the NG if the continuous time while the following conditions are established is more than the predetermined time.

#### Judgment Value

Malfunction Criteria	Threshold Value
Battery voltage	$\geq 10.9$
Terminal output voltage when ECM outputs OFF signal	High

**Time Needed for Diagnosis:** Less than 1 second

# Diagnostic Trouble Code (DTC) Detecting Criteria

## GENERAL DESCRIPTION

### FA:DTC P2402 EVAPORATIVE EMISSION SYSTEM LEAK DETECTION PUMP CONTROL CIRCUIT HIGH

#### 1. OUTLINE OF DIAGNOSIS

Detect the open or short circuit of the ELCM vacuum pump.  
Judge as NG if out of specification.

#### 2. COMPONENT DESCRIPTION

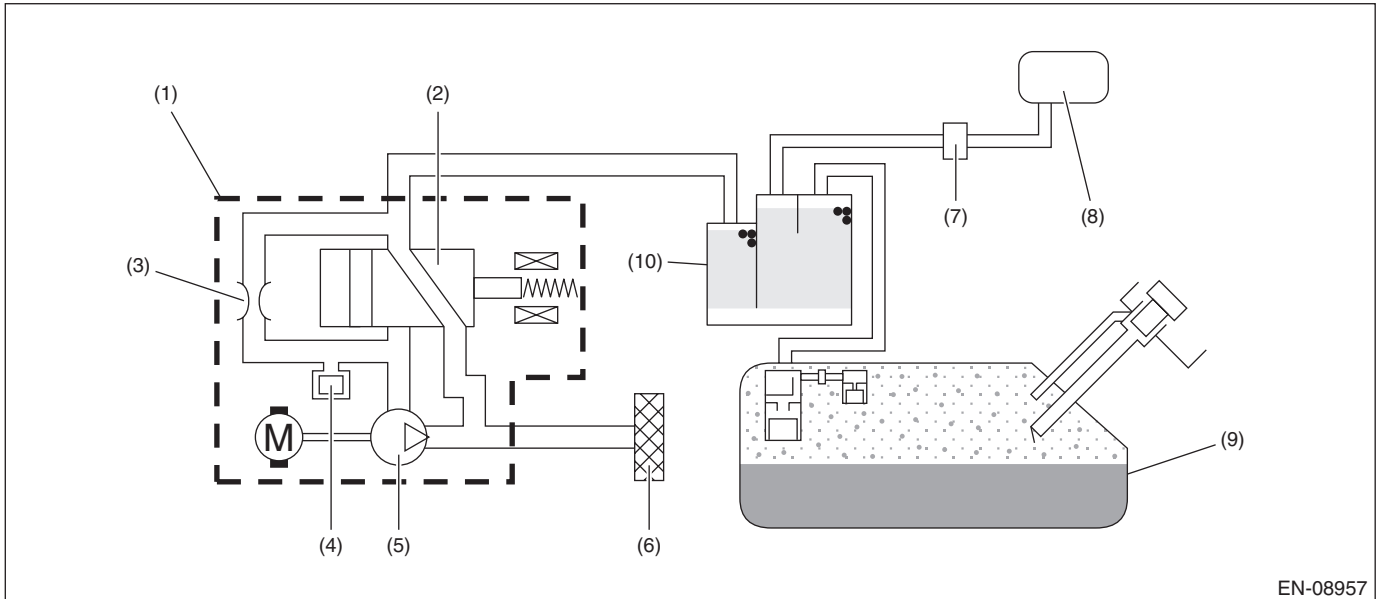

- |   |                                  |               |
|---|----------------------------------|---------------|
| (1) ELCM                                  | (5) Vacuum pump                  | (9) Fuel tank |
| (2) Switching valve                       | (6) Drain filter                 | (10) Canister |
| (3) Reference orifice (0.02 inch orifice) | (7) Purge control solenoid valve |               |
| (4) Pressure sensor                       | (8) Intake manifold              |               |

#### 3. ENABLE CONDITIONS

Secondary Parameters	Enable Conditions
None	

#### 4. GENERAL DRIVING CYCLE

Always perform the diagnosis continuously.

# Diagnostic Trouble Code (DTC) Detecting Criteria

GENERAL DESCRIPTION

## 5. DIAGNOSTIC METHOD

### • Abnormality Judgment

If the duration of time while the following conditions are met is longer than the time indicated, judge as NG.

#### Judgment Value

Malfunction Criteria	Threshold Value
Battery voltage	≥ 10.9
Terminal output voltage when ECM outputs ON signal	High

**Time Needed for Diagnosis:** 2500 ms

**Malfunction Indicator Light Illumination:** Illuminates as soon as a malfunction occurs.

### • Normality Judgment

Judge as OK and clear the NG if the continuous time while the following conditions are established is more than the predetermined time.

#### Judgment Value

Malfunction Criteria	Threshold Value
Battery voltage	≥ 10.9
Terminal output voltage when ECM outputs ON signal	Low

**Time Needed for Diagnosis:** Less than 1 second

## **FB:DTC P2404 EVAPORATIVE EMISSION SYSTEM LEAK DETECTION PUMP SENSE CIRCUIT RANGE/PERFORMANCE**

### 1. OUTLINE OF DIAGNOSIS

NOTE:

For the detection standard, refer to DTC P0455. <Ref. to GD(H4DOTC)-154, DTC P0455 EVAPORATIVE EMISSION SYSTEM LEAK DETECTED (LARGE LEAK), Diagnostic Trouble Code (DTC) Detecting Criteria.>



# Diagnostic Trouble Code (DTC) Detecting Criteria

## GENERAL DESCRIPTION

### FC:DTC P2419 EVAPORATIVE EMISSION SYSTEM SWITCHING VALVE CONTROL CIRCUIT LOW

#### 1. OUTLINE OF DIAGNOSIS

Detect the open or short circuit of the ELCM switching valve.  
Judge as NG if out of specification.

#### 2. COMPONENT DESCRIPTION

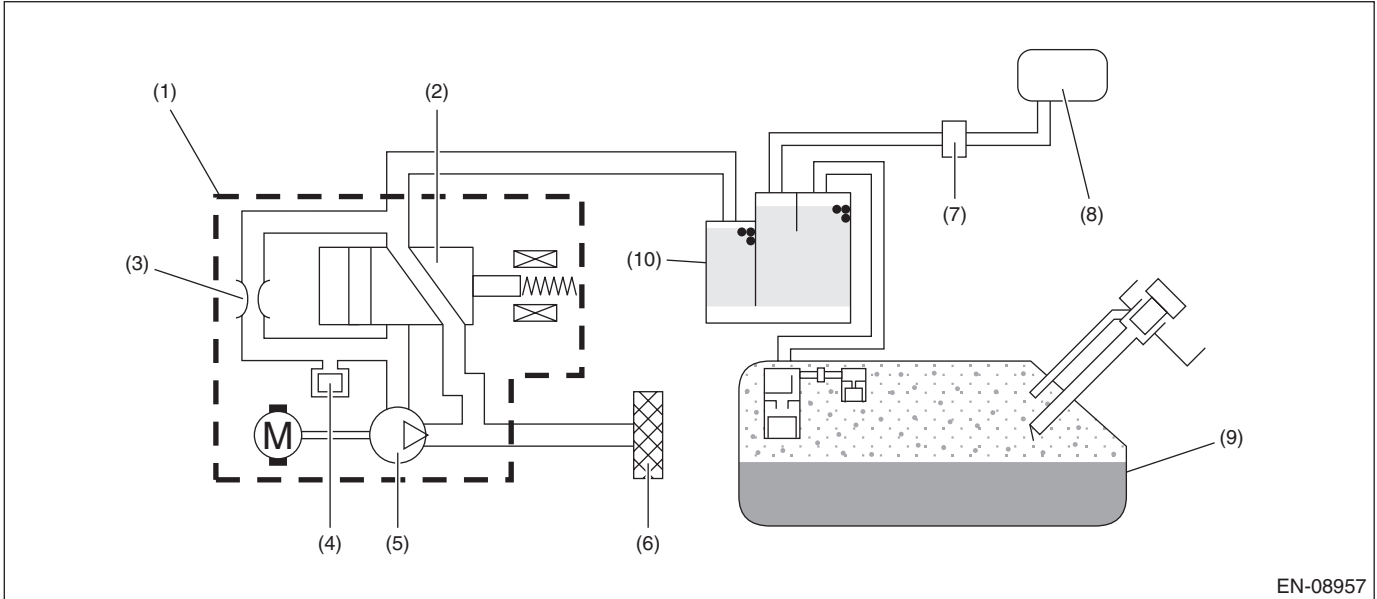

EN-08957

- |   |                                  |               |
|---|----------------------------------|---------------|
| (1) ELCM                                  | (5) Vacuum pump                  | (9) Fuel tank |
| (2) Switching valve                       | (6) Drain filter                 | (10) Canister |
| (3) Reference orifice (0.02 inch orifice) | (7) Purge control solenoid valve |               |
| (4) Pressure sensor                       | (8) Intake manifold              |               |

#### 3. ENABLE CONDITIONS

Secondary Parameters	Enable Conditions
None	

#### 4. GENERAL DRIVING CYCLE

Always perform the diagnosis continuously.

# Diagnostic Trouble Code (DTC) Detecting Criteria

GENERAL DESCRIPTION

## 5. DIAGNOSTIC METHOD

### • Abnormality Judgment

If the duration of time while the following conditions are met is longer than the time indicated, judge as NG.

#### Judgment Value

Malfunction Criteria	Threshold Value
Battery voltage	$\geq 10.9$
Terminal output voltage when ECM outputs OFF signal	Low

**Time Needed for Diagnosis:** 2500 ms

**Malfunction Indicator Light Illumination:** Illuminates as soon as a malfunction occurs.

### • Normality Judgment

Judge as OK and clear the NG if the continuous time while the following conditions are established is more than the predetermined time.

#### Judgment Value

Malfunction Criteria	Threshold Value
Battery voltage	$\geq 10.9$
Terminal output voltage when ECM outputs OFF signal	High

**Time Needed for Diagnosis:** Less than 1 second

# Diagnostic Trouble Code (DTC) Detecting Criteria

## GENERAL DESCRIPTION

### FD:DTC P2420 EVAPORATIVE EMISSION SYSTEM SWITCHING VALVE CONTROL CIRCUIT HIGH

#### 1. OUTLINE OF DIAGNOSIS

Detect the open or short circuit of the ELCM switching valve.

Judge as NG if out of specification.

#### 2. COMPONENT DESCRIPTION

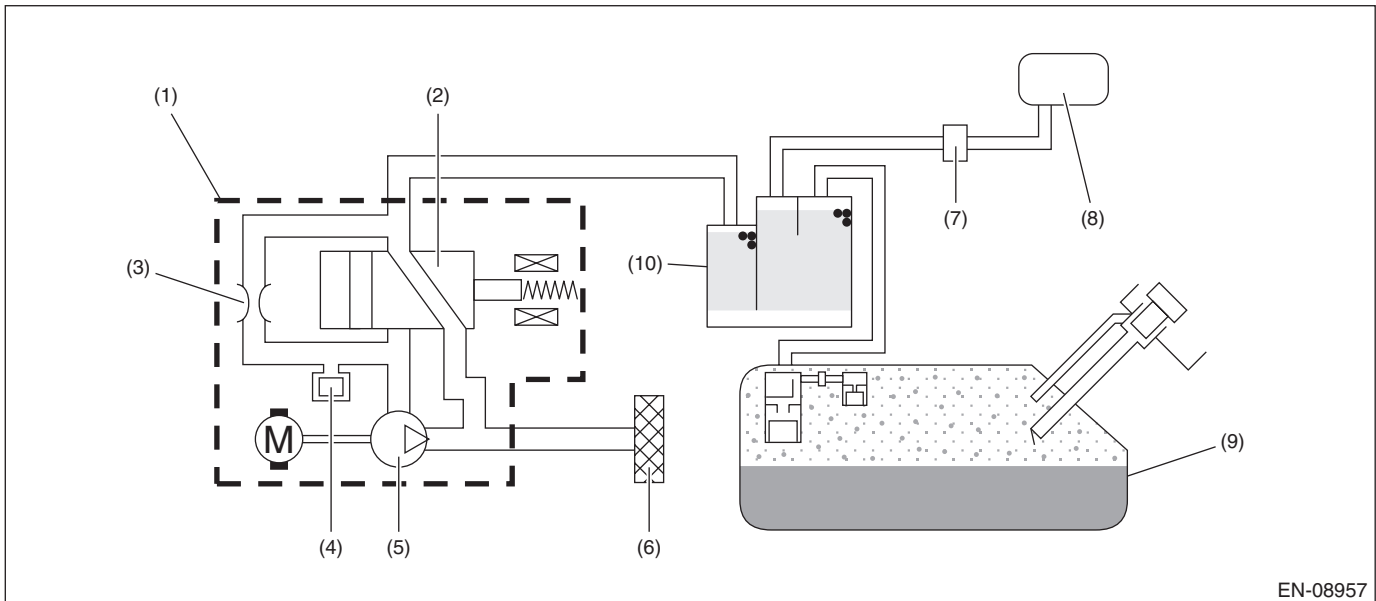

- |   |                                  |               |
|---|----------------------------------|---------------|
| (1) ELCM                                  | (5) Vacuum pump                  | (9) Fuel tank |
| (2) Switching valve                       | (6) Drain filter                 | (10) Canister |
| (3) Reference orifice (0.02 inch orifice) | (7) Purge control solenoid valve |               |
| (4) Pressure sensor                       | (8) Intake manifold              |               |

#### 3. ENABLE CONDITIONS

Secondary Parameters	Enable Conditions
None	

#### 4. GENERAL DRIVING CYCLE

Always perform the diagnosis continuously.

# Diagnostic Trouble Code (DTC) Detecting Criteria

GENERAL DESCRIPTION

## 5. DIAGNOSTIC METHOD

### • Abnormality Judgment

If the duration of time while the following conditions are met is longer than the time indicated, judge as NG.

#### Judgment Value

Malfunction Criteria	Threshold Value
Battery voltage	$\geq 10.9$
Terminal output voltage when ECM outputs ON signal	High

**Time Needed for Diagnosis:** 2500 ms

**Malfunction Indicator Light Illumination:** Illuminates as soon as a malfunction occurs.

### • Normality Judgment

Judge as OK and clear the NG if the continuous time while the following conditions are established is more than the predetermined time.

#### Judgment Value

Malfunction Criteria	Threshold Value
Battery voltage	$\geq 10.9$
Terminal output voltage when ECM outputs ON signal	Low

**Time Needed for Diagnosis:** Less than 1 second

# Diagnostic Trouble Code (DTC) Detecting Criteria

## GENERAL DESCRIPTION

### FE:DTC P2431 SECONDARY AIR INJECTION SYSTEM AIR FLOW /PRESSURE SENSOR CIRCUIT RANGE/PERFORMANCE

#### 1. OUTLINE OF DIAGNOSIS

Detect the malfunction of secondary air pressure sensor output property.

Judge as NG when the secondary air pressure sensor output is largely different from the intake manifold pressure at engine start.

#### 2. ENABLE CONDITIONS

Secondary Parameters	Enable Conditions
Engine speed	< 300 rpm
Vehicle speed	< 1 km/h (0.6 MPH)
After secondary air system stops	≥ 2976 ms

#### 3. GENERAL DRIVING CYCLE

Perform the diagnosis with ignition switch ON.

#### 4. DIAGNOSTIC METHOD

##### • Abnormality Judgment

If the duration of time while the following conditions are met is longer than the time indicated, judge as NG.

##### Judgment Value

Malfunction Criteria	Threshold Value
Secondary air pipe pressure – Intake manifold pressure	≥ 26.7 kPa (200 mmHg, 7.9 inHg)
Intake manifold pressure at engine start – Intake manifold pressure	< 1.3 kPa (9.99 mmHg, 0.4 inHg)

**Time Needed for Diagnosis:** 328 ms

**Malfunction Indicator Light Illumination:** Illuminates when malfunction occurs in 2 continuous driving cycles.

##### • Normality Judgment

Judge as OK and clear the NG if the continuous time while the following conditions are established is more than the predetermined time.

##### Judgment Value

Malfunction Criteria	Threshold Value
Secondary air pipe pressure – Intake manifold pressure	< 26.7 kPa (200 mmHg, 7.9 inHg)

**Time Needed for Diagnosis:** 262 ms

# Diagnostic Trouble Code (DTC) Detecting Criteria

GENERAL DESCRIPTION

## FF: DTC P2432 SECONDARY AIR INJECTION SYSTEM AIR FLOW /PRESSURE SENSOR CIRCUIT LOW

### 1. OUTLINE OF DIAGNOSIS

Judge as NG if out of specification.

### 2. ENABLE CONDITIONS

Secondary Parameters	Enable Conditions
None	

### 3. GENERAL DRIVING CYCLE

Always perform the diagnosis continuously.

### 4. DIAGNOSTIC METHOD

#### • Abnormality Judgment

If the duration of time while the following conditions are met is longer than the time indicated, judge as NG.

#### Judgment Value

Malfunction Criteria	Threshold Value
Ignition switch	ON
Output voltage	< 0.573 V

**Time Needed for Diagnosis:** 500 ms

**Malfunction Indicator Light Illumination:** Illuminates as soon as a malfunction occurs.

#### • Normality Judgment

Judge as OK and clear the NG if the continuous time while the following conditions are established is more than the predetermined time.

#### Judgment Value

Malfunction Criteria	Threshold Value
Ignition switch	ON
Output voltage	≥ 0.573 V

**Time Needed for Diagnosis:** Less than 1 second

# Diagnostic Trouble Code (DTC) Detecting Criteria

## GENERAL DESCRIPTION

---

### FG:DTC P2433 SECONDARY AIR INJECTION SYSTEM AIR FLOW /PRESSURE SENSOR CIRCUIT HIGH

#### 1. OUTLINE OF DIAGNOSIS

Judge as NG if out of specification.

#### 2. ENABLE CONDITIONS

Secondary Parameters	Enable Conditions
None	

#### 3. GENERAL DRIVING CYCLE

Always perform the diagnosis continuously.

#### 4. DIAGNOSTIC METHOD

##### • Abnormality Judgment

If the duration of time while the following conditions are met is longer than the time indicated, judge as NG.

##### Judgment Value

Malfunction Criteria	Threshold Value
Ignition switch	ON
Output voltage	> 4.916 V

**Time Needed for Diagnosis:** 500 ms

**Malfunction Indicator Light Illumination:** Illuminates as soon as a malfunction occurs.

##### • Normality Judgment

Judge as OK and clear the NG if the continuous time while the following conditions are established is more than the predetermined time.

##### Judgment Value

Malfunction Criteria	Threshold Value
Ignition switch	ON
Output voltage	≤ 4.916 V

**Time Needed for Diagnosis:** Less than 1 second

## Diagnostic Trouble Code (DTC) Detecting Criteria

GENERAL DESCRIPTION

---

### **FH:DTC P2440 SECONDARY AIR INJECTION SYSTEM SWITCHING VALVE STUCK OPEN (BANK1)**

#### **1. OUTLINE OF DIAGNOSIS**

**NOTE:**

For the detection standard, refer to DTC P0410. <Ref. to GD(H4DOTC)-130, DTC P0410 SECONDARY AIR INJECTION SYSTEM, Diagnostic Trouble Code (DTC) Detecting Criteria.>

### **FI: DTC P2441 SECONDARY AIR INJECTION SYSTEM SWITCHING VALVE STUCK CLOSED (BANK1)**

#### **1. OUTLINE OF DIAGNOSIS**

**NOTE:**

For the detection standard, refer to DTC P0410. <Ref. to GD(H4DOTC)-130, DTC P0410 SECONDARY AIR INJECTION SYSTEM, Diagnostic Trouble Code (DTC) Detecting Criteria.>

### **FJ: DTC P2442 SECONDARY AIR INJECTION SYSTEM SWITCHING VALVE STUCK OPEN (BANK2)**

#### **1. OUTLINE OF DIAGNOSIS**

**NOTE:**

For the detection standard, refer to DTC P0410. <Ref. to GD(H4DOTC)-130, DTC P0410 SECONDARY AIR INJECTION SYSTEM, Diagnostic Trouble Code (DTC) Detecting Criteria.>

### **FK:DTC P2443 SECONDARY AIR INJECTION SYSTEM SWITCHING VALVE STUCK CLOSED (BANK2)**

#### **1. OUTLINE OF DIAGNOSIS**

**NOTE:**

For the detection standard, refer to DTC P0410. <Ref. to GD(H4DOTC)-130, DTC P0410 SECONDARY AIR INJECTION SYSTEM, Diagnostic Trouble Code (DTC) Detecting Criteria.>



# Diagnostic Trouble Code (DTC) Detecting Criteria

## GENERAL DESCRIPTION

---

### FL:DTC P2444 SECONDARY AIR INJECTION SYSTEM PUMP STUCK ON

#### 1. OUTLINE OF DIAGNOSIS

Detect the secondary air pump malfunction (always ON).

After the secondary air pump turns to OFF, judge as NG if the secondary air pipe pressure is higher than that before the secondary air pump operation.

#### 2. ENABLE CONDITIONS

Secondary Parameters	Enable Conditions
Battery voltage	$\geq 7$ V
Engine	In operation

#### 3. GENERAL DRIVING CYCLE

Always perform the diagnosis continuously.

#### 4. DIAGNOSTIC METHOD

##### • Abnormality Judgment

If the duration of time while the following conditions are met is longer than the time indicated, judge as NG.

##### Judgment Value

Malfunction Criteria	Threshold Value
Time since secondary air control completion	$\geq 3000$ ms and $\leq 8000$ ms
Secondary air pipe pressure – Secondary air pipe pressure before operation	$> 6.7$ kPa (50 mmHg, 2 inHg)

**Time Needed for Diagnosis:** 8000 ms

**Malfunction Indicator Light Illumination:** Illuminates as soon as a malfunction occurs.

##### • Normality Judgment

Judge as OK and clear the NG if the continuous time while the following conditions are established is more than the predetermined time.

##### Judgment Value

Malfunction Criteria	Threshold Value
Time since secondary air control completion	$\geq 3000$ ms and $\leq 8000$ ms
Secondary air pipe pressure – Secondary air pipe pressure before operation	$\leq 6.7$ kPa (50 mmHg, 2 inHg)

**Time Needed for Diagnosis:** 8000 ms

# Diagnostic Trouble Code (DTC) Detecting Criteria

GENERAL DESCRIPTION

## FM:DTC P2610 ECM/PCM INTERNAL ENGINE OFF TIMER PERFORMANCE

### 1. OUTLINE OF DIAGNOSIS

Detect malfunction of soaking timer IC by the five diagnoses below.

Monitor Number	Explanation	Time required for diagnosis
Monitor #1 <Timer diagnosis>	Perform diagnosis of the soaking timer IC accuracy	196 ms
Monitor #2 <Full count diagnosis>	Perform diagnosis of the soaking timer IC counter function	4000 ms
Monitor #3 <Soaking timer IC setting diagnosis>	Perform diagnosis of communication between ECM and soaking timer IC	196 ms
Monitor #4 <Timer diagnosis (during soaking)>	Perform diagnosis of the soaking timer IC accuracy during soaking	3000 ms
Monitor #5 <Wake-up diagnosis>	Perform diagnosis of wake-up function	64 ms

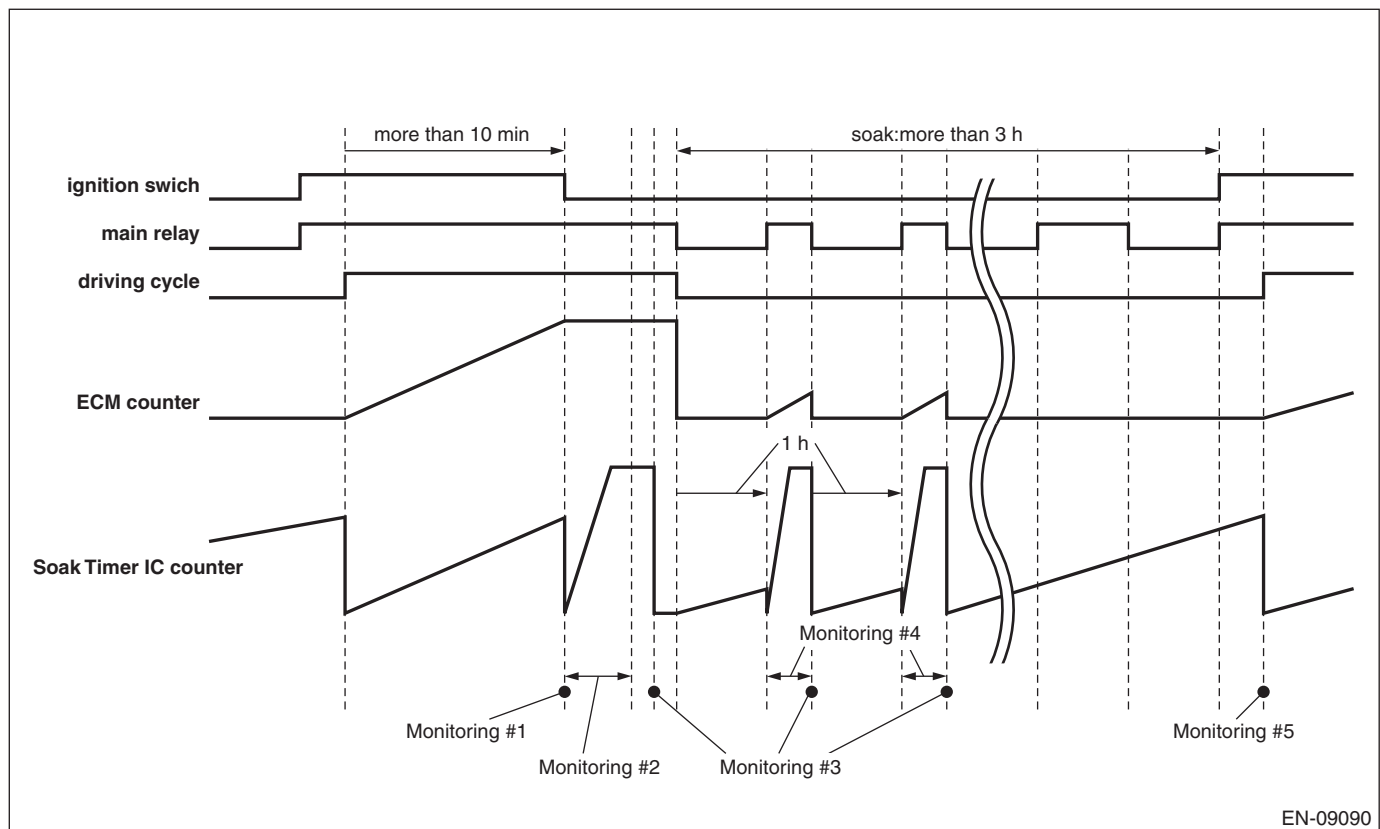

### 2. COMPONENT DESCRIPTION

The soaking timer IC is built into the ECM.

# Diagnostic Trouble Code (DTC) Detecting Criteria

## GENERAL DESCRIPTION

### 3. ENABLE CONDITIONS

Secondary Parameters	Enable Conditions
<Timer diagnosis>	
Battery voltage	$\geq 10.9 \text{ V}$
Ignition switch	OFF
Elapsed time after starting the engine	$> 600 \text{ s}$
< Full count diagnosis & soaking timer IC setting diagnosis>	
Battery voltage	$\geq 10.9 \text{ V}$
Ignition switch	OFF
<Timer diagnosis (during soaking)>	
Battery voltage	$\geq 10.9 \text{ V}$
Ignition switch	OFF
Number of wake-up	$< 5 \text{ time(s)}$
<Wake-up diagnosis>	
Ignition switch	ON
Wake-up activation time setting	Completed
Time in the soaking timer IC	$> 3600 \text{ s} \times 5 \text{ time(s)}$

### 4. GENERAL DRIVING CYCLE

Perform the diagnosis only once when 10 minutes have passed after the engine start and the ignition switch is OFF, and also when the ignition switch is ON after the soaking of five hours or more.

### 5. DIAGNOSTIC METHOD

#### <Timer diagnosis>

Start the count up operation of counters in ECM and in soaking timer IC when the engine is started.

Judge as timer malfunction if the difference between the counter in ECM and counter in soaking timer IC exceeds the allowable limit when the ignition switch is OFF.

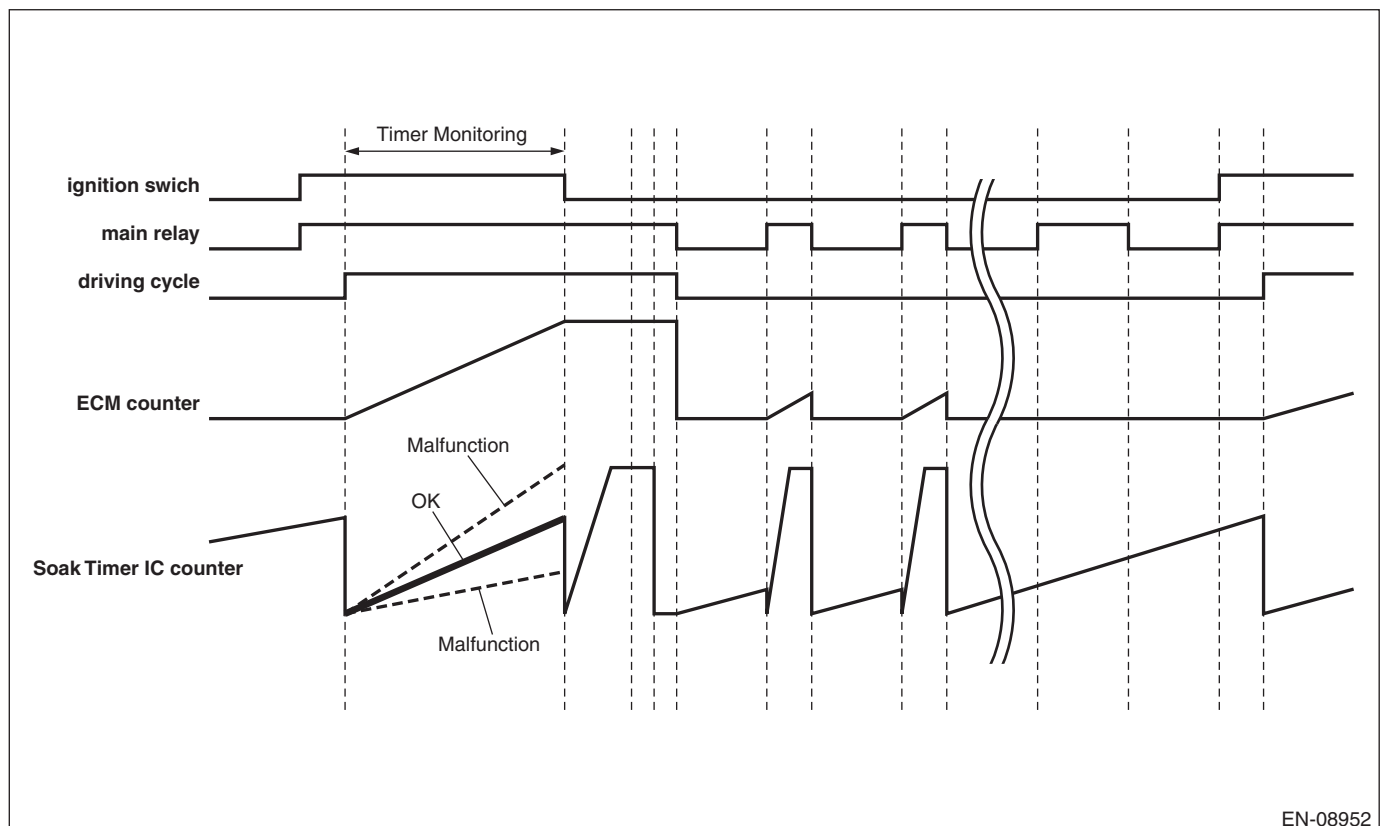

# Diagnostic Trouble Code (DTC) Detecting Criteria

GENERAL DESCRIPTION

## • Abnormality Judgment

Judge as NG when the following conditions are established.

### Judgment Value

Malfunction Criteria	Threshold Value
$ \text{osoaktimcpu} - \text{osoaktimic}  / \text{osoaktimcpu}$	$> 0.24$
osoaktimcpu = Counter in ECM osoaktimic = Counter in soaking timer IC	

## • Normality Judgment

Judge as OK when the following conditions are established.

### Judgment Value

Malfunction Criteria	Threshold Value
$ \text{osoaktimcpu} - \text{osoaktimic}  / \text{osoaktimcpu}$	$\leq 0.24$

## <Full count diagnosis>

After the timer diagnosis is completed, reset the counter in soaking timer IC and start the count up operation. Judge as full count diagnosis malfunction if counter in soaking timer IC is not \$3FF (1023 count) after 4 seconds.

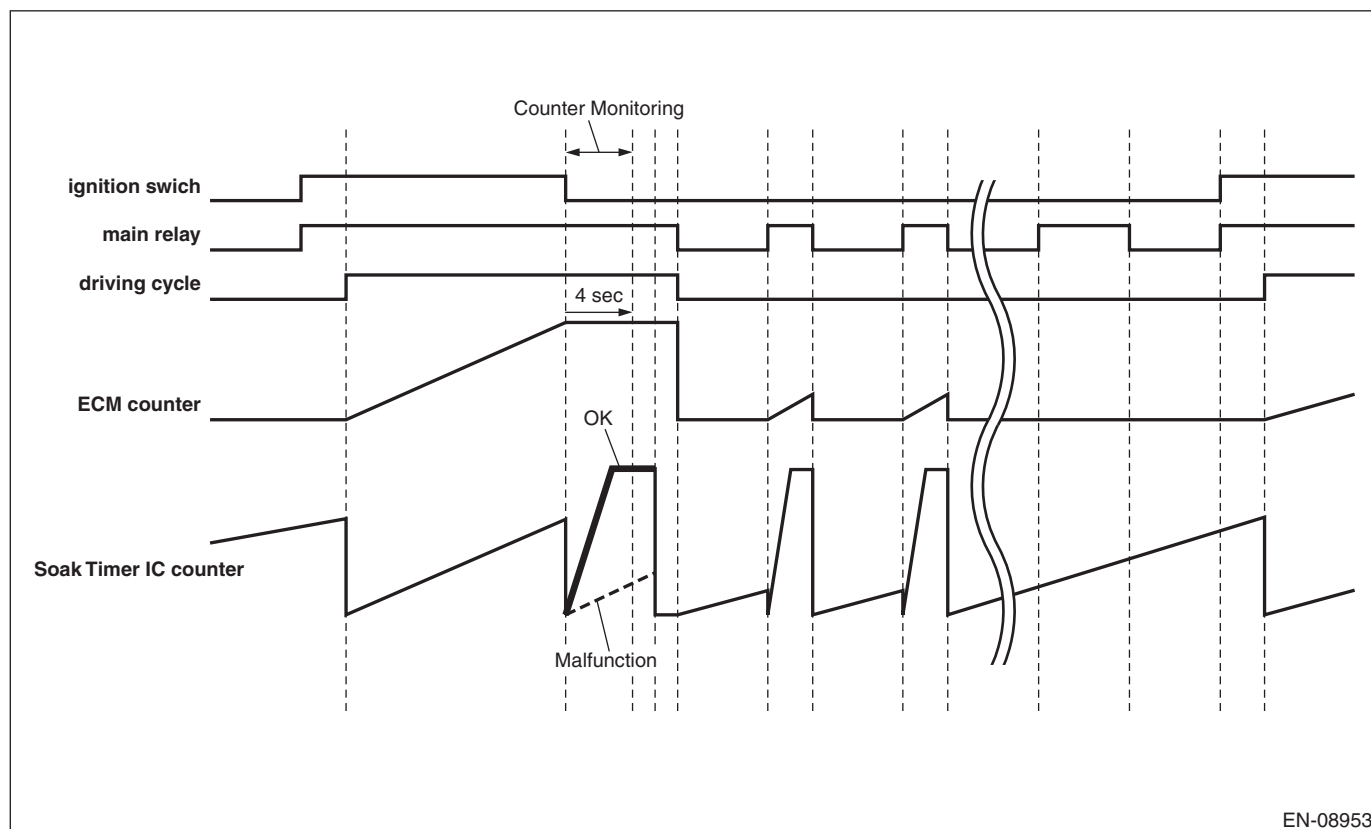

EN-08953

## • Abnormality Judgment

Judge as NG when the following conditions are established.

### Judgment Value

Malfunction Criteria	Threshold Value
osoakfctic	$\neq \$3FF$ (1023 count)
osoakfctic = Counter in soaking timer IC	

# Diagnostic Trouble Code (DTC) Detecting Criteria

## GENERAL DESCRIPTION

### • Normality Judgment

Judge as OK when the following conditions are established.

#### Judgment Value

Malfunction Criteria	Threshold Value
osoakfctnc	= \$3FF (1023 count)

### <Soaking timer IC setting diagnosis>

When setting the activation setting time to soaking timer IC, compare the writing value to soaking timer IC with read out value. Judge as malfunction if the values do not match 3 times in a row.

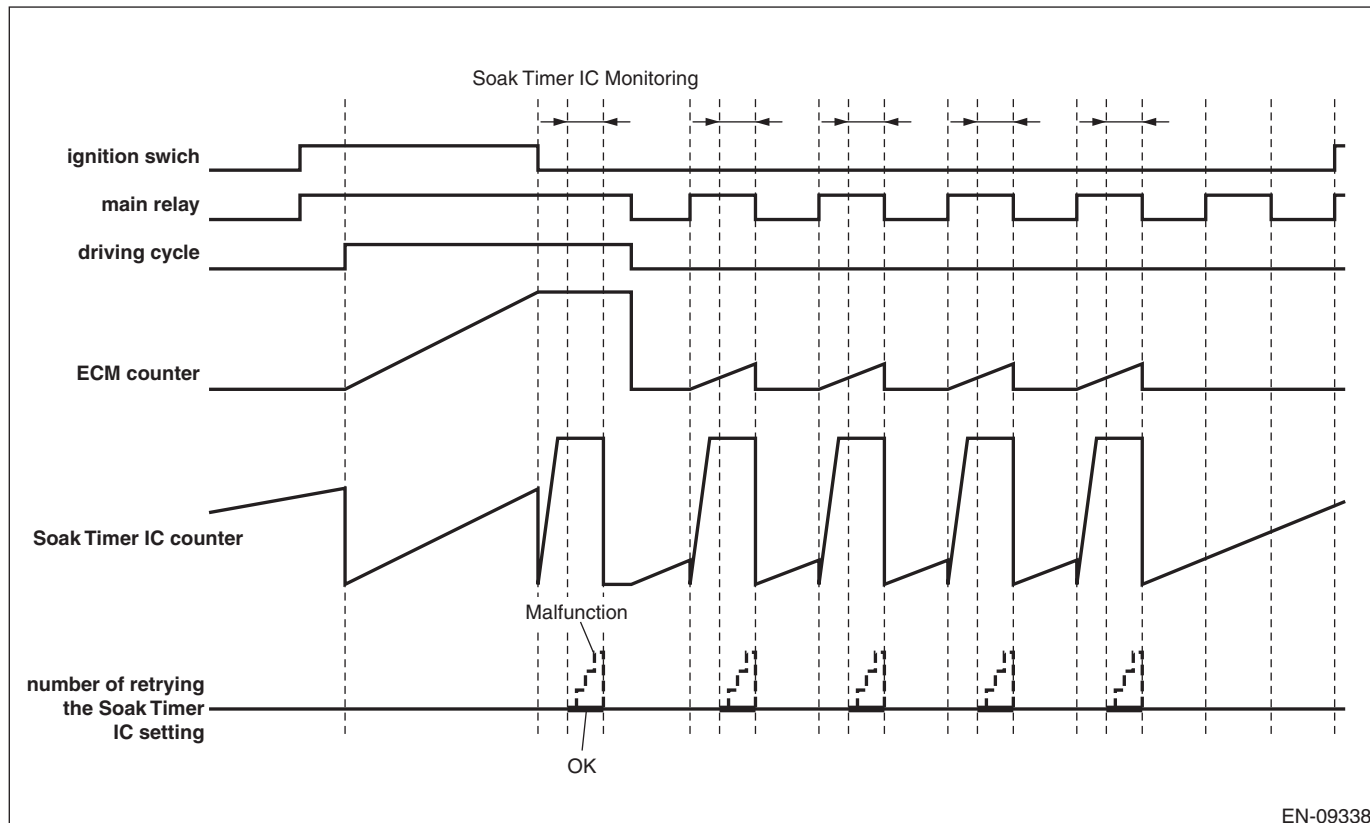

### • Abnormality Judgment

Judge as NG when the following conditions are established.

#### Judgment Value

Malfunction Criteria	Threshold Value
Writing value and read out value when setting the soaking timer	Unmatch
Number of retrying the soaking timer setting	≥ 3 times

### • Normality Judgment

Judge as OK when the following conditions are established.

#### Judgment Value

Malfunction Criteria	Threshold Value
Writing value and read out value when setting the soaking timer	Match

# Diagnostic Trouble Code (DTC) Detecting Criteria

GENERAL DESCRIPTION

## <Timer diagnosis (during soaking)>

Wake-up at the predetermined interval until five hours have passed after the ignition switch is OFF, and compare the counter in soaking timer IC with the counter in ECM.

Judge as malfunction if the counter in soaking timer IC is counted up to maximum value (1023 count) when the counter in ECM is 1637 ms, or if the counter in soaking timer IC is not counted up to maximum value (1023 count) when the counter in ECM is 2455 ms.

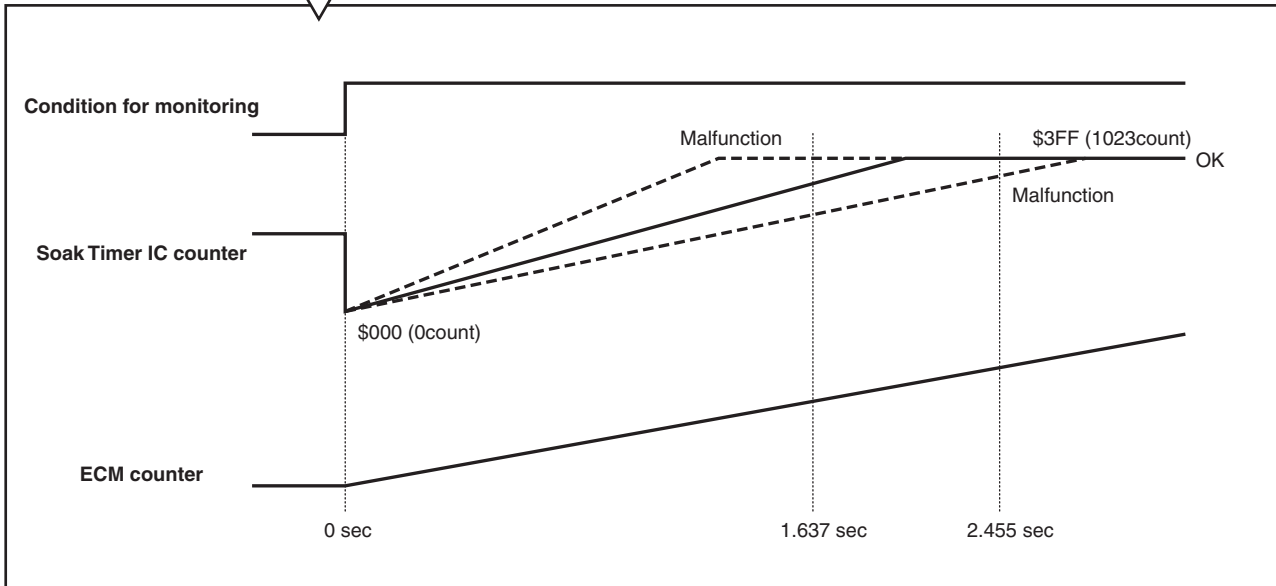
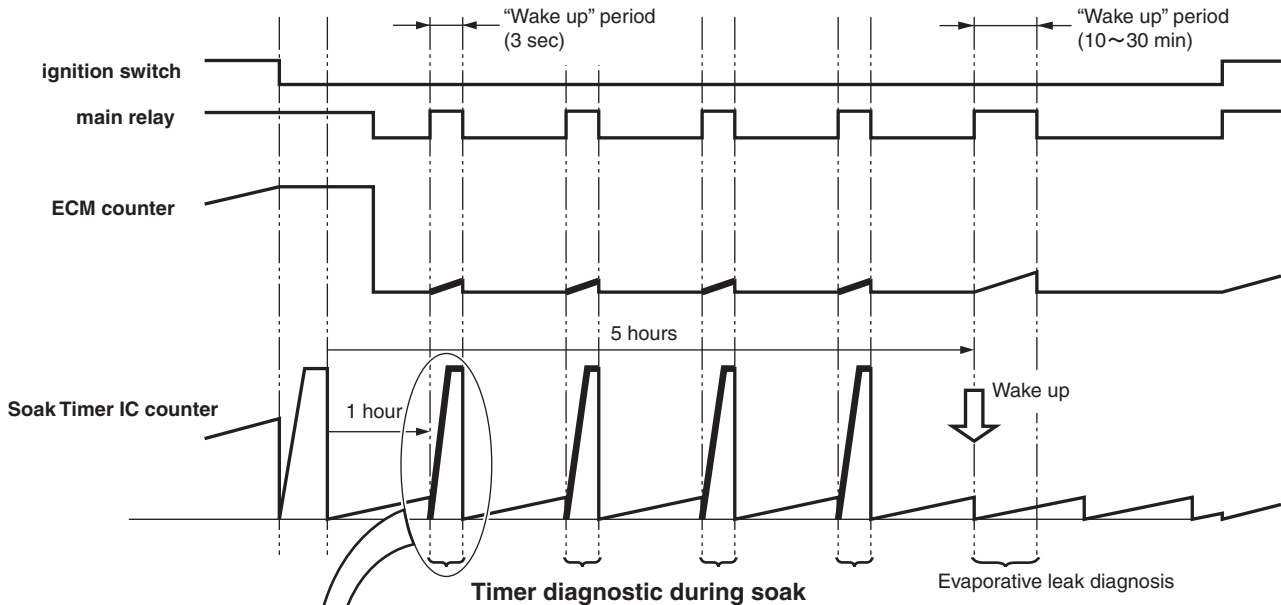

EN-08981

# Diagnostic Trouble Code (DTC) Detecting Criteria

## GENERAL DESCRIPTION

---

### • Abnormality Judgment

Judge as NG when the following conditions are established.

#### Judgment Value

Malfunction Criteria	Threshold Value
When any one of the followings is established.	
• All of the following conditions are established. Counter in ECM Counter in soaking timer IC	$\leq 1637$ ms = \$ 3FF (1023 count)
• All of the following conditions are established. Counter in ECM Counter in soaking timer IC	$\geq 2455$ ms $\neq$ \$ 3FF (1023 count)

### • Normality Judgment

Judge as OK when the following conditions are established.

#### Judgment Value

Malfunction Criteria	Threshold Value
Following conditions are established.	
• All of the following conditions are established. Counter in ECM Counter in soaking timer IC	$\leq 1637$ ms $\neq$ \$ 3FF (1023 count)
• All of the following conditions are established. Counter in ECM Counter in soaking timer IC	$\geq 2455$ ms = \$ 3FF (1023 count)

# Diagnostic Trouble Code (DTC) Detecting Criteria

GENERAL DESCRIPTION

## <Wake-up diagnosis>

Store the number of wake-up activation when the ECM wakes up by the soaking timer IC. Next time when the ignition switch is ON, if the number of wake-up activation does not reach the predetermined value even though the counter in soaking timer IC exceeds the activation setting time, judge as wake-up malfunction.

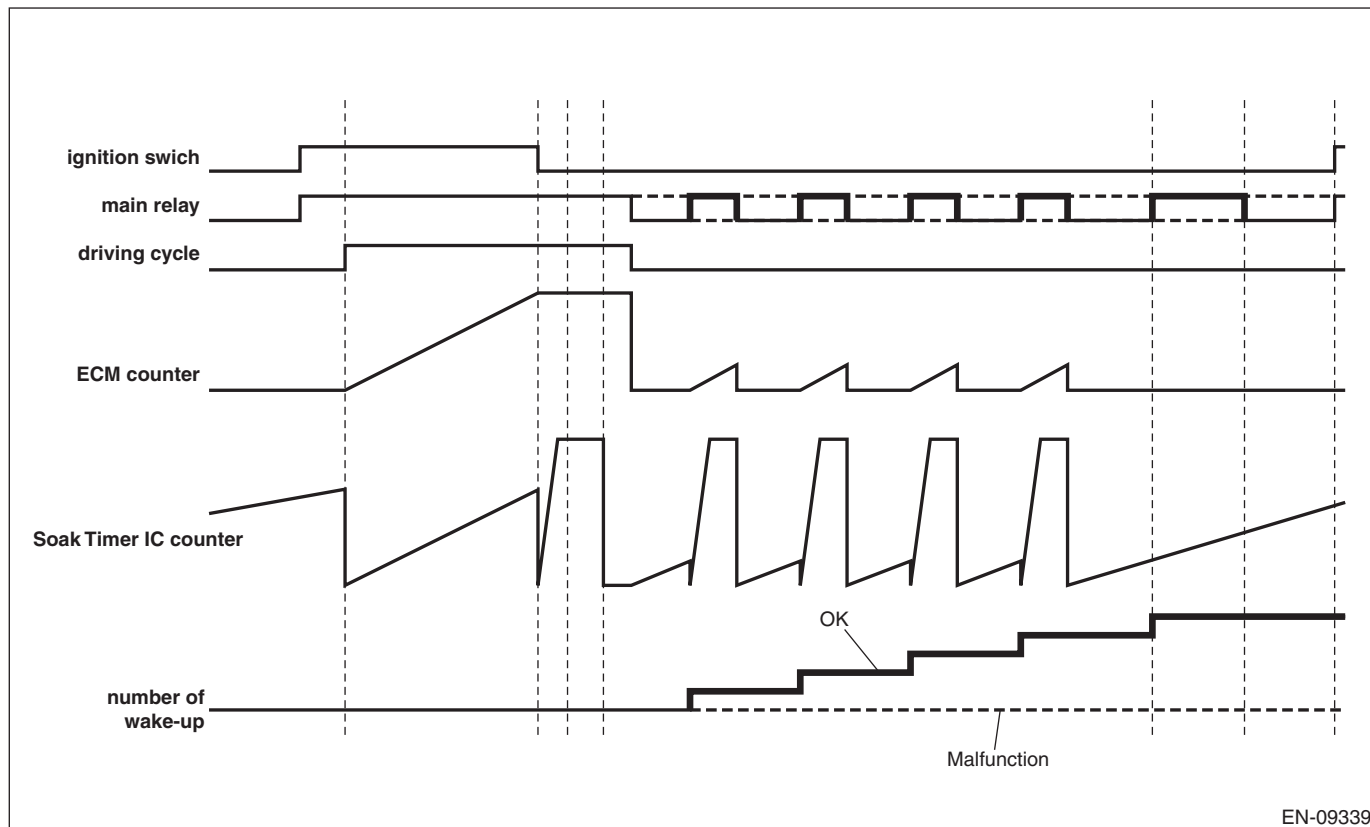

EN-09339

### • Abnormality Judgment

Judge as NG when the following conditions are established.

#### Judgment Value

Malfunction Criteria	Threshold Value
Number of wake-up	< 5 time(s)

### • Normality Judgment

Judge as OK when the following conditions are established.

#### Judgment Value

Malfunction Criteria	Threshold Value
Number of wake-up	≥ 5 time(s)



# Diagnostic Trouble Code (DTC) Detecting Criteria

## GENERAL DESCRIPTION

---

### • Abnormality Judgment

Judge as NG when the following conditions are established.

#### Judgment Value

Malfunction Criteria	Threshold Value
Ignition switch	ON
Driving cycle	Completed
When any one of the followings is established.	
• Timer diagnosis	NG
• Full count diagnosis	NG
• Soaking timer IC setting diagnosis	NG
• Timer diagnosis (during soaking)	NG
• Wake-up diagnosis	NG

**Time Needed for Diagnosis:** 18620 s (Approx. 5 hours)

**Malfunction Indicator Light Illumination:** Illuminates when malfunction occurs in 2 continuous driving cycles.

### • Normality Judgment

Judge as OK and clear the NG if the following conditions are established.

#### Judgment Value

Malfunction Criteria	Threshold Value
Ignition switch	ON
Driving cycle	Completed
All of the following conditions are established.	
• Timer diagnosis	OK
• Full count diagnosis	OK
• Soaking timer IC setting diagnosis	OK
• Timer diagnosis (during soaking)	OK
• Wake-up diagnosis	OK

**Time Needed for Diagnosis:** 18620 s (Approx. 5 hours)

# Diagnostic Trouble Code (DTC) Detecting Criteria

GENERAL DESCRIPTION

## FN:DTC U0073 CAN FAILURE, BUS 'OFF' DETECTION

### 1. OUTLINE OF DIAGNOSIS

Detect malfunction of CAN communication.

Judge as NG when CAN communication failure has occurred.

### 2. COMPONENT DESCRIPTION

*(Common Specifications)*

*CAN Protocol 2.0 B (Active)*

*Frame Format: 11 Bit ID Frame (Standard Frame)*

*Conforms to ISO11898*

*Communication Speed: 500 kbps*

### 3. ENABLE CONDITIONS

Secondary Parameters	Enable Conditions
None	

### 4. GENERAL DRIVING CYCLE

Perform the diagnosis continuously after starting the engine.

### 5. DIAGNOSTIC METHOD

#### • Abnormality Judgment

Judge as NG when the following conditions are established.

#### Judgment Value

Malfunction Criteria	Threshold Value
Battery voltage	> 10.9 V
Starter switch	OFF
Engine	run
bus off flag or error warning flag	set (error)

**Time Needed for Diagnosis:** 436 ms

**Malfunction Indicator Light Illumination:** Illuminates as soon as a malfunction occurs.

#### • Normality Judgment

Judge as OK and clear the NG if the continuous time while the following conditions are established is more than the predetermined time.

#### Judgment Value

Malfunction Criteria	Threshold Value
Engine	run
bus off flag or error warning flag	clear (No error)

**Time Needed for Diagnosis:** 1000 ms

# Diagnostic Trouble Code (DTC) Detecting Criteria

## GENERAL DESCRIPTION

---

### FO:DTC U0122 CAN (VDC) DATA NOT LOADED

#### 1. OUTLINE OF DIAGNOSIS

Detect malfunction of CAN communication.

Judge as NG when CAN communication failure has occurred between VDC CM and body integrated unit.

#### 2. COMPONENT DESCRIPTION

##### *(Common Specifications)*

**CAN Protocol 2.0 B (Active)**

**Frame Format: 11 Bit ID Frame (Standard Frame)**

**Conforms to ISO11898**

**Communication Speed: 500 kbps**

#### 3. ENABLE CONDITIONS

Secondary Parameters	Enable Conditions
None	

#### 4. GENERAL DRIVING CYCLE

Perform the diagnosis continuously after starting the engine.

#### 5. DIAGNOSTIC METHOD

##### • Abnormality Judgment

Judge as NG when the following conditions are established.

##### Judgment Value

Malfunction Criteria	Threshold Value
Battery voltage	> 10.9 V
Starter switch	OFF
Engine	run
ID received from control module connected to CAN	None during 500 milliseconds

**Time Needed for Diagnosis:** 500 ms

**Malfunction Indicator Light Illumination:** Illuminates as soon as a malfunction occurs.

##### • Normality Judgment

Judge as OK and clear the NG if the continuous time while the following conditions are established is more than the predetermined time.

##### Judgment Value

Malfunction Criteria	Threshold Value
Engine	run
ID received from control module connected to CAN	Yes

**Time Needed for Diagnosis:** 1000 ms

### FP:DTC U0140 CAN (BCU) DATA NOT LOADED

#### 1. OUTLINE OF DIAGNOSIS

NOTE:

For the detection standard, refer to DTC U0122. <Ref. to GD(H4DOTC)-286, DTC U0122 CAN (VDC) DATA NOT LOADED, Diagnostic Trouble Code (DTC) Detecting Criteria.>

# Diagnostic Trouble Code (DTC) Detecting Criteria

GENERAL DESCRIPTION

## FQ:DTC U0416 CAN (VDC) DATA ABNORMAL

### 1. OUTLINE OF DIAGNOSIS

Detect malfunction of CAN communication.

Judge as NG when data received from VDC CM and body integrated unit is not normal.

### 2. COMPONENT DESCRIPTION

*(Common Specifications)*

*CAN Protocol 2.0 B (Active)*

*Frame Format: 11 Bit ID Frame (Standard Frame)*

*Conforms to ISO11898*

*Communication Speed: 500 kbps*

### 3. ENABLE CONDITIONS

Secondary Parameters	Enable Conditions
None	

### 4. GENERAL DRIVING CYCLE

Perform the diagnosis continuously after starting the engine.

### 5. DIAGNOSTIC METHOD

#### • Abnormality Judgment

Judge as NG when the following conditions are established.

#### Judgment Value

Malfunction Criteria	Threshold Value
Battery voltage	> 10.9 V
Starter switch	OFF
Engine	run
Data updated from control module connected to CAN	None during 2000 milliseconds

**Time Needed for Diagnosis:** 2 seconds

**Malfunction Indicator Light Illumination:** Illuminates as soon as a malfunction occurs.

#### • Normality Judgment

Judge as OK and clear the NG if the continuous time while the following conditions are established is more than the predetermined time.

#### Judgment Value

Malfunction Criteria	Threshold Value
Engine	run
Data updated from control module connected to CAN	Yes

**Time Needed for Diagnosis:** 1000 ms

## FR:DTC U0422 CAN (BCU) DATA ABNORMAL

### 1. OUTLINE OF DIAGNOSIS

NOTE:

For the detection standard, refer to DTC U0416. <Ref. to GD(H4DOTC)-287, DTC U0416 CAN (VDC) DATA ABNORMAL, Diagnostic Trouble Code (DTC) Detecting Criteria.>

# Diagnostic Trouble Code (DTC) Detecting Criteria

GENERAL DESCRIPTION

---

**GD(H4DOTC)-288**

Brought to you by Ebay Seller "SubaruManuals"

**TRANSMISSION SECTION**

This service manual has been prepared to provide SUBARU service personnel with the necessary information and data for the correct maintenance and repair of SUBARU vehicles.

This manual includes the procedures for maintenance, disassembling, reassembling, inspection and adjustment of components and diagnostics for guidance of experienced mechanics.

Please peruse and utilize this manual fully to ensure complete repair work for satisfying our customers by keeping their vehicle in optimum condition. When replacement of parts during repair work is needed, be sure to use SUBARU genuine parts.

All information, illustration and specifications contained in this manual are based on the latest product information available at the time of publication approval.

<b>CONTROL SYSTEMS</b>	<b>CS</b>
<b>MANUAL TRANSMISSION AND DIFFERENTIAL</b>	<b>5MT</b>
<b>MANUAL TRANSMISSION AND DIFFERENTIAL</b>	<b>6MT</b>
<b>MANUAL TRANSMISSION AND DIFFERENTIAL (DIAGNOSTICS)</b>	<b>6MT(diag)</b>
<b>CLUTCH SYSTEM</b>	<b>CL</b>

# CONTROL SYSTEMS

# CS

---

	<b>Page</b>
1. General Description .....	2
2. MT Gear Shift Lever .....	6
3. Reverse Check Cable .....	22
4. General Diagnostic Table .....	27

# General Description

CONTROL SYSTEMS

---

## 1. General Description

### A: SPECIFICATION

Item	Specifications
Swing torque of rod against lever N (kgf, lbf)	3.7 (0.38, 0.83) or less



## B: COMPONENT

### 1. 6MT GEAR SHIFT LEVER

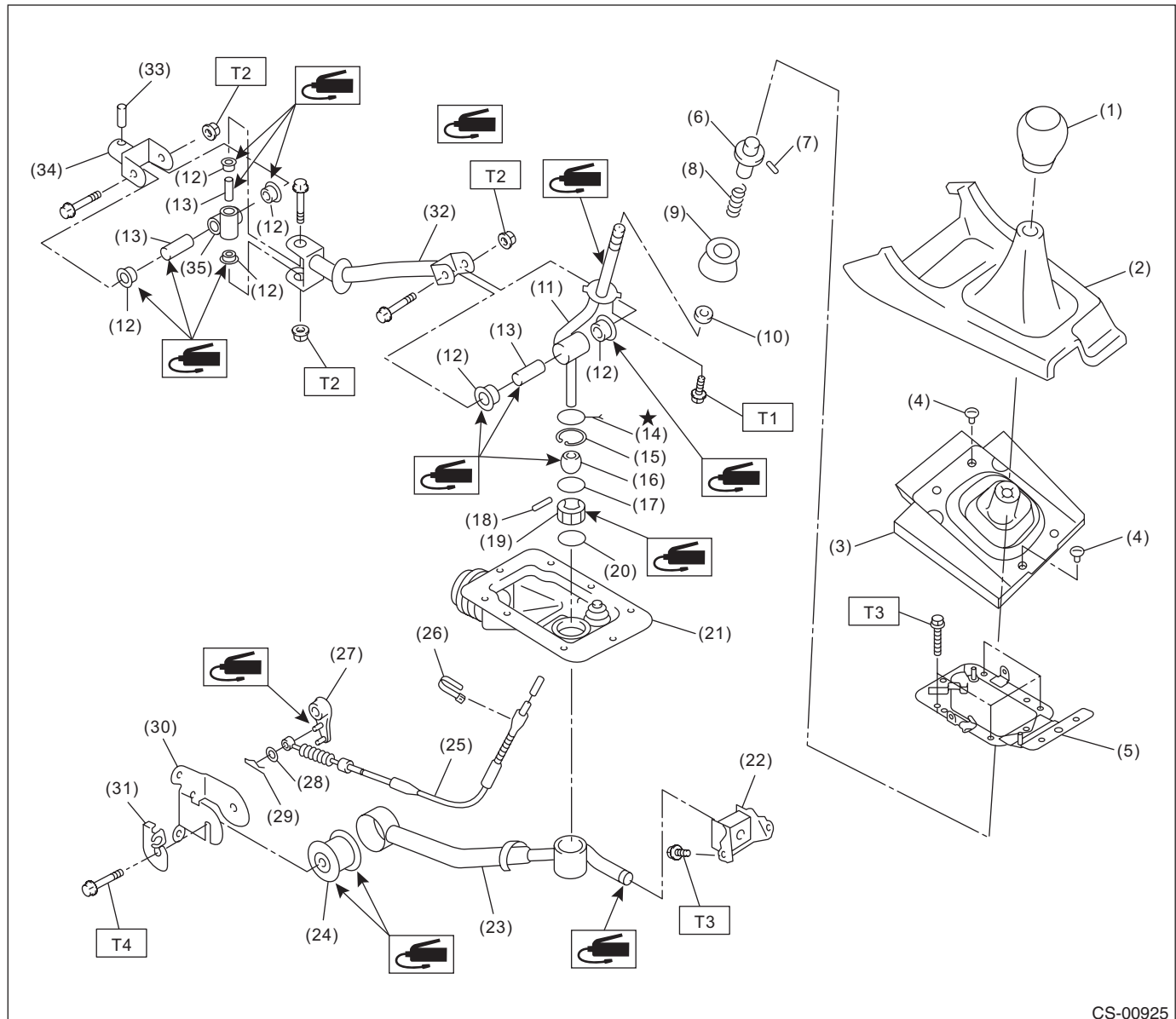

CS-00925

- |                             |                          |                  |
|-----------------------------|--------------------------|------------------|
| (1) Gear shift knob         | (15) Snap ring           | (29) Snap pin    |
| (2) Console box front       | (16) Bushing             | (30) Bracket     |
| (3) Boot and insulator ASSY | (17) O-ring              | (31) Cable plate |
| (4) Clamp                   | (18) Spring pin          | (32) Rod         |
| (5) Plate COMPL             | (19) Bushing             | (33) Spring pin  |
| (6) Slider                  | (20) O-ring              | (34) Joint       |
| (7) Spring pin              | (21) Boot                | (35) Boss        |
| (8) Spring                  | (22) Cushion rubber      |                  |
| (9) Holder                  | (23) Stay                |                  |
| (10) Seat cushion           | (24) Bushing             |                  |
| (11) Lever                  | (25) Reverse check cable |                  |
| (12) Bushing                | (26) Band clip           |                  |
| (13) Spacer                 | (27) Reverse check lever |                  |
| (14) Lock wire              | (28) Washer              |                  |

**Tightening torque: N-m (kgf-m, ft-lb)**

**T1: 1.3 (0.1, 1.0)**

**T2: 12 (1.2, 8.9)**

**T3: 18 (1.8, 13.3)**

**T4: 32 (3.3, 23.6)**

# General Description

## CONTROL SYSTEMS

### 2. 5MT GEAR SHIFT LEVER

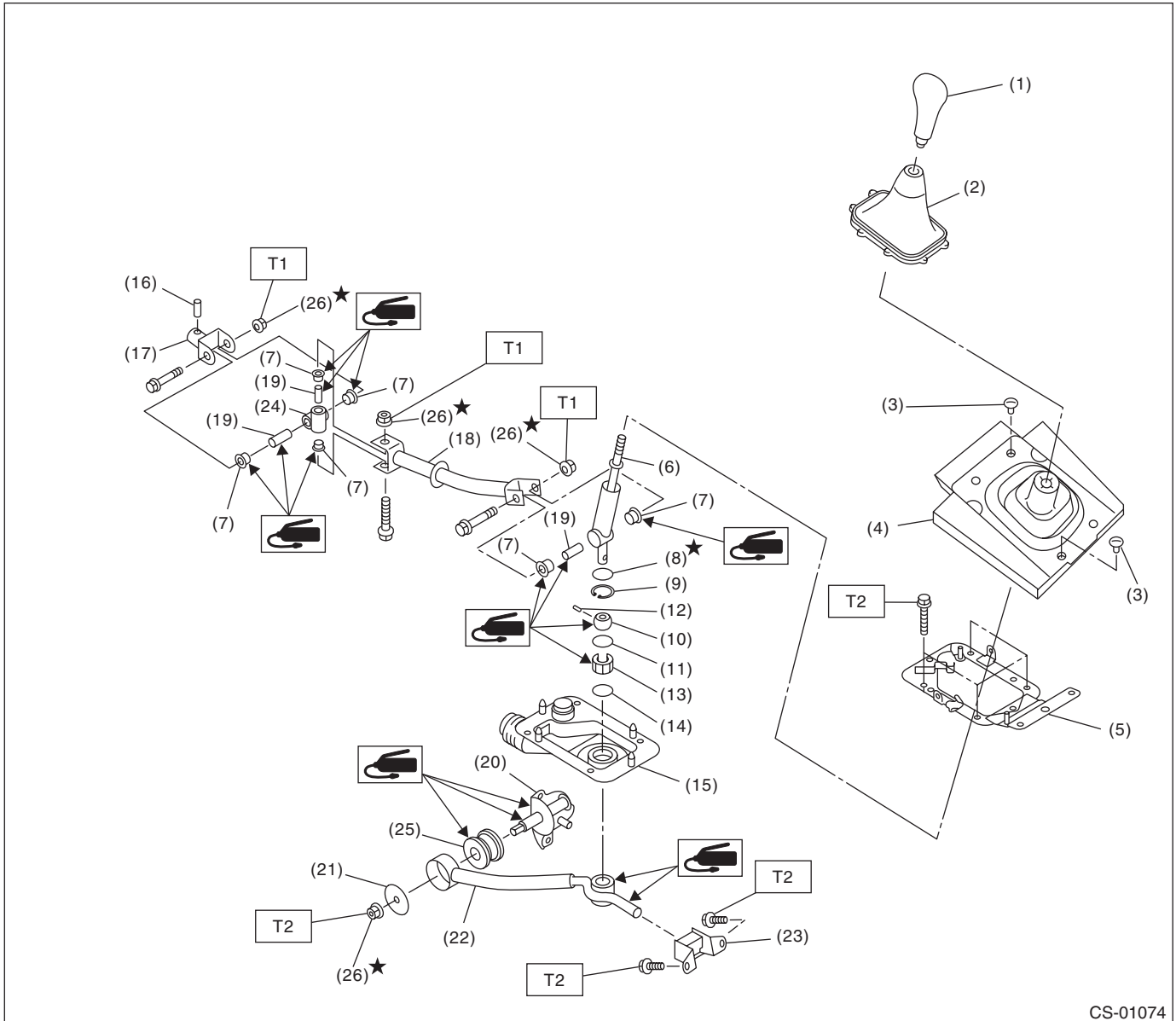

CS-01074

- |                             |                 |                       |
|-----------------------------|-----------------|-----------------------|
| (1) Gear shift knob         | (11) O-ring     | (21) Washer           |
| (2) Console boot            | (12) Spring pin | (22) Stay             |
| (3) Clamp                   | (13) Bushing B  | (23) Cushion rubber   |
| (4) Boot and insulator ASSY | (14) O-ring     | (24) Boss             |
| (5) Plate COMPL             | (15) Boot       | (25) Bushing          |
| (6) Lever                   | (16) Spring pin | (26) Self-locking nut |
| (7) Bushing                 | (17) Joint      |                       |
| (8) Lock wire               | (18) Rod        |                       |
| (9) Snap ring               | (19) Spacer     |                       |
| (10) Bushing                | (20) Bracket    |                       |

**Tightening torque: N·m (kgf·m, ft·lb)**

**T1: 12 (1.2, 8.9)**

**T2: 18 (1.8, 13.3)**

### **C: CAUTION**

- Wear appropriate work clothing, including a cap, protective goggles and protective shoes when performing any work.
- Remove contamination including dirt and corrosion before removal, installation or disassembly.
- Keep the disassembled parts in order and protect them from dust and dirt.
- Before removal, installation or disassembly, be sure to clarify the failure. Avoid unnecessary removal, installation, disassembly and replacement.
- Use SUBARU genuine fluid, grease etc. or equivalent. Do not mix fluid, grease, etc. of different grades or manufacturers.
- Be sure to tighten fasteners including bolts and nuts to the specified torque.
- Place shop jacks or rigid racks at the specified points.
- Apply grease onto sliding or revolving surfaces before installation.
- Before installing O-rings or snap rings, apply sufficient amount of fluid to avoid damage and deformation.
- Before securing a part in a vise, place cushioning material such as wood blocks, aluminum plate or cloth between the part and the vise.
- Before disconnecting electrical connectors, be sure to disconnect the negative terminal from battery.

# MT Gear Shift Lever

## CONTROL SYSTEMS

### 2. MT Gear Shift Lever

#### A: REMOVAL

##### 1. STI MODEL

- 1) Disconnect the ground cable from battery.
- 2) Remove the gear shift knob.
- 3) Remove the console box. <Ref. to EI-51, REMOVAL, Console Box.>
- 4) Remove the console side cover and console front panel. <Ref. to EI-52, CONSOLE FRONT PANEL, REMOVAL, Center Console.>
- 5) Remove the clamp.

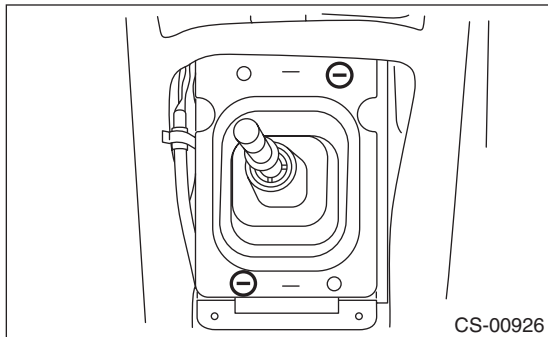

- 6) Remove the boot and insulator assembly.

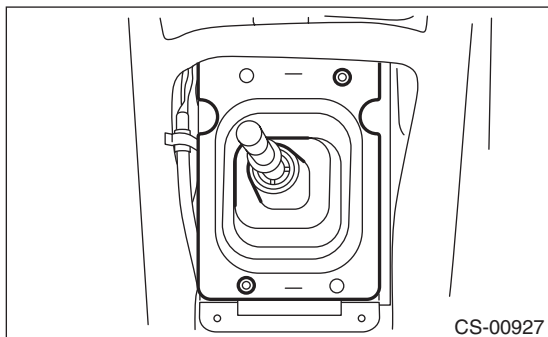

- 7) Remove the harness clamp from the plate COMPL.

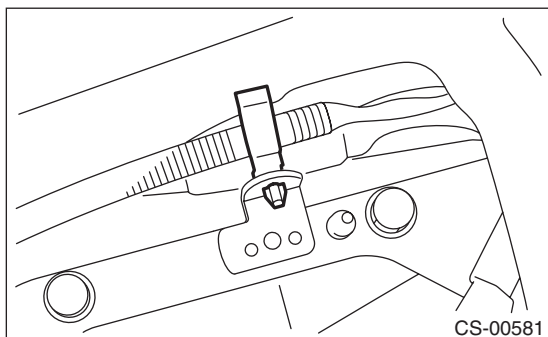

- 8) Remove the plate COMPL from the body.

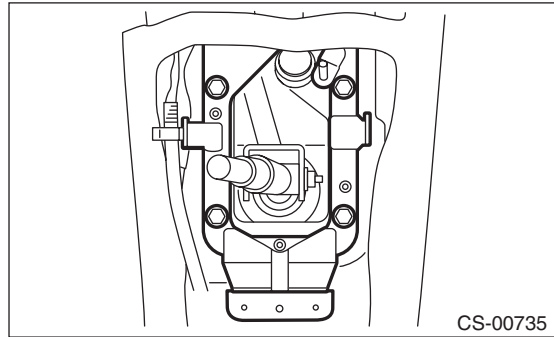

- 9) Lift up the vehicle.
- 10) Remove the under cover.
- 11) Remove the center exhaust pipe. <Ref. to EX(STI)-8, REMOVAL, Center Exhaust Pipe.>
- 12) Remove the heat shield cover.

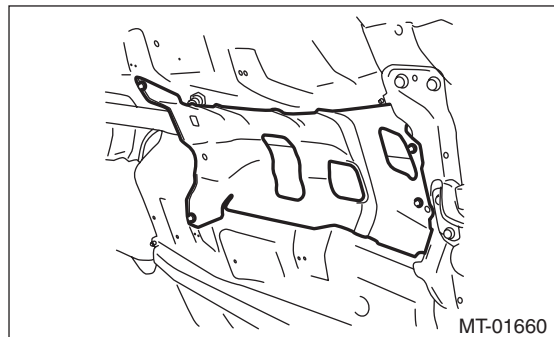

- 13) Remove the crossmember. <Ref. to 6MT-30, REMOVAL, Transmission Mounting System.>
- 14) Remove the snap pin and washer, and remove the reverse check cable from the reverse check lever.

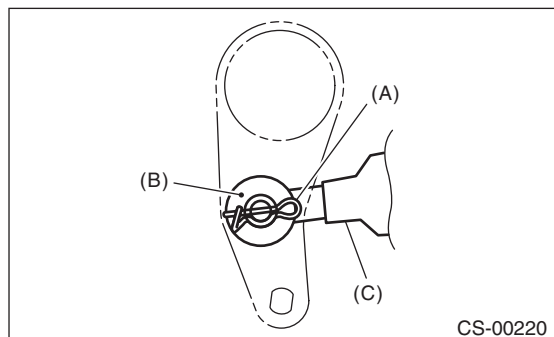

- (A) Snap pin
- (B) Washer
- (C) Reverse check cable

- 15) Move the transmission to the right side, and remove the joint COMPL, stay bolts and reverse check cable.

**NOTE:**

If the transmission is not moved aside, the joint COMPL and stay bolts may contact the body and cause damage.

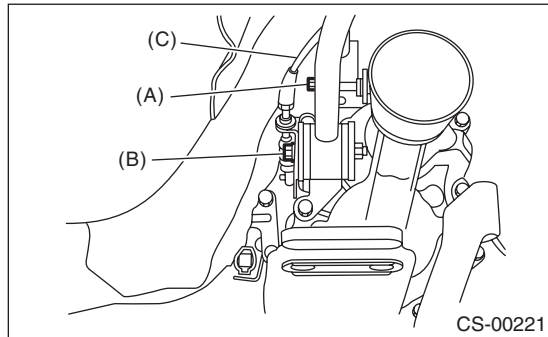

- (A) Joint COMPL bolt
- (B) Stay bolt
- (C) Reverse check cable

16) Remove the cushion rubber from the body.

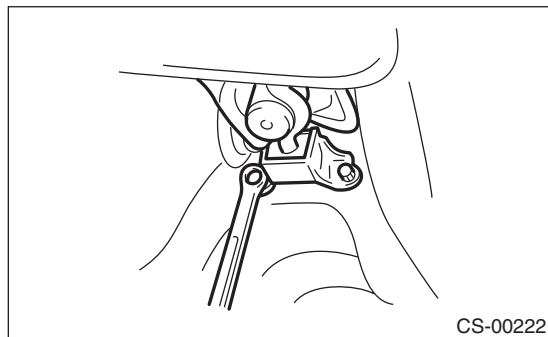

17) Lower the vehicle.

18) Remove the gear shift lever.

**2. EXCEPT FOR STI MODEL**

- 1) Disconnect the ground cable from battery.
- 2) Remove the gear shift knob.
- 3) Remove the console box. <Ref. to EI-51, REMOVAL, Console Box.>
- 4) Remove the console side cover and console front panel. <Ref. to EI-52, CONSOLE FRONT PANEL, REMOVAL, Center Console.>
- 5) Remove the clamp.

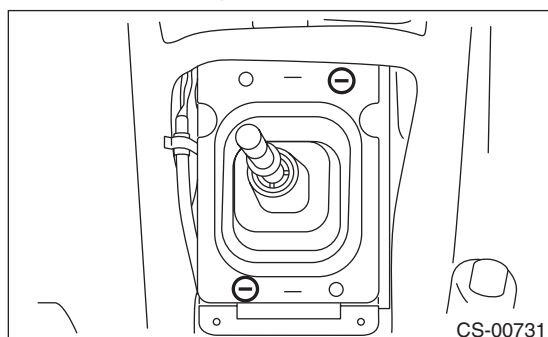

6) Remove the boot and insulator assembly.

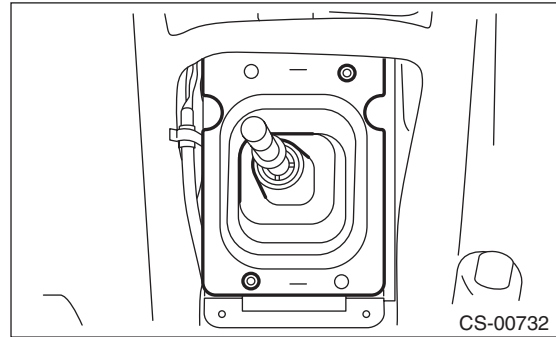

7) Remove the harness clamp from the plate COMPL.

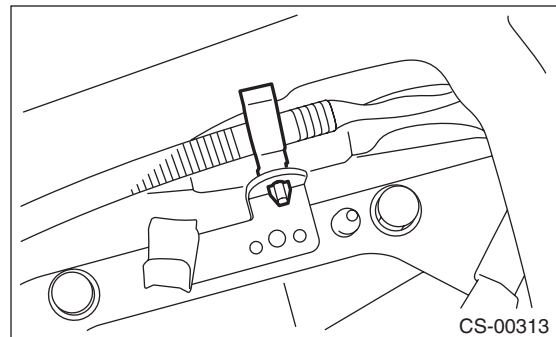

8) Remove the plate COMPL from the vehicle body.

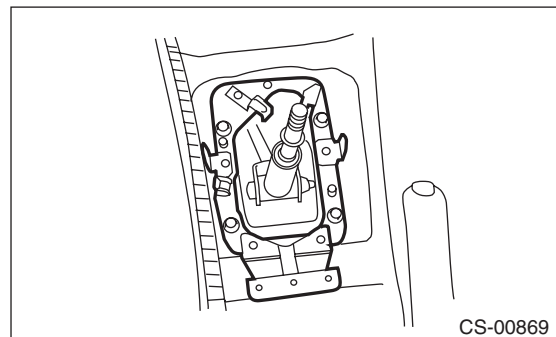

9) Lift up the vehicle.

10) Remove the center exhaust pipe (rear). <Ref. to EX(w/o STI)-2, General Description.>

11) Remove the heat shield cover.

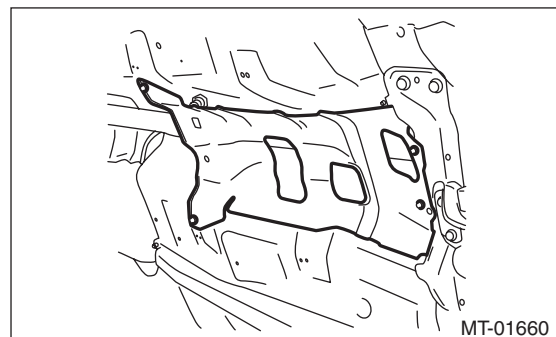

# MT Gear Shift Lever

## CONTROL SYSTEMS

12) Remove the stay from transmission bracket.

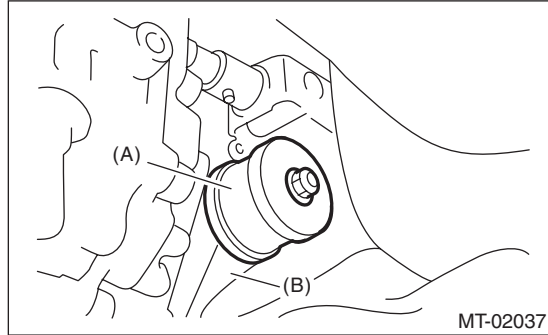

- (A) Stay
- (B) Transmission bracket

15) Extract the spring pin and remove the joint.

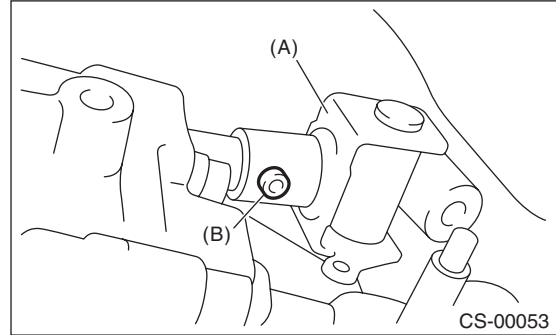

- (A) Joint
- (B) Spring pin

13) Remove the rod from joint.

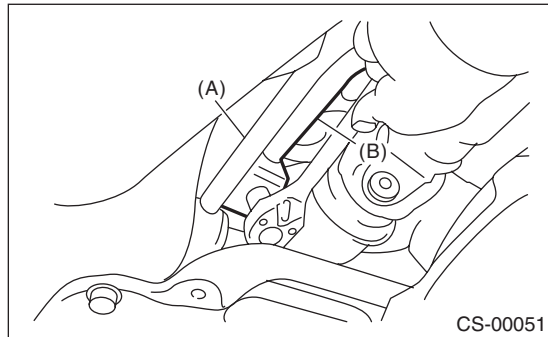

- (A) Stay
- (B) Rod

14) Remove the cushion rubber from the vehicle body.

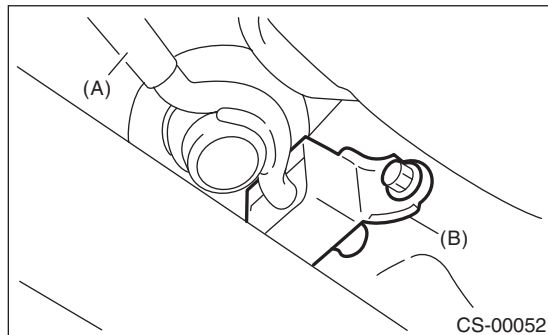

- (A) Stay
- (B) Cushion rubber

16) Lower the vehicle.

17) Remove the gear shift lever.

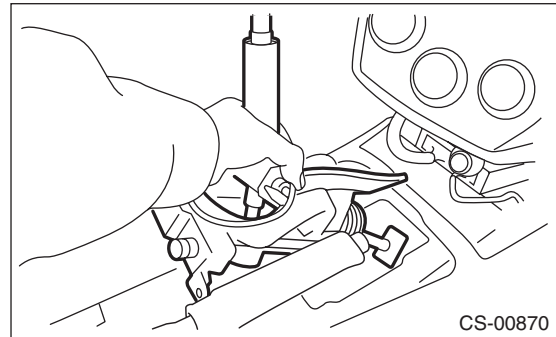

## B: INSTALLATION

### 1. STI MODEL

1) Insert the gear shift lever from the room side.

#### NOTE:

After inserting the rod and stay, temporarily put them onto transmission mount.

2) Lift up the vehicle.

3) Mount the cushion rubber on the body.

#### Tightening torque:

**18 N·m (1.8 kgf-m, 13.3 ft-lb)**

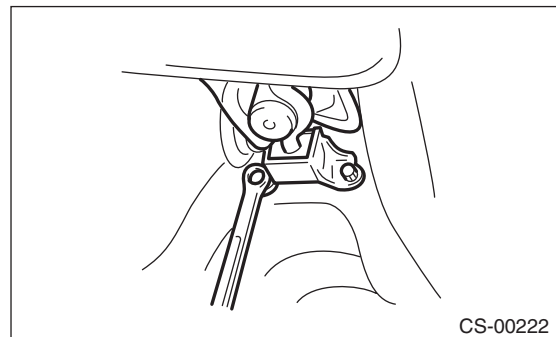

4) Move the transmission to the right side of the vehicle, and install the joint COMPL and stay.

**Tightening torque:**

**T1: 12 N·m (1.2 kgf·m, 8.9 ft·lb)**

**T2: 32 N·m (3.3 kgf·m, 23.6 ft·lb)**

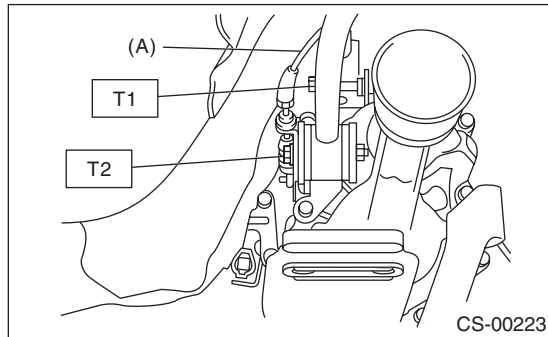

(A) Reverse check cable

5) Install the crossmember. <Ref. to 6MT-30, INSTALLATION, Transmission Mounting System.>

6) Install the reverse check cable end, washer and snap pin to the reverse check lever.

**NOTE:**

- Pay attention to the installing direction of the snap ring.
- Before installing, adjust the reverse check cable. <Ref. to CS-25, ADJUSTMENT, Reverse Check Cable.>

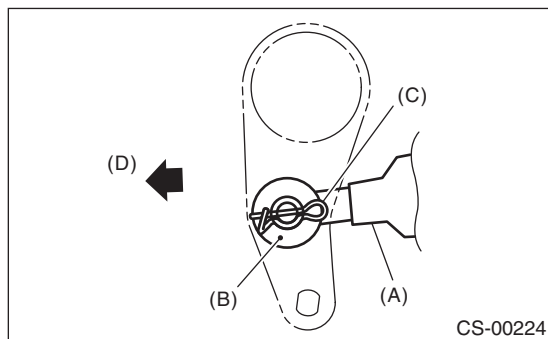

- (A) Reverse check cable
- (B) Washer
- (C) Snap pin
- (D) Front side

7) Install the heat shield cover.

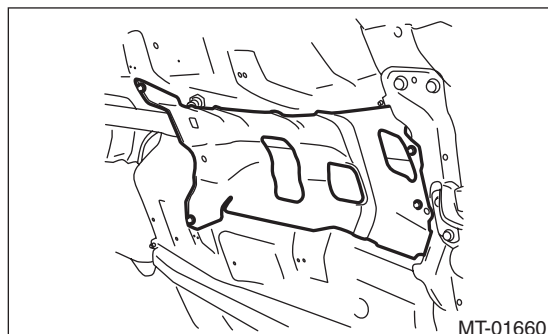

8) Install the center exhaust pipe. <Ref. to EX(w/o STI)-2, General Description.>

9) Install the under cover.

10) Install the plate COMPL.

**NOTE:**

Be careful not to twist the inner boot when installing.

**Tightening torque:**

**18 N·m (1.8 kgf·m, 13.3 ft·lb)**

- (1) Set the plate COMPL to the vehicle.
- (2) Temporarily tighten the bolt (A).
- (3) Tighten the bolt (B).
- (4) Tighten the bolt (A).
- (5) Tighten the bolts (C) and (D).

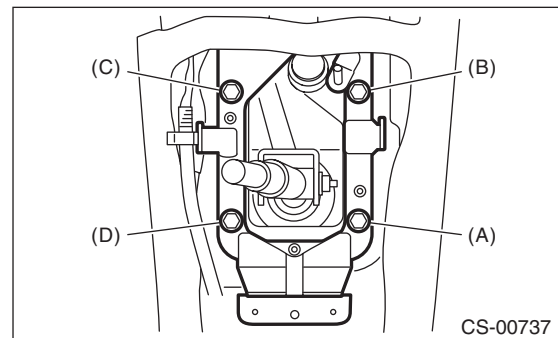

11) Install the harness clamp to the plate COMPL.

12) Install the boot and insulator assembly, and secure with a clamp.

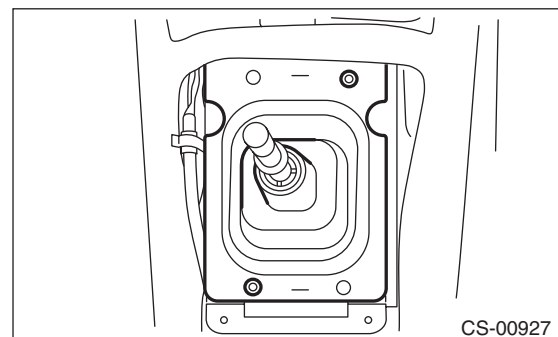

13) Install the console side cover and console front panel. <Ref. to EI-54, INSTALLATION, Center Console.>

14) Install the console box. <Ref. to EI-51, INSTALLATION, Console Box.>

15) Install the gear shift knob.

16) Make sure the gears can be shifted accurately into each gear.



# MT Gear Shift Lever

## CONTROL SYSTEMS

### 2. EXCEPT FOR STI MODEL

1) Install the joint to the transmission and secure with a spring pin.

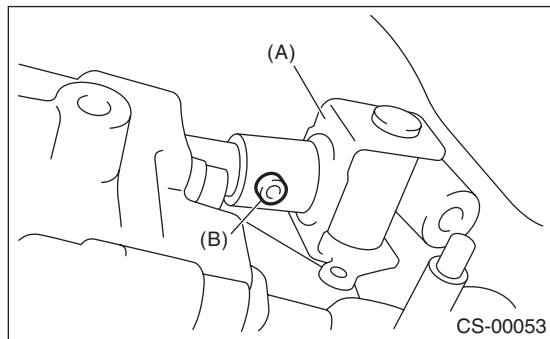

- (A) Joint
- (B) Spring pin

2) Insert the gear shift lever from the room side.

#### NOTE:

Insert the rod and the stay, and then temporarily set them onto the transmission mount.

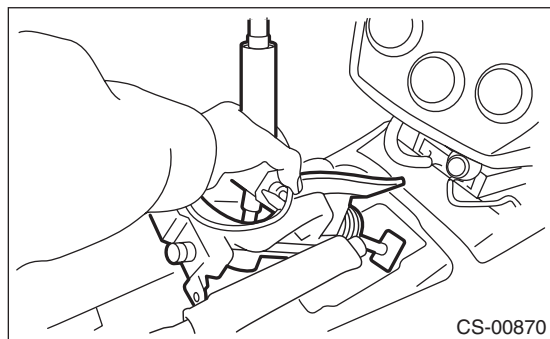

3) Lift up the vehicle.

4) Mount the cushion rubber on the vehicle body.

#### Tightening torque:

**18 N·m (1.8 kgf·m, 13.3 ft·lb)**

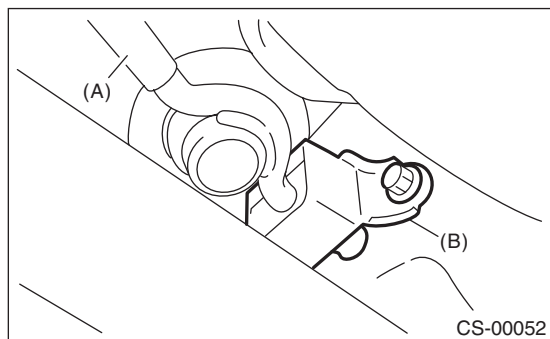

- (A) Stay
- (B) Cushion rubber

5) Using new self-locking nuts, connect the rod to the joint.

#### Tightening torque:

**12 N·m (1.2 kgf·m, 8.9 ft·lb)**

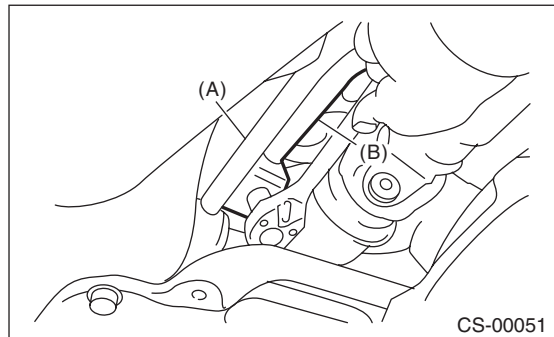

- (A) Stay
- (B) Rod

6) Using new self-locking nuts, connect the stay to the transmission bracket.

#### Tightening torque:

**18 N·m (1.8 kgf·m, 13.3 ft·lb)**

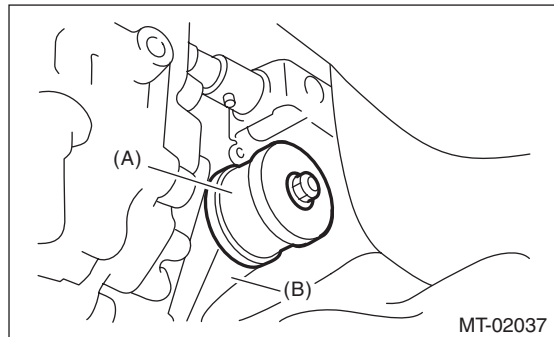

- (A) Stay
- (B) Transmission bracket

7) Install the heat shield cover. <Ref. to EI-74, INSTALLATION, Heat Shield Cover.>

8) Install the center exhaust pipe (rear). <Ref. to EX(w/o STI)-2, General Description.>

9) Install the plate COMPL to the body.

#### Tightening torque:

**18 N·m (1.8 kgf·m, 13.3 ft·lb)**

- (1) Set the plate COMPL to the vehicle.
- (2) Temporarily tighten the bolt (A).
- (3) Tighten the bolt (B).
- (4) Tighten the bolt (A).



(5) Tighten the bolts (C) and (D).

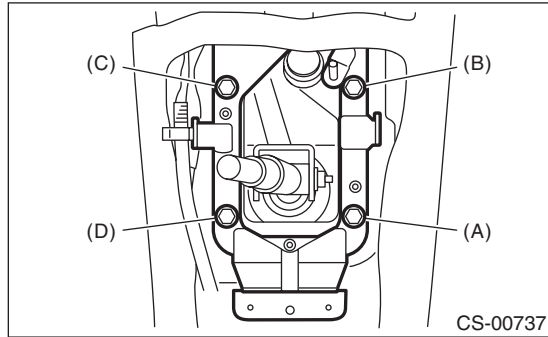

10) Install the harness clamp to the plate.

11) Install the boot and insulator assembly, and secure with a clamp.

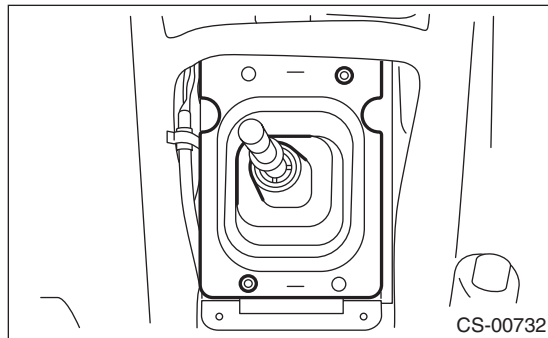

12) Install the console side cover and console front panel. <Ref. to EI-54, INSTALLATION, Center Console.>

13) Install the console box. <Ref. to EI-51, INSTALLATION, Console Box.>

14) Install the gear shift knob.

15) Make sure the gears can be shifted accurately into each gear.

16) Connect the battery ground terminal.

## C: DISASSEMBLY

### 1. STI MODEL

1) Remove the spring pin from the slider.

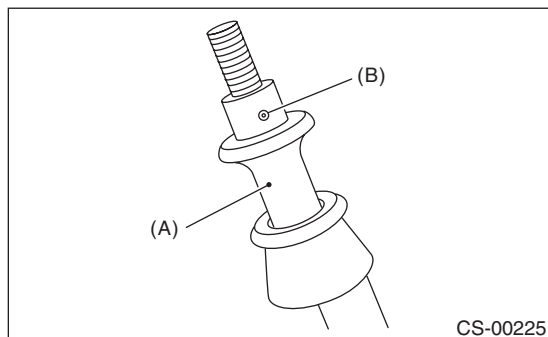

- (A) Slider
- (B) Spring pin

2) Remove the slider and spring.

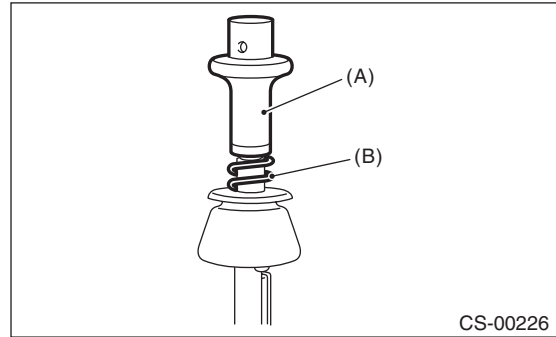

- (A) Slider
- (B) Spring

3) Cut off the band clip.

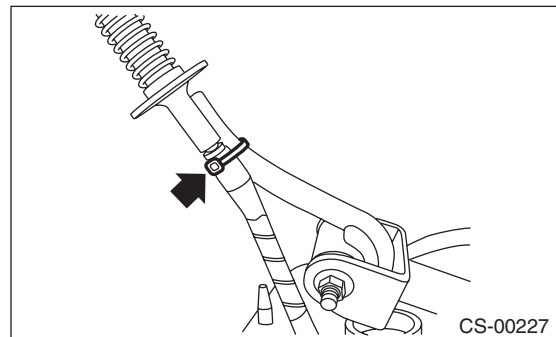

4) Remove the reverse check cable from the cable plate.

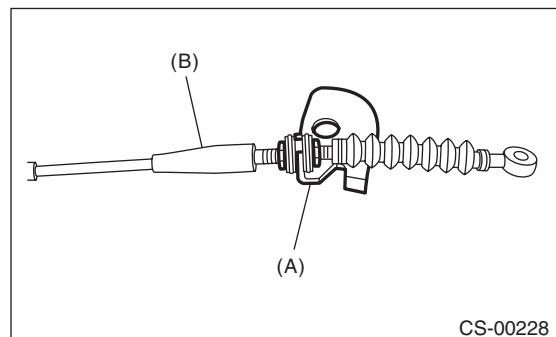

- (A) Cable plate
- (B) Reverse check cable

5) Remove the reverse check cable from the gear shift assembly.

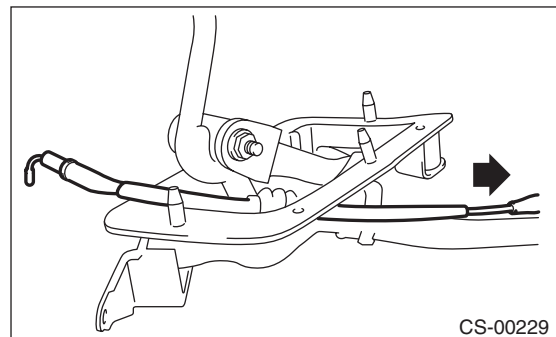

# MT Gear Shift Lever

## CONTROL SYSTEMS

6) Remove the holder and spring.

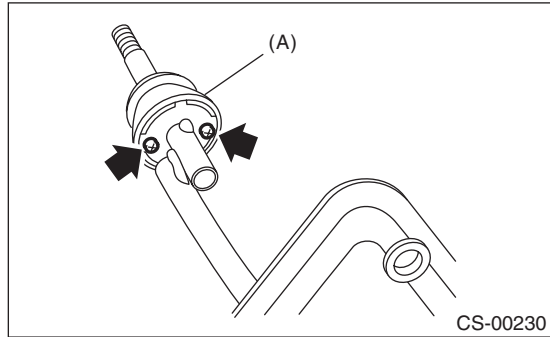

(A) Holder

9) Remove the rod from lever.

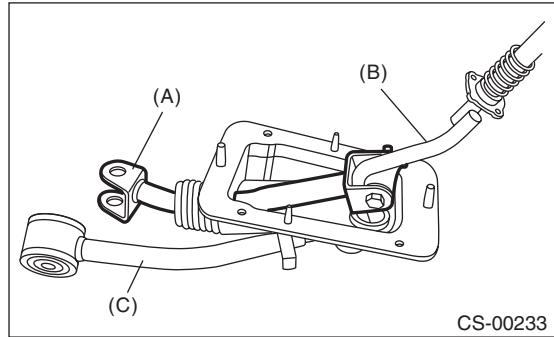

(A) Rod  
(B) Lever  
(C) Stay

7) Disassemble the lock wire.

**NOTE:**

Do not reuse the lock wire.

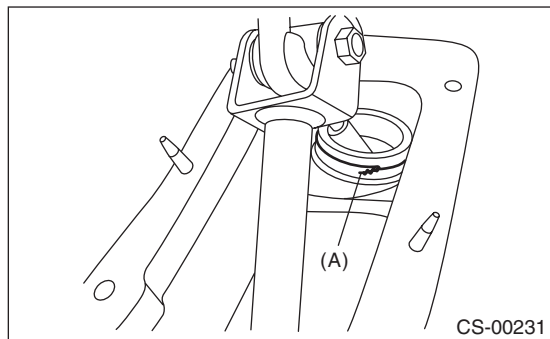

(A) Lock wire

10) Separate the rod and inner boot.

11) Remove the snap ring from the stay.

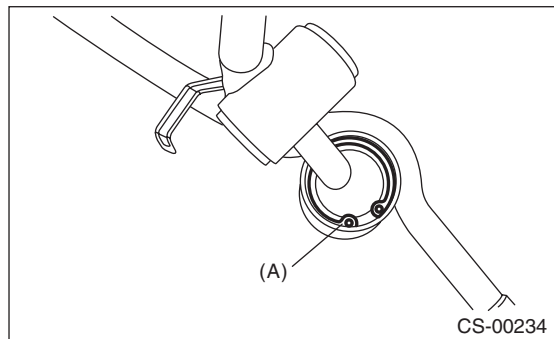

(A) Snap ring

8) Remove the boss from the rod.

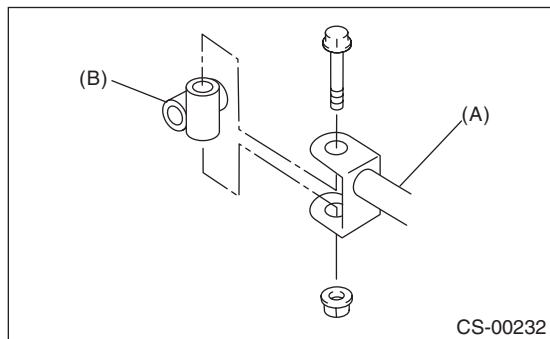

(A) Rod  
(B) Boss

12) Separate the gear shift lever and the stay.

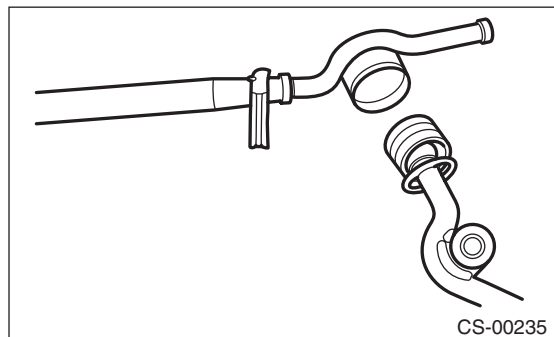

13) Remove the O-ring and bushing from the gear shift lever.

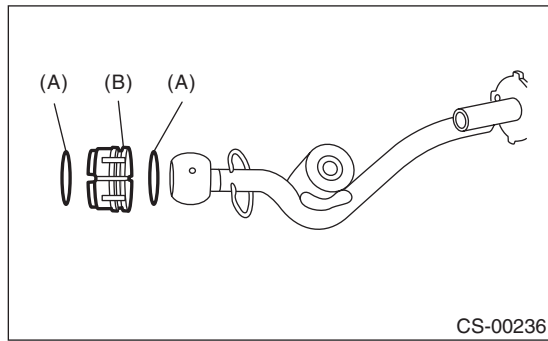

- (A) O-ring
- (B) Bushing

16) Remove the bushing and cushion rubber from the stay.

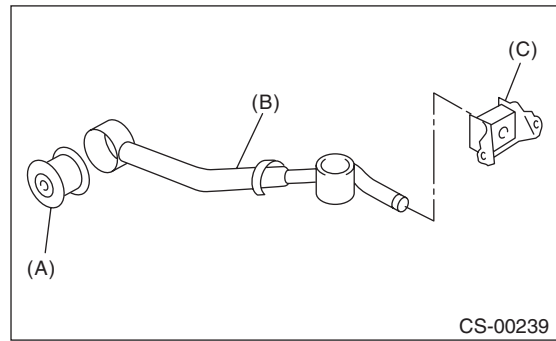

- (A) Bushing
- (B) Stay
- (C) Cushion rubber

14) Remove the spring pin, and then remove the bushing and snap ring.

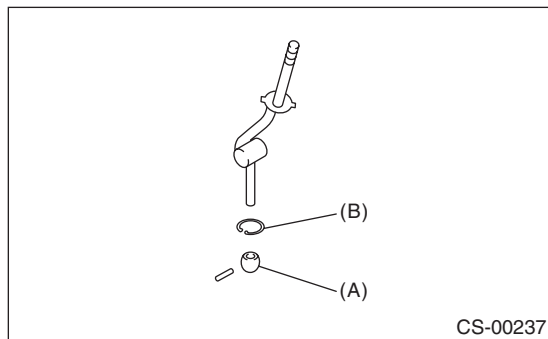

- (A) Bushing
- (B) Snap ring

## 2. EXCEPT FOR STI MODEL

1) Remove the lock wires.

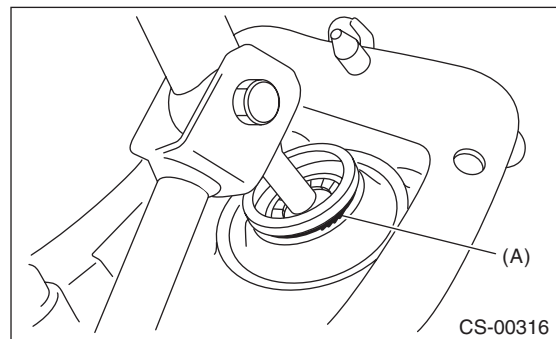

- (A) Lock wire

15) Remove the bushing and spacer from the boss.

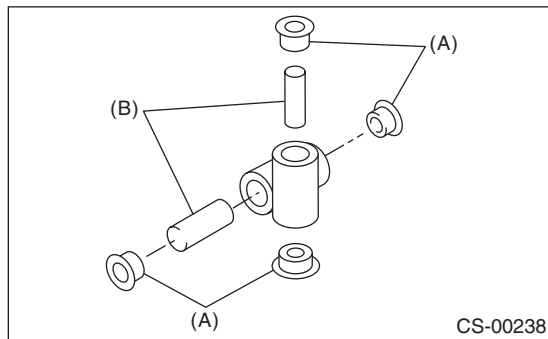

- (A) Bushing
- (B) Spacer

2) Remove the rod from lever.

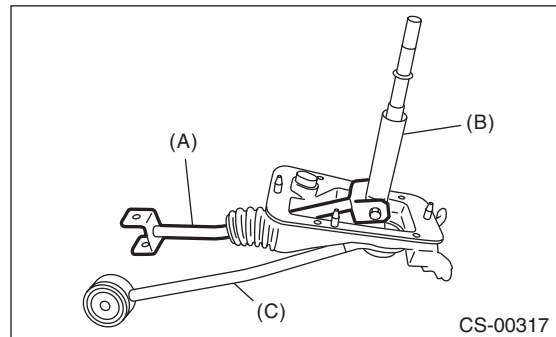

- (A) Rod
- (B) Lever
- (C) Stay

3) Separate the rod and inner boot.

# MT Gear Shift Lever

## CONTROL SYSTEMS

4) Remove the snap ring from the stay.

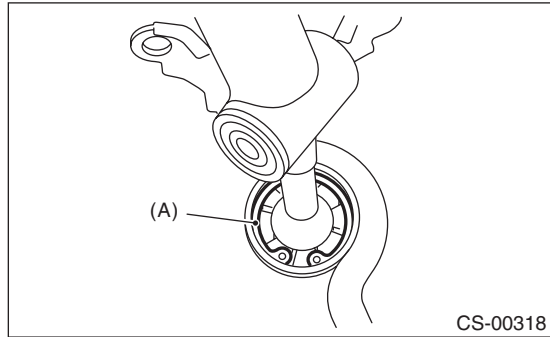

(A) Snap ring

5) Separate the gear shift lever and the stay.

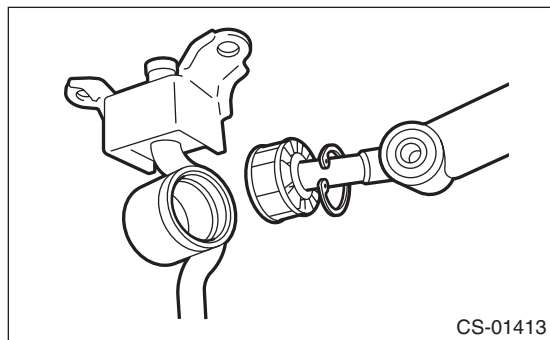

6) Remove the O-ring and bushing from the gear shift lever.

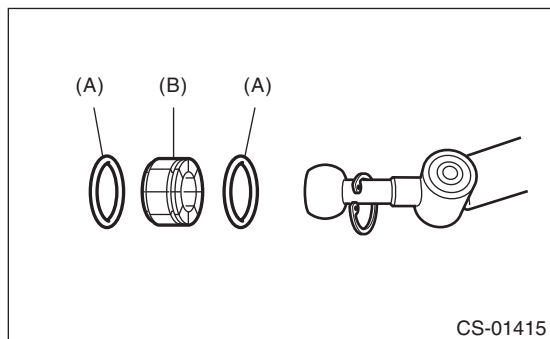

(A) O-ring  
(B) Bushing

7) Remove the spring pin, and then remove the bushing and snap ring.

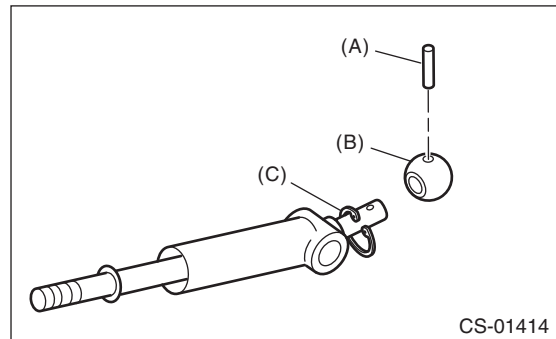

(A) Spring pin  
(B) Bushing  
(C) Snap ring

8) Remove the boss from the joint.

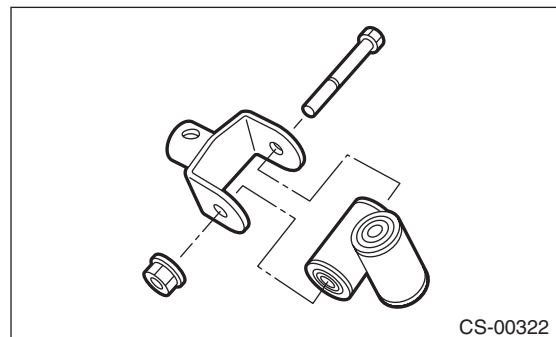

9) Remove the bushing and spacer from the boss.

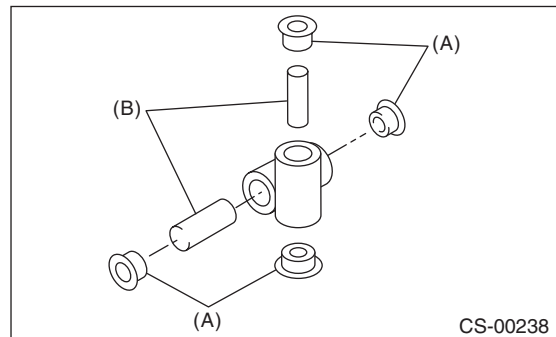

(A) Bushing  
(B) Spacer

10) Remove the bushing and cushion rubber from the stay.

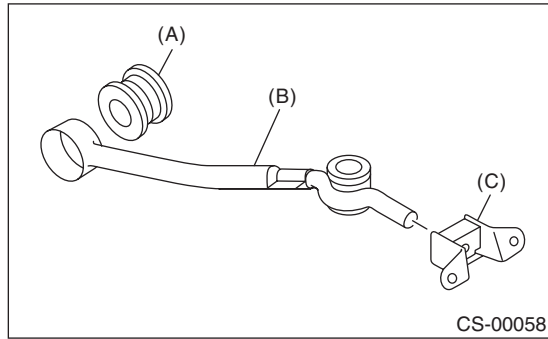

- (A) Bushing
- (B) Stay
- (C) Cushion rubber

## D: ASSEMBLY

NOTE:

- Clean all the parts before assembly.
- Apply NIGTIGHT LYW No. 2 grease or equivalent to each part. <Ref. to CS-3, 6MT GEAR SHIFT LEVER, COMPONENT, General Description.>

### 1. STI MODEL

1) Mount the bushing and cushion rubber to the stay.

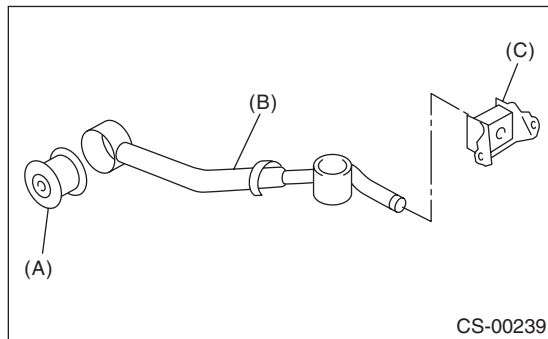

- (A) Bushing
- (B) Stay
- (C) Cushion rubber

2) Install the bushing and spacer to boss.

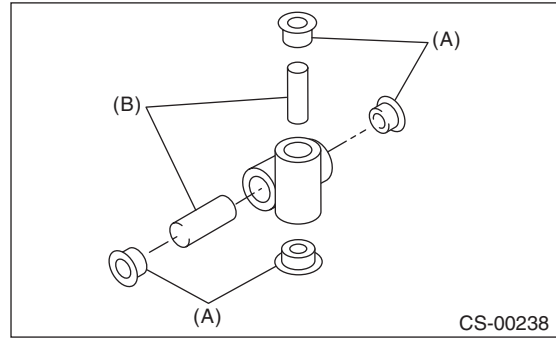

- (A) Bushing
- (B) Spacer

3) Install the snap ring to gear shift lever and install the bushing.

NOTE:

Apply grease to the bushing.

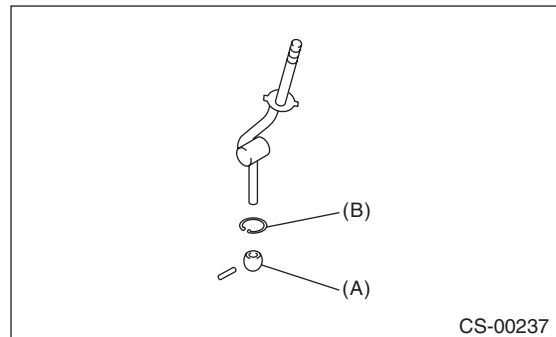

- (A) Bushing
- (B) Snap ring

4) Apply grease to the bushing and O-ring, and then install to gear shift lever.

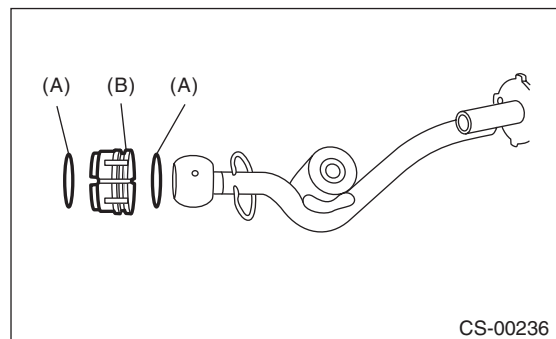

- (A) O-ring
- (B) Bushing

# MT Gear Shift Lever

## CONTROL SYSTEMS

5) Apply sufficient grease into boss, and then install the gear shift lever to the stay.

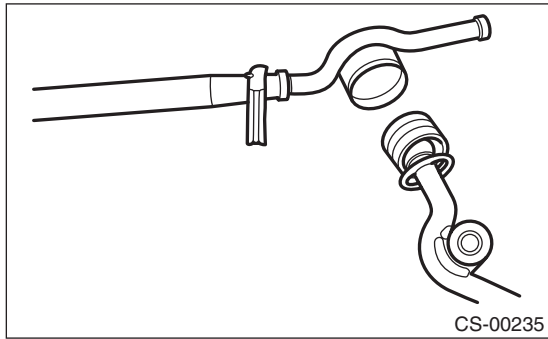

6) Install the snap ring.

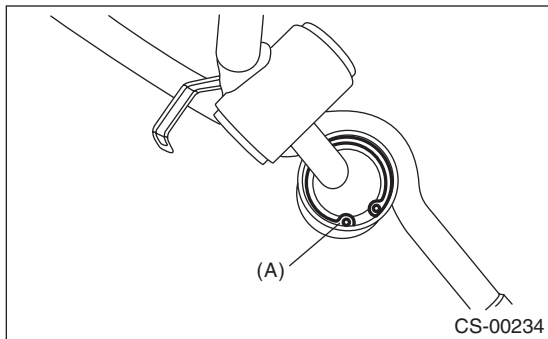

(A) Snap ring

7) Insert the gear shift lever and rod into boot hole.

8) Install the rod.

**Tightening torque:**

**12 N·m (1.2 kgf-m, 8.9 ft-lb)**

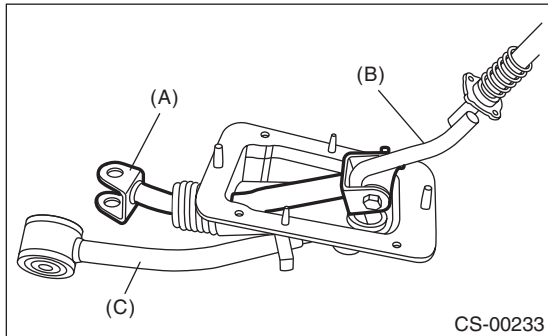

(A) Rod  
(B) Lever  
(C) Stay

9) Install the boss to the rod.

**Tightening torque:**

**12 N·m (1.2 kgf-m, 8.9 ft-lb)**

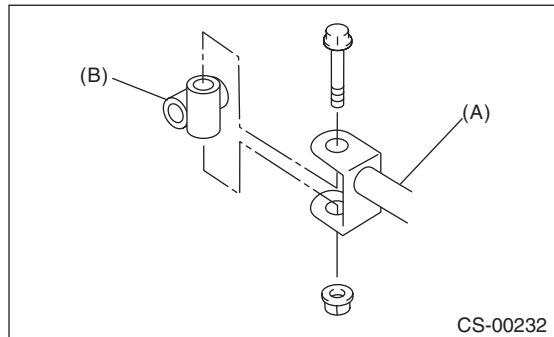

(A) Rod  
(B) Boss

10) Install a new lock wire.

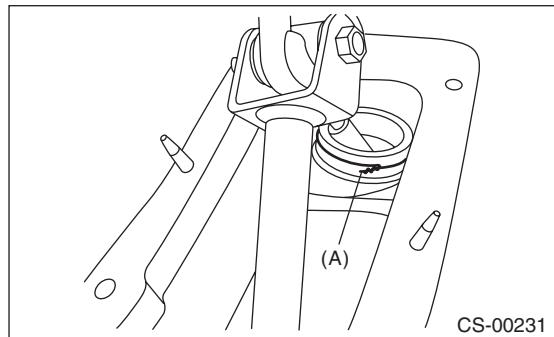

(A) Lock wire

**NOTE:**

- Install the lock wire to the stay groove.
- Bend the extra wire to the same direction of lock wire winding.

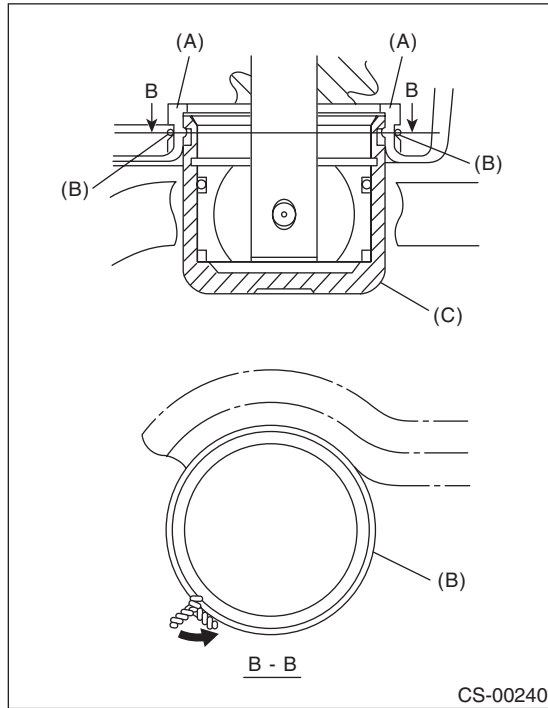

- (A) Inner boot
- (B) Lock wire
- (C) Stay

11) Install the holder.

**Tightening torque:**

**1.3 N·m (0.1 kgf-m, 1.0 ft-lb)**

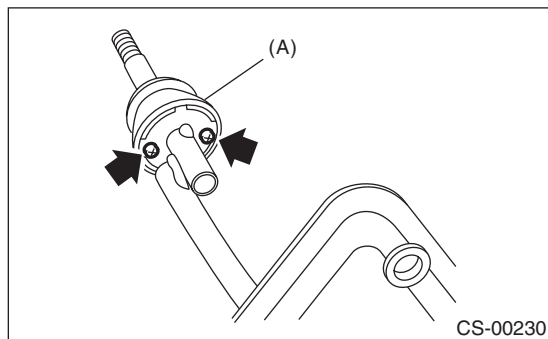

- (A) Holder

12) Insert the reverse check cable into the boot hole.

13) Insert the reverse check cable into the gear shift assembly, and fix in place with a band clip.

**NOTE:**

- Cut the excess band clip.
- Make sure that the reverse check cable is inserted into the gearshift lever with no gaps.

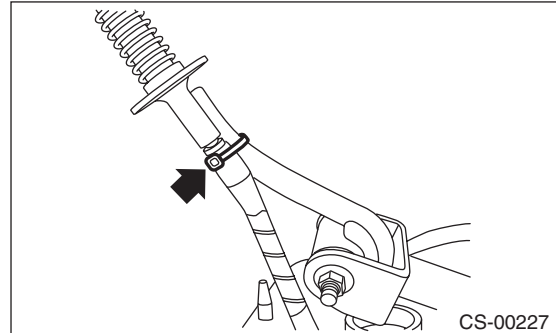

14) Install the seat cushion and spring.

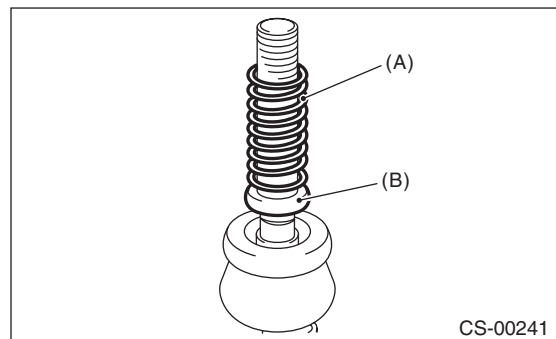

- (A) Spring
- (B) Seat cushion

15) Use the spring pin to secure the end of the slider and reverse check cable.

**NOTE:**

Apply grease to the moving part of slider.

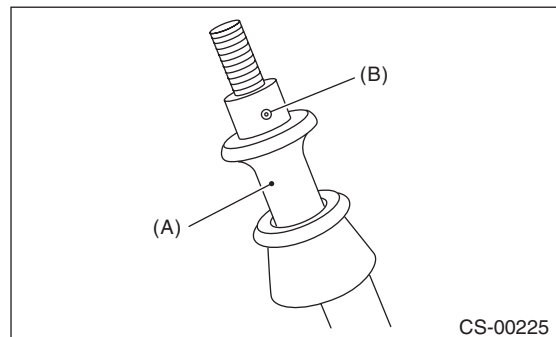

- (A) Slider
- (B) Spring pin

# MT Gear Shift Lever

## CONTROL SYSTEMS

16) With the cable pulled (the slider is lowered), adjust the distance between the edge of cable plate and the reverse check cable to 84 mm (3.31 in), and tighten the lock nut.

**Tightening torque:**

**6 N·m (0.6 kgf·m, 4.4 ft·lb)**

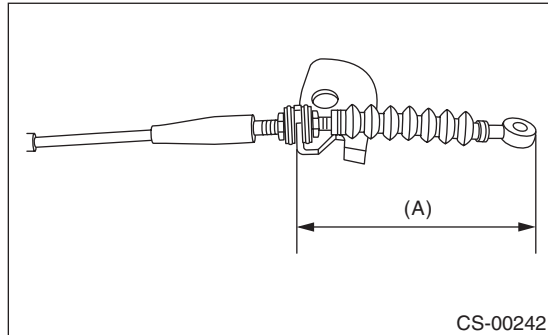

(A) 84 mm (3.31 in)

17) Secure the reverse check cable to the stay clip.

**NOTE:**

Install the reverse check cable on top of the stay.

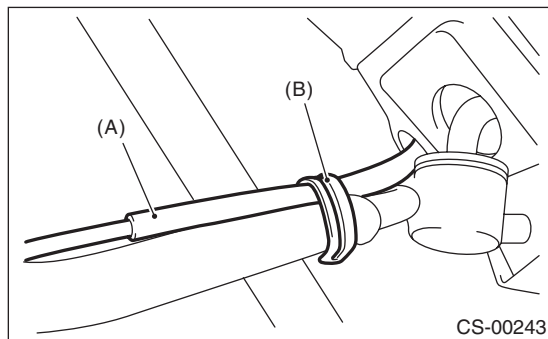

(A) Reverse check cable  
(B) Clip

## 2. EXCEPT FOR STI MODEL

**NOTE:**

- Clean all the parts before assembly.
- Apply NIGTIGHT LYW No. 2 grease or equivalent to each part. <Ref. to CS-4, 5MT GEAR SHIFT LEVER, COMPONENT, General Description.>

1) Mount the bushing and cushion rubber to the stay.

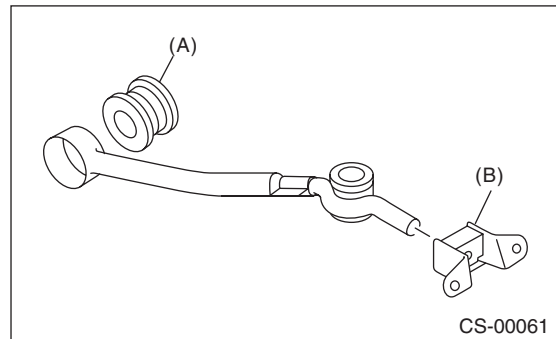

(A) Bushing  
(B) Cushion rubber

2) Install the bushing and spacer to boss.

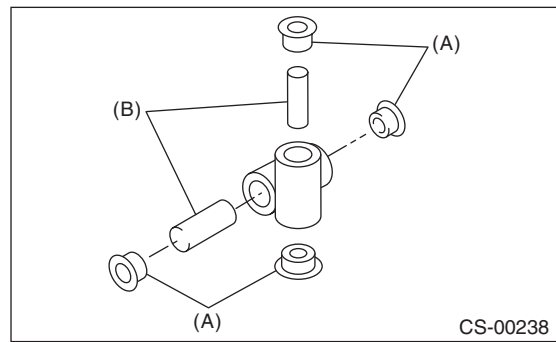

(A) Bushing  
(B) Spacer

3) Using new self-locking nuts, install the boss to the joint.

**Tightening torque:**

**12 N·m (1.2 kgf·m, 8.9 ft·lb)**

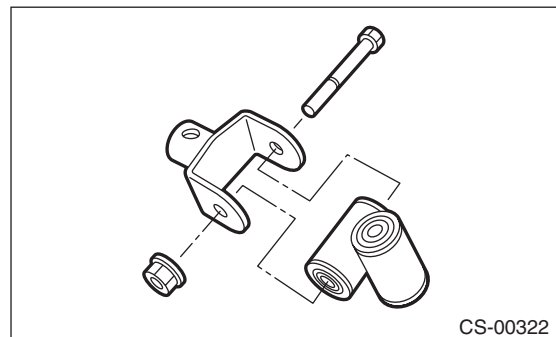



4) Install the snap ring to gear shift lever and install the bushing.

**NOTE:**

Apply grease to the bushing.

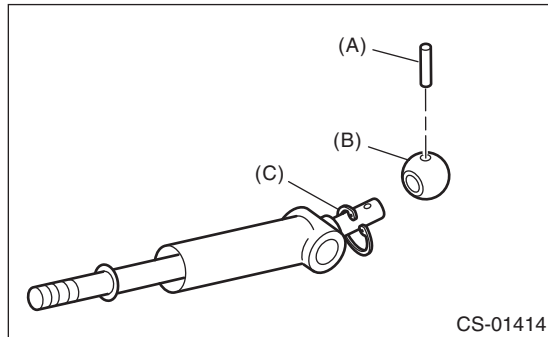

- (A) Spring pin
- (B) Bushing
- (C) Snap ring

5) Apply grease to the bushing and O-ring, and then install to gear shift lever.

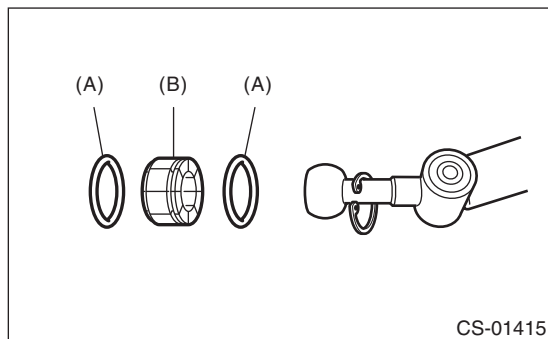

- (A) O-ring
- (B) Bushing

6) Apply sufficient grease into boss, and then install the gear shift lever to the stay.

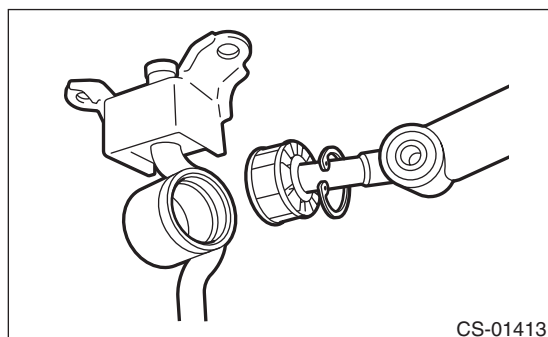

7) Install the snap ring.

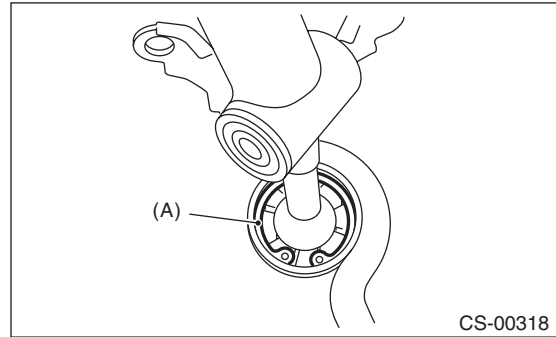

- (A) Snap ring

8) Insert the gear shift lever and rod into boot hole.

9) Install the rod.

**Tightening torque:**

**12 N·m (1.2 kgf-m, 8.9 ft-lb)**

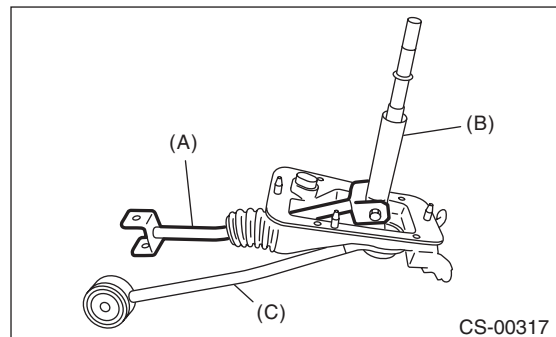

- (A) Rod
- (B) Lever
- (C) Stay

10) Install a new lock wire.

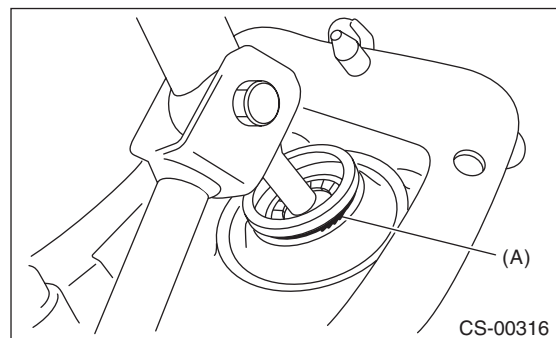

- (A) Lock wire

# MT Gear Shift Lever

## CONTROL SYSTEMS

### NOTE:

- Install the lock wire to the stay groove.
- Bend the extra wire to the same direction of lock wire winding.

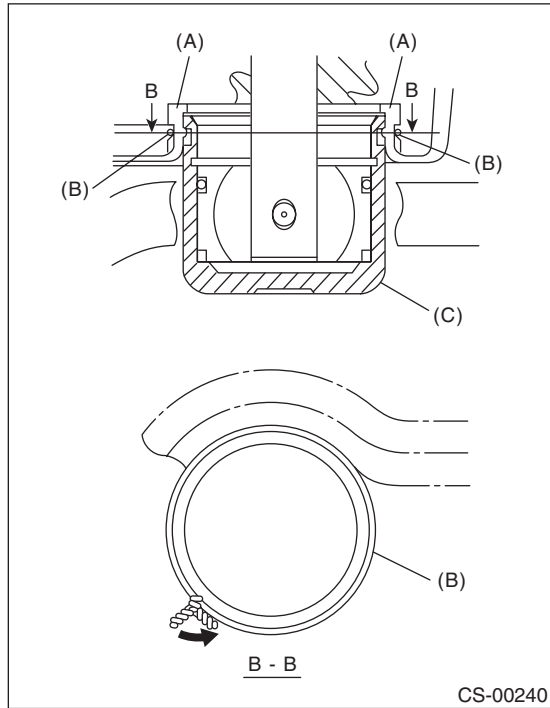

- (A) Inner boot
- (B) Lock wire
- (C) Stay

- STI model

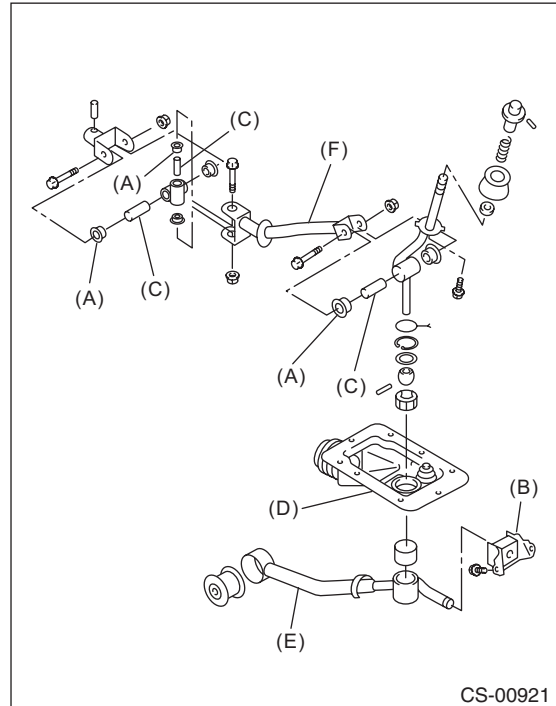

- (A) Bushing
- (B) Cushion rubber
- (C) Spacer
- (D) Boot
- (E) Stay
- (F) Rod

## E: INSPECTION

1) Check the parts (bushing, cushion rubber, spacer, boot, stay and rod, etc.) for deformation, damage and wear. If necessary, correct or replace faulty parts. Compare the removed parts with new parts to judge if there are damages or not.

- Except for STI model

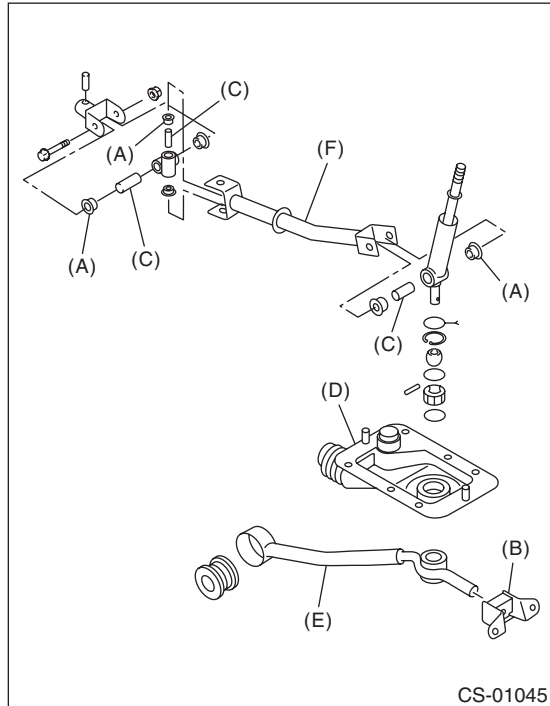

- (A) Bushing
- (B) Cushion rubber
- (C) Spacer
- (D) Boot
- (E) Stay
- (F) Rod

- Except for STI model

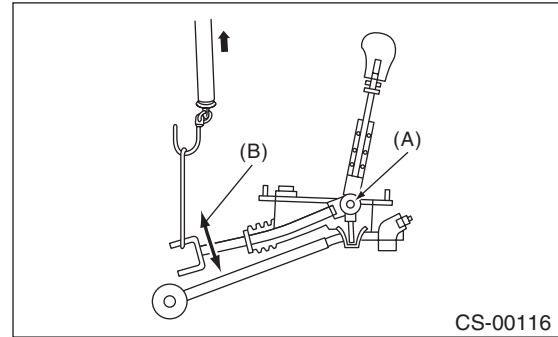

- (A) Pivot
- (B) Swing torque

2) Check the swing torque of rod linked with the gear shift lever.  
If the torque exceeds the specifications, replace the bushing or retighten nuts.

**Swing torque:**

**3.7 N (0.38 kgf, 0.83 lbf) or less**

- STI model

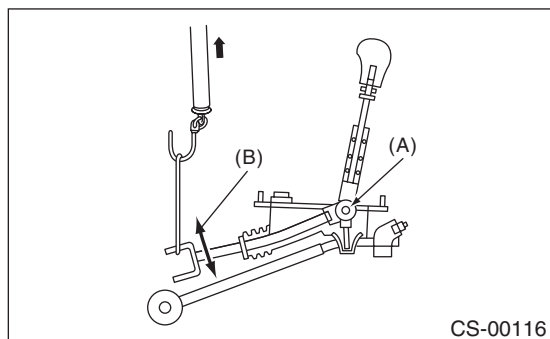

- (A) Pivot
- (B) Swing torque

# Reverse Check Cable

## CONTROL SYSTEMS

### 3. Reverse Check Cable

#### A: REMOVAL

- 1) Remove the gear shift knob.
- 2) Remove the console box. <Ref. to EI-51, REMOVAL, Console Box.>
- 3) Remove the console side cover and console front panel.
- 4) Remove the clamp.

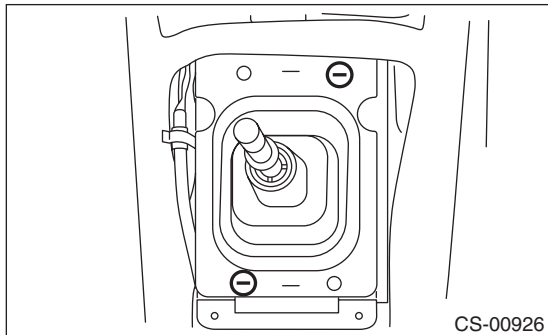

- 5) Remove the boot and insulator assembly.

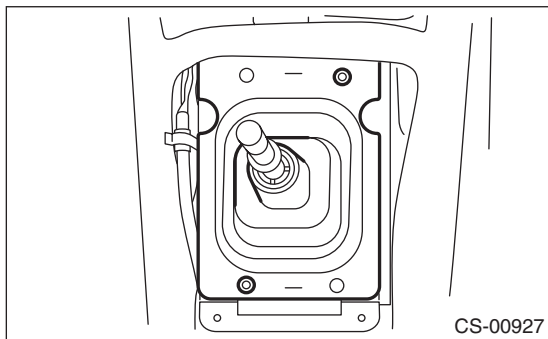

- 6) Remove the spring pin from the slider.

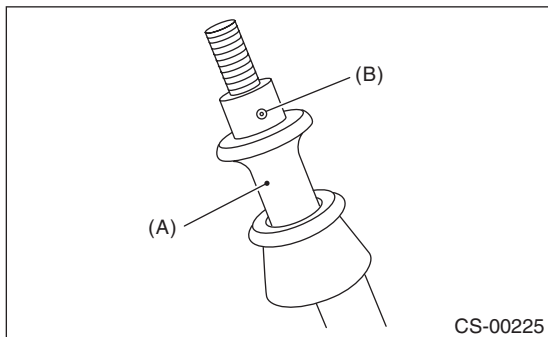

- (A) Slider
- (B) Spring pin

- 7) Remove the slider and spring.

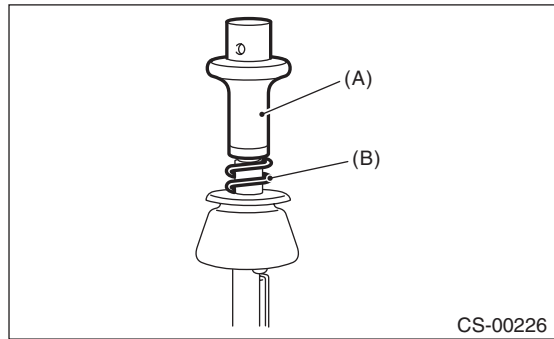

- (A) Slider
- (B) Spring

- 8) Cut the band clip, and separate the reverse check cable from the gear shift lever.

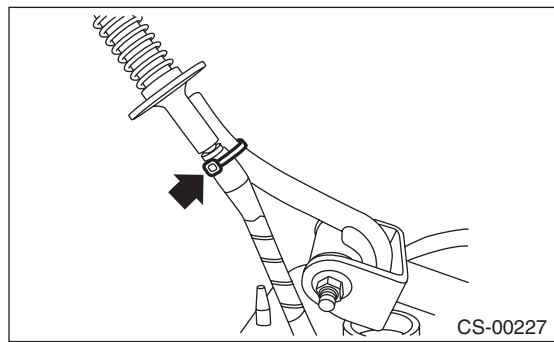

- 9) Lift up the vehicle.
- 10) Remove the under cover.
- 11) Remove the center exhaust pipe. <Ref. to EX(STI)-13, REMOVAL, Rear Exhaust Pipe.>
- 12) Remove the heat shield cover.

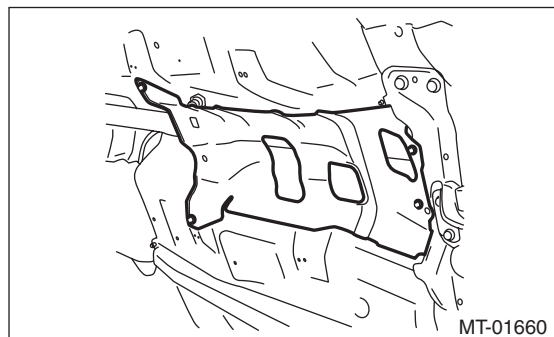

- 13) Remove the crossmember. <Ref. to 6MT-30, REMOVAL, Transmission Mounting System.>

14) Remove the snap pin and washer, and separate the reverse check cable from the reverse check lever.

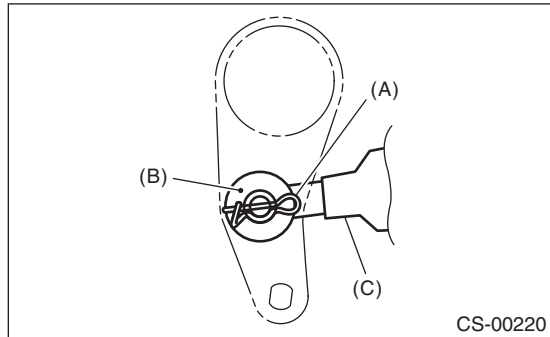

- (A) Snap pin
- (B) Washer
- (C) Reverse check cable

15) Move the transmission to the right side, and remove the stay bolts and the reverse check cable.

**NOTE:**

If the transmission is not moved aside, the stay bolts may contact the body and cause damage.

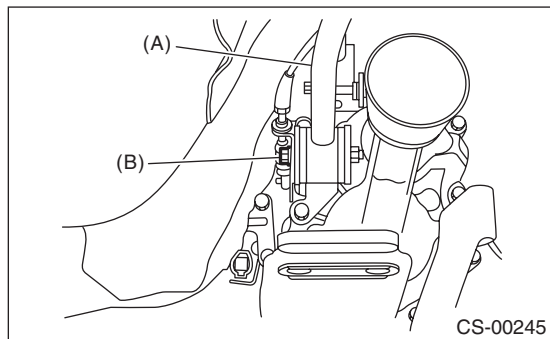

- (A) Stay
- (B) Stay bolt

16) Lift up the stay clip, and separate the stay from the reverse check cable.

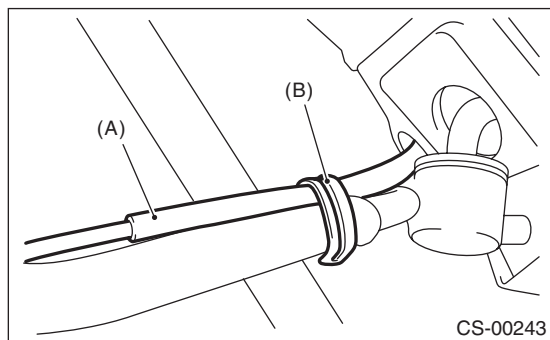

- (A) Reverse check cable
- (B) Clip

17) Pull out the reverse check cable from underside of the vehicle to remove it.

**NOTE:**

Be careful not to damage the inner boot.

18) Loosen the lock nut, and remove the reverse check cable from the cable plate.

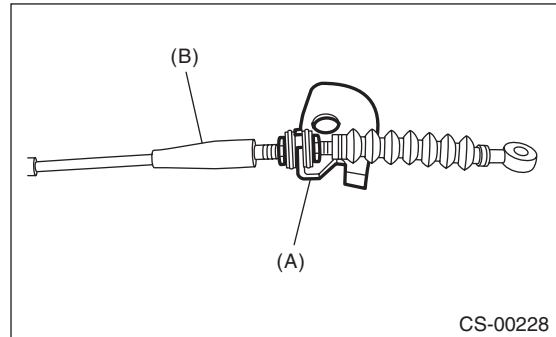

- (A) Cable plate
- (B) Reverse check cable

## B: INSTALLATION

- 1) Insert the reverse check cable into the inner boot hole from underside of the vehicle.
- 2) Insert the reverse check cable into the gear shift lever assembly, and secure it with the band clip.

**NOTE:**

- Cut the excess band clip.
- Make sure that the reverse check cable is inserted into the gearshift lever with no gaps.

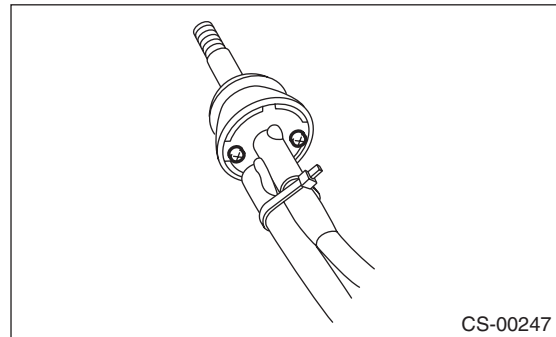

## Reverse Check Cable

### CONTROL SYSTEMS

3) Use the spring pin to secure the end of the slider and reverse check cable.

**NOTE:**

Apply grease to the moving part of slider.

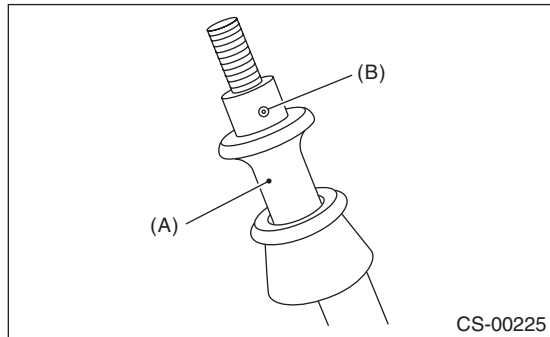

- (A) Slider
- (B) Spring pin

4) With the cable pulled (the slider is lowered), adjust the distance between the edge of cable plate and the reverse check cable to 84 mm (3.31 in), and tighten the lock nut.

**Tightening torque:**

**6 N·m (0.6 kgf·m, 4.4 ft·lb)**

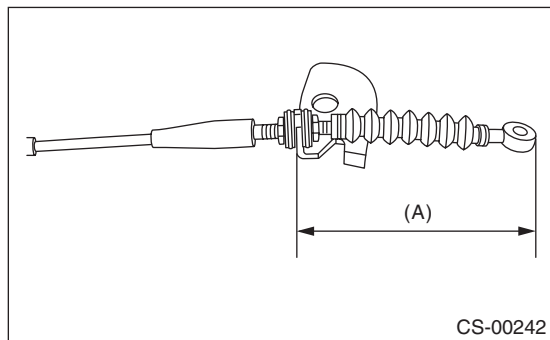

- (A) 84 mm (3.31 in)

5) Move the transmission to the right side, and install the stay.

**Tightening torque:**

**T: 32 N·m (3.3 kgf·m, 23.6 ft·lb)**

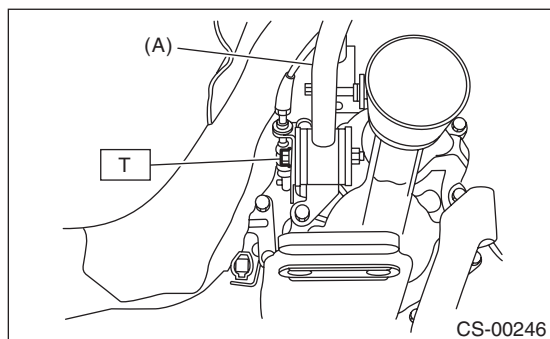

- (A) Stay

6) Install the reverse check cable, washer and snap pin to the reverse check lever.

**NOTE:**

Make sure to point the snap pin in an appropriate direction.

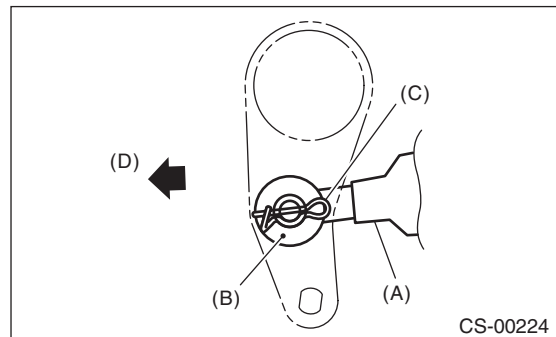

- (A) Reverse check cable
- (B) Washer
- (C) Snap pin
- (D) Front side

7) Secure the reverse check cable to the stay clip.

**NOTE:**

Install the reverse check cable on top of the stay.

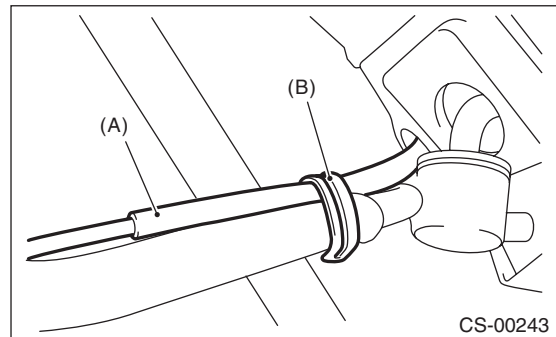

- (A) Reverse check cable
- (B) Clip

8) Install the heat shield cover.

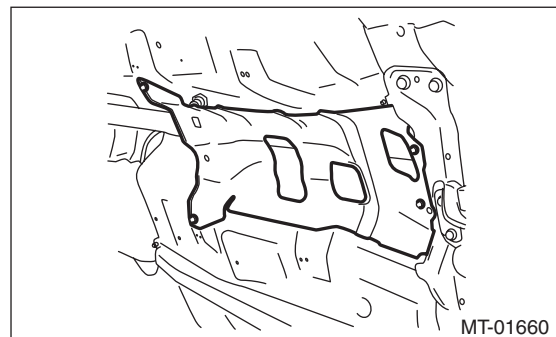

9) Install the center exhaust pipe. <Ref. to EX(STI)-13, INSTALLATION, Rear Exhaust Pipe.>

10) Install the boot and insulator assembly, and secure with a clamp.

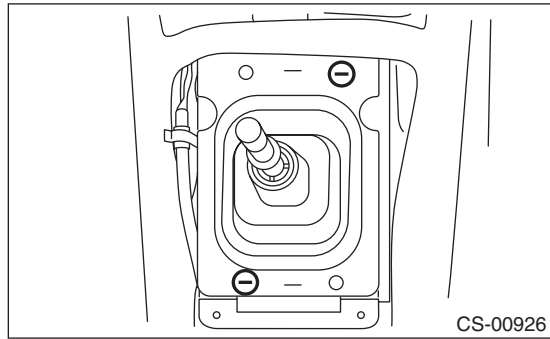

11) Install the console side cover and console front panel. <Ref. to EI-54, INSTALLATION, Center Console.>

12) Install the console box. <Ref. to EI-51, INSTALLATION, Console Box.>

13) Install the gear shift knob.

## C: INSPECTION

1) Make sure the slider moves smoothly. If it does not move, adjust the reverse check cable, or check the slider for damage. <Ref. to CS-25, ADJUSTMENT, Reverse Check Cable.>

2) Check if the gear shifts into reverse when pulling up the slider. If the gear cannot shift into reverse, adjust the reverse check cable. <Ref. to CS-25, ADJUSTMENT, Reverse Check Cable.>

3) Check that the gear does not shift into reverse when the slider is not pulled up. If the gear shifts into reverse, adjust or replace the reverse check cable. <Ref. to CS-25, ADJUSTMENT, Reverse Check Cable.>

## D: ADJUSTMENT

1) Lift up the vehicle.

2) Remove the transmission under cover.

3) Remove the center exhaust pipe. <Ref. to EX(STI)-8, REMOVAL, Center Exhaust Pipe.>

4) Remove the heat shield cover.

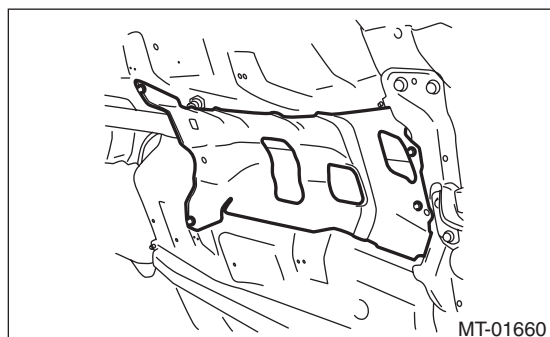

5) Remove the crossmember. <Ref. to 6MT-30, REMOVAL, Transmission Mounting System.>

6) Remove the snap pin and washer, and separate the reverse check cable from the reverse check lever.

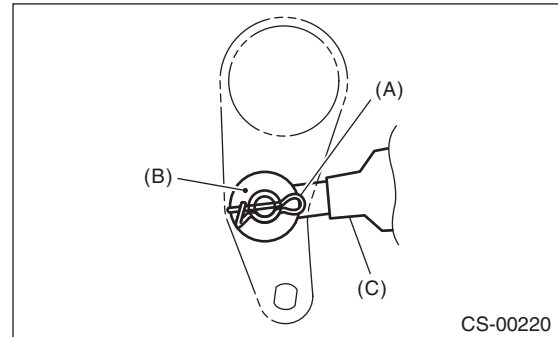

(A) Snap pin

(B) Washer

(C) Reverse check cable

7) Move the transmission to the right side, and remove the stay bolts and the reverse check cable.

### NOTE:

If the transmission is not moved aside, the stay bolts may contact the body and cause damage.

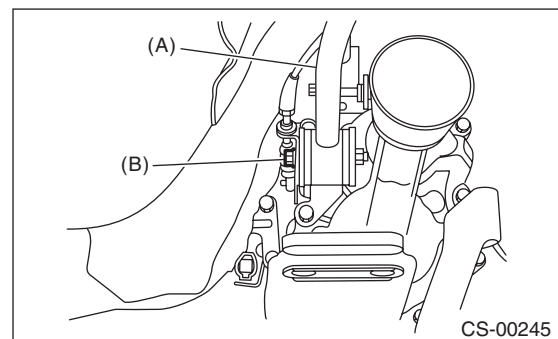

(A) Stay

(B) Stay bolt

8) With the cable pulled (the slider is lowered), adjust the distance between the edge of cable plate and the reverse check cable to 84 mm (3.31 in), and tighten the lock nut.

### Tightening torque:

**6 N·m (0.6 kgf-m, 4.4 ft-lb)**

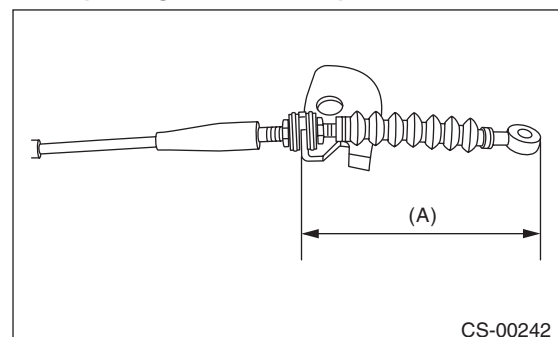

(A) 84 mm (3.31 in)

## Reverse Check Cable

### CONTROL SYSTEMS

9) Move the transmission to the right side, and install the stay.

**Tightening torque:**

**T: 32 N·m (3.3 kgf-m, 23.6 ft-lb)**

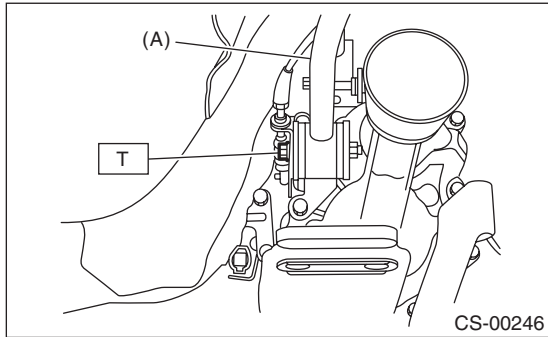

(A) Stay

10) Install the crossmember. <Ref. to 6MT-30, INSTALLATION, Transmission Mounting System.>

11) Install the heat shield cover.

**Tightening torque:**

**18 N·m (1.8 kgf-m, 13.3 ft-lb)**

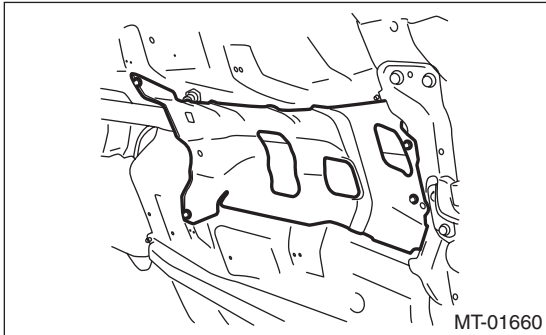

12) Install the center exhaust pipe. <Ref. to EX(STI)-9, INSTALLATION, Center Exhaust Pipe.>

13) Install the reverse check cable, washer and snap pin to the reverse check lever.

**NOTE:**

Make sure to point the snap pin in an appropriate direction.

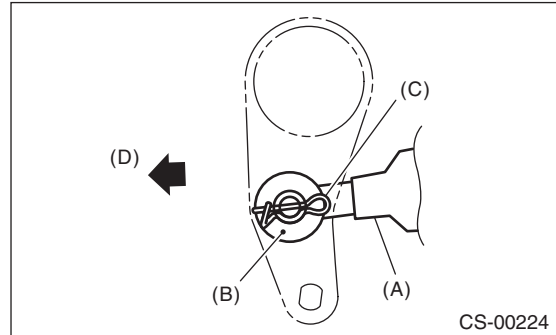

(A) Reverse check cable

(B) Washer

(C) Snap pin

(D) Front side

14) Install the transmission under cover.

**Tightening torque:**

**18 N·m (1.8 kgf-m, 13.3 ft-lb)**



## 4. General Diagnostic Table

### A: INSPECTION

Symptoms	Possible cause	Corrective action
MT gear shift lever (6MT)	Cannot shift into reverse.	Adjust the reverse check cable.
	Can shift into reverse when the slider is not pulled up.	Adjust or replace the reverse check cable.
	Slider cannot be pulled up or sticks in the pulled-up position.	<ul style="list-style-type: none"> <li>• Check the reverse check system of the transmission.</li> <li>• Adjust or replace the reverse check cable.</li> </ul>

# General Diagnostic Table

CONTROL SYSTEMS

---

# MANUAL TRANSMISSION AND DIFFERENTIAL

# 5MT

---

	<b>Page</b>
1. General Description .....	2
2. Transmission Gear Oil .....	22
3. Manual Transmission Assembly .....	23
4. Transmission Mounting System .....	29
5. Oil Seal .....	31
6. Differential Side Retainer Oil Seal .....	32
7. Switches and Harness .....	33
8. Preparation for Overhaul .....	34
9. Transfer Case and Extension Case Assembly .....	35
10. Transfer Drive Gear .....	41
11. Transfer Driven Gear .....	43
12. Center Differential .....	45
13. Reverse Check Sleeve .....	46
14. Transmission Case .....	49
15. Main Shaft Assembly for Single-Range .....	53
16. Drive Pinion Shaft Assembly .....	58
17. Front Differential Assembly .....	68
18. Reverse Idler Gear .....	75
19. Shifter Fork and Rod .....	77
20. General Diagnostic Table .....	80

# General Description

## MANUAL TRANSMISSION AND DIFFERENTIAL

---

### 1. General Description

#### A: SPECIFICATION

##### 1. MANUAL TRANSMISSION AND DIFFERENTIAL

Model		Turbo model	
Type		5-forward speeds and 1-reverse (all stage with synchromesh)	
Transmission gear ratio	1st	3.166	
	2nd	1.882	
	3rd	1.296	
	4th	0.972	
	5th	0.738	
	Reverse	3.333	
Front reduction gear	Final	Type of gear	Hypoid
		Gear ratio	3.900
Rear reduction gear	Transfer	Type of gear	Helical
		Gear ratio	1.000
	Final	Type of gear	Hypoid
		Gear ratio	3.900
Front differential	Type and number of gear	Straight bevel gear (bevel pinion: 2, bevel gear: 2)	
Center differential	Type and number of gear	Straight bevel gear (bevel pinion: 2, bevel gear: 2 and viscous coupling)	
Transmission gear oil		GL-5	
Transmission gear oil capacity		3.5 ℓ (3.7 US qt, 3.1 Imp qt)	

##### 2. TRANSMISSION GEAR OIL

**Recommended oil:**

***GL-5 (75W-90) or equivalent***

# General Description

MANUAL TRANSMISSION AND DIFFERENTIAL

## B: COMPONENT

### 1. TRANSMISSION CASE

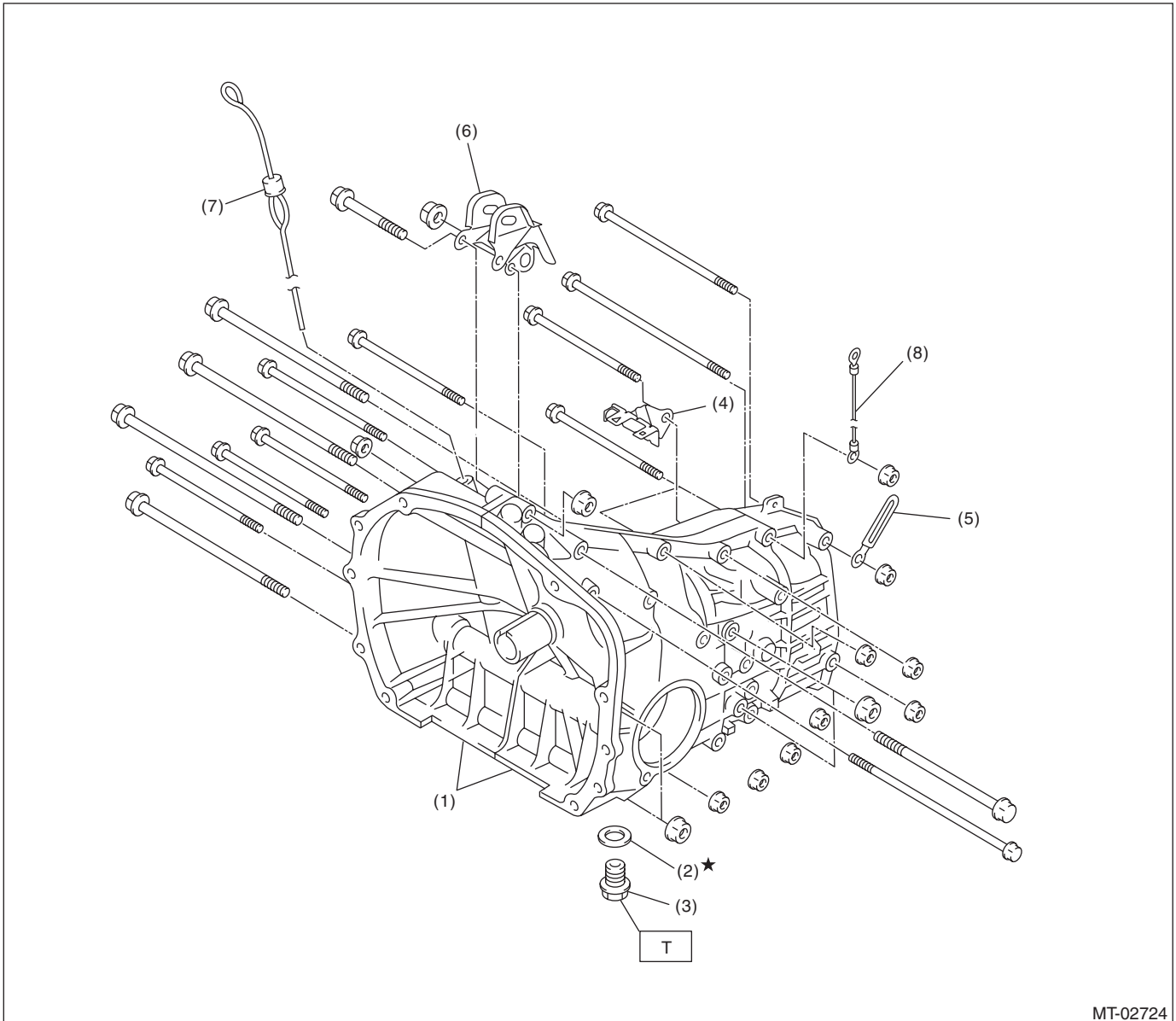

MT-02724

- |                            |                                    |
|----------------------------|------------------------------------|
| (1) Transmission case ASSY | (5) Harness clip                   |
| (2) Gasket                 | (6) Pitching stopper bracket       |
| (3) Drain plug             | (7) Oil level gauge                |
| (4) Harness bracket        | (8) Transmission radio ground cord |

**Tightening torque: N·m (kgf·m, ft·lb)**  
**T: 44 (4.5, 32.5) (Aluminum gasket, silver)**  
**70 (7.1, 51.6) (Copper gasket, brown)**  
**70 (7.1, 51.6) (Metal gasket, black)**

5MT-3

Brought to you by Ebay Seller "SubaruManuals"

# General Description

## MANUAL TRANSMISSION AND DIFFERENTIAL

### Transmission case tightening torque

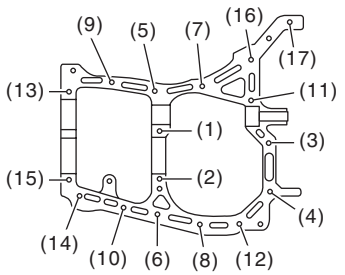
 <p>MT-00003</p>	Bolt No.	Bolt size mm	Tightening torque: N·m (kgf·m, ft·lb)
	(5) — (15)	8	25 (2.5, 18.4)
	(1) — (4) (16), (17)	10	39 (4.0, 28.8)

# General Description

## MANUAL TRANSMISSION AND DIFFERENTIAL

### 2. DRIVE PINION ASSEMBLY

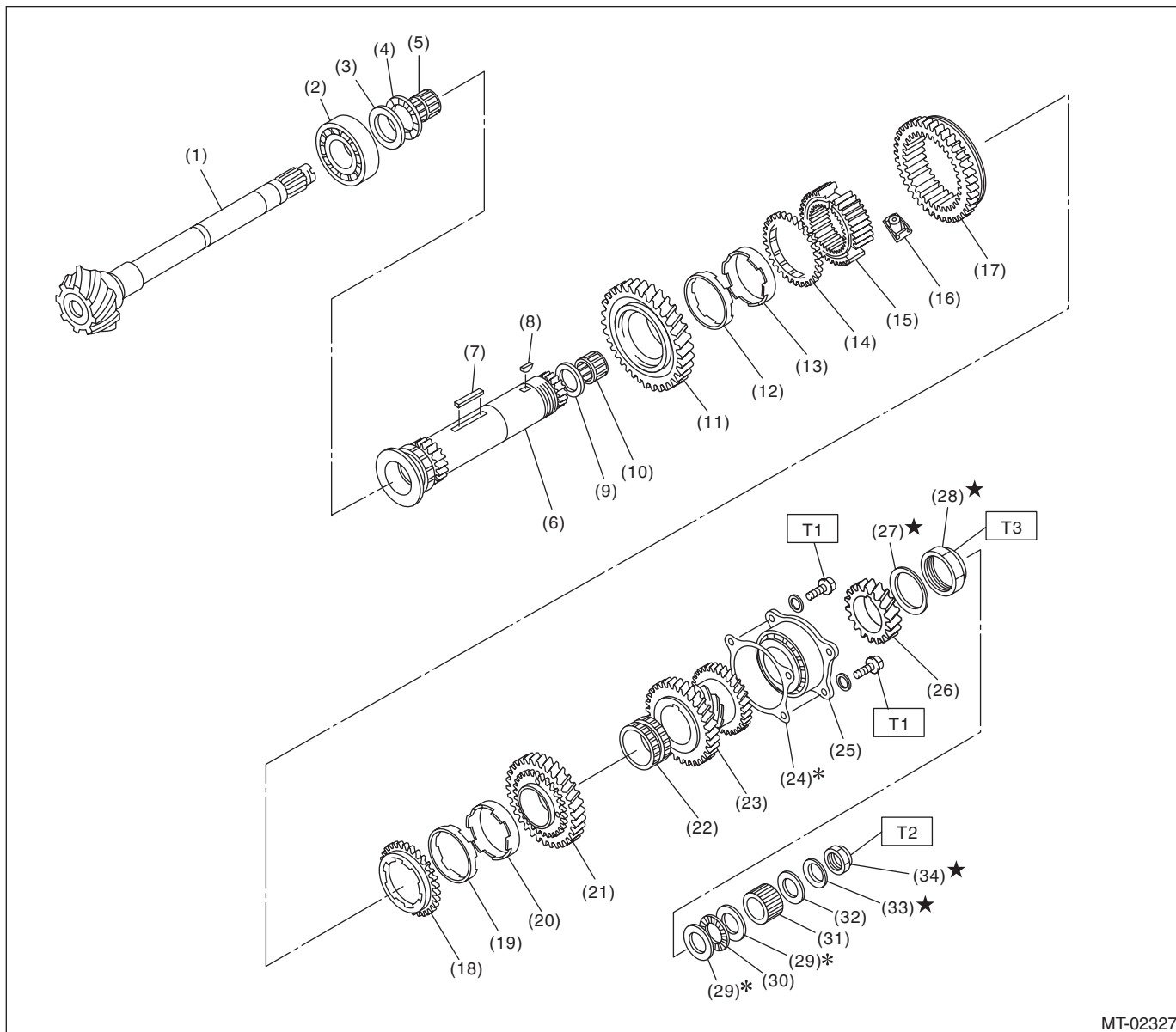

- |                         |                               |                                     |
|-------------------------|-------------------------------|-------------------------------------|
| (1) Drive pinion shaft  | (14) Outer baulk ring         | (27) Lock washer                    |
| (2) Roller bearing      | (15) 1st-2nd synchronizer hub | (28) Lock nut                       |
| (3) Washer              | (16) Ball detent              | (29) Adjusting washer               |
| (4) Thrust bearing      | (17) Reverse driven gear      | (30) Thrust bearing                 |
| (5) Needle bearing      | (18) Outer baulk ring         | (31) Differential bevel gear sleeve |
| (6) Driven shaft        | (19) Synchro cone             | (32) Washer                         |
| (7) Key                 | (20) Inner baulk ring         | (33) Lock washer                    |
| (8) Woodruff key        | (21) 2nd driven gear          | (34) Lock nut                       |
| (9) Drive pinion collar | (22) 2nd driven gear bushing  |                                     |
| (10) Needle bearing     | (23) 3rd-4th driven gear      |                                     |
| (11) 1st driven gear    | (24) Driven pinion shim       |                                     |
| (12) Inner baulk ring   | (25) Roller bearing           |                                     |
| (13) Synchro cone       | (26) 5th driven gear          |                                     |

**Tightening torque: N-m (kgf-m, ft-lb)**

**T1: 30 (3.1, 22.1)**

**T2: 120 (12.2, 88.5)**

**T3: 260 (26.5, 191.8)**

**5MT-5**

Brought to you by Ebay Seller "SubaruManuals"

# General Description

## MANUAL TRANSMISSION AND DIFFERENTIAL

### 3. MAIN SHAFT FOR SINGLE-RANGE

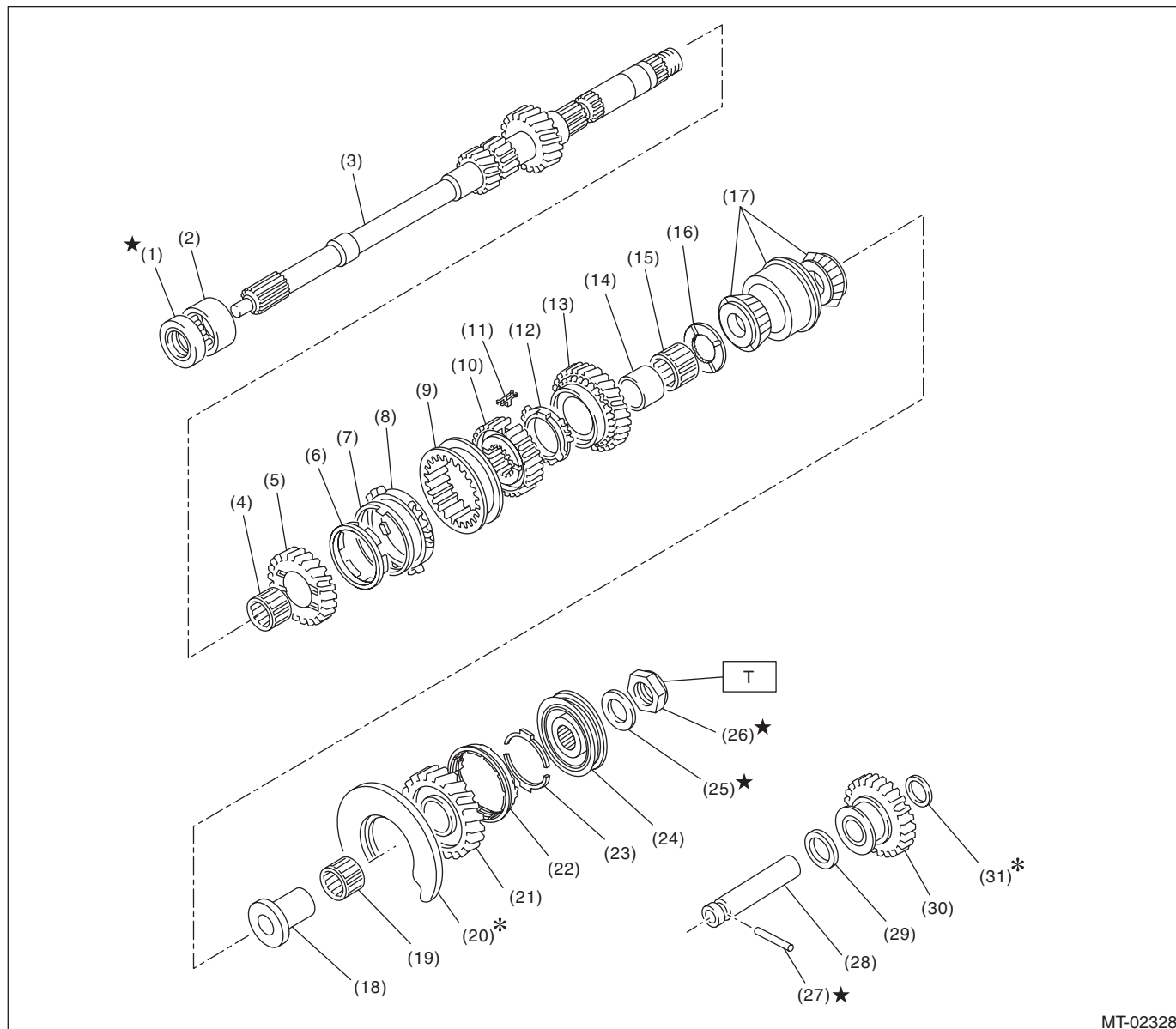

MT-02328

- |                                  |                              |                               |
|----------------------------------|------------------------------|-------------------------------|
| (1) Oil seal                     | (13) 4th drive gear          | (25) Lock washer              |
| (2) Needle bearing               | (14) 4th needle bearing race | (26) Lock nut                 |
| (3) Transmission main shaft      | (15) Needle bearing          | (27) Straight pin             |
| (4) Needle bearing               | (16) 4th gear thrust washer  | (28) Reverse idler gear shaft |
| (5) 3rd drive gear               | (17) Ball bearing            | (29) Washer                   |
| (6) Inner baulk ring             | (18) 5th needle bearing race | (30) Reverse idler gear       |
| (7) 3rd synchro cone             | (19) Needle bearing          | (31) Washer                   |
| (8) Outer baulk ring             | (20) Main shaft rear plate   |                               |
| (9) 3rd-4th coupling sleeve      | (21) 5th drive gear          |                               |
| (10) 3rd-4th synchronizer hub    | (22) 5th baulk ring          |                               |
| (11) 3rd-4th shifting insert key | (23) Baulk lever             |                               |
| (12) 4th baulk ring              | (24) 5th hub & sleeve No. 2  |                               |

**Tightening torque: N·m (kgf·m, ft·lb)**

**T: 120 (12.2, 88.5)**

**5MT-6**

Brought to you by Ebay Seller "SubaruManuals"



# General Description

## 4. SHIFTER FORK AND SHIFTER ROD

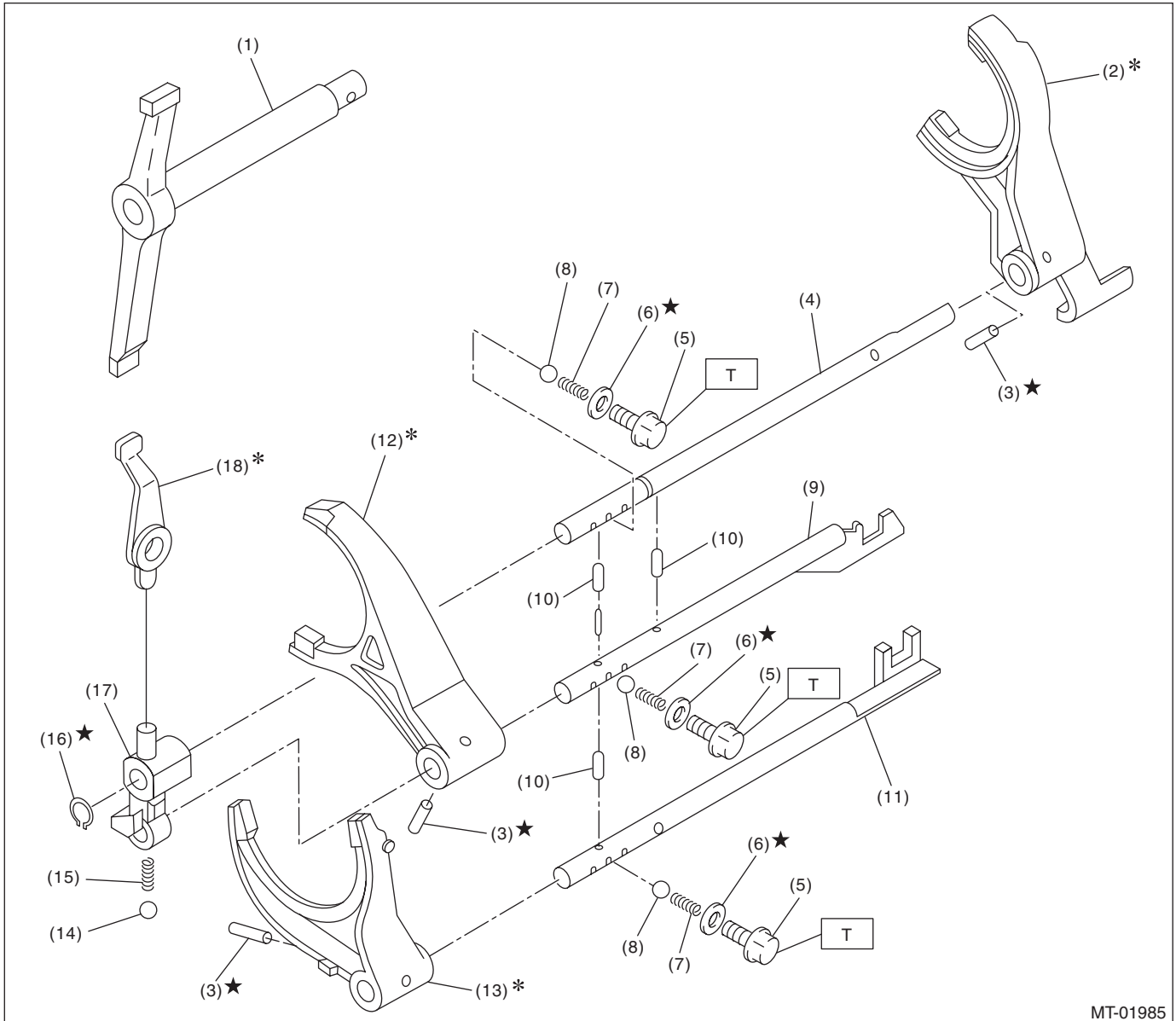

MT-01985

- |                          |                           |                            |
|--------------------------|---------------------------|----------------------------|
| (1) Shifter arm          | (8) Ball                  | (15) Spring                |
| (2) 5th shifter fork     | (9) 3rd-4th fork rod      | (16) Snap ring (outer)     |
| (3) Straight pin         | (10) Interlock plunger    | (17) Reverse fork rod arm  |
| (4) Reverse fork rod     | (11) 1st-2nd fork rod     | (18) Reverse shifter lever |
| (5) Checking ball plug   | (12) 3rd-4th shifter fork |                            |
| (6) Gasket               | (13) 1st-2nd shifter fork |                            |
| (7) Checking ball spring | (14) Ball                 |                            |

**Tightening torque: N·m (kgf·m, ft·lb)**

**T: 20 (2.0, 14.8)**

# General Description

## MANUAL TRANSMISSION AND DIFFERENTIAL

### 5. TRANSFER CASE AND EXTENSION

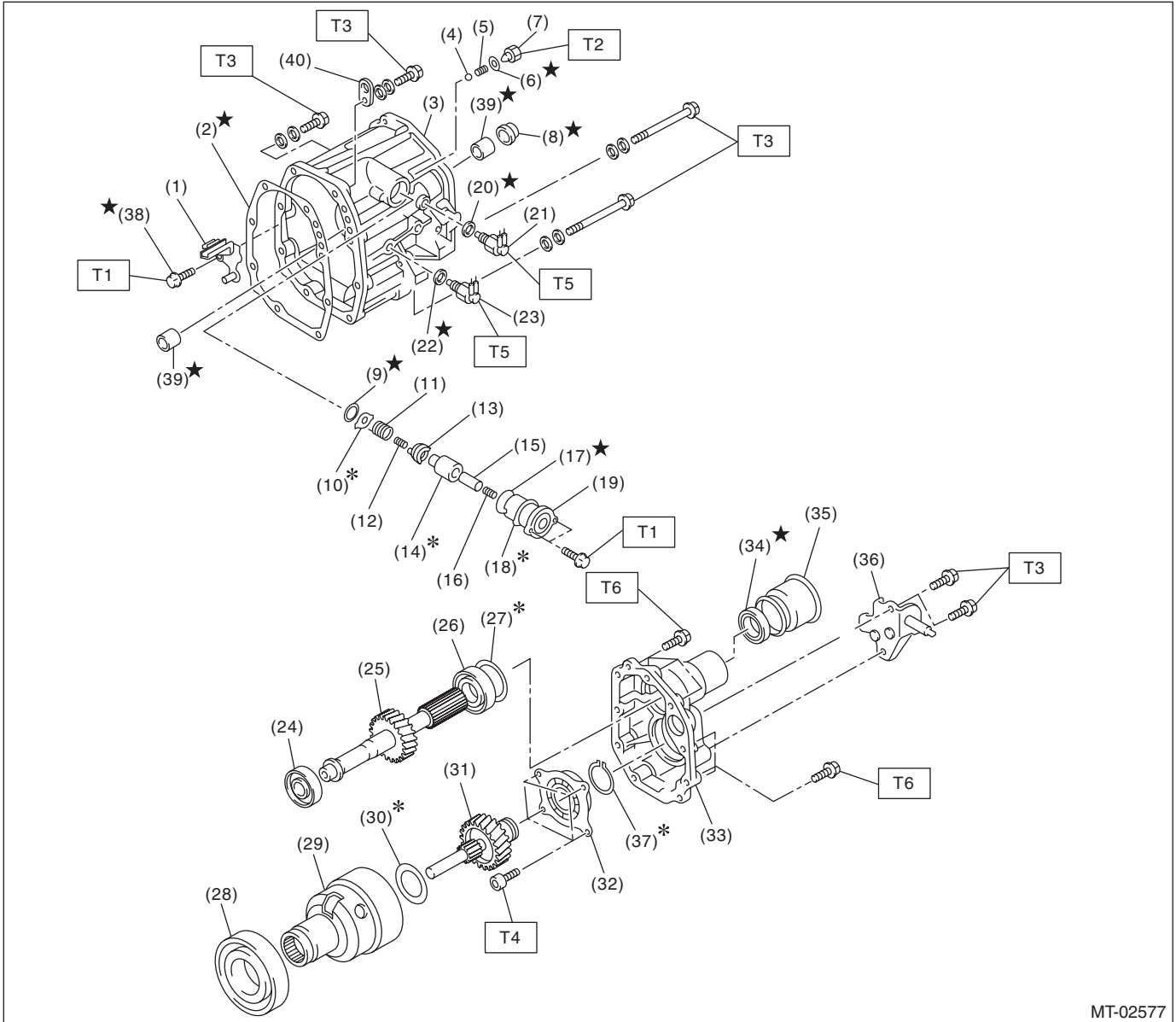

MT-02577

**5MT-8**

Brought to you by Ebay Seller "SubaruManuals"

# General Description

## MANUAL TRANSMISSION AND DIFFERENTIAL

---

(1) Oil guide	(17) O-ring	(33) Extension case
(2) Gasket	(18) Adjusting select shim	(34) Oil seal
(3) Transfer case	(19) Reverse check sleeve	(35) Dust cover
(4) Ball	(20) Gasket	(36) Shift bracket
(5) Reverse accent spring	(21) Neutral position switch	(37) Snap ring
(6) Gasket	(22) Gasket	(38) Precoat bolt
(7) Plug	(23) Back-up light switch	(39) Roller bearing
(8) Oil seal	(24) Roller bearing	(40) Transmission hanger
(9) Snap ring (inner)	(25) Transfer driven gear	
(10) Reverse check plate	(26) Roller bearing	
(11) Reverse check spring	(27) Thrust washer	
(12) Reverse return spring	(28) Ball bearing	
(13) Reverse check cam	(29) Center differential	
(14) Reverse accent shaft	(30) Thrust washer	
(15) Return spring cap	(31) Transfer drive gear	
(16) Return spring	(32) Ball bearing	

---

**Tightening torque:N-m (kgf-m, ft-lb)****T1: 6.4 (0.7, 4.7)****T2: 9.75 (1.0, 7.2)****T3: 24.5 (2.5, 18.1)****T4: 26 (2.7, 19.2)****T5: 32.3 (3.3, 23.8)****T6: 40 (4.1, 29.5)**

---

# General Description

## MANUAL TRANSMISSION AND DIFFERENTIAL

### 6. FRONT DIFFERENTIAL

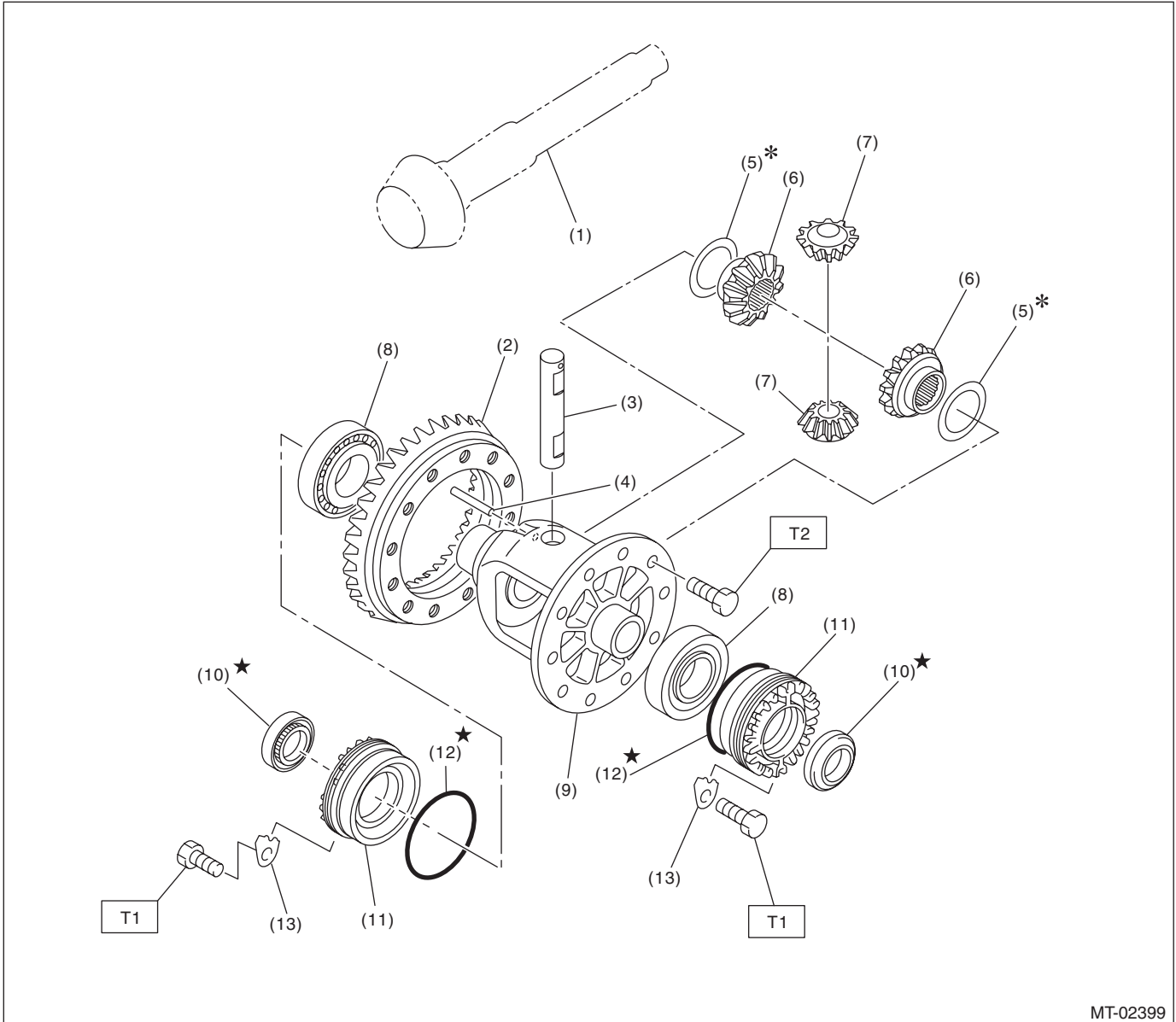

MT-02399

- |                             |                                 |                          |
|-----------------------------|---------------------------------|--------------------------|
| (1) Drive pinion shaft      | (7) Differential bevel pinion   | (13) Retainer lock plate |
| (2) Hypoid driven gear      | (8) Roller bearing              |                          |
| (3) Pinion shaft            | (9) Differential case           |                          |
| (4) Straight pin            | (10) Oil seal                   |                          |
| (5) Washer                  | (11) Differential side retainer |                          |
| (6) Differential bevel gear | (12) O-ring                     |                          |

**Tightening torque: N·m (kgf·m, ft·lb)**

**T1: 25 (2.5, 18.4)**

**T2: 62 (6.3, 45.7)**

**5MT-10**

Brought to you by Ebay Seller "SubaruManuals"

# General Description

## 7. TRANSMISSION MOUNTING

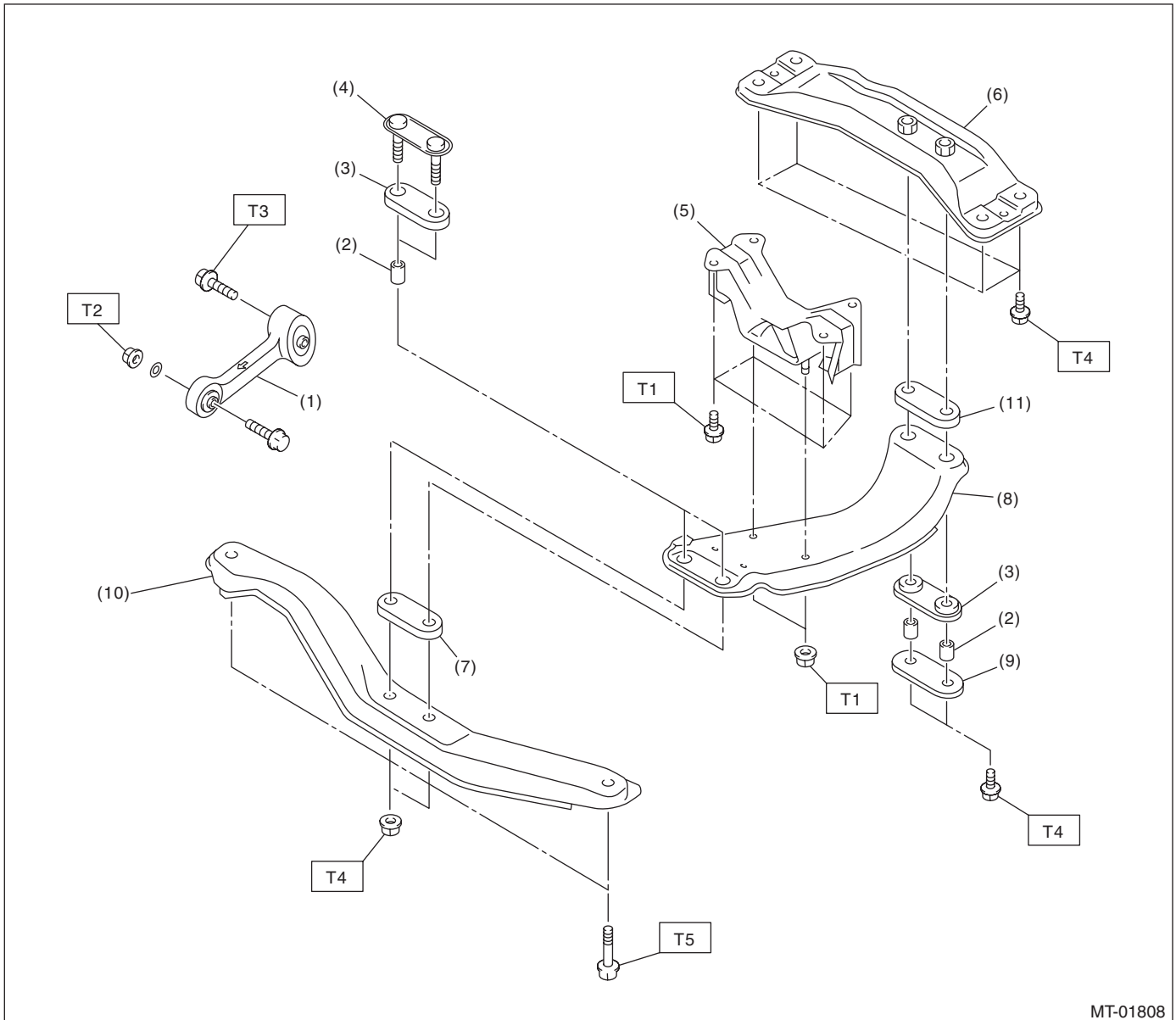

MT-01808

- |                                 |                          |
|---------------------------------|--------------------------|
| (1) Pitching stopper            | (7) Upper cushion rubber |
| (2) Spacer                      | (8) Center crossmember   |
| (3) Lower cushion rubber        | (9) Rear plate           |
| (4) Front plate                 | (10) Front crossmember   |
| (5) Transmission cushion rubber | (11) Rear cushion rubber |
| (6) Rear crossmember            |                          |

**Tightening torque: N·m (kgf·m, ft·lb)**

**T1: 35 (3.6, 25.8)**

**T2: 50 (5.1, 36.9)**

**T3: 58 (5.9, 42.8)**

**T4: 70 (7.1, 51.6)**

**T5: 140 (14.3, 103.3)**

## General Description

### MANUAL TRANSMISSION AND DIFFERENTIAL

---

#### **C: CAUTION**

- Wear appropriate work clothing, including a cap, protective goggles and protective shoes when performing any work.
- Remove contamination including dirt and corrosion before removal, installation or disassembly.
- Keep the disassembled parts in order and protect them from dust and dirt.
- Before removal, installation or disassembly, be sure to clarify the failure. Avoid unnecessary removal, installation, disassembly and replacement.
- When disassembling the case and other light alloy parts, use a plastic hammer to force it apart. Do not pry apart with screwdrivers or other tools.
- Vehicle components are extremely hot after driving. Be wary of receiving burns from heated parts.
- Use SUBARU genuine gear oil, grease or equivalent. Do not mix gear oil, grease, etc. of different grades or manufacturers.
- Be sure to tighten fasteners including bolts and nuts to the specified torque.
- Place shop jacks or rigid racks at the specified points.
- Apply gear oil onto sliding or revolving surfaces before installation.
- Replace deformed or damaged snap rings with new parts.
- Before installing O-rings or oil seals, apply sufficient amount of gear oil to avoid damage and deformation.
- Be careful not to incorrectly install or fail to install O-rings, snap rings and other such parts.
- Before securing a part on a vise, place cushioning material such as wood blocks, aluminum plate, or cloth between the part and the vise.
- Avoid damaging the mating surface of the case.
- Before applying liquid gasket, completely remove the old liquid gasket.

# General Description

MANUAL TRANSMISSION AND DIFFERENTIAL

## D: PREPARATION TOOL

### 1. SPECIAL TOOL

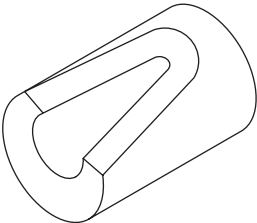
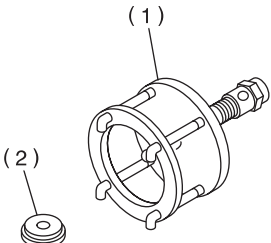
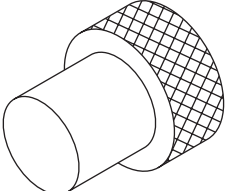
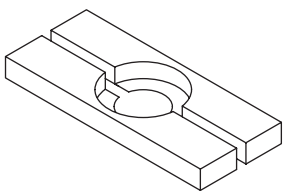
ILLUSTRATION	TOOL NUMBER	DESCRIPTION	REMARKS
 <p>ST-399411700</p>	399411700	ACCENT BALL INSTALLER	Used for installing reverse shifter rail arm.
 <p>ST-899524100</p>	899524100	PULLER SET	Used for removing and installing the front differential roller bearing. 1. Puller 2. Adapter
 <p>ST-399780104</p>	399780104	WEIGHT	Used for measuring preload on the front differential roller bearing.
 <p>ST-498077000</p>	498077000	REMOVER	<ul style="list-style-type: none"> <li>Used for removing the roller bearing of the drive pinion shaft.</li> <li>Used for removing the roller bearing of the transfer driven gear.</li> </ul>

# General Description

## MANUAL TRANSMISSION AND DIFFERENTIAL

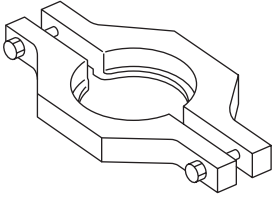
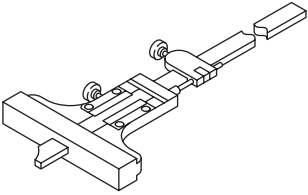
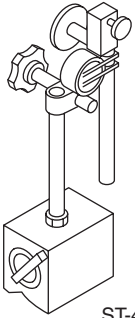
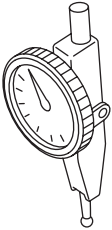
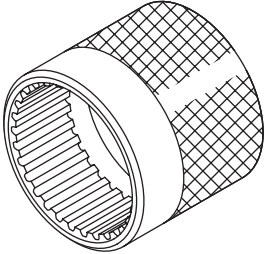
ILLUSTRATION	TOOL NUMBER	DESCRIPTION	REMARKS
 <p data-bbox="337 520 467 541">ST-498077300</p>	498077300	CENTER DIFFERENTIAL BEARING REMOVER	Used for removing the center differential cover ball bearing.
 <p data-bbox="337 877 467 898">ST-498147001</p>	498147001	DEPTH GAUGE	Used for adjusting the extension end play and main shaft end play.
 <p data-bbox="337 1239 467 1260">ST-498247001</p>	498247001	MAGNET BASE	<ul style="list-style-type: none"> <li>• Used for measuring the backlash between bevel pinion gear and hypoid gear.</li> <li>• Used together with DIAL GAUGE (498247100).</li> </ul>
 <p data-bbox="337 1596 467 1617">ST-498247100</p>	498247100	DIAL GAUGE	<ul style="list-style-type: none"> <li>• Used for measuring the backlash between bevel pinion gear and hypoid gear.</li> <li>• Used together with MAGNET BASE (498247001).</li> </ul>
 <p data-bbox="337 1953 467 1974">ST-498427100</p>	498427100	STOPPER	<ul style="list-style-type: none"> <li>• Used for removing and installing the drive pinion shaft assembly lock nut.</li> <li>• Used for backlash measurement of the hypoid gear and preload adjustment of the roller bearing.</li> </ul>



# General Description

## MANUAL TRANSMISSION AND DIFFERENTIAL

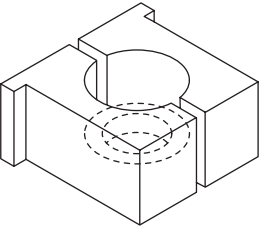
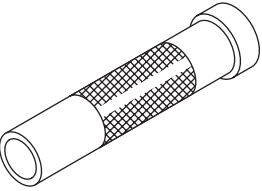
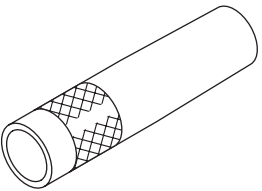
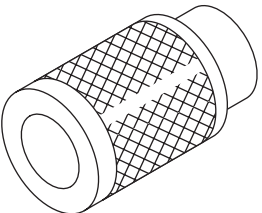
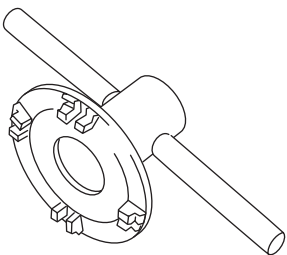
ILLUSTRATION	TOOL NUMBER	DESCRIPTION	REMARKS
 <p>ST-498937000</p>	498937000	TRANSMISSION HOLDER	Used for removing and installing the main shaft lock nut.
 <p>ST-499277100</p>	499277100	BUSHING 1-2 INSTALLER	<ul style="list-style-type: none"> <li>• Used for installing the front differential roller bearing inner race.</li> <li>• Used for installing drive pinion shaft washer.</li> </ul>
 <p>ST-499277200</p>	499277200	INSTALLER	<ul style="list-style-type: none"> <li>• Used for installing the 2nd driven gear bushing, 3rd-4th driven gear, roller bearing and 5th driven gear.</li> <li>• Used for installing drive pinion shaft washer.</li> </ul>
 <p>ST-499757002</p>	499757002	INSTALLER	<ul style="list-style-type: none"> <li>• Used for attaching the snap ring (outer 25).</li> <li>• Used for installing the roller bearing of transfer driven gear (transfer case side).</li> <li>• Used for removing the roller bearing and driven gear of the drive pinion shaft.</li> </ul>
 <p>ST18630AA010</p>	18630AA010	WRENCH COMPL RETAINER	<ul style="list-style-type: none"> <li>• Used for removing and installing the differential side retainer.</li> <li>• Used for backlash measurement of the front differential hypoid gear and preload adjustment of the roller bearing.</li> <li>• WRENCH ASSY (499787000) can also be used.</li> </ul>

**5MT-15**

Brought to you by Ebay Seller "SubaruManuals"

# General Description

## MANUAL TRANSMISSION AND DIFFERENTIAL

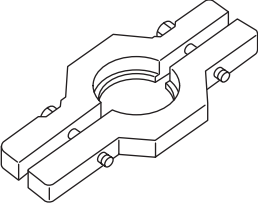
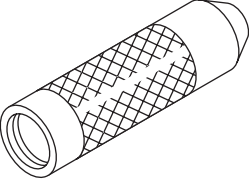
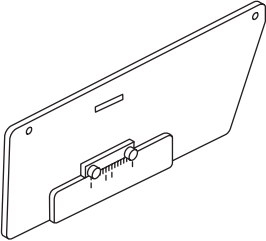
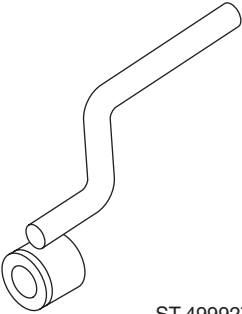
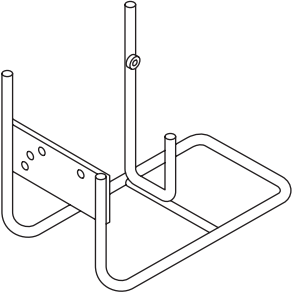
ILLUSTRATION	TOOL NUMBER	DESCRIPTION	REMARKS
 <p>ST-499857000</p>	499857000	5TH DRIVEN GEAR REMOVER	Used for removing the 5th driven gear.
 <p>ST-499877000</p>	499877000	RACE 4-5 INSTALLER	<ul style="list-style-type: none"> <li>Used for installing the 4th drive gear needle bearing race, main shaft ball bearing and 5th drive gear thrust washer.</li> <li>Used together with REMOVER (899714110).</li> </ul>
 <p>ST-499917500</p>	499917500	DRIVE PINION GAUGE ASSY	Used for adjusting the drive pinion shaft shim.
 <p>ST-499927100</p>	499927100	HANDLE	Used for backlash measurement of the front differential hypoid gear and preload adjustment of the roller bearing.
 <p>ST-499937100</p>	499937100	TRANSMISSION STAND	Used for disassembling and assembling the transmission.

5MT-16

Brought to you by Ebay Seller "SubaruManuals"

# General Description

## MANUAL TRANSMISSION AND DIFFERENTIAL

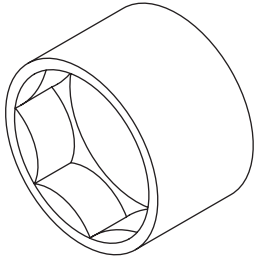
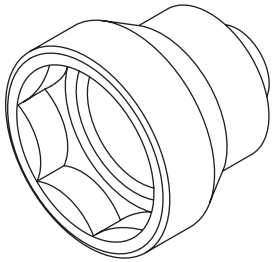
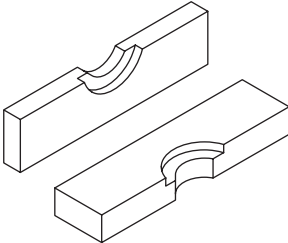
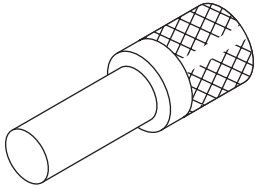
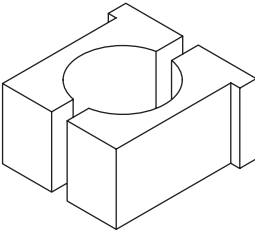
ILLUSTRATION	TOOL NUMBER	DESCRIPTION	REMARKS
 <p data-bbox="337 520 467 541">ST-499987003</p>	499987003	SOCKET WRENCH (35)	Used for removing and installing the driven pinion lock nut and main shaft lock nut.
 <p data-bbox="337 877 467 898">ST-499987300</p>	499987300	SOCKET WRENCH (50)	Used for removing and installing the driven gear assembly lock nut.
 <p data-bbox="337 1234 467 1255">ST-899714110</p>	899714110	REMOVER	Used for installing the transmission main shaft, drive pinion shaft and rear drive shaft.
 <p data-bbox="337 1598 467 1619">ST-899864100</p>	899864100	REMOVER	<ul style="list-style-type: none"> <li>• Used for removing transmission main shaft parts.</li> <li>• Used for installing the roller bearing of the transfer case.</li> <li>• Used for installing the roller bearing of transfer driven gear (extension case side).</li> <li>• Used for installing the roller bearing of transfer driven gear (transfer case side).</li> </ul>
 <p data-bbox="337 1955 467 1976">ST-899884100</p>	899884100	HOLDER	<ul style="list-style-type: none"> <li>• Used for removing and installing the drive pinion shaft lock nut.</li> <li>• Used for removing and installing the driven shaft lock nut.</li> <li>• Used for measuring the starting torque of the drive pinion shaft.</li> </ul>

# General Description

## MANUAL TRANSMISSION AND DIFFERENTIAL

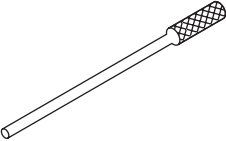
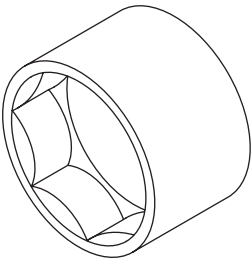
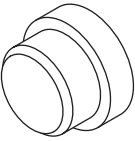
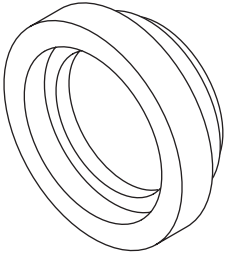
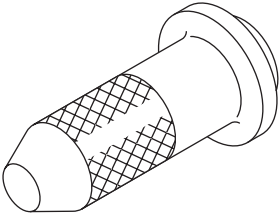
ILLUSTRATION	TOOL NUMBER	DESCRIPTION	REMARKS
 <p style="text-align: center;">ST-899904100</p>	899904100	STRAIGHT PIN REMOVER	Used for removing and installing the straight pin.
 <p style="text-align: center;">ST-899988608</p>	899988608	SOCKET WRENCH (27)	<ul style="list-style-type: none"> <li>• Used for removing and installing the drive pinion shaft lock nut.</li> <li>• Used for measuring the starting torque of the drive pinion shaft.</li> </ul>
 <p style="text-align: center;">ST-398497701</p>	398497701	ADAPTER	Used for installing the front differential roller bearing.
 <p style="text-align: center;">ST-499587000</p>	499587000	INSTALLER	Used for installing the driven shaft parts.
 <p style="text-align: center;">ST-498057300</p>	498057300	INSTALLER	Used for installing the extension oil seal.

**5MT-18**

Brought to you by Ebay Seller "SubaruManuals"

# General Description

## MANUAL TRANSMISSION AND DIFFERENTIAL

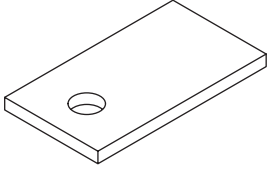
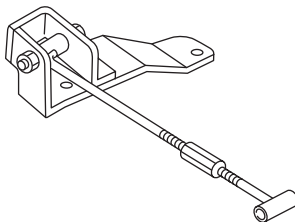
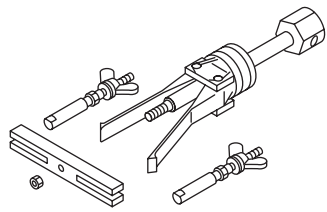
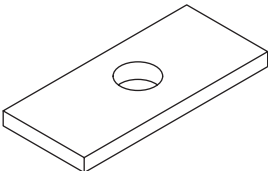
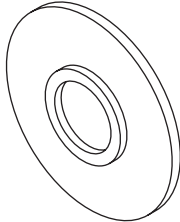
ILLUSTRATION	TOOL NUMBER	DESCRIPTION	REMARKS
 <p>ST-498255400</p>	498255400	PLATE	Used for adjusting the extension end play.
 <p>ST41099AC000</p>	41099AC000	ENGINE SUPPORT ASSY	Used for supporting engine.
 <p>ST-398527700</p>	398527700	PULLER ASSY	<ul style="list-style-type: none"> <li>• Used for removing the extension oil seal.</li> <li>• Used for removing the bearing outer race and oil seal of front differential side retainer.</li> </ul>
 <p>ST-398643600</p>	398643600	GAUGE	Used for adjusting the extension end play.
 <p>ST-398177700</p>	398177700	INSTALLER	<ul style="list-style-type: none"> <li>• Used for installing the roller bearing of transfer driven gear (extension case side).</li> <li>• Used for installing the ball bearing of the transfer drive gear.</li> </ul>

# General Description

## MANUAL TRANSMISSION AND DIFFERENTIAL

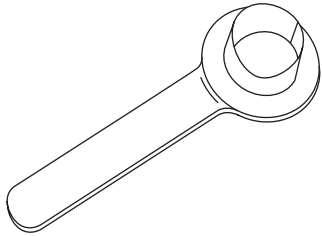
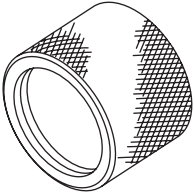
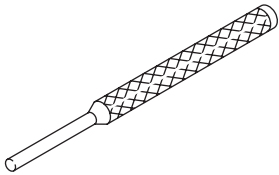
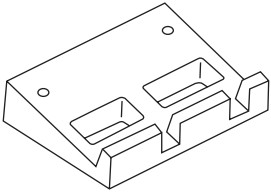
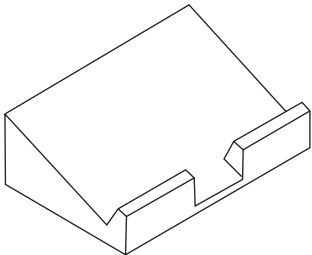
ILLUSTRATION	TOOL NUMBER	DESCRIPTION	REMARKS
 ST28399SA010	28399SA010	OIL SEAL PROTECTOR	Used for protecting the oil seal from damage when inserting the front drive shaft.
 ST18675AA000	18675AA000	DIFFERENTIAL SIDE OIL SEAL INSTALLER	Used for installing the differential side retainer oil seal.
 ST-398791700	398791700	STRAIGHT PIN REMOVER 2	Used for installing and removing the straight pin.
 ST-498267200	498267200	CYLINDER HEAD TABLE	Used for removing and installing the roller bearing of the transfer case.
 ST-498267300	498267300	CYLINDER HEAD TABLE	Used for removing and installing the roller bearing of the transfer case.

# General Description

MANUAL TRANSMISSION AND DIFFERENTIAL

---

## 2. GENERAL TOOL

TOOL NAME	REMARKS
Circuit tester	Used for measuring resistance, voltage and current.
TORX® bit T70	Used for installing and removing the drain plug.

# Transmission Gear Oil

## MANUAL TRANSMISSION AND DIFFERENTIAL

### 2. Transmission Gear Oil

#### A: INSPECTION

- 1) Park the vehicle on a level surface.
- 2) Turn the ignition switch to OFF, and wait until the engine cools.
- 3) Remove the oil level gauge and wipe it clean.
- 4) Reinsert the oil level gauge all the way. Be sure that the oil level gauge is correctly inserted in the proper direction.
- 5) Pull out the oil level gauge again, and check the oil level. If it is below the lower level, add oil through the oil level gauge hole to bring the level up to the upper level.

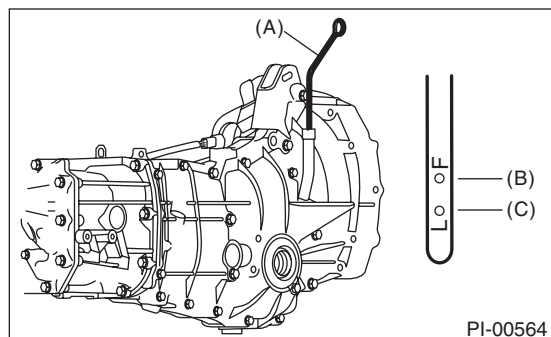

- (A) Oil level gauge
- (B) Upper level
- (C) Lower level

#### B: REPLACEMENT

- 1) Pull out the oil level gauge.
- 2) Lift up the vehicle.
- 3) Using the TORX<sup>®</sup> bit T70, remove the drain plug, and drain the transmission gear oil completely.

#### CAUTION:

- Immediately after the vehicle has been running or after idling for a long time, the transmission gear oil will be hot. Be careful not to receive burns.
  - Be careful not to spill the transmission gear oil on the exhaust pipe, to prevent emission of smoke or causing a fire. If gear oil is spilled, wipe it off completely.
- 4) Tighten the drain plug using TORX<sup>®</sup> bit T70.

#### NOTE:

- Tighten the drain plug after draining the transmission gear oil.
- Use a new gasket.

#### Tightening torque:

**44 N·m (4.5 kgf-m, 32.5 ft-lb) (Aluminum gasket silver)**

**70 N·m (7.1 kgf-m, 51.6 ft-lb) (Copper gasket brown)**

**70 N·m (7.1 kgf-m, 51.6 ft-lb) (Metal gasket black)**

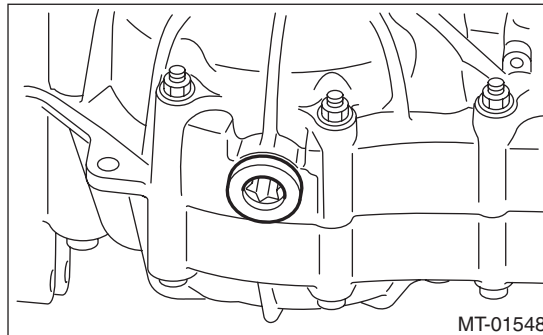

- 5) Lower the vehicle.
- 6) Pour gear oil through the oil level gauge hole.

#### Recommended gear oil:

**GL-5 (75W-90) or equivalent**

#### Gear oil capacity:

**3.5 ℓ (3.7 US qt, 3.1 Imp qt)**

- 7) Measure the transmission gear oil amount, and check that it is within the specification.



# Manual Transmission Assembly

MANUAL TRANSMISSION AND DIFFERENTIAL

## 3. Manual Transmission Assembly

### A: REMOVAL

- 1) Set the vehicle on a lift.
- 2) Open the front hood.
- 3) Disconnect the ground cable from battery.
- 4) Drain transmission gear oil completely. <Ref. to 5MT-22, REPLACEMENT, Transmission Gear Oil.>
- 5) Remove the intercooler. <Ref. to IN(w/o STI)-12, REMOVAL, Intercooler.>
- 6) Disconnect the following connector.

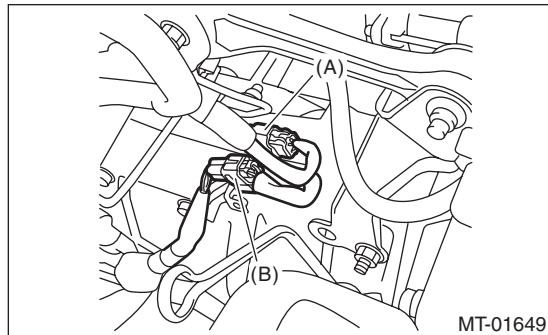

- (A) Neutral position switch and back-up light switch connector  
(B) Rear oxygen sensor connector

- 7) Disconnect the transmission radio ground terminal.

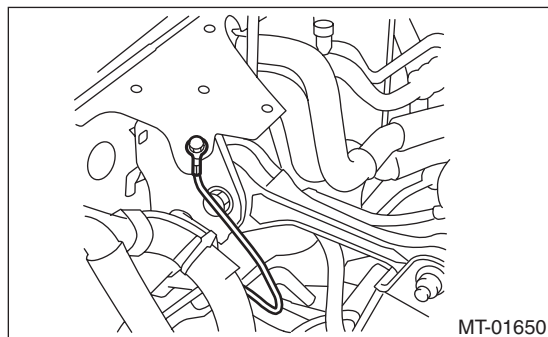

- 8) Remove the engine hanger.

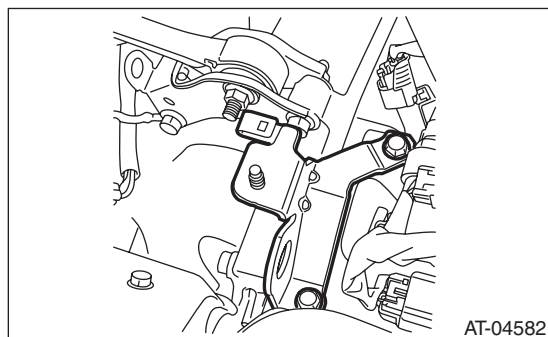

- 9) Remove the starter. <Ref. to SC(w/o STI)-2, General Description.>

- 10) Remove the operating cylinder from the transmission, and suspend on a wire.

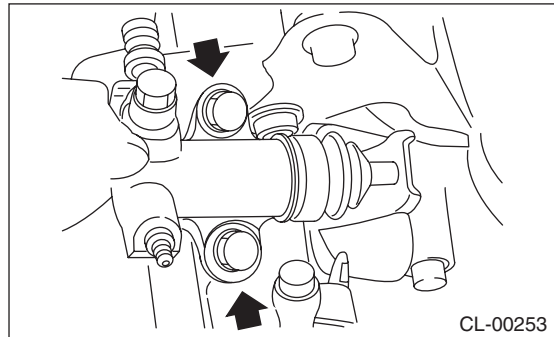

- 11) Remove the pitching stopper.

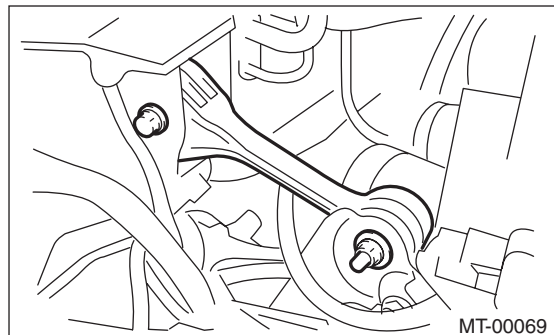

- 12) Set the ST.  
ST 41099AC000 ENGINE SUPPORT ASSY

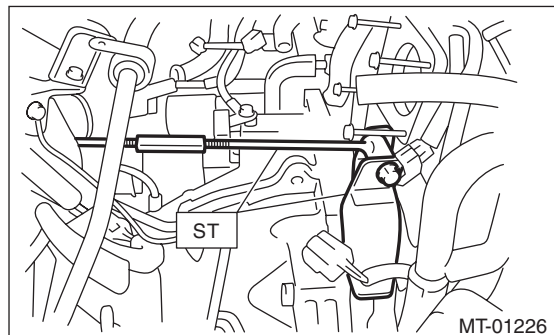

- 13) Lift up the vehicle.
- 14) Remove the center exhaust pipe. <Ref. to EX(w/o STI)-2, General Description.>
- 15) Remove the rear exhaust pipe and muffler. <Ref. to EX(w/o STI)-2, General Description.>

### CAUTION:

When removing the exhaust pipes, make sure that each exhaust pipe does not drop off.

# Manual Transmission Assembly

## MANUAL TRANSMISSION AND DIFFERENTIAL

16) Remove the bolts which hold upper side of transmission to engine.

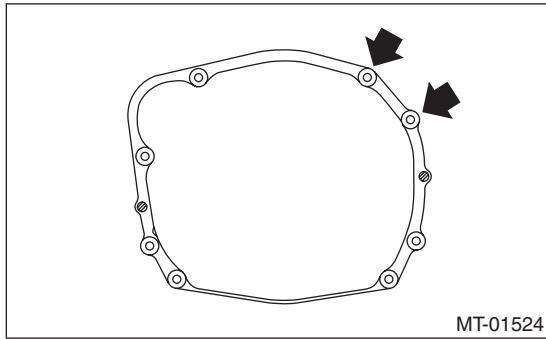

17) Remove the heat shield cover.

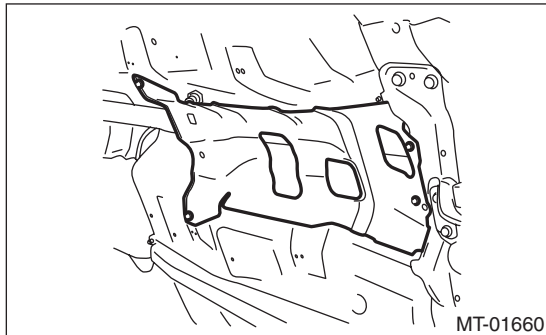

18) Remove the hangar bracket from the transmission.

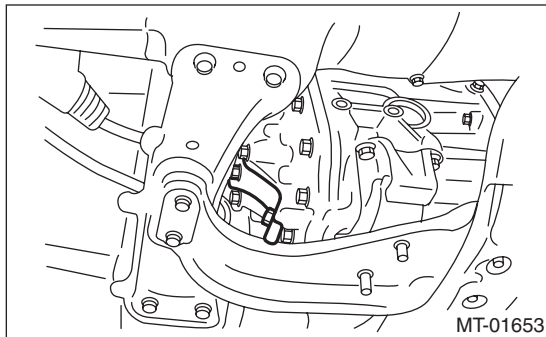

19) Remove the propeller shaft. <Ref. to DS-11, REMOVAL, Propeller Shaft.>

20) Remove the gear shift rod and the stay from the transmission.

(1) Disconnect the stay from the transmission.

(2) Disconnect the gear shift rod from the transmission.

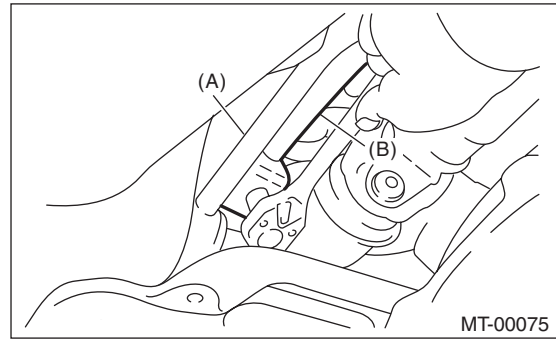

(A) Stay

(B) Gear shift rod

21) Disconnect the stabilizer link from the front arm.

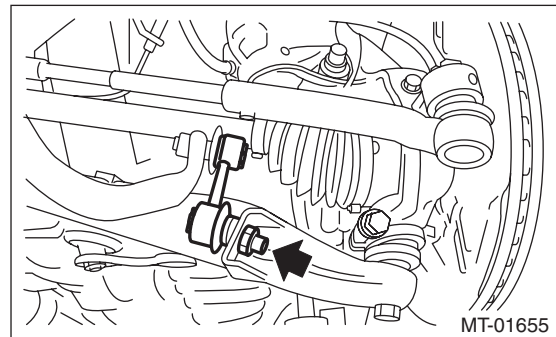

22) Remove the bolt securing the ball joint of the front arm to the housing, then separate the front arms and the housing.

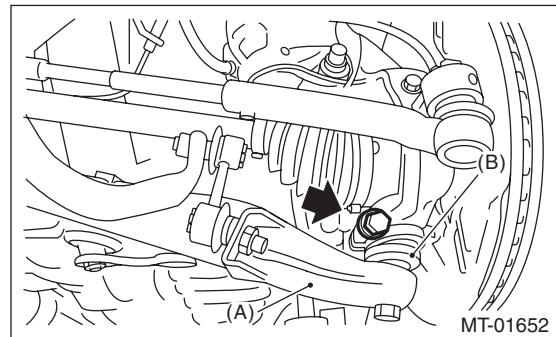

(A) Front arm

(B) Ball joint

# Manual Transmission Assembly

## MANUAL TRANSMISSION AND DIFFERENTIAL

23) Using a crowbar, remove the left and right front drive shaft from the transmission.

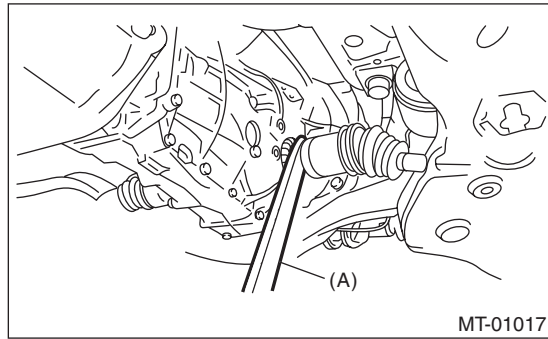

(A) Crowbar

24) Remove the bolts and nuts which hold lower side of transmission to engine.

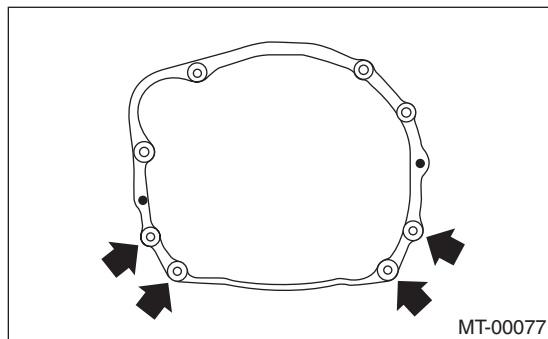

25) Place the transmission jack under the transmission.

**CAUTION:**  
Always support the transmission case with a transmission jack.

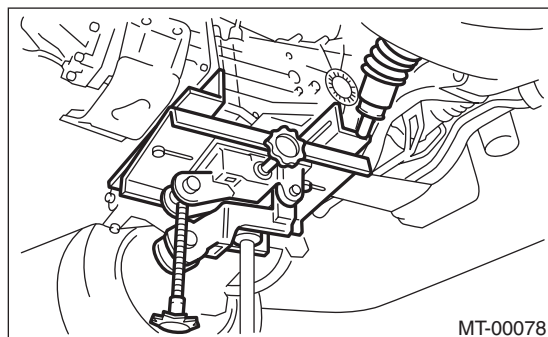

26) Remove the front crossmember and rear crossmember from the vehicle.

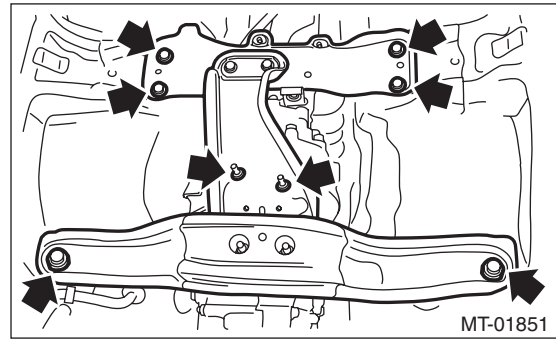

27) While lowering the transmission jack, tighten the turnbuckle of the ST, and incline the engine unit rearward.

28) Remove the transmission.

### NOTE:

Move the transmission jack towards the rear until the main shaft is withdrawn from the clutch disc.

29) Separate the transmission assembly from the transmission cushion rubber.

## B: INSTALLATION

1) Replace the differential side retainer oil seal. <Ref. to 5MT-32, REPLACEMENT, Differential Side Retainer Oil Seal.>

ST 18675AA000 DIFFERENTIAL SIDE OIL SEAL INSTALLER

### NOTE:

Be sure to replace the differential side retainer oil seal after removing the front drive shaft.

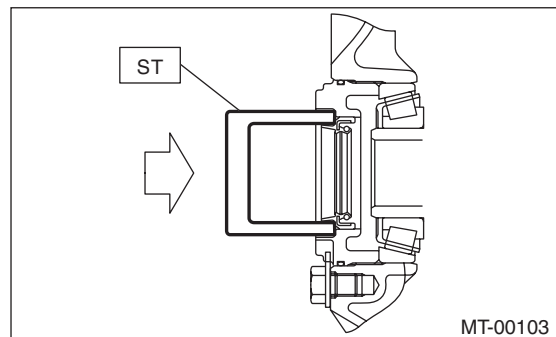

2) Tap the transmission hanger in the rear side of transmission with a rubber hammer to bend it until it is in close contact with the transmission case.

### CAUTION:

Do not apply excessive load or impact to the transmission case.

3) Install the transmission cushion rubber to the transmission, and tighten the bolt (A).

# Manual Transmission Assembly

## MANUAL TRANSMISSION AND DIFFERENTIAL

4) Install the transmission cushion rubber to the center crossmember, and tighten the nut (B).

### Tightening torque:

#### Bolt (A)

**35 N·m (3.6 kgf-m, 25.8 ft-lb)**

#### Nut (B)

**35 N·m (3.6 kgf-m, 25.8 ft-lb)**

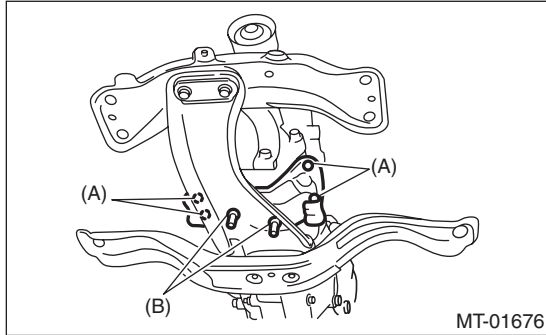

5) Install the transmission onto the engine.

- (1) Lift up the transmission gradually using a transmission jack.
- (2) Engage at the spline section.

### NOTE:

Be careful not to hit the main shaft against the clutch cover.

6) While raising the transmission jack, loosen the turnbuckle of the ST, and set the engine unit to the original position.

7) Install the front crossmember and rear crossmember.

### Tightening torque:

**T1: 70 N·m (7.1 kgf-m, 51.6 ft-lb)**

**T2: 140 N·m (14.3 kgf-m, 103.3 ft-lb)**

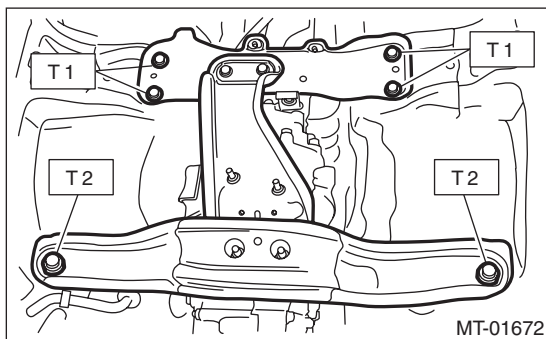

8) Take out the transmission jack.

9) Tighten the bolts and nuts which hold the lower side of transmission to the engine.

### Tightening torque:

**50 N·m (5.1 kgf-m, 36.9 ft-lb)**

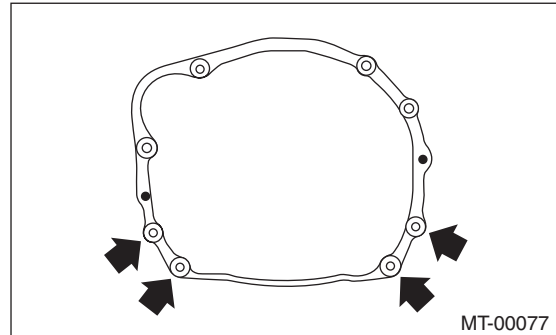

10) Connect the transmission to the engine.

- (1) Install the starter. <Ref. to SC(w/o STI)-2, General Description.>
- (2) Tighten the bolts which hold the upper side of the transmission to the engine.

### Tightening torque:

**50 N·m (5.1 kgf-m, 36.9 ft-lb)**

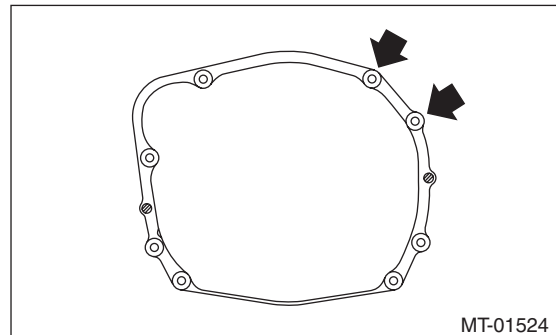

11) Remove the ST.

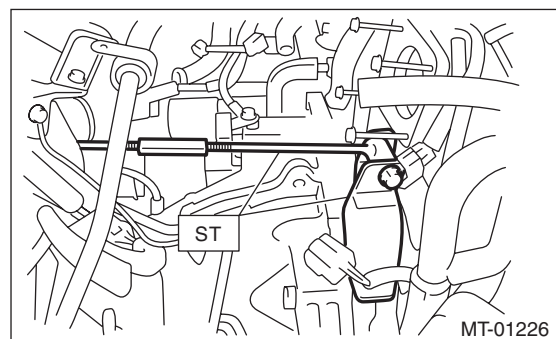

# Manual Transmission Assembly

## MANUAL TRANSMISSION AND DIFFERENTIAL

12) Install the pitching stopper.

### Tightening torque:

**T1: 50 N·m (5.1 kgf·m, 36.9 ft·lb)**

**T2: 58 N·m (5.9 kgf·m, 42.8 ft·lb)**

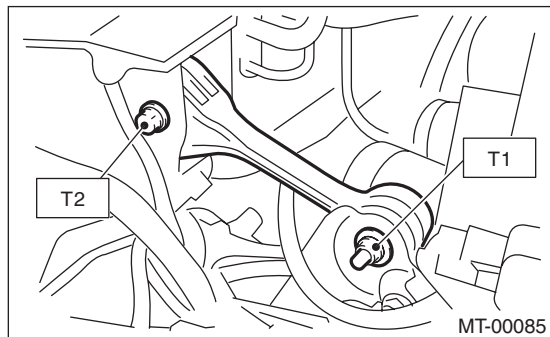

13) Lift up the vehicle.

14) Install the front drive shaft into the transmission.

ST 28399SA010 OIL SEAL PROTECTOR

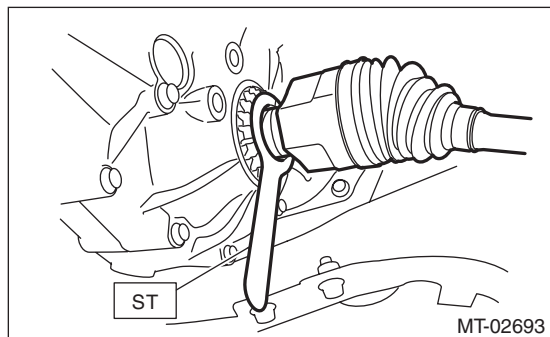

15) Insert the front arm ball joint into the housing lower part, and tighten the mounting bolt.

### Tightening torque:

**50 N·m (5.1 kgf·m, 36.9 ft·lb)**

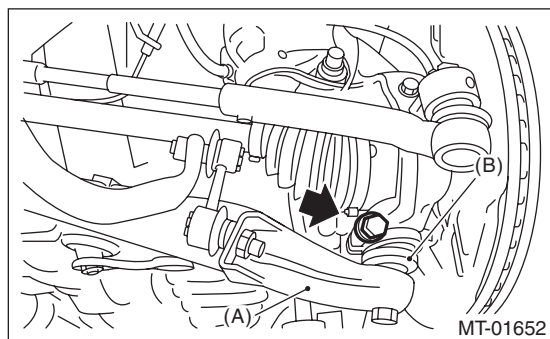

(A) Front arm

(B) Ball joint

16) Attach the stabilizer link to the front arm.

### Tightening torque:

**30 N·m (3.1 kgf·m, 22.1 ft·lb)**

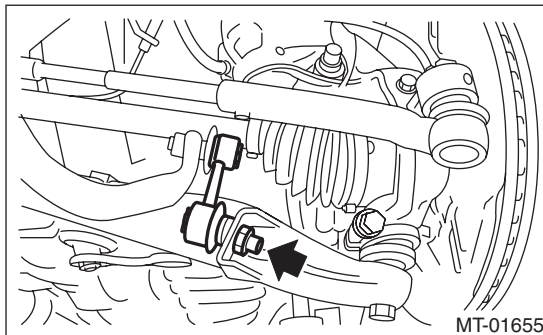

17) Attach the gear shift rod and stay.

(1) Attach the gear shift rod to the transmission.

### Tightening torque:

**12 N·m (1.2 kgf·m, 8.9 ft·lb)**

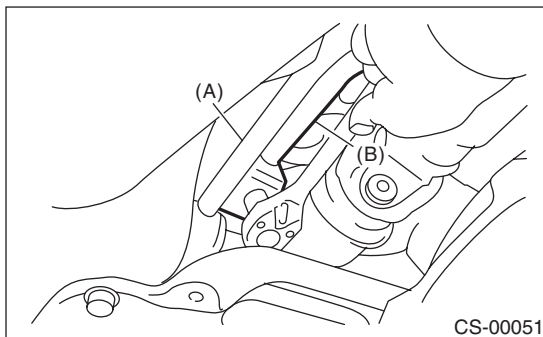

(A) Stay

(B) Gear shift rod

(2) Install the stay to the transmission bracket.

### Tightening torque:

**18 N·m (1.8 kgf·m, 13.3 ft·lb)**

18) Install the propeller shaft. <Ref. to DS-12, INSTALLATION, Propeller Shaft.>

19) Install the heat shield cover. <Ref. to EI-74, INSTALLATION, Heat Shield Cover.>

20) Install the hanger bracket to the transmission.

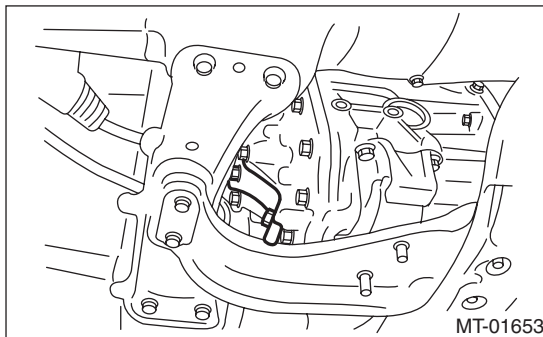

21) Install the rear exhaust pipe and muffler. <Ref. to EX(w/o STI)-2, General Description.>

22) Install the center exhaust pipe. <Ref. to EX(w/o STI)-2, General Description.>



# Manual Transmission Assembly

## MANUAL TRANSMISSION AND DIFFERENTIAL

23) Install the under cover. <Ref. to EI-28, INSTALLATION, Front Under Cover.>

24) Install the operating cylinder.

### **Tightening torque:**

**37 N·m (3.8 kgf·m, 27.3 ft·lb)**

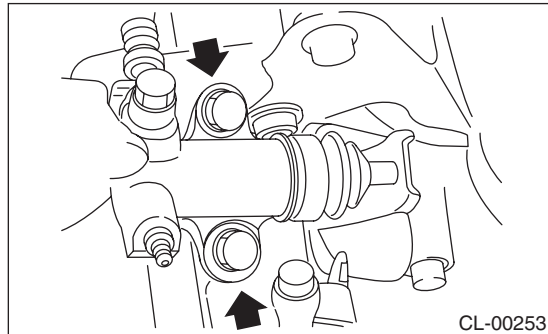

25) Install the transmission radio ground terminal.

### **Tightening torque:**

**13 N·m (1.3 kgf·m, 9.6 ft·lb)**

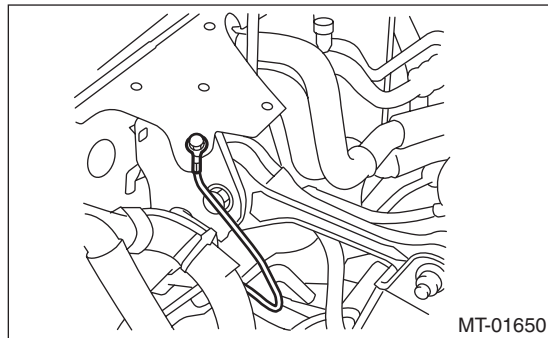

26) Install the engine hanger.

### **Tightening torque:**

**16 N·m (1.6 kgf·m, 11.8 ft·lb)**

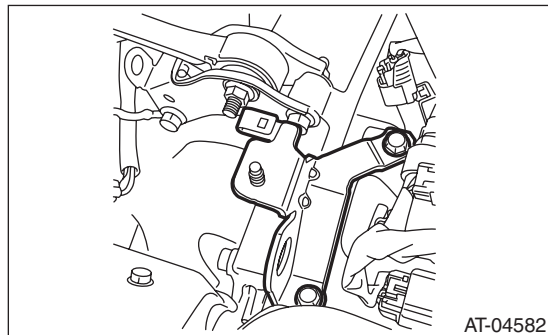

27) Connect the following connectors.

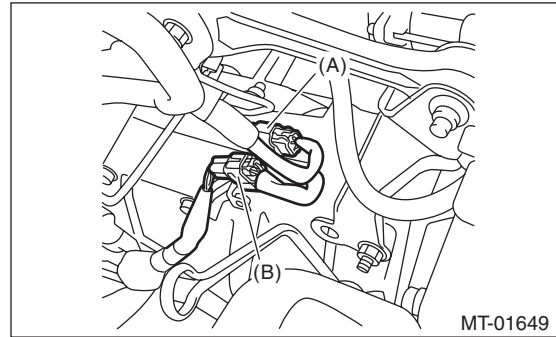

(A) Neutral position switch and back-up light switch connector

(B) Rear oxygen sensor connector

28) Install the intercooler. <Ref. to IN(w/o STI)-12, INSTALLATION, Intercooler.>

29) Connect the battery ground terminal.

30) Remove the lift arm from vehicle.

# Transmission Mounting System

MANUAL TRANSMISSION AND DIFFERENTIAL

## 4. Transmission Mounting System

### A: REMOVAL

#### 1. PITCHING STOPPER

- 1) Disconnect the ground cable from battery.
- 2) Remove the intercooler. <Ref. to IN(w/o STI)-12, REMOVAL, Intercooler.>
- 3) Remove the pitching stopper.

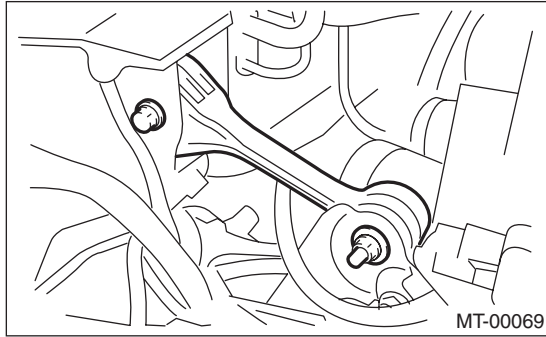

#### 2. CROSSMEMBER AND CUSHION RUBBER

- 1) Disconnect the ground cable from battery.
- 2) Lift up the vehicle.
- 3) Remove the center exhaust pipe. <Ref. to EX(w/o STI)-2, General Description.>
- 4) Remove the rear exhaust pipe and muffler. <Ref. to EX(w/o STI)-2, General Description.>
- 5) Remove the heat shield cover.

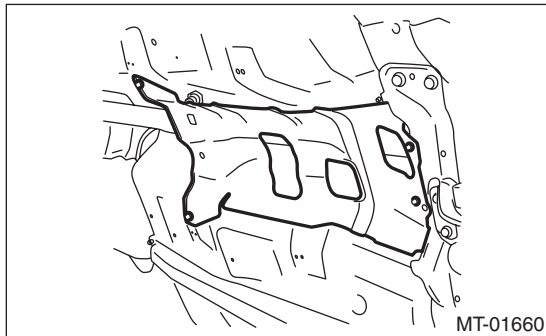

- 6) Set the transmission jack under the transmission case.

#### CAUTION:

Always support the transmission case with a transmission jack.

- 7) Remove the front crossmember and the rear crossmember.

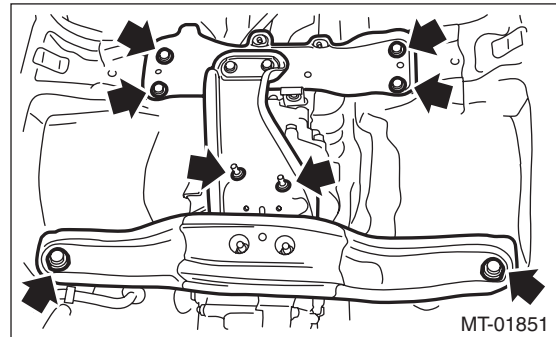

- 8) Remove the transmission cushion rubber.

### B: INSTALLATION

#### 1. PITCHING STOPPER

- 1) Install the pitching stopper.

#### Tightening torque:

**T1: 50 N·m (5.1 kgf-m, 36.9 ft-lb)**

**T2: 58 N·m (5.9 kgf-m, 42.8 ft-lb)**

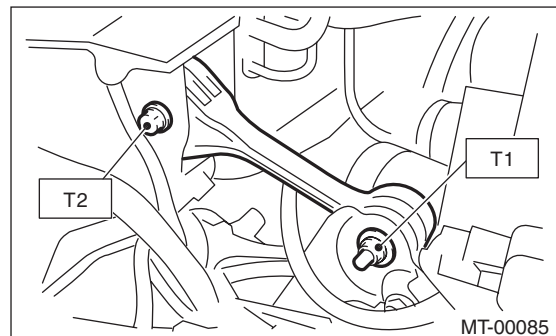

- 2) Install the intercooler. <Ref. to IN(w/o STI)-12, INSTALLATION, Intercooler.>
- 3) Connect the battery ground terminal.

#### 2. CROSSMEMBER AND CUSHION RUBBER

- 1) Install the transmission cushion rubber to the transmission, and tighten the bolt (A).

# Transmission Mounting System

## MANUAL TRANSMISSION AND DIFFERENTIAL

2) Install the transmission cushion rubber to the center crossmember, and tighten the nut (B).

### **Tightening torque:**

#### **Bolt (A)**

**35 N·m (3.6 kgf-m, 25.8 ft-lb)**

#### **Nut (B)**

**35 N·m (3.6 kgf-m, 25.8 ft-lb)**

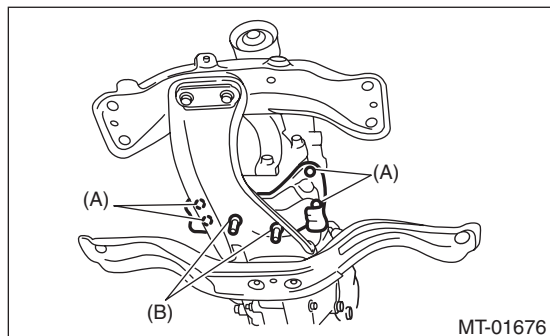

## **2. CROSSMEMBER AND CUSHION RUBBER**

Check the crossmember for bending or damage. Check that the cushion rubber does not have hardening, cracks or other damages.

3) Install the front crossmember and rear crossmember.

### **Tightening torque:**

**T1: 70 N·m (7.1 kgf-m, 51.6 ft-lb)**

**T2: 140 N·m (14.3 kgf-m, 103.3 ft-lb)**

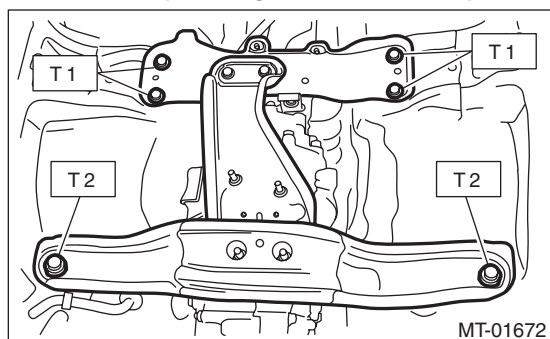

- 4) Remove the transmission jack.
- 5) Install the heat shield cover. <Ref. to EI-74, INSTALLATION, Heat Shield Cover.>
- 6) Install the center exhaust pipe. <Ref. to EX(w/o STI)-2, General Description.>
- 7) Install the rear exhaust pipe and muffler. <Ref. to EX(w/o STI)-2, General Description.>
- 8) Lower the vehicle.
- 9) Connect the battery ground terminal.

## **C: INSPECTION**

Check the following; repair or replace the faulty parts.

### **1. PITCHING STOPPER**

Check the pitching stopper for bends or damage. Check that the rubber is not stiff, cracked or otherwise damaged.



## 5. Oil Seal

### A: INSPECTION

Check for leakage of transmission gear oil from the oil seal. If there is oil leakage, replace the oil seal with the new part and check the propeller shaft.

### B: REPLACEMENT

- 1) Clean the transmission exterior.
- 2) Using the TORX® bit T70, remove the drain plug, and drain the transmission gear oil completely.
- 3) Tighten the drain plug using TORX® bit T70.

NOTE:

Use a new gasket.

**Tightening torque:**

**44 N·m (4.5 kgf·m, 32.5 ft·lb) (Aluminum gasket silver)**

**70 N·m (7.1 kgf·m, 51.6 ft·lb) (Copper gasket brown)**

**70 N·m (7.1 kgf·m, 51.6 ft·lb) (Metal gasket black)**

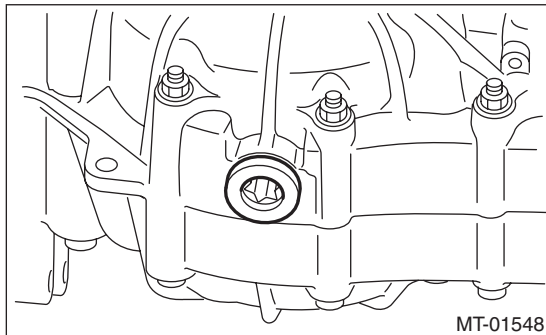

- 4) Remove the rear exhaust pipe and muffler. <Ref. to EX(w/o STI)-2, General Description.>
- 5) Remove the heat shield cover.

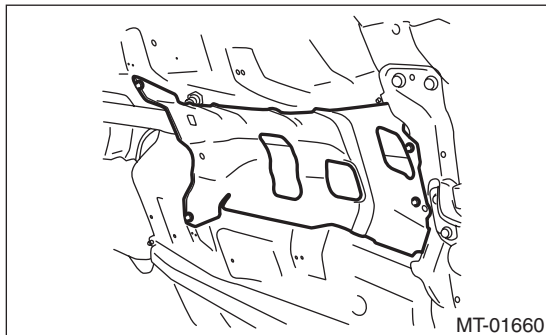

- 6) Remove the propeller shaft. <Ref. to DS-11, REMOVAL, Propeller Shaft.>

- 7) Using the ST, remove the oil seal.  
ST 398527700 PULLER ASSY

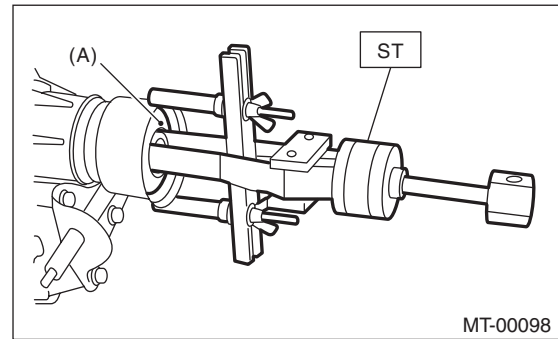

(A) Oil seal

- 8) Using the ST, install the oil seal.

NOTE:

- When grease is not applied to the oil seal lips, apply the transmission gear oil to the oil seal lips.
- Use a new oil seal.

- ST 498057300 INSTALLER

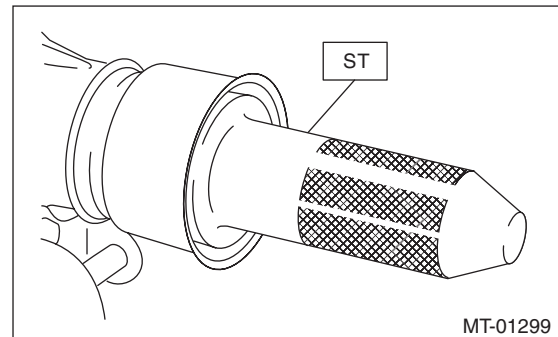

- 9) Install the propeller shaft. <Ref. to DS-12, INSTALLATION, Propeller Shaft.>
- 10) Install the heat shield cover. <Ref. to EI-74, INSTALLATION, Heat Shield Cover.>
- 11) Install the rear exhaust pipe and muffler. <Ref. to EX(w/o STI)-2, General Description.>
- 12) Pour in transmission gear oil and check the oil level. <Ref. to 5MT-22, Transmission Gear Oil.>

# Differential Side Retainer Oil Seal

MANUAL TRANSMISSION AND DIFFERENTIAL

## 6. Differential Side Retainer Oil Seal

### A: INSPECTION

Check for leakage of gear oil from differential side retainer oil seal part. If there is oil leakage, replace the oil seal with the new part and check the drive shaft.

### B: REPLACEMENT

- 1) Lift up the vehicle.
- 2) Remove the transmission gear oil drain plug using TORX® bit T70, and drain the transmission gear oil completely.

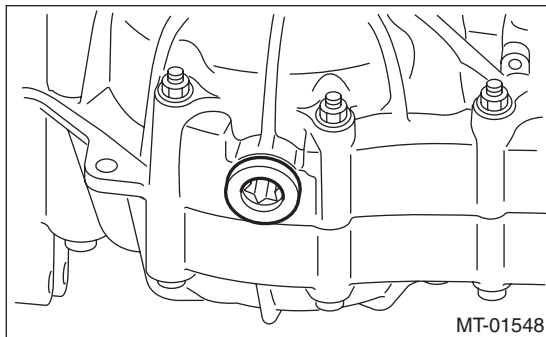

- 3) Replace the gasket with a new part and tighten the drain plug using the TORX® bit T70.

#### Tightening torque:

**44 N·m (4.5 kgf·m, 32.5 ft·lb) (Aluminum gasket silver)**

**70 N·m (7.1 kgf·m, 51.6 ft·lb) (Copper gasket brown)**

**70 N·m (7.1 kgf·m, 51.6 ft·lb) (Metal gasket black)**

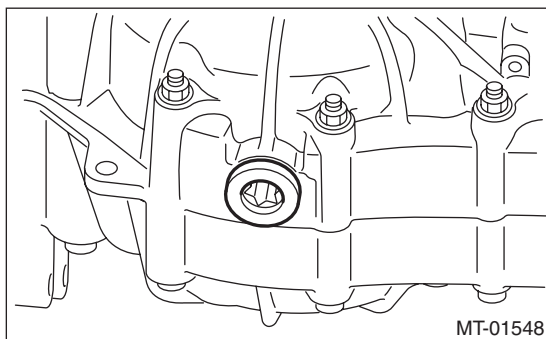

- 4) Remove the center exhaust pipe. <Ref. to EX(w/o STI)-2, General Description.>
- 5) Separate the front drive shaft from the transmission. <Ref. to DS-27, REMOVAL, Front Drive Shaft.>

- 6) Remove the differential side retainer oil seal.

#### NOTE:

- Be sure to replace the differential side retainer oil seal whenever the front drive shaft is removed from the transmission.
- Use the ST 398527700 PULLER ASSY to remove the oil seal. If removing the oil seal with a flat tip screwdriver, be careful not to scratch the differential side retainer.

- 7) Using the ST, install the differential side retainer oil seal by lightly tapping with a plastic hammer.  
ST 18675AA000 DIFFERENTIAL SIDE OIL SEAL INSTALLER

#### CAUTION:

**Apply transmission gear oil to the oil seal lips, and install the oil seal while being careful not to deform the lip.**

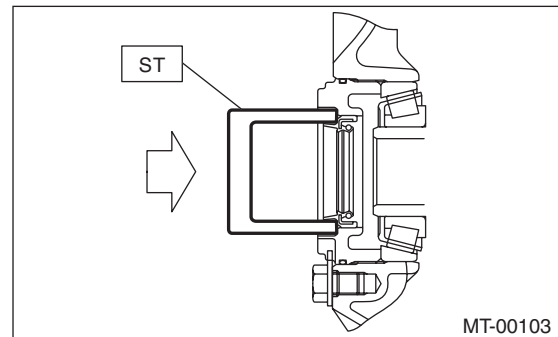

- 8) Install the front drive shaft. <Ref. to DS-27, INSTALLATION, Front Drive Shaft.>

ST 28399SA010 OIL SEAL PROTECTOR

- 9) Install the center exhaust pipe. <Ref. to EX(w/o STI)-2, General Description.>

- 10) Lower the vehicle.

- 11) Add the transmission gear oil through the oil level gauge hole. <Ref. to 5MT-22, REPLACEMENT, Transmission Gear Oil.>

## 7. Switches and Harness

### A: REMOVAL

#### 1. BACK-UP LIGHT AND NEUTRAL POSITION SWITCH

- 1) Disconnect the ground cable from battery.
- 2) Remove the intercooler. <Ref. to IN(w/o STI)-12, REMOVAL, Intercooler.>
- 3) Disconnect the connector back-up light switch & neutral position switch.

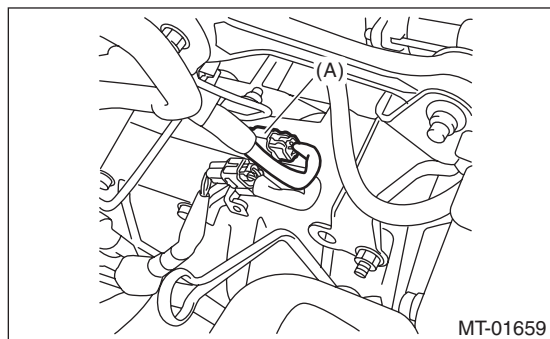

(A) Neutral position switch and back-up light switch connector

- 4) Lift up the vehicle.
- 5) Remove the back-up light switch & neutral position switch with the harness.

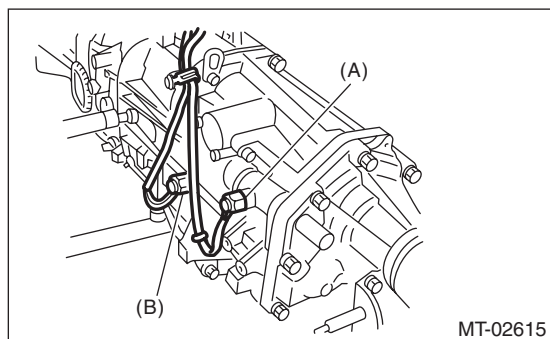

(A) Neutral position switch  
(B) Back-up light switch

### B: INSTALLATION

#### 1. BACK-UP LIGHT AND NEUTRAL POSITION SWITCH

- 1) Install the back-up light switch & neutral position switch with the harness.

**Tightening torque:**  
**32.3 N·m (3.3 kgf-m, 23.8 ft-lb)**

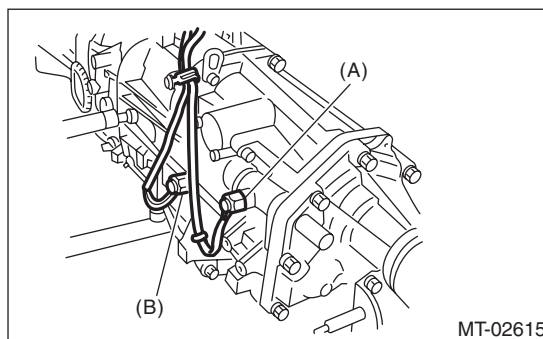

(A) Neutral position switch  
(B) Back-up light switch

- 2) Connect the connectors of back-up light switch & neutral position switch.
- 3) Install the intercooler. <Ref. to IN(w/o STI)-12, INSTALLATION, Intercooler.>
- 4) Connect the battery ground terminal.

### C: INSPECTION

#### 1. BACK-UP LIGHT SWITCH

Check the back-up light switch. <Ref. to LI-8, INSPECTION, Back-up Light System.>

#### 2. NEUTRAL POSITION SWITCH

- 1) Turn the ignition switch to OFF.
- 2) Disconnect the connector of neutral position switch.
- 3) Measure the resistance between neutral position switch terminals.

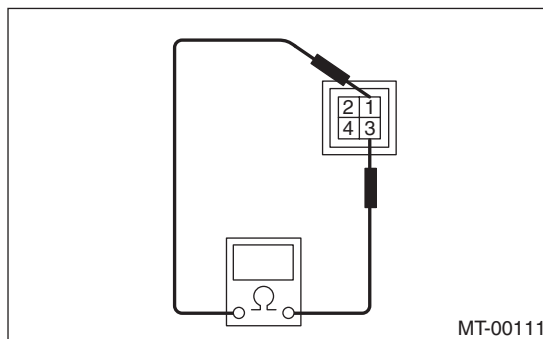

Gear shift position	Terminal No.	Specified resistance
Neutral position	1 and 3	Less than 1 Ω
Other positions		1 MΩ or more

- 4) Replace faulty parts.

# Preparation for Overhaul

## MANUAL TRANSMISSION AND DIFFERENTIAL

---

### 8. Preparation for Overhaul

#### A: PROCEDURE

- 1) Clean oil, grease, dirt and dust from the transmission.
- 2) Using the TORX® bit T70, remove the transmission gear oil drain plug, and drain the transmission gear oil completely.
- 3) Using the TORX® bit T70, tighten the transmission gear oil drain plug.

#### NOTE:

Use a new gasket.

#### Tightening torque:

**44 N·m (4.5 kgf·m, 32.5 ft·lb) (Aluminum gasket silver)**

**70 N·m (7.1 kgf·m, 51.6 ft·lb) (Copper gasket brown)**

**70 N·m (7.1 kgf·m, 51.6 ft·lb) (Metal gasket black)**

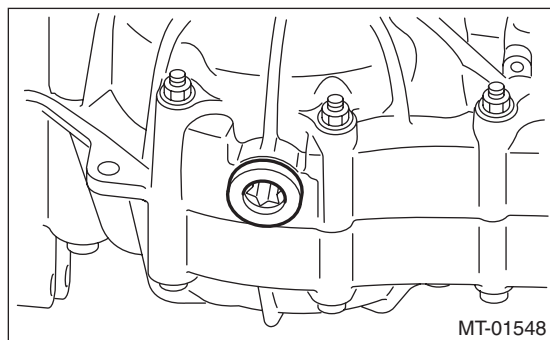

- 4) Attach the transmission to the ST.  
ST 499937100 TRANSMISSION STAND

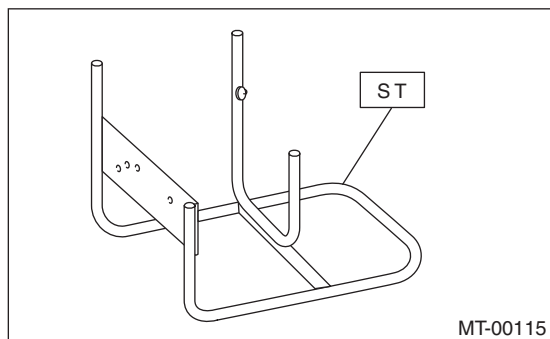

- 5) Apply oil to rotating parts before assembly.
- 6) All disassembled parts, if to be reused, should be reinstalled in the original positions and directions.
- 7) Gaskets, lock washers and lock nuts must be replaced with new ones.
- 8) Apply liquid gasket to the specified areas to prevent leakage.

# Transfer Case and Extension Case Assembly

MANUAL TRANSMISSION AND DIFFERENTIAL

## 9. Transfer Case and Extension Case Assembly

### A: REMOVAL

- 1) Remove the manual transmission assembly from the vehicle. <Ref. to 5MT-23, REMOVAL, Manual Transmission Assembly.>
- 2) Remove the back-up light switch and the neutral position switch. <Ref. to 5MT-33, REMOVAL, Switches and Harness.>
- 3) Remove the transfer case together with the extension case assembly.

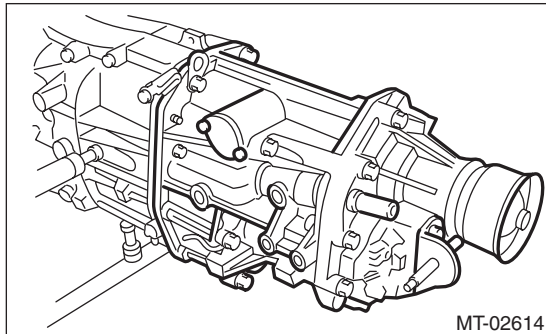

- 4) Remove the shifter arm.
- 5) Remove the extension case assembly.

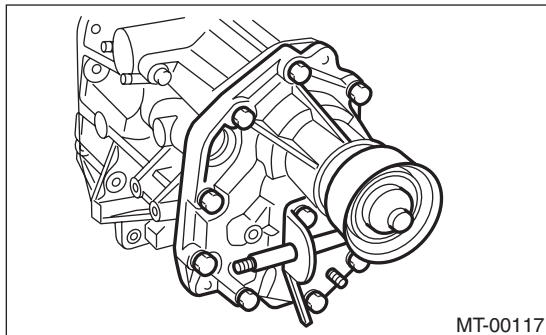

### B: INSTALLATION

- 1) Install the center differential and transfer driven gear into the transfer case.

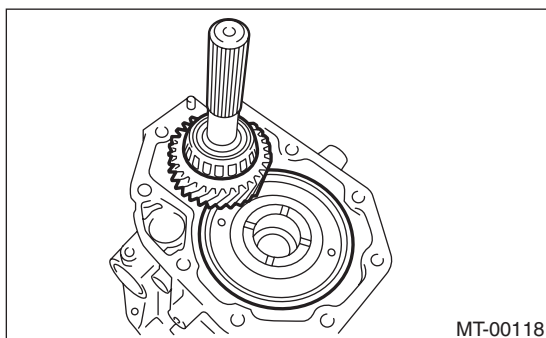

- 2) Remove the bearing outer race and thrust washer from the extension case.

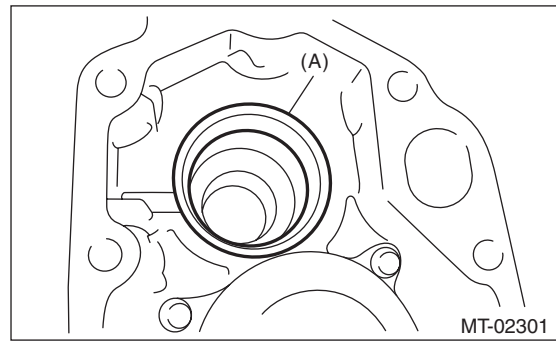

(A) Bearing outer race

- 3) While pressing the bearing outer race horizontally, rotate the driven shaft for ten turns.
- 4) Measure the height "W" between transfer case and taper roller bearing on the transfer driven gear.

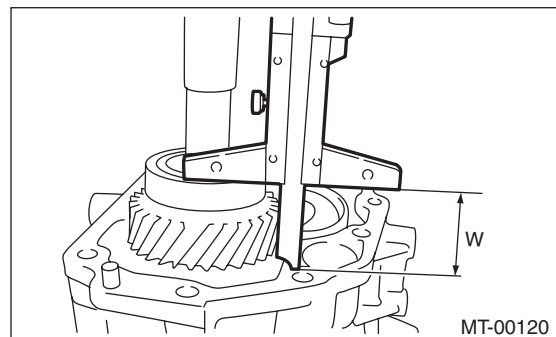

- 5) Measure depth "X" of bearing insertion part of the extension case.

#### NOTE:

Measure with bearing outer race and thrust washer removed.

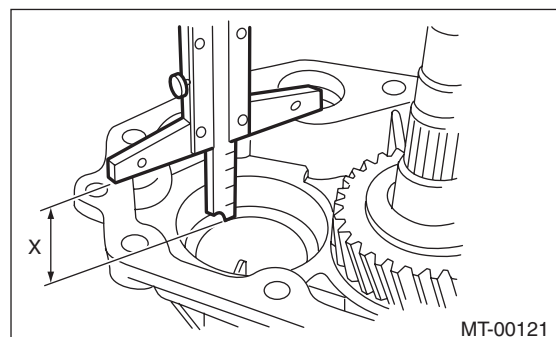

- 6) Calculate the thrust washer thickness "t" using the following calculation.

$$t = X - W + (0.15 - 0.20 \text{ mm } (0.006 - 0.008 \text{ in}))$$

# Transfer Case and Extension Case Assembly

## MANUAL TRANSMISSION AND DIFFERENTIAL

7) Select the washer with the nearest value in the following table.

**Preload of the taper roller bearing (amount of standard protrusion):**

**0.15 — 0.20 mm (0.006 — 0.008 in)**

NOTE:

Be sure that it is always within the preload.

Thrust washer (61 × 50 × t)	
Part No.	Thickness mm (in)
803050060	0.50 (0.0197)
803050061	0.55 (0.0217)
803050062	0.60 (0.0236)
803050063	0.65 (0.0256)
803050064	0.70 (0.0276)
803050065	0.75 (0.0295)
803050066	0.80 (0.0315)
803050067	0.85 (0.0335)
803050068	0.90 (0.0354)
803050069	0.95 (0.0374)
803050070	1.00 (0.0394)
803050071	1.05 (0.0413)
803050072	1.10 (0.0433)
803050073	1.15 (0.0453)
803050074	1.20 (0.0472)
803050075	1.25 (0.0492)
803050076	1.30 (0.0512)
803050077	1.35 (0.0531)
803050078	1.40 (0.0551)
803050079	1.45 (0.0571)

8) Install the selected thrust washer and bearing outer race (A) into the extension case.

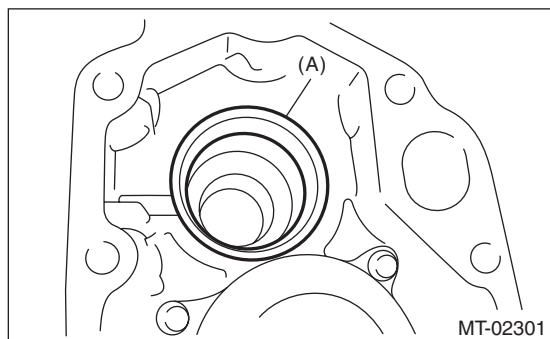

(A) Bearing outer race

9) Measure the depth "S" between transfer case and center differential.

ST 398643600 GAUGE

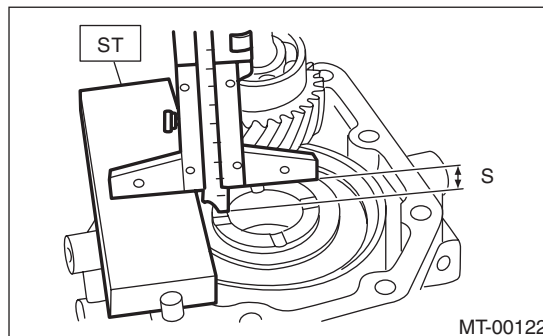

10) Measure the height "T" between the extension case and transfer drive gear.

ST 398643600 GAUGE

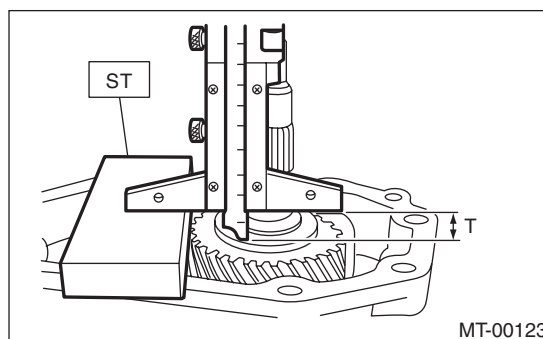

NOTE:

Thickness of ST: 15 mm (0.59 in)

11) Calculate the thrust washer thickness "U" using the following calculation.

$U = S + T - 30 \text{ mm (1.18 in)}$  [Thickness of ST]

12) Select a suitable washer in the following table.

**Standard clearance:**

**0.15 — 0.35 mm (0.0059 — 0.0138 in)**

Thrust washer	
Part No.	Thickness mm (in)
803036050	0.9 (0.035)
803036054	1.0 (0.039)
803036051	1.1 (0.043)
803036055	1.2 (0.047)
803036052	1.3 (0.051)
803036056	1.4 (0.055)
803036053	1.5 (0.059)
803036057	1.6 (0.063)
803036058	1.7 (0.067)
803036080	1.8 (0.071)
803036081	1.9 (0.075)

13) Fit the thrust washer onto the center differential.



# Transfer Case and Extension Case Assembly

MANUAL TRANSMISSION AND DIFFERENTIAL

14) Apply a proper amount of liquid gasket to the transfer case mating surface.

**Liquid gasket:**  
**THREE BOND 1215 (Part No. 004403007) or equivalent**

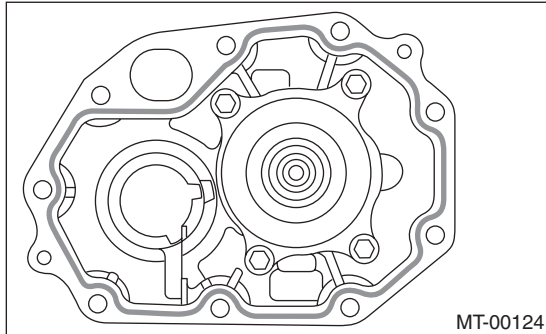

15) Attach the extension assembly to the transfer case.

**Tightening torque:**  
**40 N·m (4.1 kgf-m, 29.5 ft-lb)**

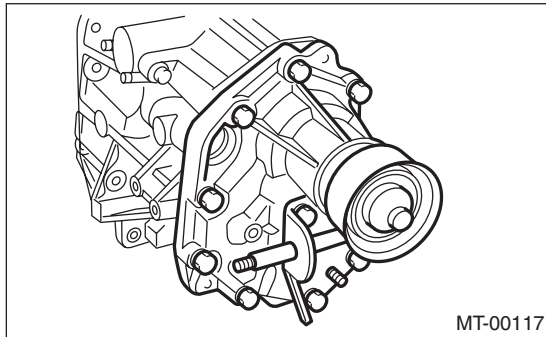

16) Attach the shifter arm to transfer case.

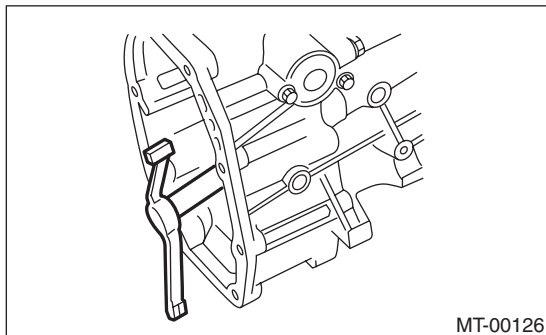

17) Attach the gasket.

**NOTE:**  
Use a new gasket.

18) Hang the shifter arm on 3rd-4th fork rod.

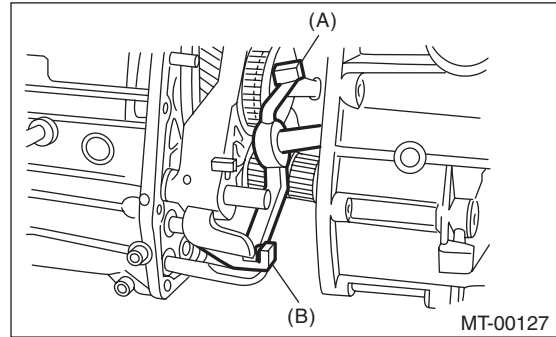

(A) Shifter arm  
(B) 3rd-4th fork rod

19) Install the extension case assembly along with the transfer case to the transmission case.

**Tightening torque:**  
**24.5 N·m (2.5 kgf-m, 18.1 ft-lb)**

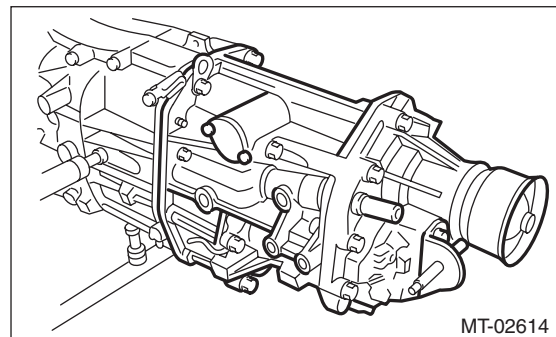

## C: DISASSEMBLY

### 1. TRANSFER CASE

- 1) Remove the reverse check sleeve assembly. <Ref. to 5MT-46, REMOVAL, Reverse Check Sleeve.>
- 2) Remove the oil guide.

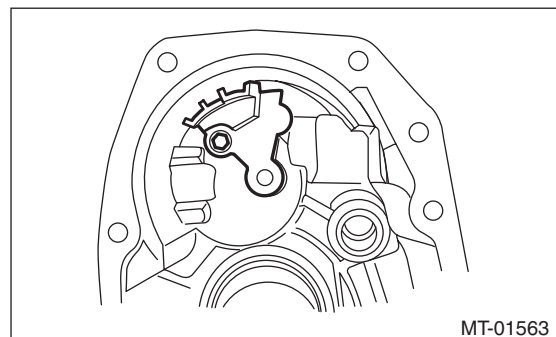

- 3) Remove the oil seal.

# Transfer Case and Extension Case Assembly

## MANUAL TRANSMISSION AND DIFFERENTIAL

4) Set ST1, ST2 and transfer case to a press.

### NOTE:

- Set the ST2 under ST1.
- Set the transfer case so that the hole for shifter arm is positioned vertically.

ST1 498267300 CYLINDER HEAD TABLE

ST2 498267200 CYLINDER HEAD TABLE

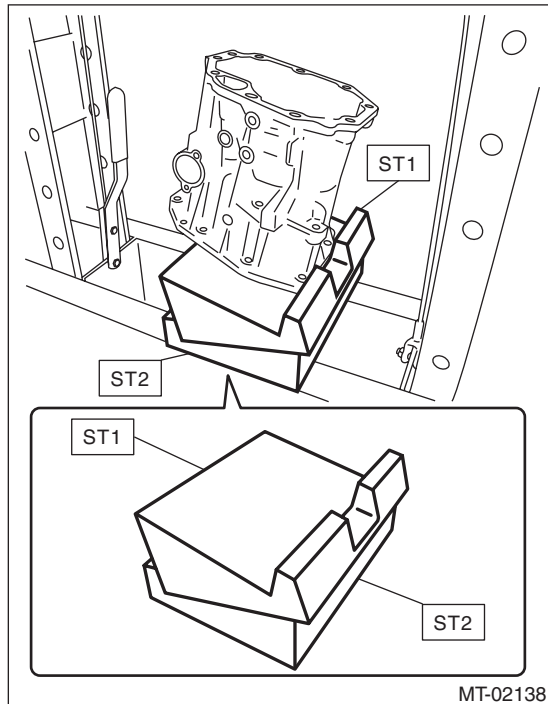

5) Using the round bar with diameter of 22 mm (0.87 in) or 23 mm (0.91 in), remove the roller bearing.

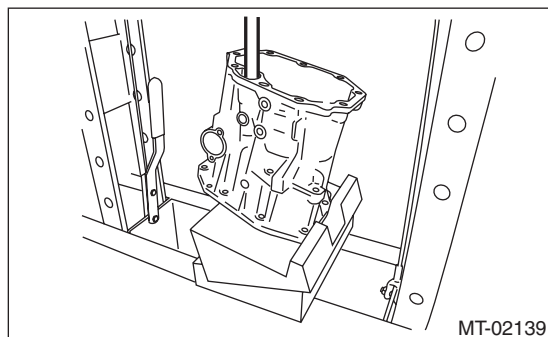

## 2. EXTENSION CASE

- 1) Remove the transfer drive gear assembly. <Ref. to 5MT-41, REMOVAL, Transfer Drive Gear.>
- 2) Remove the shift bracket.

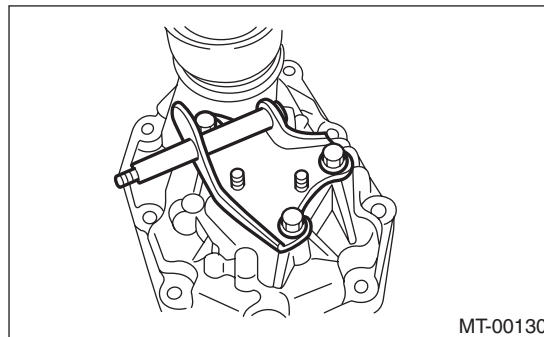

- 3) Remove the oil seal from the extension case. <Ref. to 5MT-31, Oil Seal.>

## D: ASSEMBLY

### 1. EXTENSION CASE

- 1) Using the ST, install the oil seal to the extension case. <Ref. to 5MT-31, Oil Seal.>

### NOTE:

Use a new oil seal.

- 2) Install the shift bracket to extension case.

### Tightening torque:

**24.5 N·m (2.5 kgf-m, 18.1 ft-lb)**

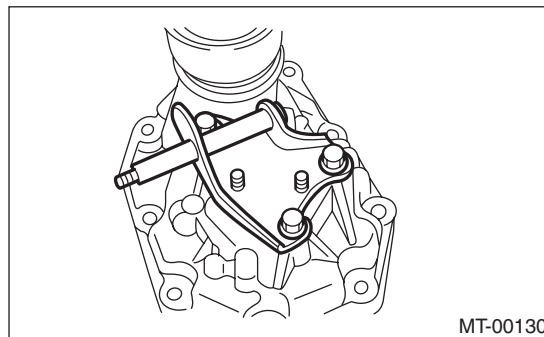

- 3) Install the transfer drive gear to the extension case. <Ref. to 5MT-41, INSTALLATION, Transfer Drive Gear.>



# Transfer Case and Extension Case Assembly

MANUAL TRANSMISSION AND DIFFERENTIAL

## 2. TRANSFER CASE

1) Set the ST1, ST2, iron plate and the transfer case to the press.

### NOTE:

- Set the ST2 under ST1.
- Set the transfer case so that the hole for shifter arm is positioned vertically.
- Insert the iron plate which is thicker than the exposed length of the transfer case knock pin between the ST and transfer case.
- Set the iron plate so that the transfer case knock pin does not ride on the iron plate.

ST1 498267300 CYLINDER HEAD TABLE

ST2 498267200 CYLINDER HEAD TABLE

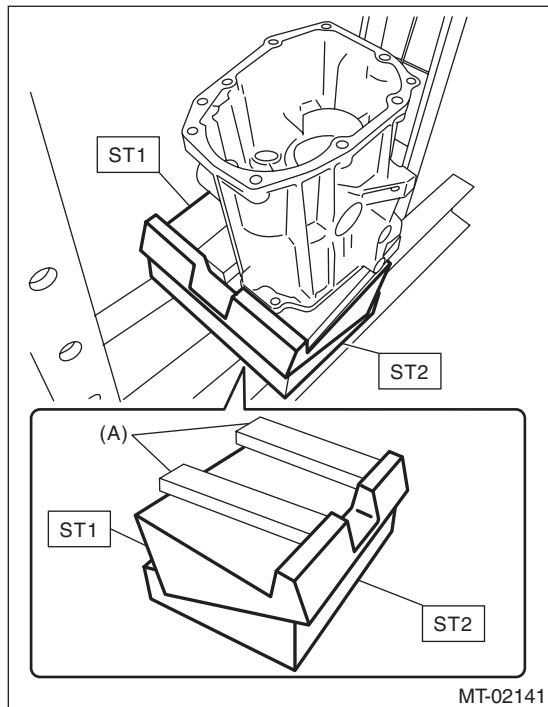

(A) Iron plate

2) Press-fit the roller bearing using the ST.

### Press-fit depth of needle bearing:

**A:  $0 \pm 0.2$  mm ( $0 \pm 0.01$  in) from the end of transfer case**

ST 899864100 REMOVER

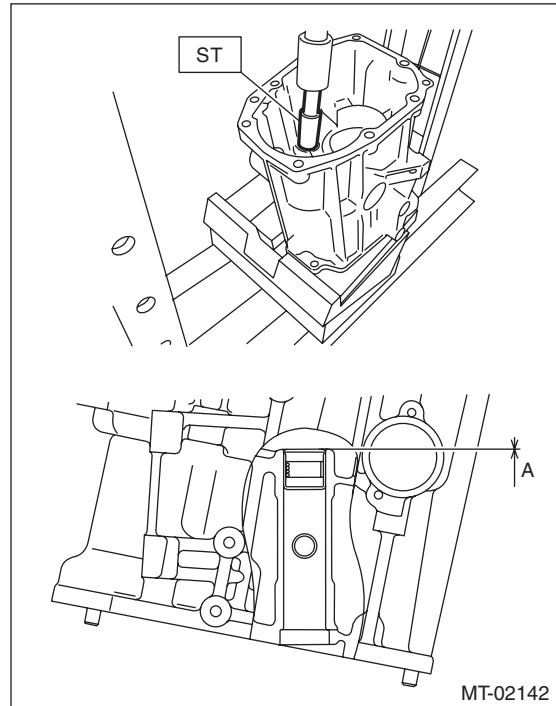

3) Remove the iron plate, and turn over the transfer case.

### NOTE:

Set the transfer case so that the hole for shifter arm is positioned vertically.

# Transfer Case and Extension Case Assembly

## MANUAL TRANSMISSION AND DIFFERENTIAL

4) Press-fit the roller bearing using the ST.

**Press-fit depth of needle bearing:**

**A:  $0 \pm 0.2$  mm ( $0 \pm 0.01$  in) from the end of transfer case**

ST 899864100 REMOVER

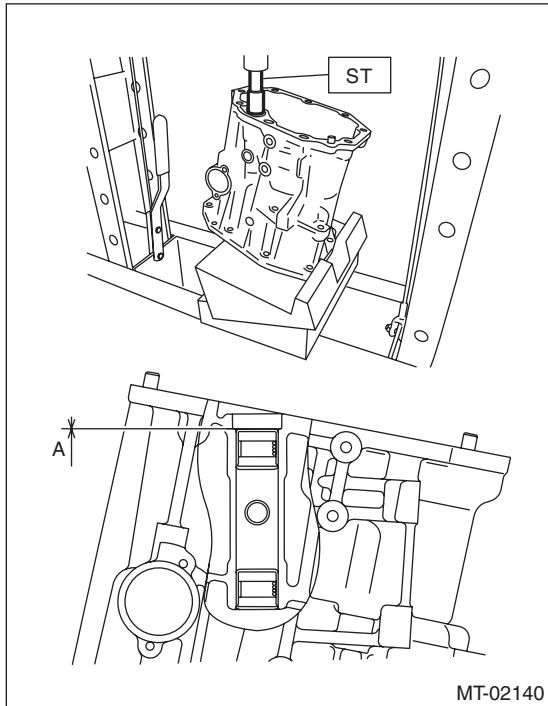

8) Install the oil seal.

**Press-fit depth of oil seal:**

**A:  $1 \pm 0.2$  mm ( $0.04 \pm 0.01$  in) from the end of transfer case**

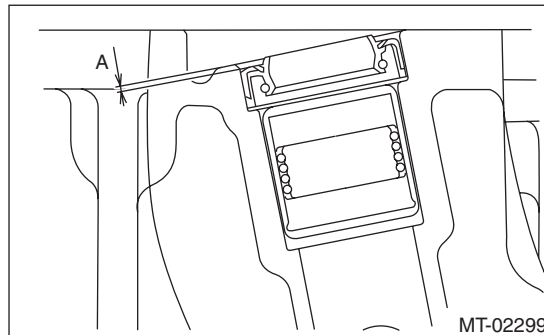

5) Install the shifter arm to the transfer case, and make sure that the shift arm moves smoothly.

6) Install the oil guide to the transfer case.

**NOTE:**

Use a new installing bolt.

**Tightening torque:**

**6.4 N·m (0.7 kgf·m, 4.7 ft·lb)**

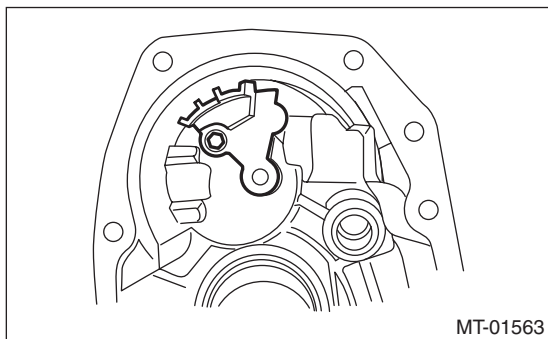

7) Install the reverse check sleeve assembly to the transfer case. <Ref. to 5MT-46, INSTALLATION, Reverse Check Sleeve.>

## 10. Transfer Drive Gear

### A: REMOVAL

- 1) Remove the manual transmission assembly from the vehicle. <Ref. to 5MT-23, REMOVAL, Manual Transmission Assembly.>
- 2) Remove the back-up light switch and the neutral position switch. <Ref. to 5MT-33, REMOVAL, Switches and Harness.>
- 3) Remove the transfer case together with the extension case assembly. <Ref. to 5MT-35, REMOVAL, Transfer Case and Extension Case Assembly.>
- 4) Remove the extension case assembly.
- 5) Remove the transfer driven gear.
- 6) Remove the transfer drive gear.

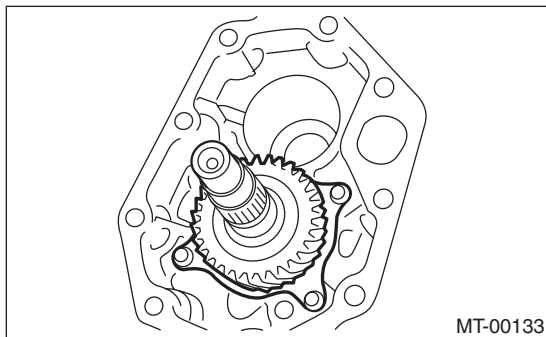

### B: INSTALLATION

- 1) Install the transfer drive gear.

#### Tightening torque:

**26 N·m (2.7 kgf-m, 19.2 ft-lb)**

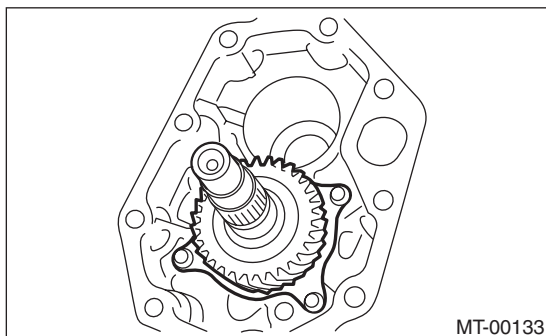

- 2) Install the transfer driven gear.
- 3) Install the extension case assembly.
- 4) Install the transfer case and the extension case assembly. <Ref. to 5MT-35, INSTALLATION, Transfer Case and Extension Case Assembly.>
- 5) Install the back-up light switch and the neutral position switch. <Ref. to 5MT-33, INSTALLATION, Switches and Harness.>
- 6) Install the manual transmission assembly to the vehicle. <Ref. to 5MT-25, INSTALLATION, Manual Transmission Assembly.>

### C: DISASSEMBLY

- 1) Remove the snap ring.

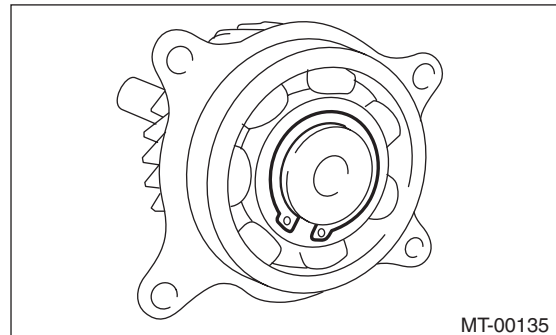

- 2) Remove the ball bearing.

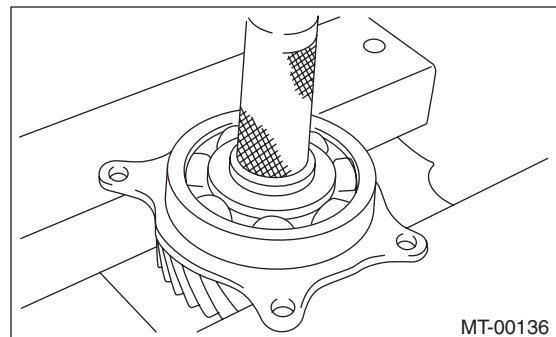

### D: ASSEMBLY

- 1) Set the ST against the inner race of the bearing, and install the drive shaft.

ST 398177700 INSTALLER

#### CAUTION:

**Do not apply a load in excess of 10 kN (1 ton, 1.1 US ton, 1.0 Imp ton).**

#### NOTE:

Use a new ball bearing.

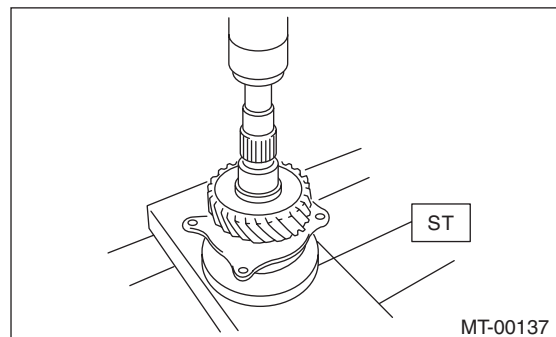

- 2) Install the snap ring on the transfer drive shaft.
- 3) Inspect the clearance between the snap ring and the ball bearing. <Ref. to 5MT-42, INSPECTION, Transfer Drive Gear.>

# Transfer Drive Gear

## MANUAL TRANSMISSION AND DIFFERENTIAL

---

### E: INSPECTION

#### 1) Bearing

Replace the bearings in the following cases.

- In case of broken or rusty bearings
- In case of worn or damaged bearings
- When the bearings fail to turn smoothly or emit noise in rotation after gear oil lubrication.

#### 2) Drive gear

If the drive gear tooth surface and shaft are excessively broken or damaged, replace the drive gear.

3) Measure the clearance between snap ring and inner race of ball bearing with a thickness gauge.

#### **Clearance:**

**0.01 — 0.15 mm (0.0004 — 0.0059 in)**

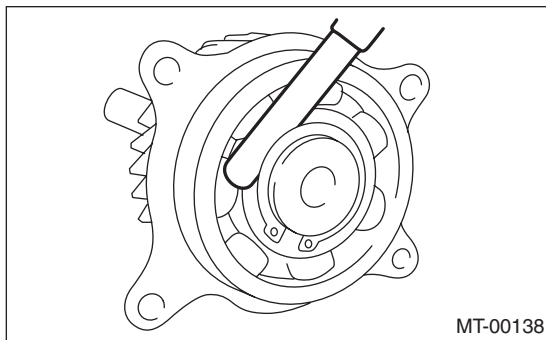

If the measurement is not within specification, select a suitable snap ring and replace it.

Snap ring (outer-30)	
Part No.	Thickness mm (in)
805030041	1.53 (0.0602)
805030042	1.65 (0.0650)
805030043	1.77 (0.0697)

## 11. Transfer Driven Gear

### A: REMOVAL

- 1) Remove the manual transmission assembly from the vehicle. <Ref. to 5MT-23, REMOVAL, Manual Transmission Assembly.>
- 2) Remove the back-up light switch and the neutral position switch. <Ref. to 5MT-33, REMOVAL, Switches and Harness.>
- 3) Remove the transfer case together with the extension case assembly. <Ref. to 5MT-35, REMOVAL, Transfer Case and Extension Case Assembly.>
- 4) Remove the extension case assembly.
- 5) Remove the transfer driven gear.

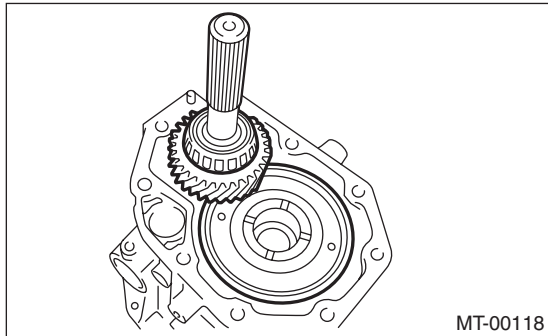

- 6) Remove bearing outer races from the extension case and transfer case.

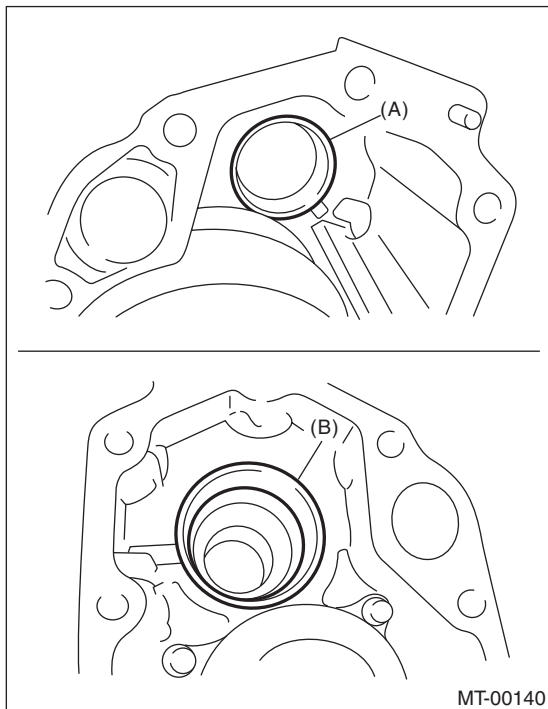

- (A) Bearing outer race (transfer case side)
- (B) Bearing outer race (extension case side)

### B: INSTALLATION

- 1) Install the bearing outer race to transfer case.

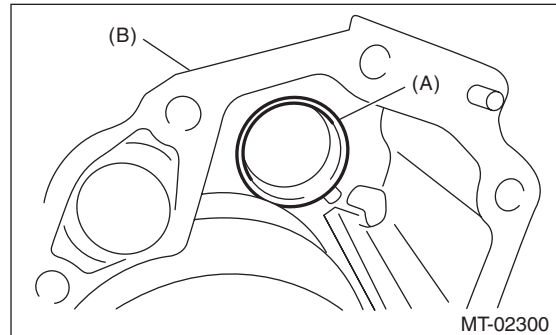

- (A) Bearing outer race
- (B) Transfer case

- 2) Install the transfer driven gear.

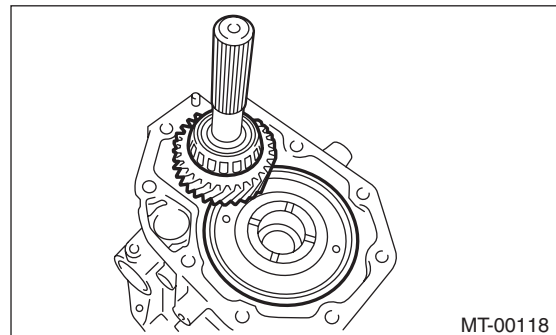

- 3) Select a thrust washer. <Ref. to 5MT-35, INSTALLATION, Transfer Case and Extension Case Assembly.>
- 4) Install the transfer case and the extension case assembly. <Ref. to 5MT-35, INSTALLATION, Transfer Case and Extension Case Assembly.>
- 5) Install the back-up light switch and the neutral position switch. <Ref. to 5MT-33, INSTALLATION, Switches and Harness.>
- 6) Install the manual transmission assembly to the vehicle. <Ref. to 5MT-25, INSTALLATION, Manual Transmission Assembly.>

# Transfer Driven Gear

## MANUAL TRANSMISSION AND DIFFERENTIAL

### C: DISASSEMBLY

1) Using the ST, remove the roller bearing (extension case side).

ST 498077000 REMOVER

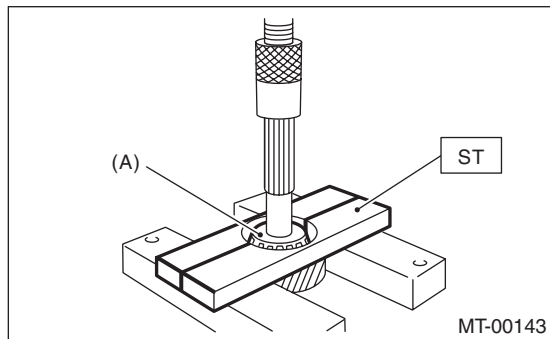

(A) Roller bearing

2) Using ST1 and ST2, remove the roller bearing (transfer case side).

ST1 498077000 REMOVER

ST2 899864100 REMOVER

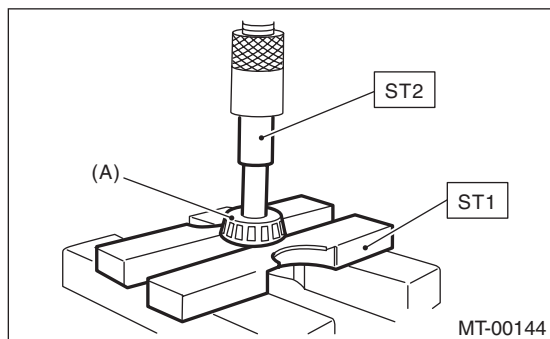

(A) Roller bearing

### D: ASSEMBLY

1) Using the ST, install the roller bearing (extension case side).

ST1 398177700 INSTALLER

ST2 899864100 REMOVER

#### CAUTION:

Do not apply a load in excess of 10 kN (1 ton, 1.1 US ton, 1.0 Imp ton).

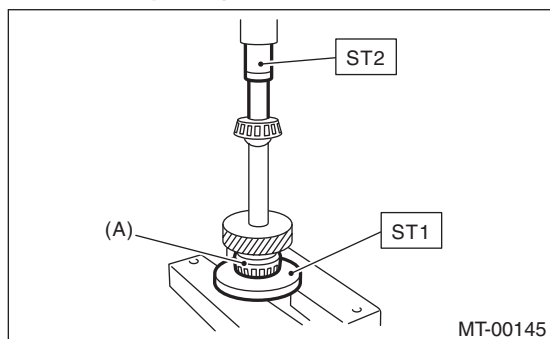

(A) Roller bearing

2) Using ST, install the roller bearing (transfer case side).

ST 499757002 INSTALLER

#### CAUTION:

Do not apply a load in excess of 10 kN (1 ton, 1.1 US ton, 1.0 Imp ton).

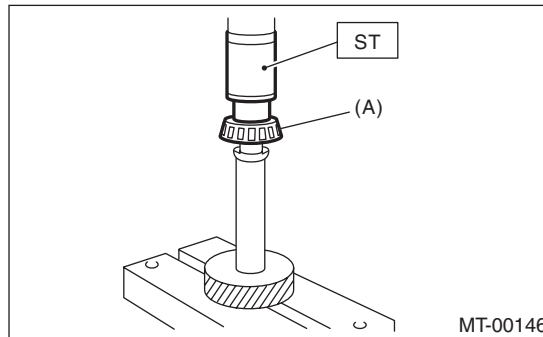

(A) Roller bearing

### E: INSPECTION

1) Bearing

Replace the bearings in the following cases.

- In case of broken or rusty bearings
- In case of worn or damaged bearings
- When the bearings fail to turn smoothly or emit noise in rotation after gear oil lubrication.

2) Driven gear

If the tooth face of driven gear and the shaft are excessively broken or damaged, replace the driven gear.

# Center Differential

MANUAL TRANSMISSION AND DIFFERENTIAL

## 12.Center Differential

### A: REMOVAL

- 1) Remove the manual transmission assembly from the vehicle. <Ref. to 5MT-23, REMOVAL, Manual Transmission Assembly.>
- 2) Remove the back-up light switch and the neutral position switch. <Ref. to 5MT-33, REMOVAL, Switches and Harness.>
- 3) Remove the transfer case together with the extension case assembly. <Ref. to 5MT-35, REMOVAL, Transfer Case and Extension Case Assembly.>
- 4) Remove the extension case assembly. <Ref. to 5MT-35, REMOVAL, Transfer Case and Extension Case Assembly.>
- 5) Remove the transfer driven gear. <Ref. to 5MT-43, REMOVAL, Transfer Driven Gear.>
- 6) Remove the center differential.

### B: INSTALLATION

- 1) Attach the center differential to transfer case.
- 2) Install the transfer driven gear. <Ref. to 5MT-43, INSTALLATION, Transfer Driven Gear.>
- 3) Install the extension case assembly. <Ref. to 5MT-35, INSTALLATION, Transfer Case and Extension Case Assembly.>
- 4) Install the transfer case together with the extension case assembly. <Ref. to 5MT-35, INSTALLATION, Transfer Case and Extension Case Assembly.>
- 5) Install the back-up light switch and the neutral position switch. <Ref. to 5MT-33, INSTALLATION, Switches and Harness.>
- 6) Install the manual transmission assembly to the vehicle. <Ref. to 5MT-25, INSTALLATION, Manual Transmission Assembly.>

### C: DISASSEMBLY

Remove the ball bearing using ST.

NOTE:

- Center differential is a non-disassembled part which should not be disassembled.

- Do not reuse the ball bearing.
- ST 498077300 CENTER DIFFERENTIAL BEARING REMOVER

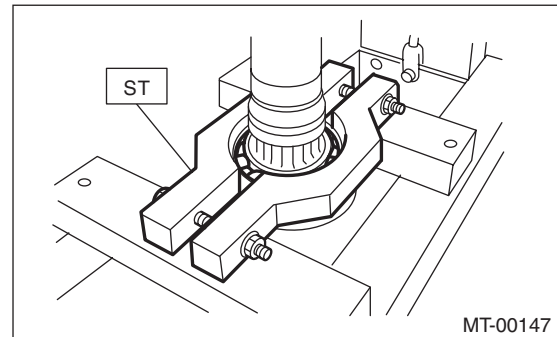

### D: ASSEMBLY

Install the ball bearing to the center differential assembly.

**CAUTION:**

- Do not apply a load in excess of 10 kN (1 ton, 1.1 US ton, 1.0 Imp ton).
- Use a new ball bearing.

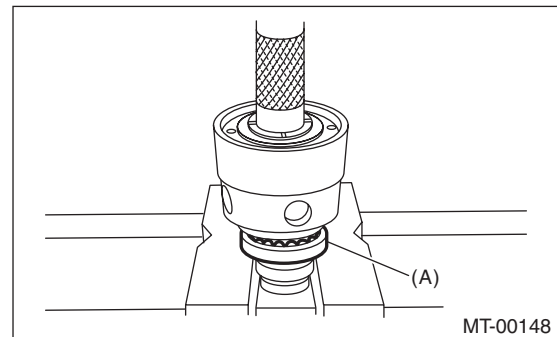

(A) Ball bearing

### E: INSPECTION

1) Bearing

Replace the bearings in the following cases.

- In case of broken or rusty bearings
- In case of worn or damaged bearings
- When the bearings fail to turn smoothly or emit noise in rotation after gear oil lubrication.
- When bearing has other defects.

2) Center differential

If there is wear or damage, replace the center differential case assembly.



# Reverse Check Sleeve

## MANUAL TRANSMISSION AND DIFFERENTIAL

### 13. Reverse Check Sleeve

#### A: REMOVAL

- 1) Remove the manual transmission assembly from the vehicle. <Ref. to 5MT-23, REMOVAL, Manual Transmission Assembly.>
- 2) Remove the transfer case together with the extension case assembly. <Ref. to 5MT-35, REMOVAL, Transfer Case and Extension Case Assembly.>
- 3) Remove the shifter arm.
- 4) Remove the plug, gasket, reverse accent spring, and reverse check ball.

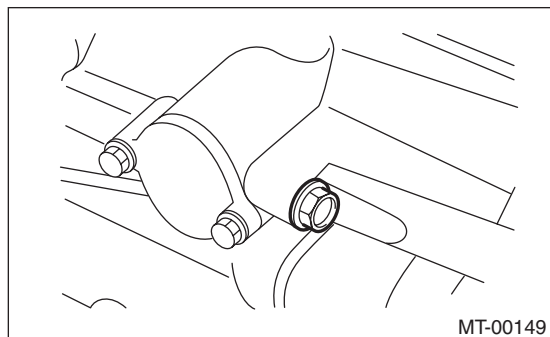

- 5) Remove the reverse check sleeve.

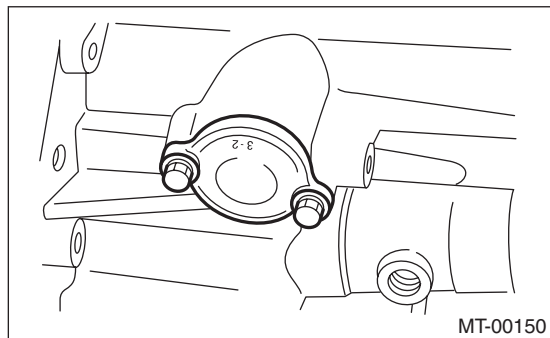

#### B: INSTALLATION

- 1) Install the reverse check sleeve.

##### Tightening torque:

**6.4 N·m (0.7 kgf·m, 4.7 ft·lb)**

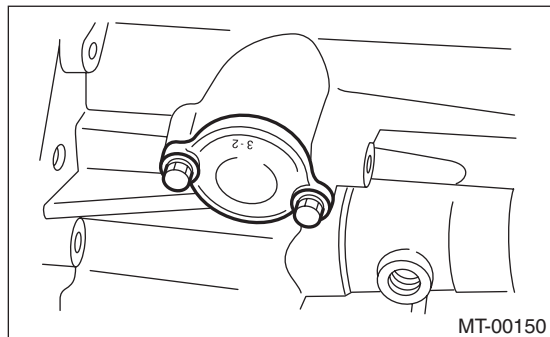

- 2) Install the reverse check ball, reverse accent spring, gasket, and plug to the transfer case.

##### NOTE:

Use a new gasket.

##### Tightening torque:

**9.75 N·m (1.0 kgf·m, 7.2 ft·lb)**

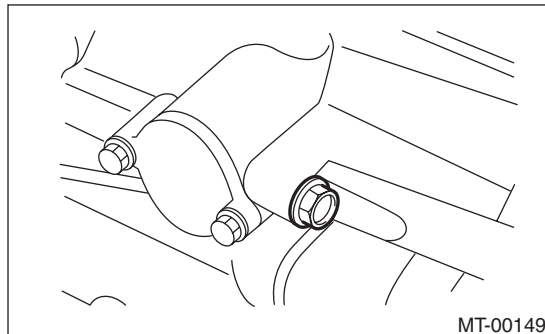

- 3) Attach the shifter arm to the transfer case assembly.
- 4) Install the transfer case together with the extension case assembly. <Ref. to 5MT-35, INSTALLATION, Transfer Case and Extension Case Assembly.>
- 5) Install the manual transmission assembly to the vehicle. <Ref. to 5MT-25, INSTALLATION, Manual Transmission Assembly.>

#### C: DISASSEMBLY

- 1) Cover the reverse check sleeve with cloth, and remove the snap ring by using screwdriver.

##### NOTE:

If the snap ring is deformed or the spring repulsive force is not enough, replace with a new snap ring.

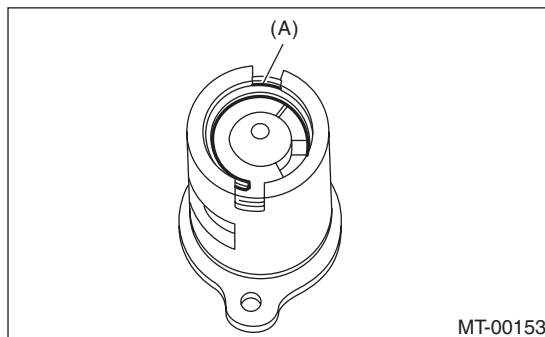

(A) Snap ring



# Reverse Check Sleeve

MANUAL TRANSMISSION AND DIFFERENTIAL

2) Remove the reverse check plate, reverse check spring, reverse check cam, return spring (5th-Reverse), reverse accent shaft, return spring cap, and return spring (1st-2nd).

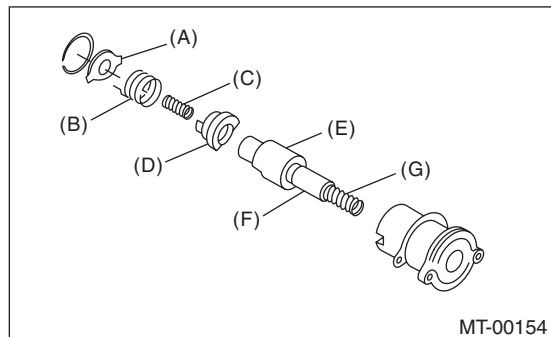

- (A) Reverse check plate
- (B) Reverse check spring
- (C) Return spring (5th-Reverse)
- (D) Reverse check cam
- (E) Reverse accent shaft
- (F) Return spring cap
- (G) Return spring (1st-2nd)

3) Remove the O-ring.

#### NOTE:

- Do not reuse the O-ring.
- Be careful not to damage the adjusting shim between reverse check sleeve assembly and case.

## D: ASSEMBLY

1) Install the return spring (1st-2nd), return spring cap, reverse accent shaft, reverse check cam, return spring (5th-Reverse) and reverse check spring to the reverse check sleeve.

#### NOTE:

Be sure to insert the curved part of reverse check spring into the check cam groove.

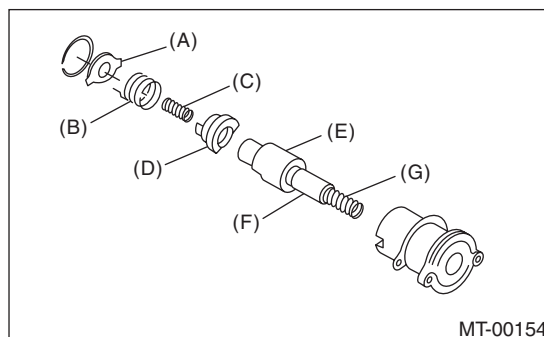

- (A) Reverse check plate
- (B) Reverse check spring
- (C) Return spring (5th-Reverse)
- (D) Reverse check cam
- (E) Reverse accent shaft
- (F) Return spring cap
- (G) Return spring (1st-2nd)

2) Hook the curved part of reverse check spring onto the reverse check plate.

3) Rotate the cam so that the protrusion on the reverse check cam is located at the plate opening.

4) While fixing the cam to that position, attach the reverse check plate to the reverse check sleeve, and secure with snap ring.

5) Insert the O-ring into the sleeve groove.

#### NOTE:

Use new O-rings.

# Reverse Check Sleeve

## MANUAL TRANSMISSION AND DIFFERENTIAL

### E: INSPECTION

- Make sure the cutout of the reverse accent shaft is aligned with the opening in the reverse check sleeve.
- Turn the cam by hand to check for smooth rotation.
- Move the cam and shaft all the way toward the plate, and make sure it releases.

If the cam does not return properly, replace the reverse check spring. If the shaft does not return, check for scratches on the inner surface of sleeve. If the sleeve is in good order, replace the spring.

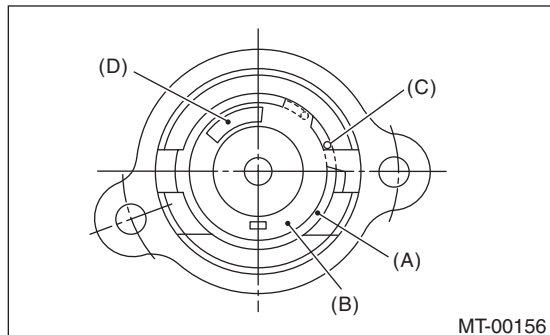

- (A) Snap ring
- (B) Reverse check plate
- (C) Reverse check spring
- (D) Reverse check cam

- Select a suitable reverse accent shaft and reverse check plate. <Ref. to 5MT-48, ADJUSTMENT, Reverse Check Sleeve.>

### F: ADJUSTMENT

#### 1. NEUTRAL POSITION ADJUSTMENT

- 1) Shift the gear into 3rd gear position.
- 2) Because of the return spring, until the arm contacts the stopper the shifter arm will feel lighter moving towards 1st/2nd gear and heavier towards the reverse gear.
- 3) Make adjustment so that the heavy stroke (reverse side) is a little heavier than the lighter stroke (1st/2nd side).
- 4) To adjust, remove the bolts holding the reverse check sleeve assembly to the case, and move the sleeve assembly outward, then place an adjustment shim between the sleeve assembly and the case to adjust the clearance.

#### CAUTION:

Be careful not to damage the O-ring when placing shims.

#### NOTE:

- When the shim is removed, the neutral position will move closer to reverse; when the shim is added, the neutral position will move closer to 1st gear.
- If it is not possible to adjust the clearance with only shims, replace the reverse accent shaft and re-adjust.

Adjusting shim	
Part No.	Thickness mm (in)
32190AA000	0.15 (0.0059)
32190AA010	0.30 (0.0118)

Reverse accent shaft		
Part No.	Mark	Remarks
32188AA130	S	Neutral position is closer to 1st gear.
32188AA140	T	Standard
32188AA150	U	Neutral position is closer to reverse gear.

#### 2. REVERSE CHECK PLATE ADJUSTMENT

- 1) Shift the shifter arm to "5th" and then to reverse to see if the reverse check mechanism operates properly.
- 2) Also check to see if the arm returns to neutral when released from the reverse position. If the arm does not return properly, replace the reverse check plate.

Reverse check plate			
Part No.	(A): No.	Angle $\theta$	Remarks
32189AA001	0	28°	Arm stops closer to 5th gear.
32189AA011	1	31°	Arm stops closer to 5th gear.
32189AA021	2	34°	Arm stops in the center.
32189AA031	3	37°	Arm stops closer to reverse gear.
32189AA041	4	40°	Arm stops closer to reverse gear.

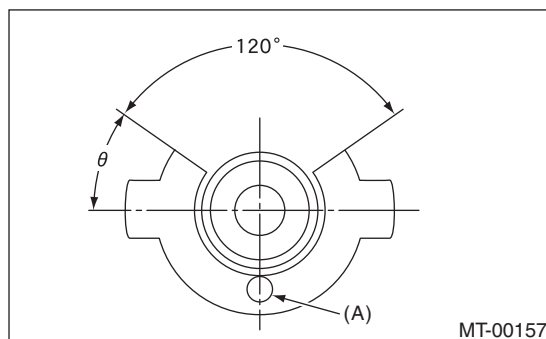

## 14. Transmission Case

### A: REMOVAL

- 1) Remove the manual transmission assembly from the vehicle. <Ref. to 5MT-23, REMOVAL, Manual Transmission Assembly.>
- 2) Remove the clutch release lever. <Ref. to CL-15, REMOVAL, Release Bearing and Lever.>
- 3) Remove the transfer case together with the extension case assembly. <Ref. to 5MT-35, REMOVAL, Transfer Case and Extension Case Assembly.>
- 4) Remove the bearing mounting bolt.

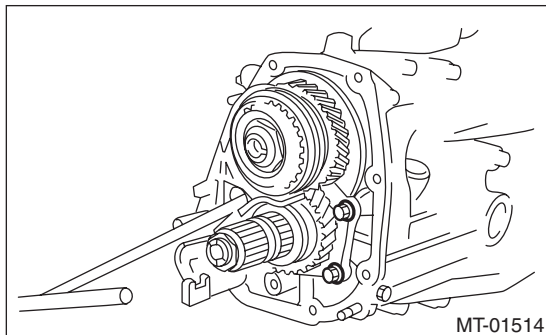

- 5) Remove the main shaft rear plate.

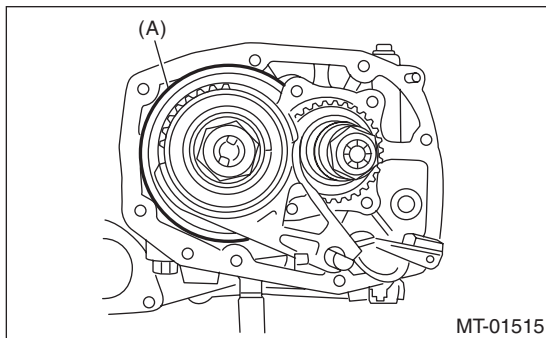

(A) Main shaft rear plate

- 6) Remove the coupling bolts and nuts, and separate the transmission case into the right and left case.

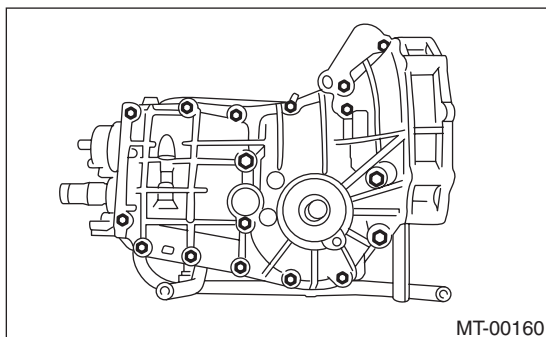

- 7) Remove the drive pinion shaft assembly from the left side of the transmission case.

#### NOTE:

Use a hammer handle, etc. to remove if too tight.

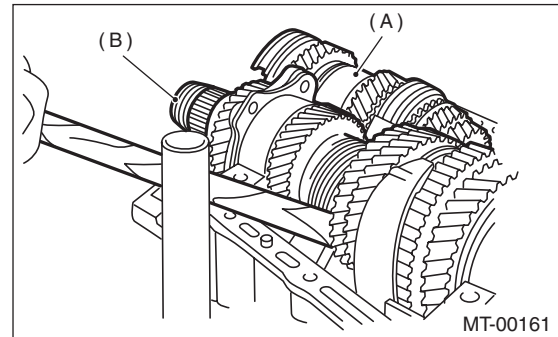

(A) Main shaft ASSY for single-range  
(B) Drive pinion shaft ASSY

- 8) Remove the main shaft assembly for single-range.
- 9) Remove the front differential assembly.

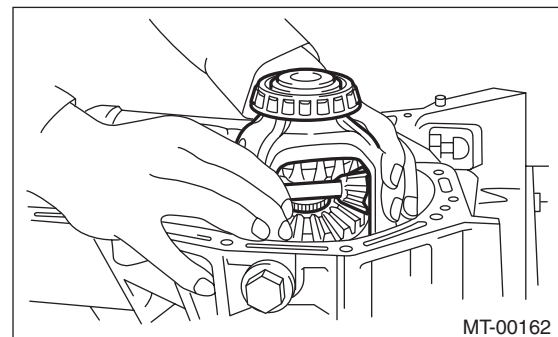

- 10) Remove the differential side retainers and bearing outer races on the left and right side. <Ref. to 5MT-68, REMOVAL, Front Differential Assembly.>

#### NOTE:

Do not confuse the right and left roller bearing outer races.

- 11) Remove the reverse idler gear. <Ref. to 5MT-75, REMOVAL, Reverse Idler Gear.>
- 12) Remove the shifter fork and rod. <Ref. to 5MT-77, REMOVAL, Shifter Fork and Rod.>

### B: INSTALLATION

- 1) Wipe off grease, oil and dust on the mating surfaces of transmission cases with cleaning solvent.
- 2) Install the shifter fork and rod. <Ref. to 5MT-77, INSTALLATION, Shifter Fork and Rod.>
- 3) Select the drive pinion shim. <Ref. to 5MT-58, INSTALLATION, Drive Pinion Shaft Assembly.>
- 4) Install the differential side retainer, from which the bearing outer race and O-ring have already been removed, to the transmission case LH side.
- 5) Install the front differential assembly.

# Transmission Case

## MANUAL TRANSMISSION AND DIFFERENTIAL

6) Install the main shaft assembly for single-range. Align the transmission case knock pin into the knock pin hole of the needle bearing.

7) Install the selected drive pinion shims and drive pinion shaft assembly.

### NOTE:

Align the roller bearing knock pin hole to the transmission case knock pin.

8) Tighten the left and right side of the transmission case with the 17 mounting bolts.

### NOTE:

- Insert bolts (11) and (16) from the LH side of the transmission case.
- Match the cases together so that the drive pinion shims are not caught between the cases.

### Tightening torque:

**8 mm bolt**

**25 N·m (2.5 kgf·m, 18.4 ft·lb)**

★ **10 mm bolt**

**39 N·m (4.0 kgf·m, 28.8 ft·lb)**

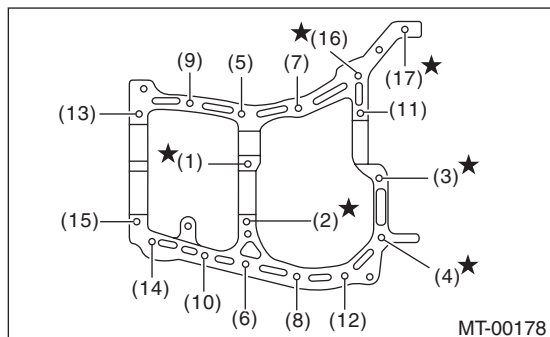

9) Install the bearing outer race to the RH side of the transmission case.

10) Tighten the bearing mounting bolts.

### Tightening torque:

**30 N·m (3.1 kgf·m, 22.1 ft·lb)**

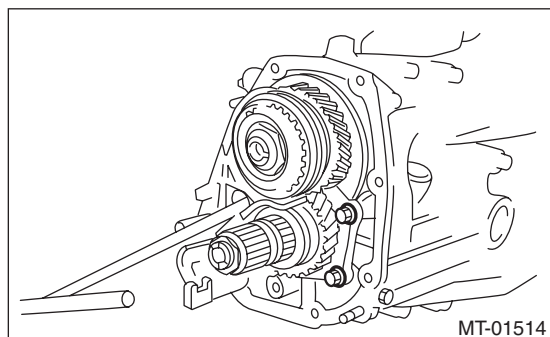

11) Adjust the backlash of the hypoid gear and the preload of the roller bearing.

(1) Attach the ST on drive pinion assembly.

ST 498427100 STOPPER

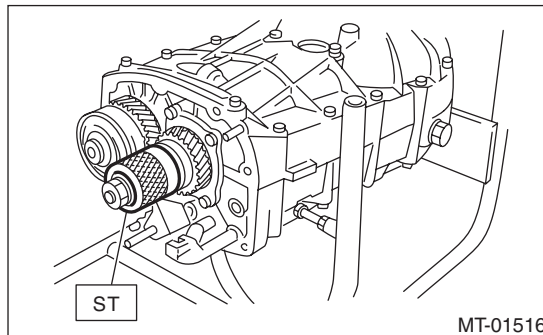

(2) Place the transmission with the LH side of case facing downward, and put ST1 on the bearing outer race.

(3) Screw the retainer assembly from the bottom into left case using ST2. Fit the ST3 on transmission main shaft. Shift the gear into 4th or 5th, and turn the shaft several times. Screw in the retainer while rotating the ST3 until a slight resistance is felt on ST2.

This is the contact point of the hypoid gear and the drive pinion shaft. Repeat the above sequence several times to ensure the contact point.

ST1 399780104 WEIGHT

ST2 18630AA010 WRENCH COMPL RETAINER

ST3 499927100 HANDLE

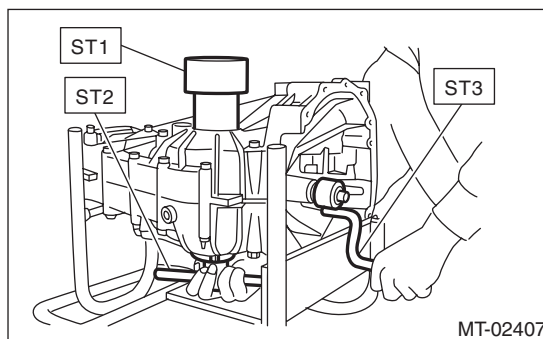

(4) Remove the WEIGHT, and screw in the side retainer without the O-ring into the RH side of the transmission case, and stop at the point where a slight resistance is felt.

# Transmission Case

## MANUAL TRANSMISSION AND DIFFERENTIAL

### NOTE:

In this condition, the backlash between hypoid gear and drive pinion shaft is zero.

ST 18630AA010 WRENCH COMPL RETAINER

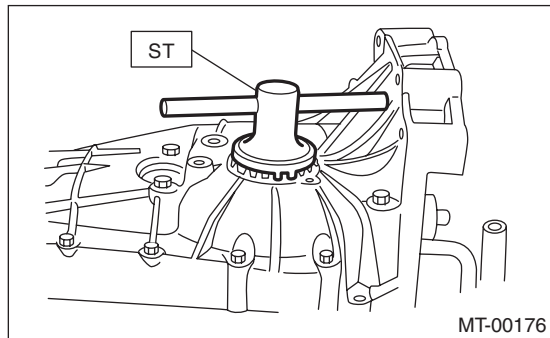

(5) Loosen the side retainer on the LH side of the transmission case by 3 notches, and turn the side retainer on the RH side of the transmission case by the same notches in order to apply backlash.

(6) Screw in the side retainer of the RH side of the transmission case additionally by 1 notch in order to apply preload on taper roller bearing.

(7) Tighten temporarily both the upper and lower lock plates, and put marks on both the side retainer and lock plate for later readjustment.

### NOTE:

If it is hard to install the lock plates, reverse the sides and install them.

(8) Turn the transmission main shaft several times while tapping around the retainer lightly with plastic hammer.

12) Inspect and adjust backlash and tooth contact of the hypoid gear. <Ref. to 5MT-72, INSPECTION, Front Differential Assembly.>

13) Separate the transmission case into left and right parts. <Ref. to 5MT-49, REMOVAL, Transmission Case.>

14) Select a main shaft rear plate. <Ref. to 5MT-57, ADJUSTMENT, Main Shaft Assembly for Single-Range.>

15) Check each shifter fork. <Ref. to 5MT-78, INSPECTION, Shifter Fork and Rod.>

16) Apply liquid gasket, then join the right side and left side of the case together.

### Liquid gasket:

**THREE BOND 1215 (Part No. 004403007) or equivalent**

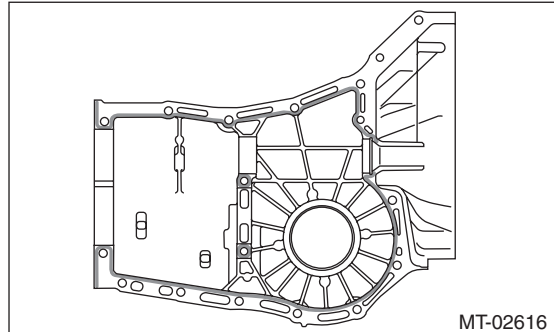

17) With brackets and clips as shown in the figure, tighten the seventeen bolts.

### NOTE:

- Insert bolts (11) and (16) from the LH side of the transmission case.

- Match the cases together so that the drive pinion shims are not caught between the cases.

### Tightening torque:

**8 mm bolt**

**25 N·m (2.5 kgf-m, 18.4 ft-lb)**

★ **10 mm bolt**

**40 N·m (4.1 kgf-m, 29.5 ft-lb)**

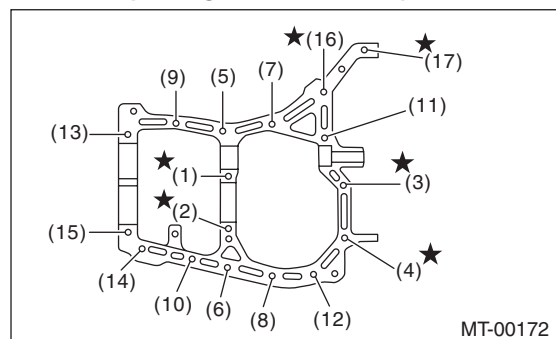

18) Tighten the bearing mounting bolts.

### Tightening torque:

**30 N·m (3.1 kgf-m, 22.1 ft-lb)**

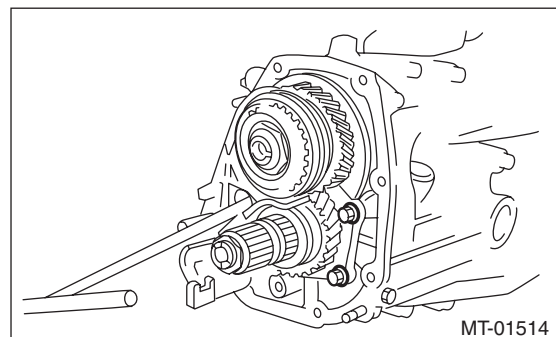

# Transmission Case

## MANUAL TRANSMISSION AND DIFFERENTIAL

---

19) Remove the lock plate. Then loosen the retainer until the O-ring groove appears. Fit the O-ring into the groove and tighten the retainer into the position where it was not loosened.

### NOTE:

- When loosening the retainer, record the number of the turns made.
- Perform this for both left and right side retainers.
- Use new O-rings.

20) Install the lock plate.

### **Tightening torque:**

***T: 25 N·m (2.5 kgf-m, 18.4 ft-lb)***

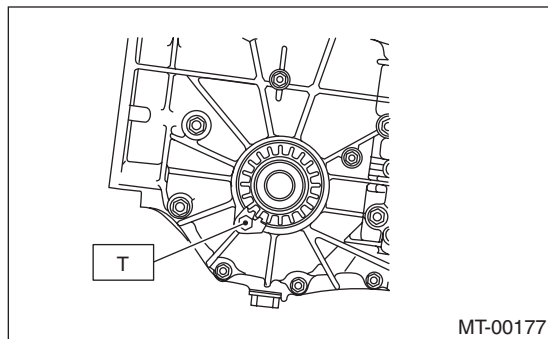

21) Install the transfer case together with the extension case assembly. <Ref. to 5MT-35, INSTALLATION, Transfer Case and Extension Case Assembly.>

22) Install the clutch release lever and bearing. <Ref. to CL-15, INSTALLATION, Release Bearing and Lever.>

23) Install the manual transmission assembly to the vehicle. <Ref. to 5MT-25, INSTALLATION, Manual Transmission Assembly.>

## **C: INSPECTION**

Check the transmission case for cracks, damage, or oil leaks.



# Main Shaft Assembly for Single-Range

MANUAL TRANSMISSION AND DIFFERENTIAL

## 15. Main Shaft Assembly for Single-Range

### A: REMOVAL

- 1) Remove the manual transmission assembly from the vehicle. <Ref. to 5MT-23, REMOVAL, Manual Transmission Assembly.>
- 2) Remove the transfer case together with the extension case assembly. <Ref. to 5MT-35, REMOVAL, Transfer Case and Extension Case Assembly.>
- 3) Remove the transmission case. <Ref. to 5MT-49, REMOVAL, Transmission Case.>
- 4) Remove the drive pinion shaft assembly. <Ref. to 5MT-58, REMOVAL, Drive Pinion Shaft Assembly.>
- 5) Remove the main shaft assembly for single-range.

### B: INSTALLATION

- 1) Install the needle bearing and oil seal to the front of the transmission single-range main shaft assembly.

#### NOTE:

- Wrap the clutch splined section with vinyl tape to prevent damage to the oil seal.
- Apply NICHIMOLY N-130 or the equivalent to the sealing lip of the oil seal.
- Use a new oil seal.

- 2) Align the transmission case knock pin into the knock pin hole of the needle bearing outer race.

#### NOTE:

Align the end face of the seal with surface (A) when installing the oil seal.

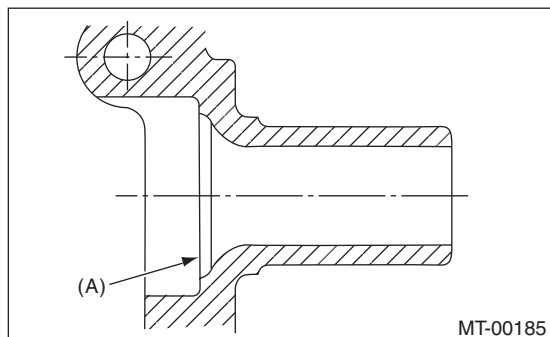

- 3) Install the drive pinion shaft assembly. <Ref. to 5MT-58, INSTALLATION, Drive Pinion Shaft Assembly.>
- 4) Install the transmission case. <Ref. to 5MT-49, INSTALLATION, Transmission Case.>
- 5) Install the transfer case together with the extension case assembly. <Ref. to 5MT-35, INSTALLATION, Transfer Case and Extension Case Assembly.>

- 6) Install the manual transmission assembly to the vehicle. <Ref. to 5MT-25, INSTALLATION, Manual Transmission Assembly.>

### C: DISASSEMBLY

- 1) Put vinyl tape around main shaft spline to protect the oil seal from damage. Then pull out the oil seal and needle bearing by hand.
- 2) Remove the lock nut and lock washer from transmission main shaft assembly for single-range.

#### NOTE:

Flatten the lock nut tab before removing the lock nut.

- |     |           |                     |
|-----|-----------|---------------------|
| ST1 | 498937000 | TRANSMISSION HOLDER |
| ST2 | 499987003 | SOCKET WRENCH (35)  |

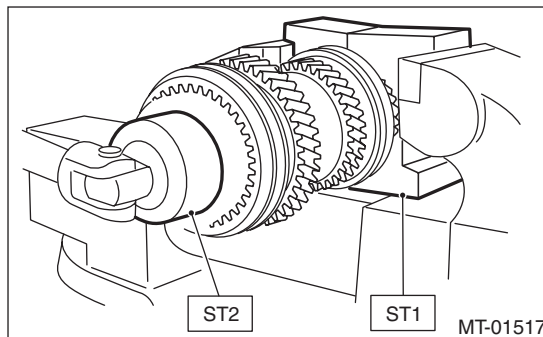

- 3) Remove the 5th hub & sleeve No. 2, baulk lever, baulk ring, 5th drive gear and needle bearing.

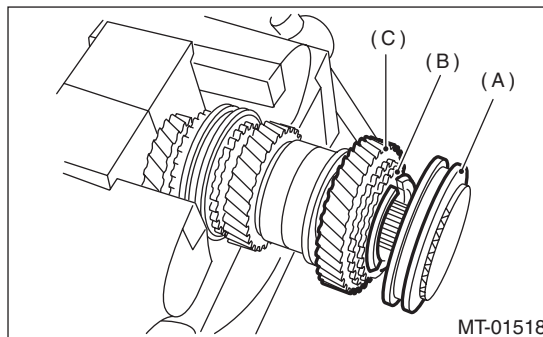

- (A) 5th hub & sleeve No. 2
- (B) Baulk ring
- (C) 5th drive gear

# Main Shaft Assembly for Single-Range

## MANUAL TRANSMISSION AND DIFFERENTIAL

4) Using ST1 and ST2, remove the rest of the parts.

### NOTE:

- When replacing the sleeve & hub, replace them as a set.
- Do not disassemble the sleeve & hub; the aligning position is pre-matched.
- If it is necessary to disassemble, mark the engaging points on the splines beforehand.

ST1 899864100 REMOVER

ST2 899714110 REMOVER

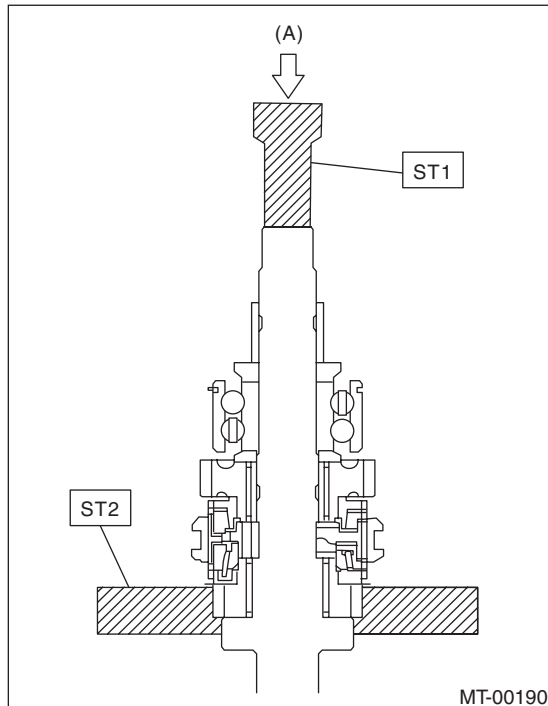

(A) Press

## D: ASSEMBLY

1) When the sleeve & hub assemblies have been disassembled, reassemble by aligning the alignment marks.

### NOTE:

Position the open ends of the spring 120° apart.

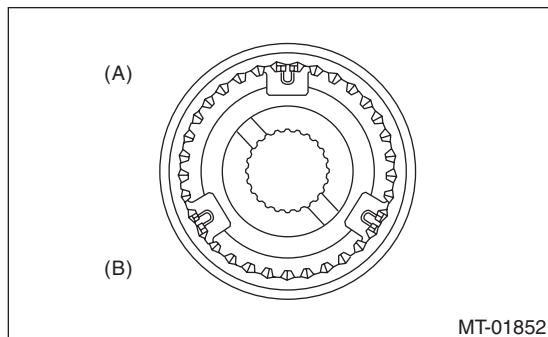

(A) 3rd-4th sleeve & hub ASSY

(B) 3rd gear side

2) Install the 3rd drive gear, outer baulk ring, synchro cone, inner baulk ring, sleeve & hub assembly for the 3rd needle bearing, on the transmission main shaft.

### NOTE:

Align the groove in baulk ring with the shifting insert.

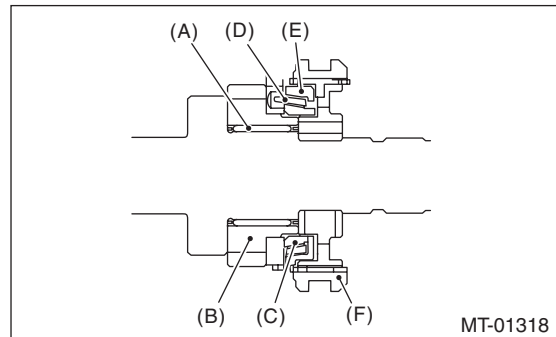

(A) 3rd needle bearing

(B) 3rd drive gear

(C) Inner baulk ring

(D) Synchro cone

(E) Outer baulk ring

(F) Sleeve & hub ASSY

3) Install the 4th needle bearing race onto transmission main shaft using ST1, ST2 and press.

### CAUTION:

**Do not apply a load in excess of 10 kN (1 ton, 1.1 US ton, 1.0 Imp ton).**

ST1 899714110 REMOVER

ST2 499877000 RACE 4-5 INSTALLER

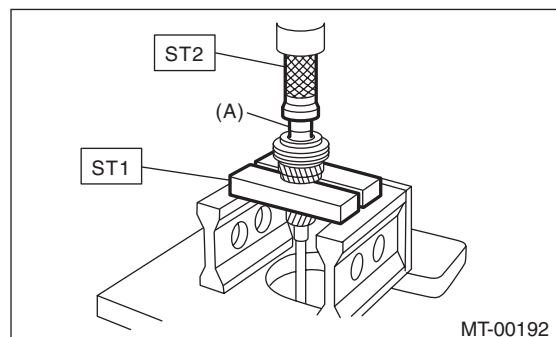

(A) 4th needle bearing race



# Main Shaft Assembly for Single-Range

MANUAL TRANSMISSION AND DIFFERENTIAL

4) Install the baulk ring, needle bearing, 4th drive gear and 4th gear thrust washer to the transmission main shaft.

**NOTE:**

- Align the baulk ring and hub & sleeve assembly with the key groove.
- Make sure the thrust washer is facing the correct direction.

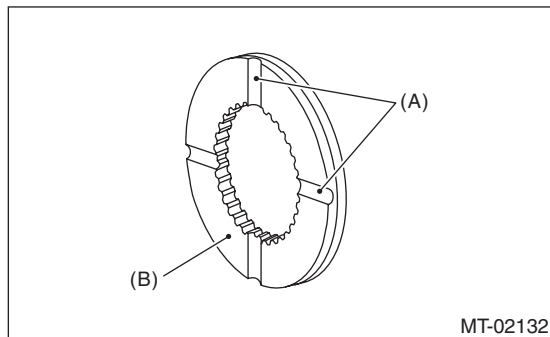

- (A) Groove
- (B) Face this surface to the 4th gear side.

5) Press-fit the double taper roller bearing into the rear section of transmission main shaft using ST1, ST2 and a press.

**CAUTION:**

**Do not apply a load in excess of 10 kN (1 ton, 1.1 US ton, 1.0 Imp ton).**

- ST1 899714110 REMOVER
- ST2 499877000 RACE 4-5 INSTALLER

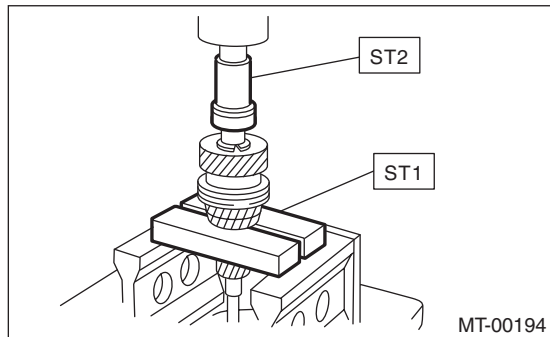

6) Install the 5th needle bearing race into the rear section of transmission main shaft using ST1 and ST2.

**CAUTION:**

**Do not apply a load in excess of 10 kN (1 ton, 1.1 US ton, 1.0 Imp ton).**

**NOTE:**

Make sure the thrust washer is facing the correct direction.

- ST1 899714110 REMOVER
- ST2 499877000 RACE 4-5 INSTALLER

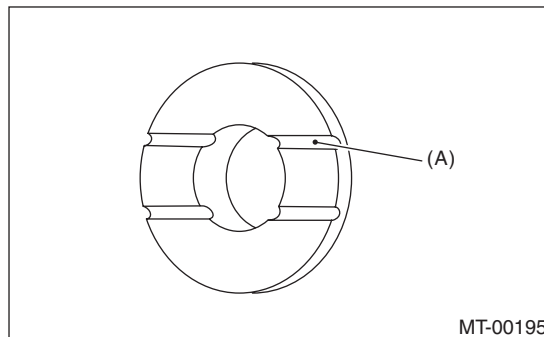

- (A) Face this surface to the 5th gear side.

7) Install rest of the parts to the rear section of the transmission main shaft.

**CAUTION:**

**• Install the baulk lever so that the concave side faces toward the 5th hub.**

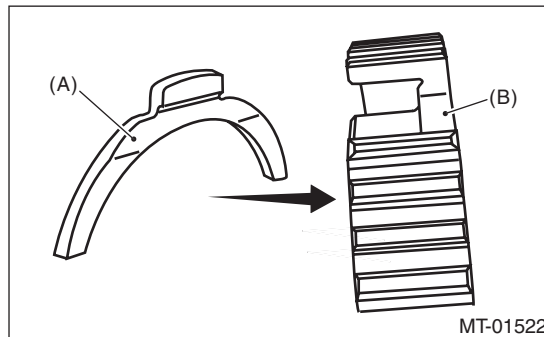

- (A) Baulk lever
- (B) 5th hub

# Main Shaft Assembly for Single-Range

## MANUAL TRANSMISSION AND DIFFERENTIAL

- Align the protruded section of baulk ring between the baulk levers.

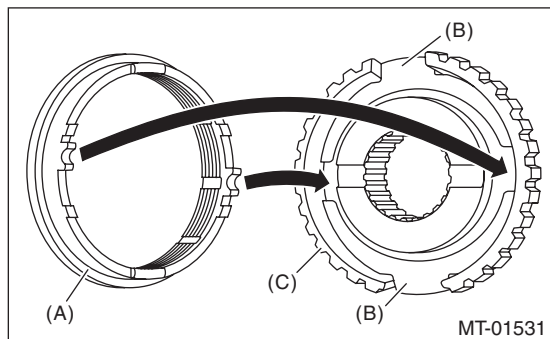

- (A) Baulk ring
- (B) Baulk lever
- (C) 5th hub

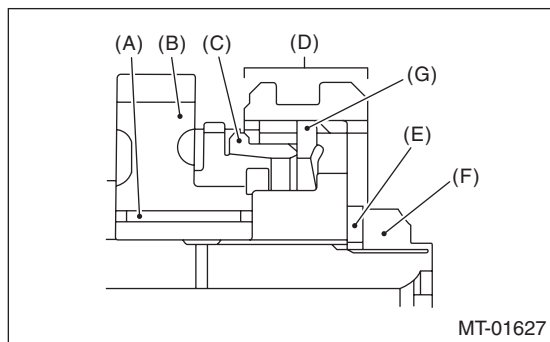

- (A) Needle bearing
- (B) 5th drive gear
- (C) Baulk ring
- (D) 5th hub & sleeve No. 2
- (E) Lock washer
- (F) Lock nut
- (G) Baulk lever

- Tighten the lock nuts to the specified torque using ST1 and ST2.

### NOTE:

Use new lock nuts and lock washers.

ST1 499987003 SOCKET WRENCH (35)

ST2 498937000 TRANSMISSION HOLDER

### Tightening torque:

**120 N·m (12.2 kgf·m, 88.5 ft·lb)**

- Crimp lock nuts in two locations after tightening.

## E: INSPECTION

Disassembled parts should be washed with cleaning solvent first, then inspected carefully.

### 1) Bearing

Replace the bearings in the following cases.

- When the bearing balls, outer races and inner races are broken or rusty.
- When the bearing is worn.
- When the bearings fail to turn smoothly or emit noise in rotation after gear oil lubrication.
- When bearing has other defects.

### 2) Bushing (each gear)

Replace the bushing in following cases.

- When the sliding surface is damaged or abnormally worn.
- When the inner wall is abnormally worn.

### 3) Gear

Replace gears in the following cases.

- Replace the gear with new part if its tooth surfaces are broken, damaged or excessively worn.
- Correct or replace if the cone that contacts the baulk ring is rough or damaged.
- Correct or replace if the inner surface or end face is damaged.

### 4) Baulk ring

Replace the baulk ring in the following cases.

- When the inner surface and end face are damaged.
- When the ring inner surface is abnormally or partially worn down.
- When the contact surface of the synchronizer ring insert section is cracked or abnormally worn.
- If the gap between the end faces of the ring and the gear splined part is excessively small, check the clearance (A) while pressing the ring against the cone.

### Clearance (A):

**0.5 mm (0.020 in) or more**

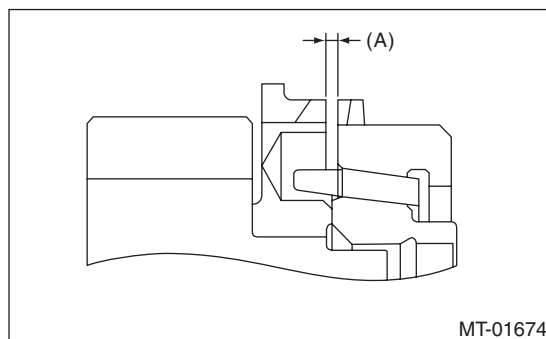

- Apply gear oil to the cone of the gear and while press-fitting the baulk ring, check there is no rotation in the circumferential direction.

### 5) Shifting insert key

Replace the insert key if deformed, excessively worn or defective in any way.

# Main Shaft Assembly for Single-Range

MANUAL TRANSMISSION AND DIFFERENTIAL

## 6) Oil seal

Replace the oil seal if the lip is deformed, hardened, worn or defective in any way.

## 7) Coupling sleeve and synchronizer hub

- Check the slipping condition of the coupling sleeve.
- Check the splines on the coupling sleeve and synchronizer hub for wear.

## 8) O-ring

Replace the O-ring if the sealing face is deformed, hardened, damaged, worn or defective in any way.

## 9) Gearshift mechanism

Repair or replace the gearshift mechanism if excessively worn, bent or defective in any way.

## F: ADJUSTMENT

Selection of main shaft rear plate:

Measure the protrusion amount (A) of ball bearing from transmission main case surface, and select a suitable plate in the following table.

### NOTE:

Before measuring, tap the end of main shaft with a plastic hammer lightly in order to make the clearance zero between the main case surface and moving flange of bearing.

Dimension (A) mm (in)	Part No.	Mark
4.00 — 4.13 (0.1575 — 0.1626)	32294AA041	1
3.87 — 4.00 (0.1524 — 0.1575)	32294AA051	2

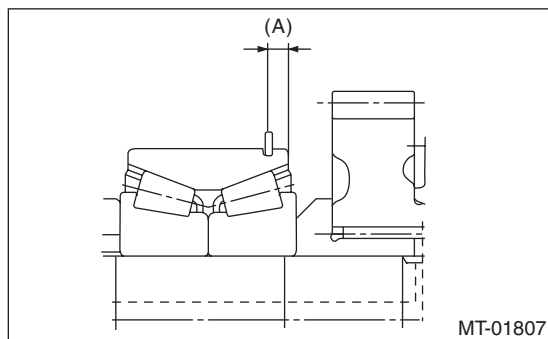

# Drive Pinion Shaft Assembly

## MANUAL TRANSMISSION AND DIFFERENTIAL

### 16. Drive Pinion Shaft Assembly

#### A: REMOVAL

- 1) Remove the manual transmission assembly from the vehicle. <Ref. to 5MT-23, REMOVAL, Manual Transmission Assembly.>
- 2) Remove the transfer case together with the extension case assembly. <Ref. to 5MT-35, REMOVAL, Transfer Case and Extension Case Assembly.>
- 3) Remove the transmission case. <Ref. to 5MT-49, REMOVAL, Transmission Case.>
- 4) Remove the drive pinion shaft assembly.

#### NOTE:

Use a hammer handle, etc. to remove if too tight.

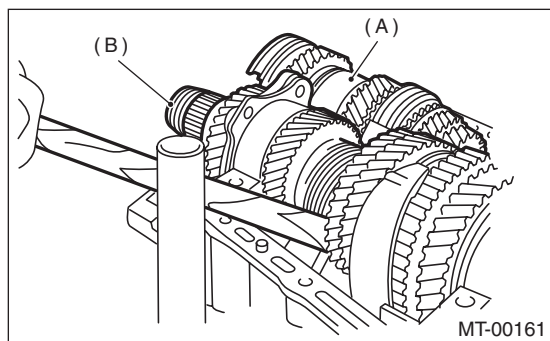

- (A) Main shaft ASSY for single-range
- (B) Drive pinion shaft ASSY

#### B: INSTALLATION

- 1) Remove the front differential assembly.
- 2) Hypoid gear set match mark/No.: The number (A) on top of the drive pinion, and the number on the hypoid driven gear are set numbers for the two gears. Use a pair having the same numbers. The figure (B) below shows a number for shim adjustment. If no number is shown, the value is zero.

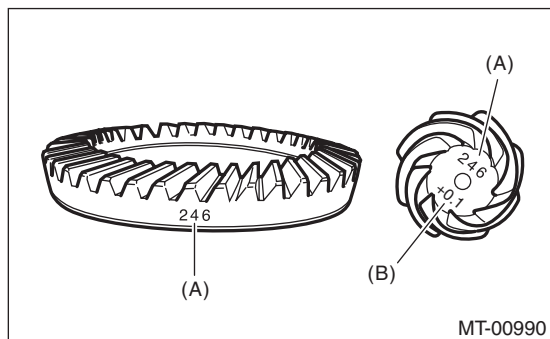

- (A) Set number
- (B) Number for shim adjustment

- 3) Place the drive pinion shaft assembly on transmission main case RH without shim and tighten the bearing mounting bolts.
- 4) Check and adjust the ST.

- (1) Loosen the two bolts and adjust so that the scale indicates 0.5 correctly when the plate end and the scale end are on the same level.
- (2) Tighten the two bolts.

ST 499917500 DRIVE PINION GAUGE ASSY

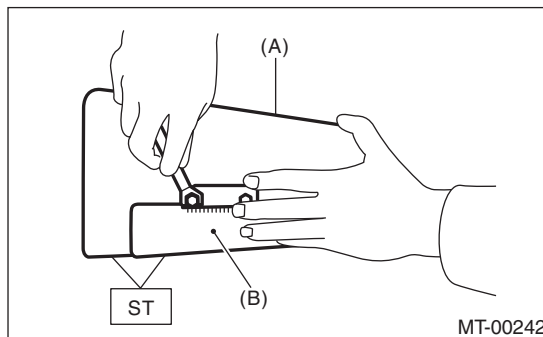

- (A) Plate
- (B) Scale

- 5) Position the ST by inserting the knock pin of ST into the knock hole of transmission case.

ST 499917500 DRIVE PINION GAUGE ASSY

- 6) Slide the drive pinion gauge scale with finger tip and read the value at the point where it matches with the end face of drive pinion.

ST 499917500 DRIVE PINION GAUGE ASSY

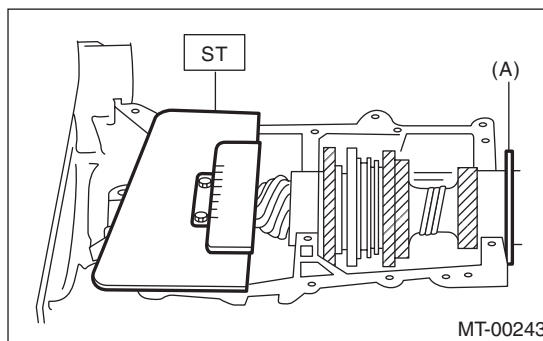

- (A) Adjust the clearance to zero without shim.

- 7) The thickness of shim shall be determined by adding the value indicated on drive pinion to the value indicated on the ST. (Add if the number on drive pinion is prefixed by +, and subtract if the number is prefixed by -.)

ST 499917500 DRIVE PINION GAUGE ASSY

# Drive Pinion Shaft Assembly

MANUAL TRANSMISSION AND DIFFERENTIAL

8) Select one to three shims in the following table for the value determined as described above, and take the shim(s) which thickness is closest to the said value.

Drive pinion shim	
Part No.	Thickness mm (in)
32295AA031	0.150 (0.0059)
32295AA041	0.175 (0.0069)
32295AA051	0.200 (0.0079)
32295AA061	0.225 (0.0089)
32295AA071	0.250 (0.0098)
32295AA081	0.275 (0.0108)
32295AA091	0.300 (0.0118)
32295AA101	0.500 (0.0197)

9) Install the front differential assembly. <Ref. to 5MT-68, INSTALLATION, Front Differential Assembly.>

10) Fit the transmission case knock pin to the knock pin hole of the roller bearing and install the drive pinion shaft assembly.

11) Install the main shaft assembly for single-range. <Ref. to 5MT-53, INSTALLATION, Main Shaft Assembly for Single-Range.>

12) Check each shifter fork. <Ref. to 5MT-78, INSPECTION, Shifter Fork and Rod.>

13) Install the transmission case. <Ref. to 5MT-49, INSTALLATION, Transmission Case.>

14) Install the transfer case together with the extension case assembly. <Ref. to 5MT-35, INSTALLATION, Transfer Case and Extension Case Assembly.>

15) Install the manual transmission assembly to the vehicle. <Ref. to 5MT-25, INSTALLATION, Manual Transmission Assembly.>

## C: DISASSEMBLY

### NOTE:

Attach a cloth to the end of driven shaft (on the frictional side of the thrust needle bearing) to prevent damage during disassembly or reassembly.

1) Flatten the tab of the lock nut. Remove the lock nut with ST1, ST2 and ST3.

ST1 899884100 HOLDER

ST2 498427100 STOPPER

ST3 899988608 SOCKET WRENCH (27)

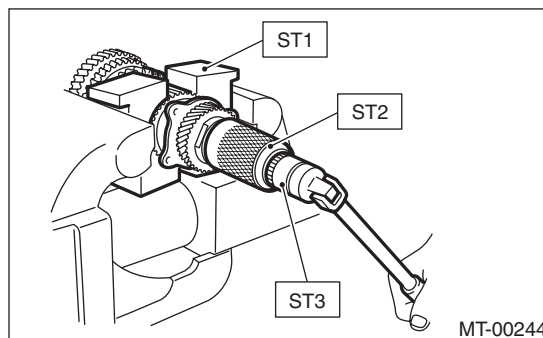

2) Draw out the drive pinion shaft from driven shaft. Remove the differential bevel gear sleeve, adjusting washer No. 1, adjusting washer No. 2, thrust bearing, needle bearing and drive pinion collar.

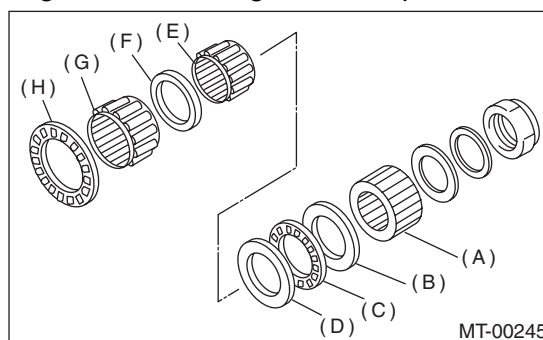

- (A) Differential bevel gear sleeve
- (B) Adjusting washer No. 1 (25 × 37.5 × t)
- (C) Thrust bearing (25 × 37.5 × 3)
- (D) Adjusting washer No. 2 (25 × 37.5 × t)
- (E) Needle bearing (25 × 30 × 20)
- (F) Drive pinion collar
- (G) Needle bearing (30 × 37 × 23)
- (H) Thrust bearing (33 × 50 × 3)

3) Remove the roller bearing and washer using ST and a press.

# Drive Pinion Shaft Assembly

## MANUAL TRANSMISSION AND DIFFERENTIAL

### NOTE:

Do not reuse the roller bearing.

ST 498077000 REMOVER

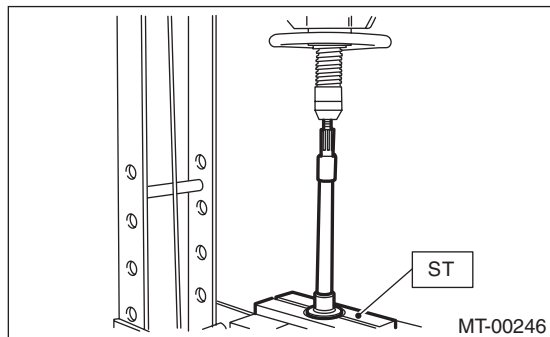

4) Flatten the tab of the lock nut. Remove the lock nut using ST1 and ST2.

ST1 499987300 SOCKET WRENCH (50)

ST2 899884100 HOLDER

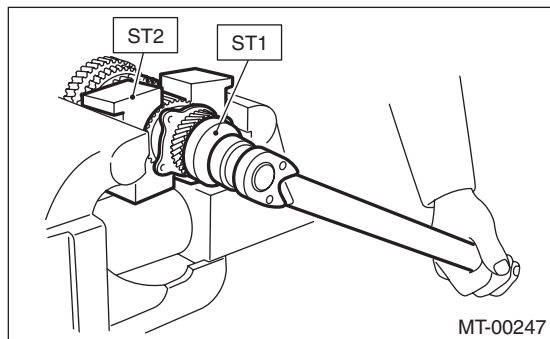

5) Remove the 5th driven gear using ST.

ST 499857000 5TH DRIVEN GEAR REMOVER

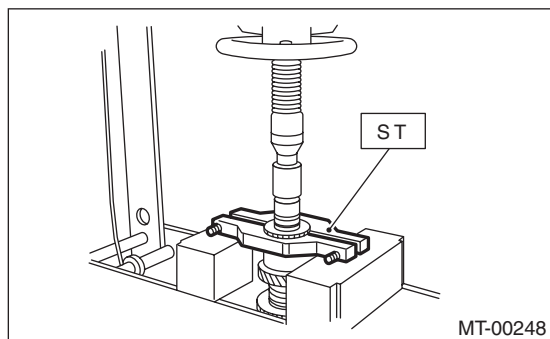

6) Remove the woodruff key.

7) Remove the roller bearing and 3rd-4th driven gear using ST1 and ST2.

ST1 499757002 INSTALLER

ST2 899714110 REMOVER

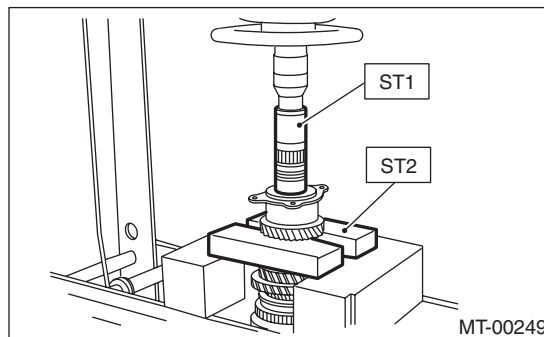

8) Remove the key.

9) Remove the 2nd driven gear, inner baulk ring, synchro cone and outer baulk ring.

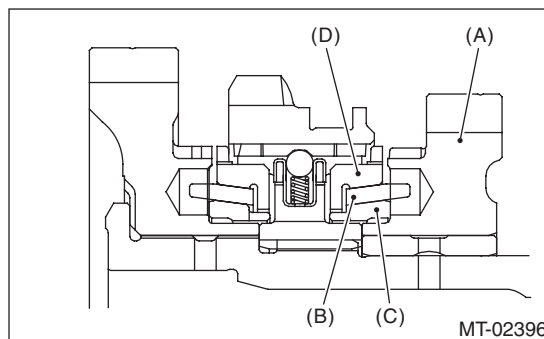

(A) 2nd driven gear

(B) Synchro cone

(C) Inner baulk ring

(D) Outer baulk ring

10) Remove the 1st driven gear, inner baulk ring, synchro cone, outer baulk ring, 2nd gear bushing and gear & hub assembly using ST1 and ST2.

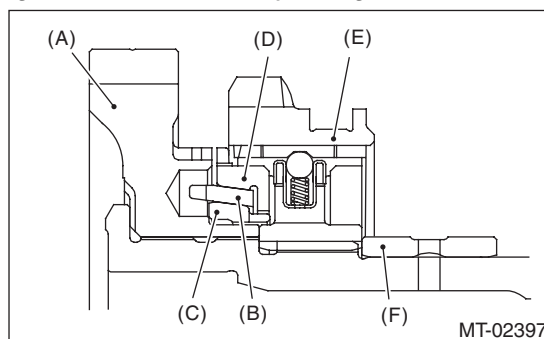

(A) 1st driven gear

(B) Synchro cone

(C) Inner baulk ring

(D) Outer baulk ring

(E) Gear & hub ASSY

(F) 2nd gear bushing

# Drive Pinion Shaft Assembly

MANUAL TRANSMISSION AND DIFFERENTIAL

**NOTE:**

If necessary, use a new gear and hub assembly as a set, when replacing the gear or hub. Because these must engage at the specified point, avoid disassembly as much as possible. If it must be disassembled, mark the engaging point on the spline beforehand.

ST1 499757002 INSTALLER

ST2 899714110 REMOVER

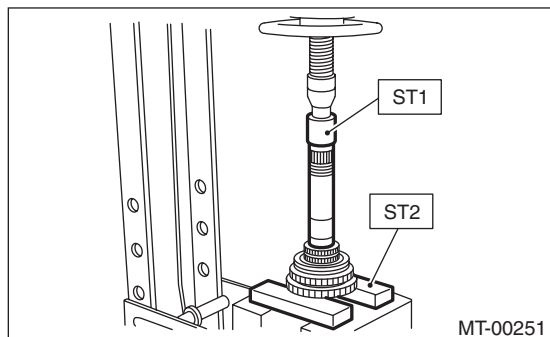

## D: ASSEMBLY

1) Install the sleeve and the gear and hub assembly by matching the alignment marks.

**NOTE:**

- Make sure that there is no large clearance at both sides of ball detent after assembly.

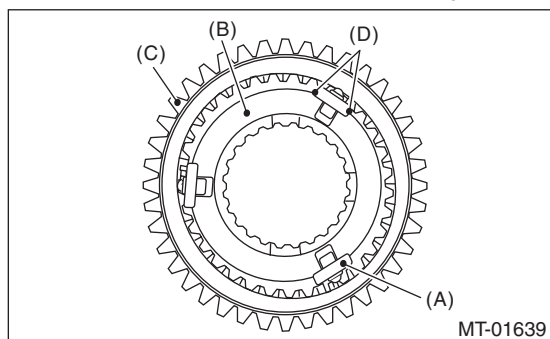

- (A) Ball detent
- (B) 1st-2nd synchronizer hub
- (C) Reverse driven gear
- (D) There is no large clearance at this part.

- Use the new gear & hub assembly, if replacing the gear or hub.

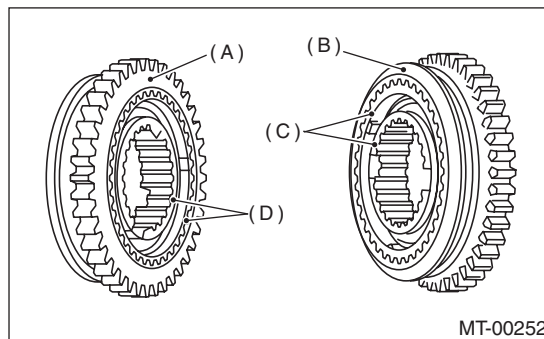

- (A) 1st gear side
- (B) 2nd gear side
- (C) Flush surface
- (D) Stepped surface

2) Install the 1st driven gear, inner baulk ring, synchro cone, outer baulk ring, and gear & hub assembly onto driven shaft.

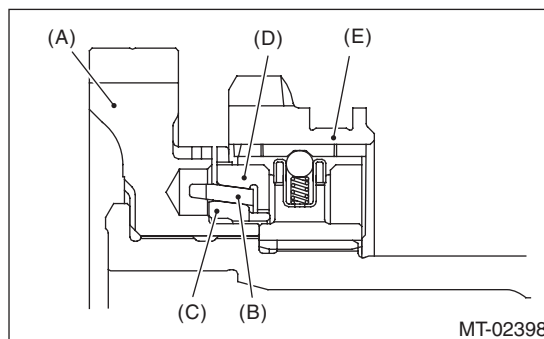

- (A) 1st driven gear
- (B) Synchro cone
- (C) Inner baulk ring
- (D) Outer baulk ring
- (E) Gear & hub ASSY

**NOTE:**

- Take care to install the gear and hub assembly in proper direction.
- Align the baulk ring and gear & hub assembly with the key groove.



# Drive Pinion Shaft Assembly

## MANUAL TRANSMISSION AND DIFFERENTIAL

3) Install the 2nd driven gear bushing onto driven shaft using ST1, ST2 and a press.

### CAUTION:

**Do not apply a load in excess of 10 kN (1 ton, 1.1 US ton, 1.0 Imp ton).**

### NOTE:

- Attach a cloth to the end of the driven shaft to prevent damage.
- When press fitting, align the oil holes of the shaft and bushing

ST1 499277200 INSTALLER

ST2 499587000 INSTALLER

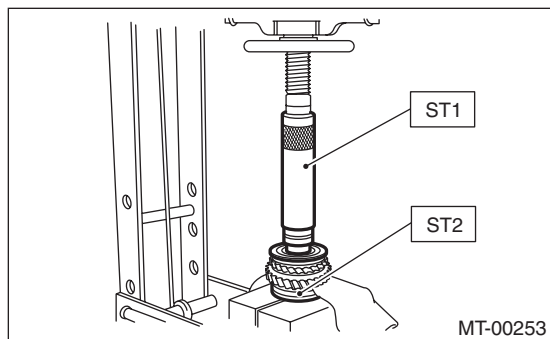

4) Install the 2nd driven gear, inner baulk ring, synchro cone and outer baulk ring, and insert them onto driven shaft.

### NOTE:

Align the groove in baulk ring with the insert.

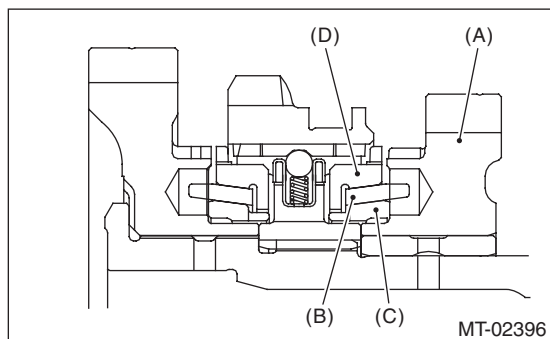

(A) 2nd driven gear

(B) Synchro cone

(C) Inner baulk ring

(D) Outer baulk ring

5) After installing key onto the driven shaft, install the 3rd-4th driven gear using ST1, ST2 and a press.

### CAUTION:

**Do not apply a load in excess of 10 kN (1 ton, 1.1 US ton, 1.0 Imp ton).**

ST1 499277200 INSTALLER

ST2 499587000 INSTALLER

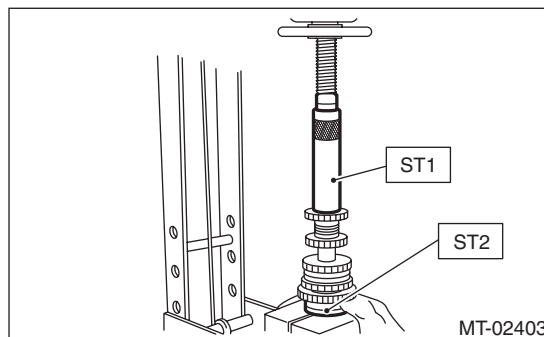

6) Install a set of roller bearings onto the driven shaft using ST1, ST2 and a press.

### CAUTION:

**Do not apply a load in excess of 10 kN (1 ton, 1.1 US ton, 1.0 Imp ton).**

ST1 499277200 INSTALLER

ST2 499587000 INSTALLER

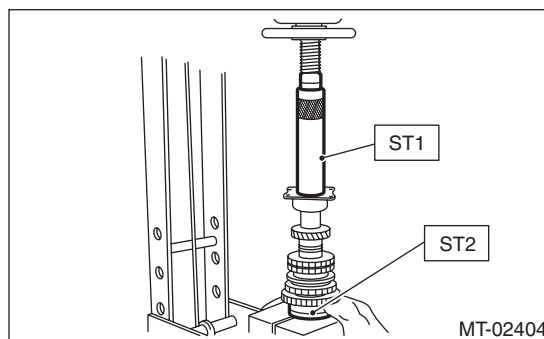

7) Position the woodruff key in groove of the rear of driven shaft. Install the 5th driven gear to the driven shaft using ST1, ST2 and a press.

### CAUTION:

**Do not apply a load in excess of 10 kN (1 ton, 1.1 US ton, 1.0 Imp ton).**

ST1 499277200 INSTALLER

ST2 499587000 INSTALLER

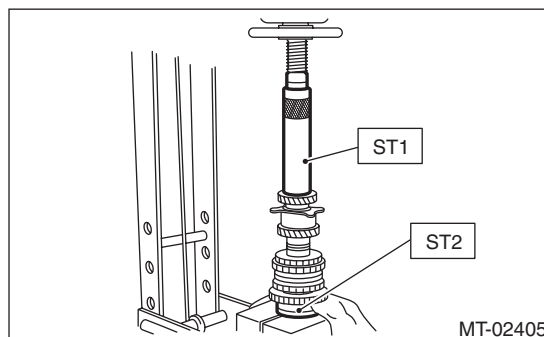



# Drive Pinion Shaft Assembly

MANUAL TRANSMISSION AND DIFFERENTIAL

8) Install the lock washer. Tighten the lock nuts to the specified torque using ST1 and ST2.

**NOTE:**

- Use new lock nuts and lock washers.
- Make sure the lock washer is installed in the proper direction.

ST1 499987300 SOCKET WRENCH (50)

ST2 899884100 HOLDER

**Tightening torque:**

**260 N·m (26.5 kgf·m, 191.8 ft·lb)**

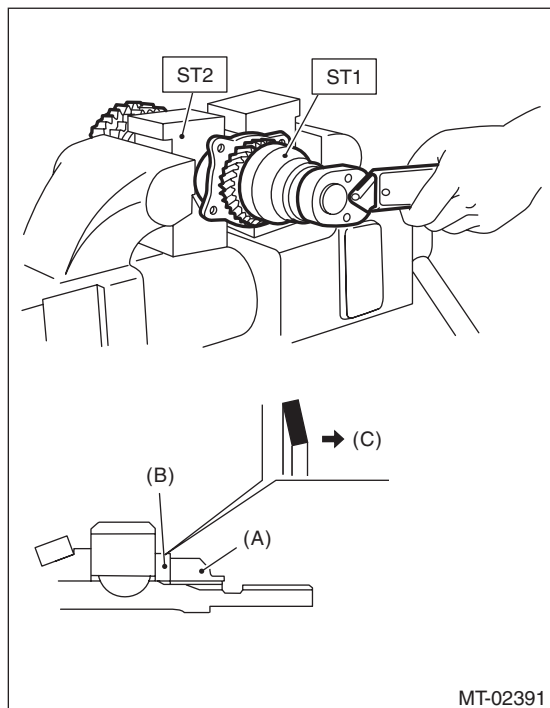

- (A) Lock nut
- (B) Lock washer
- (C) Nut side

9) Using a spring scale, check that starting torque of the roller bearing is 0.1 to 1.5 N (0.01 to 0.15 kgf, 0.02 to 0.34 lbf).

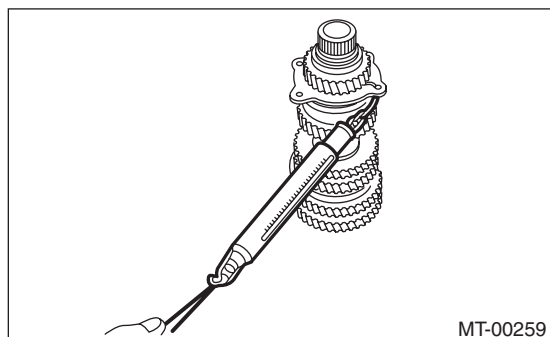

10) Crimp the lock nut at two locations so that the dimension (B) becomes 41.1 mm (1.62 in) or less.

**CAUTION:**

**When crimping the lock nut, be careful not to crack it.**

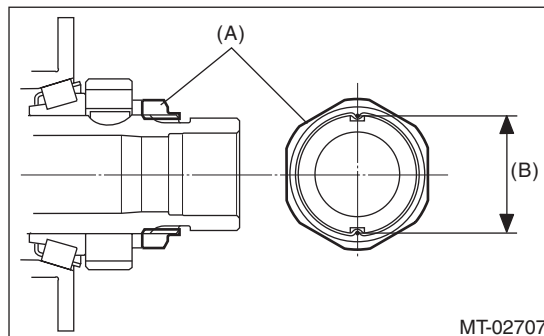

- (A) Lock nut
- (B) Outer dimension after crimping

11) Install the roller bearing onto the drive pinion shaft.

**NOTE:**

When installing the roller bearing, direct the knock pin hole of outer race toward rear.

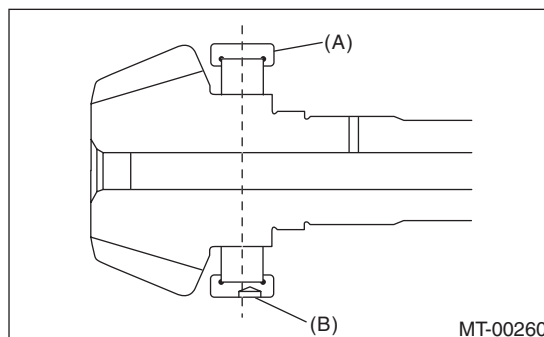

- (A) Roller bearing
- (B) Knock pin hole

12) Install the washer using ST1, ST2 and a press.

**CAUTION:**

**Do not apply a load in excess of 10 kN (1 ton, 1.1 US ton, 1.0 Imp ton).**

ST1 499277100 BUSHING 1-2 INSTALLER

ST2 499277200 INSTALLER

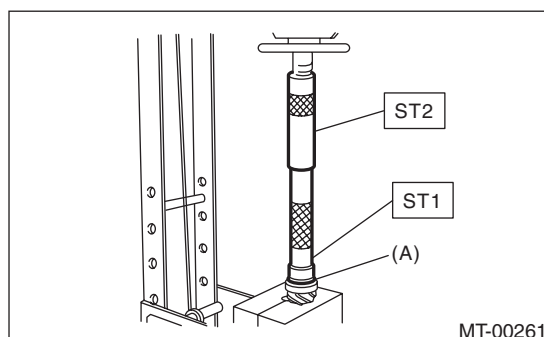

- (A) Washer

**5MT-63**

Brought to you by Ebay Seller "SubaruManuals"

# Drive Pinion Shaft Assembly

## MANUAL TRANSMISSION AND DIFFERENTIAL

13) Install the thrust bearing and needle bearing.  
Install the driven shaft assembly.

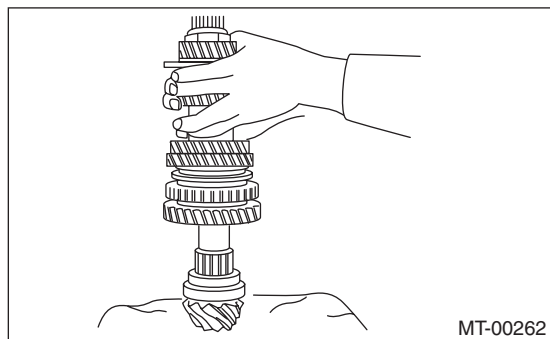

14) Install the drive pinion collar, needle bearing, adjusting washer No. 2, thrust bearing, adjusting washer No. 1 and differential bevel gear sleeve in this order.

### NOTE:

Be careful to install the spacer in the proper direction.

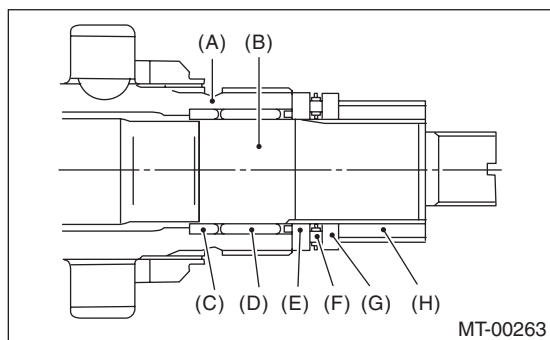

- (A) Driven shaft
- (B) Drive shaft
- (C) Drive pinion collar
- (D) Needle bearing (25 × 30 × 20)
- (E) Adjusting washer No. 2 (25 × 36 × t)
- (F) Thrust bearing (25 × 37.5 × 3)
- (G) Adjusting washer No. 1 (25 × 36 × t)
- (H) Differential bevel gear sleeve

15) Adjust the thrust bearing preload. <Ref. to 5MT-65, THRUST BEARING PRELOAD, ADJUSTMENT, Drive Pinion Shaft Assembly.>

## E: INSPECTION

Disassembled parts should be washed with cleaning solvent first, then inspected carefully.

### 1) Bearing

Replace the bearings in the following cases.

- When the bearing balls, outer races and inner races are broken or rusty.
- When the bearing is worn.
- When the bearings fail to turn smoothly or emit noise in rotation after gear oil lubrication.
- The ball bearing on the rear side of the drive pinion shaft should be checked for smooth rotation before the drive pinion shaft assembly is disassembled. In this case, because a preload is working on the bearing, its rotation feels like it is slightly dragging unlike other bearings.

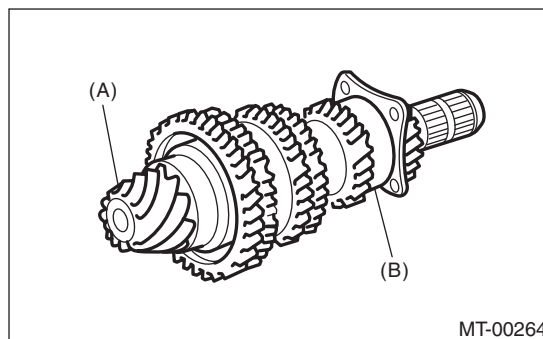

- (A) Drive pinion shaft
- (B) Ball bearing

- When bearing has other defects.

### 2) Bushing (each gear)

Replace the bushing in following cases.

- When the sliding surface is damaged or abnormally worn.
- When the inner wall is abnormally worn.

### 3) Gear

Replace gears in the following cases.

- Replace the gear with new part if its tooth surfaces are broken, damaged or excessively worn.
- Correct or replace if the cone that contacts the baulk ring is rough or damaged.
- Correct or replace if the inner surface or end face is damaged.

# Drive Pinion Shaft Assembly

MANUAL TRANSMISSION AND DIFFERENTIAL

## 4) Baulk ring, synchro cone

Replace the baulk ring and synchro cone in the following cases.

- When the inner surface and end face are damaged.
- When the baulk ring inner surface is abnormally or partially worn down.
- When the contact surface of the baulk ring insert section is cracked or abnormally worn.
- If the gap between the end faces of the baulk ring and the gear splined part is excessively small, check the clearance (A) while pressing the ring against the cone.

### Clearance (A):

**0.5 mm (0.020 in) or more**

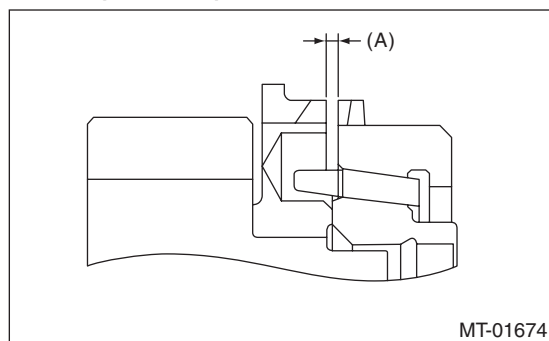

- Apply gear oil to the cone of the gear and while press-fitting the baulk ring, check there is no rotation in the circumferential direction.

## 5) Coupling sleeve and synchronizer hub

- Check the slipping condition of the coupling sleeve.

- Check the splines on the coupling sleeve and synchronizer hub for wear.

## 6) Shifting insert key

Replace the shifting insert key if deformed, excessively worn or defective in any way.

## 7) Ball detent

Replace the ball detent if deformed, excessively worn or defective in any way.

## 8) Oil seal

Replace the oil seal if the lip is deformed, hardened, worn or defective in any way.

## 9) O-ring

Replace the O-ring if the sealing face is deformed, hardened, damaged, worn or defective in any way.

## F: ADJUSTMENT

### 1. THRUST BEARING PRELOAD

- 1) Select a suitable adjusting washer No. 1 so that dimension (H) will be zero in a visual check. Position the washer ( $18.3 \times 30 \times t$ ) and lock washer ( $18 \times 30 \times 2$ ) and attach the lock nut.

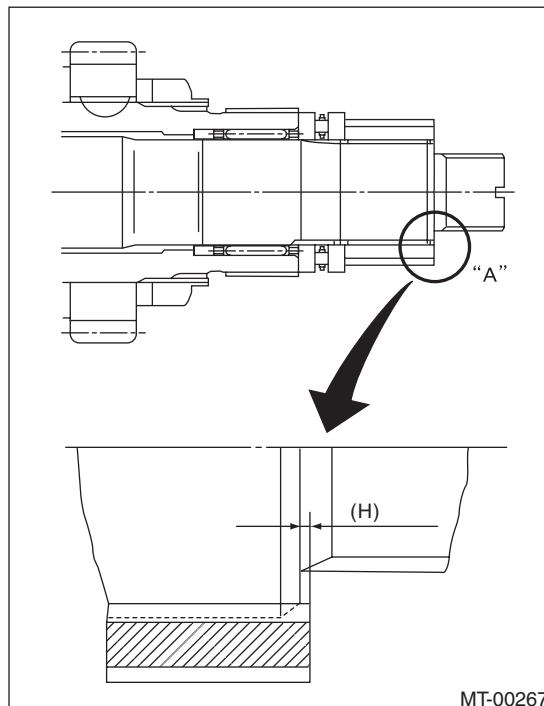

# Drive Pinion Shaft Assembly

## MANUAL TRANSMISSION AND DIFFERENTIAL

2) Using the ST1, ST2 and ST3, tighten the new lock nut to the specified torque.

### NOTE:

- Use new lock nuts and lock washers.
- Make sure the lock washer is installed in the proper direction.

### Tightening torque:

**120 N·m (12.2 kgf·m, 88.5 ft·lb)**

ST1 899884100 HOLDER  
 ST2 498427100 STOPPER  
 ST3 899988608 SOCKET WRENCH (27)

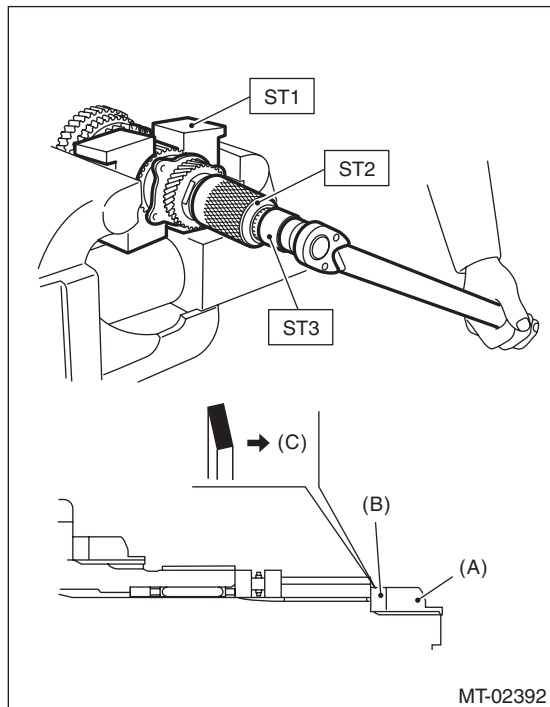

- (A) Lock nut  
 (B) Lock washer  
 (C) Nut side

3) After removing the ST2, measure the starting torque using torque driver.

ST1 899884100 HOLDER  
 ST3 899988608 SOCKET WRENCH (27)

### Starting torque:

**0.3 — 0.8 N·m (0.03 — 0.08 kgf·m, 0.22 — 0.59 ft·lb)**

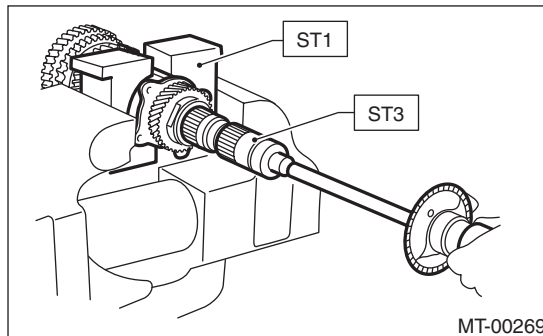

4) If the starting torque is not within the specified limit, select new adjusting washer No. 1 and re-check starting torque.

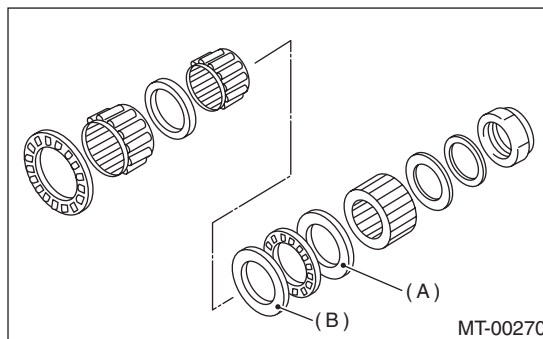

- (A) Adjusting washer No. 1  
 (B) Adjusting washer No. 2

Adjusting washer No. 1	
Part No.	Thickness mm (in)
803025051	3.925 (0.1545)
803025052	3.950 (0.1555)
803025053	3.975 (0.1565)
803025054	4.000 (0.1575)
803025055	4.025 (0.1585)
803025056	4.050 (0.1594)
803025057	4.075 (0.1604)

# Drive Pinion Shaft Assembly

5) If the specified starting torque cannot be obtained by the selection of adjusting washer No. 1, select adjusting washer No. 2 from the list below. Repeat steps 1) through 4) to adjust starting torque.

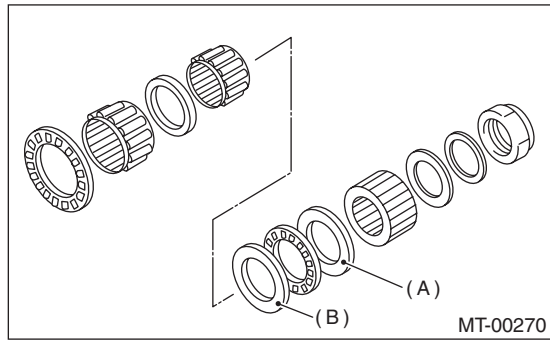

- (A) Adjusting washer No. 1
- (B) Adjusting washer No. 2

Starting torque	Dimension H	Adjusting washer No. 2
Low	Small	Select thicker one.
High	Large	Select thinner one.

Adjusting washer No. 2	
Part No.	Thickness mm (in)
803025059	3.850 (0.1516)
803025054	4.000 (0.1575)
803025058	4.150 (0.1634)

6) Recheck that the starting torque is within the specified range, then crimp the lock nut at four positions.

**CAUTION:**

**When crimping the lock nut, be careful not to crack it.**

# Front Differential Assembly

## MANUAL TRANSMISSION AND DIFFERENTIAL

### 17. Front Differential Assembly

#### A: REMOVAL

- 1) Remove the manual transmission assembly from the vehicle. <Ref. to 5MT-23, REMOVAL, Manual Transmission Assembly.>
- 2) Remove the transfer case together with the extension case assembly. <Ref. to 5MT-35, REMOVAL, Transfer Case and Extension Case Assembly.>
- 3) Remove the transmission case. <Ref. to 5MT-49, REMOVAL, Transmission Case.>
- 4) Remove the drive pinion shaft assembly. <Ref. to 5MT-58, REMOVAL, Drive Pinion Shaft Assembly.>
- 5) Remove the main shaft assembly for single-range. <Ref. to 5MT-53, REMOVAL, Main Shaft Assembly for Single-Range.>
- 6) Remove the front differential assembly.

#### NOTE:

- Do not confuse the right and left roller bearing outer races.
- Be careful not to damage the oil seal of retainer.

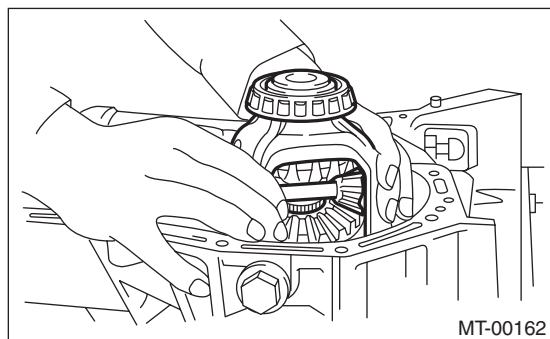

- 7) Remove the differential side retainers using ST. ST 18630AA010 WRENCH COMPL RETAINER

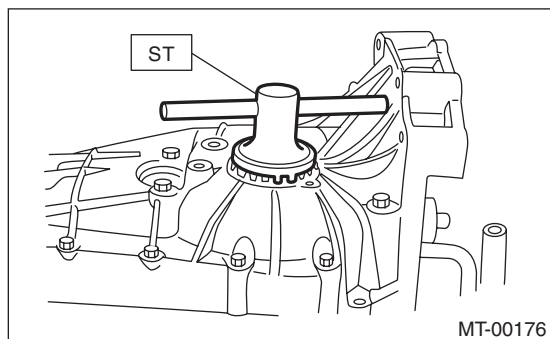

- 8) Remove the bearing outer race from the transmission case.  
ST 398527700 PULLER ASSY

#### B: INSTALLATION

- 1) Install the differential side retainers using ST. ST 18630AA010 WRENCH COMPL RETAINER
- 2) Install the bearing outer race to the transmission case.
- 3) Install the front differential assembly.

#### NOTE:

Be careful not to bend the seal lips of oil seal.

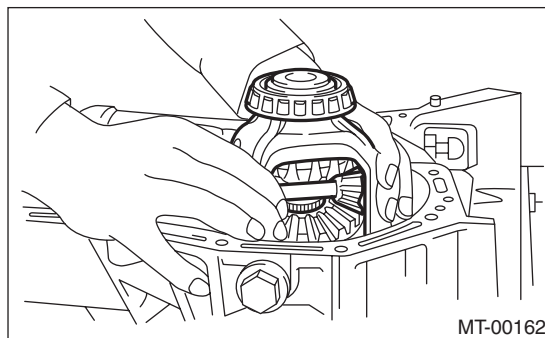

- 4) Install the main shaft assembly for single-range. <Ref. to 5MT-53, INSTALLATION, Main Shaft Assembly for Single-Range.>
- 5) Install the drive pinion shaft assembly. <Ref. to 5MT-58, INSTALLATION, Drive Pinion Shaft Assembly.>
- 6) Install the transmission case. <Ref. to 5MT-49, INSTALLATION, Transmission Case.>
- 7) Install the transfer case together with the extension case assembly. <Ref. to 5MT-35, INSTALLATION, Transfer Case and Extension Case Assembly.>
- 8) Install the manual transmission assembly to the vehicle. <Ref. to 5MT-25, INSTALLATION, Manual Transmission Assembly.>

# Front Differential Assembly

MANUAL TRANSMISSION AND DIFFERENTIAL

## C: DISASSEMBLY

### 1. DIFFERENTIAL CASE ASSEMBLY

1) Remove the twelve bolts and remove hypoid driven gear.

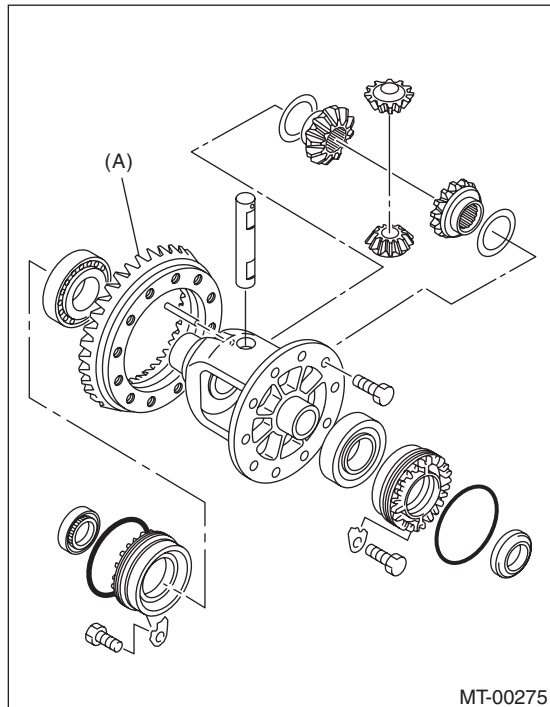

(A) Hypoid driven gear

2) Drive out the straight pin from differential assembly toward hypoid driven gear side.

ST 899904100 STRAIGHT PIN REMOVER

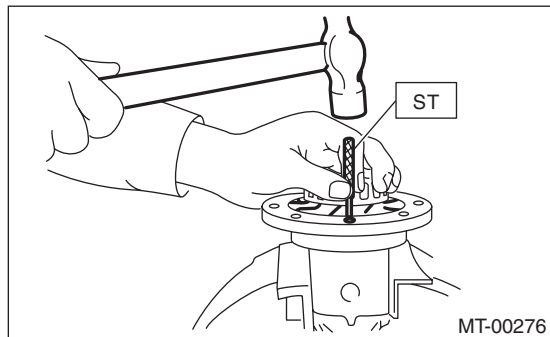

3) Pull out the pinion shaft, and remove the differential bevel pinion, differential bevel gear and washer.

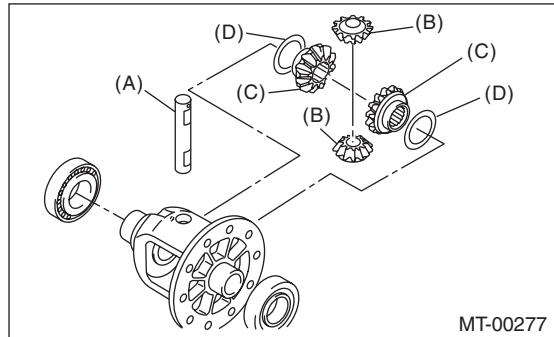

- (A) Pinion shaft
- (B) Differential bevel pinion
- (C) Differential bevel gear
- (D) Washer

4) Using the ST, remove the roller bearing.

ST 899524100 PULLER SET

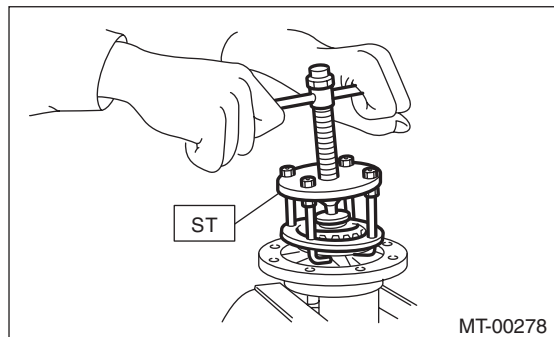

### 2. SIDE RETAINER

1) Remove the O-ring.

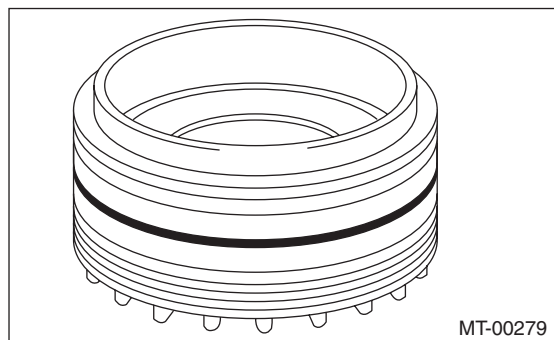



# Front Differential Assembly

## MANUAL TRANSMISSION AND DIFFERENTIAL

2) Remove the oil seal.

### NOTE:

- Remove using the flat tip screwdriver.
- Do not reuse the oil seal. Replace the oil seal with a new part.

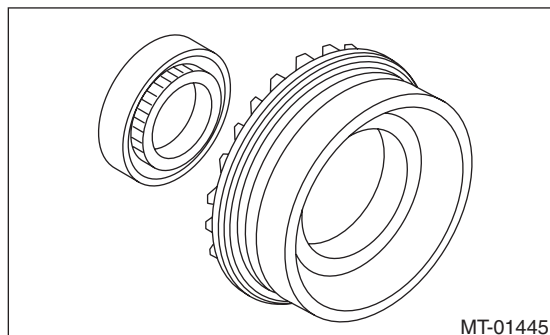

## D: ASSEMBLY

### 1. DIFFERENTIAL CASE ASSEMBLY

1) Install the differential bevel gear and differential bevel pinion together with washer, and insert the pinion shaft.

### NOTE:

Face the chamfered side of washer toward gear.

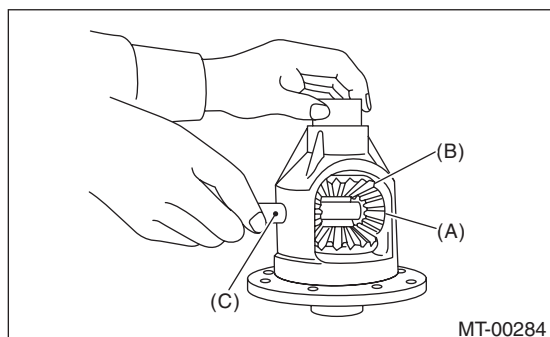

- (A) Differential bevel pinion
- (B) Differential bevel gear
- (C) Pinion shaft

2) Measure the backlash between differential bevel gear and differential pinion. If backlash is out of specifications, install a suitable washer to adjust. <Ref. to 5MT-72, BEVEL PINION GEAR BACKLASH, INSPECTION, Front Differential Assembly.>

### NOTE:

Be sure the pinion gear teeth contacts adjacent gear teeth during measurement.

ST1 498247001 MAGNET BASE

ST2 498247100 DIAL GAUGE

### Standard backlash

0.13 — 0.18 mm (0.0051 — 0.0071 in)

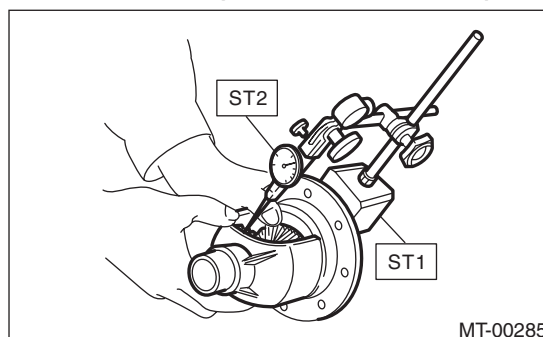

3) Align the pinion shaft and differential case with each hole, and drive the straight pin into the holes from the hypoid driven gear using the ST.

### NOTE:

Lock the straight pin after installing.

ST 899904100 STRAIGHT PIN REMOVER

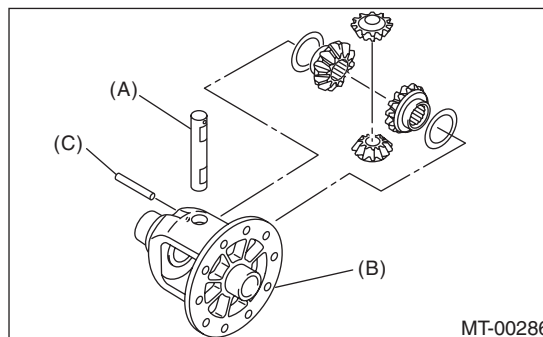

- (A) Pinion shaft
- (B) Differential case
- (C) Straight pin



# Front Differential Assembly

MANUAL TRANSMISSION AND DIFFERENTIAL

4) Install the roller bearing to differential case.

### CAUTION:

Do not apply a load in excess of 10 kN (1 ton, 1.1 US ton, 1.0 Imp ton).

### NOTE:

Be careful because the roller bearing outer races are used as a set.

ST1 499277100 BUSHING 1-2 INSTALLER

ST2 398497701 ADAPTER

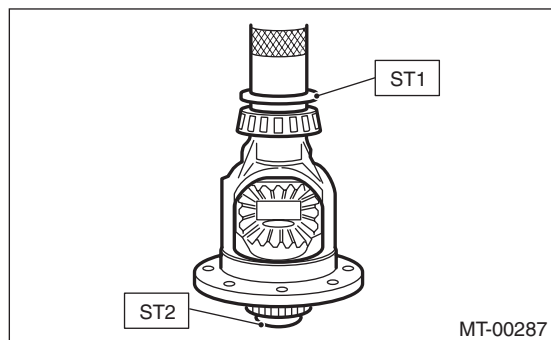

5) Install the hypoid driven gear to the differential case using twelve bolts.

### Tightening torque:

**T: 62 N·m (6.3 kgf·m, 45.7 ft·lb)**

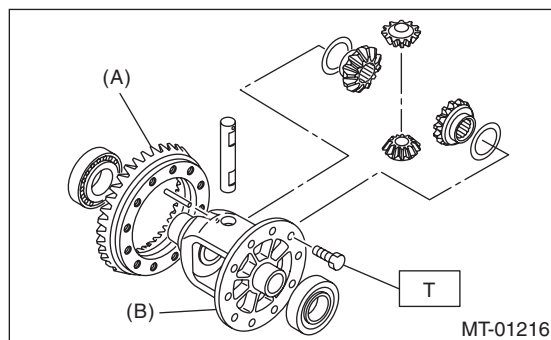

(A) Hypoid driven gear

(B) Differential case

## 2. SIDE RETAINER

1) Install the oil seal.

### NOTE:

- Use a new oil seal.
- Apply transmission gear oil to the oil seal lips, and install the oil seal while being careful not to deform the lip.
- Using the ST, install the oil seal by lightly tapping with a plastic hammer.

ST 18675AA000 DIFFERENTIAL SIDE OIL SEAL INSTALLER

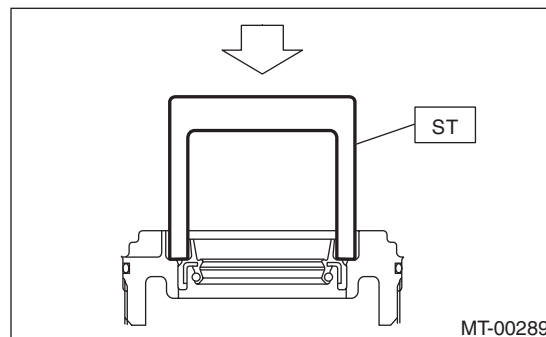

2) Install the O-ring.

### NOTE:

- Use new O-rings.
- Apply gear oil to O-ring.
- Do not stretch or damage the O-ring.

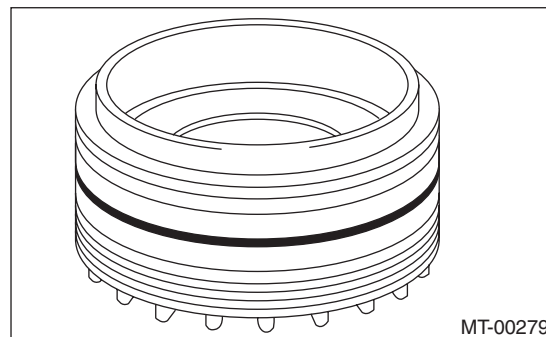

# Front Differential Assembly

## MANUAL TRANSMISSION AND DIFFERENTIAL

### E: INSPECTION

Repair or replace the differential gear in the following cases:

- When the hypoid drive gear and drive pinion shaft tooth surfaces are damaged, excessively worn, or seized.
- When the roller bearing on the drive pinion shaft has a worn or damaged roller path.
- When there is damage, wear or seizure of the differential bevel pinion, differential bevel gear, washer, pinion shaft or straight pin.
- When the differential case sliding surfaces are worn or damaged.

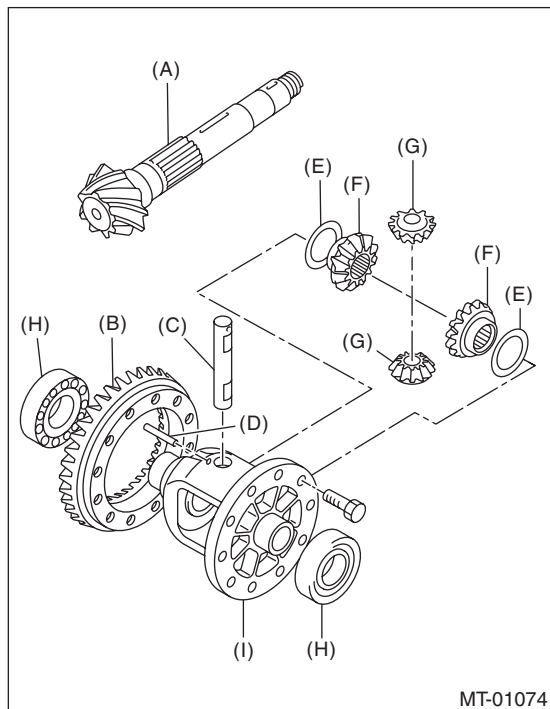

- (A) Drive pinion shaft
- (B) Hypoid driven gear
- (C) Pinion shaft
- (D) Straight pin
- (E) Washer
- (F) Differential bevel gear
- (G) Differential bevel pinion
- (H) Roller bearing
- (I) Differential case

### 1. BEVEL PINION GEAR BACKLASH

Measure the backlash between the differential bevel gear and differential bevel pinion. If backlash is out of specifications, install a suitable washer to adjust. <Ref. to 5MT-73, ADJUSTMENT, Front Differential Assembly.>

### NOTE:

Be sure the pinion gear teeth contacts adjacent gear teeth during measurement.

ST1 498247001 MAGNET BASE

ST2 498247100 DIAL GAUGE

### Standard backlash

**0.13 — 0.18 mm (0.0051 — 0.0071 in)**

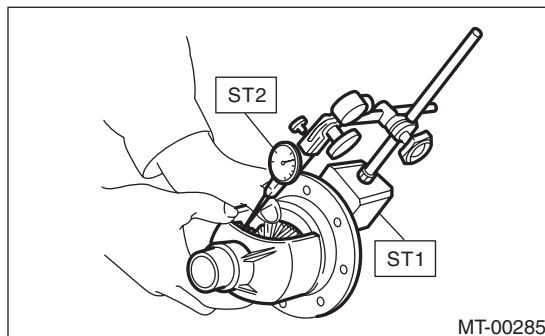

### 2. HYPOID GEAR BACKLASH

1) Set the ST1, ST2 and ST3. Insert the needle through transmission oil drain plug hole so that the needle comes in contact with the tooth surface on the right corner, and check the backlash.

ST1 498247001 MAGNET BASE

ST2 498247100 DIAL GAUGE

ST3 498255400 PLATE

2) Install SUBARU genuine axle shafts to both sides, rotate in the inversion direction so that the gauge contacts the tooth surface, and read the dial gauge

Part No. 38415AA100 Axle shaft

### Backlash

**0.13 — 0.18 mm (0.0051 — 0.0071 in)**

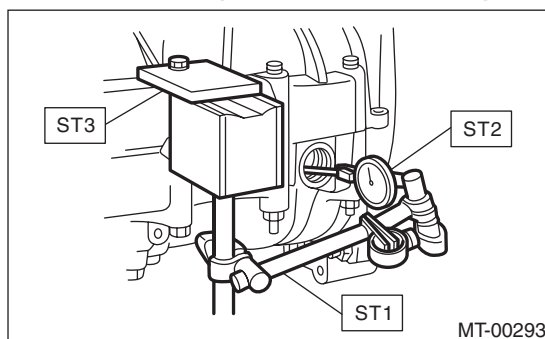

### NOTE:

If the backlash is outside the specified range, adjust it by turning the side retainer in the right side case.

# Front Differential Assembly

MANUAL TRANSMISSION AND DIFFERENTIAL

## 3. TOOTH CONTACT OF HYPOID GEAR

Check tooth contact of hypoid gear as follows: Apply a thin uniform coat of red lead on both teeth surfaces on 3 or 4 teeth of the hypoid gear. Move the hypoid gear back and forth by turning the transmission main shaft until a definite contact pattern is developed on the hypoid gear, and judge whether face contact is correct. When the contact pattern is not correct, adjust. <Ref. to 5MT-73, ADJUSTMENT, Front Differential Assembly.>

- Tooth contact is correct.

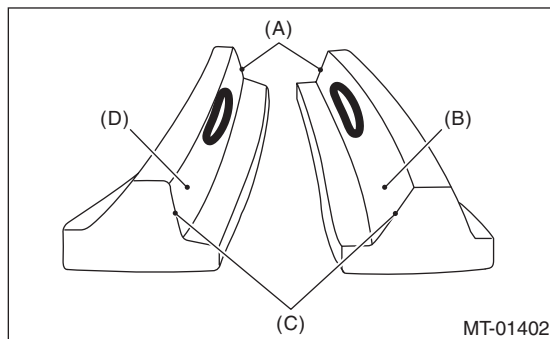

- (A) Toe
- (B) Coast side
- (C) Heel
- (D) Drive side

## F: ADJUSTMENT

### 1. BEVEL PINION GEAR BACKLASH

1) Disassemble the front differential assembly. <Ref. to 5MT-69, DISASSEMBLY, Front Differential Assembly.>

2) Select a suitable washer for the differential bevel gear from the table and install.

Washer	
Part No.	Thickness mm (in)
803038021	0.925 — 0.950 (0.0364 — 0.0374)
803038022	0.975 — 1.000 (0.0384 — 0.0394)
803038023	1.025 — 1.050 (0.0404 — 0.0413)

3) Adjust until the standard value is obtained.

**Backlash:**

**Standard**

**0.13 — 0.18 mm (0.0051 — 0.0071 in)**

## 2. HYPOID GEAR BACKLASH

Adjust the backlash by turning the side retainer in the RH side case.

ST 18630AA010 WRENCH COMPL RETAINER

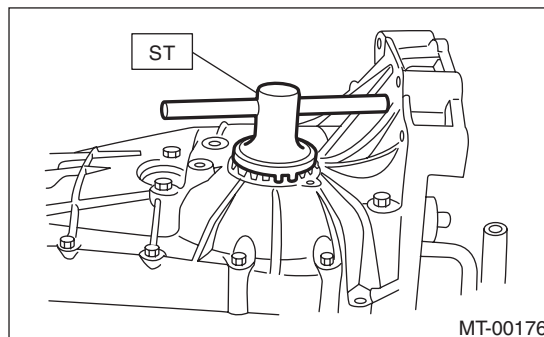

**NOTE:**

Each time the side retainer rotates by one notch (A), the backlash changes by 0.05 mm (0.020 in).

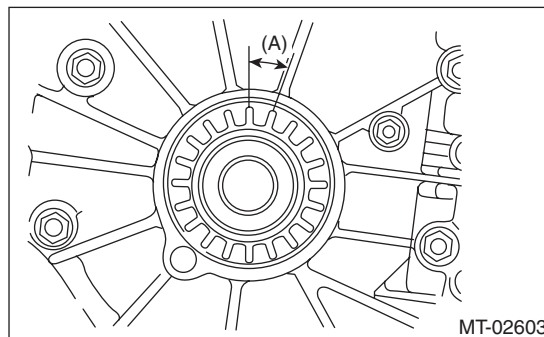

## 3. TOOTH CONTACT OF HYPOID GEAR

- 1) Adjust until correct teeth contact is obtained.
- 2) Check tooth contact, and perform the adjustment as follows.

- Correct tooth contact

**Check item: Tooth contact surface is slightly shifted toward the toe side under a no-load condition. (When driving, it moves towards the heel side.)**

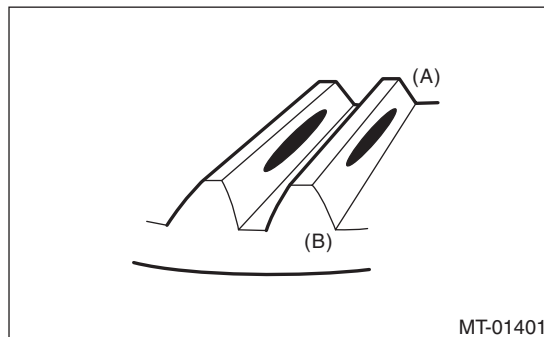

- (A) Toe side
- (B) Heel side

# Front Differential Assembly

## MANUAL TRANSMISSION AND DIFFERENTIAL

- Face contact

**Check item: Backlash is too large.**

Contact pattern

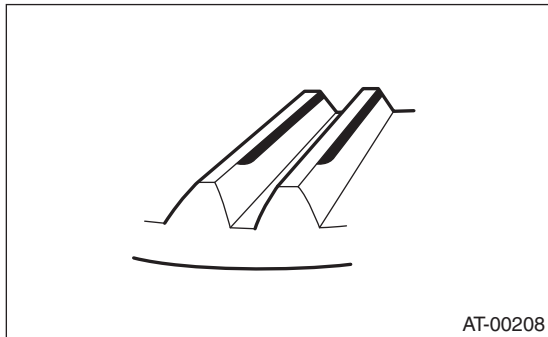

Corrective action: Tighten the side retainer to move the driven gear closer to the drive pinion shaft.

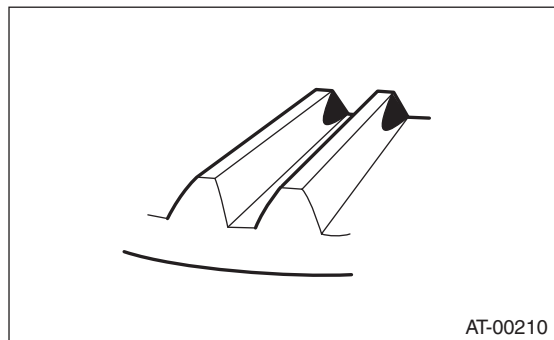
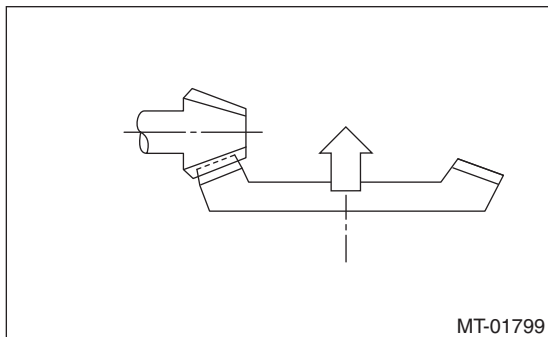

Corrective action: Increase the thickness of drive pinion shim and tighten the side retainer to move the driven gear closer to the drive pinion shaft according to the procedure for bringing drive pinion shaft away from driven gear.

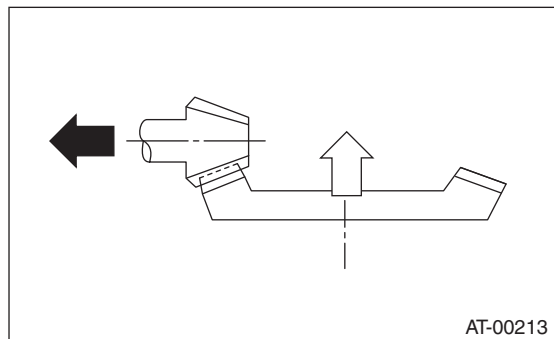

- Flank contact

**Check item: Backlash is too small.**

Contact pattern

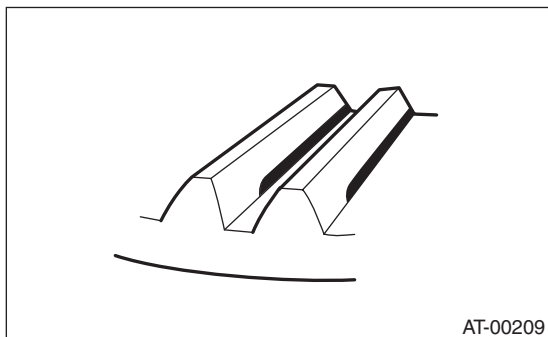

Corrective action: Loosen the side retainer to move the driven gear away from the drive pinion shaft.

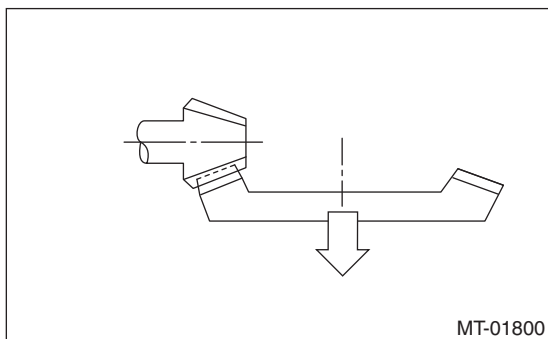

- Heel contact (outside end contact)

**Check item: Teeth contact area is too small.**

Contact pattern

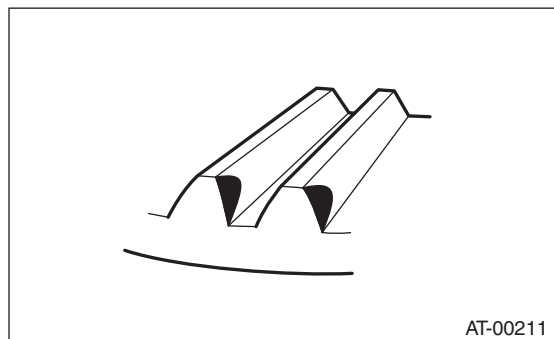

Corrective action: Reduce the thickness of drive pinion shim and loosen the side retainer to move the driven gear away from the drive pinion according to the procedure for moving drive pinion shaft closer to the driven gear.

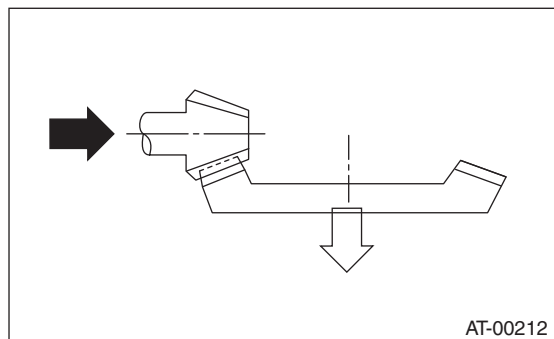

- Toe contact (inside contact)

**Check item: Teeth contact area is too small.**

Contact pattern

# Reverse Idler Gear

MANUAL TRANSMISSION AND DIFFERENTIAL

## 18. Reverse Idler Gear

### A: REMOVAL

- 1) Remove the manual transmission assembly from the vehicle. <Ref. to 5MT-23, REMOVAL, Manual Transmission Assembly.>
- 2) Remove the back-up light switch and the neutral position switch. <Ref. to 5MT-33, REMOVAL, Switches and Harness.>
- 3) Remove the transfer case together with the extension case assembly. <Ref. to 5MT-35, REMOVAL, Transfer Case and Extension Case Assembly.>
- 4) Remove the transmission case. <Ref. to 5MT-49, REMOVAL, Transmission Case.>
- 5) Remove the drive pinion shaft assembly. <Ref. to 5MT-58, REMOVAL, Drive Pinion Shaft Assembly.>
- 6) Remove the main shaft assembly for single-range. <Ref. to 5MT-53, REMOVAL, Main Shaft Assembly for Single-Range.>
- 7) Remove the front differential assembly. <Ref. to 5MT-68, REMOVAL, Front Differential Assembly.>
- 8) Remove the shifter forks and rods. <Ref. to 5MT-77, REMOVAL, Shifter Fork and Rod.>
- 9) Pull out the straight pin, and remove the reverse idler gear shaft, washer, reverse idler gear and washer.

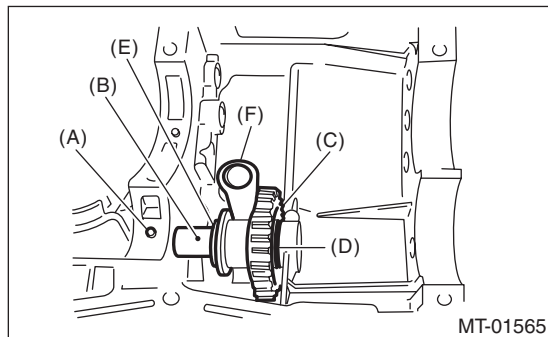

- (A) Straight pin
- (B) Reverse idler gear shaft
- (C) Reverse idler gear
- (D) Washer
- (E) Washer
- (F) Reverse shifter lever

- 10) Remove the reverse shifter lever.

### B: INSTALLATION

- 1) Install the reverse shifter lever, washer, reverse idler gear, washer and reverse idler gear shaft, and secure them with the straight pin.

#### NOTE:

- Be sure to install the reverse idler gear shaft from rear side.
- Use a new straight pin.

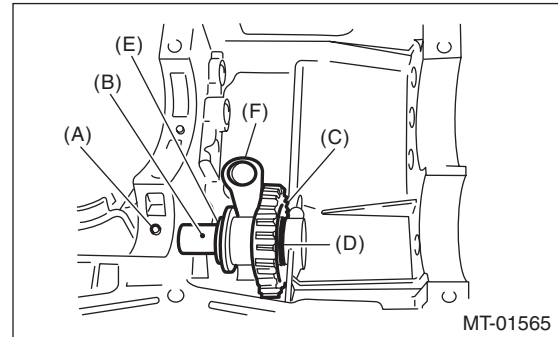

- (A) Straight pin
- (B) Reverse idler gear shaft
- (C) Reverse idler gear
- (D) Washer
- (E) Washer
- (F) Reverse shifter lever

- 2) Check and adjust clearance between the reverse idler gear and the timing case wall surface. <Ref. to 5MT-75, INSTALLATION, Reverse Idler Gear.> <Ref. to 5MT-76, ADJUSTMENT, Reverse Idler Gear.>
- 3) Install the shifter forks and rods. <Ref. to 5MT-77, INSTALLATION, Shifter Fork and Rod.>
- 4) Install the front differential assembly. <Ref. to 5MT-68, INSTALLATION, Front Differential Assembly.>
- 5) Install the main shaft assembly for single-range. <Ref. to 5MT-53, INSTALLATION, Main Shaft Assembly for Single-Range.>
- 6) Install the drive pinion shaft assembly. <Ref. to 5MT-58, INSTALLATION, Drive Pinion Shaft Assembly.>
- 7) Install the transmission case. <Ref. to 5MT-49, INSTALLATION, Transmission Case.>
- 8) Install the transfer case together with the extension case assembly. <Ref. to 5MT-35, INSTALLATION, Transfer Case and Extension Case Assembly.>
- 9) Install the back-up light switch and the neutral position switch. <Ref. to 5MT-33, INSTALLATION, Switches and Harness.>
- 10) Install the manual transmission assembly to the vehicle. <Ref. to 5MT-25, INSTALLATION, Manual Transmission Assembly.>

# Reverse Idler Gear

## MANUAL TRANSMISSION AND DIFFERENTIAL

### C: INSPECTION

1) Move the reverse shifter rod toward the reverse side. Check the clearance between the reverse idler gear and the transmission case wall surface. If out of specification, select the appropriate reverse shifter lever and adjust.

**Clearance A:**

**6.0 — 7.5 mm (0.236 — 0.295 in)**

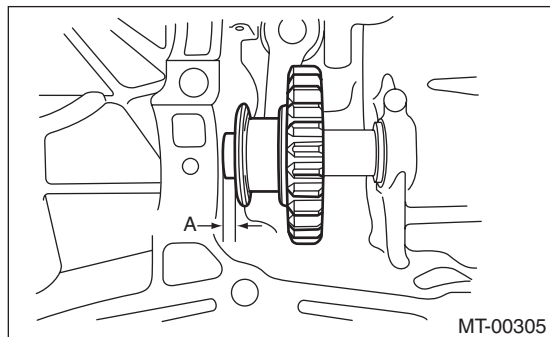

2) After installing a suitable reverse shifter lever, shift into neutral. Check the clearance between the reverse idler gear and the transmission case wall surfaces.

If out of specification, select the appropriate washer and adjust.

**Clearance:**

**0 — 0.5 mm (0 — 0.020 in)**

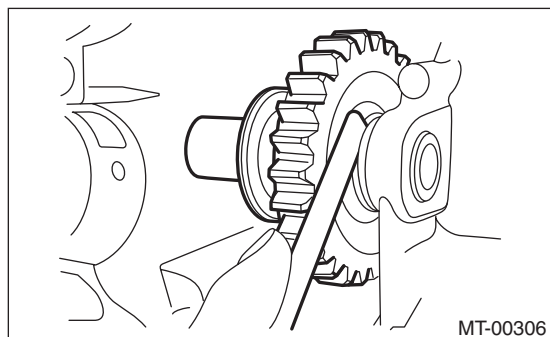

3) Check the reverse idler gear and shaft for damage. Replace if it is damaged.

### D: ADJUSTMENT

1) Select the appropriate reverse shifter lever from the table below, and adjust until the clearance between the reverse idler gear and transmission case wall is within specification.

**Clearance A:**

**6.0 — 7.5 mm (0.236 — 0.295 in)**

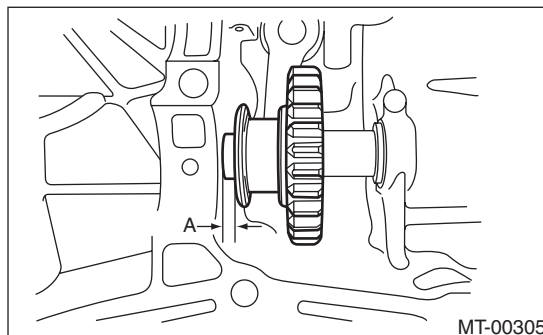

Reverse shifter lever		
Part No.	Mark	Remarks
32820AA070	7	Far from case wall
32820AA080	8	Standard
32820AA090	9	Closer to case wall

2) Select the appropriate washer from the table below, and adjust until the clearance between the reverse idler gear and transmission case wall is within specification.

**Clearance:**

**0 — 0.5 mm (0 — 0.020 in)**

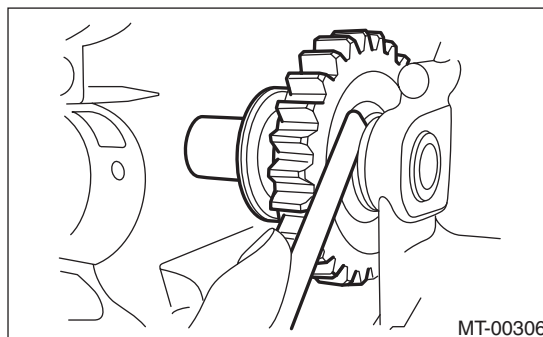

Washer	
Part No.	Thickness mm (in)
803020151	0.4 (0.016)
803020152	1.1 (0.043)
803020153	1.5 (0.059)
803020154	1.9 (0.075)
803020155	2.3 (0.091)



# Shifter Fork and Rod

MANUAL TRANSMISSION AND DIFFERENTIAL

## 19. Shifter Fork and Rod

### A: REMOVAL

1) Remove the manual transmission assembly from the vehicle. <Ref. to 5MT-23, REMOVAL, Manual Transmission Assembly.>

2) Remove the back-up light switch and the neutral position switch. <Ref. to 5MT-33, REMOVAL, Switches and Harness.>

3) Remove the transfer case together with the extension case assembly. <Ref. to 5MT-35, REMOVAL, Transfer Case and Extension Case Assembly.>

4) Remove the transmission case. <Ref. to 5MT-49, REMOVAL, Transmission Case.>

5) Remove the drive pinion shaft assembly. <Ref. to 5MT-58, REMOVAL, Drive Pinion Shaft Assembly.>

6) Remove the main shaft assembly for single-range. <Ref. to 5MT-53, REMOVAL, Main Shaft Assembly for Single-Range.>

7) Remove the front differential assembly. <Ref. to 5MT-68, REMOVAL, Front Differential Assembly.>

8) Drive out the straight pin by tapping with the ST, and remove the 5th shifter fork.

ST 398791700 STRAIGHT PIN REMOVER 2

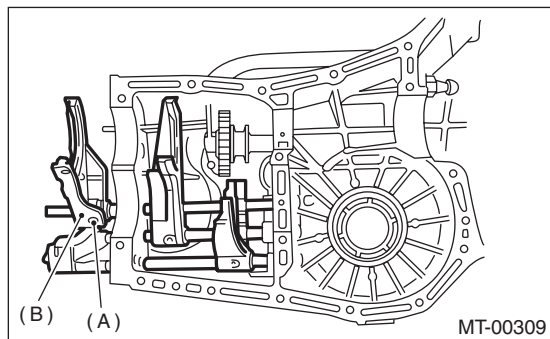

- (A) Straight pin
- (B) 5th shifter fork

9) Remove the plugs, springs and check balls.

10) Drive out the straight pin by tapping with the ST, and remove the 3rd – 4th fork rod and shifter fork.

#### NOTE:

- When removing the rod, keep other rods in neutral.

- When removing the straight pin, remove it toward the inside of case so that it does not hit against the case.

ST 398791700 STRAIGHT PIN REMOVER 2

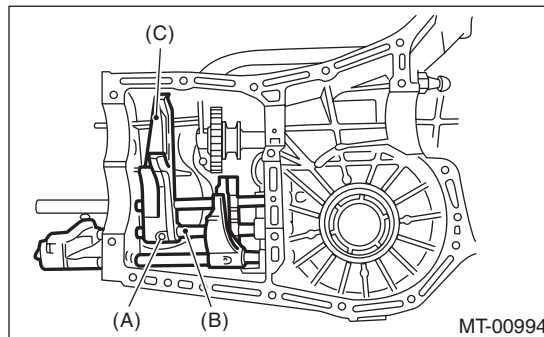

- (A) Straight pin
- (B) 3rd-4th fork rod
- (C) Shifter fork

11) Drive out the straight pin by tapping with the ST, and remove the 1st – 2nd fork rod and shifter fork.

ST 398791700 STRAIGHT PIN REMOVER 2

12) Remove the snap ring (outer), and pull out the reverse fork rod from the reverse fork rod arm. Then take out the ball, spring and interlock plunger from the reverse fork rod arm.

And then remove the rod.

#### NOTE:

When pulling out the reverse fork rod arm, be careful not to let the ball pop out of arm.

13) Remove the reverse shifter lever.

### B: INSTALLATION

1) Install the spring and ball to the reverse fork rod arm, and press in the ST.

ST 399411700 ACCENT BALL INSTALLER

2) Install the reverse fork rod through the hole on the rear of the transmission case. Press out the ST using the reverse fork rod, and fix with outer snap ring.

3) Install the interlock plunger to reverse fork rod arm.

#### NOTE:

Apply grease to the plunger to prevent it from falling.

4) Position the ball, spring and gasket in the reverse fork rod hole on the left side of transmission case, and tighten the checking ball plug.

#### NOTE:

Use a new gasket.

#### Tightening torque:

20 N·m (2.0 kgf·m, 14.8 ft·lb)

# Shifter Fork and Rod

## MANUAL TRANSMISSION AND DIFFERENTIAL

5) Install the 1st-2nd fork rod to the 1st-2nd shifter fork through the hole on the rear of the transmission case.

**NOTE:**

- Set other rods to neutral.
- Check that the positions of interlock plunger is correct.

6) Align the holes in the rod and the fork, and drive in the straight pin using the ST.

**NOTE:**

Use a new straight pin.

ST 398791700 STRAIGHT PIN REMOVER 2

7) Install the interlock plunger (thin) onto the 3rd-4th fork rod.

**NOTE:**

Apply grease to the plunger to prevent it from falling.

8) Install the 3rd-4th fork rod to the 3rd-4th shifter fork and reverse fork rod arm through the hole on the rear of the transmission case.

9) Align the holes in the rod and the fork, and drive the straight pin into these holes.

**NOTE:**

- Use a new straight pin.
- Set other fork rods to neutral.
- Check that the positions of interlock plunger is correct.

ST 398791700 STRAIGHT PIN REMOVER 2

10) Install the 5th shifter fork onto the rear of reverse fork rod. Align the holes in the two parts and drive straight pin into the specified place.

**NOTE:**

Use a new straight pin.

ST 398791700 STRAIGHT PIN REMOVER 2

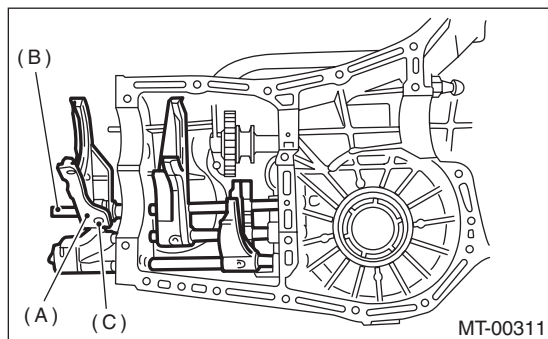

- (A) 5th shifter fork
- (B) Reverse fork rod
- (C) Straight pin

11) Position the balls, checking ball springs and gaskets to the 3rd-4th fork rod and 1st-2nd fork rod holes, and install plugs.

**NOTE:**

Use a new gasket.

**Tightening torque:**

**20 N·m (2.0 kgf·m, 14.8 ft·lb)**

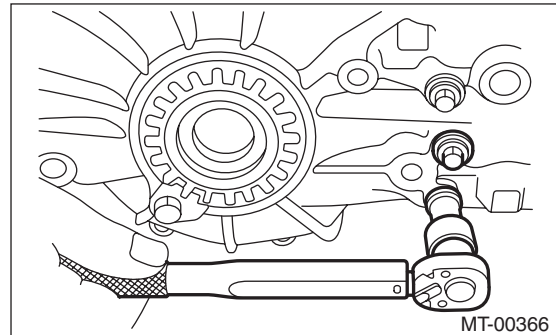

12) Install the front differential assembly. <Ref. to 5MT-68, INSTALLATION, Front Differential Assembly.>

13) Install the main shaft assembly for single-range. <Ref. to 5MT-53, INSTALLATION, Main Shaft Assembly for Single-Range.>

14) Install the drive pinion shaft assembly. <Ref. to 5MT-58, INSTALLATION, Drive Pinion Shaft Assembly.>

15) Install the transmission case. <Ref. to 5MT-49, INSTALLATION, Transmission Case.>

16) Install the transfer case together with the extension case assembly. <Ref. to 5MT-35, INSTALLATION, Transfer Case and Extension Case Assembly.>

17) Install the back-up light switch and the neutral position switch. <Ref. to 5MT-33, INSTALLATION, Switches and Harness.>

18) Install the manual transmission assembly to the vehicle. <Ref. to 5MT-25, INSTALLATION, Manual Transmission Assembly.>

## C: INSPECTION

1) Check the fork and rod for damage. Replace if it is damaged.

2) Gearshift mechanism

Repair or replace the gearshift mechanism if excessively worn, bent or defective in any way.

3) Inspect the clearance between 1st, 2nd driven gear and reverse driven gear. If any clearance is not within specifications, replace the shifter fork as required.



# Shifter Fork and Rod

**Clearance (a) and (b):**  
**9.5 mm (0.374 in)**

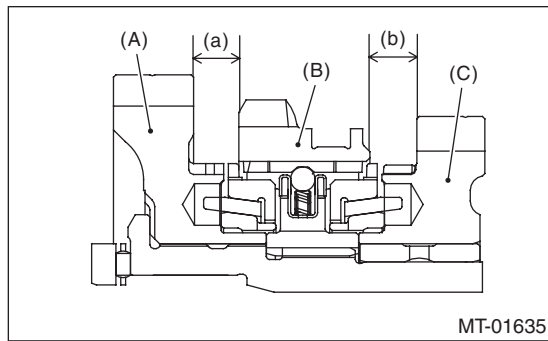

- (A) 1st driven gear
- (B) Reverse driven gear
- (C) 2nd driven gear

1st-2nd shifter fork		
Part No.	Mark	Remarks
32804AA060	1	Approaches 1st gear by 0.2 mm (0.008 in)
32804AA070	No mark	Standard
32804AA080	3	Approaches 2nd gear by 0.2 mm (0.008 in)

4) Inspect the clearance between the 3rd, 4th drive gear and the coupling sleeve. If any clearance is not within specifications, replace the shifter fork as required.

**Clearance (a) and (b):**  
**9.3 mm (0.366 in)**

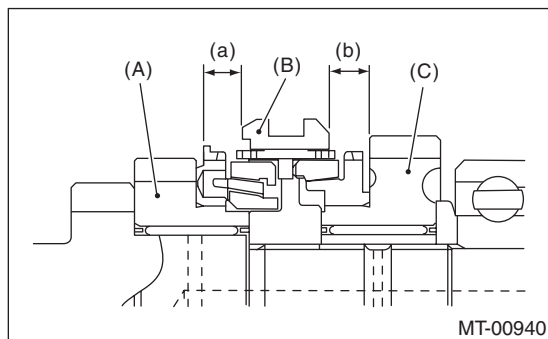

- (A) 3rd drive gear
- (B) Coupling sleeve
- (C) 4th drive gear

3rd-4th shifter fork		
Part No.	Mark	Remarks
32810AA061	1	Approaches 4th gear by 0.2 mm (0.008 in)
32810AA071	No mark	Standard
32810AA101	3	Approaches 3rd gear by 0.2 mm (0.008 in)

5) Inspect the clearance between 5th drive gear and coupling sleeve. If any clearance is not within specifications, replace the shifter fork as required.

**Clearance (a):**  
**9.3 mm (0.366 in)**

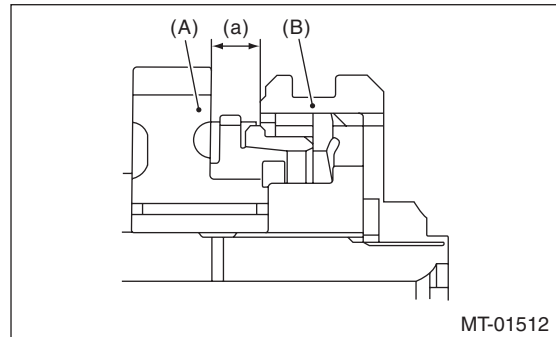

- (A) 5th drive gear
- (B) Coupling sleeve

5th shifter fork		
Part No.	Mark	Remarks
32812AA201	7	Approaches 5th gear by 0.2 mm (0.008 in)
32812AA211	No mark	Standard
32812AA221	9	Moves away from 5th gear by 0.2 mm (0.008 in)

6) Inspect the rod end clearances (A) and (B). If any clearance is not within specifications, replace the rod or fork as required.

**Clearance (A):**  
**3rd-4th — 5th**  
**0.5 — 1.3 mm (0.020 — 0.051 in)**

**Clearance (B):**  
**1st-2nd — 3rd-4th**  
**0.4 — 1.4 mm (0.016 — 0.055 in)**

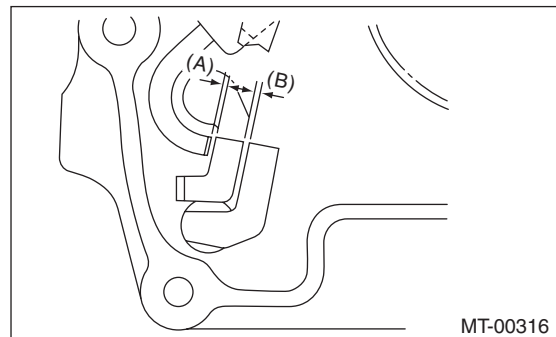

# General Diagnostic Table

MANUAL TRANSMISSION AND DIFFERENTIAL

## 20. General Diagnostic Table

### A: INSPECTION

#### 1. MANUAL TRANSMISSION

Symptoms	Possible cause	Corrective action
1. Gears are difficult to intermesh. <b>NOTE:</b> The cause for difficulty in shifting gears can be classified into two types: One is a defective gear shift system and the other is defective transmission. However, if the operation is heavy and engagement of the gears is difficult, a defective clutch disengagement may also be responsible. Check whether the clutch is correctly functioning, before checking the gear shift system and transmission.	(a) Worn, damaged or burred chamfer at internal spline of the sleeve and reverse driven gear	Replace.
	(b) Worn, damaged or burred chamfer of gear spline	Replace.
	(c) Worn or scratched bushings	Replace.
	(d) Incorrect contact or wear between synchronizer ring and gear cone	Repair or replace.
2. Gear slip-out <ul style="list-style-type: none"> <li>• Gear slips out when coasting on rough road</li> <li>• Gear slips out during acceleration</li> </ul>	(a) Defective pitching stopper adjustment	Replace.
	(b) Loose engine mounting bolts	Tighten or replace.
	(c) Worn shifter fork or broken check ball spring	Replace.
	(d) Worn or damaged ball bearing	Replace.
	(e) Excessive clearance between splines of synchronizer hub and synchronizer sleeve	Replace.
	(f) Worn tooth step of synchronizer hub (caused by slip-out of 3rd gear)	Replace.
	(g) Worn 1st driven gear and driven shaft	Replace.
	(h) Worn 2nd driven gear and bushing	Replace.
	(i) Worn 3rd drive gear and needle bearing	Replace.
	(j) Worn 4th drive gear and needle bearing	Replace.
	(k) Worn reverse idler gear and bushing	Replace.
3. Noise emitted from transmission <b>NOTE:</b> If a noise is heard when the vehicle is parked with its engine idling and if a noise ceases when the clutch is disengaged, it may be considered that the noise is coming from the transmission.	(a) Insufficient or improper lubrication	Lubricate with specified oil or replace.
	(b) Worn or damaged gears and bearings <b>NOTE:</b> If the trouble is only wear of the gear teeth surfaces, only a high whirring noise will occur at high speeds, but if any part is broken, rhythmical clicking sounds will be heard even at low speeds.	Replace.

# General Diagnostic Table

MANUAL TRANSMISSION AND DIFFERENTIAL

## 2. DIFFERENTIAL

Symptoms	Possible cause	Corrective action
<p>1. Broken differential (case, gear, bearing, etc.)</p> <p>NOTE: Noise will occur, and eventually the differential will not be able to operate due to broken pieces obstructing the gear revolution.</p>	(a) Insufficient or improper oil	Disassemble the differential and replace broken components. At the same time check other components for any trouble, and replace if necessary.
	(b) Use of vehicle under severe conditions such as excessive load or improper use of the clutch	Readjust the preload and backlash of the bearing, and the contact surface of gear.
	(c) Improper adjustment of taper roller bearing	Adjust.
	(d) Improper adjustment of the drive pinion and the hypoid driven gear	Adjust.
	(e) Excessive backlash of a vehicle under severe operating conditions due to worn differential side gear, washer or differential pinion.	Add recommended oil to the specified level. Do not use vehicle under severe operating conditions.
	(f) Loose hypoid driven gear clamping bolts	Tighten.
<p>2. Differential and hypoid gear noises</p> <p>Troubles of the differential and hypoid gear always appear as noise problems. Therefore noise is the first indication of trouble. However, noises from the engine, muffler, tire, exhaust gas, bearing, body, etc. are easily mistaken for the differential noise. Pay special attention to the hypoid gear noise because it is easily confused with other gear noises. There are the following four kinds of noises.</p> <ul style="list-style-type: none"> <li>• Gear noise when driving: If noise increases as the vehicle speed increases, it may be due to insufficient gear oil, incorrect gear engagement, damaged gears, etc.</li> <li>• Gear noise when coasting: Damaged gears due to misadjusted bearings and incorrect shim adjustment.</li> <li>• Bearing noise when driving or coasting: Cracked, broken or damaged bearings</li> <li>• Noise mainly when turning: Noise from differential side gear, differential pinion or differential pinion shaft, etc.</li> </ul>	(a) Insufficient oil	Add recommended oil to the specified level.
	(b) Improper adjustment of hypoid driven gear and drive pinion	Check the tooth contact.
	(c) Worn teeth of hypoid driven gear and drive pinion	Replace as a set. Readjust the bearing preload.
	(d) Loose roller bearing	Readjust the backlash of the hypoid driven gear to drive pinion, and check the tooth contact.
	(e) Distorted hypoid driven gear or differential case	Replace.
	(f) Worn washer and differential pinion shaft	Replace.

# General Diagnostic Table

MANUAL TRANSMISSION AND DIFFERENTIAL

---

# MANUAL TRANSMISSION AND DIFFERENTIAL

# 6MT

---

	<b>Page</b>
1. General Description .....	2
2. Transmission Gear Oil .....	27
3. Oil Seal .....	28
4. Differential Side Retainer Oil Seal .....	29
5. Transmission Mounting System .....	30
6. Manual Transmission Assembly .....	32
7. Preparation for Overhaul .....	38
8. Air Breather Hose .....	39
9. Back-up Light Switch .....	40
10. Neutral Position Switch .....	42
11. Extension Case .....	44
12. Reverse Check System .....	50
13. Transfer Drive Gear .....	53
14. Transfer Driven Gear .....	55
15. Center Differential .....	57
16. Transmission Case .....	58
17. Main Shaft Assembly .....	65
18. Driven Gear Assembly .....	79
19. Reverse Idler Gear Assembly .....	87
20. Drive Pinion Shaft Assembly .....	92
21. Front Differential Assembly .....	98
22. Shifter Fork and Rod .....	104
23. Clutch Housing .....	117
24. Driver's Control Center Differential Control Module .....	119
25. General Diagnostic Table .....	120

# General Description

## MANUAL TRANSMISSION AND DIFFERENTIAL

### 1. General Description

#### A: SPECIFICATION

##### 1. MANUAL TRANSMISSION AND FRONT DIFFERENTIAL

Type	6-forward speeds and 1-reverse		
Transmission gear ratio	1st	3.636	
	2nd	2.235	
	3rd	1.521	
	4th	1.137	
	5th	0.971	
	6th	0.756	
	Reverse	3.545	
Front reduction gear	Final	Type of gear	Hypoid
		Gear ratio	3.900
Rear reduction gear	Transfer	Type of gear	Helical
		Gear ratio	1.103
	Final	Type of gear	Hypoid
		Gear ratio	3.545
Front differential	Type and number of gear		Planetary gear (pinion gear: 8, gear: 2)
	LSD type		Helical
Center differential	Type and number of gear		Planetary gear (Internal gear: 1, pinion gear: 6, sun gear: 1, and solenoid compression variable control multiplate clutch)
Transmission gear oil			GL-5
Transmission gear oil capacity			4.1 ℓ (4.3 US qt, 3.6 Imp qt)

##### 2. TRANSMISSION GEAR OIL

**Recommended oil:**

***GL-5 (75W-90) or equivalent***

# General Description

MANUAL TRANSMISSION AND DIFFERENTIAL

## B: COMPONENT

### 1. CLUTCH HOUSING

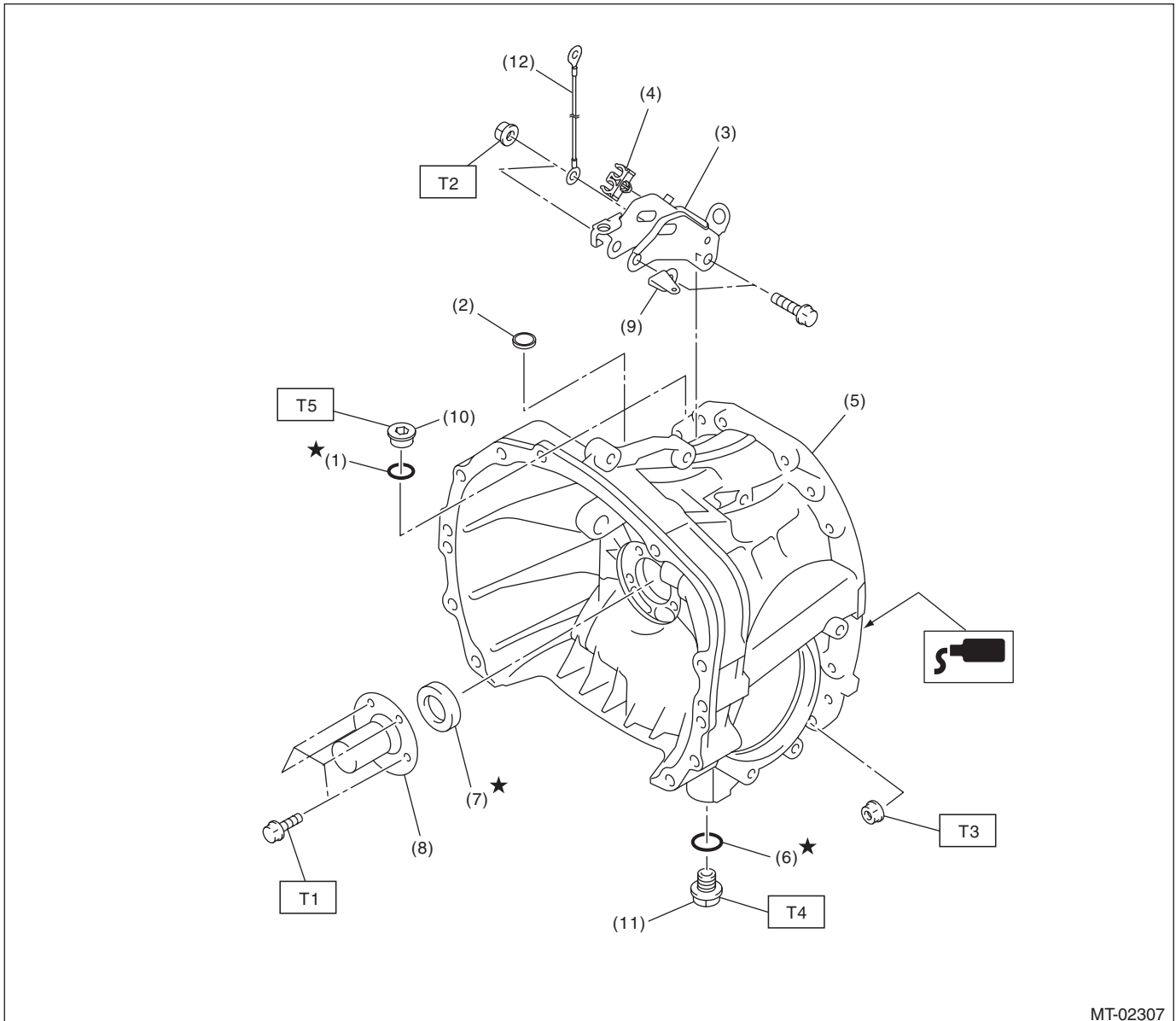

MT-02307

- |                              |                                      |
|------------------------------|--------------------------------------|
| (1) Gasket                   | (7) Oil seal                         |
| (2) Plug                     | (8) Clutch release bearing guide     |
| (3) Pitching stopper bracket | (9) Return spring bracket            |
| (4) Clip                     | (10) Plug                            |
| (5) Clutch housing           | (11) Drain plug                      |
| (6) Gasket                   | (12) Transmission radio ground cable |

**Tightening torque: N·m (kgf·m, ft·lb)**

**T1: 6.4 (0.7, 4.7)**

**T2: 41 (4.2, 30.2)**

**T3: 50 (5.1, 36.9)**

**T4: 70 (7.1, 51.6)**

**T5: 46 (4.7, 33.9)**

**6MT-3**

Brought to you by Ebay Seller "SubaruManuals"

# General Description

## MANUAL TRANSMISSION AND DIFFERENTIAL

### 2. ADAPTER PLATE

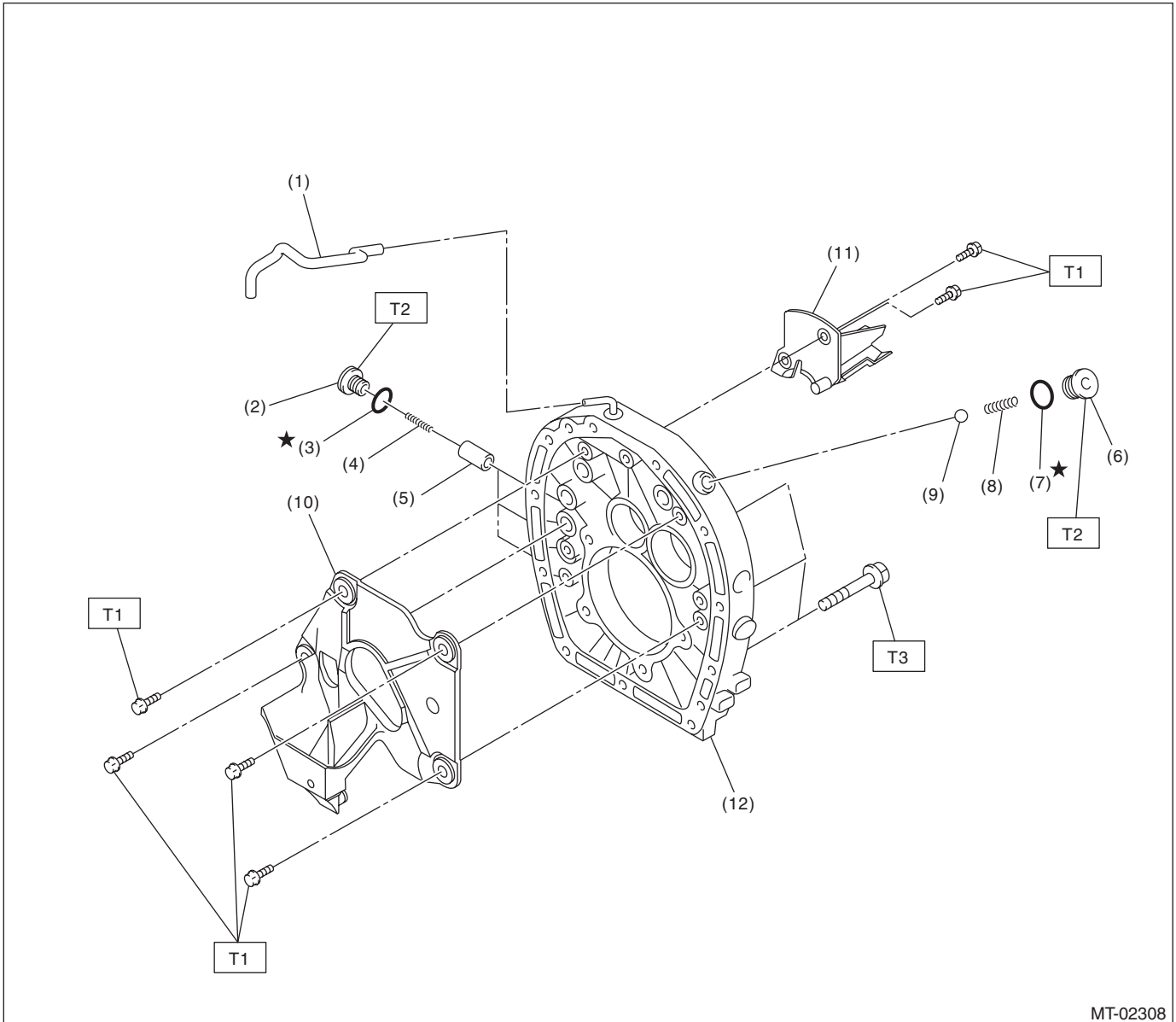

- |                     |                     |
|---------------------|---------------------|
| (1) Breather hose   | (7) O-ring          |
| (2) Check plug      | (8) Checking spring |
| (3) O-ring          | (9) Check ball      |
| (4) Checking spring | (10) Oil guide A    |
| (5) Plunger         | (11) Oil guide B    |
| (6) Check plug      | (12) Adapter plate  |

**Tightening torque: N·m (kgf·m, ft·lb)**

**T1: 18 (1.8, 13.3)**

**T2: 25 (2.5, 18.4)**

**T3: 50 (5.1, 36.9)**



# General Description

## 3. TRANSMISSION CASE

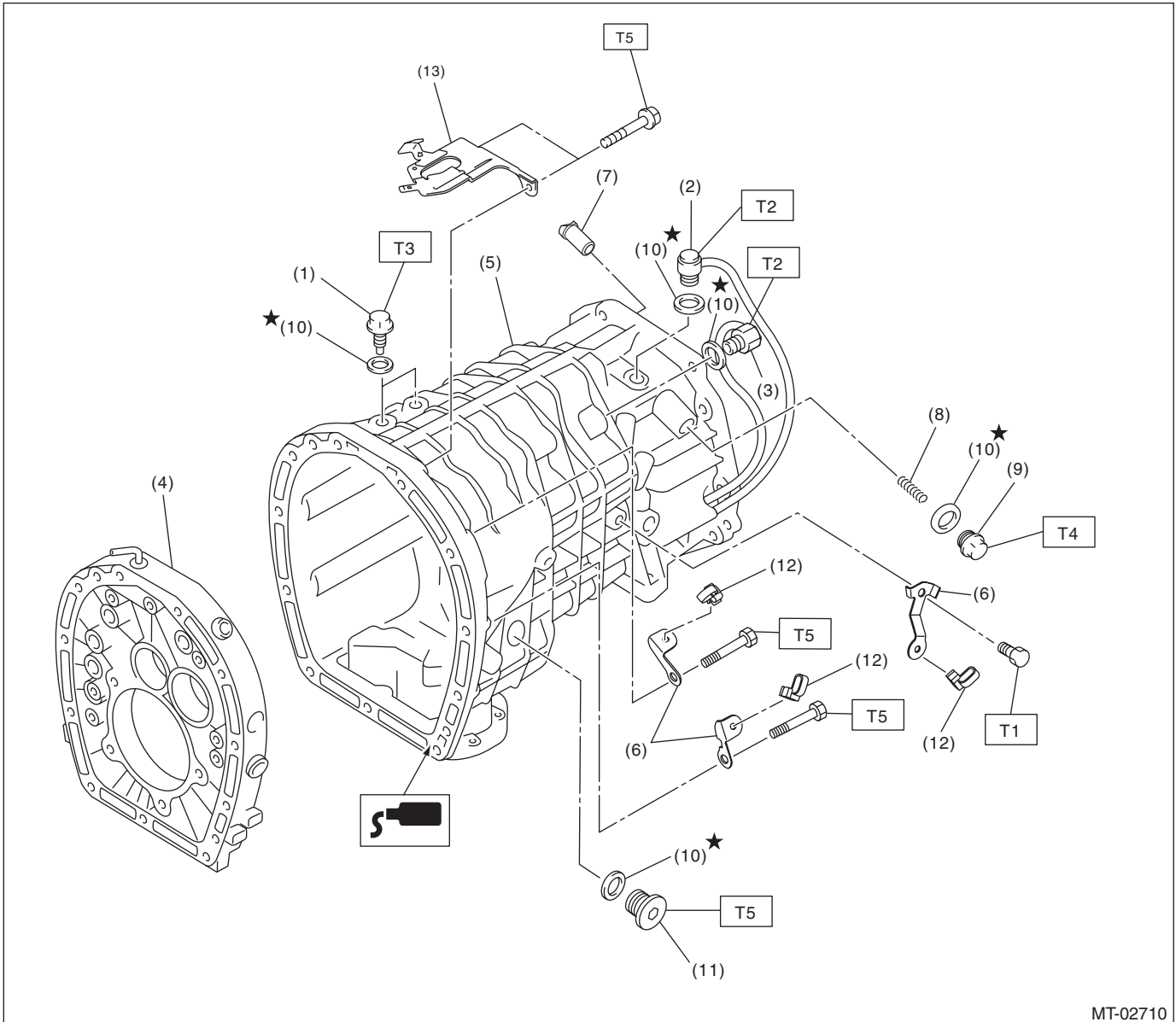

MT-02710

- |                          |                                |
|--------------------------|--------------------------------|
| (1) Pilot bolt           | (8) Spring                     |
| (2) Neutral switch       | (9) Plug                       |
| (3) Back-up light switch | (10) Gasket                    |
| (4) Adapter plate        | (11) Filler plug               |
| (5) Transmission case    | (12) Band clip                 |
| (6) Harness bracket      | (13) Transmission harness stay |
| (7) Selector plunger     |                                |

**Tightening torque: N·m (kgf·m, ft·lb)**

**T1: 16 (1.6, 11.8)**

**T2: 32 (3.3, 23.6)**

**T3: 34 (3.5, 25.1)**

**T4: 41 (4.2, 30.2)**

**T5: 50 (5.1, 36.9)**

# General Description

## MANUAL TRANSMISSION AND DIFFERENTIAL

### 4. OIL PAN & OIL GUIDE

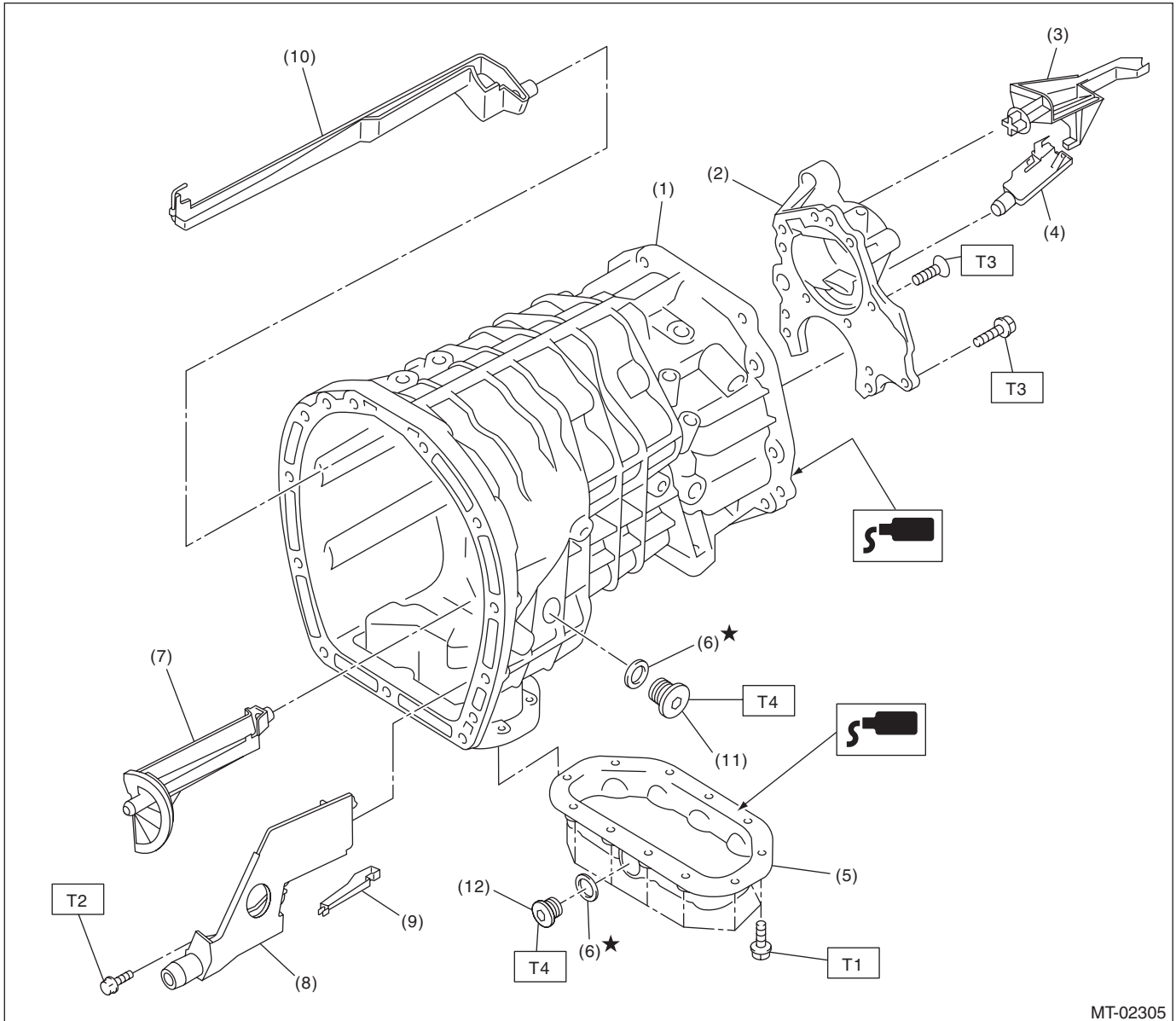

MT-02305

- |                             |                  |
|-----------------------------|------------------|
| (1) Transmission case       | (7) Oil guide F  |
| (2) Transfer bearing holder | (8) Oil guide D  |
| (3) Oil guide G             | (9) Oil guide E  |
| (4) Oil guide H             | (10) Oil guide C |
| (5) Oil pan                 | (11) Filler plug |
| (6) Gasket                  | (12) Drain plug  |

**Tightening torque: N·m (kgf·m, ft·lb)**

**T1: 6.4 (0.7, 4.7)**

**T2: 18 (1.8, 13.3)**

**T3: 25 (2.5, 18.4)**

**T4: 50 (5.1, 36.9)**

**6MT-6**

Brought to you by Ebay Seller "SubaruManuals"

# General Description

## 5. EXTENSION CASE AND CENTER DIFFERENTIAL

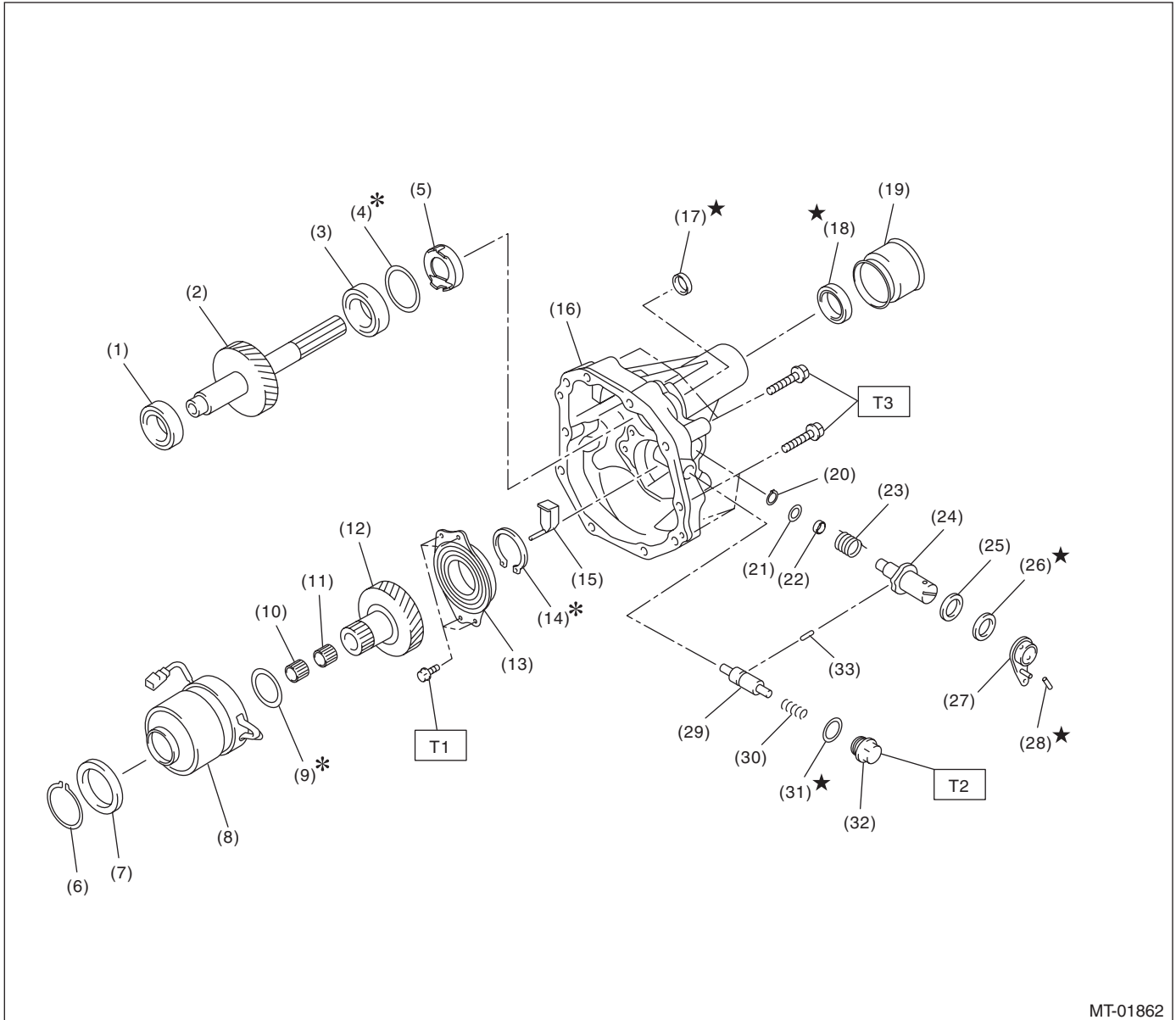

MT-01862

- |                                 |                          |                                |
|---------------------------------|--------------------------|--------------------------------|
| (1) Taper roller bearing        | (14) Snap ring           | (27) Reverse check lever COMPL |
| (2) Transfer driven gear        | (15) Oil guide           | (28) Straight pin              |
| (3) Taper roller bearing        | (16) Extension case      | (29) Reverse check plug        |
| (4) Shim                        | (17) Oil seal            | (30) Spring                    |
| (5) Oil plate                   | (18) Oil seal            | (31) Gasket                    |
| (6) Snap ring                   | (19) Dust cover          | (32) Plug                      |
| (7) Collar                      | (20) Snap ring           | (33) Plunger                   |
| (8) Center differential         | (21) Washer              |                                |
| (9) Shim                        | (22) Bushing             |                                |
| (10) Needle bearing             | (23) Spring              |                                |
| (11) Needle bearing             | (24) Reverse check shaft |                                |
| (12) Transfer drive gear        | (25) Ball bearing        |                                |
| (13) Ball bearing (with flange) | (26) Oil seal            |                                |

**Tightening torque: N·m (kgf·m, ft·lb)**

**T1: 25 (2.5, 18.4)**

**T2: 41 (4.2, 30.2)**

**T3: 48 (4.9, 35.4)**

**6MT-7**

Brought to you by Ebay Seller "SubaruManuals"

# General Description

## MANUAL TRANSMISSION AND DIFFERENTIAL

### 6. SHIFTER FORK AND FORK ROD

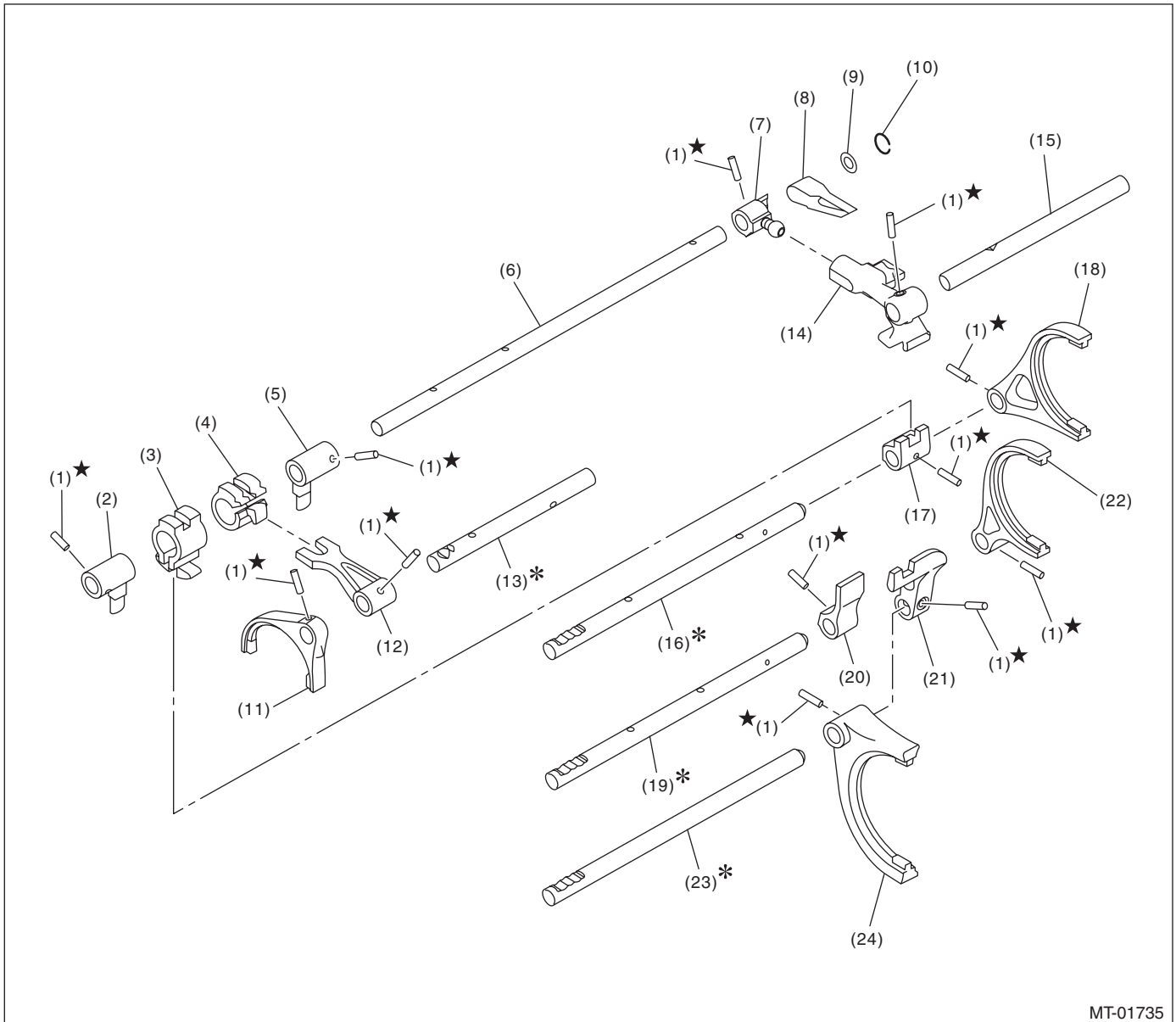

MT-01735

- |                             |                          |                          |
|-----------------------------|--------------------------|--------------------------|
| (1) Spring pin              | (9) Washer               | (17) 5th-6th shifter arm |
| (2) Interlock arm           | (10) Snap ring           | (18) 5th-6th fork COMPL  |
| (3) Interlock block         | (11) Reverse fork COMPL  | (19) 3rd-4th fork rod    |
| (4) Reverse interlock block | (12) Reverse shifter arm | (20) 3rd-4th shifter arm |
| (5) Interlock arm           | (13) Reverse fork rod    | (21) 1st-2nd shifter arm |
| (6) Striking rod            | (14) Selector arm        | (22) 3rd-4th fork COMPL  |
| (7) Selector arm No. 2      | (15) Shifter arm shaft   | (23) 1st-2nd fork rod    |
| (8) Neutral set spring      | (16) 5th-6th fork rod    | (24) 1st-2nd fork COMPL  |

**6MT-8**

Brought to you by Ebay Seller "SubaruManuals"

# General Description

## 7. MAIN SHAFT ASSY

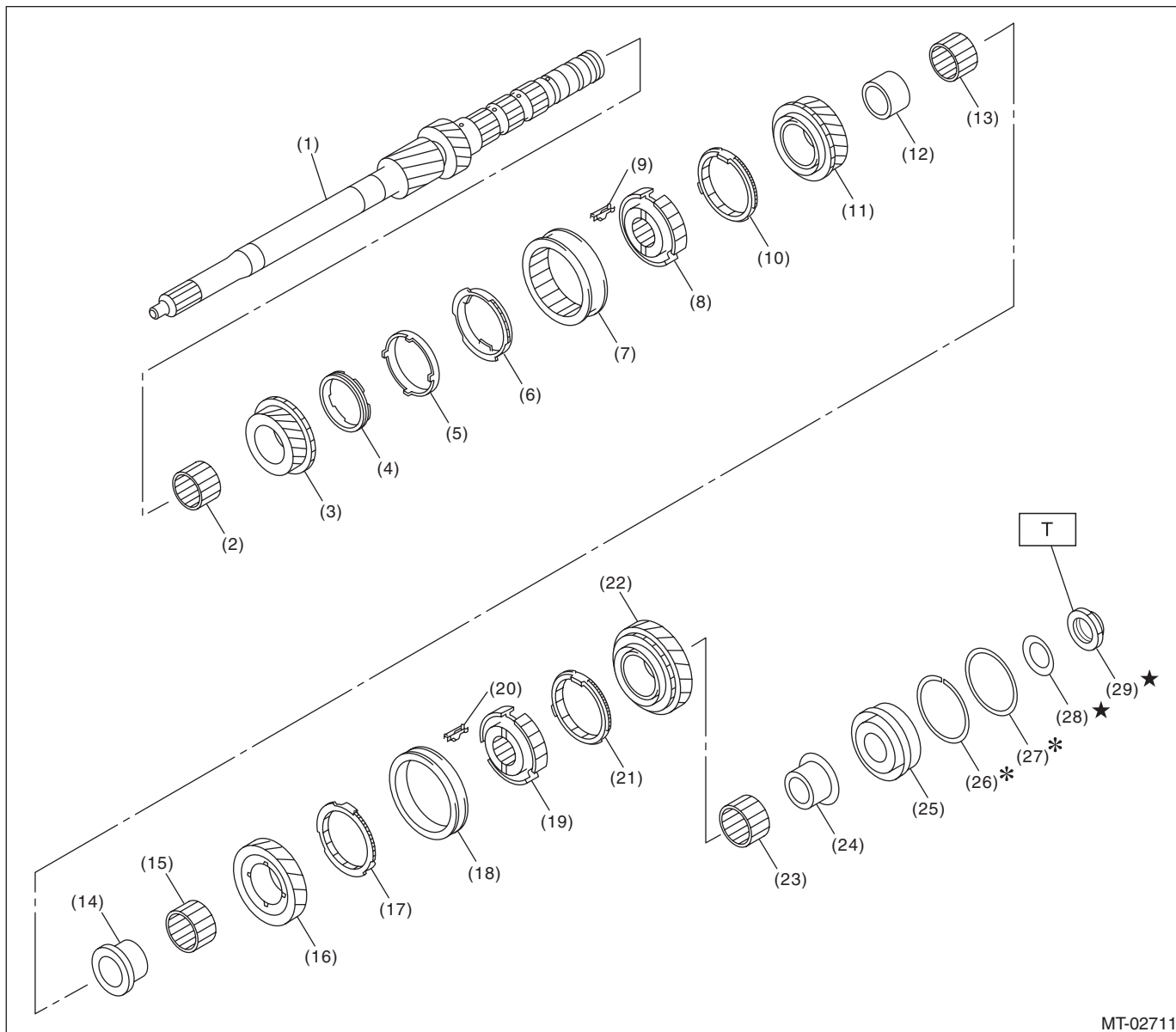

MT-02711

- |                      |                      |                           |
|----------------------|----------------------|---------------------------|
| (1) Main shaft       | (12) 4th bushing     | (23) Needle bearing       |
| (2) Needle bearing   | (13) Needle bearing  | (24) 6th bushing          |
| (3) 3rd drive gear   | (14) 5th bushing     | (25) Taper roller bearing |
| (4) Inner baulk ring | (15) Needle bearing  | (26) Snap ring            |
| (5) Synchro cone     | (16) 5th drive gear  | (27) Washer               |
| (6) Outer baulk ring | (17) 5th baulk ring  | (28) Lock washer          |
| (7) 3rd-4th sleeve   | (18) 5th-6th sleeve  | (29) Lock nut             |
| (8) 3rd-4th hub      | (19) 5th-6th hub     |                           |
| (9) Shifting insert  | (20) Shifting insert |                           |
| (10) 4th baulk ring  | (21) 6th baulk ring  |                           |
| (11) 4th gear        | (22) 6th drive gear  |                           |

**Tightening torque: N·m (kgf-m, ft-lb)**

**T: 392 (40.0, 289.1)**

# General Description

## MANUAL TRANSMISSION AND DIFFERENTIAL

### 8. DRIVE PINION SHAFT ASSY & DRIVEN GEAR ASSY

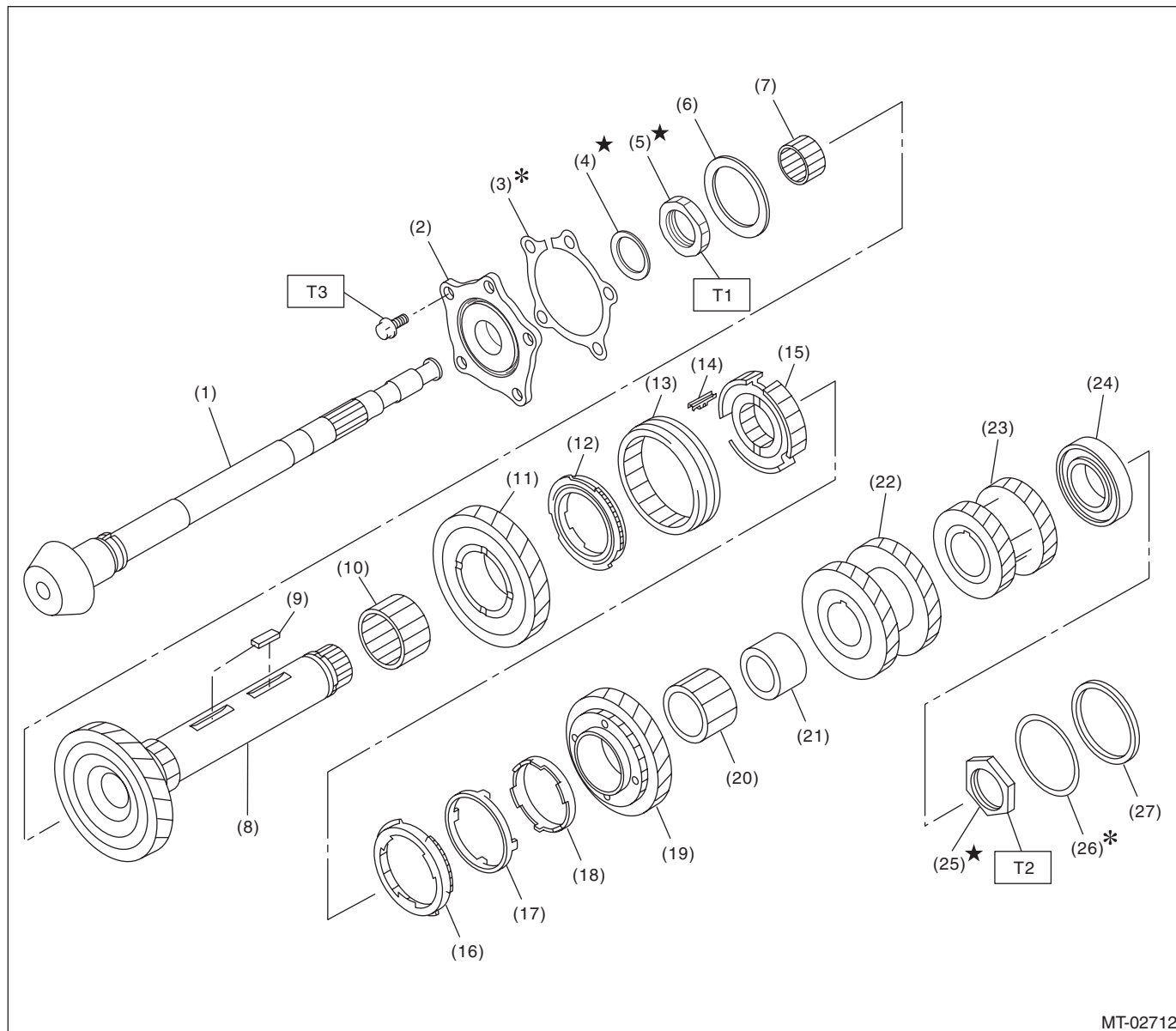

MT-02712

- |                           |                          |               |
|---------------------------|--------------------------|---------------|
| (1) Drive pinion shaft    | (13) 1st-2nd sleeve      | (25) Lock nut |
| (2) Taper roller bearing  | (14) Shifting insert     | (26) Shim     |
| (3) Drive pinion shim     | (15) 1st-2nd hub         | (27) Collar   |
| (4) Lock washer           | (16) Outer baulk ring    |               |
| (5) Lock nut              | (17) Synchro cone        |               |
| (6) Thrust bearing        | (18) Inner baulk ring    |               |
| (7) Needle bearing        | (19) 2nd driven gear     |               |
| (8) Driven shaft          | (20) Needle bearing      |               |
| (9) Key                   | (21) 2nd bushing         |               |
| (10) Needle bearing       | (22) 3rd-4th driven gear |               |
| (11) 1st driven gear      | (23) 5th-6th driven gear |               |
| (12) 1st synchronizer set | (24) Ball bearing        |               |

#### **Tightening torque:N·m (kgf·m, ft·lb)**

**T1: 285 (29.1, 210.2)**

**\* 265 (27.0, 195.4)**

**T2: 570 (58.1, 420.4)**

**\* 530 (54.0, 390.9)**

**T3: 54 (5.5, 39.8)**

\* Tightening torque when using the ST

**6MT-10**

Brought to you by Ebay Seller "SubaruManuals"

# General Description

MANUAL TRANSMISSION AND DIFFERENTIAL

## 9. REVERSE IDLER GEAR ASSY

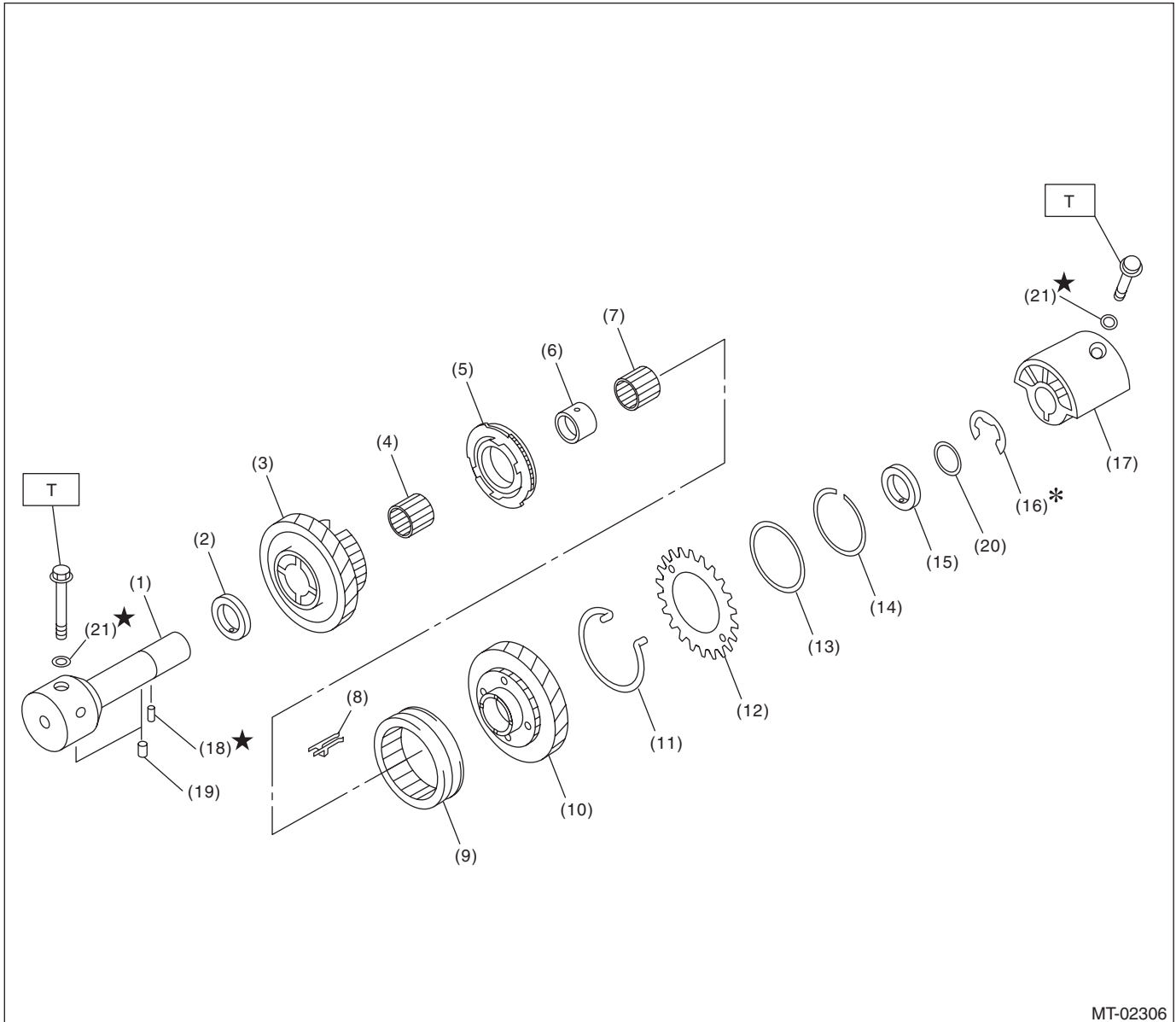

MT-02306

- |                                 |                                  |                           |
|---------------------------------|----------------------------------|---------------------------|
| (1) Base COMPL                  | (9) Reverse coupling sleeve      | (17) Reverse idler holder |
| (2) Counter high and low washer | (10) Reverse idler gear          | (18) Spring pin           |
| (3) Reverse idler gear No. 2    | (11) Spring                      | (19) Knock pin            |
| (4) Needle bearing              | (12) Sub gear                    | (20) Washer               |
| (5) Reverse idler synchro set   | (13) Friction plate              | (21) Gasket               |
| (6) Reverse idler gear bushing  | (14) Snap ring                   |                           |
| (7) Needle bearing              | (15) Counter high and low washer |                           |
| (8) Shifting insert             | (16) Snap ring                   |                           |

**Tightening torque: N·m (kgf·m, ft·lb)**

**T: 25 (2.5, 18.4)**

6MT-11

Brought to you by Ebay Seller "SubaruManuals"

# General Description

## MANUAL TRANSMISSION AND DIFFERENTIAL

### 10.FRONT DIFFERENTIAL ASSY

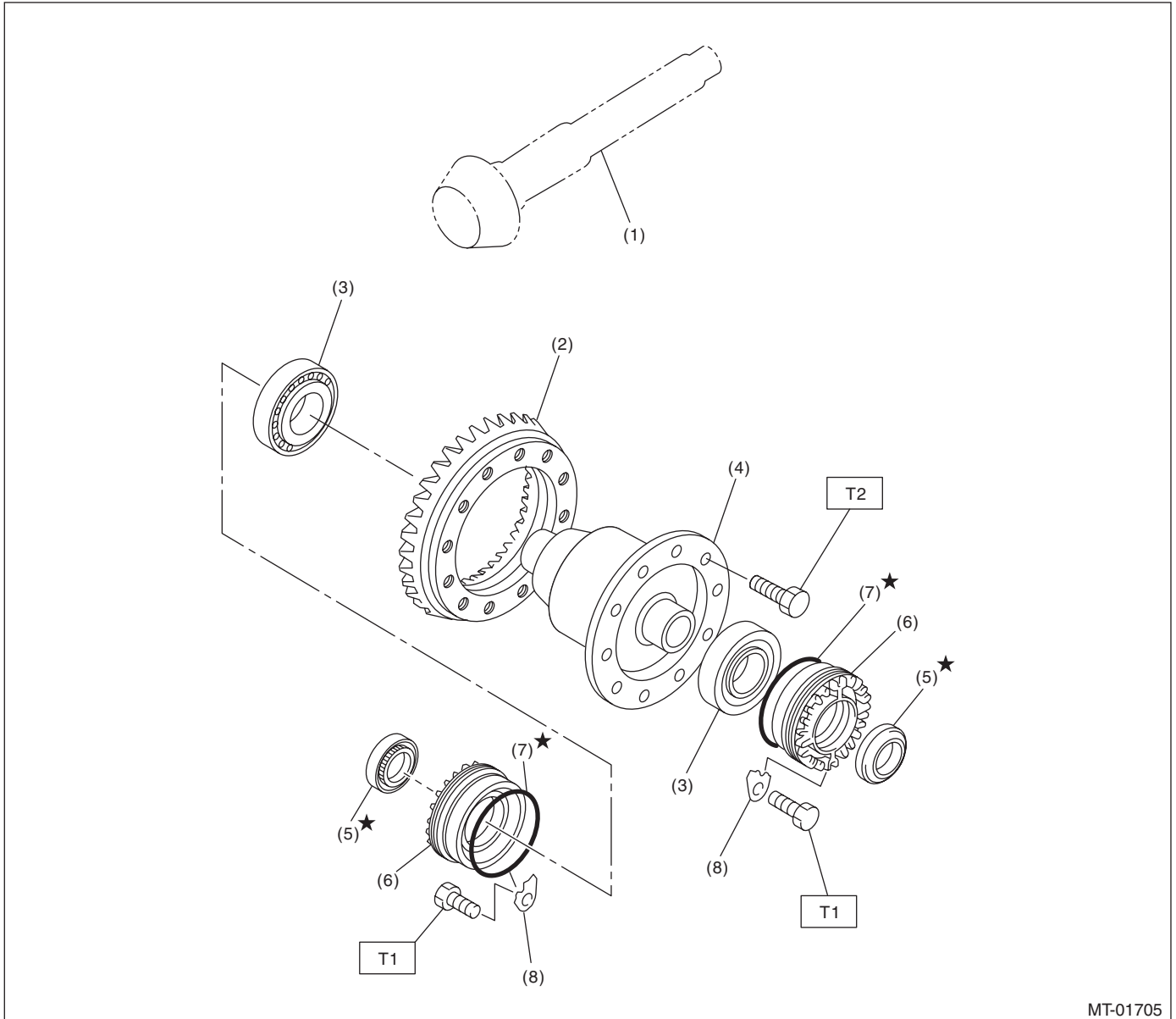

- |                        |                                |
|------------------------|--------------------------------|
| (1) Drive pinion shaft | (5) Oil seal                   |
| (2) Hypoid driven gear | (6) Differential side retainer |
| (3) Roller bearing     | (7) O-ring                     |
| (4) Differential ASSY  | (8) Retainer lock plate        |

**Tightening torque: N·m (kgf·m, ft·lb)**

**T1: 25 (2.5, 18.4)**

**T2: 69 (7.0, 50.9)**

**6MT-12**

Brought to you by Ebay Seller "SubaruManuals"



# General Description

## 11. TRANSMISSION MOUNTING

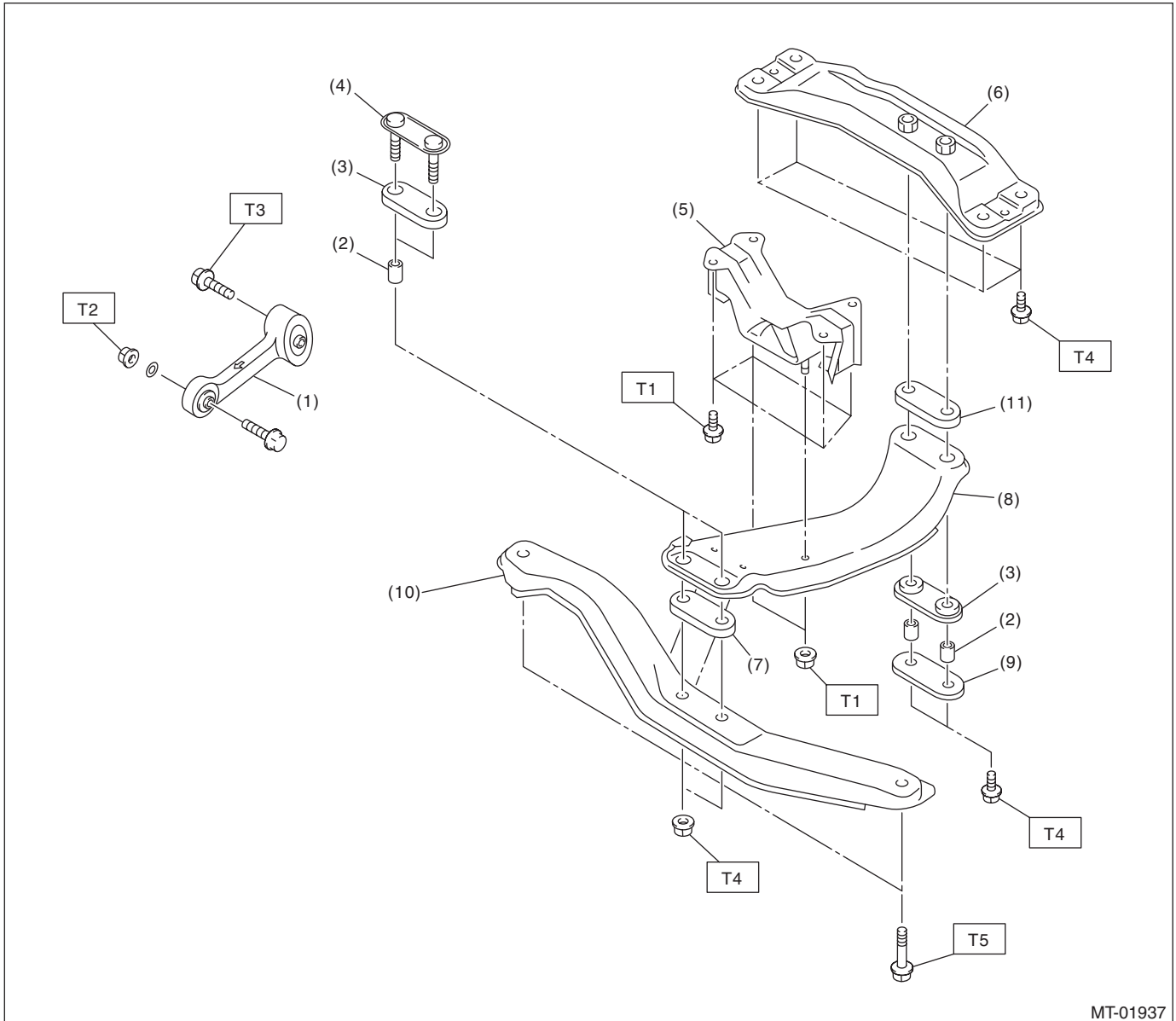

MT-01937

- |                                 |                          |
|---------------------------------|--------------------------|
| (1) Pitching stopper            | (7) Upper cushion rubber |
| (2) Spacer                      | (8) Center crossmember   |
| (3) Lower cushion rubber        | (9) Rear plate           |
| (4) Front plate                 | (10) Front crossmember   |
| (5) Transmission cushion rubber | (11) Rear cushion rubber |
| (6) Rear crossmember            |                          |

**Tightening torque: N·m (kgf·m, ft·lb)**

**T1: 35 (3.6, 25.8)**

**T2: 50 (5.1, 36.9)**

**T3: 58 (5.9, 42.8)**

**T4: 70 (7.1, 51.6)**

**T5: 140 (14.3, 103.3)**

## General Description

### MANUAL TRANSMISSION AND DIFFERENTIAL

---

#### **C: CAUTION**

- Wear appropriate work clothing, including a cap, protective goggles and protective shoes when performing any work.
- Remove contamination including dirt and corrosion before removal, installation or disassembly.
- Keep the disassembled parts in order and protect them from dust and dirt.
- Before removal, installation or disassembly, be sure to clarify the failure. Avoid unnecessary removal, installation, disassembly and replacement.
- When disassembling the case and other light alloy parts, disassemble by using a plastic hammer. Do not pry apart with screwdrivers or other tools.
- Vehicle components are extremely hot after driving. Be wary of receiving burns from heated parts.
- Use SUBARU genuine transmission gear oil, grease or equivalent. Do not mix transmission gear oil, grease etc. of different grades or manufacturers.
- Be sure to tighten fasteners including bolts and nuts to the specified torque.
- Place shop jacks or rigid racks at the specified points.
- Apply transmission gear oil onto sliding or revolving surfaces before installation.
- Always replace deformed or damaged snap rings.
- Before installing O-rings or oil seals, apply sufficient amount of transmission gear oil to avoid damage and deformation.
- Be careful not to incorrectly install or fail to install O-rings, snap rings and other such parts.
- Before securing a part on a vise, place cushioning materials such as wood blocks, aluminum plates, or waste cloth between the part and the vise.
- Avoid damaging the mating surface of the case.
- Before applying liquid gasket, completely remove the old liquid gasket.

# General Description

MANUAL TRANSMISSION AND DIFFERENTIAL

## D: PREPARATION TOOL

### 1. SPECIAL TOOL

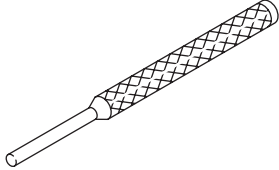
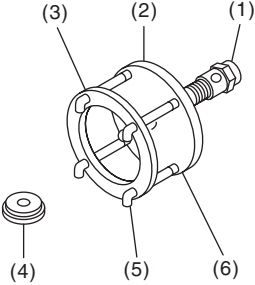
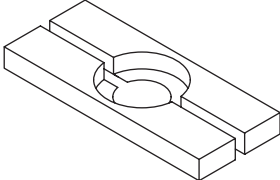
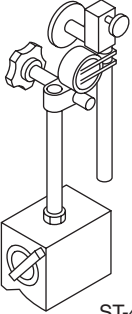
ILLUSTRATION	TOOL NUMBER	DESCRIPTION	REMARKS
 <p>ST-398791700</p>	398791700	REMOVER	Used for removing and installing the spring pin (6 mm).
 <p>ST-399527700</p>	399527700	PULLER SET	Used for removing and installing the roller bearing (differential). (1) BOLT (899521412) (2) PULLER (399527702) (3) HOLDER (399527703) (4) ADAPTER (398497701) (5) BOLT (899520107) (6) NUT (021008000)
 <p>ST-498515700</p>	498515700	REMOVER	Used for removing the roller bearing of the transfer driven gear.
 <p>ST-498247001</p>	498247001	MAGNET BASE	<ul style="list-style-type: none"> <li>Used for measuring the backlash between hypoid gears.</li> <li>Used with DIAL GAUGE (498247100).</li> </ul>

# General Description

## MANUAL TRANSMISSION AND DIFFERENTIAL

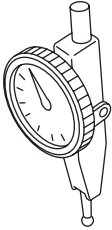
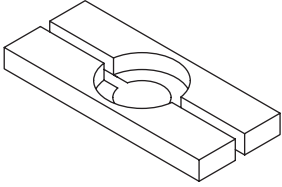
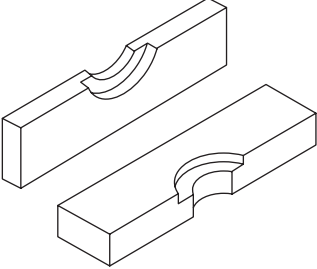
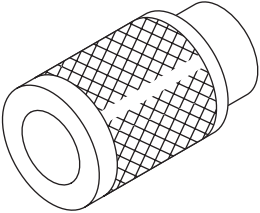
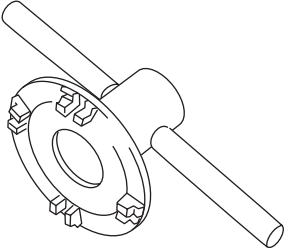
ILLUSTRATION	TOOL NUMBER	DESCRIPTION	REMARKS
 <p>ST-498247100</p>	498247100	DIAL GAUGE	<ul style="list-style-type: none"> <li>Used for measuring the backlash between hypoid gears.</li> <li>Used with MAGNET BASE (498247001).</li> </ul>
 <p>ST-498077000</p>	498077000	REMOVER	Used for removing the differential taper roller bearing.
 <p>ST-899858600</p>	899858600	REMOVER	Used for removing the roller bearing.
 <p>ST-499757002</p>	499757002	INSTALLER	Used for installing the bearing cone of transfer driven gear (transmission case side).
 <p>ST18630AA010</p>	18630AA010	WRENCH COMPL RETAINER	<ul style="list-style-type: none"> <li>Used for removing and installing the differential side retainer RH.</li> <li>WRENCH ASSY (499787000) can also be used.</li> </ul>

# General Description

## MANUAL TRANSMISSION AND DIFFERENTIAL

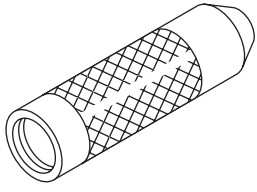
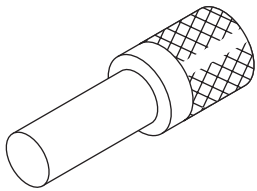
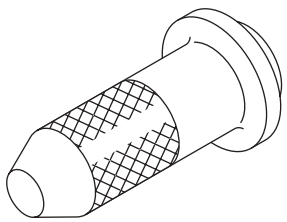
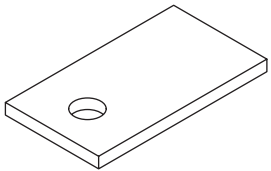
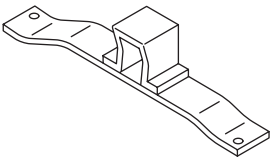
ILLUSTRATION	TOOL NUMBER	DESCRIPTION	REMARKS
 <p>ST-499877000</p>	499877000	RACE 4-5 INSTALLER	Used for disassembling the driven shaft and transfer driven gear.
 <p>ST-899864100</p>	899864100	REMOVER	Used for removing the transmission main shaft and drive pinion parts.
 <p>ST-498057300</p>	498057300	INSTALLER	Used for installing the extension oil seal.
 <p>ST-498255400</p>	498255400	PLATE	Used for measuring backlash.
 <p>ST41099AA010</p>	41099AA010	ENGINE SUPPORT BRACKET	Used for supporting engine.

# General Description

## MANUAL TRANSMISSION AND DIFFERENTIAL

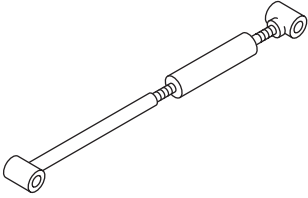
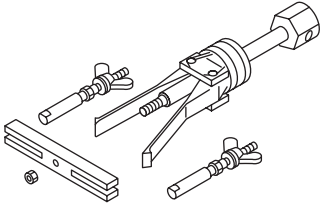
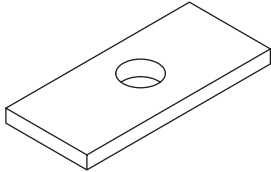
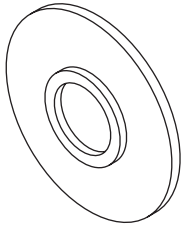
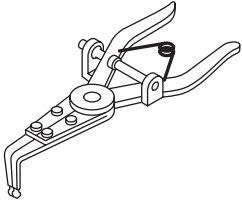
ILLUSTRATION	TOOL NUMBER	DESCRIPTION	REMARKS
 <p style="text-align: center;">ST41099AA020</p>	41099AA020	ENGINE SUPPORT	Used for supporting engine.
 <p style="text-align: center;">ST-398527700</p>	398527700	PULLER ASSY	<ul style="list-style-type: none"> <li>• Used for removing the extension case oil seal.</li> <li>• Used for removing the front differential side bearing outer race. (Used together with 18760AA000 (CLAW).)</li> </ul>
 <p style="text-align: center;">ST-398643600</p>	398643600	GAUGE	Used for adjusting total end play, extension end play and drive pinion shim.
 <p style="text-align: center;">ST-398177700</p>	398177700	INSTALLER	<ul style="list-style-type: none"> <li>• Used for assembling the main shaft.</li> <li>• Used for installing the roller bearing of transfer driven gear (extension case side).</li> </ul>
 <p style="text-align: center;">ST-399893600</p>	399893600	PLIER	<ul style="list-style-type: none"> <li>• Used for removing and installing the neutral set spring.</li> <li>• Used together with CLAW (18756AA000).</li> </ul>

**6MT-18**

Brought to you by Ebay Seller "SubaruManuals"

# General Description

## MANUAL TRANSMISSION AND DIFFERENTIAL

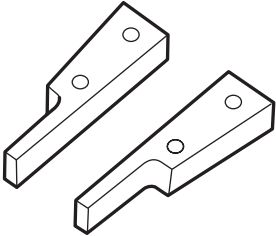
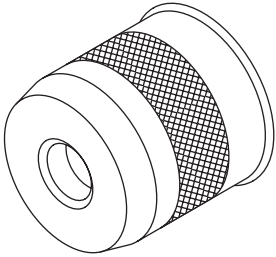
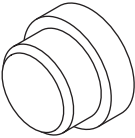
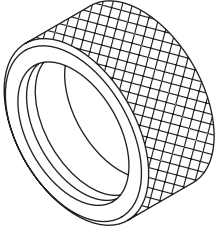
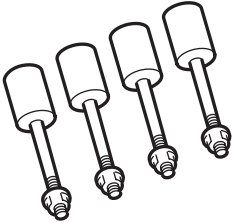
ILLUSTRATION	TOOL NUMBER	DESCRIPTION	REMARKS
 <p data-bbox="324 520 467 543">ST18756AA000</p>	18756AA000	CLAW	<ul style="list-style-type: none"> <li>• Used for removing and installing the neutral set spring.</li> <li>• Used together with PLIER (399893600).</li> </ul>
 <p data-bbox="337 873 467 896">ST-499247400</p>	499247400	INSTALLER	Used for installing the ball bearing of the transfer drive gear.
 <p data-bbox="337 1226 467 1249">ST-398497701</p>	398497701	SEAT	<ul style="list-style-type: none"> <li>• Used for installing the ball bearing of the transfer drive gear.</li> <li>• Used for installing the front differential side bearing.</li> </ul>
 <p data-bbox="337 1579 467 1602">ST-398437700</p>	398437700	INSTALLER	Used for installing the front differential side bearing.
 <p data-bbox="324 1927 467 1950">ST18632AA000</p>	18632AA000	STAND ASSY	Used for disassembling and assembling the transmission.

# General Description

## MANUAL TRANSMISSION AND DIFFERENTIAL

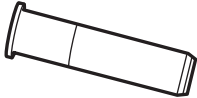
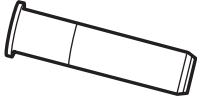
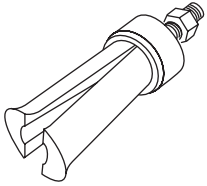
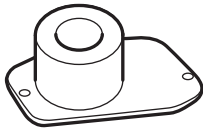
ILLUSTRATION	TOOL NUMBER	DESCRIPTION	REMARKS
 ST18671AA000	18671AA000	OIL SEAL GUIDE	<ul style="list-style-type: none"> <li>• Used for installing the reverse check shaft oil seal.</li> <li>• Used for installing the shifter arm oil seal.</li> <li>• Used together with INSTALLER (18657AA010).</li> </ul>
 ST18657AA010	18657AA010	INSTALLER	<ul style="list-style-type: none"> <li>• Used for installing the reverse check shaft oil seal.</li> <li>• Used together with OIL SEAL GUIDE (18671AA000).</li> </ul>
 ST18657AA000	18657AA000	INSTALLER	<ul style="list-style-type: none"> <li>• Used for installing the shifter arm oil seal.</li> <li>• Used together with OIL SEAL GUIDE (18671AA000).</li> </ul>
 ST18758AA000	18758AA000	PULLER	Used for removing the transfer driven gear bearing outer race.
 ST18831AA000	18831AA000	GAUGE	Used for selecting the transfer driven gear bearing thrust washer.



**6MT-20**

Brought to you by Ebay Seller "SubaruManuals"



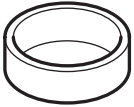

# General Description

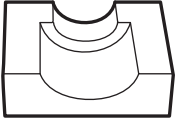
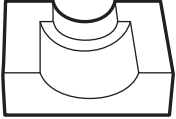
## MANUAL TRANSMISSION AND DIFFERENTIAL

ILLUSTRATION	TOOL NUMBER	DESCRIPTION	REMARKS
 <p>ST18631AA000</p>	18631AA000	HANDLE	Used for measuring the front differential backlash.
 <p>ST18754AA000</p>	18754AA000	REMOVER	Used to remove parts of the driven gear.
 <p>ST18757AA000</p>	18757AA000	STRAIGHT PIN REMOVER	Used for installing the reverse idler gear.
 <p>ST18665AA000</p>	18665AA000	HOLDER	<ul style="list-style-type: none"> <li>Used for removing and installing the main shaft lock nut.</li> <li>Used together with BASE (18664AA000).</li> </ul>
 <p>ST18666AA000</p>	18666AA000	HOLDER	<ul style="list-style-type: none"> <li>Used for removing and installing the driven shaft lock nut.</li> <li>Used together with BASE (18664AA000).</li> </ul>

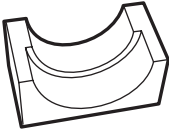
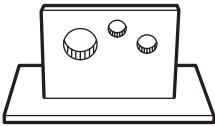

# General Description

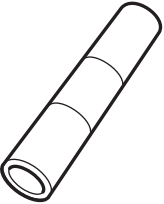
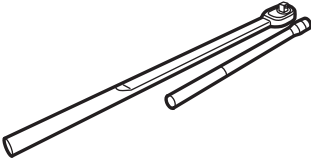
## MANUAL TRANSMISSION AND DIFFERENTIAL

ILLUSTRATION	TOOL NUMBER	DESCRIPTION	REMARKS
 <p style="text-align: center;">ST18667AA000</p>	18667AA000	HOLDER	<ul style="list-style-type: none"> <li>• Used for removing and installing the drive pinion shaft lock nut.</li> <li>• Used together with BASE (18664AA000).</li> </ul>
 <p style="text-align: center;">ST18664AA000</p>	18664AA000	BASE	<ul style="list-style-type: none"> <li>• Used for removing and installing the main shaft lock nut.</li> <li>• Used for removing and installing the drive pinion shaft lock nut.</li> <li>• Used for removing and installing the driven shaft lock nut.</li> </ul>
 <p style="text-align: center;">ST18722AA010</p>	18722AA010	REMOVER	Used for disassembling the main shaft.
 <p style="text-align: center;">ST18651AA000</p>	18651AA000	INSTALLER	Used for assembling the main shaft.
 <p style="text-align: center;">ST18852AA000</p>	18852AA000	TORQUE WRENCH	<ul style="list-style-type: none"> <li>• Used to tighten the main shaft lock nut.</li> <li>• Used to tighten the drive pinion shaft lock nut.</li> <li>• Used to tighten the driven shaft lock nut.</li> </ul>

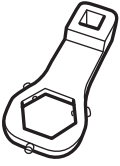
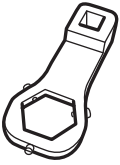

# General Description

## MANUAL TRANSMISSION AND DIFFERENTIAL

ILLUSTRATION	TOOL NUMBER	DESCRIPTION	REMARKS
 <p>ST18668AA000</p>	18668AA000	PUNCH	Used to crimp the main shaft lock nut.
 <p>ST18669AA000</p>	18669AA000	PUNCH	Used to crimp the driven shaft lock nut.
 <p>ST18670AA000</p>	18670AA000	PUNCH	Used to crimp the drive pinion shaft lock nut.
 <p>ST18620AA000</p>	18620AA000	ADAPTER WRENCH	Used for removing and installing the driven gear shaft lock nut.
 <p>ST18621AA000</p>	18621AA000	ADAPTER WRENCH	Used for removing and installing the drive pinion shaft lock nut.

# General Description

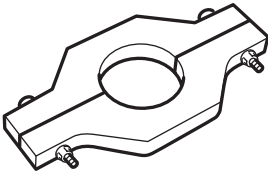
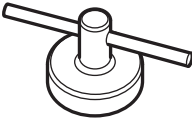
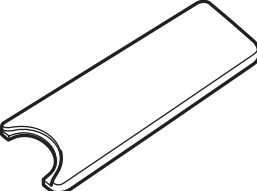
## MANUAL TRANSMISSION AND DIFFERENTIAL

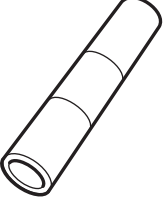
ILLUSTRATION	TOOL NUMBER	DESCRIPTION	REMARKS
 <p style="text-align: center;">ST18723AA000</p>	18723AA000	REMOVER	Used for disassembling the driven shaft.
 <p style="text-align: center;">ST18630AA000</p>	18630AA000	WRENCH ASSY	Used for removing and installing the differential side retainer LH.
 <p style="text-align: center;">ST18672AA000</p>	18672AA000	GUIDE CLIP	Used for installing the reverse idler snap ring.
 <p style="text-align: center;">ST18720AA000</p>	18720AA000	REMOVER	Used for disassembling the main shaft.
 <p style="text-align: center;">ST18654AA000</p>	18654AA000	INSTALLER	Used for assembling the driven shaft.

# General Description

## MANUAL TRANSMISSION AND DIFFERENTIAL

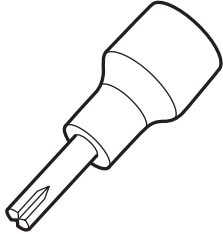
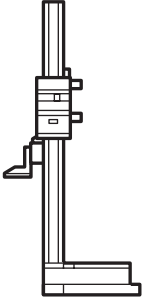
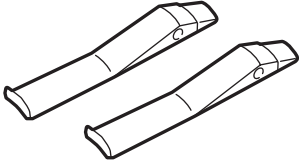
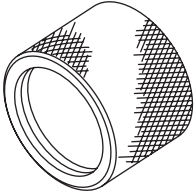
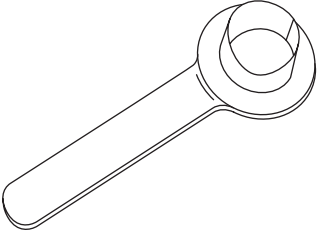
ILLUSTRATION	TOOL NUMBER	DESCRIPTION	REMARKS
 <p>ST18663AA000</p>	18663AA000	SOCKET	Used for removing and installing the transfer bearing holder.
 <p>ST18853AA000</p>	18853AA000	HEIGHT GAUGE	<ul style="list-style-type: none"> <li>• Used for selecting the shift rod.</li> <li>• Used for selecting the snap ring and washer of the main shaft.</li> </ul>
 <p>ST18760AA000</p>	18760AA000	CLAW	<ul style="list-style-type: none"> <li>• Used for removing the front differential side bearing outer race.</li> <li>• Used together with PULLER ASSY (398527700).</li> </ul>
 <p>ST18675AA000</p>	18675AA000	DIFFERENTIAL SIDE OIL SEAL INSTALLER	Used for installing the differential side retainer oil seal.
 <p>ST28399SA010</p>	28399SA010	OIL SEAL PROTECTOR	Used for protecting oil seal when installing front drive shaft.

6MT-25

Brought to you by Ebay Seller "SubaruManuals"

# General Description

## MANUAL TRANSMISSION AND DIFFERENTIAL

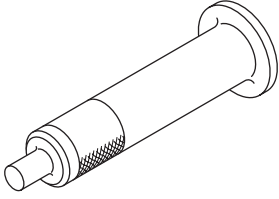
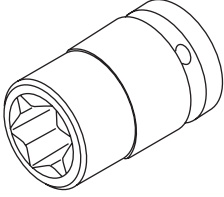
ILLUSTRATION	TOOL NUMBER	DESCRIPTION	REMARKS
 ST18657AA020	18657AA020	OIL SEAL INSTALLER	Used for installing the oil seal.
 ST18270KA020	18270KA020	SOCKET (E20)	Used for removing and installing the hypoid driven gear.

## 2. GENERAL TOOL

TOOL NAME	REMARKS
Circuit tester	Used for measuring resistance, voltage and current.
TORX® bit T70	Used for removing and installing transmission gear oil drain plug.
Depth gauge	Used for measuring the transmission end play.

# Transmission Gear Oil

MANUAL TRANSMISSION AND DIFFERENTIAL

## 2. Transmission Gear Oil

### A: INSPECTION

- 1) Lift up the vehicle.
- 2) Remove the transmission under cover.
- 3) Remove the filler plug, and then check the transmission gear oil.

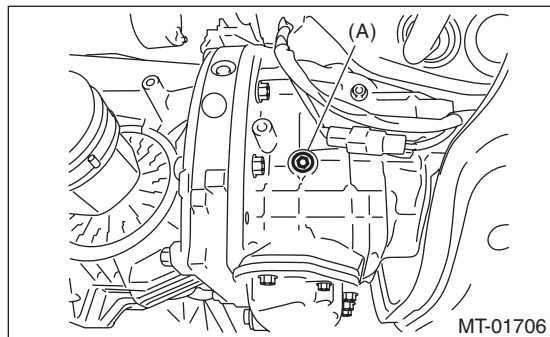

(A) Filler plug

- 4) Check that the transmission gear oil level is up to the bottom of the filler plug. If the transmission gear oil level is low, refill up to the bottom of filler plug.
- 5) Using a new gasket, and tighten the filler plug.

#### **Tightening torque:**

**50 N·m (5.1 kgf-m, 36.9 ft-lb)**

### B: REPLACEMENT

- 1) Lift up the vehicle.
- 2) Remove the transmission under cover.
- 3) Remove the filler plug.

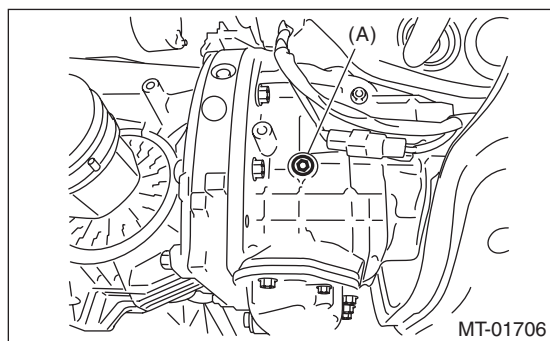

(A) Filler plug

- 4) Remove the two drain plugs (oil pan side, clutch housing side), and then drain the transmission gear oil completely.

#### **CAUTION:**

- Immediately after running the vehicle or after idling for a long time, the transmission gear oil will be hot. Be careful not to receive burns.
- Be careful not to spill the transmission gear oil on exhaust pipe to prevent it from emitting smoke or causing fires. If transmission gear oil is spilled on the exhaust pipe, wipe it off completely.

#### **NOTE:**

- Tighten the drain plug of the transmission gear oil after draining the transmission gear oil.
- Always use a new gasket.
- Use TORX® bit T70 to remove and install the drain plug on clutch housing side.

#### **Tightening torque:**

##### **Oil pan side**

**50 N·m (5.1 kgf-m, 36.9 ft-lb)**

##### **Clutch housing side**

**70 N·m (7.1 kgf-m, 51.6 ft-lb)**

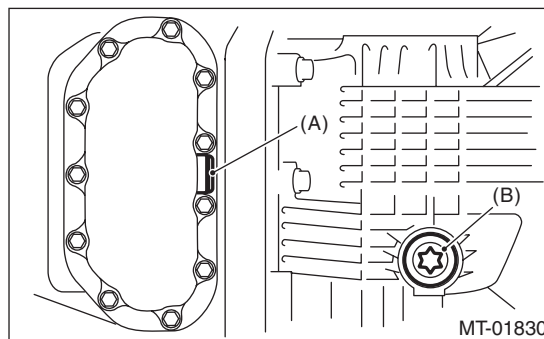

(A) Drain plug (oil pan side)

(B) Drain plug (clutch housing side)

- 5) Pour transmission gear oil to the bottom end of filler plug.

#### **NOTE:**

Carefully refill transmission gear oil while checking the level. Excessive or insufficient oil must be avoided.

#### **Recommended gear oil**

**GL-5 (75W-90) or equivalent**

#### **Transmission gear oil capacity**

**4.1 ℓ (4.3 US qt, 3.6 Imp qt)**

- 6) Check the level of the transmission gear oil.
- 7) Using a new gasket, and tighten the filler plug.

#### **Tightening torque:**

**50 N·m (5.1 kgf-m, 36.9 ft-lb)**

# Oil Seal

## MANUAL TRANSMISSION AND DIFFERENTIAL

### 3. Oil Seal

#### A: INSPECTION

Check that there is no oil leaking from the oil seal. If there is any deformation, hardening, wear or other malfunctions of the oil seal, perform the following:

- Replace the oil seal.
- Inspect the propeller shaft.

#### B: REPLACEMENT

- 1) Clean the transmission exterior.
- 2) Drain transmission gear oil completely. <Ref. to 6MT-27, REPLACEMENT, Transmission Gear Oil.>
- 3) Remove the rear exhaust pipe and muffler. <Ref. to EX(STI)-13, REMOVAL, Rear Exhaust Pipe.> <Ref. to EX(STI)-15, REMOVAL, Muffler.>
- 4) Remove the heat shield cover.
- 5) Remove the propeller shaft. <Ref. to DS-11, REMOVAL, Propeller Shaft.>
- 6) Using the ST, remove the oil seal.

ST 398527700 PULLER ASSY

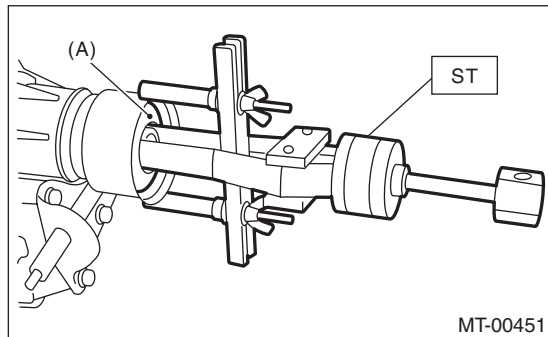

(A) Oil seal

- 7) Using the ST, install the oil seal.

#### NOTE:

- When grease is not applied to the oil seal lips, apply the transmission gear oil to the oil seal lips.
- Use a new oil seal.

ST 498057300 INSTALLER

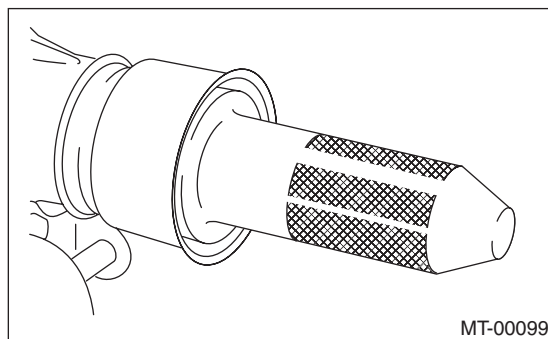

- 8) Install the propeller shaft. <Ref. to DS-12, INSTALLATION, Propeller Shaft.>
- 9) Install the heat shield cover.

10) Install the rear exhaust pipe and muffler. <Ref. to EX(STI)-13, INSTALLATION, Rear Exhaust Pipe.> <Ref. to EX(STI)-15, INSTALLATION, Muffler.>

11) Pour in transmission gear oil and check the oil level. <Ref. to 6MT-27, REPLACEMENT, Transmission Gear Oil.>



## 4. Differential Side Retainer Oil Seal

### A: INSPECTION

Check that there is no oil leaking from the differential side retainer oil seal. If there is oil leakage, perform the following procedures.

- Replace the oil seal.
- Check the front drive shaft.

### B: REPLACEMENT

- 1) Lift up the vehicle.
- 2) Remove the front exhaust pipe and center exhaust pipe. <Ref. to EX(STI)-6, REMOVAL, Front Exhaust Pipe.>
- 3) Drain transmission gear oil completely. <Ref. to 6MT-27, REPLACEMENT, Transmission Gear Oil.>
- 4) Separate the front drive shaft from the transmission. <Ref. to DS-27, REMOVAL, Front Drive Shaft.>
- 5) Remove the differential side retainer oil seal by using a flat tip screwdriver or similar tools.
- 6) Using the ST, install the differential side retainer oil seal by lightly tapping with a hammer.  
ST 18675AA000 DIFFERENTIAL SIDE OIL SEAL INSTALLER
- 7) Apply transmission gear oil to the oil seal lips.
- 8) Set the ST to the side retainer.  
ST 28399SA010 OIL SEAL PROTECTOR
- 9) Install the front drive shaft into the transmission.

#### NOTE:

- Replace the circlip of drive shaft with a new part.
- 10) Install the front drive shaft into transmission, remove the ST and insert the drive shaft securely.  
ST 28399SA010 OIL SEAL PROTECTOR
  - 11) Install the front exhaust pipe and the center exhaust pipe. <Ref. to EX(STI)-6, INSTALLATION, Front Exhaust Pipe.>
  - 12) Pour transmission gear oil to the bottom end of filler plug. <Ref. to 6MT-27, REPLACEMENT, Transmission Gear Oil.>
  - 13) Lower the vehicle.

# Transmission Mounting System

MANUAL TRANSMISSION AND DIFFERENTIAL

## 5. Transmission Mounting System

### A: REMOVAL

#### 1. PITCHING STOPPER

- 1) Disconnect the ground cable from battery.
- 2) Remove the intercooler. <Ref. to IN(STI)-12, REMOVAL, Intercooler.>
- 3) Remove the pitching stopper.

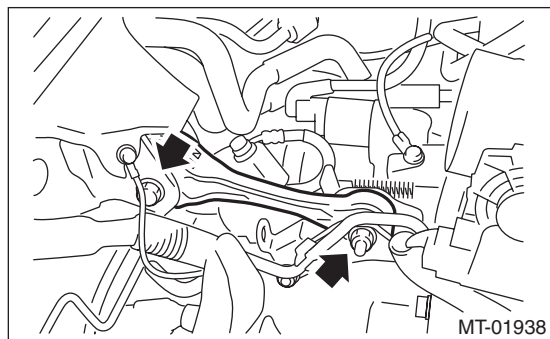

#### 2. CROSSMEMBER AND CUSHION RUBBER

- 1) Disconnect the ground cable from battery.
- 2) Lift up the vehicle.
- 3) Remove the transmission under cover.
- 4) Remove the center exhaust pipe. <Ref. to EX(STI)-8, REMOVAL, Center Exhaust Pipe.>
- 5) Remove the rear exhaust pipe and muffler. <Ref. to EX(STI)-13, REMOVAL, Rear Exhaust Pipe.> <Ref. to EX(STI)-15, REMOVAL, Muffler.>
- 6) Remove the heat shield cover.
- 7) Set the transmission jack under the transmission body.

#### CAUTION:

Always support the transmission case with a transmission jack.

- 8) Remove the rear crossmember.

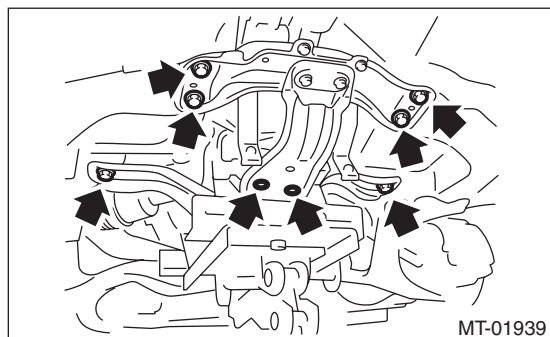

- 9) Remove the transmission cushion rubber.

### B: INSTALLATION

#### 1. PITCHING STOPPER

- 1) Install the pitching stopper.

#### Tightening torque:

**T1: 50 N·m (5.1 kgf-m, 36.9 ft-lb)**

**T2: 58 N·m (5.9 kgf-m, 42.8 ft-lb)**

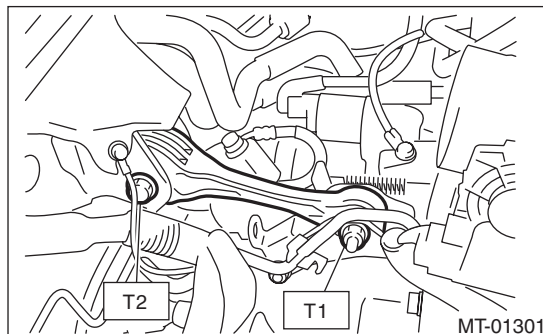

- 2) Install the intercooler. <Ref. to IN(STI)-13, INSTALLATION, Intercooler.>
- 3) Connect the ground cable to battery.

#### 2. CROSSMEMBER AND CUSHION RUBBER

- 1) Install the transmission cushion rubber.

#### Tightening torque:

**35 N·m (3.6 kgf-m, 25.8 ft-lb)**

- 2) Install the crossmember.

#### Tightening torque:

**T1: 35 N·m (3.6 kgf-m, 25.8 ft-lb)**

**T2: 70 N·m (7.1 kgf-m, 51.6 ft-lb)**

**T3: 140 N·m (14.3 kgf-m, 103 ft-lb)**

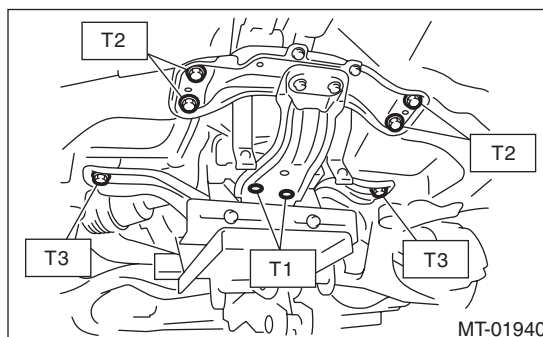

- 3) Remove the transmission jack.
- 4) Install the heat shield cover.
- 5) Install the rear exhaust pipe and muffler. <Ref. to EX(STI)-13, INSTALLATION, Rear Exhaust Pipe.> <Ref. to EX(STI)-15, INSTALLATION, Muffler.>
- 6) Install the center exhaust pipe. <Ref. to EX(STI)-9, INSTALLATION, Center Exhaust Pipe.>

## **C: INSPECTION**

Perform the following inspection procedures and repair or replace faulty parts.

### **1. PITCHING STOPPER**

Check the pitching stopper for bends or damage. Check that the rubber is not stiff, cracked or otherwise damaged.

### **2. CROSSMEMBER AND CUSHION RUBBER**

Check the crossmember for bending or damage. Check that the cushion rubber is not stiff, cracked, or otherwise damaged.

# Manual Transmission Assembly

## MANUAL TRANSMISSION AND DIFFERENTIAL

### 6. Manual Transmission Assembly

#### A: REMOVAL

1) Change the bolt installation position from (A) to (B), then open the front hood completely.

**Tightening torque:**

**7.5 N·m (0.8 kgf-m, 5.5 ft-lb)**

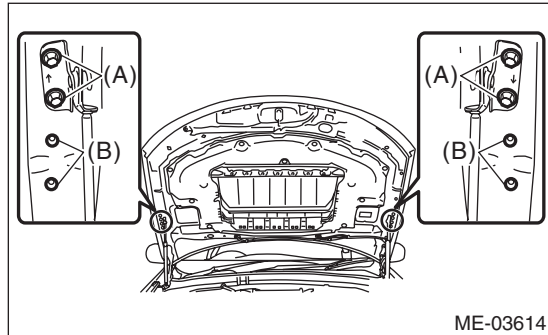

- 2) Disconnect the ground cable from battery.
- 3) Remove the intercooler. <Ref. to IN(STI)-12, REMOVAL, Intercooler.>
- 4) Disconnect the following harness connectors, and then remove the engine hanger rear.

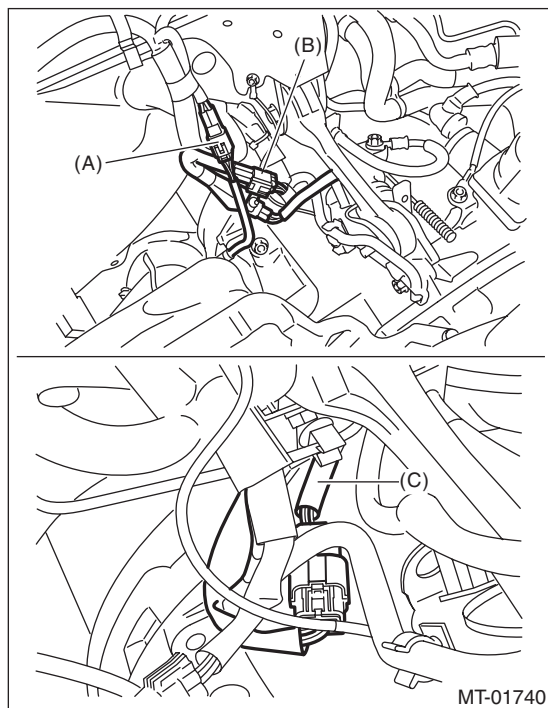

- (A) Front oxygen (A/F) sensor connector
- (B) Rear oxygen sensor connector
- (C) Neutral position switch backup light switch connector

5) Remove the secondary air combination valve. <Ref. to EC(STI)-29, SECONDARY AIR COMBINATION VALVE LH, REMOVAL, Secondary Air Combination Valve.>

6) Disconnect the transmission radio ground terminal.

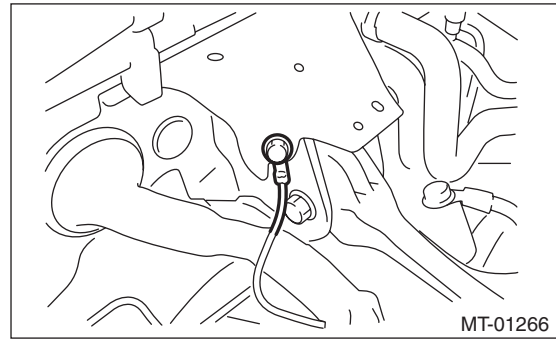

7) Remove the starter assembly. <Ref. to SC(STI)-7, REMOVAL, Starter.>

8) Remove the operating cylinder from the transmission.

**NOTE:**

Hang the removed operating cylinder with a piece of wire.

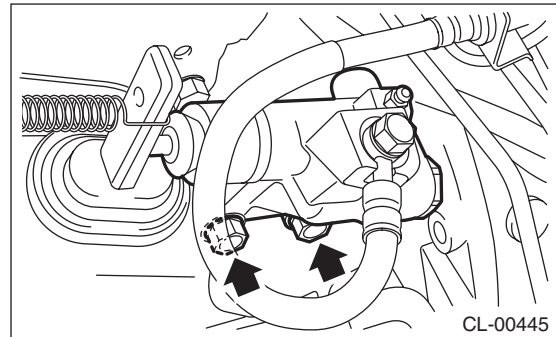

9) Remove the return spring from the release fork.

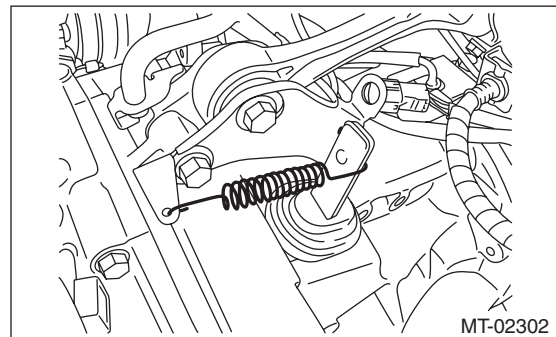

10) Remove the pitching stopper. <Ref. to 6MT-30, PITCHING STOPPER, REMOVAL, Transmission Mounting System.>

11) Remove the pitching stopper bracket, return spring bracket, and transmission radio ground cable.

# Manual Transmission Assembly

## MANUAL TRANSMISSION AND DIFFERENTIAL

12) Set the ST.

ST1 41099AA010 ENGINE SUPPORT BRACKET

ST2 41099AA020 ENGINE SUPPORT

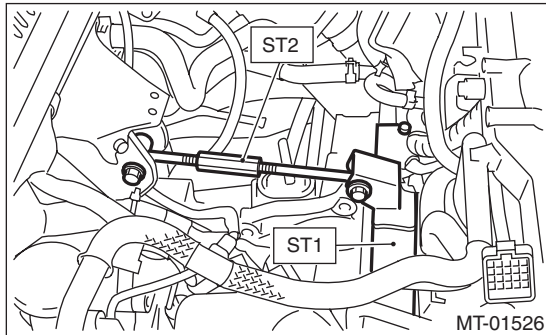

13) Remove the clutch release shaft.

- (1) Remove the plug using a hexagon wrench.
- (2) Attach a 6 mm (0.24 in) bolt to the release shaft, and pull out the release shaft.
- (3) Lift the release fork, and remove from the claw of the release bearing. Pull the release fork to the engine side, and make it so that it moves freely.

14) Remove the bolts which hold upper side of transmission to engine.

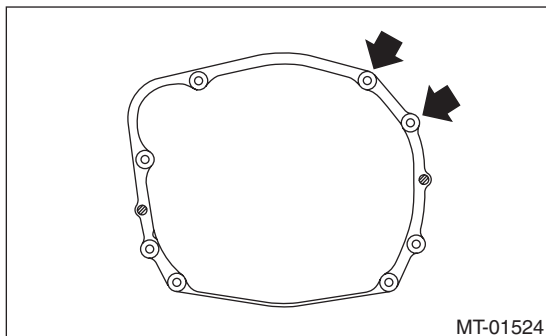

15) Remove the front wheels.

16) Lift up the vehicle, and remove the transmission under cover.

17) Drain transmission gear oil completely. <Ref. to 6MT-27, REPLACEMENT, Transmission Gear Oil.>

18) Remove the center exhaust pipe. <Ref. to EX(STI)-8, REMOVAL, Center Exhaust Pipe.>

19) Remove the heat shield cover.

20) Remove the propeller shaft. <Ref. to DS-11, REMOVAL, Propeller Shaft.>

21) Remove the front stabilizer link.

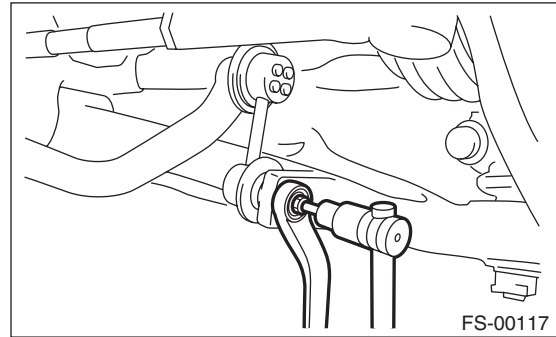

22) Remove the ball joint of front arm from the housing.

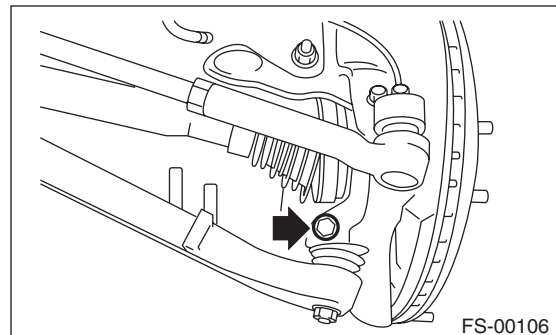

23) Remove the front drive shaft. <Ref. to DS-27, REMOVAL, Front Drive Shaft.>

24) Set the transmission jack under the transmission, and remove the front crossmember and rear crossmember.

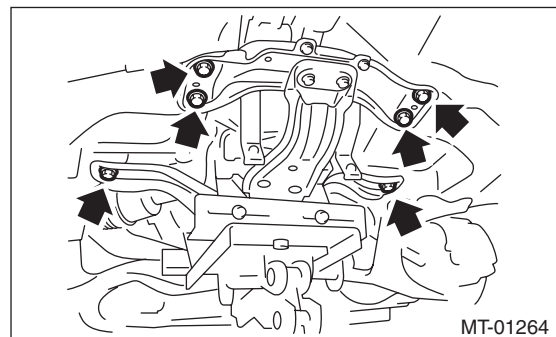

25) Move the transmission to the right side of the vehicle, and remove the joint COMPL, stay bolts and reverse check cable.

# Manual Transmission Assembly

## MANUAL TRANSMISSION AND DIFFERENTIAL

### NOTE:

If the transmission is not moved aside, the joint COMPL and stay bolts may contact the body and cause damage.

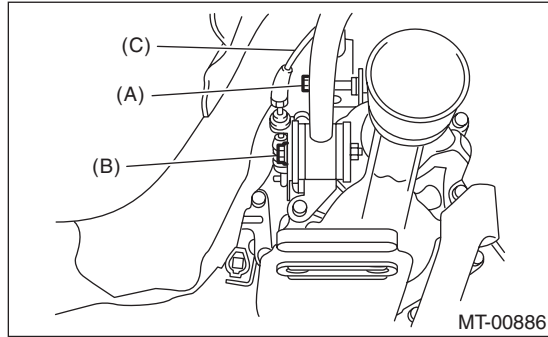

- (A) Joint COMPL bolt
- (B) Stay bolt
- (C) Reverse check cable

26) Tighten the turnbuckle of the ST to tilt the engine assembly towards the back.

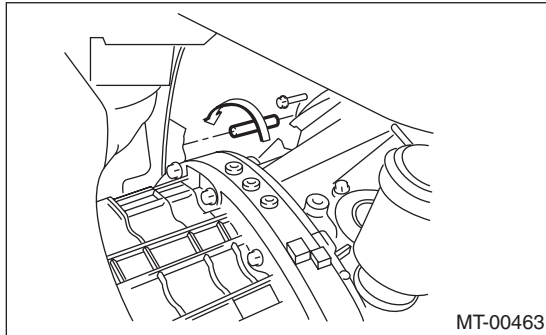

27) Remove the bolts and nuts holding the bottom of transmission to the engine, and remove the transmission from the vehicle.

### NOTE:

- During removal, be careful not to hit the transmission against the body when pulling towards the rear.
- The clutch pipe and breather pipe may interfere with each other. Remove carefully.

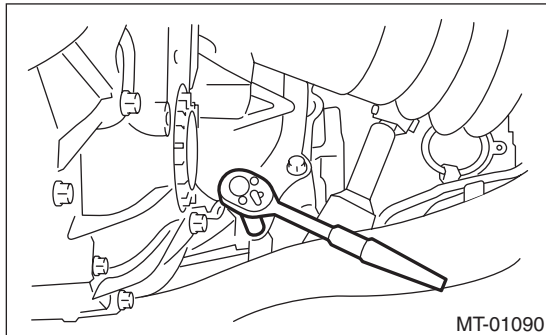

## B: INSTALLATION

- 1) Set the release fork, release bearing and release shaft to the transmission. <Ref. to CL-15, INSTALLATION, Release Bearing and Lever.>
- 2) Replace the front differential side retainer oil seal. <Ref. to 6MT-29, REPLACEMENT, Differential Side Retainer Oil Seal.>

### NOTE:

Be sure to replace the differential side oil seal after the procedure of removing front drive shaft from transmission.

- 3) Strike and bend the transmission hanger of transmission rear with a rubber hammer etc. so that it gets in contact with the transmission case.

### CAUTION:

**Do not apply extra overload or impact to the transmission case.**

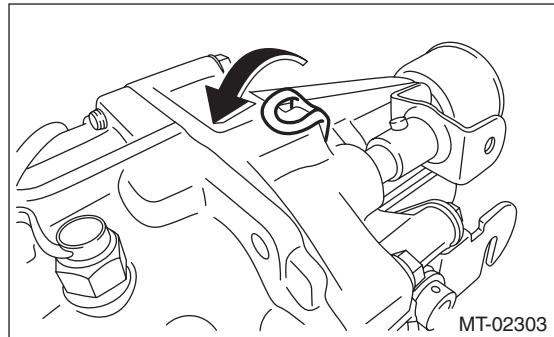

- 4) Install the transmission onto the engine.
- 5) Tighten the bolts and nuts which hold the lower side of transmission to the engine.

### NOTE:

- Make sure that the main shaft spline is completely inserted.
- Make sure that the rear end of the engine is set low.

### Tightening torque:

**50 N·m (5.1 kgf-m, 36.9 ft-lb)**

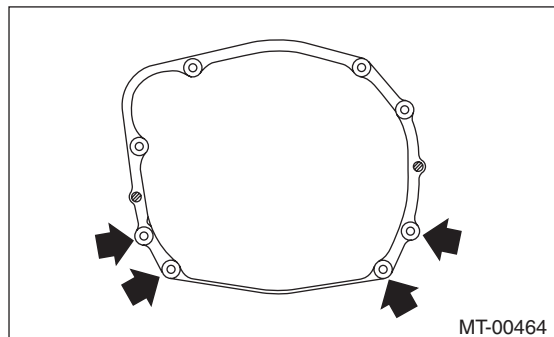



# Manual Transmission Assembly

## MANUAL TRANSMISSION AND DIFFERENTIAL

6) Loosen the turnbuckle of ST to return the engine to its original position.

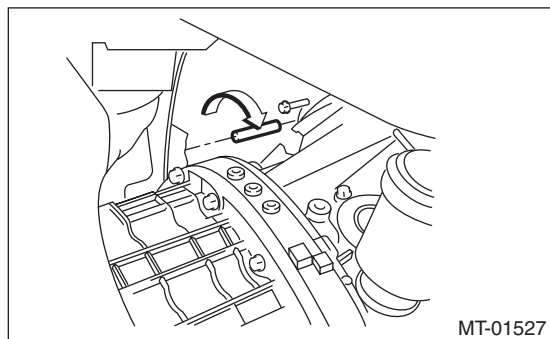

7) Move the transmission to the right side of the vehicle, and attach the joint COMPL, stay bolts and reverse check cable.

**Tightening torque:**

**T1: 12 N·m (1.2 kgf·m, 8.9 ft·lb)**

**T2: 32 N·m (3.3 kgf·m, 23.6 ft·lb)**

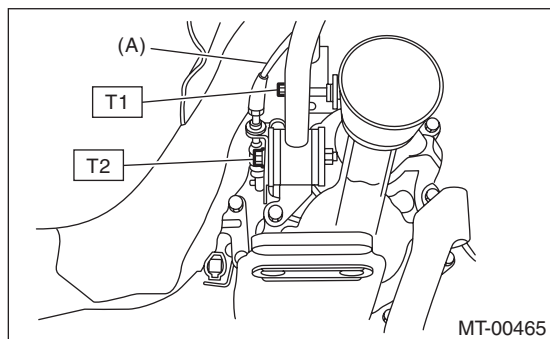

(A) Reverse check cable

8) Install the front crossmember and rear crossmember.

**Tightening torque:**

**T1: 70 N·m (7.1 kgf·m, 51.6 ft·lb)**

**T2: 140 N·m (14.3 kgf·m, 103 ft·lb)**

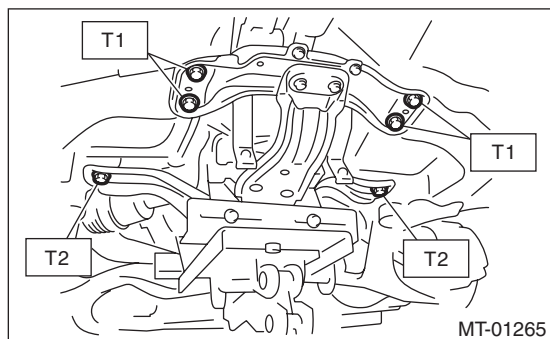

9) Lower the vehicle.

10) Tighten the bolts which hold the upper side of the transmission to the engine.

**Tightening torque:**

**50 N·m (5.1 kgf·m, 36.9 ft·lb)**

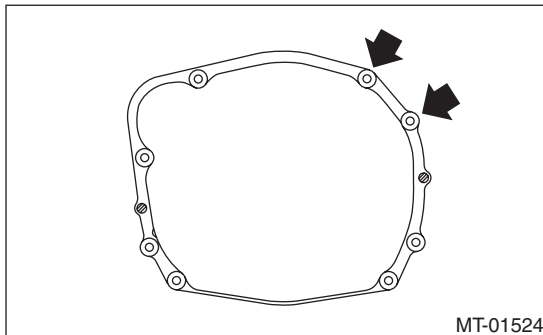

11) Make sure that the release bearing is completely inserted.

**NOTE:**

- Push the release fork towards the operating cylinder side until a clicking sound is heard. Pull the release fork towards the engine side. If the release fork is not in contact with the case, the setting is complete.
- Confirm that the boot cover is set securely.

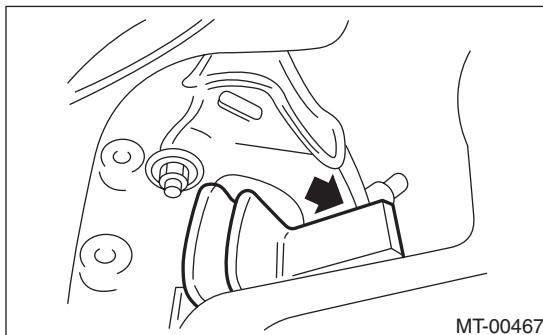

12) Install the pitching stopper bracket, return spring bracket, and transmission radio ground cable.

**Tightening torque:**

**41 N·m (4.2 kgf·m, 30.2 ft·lb)**

13) Install the pitching stopper.

**Tightening torque:**

**T1: 50 N·m (5.1 kgf·m, 36.9 ft·lb)**

**T2: 58 N·m (5.9 kgf·m, 42.8 ft·lb)**

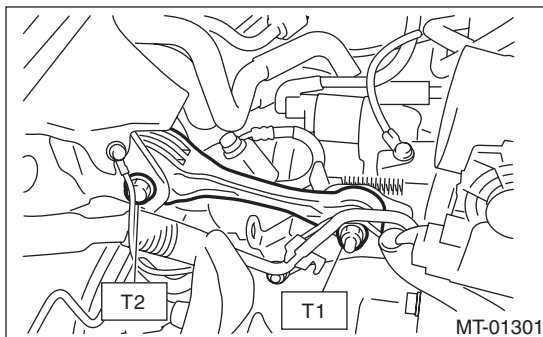

# Manual Transmission Assembly

## MANUAL TRANSMISSION AND DIFFERENTIAL

14) Install the return spring.

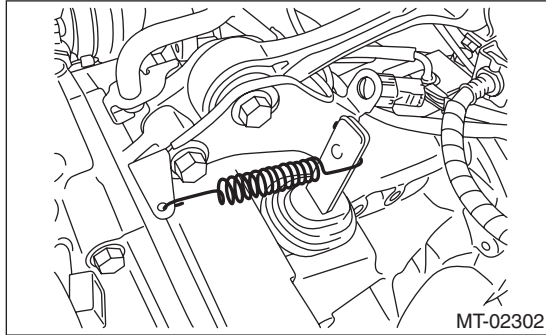

15) Install the clutch operating cylinder.

**Tightening torque:**

**41 N·m (4.2 kgf·m, 30.2 ft·lb)**

NOTE:

Check that the clutch hose is routed properly.

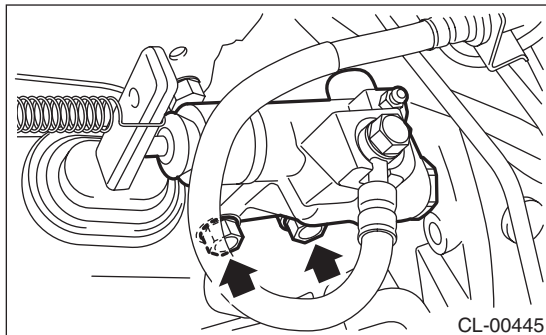

16) Install the starter assembly. <Ref. to SC(STI)-7, INSTALLATION, Starter.>

17) Install the transmission radio ground terminal.

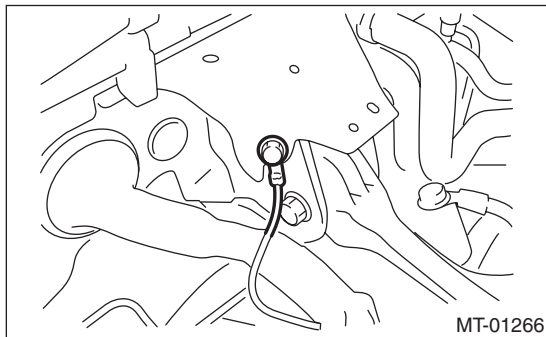

18) Install the secondary air combination valve. <Ref. to EC(STI)-30, SECONDARY AIR COMBINATION VALVE LH, INSTALLATION, Secondary Air Combination Valve.>

19) Connect the following harness connectors, then attach the engine hanger rear.



(A) Front oxygen (A/F) sensor connector

(B) Rear oxygen sensor connector

(C) Neutral position switch backup light switch connector

20) Lift up the vehicle.

21) Set the ST to side retainer.

ST 28399SA010 OIL SEAL PROTECTOR

22) Install the front drive shaft into the transmission.

NOTE:

Replace the circlip of drive shaft with a new part.

23) Install the front drive shaft into transmission, remove the ST and insert the drive shaft securely.

ST 28399SA010 OIL SEAL PROTECTOR

24) Install the ball joint of the front arm.

**Tightening torque:**

**50 N·m (5.1 kgf·m, 36.9 ft·lb)**

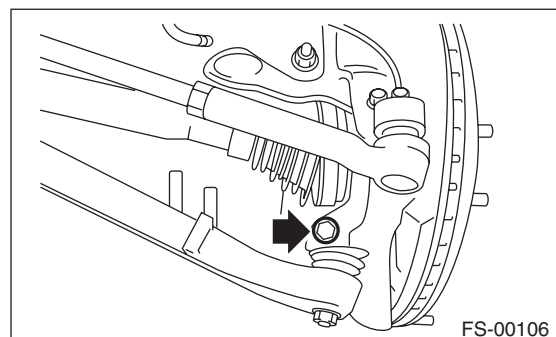



25) Install the front stabilizer link.

**Tightening torque:**

**45 N·m (4.6 kgf·m, 33.2 ft·lb)**

**NOTE:**

Use a new self-locking nut.

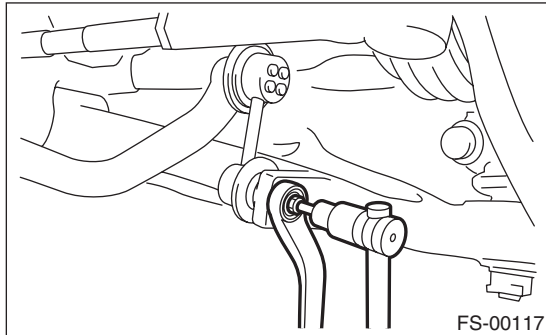

26) Install the propeller shaft. <Ref. to DS-12, INSTALLATION, Propeller Shaft.>

27) Install the heat shield cover.

28) Install the center exhaust pipe. <Ref. to EX(STI)-9, INSTALLATION, Center Exhaust Pipe.>

29) Fill the transmission gear oil. <Ref. to 6MT-27, REPLACEMENT, Transmission Gear Oil.>

30) Install the transmission under cover.

31) Install the intercooler. <Ref. to IN(STI)-13, INSTALLATION, Intercooler.>

32) Connect the battery ground terminal.

# Preparation for Overhaul

MANUAL TRANSMISSION AND DIFFERENTIAL

---

## 7. Preparation for Overhaul

### A: PROCEDURE

1) Clean oil, grease, dirt and dust from the transmission.

2) Attach the transmission to the ST.

ST 18632AA000 STAND ASSY

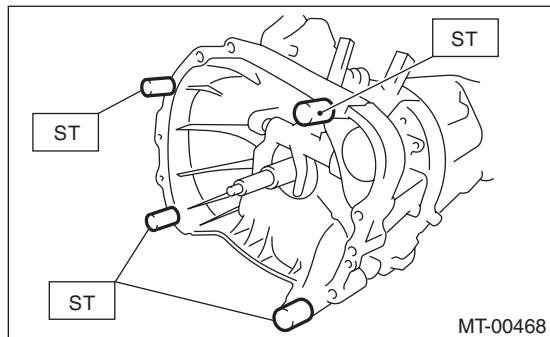

3) Apply oil to rotating parts before assembly.

4) When reusing disassembled parts, reinstall in the original positions and directions.

5) Gaskets, lock washers and lock nuts must be replaced with new parts.

6) Apply liquid gasket to the specified areas to prevent leakage.

## 8. Air Breather Hose

### A: REMOVAL

Disconnect the air breather hose.

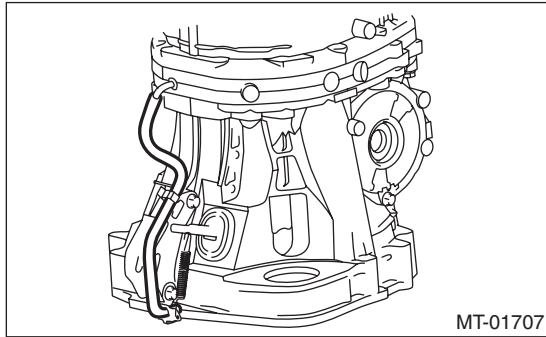

### B: INSTALLATION

Connect the air breather hose.

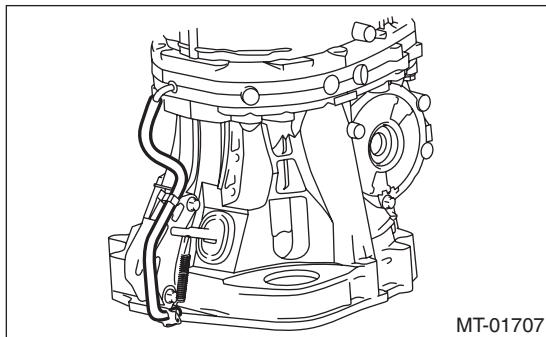

### C: INSPECTION

Make sure the hose is not cracked or clogged.

# Back-up Light Switch

MANUAL TRANSMISSION AND DIFFERENTIAL

## 9. Back-up Light Switch

### A: REMOVAL

- 1) Remove the manual transmission assembly from the vehicle. <Ref. to 6MT-32, REMOVAL, Manual Transmission Assembly.>
- 2) Disconnect the back-up light switch connector.

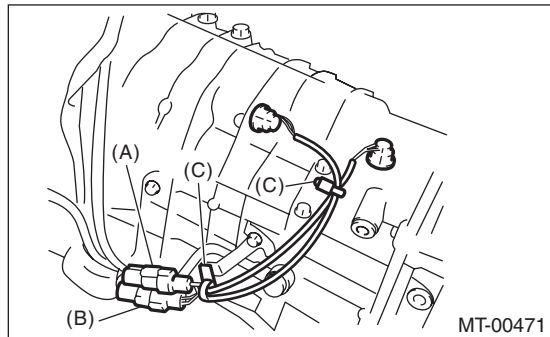

- (A) Back-up light switch connector (Gray)
- (B) Neutral position switch connector (Brown)
- (C) Clip

- 3) Disconnect the back-up light switch.

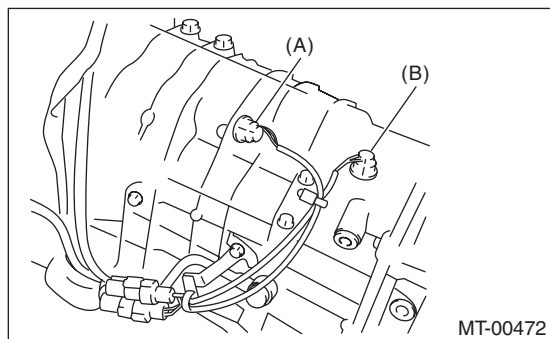

- (A) Back-up light switch
- (B) Neutral position switch

### B: INSTALLATION

- 1) Install the back-up light switch.

NOTE:

Use a new gasket.

**Tightening torque:**

**32 N·m (3.3 kgf·m, 23.6 ft·lb)**

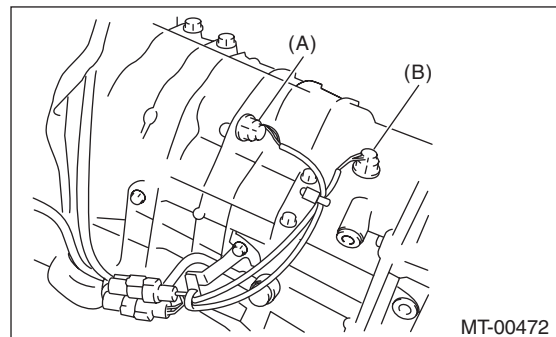

- (A) Back-up light switch
- (B) Neutral position switch

- 2) Connect the back-up light switch connector.

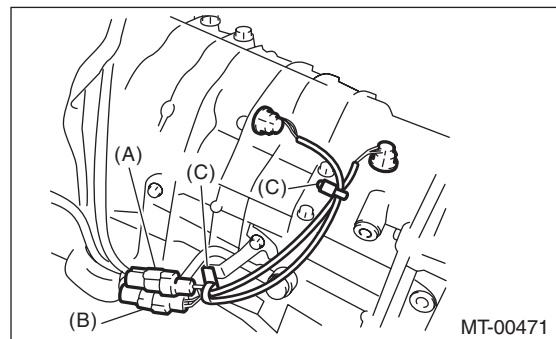

- (A) Back-up light switch connector (Gray)
- (B) Neutral position switch connector (Brown)
- (C) Clip

- 3) Install the manual transmission assembly to the vehicle. <Ref. to 6MT-34, INSTALLATION, Manual Transmission Assembly.>

### C: INSPECTION

- 1) Disconnect the ground cable from battery.
- 2) Remove the intercooler. <Ref. to IN(STI)-12, REMOVAL, Intercooler.>

# Back-up Light Switch

3) Disconnect the transmission harness and chassis harness.

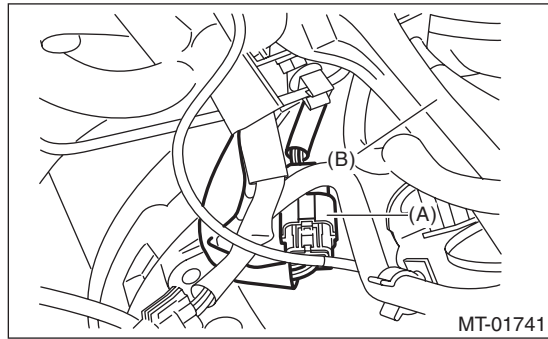

- (A) Transmission harness connectors
- (B) Pitching stopper

4) Measure the resistance between the back-up light switch terminals. If it is not within the specification, replace the back-up light switch.

Gear shift position	Terminal No.	Standard
Back position	3 and 6	Less than 1 $\Omega$
Other positions		1 M $\Omega$ or more

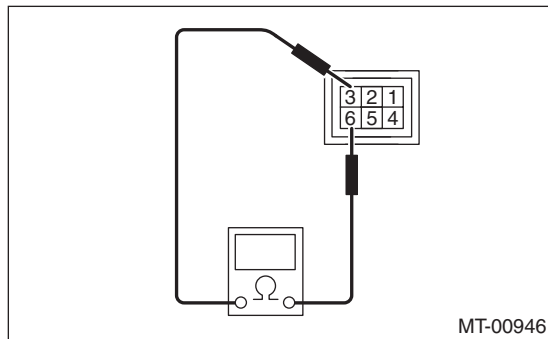

# Neutral Position Switch

## MANUAL TRANSMISSION AND DIFFERENTIAL

### 10. Neutral Position Switch

#### A: REMOVAL

- 1) Remove the manual transmission assembly from the vehicle. <Ref. to 6MT-32, REMOVAL, Manual Transmission Assembly.>
- 2) Disconnect the connector and clip of the neutral position switch.

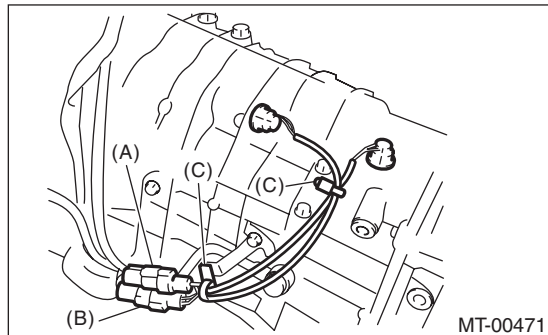

- (A) Back-up light switch connector (Gray)
- (B) Neutral position switch connector (Brown)
- (C) Clip

- 3) Remove the neutral position switch.

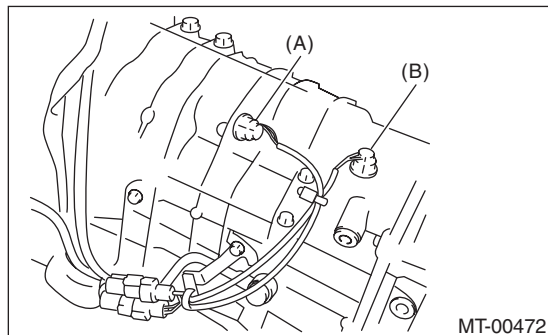

- (A) Back-up light switch
- (B) Neutral position switch

#### B: INSTALLATION

- 1) Install the neutral position switch.

#### NOTE:

Use a new gasket.

#### Tightening torque:

**32 N·m (3.3 kgf-m, 23.6 ft-lb)**

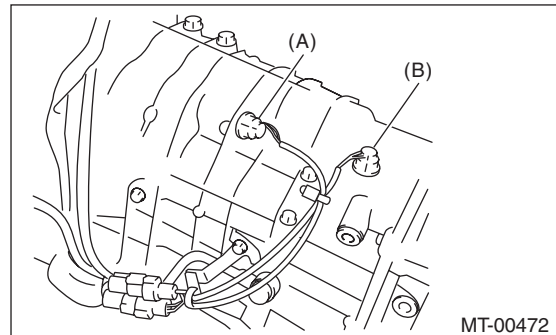

- (A) Back-up light switch
- (B) Neutral position switch

- 2) Connect the connector and clip of the neutral position switch.

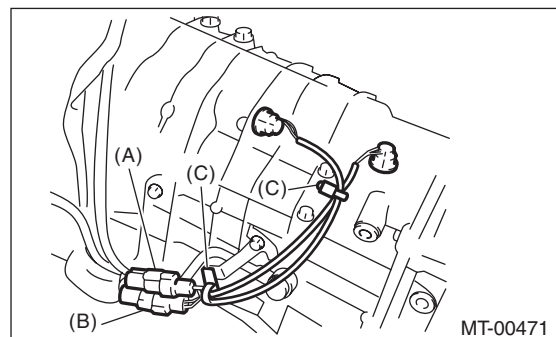

- (A) Back-up light switch connector (Gray)
- (B) Neutral position switch connector (Brown)
- (C) Clip

- 3) Install the manual transmission assembly to the vehicle. <Ref. to 6MT-34, INSTALLATION, Manual Transmission Assembly.>

#### C: INSPECTION

- 1) Disconnect the ground cable from battery.
- 2) Remove the intercooler. <Ref. to IN(STI)-12, REMOVAL, Intercooler.>

# Neutral Position Switch

3) Disconnect the transmission harness and chassis harness.

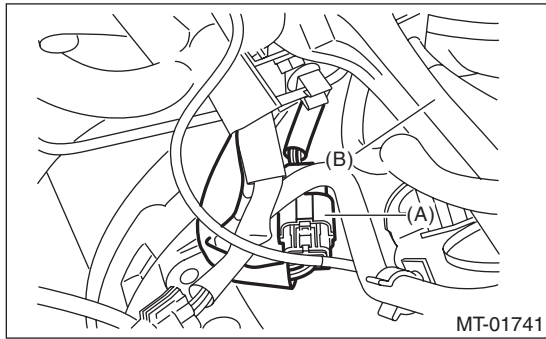

- (A) Transmission harness connectors
- (B) Pitching stopper

4) Measure the resistance between neutral position switch terminals. If not within the standard values, replace the neutral position switch.

Gear shift position	Terminal No.	Standard
Neutral position	2 and 5	Less than 1 $\Omega$
Other positions		1 M $\Omega$ or more

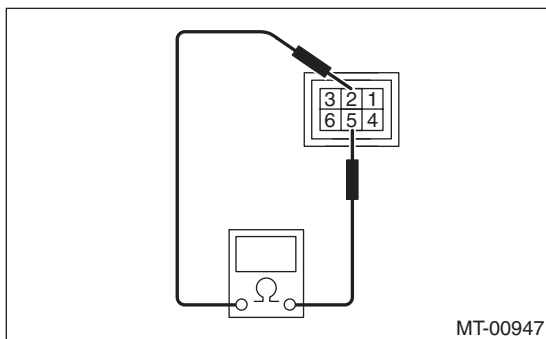

# Extension Case

## MANUAL TRANSMISSION AND DIFFERENTIAL

### 11.Extension Case

#### A: REMOVAL

- 1) Remove the manual transmission assembly from the vehicle. <Ref. to 6MT-32, REMOVAL, Manual Transmission Assembly.>
- 2) Prepare the transmission for overhaul. <Ref. to 6MT-38, Preparation for Overhaul.>
- 3) Remove the extension case.

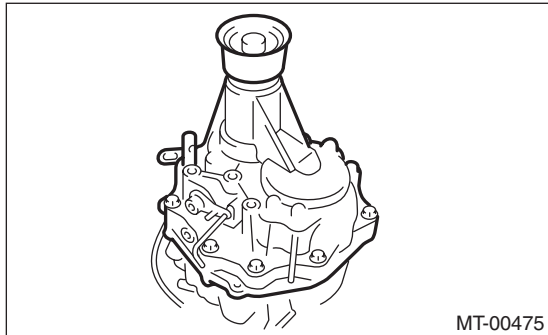

- 4) Remove any remaining liquid gasket from the extension case and transmission case.

#### B: INSTALLATION

- 1) Select the thrust washer of the transfer driven gear, and attach to the extension case. <Ref. to 6MT-46, ADJUSTMENT, Extension Case.>
- 2) Apply a thin coat of oil to the outer surface of the bearing cone, and attach to the extension case.
- 3) Select the thrust washer of the transfer drive gear, and attach to the center differential.
- 4) Apply liquid gasket to the transmission case.

#### Liquid gasket:

**THREE BOND 1215 (Part No. 004403007) or equivalent**

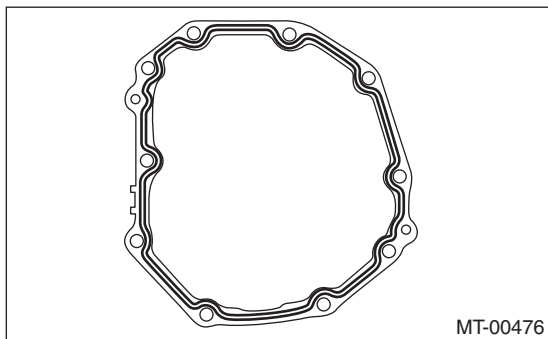

- 5) Install the extension case.

#### Tightening torque:

**48 N·m (4.9 kgf·m, 35.4 ft·lb)**

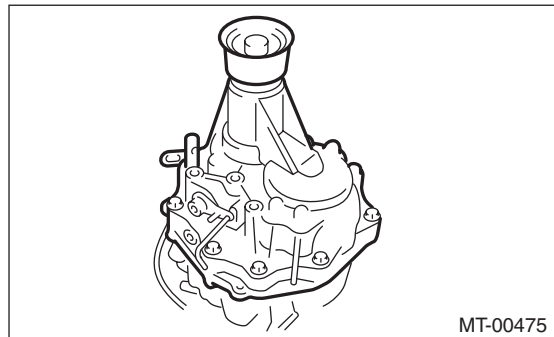

#### NOTE:

Insert the stopper section of the center differential between the oil guide.

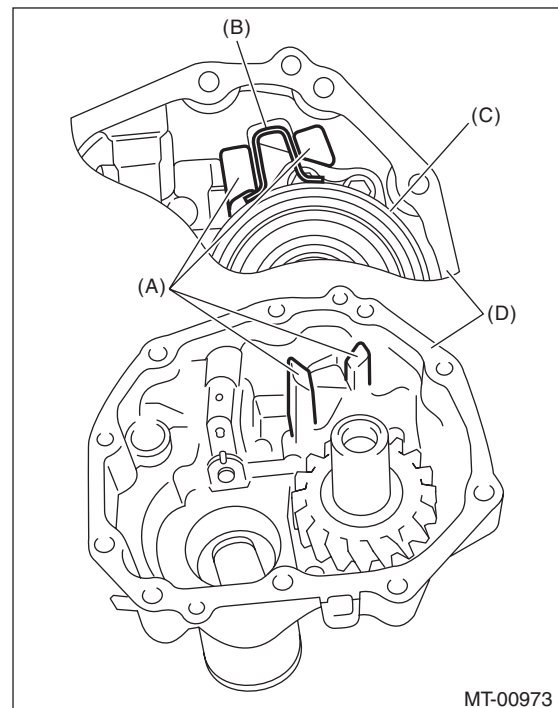

- (A) Oil guide
- (B) Stopper
- (C) Center differential
- (D) Extension case

- 6) Install the manual transmission assembly to the vehicle. <Ref. to 6MT-34, INSTALLATION, Manual Transmission Assembly.>



# Extension Case

MANUAL TRANSMISSION AND DIFFERENTIAL

## C: DISASSEMBLY

- 1) Remove the transfer drive gear. <Ref. to 6MT-53, REMOVAL, Transfer Drive Gear.>
- 2) Remove the oil guide.

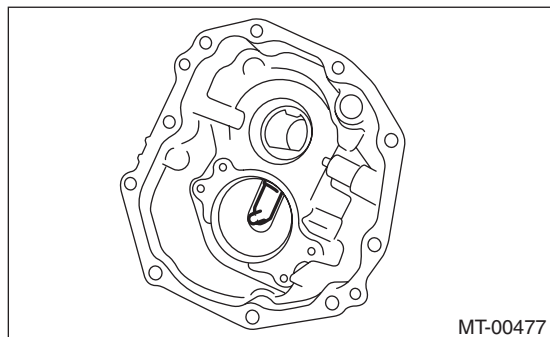

- 3) Remove the shift bracket.

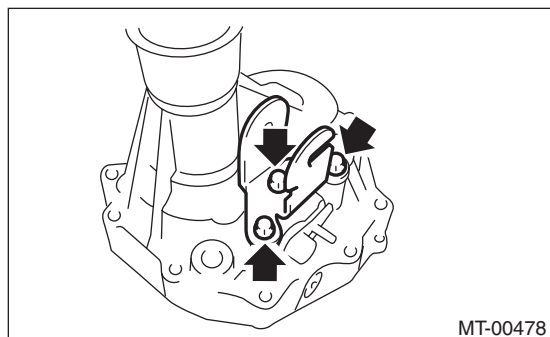

- 4) Remove the bearing cone using the ST.  
ST 18758AA000 PULLER

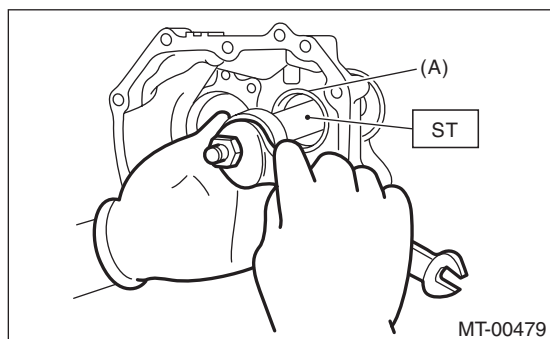

(A) Bearing cone

- 5) Remove the thrust washer and oil plate.

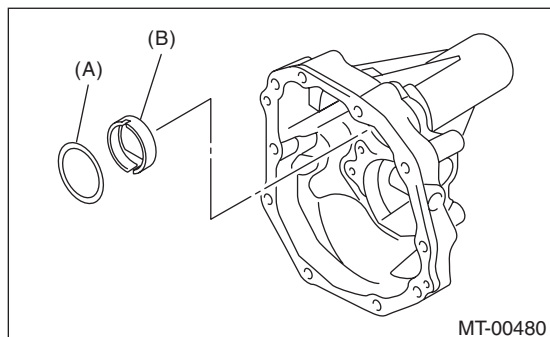

(A) Thrust washer  
(B) Oil plate

- 6) Remove the shifter arm oil seal.

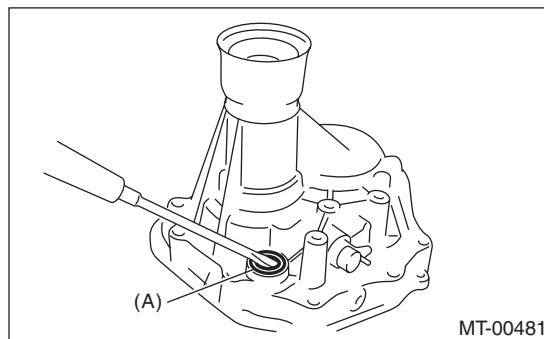

(A) Oil seal

- 7) Remove the reverse check system. <Ref. to 6MT-50, REMOVAL, Reverse Check System.>
- 8) Remove the extension oil seal. <Ref. to 6MT-28, REPLACEMENT, Oil Seal.>

## D: ASSEMBLY

- 1) Install the reverse check system. <Ref. to 6MT-51, INSTALLATION, Reverse Check System.>
- 2) Install the extension case oil seal. <Ref. to 6MT-28, REPLACEMENT, Oil Seal.>
- 3) Install a shifter arm oil seal using the ST.  
ST1 18657AA000 INSTALLER  
ST2 18671AA000 OIL SEAL GUIDE

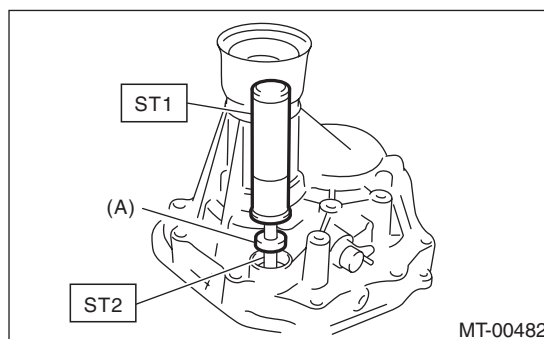

(A) Oil seal

- 4) Install the oil plate.

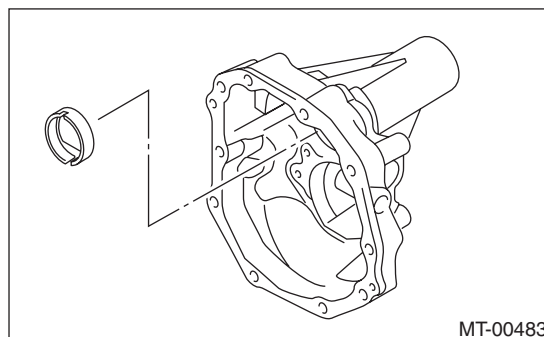

- 5) Select the thrust washer of the bearing, and attach to the extension case. <Ref. to 6MT-46, ADJUSTMENT, Extension Case.>

6MT-45

Brought to you by Ebay Seller "SubaruManuals"

# Extension Case

## MANUAL TRANSMISSION AND DIFFERENTIAL

- 6) Apply a thin coat of oil to the outer surface of the bearing cone, and attach to the extension case.
- 7) Install the shift bracket.

### Tightening torque:

**25 N·m (2.5 kgf·m, 18.4 ft·lb)**

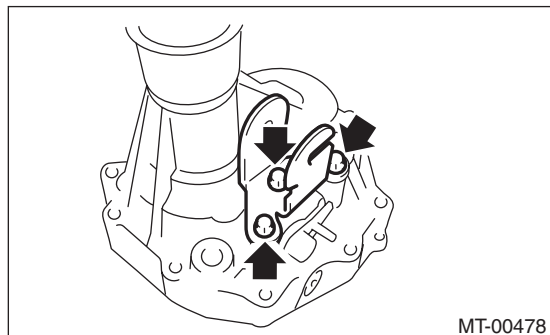

- 8) Attach the oil guide and the transfer driven gear. <Ref. to 6MT-53, INSTALLATION, Transfer Drive Gear.>

## E: INSPECTION

- 1) Check to make sure there is no damage or cracks on the extension case. If damage or cracking is found, replace the extension case.
- 2) Inspect for oil leaks at the extension case and transmission case oil seals and mating surfaces. If there are oil leaks, replace the oil seal and liquid gasket.

## F: ADJUSTMENT

### 1. TRANSFER DRIVEN GEAR BEARING THRUST WASHER ADJUSTMENT

- 1) Remove the bearing cone from the extension case using the ST.

ST 18758AA000 PULLER

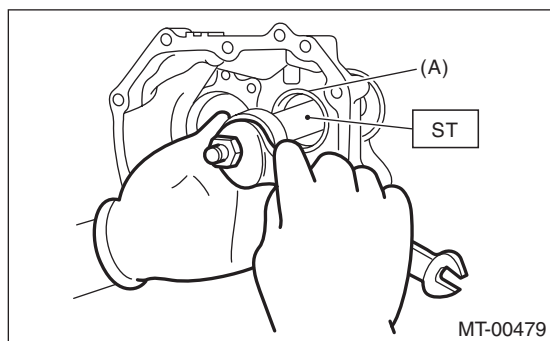

(A) Bearing cone

- 2) Remove the thrust washer.

- 3) Measure depth "Z" between the extension case end area and bearing cone contact area.

ST 398643600 GAUGE

### NOTE:

When measuring depth "Z", subtract the thickness of the ST [15 mm (0.59 in)] from the measured value.

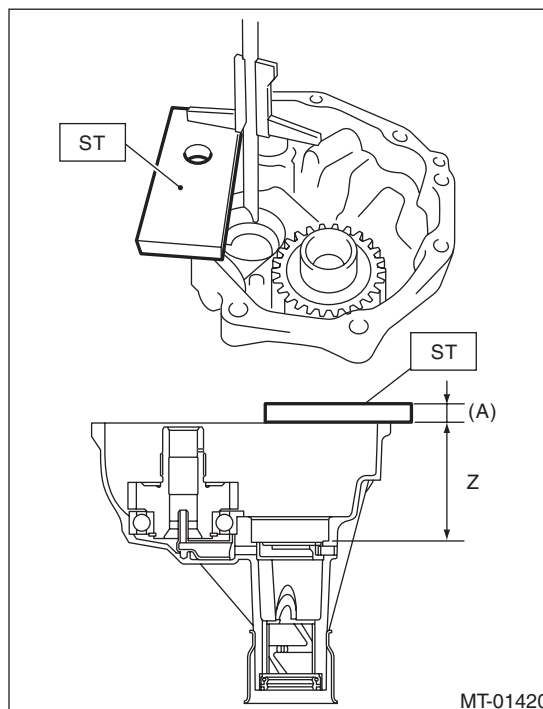

(A) 15 mm (0.59 in)

- 4) Remove the transfer driven gear. <Ref. to 6MT-55, REMOVAL, Transfer Driven Gear.>

- 5) Remove the center differential. <Ref. to 6MT-57, REMOVAL, Center Differential.>

- 6) Remove the oil guides G and H.

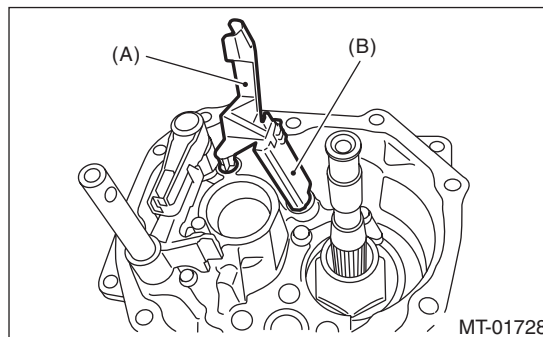

(A) Oil guide G

(B) Oil guide H

# Extension Case

## MANUAL TRANSMISSION AND DIFFERENTIAL

7) Remove the snap ring and flat washer from the selector arm area.

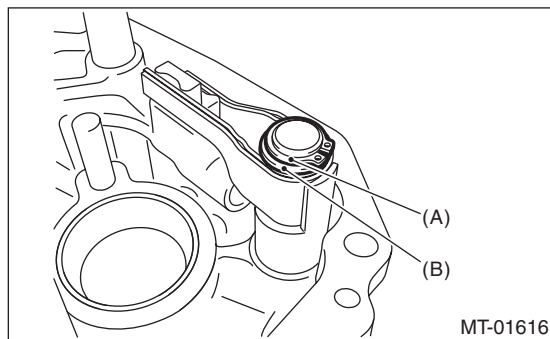

- (A) Snap ring
- (B) Flat washer

8) Using an ST, remove the neutral set spring and support.

ST1 18756AA000 CLAW  
ST2 399893600 PLIER

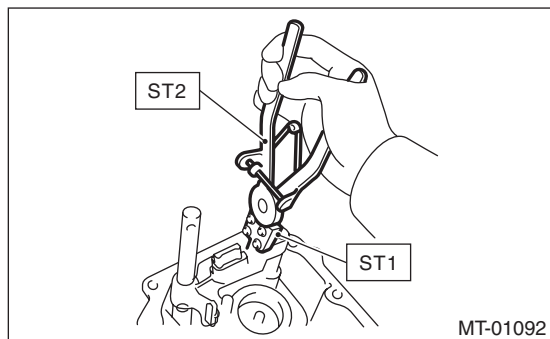

9) Lift the striking rod, and remove the spring pin.

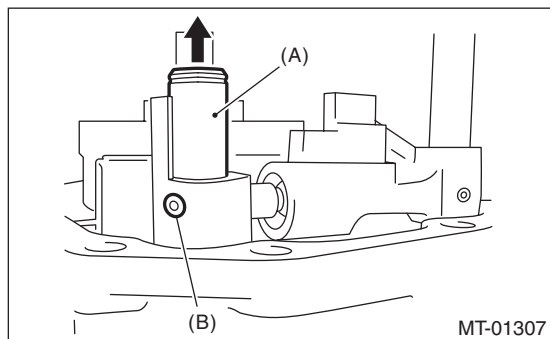

- (A) Striking rod
- (B) Spring pin

10) Remove the selector arm No. 2, shifter arm, selector plunger and spring.

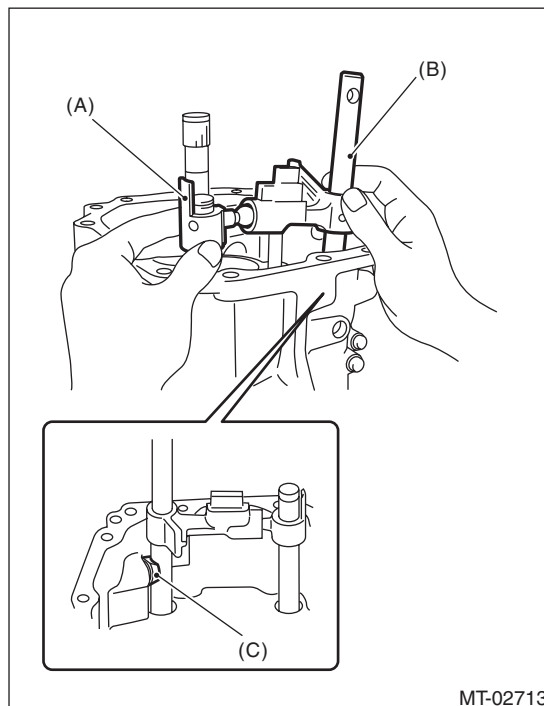

- (A) Selector arm No. 2
- (B) Shifter arm
- (C) Selector plunger

11) Attach the bearing cone to the transfer driven gear.

12) Set the ST.

ST 18831AA000 GAUGE

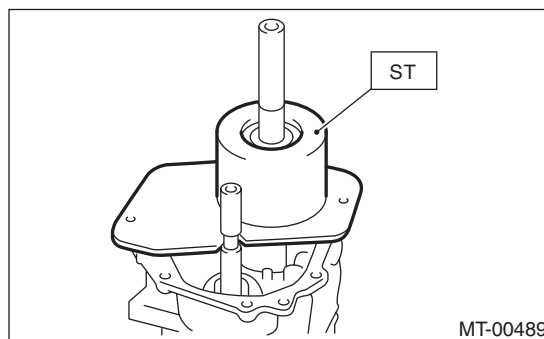

13) Turn the transfer driven gear 10 or more times to seat the bearing properly.

## Extension Case

### MANUAL TRANSMISSION AND DIFFERENTIAL

14) Measure depth "Y" between the end of the ST and the bearing cone.

ST 18831AA000 GAUGE

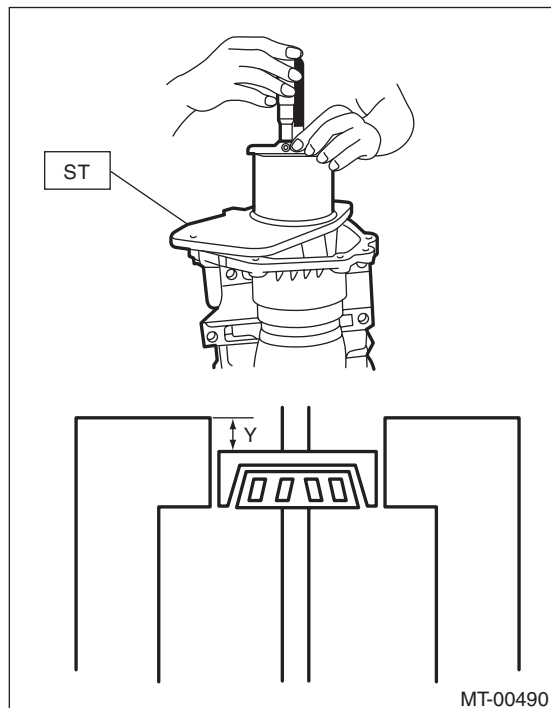

15) Using the following calculation, calculate the transfer driven gear bearing thrust washer value "t".  
 $t = Z - (100 - Y) - \{0.02 - 0.11 \text{ mm (0.0008 - 0.0043 in)}\}$

t mm (in)	Transfer driven gear bearing thrust washer thickness
Y mm (in)	Depth between the end of the ST and the bearing cone
Z mm (in)	Depth between the end of the extension case and the bearing cone contact area
0.02 — 0.11 mm (0.0008 — 0.0043 in)	Standard clearance between the thrust washer and taper roller bearing
100 mm (3.94 in)	Height of ST

16) Refer to the calculated value "t" to select the closest thrust washer from the following table.

**Standard clearance between the thrust washer and taper roller bearing**

**0.02 — 0.11 mm (0.0008 — 0.0043 in)**

NOTE:

Match to be within the standard clearance range.

Thrust washer (50 × 61 × t)	
Part No.	Thickness t mm (in)
803050060	0.50 (0.0197)
803050061	0.55 (0.0217)
803050062	0.60 (0.0236)
803050063	0.65 (0.0256)
803050064	0.70 (0.0276)
803050065	0.75 (0.0295)
803050066	0.80 (0.0315)
803050067	0.85 (0.0335)
803050068	0.90 (0.0354)
803050069	0.95 (0.0374)
803050070	1.00 (0.0394)
803050071	1.05 (0.0413)
803050072	1.10 (0.0433)
803050073	1.15 (0.0453)
803050074	1.20 (0.0472)
803050075	1.25 (0.0492)
803050076	1.30 (0.0512)
803050077	1.35 (0.0531)
803050078	1.40 (0.0551)
803050079	1.45 (0.0570)

17) Install the selector arm No. 2, shifter arm, selector plunger and spring.

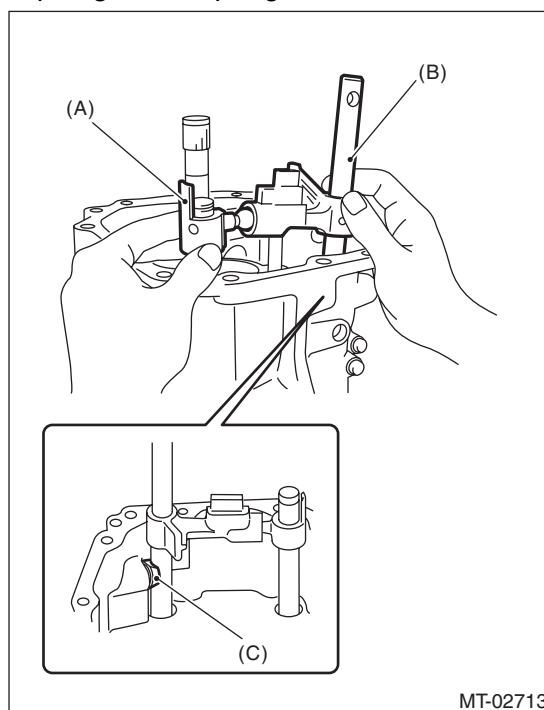

- (A) Selector arm No. 2
- (B) Shifter arm
- (C) Selector plunger

# Extension Case

MANUAL TRANSMISSION AND DIFFERENTIAL

- 18) Install a new spring pin.
- 19) Using the ST, install the neutral set spring and support.

ST1 18756AA000 CLAW

ST2 399893600 PLIER

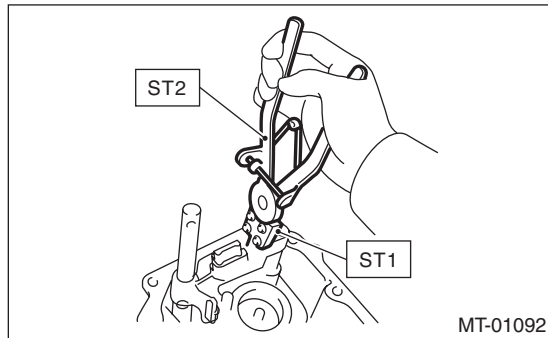

- 20) Install the flat washer and snap ring to the selector arm area.

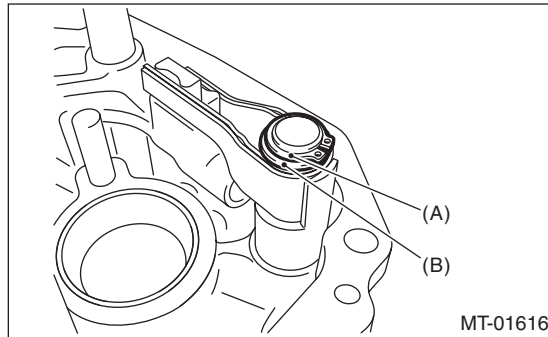

- (A) Snap ring
- (B) Flat washer

- 21) Install the center differential. <Ref. to 6MT-57, INSTALLATION, Center Differential.>

## 2. TRANSFER DRIVE GEAR THRUST WASHER SELECTION

- 1) Measure height "Z" between the transmission case end area and ST.

ST 398643600 GAUGE

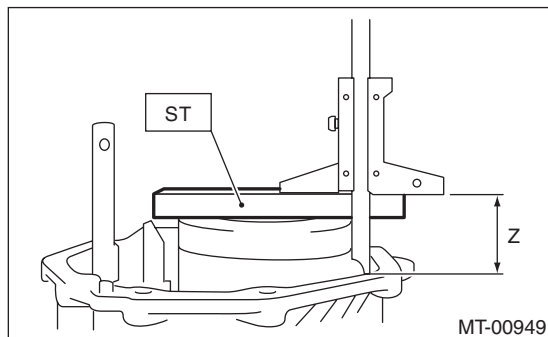

- 2) Measure depth "Y" between the end of the ST and the transfer drive gear.

ST 398643600 GAUGE

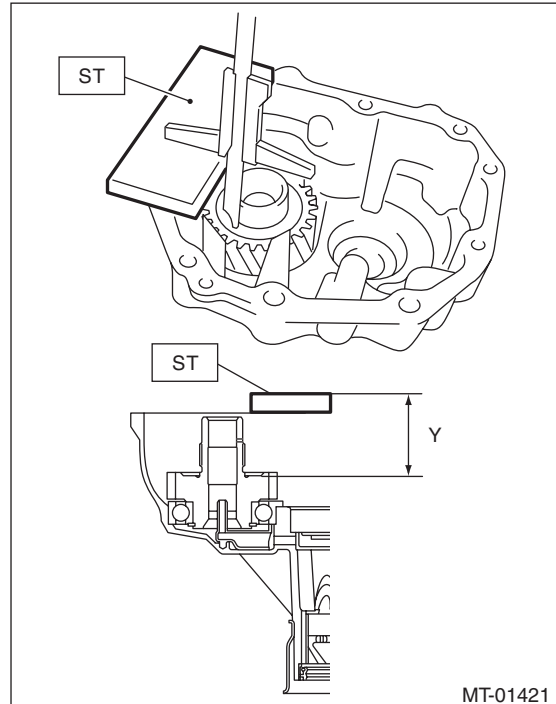

- 3) Using the following calculation, calculate the transfer drive gear thrust washer value "t".

$$t = \{Y - 15 \text{ mm (0.59 in)}\} - \{Z - 15 \text{ mm (0.59 in)}\} - 0.75 - 0.95 \text{ mm (0.030 - 0.037 in)}$$

t mm (in)	Transfer drive gear thrust washer thickness
Y mm (in)	Depth between the end of the ST and the transfer drive gear
Z mm (in)	Height from the end of the transmission case to the end of the ST.
0.75 — 0.95 mm (0.030 — 0.037 in)	Standard clearance between the thrust washer and transfer drive gear
15 mm (0.591 in)	Thickness of ST

- 4) Refer to the calculated value "t" to select the closest thrust washer from the following table.

### Standard clearance between the thrust washer and transfer drive gear

**0.75 — 0.95 mm (0.030 — 0.037 in)**

NOTE:

Match to be within the standard clearance range.

Thrust washer (36.3 × 52 × t)	
Part No.	Thickness mm (in)
803036070	0.80 (0.0315)
803036071	0.95 (0.0374)
803036072	1.10 (0.0433)
803036073	1.25 (0.0492)
803036074	1.40 (0.0551)
803036075	0.65 (0.0256)

- 5) Install the selected thrust washer.

6MT-49

Brought to you by Ebay Seller "SubaruManuals"

# Reverse Check System

## MANUAL TRANSMISSION AND DIFFERENTIAL

### 12.Reverse Check System

#### A: REMOVAL

- 1) Remove the manual transmission assembly from the vehicle. <Ref. to 6MT-32, REMOVAL, Manual Transmission Assembly.>
- 2) Prepare the transmission for overhaul. <Ref. to 6MT-38, Preparation for Overhaul.>
- 3) Remove the extension case. <Ref. to 6MT-44, REMOVAL, Extension Case.>
- 4) Remove the snap ring and washer from the reverse check shaft.

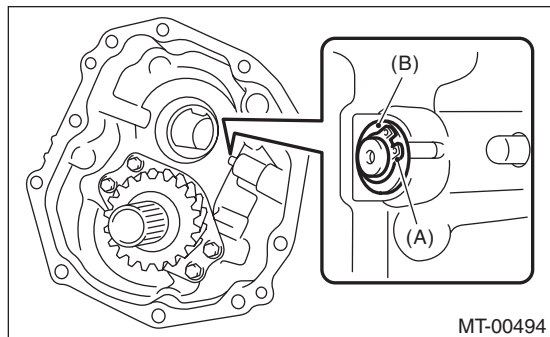

- (A) Snap ring
- (B) Washer

- 5) Remove the reverse check shaft and spring from the extension case.

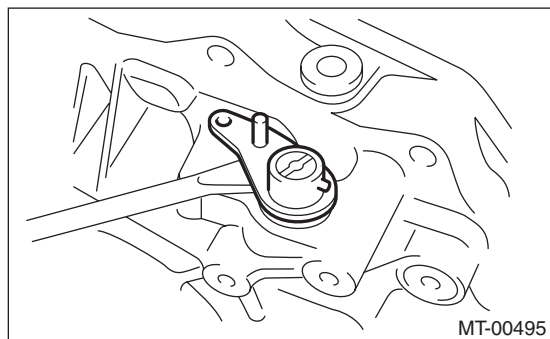

- 6) Remove the spring pin, and remove the reverse check lever and oil seal from the reverse check shaft.

NOTE:  
Do not reuse the oil seal.

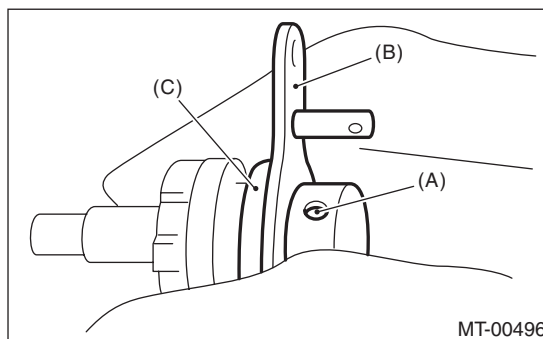

- (A) Spring pin
- (B) Reverse check lever
- (C) Oil seal

- 7) Remove the plug from the extension case, and remove the gasket, spring and plunger.

NOTE:  
Do not reuse the gasket.

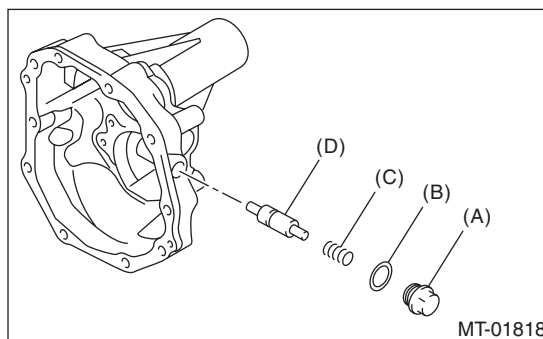

- (A) Plug
- (B) Gasket
- (C) Spring
- (D) Plunger

- 8) Remove the reverse lock plunger.

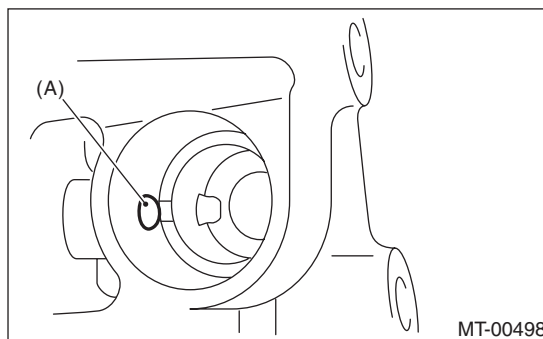

- (A) Reverse lock plunger



# Reverse Check System

MANUAL TRANSMISSION AND DIFFERENTIAL

## B: INSTALLATION

- 1) Insert the reverse lock plunger.
- 2) Install the reverse check plug, spring, gasket, and plug in order.

### Tightening torque:

**41 N·m (4.2 kgf·m, 30.2 ft·lb)**

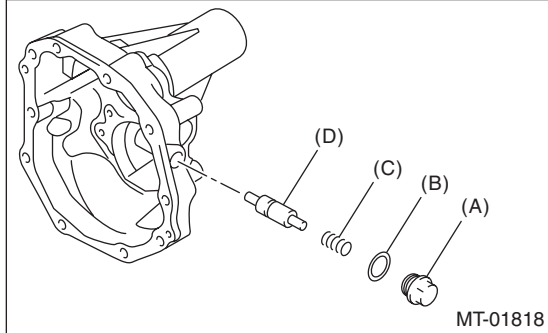

- (A) Plug
- (B) Gasket
- (C) Spring
- (D) Reverse check plug

- 3) Install the spring and reverse check shaft to the extension case.

### NOTE:

Confirm that the end of the spring matches the hole of the reverse check shaft and the cut out of the extension case.

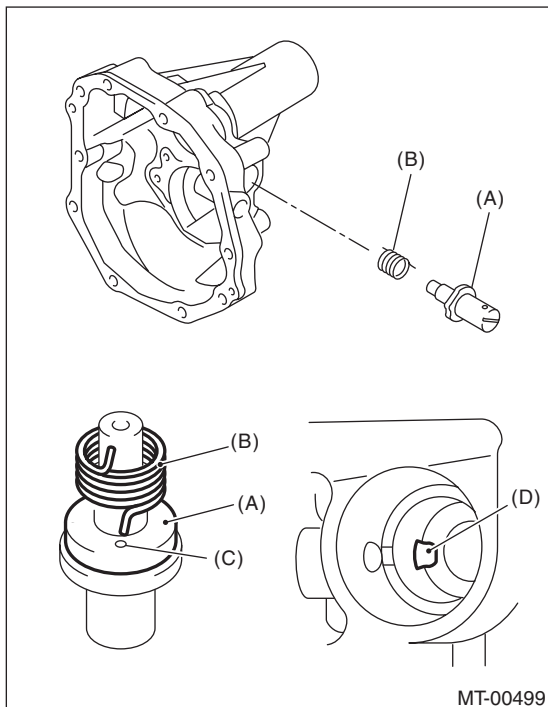

- (A) Reverse check shaft
- (B) Spring
- (C) Hole
- (D) Cut out

- 4) Install the washer and snap ring.

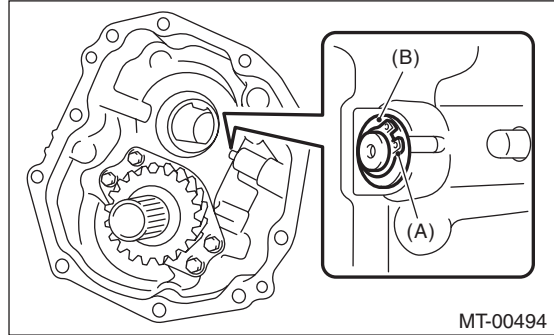

- (A) Snap ring
- (B) Washer

- 5) Attach ST1 to the reverse check shaft. Install the new oil seal, and push it in using ST2.

ST1 18671AA000 OIL SEAL GUIDE

ST2 18657AA010 INSTALLER

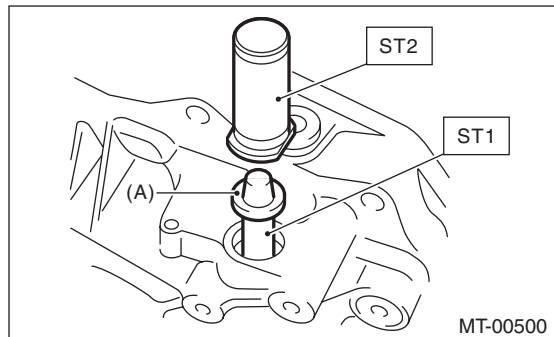

- (A) Oil seal

- 6) Insert the reverse check lever, and turn the reverse check shaft until the plunger is first pushed in.

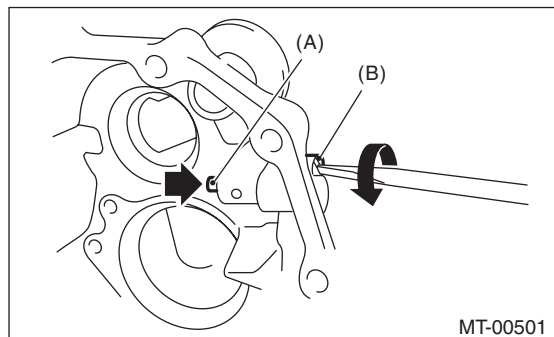

- (A) Plunger
- (B) Reverse check shaft

6MT-51

Brought to you by Ebay Seller "SubaruManuals"

# Reverse Check System

## MANUAL TRANSMISSION AND DIFFERENTIAL

7) Match the hole of the reverse check lever and the reverse check shaft, and attach the straight pin.

### NOTE:

Use a new straight pin.

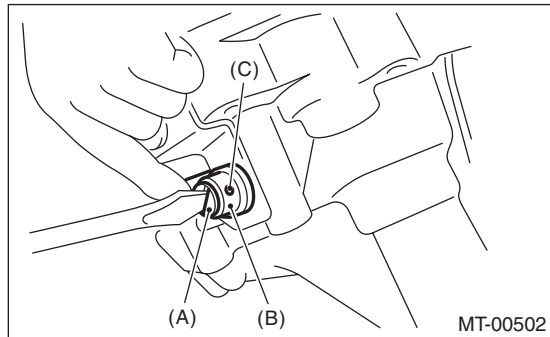

- (A) Reverse check shaft
- (B) Reverse check lever
- (C) Hole

8) Check that the reverse check is operating correctly. <Ref. to 6MT-52, INSPECTION, Reverse Check System.>

9) Install the extension case. <Ref. to 6MT-44, INSTALLATION, Extension Case.>

10) Install the manual transmission assembly to the vehicle. <Ref. to 6MT-34, INSTALLATION, Manual Transmission Assembly.>

## C: INSPECTION

- 1) Check that there is no damage on any parts.
- 2) Check that the reverse check lever is operating smoothly.
- 3) Inspect that there is no oil leak at the oil seal section of the reverse check shaft. If there is oil leakage, replace the oil seal.
- 4) Check the operation of the reverse check.

(1) When the reverse check lever is in the following position, the plunger is pressed, or the gear can shift into reverse.

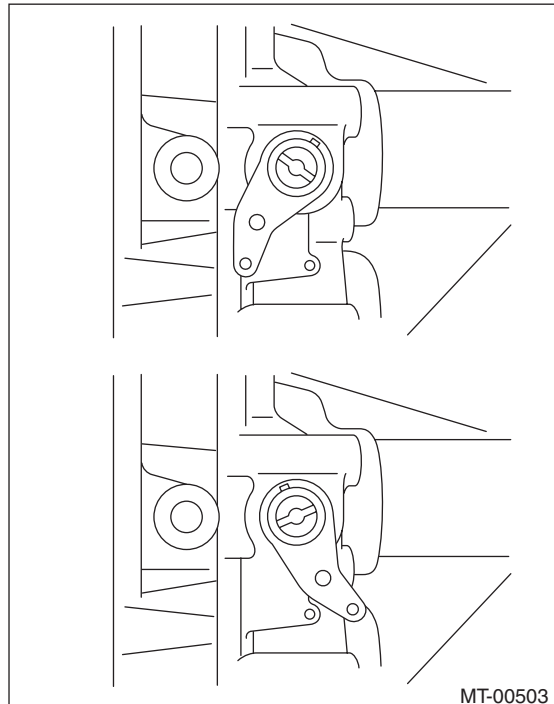

(2) When the reverse check lever is in the following position, the plunger is not pressed, or the gear cannot shift into reverse.

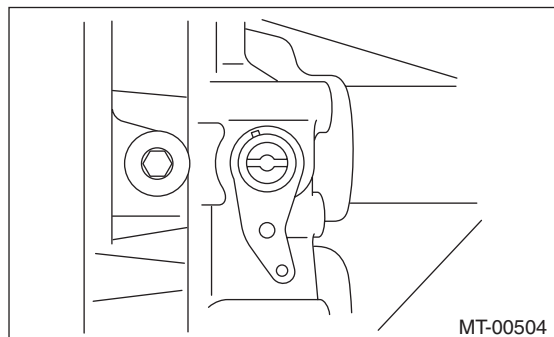

5) If it is not as specified, reassemble the reverse check system.



# Transfer Drive Gear

MANUAL TRANSMISSION AND DIFFERENTIAL

## 13. Transfer Drive Gear

### A: REMOVAL

- 1) Remove the manual transmission assembly from the vehicle. <Ref. to 6MT-32, REMOVAL, Manual Transmission Assembly.>
- 2) Prepare the transmission for overhaul. <Ref. to 6MT-38, Preparation for Overhaul.>
- 3) Remove the extension case. <Ref. to 6MT-44, REMOVAL, Extension Case.>
- 4) Remove the transfer drive gear.

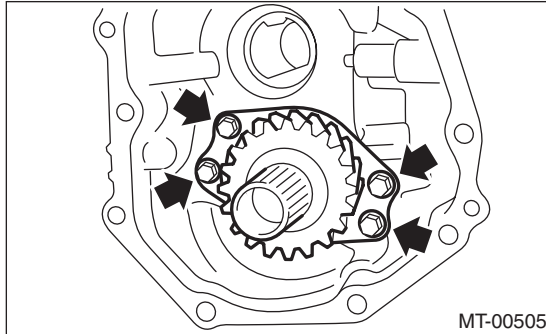

### B: INSTALLATION

- 1) Install the transfer drive gear.

#### *Tightening torque:*

**25 N·m (2.5 kgf-m, 18.4 ft-lb)**

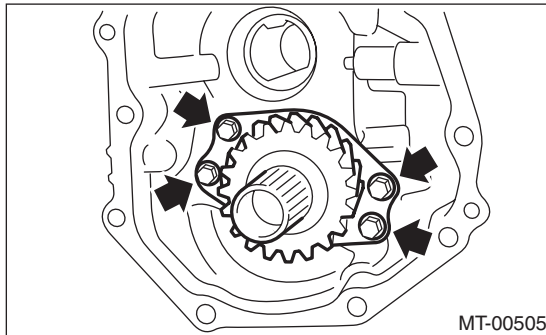

- 2) When the ball bearing, transfer drive gear or snap ring are replaced, select an appropriate thrust washer for the transfer drive gear. <Ref. to 6MT-45, ASSEMBLY, Extension Case.>
- 3) Install the extension case. <Ref. to 6MT-44, INSTALLATION, Extension Case.>
- 4) Install the manual transmission assembly to the vehicle. <Ref. to 6MT-34, INSTALLATION, Manual Transmission Assembly.>

### C: DISASSEMBLY

- 1) Remove the snap ring.

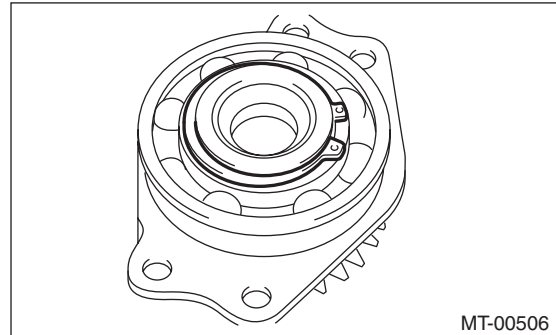

- 2) Remove the bearing using the ST.  
ST 499877000 RACE 4-5 INSTALLER

#### NOTE:

Do not reuse the ball bearing.

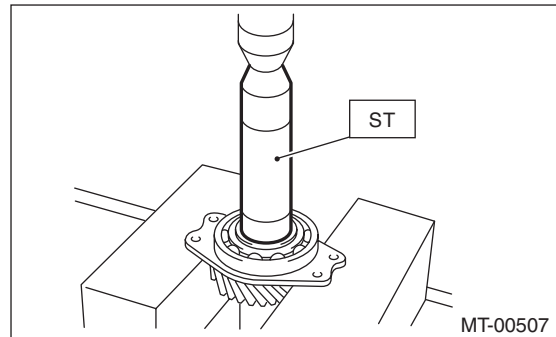

### D: ASSEMBLY

- 1) Using the ST, install the ball bearing.

#### NOTE:

Use a new ball bearing.

ST1 499247400 INSTALLER

ST2 398497701 SEAT

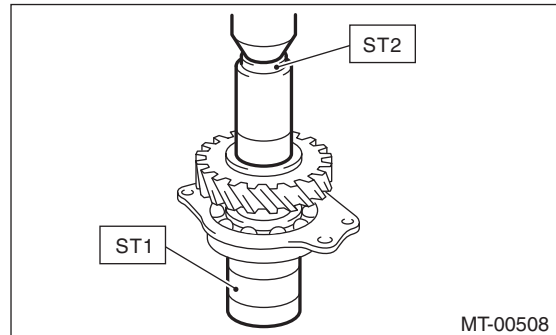

# Transfer Drive Gear

## MANUAL TRANSMISSION AND DIFFERENTIAL

2) Install the snap ring.

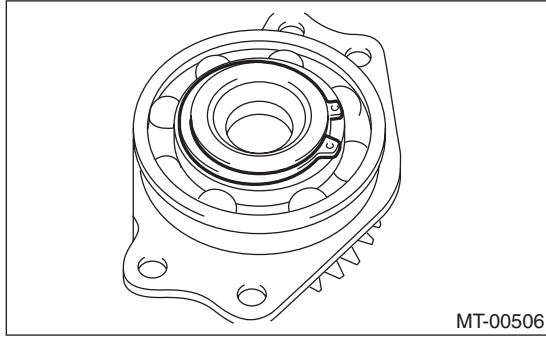

3) Inspect the clearance between the snap ring and the ball bearing. <Ref. to 6MT-54, INSPECTION, Transfer Drive Gear.>

### E: INSPECTION

1) Bearing

Replace the bearings in the following cases.

- Damage or rust on the bearings
- Wear, or damage
- The bearing does not rotate smoothly or an abnormal noise is emitted.

2) Drive gear

Replace the drive gear in following case:

- If the drive gear tooth surface and shaft are excessively damaged or broken.

3) Measure the clearance between the snap ring and ball bearing inner race with a thickness gauge.

**Standard clearance between the snap ring and inner race:**

**0 — 0.15 mm (0 — 0.0059 in)**

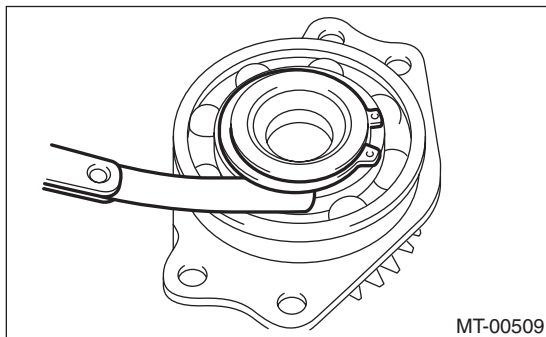

4) If the measurement is out of specifications, reselect an appropriate snap ring.

Snap ring	
Part No.	Thickness mm (in)
805045050	1.76 (0.069)
805045060	1.88 (0.074)
805045070	2.00 (0.079)

After replacing the snap ring, reinspect the clearance.

# Transfer Driven Gear

MANUAL TRANSMISSION AND DIFFERENTIAL

## 14. Transfer Driven Gear

### A: REMOVAL

- 1) Remove the manual transmission assembly from the vehicle. <Ref. to 6MT-32, REMOVAL, Manual Transmission Assembly.>
- 2) Prepare the transmission for overhaul. <Ref. to 6MT-38, Preparation for Overhaul.>
- 3) Remove the extension case. <Ref. to 6MT-44, REMOVAL, Extension Case.>
- 4) Remove the transfer driven gear.

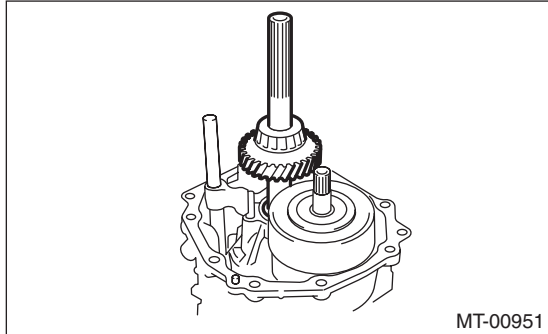

### B: INSTALLATION

- 1) Install the transfer driven gear.

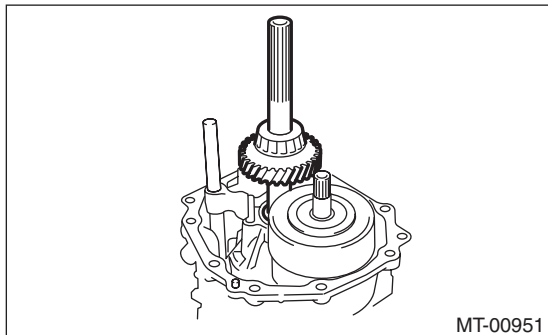

- 2) When the bearing or the transfer driven gear is replaced, select an appropriate thrust washer for the transfer driven gear. <Ref. to 6MT-46, ADJUSTMENT, Extension Case.>
- 3) Install the extension case. <Ref. to 6MT-44, INSTALLATION, Extension Case.>
- 4) Install the manual transmission assembly to the vehicle. <Ref. to 6MT-34, INSTALLATION, Manual Transmission Assembly.>

### C: DISASSEMBLY

- 1) Using the ST, remove the roller bearing (extension case side).

ST 498515700 REMOVER

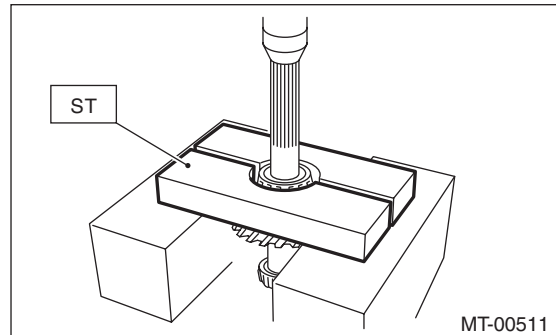

- 2) Using the ST, remove the roller bearing (transmission case side).

ST1 899858600 REMOVER

ST2 899864100 REMOVER

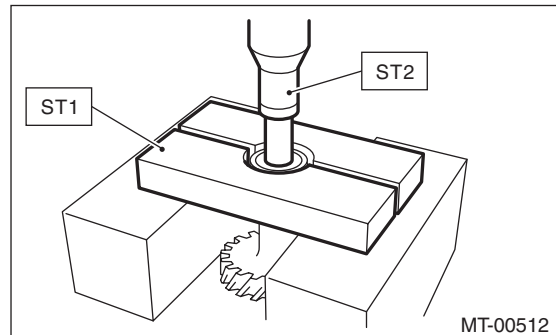

### D: ASSEMBLY

- 1) Using the ST, install the roller bearing (extension case side).

ST1 398177700 INSTALLER

ST2 899864100 REMOVER

### CAUTION:

Do not apply pressure in excess of 10 kN (1 ton, 1.1 US ton, 1.0 Imp ton).

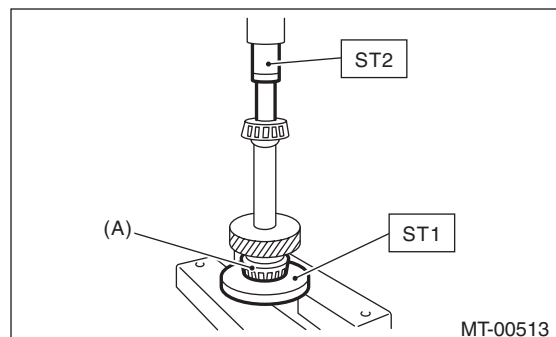

(A) Roller bearing

# Transfer Driven Gear

## MANUAL TRANSMISSION AND DIFFERENTIAL

---

2) Using the ST, install the roller bearing (transmission case side).

ST 499757002 INSTALLER

### CAUTION:

**Do not apply pressure in excess of 10 kN (1 ton, 1.1 US ton, 1.0 Imp ton).**

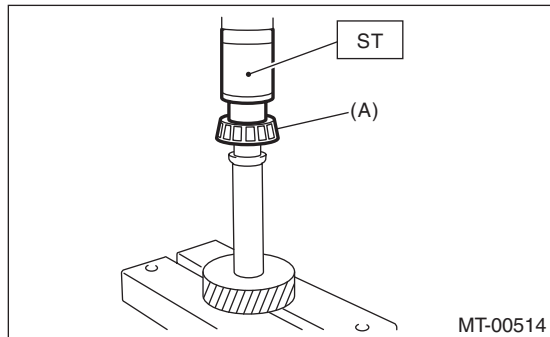

(A) Roller bearing

## E: INSPECTION

### 1) Bearing

Replace the bearings in the following cases.

- Damage or rust on the bearings
- Wear or damage
- After applying transmission gear oil, bearing does not rotate smoothly or an abnormal noise is emitted.

### 2) Driven gear

Replace the driven gear in the following cases.

- If the driven gear tooth surface and shaft are excessively damaged or broken.

# Center Differential

## 15.Center Differential

### A: REMOVAL

- 1) Remove the manual transmission case from the vehicle. <Ref. to 6MT-32, REMOVAL, Manual Transmission Assembly.>
- 2) Prepare the transmission for overhaul. <Ref. to 6MT-38, Preparation for Overhaul.>
- 3) Remove the extension case. <Ref. to 6MT-44, REMOVAL, Extension Case.>
- 4) Remove the transfer driven gear. <Ref. to 6MT-55, REMOVAL, Transfer Driven Gear.>
- 5) Disconnect the center differential connector.
- 6) Remove the thrust washer and center differential.

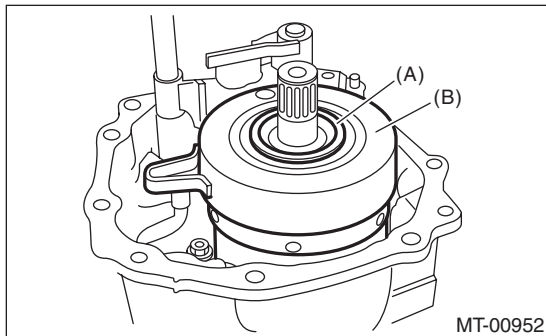

- (A) Thrust washer
- (B) Center differential

- 7) Remove the needle bearing.

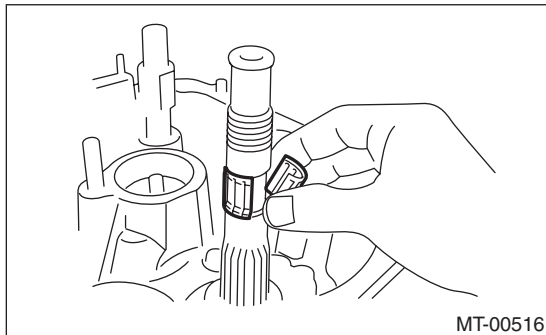

### B: INSTALLATION

- 1) Install the needle bearing.

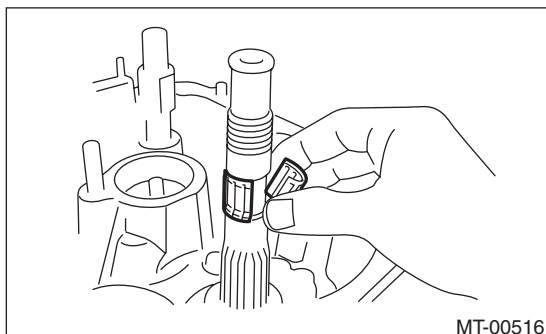

- 2) Install the thrust washer and center differential.

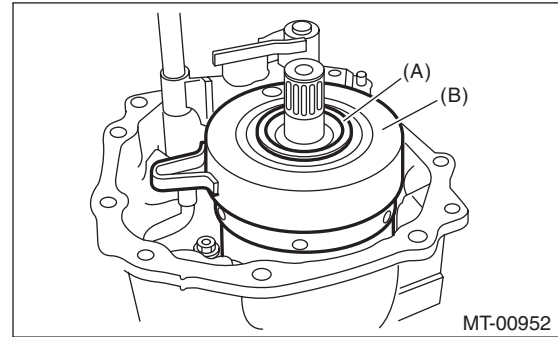

- (A) Thrust washer
- (B) Center differential

- 3) When replacing the center differential, select and install the appropriate transfer drive gear and thrust washer. <Ref. to 6MT-46, ADJUSTMENT, Extension Case.>
- 4) Connect the center differential connector, and affix to the oil guide.
- 5) Install the transfer driven gear. <Ref. to 6MT-55, INSTALLATION, Transfer Driven Gear.>
- 6) Install the extension case. <Ref. to 6MT-44, INSTALLATION, Extension Case.>
- 7) Install the manual transmission case assembly to the vehicle. <Ref. to 6MT-34, INSTALLATION, Manual Transmission Assembly.>

### C: INSPECTION

Check that there is no damage on the center differential. Replace if damaged.

# Transmission Case

## MANUAL TRANSMISSION AND DIFFERENTIAL

### 16. Transmission Case

#### A: REMOVAL

- 1) Remove the manual transmission assembly from the vehicle. <Ref. to 6MT-32, REMOVAL, Manual Transmission Assembly.>
- 2) Prepare the transmission for overhaul. <Ref. to 6MT-38, Preparation for Overhaul.>
- 3) Remove the neutral position switch, back-up light switch and harness. <Ref. to 6MT-42, REMOVAL, Neutral Position Switch.> <Ref. to 6MT-40, REMOVAL, Back-up Light Switch.>
- 4) Remove the extension case. <Ref. to 6MT-44, REMOVAL, Extension Case.>
- 5) Remove the transfer driven gear. <Ref. to 6MT-55, REMOVAL, Transfer Driven Gear.>
- 6) Remove the center differential. <Ref. to 6MT-57, REMOVAL, Center Differential.>
- 7) Remove the oil guides G and H.

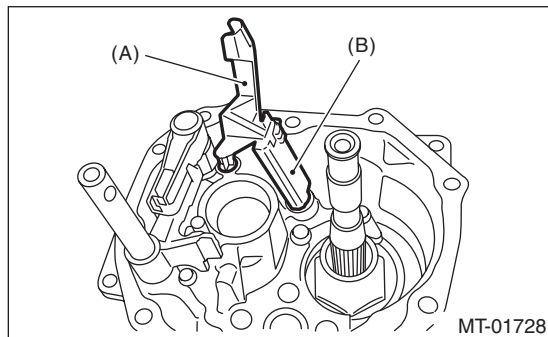

- (A) Oil guide G
- (B) Oil guide H

- 8) Remove the snap ring and flat washer from the selector arm area.

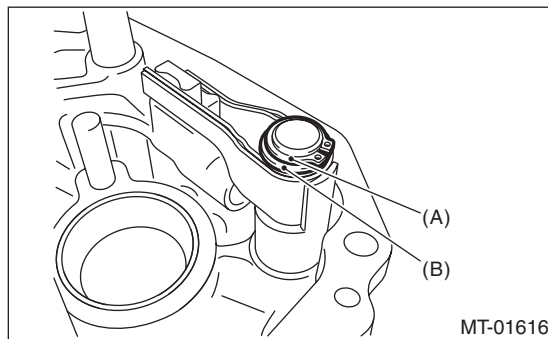

- (A) Snap ring
- (B) Flat washer

- 9) Using an ST, remove the neutral set spring and support.

ST1 18756AA000 CLAW  
ST2 399893600 PLIER

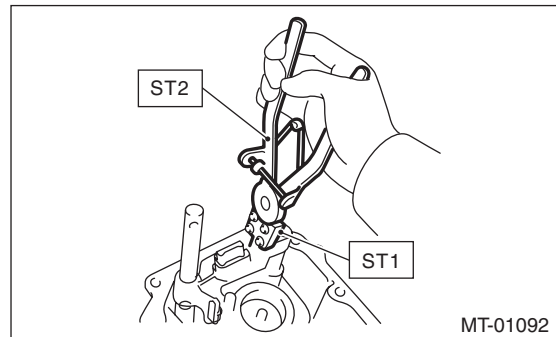

- 10) Lift the striking rod, and remove the spring pin.

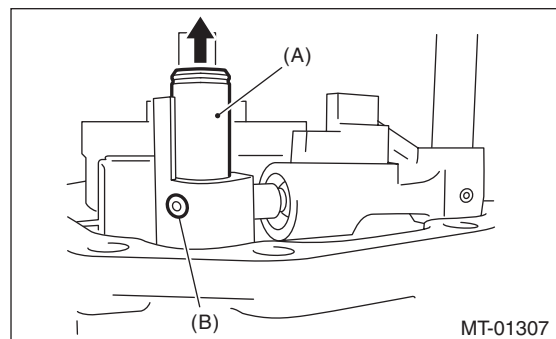

- (A) Striking rod
- (B) Spring pin

# Transmission Case

## MANUAL TRANSMISSION AND DIFFERENTIAL

11) Remove the selector arm No. 2, shifter arm, selector plunger and spring.

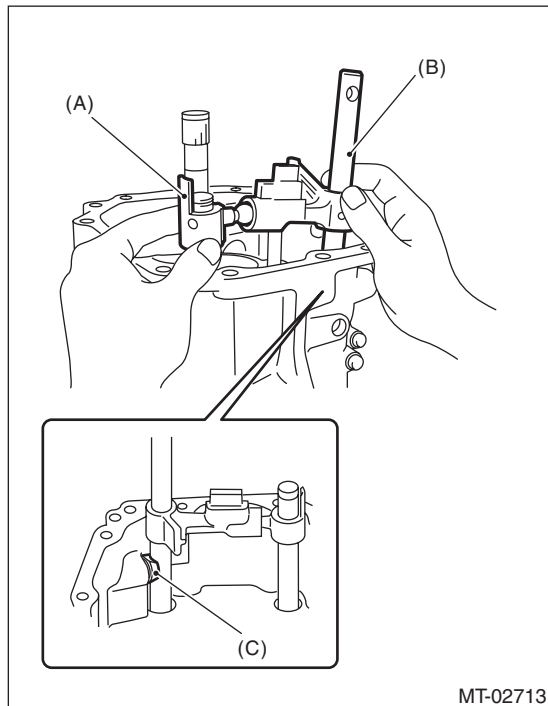

- (A) Selector arm No. 2
- (B) Shifter arm
- (C) Selector plunger

12) Remove the transfer bearing holder.

NOTE:

Using a general tool may cause damage. Remove the bolt using the ST.

ST 18663AA000 SOCKET

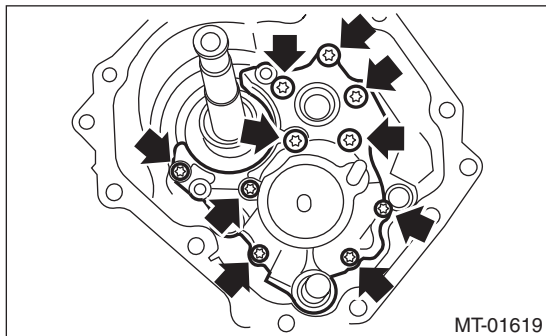

13) Remove the washer on the main shaft section.

14) Remove the driven gear assembly shim and spacer.

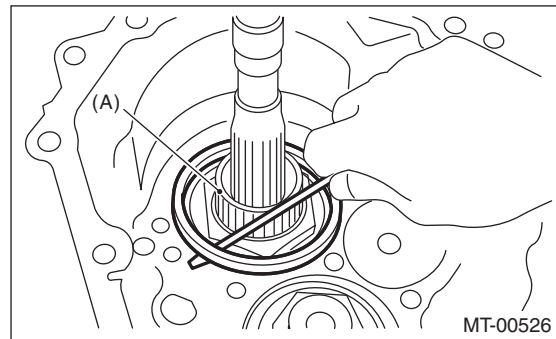

(A) Driven gear ASSY

15) Remove the snap ring.

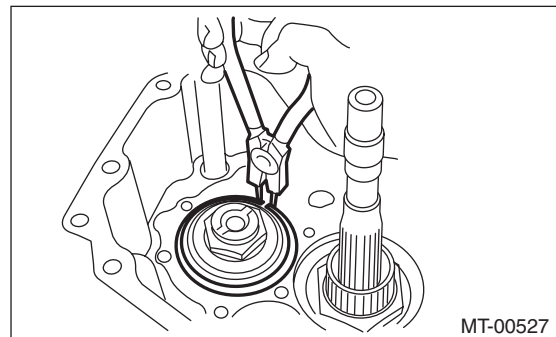

16) Remove the pilot bolt.

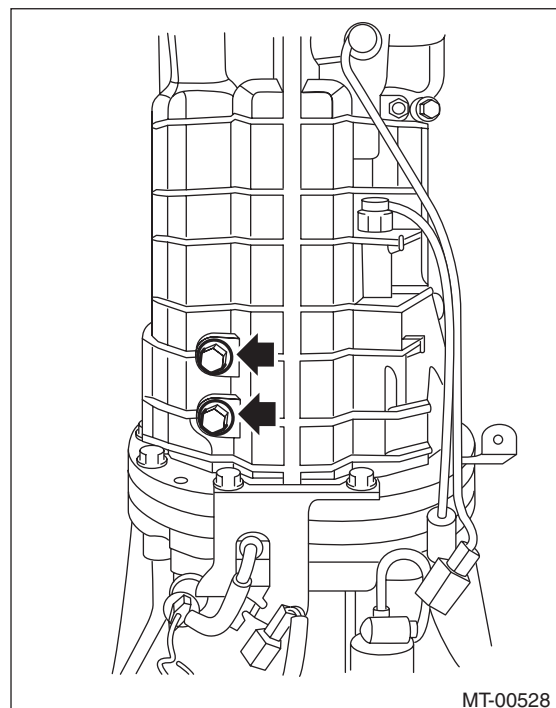



# Transmission Case

## MANUAL TRANSMISSION AND DIFFERENTIAL

17) Remove the holder reverse bolt.

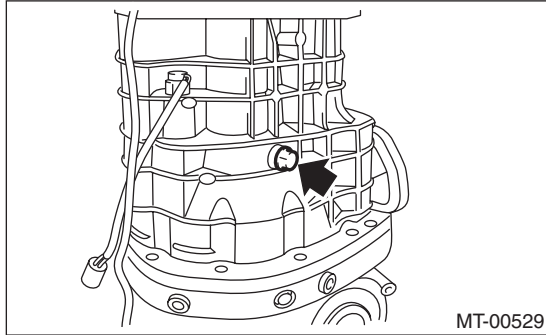

18) Remove the transmission case.

### NOTE:

If the oil guide is caught between the shift fork, it may be difficult to remove the transmission case. Move the oil guide, then remove. Do not pull on the transmission case with excessive force.

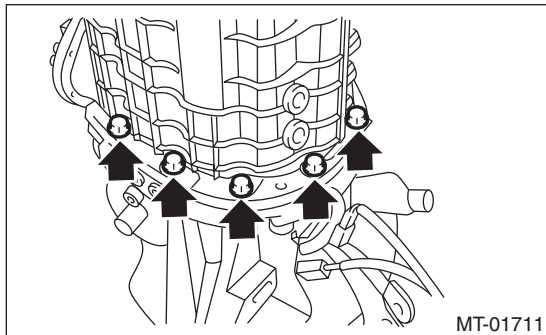

19) Remove any remaining liquid gasket from the transmission case and adapter plate.

## B: INSTALLATION

1) Check that the shifter fork and the interlock block are both shifted into the neutral position. If they are not, shift into the neutral position.

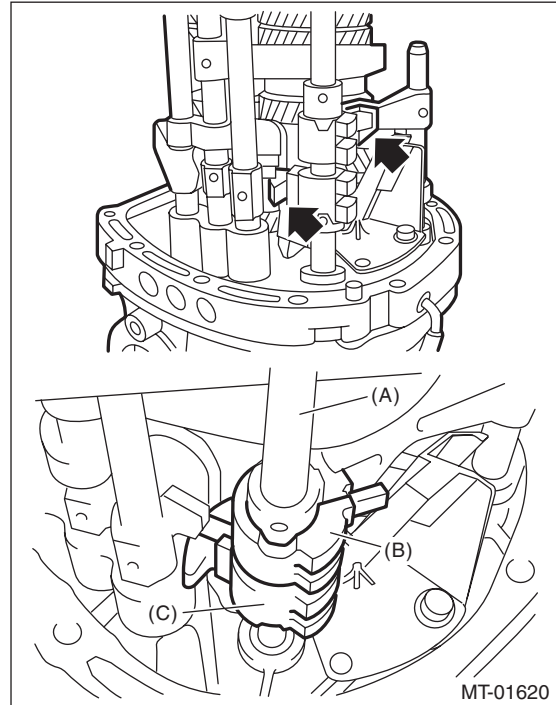

- (A) Striking rod
- (B) Reverse interlock block
- (C) Interlock block

2) Apply liquid gasket to the adapter plate.

### Liquid gasket:

**THREE BOND 1215 (Part No. 004403007) or equivalent**

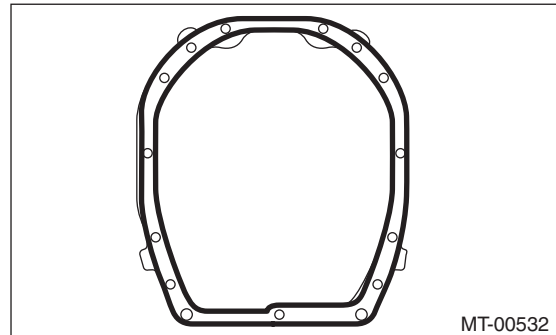

3) Install the transmission case.



# Transmission Case

## MANUAL TRANSMISSION AND DIFFERENTIAL

4) By inspecting from the pilot bolt attachment hole, check that the interlock block and the reverse interlock block are aligned to the neutral position. If not aligned, remove the transmission case, and shift the shifter fork and interlock block to the neutral position.

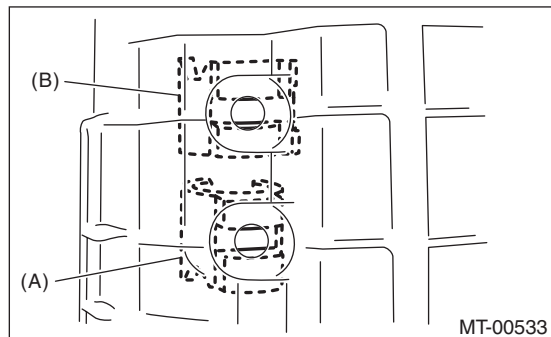

- (A) Interlock block
- (B) Reverse interlock block

5) Use a new gasket to temporarily attach the pilot bolt.

6) Affix the transmission case with the bolts and nuts.

### **Tightening torque:**

**50 N·m (5.1 kgf·m, 36.9 ft·lb)**

7) Tighten the pilot bolt.

### **Tightening torque:**

**34 N·m (3.5 kgf·m, 25.1 ft·lb)**

8) Tighten the holder reverse bolt.

### **Tightening torque:**

**25 N·m (2.5 kgf·m, 18.4 ft·lb)**

9) Install the snap ring and washer for the main shaft assembly, and washer and collar for the driven gear assembly.

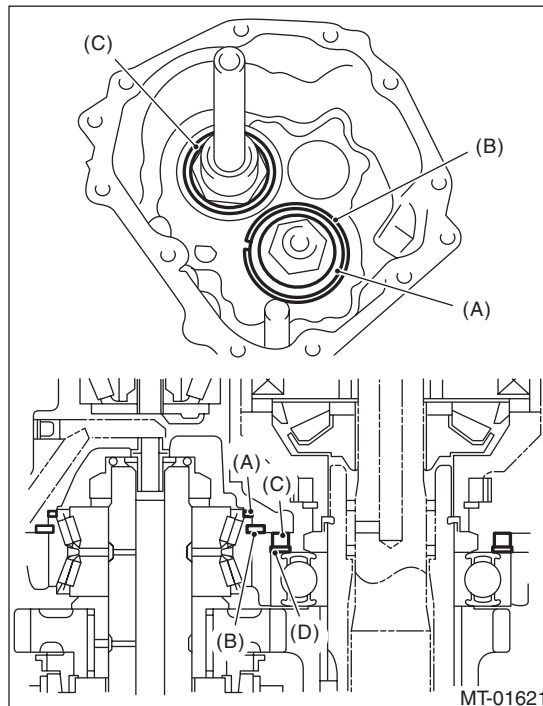

- (A) Washer
- (B) Snap ring
- (C) Collar
- (D) Washer

10) Install the transfer bearing holder.

### **Tightening torque:**

**25 N·m (2.5 kgf·m, 18.4 ft·lb)**

ST 18663AA000 SOCKET

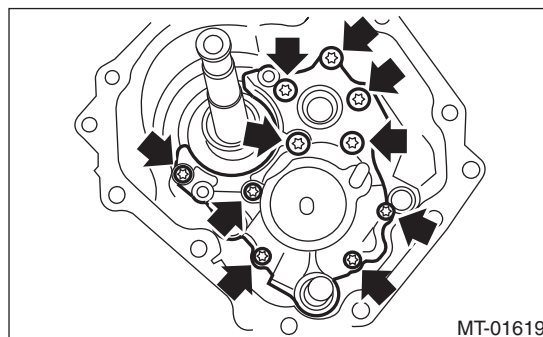

11) When replacing the transfer bearing holder, select the appropriate transfer driven gear and thrust washer, and install to the extension case. <Ref. to 6MT-46, ADJUSTMENT, Extension Case.>

# Transmission Case

## MANUAL TRANSMISSION AND DIFFERENTIAL

12) Install the selector arm No. 2, shifter arm, selector plunger and spring.

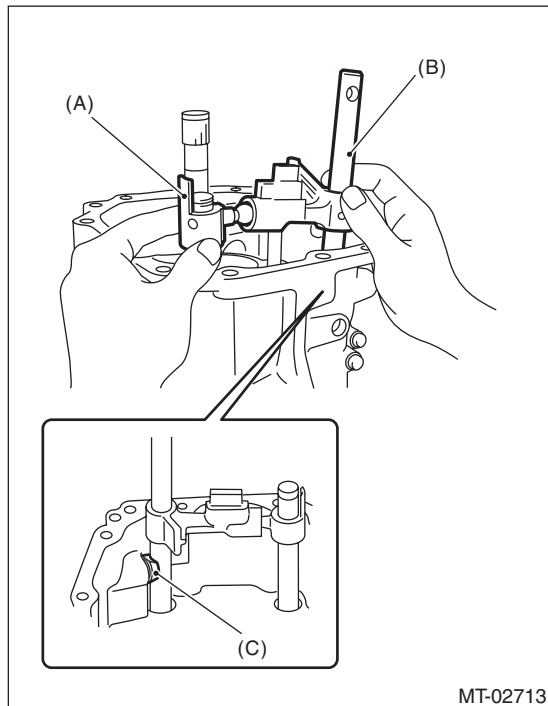

- (A) Selector arm No. 2
- (B) Shifter arm
- (C) Selector plunger

13) Install a new spring pin.

14) Using the ST, install the neutral set spring.

ST1 18756AA000 CLAW

ST2 399893600 PLIER

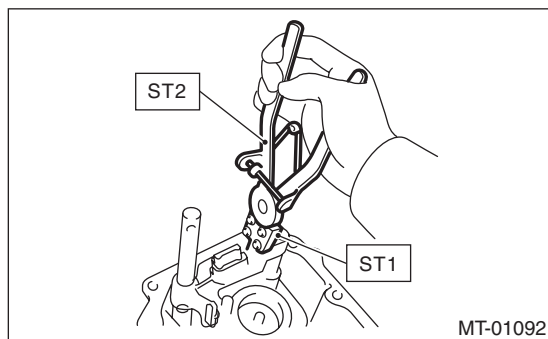

15) Install the snap ring and flat washer to the selector arm area.

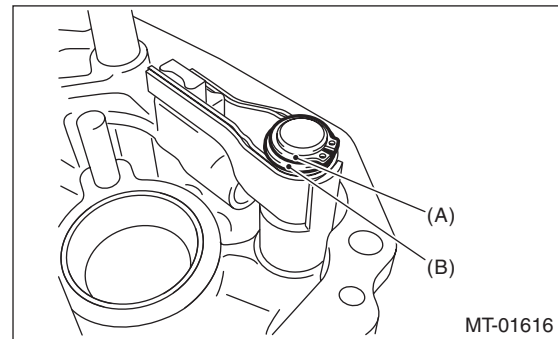

- (A) Snap ring
- (B) Flat washer

16) Install the oil guides G and H.

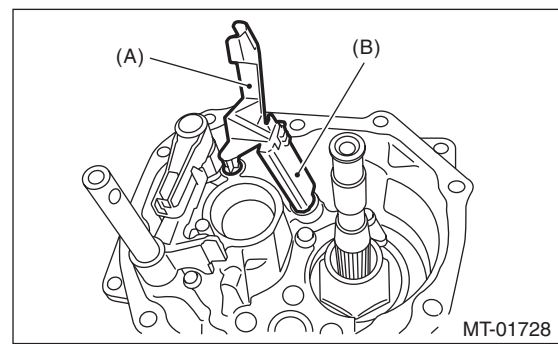

- (A) Oil guide G
- (B) Oil guide H

17) Install the center differential. <Ref. to 6MT-57, INSTALLATION, Center Differential.>

18) Install the transfer driven gear. <Ref. to 6MT-55, INSTALLATION, Transfer Driven Gear.>

19) Install the extension case. <Ref. to 6MT-44, INSTALLATION, Extension Case.>

20) Install the neutral position switch, back-up light switch and harness. <Ref. to 6MT-42, INSTALLATION, Neutral Position Switch.> <Ref. to 6MT-40, INSTALLATION, Back-up Light Switch.>

21) Install the manual transmission assembly to the vehicle. <Ref. to 6MT-34, INSTALLATION, Manual Transmission Assembly.>

## C: DISASSEMBLY

1) Remove the transmission harness from the transmission case.

### NOTE:

Remove the connector by disengaging the connector claw from the inside of the transmission.

# Transmission Case

MANUAL TRANSMISSION AND DIFFERENTIAL

2) Remove the oil guides C, D, E, F and harness bracket.

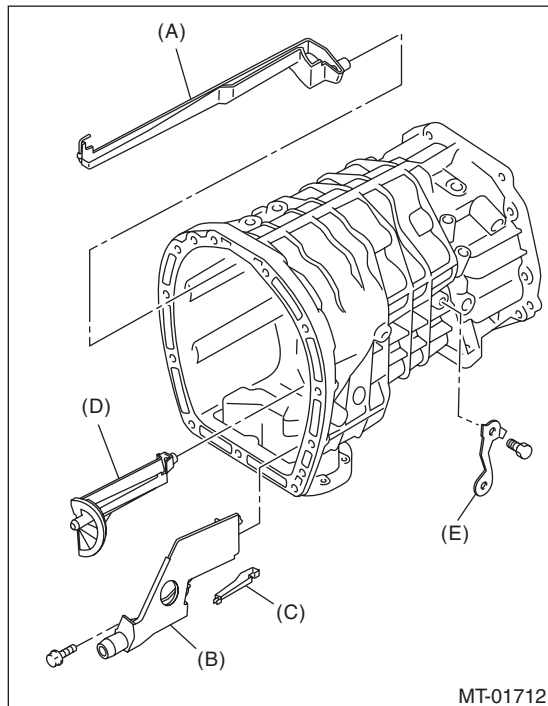

- (A) Oil guide C
- (B) Oil guide D
- (C) Oil guide E
- (D) Oil guide F
- (E) Harness bracket

3) Remove the oil pan.

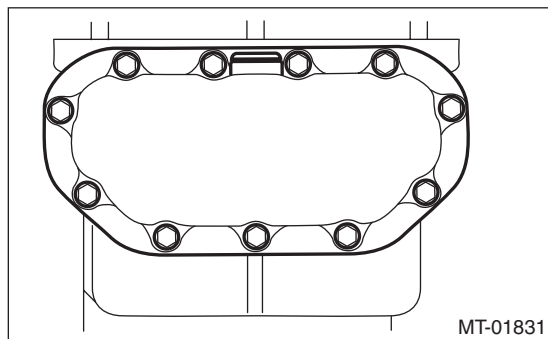

4) Remove any remaining liquid gasket from the transmission case and oil pan.

## D: ASSEMBLY

1) Apply liquid gasket to the oil pan.

**Liquid gasket:**

**THREE BOND 1215 (Part No. 004403007) or equivalent**

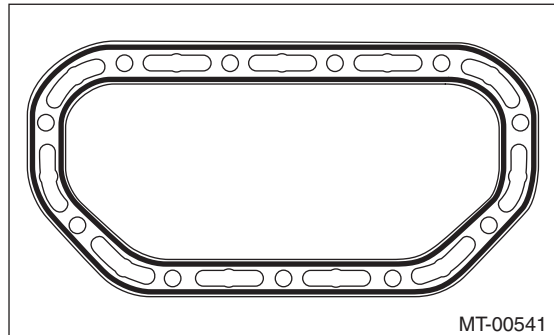

2) Install the oil pan.

**Tightening torque:**

**6.4 N·m (0.7 kgf-m, 4.7 ft-lb)**

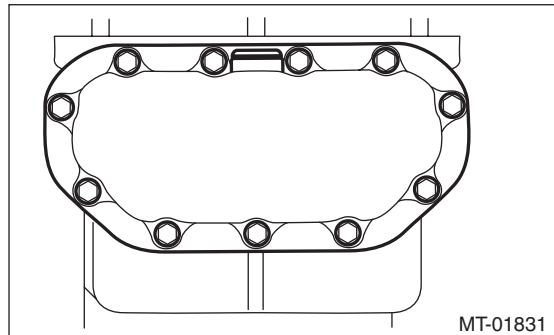

# Transmission Case

## MANUAL TRANSMISSION AND DIFFERENTIAL

3) Install the oil guides C, D, E, F and harness bracket.

### Tightening torque:

**T1: 16 N·m (1.6 kgf-m, 11.8 ft-lb)**

**T2: 18 N·m (1.8 kgf-m, 13.3 ft-lb)**

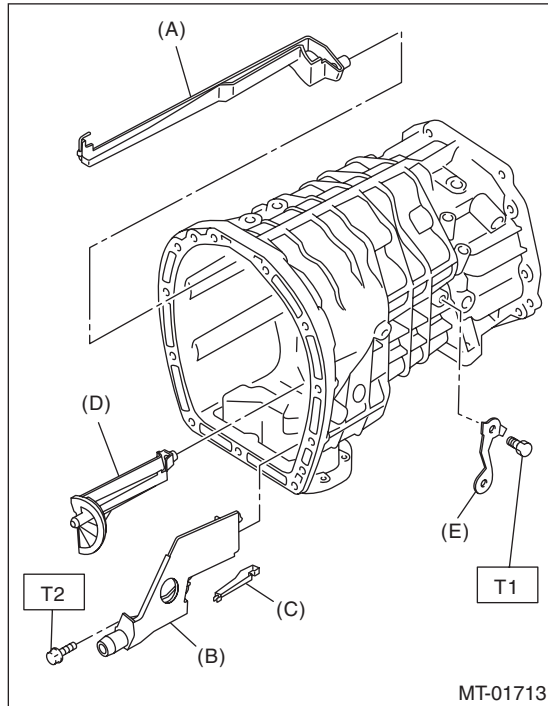

- (A) Oil guide C
- (B) Oil guide D
- (C) Oil guide E
- (D) Oil guide F
- (E) Harness bracket

4) Attach the transmission harness to the transmission.

### NOTE:

Install the transmission harness connector by aligning the protrusions of the transmission and transmission harness connector.

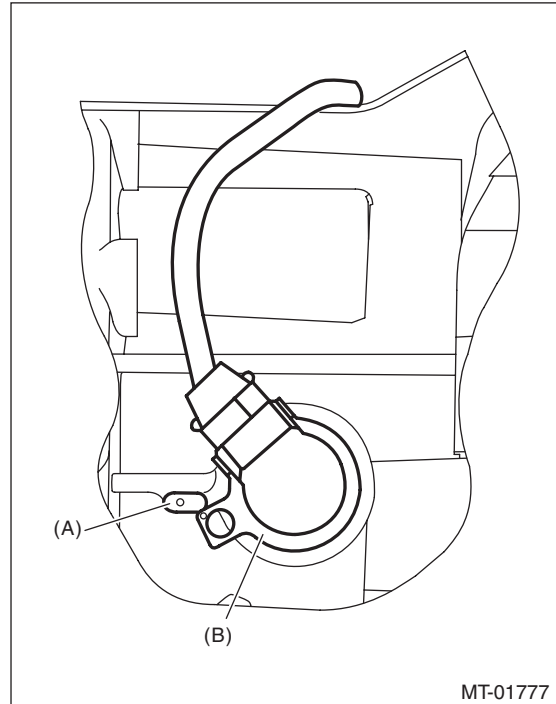

- (A) Protrusion
- (B) Transmission harness connectors

## E: INSPECTION

- 1) If the sludge is accumulated in the oil pan, use a waste cloth to wipe it off completely.
- 2) Check that there is no damage on any parts. Replace damaged parts with new parts.

# Main Shaft Assembly

MANUAL TRANSMISSION AND DIFFERENTIAL

## 17. Main Shaft Assembly

### A: REMOVAL

- 1) Remove the manual transmission assembly from the vehicle. <Ref. to 6MT-32, REMOVAL, Manual Transmission Assembly.>
- 2) Prepare the transmission for overhaul. <Ref. to 6MT-38, Preparation for Overhaul.>
- 3) Remove the neutral position switch, back-up light switch and harness. <Ref. to 6MT-42, REMOVAL, Neutral Position Switch.> <Ref. to 6MT-40, REMOVAL, Back-up Light Switch.>
- 4) Remove the extension case. <Ref. to 6MT-44, REMOVAL, Extension Case.>
- 5) Remove the transfer driven gear. <Ref. to 6MT-55, REMOVAL, Transfer Driven Gear.>
- 6) Remove the center differential. <Ref. to 6MT-57, REMOVAL, Center Differential.>
- 7) Remove the transmission case. <Ref. to 6MT-58, REMOVAL, Transmission Case.>
- 8) Remove the striking rod.
- 9) Remove the oil guide B.

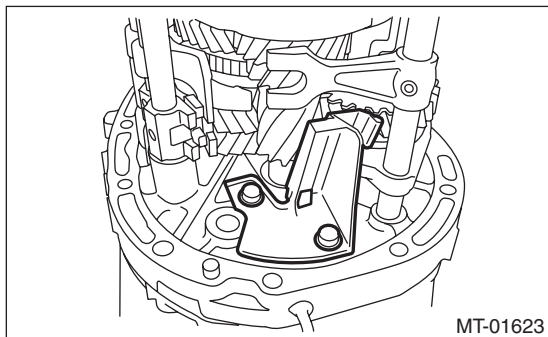

- 10) Use a screwdriver to shift to the 4th gear position.

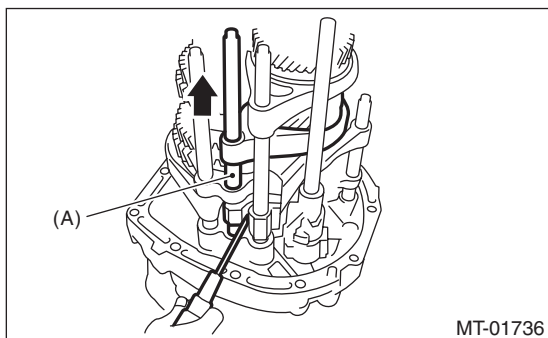

(A) 3rd-4th shift rod

- 11) Remove the reverse idler holder.

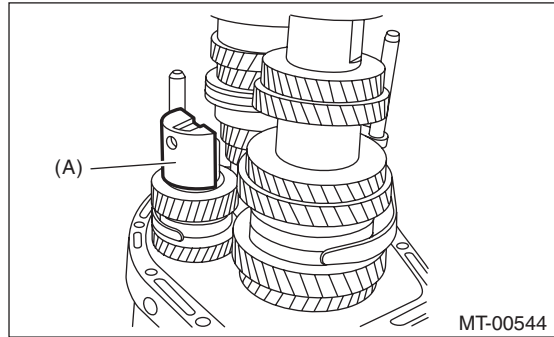

(A) Reverse idler holder

- 12) Remove the check plug, O-ring, check spring, plunger and check ball from the adapter plate.

### NOTE:

Do not reuse the gasket.

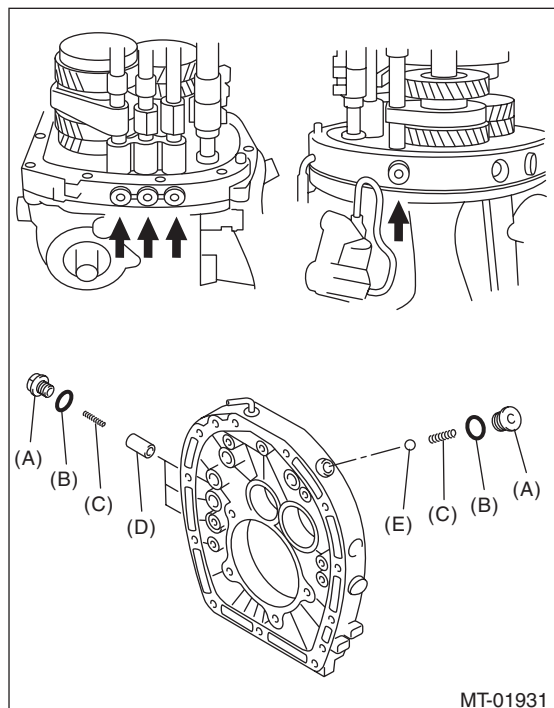

- (A) Check plug
- (B) O-ring
- (C) Checking spring
- (D) Plunger
- (E) Check ball

# Main Shaft Assembly

## MANUAL TRANSMISSION AND DIFFERENTIAL

13) Remove the bolt and gasket holding the reverse idler shaft.

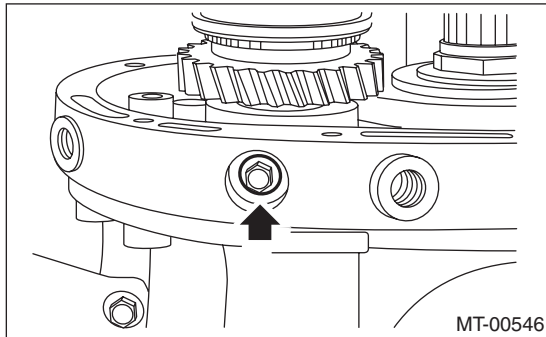

14) Push the main shaft assembly, driven gear assembly, reverse idler gear and shifter forks to remove from the adapter plate all at once.

### NOTE:

A helper is required to perform this work.

## B: INSTALLATION

1) Adjust the 3rd-4th and 5th-6th shifter fork rods.  
<Ref. to 6MT-109, ADJUSTMENT, Shifter Fork and Rod.>

2) Turn the sub gear counterclockwise for approximately 3 teeth. Match the sub gear and reverse idler gear holes, and insert the ST.

ST 18757AA000 STRAIGHT PIN

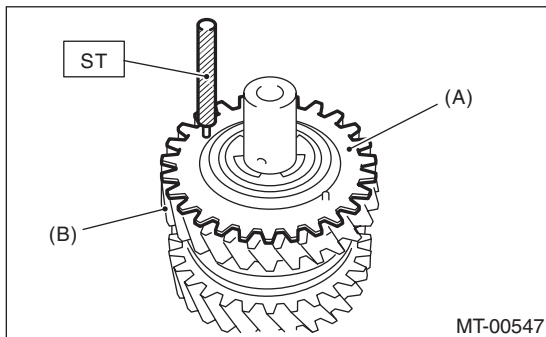

- (A) Sub gear
- (B) Reverse idler gear

3) Attach the driven gear assembly to the 1st-2nd shifter fork assembly.

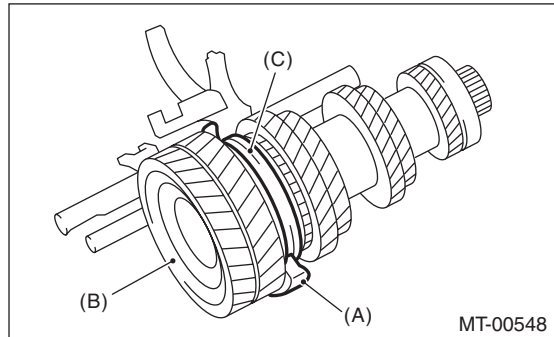

- (A) 1st-2nd shifter fork
- (B) Driven gear ASSY
- (C) 1st-2nd sleeve

4) Attach the main shaft assembly to the 3rd-4th shifter fork, and assemble to the driven gear assembly.

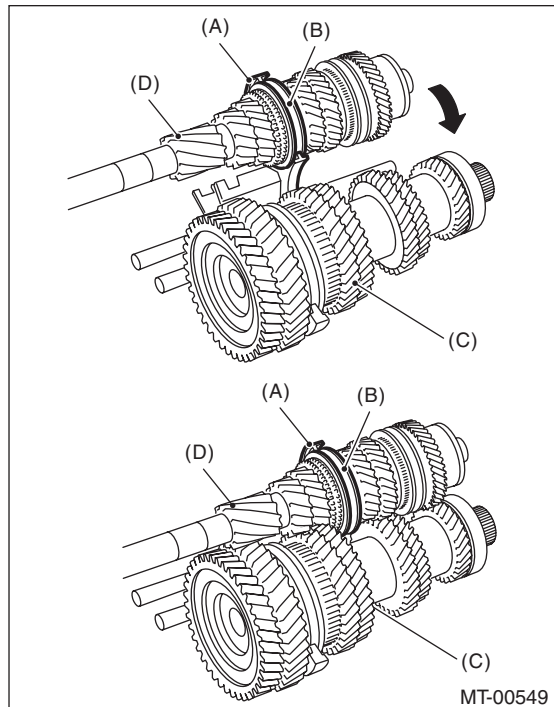

- (A) 3rd-4th shifter fork
- (B) 3rd-4th sleeve
- (C) Driven gear ASSY
- (D) Main shaft ASSY



# Main Shaft Assembly

MANUAL TRANSMISSION AND DIFFERENTIAL

5) Attach the 5th-6th shifter fork assembly to the main shaft assembly.

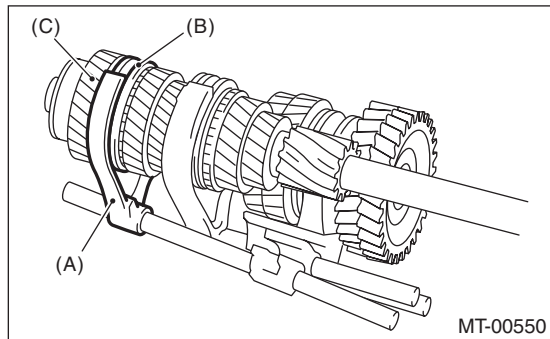

- (A) 5th-6th shifter fork
- (B) 5th-6th sleeve
- (C) Main shaft ASSY

6) Attach the reverse shifter fork assembly to the reverse idler gear assembly.

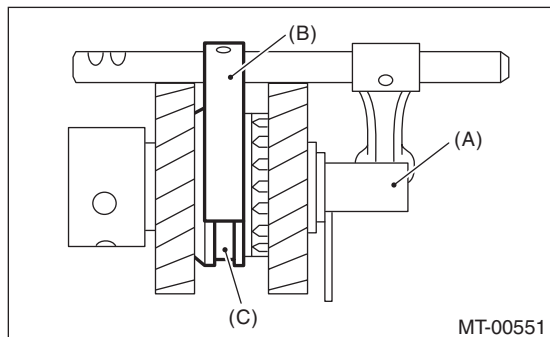

- (A) Reverse idler gear ASSY
- (B) Reverse shifter fork
- (C) Reverse sleeve

7) Install the reverse idler gear assembly.

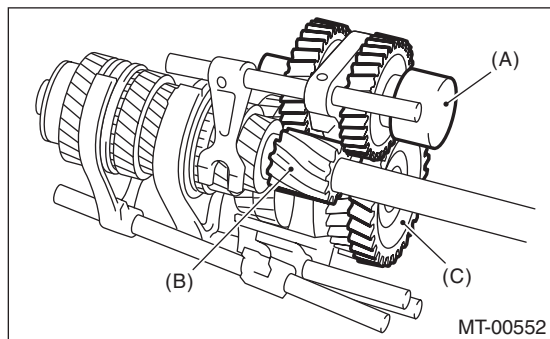

- (A) Reverse idler gear ASSY
- (B) 1st drive gear
- (C) Reverse gear

8) Install the thrust bearing of the driven gear assembly.

9) Push on the shifter forks, main shaft assembly, driven gear assembly and reverse idler gear assemblies, to attach to the adapter plate all at once.

NOTE:

A helper is required to perform this work.

10) Install the plunger, check spring, new O-ring and check plugs.

**Tightening torque:**

**25 N·m (2.5 kgf-m, 18.4 ft-lb)**

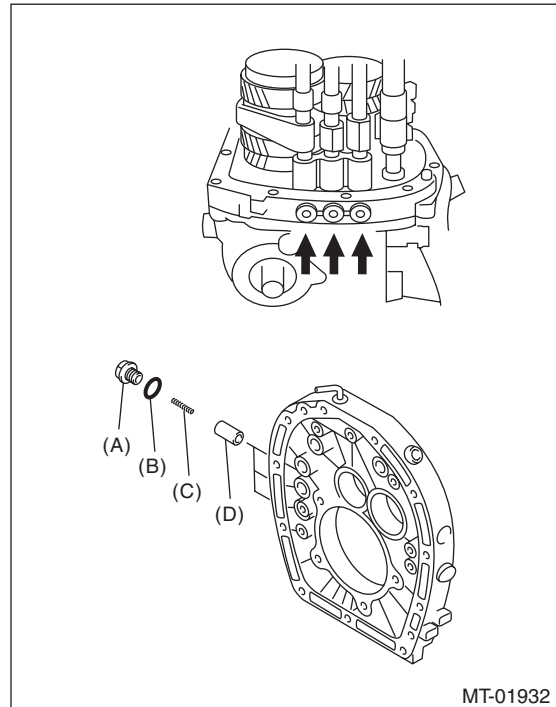

- (A) Check plug
- (B) O-ring
- (C) Checking spring
- (D) Plunger

# Main Shaft Assembly

## MANUAL TRANSMISSION AND DIFFERENTIAL

11) Install the check ball, check spring, new O-ring and check plugs.

**Tightening torque:**

**25 N·m (2.5 kgf·m, 18.4 ft·lb)**

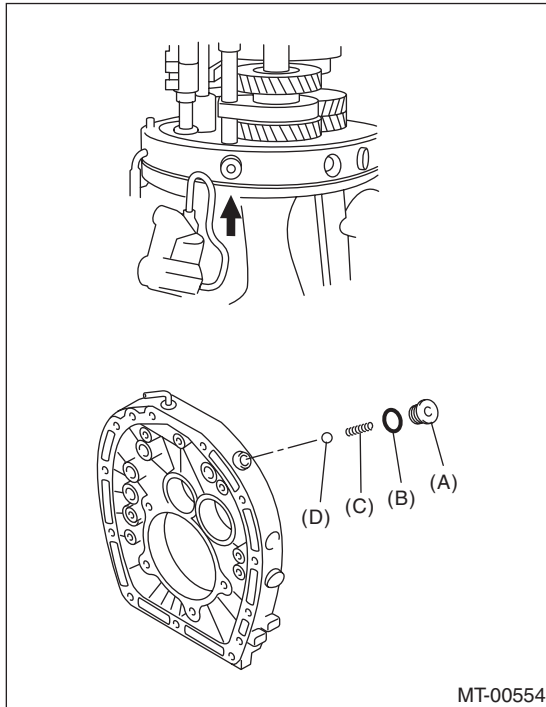

- (A) Check plug
- (B) O-ring
- (C) Checking spring
- (D) Check ball

12) Attach the bolt and a new gasket.

**Tightening torque:**

**25 N·m (2.5 kgf·m, 18.4 ft·lb)**

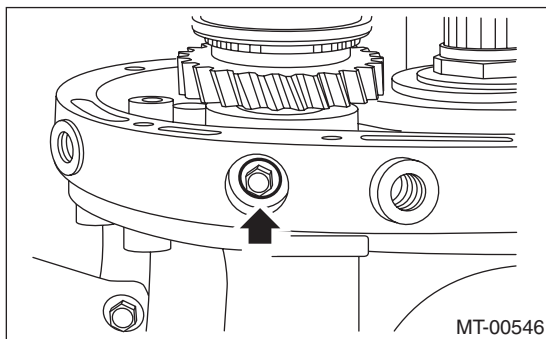

13) Use a screwdriver to shift to the 4th gear position.

14) Install the reverse idler holder.

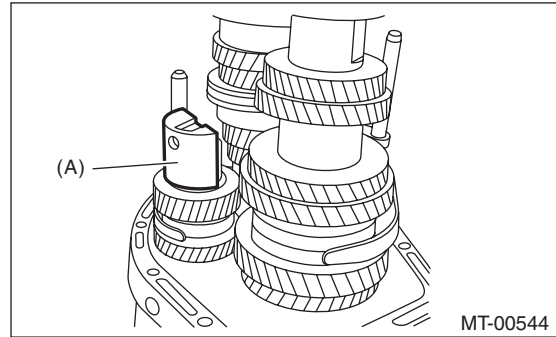

- (A) Reverse idler holder

15) Install the oil guide B.

**Tightening torque:**

**18 N·m (1.8 kgf·m, 13.3 ft·lb)**

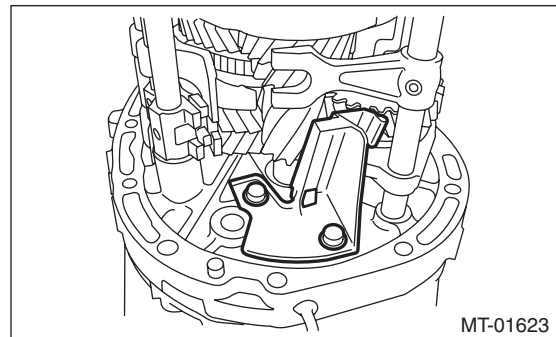

16) Install the striking rod.

17) Install the transmission case. <Ref. to 6MT-60, INSTALLATION, Transmission Case.>

18) Install the selected main shaft snap ring and washers.

19) Install the center differential. <Ref. to 6MT-57, INSTALLATION, Center Differential.>

20) Install the transfer driven gear. <Ref. to 6MT-55, INSTALLATION, Transfer Driven Gear.>

21) Install the extension case. <Ref. to 6MT-44, INSTALLATION, Extension Case.>

22) Install the neutral position switch, back-up light switch and harness. <Ref. to 6MT-42, INSTALLATION, Neutral Position Switch.> <Ref. to 6MT-40, INSTALLATION, Back-up Light Switch.>

23) Install the manual transmission assembly to the vehicle. <Ref. to 6MT-34, INSTALLATION, Manual Transmission Assembly.>

## C: DISASSEMBLY

### NOTE:

Individual sleeves and hubs meet at a specified position. Before disassembly, mark the meeting position of the sleeve and hub.

- 1) Affix the ST to the work table.  
ST 18664AA000 BASE
- 2) Flatten the tab of the lock nut.



# Main Shaft Assembly

## MANUAL TRANSMISSION AND DIFFERENTIAL

3) Set the main shaft assembly to the ST, and remove the lock nut and lock washer.

ST1 18665AA000 HOLDER

ST2 18664AA000 BASE

NOTE:

Use a 38 mm socket wrench.

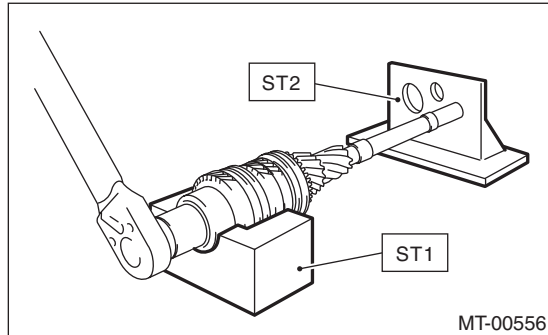

4) Remove the main shaft assembly from the ST.

5) Set the ST1 to the 6th drive gear, and use a press to remove the taper roller bearing, bushing and 6th drive gear.

ST1 18722AA010 REMOVER

ST2 899864100 REMOVER

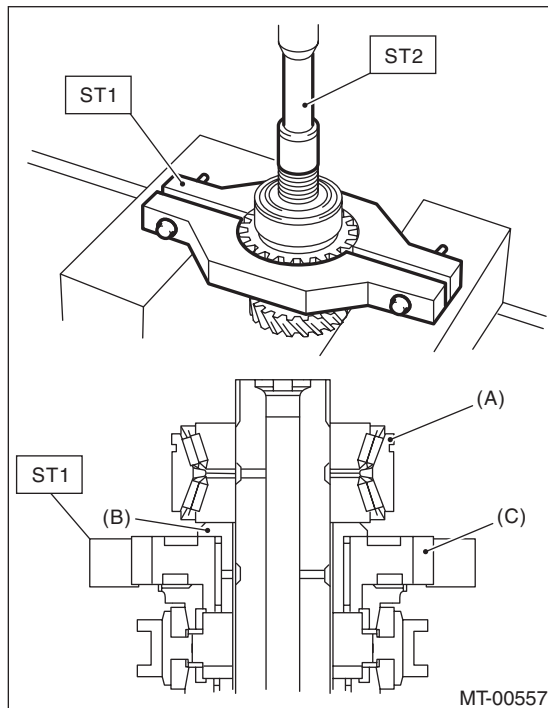

- (A) Taper roller bearing
- (B) Bushing
- (C) 6th drive gear

6) Remove the 5th-6th sleeve, 6th needle bearing and 6th baulk ring.

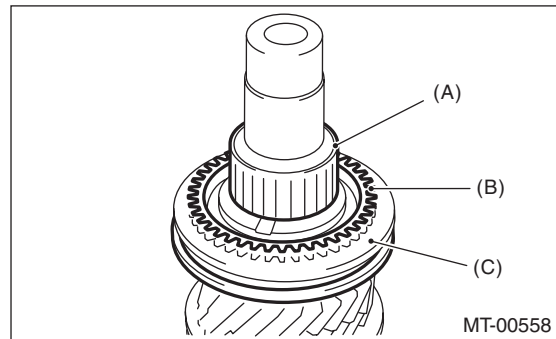

- (A) Needle bearing
- (B) 6th baulk ring
- (C) 5th-6th sleeve

7) Set the ST to the 3rd drive gear, and use a press to remove individual parts.

ST 18720AA000 REMOVER

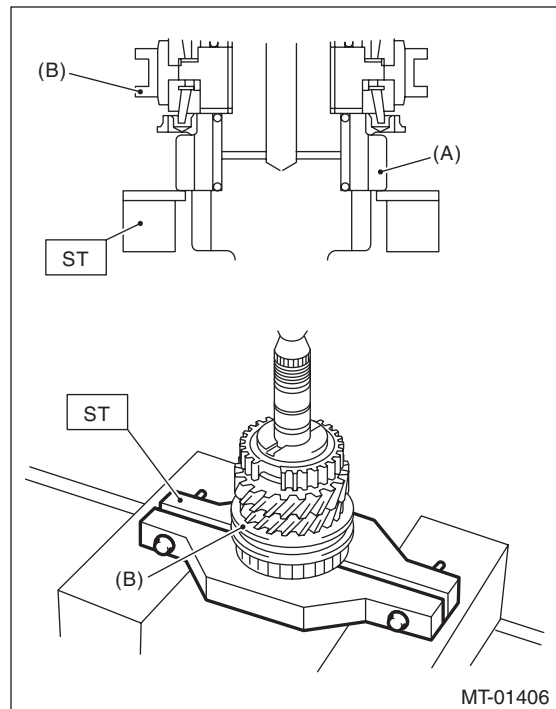

- (A) 3rd drive gear
- (B) 3rd-4th sleeve

## D: ASSEMBLY

NOTE:

When replacing the following parts, replace as a set.

- Sleeve and hub
- Outer baulk ring, 3rd synchro cone and inner baulk ring
- Taper roller bearing

# Main Shaft Assembly

## MANUAL TRANSMISSION AND DIFFERENTIAL

- 1) Apply adequate transmission gear oil to the main shaft, 3rd needle bearing and 3rd drive gear inner surface.
- 2) Install the 3rd needle bearing and 3rd drive gear to the main shaft.

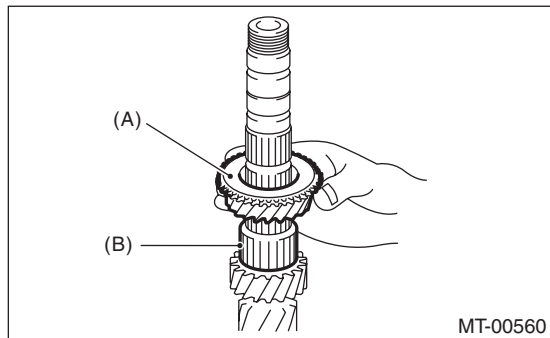

- (A) 3rd drive gear
- (B) 3rd needle bearing

- 3) Install the inner baulk ring, 3rd synchro cone and outer baulk ring.

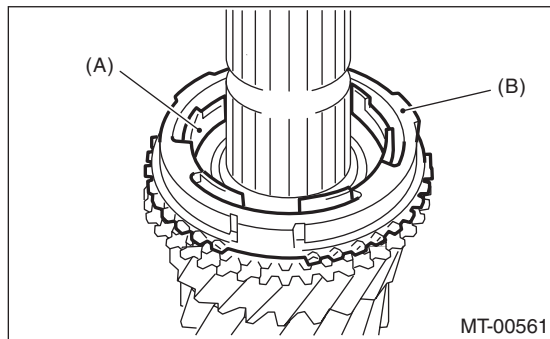

- (A) Inner baulk ring
- (B) Outer baulk ring

### NOTE:

Install the 3rd synchro cone by aligning the protrusion of the 3rd synchro cone with the hole on the 3rd drive gear.

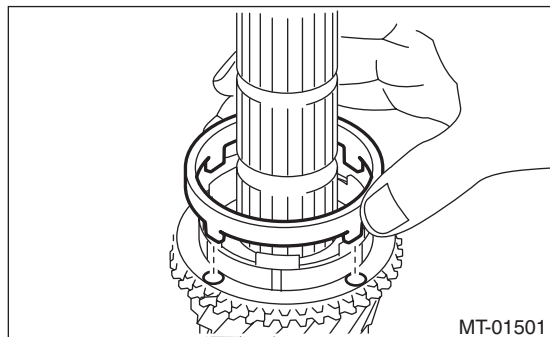

- 4) Install the 3rd-4th hub and 4th bushing.

- (1) Being careful of the install direction of the 3rd-4th hub, set to the main shaft.

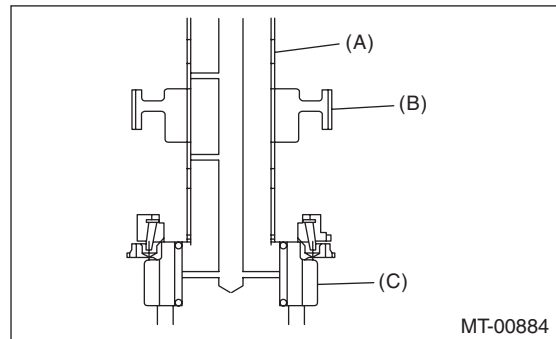

- (A) Main shaft
- (B) 3rd-4th hub
- (C) 3rd drive gear

- (2) With the main shaft oil hole and 4th bushing oil hole out of alignment, attach to the main shaft.

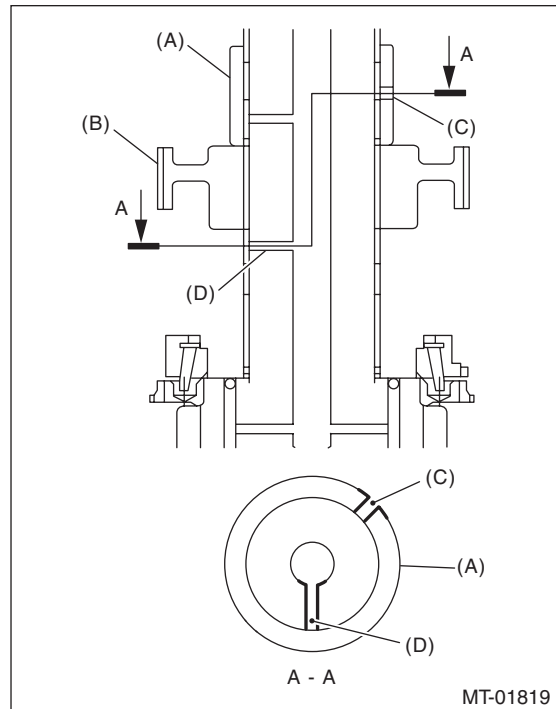

- (A) 4th bushing
- (B) 3rd-4th hub
- (C) 4th bushing oil hole
- (D) Main shaft oil hole

- (3) Using the ST, push in to the 3rd-4th hub and 4th bushing all at once.

ST1 18651AA000 INSTALLER  
ST2 398177700 INSTALLER

### CAUTION:

Do not apply pressure in excess of 40 kN (4.0 ton, 4.4 US ton, 3.9 Imp ton).

# Main Shaft Assembly

**NOTE:**

When pushing into the 3rd-4th hub and 4th bushing, move the outer baulk ring to match the protrusion of the outer baulk ring and the cut out on the 3rd-4th bushing.

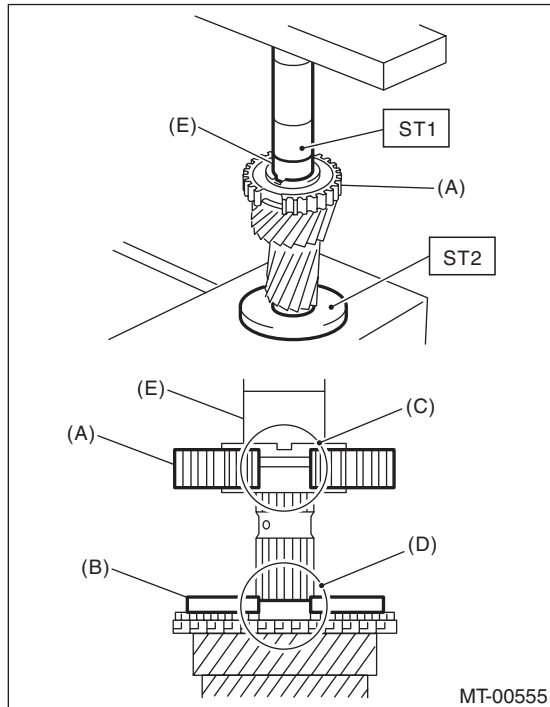

- (A) 3rd-4th hub
- (B) Outer baulk ring
- (C) Cut out on the 3rd-4th hub
- (D) Protrusion of the outer baulk ring
- (E) 4th bushing

5) Make sure that the 3rd drive gear can be turned smoothly by hand. If it does not turn smoothly, re-assemble.

6) Attach the 3rd-4th shifting insert key at the appropriate position of the 3rd-4th sleeve.

**NOTE:**

- The location angle of each shifting insert key is 120°.

- Refer to the following figure to install the shifting insert key.

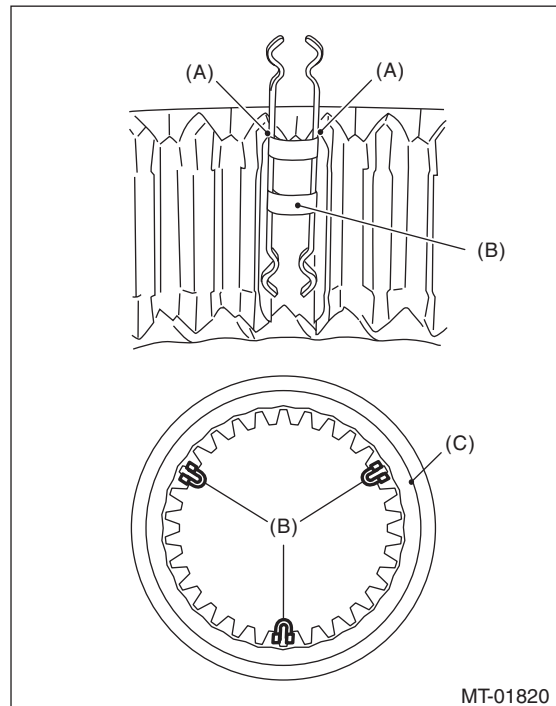

- (A) Attach the straight part of the shifting insert key to the sleeve convex portion.
- (B) 3rd-4th shifting insert key
- (C) 3rd-4th sleeve

7) Attach the 3rd-4th sleeve to the 3rd-4th hub.

**NOTE:**

- There is an identification groove on the 3rd-4th sleeve.
- Place the groove towards the 3rd drive gear, and attach the 3rd-4th sleeve.

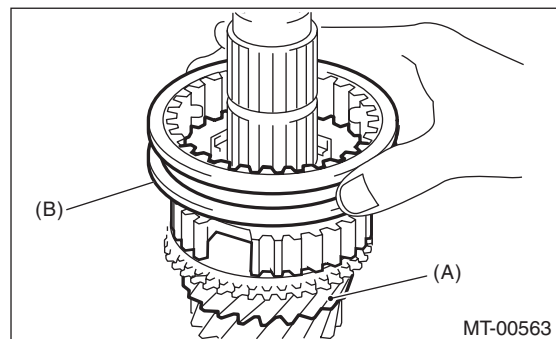

- (A) 3rd drive gear
- (B) 3rd-4th sleeve identification groove (1)

# Main Shaft Assembly

## MANUAL TRANSMISSION AND DIFFERENTIAL

8) Install the 4th baulk ring.

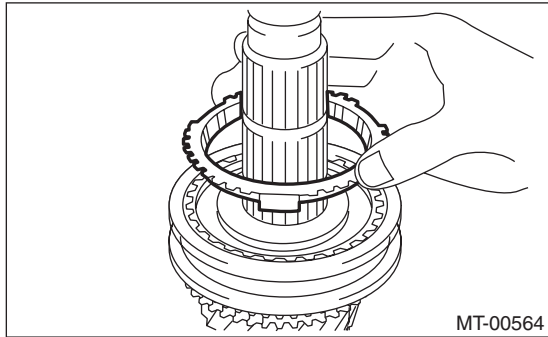

9) Apply adequate transmission gear oil to the main shaft, 4th needle bearing and 4th drive gear inner surface.

10) Install the 4th needle bearing and 4th drive gear.

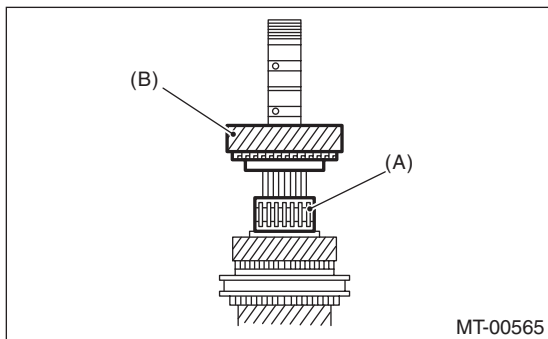

- (A) 4th needle bearing
- (B) 4th drive gear

11) Install the 5th bushing.

(1) With the main shaft oil hole and 5th bushing oil hole out of alignment, attach to the main shaft.

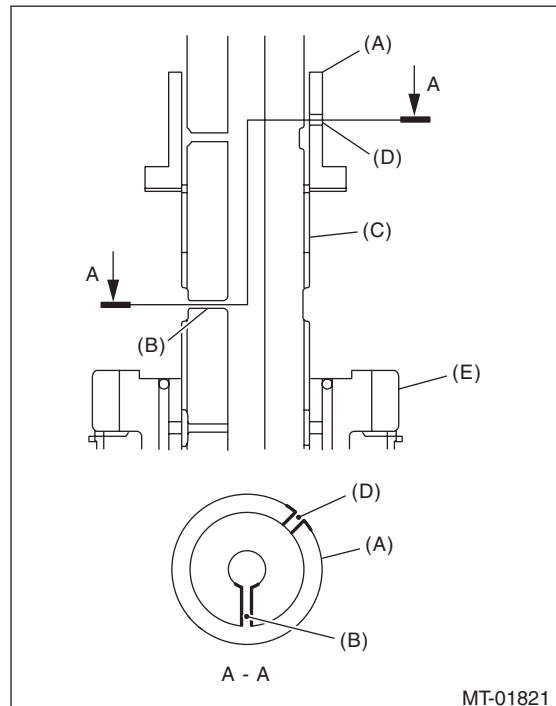

- (A) 5th bushing
- (B) Main shaft oil hole
- (C) Main shaft
- (D) 5th bushing oil hole
- (E) 4th drive gear

(2) Using the ST, push into the 5th bushing.  
ST1 18651AA000 INSTALLER  
ST2 398177700 INSTALLER

### CAUTION:

Do not apply pressure in excess of 40 kN (4.0 ton, 4.4 US ton, 3.9 Imp ton).

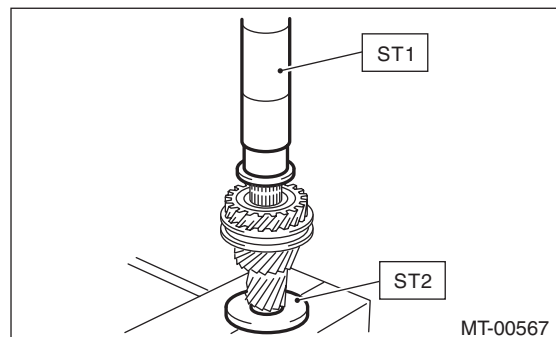

12) Make sure that the 4th drive gear can be turned smoothly by hand. If it does not turn smoothly, re-assemble.

13) Apply adequate transmission gear oil to the main shaft, 5th needle bearing and 5th drive gear inner surface.

# Main Shaft Assembly

MANUAL TRANSMISSION AND DIFFERENTIAL

14) Install the 5th needle bearing and 5th drive gear.

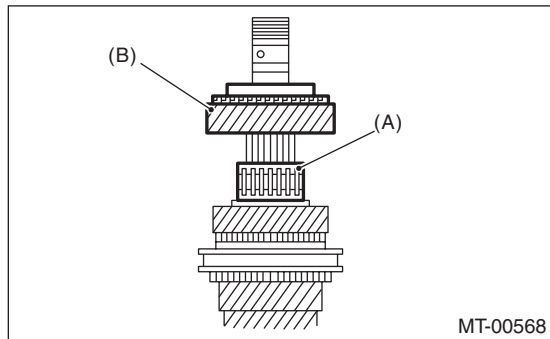

- (A) 5th needle bearing
- (B) 5th drive gear

15) Install the 5th baulk ring.

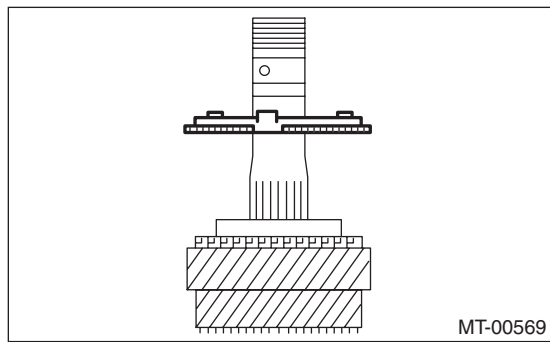

16) Install the 5th-6th hub.

(1) Being careful of the install direction of the 5th-6th hub, set to the main shaft.

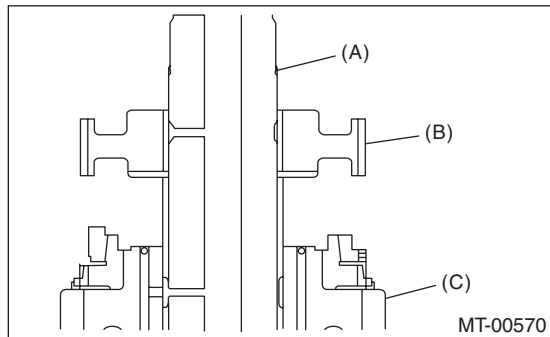

- (A) Main shaft
- (B) 5th-6th hub
- (C) 5th drive gear

(2) Using the ST, push into the 5th-6th hub.

ST1 18651AA000 INSTALLER

ST2 398177700 INSTALLER

### CAUTION:

Do not apply pressure in excess of 40 kN (4.0 ton, 4.4 US ton, 3.9 Imp ton).

### NOTE:

When pushing into the 5th-6th hub, move the outer baulk ring to match the protrusion of the outer baulk ring and the cut out on the 5th-6th bushing.

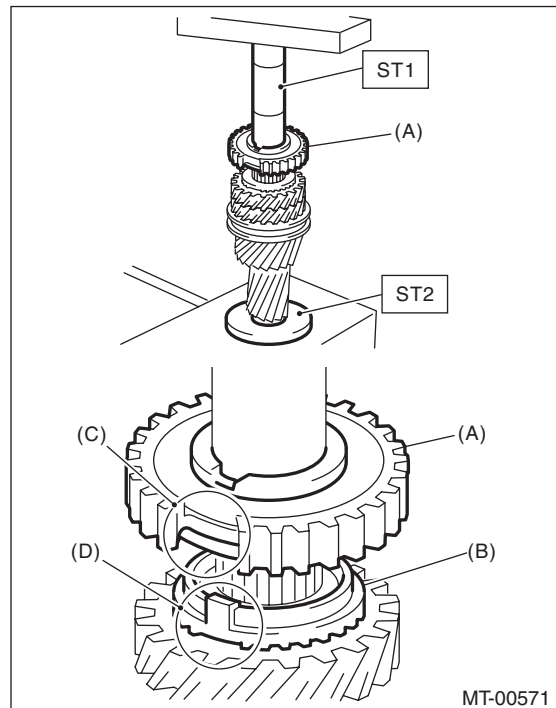

- (A) 5th-6th hub
- (B) Outer baulk ring
- (C) Cut out on the 5th-6th hub
- (D) Protrusion of the outer baulk ring

17) Make sure that the 5th drive gear can be turned smoothly by hand. If it does not turn smoothly, re-assemble.

# Main Shaft Assembly

## MANUAL TRANSMISSION AND DIFFERENTIAL

18) Attach the 5th-6th shifting insert key at the appropriate position of the 5th-6th sleeve.

**NOTE:**

- The location angle of each shifting insert key is 120°.
- Refer to the following figure to install the shifting insert key.

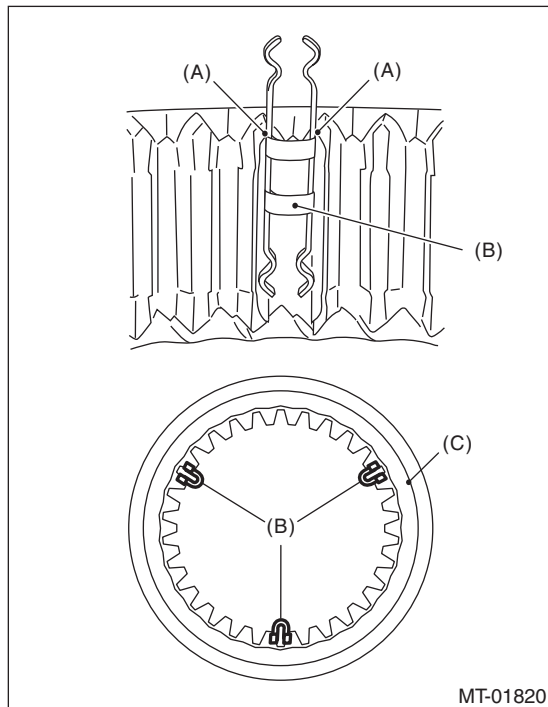

- (A) Attach the straight part of the shifting insert key to the sleeve convex portion.
- (B) 5th-6th shifting insert key
- (C) 5th-6th sleeve

19) Attach the 5th-6th sleeve to the 5th-6th hub.

**NOTE:**

- There are two identification grooves on the 5th-6th sleeve.
- Place the grooves towards the 5th drive gear, and attach the 5th-6th sleeve.

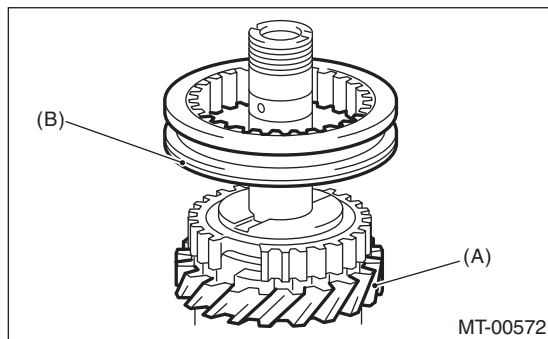

- (A) 5th drive gear
- (B) 5th-6th sleeve identification groove (2)

20) Install the 6th baulk ring.

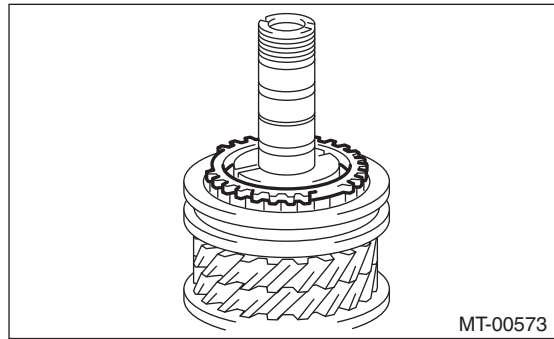

21) Apply adequate transmission gear oil to the main shaft, 6th needle bearing and 6th drive gear inner surface.

22) Install the 6th drive gear.

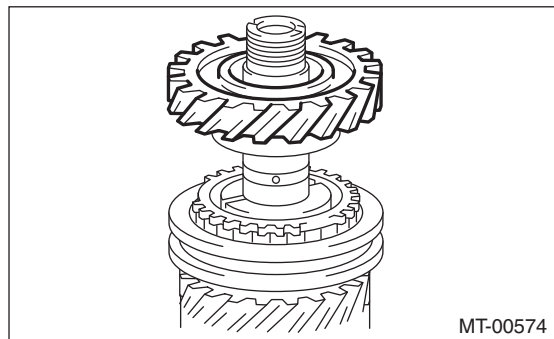

23) Install the 6th needle bearing.

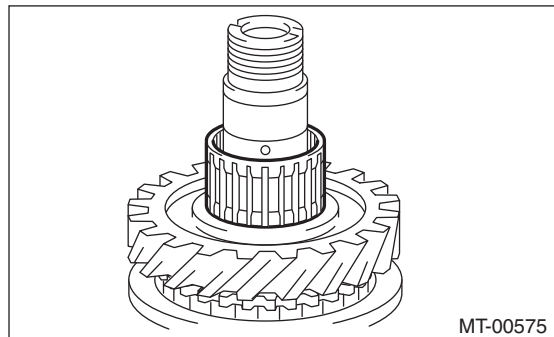

24) With 6th bushing oil hole and the main shaft oil hole out of alignment, attach to the main shaft.

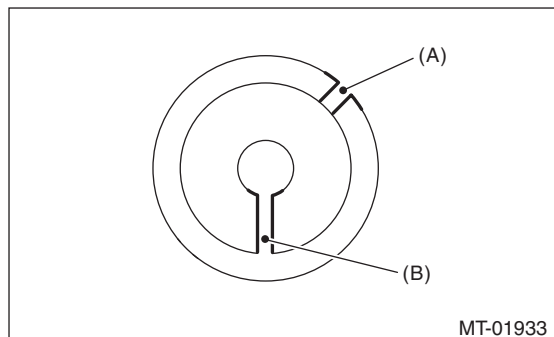

- (A) 6th bushing oil hole
- (B) Main shaft oil hole

# Main Shaft Assembly

MANUAL TRANSMISSION AND DIFFERENTIAL

25) Using the ST, install the 6th bushing.

ST1 18651AA000 INSTALLER

ST2 398177700 INSTALLER

### CAUTION:

Do not apply pressure in excess of 40 kN (4.0 ton, 4.4 US ton, 3.9 Imp ton).

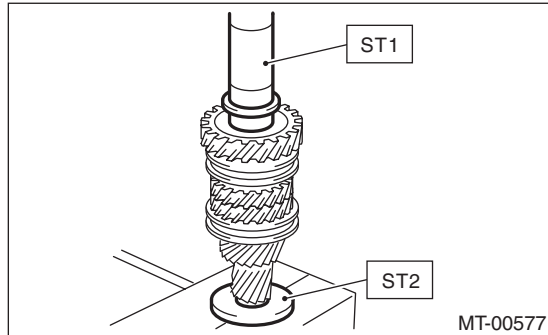

26) Make sure that the 6th drive gear can be turned smoothly by hand. If it does not turn smoothly, re-assemble.

27) Using the ST, install the inner bearing of the taper roller bearing.

ST1 18651AA000 INSTALLER

ST2 398177700 INSTALLER

### CAUTION:

Do not apply pressure in excess of 40 kN (4.0 ton, 4.4 US ton, 3.9 Imp ton).

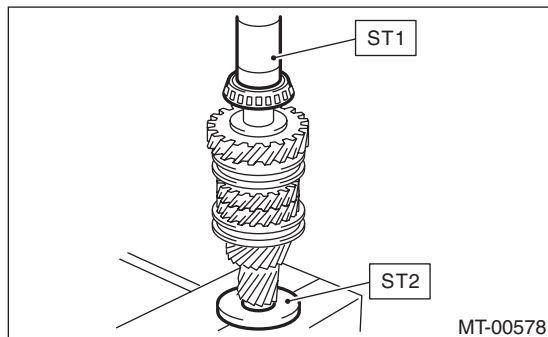

28) Using the ST, install the outer race and the outer bearing of the taper roller bearing.

ST1 18651AA000 INSTALLER

ST2 398177700 INSTALLER

### CAUTION:

Do not apply pressure in excess of 40 kN (4.0 ton, 4.4 US ton, 3.9 Imp ton).

### NOTE:

- Confirm that the outer race is installed in the proper direction.
- Push in until there is no backlash on the outer race and the bearing turns smoothly by hand.

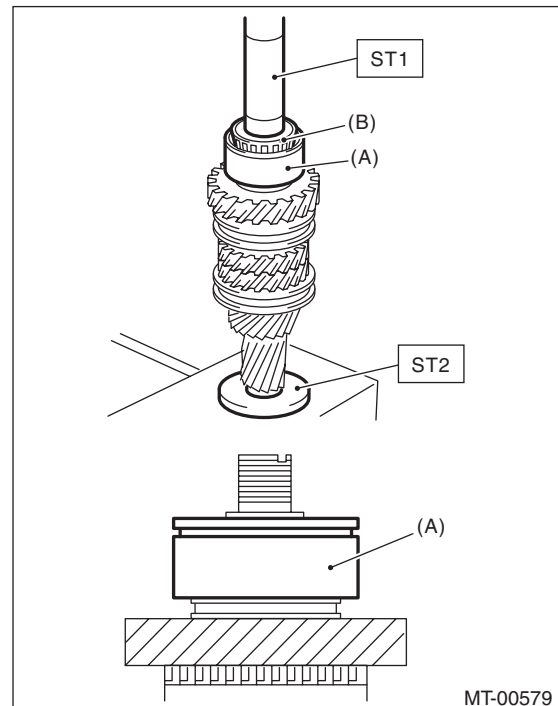

(A) Outer race

(B) Outer bearing of the taper roller bearing

29) Make sure that the taper roller bearing turns smoothly by hand. If it does not rotate smoothly, replace the taper roller bearing as a set, and re-assemble.

30) Attach a new lock washer and a new lock nut.

6MT-75

Brought to you by Ebay Seller "SubaruManuals"



# Main Shaft Assembly

## MANUAL TRANSMISSION AND DIFFERENTIAL

31) Set the main shaft assembly to the ST, and tighten the lock nut.

ST1 18665AA000 HOLDER

ST2 18664AA000 BASE

### NOTE:

Make sure the lock washer is installed in the proper direction.

### Tightening torque:

**392 N·m (40.0 kgf·m, 289.1 ft·lb)**

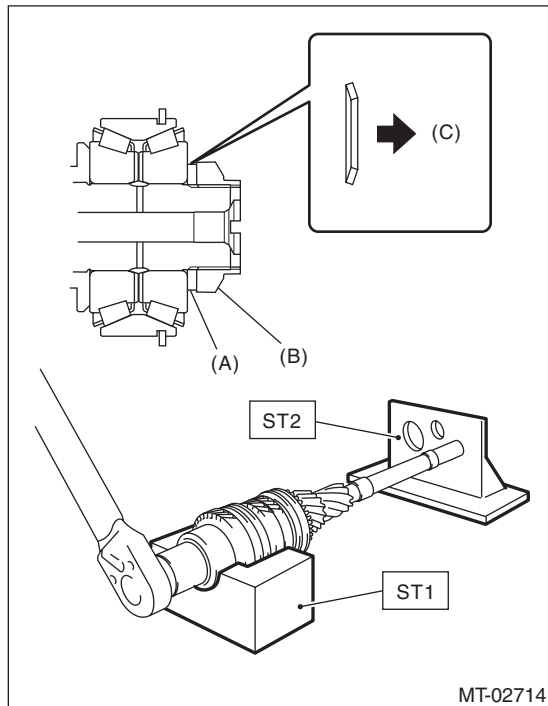

- (A) Lock washer
- (B) Lock nut
- (C) Nut side

32) Using the ST, crimp the lock nut in 4 locations, with dimensions within  $A 27 \pm 0.3$  mm ( $1.06 \pm 0.01$  in).

ST 18668AA000 PUNCH

### NOTE:

Do not damage the crimp area of the lock nut.

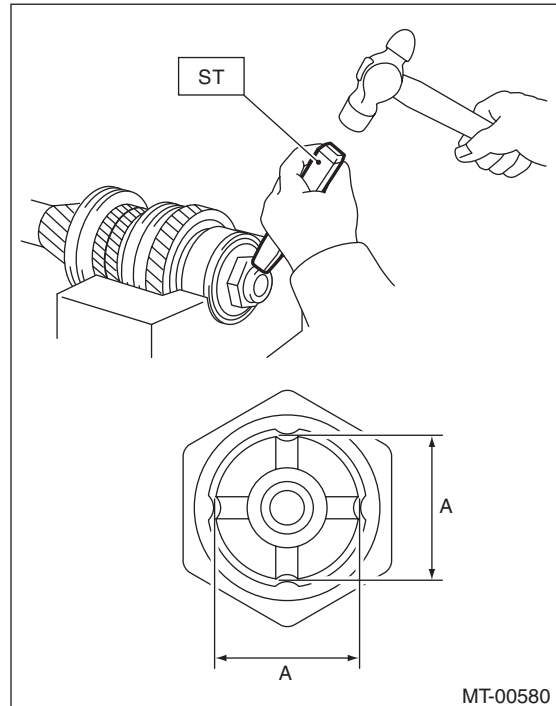

## E: INSPECTION

Disassembled parts should be washed with cleaning solvent first, then inspected carefully.

### 1) Bearing

Replace the bearings in the following cases.

- Wear, rusting or damage of the bearings
- The bearing does not rotate smoothly or an abnormal noise is emitted when turning.
- The bearing has other defects.

### 2) Bushing (each gear)

Replace the bushing in following cases.

- The sliding surface is damaged or abnormally worn.

### 3) Gear

Replace gears in the following cases.

- The gear teeth surface is damaged or excessively worn.
- The contact area of the baulk ring is damaged.
- The inner face of the gear is worn.

### 4) Baulk ring, synchro cone

Replace the baulk ring and synchro cone in the following cases.

- Wear, rusting or damage of the baulk ring



# Main Shaft Assembly

MANUAL TRANSMISSION AND DIFFERENTIAL

## 5) Shifting insert key

Replace the shifting insert key if deformed, excessively worn or defective in any way.

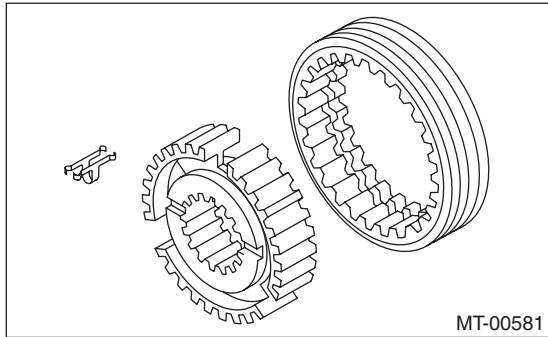

## NOTE:

- The adapter plate will be the base point for the measurement. Use a scraper to remove any gasket material remaining on the end face.
- During measurement, do not place the height gauge in the shaded area shown in the figure.

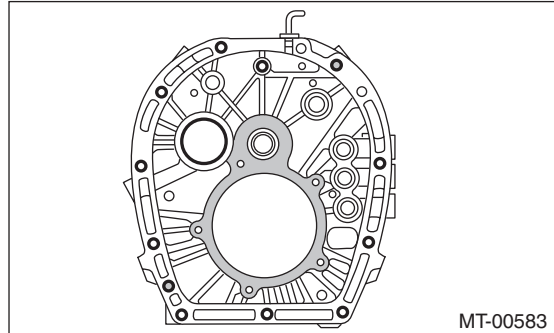

## F: ADJUSTMENT

### 1. MAIN SHAFT SNAP RING & WASHER SELECTION

#### NOTE:

In the following conditions, perform the procedures below.

- 1st to 6th driven gear replacement
- 1st and 2nd synchro ring assembly replacement
- Ball bearing replacement
- Adapter plate replacement
- Driven shaft replacement

1) Insert the drive pinion assembly into the adapter plate.

#### NOTE:

Confirm that the thrust bearing outer race has not been removed and the drive pinion is not lifted.

2) Set the height gauge to the adapter plate. Lower the height gauge indicator to the mating surface of the adapter plate and case, and set to zero points.

ST 18853AA000 HEIGHT GAUGE

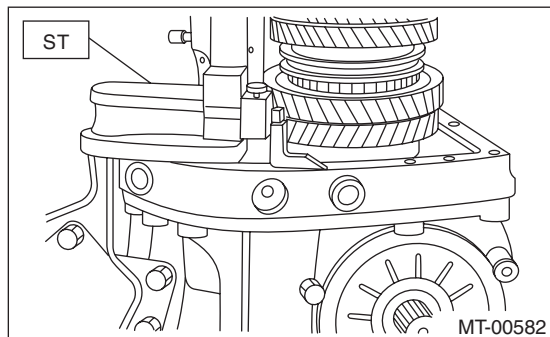

3) Measure the height to the ball bearing end face (height H).

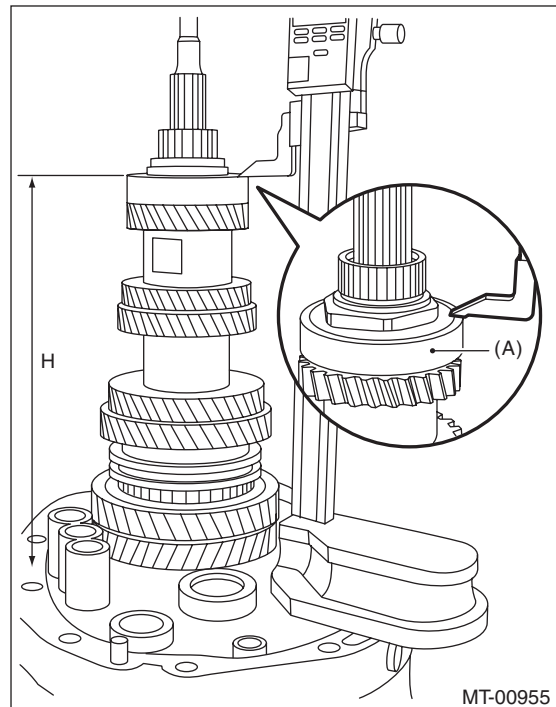

(A) Ball bearing

# Main Shaft Assembly

## MANUAL TRANSMISSION AND DIFFERENTIAL

### NOTE:

Set the height gauge indicator near the measurement target, and lock dial (1) as shown in the figure. Turn dial (2), and set the indicator to the end face of the bearing.

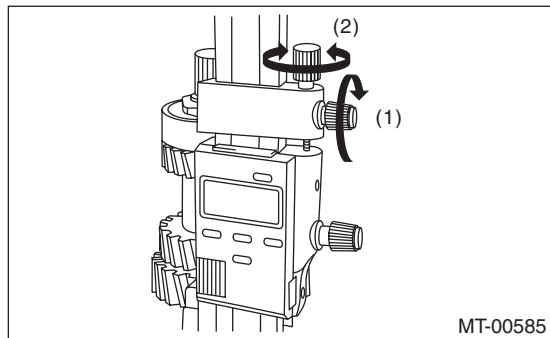

Turn approximately 120° at a time, and measure the ball bearing in 5 locations. Round down the 2 highest and 2 lowest measurement values. The remaining center value is used as the measurement value.

4) According to the measurement value, select the snap ring and washer from the following table.

Snap ring		
H: mm (in)	Part No.	Thickness: mm (in)
270.83 — 271.40 (10.66 — 10.69)	805072010	1.65 (0.065)
271.41 — 271.98 (10.69 — 10.71)	805072011	1.95 (0.077)
271.99 — 272.56 (10.71 — 10.73)	805072012	2.25 (0.089)

Washer		
H: mm (in)	Part No.	Thickness: mm (in)
270.83 — 271.40 (10.66 — 10.69)	803067012	1.6 (0.063)
271.41 — 271.98 (10.69 — 10.71)	803067011	1.3 (0.051)
271.99 — 272.56 (10.71 — 10.73)	803067010	1.0 (0.039)

## 18. Driven Gear Assembly

### A: REMOVAL

- 1) Remove the manual transmission assembly from the vehicle. <Ref. to 6MT-32, REMOVAL, Manual Transmission Assembly.>
- 2) Prepare the transmission for overhaul. <Ref. to 6MT-38, Preparation for Overhaul.>
- 3) Remove the neutral position switch, back-up light switch and harness. <Ref. to 6MT-42, REMOVAL, Neutral Position Switch.> <Ref. to 6MT-40, REMOVAL, Back-up Light Switch.>
- 4) Remove the extension case. <Ref. to 6MT-44, REMOVAL, Extension Case.>
- 5) Remove the transfer driven gear. <Ref. to 6MT-55, REMOVAL, Transfer Driven Gear.>
- 6) Remove the center differential. <Ref. to 6MT-57, REMOVAL, Center Differential.>
- 7) Remove the transmission case. <Ref. to 6MT-58, REMOVAL, Transmission Case.>
- 8) Remove the driven gear assembly. <Ref. to 6MT-65, REMOVAL, Main Shaft Assembly.>
- 9) Remove the 1st needle bearing.

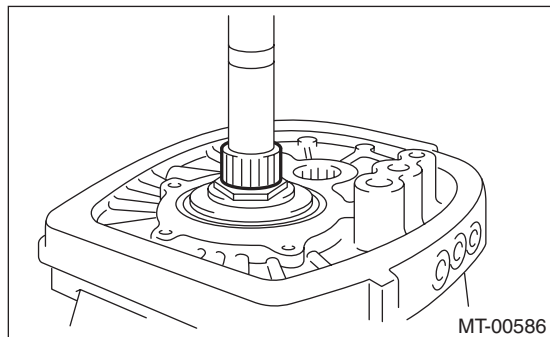

- 10) Remove the thrust needle bearing.

### B: INSTALLATION

- 1) Adjust the main shaft snap ring. <Ref. to 6MT-77, ADJUSTMENT, Main Shaft Assembly.>
- 2) Adjust the 1st-2nd shifter rod. <Ref. to 6MT-109, ADJUSTMENT, Shifter Fork and Rod.>
- 3) Install the thrust needle bearing.

#### NOTE:

Confirm that the thrust needle bearing is installed in the proper direction.

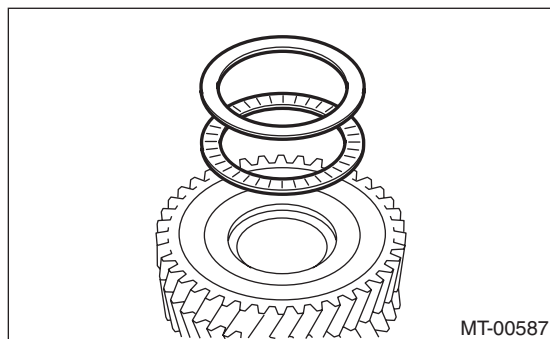

- 4) Install the 1st needle bearing.
- 5) Install the driven gear assembly. <Ref. to 6MT-66, INSTALLATION, Main Shaft Assembly.>
- 6) Install the transmission case. <Ref. to 6MT-60, INSTALLATION, Transmission Case.>
- 7) Adjust the backlash of the driven gear assembly in the axial direction. <Ref. to 6MT-86, ADJUSTMENT, Driven Gear Assembly.>
- 8) Install the center differential. <Ref. to 6MT-57, INSTALLATION, Center Differential.>
- 9) Install the transfer driven gear. <Ref. to 6MT-55, INSTALLATION, Transfer Driven Gear.>
- 10) Install the extension case. <Ref. to 6MT-44, INSTALLATION, Extension Case.>
- 11) Install the neutral position switch, back-up light switch and harness. <Ref. to 6MT-42, INSTALLATION, Neutral Position Switch.> <Ref. to 6MT-40, INSTALLATION, Back-up Light Switch.>
- 12) Install the manual transmission assembly to the vehicle. <Ref. to 6MT-34, INSTALLATION, Manual Transmission Assembly.>

### C: DISASSEMBLY

#### NOTE:

Individual sleeves and hubs meet at a specified position. Before disassembly, mark the meeting position of the sleeve and hub.

- 1) Affix the ST to the work table.  
ST 18664AA000 BASE
- 2) Flatten the tab of the lock nut.
- 3) Attach ST3 to the lock nut, set the driven gear assembly to the ST, and remove the lock nut.  
ST1 18666AA000 HOLDER  
ST2 18664AA000 BASE  
ST3 18620AA000 ADAPTER WRENCH

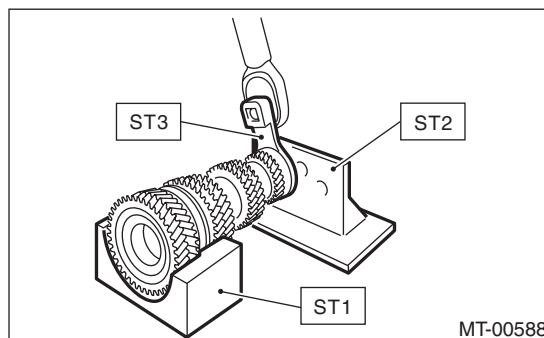

# Driven Gear Assembly

## MANUAL TRANSMISSION AND DIFFERENTIAL

4) Attach ST1 to the 6th driven gear, then remove the ball bearing and 5th-6th driven gear.

ST1 18723AA000 REMOVER

ST2 499877000 RACE 4-5 INSTALLER

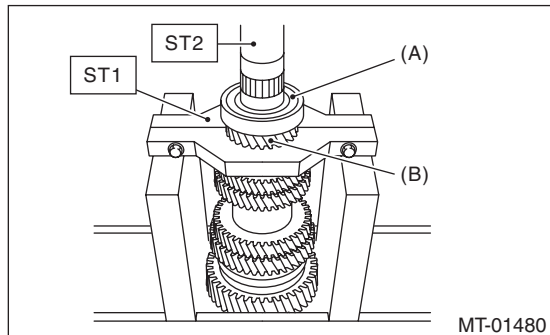

(A) Ball bearing

(B) 5th-6th driven gear

5) Attach ST1 to the 4th driven gear, then remove the 3rd-4th driven gear.

ST1 18723AA000 REMOVER

ST2 499877000 RACE 4-5 INSTALLER

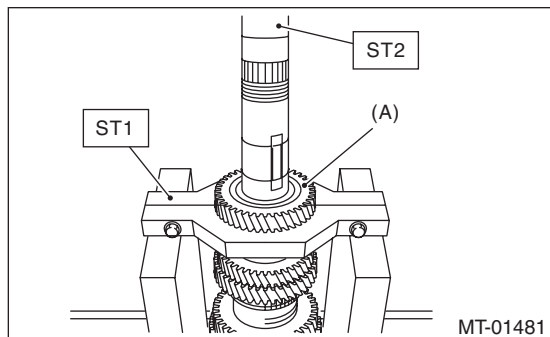

(A) 3rd-4th driven gear

6) Remove the driven gear key.

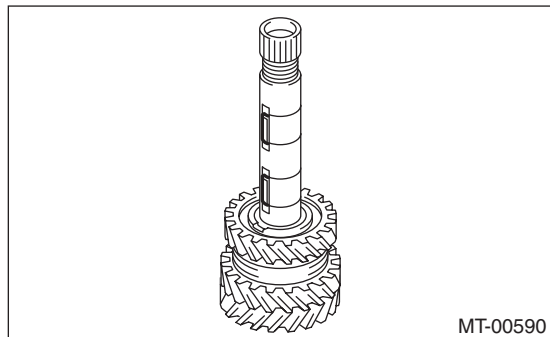

7) Remove the 2nd gear.

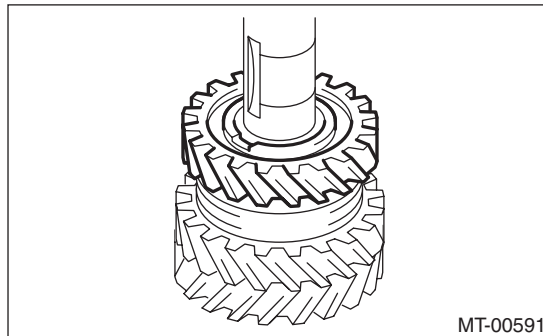

8) Remove the needle bearing and 1st-2nd sleeve.

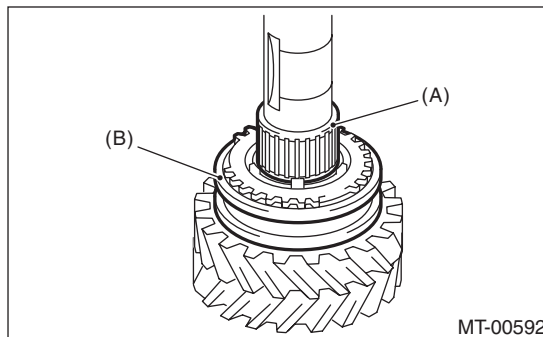

(A) Needle bearing

(B) 1st-2nd sleeve

9) Remove the outer baulk ring, 2nd synchro cone and inner baulk ring.

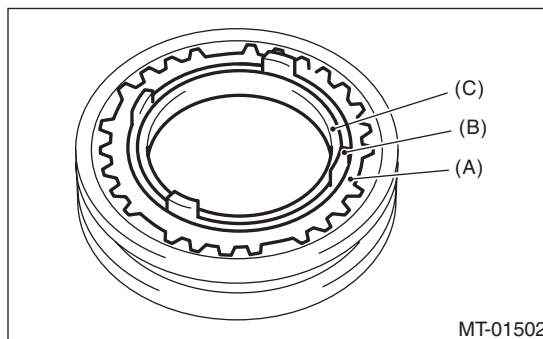

(A) Outer baulk ring

(B) 2nd synchro cone

(C) Inner baulk ring

# Driven Gear Assembly

MANUAL TRANSMISSION AND DIFFERENTIAL

10) Using the ST, remove individual parts.  
ST 18754AA000 REMOVER

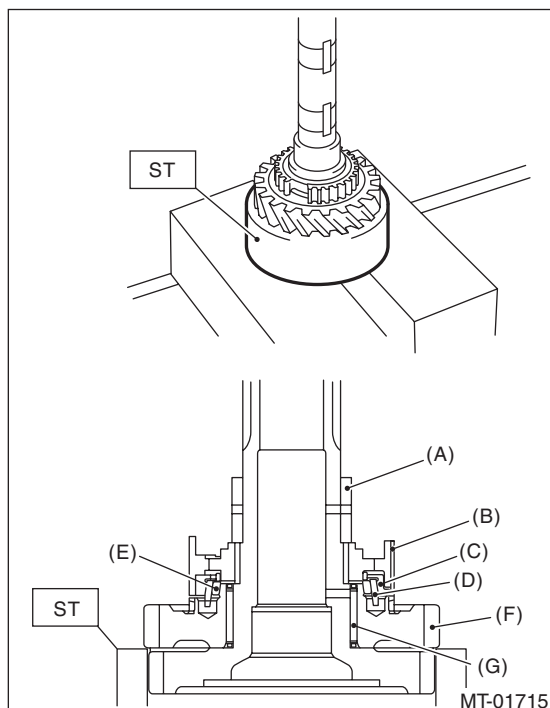

- (A) 2nd bushing
- (B) 1st-2nd hub
- (C) Outer baulk ring
- (D) 1st synchro cone
- (E) Inner baulk ring
- (F) 1st driven gear
- (G) 1st needle bearing

## D: ASSEMBLY

### NOTE:

When replacing the following parts, replace as a set.

- Sleeve and hub
- Outer baulk ring, 1st synchro cone and inner baulk ring
- Outer baulk ring, 2nd synchro cone and inner baulk ring

1) Apply adequate transmission gear oil to the main shaft, 1st needle bearing and 1st driven gear inner surface.

2) Install the 1st needle bearing.

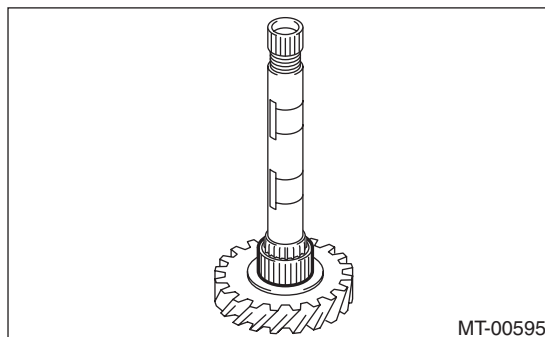

3) Attach the 1st driven gear to the driven shaft.

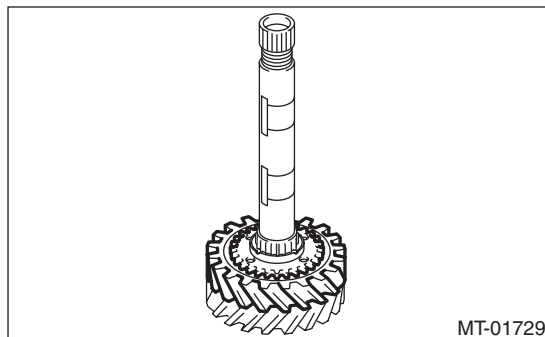

4) Install the inner baulk ring.

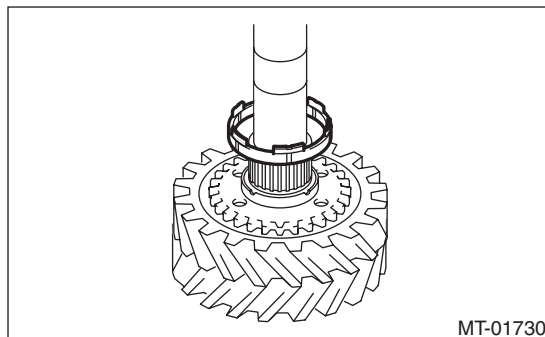

5) Match the protrusion of the 1st synchro cone to the hole of the 1st driven gear, then install.

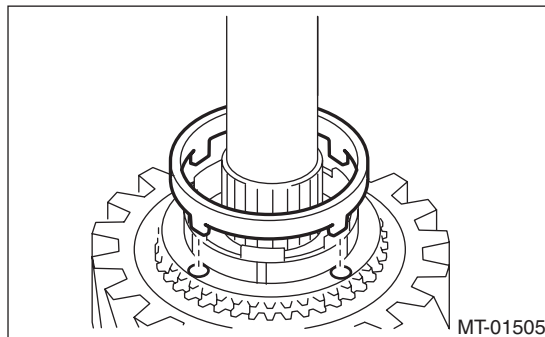

# Driven Gear Assembly

## MANUAL TRANSMISSION AND DIFFERENTIAL

6) Install the outer baulk ring.

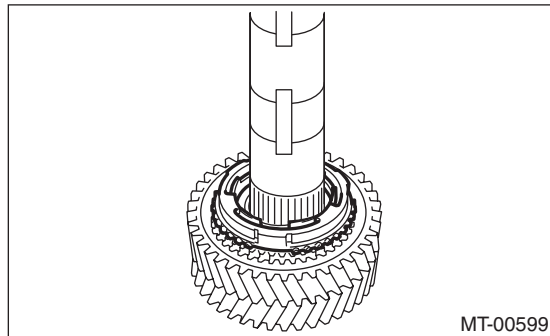

7) Install the 1st-2nd hub.

### NOTE:

- Match the cut out of the 1st-2nd hub with the protrusion on the outer baulk ring, then install.
- Make sure that the 1st-2nd hub is installed in the correct direction.

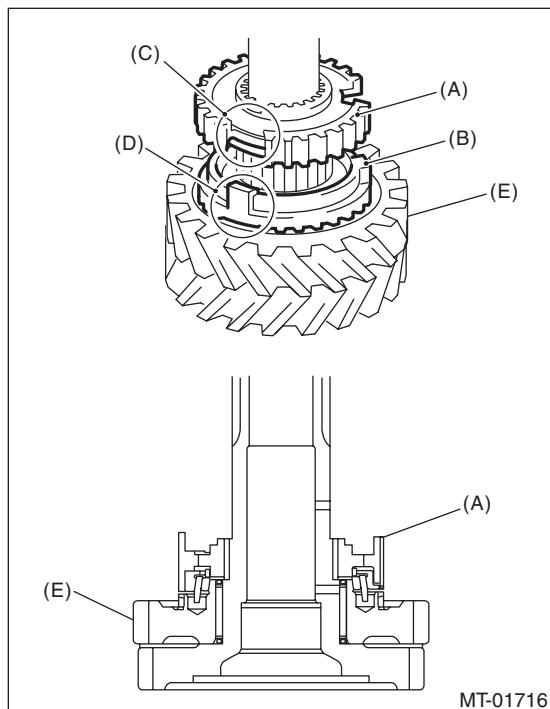

- (A) 1st-2nd hub
- (B) Outer baulk ring
- (C) 1st-2nd hub cut out section
- (D) Protrusion of the outer baulk ring
- (E) 1st driven gear

8) Using the ST, install the 1st-2nd hub and 2nd bush.

ST 18654AA000 INSTALLER

### CAUTION:

Do not apply pressure in excess of 40 kN (4.0 ton, 4.4 US ton, 3.9 Imp ton).

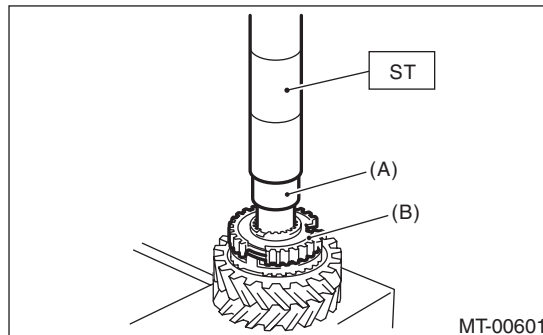

- (A) 2nd bushing
- (B) 1st-2nd hub

9) Make sure that the 1st driven gear can be turned smoothly by hand. If it does not turn smoothly, re-assemble.

10) Attach the 1st-2nd sleeve to the 1st-2nd hub.

### NOTE:

- Make sure that the 1st-2nd sleeve is installed in the correct direction.
- Align the 1st-2nd hub cut out section (three places) and the key grooves (three places) of shifting insert key that are located inside the 1st-2nd sleeve.
- Set the 1st-2nd sleeve and 1st driven gear so that they contact each other.

# Driven Gear Assembly

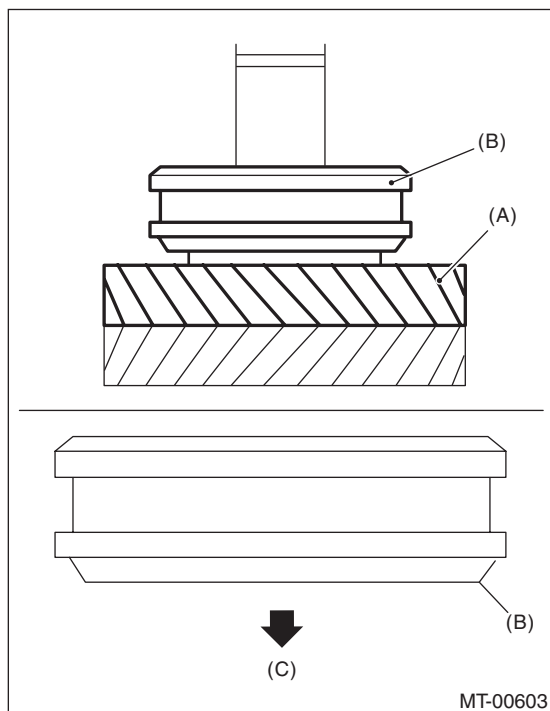

- (A) 1st driven gear
- (B) 1st-2nd sleeve
- (C) 1st driven gear side

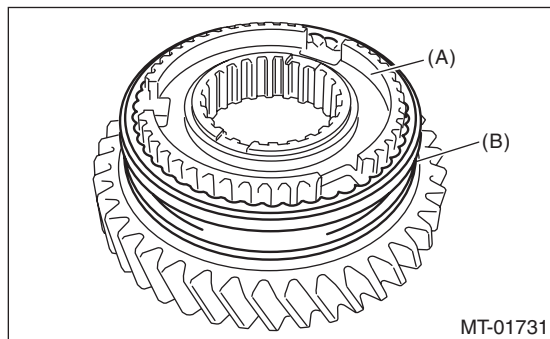

- (A) 1st-2nd hub
- (B) 1st-2nd sleeve

11) Attach the shifting insert key to the appropriate position of the 1st-2nd sleeve.

**NOTE:**

- The location angle of each shifting insert key is 120°.
- Install the shifting insert key to the key grooves (three places) of shifting insert key that are located inside the 1st-2nd sleeve.

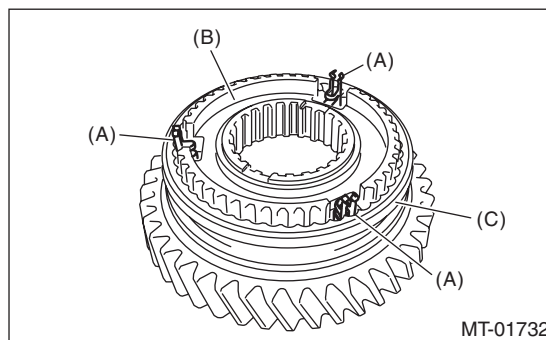

- (A) Shifting insert key
- (B) 1st-2nd hub
- (C) 1st-2nd sleeve

12) Install the outer baulk ring.

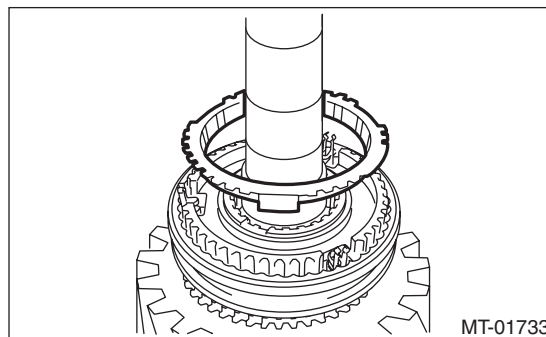

13) Install the 2nd synchro cone.

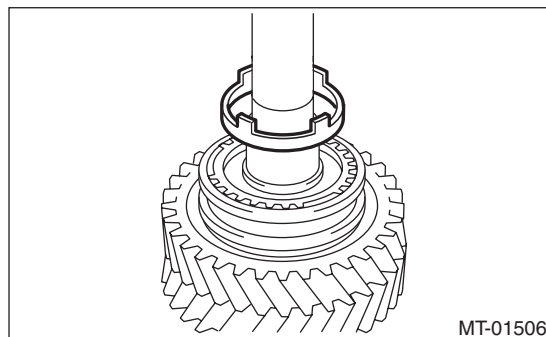

14) Install the inner baulk ring.

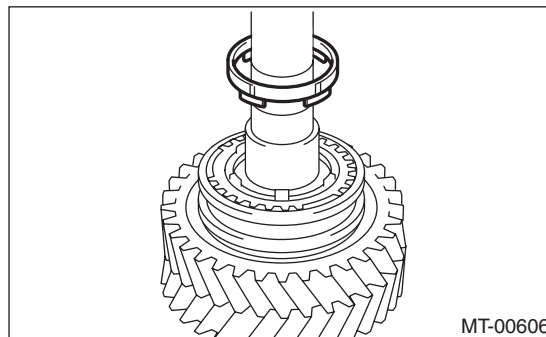

15) Apply adequate transmission gear oil to the bushing, 2nd needle bearing and 2nd driven gear inner surface.



# Driven Gear Assembly

## MANUAL TRANSMISSION AND DIFFERENTIAL

16) Install the 2nd needle bearing and 2nd driven gear.

**NOTE:**

Match the protrusion of the 2nd synchro cone to the hole of the 2nd driven gear, then install.

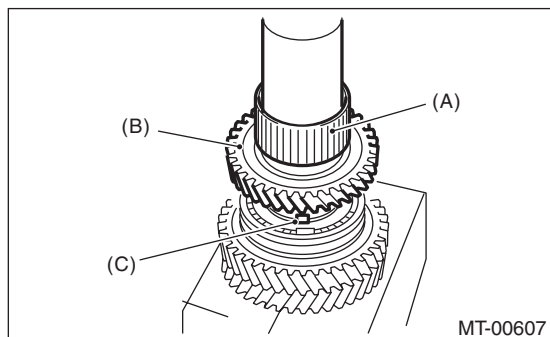

- (A) 2nd needle bearing
- (B) 2nd driven gear
- (C) Protrusion of the 2nd synchro cone

17) Attach the key.

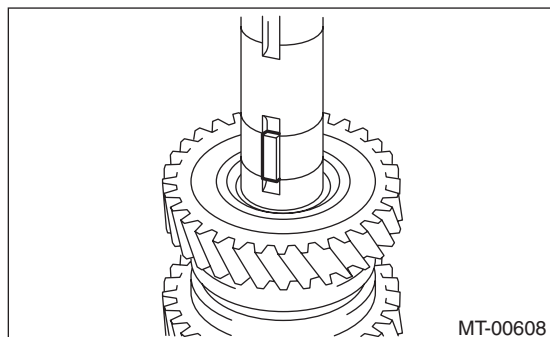

18) Using the ST, install the 3rd-4th driven gear.  
ST 18654AA000 INSTALLER

**CAUTION:**

**Do not apply pressure in excess of 40 kN (4.0 ton, 4.4 US ton, 3.9 Imp ton).**

**NOTE:**

- Make sure that the 3rd-4th driven gear is installed in the correct direction.
- Match the groove on the 3rd-4th driven gear to the key.

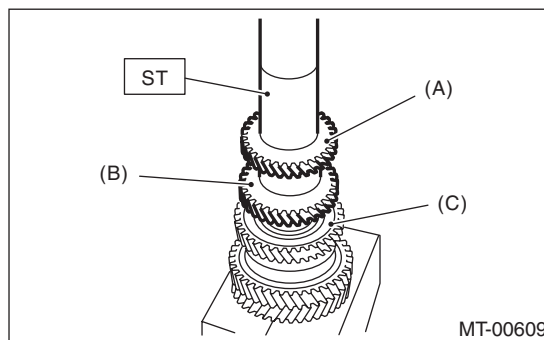

- (A) 4th gear
- (B) 3rd gear
- (C) 2nd gear

19) Make sure that the 2nd driven gear can be turned smoothly by hand. If it does not turn smoothly, reassemble.

20) Attach the key.

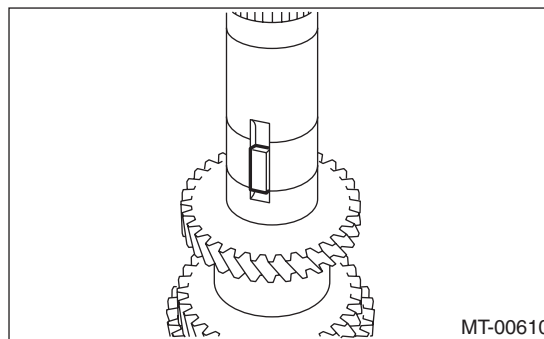

21) Using the ST, install the 5th-6th driven gear.  
ST 18654AA000 INSTALLER

**CAUTION:**

**Do not apply pressure in excess of 40 kN (4.0 ton, 4.4 US ton, 3.9 Imp ton).**

**NOTE:**

- Make sure that the 5th-6th driven gear is installed in the correct direction.
- Match the groove on the 5th-6th driven gear to the key.

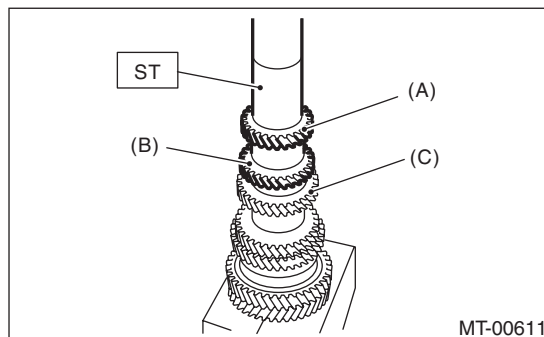

- (A) 6th gear
- (B) 5th gear
- (C) 4th gear



# Driven Gear Assembly

MANUAL TRANSMISSION AND DIFFERENTIAL

22) Using the ST, install the ball bearing.  
ST 18654AA000 INSTALLER

**CAUTION:**

**Do not apply pressure in excess of 40 kN (4.0 ton, 4.4 US ton, 3.9 Imp ton).**

**NOTE:**

Face the sealing section of the ball bearing to the lock nut side, and install the ball bearing.

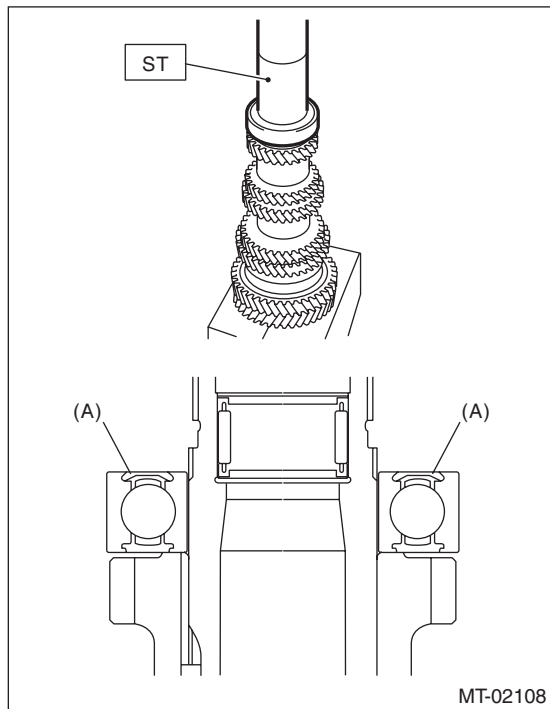

(A) Sealing

23) Make sure that the ball bearing turns smoothly by hand. If it does not turn smoothly, reassemble.

24) Install a new lock nut.

25) Attach ST3 to the lock nut, attach ST to the driven gear assembly, and tighten the lock nut.

ST1 18666AA000 HOLDER

ST2 18664AA000 BASE

ST3 18620AA000 ADAPTER WRENCH

ST4 18852AA000 TORQUE WRENCH

**Tightening torque:**

**530 N·m (54.0 kgf·m, 390.9 ft·lb)**

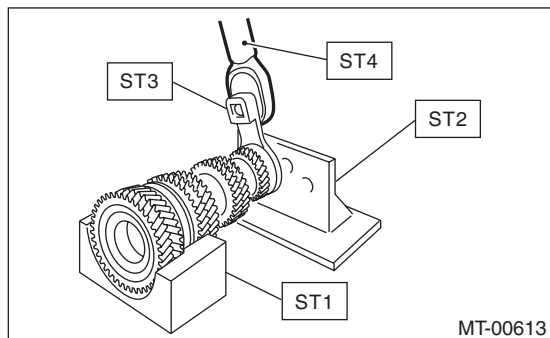

MT-00613

**NOTE:**

When using a torque wrench other than ST4, use the calculation below to calculate and tighten the lock nut.

$$T = L1 / (0.1 + L1) \times 570$$

T	N·m (kgf·m, ft·lb)	Torque wrench setting
L1	m (in)	Torque wrench length
	0.1 m (3.94 in)	Length of ST
570 N·m (58.1 kgf·m, 420 ft·lb)		Tightening torque (lock nut)

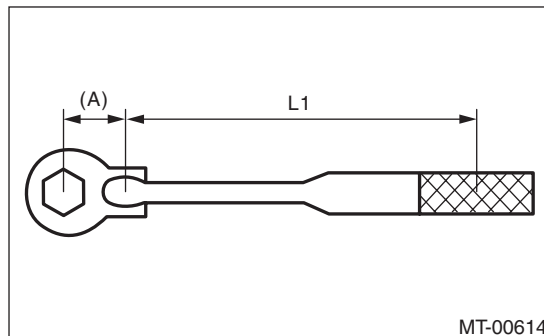

MT-00614

(A) 0.1 m (3.94 in)

26) Using the ST, crimp the lock nut in 4 locations, with dimensions within A 44±0.5 mm (1.73±0.02 in).

ST 18669AA000 PUNCH DRIVEN SHAFT

**NOTE:**

Do not damage the crimp area of the lock nut.

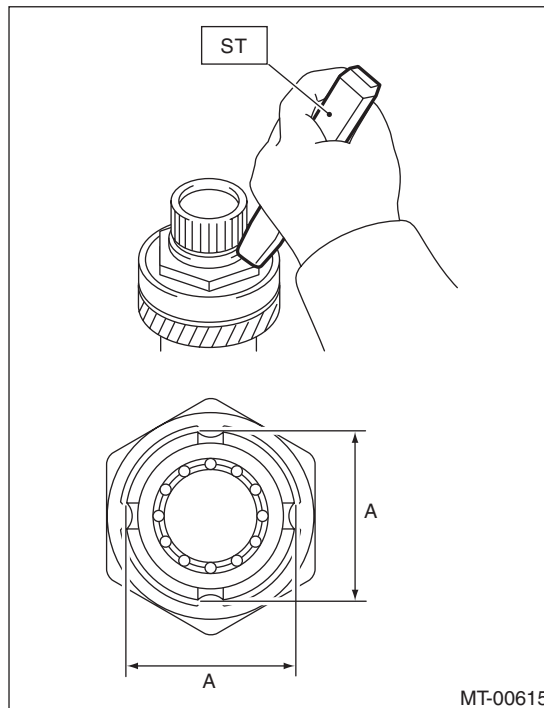

MT-00615

# Driven Gear Assembly

## MANUAL TRANSMISSION AND DIFFERENTIAL

### E: INSPECTION

Disassembled parts should be washed with cleaning solvent first, then inspected carefully.

#### 1) Bearing

Replace the bearings in the following cases.

- Wear, rusting or damage of the bearings
- The bearing does not rotate smoothly or an abnormal noise is emitted when turning.
- The bearing has other defects.

#### 2) Bushing (each gear)

Replace the bushing in following cases.

- The sliding surface is damaged or abnormally worn.

#### 3) Gear

Replace gears in the following cases.

- The gear teeth surface is damaged or excessively worn.
- The contact area of the baulk ring is damaged.
- The inner face of the gear is worn.

#### 4) Baulk ring, synchro cone

Replace the baulk ring and synchro cone in the following cases.

- Wear, rusting or damage of the baulk ring

#### 5) Shifting insert key

Replace the shifting insert key if deformed, excessively worn or defective in any way.

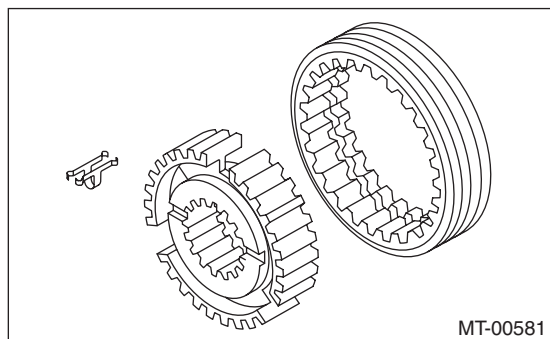

### F: ADJUSTMENT

1) Measure the length "H" from the transmission case and transfer bearing holder mating surface, to the end face of the ball bearing.

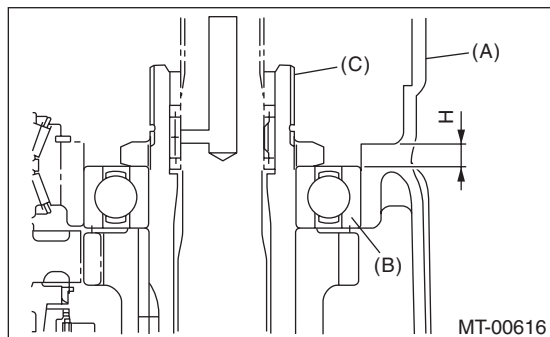

- (A) Transmission case
- (B) Ball bearing
- (C) Driven gear ASSY

2) Using the following calculation, calculate the thickness of the driven gear assembly washer.

$$T = H - \{5.8 \pm 0.05 \text{ mm (0.23} \pm 0.002 \text{ in)}\} - \{0.1 - 0.3 \text{ mm (0.0039} - 0.0118 \text{ in)}\}$$

T	Washer thickness
H	Length from the transmission case and transfer bearing holder mating surface to the end face of the ball bearing
5.8±0.05 mm (0.23±0.002 in)	Collar thickness
0.1 — 0.3 mm (0.0039 — 0.0118 in)	Driven gear assembly axial direction backlash standard

3) Select 0 to 3 washers from the following table, and adjust to the backlash that is closest to the standard value.

**Driven gear assembly axial direction backlash standard:**

**0.1 — 0.3 mm (0.0039 — 0.0118 in)**

Washer	
Part No.	Thickness T mm (in)
803072030	0.15 (0.0059)
803072031	0.30 (0.0118)
803072032	0.45 (0.0177)
803072033	0.60 (0.0236)

## 19. Reverse Idler Gear Assembly

### A: REMOVAL

- 1) Remove the manual transmission assembly from the vehicle. <Ref. to 6MT-32, REMOVAL, Manual Transmission Assembly.>
- 2) Prepare the transmission for overhaul. <Ref. to 6MT-38, Preparation for Overhaul.>
- 3) Remove the neutral position switch, back-up light switch and harness. <Ref. to 6MT-42, REMOVAL, Neutral Position Switch.> <Ref. to 6MT-40, REMOVAL, Back-up Light Switch.>
- 4) Remove the extension case. <Ref. to 6MT-44, REMOVAL, Extension Case.>
- 5) Remove the transfer driven gear. <Ref. to 6MT-55, REMOVAL, Transfer Driven Gear.>
- 6) Remove the center differential. <Ref. to 6MT-57, REMOVAL, Center Differential.>
- 7) Remove the transmission case. <Ref. to 6MT-58, REMOVAL, Transmission Case.>
- 8) Remove the reverse idler gear assembly. <Ref. to 6MT-65, REMOVAL, Main Shaft Assembly.>

### B: INSTALLATION

- 1) Select the reverse fork rod. <Ref. to 6MT-109, ADJUSTMENT, Shifter Fork and Rod.>
- 2) Install the reverse idler gear assembly. <Ref. to 6MT-66, INSTALLATION, Main Shaft Assembly.>
- 3) Install the transmission case. <Ref. to 6MT-60, INSTALLATION, Transmission Case.>
- 4) Install the center differential. <Ref. to 6MT-57, INSTALLATION, Center Differential.>
- 5) Install the transfer driven gear. <Ref. to 6MT-55, INSTALLATION, Transfer Driven Gear.>
- 6) Install the extension case. <Ref. to 6MT-44, INSTALLATION, Extension Case.>
- 7) Install the neutral position switch, back-up light switch and harness. <Ref. to 6MT-42, INSTALLATION, Neutral Position Switch.> <Ref. to 6MT-40, INSTALLATION, Back-up Light Switch.>
- 8) Install the manual transmission assembly to the vehicle. <Ref. to 6MT-34, INSTALLATION, Manual Transmission Assembly.>

### C: DISASSEMBLY

#### NOTE:

Sleeves and reverse gears meet at a specified position. Before disassembly, mark the meeting position of the sleeve and hub.

- 1) Remove the spring pin.

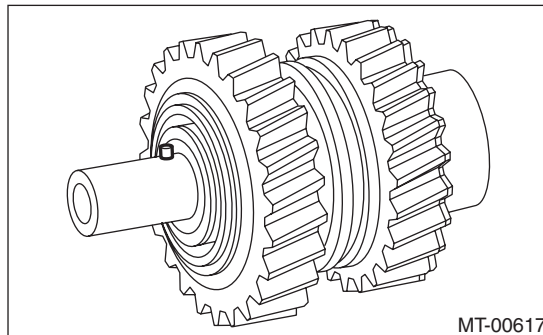

- 2) Remove the snap ring and washer.

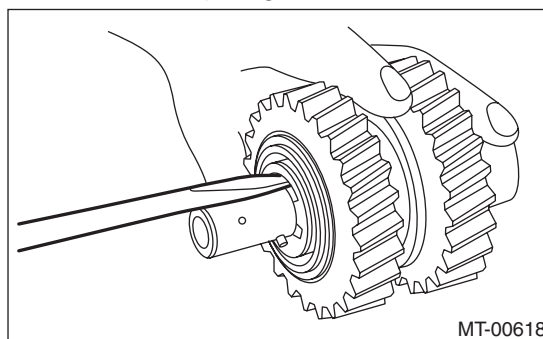

- 3) Remove the counter high & low washer and reverse idler gear.

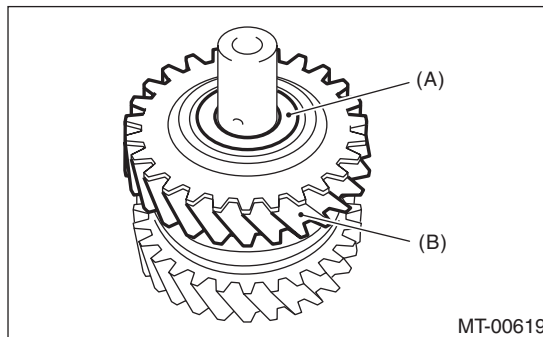

- (A) Counter high and low washer  
 (B) Reverse idler gear

# Reverse Idler Gear Assembly

## MANUAL TRANSMISSION AND DIFFERENTIAL

4) Remove the knock pin and reverse idler gear needle bearing.

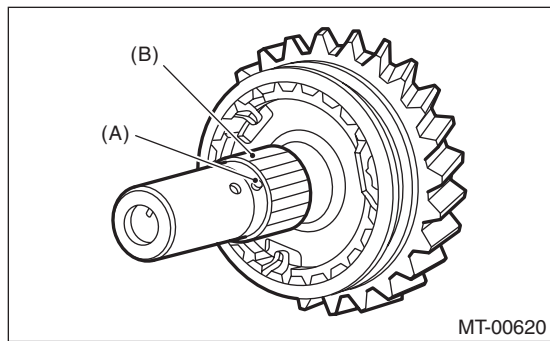

- (A) Knock pin
- (B) Reverse idler gear needle bearing

5) Remove the collar.

6) Remove the reverse sleeve.

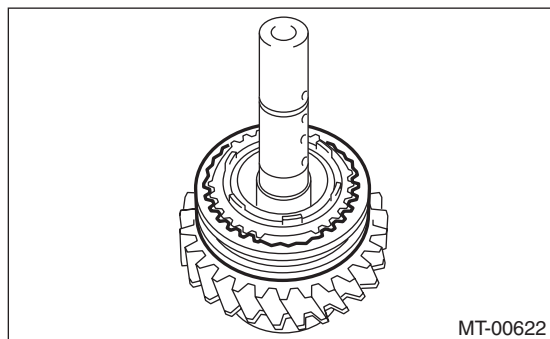

7) Remove the outer baulk ring, reverse synchro cone and inner baulk ring from the reverse sleeve.

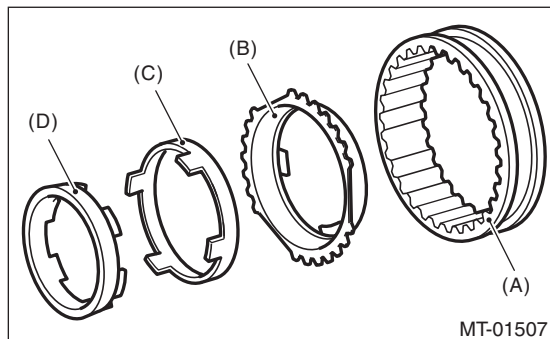

- (A) Reverse sleeve
- (B) Outer baulk ring
- (C) Reverse synchro cone
- (D) Inner baulk ring

8) Remove reverse idler gear No. 2.

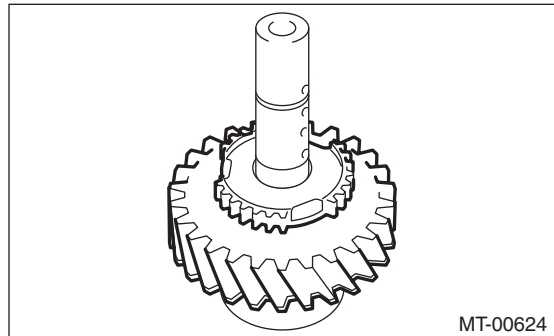

9) Remove the counter high & low washer and needle bearing.

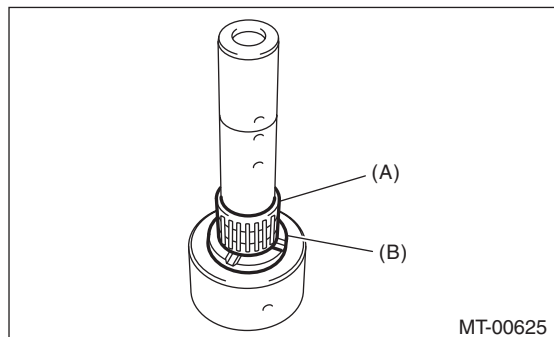

- (A) Needle bearing
- (B) Counter high and low washer

10) Remove the knock pin.

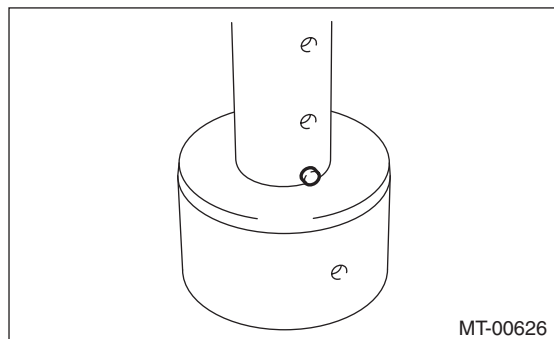

11) Remove the snap ring and friction plate from reverse gear.

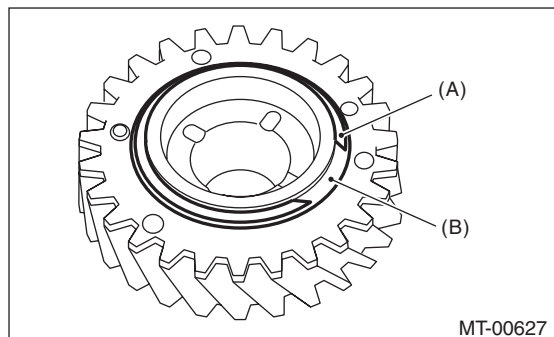

- (A) Snap ring
- (B) Friction plate

# Reverse Idler Gear Assembly

MANUAL TRANSMISSION AND DIFFERENTIAL

12) Remove the sub gear and spring.

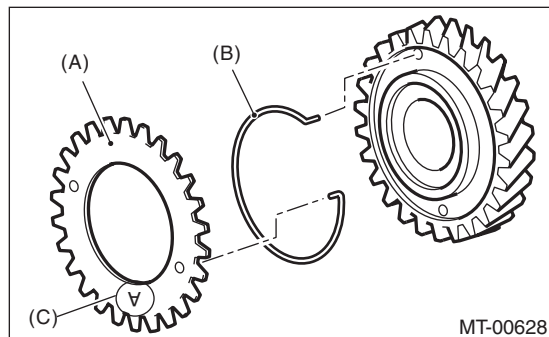

- (A) Sub gear
- (B) Spring
- (C) Stamp (marking A)

## D: ASSEMBLY

1) Attach the sub gear and spring.

NOTE:

- Turn the white marking on the hook section towards the sub gear side, and attach the spring.
- Point the stamp (marking A) towards the outside, and install the sub gear.

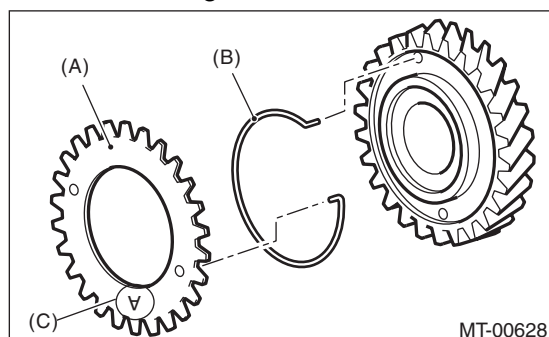

- (A) Sub gear
- (B) Spring
- (C) Stamp (marking A)

- While paying attention to the direction of the sub gear attachment hole, attach the spring and sub gear.

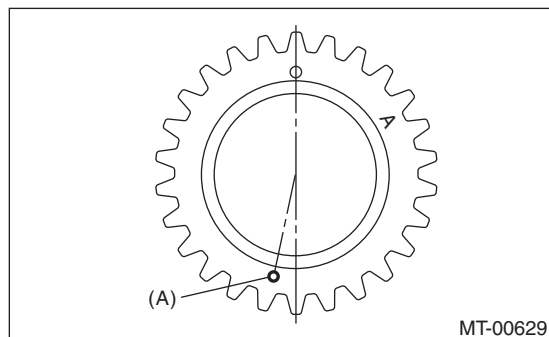

- (A) Attachment hole

2) Install the friction plate and snap ring.

NOTE:

Confirm that the friction plate is installed in the proper direction.

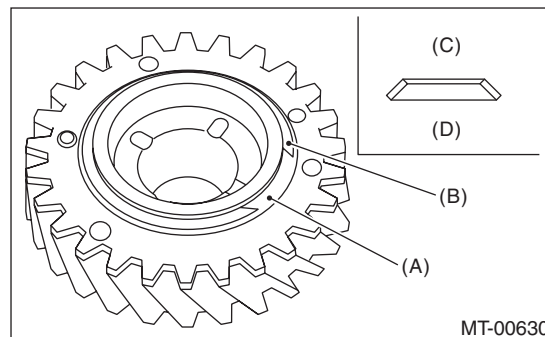

- (A) Friction plate
- (B) Snap ring
- (C) Snap ring side
- (D) Sub gear side

3) Apply adequate transmission gear oil to the shaft, needle bearing and reverse drive gear inner surface.

4) Install the knock pin.

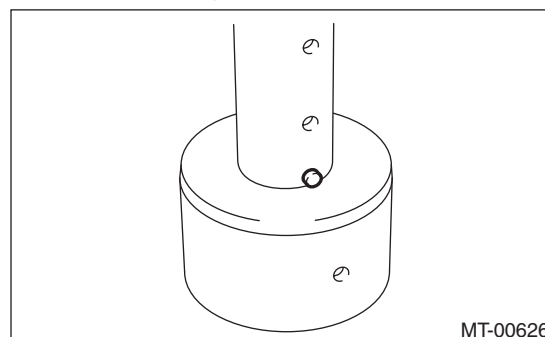

5) Install the counter high & low washer and needle bearing.

NOTE:

Point the groove towards the reverse idler gear, and attach the washer.

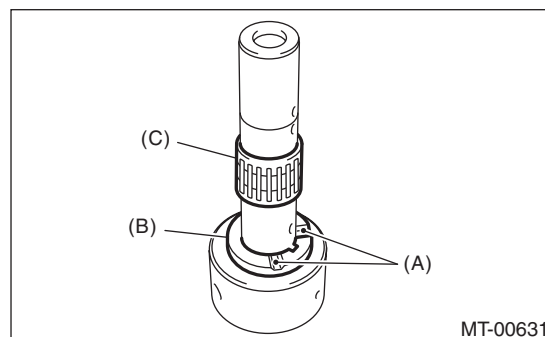

- (A) Groove
- (B) Counter high and low washer
- (C) Needle bearing

# Reverse Idler Gear Assembly

## MANUAL TRANSMISSION AND DIFFERENTIAL

6) Install the reverse idler gear No. 2.

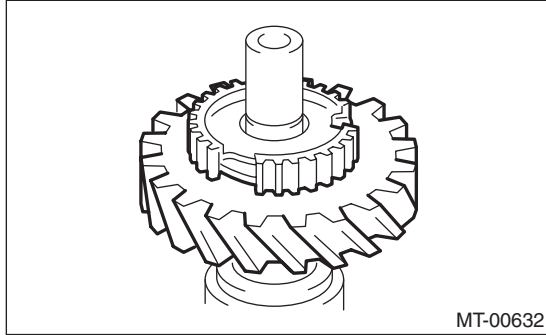

7) Attach the shifting insert key to the appropriate location of the reverse sleeve.

NOTE:

- The location angle of each shifting insert key is 120°.
- Refer to the following figure to install the shifting insert key.

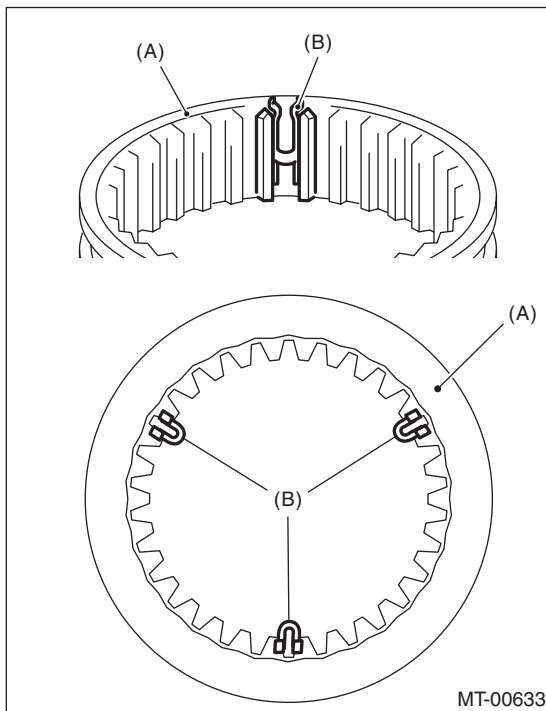

- (A) Reverse sleeve  
(B) Shifting insert key

8) Attach the reverse sleeve to the reverse idler gear No. 2.

NOTE:

Confirm that the reverse sleeve is installed in the proper direction.

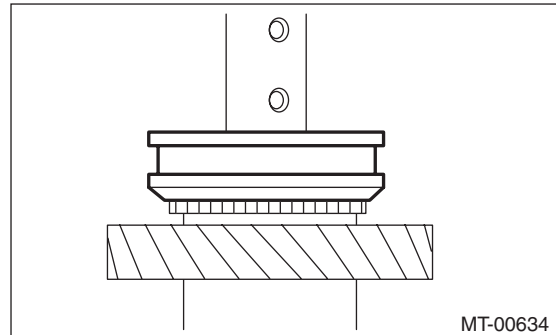

9) Apply adequate transmission gear oil to the collar, needle bearing and reverse drive gear inner surface.

10) Install the outer baulk ring, reverse synchro cone and inner baulk ring.

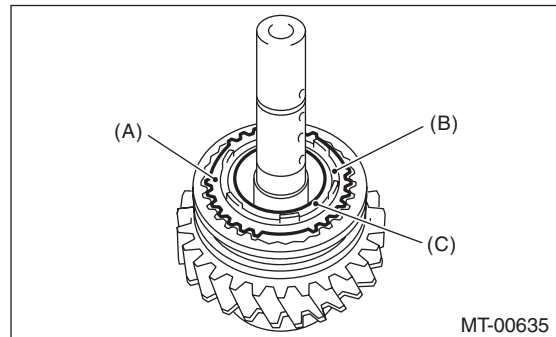

- (A) Outer baulk ring  
(B) Reverse synchro cone  
(C) Inner baulk ring

11) Install the collar and needle bearing, then the knock pin.

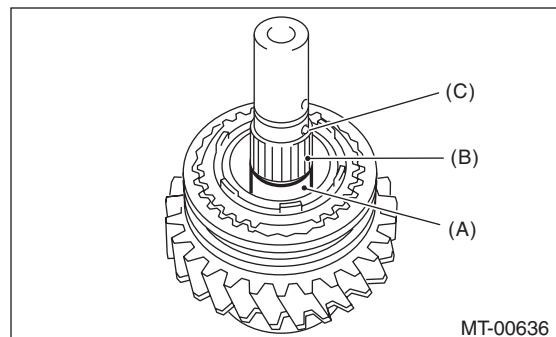

- (A) Collar  
(B) Needle bearing  
(C) Knock pin



# Reverse Idler Gear Assembly

12) Match the protrusion of the reverse synchro cone to the hole on the reverse idler gear, and install the reverse idler gear.

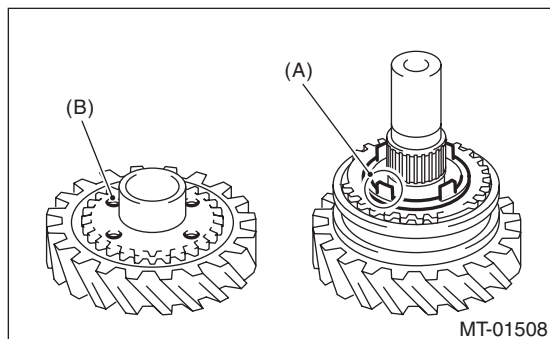

(A) Protrusion on the reverse synchro cone  
(B) Hole of the reverse idler gear

13) Point the groove towards the reverse idler gear, and attach the counter high & low washer and the washer.

14) Using the ST, install the snap ring.  
ST 18672AA000 GUIDE CLIP

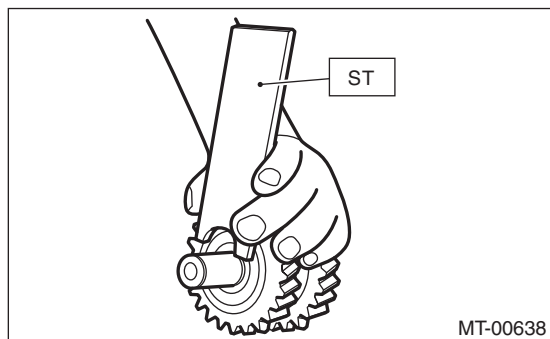

MT-00638

15) Inspect and adjust the clearance between the snap ring and the washer. <Ref. to 6MT-91, INSPECTION, Reverse Idler Gear Assembly.>

16) Install a new spring pin.

## E: INSPECTION

Disassembled parts should be washed with cleaning solvent first, then inspected carefully.

1) Bearing

Replace the bearings in the following cases.

- Wear, rusting or damage of the bearings
- The bearing does not rotate smoothly or an abnormal noise is emitted when turning.
- The bearing has other defects.

2) Bushing (each gear)

Replace the bushing in following cases.

- The sliding surface is damaged or abnormally worn.

3) Gear

Replace gears in the following cases.

- The gear teeth surface is damaged or excessively worn.
- The contact area of the baulk ring is damaged.
- The inner face of the gear is worn.

4) Baulk ring, synchro cone

Replace the baulk ring and synchro cone in the following cases.

- Wear, rusting or damage of the baulk ring

5) Shifting insert key

Replace the shifting insert key if deformed, excessively worn or defective in any way.

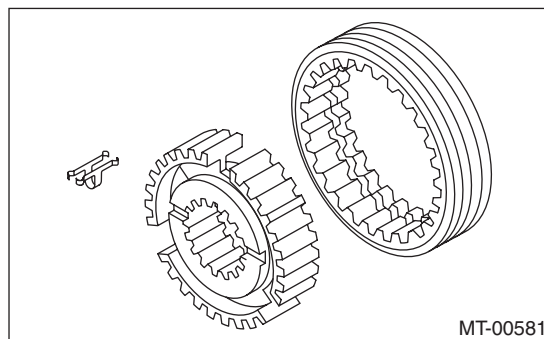

MT-00581

6) Check clearance between the snap ring and washer.

### Clearance specification:

**0.1 — 0.3 mm (0.0039 — 0.0118 in)**

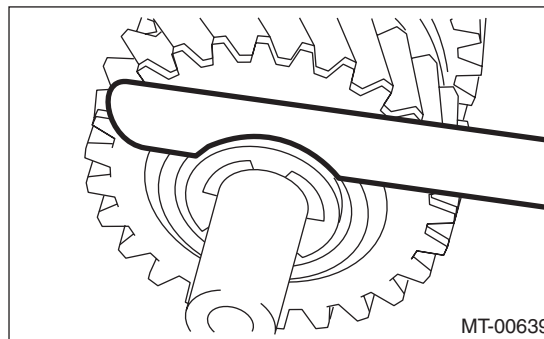

MT-00639

If the clearance is out of the specification, select a snap ring from the following table and replace it.

Snap ring	
Part No.	Thickness mm (in)
031319000	1.50 (0.059)
805019030	1.60 (0.062)
805019010	1.72 (0.068)

After replacing the snap ring, inspect the clearance.

# Drive Pinion Shaft Assembly

MANUAL TRANSMISSION AND DIFFERENTIAL

## 20. Drive Pinion Shaft Assembly

### A: REMOVAL

- 1) Remove the manual transmission assembly from the vehicle. <Ref. to 6MT-32, REMOVAL, Manual Transmission Assembly.>
- 2) Prepare the transmission for overhaul. <Ref. to 6MT-38, Preparation for Overhaul.>
- 3) Remove the neutral position switch, back-up light switch and harness. <Ref. to 6MT-42, REMOVAL, Neutral Position Switch.> <Ref. to 6MT-40, REMOVAL, Back-up Light Switch.>
- 4) Remove the extension case. <Ref. to 6MT-44, REMOVAL, Extension Case.>
- 5) Remove the transfer driven gear. <Ref. to 6MT-55, REMOVAL, Transfer Driven Gear.>
- 6) Remove the center differential. <Ref. to 6MT-57, REMOVAL, Center Differential.>
- 7) Remove the transmission case. <Ref. to 6MT-58, REMOVAL, Transmission Case.>
- 8) Remove the individual gear assemblies. <Ref. to 6MT-65, REMOVAL, Main Shaft Assembly.>
- 9) Remove the drive pinion shaft assembly.

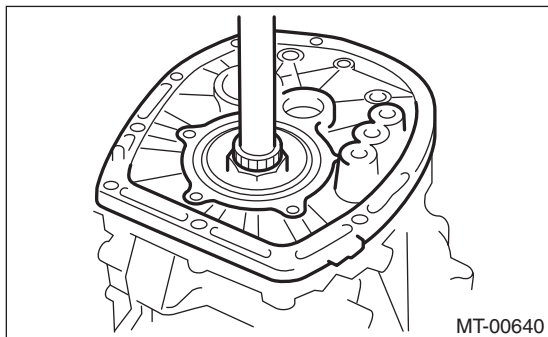

### B: INSTALLATION

- 1) Remove any remaining gasket material from the drive plate and clutch housing.
- 2) Apply liquid gasket to the clutch housing.

#### Liquid gasket:

**THREE BOND 1215 (Part No. 004403007) or equivalent**

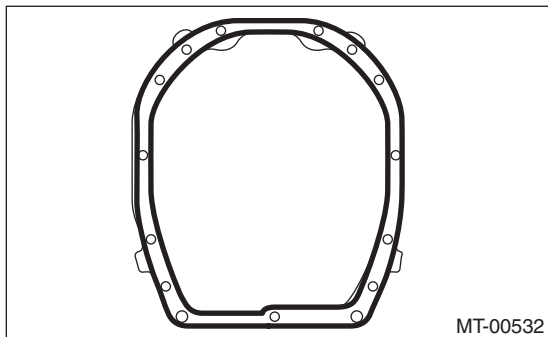

- 3) Install the individual gear assemblies. <Ref. to 6MT-66, INSTALLATION, Main Shaft Assembly.>

- 4) Install the transmission case. <Ref. to 6MT-60, INSTALLATION, Transmission Case.>
- 5) Install the center differential. <Ref. to 6MT-57, INSTALLATION, Center Differential.>
- 6) Install the transfer driven gear. <Ref. to 6MT-55, INSTALLATION, Transfer Driven Gear.>
- 7) Install the extension case. <Ref. to 6MT-44, INSTALLATION, Extension Case.>
- 8) Install the neutral position switch, back-up light switch and harness. <Ref. to 6MT-42, INSTALLATION, Neutral Position Switch.> <Ref. to 6MT-40, INSTALLATION, Back-up Light Switch.>
- 9) Install the manual transmission assembly to the vehicle. <Ref. to 6MT-34, INSTALLATION, Manual Transmission Assembly.>

### C: DISASSEMBLY

#### NOTE:

Replace the drive pinion shaft and hypoid driven gear as a set.

- 1) Remove the oil guide A.

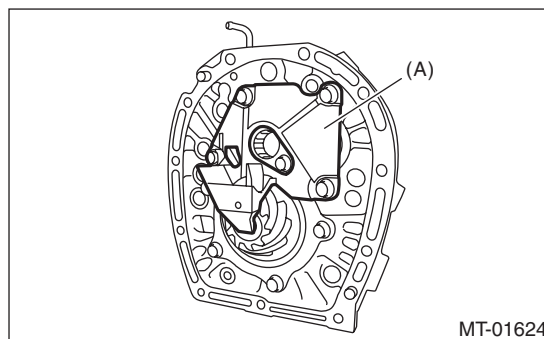

(A) Oil guide A

- 2) Remove the drive pinion shaft and shim from the adapter plate.

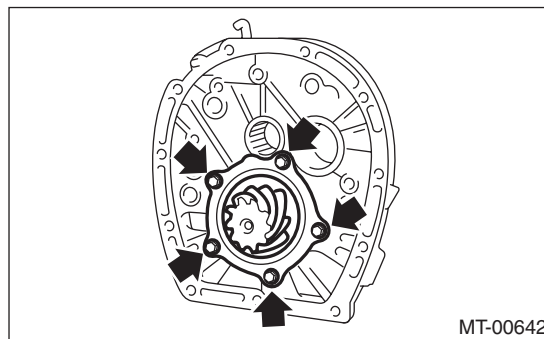

- 3) Affix the ST to the work table.  
ST 18664AA000 BASE
- 4) Flatten the tab of the lock nut.



# Drive Pinion Shaft Assembly

MANUAL TRANSMISSION AND DIFFERENTIAL

5) Attach ST3 to the lock nut, and set the drive pinion shaft to ST. Remove the lock nut and lock washer.

ST1 18667AA000 HOLDER

ST2 18664AA000 BASE

ST3 18621AA000 ADAPTER WRENCH

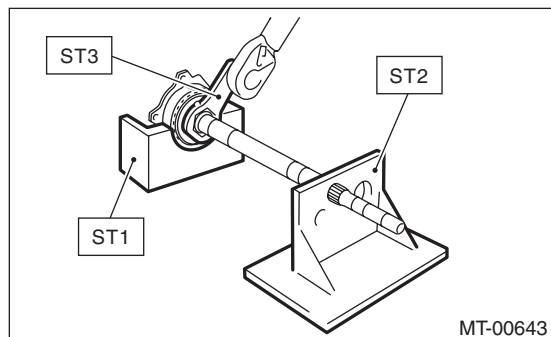

6) Using the ST, remove the taper roller bearing assembly.

ST 18723AA000 REMOVER

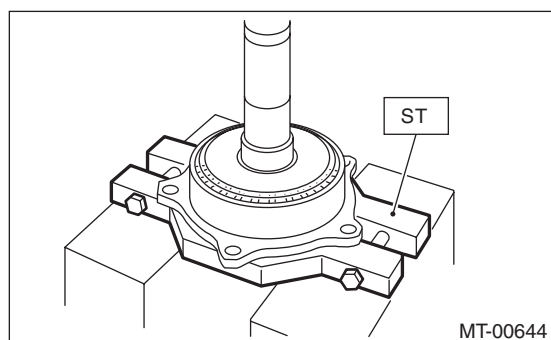

## D: ASSEMBLY

1) Using the ST, measure drive pinion measurement A.

NOTE:

When selecting the drive pinion shim, refer to measurement A.

ST 398643600 GAUGE

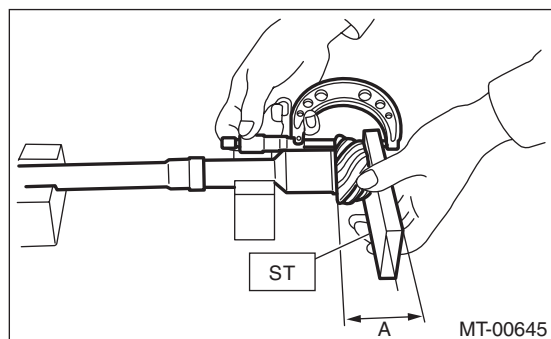

2) Using the ST and a press, attach the inner bearing of the taper roller bearing to the drive pinion shaft.

ST 18723AA000 REMOVER

CAUTION:

Do not apply pressure in excess of 40 kN (4.0 ton, 4.4 US ton, 3.9 Imp ton).

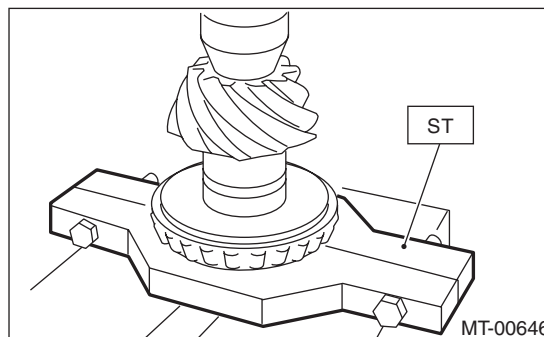

3) Using the ST and a press, attach the outer race and the taper roller bearing to the drive pinion shaft.

ST 18723AA000 REMOVER

NOTE:

Push in to a position where the bearing rotates smoothly.

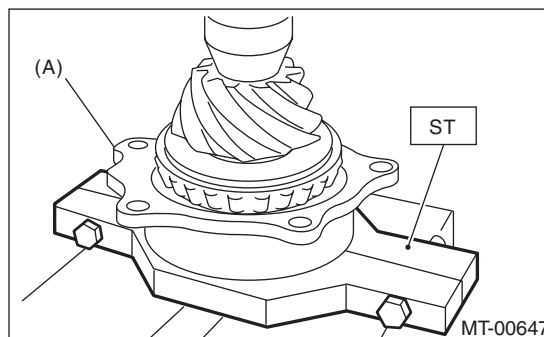

(A) Outer race

4) Attach a new lock washer and a new lock nut.

5) Set the ST to the drive pinion, and tighten the lock nut.

ST1 18667AA000 HOLDER

ST2 18664AA000 BASE

ST3 18621AA000 ADAPTER WRENCH

ST4 18852AA000 TORQUE WRENCH

NOTE:

- Tighten using the ST and the straight line torque wrench.
- Make sure the lock washer is installed in the proper direction.

# Drive Pinion Shaft Assembly

MANUAL TRANSMISSION AND DIFFERENTIAL

## Tightening torque:

**265 N·m (27.0 kgf·m, 195.4 ft·lb)**

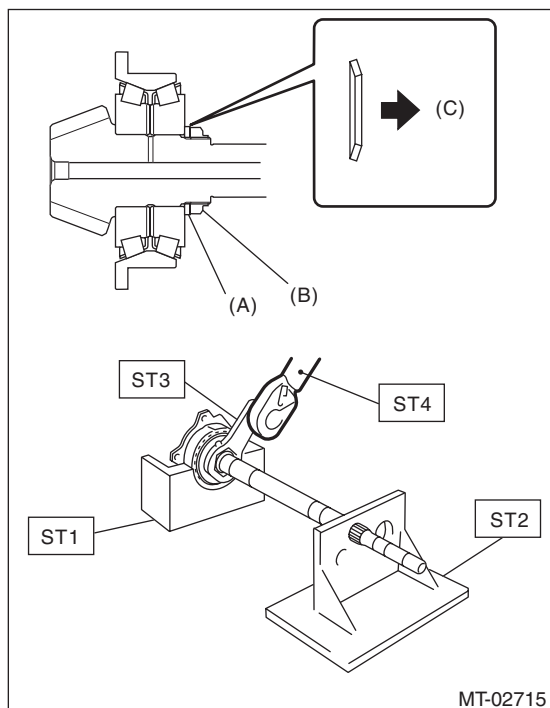

- (A) Lock washer
- (B) Lock nut
- (C) Nut side

## NOTE:

When using a torque wrench other than ST4, use the calculation below to calculate and tighten the lock nut.

Tighten using the ST and the straight line torque wrench.

$$T = L1 / (0.1 + L1) \times 285$$

T	N·m (kgf·m, ft·lb)	Torque wrench setting
L1	m (in)	Torque wrench length
0.1 m (3.94 in)		Length of ST
285 N·m (29.0 kgf·m, 210 ft·lb)		Tightening torque (lock nut)

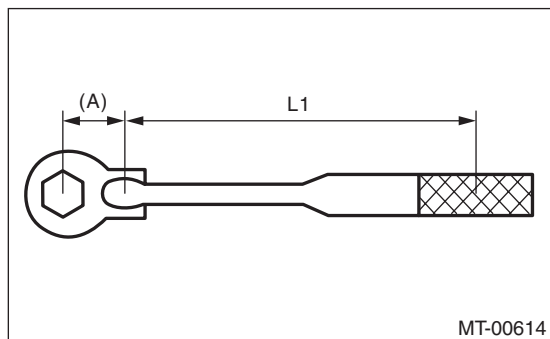

- (A) 0.1 m (3.94 in)

6) Measure the starting torque. <Ref. to 6MT-95, INSPECTION, Drive Pinion Shaft Assembly.>

7) Using the ST, crimp the lock nut in 2 locations, with dimensions within A 37±0.5 mm (1.46±0.02 in).

ST 18670AA000 PUNCH

## NOTE:

Do not damage the crimp area of the lock nut.

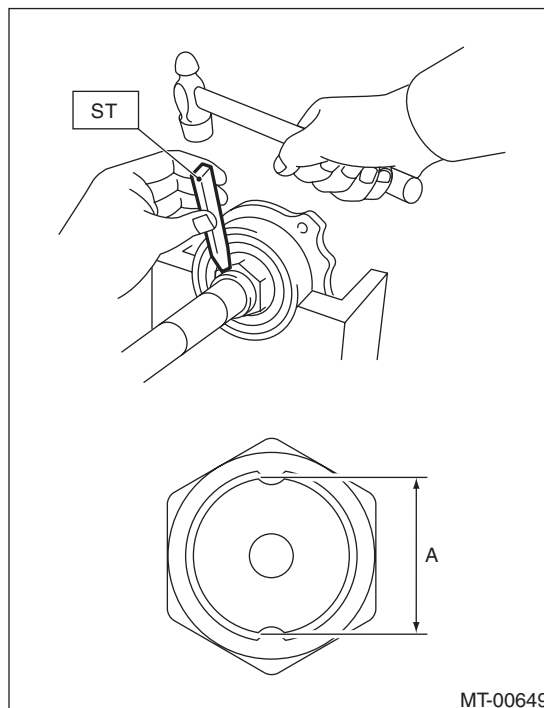

8) Using the ST, measure drive pinion measurement B.

ST 398643600 GAUGE

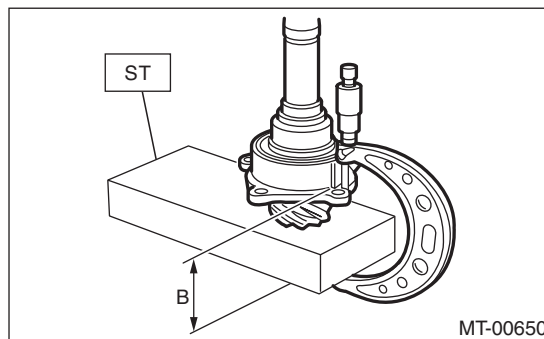

# Drive Pinion Shaft Assembly

MANUAL TRANSMISSION AND DIFFERENTIAL

9) Calculate from the calculation below to select 1 or 2 drive pinion shims from the following table.  
 $6.5 \pm 0.0625 \text{ mm} - (B - A)$  [ $0.26 \pm 0.0025 \text{ in} - (B - A)$ ]

NOTE:

A: Measurement value in step 1)

B: Measurement value in step 8)

Drive pinion shim	
Part No.	Thickness mm (in)
32295AA270	0.15 (0.0059)
32295AA280	0.175 (0.0069)
32295AA290	0.20 (0.0079)
32295AA300	0.225 (0.0089)
32295AA310	0.25 (0.0098)
32295AA320	0.275 (0.0108)

10) Apply transmission gear oil to the side face of the taper roller bearing, and attach the drive pinion shaft and the selected shims to the adapter plate.

**Tightening torque:**

**54 N·m (5.5 kgf·m, 39.8 ft·lb)**

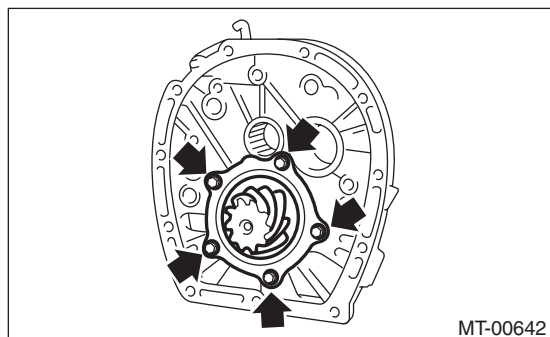

11) Install the oil guide A.

**Tightening torque:**

**18 N·m (1.8 kgf·m, 13.3 ft·lb)**

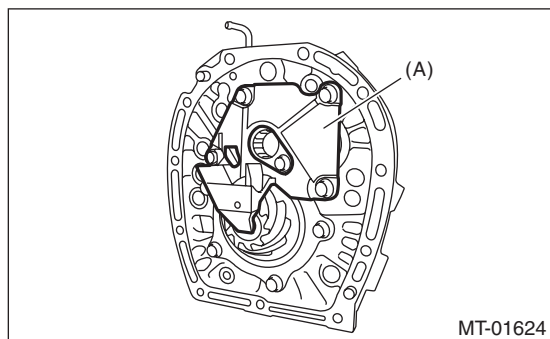

(A) Oil guide A

## E: INSPECTION

1) Using a spring scale, measure the starting torque. If the starting torque is outside the specification range, replace the taper roller bearing.

**Starting torque:**

**0 — 0.95 N (0 — 0.097 kgf, 0 — 0.21 lbf)**

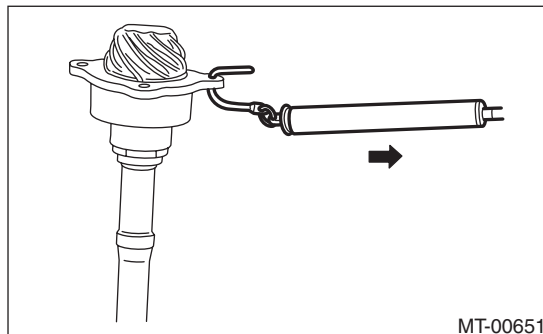

2) Gear

Replace gears in the following cases.

- The gear teeth surface is damaged or excessively worn.

3) Bearing

Replace the bearings in the following cases.

- Wear, rusting or damage of the bearings
- The bearing does not rotate smoothly or an abnormal noise is emitted when turning.

4) Adapter plate

Replace the adapter plate in the following cases:

- Wear, rusting or damage of the bearings
- Damage of the adapter plate

5) Check that the pipes and pipe chambers are not damaged or clogged. Repair or replace if damaged or clogged.

## F: ADJUSTMENT

1) Inspect and adjust the hypoid driven gear-to-drive pinion backlash. <Ref. to 6MT-102, HYPOID GEAR BACKLASH, ADJUSTMENT, Front Differential Assembly.>

2) Apply a thin uniform coat of lead-free red dye on the surfaces of 3 or 4 hypoid driven gear teeth.

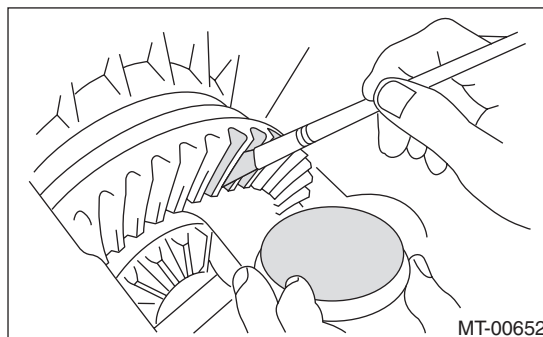

# Drive Pinion Shaft Assembly

## MANUAL TRANSMISSION AND DIFFERENTIAL

3) Install the drive pinion shaft assembly to the clutch housing, and tighten at least 4 bolts.

### NOTE:

Install with the remaining liquid gasket, so that the clutch housing and the adapter plate will not be damaged.

### Tightening torque:

**50 N·m (5.1 kgf·m, 36.9 ft·lb)**

4) Turn a few times using the ST.

ST 18631AA000 HANDLE

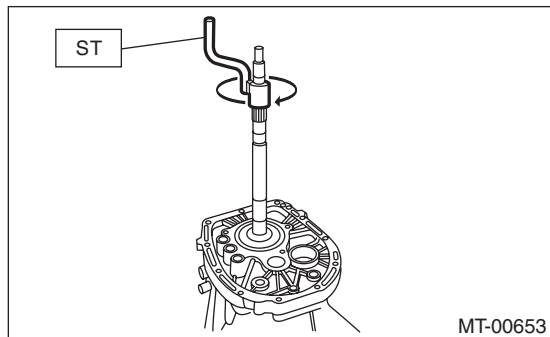

5) Remove the drive pinion shaft assembly, and inspect the mating condition of the teeth. If the tooth contact is not correct, adjust the backlash or shim thickness.

- Correct tooth contact

**Check item: Tooth contact surface is slightly shifted toward the toe side under a no-load condition. (When driving, it moves towards the heel side.)**

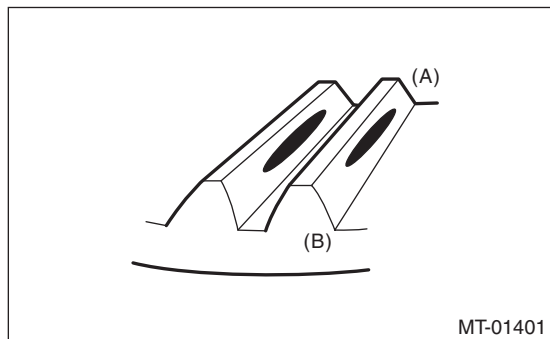

- (A) Toe side
- (B) Heel side

- Face contact

**Check item: Backlash is too large.**

Contact pattern

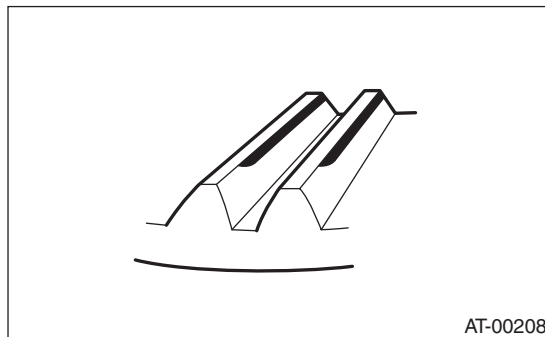

Corrective action: Tighten the side retainer to move the driven gear closer to the drive pinion shaft.

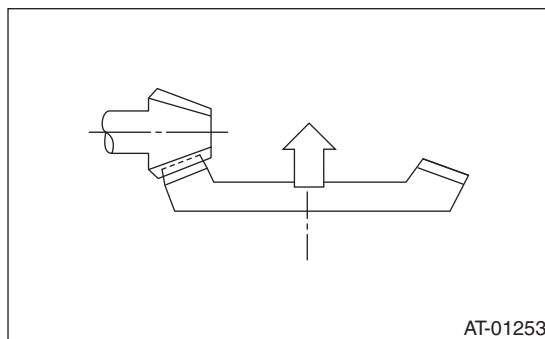

- Flank contact

**Check item: Backlash is too small.**

Contact pattern

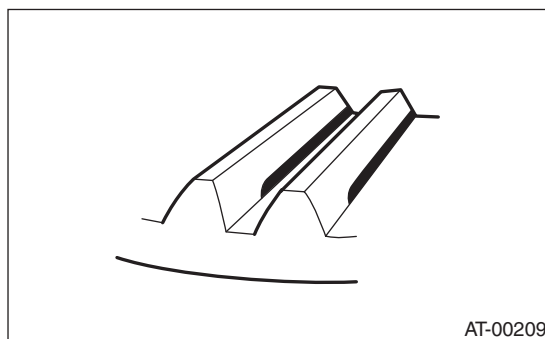

Corrective action: Loosen the side retainer to move the driven gear away from the drive pinion shaft.

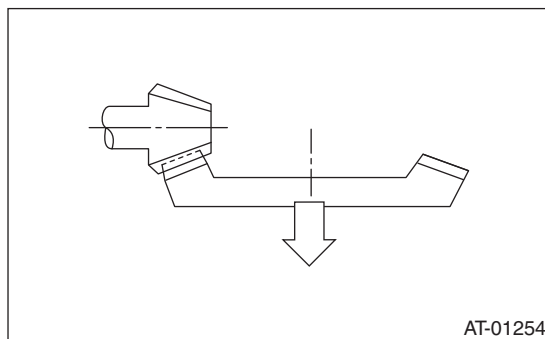

# Drive Pinion Shaft Assembly

- Toe contact (inside contact)

**Check item: Teeth contact area is too small.**

Contact pattern

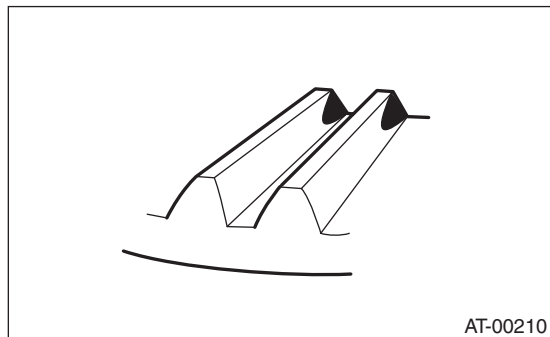

Adjustment: Reduce the thickness of the drive pinion shim according to the procedure for moving the drive pinion away from the driven gear.

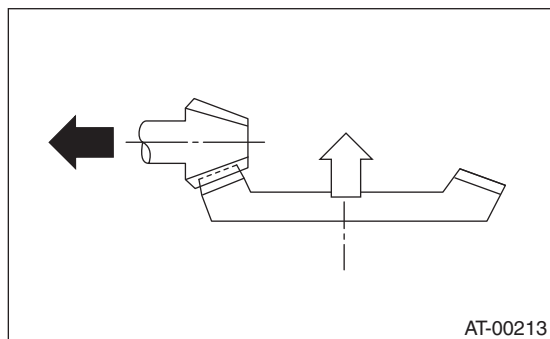

- Heel contact (outside end contact)

**Check item: Teeth contact area is too small.**

Contact pattern

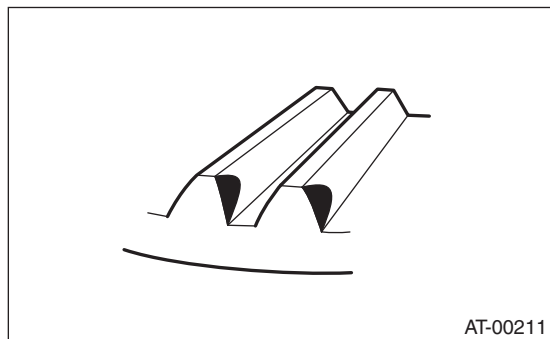

Adjustment: Increase thickness of the drive pinion shim according to the procedures for moving the drive pinion closer to the driven gear.

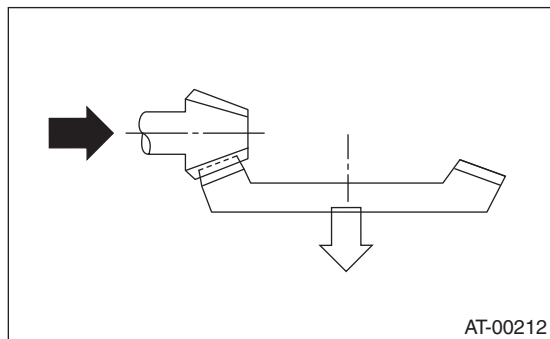

# Front Differential Assembly

## MANUAL TRANSMISSION AND DIFFERENTIAL

### 21. Front Differential Assembly

#### A: REMOVAL

- 1) Remove the manual transmission assembly. <Ref. to 6MT-32, REMOVAL, Manual Transmission Assembly.>
- 2) Prepare the transmission for overhaul. <Ref. to 6MT-38, Preparation for Overhaul.>
- 3) Remove the neutral position switch, back-up light switch and harness. <Ref. to 6MT-42, REMOVAL, Neutral Position Switch.> <Ref. to 6MT-40, REMOVAL, Back-up Light Switch.>
- 4) Remove the extension case. <Ref. to 6MT-44, REMOVAL, Extension Case.>
- 5) Remove the transfer driven gear. <Ref. to 6MT-55, REMOVAL, Transfer Driven Gear.>
- 6) Remove the center differential. <Ref. to 6MT-57, REMOVAL, Center Differential.>
- 7) Remove the transmission case. <Ref. to 6MT-58, REMOVAL, Transmission Case.>
- 8) Remove the individual gear assemblies. <Ref. to 6MT-65, REMOVAL, Main Shaft Assembly.>
- 9) Remove the drive pinion shaft assembly. <Ref. to 6MT-92, REMOVAL, Drive Pinion Shaft Assembly.>
- 10) Remove the lock plates on both sides.

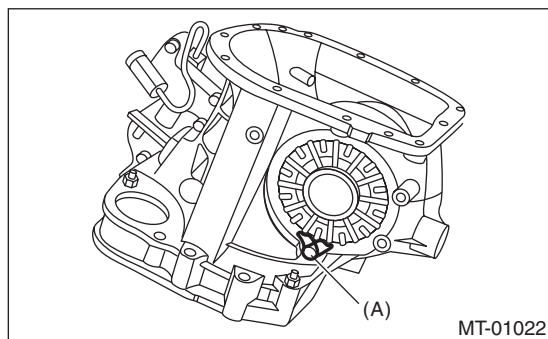

(A) Lock plate

- 11) Remove the differential side retainers on both sides using the ST.

ST1 18630AA010 WRENCH COMPL RETAINER (RH SIDE)

ST2 18630AA000 WRENCH ASSY (LH SIDE)

#### NOTE:

Be careful not to damage the section where the clutch case retainer will be attached.

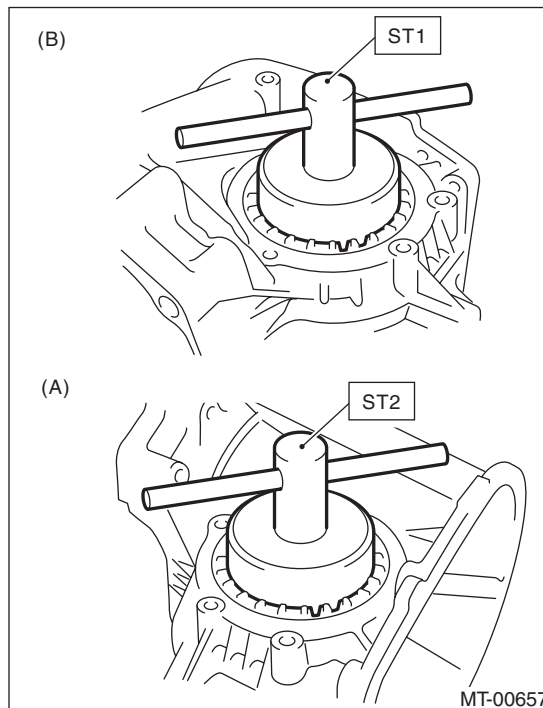

(A) LH side

(B) RH side

- 12) Remove the front differential.

#### B: INSTALLATION

- 1) Install the differential assembly to the clutch housing.
- 2) Apply oil to the screw threads of the side retainer.
- 3) Remove the O-rings on both sides of the side retainer.
- 4) Install the differential side retainers to both sides, using the ST.

ST1 18630AA010 WRENCH COMPL RETAINER (RH SIDE)

ST2 18630AA000 WRENCH ASSY (LH SIDE)

# Front Differential Assembly

MANUAL TRANSMISSION AND DIFFERENTIAL

## NOTE:

Be careful not to damage the oil seal.

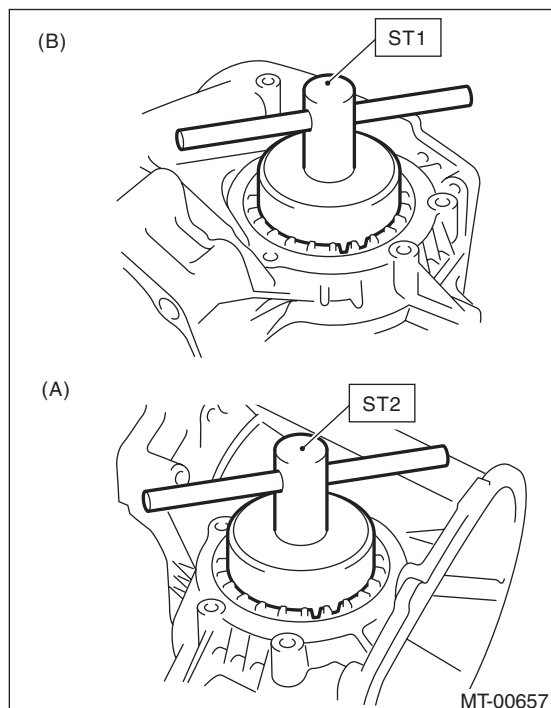

- (A) LH side
- (B) RH side

5) Inspect and adjust the hypoid gear backlash. <Ref. to 6MT-102, HYPOID GEAR BACKLASH, INSPECTION, Front Differential Assembly.>

6) Inspect and adjust the tooth contact. <Ref. to 6MT-95, ADJUSTMENT, Drive Pinion Shaft Assembly.>

7) Mark the mating positions of the left and right side retainers and the clutch housing.

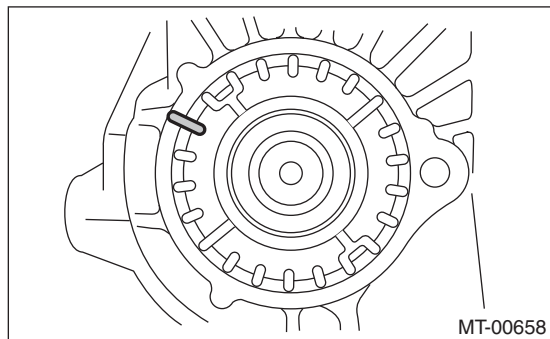

8) Remove the differential side retainers from both sides.

## NOTE:

When removing the side retainer, record how many times it was turned to remove.

9) Install new O-rings to the side retainers on both sides.

10) Attach the differential side retainers to both sides.

## NOTE:

When attaching, turn the side retainer the same number of turns it took to remove, and align the marks.

11) Install the lock plate.

## Tightening torque:

**25 N·m (2.5 kgf·m, 18.4 ft·lb)**

## NOTE:

Be careful not to confuse the left and right side lock plates.

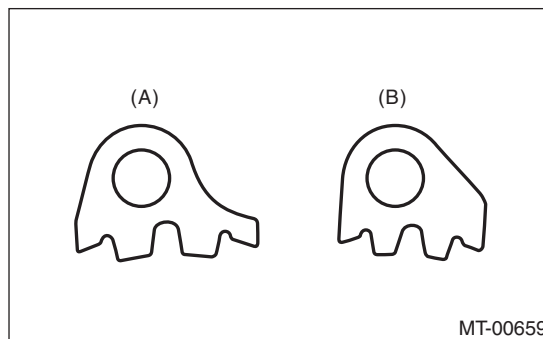

- (A) LH
- (B) RH

12) Remove any remaining liquid gasket from the clutch housing and adapter plate.

13) Apply liquid gasket to the clutch housing.

## Liquid gasket:

**THREE BOND 1215 (Part No. 004403007) or equivalent**

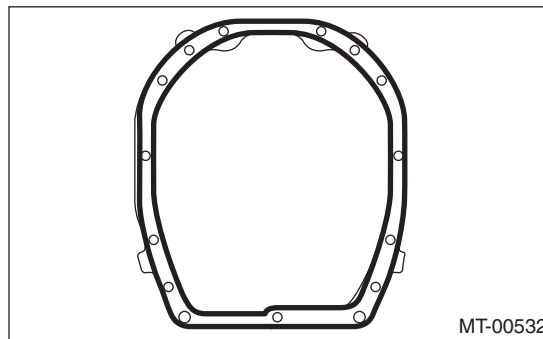

14) Install the drive pinion shaft assembly. <Ref. to 6MT-92, INSTALLATION, Drive Pinion Shaft Assembly.>

15) Install the individual gear assemblies all at once. <Ref. to 6MT-66, INSTALLATION, Main Shaft Assembly.>

16) Install the transmission case. <Ref. to 6MT-60, INSTALLATION, Transmission Case.>

17) Install the center differential. <Ref. to 6MT-57, INSTALLATION, Center Differential.>

18) Install the transfer driven gear. <Ref. to 6MT-55, INSTALLATION, Transfer Driven Gear.>

19) Install the extension case. <Ref. to 6MT-44, INSTALLATION, Extension Case.>

**6MT-99**

Brought to you by Ebay Seller "SubaruManuals"



# Front Differential Assembly

## MANUAL TRANSMISSION AND DIFFERENTIAL

20) Install the neutral position switch, back-up light switch and harness. <Ref. to 6MT-42, INSTALLATION, Neutral Position Switch.> <Ref. to 6MT-40, INSTALLATION, Back-up Light Switch.>

21) Install the manual transmission assembly to the vehicle. <Ref. to 6MT-34, INSTALLATION, Manual Transmission Assembly.>

### C: DISASSEMBLY

#### 1. DIFFERENTIAL CASE

1) Fix the differential assembly on a vice, and remove the hypoid driven gear.

ST 18270KA020 SOCKET (E20)

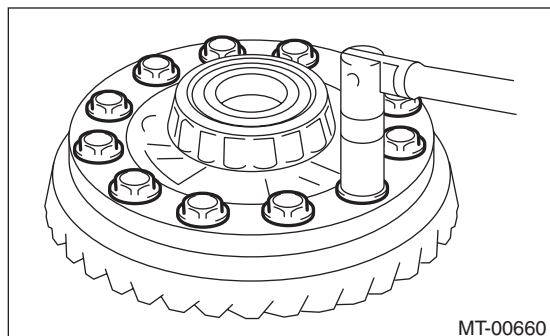

2) Remove the side bearing of the hypoid driven gear using the ST.

ST 399527700 PULLER SET

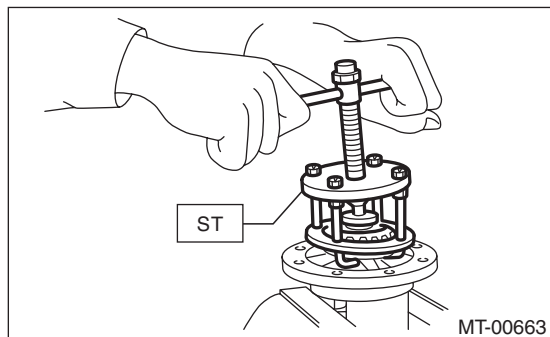

3) Using the ST, remove the roller bearing.

ST 498077000 REMOVER

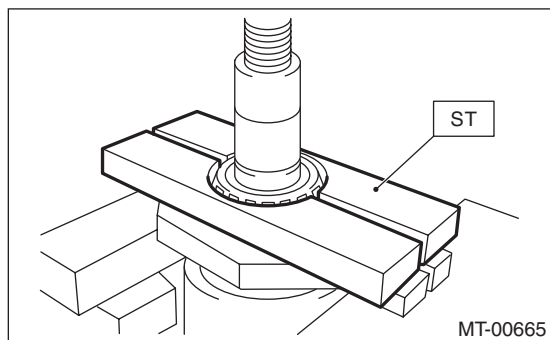

#### 2. SIDE RETAINER

1) Remove the O-ring.

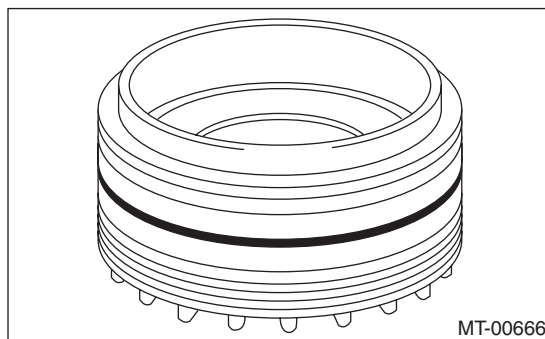

2) Remove the oil seal.

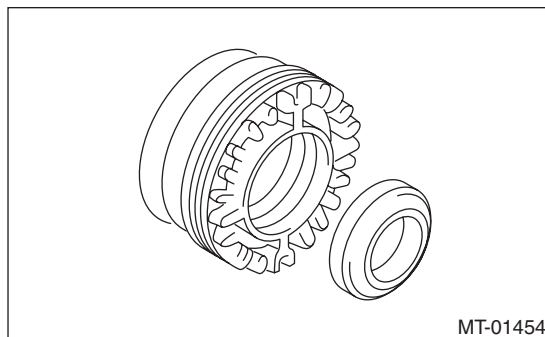

3) Remove the claw of ST1, and attach the claw of ST2.

ST1 398527700 PULLER ASSY

ST2 18760AA000 CLAW

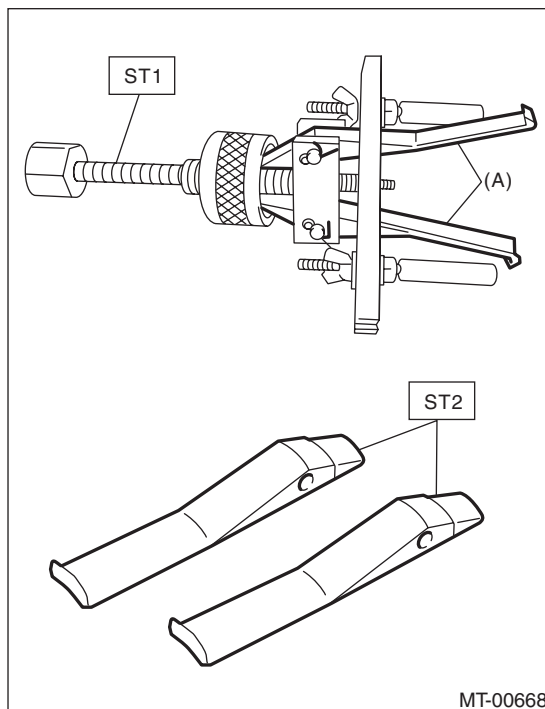

(A) CLAW



# Front Differential Assembly

MANUAL TRANSMISSION AND DIFFERENTIAL

4) Remove the bearing outer race from the side retainer, using the ST.

ST1 398527700 PULLER ASSY

ST2 18760AA000 CLAW

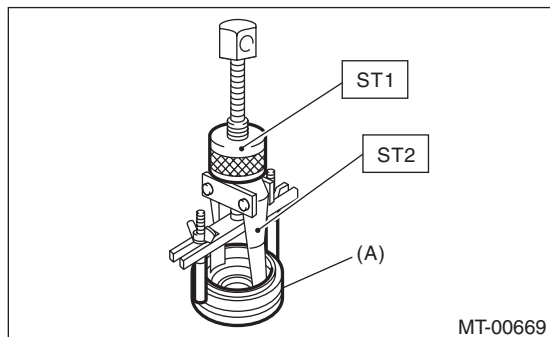

(A) Side retainer

## D: ASSEMBLY

### 1. DIFFERENTIAL CASE

1) Use the ST to attach the RH and LH bearing inner races to the differential case.

ST1 398437700 INSTALLER

ST2 398497701 SEAT

#### CAUTION:

Do not apply pressure in excess of 20 kN (2.0 ton, 2.2 US ton, 2.0 Imp ton).

#### NOTE:

Always replace inner races and outer races as a set.

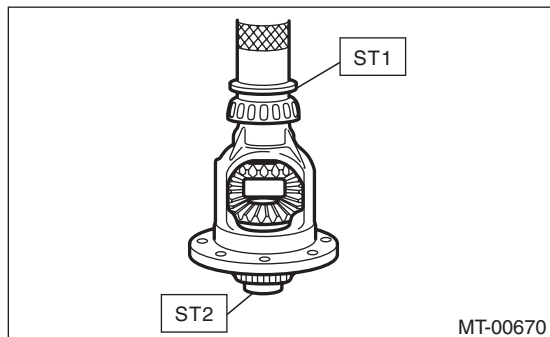

2) Attach the hypoid driven gear to the differential case.

ST 18270KA020 SOCKET (E20)

#### Tightening torque:

69 N·m (7.0 kgf·m, 50.9 ft·lb)

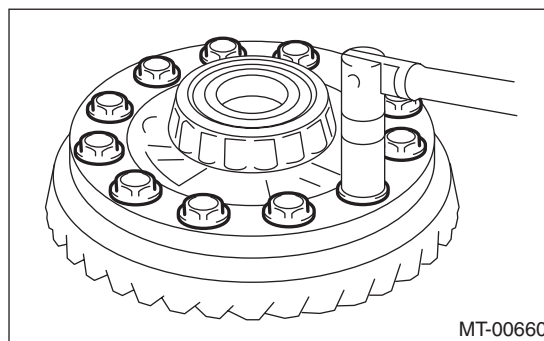

### 2. SIDE RETAINER

#### NOTE:

Install the oil seal and O-ring of side retainer after the adjustment of backlash and tooth contact.

1) Install the bearing outer race to side retainer.

2) Using the ST, install the oil seal.

ST 18675AA000 DIFFERENTIAL SIDE OIL SEAL INSTALLER

#### NOTE:

- Use a new oil seal.
- Apply oil to the oil seal lips.

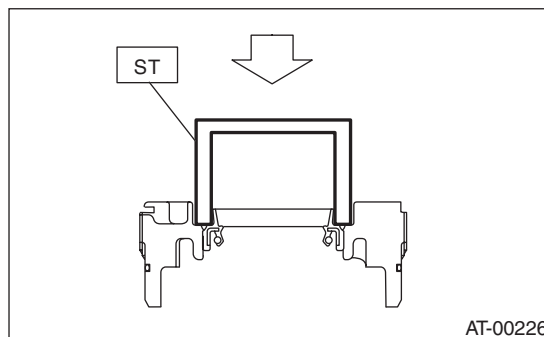

3) Install the O-ring.

#### NOTE:

Use new O-rings.

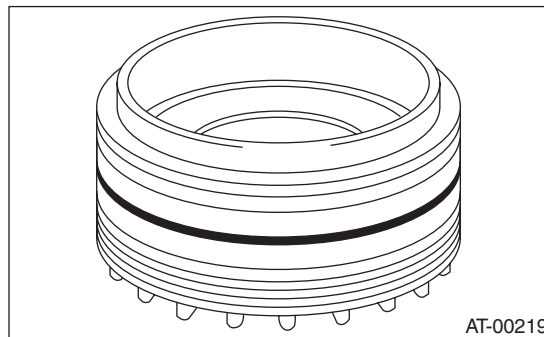

# Front Differential Assembly

## MANUAL TRANSMISSION AND DIFFERENTIAL

### E: INSPECTION

Repair or replace the differential in the following cases:

- If gears are damaged, seized, or are excessively worn.
- If differential case sliding surfaces are damaged, seized, or are excessively worn.
- If there is damage, rust or wear in the bearings or bearing locations.
- If the bearing does not rotate smoothly or an abnormal noise is emitted when turning.

#### 1. HYPOID GEAR BACKLASH

Inspect the hypoid gear backlash. Adjust if out of standard. <Ref. to 6MT-102, HYPOID GEAR BACKLASH, ADJUSTMENT, Front Differential Assembly.>

#### 2. TOOTH CONTACT OF HYPOID GEAR

1) Check that the hypoid gear backlash is within the standard value. Adjust if out of standard. <Ref. to 6MT-102, HYPOID GEAR BACKLASH, ADJUSTMENT, Front Differential Assembly.>

2) Apply a thin uniform coat of lead-free red dye on the surfaces of 3 or 4 hypoid driven gear teeth.

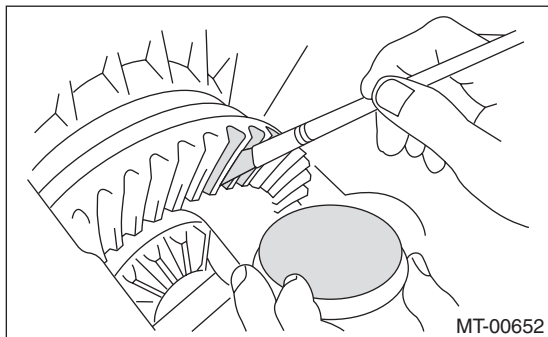

3) Attach the drive pinion shaft assembly, and affix with at least 4 bolts.

#### NOTE:

Use old gaskets and washers to prevent the mating surfaces of the housing from becoming damaged.

#### Tightening torque:

**50 N·m (5.1 kgf·m, 36.9 ft·lb)**

4) Turn the drive pinion shaft to the left and right for several turns.

5) Remove the drive pinion shaft assembly, and inspect the mating condition of the teeth. If tooth contact is not correct, perform adjustment. <Ref. to 6MT-95, ADJUSTMENT, Drive Pinion Shaft Assembly.>

- Correct tooth contact

#### NOTE:

In a no load condition, the tooth contact from the center to the toe side is 50-60% (While driving, the tooth contact will shift towards the heel side).

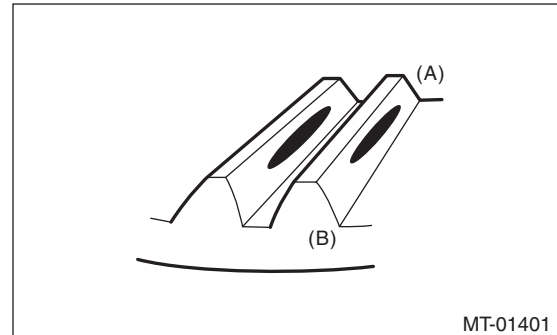

(A) Toe side

(B) Heel side

### F: ADJUSTMENT

#### 1. HYPOID GEAR BACKLASH

1) Attach the RH and LH side retainers.

ST1 18630AA010 WRENCH COMPL RETAINER (RH SIDE)

ST2 18630AA000 WRENCH ASSY (LH SIDE)

#### NOTE:

• Twist in the RH side side retainer a little further than the LH side.

• WRENCH ASSY (499787000) can also be used.

2) Attach the drive pinion shaft assembly, and affix with 5 bolts.

#### NOTE:

Use old gaskets and washers to prevent the mating surfaces of the housing from becoming damaged.

#### Tightening torque:

**50 N·m (5.1 kgf·m, 36.9 ft·lb)**

3) Using the ST, loosen the differential side retainer RH, and twist in the differential side retainer LH until the hypoid driven gear just contacts the drive pinion.

ST1 18630AA010 WRENCH COMPL RETAINER (RH SIDE)

ST2 18630AA000 WRENCH ASSY (LH SIDE)

# Front Differential Assembly

MANUAL TRANSMISSION AND DIFFERENTIAL

4) Use the ST to turn the drive pinion shaft a few times.

ST 18631AA000 HANDLE

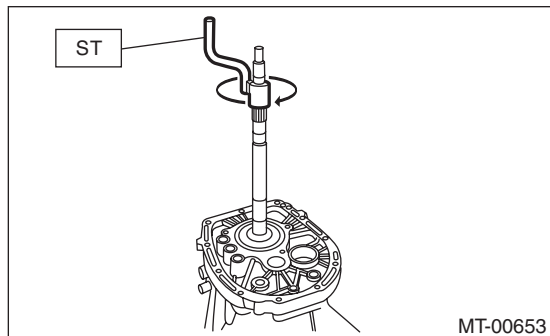

5) Repeat steps 3) and 4) until differential side retainer LH does not turn anymore. For differential side retainer RH, screw in until the inner race and outer race just comes into contact. This is the "zero" backlash state.

6) Mark the mating positions of the left and right side retainers and the clutch housing.

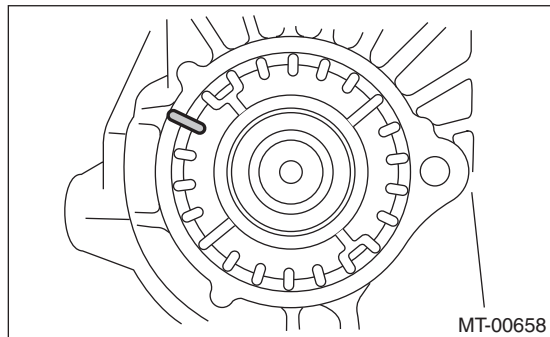

7) Turn the back differential side retainer LH by 3 notches, and screw in the differential side retainer RH by 3 notches.

8) Temporarily attach the LH side retainer lock plate.

9) Turn the differential side retainer RH by 1.25 notches.

10) Temporarily attach the RH side retainer lock plate.

## NOTE:

- If the lock plate cannot be aligned, adjust the position toward the tightened side.
- The notch on the lock plate moves by 0.5 notch if the lock plate is turned upside down when installed.

11) Use the ST to fix the drive pinion shaft in place.  
ST 18621AA000 ADAPTER WRENCH

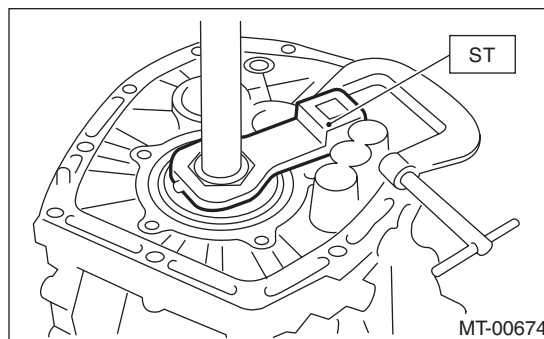

12) Install the SUBARU genuine axle shaft to the front differential left and right sides.

Part No. 38415AA000 Axle shaft

13) Move the axle shaft, and measure the hypoid gear backlash.

ST1 498255400 PLATE

ST2 498247001 MAGNET BASE

ST3 498247100 DIAL GAUGE

## Hypoid gear backlash:

0.13 — 0.18 mm (0.0051 — 0.0071 in)

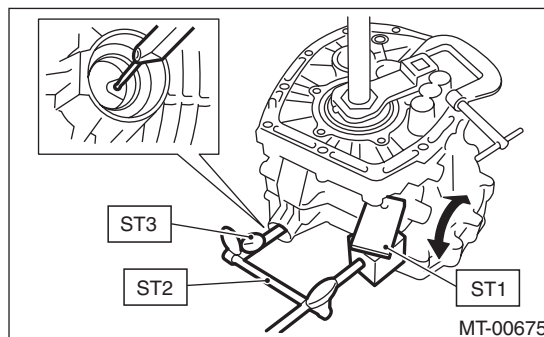

14) If the backlash is out of specified range, remove the left and right retainer lock plates and loosen RH side differential side retainer. Then, adjust the LH side differential side retainer by turning it, and attach the LH side retainer lock plate.

15) Screw in the RH side differential side retainer until the inner race and outer race just come into contact.

## 2. TOOTH CONTACT OF HYPOID GEAR

Regarding teeth contact conditions, refer to the drive pinion section. <Ref. to 6MT-102, TOOTH CONTACT OF HYPOID GEAR, INSPECTION, Front Differential Assembly.>

# Shifter Fork and Rod

MANUAL TRANSMISSION AND DIFFERENTIAL

## 22. Shifter Fork and Rod

### A: REMOVAL

- 1) Remove the manual transmission assembly from the vehicle. <Ref. to 6MT-32, REMOVAL, Manual Transmission Assembly.>
- 2) Prepare the transmission for overhaul. <Ref. to 6MT-38, Preparation for Overhaul.>
- 3) Remove the neutral position switch, back-up light switch and harness. <Ref. to 6MT-42, REMOVAL, Neutral Position Switch.> <Ref. to 6MT-40, REMOVAL, Back-up Light Switch.>
- 4) Remove the extension case. <Ref. to 6MT-44, REMOVAL, Extension Case.>
- 5) Remove the transfer driven gear. <Ref. to 6MT-55, REMOVAL, Transfer Driven Gear.>
- 6) Remove the center differential. <Ref. to 6MT-57, REMOVAL, Center Differential.>
- 7) Remove the transmission case. <Ref. to 6MT-58, REMOVAL, Transmission Case.>
- 8) Remove the individual gear assemblies. <Ref. to 6MT-65, REMOVAL, Main Shaft Assembly.>

### B: INSTALLATION

- 1) Install the individual gear assemblies all at once. <Ref. to 6MT-66, INSTALLATION, Main Shaft Assembly.>
- 2) Install the transmission case. <Ref. to 6MT-60, INSTALLATION, Transmission Case.>
- 3) Install the center differential. <Ref. to 6MT-57, INSTALLATION, Center Differential.>
- 4) Install the transfer driven gear. <Ref. to 6MT-55, INSTALLATION, Transfer Driven Gear.>
- 5) Install the extension case. <Ref. to 6MT-44, INSTALLATION, Extension Case.>
- 6) Install the neutral position switch, back-up light switch and harness. <Ref. to 6MT-42, INSTALLATION, Neutral Position Switch.> <Ref. to 6MT-40, INSTALLATION, Back-up Light Switch.>
- 7) Install the manual transmission assembly to the vehicle. <Ref. to 6MT-34, INSTALLATION, Manual Transmission Assembly.>

### C: DISASSEMBLY

#### NOTE:

Discard the removed spring pin, and replace with a new part.

### 1. REVERSE SHIFTER FORK

- 1) Remove the reverse fork using the ST.  
ST 398791700 REMOVER

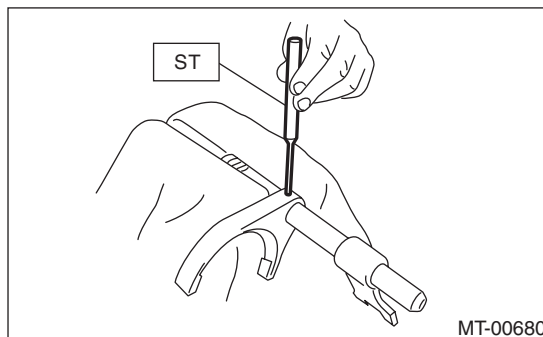

- 2) Remove the reverse shifter arm using the ST.  
ST 398791700 REMOVER

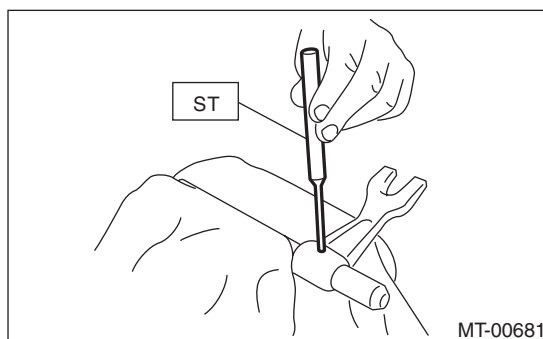

### 2. 1ST-2ND, 3RD-4TH SHIFTER FORK

- 1) Using the ST, remove the 3rd-4th shifter fork.  
ST 398791700 REMOVER

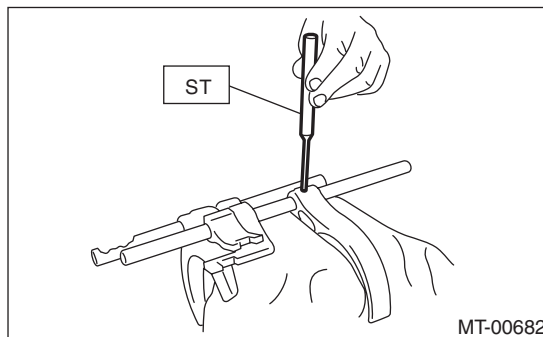

- 2) Using the ST, remove the 3rd-4th shifter arm.  
ST 398791700 REMOVER

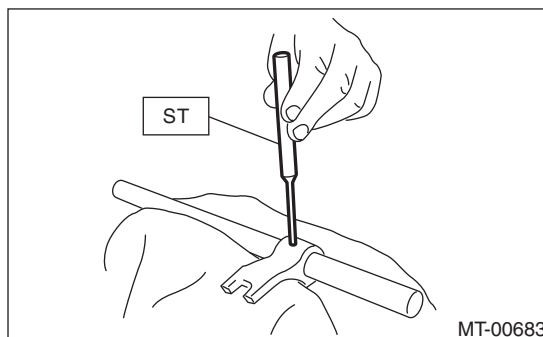

# Shifter Fork and Rod

MANUAL TRANSMISSION AND DIFFERENTIAL

3) Using the ST, remove the 1st-2nd shifter arm and 1st-2nd shifter fork.

ST 398791700 REMOVER

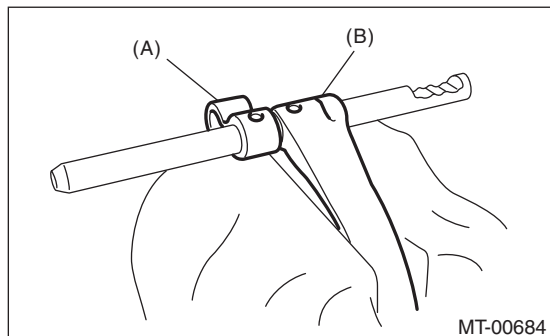

- (A) 1st-2nd shifter arm
- (B) 1st-2nd shifter fork

### 3. 5TH-6TH SHIFTER FORK

1) Using the ST, remove the 5th-6th shifter fork.

ST 398791700 REMOVER

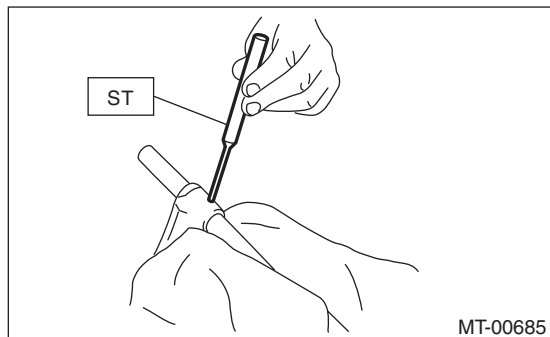

2) Using the ST, remove the 5th-6th shifter arm.

ST 398791700 REMOVER

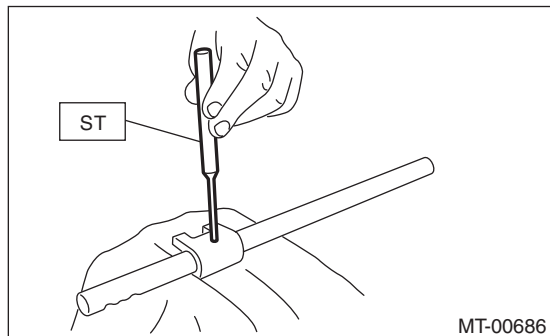

### 4. SHIFTER ARM SHAFT

Remove the selector arm using the ST.

ST 398791700 REMOVER

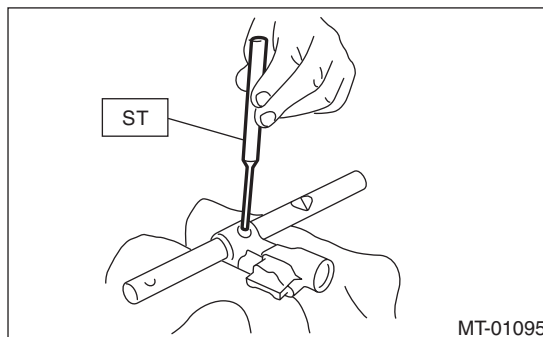

### 5. STRIKING ROD

1) Remove the reverse interlock block and the interlock block from the striking rod.

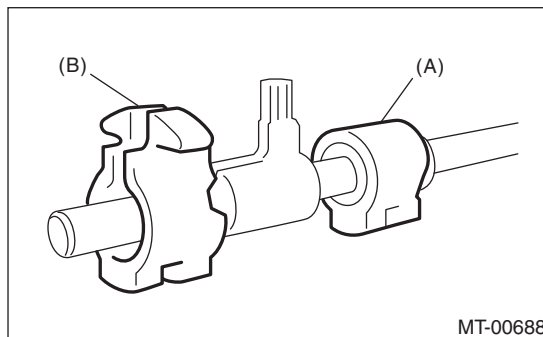

- (A) Reverse interlock block
- (B) Interlock block

2) Remove the reverse interlock arm using the ST.

ST 398791700 REMOVER

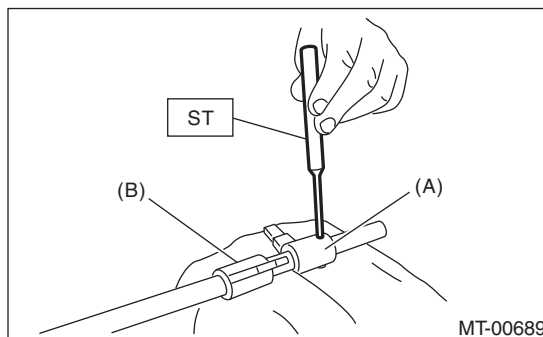

- (A) Reverse interlock arm
- (B) Interlock arm

# Shifter Fork and Rod

## MANUAL TRANSMISSION AND DIFFERENTIAL

3) Remove the interlock arm using the ST.  
ST 398791700 REMOVER

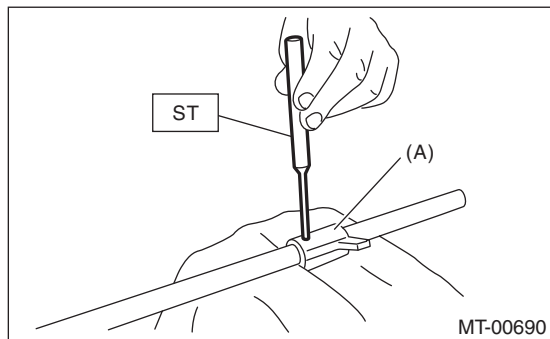

(A) Interlock arm

NOTE:  
Confirm that the reverse arm and rod are installed in the proper direction.

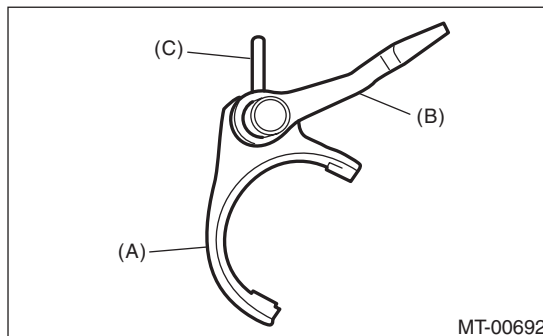

(A) Reverse arm

(B) Reverse rod

(C) Spring pin

## D: ASSEMBLY

### 1. REVERSE SHIFTER FORK

1) Using the ST, install the reverse fork.  
ST 398791700 REMOVER

NOTE:

Confirm that the reverse fork and rod are installed in the proper direction.

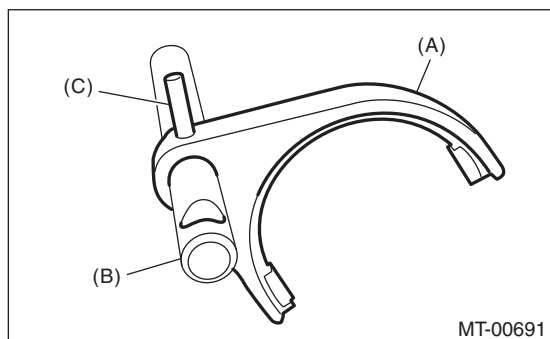

(A) Reverse fork

(B) Reverse rod

(C) Spring pin

### 2. 1ST-2ND, 3RD-4TH SHIFTER FORK

1) Using the ST, install the 1st-2nd shifter fork.  
ST 398791700 REMOVER

NOTE:

Make sure that the 1st-2nd shifter fork and rod are installed in the correct direction.

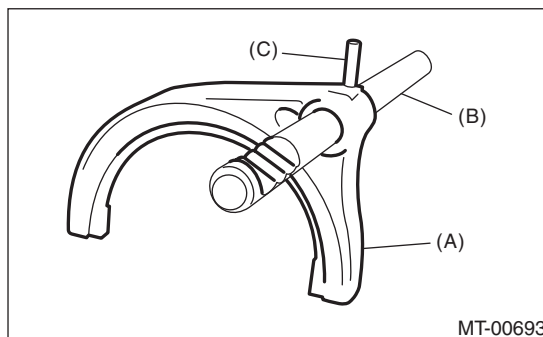

(A) 1st-2nd shifter fork

(B) 1st-2nd shifter rod

(C) Spring pin

2) Using the ST, install the reverse arm.  
ST 398791700 REMOVER

# Shifter Fork and Rod

MANUAL TRANSMISSION AND DIFFERENTIAL

2) Using the ST, install the 1st-2nd shifter arm.  
ST 398791700 REMOVER

**NOTE:**

Make sure that the 1st-2nd shifter arm and fork are installed in the correct direction.

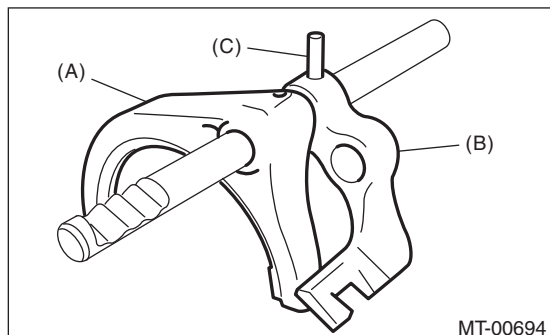

- (A) 1st-2nd shifter fork
- (B) 1st-2nd shifter arm
- (C) Spring pin

3) Using the ST, install the 3rd-4th shifter arm.  
ST 398791700 REMOVER

**NOTE:**

Make sure that the 3rd-4th shifter arm and rod are installed in the correct direction.

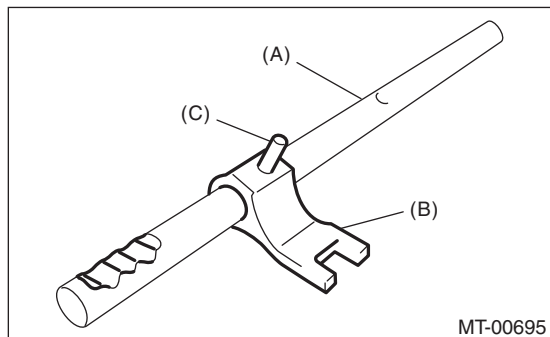

- (A) 3rd-4th shifter rod
- (B) 3rd-4th shifter arm
- (C) Spring pin

4) Attach the 3rd-4th fork rod to the 1st-2nd shifter arm.

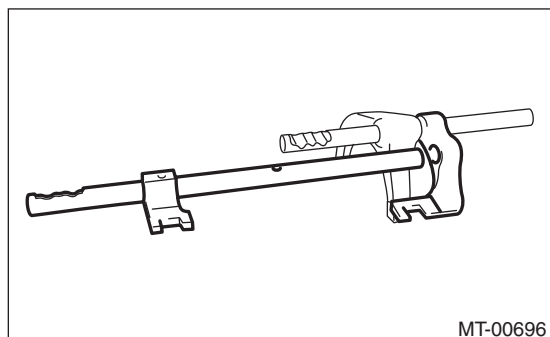

5) Using the ST, install the 3rd-4th shifter fork.  
ST 398791700 REMOVER

**NOTE:**

Make sure that the 3rd-4th shifter fork is installed in the correct direction.

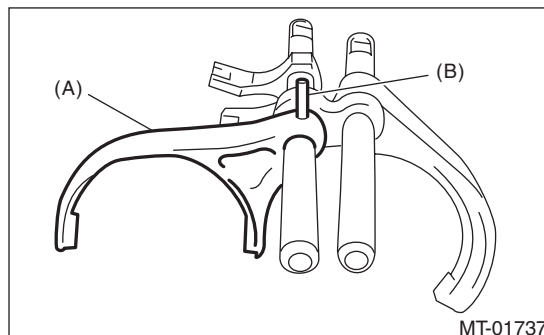

- (A) 3rd-4th shifter fork
- (B) Spring pin

### 3. 5TH-6TH SHIFTER FORK

1) Using the ST, install the 5th-6th shifter arm.  
ST 398791700 REMOVER

**NOTE:**

Make sure that the 5th-6th shifter arm and rod are installed in the correct direction.

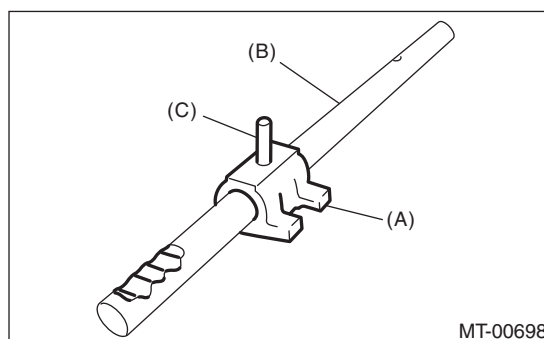

- (A) 5th-6th shifter arm
- (B) 5th-6th shifter rod
- (C) Spring pin

2) Using the ST, install the 5th-6th shifter fork.  
ST 398791700 REMOVER



# Shifter Fork and Rod

## MANUAL TRANSMISSION AND DIFFERENTIAL

### NOTE:

Check that the 5th-6th shifter fork and arm are installed.

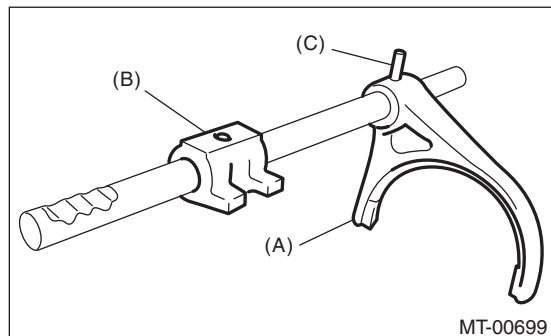

- (A) 5th-6th shifter fork
- (B) 5th-6th shifter arm
- (C) Spring pin

### 4. SHIFTER ARM SHAFT

Using the ST, install the selector arm.

ST 398791700 REMOVER

### NOTE:

Confirm that the selector arm and rod are installed in the proper direction.

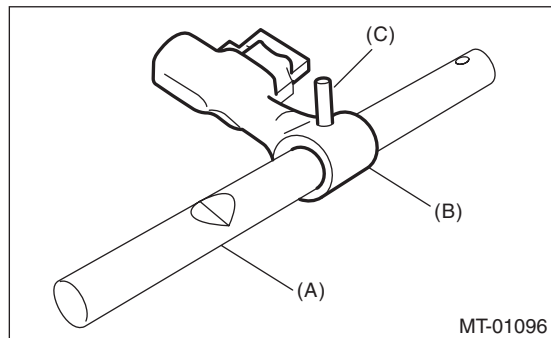

- (A) Selector rod
- (B) Selector arm
- (C) Spring pin

### 5. STRIKING ROD

1) Using the ST, install the reverse interlock arm and interlock arm.

ST 398791700 REMOVER

### NOTE:

- Confirm that the reverse interlock arm and rod are installed in the proper direction.
- Confirm that the interlock arm and rod are installed in the proper direction.

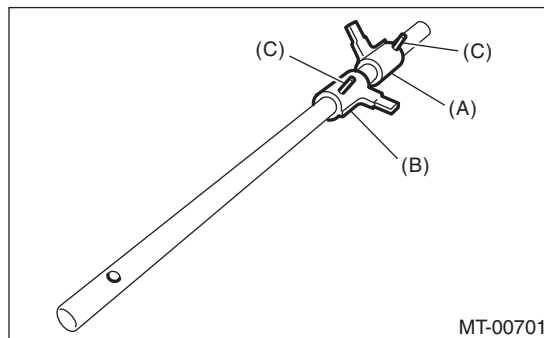

- (A) Reverse interlock arm
- (B) Interlock arm
- (C) Spring pin

2) Attach the reverse interlock block and interlock block to the striking rod.

### NOTE:

Confirm that the reverse interlock block and interlock block are installed in the proper direction.

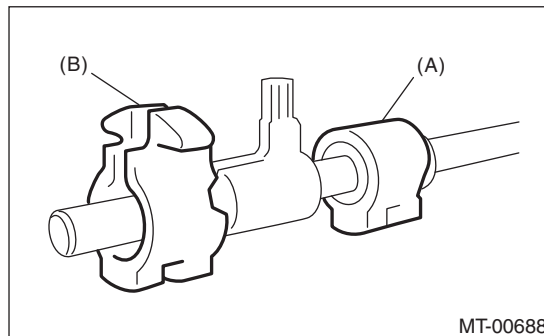

- (A) Reverse interlock block
- (B) Interlock block

### E: INSPECTION

1) Check the shift shaft and shift rod for damage. Replace if damaged.

2) Repair or replace the gearshift mechanism if excessively worn, bent or defective in any way.



# Shifter Fork and Rod

## F: ADJUSTMENT

### 1. 1ST-2ND FORK ROD SELECTION

#### NOTE:

In the following conditions, perform the procedures below.

- Replacement of the 1st and 2nd driven gear
- 1st and 2nd synchro ring assembly replacement
- Adapter plate replacement
- Driven shaft replacement
- 1st-2nd hub and sleeve assembly replacement.

1) Insert the drive pinion assembly into the adapter plate.

#### NOTE:

Confirm that the thrust bearing outer race has not been removed and the drive pinion is not lifted.

2) Set the height gauge to the adapter plate. Lower the height gauge indicator to the mating surface of the adapter plate and case, and set to zero points.

ST 18853AA000 HEIGHT GAUGE

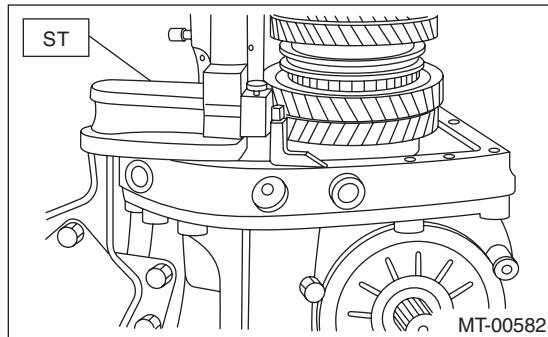

#### NOTE:

- The adapter plate will be the base point for the measurement. Use a scraper to remove any gasket material remaining on the end face.
- During measurement, do not place the height gauge in the shaded area shown in the figure.

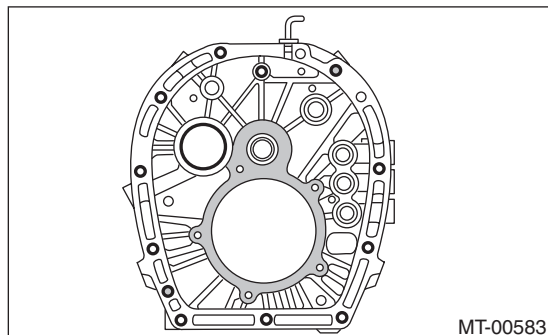

3) Select the main shaft snap ring. <Ref. to 6MT-77, ADJUSTMENT, Main Shaft Assembly.>

4) Measure "B1" and "B2" as shown in the figure.

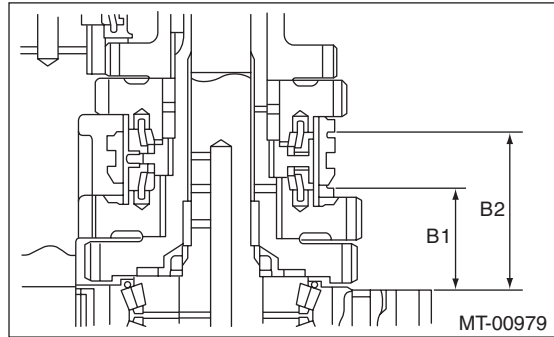

5) Shift down the 1st-2nd sleeve all the way to the 1st driven gear side, and measure "B1".

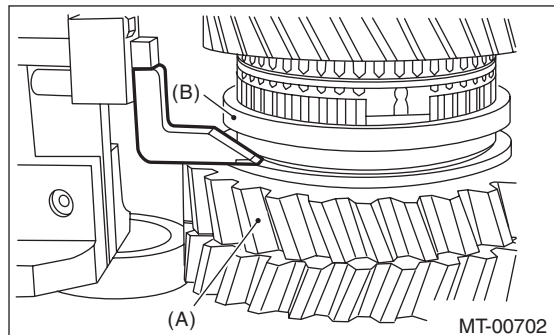

(A) 1st driven gear

(B) 1st-2nd sleeve

#### NOTE:

- Set the height gauge indicator near the measurement target, and lock dial (1) as shown in the figure. Turn dial (2), and set the indicator to the 1st side end surface of the sleeve.
- Turn approximately 72° at a time, and measure the sleeve in 5 locations. Round down the 2 highest and 2 lowest measurement values. The remaining center value is used as the measurement value.

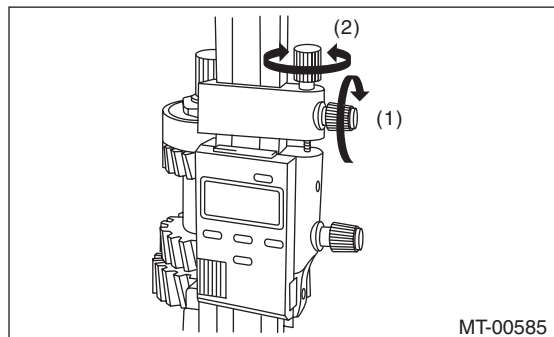

# Shifter Fork and Rod

## MANUAL TRANSMISSION AND DIFFERENTIAL

6) Set the height gauge indicator upside down.

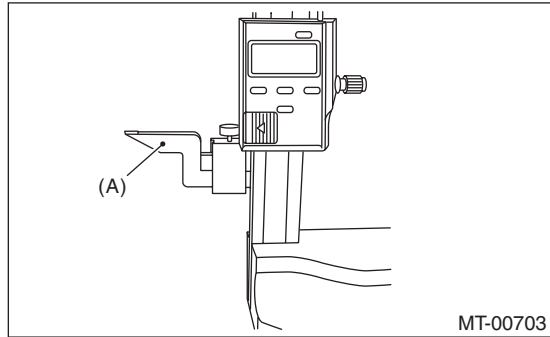

(A) Indicator

7) Shift up the 1st-2nd sleeve all the way to the 2nd driven gear side, and measure "B2".

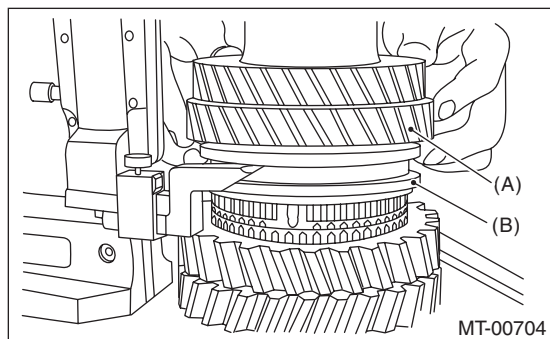

(A) 2nd driven gear  
(B) 1st-2nd sleeve

### NOTE:

- Set the height gauge indicator near the measurement target, and lock dial (1) as shown in the figure. Turn dial (2), and set the indicator to the 2nd side end surface of the sleeve.
- The measurement is to be performed with two persons, while holding the sleeve straight.
- Turn approximately 72° at a time, and measure the sleeve in 5 locations. Round down the 2 highest and 2 lowest measurement values. The remaining center value is used as the measurement value.

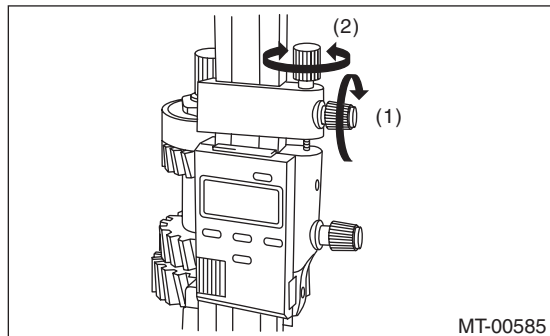

8) According to both of the measurements, calculate the neutral position of the 1st-2nd sleeve. From the following calculation, select a fork rod which matches the calculated value.

$$\text{Calculation: } T = (B1 + B2) / 2$$

T: 1st-2nd sleeve center position

B1: Height from the adapter plate end to the sleeve end, when shifted to 1st gear

B2: Measured height from the adapter plate end to the sleeve end, when shifted to 2nd gear: +55 mm (2.17 in)

### NOTE:

Attach the indicator upside down in comparison to the setting procedures for the zero point. Add "d1" [Value: 55 mm (2.17 in)] from the figure below to "B2", and measure "B2".

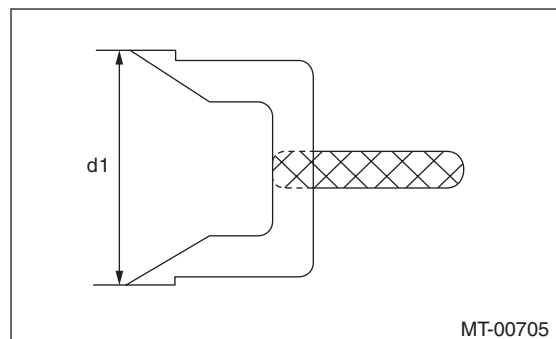

T mm (in)	Lot No. (marking)
62.58 — 62.78 (2.4638 — 2.4717)	32801AA310 (5)
62.78 — 62.98 (2.4717 — 2.4795)	32801AA320 (4)
62.98 — 63.18 (2.4795 — 2.4874)	32801AA330 (2)
63.18 — 63.38 (2.4874 — 2.4953)	32801AA340 (1)
63.38 — 63.58 (2.4953 — 2.5031)	32801AA350 (3)

## 2. 3RD-4TH FORK ROD SELECTION

### NOTE:

In the following conditions, perform the procedures below.

- Main shaft replacement
  - 3rd, and 3rd to 6th drive gear and bushing replacement
  - 3rd, and 3rd to 6th synchro assembly replacement
  - 3rd-4th hub and sleeve assembly replacement
- 1) Insert the main shaft assembly into the adapter plate.

# Shifter Fork and Rod

2) Set the height gauge to the adapter plate. Lower the height gauge indicator to the top surface of the snap ring groove, and set to the zero point on the upper side of the main rear bearing.

ST 18853AA000 HEIGHT GAUGE

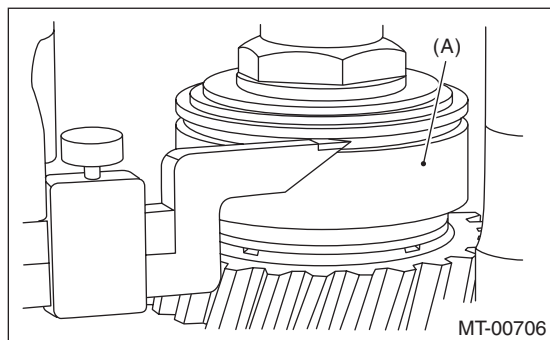

(A) Ball bearing

**NOTE:**

- The height gauge will be set on the adapter plate during the measurement. Use a scraper to remove any gasket material remaining on the end face.
- During measurement, do not place the height gauge in the shaded area shown in the figure.

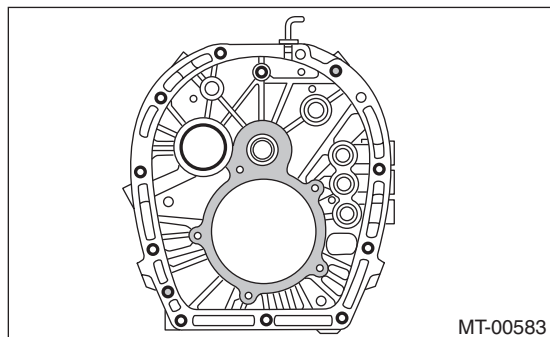

3) Use a height gauge to measure "C1" and "C2" as shown in the figure.

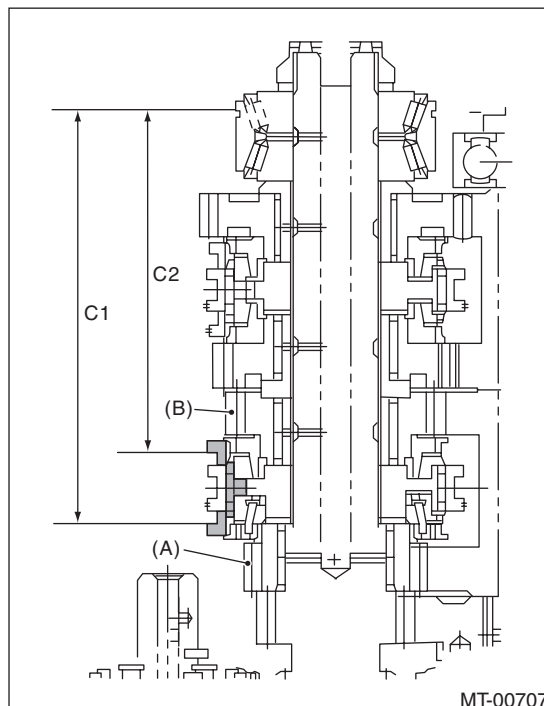

- (A) 3rd drive gear
- (B) 4th drive gear

(1) Shift up the 3rd-4th sleeve all the way to the 4th drive gear side, and measure "C2".

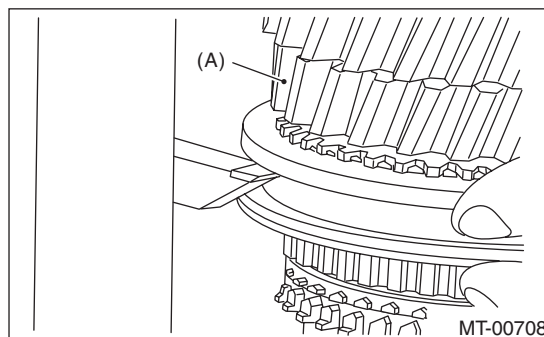

(A) 4th drive gear

**NOTE:**

- Set the height gauge indicator near the measurement target, and lock dial (1) as shown in the figure.
- Turn dial (2), and set the indicator to the 4th side end surface of the sleeve.
- The measurement is to be performed with two persons, while holding the sleeve straight.

## Shifter Fork and Rod

### MANUAL TRANSMISSION AND DIFFERENTIAL

- Turn approximately 72° at a time, and measure the sleeve in 5 locations. Round down the 2 highest and 2 lowest measurement values. The remaining center value is used as the measurement value.

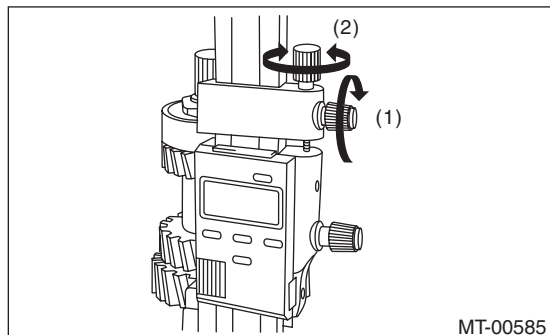

(2) Set the height gauge indicator upside down.

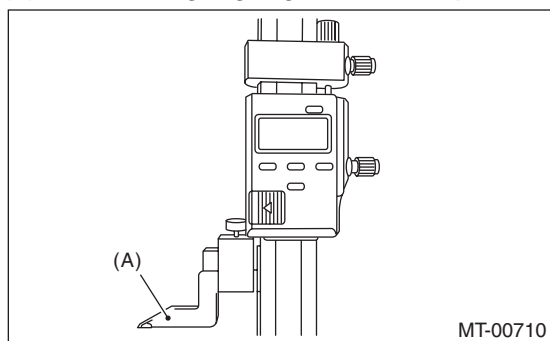

(A) Indicator

(3) Shift down the 3rd-4th sleeve all the way to the 3rd drive gear side, and measure "C1".

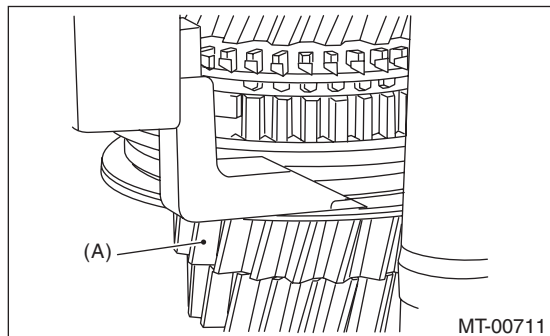

(A) 3rd drive gear

#### NOTE:

- Set the height gauge indicator near the measurement target, and lock dial (1) as shown in the figure. Turn dial (2), and set the indicator to the 3rd side end surface of the sleeve.

- Turn approximately 72° at a time, and measure the sleeve in 5 locations. Round down the 2 highest and 2 lowest measurement values. The remaining center value is used as the measurement value.

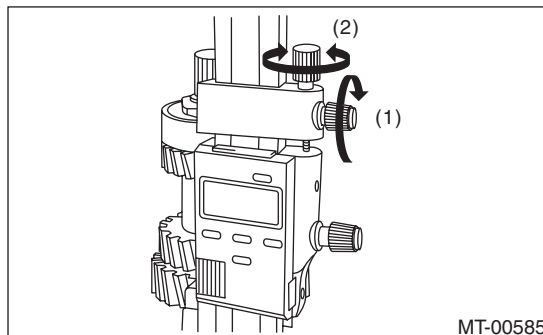

4) According to both of the measurements, calculate the neutral position of the 3rd-4th sleeve. From the following calculation, select a fork rod which matches the calculated value.

$$\text{Calculation: } T = (C1 + C2) / 2$$

T: 3rd-4th sleeve center position

C1: Measured depth from the main shaft rear bearing snap ring groove to the sleeve end, when shifted to 3rd gear: +55 mm (2.17 in)

C2: Measured depth from the main shaft rear bearing snap ring groove to the sleeve end, when shifted to 4th gear

#### NOTE:

Attach the indicator upside down in comparison to the setting procedures for the zero point. Add "d1" [Value: 55 mm (2.17 in)] from the figure below to "C1", and measure "C1".

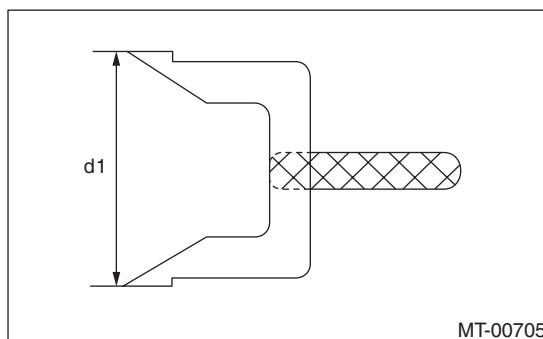

# Shifter Fork and Rod

MANUAL TRANSMISSION AND DIFFERENTIAL

T mm (in)	Lot No. (marking)		
	M.SFT Snap ring 805072010 [t = 1.65 mm (0.065 in)]	M.SFT Snap ring 805072011 [t = 1.95 mm (0.077 in)]	M.SFT Snap ring 805072012 [t = 2.25 mm (0.089 in)]
137.22 — 137.52 (5.4024 — 5.4142)	32809AA171 (none)	32809AA181 (2)	32809AA191 (4)
137.52 — 137.82 (5.4142 — 5.4260)	32809AA161 (1)	32809AA171 (none)	32809AA181 (2)
137.82 — 138.12 (5.4260 — 5.4379)	32809AA141 (3)	32809AA161 (1)	32809AA171 (none)

T = Thickness

## 3. 5TH-6TH FORK ROD SELECTION

### NOTE:

In the following conditions, perform the procedures below.

- Main shaft replacement
- 3rd to 6th drive gear and bushing replacement
- 3rd to 6th synchro ring assembly replacement
- 3rd-4th hub and sleeve assembly replacement
- 5th-6th hub and sleeve assembly replacement

1) Insert the main shaft assembly into the adapter plate.

2) Set the height gauge to the adapter plate. Lower the height gauge indicator to the upper face of the snap ring groove or the upper side of the main rear bearing. Set to zero point.

ST 18853AA000 HEIGHT GAUGE

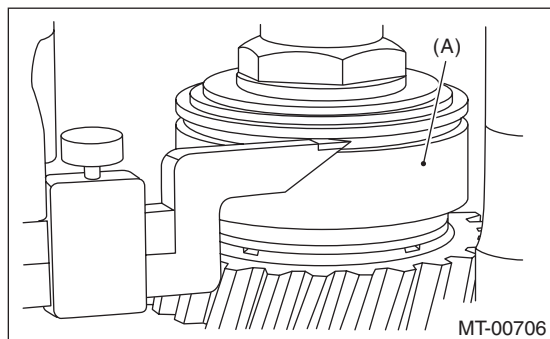

(A) Ball bearing

### NOTE:

- The height gauge will be set on the adapter plate during the measurement. Use a scraper to remove any gasket material remaining on the end face.

- During measurement, do not place the height gauge in the shaded area shown in the figure.

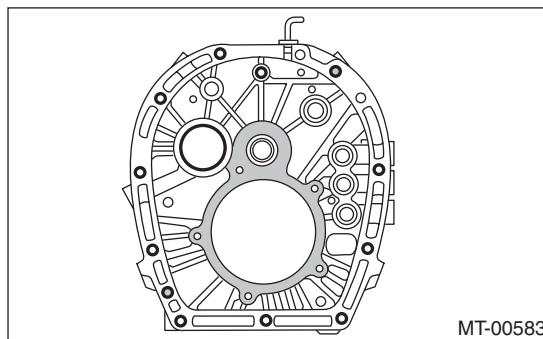

3) Use a height gauge to measure "D1" and "D2" as shown in the figure.

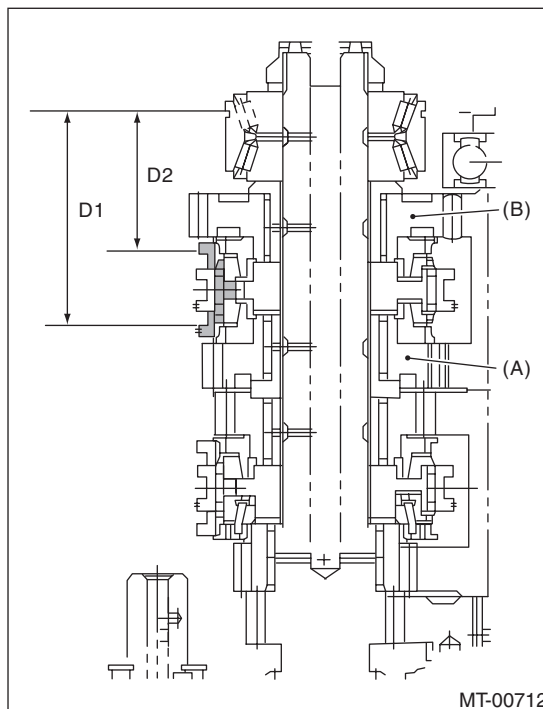

(A) 5th drive gear

(B) 6th drive gear

(1) Shift up the 5th-6th sleeve all the way to the 6th drive gear side, and measure "D2".

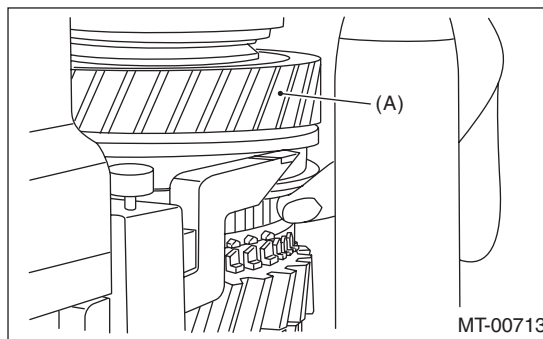

(A) 6th drive gear

# Shifter Fork and Rod

## MANUAL TRANSMISSION AND DIFFERENTIAL

### NOTE:

- Set the height gauge indicator near the measurement target, and lock dial (1) as shown in the figure. Turn dial (2), and set the indicator to the 6th side end surface of the sleeve.
- The measurement is to be performed with two persons, while holding the sleeve straight.
- Turn approximately 72° at a time, and measure the sleeve in 5 locations. Round down the 2 highest and 2 lowest measurement values. The remaining center value is used as the measurement value.

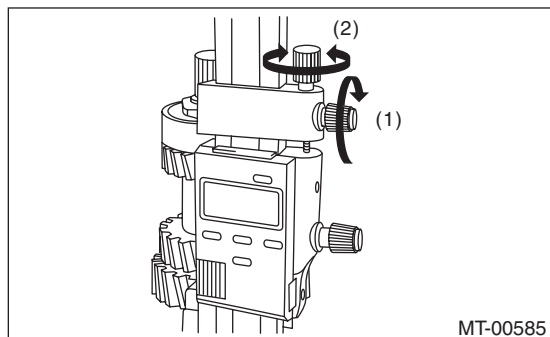

(2) Set the height gauge indicator upside down.

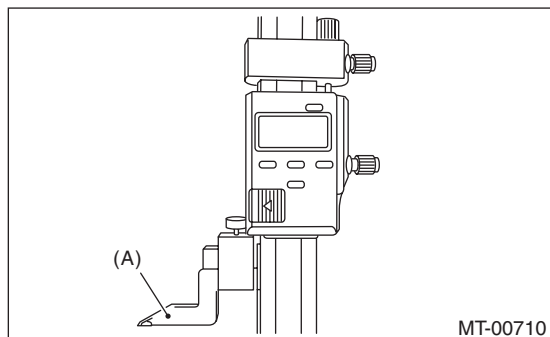

(A) Indicator

(3) Shift down the 5th-6th sleeve all the way to the 5th drive gear side, and measure "D1".

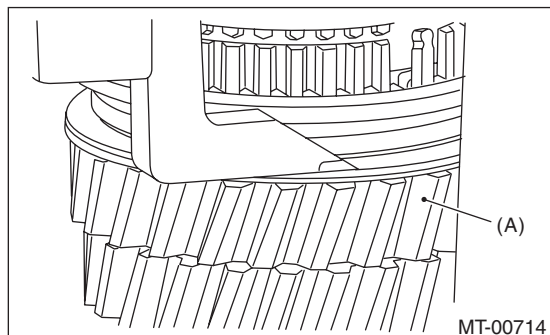

(A) 5th drive gear

### NOTE:

- Set the height gauge indicator near the measurement target, and lock dial (1) as shown in the figure. Turn dial (2), and set the indicator to the 5th side end surface of the sleeve.

- Turn approximately 72° at a time, and measure the sleeve in 5 locations. Round down the 2 highest and 2 lowest measurement values. The remaining center value is used as the measurement value.

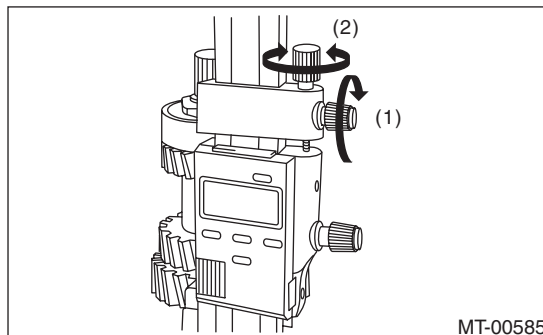

4) According to both of the measurements, calculate the neutral position of the 5th-6th sleeve. From the following calculation, select a fork rod which matches the calculated value.

$$\text{Calculation: } T = (D1 + D2) / 2$$

T: 5th-6th sleeve center position

D1: Measured length from the shaft rear bearing snap ring groove to the sleeve groove end, when shifted to 5th gear [Value: +55 mm (2.17 in)]

D2: Measured length from the main shaft rear bearing snap ring groove to the sleeve groove end, when shifted to 6th gear

### NOTE:

Attach the indicator upside down in comparison to the setting procedures for the zero point. Add "d1" [Value: 55 mm (2.17 in)] from the figure below to "D1", and measure "D1".

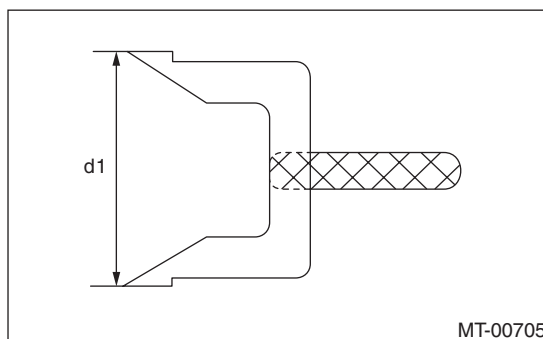



# Shifter Fork and Rod

MANUAL TRANSMISSION AND DIFFERENTIAL

T mm (in)	Lot No. (marking)		
	M.SFT Snap ring 805072010 [t = 1.65 mm (0.065 in)]	M.SFT Snap ring 805072011 [t = 1.95 mm (0.077 in)]	M.SFT Snap ring 805072012 [t = 2.25 mm (0.089 in)]
64.12 — 64.42 (2.5244 — 2.5362)	32945AA021 (none)	32945AA031 (2)	32945AA041 (4)
64.42 — 64.72 (2.5362 — 2.5480)	32945AA011 (1)	32945AA021 (none)	32945AA031 (2)
64.72 — 65.02 (2.5480 — 2.5598)	32945AA001 (3)	32945AA011 (1)	32945AA021 (none)

T = Thickness

## 4. REVERSE FORK ROD SELECTION

### NOTE:

In the following conditions, perform the procedures below.

- Reverse idler gear replacement.
- Reverse idler gear No. 2 replacement.
- Adapter plate replacement.
- Base replacement.

1) Insert the reverse idler gear assembly into the adapter plate.

2) Tighten the base COMPL attachment bolts.

### Tightening torque:

**25 N·m (2.5 kgf·m, 18.4 ft·lb)**

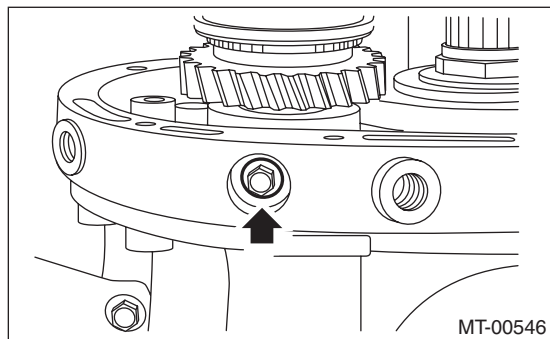

3) Set the height gauge to the adapter plate. Lower the height gauge indicator to the mating surface of the adapter plate and case, and set to zero points.  
ST 18853AA000 HEIGHT GAUGE

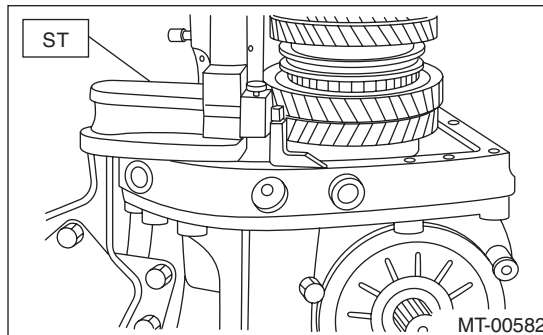

### NOTE:

- The adapter plate will be the base point for the measurement. Use a scraper to remove any gasket material remaining on the end face.
- During measurement, do not place the height gauge in the shaded area shown in the figure.

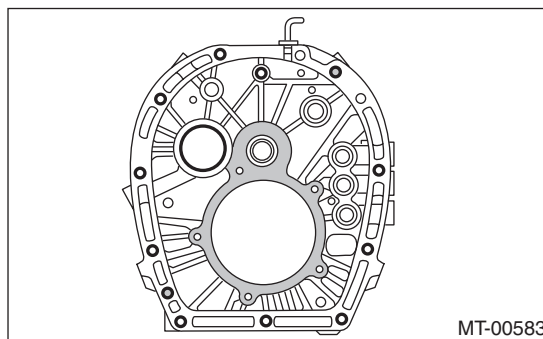

# Shifter Fork and Rod

## MANUAL TRANSMISSION AND DIFFERENTIAL

4) Shift the reverse sleeve to the reverse idler gear No. 2, and measure "T".

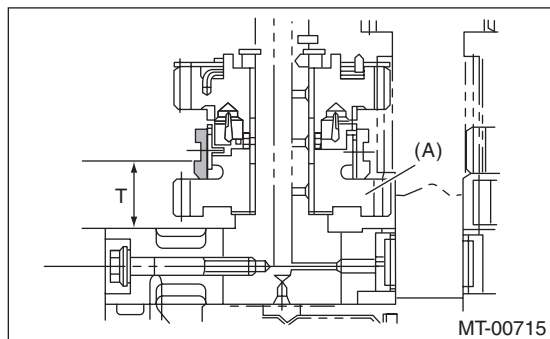

(A) Reverse idler gear No. 2

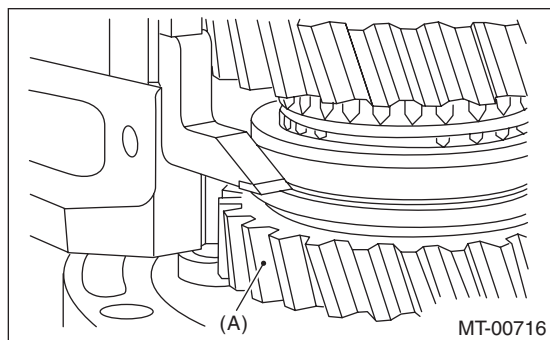

(A) Reverse idler gear No. 2

5) Calculate the neutral position of the reverse sleeve according to the measurement. From the following calculation, select a fork rod which matches the calculated value.

Calculation:  $T + 4.8 \text{ mm (0.189 in)}$

$T + 4.8 \text{ mm (0.189 in)}$ mm (in)	Lot No. (marking)
33.50 — 33.80 (1.3189 — 1.3307)	32816AA110 (1)
33.80 — 34.10 (1.3307 — 1.3425)	32816AA130 (none)
34.10 — 34.40 (1.3425 — 1.3543)	32816AA140 (2)

T = Thickness

### NOTE:

- Set the height gauge indicator near the measurement target, and lock dial (1) as shown in the figure. Turn dial (2), and set the indicator to the end face of the reverse sleeve side.
- Turn approximately  $72^\circ$  at a time, and measure the sleeve in 5 locations. Round down the 2 highest and 2 lowest measurement values. The remaining center value is used as the measurement value.

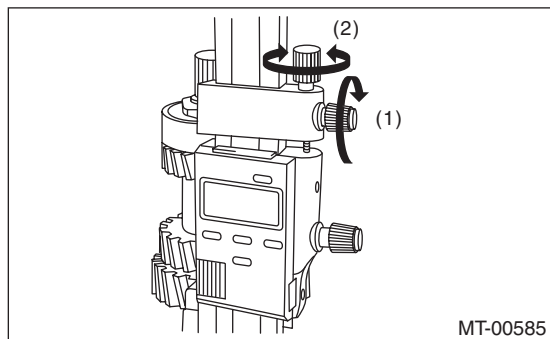



## 23. Clutch Housing

### A: REMOVAL

- 1) Remove the manual transmission assembly from the vehicle. <Ref. to 6MT-32, REMOVAL, Manual Transmission Assembly.>
- 2) Prepare the transmission for overhaul. <Ref. to 6MT-38, Preparation for Overhaul.>
- 3) Remove the neutral position switch, back-up light switch and harness. <Ref. to 6MT-42, REMOVAL, Neutral Position Switch.> <Ref. to 6MT-40, REMOVAL, Back-up Light Switch.>
- 4) Remove the extension case. <Ref. to 6MT-44, REMOVAL, Extension Case.>
- 5) Remove the transfer driven gear. <Ref. to 6MT-55, REMOVAL, Transfer Driven Gear.>
- 6) Remove the center differential. <Ref. to 6MT-57, REMOVAL, Center Differential.>
- 7) Remove the transmission case. <Ref. to 6MT-58, REMOVAL, Transmission Case.>
- 8) Remove the individual gear assemblies. <Ref. to 6MT-65, REMOVAL, Main Shaft Assembly.>
- 9) Remove the drive pinion shaft assembly. <Ref. to 6MT-92, REMOVAL, Drive Pinion Shaft Assembly.>
- 10) Remove the front differential assembly. <Ref. to 6MT-98, REMOVAL, Front Differential Assembly.>

### B: INSTALLATION

- 1) Install the pitching stopper bracket.

#### **Tightening torque:**

**41 N·m (4.2 kgf·m, 30.2 ft·lb)**

- 2) Install the front differential assembly. <Ref. to 6MT-98, INSTALLATION, Front Differential Assembly.>
- 3) Install the drive pinion shaft assembly. <Ref. to 6MT-92, INSTALLATION, Drive Pinion Shaft Assembly.>
- 4) Install the individual gear assemblies all at once. <Ref. to 6MT-66, INSTALLATION, Main Shaft Assembly.>
- 5) Install the transmission case. <Ref. to 6MT-60, INSTALLATION, Transmission Case.>
- 6) Install the center differential. <Ref. to 6MT-57, INSTALLATION, Center Differential.>
- 7) Install the transfer driven gear. <Ref. to 6MT-55, INSTALLATION, Transfer Driven Gear.>
- 8) Install the extension case. <Ref. to 6MT-44, INSTALLATION, Extension Case.>
- 9) Install the neutral position switch, back-up light switch and harness. <Ref. to 6MT-42, INSTALLATION, Neutral Position Switch.> <Ref. to 6MT-40, INSTALLATION, Back-up Light Switch.>

- 10) Install the manual transmission assembly to the vehicle. <Ref. to 6MT-34, INSTALLATION, Manual Transmission Assembly.>

### C: DISASSEMBLY

- 1) Remove the clutch release bearing guide.

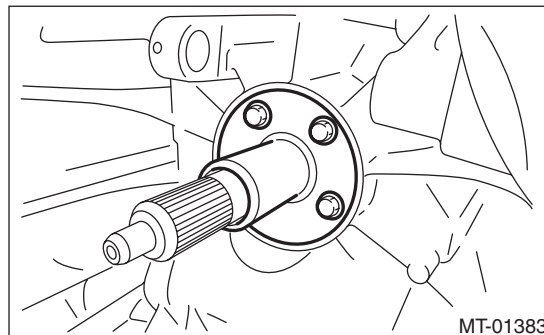

- 2) Remove the oil seal.

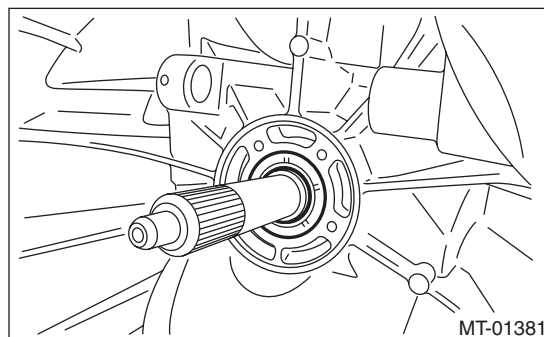

### D: ASSEMBLY

- 1) Attach the oil seal to the clutch housing, being careful not to damage the seal.

#### NOTE:

Use a new oil seal.

ST 18657AA020 OIL SEAL INSTALLER

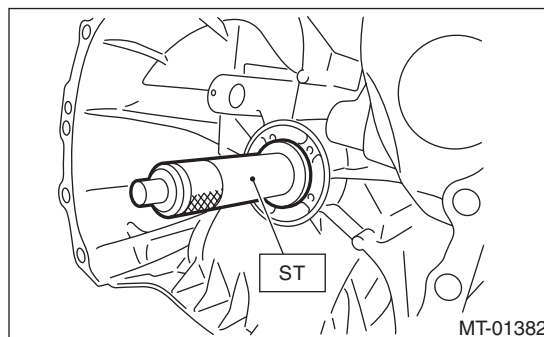

# Clutch Housing

## MANUAL TRANSMISSION AND DIFFERENTIAL

---

2) Install the clutch release bearing guide.

**Tightening torque:**

**6.4 N·m (0.7 kgf·m, 4.7 ft·lb)**

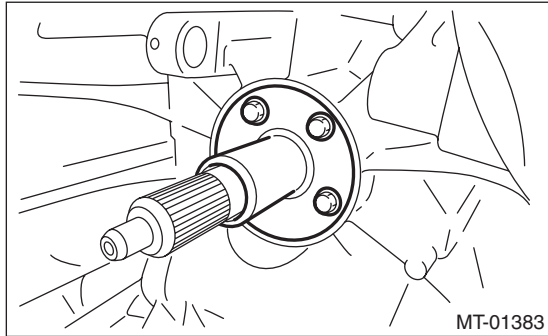

### **E: INSPECTION**

1) Check to make sure there is no damage or cracks on the clutch housing. If there is excessive damage, replace the clutch housing.

2) Inspect the clutch housing for transmission gear oil leakage. If any oil leaks are found, repair or replace the applicable part.

## 24. Driver's Control Center Differential Control Module

### A: REMOVAL

- 1) Disconnect the ground cable from battery.
- 2) Remove the instrument panel lower. <Ref. to EI-54, INSTRUMENT PANEL LOWER, REMOVAL, Center Console.>
- 3) Remove the driver's control center differential control module by disconnecting the connector.

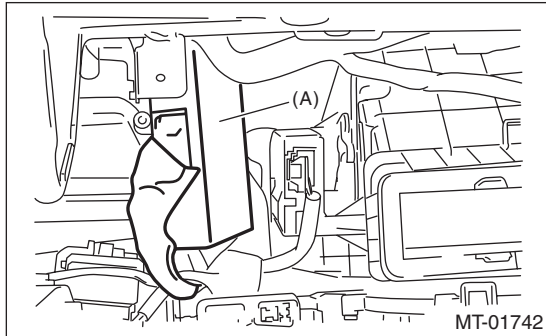

(A) Driver's control center differential control module

### B: INSTALLATION

Install in the reverse order of removal.

#### ***Tightening torque:***

***15 N·m (1.5 kgf·m, 11.1 ft·lb)***

# General Diagnostic Table

MANUAL TRANSMISSION AND DIFFERENTIAL

## 25. General Diagnostic Table

### A: INSPECTION

#### 1. MANUAL TRANSMISSION

Symptoms	Possible cause	Corrective action
1. Gears are difficult to engage. NOTE: If it is difficult to shift, there are two possible causes. One is a defective gear shift system and the other is defective transmission. However, if the operation is heavy and engagement of the gears is difficult, a defective clutch function may also be responsible. Check whether the clutch is correctly functioning, before checking the gear shift system and transmission.	(a) Worn, damaged or burred chamfer at internal spline of the sleeve	Replace.
	(b) Gear spline wear, damage, dents	Replace.
	(c) Worn or scratched bushings	Replace.
	(d) Incorrect contact or wear between synchronizer ring and gear cone	Repair or replace.
2. Gear slip-out <ul style="list-style-type: none"> <li>• Gear slips out when coasting on rough road.</li> <li>• Gear slips out during acceleration.</li> </ul>	(a) Defective pitching stopper adjustment	Adjust.
	(b) Loose engine mounting bolts	Tighten or replace.
	(c) Worn shifter fork, broken shifter fork rail spring	Replace.
	(d) Worn or damaged ball bearing	Replace.
	(e) Excessive clearance between splines of synchronizer hub and synchronizer sleeve	Replace.
	(f) Worn in the synchronizer hub chamfer angle	Replace.
	(g) Worn 1st driven gear, needle bearing and race	Replace.
	(h) Worn 2nd driven gear, needle bearing and race	Replace.
	(i) Worn 3rd drive gear and bushing	Replace.
	(j) Worn 4th drive gear and bushing	Replace.
	(k) Worn 5th drive gear and bushing	Replace.
	(l) Worn 6th drive gear and bushing	Replace.
	(m) Worn reverse idler gear and bushing	Replace.
3. Noise emitted from transmission NOTE: If a noise is heard when the vehicle is parked with its engine idling and ceases when the clutch is disengaged, it may be considered that the noise is coming from the transmission.	(a) Insufficient or improper lubrication	Replenish or replace with the specified amount of recommended oil.
	(b) Worn or damaged gears and bearings NOTE: If the trouble is only wear of the gear teeth surfaces, only a high whirring noise will occur at high speeds, but if any part is broken, rhythmical clicking sounds will be heard even at low speeds.	Replace.

# General Diagnostic Table

MANUAL TRANSMISSION AND DIFFERENTIAL

## 2. DIFFERENTIAL

Symptoms	Possible cause	Corrective action
<p>1. Broken differential (case, gear, bearing, etc.)</p> <p>NOTE: Noise will occur, and eventually the differential will not be able to operate due to broken pieces obstructing the gear revolution.</p>	(a) Insufficient or improper oil	Disassemble the differential and replace broken components. At the same time check other components for any trouble, and replace if necessary.
	(b) Use of vehicle under severe conditions such as excessive load and improper use of the clutch	Readjust the preload and backlash of the bearing, and the contact surface of gear.
	(c) Improper adjustment of taper roller bearing	Adjust.
	(d) Improper adjustment of the drive pinion and the hypoid driven gear	Adjust.
	(e) Loose hypoid driven gear clamping bolts	Tighten.
<p>2. Differential and hypoid gear noise</p> <p>Troubles of the differential and hypoid gear always appear as noise problems. Therefore noise is the first indication of trouble. However, noise from the engine, muffler, tire, exhaust gas, bearing, body, etc. are easily mistaken for noise from the differential. Pay special attention to the hypoid gear noise because it is easily confused with other gear noises. There are the following four kinds of noises.</p> <ul style="list-style-type: none"> <li>• Gear noise when driving: If noise increases as the vehicle speed increases, it may be due to insufficient gear oil, incorrect gear engagement, damaged gears, etc.</li> <li>• Gear noise during coasting: Damaged gears due to misadjusted bearings and incorrect shim adjustment.</li> <li>• Bearing noise when driving or coasting: Cracked, broken or damaged bearings.</li> </ul>	(a) Insufficient oil	Replenish or replace with the specified amount of recommended oil.
	(b) Improper adjustment of hypoid driven gear and drive pinion	Check the tooth contact.
	(c) Worn teeth of hypoid driven gear and drive pinion	Replace as a set. Readjust the bearing preload.
	(d) Loose roller bearing	Readjust the backlash of the hypoid driven gear to drive pinion, and check the tooth contact.
	(e) Distorted hypoid driven gear or differential case	Replace.

# General Diagnostic Table

MANUAL TRANSMISSION AND DIFFERENTIAL

---

# MANUAL TRANSMISSION AND DIFFERENTIAL (DIAGNOSTICS)

## *6MT(diag)*

---

	<b>Page</b>
1. Basic Diagnostic Procedure .....	2
2. Check List for Interview .....	3
3. General Description .....	4
4. Electrical Component Location .....	5
5. Driver's Control Center Differential (DCCD) Control Module I/O Signal ....	8
6. Subaru Select Monitor .....	10
7. Read Current Data .....	11
8. Read Diagnostic Trouble Code (DTC) .....	12
9. Clear Memory Mode .....	13
10. Driver's Control Center Differential (DCCD) Manual Mode Display .....	14
11. Diagnostic Procedure for Subaru Select Monitor Communication .....	17
12. List of Diagnostic Trouble Code (DTC) .....	20
13. Diagnostic Procedure with Diagnostic Trouble Code (DTC) .....	21
14. Diagnostic Procedure without Diagnostic Trouble Code (DTC) .....	32
15. Diagnostics with Phenomenon .....	38

# Basic Diagnostic Procedure

## MANUAL TRANSMISSION AND DIFFERENTIAL (DIAGNOSTICS)

### 1. Basic Diagnostic Procedure

#### A: PROCEDURE

	Step	Check	Yes	No
1	<p><b>START INSPECTIONS.</b></p> <p>1) Use the Check List for Interview to confirm the condition of the problem from the user. &lt;Ref. to 6MT(diag)-3, Check List for Interview.&gt;</p> <p>2) Check the items related to DCCD.</p> <ul style="list-style-type: none"> <li>• General inspection &lt;Ref. to 6MT(diag)-4, INSPECTION, General Description.&gt;</li> <li>• Disconnection of harness connector</li> <li>• Visual check for harness connector damage</li> <li>• Oil leakage</li> </ul>	Are items related to DCCD OK?	Go to step 2.	Repair the defective items.
2	<p><b>CHECK DTC.</b></p> <p>Read the DTC. &lt;Ref. to 6MT(diag)-10, Subaru Select Monitor.&gt;</p> <p>NOTE:</p> <ul style="list-style-type: none"> <li>• Refer to "List of Diagnostic Trouble Code (DTC)" for DTC. &lt;Ref. to 6MT(diag)-20, List of Diagnostic Trouble Code (DTC).&gt;</li> <li>• If the communication function of Subaru Select Monitor cannot be executed normally, check communication circuit. &lt;Ref. to 6MT(diag)-10, Subaru Select Monitor.&gt;</li> </ul>	Is DTC displayed?	Record all DTC. Go to step 3.	Inspect based on the general diagnosis table. <Ref. to 6MT(diag)-38, Diagnostics with Phenomenon.>
3	<p><b>CHECK FREEZE FRAME DATA.</b></p> <p>Using the Subaru Select Monitor, check the Freeze Frame Data.</p>	Are freeze frame data recorded?	Record the Freeze Frame Data. Go to step 4.	Go to step 4.
4	<p><b>PERFORM DIAGNOSIS.</b></p> <p>1) Inspect and repair all DTC using the "Diagnostic Procedure with Diagnostic Trouble Code (DTC)". &lt;Ref. to 6MT(diag)-21, Diagnostic Procedure with Diagnostic Trouble Code (DTC).&gt;</p> <p>NOTE:</p> <p>Refer to "List of Diagnostic Trouble Code (DTC)" for DTC. &lt;Ref. to 6MT(diag)-20, List of Diagnostic Trouble Code (DTC).&gt;</p> <p>2) Start the engine.</p> <p>3) Read the DTC using Subaru Select Monitor. &lt;Ref. to 6MT(diag)-10, Subaru Select Monitor.&gt;</p>	Is DTC displayed?	Record all DTC using the "Diagnostic Procedure with Diagnostic Trouble Code (DTC)" for the inspection. <Ref. to 6MT(diag)-21, Diagnostic Procedure with Diagnostic Trouble Code (DTC).> Repeat execute diagnosis until DTC no longer appears.	Inspect based on the general diagnosis table. <Ref. to 6MT(diag)-38, Diagnostics with Phenomenon.>



# Check List for Interview

MANUAL TRANSMISSION AND DIFFERENTIAL (DIAGNOSTICS)

## 2. Check List for Interview

### A: CHECK

Check the following items when a problem has occurred.

**NOTE:**

Use copies of this page for interviewing customers.

Customer's name			
Date of purchase			
Date of repair			
Transmission model	Transmission	V.I.N.	
Odometer distance	km or miles		
Frequency	<input type="checkbox"/> Continuous <input type="checkbox"/> Intermittent (      times a day)		
Weather	<input type="checkbox"/> Fine <input type="checkbox"/> Cloudy <input type="checkbox"/> Rainy <input type="checkbox"/> Snowy <input type="checkbox"/> Other (                                  )		
Place	<input type="checkbox"/> Highland <input type="checkbox"/> Suburbs <input type="checkbox"/> Inner city <input type="checkbox"/> Uphill <input type="checkbox"/> Rough road <input type="checkbox"/> Other (                                  )		
Ambient air temperature	<input type="checkbox"/> Hot <input type="checkbox"/> Warm <input type="checkbox"/> Cool <input type="checkbox"/> Cold		
Vehicle speed	km/h (MPH)		
DCCD manual mode display	<input type="checkbox"/> Flashing		<input type="checkbox"/> Other than flashing
Driving condition	<input type="checkbox"/> Not affected <input type="checkbox"/> While decelerating	<input type="checkbox"/> At starting <input type="checkbox"/> While accelerating	<input type="checkbox"/> While turning ( <input type="checkbox"/> RH/ <input type="checkbox"/> LH) <input type="checkbox"/> When cruising
Symptoms	<input type="checkbox"/> Will not change to AUTO or MANUAL		
	<input type="checkbox"/> The forward/rear torque distribution does not change		
	<input type="checkbox"/> Will not become differential free		
	<input type="checkbox"/> Will not become differential lock		
	<input type="checkbox"/> A tight corner braking symptom occurs in AUTO mode or in MANUAL mode with differential free		
	<input type="checkbox"/> Noise or vibration		
<input type="checkbox"/> Other (                                  )			

# General Description

MANUAL TRANSMISSION AND DIFFERENTIAL (DIAGNOSTICS)

## 3. General Description

### A: CAUTION

The airbag system wiring harness is routed near the DCCD control module.

#### CAUTION:

- Airbag system wiring harnesses and connectors are yellow. Do not use an electric test equipment to check these circuits.
- Be careful not to damage the airbag system wiring harness when performing diagnostics or repair of the DCCD control module.
- When measuring the voltage and resistance of each control module or each sensor, use a tapered pin with a diameter of less than 0.64 mm (0.025 in) in order to avoid poor contact. Also, do not insert the pin more than 5 mm (0.2 in) into the part.

### B: INSPECTION

#### 1. POWER SUPPLY

1) Measure the battery voltage and specific gravity of the electrolyte.

**Standard voltage: 12 V or more**

**Specific gravity: 1.260 or more**

2) Check the fuse condition.

3) Check the connecting condition of harness and harness connector.

### C: PREPARATION TOOL

#### 1. SPECIAL TOOL

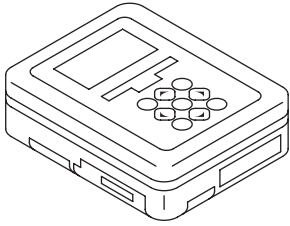
ILLUSTRATION	TOOL NUMBER	DESCRIPTION	REMARKS
 ST1B022XU0	1B022XU0	SUBARU SELECT MONITOR III KIT	Troubleshooting for electrical system

#### 2. GENERAL TOOL

TOOL NAME	REMARKS
Circuit tester	Used for measuring resistance, voltage and current.
Oscilloscope	Used for measuring the sensor.

# Electrical Component Location

MANUAL TRANSMISSION AND DIFFERENTIAL (DIAGNOSTICS)

## 4. Electrical Component Location

### A: LOCATION

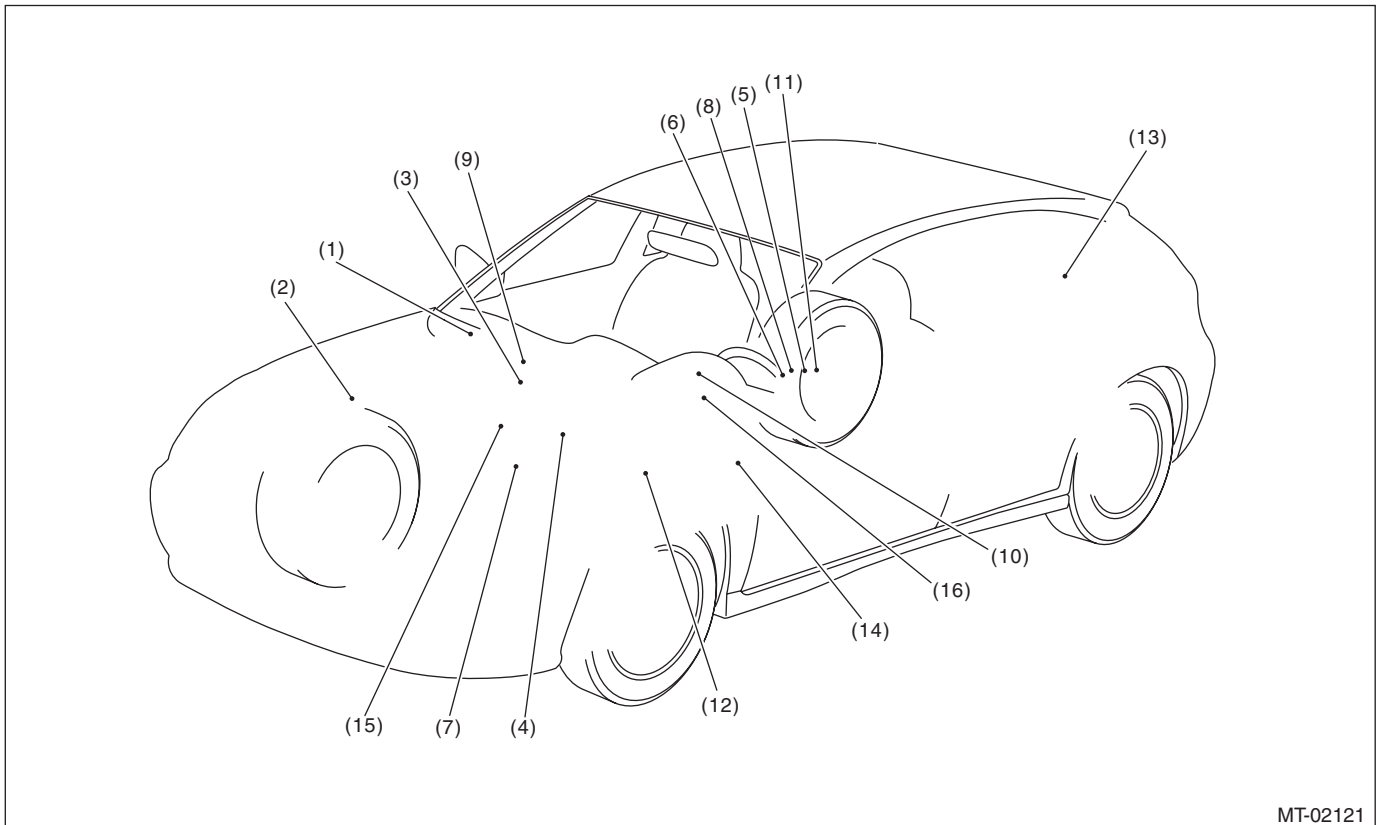

MT-02121

- |   |                               |   |
|---|-------------------------------|---|
| (1) Engine control module (ECM)                               | (7) Center differential       | (12) Stop light switch                        |
| (2) VDC control module and hydraulic control unit (VDCCM&H/U) | (8) Mode change switch        | (13) Rear differential oil temperature switch |
| (3) DCCD control module                                       | (9) DCCD relay                | (14) Data link connector                      |
| (4) Throttle position sensor                                  | (10) DCCD manual mode display | (15) Neutral position switch                  |
| (5) Yaw rate & G sensor                                       | (11) Parking brake switch     | (16) Steering angle sensor                    |
| (6) C.DIFF +/- switch   |                               |   |

# Electrical Component Location

## MANUAL TRANSMISSION AND DIFFERENTIAL (DIAGNOSTICS)

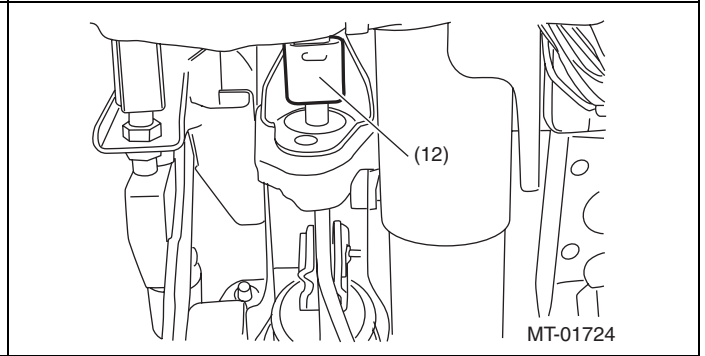
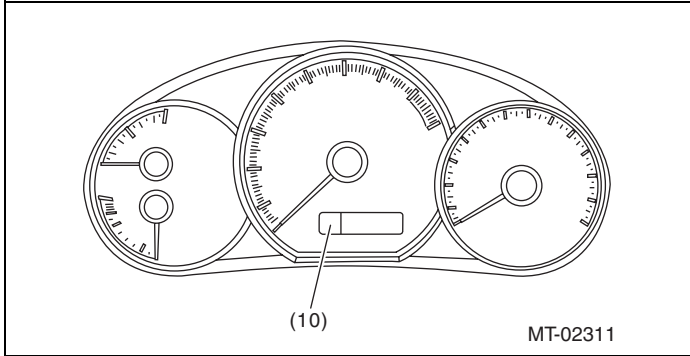
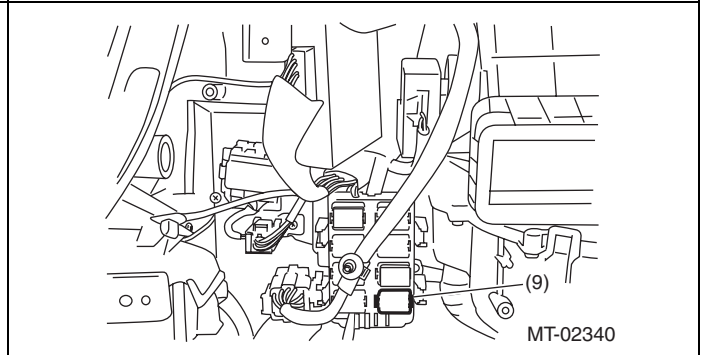
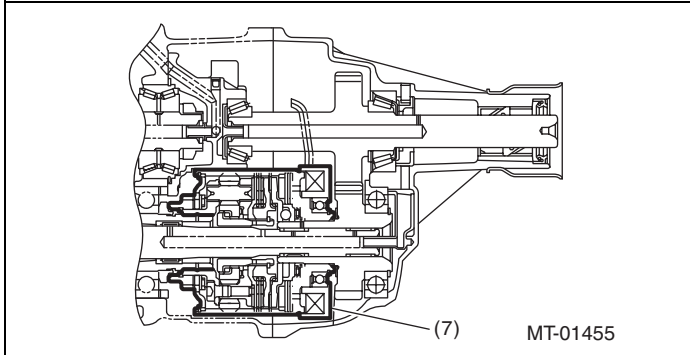
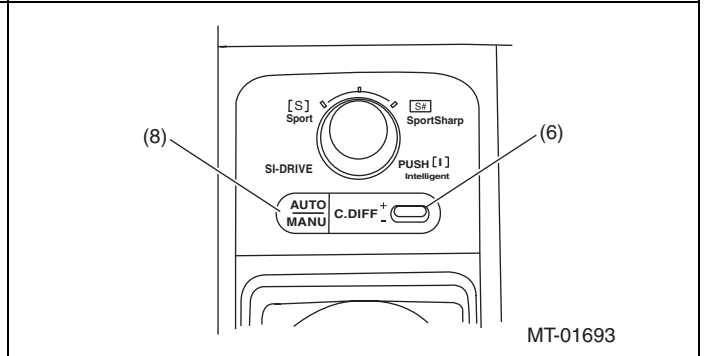
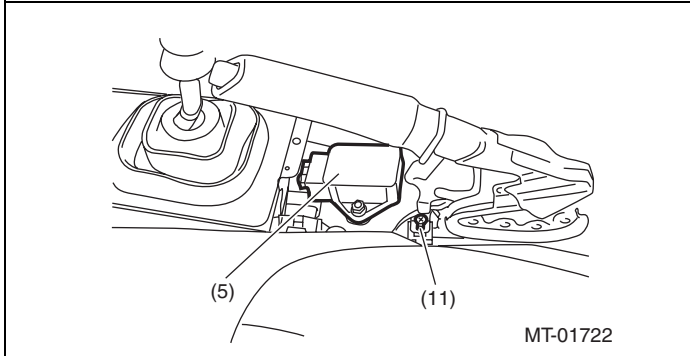
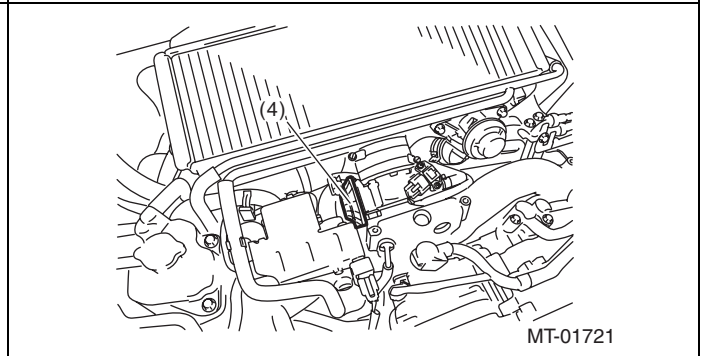
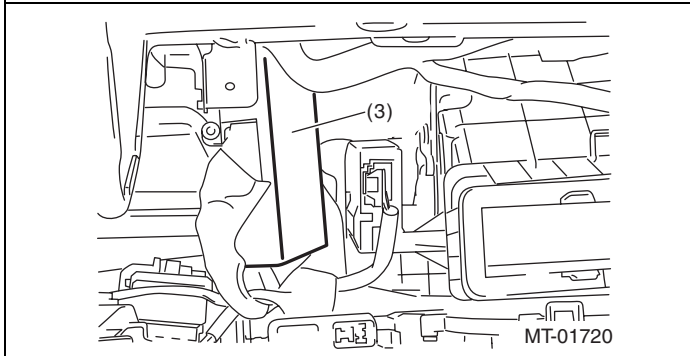
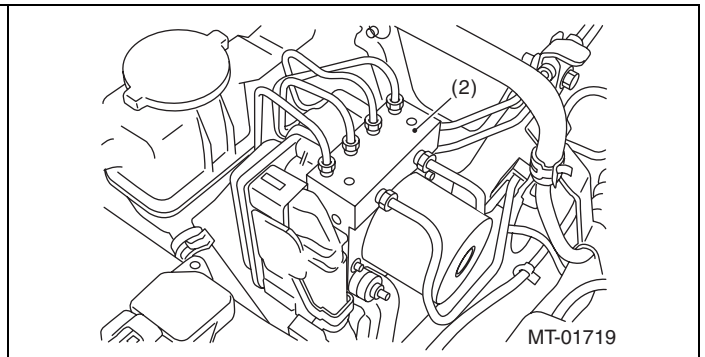
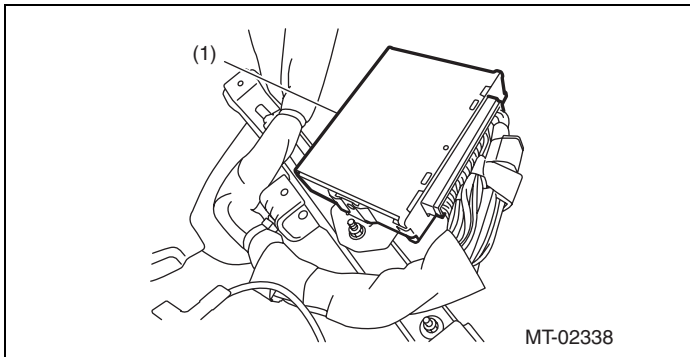

# Electrical Component Location

## MANUAL TRANSMISSION AND DIFFERENTIAL (DIAGNOSTICS)

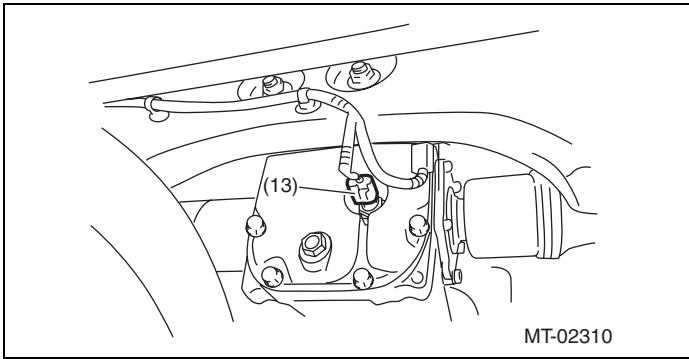

MT-02310

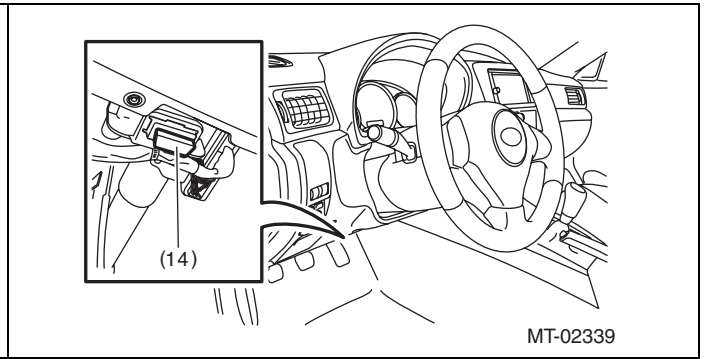

MT-02339

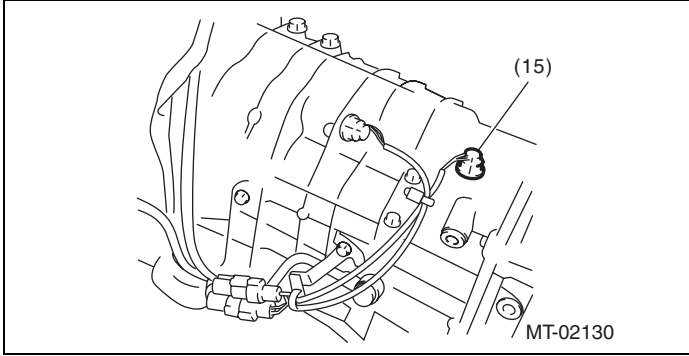

MT-02130

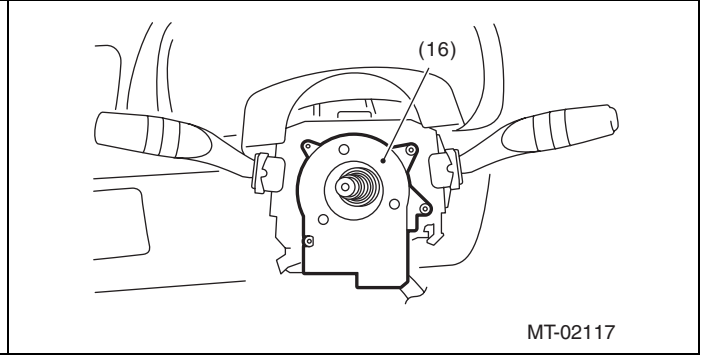

MT-02117

# Driver's Control Center Differential (DCCD) Control Module I/O Signal

MANUAL TRANSMISSION AND DIFFERENTIAL (DIAGNOSTICS)

## 5. Driver's Control Center Differential (DCCD) Control Module I/O Signal

### A: ELECTRICAL SPECIFICATION

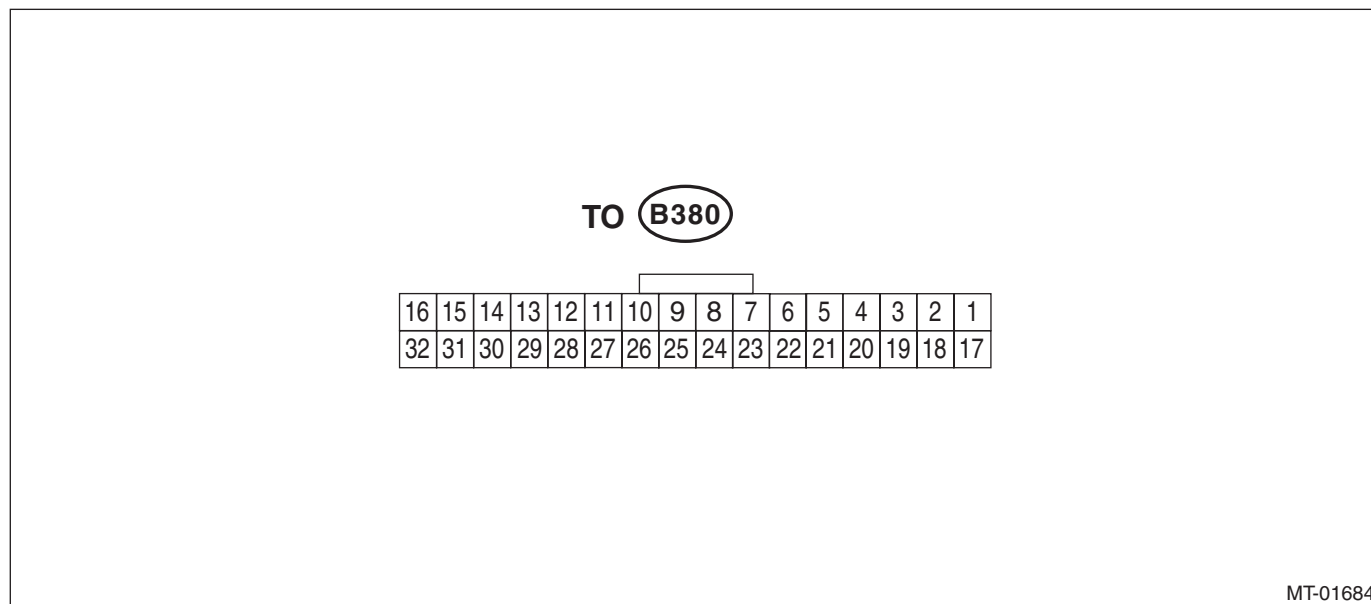

Check with ignition switch ON.					
Item	Measured terminal (Connector & Terminal No.)		Measuring condition	Voltage (V)	Resistance (Ω)
	Positive terminal	Ground terminal			
DCCD output	(B380) No. 15	(B380) No. 32	When differential is locked (when DCCD manual mode display is locked)	5.5 — 8.0	1.2 — 2.5
			When differential is free (When the parking brake is pulled)	Less than 0.5	
DCCD power supply	(B380) No. 13	Chassis ground	Ignition switch ON	10 — 13	—
	(B380) No. 14				—
Backup power supply	(B380) No. 12	Chassis ground	—	10 — 13	—
Ignition power supply	(B380) No. 11	Chassis ground	Ignition switch ON	10 — 13	—
DCCD relay	(B380) No. 7	Chassis ground	Ignition switch ON	Less than 1.0	—
Mode change switch	(B380) No. 6	Chassis ground	When the switch is not pressed	8.0 or more	—
			When the switch is pressed	Less than 1	—
Rear differential oil temperature switch	(B380) No. 5	Chassis ground	When the rear differential switch is ON	0.4 or more	—
			When the rear differential switch is OFF	Less than 8.0	—
CAN communication signal (+)	(B380) No. 2	Chassis ground	Ignition switch ON	Pulse signal	
CAN communication signal (-)	(B380) No. 18	Chassis ground	Ignition switch ON	Pulse signal	
Data link signal (Subaru Select Monitor)	(B380) No. 1	Chassis ground	—	—	—

# Driver's Control Center Differential (DCCD) Control Module I/O Signal

MANUAL TRANSMISSION AND DIFFERENTIAL (DIAGNOSTICS)

Check with ignition switch ON.					
Item	Measured terminal (Connector & Terminal No.)		Measuring condition	Voltage (V)	Resistance ( $\Omega$ )
	Positive terminal	Ground terminal			
System ground circuit	(B380) No. 28	Chassis ground	—	0	Less than 1.0
	(B380) No. 29	Chassis ground			
	(B380) No. 30	Chassis ground			
	(B380) No. 31	Chassis ground			
System ground circuit	(B380) No. 17	Chassis ground	—	0	Less than 1.0
Up switch	(B380) No. 22	Chassis ground	When the switch is not pressed/is pressed	8.0/1.0	
Down switch	(B380) No. 4	Chassis ground	When the switch is not pressed/is pressed	8.0/1.0	

## B: WIRING DIAGRAM

Refer to "WIRING DIAGRAM". <Ref. to WI-72, Driver's Control Center Differential Control System.>

# Subaru Select Monitor

MANUAL TRANSMISSION AND DIFFERENTIAL (DIAGNOSTICS)

---

## 6. Subaru Select Monitor

### A: OPERATION

1) Prepare the Subaru Select Monitor kit.

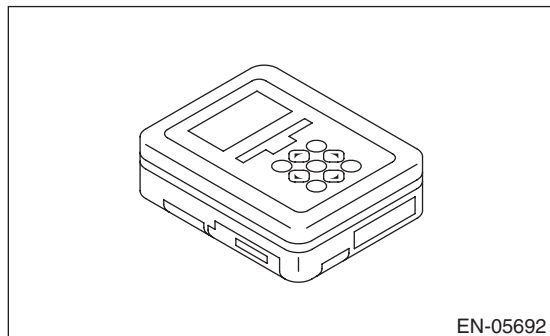

2) Prepare PC with Subaru Select Monitor installed.

3) Connect the USB cable to SDI (Subaru Diagnosis Interface) and USB port on the personal computer (dedicated port for the Subaru Select Monitor).

#### NOTE:

The dedicated port for the Subaru Select Monitor means the USB port which was used to install the Subaru Select Monitor.

4) Connect the diagnosis cable to SDI.

5) Connect SDI to data link connector located in the lower portion of the instrument panel (on the driver's side).

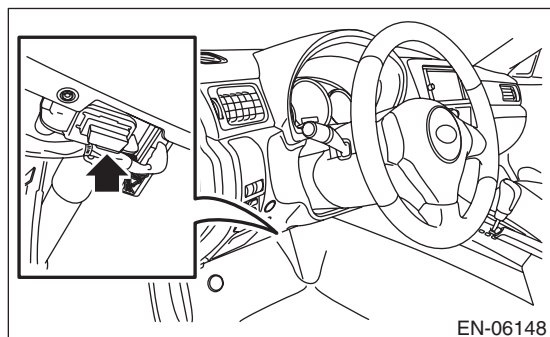

#### CAUTION:

**Do not connect scan tools other than the Subaru Select Monitor.**

6) Start the PC.

7) Turn the ignition switch to ON.

8) Run the "PC application for Subaru Select Monitor".



# Read Current Data

MANUAL TRANSMISSION AND DIFFERENTIAL (DIAGNOSTICS)

## 7. Read Current Data

### A: OPERATION

- 1) Using the Subaru Select Monitor, on the «Main Menu» display, select {Each System Check}.
  - 2) On «System Selection Menu» display, select {Transmission Control System}.
  - 3) After the {Center Differential Control} is displayed, select [OK].
  - 4) On «Transmission Diagnosis» display, select {Current Data Display & Save}.
  - 5) Select {Normal sampling} on the «Current Data Display & Save» screen.
  - 6) Using the scroll key, scroll the display screen up or down until the desired data is shown.
- A list of the support data is shown in the following table.

Item	Display	Unit of measure
Center differential actual current	C-Diff. Real Current	A
Center differential indicated current	C-Diff. Indicate Current	A
Front vehicle speed sensor (RH)	FR Wheel Speed	km/h or MPH
Front vehicle speed sensor (LH)	FL Wheel Speed	km/h or MPH
Rear vehicle speed sensor (RH)	RR Wheel Speed	km/h or MPH
Rear vehicle speed sensor (LH)	RL Wheel Speed	km/h or MPH
Yaw rate & G sensor	Lateral G	m/s <sup>2</sup>
Yaw rate & G sensor	Yaw Rate	deg/s
Steering angle	Steering Angle Sensor	deg
Engine speed signal	Engine Speed	rpm
Stop light switch signal	Stop Light Switch	ON or OFF
Rear differential oil temperature switch signal	RR Diff. Oil Temp SW	ON or OFF
Down shift signal	Down Switch	ON or OFF
Up shift signal	Up Switch	ON or OFF
AUTO selection mode	DCCD Mode	*1
Manual mode torque distribution	DCCD Torque Distribution	*2
Battery voltage	Battery Voltage	V
Accelerator position	Accel. Opening Angle	%
Parking switch	Parking Position Switch	ON or OFF
Center differential relay	Center Diff. Relay	ON or OFF
Mode change switch	AUTO/MANUAL Mode Switch	ON or OFF
Neutral signal	Neutral Position Switch	Neutral or other than neutral

\*1: Displayed by the number

0 in the manual mode

1 in AUTO[-] / 2 in AUTO / 3 in AUTO[+]

\*2: Displayed by the number

0 in AUTO mode

1 (Free), 2, 3, 4, 5, 6 (LOCK) in manual mode

#### NOTE:

For detailed operation procedures, refer to “PC application help for Subaru Select Monitor”.

## Read Diagnostic Trouble Code (DTC)

MANUAL TRANSMISSION AND DIFFERENTIAL (DIAGNOSTICS)

---

### 8. Read Diagnostic Trouble Code (DTC)

#### A: OPERATION

- 1) Using the Subaru Select Monitor, on the «Main Menu» display, select {Each System Check}.
- 2) On «System Selection Menu» display, select {Transmission Control System}.
- 3) After the {Center Differential Control} is displayed, select [OK].
- 4) On «Transmission Diagnosis» display, select {Diagnostic Code(s) Display}.
- 5) On the «Diagnostic Code(s) Display» screen, select the {Temporary Diagnostic Code(s)} or {Memorized Diagnostic Code(s)}

#### NOTE:

- For detailed operation procedures, refer to “PC application help for Subaru Select Monitor”.
- For details concerning DTCs, refer to “List of Diagnostic Trouble Code (DTC)”. <Ref. to 6MT(diag)-20, List of Diagnostic Trouble Code (DTC).>

# Clear Memory Mode

MANUAL TRANSMISSION AND DIFFERENTIAL (DIAGNOSTICS)

---

## 9. Clear Memory Mode

### A: OPERATION

- 1) Place the shift lever in neutral.
- 2) Using the Subaru Select Monitor, on the «Main Menu» display, select {Each System Check}.
- 3) On «System Selection Menu» display, select {Transmission Control System}.
- 4) After the {Center Differential Control} is displayed, select [OK].
- 5) On «Transmission Diagnosis» display, select {Clear Memory}.
- 6) When “Done. Turn off the ignition switch.” is displayed, select [OK].
- 7) Turn the Subaru Select Monitor and ignition switch to OFF. To turn the ignition switch to ON again, wait for 10 seconds or more.

#### NOTE:

- To clear the previous DTC, use {Clear Memory}.
- For detailed operation procedures, refer to “PC application help for Subaru Select Monitor”.

# Driver's Control Center Differential (DCCD) Manual Mode Display

MANUAL TRANSMISSION AND DIFFERENTIAL (DIAGNOSTICS)

## 10.Driver's Control Center Differential (DCCD) Manual Mode Display

### A: OPERATION

When there is a problem with a part or module, DCCD manual mode display blinks. (DCCD manual mode display blinks even in AUTO mode condition.) The blinking starts from when the problem is detected, and continues until the ignition switch is turned OFF. The faulty parts can be recognized by reading DTC with the Subaru Select Monitor.

DCCD manual mode display is as shown in the figure.

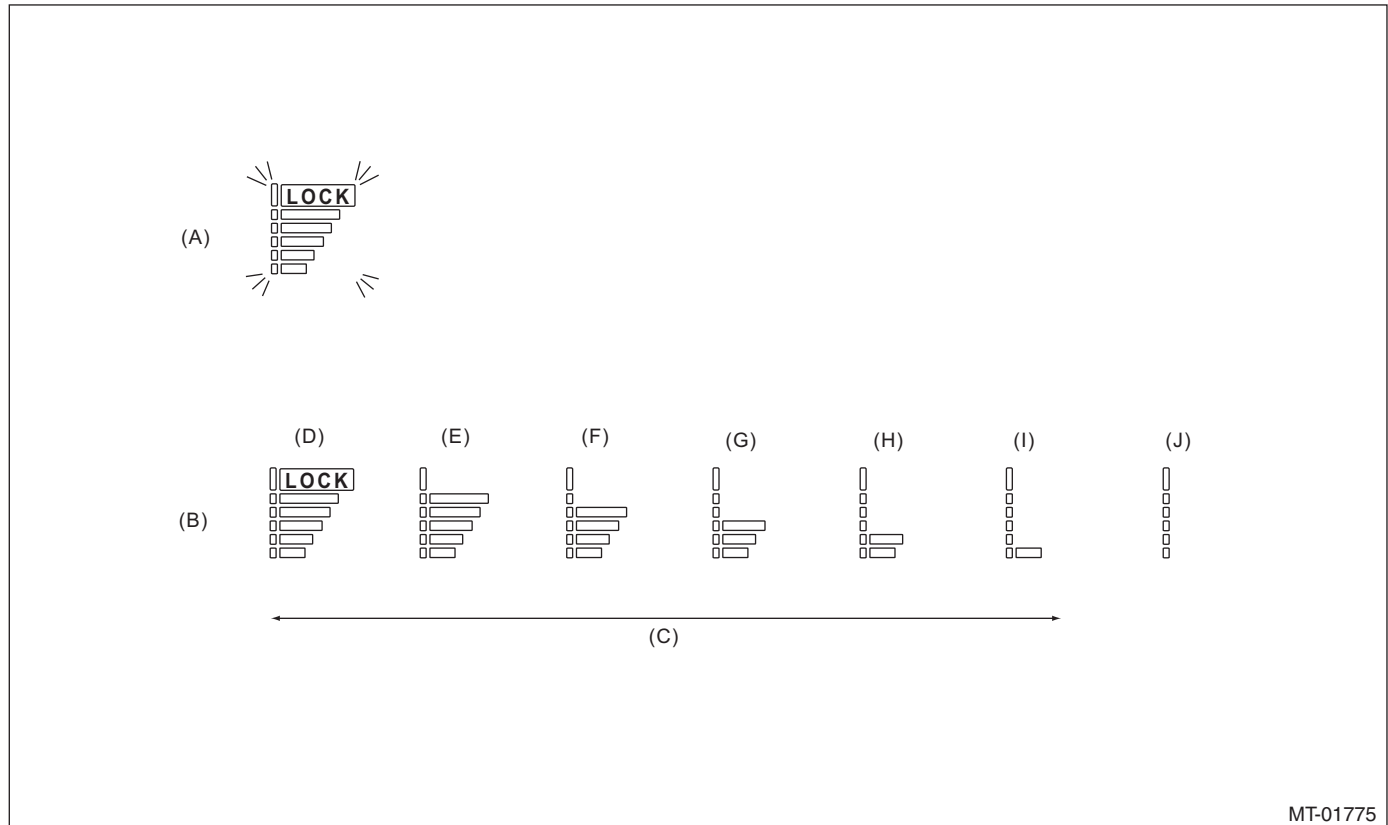

MT-01775

- |                                      |       |                            |
|--------------------------------------|-------|----------------------------|
| (A) If faulty (blinks at 1 Hz cycle) | (E) 5 | (H) 2                      |
| (B) If normal                        | (F) 4 | (I) 1 (FREE)               |
| (C) Manual mode display              | (G) 3 | (J) No display (AUTO mode) |
| (D) 6 (LOCK)                         |       |                            |

# Driver's Control Center Differential (DCCD) Manual Mode Display

MANUAL TRANSMISSION AND DIFFERENTIAL (DIAGNOSTICS)

## B: INSPECTION

### DIAGNOSIS:

DCCD manual mode display is open or shorted.

### TROUBLE SYMPTOM:

DCCD manual mode display does not illuminate in manual mode.

### WIRING DIAGRAM:

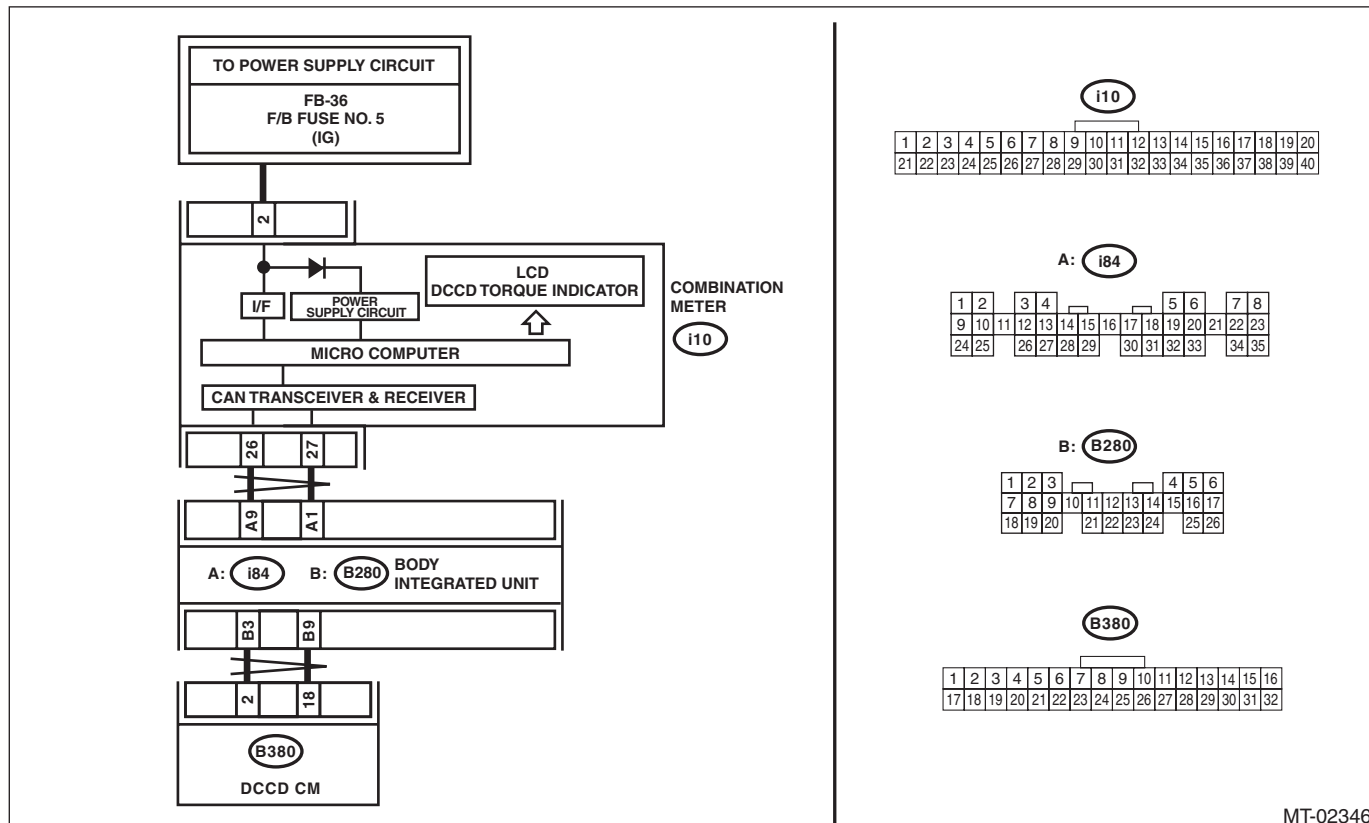

MT-02346

Step	Check	Yes	No
<b>1</b>	<b>CHECK BODY INTEGRATED UNIT.</b> Read the DTC of body integrated unit using Subaru Select Monitor.	Is DTC displayed?	Perform the diagnosis according to DTC. Go to step 2.
<b>2</b>	<b>CHECK COMBINATION METER.</b> Perform the self-diagnosis of combination meter. <Ref. to IDI-5, INSPECTION, Combination Meter System.>	Is the self-diagnosis of combination meter OK?	Go to step 3. Repair it according to combination meter diagnostics.
<b>3</b>	<b>CHECK IGNITION POWER SUPPLY CIRCUIT OF DCCD CONTROL MODULE.</b> 1) Connect the Subaru Select Monitor to the vehicle. 2) Turn the ignition switch to ON. 3) Read the data of «Battery voltage» using Subaru Select Monitor.	Is the voltage 11 V or more?	Go to step 4. Repair the open circuit of harness between fuse (F/B No. 12) and DCCD control module, or between fuse (F/B No. 12) and battery.
<b>4</b>	<b>CHECK DTC.</b>	Is DTC P1720 displayed?	Perform the diagnosis according to DTC. Go to step 5.
<b>5</b>	<b>CHECK MODE CHANGE SWITCH.</b> Read the data of «AUTO/MANUAL Mode Switch» using the Subaru Select Monitor.	Does the display change to ON/OFF according to the mode change switch operation?	Go to step 6. Diagnose the mode change switch.
<b>6</b>	<b>CHECK C.DIFF +/- SWITCH (UP/DOWN).</b> Read the data of «Up Switch» and «Down Switch» using the Subaru Select Monitor.	Does the display change to ON/OFF according to the C.DIFF +/- switch operation?	Go to step 7. Check the C.DIFF +/- switch.

# Driver's Control Center Differential (DCCD) Manual Mode Display

## MANUAL TRANSMISSION AND DIFFERENTIAL (DIAGNOSTICS)

Step	Check	Yes	No
<b>7</b> <b>CHECK INDICATION OF DCCD MANUAL MODE DISPLAY.</b> Press the mode change switch to enter the manual mode.	Does the DCCD manual mode display illuminate?	Go to step <b>8</b> .	Check the poor contact.
<b>8</b> <b>CHECK INDICATION OF DCCD MANUAL MODE DISPLAY.</b> Read the data of «DCCD Torque Allocation» using the Subaru Select Monitor.	Does the DCCD manual mode display change according to the C.DIFF +/- switch operation?	Go to step <b>9</b> .	Check the poor contact.
<b>9</b> <b>CHECK OTHER DTC.</b>	Is any other DTC displayed?	Perform the diagnosis according to DTC.	DCCD manual mode display is OK.

# Diagnostic Procedure for Subaru Select Monitor Communication

MANUAL TRANSMISSION AND DIFFERENTIAL (DIAGNOSTICS)

## 11. Diagnostic Procedure for Subaru Select Monitor Communication

### A: COMMUNICATION FOR INITIALIZING IMPOSSIBLE

#### DIAGNOSIS:

Defective harness connector

#### TROUBLE SYMPTOM:

Subaru Select Monitor communication failure

#### WIRING DIAGRAM:

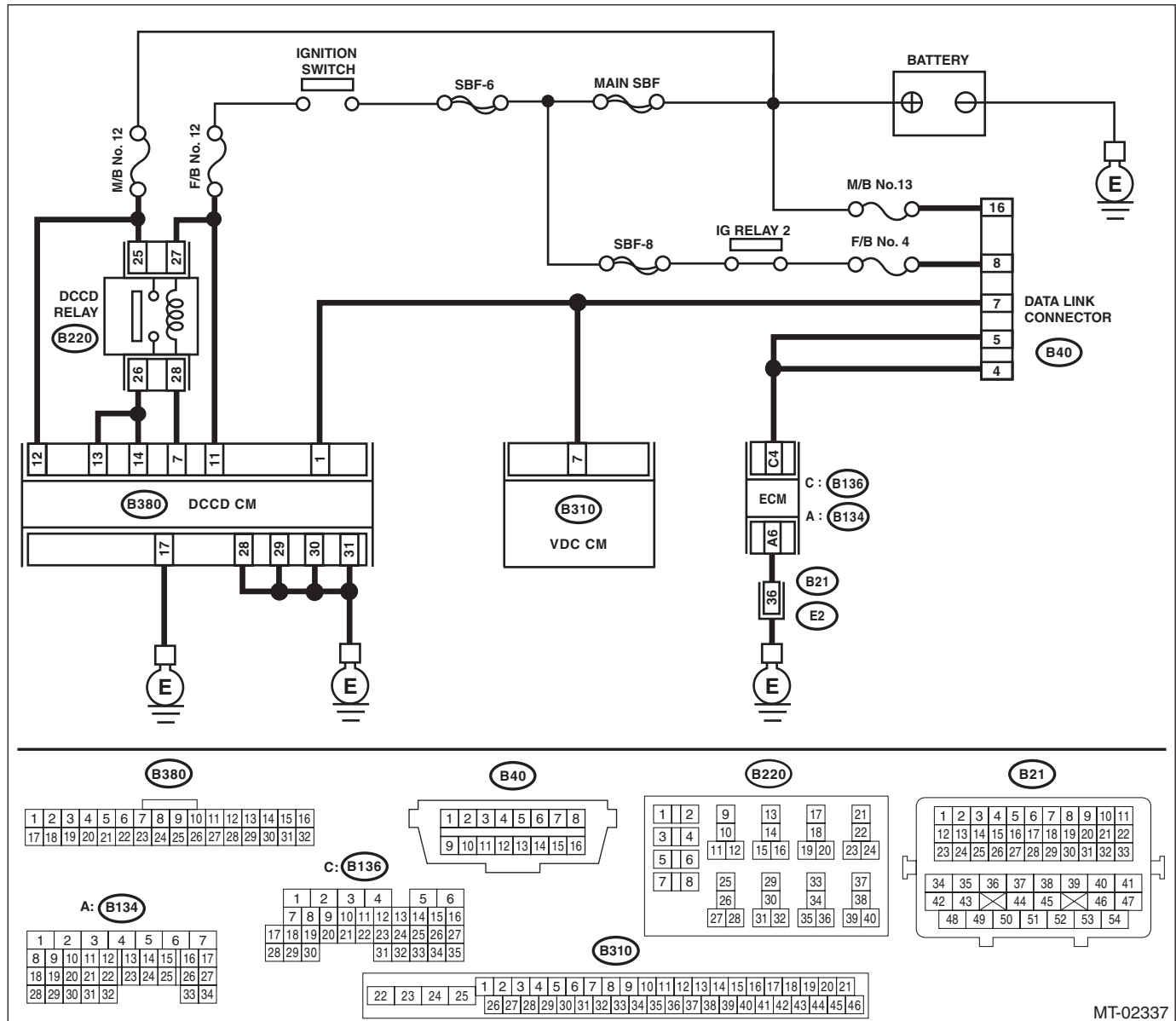

MT-02337

Step	Check	Yes	No
1	<b>CHECK INSTALLATION OF DCCD CONTROL MODULE.</b> Turn the ignition switch to OFF.	Go to step 2.	Connect the DCCD control module connector to DCCD control module.

# Diagnostic Procedure for Subaru Select Monitor Communication

## MANUAL TRANSMISSION AND DIFFERENTIAL (DIAGNOSTICS)

Step	Check	Yes	No
<b>2 CHECK SUBARU SELECT MONITOR POWER SUPPLY CIRCUIT.</b> Measure the voltage between data link connector and chassis ground. <b>Connector &amp; terminal</b> <b>(B40) No. 16 (+) — Chassis ground (-):</b>	Is the voltage 10 V or more?	Go to step 3.	Repair harness connector between the battery and data link connector, and poor contact of the connector.
<b>3 CHECK SUBARU SELECT MONITOR GROUND CIRCUIT.</b> Measure the resistance of harness between data link connector and chassis ground. <b>Connector &amp; terminal</b> <b>(B40) No. 4 — Chassis ground:</b> <b>(B40) No. 5 — Chassis ground:</b>	Is the resistance less than 1 $\Omega$ ?	Go to step 4.	Repair the open circuit of harness between data link connector and ground terminal, and poor contact of connector.
<b>4 CHECK COMMUNICATION OF SUBARU SELECT MONITOR.</b> 1) Turn the ignition switch to ON. 2) Check communication with the transmission system.	Is the name of system displayed on Subaru Select Monitor?	System is normal.	Go to step 5.
<b>5 CHECK COMMUNICATION OF SUBARU SELECT MONITOR.</b> 1) Turn the ignition switch to OFF. 2) Disconnect the connector from DCCD control module. 3) Turn the ignition switch to ON. 4) Check communication with the engine system.	Is the name of system displayed on Subaru Select Monitor?	Go to step 7.	Go to step 6.
<b>6 CHECK COMMUNICATION OF SUBARU SELECT MONITOR.</b> 1) Turn the ignition switch to OFF. 2) Connect the DCCD control module connector. 3) Disconnect the connector from ECM. 4) Turn the ignition switch to ON. 5) Check communication with the transmission system.	Is the name of system displayed on Subaru Select Monitor?	Inspect the ECM.	Go to step 7.
<b>7 CHECK HARNESS CONNECTOR BETWEEN EACH CONTROL MODULE AND DATA LINK CONNECTOR.</b> 1) Turn the ignition switch to OFF. 2) Disconnect the connectors from DCCD control module and ECM. 3) Measure the resistance between data link connector and chassis ground. <b>Connector &amp; terminal</b> <b>(B40) No. 7 — Chassis ground:</b>	Is the resistance 1 M $\Omega$ or more?	Go to step 8.	Check harness and connector between each control module and data link connector.
<b>8 CHECK HARNESS CONNECTOR BETWEEN EACH CONTROL MODULE AND DATA LINK CONNECTOR.</b> 1) Disconnect the all modules that communicate with Subaru Select Monitor. 2) Turn the ignition switch to ON. 3) Measure the voltage between data link connector and chassis ground. <b>Connector &amp; terminal</b> <b>(B40) No. 7 (+) — Chassis ground (-):</b>	Is the voltage 1 V or more?	Check harness and connector between each control module and data link connector.	Go to step 9.



# Diagnostic Procedure for Subaru Select Monitor Communication

MANUAL TRANSMISSION AND DIFFERENTIAL (DIAGNOSTICS)

Step	Check	Yes	No
<p><b>9 CHECK HARNESS CONNECTOR BETWEEN DCCD CONTROL MODULE AND DATA LINK CONNECTOR.</b> Measure the resistance between DCCD control module connector and data link connector. <b>Connector &amp; terminal</b> <b>(B380) No. 1 — (B40) No. 7:</b></p>	Is the resistance less than 1 $\Omega$ ?	Go to step 10.	Check harness and connector between DCCD control module and data link connector.
<p><b>10 CHECK POOR CONTACT OF DCCD CONTROL MODULE CONNECTOR.</b></p>	Is there poor contact of connector?	Repair the poor contact.	Go to step 11.
<p><b>11 CHECK POWER SUPPLY OF DCCD CONTROL MODULE.</b> 1) Disconnect the connector from DCCD control module. 2) Turn the ignition switch to ON. 3) Measure the voltage between DCCD control module connector and chassis ground. <b>Connector &amp; terminal</b> <b>(B380) No. 12 (+) — Chassis ground (-):</b> <b>(B380) No. 13 (+) — Chassis ground (-):</b> <b>(B380) No. 14 (+) — Chassis ground (-):</b></p>	Are the voltages 10 — 13 V?	Go to step 15.	Go to step 12.
<p><b>12 CHECK POWER SUPPLY CIRCUIT OF FUSE (M/B NO. 12).</b> 1) Turn the ignition switch to OFF. 2) Remove the fuse (M/B No. 12).</p>	Is the fuse (M/B No. 12) blown out?	Replace the fuse (M/B No. 12). If the new fuse (M/B No. 12) has blown out easily, repair the short circuit of harness between fuse (M/B No. 12) and DCCD control module.	Go to step 13.
<p><b>13 CHECK POWER SUPPLY CIRCUIT OF FUSE (F/B NO. 12).</b> Remove the fuse (F/B No. 12).</p>	Is the fuse (F/B No. 12) blown out?	Replace the fuse (F/B No. 12). If the new fuse (F/B No. 12) has blown out easily, repair the short circuit of harness between fuse (F/B No. 12) and DCCD control module.	Go to step 14.
<p><b>14 CHECK POWER SUPPLY CIRCUIT OF DCCD CONTROL MODULE.</b> Measure the resistance between the battery (+) terminal and fuse. <b>Battery &amp; terminal</b> <b>Battery (+) — M/B No. 12:</b> <b>Battery (+) — F/B No. 12:</b></p>	Is the resistance less than 1 $\Omega$ ?	Repair the open circuit.	Go to step 15.
<p><b>15 CHECK HARNESS CONNECTOR BETWEEN DCCD CONTROL MODULE AND CHASSIS GROUND.</b> 1) Turn the ignition switch to OFF. 2) Measure the resistance between DCCD control module and chassis ground. <b>Connector &amp; terminal</b> <b>(B380) No. 28 — Chassis ground:</b> <b>(B380) No. 29 — Chassis ground:</b> <b>(B380) No. 30 — Chassis ground:</b> <b>(B380) No. 31 — Chassis ground:</b></p>	Is the resistance less than 1 $\Omega$ ?	Check the poor contact.	Repair the short circuit or poor contact of harness between DCCD control module and transmission connector.

## List of Diagnostic Trouble Code (DTC)

MANUAL TRANSMISSION AND DIFFERENTIAL (DIAGNOSTICS)

---

### 12. List of Diagnostic Trouble Code (DTC)

#### A: LIST

##### 1. SUBARU SELECT MONITOR DISPLAY

DTC	Item	Content of diagnosis	Reference
P1521	Brake Switch Circuit Range	Stop light switch circuit is open or shorted.	<Ref. to 6MT(diag)-21, DTC P1521 BRAKE SWITCH CIRCUIT RANGE, Diagnostic Procedure with Diagnostic Trouble Code (DTC).>
P1720	DCCD CAN System Circuit	CAN communication circuit is open or shorted.	<Ref. to 6MT(diag)-23, DTC P1720 DCCD CAN SYSTEM CIRCUIT, Diagnostic Procedure with Diagnostic Trouble Code (DTC).>
P1767	DCCD Steering Angle Sensor	Open, short or communication failure of the steering angle sensor circuit	<Ref. to 6MT(diag)-24, DTC P1767 DCCD STEERING ANGLE SENSOR, Diagnostic Procedure with Diagnostic Trouble Code (DTC).>
P1769	Yaw Rate & Lateral G Sensor Malfunction	Yaw rate & lateral G sensor malfunction	<Ref. to 6MT(diag)-26, DTC P1769 YAW RATE & LATERAL G SENSOR MALFUNCTION, Diagnostic Procedure with Diagnostic Trouble Code (DTC).>
P1875	Circuit of Center Diff	Open or short in the driver's control center differential circuit	<Ref. to 6MT(diag)-28, DTC P1875 CIRCUIT OF CENTER DIFF, Diagnostic Procedure with Diagnostic Trouble Code (DTC).>

# Diagnostic Procedure with Diagnostic Trouble Code (DTC)

MANUAL TRANSMISSION AND DIFFERENTIAL (DIAGNOSTICS)

## 13. Diagnostic Procedure with Diagnostic Trouble Code (DTC)

### A: DTC P1521 BRAKE SWITCH CIRCUIT RANGE

#### DIAGNOSIS:

Stop light switch circuit is open or shorted.

#### TROUBLE SYMPTOM:

ABS does not operate.

#### WIRING DIAGRAM:

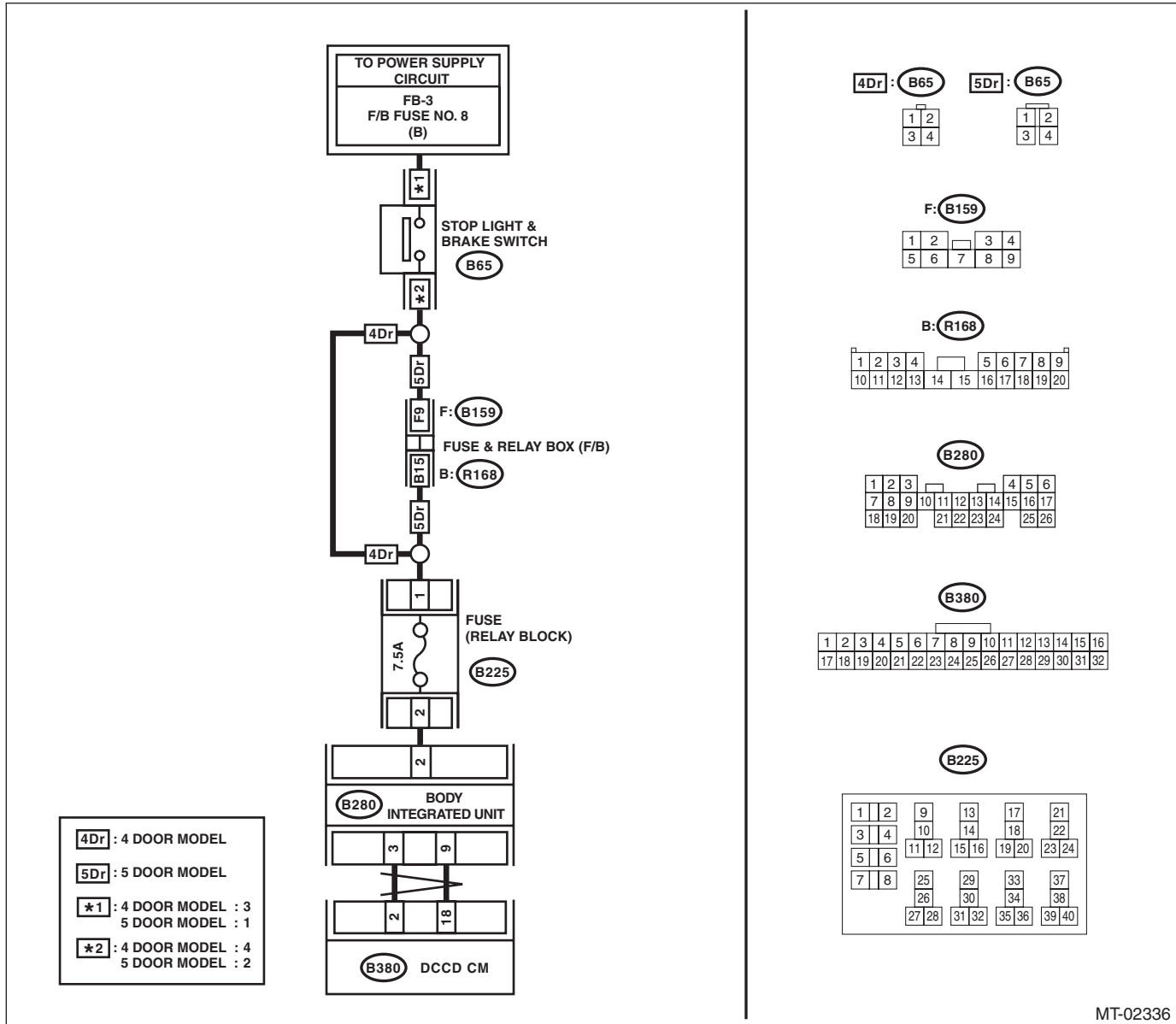

Step	Check	Yes	No
1	<b>CHECK DTC.</b> Does the DTC related to stop light SW appear in the VDC diagnostics test mode?	Perform the diagnosis according to DTC.	Go to step 2.

# Diagnostic Procedure with Diagnostic Trouble Code (DTC)

## MANUAL TRANSMISSION AND DIFFERENTIAL (DIAGNOSTICS)

Step	Check	Yes	No
<b>2</b> <b>CHECK IGNITION POWER SUPPLY CIRCUIT OF DCCD CONTROL MODULE.</b> 1) Connect the Subaru Select Monitor to the vehicle. 2) Turn the ignition switch to ON. 3) Read the data of «Battery voltage» using Subaru Select Monitor.	Is the voltage 11 V or more?	Go to step 3.	Repair the open circuit of harness between fuse (F/B No. 12) and DCCD control module, or between fuse (F/B No. 12) and battery.
<b>3</b> <b>CHECK DTC.</b>	Is DTC P1720 displayed?	Perform the diagnosis according to DTC.	Go to step 4.
<b>4</b> <b>CHECK DCCD CONTROL MODULE.</b> 1) Turn the ignition switch to ON. 2) Read the data of «Stop Light Switch» using Subaru Select Monitor.	Does the «Stop Light Switch» change to ON/OFF according to the depressing/releasing operation of brake?	Go to step 5.	Check the poor contact.
<b>5</b> <b>CHECK OTHER DTC.</b>	Is a DTC other than DTC P1521 displayed?	Perform the diagnosis according to DTC.	The stop light switch is currently normal.

# Diagnostic Procedure with Diagnostic Trouble Code (DTC)

MANUAL TRANSMISSION AND DIFFERENTIAL (DIAGNOSTICS)

---

## **B: DTC P1720 DCCD CAN SYSTEM CIRCUIT**

### NOTE:

For the diagnostic procedure, refer to DTC U1216. <Ref. to LAN(diag)-56, DTC U1216 HIGH-SPEED CAN (DCCD) DATA ERROR, Diagnostic Procedure with Diagnostic Trouble Code (DTC).>

# Diagnostic Procedure with Diagnostic Trouble Code (DTC)

MANUAL TRANSMISSION AND DIFFERENTIAL (DIAGNOSTICS)

## C: DTC P1767 DCCD STEERING ANGLE SENSOR

### DIAGNOSIS:

Open, short or communication failure of the steering angle sensor circuit

### TROUBLE SYMPTOM:

A tight corner braking symptom occurs.

### WIRING DIAGRAM:

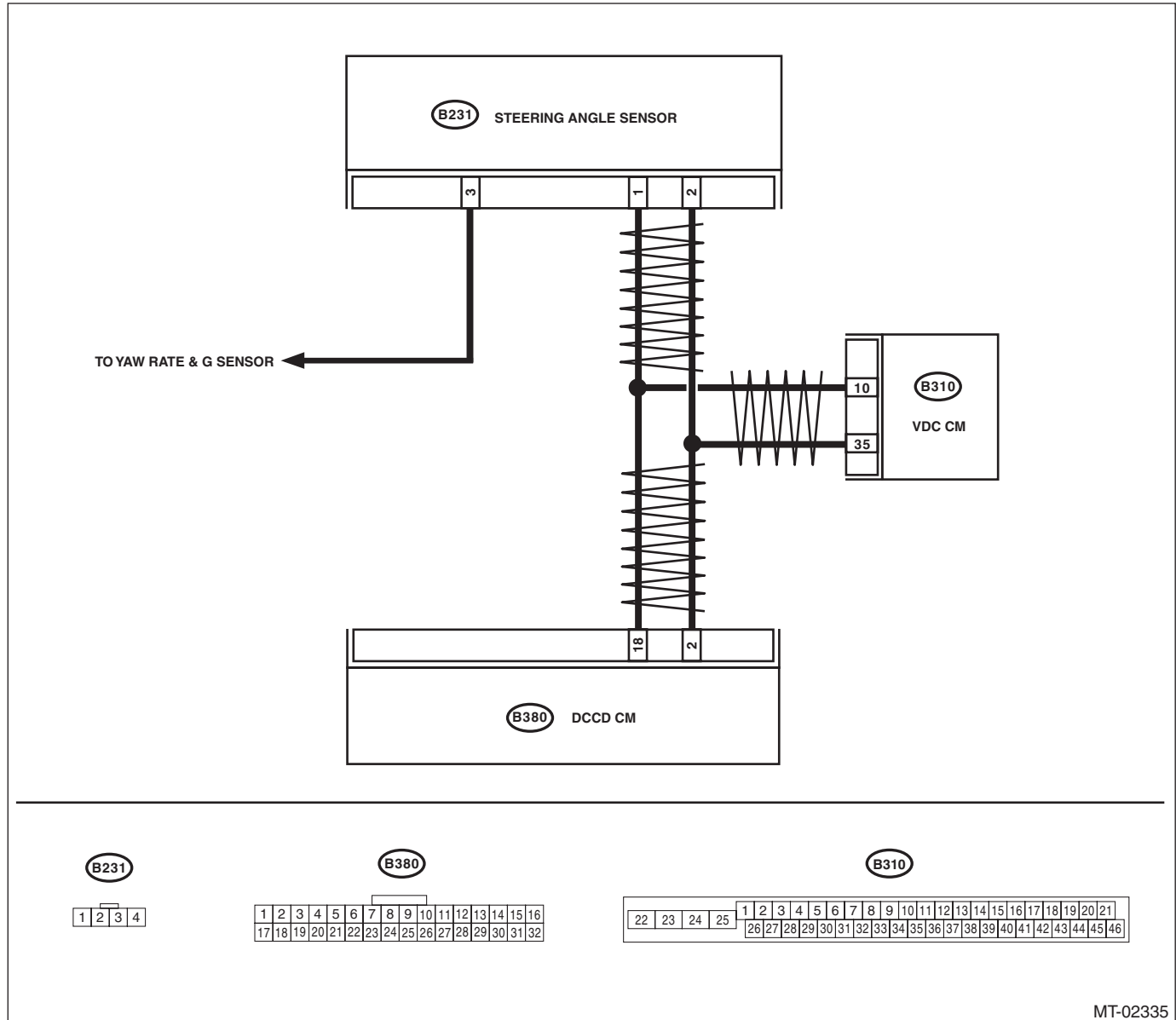

Step	Check	Yes	No	
1	<b>CHECK DTC.</b>	Does the DTC related to steering angle sensor appear in the VDC diagnostics test mode?	Perform the diagnosis according to DTC.	Go to step 2.
2	<b>CHECK IGNITION POWER SUPPLY CIRCUIT OF DCCD CONTROL MODULE.</b> 1) Connect the Subaru Select Monitor to the vehicle. 2) Turn the ignition switch to ON. 3) Read the data of «Battery voltage» using Subaru Select Monitor.	Is the voltage 11 V or more?	Go to step 3.	Repair the open circuit of harness between fuse (F/B No. 12) and DCCD control module, or between fuse (F/B No. 12) and battery.

# Diagnostic Procedure with Diagnostic Trouble Code (DTC)

MANUAL TRANSMISSION AND DIFFERENTIAL (DIAGNOSTICS)

	Step	Check	Yes	No
3	<b>CHECK DTC.</b>	Is DTC P1720 displayed?	Perform the diagnosis according to DTC.	Go to step 4.
4	<b>CHECK DCCD CONTROL MODULE.</b> 1) Turn the ignition switch to ON. 2) Read the data of «Steering Angle Sensor» using Subaru Select Monitor.	Does the Subaru Select Monitor value change according to the input from the steering to the right and left?	Go to step 5.	Go to step 6.
5	<b>CHECK DTC.</b> 1) Clear the memory. 2) Start the engine. 3) Read the DTC.	Is DTC P1767 displayed?	Replace the steering angle sensor.	Go to step 6.
6	<b>CHECK OTHER DTC.</b>	Is a DTC other than DTC P1767 displayed?	Perform the diagnosis according to DTC.	The steering angle sensor circuit is currently operating properly.

# Diagnostic Procedure with Diagnostic Trouble Code (DTC)

MANUAL TRANSMISSION AND DIFFERENTIAL (DIAGNOSTICS)

## D: DTC P1769 YAW RATE & LATERAL G SENSOR MALFUNCTION

### DIAGNOSIS:

Malfunction information transmitted from the yaw rate & G sensor

### TROUBLE SYMPTOM:

A tendency to understeer occurs during high speed cornering.

### WIRING DIAGRAM:

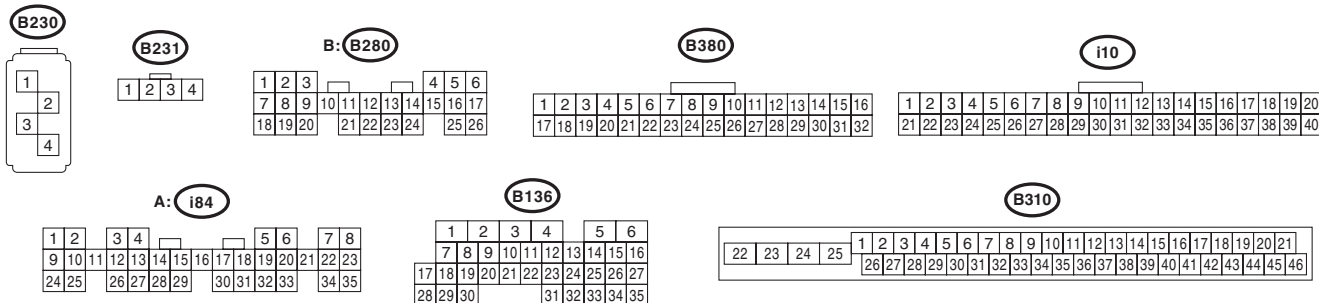
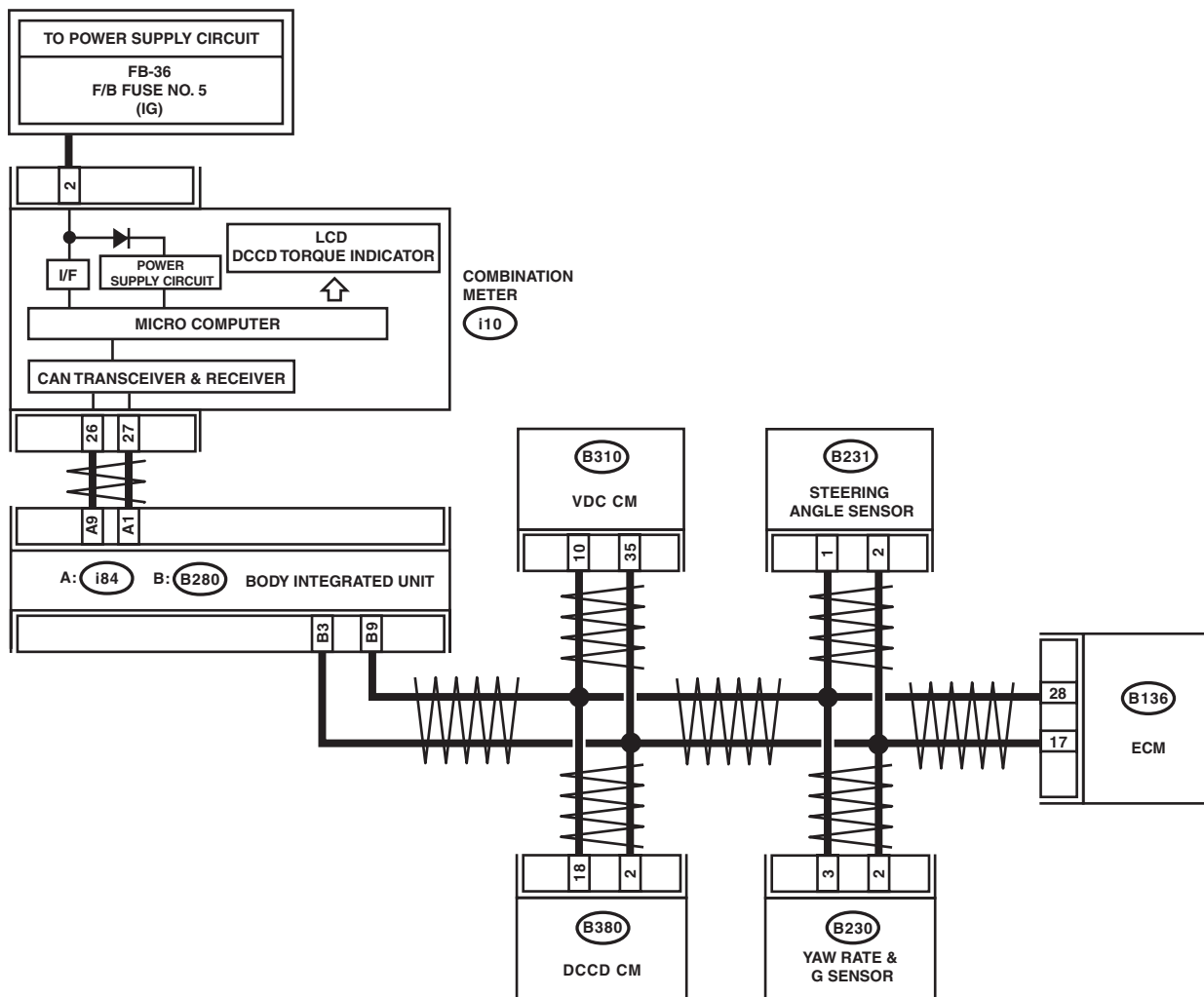

MT-02334



# Diagnostic Procedure with Diagnostic Trouble Code (DTC)

MANUAL TRANSMISSION AND DIFFERENTIAL (DIAGNOSTICS)

	Step	Check	Yes	No
1	<b>CHECK DTC.</b>	Does the DTC related to G sensor or yaw rate sensor appear in the VDC diagnostics test mode?	Perform the diagnosis according to DTC.	Go to step 2.
2	<b>CHECK IGNITION POWER SUPPLY CIRCUIT OF DCCD CONTROL MODULE.</b> 1) Connect the Subaru Select Monitor to the vehicle. 2) Turn the ignition switch to ON. 3) Read the data of «Battery voltage» using Subaru Select Monitor.	Is the voltage 11 V or more?	Go to step 3.	Repair the open circuit of harness between fuse (F/B No. 12) and DCCD control module, or between fuse (F/B No. 12) and battery.
3	<b>CHECK DTC.</b>	Is DTC P1720 displayed?	Perform the diagnosis according to DTC.	Go to step 4.
4	<b>CHECK DCCD CONTROL MODULE.</b> 1) Drive the vehicle on a flat road. 2) Stop the vehicle with the front wheels in a straight forward direction. 3) Read the data of «Yaw Rate» and «Lateral G» using the Subaru Select Monitor.	Does the yaw rate and lateral G value change according to the vehicle behavior? When the vehicle stops, is the yaw rate value within $-4 \text{ — } 4 \text{ deg/s}$ , and also is the lateral G value within $-1.5 \text{ — } 1.5 \text{ m/s}^2$ ?	Go to step 5.	Go to step 6.
5	<b>CHECK DTC.</b> 1) Clear the memory. 2) Start the engine. 3) Read the DTC.	Is DTC P1769 displayed?	Replace the yaw rate & G sensor.	Go to step 6.
6	<b>CHECK OTHER DTC.</b>	Is a DTC other than DTC P1769 displayed?	Perform the diagnosis according to DTC.	Yaw rate & G sensors are currently normal.

# Diagnostic Procedure with Diagnostic Trouble Code (DTC)

## MANUAL TRANSMISSION AND DIFFERENTIAL (DIAGNOSTICS)

### E: DTC P1875 CIRCUIT OF CENTER DIFF

#### DIAGNOSIS:

Center differential output signal circuit is open or shorted.

#### TROUBLE SYMPTOM:

- Center differential does not operate.
- The lock ratio of the center differential does not change, or malfunction occurs.
- A tight corner braking symptom occurs.
- An oversteer tendency will become apparent.
- A tendency to understeer occurs during high speed cornering.

#### WIRING DIAGRAM:

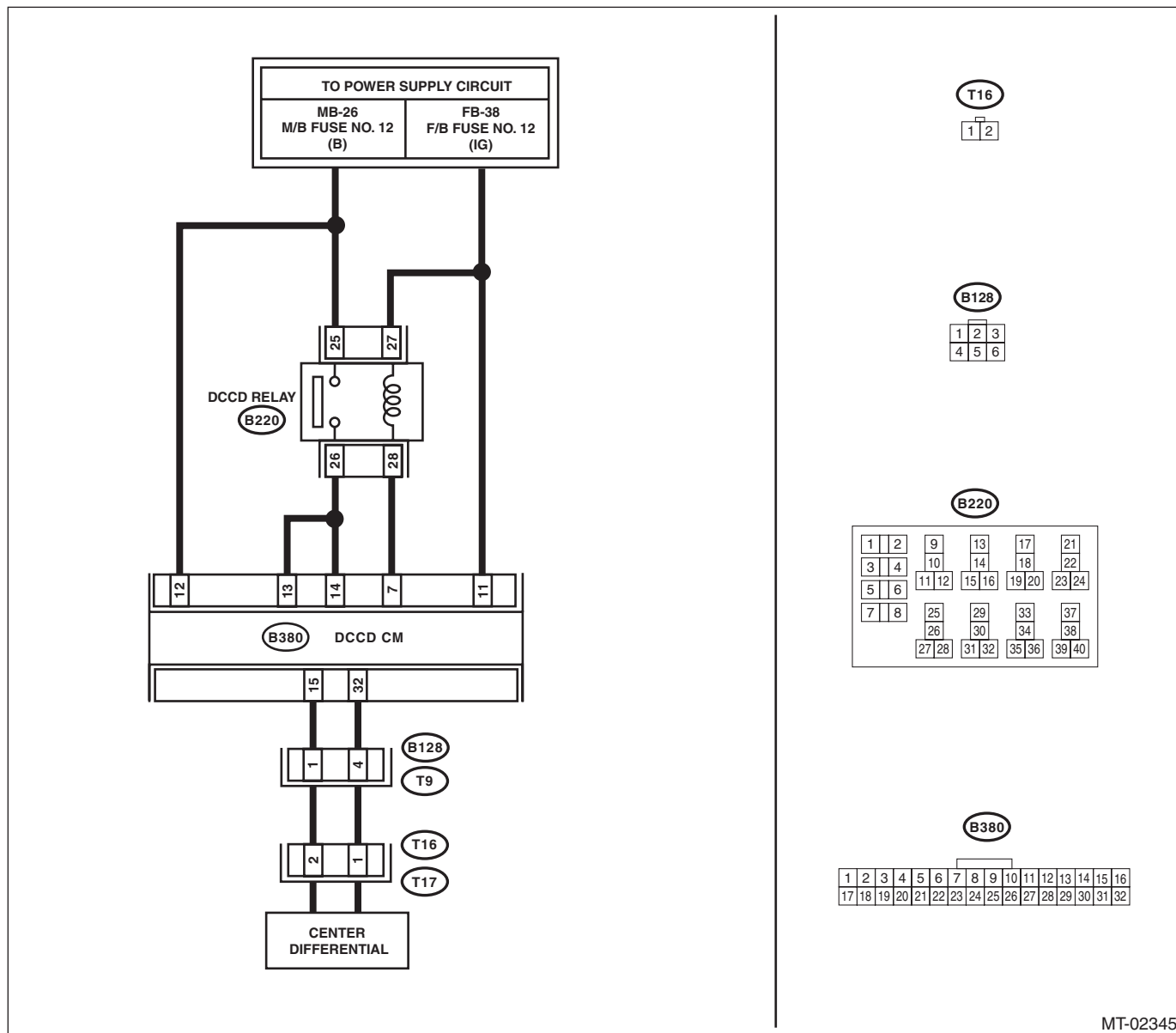

MT-02345

# Diagnostic Procedure with Diagnostic Trouble Code (DTC)

MANUAL TRANSMISSION AND DIFFERENTIAL (DIAGNOSTICS)

Step	Check	Yes	No
<p><b>1</b></p> <p><b>CHECK HARNESS BETWEEN DCCD CONTROL MODULE AND TRANSMISSION HARNESS.</b></p> <p>1) Turn the ignition switch to OFF. 2) Disconnect the DCCD control module harness connector. 3) Disconnect the transmission harness connector and the bulk harness connector. 4) Measure resistance of the harness between DCCD control module harness connector and the transmission harness connector.</p> <p><b>Connector &amp; terminal</b> <b>(B380) No. 15 — (B128) No. 1:</b> <b>(B380) No. 32 — (B128) No. 4:</b></p>	<p>Is the resistance less than 1 Ω?</p>	<p>Go to step 2.</p>	<p>Repair the bulk harness open circuit between DCCD control module and transmission harness.</p>
<p><b>2</b></p> <p><b>CHECK HARNESS BETWEEN DCCD CONTROL MODULE AND TRANSMISSION HARNESS.</b></p> <p>Measure the resistance between DCCD control module harness connector and chassis ground.</p> <p><b>Connector &amp; terminal</b> <b>(B380) No. 15 — Chassis ground:</b> <b>(B380) No. 32 — Chassis ground:</b></p>	<p>Is the resistance 1 MΩ or more?</p>	<p>Go to step 3.</p>	<p>Repair the bulk harness short circuit between DCCD control module and transmission harness.</p>
<p><b>3</b></p> <p><b>CHECK CENTER DIFFERENTIAL.</b></p> <p>Measure the resistance between transmission harness connector terminals.</p> <p><b>Connector &amp; terminal</b> <b>(T9) No. 1 — No. 4:</b></p>	<p>Is the resistance 1.2 — 2.5 Ω?</p>	<p>Go to step 4.</p>	<p>Replace the center differential.</p>
<p><b>4</b></p> <p><b>CHECK OUTPUT SIGNAL OF DCCD CONTROL MODULE.</b></p> <p>1) Connect all harness connectors. 2) Turn the ignition switch to ON. 3) Release the parking brake. 4) Press the mode change switch to enter the manual mode. 5) Press the C.DIFF +/- switch to enter the lock position. 6) Measure the voltage between DCCD control module harness connectors.</p> <p><b>Connector &amp; terminal</b> <b>(B380) No. 15 (+) — No. 32 (-):</b></p>	<p>Is the voltage 5.5 — 8.0 V?</p>	<p>Go to step 5.</p>	<p>Go to step 6.</p>
<p><b>5</b></p> <p><b>CHECK OUTPUT SIGNAL OF DCCD CONTROL MODULE.</b></p> <p>1) Move the C.DIFF +/- switch from the differential lock position to the differential free position. 2) Read the voltage between DCCD control module harness connectors.</p> <p><b>Connector &amp; terminal</b> <b>(B380) No. 15 (+) — No. 32 (-):</b></p>	<p>Does the voltage drop in stages according to the DCCD manual mode display?</p>	<p>Circuit is currently operating properly.</p>	<p>Go to step 6.</p>

# Diagnostic Procedure with Diagnostic Trouble Code (DTC)

## MANUAL TRANSMISSION AND DIFFERENTIAL (DIAGNOSTICS)

Step	Check	Yes	No
<b>6 CHECK FUSE (M/B NO. 12).</b> 1) Turn the ignition switch to OFF. 2) Remove the fuse (M/B No. 12).	Is the fuse (M/B No. 12) blown out?	Replace the fuse (M/B No. 12). If the new fuse (M/B No. 12) has blown out easily, check for the short circuit to chassis ground of harness between fuse (M/B No. 12) and DCCD control module, or between fuse (M/B No. 12) and relay.	Go to step 7.
<b>7 CHECK POWER SUPPLY CIRCUIT OF DCCD RELAY.</b> 1) Install the fuse. 2) Turn the ignition switch to OFF. 3) Disconnect the DCCD relay harness connector. 4) Measure the voltage between DCCD relay harness connector and chassis ground. <i>Connector &amp; terminal</i> <i>(B220) No. 25 (+) — Chassis ground (-):</i>	Is the voltage 10 V or more?	Go to step 8.	Repair the open or short circuit between fuse (M/B No. 12), DCCD relay, and battery.
<b>8 CHECK IGNITION POWER SUPPLY CIRCUIT OF DCCD RELAY.</b> 1) Turn the ignition switch to ON. 2) Measure the voltage between DCCD relay and chassis ground. <i>Connector &amp; terminal</i> <i>(B220) No. 27 (+) — Chassis ground (-):</i>	Is the voltage 10 V or more?	Go to step 9.	Repair the open circuit between fuse (F/B No. 12), DCCD relay, and battery.
<b>9 CHECK HARNESS BETWEEN DCCD CONTROL MODULE AND DCCD RELAY.</b> 1) Turn the ignition switch to OFF. 2) Disconnect the connector from DCCD control module. 3) Measure resistance of the harness between DCCD control module connector and DCCD relay connector. <i>Connector &amp; terminal</i> <i>(B380) No. 7 — (B220) No. 28:</i> <i>(B380) No. 13 — (B220) No. 26:</i> <i>(B380) No. 14 — (B220) No. 26:</i>	Is the resistance less than 1 $\Omega$ ?	Go to step 10.	Repair the open circuit of harness between DCCD control module connector and DCCD relay connector.
<b>10 CHECK HARNESS BETWEEN DCCD CONTROL MODULE AND DCCD RELAY.</b> Measure the resistance of harness between DCCD control module connector and chassis ground. <i>Connector &amp; terminal</i> <i>(B380) No. 7 — Chassis ground:</i> <i>(B380) No. 13 — Chassis ground:</i> <i>(B380) No. 14 — Chassis ground:</i>	Is the resistance 1 M $\Omega$ or more?	Go to step 11.	Repair the short circuit of harness between DCCD control module connector and DCCD relay connector.
<b>11 CHECK DCCD RELAY.</b> Measure the resistance between DCCD relay terminals. <i>Connector &amp; terminal</i> <i>(B220) No. 25 — No. 26:</i>	Is the resistance 1 M $\Omega$ or more?	Go to step 12.	Replace the DCCD relay.

# Diagnostic Procedure with Diagnostic Trouble Code (DTC)

MANUAL TRANSMISSION AND DIFFERENTIAL (DIAGNOSTICS)

Step	Check	Yes	No
<b>12 CHECK DCCD RELAY.</b> Connect the battery positive lead to terminal No. 27 and the negative lead to terminal No. 28, then measure the resistance between DCCD relay terminals. <b>Connector &amp; terminal</b> <b>(B220) No. 25 — No. 26:</b>	Is the resistance less than 1 $\Omega$ ?	Go to step 13.	Replace the DCCD relay.
<b>13 CHECK DCCD CONTROL MODULE RELAY DRIVE CIRCUIT.</b> 1) Connect all connectors. 2) Turn the ignition switch to ON. 3) Measure the voltage between DCCD control module and chassis ground. <b>Connector &amp; terminal</b> <b>(B380) No. 7 (+) — Chassis ground (-):</b>	Is the voltage less than 1 V?	Go to step 14.	Go to step 17.
<b>14 CHECK IGNITION POWER SUPPLY CIRCUIT OF DCCD CONTROL MODULE.</b> Measure the voltage between DCCD control module and chassis ground. <b>Connector &amp; terminal</b> <b>(B380) No. 13 (+) — Chassis ground (-):</b> <b>(B380) No. 14 (+) — Chassis ground (-):</b>	Is the voltage 8 V or more?	Go to step 15.	Go to step 17.
<b>15 CHECK CENTER DIFFERENTIAL.</b> 1) Turn the ignition switch to OFF. 2) Connect the Subaru Select Monitor to data link connector. 3) Turn the ignition switch to ON. 4) Run the Subaru Select Monitor. 5) Press the mode change switch to enter the manual mode. 6) Release the parking brake. 7) Press the C.DIFF +/- switch to enter the lock position. 8) Read the data of «C-Diff. Indicate Current» and «C-Diff. Real Current» using Subaru Select Monitor.	Are «C-Diff. Indicate Current» and «C-Diff. Real Current» both approximately 3.6 — 4.0 A?	Go to step 16.	Go to step 17.
<b>16 CHECK CENTER DIFFERENTIAL.</b> 1) Using Subaru Select Monitor, operate the C.DIFF +/- switch so that «C-Diff. Indicate Current» becomes 1.6A. 2) Read the data of «C-Diff. Real Current» using Subaru Select Monitor.	Is «C-Diff. Real Current» about the same as «C-Diff. Indicate Current»?	Go to step 18.	Go to step 17.
<b>17 CHECK POOR CONTACT OF HARNESS CONNECTORS.</b>	Is there poor contact of the harness connector?	Repair the poor contact.	Go to step 18.
<b>18 CHECK DTC.</b> 1) Clear the memory. <Ref. to 6MT(diag)-13, Clear Memory Mode.> 2) Read the DTC using the Select Monitor. <Ref. to 6MT(diag)-12, Read Diagnostic Trouble Code (DTC).>	Is P1875 displayed?	Check the poor contact.	Go to step 19.
<b>19 CHECK DTC.</b>	Are DTCs other than P1875 displayed?	Perform the diagnosis according to DTC.	The center differential circuit is currently operating properly.

# Diagnostic Procedure without Diagnostic Trouble Code (DTC)

MANUAL TRANSMISSION AND DIFFERENTIAL (DIAGNOSTICS)

## 14. Diagnostic Procedure without Diagnostic Trouble Code (DTC)

### A: CHECK REAR DIFFERENTIAL OIL TEMPERATURE SWITCH

#### DIAGNOSIS:

Input signal circuit of rear differential oil temperature switch is open or shorted.

#### TROUBLE SYMPTOM:

- Center differential remains free
- An oversteer tendency will become apparent.
- Rear differential oil temperature warning light illuminates.

#### WIRING DIAGRAM:

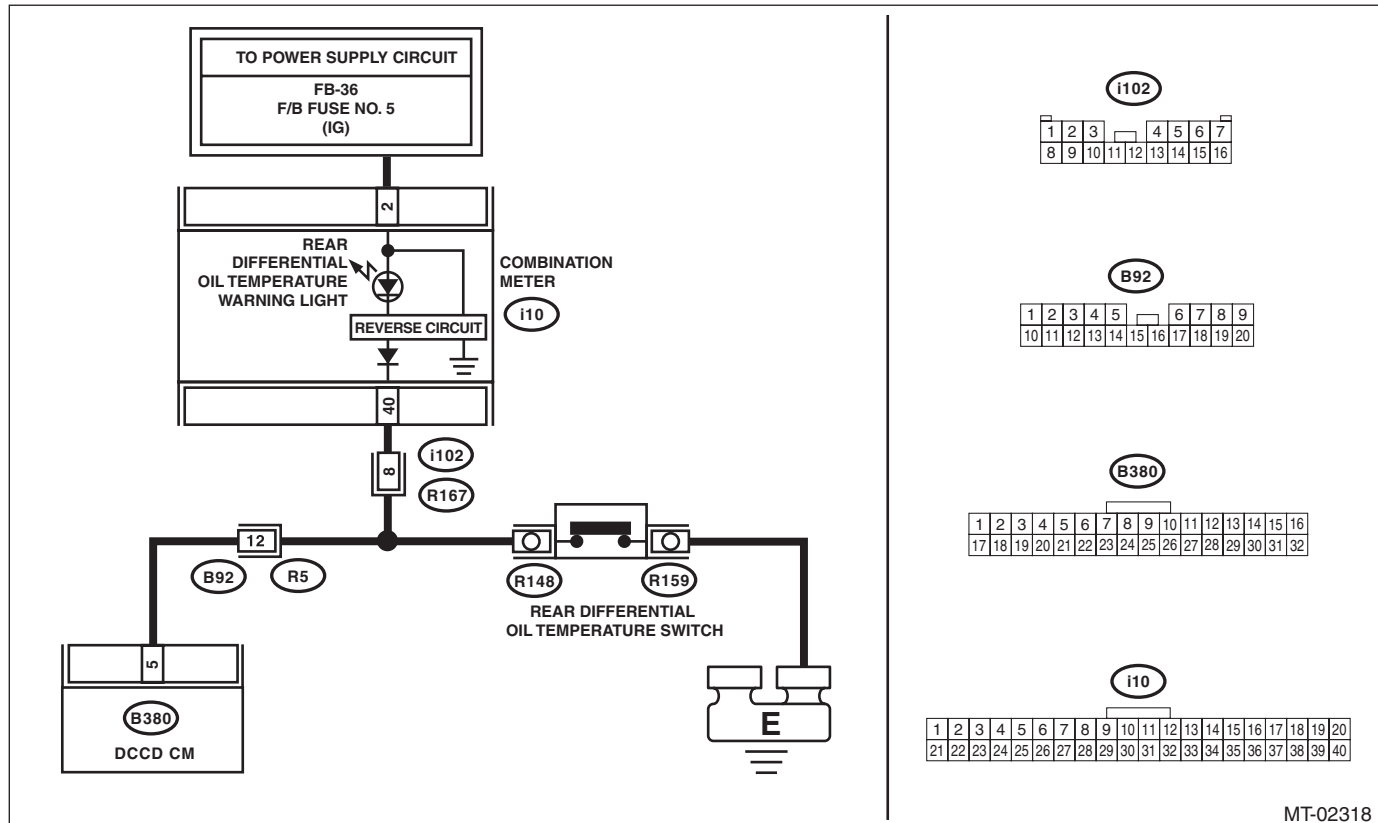

MT-02318

Step	Check	Yes	No
<p><b>1 CHECK REAR DIFFERENTIAL OIL TEMPERATURE SWITCH WARNING LIGHT CIRCUIT.</b></p> <p>1) Turn the ignition switch to OFF.                      2) Disconnect the DCCD control module harness connector.                      3) Turn the ignition switch to ON.                      4) Measure the voltage of the rear differential oil temperature switch.</p> <p><b>Connector &amp; terminal</b>  <b>(B380) No. 5 (+) — Chassis ground (-):</b></p>	Is the voltage less than 0.4 V?	Go to step 6.	Go to step 2.

# Diagnostic Procedure without Diagnostic Trouble Code (DTC)

MANUAL TRANSMISSION AND DIFFERENTIAL (DIAGNOSTICS)

Step	Check	Yes	No
<b>2 CHECK HARNESS BETWEEN DCCD CONTROL MODULE AND COMBINATION METER.</b> 1) Turn the ignition switch to OFF. 2) Disconnect the harness connector from the combination meter. 3) Disconnect the connector from the rear differential oil temperature switch. 4) Measure the resistance between combination meter and DCCD control module harness connectors.  <b>Connector &amp; terminal</b> <b>(B380) No. 5 — (i10) No. 40:</b>	Is the resistance less than 1 $\Omega$ ?	Go to step 3.	Repair the open circuit between DCCD control module and the combination meter.
<b>3 CHECK HARNESS BETWEEN DCCD CONTROL MODULE AND REAR DIFFERENTIAL OIL TEMPERATURE SWITCH.</b> Measure the resistance between DCCD control module harness connector and rear differential oil temperature switch harness connector.  <b>Connector &amp; terminal</b> <b>(B380) No. 5 — (R148) No. 1:</b>	Is the resistance less than 1 $\Omega$ ?	Go to step 4.	Repair the open circuit between DCCD control module and rear differential oil temperature switch.
<b>4 CHECK REAR DIFFERENTIAL OIL TEMPERATURE SWITCH GROUND CIRCUIT.</b> 1) Disconnect the harness connector from the bracket ground of the rear differential. 2) Measure the resistance between the rear differential oil temperature switch ground harness connector and chassis ground.  <b>Connector &amp; terminal</b> <b>(R159) No. 1 — Chassis ground:</b>	Is the resistance 1 M $\Omega$ or more?	Repair the open circuit of the rear differential oil temperature ground circuit, and contact failure of the harness connector.	Go to step 5.
<b>5 CHECK REAR DIFFERENTIAL OIL TEMPERATURE SWITCH.</b> Measure the resistance between the rear differential oil temperature switch and the rear differential oil temperature switch body.  <b>Connector &amp; terminal</b> <b>(R148) No. 1 — Rear differential oil temperature switch body:</b>	Is the resistance less than 1 $\Omega$ ?	Go to step 6.	Replace the rear differential oil temperature switch.
<b>6 CHECK REAR DIFFERENTIAL OIL TEMPERATURE WARNING LIGHT.</b> 1) Turn the ignition switch to ON. 2) Short the chassis ground and the combination meter harness connector.  <b>Connector &amp; terminal</b> <b>(i10) No. 40 (+) — Chassis ground (-):</b>	Does the rear differential oil temperature light turn OFF?	Check the poor contact.	Check the combination meter.

# Diagnostic Procedure without Diagnostic Trouble Code (DTC)

## MANUAL TRANSMISSION AND DIFFERENTIAL (DIAGNOSTICS)

### B: CHECK PARKING BRAKE SWITCH

#### DIAGNOSIS:

Input signal circuit of parking brake switch is open or shorted.

#### TROUBLE SYMPTOM:

- It does not show a differential free tendency even when the parking brake switch is applied.
- Remains differential free even when the parking brake switch is released.

#### WIRING DIAGRAM:

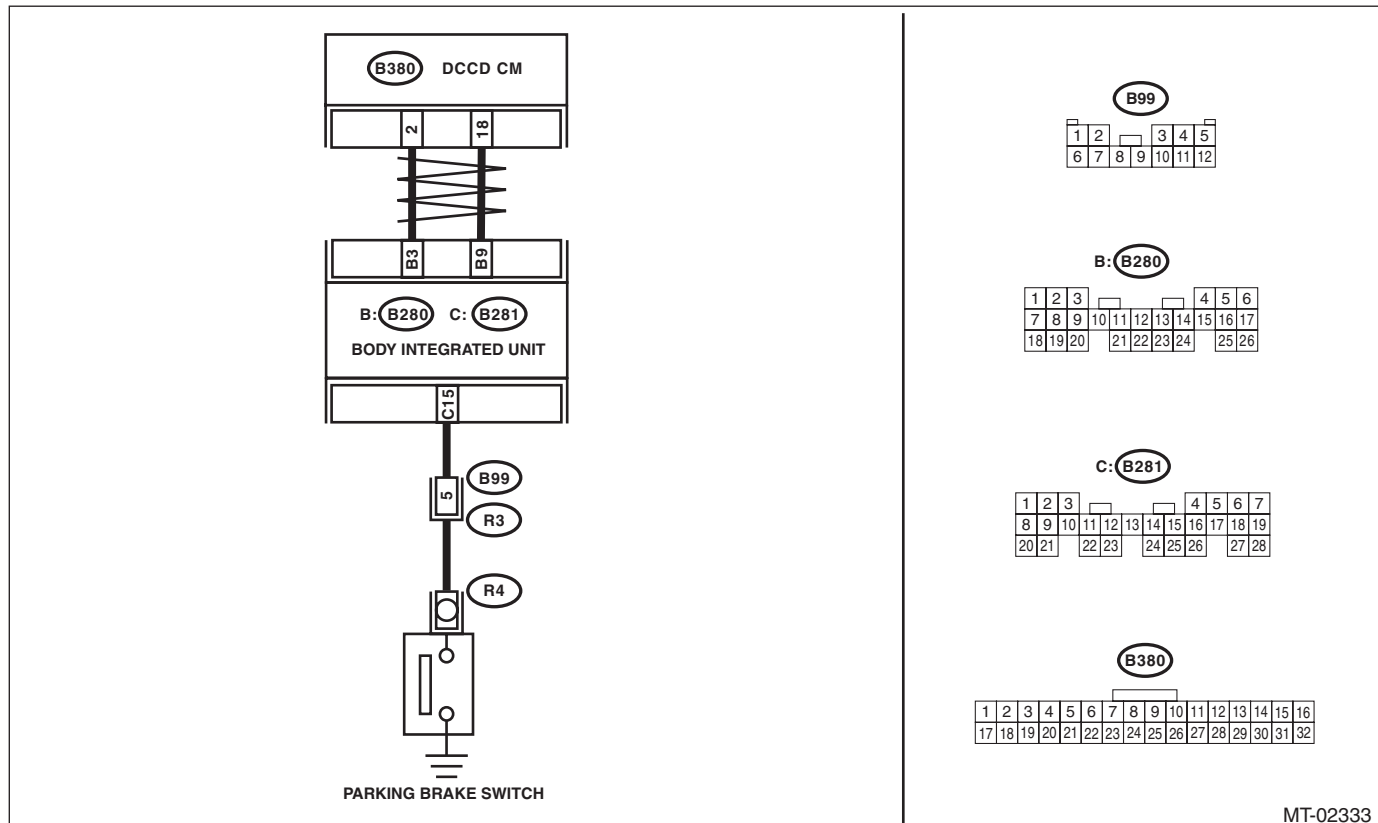

MT-02333

Step	Check	Yes	No	
1	<b>CHECK IGNITION CIRCUIT OF DCCD CONTROL MODULE.</b> 1) Connect the Subaru Select Monitor to the vehicle. 2) Turn the ignition switch to ON. 3) Read the data of «Battery voltage» using Subaru Select Monitor.	Is the voltage 11 V or more?	Go to step 2.	Repair the open circuit of harness between fuse (F/B No. 12) and DCCD control module, or between fuse (F/B No. 12) and battery.
2	<b>CHECK DTC.</b>	Is DTC P1720 displayed?	Perform the diagnosis according to DTC.	Go to step 3.
3	<b>CHECK DCCD CONTROL MODULE.</b> 1) Operate the parking brake lever. 2) Read the data of «Parking Position Switch» using Subaru Select Monitor.	Is the ON/OFF normally detected?	The parking brake switch circuit is currently operating properly.	Go to step 4.
4	<b>CHECK BODY INTEGRATED UNIT.</b> 1) Operate the parking brake lever. 2) Read the data of «Parking Position Switch» using Subaru Select Monitor.	Is the ON/OFF normally detected?	Go to step 7.	Go to step 5.



# Diagnostic Procedure without Diagnostic Trouble Code (DTC)

MANUAL TRANSMISSION AND DIFFERENTIAL (DIAGNOSTICS)

Step	Check	Yes	No
<b>5</b> <b>CHECK HARNESS BETWEEN BODY INTEGRATED UNIT AND PARKING BRAKE SWITCH.</b> 1) Turn the ignition switch to OFF. 2) Disconnect the connector from body integrated unit. 3) Check for open circuit, short circuit to battery and short circuit to ground between the body integrated unit connector and parking brake switch connector. <b>Connector &amp; terminal</b> <b>(B281) No. 15 — (R4) No. 1:</b>	Is the harness normal?	Go to step 6.	Repair or replace the harness.
<b>6</b> <b>CHECK PARKING BRAKE SWITCH.</b> Measure the resistance between parking brake switch terminals.	Is the resistance less than 10 $\Omega$ when the parking brake lever is pulled? Is the resistance 1 M $\Omega$ or more when the parking brake lever is lowered?	Replace the body integrated unit.	Replace the parking brake switch.
<b>7</b> <b>CHECK DTC.</b> Check DTC of body integrated unit.	Is the DTC related to CAN displayed?	Perform the diagnosis according to DTC.	Check the poor contact of DCCD system.

# Diagnostic Procedure without Diagnostic Trouble Code (DTC)

## MANUAL TRANSMISSION AND DIFFERENTIAL (DIAGNOSTICS)

### C: CHECK DCCD MULTI SELECT SWITCH

#### DIAGNOSIS:

Input signal of DCCD multi select switch is open or shorted.

#### TROUBLE SYMPTOM:

- Does not enter the manual mode or auto mode when the mode change switch is pressed.
- Mode does not change in AUTO mode.
- Initial torque can not be changed in manual mode.

#### NOTE:

Other switch input can not be received if either mode change switch or C.DIFF +/- switch is stuck ON.

#### WIRING DIAGRAM:

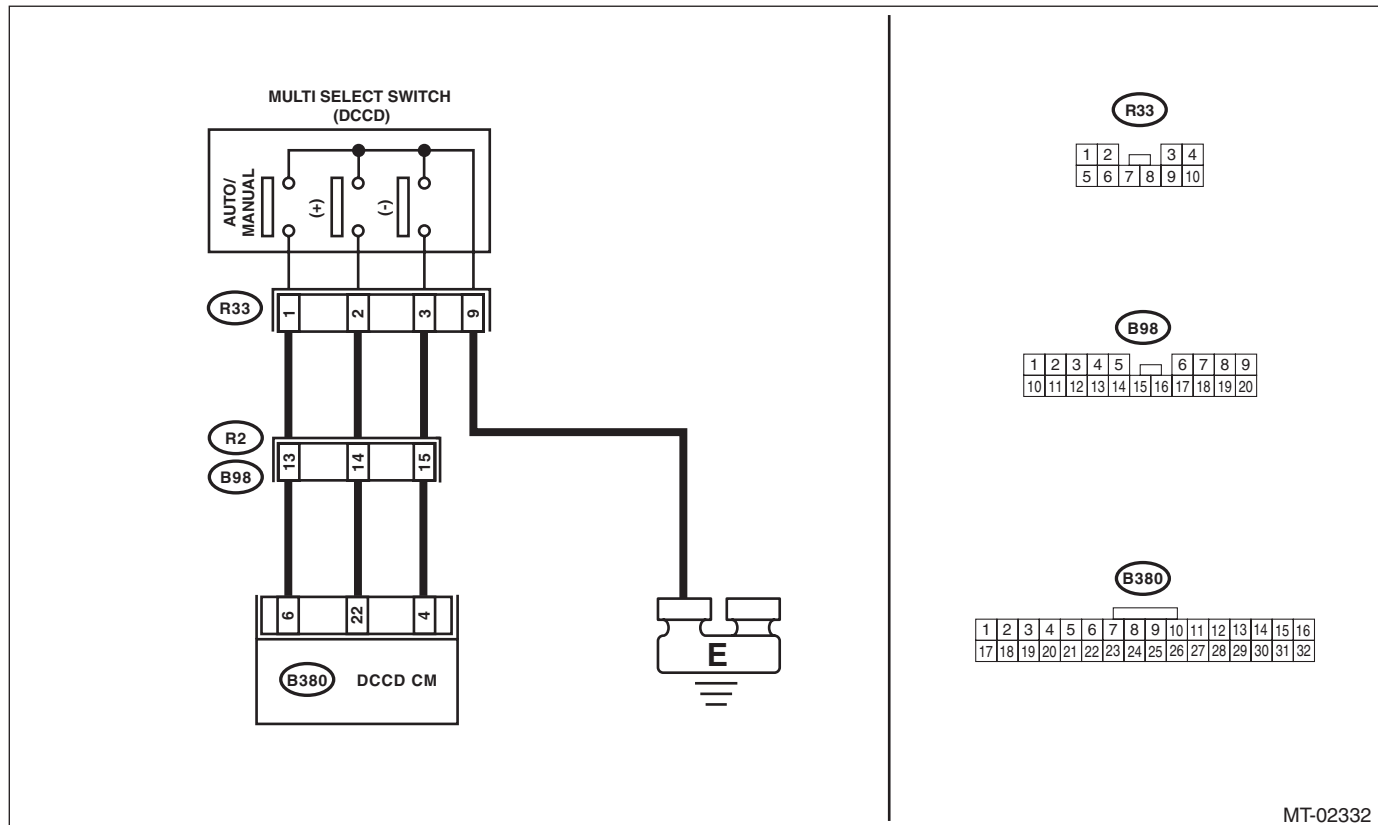

MT-02332

Step	Check	Yes	No
<b>1 CHECK DCCD CONTROL MODULE.</b> 1) Display the current data «AUTO/MANUAL Mode Switch» of DCCD control module, using Subaru Select Monitor. 2) Press the manual mode change switch.	Does the data change from OFF/ON?	Go to step 2.	Go to step 4.
<b>2 CHECK DCCD CONTROL MODULE.</b> 1) Display the current data «Up Switch» of DCCD control module, using Subaru Select Monitor. 2) Push the multi select switch toward plus.	Does the data change from OFF/ON?	Go to step 3.	Go to step 5.
<b>3 CHECK DCCD CONTROL MODULE.</b> 1) Display the current data «Down Switch» of DCCD control module, using Subaru Select Monitor. 2) Push the multi select switch toward minus.	Does the data change from OFF/ON?	The switch circuit is normal.	Go to step 6.

# Diagnostic Procedure without Diagnostic Trouble Code (DTC)

MANUAL TRANSMISSION AND DIFFERENTIAL (DIAGNOSTICS)

Step	Check	Yes	No
<b>4 CHECK MODE CHANGE SWITCH.</b> 1) Disconnect the multi select switch connector. 2) Press the mode change switch. 3) Using the tester, measure the resistance between terminals. <b>Connector &amp; terminal</b> <b>(R33) No. 1 — No. 9:</b>	Is the resistance less than 1 Ω?	Go to step 7.	Replace the multi select switch. <Ref. to FU(STI)-58, SI-DRIVE (SUBARU Intelligent Drive) Selector.>
<b>5 CHECK MULTI SELECT SWITCH.</b> 1) Push the multi select switch toward plus. 2) Using the tester, measure the resistance between terminals. <b>Connector &amp; terminal</b> <b>(R33) No. 2 — No. 9:</b>	Is the resistance less than 1 Ω?	Go to step 7.	Replace the multi select switch. <Ref. to FU(STI)-58, SI-DRIVE (SUBARU Intelligent Drive) Selector.>
<b>6 CHECK MULTI SELECT SWITCH.</b> 1) Push the multi select switch toward minus. 2) Using the tester, measure the resistance between terminals. <b>Connector &amp; terminal</b> <b>(R33) No. 3 — No. 9:</b>	Is the resistance less than 1 Ω?	Go to step 7.	Replace the multi select switch. <Ref. to FU(STI)-58, SI-DRIVE (SUBARU Intelligent Drive) Selector.>
<b>7 CHECK HARNESS.</b> Use a tester to measure the resistance between the multi select switch harness connector and chassis ground. <b>Connector &amp; terminal</b> <b>(R33) No. 9 — Chassis ground:</b>	Is the resistance less than 1 Ω?	Go to step 8.	Repair or replace the ground circuit.
<b>8 CHECK HARNESS.</b> 1) Disconnect the connector from DCCD control module. 2) Use a tester to measure the resistance between the DCCD control module and the multi select switch. <b>Connector &amp; terminal</b> <b>(R33) No. 1 — (B380) No. 6:</b> <b>(R33) No. 2 — (B380) No. 22:</b> <b>(R33) No. 3 — (B380) No. 4:</b>	Is the resistance less than 1 Ω?	Go to step 9.	Repair or replace the open circuit of the harness.
<b>9 CHECK HARNESS.</b> Using the tester, measure the resistance between terminals. <b>Connector &amp; terminal</b> <b>(R33) No. 1 — (R33) No. 2:</b> <b>(R33) No. 1 — (R33) No. 3:</b> <b>(R33) No. 3 — (R33) No. 2:</b>	Is the resistance 1 MΩ or more?	Go to step 10.	Repair or replace the short of harness.
<b>10 CHECK HARNESS.</b> Using the tester, measure the resistance between terminals. <b>Connector &amp; terminal</b> <b>(R33) No. 1 — Chassis ground:</b> <b>(R33) No. 2 — Chassis ground:</b> <b>(R33) No. 3 — Chassis ground:</b>	Is the resistance 1 MΩ or more?	Check the poor contact.	Repair or replace the short of harness.

## Diagnostics with Phenomenon

MANUAL TRANSMISSION AND DIFFERENTIAL (DIAGNOSTICS)

### 15. Diagnostics with Phenomenon

#### A: INSPECTION

Symptoms	Faulty parts
A tight corner braking symptom occurs.	<ul style="list-style-type: none"> <li>• VDCCM&amp;H/U</li> <li>• ABS wheel speed sensor</li> <li>• Yaw rate &amp; G sensor</li> <li>• Steering angle sensor</li> <li>• CAN communication signal</li> <li>• Center differential</li> <li>• C.DIFF +/- switch</li> <li>• Mode change switch</li> <li>• Tire/Wheel</li> <li>• DCCD control module</li> <li>• ECM</li> <li>• Body integrated unit</li> </ul>
An oversteer tendency will become apparent.	<ul style="list-style-type: none"> <li>• Throttle position sensor</li> <li>• ECM</li> <li>• C.DIFF +/- switch</li> <li>• Mode change switch</li> <li>• Tire/Wheel</li> <li>• DCCD control module</li> <li>• Center differential</li> <li>• DCCD relay</li> <li>• Rear differential oil temperature switch</li> <li>• Neutral position switch</li> <li>• Steering angle sensor</li> <li>• VDCCM&amp;H/U</li> <li>• CAN communication signal</li> <li>• Body integrated unit</li> <li>• Yaw rate &amp; G sensor</li> </ul>
A tendency to understeer occurs during high speed cornering.	<ul style="list-style-type: none"> <li>• VDCCM&amp;H/U</li> <li>• ABS wheel speed sensor</li> <li>• CAN communication signal</li> <li>• Throttle position sensor</li> <li>• Yaw rate &amp; G sensor</li> <li>• Center differential</li> <li>• ECM</li> <li>• Engine speed signal</li> <li>• Neutral position switch</li> <li>• Steering angle sensor</li> <li>• Body integrated unit</li> </ul>
Torque characteristics of the center differential do not change.	<ul style="list-style-type: none"> <li>• C.DIFF +/- switch</li> <li>• DCCD relay</li> <li>• Center differential</li> <li>• DCCD control module</li> </ul>
DCCD indicator does not operate. (is not displayed)	<ul style="list-style-type: none"> <li>• Combination meter</li> <li>• DCCD control module</li> </ul>
DCCD indicator does not operate even when the C.DIFF +/- switch is operated. (Displayed but does not change. or, the display blinks.)	<ul style="list-style-type: none"> <li>• C.DIFF +/- switch</li> <li>• Combination meter</li> <li>• DCCD control module</li> </ul>
DCCD AUTO mode does not operate even when the C.DIFF +/- switch is operated. (Displayed but does not change.)	<ul style="list-style-type: none"> <li>• Mode change switch</li> <li>• Combination meter</li> <li>• DCCD control module</li> <li>• Body integrated unit</li> <li>• CAN communication signal</li> </ul>

# Diagnostics with Phenomenon

## MANUAL TRANSMISSION AND DIFFERENTIAL (DIAGNOSTICS)

Symptoms	Faulty parts
DCCD AUTO mode display does not illuminate.	<ul style="list-style-type: none"> <li>• Mode change switch</li> <li>• Combination meter</li> <li>• DCCD control module</li> <li>• Body integrated unit</li> <li>• CAN communication signal</li> </ul>
Will not become differential free or remains differential free.	<ul style="list-style-type: none"> <li>• Parking brake switch</li> <li>• Center differential</li> <li>• Mode change switch</li> <li>• C.DIFF +/- switch</li> <li>• Rear differential</li> <li>• Tire/Wheel</li> <li>• DCCD relay</li> <li>• Rear differential oil temperature switch</li> <li>• DCCD control module</li> <li>• ECM</li> <li>• Body integrated unit</li> <li>• VDCCM&amp;H/U</li> <li>• Yaw rate &amp; G sensor</li> <li>• CAN communication signal</li> </ul>
ABS does not operate.	<ul style="list-style-type: none"> <li>• VDCCM&amp;H/U</li> <li>• CAN communication signal</li> <li>• Stop light switch</li> <li>• DCCD control module</li> <li>• ECM</li> <li>• Body integrated unit</li> <li>• Yaw rate &amp; G sensor</li> </ul>
Will not lock the differential or the differential is continually locked.	<ul style="list-style-type: none"> <li>• VDCCM&amp;H/U</li> <li>• ABS wheel speed sensor</li> <li>• CAN communication signal</li> <li>• Center differential</li> <li>• C.DIFF +/- switch</li> <li>• Mode change switch</li> <li>• Tire/Wheel</li> <li>• DCCD control module</li> <li>• DCCD relay</li> <li>• ECM</li> <li>• Body integrated unit</li> <li>• Yaw rate &amp; G sensor</li> </ul>

# Diagnostics with Phenomenon

MANUAL TRANSMISSION AND DIFFERENTIAL (DIAGNOSTICS)

---

**6MT(diag)-40**

Brought to you by Ebay Seller "SubaruManuals"

# CLUTCH SYSTEM

# CL

---

	<b>Page</b>
1. General Description .....	2
2. Clutch Disc and Cover .....	11
3. Flywheel .....	14
4. Release Bearing and Lever .....	15
5. Operating Cylinder .....	19
6. Master Cylinder .....	22
7. Clutch Pipe and Hose .....	25
8. Clutch Fluid .....	26
9. Clutch Fluid Air Bleeding .....	27
10. Clutch Pedal .....	29
11. Clutch Switch .....	33
12. General Diagnostic Table .....	36

# General Description

## CLUTCH SYSTEM

### 1. General Description

#### A: SPECIFICATION

Model		STI	Except for STI
Transmission type		6MT	5MT
Clutch cover	Type	Pull type	Push type
	Diaphragm set load N (kgf, lbf)	9,120 (930, 2051)	7,450 (760, 1,675)
Clutch disc	Facing material		Woven (Non-asbestos)
	O.D. × I.D. × thickness mm (in)	Clutch cover side	240 × 160 × 3.5 (9.45 × 6.30 × 0.138)
		Flywheel side	240 × 160 × 3.2 (9.45 × 6.30 × 0.126)
	Splines outer diameter mm (in)		25.2 (0.992), (Number of teeth: 24)
	Depth of rivet head mm (in)	Clutch cover side	1.65 — 2.25 (0.065 — 0.089)
		Flywheel side	1.35 — 1.95 (0.053 — 0.077)
		Limit of sinking	0.3 (0.012)
Deflection limit mm (in)		0.7 (0.028) at R = 115 (4.53)	0.7 (0.028) at R = 110 (4.33)
Release bearing		Grease-packed self-aligning	
Clutch pedal	Full stroke mm (in)	130 — 135 (5.12 — 5.31)	135 — 140 (5.31 — 5.51)
	Free play mm (in)	5 — 11 (0.20 — 0.43)	
Flywheel	Type	Conventional	Flexible



## B: COMPONENT

### 1. CLUTCH ASSEMBLY

- STI model

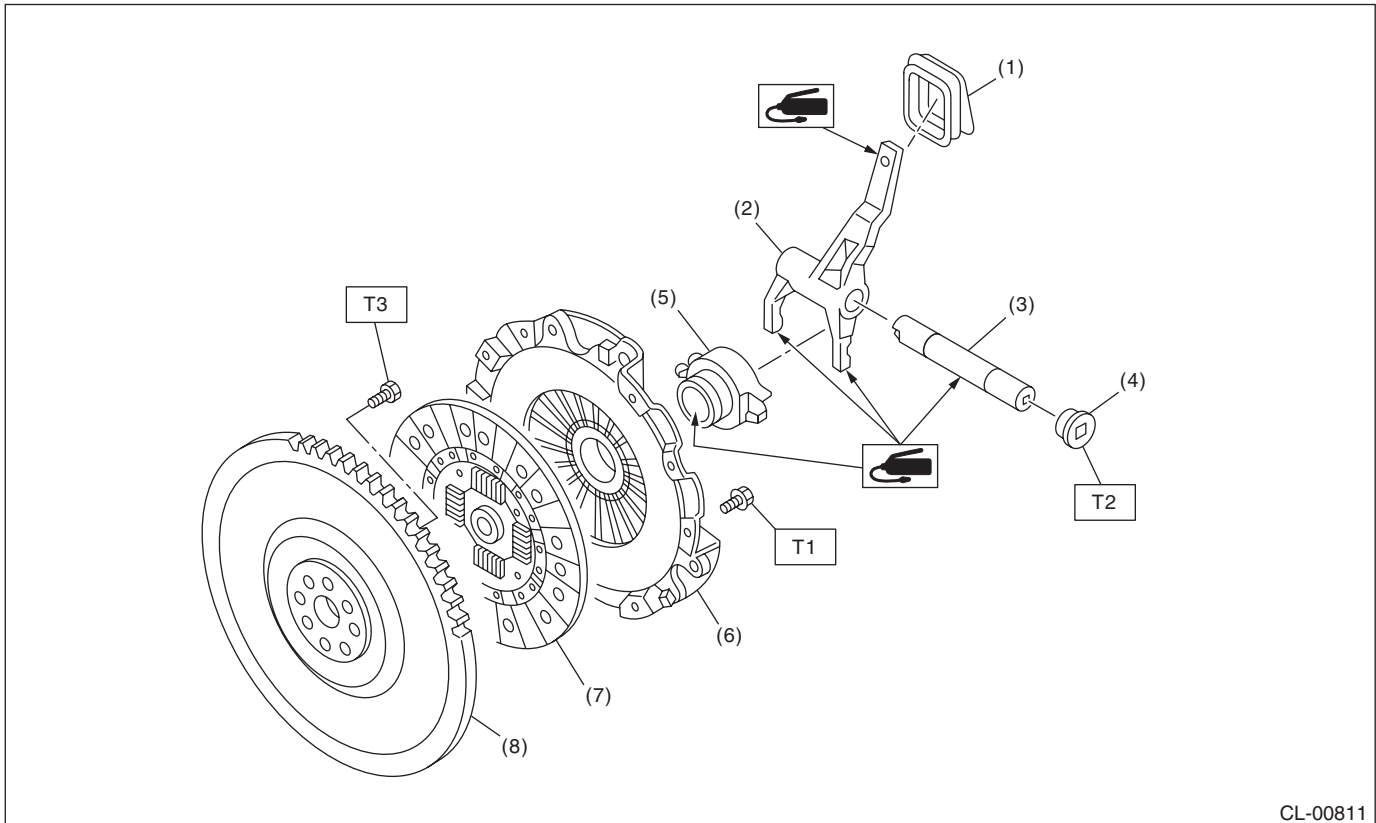

CL-00811

- |                                |                           |
|--------------------------------|---------------------------|
| (1) Dust cover                 | (5) Release bearing       |
| (2) Release lever              | (6) Clutch cover          |
| (3) Clutch release lever shaft | (7) Clutch disc           |
| (4) Plug                       | (8) Conventional flywheel |

**Tightening torque: N·m (kgf·m, ft·lb)**

**T1: 16 (1.6, 11.8)**

**T2: 48 (4.9, 35.4)**

**T3: 75 (7.6, 55.3)**

# General Description

## CLUTCH SYSTEM

- Except for STI model

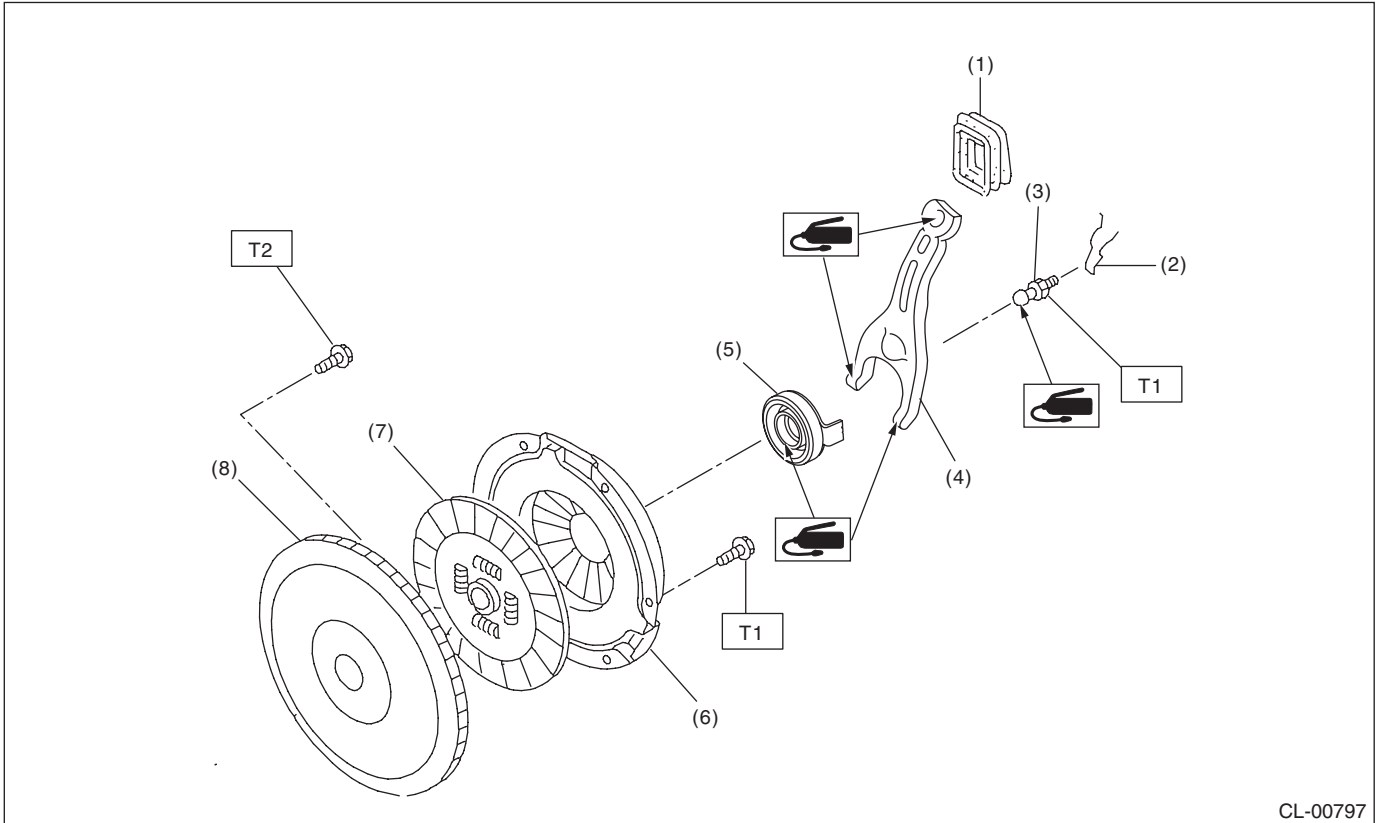

CL-00797

- |                   |                     |
|-------------------|---------------------|
| (1) Dust cover    | (5) Release bearing |
| (2) Lever spring  | (6) Clutch cover    |
| (3) Pivot         | (7) Clutch disc     |
| (4) Release lever | (8) Flywheel        |

**Tightening torque: N·m (kgf·m, ft·lb)**

**T1: 16 (1.6, 11.8)**

**T2: 75 (7.6, 55.3)**

### 2. CLUTCH PIPE AND HOSE

- STI model

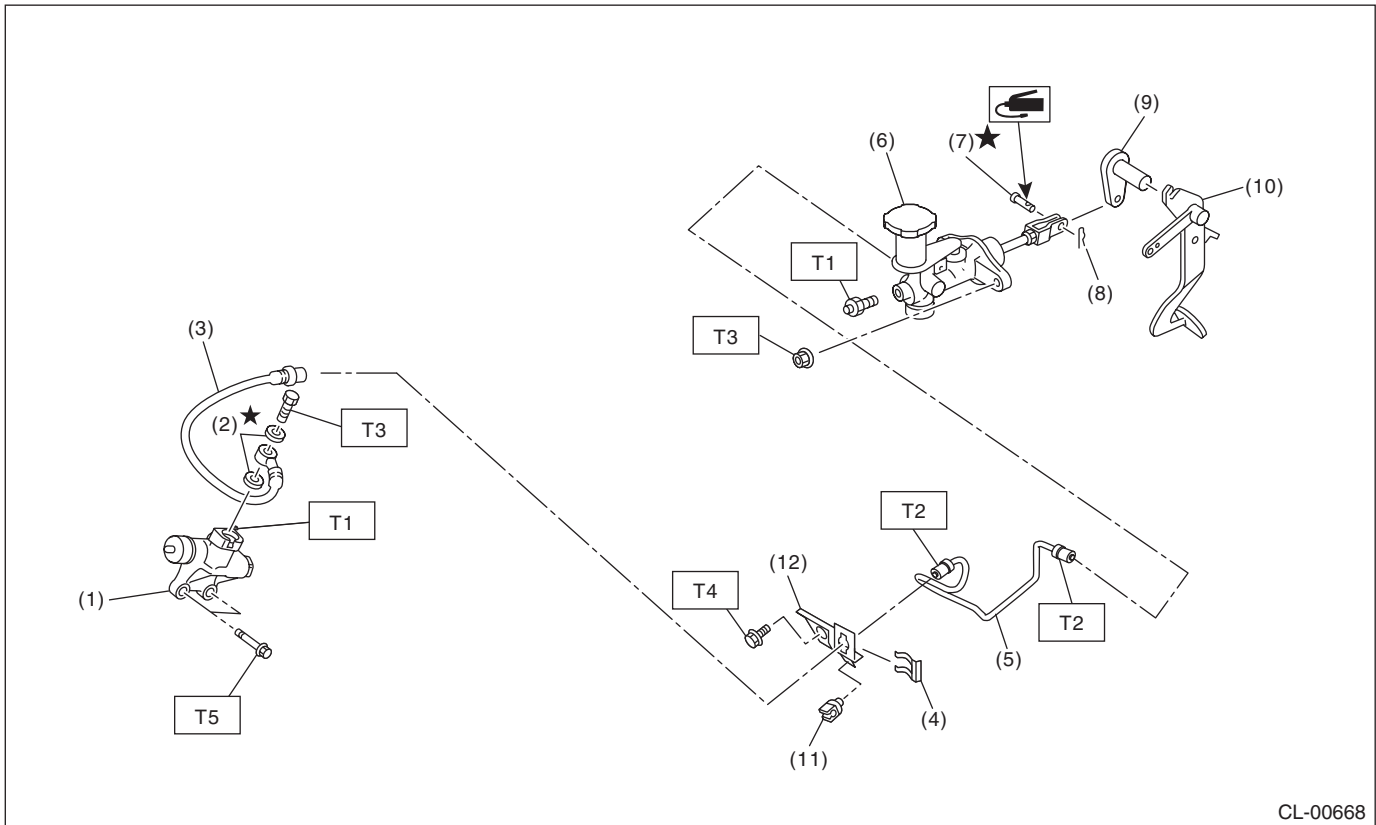

CL-00668

- |                          |                |
|--------------------------|----------------|
| (1) Operating cylinder   | (7) Clevis pin |
| (2) Washer               | (8) Snap pin   |
| (3) Clutch hose          | (9) Lever      |
| (4) Clip                 | (10) Pedal     |
| (5) Clutch pipe          | (11) Clamp     |
| (6) Master cylinder ASSY | (12) Bracket   |

**Tightening torque: N·m (kgf-m, ft-lb)**

**T1: 7.8 (0.8, 5.8)**

**T2: 15 (1.5, 11.1)**

**T3: 18 (1.8, 13.3)**

**T4: 25 (2.5, 18.4)**

**T5: 41 (4.2, 30.2)**

# General Description

## CLUTCH SYSTEM

- Except for STI model

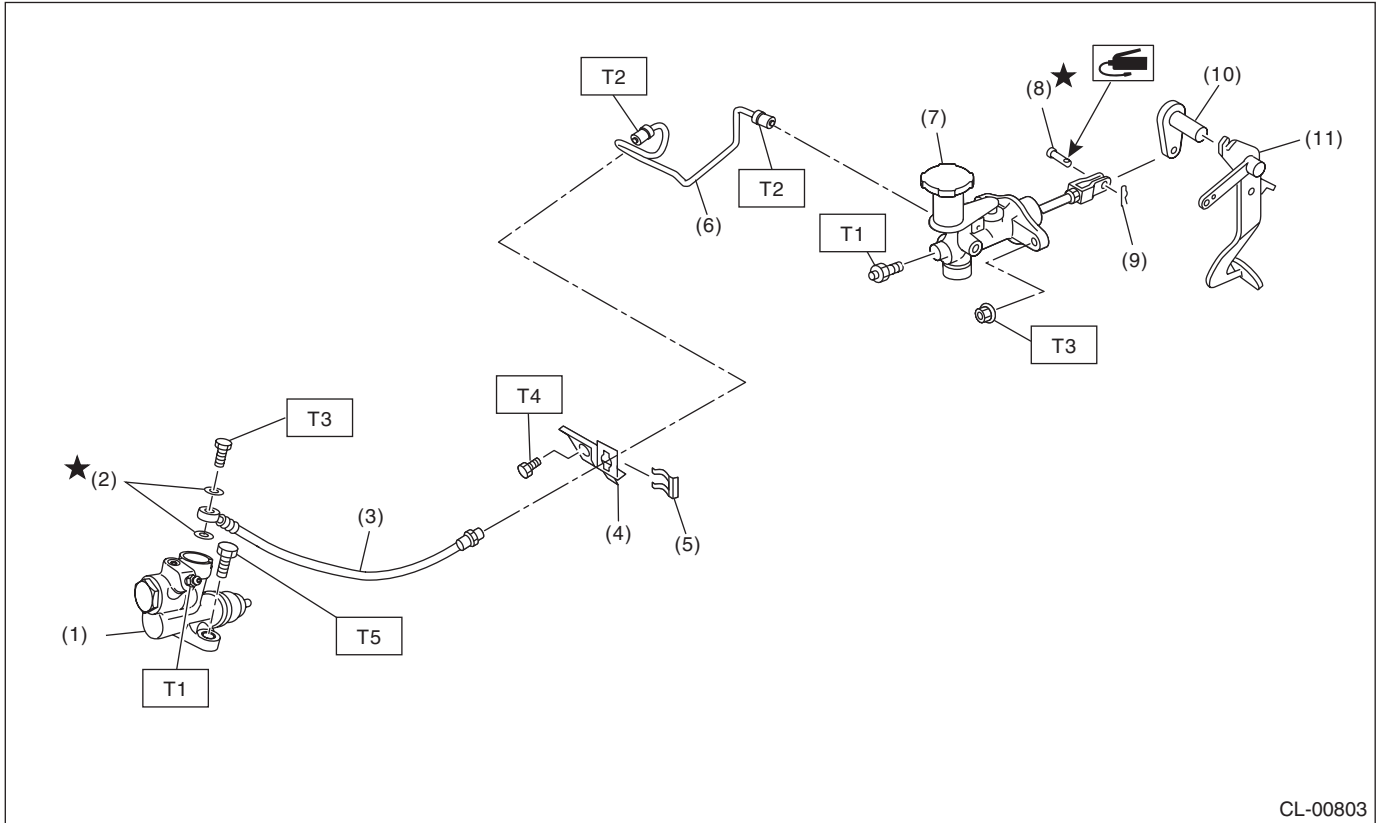

CL-00803

- |                        |                          |
|------------------------|--------------------------|
| (1) Operating cylinder | (7) Master cylinder ASSY |
| (2) Washer             | (8) Clevis pin           |
| (3) Clutch hose        | (9) Snap pin             |
| (4) Bracket            | (10) Lever               |
| (5) Clip               | (11) Pedal               |
| (6) Clutch pipe        |                          |

### **Tightening torque: N·m (kgf-m, ft-lb)**

**T1: 7.8 (0.8, 5.8)**

**T2: 15 (1.5, 11.1)**

**T3: 18 (1.8, 13.3)**

**T4: 25 (2.5, 18.4)**

**T5: 37 (3.8, 27.3)**

## 3. OPERATING CYLINDER

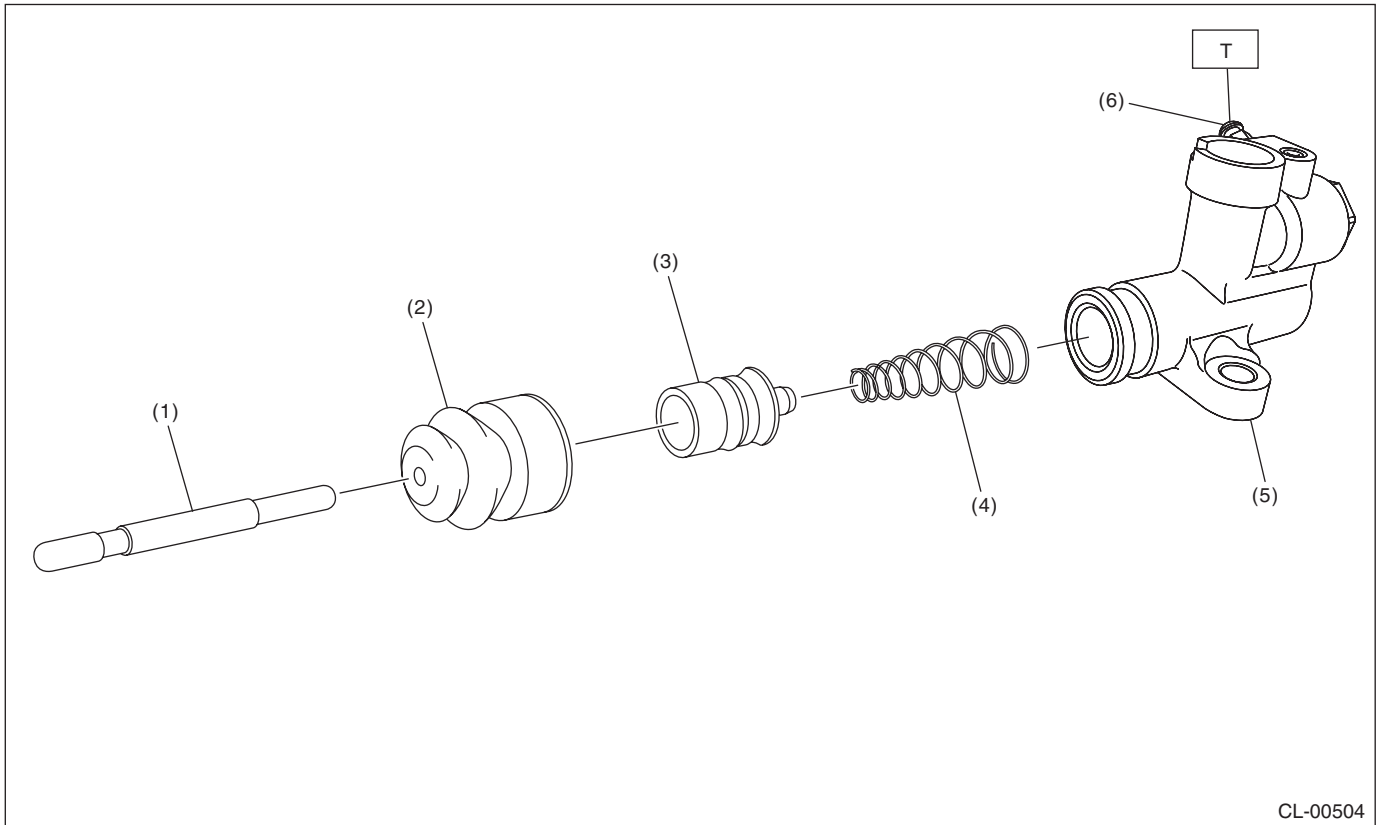

- |              |                        |
|--------------|------------------------|
| (1) Push rod | (4) Piston spring      |
| (2) Boot     | (5) Operating cylinder |
| (3) Piston   | (6) Breather screw     |

**Tightening torque: N·m (kgf·m, ft·lb)**  
**T: 7.8 (0.8, 5.8)**

# General Description

## CLUTCH SYSTEM

### 4. MASTER CYLINDER

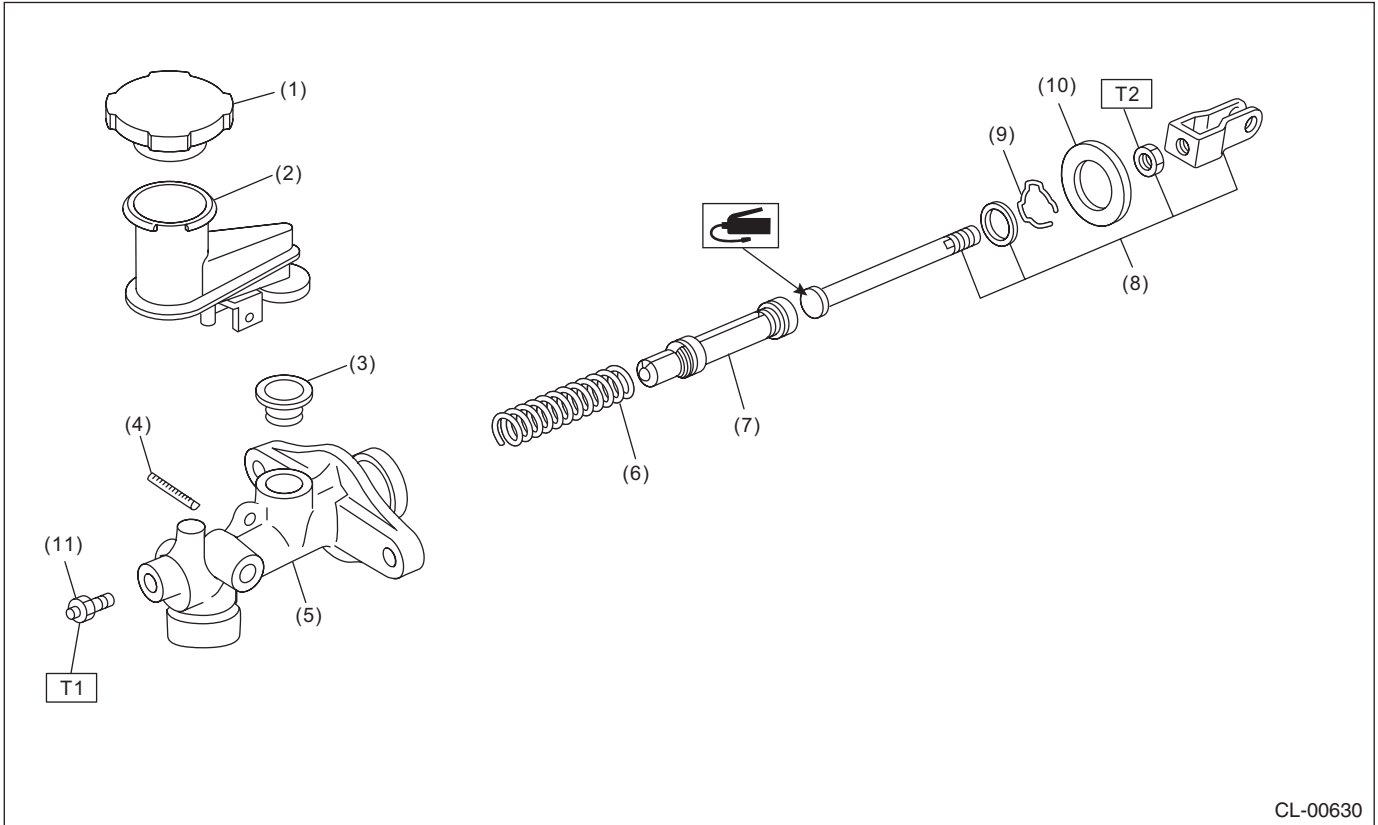

- (1) Reservoir cap
- (2) Reservoir tank
- (3) Oil seal
- (4) Straight pin
- (5) Master cylinder

- (6) Return spring
- (7) Piston
- (8) Push rod ASSY
- (9) Piston stop ring
- (10) Seat

- (11) Breather screw

**Tightening torque: N·m (kgf·m, ft·lb)**

**T1: 7.8 (0.8, 5.8)**

**T2: 10 (1.0, 7.4)**

### 5. CLUTCH PEDAL

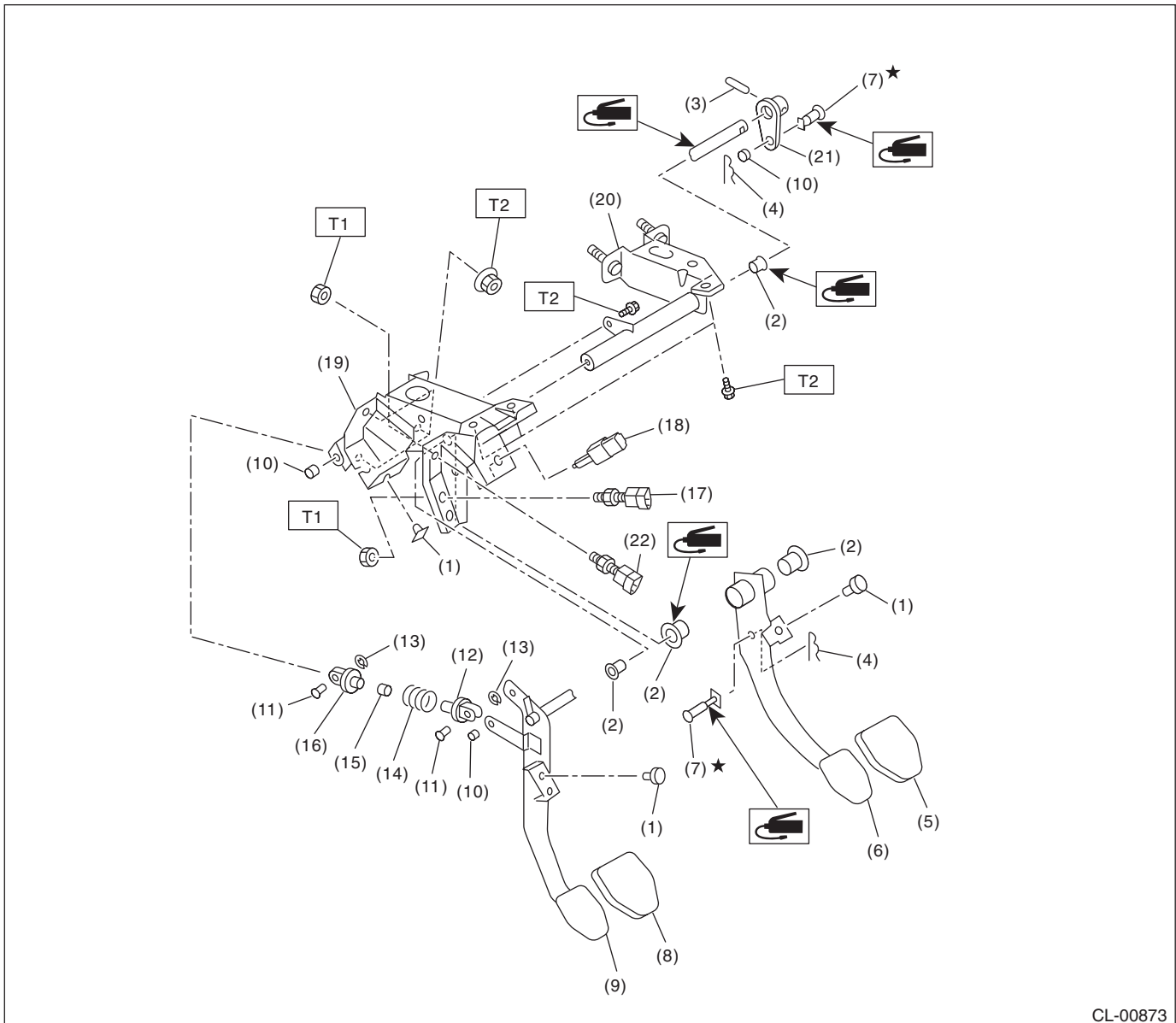

CL-00873

- |                      |                        |                                     |
|----------------------|------------------------|-------------------------------------|
| (1) Stopper          | (10) Bushing C         | (19) Pedal bracket                  |
| (2) Bushing          | (11) Clutch clevis pin | (20) Clutch master cylinder bracket |
| (3) Spring pin       | (12) Assist rod A      | (21) Lever                          |
| (4) Snap pin         | (13) Clip              | (22) Clutch start switch            |
| (5) Brake pedal pad  | (14) Assist spring     |                                     |
| (6) Brake pedal      | (15) Assist bushing    |                                     |
| (7) Clevis pin       | (16) Assist rod B      |                                     |
| (8) Clutch pedal pad | (17) Clutch switch     |                                     |
| (9) Clutch pedal     | (18) Stop light switch |                                     |

**Tightening torque: N·m (kgf·m, ft·lb)**

**T1: 8 (0.8, 5.9)**

**T2: 18 (1.8, 13.3)**

## General Description

### CLUTCH SYSTEM

#### C: CAUTION

- Wear appropriate work clothing, including a cap, protective goggles and protective shoes when performing any work.
- Remove contamination including dirt and corrosion before removal, installation or disassembly.
- Keep the disassembled parts in order and protect them from dust and dirt.
- Before removal, installation or disassembly, be sure to clarify the failure. Avoid unnecessary removal, installation, disassembly and replacement.
- Vehicle components are extremely hot after driving. Be wary of receiving burns from heated parts.
- Use SUBARU genuine fluid, grease etc. or equivalent. Do not mix fluid, grease, etc. of different grades or manufacturers.
- Be sure to tighten fasteners including bolts and nuts to the specified torque.
- Place shop jacks or rigid racks at the specified points.
- Apply grease onto sliding or revolving surfaces before installation.
- Before installing O-rings or snap rings, apply sufficient amount of fluid to avoid damage and deformation.
- Before securing a part in a vise, place cushioning material such as wood blocks, aluminum plate or cloth between the part and the vise.
- Keep fluid away from the vehicle body. If any fluid contacts the vehicle body, immediately flush the area with water.

#### D: PREPARATION TOOL

##### 1. SPECIAL TOOL

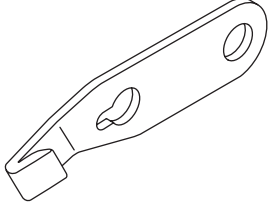
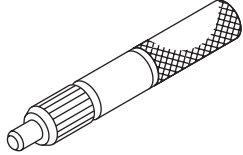
ILLUSTRATION	TOOL NUMBER	DESCRIPTION	REMARKS
 ST-498497100	498497100	CRANKSHAFT STOPPER	Used for stopping rotation of the flywheel.
 ST-499747100	499747100	CLUTCH DISC GUIDE	Used for installing the clutch disc to the flywheel.

##### 2. GENERAL TOOL

TOOL NAME	REMARKS
Circuit tester	Used for measuring resistance, voltage and ampere.
Dial gauge	Used for measuring clutch disc run-out.
Depth gauge	Used for measuring clutch disc wear.



## 2. Clutch Disc and Cover

### A: REMOVAL

1) Remove the transmission assembly from the vehicle. <Ref. to 6MT-32, REMOVAL, Manual Transmission Assembly.> <Ref. to 5MT-23, REMOVAL, Manual Transmission Assembly.>

2) Attach the ST on the flywheel.

ST 499747100 CLUTCH DISC GUIDE

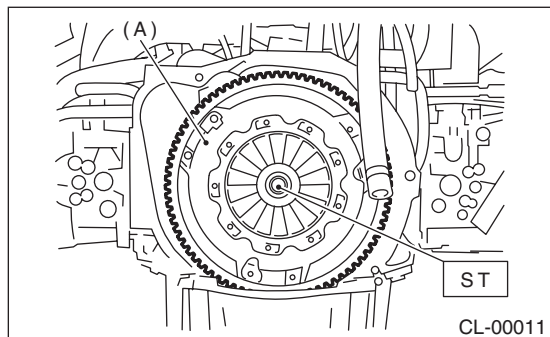

(A) Clutch cover

3) Remove the clutch cover and clutch disc.

NOTE:

- Take care not to allow oil to touch the clutch disc face.
- Do not disassemble the clutch cover or clutch disc.

### B: INSTALLATION

1) Insert the ST into the clutch disc and attach to the flywheel by inserting the ST end into pilot bearing.

NOTE:

When installing the clutch disc, be careful to attach in the correct direction.

ST 499747100 CLUTCH DISC GUIDE

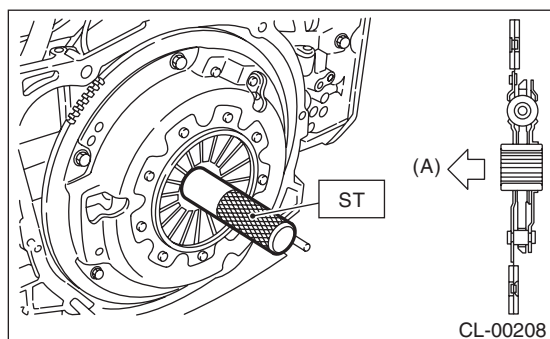

(A) Flywheel side

2) Install the clutch cover to the flywheel and tighten the bolts to the specified torque.

NOTE:

- When installing a clutch cover to the flywheel, position the clutch cover so that the spacing between the unbalance marks (paint mark) on the flywheel and clutch cover is 120° or more apart. (The unbalance mark indicates the direction of residual unbalance.)
- Note the front and rear of the clutch disc when installing.
- Temporarily tighten the bolts by hand. Each bolt should be tightened to the specified torque in a crisscross order.

**Tightening torque:**

**16 N·m (1.6 kgf·m, 11.8 ft·lb)**

- STI model

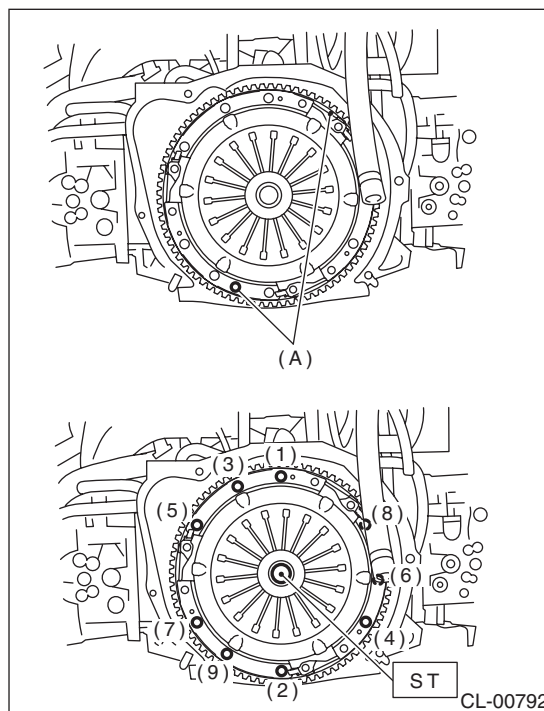

(A) Unbalance mark (paint)

# Clutch Disc and Cover

## CLUTCH SYSTEM

- Except for STI model

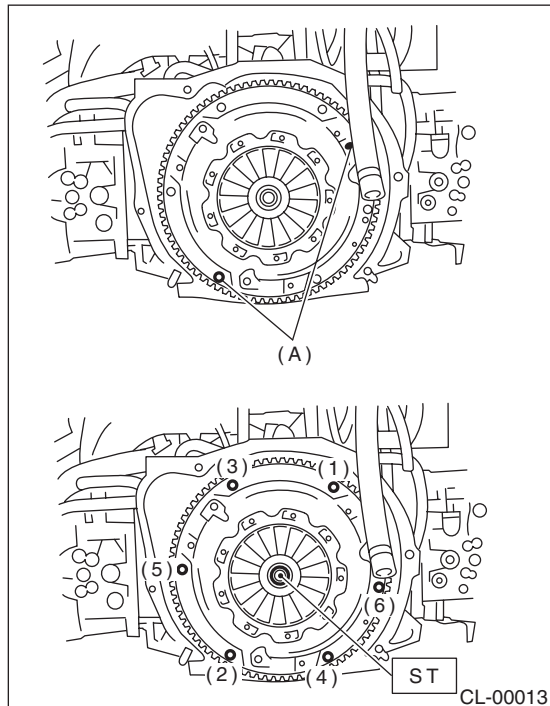

(A) Unbalance mark (paint)

- 3) Remove the ST.

ST 499747100 CLUTCH DISC GUIDE

- 4) Install the transmission assembly. <Ref. to 6MT-34, INSTALLATION, Manual Transmission Assembly.> <Ref. to 5MT-25, INSTALLATION, Manual Transmission Assembly.>

## C: INSPECTION

### 1. CLUTCH DISC

- 1) Facing wear

Measure the depth from the facing surface to the rivet head. Replace if the face is worn locally or worn down to less than the specified value.

**Depth to rivet head:**

**Limit of sinking**

**0.3 mm (0.012 in)**

NOTE:

Do not wash the clutch disc with any type of cleaning fluid.

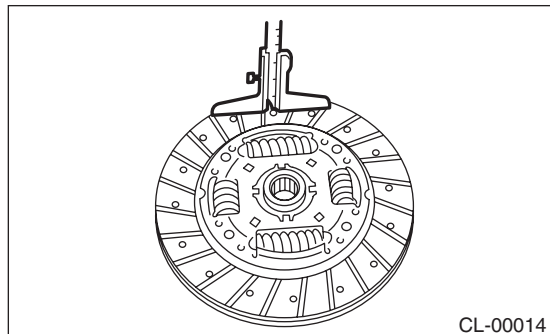

- 2) Hardened facing

Replace the clutch disc.

- 3) Oil soakage on facing

Replace the clutch disc and inspect the transmission front oil seal, transmission case mating surface, engine rear oil seal and other locations for oil leakage.

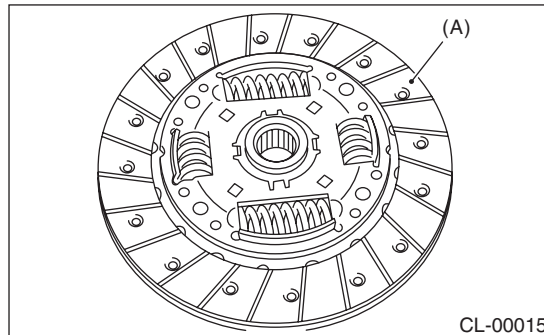

(A) Clutch facing

- 4) Deflection on facing

If deflection exceeds the specified value at the outer circumference of the facing, replace the clutch disc.

ST 499747100 CLUTCH DISC GUIDE

**Limit for deflection:**

**STI model**

**0.7 mm (0.028 in) at R = 115 mm (4.53 in)**

**Except for STI model**

**0.7 mm (0.028 in) at R = 110 mm (4.33 in)**

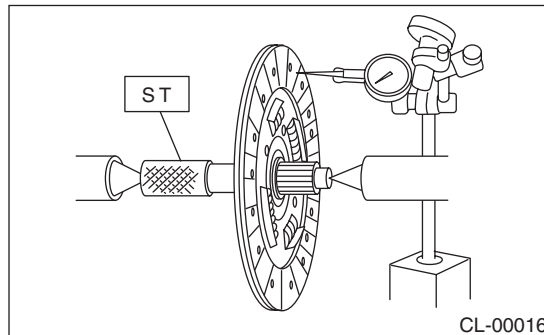

5) If there is spline wear, loose rivets, failed damper springs, etc., replace the clutch disc.

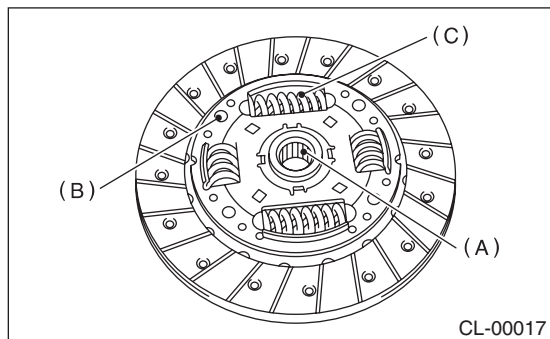

- (A) Spline
- (B) Rivet
- (C) Damper spring

## 2. CLUTCH COVER

### NOTE:

Visually check the following items without disassembling, and replace or repair if defective.

- 1) Loose thrust rivet
- 2) Damaged or worn bearing contact area at the center of diaphragm spring

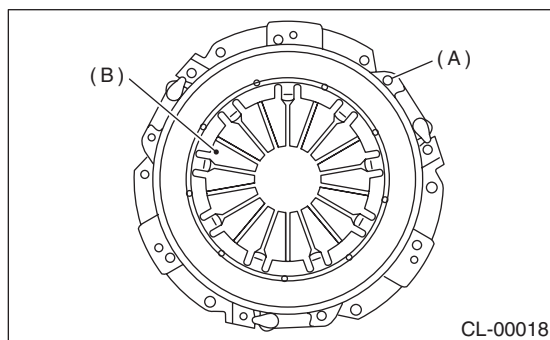

- (A) Thrust rivet
- (B) Diaphragm spring

3) Damaged or worn disc contact surface of the pressure plate

4) Loose strap plate installation area

5) Worn diaphragm sliding area

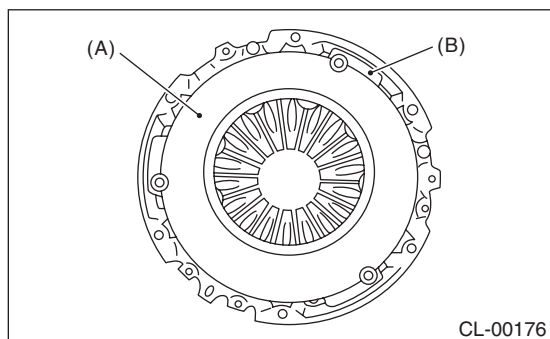

- (A) Pressure plate
- (B) Strap plate

# Flywheel

## CLUTCH SYSTEM

### 3. Flywheel

#### A: REMOVAL

1) Remove the transmission assembly. <Ref. to 6MT-32, REMOVAL, Manual Transmission Assembly.> <Ref. to 5MT-23, REMOVAL, Manual Transmission Assembly.>

2) Remove the clutch cover and clutch disc. <Ref. to CL-11, REMOVAL, Clutch Disc and Cover.>

3) Using the ST, remove the flywheel.

ST 498497100 CRANKSHAFT STOPPER

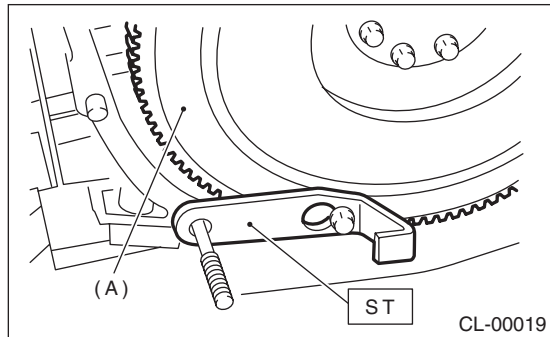

(A) Flywheel

#### B: INSTALLATION

1) Install the flywheel and ST.

ST 498497100 CRANKSHAFT STOPPER

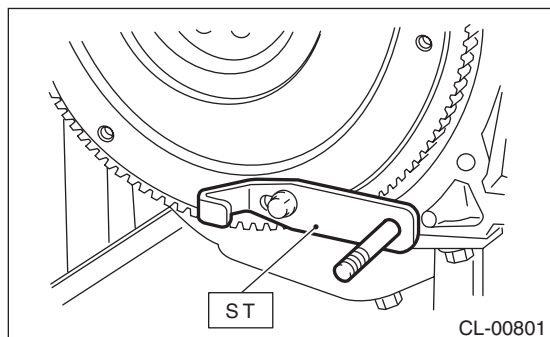

2) Tighten the flywheel mounting bolts to the specified torque.

#### NOTE:

Tighten the flywheel attachment bolts gradually. Each bolt should be tightened to the specified torque in crisscross order.

#### Tightening torque:

75 N·m (7.6 kgf·m, 55.3 ft·lb)

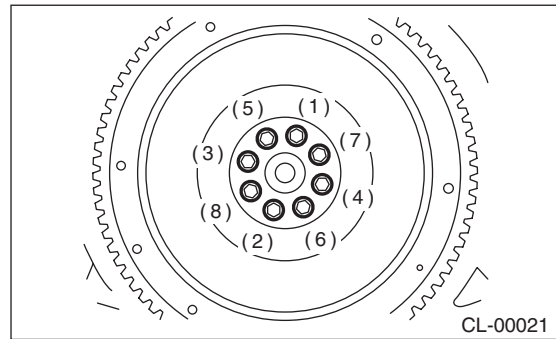

3) Install the clutch disc and cover. <Ref. to CL-11, INSTALLATION, Clutch Disc and Cover.>

4) Install the transmission assembly. <Ref. to 6MT-34, INSTALLATION, Manual Transmission Assembly.> <Ref. to 5MT-25, INSTALLATION, Manual Transmission Assembly.>

#### C: INSPECTION

##### CAUTION:

**Because the center bearing is grease-sealed and is a non-lubrication type, do not wash with gasoline or solvents.**

1) If there is damage or defectiveness in the facing sliding surface or ring gear, replace the flywheel.

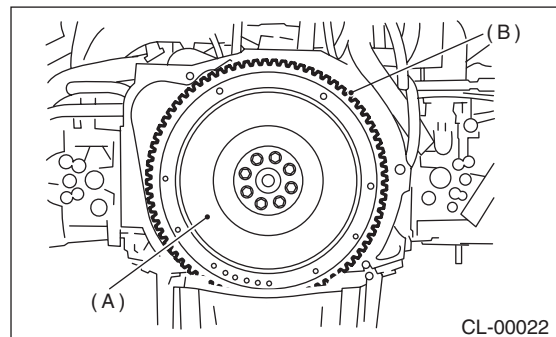

(A) Flywheel

(B) Ring gear

2) Smoothness of rotation

Rotate the ball bearing while applying pressure in the thrust direction.

3) If noise or excessive play is noted, replace the flywheel.

## 4. Release Bearing and Lever

### A: REMOVAL

#### 1. STI MODEL

- 1) Remove the transmission assembly from the vehicle. <Ref. to 6MT-32, REMOVAL, Manual Transmission Assembly.>
- 2) Remove the release lever from the transmission.
- 3) Using a flat tip screwdriver, remove the release bearing from the clutch cover.

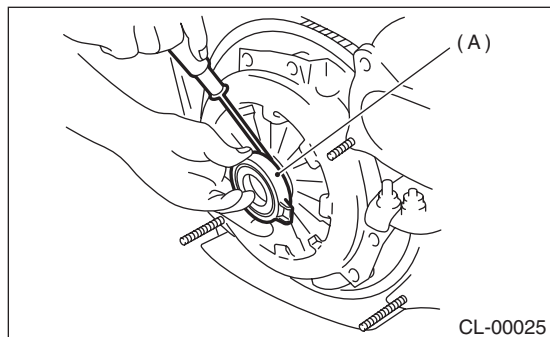

(A) Release bearing

#### 2. EXCEPT FOR STI MODEL

- 1) Remove the transmission assembly from the vehicle. <Ref. to 5MT-23, REMOVAL, Manual Transmission Assembly.>
- 2) Remove the dust cover.

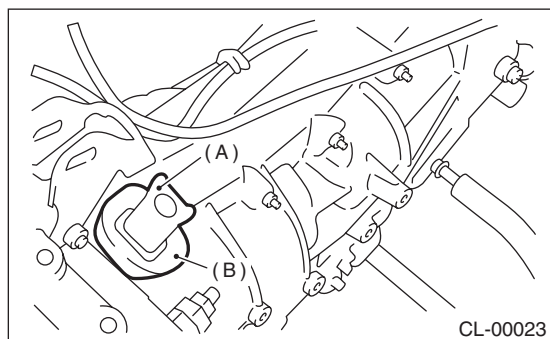

(A) Release lever  
(B) Dust cover

- 3) Remove the lever spring from the pivot with a screwdriver by accessing it through the clutch housing release lever hole. Then remove the release lever and release bearing as a unit.

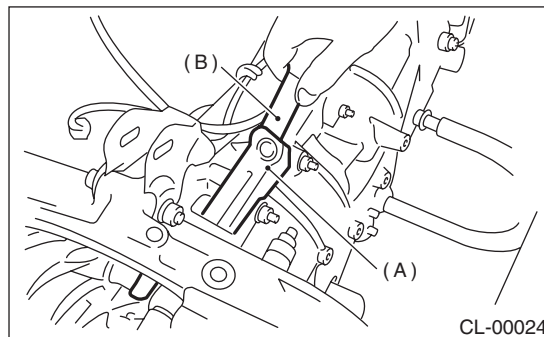

(A) Release lever  
(B) Screwdriver

### B: INSTALLATION

#### 1. STI MODEL

##### NOTE:

Apply the specified grease to lubricate to the following points before installation.

- Release lever shaft
- Contact surface of release lever and bearing
- Transmission main shaft spline
- Contact surface of release bearing and clutch release bearing guide

##### Grease:

**NICHIMOLY N-130 or equivalent**

- 1) Attach the release bearing to the transmission.
- 2) Insert the release lever into the release bearing tab.

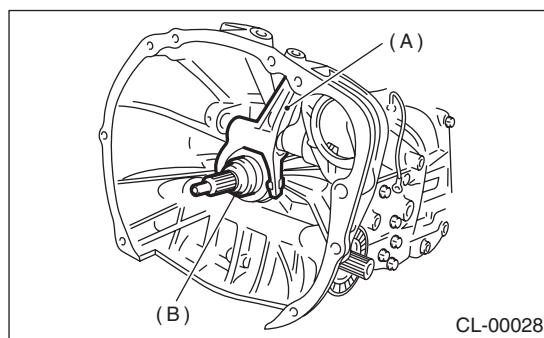

(A) Release lever  
(B) Release bearing

# Release Bearing and Lever

## CLUTCH SYSTEM

3) Insert the release lever shaft into the release lever.

**NOTE:**

Make sure the cut portion of the release lever shaft comes into contact with the spring pin.

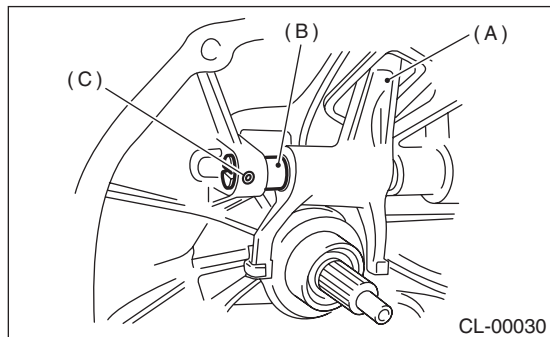

- (A) Release lever
- (B) Release lever shaft
- (C) Spring pin

4) Tighten the plugs.

**Tightening torque:**

**48 N·m (4.9 kgf·m, 35.4 ft·lb)**

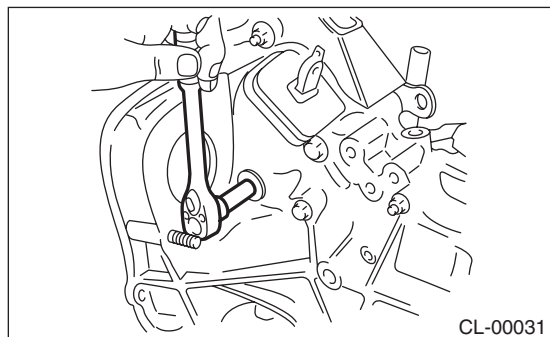

5) Check the bearing for smooth movement by operating the release lever.

6) Apply grease to the contact surface of the release lever and operating cylinder.

**Grease:**

**NICHIMOLY N-130 or equivalent**

7) Apply grease to splines.

**Grease:**

**NICHIMOLY N-130 or equivalent**

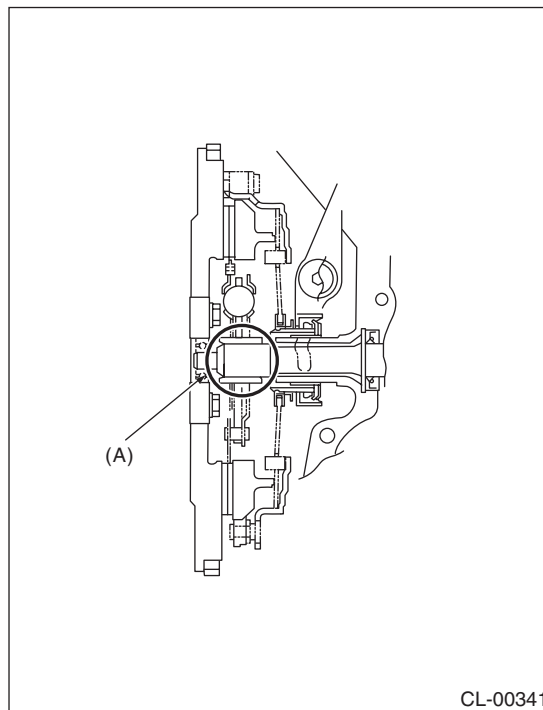

(A) Spline

8) Install the transmission assembly. <Ref. to 6MT-34, INSTALLATION, Manual Transmission Assembly.>

## 2. EXCEPT FOR STI MODEL

**NOTE:**

Apply the specified grease to lubricate to the following points before installation.

- Contact surface of lever and pivot
- Contact surface of lever and bearing
- Transmission main shaft spline
- Contact surface of release bearing and transmission case

**Grease:**

**NICHIMOLY N-130 or equivalent**

1) Install the release bearing by inserting the release lever into the clutch housing release lever hole. Then, fit the lever spring onto the raised portion of the pivot by pushing the release lever to the pivot and twisting it to both sides.



2) Install the dust cover.

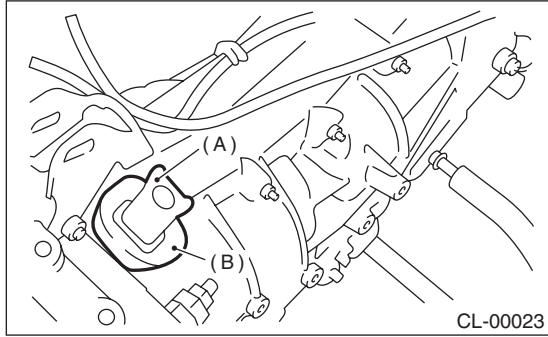

(A) Release lever  
(B) Dust cover

3) Check the bearing for smooth movement by operating the release lever.

4) Apply grease to the contact surface of the release lever and operating cylinder.

**Grease:**

**NICHIMOLY N-130 or equivalent**

5) Install the transmission assembly. <Ref. to 5MT-25, INSTALLATION, Manual Transmission Assembly.>

## C: INSPECTION

### 1. RELEASE BEARING

**CAUTION:**

**Since this bearing is grease-sealed and is a non-lubrication type, do not wash with gasoline or any other solvent when servicing the clutch.**

1) Check the bearing for smooth movement by applying force to the bearing in the radial direction.

**Radial direction stroke:**

**1.6 mm (0.063 in)**

• **STI model**

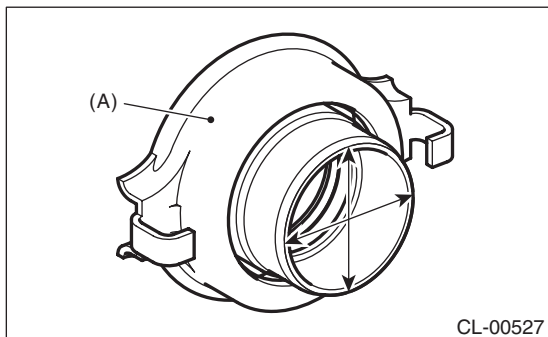

(A) Bearing case

• **Except for STI model**

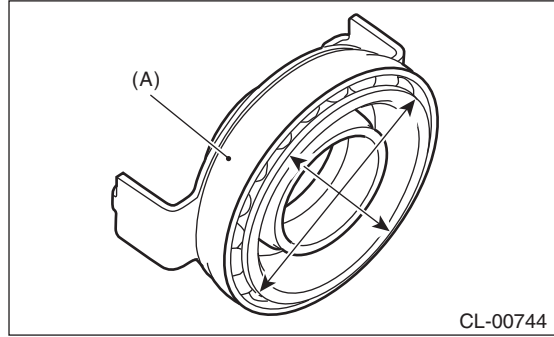

(A) Bearing case

2) While applying force to the bearing in the rotational direction, check the bearing for smooth rotation.

• **STI model**

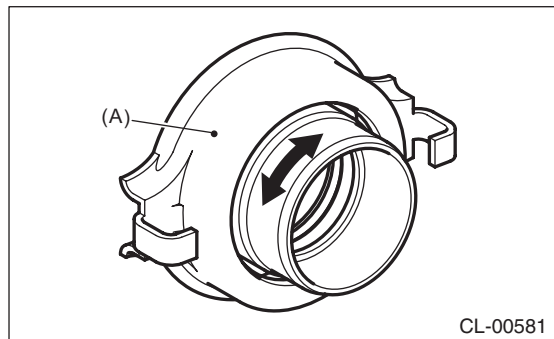

(A) Bearing case

• **Except for STI model**

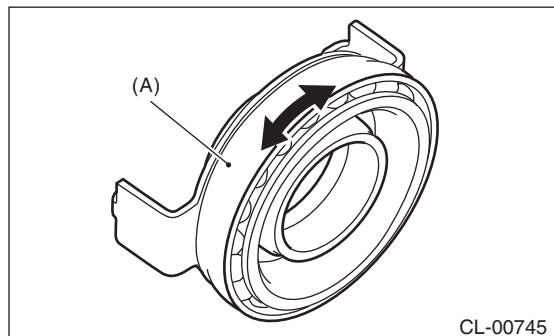

(A) Bearing case

3) Check for wear and damage at the bearing case surface in contact with the lever.

# Release Bearing and Lever

## CLUTCH SYSTEM

---

### 2. RELEASE LEVER

Check for wear in release shaft contact area and release bearing case contact area of the lever.

- **STI model**

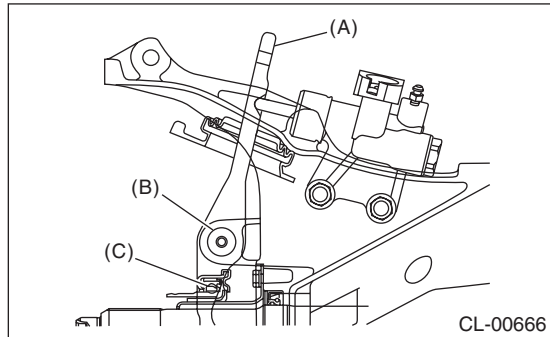

- (A) Release lever
- (B) Release shaft
- (C) Release bearing

- **Except for STI model**

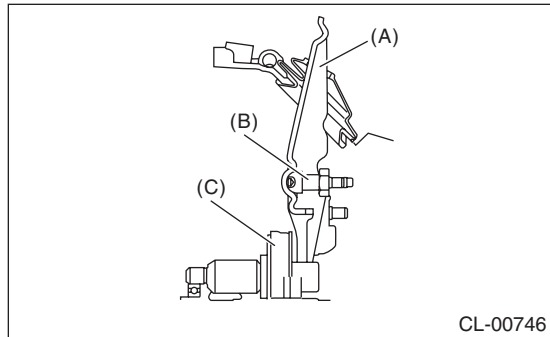

- (A) Release lever
- (B) Pivot
- (C) Release bearing



## 5. Operating Cylinder

### A: REMOVAL

1) Remove the intercooler. <Ref. to IN(STI)-12, REMOVAL, Intercooler.> <Ref. to IN(w/o STI)-12, REMOVAL, Intercooler.>

2) Disconnect the clutch hose from the operating cylinder.

#### CAUTION:

- Cover the hose joint to prevent the clutch fluid from flowing out.
- Do not loosen or remove the cap bolts.
- STI model

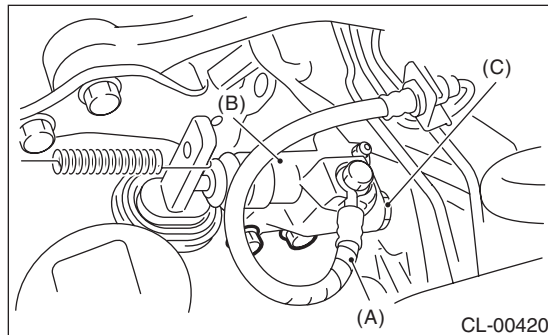

- (A) Clutch hose
- (B) Operating cylinder
- (C) Cap bolt

- Except for STI model

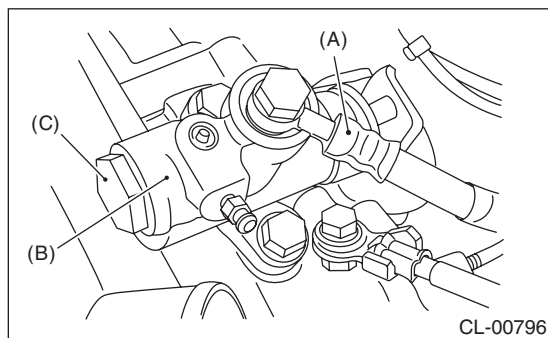

- (A) Clutch hose
- (B) Operating cylinder
- (C) Cap bolt

3) Remove the operating cylinder from the transmission.

- STI model

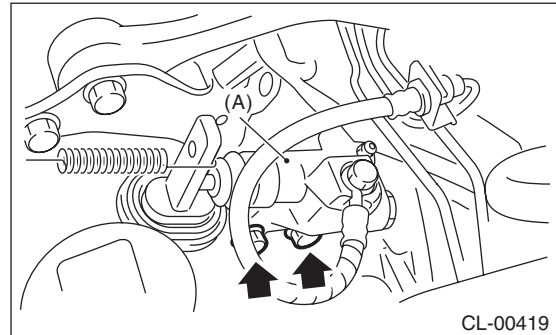

- (A) Operating cylinder

- Except for STI model

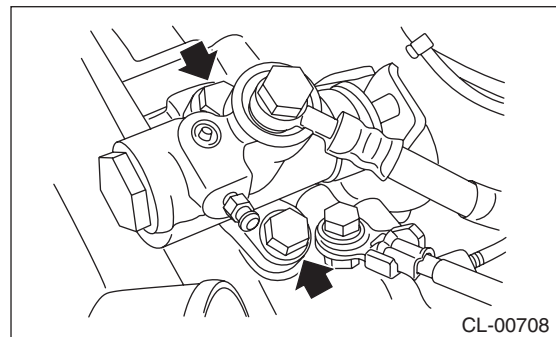

# Operating Cylinder

## CLUTCH SYSTEM

### B: INSTALLATION

1) Install in the reverse order of removal.

#### NOTE:

- Use a new gasket.
- Before installing the operating cylinder, apply grease to the contact point of the release lever and operating cylinder.

#### Grease

##### **NICHIMOLY N-130 or equivalent**

- Be sure to install the clutch hose with the mark side facing upward.
- Be careful not to twist the clutch hose during installation.
- STI model

#### Tightening torque:

**T1: 18 N·m (1.8 kgf-m, 13.3 ft-lb)**

**T2: 41 N·m (4.2 kgf-m, 30.2 ft-lb)**

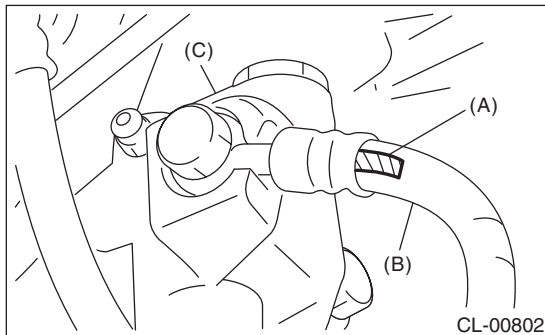
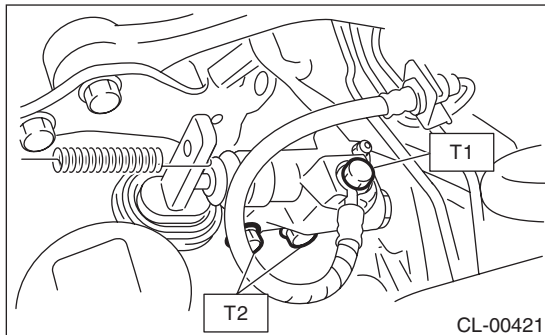

- (A) Mark
- (B) Clutch hose
- (C) Operating cylinder

- Except for STI model

#### Tightening torque:

**T1: 18 N·m (1.8 kgf-m, 13.3 ft-lb)**

**T2: 37 N·m (3.8 kgf-m, 27.3 ft-lb)**

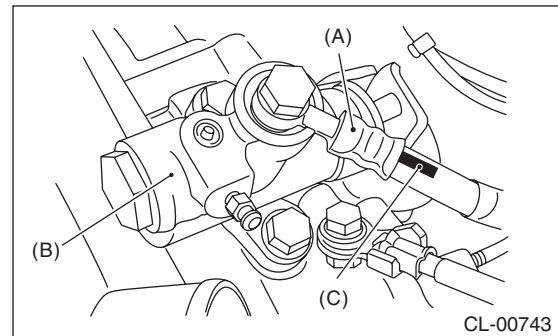
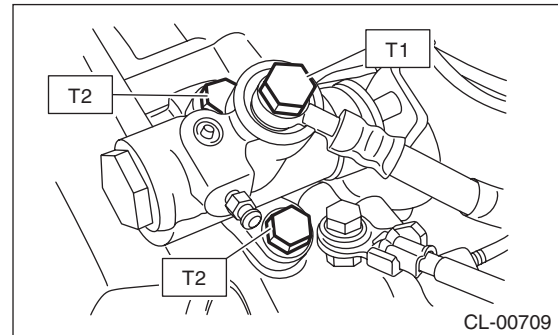

- (A) Clutch hose
- (B) Operating cylinder
- (C) Mark

2) After bleeding air from the operating cylinder, ensure that the clutch operates properly.

<Ref. to CL-27, Clutch Fluid Air Bleeding.>

### C: DISASSEMBLY

#### CAUTION:

**Do not disassemble the STI model.**

1) Remove the boot and push rod.

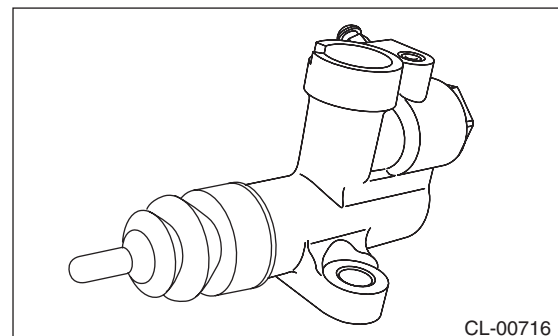

2) Apply compressed air through clutch hose attachment hole.

**NOTE:**

Face the piston hole down and place a piece of wood underneath to prevent the piston from popping out.

3) Separate the piston and piston spring.

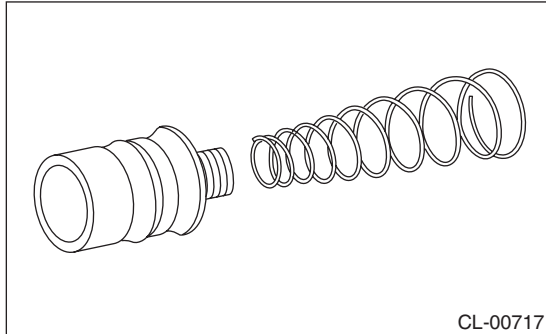

## D: ASSEMBLY

**NOTE:**

During assembly, apply hydraulic oil to all parts.

**Recommended clutch fluid:**

**New FMVSS No. 116 DOT3 or DOT4**

1) Install the piston spring onto the piston.

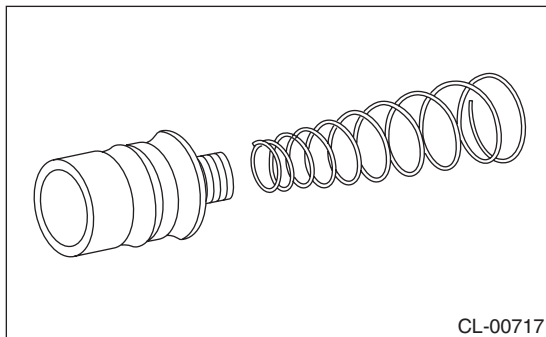

2) Insert piston into the operating cylinder.

3) Install push rod to the boot.

4) Install boot and push rod to the operating cylinder.

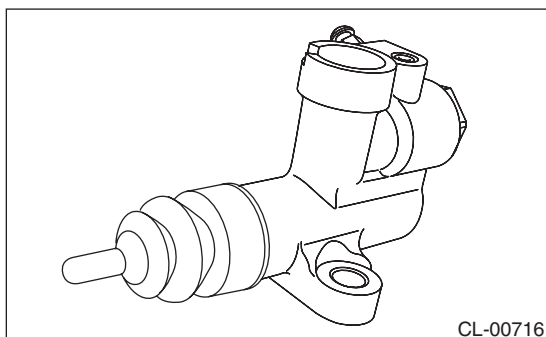

## E: INSPECTION

1) Check that the operating cylinder is not damaged. If operating cylinder is damaged, replace it.

2) Check the operating cylinder for fluid leakage or damage on the boot. Replace the operating cylinder if leaks or damages are noted.

# Master Cylinder

## CLUTCH SYSTEM

### 6. Master Cylinder

#### A: REMOVAL

- 1) Disconnect the ground cable from battery.
- 2) Thoroughly drain the clutch fluid from the reservoir tank.
- 3) Remove the instrument panel lower cover. <Ref. to EI-49, REMOVAL, Instrument Panel Lower Cover.>
- 4) Remove the instrument panel lower cover. <Ref. to EI-49, REMOVAL, Instrument Panel Lower Cover.>
- 5) Remove the snap pin and clevis pin, and then separate the push rod of the master cylinder from clutch pedal.

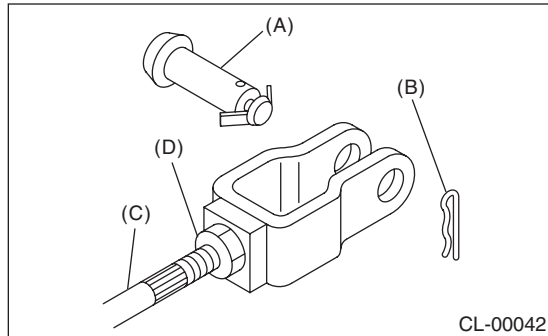

- (A) Clevis pin
- (B) Snap pin
- (C) Push rod
- (D) Lock nut

- 6) Remove the intercooler. <Ref. to IN(STI)-12, REMOVAL, Intercooler.> <Ref. to IN(w/o STI)-12, REMOVAL, Intercooler.>
- 7) Remove the clutch pipe from the master cylinder.

- 8) Remove the master cylinder and reservoir tank as a unit.

#### CAUTION:

**Be careful not to spill the brake fluid. Brake fluid spilled on the vehicle body will harm the paint surface; wash it off with water and wipe clean quickly if spilled.**

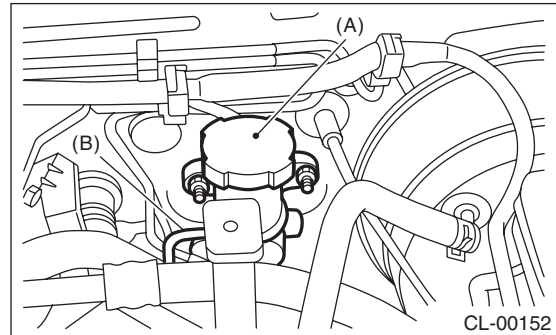

- (A) Master cylinder
- (B) Clutch pipe

#### B: INSTALLATION

- 1) Install the master cylinder to the vehicle body, and connect the clutch pipe to the master cylinder.

#### Tightening torque:

**T1: 15 N·m (1.5 kgf-m, 11.1 ft-lb)**

**T2: 18 N·m (1.8 kgf-m, 13.3 ft-lb)**

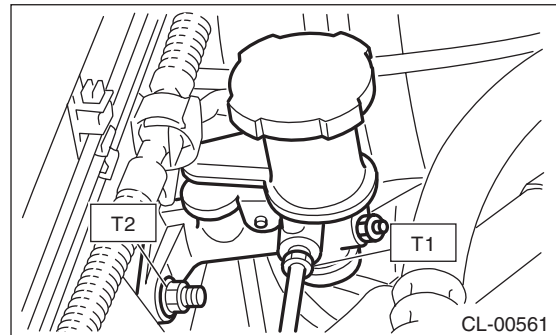

2) Connect the push rod of the master cylinder to the clutch pedal, and install the clevis pin and snap pin.

**CAUTION:**

**Always use a new clevis pin.**

**NOTE:**

Apply grease to the clevis pin.

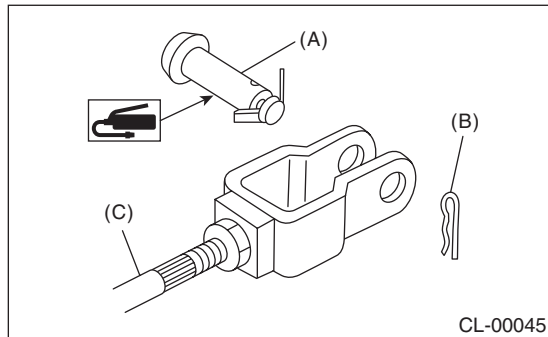

- (A) Clevis pin
- (B) Snap pin
- (C) Push rod

3) Refill the reservoir tank with recommended clutch fluid.

4) After bleeding air from the clutch system, ensure that the clutch operates properly.

<Ref. to CL-27, Clutch Fluid Air Bleeding.>

5) Install the intercooler. <Ref. to IN(STI)-13, INSTALLATION, Intercooler.> <Ref. to IN(w/o STI)-12, INSTALLATION, Intercooler.>

6) Connect the battery ground terminal.

**C: DISASSEMBLY**

1) Remove the straight pin and reservoir tank.

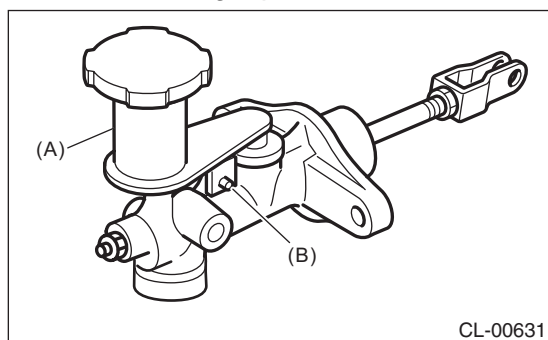

- (A) Reservoir tank
- (B) Straight pin

2) Remove the oil seal.

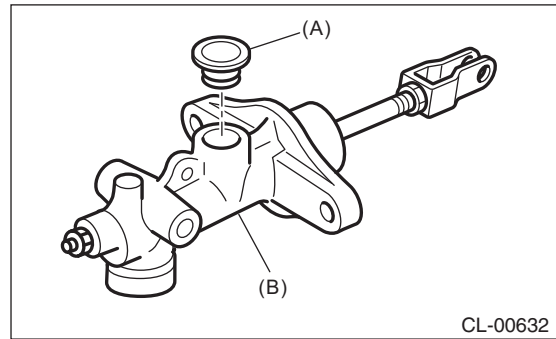

- (A) Oil seal
- (B) Master cylinder

3) Move the seat towards the rear.

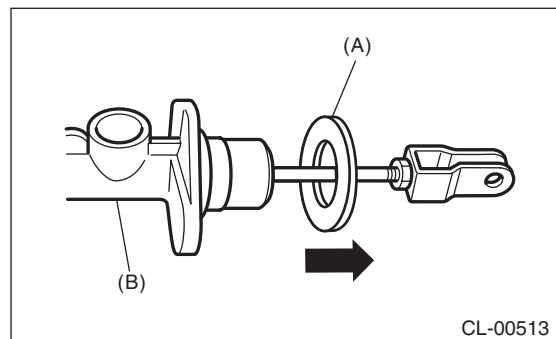

- (A) Seat
- (B) Master cylinder

4) Remove the piston stop ring.

**CAUTION:**

**When removing the piston stop ring, be careful to prevent the rod, washer, piston and return spring from popping out.**

**D: ASSEMBLY**

1) Apply a coat of grease to the contact surfaces of the push rod and piston before installation.

**Grease:**

**SILICONE GREASE G-40M (Part No. 004404003) or equivalent**

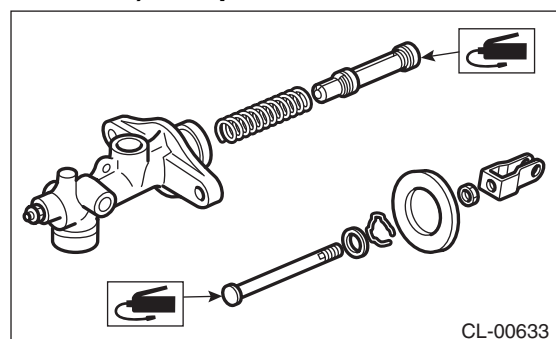

# Master Cylinder

## CLUTCH SYSTEM

---

2) Assemble in the reverse order of disassembly.

**Tightening torque:**

**10 N·m (1.0 kgf·m, 7.4 ft·lb)**

### E: INSPECTION

If any damage, deformation, wear, swelling, rust or other faults are found on the cylinder, piston, push rod, reservoir tank, return spring, breather screw, seat or hose, replace the faulty part.

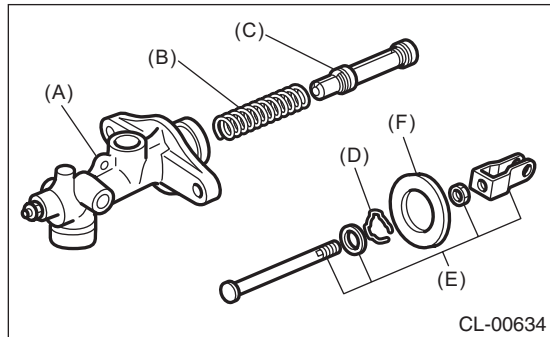

- (A) Master cylinder body
- (B) Return spring
- (C) Piston
- (D) Piston stop ring
- (E) Push rod ASSY
- (F) Seat

## 7. Clutch Pipe and Hose

### A: REMOVAL

- 1) Disconnect the ground cable from battery.
- 2) Remove the intercooler. <Ref. to IN(STI)-12, REMOVAL, Intercooler.> <Ref. to IN(w/o STI)-12, REMOVAL, Intercooler.>
- 3) Drain the clutch fluid. <Ref. to CL-26, Clutch Fluid.>
- 4) Disconnect the clutch pipe from the clutch hose and master cylinder.
- 5) Remove the clip, then remove the clutch hose from the bracket.

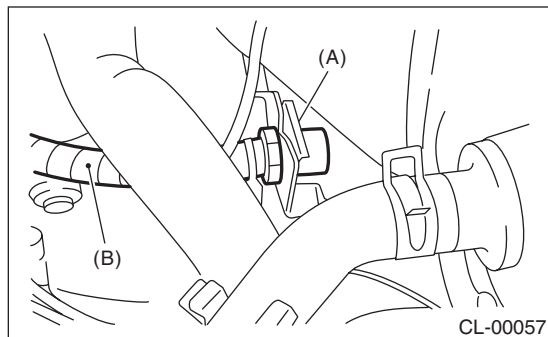

- (A) Clip  
(B) Clutch hose

- 6) Disconnect the hose from operating cylinder.
- 7) Remove the clutch bracket.

### B: INSTALLATION

Install in the reverse order of removal.

#### NOTE:

Bleed air from the clutch fluid. <Ref. to CL-27, Clutch Fluid Air Bleeding.>

#### Tightening torque:

**T1: 15 N·m (1.5 kgf-m, 11.1 ft-lb)**

**T2: 18 N·m (1.8 kgf-m, 13.3 ft-lb)**

**T3: 25 N·m (2.5 kgf-m, 18.4 ft-lb)**

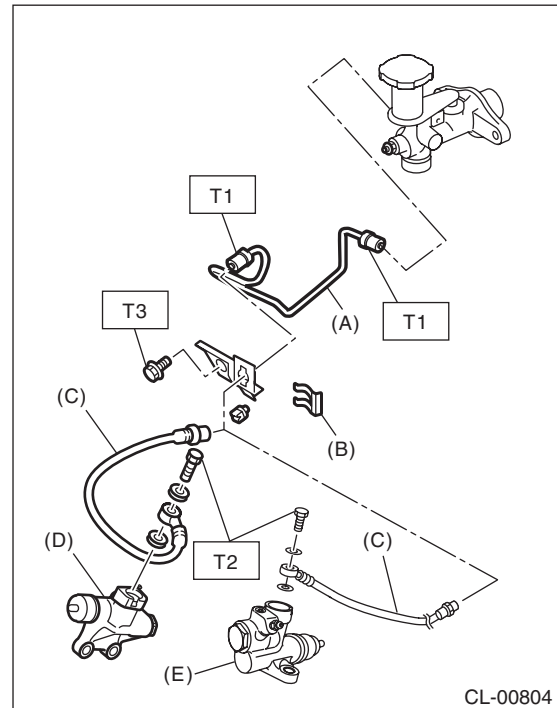

- (A) Clutch pipe  
(B) Clip  
(C) Clutch hose  
(D) STI model  
(E) Except for STI model

### C: INSPECTION

Check the pipes and hoses for breaks and damage. Check joints for fluid leakage. If crack, breakage or damage is found, repair or replace the faulty pipe or hose.

### 8. Clutch Fluid

#### A: INSPECTION

- 1) Park the vehicle on a level surface.
- 2) Inspect the fluid level using the scale on the outside of the reservoir tank. If the level is below "MIN", add fluid to bring it up to "MAX", and also inspect for leakage.

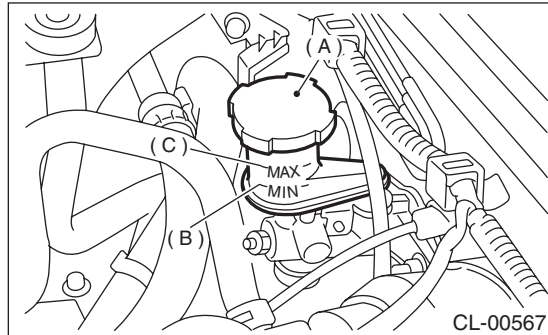

- (A) Reservoir tank
- (B) MIN. level
- (C) MAX. level

#### B: REPLACEMENT

##### CAUTION:

- Use new FMVSS No. 116 DOT3 or DOT4.
- Cover the breather with cloth to prevent brake fluid from being splashed on surrounding parts when loosening the breather.
- Avoid mixing brake fluid of different brands to prevent fluid performance from degrading.
- Be careful not to allow dirt or dust to enter the reservoir tank.

##### NOTE:

- During bleeding operation, keep the clutch reservoir tank filled with brake fluid to prevent entry of air.
- Clutch pedal must be operated very slowly.
- Bleed air from the oil line with help of a co-worker.
- The amount of brake fluid required is approximately 70 m $\ell$  (2.4 US fl oz, 2.5 Imp fl oz) for total clutch system.

- 1) Remove the intercooler. <Ref. to IN(STI)-12, REMOVAL, Intercooler.> <Ref. to IN(w/o STI)-12, REMOVAL, Intercooler.>
- 2) Drain the brake fluid from the reservoir tank.
- 3) Refill the reservoir tank with recommended brake fluid.

##### **Recommended brake fluid:**

**New FMVSS No. 116 DOT3 or DOT4**

- 4) If necessary, bleed air from the clutch fluid. <Ref. to CL-27, Clutch Fluid Air Bleeding.>

- 5) Install the intercooler. <Ref. to IN(STI)-13, INSTALLATION, Intercooler.> <Ref. to IN(w/o STI)-12, INSTALLATION, Intercooler.>



## 9. Clutch Fluid Air Bleeding

### A: PROCEDURE

#### 1. STI MODEL

**NOTE:**

Bleed air from the oil line with help of a co-worker.

1) Remove the intercooler. <Ref. to IN(STI)-12, REMOVAL, Intercooler.>

2) Remove the operating cylinder.

**NOTE:**

Do not remove the clutch hose.

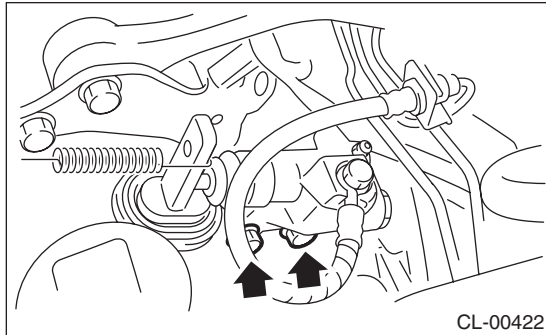

3) Hold the piston with a clamp to prevent piston from popping out.

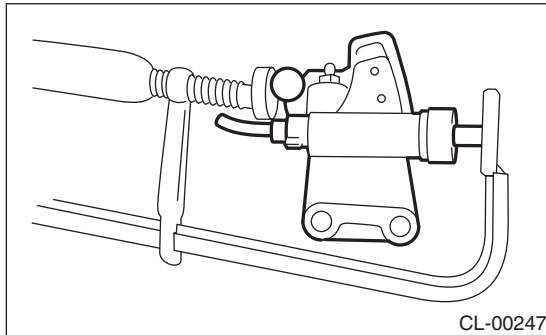

4) Fit one end of a vinyl tube into the air breather of the operating cylinder, and put the other end into a clutch fluid container.

5) Slowly depress the clutch pedal and keep it depressed. Open the air breather to discharge air together with the clutch fluid. Release the air breather for 1 or 2 seconds. Next, close the air breather, and slowly release the clutch pedal.

**NOTE:**

When performing this procedure, place the screw portion of the air breather higher than the end of operating cylinder.

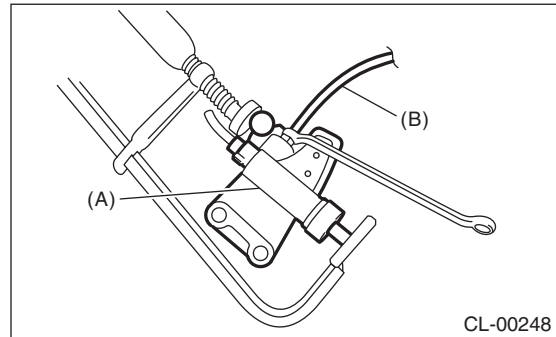

- (A) Operating cylinder
- (B) Vinyl tube

6) Repeat procedure 5), until there are no more air bubbles appearing from the air breather.

**CAUTION:**

**Cover the air breather with cloth to prevent clutch fluid from being splashed on surrounding parts when loosening the breather.**

7) Tighten the air breather.

**Tightening torque:**

**7.8 N·m (0.8 kgf·m, 5.8 ft·lb)**

8) Install the operating cylinder.

**Tightening torque:**

**41 N·m (4.2 kgf·m, 30.2 ft·lb)**

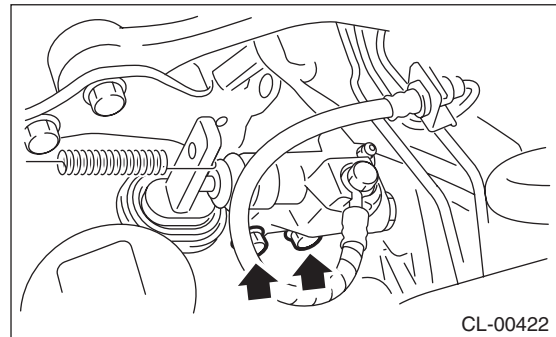

9) After stepping on the clutch pedal, make sure that there are no leaks evident in the entire clutch system.

10) After bleeding the air from clutch system, ensure that the clutch operates properly.

11) Install the intercooler. <Ref. to IN(STI)-13, INSTALLATION, Intercooler.>

# Clutch Fluid Air Bleeding

## CLUTCH SYSTEM

### 2. EXCEPT FOR STI MODEL

#### NOTE:

Bleed air from the oil line with help of a co-worker.

- 1) Remove the intercooler. <Ref. to IN(w/o STI)-12, REMOVAL, Intercooler.>

- 2) Fit one end of a vinyl tube into the air breather of the operating cylinder, and put the other end into a clutch fluid container.

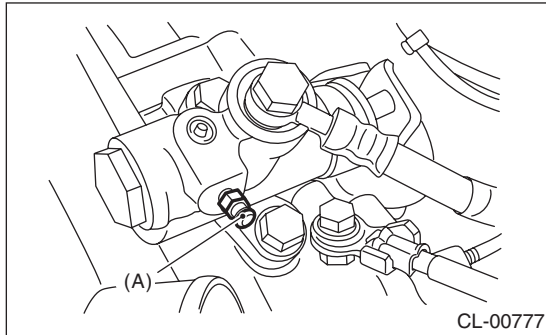

(A) Air breather

- 3) Slowly depress the clutch pedal several times and keep it depressed. Open the air breather to discharge air together with the clutch fluid. Release the air breather for 1 or 2 seconds. Next, close the air breather, and slowly release the clutch pedal.

#### CAUTION:

**Cover the air breather with cloth to prevent clutch fluid from being splashed on surrounding parts when loosening the breather.**

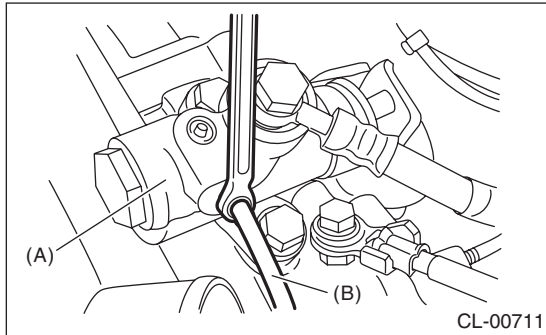

(A) Operating cylinder

(B) Vinyl tube

- 4) Repeat procedure 3), until there are no more air bubbles appearing from the air breather.

- 5) Tighten the air breather.

#### Tightening torque:

**T: 7.8 N·m (0.8 kgf·m, 5.8 ft·lb)**

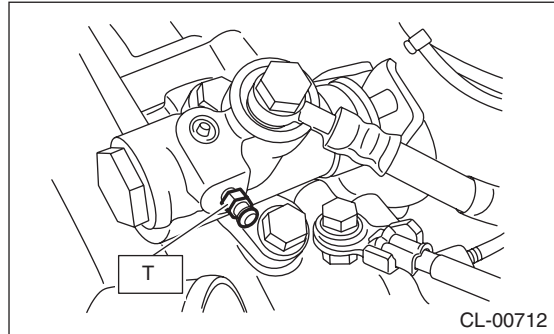

- 6) After stepping on the clutch pedal, make sure that there are no leaks evident in the entire clutch system.

- 7) After bleeding the air from clutch system, ensure that the clutch operates properly.

- 8) Install the intercooler. <Ref. to IN(w/o STI)-12, INSTALLATION, Intercooler.>

## 10. Clutch Pedal

### A: REMOVAL

- 1) Disconnect the ground cable from battery.
- 2) Remove the steering column. <Ref. to PS-15, REMOVAL, Steering Column.>
- 3) Disconnect the connector from the stop light switch and clutch switch.
- 4) Remove the snap pins from clevis pins which secure the lever to the push rod and operating rod.
- 5) Pull out the clevis pins which secures the lever to the push rod and operating rod.

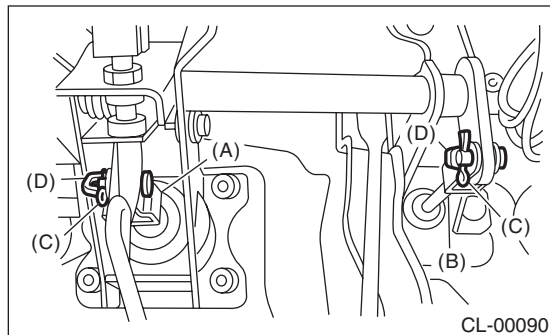

- (A) Operating rod
- (B) Push rod
- (C) Snap pin
- (D) Clevis pin

- 6) Remove the intercooler.  
<Ref. to IN(STI)-12, REMOVAL, Intercooler.>  
<Ref. to IN(w/o STI)-12, REMOVAL, Intercooler.>
- 7) Remove the nut which secures the clutch master cylinder.

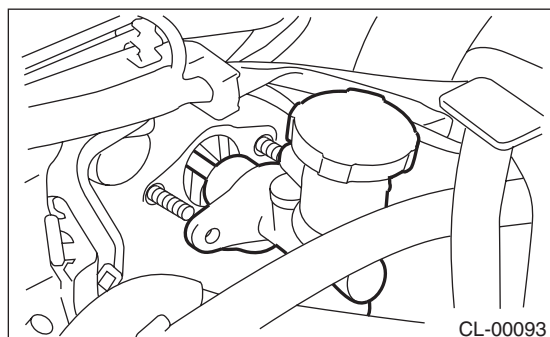

- 8) Remove the bolts and nuts which secure the brake pedal and clutch pedal, and remove the pedal assembly.

### B: INSTALLATION

- 1) Install in the reverse order of removal.

#### CAUTION:

**Always use a new clevis pin.**

- 2) Adjust the clutch pedal after installation. <Ref. to CL-30, ADJUSTMENT, Clutch Pedal.>

- 3) Adjust the clutch start switch. <Ref. to CL-35, ADJUSTMENT, Clutch Switch.>

### C: DISASSEMBLY

- 1) Remove the clutch switches.
- 2) Remove the clip, assist spring, rod and bushing.

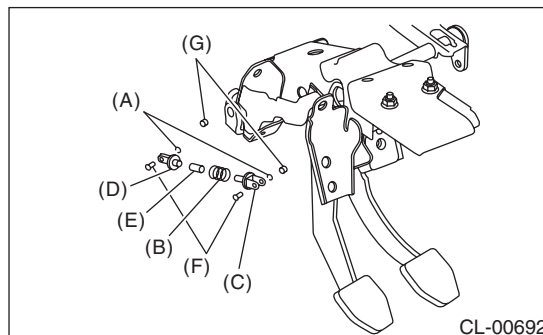

- (A) Clip
- (B) Assist spring
- (C) Assist rod A
- (D) Assist rod B
- (E) Assist bushing
- (F) Clutch clevis pin
- (G) Bushing

- 3) Remove the spring pin and lever.

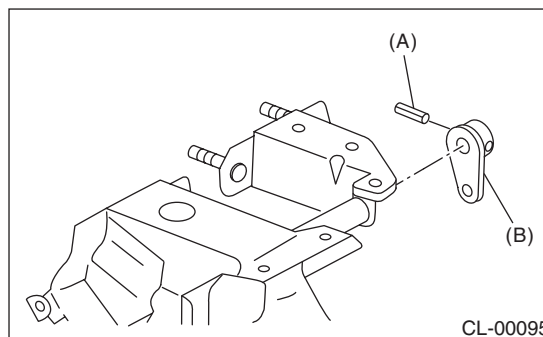

- (A) Spring pin
- (B) Lever

- 4) Remove the clutch pedal and bushings.

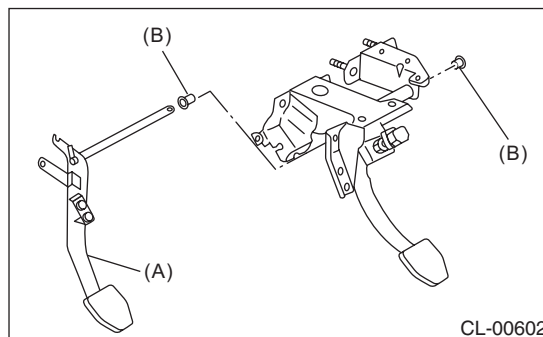

- (A) Clutch pedal
- (B) Bushing

# Clutch Pedal

## CLUTCH SYSTEM

5) Remove the stopper and clutch pedal pad from the clutch pedal.

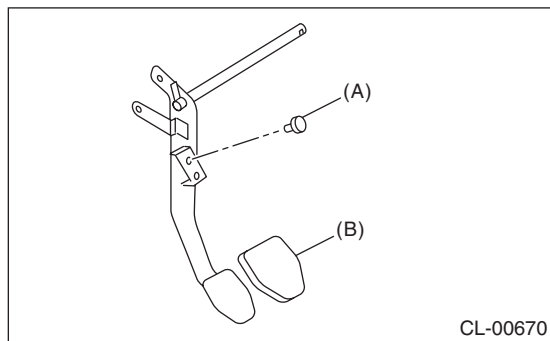

- (A) Stopper
- (B) Clutch pedal pad

6) Remove the stopper from the clutch pedal bracket.

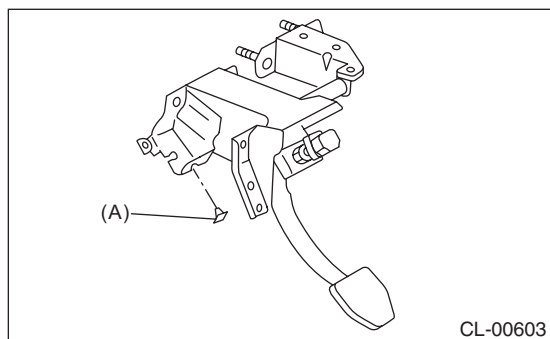

- (A) Stopper

## D: ASSEMBLY

- 1) Attach the stopper and clutch pedal pad to the clutch pedal.
- 2) Install the clutch switch to the pedal bracket.
- 3) Clean the pedal bushing holes of the clutch pedal and the brake pedal, apply grease, and install the pedal bushings.
- 4) Install the clutch pedal, brake pedal and lever to the pedal bracket, and fix with a spring pin.
- 5) Install the assist rod A, assist rod B, assist bushing and assist spring to the clutch pedal and pedal bracket.

## E: INSPECTION

Move the clutch pedal pads in the lateral direction with a force of approximately 10 N (1 kgf, 2 lbf) to check that the clutch pedal deflection is within the service limit.

### CAUTION:

If the play exceeds the service limit, replace the bushing with a new part.

### Deflection of the clutch pedal:

#### Service limit

4.0 mm (0.157 in) or less

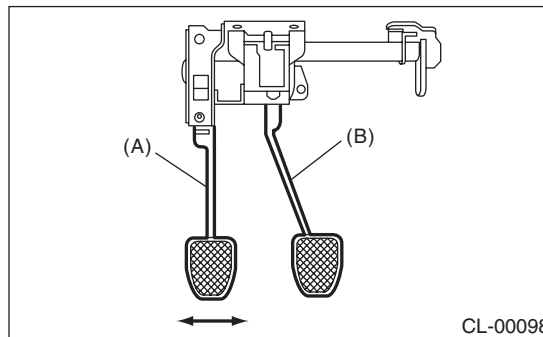

- (A) Clutch pedal
- (B) Brake pedal

## F: ADJUSTMENT

- 1) Turn the lock nut until the full stroke of clutch pedal becomes within the specification.

### CAUTION:

When adjusting the full stroke of clutch pedal, do not turn the clutch switch.

### NOTE:

If the lock nut cannot adjust the full stroke of clutch pedal to the specified value, adjust it by turning the master cylinder push rod.

### Clutch pedal full stroke A:

#### STI model

130 — 135 mm (5.12 — 5.31 in)

#### Except for STI model

135 — 140 mm (5.31 — 5.51 in)

### Tightening torque (Clutch switch lock nut):

T: 8 N·m (0.8 kgf·m, 5.9 ft·lb)

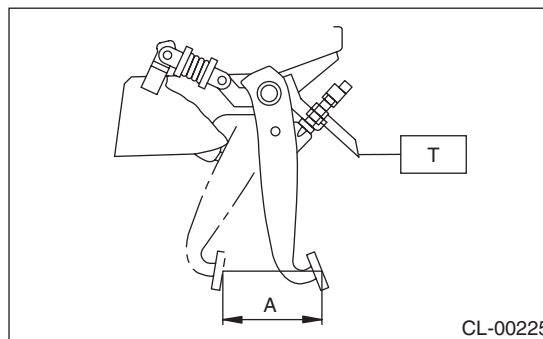

- 2) If the full stroke is not within the specified value, loosen the clutch switch lock nut to adjust.

### Tightening torque:

8 N·m (0.8 kgf·m, 5.9 ft·lb)

3) Loosen the push rod lock nuts.

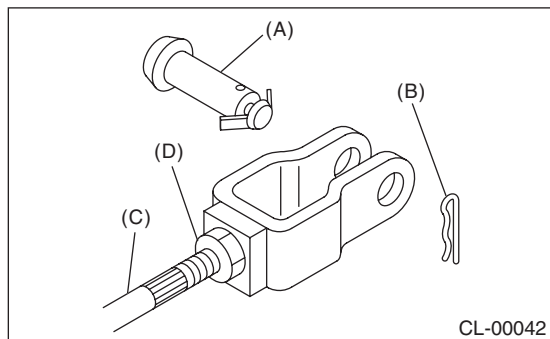

- (A) Clevis pin
- (B) Snap pin
- (C) Push rod
- (D) Push rod lock nut

4) Rotate the push rod to adjust.

- (1) Make sure that the clutch pedal contacts the clutch switch side when the pedal is released.
- (2) Make sure that the clutch pedal contacts the clutch pedal bracket stopper when the clutch pedal is at the maximum stroke position.

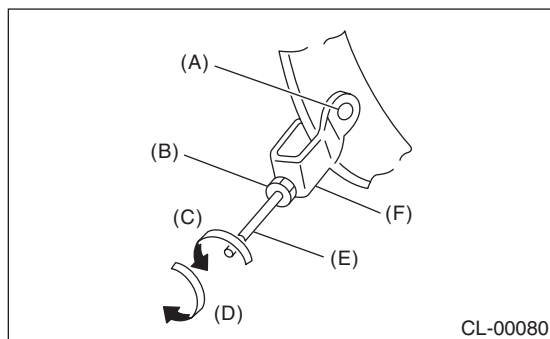

- (A) Clevis hole
- (B) Push rod lock nut
- (C) In the shorter direction
- (D) In the longer direction
- (E) Push rod
- (F) Clevis

5) Turn the push rod to shorten until a clearance is gained on the clutch switch side.

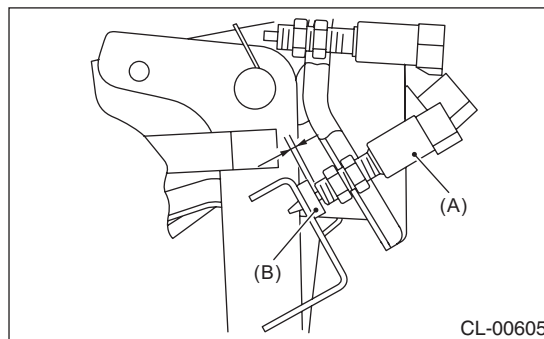

- (A) Clutch switch
- (B) Stopper

6) Turn the push rod to lengthen until clutch pedal contacts the clutch switch.

7) Turn further in the direction that will shorten the push rod (arrow direction shown in figure) by 270°.

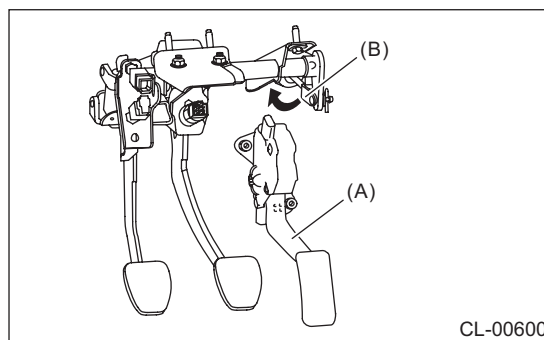

- (A) Accelerator pedal
- (B) Clevis

8) Check that the clevis pin moves smoothly by moving it in the left and right directions.

9) Tighten the push rod lock nut.

**Tightening torque (Push rod lock nut):**  
**T: 10 N·m (1.0 kgf-m, 7.4 ft-lb)**

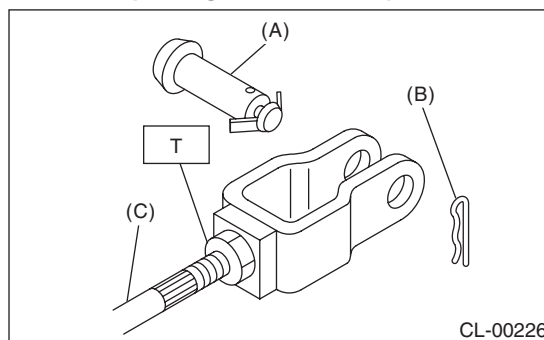

- (A) Clevis pin
- (B) Snap pin
- (C) Push rod

# Clutch Pedal

## CLUTCH SYSTEM

10) Depress and release the clutch pedal two or three times to ensure that the clutch pedal and release lever operate smoothly. If the clutch pedal and release lever do not operate smoothly, bleed air from the clutch hydraulic system. <Ref. to CL-27, Clutch Fluid Air Bleeding.>

11) Measure the clutch pedal full stroke length again to ensure that it is within specifications. If it is not within specifications, repeat adjustment procedures again from the beginning.

### Clutch pedal full stroke:

#### STI model

130 — 135 mm (5.12 — 5.31 in)

#### Except for STI model

135 — 140 mm (5.31 — 5.51 in)

12) Push the release lever until the operating cylinder push rod retracts. Make sure that the clutch fluid level in the reservoir tank increases. If the clutch fluid level increases, the hydraulic clutch is properly adjusted. If the fluid level does not increase or the push rod does not retract, replace the master cylinder with a new part. <Ref. to CL-22, Master Cylinder.>

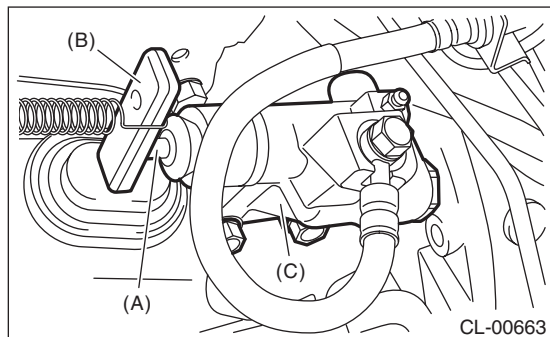

- (A) Push rod
- (B) Release lever
- (C) Operating cylinder

13) Push the release lever until the operating cylinder push rod retracts. Check that the clutch fluid level in the reservoir tank increases.

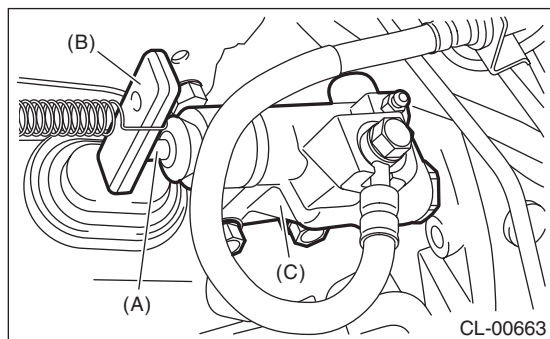

- (A) Push rod
- (B) Release lever
- (C) Operating cylinder

14) If the clutch fluid level increases, hydraulic clutch play is correct.

15) If the clutch fluid level does not increase or push rod does not retract, readjust the clutch pedal.

16) Check the fluid level using the scale on the outside of the reservoir tank. If the level is below "MIN", fill fluid up to "MAX" level.

### Recommended clutch fluid:

**New FMVSS No. 116 DOT3 or DOT4**

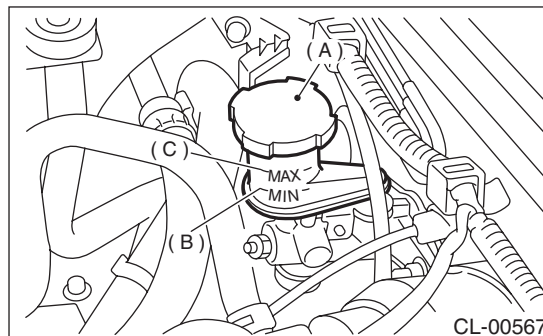

- (A) Reservoir tank
- (B) MIN. level
- (C) MAX. level



## 11. Clutch Switch

### A: REMOVAL

- 1) Disconnect the ground cable from battery.
- 2) Remove the instrument panel lower cover.
- 3) Disconnect the connector from the clutch switch.
- 4) Remove the clutch switches.

### B: INSTALLATION

#### 1. CLUTCH SWITCH (CRUISE CONTROL)

- 1) Move the clevis pin of push rod to left and right, retain it at the position where it moves smoothly, and measure the clutch pedal stroke.

#### Clutch pedal full stroke A:

##### STI model

130 — 135 mm (5.12 — 5.31 in)

##### Except for STI model

135 — 140 mm (5.31 — 5.51 in)

#### Tightening torque:

T: 8 N·m (0.8 kgf·m, 5.9 ft·lb)

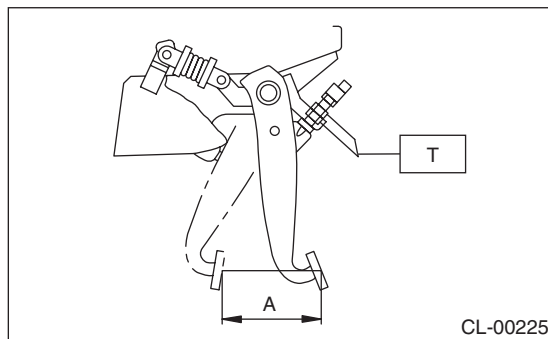

- 2) If the clutch pedal stroke is out of specification, adjust the stroke. <Ref. to CL-30, ADJUSTMENT, Clutch Pedal.>
- 3) Connect the clutch switch connector.

#### 2. CLUTCH START SWITCH

- 1) Fully depress the clutch pedal and hold it.

- 2) Install the clutch pedal plate and clutch switch so that the gap between them is 1.1 — 2.1 mm (0.04 — 0.08 in), and then tighten the lock nut.

#### Tightening torque:

8 N·m (0.8 kgf·m, 5.9 ft·lb)

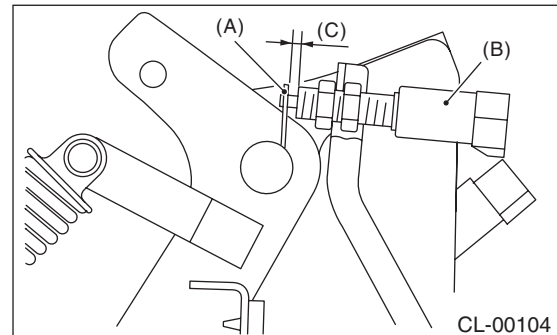

- (A) Plate
- (B) Clutch start switch
- (C) 1.1 — 2.1 mm (0.04 — 0.08 in)

- 3) Connect the clutch switch connector.
- 4) Make sure that engine does not start with clutch pedal not depressed.
- 5) Make sure that engine starts with clutch pedal fully depressed.

### C: INSPECTION

#### 1. CLUTCH START SWITCH

- 1) Perform the following inspections. If the clutch start switch does not operate normally, adjust the switch, and check it again. <Ref. to CL-35, ADJUSTMENT, Clutch Switch.>
  - Make sure that engine does not start with clutch pedal not depressed.
  - Make sure that engine starts with clutch pedal fully depressed.

# Clutch Switch

## CLUTCH SYSTEM

2) When the clutch start switch does not operate normally even if it is adjusted, check the clutch start switch for continuity.

(1) Remove the clutch start switch. <Ref. to CL-33, REMOVAL, Clutch Switch.>

(2) Measure the resistance between terminal 1 and 2 of the switch. If the resistance is not at the standard value, replace the switch.

Condition	Terminal No.	Specified resistance
ON	No. 1 — No. 2	Less than 1 $\Omega$
OFF	No. 1 — No. 2	1 M $\Omega$ or more

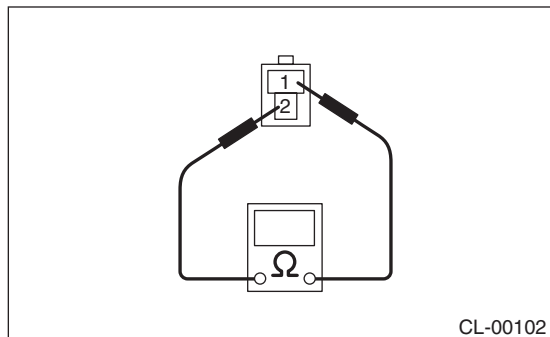

(3) Check that the switch is turned on and off in Dimension L.

### Dimension L:

4 — 5.5 mm (0.16 — 0.22 in)

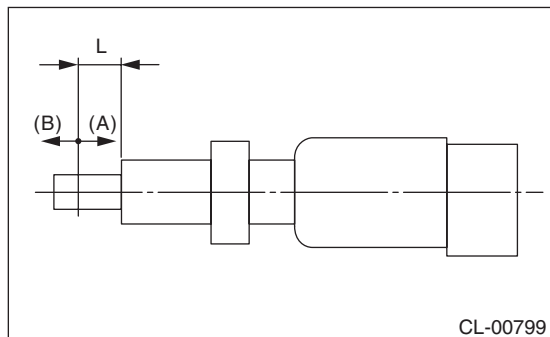

- (A) ON
- (B) OFF

## 2. CLUTCH SWITCH

1) Check the clutch switch for continuity.

(1) Disconnect the connector of clutch switch.

(2) Measure the resistance between terminal 1 and 2 of the switch. If the resistance is not within the specification, check the clutch stroke and installation condition, and check the clutch switch again.

Condition	Terminal No.	Specified resistance
When clutch pedal is depressed	No. 1 — No. 2	1 M $\Omega$ or more
When the clutch pedal is not depressed	No. 1 — No. 2	Less than 1 $\Omega$

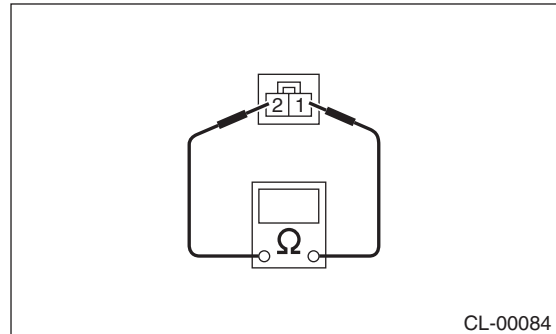

2) When the clutch switch does not operate normally even if the clutch stroke and installation condition are normal, check the clutch switch for continuity.

(1) Remove the clutch switches. <Ref. to CL-33, REMOVAL, Clutch Switch.>

(2) Measure the resistance between terminal 1 and 2 of the switch. If the resistance is not at the standard value, replace the switch.

Condition	Terminal No.	Specified resistance
ON	No. 1 — No. 2	Less than 1 $\Omega$
OFF	No. 1 — No. 2	1 M $\Omega$ or more

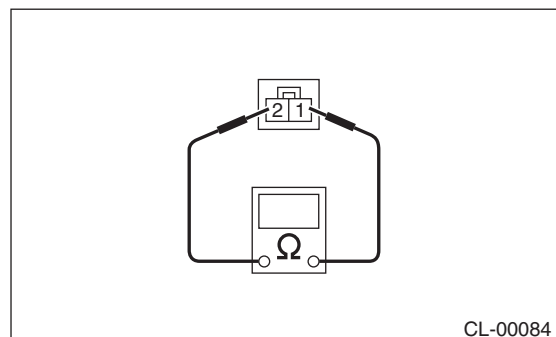

(3) Check that the switch is turned on and off in Dimension L.



**Dimension L:**

**5 — 6.5 mm (0.2 — 0.26 in)**

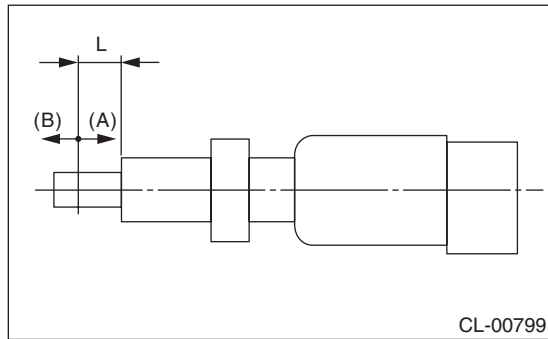

- (A) ON
- (B) OFF

**D: ADJUSTMENT**

1) Loosen the lock nut of clutch start switch.

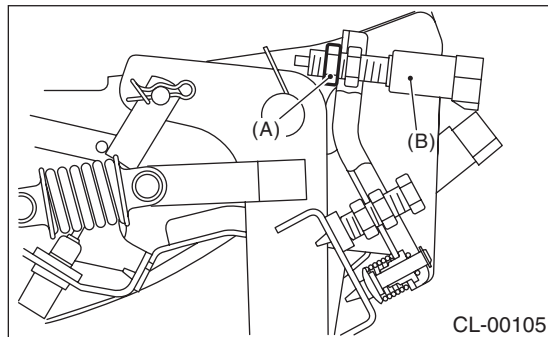

- (A) Lock nut
- (B) Clutch start switch

2) Fully depress the clutch pedal and hold it.  
 3) Adjust the gap of the clutch pedal plate and the clutch switch to be 1.1 — 2.1 mm (0.04 — 0.08 in).

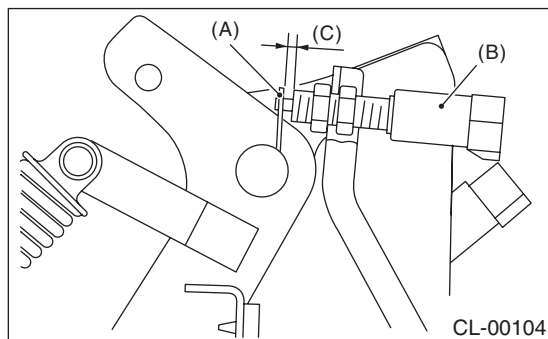

- (A) Plate
- (B) Clutch start switch
- (C) 1.1 — 2.1 mm (0.04 — 0.08 in)

4) Tighten the lock nut.

**Tightening torque:**

**8 N·m (0.8 kgf·m, 5.9 ft·lb)**

# General Diagnostic Table

## CLUTCH SYSTEM

### 12. General Diagnostic Table

#### A: INSPECTION

##### 1. CLUTCH

Symptoms	Possible cause	Corrective action
<p>1. Clutch slippage. It is hard to perceive clutch slippage in the early stage, but pay attention to the following symptoms.</p> <ul style="list-style-type: none"> <li>• Engine speeds up when shifting.</li> <li>• High-speed driving is not possible; especially rapid acceleration is not possible and vehicle speed does not increase in proportion to the increase in engine speed.</li> <li>• Power drops particularly when ascending a slope, and there is a burning smell of the clutch plate.</li> <li>• Method of testing: Park the vehicle and fully apply the parking brake. Disengage the clutch and shift the transmission gear into the 1st. Gradually increase the engine speed while gradually allowing the clutch to engage. The clutch function is satisfactory if the engine stalls. However, the clutch is slipping if the vehicle does not move forward and the engine does not stall.</li> </ul>	(a) Oil on the clutch face	Replace.
	(b) Worn clutch face	Replace.
	(c) Deteriorated diaphragm spring	Replace.
	(d) Warped pressure plate or flywheel	Repair or replace.
	(e) Defective release bearing holder	Repair or replace.
<p>2. Clutch drags. As a symptom of this trouble, a harsh scratching noise occurs and control becomes difficult when shifting gears. The symptom becomes more apparent when shifting into the 1st gear. However, because most trouble of this sort is due to a defective synchronization mechanism, perform the following tests.</p> <ul style="list-style-type: none"> <li>• Method of testing: &lt;Ref. to CL-37, DIAGNOSTIC DIAGRAM OF CLUTCH DRAG, INSPECTION, General Diagnostic Table.&gt;</li> </ul> <p>The problem is caused by insufficient disengagement of the clutch if an abnormal noise occurs during this test.</p>	(a) Worn or rusty clutch disc hub spline	Replace the clutch disc.
	(b) Excessive deflection of clutch disc face	Repair or replace.
	(c) Crankshaft pilot needle bearing sticking	Replace.
	(d) Cracked clutch disc face	Replace.
	(e) Stuck clutch disc (smeared by oil or water)	Replace.
<p>3. Clutch chatters. Clutch chattering is an unpleasant vibration to the whole vehicle when the vehicle is just started with clutch partially engaged.</p>	(a) Adhesion of oil on the clutch face	Replace the clutch disc.
	(b) Weak or broken damper spring	Replace the clutch disc.
	(c) Poor contact of the disc surface or excessively worn disc	Replace the faulty clutch disc.
	(d) Warped pressure plate or flywheel	Repair or replace.
	(e) Loose disc rivets	Replace the clutch disc.
	(f) Loose engine mounting	Retighten or replace mounting.
	(g) Loose pitching stopper	Retighten or replace the pitching stopper.

# General Diagnostic Table

CLUTCH SYSTEM

Symptoms	Possible cause	Corrective action
4. Noisy clutch Examine whether the noise is generated when the clutch is disengaged, engaged, or partially engaged.	(a) Broken, worn or insufficiently lubricated release bearing	Replace the release bearing.
	(b) Insufficient lubrication of the pilot bearing	Replace the pilot bearing.
	(c) Loose clutch disc hub	Replace the clutch disc.
	(d) Loose damper spring retainer	Replace the clutch disc.
	(e) Deteriorated or broken damper spring	Replace the clutch disc.
5. Clutch grabs suddenly. When starting the vehicle with the clutch partially engaged, the clutch engages suddenly and the vehicle jumps instead of making a smooth start.	(a) Grease or oil on facing	Replace the clutch disc.
	(b) Deteriorated cushioning spring	Replace the clutch disc.
	(c) Worn or rusted spline of clutch disc or main shaft	Take off rust, apply grease or replace clutch disc or main shaft.
	(d) Deteriorated or broken damper spring	Replace the clutch disc.
	(e) Loose engine mounting	Retighten or replace mounting.
	(f) Deteriorated diaphragm spring	Replace.

## 2. CLUTCH PEDAL

Symptoms	Corrective action
Insufficient pedal play	Adjust the free play of the pedal.
Insufficient clutch pedal free play	Adjust the free play of the pedal.
Excessively worn and damaged pedal shaft and/or bushing	Replace the bushing or shaft with a new part.

## 3. DIAGNOSTIC DIAGRAM OF CLUTCH DRAG

Step	Check	Yes	No
<b>1</b> <b>CHECK GEAR NOISE.</b> 1) Start the engine. 2) While idling the engine, step on the clutch pedal and quickly shift from neutral to reverse.	Is there any abnormal noise from the transmission gear?	Go to step 2.	Clutch is normal.
<b>2</b> <b>CHECK GEAR NOISE.</b> Depress the clutch pedal at idle and shift from neutral to reverse within 0.5 — 1.0 second.	Is there any abnormal noise from the transmission gear?	Go to step 3.	Defective transmission or excessive clutch drag torque. Inspect pilot bearing, clutch disc, transmission and clutch disc hub spline.
<b>3</b> <b>CHECK GEAR NOISE.</b> 1) Depress the clutch pedal at idle and shift from neutral to reverse within 0.5 — 1.0 second. 2) While stepping on the clutch pedal, shift from neutral to reverse, reverse to neutral several times.	Is there any abnormal noise from the transmission gear?	Inadequate clutch disengage. Inspect the clutch disc, clutch cover, clutch release, and clutch pedal free play.	Clutch and fly-wheel seizure. Inspect the clutch disc and the spline of the clutch disc hub.

# General Diagnostic Table

CLUTCH SYSTEM

---

**CHASSIS SECTION**

This service manual has been prepared to provide SUBARU service personnel with the necessary information and data for the correct maintenance and repair of SUBARU vehicles.

This manual includes the procedures for maintenance, disassembling, reassembling, inspection and adjustment of components and diagnostics for guidance of experienced mechanics.

Please peruse and utilize this manual fully to ensure complete repair work for satisfying our customers by keeping their vehicle in optimum condition. When replacement of parts during repair work is needed, be sure to use SUBARU genuine parts.

All information, illustration and specifications contained in this manual are based on the latest product information available at the time of publication approval.

<b>FRONT SUSPENSION</b>	<b>FS</b>
<b>REAR SUSPENSION</b>	<b>RS</b>
<b>WHEEL AND TIRE SYSTEM</b>	<b>WT</b>
<b>TIRE PRESSURE MONITORING SYSTEM (DIAGNOSTICS)</b>	<b>TPM(diag)</b>
<b>DIFFERENTIALS</b>	<b>DI</b>
<b>TRANSFER CASE</b>	<b>TC</b>
<b>DRIVE SHAFT SYSTEM</b>	<b>DS</b>
<b>VEHICLE DYNAMICS CONTROL (VDC)</b>	<b>VDC</b>
<b>VEHICLE DYNAMICS CONTROL (VDC) (DIAGNOSTICS)</b>	<b>VDC(diag)</b>
<b>BRAKE</b>	<b>BR</b>
<b>PARKING BRAKE</b>	<b>PB</b>
<b>POWER ASSISTED SYSTEM (POWER STEERING)</b>	<b>PS</b>

# FRONT SUSPENSION

# FS

---

	<b>Page</b>
1. General Description .....	2
2. Wheel Alignment .....	8
3. Front Crossmember Support Plate .....	16
4. Front Stabilizer .....	17
5. Front Ball Joint .....	18
6. Front Arm .....	20
7. Front Strut .....	24
8. Front Crossmember .....	27
9. General Diagnostic Table .....	28

# General Description

## FRONT SUSPENSION

### 1. General Description

#### A: SPECIFICATION

Model		Except for STI model	STI model	
Front	Wheel arch height (Tolerance: $+12\text{ mm}$ $-24\text{ mm}$ ( $+0.47\text{ in}$ $-0.94\text{ in}$ ))	mm (in)	376 (14.8)	371 (14.6)
	Camber (Tolerance: $\pm 0^\circ 45'$ Differences between RH and LH: 45' or less)		$-0^\circ 50'$	$-0^\circ 45'$
	Caster (Referential Value)		$6^\circ 30'$	$6^\circ 30'$
	Steering angle (Tolerance: $\pm 1.5^\circ$ )	Inner wheel	$36.6^\circ$	$36.6^\circ$
		Outer wheel	$32.2^\circ$	$32.2^\circ$
	Toe-in		mm (in)	$0 \pm 3$ ( $0 \pm 0.12$ ) Toe angle (sum of both wheels): $0^\circ \pm 0^\circ 15'$
Kingpin angle (Referential Value)		$15^\circ 15'$	$15^\circ 15'$	
Rear	Wheel arch height (Tolerance: $+12\text{ mm}$ $-24\text{ mm}$ ( $+0.47\text{ in}$ $-0.94\text{ in}$ ))	mm (in)	370 (14.6)	365 (14.4)
	Camber (Tolerance: $\pm 0^\circ 45'$ Differences between RH and LH: 45' or less)		17-inch tire: $-1^\circ 35'$	$-1^\circ 30'$
	Toe-in		mm (in)	$0 \pm 3$ ( $0 \pm 0.12$ ) Toe angle (sum of both wheels): $0^\circ \pm 0^\circ 15'$
	Thrust angle (Tolerance: $\pm 0^\circ 30'$ )			$0^\circ$

#### NOTE:

- Front and rear toe-in and front camber can be adjusted. Adjust if the toe-in or camber tolerance exceeds specifications.
- Other items indicated in the specifications is not equipped with adjustment mechanisms. If other items exceed specifications, check the suspension parts and connections for deformation. If defective, replace with new parts.

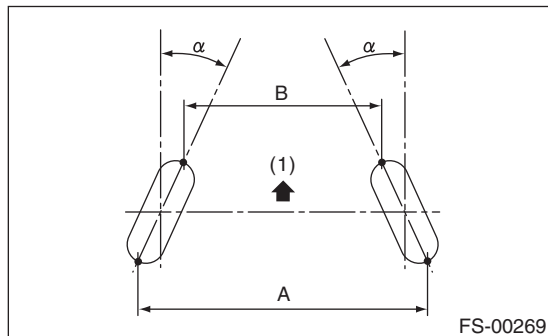

(1) Front

A – B = Positive: Toe-in, Negative: Toe-out

$\alpha$  = Individual toe angles

# General Description

FRONT SUSPENSION

## B: COMPONENT

- Except for STI model

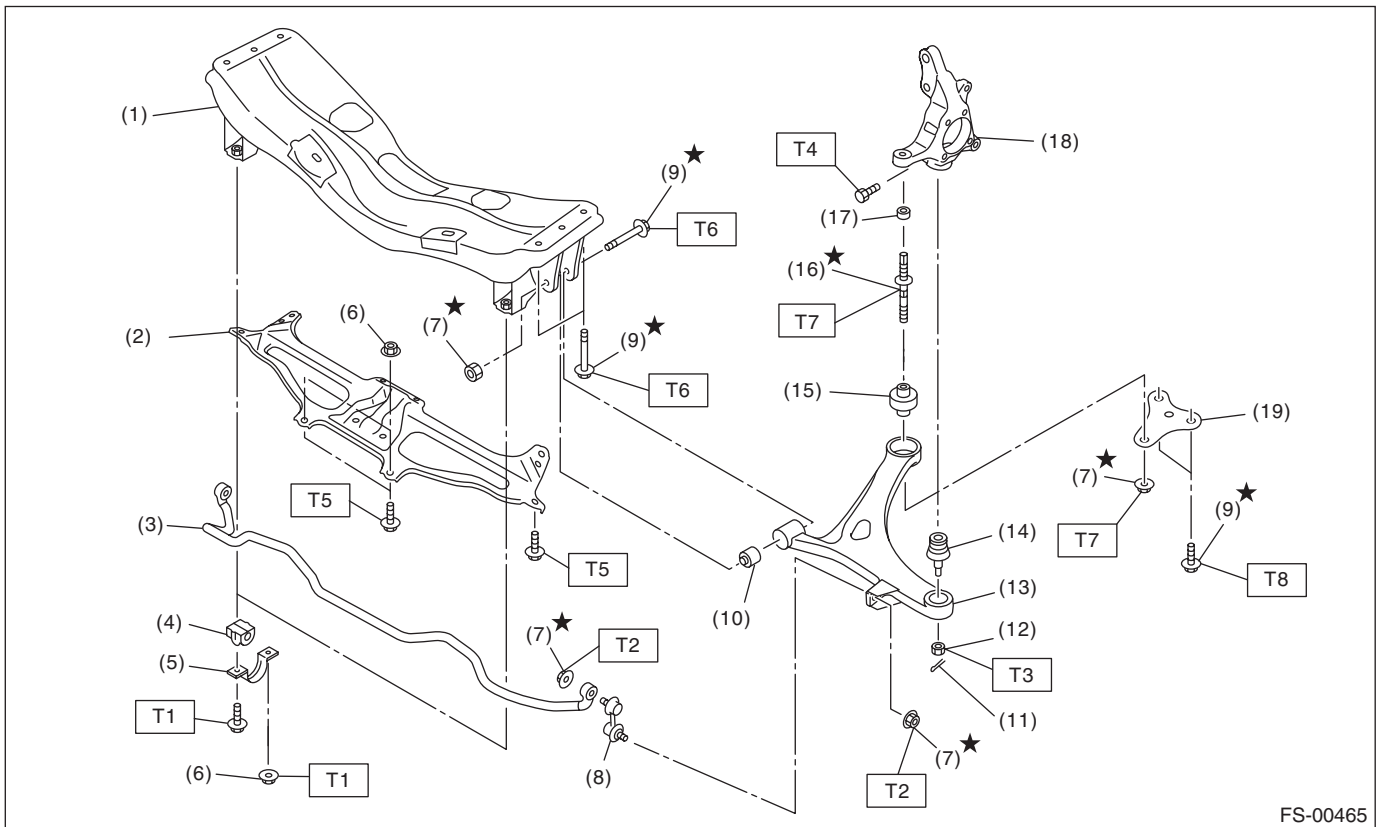

FS-00465

- |                               |                    |
|-------------------------------|--------------------|
| (1) Front crossmember         | (11) Cotter pin    |
| (2) Crossmember support plate | (12) Castle nut    |
| (3) Stabilizer                | (13) Front arm     |
| (4) Bushing                   | (14) Ball joint    |
| (5) Bracket                   | (15) Rear bushing  |
| (6) Flange nut                | (16) Stud bolt     |
| (7) Flange nut                | (17) Stopper       |
| (8) Stabilizer link           | (18) Housing       |
| (9) Bolt                      | (19) Support plate |
| (10) Front bushing            |                    |

### **Tightening torque: N·m (kgf·m, ft·lb)**

**T1: 25 (2.5, 18.4)**

**T2: 38 (3.9, 28.0)**

**T3: 39 (4.0, 28.8)**

**T4: 50 (5.1, 36.9)**

**T5: 60 (6.1, 44.3)**

**T6: 95 (9.7, 70.1)**

**T7: 110 (11.2, 81.1)**

**T8: 150 (15.3, 110.6)**

**FS-3**

Brought to you by Ebay Seller "SubaruManuals"



# General Description

## FRONT SUSPENSION

### • STI model

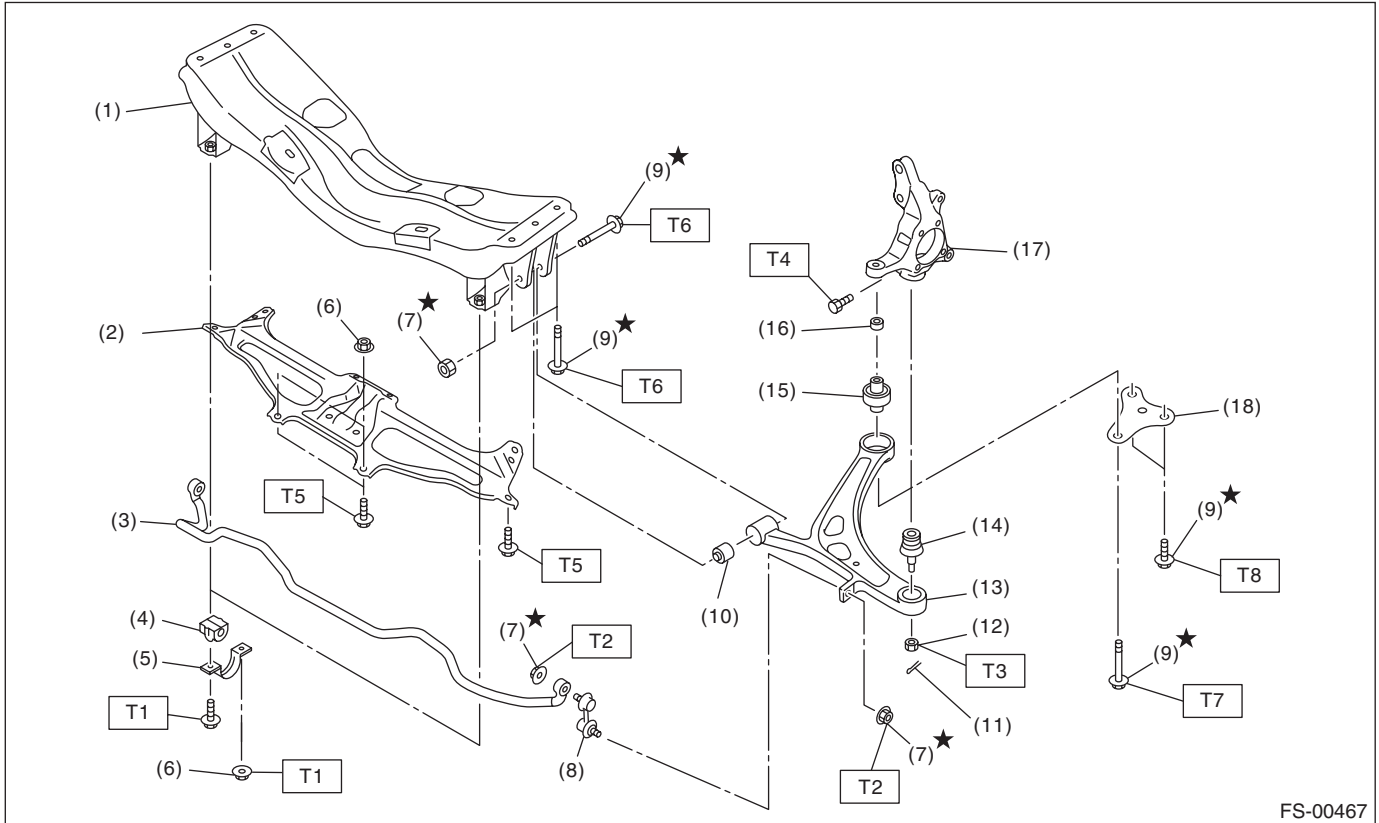

FS-00467

- |                               |                          |
|-------------------------------|--------------------------|
| (1) Front crossmember         | (10) Front bushing       |
| (2) Crossmember support plate | (11) Cotter pin          |
| (3) Stabilizer                | (12) Castle nut          |
| (4) Bushing                   | (13) Front arm           |
| (5) Bracket                   | (14) Ball joint          |
| (6) Flange nut                | (15) Pillow ball bushing |
| (7) Flange nut                | (16) Stopper             |
| (8) Stabilizer link           | (17) Housing             |
| (9) Bolt                      | (18) Support plate       |

#### **Tightening torque: N·m (kgf·m, ft·lb)**

**T1: 25 (2.5, 18.4)**

**T2: 38 (3.9, 28.0)**

**T3: 39 (4.0, 28.8)**

**T4: 50 (5.1, 36.9)**

**T5: 60 (6.1, 44.3)**

**T6: 95 (9.7, 70.1)**

**T7: 140 (14.3, 103.3)**

**T8: 150 (15.3, 110.6)**

### • Strut

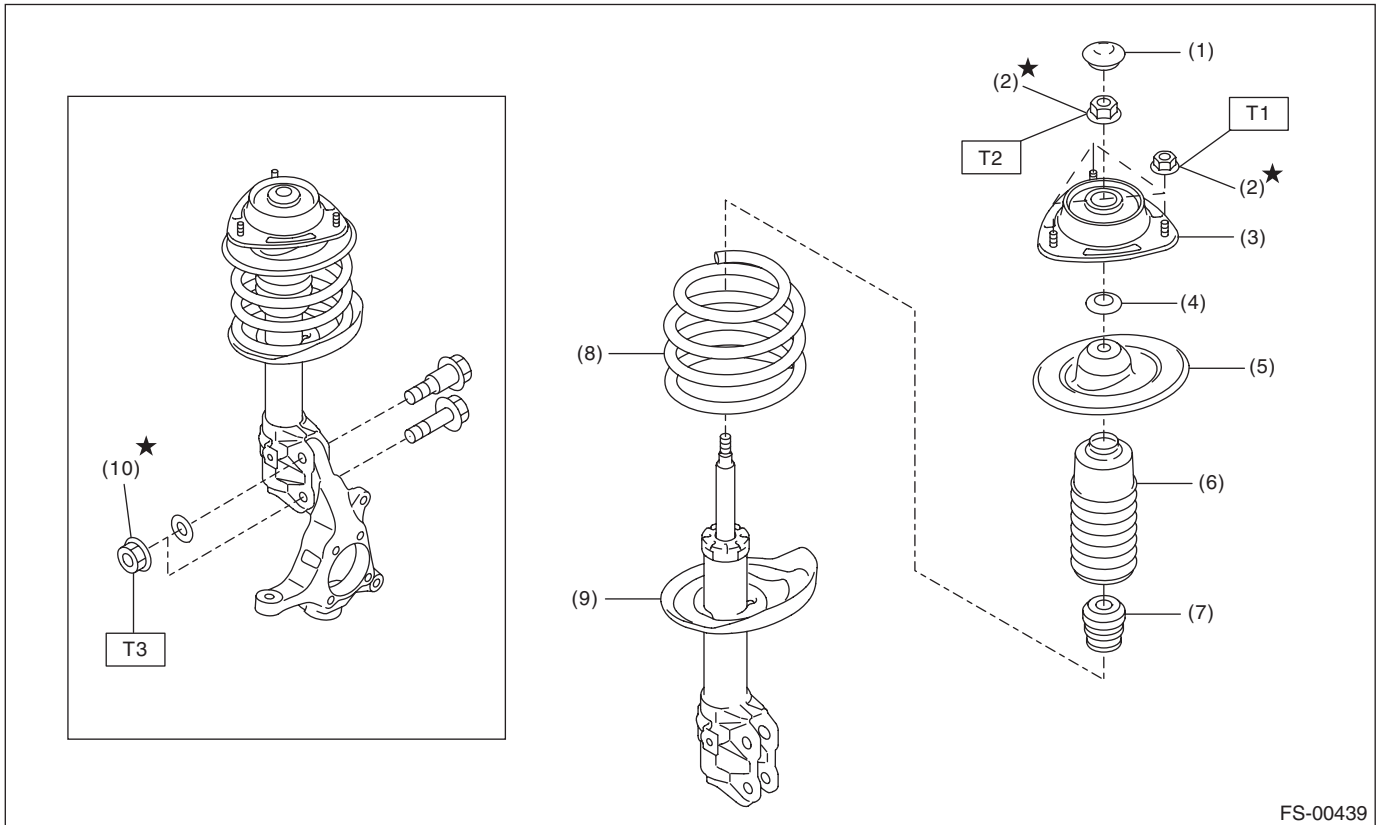

FS-00439

- |                       |                 |
|-----------------------|-----------------|
| (1) Dust seal         | (6) Dust cover  |
| (2) Self-locking nut  | (7) Helper      |
| (3) Strut mount       | (8) Coil spring |
| (4) Spacer            | (9) Strut       |
| (5) Upper spring seat | (10) Flange nut |

#### **Tightening torque: N·m (kgf-m, ft-lb)**

**T1: 20 (2.0, 14.8)**

**T2: 55 (5.6, 40.6)**

**T3: 155 (15.8, 114.3)**

### C: CAUTION

- Wear appropriate work clothing, including a cap, protective goggles and protective shoes when performing any work.
- Before removal, installation or disassembly, be sure to clarify the failure. Avoid unnecessary removal, installation, disassembly and replacement.
- Use SUBARU genuine grease etc. or equivalent. Do not mix grease etc. of different grades or manufacturers.
- Before securing a part on a vise, place cushioning material such as wood blocks, aluminum plate, or cloth between the part and the vise.
- Be sure to tighten fasteners including bolts and nuts to the specified torque.
- Place shop jacks or rigid racks at the specified points.

# General Description

## FRONT SUSPENSION

### D: PREPARATION TOOL

#### 1. SPECIAL TOOL

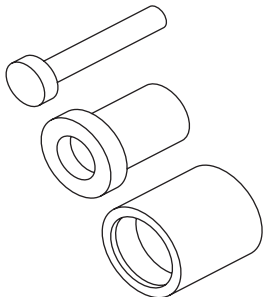
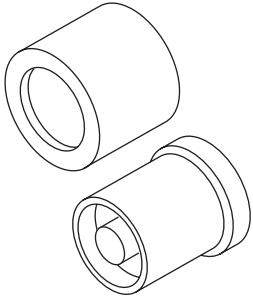
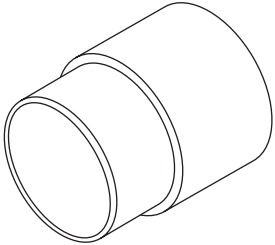
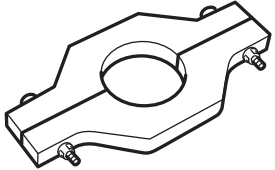
ILLUSTRATION	TOOL NUMBER	DESCRIPTION	REMARKS
 <p>ST-927680000</p>	927680000	INSTALLER & REMOVER SET	Used for replacing front arm front bushing.
 <p>ST20099AE020</p>	20099AE020	INSTALLER & REMOVER	Used for replacing pillow ball bushing of aluminum front arm.
 <p>ST28099PA010</p>	28099PA010	HOUSING STAND	<ul style="list-style-type: none"> <li>• Used for removing pillow ball bushing of aluminum front arm.</li> <li>• Used together with INSTALLER &amp; REMOVER (20099AE020).</li> </ul>
 <p>ST18723AA000</p>	18723AA000	REMOVER	<ul style="list-style-type: none"> <li>• Used for assembling pillow ball bushing of aluminum front arm.</li> <li>• Used together with INSTALLER &amp; REMOVER (20099AE020).</li> </ul>

# General Description

FRONT SUSPENSION

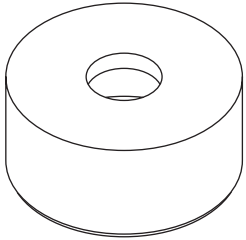
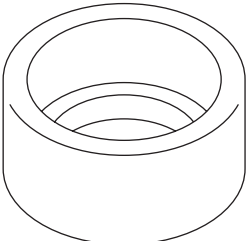
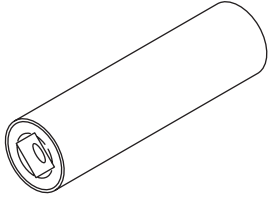
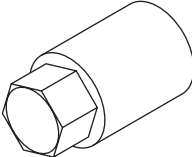
ILLUSTRATION	TOOL NUMBER	DESCRIPTION	REMARKS
 ST20299AG000	20299AG000	REMOVER	<ul style="list-style-type: none"> <li>• Used for replacing front arm rear bushing.</li> <li>• Used together with BASE (20299AG010).</li> </ul>
 ST20299AG010	20299AG010	BASE	<ul style="list-style-type: none"> <li>• Used for replacing front arm rear bushing.</li> <li>• Used together with REMOVER (20299AG000).</li> </ul>
 ST20299AG020	20299AG020	STUD BOLT SOCKET	Used for removing and installing the stud bolt for front arm installing portion.
 ST20399AG000	20399AG000	STRUT MOUNT SOCKET	Used for disassembling and assembling strut mount.

## 2. GENERAL TOOL

TOOL NAME	REMARKS
Alignment gauge	Used for measuring wheel alignment.
Alignment gauge adapter	Used for measuring wheel alignment.
Turning radius gauge	Used for measuring wheel alignment.
Toe-in gauge	Used for toe-in measurement.
Dial gauge	Used for damper strut measurement.
Coil spring compressor	Used for strut assembly/disassembly.

**FS-7**

Brought to you by Ebay Seller "SubaruManuals"

# Wheel Alignment

## FRONT SUSPENSION

## 2. Wheel Alignment

### A: INSPECTION

Check the following items before performing the wheel alignment measurement.

- Tire inflation pressure
- Uneven wear of RH and LH tires, or difference of sizes
- Tire runout
- Excessive play and wear of ball joint
- Excessive play and wear of tie-rod end
- Excessive play of wheel bearing
- Right and left wheel base imbalance
- Deformation and excessive play of steering link
- Deformation and excessive play of suspension parts

Check, adjust and measure the wheel alignment in accordance with the procedures indicated in the figure.

Wheel arch height (front and rear wheels) <Ref. to FS-8, WHEEL ARCH HEIGHT, INSPECTION, Wheel Alignment.>
↓
Camber (front and rear wheels) <Ref. to FS-10, CAMBER, INSPECTION, Wheel Alignment.>
↓
Caster (front wheel) <Ref. to FS-11, CASTER, INSPECTION, Wheel Alignment.>
↓
Steering angle <Ref. to FS-12, STEERING ANGLE, INSPECTION, Wheel Alignment.>
↓
Front wheel toe-in <Ref. to FS-12, FRONT WHEEL TOE-IN, INSPECTION, Wheel Alignment.>
↓
Rear wheel toe-in <Ref. to FS-13, REAR WHEEL TOE-IN, INSPECTION, Wheel Alignment.>
↓
Thrust angle <Ref. to FS-15, THRUST ANGLE, INSPECTION, Wheel Alignment.>

### 1. WHEEL ARCH HEIGHT

- 1) Park the vehicle on a level surface.
- 2) Empty the vehicle so that it is at "curb weight". (Empty the luggage compartment, load the spare tire, jack and service tools, and fill up the fuel tank.)
- 3) Set the steering wheel in a straight-ahead position, and stabilize the suspension by moving the vehicle in a straight line for 5 m (16 ft) or more.
- 4) Suspend a thread from the wheel arch (point "A" in the figure (FS-00442)) and affix at a position directly above the center of wheel.

# Wheel Alignment

## FRONT SUSPENSION

5) Measure the distance between the point "A" (end of curve) and the center of wheel.

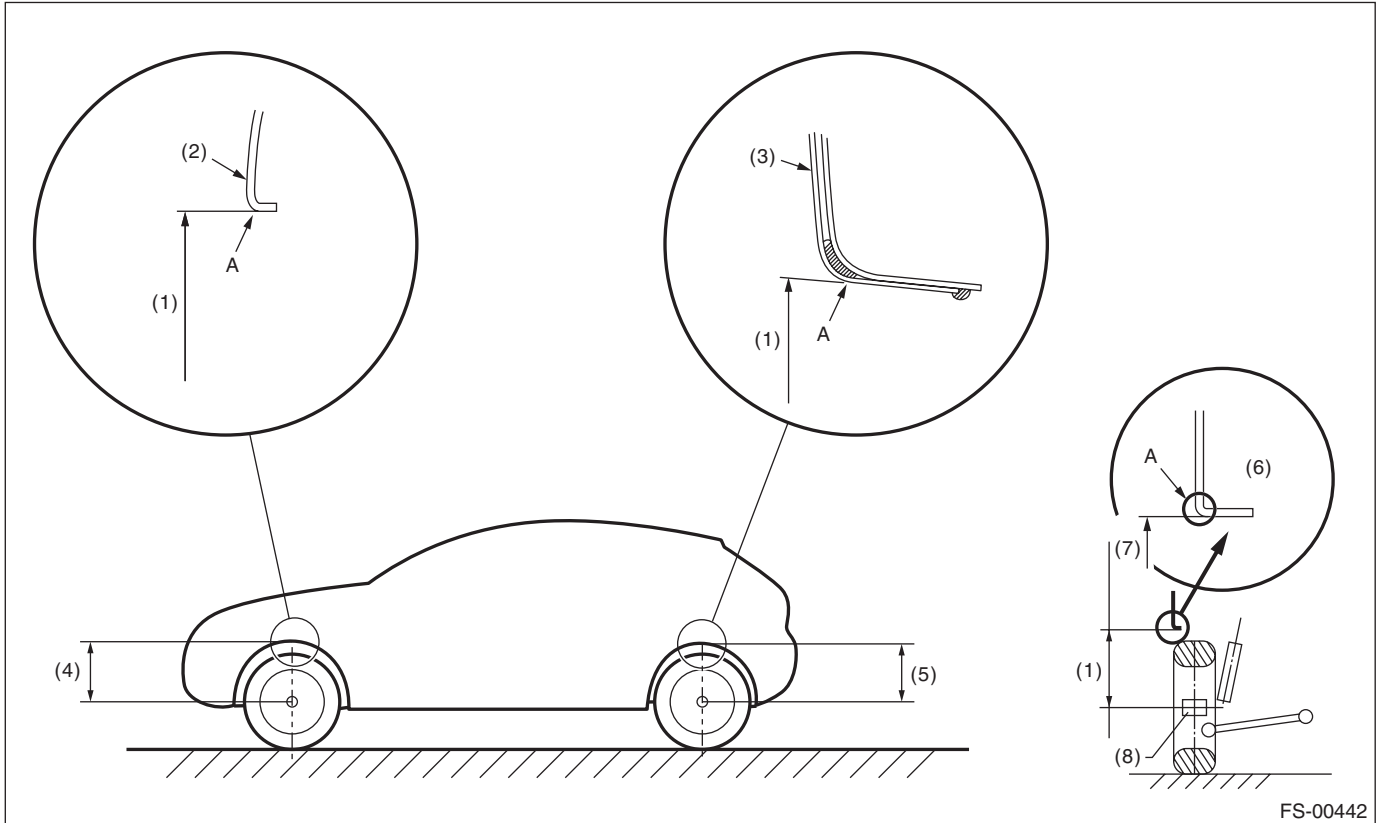

FS-00442

- |                       |                             |                          |
|-----------------------|-----------------------------|--------------------------|
| (1) Wheel arch height | (4) Front wheel arch height | (7) Point of measurement |
| (2) Front fender      | (5) Rear wheel arch height  | (8) End of spindle       |
| (3) Rear quarter      | (6) Flange bend line        |                          |

Wheel arch height specification mm (in) (Tolerance $+12\text{ mm}$ $-24\text{ mm}$ ( $+0.47\text{ in}$ $-0.94\text{ in}$ ))		
Model	Except for STI model	STI model
Front	376 (14.8)	371 (14.6)
Rear	370 (14.6)	365 (14.4)

# Wheel Alignment

## FRONT SUSPENSION

### 2. CAMBER

#### • Inspection

- 1) Place the front wheel on the turning radius gauge. Make sure the ground contact surfaces of the front and rear wheels are at the same height.
- 2) Set the adapter into the center of wheel, and then set the wheel alignment gauge.

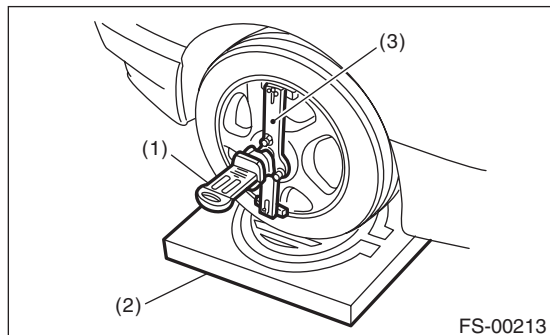

- (1) Alignment gauge
- (2) Turning radius gauge
- (3) Adapter

- 3) Measure the camber angle in accordance with the operation manual for wheel alignment gauge.

Model	Camber (Difference between RH and LH 45' or less)
Except for STI model	$-0^{\circ}50' \pm 0^{\circ}45'$
STI model	$-0^{\circ}45' \pm 0^{\circ}45'$

#### • Front camber adjustment

- 1) When adjusting the camber, adjust it to the following value.

Model	Camber (Difference between RH and LH 30' or less)
Except for STI model	$-0^{\circ}50' \pm 0^{\circ}30'$
STI model	$-0^{\circ}45' \pm 0^{\circ}30'$

- 2) Loosen the two flange nuts located at the front lower section of the strut.

#### NOTE:

When the adjusting bolt needs to be loosened or tightened, hold its head with a wrench and turn the flange nut.

- 3) Turn the camber adjusting bolt so that the camber is set at specification.

#### NOTE:

Moving the adjusting bolt by one scale changes the camber by approximately  $0^{\circ}15'$ .

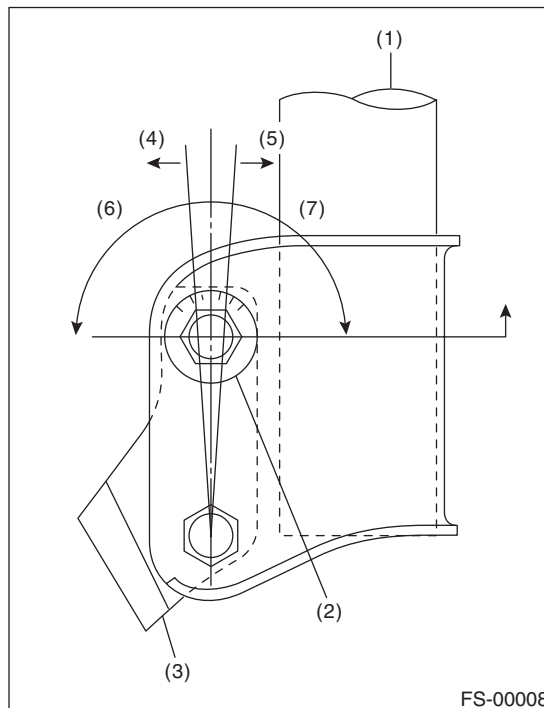

- (1) Strut
- (2) Adjusting bolt
- (3) Housing
- (4) Outer
- (5) Inner
- (6) Camber is increased.
- (7) Camber is decreased.

# Wheel Alignment

FRONT SUSPENSION

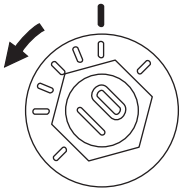
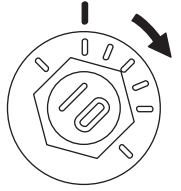
To increase camber.	
Rotate the left side counterclockwise.	Rotate the right side clockwise.
	
FS-00009	FS-00010

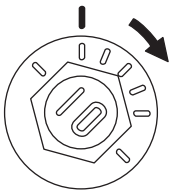
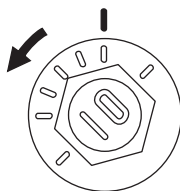
To decrease camber.	
Rotate the left side clockwise.	Rotate the right side counterclockwise.
	
FS-00010	FS-00009

4) Tighten two new flange nuts.

**Tightening torque:**

**155 N·m (15.8 kgf·m, 114.3 ft·lb)**

### 3. CASTER

• **Inspection**

- 1) Place the front wheel on the turning radius gauge. Make sure the ground contact surfaces of the front and rear wheels are at the same height.
- 2) Set the adapter into the center of wheel, and then set the wheel alignment gauge.

3) Measure the caster angle in accordance with the operation manual for wheel alignment gauge.

Model	Caster
Except for STI model	6°30'
STI model	6°30'

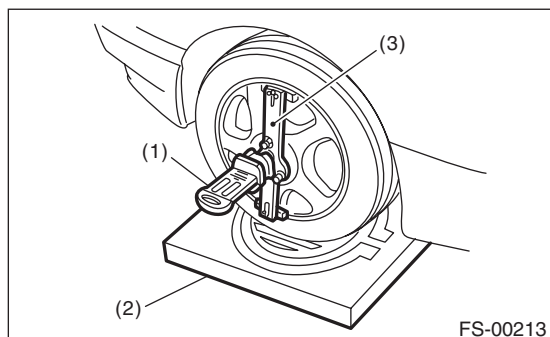

- (1) Alignment gauge
- (2) Turning radius gauge
- (3) Adapter



# Wheel Alignment

## FRONT SUSPENSION

### 4. STEERING ANGLE

#### • Inspection

- 1) Place the vehicle on turning radius gauge.
- 2) While depressing the brake pedal, turn the steering wheel fully to the left and right. With the steering wheel held at each fully turned position, measure both the inner and outer wheel steering angles.

Model	Inner wheel	Outer wheel
Except for STI model	$36.6^{\circ} \pm 1.5^{\circ}$	$32.2^{\circ} \pm 1.5^{\circ}$
STI model	$36.6^{\circ} \pm 1.5^{\circ}$	$32.2^{\circ} \pm 1.5^{\circ}$

#### • Adjustment

- 1) Turn the tie-rod to adjust the steering angle of both inner and outer wheels.
- 2) Check the toe-in.

#### NOTE:

Correct the boot if it is twisted.

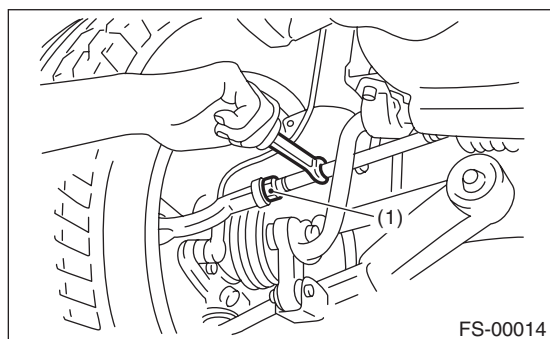

(1) Lock nut

### 5. FRONT WHEEL TOE-IN

#### • Inspection

#### Toe-in:

**$0 \pm 3 \text{ mm } (0 \pm 0.12 \text{ in})$**

- 1) Set the toe-in gauge in the position at wheel axis center height behind the right and left front tires.
- 2) Place a mark at the center of both left and right tires, and measure distance "A" between the marks.
- 3) Move the vehicle forward to rotate the tires  $180^{\circ}$ .

#### NOTE:

Be sure to rotate the tires in the forward direction.

- 4) Measure the distance "B" between the left and right marks. Find toe-in using the following calculation:

$$A - B = \text{Toe-in}$$

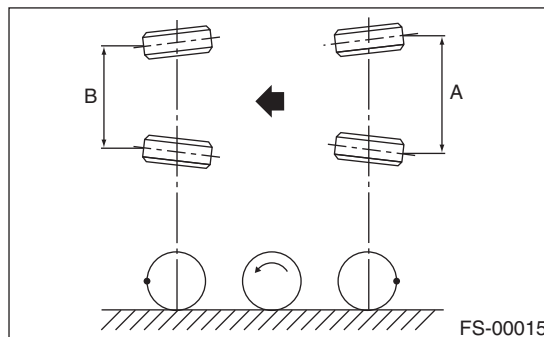

#### • Adjustment

When adjusting the toe-in, adjust it to the following value.

#### Toe-in:

**$0 \pm 2 \text{ mm } (0 \pm 0.08 \text{ in})$**

- 1) Check that the left and right wheel steering angles are within specification.
- 2) Loosen the left and right side steering tie-rod lock nuts.
- 3) Turn the left and right tie-rods by equal amounts until the toe-in is at the specification. Both the left and right tie-rods are right-hand threaded. To increase toe-in, turn both tie-rods clockwise by equal amount (viewing from the inside of vehicle).

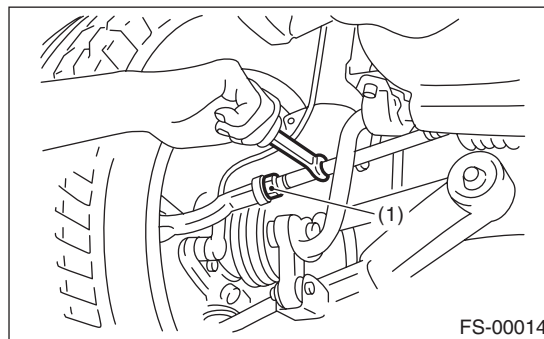

(1) Lock nut

- 4) Tighten the tie-rod lock nut.

#### Tightening torque:

**$85 \text{ N}\cdot\text{m } (8.7 \text{ kgf}\cdot\text{m}, 62.7 \text{ ft}\cdot\text{lb})$**

#### NOTE:

Check and correct the tie-rod boot if twisted.

## 6. REAR WHEEL TOE-IN

### • Inspection

#### **Toe-in:**

**$0 \pm 3$  mm ( $0 \pm 0.12$  in)**

Refer to FRONT WHEEL TOE-IN for rear toe-in inspection procedures. <Ref. to FS-12, FRONT WHEEL TOE-IN, INSPECTION, Wheel Alignment.>

### • Adjustment

When adjusting, adjust it to the following value.

#### **Toe-in:**

**$0 \pm 2$  mm ( $0 \pm 0.08$  in)**

1) Loosen the self-locking nut on the inner side of front lateral link.

#### NOTE:

When loosening or tightening the adjusting bolt, hold the bolt head and turn the self-locking nut.

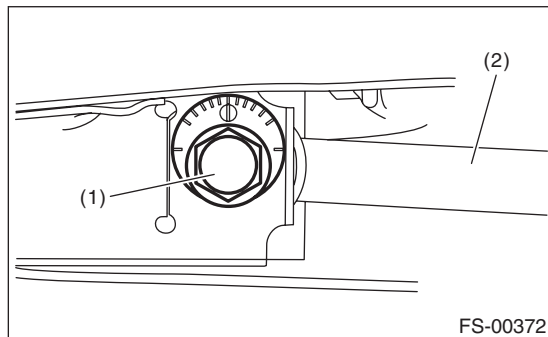

(1) Adjusting bolt

(2) Lateral link

2) Turn the adjusting bolt until toe-in is within the specification.

#### NOTE:

When the left and right wheels are adjusted for toe-in at the same time, the movement of one scale graduation changes toe-in by approx. 1.3 mm (0.05 in).

# Wheel Alignment

## FRONT SUSPENSION

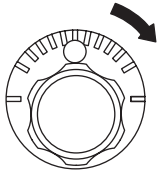
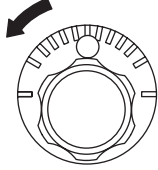
To increase toe-in.	
Rotate the left side clockwise.	Rotate the right side counterclockwise.
	
FS-00018	FS-00019

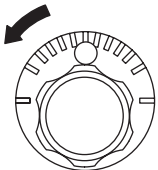
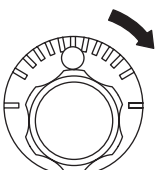
To decrease toe-in.	
Rotate the left side counterclockwise.	Rotate the right side clockwise.
	
FS-00019	FS-00018

3) Attach and tighten a new self-locking nut.

**Tightening torque:**

**100 N·m (10.2 kgf·m, 73.8 ft·lb)**

## 7. THRUST ANGLE

### • Inspection

- 1) Park the vehicle on a level surface.
- 2) Move the vehicle 3 to 4 meters (10 to 13 feet) straight forward.
- 3) Draw the center of loci for both the front and rear axles.
- 4) Measure distance "L" between the center lines of the axle loci.

### Thrust angle

$0^{\circ} \pm 30'$

**Less than 30' when "L" is 23 mm (0.9 in) or less**

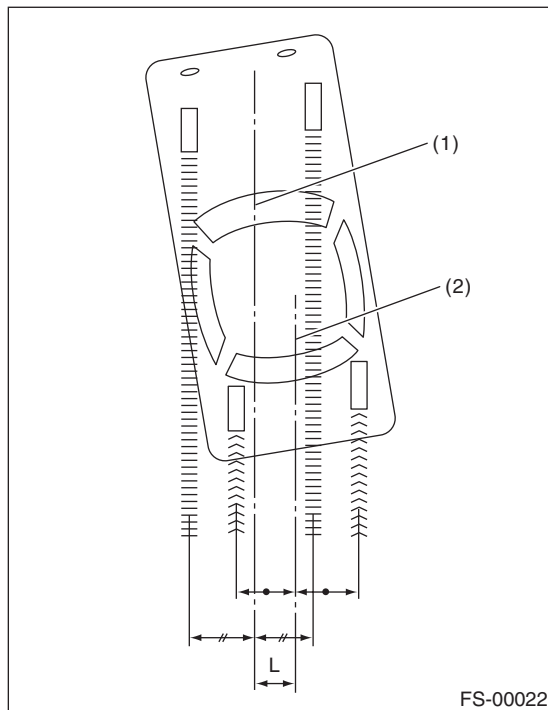

- (1) Center line of loci (front axle)
- (2) Center line of loci (rear axle)

### • Adjustment

When adjusting, adjust it to the following value.

### Thrust angle

$0^{\circ} \pm 20'$

**Less than 20' when "L" is 15 mm (0.6 in) or less**

- 1) Make thrust angle adjustments by turning the toe-in adjusting bolts of the rear suspension equally in the same direction.
- 2) When one rear wheel is adjusted in a toe-in direction, adjust the other rear wheel equally in toe-out direction, in order to make the thrust angle adjustment.

- 3) When the left and right adjusting bolts are turned by one graduation, the thrust angle will change approx. 15' ("L" is approx. 11 mm (0.43 in)).

### NOTE:

Thrust angle is a mean value of left and right wheel toe angles in relation to the vehicle body center line. Vehicle is driven straight in the thrust angle direction while slanting in the oblique direction depending on the degree of the mean thrust angle.

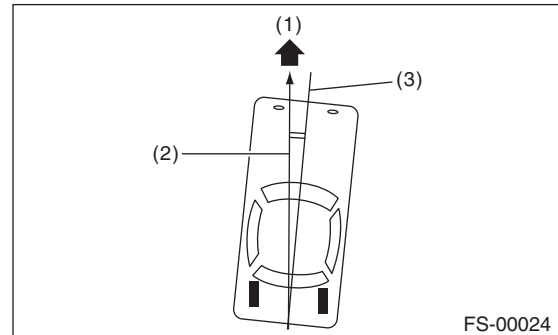

- (1) Front
- (2) Thrust angle
- (3) Body center line

### Thrust angle: $\gamma = (\alpha - \beta)/2$

$\alpha$ : Rear RH wheel toe-in angle

$\beta$ : Rear LH wheel toe-in angle

Substitute only the positive toe-in values from each wheel into  $\alpha$  and  $\beta$  in the calculation.

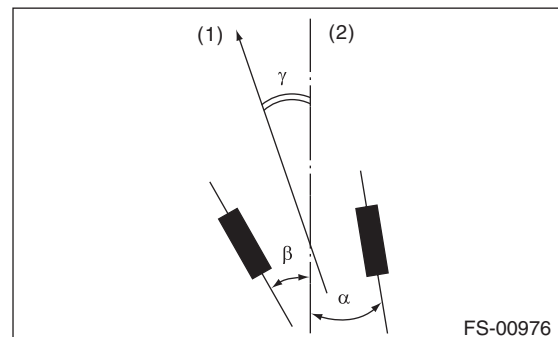

- (1) Front
- (2) Body center line

# Front Crossmember Support Plate

FRONT SUSPENSION

---

## 3. Front Crossmember Support Plate

### A: REMOVAL

- 1) Lift up the vehicle.
- 2) Remove the front under cover. <Ref. to EI-28, REMOVAL, Front Under Cover.>
- 3) Remove the bolt, and remove the front crossmember support plate.

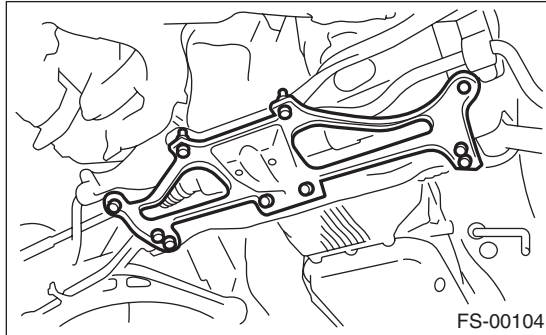

### B: INSTALLATION

Install each part in the reverse order of removal.

#### ***Tightening torque:***

***60 N·m (6.1 kgf·m, 44.3 ft·lb)***

## 4. Front Stabilizer

### A: REMOVAL

- 1) Lift up the vehicle, and then remove the front wheels.
- 2) Remove the front under cover. <Ref. to EI-28, REMOVAL, Front Under Cover.>
- 3) Remove the front crossmember support plate. <Ref. to FS-16, REMOVAL, Front Crossmember Support Plate.>
- 4) Remove the stabilizer link.



- 5) Remove the stabilizer bracket.

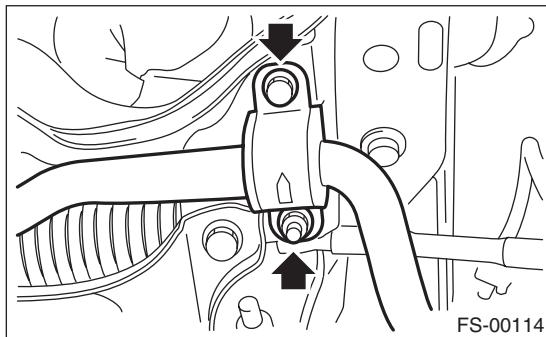

### B: INSTALLATION

Install each part in the reverse order of removal.

#### CAUTION:

- Use a new flange nut.
- Ensure the stabilizer bushing and stabilizer have the same identification colors.
- Install the stabilizer bushing (front crossmember side) while aligning it with the paint mark on stabilizer.

- The stabilizer bracket has a set orientation. Install it with the arrow mark facing the upper side of the vehicle.

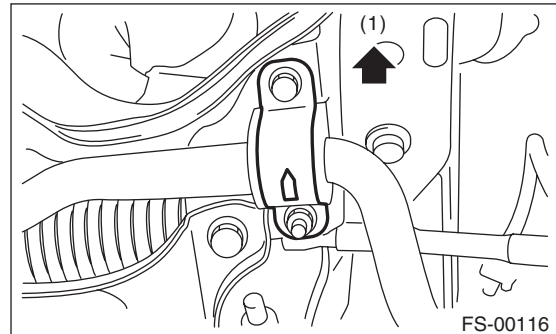

(1) Front side of vehicle

#### Tightening torque:

##### Stabilizer link:

**38 N·m (3.9 kgf-m, 28.0 ft-lb)**

##### Stabilizer bracket:

**25 N·m (2.5 kgf-m, 18.4 ft-lb)**

##### Tie-rod end (castle nut):

**27 N·m (2.75 kgf-m, 19.9 ft-lb)**

### C: INSPECTION

- 1) Check the bushing for abnormal cracks, fatigue or damage.
- 2) Check the stabilizer link for damage.

# Front Ball Joint

## FRONT SUSPENSION

### 5. Front Ball Joint

#### A: REMOVAL

- 1) Lift up the vehicle, and then remove the front wheels.
- 2) Remove the front under cover. <Ref. to EI-28, REMOVAL, Front Under Cover.>
- 3) Remove the bolt, and remove the front crossmember support plate.

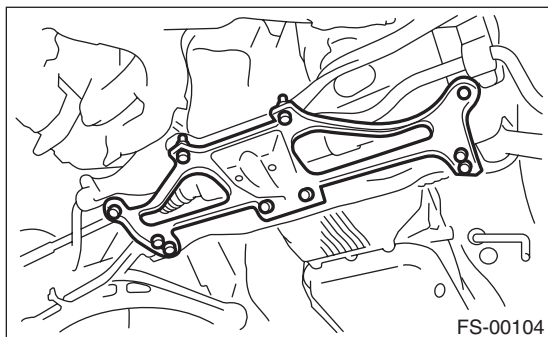

- 4) Remove the both sides of stabilizer bracket.

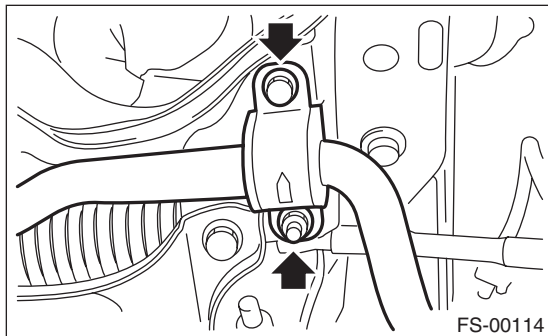

- 5) Pull out the pin from ball stud, remove the castle nut, and extract the ball stud from front arm.
- 6) Remove the bolt installing ball joint to housing.

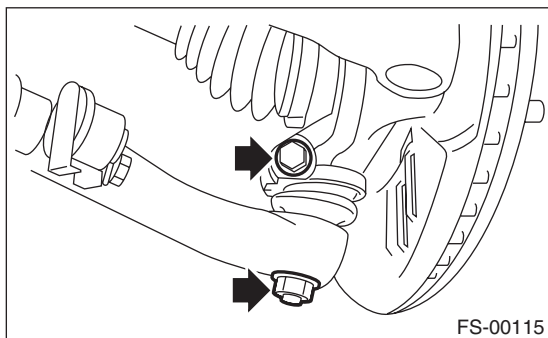

- 7) Extract the ball joint from housing.

#### B: INSTALLATION

- 1) Insert the ball joint into housing.

#### CAUTION:

Do not apply grease to the tapered portion of ball stud.

#### Tightening torque (Bolt):

**50 N·m (5.1 kgf·m, 36.9 ft·lb)**

- 2) Install the ball joint into front arm.

#### Tightening torque (Castle nut):

**39 N·m (4.0 kgf·m, 28.8 ft·lb)**

- 3) Retighten the castle nut further up to 60° until the hole in the ball stud is aligned with a slot in castle nut. Then, insert a new cotter pin and bend it around the castle nut.
- 4) Install the stabilizer bracket.

#### NOTE:

The stabilizer bracket has a set orientation. Install it with the arrow mark facing the upper side of the vehicle.

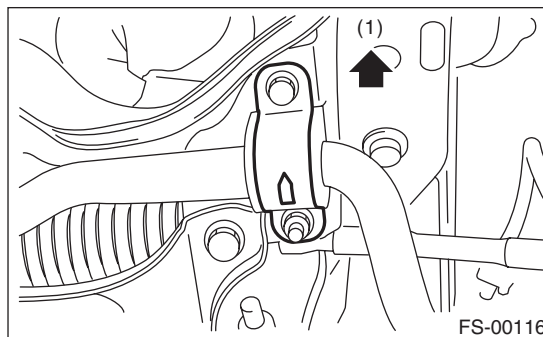

(1) Front side of vehicle

#### Tightening torque:

**25 N·m (2.5 kgf·m, 18.4 ft·lb)**

- 5) Install the front crossmember support plate.

#### Tightening torque:

**60 N·m (6.1 kgf·m, 44.3 ft·lb)**

- 6) Install the front wheels.

#### C: INSPECTION

- 1) Measure the play of the ball joint using the following procedures. Replace with a new part if the play exceeds specification.

(1) With 686 N (70 kgf, 154 lbf) loaded in direction shown in the figure, measure the length  $Q_1$ .

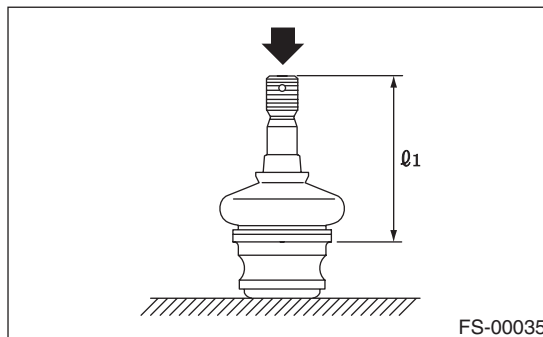

(2) With 686 N (70 kgf, 154 lbf) loaded in direction shown in the figure, measure the length  $l_2$ .

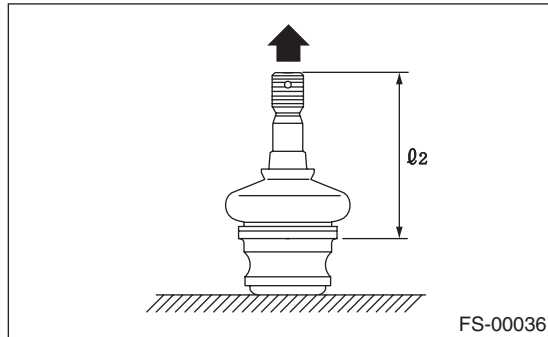

(3) Determine free play using the following formula.

$$S = l_2 - l_1$$

(4) Replace with a new part if the play exceeds specification.

### **Front ball joint**

#### **Specification for replacement S:**

**Less than 0.3 mm (0.012 in)**

- 2) If the play is within specification, visually check the dust cover.
- 3) Remove the ball joint and cover, and check for wear, damage or cracks. If any damage is found, replace the corresponding part.
- 4) If the dust cover is damaged, replace with a new ball joint.



# Front Arm

## FRONT SUSPENSION

### 6. Front Arm

#### A: REMOVAL

- 1) Lift up the vehicle, and then remove the front wheels.
- 2) Remove the front crossmember support plate. <Ref. to FS-16, REMOVAL, Front Crossmember Support Plate.>
- 3) Remove the front stabilizer. <Ref. to FS-17, REMOVAL, Front Stabilizer.>
- 4) Remove the ball joint of front arm.

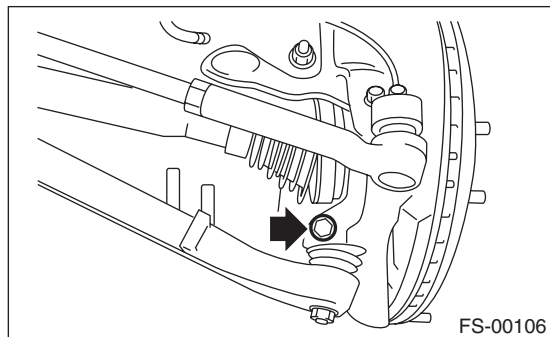

- 5) Remove the nut securing the front arm to crossmember. (Do not remove the bolt.)

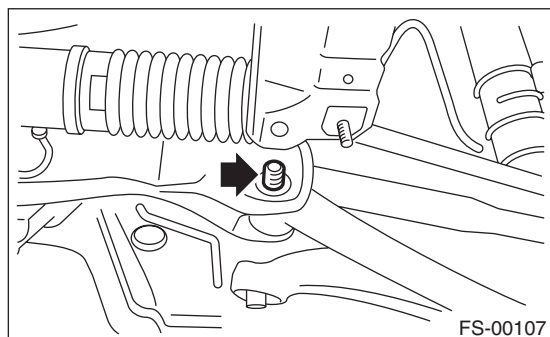

- 6) Remove the front arm support plate.

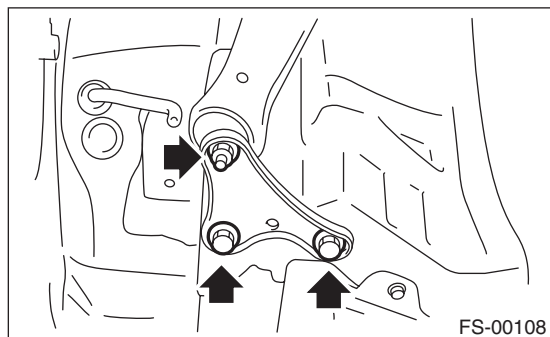

- 7) Remove the bolt securing front arm to crossmember and pull the front arm out of the crossmember.

- 8) To remove the stud bolt, use the ST. (Except for STI model)

#### CAUTION:

**Do not remove the stud bolt unnecessarily. Always replace the parts with new parts when removed.**

ST 20299AG020 STUD BOLT SOCKET

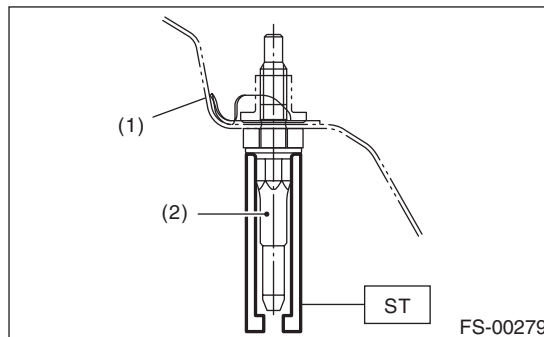

(1) Vehicle body

(2) Stud bolt

#### B: INSTALLATION

- 1) Using the ST, install the stud bolt.  
ST 20299AG020 STUD BOLT SOCKET

#### Tightening torque:

**110 N·m (11.2 kgf-m, 81.1 ft-lb)**

- 2) Using new bolts and self-locking nuts, temporarily tighten the front arm to crossmember.

- 3) Attach the support plate.

- Except for STI model

Secure the front arm to body, and then install the support plate with new bolts and self-locking nuts.

- STI model

Secure the front arm to body, and then install the support plate with new bolts.

#### Tightening torque:

##### Support plate to Front arm:

**Except for STI model: 110 N·m (11.2 kgf-m, 81.1 ft-lb)**

**STI model: 140 N·m (14.3 kgf-m, 103.3 ft-lb)**

##### Support plate to Body:

**150 N·m (15.3 kgf-m, 110.6 ft-lb)**

- 4) Install the ball joint into housing.

#### Tightening torque:

**50 N·m (5.1 kgf-m, 36.9 ft-lb)**

- 5) Install the stabilizer. <Ref. to FS-17, INSTALLATION, Front Stabilizer.>

- 6) Install the front wheels.

7) Lower the vehicle from lift, and tighten the bolt which secures the front arm to crossmember with wheels in full contact with the ground and the vehicle at curb weight.

**Tightening torque:**

**95 N·m (9.7 kgf·m, 70.1 ft-lb)**

8) Inspect the wheel alignment and adjust if necessary.

## C: DISASSEMBLY

### 1. FRONT BUSHING

Using the ST and a press, remove the front bushing.

ST 927680000 INSTALLER & REMOVER SET

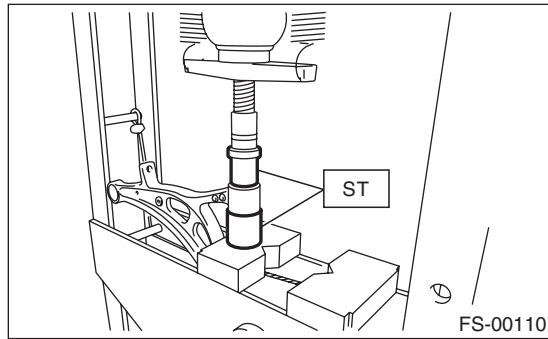

FS-00110

### 2. REAR BUSHING

#### Steel front arm

1) Put an alignment mark on the front arm based on the center of rear bushing recess portion.

**CAUTION:**

**Always put an alignment mark for aligning the position on bushing installation.**

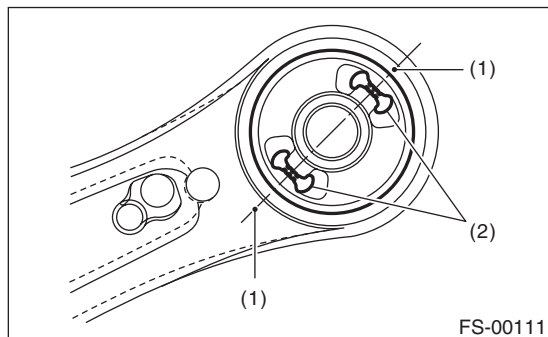

FS-00111

- (1) Put an alignment mark.
- (2) Recess section

2) Using the ST and a press, remove the rear bushing.

ST1 20299AG000 REMOVER

ST2 20299AG010 BASE

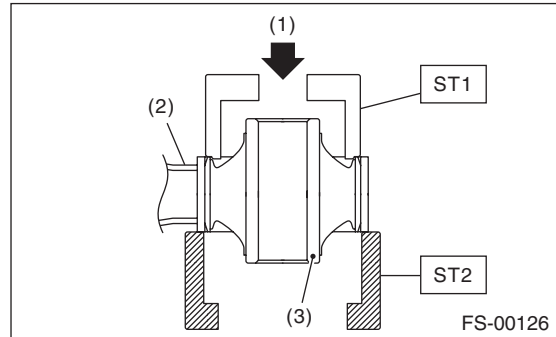

FS-00126

- (1) Press
- (2) Front arm
- (3) Rear bushing

#### Aluminum front arm

1) Put an alignment mark on the front arm based on the center of pillow ball bushing recess portion.

**CAUTION:**

**Always put an alignment mark for aligning the position on bushing installation.**

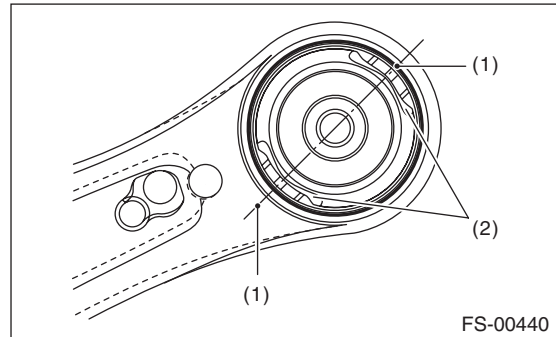

FS-00440

- (1) Put an alignment mark.
- (2) Recess section

# Front Arm

## FRONT SUSPENSION

2) Using the ST and a press, remove the pillow ball bushing.

ST1 20099AE020 INSTALLER & REMOVER  
ST2 28099PA010 HOUSING STAND

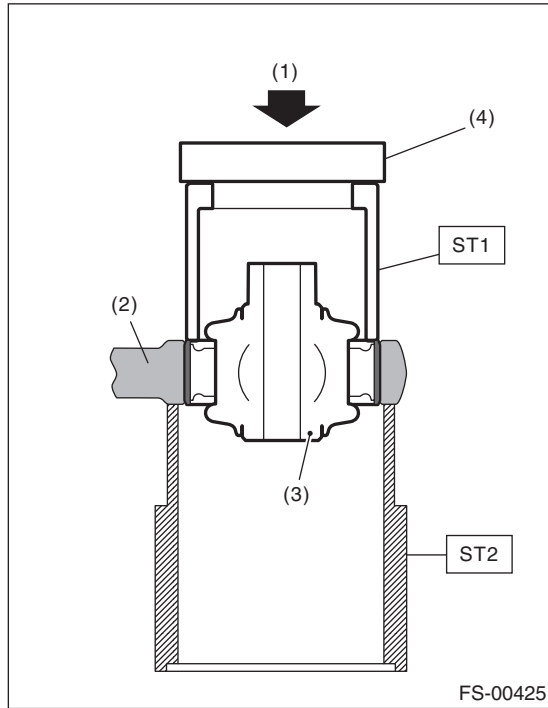

- (1) Press
- (2) Front arm
- (3) Pillow ball bushing
- (4) Plate

### NOTE:

Place the plate on the ST1 to use the press.

## D: ASSEMBLY

### 1. FRONT BUSHING

Assemble each part in the reverse order of disassembly.

### 2. REAR BUSHING

#### Steel front arm

1) Install the rear bushing with its longer inner cylinder facing upward and the shorter facing downward and protruding part rearward as shown in the figure.

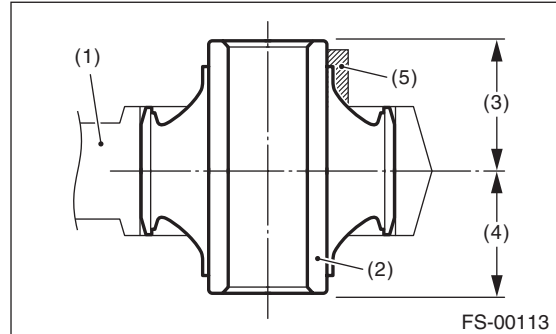

- (1) Front arm
- (2) Bushing inner cylinder
- (3) Longer
- (4) Shorter
- (5) Protrusion portion

2) Align the center of rear bushing recess portion with the aligning mark on the front arm.

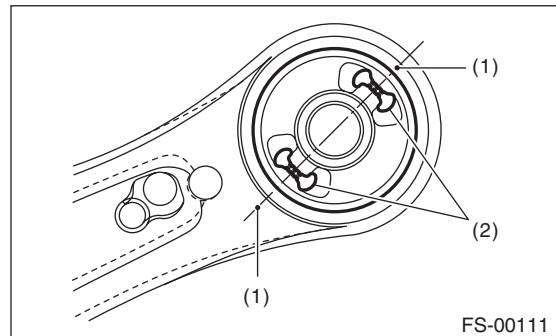

- (1) Alignment mark
- (2) Recess section

3) Using the ST and a press, install the rear bushing.

ST1 20299AG000 REMOVER  
ST2 20299AG010 BASE

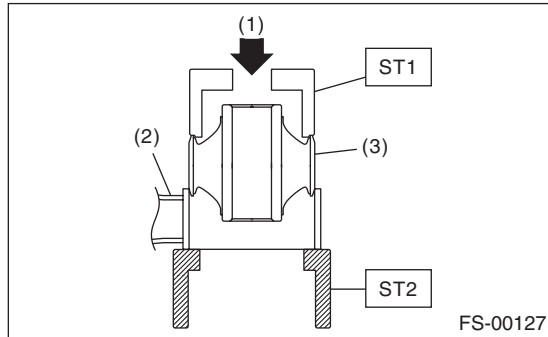

- (1) Press
- (2) Front arm
- (3) Rear bushing

### Aluminum front arm

1) Install the pillow ball bushing with its longer inner cylinder facing upward and the shorter facing downward as shown in the figure.

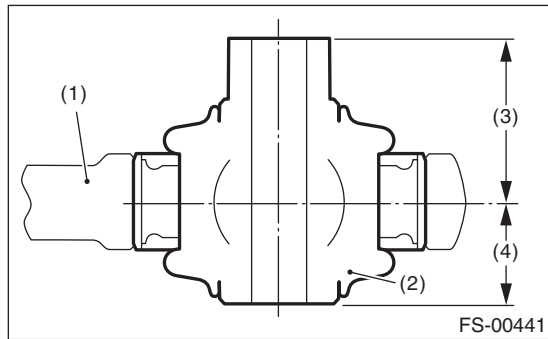

- (1) Front arm
- (2) Bushing inner cylinder
- (3) Longer
- (4) Shorter

2) Align the center of rear bushing recess portion with the aligning mark on the front arm.

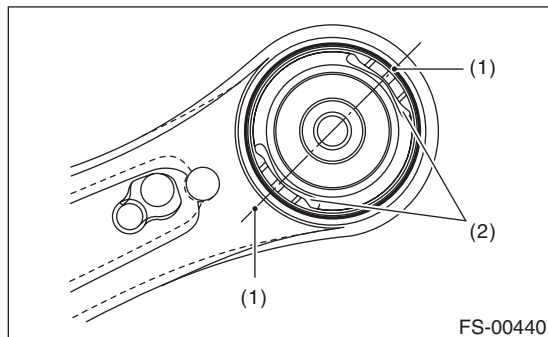

- (1) Alignment mark
- (2) Recess section

3) Using the ST and a press, install the rear bushing.

ST1 20299AE020 INSTALLER & REMOVER  
ST2 18723AA000 REMOVER ASSY (GEAR DRIVEN)

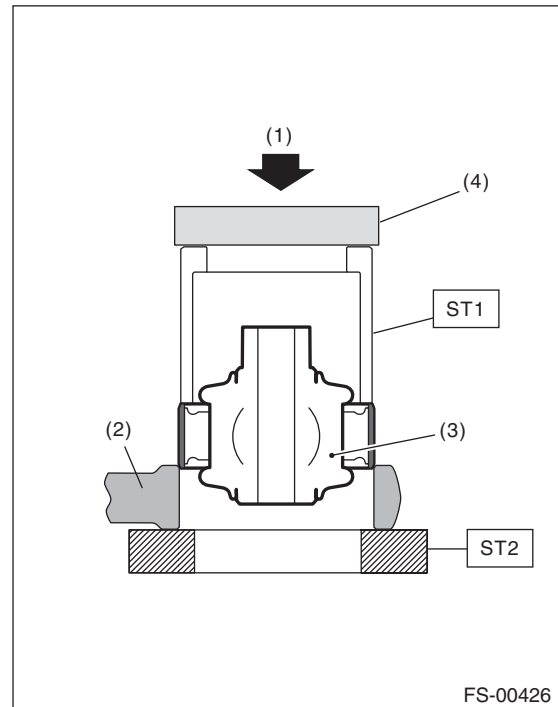

- (1) Press
- (2) Front arm
- (3) Rear bushing
- (4) Plate

### NOTE:

Place the plate on the ST1 to use the press.

### E: INSPECTION

- 1) Check the front arm for damage or cracks, and correct or replace if defective.
- 2) Check the bushing for abnormal fatigue or damage.
- 3) Check the pillow ball bushing for damage or cracks, and replace if defective.
- 4) Try to wobble the pillow ball bushing. Replace the pillow ball bushing if backlash or resistance are found.

# Front Strut

## FRONT SUSPENSION

### 7. Front Strut

#### A: REMOVAL

- 1) Lift up the vehicle, and then remove the front wheels.
- 2) Place an alignment mark on the camber adjusting bolt and strut.
- 3) Remove the brake hose bracket.

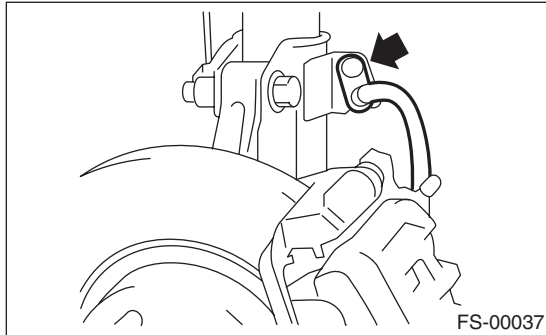

- 4) Remove the bolt securing the ABS wheel speed sensor harness.

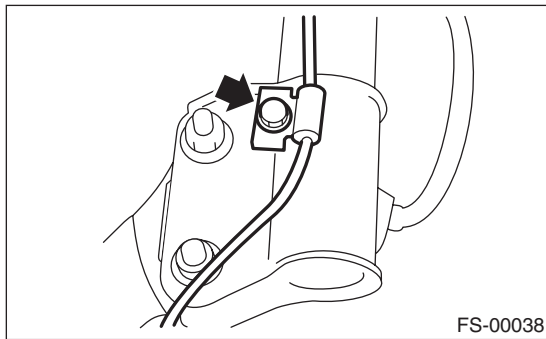

- 5) Remove the two bolts securing the housing to the strut.

#### NOTE:

While holding the head of the adjusting bolt, loosen the flange nut.

- 6) Remove the three nuts securing strut mount to body.

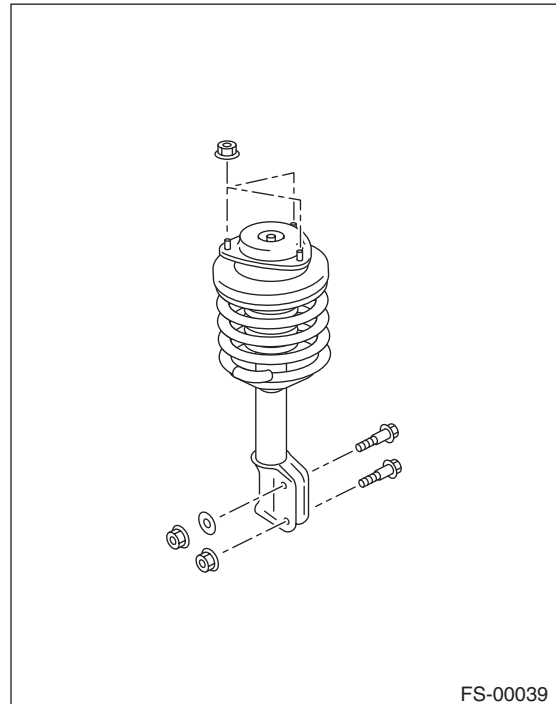

#### B: INSTALLATION

- 1) Install the strut mount at the upper side of strut to body, and tighten it with new self-locking nuts.

#### **Tightening torque:**

**20 N·m (2.0 kgf-m, 14.8 ft-lb)**

- 2) Align alignment marks on the camber adjusting bolt and strut.

Using new flange nuts, install the strut to the housing.

#### NOTE:

While holding the head of adjusting bolt, tighten the flange nut.

#### **Tightening torque:**

**155 N·m (15.8 kgf-m, 114.3 ft-lb)**

- 3) Secure the ABS wheel speed sensor harness to the strut.

#### **Tightening torque:**

**33 N·m (3.4 kgf-m, 24.3 ft-lb)**

- 4) Install the brake hose bracket.

#### **Tightening torque:**

**33 N·m (3.4 kgf-m, 24.3 ft-lb)**

- 5) Install the front wheels.
- 6) Inspect the wheel alignment and adjust if necessary.

## C: DISASSEMBLY

1) Using a coil spring compressor, compress the coil spring.

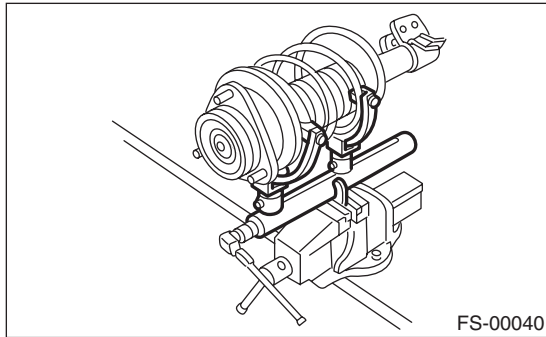

2) Using the ST, remove the self-locking nut.  
ST 20399AG000 STRUT MOUNT SOCKET

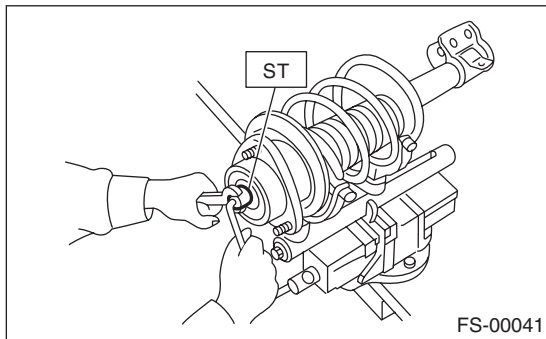

3) Remove the strut mount and upper spring seat from strut.  
4) Gradually decrease the compression force of compressor, and remove the coil spring.  
5) Remove the dust cover.

## D: ASSEMBLY

1) Using a coil spring compressor, compress the coil spring.

### NOTE:

Make sure that the vertical install direction of the coil spring is as shown in the figure.

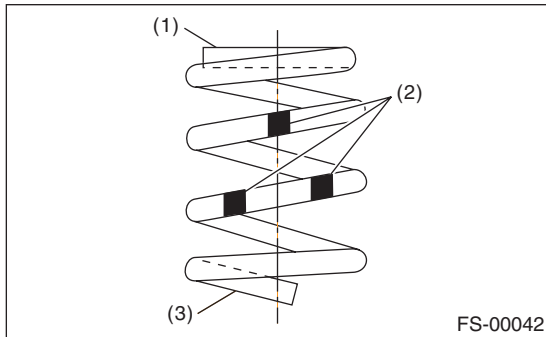

- (1) Diameter is small (upper part)
- (2) Identification paint
- (3) Diameter is large (bottom part)

2) Set the coil spring correctly so that its end face seats well in the spring seat as shown in the figure.

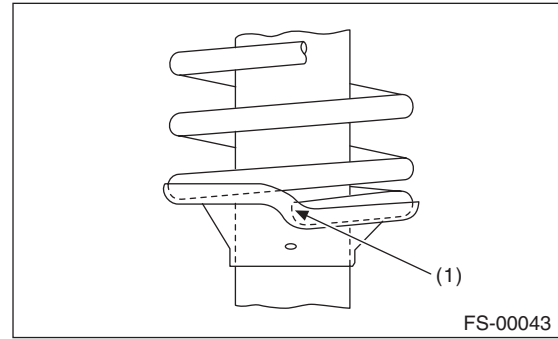

(1) Coil spring end face

3) Install the dust cover to the piston rod.  
4) Pull the piston rod fully upward, and install the spring seat.

### NOTE:

Position the upper spring seat as shown in the figure.

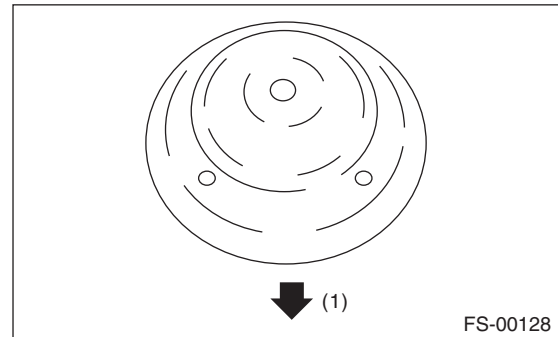

(1) Outside of body

5) Install the strut mount and spacer to piston rod, and temporarily attach and tighten a new self locking nut.

6) Using a hexagon wrench to prevent strut rod from turning, tighten the new self-locking nut with ST.

ST 20399AG000 STRUT MOUNT SOCKET

### Tightening torque:

**55 N·m (5.6 kgf-m, 40.6 ft-lb)**

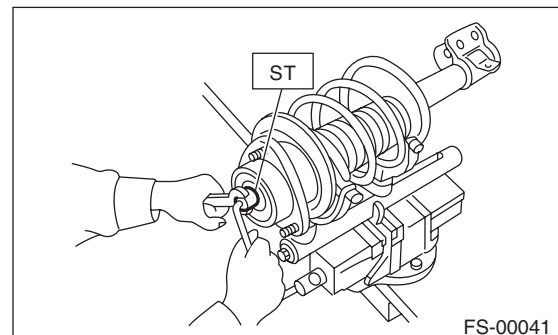

7) Loosen the coil spring compressor carefully.

# Front Strut

## FRONT SUSPENSION

### E: INSPECTION

Check the removed part for wear, damage and cracks, and then repair or replace it if defective.

#### 1. STRUT

- 1) Check for oil leaks.
- 2) Move the piston rod up and down to check that it operates smoothly without any hitch.
- 3) Piston rod play

- Measure the play as follows:

Fix the outer shell in place and fully extend the rod. Set a dial gauge at the end of rod L [10 mm (0.39 in)], and then read the dial gauge indication  $P_1$  while applying a force of W [20 N (2 kgf, 4 lbf)] to the threaded portion. Apply a force of 20 N (2 kgf, 4 lbf) from the opposite direction of "W", and then read the dial gauge indication  $P_2$ .

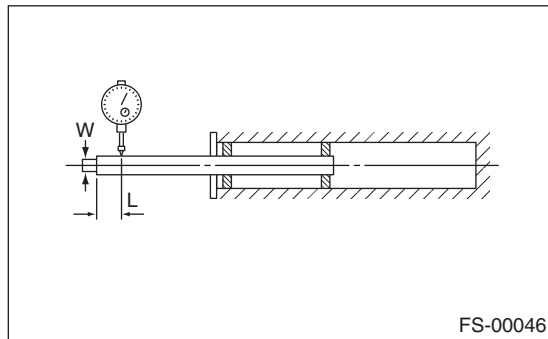

**Play limit ( $P_1 + P_2$ ):**  
**0.8 mm (0.031 in)**

If the play exceeds limit, replace the strut.

#### 2. STRUT MOUNT

Check the rubber part for deformation, cracks or deterioration, and then replace it with a new part if defective.

#### 3. DUST COVER

If cracks or damage are found, replace with a new part.

#### 4. COIL SPRING

If a permanent strain is found, replaced it with a new part.

#### 5. HELPER

If major cracks or damage are found, replace it with a new part. (Except for STI model)

### F: DISPOSAL

#### CAUTION:

- Before handling struts, be sure to wear goggles to protect eyes from gas, oil and cutting powder.
  - Do not disassemble the strut damper or throw into flames.
  - When discarding gas filled struts, drill holes in them to purge the gas.
- 1) Place the strut on a level surface with the piston rod fully expanded.
  - 2) Using a 2 — 3 mm (0.08 — 0.12 in) dia. drill, make a hole into the position (1) first, and then (2).

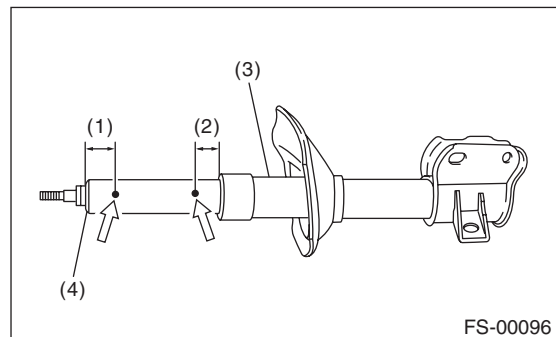

- (1) 20 mm (0.78 in)
- (2) 10 mm (0.39 in)
- (3) Strut
- (4) Damping tube



## 8. Front Crossmember

### A: REMOVAL

- 1) Lift up the vehicle, and then remove the front wheels.
- 2) Remove the front exhaust pipe.
- 3) Remove the front crossmember support plate. <Ref. to FS-16, REMOVAL, Front Crossmember Support Plate.>
- 4) Remove the front stabilizer. <Ref. to FS-17, REMOVAL, Front Stabilizer.>
- 5) Disconnect the tie-rod ends from the housing.
- 6) Remove the front arm. <Ref. to FS-20, REMOVAL, Front Arm.>
- 7) Remove the nuts which install the engine mounting cushion rubber onto the crossmember.

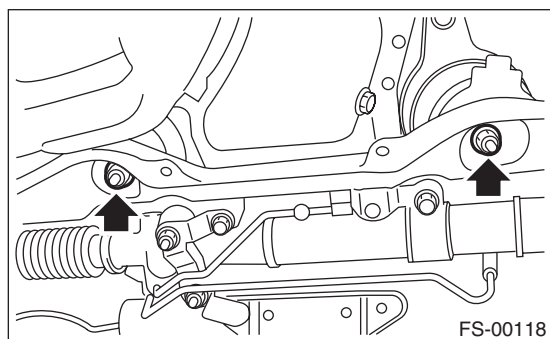

- 8) Remove the steering universal joint.
- 9) Disconnect the power steering hose from the steering gearbox.
- 10) Lift the engine by approx. 10 mm (0.39 in) by using the chain block.
- 11) Support the crossmember with jack, remove the bolts which secure the crossmember to the vehicle body, and gradually lower the crossmember together with the steering gearbox.

### CAUTION:

**When removing the crossmember downward, make sure that the tie-rod end does not interfere with the drive shaft boot.**

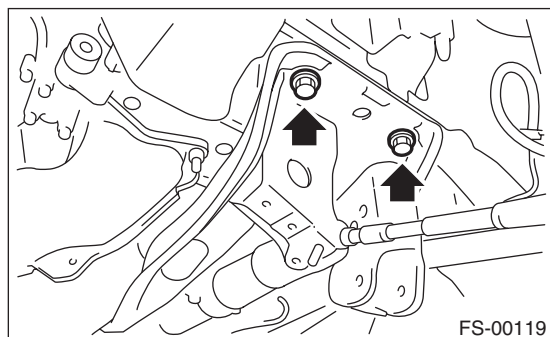

### B: INSTALLATION

- 1) Install each part in the reverse order of removal.

#### CAUTION:

- Use a new bolt and self-locking nut. For parts which are not reusable, refer to COMPONENT. <Ref. to FS-3, COMPONENT, General Description.>
- Always tighten the bushing in the state where the vehicle is at curb weight and the wheels are in full contact with the ground.

#### Tightening torque:

##### Crossmember to Body:

95 N·m (9.7 kgf-m, 70.1 ft-lb)

##### Engine mounting to Crossmember:

85 N·m (8.7 kgf-m, 62.7 ft-lb)

##### Front arm to Crossmember:

95 N·m (9.7 kgf-m, 70.1 ft-lb)

##### Front arm to Support plate:

110 N·m (11.2 kgf-m, 81.1 ft-lb)

##### Support plate body:

150 N·m (15.3 kgf-m, 110.6 ft-lb)

##### Tie-rod end to Housing:

27 N·m (2.8 kgf-m, 19.9 ft-lb)

After tightening to the specified torque, tighten the castle nut further but within 60° until the hole in the ball stud is aligned with a slot in castle nut

#### Tightening torque:

##### Universal joint:

24 N·m (2.4 kgf-m, 17.7 ft-lb)

##### Stabilizer bracket:

25 N·m (2.5 kgf-m, 18.4 ft-lb)

##### Stabilizer link:

38 N·m (3.9 kgf-m, 28.0 ft-lb)

##### Power steering hose to Steering gearbox:

15 N·m (1.5 kgf-m, 11.1 ft-lb)

- 2) Purge air from the power steering system.
- 3) Inspect the wheel alignment and adjust if necessary.

### C: INSPECTION

Check the crossmember for damage or cracks, and correct or replace if defective.



# General Diagnostic Table

## FRONT SUSPENSION

### 9. General Diagnostic Table

#### A: INSPECTION

##### 1. IMPROPER VEHICLE POSTURE OR IMPROPER WHEEL ARCH HEIGHT

Possible cause	Corrective action
(1) Permanent distortion or damage of the coil spring	Replace.
(2) Rough operation of strut or shock absorber	Replace.
(3) Improper installation of strut or shock absorber	Replace with appropriate parts.
(4) Installation of the wrong coil spring	Replace with appropriate parts.

##### 2. POOR RIDE COMFORT

- 1) Large rebound shock
- 2) Rocking of the vehicle continues too long after running over bump and hump.
- 3) Excessive shock in bumping

Possible cause	Corrective action
(1) Damaged coil spring	Replace.
(2) Overinflation of tires	Adjust.
(3) Improper wheel arch height	Replace the coil springs with new parts.
(4) Fault in operation of strut or shock absorber	Replace.
(5) Damage or deformation of strut mount or shock absorber mount	Replace.
(6) Unsuitable length (maximum or minimum) of strut or shock absorber	Replace with appropriate parts.
(7) Abnormal deformation or loss of bushing	Replace.
(8) Deformation or damage of helper in strut assembly or shock absorber	Replace.
(9) Oil leakage from the strut or shock absorber	Replace.

##### 3. NOISE

Possible cause	Corrective action
(1) Wear or damage of strut or shock absorber component parts	Replace.
(2) Loosening of the suspension link installing bolt	Tighten to the specified torque.
(3) Abnormal deformation or loss of bushing	Replace.
(4) Unsuitable length (maximum or minimum) of strut or shock absorber	Replace with appropriate parts.
(5) Damaged coil spring	Replace.
(6) Wear or damage of the ball joint	Replace.
(7) Deformation of the stabilizer clamp	Replace.

# REAR SUSPENSION

# RS

---

	<b>Page</b>
1. General Description .....	2
2. Wheel Alignment .....	8
3. Rear Stabilizer .....	9
4. Rear Trailing Link .....	10
5. Upper Arm .....	13
6. Rear Shock Absorber .....	14
7. Front Lateral Link .....	15
8. Rear Lateral Link .....	16
9. Rear Sub Frame .....	17
10. General Diagnostic Table .....	19

# General Description

## REAR SUSPENSION

### 1. General Description

#### A: SPECIFICATION

Refer to "FS" section for rear suspension specifications. <Ref. to FS-2, SPECIFICATION, General Description.>

#### NOTE:

- Front and rear toe-in and front camber can be adjusted. Adjust if the toe-in or camber tolerance exceeds specifications.
- Other items indicated in the specifications is not equipped with adjustment mechanisms. If other items exceed specifications, check the suspension parts and connections for deformation. If defective, replace with new parts.

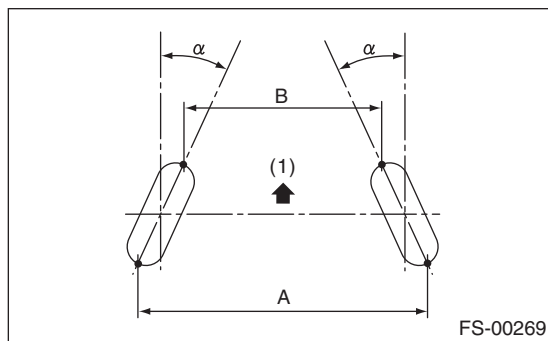

(1) Front

A – B = Positive: Toe-in, Negative: Toe-out  
 $\alpha$  = Individual toe angles

### B: COMPONENT

#### 1. REAR SUSPENSION

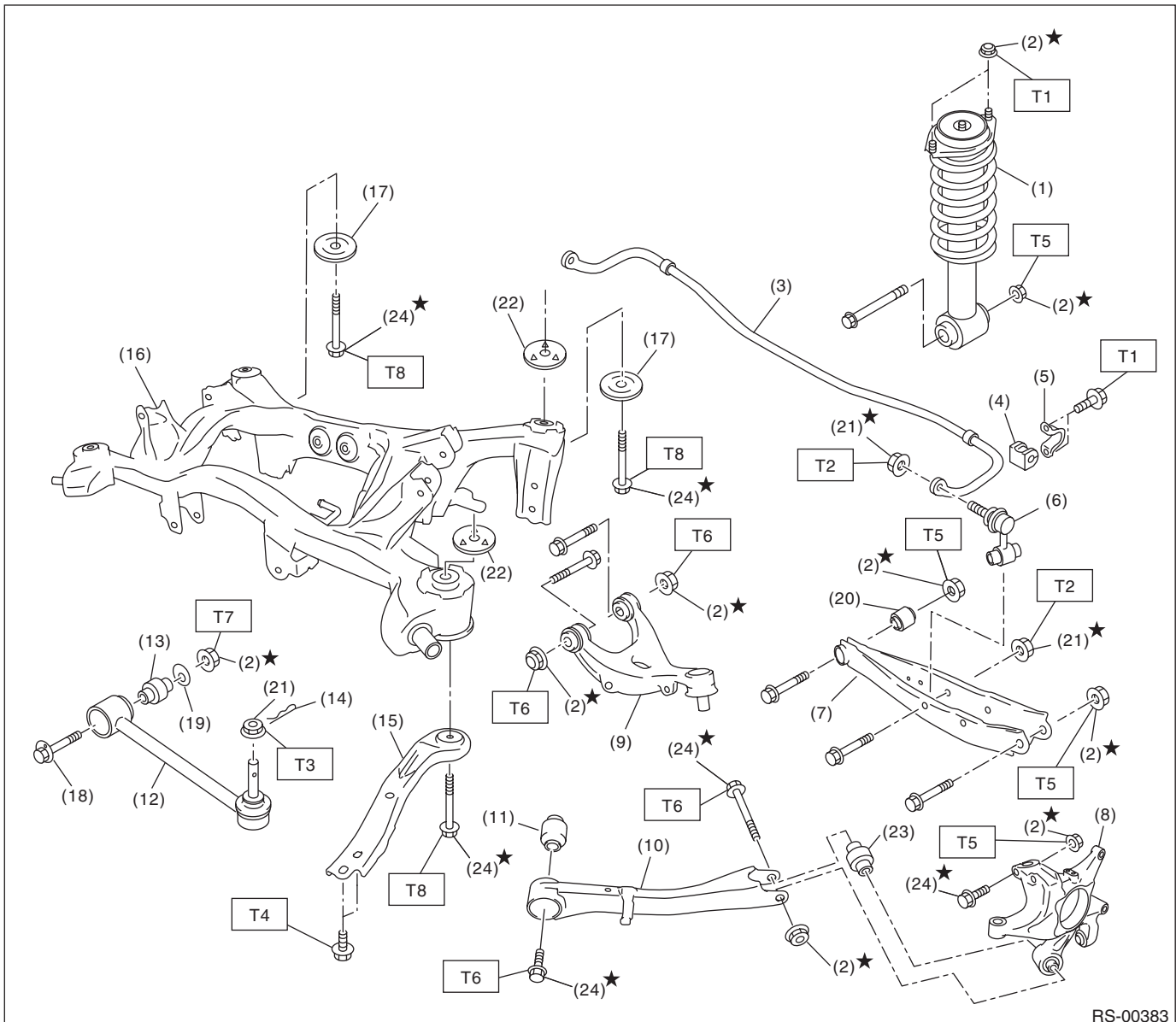

RS-00383

- |                            |   |
|----------------------------|---|
| (1) Shock absorber         | (13) Front lateral link bushing           |
| (2) Self-locking nut       | (14) Snap pin                             |
| (3) Rear stabilizer        | (15) Front sub frame support plate        |
| (4) Stabilizer bushing     | (16) Rear sub frame                       |
| (5) Stabilizer clamp       | (17) Rear sub frame stopper plate (lower) |
| (6) Stabilizer link        | (18) Adjusting bolt                       |
| (7) Rear lateral link      | (19) Adjusting washer                     |
| (8) Rear housing           | (20) Rear lateral link bushing            |
| (9) Upper arm              | (21) Flange nut                           |
| (10) Trailing link         | (22) Rear sub frame stopper plate (upper) |
| (11) Trailing link bushing | (23) Rear housing bushing                 |
| (12) Front lateral link    | (24) Bolt                                 |

#### **Tightening torque: N·m (kgf·m, ft·lb)**

**T1: 30 (3.1, 22.1)**

**T2: 38 (3.9, 28)**

**T3: 60 (6.1, 44.3)**

**T4: 70 (7.1, 51.6)**

**T5: 80 (8.2, 59)**

**T6: 90 (9.2, 66.4)**

**T7: 100 (10.2, 73.8)**

**T8: 145 (14.8, 106.9)**

# General Description

## REAR SUSPENSION

### 2. SHOCK ABSORBER

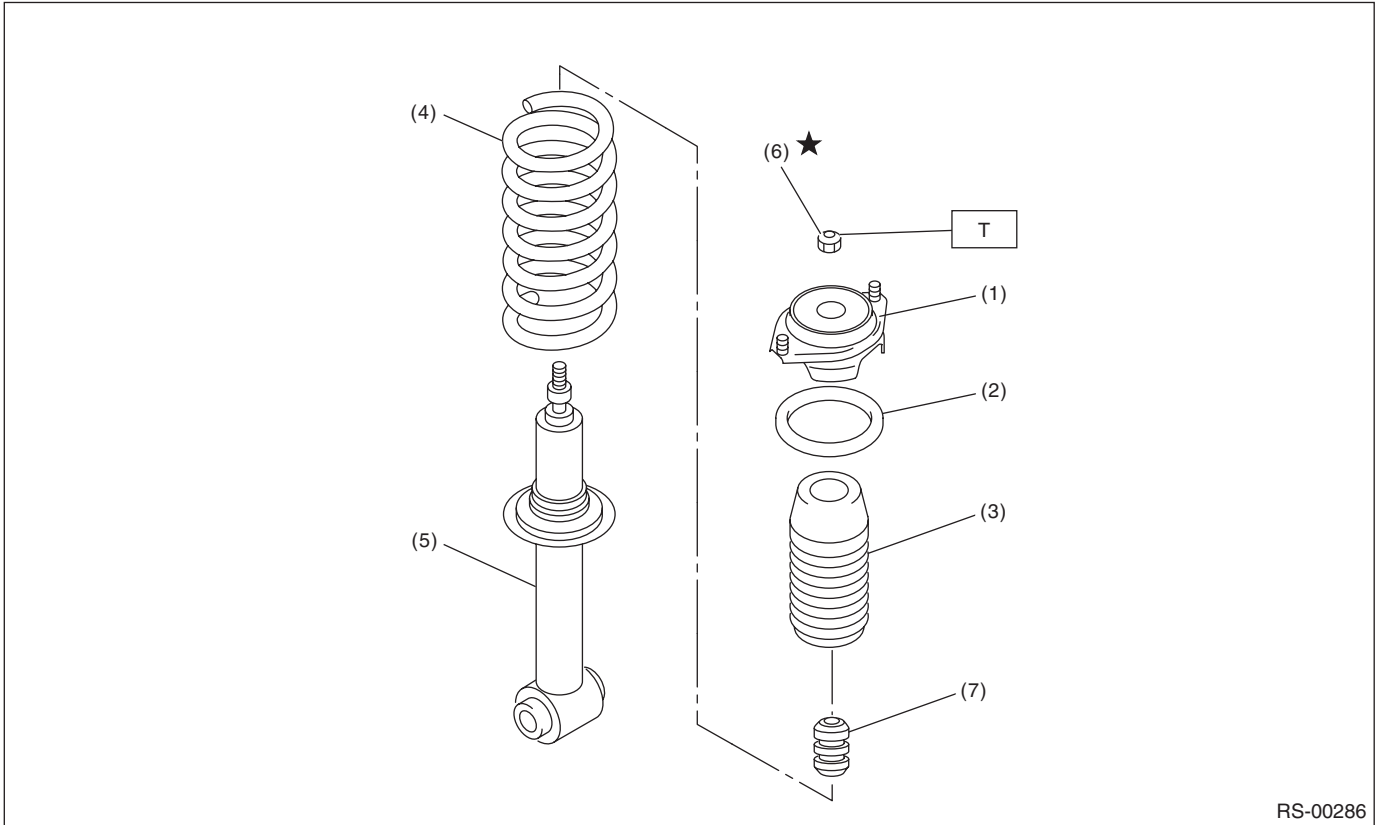

RS-00286

- |                        |                      |
|------------------------|----------------------|
| (1) Mount              | (5) Shock absorber   |
| (2) Upper rubber sheet | (6) Self-locking nut |
| (3) Dust cover         | (7) Helper           |
| (4) Coil spring        |                      |

**Tightening torque: N·m (kgf·m, ft·lb)**

**T: 25 (2.5, 18.4)**

## C: CAUTION

Please clearly understand and adhere to the following general precautions. They must be strictly followed to avoid minor or serious injury to the person doing the work or people in the area.

### 1. CAUTIONS

- Wear appropriate work clothing, including a cap, protective goggles and protective shoes when performing any work.
- Before disposing of shock absorbers, be sure to bleed the gas out completely. Also, do not expose to flames or fire.
- Before removal, installation or disassembly, be sure to clarify the failure. Avoid unnecessary removal, installation, disassembly and replacement.
- Use SUBARU genuine grease etc. or equivalent. Do not mix grease etc. of different grades or manufacturers.
- Before securing a part on a vise, place cushioning material such as wood blocks, aluminum plate, or cloth between the part and the vise.
- Be sure to tighten fasteners including bolts and nuts to the specified torque.
- Place shop jacks or rigid racks at the specified points.

### 2. OIL

When handling oil, adhere to the following to prevent unexpected accident.

- Prepare container and waste cloths when performing work which oil could possibly spill. If oil spills, wipe it off immediately to prevent from penetrating into floor or flowing outside, for environmental protection.
- Follow all government regulations concerning disposal of refuse when disposing.

## D: PREPARATION TOOL

### 1. SPECIAL TOOL

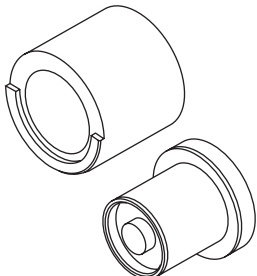
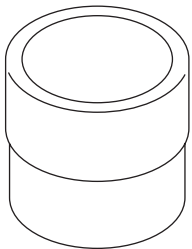
ILLUSTRATION	TOOL NUMBER	DESCRIPTION	REMARKS
 <p style="text-align: center;">ST20099AE000</p>	20099AE000	INSTALLER & REMOVER	Used for replacing the front lateral link bushing.
 <p style="text-align: center;">ST-499755602</p>	499755602	PRESS	Used for replacing the rear trailing link bushing.

# General Description

## REAR SUSPENSION

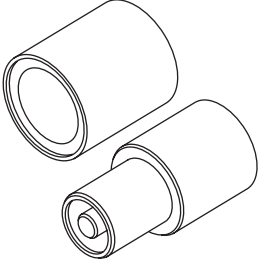
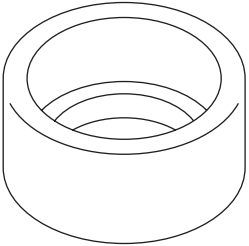
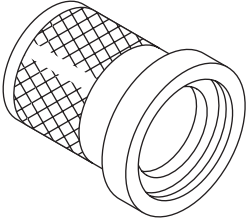
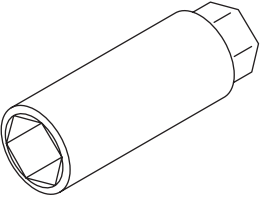
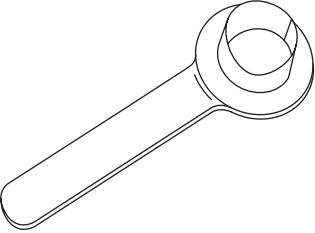
ILLUSTRATION	TOOL NUMBER	DESCRIPTION	REMARKS
 <p style="text-align: center;">ST20099AE010</p>	20099AE010	INSTALLER & REMOVER	Used for replacing the rear lateral link bushing.
 <p style="text-align: center;">ST20299AG010</p>	20299AG010	BASE	Used for replacing the rear trailing link bushing.
 <p style="text-align: center;">ST-899874100</p>	899874100	INSTALLER	Used for replacing the rear trailing link bushing.
 <p style="text-align: center;">ST20399FG000</p>	20399FG000	STRUT MOUNT SOCKET	<ul style="list-style-type: none"> <li>• Used for removing and installing shock mount.</li> <li>• Used for checking torque of shock mount center nut.</li> </ul>
 <p style="text-align: center;">ST28099PA090</p>	28099PA090	OIL SEAL PROTEC- TOR	<ul style="list-style-type: none"> <li>• Used for installing the rear drive shaft to the rear differential.</li> <li>• For oil seal protection</li> </ul>

# General Description

REAR SUSPENSION

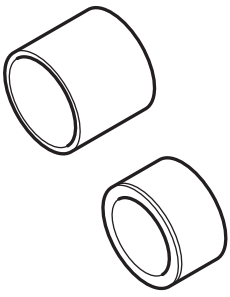
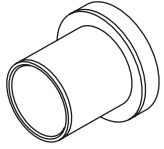
ILLUSTRATION	TOOL NUMBER	DESCRIPTION	REMARKS
 <p>ST20099PA010</p>	20099PA010	INSTALLER & REMOVER	<ul style="list-style-type: none"> <li>• Used for replacing the bushing of the rear housing.</li> <li>• Used together with BUSHING REMOVER (20099FG000).</li> </ul>
 <p>ST20099FG000</p>	20099FG000	BUSHING REMOVER	<ul style="list-style-type: none"> <li>• Used for replacing the bushing of the rear housing.</li> <li>• Used together with INSTALLER &amp; REMOVER (20099PA010).</li> </ul>

## 2. GENERAL TOOL

TOOL NAME	REMARKS
Alignment tester	Used for measuring wheel alignment.
Toe-in gauge	Used for toe-in measurement.
Jack	Used for removing and installing suspension.
Bearing puller	Used for removing bushings.
Coil spring compressor	Used for disassembling and assembling shock absorber.



# Wheel Alignment

REAR SUSPENSION

---

## 2. Wheel Alignment

### A: INSPECTION

NOTE:

Measure and adjust the front and rear wheel alignment at a time. Refer to "FS" section for measurement and adjustment of wheel alignment. <Ref. to FS-8, INSPECTION, Wheel Alignment.>

## 3. Rear Stabilizer

### A: REMOVAL

- 1) Lift up the vehicle, and then remove the rear wheels.
- 2) Remove the stabilizer link.

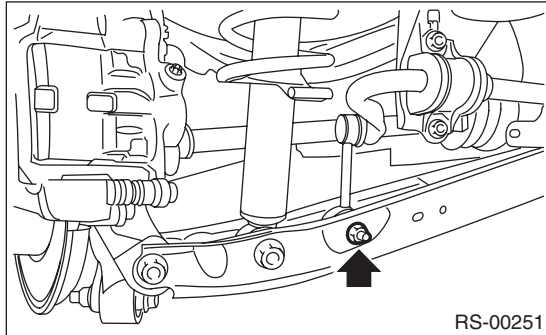

- 3) Remove the stabilizer clamp.

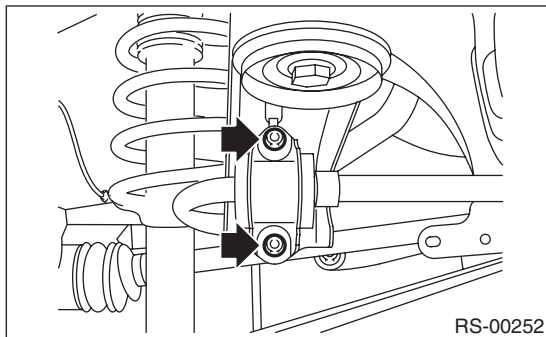

### B: INSTALLATION

#### CAUTION:

- Be sure to use a new flange nut and self-locking nut.
- Always tighten the bushing in the state where the vehicle is at curb weight and the wheels are in full contact with the ground.
- Align the paint mark end of stabilizer to the end of bushing when installing.

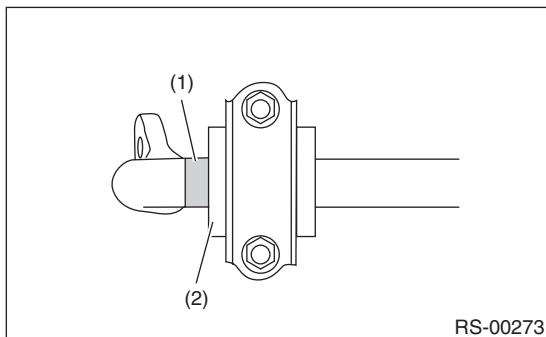

- (1) Identification paint
- (2) Bushing

Install each part in the reverse order of removal.

#### Tightening torque:

##### Stabilizer link

38 N·m (3.9 kgf-m, 28 ft-lb)

##### Stabilizer clamp

30 N·m (3.1 kgf-m, 22.1 ft-lb)

### C: INSPECTION

- 1) Check the bushing for abnormal cracks, fatigue or damage.
- 2) Check the stabilizer link for damage.

# Rear Trailing Link

## REAR SUSPENSION

### 4. Rear Trailing Link

#### A: REMOVAL

- 1) Lift up the vehicle, and then remove the rear wheels.
- 2) Remove the bracket, and remove the parking brake cable from the guide.

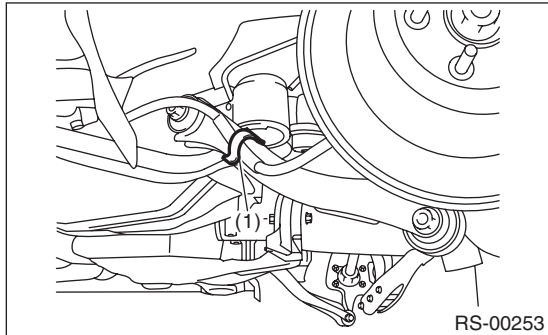

(1) Guide

- 3) Remove the trailing link.

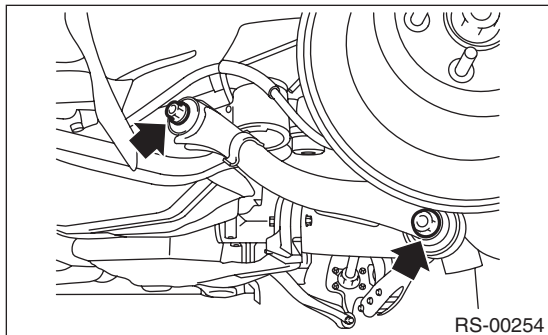

#### B: INSTALLATION

##### CAUTION:

- Be sure to use a new self-locking nut.
- Always tighten the bushing in the state where the vehicle is at curb weight and the wheels are in full contact with the ground.

Install each part in the reverse order of removal.

##### Tightening torque:

**90 N·m (9.2 kgf·m, 66.4 ft·lb)**

#### C: DISASSEMBLY

##### 1. REAR TRAILING LINK BUSHING

Using the ST A and ST B, press the bushing out.

ST A 8998741000 INSTALLER

ST B 499755602 PRESS

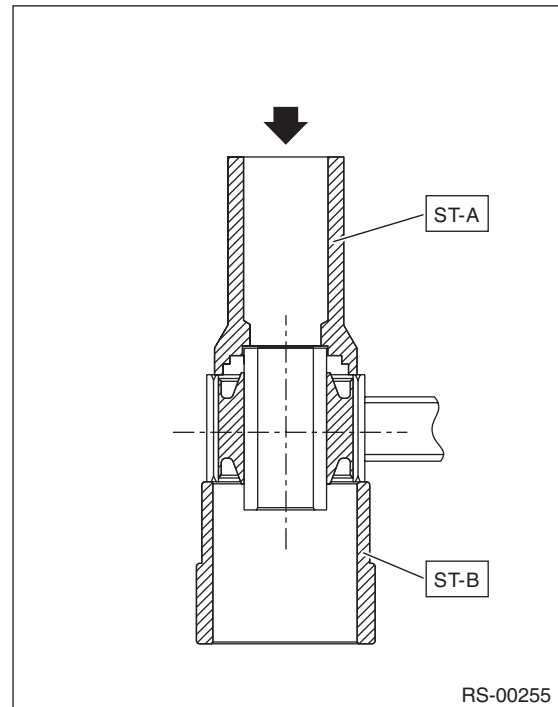

##### 2. REAR HOUSING BUSHING

- 1) Remove the rear housing. <Ref. to DS-20, REMOVAL, Rear Axle.>

2) Using the ST and a hydraulic press, push out the bushing.

- ST 1 200099FG000 BUSHING REMOVER
- ST 2 20099PA010 INSTALLER & REMOVER (BASE)

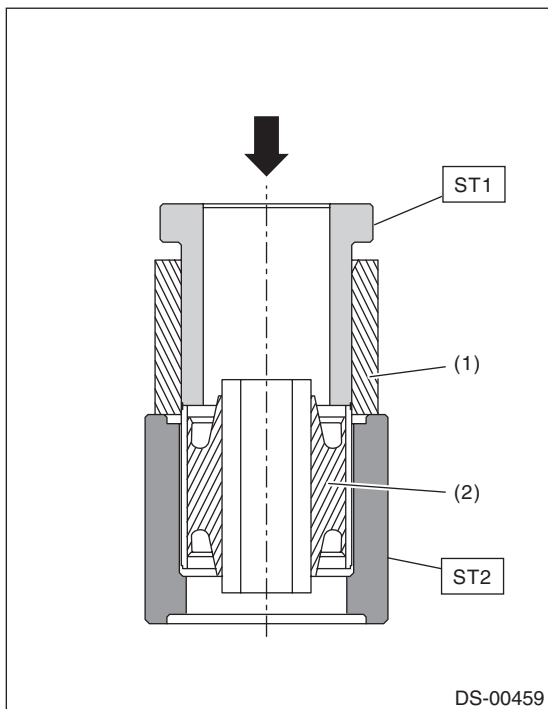
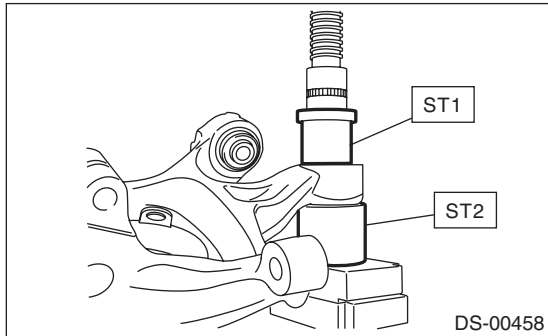

- (1) Rear housing
- (2) Bushing

## D: ASSEMBLY

### 1. REAR TRAILING LINK BUSHING

Using the ST A and ST B, press-fit the bushing.

#### CAUTION:

**Make sure to press the bushing straight in.**

- ST A 8998741000 INSTALLER
- ST B 20299AG010 BASE

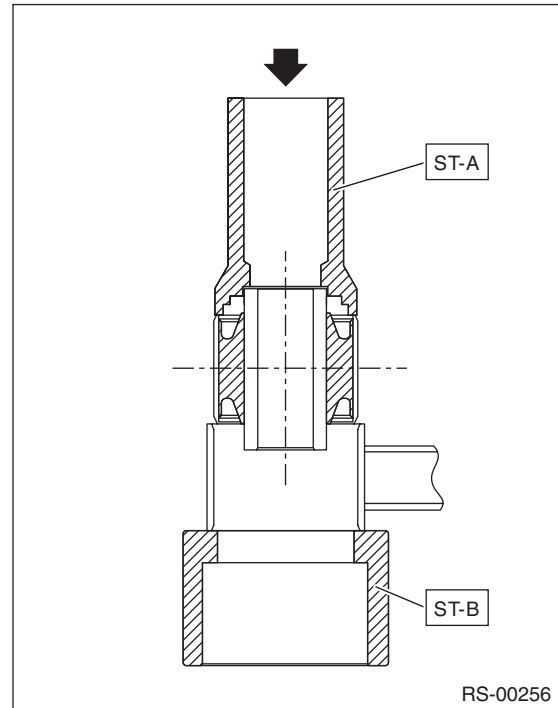

# Rear Trailing Link

## REAR SUSPENSION

### 2. REAR HOUSING BUSHING

Press-fit the bushing using ST and the hydraulic press.

#### CAUTION:

**Make sure to press the bushing straight in.**

ST 1 20099FG000 BUSHING REMOVER

ST 2 20099PA010 INSTALLER & REMOVER  
(BASE)

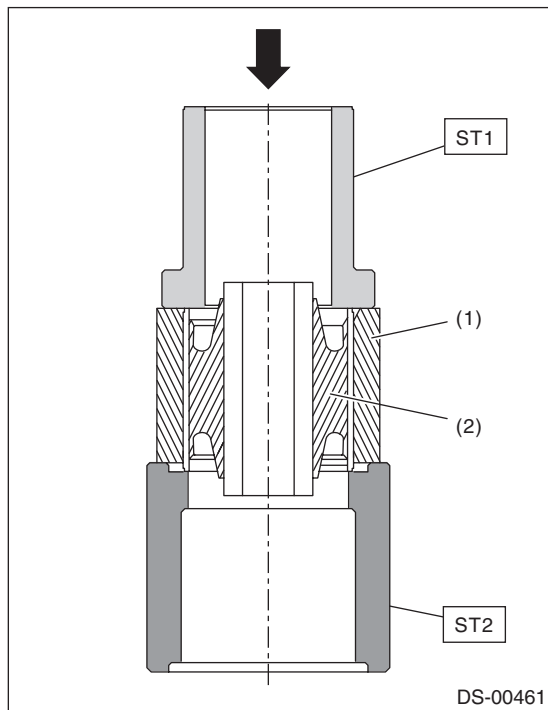
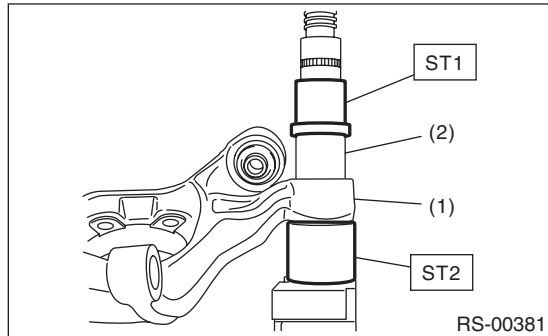

- (1) Rear housing
- (2) Bushing

### E: INSPECTION

Perform visual check for damage or bend on the trailing link.

## 5. Upper Arm

### A: REMOVAL

- 1) Remove the rear sub frame. <Ref. to RS-17, REMOVAL, Rear Sub Frame.>
- 2) Remove the rear ABS wheel speed sensor bracket.

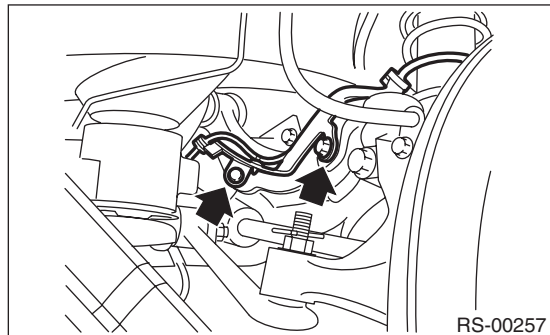

- 3) Remove the bolts, then remove the upper arm.

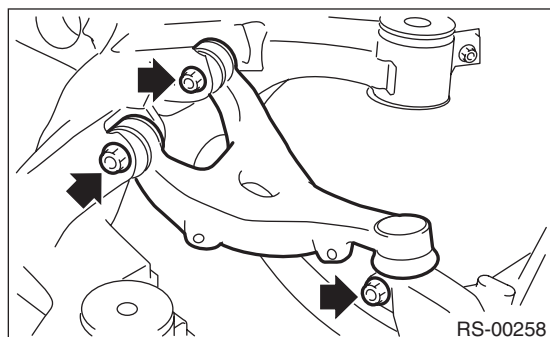

### B: INSTALLATION

#### CAUTION:

- Be sure to use a new self-locking nut.
- Always tighten the bushing when the arm is positioned in the state where the vehicle is at curb weight and the wheels are in full contact with the ground.

- 1) Install each part in the reverse order of removal.
- 2) Inspect the wheel alignment and adjust if necessary.

#### Tightening torque:

**Upper arm — Rear sub frame**  
 90 N·m (9.2 kgf·m, 66.4 ft·lb)

**Upper arm — Rear housing**  
 80 N·m (8.2 kgf·m, 59 ft·lb)

**Rear ABS wheel speed sensor bracket**  
 7.5 N·m (0.76 kgf·m, 5.5 ft·lb)

### C: INSPECTION

- 1) Visually check the upper arm for damage and deformation.
- 2) Visually check the bushing for abnormal cracks, fatigue or damage.

# Rear Shock Absorber

## REAR SUSPENSION

### 6. Rear Shock Absorber

#### A: REMOVAL

- 1) Remove the luggage floor mat. (5 door model)
- 2) Remove the strut cap of the quarter trim.
- 3) Remove the trunk room mat. (4 door model)
- 4) Lift up the vehicle, and then remove the rear wheels.
- 5) Remove the nut and disconnect the rear stabilizer link.
- 6) Remove the shock absorber lower bolt.
- 7) Disconnect the rear lateral link.

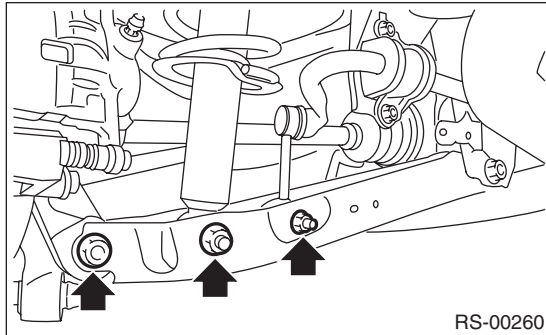

- 8) Remove the shock absorber mount nut.

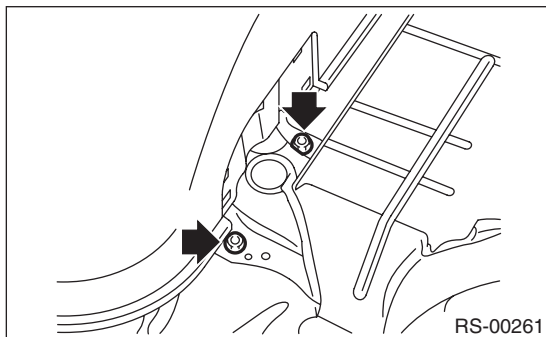

- 9) Remove the shock absorber.

#### B: INSTALLATION

##### CAUTION:

- Be sure to use a new self-locking nut.
- Always tighten the bushing in the state where the vehicle is at curb weight and the wheels are in full contact with the ground.

- 1) Install each part in the reverse order of removal.

##### Tightening torque:

Refer to "COMPONENT" of "General Description" for the tightening torque. <Ref. to RS-3, COMPONENT, General Description.>

- 2) Check the wheel alignment and adjust it if necessary.

#### C: DISASSEMBLY

Refer to "Front Strut" for disassembly procedure. <Ref. to FS-25, DISASSEMBLY, Front Strut.>

#### D: ASSEMBLY

Refer to "Front Strut" for installation procedures. <Ref. to FS-25, ASSEMBLY, Front Strut.>

#### E: INSPECTION

Refer to "Front Strut" for inspection procedures. <Ref. to FS-26, INSPECTION, Front Strut.>

#### F: DISPOSAL

##### CAUTION:

- Before handling the shock absorber, be sure to wear goggles to protect eyes from gas, oil and cutting powder.
- Do not disassemble the shock absorber or place it into a fire.
- Drill a hole into shock absorbers in case of discarding shock absorbers filled with gas.

- 1) Place the shock absorber on a level surface with the piston rod fully expanded.
- 2) Make a hole into the specified position 30 mm (1.18 in) deep using a drill with 2 — 3 mm (0.08 — 0.12 in) diameter.

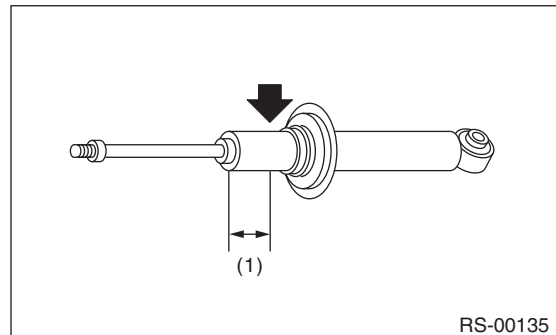

(1) 40 mm (1.57 in)

## 7. Front Lateral Link

### A: REMOVAL

- 1) Lift up the vehicle, and then remove the rear wheels.
- 2) Remove the rear trailing link. <Ref. to RS-10, REMOVAL, Rear Trailing Link.>
- 3) Remove the snap pin and nut.

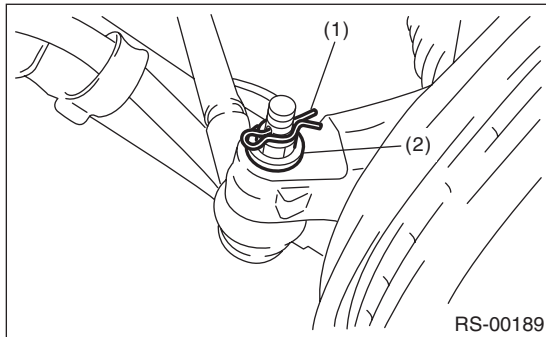

- (1) Snap pin
- (2) Nut

- 4) Using a puller, remove the ball joint.

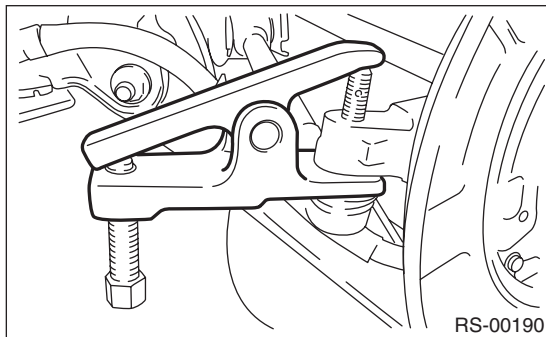

- 5) Scribe an alignment mark on the front lateral link adjusting bolt and rear sub frame.
- 6) Remove the adjusting bolt, and remove the front lateral link.

### CAUTION:

**When removing the adjusting bolt, make sure to fix the bolt head in place when loosening the nut.**

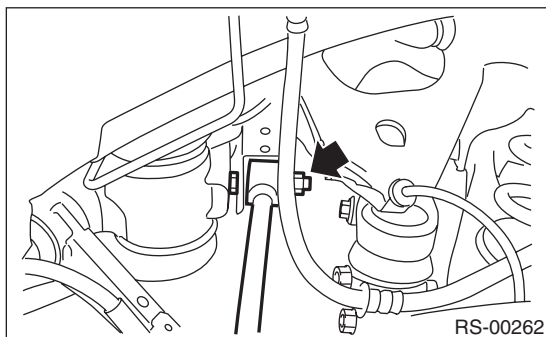

### B: INSTALLATION

#### CAUTION:

- Be sure to use a new self-locking nut.
- Always tighten the bushing in the state where the vehicle is at curb weight and the wheels are in full contact with the ground.

- 1) Install each part in the reverse order of removal.

#### Tightening torque:

**Front lateral link — Sub frame**

**100 N·m (10.2 kgf-m, 73.8 ft-lb)**

**Front lateral link — Rear axle housing**

**60 N·m (6.1 kgf-m, 44.3 ft-lb)**

- 2) Inspect the wheel alignment and adjust if necessary.

### C: INSPECTION

Visually check the front lateral link for damage and deformation.

### D: DISASSEMBLY

Using the ST A and ST B, press the bushing out.

ST A 20099AE000 INSTALLER & REMOVER

ST B 20099AE000 INSTALLER & REMOVER

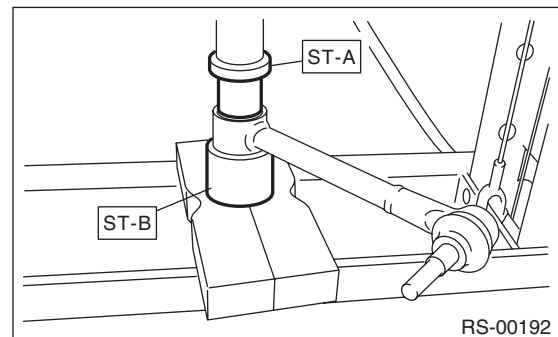

### E: ASSEMBLY

Using the ST A and ST B, press-fit the bushing.

#### CAUTION:

**Make sure to press the bushing straight in.**

ST A 20099AE000 INSTALLER & REMOVER

ST B 20099AE000 INSTALLER & REMOVER



# Rear Lateral Link

## REAR SUSPENSION

### 8. Rear Lateral Link

#### A: REMOVAL

- 1) Lift up the vehicle, and then remove the rear wheels.
- 2) Remove the nut and disconnect the stabilizer link.
- 3) Remove the shock absorber lower bolt.
- 4) Remove the bolt, and remove rear lateral link.

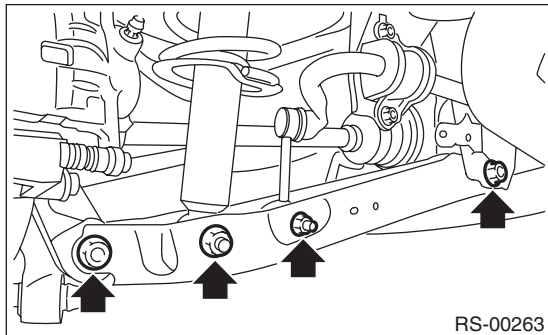

#### B: INSTALLATION

##### CAUTION:

- Be sure to use a new self-locking nut.
- Always tighten the bushing in the state where the vehicle is at curb weight and the wheels are in full contact with the ground.

- 1) Install each part in the reverse order of removal.

##### Tightening torque:

###### Rear lateral link

80 N·m (8.2 kgf·m, 59.0 ft·lb)

###### Shock absorber

80 N·m (8.2 kgf·m, 59.0 ft·lb)

###### Stabilizer link

38 N·m (3.9 kgf·m, 28 ft·lb)

- 2) Inspect the wheel alignment and adjust if necessary.

#### C: DISASSEMBLY

Using the ST A and ST B, press the bushing out.

ST A 20099AE010 INSTALLER & REMOVER

ST B 20099AE010 INSTALLER & REMOVER

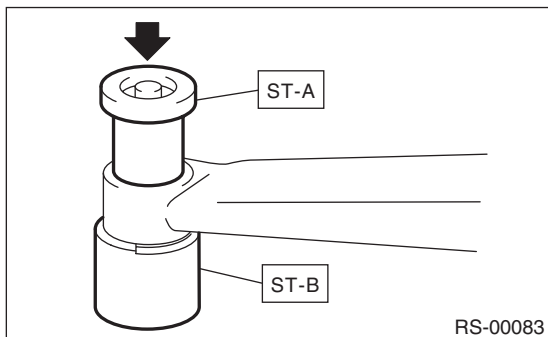

#### D: ASSEMBLY

Using the ST A and ST B, press-fit the bushing.

ST A 20099AE010 INSTALLER & REMOVER

ST B 20099AE010 INSTALLER & REMOVER

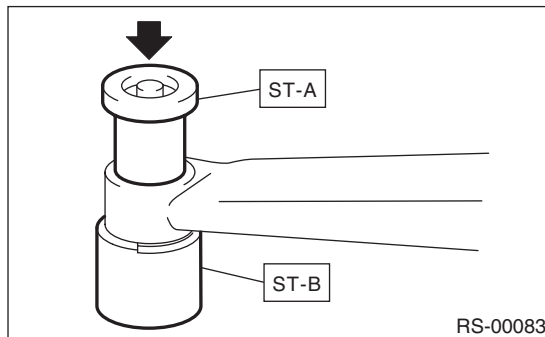

#### E: INSPECTION

Visually check the rear lateral link for damage and deformation.

## 9. Rear Sub Frame

### A: REMOVAL

- 1) Lift up the vehicle, and then remove the rear wheels.
- 2) Separate the front exhaust pipe and rear exhaust pipe.
- 3) Remove the rear exhaust pipe and muffler.
- 4) Remove the propeller shaft. <Ref. to DS-11, REMOVAL, Propeller Shaft.>
- 5) Remove the rear ABS wheel speed sensor from the rear housing.

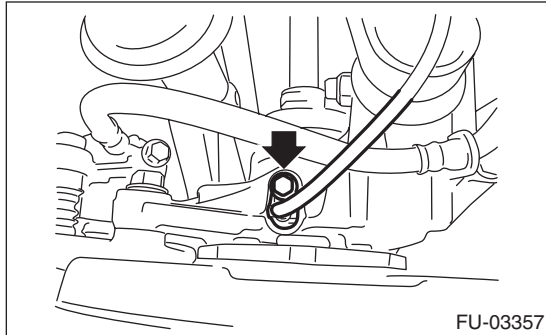

- 6) Remove the brake hose bracket from rear housing.

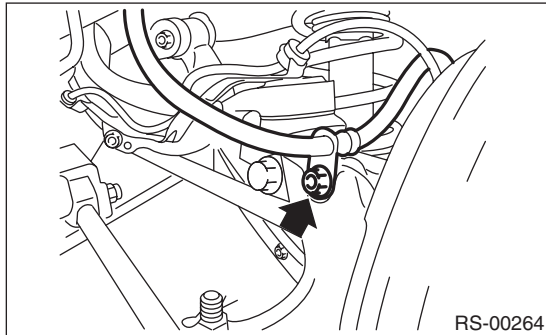

- 7) Remove the rear disc brake caliper, and suspend it from the shock absorber. (Disc brake model)

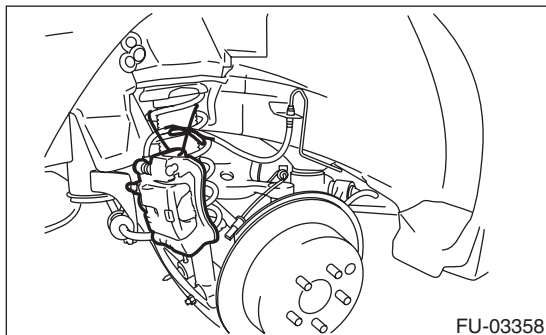

- 8) Remove the rear parking brake cable from the parking brake assembly. <Ref. to PB-6, REMOVAL, Parking Brake Assembly (Rear Disc Brake).>

- 9) Disconnect the ABS wheel speed sensor connector.

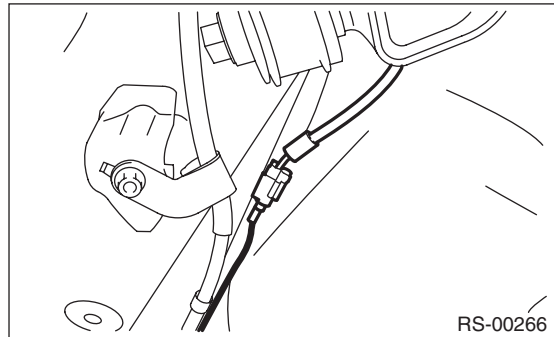

- 10) Remove the shock absorber lower bolt.

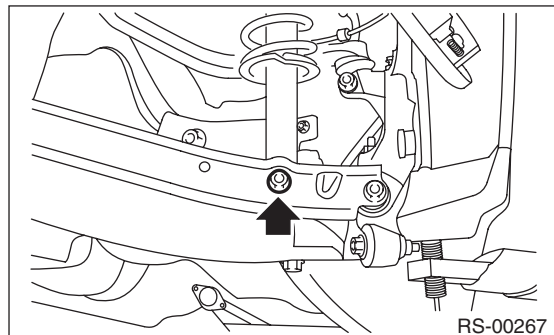

- 11) Support the sub frame using a jack.
- 12) Remove the support plate.

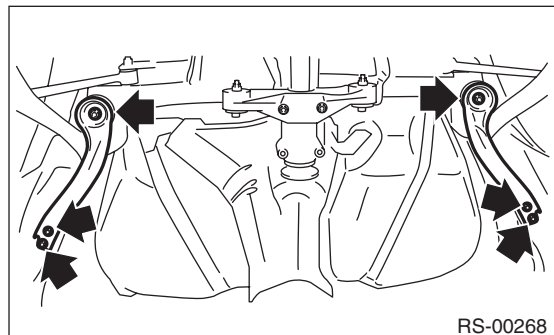

- 13) Remove the rear sub frame.

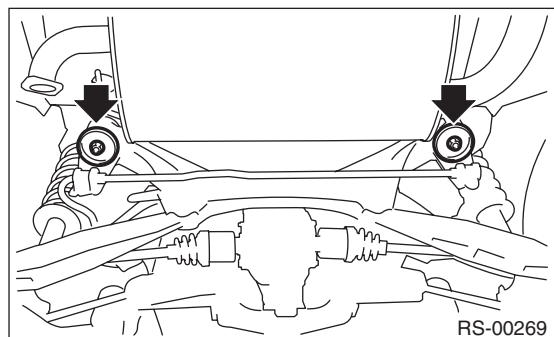

## B: INSTALLATION

### CAUTION:

- Be sure to use a new self-locking nut.
- Always tighten the bushing in the state where the vehicle is at curb weight and the wheels are in full contact with the ground.

1) Install each part in the reverse order of removal.

### *Tightening torque:*

*Refer to "COMPONENT" of "General Description" for the tightening torque. <Ref. to RS-3, COMPONENT, General Description.>*

2) Inspect the wheel alignment and adjust if necessary.

## C: INSPECTION

Check the removed parts for wear, damage and crack, and repair or replace them if faulty.

## 10. General Diagnostic Table

### A: INSPECTION

#### 1. IMPROPER VEHICLE POSTURE OR IMPROPER WHEEL ARCH HEIGHT

Possible cause	Corrective action
(1) Permanent distortion or damaged coil spring	Replace.
(2) Rough operation of strut or shock absorber	Replace.
(3) Improper installation of strut or shock absorber	Replace with proper parts.
(4) Installation of the wrong coil spring	Replace with proper parts.

#### 2. POOR RIDE COMFORT

- 1) Large rebound shock
- 2) Rocking of the vehicle continues too long after running over bump and hump.
- 3) Excessive shock in bumping

Possible cause	Corrective action
(1) Damaged coil spring	Replace.
(2) Overinflation of tires	Adjust.
(3) Improper wheel arch height	Replace the coil springs with new parts.
(4) Fault in operation of strut or shock absorber	Replace.
(5) Damage or deformation of strut mount or shock absorber mount	Replace.
(6) Unsuitable length (maximum or minimum) of strut or shock absorber	Replace with appropriate parts.
(7) Deformation or loss of bushing	Replace.
(8) Deformation or damage of helper in strut assembly or shock absorber	Replace.
(9) Oil leakage from the strut or shock absorber	Replace.

#### 3. NOISE

Possible cause	Corrective action
(1) Wear or damage of strut or shock absorber component parts	Replace.
(2) Loosening of the suspension link installing bolt	Tighten to the specified torque.
(3) Deformation or loss of bushing	Replace.
(4) Unsuitable length (maximum or minimum) of strut or shock absorber	Replace with appropriate parts.
(5) Damaged coil spring	Replace.
(6) Wear or damage of the ball joint	Replace.
(7) Deformation of the stabilizer clamp	Replace.

# General Diagnostic Table

REAR SUSPENSION

---

**RS-20**

Brought to you by Ebay Seller "SubaruManuals"

# WHEEL AND TIRE SYSTEM

# WT

---

	<b>Page</b>
1. General Description .....	2
2. Tire and Wheel .....	4
3. "T-type" Tire .....	7
4. Tire Pressure Monitoring System .....	8
5. General Diagnostic Table .....	10

# General Description

## WHEEL AND TIRE SYSTEM

### 1. General Description

#### A: SPECIFICATION

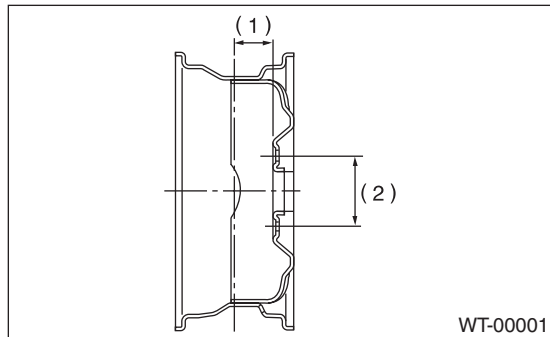

- (1) Offset  
(2) P.C.D.

Model	Tire size	Wheel size	Offset mm (in)	P.C.D. mm (in)	Tire inflation pressure kPa (kgf/cm <sup>2</sup> , psi)	
					Front wheel	Rear wheel
STI model	Standard type	245/40R18 93W	18 × 8 <sup>1</sup> / <sub>2</sub> J	55 (2.17)	114.3 (4.50)	*1
	"T-type" Tire	T135/70D17 102M	17 × 4T	30 (1.18)		
Except for STI model	Standard type	235/45R17 94W	17 × 8J	53 (2.09)	100 (3.94)	
	"T-type" Tire	T135/70D17 102M	17 × 4T	30 (1.18)		

\*1: Size and inflation pressure of the standard equipment tire, spare tire for emergency and appropriate tire for equipment are described on the "Tire inflation pressure" label attached to the body side of the driver's door.

#### NOTE:

"T-type" tire for temporary use is equipped as a spare tire.

#### 1. SERVICE DATA

Part	Axial runout	Radial runout
Steel wheel	1.5 mm (0.059 in)	
Aluminum wheel	1.0 mm (0.039 in)	

## B: COMPONENT

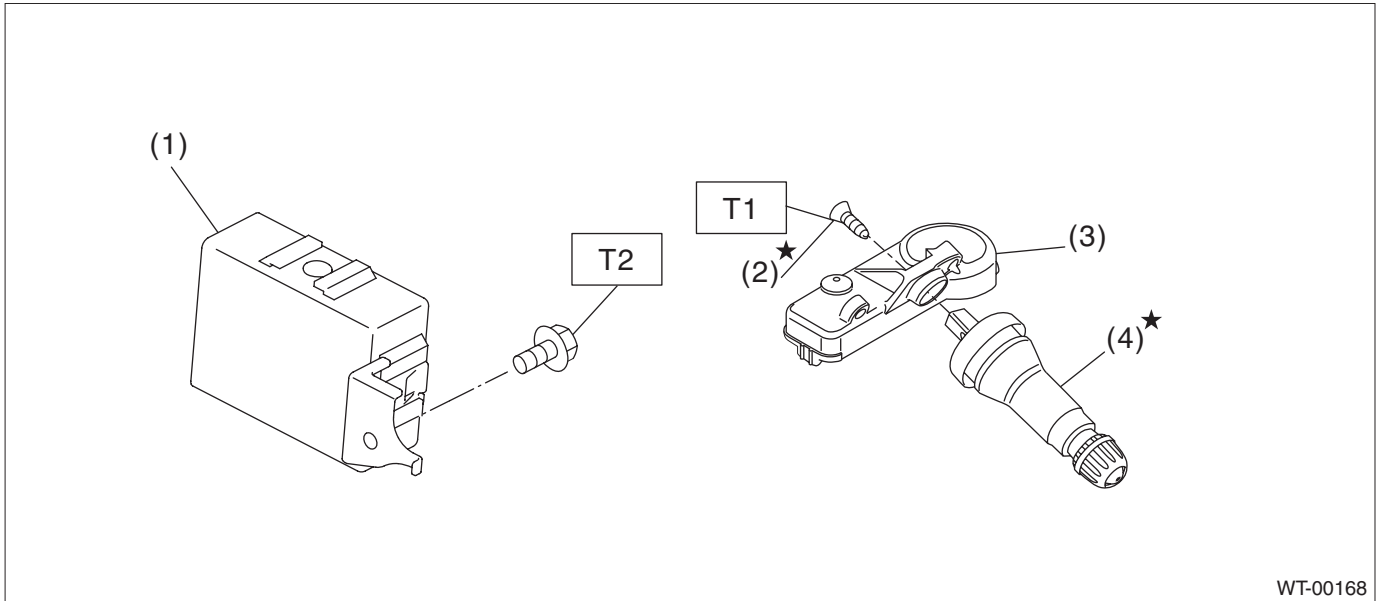

- |   |                                |
|---|--------------------------------|
| (1) TPMS & keyless entry control module | (3) Transmitter (snap in type) |
| (2) Screw                               | (4) Valve                      |

**Tightening torque: N·m (kgf·m, ft·lb)**

**T1: 1.4 (0.14, 1)**

**T2: 7.5 (0.76, 5.5)**

## C: PREPARATION TOOL

### 1. GENERAL TOOL

TOOL NAME	REMARKS
Air pressure gauge	Used for measuring tire air pressure.
Dial gauge	Used for measuring wheel runout.



# Tire and Wheel

## WHEEL AND TIRE SYSTEM

## 2. Tire and Wheel

### A: REMOVAL

- 1) Lift up the vehicle.
- 2) Remove the wheel nut.
- 3) Remove the wheels.

#### NOTE:

When removing the wheels, be careful not to damage the hub bolts.

### B: INSTALLATION

- 1) Install the wheels to vehicle.
- 2) Tighten the wheel nuts to the specified torque.

#### **Tightening torque:**

**100 N·m (10.2 kgf·m, 73.8 ft·lb)**

### C: INSPECTION

#### 1. TIRES

#### CAUTION:

**When replacing a tire, make sure to use only tires of the same size, construction and load range as originally installed.**

- 1) Tire size and tire inflation pressure check <Ref. to WT-2, SPECIFICATION, General Description.>
- 2) Cracks, damage and wear check
- 3) Tire runout check
  - (1) Lift up the vehicle.
  - (2) Slowly rotate the wheel to check rim "runout" using a dial gauge.

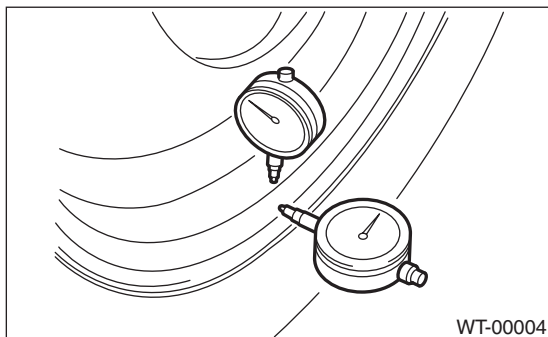

- Aluminum wheel

Axial runout limit	Radial runout limit
1.0 mm (0.039 in)	

- Steel wheel

Axial runout limit	Radial runout limit
1.5 mm (0.059 in)	

- (3) If the rim runout exceeds service limit, replace the wheel.

## 2. TIRE ROTATION

**NOTE:**

Rotate tires periodically (12,500 km/7,500 miles) in order to prolong life and to prevent uneven wear. Rotate tires as shown in the figure depending on whether or not the direction of the tire rotation is specified.

- When the direction of tire rotation is not specified

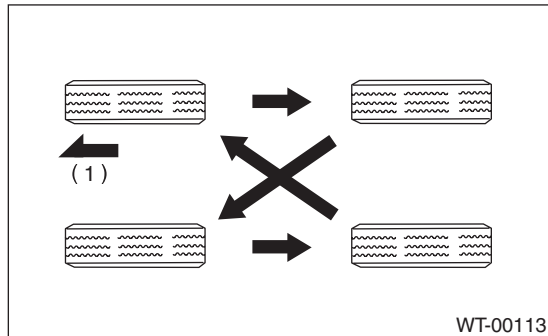

(1) Front side of vehicle

- When the direction of tire rotation is specified

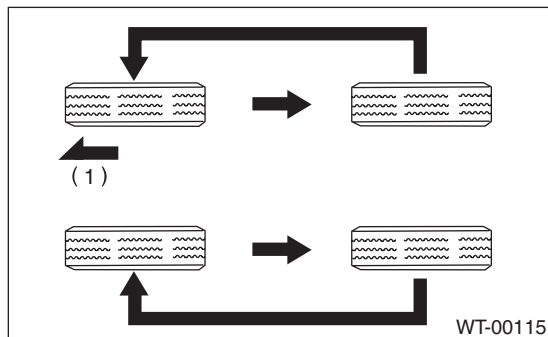

(1) Front side of vehicle

# Tire and Wheel

## WHEEL AND TIRE SYSTEM

---

### 3. WHEEL BALANCING

- 1) Using the wheel balancer, measure wheel balance.
- 2) Adjust the wheel balancing.

#### NOTE:

- Unbalance after adjusting the wheel balancing should be 5 g (0.18 oz) or less.
- When using the adhesive type weight, degrease the surface where the adhesive type weight will be applied securely.
- After applying the adhesive type weight, apply a force to the weight and attain full adhesion.
- Using the knock-on type weight, check the size of the knock-on part.

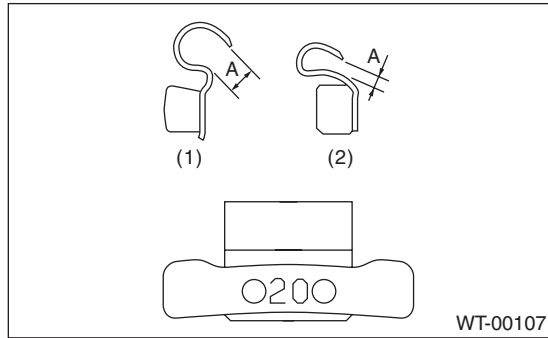

- (1) Knock-on type weight for aluminum wheel
- (2) Knock-on type weight for steel wheel

#### **Service limit A:**

**Knock-on type weight for steel wheel:**

**2.0 mm (0.079 in)**

**Knock-on type weight for aluminum wheel:**

**5.0 mm (0.197 in)**

## 3. “T-type” Tire

### A: NOTE

#### CAUTION:

- The “T-type” tire is only for temporary use. Replace with a conventional tire as soon as possible.
- Do not use tire chains for “T-type” tires. Because tire size is small, tire chains can not be installed and will damage the vehicle and tires.
- Do not drive at a speed greater than 80 km/h (50 MPH).
- Drive the vehicle as slowly as possible and avoid bumps on the road.

“T-type” tire for temporary use is prepared as a spare tire.

### B: REPLACEMENT

#### CAUTION:

The “T-type” tire is only for temporary use. Replace with a conventional tire as soon as possible.

Refer to “Tire & Wheel” for removal and installation of the “T-type” tire. <Ref. to WT-4, Tire and Wheel.>

### C: INSPECTION

Refer to “Tire & Wheel” for inspection of the “T-type” tire. <Ref. to WT-4, TIRES, INSPECTION, Tire and Wheel.>

# Tire Pressure Monitoring System

## WHEEL AND TIRE SYSTEM

### 4. Tire Pressure Monitoring System

#### A: REMOVAL

##### 1. TRANSMITTER (SNAP IN TYPE)

- 1) Remove the wheels from the vehicle. <Ref. to WT-4, REMOVAL, Tire and Wheel.>
- 2) Remove the tires from wheels.

#### CAUTION:

Use a tire changer when removing the tire from the wheel.

- 3) Loosen the screw to remove the transmitter from the valve stem.

#### NOTE:

Replace the valve and screw with a new part when reusing transmitter.

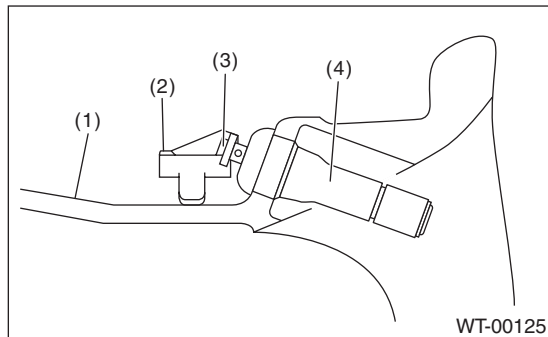

- (1) Wheel
- (2) Transmitter
- (3) Screw
- (4) Valve

- 4) Remove the valve from the wheel.

##### 2. TPMS & KEYLESS ENTRY CONTROL MODULE

#### NOTE:

TPMS control module is integrated into keyless entry control module.

- 1) Disconnect the ground cable from battery.
- 2) Remove the left rear quarter trim. (5 door model) <Ref. to EI-60, REMOVAL, Rear Quarter Trim.>
- 3) Remove the rear shelf trim. (4 door model) <Ref. to EI-62, REMOVAL, Rear Shelf Trim.>
- 4) Disconnect the harness connector.

- 5) Remove the bolt and then remove the TPMS & keyless entry control module.

- 5 door model

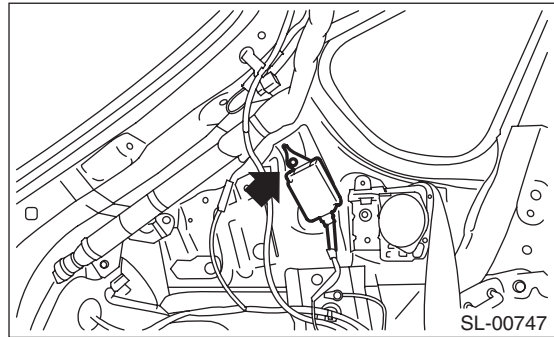

- 4 door model

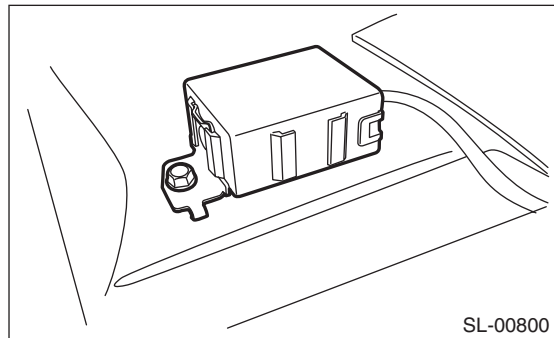

#### B: INSTALLATION

##### 1. TRANSMITTER (SNAP IN TYPE)

#### CAUTION:

Use the new transmitter assembly or replace the new valve and screw, when installing.

- 1) Replace the valve and screw with a new part when reusing transmitter.

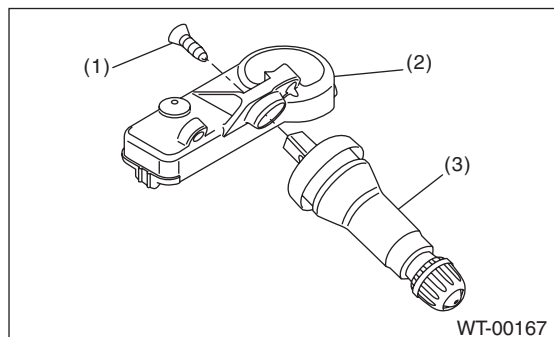

- (1) Screw
- (2) Transmitter
- (3) Valve

#### Tightening torque:

1.4 N-m (0.14 kgf-m, 1 ft-lb)

2) Install the transmitter to the wheel by aligning it with valve hole.

**NOTE:**

When using the jig that pulls the valve cap by hooking its neck part, use another short-type cap.

3) Install the tires to wheels.

**CAUTION:**

- Use a tire changer when installing tire to wheel.
- To prevent damaging the transmitter, set the tire changer boom in the position as shown in the figure.

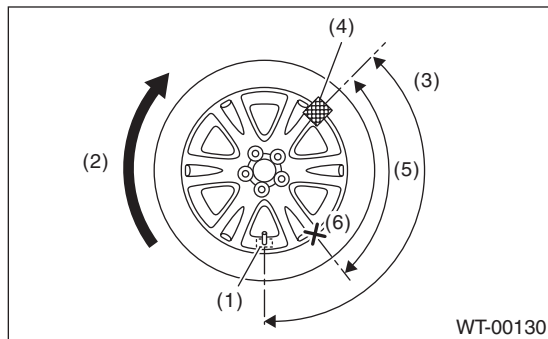

- (1) Transmitter
- (2) Direction of turn table rotation
- (3) 135°
- (4) Tire changer boom
- (5) 90°
- (6) Starting point for fitting the bead to the rim

4) Install the wheels to vehicle. <Ref. to WT-4, INSTALLATION, Tire and Wheel.>

5) Register the transmitter ID to the TPMS & keyless entry control module. <Ref. to TPM(diag)-8, REGISTER TRANSMITTER ID, OPERATION, Subaru Select Monitor.>

## 2. TPMS & KEYLESS ENTRY CONTROL MODULE

Install each part in the reverse order of removal.

**Tightening torque:**

**7.5 N·m (0.76 kgf-m, 5.5 ft-lb)**

### C: ADJUSTMENT

Re-register the transmitter ID when transmitter has been replaced. <Ref. to TPM(diag)-8, REGISTER TRANSMITTER ID, OPERATION, Subaru Select Monitor.>

Re-register the keyless transmitter when TPMS & keyless entry control module has been replaced. <Ref. to SL-49, REGISTRATION OF KEYLESS TRANSMITTER WITH SUBARU SELECT MONITOR, REPLACEMENT, Transmitter.>

# General Diagnostic Table

## WHEEL AND TIRE SYSTEM

### 5. General Diagnostic Table

#### A: INSPECTION

Symptoms	Possible cause	Corrective action
Wheel is out of balance.	Improperly inflated tire.	Adjust the tire pressure.
	Uneven wear	Check the tire referring to Abnormal tire wear in this table, carry out the procedure and replace the tire.
	Front wheel alignment	Check the front wheel alignment. <Ref. to FS-8, INSPECTION, Wheel Alignment.>
	Rear wheel alignment	Check the rear wheel alignment. <Ref. to RS-8, INSPECTION, Wheel Alignment.>
	Front strut	Check the front strut. <Ref. to FS-26, INSPECTION, Front Strut.>
	Rear shock absorber	Check the rear shock absorber. <Ref. to RS-14, INSPECTION, Rear Shock Absorber.>
	Front axle	Check the front axle. <Ref. to DS-17, INSPECTION, Front Axle.>
	Front hub unit bearing	Check the front hub unit bearing. <Ref. to DS-19, INSPECTION, Front Hub Unit Bearing.>
	Rear hub unit bearing	Check the rear hub unit bearing. <Ref. to DS-26, INSPECTION, Rear Hub Unit Bearing.>
Vehicle is abnormally out of balance.	Improperly inflated tire.	Adjust the tire pressure.
	Uneven wear	Check the tire referring to Abnormal tire wear in this table, carry out the procedure and replace the tire.
	Front stabilizer	Inspect the front stabilizer. <Ref. to FS-17, INSPECTION, Front Stabilizer.>
	Front wheel alignment	Check the front wheel alignment. <Ref. to FS-8, INSPECTION, Wheel Alignment.>
	Rear wheel alignment	Check the rear wheel alignment. <Ref. to RS-8, INSPECTION, Wheel Alignment.>
Abnormal wheel vibration	Improperly inflated tire.	Adjust the tire pressure.
	Uneven wear	Check the tire referring to Abnormal tire wear in this table, carry out the procedure and replace the tire.
	Improper wheel balancing	Check the wheel balance. <Ref. to WT-6, WHEEL BALANCING, INSPECTION, Tire and Wheel.>
	Front axle	Check the front axle. <Ref. to DS-17, INSPECTION, Front Axle.>
	Front hub unit bearing	Check the front hub unit bearing. <Ref. to DS-19, INSPECTION, Front Hub Unit Bearing.>
	Rear hub unit bearing	Check the rear hub unit bearing. <Ref. to DS-26, INSPECTION, Rear Hub Unit Bearing.>
Abnormal tire wear	Improperly inflated tire.	Adjust the tire pressure.
	Improper wheel balancing	Check the wheel balance. <Ref. to WT-6, WHEEL BALANCING, INSPECTION, Tire and Wheel.>
	Front wheel alignment	Check the front wheel alignment. <Ref. to FS-8, INSPECTION, Wheel Alignment.>
	Rear wheel alignment	Check the rear wheel alignment. <Ref. to RS-8, INSPECTION, Wheel Alignment.>

# TIRE PRESSURE MONITORING SYSTEM (DIAGNOSTICS)

## *TPM(diag)*

---

	<b>Page</b>
1. Basic Diagnostic Procedure .....	2
2. General Description .....	3
3. Electrical Component Location .....	5
4. Control Module I/O Signal .....	6
5. Subaru Select Monitor .....	7
6. Read Diagnostic Trouble Code (DTC) .....	12
7. Inspection Mode .....	13
8. Clear Memory Mode .....	14
9. Tire Pressure Warning Light / Trouble Indicator Light Illumination Pattern .....	15
10. List of Diagnostic Trouble Code (DTC) .....	20
11. Diagnostic Procedure with Diagnostic Trouble Code (DTC) .....	22
12. General Diagnostic Table .....	32



# Basic Diagnostic Procedure

## TIRE PRESSURE MONITORING SYSTEM (DIAGNOSTICS)

### 1. Basic Diagnostic Procedure

#### A: PROCEDURE

##### CAUTION:

**Remove foreign matter (dust, water, oil etc.) from the TPMS & keyless entry control module connector when removing and installing.**

##### NOTE:

To check harness for open or short circuits, shake the suspected trouble spot or connector.

Step	Check	Yes	No
<b>1</b> <b>CHECK PRE-INSPECTION.</b> 1) Check with the user regarding when the warning light lit or started blinking. 2) Before performing diagnostics, check all components which may adversely affect the tire pressure monitor system. <Ref. to TPM(diag)-3, INSPECTION, General Description.>	Is the component that might affect the tire pressure monitor system normal?	Go to step 2.	Repair or replace each component.
<b>2</b> <b>CHECK DIAGNOSTIC TROUBLE CODE (DTC).</b> 1) Turn the ignition switch to OFF. 2) Connect the Subaru Select Monitor to data link connector. 3) Turn the ignition switch to ON and run the Subaru Select Monitor. NOTE: If the communication function of the Subaru Select Monitor cannot be executed normally, check the communication circuit. <Ref. to TPM(diag)-10, COMMUNICATION FOR INITIALIZING IMPOSSIBLE, INSPECTION, Subaru Select Monitor.> 4) Read the DTC. <Ref. to TPM(diag)-12, OPERATION, Read Diagnostic Trouble Code (DTC).>	Is DTC displayed?	Go to step 4.	Go to step 3.
<b>3</b> <b>PERFORM GENERAL DIAGNOSTICS.</b> 1) Perform the inspection by referring to "General Diagnostic Table". <Ref. to TPM(diag)-32, General Diagnostic Table.> 2) Perform the Clear Memory Mode. <Ref. to TPM(diag)-8, CLEAR MEMORY, OPERATION, Subaru Select Monitor.> 3) Perform the Inspection Mode. <Ref. to TPM(diag)-13, Inspection Mode.> 4) Read the DTC. <Ref. to TPM(diag)-7, READ DIAGNOSTIC TROUBLE CODE (DTC), OPERATION, Subaru Select Monitor.> Check the DTC is not displayed.	Does the tire pressure warning light illuminates for about 2 seconds and then goes off after turning on the ignition switch, and then go out?	Finish the diagnosis.	Check the tire inflation pressure warning light blinking patterns. <Ref. to TPM(diag)-15, INSPECTION, Tire Pressure Warning Light / Trouble Indicator Light Illumination Pattern.>
<b>4</b> <b>PERFORM DIAGNOSIS.</b> 1) Refer to "List of Diagnostic Trouble Code (DTC)". 2) Correct the cause of trouble. 3) Perform the Clear Memory Mode. <Ref. to TPM(diag)-8, CLEAR MEMORY, OPERATION, Subaru Select Monitor.> 4) Perform the drive test. Drive the vehicle at 40 km/h (25 MPH) or faster for at least 10 minutes. 5) Read the DTC. <Ref. to TPM(diag)-7, READ DIAGNOSTIC TROUBLE CODE (DTC), OPERATION, Subaru Select Monitor.>	Is DTC displayed?	Repeat steps 1 to 4 until DTC is not shown.	Finish the diagnosis.

# General Description

TIRE PRESSURE MONITORING SYSTEM (DIAGNOSTICS)

## 2. General Description

### A: CAUTION

#### 1. SRS AIRBAG SYSTEM

Airbag system wiring harness is routed near the TPM control module.

#### CAUTION:

- Do not use electrical test equipment on any of the airbag system wiring harness circuits.
- Be careful not to damage the wiring harness of the airbag system when servicing the TPMS & keyless entry control module.

#### 2. TPMS & KEYLESS ENTRY CONTROL MODULE

- If the transmitter is replaced, ID registration for the transmitter is required. <Ref. to TPM(diag)-8, REGISTER TRANSMITTER ID, OPERATION, Subaru Select Monitor.>
- When adjusting tire pressure indoors in winter, there is a big temperature difference between the indoor facilities and outside. Once the car is outside where the temperature is lower, the air pressure in the tires will drop, causing the tire pressure warning light to illuminate, even if the pressure in the tires was adjusted to standard values indoors. To avoid this, it is necessary to adjust the tire pressure to the high side in consideration of the difference in temperature between inside and outside according to the following table.

235/45R17, 245/40R18

Temperature °C (°F)	Indoor temperature	15.5 (60)		
	Ambient temperature	-1 (30)	-12 (10)	-23 (-10)
Air pressure kPa (psi)	Front	250 (36)	265 (38)	280 (40)
	Rear	240 (35)	255 (37)	270 (39)

### B: INSPECTION

Before performing diagnosis, check the following item which might affect the quality of the tire pressure monitoring system.

#### 1. TIRES

- Inspect that the tire pressure is within the specification while the tire is cool. (Refer to Tire Caution Label.)
- Check the tires for damage or the insertion of foreign matters.

#### 2. BATTERY

Check that amount of battery fluid, gravity and voltage are within the specifications.

**Standard voltage: 12 V or more**

**Specific gravity: 1.260 or more**

## General Description

TIRE PRESSURE MONITORING SYSTEM (DIAGNOSTICS)

---

### C: PREPARATION TOOL

#### 1. SPECIAL TOOL

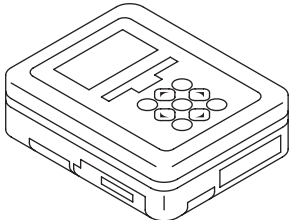
ILLUSTRATION	TOOL NUMBER	DESCRIPTION	REMARKS
 ST1B022XU0	1B022XU0	SUBARU SELECT MONITOR III KIT	Used for troubleshooting the electrical system.

#### 2. GENERAL TOOL

TOOL NAME	REMARKS
Circuit tester	Used for measuring resistance, voltage and current.
Transmitter registration tool	Used to register the transmitter ID. Manufacturer: Kent-Moore Item number: J45295

# Electrical Component Location

## TIRE PRESSURE MONITORING SYSTEM (DIAGNOSTICS)

### 3. Electrical Component Location

#### A: LOCATION

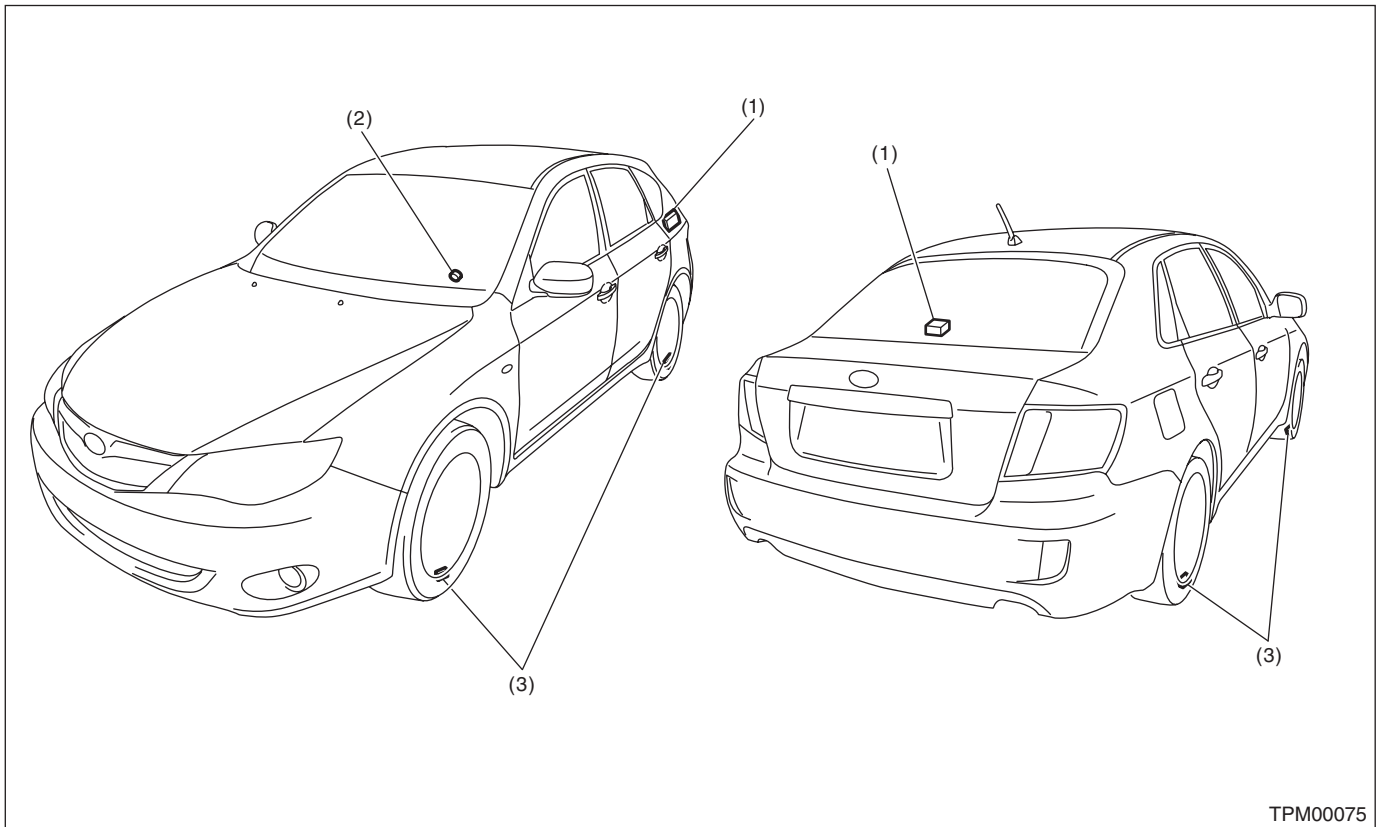

TPM00075

(1) TPMS & keyless entry control module

(2) Tire pressure warning light

(3) Snap-in type transmitter

• 5 DOOR MODEL

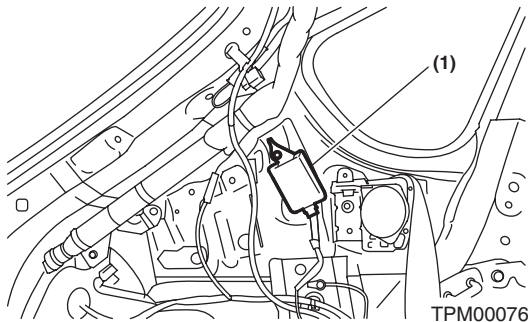

TPM00076

• 4 DOOR MODEL

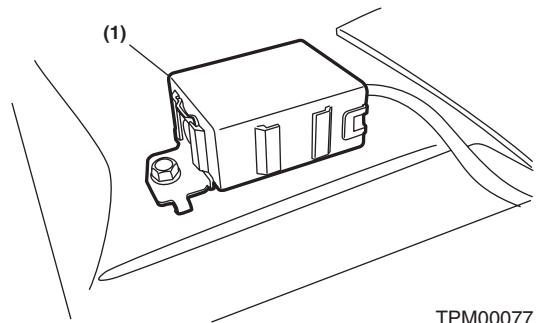

TPM00077

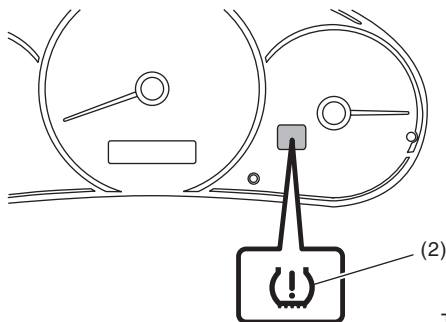

TPM00048

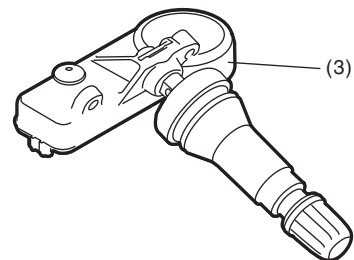

TPM00049

TPM(diag)-5

Brought to you by Ebay Seller "SubaruManuals"

# Control Module I/O Signal

TIRE PRESSURE MONITORING SYSTEM (DIAGNOSTICS)

## 4. Control Module I/O Signal

### A: ELECTRICAL SPECIFICATION

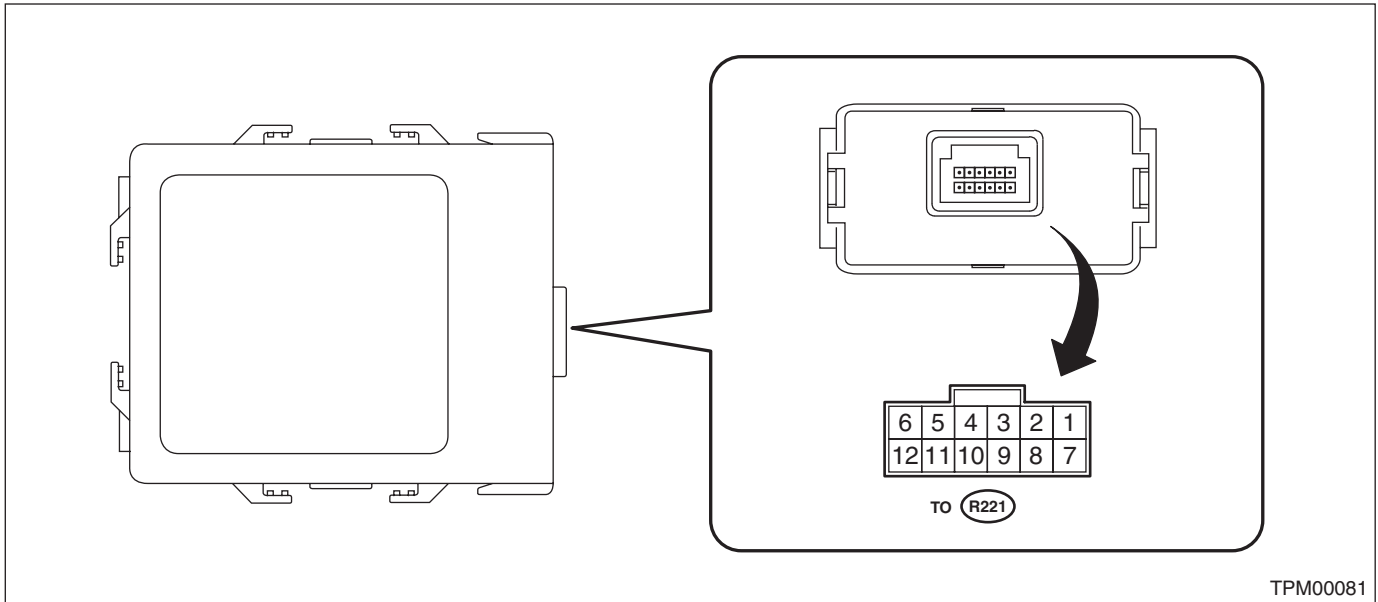

TPM00081

Terminal No.	Content	Measured value and measuring conditions	Remarks
1	—	—	—
2	Tire pressure warning light output	Illuminate when malfunction occurs, or tire pressure decreases	System failure: blinks 25 times → illuminates Tire pressure decreases: turns on
3	Speed sensor signal	While driving (Pulse signal)	Change according to vehicle speed
4	Ignition power supply	IG switch ON (Battery voltage)	—
5	GND	0 V (Always)	—
6	Battery power supply	Battery voltage (Always)	—
7	—	—	—
8	—	—	—
9	—	—	—
10	—	—	—
11	Body integrated unit	—	—
12	Select monitor communication	Serial communication	—

### B: WIRING DIAGRAM

<Ref. to WI-71, WIRING DIAGRAM, Tire Pressure Monitoring System.>

# Subaru Select Monitor

TIRE PRESSURE MONITORING SYSTEM (DIAGNOSTICS)

## 5. Subaru Select Monitor

### A: OPERATION

#### 1. READ DIAGNOSTIC TROUBLE CODE (DTC)

1) Prepare the Subaru Select Monitor kit. <Ref. to TPM(diag)-4, SPECIAL TOOL, PREPARATION TOOL, General Description.>

2) Connect the diagnosis cable to Subaru Select Monitor.

3) Connect the Subaru Select Monitor to data link connector.

(1) Data link connector is located in the lower portion of instrument panel (on the driver's side).

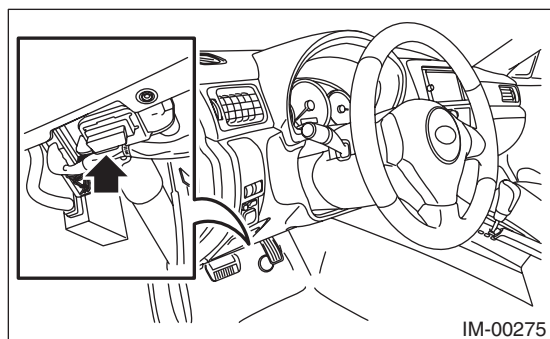

(2) Connect the diagnosis cable to data link connector.

#### CAUTION:

**Do not connect scan tools other than the Subaru Select Monitor.**

4) Turn the ignition switch to ON and run the Subaru Select Monitor.

5) On «Main Menu» display, select {Each System Check}.

6) On «System Selection Menu» display, select {Tire pressure monitor}.

7) On «Tire pressure monitor diagnosis» display, select {Diagnostic Code(s) Display}.

#### NOTE:

- For detailed operation procedures, refer to “PC application help for Subaru Select Monitor”.
- For details concerning DTCs, refer to List of Diagnostic Trouble Code (DTC). <Ref. to TPM(diag)-20, List of Diagnostic Trouble Code (DTC).>
- All DTCs detected will be displayed.
- If a particular DTC is not properly stored in memory (due to a voltage drop of the TPMS & keyless entry control module power supply, etc.) when a problem occurs, a DTC suffixed with a question mark will appear on the Subaru Select Monitor display. This shows it may be an unreliable reading.

8) If TPMS & keyless entry control module and Subaru Select Monitor cannot communicate, check the communication circuit. <Ref. to TPM(diag)-10, COMMUNICATION FOR INITIALIZING IMPOSSIBLE, INSPECTION, Subaru Select Monitor.>

9) When DTC is not displayed, check the tire inflation pressure warning light blinking patterns. <Ref. to TPM(diag)-15, INSPECTION, Tire Pressure Warning Light / Trouble Indicator Light Illumination Pattern.>

# Subaru Select Monitor

## TIRE PRESSURE MONITORING SYSTEM (DIAGNOSTICS)

### 2. DATA DISPLAY

- 1) On «Main Menu» display, select {Each System Check}.
  - 2) On «System Selection Menu» display, select {Tire pressure monitor}.
  - 3) After the {Tire pressure monitor} is displayed, select [OK].
  - 4) On «Tire pressure monitor diagnosis» display, select {Data Display}, and then necessary data will be displayed.
- A list of the support data is shown in the following table.

#### 1. Data monitor (Analog)

Display	Contents to be displayed	Unit of measure
Tire 1 FN code	LEARN, LOW BAT, OFF, WAKE, RE ME, NORMAL	LEARN: Transmitted transmitter ID using the transmitter registration tool LOW BAT: Transmitter battery voltage running low OFF: Transmitter function stops (no data transmission) RE ME: Tire air changes $\pm 8.4$ kPa WAKE: When data transmission is started from a stopped state. NORMAL: Conditions other than above
Tire 2 FN code		
Tire 3 FN code		
Tire 4 FN code		
Tire 1 air pressure	Value converted to tire pressure from data delivered from transmitter is displayed. (The figure may differ from the actual measured values.)	kPa, psig, mmHg, inHg
Tire 2 air pressure		kPa, psig, mmHg, inHg
Tire 3 air pressure		kPa, psig, mmHg, inHg
Tire 4 air pressure		kPa, psig, mmHg, inHg
Vehicle Speed	Vehicle speed signal which is input in control module	km/h, MPH
Pressure warning	Threshold where tire pressure warning light illuminates	kPa, psig, mmHg, inHg
Return pressure	Threshold where tire pressure warning light goes out	kPa, psig, mmHg, inHg

### 3. CLEAR MEMORY

- 1) On «Main Menu» display, select {Each System Check}.
- 2) On «System Selection Menu» display, select {Tire pressure monitor}.
- 3) After the {Tire pressure monitor} is displayed, select [OK].
- 4) On «Tire pressure monitor diagnosis» display, select {Clear Memory}.
- 5) When “Done” and “Turn off the ignition switch.” are shown on the display screen, turn the Subaru Select Monitor and the ignition switch to OFF.

#### NOTE:

For details concerning the operation procedure, refer to “PC application help for Subaru Select Monitor”.

### 4. REGISTER TRANSMITTER ID

Perform the registration procedure of the transmitter in the following cases:

- Transmitter replaced.
- TPMS & keyless entry control module replaced.

#### NOTE:

- If registration of the transmitter ID is not possible after 2 attempts, replace TPMS & keyless entry control module. <Ref. to WT-8, TPMS & KEYLESS ENTRY CONTROL MODULE, REMOVAL, Tire Pressure Monitoring System.> <Ref. to WT-9, TPMS & KEYLESS ENTRY CONTROL MODULE, INSTALLATION, Tire Pressure Monitoring System.>
- During the registration, turn the ignition switch to OFF and end the Subaru Select Monitor. Or if the registration is not performed for 5 minutes or more, the registration mode is cancelled.
- When rotating tires, there is no affect on the performance or functions of the tire pressure monitoring control module even if the transmitter (ID) is not registered, however, the tire position displayed on the Subaru Select Monitor will be incorrect.

- 1) Adjust all tire pressures to the specifications.

# Subaru Select Monitor

## TIRE PRESSURE MONITORING SYSTEM (DIAGNOSTICS)

- 2) Connect Subaru Select Monitor and select the {Each System Check} on the «Main Menu».
- 3) On «System Selection Menu» display, select {Tire pressure monitor}.
- 4) After the {Tire pressure monitor} is displayed, select [OK].
- 5) On «Tire pressure monitor diagnosis» display, select {Transmitter ID regist confirm}.
- 6) {ID registration mode When execute Registered ID is deleted. Continue?} is displayed, select [OK].
- 7) Contact the transmitter registration tool to the side wall area near the air valve on the front left tire, and press the switch. The transmitter ID is sent to the TPMS & keyless entry control module. (At this time, the tire pressure warning light blinks to confirm that the registration has started.)

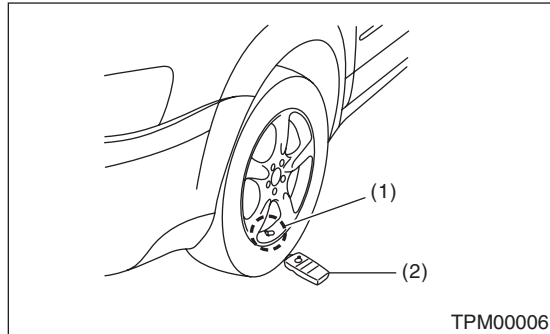

- (1) Air valve (transmitter)
- (2) Transmitter registration tool

### NOTE:

- The registration order of transmitter ID is not specified.
  - The transmitter registration tool is used by touching the side wall area near the transmitter.
  - If registration procedure stop in the halfway (turning ignition switch to OFF, wrong registration order, etc), proceed from step 5).
- 8) When ID registration is completed, the tire pressure warning light remains lit for approximately 2 seconds, to end the registration. Switch to the screen displaying the transmitter ID on the Subaru Select Monitor display. <Ref. to TPM(diag)-9, DISPLAY TRANSMITTER (ID), OPERATION, Subaru Select Monitor.>
  - 9) Check the transmitter ID that was registered, then perform a driving test. <Ref. to TPM(diag)-13, PROCEDURE, Inspection Mode.>

## 5. DISPLAY TRANSMITTER (ID)

- 1) On «Main Menu» display, select {Each System Check}.
- 2) On «System Selection Menu» display, select {Tire pressure monitor}.
- 3) After the {Tire pressure monitor} is displayed, select [OK].
- 4) On «Tire pressure monitor diagnosis» display, select {Transmitter ID regist confirm}.
- 5) Select the {Transmitter ID monitor} and then select [OK] to display the transmitter ID.



# Subaru Select Monitor

## TIRE PRESSURE MONITORING SYSTEM (DIAGNOSTICS)

### B: INSPECTION

#### 1. COMMUNICATION FOR INITIALIZING IMPOSSIBLE

##### DETECTING CONDITION:

Defective harness connector

##### TROUBLE SYMPTOM:

Communication is impossible between the TPMS & keyless entry control module and the Subaru Select Monitor.

##### WIRING DIAGRAM:

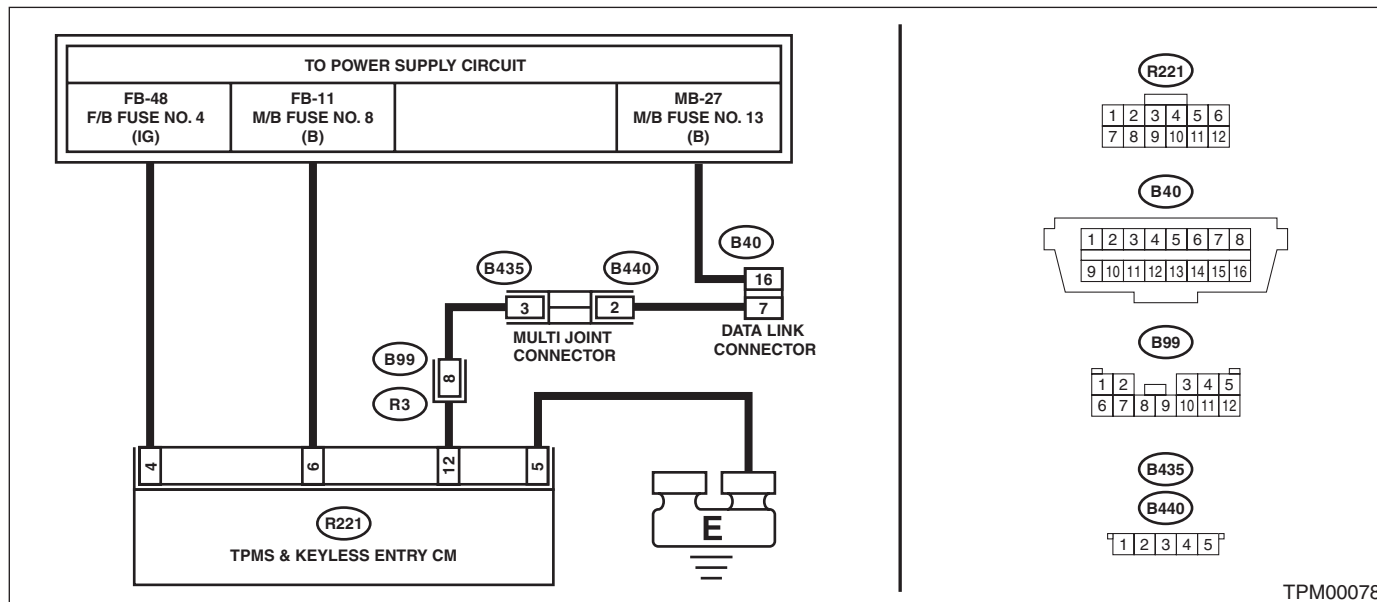

Step	Check	Yes	No
1	<b>CHECK IGNITION SWITCH.</b> Is the ignition switch ON?	Go to step 2.	Turn the ignition switch to ON, and select TPM mode using Subaru Select Monitor.
2	<b>CHECK BATTERY.</b> Is the voltage 11 V or more?	Go to step 3.	Charge or replace the battery.
3	<b>CHECK BATTERY TERMINAL.</b> Is there poor contact at battery terminal?	Repair or tighten the battery terminal.	Go to step 4.
4	<b>CHECK SUBARU SELECT MONITOR COMMUNICATION.</b> 1) Turn the ignition switch to ON. 2) Using the Subaru Select Monitor, check whether communication to other systems can be executed normally. Is the system name displayed on Subaru Select Monitor?	Go to step 8.	Go to step 5.
5	<b>CHECK SUBARU SELECT MONITOR COMMUNICATION.</b> 1) Turn the ignition switch to OFF. 2) Disconnect the TPMS & keyless entry control module. 3) Turn the ignition switch to ON. 4) Check whether communication to other systems can be executed normally. Is the system name displayed on Subaru Select Monitor?	Replace the TPMS & keyless entry control module. <Ref. to WT-8, TPMS & KEYLESS ENTRY CONTROL MODULE, REMOVAL, Tire Pressure Monitoring System.>	Go to step 6.

# Subaru Select Monitor

## TIRE PRESSURE MONITORING SYSTEM (DIAGNOSTICS)

Step	Check	Yes	No	
6	<p><b>CHECK HARNESS CONNECTOR BETWEEN EACH CONTROL MODULE AND DATA LINK CONNECTOR.</b></p> <p>1) Turn the ignition switch to OFF. 2) Disconnect the TPMS &amp; keyless entry control module. 3) Measure the resistance between data link connector and chassis ground.</p> <p><b>Connector &amp; terminal</b> <b>(B40) No. 7 — Chassis ground:</b></p>	Is the resistance 1 M $\Omega$ or more?	Go to step 7.	Repair the harness and connector between each control module and data link connector.
7	<p><b>CHECK OUTPUT SIGNAL TO TPMS &amp; KEYLESS ENTRY CONTROL MODULE.</b></p> <p>1) Turn the ignition switch to ON. 2) Measure the voltage between TPMS &amp; keyless entry control module and chassis ground.</p> <p><b>Connector &amp; terminal</b> <b>(B40) No. 7 (+) — Chassis ground (-):</b></p>	Is the voltage less than 1 V?	Go to step 8.	Repair the harness and connector between each control module and data link connector.
8	<p><b>CHECK HARNESS CONNECTOR BETWEEN TPMS &amp; KEYLESS ENTRY CONTROL MODULE AND DATA LINK CONNECTOR.</b></p> <p>1) Turn the ignition switch to OFF. 2) Measure the resistance between the TPMS &amp; keyless entry control module connector and the data link connector.</p> <p><b>Connector &amp; terminal</b> <b>(R221) No. 12 — (B40) No. 7:</b></p>	Is the resistance less than 0.5 $\Omega$ ?	Go to step 9.	Repair the harness and connector between TPMS & keyless entry control module and data link connector.
9	<p><b>CHECK TPMS &amp; KEYLESS ENTRY CONTROL MODULE CONNECTOR.</b></p>	Is TPMS & keyless entry control module connector inserted until it locks?	Go to step 10.	Insert the connector into the TPMS & keyless entry control module.
10	<p><b>CHECK POWER SUPPLY CIRCUIT.</b></p> <p>1) Turn the ignition switch to ON. 2) Measure the ignition power supply voltage between TPMS &amp; keyless entry control module connector and chassis ground.</p> <p><b>Connector &amp; terminal</b> <b>(R221) No. 4 (+) — Chassis ground (-):</b></p>	Is the voltage 10 — 15 V?	Go to step 11.	Repair open circuit of the harness between TPMS & keyless entry control module and battery.
11	<p><b>CHECK HARNESS CONNECTOR BETWEEN TPMS &amp; KEYLESS ENTRY CONTROL MODULE AND CHASSIS GROUND.</b></p> <p>1) Turn the ignition switch to OFF. 2) Disconnect the connector from the TPMS &amp; keyless entry control module. 3) Measure the resistance of harness between TPMS &amp; keyless entry control module and chassis ground.</p> <p><b>Connector &amp; terminal</b> <b>(R221) No. 5 — Chassis ground:</b></p>	Is the resistance less than 0.5 $\Omega$ ?	Go to step 12.	Repair open circuit of the harness of the TPMS & keyless entry control module.
12	<p><b>CHECK POOR CONTACT OF CONNECTOR.</b></p>	Is there poor contact of TPMS & keyless entry control module power supply, ground circuit and data link connector?	Repair the connector.	Replace the TPMS & keyless entry control module. <Ref. to WT-8, TPMS & KEYLESS ENTRY CONTROL MODULE, REMOVAL, Tire Pressure Monitoring System.>

## Read Diagnostic Trouble Code (DTC)

TIRE PRESSURE MONITORING SYSTEM (DIAGNOSTICS)

---

### 6. Read Diagnostic Trouble Code (DTC)

#### A: OPERATION

For details about reading of DTCs, refer to “Subaru Select Monitor”. <Ref. to TPM(diag)-7, Subaru Select Monitor.>

### 7. Inspection Mode

#### A: PROCEDURE

Reproduce the malfunction occurrence condition as much as possible. Drive the vehicle at 40 km/h (25 MPH) or faster for at least ten minutes.

## Clear Memory Mode

TIRE PRESSURE MONITORING SYSTEM (DIAGNOSTICS)

---

### 8. Clear Memory Mode

#### A: OPERATION

For details concerning DTC clear operation, refer to "Subaru Select Monitor". <Ref. to TPM(diag)-7, Subaru Select Monitor.>

# Tire Pressure Warning Light / Trouble Indicator Light Illumination Pattern

TIRE PRESSURE MONITORING SYSTEM (DIAGNOSTICS)

## 9. Tire Pressure Warning Light / Trouble Indicator Light Illumination Pattern

### A: INSPECTION

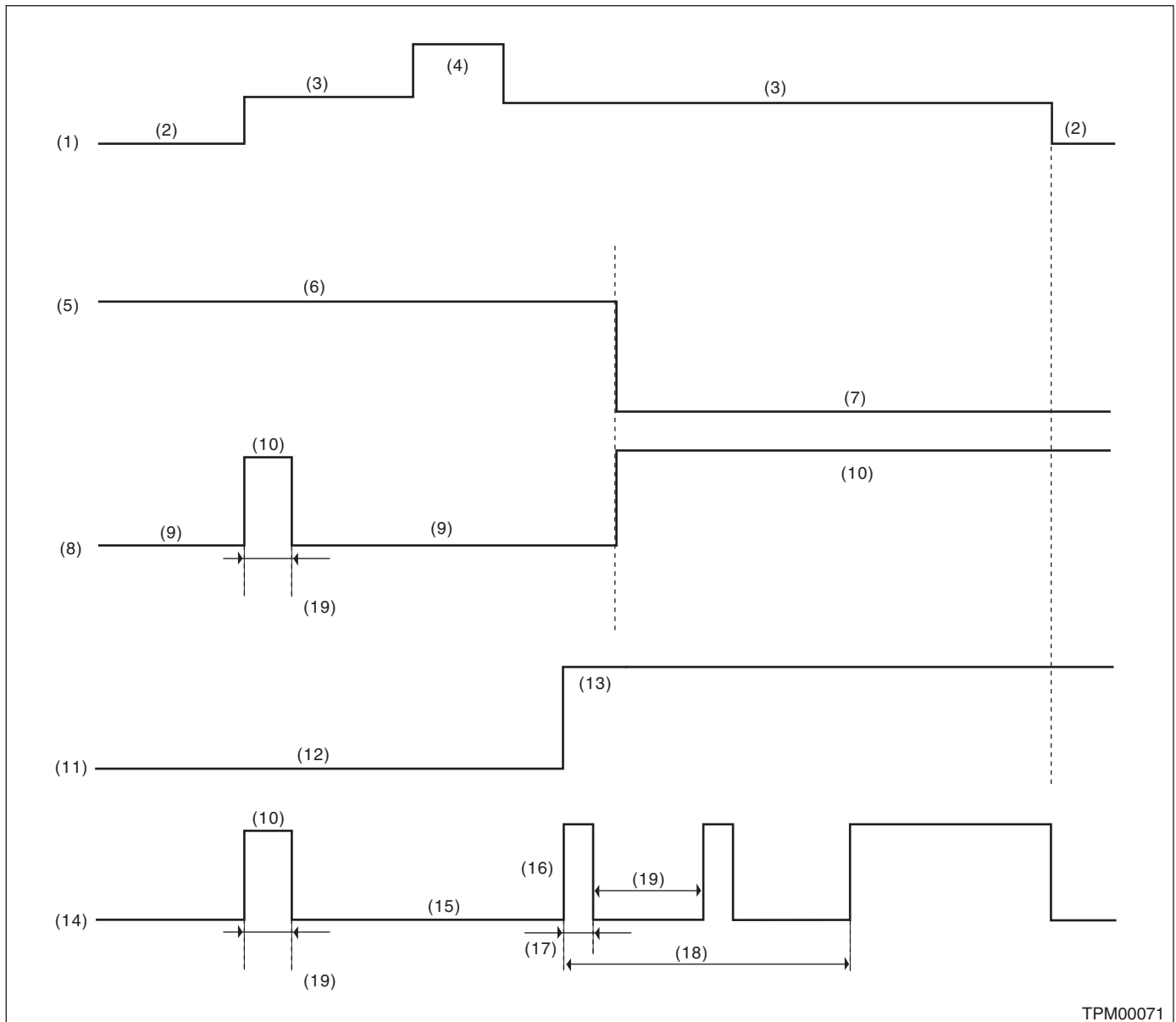

TPM00071

- |  |  |                      |
|--|--|----------------------|
| (1) Ignition switch  | (8) Tire inflation pressure warning light (pressure condition) | (15) Light OFF       |
| (2) OFF  | (9) Light OFF  | (16) Blink           |
| (3) ON   | (10) Light ON  | (17) 1 second        |
| (4) Start  | (11) System status   | (18) Blinks 25 times |
| (5) Tire inflation pressure  | (12) Normal  | (19) 2 seconds       |
| (6) Meet the specification   | (13) Malfunction   |                      |
| (7) Less than standard value (For the pressure warning level, refer to CURRENT DATA.) <Ref. to TPM(diag)-8, DATA DISPLAY, OPERATION, Subaru Select Monitor.> | (14) Tire inflation pressure warning light (system condition)  |                      |

TPM(diag)-15

Brought to you by Ebay Seller "SubaruManuals"

# Tire Pressure Warning Light / Trouble Indicator Light Illumination Pattern

## TIRE PRESSURE MONITORING SYSTEM (DIAGNOSTICS)

---

1) When the tire pressure warning light does not illuminate in accordance with this illumination pattern, there must be an electrical malfunction.

2) If the tire pressure warning light does not go off, check the TPMS & keyless entry control module/warning light circuit and the combination meter circuit. <Ref. to TPM(diag)-17, TIRE PRESSURE WARNING LIGHT DOES NOT COME OFF, Tire Pressure Warning Light / Trouble Indicator Light Illumination Pattern.>

### NOTE:

If the problem is fixed while driving at approximately 40 km/h (25 MPH) after the tire pressure warning light blinks/lights, the warning light goes out and the tire pressure monitor system operates normally. (If there is a decrease in tire pressure, or a malfunction of the system, the malfunction history is displayed.)

## **B: TIRE PRESSURE WARNING LIGHT DOES NOT COME ON**

### **DETECTING CONDITION:**

Defective combination meter

### **TROUBLE SYMPTOM:**

When the ignition switch is turned to ON, the tire pressure warning light does not turn on (for approx. 2 seconds).

Step	Check	Yes	No
1 <b>CHECK DIAGNOSTIC TROUBLE CODE (DTC).</b> Connect the Subaru Select Monitor, and read the Diagnostic Trouble Code. <Ref. to TPM(diag)-7, READ DIAGNOSTIC TROUBLE CODE (DTC), OPERATION, Subaru Select Monitor.>	Is diagnostics code (DTC) displayed?	Perform the diagnosis according to the DTC. <Ref. to TPM(diag)-20, List of Diagnostic Trouble Code (DTC).>	Replace the combination meter. <Ref. to IDI-16, REMOVAL, Combination Meter.>

# Tire Pressure Warning Light / Trouble Indicator Light Illumination Pattern

TIRE PRESSURE MONITORING SYSTEM (DIAGNOSTICS)

## C: TIRE PRESSURE WARNING LIGHT DOES NOT COME OFF

### DETECTING CONDITION:

- Defective combination meter
- Tires pressure drop
- Transmitter ID not registered

### TROUBLE SYMPTOM:

Tire pressure warning light remains illuminating after engine starts.

Step	Check	Yes	No
<b>1</b> <b>CHECK DTC.</b> Connect the Subaru Select Monitor, and read the Diagnostic Trouble Code. <Ref. to TPM(diag)-7, READ DIAGNOSTIC TROUBLE CODE (DTC), OPERATION, Subaru Select Monitor.>	Is a DTC displayed?	Perform the diagnosis according to the DTC. <Ref. to TPM(diag)-20, List of Diagnostic Trouble Code (DTC).>	Go to step 2.
<b>2</b> <b>CHECK TRANSMITTER (ID).</b> Display the transmitter ID of the tire pressure monitor system.	Is the transmitter ID registered?	Go to step 3.	Register the transmitter ID. <Ref. to TPM(diag)-8, REGISTER TRANSMITTER ID, OPERATION, Subaru Select Monitor.>
<b>3</b> <b>CHECK TRANSMITTER DATA OUTPUT.</b> 1) Select data display of the tire pressure monitoring. 2) Start the engine and check the tire pressure warning light output.	Is the warning light output ON?	Replace the TPMS & keyless entry control module. <Ref. to WT-8, TPMS & KEYLESS ENTRY CONTROL MODULE, REMOVAL, Tire Pressure Monitoring System.>	Replace the combination meter. <Ref. to IDI-16, REMOVAL, Combination Meter.>



# Tire Pressure Warning Light / Trouble Indicator Light Illumination Pattern

## TIRE PRESSURE MONITORING SYSTEM (DIAGNOSTICS)

### D: TIRE PRESSURE WARNING LIGHT IS 25 TIMES BLINKING AND TURN ON DETECTING CONDITION:

- Defective TPMS & keyless entry control module
- Defective harness
- Transmitter is faulty.

### TROUBLE SYMPTOM:

Every time the engine starts, tire pressure warning light blinks 25 times and then illuminates.

### WIRING DIAGRAM:

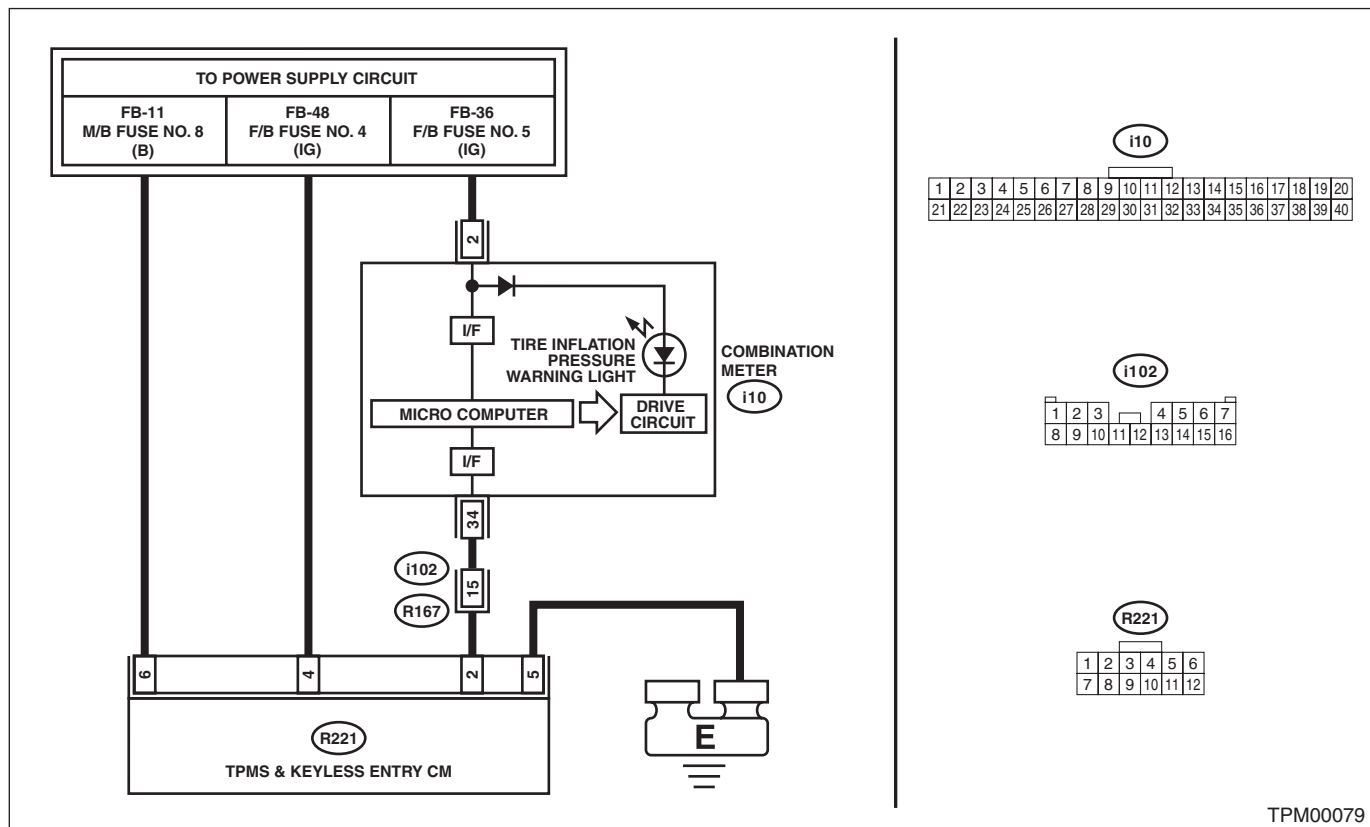

Step	Check	Yes	No	
1	<b>CHECK DTC.</b> Connect the Subaru Select Monitor, and read the Diagnostic Trouble Code. <Ref. to TPM(diag)-7, READ DIAGNOSTIC TROUBLE CODE (DTC), OPERATION, Subaru Select Monitor.>	Is diagnostics code (DTC) displayed?	Perform the diagnosis according to the DTC. <Ref. to TPM(diag)-20, List of Diagnostic Trouble Code (DTC).>	Go to step 2.
2	<b>CHECK HARNESS.</b> 1) Connect the Subaru Select Monitor to the terminal No. 2 of the TPMS & keyless entry control module connector (R221). <b>Connector &amp; terminal</b> <b>(R221) No. 2 (+) — Chassis ground (-):</b> 2) Turn the ignition switch to ON, and select "Oscilloscope" from the Main Menu of Subaru Select Monitor. 3) Check the voltage displayed.	Is the voltage 10 V or more?	Go to step 3.	Go to step 4.

# Tire Pressure Warning Light / Trouble Indicator Light Illumination Pattern

## TIRE PRESSURE MONITORING SYSTEM (DIAGNOSTICS)

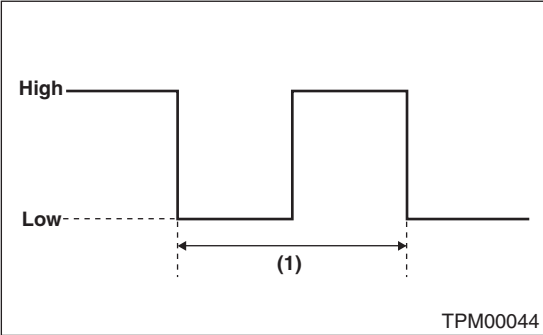
Step	Check	Yes	No
<p><b>3</b></p> <p><b>CHECK HARNESS.</b></p> <p>1) Check the output waveform displayed in the oscilloscope of Subaru Select Monitor.</p> 	<p>Is the pattern the same output waveform as shown in the figure?</p> <p>(1) 400±9 ms Duty 50%</p> <p>High: Battery voltage</p> <p>Low: 1.5 V or less</p>	<p>Check the combination meter. &lt;Ref. to IDI-5, INSPECTION, Combination Meter System.&gt;</p>	<p>Replace the TPMS &amp; keyless entry control module. &lt;Ref. to WT-8, REMOVAL, Tire Pressure Monitoring System.&gt;</p>
<p><b>4</b></p> <p><b>CHECK HARNESS.</b></p> <p>1) Disconnect the TPMS &amp; keyless entry control module connector.</p> <p>2) Connect the Subaru Select Monitor to the terminal No. 2 of the TPMS &amp; keyless entry control module connector (R221).</p> <p><b>Connector &amp; terminal</b></p> <p><b>(R221) No. 2 (+) — Chassis ground (-):</b></p> <p>3) Turn the ignition switch to ON, and select "Oscilloscope" from the Main Menu of Subaru Select Monitor.</p> <p>4) Check the voltage displayed.</p>	<p>Is the voltage 10 V or more?</p>	<p>Replace the TPMS &amp; keyless entry control module. &lt;Ref. to WT-8, REMOVAL, Tire Pressure Monitoring System.&gt;</p>	<p>The harness between the combination meter connector and the TPMS &amp; keyless entry control module connector is shorted or open. Repair or replace the harness.</p>

## List of Diagnostic Trouble Code (DTC)

TIRE PRESSURE MONITORING SYSTEM (DIAGNOSTICS)

### 10. List of Diagnostic Trouble Code (DTC)

#### A: LIST

DTC	Item	Contents of diagnosis	Remarks
11	Tire 1 Air Pressure Decrease	Tire pressure of tire 1 is reduced.	<Ref. to TPM(diag)-22, DTC 11 TIRE 1 AIR PRESSURE DECREASE, Diagnostic Procedure with Diagnostic Trouble Code (DTC).>
12	Tire 2 Air Pressure Decrease	Tire pressure of tire 2 is reduced.	<Ref. to TPM(diag)-22, DTC 12 TIRE 2 AIR PRESSURE DECREASE, Diagnostic Procedure with Diagnostic Trouble Code (DTC).>
13	Tire 3 Air Pressure Decrease	Tire pressure of tire 3 is reduced.	<Ref. to TPM(diag)-22, DTC 13 TIRE 3 AIR PRESSURE DECREASE, Diagnostic Procedure with Diagnostic Trouble Code (DTC).>
14	Tire 4 Air Pressure Decrease	Tire pressure of tire 4 is reduced.	<Ref. to TPM(diag)-23, DTC 14 TIRE 4 AIR PRESSURE DECREASE, Diagnostic Procedure with Diagnostic Trouble Code (DTC).>
21	Transmitter 1 No Data	Data cannot be received from transmitter 1.	<Ref. to TPM(diag)-23, DTC 21 TRANSMITTER 1 NO DATA, Diagnostic Procedure with Diagnostic Trouble Code (DTC).>
22	Transmitter 2 No Data	Data cannot be received from transmitter 2.	<Ref. to TPM(diag)-23, DTC 22 TRANSMITTER 2 NO DATA, Diagnostic Procedure with Diagnostic Trouble Code (DTC).>
23	Transmitter 3 No Data	Data cannot be received from transmitter 3.	<Ref. to TPM(diag)-23, DTC 23 TRANSMITTER 3 NO DATA, Diagnostic Procedure with Diagnostic Trouble Code (DTC).>
24	Transmitter 4 No Data	Data cannot be received from transmitter 4.	<Ref. to TPM(diag)-24, DTC 24 TRANSMITTER 4 NO DATA, Diagnostic Procedure with Diagnostic Trouble Code (DTC).>
31	Transmitter 1 Pressure Data Abnormal	Transmitter 1 data contents are abnormal.	<Ref. to TPM(diag)-25, DTC 31 TRANSMITTER 1 PRESSURE DATA ABNORMAL, Diagnostic Procedure with Diagnostic Trouble Code (DTC).>
32	Transmitter 2 Pressure Data Abnormal	Transmitter 2 data contents are abnormal.	<Ref. to TPM(diag)-25, DTC 32 TRANSMITTER 2 PRESSURE DATA ABNORMAL, Diagnostic Procedure with Diagnostic Trouble Code (DTC).>
33	Transmitter 3 Pressure Data Abnormal	Transmitter 3 data contents are abnormal.	<Ref. to TPM(diag)-25, DTC 33 TRANSMITTER 3 PRESSURE DATA ABNORMAL, Diagnostic Procedure with Diagnostic Trouble Code (DTC).>
34	Transmitter 4 Pressure Data Abnormal	Transmitter 4 data contents are abnormal.	<Ref. to TPM(diag)-26, DTC 34 TRANSMITTER 4 PRESSURE DATA ABNORMAL, Diagnostic Procedure with Diagnostic Trouble Code (DTC).>
41	Transmitter 1 Function Code Abnormal	Function code has error.	<Ref. to TPM(diag)-27, DTC 41 TRANSMITTER 1 FUNCTION CODE ABNORMAL, Diagnostic Procedure with Diagnostic Trouble Code (DTC).>

**TPM(diag)-20**

Brought to you by Ebay Seller "SubaruManuals"

# List of Diagnostic Trouble Code (DTC)

## TIRE PRESSURE MONITORING SYSTEM (DIAGNOSTICS)

DTC	Item	Contents of diagnosis	Remarks
42	Transmitter 2 Function Code Abnormal	Function code has error.	<Ref. to TPM(diag)-27, DTC 42 TRANSMITTER 2 FUNCTION CODE ABNORMAL, Diagnostic Procedure with Diagnostic Trouble Code (DTC).>
43	Transmitter 3 Function Code Abnormal	Function code has error.	<Ref. to TPM(diag)-27, DTC 43 TRANSMITTER 3 FUNCTION CODE ABNORMAL, Diagnostic Procedure with Diagnostic Trouble Code (DTC).>
44	Transmitter 4 Function Code Abnormal	Function code has error.	<Ref. to TPM(diag)-28, DTC 44 TRANSMITTER 4 FUNCTION CODE ABNORMAL, Diagnostic Procedure with Diagnostic Trouble Code (DTC).>
51	Transmitter 1 Battery Voltage Decrease	Transmitter battery voltage is low.	<Ref. to TPM(diag)-29, DTC 51 TRANSMITTER 1 BATTERY VOLTAGE DECREASE, Diagnostic Procedure with Diagnostic Trouble Code (DTC).>
52	Transmitter 2 Battery Voltage Decrease	Transmitter battery voltage is low.	<Ref. to TPM(diag)-29, DTC 52 TRANSMITTER 2 BATTERY VOLTAGE DECREASE, Diagnostic Procedure with Diagnostic Trouble Code (DTC).>
53	Transmitter 3 Battery Voltage Decrease	Transmitter battery voltage is low.	<Ref. to TPM(diag)-29, DTC 53 TRANSMITTER 3 BATTERY VOLTAGE DECREASE, Diagnostic Procedure with Diagnostic Trouble Code (DTC).>
54	Transmitter 4 Battery Voltage Decrease	Transmitter battery voltage is low.	<Ref. to TPM(diag)-30, DTC 54 TRANSMITTER 4 BATTERY VOLTAGE DECREASE, Diagnostic Procedure with Diagnostic Trouble Code (DTC).>
61	Vehicle Speed is Abnormal	Vehicle speed signal is not input to the control module when the vehicle speed is 6 km/h (3.7 MPH) or more.	<Ref. to TPM(diag)-31, DTC 61 VEHICLE SPEED IS ABNORMAL, Diagnostic Procedure with Diagnostic Trouble Code (DTC).>

## Diagnostic Procedure with Diagnostic Trouble Code (DTC)

TIRE PRESSURE MONITORING SYSTEM (DIAGNOSTICS)

---

### 11. Diagnostic Procedure with Diagnostic Trouble Code (DTC)

#### **A: DTC 11 TIRE 1 AIR PRESSURE DECREASE**

NOTE:

Refer to DTC 14 for diagnostic procedure. <Ref. to TPM(diag)-23, DTC 14 TIRE 4 AIR PRESSURE DECREASE, Diagnostic Procedure with Diagnostic Trouble Code (DTC).>

#### **B: DTC 12 TIRE 2 AIR PRESSURE DECREASE**

NOTE:

Refer to DTC 14 for diagnostic procedure. <Ref. to TPM(diag)-23, DTC 14 TIRE 4 AIR PRESSURE DECREASE, Diagnostic Procedure with Diagnostic Trouble Code (DTC).>

#### **C: DTC 13 TIRE 3 AIR PRESSURE DECREASE**

NOTE:

Refer to DTC 14 for diagnostic procedure. <Ref. to TPM(diag)-23, DTC 14 TIRE 4 AIR PRESSURE DECREASE, Diagnostic Procedure with Diagnostic Trouble Code (DTC).>

# Diagnostic Procedure with Diagnostic Trouble Code (DTC)

TIRE PRESSURE MONITORING SYSTEM (DIAGNOSTICS)

## D: DTC 14 TIRE 4 AIR PRESSURE DECREASE

### DTC DETECTING CONDITION:

Inflation pressure of tires dropped below the specified value.

### NOTE:

For the specifications, refer to CURRENT DATA. <Ref. to TPM(diag)-8, DATA DISPLAY, OPERATION, Subaru Select Monitor.>

### TROUBLE SYMPTOM:

Tire pressure warning light illuminates.

Step	Check	Yes	No
<b>1</b> <b>CHECK TIRES.</b> Lift up the vehicle and check for damage in the tires.	Are there cracks or damage?	Replace the tire.	Go to step 2.
<b>2</b> <b>CHECK TIRES.</b> Check the tire air pressure.	Is the tire pressure in the specifications?	Go to step 3.	Adjust the air pressure.
<b>3</b> <b>CHECK TRANSMITTER.</b> Drive the vehicle at 40 km/h (25 MPH) or faster and compare the data from the transmitter on the four wheels.	Is there a transmitter with different data?	Replace the transmitter (tire pressure sensor). <Ref. to WT-8, Tire Pressure Monitoring System.>	Go to step 4.
<b>4</b> <b>PERFORM DRIVING TEST.</b> 1) Perform the Clear Memory Mode. <Ref. to TPM(diag)-8, CLEAR MEMORY, OPERATION, Subaru Select Monitor.> 2) Perform a driving test. <Ref. to TPM(diag)-13, PROCEDURE, Inspection Mode.> 3) Read the DTC. <Ref. to TPM(diag)-7, READ DIAGNOSTIC TROUBLE CODE (DTC), OPERATION, Subaru Select Monitor.>	Is DTC displayed?	Inspect by referring to "Diagnostic Procedure with Diagnostic Trouble Code (DTC)". <Ref. to TPM(diag)-22, Diagnostic Procedure with Diagnostic Trouble Code (DTC).>	Finish the diagnosis.

### CAUTION:

When driving vehicle to perform driving test, there should be always 2 persons (driver and checker) to check.

## E: DTC 21 TRANSMITTER 1 NO DATA

### NOTE:

Refer to DTC 24 for diagnostic procedure. <Ref. to TPM(diag)-24, DTC 24 TRANSMITTER 4 NO DATA, Diagnostic Procedure with Diagnostic Trouble Code (DTC).>

## F: DTC 22 TRANSMITTER 2 NO DATA

### NOTE:

Refer to DTC 24 for diagnostic procedure. <Ref. to TPM(diag)-24, DTC 24 TRANSMITTER 4 NO DATA, Diagnostic Procedure with Diagnostic Trouble Code (DTC).>

## G: DTC 23 TRANSMITTER 3 NO DATA

### NOTE:

Refer to DTC 24 for diagnostic procedure. <Ref. to TPM(diag)-24, DTC 24 TRANSMITTER 4 NO DATA, Diagnostic Procedure with Diagnostic Trouble Code (DTC).>

# Diagnostic Procedure with Diagnostic Trouble Code (DTC)

## TIRE PRESSURE MONITORING SYSTEM (DIAGNOSTICS)

### H: DTC 24 TRANSMITTER 4 NO DATA

#### DTC DETECTING CONDITION:

Data from each transmitter is not received for 8 minutes.

#### TROUBLE SYMPTOM:

Tire pressure warning light blinks 25 times and then illuminates.

Step	Check	Yes	No
<b>1 START FL TRANSMITTER.</b> 1) Connect the Subaru Select Monitor and then turn the ignition switch to ON. 2) Select "Transmit ID data monitor". <Ref. to TPM(diag)-9, DISPLAY TRANSMITTER (ID), OPERATION, Subaru Select Monitor.> 3) Use the transmitter registration tool and transmit the ID from the FL transmitter to check "Latest reception ID".	Is "Latest reception ID" updated?	Go to step 2.	Replace front left transmitter.
<b>2 CHECK FL TRANSMITTER ID.</b> Check the ID displayed in the updated ID display and the tire 1 registered ID.	Are the two IDs same?	Go to step 3.	Record the received ID update as the FL transmitter. Go to step 3.
<b>3 START FR TRANSMITTER.</b> Use the transmitter registration tool and transmit the ID from the FR transmitter to check "Latest reception ID".	Is "Latest reception ID" updated?	Go to step 4.	Replace the front right transmitter.
<b>4 CHECK FR TRANSMITTER ID.</b> Check the ID displayed in the updated ID display and the tire 2 registered ID.	Are the two IDs same?	Go to step 5.	Record the received ID update as the FR transmitter. Go to step 5.
<b>5 START RR TRANSMITTER.</b> Use the transmitter registration tool and transmit the ID from the RR transmitter to check "Latest reception ID".	Is "Latest reception ID" updated?	Go to step 6.	Replace the RR transmitter.
<b>6 CHECK RR TRANSMITTER ID.</b> Check the ID displayed in the updated ID display and the tire 3 registered ID.	Are the two IDs same?	Go to step 7.	Record the received ID update as the RR transmitter. Go to step 7.
<b>7 START RL TRANSMITTER.</b> Use the transmitter registration tool and transmit the ID from the RL transmitter to check "Latest reception ID".	Is "Latest reception ID" updated?	Go to step 8.	Replace the RL transmitter.
<b>8 CHECK RL TRANSMITTER ID.</b> Check the ID displayed in the updated ID display and the tire 4 registered ID.	Are the two IDs same?	Go to step 9.	Record the received ID update as the RL transmitter. Go to step 9.
<b>9 CHECK MALFUNCTION TRANSMITTER.</b>	Is ID recorded by this procedure?	Go to step 10.	Go to step 1.
<b>10 CHECK MALFUNCTION TRANSMITTER.</b> Check the registered ID of the transmitter indicated by DTC.	Is there checked ID in the record?	Replace the transmitter of the recorded position.	Replace the transmitter showing the latest ID that is not included in the registered IDs.

#### CAUTION:

When driving vehicle to perform driving test, there should be always 2 persons (driver and checker) to check.

# Diagnostic Procedure with Diagnostic Trouble Code (DTC)

TIRE PRESSURE MONITORING SYSTEM (DIAGNOSTICS)

---

## **I: DTC 31 TRANSMITTER 1 PRESSURE DATA ABNORMAL**

NOTE:

Refer to DTC 34 for diagnostic procedure. <Ref. to TPM(diag)-26, DTC 34 TRANSMITTER 4 PRESSURE DATA ABNORMAL, Diagnostic Procedure with Diagnostic Trouble Code (DTC).>

## **J: DTC 32 TRANSMITTER 2 PRESSURE DATA ABNORMAL**

NOTE:

Refer to DTC 34 for diagnostic procedure. <Ref. to TPM(diag)-26, DTC 34 TRANSMITTER 4 PRESSURE DATA ABNORMAL, Diagnostic Procedure with Diagnostic Trouble Code (DTC).>

## **K: DTC 33 TRANSMITTER 3 PRESSURE DATA ABNORMAL**

NOTE:

Refer to DTC 34 for diagnostic procedure. <Ref. to TPM(diag)-26, DTC 34 TRANSMITTER 4 PRESSURE DATA ABNORMAL, Diagnostic Procedure with Diagnostic Trouble Code (DTC).>



# Diagnostic Procedure with Diagnostic Trouble Code (DTC)

## TIRE PRESSURE MONITORING SYSTEM (DIAGNOSTICS)

### L: DTC 34 TRANSMITTER 4 PRESSURE DATA ABNORMAL

#### DTC DETECTING CONDITION:

- When comparing the data from each transmitter to the previous data, the change is large.
- The pressure exceeds what the transmitter can measure. (Excessive pressure)

#### TROUBLE SYMPTOM:

Tire pressure warning light blinks 25 times and then illuminates.

Step	Check	Yes	No
<b>1 START FL TRANSMITTER.</b> 1) Connect the Subaru Select Monitor and then turn the ignition switch to ON. 2) Select "Transmit ID data monitor". <Ref. to TPM(diag)-9, DISPLAY TRANSMITTER (ID), OPERATION, Subaru Select Monitor.> 3) Use the transmitter registration tool and transmit the ID from the FL transmitter to check "Latest reception ID".	Is "Latest reception ID" updated?	Go to step 2.	Replace front left transmitter.
<b>2 CHECK FL TRANSMITTER ID.</b> Check the ID displayed in the updated ID display and the tire 1 registered ID.	Are the two IDs same?	Go to step 3.	Record the received ID update as the FL transmitter. Go to step 3.
<b>3 START FR TRANSMITTER.</b> Use the transmitter registration tool and transmit the ID from the FR transmitter to check "Latest reception ID".	Is "Latest reception ID" updated?	Go to step 4.	Replace the front right transmitter.
<b>4 CHECK FR TRANSMITTER ID.</b> Check the ID displayed in the updated ID display and the tire 2 registered ID.	Are the two IDs same?	Go to step 5.	Record the received ID update as the FR transmitter. Go to step 5.
<b>5 START RR TRANSMITTER.</b> Use the transmitter registration tool and transmit the ID from the RR transmitter to check "Latest reception ID".	Is "Latest reception ID" updated?	Go to step 6.	Replace the RR transmitter.
<b>6 CHECK RR TRANSMITTER ID.</b> Check the ID displayed in the updated ID display and the tire 3 registered ID.	Are the two IDs same?	Go to step 7.	Record the received ID update as the RR transmitter. Go to step 7.
<b>7 START RL TRANSMITTER.</b> Use the transmitter registration tool and transmit the ID from the RL transmitter to check "Latest reception ID".	Is "Latest reception ID" updated?	Go to step 8.	Replace the RL transmitter.
<b>8 CHECK RL TRANSMITTER ID.</b> Check the ID displayed in the updated ID display and the tire 4 registered ID.	Are the two IDs same?	Go to step 9.	Record the received ID update as the RL transmitter. Go to step 9.
<b>9 CHECK MALFUNCTION TRANSMITTER.</b>	Is ID recorded by this procedure?	Go to step 10.	Go to step 1.
<b>10 CHECK MALFUNCTION TRANSMITTER.</b> Check the registered ID of the transmitter indicated by DTC.	Is there checked ID in the record?	Replace the transmitter of the recorded position.	Replace the transmitter showing the latest ID that is not included in the registered IDs.

# Diagnostic Procedure with Diagnostic Trouble Code (DTC)

TIRE PRESSURE MONITORING SYSTEM (DIAGNOSTICS)

---

## **M: DTC 41 TRANSMITTER 1 FUNCTION CODE ABNORMAL**

NOTE:

Refer to DTC 44 for diagnostic procedure. <Ref. to TPM(diag)-28, DTC 44 TRANSMITTER 4 FUNCTION CODE ABNORMAL, Diagnostic Procedure with Diagnostic Trouble Code (DTC).>

## **N: DTC 42 TRANSMITTER 2 FUNCTION CODE ABNORMAL**

NOTE:

Refer to DTC 44 for diagnostic procedure. <Ref. to TPM(diag)-28, DTC 44 TRANSMITTER 4 FUNCTION CODE ABNORMAL, Diagnostic Procedure with Diagnostic Trouble Code (DTC).>

## **O: DTC 43 TRANSMITTER 3 FUNCTION CODE ABNORMAL**

NOTE:

Refer to DTC 44 for diagnostic procedure. <Ref. to TPM(diag)-28, DTC 44 TRANSMITTER 4 FUNCTION CODE ABNORMAL, Diagnostic Procedure with Diagnostic Trouble Code (DTC).>

# Diagnostic Procedure with Diagnostic Trouble Code (DTC)

## TIRE PRESSURE MONITORING SYSTEM (DIAGNOSTICS)

### P: DTC 44 TRANSMITTER 4 FUNCTION CODE ABNORMAL

#### DTC DETECTING CONDITION:

Unexpected function codes received from each transmitter.

#### TROUBLE SYMPTOM:

Tire pressure warning light blinks 25 times and then illuminates.

Step	Check	Yes	No
<b>1 START FL TRANSMITTER.</b> 1) Connect the Subaru Select Monitor and then turn the ignition switch to ON. 2) Select "Transmit ID data monitor". <Ref. to TPM(diag)-9, DISPLAY TRANSMITTER (ID), OPERATION, Subaru Select Monitor.> 3) Use the transmitter registration tool and transmit the ID from the FL transmitter to check "Latest reception ID".	Is "Latest reception ID" updated?	Go to step 2.	Replace front left transmitter.
<b>2 CHECK FL TRANSMITTER ID.</b> Check the ID displayed in the updated ID display and the tire 1 registered ID.	Are the two IDs same?	Go to step 3.	Record the received ID update as the FL transmitter. Go to step 3.
<b>3 START FR TRANSMITTER.</b> Use the transmitter registration tool and transmit the ID from the FR transmitter to check "Latest reception ID".	Is "Latest reception ID" updated?	Go to step 4.	Replace the front right transmitter.
<b>4 CHECK FR TRANSMITTER ID.</b> Check the ID displayed in the updated ID display and the tire 2 registered ID.	Are the two IDs same?	Go to step 5.	Record the received ID update as the FR transmitter. Go to step 5.
<b>5 START RR TRANSMITTER.</b> Use the transmitter registration tool and transmit the ID from the RR transmitter to check "Latest reception ID".	Is "Latest reception ID" updated?	Go to step 6.	Replace the RR transmitter.
<b>6 CHECK RR TRANSMITTER ID.</b> Check the ID displayed in the updated ID display and the tire 3 registered ID.	Are the two IDs same?	Go to step 7.	Record the received ID update as the RR transmitter. Go to step 7.
<b>7 START RL TRANSMITTER.</b> Use the transmitter registration tool and transmit the ID from the RL transmitter to check "Latest reception ID".	Is "Latest reception ID" updated?	Go to step 8.	Replace the RL transmitter.
<b>8 CHECK RL TRANSMITTER ID.</b> Check the ID displayed in the updated ID display and the tire 4 registered ID.	Are the two IDs same?	Go to step 9.	Record the received ID update as the RL transmitter. Go to step 9.
<b>9 CHECK MALFUNCTION TRANSMITTER.</b>	Is ID recorded by this procedure?	Go to step 10.	Check again. Go to step 1.
<b>10 CHECK MALFUNCTION TRANSMITTER.</b> Check the registered ID of the transmitter indicated by DTC.	Is there checked ID in the record?	Replace the transmitter of the recorded position.	Replace the transmitter showing the latest ID that is not included in the registered IDs.

# Diagnostic Procedure with Diagnostic Trouble Code (DTC)

TIRE PRESSURE MONITORING SYSTEM (DIAGNOSTICS)

---

## **Q: DTC 51 TRANSMITTER 1 BATTERY VOLTAGE DECREASE**

NOTE:

Refer to DTC 54 for diagnostic procedure. <Ref. to TPM(diag)-30, DTC 54 TRANSMITTER 4 BATTERY VOLTAGE DECREASE, Diagnostic Procedure with Diagnostic Trouble Code (DTC).>

## **R: DTC 52 TRANSMITTER 2 BATTERY VOLTAGE DECREASE**

NOTE:

Refer to DTC 54 for diagnostic procedure. <Ref. to TPM(diag)-30, DTC 54 TRANSMITTER 4 BATTERY VOLTAGE DECREASE, Diagnostic Procedure with Diagnostic Trouble Code (DTC).>

## **S: DTC 53 TRANSMITTER 3 BATTERY VOLTAGE DECREASE**

NOTE:

Refer to DTC 54 for diagnostic procedure. <Ref. to TPM(diag)-30, DTC 54 TRANSMITTER 4 BATTERY VOLTAGE DECREASE, Diagnostic Procedure with Diagnostic Trouble Code (DTC).>

# Diagnostic Procedure with Diagnostic Trouble Code (DTC)

TIRE PRESSURE MONITORING SYSTEM (DIAGNOSTICS)

---

## T: DTC 54 TRANSMITTER 4 BATTERY VOLTAGE DECREASE

### DTC DETECTING CONDITION:

Low battery signals received 20 times from each transmitter.

### TROUBLE SYMPTOM:

Tire pressure warning light blinks 25 times and then illuminates.

	Step	Check	Yes	No
1	<b>CHECK TRANSMITTER.</b> 1) Replace all transmitters and register their IDs. <Ref. to TPM(diag)-8, REGISTER TRANSMITTER ID, OPERATION, Subaru Select Monitor.> 2) Perform the Clear Memory Mode, and perform driving test.	Is the fault eliminated?	Internal battery of the transmitter had worn out.	Replace the TPMS & keyless entry control module. <Ref. to WT-8, TPMS & KEYLESS ENTRY CONTROL MODULE, REMOVAL, Tire Pressure Monitoring System.>

# Diagnostic Procedure with Diagnostic Trouble Code (DTC)

TIRE PRESSURE MONITORING SYSTEM (DIAGNOSTICS)

## U: DTC 61 VEHICLE SPEED IS ABNORMAL

### DTC DETECTING CONDITION:

Vehicle speed function codes were received from the transmitter, but the vehicle speed signal was not input to the module.

### TROUBLE SYMPTOM:

Tire pressure warning light blinks 25 times and then illuminates.

### WIRING DIAGRAM:

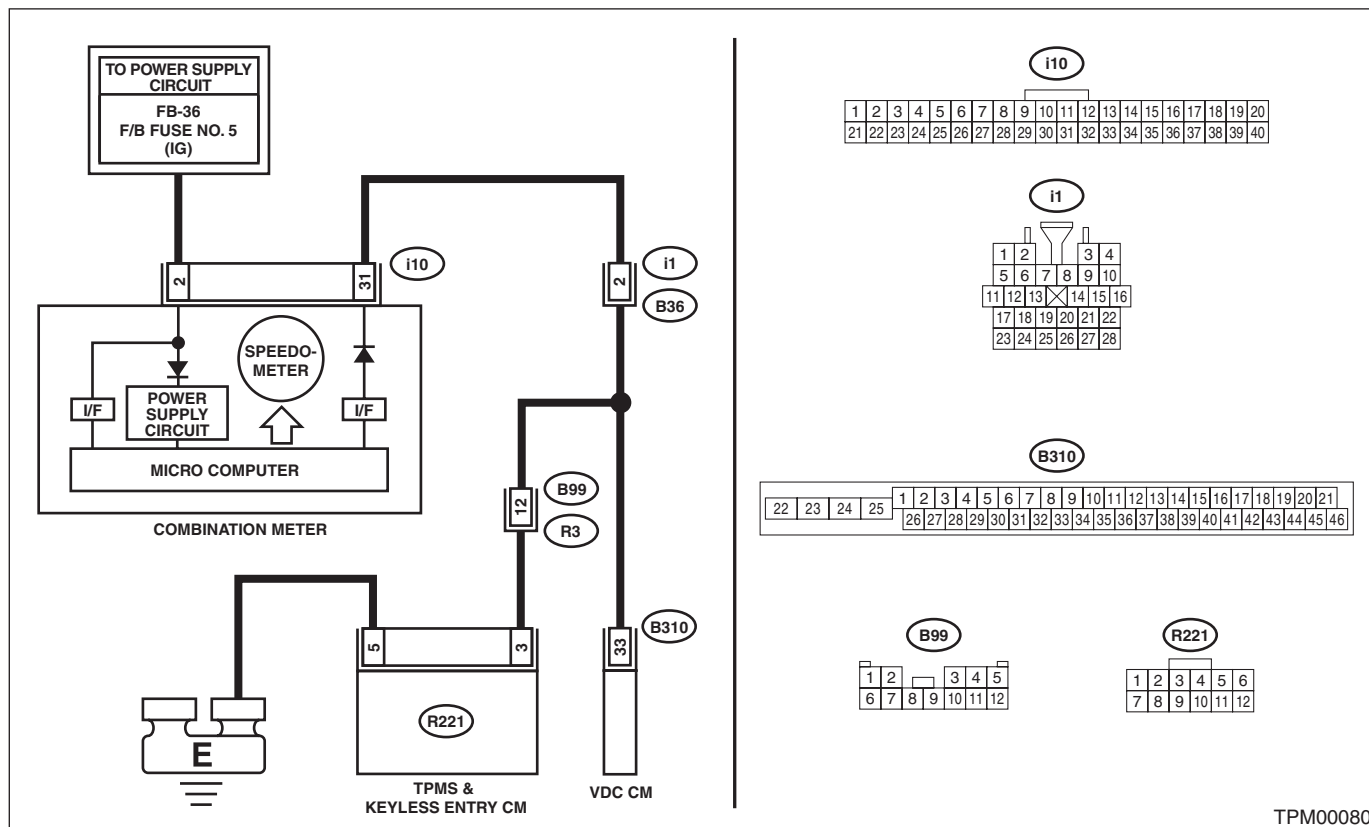

TPM00080

Step	Check	Yes	No
<b>1 CHECK TPMS &amp; KEYLESS ENTRY CONTROL MODULE.</b> 1) Connect an oscilloscope to the terminal No. 3 of the TPMS & keyless entry control module connector (R221). <b>Connector &amp; terminal</b> <b>(R221) No. 3 (+) — Chassis ground (-):</b> 2) Lift up the vehicle and then drive the vehicle at 40 km/h (25 MPH) and check the vehicle speed signal at that time.	Is the vehicle speed being input?	Replace the TPMS & keyless entry control module. <Ref. to WT-8, TPMS & KEYLESS ENTRY CONTROL MODULE, REMOVAL, Tire Pressure Monitoring System.>	Go to step 2.
<b>2 CHECK HARNESS.</b> 1) Disconnect the combination meter connector (i10). 2) Connect the tester to the TPMS & keyless entry control module connector (R221) and combination meter connector (i10), and measure the resistance. <b>Connector &amp; terminal</b> <b>(R221) No. 3 — (i10) No. 31:</b>	Is the resistance less than 0.5 Ω?	Replace the combination meter. <Ref. to IDI-16, REMOVAL, Combination Meter.>	Repair or replace the open circuit of the harness.

# General Diagnostic Table

TIRE PRESSURE MONITORING SYSTEM (DIAGNOSTICS)

---

## 12.General Diagnostic Table

### A: INSPECTION

Symptoms		Faulty parts
Tire pressure warning light illuminates.	Tire pressure is reduced.	<ul style="list-style-type: none"><li>• Improper tire pressure adjustment.</li><li>• Punctured tire</li></ul>
Tire pressure warning light blinks 25 times and then illuminates.	Tire pressure monitoring system has malfunction.	<ul style="list-style-type: none"><li>• Air pressure sensor malfunction</li><li>• Air pressure sensor is out of battery.</li><li>• Defective TPMS &amp; keyless entry control module</li><li>• Defective vehicle harness</li><li>• Defective combination meter</li></ul>
Tire pressure is dropping but the warning light does not illuminate.	Tire pressure warning light does not illuminate.	<ul style="list-style-type: none"><li>• Air pressure sensor malfunction</li><li>• Defective TPMS &amp; keyless entry control module</li><li>• Defective combination meter</li></ul>

# DIFFERENTIALS

# *DI*

---

	<b>Page</b>
1. General Description .....	2
2. Differential Gear Oil .....	18
3. Front Differential Assembly .....	21
4. Rear Differential (T-type) .....	22
5. Rear Differential Front Oil Seal .....	52
6. Rear Differential Side Oil Seal .....	54
7. Rear Differential Front Member .....	55
8. Rear Differential Mount Bushing .....	56
9. General Diagnostic Table .....	60



# General Description

## DIFFERENTIALS

### 1. General Description

#### A: SPECIFICATION

##### 1. REAR DIFFERENTIAL

When replacing a rear differential assembly, select the correct one according to the following table.

##### NOTE:

Using a different rear differential assembly will cause the drive train and tires to drag or emit abnormal noise.

Model	2.5 L high power turbo	2.5 L Turbo
	6MT	5MT
Rear differential type	T-type	
Identification	H3	B2
LSD type	Torsen	—
Type of gear	Hypoid gear	
Gear ratio (Number of gear teeth)	3.545 (39/11)	3.900 (39/10)
Oil capacity	1.0 ℓ (1.1 US qt, 0.9 Imp qt)	0.8 ℓ (0.8 US qt, 0.7 Imp qt)
Rear differential gear oil	GL-5	

##### 2. IDENTIFICATION

Identification positions are shown in the following figures. For details concerning identification, refer to the "ID" section.

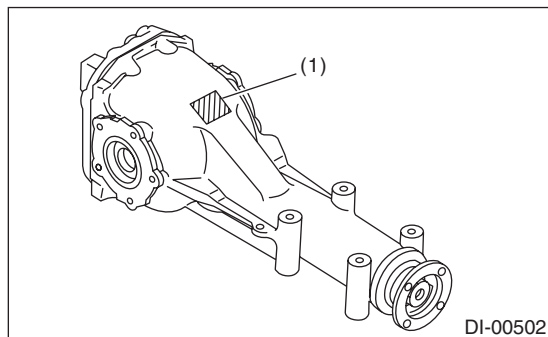

(1) Identification

##### 3. REAR DIFFERENTIAL GEAR OIL

##### Recommended gear oil:

**GL-5 (75W-90) or equivalent**

##### CAUTION:

**Each oil manufacturer has its base oil and additives. Thus, do not mix two or more brands.**

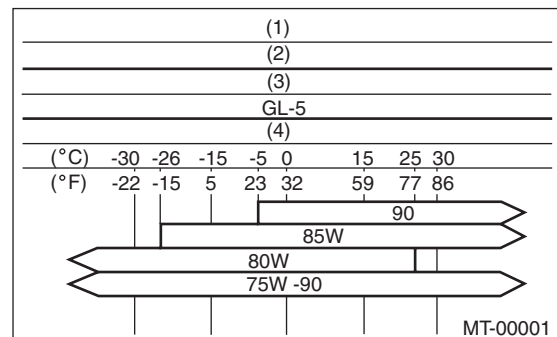

- (1) Item
- (2) Rear differential gear oil
- (3) API classification
- (4) SAE viscosity No. and applicable temperature

# General Description

DIFFERENTIALS

## 4. SERVICE DATA

Drive pinion bearing preload (For new bearing)	Measured with spring measurement (Measured at companion flange bolt hole) N (kgf, lbf)	T-type (B2)	18.1 — 38.8 (1.8 — 4.0, 4.1 — 8.7)
		T-type (H3)	24.1 — 38.6 (2.5 — 3.9, 5.4 — 8.7)
	Measured with torque wrench N·m (kgf·m, ft·lb)	T-type (B2)	0.69 — 1.47 (0.07 — 0.15, 0.51 — 1.08)
		T-type (H3)	0.98 — 1.57 (0.10 — 0.16, 0.72 — 1.16)
Side gear backlash	mm (in)	T-type (B2)	0.10 — 0.20 (0.004 — 0.008)
Side bearing standard width		mm (in)	20.00 (0.7874)
Hypoid driven gear to drive pinion backlash		mm (in)	0.10 — 0.20 (0.004 — 0.008)
Hypoid driven gear runout on its back surface		mm (in)	0.05 (0.002)
Companion flange mating surface runout		mm (in)	0.08 (0.003)
Companion flange runout on its inner surface		mm (in)	0.08 (0.003)
Total preload (Measured from the companion flange bolt hole)	N (kgf, lbf)	T-type (B2)	20.7 — 54.4 (2.1 — 5.5, 4.7 — 12.2)
		T-type (H3)	26.5 — 53 (2.7 — 5.4, 6.0 — 11.9)

## 5. ADJUSTING PARTS

- T-type (B2)

	Part No.	Length mm (in)
Preload adjusting spacer	383695201	56.2 (2.213)
	383695202	56.4 (2.220)
	383695203	56.6 (2.228)
	383695204	56.8 (2.236)
	383695205	57.0 (2.244)
	383695206	57.2 (2.252)

	Part No.	Thickness mm (in)
Preload adjusting washer	383705200	2.59 (0.1020)
	383715200	2.57 (0.1012)
	383725200	2.55 (0.1004)
	383735200	2.53 (0.0996)
	383745200	2.51 (0.0988)
	383755200	2.49 (0.0980)
	383765200	2.47 (0.0972)
	383775200	2.45 (0.0965)
	383785200	2.43 (0.0957)
	383795200	2.41 (0.0949)
	383805200	2.39 (0.0941)
	383815200	2.37 (0.0933)
	383825200	2.35 (0.0925)
	383835200	2.33 (0.0917)
	383845200	2.31 (0.0909)

## General Description

### DIFFERENTIALS

	Part No.	Thickness mm (in)
Pinion height adjusting washer	383495200	3.09 (0.1217)
	383505200	3.12 (0.1228)
	383515200	3.15 (0.1240)
	383525200	3.18 (0.1252)
	383535200	3.21 (0.1264)
	383545200	3.24 (0.1276)
	383555200	3.27 (0.1287)
	383565200	3.30 (0.1299)
	383575200	3.33 (0.1311)
	383585200	3.36 (0.1323)
	383595200	3.39 (0.1335)
	383605200	3.42 (0.1346)
	383615200	3.45 (0.1358)
	383625200	3.48 (0.1370)
	383635200	3.51 (0.1382)
	383645200	3.54 (0.1394)
	383655200	3.57 (0.1406)
	383665200	3.60 (0.1417)
	383675200	3.63 (0.1429)
	383685200	3.66 (0.1441)
Side gear thrust washer	383445201	0.75 — 0.80 (0.0295 — 0.0315)
	383445202	0.80 — 0.85 (0.0315 — 0.0335)
	383445203	0.85 — 0.90 (0.0335 — 0.0354)
Side retainer shim	383475201	0.20 (0.0079)
	383475202	0.25 (0.0098)
	383475203	0.30 (0.0118)
	383475204	0.40 (0.0157)
	383475205	0.50 (0.0197)

# General Description

DIFFERENTIALS

- T-type (H3)

	Part No.	Length mm (in)
Preload adjusting spacer	31454AA130	52.2 (2.055)
	31454AA140	52.4 (2.063)
	31454AA150	52.6 (2.071)
	31454AA160	52.8 (2.079)
	31454AA170	53.0 (2.087)
	31454AA180	53.2 (2.094)

	Part No.	Thickness mm (in)
Preload adjusting washer	383705200	2.59 (0.1020)
	383715200	2.57 (0.1012)
	383725200	2.55 (0.1004)
	383735200	2.53 (0.0996)
	383745200	2.51 (0.0988)
	383755200	2.49 (0.0980)
	383765200	2.47 (0.0972)
	383775200	2.45 (0.0965)
	383785200	2.43 (0.0957)
	383795200	2.41 (0.0949)
	383805200	2.39 (0.0941)
	383815200	2.37 (0.0933)
	383825200	2.35 (0.0925)
	383835200	2.33 (0.0917)
	383845200	2.31 (0.0909)
Pinion height adjusting washer	38336AA230	3.09 (0.1217)
	38336AA240	3.12 (0.1228)
	38336AA250	3.15 (0.1240)
	38336AA260	3.18 (0.1252)
	38336AA270	3.21 (0.1264)
	38336AA280	3.24 (0.1276)
	38336AA290	3.27 (0.1287)
	38336AA300	3.30 (0.1299)
	38336AA310	3.33 (0.1311)
	38336AA320	3.36 (0.1323)
	38336AA330	3.39 (0.1335)
	38336AA340	3.42 (0.1346)
	38336AA350	3.45 (0.1358)
	38336AA360	3.48 (0.1370)
	38336AA370	3.51 (0.1382)
	38336AA380	3.54 (0.1394)
	38336AA390	3.57 (0.1406)
	38336AA400	3.60 (0.1417)
38336AA410	3.63 (0.1429)	
38336AA420	3.66 (0.1441)	
Side retainer shim	383475201	0.20 (0.0079)
	383475202	0.25 (0.0098)
	383475203	0.30 (0.0118)
	383475204	0.40 (0.0157)
	383475205	0.50 (0.0197)

DI-5

Brought to you by Ebay Seller "SubaruManuals"

# General Description

## DIFFERENTIALS

### B: COMPONENT

#### 1. REAR DIFFERENTIAL (T-TYPE (B2))

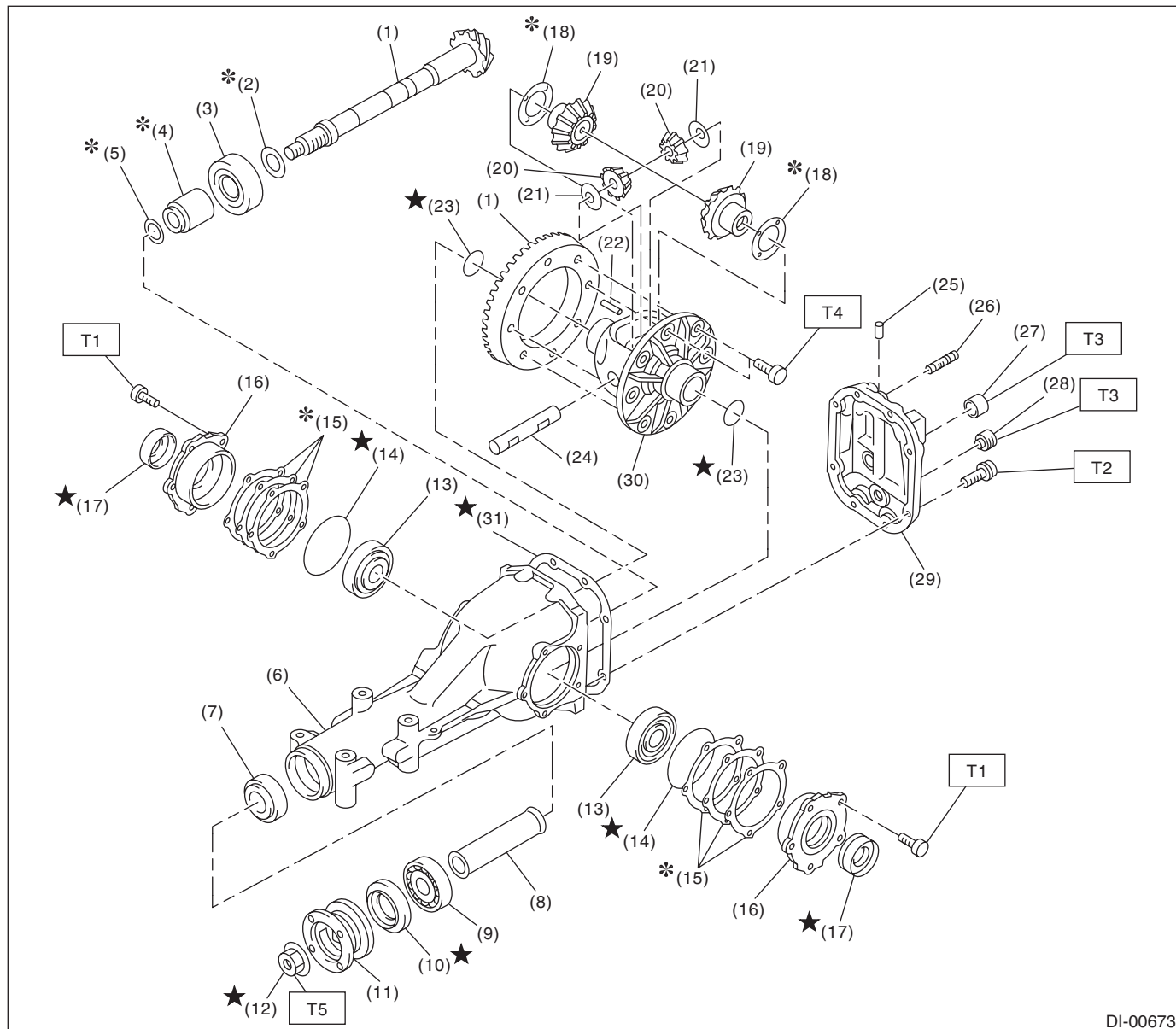

DI-00673

- |   |                              |                        |
|---|------------------------------|------------------------|
| (1) Hypoid driven gear and drive pinion set | (14) O-ring                  | (27) Filler plug       |
| (2) Pinion height adjusting washer          | (15) Side retainer shim      | (28) Drain plug        |
| (3) Rear bearing                            | (16) Side retainer           | (29) Rear cover        |
| (4) Preload adjusting spacer                | (17) Side oil seal           | (30) Differential case |
| (5) Preload adjusting washer                | (18) Side gear thrust washer | (31) Gasket            |
| (6) Differential carrier                    | (19) Side gear               |                        |
| (7) Front bearing                           | (20) Pinion mate gear        |                        |
| (8) Spacer                                  | (21) Pinion mate gear washer |                        |
| (9) Pilot bearing                           | (22) Pinion shaft lock pin   |                        |
| (10) Front oil seal                         | (23) Snap ring               |                        |
| (11) Companion flange                       | (24) Pinion mate shaft       |                        |
| (12) Self-locking nut                       | (25) Air breather cap        |                        |
| (13) Side bearing                           | (26) Stud bolt               |                        |

#### **Tightening torque: N-m (kgf-m, ft-lb)**

**T1: 10.5 (1.1, 7.7)**

**T2: 29.5 (3.0, 21.8)**

**T3: 49 (5.0, 36.1)**

**T4: 103 (10.5, 76.0)**

**T5: 181.5 (18.5, 133.9)**

**DI-6**

Brought to you by Ebay Seller "SubaruManuals"

## 2. REAR DIFFERENTIAL (T-TYPE (H3))

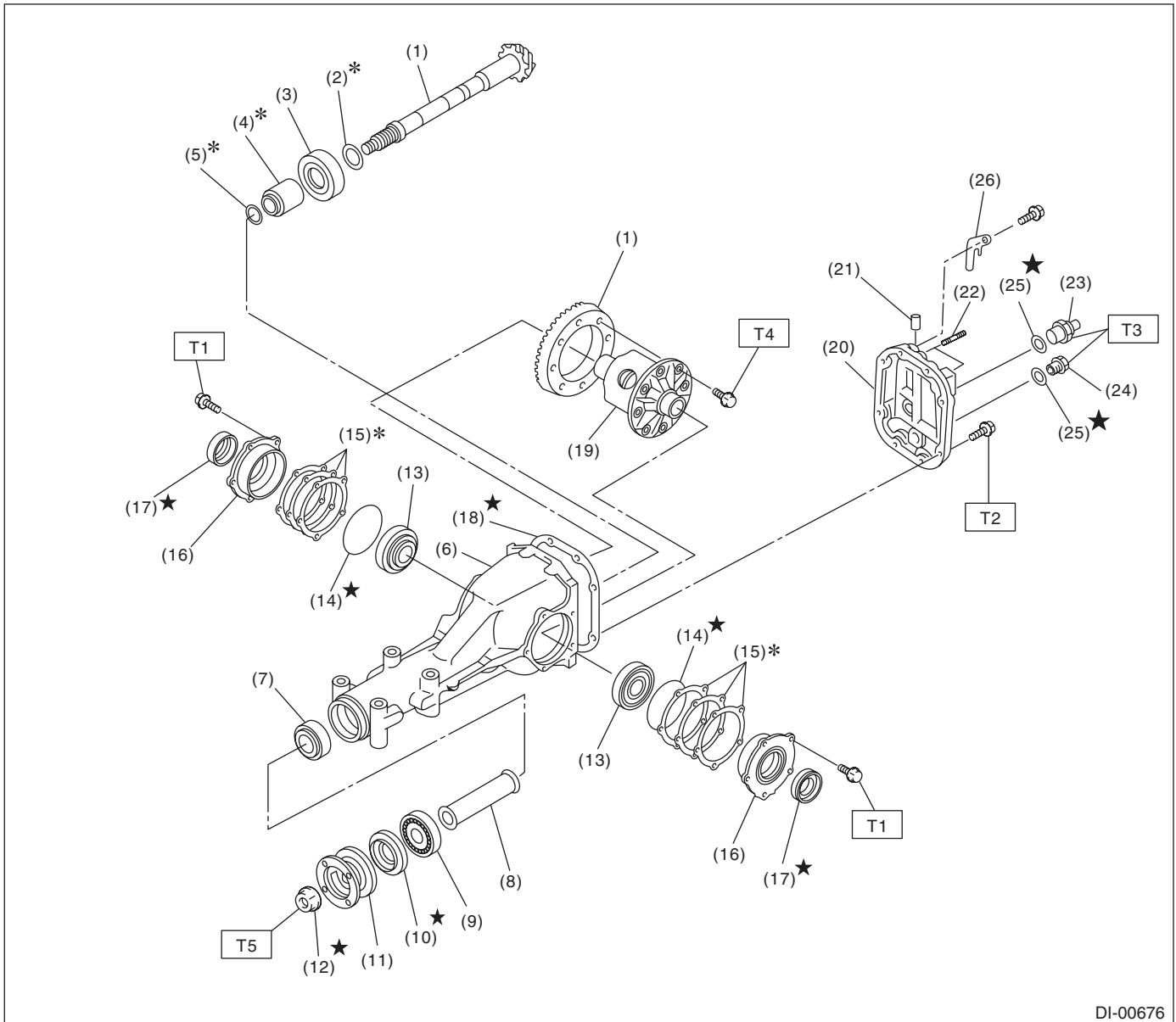

DI-00676

- |   |                             |                             |
|---|-----------------------------|-----------------------------|
| (1) Hypoid driven gear and drive pinion set | (12) Self-locking nut       | (23) Oil temperature switch |
| (2) Pinion height adjusting washer          | (13) Side bearing           | (24) Drain plug             |
| (3) Rear bearing                            | (14) O-ring                 | (25) Gasket                 |
| (4) Preload adjusting spacer                | (15) Side retainer shim     | (26) Stay ground            |
| (5) Preload adjusting washer                | (16) Side retainer          |                             |
| (6) Differential carrier                    | (17) Side oil seal          |                             |
| (7) Front bearing                           | (18) Gasket                 |                             |
| (8) Spacer                                  | (19) Differential case ASSY |                             |
| (9) Pilot bearing                           | (20) Rear cover             |                             |
| (10) Front oil seal                         | (21) Air breather cap       |                             |
| (11) Companion flange                       | (22) Stud bolt              |                             |

**Tightening torque: N·m (kgf·m, ft·lb)**

**T1: 10.5 (1.1, 7.7)**

**T2: 44 (4.5, 32.5)**

**T3: 60 (6.1, 44.3)**

**T4: 103 (10.5, 76.0)**

**T5: 181.5 (18.5, 133.9)**

# General Description

## DIFFERENTIALS

### 3. REAR DIFFERENTIAL MOUNTING SYSTEM

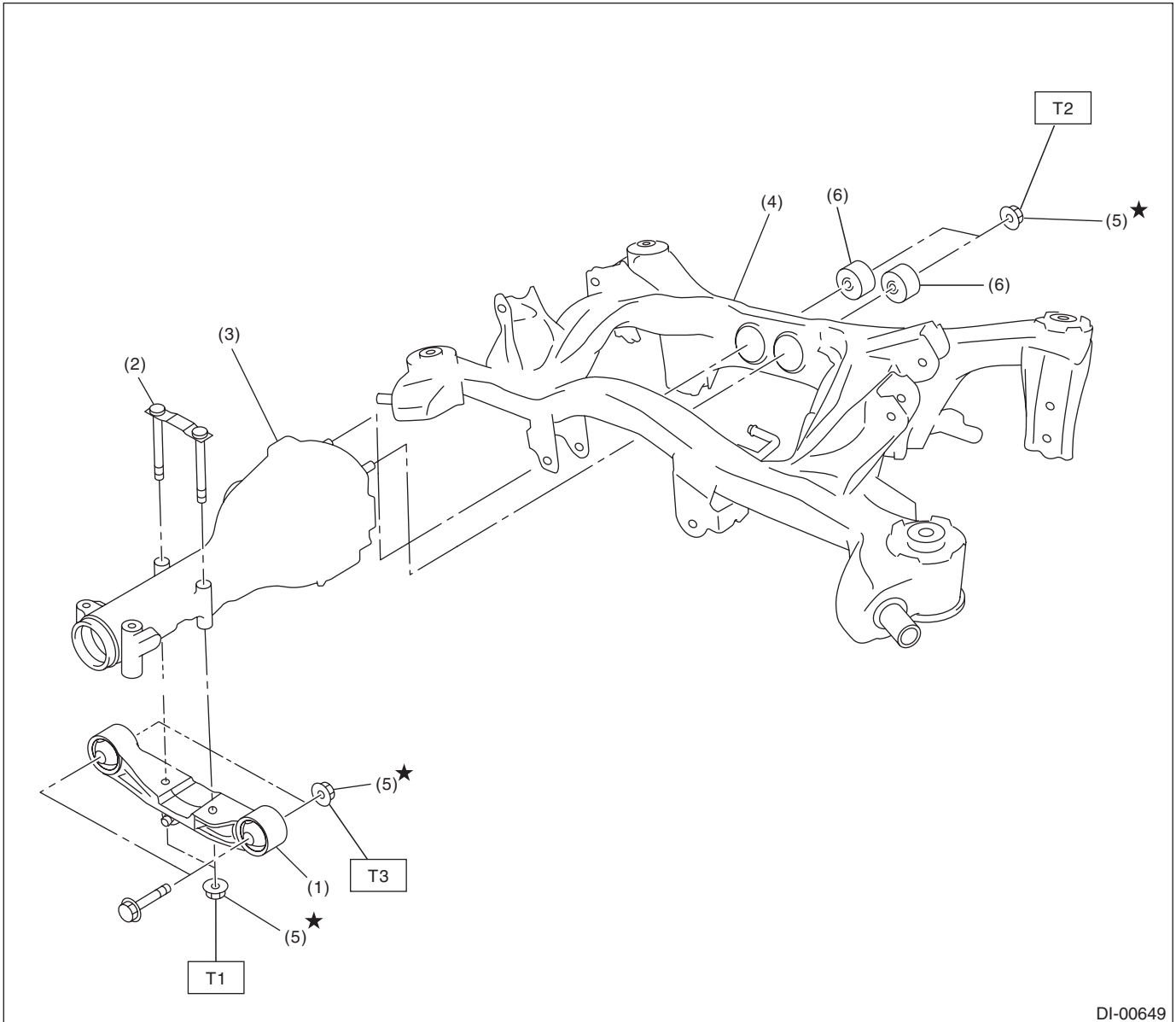

DI-00649

- |                                    |  |
|------------------------------------|--|
| (1) Rear differential front member | (4) Sub frame                          |
| (2) Rear differential member plate | (5) Self-locking nut                   |
| (3) Rear differential ASSY         | (6) Rear differential mounting bushing |

**Tightening torque: N·m (kgf·m, ft·lb)**

**T1: 50 (5.1, 36.9)**

**T2: 70 (7.1, 51.6)**

**T3: 110 (11.2, 81.1)**

## C: CAUTION

- Wear appropriate work clothing, including a cap, protective goggles and protective shoes when performing any work.
- Remove contamination including dirt and corrosion before removal, installation or disassembly.
- Keep the disassembled parts in order and protect them from dust and dirt.
- Before removal, installation or disassembly, be sure to clarify the failure. Avoid unnecessary removal, installation, disassembly and replacement.
- Vehicle components are extremely hot after driving. Be wary of receiving burns from heated parts.
- Use SUBARU genuine gear oil, grease. Do not mix gear oil, grease, etc. of different grades or manufacturers.
- Be sure to tighten fasteners including bolts and nuts to the specified torque.
- Place shop jacks or rigid racks at the specified points.
- Apply gear oil onto sliding or revolving surfaces before installation.
- Before installing the O-ring or snap ring, apply a sufficient amount of gear oil to avoid damage and deformation.
- Before securing a part on a vise, place cushioning material such as wood blocks, aluminum plate, or cloth between the part and the vise.
- Avoid damaging the mating surface of the case.

## D: PREPARATION TOOL

### 1. SPECIAL TOOL

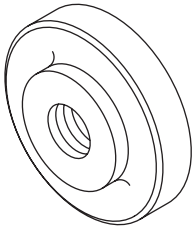
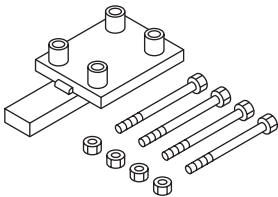
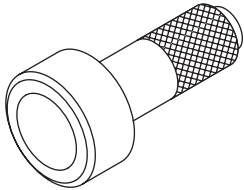
ILLUSTRATION	TOOL NUMBER	DESCRIPTION	REMARKS
 ST-398477702	398477702	DRIFT	Used for installing the front bearing race.
 ST-398217700	398217700	ATTACHMENT SET	Stand for rear differential carrier disassembly and assembly.
 ST-498447120	498447120	INSTALLER	Used for installing the front oil seal.



# General Description

## DIFFERENTIALS

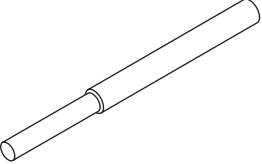
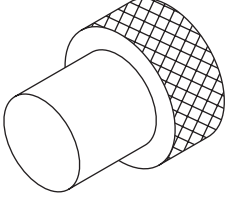
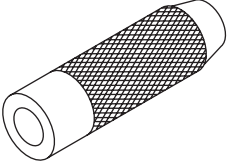
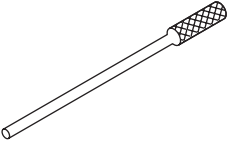
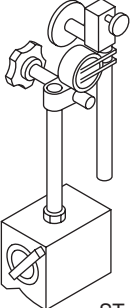
ILLUSTRATION	TOOL NUMBER	DESCRIPTION	REMARKS
 <p style="text-align: center;">ST-398467700</p>	398467700	DRIFT	Used for removing drive pinion shaft, pilot bearing and front bearing cone.
 <p style="text-align: center;">ST-399780104</p>	399780104	WEIGHT	<ul style="list-style-type: none"> <li>• Used for installing the pilot bearing companion flange.</li> <li>• Used for installing the front bearing cone. (T-type (B2))</li> </ul>
 <p style="text-align: center;">ST-899580100</p>	899580100	INSTALLER	<ul style="list-style-type: none"> <li>• Used for installing the pilot bearing.</li> <li>• Used for installing the front bearing cone. (T-type (B2))</li> </ul>
 <p style="text-align: center;">ST-899904100</p>	899904100	STRAIGHT PIN REMOVER	Used for removing and installing the pinion mate shaft lock pin. (T-type (B2))
 <p style="text-align: center;">ST-498247001</p>	498247001	MAGNET BASE	<ul style="list-style-type: none"> <li>• Used for measuring the backlash of hypoid gear.</li> <li>• Used together with DIAL GAUGE (498247100).</li> </ul>

# General Description

DIFFERENTIALS

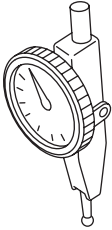
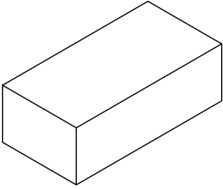
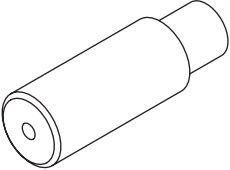
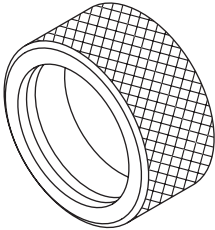
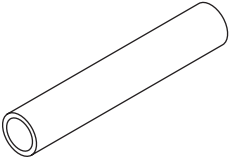
ILLUSTRATION	TOOL NUMBER	DESCRIPTION	REMARKS
 <p>ST-498247100</p>	498247100	DIAL GAUGE	<ul style="list-style-type: none"> <li>Used for measuring the backlash of hypoid gear.</li> <li>Used together with MAGNET BASE (498247001).</li> </ul>
 <p>ST-398507704</p>	398507704	BLOCK	Used for adjusting pinion height and preload. (T-type (B2))
 <p>ST-398457700</p>	398457700	ATTACHMENT	Used for removing the side retainer.
 <p>ST-398437700</p>	398437700	DRIFT	Used for installing the side oil seal.
 <p>ST-398507703</p>	398507703	DUMMY COLLAR	<ul style="list-style-type: none"> <li>Used for adjusting pinion height and preload.</li> <li>Used for installing the front bearing cone.</li> </ul>

DI-11

Brought to you by Ebay Seller "SubaruManuals"

# General Description

## DIFFERENTIALS

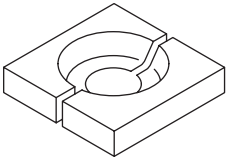
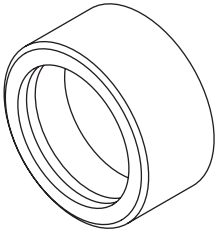
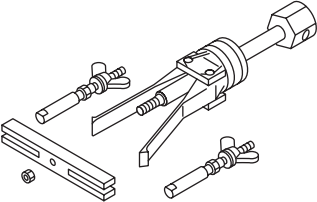
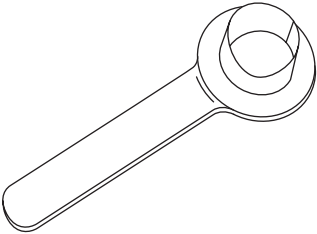
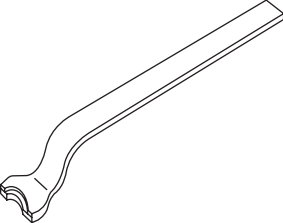
ILLUSTRATION	TOOL NUMBER	DESCRIPTION	REMARKS
 <p style="text-align: center;">ST-398517700</p>	398517700	REPLACER	Used for removing rear bearing cone.
 <p style="text-align: center;">ST-398487700</p>	398487700	DRIFT	Used for installing side bearing cone.
 <p style="text-align: center;">ST-398527700</p>	398527700	PULLER ASSY	<ul style="list-style-type: none"> <li>• Used for removing front oil seal.</li> <li>• Used for removing the side bearing race.</li> </ul>
 <p style="text-align: center;">ST28099PA090</p>	28099PA090	OIL SEAL PROTECTOR	Used for installing the rear drive shaft to the rear differential. (For oil seal protection)
 <p style="text-align: center;">ST28099PA100</p>	28099PA100	DRIVE SHAFT REMOVER	Used for removing the rear drive shaft from rear differential.

# General Description

DIFFERENTIALS

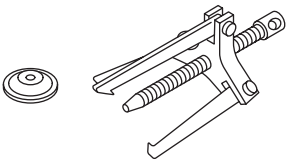
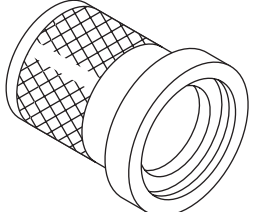
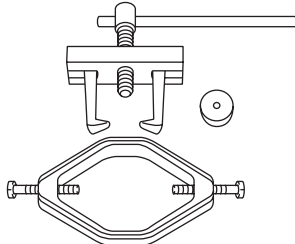
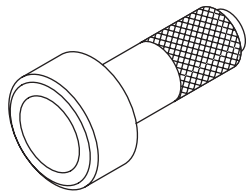
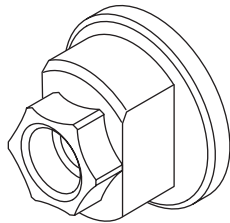
ILLUSTRATION	TOOL NUMBER	DESCRIPTION	REMARKS
 <p data-bbox="337 520 467 541">ST-399703600</p>	399703600	PULLER ASSY	Used for removing companion flange.
 <p data-bbox="337 873 467 894">ST-899874100</p>	899874100	INSTALLER	Used for installing the companion flange.
 <p data-bbox="324 1226 470 1247">ST18759AA000</p>	18759AA000	PULLER ASSY	Used for removing the side bearing cone.
 <p data-bbox="337 1579 467 1600">ST-398417700</p>	398417700	DRIFT	Used for installing side bearing race.
 <p data-bbox="337 1923 467 1944">ST-498937110</p>	498937110	HOLDER DRIVE PINION	Used for installing the pilot bearing and the companion flange. (T-type (H3))

# General Description

## DIFFERENTIALS

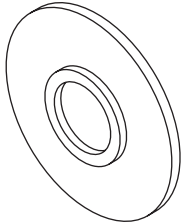
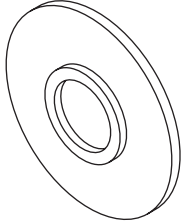
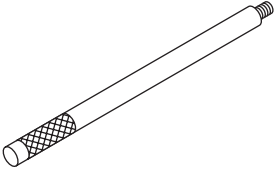
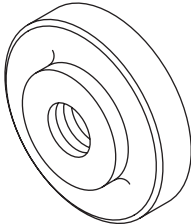
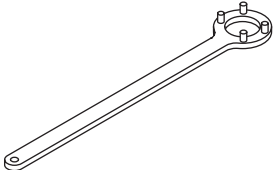
ILLUSTRATION	TOOL NUMBER	DESCRIPTION	REMARKS
 <p style="text-align: center;">ST18674AA000</p>	18674AA000	INSTALLER	Used for installing the rear bearing cone. (T-type (H3))
 <p style="text-align: center;">ST-398177700</p>	398177700	INSTALLER	Used for installing the rear bearing cone. (T-type (B2))
 <p style="text-align: center;">ST-398477701</p>	398477701	HANDLE	Used for installing the front and rear bearing races. (T-type (B2))
 <p style="text-align: center;">ST-398477703</p>	398477703	DRIFT 2	Used for installing the rear bearing race. (T-type (B2))
 <p style="text-align: center;">ST-498427200</p>	498427200	FLANGE WRENCH	Used for preventing rotation of companion flange when loosening and tightening self-lock nut. (T-type (B2))

# General Description

DIFFERENTIALS

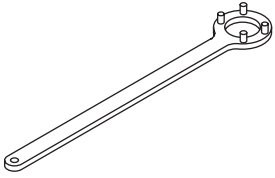
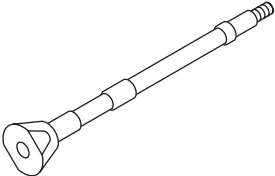
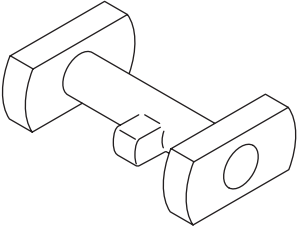
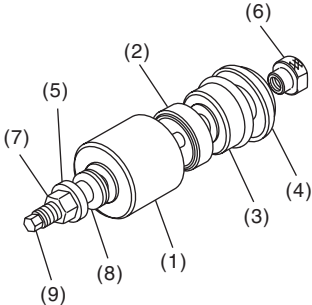
ILLUSTRATION	TOOL NUMBER	DESCRIPTION	REMARKS
 <p>ST18633AA000</p>	18633AA000	WRENCH COMPL	Used for preventing rotation of companion flange when loosening and tightening self-lock nut. (T-type (H3))
 <p>ST-398507702</p>	398507702	DUMMY SHAFT	Used for adjusting pinion height and preload. (T-type (B2))
 <p>ST-398507701</p>	398507701	DIFFERENTIAL CARRIER GAUGE	Used for adjusting pinion height. (T-type (B2))
 <p>ST41399FG001</p>	41399FG001	SPECIAL TOOL ASSY	<ul style="list-style-type: none"> <li>• Used for removing and installing the rear differential mount bushing.</li> <li>• Use (1), (3), (5), (6), (7), (8) and (9) for removal.</li> <li>• Use (2), (4), (5), (6), (7), (8) and (9) for installation.</li> </ul> <p>(1) SPECIAL TOOL A (41399FG010)            (2) SPECIAL TOOL B (41399FG020)            (3) SPECIAL TOOL C (41399FG031)            (4) SPECIAL TOOL D (41399FG041)            (5) SPECIAL TOOL SLEEVE (41399FG050)            (6) SPECIAL TOOL RING (41399FG061)            (7) SPECIAL TOOL NUT (41399FG070)            (8) SPECIAL TOOL BEARING (41399FG080)            (9) SPECIAL TOOL SHAFT (41399FG091)</p>

# General Description

## DIFFERENTIALS

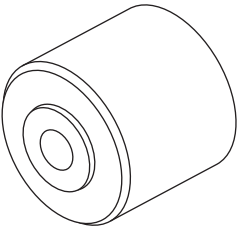
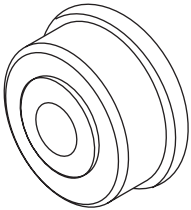
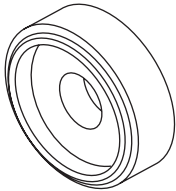
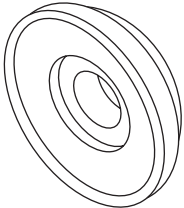
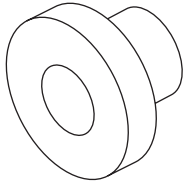
ILLUSTRATION	TOOL NUMBER	DESCRIPTION	REMARKS
 <p style="text-align: center;">ST41399FG010</p>	41399FG010	SPECIAL TOOL A	<ul style="list-style-type: none"> <li>• Used for removing the rear differential mount bushing.</li> <li>• For combination of tools for removal, refer to "SPECIAL TOOL ASSY (41399FG001)".</li> </ul>
 <p style="text-align: center;">ST41399FG020</p>	41399FG020	SPECIAL TOOL B	<ul style="list-style-type: none"> <li>• Used for installing the rear differential mount bushing.</li> <li>• For combination of tools for installation, refer to "SPECIAL TOOL ASSY (41399FG001)".</li> </ul>
 <p style="text-align: center;">ST41399FG031</p>	41399FG031	SPECIAL TOOL C	<ul style="list-style-type: none"> <li>• Used for removing the rear differential mount bushing.</li> <li>• For combination of tools for removal, refer to "SPECIAL TOOL ASSY (41399FG001)".</li> </ul>
 <p style="text-align: center;">ST41399FG041</p>	41399FG041	SPECIAL TOOL D	<ul style="list-style-type: none"> <li>• Used for installing the rear differential mount bushing.</li> <li>• For combination of tools for installation, refer to "SPECIAL TOOL ASSY (41399FG001)".</li> </ul>
 <p style="text-align: center;">ST41399FG050</p>	41399FG050	SPECIAL TOOL SLEEVE	<ul style="list-style-type: none"> <li>• Used for removing and installing the rear differential mount bushing.</li> <li>• For combination of tools for removal and installation, refer to "SPECIAL TOOL ASSY (41399FG001)".</li> </ul>

# General Description

DIFFERENTIALS

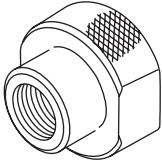
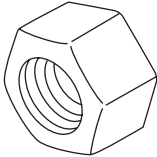
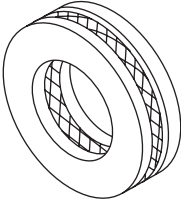
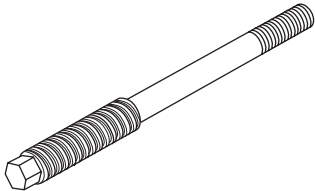
ILLUSTRATION	TOOL NUMBER	DESCRIPTION	REMARKS
 ST41399FG061	41399FG061	SPECIAL TOOL RING	<ul style="list-style-type: none"> <li>• Used for removing and installing the rear differential mount bushing.</li> <li>• For combination of tools for removal and installation, refer to "SPECIAL TOOL ASSY (41399FG001)".</li> </ul>
 ST41399FG070	41399FG070	SPECIAL TOOL NUT	<ul style="list-style-type: none"> <li>• Used for removing and installing the rear differential mount bushing.</li> <li>• For combination of tools for removal and installation, refer to "SPECIAL TOOL ASSY (41399FG001)".</li> </ul>
 ST41399FG080	41399FG080	SPECIAL TOOL BEARING	<ul style="list-style-type: none"> <li>• Used for removing and installing the rear differential mount bushing.</li> <li>• For combination of tools for removal and installation, refer to "SPECIAL TOOL ASSY (41399FG001)".</li> </ul>
 ST41399FG091	41399FG091	SPECIAL TOOL SHAFT	<ul style="list-style-type: none"> <li>• Used for removing and installing the rear differential mount bushing.</li> <li>• For combination of tools for removal and installation, refer to "SPECIAL TOOL ASSY (41399FG001)".</li> </ul>

## 2. GENERAL TOOL

TOOL NAME	REMARKS
Transmission jack	Used for removing and installing the rear differential.
Puller	Used for removing the side retainer.
Thickness gauge	Used for measuring clearance.



# Differential Gear Oil

## DIFFERENTIALS

### 2. Differential Gear Oil

#### A: INSPECTION

- 1) Disconnect the ground cable from battery.
- 2) Lift up the vehicle.
- 3) Disconnect the oil temperature switch connector. (T-type (H3))

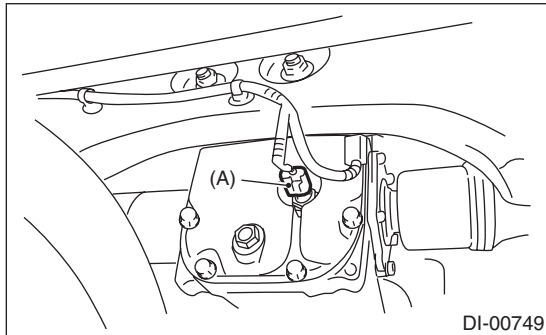

(A) Oil temperature switch connector

- 4) Remove the filler plug or the oil temperature switch, and then check the gear oil. Replace the gear oil if it is contaminated, deteriorated or cloudy. <Ref. to DI-18, REPLACEMENT, Differential Gear Oil.>

#### NOTE:

Remove the oil temperature switch and adapter as a unit.

- 5) Check that the gear oil level is within  $-5\text{ mm}$  ( $-0.2\text{ in}$ ) from the bottom of the filler plug hole or of the oil temperature switch hole. If the level is low, confirm that there is no oil leakage and refill up to the bottom of filler plug hole or the oil temperature switch hole.

- T-type (B2)

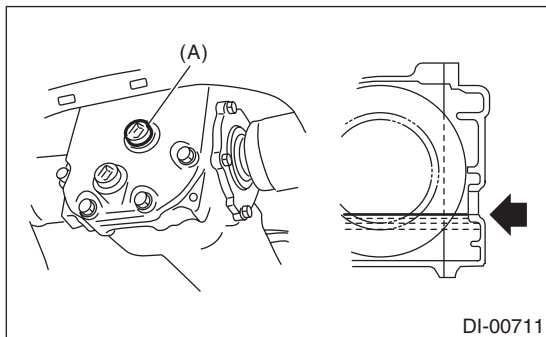

(A) Filler plug

- T-type (H3)

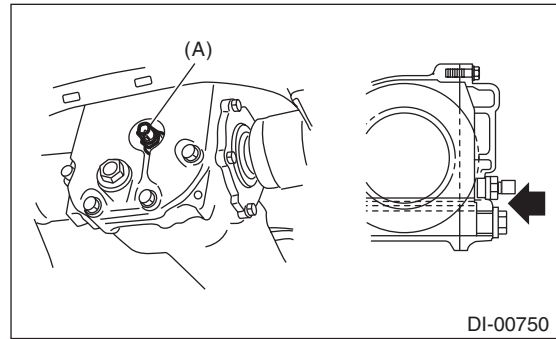

(A) Oil temperature switch

#### B: REPLACEMENT

##### CAUTION:

- Gear oil is extremely hot just after driving. Be wary of receiving burns.
- Be careful not to spill the differential gear oil on exhaust pipe. If gear oil is spilled, wipe it off completely.

- 1) Disconnect the ground cable from battery.
- 2) Lift up the vehicle.
- 3) Disconnect the oil temperature switch connector. (T-type (H3))

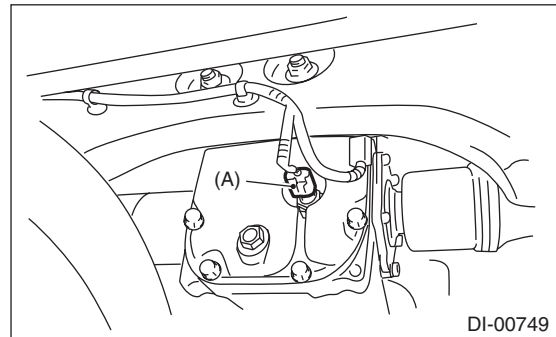

(A) Oil temperature switch connector

4) Remove the drain plug and filler plug or the oil temperature switch, and drain the gear oil.

**NOTE:**

Remove the oil temperature switch and adapter as a unit.

- T-type (B2)

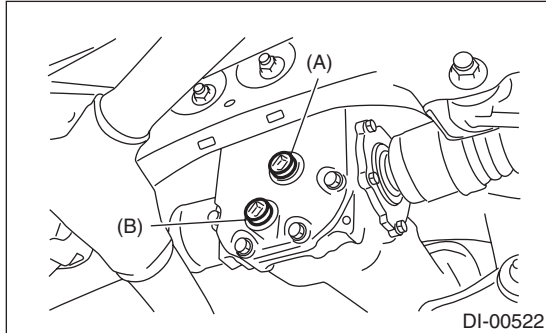

(A) Filler plug  
(B) Drain plug

- T-type (H3)

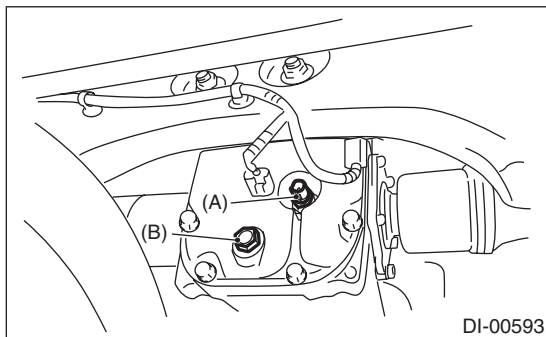

(A) Oil temperature switch  
(B) Drain plug

5) Tighten the drain plug.

**NOTE:**

- For the T-type (B2), apply liquid gasket to the drain plug.
- For T-type (H3), use a new gasket.

**Liquid gasket:**

**THREE BOND 1105 (Part No. 004403010) or equivalent**

**Tightening torque:**

**T-type (B2)**

**49 N·m (5.0 kgf·m, 36.1 ft·lb)**

**T-type (H3)**

**60 N·m (6.1 kgf·m, 44.3 ft·lb)**

6) Fill the differential carrier with gear oil to the bottom of filler plug hole or the oil temperature switch hole.

**NOTE:**

Carefully refill gear oil while watching the level. Excessive or insufficient oil must be avoided.

**Recommended gear oil:**

**<Ref. to DI-2, SPECIFICATION, General Description.>**

**Oil capacity:**

**6MT model**

**1.0 ℓ (1.1 US qt, 0.9 Imp qt)**

**5MT model**

**0.8 ℓ (0.8 US qt, 0.7 Imp qt)**

- T-type (B2)

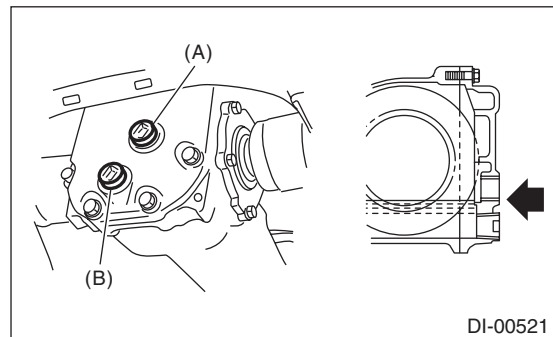

(A) Filler plug  
(B) Drain plug

- T-type (H3)

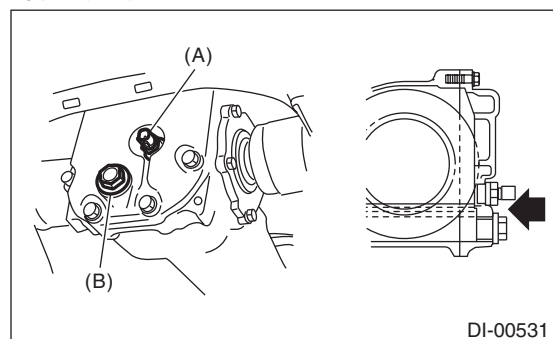

(A) Oil temperature switch  
(B) Drain plug

# Differential Gear Oil

## DIFFERENTIALS

---

7) Install the filler plug or the oil temperature switch.

### NOTE:

- For the T-type (B2), apply liquid gasket to the drain plug.
- For T-type (H3), use a new gasket.
- Install the oil temperature switch and adapter as a unit.

### **Liquid gasket:**

**THREE BOND 1105 (Part No. 004403010) or equivalent**

### **Tightening torque:**

#### **T-type (B2)**

**49 N·m (5.0 kgf·m, 36.1 ft·lb)**

#### **T-type (H3)**

**60 N·m (6.1 kgf·m, 44.3 ft·lb)**

8) Connect the oil temperature switch connector.  
(T-type (H3))

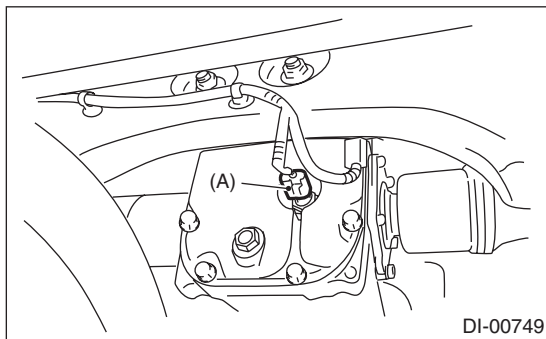

(A) Oil temperature switch connector

9) Lower the vehicle.

10) Connect the battery ground terminal.

## 3. Front Differential Assembly

### A: NOTE

- 6MT

For front differential for the 6MT, refer to the "6MT" section. <Ref. to 6MT-98, Front Differential Assembly.>

- 5MT

For front differential for the 5MT, refer to the "5MT" section. <Ref. to 5MT-68, Front Differential Assembly.>

## Rear Differential (T-type)

### DIFFERENTIALS

## 4. Rear Differential (T-type)

### A: REMOVAL

- 1) Disconnect the ground cable from battery.
- 2) Place the gear shift lever in neutral.
- 3) Release the parking brake.
- 4) Loosen the wheel nuts.
- 5) Lift up the vehicle.
- 6) Remove the wheels.
- 7) Disconnect the oil temperature switch connector and ground connector. (H3)

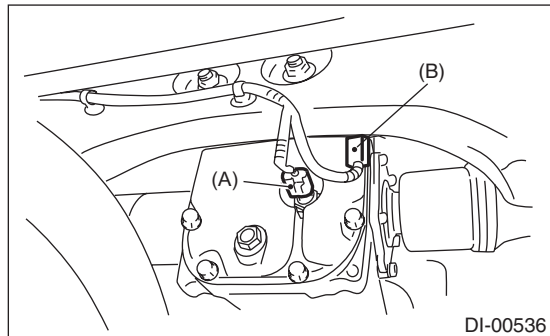

- (A) Oil temperature switch connector  
(B) Ground connector

- 8) Drain differential gear oil. <Ref. to DI-18, REPLACEMENT, Differential Gear Oil.>
- 9) Remove the rear exhaust pipe and muffler. <Ref. to EX(w/o STI)-2, General Description.> <Ref. to EX(STI)-13, REMOVAL, Rear Exhaust Pipe.> <Ref. to EX(w/o STI)-2, General Description.> <Ref. to EX(STI)-15, REMOVAL, Muffler.>
- 10) Remove the heat shield cover.

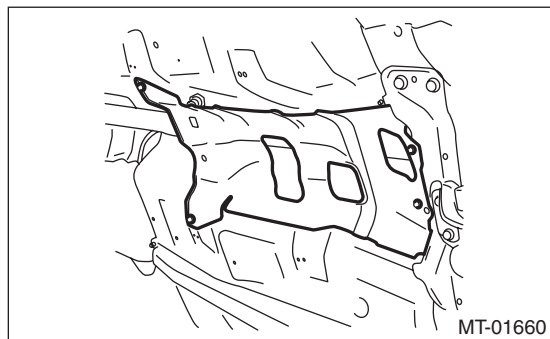

- 11) Remove the propeller shaft. <Ref. to DS-11, REMOVAL, Propeller Shaft.>

- 12) Remove the DOJ of rear drive shaft from rear differential.

- (1) Remove the ABS wheel speed sensor cable from the clamp.

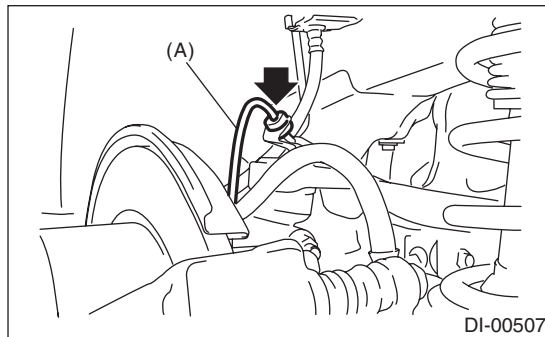

- (A) ABS wheel speed sensor cable

- (2) Remove the bolts which secure the rear stabilizer link to the rear lateral link.

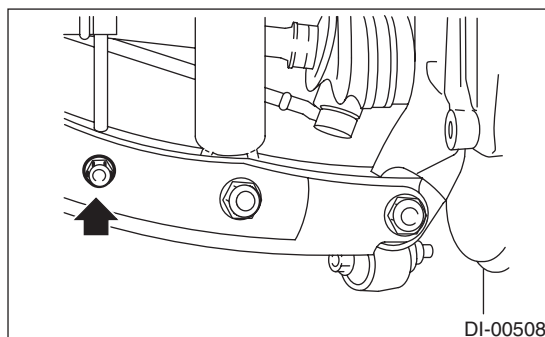

- (3) Remove the bolts which secure the shock absorber to the rear lateral link.

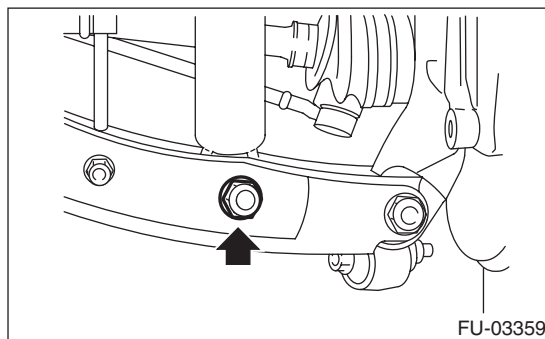

- (4) Remove the bolts which secure the rear lateral link to the housing.

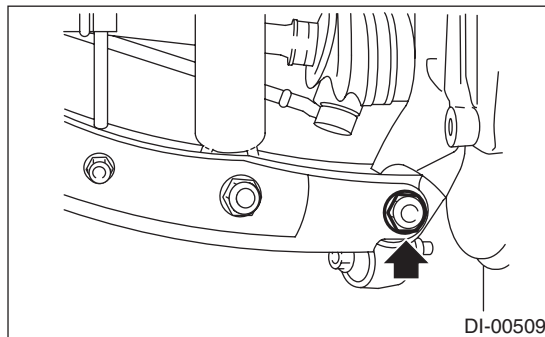

(5) Remove the bolts which secure the trailing link to the housing.

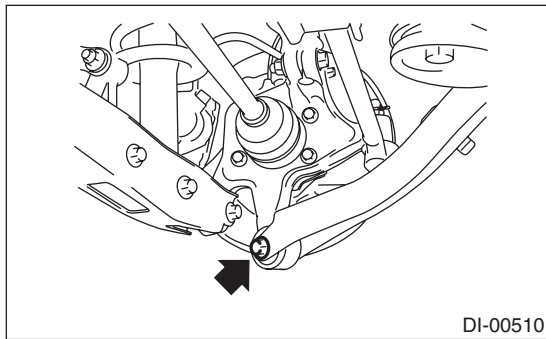

(6) Remove the DOJ from the rear differential by using ST.

**NOTE:**

When removing the DOJ from the rear differential, fit the ST to the bolts as shown in the figure so as not to damage the side retainer.

ST 28099PA100 DRIVE SHAFT REMOVER

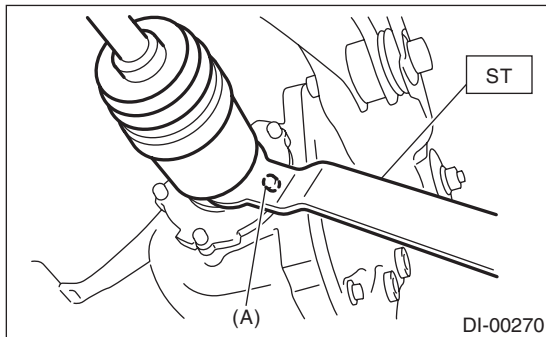

(A) Bolt

13) Suspend the rear drive shaft to the rear cross-member using wire.

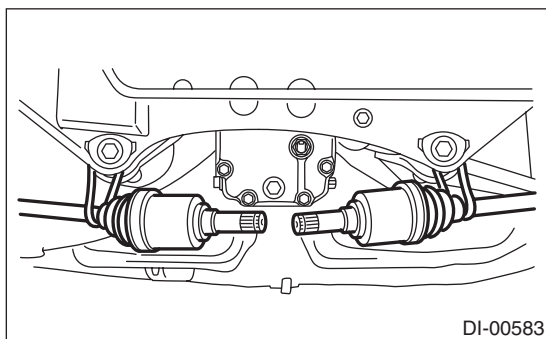

14) Support the rear differential with the transmission jack.

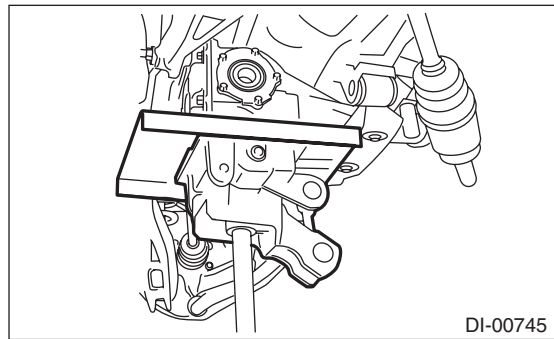

15) Remove the rear differential front member.

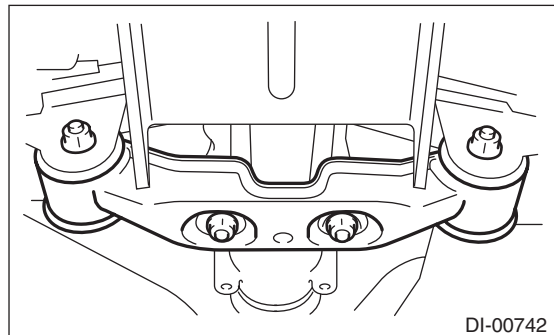

16) Remove the self-lock nuts which hold the rear differential to the rear crossmember.

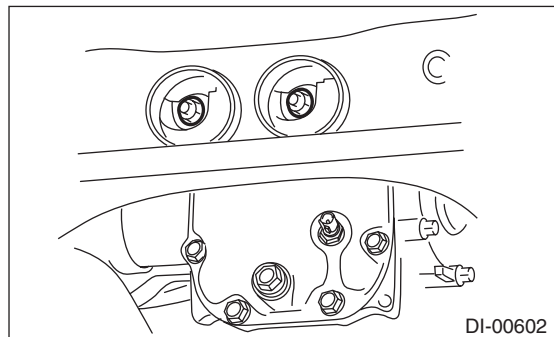

17) While slowly lowering the transmission jack, move the rear differential forward, and remove the rear differential from the vehicle.

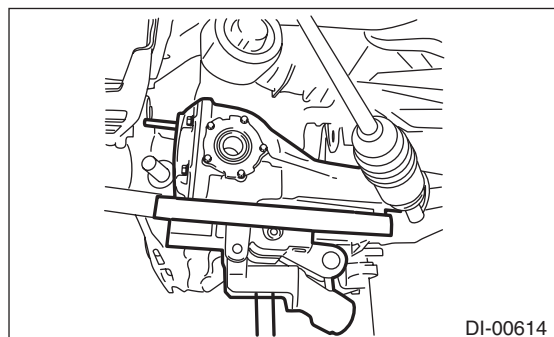

# Rear Differential (T-type)

## DIFFERENTIALS

18) Remove the rear differential member plate from the rear differential.

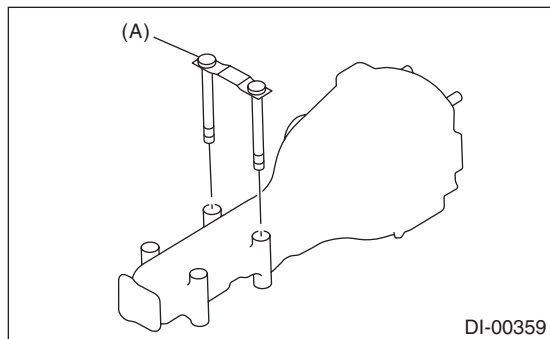

(A) Rear differential member plate

## B: INSTALLATION

1) Attach the rear differential member plate to the rear differential.

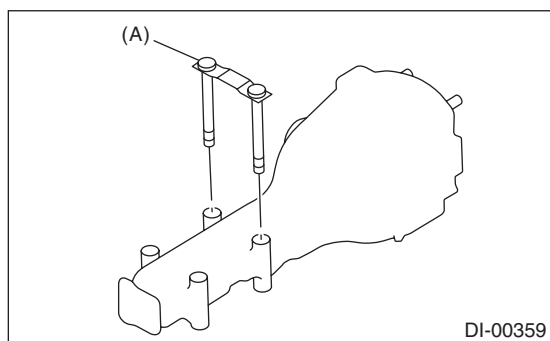

(A) Rear differential member plate

2) Set the rear differential to transmission jack.

3) Adjust the transmission jack and properly insert the rear differential stud bolt into rear crossmember bushing.

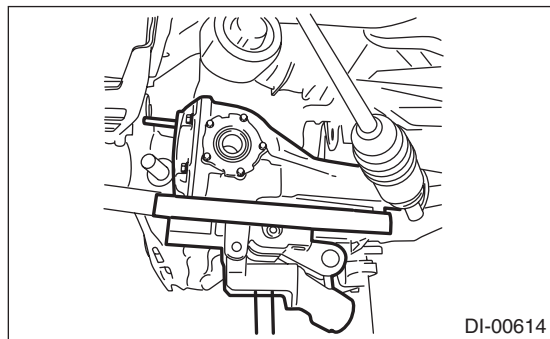

4) After inserting the rear differential stud bolt into the rear crossmember bushing, lift up the transmission jack and align the rear differential to its attachment position.

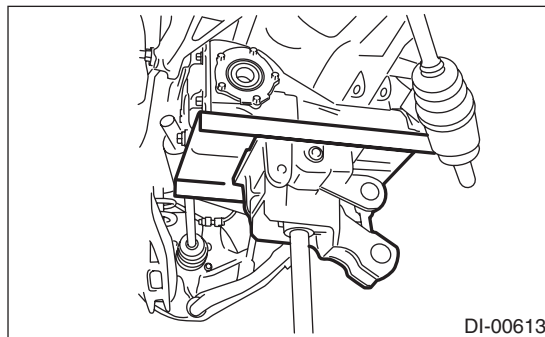

5) Tighten a new self-locking nut temporarily to rear crossmember.

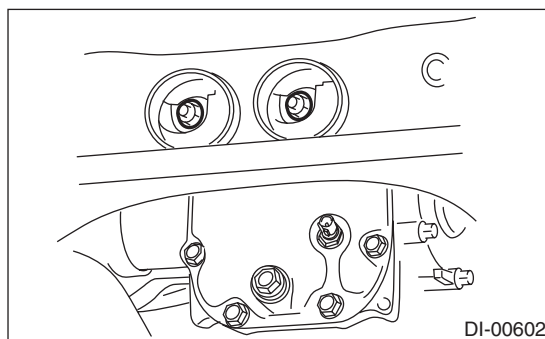

6) Install the rear differential front member with a new self-locking nut.

### Tightening torque:

**T1: 50 N·m (5.1 kgf-m, 36.9 ft-lb)**

**T2: 110 N·m (11.2 kgf-m, 81.1 ft-lb)**

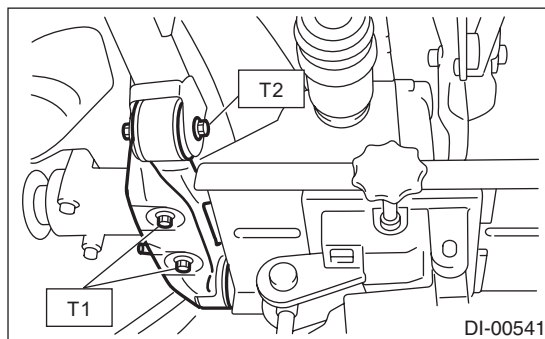



7) Tighten the self-locking nut.

**Tightening torque:**

**70 N·m (7.1 kgf·m, 51.6 ft·lb)**

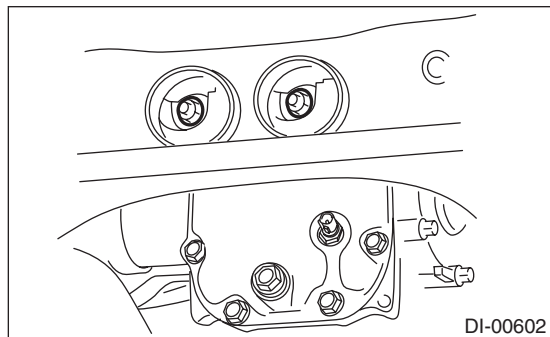

8) Attach the ST to rear differential.

ST 28099PA090 OIL SEAL PROTECTOR

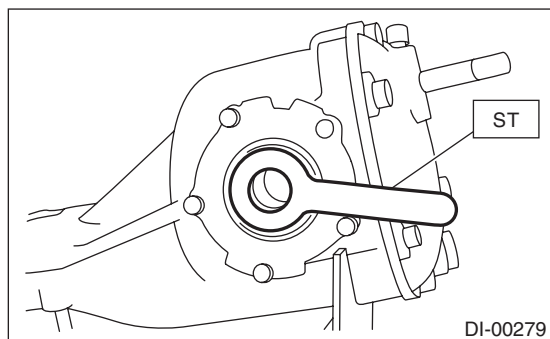

9) Insert the spline shaft until the spline portion comes inside the side oil seal.

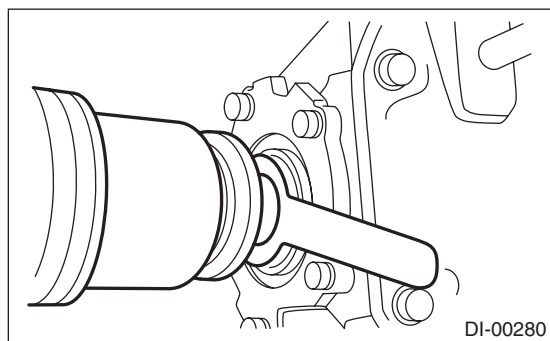

10) Remove ST from rear differential.

11) Push the housing to fully insert the DOJ into the rear differential.

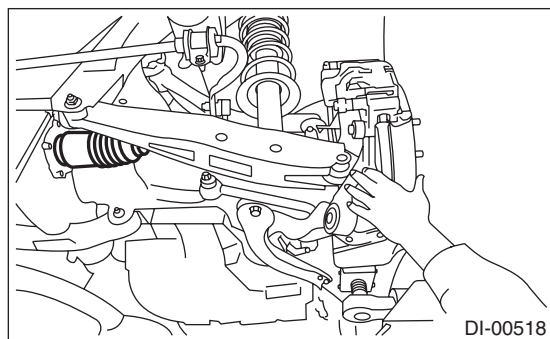

12) Lower the transmission jack.

13) Installing procedure hereafter is in the reverse order of removal.

14) After installing, fill the differential carrier with gear oil up to the bottom of the filler plug or the oil temperature switch hole. <Ref. to DI-18, REPLACEMENT, Differential Gear Oil.>

15) Inspect the wheel alignment and adjust if necessary.

## C: DISASSEMBLY

### 1. T-TYPE (B2)

To detect the real cause of trouble, inspect the following items before disassembling.

- Tooth contact and backlash between hypoid driven gear and drive pinion
- Hypoid driven gear runout on its back surface
- Total preload of drive pinion

1) Set the ST on vise and install the differential assembly to ST.

ST 398217700 ATTACHMENT SET

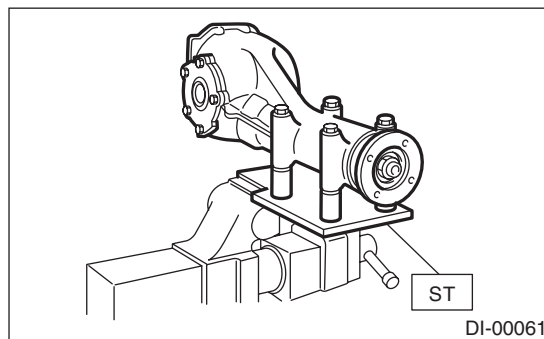

2) Remove the drain plug and filler plug.

3) Remove the air breather cap.

**NOTE:**

- Do not attempt to remove the air breather cap unless necessary.
- Whenever the air breather cap is removed, replace it with a new part.

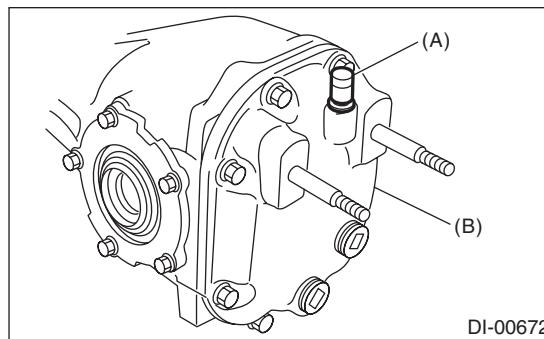

- (A) Air breather cap
- (B) Rear cover

4) Remove the bolts, and then remove the rear cover.



## Rear Differential (T-type)

### DIFFERENTIALS

5) Remove the side retainer attachment bolts, set the ST to differential case, and extract the side retainers RH and LH with a puller.

#### NOTE:

- Side retainer shim of each side should be kept together with its mating retainer.
- Keep the side retainers separate by attaching tags or in similar ways to make it possible to identify RH and LH sides during reassembly.

ST 398457700 ATTACHMENT

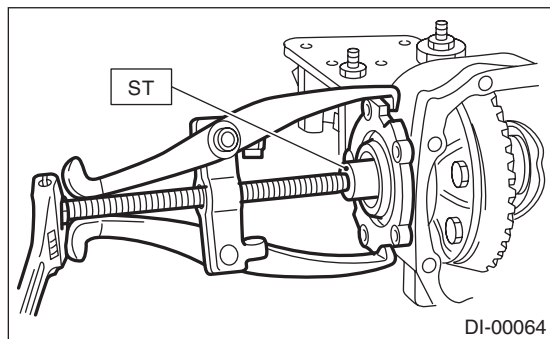

DI-00064

6) Remove the oil seal and O-ring from the side retainer.

7) Pull out the differential case assembly from the differential carrier.

#### NOTE:

Be careful not to hit the teeth of hypoid driven gear against the differential carrier.

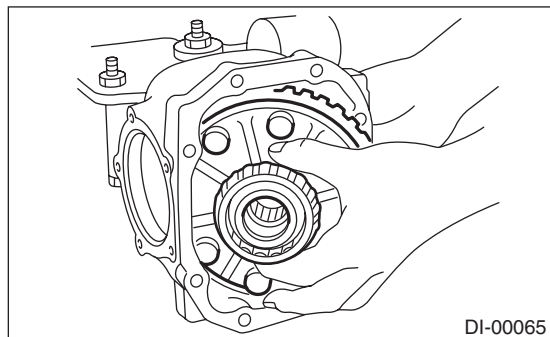

DI-00065

8) When replacing the side bearing, remove the bearing cup from the side retainer using ST.

ST 398527700 PULLER ASSY

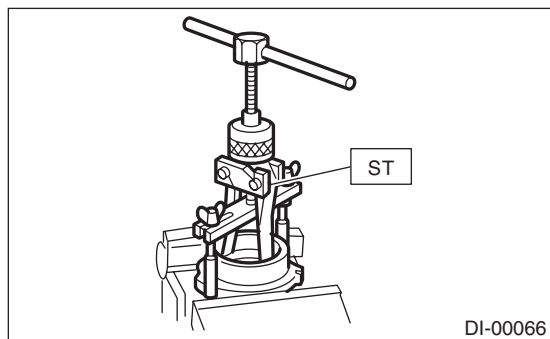

DI-00066

9) Using the ST, remove the bearing cone.

#### NOTE:

- Do not attempt to disassemble the parts unless necessary.
- Set the puller so that its claws catch the edge of the bearing cone.
- Never mix up the RH and LH bearing races and cones.

ST 18759AA000 PULLER ASSY

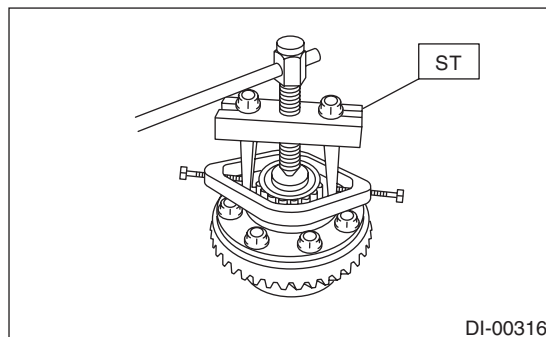

DI-00316

10) Remove the hypoid driven gear by loosening hypoid driven gear bolts.

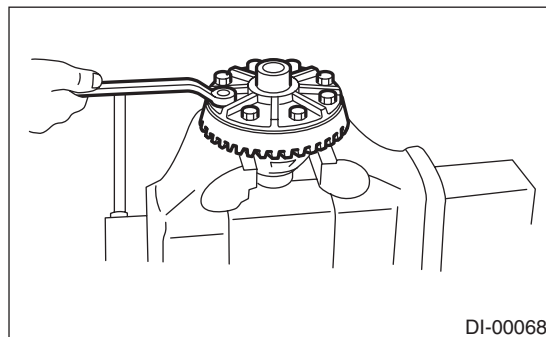

DI-00068

11) Remove the pinion shaft lock pin from driven gear side using ST.

ST 899904100 STRAIGHT PIN REMOVER

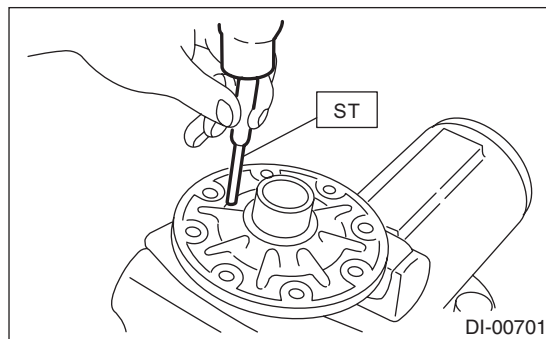

DI-00701

12) Draw out the pinion mate shaft and remove pinion mate gears, side gears and thrust washers.

**NOTE:**

The gears and thrust washers should be marked or kept separately right and left, and front and rear.

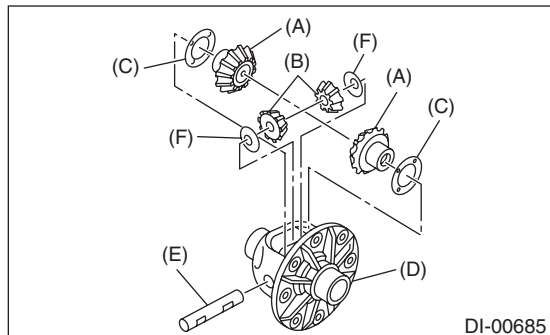

- (A) Side gear
- (B) Pinion mate gear
- (C) Side gear thrust washer
- (D) Differential case
- (E) Pinion mate shaft
- (F) Pinion mate gear washer

13) Remove the self-locking nut while securing the companion flange with ST.

ST 498427200 FLANGE WRENCH

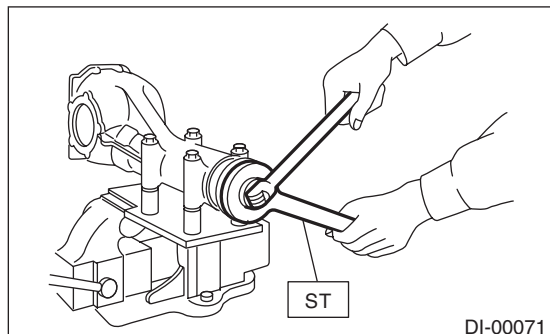

14) Extract the companion flange with a puller.

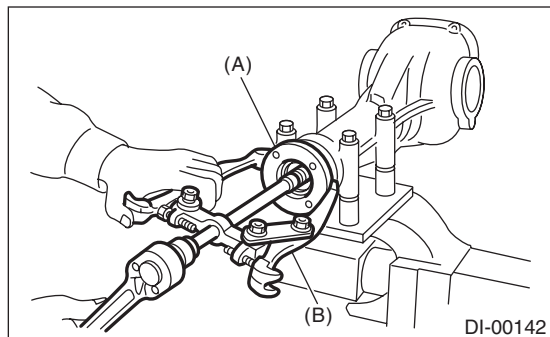

- (A) Companion flange
- (B) Puller

15) Press the end of drive pinion shaft by using the ST, and remove the drive pinion shaft, rear bearing cone, preload adjusting spacer and washer.

**NOTE:**

Hold the drive pinion so as not to drop it.

ST 398467700 DRIFT

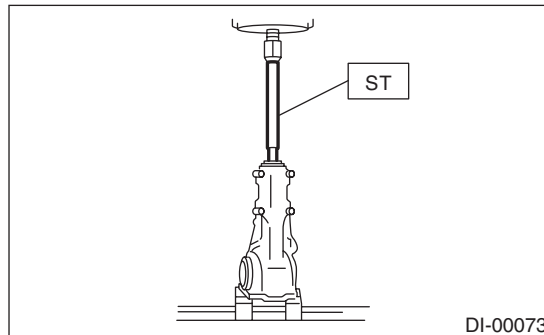

16) Remove the rear bearing cone from drive pinion while supporting the cone with ST.

**NOTE:**

Place the replacer so that its center-recessed side faces the bearing cone.

ST 398517700 REPLACER

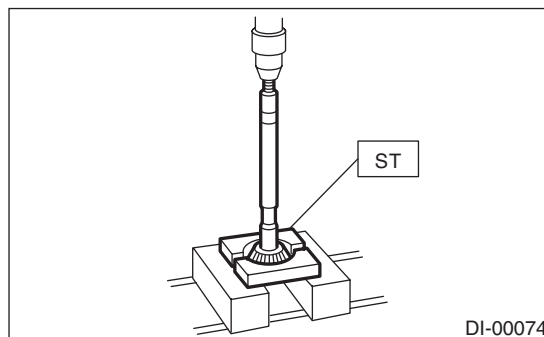

17) Remove the front oil seal from differential carrier using ST.

ST 398527700 PULLER ASSY

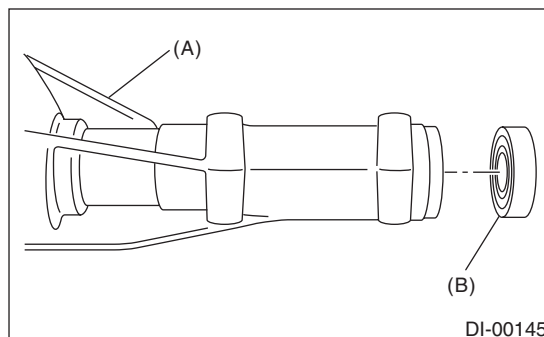

- (A) Differential carrier
- (B) Front oil seal

# Rear Differential (T-type)

## DIFFERENTIALS

18) Remove the pilot bearing together with the front bearing cone and spacer using the ST.

ST 398467700 DRIFT

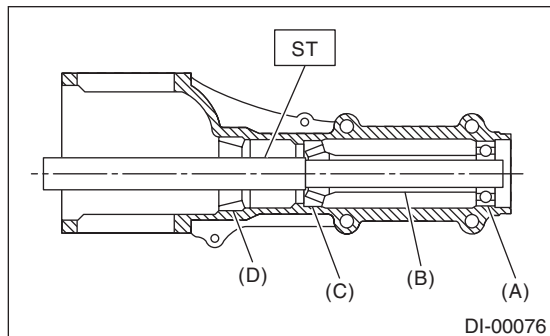

- (A) Pilot bearing
- (B) Spacer
- (C) Front bearing
- (D) Rear bearing cup

19) When replacing the bearings, hit out the front bearing cup and rear bearing cup in this order using a brass bar.

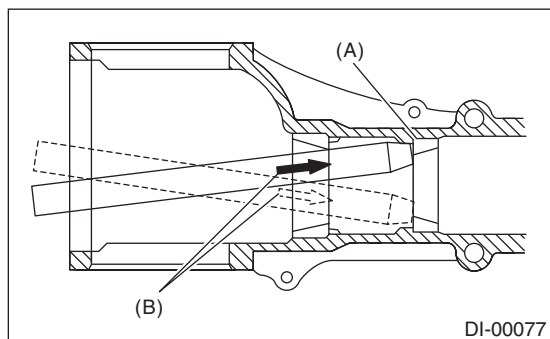

- (A) 2 cutout portions along diagonal lines
- (B) Tap alternately with brass bar.

## 2. T-TYPE (H3)

To detect the real cause of trouble, inspect the following items before disassembling.

- Tooth contact and backlash between hypoid driven gear and drive pinion
- Hypoid driven gear runout on its back surface
- Total preload of drive pinion

1) Set the ST on vise and install the differential assembly to ST.

ST 398217700 ATTACHMENT SET

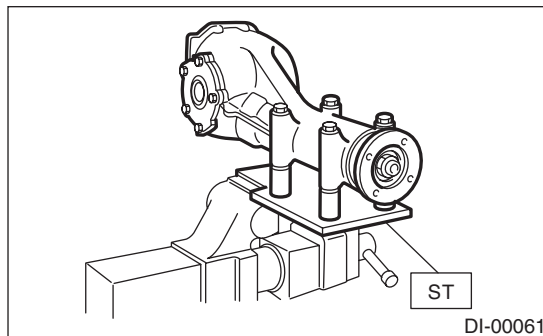

2) Remove the drain plug and oil temperature switch, and drain the gear oil.

NOTE:

Remove the oil temperature switch and adapter as a unit.

3) Remove the air breather cap.

NOTE:

- Do not attempt to remove the air breather cap unless necessary.
- Whenever the air breather cap is removed, replace it with a new part.

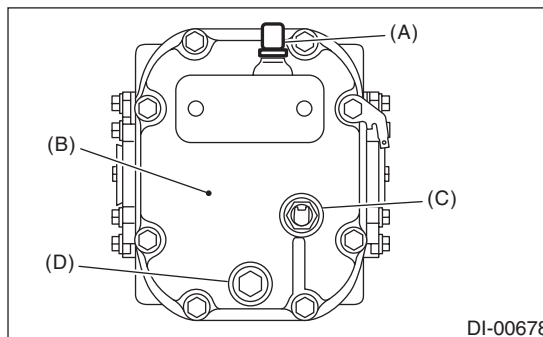

- (A) Air breather cap
- (B) Rear cover
- (C) Oil temperature switch
- (D) Drain plug

4) Remove the bolts, and then remove the rear cover.

5) Remove the side retainer attachment bolts, set the ST to differential case, and extract the side retainers RH and LH with a puller.

NOTE:

- Side retainer shim of each side should be kept together with its mating retainer.

- Keep the side retainers separate by attaching tags or in similar ways to make it possible to identify RH and LH sides during reassembly.

ST 398457700 ATTACHMENT

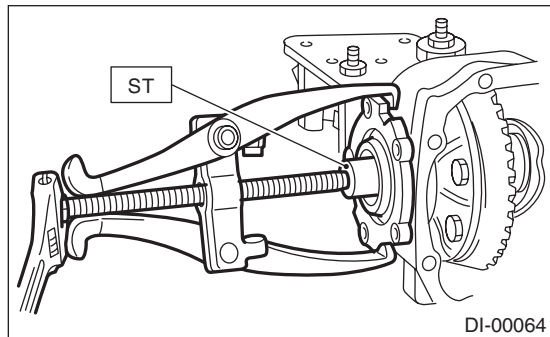

- 6) Remove the oil seal and O-ring from the side retainer.

- 7) Pull out the differential case assembly from the differential carrier.

**NOTE:**

Be careful not to hit the teeth of hypoid driven gear against the differential carrier.

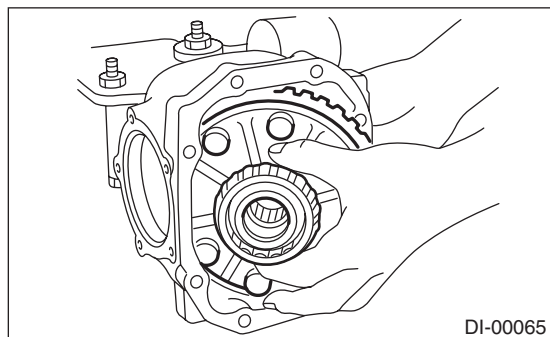

- 8) When replacing the side bearing, remove the bearing cup from the side retainer using ST.

ST 398527700 PULLER ASSY

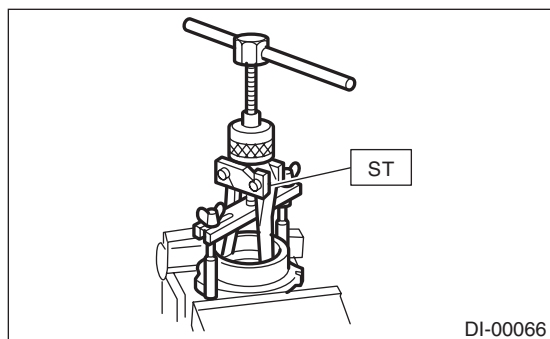

- 9) Using the ST, remove the bearing cone.

**NOTE:**

- Do not attempt to disassemble the parts unless necessary.
- Set the puller so that its claws catch the edge of the bearing cone.
- Never mix up the RH and LH bearing races and cones.

ST 18759AA000 PULLER ASSY

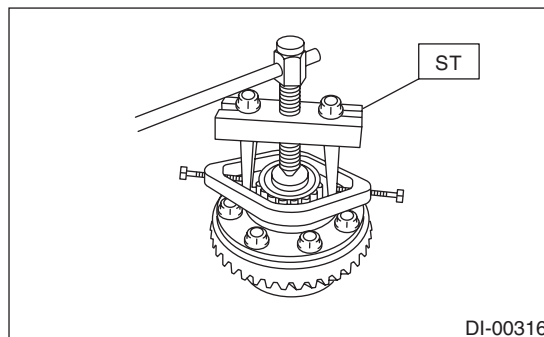

- 10) Remove the hypoid driven gear by loosening hypoid driven gear bolts.

**NOTE:**

Do not disassemble the differential case assembly.

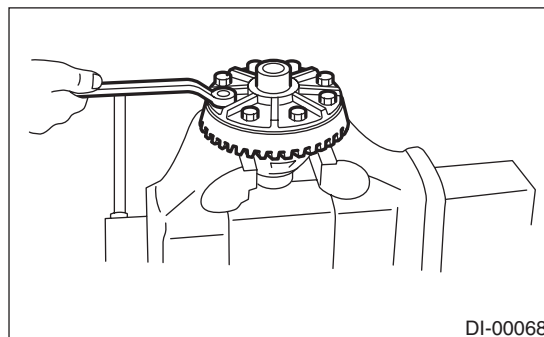

- 11) Remove the self-locking nut while securing the companion flange with ST.

ST 18633AA000 WRENCH COMPL

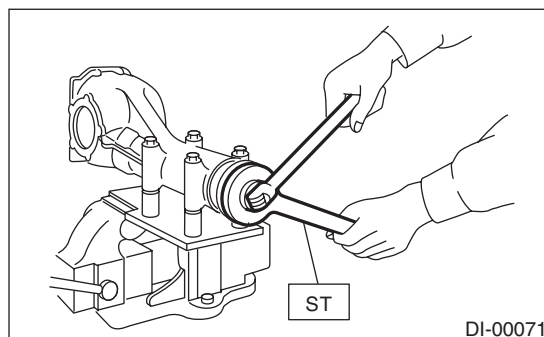

# Rear Differential (T-type)

## DIFFERENTIALS

12) Extract the companion flange with a puller.

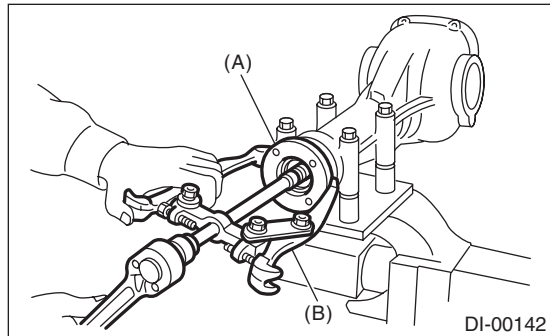

- (A) Companion flange
- (B) Puller

13) Press the end of drive pinion shaft by using the ST, and remove the drive pinion shaft, rear bearing cone, preload adjusting spacer and washer.

NOTE:

Hold the drive pinion so as not to drop it.

ST 398467700 DRIFT

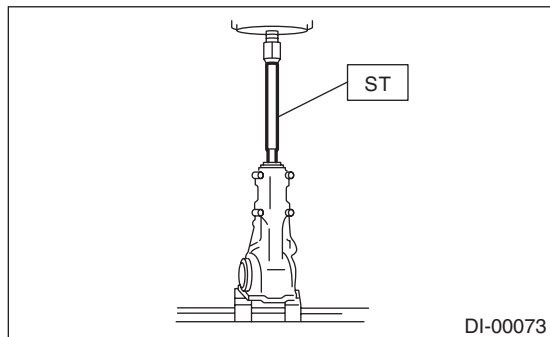

14) Remove the rear bearing cone from drive pinion by supporting the cone with ST.

NOTE:

Place the replacer so that its center-recessed side faces the bearing cone.

ST 398517700 REPLACER

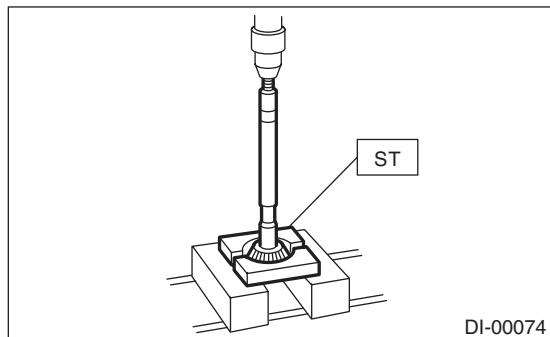

15) Remove the front oil seal from differential carrier using ST.

ST 398527700 PULLER ASSY

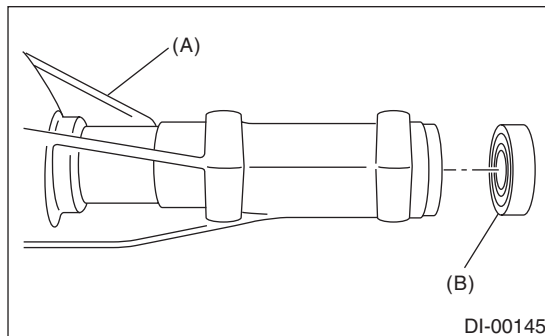

- (A) Differential carrier
- (B) Front oil seal

16) Remove the pilot bearing together with the front bearing cone and spacer using the ST.

ST 398467700 DRIFT

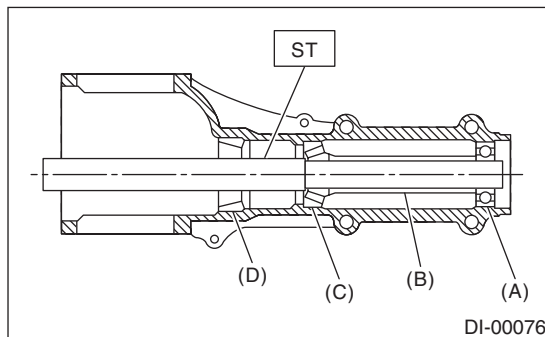

- (A) Pilot bearing
- (B) Spacer
- (C) Front bearing
- (D) Rear bearing cup

17) When replacing the bearings, use a brass bar to tap out the front bearing cup and rear bearing cup (in this order).

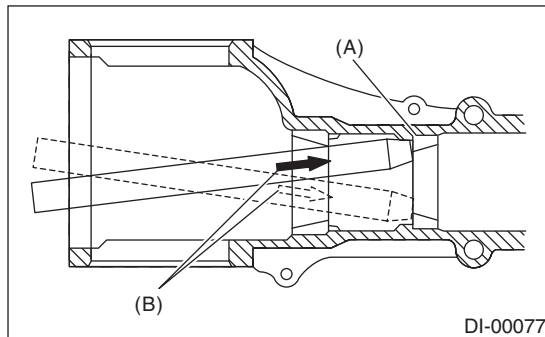

- (A) 2 cutout portions along diagonal lines
- (B) Tap alternately with brass bar.

## D: ASSEMBLY

### 1. T-TYPE (B2)

**NOTE:**

- Assemble in the reverse order of disassembly.
- Check and adjust each part during assembly.
- Keep the shims and washers in order, so that they are not improperly installed.
- Thoroughly clean the surfaces on which the shims, washers and bearings are to be installed.
- Apply gear oil when installing the bearings and thrust washers.
- Be careful not to mix up the RH and LH bearing races.
- Use a new O-ring and gasket.
- Replace the oil seal with a new part at every disassembly.
- Be careful not to mix up the oil seal RH and LH.
- Apply differential gear oil to the lips when installing the oil seal.

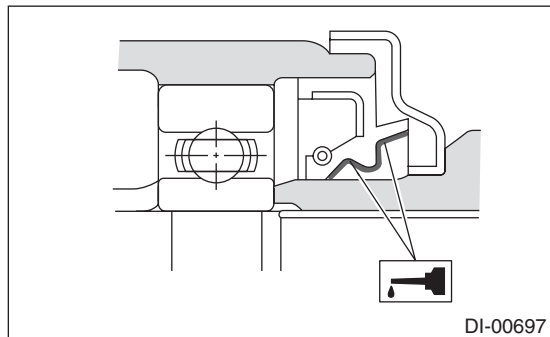

#### 1) Adjusting preload for front and rear bearings

**NOTE:**

Adjust the bearing preload between front and rear bearings with spacer and washer. Pinion height adjusting washer is not affected by this adjustment. The adjustment must not be carried out with oil seal inserted.

(1) Install the rear bearing race into the differential carrier using ST1 and ST2.

- ST1 398477701 HANDLE  
ST2 398477703 DRIFT 2

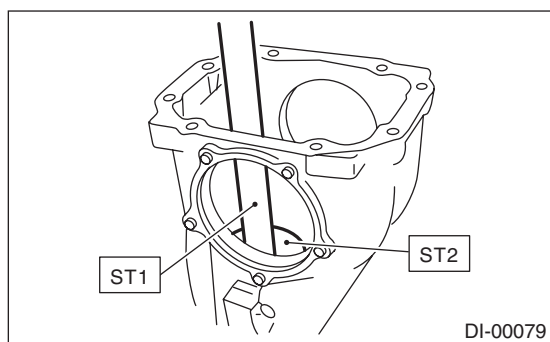

(2) Install the front bearing race to the differential carrier using ST1 and ST2.

- ST1 398477701 HANDLE  
ST2 398477702 DRIFT

(3) Insert the ST1 (DUMMY SHAFT) into carrier with the pinion height adjusting washer and rear bearing cone fitted onto it.

**NOTE:**

- If tooth contact (drive pinion, hypoid driven gear) is normal in the inspection before disassembling, verify that the washer is not deformed, and then re-use the used washer.
- Use new rear bearing cone.

(4) Install the preload adjusting spacer and washer, front bearing cone, ST2, companion flange and self-locking nut.

- ST1 398507702 DUMMY SHAFT  
ST2 398507703 DUMMY COLLAR

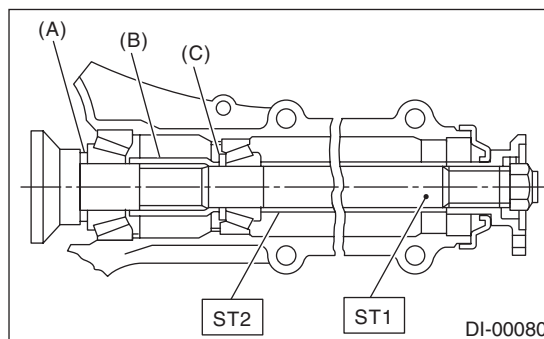

- (A) Pinion height adjusting washer  
(B) Preload adjusting spacer  
(C) Preload adjusting washer

(5) Turn the ST1 by hand to smooth the bearing, and tighten the self-locking nut while measuring the initial load or initial torque with a spring scale or torque wrench. Select the preload adjusting washer and spacer so that the specified preload is obtained when nut is tightened to the specified torque.

# Rear Differential (T-type)

## DIFFERENTIALS

### NOTE:

- Use a new self-locking nut.
- Measure the preload in direction of tangent to the flange.
- Be careful not to give excessive preload.
- When tightening the self-locking nut, lock ST1 with ST2 as shown in the figure.

ST1 398507702 DUMMY SHAFT

ST2 398507704 BLOCK

### Tightening torque:

**181.5 N·m (18.5 kgf-m, 133.9 ft-lb)**

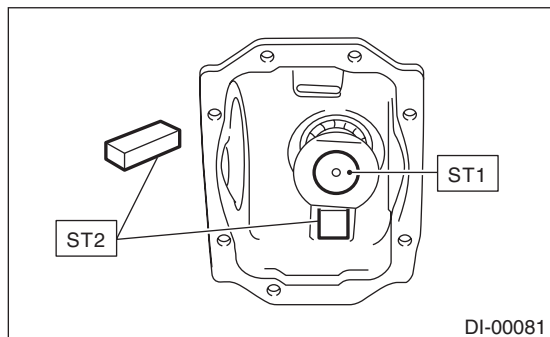

### Initial load:

**18.1 — 38.8 N (1.8 — 4.0 kgf, 4.1 — 8.7 lbf)**

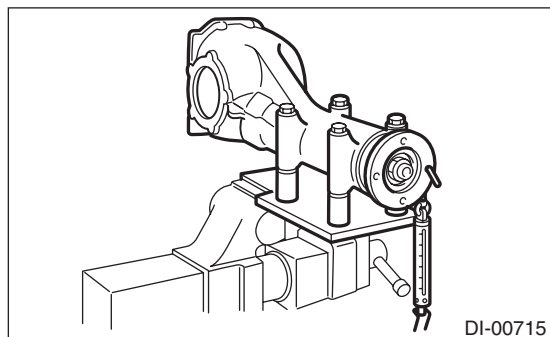

### Initial torque:

**0.69 — 1.47 N·m (0.07 — 0.15 kgf-m, 0.51 — 1.08 ft-lb)**

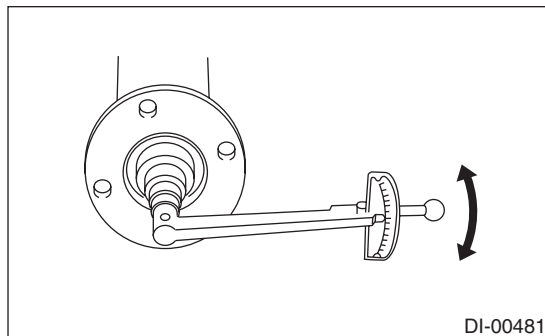

### Preload adjusting washer

Part No.	Thickness mm (in)
383705200	2.59 (0.1020)
383715200	2.57 (0.1012)
383725200	2.55 (0.1004)
383735200	2.53 (0.0996)
383745200	2.51 (0.0988)
383755200	2.49 (0.0980)
383765200	2.47 (0.0972)
383775200	2.45 (0.0965)
383785200	2.43 (0.0957)
383795200	2.41 (0.0949)
383805200	2.39 (0.0941)
383815200	2.37 (0.0933)
383825200	2.35 (0.0925)
383835200	2.33 (0.0917)
383845200	2.31 (0.0909)

### Preload adjusting spacer

Part No.	Length mm (in)
383695201	56.2 (2.213)
383695202	56.4 (2.220)
383695203	56.6 (2.228)
383695204	56.8 (2.236)
383695205	57.0 (2.244)
383695206	57.2 (2.252)



# Rear Differential (T-type)

2) Adjusting drive pinion height:  
Adjust the drive pinion height with pinion height adjusting washer installed between the rear bearing cone and the back of pinion gear.

(1) Attach the ST2.

**NOTE:**

At this time, install a provisionally selected or previously used pinion height adjusting washer. Measure and record the thickness.

- ST1 398507702 DUMMY SHAFT
- ST2 398507701 DIFFERENTIAL CARRIER GAUGE
- ST3 398507703 DUMMY COLLAR

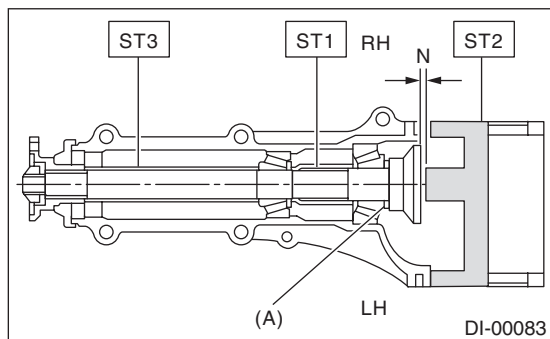

(A) Pinion height adjusting washer

(2) Measure the clearance “N” between the end of ST2 and the end surface of ST1 by using a thickness gauge.

**NOTE:**

Make sure there is no clearance between the differential carrier and ST2.

- ST1 398507702 DUMMY SHAFT
- ST2 398507701 DIFFERENTIAL CARRIER GAUGE

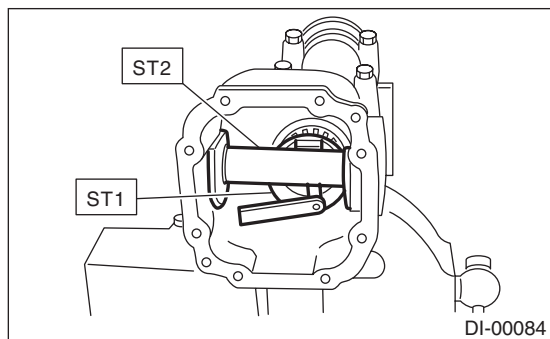

(3) Obtain the thickness of pinion height adjusting washer to be inserted from the following formula, and replace the temporarily installed washer with this one.

$$T = T_o + N - (H \times 0.01) - 0.20 \text{ mm (0.0079 in)}$$

T	Thickness of pinion height adjusting washer mm (in)
T <sub>o</sub>	Thickness of washer temporarily inserted mm (in)
N	Clearance of thickness gauge mm (in)
H	Figure marked on drive pinion head
Memo:	

(Example of calculation)

$$T_o = 3.39 \text{ mm (0.1335 in)}$$

$$N = 0.24 \text{ mm (0.0094 in)}$$

$$H = + 1$$

$$T = 3.39 \text{ mm (0.1335 in)} + 0.24 \text{ mm (0.0094 in)} - 0.01 \text{ mm (0.0004 in)} - 0.20 \text{ mm (0.0079 in)} = 3.42 \text{ mm (0.1346 in)}$$

Result: Thickness = 3.42 mm (0.1346 in)

Therefore use washer 383605200.

Pinion height adjusting washer	
Part No.	Thickness mm (in)
383495200	3.09 (0.1217)
383505200	3.12 (0.1228)
383515200	3.15 (0.1240)
383525200	3.18 (0.1252)
383535200	3.21 (0.1264)
383545200	3.24 (0.1276)
383555200	3.27 (0.1287)
383565200	3.30 (0.1299)
383575200	3.33 (0.1311)
383585200	3.36 (0.1323)
383595200	3.39 (0.1335)
383605200	3.42 (0.1346)
383615200	3.45 (0.1358)
383625200	3.48 (0.1370)
383635200	3.51 (0.1382)
383645200	3.54 (0.1394)
383655200	3.57 (0.1406)
383665200	3.60 (0.1417)
383675200	3.63 (0.1429)
383685200	3.66 (0.1441)



# Rear Differential (T-type)

## DIFFERENTIALS

3) Install the selected pinion height adjusting washer on drive pinion, and press the rear bearing cone into position with ST.

ST 398177700 INSTALLER

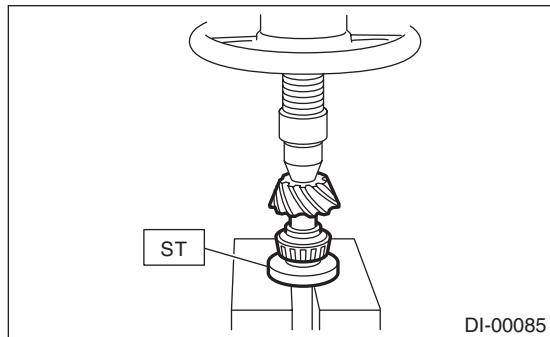

4) Insert the drive pinion into the differential carrier, and install the preselected preload adjusting spacer and washer.

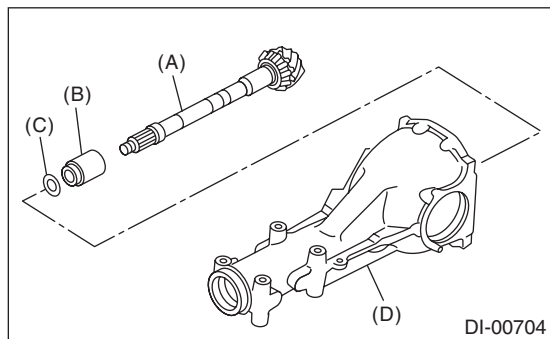

- (A) Drive pinion
- (B) Preload adjusting spacer
- (C) Preload adjusting washer
- (D) Differential carrier

5) Press-fit the front bearing cone with ST1, ST2 and ST3.

ST1 398507703 DUMMY COLLAR  
ST2 399780104 WEIGHT  
ST3 899580100 INSTALLER

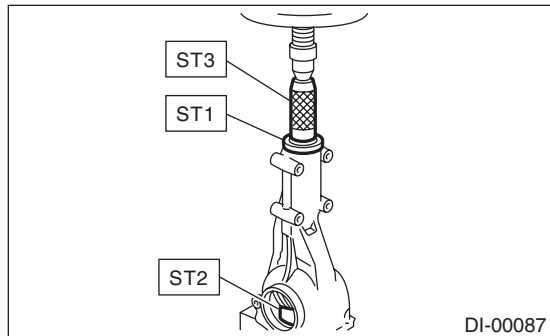

6) Insert the spacer, then press-fit the pilot bearing with ST1 and ST2.

ST1 399780104 WEIGHT  
ST2 899580100 INSTALLER

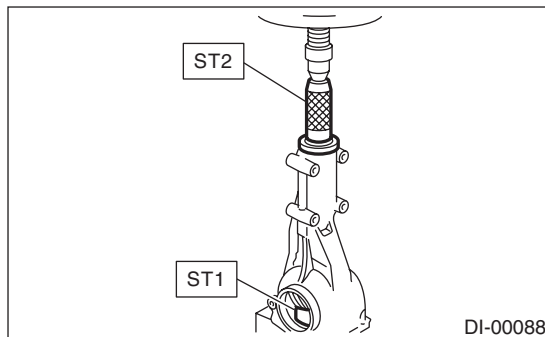

7) Using the ST, install the oil seal.

NOTE:

- Use a new oil seal.
- Press-fit until the oil seal end comes 1 mm (0.04 in) inward from end of carrier.
- Apply differential gear oil to the oil seal lips.

ST 498447120 INSTALLER

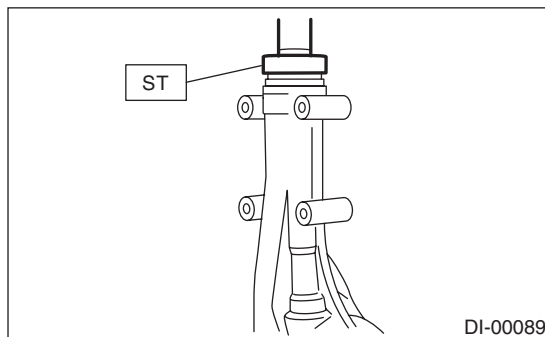

8) Press-fit the companion flange with ST1 and ST2.

NOTE:

Be careful not to damage the bearing.

ST1 899874100 INSTALLER  
ST2 399780104 WEIGHT

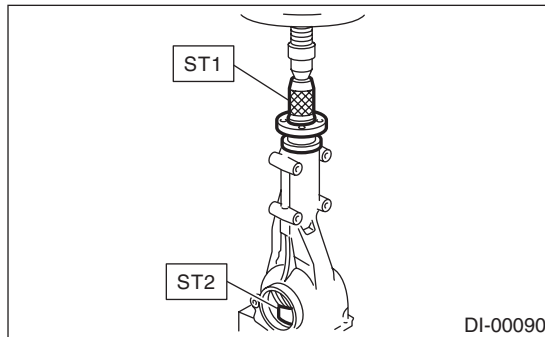

9) Apply seal material on the drive pinion shaft thread and new self-locking nut seat.

**Seal material:**

**THREE BOND 1324 (Part No. 004403042) or equivalent**

10) Attach the new self-locking nut and use the ST to fix the companion flange in place, then tighten the self-locking nut.

**Tightening torque:**

**181.5 N·m (18.5 kgf·m, 133.9 ft·lb)**

ST 498427200 FLANGE WRENCH

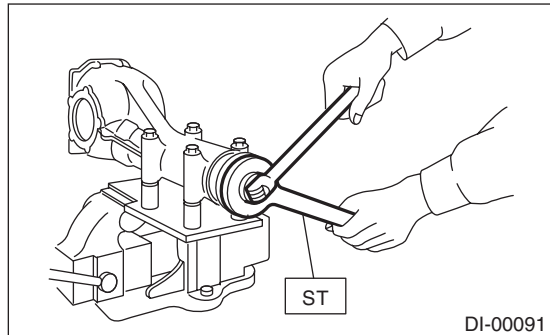

11) Check the initial torque or initial load.

**Initial load:**

**18.1 — 38.8 N (1.8 — 4.0 kgf, 4.1 — 8.7 lbf)**

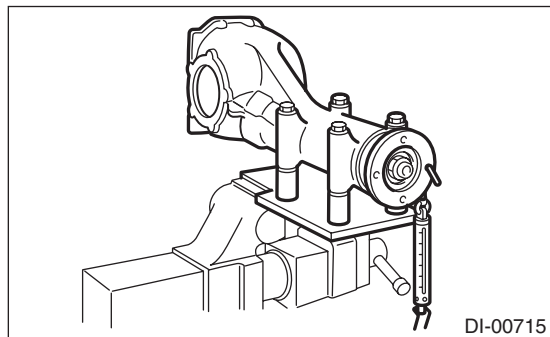

**Initial torque:**

**0.69 — 1.47 N·m (0.07 — 0.15 kgf·m, 0.51 — 1.08 ft·lb)**

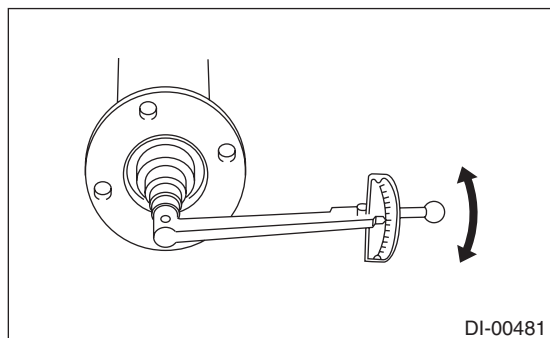

12) Assembling differential case

Install the side gears and pinion mate gears, with their side gear thrust washers and pinion mate shaft, into the differential case.

**NOTE:**

- Apply gear oil on both sides of the washer and on the side gear shaft before installing.
- Insert the pinion mate shaft into the differential case by aligning the lock pin holes.

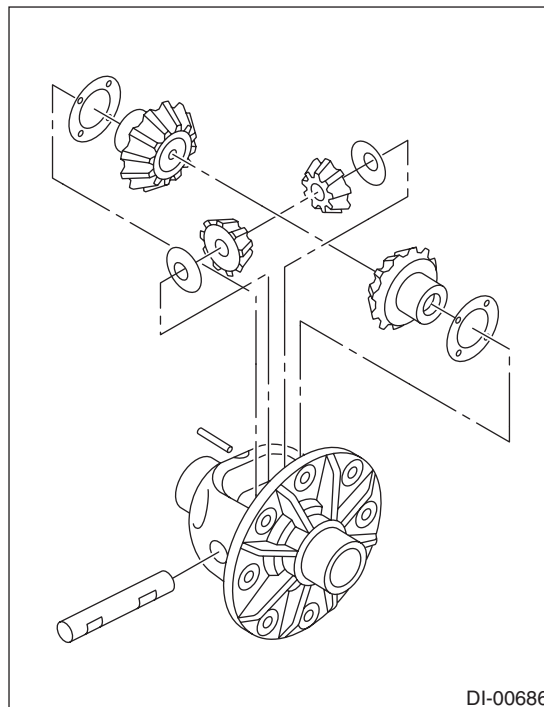

(1) Measure the side gear backlash.

**Side gear backlash:**

**0.10 — 0.20 mm (0.004 — 0.008 in)**

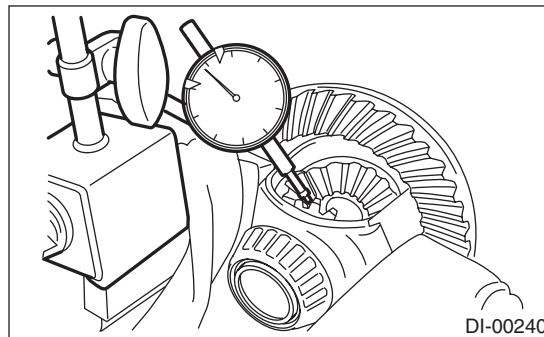

(2) Adjust the backlash as specified by selecting side gear thrust washer.

Side gear thrust washer	
Part No.	Thickness mm (in)
383445201	0.75 — 0.80 (0.0295 — 0.0315)
383445202	0.80 — 0.85 (0.0315 — 0.0335)
383445203	0.85 — 0.90 (0.0335 — 0.0354)

(3) Check the condition of rotation after applying oil to the gear tooth surfaces and thrust washer surfaces.

(4) Drive the pinion shaft lock pin into the differential case.

## Rear Differential (T-type)

### DIFFERENTIALS

13) Install the driven gear to the differential case.

**NOTE:**

- Before installing bolts, apply seal material to bolt threads.

**Seal material:**

**THREE BOND 1324 (Part No. 004403042) or equivalent**

- Make sure there is no clearance between the differential case and driven gear.
- Tighten opposing bolts in order.

**Tightening torque:**

**103 N·m (10.5 kgf·m, 76.0 ft·lb)**

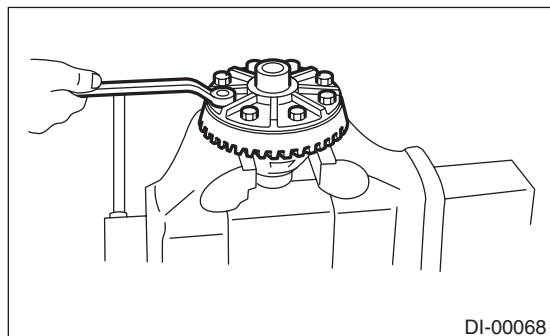

14) Using the ST, press-fit the side bearing cone to the differential case.

ST 398487700 DRIFT

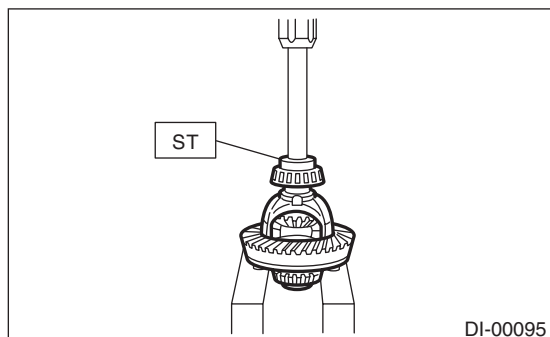

15) Using the ST, press-fit the side bearing outer race to the side retainer.

**CAUTION:**

**Make sure that the bearing outer races and cones are properly assembled.**

ST 398417700 DRIFT

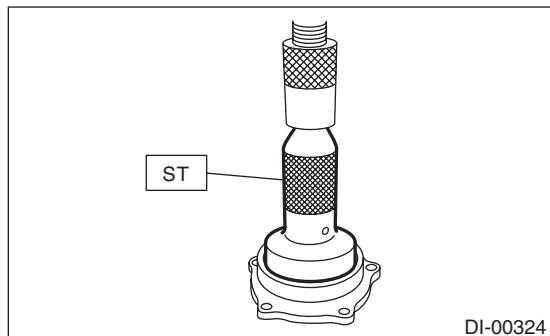

16) Side retainer shim adjustment

(1) The hypoid driven gear backlash and side bearing preload can be adjusted by the side retainer shim thickness.

(2) Install the differential case assembly into differential carrier in the reverse order of disassembly.

**NOTE:**

Be careful not to hit the teeth of hypoid driven gear against the differential carrier.

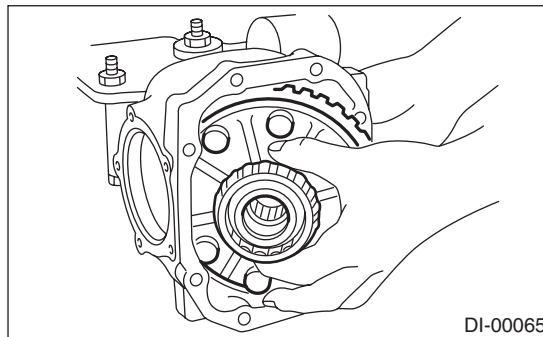

(3) Install the side retainer shim.

**NOTE:**

- Be careful not to mix up the side retainer shim RH and LH.
- Replace broken or corroded side retainer shims with a new part of the same thickness.

Side retainer shim	
Part No.	Thickness mm (in)
383475201	0.20 (0.0079)
383475202	0.25 (0.0098)
383475203	0.30 (0.0118)
383475204	0.40 (0.0157)
383475205	0.50 (0.0197)

(4) Align the arrow mark on the differential carrier with the arrow mark on the side retainer when installing the side retainer.

**NOTE:**

Be careful that the side bearing outer race is not damaged by the bearing roller.

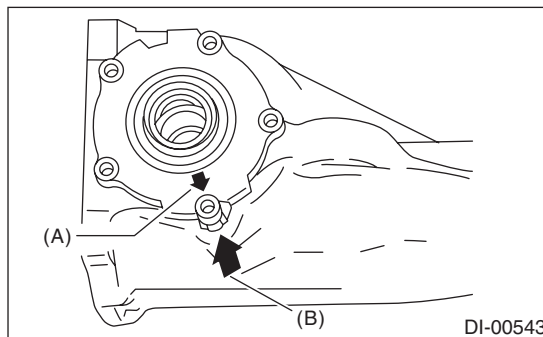

(A) Arrow mark (on the side retainer)

(B) Arrow mark (on the differential carrier)

(5) Tighten the side retainer bolts.

**Tightening torque:**

**10.5 N·m (1.1 kgf·m, 7.7 ft·lb)**

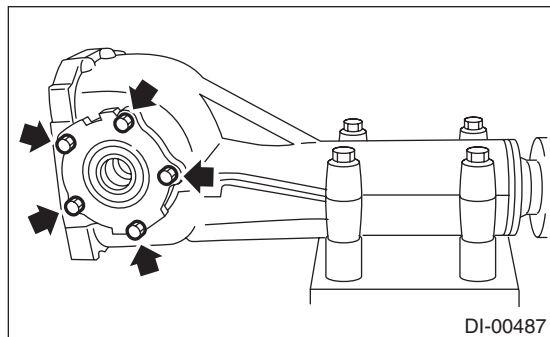

(6) Measure the hypoid driven gear to drive pinion backlash. Set the magnet base on differential carrier. Align the contact point of dial gauge with tooth face of hypoid driven gear, and move hypoid driven gear while holding drive pinion still. Read the value indicated on dial gauge. If the backlash is outside the standard range, adjust the side retainer shim by the following method.

•When backlash is less than 0.1 mm (0.004 in):

Reduce the thickness of shim on the back side of the hypoid driven gear and increase the thickness of shims on the teeth side of the hypoid driven gear.

•When backlash exceeds 0.2 mm (0.008 in):

Increase the thickness of shim on the back side of the hypoid driven gear and reduce the thickness of shims on the teeth side of the hypoid driven gear.

**Backlash:**

**0.10 — 0.20 mm (0.004 — 0.008 in)**

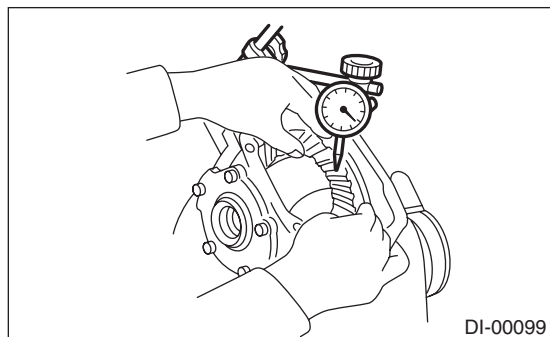

(7) Measure the total preload of the drive pinion. If the total preload is not within specification, adjust the thickness of side retainer shims, increasing/reducing both shims by an even amount at a time.

**Total preload:**

**20.7 — 54.4 N (2.1 — 5.5 kgf, 4.7 — 12.2 lbf)**

17) Recheck the hypoid driven gear to drive pinion backlash.

**Backlash:**

**0.10 — 0.20 mm (0.004 — 0.008 in)**

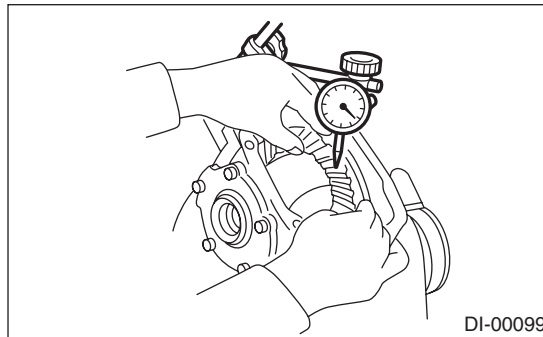

18) Check pinion and hypoid driven gears rotate smoothly and make sure of the hypoid driven gear runout on its back surface. If the hypoid driven gear runout on its back surface exceeds the specification, check for any foreign objects between the hypoid driven gear and differential case, and for any deformation of the case or gear.

**Hypoid driven gear back surface runout:**

**0.05 mm (0.002 in)**

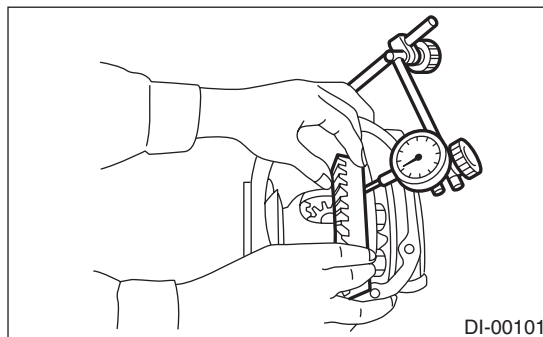

19) Check and adjustment of the tooth contact of hypoid driven gear and drive pinion

(1) Apply lead-free red dye evenly on the both sides of three to four teeth of the hypoid driven gear. Check the contact pattern after rotating the hypoid driven gear several revolutions back and forth until a definite contact pattern appears on the hypoid driven gear.

(2) When the contact pattern is not correct, re-adjust.

**NOTE:**

Be sure to wipe off the lead-free red dye completely after the adjustment is completed.

# Rear Differential (T-type)

## DIFFERENTIALS

- Correct tooth contact

**Check item: Tooth contact pattern is slightly shifted toward toe side under no-load rotation. (When driving, it moves towards the heel side.)**

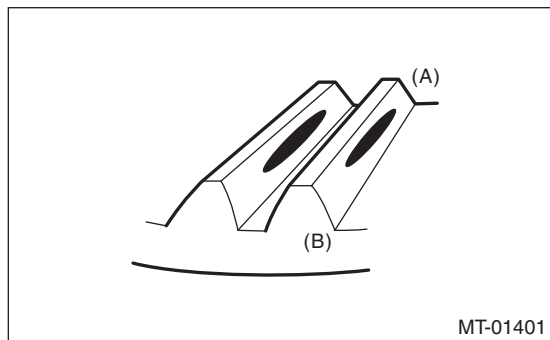

- (A) Toe side
- (B) Heel side

- Face contact

**Check item: Backlash is too large.**  
Contact pattern

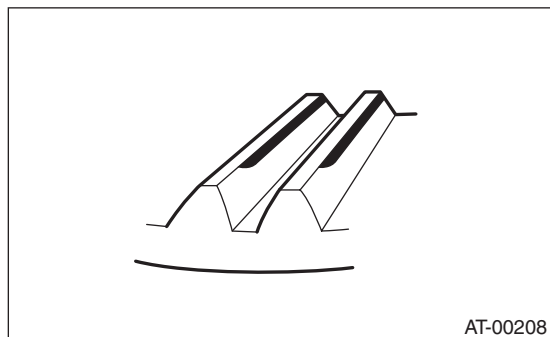

Corrective action: Increase thickness of pinion height adjusting washer according to the procedure for bringing drive pinion close to hypoid driven gear side.

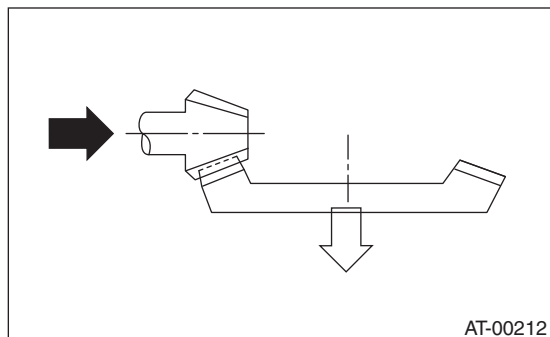

- Flank contact

**Check item: Backlash is too small.**  
Contact pattern

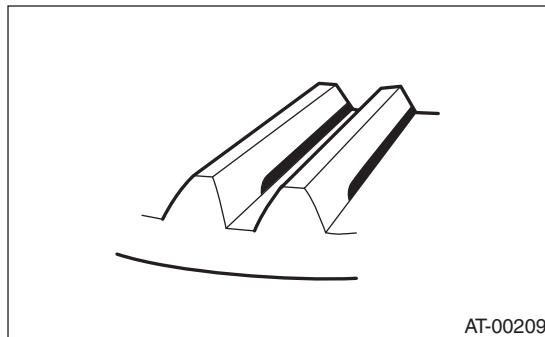

Corrective action: Reduce the thickness of pinion height adjusting washer according to the procedure for bringing drive pinion away from hypoid driven gear.

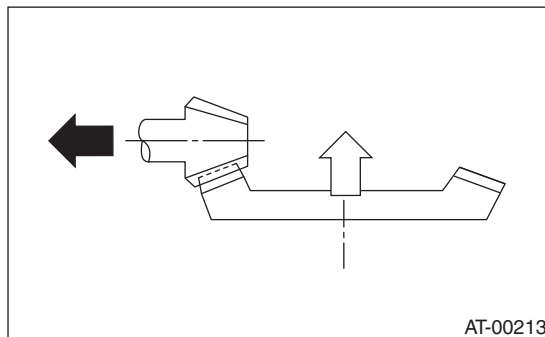

- Toe contact (inside contact)

**Check item: Teeth contact area is too small.**  
Contact pattern

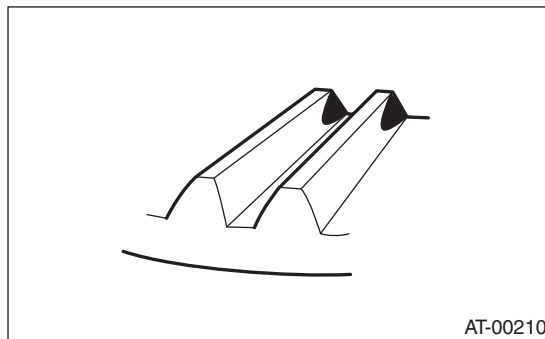

Corrective action: Reduce the thickness of pinion height adjusting washer according to the procedure for bringing drive pinion away from hypoid driven gear.

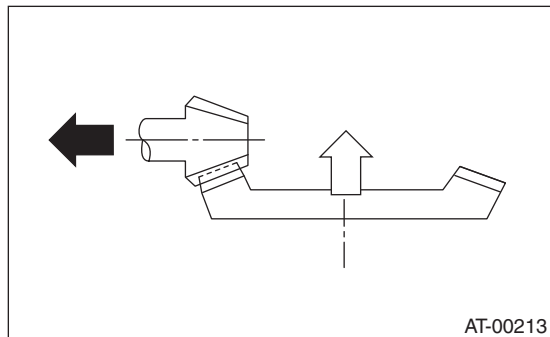

• Heel contact (outside end contact)  
**Check item: Teeth contact area is too small.**  
 Contact pattern

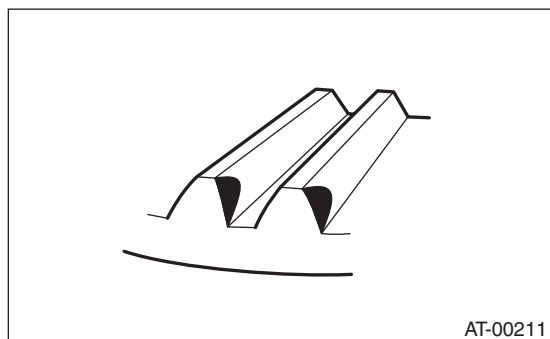

Corrective action: Increase thickness of pinion height adjusting washer according to the procedure for bringing drive pinion close to hypoid driven gear side.

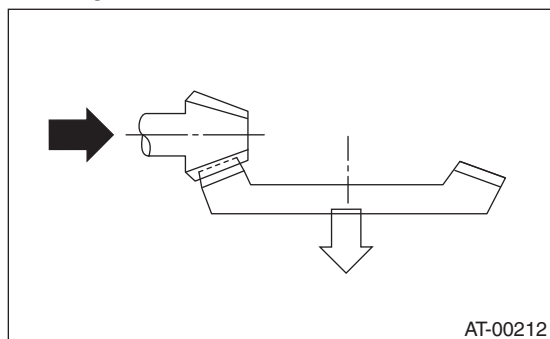

20) If proper tooth contact is not obtained, readjust the drive pinion height by changing the RH and LH side retainer shims and the hypoid gear backlash.

(1) Drive pinion height

- ST1 398507702 DUMMY SHAFT
- ST2 398507701 DIFFERENTIAL CARRIER GAUGE

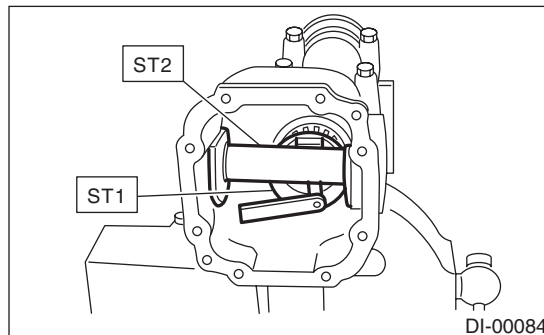

$$T = T_o + N - (H \times 0.01) - 0.20 \text{ mm (0.008 in)}$$

T	Thickness of pinion height adjusting washer mm (in)
T <sub>o</sub>	Thickness of washer temporarily inserted mm (in)
N	Clearance of thickness gauge mm (in)
H	Figure marked on drive pinion head

(2) Hypoid gear backlash

**Backlash:**

**0.10 — 0.20 mm (0.004 — 0.008 in)**

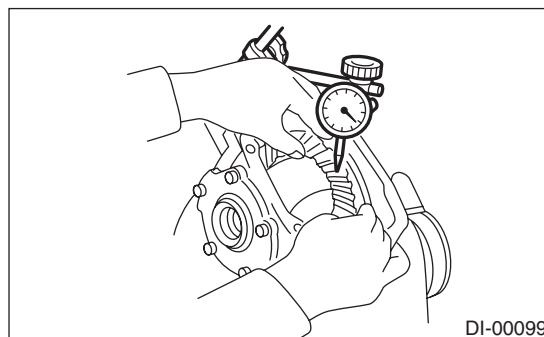

- 21) Remove the RH and LH side retainers.
- 22) Install the O-ring to left and right side retainers.

**NOTE:**

Use new O-rings.

23) Install the oil seal to the side retainer of both sides. <Ref. to DI-54, REPLACEMENT, Rear Differential Side Oil Seal.>



## Rear Differential (T-type)

### DIFFERENTIALS

24) Align the arrow mark on the differential carrier with the arrow mark on the side retainer when installing the side retainer.

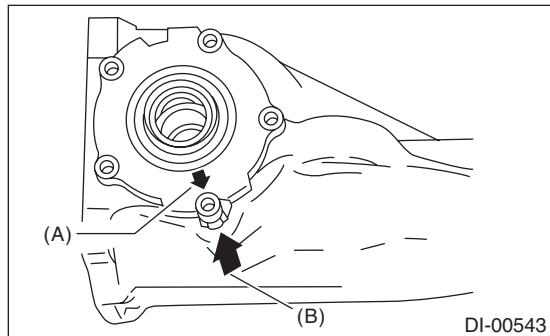

- (A) Arrow mark (on the side retainer)  
(B) Arrow mark (on the differential carrier)

25) Apply liquid gasket to the bolts indicated by arrows, and tighten the bolts.

#### **Liquid gasket:**

**THREE BOND 1110B (Part No. K0879Y0020) or equivalent**

#### **Tightening torque:**

**10.5 N·m (1.1 kgf-m, 7.7 ft-lb)**

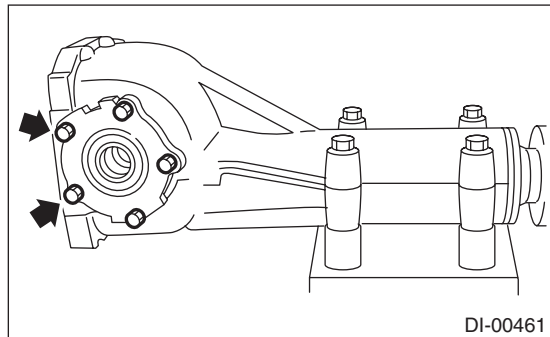

26) Install the gasket and rear cover, and tighten the bolts to specified torque.

#### **NOTE:**

Use a new gasket.

#### **Tightening torque:**

**29.5 N·m (3.0 kgf-m, 21.8 ft-lb)**

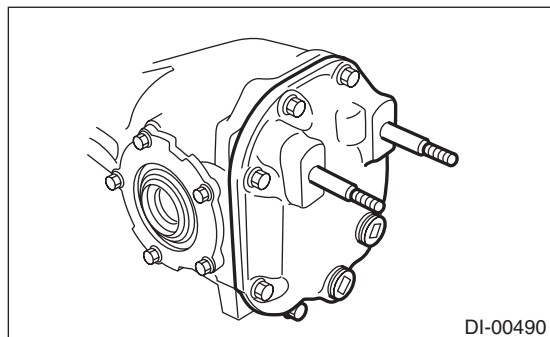

27) Install the air breather cap.

#### **NOTE:**

When installing the air breather cap, do not tap section (A). Be sure to tap section (B) to install.

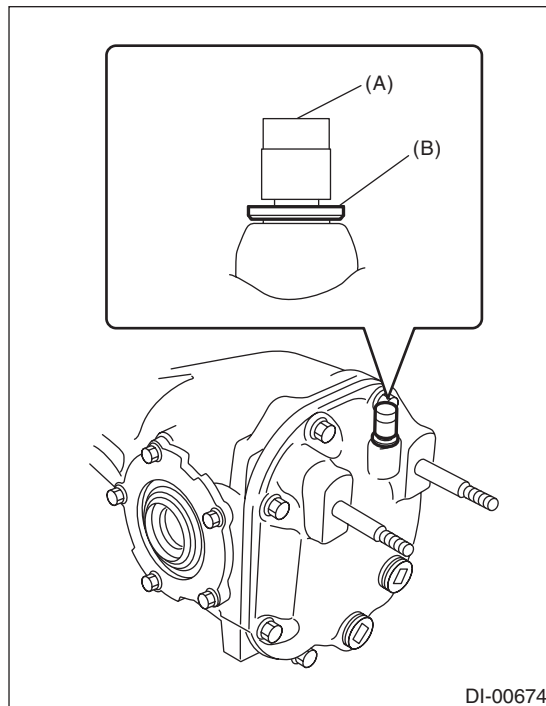

28) Install the drain plug.

#### **NOTE:**

Apply liquid gasket to the drain plug.

#### **Liquid gasket:**

**THREE BOND 1105 (Part No. 004403010) or equivalent**

#### **Tightening torque:**

**49 N·m (5.0 kgf-m, 36.1 ft-lb)**

29) Install the filler plug.

#### **NOTE:**

After installing the rear differential assembly to the vehicle, fill the gear oil, then apply liquid gasket, and tighten to the specified torque. <Ref. to DI-18, REPLACEMENT, Differential Gear Oil.>

## 2. T-TYPE (H3)

#### **NOTE:**

- Assemble in the reverse order of disassembly.
- Check and adjust each part during assembly.
- Keep the shims and washers in order, so that they are not improperly installed.
- Thoroughly clean the surfaces on which the shims, washers and bearings are to be installed.
- Apply gear oil when installing the bearings and thrust washers.
- Be careful not to mix up the RH and LH bearing races.
- Use a new O-ring and gasket.

- Replace the oil seal with a new part at every disassembly.
- Be careful not to mix up the oil seal RH and LH.
- Apply differential gear oil to the lips when installing the oil seal.

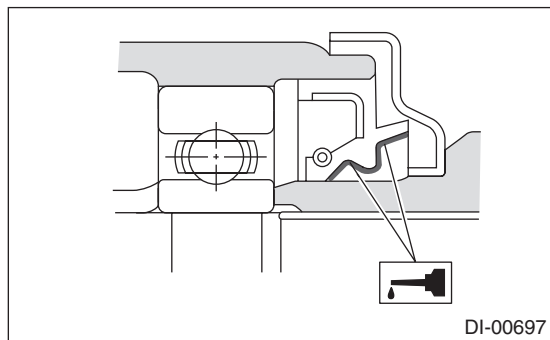

1) Adjusting preload for front and rear bearings

**NOTE:**

Adjust the bearing preload between front and rear bearings with spacer and washer. Pinion height adjusting washer is not affected by this adjustment. The adjustment must not be carried out with oil seal inserted.

2) Using the ST, press-fit the rear bearing race to the differential carrier.

ST 398417700 DRIFT

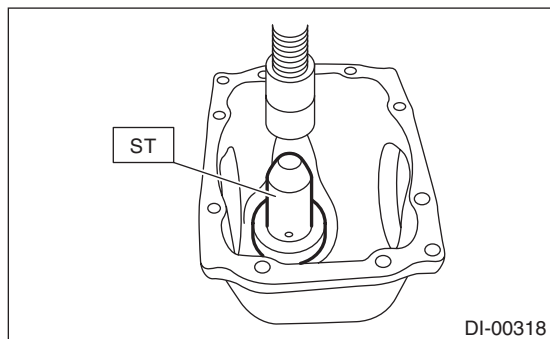

3) Using the ST, press-fit the front bearing race to the differential carrier.

ST 398477702 DRIFT

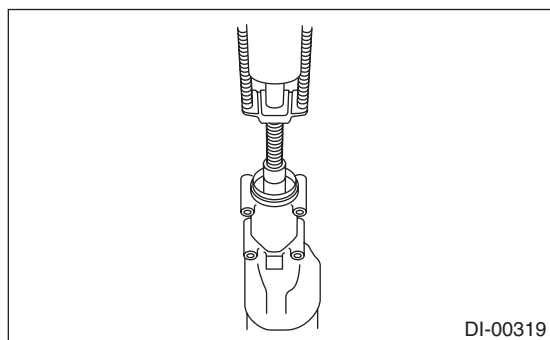

4) Selecting the pinion height adjusting washer

(1) Measure the thickness of the inserted pinion height adjusting washer.

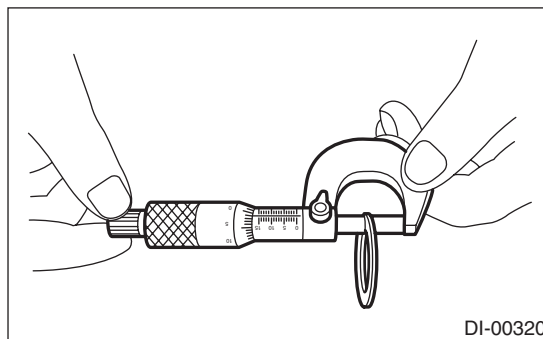

(2) Read the markings on both the current drive pinion gear and the new pinion gear.

**NOTE:**

No marking means 0 (zero).

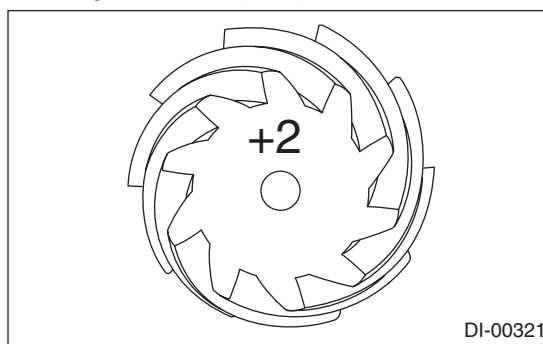

(3) Calculate the thickness of pinion height adjusting washer to be inserted from the following formula, and replace the installed washer with a new washer of the calculated thickness.

$$T = T1 + (T2 \times 0.01 - T3 \times 0.01)$$

T	Thickness of selected pinion height adjusting washer mm (in)
T1	Thickness of inserted pinion height adjusting washer mm (in)
T2	Number of the installed drive pinion gear marking mm (in)
T3	Number of new drive pinion gear marking mm (in)

(Example of calculation)

T1 = 3.30 mm (0.1299 in), T2 = +2, T3 = -1  
 $T = 3.30 \text{ mm (0.1299 in)} + \{(2 \times 0.01) - (-1 \times 0.01)\} = 3.33 \text{ mm (0.1311 in)}$   
 Result: Thickness = 3.33 mm (0.1311 in)  
 The washer with part number 38336AA310 is used.



# Rear Differential (T-type)

## DIFFERENTIALS

Pinion height adjusting washer	
Part No.	Thickness mm (in)
38336AA230	3.09 (0.1217)
38336AA240	3.12 (0.1228)
38336AA250	3.15 (0.1240)
38336AA260	3.18 (0.1252)
38336AA270	3.21 (0.1264)
38336AA280	3.24 (0.1276)
38336AA290	3.27 (0.1287)
38336AA300	3.30 (0.1299)
38336AA310	3.33 (0.1311)
38336AA320	3.36 (0.1323)
38336AA330	3.39 (0.1335)
38336AA340	3.42 (0.1346)
38336AA350	3.45 (0.1358)
38336AA360	3.48 (0.1370)
38336AA370	3.51 (0.1382)
38336AA380	3.54 (0.1394)
38336AA390	3.57 (0.1406)
38336AA400	3.60 (0.1417)
38336AA410	3.63 (0.1429)
38336AA420	3.66 (0.1441)

5) Install the selected pinion height adjusting washer on drive pinion, and push the rear bearing cone into position with ST.

ST 18674AA000 INSTALLER

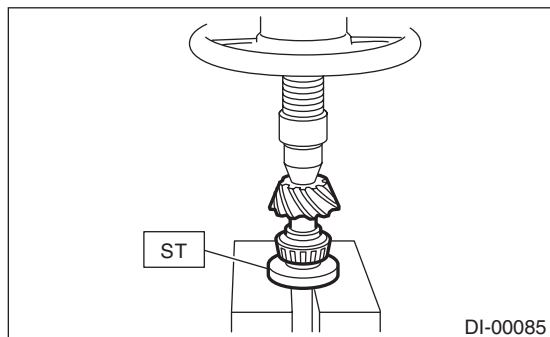

6) Insert the drive pinion into the differential carrier, and install the originally attached preload adjusting spacer and washer.

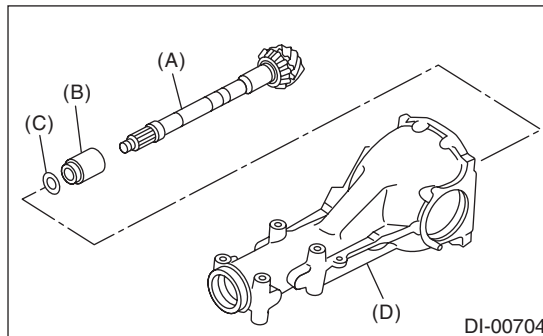

- (A) Drive pinion
- (B) Preload adjusting spacer
- (C) Preload adjusting washer
- (D) Differential carrier

7) Insert the spacer and press-fit the pilot bearing using ST.

- ST1 399780104 WEIGHT
- ST2 899580100 INSTALLER
- ST3 398507703 DUMMY COLLAR
- ST4 498937110 HOLDER DRIVE PINION

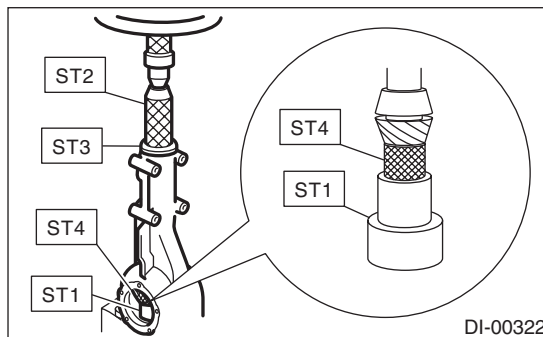

8) Press-fit the companion flange with ST1, ST2, and ST3.

NOTE:

Be careful not to damage the bearing.

- ST1 899874100 INSTALLER
- ST2 399780104 WEIGHT
- ST3 498937110 HOLDER DRIVE PINION

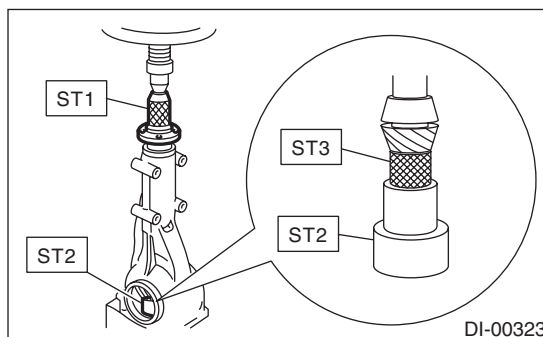

9) Attach the self-locking nut and use the ST to fix the companion flange in place, then tighten the self-locking nut.

**Tightening torque:**

**181.5 N·m (18.5 kgf·m, 133.9 ft·lb)**

ST 18633AA000 WRENCH COMPL

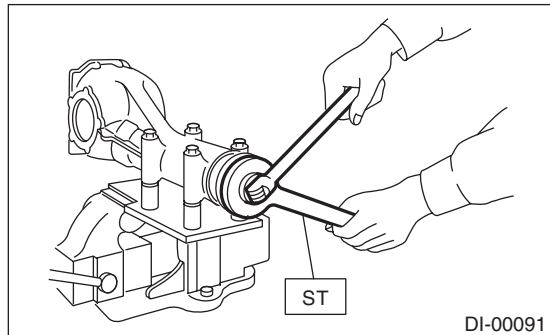

10) Rotate the drive pinion shaft 10 times or more to fit it in the respective taper roller bearing, and then measure the initial load or initial torque.

**Initial load:**

**24.1 — 38.6 N (2.5 — 3.9 kgf, 5.4 — 8.7 lbf)**

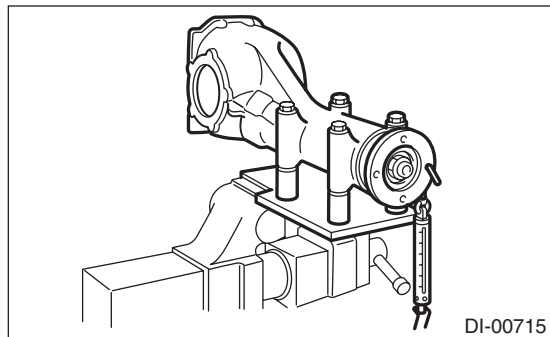

**Initial torque:**

**0.98 — 1.57 N·m (0.10 — 0.16 kgf·m, 0.72 — 1.16 ft·lb)**

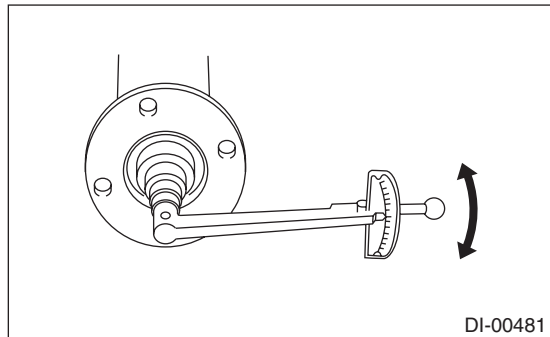

11) When the bearing preload is out of the specified range, select the preload adjusting washer and spacer from the following table in order to make it within the specified range.

Preload adjusting washer	
Part No.	Thickness mm (in)
383705200	2.59 (0.1020)
383715200	2.57 (0.1012)
383725200	2.55 (0.1004)
383735200	2.53 (0.0996)
383745200	2.51 (0.0988)
383755200	2.49 (0.0980)
383765200	2.47 (0.0972)
383775200	2.45 (0.0965)
383785200	2.43 (0.0957)
383795200	2.41 (0.0949)
383805200	2.39 (0.0941)
383815200	2.37 (0.0933)
383825200	2.35 (0.0925)
383835200	2.33 (0.0917)
383845200	2.31 (0.0909)

Preload adjusting spacer	
Part No.	Length mm (in)
31454AA130	52.2 (2.055)
31454AA140	52.4 (2.063)
31454AA150	52.6 (2.071)
31454AA160	52.8 (2.079)
31454AA170	53.0 (2.087)
31454AA180	53.2 (2.094)

12) Remove the self-locking nut while securing the companion flange with ST.

ST 18633AA000 WRENCH COMPL

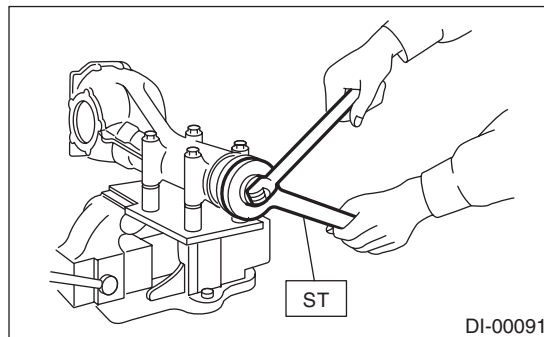

# Rear Differential (T-type)

## DIFFERENTIALS

13) Extract the companion flange with a puller.

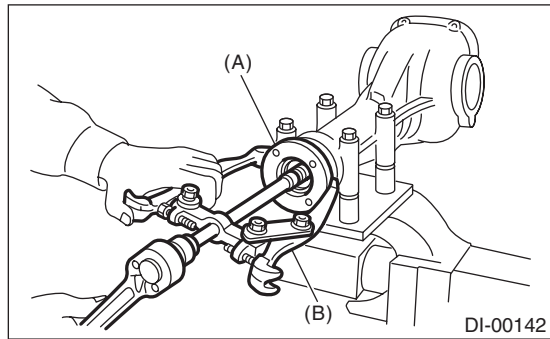

- (A) Companion flange
- (B) Puller

14) Using the ST, install the oil seal.

### NOTE:

- Use a new oil seal.
- Press-fit until the oil seal end comes 1 mm (0.04 in) inward from end of carrier.
- Apply differential gear oil to the oil seal lips.

ST 498447120 INSTALLER

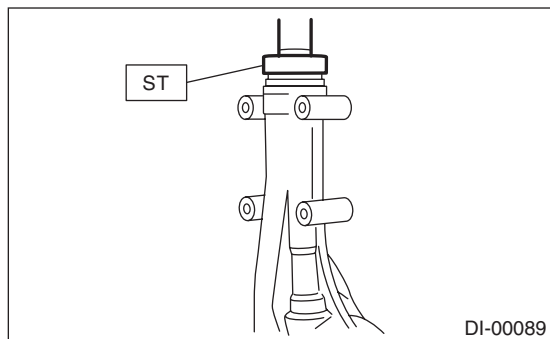

15) Press-fit the companion flange with ST1, ST2, and ST3.

ST1 899874100 INSTALLER

ST2 399780104 WEIGHT

ST3 498937110 HOLDER DRIVE PINION

### NOTE:

Be careful not to damage the bearing.

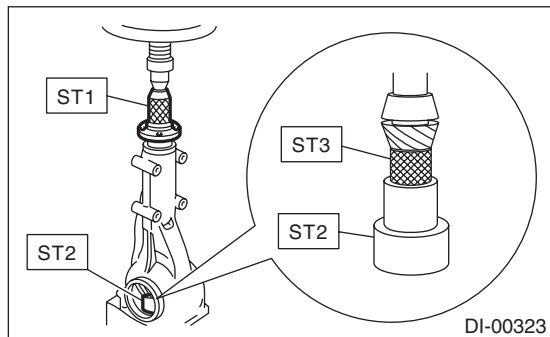

16) Apply seal material on the drive pinion shaft thread and new self-locking nut seat.

### Seal material:

**THREE BOND 1324 (Part No. 004403042) or equivalent**

17) Attach the new self-locking nut and use the ST to fix the companion flange in place, then tighten the self-locking nut.

### Tightening torque:

**181.5 N·m (18.5 kgf·m, 133.9 ft·lb)**

ST 18633AA000 WRENCH COMPL

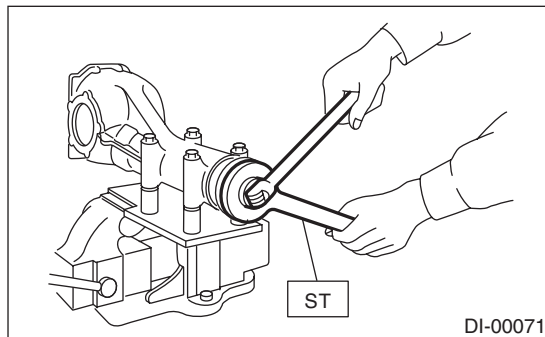

18) Check the initial torque or initial load.

### Initial load:

**24.1 — 38.6 N (2.5 — 3.9 kgf, 5.4 — 8.7 lbf)**

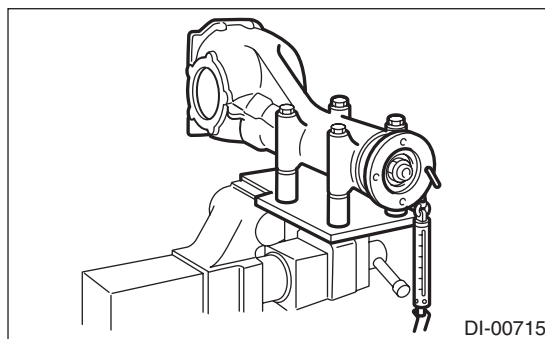

### Initial torque:

**0.98 — 1.57 N·m (0.10 — 0.16 kgf·m, 0.72 — 1.16 ft·lb)**

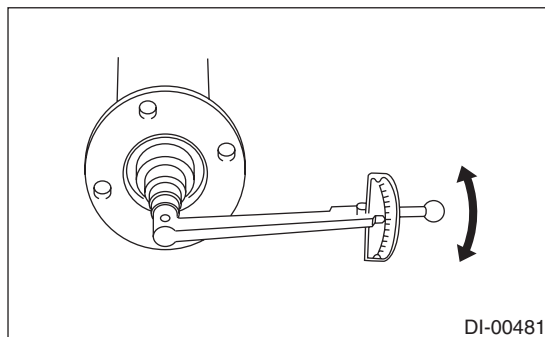

19) Install the driven gear to the differential case.

**NOTE:**

- Before installing bolts, apply seal material to bolt threads.

**Seal material:**

**THREE BOND 1324 (Part No. 004403042) or equivalent**

- Make sure there is no clearance between the differential case and driven gear.
- Tighten opposing bolts in order.

**Tightening torque:**

**103 N·m (10.5 kgf·m, 76.0 ft·lb)**

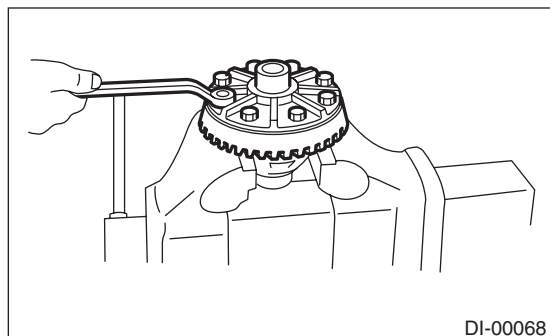

DI-00068

20) Using the ST, press-fit the side bearing to the differential case.

ST 398487700 DRIFT

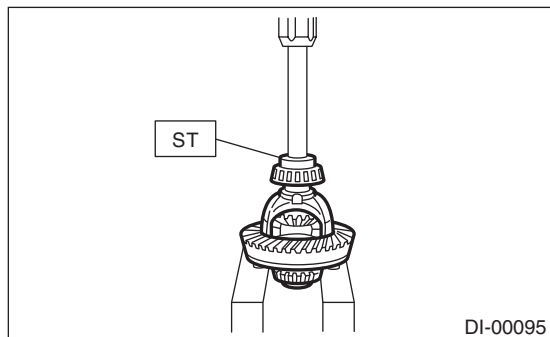

DI-00095

21) Using the ST, press-fit the side bearing outer race to the side retainer.

**CAUTION:**

**Make sure that the bearing outer races and cones are properly assembled.**

ST 398417700 DRIFT

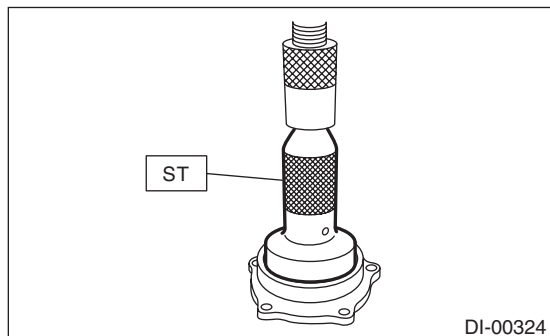

DI-00324

22) Side retainer shim adjustment

(1) The hypoid driven gear backlash and side bearing preload can be adjusted by the side retainer shim thickness.

(2) Install the differential case assembly into differential carrier in the reverse order of disassembly.

**NOTE:**

Be careful not to hit the teeth of hypoid driven gear against the differential carrier.

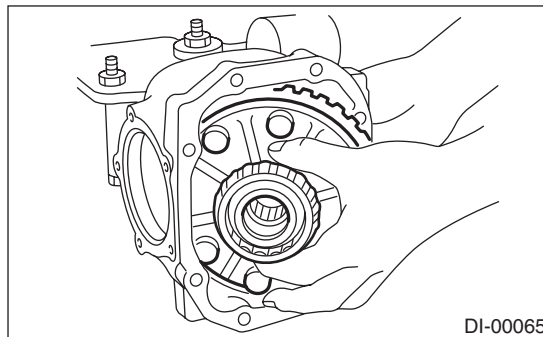

DI-00065

(3) Install the side retainer shim.

**NOTE:**

- Be careful not to mix up the side retainer shim RH and LH.
- Replace broken or corroded side retainer shims with a new part of the same thickness.

Side retainer shim	
Part No.	Thickness mm (in)
383475201	0.20 (0.0079)
383475202	0.25 (0.0098)
383475203	0.30 (0.0118)
383475204	0.40 (0.0157)
383475205	0.50 (0.0197)

(4) During installation, align the arrow mark on the differential carrier with the arrow mark on the side retainer when installing the side retainer.

**NOTE:**

Be careful that side bearing outer race is not damaged by the bearing roller.

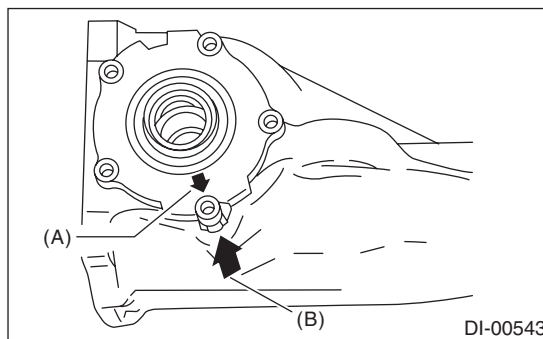

DI-00543

(A) Arrow mark (on the side retainer)

(B) Arrow mark (on the differential carrier)

## Rear Differential (T-type)

### DIFFERENTIALS

(5) Tighten the side retainer bolts.

#### **Tightening torque:**

**10.5 N·m (1.1 kgf·m, 7.7 ft·lb)**

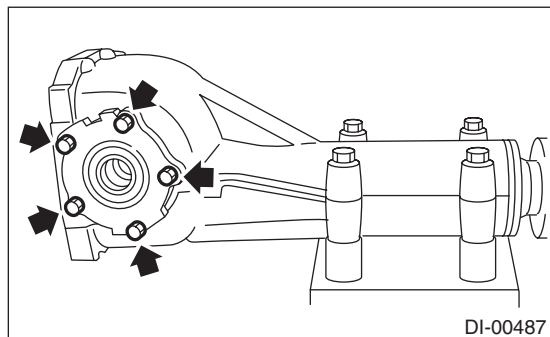

(6) Measure the hypoid driven gear to drive pinion backlash. Set the magnet base on differential carrier. Align the contact point of dial gauge with tooth face of hypoid driven gear, and move hypoid driven gear while holding drive pinion still. Read the value indicated on dial gauge. If the backlash is outside the standard range, adjust the side retainer shim by the following method.

- **When backlash is less than 0.1 mm (0.004 in):**

Reduce the thickness of shim on the back side of the hypoid driven gear and increase the thickness of shims on the teeth side of the hypoid driven gear.

- **When backlash exceeds 0.2 mm (0.008 in):**

Increase the thickness of shim on the back side of the hypoid driven gear and reduce the thickness of shims on the teeth side of the hypoid driven gear.

#### **Backlash:**

**0.10 — 0.20 mm (0.004 — 0.008 in)**

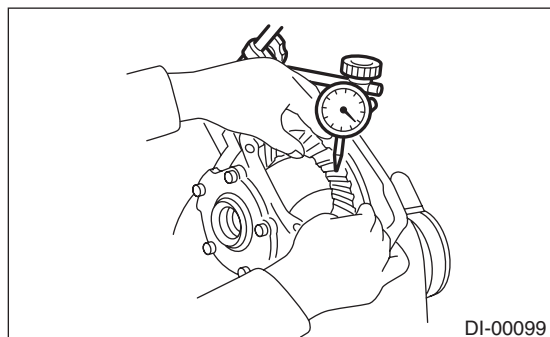

(7) Measure the total preload of the drive pinion. If the total preload is not within specification, adjust the thickness of side retainer shims, increasing/reducing both shims by an even amount on both sides.

#### **Total preload:**

**26.5 — 53 N (2.7 — 5.4 kgf, 6.0 — 11.9 lbf)**

23) Recheck the hypoid driven gear to drive pinion backlash.

#### **Backlash:**

**0.10 — 0.20 mm (0.004 — 0.008 in)**

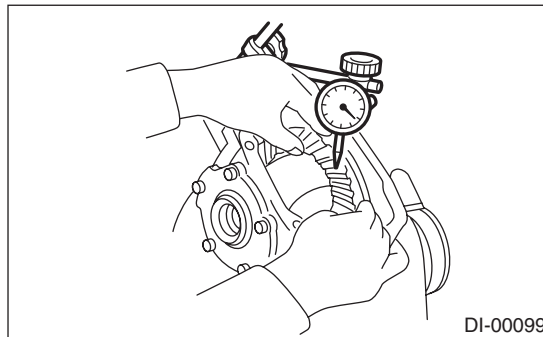

24) Check drive pinion and hypoid driven gears rotate smoothly and make sure of the hypoid driven gear runout on its back surface. If the runout on the back side of the hypoid driven gear exceeds the specification, check for any foreign material between the hypoid driven gear and differential case, and for any deformation of the case or gear.

#### **Hypoid driven gear back surface runout:**

**0.05 mm (0.002 in)**

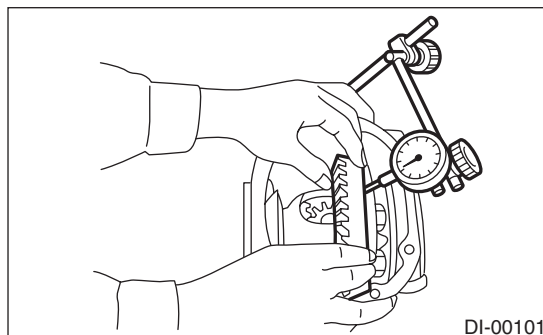

25) Checking and adjusting the tooth contact of hypoid driven gear

(1) Apply lead-free red dye evenly on the both sides of three to four teeth of the hypoid driven gear. Check the contact pattern after rotating the hypoid driven gear several revolutions back and forth until a definite contact pattern appears on the hypoid driven gear.

(2) When the contact pattern is not correct, re-adjust.

#### **NOTE:**

Be sure to wipe off the lead-free red dye completely after the adjustment is completed.

- Correct tooth contact

**Check item: Tooth contact pattern is slightly shifted toward toe side under no-load rotation. (When driving, it moves towards the heel side.)**

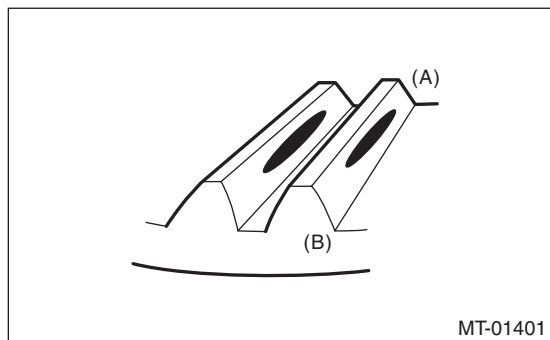

(A) Toe side  
(B) Heel side

- Face contact

**Check item: Backlash is too large.**  
Contact pattern

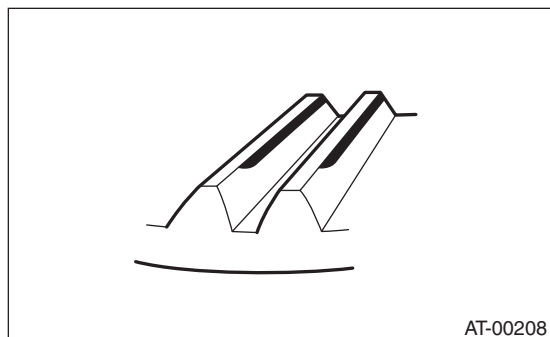

Corrective action: Increase thickness of pinion height adjusting washer according to the procedure for bringing drive pinion close to hypoid driven gear side.

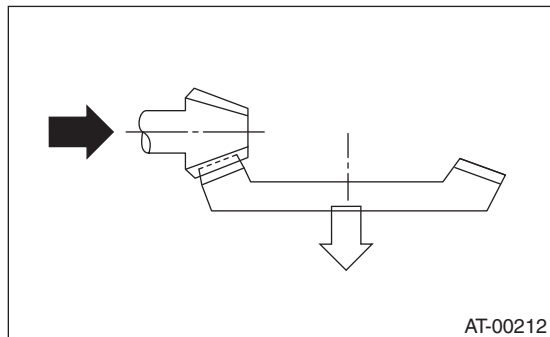

- Flank contact

**Check item: Backlash is too small.**  
Contact pattern

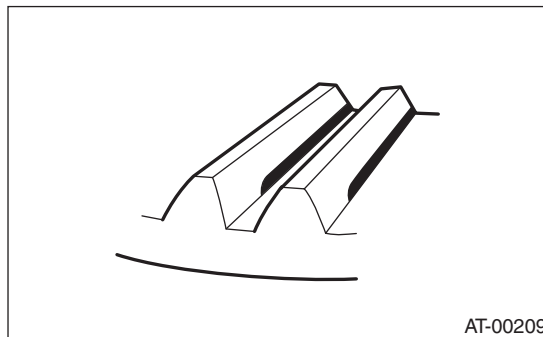

Corrective action: Reduce the thickness of pinion height adjusting washer according to the procedure for bringing drive pinion away from hypoid driven gear.

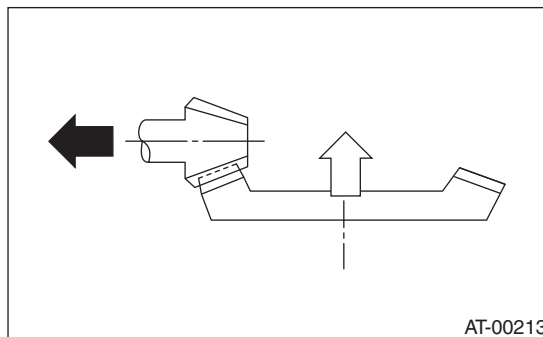

- Toe contact (inside contact)

**Check item: Teeth contact area is too small.**  
Contact pattern

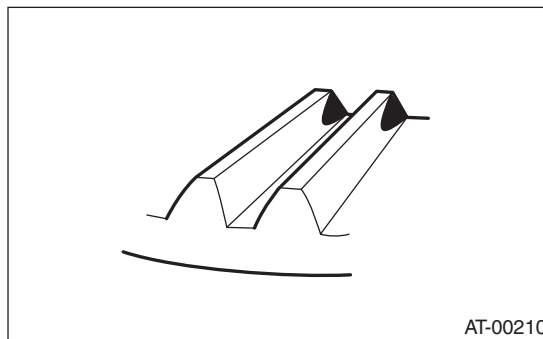

## Rear Differential (T-type)

### DIFFERENTIALS

Corrective action: Reduce the thickness of pinion height adjusting washer according to the procedure for bringing drive pinion away from hypoid driven gear.

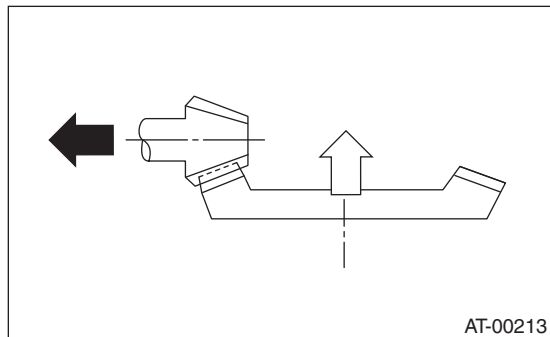

- Heel contact (outside end contact)

**Check item: Teeth contact area is too small.**

Contact pattern

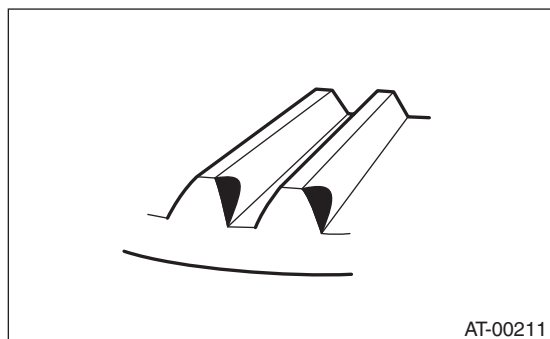

Corrective action: Increase thickness of pinion height adjusting washer according to the procedure for bringing drive pinion close to hypoid driven gear side.

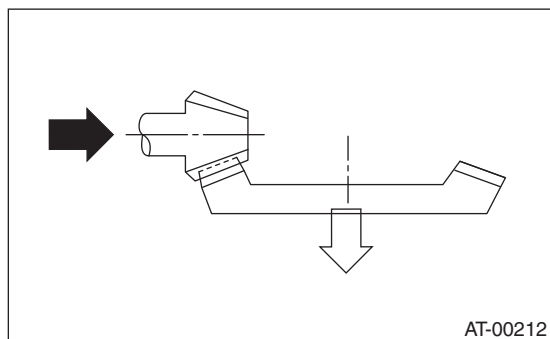

26) If proper tooth contact is not obtained, readjust the drive pinion height by changing the RH and LH side retainer shims and the hypoid gear backlash.

27) Remove the RH and LH side retainers.

28) Install the O-ring to left and right side retainers.

NOTE:

Use new O-rings.

29) Install the oil seal to the side retainer of both sides. <Ref. to DI-54, REPLACEMENT, Rear Differential Side Oil Seal.>

30) Align the arrow mark on the differential carrier with the arrow mark on the side retainer during installation.

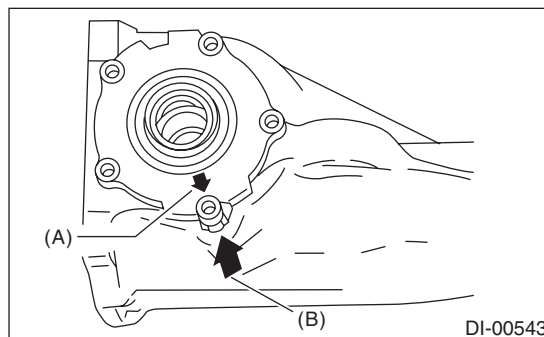

(A) Arrow mark (on the side retainer)

(B) Arrow mark (on the differential carrier)

31) Apply liquid gasket to the bolts indicated by arrows, and tighten the side retainer bolt.

**Liquid gasket:**

**THREE BOND 1110B (Part No. K0879Y0020) or equivalent**

**Tightening torque:**

**10.5 N·m (1.1 kgf·m, 7.7 ft·lb)**

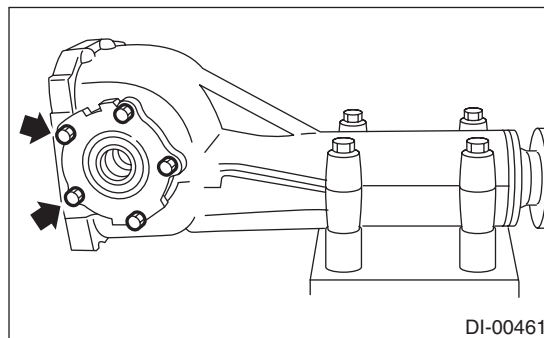

32) Install the gasket and rear cover, and tighten the bolts to specified torque.

NOTE:

Use a new gasket.

**Tightening torque:**

**44 N·m (4.5 kgf·m, 32.5 ft·lb)**

33) Install the air breather cap.



**NOTE:**

When installing the air breather cap, do not tap section (A). Be sure to tap section (B) to install.

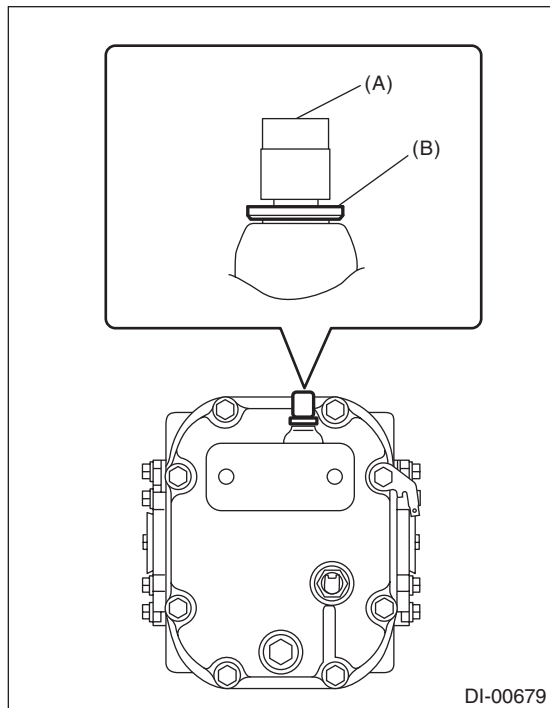

DI-00679

34) Install the drain plug.

**NOTE:**

Use a new gasket.

**Tightening torque:**

**60 N·m (6.1 kg·m, 44.3 ft·lb)**

35) Install the oil temperature switch.

**NOTE:**

- Install the oil temperature switch and adapter as a unit.
- After installing the rear differential assembly to the vehicle, fill the gear oil, then use a new gasket, and tighten to the specified torque. <Ref. to DI-18, REPLACEMENT, Differential Gear Oil.>

**E: INSPECTION**

Wash all the disassembled parts clean, and examine them for wear, damage and other defects. Repair or replace the defective parts as necessary.

1) Hypoid driven gear and drive pinion

- If there is evidently an abnormal tooth contact, find out the cause and adjust until the teeth contact correctly. Replace the gear if there is an excessive worn or an incapable adjustment.
- If crack, cutout or seizure is found, replace the parts as a set. Slight damage of some teeth can be corrected by oil stone or the like.

2) Side gear and pinion mate gear

- Replace if cracks, scoring or other defects are evident on the tooth surface.

- Replace if thrust washer contact surface is worn or seized. Slight damages of the surface can be corrected by oil stones or equivalent.

3) Bearing

Replace if seizure, peeling, wear, rust, dragging during rotation, noise or other defect is evident.

4) Thrust washer of the side gear and pinion mate gear

Replace if seized, flawed, abnormally worn or having other defects.

5) Oil seal

Replace if deformed or damaged, and at every disassembling.

6) Differential carrier

Replace if the bearing bores are worn or damaged.

7) Differential case

Replace if sliding surfaces are abnormally worn, burned, or cracked.

8) Companion flange

Replace if the oil seal lip contact surface shows cracking.

9) Rear differential oil temperature switch (T-type (H3))

Check the rear differential oil temperature switch for continuity.

Resistance	Criteria
Less than 1 Ω	Normal
1 MΩ or more	Replacement

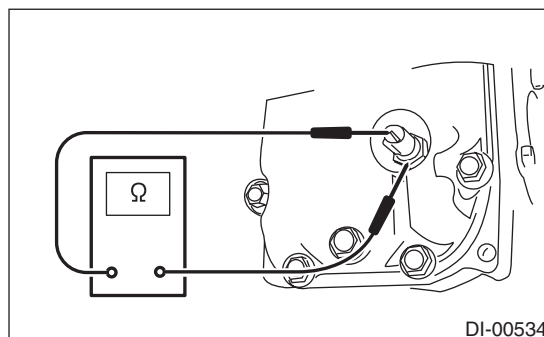

DI-00534



# Rear Differential (T-type)

## DIFFERENTIALS

### 1. SIDE GEAR BACKLASH (T-TYPE (B2))

Using a dial gauge, check the backlash of side gear.

#### **Side gear backlash:**

**0.10 — 0.20 mm (0.004 — 0.008 in)**

If the side gear backlash is not within the specification, select the side gear thrust washer and adjust the side gear backlash to the specification.

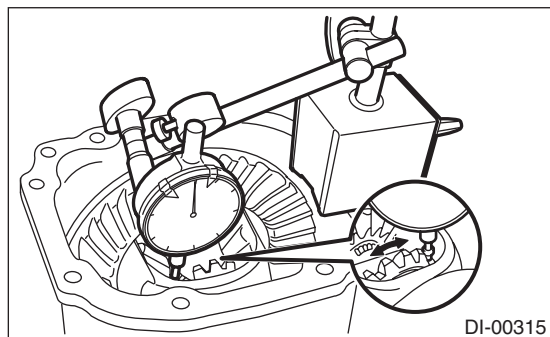

### 2. HYPOID DRIVEN GEAR BACKLASH

Using a dial gauge, check the backlash of hypoid driven gear.

#### **Hypoid driven gear backlash:**

**0.10 — 0.20 mm (0.004 — 0.008 in)**

If the hypoid driven gear backlash is not within the specification, adjust the side bearing preload or repair if necessary.

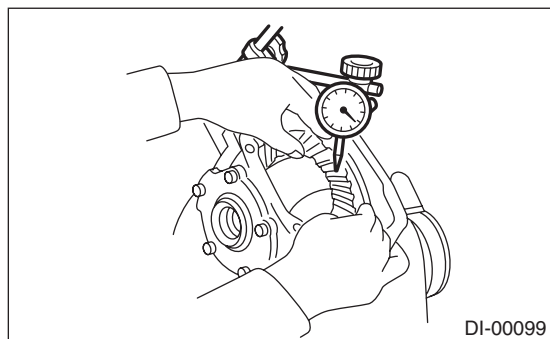

### 3. HYPOID DRIVEN GEAR RUNOUT ON ITS BACK SURFACE

Using a dial gauge, check the hypoid driven gear back surface runout.

#### **Hypoid driven gear back surface runout:**

**0.05 mm (0.002 in)**

If the hypoid driven gear runout exceeds specification, replace the hypoid driven gear.

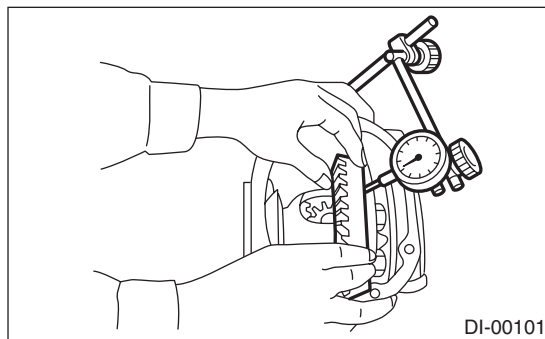

### 4. TOOTH CONTACT BETWEEN HYPOID DRIVEN GEAR AND DRIVE PINION

Inspect the tooth contact between the hypoid driven gear and drive pinion. <Ref. to DI-31, ASSEMBLY, Rear Differential (T-type).>

### 5. TOTAL PRELOAD

Using a spring scale, check the total preload.

#### **Total preload:**

##### **T-type (B2):**

**20.7 — 54.4 N (2.1 — 5.5 kgf, 4.7 — 12.2 lbf)**

##### **T-type (H3):**

**26.5 — 53 N (2.7 — 5.4 kgf, 6.0 — 11.9 lbf)**

If the total preload is not within the specification, adjust the side retainer shim.

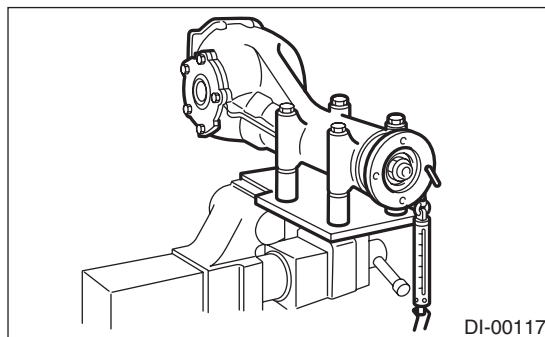

## 6. COMPANION FLANGE

- 1) If rust or dirt is attached to the companion flange, remove them.
- 2) Set a dial gauge at a companion flange surface (mating surface of propeller shaft and companion flange), and then measure the companion flange runout.

### Limit of runout:

**0.08 mm (0.003 in)**

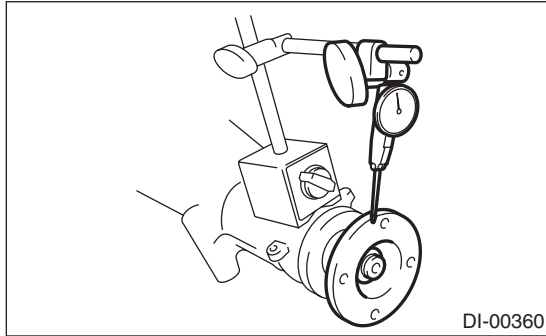

- 3) Set the gauge inside of the companion flange, and measure the runout.

### Limit of runout:

**0.08 mm (0.003 in)**

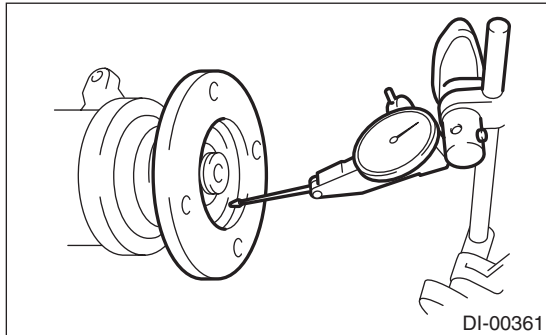

- 4) If either runout exceeds the limit, move the phase of companion flange and drive pinion 90° each, and find the point where the runout is within the limit.
- 5) If the runout exceeds the limit after changing the phase, replace the companion flange and recheck the runout.
- 6) If the runout exceeds the limit after replacing the companion flange, the drive pinion may be assembled incorrectly or bearing is faulty.

## F: ADJUSTMENT

### 1. SIDE GEAR BACKLASH (T-TYPE (B2))

Adjust the side gear backlash. <Ref. to DI-31, ASSEMBLY, Rear Differential (T-type).>

### 2. HYPOID DRIVEN GEAR BACKLASH

Adjust hypoid driven gear backlash. <Ref. to DI-31, ASSEMBLY, Rear Differential (T-type).>

### 3. TOOTH CONTACT BETWEEN HYPOID DRIVEN GEAR AND DRIVE PINION

Adjust the tooth contact between hypoid driven gear and drive pinion gear. <Ref. to DI-31, ASSEMBLY, Rear Differential (T-type).>

### 4. TOTAL PRELOAD

Adjust the side retainer shim. <Ref. to DI-31, ASSEMBLY, Rear Differential (T-type).>

# Rear Differential Front Oil Seal

## DIFFERENTIALS

### 5. Rear Differential Front Oil Seal

#### A: INSPECTION

Check that there is no leakage from front oil seal portion. If there is any leakage replace the oil seal and inspect the propeller shaft.

#### B: REPLACEMENT

- 1) Disconnect the ground cable from battery.
- 2) Shift the select lever or gear shift lever to neutral.
- 3) Release the parking brake.
- 4) Lift up the vehicle.
- 5) Disconnect the oil temperature switch connector. (T-type (H3))

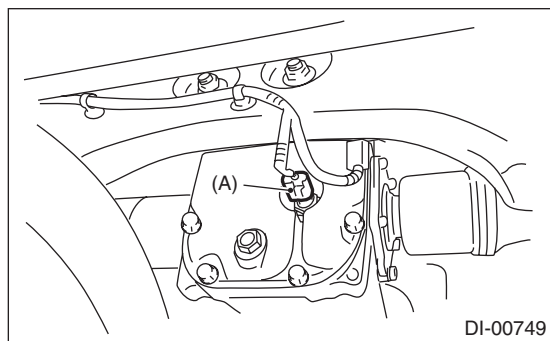

(A) Oil temperature switch connector

- 6) Remove the drain plug and filler plug or the oil temperature switch, and drain the gear oil.

#### NOTE:

Remove the oil temperature switch and adapter as a unit.

- T-type (B2)

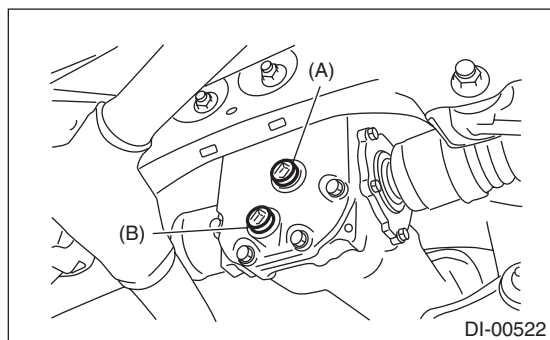

(A) Filler plug  
(B) Drain plug

- T-type (H3)

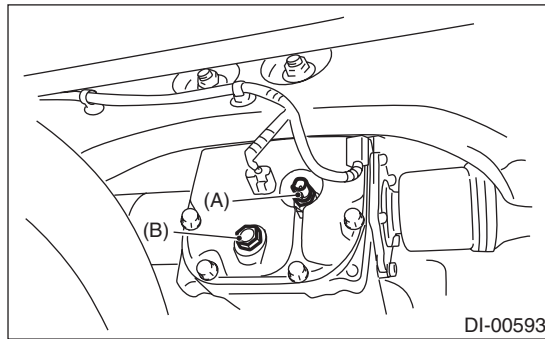

(A) Oil temperature switch  
(B) Drain plug

- 7) Install the drain plug.

#### NOTE:

- For the T-type (B2), apply liquid gasket to the drain plug.
- For T-type (H3), use a new gasket.

#### Liquid gasket:

**THREE BOND 1105 (Part No. 004403010) or equivalent**

#### Tightening torque:

**T-type (B2);**

**49 N·m (5.0 kgf-m, 36.1 ft-lb)**

**T-type (H3);**

**60 N·m (6.1 kgf-m, 44.3 ft-lb)**

- 8) Remove the rear exhaust pipe and muffler.

- 6MT model  
<Ref. to EX(STI)-13, REMOVAL, Rear Exhaust Pipe.> <Ref. to EX(STI)-15, REMOVAL, Muffler.>
- 5MT model  
<Ref. to EX(w/o STI)-2, General Description.>

- 9) Remove the heat shield cover.

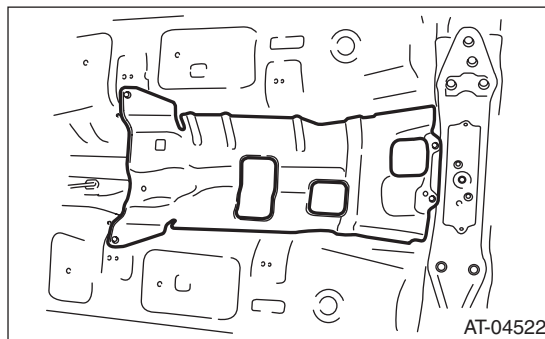

- 10) Remove the propeller shaft. <Ref. to DS-11, REMOVAL, Propeller Shaft.>
- 11) Check the initial torque and write it down.

12) Remove the self-locking nut while holding the companion flange with ST.

ST 18633AA000 WRENCH COMPL (T-TYPE (H3))

ST 498427200 FLANGE WRENCH (T-TYPE (B2))

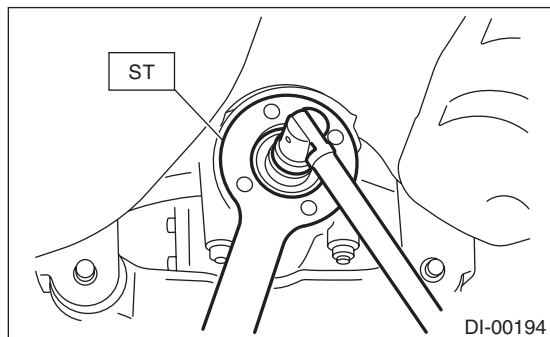

13) Remove the companion flange using ST.

ST 399703600 PULLER ASSY

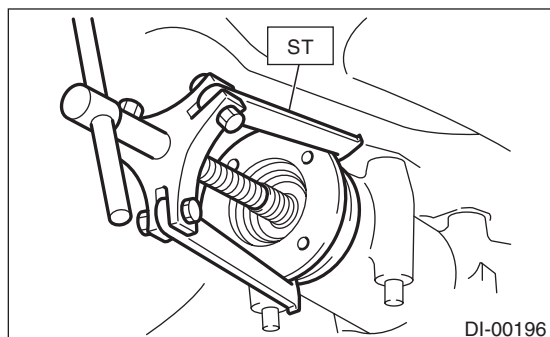

14) Remove the oil seal using ST or screwdriver.

ST 398527700 PULLER ASSY

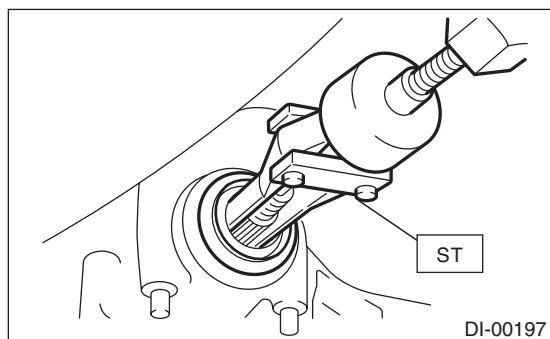

15) Using the ST, install the oil seal.

NOTE:

- Use a new oil seal.

- Apply differential gear oil to the oil seal lips.

ST 498447120 INSTALLER

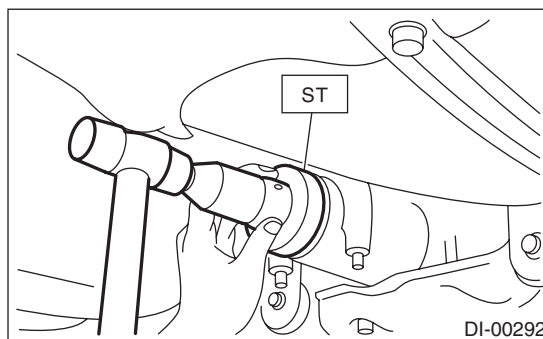

16) Use a plastic hammer to install companion flange.

17) Tighten the self-locking nut to the specified torque so that the rotating resistance of the companion flange is the same value as that before replacing the oil seal.

NOTE:

- Use a new self-locking nut.
- Before installing the self-locking nut, apply seal material to self-locking nut threads.

**Seal material:**

**THREE BOND 1324 (Part No. 004403042) or equivalent**

**Tightening torque:**

**167 — 196 N·m (17.0 — 20.0 kgf·m, 123.2 — 144.6 ft·lb)**

ST 18633AA000 WRENCH COMPL (T-TYPE (H3))

ST 498427200 FLANGE WRENCH (T-TYPE (B2))

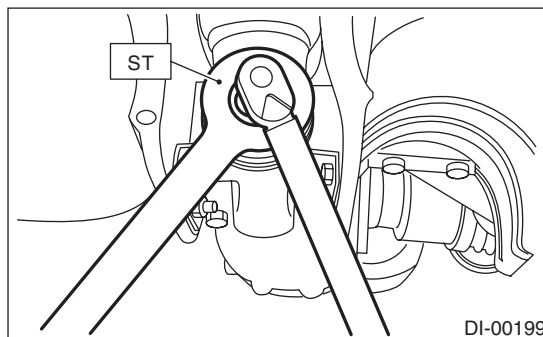

18) Hereafter, reassemble in the reverse order of disassembly.

19) After installing, fill the differential carrier with gear oil up to the bottom of the filler plug hole or the oil temperature switch hole. <Ref. to DI-18, REPLACEMENT, Differential Gear Oil.>

# Rear Differential Side Oil Seal

## DIFFERENTIALS

### 6. Rear Differential Side Oil Seal

#### A: INSPECTION

Check that there is no oil leakage from the side oil seal. If there is any leakage, replace the oil seal.

#### B: REPLACEMENT

1) Remove the rear differential. <Ref. to DI-22, REMOVAL, Rear Differential (T-type).>

2) Remove the rear differential side oil seal using a ST or screwdriver wrapped with vinyl tape to prevent the side retainer from scratching.

ST 398527700 PULLER ASSY

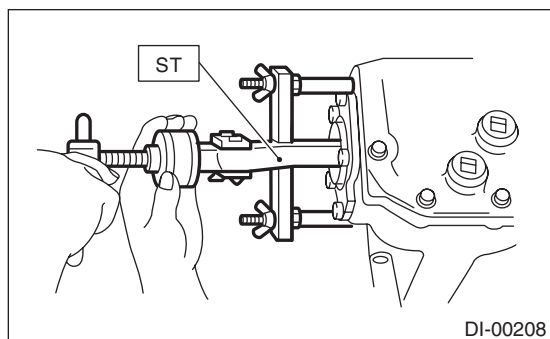

3) Using the ST, install the side oil seal.

#### NOTE:

- Use a new oil seal.
- Apply differential gear oil to the oil seal lips.

ST 398437700 DRIFT

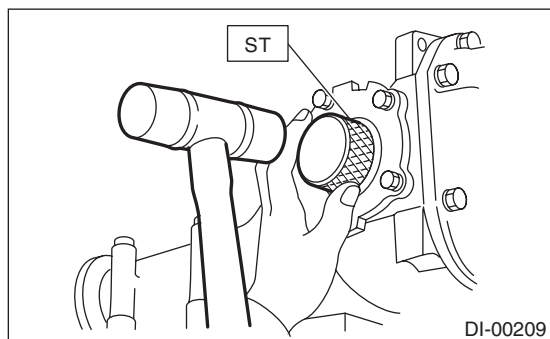

4) Install the rear differential. <Ref. to DI-24, INSTALLATION, Rear Differential (T-type).>

## 7. Rear Differential Front Member

### A: REMOVAL

- 1) Disconnect the ground cable from battery.
- 2) Lift up the vehicle.
- 3) Support the rear differential using transmission jack, and then remove the rear differential front member.

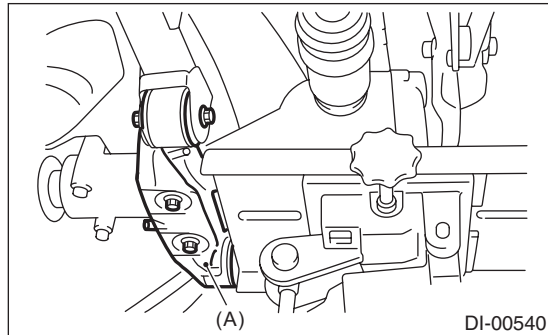

(A) Rear differential front member

### B: INSTALLATION

Install the rear differential front member with a new self-locking nut.

#### **Tightening torque:**

**T1: 50 N·m (5.1 kgf-m, 36.9 ft-lb)**

**T2: 110 N·m (11.2 kgf-m, 81.1 ft-lb)**

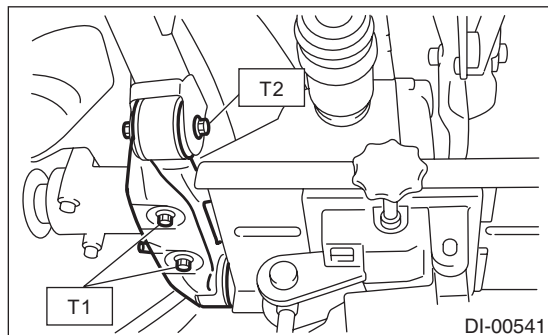

### C: INSPECTION

- 1) Check the rear differential front member for damage, bend and corrosion.  
If damage, bend or corrosion is excessive, replace the rear differential front member.
- 2) Check the bushings of rear differential front member for cracking, hardening and damage.  
If cracking, hardening or damage is excessive, replace rear differential front member.

# Rear Differential Mount Bushing

## DIFFERENTIALS

### 8. Rear Differential Mount Bushing

#### A: INSPECTION

Check the rear differential mounting bushing for cracks, hardening, or damage. If cracking, hardening, or damage is excessive, replace the rear differential mounting bushing.

#### B: REPLACEMENT

##### CAUTION:

**If there was so much rust in the rear differential mount bushing, remove the rust before starting work.**

1) Remove the rear differential. <Ref. to DI-22, REMOVAL, Rear Differential (T-type).>

2) Fit the ST to the periphery of the sub frame cylinder, and make sure that the ST does not contact with welded spots or spatters.

ST 41399FG010 SPECIAL TOOL A

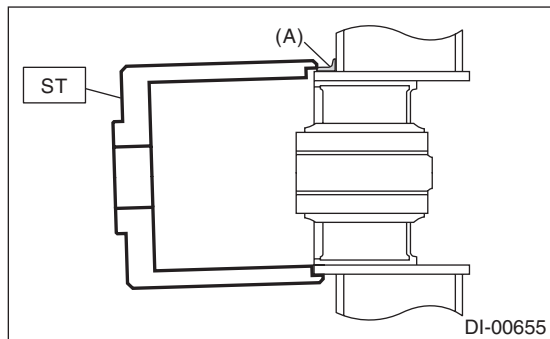

(A) Welded spot

3) If the ST contacts with welded spots or spatters, remove the excessive welds or spatters with sander or the equivalent so that the ST contacts the cylinder peripheral part.

##### CAUTION:

**Performing the operation with the ST contacting with welded spots or spatters may break the ST. Be sure to remove excessive welds or spatters before the operation.**

4) Set ST1, ST2, ST3, ST4 and ST5 as shown in the figure.

ST1 41399FG091 SPECIAL TOOL SHAFT

ST2 41399FG070 SPECIAL TOOL NUT

ST3 41399FG050 SPECIAL TOOL SLEEVE

ST4 41399FG080 SPECIAL TOOL BEARING

ST5 41399FG010 SPECIAL TOOL A

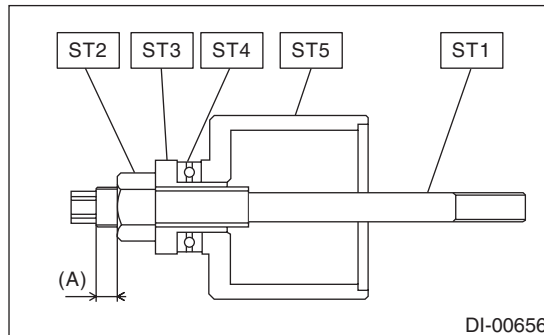

(A) 5 mm (0.2 in) or less

5) Fit and hold the ST1 and ST2 to the rear differential mount bushing from the rear side of vehicle.

ST1 41399FG031 SPECIAL TOOL C

ST2 41399FG061 SPECIAL TOOL RING

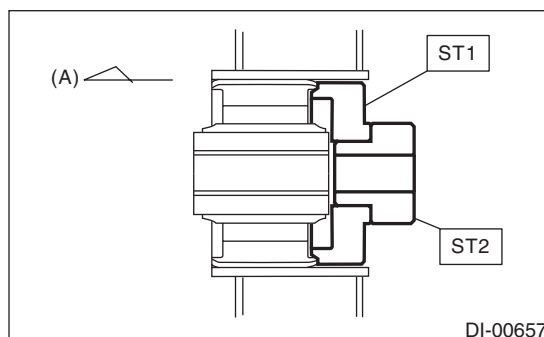

(A) Front side of vehicle



# Rear Differential Mount Bushing

DIFFERENTIALS

6) Insert the ST set in the step 4) through the rear differential mount bushing hole from the front side of vehicle, and screw in the ST1 by hand till the front end of ST1 comes out slightly from the rear end of ST2.

ST1 41399FG091 SPECIAL TOOL SHAFT  
ST2 41399FG061 SPECIAL TOOL RING

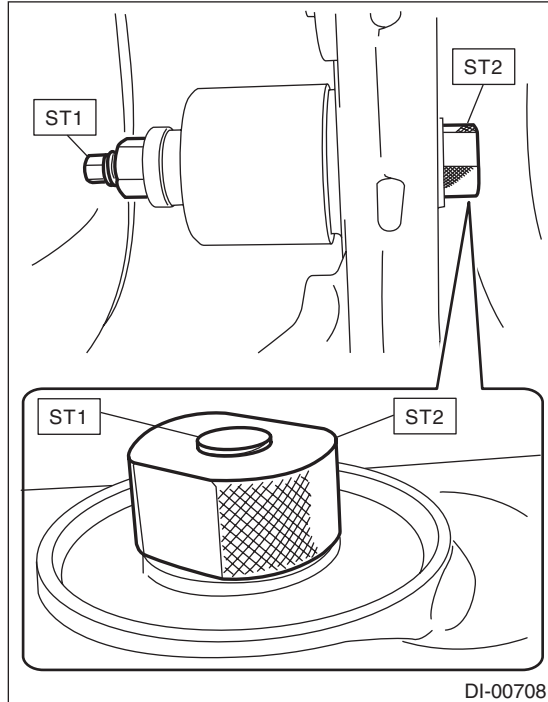

7) Hold the ST1 to prevent it from rotating, and screw in the ST3 by hand till there is no loose fit on the ST2.

### CAUTION:

**When setting the ST to the vehicle, always make sure that the ST2 fits the periphery of the sub frame cylinder and is not tilted.**

ST1 41399FG091 SPECIAL TOOL SHAFT  
ST2 41399FG010 SPECIAL TOOL A  
ST3 41399FG070 SPECIAL TOOL NUT

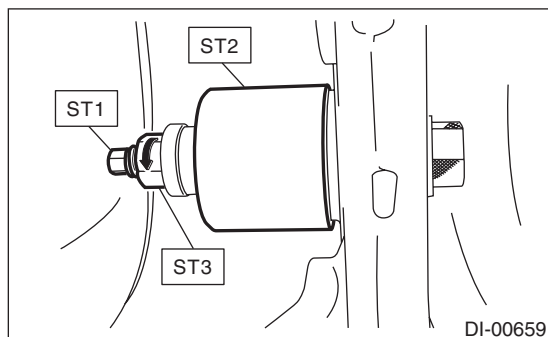

8) Hold the ST1 with a tool to prevent it from rotating, and screw in the ST2 to remove the rear differential mount bushing.

### CAUTION:

- Rotation of ST1 will damage the screw at the rear end of rear differential mount bushing. Never rotate the ST1.
- If the ST starts to tilt while removing the rear differential mount bushing, stop the work and set the ST again.

ST1 41399FG091 SPECIAL TOOL SHAFT  
ST2 41399FG070 SPECIAL TOOL NUT

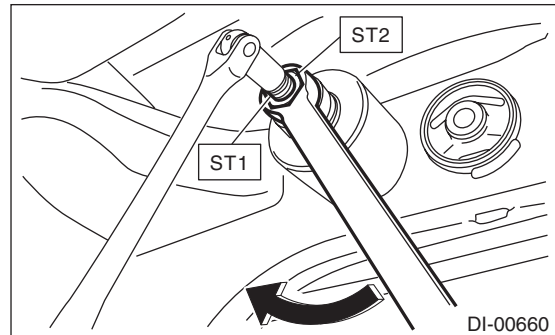

9) Set ST1, ST2, ST3, ST4, ST5 and rear differential mount bushing as shown in the figure.

### NOTE:

- Set the ST2 nut near to the end of ST1 screw.
- Hold the rear differential mount bushing with the marked side facing toward the rear of the vehicle, and set the rear differential mount bushing to the ST so that the arrow mark faces upward.



# Rear Differential Mount Bushing

## DIFFERENTIALS

- Mark the bottom end of rear differential mount bushing to identify the installing direction.

- ST1 41399FG091 SPECIAL TOOL SHAFT
- ST2 41399FG070 SPECIAL TOOL NUT
- ST3 41399FG050 SPECIAL TOOL SLEEVE
- ST4 41399FG080 SPECIAL TOOL BEARING
- ST5 41399FG020 SPECIAL TOOL B

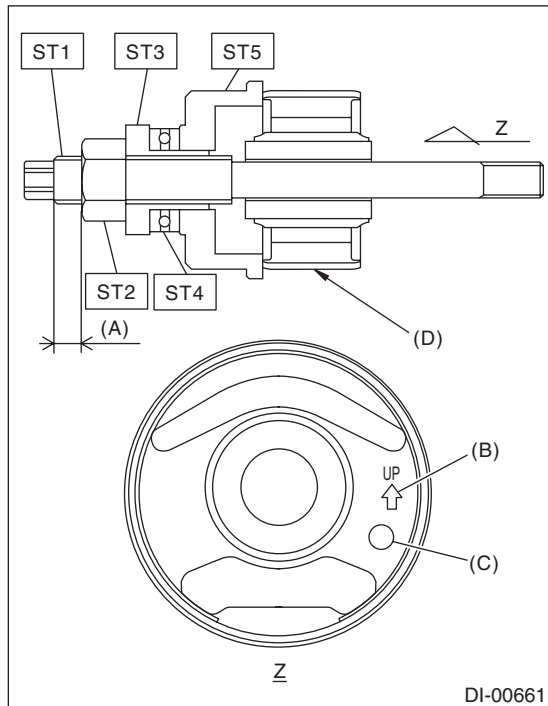

- (A) 8 mm (0.31 in) or more
- (B) Arrow mark
- (C) Mark
- (D) Marked position

- 10) Attach ST1 to the ST2, and fit and hold the STs as a unit to the sub frame from the rear side of vehicle.

- ST1 41399FG061 SPECIAL TOOL RING
- ST2 41399FG041 SPECIAL TOOL D

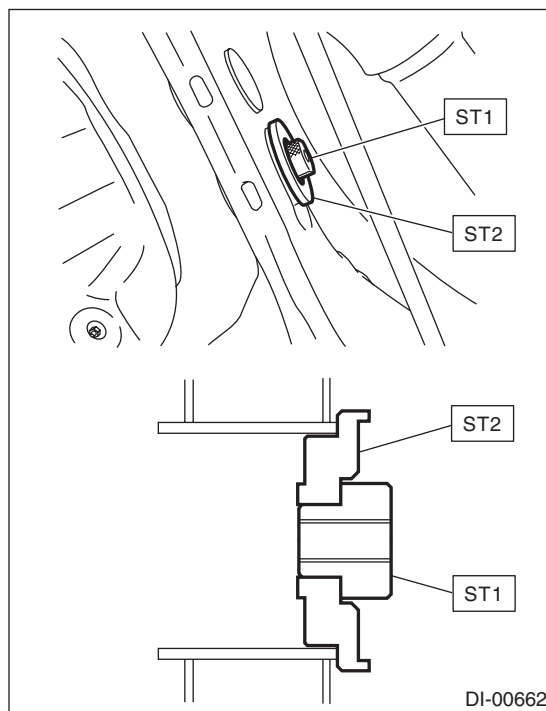

- 11) Insert the ST set in the step 9) through the sub frame from the front side of vehicle, and screw in the ST1 by hand till the front end of ST1 comes out slightly from the rear end of ST2.

### CAUTION:

**Set the rear differential mount bushing with its mark facing the bottom end direction.**

- ST1 41399FG091 SPECIAL TOOL SHAFT
- ST2 41399FG061 SPECIAL TOOL RING

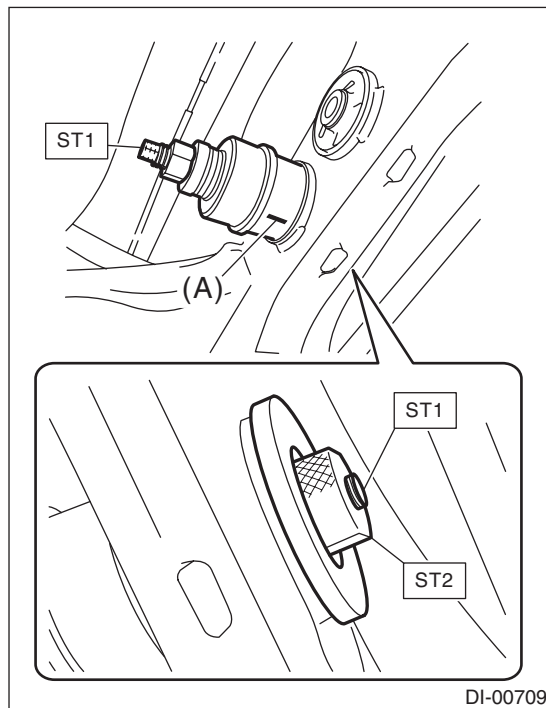

- (A) Mark

12) Hold the ST1 to prevent it from rotating, and screw in the ST2 by hand till there is no loose fit on the ST and the rear differential mount bushing.

**CAUTION:**

**Make sure that the ST and rear differential mount bushing are not tilted.**

ST1 41399FG091 SPECIAL TOOL SHAFT

ST2 41399FG070 SPECIAL TOOL NUT

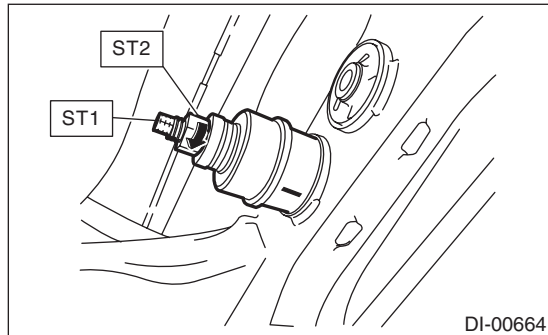

13) Screw in the ST2 while holding the ST1 with a tool to prevent it from rotating, and press-fit the rear differential mount bushing to the front end of sub frame cylinder.

ST1 41399FG091 SPECIAL TOOL SHAFT

ST2 41399FG070 SPECIAL TOOL NUT

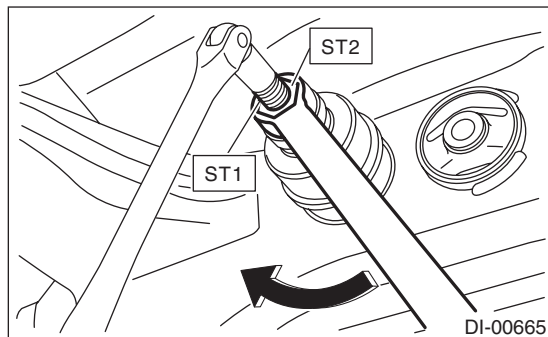

14) Make sure that the rear differential mount bushing is inserted to the front end of sub frame cylinder.

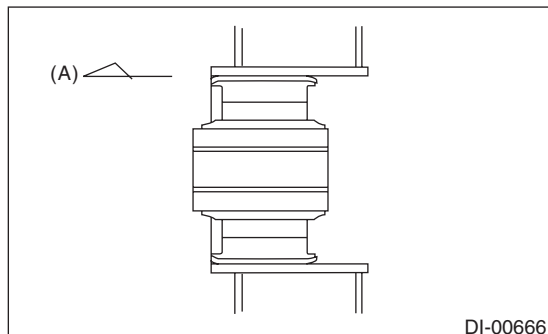

(A) Front side of vehicle

15) Install the rear differential. <Ref. to DI-24, INSTALLATION, Rear Differential (T-type).>

# General Diagnostic Table

## DIFFERENTIALS

### 9. General Diagnostic Table

#### A: INSPECTION

Symptom or trouble	Possible cause	Remedy
<b>1. Oil leakage</b>	(1) Worn, scratched, or incorrectly seated front or side oil seal. Scored, battered or excessively worn sliding surface of companion flange.	Repair or replace.
	(2) Clogged or damaged air breather cap.	Clean, repair or replace.
	(3) Loose bolts on the side retainer, or incorrectly fitted O-ring.	Tighten the bolts to specified torque. Replace the O-ring.
	(4) Loose rear cover attachment bolts or damaged gasket.	Replace the gasket, and tighten the bolts to specified torque.
	(5) Loose filler plug or drain plug.	<ul style="list-style-type: none"> <li>Apply liquid gasket, and tighten to the specified torque. (T-type (B2))</li> <li>Replace the gasket, and tighten to the specified torque. (T-type (H3))</li> </ul>
	(6) Wear, damage or incorrect fitting of drive shaft, side retainer or oil seal.	Repair or replace.
<b>2. Seizure</b> NOTE: Seized or damaged parts should be replaced, and also other parts should be thoroughly checked for any defect and should be repaired or replaced as required.	(1) Insufficient backlash for hypoid gear.	Readjust or replace.
	(2) Excessive preload for side, rear or front bearing.	Readjust or replace.
	(3) Insufficient or improper oil used.	Add recommended differential oil to the specified level.
<b>3. Damage</b> NOTE: Damaged parts should be replaced, and also other parts should be thoroughly checked for any defect and should be repaired or replaced as required.	(1) Improper backlash for hypoid gear.	Readjust or replace.
	(2) Insufficient or excessive preload for side, rear or front bearing.	Readjust or replace.
	(3) Excessive backlash for side gear.	<ul style="list-style-type: none"> <li>Replace gear or thrust washer. (T-type (B2))</li> <li>Replace the differential case assembly. (T-type (H3))</li> </ul>
	(4) Loose bolts and nuts such as hypoid driven gear bolt.	Retighten.
	(5) Damage due to overloading.	Replace.
<b>4. Noises when starting or shifting gears</b> NOTE: Noises may be caused by differential assembly, universal joint, wheel bearing, etc. Find out what is actually making noise before disassembling.	(1) Improper tooth contact of hypoid driven gear and drive pinion	Readjust. (Drive pinion shim adjustment, backlash adjustment)
	(2) Excessive backlash for hypoid driven gear	Replace the gear or the pinion height adjusting washer.
	(3) Excessive backlash for side gear.	<ul style="list-style-type: none"> <li>Replace gear or thrust washer. (T-type (B2))</li> <li>Replace the differential case assembly. (T-type (H3))</li> </ul>
	(4) Insufficient preload for front or rear bearing.	Readjust.
	(5) Loose drive pinion nut.	Tighten to the specified torque.
	(6) Loose bolts and nuts such as side retainer attachment bolt.	Tighten to the specified torque.

# General Diagnostic Table

## DIFFERENTIALS

Symptom or trouble	Possible cause	Remedy
<b>5. Noises when cornering</b>	(1) Damaged differential gear.	<ul style="list-style-type: none"> <li>• Replace the differential gear. (T-type (B2))</li> <li>• Replace the differential case assembly. (T-type (H3))</li> </ul>
	(2) Excessive wear or damage of thrust washer.	Replace the thrust washer. (T-type (B2))
	(3) Broken pinion mate shaft.	Replace the pinion mate shaft. (T-type (B2))
	(4) Stuck or damaged side bearing	Replace.
<b>6. Gear noise</b> NOTE: Since noises from engine, muffler, transmission, propeller shaft, wheel bearings, tires, and body are sometimes mistaken for noises from differential assembly, be careful in checking them. Inspection methods to locate noises include coasting, accelerating, cruising, and lifting-up all four wheels. Perform these inspections according to the condition of trouble. When listening to noises, shift the gear into four-wheel drive and fourth speed position, trying to pick up only differential noise.	(1) Improper tooth contact of hypoid driven gear and drive pinion	Readjust or replace the hypoid gear set.
	(2) Improper backlash of the hypoid driven gear	Readjust.
	(3) Scored or chipped teeth of hypoid gear.	Replace hypoid gear set.
	(4) Scuffed hypoid gear	Replace hypoid gear set.
	(5) Improper preload for front or rear bearings.	Readjust.
	(6) Stuck, scored or chipped teeth of front or rear bearing	Replace.
	(7) Stuck, scored or chipped teeth of side bearing	Replace.
	(8) Vibrating differential gear.	Replace the differential gear.

# General Diagnostic Table

DIFFERENTIALS

---

# TRANSFER CASE

# TC

---

	<b>Page</b>
1. General Description .....	2
2. Extension Case .....	3
3. Transfer Case and Extension Case Assembly .....	4
4. Oil Seal .....	5
5. Transfer Drive Gear .....	6
6. Transfer Driven Gear .....	7
7. Center Differential .....	8

## 1. General Description

### A: NOTE

For general description, refer to "6MT" or "5MT" section.

6MT model:

<Ref. to 6MT-2, General Description.>

5MT model:

<Ref. to 5MT-2, General Description.>

## 2. Extension Case

### A: NOTE

For removal, installation and inspection, refer to "6MT" section. <Ref. to 6MT-44, Extension Case.>



# Transfer Case and Extension Case Assembly

TRANSFER CASE

---

## **3. Transfer Case and Extension Case Assembly**

### **A: NOTE**

For removal, installation and inspection, refer to "5MT" section. <Ref. to 5MT-35, Transfer Case and Extension Case Assembly.>

## 4. Oil Seal

### A: NOTE

For inspection and replacement, refer to "6MT" or "5MT" section.

6MT model:

<Ref. to 6MT-28, Oil Seal.>

5MT model:

<Ref. to 5MT-31, Oil Seal.>

## 5. Transfer Drive Gear

### A: NOTE

For removal, installation and inspection, refer to "6MT" or "5MT" section.

6MT model:

<Ref. to 6MT-53, Transfer Drive Gear.>

5MT model:

<Ref. to 5MT-41, Transfer Drive Gear.>

## 6. Transfer Driven Gear

### A: NOTE

For removal, installation and inspection, refer to "6MT" or "5MT" section.

6MT model:

<Ref. to 6MT-55, Transfer Driven Gear.>

5MT model:

<Ref. to 5MT-43, Transfer Driven Gear.>

# Center Differential

TRANSFER CASE

---

## 7. Center Differential

### A: NOTE

For removal, installation and inspection, refer to "6MT" or "5MT" section.

6MT model:

<Ref. to 6MT-57, Center Differential.>

5MT model:

<Ref. to 5MT-45, Center Differential.>

# DRIVE SHAFT SYSTEM

# DS

---

	<b>Page</b>
1. General Description .....	2
2. Propeller Shaft .....	11
3. Front Axle .....	14
4. Front Hub Unit Bearing .....	18
5. Rear Axle .....	20
6. Rear Hub Unit Bearing .....	24
7. Front Drive Shaft .....	27
8. Rear Drive Shaft .....	34
9. General Diagnostic Table .....	42

# General Description

## DRIVE SHAFT SYSTEM

### 1. General Description

#### A: SPECIFICATION

##### 1. PROPELLER SHAFT

Model		Except for STI model	STI model
Propeller shaft type		EDJ	3UJ+CPS
Front propeller shaft Joint-to-joint length: $L_1$	mm (in)	675 (26.75)	633 (24.92)
Rear propeller shaft Joint-to-Joint length: $L_2$	mm (in)	735 (28.94)	728.5 (28.68)
Outer diameter of tube:	mm (in)	$D_1$	63.5 (2.499)
		$D_2$	57.5 (2.264)

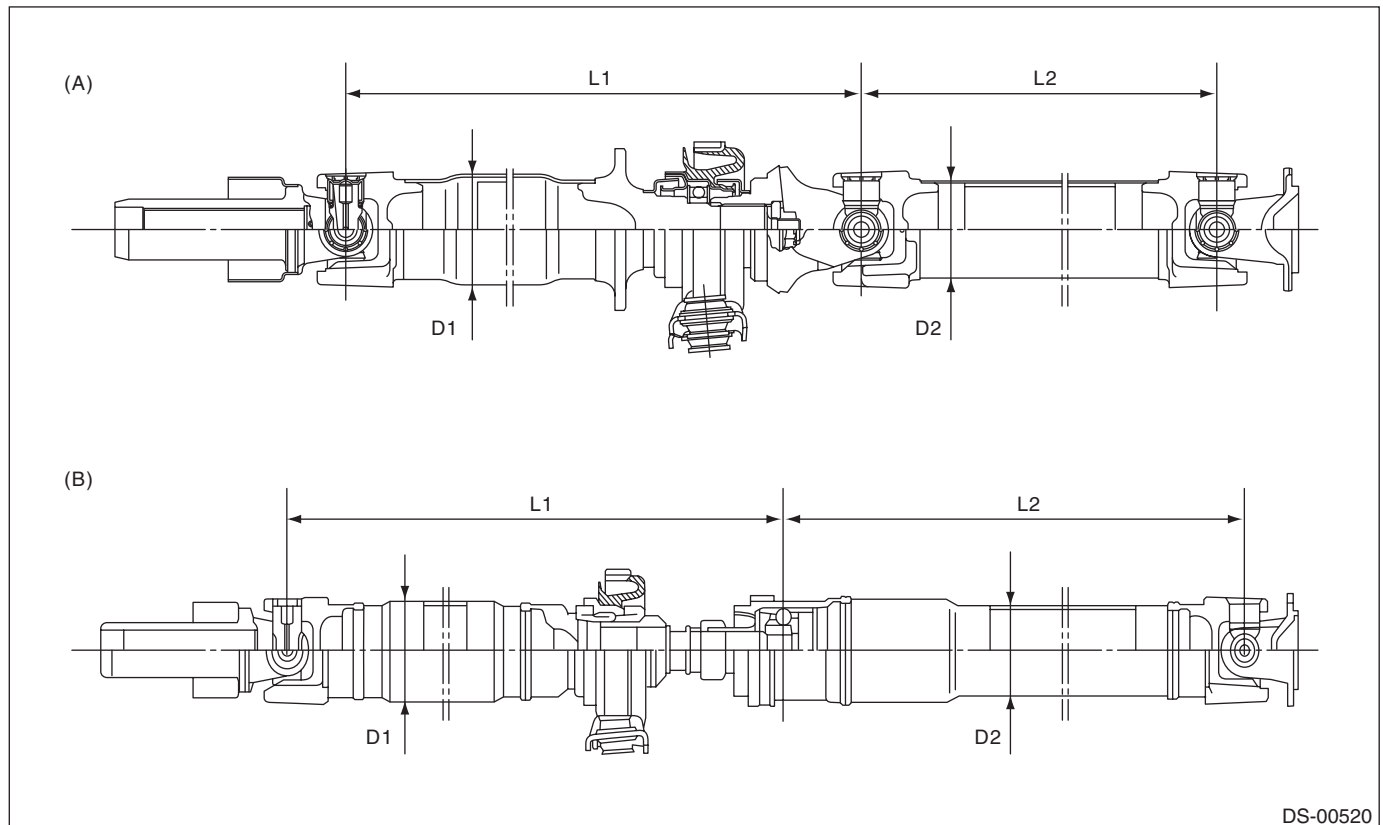

DS-00520

(A) 3UJ type

(B) EDJ type

# General Description

## 2. FRONT DRIVE SHAFT ASSEMBLY

Model	Type of drive shaft	Axle diameter $\phi$ mm (in)	Axle length mm (in)
Except for STI model	EBJ + PTJ	22 (0.87)	361.4 (14.23)
STI model	AC + AAR	28 (1.10)	343.1 (13.51)

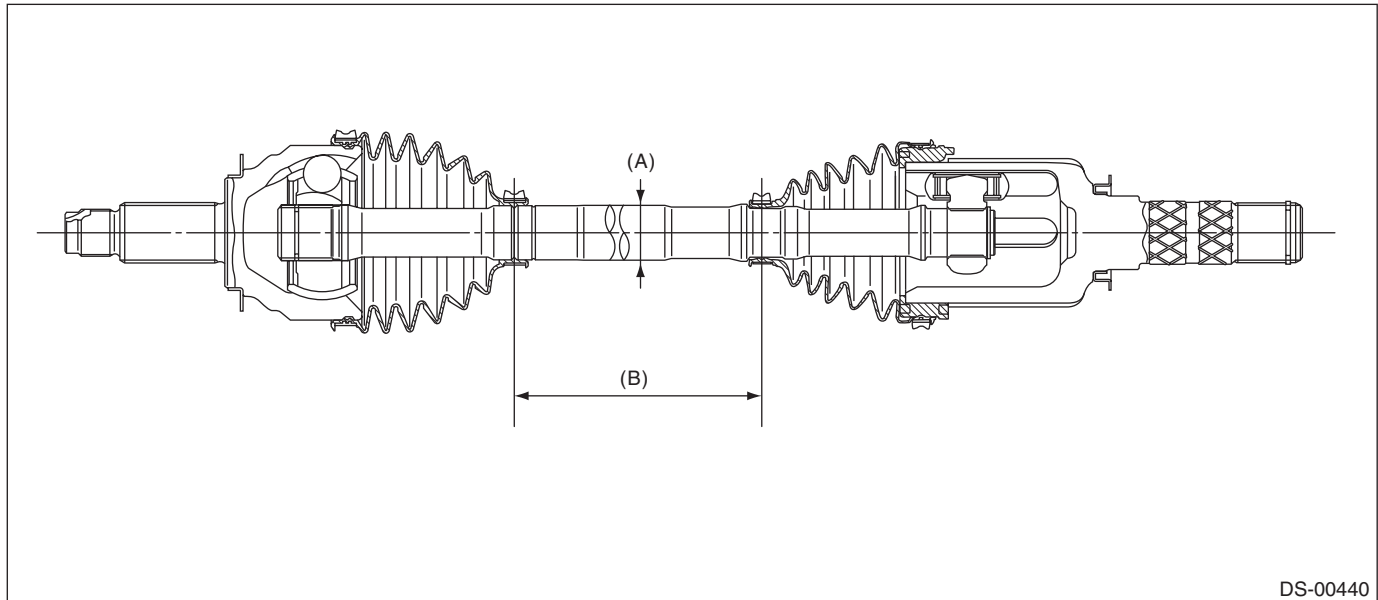

DS-00440

(A) Axle diameter

(B) Axle length

## 3. REAR DRIVE SHAFT ASSEMBLY

Model	Type of drive shaft	Axle diameter $\phi$ mm (in)	Axle length mm (in)
Except for STI model	EBJ + DOJ	22 (0.87)	383.1 (15.08)
STI model	EBJ + EDJ	25 (0.98)	339.5 (13.37)

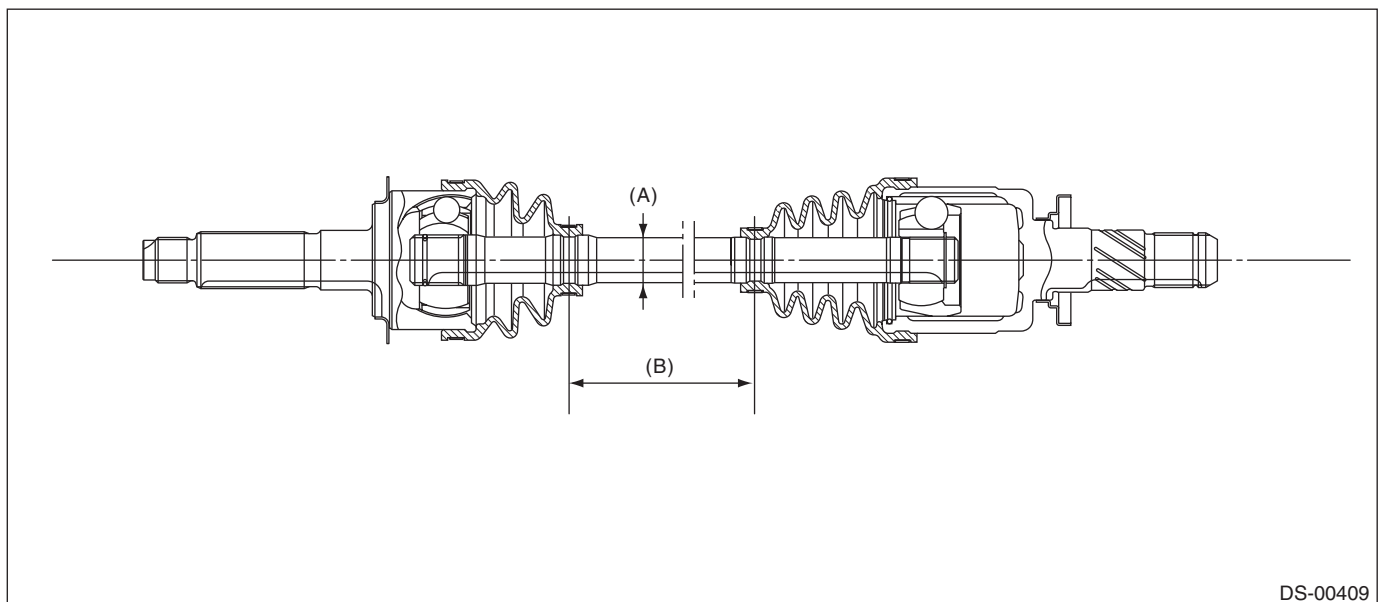

DS-00409

(A) Axle diameter

(B) Axle length



# General Description

## DRIVE SHAFT SYSTEM

### B: COMPONENT

#### 1. PROPELLER SHAFT

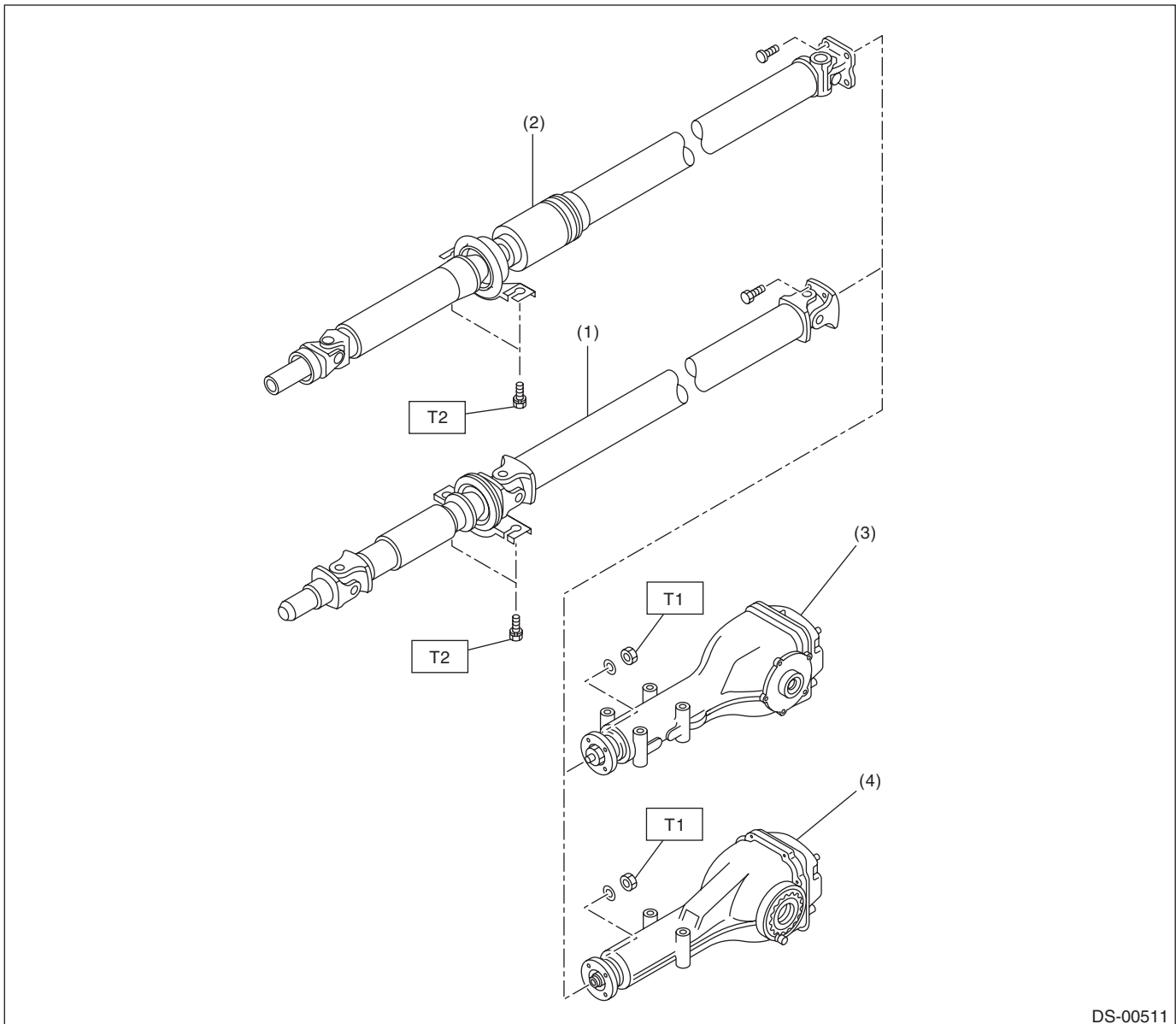

DS-00511

- (1) Propeller shaft (3UJ type)
- (2) Propeller shaft (DOJ-type)

- (3) Rear differential (T-type)
- (4) Rear differential (VA2-type)

**Tightening torque: N·m (kgf·m, ft·lb)**

**T1: 31 (3.16, 22.9)**

**T2: 52 (5.30, 38.4)**

## 2. FRONT AXLE

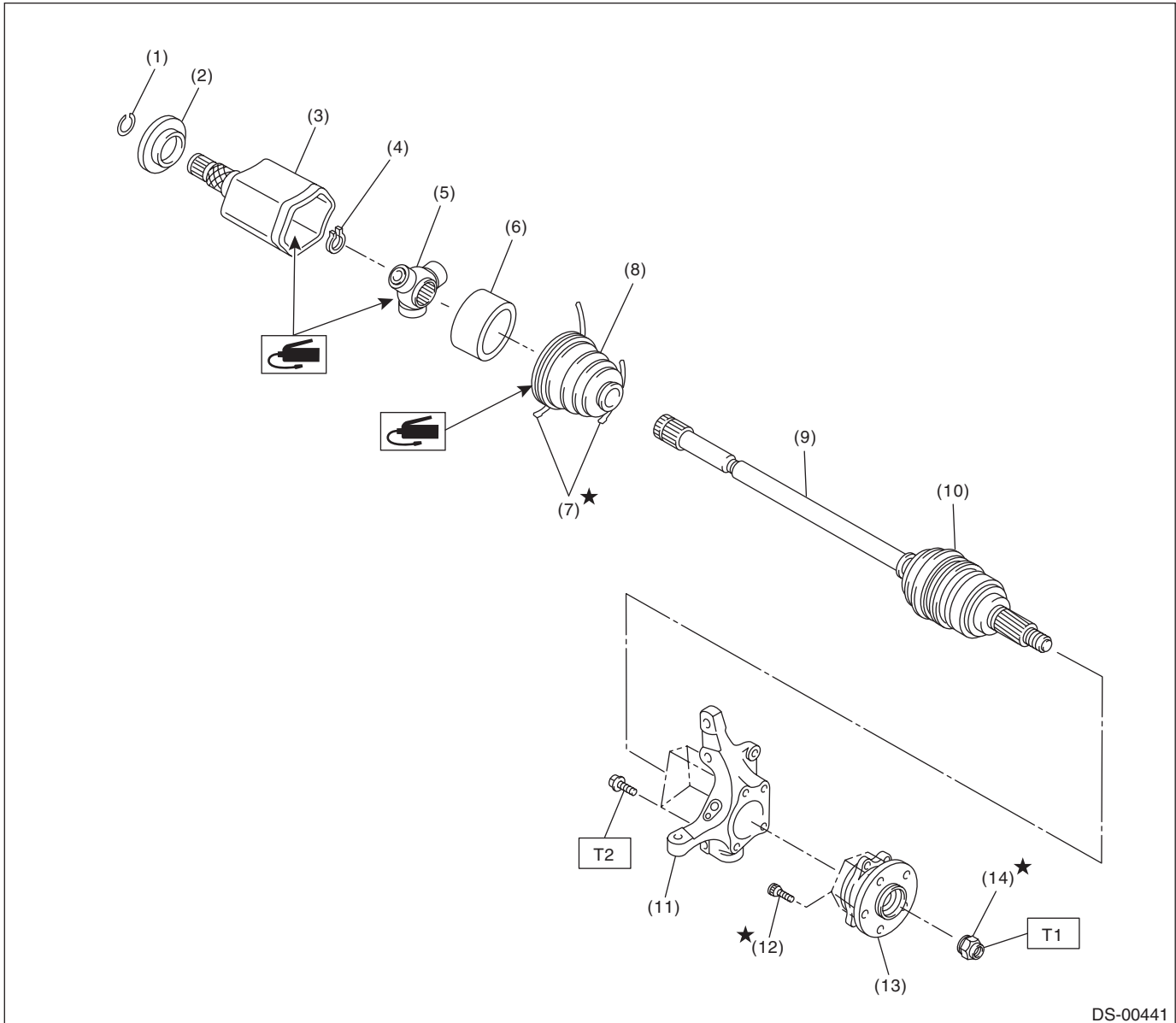

DS-00441

- |                      |                   |                             |
|----------------------|-------------------|-----------------------------|
| (1) Circlip          | (7) Boot band     | (13) Front hub unit bearing |
| (2) Baffle plate     | (8) Boot (AAR)    | (14) Axle nut               |
| (3) Outer race (AAR) | (9) AC shaft ASSY |                             |
| (4) Snap ring        | (10) Boot (AC)    |                             |
| (5) Trunnion         | (11) Housing      |                             |
| (6) Grommet          | (12) Hub bolt     |                             |

**Tightening torque: N·m (kgf·m, ft·lb)**

**T1: 220 (22.43, 162.3)**

**T2: 65 (6.63, 47.9)**

# General Description

## DRIVE SHAFT SYSTEM

### 3. REAR AXLE

- Except for STI model

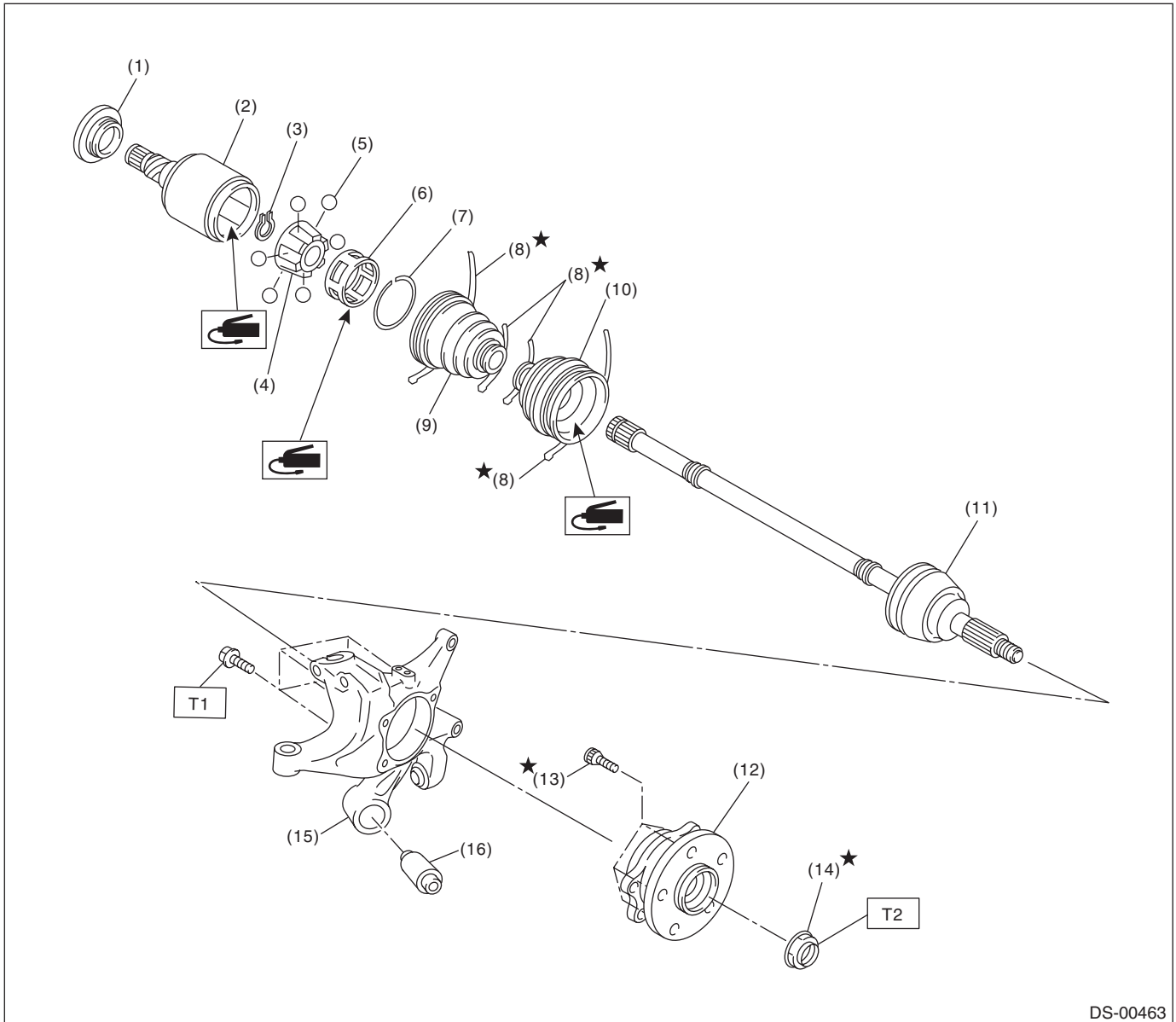

DS-00463

- |                      |                            |                        |
|----------------------|----------------------------|------------------------|
| (1) Baffle plate     | (8) Boot band              | (15) Rear axle housing |
| (2) Outer race (DOJ) | (9) Boot (DOJ)             | (16) Bushing           |
| (3) Snap ring        | (10) Boot (BJ)             |                        |
| (4) Inner race       | (11) EBJ shaft ASSY        |                        |
| (5) Ball             | (12) Rear hub unit bearing |                        |
| (6) Cage             | (13) Hub bolt              |                        |
| (7) Snap ring        | (14) Axle nut              |                        |

**Tightening torque: N·m (kgf·m, ft·lb)**

**T1: 65 (6.63, 47.9)**

**T2: 190 (19.37, 140.1)**

# General Description

- STI model

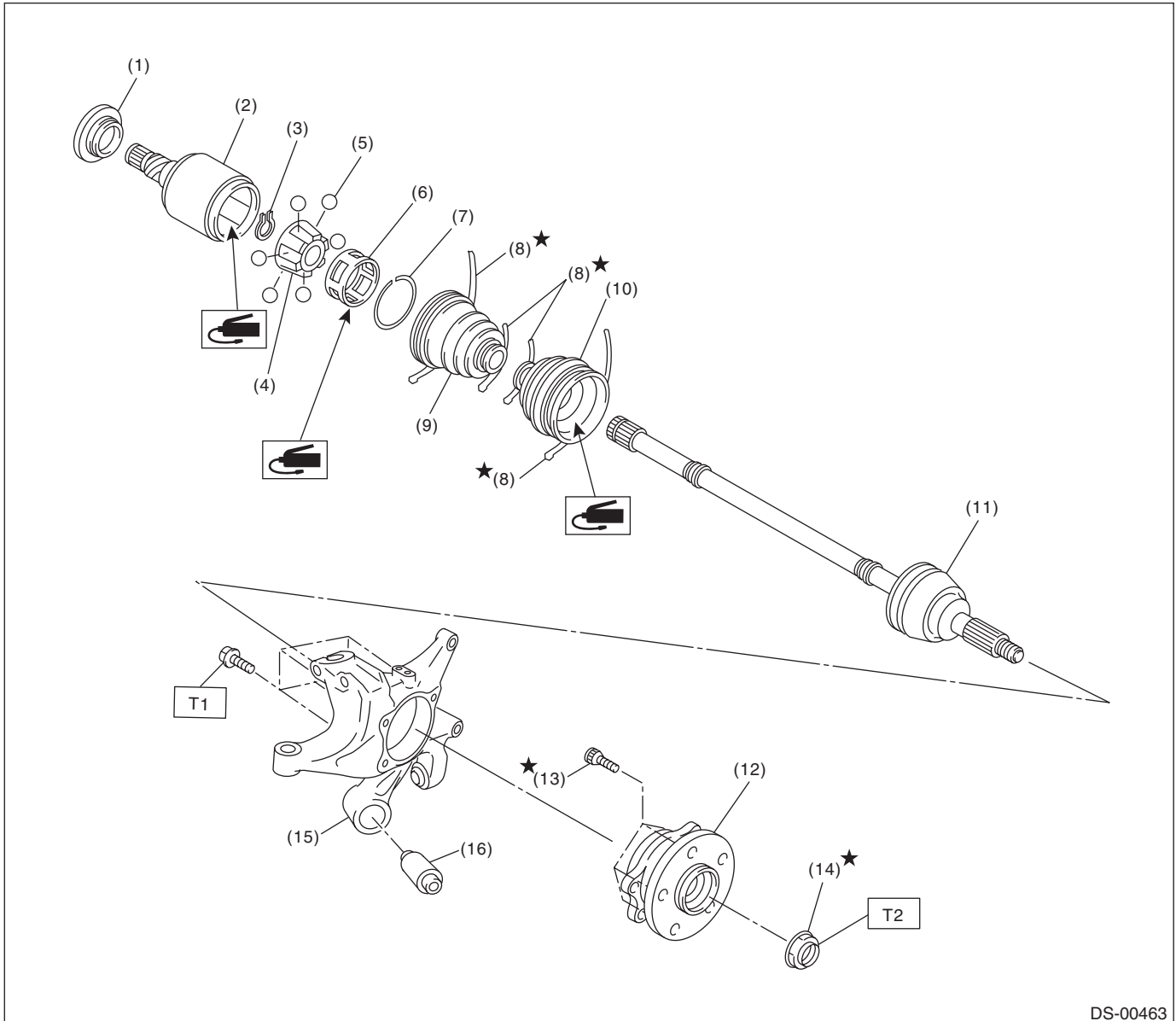

- |                      |                            |                        |
|----------------------|----------------------------|------------------------|
| (1) Baffle plate     | (8) Boot band              | (15) Rear axle housing |
| (2) Outer race (EDJ) | (9) Boot (EDJ)             | (16) Bushing           |
| (3) Snap ring        | (10) Boot (EBJ)            |                        |
| (4) Inner race       | (11) EBJ shaft ASSY        |                        |
| (5) Ball             | (12) Rear hub unit bearing |                        |
| (6) Cage             | (13) Hub bolt              |                        |
| (7) Snap ring        | (14) Axle nut              |                        |

**Tightening torque: N·m (kgf·m, ft·lb)**

**T1: 65 (6.63, 47.9)**

**T2: 190 (19.37, 140.1)**

## General Description

### DRIVE SHAFT SYSTEM

---

#### **C: CAUTION**

- Wear appropriate work clothing, including a cap, protective goggles and protective shoes when performing any work.
- Remove contamination including dirt and corrosion before removal, installation or disassembly.
- Keep the disassembled parts in order and protect them from dust and dirt.
- Before removal, installation or disassembly, be sure to clarify the failure. Avoid unnecessary removal, installation, disassembly and replacement.
- Vehicle components are extremely hot after driving. Be wary of receiving burns from heated parts.
- Use SUBARU genuine grease etc. or equivalent. Do not mix grease etc. of different grades or manufacturers.
- Be sure to tighten fasteners including bolts and nuts to the specified torque.
- Place shop jacks or rigid racks at the specified points.
- Apply grease onto sliding or revolving surfaces before installation.
- Before installing snap rings, apply sufficient amount of grease to avoid damage and deformation.
- Before securing a part on a vise, place cushioning materials such as wood blocks, aluminum plates, or waste cloth between the part and the vise.

## D: PREPARATION TOOL

### 1. SPECIAL TOOL

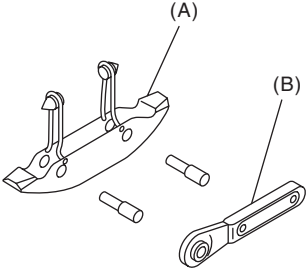
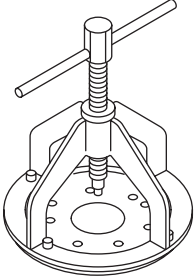
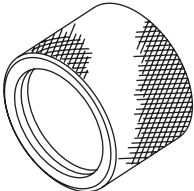
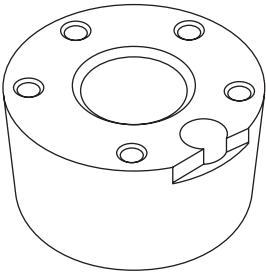
ILLUSTRATION	TOOL NUMBER	DESCRIPTION	REMARKS
 <p style="text-align: center;">ST-925091000</p>	925091000	BAND TIGHTENING TOOL	Used for tightening the boot band. (A) Jig for the band (B) Ratchet wrench
 <p style="text-align: center;">ST-926470000</p>	926470000	AXLE SHAFT PULLER	<ul style="list-style-type: none"> <li>• Used for removing the axle shaft.</li> <li>• Used together with AXLE SHAFT PULLER PLATE (28099PA110).</li> </ul>
 <p style="text-align: center;">ST18675AA000</p>	18675AA000	DIFFERENTIAL SIDE OIL SEAL INSTALLER	Used for installing the differential side retainer oil seal.
 <p style="text-align: center;">ST28099PA080</p>	28099PA080	HUB STAND	Used for assembling hub bolt in hub.

# General Description

## DRIVE SHAFT SYSTEM

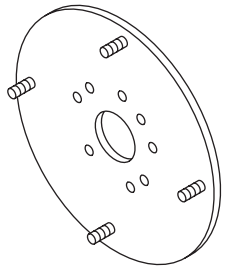
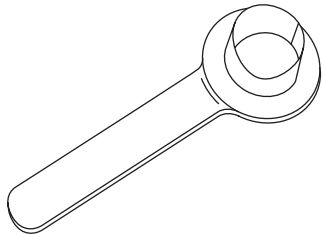
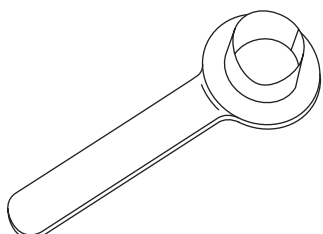
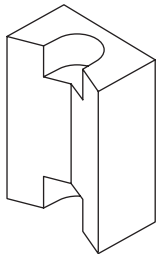
ILLUSTRATION	TOOL NUMBER	DESCRIPTION	REMARKS
 <p style="text-align: center;">ST28099PA110</p>	28099PA110	AXLE SHAFT PULLER PLATE	Exchange with the plate of the AXLE SHAFT PULLER (926470000) to use.
 <p style="text-align: center;">ST28099PA090</p>	28099PA090	OIL SEAL PROTECTOR	<ul style="list-style-type: none"> <li>• Used for installing the rear drive shaft to the rear differential.</li> <li>• For protecting the oil seal.</li> </ul>
 <p style="text-align: center;">ST28399SA010</p>	28399SA010	OIL SEAL PROTECTOR	<ul style="list-style-type: none"> <li>• Used for installing front drive shaft into front differential.</li> <li>• For protecting the oil seal.</li> </ul>
 <p style="text-align: center;">ST28399AG000</p>	28399AG000	HUB STAND	Used for extracting hub bolt.

## 2. GENERAL TOOL

TOOL NAME	REMARKS
Puller	Used for removing the ball joint from knuckle arm.
Dial gauge	Used for inspecting the propeller shaft run-out.
Extension cap	Used for preventing leakage of gear oil or ATF.
Crowbar	Used for extracting drive shaft.

## 2. Propeller Shaft

### A: REMOVAL

**NOTE:**

- Before removing propeller shaft, wrap metal parts with a cloth or rubber material.
- In case of a EDJ type, wrap the metal parts at the rubber boot of center EDJ with a cloth or rubber material before removing propeller shaft, as shown in the figure. The rubber boot may be damaged due to interference with adjacent metal parts while bending the EDJ during removal.

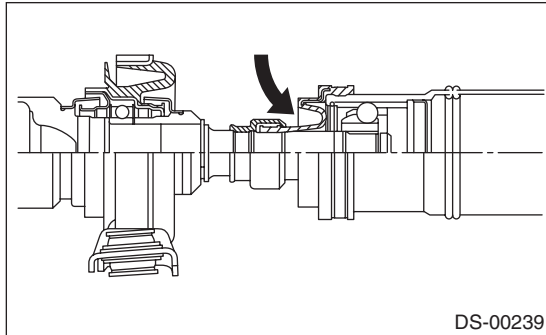

- 1) Disconnect the ground cable from battery.
- 2) Shift the select lever or gear shift lever to neutral.
- 3) Release the parking brake.
- 4) Lift up the vehicle.
- 5) Remove the center exhaust pipe.
- 6) Remove the rear exhaust pipe and muffler.
- 7) Remove the heat shield cover.

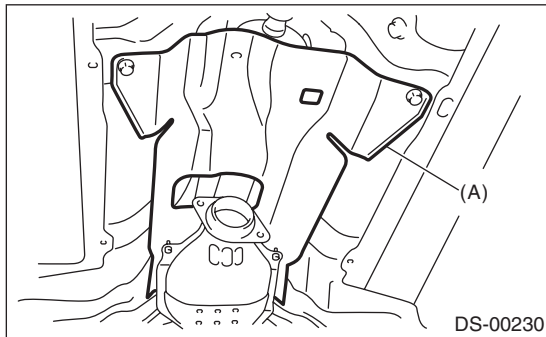

(A) Heat shield cover

- 8) Make alignment marks on the flange yoke and rear differential before removal.

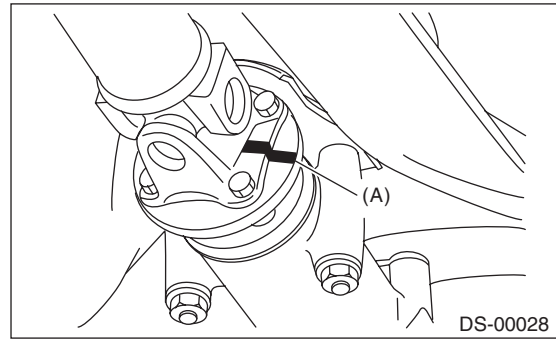

(A) Alignment mark

- 9) Remove the three bolts holding the propeller shaft to the rear differential.
- 10) Remove the remaining bolt.
- 11) Remove the two bolts which hold center bearing to vehicle body.

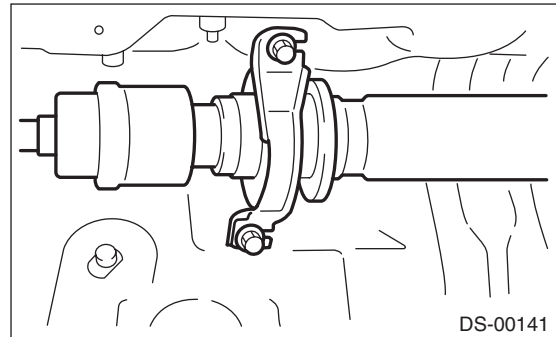

- 12) Remove the propeller shaft from transmission.

**CAUTION:**

- Be careful not to damage oil seals and contact surface of the sleeve yoke.
- Cover the center exhaust pipe with a cloth to keep off any oil spilled from transmission when removing propeller shaft.

**NOTE:**

Use a container to catch oil flowing from propeller shaft.

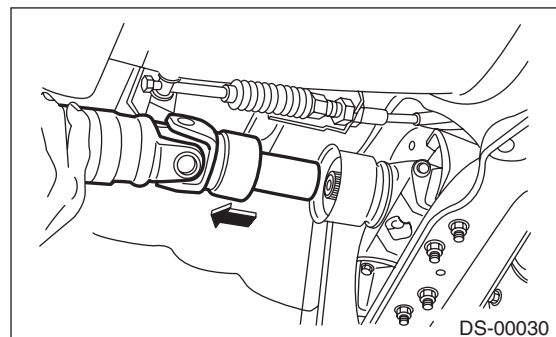

- 13) Install extension cap (A) to the transmission.



# Propeller Shaft

## DRIVE SHAFT SYSTEM

### NOTE:

If extension cap (A) is not available, place vinyl bag over opening and fasten with string to prevent gear oil from leaking.

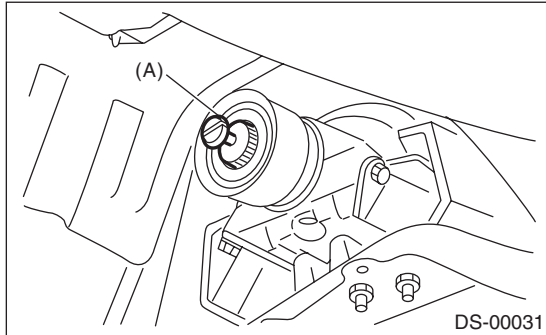

### B: INSTALLATION

1) Insert the sleeve yoke into the transmission and attach center bearing to body.

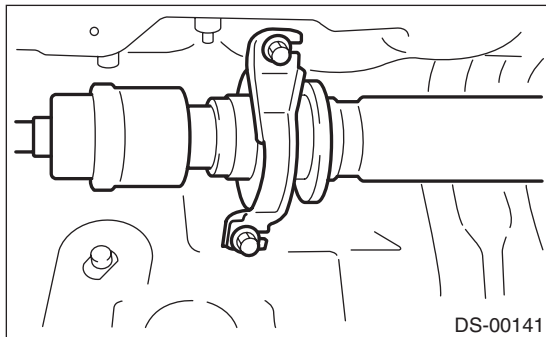

### Tightening torque:

**52 N·m (5.30 kgf·m, 38.4 ft·lb)**

2) Align the alignment marks (A), and connect the flange yoke and rear differential.

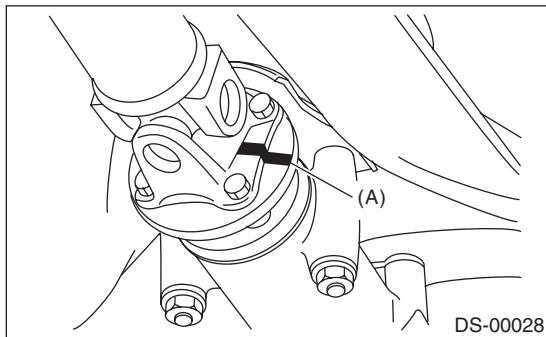

### Tightening torque:

**31 N·m (3.16 kgf·m, 22.9 ft·lb)**

- 3) Install the heat shield cover.
- 4) Install the center exhaust pipe.
- 5) Install the rear exhaust pipe and muffler.
- 6) Lower the vehicle.
- 7) Connect the battery ground terminal.

### C: INSPECTION

#### NOTE:

Do not disassemble propeller shaft. Check the following and replace if necessary.

- Dents or cracks on the tube surface
- Splines for deformation or abnormal wear
- Unsmooth joint operation or abnormal noise
- Center bearing for free play, noise or non-smooth operation.
- Oil seals for abnormal wear or damage
- Damaged center bearing

Check the following points with propeller shaft installed in vehicle.

#### 1. JOINTS AND CONNECTIONS

- 1) Remove the center exhaust pipe.
- 2) Remove the heat shield cover.
- 3) Check for any looseness of the yoke flange mounting bolts which connect to the rear differential and center bearing bracket mounting bolts.

#### 2. SPLINES AND BEARING

- 1) Remove the center exhaust pipe.
- 2) Remove the rear exhaust pipe and muffler.
- 3) Remove the heat shield cover.
- 4) Turn the propeller shaft by hand to see if abnormal free play exists at splines. Also move yokes to see if abnormal free play exists at spiders and bearings.

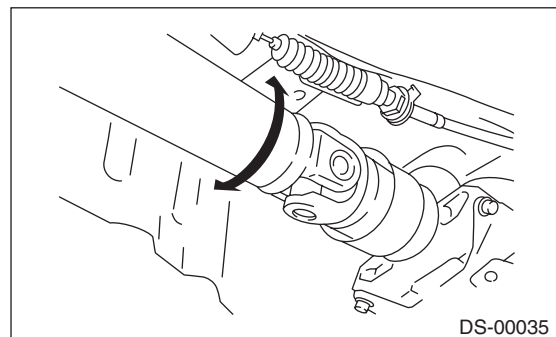

### 3. RUNOUT OF PROPELLER SHAFT

- 1) Remove the center exhaust pipe.
- 2) Remove the rear exhaust pipe and muffler.
- 3) Remove the heat shield cover.
- 4) Set the dial gauge with its indicator stem at the center of the propeller shaft tube.
- 5) Turn the propeller shaft slowly by hands to check for runout of the propeller shaft.

**Runout:**

**Limit: 0.6 mm (0.024 in)**

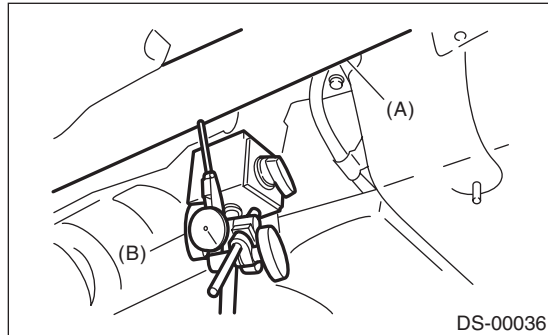

- (A) Propeller shaft
- (B) Dial gauge

### 4. CENTER BEARING FREE PLAY

- 1) Remove the front and center exhaust pipes.
- 2) Remove the rear exhaust pipe and muffler.
- 3) Remove the heat shield cover.
- 4) Move the propeller shaft near the center bearing up, down, left, right by hand, to check for any abnormal free play of the bearings.

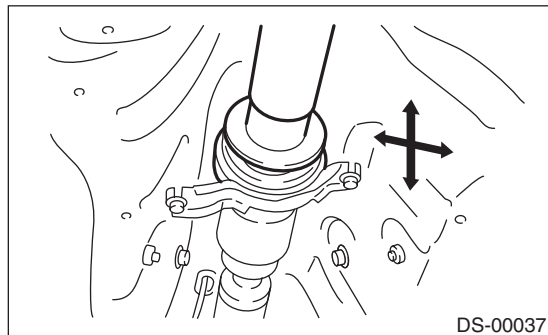

# Front Axle

## DRIVE SHAFT SYSTEM

### 3. Front Axle

#### A: REMOVAL

- 1) Lift up the vehicle, and then remove the front wheels.
- 2) Lift the crimped section of axle nut.

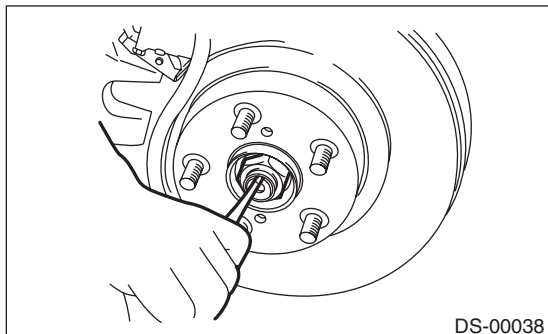

- 3) Remove the axle nut using a socket wrench while depressing the brake pedal.

#### CAUTION:

Do not loosen the axle nut while the front axle is loaded. Doing so may damage the hub bearing.

- 4) Remove the stabilizer link.

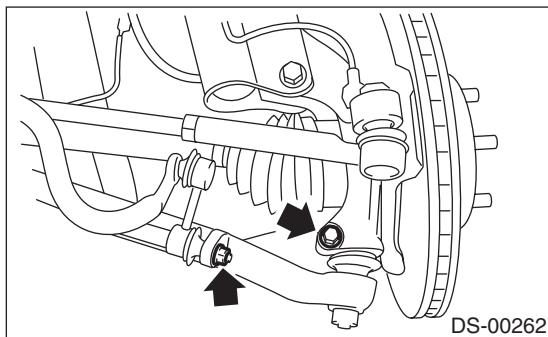

- 5) Remove the disc brake caliper from the housing, and suspend it from strut using a wire.
- 6) Remove the disc rotor from the hub.

#### NOTE:

If it is difficult to remove the disc rotor from the hub, drive the 8 mm bolt into the threaded end of rotor, and then remove the rotor.

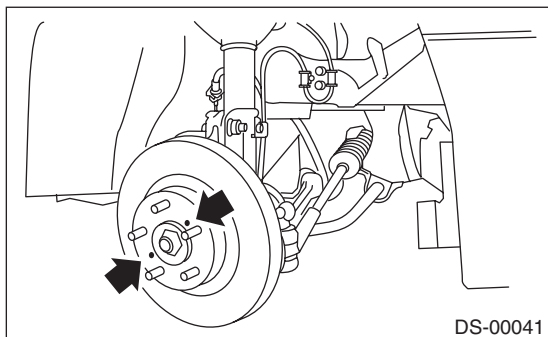

- 7) Remove the cotter pin and castle nut securing the tie-rod end to the housing knuckle arm.

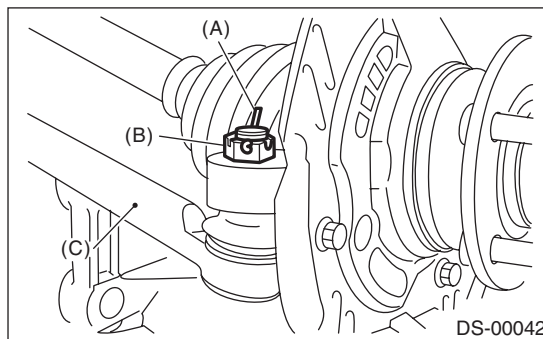

- (A) Cotter pin
- (B) Castle nut
- (C) Tie-rod

- 8) Using a puller, remove the tie-rod ball joint from knuckle arm.

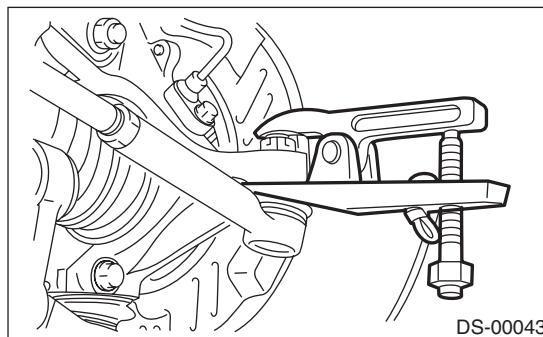

- 9) Remove the ABS wheel speed sensor assembly and harness.

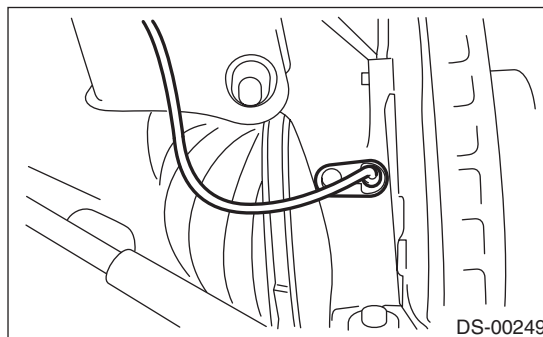

- 10) Remove the bolts which secure the sensor harness to the strut.

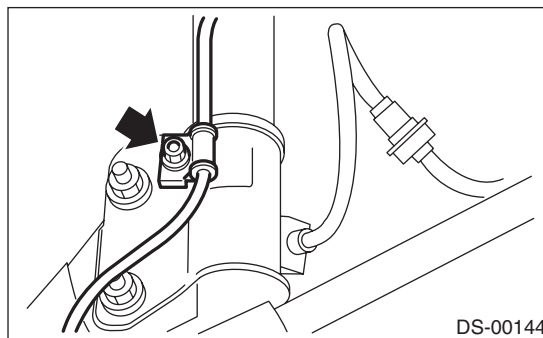

- 11) Remove the front arm ball joint from the housing.

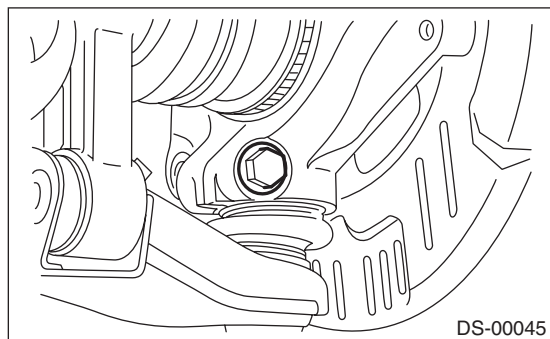

- 12) Remove the front drive shaft from the transmission.

- 13) Remove the front drive shaft assembly from the hub. If it is hard to remove, use the ST.

ST1 926470000 AXLE SHAFT PULLER  
ST2 28099PA110 AXLE SHAFT PULLER PLATE

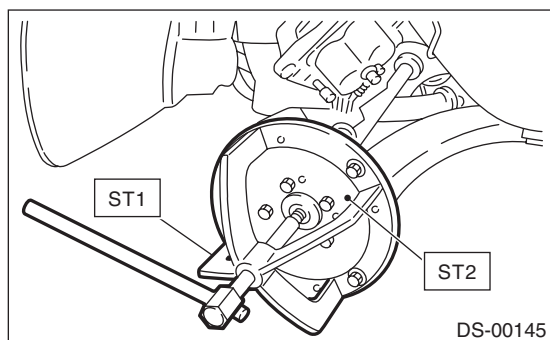

- 14) After scribing an alignment mark on camber adjusting bolt head, remove the bolts which connect the housing and strut, and disconnect the housing from strut.

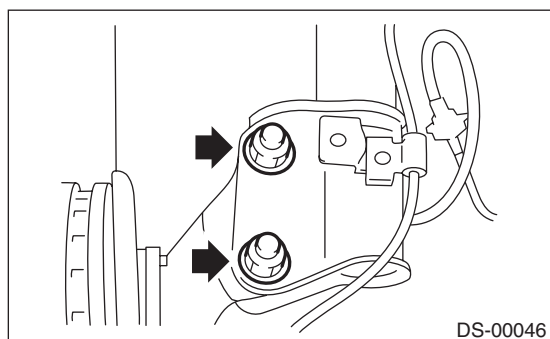

## B: INSTALLATION

- 1) Align the alignment mark on the camber adjusting bolt head, and tighten the housing and strut using a new flange nut.

### Tightening torque:

**155 N·m (15.81 kgf·m, 114.3 ft·lb)**

- 2) Install the front drive shaft. <Ref. to DS-27, INSTALLATION, Front Drive Shaft.>

- 3) Install the front arm ball joint to the housing.

### Tightening torque:

**50 N·m (5.10 kgf·m, 36.9 ft·lb)**

- 4) Install the ABS sensor harness to the strut.  
5) Install the ABS wheel speed sensor on the housing.

### Tightening torque:

**7.5 N·m (0.76 kgf·m, 5.5 ft·lb)**

- 6) Install the disc rotor to hub.  
7) Install the disc brake caliper on the housing.

### Tightening torque:

**17-inch type**

**155 N·m (15.81 kgf·m, 114.3 ft·lb)**

**16-inch type**

**80 N·m (8.16 kgf·m, 59 ft·lb)**

- 8) Install the stabilizer link.

### Tightening torque:

**38 N·m (3.87 kgf·m, 28 ft·lb)**

- 9) Connect the tie-rod end ball joint to the knuckle arm with a castle nut.

### CAUTION:

When connecting the tie-rod, do not hit the cap at bottom of tie-rod end with a hammer.

### Tightening torque:

**27 N·m (2.75 kgf·m, 19.9 ft·lb)**

- 10) Tighten the castle nut to specified torque and tighten further within 60° until the pin hole is aligned with the slot in the nut. Bend the cotter pin to lock.

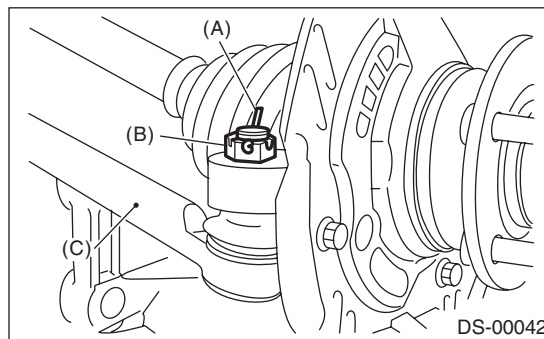

- (A) Cotter pin  
(B) Castle nut  
(C) Tie-rod

- 11) While depressing the brake pedal, tighten a new axle nut to the specified torque and lock it securely.

### CAUTION:

Do not apply weight to the front axle before tightening the axle nut. Doing so may damage the hub bearing.

### Tightening torque:

**220 N·m (22.43 kgf·m, 162.3 ft·lb)**

# Front Axle

## DRIVE SHAFT SYSTEM

12) After tightening the axle nut, lock it securely.

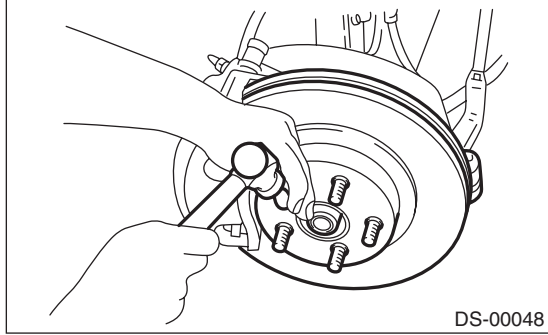

13) Install the wheel.

### Tightening torque:

**100 N·m (10.20 kgf·m, 73.8 ft·lb)**

14) Connect the battery ground terminal.

15) Inspect the wheel alignment and adjust if necessary.

## C: DISASSEMBLY

1) Remove the four bolts from the housing (A), and remove the front hub unit bearing and disc cover.

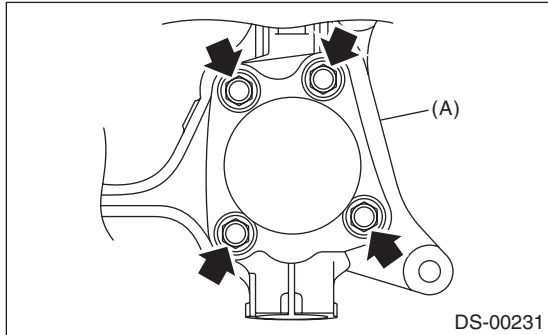

### CAUTION:

- Do not get closer the tool which charged magnetism to magnetic encoder.
- Be careful not to damage the magnetic encoder.

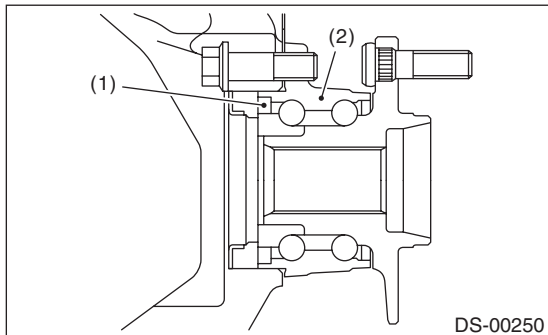

- (1) Magnetic encoder
- (2) Front hub unit bearing

2) Disassemble the front hub unit bearing. <Ref. to DS-19, DISASSEMBLY, Front Hub Unit Bearing.>

## D: ASSEMBLY

1) Assemble the front hub unit bearing. <Ref. to DS-19, ASSEMBLY, Front Hub Unit Bearing.>

2) Place the disc cover between housing (A) and front hub unit, and tighten the four bolts.

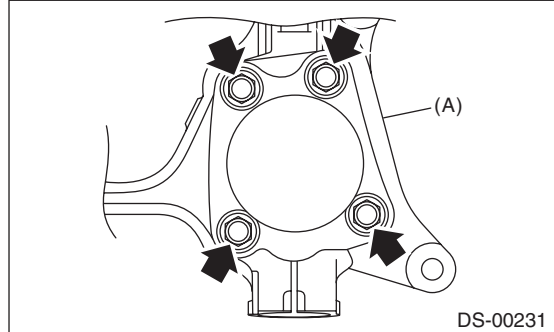

### Tightening torque:

**65 N·m (6.63 kgf·m, 47.9 ft·lb)**

### CAUTION:

- Do not get closer the tool which charged magnetism to magnetic encoder.
- Be careful not to damage the magnetic encoder.

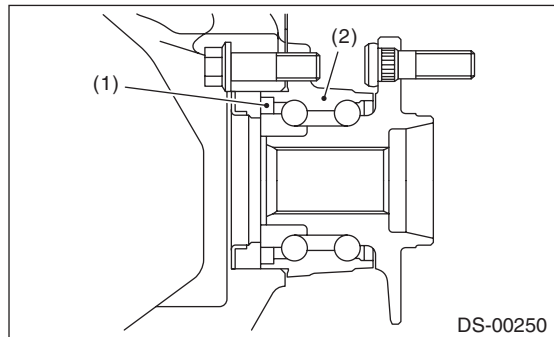

- (1) Magnetic encoder
- (2) Front hub unit bearing

## E: INSPECTION

1) Moving the front tire up and down by hand, check there is no play in bearing, and check the wheel rotates smoothly.

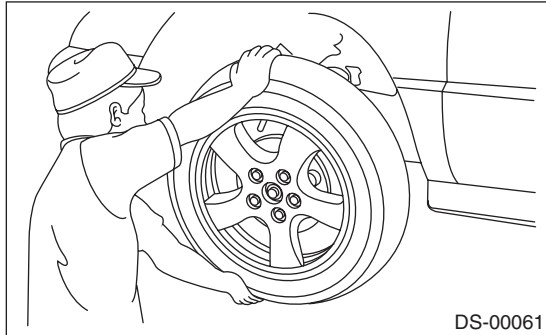

2) Inspect the lean of axis direction using a dial gauge. Replace the bearing if the load range exceeds the limitation.

### **Service limit:**

**Maximum: 0.05 mm (0.0020 in)**

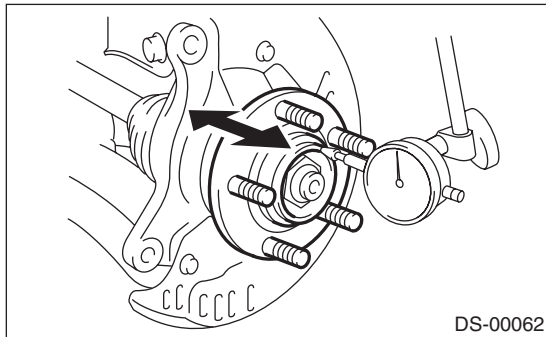



# Front Hub Unit Bearing

DRIVE SHAFT SYSTEM

## 4. Front Hub Unit Bearing

### A: REMOVAL

- 1) Lift up the vehicle, and then remove the front wheels.
- 2) Lift the crimped section of axle nut.

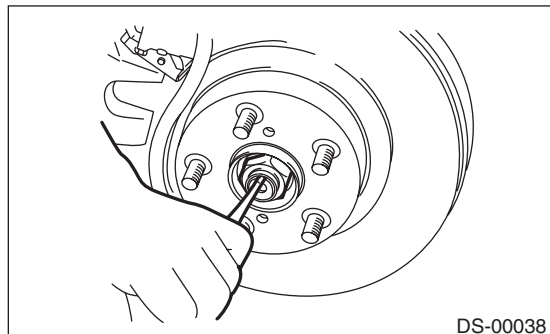

- 3) Remove the axle nut using a socket wrench while depressing the brake pedal.

#### CAUTION:

**Do not loosen the axle nut while the front axle is loaded. Doing so may damage the hub bearing.**

- 4) Remove the disc brake caliper from the housing, and suspend it from strut using a wire.
- 5) Remove the disc rotor from the hub.

#### NOTE:

If it is difficult to remove the disc rotor from the hub, drive the 8 mm bolt into the threaded end of rotor, and then remove the rotor.

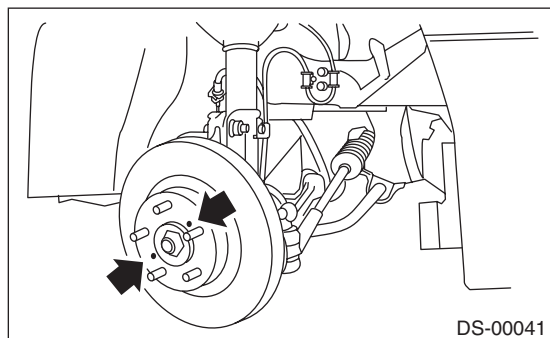

- 6) Remove the four bolts from the housing.

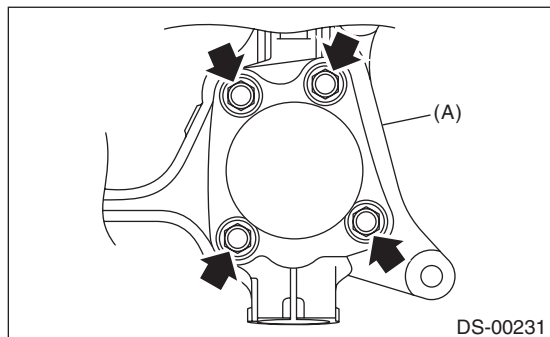

(A) Housing

#### CAUTION:

- Do not get closer the tool which charged magnetism to magnetic encoder.
- Be careful not to damage the magnetic encoder.

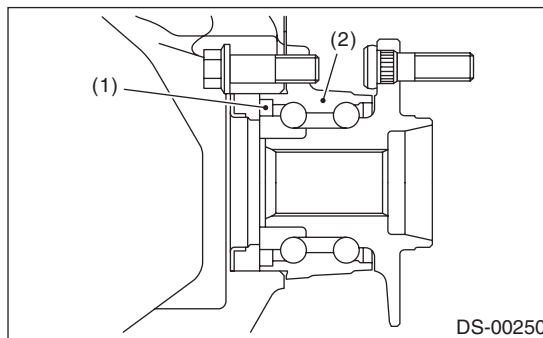

- (1) Magnetic encoder
- (2) Front hub unit bearing

- 7) Remove the front hub unit bearing. If it is hard to remove, use the ST.

ST1 926470000 AXLE SHAFT PULLER  
ST2 28099PA110 AXLE SHAFT PULLER PLATE

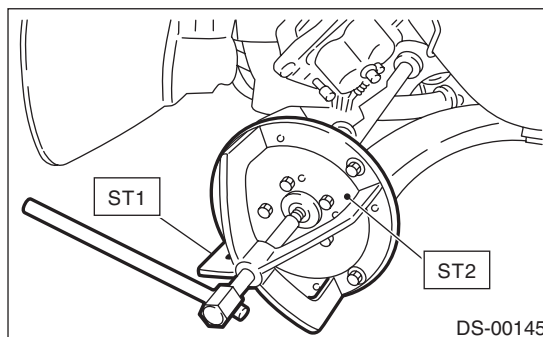

### B: INSTALLATION

- 1) Place the disc cover between housing (A) and front hub unit, and tighten the four bolts.

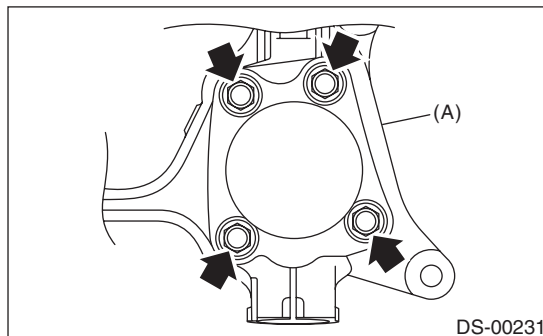

#### Tightening torque:

**65 N·m (6.63 kgf·m, 47.9 ft·lb)**

- 2) Install the front drive shaft. <Ref. to DS-27, INSTALLATION, Front Drive Shaft.>
- 3) Tighten the axle nut temporarily.
- 4) Install the disc rotor to hub.

5) Install the disc brake caliper on the housing.

**Tightening torque:**

**17-inch type**

**155 N·m (15.81 kgf·m, 114.3 ft·lb)**

**16-inch type**

**80 N·m (8.16 kgf·m, 59 ft·lb)**

6) While depressing the brake pedal, tighten a new axle nut to the specified torque and lock it securely.

**CAUTION:**

**Do not apply weight to the front axle before tightening the axle nut. Doing so may damage the hub bearing.**

**Tightening torque:**

**220 N·m (22.43 kgf·m, 162.3 ft·lb)**

7) After tightening the axle nut, lock it securely.

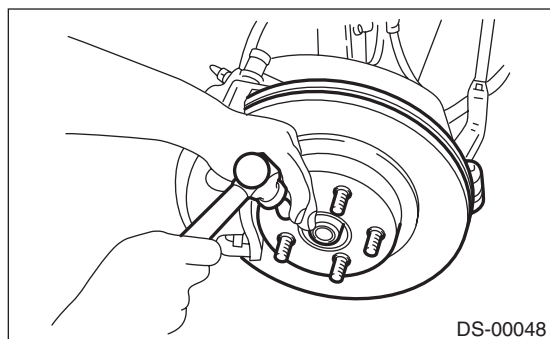

8) Install the wheel.

**Tightening torque:**

**100 N·m (10.20 kgf·m, 73.8 ft·lb)**

## C: DISASSEMBLY

Using the ST and a hydraulic press, push out the hub bolts.

**CAUTION:**

- **Be careful not to hammer the hub bolts. This may deform the hub.**
- **Do not reuse the hub bolt.**

ST 28399AG000 HUB STAND

**NOTE:**

Since the hub unit bearing (1) can not be disassembled, only hub bolts can be removed.

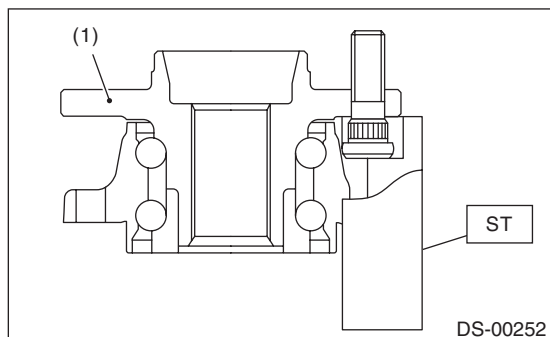

## D: ASSEMBLY

1) Attach the hub to the ST securely.  
ST 28099PA080 HUB STAND

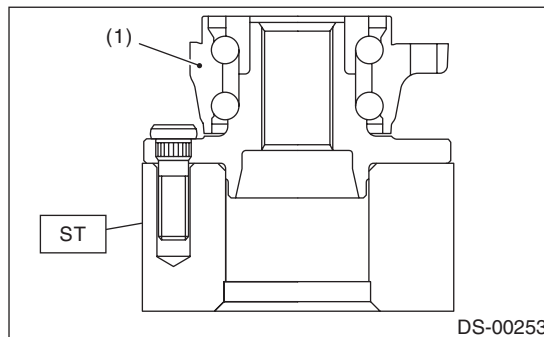

(1) Front hub unit bearing

2) Using a press, press the new hub bolts until their seating surfaces contact the hub.

**NOTE:**

Use the 12 mm (0.47 in) dia. holes in the HUB STAND to prevent bolts from tilting.

## E: INSPECTION

Refer to "Front Axle" for inspection procedures.  
<Ref. to DS-17, INSPECTION, Front Axle.>

**CAUTION:**

**If there is any fault in the bearing, replace hub unit bearing.**



# Rear Axle

## DRIVE SHAFT SYSTEM

### 5. Rear Axle

#### A: REMOVAL

- 1) Disconnect the ground cable from battery.
- 2) Lift up the vehicle, and then remove the rear wheels.
- 3) Lift the crimped section of axle nut.

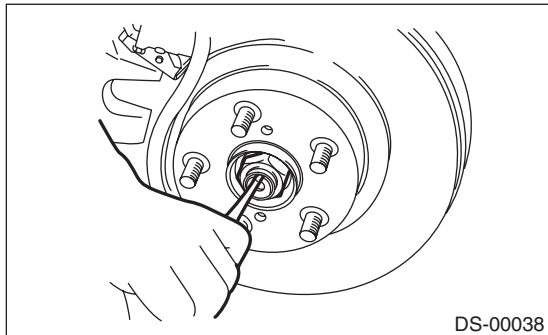

- 4) Remove the axle nut using a socket wrench while depressing the brake pedal.

#### CAUTION:

**Do not loosen the axle nut while the rear axle is loaded. Doing so may damage the hub bearing.**

- 5) Remove the brake hose bracket and the rear ABS wheel speed sensor.

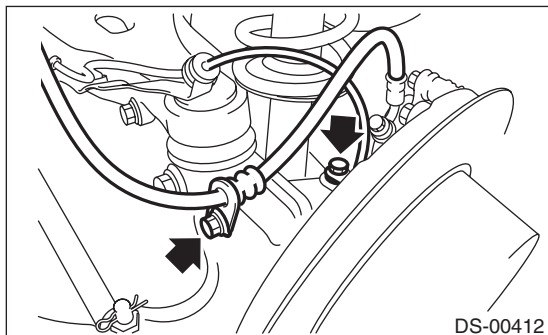

- 6) Remove the disc brake caliper from the rear housing, and suspend it from vehicle using a string.

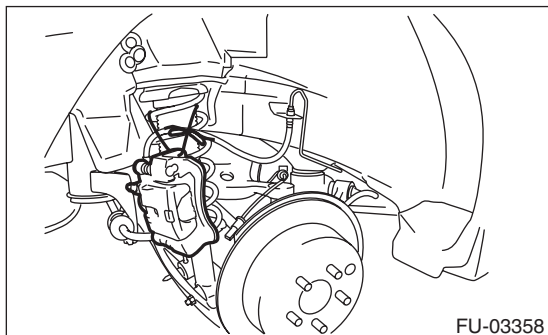

- 7) Remove the rear disc rotor.

- 8) Remove the four bolts from the rear housing.

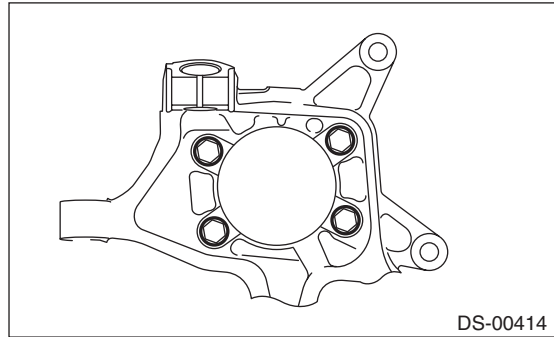

- 9) Remove the rear hub unit bearing.

#### CAUTION:

- Be careful not to damage the magnetic encoder.
- Do not get closer the tool which charged magnetism to magnetic encoder.

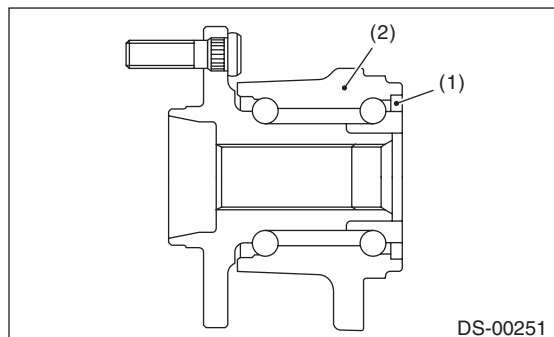

- (1) Magnetic encoder
- (2) Rear hub unit bearing

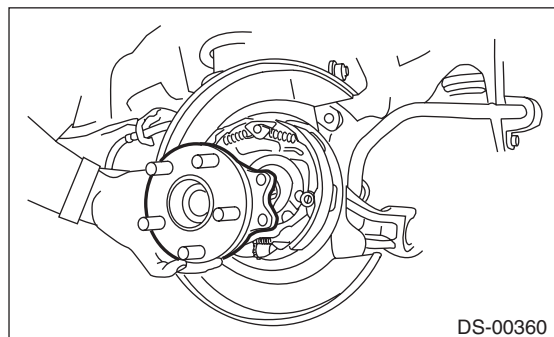

**NOTE:**

If it is hard to remove, use the ST.

ST1 926470000 AXLE SHAFT PULLER  
 ST2 28099PA110 AXLE SHAFT PULLER  
 PLATE

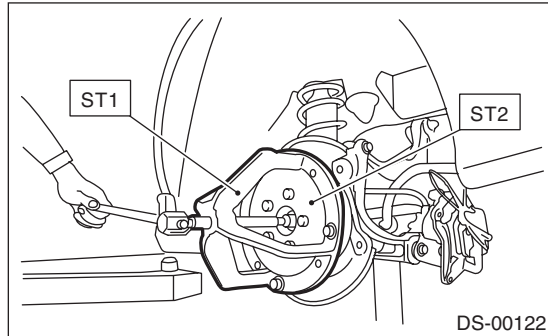

10) Remove the snap pin and nut from the front lateral link.

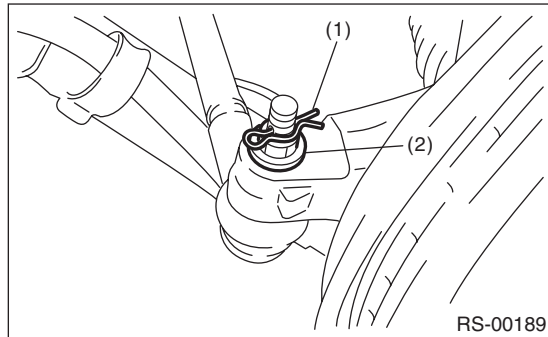

- (1) Snap pin
- (2) Nut

11) Separate the rear housing and the ball joint using the puller.

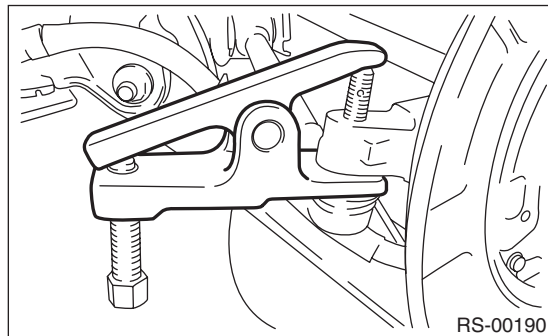

12) Separate the upper arm, trailing link and rear lateral link from the rear housing.

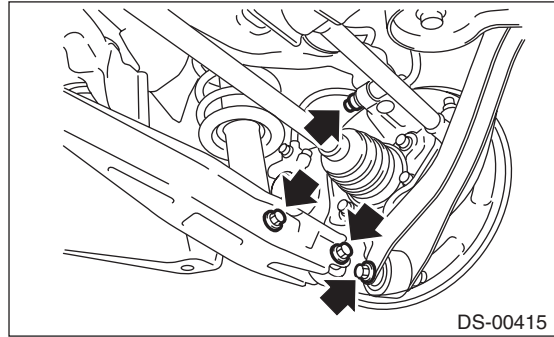

13) Remove the rear axle.

## B: INSTALLATION

1) Temporarily tighten the rear housing to the upper arm.

2) Aligning with the mounting hole of the rear brake back plate, temporarily tighten the rear hub unit bearing to the rear housing.

**CAUTION:**

- Be careful not to damage the magnetic encoder.
- Do not get closer the tool which charged magnetism to magnetic encoder.

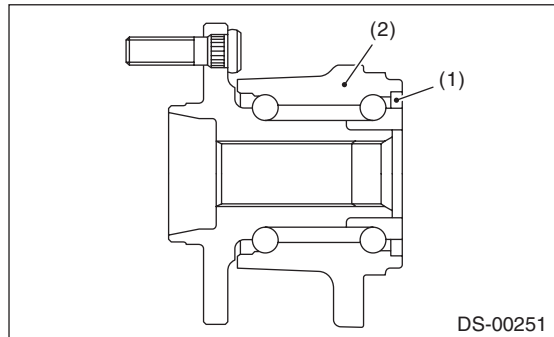

- (1) Magnetic encoder
- (2) Rear hub unit bearing

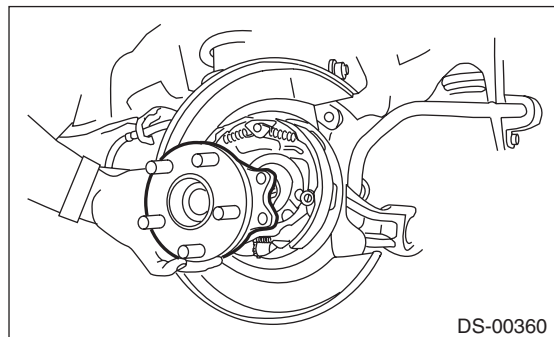

3) Attach the rear drive shaft to the rear hub unit bearing.

4) Tighten the new axle nut temporarily.

**CAUTION:**

Use new axle nuts.

## Rear Axle

### DRIVE SHAFT SYSTEM

5) Attach the links to the rear housing and tighten them to the specified torque.

#### **Tightening torque:**

##### **Upper arm**

**80 N·m (8.16 kgf·m, 59 ft·lb)**

##### **Front lateral link**

**60 N·m (6.12 kgf·m, 44.3 ft·lb)**

##### **Rear lateral link**

**80 N·m (8.16 kgf·m, 59 ft·lb)**

##### **Trailing link**

**90 N·m (9.18 kgf·m, 66.4 ft·lb)**

6) Tighten the four bolts of the rear housing.

#### **Tightening torque:**

**65 N·m (6.63 kgf·m, 47.9 ft·lb)**

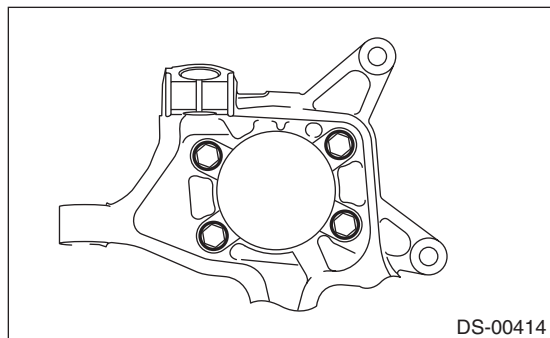

7) Install the rear disc rotor.

8) Install the rear disc brake caliper on the rear housing.

#### **Tightening torque:**

##### **17-inch type**

**65 N·m (6.63 kgf·m, 47.9 ft·lb)**

##### **15-inch type**

**66 N·m (6.73 kgf·m, 48.7 ft·lb)**

9) Install the brake hose bracket and rear ABS wheel speed sensor.

#### **Tightening torque:**

##### **Brake hose bracket**

**33 N·m (3.36 kgf·m, 24.3 ft·lb)**

##### **Rear ABS wheel speed sensor**

**7.5 N·m (0.76 kgf·m, 5.5 ft·lb)**

10) While pressing the brake pedal, tighten the new axle nuts to the specified torque.

#### **CAUTION:**

**Do not apply weight to the rear axle before tightening the axle nut. Doing so may damage the hub bearing.**

#### **Tightening torque:**

**190 N·m (19.37 kgf·m, 140.1 ft·lb)**

11) After tightening the axle nut, lock it securely.

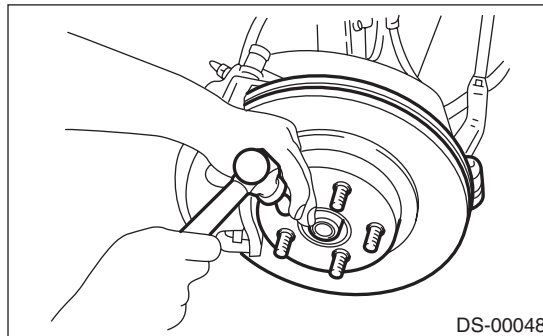

12) Install the rear wheels.

#### **Tightening torque:**

**100 N·m (10.20 kgf·m, 73.8 ft·lb)**

13) Connect the battery ground terminal.

14) Inspect the wheel alignment and adjust if necessary.

## **C: DISASSEMBLY**

### **1. REAR HUB UNIT BEARING**

1) Remove the four bolts from the rear housing, and remove the rear hub unit bearing and back plate.

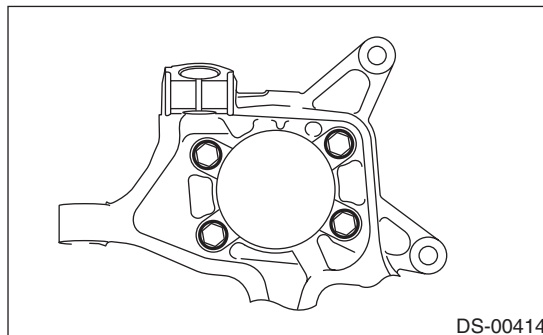

#### **CAUTION:**

- Be careful not to damage the magnetic encoder.
- Do not get closer the tool which charged magnetism to magnetic encoder.

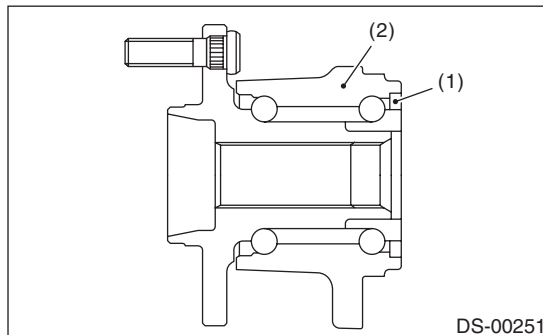

- (1) Magnetic encoder  
(2) Rear hub unit bearing

2) Disassemble the rear hub unit bearing. <Ref. to DS-25, DISASSEMBLY, Rear Hub Unit Bearing.>

## 2. BUSHING

For the removal procedure of bushing, refer to "Rear Trailing Link" in "REAR SUSPENSION". <Ref. to RS-10, REAR HOUSING BUSHING, DISASSEMBLY, Rear Trailing Link.>

## D: ASSEMBLY

### 1. REAR HUB UNIT BEARING

Assemble each part in the reverse order of disassembly.

#### *Tightening torque:*

#### *Rear hub unit bearing*

**65 N·m (6.63 kgf·m, 47.9 ft·lb)**

## 2. BUSHING

For the installation procedure of bushing, refer to "Rear Trailing Link" in "REAR SUSPENSION". <Ref. to RS-12, REAR HOUSING BUSHING, ASSEMBLY, Rear Trailing Link.>

## E: INSPECTION

1) Moving the rear tire up and down by hand, check that there is no backlash in bearing, and check that the wheel rotates smoothly.

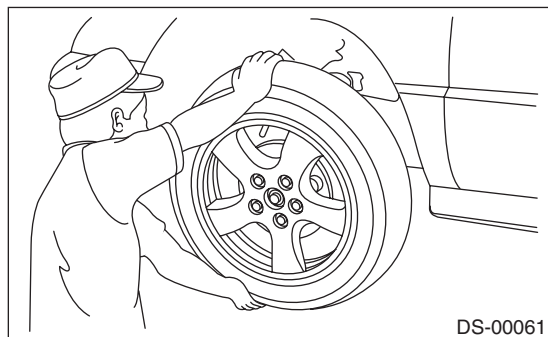

2) Inspect the lean of axis direction using a dial gauge. Replace the bearing if the load range exceeds the limitation.

#### *Service limit:*

**Maximum: 0.05 mm (0.0020 in)**

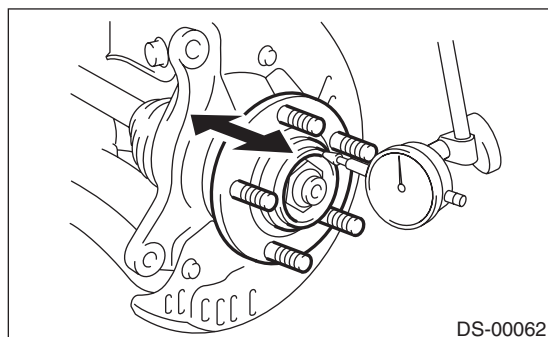

# Rear Hub Unit Bearing

## DRIVE SHAFT SYSTEM

### 6. Rear Hub Unit Bearing

#### A: REMOVAL

- 1) Lift up the vehicle, and then remove the rear wheels.
- 2) Lift the crimped section of axle nut.

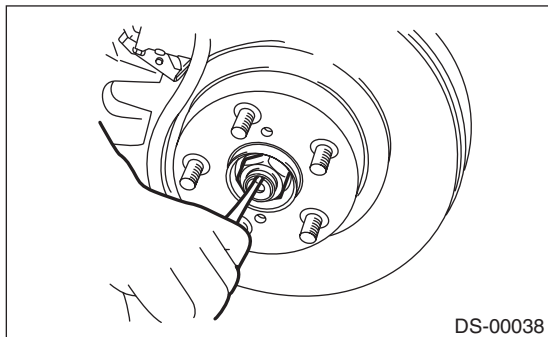

- 3) Remove the axle nut using a socket wrench while depressing the brake pedal.

#### CAUTION:

**Do not loosen the axle nut while the rear axle is loaded. Doing so may damage the hub bearing.**

- 4) Remove the disc brake caliper from the rear housing, and suspend it from vehicle using a string.

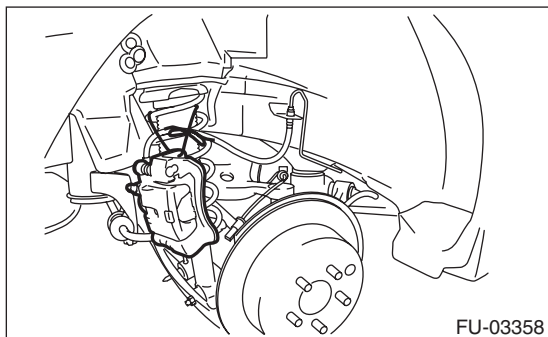

- 5) Remove the rear disc rotor.
- 6) Remove the four bolts from the rear housing.

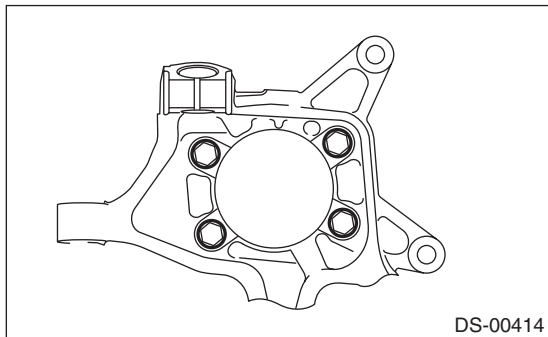

- 7) Remove the rear hub unit bearing.

#### CAUTION:

- Be careful not to damage the magnetic encoder.
- Do not get closer the tool which charged magnetism to magnetic encoder.

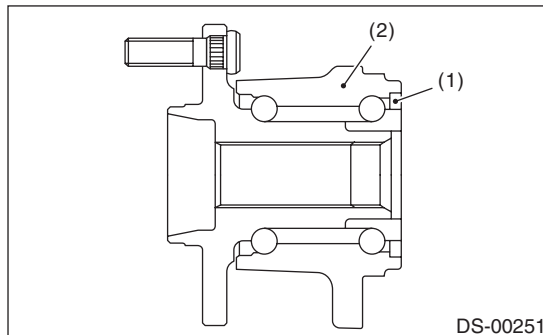

- (1) Magnetic encoder
- (2) Rear hub unit bearing

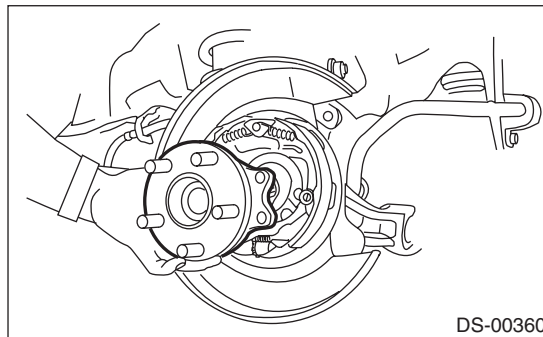

#### NOTE:

If it is hard to remove, use the ST.

- ST1 926470000 AXLE SHAFT PULLER  
ST2 28099PA110 AXLE SHAFT PULLER PLATE

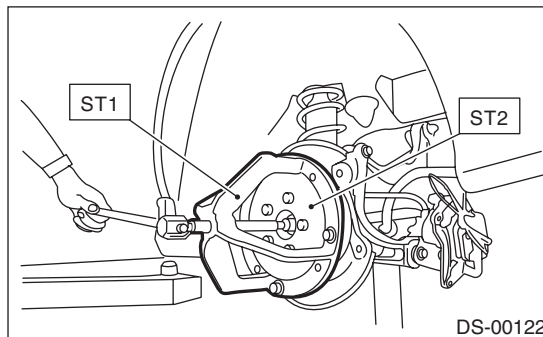

**B: INSTALLATION**

1) Aligning with the mounting hole of the rear brake back plate, temporarily tighten the rear hub unit bearing to the rear housing.

**CAUTION:**

- Be careful not to damage the magnetic encoder.
- Do not get closer the tool which charged magnetism to magnetic encoder.

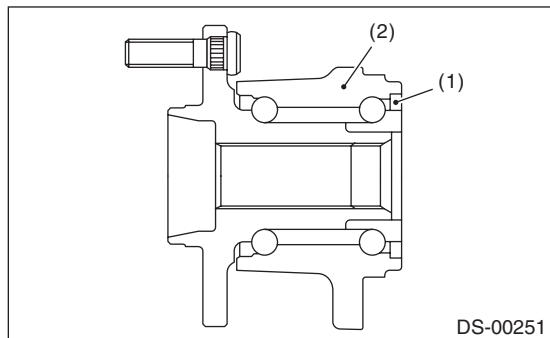

- (1) Magnetic encoder  
(2) Rear hub unit bearing

2) Tighten the four bolts of the rear housing.

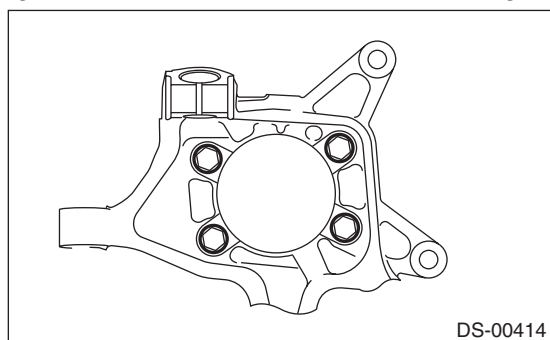
**Tightening torque:**

**65 N·m (6.63 kgf·m, 47.9 ft·lb)**

3) Tighten the new axle nut temporarily.

4) Install the rear disc rotor.

5) Install the disc brake caliper on the rear housing.

**Tightening torque:**

**17-inch type**

**65 N·m (6.63 kgf·m, 47.9 ft·lb)**

**15-inch type**

**66 N·m (6.73 kgf·m, 48.7 ft·lb)**

6) While pressing the brake pedal, tighten the new axle nuts to the specified torque.

**Tightening torque:**

**190 N·m (19.4 kgf·m, 140.1 ft·lb)**

**CAUTION:**

Do not apply weight to the rear axle before tightening the axle nut. Doing so may damage the hub bearing.

7) After tightening the axle nut, lock it securely.

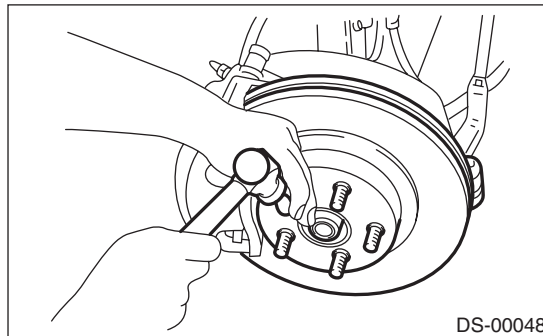

8) Install the rear wheels.

**Tightening torque:**

**100 N·m (10.20 kgf·m, 73.8 ft·lb)**

**C: DISASSEMBLY**

Using the ST and a hydraulic press, push out the hub bolts.

**CAUTION:**

- Be careful not to hammer the hub bolts. This may deform the hub.
- Do not reuse the hub bolt.

ST 28399AG000 HUB STAND

**NOTE:**

Since the hub unit bearing can not be disassembled, only hub bolts can be removed.

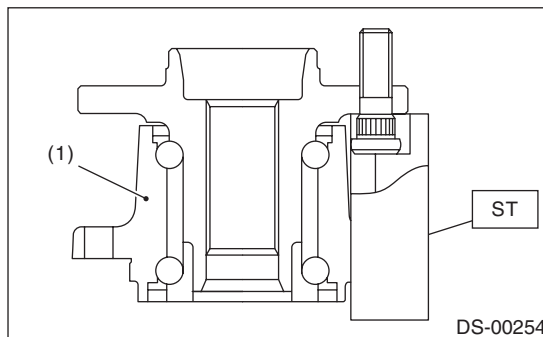

- (1) Rear hub unit bearing

# Rear Hub Unit Bearing

## DRIVE SHAFT SYSTEM

### D: ASSEMBLY

- 1) Attach the hub to the ST securely.  
ST 28099PA080 HUB STAND

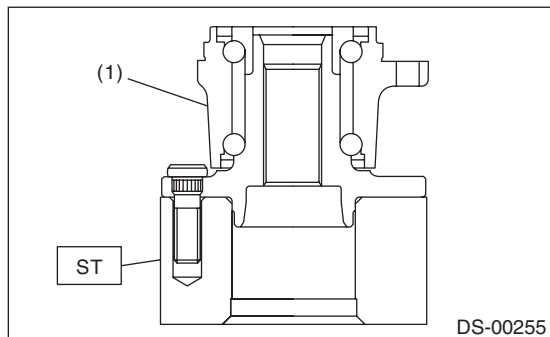

(1) Rear hub unit bearing

- 2) Using a press, press the new hub bolts until their seating surfaces contact the hub.

#### NOTE:

Use the 12 mm (0.47 in) dia. holes in the HUB STAND to prevent bolts from tilting.

### E: INSPECTION

- 1) Moving the rear tire up and down by hand, check there is no backlash in bearing, and check the wheel rotates smoothly.

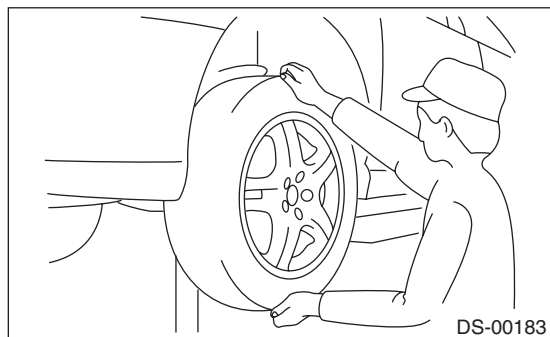

- 2) Inspect the lean of axis direction using a dial gauge. Replace the hub bearing if the play exceeds the limit value.

#### Service limit:

**Maximum: 0.05 mm (0.0020 in)**

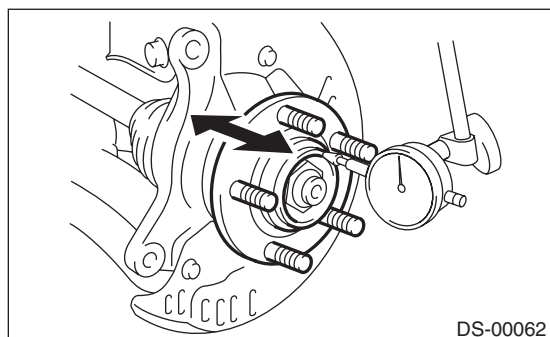



## 7. Front Drive Shaft

### A: REMOVAL

- 1) Disconnect the ground cable from battery.
- 2) Lift up the vehicle, and then remove the front wheels.
- 3) Lift the crimped section of axle nut.

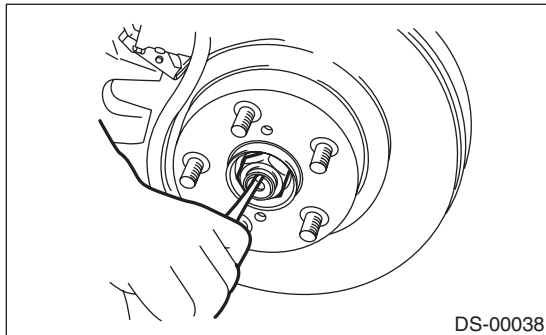

- 4) Remove the axle nut using a socket wrench while depressing the brake pedal.

#### CAUTION:

**Do not loosen the axle nut while the front axle is loaded. Doing so may damage the hub bearing.**

- 5) Drain the transmission gear oil.
- 6) Remove the stabilizer link from front arm.
- 7) Disconnect the front arm ball joint from the housing.

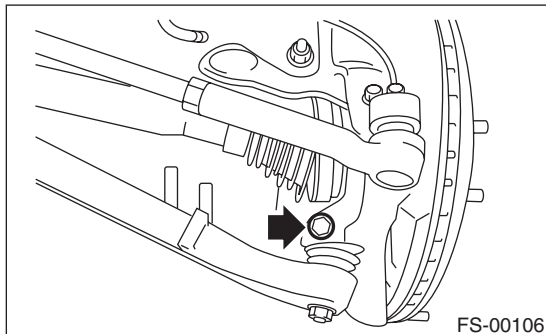

- 8) Remove the front drive shaft assembly. If it is hard to remove, use ST1 and ST2.

ST1 926470000 AXLE SHAFT PULLER  
ST2 28099PA110 AXLE SHAFT PULLER PLATE

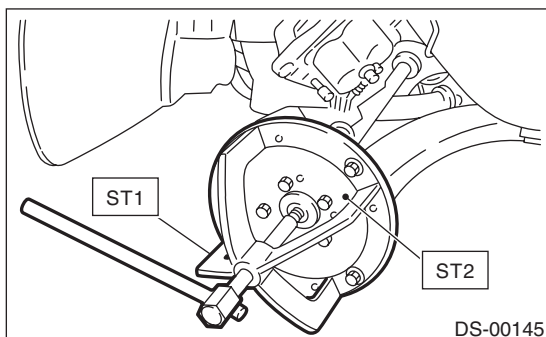

- 9) Using a bar, remove the front drive shaft from transmission.

#### CAUTION:

**Be careful not to allow the bar to damage holder area.**

### B: INSTALLATION

- 1) Replace the differential side retainer oil seal with a new part.

#### NOTE:

After pulling out the drive shaft, be sure to replace with a new oil seal.

**6MT model:** <Ref. to 6MT-29, REPLACEMENT, Differential Side Retainer Oil Seal.>

**5MT model:** <Ref. to 5MT-32, REPLACEMENT, Differential Side Retainer Oil Seal.>

- 2) Insert the AC into hub splines.
- 3) Draw the drive shaft into specified position.

#### CAUTION:

**Do not hammer drive shaft when installing it.**

- 4) Tighten the axle nut temporarily.
- 5) Using the ST, install the front drive shaft to transmission.

ST 28399SA010 OIL SEAL PROTECTOR

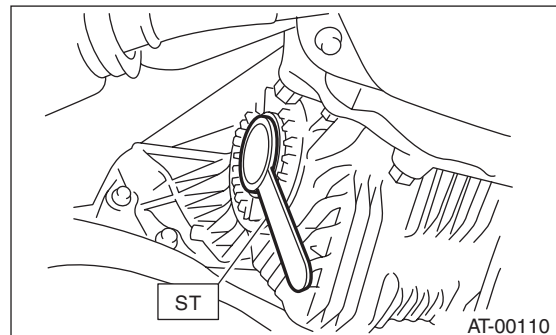

- 6) Connect the front arm ball joint to the housing.

#### Tightening torque:

**50 N·m (5.10 kgf·m, 36.9 ft·lb)**

- 7) Install the stabilizer link.

#### CAUTION:

**Be sure to use a new self-locking nut.**

#### Tightening torque:

**38 N·m (3.87 kgf·m, 28 ft·lb)**

- 8) While pressing the brake pedal, tighten the new axle nuts to the specified torque.

#### CAUTION:

**Do not apply weight to the front axle before tightening the axle nut. Doing so may damage the hub bearing.**

#### Tightening torque:

**220 N·m (22.43 kgf·m, 162.3 ft·lb)**

- 9) After tightening axle nut, lock it securely.



# Front Drive Shaft

## DRIVE SHAFT SYSTEM

- 10) Fill transmission gear oil.
- 11) Install the front wheels.

### Tightening torque:

**100 N·m (10.20 kgf·m, 73.8 ft·lb)**

- 12) Connect the battery ground terminal.
- 13) Inspect the wheel alignment and adjust if necessary.

## C: DISASSEMBLY

### 1. EXCEPT FOR STI MODEL

- 1) Place alignment marks on the shaft and outer race.

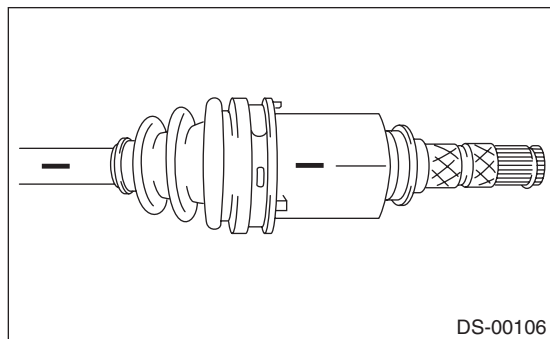

- 2) Remove the PTJ boot band and boot.

### CAUTION:

**Be careful not to damage the boot.**

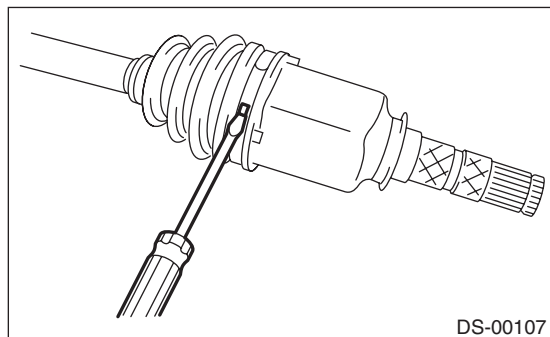

- 3) Remove the snap ring from PTJ outer race.

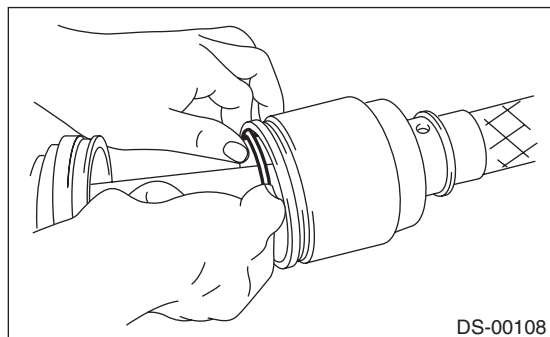

- 4) Remove the PTJ outer race from shaft assembly.
- 5) Wipe off grease.

### CAUTION:

**The grease is a special type of grease. Do not mix with other grease.**

- 6) Place alignment marks on the roller kit and trunnion.

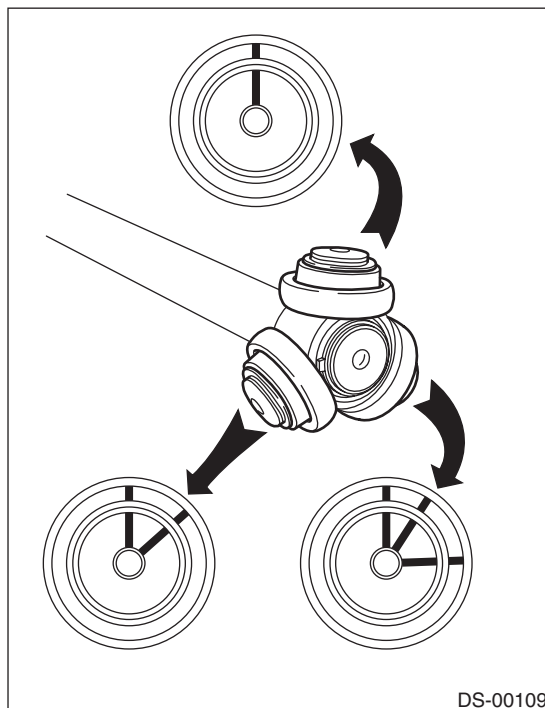

- 7) Remove the roller kit from trunnion.

### CAUTION:

**Be careful with the roller kit position.**

- 8) Place alignment marks on the trunnion and shaft.

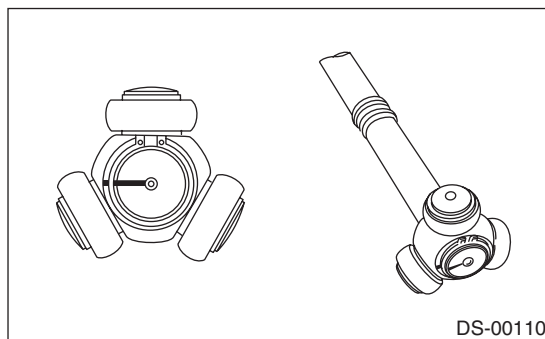

- 9) Remove the snap ring and trunnion.

### CAUTION:

**Be sure to wrap shaft splines with vinyl tape to protect the boot from scratches.**

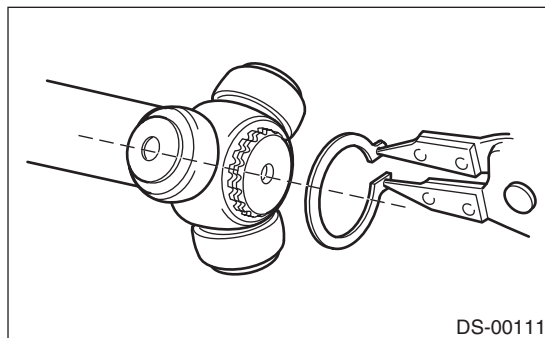

- 10) Remove the PTJ boot.

11) Remove the O-ring from the groove of the shaft.

**NOTE:**

The EBJ is a non-disassembly part, so the axle disassembly stops here.

**2. STI MODEL**

1) Place alignment marks on the shaft and outer race.

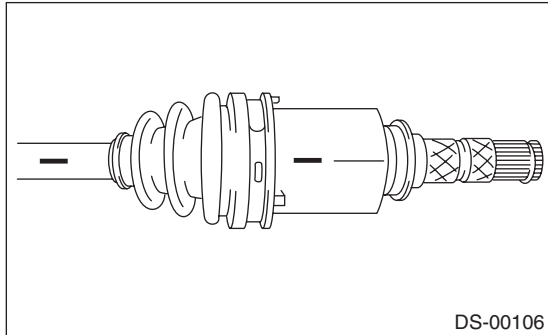

2) Remove the AAR boot band and boot.

**CAUTION:**

**Be careful not to damage the boot.**

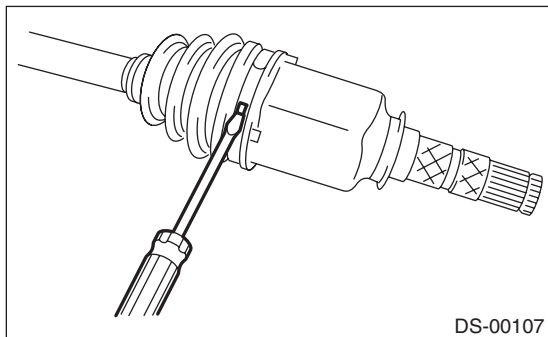

3) Place the drive shaft between wooden blocks and fix it on a vise.

**CAUTION:**

**Do not set the only drive shaft on a vise.**

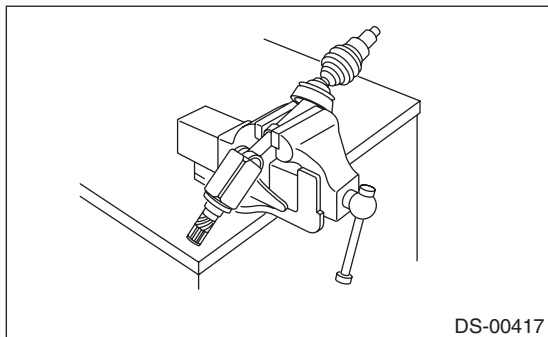

4) Tap the staking area of the outer race alternately with a plastic or wooden bar, and remove one roller at a time.

**CAUTION:**

- Tap the staking area (A) of the outer race.
- Do not use a metal bar as the outer race may deform.
- Be careful not to damage the roller parts.

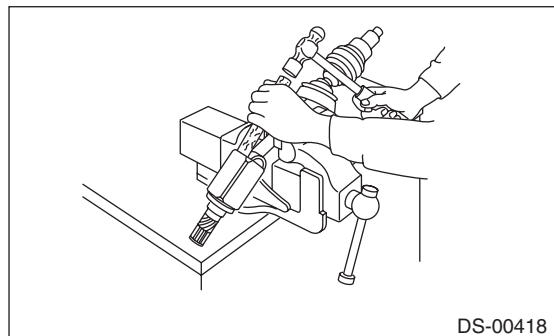
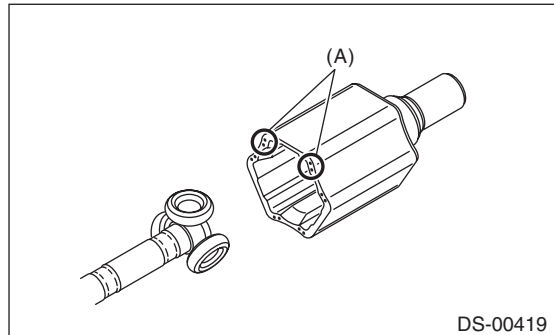

5) Remove the outer race from shaft assembly.

**CAUTION:**

**Make sure to have your associate held the outer race when removing the third roller to prevent the outer race from falling.**

6) Wipe off grease.

**CAUTION:**

**The grease is a special type of grease. Do not mix with other grease.**

# Front Drive Shaft

## DRIVE SHAFT SYSTEM

7) Place alignment marks on the roller kit and trunnion.

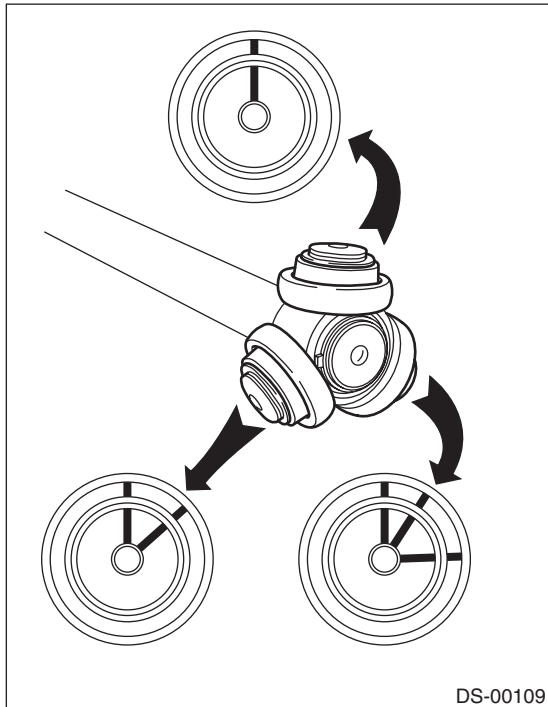

8) Remove the roller kit from trunnion.

**CAUTION:**

**Be careful with the roller kit position.**

9) Place alignment marks on the trunnion and shaft.

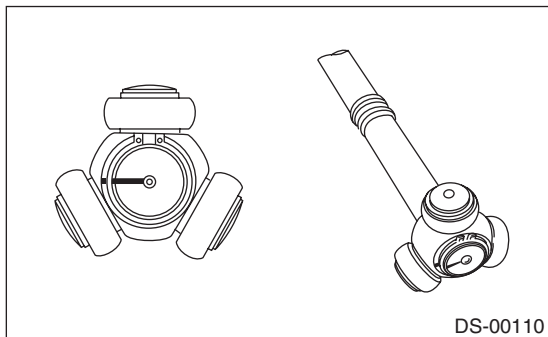

10) Remove the snap ring and trunnion.

**CAUTION:**

**Be sure to wrap shaft splines with vinyl tape to protect the boot from scratches.**

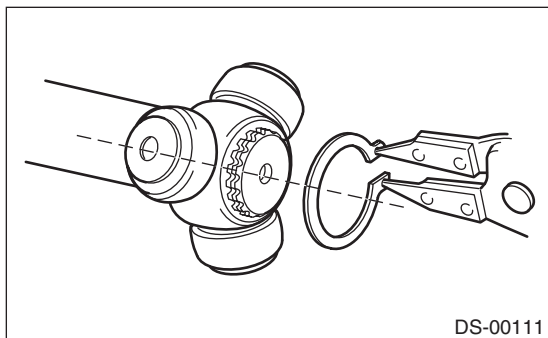

11) Remove the AAR boot.

**NOTE:**

The AC is a non-disassembly part, so the drive shaft disassembly stops here.

## D: ASSEMBLY

### 1. EXCEPT FOR STI MODEL

1) Roll up a thick piece of paper to a size where the shaft can pass through, and affix with tape to form a cylinder.

2) Attach a new O-ring on this cylinder.

**CAUTION:**

- Always use a new O-ring.
- Be careful that the O-ring does not become scratched and that there are no foreign objects attached to it.
- Make sure to install the O-ring so that it does not twist as much as possible.
- Do not stretch the O-ring to 30 mm (1.18 in) inner diameter or more.

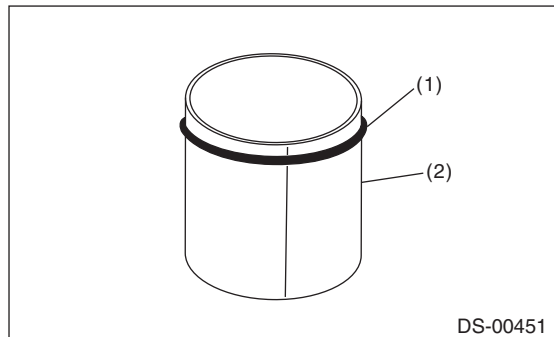

(1) O-ring

(2) Cylinder made with thick paper, etc.

3) Pass the cylinder material onto the shaft, and slide in the direction of the shaft axis.

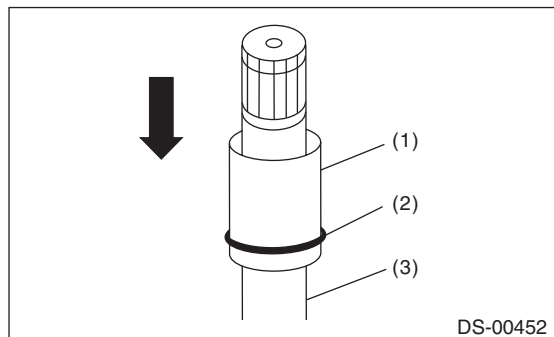

(1) Cylinder material

(2) O-ring

(3) Shaft

4) Clean the shaft boot groove, and wipe off the grease.

5) Slide the cylinder material near the shaft boot groove, and move the O-ring from the cylinder material onto the shaft boot groove.

**CAUTION:**

- Attach the O-ring to the shaft boot groove center.
- Be careful that the O-ring does not become scratched and that there are no foreign objects attached to it.
- Make sure to install the O-ring so that it does not twist as much as possible.
- With the O-ring attached, do not wash with kerosene, gasoline, etc.

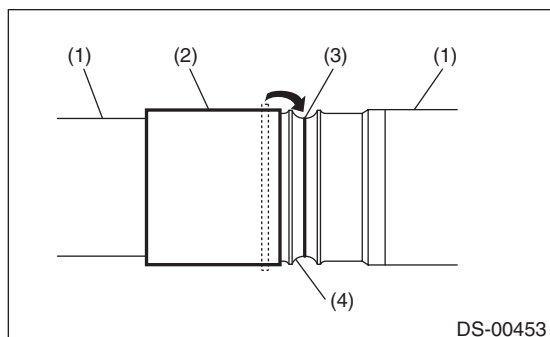

- (1) Shaft
- (2) Cylinder material
- (3) O-ring
- (4) Boot groove

6) Pass the PTJ small diameter boot band through the shaft.

7) Wrap vinyl tape around the splines of the shaft.

**CAUTION:**

To prevent damage to the boots, make sure to always wrap with vinyl tape for protection.

8) Install a new PTJ boot.

**CAUTION:**

Make sure to fit securely on the boot groove of the shaft.

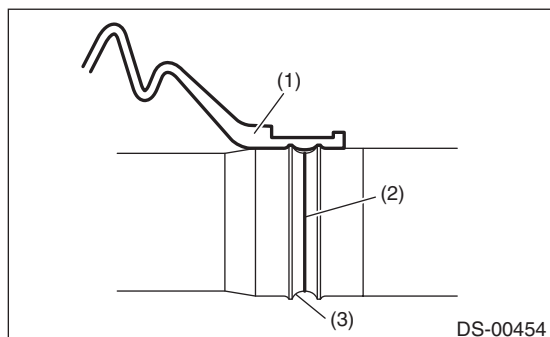

- (1) PTJ boot
- (2) O-ring
- (3) Boot groove

9) Match the alignment marks, and attach the trunnion onto the shaft.

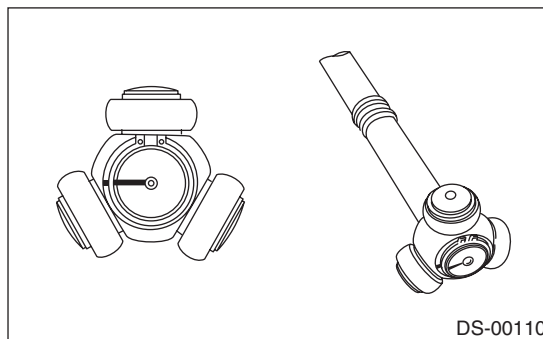

10) Attach the snap ring to the shaft.

**CAUTION:**

Confirm that the snap ring is completely fitted in the shaft groove.

11) Fill 100 to 110 g (3.53 to 3.88 oz) of specified grease into the interior of the PTJ outer race.

**Grease:**

**NKG302**

12) Apply a thin coat of specified grease to the roller kit and trunnion.

13) Match the alignment marks of the roller kit and trunnion, and attach the roller kit.

**CAUTION:**

Be careful with the roller kit position.

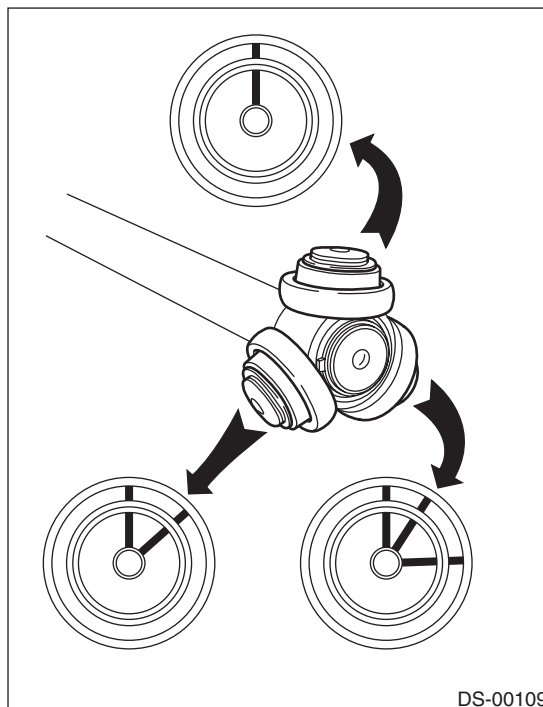

# Front Drive Shaft

## DRIVE SHAFT SYSTEM

14) Match the alignment marks of the shaft and outer race, and attach the outer race.

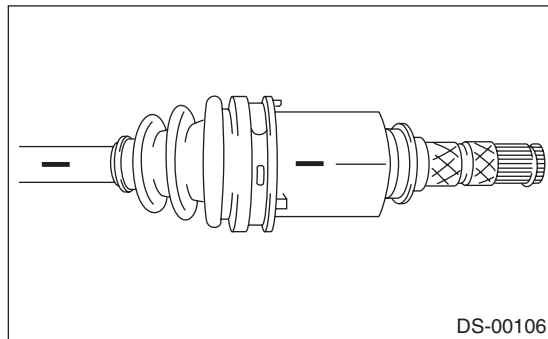

15) Install the snap ring in the groove of the PTJ outer race.

### CAUTION:

**Pull the shaft lightly and make sure that the snap ring is completely fitted in the groove.**

16) Apply an even coat of the specified grease 30 to 40 g (1.06 to 1.41 oz) to the entire inner surface of boot.

17) Attach the PTJ boot taking care not to twist it.

### CAUTION:

- Clean the large end of PTJ boot and the boot groove well, and remove the grease and other substances.

- When installing the PTJ boot, position the outer race of the PTJ at center of the stroke.

18) Set the new boot band at the specified position.

19) Tighten the boot bands using ST, torque wrench and socket flex handle.

ST 28099AC000 BOOT BAND PLIER

### CAUTION:

**The large boot band is to be tightened so that the omega shaped part is at the position indicated in the figure below.**

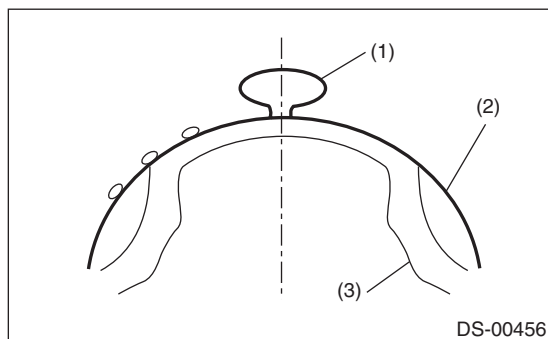

- (1) Omega shaped part
- (2) Boot band
- (3) Outer race

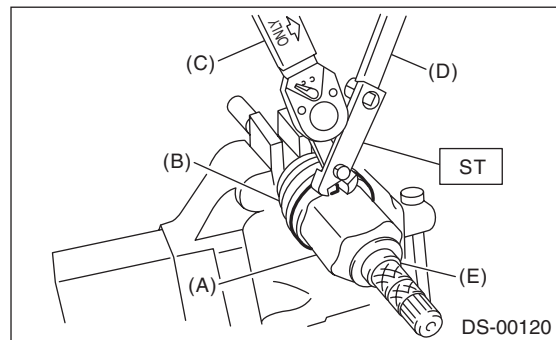

- Large boot band
- Boot
- Torque wrench
- Socket flex handle
- Outer race

### Tightening torque:

#### Large boot band

**178 N·m (18.2 kgf·m, 131.3 ft·lb)**

#### Small boot band

**145 N·m (14.8 kgf·m, 106.9 ft·lb)**

20) Extend and retract the PTJ repeatedly so that grease is spread evenly.

## 2. STI MODEL

### NOTE:

Use specified grease.

### AAR side:

#### ONE LUBER C

- 1) Pass the AAR boot through the shaft.
- 2) Align alignment marks and install the trunnion on the shaft. Install the snap ring into the shaft groove securely.

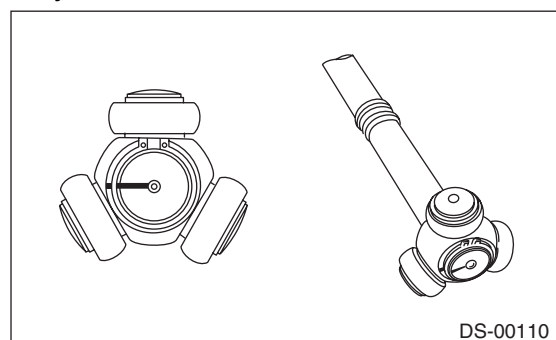

3) Fill 50 to 60 g (1.76 to 2.12 oz) of specified grease into the interior of AAR outer race.

4) Apply a thin coat of specified grease to the roller and trunnion.

5) Place the drive shaft between wooden blocks and fix it on a vise.

### CAUTION:

**Do not set the only drive shaft on a vise.**

6) Align the alignment marks on the shaft and outer race.

7) Tap the insertion upper part of the outer race alternately using a plastic or wood bar shown in the figure, and then insert the roller one by one.

**CAUTION:**

- Do not use a metal bar as the outer race may deform.
- Do not tap on the end of outer race (shaft part).
- Be careful not to deform the baffle plate.

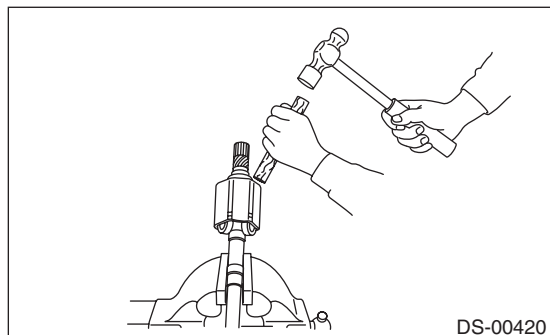

8) Apply an even coat of the specified grease 30 to 40 g (1.06 to 1.41 oz) to the entire inner surface of boot.

9) Install the AAR boot and grommet taking care not to twist it.

**CAUTION:**

- Replace the boot and grommet as a set.
- Do not let grease get on groove of the outer race side.

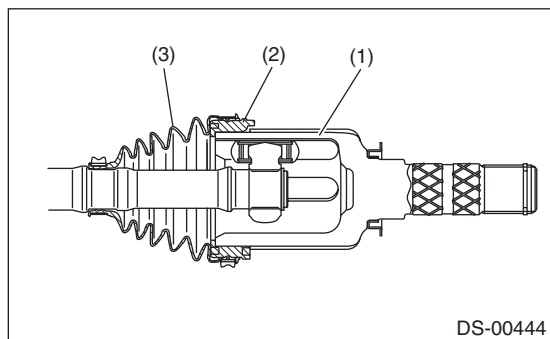

- (1) Outer race
- (2) Grommet
- (3) Boot

10) Insert a flat tip screwdriver, etc. between outer race and grommet to make pressure inside of boot as high as barometric pressure.

11) Install the new large boot band and small boot band at the required positions.

12) Tighten the boot bands using ST, torque wrench and socket flex handle.

ST 28099AC000 BOOT BAND PLIER

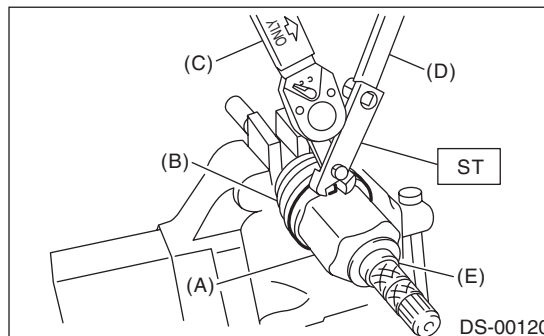

- (A) Large boot band
- (B) Boot
- (C) Torque wrench
- (D) Socket flex handle
- (E) AAR

**Clearance at the crimped section of the boot band:**

- Large boot band**  
1 mm (0.04 in) or less
- Small boot band**  
1 mm (0.04 in) or less

13) Extend and retract the AAR repeatedly to provide an equal coating of grease.

**E: INSPECTION**

Check the removed parts for damage, wear, corrosion etc. If faulty, repair or replace.

- PTJ (pillow tripod joint)  
Check for seizure, corrosion, damage, wear and excessive play.
- EBJ (high-efficiency compact ball fixed joint)  
Check for seizure, corrosion, damage and excessive play.
- AAR and AC  
Check for seizure, corrosion, damage, wear and excessive play.
- Shaft  
Check for excessive bending, twisting, damage and wear.
- Boot  
Check for wear, warping, breakage and scratches.
- Grease  
Check for discoloration and fluidity.



# Rear Drive Shaft

## DRIVE SHAFT SYSTEM

### 8. Rear Drive Shaft

#### A: REMOVAL

- 1) Disconnect the ground cable from battery.
- 2) Lift up the vehicle, and then remove the rear wheels.
- 3) Lift the crimped section of axle nut.

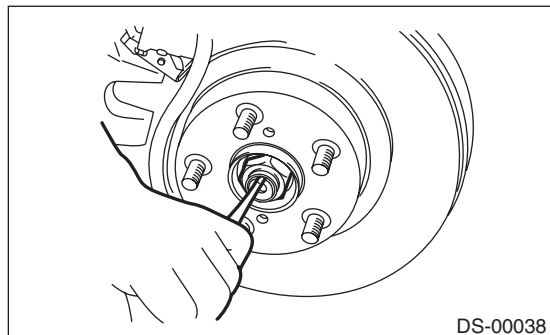

- 4) Remove the axle nut using a socket wrench while depressing the brake pedal.

#### CAUTION:

**Do not loosen the axle nut while the rear axle is loaded. Doing so may damage the hub bearing.**

- 5) Drain differential gear oil.
  - 6) Remove the rear trailing link. <Ref. to RS-10, REMOVAL, Rear Trailing Link.>
  - 7) Remove the rear lateral link. <Ref. to RS-16, REMOVAL, Rear Lateral Link.>
  - 8) Remove the rear drive shaft from the rear differential by using the ST.
- ST 28099PA100 DRIVE SHAFT REMOVER

#### NOTE:

Fit the ST to the bolts as shown in the figure to prevent damage of the side bearing retainer.

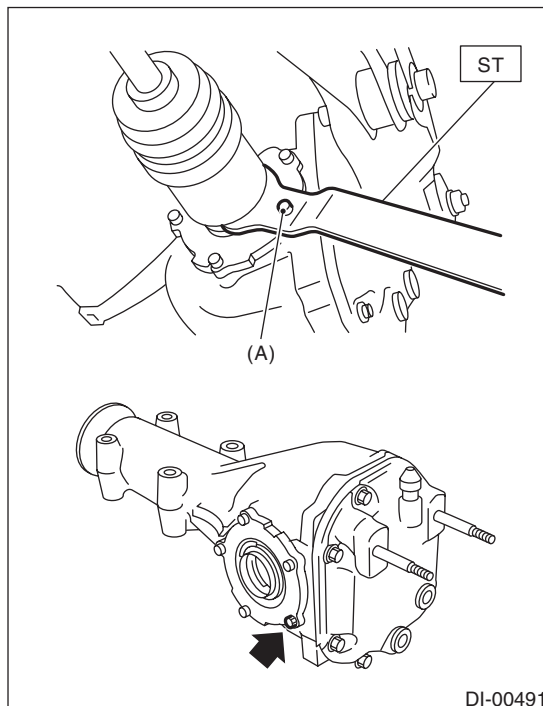

(A) Bolt

- 9) Remove the rear drive shaft from the rear axle. If it is hard to remove, use ST1 and ST2.

ST1 926470000 AXLE SHAFT PULLER  
ST2 28099PA110 AXLE SHAFT PULLER PLATE

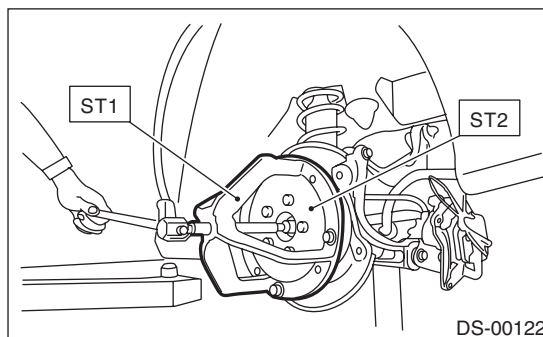

## B: INSTALLATION

1) Replace the rear differential side oil seal. <Ref. to DI-54, REPLACEMENT, Rear Differential Side Oil Seal.>

**NOTE:**

After pulling out the drive shaft, be sure to replace with a new oil seal.

2) Insert the EBJ into rear hub splines.

**CAUTION:**

- Be careful not to damage the magnetic encoder.
- Do not get closer the tool which charged magnetism to magnetic encoder.

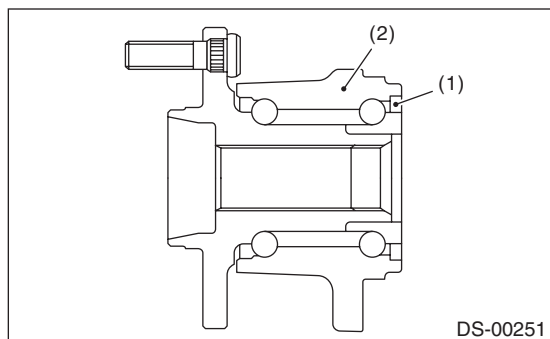

- (1) Magnetic encoder
- (2) Rear hub unit bearing

3) Draw the rear drive shaft into specified position.

**CAUTION:**

**Do not hammer drive shaft when installing it.**

4) Tighten the axle nut temporarily.

5) Using the ST, install the rear drive shaft to the rear differential.

ST 28099PA090 OIL SEAL PROTECTOR

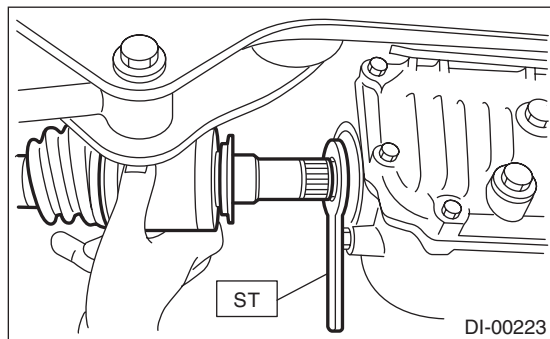

6) Attach the links to the rear housing and tighten them to the specified torque.

**Tightening torque:**

**Stabilizer link**

**38 N·m (3.87 kgf-m, 28 ft-lb)**

**Shock absorber**

**80 N·m (8.16 kgf-m, 59 ft-lb)**

**Rear lateral link**

**80 N·m (8.16 kgf-m, 59 ft-lb)**

**Trailing link**

**90 N·m (9.18 kgf-m, 66.4 ft-lb)**

7) While pressing the brake pedal, tighten the new axle nuts to the specified torque.

**CAUTION:**

**Do not apply weight to the rear axle before tightening the axle nut. Doing so may damage the hub bearing.**

**Tightening torque:**

**190 N·m (19.37 kgf-m, 140.1 ft-lb)**

8) Lock the axle nut securely.

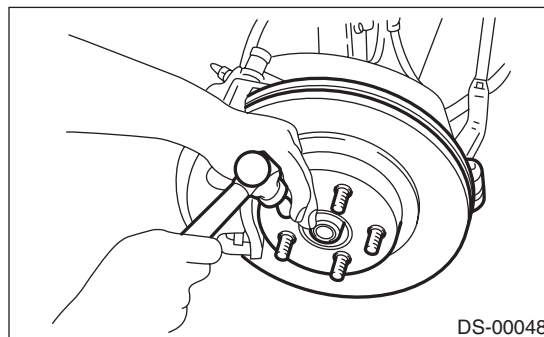

9) Fill differential gear oil.

10) Install the rear wheels.

**Tightening torque:**

**100 N·m (10.20 kgf-m, 73.8 ft-lb)**

11) Connect the battery ground terminal.

12) Inspect the wheel alignment and adjust if necessary.



# Rear Drive Shaft

## DRIVE SHAFT SYSTEM

### C: DISASSEMBLY

#### 1. EXCEPT FOR STI MODEL

1) Using a flat tip screwdriver or plier, loosen the boot band on the large end of DOJ boot.

#### CAUTION:

Be careful not to damage the boot.

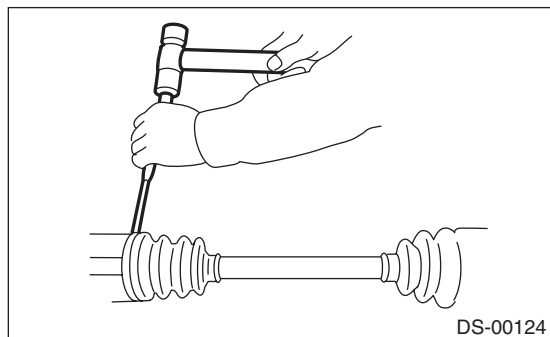

2) Remove the boot band on the small end of DOJ boot in the same manner.

3) Remove the large end of DOJ boot from DOJ outer race.

4) Remove the round snap ring at the neck of DOJ outer race with a flat tip screwdriver.

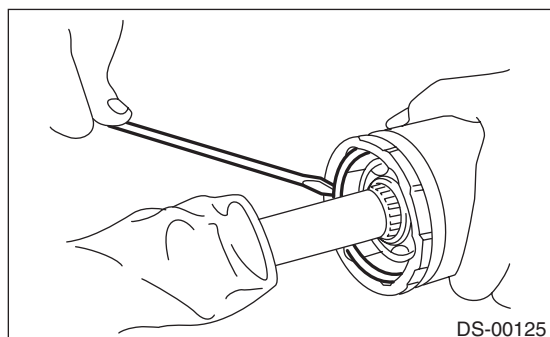

5) Take out the DOJ outer race from the shaft assembly.

6) Wipe off the grease and take out the ball bearings.

#### CAUTION:

The grease is a special grease (grease for constant velocity joints). Do not mix with other greases.

#### NOTE:

Disassemble exercising care not to lose balls.

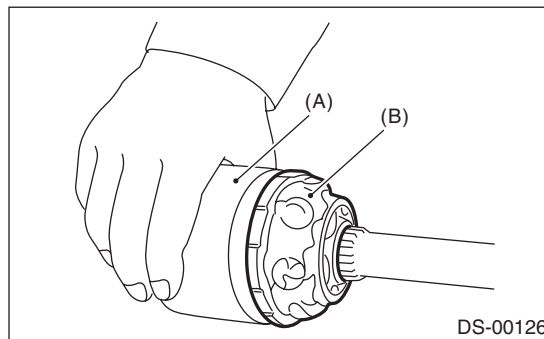

(A) Outer race

(B) Grease

7) To remove the cage from inner race, turn the cage by a half pitch to the track groove of inner race and shift the cage.

8) Using pliers, remove the snap ring fixing the inner race to the shaft.

9) Take out the DOJ inner race.

10) Take off the DOJ cage from shaft and remove the DOJ boot.

#### CAUTION:

Wrap shaft splines with vinyl tape to protect the boot from scratches.

11) Remove the EBJ boot using the same procedures as for the DOJ boot.

#### NOTE:

The EBJ is a non-disassembly part, so the drive shaft disassembly stops here.

#### 2. STI MODEL

1) Using a flat tip screwdriver or plier, loosen the boot band on the large end of EDJ boot.

#### CAUTION:

Be careful not to damage the boot.

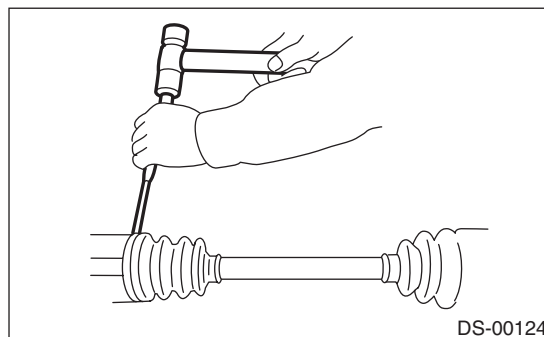

2) Remove the boot band on the small end of EDJ boot in the same manner.

3) Remove the large end of EDJ boot from EDJ outer race.

4) Remove the round snap ring at the neck of EDJ outer race with a flat tip screwdriver.

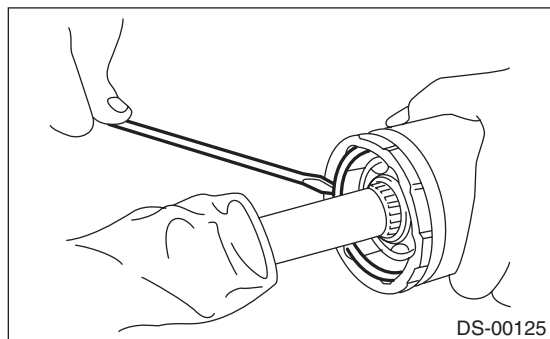

5) Remove the EDJ outer race from shaft assembly.

6) Wipe off the grease and take out the ball bearings.

**CAUTION:**  
The grease is a special grease (grease for constant velocity joints). Do not mix with other greases.

**NOTE:**  
Disassemble exercising care not to lose balls.

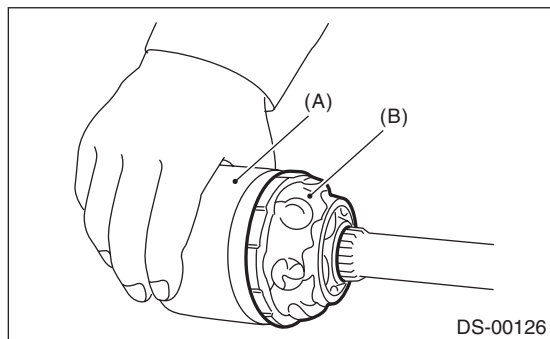

(A) Outer race  
(B) Grease

7) To remove the cage from inner race, turn the cage by a half pitch to the track groove of inner race and shift the cage.

8) Using pliers, remove the snap ring fixing the inner race to the shaft.

9) Take out the EDJ inner race.

10) Take off the EDJ cage from shaft and remove the EDJ boot.

**CAUTION:**  
Wrap shaft splines with vinyl tape to protect the boot from scratches.

11) Remove the EBJ boot using the same procedures as for the EDJ boot.

**NOTE:**  
The EBJ is a non-disassembly part, so the drive shaft disassembly stops here.

## D: ASSEMBLY

### 1. STI MODEL

**CAUTION:**  
Wrap shaft splines with vinyl tape to protect the boot from scratches.

**NOTE:**  
Use specified grease.

**EBJ side:**  
**NKG814**

**EDJ side:**  
**NKG814**

1) Install the EBJ boot to the specified position, and fill it with 50 to 60 g (1.76 to 2.12 oz) of specified grease.

2) Place the EDJ boot at the center of shaft.

3) Insert the EDJ cage onto shaft.

**NOTE:**  
Insert the cage with the cutout portion facing the shaft end, since the cage has an orientation.

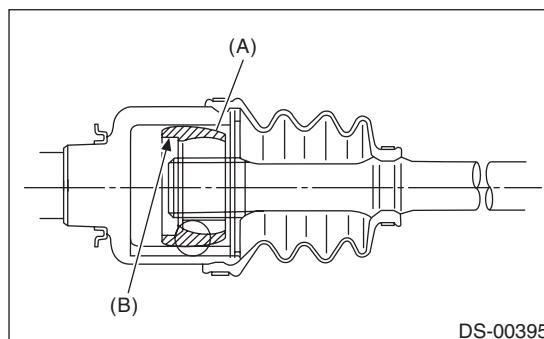

(A) Cage  
(B) Cutout portion

4) Install the EDJ inner race on shaft and fix the snap ring in place with pliers.

**NOTE:**  
Confirm that the snap ring is completely fitted in the shaft groove.

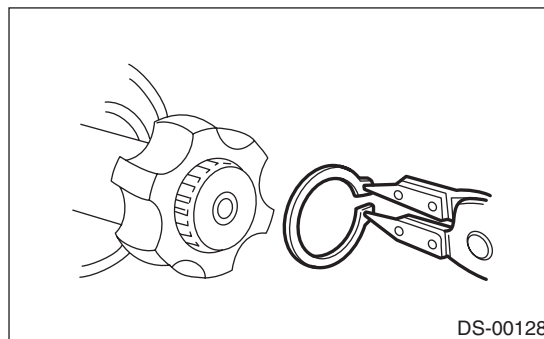

DS-00128

# Rear Drive Shaft

## DRIVE SHAFT SYSTEM

5) Install the cage to inner race fixed upon shaft.

### NOTE:

Fit the cage with the protruding section aligned with the track on the inner race, and turn by a half pitch.

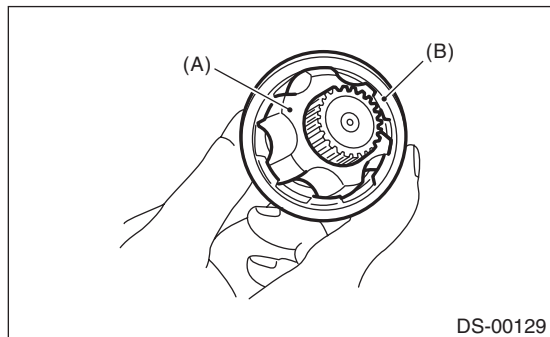

- (A) Inner race
- (B) Cage

6) Fill 80 to 90 g (2.82 to 3.17 oz) of specified grease into the inner side of the EDJ outer race.

7) Apply a thin coat of specified grease to the cage pocket and ball.

8) Insert the ball bearings into the cage pocket.

9) Align the outer race track and ball positions, and place the shaft, inner race, cage and ball bearings in the original positions, and then fix outer race in place.

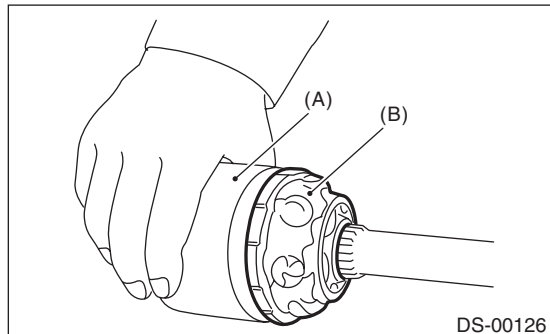

- (A) Outer race
- (B) Grease

10) Install the snap ring in the groove on the EDJ outer race.

### NOTE:

- Assure that the balls, cage and inner race are completely fitted in the outer race of EDJ.
- Use care not to place the matched position of snap ring in the ball groove of outer race.
- Pull the shaft lightly and assure that the circlip is completely fitted in the groove.

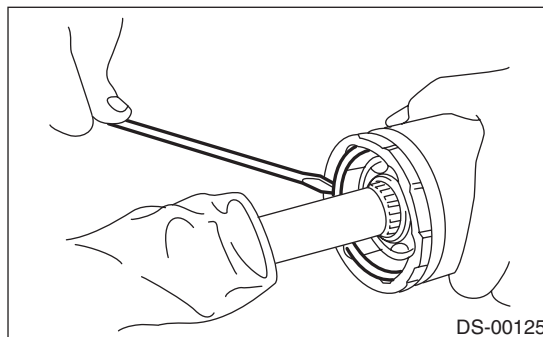

11) Apply an even coat of the specified grease [20 to 30 g (0.71 to 1.06 oz)] to the entire inner surface of boot. Also apply grease to the shaft.

12) Install the EDJ boot taking care not to twist it.

### NOTE:

- The inside of the large end of EDJ boot and the boot groove shall be cleaned so as to be free from grease and other substances.
- When installing the EDJ boot, position the outer race of EDJ at center of the stroke.

13) Put a new band through the clip and wind twice in the band groove of the boot.

14) Pinch the end of band with pliers. Hold the clip and tighten securely.

### NOTE:

When tightening boot, use care so that the air within the boot is appropriate.

15) Tighten the band using the ST.

ST 925091000 BAND TIGHTENING TOOL

### NOTE:

Tighten the band until it cannot be moved by hand.

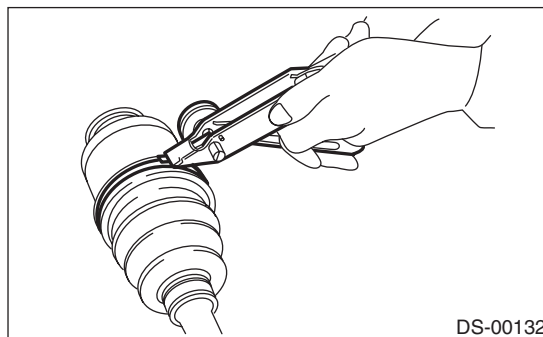

16) Tap the clip with the punch provided at the end of the ST.

ST 925091000 BAND TIGHTENING TOOL

NOTE:

Tap to an extent that the boot underneath is not damaged.

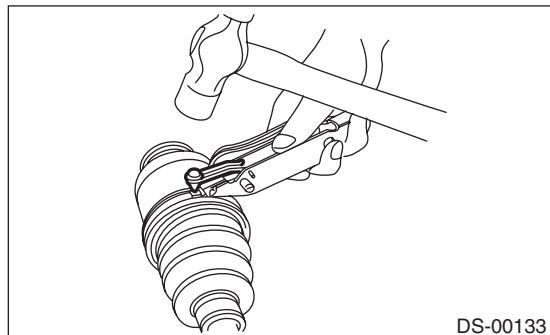

17) Cut off the band with an allowance of about 10 mm (0.39 in) left from the clip and bend this allowance over the clip.

NOTE:

Be careful so that the end of the band is in close contact with clip.

18) Install the EBJ boot using the same procedures as for the EDJ boot.

19) Extend and retract the EDJ repeatedly to provide an equal coating of grease.

## 2. EXCEPT FOR STI MODEL

**CAUTION:**

**Wrap shaft splines with vinyl tape to protect the boot from scratches.**

NOTE:

Use specified grease.

**EBJ side:**

**NKG814**

**DOJ side:**

**NKG814**

1) Install the EBJ boot to the specified position, and fill it with 50 to 60 g (1.76 to 2.12 oz) of specified grease.

2) Place the DOJ boot at the center of shaft.

3) Insert the DOJ cage onto shaft.

NOTE:

Insert the cage with the cutout portion facing the shaft end, since the cage has an orientation.

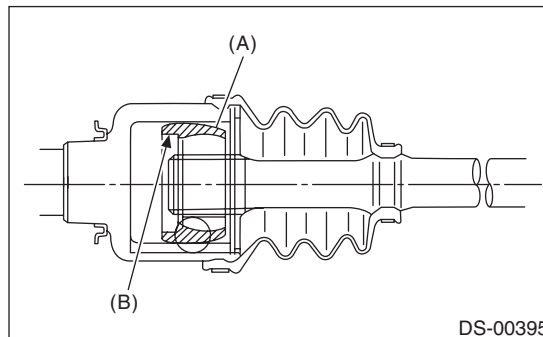

(A) Cage

(B) Cutout portion

4) Install the DOJ inner race on shaft and fix the snap ring in place with pliers.

NOTE:

Confirm that the snap ring is completely fitted in the shaft groove.

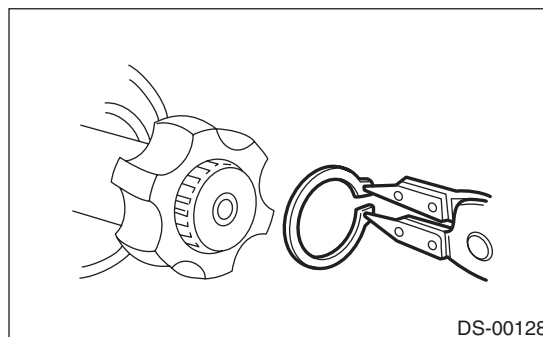

5) Install the cage to inner race fixed upon shaft.

NOTE:

Fit the cage with the protruding section aligned with the track on the inner race, and turn by a half pitch.

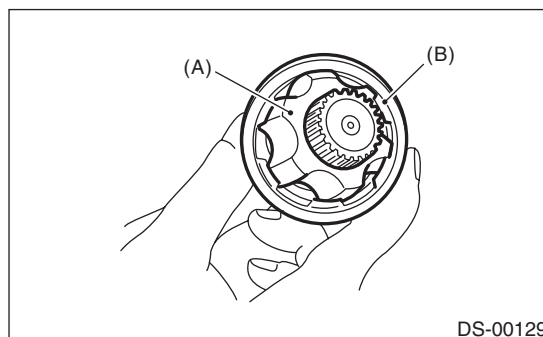

(A) Inner race

(B) Cage

6) Fill 80 to 90 g (2.82 to 3.17 oz) of specified grease into the inner side of the DOJ outer race.

## Rear Drive Shaft

### DRIVE SHAFT SYSTEM

7) Apply a thin coat of specified grease to the cage pocket and ball.

8) Insert the ball bearings into the cage pocket.

9) Align the outer race track and ball positions, and place the shaft, inner race, cage and ball bearings in the original positions, and then fix outer race in place.

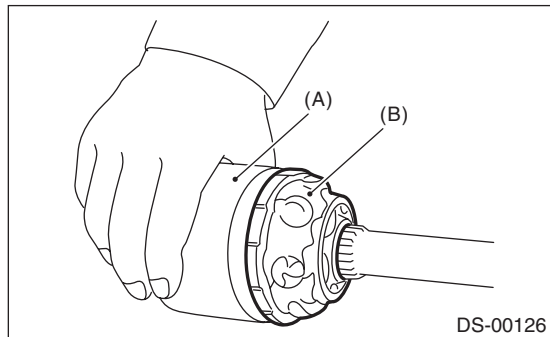

- (A) Outer race
- (B) Grease

10) Install the snap ring in the groove on the DOJ outer race.

#### NOTE:

- Assure that the balls, cage and inner race are completely fitted in the outer race of DOJ.
- Use care not to place the matched position of snap ring in the ball groove of outer race.
- Pull the shaft lightly and assure that the circlip is completely fitted in the groove.

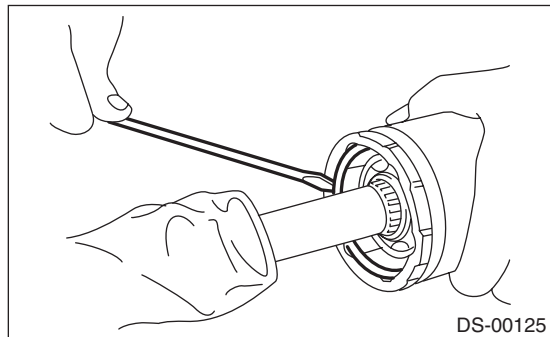

11) Apply an even coat of the specified grease [20 to 30 g (0.71 to 1.06 oz)] to the entire inner surface of boot. Also apply grease to the shaft.

12) Install the DOJ boot taking care not to twist it.

#### NOTE:

- The inside of the large end of DOJ boot and the boot groove shall be cleaned so as to be free from grease and other substances.
- When installing the DOJ boot, position the outer race of DOJ at center of the stroke.

13) Put a new band through the clip and wind twice in the band groove of the boot.

14) Pinch the end of band with pliers. Hold the clip and tighten securely.

#### NOTE:

When tightening boot, use care so that the air within the boot is appropriate.

15) Tighten the band using the ST.

ST 925091000 BAND TIGHTENING TOOL

#### NOTE:

Tighten the band until it cannot be moved by hand.

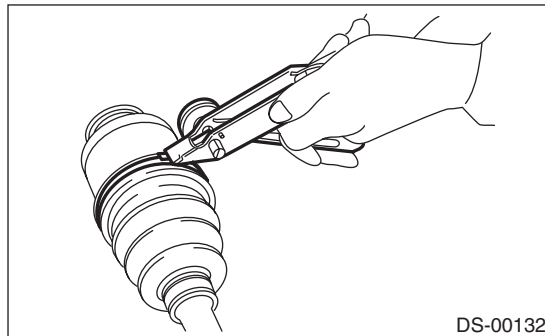

16) Tap the clip with the punch provided at the end of the ST.

ST 925091000 BAND TIGHTENING TOOL

#### NOTE:

Tap to an extent that the boot underneath is not damaged.

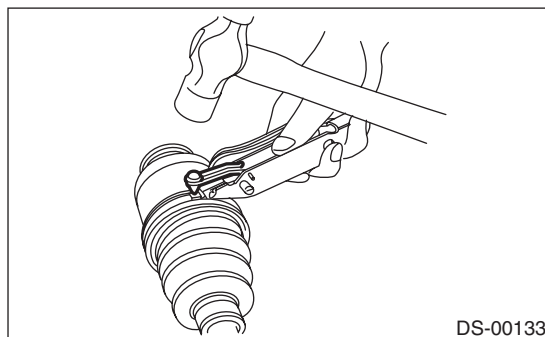

17) Cut off the band with an allowance of about 10 mm (0.39 in) left from the clip and bend this allowance over the clip.

#### NOTE:

Be careful so that the end of the band is in close contact with clip.

18) Install the EBJ boot using the same procedures as for the DOJ boot.

19) Extend and retract the DOJ repeatedly to provide an equal coating of grease.

## E: INSPECTION

Check the removed parts for damage, wear, corrosion etc. Repair or replace if defective.

- EDJ (high-efficiency compact double offset joint)

Check for seizure, corrosion, damage, wear and excessive play.

- DOJ (Double Offset Joint)

Check for seizure, corrosion, damage, wear and excessive play.

- EBJ (high-efficiency compact ball fixed joint)

Check for seizure, corrosion, damage, wear and excessive play.

- Shaft

Check for excessive bending, twisting, damage and wear.

- Boot

Check for wear, warping, breakage and scratches.

- Grease

Check for discoloration and fluidity.

# General Diagnostic Table

## DRIVE SHAFT SYSTEM

### 9. General Diagnostic Table

#### A: INSPECTION

**NOTE:**

Vibration while cruising may be caused by an unbalanced tire, improper tire inflation pressure, improper wheel alignment, etc.

Symptoms	Possible cause	Corrective action
<b>Noise or vibration from propeller shaft</b>	Center bearing	Check the center bearing. <Ref. to DS-13, CENTER BEARING FREE PLAY, INSPECTION, Propeller Shaft.>
	Runout of propeller shaft	Check for deflection of the propeller shaft. <Ref. to DS-13, RUNOUT OF PROPELLER SHAFT, INSPECTION, Propeller Shaft.>
	Loose or gap at connections	Check the joints and connectors. <Ref. to DS-12, JOINTS AND CONNECTIONS, INSPECTION, Propeller Shaft.> Check the spline and bearing. <Ref. to DS-12, SPLINES AND BEARING, INSPECTION, Propeller Shaft.>
<b>Abnormal wheel vibration</b>	Wheel is out of balance.	Check the wheel balance. <Ref. to WT-6, WHEEL BALANCING, INSPECTION, Tire and Wheel.>
	Front wheel alignment	Check the front wheel alignment. <Ref. to FS-8, INSPECTION, Wheel Alignment.>
	Rear wheel alignment	Check the rear wheel alignment. <Ref. to RS-8, INSPECTION, Wheel Alignment.>
	Front strut	Check the front strut. <Ref. to FS-26, INSPECTION, Front Strut.>
	Rear shock absorber	Check the rear shock absorber. <Ref. to RS-14, INSPECTION, Rear Shock Absorber.>
	Front drive shaft	Check the front drive shaft. <Ref. to DS-33, INSPECTION, Front Drive Shaft.>
	Rear drive shaft	Check the rear drive shaft. <Ref. to DS-41, INSPECTION, Rear Drive Shaft.>
	Front hub unit bearing	Check the front hub unit bearing. <Ref. to DS-19, INSPECTION, Front Hub Unit Bearing.>
	Rear hub unit bearing	Check the rear hub unit bearing. <Ref. to DS-26, INSPECTION, Rear Hub Unit Bearing.>
<b>Noise from the underbody</b>	Wheel is out of balance.	Check the wheel balance. <Ref. to WT-6, WHEEL BALANCING, INSPECTION, Tire and Wheel.>
	Front wheel alignment	Check the front wheel alignment. <Ref. to FS-8, INSPECTION, Wheel Alignment.>
	Rear wheel alignment	Check the rear wheel alignment. <Ref. to RS-8, INSPECTION, Wheel Alignment.>
	Front strut	Check the front strut. <Ref. to FS-26, INSPECTION, Front Strut.>
	Rear shock absorber	Check the rear shock absorber. <Ref. to RS-14, INSPECTION, Rear Shock Absorber.>

# VEHICLE DYNAMICS CONTROL (VDC)

# VDC

---

	<b>Page</b>
1. General Description .....	2
2. Vehicle Dynamics Control System .....	7
3. VDC Control Module and Hydraulic Control Unit (VDCCM&H/U) .....	8
4. ABS Sequence Control .....	14
5. VDC Sequence Control .....	17
6. Yaw Rate and G Sensor .....	20
7. Steering Angle Sensor .....	22
8. Front ABS Wheel Speed Sensor .....	24
9. Rear ABS Wheel Speed Sensor .....	26
10. Front Magnetic Encoder .....	27
11. Rear Magnetic Encoder .....	28
12. VDC OFF Switch .....	29



# General Description

VEHICLE DYNAMICS CONTROL (VDC)

## 1. General Description

### A: SPECIFICATION

Item		Specification or identification		
ABS wheel speed sensor	ABS wheel speed sensor gap (for reference)	Front	0.77 — 1.43 mm (0.030 — 0.056 in)	
		Rear	0.43 — 1.78 mm (0.017 — 0.070 in)	
	Identifications of harness (marks, color)	Front	RH	K1 (White)
			LH	K2 (Yellow)
		Rear	RH	P5 (White)
			LH	P6 (Yellow)
VDCCM&H/U Identification		STI model	SN	
		Except for STI model	SM	

## B: COMPONENT

### 1. ABS WHEEL SPEED SENSOR

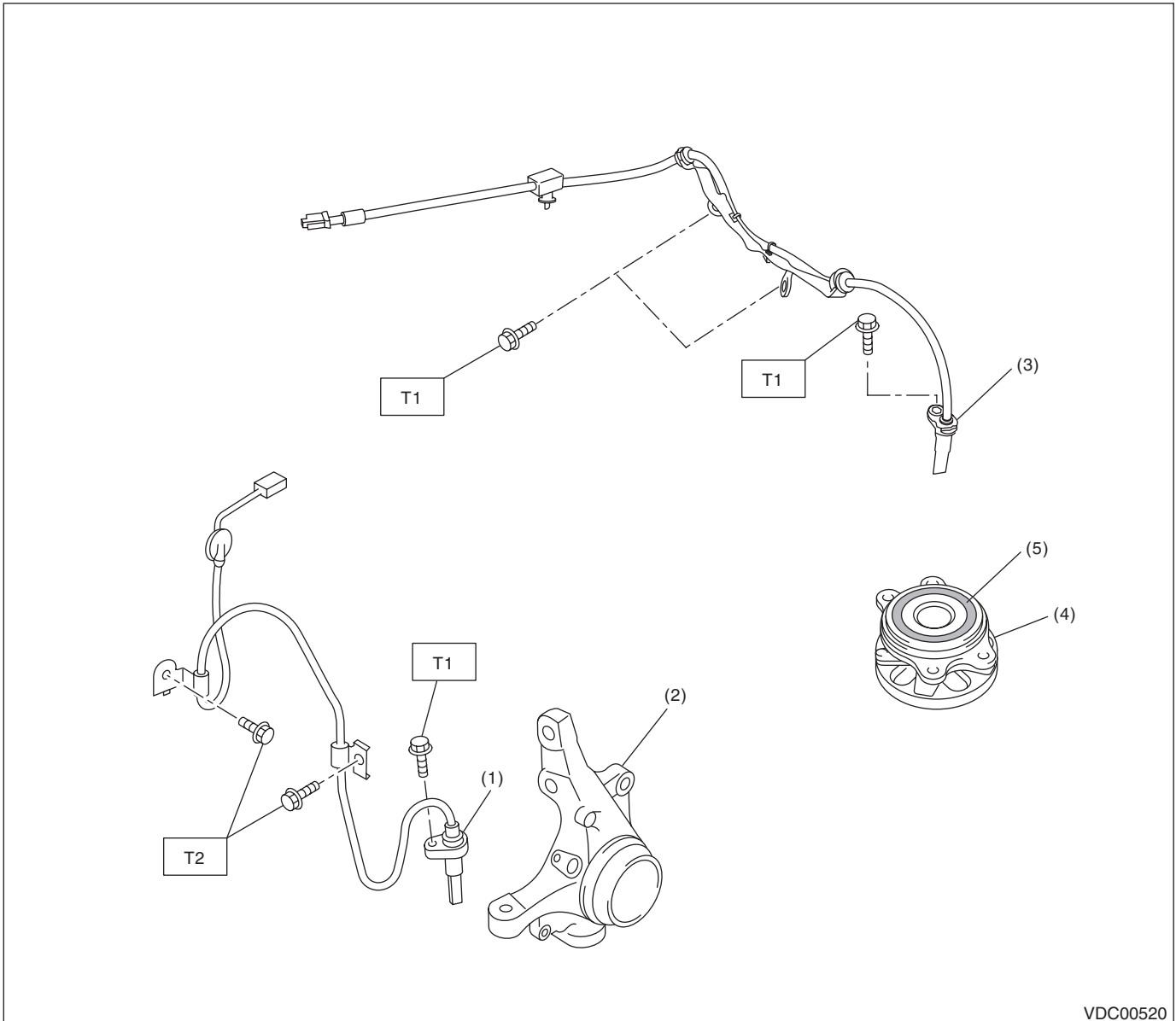

- |                                  |                      |
|----------------------------------|----------------------|
| (1) Front ABS wheel speed sensor | (4) Hub unit bearing |
| (2) Front housing                | (5) Magnetic encoder |
| (3) Rear ABS wheel speed sensor  |                      |

**Tightening torque: N·m (kgf·m, ft·lb)**

**T1: 7.5 (0.76, 5.5)**

**T2: 33 (3.36, 24.3)**

# General Description

VEHICLE DYNAMICS CONTROL (VDC)

## 2. YAW RATE & G SENSOR

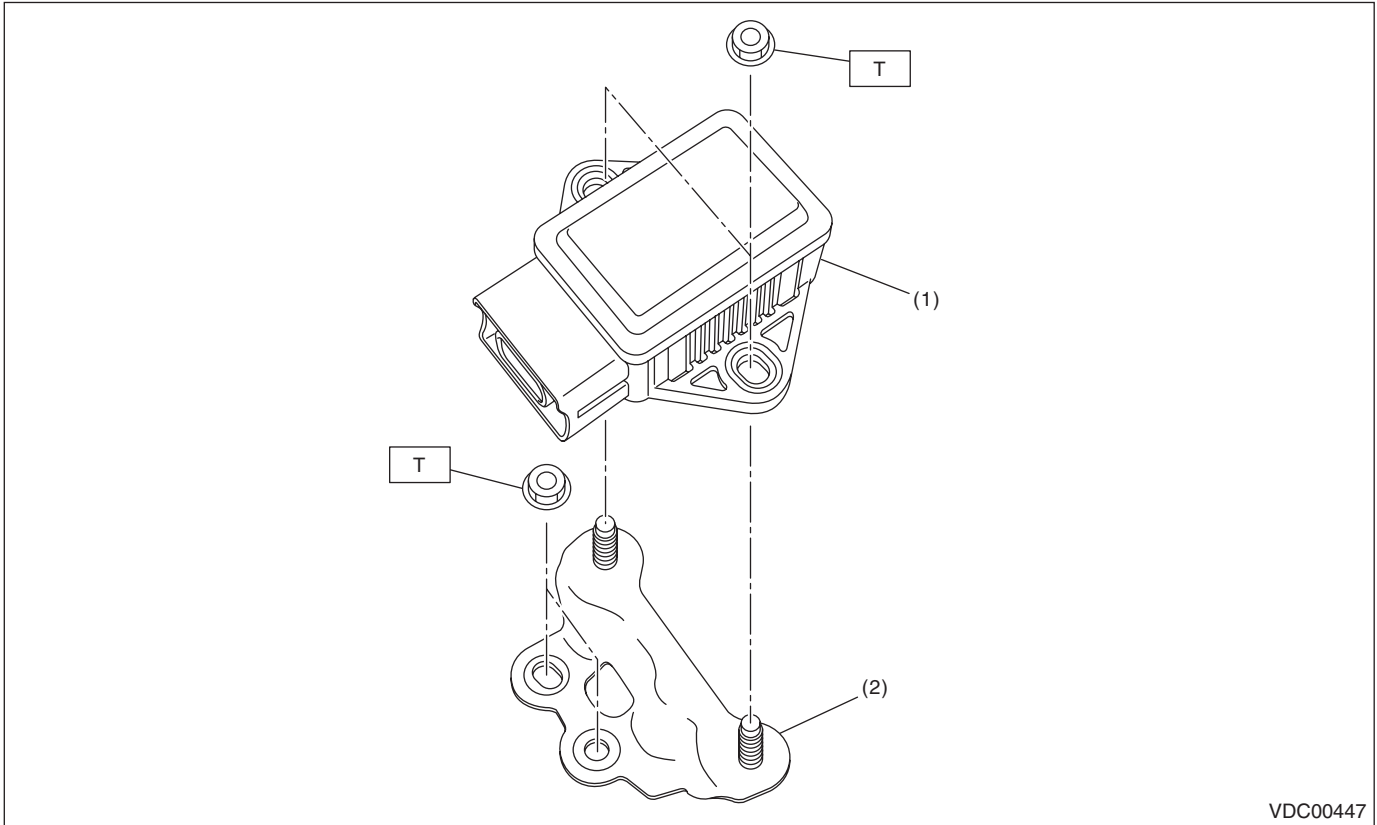

VDC00447

(1) Yaw rate & G sensor

(2) Bracket

**Tightening torque: N·m (kgf·m, ft·lb)**

**T: 7.5 (0.76, 5.5)**

## 3. STEERING ANGLE SENSOR

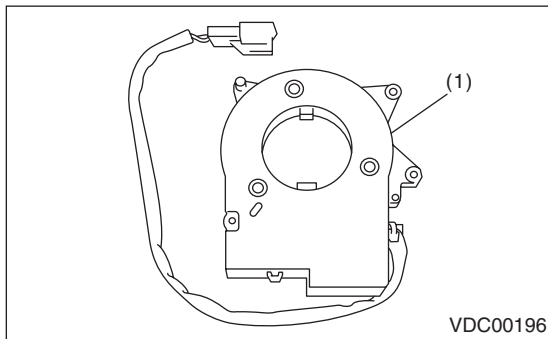

(1) Steering angle sensor

# General Description

VEHICLE DYNAMICS CONTROL (VDC)

## 4. VDC CONTROL MODULE & HYDRAULIC CONTROL UNIT (VDCCM&H/U)

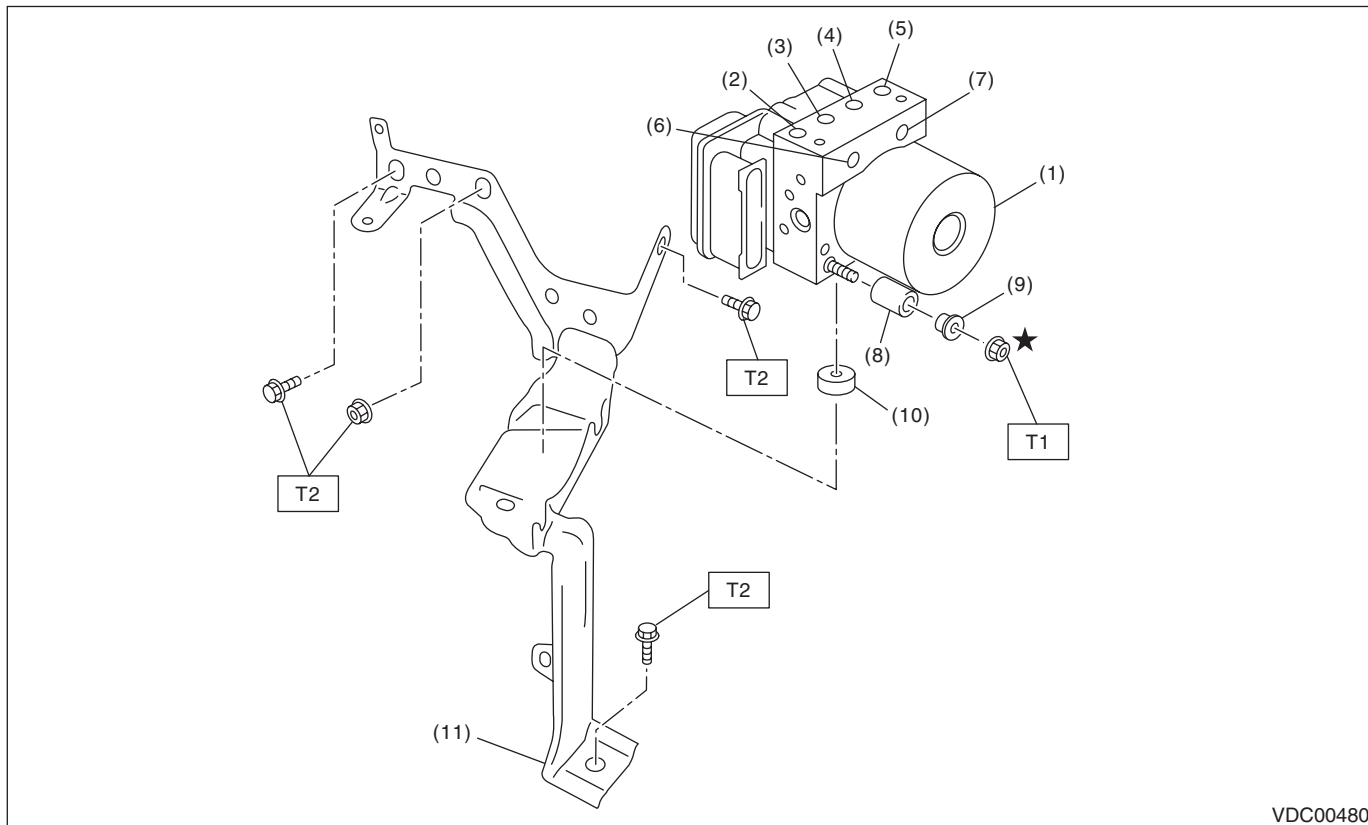

VDC00480

- |   |                     |              |
|---|---------------------|--------------|
| (1) VDC control module and hydraulic control unit (VDCCM&H/U) | (6) Primary inlet   | (11) Bracket |
| (2) Front RH outlet   | (7) Secondary inlet |              |
| (3) Rear LH outlet  | (8) Damper          |              |
| (4) Rear RH outlet  | (9) Spacer          |              |
| (5) Front LH outlet   | (10) Damper         |              |

**Tightening torque: N·m (kgf·m, ft·lb)**

**T1: 7.5 (0.76, 5.5)**

**T2: 33 (3.36, 24.3)**

**VDC-5**

Brought to you by Ebay Seller "SubaruManuals"

# General Description

## VEHICLE DYNAMICS CONTROL (VDC)

### C: CAUTION

- Wear appropriate work clothing, including a helmet, protective goggles and protective shoes when performing any work.
- Remove contamination including dirt and corrosion before removal, installation or disassembly.
- Keep the disassembled parts in order and protect them from dust and dirt.
- Before disconnecting connectors of sensors or units, be sure to disconnect the ground cable from battery.
- Before removal, installation or disassembly, be sure to clarify the failure. Avoid unnecessary removal, installation, disassembly and replacement.
- Vehicle components are extremely hot after driving. Be wary of receiving burns from heated parts.
- Be sure to tighten fasteners including bolts and nuts to the specified torque.
- Place shop jacks or rigid racks at the specified points.

### D: PREPARATION TOOL

#### 1. SPECIAL TOOL

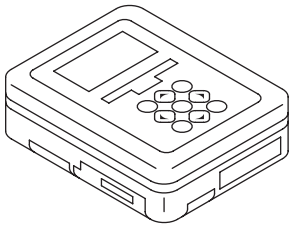
ILLUSTRATION	TOOL NUMBER	DESCRIPTION	REMARKS
 ST1B022XU0	1B022XU0	SUBARU SELECT MONITOR III KIT	Used for troubleshooting the electrical system.

#### 2. GENERAL TOOL

TOOL NAME	REMARKS
Circuit tester	Used for measuring resistance and voltage.
Pressure gauge	Used for measuring oil pressure.
Oscilloscope	Used for measuring the sensor.
TORX® bit E5	Used for replacing VDC control module.

## 2. Vehicle Dynamics Control System

### A: WIRING DIAGRAM

Refer to "Vehicle Dynamics Control System" in the wiring diagram. <Ref. to WI-67, WIRING DIAGRAM, Vehicle Dynamics Control System.>

### B: ELECTRICAL SPECIFICATION

Refer to the Control Module I/O Signal of the "Vehicle Dynamics Control System (VDC) (DIAGNOSTICS)". <Ref. to VDC(diag)-14, ELECTRICAL SPECIFICATION, Control Module I/O Signal.>

### C: INSPECTION

Refer to the "Vehicle Dynamics Control System (VDC) (DIAGNOSTICS)". <Ref. to VDC(diag)-117, INSPECTION, General Diagnostic Table.>

### D: NOTE

For operation procedures of each component of the vehicle dynamics control system, refer to the respective section.

- VDC control module & hydraulic control unit (VDCCM&H/U): <Ref. to VDC-8, VDC Control Module and Hydraulic Control Unit (VDCCM&H/U).>
- Yaw rate & G sensor: <Ref. to VDC-20, Yaw Rate and G Sensor.>
- Steering angle sensor: <Ref. to VDC-22, Steering Angle Sensor.>
- Front ABS wheel speed sensor: <Ref. to VDC-24, Front ABS Wheel Speed Sensor.>
- Rear ABS wheel speed sensor: <Ref. to VDC-26, Rear ABS Wheel Speed Sensor.>
- Front magnetic encoder: <Ref. to VDC-27, Front Magnetic Encoder.>
- Rear magnetic encoder: <Ref. to VDC-28, Rear Magnetic Encoder.>
- VDC OFF switch: <Ref. to VDC-29, VDC OFF Switch.>

# VDC Control Module and Hydraulic Control Unit (VDCCM&H/U)

VEHICLE DYNAMICS CONTROL (VDC)

## 3. VDC Control Module and Hydraulic Control Unit (VDCCM&H/U)

### A: REMOVAL

- 1) Disconnect the ground cable from battery.
- 2) Use compressed air to remove moisture and dust around the VDCCM&H/U.

#### NOTE:

If the terminals become dirty, it may cause improper contact.

- 3) Lift the lock lever and Disconnect the VDCCM&H/U connector.

#### CAUTION:

**Do not pull on the harness when disconnecting the connector.**

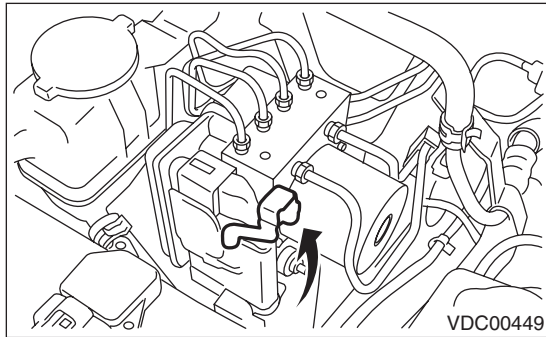

- 4) Disconnect the brake pipes from the VDCCM&H/U.
- 5) Wrap the brake pipe with a vinyl bag so as not to spill the brake fluid on the vehicle body.

#### CAUTION:

**If brake fluid is spilled on the painted surface of the vehicle body, wash it off immediately with water and wipe clean.**

- 6) Remove the nuts and remove the VDCCM&H/U.

#### CAUTION:

- Do not drop or bump the VDCCM&H/U.
- Do not turn the VDCCM&H/U upside down or place it sideways for storage.
- Be careful not to let foreign matter enter the VDCCM&H/U.
- Be careful that no water enters the connectors.

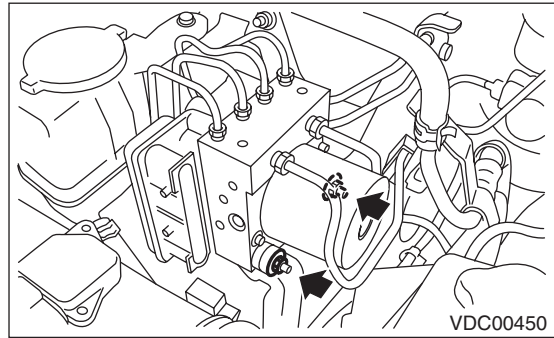

- 7) Remove the VDCCM&H/U bracket.

### B: INSTALLATION

- 1) Install the VDCCM&H/U bracket.

#### Tightening torque:

**33 N·m (3.36 kgf-m, 24.3 ft-lb)**

- 2) Install the VDCCM&H/U with a new nut by aligning the damper groove of the VDCCM&H/U to the bracket side claw.

#### Tightening torque:

**7.5 N·m (0.76 kgf-m, 5.5 ft-lb)**

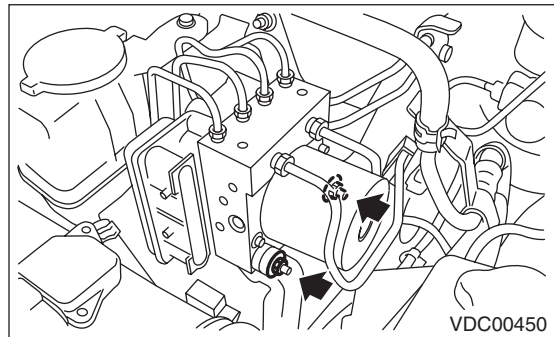

- 3) Connect the brake pipes to their correct VDCCM&H/U positions.

#### Tightening torque:

**T1: 15 N·m (1.53 kgf-m, 11.1 ft-lb)**

**T2: 19 N·m (1.94 kgf-m, 14 ft-lb)**

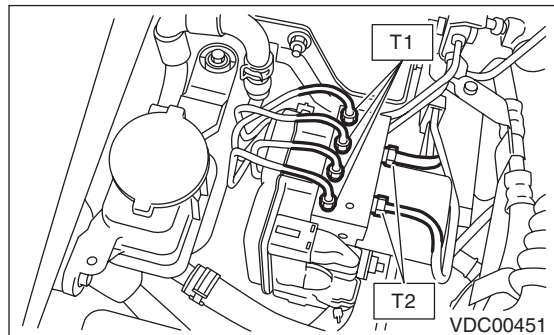

# VDC Control Module and Hydraulic Control Unit (VDCCM&H/U)

VEHICLE DYNAMICS CONTROL (VDC)

4) Connect the VDCCM&H/U connector.

## NOTE:

- Be sure to remove all foreign matter from inside the connector before connecting.
- Make sure the VDCCM&H/U connector is securely locked.

5) Bleed air from the brake system. <Ref. to BR-39, PROCEDURE, Air Bleeding.>

6) Check the parameter to confirm that the applied models and grades of the relevant vehicle are included. <Ref. to VDC(diag)-21, PARAMETER CHECK, OPERATION, Subaru Select Monitor.>

7) If the applied model and grade of the target vehicle are not included on the {Confirm on parameter} display screen, perform parameter selection and registration. <Ref. to VDC(diag)-20, PARAMETER SELECTION, OPERATION, Subaru Select Monitor.>

## NOTE:

- When the VDCCM&H/U is replaced with a new part, be sure to perform the selection · registration operation.
- For the selection and registration of parameter, the Subaru Select Monitor is required.
- When the registration has not been performed, the DTC code "Parameter selection error" is detected together with the ABS/EBD/VDC warning light illumination.

## C: INSPECTION

1) Check the condition of connection and settlement of connector.

2) Check the mark used for VDCCM&H/U identification.

Refer to "SPECIFICATION" for identification mark. <Ref. to VDC-2, SPECIFICATION, General Description.>

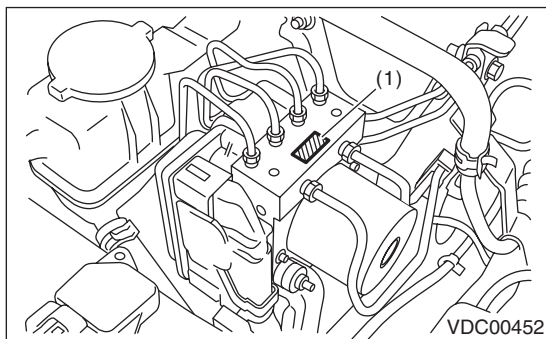

(1) Identification mark

## 1. CHECKING THE HYDRAULIC UNIT ABS OPERATION BY PRESSURE GAUGE

- 1) Lift up the vehicle, and then remove the wheel.
- 2) Remove the air bleeder screws from FL and FR caliper bodies.

3) Connect two pressure gauges to FL and FR caliper bodies.

## CAUTION:

- Use a pressure gauge used exclusively for brake fluid measurement.
- Do not use the pressure gauge used for the measurement of transmission oil. Doing so will cause the piston seal to expand and deform.

## NOTE:

Wrap sealing tape around the pressure gauge.

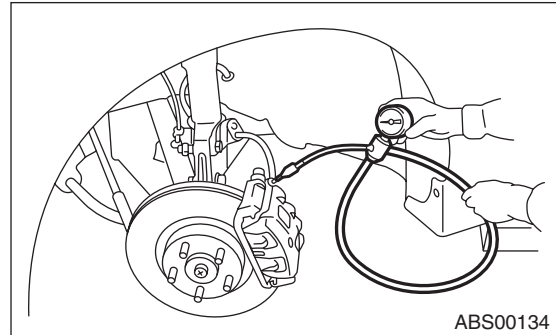

4) Bleed air from the pressure gauges and the FL and FR caliper bodies.

5) Perform ABS sequence control. <Ref. to VDC-14, ABS Sequence Control.>

6) When the hydraulic unit begins to work, first the FL side performs decompression, hold and compression, and then the FR side performs decompression, hold and compression.

7) Read values indicated on the pressure gauge and check if the fluctuation of the values between decompression and compression meets the standard values. Depress the brake pedal and check that the kick-back is normal, and tightness is normal.

	Front wheel	Rear wheel
Initial value	3,500 kPa (36 kgf/cm <sup>2</sup> , 511 psi)	3,500 kPa (36 kgf/cm <sup>2</sup> , 511 psi)
When depressurized	500 kPa (5 kgf/cm <sup>2</sup> , 73 psi) or less	500 kPa (5 kgf/cm <sup>2</sup> , 73 psi) or less
When pressurized	3,500 kPa (36 kgf/cm <sup>2</sup> , 511 psi) or more	3,500 kPa (36 kgf/cm <sup>2</sup> , 511 psi) or more

8) Disconnect the pressure gauges from FL and FR caliper bodies.

9) Install the air bleeder screws of FL and FR caliper bodies.

10) Remove the air bleeder screws from RL and RR caliper bodies.

11) Connect two pressure gauges to RL and RR caliper bodies.

12) Bleed air from the brake system. <Ref. to BR-39, PROCEDURE, Air Bleeding.>



# VDC Control Module and Hydraulic Control Unit (VDCCM&H/U)

## VEHICLE DYNAMICS CONTROL (VDC)

13) Bleed air from RL and RR caliper bodies, and pressure gauge.

14) Perform ABS sequence control. <Ref. to VDC-14, ABS Sequence Control.>

15) When the hydraulic unit begins to work, first the RR side performs decompression, hold and compression, and then the RL side performs decompression, hold and compression.

16) Read values indicated on the pressure gauge and check if the fluctuation of the values between decompression and compression meets specification. Depress the brake pedal and check that the kick-back is normal, and tightness is normal.

17) Disconnect the pressure gauge from the RL and RR caliper bodies.

18) Install the air bleeder screws of RL and RR caliper bodies.

19) Bleed air from the brake system. <Ref. to BR-39, PROCEDURE, Air Bleeding.>

## 2. CHECKING THE HYDRAULIC UNIT ABS OPERATION WITH THE BRAKE TESTER

1) Set wheels other than the one to measure on free rollers.

2) Prepare for ABS sequence control. <Ref. to VDC-14, ABS Sequence Control.>

3) Set the front wheels or rear wheels on the brake tester and set the gear to "neutral".

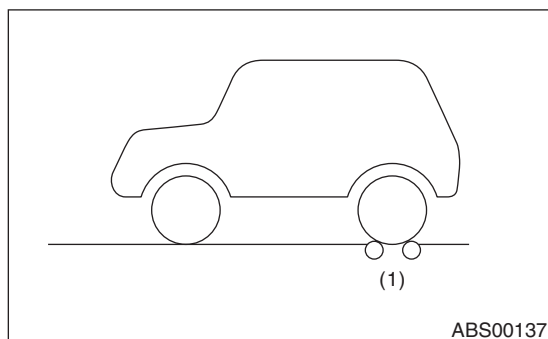
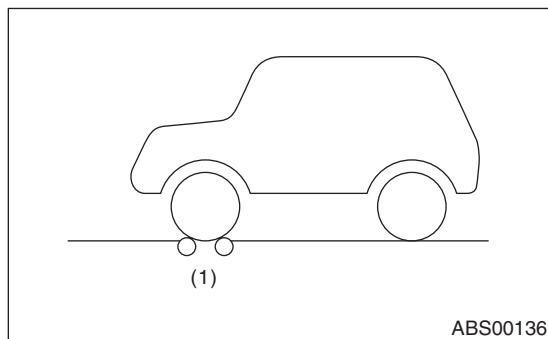

(1) Brake tester

4) Operate the brake tester.

5) Perform ABS sequence control. <Ref. to VDC-14, ABS Sequence Control.>

6) When the hydraulic unit begins to work, check the following work sequence.

(1) The FL wheel performs decompression, hold and compression in sequence, and subsequently the FR wheel repeats the cycle.

(2) The RR wheel performs decompression, hold and compression in sequence, and subsequently the RL wheel repeats the cycle.

7) Read values indicated on the brake tester and check if the fluctuation of the values between decompression and compression meets specification.

	Front wheel	Rear wheel
Initial value	1,000 N (102 kgf, 225 lbf)	1,000 N (102 kgf, 225 lbf)
When depressurized	500 N (51 kgf, 112 lbf) or less	500 N (51 kgf, 112 lbf) or less
When pressurized	1,000 N (102 kgf, 225 lbf) or more	1,000 N (102 kgf, 225 lbf) or more

8) After the inspection, depress the brake pedal and check that it is not abnormally hard, and tightness is normal.

## 3. CHECKING THE HYDRAULIC UNIT VDC OPERATION USING A PRESSURE GAUGE

1) Lift up the vehicle, and then remove the wheel.

2) Remove the air bleeder screws from FL and FR caliper bodies.

3) Connect two pressure gauges to FL and FR caliper bodies.

### CAUTION:

- Use a pressure gauge used exclusively for brake fluid measurement.
- Do not use a pressure gauge used for the measuring transmission oil pressure, as the piston seal may expand and deform.

### NOTE:

Wrap sealing tape around the pressure gauge.

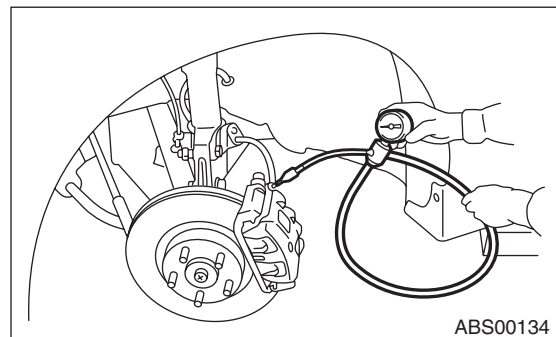

4) Bleed air from the pressure gauge.

5) Perform VDC sequence control. <Ref. to VDC-17, VDC Sequence Control.>

# VDC Control Module and Hydraulic Control Unit (VDCCM&H/U)

VEHICLE DYNAMICS CONTROL (VDC)

6) When the hydraulic unit begins to work, first the FL side performs compression, hold, and decompression, and then the FR side performs compression, hold, and decompression.

7) Read values indicated on the pressure gauge and check if the fluctuation of the values between decompression and compression meets specification. Depress the brake pedal and check that it is not abnormally hard, and tightness is normal.

	Front wheel	Rear wheel
When pressurized	3,000 kPa (31 kgf/cm <sup>2</sup> , 441 psi) or more	3,000 kPa (31 kgf/cm <sup>2</sup> , 441 psi) or more
When depressurized	500 kPa (5 kgf/cm <sup>2</sup> , 73 psi) or less	500 kPa (5 kgf/cm <sup>2</sup> , 73 psi) or less

8) Disconnect the pressure gauges from FL and FR caliper bodies.

9) Install the air bleeder screws of FL and FR caliper bodies.

10) Remove the air bleeder screws from RL and RR caliper bodies.

11) Connect two pressure gauges to RL and RR caliper bodies.

12) Bleed air from RL and RR caliper bodies, and pressure gauge.

13) Perform VDC sequence control. <Ref. to VDC-17, VDC Sequence Control.>

14) When the hydraulic unit begins to work, first the RR side performs compression, hold, and decompression, and then the RL side performs compression, hold, and decompression.

15) Read the values indicated on the pressure gauges and check if it is within specification. Depress the brake pedal and check that it is not abnormally hard, and tightness is normal.

16) Disconnect the pressure gauge from the RL and RR caliper bodies.

17) Install the air bleeder screws of RL and RR caliper bodies.

18) Bleed air from the brake system. <Ref. to BR-39, PROCEDURE, Air Bleeding.>

## 4. CHECK HYDRAULIC UNIT VDC OPERATION WITH BRAKE TESTER

1) Set wheels other than the one to measure on free rollers.

2) Prepare to operate the VDC sequence control. <Ref. to VDC-17, VDC Sequence Control.>

3) Set the front wheels or rear wheels on the brake tester and set the gear to neutral.

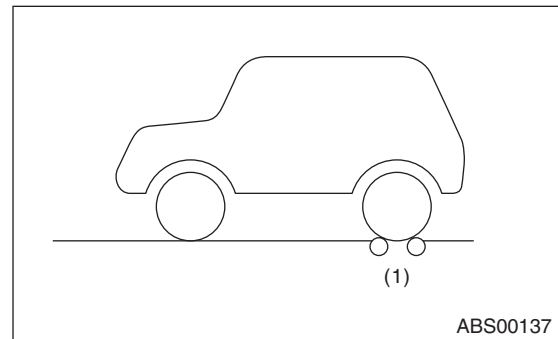
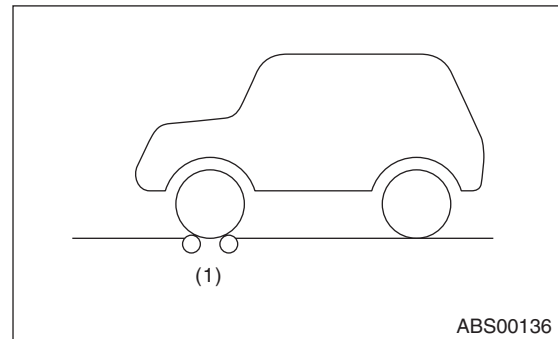

(1) Brake tester

4) Operate the brake tester.

5) Perform VDC sequence control. <Ref. to VDC-17, VDC Sequence Control.>

6) When the hydraulic unit begins to work, check the following work sequence.

(1) The FL wheel performs compression, hold and decompression in sequence, and subsequently the FR wheel repeats the cycle.

(2) The RR wheel performs compression, hold and decompression in sequence, and subsequently the RL wheel repeats the cycle.

7) Read values indicated on the brake tester and check if the fluctuation of the values between decompression and compression meets specification.

	Front wheel	Rear wheel
When pressurized	2,000 N (204 kgf, 450 lbf) or more	2,000 N (204 kgf, 450 lbf) or more
When depressurized	500 N (51 kgf, 112 lbf) or less	500 N (51 kgf, 112 lbf) or less

8) After the inspection, depress the brake pedal and check that it is not abnormally hard, and tightness is normal.

# VDC Control Module and Hydraulic Control Unit (VDCCM&H/U)

VEHICLE DYNAMICS CONTROL (VDC)

## D: REPLACEMENT

### CAUTION:

- Because the pressure sensor built into the H/U is easily damaged by static electricity, start the operation after performing static electricity measures.
- Be careful not to touch the sensors in the H/U to prevent damage.
- Because the seal of the VDCCM cannot be replaced, do not pull or peel it by lifting it up.
- Because the screw of the H/U will become slightly worn in every replacement procedure, 5 times is the maximum number of times for replacement. If a problem is found such as not being able to torque the screw to specifications even before 5 replacement operations are performed, replace the H/U body.
- When installing the VDCCM, always use new screws.
- When the sealing surface of the VDCCM or H/U is dirty or damaged and it cannot be cleaned or repaired, replace with a new part.

1) Remove the VDCCM&H/U. <Ref. to VDC-8, REMOVAL, VDC Control Module and Hydraulic Control Unit (VDCCM&H/U).>

2) To prevent entry of foreign objects and brake fluid leakage, plug the oil pressure port of the VDCCM&H/U using a screw plug, etc.

3) Set the pump motor section of the removed VDCCM&H/U face down on a vise.

### NOTE:

Before securing a part on a vise, place cushioning material such as wood blocks, aluminum plate, or cloth between the part and the vise.

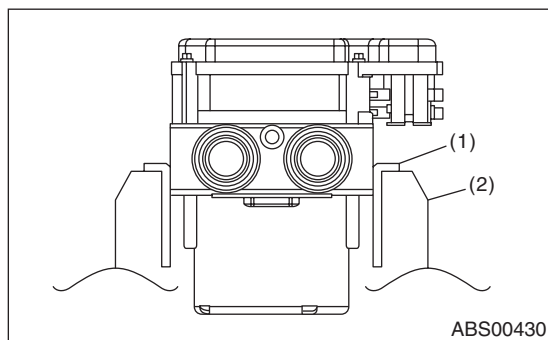

- (1) Aluminum plate, etc.  
(2) Vise

4) Using TORX<sup>®</sup> bit E5, remove the four screws of VDCCM.

### NOTE:

Do not re-use the screws.

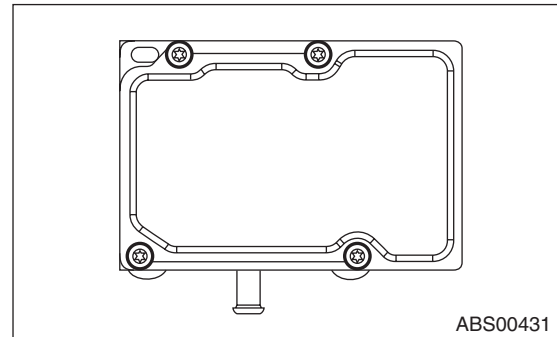

5) Slowly pull out the VDCCM upward from the H/U.

### NOTE:

To prevent damaging of coil section, remove the VDCCM straight up from H/U without twisting.

6) Make sure there is no dirt or damage on the sealing surface of the H/U.

### CAUTION:

• Do not clean the VDCCM&H/U by applying compressed air.

• Even if damage is found on the H/U seal, do not attempt repair by filing or with a metal scraper. To remove the seal residue, always use a plastic scraper. Do not use chemical such as paint thinner, etc., to clean.

7) Position the coil of the new VDCCM to align with the H/U valve.

8) To prevent deformation of the VDCCM housing cover, hold the corner of VDCCM and install it to the H/U without tilting.

9) Using a TORX<sup>®</sup> bit E5, attach/tighten new screws in the order of (1) through (4).

### CAUTION:

Always use new screws.

### Tightening torque:

1.5 N·m (0.15 kgf·m, 1.1 ft·lb)

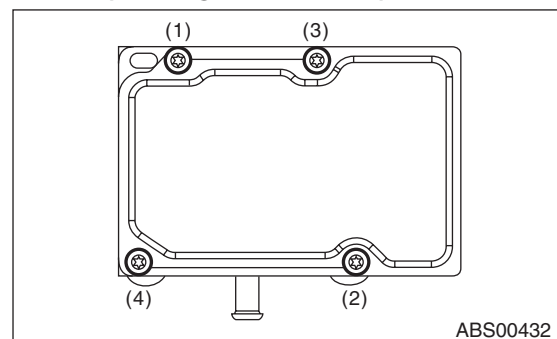

10) Check that there is no foreign matter in mating surface between the VDCCM&H/U.

11) Using a TORX® bit E5, tighten the screws in the order of (1) through (4) again.

### **Tightening torque:**

**3 N·m (0.31 kgf·m, 2.2 ft·lb)**

12) Check that there is no gap in the mating surface between VDCCM&H/U.

13) Install the VDCCM&H/U to the vehicle.

14) Bleed air from the brake system. <Ref. to BR-39, PROCEDURE, Air Bleeding.>

15) Perform the selection · registration operation of parameter. <Ref. to VDC(diag)-20, PARAMETER SELECTION, OPERATION, Subaru Select Monitor.>

### **NOTE:**

- After replacing the VDCCM, be sure to perform the selection · registration operation of parameter.
- For the selection and registration of parameter, the Subaru Select Monitor is required.
- When the registration has not been performed, the DTC code “Parameter selection error” is detected together with the ABS/EBD/VDC warning light illumination.

16) Check the parameter to confirm that the applied models and grades of the relevant vehicle are included. <Ref. to VDC(diag)-21, PARAMETER CHECK, OPERATION, Subaru Select Monitor.>

17) If the applied models and grades of the relevant vehicle are not included, perform the selection · registration operation of parameter with the {Confirm on parameter} screen again. <Ref. to VDC(diag)-20, PARAMETER SELECTION, OPERATION, Subaru Select Monitor.>

18) Execute Clear Memory after parameter selection and registration operations because the DTC for “Parameter selection error” is memorized.

## **E: ADJUSTMENT**

When the following replacement, removal and installation are performed, be sure to perform the centering of the steering angle sensor and zero point setting of yaw rate & G sensor.

- VDCCM&H/U
- Steering angle sensor
- Yaw rate & G sensor
- Steering wheel parts (Including airbag)
- Suspension parts
- Wheel alignment adjustment

1) Park the vehicle straight on a level surface. (With engine operating in the “Neutral” range)

2) Check that steering wheel is positioned at the center. (When the center position is not correct, adjust the wheel alignment.)

3) Set the Subaru Select Monitor to the vehicle, and select the {Set mode Str.A.Sen.N&Lat.GSen.Op} in the «Function Check Sequence» screen. (Follow the steps on the display.)

4) On «Brake Control System» display, select {Current Data Display & Save}, and check that the steering angle sensor shows “0 deg”.

5) When the “0 deg” is not displayed, repeat the above steps and check that the “0 deg” is displayed.

6) Drive the vehicle for 10 minutes, and check that the ABS and VDC warning light is not illuminated.

7) Check that there is no unnecessary VDC operation or steering control loss. If there is a malfunction, repeat the steps above.

# ABS Sequence Control

VEHICLE DYNAMICS CONTROL (VDC)

---

## 4. ABS Sequence Control

### A: OPERATION

- 1) While the ABS sequence control is being performed, the operation of the hydraulic unit can be checked using the brake tester or pressure gauge after the hydraulic unit solenoid valve operation.
- 2) ABS sequence control can be started by the Subaru Select Monitor.

#### 1. ABS SEQUENCE CONTROL WITH SUBARU SELECT MONITOR

##### NOTE:

In the event of any trouble, the ABS sequence control will not operate.

- 1) Connect the Subaru Select Monitor to data link connector under the driver's side instrument panel lower cover.
- 2) Turn the ignition switch to ON.
- 3) Run the "PC application for Subaru Select Monitor".
- 4) Set the Subaru Select Monitor to "Brake Control System" mode.
- 5) When the "Function Check Sequence" is selected, the "ABS sequence control" will start.
- 6) Execute the following operations when the message "Press Brake Pedal Firmly" is displayed.
  - (1) When using a brake tester, press the brake pedal pad with a force of 1,000 N (102 kgf, 225 lbf).
  - (2) When using a pressure gauge, press the brake pedal so that the pressure gauge indicates 3,500 kPa (36 kgf/cm<sup>2</sup>, 511 psi).
- 7) Press the "OK" after "Press "OK"" is displayed.
- 8) The brake system being operated is displayed on the Subaru Select Monitor.



# ABS Sequence Control

## VEHICLE DYNAMICS CONTROL (VDC)

---

- |                             |                             |                                 |
|-----------------------------|-----------------------------|---------------------------------|
| (1) All wheel speed         | (11) RR compression valve   | (20) 0.6 sec.                   |
| (2) Ignition key            | (12) RL decompression valve | (21) 0.4 sec.                   |
| (3) ABS warning light       | (13) RL compression valve   | (22) Point A                    |
| (4) Stop light switch       | (14) Pump motor             | (23) Reset                      |
| (5) Valve relay             | (15) 1.5 sec.               | (24) Master cylinder pressure   |
| (6) FL decompression valve  | (16) Light OFF              | (25) FL wheel cylinder pressure |
| (7) FL compression valve    | (17) Light ON               | (26) FR wheel cylinder pressure |
| (8) FR decompression valve  | (18) 1.0 sec.               | (27) RR wheel cylinder pressure |
| (9) FR compression valve    | (19) 1.4 sec.               | (28) RL wheel cylinder pressure |
| (10) RR decompression valve |                             |                                 |

### NOTE:

The control operation starts at point A.

## **B: SPECIFICATION**

### **1. CONDITIONS FOR COMPLETION OF ABS SEQUENCE CONTROL**

When the following conditions develop, the ABS sequence control stops and ABS operation is returned to the normal control mode.

- When the speed of at least one wheel reaches 10 km/h (6 MPH).
- When the brake pedal is released during ABS sequence control and the stop light switch becomes OFF.
- After completion of ABS sequence control.
- When a malfunction is detected.

## 5. VDC Sequence Control

### A: OPERATION

- 1) While the VDC sequence control is performed, the operation of the hydraulic unit can be checked using the brake tester or pressure gauge after the hydraulic unit solenoid valve is operated.
- 2) VDC sequence control can be started by Subaru Select Monitor.

#### 1. VDC SEQUENCE CONTROL WITH SUBARU SELECT MONITOR

**NOTE:**

In the event of any trouble, sequence control will not operate.

- 1) Connect the Subaru Select Monitor to data link connector under the driver's side instrument panel lower cover.
- 2) Turn the ignition switch to ON.
- 3) Run the "PC application for Subaru Select Monitor".
- 4) Set the Subaru Select Monitor to "Brake Control System" mode.
- 5) When the "VDC Inspection Mode" is selected from the "Function Check Sequence" menu, the "VDC sequence control" will start.
- 6) Press the "OK" after "Press "OK"" is displayed.
- 7) Operation points will be displayed on Subaru Select Monitor.



# VDC Sequence Control

VEHICLE DYNAMICS CONTROL (VDC)

## 2. CONDITIONS FOR VDC SEQUENCE CONTROL

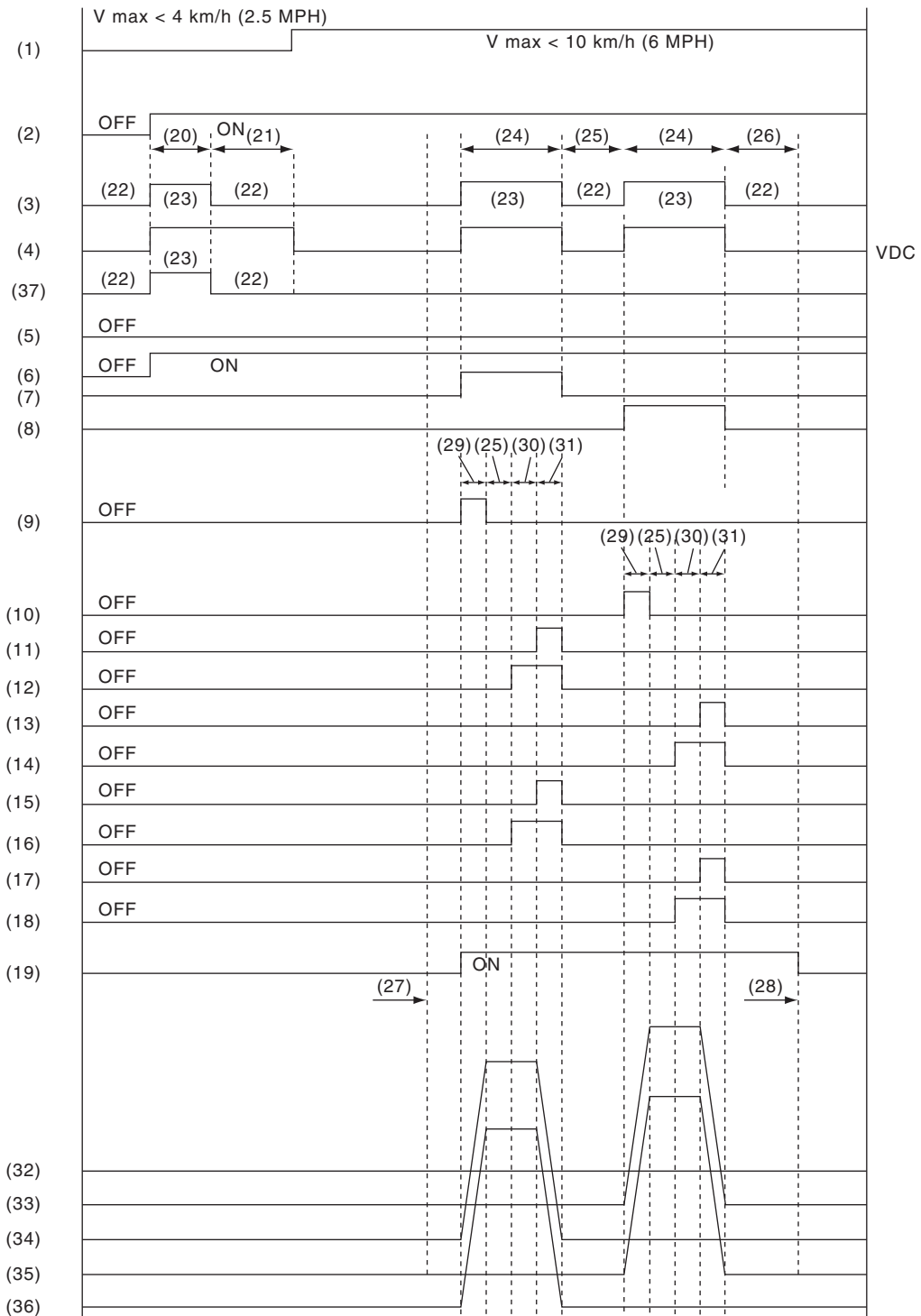

VDC00607

# VDC Sequence Control

VEHICLE DYNAMICS CONTROL (VDC)

---

(1) All wheel speed	(14) FR compression valve	(26) 1.6 seconds
(2) Ignition key	(15) RR decompression valve	(27) Point A
(3) ABS warning light	(16) RR compression valve	(28) Reset
(4) VDC warning light	(17) RL decompression valve	(29) 0.8 seconds
(5) Stop light switch	(18) RL compression valve	(30) 1.2 seconds
(6) Valve relay	(19) Pump motor	(31) 0.4 seconds
(7) VDC switching valve 1 FL	(20) 1.5 seconds	(32) Master cylinder pressure
(8) VDC switching valve 1 FR	(21) Approx. 3 seconds	(33) FR wheel cylinder pressure
(9) VDC switching valve 2 FL	(22) Light OFF	(34) FL wheel cylinder pressure
(10) VDC switching valve 2 FR	(23) Light ON	(35) RL wheel cylinder pressure
(11) FL decompression valve	(24) 3.4 seconds	(36) RR wheel cylinder pressure
(12) FL compression valve	(25) 1 second	(37) Hill start assist warning light
(13) FR decompression valve		

## NOTE:

The control operation starts at point A.

## B: SPECIFICATION

### 1. CONDITIONS FOR COMPLETION OF VDC SEQUENCE CONTROL

When the following conditions develop, the VDC sequence control stops and VDC operation is returned to the normal control mode.

- When the speed of at least one wheel reaches 10 km/h (6 MPH).
- When the brake pedal is pressed during sequence control and the stop light switch is set to ON.
- After completion of VDC sequence control.
- When a malfunction is detected.

# Yaw Rate and G Sensor

VEHICLE DYNAMICS CONTROL (VDC)

---

## 6. Yaw Rate and G Sensor

### A: REMOVAL

- 1) Disconnect the ground cable from battery.
- 2) Remove the console box. <Ref. to EI-51, Console Box.>
- 3) Disconnect the connector from yaw rate & G sensor.
- 4) Remove the nut and remove the yaw rate & G sensor.

### CAUTION:

**Do not drop or hit the yaw rate & G sensor.**

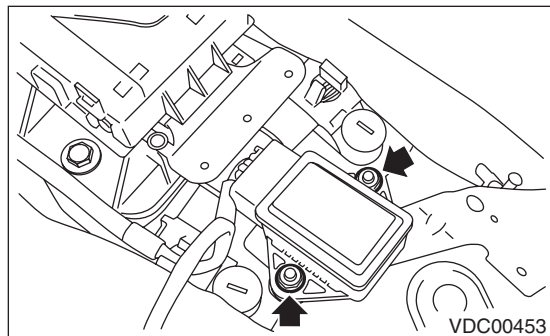

### B: INSTALLATION

Install each part in the reverse order of removal.

#### *Tightening torque:*

**7.5 N·m (0.76 kgf·m, 5.5 ft·lb)**

### CAUTION:

After completion of installation, set the following two positions.

- Positioning to the center of steering angle sensor
  - Positioning the yaw rate & G sensors to zero
- The above procedure is required VDCCM&H/U to identify the vehicle position afterward. For the setting procedures of the 2 steps above, refer to "VDC Control Module and Hydraulic Control Unit (VDCCM&H/U)". <Ref. to VDC-13, ADJUSTMENT, VDC Control Module and Hydraulic Control Unit (VDCCM&H/U).>

# Yaw Rate and G Sensor

VEHICLE DYNAMICS CONTROL (VDC)

## C: INSPECTION

### 1. YAW RATE & G SENSOR SIGNAL

Step	Check	Yes	No
<b>1 CHECK YAW RATE &amp; G SENSOR.</b> 1) Turn the ignition switch to OFF. 2) Connect the Subaru Select Monitor connector to the data link connector. 3) Turn the ignition switch to ON. 4) Set the Subaru Select Monitor connector to the {Brake Control System} mode. 5) Select {Current Data Display & Save}. 6) Read the output of yaw rate & G sensor.	Are the indicated values when the vehicle is placed horizontally, Lateral G sensor: $-1.5 \text{ — } 1.5 \text{ m/s}^2$ , Yaw rate sensor: $-4 \text{ — } 4 \text{ deg/s}$ ?	Go to step 2.	Repair the harness connector between yaw rate & G sensor and VDCCM&H/U. Or replace yaw rate & G sensor.
<b>2 CHECK G SENSOR.</b> 1) Remove the console box. 2) Remove the yaw rate & G sensor from vehicle without disconnecting the connector. 3) Read the display of Subaru Select Monitor. NOTE: When the yaw rate & G sensor is moved with its power supply on, DTC of yaw rate & G sensor may be recorded.	Is the value $6.8 \text{ — } 12.8 \text{ m/s}^2$ when the yaw rate & G sensor is inclined $90^\circ$ to the forward?	Go to step 3.	Repair the harness connector between yaw rate & G sensor and VDCCM&H/U. Or replace yaw rate & G sensor.
<b>3 CHECK G SENSOR.</b> Read the display of Subaru Select Monitor. NOTE: When the yaw rate & G sensor is moved with its power supply on, DTC of yaw rate & G sensor may be recorded.	Is the value $-6.8 \text{ — } -12.8 \text{ m/s}^2$ when the yaw rate & G sensor is inclined $90^\circ$ to the rearward?	Go to step 4.	Repair the harness connector between yaw rate & G sensor and VDCCM&H/U. Or replace yaw rate & G sensor.
<b>4 CHECK G SENSOR.</b> Read the display of Subaru Select Monitor. NOTE: When the yaw rate & G sensor is moved with its power supply on, DTC of yaw rate & G sensor may be recorded.	Is the value $6.8 \text{ — } 12.8 \text{ m/s}^2$ when the yaw rate & G sensor is inclined $90^\circ$ to the right?	Go to step 5.	Repair the harness connector between yaw rate & G sensor and VDCCM&H/U. Or replace yaw rate & G sensor.
<b>5 CHECK G SENSOR.</b> Read the display of Subaru Select Monitor. NOTE: When the yaw rate & G sensor is moved with its power supply on, DTC of yaw rate & G sensor may be recorded.	Is the value $-6.8 \text{ — } -12.8 \text{ m/s}^2$ when the yaw rate & G sensor is inclined $90^\circ$ to the left?	Yaw rate & G sensors are normal.	Repair the harness connector between yaw rate & G sensor and VDCCM&H/U. Or replace yaw rate & G sensor.

# Steering Angle Sensor

VEHICLE DYNAMICS CONTROL (VDC)

## 7. Steering Angle Sensor

### A: REPLACEMENT

#### CAUTION:

- Do not perform the removal except unless replacing.
- If the sensor needs replacement, replace along with the combination switch assembly once every three times for the protection of the threaded portion.

- 1) Set the steering wheel in a straight-ahead position.
- 2) Disconnect the ground cable from battery.
- 3) Remove the driver's airbag module. <Ref. to AB-16, REMOVAL, Driver's Airbag Module.>

#### WARNING:

Always refer to "Airbag System" when performing the airbag module repair service. <Ref. to AB-5, CAUTION, General Description.>

- 4) Remove the steering wheel. <Ref. to PS-12, REMOVAL, Steering Wheel.>
- 5) Remove the screws and remove the steering column cover lower.

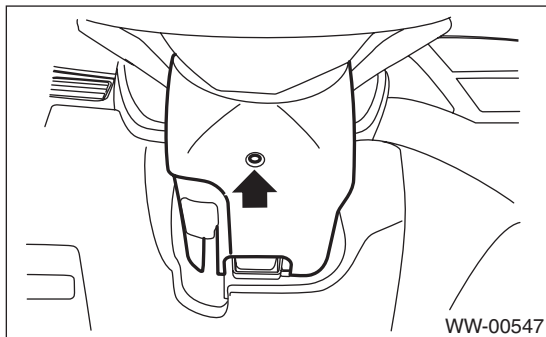

- 6) Remove the harness cover lock.
- 7) Remove the screws and detach the knee protector.

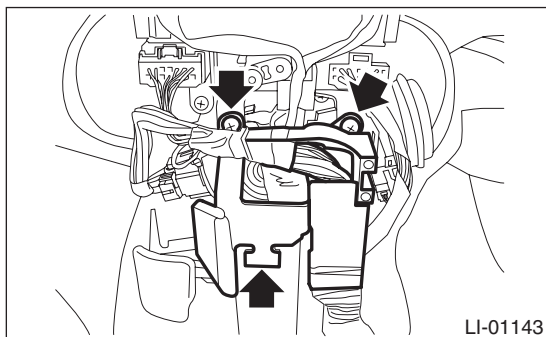

- 8) Remove the screws and remove the steering column cover upper.

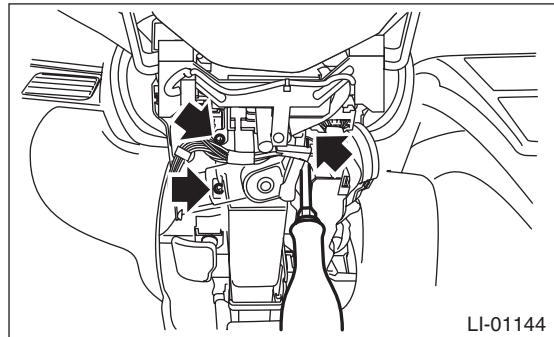

- 9) Disconnect the connector of roll connector and steering angle sensor.
- 10) Remove the screws which secure the roll connector to steering column.

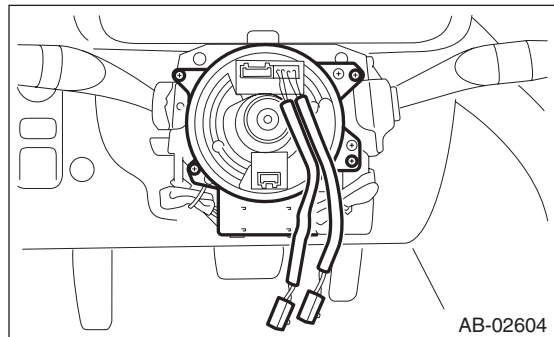

- 11) Remove the vinyl tape binding the harness, and remove the steering angle sensor from roll connector.

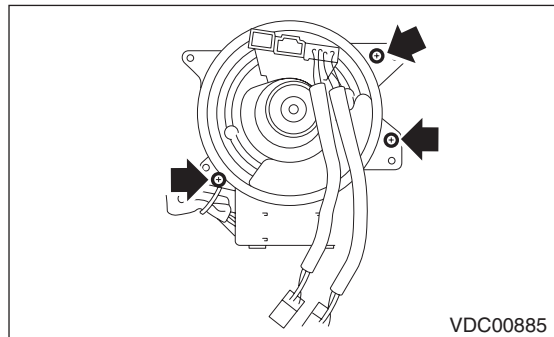

- 12) Turn the protrusion portion of new steering angle sensor to match the alignment mark of inspection hole.

# Steering Angle Sensor

VEHICLE DYNAMICS CONTROL (VDC)

## CAUTION:

Be careful not to allow foreign matter to enter into inspection hole.

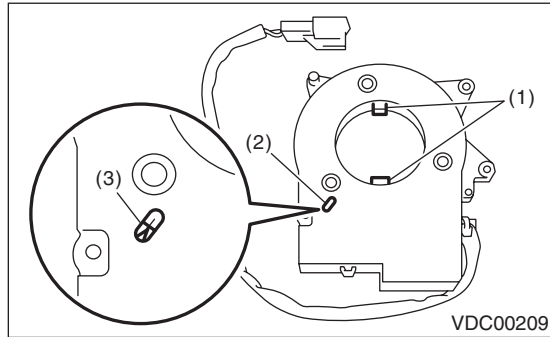

- (1) Protrusion portion
- (2) Inspection hole
- (3) Alignment mark

13) Align the center of roll connector. <Ref. to AB-27, INSTALLATION, Roll Connector.>

14) Apply the grease provided with the new part on the 4 locations of the protrusion on the steering angle sensor.

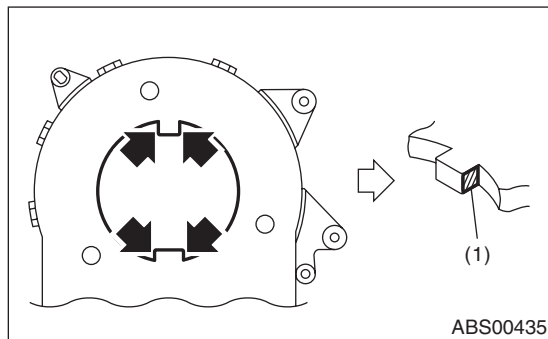

- (1) Grease application location

15) Align the position of the protrusion and install roll connector to steering angle sensor.

## Tightening torque:

**0.5 N·m (0.05 kgf·m, 0.36 ft·lb)**

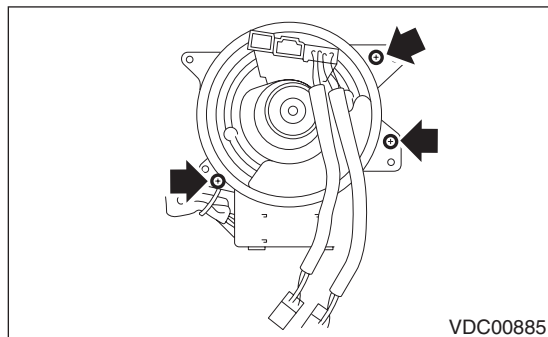

16) Install the roll connector to combination switch and bind the harness with vinyl tape as originally bound.

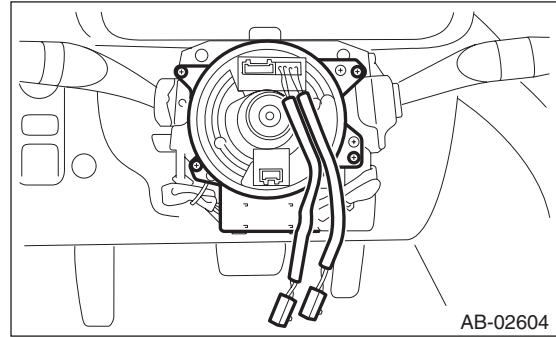

17) Install the steering wheel. <Ref. to PS-12, INSTALLATION, Steering Wheel.>

## Tightening torque:

**39 N·m (3.98 kgf·m, 28.8 ft·lb)**

18) Install the airbag module to the steering wheel. <Ref. to AB-16, INSTALLATION, Driver's Airbag Module.>

## WARNING:

Always refer to "Airbag System" before performing the service operation. <Ref. to AB-5, CAUTION, General Description.>

19) Connect the ground cable to battery.

## CAUTION:

After completion of installation, adjust the following two positions.

- Positioning to the center of steering angle sensor
  - Positioning the yaw rate & G sensors to zero
- The above procedure is required for the VDC-CM to identify vehicle position afterward. For the setting procedures of the 2 steps above, refer to "Adjustment" in "VDC Control Module & Hydraulic Control Unit (VDCCM&H/U)". <Ref. to VDC-13, ADJUSTMENT, VDC Control Module and Hydraulic Control Unit (VDCCM&H/U).>

# Front ABS Wheel Speed Sensor

VEHICLE DYNAMICS CONTROL (VDC)

## 8. Front ABS Wheel Speed Sensor

### A: REMOVAL

- 1) Disconnect the ground cable from battery.
- 2) Disconnect the ABS wheel speed sensor connector located next to the front strut mounting house in the engine compartment.
- 3) Remove the bolts and then remove the sensor harness bracket.

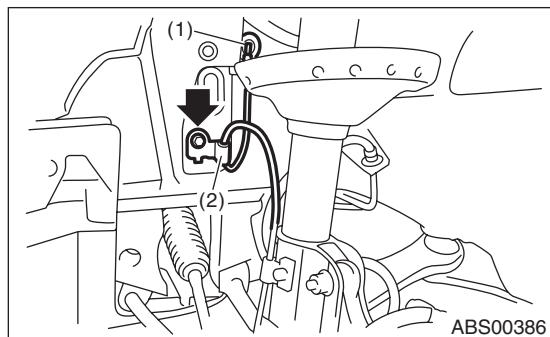

- (1) To the front ABS wheel speed sensor connector
- (2) Sensor harness bracket

- 4) Remove the bolts which secure the sensor harness to the front strut.
- 5) Remove the bolts, and remove the front ABS wheel speed sensor from the front housing.

### CAUTION:

- Be careful not to damage the sensor.
- Do not apply excessive force to the sensor harness.

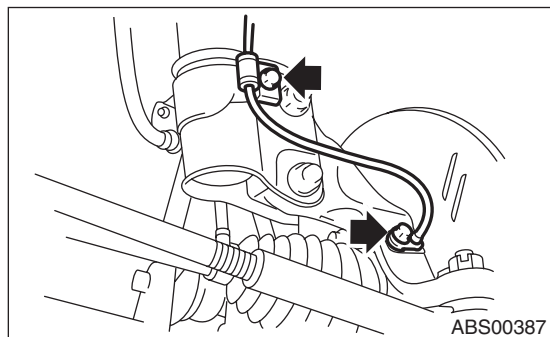

### B: INSTALLATION

#### CAUTION:

Be careful not to damage the sensor.  
Install each part in the reverse order of removal.

#### Tightening torque:

##### Sensor:

7.5 N·m (0.76 kgf·m, 5.5 ft·lb)

##### Bracket:

33 N·m (3.36 kgf·m, 24.3 ft·lb)

#### NOTE:

- Check the identification (mark) on the harness to make sure there is no warpage. (RH: K1 (White), LH: K2 (Yellow))
- Check if the harness is not pulled and does not come in contact with the suspension or body during steering wheel effort.

### C: INSPECTION

#### 1. CHECK WITH SUBARU SELECT MONITOR

- 1) Connect the Subaru Select Monitor to the data link connector.
- 2) Select {Current Data Display & Save}. Check if the speed indicated on the display changes in the same manner as the speedometer reading during acceleration/deceleration when the steering wheel is in the straight-ahead position.
- 3) If the speed indicated on the display does not change, check the ABS wheel speed sensor. <Ref. to VDC-24, ABS WHEEL SPEED SENSOR, INSPECTION, Front ABS Wheel Speed Sensor.>

#### 2. ABS WHEEL SPEED SENSOR

- 1) Check the tip of the ABS wheel speed sensor for foreign particles or damage. If necessary, clean the tip or replace the ABS wheel speed sensor.
- 2) Check the ABS wheel speed sensor cable for discontinuity. If defective, replace the ABS wheel speed sensor.

# Front ABS Wheel Speed Sensor

VEHICLE DYNAMICS CONTROL (VDC)

3) Connect a 12 V power supply to No. 2 terminal of sensor connector as shown in the figure, then attach resistance to the No. 1 terminal. Rotate the wheel at about 2.75 km/h (2 MPH), and measure the voltage using an oscilloscope.

**Standard value of output voltage:**

**0.7 — 1.4 V**

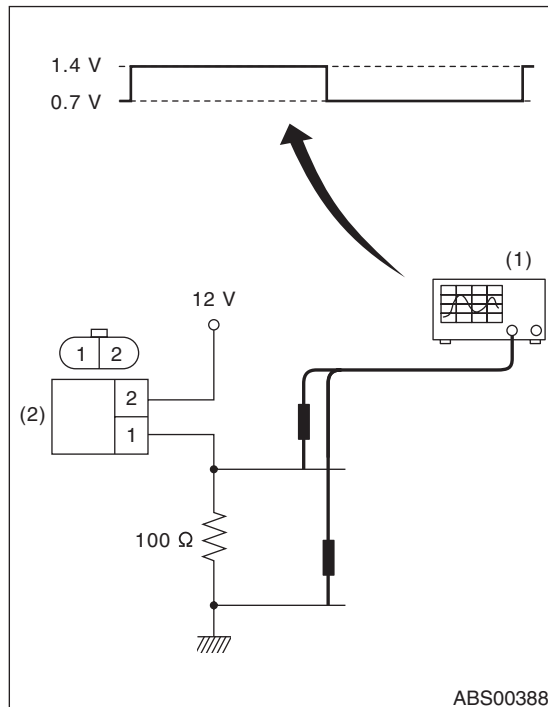

(1) Oscilloscope

(2) ABS wheel speed sensor

4) Replace the ABS wheel speed sensor if the inspection result is not within the standard value.



# Rear ABS Wheel Speed Sensor

VEHICLE DYNAMICS CONTROL (VDC)

## 9. Rear ABS Wheel Speed Sensor

### A: REMOVAL

- 1) Disconnect the ground cable from battery.
- 2) Disconnect the connector from the rear ABS wheel speed sensor.

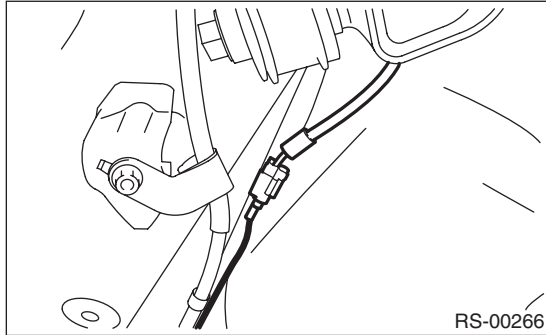

- 3) Remove the sensor harness clamp of the rear sub frame.

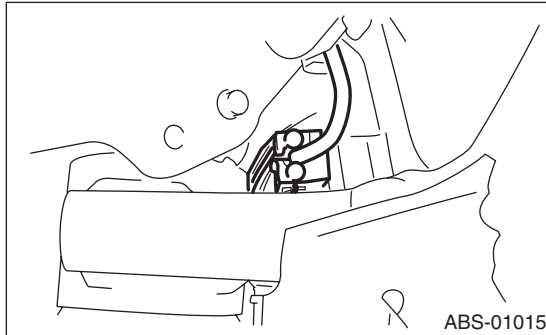

- 4) Remove the bolts and then remove the sensor harness bracket from the upper arm.

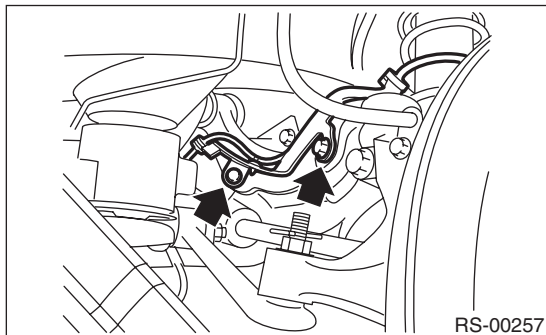

- 5) Remove the bolts, and remove the rear ABS wheel speed sensor from the rear axle.

### CAUTION:

- Be careful not to damage the sensor.
- Do not apply excessive force to the sensor harness.

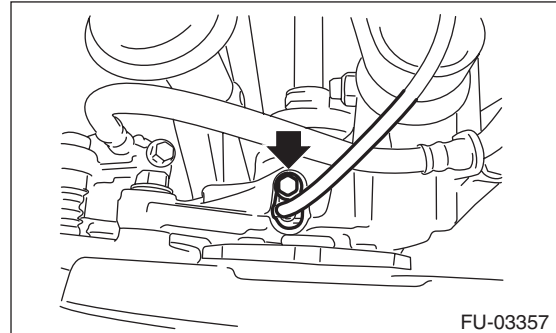

### B: INSTALLATION

#### CAUTION:

Be careful not to damage the sensor.

Install each part in the reverse order of removal.

#### Tightening torque:

##### Sensor:

7.5 N·m (0.76 kgf·m, 5.5 ft·lb)

##### Bracket:

7.5 N·m (0.76 kgf·m, 5.5 ft·lb)

#### NOTE:

Check the identification (mark) on the harness to make sure there is no warpage. (RH: P5 (White), LH: P6 (Yellow))

### C: INSPECTION

#### 1. ABS WHEEL SPEED SENSOR

Refer to "INSPECTION" in "Front ABS Wheel Speed Sensor". <Ref. to VDC-24, INSPECTION, Front ABS Wheel Speed Sensor.>

## 10. Front Magnetic Encoder

### A: REMOVAL

Refer to "Front Hub Bearing" for removal, because the front magnetic encoder is integrated with front hub bearing. <Ref. to DS-18, REMOVAL, Front Hub Unit Bearing.>

### B: INSTALLATION

Refer to "Front Hub Bearing" for installation, because the front magnetic encoder is integrated with front hub bearing. <Ref. to DS-18, INSTALLATION, Front Hub Unit Bearing.>

### C: INSPECTION

Visually check the magnetic encoder for any damage. If necessary, replace with a new hub unit bearing.

#### NOTE:

Because the magnetic encoder is integrated with hub unit bearing assembly, replace the hub unit bearing with a new part if there is any defect found on the magnetic encoder.

### 11.Rear Magnetic Encoder

#### A: REMOVAL

Refer to "Rear Hub Unit Bearing" for removal, because the rear magnetic encoder is integrated with rear hub unit bearing. <Ref. to DS-24, REMOVAL, Rear Hub Unit Bearing.>

#### B: INSTALLATION

Refer to "Rear Hub Unit Bearing" for installation, because the rear magnetic encoder is integrated with rear hub unit bearing. <Ref. to DS-25, INSTALLATION, Rear Hub Unit Bearing.>

#### C: INSPECTION

Visually check the magnetic encoder parts for any damage. If necessary, replace with a new hub unit bearing.

#### NOTE:

Because the magnetic encoder is integrated with hub unit bearing assembly, replace the hub unit bearing with a new part if there is any defect found on the magnetic encoder.

## 12.VDC OFF Switch

### A: REMOVAL

NOTE:

VDC mode change switch is equipped with STI MT model only, and it is also used as VDC OFF switch.

- 1) Remove the instrument panel lower cover. <Ref. to EI-49, REMOVAL, Instrument Panel Lower Cover.>
- 2) Remove the screws, and then remove the VDC OFF switch.

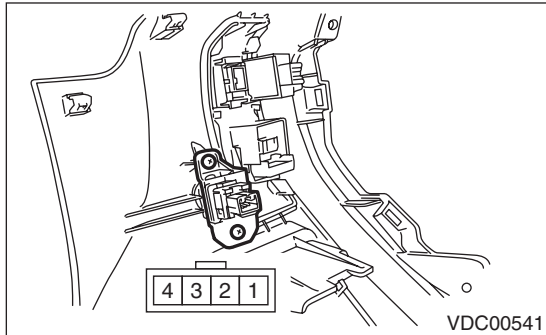

### B: INSTALLATION

Install each part in the reverse order of removal.

### C: INSPECTION

- 1) Check the resistance between the VDC OFF switch terminals.

Switch position	Terminal No.	Standard
OFF	2 — 3	1 M $\Omega$ or more
ON	2 — 3	Less than 1 $\Omega$

- 2) Replace the VDC OFF switch if the inspection result is not within the standard value.

# VDC OFF Switch

VEHICLE DYNAMICS CONTROL (VDC)

---

**VDC-30**

Brought to you by Ebay Seller "SubaruManuals"

# VEHICLE DYNAMICS CONTROL (VDC) (DIAGNOSTICS)

## *VDC(diag)*

---

	<b>Page</b>
1. Basic Diagnostic Procedure .....	2
2. Check List for Interview .....	4
3. General Description .....	10
4. Electrical Component Location .....	12
5. Control Module I/O Signal .....	14
6. Subaru Select Monitor .....	18
7. Read Diagnostic Trouble Code (DTC) .....	25
8. Inspection Mode .....	26
9. Clear Memory Mode .....	27
10. Warning Light Illumination Pattern .....	28
11. List of Diagnostic Trouble Code (DTC) .....	48
12. Diagnostic Procedure with Diagnostic Trouble Code (DTC) .....	53
13. General Diagnostic Table .....	117

# Basic Diagnostic Procedure

VEHICLE DYNAMICS CONTROL (VDC) (DIAGNOSTICS)

## 1. Basic Diagnostic Procedure

### A: PROCEDURE

#### CAUTION:

Remove foreign matter (dust, water, oil etc.) from the VDCCM&H/U connector during removal and installation.

#### NOTE:

- To check the harness for open or short circuits, shake problem spot or connector.
- Refer to "Check List for Interview". <Ref. to VDC(diag)-4, Check List for Interview.>

Step	Check	Yes	No
<b>1 CHECK PRE-INSPECTION.</b> 1) Ask the customer when and how the trouble occurred using the interview check list. <Ref. to VDC(diag)-4, Check List for Interview.> 2) Before performing diagnostics, check the component which might affect VDC problems. <Ref. to VDC(diag)-10, INSPECTION, General Description.>	Is the component that might influence the VDC problem normal?	Go to step 2.	Repair or replace each component.
<b>2 CHECK INDICATION OF DTC.</b> 1) Turn the ignition switch to OFF. 2) Connect the Subaru Select Monitor to data link connector. 3) Turn the ignition switch to ON and run the Subaru Select Monitor. 4) Read the DTC using the Subaru Select Monitor. <Ref. to VDC(diag)-25, OPERATION, Read Diagnostic Trouble Code (DTC).> NOTE: If the communication function of the Subaru Select Monitor cannot be executed properly, check the communication circuit. <Ref. to VDC(diag)-22, COMMUNICATION FOR INITIALIZING IMPOSSIBLE, INSPECTION, Subaru Select Monitor.>	Is DTC displayed on Subaru Select Monitor?	Record the DTC. Go to step 4.	Go to step 3.
<b>3 PERFORM GENERAL DIAGNOSTICS.</b> 1) Perform the inspection by referring to "General Diagnostic Table". <Ref. to VDC(diag)-117, INSPECTION, General Diagnostic Table.> 2) Perform the Clear Memory Mode. <Ref. to VDC(diag)-27, OPERATION, Clear Memory Mode.> 3) Perform the Inspection Mode. <Ref. to VDC(diag)-26, PROCEDURE, Inspection Mode.> 4) Read the DTC. <Ref. to VDC(diag)-25, OPERATION, Read Diagnostic Trouble Code (DTC).> 5) Check the DTC is not displayed.	Do the VDC warning light and ABS warning light go off after starting the engine?	Finish the diagnosis.	Check the combination meter circuit. <Ref. to VDC(diag)-35, ABS WARNING LIGHT DOES NOT GO OFF, Warning Light Illumination Pattern.> <Ref. to VDC(diag)-39, VDC WARNING LIGHT AND VDC INDICATOR LIGHT DO NOT GO OFF, Warning Light Illumination Pattern.>
<b>4 CHECK FREEZE FRAME DATA.</b> Using the Subaru Select Monitor, check the freeze frame data of the VDC control module.	Are freeze frame data recorded?	Record the freeze frame data. Go to step 5.	Go to step 5.

VDC(diag)-2

Brought to you by Ebay Seller "SubaruManuals"

# Basic Diagnostic Procedure

VEHICLE DYNAMICS CONTROL (VDC) (DIAGNOSTICS)

	Step	Check	Yes	No
5	<b>PERFORM DIAGNOSIS.</b> 1) Refer to "List of Diagnostic Trouble Code (DTC)". NOTE: For the DTC list, refer to "List of Diagnostic Trouble Code (DTC)". <Ref. to VDC(diag)-48, LIST, List of Diagnostic Trouble Code (DTC).> 2) Correct the cause of trouble. 3) Perform the Clear Memory Mode. <Ref. to VDC(diag)-27, OPERATION, Clear Memory Mode.> 4) Perform the Inspection Mode. <Ref. to VDC(diag)-26, PROCEDURE, Inspection Mode.> 5) Read the DTC. <Ref. to VDC(diag)-25, OPERATION, Read Diagnostic Trouble Code (DTC).>	Is DTC displayed?	Repeat step 5 until DTC is not shown.	Finish the diagnosis.



## Check List for Interview

VEHICLE DYNAMICS CONTROL (VDC) (DIAGNOSTICS)

---

### 2. Check List for Interview

#### A: CHECK

Check the following item about the vehicle's state.

#### 1. STATE OF ABS WARNING LIGHT

ABS warning light illuminates.	<input type="checkbox"/> Always <input type="checkbox"/> Sometimes <input type="checkbox"/> Only once <input type="checkbox"/> Does not illuminate • When/How long does it illuminate?																																										
Ignition key position	<input type="checkbox"/> LOCK <input type="checkbox"/> ACC <input type="checkbox"/> ON (Before starting engine) <input type="checkbox"/> START <input type="checkbox"/> ON (After starting engine, engine is running) <input type="checkbox"/> ON (After starting engine, engine is at a standstill)																																										
Timing	<table style="width: 100%; border-collapse: collapse;"> <tr> <td style="width: 60%;"><input type="checkbox"/> Immediately after turning the ignition switch to ON</td> <td colspan="2"></td> </tr> <tr> <td><input type="checkbox"/> Immediately after turning the ignition switch to START</td> <td colspan="2"></td> </tr> <tr> <td><input type="checkbox"/> When accelerating</td> <td style="text-align: center;">—</td> <td style="text-align: right;">km/h</td> </tr> <tr> <td></td> <td style="text-align: center;">—</td> <td style="text-align: right;">MPH</td> </tr> <tr> <td><input type="checkbox"/> While driving at a constant speed</td> <td style="text-align: center;">km/h</td> <td style="text-align: right;">MPH</td> </tr> <tr> <td><input type="checkbox"/> While decelerating</td> <td style="text-align: center;">—</td> <td style="text-align: right;">km/h</td> </tr> <tr> <td></td> <td style="text-align: center;">—</td> <td style="text-align: right;">MPH</td> </tr> <tr> <td><input type="checkbox"/> When turning to the right</td> <td style="border: 1px solid black;">Steering angle:</td> <td style="border: 1px solid black;">deg</td> </tr> <tr> <td></td> <td style="border: 1px solid black;">Steering time:</td> <td style="border: 1px solid black;">Sec.</td> </tr> <tr> <td><input type="checkbox"/> When turning to the left</td> <td style="border: 1px solid black;">Steering angle:</td> <td style="border: 1px solid black;">deg</td> </tr> <tr> <td></td> <td style="border: 1px solid black;">Steering time:</td> <td style="border: 1px solid black;">Sec.</td> </tr> <tr> <td><input type="checkbox"/> When other electrical parts are operating</td> <td colspan="2"></td> </tr> <tr> <td colspan="3">• Part name:</td> </tr> <tr> <td colspan="3">• Operating condition:</td> </tr> </table>	<input type="checkbox"/> Immediately after turning the ignition switch to ON			<input type="checkbox"/> Immediately after turning the ignition switch to START			<input type="checkbox"/> When accelerating	—	km/h		—	MPH	<input type="checkbox"/> While driving at a constant speed	km/h	MPH	<input type="checkbox"/> While decelerating	—	km/h		—	MPH	<input type="checkbox"/> When turning to the right	Steering angle:	deg		Steering time:	Sec.	<input type="checkbox"/> When turning to the left	Steering angle:	deg		Steering time:	Sec.	<input type="checkbox"/> When other electrical parts are operating			• Part name:			• Operating condition:		
<input type="checkbox"/> Immediately after turning the ignition switch to ON																																											
<input type="checkbox"/> Immediately after turning the ignition switch to START																																											
<input type="checkbox"/> When accelerating	—	km/h																																									
	—	MPH																																									
<input type="checkbox"/> While driving at a constant speed	km/h	MPH																																									
<input type="checkbox"/> While decelerating	—	km/h																																									
	—	MPH																																									
<input type="checkbox"/> When turning to the right	Steering angle:	deg																																									
	Steering time:	Sec.																																									
<input type="checkbox"/> When turning to the left	Steering angle:	deg																																									
	Steering time:	Sec.																																									
<input type="checkbox"/> When other electrical parts are operating																																											
• Part name:																																											
• Operating condition:																																											

# Check List for Interview

VEHICLE DYNAMICS CONTROL (VDC) (DIAGNOSTICS)

## 2. STATE OF VDC WARNING LIGHT & VDC INDICATOR LIGHT

VDC warning light & VDC indicator light illuminates.	<input type="checkbox"/> Always <input type="checkbox"/> Sometimes <input type="checkbox"/> Only once <input type="checkbox"/> Does not illuminate • When/How long does it illuminate?		
Ignition key position	<input type="checkbox"/> LOCK <input type="checkbox"/> ACC <input type="checkbox"/> ON (before starting engine) <input type="checkbox"/> START <input type="checkbox"/> ON (after starting engine, engine is running) <input type="checkbox"/> ON (after starting engine, engine is at a standstill)		
Timing	<input type="checkbox"/> Immediately after turning the ignition switch to ON <input type="checkbox"/> Immediately after turning the ignition switch to START		
	<input type="checkbox"/> While accelerating	—	km/h
		—	MPH
	<input type="checkbox"/> While driving at a constant speed	km/h	MPH
	<input type="checkbox"/> While decelerating	—	km/h
		—	MPH
	<input type="checkbox"/> When turning to the right	Steering angle:	deg
		Steering time:	Sec.
	<input type="checkbox"/> When turning to the left	Steering angle:	deg
		Steering time:	Sec.
<input type="checkbox"/> When other electrical parts are operating			
• Part name: • Operating condition:			

## Check List for Interview

VEHICLE DYNAMICS CONTROL (VDC) (DIAGNOSTICS)

### 3. STATE OF VDC OFF & VDC TRACTION MODE INDICATOR LIGHT

NOTE:

This check list for interview is applied to 6MT model.

The VDC OFF & VDC traction mode indicator light illuminates.	<input type="checkbox"/> Always <input type="checkbox"/> Sometimes <input type="checkbox"/> Only once <input type="checkbox"/> Does not illuminate • When/How long does it illuminate?		
Ignition key position	<input type="checkbox"/> LOCK <input type="checkbox"/> ACC <input type="checkbox"/> ON (before starting engine) <input type="checkbox"/> START <input type="checkbox"/> ON (after starting engine, engine is running) <input type="checkbox"/> ON (after starting engine, engine is at a standstill)		
Timing	<input type="checkbox"/> Immediately after turning the ignition switch to ON <input type="checkbox"/> Immediately after turning the ignition switch to START		
	<input type="checkbox"/> While accelerating	—	km/h
		—	MPH
	<input type="checkbox"/> While driving at a constant speed	km/h	MPH
	<input type="checkbox"/> While decelerating	—	km/h
		—	MPH
	<input type="checkbox"/> When turning to the right	Steering angle:	deg
		Steering time:	Sec.
	<input type="checkbox"/> When turning to the left	Steering angle:	deg
		Steering time:	Sec.
<input type="checkbox"/> When other electrical parts are operating	• Part name: • Operating condition:		

# Check List for Interview

VEHICLE DYNAMICS CONTROL (VDC) (DIAGNOSTICS)

## 4. STATE OF VDC OFF INDICATOR LIGHT

NOTE:

This check list for interview is applied to 5MT model.

VDC OFF indicator light comes on.	<input type="checkbox"/> Always <input type="checkbox"/> Sometimes <input type="checkbox"/> Only once <input type="checkbox"/> Does not illuminate • When/How long does it illuminate?		
Ignition key position	<input type="checkbox"/> LOCK <input type="checkbox"/> ACC <input type="checkbox"/> ON (before starting engine) <input type="checkbox"/> START <input type="checkbox"/> ON (after starting engine, engine is running) <input type="checkbox"/> ON (after starting engine, engine is at a standstill)		
Timing	<input type="checkbox"/> Immediately after turning the ignition switch to ON <input type="checkbox"/> Immediately after turning the ignition switch to START		
	<input type="checkbox"/> While accelerating	—	km/h
		—	MPH
	<input type="checkbox"/> While driving at a constant speed	km/h	MPH
	<input type="checkbox"/> While decelerating	—	km/h
		—	MPH
	<input type="checkbox"/> When turning to the right	Steering angle:	deg
		Steering time:	Sec.
	<input type="checkbox"/> When turning to the left	Steering angle:	deg
		Steering time:	Sec.
	<input type="checkbox"/> When other electrical parts are operating		
	• Part name: • Operating condition:		

## Check List for Interview

VEHICLE DYNAMICS CONTROL (VDC) (DIAGNOSTICS)

### 5. CONDITIONS UNDER WHICH TROUBLE OCCURS

Environment	a) Weather	<input type="checkbox"/> Fine <input type="checkbox"/> Cloudy <input type="checkbox"/> Rainy <input type="checkbox"/> Snowy <input type="checkbox"/> Others:
	b) Ambient temperature	°C (°F)
	c) Road	<input type="checkbox"/> Inner city <input type="checkbox"/> Suburbs <input type="checkbox"/> Highway <input type="checkbox"/> Local street <input type="checkbox"/> Uphill <input type="checkbox"/> Downhill <input type="checkbox"/> Paved road <input type="checkbox"/> Gravel road <input type="checkbox"/> Muddy road <input type="checkbox"/> Sandy place <input type="checkbox"/> Straight road <input type="checkbox"/> Sharp curve <input type="checkbox"/> Gentle curve <input type="checkbox"/> S-curve <input type="checkbox"/> Road with a slope on both sides <input type="checkbox"/> Others:
	d) Road surface	<input type="checkbox"/> Dry <input type="checkbox"/> Wet <input type="checkbox"/> Covered with fresh snow <input type="checkbox"/> Covered with hardened snow <input type="checkbox"/> Frozen slope <input type="checkbox"/> Others:

# Check List for Interview

## VEHICLE DYNAMICS CONTROL (VDC) (DIAGNOSTICS)

Condition	a) Brakes	Deceleration: <span style="float: right;">G</span>
		<input type="checkbox"/> continuous / <input type="checkbox"/> intermittent
	b) Accelerator	Acceleration: <span style="float: right;">G</span>
		<input type="checkbox"/> continuous / <input type="checkbox"/> intermittent
	c) Vehicle speed	km/h   <span style="float: right;">MPH</span>
		<input type="checkbox"/> Advancing
		<input type="checkbox"/> When accelerating
		<input type="checkbox"/> While decelerating
		<input type="checkbox"/> At low speed
		<input type="checkbox"/> When turning
		<input type="checkbox"/> Others:
	d) Tire inflation pressure	Front RH tire: <span style="float: right;">kPa</span>
		Front LH tire: <span style="float: right;">kPa</span>
		Rear RH tire: <span style="float: right;">kPa</span>
		Rear LH tire: <span style="float: right;">kPa</span>
	e) Degree of wear	Front RH tire: <span style="float: right;">mm (in)</span>
		Front LH tire: <span style="float: right;">mm (in)</span>
		Rear RH tire: <span style="float: right;">mm (in)</span>
		Rear LH tire: <span style="float: right;">mm (in)</span>
	f) Steering wheel	<input type="checkbox"/> Sharp turning
	<input type="checkbox"/> Gentle turning	
	<input type="checkbox"/> Straight forward motion	
	<input type="checkbox"/> Gentle return	
	<input type="checkbox"/> Sharp return	
g) Tire/Wheel size	<input type="checkbox"/> Specified size	
	<input type="checkbox"/> Except specification (            )	
h) Tire variation	<input type="checkbox"/> Summer tire	
	<input type="checkbox"/> Studless tire (Brand:            )	
i) Tire chain is attached: <input type="checkbox"/> Yes / <input type="checkbox"/> No		
j) Using T-type tires: <input type="checkbox"/> Yes / <input type="checkbox"/> No		
k) Condition of suspension alignment:		
l) Load condition:		
m) Repaired parts are used: <input type="checkbox"/> Yes / <input type="checkbox"/> No		
• Content:		
n) Others:		

# General Description

VEHICLE DYNAMICS CONTROL (VDC) (DIAGNOSTICS)

---

## 3. General Description

### A: CAUTION

#### 1. SUPPLEMENTAL RESTRAINT SYSTEM "AIRBAG"

Airbag system wiring harness is routed near the ABS wheel speed sensor and VDCCM&H/U.

#### CAUTION:

- Do not use electrical test equipment on wiring harness and connector circuits of the airbag system.
- Be careful not to damage the airbag system wiring harness when servicing the ABS wheel speed sensor and VDCCM&H/U.

### B: INSPECTION

Before performing diagnosis, check the following items which might affect VDC problems.

#### 1. BATTERY

Measure the battery voltage and check electrolyte.

#### *Standard voltage:*

**12 V or more**

#### *Specific gravity:*

**1.260 or more**

#### 2. GROUND

Check the tightening torque of ground (GB-5) bolt of VDC.

#### *Tightening torque:*

**13 N·m (1.3 kgf·m, 9.6 ft-lb)**

#### 3. BRAKE FLUID

- 1) Check the brake fluid level.
- 2) Check the brake fluid for leaks.

#### 4. HYDRAULIC UNIT

Check the hydraulic unit.

- When using the brake tester <Ref. to VDC-10, CHECKING THE HYDRAULIC UNIT ABS OPERATION WITH THE BRAKE TESTER, INSPECTION, VDC Control Module and Hydraulic Control Unit (VDCCM&H/U).>
- When not using the brake tester <Ref. to VDC-9, CHECKING THE HYDRAULIC UNIT ABS OPERATION BY PRESSURE GAUGE, INSPECTION, VDC Control Module and Hydraulic Control Unit (VDCCM&H/U).>

#### 5. BRAKE DRAG

Check for brake drag.

#### 6. BRAKE PAD AND ROTOR

Check the brake pad and rotor.

- Front <Ref. to BR-16, INSPECTION, Front Brake Pad.> <Ref. to BR-17, INSPECTION, Front Disc Rotor.>
- Rear <Ref. to BR-24, INSPECTION, Rear Brake Pad.> <Ref. to BR-26, INSPECTION, Rear Disc Rotor.>

#### 7. TIRES

Check the tire specifications, tire wear and air pressure. <Ref. to WT-2, SPECIFICATION, General Description.>

# General Description

VEHICLE DYNAMICS CONTROL (VDC) (DIAGNOSTICS)

## C: PREPARATION TOOL

### 1. SPECIAL TOOL

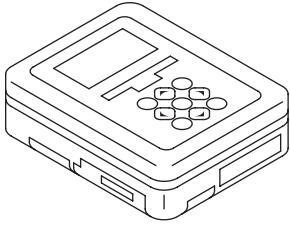
ILLUSTRATION	TOOL NUMBER	DESCRIPTION	REMARKS
 ST1B022XU0	1B022XU0	SUBARU SELECT MONITOR III KIT	Used for troubleshooting the electrical system.

### 2. GENERAL TOOL

TOOL NAME	REMARKS
Circuit tester	Used for measuring resistance, voltage and current.
Oscilloscope	Used for measuring the sensor.



# Electrical Component Location

VEHICLE DYNAMICS CONTROL (VDC) (DIAGNOSTICS)

## 4. Electrical Component Location

### A: LOCATION

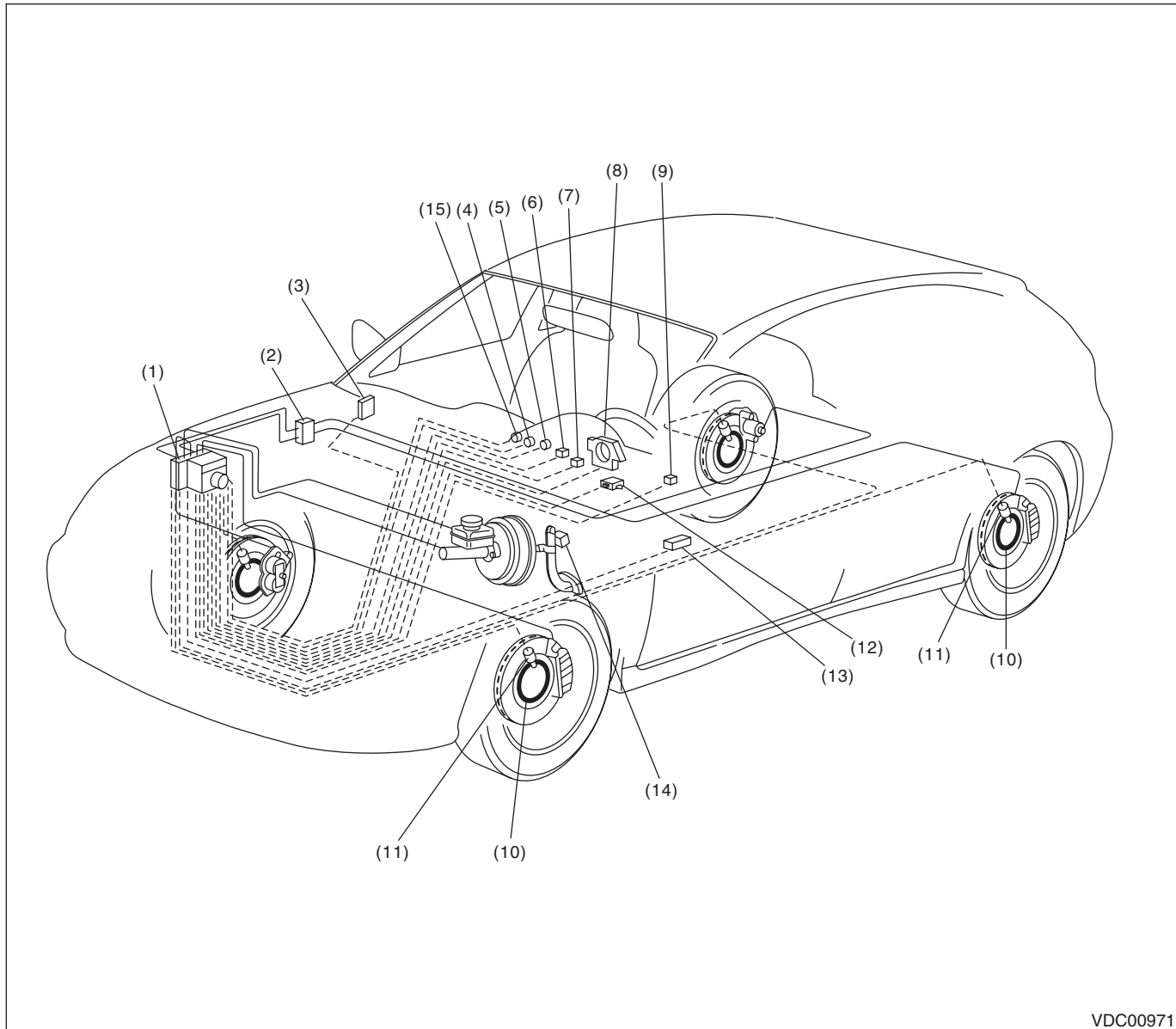

VDC00971

- |   |  |                                      |
|---|--|--------------------------------------|
| (1) VDC control module and hydraulic control unit (VDCCM&H/U) | (6) VDC OFF & VDC traction mode indicator light (6MT model)<br>VDC OFF indicator light (5MT model) | (11) ABS wheel speed sensor          |
| (2) Connector   | (7) VDC warning light & VDC indicator light  | (12) Yaw rate & G sensor             |
| (3) Engine control module (ECM)                               | (8) Steering angle sensor  | (13) Data link connector             |
| (4) Brake warning light (EBD warning light)                   | (9) VDC OFF switch   | (14) Stop light and brake switch     |
| (5) ABS warning light   | (10) Magnetic encoder  | (15) Hill start assist warning light |

**VDC(diag)-12**

Brought to you by Ebay Seller "SubaruManuals"

# Electrical Component Location

## VEHICLE DYNAMICS CONTROL (VDC) (DIAGNOSTICS)

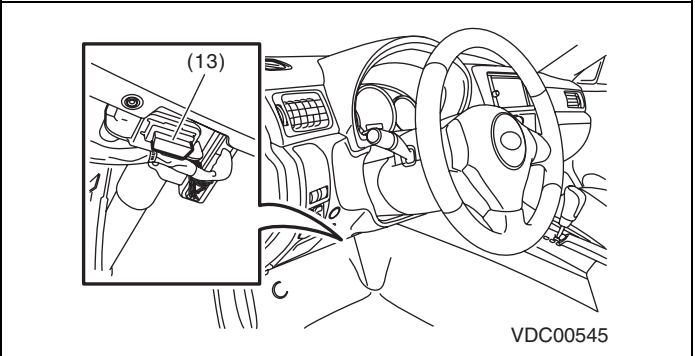
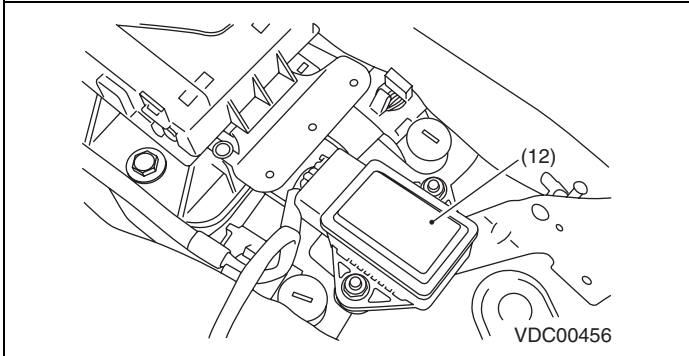
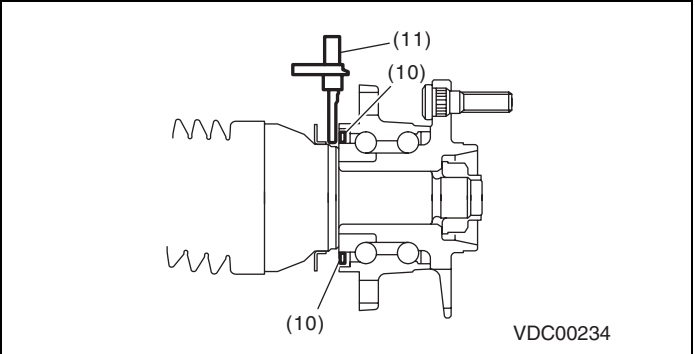
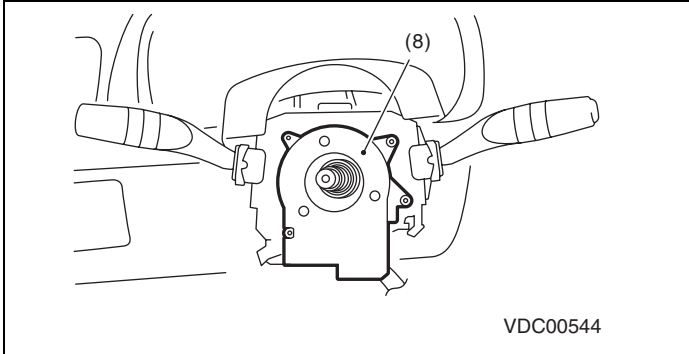
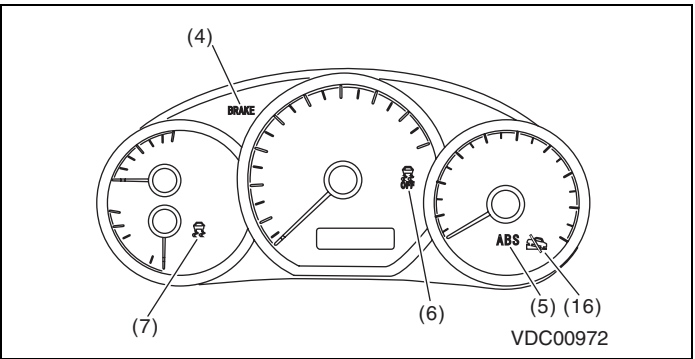
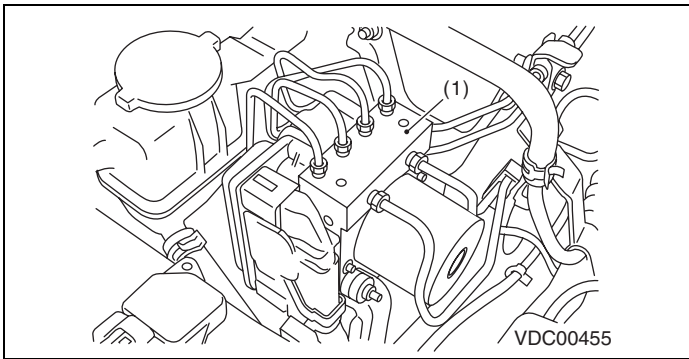

# Control Module I/O Signal

VEHICLE DYNAMICS CONTROL (VDC) (DIAGNOSTICS)

## 5. Control Module I/O Signal

### A: ELECTRICAL SPECIFICATION

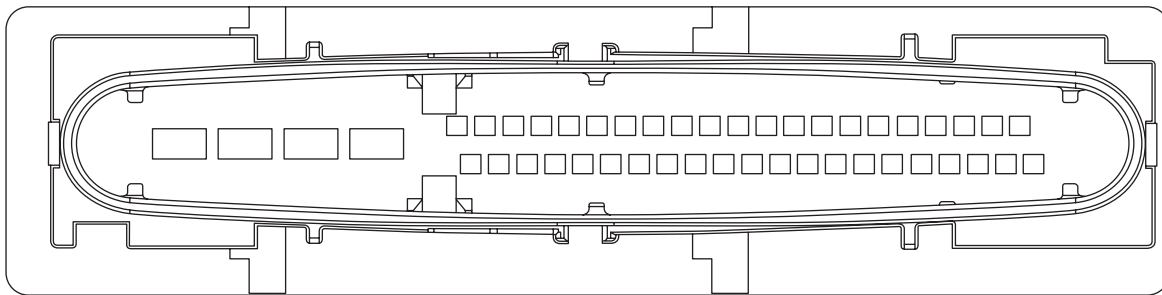

**B310**

22	23	24	25	1	2	3	4	5	6	7	8	9	10	11	12	13	14	15	16	17	18	19	20	21
				26	27	28	29	30	31	32	33	34	35	36	37	38	39	40	41	42	43	44	45	46

VDC00457

#### NOTE:

- Terminal numbers in VDCCM&H/U connector are shown in the figure.
- When the connector is removed from the VDCCM&H/U, the brake warning light (EBD warning light), ABS warning light, VDC OFF & VDC traction mode indicator light (6MT model), VDC OFF indicator light (5MT model), VDC warning light & VDC indicator light, and the hill start assist warning light illuminate.

# Control Module I/O Signal

VEHICLE DYNAMICS CONTROL (VDC) (DIAGNOSTICS)

Content		Terminal No. (+) — (-)	Input/Output signal	
			Measured value and measuring conditions	
Power supply		28 — 25	10 — 15 V when the ignition switch is ON.	
ABS wheel speed sensor	Front LH wheel	Power supply	26 — 25	4.5 — 16.5 V
		Signal	1	5.9 — 16.8 mA: Rectangle waveform
	Front RH wheel	Power supply	5 — 25	4.5 — 16.5 V
		Signal	6	5.9 — 16.8 mA: Rectangle waveform
	Rear LH wheel	Power supply	2 — 25	4.5 — 16.5 V
		Signal	27	5.9 — 16.8 mA: Rectangle waveform
	Rear RH wheel	Power supply	3 — 25	4.5 — 16.5 V
		Signal	4	5.9 — 16.8 mA: Rectangle waveform
CAN communication line (+)		35	2.5 — 1.5 V pulse signal	
CAN communication line (-)		10	3.5 — 2.5 V pulse signal	
Valve relay power supply		24 — 25	10 — 15 V when the ignition switch is ON.	
Motor relay power supply		23 — 22	10 — 15 V when the ignition switch is ON.	
Stop light switch		30 — 25	1.5 V or less when the stop light is OFF; otherwise, 10 — 15 V when the stop light is ON.	
Subaru Select Monitor		7 — 25	0 ↔ 12 V pulse (in communication)	
Vehicle speed output signal		33	0 ↔ 5 V pulse	
VDC OFF switch		31 — 25	1 Ω or less when the switch is ON; 1 MΩ or more when the switch is OFF.	
Ground		25	—	

# Control Module I/O Signal

VEHICLE DYNAMICS CONTROL (VDC) (DIAGNOSTICS)

## B: WIRING DIAGRAM

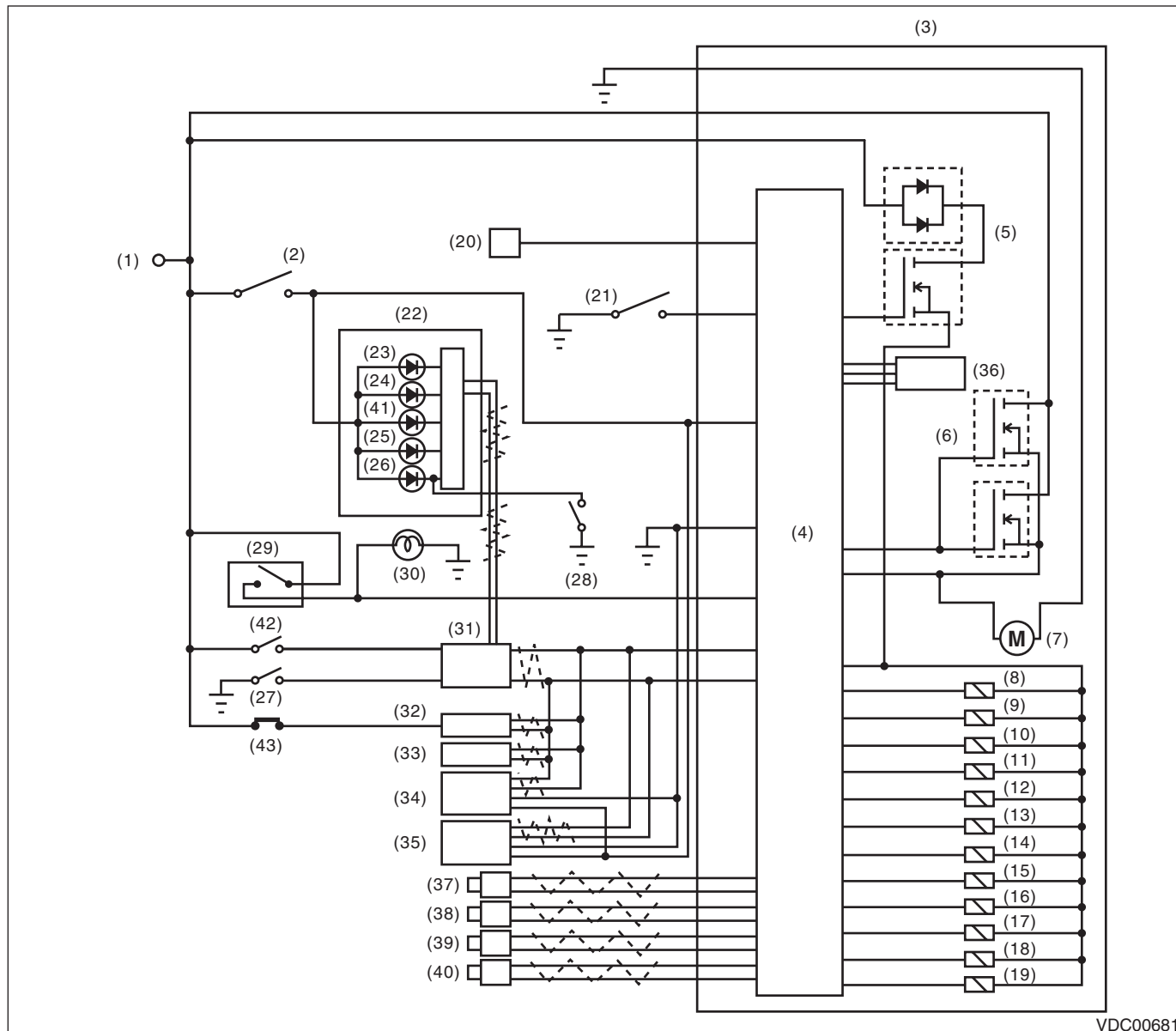

VDC00681

VDC(diag)-16

Brought to you by Ebay Seller "SubaruManuals"

# Control Module I/O Signal

## VEHICLE DYNAMICS CONTROL (VDC) (DIAGNOSTICS)

---

(1) Battery	(16) Primary cut solenoid valve	(31) Body integrated unit
(2) Ignition switch	(17) Primary suction solenoid valve	(32) Engine control module (ECM)
(3) VDC control module and hydraulic control unit (VDCCM&H/U)	(18) Secondary cut solenoid valve	(33) Driver's control center differential control module (6MT model only)
(4) VDC control module	(19) Secondary suction solenoid valve	(34) Steering angle sensor
(5) Valve relay	(20) Data link connector	(35) Yaw rate & G sensor
(6) Motor relay	(21) VDC OFF switch	(36) Pressure sensor
(7) Motor	(22) Combination meter	(37) Front ABS wheel speed sensor LH
(8) Front inlet solenoid valve LH	(23) VDC OFF & VDC traction mode indicator light (6MT model) VDC OFF indicator light (5MT model)	(38) Front ABS wheel speed sensor RH
(9) Front outlet solenoid valve LH	(24) VDC warning light & VDC indicator light	(39) Rear ABS wheel speed sensor LH
(10) Front inlet solenoid valve RH	(25) ABS warning light	(40) Rear ABS wheel speed sensor RH
(11) Front outlet solenoid valve RH	(26) Brake warning light (EBD warning light)	(41) Hill start assist warning light
(12) Rear inlet solenoid valve LH	(27) Parking brake switch	(42) Back-up light switch
(13) Rear outlet solenoid valve LH	(28) Brake fluid level switch	(43) Clutch switch
(14) Rear inlet solenoid valve RH	(29) Stop light and brake switch	
(15) Rear outlet solenoid valve RH	(30) Stop light	

# Subaru Select Monitor

VEHICLE DYNAMICS CONTROL (VDC) (DIAGNOSTICS)

## 6. Subaru Select Monitor

### A: OPERATION

#### 1. HOW TO USE SUBARU SELECT MONITOR

1) Prepare the Subaru Select Monitor kit. <Ref. to VDC(diag)-11, SPECIAL TOOL, PREPARATION TOOL, General Description.>

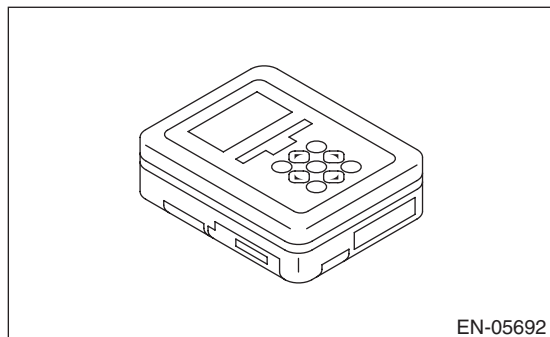

2) Prepare PC with Subaru Select Monitor installed.

3) Connect the USB cable to SDI (Subaru Diagnosis Interface) and USB port on the personal computer (dedicated port for the Subaru Select Monitor).

#### NOTE:

The dedicated port for the Subaru Select Monitor means the USB port which was used to install the Subaru Select Monitor.

4) Connect the diagnosis cable to SDI.

5) Connect SDI to data link connector located in the lower portion of the instrument panel (on the driver's side).

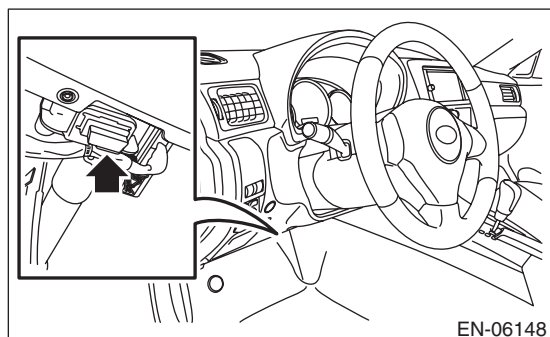

#### CAUTION:

**Do not connect the scan tools other than the Subaru Select Monitor.**

6) Start the PC.

7) Turn the ignition switch to ON (engine OFF) and run the "PC application for Subaru Select Monitor".

#### NOTE:

For detailed operation procedures, refer to "PC application help for Subaru Select Monitor".

8) If VDC and Subaru Select Monitor cannot communicate, check the communication circuit. <Ref. to VDC(diag)-22, COMMUNICATION FOR INITIALIZING IMPOSSIBLE, INSPECTION, Subaru Select Monitor.>

9) Record the DTC and data.

# Subaru Select Monitor

VEHICLE DYNAMICS CONTROL (VDC) (DIAGNOSTICS)

## 2. READ CURRENT DATA

- 1) On «Main Menu» display, select {Each System Check}.
  - 2) On «System Selection Menu» display, select {Brake Control System}.
  - 3) When {VDC} is displayed, select the [OK] button.
  - 4) On «Brake Control Diagnosis» display, select {Current Data Display & Save}.
  - 5) On «Data Display Menu» display, select the data display method.
  - 6) Using the scroll key, scroll the display screen up or down until necessary data is shown.
- A list of the support data is shown in the following table.

Display	Contents to be displayed	Unit of measure
FR Wheel Speed	Wheel speed detected by front ABS wheel speed sensor RH is displayed.	km/h or MPH
FL Wheel Speed	Wheel speed detected by front ABS wheel speed sensor LH is displayed.	km/h or MPH
RR Wheel Speed	Wheel speed detected by rear ABS wheel speed sensor RH is displayed.	km/h or MPH
RL Wheel Speed	Wheel speed detected by rear ABS wheel speed sensor LH is displayed.	km/h or MPH
Steer Angle Sensor Op	Steering angle detected by steering angle sensor is displayed.	deg
Yaw Rate Sensor Output	Vehicle angular speed detected by yaw rate sensor is displayed.	deg/s
Pressure Sensor Output	Brake fluid pressure detected by pressure sensor is displayed.	bar
Lateral G sensor Output	Vehicle lateral acceleration detected by lateral G sensor is displayed.	m/s <sup>2</sup>
IG power supply voltage	Voltage supplied to VDCCM&H/U is displayed.	V
E/G Control Stop Flag	Engine control command signal is displayed.	1 or 0
ABS Control Flag	ABS operation condition is displayed.	ON or OFF
EBD Control Flag	EBD operation condition is displayed.	ON or OFF
TCS Control Flag	TCS operation condition is displayed.	ON or OFF
VDC Control Flag	VDC operation condition is displayed.	ON or OFF
OFF Lamp	ON/OFF condition of VDC OFF & VDC traction mode indicator light (6MT model) or VDC OFF indicator light (5MT model) is displayed.	ON or OFF
EBD Warning Light	ON operation of the EBD warning light is displayed.	ON or OFF
ABS Warning Light	ON operation of the ABS warning light is displayed.	ON or OFF
VDC Warning Light	ON operation of the VDC warning light is displayed.	ON or OFF
Valve Relay Signal	Valve relay operation signal is displayed.	ON or OFF
Motor Relay Signal	Motor relay operation signal is displayed.	ON or OFF
M. Relay monitor Voltage	Voltage applied to the motor relay is displayed.	V
OFF SW Signal	Operation condition of VDC OFF switch is displayed.	ON or OFF
Brake SW	Brake ON/OFF is displayed.	ON or OFF
Fr Rr G sensor Output	Vehicle longitudinal acceleration detected by longitudinal G sensor is displayed.	m/s <sup>2</sup>
Clutch Signal	Clutch ON/OFF is displayed.	ON or OFF
Reverse Signal	Reverse gear ON/OFF is displayed.	ON or OFF

### NOTE:

For detailed operation procedures, refer to “PC application help for Subaru Select Monitor”.

## 3. FUNCTION CHECK

Display	Contents of display	Index No.
ABS Sequence Control Mode	Operate the valve and pump motor continuously to perform the ABS sequence control.	<Ref. to VDC-14, ABS Sequence Control.>
VDC Check Mode	Operate the valve and pump motor continuously to perform the VDC sequence control.	<Ref. to VDC-17, VDC Sequence Control.>
Set up mode for Neutral of Steering Angle Sensor & Lateral G Sensor 0 point	Set the steering angle sensor neutral position and the lateral G sensor “0” point.	<Ref. to VDC-22, Steering Angle Sensor.>



# Subaru Select Monitor

## VEHICLE DYNAMICS CONTROL (VDC) (DIAGNOSTICS)

### 4. FREEZE FRAME DATA

#### NOTE:

- Data stored at the time of trouble occurrence is shown on display.
- Each time a trouble occurs, the latest information is stored in the freeze frame data in memory.
- If a freeze frame data is not properly stored in memory (due to a drop in VDCCM power supply, etc.), a DTC suffixed with a question mark “?” appears on the Subaru Select Monitor display. This shows it may be an unreliable reading.

Display	Contents to be displayed
Steering Angle Sensor Op	Steering angle detected by steering angle sensor is displayed.
Yaw Rate Sensor Output	Vehicle angular speed detected by yaw rate sensor is displayed.
Lateral G sensor Output	Vehicle lateral acceleration detected by lateral G sensor is displayed.
Pressure Sensor Output	Brake fluid pressure detected by pressure sensor is displayed.
Vehicle Speed	Vehicle speed calculated by VDC control module is displayed.
FR Wheel Speed	Wheel speed detected by front ABS wheel speed sensor RH is displayed in km/h or MPH.
FL Wheel Speed	Wheel speed detected by front ABS wheel speed sensor LH is displayed in km/h or MPH.
RR Wheel Speed	Wheel speed detected by rear ABS wheel speed sensor RH is displayed in km/h or MPH.
RL Wheel Speed	Wheel speed detected by rear ABS wheel speed sensor LH is displayed in km/h or MPH.
Accel. Opening Angle	Acceleration opening is displayed.
Engine Speed	Engine speed on malfunction occurrence is displayed.
Gear Position	Gear position on malfunction occurrence is displayed.
IG power supply voltage	Voltage supplied to VDC control module is displayed.
Steering angle flag	Whether the absolute angle of the steering angle sensor was determined is displayed.
E/G Control Stop Flag	Engine control command signal is displayed.
VDC Control Flag	VDC control condition is displayed.
EBD Control Flag	EBD control condition is displayed.
TCS Control Flag	TCS control condition is displayed.
ABS Control Flag	ABS control condition is displayed.
OFF Switch Detection	ON/OFF condition of the VDC operated by the driver is displayed.
Brake Switch	Brake ON/OFF is displayed.

Display	Contents to be displayed
Longitudinal G sensor output	Vehicle longitudinal acceleration detected by longitudinal G sensor is displayed.
Clutch Switch	Clutch ON/OFF is displayed.
Reverse Signal	Reverse gear ON/OFF is displayed.

### 5. PARAMETER SELECTION

#### CAUTION:

- **Subaru Select Monitor is required for parameter selection.**
- **This function can be used for the replacement part of VDCCM&H/U and VDCCM.**

#### NOTE:

- When the VDCCM is replaced with a replacement part, be sure to perform the parameter selection/registration to the VDCCM using this function.
- For confirmation of applied models, refer to the “Model number plate” attached to the vehicles. <Ref. to ID-2, IDENTIFICATION, Identification.>
- When the applied model is entered wrong, re-entry is possible.
- When the registration has not been performed, the DTC code “Parameter selection error” is detected together with the ABS/EBD/VDC warning light illumination.

- 1) Connect the Subaru Select Monitor.
- 2) On «Main Menu» display, select {Each System Check}.
- 3) On «System Selection Menu» display, select {Brake Control System}.
- 4) When {VDC} is displayed, select the [OK] button.
- 5) On «Brake Control Diagnosis» display, select {Select Parameter}.
- 6) Check the applied model and option code indicated in the “Model number plate”. <Ref. to ID-2, IDENTIFICATION, Identification.>
- 7) Enter the applied model of 7-digit alphanumeric characters and press the [Enter] key.
- 8) When the option code input screen appears after entering the applied model, enter the option code consisting of 4-digit alphanumeric characters, and press the [Enter] key. When the option code is 3 digits, add “0” in front and enter the code as 4 digits.
- 9) When the confirmation screen indicating the vehicle information appears, check that the correct applied model and grade are displayed and click the [OK] button.

#### NOTE:

- When the displayed applied model and grade are different from those of the vehicle, perform registration operations again after clicking the [OK] button.
- 10) Execute Clear Memory after parameter selection and registration operations because the DTC for “Parameter selection error” is memorized.

### 6. PARAMETER CHECK

#### NOTE:

The parameter data registered in the VDCCM is shown on the display.

- 1) Connect the Subaru Select Monitor.
- 2) On «Main Menu» display, select {Each System Check}.
- 3) On «System Selection Menu» display, select {Brake Control System}.
- 4) Click the [OK] button after {VDC} is displayed.
- 5) On «Brake Control Diagnosis» display, select {Confirm on parameter}.
- 6) On the {Confirm on parameter} display screen, check that the applied model and grade of the target vehicle are included, and click the [OK] button.
- 7) If the applied model and grade of the target vehicle are not included on the {Confirm on parameter} display screen, perform parameter selection and registration. <Ref. to VDC(diag)-20, PARAMETER SELECTION, OPERATION, Subaru Select Monitor.>

# Subaru Select Monitor

VEHICLE DYNAMICS CONTROL (VDC) (DIAGNOSTICS)

## B: INSPECTION

### 1. COMMUNICATION FOR INITIALIZING IMPOSSIBLE

#### DETECTING CONDITION:

Defective harness connector

#### TROUBLE SYMPTOM:

Communication is impossible between VDC and Subaru Select Monitor.

#### WIRING DIAGRAM:

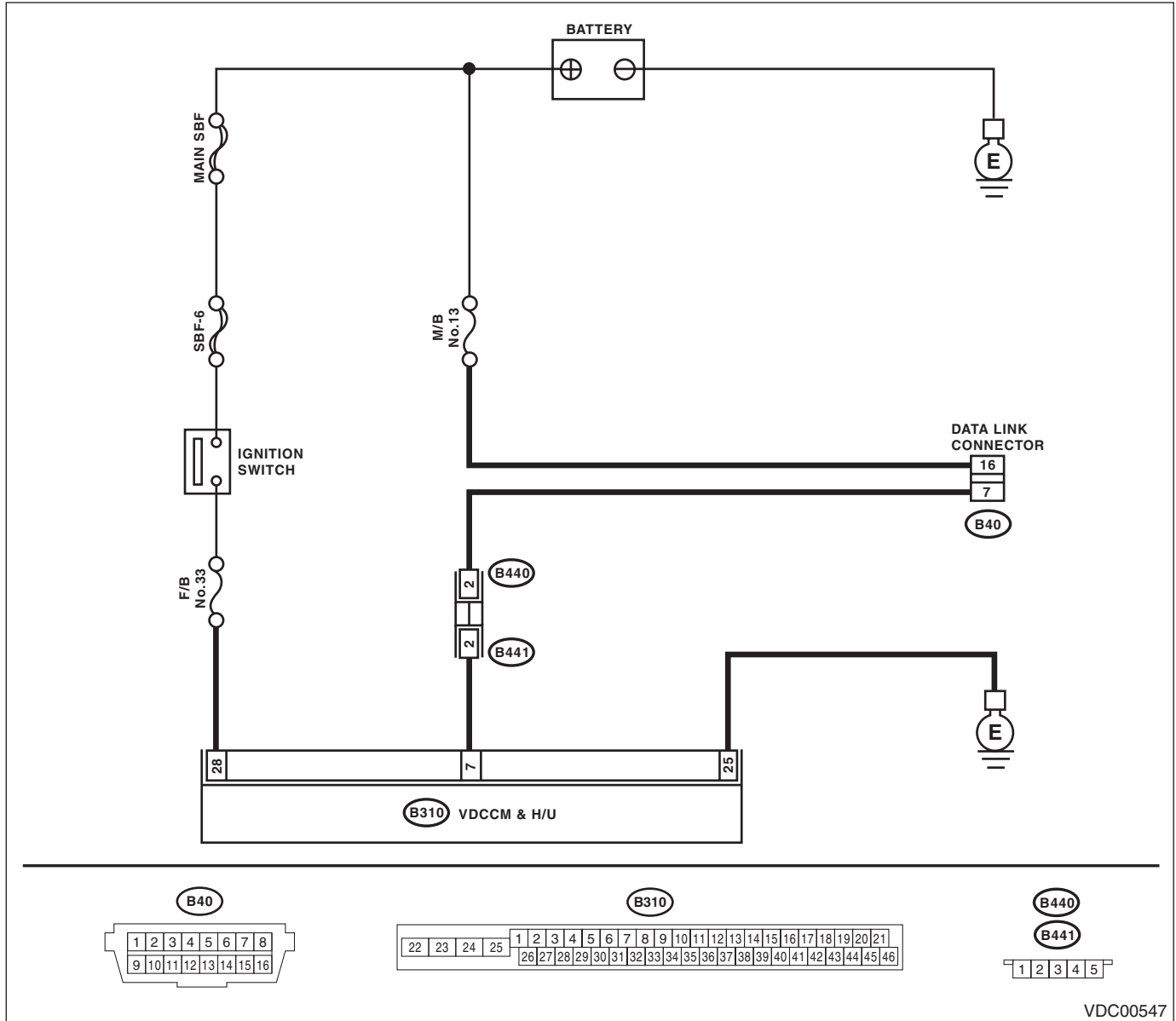

Step	Check	Yes	No
1	<b>CHECK IGNITION SWITCH.</b>	Go to step 2.	Turn the ignition switch to ON, and select VDC mode using Subaru Select Monitor.
2	<b>CHECK BATTERY.</b> 1) Turn the ignition switch to OFF. 2) Measure the battery voltage.	Go to step 3.	Charge or replace the battery.

# Subaru Select Monitor

## VEHICLE DYNAMICS CONTROL (VDC) (DIAGNOSTICS)

Step	Check	Yes	No	
<b>3</b>	<b>CHECK BATTERY TERMINAL.</b>	Is there poor contact at battery terminal?	Repair or tighten the battery terminal.	Go to step 4.
<b>4</b>	<b>CHECK SUBARU SELECT MONITOR COMMUNICATION.</b> 1) Turn the ignition switch to ON. 2) Using the Subaru Select Monitor, check whether communication to other systems can be executed normally.	Is the system name displayed on Subaru Select Monitor?	Go to step 8.	Go to step 5.
<b>5</b>	<b>CHECK SUBARU SELECT MONITOR COMMUNICATION.</b> 1) Turn the ignition switch to OFF. 2) Disconnect the VDCCM&H/U connector. 3) Turn the ignition switch to ON. 4) Check whether communication to other systems can be executed normally.	Is the system name displayed on Subaru Select Monitor?	Replace the VDCCM only. <Ref. to VDC-12, REPLACEMENT, VDC Control Module and Hydraulic Control Unit (VDCCM&H/U).>	Go to step 6.
<b>6</b>	<b>CHECK HARNESS CONNECTOR BETWEEN EACH CONTROL MODULE AND DATA LINK CONNECTOR.</b> 1) Turn the ignition switch to OFF. 2) Disconnect the connectors from ECM, air-bag CM, TPMS & keyless entry CM, DCCD CM (6MT model only) and body integrated unit. <b>CAUTION:</b> <b>When disconnecting the connector from air-bag CM, always follow the precautions on AB section. &lt;Ref. to AB-5, CAUTION, General Description.&gt;</b> 3) Measure the resistance between data link connector and chassis ground. <b>Connector &amp; terminal</b> <b>(B40) No. 7 — Chassis ground:</b>	Is the resistance 1 M $\Omega$ or more?	Go to step 7.	Repair the harness and connector between each control module and data link connector.
<b>7</b>	<b>CHECK HARNESS CONNECTOR BETWEEN VDCCM&amp;H/U AND DATA LINK CONNECTOR.</b> 1) Turn the ignition switch to ON. 2) Measure the voltage between data link connector and chassis ground. <b>Connector &amp; terminal</b> <b>(B40) No. 7 (+) — Chassis ground (-):</b>	Is the voltage less than 1 V?	Go to step 8.	Repair the harness and connector between each control module and data link connector.
<b>8</b>	<b>CHECK HARNESS CONNECTOR BETWEEN VDCCM&amp;H/U AND DATA LINK CONNECTOR.</b> Measure the resistance between VDCCM&H/U connector and data link connector. <b>Connector &amp; terminal</b> <b>(B310) No. 7 — (B40) No. 7:</b>	Is the resistance less than 1 $\Omega$ ?	Go to step 9.	Repair harness and connector between VDCCM&H/U and data link connector.
<b>9</b>	<b>CHECK INSTALLATION OF VDCCM&amp;H/U CONNECTOR.</b> Turn the ignition switch to OFF.	Is the VDCCM&H/U connector inserted into VDCCM&H/U until the clamp locks onto it?	Go to step 10.	Insert VDCCM&H/U connector into VDCCM&H/U.
<b>10</b>	<b>CHECK POWER SUPPLY CIRCUIT.</b> 1) Turn the ignition switch to ON. (engine OFF) 2) Measure the ignition power supply voltage between VDCCM&H/U connector and chassis ground. <b>Connector &amp; terminal</b> <b>(B310) No. 28 (+) — Chassis ground (-):</b>	Is the voltage 10 — 15 V?	Go to step 11.	Repair the open circuit and poor contact of the connector between VDCCM&H/U and battery.

# Subaru Select Monitor

## VEHICLE DYNAMICS CONTROL (VDC) (DIAGNOSTICS)

Step	Check	Yes	No
<b>11 CHECK HARNESS CONNECTOR BETWEEN VDCCM&amp;H/U AND CHASSIS GROUND.</b> 1) Turn the ignition switch to OFF. 2) Disconnect the connector from the VDCCM&H/U. 3) Measure the resistance of harness between VDCCM&H/U connector and chassis ground. <i><b>Connector &amp; terminal (B310) No. 25 — Chassis ground:</b></i>	Is the resistance less than 10 $\Omega$ ?	Go to step 12.	Repair the open circuit of VDCCM&H/U ground harness and poor contact of connector.
<b>12 CHECK POOR CONTACT OF CONNECTOR.</b>	Is there poor contact of control module power supply, ground circuit and data link connector?	Repair the connector.	Replace the VDCCM only. <Ref. to VDC-12, REPLACEMENT, VDC Control Module and Hydraulic Control Unit (VDCCM&H/U).>

# Read Diagnostic Trouble Code (DTC)

VEHICLE DYNAMICS CONTROL (VDC) (DIAGNOSTICS)

## 7. Read Diagnostic Trouble Code (DTC)

### A: OPERATION

- 1) On «Main Menu» display, select {Each System Check}.
- 2) On «System Selection Menu» display, select {Brake Control System}.
- 3) Click the [OK] button after {VDC} is displayed.
- 4) On «Brake Control Diagnosis» display, select {Diagnostic Code(s) Display}.
- 5) Record the DTC and data.

#### NOTE:

- For detailed operation procedures, refer to “PC application help for Subaru Select Monitor”.
- For details concerning DTCs, refer to “List of Diagnostic Trouble Code (DTC)”. <Ref. to VDC(diag)-48, List of Diagnostic Trouble Code (DTC).>
- Up to 3 DTCs are displayed in the order of detection.
- If a particular DTC is not stored in memory properly at the occurrence of problem (due to a drop in VDCCM&H/U power supply etc.), the DTC suffixed with a question mark “?” is displayed on Subaru Select Monitor display screen. This shows it may be an unreliable reading.

Display	Contents to be displayed
(Current)	The current DTC is displayed on Subaru Select Monitor display screen.
(Before 1)	The latest DTC from the history of previous problems is displayed on Subaru Select Monitor display screen.
(Before 2)	The second latest DTC from the history of previous problems is displayed on the Subaru Select Monitor display screen.
(Before 3)	The third latest DTC from the history of previous problems is displayed on Subaru Select Monitor display screen.

## Inspection Mode

VEHICLE DYNAMICS CONTROL (VDC) (DIAGNOSTICS)

---

### 8. Inspection Mode

#### A: PROCEDURE

Reproduce the malfunction occurrence condition as much as possible.

Drive the vehicle at least ten minutes.

#### NOTE:

Make sure the vehicle is not dragged to one side under usual driving condition.

# Clear Memory Mode

VEHICLE DYNAMICS CONTROL (VDC) (DIAGNOSTICS)

---

## 9. Clear Memory Mode

### A: OPERATION

- 1) On «Main Menu» display, select {Each System Check}.
- 2) On «System Selection Menu» display, select {Brake Control System}.
- 3) When {VDC} is displayed, select the [OK] button.
- 4) On «Brake Control Diagnosis» display, select {Clear Memory}.
- 5) When «Clear Memory ?» is shown on the screen, click the “YES” button.
- 6) When «Done» and «Turn Ignition Switch OFF» are shown on the screen, turn the ignition switch to OFF.

#### NOTE:

For detailed operation procedures, refer to “PC application help for Subaru Select Monitor”.



# Warning Light Illumination Pattern

VEHICLE DYNAMICS CONTROL (VDC) (DIAGNOSTICS)

## 10.Warning Light Illumination Pattern

### A: INSPECTION

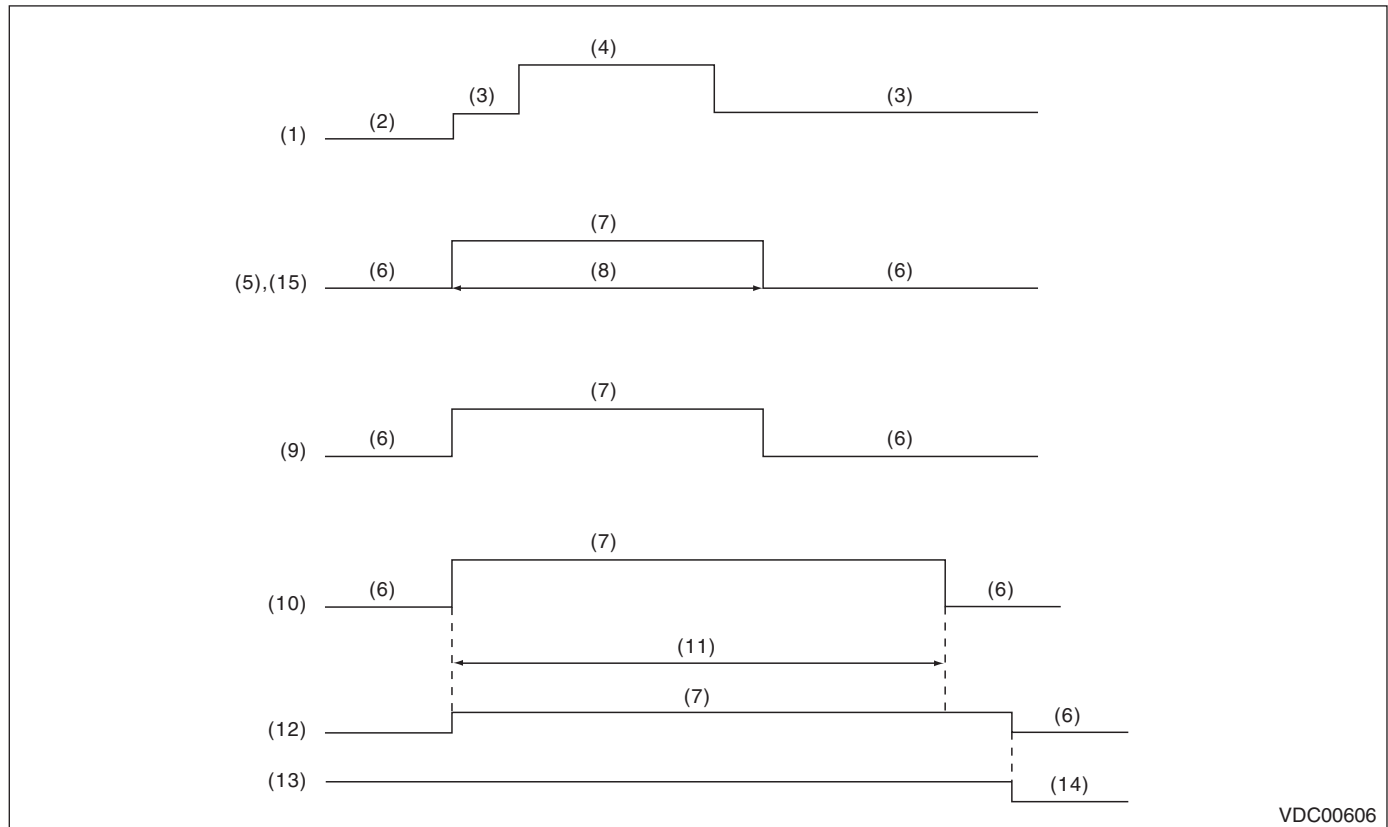

VDC00606

- |                       |  |  |
|-----------------------|--|--|
| (1) Ignition switch   | (6) Light OFF  | (11) Several seconds (depending on engine coolant temperature) |
| (2) OFF               | (7) Light ON   | (12) Brake warning light (EBD warning light)                   |
| (3) ON                | (8) 2 seconds  | (13) Parking brake   |
| (4) Engine start      | (9) VDC OFF & VDC traction mode indicator light (6MT model)<br>VDC OFF indicator light (5MT model) | (14) Released  |
| (5) ABS warning light | (10) VDC warning light & VDC indicator light   | (15) Hill start assist warning light                           |

#### NOTE:

- The illumination pattern above shows proper condition.
- While hill start assist is OFF, hill start assist warning light (15) always illuminates to indicate that hill start assist does not operate. (6MT model only)

# Warning Light Illumination Pattern

VEHICLE DYNAMICS CONTROL (VDC) (DIAGNOSTICS)

1) When warning lights or indicator lights do not illuminate in accordance with this illumination pattern, there must be an electrical malfunction.

2) When warning lights or indicator lights remain constantly OFF, check the combination meter circuit or CAN communication circuit. <Ref. to VDC(diag)-32, VDC WARNING LIGHT & VDC INDICATOR LIGHT, VDC OFF & VDC TRACTION MODE INDICATOR LIGHT DO NOT COME ON, Warning Light Illumination Pattern.> <Ref. to VDC(diag)-33, VDC WARNING LIGHT & VDC INDICATOR LIGHT, VDC OFF INDICATOR LIGHT DO NOT COME ON, Warning Light Illumination Pattern.> <Ref. to VDC(diag)-34, ABS WARNING LIGHT DOES NOT COME ON, Warning Light Illumination Pattern.> <Ref. to VDC(diag)-34, HILL START ASSIST WARNING LIGHT DOES NOT COME ON, Warning Light Illumination Pattern.>

3) When ABS warning light does not go off, check the combination meter circuit or CAN communication circuit. <Ref. to VDC(diag)-35, ABS WARNING LIGHT DOES NOT GO OFF, Warning Light Illumination Pattern.>

4) When hill start assist warning light does not go off, check the status of hill start assist OFF mode setting, combination meter circuit, or CAN communication circuit. <Ref. to VDC(diag)-36, HILL START ASSIST WARNING LIGHT DOES NOT GO OFF, Warning Light Illumination Pattern.>

5) When the VDC OFF & VDC traction mode indicator light (6MT model), VDC OFF indicator light (5MT model), or VDC warning light & VDC indicator light does not go off, check the combination meter circuit or CAN communication circuit. <Ref. to VDC(diag)-37, VDC OFF & VDC TRACTION MODE INDICATOR LIGHT DO NOT GO OFF, Warning Light Illumination Pattern.> <Ref. to VDC(diag)-38, VDC OFF INDICATOR LIGHT DOES NOT GO OFF, Warning Light Illumination Pattern.> <Ref. to VDC(diag)-39, VDC WARNING LIGHT AND VDC INDICATOR LIGHT DO NOT GO OFF, Warning Light Illumination Pattern.>

## NOTE:

- Even though the ABS warning light does not go off after 2 seconds from ABS warning light illumination, the ABS system operates normally when the warning light goes off while driving at approximately 12 km/h (7 MPH). However, the ABS system does not work while the ABS warning light is illuminated.
- It may take several minutes before the VDC warning light & VDC indicator light goes off, if the vehicle is parked under low temperature for a specified time. This is not defective because it is resulted from low engine coolant temperature.

- With the vehicle jack-up/lift-up or set on free rollers, when the wheels lock or spin after starting the engine, ABS warning light, and VDC warning light & VDC indicator light may illuminate because VDC-CM&H/U detects the abnormal conditions from ABS wheel speed sensors. In this case, this is not a malfunction. Perform the Clear Memory Mode. <Ref. to VDC(diag)-27, Clear Memory Mode.>

# Warning Light Illumination Pattern

## VEHICLE DYNAMICS CONTROL (VDC) (DIAGNOSTICS)

### 6) Warning light illumination pattern at VDC multi mode change (6MT model only)

If the VDC OFF & VDC traction mode indicator light illumination pattern when the VDC OFF switch is operated does not match the following, check the VDC OFF switch circuit, CAN communication circuit or combination meter circuit. <Ref. to VDC(diag)-42, VDC MULTI MODE, VDC MODE DOES NOT CHANGE, Warning Light Illumination Pattern.>

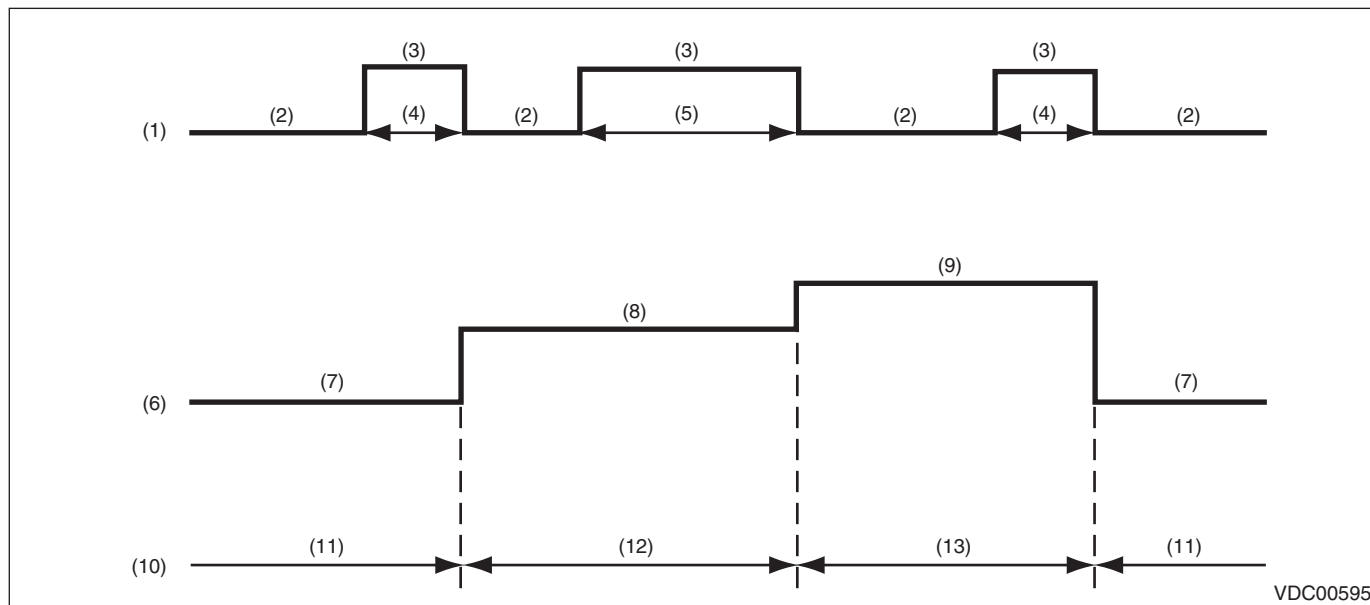

- |   |   |                    |
|---|---|--------------------|
| (1) VDC OFF switch                        | (6) VDC OFF & VDC traction mode indicator light | (10) VDC mode      |
| (2) OFF                                   | (7) Light OFF                                   | (11) Normal mode   |
| (3) ON                                    | (8) Green light                                 | (12) Traction mode |
| (4) 2 seconds or less                     | (9) Yellow illumination                         | (13) OFF mode      |
| (5) 2 seconds or more, 10 seconds or less |   |                    |

# Warning Light Illumination Pattern

VEHICLE DYNAMICS CONTROL (VDC) (DIAGNOSTICS)

## 7) Warning light illumination pattern at hill start assist OFF mode change (6MT model only)

When the VDC OFF switch is kept pressed, the VDC OFF & VDC traction mode indicator light illuminates in green at first, then turns yellow, and then goes off in approx. 8 seconds. If the switch is released in 5 seconds after the light goes off then pressed again in 2 seconds, hill start assist warning light illuminates then mode is changed to hill start assist OFF mode. If hill start assist function ON/OFF does not change, check VDC OFF switch circuit, CAN communication circuit or combination meter circuit. <Ref. to VDC(diag)-45, HILL START ASSIST ON/OFF MODE, VDC MODE DOES NOT CHANGE, Warning Light Illumination Pattern.>

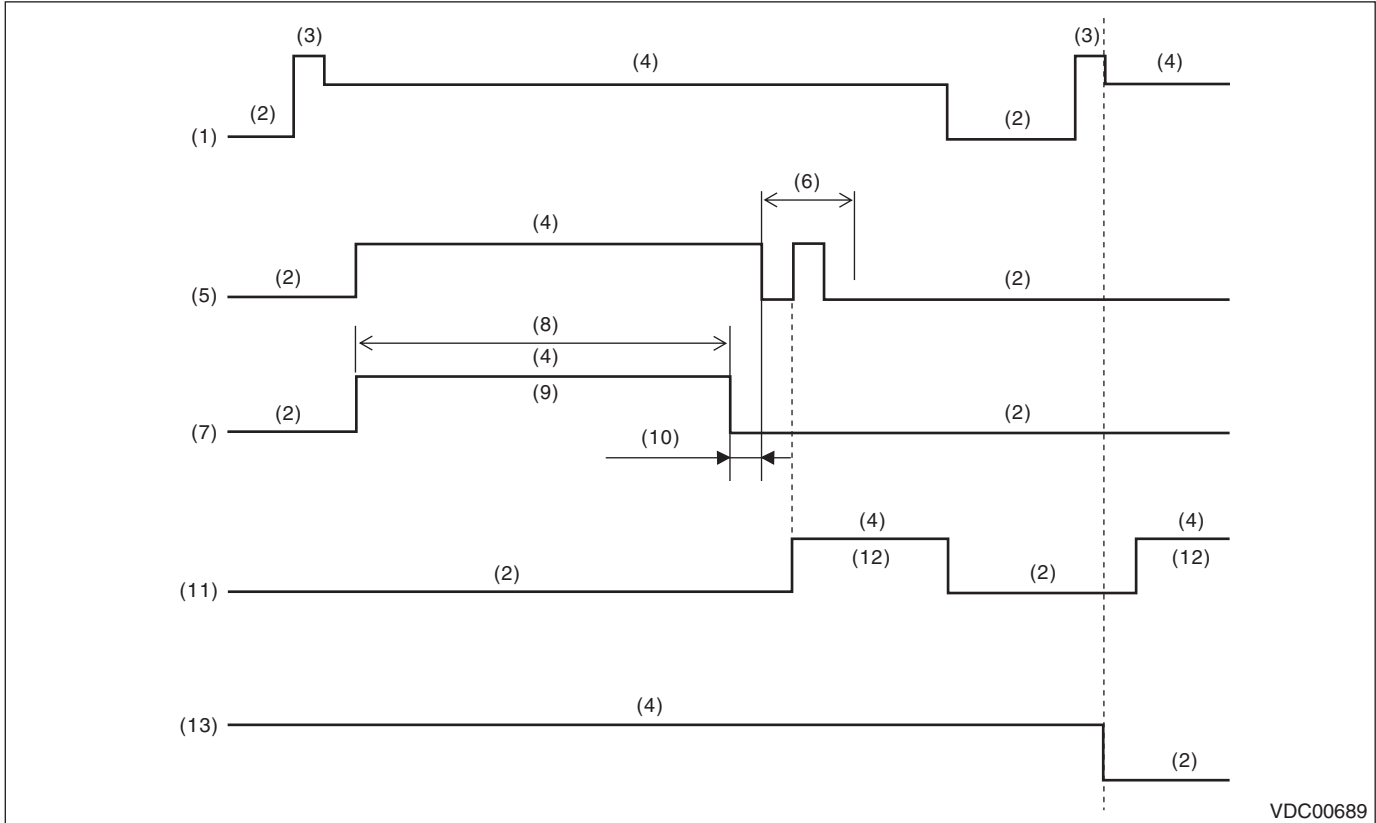

VDC00689

- |                    |  |                                      |
|--------------------|--|--------------------------------------|
| (1) Ignition key   | (6) 2 seconds or less                                | (10) 5 seconds or less               |
| (2) OFF            | (7) VDC OFF & VDC traction mode indicator light      | (11) Hill start assist warning light |
| (3) Start          | (8) Approx. 8 seconds (until (7) goes off)           | (12) Yellow illumination             |
| (4) ON             | (9) Illumination changes from in green to in yellow. | (13) Hill start assist function      |
| (5) VDC OFF switch |  |                                      |

### NOTE:

- Hill start assist warning light always illuminates to inform that the hill start assist does not operate during hill start assist OFF mode.
- For procedure of changing hill start assist function ON/OFF, refer to "Hill start assist". <Ref. to BR-48, OPERATION, Hill Start Assist.>

## Warning Light Illumination Pattern

VEHICLE DYNAMICS CONTROL (VDC) (DIAGNOSTICS)

### B: VDC WARNING LIGHT & VDC INDICATOR LIGHT, VDC OFF & VDC TRAC- TION MODE INDICATOR LIGHT DO NOT COME ON

NOTE:

This diagnosis is applied to 6MT model.

**DETECTING CONDITION:**

- Defective combination meter
- Defective CAN communication

**TROUBLE SYMPTOM:**

When the ignition switch is turned to ON (engine OFF), the VDC OFF & VDC traction mode indicator light, and VDC warning light & VDC indicator light do not illuminate.

NOTE:

When the VDC OFF switch is pressed for 10 seconds or more, the VDC traction mode indicator light goes off, and subsequent switch operations are not accepted. When turning the ignition switch from OFF to ON, the OFF operation enabled status is restored.

Step	Check	Yes	No
<b>1</b> <b>CHECK OTHER INDICATOR LIGHT.</b> Turn the ignition switch to ON.	Does other indicator light illuminate soon after "ON"?	Go to step 2.	Perform the self-diagnosis of combination meter.
<b>2</b> <b>CHECK VDCCM.</b> When the engine does not start, display the current data of VDCCM using Subaru Select Monitor.	Is the «VDC Warning Light» output ON?	Go to step 3.	Replace the VDCCM only. <Ref. to VDC-12, REPLACEMENT, VDC Control Module and Hydraulic Control Unit (VDCCM&H/U).>
<b>3</b> <b>CHECK LAN SYSTEM.</b> Perform the diagnosis for LAN system. <Ref. to LAN(diag)-2, Basic Diagnostic Procedure.>	Is there any fault in LAN system?	Perform the diagnosis according to DTC for LAN system. <Ref. to LAN(diag)-33, List of Diagnostic Trouble Code (DTC).>	Go to step 4.
<b>4</b> <b>CHECK COMBINATION METER.</b> Check the combination meter. <Ref. to IDI-5, INSPECTION, Combination Meter System.>	Is combination meter OK?	Replace the VDCCM only. <Ref. to VDC-12, REPLACEMENT, VDC Control Module and Hydraulic Control Unit (VDCCM&H/U).>	Replace the combination meter. <Ref. to IDI-16, Combination Meter.>

# Warning Light Illumination Pattern

VEHICLE DYNAMICS CONTROL (VDC) (DIAGNOSTICS)

## C: VDC WARNING LIGHT & VDC INDICATOR LIGHT, VDC OFF INDICATOR LIGHT DO NOT COME ON

NOTE:

This diagnosis is applied to 5MT model.

**DETECTING CONDITION:**

- Defective combination meter
- Defective CAN communication

**TROUBLE SYMPTOM:**

When the ignition switch is turned to ON (engine OFF), VDC OFF indicator light and VDC warning light & VDC indicator light do not illuminate.

NOTE:

When pressing the VDC OFF switch for 10 seconds or more, the VDC OFF indicator light goes off and cannot operate any more. When turning the ignition switch from OFF to ON, the OFF operation enabled status is restored.

Step	Check	Yes	No	
<b>1</b>	<b>CHECK OTHER INDICATOR LIGHT.</b> Turn the ignition switch to ON.	Does other indicator light illuminate soon after "ON"?	Go to step 2.	Perform the self-diagnosis of combination meter.
<b>2</b>	<b>CHECK VDCCM.</b> When the engine does not start, display the current data of VDCCM using Subaru Select Monitor.	Is the «VDC Warning Light» output ON?	Go to step 3.	Replace the VDCCM only. <Ref. to VDC-12, REPLACEMENT, VDC Control Module and Hydraulic Control Unit (VDCCM&H/U).>
<b>3</b>	<b>CHECK LAN SYSTEM.</b> Perform the diagnosis for LAN system. <Ref. to LAN(diag)-2, Basic Diagnostic Procedure.>	Is there any fault in LAN system?	Perform the diagnosis according to DTC for LAN system. <Ref. to LAN(diag)-33, List of Diagnostic Trouble Code (DTC).>	Go to step 4.
<b>4</b>	<b>CHECK COMBINATION METER.</b> Check the combination meter. <Ref. to IDI-5, INSPECTION, Combination Meter System.>	Is combination meter OK?	Replace the VDCCM only. <Ref. to VDC-12, REPLACEMENT, VDC Control Module and Hydraulic Control Unit (VDCCM&H/U).>	Replace the combination meter. <Ref. to IDI-16, Combination Meter.>

## Warning Light Illumination Pattern

VEHICLE DYNAMICS CONTROL (VDC) (DIAGNOSTICS)

### D: ABS WARNING LIGHT DOES NOT COME ON

#### DETECTING CONDITION:

- Defective combination meter
- Defective CAN communication

#### TROUBLE SYMPTOM:

When the ignition switch is turned to ON (engine OFF), ABS warning light and hill start assist warning light do not come on.

Step	Check	Yes	No
<b>1</b> <b>CHECK OTHER LIGHTS TURN ON.</b> Turn the ignition switch to ON. (engine OFF)	Do other warning lights illuminate?	Go to step 2.	Check the combination meter.
<b>2</b> <b>READ DTC.</b> Read the DTC. <Ref. to VDC(diag)-25, Read Diagnostic Trouble Code (DTC).>	Is DTC displayed?	Perform the diagnosis according to DTC. <Ref. to VDC(diag)-48, List of Diagnostic Trouble Code (DTC).>	Go to step 3.
<b>3</b> <b>CHECK LAN SYSTEM.</b> Perform the diagnosis for LAN system. <Ref. to LAN(diag)-2, Basic Diagnostic Procedure.>	Is there any fault in LAN system?	Perform the diagnosis according to DTC for LAN system. <Ref. to LAN(diag)-33, List of Diagnostic Trouble Code (DTC).>	Go to step 4.
<b>4</b> <b>CHECK COMBINATION METER.</b> Check the combination meter. <Ref. to IDI-5, INSPECTION, Combination Meter System.>	Is combination meter OK?	Replace the VDCCM only. <Ref. to VDC-12, REPLACEMENT, VDC Control Module and Hydraulic Control Unit (VDCCM&H/U).>	Replace the combination meter. <Ref. to IDI-16, Combination Meter.>

### E: HILL START ASSIST WARNING LIGHT DOES NOT COME ON

For the diagnostic procedures, refer to "ABS WARNING LIGHT DOES NOT COME ON". <Ref. to VDC(diag)-34, ABS WARNING LIGHT DOES NOT COME ON, Warning Light Illumination Pattern.>

# Warning Light Illumination Pattern

VEHICLE DYNAMICS CONTROL (VDC) (DIAGNOSTICS)

## F: ABS WARNING LIGHT DOES NOT GO OFF

### DETECTING CONDITION:

- Defective combination meter
- Defective CAN communication

### TROUBLE SYMPTOM:

When starting the engine, the ABS warning light is kept ON.

	Step	Check	Yes	No
1	<b>READ DTC.</b> Read the DTC. <Ref. to VDC(diag)-25, Read Diagnostic Trouble Code (DTC).>	Is DTC displayed?	Perform the diagnosis according to DTC. <Ref. to VDC(diag)-48, List of Diagnostic Trouble Code (DTC).>	Go to step 2.
2	<b>CHECK LAN SYSTEM.</b> Perform the diagnosis for LAN system. <Ref. to LAN(diag)-2, Basic Diagnostic Procedure.>	Is there any fault in LAN system?	Perform the diagnosis according to DTC for LAN system. <Ref. to LAN(diag)-33, List of Diagnostic Trouble Code (DTC).>	Go to step 3.
3	<b>CHECK COMBINATION METER.</b> Check the combination meter. <Ref. to IDI-5, INSPECTION, Combination Meter System.>	Is combination meter OK?	Replace the VDCCM only. <Ref. to VDC-12, REPLACEMENT, VDC Control Module and Hydraulic Control Unit (VDCCM&H/U).>	Replace the combination meter. <Ref. to IDI-16, Combination Meter.>



## Warning Light Illumination Pattern

VEHICLE DYNAMICS CONTROL (VDC) (DIAGNOSTICS)

### G: HILL START ASSIST WARNING LIGHT DOES NOT GO OFF

**DETECTING CONDITION:**

- Defective combination meter
- Defective CAN communication

**TROUBLE SYMPTOM:**

When starting the engine, the hill start assist warning light is kept ON.

Step	Check	Yes	No	
<b>1</b>	<b>CHECK TRANSMISSION TYPE.</b>	Is the transmission type 6MT?	Go to step 2.	Go to step 3.
<b>2</b>	<b>RELEASE HILL ASSIST OFF MODE.</b> Perform the procedure for releasing hill assist OFF mode. <Ref. to BR-48, OPERATION, Hill Start Assist.>	Does the hill start assist warning light go off?	VDC is normal.	Go to step 3.
<b>3</b>	<b>READ DTC.</b> Read the DTC. <Ref. to VDC(diag)-25, Read Diagnostic Trouble Code (DTC).>	Is DTC displayed?	Perform the diagnosis according to DTC. <Ref. to VDC(diag)-48, List of Diagnostic Trouble Code (DTC).>	Go to step 4.
<b>4</b>	<b>CHECK LAN SYSTEM.</b> Perform the diagnosis for LAN system. <Ref. to LAN(diag)-2, Basic Diagnostic Procedure.>	Is there any fault in LAN system?	Perform the diagnosis according to DTC for LAN system. <Ref. to LAN(diag)-33, List of Diagnostic Trouble Code (DTC).>	Go to step 5.
<b>5</b>	<b>CHECK COMBINATION METER.</b> Check the combination meter. <Ref. to IDI-5, INSPECTION, Combination Meter System.>	Is combination meter OK?	Replace the VDCCM only. <Ref. to VDC-12, REPLACEMENT, VDC Control Module and Hydraulic Control Unit (VDCCM&H/U).>	Replace the combination meter. <Ref. to IDI-16, Combination Meter.>

# Warning Light Illumination Pattern

VEHICLE DYNAMICS CONTROL (VDC) (DIAGNOSTICS)

## H: VDC OFF & VDC TRACTION MODE INDICATOR LIGHT DO NOT GO OFF

### NOTE:

This diagnosis is applied to 6MT model.

### DETECTING CONDITION:

- Defective combination meter
- Defective CAN communication
- VDC OFF switch is shorted.

### TROUBLE SYMPTOM:

When starting the engine, VDC OFF indicator light is kept ON.

### NOTE:

When pressing the VDC OFF switch for 10 seconds or more, the VDC OFF indicator light goes off and cannot operate any more. When turning the ignition switch from OFF to ON, the OFF operation enabled status is restored.

	Step	Check	Yes	No
1	<b>READ DTC.</b> Read the DTC. <Ref. to VDC(diag)-25, Read Diagnostic Trouble Code (DTC).>	Is DTC displayed?	Perform the diagnosis according to DTC. <Ref. to VDC(diag)-48, List of Diagnostic Trouble Code (DTC).>	Go to step 2.
2	<b>CHECK VDC OFF SWITCH.</b> Remove and check VDC OFF switch. <Ref. to VDC-29, VDC OFF Switch.>	Is the VDC OFF switch normal?	Go to step 3.	Replace the VDC OFF switch. <Ref. to VDC-29, VDC OFF Switch.>
3	<b>CHECK LAN SYSTEM.</b> Perform the diagnosis for LAN system. <Ref. to LAN(diag)-2, Basic Diagnostic Procedure.>	Is there any fault in LAN system?	Perform the diagnosis according to DTC for LAN system. <Ref. to LAN(diag)-33, List of Diagnostic Trouble Code (DTC).>	Go to step 4.
4	<b>CHECK COMBINATION METER.</b> Check the combination meter. <Ref. to IDI-5, INSPECTION, Combination Meter System.>	Is combination meter OK?	Replace the VDCCM only. <Ref. to VDC-12, REPLACEMENT, VDC Control Module and Hydraulic Control Unit (VDCCM&H/U).>	Replace the combination meter. <Ref. to IDI-16, Combination Meter.>

## Warning Light Illumination Pattern

VEHICLE DYNAMICS CONTROL (VDC) (DIAGNOSTICS)

---

### I: VDC OFF INDICATOR LIGHT DOES NOT GO OFF

NOTE:

This diagnosis is applied to 5MT model.

**DETECTING CONDITION:**

- Defective combination meter
- Defective CAN communication
- VDC OFF switch is shorted.

**TROUBLE SYMPTOM:**

When starting the engine, VDC OFF indicator light is kept ON.

NOTE:

When pressing the VDC OFF switch for 10 seconds or more, the VDC OFF indicator light goes off and cannot operate any more. When turning the ignition switch from OFF to ON, the OFF operation enabled status is restored.

Step	Check	Yes	No
<b>1 READ DTC.</b> Read the DTC. <Ref. to VDC(diag)-25, Read Diagnostic Trouble Code (DTC).>	Is DTC displayed?	Perform the diagnosis according to DTC. <Ref. to VDC(diag)-48, List of Diagnostic Trouble Code (DTC).>	Go to step 2.
<b>2 CHECK VDC OFF SWITCH.</b> Remove and check VDC OFF switch. <Ref. to VDC-29, VDC OFF Switch.>	Is the VDC OFF switch normal?	Go to step 3.	Replace the VDC OFF switch. <Ref. to VDC-29, VDC OFF Switch.>
<b>3 CHECK LAN SYSTEM.</b> Perform the diagnosis for LAN system. <Ref. to LAN(diag)-2, Basic Diagnostic Procedure.>	Is there any fault in LAN system?	Perform the diagnosis according to DTC for LAN system. <Ref. to LAN(diag)-33, List of Diagnostic Trouble Code (DTC).>	Go to step 4.
<b>4 CHECK COMBINATION METER.</b> Check the combination meter. <Ref. to IDI-5, INSPECTION, Combination Meter System.>	Is combination meter OK?	Replace the VDCCM only. <Ref. to VDC-12, REPLACEMENT, VDC Control Module and Hydraulic Control Unit (VDCCM&H/U).>	Replace the combination meter. <Ref. to IDI-16, Combination Meter.>

# Warning Light Illumination Pattern

VEHICLE DYNAMICS CONTROL (VDC) (DIAGNOSTICS)

## J: VDC WARNING LIGHT AND VDC INDICATOR LIGHT DO NOT GO OFF

### DETECTING CONDITION:

- Defective combination meter
- Defective CAN communication
- Defective engine

### TROUBLE SYMPTOM:

When starting the engine, the VDC warning light & VDC indicator light remains lit.

Step	Check	Yes	No
<b>1 READ DTC.</b> Read the DTC. <Ref. to VDC(diag)-25, Read Diagnostic Trouble Code (DTC).>	Is DTC displayed?	Perform the diagnosis according to DTC. <Ref. to VDC(diag)-48, List of Diagnostic Trouble Code (DTC).>	Go to step 2.
<b>2 CHECK ENGINE.</b>	Does the malfunction indicator light illuminate?	Repair the engine.	Go to step 3.
<b>3 CHECK ENGINE COOLANT TEMPERATURE.</b> Warm up the engine, and check if the VDC warning light & VDC indicator light illumination condition changes.	When the engine coolant temperature is too low, the VDC warning light & VDC indicator light illuminates. Do the lights go off when the engine is warmed up?	Normal	Go to step 4.
<b>4 CHECK LAN SYSTEM.</b> Perform the diagnosis for LAN system. <Ref. to LAN(diag)-2, Basic Diagnostic Procedure.>	Is there any fault in LAN system?	Perform the diagnosis according to DTC for LAN system. <Ref. to LAN(diag)-33, List of Diagnostic Trouble Code (DTC).>	Go to step 5.
<b>5 CHECK COMBINATION METER.</b> Check the combination meter. <Ref. to IDI-5, INSPECTION, Combination Meter System.>	Is combination meter OK?	Replace the VDCCM only. <Ref. to VDC-12, REPLACEMENT, VDC Control Module and Hydraulic Control Unit (VDCCM&H/U).>	Replace the combination meter. <Ref. to IDI-16, Combination Meter.>

# Warning Light Illumination Pattern

VEHICLE DYNAMICS CONTROL (VDC) (DIAGNOSTICS)

## K: BRAKE WARNING LIGHT DOES NOT GO OFF

### DETECTING CONDITION:

- Brake warning light circuit is shorted.
- Defective sensor/connector
- Defective CAN communication

### TROUBLE SYMPTOM:

After starting the engine, the brake warning light remains lit though the parking lever is released.

### WIRING DIAGRAM:

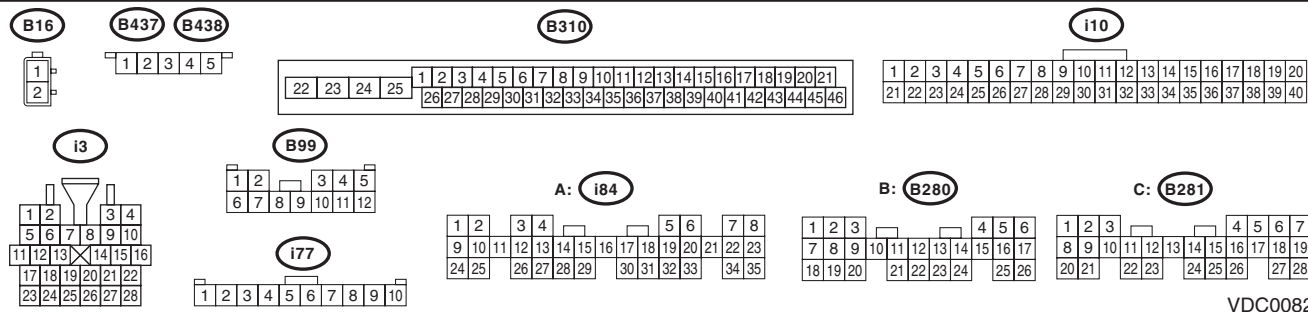
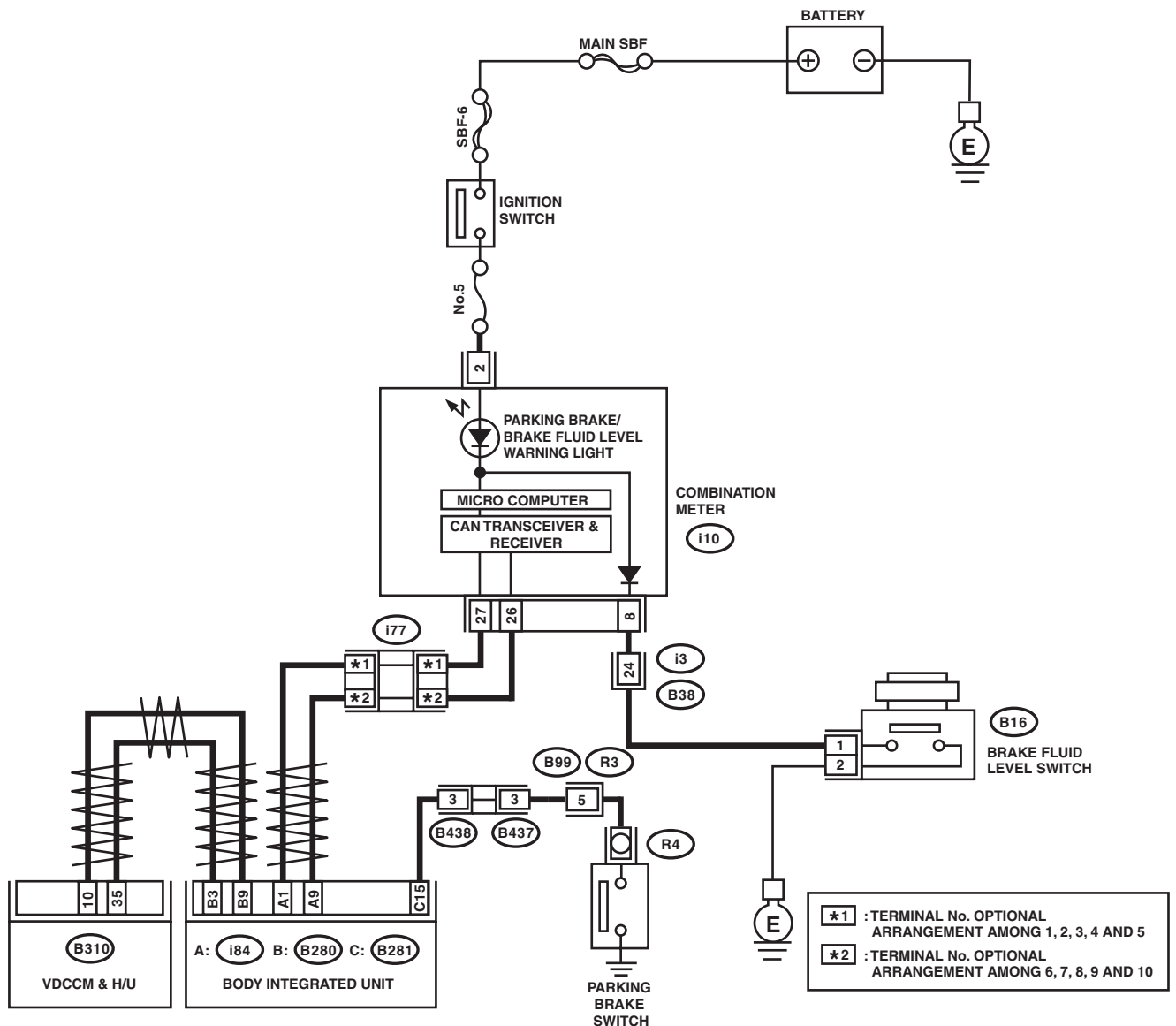

VDC00828

# Warning Light Illumination Pattern

VEHICLE DYNAMICS CONTROL (VDC) (DIAGNOSTICS)

Step	Check	Yes	No
<b>1 CHECK INSTALLATION OF VDCCM&amp;H/U CONNECTOR.</b> 1) Turn the ignition switch to OFF. 2) Check that the VDCCM&H/U connector is inserted until it is locked by clamp.	Is the connector firmly inserted?	Go to step 2.	Insert the VDCCM&H/U connector until it is locked by clamp.
<b>2 READ DTC.</b> Read the DTC. <Ref. to VDC(diag)-25, Read Diagnostic Trouble Code (DTC).>	Is DTC displayed?	Perform the diagnosis according to DTC. <Ref. to VDC(diag)-48, List of Diagnostic Trouble Code (DTC).>	Go to step 3.
<b>3 CHECK BRAKE FLUID AMOUNT.</b> Check the amount of brake fluid in the reservoir tank of master cylinder.	Does the level of the brake fluid amount fall between the lines of "MAX" and "MIN"?	Go to step 4.	Replenish brake fluid to the specified value.
<b>4 CHECK BRAKE FLUID LEVEL SWITCH.</b> 1) Turn the ignition switch to OFF. 2) Disconnect the level switch connector (B16) from master cylinder. 3) Measure the resistance of master cylinder terminals.  <i>Terminals</i> <i>No. 1 — No. 2:</i>	Is the resistance 1 MΩ or more?	Go to step 5.	Replace the master cylinder. <Ref. to BR-32, Master Cylinder.>
<b>5 CHECK GROUND SHORT OF HARNESS.</b> 1) Disconnect the connector (i10) from combination meter. 2) Measure the resistance between combination meter connector and chassis ground.  <i>Connector &amp; terminal</i> <i>(i10) No. 8 — Chassis ground:</i>	Is the resistance 1 MΩ or more?	Go to step 6.	Repair the harness between combination meter and brake fluid level switch.
<b>6 CHECK PARKING BRAKE SWITCH.</b> 1) Disconnect the connector (R4) from parking brake switch. 2) Release the parking brake. 3) Measure the resistance between parking brake switch terminal and chassis ground.	Is the resistance 1 MΩ or more?	Go to step 7.	Replace the parking brake switch.
<b>7 CHECK GROUND SHORT OF HARNESS.</b> 1) Disconnect the connector (B281) from body integrated unit. 2) Measure the resistance between body integrated unit connector and chassis ground.  <i>Connector &amp; terminal</i> <i>(B281) No. 15 — Chassis ground:</i>	Is the resistance 1 MΩ or more?	Go to step 8.	Repair the harness between body integrated unit and parking brake switch.
<b>8 CHECK POOR CONTACT OF CONNECTOR.</b> Check for poor contact of all connectors.	Is there poor contact?	Repair the connector.	Go to step 9.
<b>9 CHECK LAN SYSTEM.</b> Perform the diagnosis for LAN system. <Ref. to LAN(diag)-2, Basic Diagnostic Procedure.>	Is there any fault in LAN system?	Perform the diagnosis according to DTC for LAN system. <Ref. to LAN(diag)-33, List of Diagnostic Trouble Code (DTC).>	Go to step 10.
<b>10 CHECK COMBINATION METER.</b> Check the combination meter. <Ref. to IDI-5, INSPECTION, Combination Meter System.>	Is combination meter OK?	Replace the VDCCM only. <Ref. to VDC-12, REPLACEMENT, VDC Control Module and Hydraulic Control Unit (VDCCM&H/U).>	Replace the combination meter. <Ref. to IDI-16, Combination Meter.>

**VDC(diag)-41**

Brought to you by Ebay Seller "SubaruManuals"

# Warning Light Illumination Pattern

VEHICLE DYNAMICS CONTROL (VDC) (DIAGNOSTICS)

---

## **L: VDC MODE DOES NOT CHANGE**

### **1. VDC MULTI MODE**

NOTE:

This diagnosis is applied to 6MT model.

#### **DETECTING CONDITION**

- Defective combination meter
- Defective CAN communication
- Defective VDC OFF switch

#### **TROUBLE SYMPTOM:**

Even when the VDC OFF switch is operated, the VDC traction mode indicator light does not illuminate, or the illumination color does not change. (The VDC mode does not change)

NOTE:

- When the VDC OFF switch is pressed (2 seconds or less), the VDC traction mode indicator light illuminates in green. (Traction mode)
- When the VDC OFF switch is held down (2 seconds or more, 10 seconds or less), the VDC traction mode indicator light illuminates in yellow. (VDC OFF mode)
- When the VDC OFF switch is pressed for 10 seconds or more, the VDC traction mode indicator light goes off, and subsequent switch operations are not accepted. When turning the ignition switch from OFF to ON, the OFF operation enabled status is restored.

# Warning Light Illumination Pattern

VEHICLE DYNAMICS CONTROL (VDC) (DIAGNOSTICS)

## WIRING DIAGRAM:

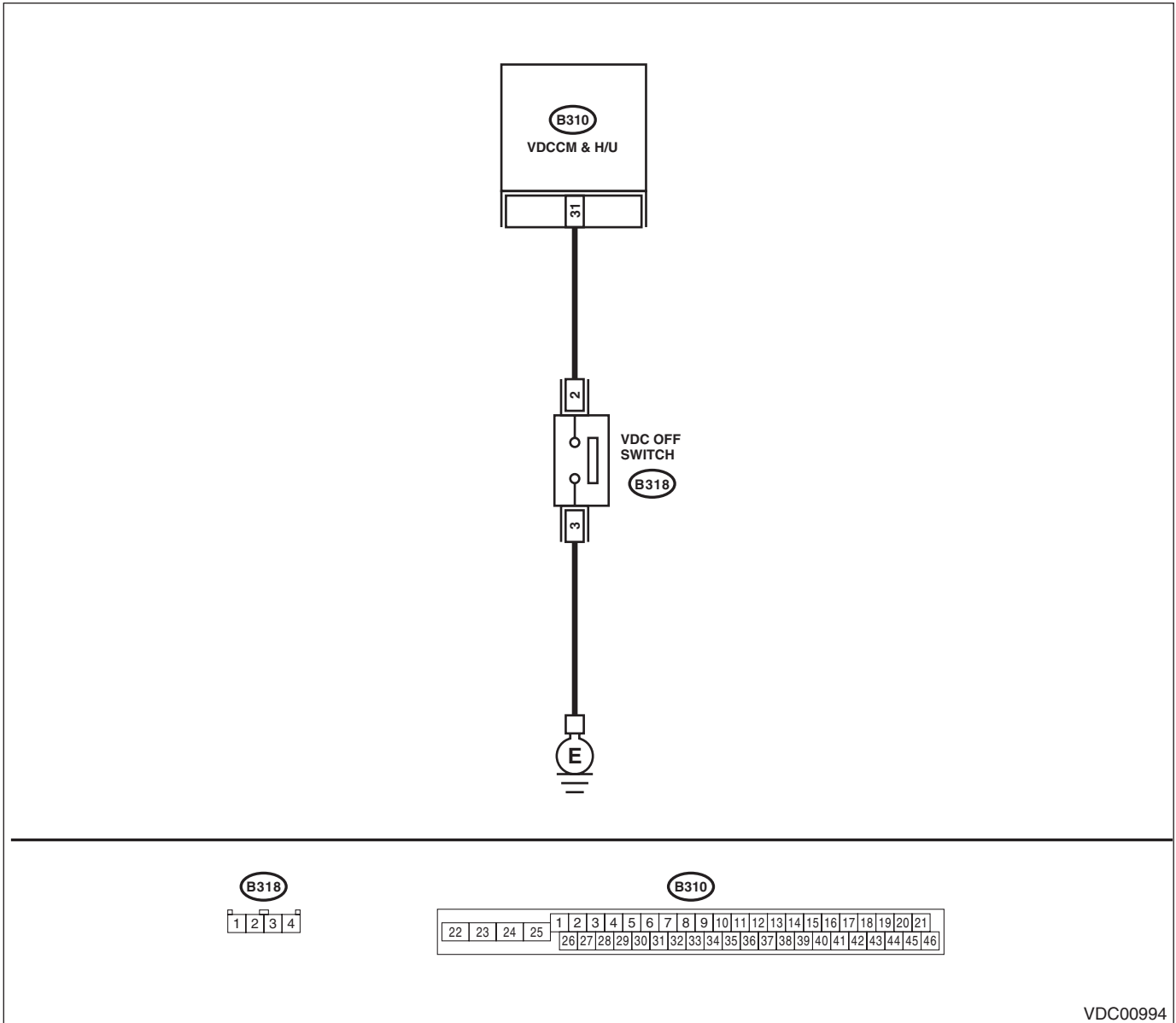

VDC00994

Step	Check	Yes	No
<b>1</b> <b>READ DTC.</b> Read the DTC. <Ref. to VDC(diag)-25, Read Diagnostic Trouble Code (DTC).>	Is DTC displayed?	Perform the diagnosis according to DTC. <Ref. to VDC(diag)-48, List of Diagnostic Trouble Code (DTC).>	Go to step 2.
<b>2</b> <b>CHECK HARNESS.</b> 1) Turn the ignition switch to OFF. 2) Disconnect the connector from the VDCCM&H/U and VDC OFF switch. 3) Measure the resistance of harness between the VDCCM&H/U and VDC OFF switch connectors. <b>Connector &amp; terminal</b> <b>(B310) No. 31 — (B318) No. 2:</b>	Is the resistance less than 1 Ω?	Go to step 3.	Repair the harness between the VDCCM&H/U and VDC OFF switch connectors.

VDC(diag)-43

Brought to you by Ebay Seller "SubaruManuals"



## Warning Light Illumination Pattern

### VEHICLE DYNAMICS CONTROL (VDC) (DIAGNOSTICS)

Step	Check	Yes	No
<b>3</b> <b>CHECK GROUND SHORT OF HARNESS.</b> Measure the resistance between VDCCM&H/U connector and chassis ground. <i><b>Connector &amp; terminal</b></i> <i><b>(B310) No. 31 — Chassis ground:</b></i>	Is the resistance 1 M $\Omega$ or more?	Go to step 4.	Repair the harness between the VDCCM&H/U and VDC OFF switch connectors.
<b>4</b> <b>CHECK HARNESS.</b> Measure the resistance of harness between VDC OFF switch connector and chassis ground. <i><b>Connector &amp; terminal</b></i> <i><b>(B318) No. 3 — Chassis ground:</b></i>	Is the resistance less than 10 $\Omega$ ?	Go to step 5.	Repair the harness between the VDC OFF switch connector and chassis ground.
<b>5</b> <b>CHECK VDC OFF SWITCH.</b> Check the VDC OFF switch. <Ref. to VDC-29, INSPECTION, VDC OFF Switch.>	Is the VDC OFF switch normal?	Go to step 6.	Replace the VDC OFF switch. <Ref. to VDC-29, VDC OFF Switch.>
<b>6</b> <b>CHECK LAN SYSTEM.</b> Perform the diagnosis for LAN system. <Ref. to LAN(diag)-2, Basic Diagnostic Procedure.>	Is there any fault in LAN system?	Perform the diagnosis according to DTC for LAN system. <Ref. to LAN(diag)-33, List of Diagnostic Trouble Code (DTC).>	Go to step 7.
<b>7</b> <b>CHECK COMBINATION METER.</b> Check the combination meter. <Ref. to IDI-5, INSPECTION, Combination Meter System.>	Is combination meter OK?	Replace the VDCCM only. <Ref. to VDC-12, REPLACEMENT, VDC Control Module and Hydraulic Control Unit (VDCCM&H/U).>	Replace the combination meter. <Ref. to IDI-16, Combination Meter.>

# Warning Light Illumination Pattern

VEHICLE DYNAMICS CONTROL (VDC) (DIAGNOSTICS)

---

## 2. HILL START ASSIST ON/OFF MODE

### DETECTING CONDITION

- Defective combination meter
- Defective CAN communication
- Defective VDC OFF switch

### TROUBLE SYMPTOM:

Hill start assist warning light does not illuminate or go off when hill start assist function ON/OFF is changed. (Hill start assist mode does not change.)

### NOTE:

- When the VDC OFF switch is kept pressed, the VDC traction mode indicator light illuminates in green at first, then turns yellow, and then goes off in approx. 8 seconds. If the switch is released in 5 seconds after the light goes off then pressed again in 2 seconds, hill start assist warning light illuminates then mode is changed to hill start assist OFF mode.
- Hill start assist warning light always illuminates to inform that the hill start assist does not operate during hill start assist OFF mode.
- For procedure of changing hill start assist function ON/OFF, refer to "Hill start assist". <Ref. to BR-48, OPERATION, Hill Start Assist.>
- When the VDC OFF switch is held down for 10 seconds or more and the VDC traction mode indicator light goes off, if the switch is not pressed again within 5 seconds, subsequent switch operations will not be accepted. When turning the ignition switch from OFF to ON, the operation enabled status is restored.

# Warning Light Illumination Pattern

VEHICLE DYNAMICS CONTROL (VDC) (DIAGNOSTICS)

## WIRING DIAGRAM:

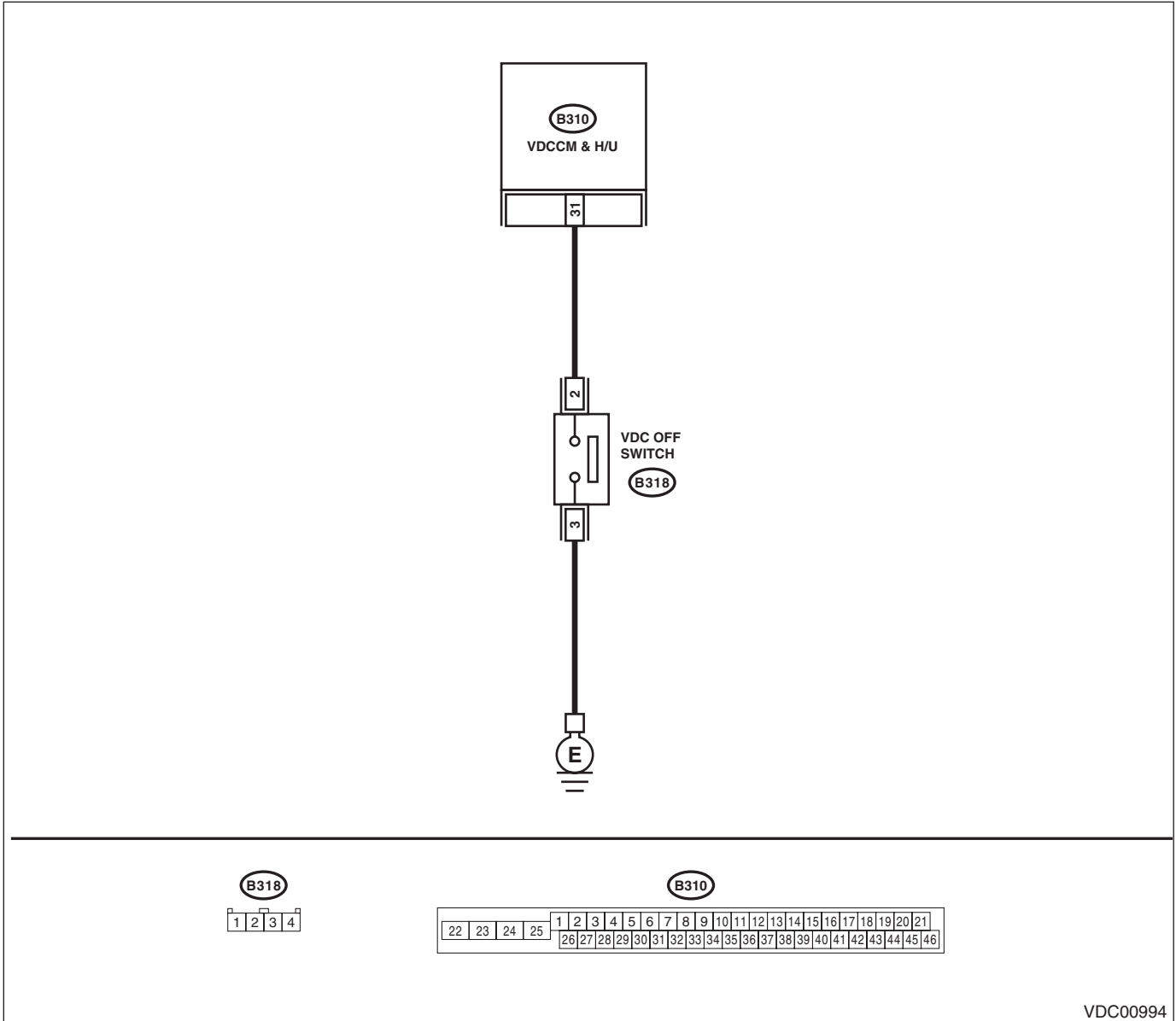

Step	Check	Yes	No
<b>1</b> <b>READ DTC.</b> Read the DTC. <Ref. to VDC(diag)-25, Read Diagnostic Trouble Code (DTC).>	Is DTC displayed?	Perform the diagnosis according to DTC. <Ref. to VDC(diag)-48, List of Diagnostic Trouble Code (DTC).>	Go to step 2.
<b>2</b> <b>CHECK HARNESS.</b> 1) Turn the ignition switch to OFF. 2) Disconnect the connector from the VDCCM&H/U and VDC OFF switch. 3) Measure the resistance of harness between the VDCCM&H/U and VDC OFF switch connectors.  <b>Connector &amp; terminal</b> <b>(B310) No. 31 — (B318) No. 2:</b>	Is the resistance less than 1 Ω?	Go to step 3.	Repair the harness between the VDCCM&H/U and VDC OFF switch connectors.

**VDC(diag)-46**

Brought to you by Ebay Seller "SubaruManuals"

# Warning Light Illumination Pattern

VEHICLE DYNAMICS CONTROL (VDC) (DIAGNOSTICS)

Step	Check	Yes	No
<b>3</b> <b>CHECK GROUND SHORT OF HARNESS.</b> Measure the resistance between VDCCM&H/U connector and chassis ground. <i><b>Connector &amp; terminal</b></i> <i><b>(B310) No. 31 — Chassis ground:</b></i>	Is the resistance 1 M $\Omega$ or more?	Go to step 4.	Repair the harness between the VDCCM&H/U and VDC OFF switch connectors.
<b>4</b> <b>CHECK HARNESS.</b> Measure the resistance of harness between VDC OFF switch connector and chassis ground. <i><b>Connector &amp; terminal</b></i> <i><b>(B318) No. 3 — Chassis ground:</b></i>	Is the resistance less than 10 $\Omega$ ?	Go to step 5.	Repair the harness between the VDC OFF switch connector and chassis ground.
<b>5</b> <b>CHECK VDC OFF SWITCH.</b> Check the VDC OFF switch. <Ref. to VDC-29, INSPECTION, VDC OFF Switch.>	Is the VDC OFF switch normal?	Go to step 6.	Replace the VDC OFF switch. <Ref. to VDC-29, VDC OFF Switch.>
<b>6</b> <b>CHECK LAN SYSTEM.</b> Perform the diagnosis for LAN system. <Ref. to LAN(diag)-2, Basic Diagnostic Procedure.>	Is there any fault in LAN system?	Perform the diagnosis according to DTC for LAN system. <Ref. to LAN(diag)-33, List of Diagnostic Trouble Code (DTC).>	Go to step 7.
<b>7</b> <b>CHECK COMBINATION METER.</b> Check the combination meter. <Ref. to IDI-5, INSPECTION, Combination Meter System.>	Is combination meter OK?	Replace the VDCCM only. <Ref. to VDC-12, REPLACEMENT, VDC Control Module and Hydraulic Control Unit (VDCCM&H/U).>	Replace the combination meter. <Ref. to IDI-16, Combination Meter.>

## List of Diagnostic Trouble Code (DTC)

VEHICLE DYNAMICS CONTROL (VDC) (DIAGNOSTICS)

### 11. List of Diagnostic Trouble Code (DTC)

#### A: LIST

DTC	Detailed code	Item	Content of diagnosis	Reference
C0021	07B1H 07B2H 07C0H	Front Right ABS Sensor Circuit Open or Short	Open/high input of front ABS wheel speed sensor RH	<Ref. to VDC(diag)-53, DTC C0021 FRONT RIGHT ABS SENSOR CIRCUIT OPEN OR SHORT, Diagnostic Procedure with Diagnostic Trouble Code (DTC).>
C0022	0720H 072FH 0736H 0737H 0738H 073AH 073CH	Front Right ABS Sensor Signal	Front ABS wheel speed sensor RH signal malfunction	<Ref. to VDC(diag)-56, DTC C0022 FRONT RIGHT ABS SENSOR SIGNAL, Diagnostic Procedure with Diagnostic Trouble Code (DTC).>
C0023	06B1H 06B2H 06C0H	Front Left ABS Sensor Circuit Open or Short	Open/high input of front ABS wheel speed sensor LH	<Ref. to VDC(diag)-53, DTC C0023 FRONT LEFT ABS SENSOR CIRCUIT OPEN OR SHORT, Diagnostic Procedure with Diagnostic Trouble Code (DTC).>
C0024	0620H 062FH 0636H 0637H 0638H 063AH 063CH	Front Left ABS Sensor Signal	Front ABS wheel speed sensor LH signal malfunction	<Ref. to VDC(diag)-56, DTC C0024 FRONT LEFT ABS SENSOR SIGNAL, Diagnostic Procedure with Diagnostic Trouble Code (DTC).>
C0025	09B1H 09B2H 09C0H	Rear Right ABS Sensor Circuit Open or Short	Open/high input of rear ABS wheel speed sensor RH	<Ref. to VDC(diag)-53, DTC C0025 REAR RIGHT ABS SENSOR CIRCUIT OPEN OR SHORT, Diagnostic Procedure with Diagnostic Trouble Code (DTC).>
C0026	0920H 092FH 0936H 0937H 0938H 093AH 093CH	Rear Right ABS Sensor Signal	Rear ABS wheel speed sensor RH signal malfunction	<Ref. to VDC(diag)-56, DTC C0026 REAR RIGHT ABS SENSOR SIGNAL, Diagnostic Procedure with Diagnostic Trouble Code (DTC).>
C0027	08B1H 08B2H 08C0H	Rear Left ABS Sensor Circuit Open or Short	Open/high input of rear ABS wheel speed sensor LH	<Ref. to VDC(diag)-54, DTC C0027 REAR LEFT ABS SENSOR CIRCUIT OPEN OR SHORT, Diagnostic Procedure with Diagnostic Trouble Code (DTC).>
C0028	0820H 082FH 0836H 0837H 0838H 083AH 083CH	Rear Left ABS Sensor Signal	Rear ABS wheel speed sensor LH signal malfunction	<Ref. to VDC(diag)-57, DTC C0028 REAR LEFT ABS SENSOR SIGNAL, Diagnostic Procedure with Diagnostic Trouble Code (DTC).>
C0029	0A10H 0A41H 0A4BH 0A4DH 0A52H 0A56H 0A60H	Wheel Speed Sensor Signal of One of The Wheels	ABS wheel speed sensor signal malfunction in one of four wheels	<Ref. to VDC(diag)-60, DTC C0029 ANY OF WHEEL SENSORS SIGNAL, Diagnostic Procedure with Diagnostic Trouble Code (DTC).>
C0031	0DB8H 0DC0H 0DC1H 0DD0H	FR Hold Valve Malfunction	Front inlet solenoid valve RH malfunction in VDCCM&H/U	<Ref. to VDC(diag)-62, DTC C0031 FR HOLD VALVE MALFUNCTION, Diagnostic Procedure with Diagnostic Trouble Code (DTC).>

**VDC(diag)-48**

Brought to you by Ebay Seller "SubaruManuals"

# List of Diagnostic Trouble Code (DTC)

VEHICLE DYNAMICS CONTROL (VDC) (DIAGNOSTICS)

DTC	Detailed code	Item	Content of diagnosis	Reference
C0032	0EB8H 0EC0H 0EC1H 0ED0H	FR Pressure Reducing Valve Malfunction	Front outlet solenoid valve RH malfunction in VDCCM&H/U	<Ref. to VDC(diag)-62, DTC C0032 FR PRESSURE REDUCING VALVE MALFUNCTION, Diagnostic Procedure with Diagnostic Trouble Code (DTC).>
C0033	0BB8H 0BC0H 0BC1H 0BD0H	FL Hold Valve Malfunction	Front inlet solenoid valve LH malfunction in VDCCM&H/U	<Ref. to VDC(diag)-62, DTC C0033 FL HOLD VALVE MALFUNCTION, Diagnostic Procedure with Diagnostic Trouble Code (DTC).>
C0034	0CB8H 0CC0H 0CC1H 0CD0H	FL Pressure Reducing Valve Malfunction	Front outlet solenoid valve LH malfunction in VDCCM&H/U	<Ref. to VDC(diag)-62, DTC C0034 FL PRESSURE REDUCING VALVE MALFUNCTION, Diagnostic Procedure with Diagnostic Trouble Code (DTC).>
C0035	11B8H 11C0H 11C1H 11D0H	RR Hold Valve Malfunction	Rear inlet solenoid valve RH malfunction in VDCCM&H/U	<Ref. to VDC(diag)-62, DTC C0035 RR HOLD VALVE MALFUNCTION, Diagnostic Procedure with Diagnostic Trouble Code (DTC).>
C0036	12B8H 12C0H 12C1H 12D0H	RR Pressure Reducing Valve Malfunction	Rear outlet solenoid valve RH malfunction in VDCCM&H/U	<Ref. to VDC(diag)-62, DTC C0036 RR PRESSURE REDUCING VALVE MALFUNCTION, Diagnostic Procedure with Diagnostic Trouble Code (DTC).>
C0037	0FB8H 0FC0H 0FC1H 0FD0H	RL Hold Valve Malfunction	Rear inlet solenoid valve LH malfunction in VDCCM&H/U	<Ref. to VDC(diag)-63, DTC C0037 RL HOLD VALVE MALFUNCTION, Diagnostic Procedure with Diagnostic Trouble Code (DTC).>
C0038	10B8H 10C0H 10C1H 10D0H	RL Pressure Reducing Valve Malfunction	Rear outlet solenoid valve LH malfunction in VDCCM&H/U	<Ref. to VDC(diag)-63, DTC C0038 RL PRESSURE REDUCING VALVE MALFUNCTION, Diagnostic Procedure with Diagnostic Trouble Code (DTC).>
C0039	0FB5H 11B5H	Any One of Four Solenoid Valves	Solenoid valve malfunction in one of four wheels	<Ref. to VDC(diag)-63, DTC C0039 ANY ONE OF FOUR SOLENOID VALVES, Diagnostic Procedure with Diagnostic Trouble Code (DTC).>
C0041	—	ECM	VDC control module malfunction	<Ref. to VDC(diag)-66, DTC C0041 ECM, Diagnostic Procedure with Diagnostic Trouble Code (DTC).>
	1630H 1645H 16C0H	Parameter Selection Error	VDC control module parameter selection failure	<Ref. to VDC(diag)-68, DTC C0041 PARAMETER SELECTION ERROR, Diagnostic Procedure with Diagnostic Trouble Code (DTC).>
C0042	0316H 031CH 0322H 0324H	Power Supply Voltage Failure	Power voltage malfunction	<Ref. to VDC(diag)-69, DTC C0042 POWER SUPPLY VOLTAGE FAILURE, Diagnostic Procedure with Diagnostic Trouble Code (DTC).>
C0045	2922H 2932H	Incorrect VDC Control Module Specifications	Different VDC control module specification	<Ref. to VDC(diag)-71, DTC C0045 INCORRECT VDC CONTROL MODULE SPECIFICATIONS, Diagnostic Procedure with Diagnostic Trouble Code (DTC).>

**VDC(diag)-49**

Brought to you by Ebay Seller "SubaruManuals"

## List of Diagnostic Trouble Code (DTC)

### VEHICLE DYNAMICS CONTROL (VDC) (DIAGNOSTICS)

DTC	Detailed code	Item	Content of diagnosis	Reference
C0047	1504H	CAN Commu- nication	Improper CAN com- munication	<Ref. to VDC(diag)-72, DTC C0047 CAN COMMUNICATION, Diagnostic Procedure with Diagnostic Trouble Code (DTC).>
	1505H			
	1506H			
	1507H			
	1508H			
	150EH			
	1512H			
	1514H			
	1518H			
	1519H			
	151AH			
	151DH			
	151EH			
	151FH			
1520H				
1531H				
1540H				
15C0H				
C0051	021FH	Valve Relay	Valve Relay	<Ref. to VDC(diag)-74, DTC C0051 VALVE RELAY, Diagnostic Procedure with Diagnostic Trouble Code (DTC).>
	0220H			
	0221H			
	0280H			
	0281H			
	02B0H			
	02B1H			
02C0H				
C0052	0562H	Motor and Motor Relay Off Failure	Motor/motor relay OFF malfunction	<Ref. to VDC(diag)-76, DTC C0052 MOTOR AND MOTOR RELAY OFF FAILURE, Diagnostic Procedure with Diagnostic Trouble Code (DTC).>
	0574H			
	0580H			
C0052	05A0H	Motor and Motor Relay On Failure	Motor/motor relay ON malfunction	<Ref. to VDC(diag)-78, DTC C0052 MOTOR AND MOTOR RELAY ON FAILURE, Diagnostic Procedure with Diagnostic Trouble Code (DTC).>
	0560H	Motor Malfunc- tion	Motor	<Ref. to VDC(diag)-80, DTC C0052 MOTOR MALFUNCTION, Diagnostic Procedure with Diagnostic Trouble Code (DTC).>
C0054	04B0H	BLS Circuit Open	BLS open circuit	<Ref. to VDC(diag)-81, DTC C0054 BLS CIRCUIT OPEN, Diag- nostic Procedure with Diagnostic Trouble Code (DTC).>
	043CH	BLS On Mal- function	BLS ON malfunction	<Ref. to VDC(diag)-83, DTC C0054 BLS ON MALFUNCTION, Diagnostic Procedure with Diagnostic Trouble Code (DTC).>
	04C1H	BLS Off Mal- function	BLS OFF Malfunc- tion	<Ref. to VDC(diag)-85, DTC C0054 BLS OFF MALFUNCTION, Diagnostic Procedure with Diagnostic Trouble Code (DTC).>
C0056	1760H 1770H 1780H	G Sensor Sig- nal	Abnormal longitudi- nal G sensor output signal	<Ref. to VDC(diag)-87, DTC C0056 G SENSOR SIGNAL, Diag- nostic Procedure with Diagnostic Trouble Code (DTC).>
C0057	2931H	ECM Commu- nication Circuit	CAN communication failure of engine con- trol module	<Ref. to VDC(diag)-89, DTC C0057 ECM COMMUNICATION CIRCUIT, Diagnostic Procedure with Diagnostic Trouble Code (DTC).>
	2930H	ECM Control System	Coordinate control prohibition of engine control module	<Ref. to VDC(diag)-90, DTC C0057 ECM CONTROL SYSTEM, Diagnostic Procedure with Diagnostic Trouble Code (DTC).>
C0061	19B8H 19C0H 19C1H 19D0H	Normal Open- ing Valve 1 Malfunction	Secondary cut valve malfunction in VDCCM&H/U	<Ref. to VDC(diag)-63, DTC C0061 NORMAL OPENING VALVE 1 MALFUNCTION, Diagnostic Procedure with Diagnos- tic Trouble Code (DTC).>
C0062	1AB8H 1AC0H 1AC1H 1AD0H	Normal Open- ing Valve 2 Malfunction	Primary cut valve malfunction in VDCCM&H/U	<Ref. to VDC(diag)-63, DTC C0062 NORMAL OPENING VALVE 2 MALFUNCTION, Diagnostic Procedure with Diagnos- tic Trouble Code (DTC).>

**VDC(diag)-50**

Brought to you by Ebay Seller "SubaruManuals"

# List of Diagnostic Trouble Code (DTC)

VEHICLE DYNAMICS CONTROL (VDC) (DIAGNOSTICS)

DTC	Detailed code	Item	Content of diagnosis	Reference
C0063	1BB8H 1BC0H 1BC1H 1BD0H	Normal Closing Valve 1 Malfunction	Secondary suction valve malfunction in VDCCM&H/U	<Ref. to VDC(diag)-63, DTC C0063 NORMAL CLOSING VALVE 1 MALFUNCTION, Diagnostic Procedure with Diagnostic Trouble Code (DTC).>
C0064	1CB8H 1CC0H 1CC1H 1CD0H	Normal Closing Valve 2 Malfunction	Primary suction valve malfunction in VDCCM&H/U	<Ref. to VDC(diag)-64, DTC C0064 NORMAL CLOSING VALVE 2 MALFUNCTION, Diagnostic Procedure with Diagnostic Trouble Code (DTC).>
C0071	2130H	Steering Angle Sensor Offset Is Too Big	Excessive steering angle sensor output offset	<Ref. to VDC(diag)-91, DTC C0071 STEERING ANGLE SENSOR OFFSET IS TOO BIG, Diagnostic Procedure with Diagnostic Trouble Code (DTC).>
	2134H	Change Range of Steering Angle Sensor Is Too Big	Excessive variation amount of steering angle sensor output	<Ref. to VDC(diag)-93, DTC C0071 CHANGE RANGE OF STEERING ANGLE SENSOR IS TOO BIG, Diagnostic Procedure with Diagnostic Trouble Code (DTC).>
	212EH 2132H 2136H 2138H 213CH 2150H 2151H 2152H 2153H 2154H 2155H 2156H 2157H 2158H 2159H 215AH	Steer Angle Sensor Op	Steering angle sensor output	<Ref. to VDC(diag)-95, DTC C0071 STEER ANGLE SENSOR OP, Diagnostic Procedure with Diagnostic Trouble Code (DTC).>
	2104H	Steering Angle Sensor Malfunction	Steering angle sensor power supply malfunction	<Ref. to VDC(diag)-97, DTC C0071 STEERING ANGLE SENSOR MALFUNCTION, Diagnostic Procedure with Diagnostic Trouble Code (DTC).>



## List of Diagnostic Trouble Code (DTC)

### VEHICLE DYNAMICS CONTROL (VDC) (DIAGNOSTICS)

DTC	Detailed code	Item	Content of diagnosis	Reference
C0072	1E1AH 1E1EH 1E22H 1E26H 1E28H 1E2CH 1E34H 1E38H 1E3AH 1E3FH	Abnormal Yaw Rate Sensor Output	Yaw rate sensor output	<Ref. to VDC(diag)-99, DTC C0072 ABNORMAL YAW RATE SENSOR OUTPUT, Diagnostic Procedure with Diagnostic Trouble Code (DTC).>
	1EB6H	Voltage Inputted to Yaw Rate Sensor Exceeds Specification	Yaw rate sensor power supply/output	<Ref. to VDC(diag)-101, DTC C0072 VOLTAGE INPUTTED TO YAW RATE SENSOR EXCEEDS SPECIFICATION, Diagnostic Procedure with Diagnostic Trouble Code (DTC).>
	1E30H	Change Range of Yaw Rate Sensor Signal Is Too Big	Excessive variation amount of yaw rate sensor output	<Ref. to VDC(diag)-103, DTC C0072 CHANGE RANGE OF YAW RATE SENSOR SIGNAL IS TOO BIG, Diagnostic Procedure with Diagnostic Trouble Code (DTC).>
	1EB7H 1EBFH 1EB5H 1EBCH 1EBDH 1EBEH 1EC0H 1EC2H 1EC3H 1EC4H 1EC6H 1ECEH 1ECFH 1ED0H 1ED3H 1ED4H 1ED5H	Yaw Rate Sensor Communication	Yaw rate sensor communication	<Ref. to VDC(diag)-105, DTC C0072 YAW RATE SENSOR COMMUNICATION, Diagnostic Procedure with Diagnostic Trouble Code (DTC).>
	1EB9H 1ED6H	Sensor Type Abnormal	Different yaw rate sensor specification	<Ref. to VDC(diag)-107, DTC C0072 SENSOR TYPE ABNORMAL, Diagnostic Procedure with Diagnostic Trouble Code (DTC).>
C0073	1D46H 1D47H	Lateral G Sensor Offset Is Too Big	Excessive amount of lateral G sensor output offset	<Ref. to VDC(diag)-107, DTC C0073 LATERAL G SENSOR OFFSET IS TOO BIG, Diagnostic Procedure with Diagnostic Trouble Code (DTC).>
	1D44H 1D45H	Abnormal Lateral G Sensor Output	Lateral G sensor output	<Ref. to VDC(diag)-107, DTC C0073 ABNORMAL LATERAL G SENSOR OUTPUT, Diagnostic Procedure with Diagnostic Trouble Code (DTC).>
	1D49H	Excessive Lateral G Sensor Signal	Excessive lateral G sensor output	<Ref. to VDC(diag)-108, DTC C0073 EXCESSIVE LATERAL G SENSOR SIGNAL, Diagnostic Procedure with Diagnostic Trouble Code (DTC).>
C0074	1F4EH 1F4FH 1FB1H 1FC0H	Pressure Sensor	Pressure sensor	<Ref. to VDC(diag)-110, DTC C0074 PRESSURE SENSOR, Diagnostic Procedure with Diagnostic Trouble Code (DTC).>
C0075	2510H 2520H	Reverse Signal	Abnormal reverse signal	<Ref. to VDC(diag)-111, DTC C0075 REVERSE SIGNAL, Diagnostic Procedure with Diagnostic Trouble Code (DTC).>
C0076	2610H 2620H	Clutch Signal	Abnormal clutch signal	<Ref. to VDC(diag)-113, DTC C0076 CLUTCH SIGNAL, Diagnostic Procedure with Diagnostic Trouble Code (DTC).>
C0081	2201H 2202H	System Failure	System malfunction	<Ref. to VDC(diag)-116, DTC C0081 SYSTEM FAILURE, Diagnostic Procedure with Diagnostic Trouble Code (DTC).>

**VDC(diag)-52**

Brought to you by Ebay Seller "SubaruManuals"

## Diagnostic Procedure with Diagnostic Trouble Code (DTC)

VEHICLE DYNAMICS CONTROL (VDC) (DIAGNOSTICS)

---

### 12. Diagnostic Procedure with Diagnostic Trouble Code (DTC)

#### **A: DTC C0021 FRONT RIGHT ABS SENSOR CIRCUIT OPEN OR SHORT**

**NOTE:**

For the diagnostic procedure, refer to "DTC C0027 REAR LEFT ABS SENSOR CIRCUIT OPEN OR SHORT". <Ref. to VDC(diag)-54, DTC C0027 REAR LEFT ABS SENSOR CIRCUIT OPEN OR SHORT, Diagnostic Procedure with Diagnostic Trouble Code (DTC).>

#### **B: DTC C0023 FRONT LEFT ABS SENSOR CIRCUIT OPEN OR SHORT**

**NOTE:**

For the diagnostic procedure, refer to "DTC C0027 REAR LEFT ABS SENSOR CIRCUIT OPEN OR SHORT". <Ref. to VDC(diag)-54, DTC C0027 REAR LEFT ABS SENSOR CIRCUIT OPEN OR SHORT, Diagnostic Procedure with Diagnostic Trouble Code (DTC).>

#### **C: DTC C0025 REAR RIGHT ABS SENSOR CIRCUIT OPEN OR SHORT**

**NOTE:**

For the diagnostic procedure, refer to "DTC C0027 REAR LEFT ABS SENSOR CIRCUIT OPEN OR SHORT". <Ref. to VDC(diag)-54, DTC C0027 REAR LEFT ABS SENSOR CIRCUIT OPEN OR SHORT, Diagnostic Procedure with Diagnostic Trouble Code (DTC).>

# Diagnostic Procedure with Diagnostic Trouble Code (DTC)

VEHICLE DYNAMICS CONTROL (VDC) (DIAGNOSTICS)

## D: DTC C0027 REAR LEFT ABS SENSOR CIRCUIT OPEN OR SHORT

### DTC DETECTING CONDITION:

- Defective ABS wheel speed sensor (broken wire, input voltage too high)
- Defective harness connector

### TROUBLE SYMPTOM:

- ABS does not operate.
- VDC does not operate.

### WIRING DIAGRAM:

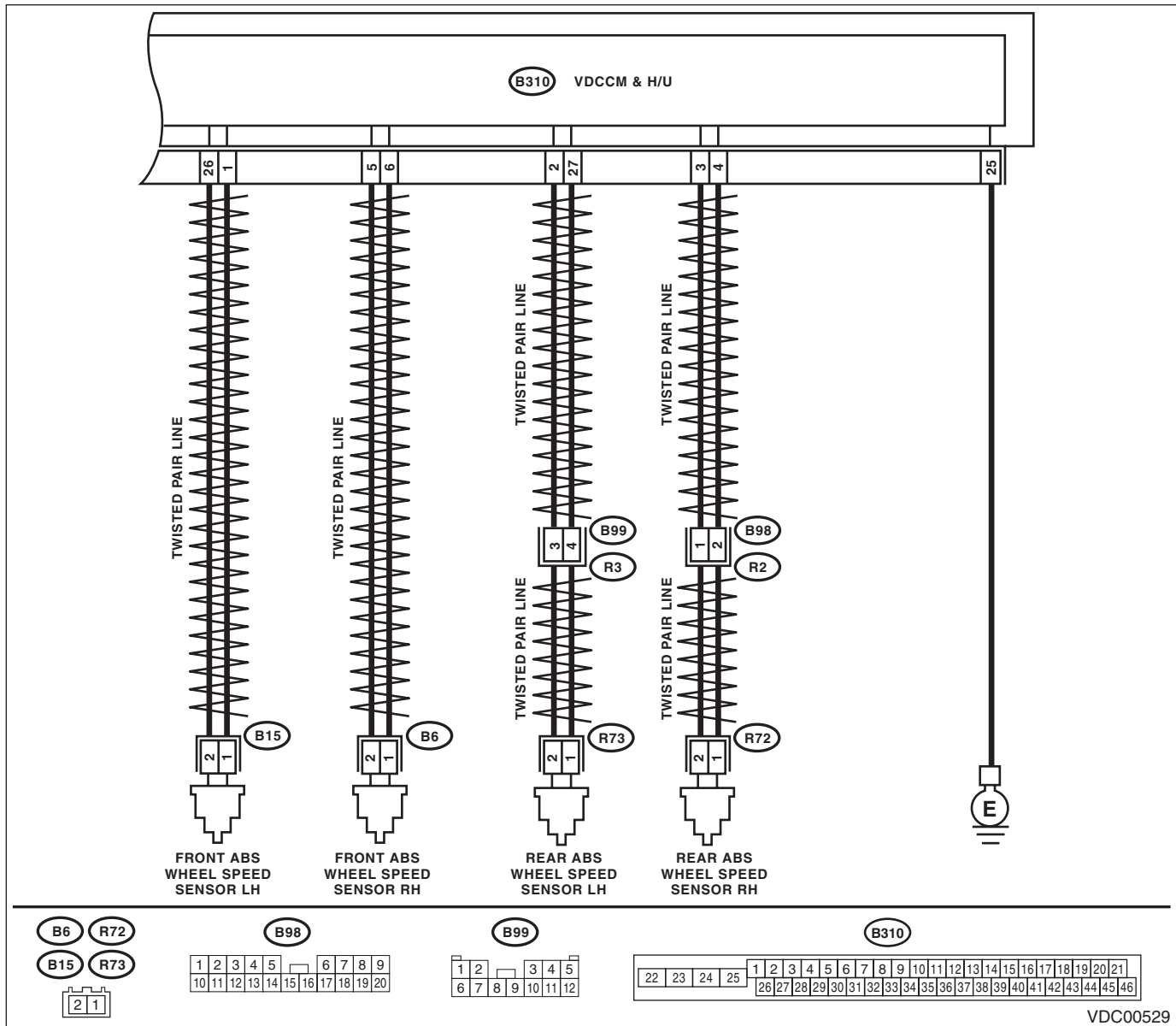

VDC00529

Step	Check	Yes	No
1	<b>CHECK POOR CONTACT OF CONNECTOR.</b> Check if there is poor contact between VDCCM&H/U and ABS wheel speed sensor.	Is there poor contact?	Repair the connector. Go to step 2.

# Diagnostic Procedure with Diagnostic Trouble Code (DTC)

VEHICLE DYNAMICS CONTROL (VDC) (DIAGNOSTICS)

Step	Check	Yes	No
<p><b>2</b></p> <p><b>CHECK HARNESS CONNECTOR BETWEEN VDCCM&amp;H/U AND ABS WHEEL SPEED SENSOR.</b></p> <p>1) Disconnect the connector (B310) from the VDCCM&amp;H/U.</p> <p>2) Disconnect the connector from ABS wheel speed sensor.</p> <p>3) Measure the resistance between VDCCM&amp;H/U connector and ABS wheel speed sensor connector.</p> <p><b>Connector &amp; terminal</b></p> <p><b>DTC C0021</b> (B310) No. 6 — (B6) No. 1: (B310) No. 5 — (B6) No. 2:</p> <p><b>DTC C0023</b> (B310) No. 1 — (B15) No. 1: (B310) No. 26 — (B15) No. 2:</p> <p><b>DTC C0025</b> (B310) No. 4 — (R72) No. 1: (B310) No. 3 — (R72) No. 2:</p> <p><b>DTC C0027</b> (B310) No. 27 — (R73) No. 1: (B310) No. 2 — (R73) No. 2:</p>	Is the resistance less than 1 Ω?	Go to step 3.	Repair the harness connector between VDCCM&H/U and ABS wheel speed sensor.
<p><b>3</b></p> <p><b>CHECK GROUND SHORT OF HARNESS.</b></p> <p>Measure the resistance between VDCCM&amp;H/U connector and chassis ground.</p> <p><b>Connector &amp; terminal</b></p> <p><b>DTC C0021</b> (B310) No. 6 — Chassis ground:</p> <p><b>DTC C0023</b> (B310) No. 1 — Chassis ground:</p> <p><b>DTC C0025</b> (B310) No. 4 — Chassis ground:</p> <p><b>DTC C0027</b> (B310) No. 27 — Chassis ground:</p>	Is the resistance 1 MΩ or more?	Go to step 4.	Repair the harness connector between VDCCM&H/U and ABS wheel speed sensor.
<p><b>4</b></p> <p><b>CHECK ABS WHEEL SPEED SENSOR POWER SUPPLY CIRCUIT.</b></p> <p>1) Connect the VDCCM&amp;H/U connector.</p> <p>2) Turn the ignition switch to ON.</p> <p>3) Measure the voltage between ABS wheel speed sensor connector and chassis ground.</p> <p><b>Connector &amp; terminal</b></p> <p><b>DTC C0021</b> (B6) No. 2 (+) — Chassis ground (-):</p> <p><b>DTC C0023</b> (B15) No. 2 (+) — Chassis ground (-):</p> <p><b>DTC C0025</b> (R72) No. 2 (+) — Chassis ground (-):</p> <p><b>DTC C0027</b> (R73) No. 2 (+) — Chassis ground (-):</p>	Is the voltage 5 — 16 V?	Go to step 6.	Go to step 5.
<p><b>5</b></p> <p><b>CHECK VDCCM&amp;H/U POWER SUPPLY CIRCUIT.</b></p> <p>1) Turn the ignition switch to OFF.</p> <p>2) Disconnect the VDCCM&amp;H/U connector.</p> <p>3) Turn the ignition switch to ON.</p> <p>4) Measure the voltage between VDCCM&amp;H/U connector terminals.</p> <p><b>Connector &amp; terminal</b> (B310) No. 28 (+) — (B310) No. 25 (-):</p>	Is the voltage 10 — 15 V?	Go to step 6.	Check the generator, battery and VDCCM&H/U power supply circuit.

# Diagnostic Procedure with Diagnostic Trouble Code (DTC)

## VEHICLE DYNAMICS CONTROL (VDC) (DIAGNOSTICS)

Step	Check	Yes	No
<b>6</b> <b>CHECK ABS WHEEL SPEED SENSOR SIGNAL.</b> 1) Install the ABS wheel speed sensor. 2) Prepare an oscilloscope. 3) Check the ABS wheel speed sensor. <Ref. to VDC-24, ABS WHEEL SPEED SENSOR, INSPECTION, Front ABS Wheel Speed Sensor.>	Is the pattern the same waveform as shown in the figure?	Go to step 7.	Replace the ABS wheel speed sensor. <Ref. to VDC-24, Front ABS Wheel Speed Sensor.>
<b>7</b> <b>CHECK VDCCM&amp;H/U.</b> 1) Connect all connectors. 2) Clear the memory. <Ref. to VDC(diag)-27, Clear Memory Mode.> 3) Perform the Inspection Mode. <Ref. to VDC(diag)-26, Inspection Mode.> 4) Read the DTC.	Is the same DTC displayed?	Replace the VDCCM only. <Ref. to VDC-12, REPLACEMENT, VDC Control Module and Hydraulic Control Unit (VDCCM&H/U).>	Go to step 8.
<b>8</b> <b>CHECK OTHER DTC DETECTION.</b>	Is any other DTC displayed?	Perform the diagnosis according to DTC. <Ref. to VDC(diag)-48, List of Diagnostic Trouble Code (DTC).>	It results from a temporary noise interference.

### E: DTC C0022 FRONT RIGHT ABS SENSOR SIGNAL

#### NOTE:

For the diagnostic procedure, refer to "DTC C0028 REAR LEFT ABS SENSOR SIGNAL". <Ref. to VDC(diag)-57, DTC C0028 REAR LEFT ABS SENSOR SIGNAL, Diagnostic Procedure with Diagnostic Trouble Code (DTC).>

### F: DTC C0024 FRONT LEFT ABS SENSOR SIGNAL

#### NOTE:

For the diagnostic procedure, refer to "DTC C0028 REAR LEFT ABS SENSOR SIGNAL". <Ref. to VDC(diag)-57, DTC C0028 REAR LEFT ABS SENSOR SIGNAL, Diagnostic Procedure with Diagnostic Trouble Code (DTC).>

### G: DTC C0026 REAR RIGHT ABS SENSOR SIGNAL

#### NOTE:

For the diagnostic procedure, refer to "DTC C0028 REAR LEFT ABS SENSOR SIGNAL". <Ref. to VDC(diag)-57, DTC C0028 REAR LEFT ABS SENSOR SIGNAL, Diagnostic Procedure with Diagnostic Trouble Code (DTC).>

# Diagnostic Procedure with Diagnostic Trouble Code (DTC)

VEHICLE DYNAMICS CONTROL (VDC) (DIAGNOSTICS)

## H: DTC C0028 REAR LEFT ABS SENSOR SIGNAL

### DTC DETECTING CONDITION:

- Defective ABS wheel speed sensor signal (noise, irregular signal, etc.)
- Defective harness connector

### TROUBLE SYMPTOM:

- ABS does not operate.
- VDC does not operate.

### WIRING DIAGRAM:

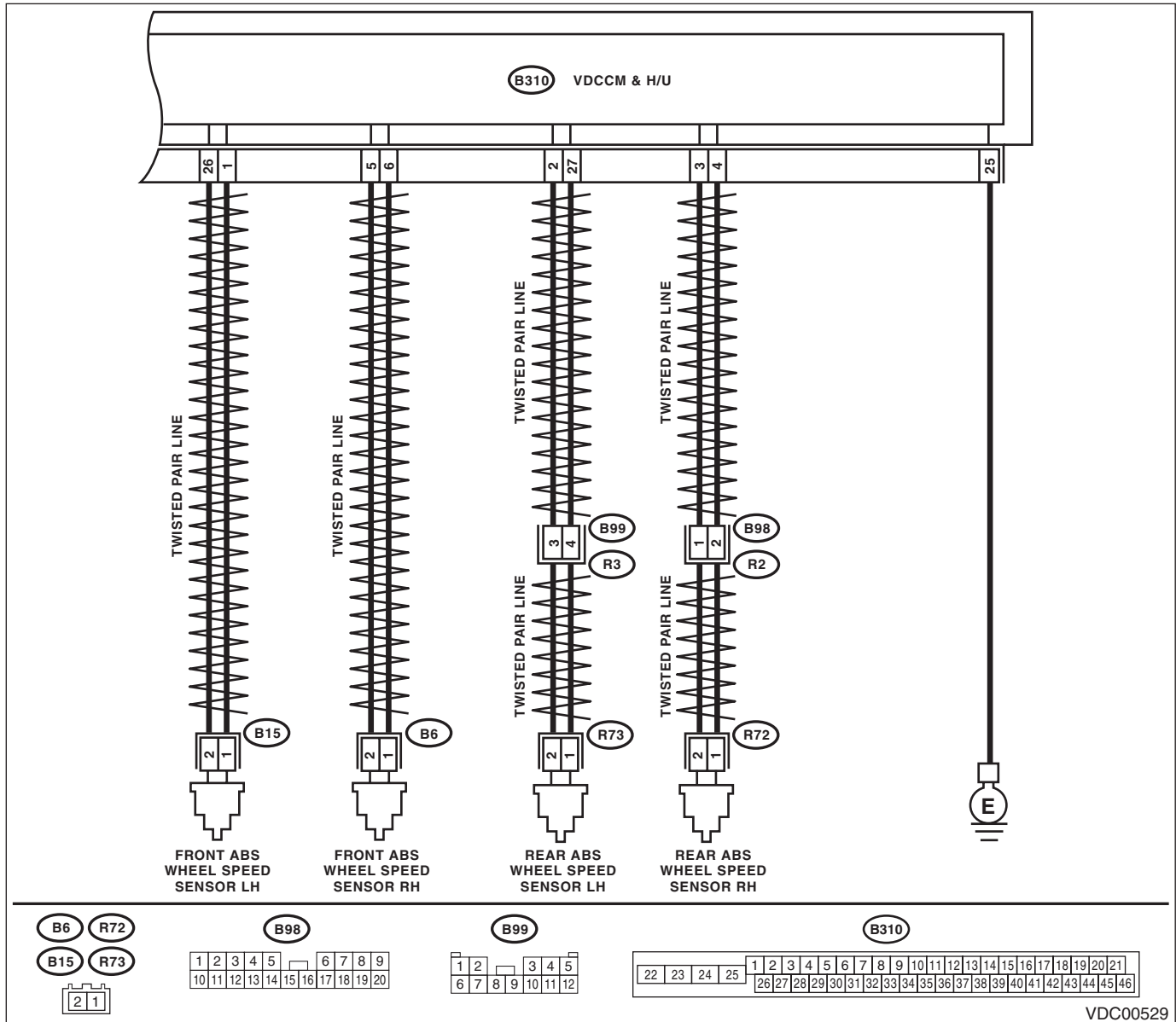

VDC00529

Step	Check	Yes	No
<b>1</b> <b>CHECK OUTPUT OF ABS WHEEL SPEED SENSOR USING SUBARU SELECT MONITOR.</b> 1) Select "Current Data Display & Save" on the Subaru Select Monitor. 2) Read the defective ABS wheel speed sensor output.	Does the speed indicated on the display change in response to the speedometer reading during acceleration/deceleration when the steering wheel is in the straight-ahead position?	Go to step 2.	Go to step 7.

# Diagnostic Procedure with Diagnostic Trouble Code (DTC)

## VEHICLE DYNAMICS CONTROL (VDC) (DIAGNOSTICS)

Step	Check	Yes	No
<b>2</b>	<b>CHECK POOR CONTACT OF CONNECTOR.</b> Turn the ignition switch to OFF.	Is there poor contact of connectors between VDCCM&H/U and ABS wheel speed sensor?	Repair the connector. Go to step 3.
<b>3</b>	<b>CHECK CAUSE OF SIGNAL NOISE.</b> Make sure the radio wave devices and electronic components are installed correctly.	Are the radio wave devices and electronic components installed correctly?	Go to step 4. Install the radio wave devices and electronic components properly.
<b>4</b>	<b>CHECK CAUSE OF SIGNAL NOISE.</b> Check if the noise sources (such as an antenna) are installed near the sensor harness.	Are noise sources installed?	Install the noise sources apart from sensor harness. Go to step 5.
<b>5</b>	<b>CHECK VDCCM&amp;H/U.</b> 1) Connect all connectors. 2) Clear the memory. <Ref. to VDC(diag)-27, Clear Memory Mode.> 3) Perform the Inspection Mode. <Ref. to VDC(diag)-26, Inspection Mode.> 4) Read the DTC.	Is the same DTC displayed?	Replace the VDCCM only. <Ref. to VDC-12, REPLACEMENT, VDC Control Module and Hydraulic Control Unit (VDCCM&H/U).> Go to step 6.
<b>6</b>	<b>CHECK OTHER DTC DETECTION.</b>	Is any other DTC displayed?	Perform the diagnosis according to DTC. <Ref. to VDC(diag)-48, List of Diagnostic Trouble Code (DTC).> It results from a temporary noise interference.
<b>7</b>	<b>CHECK INSTALLATION OF ABS WHEEL SPEED SENSOR.</b>	Is the ABS wheel speed sensor installation bolt tightened to 7.5 N·m (0.76 kgf·m, 5.5 ft·lb)?	Go to step 8. Tighten the ABS wheel speed sensor installation bolts.
<b>8</b>	<b>CHECK ABS WHEEL SPEED SENSOR SIGNAL.</b> 1) Install the ABS wheel speed sensor. 2) Prepare an oscilloscope. 3) Check the ABS wheel speed sensor. <Ref. to VDC-24, ABS WHEEL SPEED SENSOR, INSPECTION, Front ABS Wheel Speed Sensor.>	Does the oscilloscope indicate the waveform pattern like shown in the figure when the tire is slowly turned? Does the oscilloscope indication repeat the waveform pattern like shown in the figure when the tire is slowly turned in equal speed for one rotation or more?	Go to step 10. Go to step 9.
<b>9</b>	<b>CHECK ABS WHEEL SPEED SENSOR OR MAGNETIC ENCODER.</b>	Are there foreign matter, breakage or damage at the tip of ABS wheel speed sensor or magnetic encoder?	Remove dirt thoroughly. Also replace the ABS wheel speed sensor or magnetic encoder as a unit with hub unit bearing if it is broken or damaged. Go to step 10.
<b>10</b>	<b>CHECK CAUSE OF SIGNAL NOISE.</b> Make sure the radio wave devices and electronic components are installed correctly.	Are the radio wave devices and electronic components installed correctly?	Go to step 11. Install the radio wave devices and electronic components properly.
<b>11</b>	<b>CHECK CAUSE OF SIGNAL NOISE.</b> Check if the noise sources (such as an antenna) are installed near the sensor harness.	Are noise sources installed?	Install the noise sources apart from sensor harness. Go to step 12.

# Diagnostic Procedure with Diagnostic Trouble Code (DTC)

VEHICLE DYNAMICS CONTROL (VDC) (DIAGNOSTICS)

Step	Check	Yes	No
<b>12</b> <b>CHECK VDCCM&amp;H/U.</b> 1) Connect all connectors. 2) Clear the memory. <Ref. to VDC(diag)-27, Clear Memory Mode.> 3) Perform the Inspection Mode. <Ref. to VDC(diag)-26, Inspection Mode.> 4) Read the DTC.	Is the same DTC displayed?	Replace the VDCCM only. <Ref. to VDC-12, REPLACEMENT, VDC Control Module and Hydraulic Control Unit (VDCCM&H/U).>	Go to step 13.
<b>13</b> <b>CHECK OTHER DTC DETECTION.</b>	Is any other DTC displayed?	Perform the diagnosis according to DTC. <Ref. to VDC(diag)-48, List of Diagnostic Trouble Code (DTC).>	It results from a temporary noise interference. NOTE: Though the ABS warning light remains on at this time, this is normal. Drive the vehicle at 12 km/h (7 MPH) or more in order to turn ABS warning light off. Be sure to drive the vehicle and check that the warning light goes off.



# Diagnostic Procedure with Diagnostic Trouble Code (DTC)

VEHICLE DYNAMICS CONTROL (VDC) (DIAGNOSTICS)

## I: DTC C0029 ANY OF WHEEL SENSORS SIGNAL

### DTC DETECTING CONDITION:

- Defective ABS wheel speed sensor signal (noise, irregular signal, etc.)
- Defective magnetic encoder
- When a wheel is turned freely for a long time

### TROUBLE SYMPTOM:

- ABS does not operate.
- VDC does not operate.
- EBD may not operate.

### NOTE:

Brake warning light comes on as well as ABS warning light when EBD does not operate.

### WIRING DIAGRAM:

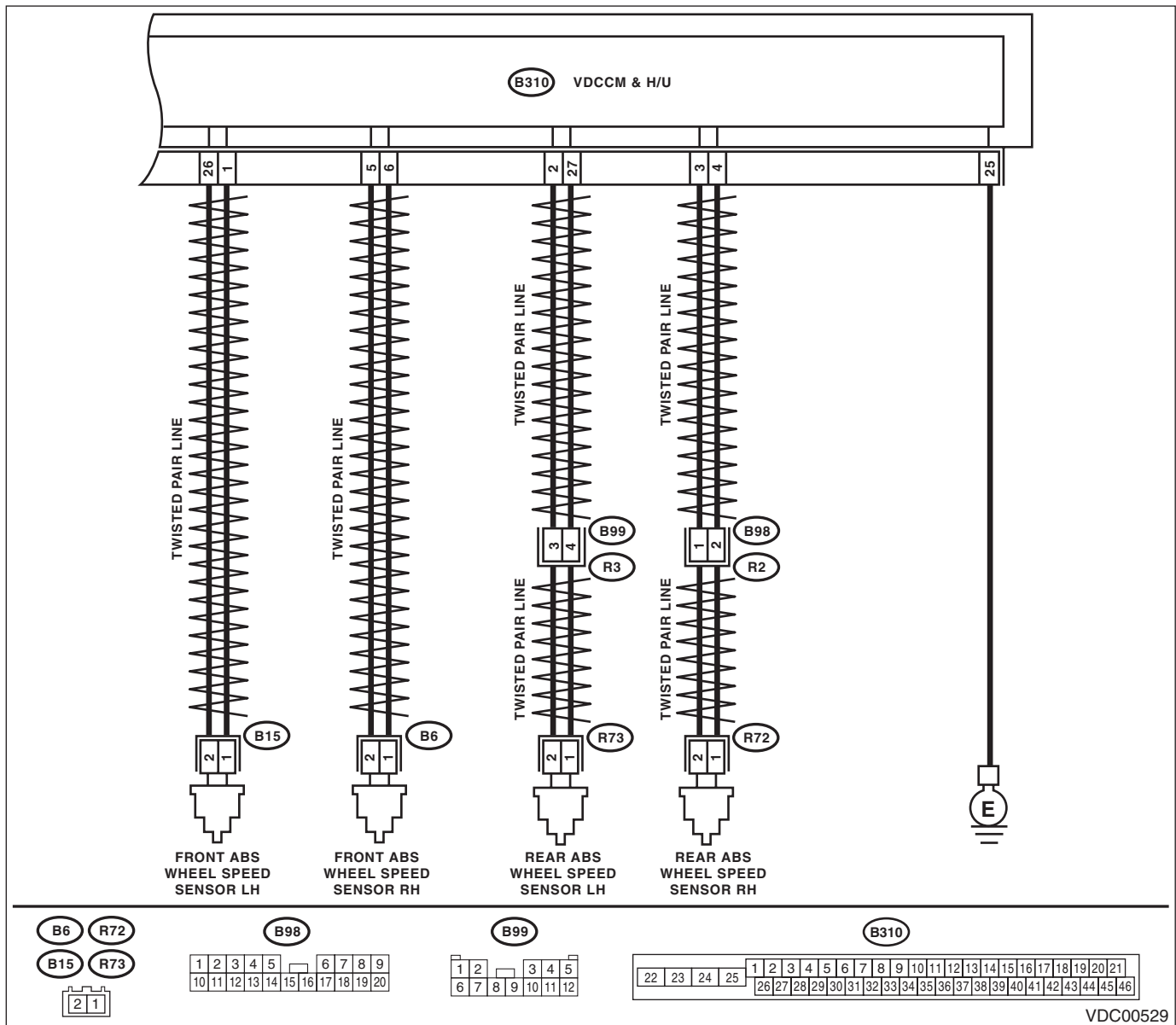

# Diagnostic Procedure with Diagnostic Trouble Code (DTC)

VEHICLE DYNAMICS CONTROL (VDC) (DIAGNOSTICS)

	Step	Check	Yes	No
1	<b>WHETHER A WHEEL TURNED FREELY OR NOT.</b> Check if the wheels have been turned freely for one minute or more, such as when the vehicle is jacked-up, under full-lock cornering or when the wheels are not in contact with road surface.	Did the wheels turn freely?	VDC is normal. Clear the memory. NOTE: This diagnostic trouble code may sometimes occur if the wheels turn freely for a long time, for example when the vehicle is towed or jacked-up, or when steering wheel is continuously turned all the way.	Go to step 2.
2	<b>CHECK TIRE SPECIFICATIONS.</b> Turn the ignition switch to OFF.	Are the tire specifications correct?	Go to step 3.	Replace the tire.
3	<b>CHECK WEAR OF TIRE.</b>	Is the tire worn excessively?	Replace the tire.	Go to step 4.
4	<b>CHECK TIRE INFLATION PRESSURE.</b>	Is the tire pressure correct?	Go to step 5.	Adjust the tire pressure.
5	<b>CHECK INSTALLATION OF ABS WHEEL SPEED SENSOR.</b>	Are the ABS wheel speed sensor installation bolts tightened 7.5 N·m (0.76 kgf-m, 5.5 ft-lb)? (For four wheels)	Go to step 6.	Tighten the ABS wheel speed sensor installation bolts.
6	<b>CHECK ABS WHEEL SPEED SENSOR SIGNAL.</b> 1) Install the ABS wheel speed sensor. 2) Prepare an oscilloscope. 3) Check the ABS wheel speed sensor. <Ref. to VDC-24, ABS WHEEL SPEED SENSOR, INSPECTION, Front ABS Wheel Speed Sensor.>	Does the oscilloscope indicate the waveform pattern like shown in the figure when the tire is slowly turned? Does the oscilloscope indication repeat the waveform pattern like shown in the figure when the tire is slowly turned in equal speed for one rotation or more?	Go to step 8.	Go to step 7.
7	<b>CHECK ABS WHEEL SPEED SENSOR OR MAGNETIC ENCODER.</b>	Are there foreign matter, breakage or damage at the tip of ABS wheel speed sensor or magnetic encoder?	Remove dirt thoroughly. Also replace the ABS wheel speed sensor or magnetic encoder as a unit with hub unit bearing if it is broken or damaged.	Go to step 8.
8	<b>CHECK VDCCM&amp;H/U.</b> 1) Connect all connectors. 2) Clear the memory. <Ref. to VDC(diag)-27, Clear Memory Mode.> 3) Perform the Inspection Mode. <Ref. to VDC(diag)-26, Inspection Mode.> 4) Read the DTC.	Is the same DTC displayed?	Replace the VDCCM only. <Ref. to VDC-12, REPLACEMENT, VDC Control Module and Hydraulic Control Unit (VDCCM&H/U).>	Go to step 9.

# Diagnostic Procedure with Diagnostic Trouble Code (DTC)

VEHICLE DYNAMICS CONTROL (VDC) (DIAGNOSTICS)

Step	Check	Yes	No
9 <b>CHECK OTHER DTC DETECTION.</b>	Is any other DTC displayed?	Perform the diagnosis according to DTC. <Ref. to VDC(diag)-48, List of Diagnostic Trouble Code (DTC).>	It results from a temporary noise interference. NOTE: Though the ABS warning light remains on at this time, this is normal. Drive the vehicle at 12 km/h (7 MPH) or more in order to turn ABS warning light off. Be sure to drive the vehicle and check that the warning light goes off.

## J: DTC C0031 FR HOLD VALVE MALFUNCTION

NOTE:

For the diagnostic procedure, refer to "DTC C0064 NORMAL CLOSING VALVE 2 MALFUNCTION". <Ref. to VDC(diag)-64, DTC C0064 NORMAL CLOSING VALVE 2 MALFUNCTION, Diagnostic Procedure with Diagnostic Trouble Code (DTC).>

## K: DTC C0032 FR PRESSURE REDUCING VALVE MALFUNCTION

NOTE:

For the diagnostic procedure, refer to "DTC C0064 NORMAL CLOSING VALVE 2 MALFUNCTION". <Ref. to VDC(diag)-64, DTC C0064 NORMAL CLOSING VALVE 2 MALFUNCTION, Diagnostic Procedure with Diagnostic Trouble Code (DTC).>

## L: DTC C0033 FL HOLD VALVE MALFUNCTION

NOTE:

For the diagnostic procedure, refer to "DTC C0064 NORMAL CLOSING VALVE 2 MALFUNCTION". <Ref. to VDC(diag)-64, DTC C0064 NORMAL CLOSING VALVE 2 MALFUNCTION, Diagnostic Procedure with Diagnostic Trouble Code (DTC).>

## M: DTC C0034 FL PRESSURE REDUCING VALVE MALFUNCTION

NOTE:

For the diagnostic procedure, refer to "DTC C0064 NORMAL CLOSING VALVE 2 MALFUNCTION". <Ref. to VDC(diag)-64, DTC C0064 NORMAL CLOSING VALVE 2 MALFUNCTION, Diagnostic Procedure with Diagnostic Trouble Code (DTC).>

## N: DTC C0035 RR HOLD VALVE MALFUNCTION

NOTE:

For the diagnostic procedure, refer to "DTC C0064 NORMAL CLOSING VALVE 2 MALFUNCTION". <Ref. to VDC(diag)-64, DTC C0064 NORMAL CLOSING VALVE 2 MALFUNCTION, Diagnostic Procedure with Diagnostic Trouble Code (DTC).>

## O: DTC C0036 RR PRESSURE REDUCING VALVE MALFUNCTION

NOTE:

For the diagnostic procedure, refer to "DTC C0064 NORMAL CLOSING VALVE 2 MALFUNCTION". <Ref. to VDC(diag)-64, DTC C0064 NORMAL CLOSING VALVE 2 MALFUNCTION, Diagnostic Procedure with Diagnostic Trouble Code (DTC).>

VDC(diag)-62

Brought to you by Ebay Seller "SubaruManuals"

# Diagnostic Procedure with Diagnostic Trouble Code (DTC)

VEHICLE DYNAMICS CONTROL (VDC) (DIAGNOSTICS)

---

## **P: DTC C0037 RL HOLD VALVE MALFUNCTION**

### NOTE:

For the diagnostic procedure, refer to "DTC C0064 NORMAL CLOSING VALVE 2 MALFUNCTION". <Ref. to VDC(diag)-64, DTC C0064 NORMAL CLOSING VALVE 2 MALFUNCTION, Diagnostic Procedure with Diagnostic Trouble Code (DTC).>

## **Q: DTC C0038 RL PRESSURE REDUCING VALVE MALFUNCTION**

### NOTE:

For the diagnostic procedure, refer to "DTC C0064 NORMAL CLOSING VALVE 2 MALFUNCTION". <Ref. to VDC(diag)-64, DTC C0064 NORMAL CLOSING VALVE 2 MALFUNCTION, Diagnostic Procedure with Diagnostic Trouble Code (DTC).>

## **R: DTC C0039 ANY ONE OF FOUR SOLENOID VALVES**

### NOTE:

For the diagnostic procedure, refer to "DTC C0064 NORMAL CLOSING VALVE 2 MALFUNCTION". <Ref. to VDC(diag)-64, DTC C0064 NORMAL CLOSING VALVE 2 MALFUNCTION, Diagnostic Procedure with Diagnostic Trouble Code (DTC).>

## **S: DTC C0061 NORMAL OPENING VALVE 1 MALFUNCTION**

### NOTE:

For the diagnostic procedure, refer to "DTC C0064 NORMAL CLOSING VALVE 2 MALFUNCTION". <Ref. to VDC(diag)-64, DTC C0064 NORMAL CLOSING VALVE 2 MALFUNCTION, Diagnostic Procedure with Diagnostic Trouble Code (DTC).>

## **T: DTC C0062 NORMAL OPENING VALVE 2 MALFUNCTION**

### NOTE:

For the diagnostic procedure, refer to "DTC C0064 NORMAL CLOSING VALVE 2 MALFUNCTION". <Ref. to VDC(diag)-64, DTC C0064 NORMAL CLOSING VALVE 2 MALFUNCTION, Diagnostic Procedure with Diagnostic Trouble Code (DTC).>

## **U: DTC C0063 NORMAL CLOSING VALVE 1 MALFUNCTION**

### NOTE:

For the diagnostic procedure, refer to "DTC C0064 NORMAL CLOSING VALVE 2 MALFUNCTION". <Ref. to VDC(diag)-64, DTC C0064 NORMAL CLOSING VALVE 2 MALFUNCTION, Diagnostic Procedure with Diagnostic Trouble Code (DTC).>

# Diagnostic Procedure with Diagnostic Trouble Code (DTC)

VEHICLE DYNAMICS CONTROL (VDC) (DIAGNOSTICS)

## V: DTC C0064 NORMAL CLOSING VALVE 2 MALFUNCTION

### DTC DETECTING CONDITION:

- Defective harness connector
- Defective VDCH/U solenoid valve

### TROUBLE SYMPTOM:

- ABS does not operate.
- EBD does not operate.
- VDC does not operate.

### WIRING DIAGRAM:

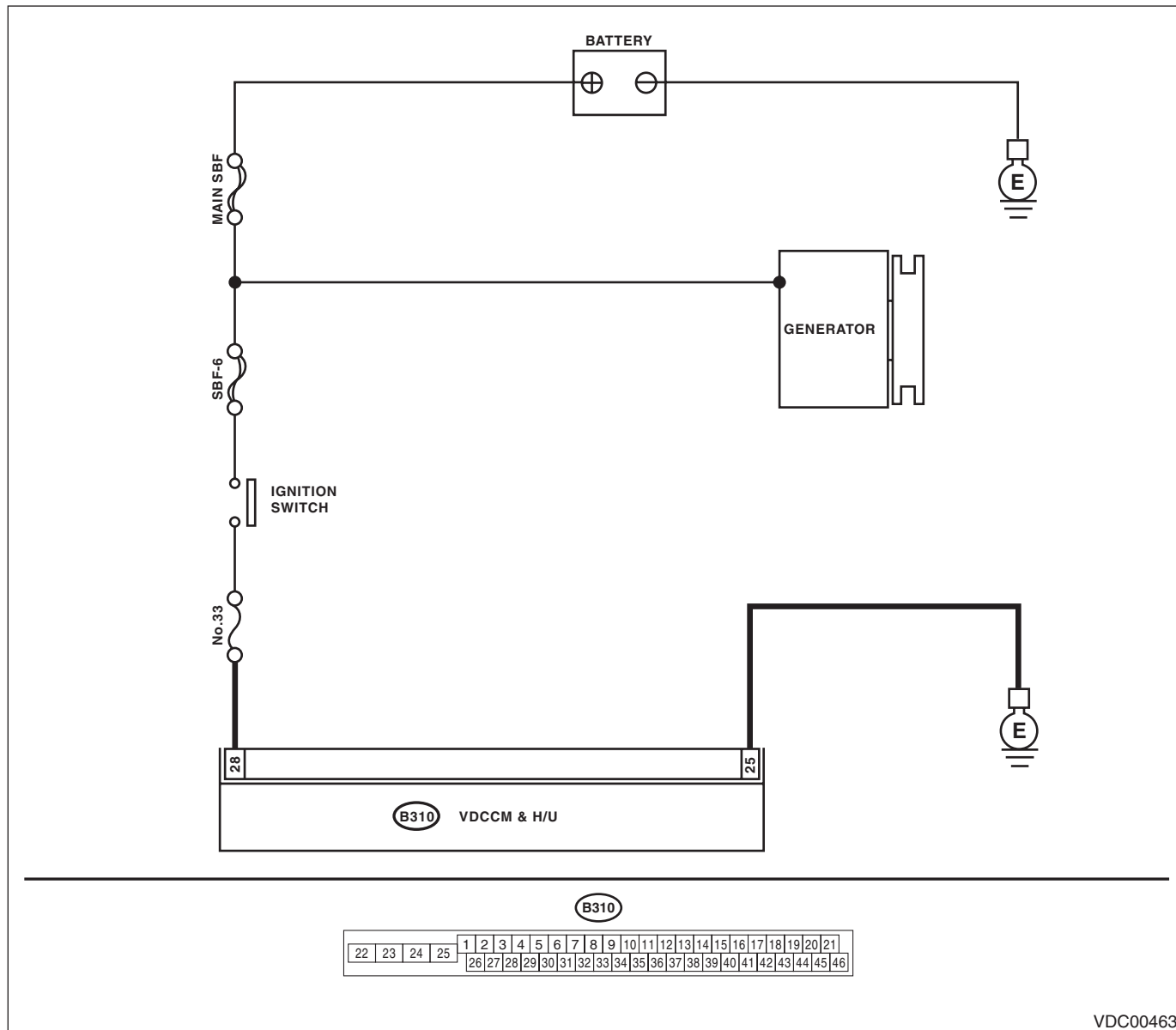

VDC00463

# Diagnostic Procedure with Diagnostic Trouble Code (DTC)

VEHICLE DYNAMICS CONTROL (VDC) (DIAGNOSTICS)

	Step	Check	Yes	No
1	<b>CHECK VDCCM&amp;H/U INPUT VOLTAGE.</b> 1) Turn the ignition switch to OFF. 2) Disconnect the connector from the VDCCM&H/U. 3) Run the engine at idle. 4) Measure the voltage between VDCCM&H/U connector and chassis ground. <b>Connector &amp; terminal</b> <b>(B310) No. 28 (+) — Chassis ground (-):</b>	Is the voltage 10 — 15 V?	Go to step 2.	Repair the power supply circuit.
2	<b>CHECK VDCCM&amp;H/U GROUND CIRCUIT.</b> 1) Turn the ignition switch to OFF. 2) Measure the resistance between VDCCM&H/U connector and chassis ground. <b>Connector &amp; terminal</b> <b>(B310) No. 25 — Chassis ground:</b>	Is the resistance less than 10 $\Omega$ ?	Go to step 3.	Repair the VDCCM&H/U ground harness.
3	<b>CHECK POOR CONTACT OF CONNECTORS.</b>	Is there poor contact of connector between generator, battery and VDCCM&H/U?	Repair the connector.	Go to step 4.
4	<b>CHECK VDCCM&amp;H/U.</b> 1) Connect all connectors. 2) Clear the memory. <Ref. to VDC(diag)-27, Clear Memory Mode.> 3) Perform the Inspection Mode. <Ref. to VDC(diag)-26, Inspection Mode.> 4) Read the DTC.	Is the same DTC displayed?	Replace the VDCCM&H/U. <Ref. to VDC-8, VDC Control Module and Hydraulic Control Unit (VDCCM&H/U).>	Go to step 5.
5	<b>CHECK OTHER DTC DETECTION.</b>	Is any other DTC displayed?	Perform the diagnosis according to DTC. <Ref. to VDC(diag)-48, List of Diagnostic Trouble Code (DTC).>	Temporary poor contact occurs.

# Diagnostic Procedure with Diagnostic Trouble Code (DTC)

VEHICLE DYNAMICS CONTROL (VDC) (DIAGNOSTICS)

## W: DTC C0041 ECM

### DTC DETECTING CONDITION:

Defective VDCCM&H/U

### TROUBLE SYMPTOM:

- ABS does not operate.
- EBD does not operate.
- VDC does not operate.

### WIRING DIAGRAM:

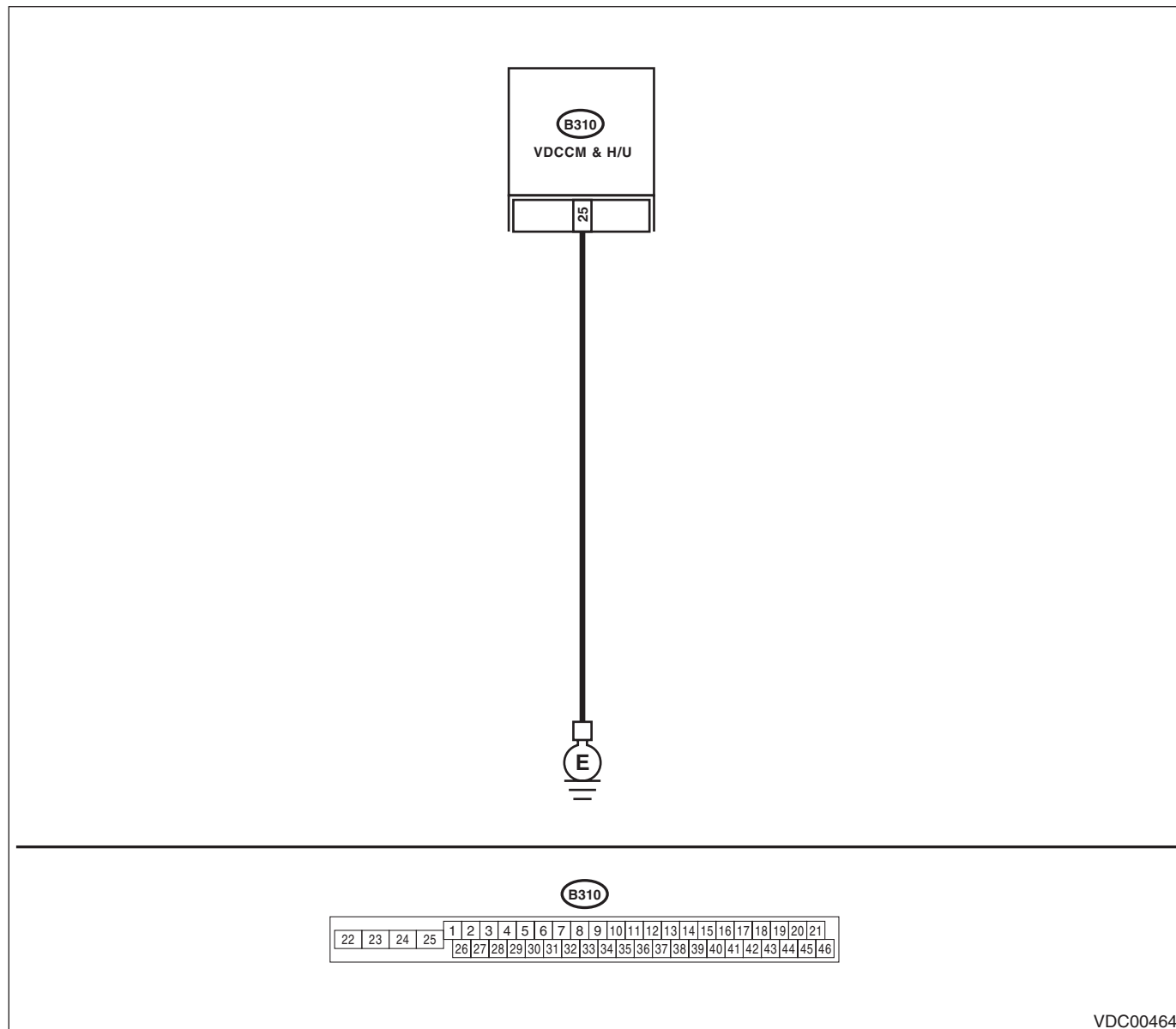

VDC00464

	Step	Check	Yes	No
1	<b>CHECK VDCCM&amp;H/U GROUND CIRCUIT.</b> 1) Turn the ignition switch to OFF. 2) Disconnect the connector from the VDCCM&H/U. 3) Measure the resistance between VDCCM&H/U and chassis ground. <b>Connector &amp; terminal</b> <b>(B310) No. 25 — Chassis ground:</b>	Is the resistance less than 10 Ω?	Go to step 2.	Repair the VDCCM&H/U ground harness.

# Diagnostic Procedure with Diagnostic Trouble Code (DTC)

VEHICLE DYNAMICS CONTROL (VDC) (DIAGNOSTICS)

Step	Check	Yes	No
<b>2</b>	<b>CHECK POOR CONTACT OF CONNECTORS.</b>	Is there poor contact of the connector between the battery, ignition switch and VDCCM&H/U?	Repair the connector. Go to step 3.
<b>3</b>	<b>CHECK CAUSE OF SIGNAL NOISE.</b>	Are the radio wave devices and electronic components installed correctly?	Go to step 4. Install the radio wave devices and electronic components properly.
<b>4</b>	<b>CHECK CAUSE OF SIGNAL NOISE.</b>	Is there a noise source (such as an antenna) installed near the sensor harness?	Install the noise sources apart from sensor harness. Go to step 5.
<b>5</b>	<b>CHECK VDCCM&amp;H/U.</b> 1) Connect all connectors. 2) Clear the memory. <Ref. to VDC(diag)-27, Clear Memory Mode.> 3) Perform the Inspection Mode. <Ref. to VDC(diag)-26, Inspection Mode.> 4) Read the DTC.	Is the same DTC displayed?	Replace the VDCCM only. <Ref. to VDC-12, REPLACEMENT, VDC Control Module and Hydraulic Control Unit (VDCCM&H/U).> Go to step 6.
<b>6</b>	<b>CHECK OTHER DTC DETECTION.</b>	Is any other DTC displayed?	Perform the diagnosis according to DTC. <Ref. to VDC(diag)-48, List of Diagnostic Trouble Code (DTC).> Temporary poor contact occurs.



# Diagnostic Procedure with Diagnostic Trouble Code (DTC)

VEHICLE DYNAMICS CONTROL (VDC) (DIAGNOSTICS)

## X: DTC C0041 PARAMETER SELECTION ERROR

### DTC DETECTING CONDITION:

VDCCM parameter selection error

### TROUBLE SYMPTOM:

- ABS does not operate.
- EBD does not operate.
- VDC does not operate.

### NOTE:

When the VDCCM or VDCCM&H/U is replaced, this DTC may be stored.

Step	Check	Yes	No
<b>1</b>	<b>CHECK VDCCM&amp;H/U REPLACEMENT HISTORY.</b>	Go to step 2.	Go to step 3.
<b>2</b>	<b>CHECK VDCCM IDENTIFICATION SYMBOL.</b> Check the identification symbol of the seal attached on the side of the VDCCM. 5MT: SM 6MT: SN	Go to step 4.	Replace the VDCCM only. <Ref. to VDC-12, REPLACEMENT, VDC Control Module and Hydraulic Control Unit (VDCCM&H/U).>
<b>3</b>	<b>CHECK VDCCM&amp;H/U IDENTIFICATION SYMBOL.</b> Check the identification symbol stamped on the upper part of the H/U. 5MT: SM 6MT: SN	Go to step 4.	Replace the VDCCM&H/U. <Ref. to VDC-8, VDC Control Module and Hydraulic Control Unit (VDCCM&H/U).>
<b>4</b>	<b>CHECK PARAMETER SELECTED IN VDC-CM.</b> <Ref. to VDC(diag)-21, PARAMETER CHECK, OPERATION, Subaru Select Monitor.>	Replace the VDCCM only. <Ref. to VDC-12, REPLACEMENT, VDC Control Module and Hydraulic Control Unit (VDCCM&H/U).>	Select and register the correct parameter. <Ref. to VDC(diag)-20, PARAMETER SELECTION, OPERATION, Subaru Select Monitor.>

# Diagnostic Procedure with Diagnostic Trouble Code (DTC)

VEHICLE DYNAMICS CONTROL (VDC) (DIAGNOSTICS)

## Y: DTC C0042 POWER SUPPLY VOLTAGE FAILURE

### DTC DETECTING CONDITION:

Improper VDCCM&H/U power supply voltage

### TROUBLE SYMPTOM:

- ABS does not operate.
- EBD may not operate.
- VDC does not operate.

### NOTE:

Warning lights go off if voltage returns.

### WIRING DIAGRAM:

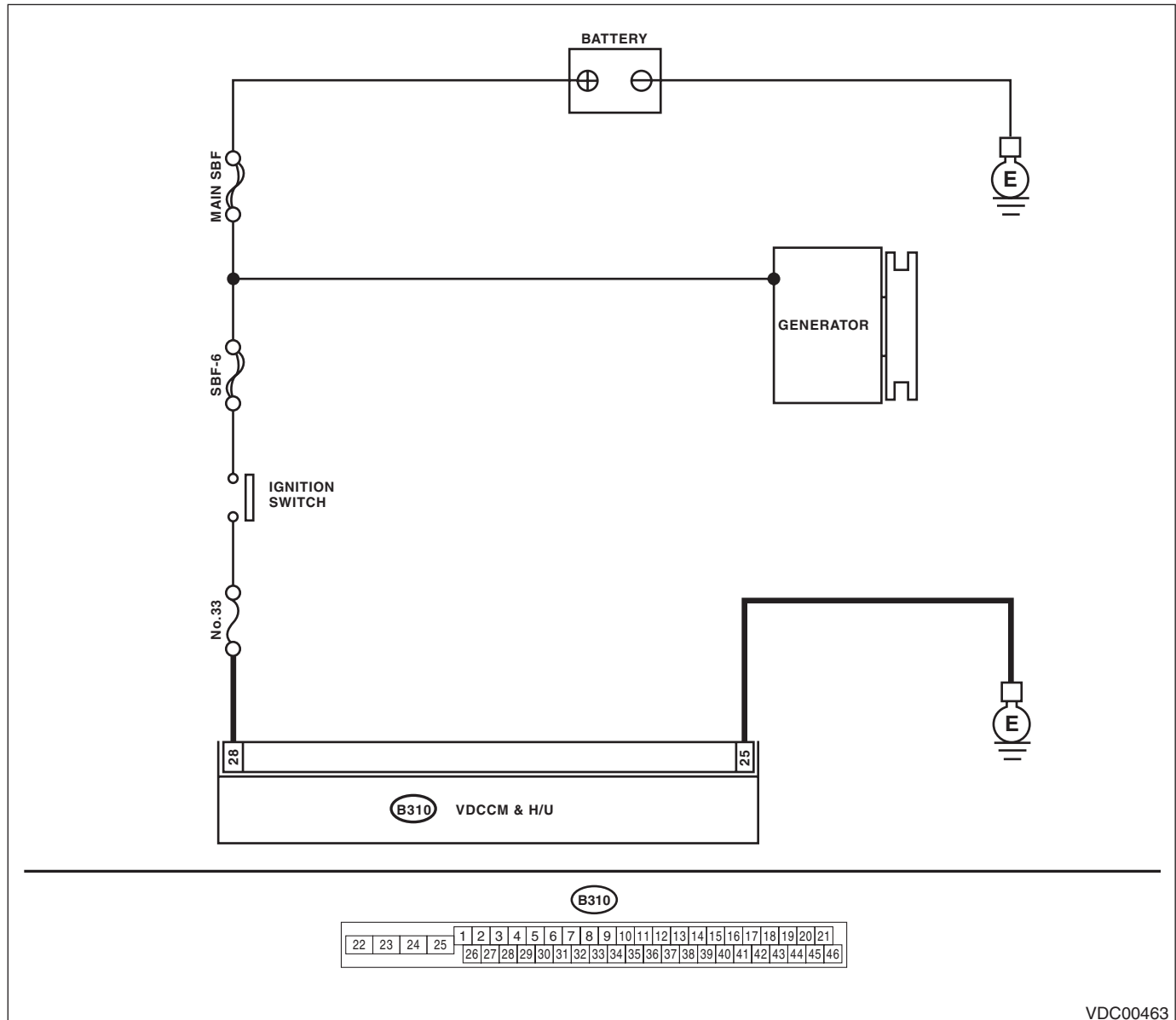

VDC00463

# Diagnostic Procedure with Diagnostic Trouble Code (DTC)

## VEHICLE DYNAMICS CONTROL (VDC) (DIAGNOSTICS)

Step	Check	Yes	No
<b>1 CHECK GENERATOR.</b> 1) Start the engine. 2) Run the engine at idle after warming up. 3) Measure the voltage between generator terminal B and chassis ground. <b>Terminals</b> <b>Generator terminal B (+) — Chassis ground (-):</b>	Is the voltage 10 — 15 V?	Go to step 2.	Repair the generator.
<b>2 CHECK BATTERY TERMINAL.</b> Turn the ignition switch to OFF.	Are the positive and negative battery terminals clamped tightly?	Go to step 3.	Tighten the terminal.
<b>3 CHECK VDCCM&amp;H/U INPUT VOLTAGE.</b> 1) Disconnect the connector from the VDCCM&H/U. 2) Run the engine at idle. 3) Operate devices such as headlights, air conditioner, defogger, etc. which produce an electrical load. 4) Measure the voltage between VDCCM&H/U connector and chassis ground. <b>Connector &amp; terminal</b> <b>(B310) No. 28 (+) — Chassis ground (-):</b>	Is the voltage 10 — 15 V?	Go to step 4.	Repair the power supply circuit.
<b>4 CHECK VDCCM&amp;H/U GROUND CIRCUIT.</b> 1) Turn the ignition switch to OFF. 2) Measure the resistance between VDCCM&H/U connector and chassis ground. <b>Connector &amp; terminal</b> <b>(B310) No. 25 — Chassis ground:</b>	Is the resistance less than 10 $\Omega$ ?	Go to step 5.	Repair the VDCCM&H/U ground harness.
<b>5 CHECK POOR CONTACT OF CONNECTORS.</b>	Is there poor contact of connector between generator, battery and VDCCM&H/U?	Repair the connector.	Go to step 6.
<b>6 CHECK VDCCM&amp;H/U.</b> 1) Connect all connectors. 2) Clear the memory. <Ref. to VDC(diag)-27, Clear Memory Mode.> 3) Perform the Inspection Mode. <Ref. to VDC(diag)-26, Inspection Mode.> 4) Read the DTC.	Is the same DTC displayed?	Replace the VDCCM only. <Ref. to VDC-12, REPLACEMENT, VDC Control Module and Hydraulic Control Unit (VDCCM&H/U).>	Go to step 7.
<b>7 CHECK OTHER DTC DETECTION.</b>	Is any other DTC displayed?	Perform the diagnosis according to DTC. <Ref. to VDC(diag)-48, List of Diagnostic Trouble Code (DTC).>	Temporary poor contact occurs.

# Diagnostic Procedure with Diagnostic Trouble Code (DTC)

VEHICLE DYNAMICS CONTROL (VDC) (DIAGNOSTICS)

## Z: DTC C0045 INCORRECT VDC CONTROL MODULE SPECIFICATIONS

### DTC DETECTING CONDITION:

Different control module specification

### TROUBLE SYMPTOM:

- ABS does not operate.
- VDC does not operate.

### NOTE:

When parameter selection for VDCCM is improper, this DTC may be memorized.

Step	Check	Yes	No
<b>1</b>	<b>CHECK VDCCM REPLACEMENT HISTORY.</b> Is there history of VDCCM replacement by itself?	Go to step 2.	Go to step 3.
<b>2</b>	<b>CHECK VDCCM IDENTIFICATION SYMBOL.</b> Check the identification symbol of the seal attached on the side of the VDCCM. 5MT: SM 6MT: SN	Go to step 4.	Replace the VDCCM only. <Ref. to VDC-12, REPLACEMENT, VDC Control Module and Hydraulic Control Unit (VDCCM&H/U).>
<b>3</b>	<b>CHECK VDCCM&amp;H/U IDENTIFICATION SYMBOL.</b> Check the identification symbol stamped on the upper part of the H/U. 5MT: SM 6MT: SN	Go to step 4.	Replace the VDCCM&H/U. <Ref. to VDC-8, VDC Control Module and Hydraulic Control Unit (VDCCM&H/U).>
<b>4</b>	<b>CHECK PARAMETER SELECTED IN VDCCM.</b> <Ref. to VDC(diag)-21, PARAMETER CHECK, OPERATION, Subaru Select Monitor.>	Go to step 5.	Select and register the correct parameter. <Ref. to VDC(diag)-20, PARAMETER SELECTION, OPERATION, Subaru Select Monitor.>
<b>5</b>	<b>CHECK ECM SPECIFICATION.</b> Check the ECM specification.	Go to step 6.	Replace the ECM. <Ref. to FU(STI)-59, Engine Control Module (ECM).> <Ref. to FU(w/o STI)-58, Engine Control Module (ECM).>
<b>6</b>	<b>CHECK VDCCM&amp;H/U.</b> 1) Connect all connectors. 2) Clear the memory. <Ref. to VDC(diag)-27, Clear Memory Mode.> 3) Perform the Inspection Mode. <Ref. to VDC(diag)-26, Inspection Mode.> 4) Read the DTC.	Replace the VDCCM only. <Ref. to VDC-12, REPLACEMENT, VDC Control Module and Hydraulic Control Unit (VDCCM&H/U).>	Go to step 7.
<b>7</b>	<b>CHECK OTHER DTC DETECTION.</b> Is any other DTC displayed?	Perform the diagnosis according to DTC. <Ref. to VDC(diag)-48, List of Diagnostic Trouble Code (DTC).>	It results from a temporary noise interference.

# Diagnostic Procedure with Diagnostic Trouble Code (DTC)

VEHICLE DYNAMICS CONTROL (VDC) (DIAGNOSTICS)

## AA:DTC C0047 CAN COMMUNICATION

### DTC DETECTING CONDITION:

CAN communication line circuit is open or shorted.

### TROUBLE SYMPTOM:

- ABS does not operate.
- VDC does not operate.

### WIRING DIAGRAM:

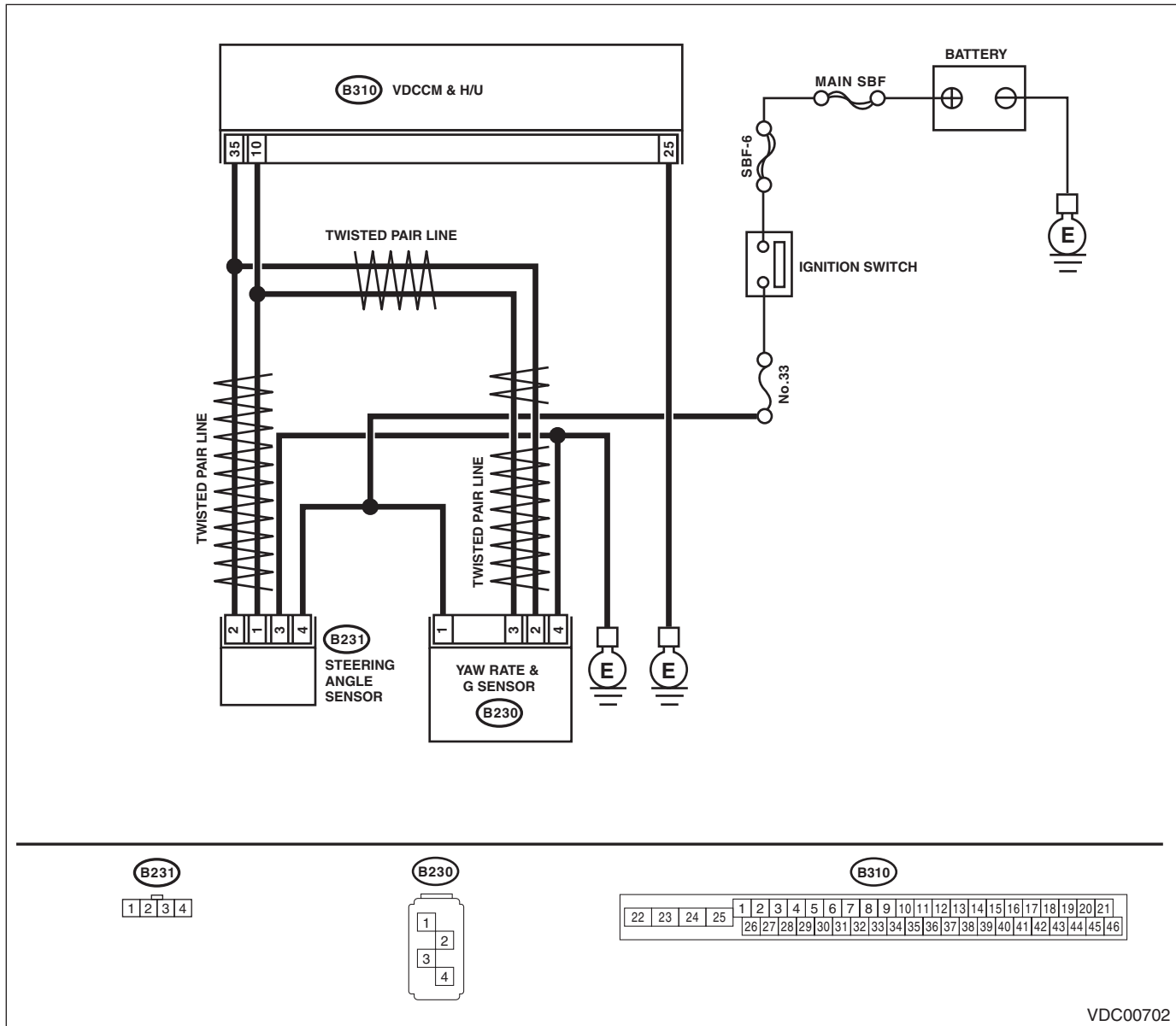

VDC00702

Step	Check	Yes	No	
1	<b>CHECK LAN SYSTEM.</b> Perform the diagnosis for LAN system. <Ref. to LAN(diag)-2, Basic Diagnostic Procedure.>	Is there any fault in LAN system?	Perform the diagnosis according to DTC for LAN system. <Ref. to LAN(diag)-33, List of Diagnostic Trouble Code (DTC).>	Go to step 2.
2	<b>CHECK POOR CONTACT OF CONNECTORS.</b>	Is there poor contact of VDCCM&H/U connector?	Repair the connector.	Go to step 3.

VDC(diag)-72

Brought to you by Ebay Seller "SubaruManuals"

# Diagnostic Procedure with Diagnostic Trouble Code (DTC)

VEHICLE DYNAMICS CONTROL (VDC) (DIAGNOSTICS)

Step	Check	Yes	No
<b>3 CHECK OUTPUT OF STEERING ANGLE SENSOR WITH SUBARU SELECT MONITOR.</b> 1) Select "Current Data Display & Save" on the Subaru Select Monitor. <Ref. to VDC(diag)-19, READ CURRENT DATA, OPERATION, Subaru Select Monitor.> 2) Check the steering angle sensor output.	Does the output signal change?	Go to step 4.	Check output of the steering angle sensor. <Ref. to VDC(diag)-95, DTC C0071 STEER ANGLE SENSOR OP, Diagnostic Procedure with Diagnostic Trouble Code (DTC).>
<b>4 CHECK OUTPUT OF YAW RATE &amp; G SENSOR WITH SUBARU SELECT MONITOR.</b> 1) Select "Current Data Display & Save" on the Subaru Select Monitor. <Ref. to VDC(diag)-19, READ CURRENT DATA, OPERATION, Subaru Select Monitor.> 2) Check the yaw rate & G sensor output.	Does the output signal change?	Go to step 5.	Check output of the yaw rate & G sensor. <Ref. to VDC(diag)-105, DTC C0072 YAW RATE SENSOR COMMUNICATION, Diagnostic Procedure with Diagnostic Trouble Code (DTC).>
<b>5 CHECK VDCCM&amp;H/U.</b> 1) Connect all connectors. 2) Clear the memory. <Ref. to VDC(diag)-27, Clear Memory Mode.> 3) Perform the Inspection Mode. <Ref. to VDC(diag)-26, Inspection Mode.> 4) Read the DTC.	Is the same DTC displayed?	Replace the VDCCM only. <Ref. to VDC-12, REPLACEMENT, VDC Control Module and Hydraulic Control Unit (VDCCM&H/U).>	Temporary poor contact occurs.

# Diagnostic Procedure with Diagnostic Trouble Code (DTC)

VEHICLE DYNAMICS CONTROL (VDC) (DIAGNOSTICS)

## AB:DTC C0051 VALVE RELAY

### DTC DETECTING CONDITION:

Defective valve relay

### TROUBLE SYMPTOM:

- ABS does not operate.
- EBD does not operate.
- VDC does not operate.

### WIRING DIAGRAM:

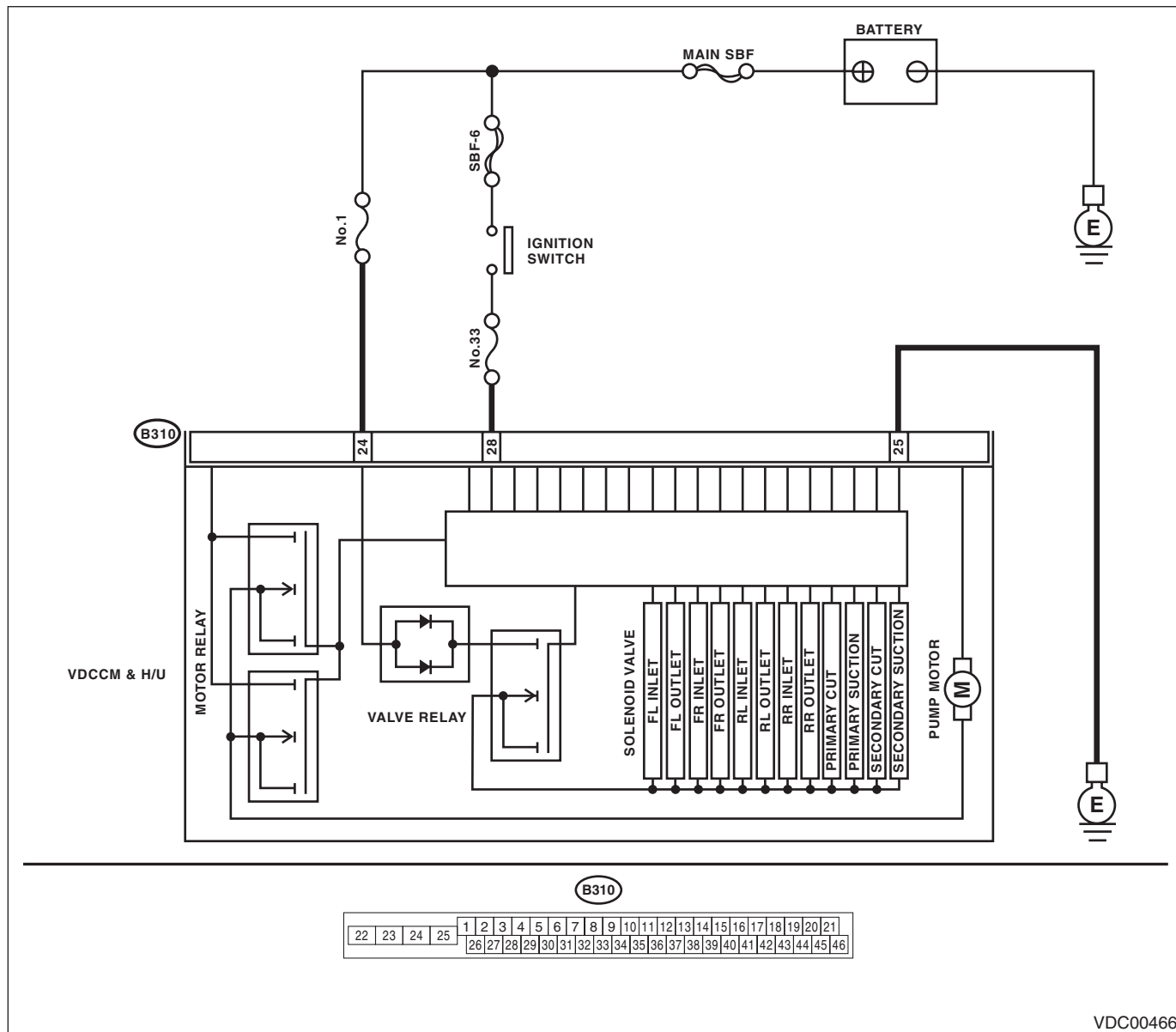

VDC00466

# Diagnostic Procedure with Diagnostic Trouble Code (DTC)

VEHICLE DYNAMICS CONTROL (VDC) (DIAGNOSTICS)

Step	Check	Yes	No
<b>1 CHECK VDCCM&amp;H/U INPUT VOLTAGE.</b> 1) Turn the ignition switch to OFF. 2) Disconnect the connector from the VDCCM&H/U. 3) Run the engine at idle. 4) Measure the voltage between VDCCM&H/U connector and chassis ground. <b>Connector &amp; terminal</b> <b>(B310) No. 28 (+) — Chassis ground (-):</b> <b>(B310) No. 24 (+) — Chassis ground (-):</b>	Is the voltage 10 — 15 V?	Go to step 2.	Repair the power supply circuit.
<b>2 CHECK VDCCM&amp;H/U INPUT VOLTAGE.</b> Calculate the voltage difference measured in step 1. A: (B310) No. 28 (+) — Chassis ground (-): B: (B310) No. 24 (+) — Chassis ground (-):	Is the voltage difference between A and B 2 V or more?	Repair the power supply circuit.	Go to step 3.
<b>3 CHECK VDCCM&amp;H/U GROUND CIRCUIT.</b> 1) Turn the ignition switch to OFF. 2) Measure the resistance between VDCCM&H/U connector and chassis ground. <b>Connector &amp; terminal</b> <b>(B310) No. 25 — Chassis ground:</b>	Is the resistance less than 10 $\Omega$ ?	Go to step 4.	Repair the VDCCM&H/U ground harness.
<b>4 CHECK VDCCM&amp;H/U VALVE RELAY.</b> Measure the resistance between VDCCM&H/U terminals. <b>Terminals</b> <b>No. 24 — No. 25:</b>	Is the resistance 1 M $\Omega$ or more?	Go to step 5.	Replace the VDCCM&H/U. <Ref. to VDC-8, VDC Control Module and Hydraulic Control Unit (VDCCM&H/U).>
<b>5 CHECK POOR CONTACT OF CONNECTORS.</b>	Is there poor contact of connector between generator, battery and VDCCM&H/U?	Repair the connector.	Go to step 6.
<b>6 CHECK VDCCM&amp;H/U.</b> 1) Connect all connectors. 2) Clear the memory. <Ref. to VDC(diag)-27, Clear Memory Mode.> 3) Perform the Inspection Mode. <Ref. to VDC(diag)-26, Inspection Mode.> 4) Read the DTC.	Is the same DTC displayed?	Replace the VDCCM only. <Ref. to VDC-12, REPLACEMENT, VDC Control Module and Hydraulic Control Unit (VDCCM&H/U).>	Go to step 7.
<b>7 CHECK OTHER DTC DETECTION.</b>	Is any other DTC displayed?	Perform the diagnosis according to DTC. <Ref. to VDC(diag)-48, List of Diagnostic Trouble Code (DTC).>	Temporary poor contact occurs.



# Diagnostic Procedure with Diagnostic Trouble Code (DTC)

VEHICLE DYNAMICS CONTROL (VDC) (DIAGNOSTICS)

## AC:DTC C0052 MOTOR AND MOTOR RELAY OFF FAILURE

### DTC DETECTING CONDITION:

- Defective motor and motor relay
- Defective harness connector

### TROUBLE SYMPTOM:

- ABS does not operate.
- VDC does not operate.
- EBD may not operate.

### WIRING DIAGRAM:

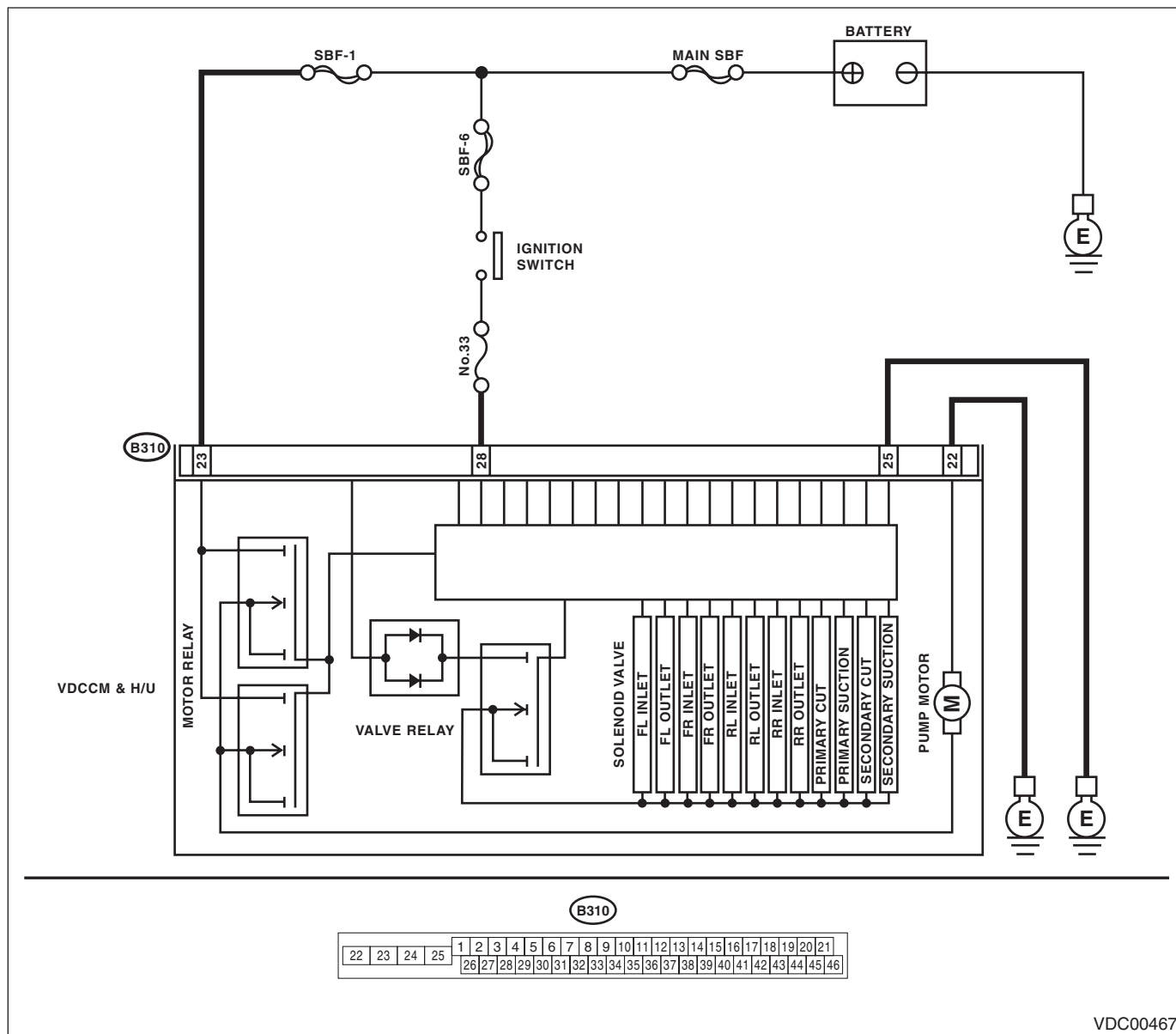

VDC00467

# Diagnostic Procedure with Diagnostic Trouble Code (DTC)

VEHICLE DYNAMICS CONTROL (VDC) (DIAGNOSTICS)

	Step	Check	Yes	No
1	<b>CHECK VDCCM&amp;H/U INPUT VOLTAGE.</b> 1) Turn the ignition switch to OFF. 2) Disconnect the connector from the VDCCM&H/U. 3) Turn the ignition switch to ON. 4) Measure the voltage between VDCCM&H/U connector and chassis ground. <b>Connector &amp; terminal</b> <b>(B310) No. 23 (+) — Chassis ground (-):</b> <b>(B310) No. 28 (+) — Chassis ground (-):</b>	Is the voltage 10 — 15 V?	Go to step 2.	Repair the VDCCM&H/U power supply circuit.
2	<b>CHECK INSTALLATION OF MOTOR GROUND.</b>	Is the motor ground terminal installation bolt tightened 33 N·m (3.4 kgf-m, 24.3 ft-lb)?	Go to step 3.	Tighten the motor ground terminal installation bolt.
3	<b>CHECK VDCCM&amp;H/U GROUND CIRCUIT.</b> 1) Turn the ignition switch to OFF. 2) Measure the resistance between VDCCM&H/U connector and chassis ground. <b>Connector &amp; terminal</b> <b>(B310) No. 25 — Chassis ground:</b> <b>(B310) No. 22 — Chassis ground:</b>	Is the resistance less than 10 Ω?	Go to step 4.	Repair the VDCCM&H/U ground harness.
4	<b>CHECK VDCCM&amp;H/U MOTOR RELAY.</b> Measure the resistance between VDCCM&H/U terminals. <b>Terminals</b> <b>No. 23 — No. 22:</b>	Is the resistance 1 MΩ or more?	Go to step 5.	Replace the VDCCM&H/U. <Ref. to VDC-8, VDC Control Module and Hydraulic Control Unit (VDCCM&H/U).>
5	<b>CHECK POOR CONTACT OF CONNECTORS.</b> Turn the ignition switch to OFF.	Is there poor contact of connector between generator, battery and VDCCM&H/U?	Repair the connector.	Go to step 6.
6	<b>CHECK VDCCM&amp;H/U.</b> 1) Connect all connectors. 2) Clear the memory. <Ref. to VDC(diag)-27, Clear Memory Mode.> 3) Perform the Inspection Mode. <Ref. to VDC(diag)-26, Inspection Mode.> 4) Read the DTC.	Is the same DTC displayed?	Replace the VDCCM&H/U. <Ref. to VDC-8, VDC Control Module and Hydraulic Control Unit (VDCCM&H/U).>	Go to step 7.
7	<b>CHECK OTHER DTC DETECTION.</b>	Is any other DTC displayed?	Perform the diagnosis according to DTC. <Ref. to VDC(diag)-48, List of Diagnostic Trouble Code (DTC).>	Temporary poor contact occurs. NOTE: Though the ABS warning light remains on at this time, this is normal. Drive the vehicle at 12 km/h (7 MPH) or more in order to turn ABS warning light off. Be sure to drive the vehicle and check that the warning light goes off.

# Diagnostic Procedure with Diagnostic Trouble Code (DTC)

VEHICLE DYNAMICS CONTROL (VDC) (DIAGNOSTICS)

## AD:DTC C0052 MOTOR AND MOTOR RELAY ON FAILURE

### DTC DETECTING CONDITION:

- Defective motor relay
- Defective harness connector

### TROUBLE SYMPTOM:

- ABS does not operate.
- VDC does not operate.
- EBD may not operate.

### WIRING DIAGRAM:

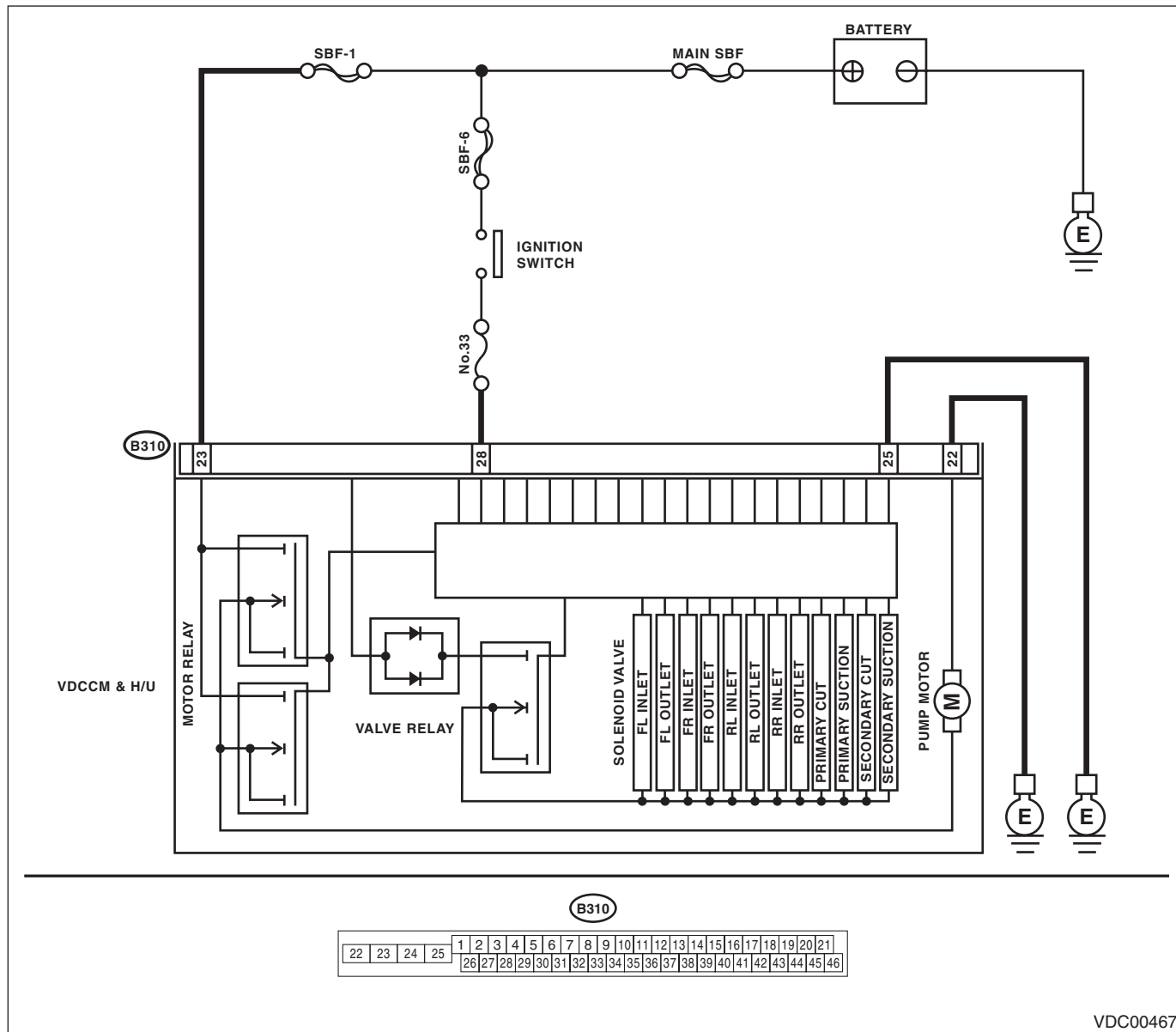

Step	Check	Yes	No
<b>1</b> <b>CHECK VDCCM&amp;H/U MOTOR RELAY.</b> 1) Turn the ignition switch to OFF. 2) Disconnect the connector from the VDCCM&H/U. 3) Measure the resistance between VDCCM&H/U terminals. <b>Terminals</b> <b>No. 23 — No. 22:</b>	Is the resistance 1 MΩ or more?	Go to step 2.	Replace the VDCCM&H/U. <Ref. to VDC-8, VDC Control Module and Hydraulic Control Unit (VDCCM&H/U).>

VDC(diag)-78

Brought to you by Ebay Seller "SubaruManuals"

# Diagnostic Procedure with Diagnostic Trouble Code (DTC)

VEHICLE DYNAMICS CONTROL (VDC) (DIAGNOSTICS)

Step	Check	Yes	No
<b>2</b> <b>CHECK VDCCM&amp;H/U.</b> 1) Connect all connectors. 2) Clear the memory. <Ref. to VDC(diag)-27, Clear Memory Mode.> 3) Perform the Inspection Mode. <Ref. to VDC(diag)-26, Inspection Mode.> 4) Read the DTC.	Is the same DTC displayed?	Replace the VDCCM only. <Ref. to VDC-12, REPLACEMENT, VDC Control Module and Hydraulic Control Unit (VDCCM&H/U).>	Go to step 3.
<b>3</b> <b>CHECK OTHER DTC DETECTION.</b>	Is any other DTC displayed?	Perform the diagnosis according to DTC. <Ref. to VDC(diag)-48, List of Diagnostic Trouble Code (DTC).>	Temporary poor contact occurs. NOTE: Though the ABS warning light remains on at this time, this is normal. Drive the vehicle at 12 km/h (7 MPH) or more in order to turn ABS warning light off. Be sure to drive the vehicle and check that the warning light goes off.

# Diagnostic Procedure with Diagnostic Trouble Code (DTC)

VEHICLE DYNAMICS CONTROL (VDC) (DIAGNOSTICS)

---

## **AE:DTC C0052 MOTOR MALFUNCTION**

### **DTC DETECTING CONDITION:**

- Defective motor
- Defective motor relay
- Defective harness connector

### **TROUBLE SYMPTOM:**

- ABS does not operate.
- VDC does not operate.
- EBD may not operate.

### **NOTE:**

For the diagnostic procedure, refer to "DTC C0052 MOTOR AND MOTOR RELAY OFF FAILURE". <Ref. to VDC(diag)-76, DTC C0052 MOTOR AND MOTOR RELAY OFF FAILURE, Diagnostic Procedure with Diagnostic Trouble Code (DTC).>

# Diagnostic Procedure with Diagnostic Trouble Code (DTC)

VEHICLE DYNAMICS CONTROL (VDC) (DIAGNOSTICS)

## AF:DTC C0054 BLS CIRCUIT OPEN

### DTC DETECTING CONDITION:

Defective stop light switch

### TROUBLE SYMPTOM:

- ABS does not operate.
- VDC does not operate.

### WIRING DIAGRAM:

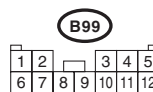
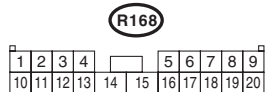
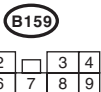
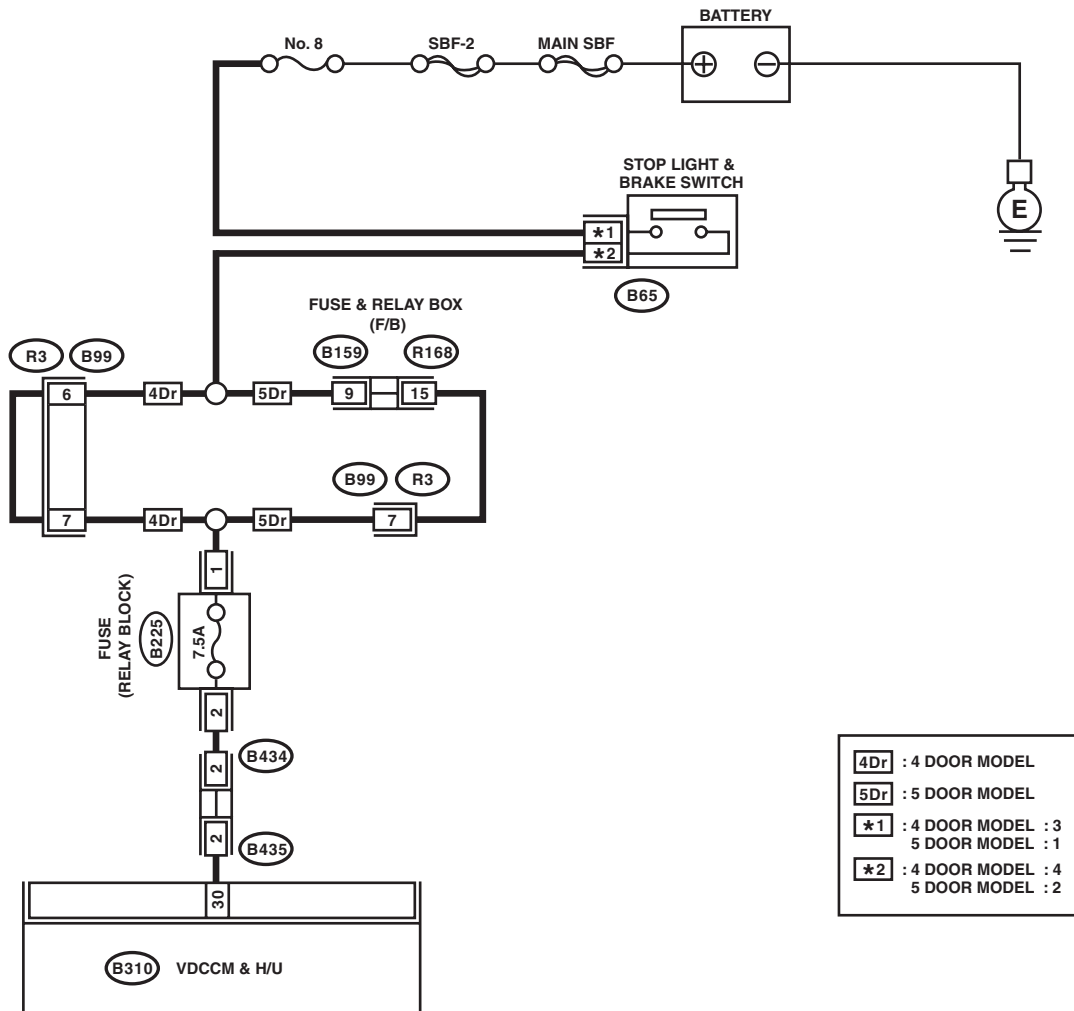

VDC00819

# Diagnostic Procedure with Diagnostic Trouble Code (DTC)

## VEHICLE DYNAMICS CONTROL (VDC) (DIAGNOSTICS)

Step	Check	Yes	No
<b>1 CHECK OUTPUT OF STOP LIGHT SWITCH WITH SUBARU SELECT MONITOR.</b> 1) Select "Current Data Display & Save" on the Subaru Select Monitor. <Ref. to VDC(diag)-19, READ CURRENT DATA, OPERATION, Subaru Select Monitor.> 2) Release the brake pedal. 3) Read the stop light switch output in Subaru Select Monitor.	Is "OFF" displayed on the screen?	Go to step 2.	Go to step 3.
<b>2 CHECK OUTPUT OF STOP LIGHT SWITCH WITH SUBARU SELECT MONITOR.</b> 1) Depress the brake pedal. 2) Read the stop light switch output in Subaru Select Monitor.	Is "ON" displayed on the screen?	Go to step 6.	Go to step 3.
<b>3 CHECK IF STOP LIGHTS ILLUMINATE.</b> Depress the brake pedal.	Does the stop light illuminate?	Go to step 4.	Repair the stop light circuit.
<b>4 CHECK FUSE.</b> Check the fuse (B225) in the relay block.	Is the fuse OK?	Go to step 5.	Replace the fuse.
<b>5 CHECK OPEN CIRCUIT OF HARNESS.</b> 1) Turn the ignition switch to OFF. 2) Disconnect the connector from the VDCCM&H/U. 3) Depress the brake pedal. 4) Measure the voltage between VDCCM&H/U connector and chassis ground. <b>Connector &amp; terminal</b> <b>(B310) No. 30 (+) — Chassis ground (-):</b>	Is the voltage 10 — 15 V?	Go to step 6.	Repair the harness between stop light switch and VDCCM&H/U connector.
<b>6 CHECK POOR CONTACT OF CONNECTORS.</b>	Is there poor contact of connector between stop light switch and VDCCM&H/U?	Repair the connector.	Go to step 7.
<b>7 CHECK VDCCM&amp;H/U.</b> 1) Connect all connectors. 2) Clear the memory. <Ref. to VDC(diag)-27, Clear Memory Mode.> 3) Perform the Inspection Mode. <Ref. to VDC(diag)-26, Inspection Mode.> 4) Read the DTC.	Is the same DTC displayed?	Replace the VDCCM only. <Ref. to VDC-12, REPLACEMENT, VDC Control Module and Hydraulic Control Unit (VDCCM&H/U).>	Go to step 8.
<b>8 CHECK OTHER DTC DETECTION.</b>	Is any other DTC displayed?	Perform the diagnosis according to DTC. <Ref. to VDC(diag)-48, List of Diagnostic Trouble Code (DTC).>	Temporary poor contact occurs.

# Diagnostic Procedure with Diagnostic Trouble Code (DTC)

VEHICLE DYNAMICS CONTROL (VDC) (DIAGNOSTICS)

## AG:DTC C0054 BLS ON MALFUNCTION

### DTC DETECTING CONDITION:

Defective stop light switch

### TROUBLE SYMPTOM:

- ABS does not operate.
- VDC does not operate.

### WIRING DIAGRAM:

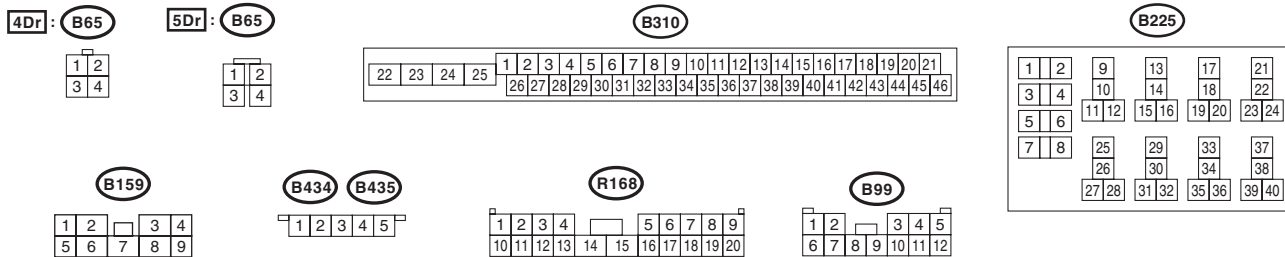
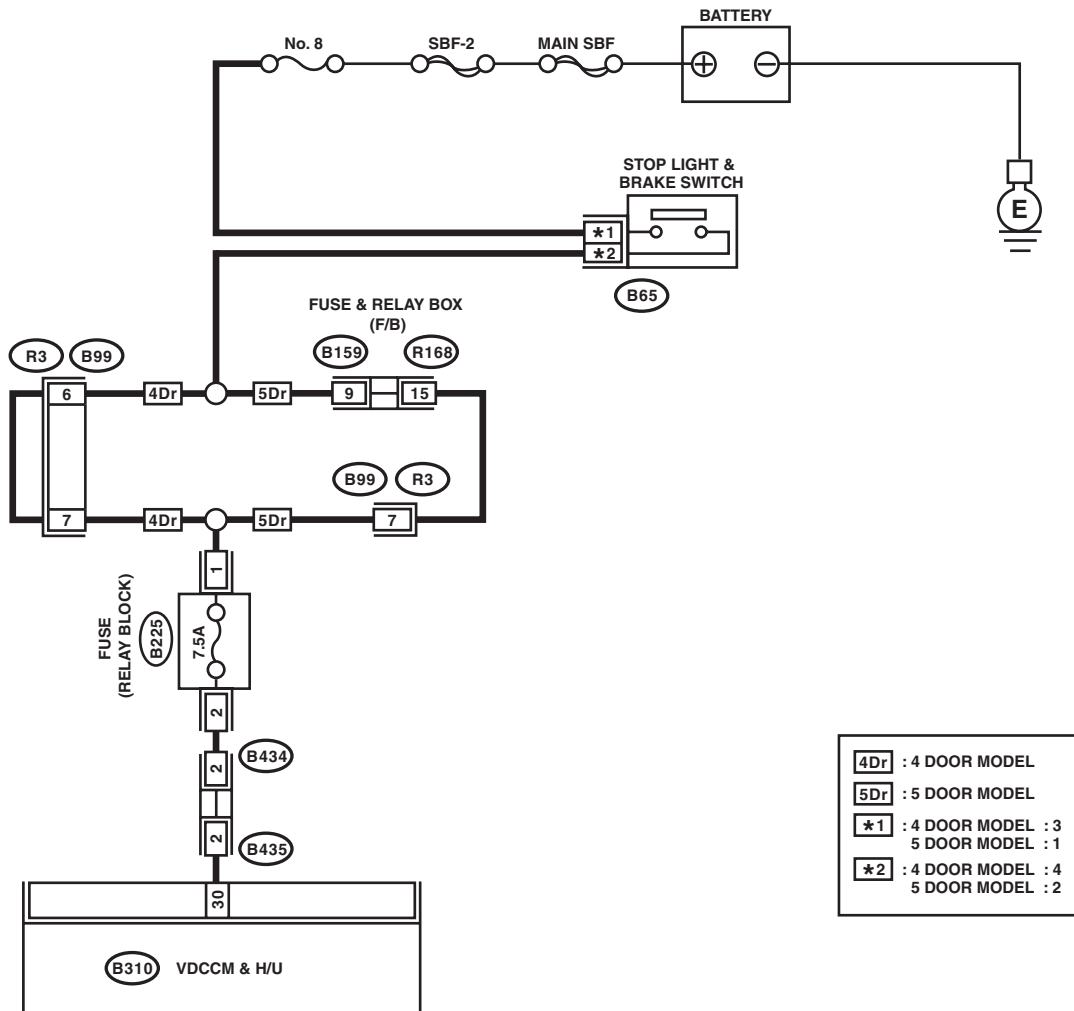

VDC00819



# Diagnostic Procedure with Diagnostic Trouble Code (DTC)

## VEHICLE DYNAMICS CONTROL (VDC) (DIAGNOSTICS)

	Step	Check	Yes	No
1	<b>CHECK STOP LIGHT SWITCH.</b> 1) Turn the ignition switch to OFF. 2) Disconnect the stop light switch connector. 3) Measure the resistance of stop light switch terminals. <b>Connector &amp; terminal</b> <b>4 door model</b> <b>(B65) No. 3 — No. 4:</b> <b>5 door model</b> <b>(B65) No. 1 — No. 2:</b>	Is the resistance 1 MΩ or more when switch is OFF (when pedal is not depressed)?	Go to step 2.	Replace the stop light switch. <Ref. to BR-46, Stop Light Switch.>
2	<b>INTERVIEW CUSTOMERS.</b> Make sure that the operation was performed in which accelerator pedal and brake pedal were depressed simultaneously (with depressing brake pedal with left foot).	Were the acceleration pedal and brake pedal depressed simultaneously?	System is normal. (DTC may be recorded while brake is applied during driving.)	Go to step 3.
3	<b>CHECK VDCCM&amp;H/U.</b> 1) Connect all connectors. 2) Clear the memory. <Ref. to VDC(diag)-27, Clear Memory Mode.> 3) Perform the Inspection Mode. <Ref. to VDC(diag)-26, Inspection Mode.> 4) Read the DTC.	Is the same DTC displayed?	Replace the VDCCM only. <Ref. to VDC-12, REPLACEMENT, VDC Control Module and Hydraulic Control Unit (VDCCM&H/U).>	Go to step 4.
4	<b>CHECK OTHER DTC DETECTION.</b>	Is any other DTC displayed?	Perform the diagnosis according to DTC. <Ref. to VDC(diag)-48, List of Diagnostic Trouble Code (DTC).>	Temporary poor contact occurs.

# Diagnostic Procedure with Diagnostic Trouble Code (DTC)

VEHICLE DYNAMICS CONTROL (VDC) (DIAGNOSTICS)

## AH:DTC C0054 BLS OFF MALFUNCTION

### DTC DETECTING CONDITION:

Defective stop light switch

### TROUBLE SYMPTOM:

- ABS does not operate.
- VDC does not operate.

### WIRING DIAGRAM:

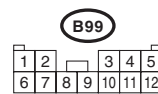
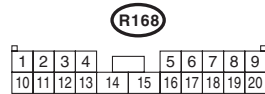
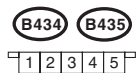
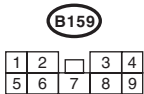
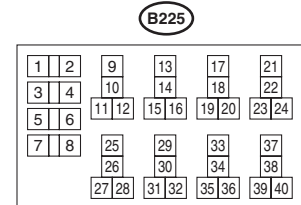
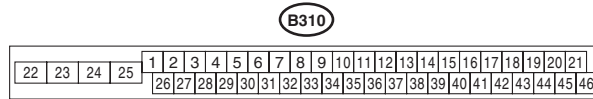
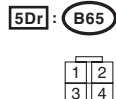
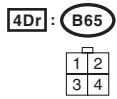
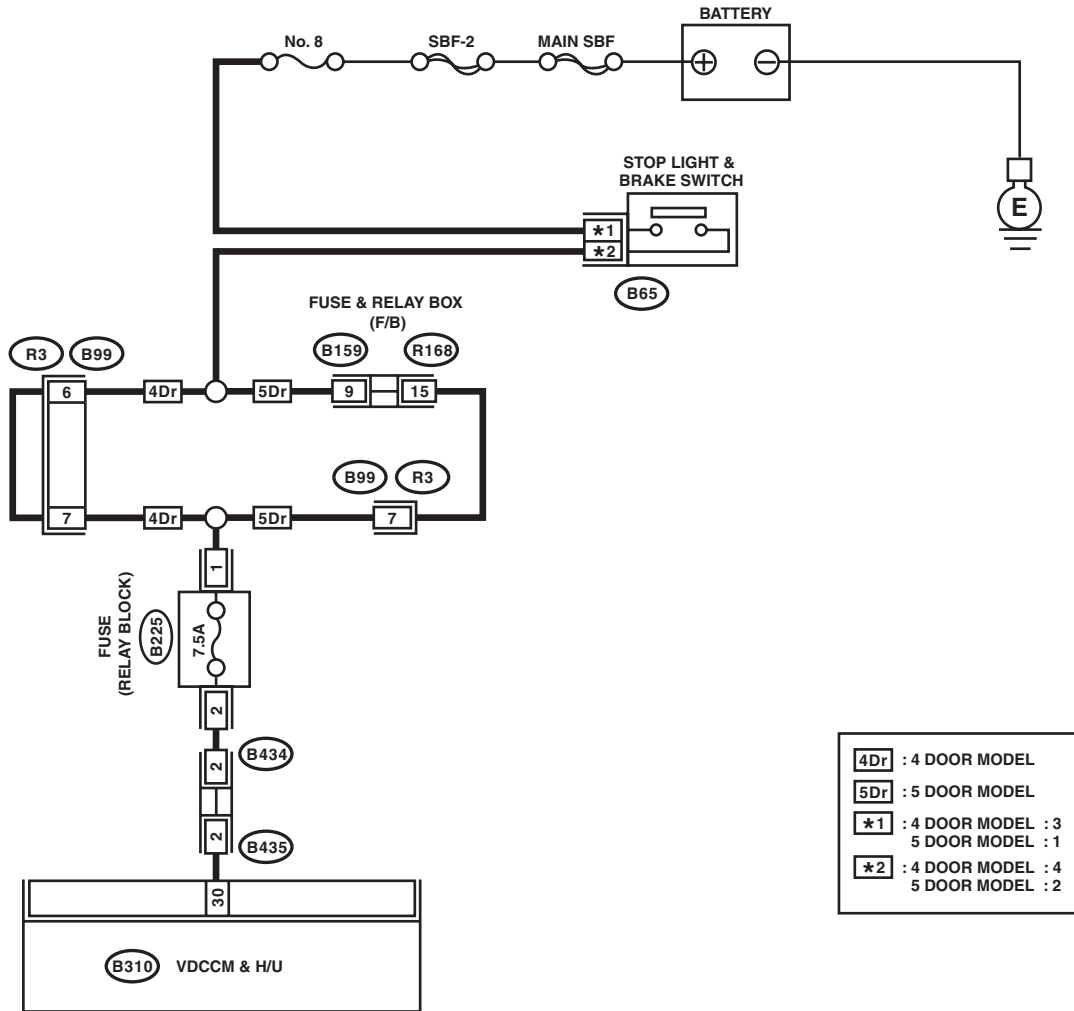

VDC00819

# Diagnostic Procedure with Diagnostic Trouble Code (DTC)

## VEHICLE DYNAMICS CONTROL (VDC) (DIAGNOSTICS)

	Step	Check	Yes	No
1	<b>CHECK STOP LIGHT SWITCH.</b> 1) Turn the ignition switch to OFF. 2) Disconnect the stop light switch connector. 3) Measure the resistance of stop light switch terminals. <b>Connector &amp; terminal</b> <b>4 door model</b> <b>(B65) No. 3 — No. 4:</b> <b>5 door model</b> <b>(B65) No. 1 — No. 2:</b>	Is the resistance 1 $\Omega$ or less when the switch is ON (when pedal is depressed)?	Go to step 2.	Replace the stop light switch. <Ref. to BR-46, Stop Light Switch.>
2	<b>CHECK STOP LIGHT POWER SUPPLY.</b> Measure the voltage between stop light switch terminal and chassis ground. <b>Connector &amp; terminal</b> <b>4 door model</b> <b>(B65) No. 3 (+) — Chassis ground (-):</b> <b>5 door model</b> <b>(B65) No. 1 (+) — Chassis ground (-):</b>	Is the voltage 10 — 15 V?	Go to step 3.	Repair the stop light power supply circuit.
3	<b>CHECK STOP LIGHT SWITCH HARNESS.</b> 1) Disconnect the connector from the VDCCM&H/U. 2) Measure the resistance between VDCCM&H/U and stop light switch. <b>Connector &amp; terminal</b> <b>4 door model</b> <b>(B65) No. 4 — (B310) No. 30:</b> <b>5 door model</b> <b>(B65) No. 2 — (B310) No. 30:</b>	Is the resistance less than 1 $\Omega$ ?	Go to step 4.	Repair the stop light switch circuit.
4	<b>CHECK POOR CONTACT OF CONNECTORS.</b>	Is there poor contact of connector between stop light switch and VDCCM&H/U?	Repair the connector.	Go to step 5.
5	<b>CHECK VDCCM&amp;H/U.</b> 1) Connect all connectors. 2) Clear the memory. <Ref. to VDC(diag)-27, Clear Memory Mode.> 3) Perform the Inspection Mode. <Ref. to VDC(diag)-26, Inspection Mode.> 4) Read the DTC.	Is the same DTC displayed?	Replace the VDCCM only. <Ref. to VDC-12, REPLACEMENT, VDC Control Module and Hydraulic Control Unit (VDCCM&H/U).>	Go to step 6.
6	<b>CHECK OTHER DTC DETECTION.</b>	Is any other DTC displayed?	Perform the diagnosis according to DTC. <Ref. to VDC(diag)-48, List of Diagnostic Trouble Code (DTC).>	Temporary poor contact occurs.

# Diagnostic Procedure with Diagnostic Trouble Code (DTC)

VEHICLE DYNAMICS CONTROL (VDC) (DIAGNOSTICS)

## AI: DTC C0056 G SENSOR SIGNAL

### DTC DETECTING CONDITION:

Defective longitudinal G sensor output signal

### TROUBLE SYMPTOM:

Hill start assist does not operate.

### WIRING DIAGRAM:

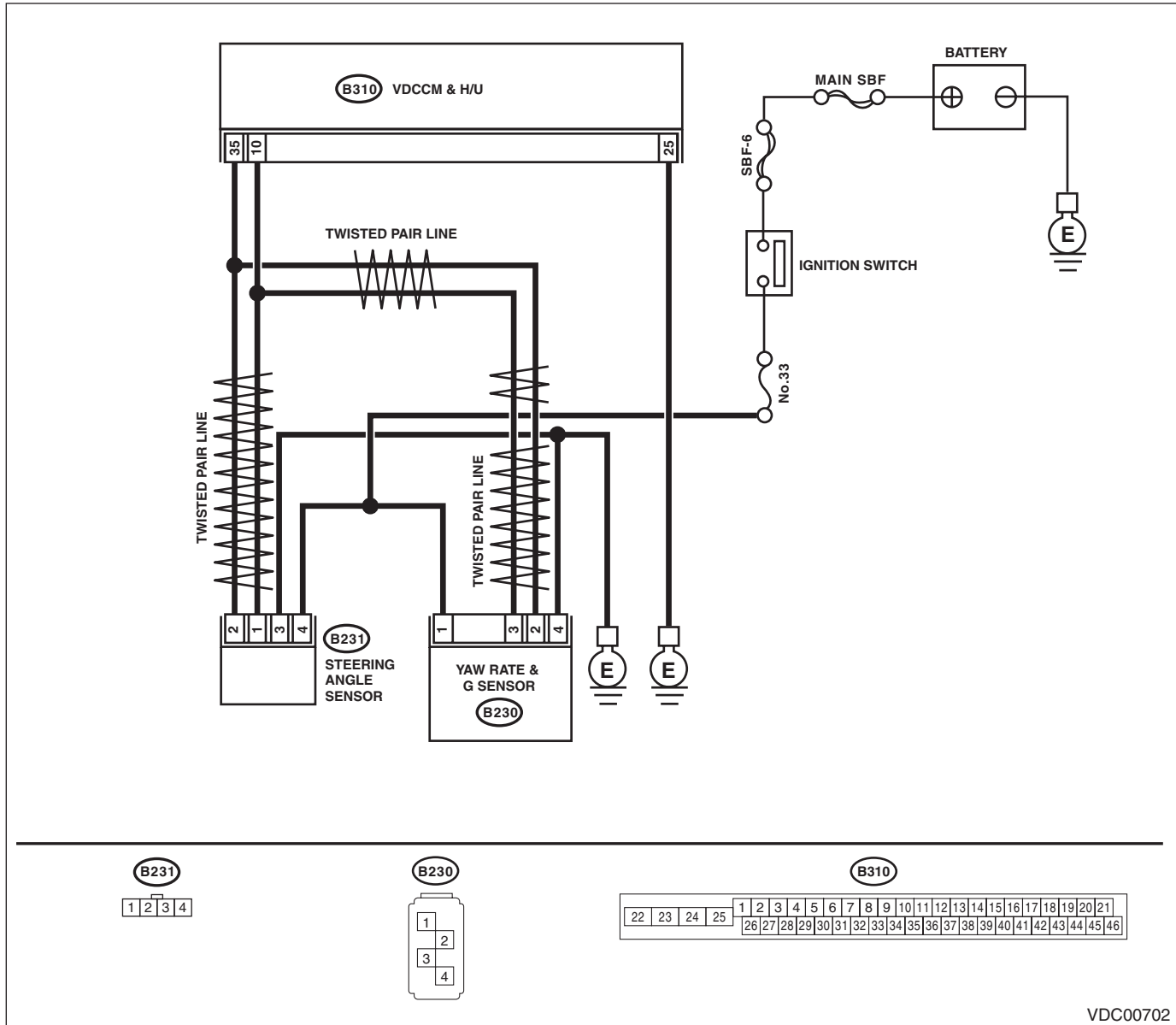

VDC00702

Step	Check	Yes	No
1	<p><b>WHETHER A WHEEL TURNED FREELY OR NOT.</b></p> <p>Check if the wheels have been turned freely for one minute or more, such as when the vehicle is jacked-up, under full-lock cornering or when the wheels are not in contact with road surface.</p>	<p>Did the wheels turn freely?</p> <p>VDC is normal. Clear the memory.</p>	<p>Go to step 2.</p>

# Diagnostic Procedure with Diagnostic Trouble Code (DTC)

## VEHICLE DYNAMICS CONTROL (VDC) (DIAGNOSTICS)

Step	Check	Yes	No
<b>2 CHECK OUTPUT OF LONGITUDINAL G SENSOR USING SUBARU SELECT MONITOR.</b> 1) Park the vehicle on a level surface. 2) Select {Current Data Display & Save} in Subaru Select Monitor. <Ref. to VDC(diag)-19, READ CURRENT DATA, OPERATION, Subaru Select Monitor.> 3) Read the indication of longitudinal G sensor output.	Is the indicated reading on the monitor display $-1.2 - 1.2$ m/s <sup>2</sup> ?	Go to step 3.	Replace the yaw rate & G sensor. <Ref. to VDC-20, Yaw Rate and G Sensor.>
<b>3 CHECK OUTPUT OF LONGITUDINAL G SENSOR USING SUBARU SELECT MONITOR.</b> 1) Turn the ignition switch to OFF. 2) Remove the yaw rate & G sensors from vehicle. <Ref. to VDC-20, Yaw Rate and G Sensor.> 3) Turn the ignition switch to ON, and select the {Current Data Display & Save} in Subaru Select Monitor. <Ref. to VDC(diag)-19, READ CURRENT DATA, OPERATION, Subaru Select Monitor.> 4) Read the indication of longitudinal G sensor output.	When the yaw rate & G sensor is inclined 90° to the front, is the indicated value $6.8 - 12.8$ m/s <sup>2</sup> ?	Go to step 4.	Replace the yaw rate & G sensor. <Ref. to VDC-20, Yaw Rate and G Sensor.>
<b>4 CHECK OUTPUT OF LONGITUDINAL G SENSOR USING SUBARU SELECT MONITOR.</b> Read the indication of longitudinal G sensor output.	When the yaw rate & G sensor is inclined 90° to the rear, is the indicated value $-6.8 - -12.8$ m/s <sup>2</sup> ?	Go to step 5.	Replace the yaw rate & G sensor. <Ref. to VDC-20, Yaw Rate and G Sensor.>
<b>5 CHECK POOR CONTACT OF CONNECTOR.</b> Turn the ignition switch to OFF.	Is there poor contact of connector between VDCCM&H/U and yaw rate & G sensor?	Repair the connector.	Go to step 6.
<b>6 CHECK VDCCM&amp;H/U.</b> 1) Connect all connectors. 2) Clear the memory. <Ref. to VDC(diag)-27, Clear Memory Mode.> 3) Perform the Inspection Mode. <Ref. to VDC(diag)-26, Inspection Mode.> 4) Read the DTC.	Is the same DTC displayed?	Replace the VDCCM only. <Ref. to VDC-12, REPLACEMENT, VDC Control Module and Hydraulic Control Unit (VDCCM&H/U).>	Go to step 7.
<b>7 CHECK OTHER DTC DETECTION.</b>	Is any other DTC displayed?	Perform the diagnosis according to DTC. <Ref. to VDC(diag)-48, List of Diagnostic Trouble Code (DTC).>	Temporary poor contact occurs.

# Diagnostic Procedure with Diagnostic Trouble Code (DTC)

VEHICLE DYNAMICS CONTROL (VDC) (DIAGNOSTICS)

## AJ:DTC C0057 ECM COMMUNICATION CIRCUIT

### DTC DETECTING CONDITION:

No CAN signal from ECM.

### TROUBLE SYMPTOM:

- ABS does not operate.
- VDC does not operate.

Step	Check	Yes	No	
1	<b>CHECK LAN SYSTEM.</b> Perform the diagnosis for LAN system. <Ref. to LAN(diag)-2, Basic Diagnostic Procedure.>	Is there any fault in LAN system?	Perform the diagnosis according to DTC for LAN system. <Ref. to LAN(diag)-33, List of Diagnostic Trouble Code (DTC).>	Go to step 2.
2	<b>CHECK POOR CONTACT OF CONNECTORS.</b>	Is there poor contact of ECM connector?	Repair the connector.	Go to step 3.
3	<b>CHECK ECM.</b> Refer to the basic diagnostic procedure for Engine (diagnostics).	Is ECM normal?	Go to step 4.	Replace the ECM.
4	<b>CHECK VDCCM&amp;H/U.</b> 1) Connect all connectors. 2) Clear the memory. <Ref. to VDC(diag)-27, Clear Memory Mode.> 3) Perform the Inspection Mode. <Ref. to VDC(diag)-26, Inspection Mode.> 4) Read the DTC.	Is the same DTC displayed?	Replace the VDCCM only. <Ref. to VDC-12, REPLACEMENT, VDC Control Module and Hydraulic Control Unit (VDCCM&H/U).>	Go to step 5.
5	<b>CHECK OTHER DTC DETECTION.</b>	Is any other DTC displayed?	Perform the diagnosis according to DTC. <Ref. to VDC(diag)-48, List of Diagnostic Trouble Code (DTC).>	It results from a temporary noise interference.

# Diagnostic Procedure with Diagnostic Trouble Code (DTC)

VEHICLE DYNAMICS CONTROL (VDC) (DIAGNOSTICS)

## AK:DTC C0057 ECM CONTROL SYSTEM

### DTC DETECTING CONDITION:

Cooperation control prohibition of ECM

### TROUBLE SYMPTOM:

- ABS does not operate.
- VDC does not operate.

### NOTE:

Warning lights go off if the cooperation control of ECM returns.

Step	Check	Yes	No	
1	<b>CHECK WARNING LIGHT.</b> Check whether the VDC warning light illuminates after driving for 1 minute or more at a speed of 10 km/h or more.	Does the VDC warning light illuminate?	Go to step 2.	VDC is normal. Perform the Clear Memory Mode. NOTE: DTC may be re-recorded if cranking is performed during driving.
2	<b>CHECK POOR CONTACT OF CONNECTORS.</b>	Is there poor contact of ECM connector?	Repair the connector.	Go to step 3.
3	<b>CHECK ECM.</b> Refer to the basic diagnostic procedure for Engine (diagnostics).	Is ECM normal?	Go to step 4.	Replace the ECM.
4	<b>CHECK VDCCM&amp;H/U.</b> 1) Connect all connectors. 2) Perform the Clear Memory Mode. <Ref. to VDC(diag)-27, Clear Memory Mode.> 3) Perform the Inspection Mode. <Ref. to VDC(diag)-26, Inspection Mode.> 4) Read the DTC.	Is the same DTC displayed?	Replace the VDCCM only. <Ref. to VDC-12, REPLACEMENT, VDC Control Module and Hydraulic Control Unit (VDCCM&H/U).>	Go to step 5.
5	<b>CHECK OTHER DTC DETECTION.</b>	Is any other DTC displayed?	Perform the diagnosis according to DTC. <Ref. to VDC(diag)-48, List of Diagnostic Trouble Code (DTC).>	It results from a temporary noise interference.

# Diagnostic Procedure with Diagnostic Trouble Code (DTC)

VEHICLE DYNAMICS CONTROL (VDC) (DIAGNOSTICS)

## AL:DTC C0071 STEERING ANGLE SENSOR OFFSET IS TOO BIG

### DTC DETECTING CONDITION:

Defective steering angle sensor

### TROUBLE SYMPTOM:

VDC does not operate.

### WIRING DIAGRAM:

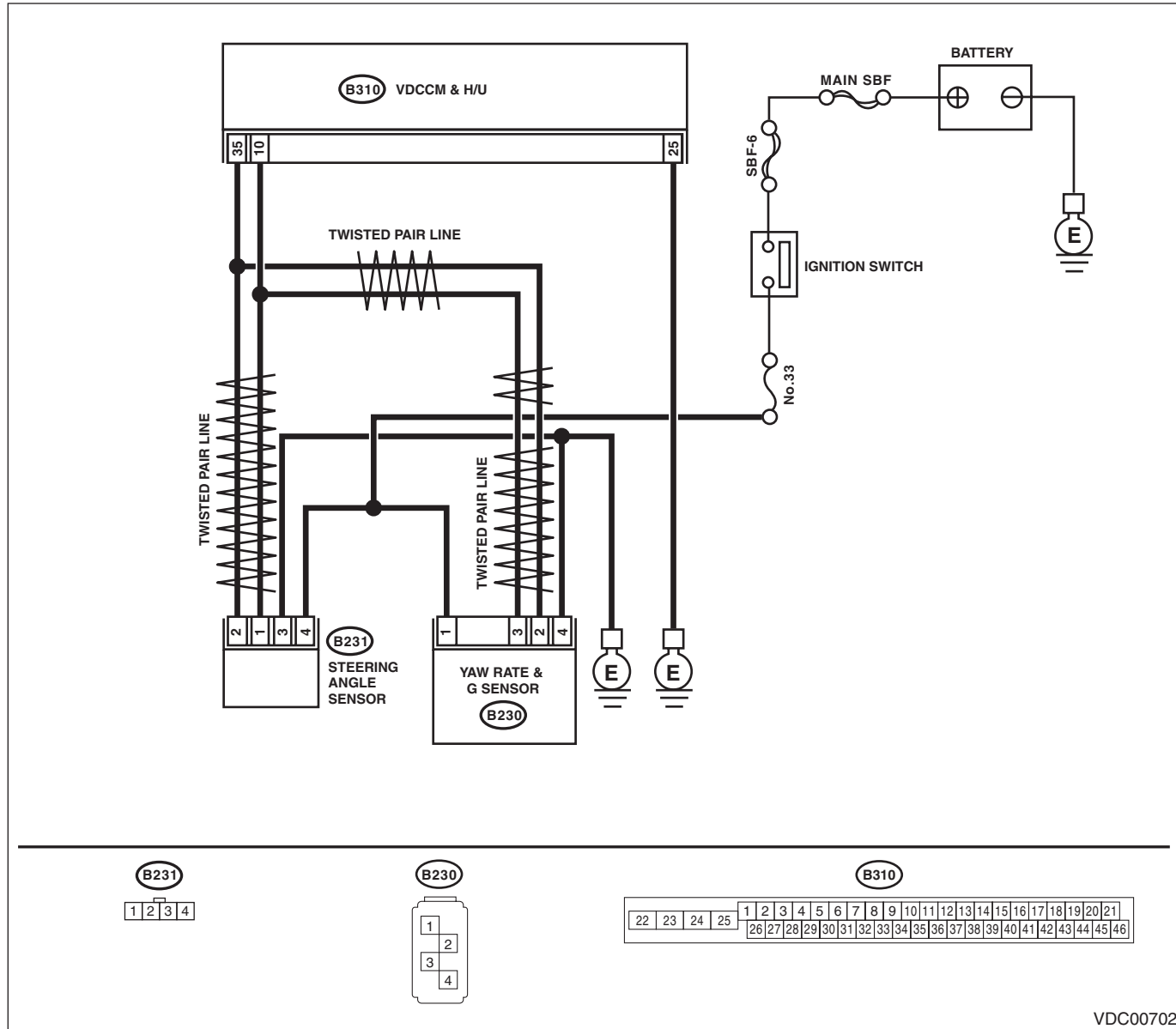

VDC00702

Step	Check	Yes	No
<b>1 CHECK STEERING WHEEL.</b> 1) Drive the vehicle on a flat road. 2) Park the vehicle straight. 3) Check the steering wheel for deviation from center.	Is the deviation from the center of steering wheel less than 5°?	Go to step 2.	Perform the centering adjustment of steering wheel.



# Diagnostic Procedure with Diagnostic Trouble Code (DTC)

## VEHICLE DYNAMICS CONTROL (VDC) (DIAGNOSTICS)

Step	Check	Yes	No
<b>2</b> <b>CHECK VDCCM&amp;H/U.</b> 1) Turn the ignition switch to OFF. 2) Connect all connectors. 3) Clear the memory. <Ref. to VDC(diag)-27, Clear Memory Mode.> 4) Perform the Inspection Mode. <Ref. to VDC(diag)-26, Inspection Mode.> 5) Read the DTC.	Is the same DTC displayed?	Replace the VDCCM only. <Ref. to VDC-12, REPLACEMENT, VDC Control Module and Hydraulic Control Unit (VDCCM&H/U).>	Go to step 3.
<b>3</b> <b>CHECK OTHER DTC DETECTION.</b>	Is any other DTC displayed?	Perform the diagnosis according to DTC. <Ref. to VDC(diag)-48, List of Diagnostic Trouble Code (DTC).>	Temporary poor contact occurs.

# Diagnostic Procedure with Diagnostic Trouble Code (DTC)

VEHICLE DYNAMICS CONTROL (VDC) (DIAGNOSTICS)

## AM:DTC C0071 CHANGE RANGE OF STEERING ANGLE SENSOR IS TOO BIG

### DTC DETECTING CONDITION:

Defective steering angle sensor

### TROUBLE SYMPTOM:

VDC does not operate.

### WIRING DIAGRAM:

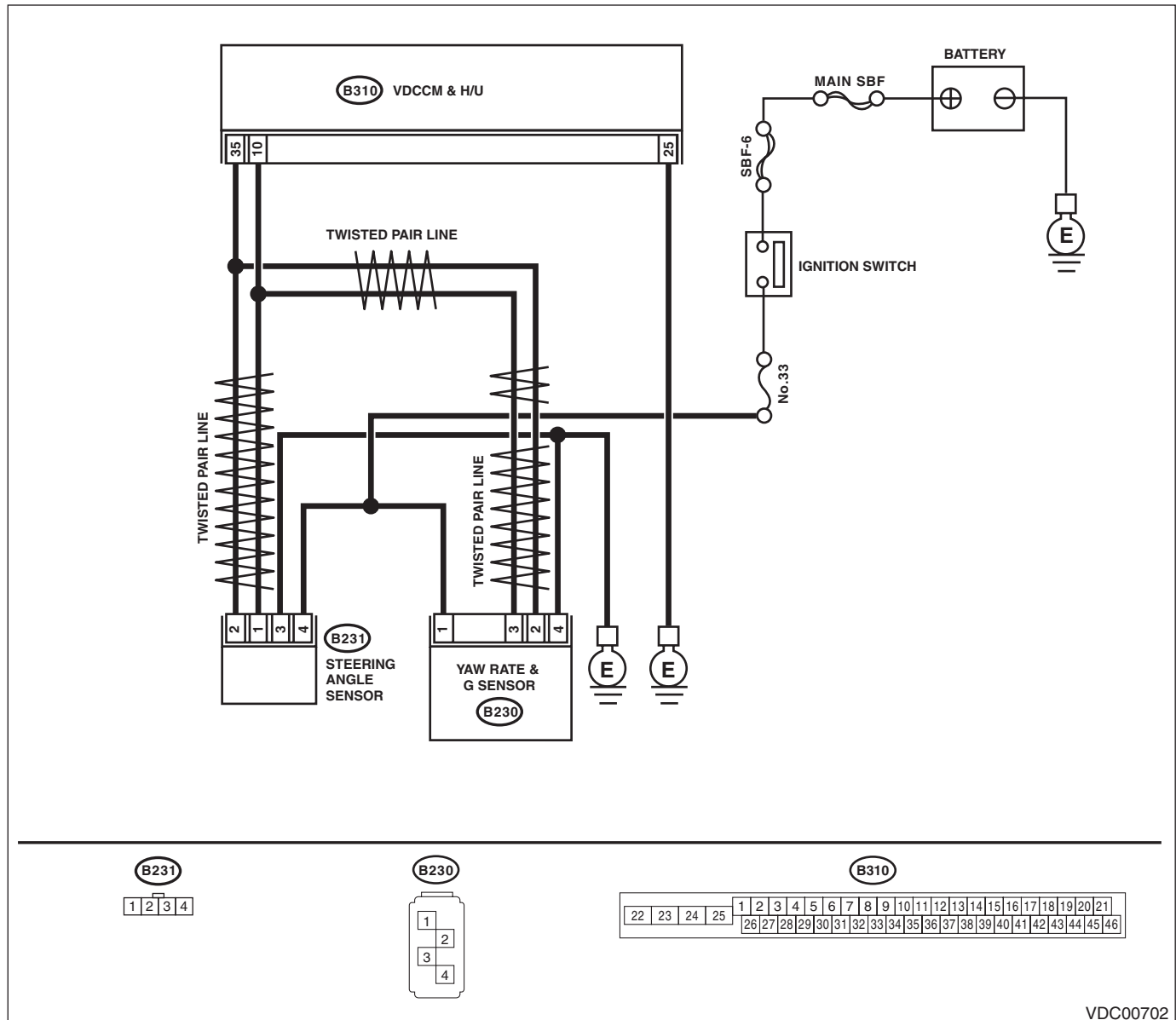

VDC00702

Step	Check	Yes	No
<b>1 CHECK VDCCM&amp;H/U.</b> 1) Turn the ignition switch to OFF. 2) Connect all connectors. 3) Clear the memory. <Ref. to VDC(diag)-27, Clear Memory Mode.> 4) Perform the Inspection Mode. <Ref. to VDC(diag)-26, Inspection Mode.> 5) Read the DTC.	Is the same DTC displayed?	Replace the VDCCM only. <Ref. to VDC-12, REPLACEMENT, VDC Control Module and Hydraulic Control Unit (VDCCM&H/U).>	Go to step 2.

# Diagnostic Procedure with Diagnostic Trouble Code (DTC)

VEHICLE DYNAMICS CONTROL (VDC) (DIAGNOSTICS)

Step	Check	Yes	No
<b>2</b> <b>CHECK OTHER DTC DETECTION.</b>	Is any other DTC displayed?	Perform the diagnosis according to DTC. <Ref. to VDC(diag)-48, List of Diagnostic Trouble Code (DTC).>	Temporary poor contact occurs.

# Diagnostic Procedure with Diagnostic Trouble Code (DTC)

VEHICLE DYNAMICS CONTROL (VDC) (DIAGNOSTICS)

## AN:DTC C0071 STEER ANGLE SENSOR OP

### DTC DETECTING CONDITION:

Signal does not come from steering angle sensor.

### TROUBLE SYMPTOM:

VDC does not operate.

### WIRING DIAGRAM:

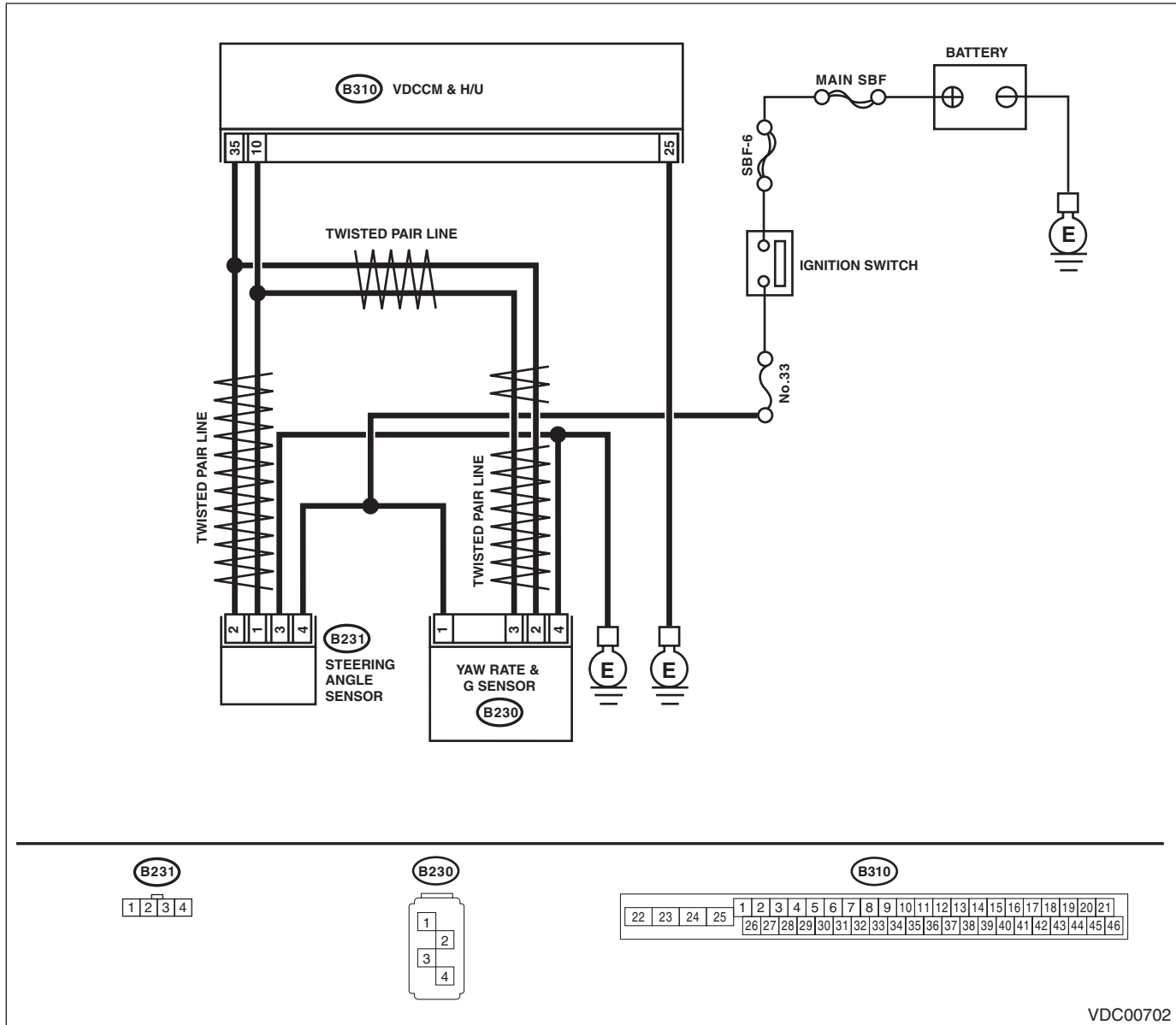

VDC00702

Step	Check	Yes	No
<b>1 CHECK POWER SUPPLY FOR STEERING ANGLE SENSOR.</b> 1) Turn the ignition switch to OFF. 2) Disconnect the connector from steering angle sensor. 3) Turn the ignition switch to ON. 4) Measure the voltage between steering angle sensor and chassis ground. <b>Connector &amp; terminal</b> <b>(B231) No. 4 (+) — Chassis ground (-):</b>	Is the voltage 10 — 15 V?	Go to step 2.	Repair the steering angle sensor power supply circuit.

# Diagnostic Procedure with Diagnostic Trouble Code (DTC)

## VEHICLE DYNAMICS CONTROL (VDC) (DIAGNOSTICS)

Step	Check	Yes	No
<b>2 CHECK GROUND CIRCUIT OF STEERING ANGLE SENSOR.</b> Measure the resistance between steering angle sensor and chassis ground. <i><b>Connector &amp; terminal</b></i> <i><b>(B231) No. 3 — Chassis ground:</b></i>	Is the resistance less than 10 $\Omega$ ?	Go to step 3.	Repair ground circuit in the steering angle sensor.
<b>3 CHECK STEERING ANGLE SENSOR HARNESS.</b> 1) Disconnect the connector from the VDCCM&H/U. 2) Measure the resistance between VDCCM&H/U and steering angle sensor. <i><b>Connector &amp; terminal</b></i> <i><b>(B231) No. 1 — (B310) No. 10:</b></i> <i><b>(B231) No. 2 — (B310) No. 35:</b></i>	Is the resistance less than 1 $\Omega$ ?	Go to step 4.	Repair the harness between the steering angle sensor and VDCCM&H/U.
<b>4 CHECK GROUND SHORT CIRCUIT OF STEERING ANGLE SENSOR HARNESS.</b> Measure the resistance between steering angle sensor and chassis ground. <i><b>Connector &amp; terminal</b></i> <i><b>(B231) No. 1 — Chassis ground:</b></i> <i><b>(B231) No. 2 — Chassis ground:</b></i>	Is the resistance 1 M $\Omega$ or more?	Go to step 5.	Repair the harness between the steering angle sensor and VDCCM&H/U.
<b>5 CHECK STEERING ANGLE SENSOR.</b> 1) Turn the ignition switch to OFF. 2) Connect all connectors. 3) Clear the memory. <Ref. to VDC(diag)-27, Clear Memory Mode.> 4) Perform the Inspection Mode. <Ref. to VDC(diag)-26, Inspection Mode.> 5) Read the DTC.	Is the same DTC displayed?	Go to step 6.	Go to step 7.
<b>6 CHECK VDCCM&amp;H/U.</b> 1) Turn the ignition switch to OFF. 2) Replace the steering angle sensor. <Ref. to VDC-22, Steering Angle Sensor.> 3) Clear the memory. <Ref. to VDC(diag)-27, Clear Memory Mode.> 4) Perform the Inspection Mode. <Ref. to VDC(diag)-26, Inspection Mode.> 5) Read the DTC.	Is the same DTC displayed?	Replace the VDCCM only. <Ref. to VDC-12, REPLACEMENT, VDC Control Module and Hydraulic Control Unit (VDCCM&H/U).>	Go to step 8.
<b>7 CHECK OTHER DTC DETECTION.</b>	Is any other DTC displayed?	Perform the diagnosis according to DTC. <Ref. to VDC(diag)-48, List of Diagnostic Trouble Code (DTC).>	Temporary poor contact occurs.
<b>8 CHECK OTHER DTC DETECTION.</b>	Is any other DTC displayed?	Perform the diagnosis according to DTC. <Ref. to VDC(diag)-48, List of Diagnostic Trouble Code (DTC).>	Original steering angle sensor malfunction

# Diagnostic Procedure with Diagnostic Trouble Code (DTC)

VEHICLE DYNAMICS CONTROL (VDC) (DIAGNOSTICS)

## AO:DTC C0071 STEERING ANGLE SENSOR MALFUNCTION

### DTC DETECTING CONDITION:

Defective steering angle sensor

### TROUBLE SYMPTOM:

- ABS does not operate.
- VDC does not operate.

### NOTE:

- Warning light does not illuminate though problem is detected.
- The ABS and VDC operate normally if voltage returns.

### WIRING DIAGRAM:

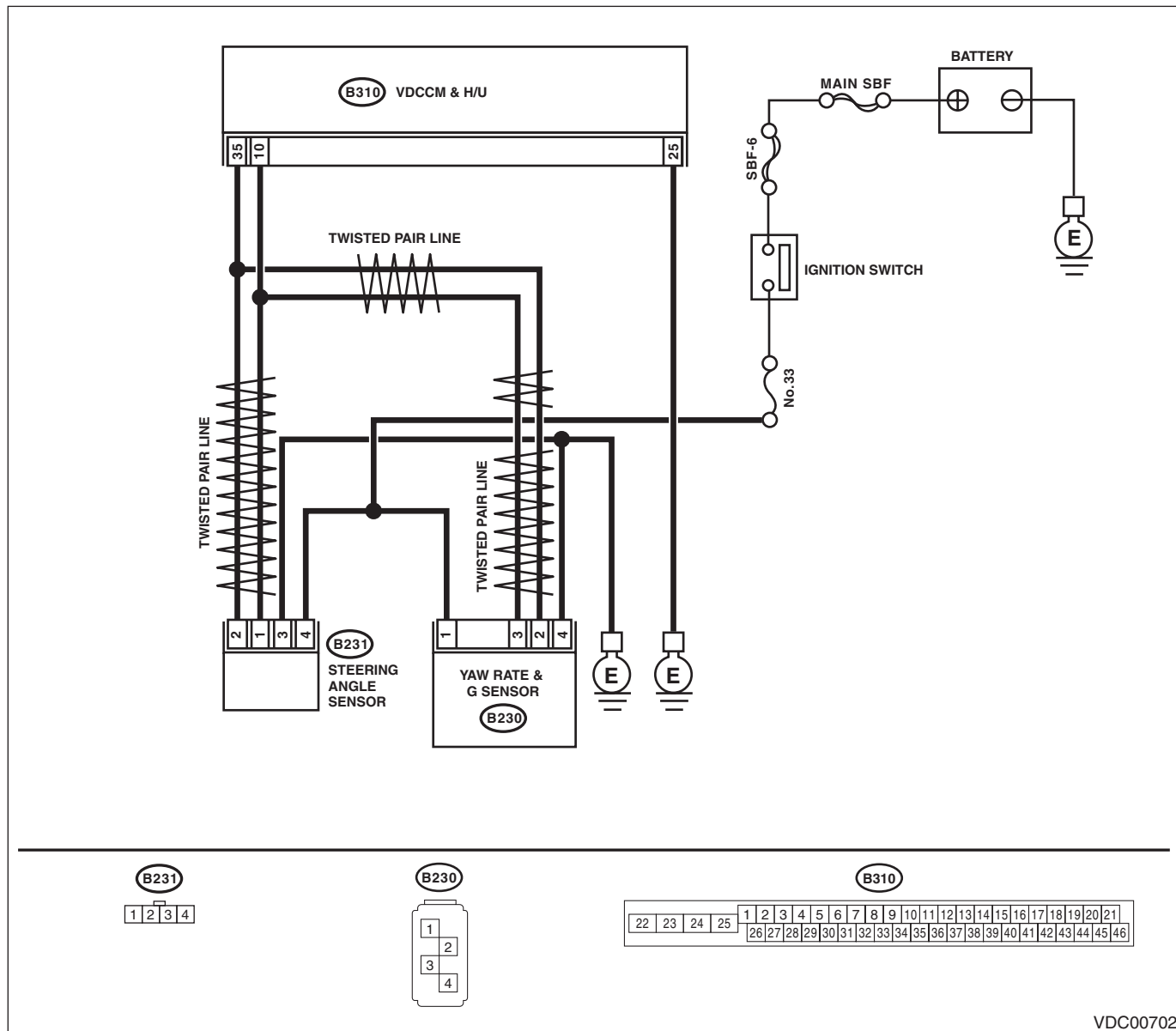

VDC00702

# Diagnostic Procedure with Diagnostic Trouble Code (DTC)

## VEHICLE DYNAMICS CONTROL (VDC) (DIAGNOSTICS)

Step	Check	Yes	No
<b>1 CHECK POWER SUPPLY FOR STEERING ANGLE SENSOR.</b> 1) Turn the ignition switch to OFF. 2) Disconnect the connector from steering angle sensor. 3) Turn the ignition switch to ON. 4) Measure the voltage between steering angle sensor and chassis ground. <b>Connector &amp; terminal</b> <b>(B231) No. 4 (+) — Chassis ground (-):</b>	Is the voltage 10 — 15 V?	Go to step 2.	Repair the steering angle sensor power supply circuit.
<b>2 CHECK GROUND CIRCUIT OF STEERING ANGLE SENSOR.</b> Measure the resistance between steering angle sensor and chassis ground. <b>Connector &amp; terminal</b> <b>(B231) No. 3 — Chassis ground:</b>	Is the resistance less than 10 $\Omega$ ?	Go to step 3.	Repair ground circuit in the steering angle sensor.
<b>3 CHECK STEERING ANGLE SENSOR.</b> 1) Turn the ignition switch to OFF. 2) Connect all connectors. 3) Clear the memory. <Ref. to VDC(diag)-27, Clear Memory Mode.> 4) Perform the Inspection Mode. <Ref. to VDC(diag)-26, Inspection Mode.> 5) Read the DTC.	Is the same DTC displayed?	Go to step 4.	Go to step 5.
<b>4 CHECK VDCCM&amp;H/U.</b> 1) Turn the ignition switch to OFF. 2) Replace the steering angle sensor. <Ref. to VDC-22, Steering Angle Sensor.> 3) Clear the memory. <Ref. to VDC(diag)-27, Clear Memory Mode.> 4) Perform the Inspection Mode. <Ref. to VDC(diag)-26, Inspection Mode.> 5) Read the DTC.	Is the same DTC displayed?	Replace the VDCCM only. <Ref. to VDC-12, REPLACEMENT, VDC Control Module and Hydraulic Control Unit (VDCCM&H/U).>	Go to step 6.
<b>5 CHECK OTHER DTC DETECTION.</b>	Is any other DTC displayed?	Perform the diagnosis according to DTC. <Ref. to VDC(diag)-48, List of Diagnostic Trouble Code (DTC).>	Temporary poor contact occurs.
<b>6 CHECK OTHER DTC DETECTION.</b>	Is any other DTC displayed?	Perform the diagnosis according to DTC. <Ref. to VDC(diag)-48, List of Diagnostic Trouble Code (DTC).>	Original steering angle sensor malfunction

# Diagnostic Procedure with Diagnostic Trouble Code (DTC)

VEHICLE DYNAMICS CONTROL (VDC) (DIAGNOSTICS)

## AP:DTC C0072 ABNORMAL YAW RATE SENSOR OUTPUT

### DTC DETECTING CONDITION:

Defective yaw rate sensor

### TROUBLE SYMPTOM:

VDC does not operate.

### WIRING DIAGRAM:

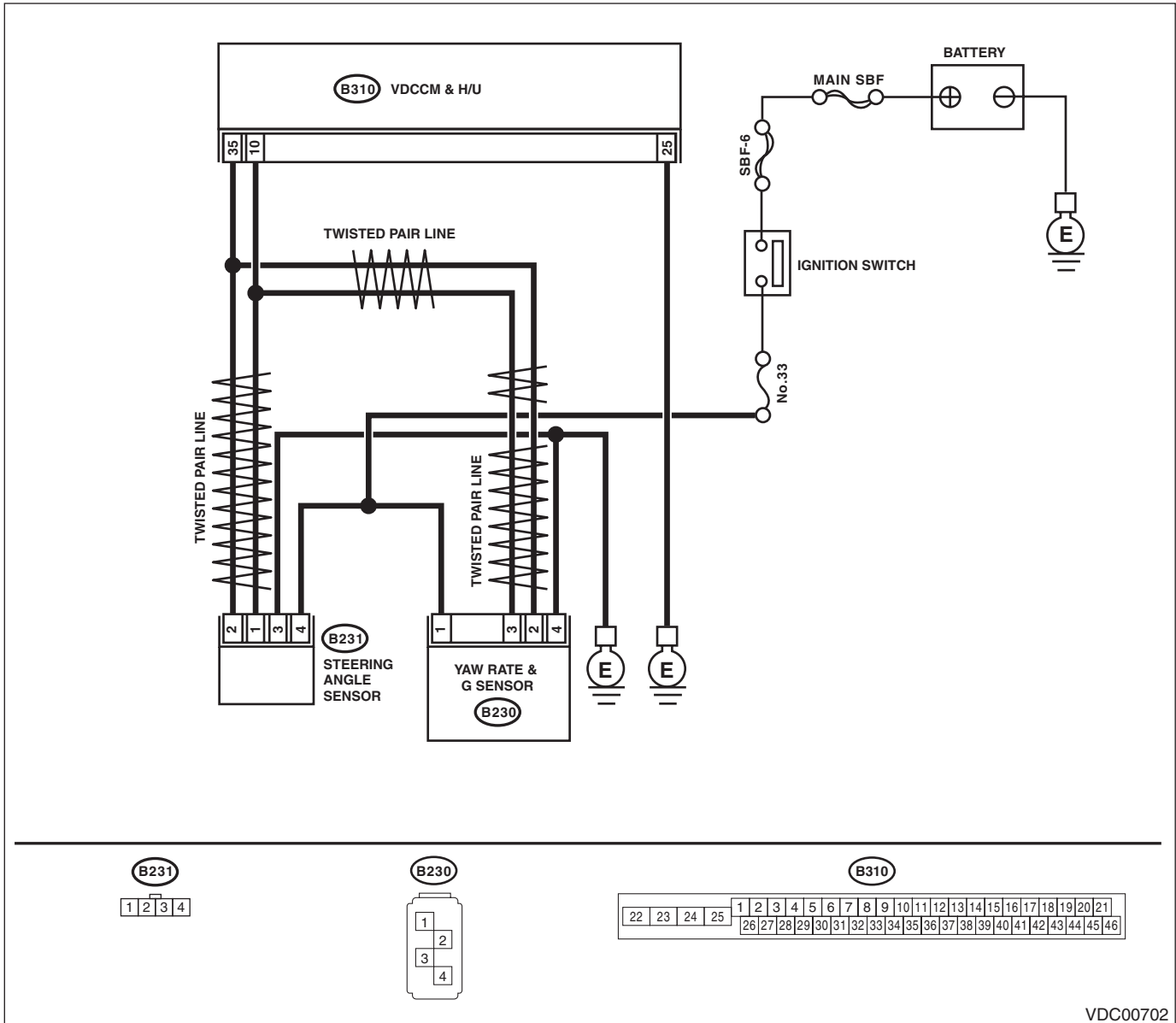

VDC00702

Step	Check	Yes	No	
1	<b>INTERVIEW CUSTOMERS.</b> Check if the vehicle ran the road with banks or sandy surface (which does not mean a dirt road).	Did the vehicle run the road with banks or sandy surface (which does not mean a dirt road)?	VDCCM&H/U may record DTC when the vehicle ran the road with banks or sandy surface (which does not mean a dirt road).	Go to step 2.
2	<b>CHECK YAW RATE &amp; G SENSOR INSTALLATION.</b>	Is the yaw rate & G sensor installation bolt tightened to 7.5 N·m (0.76 kgf-m, 5.5 ft-lb)?	Go to step 3.	Tighten the yaw rate & G sensor installation bolt.



# Diagnostic Procedure with Diagnostic Trouble Code (DTC)

## VEHICLE DYNAMICS CONTROL (VDC) (DIAGNOSTICS)

Step	Check	Yes	No
<b>3 CHECK OUTPUT OF YAW RATE &amp; G SENSOR WITH SUBARU SELECT MONITOR.</b> 1) Drive the vehicle on a flat road. 2) Park the vehicle straight. 3) Select {Current Data Display & Save} in Subaru Select Monitor. <Ref. to VDC(diag)-19, READ CURRENT DATA, OPERATION, Subaru Select Monitor.> 4) Read the yaw rate output displayed on display.	Is the reading indicated on monitor display -4 — 4 deg/s?	Go to step 4.	Replace the yaw rate & G sensor. <Ref. to VDC-20, Yaw Rate and G Sensor.>
<b>4 CHECK OUTPUT OF STEERING ANGLE SENSOR WITH SUBARU SELECT MONITOR.</b> 1) Drive the vehicle on a flat road. 2) Park the vehicle straight. 3) Select {Current Data Display & Save} in Subaru Select Monitor. <Ref. to VDC(diag)-19, READ CURRENT DATA, OPERATION, Subaru Select Monitor.> 4) Read the steering angle sensor output displayed on display.	Is the reading indicated on monitor display -5 — 5°?	Go to step 5.	Perform the centering adjustment of steering wheel.
<b>5 CHECK YAW RATE &amp; G SENSOR.</b> 1) Turn the ignition switch to OFF. 2) Connect all connectors. 3) Clear the memory. <Ref. to VDC(diag)-27, Clear Memory Mode.> 4) Perform the Inspection Mode. <Ref. to VDC(diag)-26, Inspection Mode.> 5) Read the DTC.	Is the same DTC displayed?	Go to step 6.	Go to step 7.
<b>6 CHECK VDCCM&amp;H/U.</b> 1) Turn the ignition switch to OFF. 2) Replace the yaw rate & G sensor. <Ref. to VDC-20, Yaw Rate and G Sensor.> 3) Clear the memory. <Ref. to VDC(diag)-27, Clear Memory Mode.> 4) Perform the Inspection Mode. <Ref. to VDC(diag)-26, Inspection Mode.> 5) Read the DTC.	Is the same DTC displayed?	Replace the VDCCM only. <Ref. to VDC-12, REPLACEMENT, VDC Control Module and Hydraulic Control Unit (VDCCM&H/U).>	Go to step 8.
<b>7 CHECK OTHER DTC DETECTION.</b>	Is any other DTC displayed?	Perform the diagnosis according to DTC. <Ref. to VDC(diag)-48, List of Diagnostic Trouble Code (DTC).>	Temporary poor contact occurs.
<b>8 CHECK OTHER DTC DETECTION.</b>	Is any other DTC displayed?	Perform the diagnosis according to DTC. <Ref. to VDC(diag)-48, List of Diagnostic Trouble Code (DTC).>	Malfunction is found in original yaw rate & G sensor.

# Diagnostic Procedure with Diagnostic Trouble Code (DTC)

VEHICLE DYNAMICS CONTROL (VDC) (DIAGNOSTICS)

## AQ:DTC C0072 VOLTAGE INPUTTED TO YAW RATE SENSOR EXCEEDS SPECIFICATION

### DTC DETECTING CONDITION:

Defective yaw rate sensor

### TROUBLE SYMPTOM:

VDC does not operate.

### WIRING DIAGRAM:

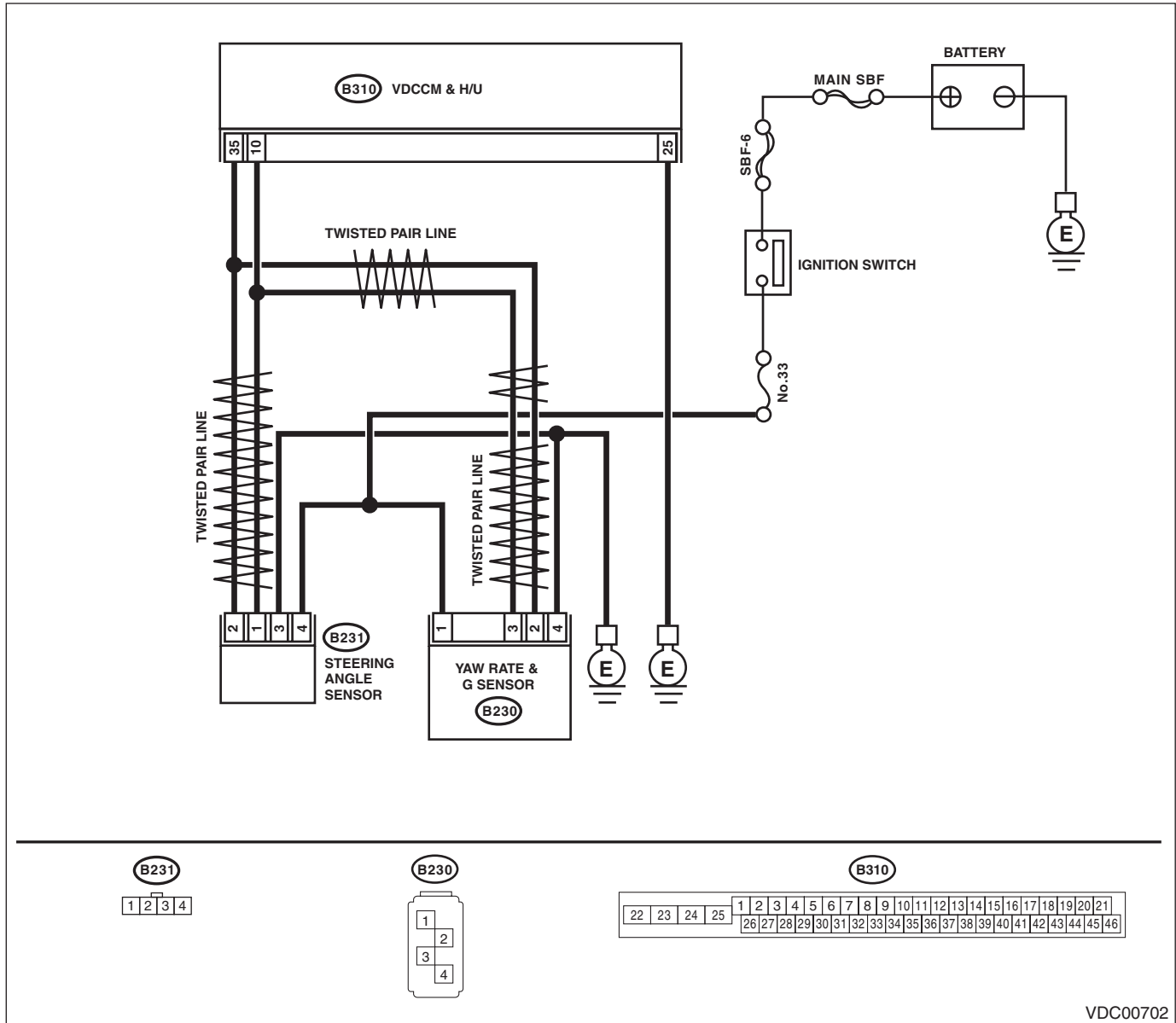

VDC00702

Step	Check	Yes	No
<b>1</b> <b>CHECK POWER SUPPLY OF YAW RATE &amp; G SENSOR.</b> 1) Turn the ignition switch to OFF. 2) Disconnect the connector from yaw rate & G sensor. 3) Turn the ignition switch to ON. 4) Measure the voltage between yaw rate & G sensor and chassis ground. <b>Connector &amp; terminal</b> <b>(B230) No. 1 (+) — Chassis ground (-):</b>	Is the voltage 10 — 15 V?	Go to step 2.	Repair the yaw rate & G sensor power supply circuit.

## Diagnostic Procedure with Diagnostic Trouble Code (DTC)

### VEHICLE DYNAMICS CONTROL (VDC) (DIAGNOSTICS)

Step	Check	Yes	No
<b>2 CHECK YAW RATE &amp; G SENSOR GROUND CIRCUIT.</b> Measure the resistance between yaw rate & G sensor and chassis ground. <b>Connector &amp; terminal</b> <b>(B230) No. 4 — Chassis ground:</b>	Is the resistance less than 10 $\Omega$ ?	Go to step 3.	Repair the yaw rate & G sensor ground circuit.
<b>3 CHECK YAW RATE &amp; G SENSOR.</b> 1) Turn the ignition switch to OFF. 2) Connect all connectors. 3) Clear the memory. <Ref. to VDC(diag)-27, Clear Memory Mode.> 4) Perform the Inspection Mode. <Ref. to VDC(diag)-26, Inspection Mode.> 5) Read the DTC.	Is the same DTC displayed?	Replace the yaw rate & G sensor. <Ref. to VDC-20, Yaw Rate and G Sensor.>	Go to step 4.
<b>4 CHECK OTHER DTC DETECTION.</b>	Is any other DTC displayed?	Perform the diagnosis according to DTC. <Ref. to VDC(diag)-48, List of Diagnostic Trouble Code (DTC).>	Temporary poor contact occurs.

# Diagnostic Procedure with Diagnostic Trouble Code (DTC)

VEHICLE DYNAMICS CONTROL (VDC) (DIAGNOSTICS)

## AR:DTC C0072 CHANGE RANGE OF YAW RATE SENSOR SIGNAL IS TOO BIG

### DTC DETECTING CONDITION:

Defective yaw rate sensor

### TROUBLE SYMPTOM:

VDC does not operate.

### WIRING DIAGRAM:

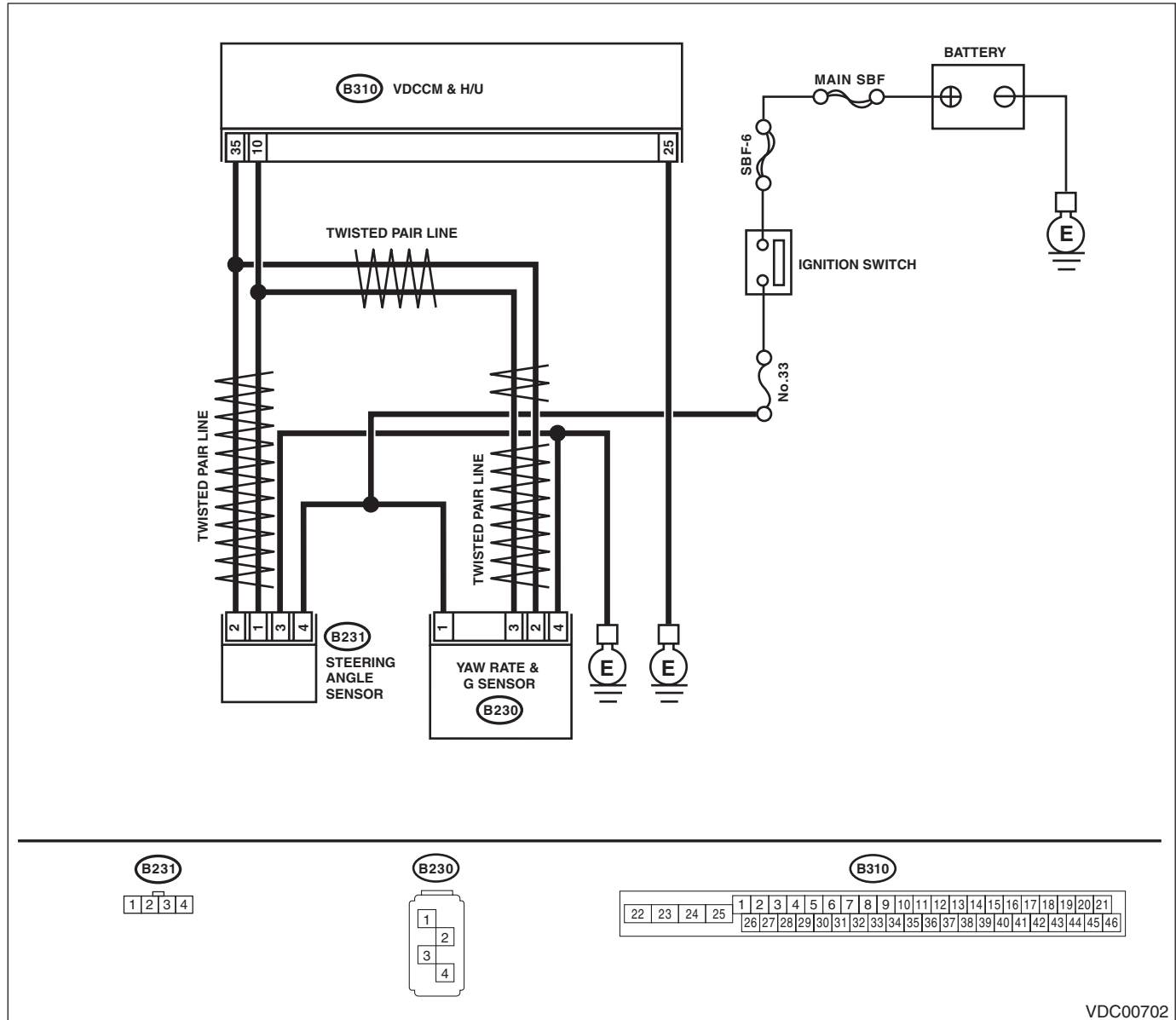

VDC00702

Step	Check	Yes	No	
1	<b>INTERVIEW CUSTOMERS.</b> Check if the vehicle ran the road with banks or sandy surface (which does not mean a dirt road).	Did the vehicle run the road with banks or sandy surface (which does not mean a dirt road)?	VDCCM&H/U may record DTC when the vehicle ran the road with banks or sandy surface (which does not mean a dirt road).	Go to step 2.
2	<b>CHECK YAW RATE &amp; G SENSOR INSTALLATION.</b>	Is the yaw rate & G sensor installation bolt tightened to 7.5 N·m (0.76 kgf-m, 5.5 ft-lb)?	Go to step 3.	Tighten the yaw rate & G sensor installation bolt.

# Diagnostic Procedure with Diagnostic Trouble Code (DTC)

## VEHICLE DYNAMICS CONTROL (VDC) (DIAGNOSTICS)

Step	Check	Yes	No
<b>3 CHECK POWER SUPPLY OF YAW RATE &amp; G SENSOR.</b> 1) Turn the ignition switch to OFF. 2) Disconnect the connector from yaw rate & G sensor. 3) Turn the ignition switch to ON. 4) Measure the voltage between yaw rate & G sensor and chassis ground. <i><b>Connector &amp; terminal</b></i> <i><b>(B230) No. 1 (+) — Chassis ground (-):</b></i>	Is the voltage 10 — 15 V?	Go to step 4.	Repair the yaw rate & G sensor power supply circuit.
<b>4 CHECK YAW RATE &amp; G SENSOR GROUND CIRCUIT.</b> Measure the resistance between yaw rate & G sensor and chassis ground. <i><b>Connector &amp; terminal</b></i> <i><b>(B230) No. 4 — Chassis ground:</b></i>	Is the resistance less than 10 $\Omega$ ?	Go to step 5.	Repair the yaw rate & G sensor ground circuit.
<b>5 CHECK OUTPUT OF YAW RATE &amp; G SENSOR WITH SUBARU SELECT MONITOR.</b> 1) Drive the vehicle on a flat road. 2) Park the vehicle straight. 3) Select {Current Data Display & Save} in Subaru Select Monitor. <Ref. to VDC(diag)-19, READ CURRENT DATA, OPERATION, Subaru Select Monitor.> 4) Read the yaw rate output displayed on display.	Is the reading indicated on monitor display -4 — 4 deg/s?	Go to step 6.	Replace the yaw rate & G sensor. <Ref. to VDC-20, Yaw Rate and G Sensor.>
<b>6 CHECK YAW RATE &amp; G SENSOR.</b> 1) Turn the ignition switch to OFF. 2) Connect all connectors. 3) Clear the memory. <Ref. to VDC(diag)-27, Clear Memory Mode.> 4) Perform the Inspection Mode. <Ref. to VDC(diag)-26, Inspection Mode.> 5) Read the DTC.	Is the same DTC displayed?	Go to step 7.	Go to step 8.
<b>7 CHECK VDCCM&amp;H/U.</b> 1) Turn the ignition switch to OFF. 2) Replace the yaw rate & G sensor. <Ref. to VDC-20, Yaw Rate and G Sensor.> 3) Clear the memory. <Ref. to VDC(diag)-27, Clear Memory Mode.> 4) Perform the Inspection Mode. <Ref. to VDC(diag)-26, Inspection Mode.> 5) Read the DTC.	Is the same DTC displayed?	Replace the VDCCM only. <Ref. to VDC-12, REPLACEMENT, VDC Control Module and Hydraulic Control Unit (VDCCM&H/U).>	Go to step 9.
<b>8 CHECK OTHER DTC DETECTION.</b>	Is any other DTC displayed?	Perform the diagnosis according to DTC. <Ref. to VDC(diag)-48, List of Diagnostic Trouble Code (DTC).>	Temporary poor contact occurs.
<b>9 CHECK OTHER DTC DETECTION.</b>	Is any other DTC displayed?	Perform the diagnosis according to DTC. <Ref. to VDC(diag)-48, List of Diagnostic Trouble Code (DTC).>	Malfunction is found in original yaw rate & G sensor.

# Diagnostic Procedure with Diagnostic Trouble Code (DTC)

VEHICLE DYNAMICS CONTROL (VDC) (DIAGNOSTICS)

## AS:DTC C0072 YAW RATE SENSOR COMMUNICATION

### DTC DETECTING CONDITION:

Communication failure between yaw rate sensor and VDCCM

### TROUBLE SYMPTOM:

- ABS does not operate.
- VDC does not operate.

### WIRING DIAGRAM:

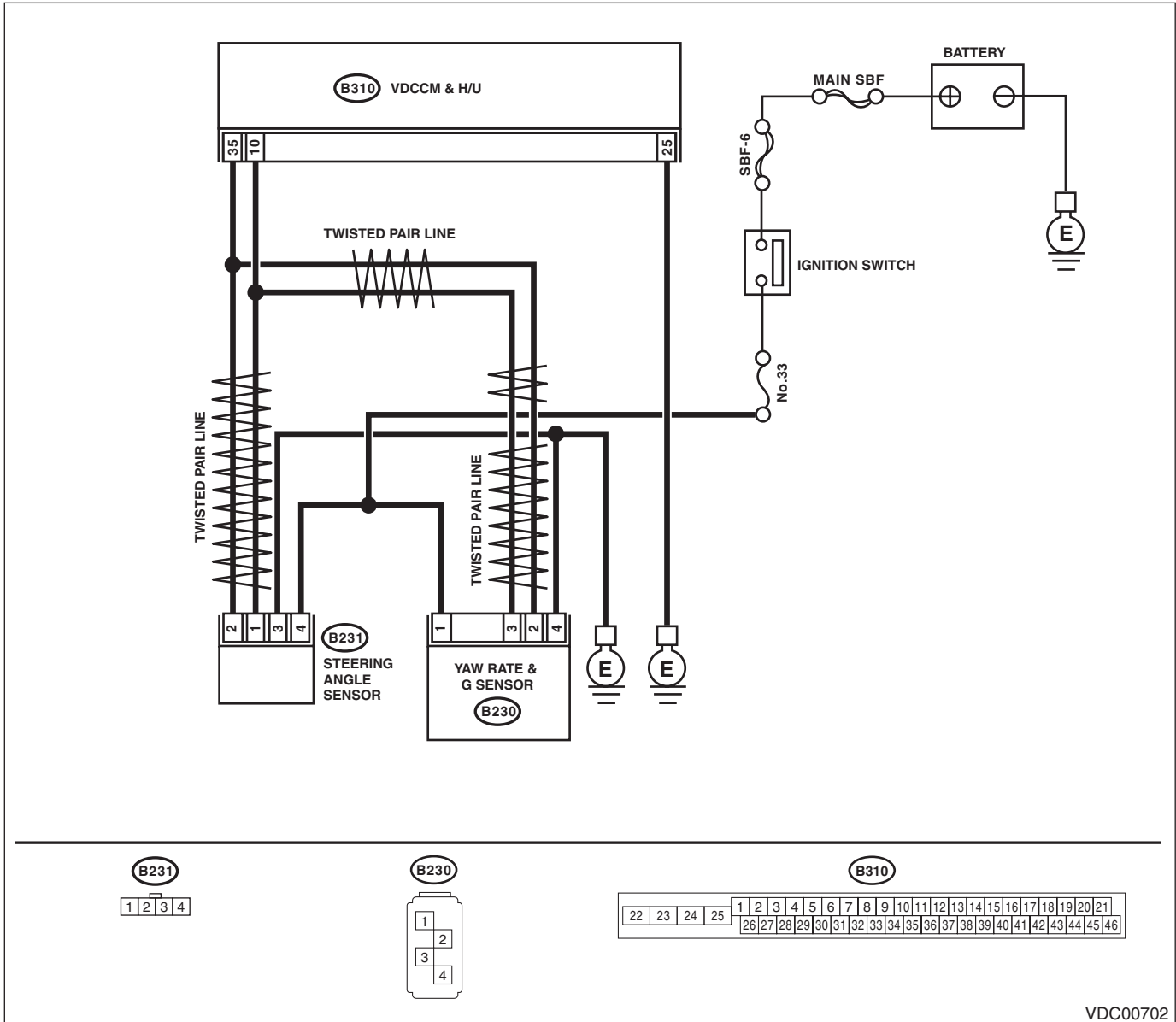

VDC00702

Step	Check	Yes	No
<b>1 CHECK POWER SUPPLY FOR YAW RATE &amp; G SENSOR.</b> 1) Turn the ignition switch to OFF. 2) Disconnect the connector from yaw rate & G sensor. 3) Turn the ignition switch to ON. 4) Measure the voltage between yaw rate & G sensor and chassis ground. <b>Connector &amp; terminal</b> <b>(B230) No. 1 (+) — Chassis ground (-):</b>	Is the voltage 10 — 15 V?	Go to step 2.	Repair the yaw rate & G sensor power supply circuit.

VDC(diag)-105

Brought to you by Ebay Seller "SubaruManuals"

# Diagnostic Procedure with Diagnostic Trouble Code (DTC)

## VEHICLE DYNAMICS CONTROL (VDC) (DIAGNOSTICS)

Step	Check	Yes	No
<b>2 CHECK YAW RATE &amp; G SENSOR GROUND CIRCUIT.</b> Measure the resistance between yaw rate & G sensor and chassis ground. <i><b>Connector &amp; terminal</b></i> <i><b>(B230) No. 4 — Chassis ground:</b></i>	Is the resistance less than 10 $\Omega$ ?	Go to step 3.	Repair the yaw rate & G sensor ground circuit.
<b>3 CHECK YAW RATE &amp; G SENSOR HARNESS.</b> 1) Disconnect the connector from the VDCCM&H/U. 2) Measure the resistance between VDCCM&H/U and yaw rate & G sensor. <i><b>Connector &amp; terminal</b></i> <i><b>(B230) No. 3 — (B310) No. 10:</b></i> <i><b>(B230) No. 2 — (B310) No. 35:</b></i>	Is the resistance less than 1 $\Omega$ ?	Go to step 4.	Repair the harness between yaw rate & G sensor and VDCCM&H/U.
<b>4 CHECK GROUND SHORT CIRCUIT IN YAW RATE &amp; G SENSOR HARNESS.</b> Measure the resistance between yaw rate & G sensor and chassis ground. <i><b>Connector &amp; terminal</b></i> <i><b>(B230) No. 2 — Chassis ground:</b></i> <i><b>(B230) No. 3 — Chassis ground:</b></i>	Is the resistance 1 M $\Omega$ or more?	Go to step 5.	Repair the harness between yaw rate & G sensor and VDCCM&H/U.
<b>5 CHECK YAW RATE &amp; G SENSOR.</b> 1) Turn the ignition switch to OFF. 2) Connect all connectors. 3) Clear the memory. <Ref. to VDC(diag)-27, Clear Memory Mode.> 4) Perform the Inspection Mode. <Ref. to VDC(diag)-26, Inspection Mode.> 5) Read the DTC.	Is the same DTC displayed?	Go to step 6.	Go to step 7.
<b>6 CHECK YAW RATE &amp; G SENSOR.</b> 1) Turn the ignition switch to OFF. 2) Replace the yaw rate & G sensor. <Ref. to VDC-20, Yaw Rate and G Sensor.> 3) Clear the memory. <Ref. to VDC(diag)-27, Clear Memory Mode.> 4) Perform the Inspection Mode. <Ref. to VDC(diag)-26, Inspection Mode.> 5) Read the DTC.	Is the same DTC displayed?	Replace the VDCCM only. <Ref. to VDC-12, REPLACEMENT, VDC Control Module and Hydraulic Control Unit (VDCCM&H/U).>	Go to step 8.
<b>7 CHECK OTHER DTC DETECTION.</b>	Is any other DTC displayed?	Perform the diagnosis according to DTC. <Ref. to VDC(diag)-48, List of Diagnostic Trouble Code (DTC).>	Temporary poor contact occurs.
<b>8 CHECK OTHER DTC DETECTION.</b>	Is any other DTC displayed?	Perform the diagnosis according to DTC. <Ref. to VDC(diag)-48, List of Diagnostic Trouble Code (DTC).>	Malfunction is found in original yaw rate & G sensor.

# Diagnostic Procedure with Diagnostic Trouble Code (DTC)

VEHICLE DYNAMICS CONTROL (VDC) (DIAGNOSTICS)

## AT:DTC C0072 SENSOR TYPE ABNORMAL

### DTC DETECTING CONDITION:

Different yaw rate sensor specification

### TROUBLE SYMPTOM:

- VDC does not operate.
- Hill start assist does not operate.

Step	Check	Yes	No
1 <b>CHECK YAW RATE &amp; G SENSOR IDENTIFICATION MARK.</b> Check the identification mark on the sticker applied on the top of the yaw rate & G sensor.	Is the identification symbol correct? MT: R	Go to step 2.	Replace the yaw rate & G sensor with a genuine part. <Ref. to VDC-20, Yaw Rate and G Sensor.>
2 <b>CHECK VDCCM&amp;H/U IDENTIFICATION SYMBOL.</b> Check the identification mark stamped on the upper side of the H/U. 5MT: SM 6MT: SN	Is the identification symbol correct?	Replace the VDCCM only. <Ref. to VDC-12, REPLACEMENT, VDC Control Module and Hydraulic Control Unit (VDCCM&H/U).>	Replace the VDCCM&H/U. <Ref. to VDC-8, VDC Control Module and Hydraulic Control Unit (VDCCM&H/U).>

## AU:DTC C0073 LATERAL G SENSOR OFFSET IS TOO BIG

### NOTE:

For the diagnostic procedure, refer to "DTC C0073 EXCESSIVE LATERAL G SENSOR SIGNAL". <Ref. to VDC(diag)-108, DTC C0073 EXCESSIVE LATERAL G SENSOR SIGNAL, Diagnostic Procedure with Diagnostic Trouble Code (DTC).>

## AV:DTC C0073 ABNORMAL LATERAL G SENSOR OUTPUT

### NOTE:

For the diagnostic procedure, refer to "DTC C0073 EXCESSIVE LATERAL G SENSOR SIGNAL". <Ref. to VDC(diag)-108, DTC C0073 EXCESSIVE LATERAL G SENSOR SIGNAL, Diagnostic Procedure with Diagnostic Trouble Code (DTC).>



# Diagnostic Procedure with Diagnostic Trouble Code (DTC)

VEHICLE DYNAMICS CONTROL (VDC) (DIAGNOSTICS)

## AW:DTC C0073 EXCESSIVE LATERAL G SENSOR SIGNAL

### DTC DETECTING CONDITION:

Defective lateral G sensor

### TROUBLE SYMPTOM:

VDC does not operate.

### WIRING DIAGRAM:

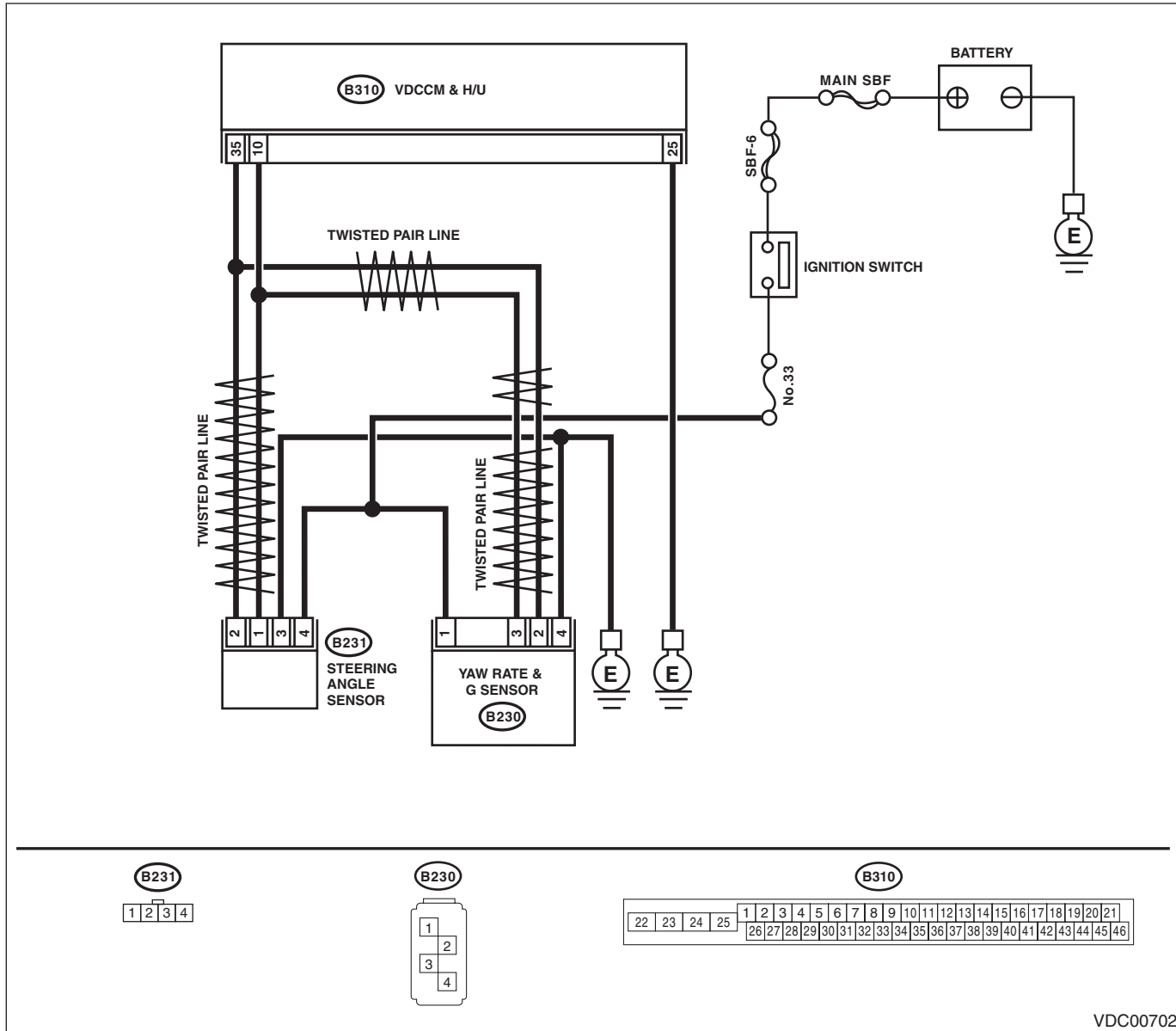

VDC00702

Step	Check	Yes	No	
1	<b>CHECK YAW RATE &amp; G SENSOR INSTALLATION.</b>	Is the yaw rate & G sensor installation bolt tightened to 7.5 N·m (0.76 kgf-m, 5.5 ft-lb)?	Go to step 2.	Tighten the yaw rate & G sensor installation bolt.

# Diagnostic Procedure with Diagnostic Trouble Code (DTC)

VEHICLE DYNAMICS CONTROL (VDC) (DIAGNOSTICS)

Step	Check	Yes	No
<b>2 CHECK OUTPUT OF LATERAL G SENSOR WITH SUBARU SELECT MONITOR.</b> 1) Park the vehicle on a level surface. 2) Select {Current Data Display & Save} in Subaru Select Monitor. <Ref. to VDC(diag)-19, READ CURRENT DATA, OPERATION, Subaru Select Monitor.> 3) Read the lateral G sensor output displayed on screen.	Is the indicated reading on the monitor display $-1.5 - 1.5$ m/s <sup>2</sup> ?	Go to step 3.	Replace the yaw rate & G sensor. <Ref. to VDC-20, Yaw Rate and G Sensor.>
<b>3 CHECK OUTPUT OF LATERAL G SENSOR WITH SUBARU SELECT MONITOR.</b> 1) Turn the ignition switch to OFF. 2) Remove the yaw rate & G sensors from vehicle. 3) Turn the ignition switch to ON, and select the {Current Data Display & Save} in Subaru Select Monitor. <Ref. to VDC(diag)-19, READ CURRENT DATA, OPERATION, Subaru Select Monitor.> 4) Read the lateral G sensor output displayed on screen.	When the yaw rate & G sensor is inclined 90° to the right, is the indicated value $6.8 - 12.8$ m/s <sup>2</sup> ?	Go to step 4.	Replace the yaw rate & G sensor. <Ref. to VDC-20, Yaw Rate and G Sensor.>
<b>4 CHECK LATERAL G SENSOR WITH SUBARU SELECT MONITOR.</b> Read the lateral G sensor output displayed on screen.	When the yaw rate & G sensor is inclined 90° to the left, is the indicated value $-6.8 - -12.8$ m/s <sup>2</sup> ?	Go to step 5.	Replace the yaw rate & G sensor. <Ref. to VDC-20, Yaw Rate and G Sensor.>
<b>5 CHECK POOR CONTACT OF CONNECTORS.</b> Turn the ignition switch to OFF.	Is there poor contact of connector between VDCCM&H/U and yaw rate & G sensor?	Repair the connector.	Go to step 6.
<b>6 CHECK VDCCM&amp;H/U.</b> 1) Connect all connectors. 2) Clear the memory. <Ref. to VDC(diag)-27, Clear Memory Mode.> 3) Perform the Inspection Mode. <Ref. to VDC(diag)-26, Inspection Mode.> 4) Read the DTC.	Is the same DTC displayed?	Replace the VDCCM only. <Ref. to VDC-12, REPLACEMENT, VDC Control Module and Hydraulic Control Unit (VDCCM&H/U).>	Go to step 7.
<b>7 CHECK OTHER DTC DETECTION.</b>	Is any other DTC displayed?	Perform the diagnosis according to DTC. <Ref. to VDC(diag)-48, List of Diagnostic Trouble Code (DTC).>	Temporary poor contact occurs.

# Diagnostic Procedure with Diagnostic Trouble Code (DTC)

VEHICLE DYNAMICS CONTROL (VDC) (DIAGNOSTICS)

## AX:DTC C0074 PRESSURE SENSOR

### DTC DETECTING CONDITION:

Defective pressure sensor

### TROUBLE SYMPTOM:

- ABS does not operate.
- VDC does not operate.

Step	Check	Yes	No	
1	<b>CHECK STOP LIGHT SWITCH CIRCUIT.</b> Check stop light switch open circuit.	Is the stop light switch circuit OK?	Go to step 2.	Repair the stop light switch circuit. NOTE: If there is malfunction in the stop light circuit, DTC may be recorded in the memory.
2	<b>CHECK OUTPUT OF PRESSURE SENSOR WITH SUBARU SELECT MONITOR.</b> 1) Select {Current Data Display & Save} in Subaru Select Monitor. <Ref. to VDC(diag)-19, READ CURRENT DATA, OPERATION, Subaru Select Monitor.> 2) Read the pressure sensor output displayed on display.	When the brake pedal is released, is the displayed value -40 — 40 bar?	Go to step 3.	Replace the VDCCM&H/U. <Ref. to VDC-8, VDC Control Module and Hydraulic Control Unit (VDCCM&H/U).>
3	<b>CHECK OUTPUT OF PRESSURE SENSOR WITH SUBARU SELECT MONITOR.</b> 1) Select {Current Data Display & Save} in Subaru Select Monitor. <Ref. to VDC(diag)-19, READ CURRENT DATA, OPERATION, Subaru Select Monitor.> 2) Read the pressure sensor output displayed on display.	When the brake pedal is operated, does the pressure sensor output value displayed on the screen change in accordance with the brake pedal?	Go to step 4.	Replace the VDCCM&H/U. <Ref. to VDC-8, VDC Control Module and Hydraulic Control Unit (VDCCM&H/U).>
4	<b>CHECK PRESSURE SENSOR.</b> 1) Clear the memory. <Ref. to VDC(diag)-27, Clear Memory Mode.> 2) Perform the Inspection Mode. <Ref. to VDC(diag)-26, Inspection Mode.> 3) Read the DTC.	Is the same DTC displayed?	Replace the VDCCM&H/U. <Ref. to VDC-8, VDC Control Module and Hydraulic Control Unit (VDCCM&H/U).>	Go to step 5.
5	<b>CHECK OTHER DTC DETECTION.</b>	Is any other DTC displayed?	Perform the diagnosis according to DTC. <Ref. to VDC(diag)-48, List of Diagnostic Trouble Code (DTC).>	It results from a temporary noise interference.

# Diagnostic Procedure with Diagnostic Trouble Code (DTC)

VEHICLE DYNAMICS CONTROL (VDC) (DIAGNOSTICS)

## AY:DTC C0075 REVERSE SIGNAL

### DTC DETECTING CONDITION:

Abnormal reverse signal

### TROUBLE SYMPTOM:

Hill start assist does not operate.

### WIRING DIAGRAM:

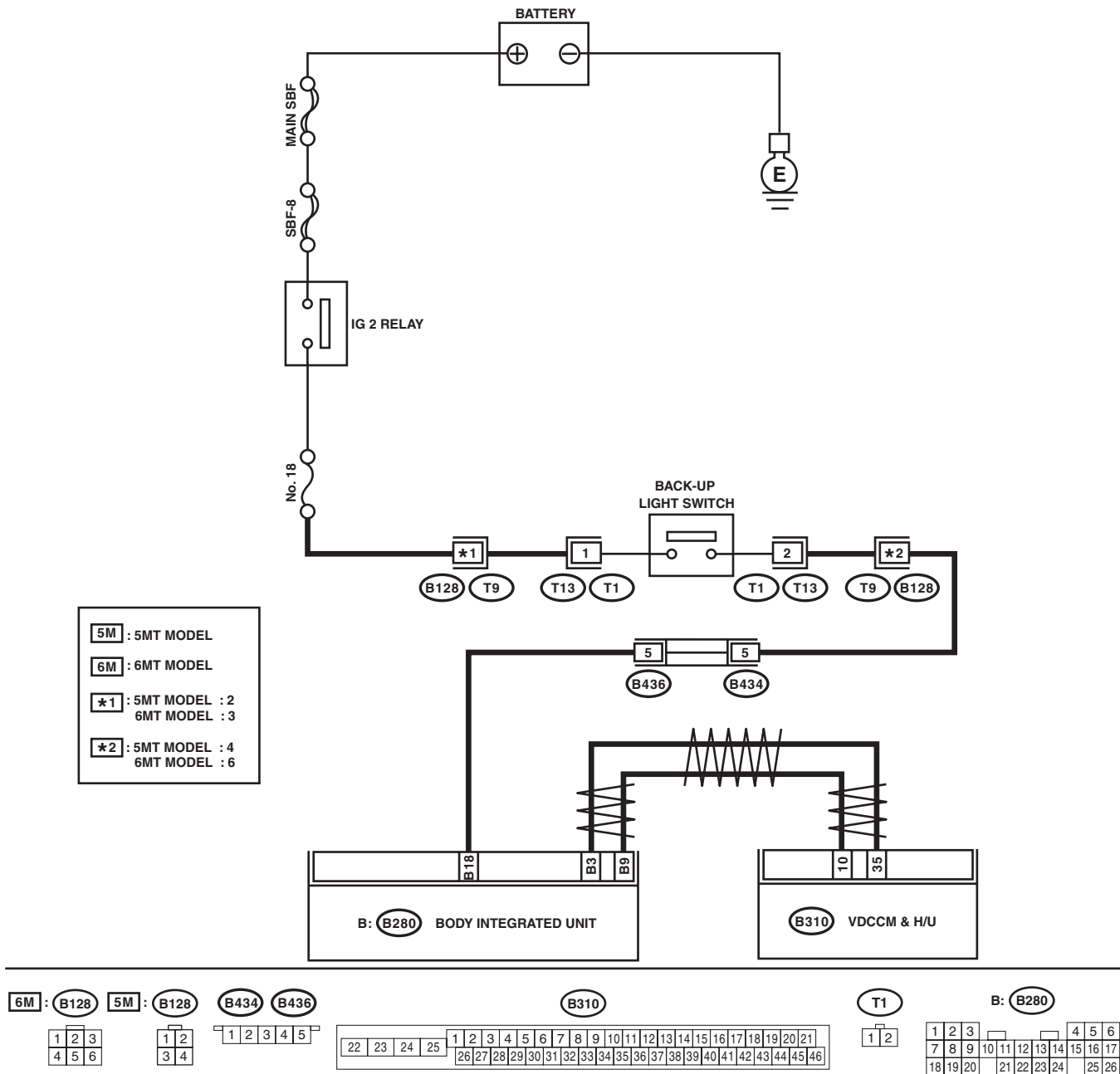

VDC00890

# Diagnostic Procedure with Diagnostic Trouble Code (DTC)

## VEHICLE DYNAMICS CONTROL (VDC) (DIAGNOSTICS)

	Step	Check	Yes	No
1	<b>CHECK LAN SYSTEM.</b> Perform the diagnosis for LAN system. <Ref. to LAN(diag)-2, Basic Diagnostic Procedure.>	Is there any fault in LAN system?	Perform the diagnosis according to DTC for LAN system. <Ref. to LAN(diag)-33, List of Diagnostic Trouble Code (DTC).>	Go to step 2.
2	<b>CHECK REVERSE SIGNAL USING SUBARU SELECT MONITOR.</b> 1) Select "Current Data Display & Save" on the Subaru Select Monitor. <Ref. to VDC(diag)-19, READ CURRENT DATA, OPERATION, Subaru Select Monitor.> 2) Read the indication of reverse signal.	Is "OFF" displayed when the shift lever is placed in any position other than reverse, and is "ON" displayed in reverse position?	Go to step 5.	Go to step 3.
3	<b>CHECK BACK-UP LIGHT ILLUMINATION.</b> 1) Turn the ignition switch to ON. 2) Place the shift lever in reverse position.	Does the back-up light illuminate?	Go to step 4.	Repair the back-up light circuit.
4	<b>CHECK HARNESS BETWEEN BODY INTEGRATED UNIT AND BACK-UP LIGHT SWITCH.</b> 1) Turn the ignition switch to OFF. 2) Disconnect the connectors from body integrated unit and back-up light switch. 3) Measure the resistance of harness between body integrated unit and back-up light switch connector. <b>Connector &amp; terminal (B280) No. 18 — (T13) No. 2:</b>	Is the resistance less than 1 $\Omega$ ?	Replace the back-up light switch. <Ref. to 5MT-33, Switches and Harness.> <Ref. to 6MT-40, Back-up Light Switch.>	Repair the harness between body integrated unit and back-up light switch connector.
5	<b>CHECK VDCCM&amp;H/U.</b> 1) Connect all connectors. 2) Clear the memory. <Ref. to VDC(diag)-27, Clear Memory Mode.> 3) Perform the Inspection Mode. <Ref. to VDC(diag)-26, Inspection Mode.> 4) Read the DTC.	Is the same DTC displayed?	Replace the VDCCM only. <Ref. to VDC-12, REPLACEMENT, VDC Control Module and Hydraulic Control Unit (VDCCM&H/U).>	Go to step 6.
6	<b>CHECK OTHER DTC DETECTION.</b>	Is any other DTC displayed?	Perform the diagnosis according to DTC. <Ref. to VDC(diag)-48, List of Diagnostic Trouble Code (DTC).>	Temporary poor contact occurs.

# Diagnostic Procedure with Diagnostic Trouble Code (DTC)

VEHICLE DYNAMICS CONTROL (VDC) (DIAGNOSTICS)

---

## AZ:DTC C0076 CLUTCH SIGNAL

### DTC DETECTING CONDITION:

Abnormal clutch signal

### TROUBLE SYMPTOM:

Hill start assist does not operate.

### NOTE:

Depending on the user clutch operation patterns, the hill start assist warning light may illuminate for a while, and then go off.

### Illumination condition:

While the vehicle speed is above 10 km/h, and the clutch switch signal ON (depressed) condition continues five minutes or more, if the vehicle speed lowers below 10 km/h, the module judge as abnormal (clutch switch stuck ON), and then turn on the warning light.

### Turning off condition:

If the clutch switch signal OFF (foot released) condition continues one second, the module turns off the warning light.

The hill start assist function does not operate, while the warning light illuminates.

# Diagnostic Procedure with Diagnostic Trouble Code (DTC)

VEHICLE DYNAMICS CONTROL (VDC) (DIAGNOSTICS)

## WIRING DIAGRAM:

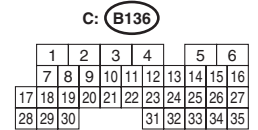
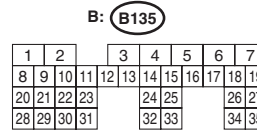
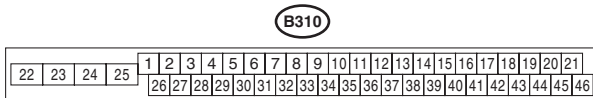
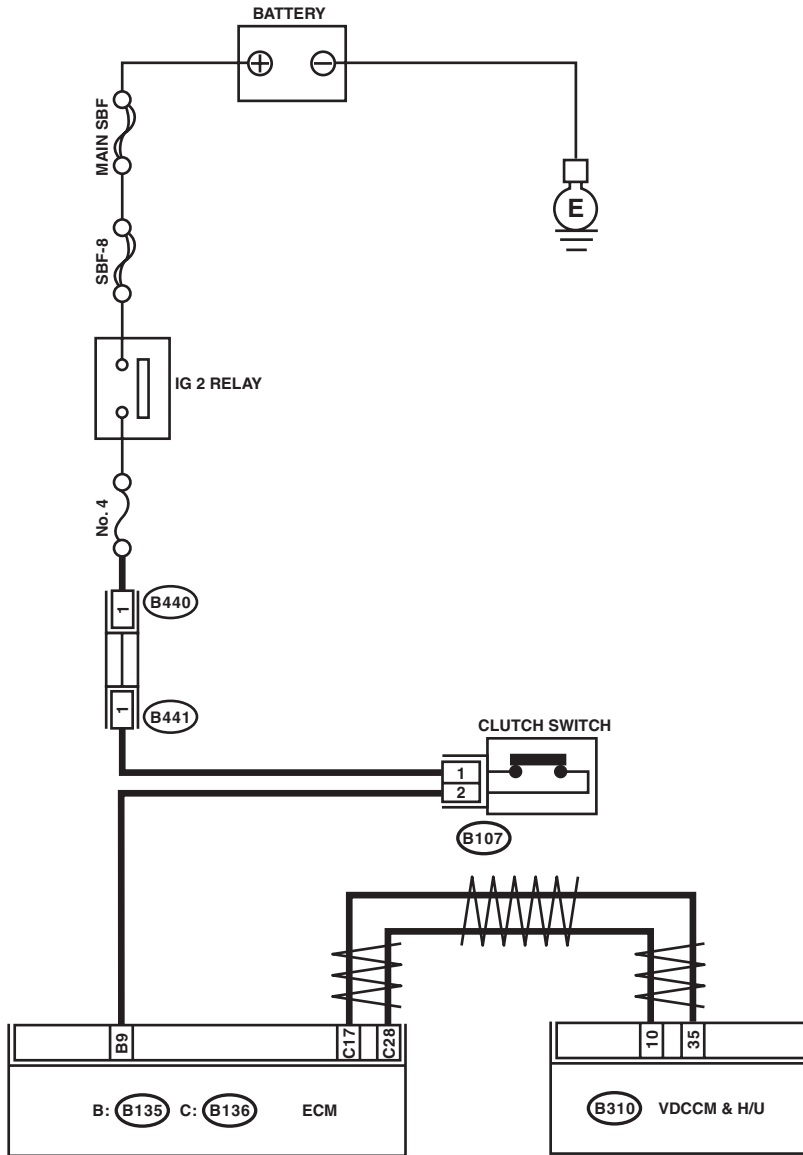

VDC00891

Step	Check	Yes	No
1	<b>CHECK LAN SYSTEM.</b> Perform the diagnosis for LAN system. <Ref. to LAN(diag)-2, Basic Diagnostic Procedure.>	Is there any fault in LAN system?  Perform the diagnosis according to DTC for LAN system. <Ref. to LAN(diag)-33, List of Diagnostic Trouble Code (DTC).>	Go to step 2.

**VDC(diag)-114**

Brought to you by Ebay Seller "SubaruManuals"

# Diagnostic Procedure with Diagnostic Trouble Code (DTC)

VEHICLE DYNAMICS CONTROL (VDC) (DIAGNOSTICS)

Step	Check	Yes	No
<b>2 CHECK CLUTCH SIGNAL USING SUBARU SELECT MONITOR.</b> 1) Select "Current Data Display & Save" on the Subaru Select Monitor. <Ref. to VDC(diag)-19, READ CURRENT DATA, OPERATION, Subaru Select Monitor.> 2) Read the indication of clutch switch signal.	Is "OFF" displayed when the clutch pedal is not depressed, and is "ON" displayed when depressed?	Go to step 5.	Go to step 3.
<b>3 CHECK CLUTCH SIGNAL OF ECM USING SUBARU SELECT MONITOR.</b> 1) Select "Current Data Display & Save" on Subaru Select Monitor. <Ref. to EN(H4DOTC)(diag)-41, READ CURRENT DATA FOR ENGINE (NORMAL MODE), OPERATION, Subaru Select Monitor.> 2) Read the indication of clutch switch signal.	Is "OFF" displayed when the clutch pedal is not depressed, and is "ON" displayed when depressed?	Go to step 5.	Go to step 4.
<b>4 CHECK HARNESS BETWEEN ECM AND CLUTCH SWITCH.</b> 1) Turn the ignition switch to OFF. 2) Disconnect the connectors from ECM and clutch switch. 3) Measure the resistance of harness between ECM and clutch switch connector. <b>Connector &amp; terminal</b> <b>(B135) No. 9 — (B107) No. 2:</b>	Is the resistance less than 1 Ω?	Repair the power supply circuit of clutch switch. Or replace the clutch switch. <Ref. to CL-33, Clutch Switch.>	Repair the harness between ECM and clutch switch connector.
<b>5 CHECK VDCCM&amp;H/U.</b> 1) Connect all connectors. 2) Clear the memory. <Ref. to VDC(diag)-27, Clear Memory Mode.> 3) Perform the Inspection Mode. <Ref. to VDC(diag)-26, Inspection Mode.> 4) Read the DTC.	Is the same DTC displayed?	Replace the VDCCM only. <Ref. to VDC-12, REPLACEMENT, VDC Control Module and Hydraulic Control Unit (VDCCM&H/U).>	Go to step 6.
<b>6 CHECK OTHER DTC DETECTION.</b>	Is any other DTC displayed?	Perform the diagnosis according to DTC. <Ref. to VDC(diag)-48, List of Diagnostic Trouble Code (DTC).>	Temporary poor contact occurs.



# Diagnostic Procedure with Diagnostic Trouble Code (DTC)

VEHICLE DYNAMICS CONTROL (VDC) (DIAGNOSTICS)

---

## BA:DTC C0081 SYSTEM FAILURE

### DTC DETECTING CONDITION:

VDC long time sequential control

### TROUBLE SYMPTOM:

- ABS does not operate.
- VDC does not operate.

Step	Check	Yes	No
<b>1</b> <b>CHECK POOR CONTACT OF CONNECTOR.</b>	Is there poor contact of the VDCCM&H/U and yaw rate & G sensor connector?	Repair the connector.	Go to step 2.
<b>2</b> <b>CHECK VDCCM&amp;H/U.</b> 1) Replace the yaw rate & G sensor. <Ref. to VDC-20, Yaw Rate and G Sensor.> 2) Connect all connectors. 3) Clear the memory. <Ref. to VDC(diag)-27, Clear Memory Mode.> 4) Perform the Inspection Mode. <Ref. to VDC(diag)-26, Inspection Mode.> 5) Read the DTC.	Is the same DTC displayed?	Replace the VDCCM&H/U. <Ref. to VDC-8, VDC Control Module and Hydraulic Control Unit (VDCCM&H/U).>	Malfunction is found in original yaw rate & G sensor.

# General Diagnostic Table

VEHICLE DYNAMICS CONTROL (VDC) (DIAGNOSTICS)

## 13.General Diagnostic Table

### A: INSPECTION

Symptoms		Main probable cause	Other probable cause
Poor brake performance	Long braking/stopping distance	<ul style="list-style-type: none"> <li>• VDCCM&amp;H/U</li> <li>• Brake pad</li> <li>• Aeration to brake line</li> <li>• Tire specifications, tire wear and air pressures</li> <li>• Incorrect wiring or piping connections</li> </ul>	<ul style="list-style-type: none"> <li>• Defective ABS wheel speed sensor or sensor gap</li> <li>• Defective steering angle sensor or improper neutral position</li> <li>• Defective yaw rate &amp; G sensor or improper installation</li> <li>• Master cylinder</li> <li>• Brake caliper</li> <li>• Disc rotor</li> <li>• Brake pipe</li> <li>• Brake booster</li> </ul>
	Wheel lock	<ul style="list-style-type: none"> <li>• VDCCM&amp;H/U</li> <li>• Defective ABS wheel speed sensor or sensor gap</li> <li>• Incorrect wiring or piping connections</li> </ul>	<ul style="list-style-type: none"> <li>• Defective steering angle sensor or improper neutral position</li> <li>• Defective yaw rate &amp; G sensor or improper installation</li> <li>• Brake caliper</li> <li>• Brake pipe</li> </ul>
	Brake drag	<ul style="list-style-type: none"> <li>• VDCCM&amp;H/U</li> <li>• Defective ABS wheel speed sensor or sensor gap</li> <li>• Master cylinder</li> <li>• Brake caliper</li> <li>• Parking brake</li> <li>• Axle and wheels</li> <li>• Brake pedal play</li> </ul>	<ul style="list-style-type: none"> <li>• Defective steering angle sensor or improper neutral position</li> <li>• Defective yaw rate &amp; G sensor or improper installation</li> <li>• Brake pad</li> <li>• Brake pipe</li> </ul>
	Long brake pedal stroke	<ul style="list-style-type: none"> <li>• Aeration to brake line</li> <li>• Brake pedal play</li> </ul>	<ul style="list-style-type: none"> <li>• VDCCM&amp;H/U</li> <li>• Master cylinder</li> <li>• Brake caliper</li> <li>• Brake pad</li> <li>• Brake pipe</li> <li>• Brake booster</li> </ul>
	Vehicle vertical pitching	<ul style="list-style-type: none"> <li>• VDCCM&amp;H/U</li> <li>• Road surface (uneven)</li> <li>• Suspension play or fatigue (reduced damping)</li> <li>• Incorrect wiring or piping connections</li> </ul>	<ul style="list-style-type: none"> <li>• Defective ABS wheel speed sensor or sensor gap</li> <li>• Defective steering angle sensor or improper neutral position</li> <li>• Defective yaw rate &amp; G sensor or improper installation</li> </ul>
Poor brake performance	Unstable or uneven braking	<ul style="list-style-type: none"> <li>• VDCCM&amp;H/U</li> <li>• Defective ABS wheel speed sensor or sensor gap</li> <li>• Brake caliper</li> <li>• Brake pad</li> <li>• Road surface (uneven)</li> <li>• Tire specifications, tire wear and air pressures</li> <li>• Incorrect wiring or piping connections</li> </ul>	<ul style="list-style-type: none"> <li>• Defective ABS wheel speed sensor or sensor gap</li> <li>• Defective steering angle sensor or improper neutral position</li> <li>• Defective yaw rate &amp; G sensor or improper installation</li> <li>• Master cylinder</li> <li>• Disc rotor</li> <li>• Brake pipe</li> <li>• Axle and wheels</li> <li>• Road with crowns or banks</li> <li>• Suspension play or fatigue (reduced damping)</li> </ul>

# General Diagnostic Table

## VEHICLE DYNAMICS CONTROL (VDC) (DIAGNOSTICS)

Symptoms		Main probable cause	Other probable cause
Vibration or noise <ul style="list-style-type: none"> <li>• When braking suddenly</li> <li>• When accelerating suddenly</li> <li>• While driving on a slippery road</li> </ul>	Excessive brake pedal vibration	<ul style="list-style-type: none"> <li>• Road surface (uneven)</li> <li>• Incorrect wiring or piping connections</li> </ul>	<ul style="list-style-type: none"> <li>• VDCCM&amp;H/U</li> <li>• Brake booster</li> <li>• Suspension play or fatigue (reduced damping)</li> </ul>
	Noise from VDCH/U	<ul style="list-style-type: none"> <li>• VDCCM&amp;H/U (mount bushing)</li> <li>• Defective ABS wheel speed sensor or sensor gap</li> <li>• Brake pipe</li> </ul>	<ul style="list-style-type: none"> <li>• VDCCM&amp;H/U</li> <li>• Defective steering angle sensor or improper neutral position</li> <li>• Defective yaw rate &amp; G sensor or improper installation</li> </ul>
	Noise from the front side of vehicle	<ul style="list-style-type: none"> <li>• VDCCM&amp;H/U (mount bushing)</li> <li>• Defective ABS wheel speed sensor or sensor gap</li> <li>• Master cylinder</li> <li>• Brake caliper</li> <li>• Brake pad</li> <li>• Disc rotor</li> <li>• Brake pipe</li> <li>• Brake booster</li> <li>• Suspension play or fatigue (reduced damping)</li> </ul>	<ul style="list-style-type: none"> <li>• Axle and wheels</li> <li>• Tire specifications, tire wear and air pressures</li> </ul>
	Noise from the rear side of vehicle	<ul style="list-style-type: none"> <li>• Defective ABS wheel speed sensor or sensor gap</li> <li>• Brake caliper</li> <li>• Brake pad</li> <li>• Disc rotor</li> <li>• Parking brake</li> <li>• Brake pipe</li> <li>• Suspension play or fatigue (reduced damping)</li> </ul>	<ul style="list-style-type: none"> <li>• Axle and wheels</li> <li>• Tire specifications, tire wear and air pressures</li> </ul>
Engine does not accelerate or goes into a stall when accelerating suddenly or driving on a slippery surface.		<ul style="list-style-type: none"> <li>• VDCCM&amp;H/U</li> <li>• Defective ABS wheel speed sensor or sensor gap</li> <li>• Master cylinder</li> <li>• Brake caliper</li> <li>• Parking brake</li> <li>• Incorrect wiring or piping</li> </ul>	<ul style="list-style-type: none"> <li>• Defective steering angle sensor or improper neutral position</li> <li>• Defective yaw rate &amp; G sensor or improper installation</li> <li>• Brake pad</li> <li>• Brake pipe</li> </ul>

# General Diagnostic Table

## VEHICLE DYNAMICS CONTROL (VDC) (DIAGNOSTICS)

Symptoms		Main probable cause	Other probable cause
Poor change-direction-operation stability of TCS	Deviation to right or left direction	<ul style="list-style-type: none"> <li>• VDCCM&amp;H/U</li> <li>• Defective ABS wheel speed sensor or sensor gap</li> <li>• Defective steering angle sensor or improper neutral position</li> <li>• Defective yaw rate &amp; G sensor or improper installation</li> <li>• Brake caliper</li> <li>• Brake pad</li> <li>• Wheel alignment</li> <li>• Road surface (uneven)</li> <li>• Road with crowns or banks</li> <li>• Tire specifications, tire wear and air pressures</li> <li>• Incorrect wiring or piping connections</li> </ul>	<ul style="list-style-type: none"> <li>• Disc rotor</li> <li>• Brake pipe</li> <li>• Axle and wheels</li> <li>• Suspension play or fatigue (reduced damping)</li> </ul>
	Vehicle spin	<ul style="list-style-type: none"> <li>• VDCCM&amp;H/U</li> <li>• Defective ABS wheel speed sensor or sensor gap</li> <li>• Defective steering angle sensor or improper neutral position</li> <li>• Defective yaw rate &amp; G sensor or improper installation</li> <li>• Brake pad</li> <li>• Tire specifications, tire wear and air pressures</li> <li>• Incorrect wiring or piping connections</li> </ul>	<ul style="list-style-type: none"> <li>• Brake caliper</li> <li>• Brake pipe</li> </ul>
Steering wheel drag while driving		<ul style="list-style-type: none"> <li>• VDCCM&amp;H/U</li> <li>• Defective ABS wheel speed sensor or sensor gap</li> <li>• Defective steering angle sensor or improper neutral position</li> <li>• Defective yaw rate &amp; G sensor or improper installation</li> <li>• Incorrect wiring or piping connections</li> <li>• Power steering system</li> </ul>	<ul style="list-style-type: none"> <li>• Brake caliper</li> <li>• Brake pad</li> <li>• Disc rotor</li> <li>• Wheel alignment</li> <li>• Road surface (uneven)</li> <li>• Road with crowns or banks</li> <li>• Suspension play or fatigue (reduced damping)</li> <li>• Tire specifications, tire wear and air pressures</li> </ul>
VDC operates while driving normally.		<ul style="list-style-type: none"> <li>• VDCCM&amp;H/U</li> <li>• Defective ABS wheel speed sensor or sensor gap</li> <li>• Defective steering angle sensor or improper neutral position</li> <li>• Defective yaw rate &amp; G sensor or improper installation</li> <li>• Wheel alignment</li> <li>• Road surface (uneven)</li> <li>• Road with crowns or banks</li> <li>• Suspension play or fatigue (reduced damping)</li> <li>• Tire specifications, tire wear and air pressures</li> <li>• Incorrect wiring or piping connections</li> <li>• Power steering system</li> </ul>	

# General Diagnostic Table

## VEHICLE DYNAMICS CONTROL (VDC) (DIAGNOSTICS)

Symptoms	Main probable cause	Other probable cause
VDC OFF indicator light does not illuminate when the VDC OFF switch is depressed. (5MT model) NOTE: When pressing VDC OFF switch for 10 seconds or more, VDC OFF indicator light goes off and cannot operate any more. When turning the ignition switch from OFF to ON, the previous status is restored.	<ul style="list-style-type: none"><li>• Harness</li><li>• Combination meter</li><li>• VDC OFF switch</li></ul>	
VDC traction mode indicator light does not illuminate when the VDC OFF switch is depressed. (6MT model) NOTE: When the VDC OFF switch is pressed for 10 seconds or more, the VDC traction mode indicator light goes off, and operation cannot be continued. When turning the ignition switch from OFF to ON, the previous status is restored.	<ul style="list-style-type: none"><li>• Harness</li><li>• Combination meter</li><li>• VDC OFF switch</li></ul>	

# BRAKE

# *BR*

---

	<b>Page</b>
1. General Description .....	2
2. Front Brake Pad .....	14
3. Front Disc Rotor .....	17
4. Front Disc Brake Assembly .....	18
5. Rear Brake Pad .....	23
6. Rear Disc Rotor .....	26
7. Rear Disc Brake Assembly .....	28
8. Master Cylinder .....	32
9. Brake Booster .....	34
10. Brake Fluid .....	38
11. Air Bleeding .....	39
12. Brake Hose .....	41
13. Brake Pipe .....	43
14. Brake Pedal .....	44
15. Stop Light Switch .....	46
16. Hill Start Assist .....	48
17. General Diagnostic Table .....	50

# General Description

## BRAKE

### 1. General Description

#### A: SPECIFICATION

Front disc brake	Size		17-inch type	16-inch type
	Type		Disc (Opposed type, ventilated)	Disc (Floating type, ventilated)
	Effective disc diameter	mm (in)	268 (10.55)	244 (9.61)
	Disc thickness × Diameter	mm (in)	30 × 326 (1.18 × 12.83)	24 × 294 (0.94 × 11.57)
	Effective cylinder diameter	mm (in)	40.0 × 2, 46.0 × 2 (1.575 × 2, 1.811 × 2)	42.8 (1.685) × 2
	Pad dimensions (Length × Width × Thickness)	mm (in)	131.8 × 60.5 × 8.9 (5.189 × 2.382 × 0.35)	117.8 × 50.5 × 11.0 (4.638 × 1.988 × 0.433)
	Clearance adjustment		Automatic adjustment	
Rear disc brake	Size		17-inch type	15-inch type
	Type		Disc (Opposed type, ventilated)	Disc (Floating type, solid)
	Effective disc diameter	mm (in)	268 (10.55)	250 (9.84)
	Disc thickness × Diameter	mm (in)	20 × 316 (0.79 × 12.44)	10 × 286 (0.39 × 11.26)
	Effective cylinder diameter	mm (in)	40.0 (1.575) × 2	38.1 (1.500)
	Pad dimensions (Length × Width × Thickness)	mm (in)	76.8 × 45.0 × 9.0 (3.024 × 1.772 × 0.354)	92.0 × 33.0 × 9.0 (3.622 × 1.299 × 0.354)
	Clearance adjustment		Automatic adjustment	
Master cylinder	Type		Tandem	
	Effective diameter	mm (in)	23.8 (15/16)	
	Reservoir type		Sealed type	
	Brake fluid reservoir capacity	cm <sup>3</sup> (cu in)	205 (12.51)	
Brake booster	Type		Vacuum suspended	
	Effective diameter	mm (in)	208 + 229 (8.19 + 9.02)	
Brake line		Dual circuit system		
Brake fluid	<b>CAUTION:</b> <ul style="list-style-type: none"> <li>• Avoid mixing brake fluid of different brands to prevent fluid performance from degrading.</li> <li>• When filling with brake fluid, be careful not to allow any dust to enter the reservoir.</li> <li>• Use new SUBARU genuine brake fluid when replacing or re-filling the fluid.</li> </ul>			FMVSS No. 116, DOT3, or DOT4

# General Description

BRAKE

**NOTE:**

Refer to "PB" section for parking brake specifications. <Ref. to PB-2, SPECIFICATION, General Description.>

Item			Standard	Limit	
Front brake	Pad thickness	mm (in)	16-inch type	11 (0.43)	1.5 (0.059)
			17-inch type	8.9 (0.35)	1.2 (0.047)
	Disc thickness	mm (in)	16-inch type	24 (0.94)	22 (0.87)
			17-inch type	30 (1.18)	28 (1.10)
	Disc runout	mm (in)	16-inch type	—	0.050 (0.0020)
			17-inch type	—	0.075 (0.0030)
Rear brake	Pad thickness	mm (in)	15-inch type	9.0 (0.354)	1.5 (0.059)
			17-inch type	9.0 (0.354)	1.2 (0.047)
	Disc thickness	mm (in)	15-inch type	10 (0.39)	8.5 (0.335)
			17-inch type	20 (0.79)	18 (0.71)
	Disc runout	mm (in)	15-inch type	—	0.050 (0.0020)
			17-inch type	—	0.070 (0.0028)
Parking brake	Inside diameter		mm (in)	190 (7.48)	191 (7.52)
	Lining thickness		mm (in)	2.8 (0.11)	1.5 (0.059)
	Lever stroke			7 — 8 notches/200 N (20 kgf, 45 lbf)	

		Brake pedal force N (kgf, lbf)	Fluid pressure kPa (kgf/cm <sup>2</sup> , psi)		
			17-inch type	16-inch type	
Brake booster	Brake fluid pressure with engine stopped	147 (15, 33)	545 (6, 79)		
		294 (30, 66)	1,564 (16, 227)		
	Brake fluid pressure with engine running and vacuum pressure at 66.7 kPa (500 mmHg, 19.69 inHg)	147 (15, 33)	4,984 (51, 723)	6,003 (61, 871)	
		294 (30, 66)	10,249 (105, 1,486)	11,273 (115, 1,635)	

Brake pedal	Free play	mm (in)	0.5 — 2 (0.020 — 0.079) [When pulling the brake pedal upward with a force of less than 10 N (1 kgf, 2 lbf)]
-------------	-----------	---------	--



# General Description

## BRAKE

### B: COMPONENT

#### 1. FRONT DISC BRAKE (17-INCH TYPE)

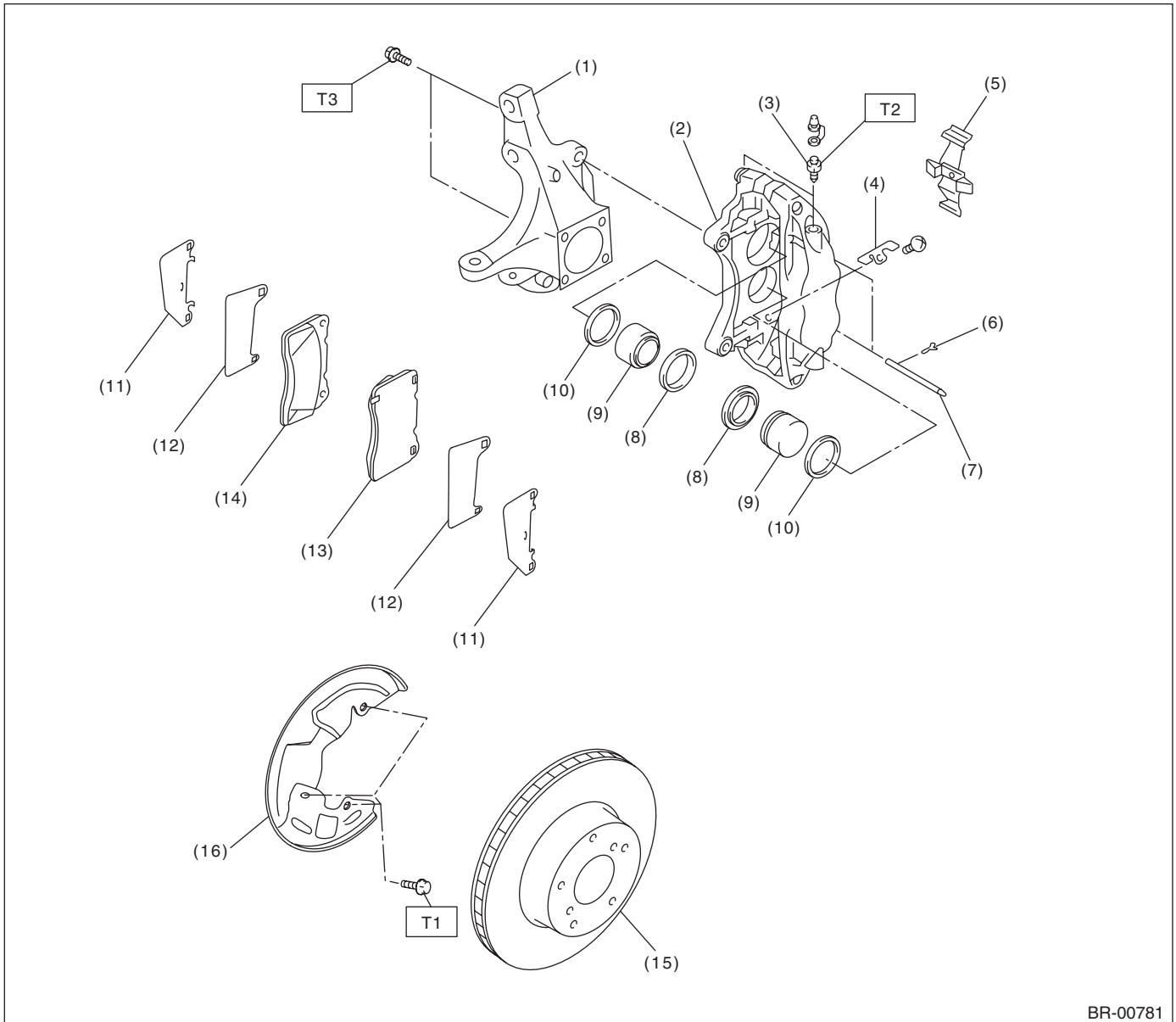

- (1) Housing
- (2) Caliper body
- (3) Air bleeder screw
- (4) Guide plate
- (5) Cross spring
- (6) Clip
- (7) Pad pin

- (8) Piston boot
- (9) Piston
- (10) Piston seal
- (11) Pad shim (outer)
- (12) Pad shim (inner)
- (13) Pad (outside)
- (14) Pad (inside)

- (15) Disc rotor
- (16) Disc cover

---

**Tightening torque: N·m (kgf·m, ft·lb)**

**T1: 18 (1.84, 13.3)**

**T2: 20 (2.04, 14.8)**

**T3: 155 (15.81, 114.3)**

---

## 2. FRONT DISC BRAKE (16-INCH TYPE)

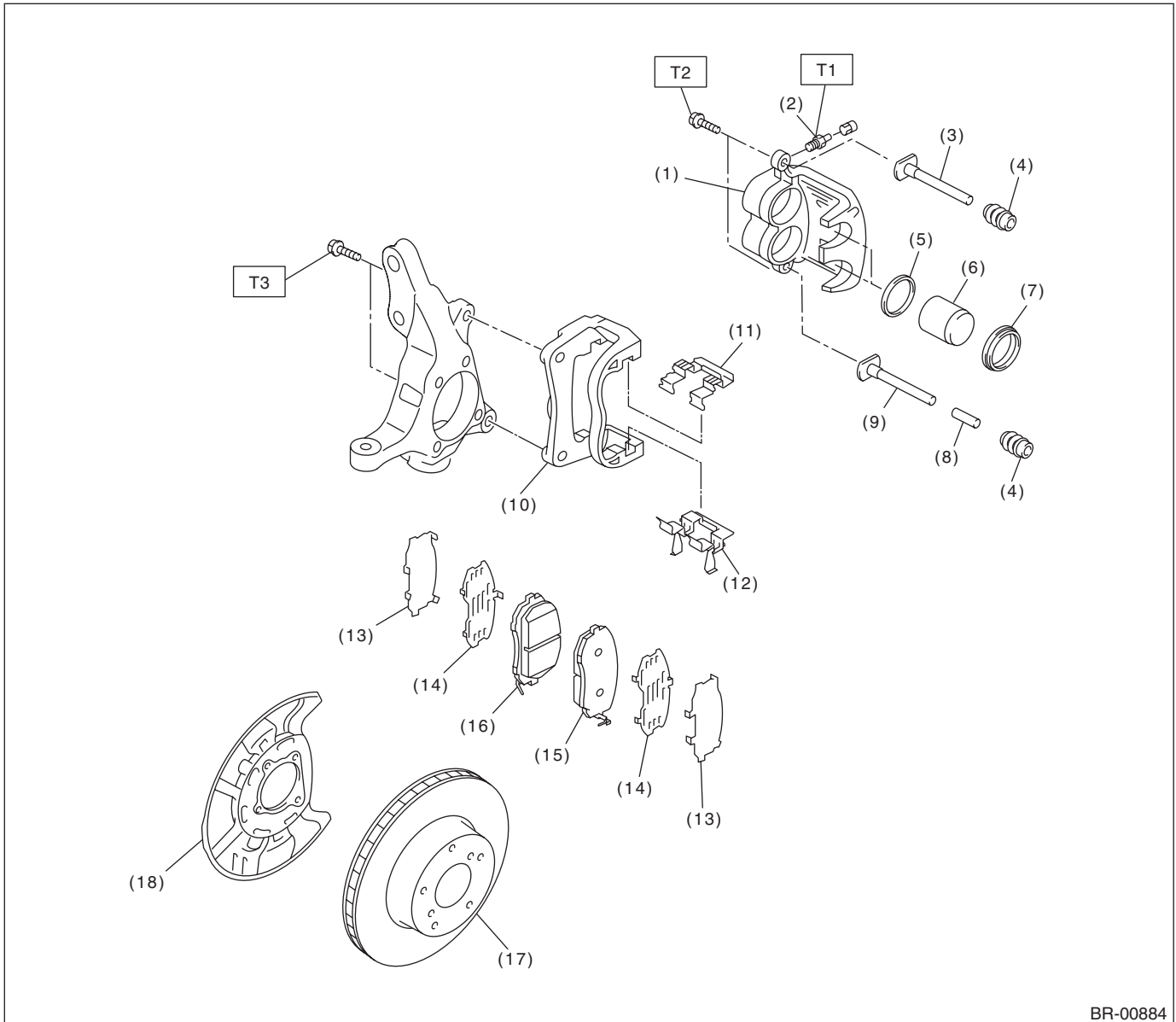

BR-00884

- |                       |                     |                 |
|-----------------------|---------------------|-----------------|
| (1) Caliper body      | (9) Lock pin        | (17) Disc rotor |
| (2) Air bleeder screw | (10) Support        | (18) Disc cover |
| (3) Guide pin         | (11) Pad clip upper |                 |
| (4) Pin boot          | (12) Pad clip lower |                 |
| (5) Piston seal       | (13) Outer shim     |                 |
| (6) Piston            | (14) Inner shim     |                 |
| (7) Piston boot       | (15) Pad (outside)  |                 |
| (8) Bushing           | (16) Pad (inside)   |                 |

**Tightening torque: N·m (kgf-m, ft-lb)**

**T1: 8 (0.82, 5.9)**

**T2: 27 (2.75, 19.9)**

**T3: 80 (8.16, 59)**

# General Description

## BRAKE

### 3. REAR DISC BRAKE (17-INCH TYPE)

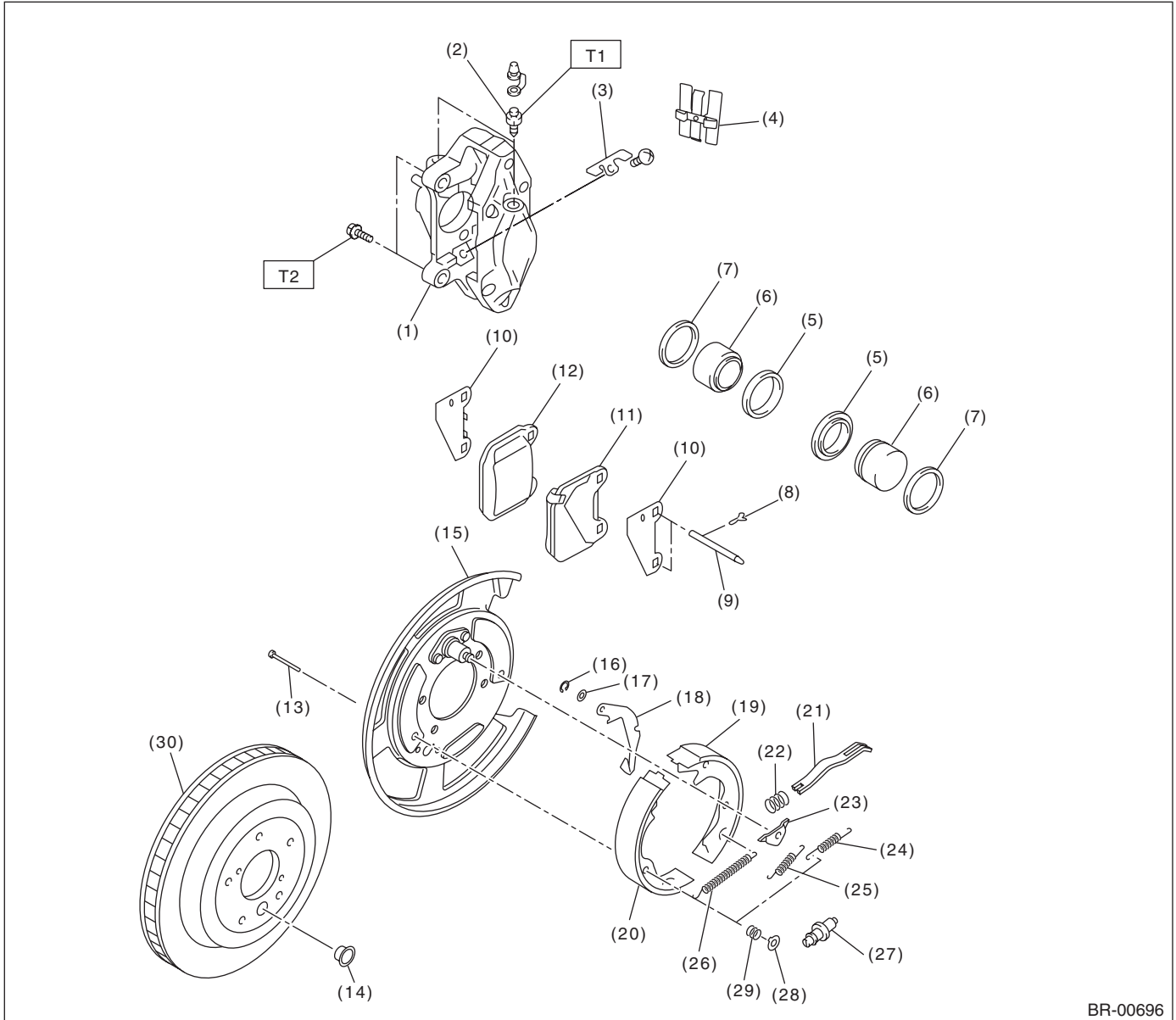

BR-00696

- |                       |                                     |                                 |
|-----------------------|-------------------------------------|---------------------------------|
| (1) Caliper body      | (13) Shoe hold-down pin             | (25) Primary shoe return spring |
| (2) Air bleeder screw | (14) Adjusting hole cover           | (26) Adjusting spring           |
| (3) Guide plate       | (15) Back plate                     | (27) Adjusting screw            |
| (4) Cross spring      | (16) Retainer                       | (28) Shoe hold-down cup         |
| (5) Piston boot       | (17) Wave washer                    | (29) Shoe hold-down spring      |
| (6) Piston            | (18) Parking brake lever            | (30) Disc rotor                 |
| (7) Piston seal       | (19) Parking brake shoe (secondary) |                                 |
| (8) Clip              | (20) Parking brake shoe (primary)   |                                 |
| (9) Pad pin           | (21) Strut                          |                                 |
| (10) Pad shim         | (22) Strut shoe spring              |                                 |
| (11) Pad (outside)    | (23) Shoe guide plate               |                                 |
| (12) Pad (inside)     | (24) Secondary shoe return spring   |                                 |

**Tightening torque: N·m (kgf·m, ft·lb)**

**T1: 20 (2.04, 14.8)**

**T2: 65 (6.63, 47.9)**

**BR-6**

Brought to you by Ebay Seller "SubaruManuals"

## 4. REAR DISC BRAKE (15-INCH TYPE)

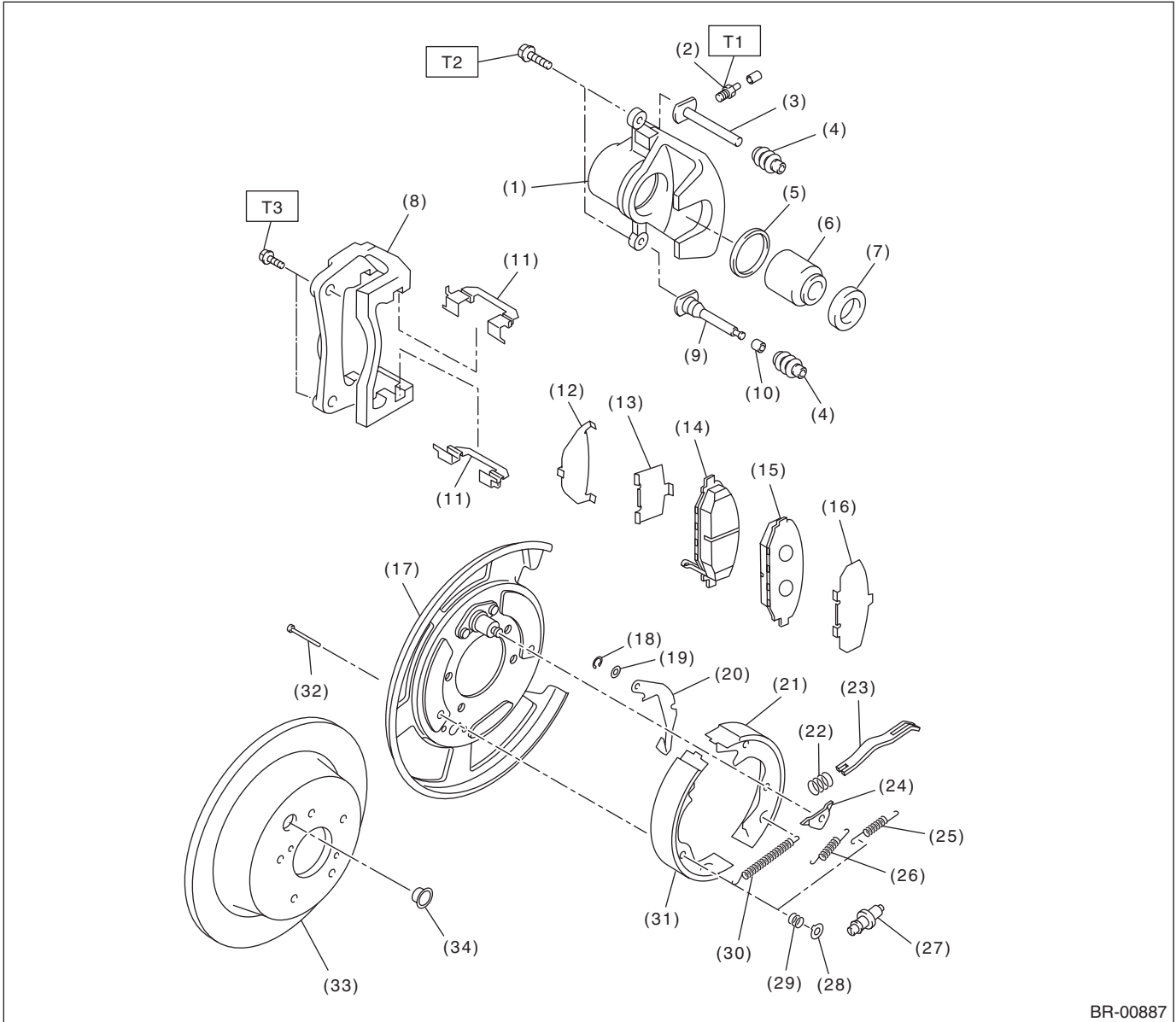

BR-00887

- |  |   |   |
|--|---|---|
| <p>(1) Caliper body<br/>                 (2) Air bleeder screw<br/>                 (3) Guide pin (black)<br/>                 (4) Pin boot<br/>                 (5) Piston seal<br/>                 (6) Piston<br/>                 (7) Piston boot<br/>                 (8) Support<br/>                 (9) Lock pin (silver)<br/>                 (10) Bushing<br/>                 (11) Pad clip<br/>                 (12) Outer shim<br/>                 (13) Inner shim</p> | <p>(14) Inner pad<br/>                 (15) Outer pad<br/>                 (16) Shim<br/>                 (17) Back plate<br/>                 (18) Retainer<br/>                 (19) Wave washer<br/>                 (20) Lever<br/>                 (21) Parking brake shoe (secondary)<br/>                 (22) Strut spring<br/>                 (23) Strut<br/>                 (24) Shoe guide plate<br/>                 (25) Secondary shoe return spring<br/>                 (26) Primary shoe return spring</p> | <p>(27) Adjusting screw<br/>                 (28) Shoe hold-down cup<br/>                 (29) Shoe hold-down spring<br/>                 (30) Adjusting spring<br/>                 (31) Parking brake shoe (primary)<br/>                 (32) Shoe hold-down pin<br/>                 (33) Disc rotor<br/>                 (34) Adjusting hole cover</p> |
|--|---|---|

---

**Tightening torque: N-m (kgf-m, ft-lb)**

**T1: 8 (0.82, 5.9)**

**T2: 27 (2.75, 19.9)**

**T3: 66 (6.73, 48.7)**

---

# General Description

BRAKE

## 5. MASTER CYLINDER

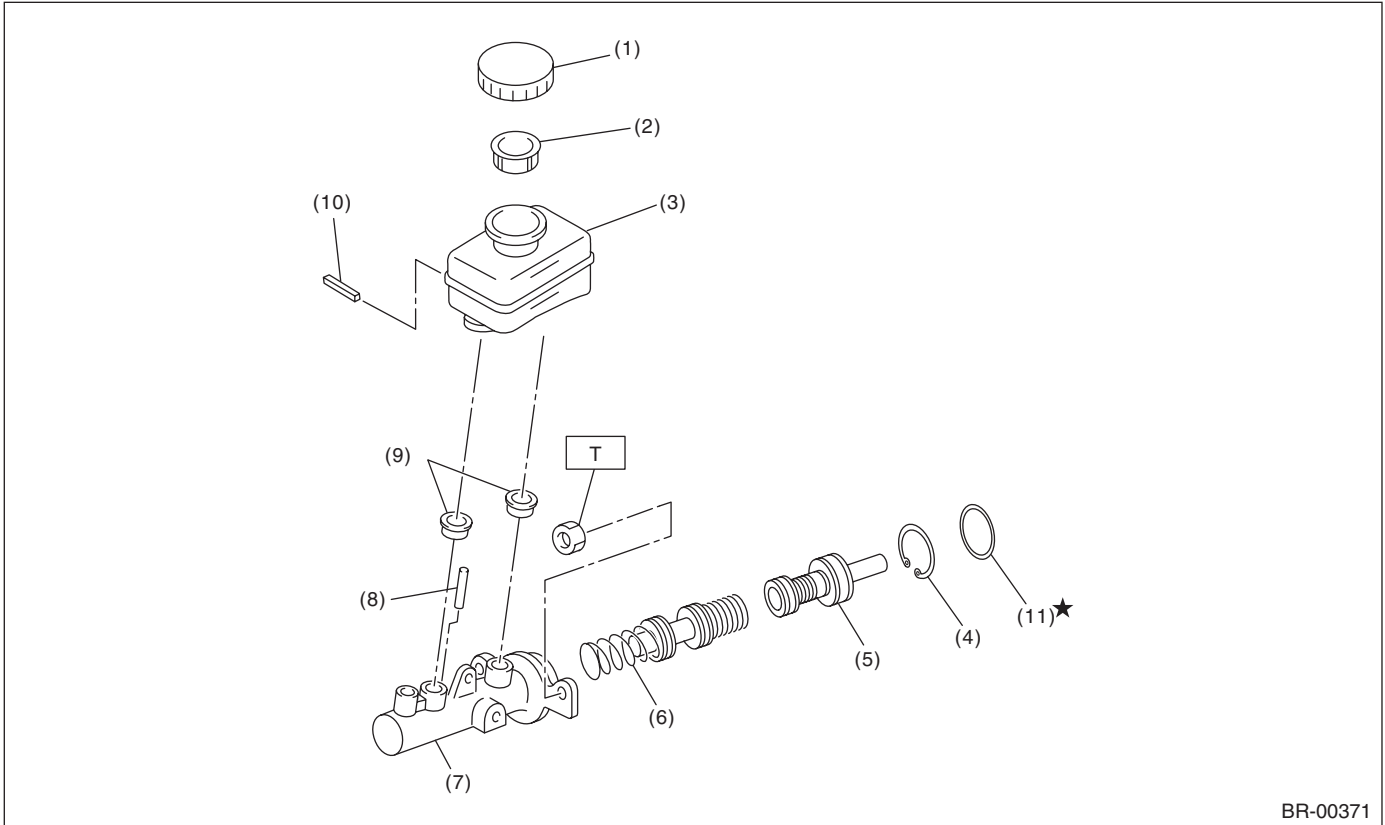

BR-00371

- (1) Cap
- (2) Filter
- (3) Reservoir tank
- (4) C-ring
- (5) Primary piston

- (6) Secondary piston
- (7) Cylinder body
- (8) Cylinder pin
- (9) Seal
- (10) Pin

- (11) O-ring

**Tightening torque: N·m (kgf·m, ft·lb)**

**T: 13 (1.33, 9.6)**

## 6. FRONT BRAKE PIPES AND HOSES

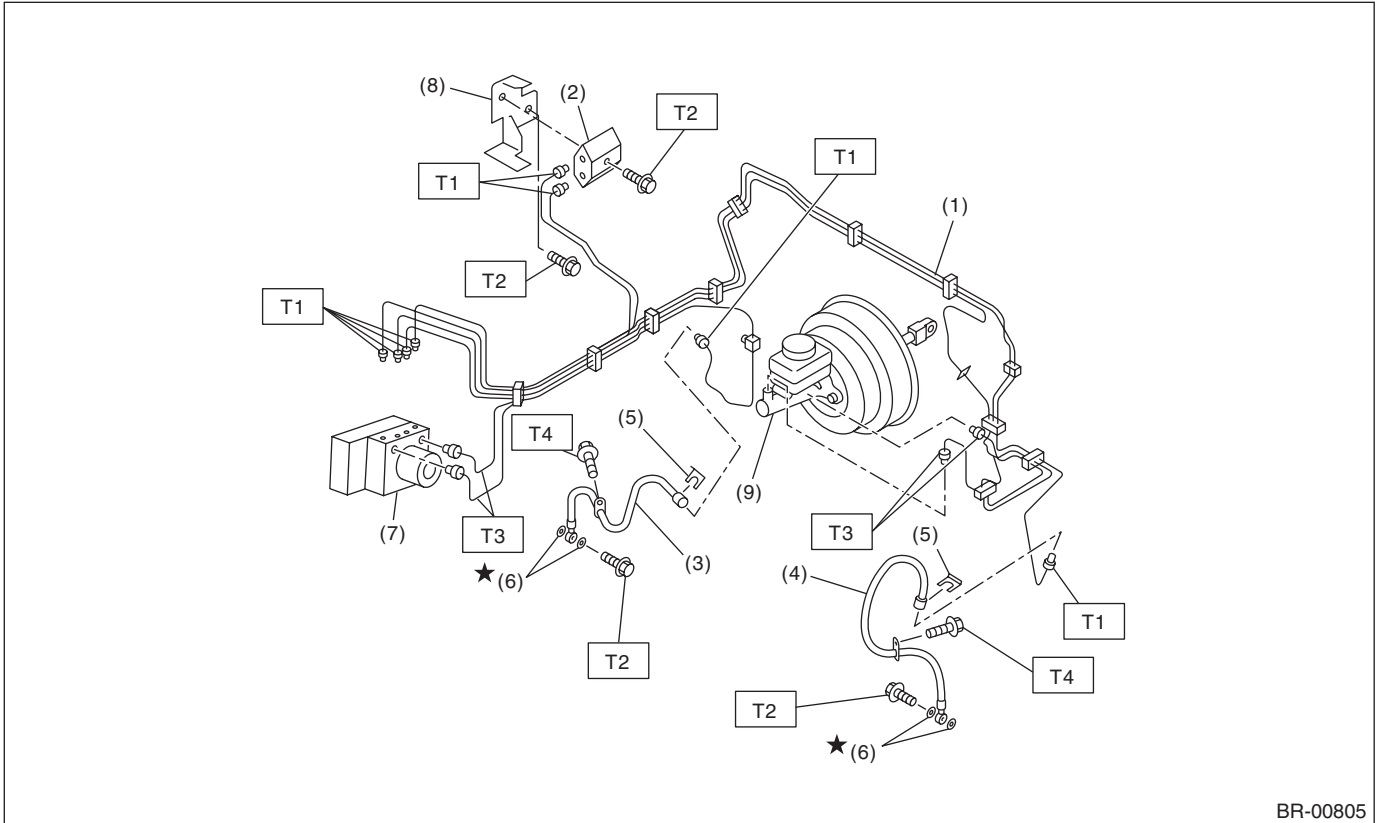

BR-00805

- (1) Front brake pipe ASSY
- (2) Two-way connector
- (3) Front brake hose RH
- (4) Front brake hose LH
- (5) Clamp

- (6) Gasket
- (7) VDC control module and hydraulic control unit (VDCCM&H/U)
- (8) Bracket
- (9) Master cylinder

<b>Tightening torque: N·m (kgf-m, ft-lb)</b>	
<b>T1:</b>	<b>15 (1.53, 11.1)</b>
<b>T2:</b>	<b>18 (1.84, 13.3)</b>
<b>T3:</b>	<b>19 (1.94, 14)</b>
<b>T4:</b>	<b>33 (3.36, 24.3)</b>

# General Description

## BRAKE

### 7. CENTER AND REAR BRAKE PIPES & HOSES

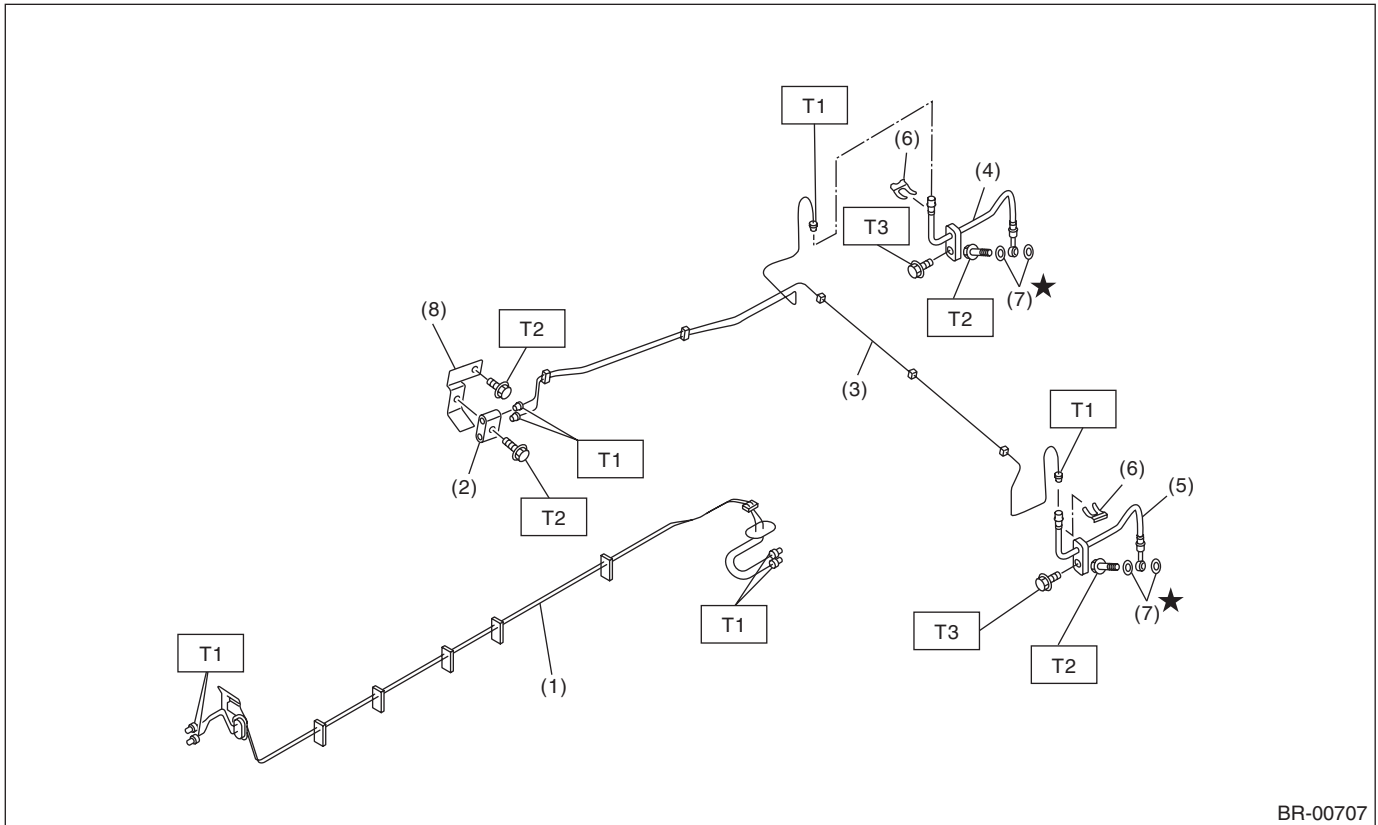

BR-00707

- |                            |                        |
|----------------------------|------------------------|
| (1) Center brake pipe ASSY | (5) Rear brake hose LH |
| (2) Two-way connector      | (6) Clamp              |
| (3) Rear brake pipe ASSY   | (7) Gasket             |
| (4) Rear brake hose RH     | (8) Bracket            |

**Tightening torque: N·m (kgf·m, ft·lb)**

**T1: 15 (1.53, 11.1)**

**T2: 18 (1.84, 13.3)**

**T3: 33 (3.36, 24.3)**

### 8. BRAKE BOOSTER

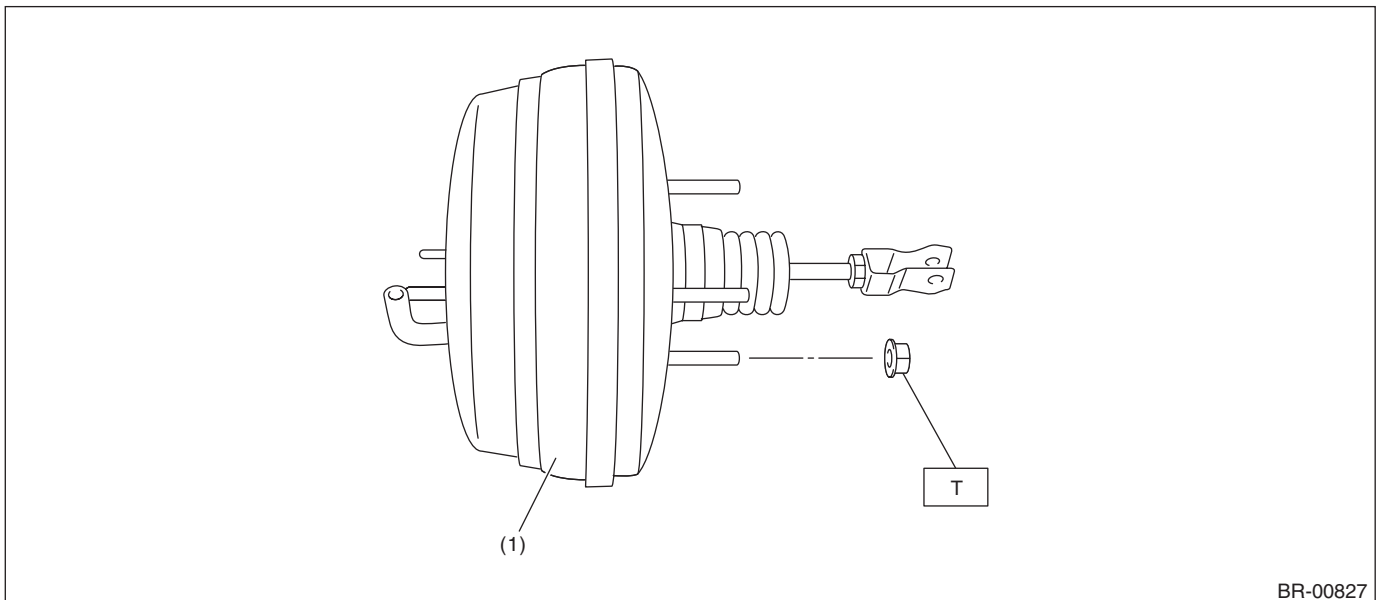

BR-00827

- (1) Brake booster

**Tightening torque: N·m (kgf·m, ft·lb)**

**T: 18 (1.84, 13.3)**

**BR-10**

Brought to you by Ebay Seller "SubaruManuals"

## 9. BRAKE PEDAL

- 6MT model

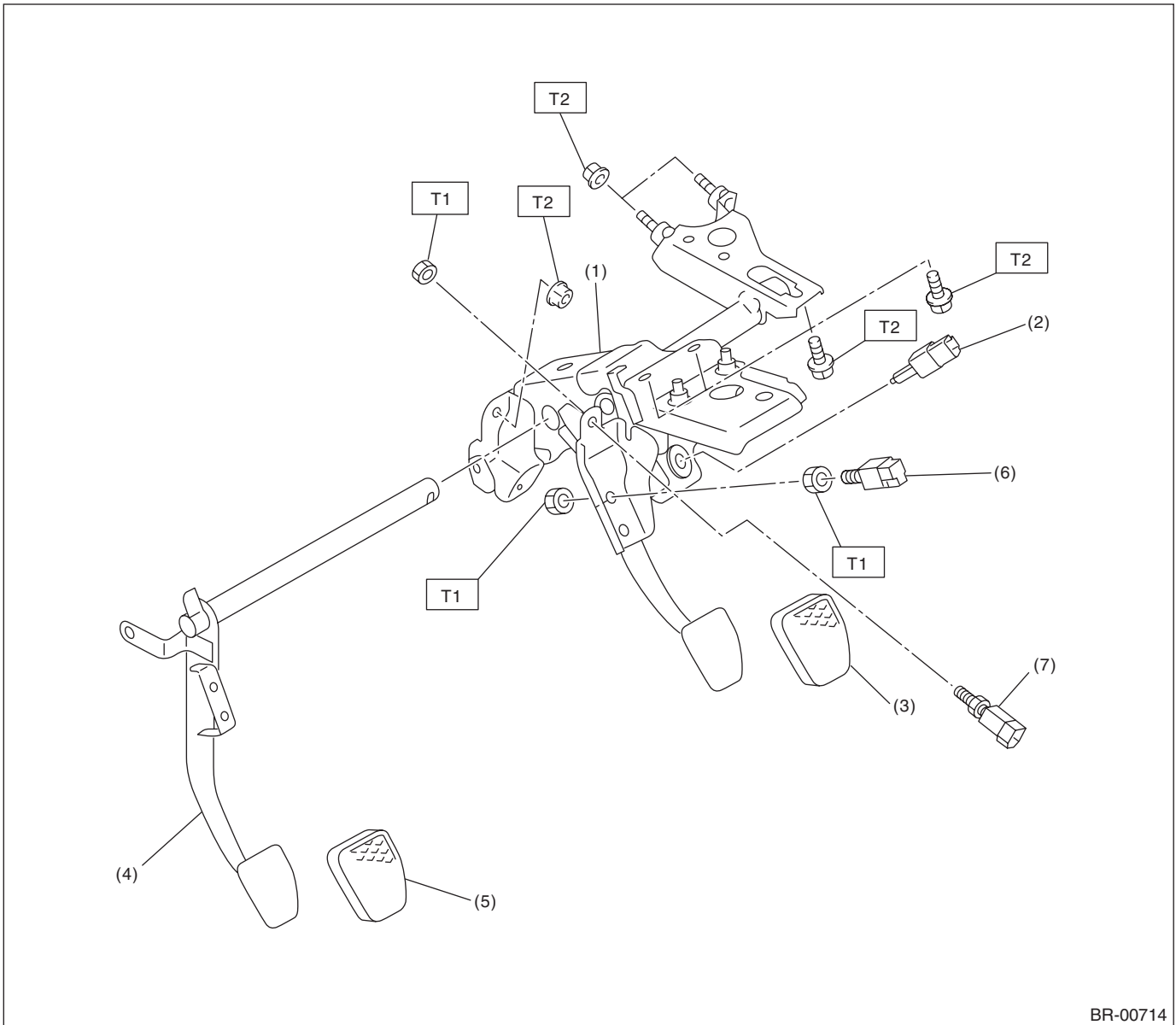

BR-00714

- |                       |                                    |
|-----------------------|------------------------------------|
| (1) Brake pedal ASSY  | (5) Clutch pedal pad               |
| (2) Stop light switch | (6) Clutch switch (cruise control) |
| (3) Brake pedal pad   | (7) Clutch switch (clutch start)   |
| (4) Clutch pedal      |                                    |

**Tightening torque: N·m (kgf·m, ft·lb)**

**T1: 8 (0.82, 5.9)**

**T2: 18 (1.84, 13.3)**



# General Description

## BRAKE

- 5MT model

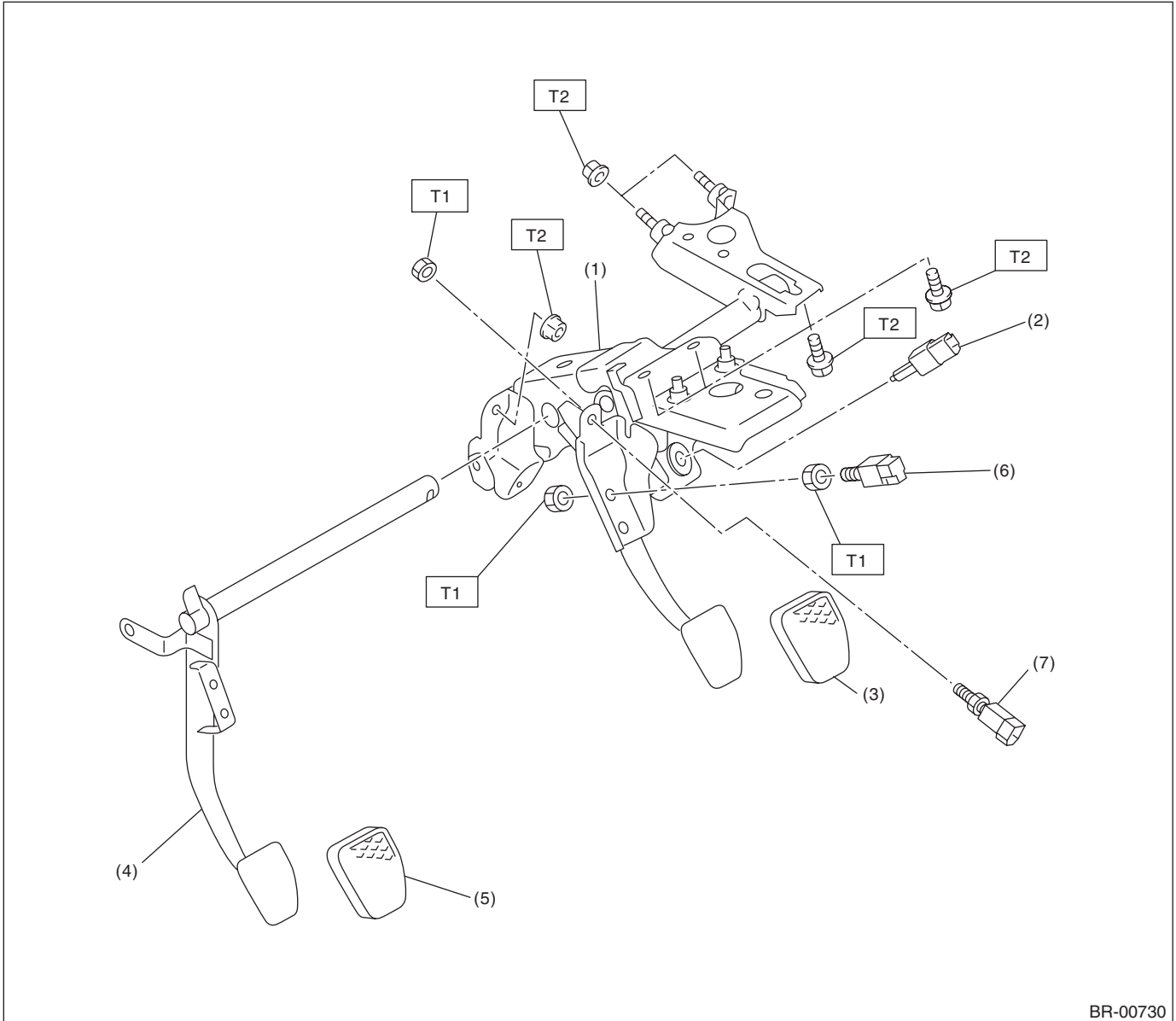

- |                       |                                    |
|-----------------------|------------------------------------|
| (1) Brake pedal ASSY  | (5) Clutch pedal pad               |
| (2) Stop light switch | (6) Clutch switch (cruise control) |
| (3) Brake pedal pad   | (7) Clutch switch (clutch start)   |
| (4) Clutch pedal      |                                    |

**Tightening torque: N·m (kgf·m, ft·lb)**

**T1: 8 (0.82, 5.8)**

**T2: 18 (1.84, 13.3)**

## C: CAUTION

- Wear appropriate work clothing, including a helmet, protective goggles and protective shoes when performing any work.
- Before removal, installation or disassembly, be sure to clarify the failure. Avoid unnecessary removal, installation, disassembly and replacement.
- Use SUBARU genuine grease etc. or equivalent. Do not mix grease etc. of different grades or manufacturers.
- Before securing a part on a vise, place cushioning material such as wood blocks, aluminum plate, or cloth between the part and the vise.
- Be sure to tighten fasteners including bolts and nuts to the specified torque.
- Place shop jacks or rigid racks at the specified points.

## D: PREPARATION TOOL

### 1. GENERAL TOOL

TOOL NAME	REMARKS
Snap ring pliers	Used for removing and installing snap rings.

# Front Brake Pad

## BRAKE

### 2. Front Brake Pad

#### A: REMOVAL

##### 1. 17-INCH TYPE

- 1) Lift up the vehicle, and then remove the front wheels.
- 2) Remove clips (1).

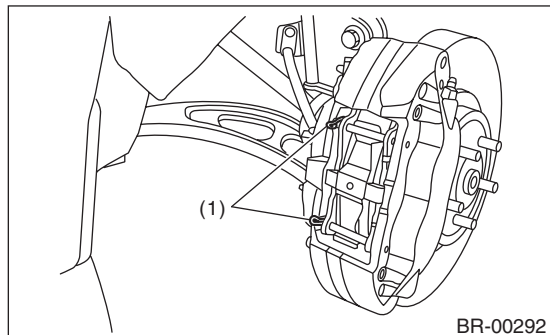

- 3) Remove the pad pins (1) and cross spring (2).

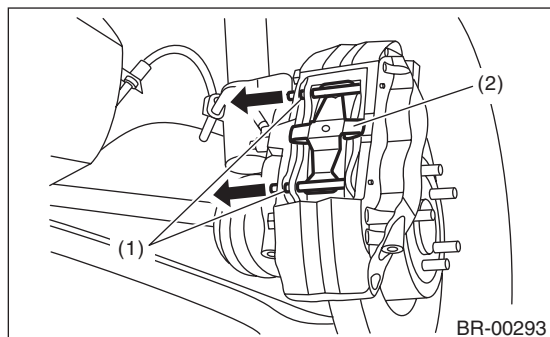

- 4) Spread apart the pads using a pair of wrenches and push back the piston.

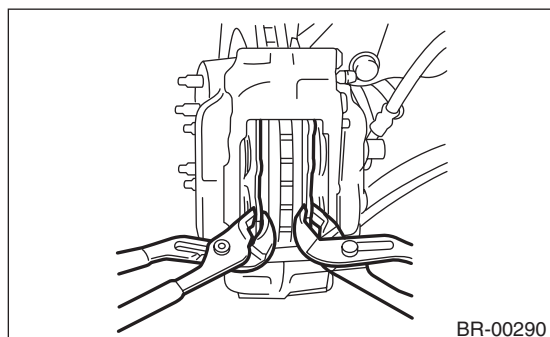

- 5) Remove the pads.

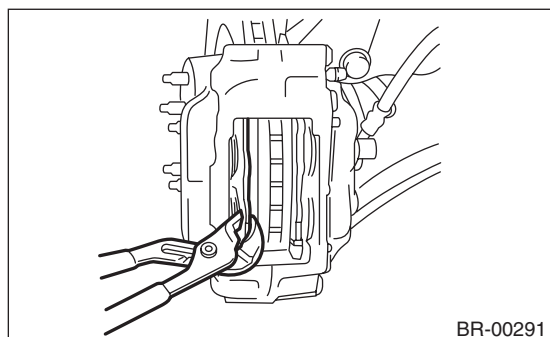

##### 2. 16-INCH TYPE

- 1) Lift up the vehicle, and then remove the front wheels.
- 2) Remove the caliper bolt.

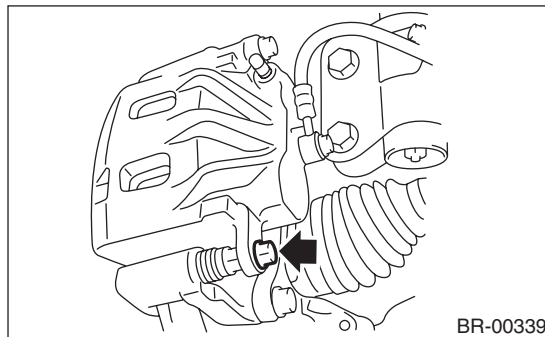

- 3) Raise the caliper body and support it.

#### NOTE:

Do not disconnect the brake hose from the caliper body.

- 4) Remove the pads.

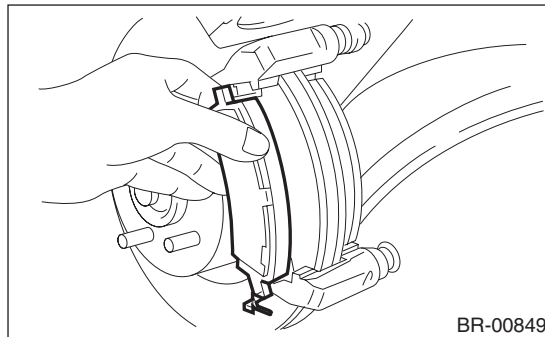

#### B: INSTALLATION

##### 1. 17-INCH TYPE

- 1) Apply a thin coat of Molykote M7439 (Part No. 003602001) or grease contained in the pad kit to the side of the pad.

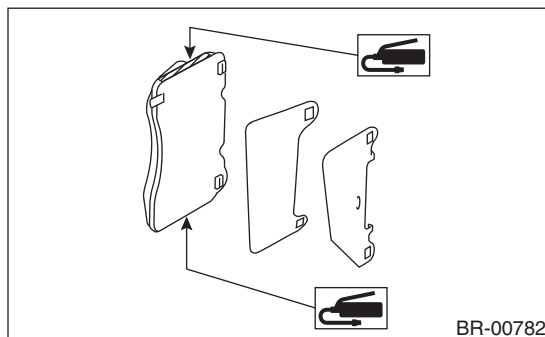

2) Apply a thin coat of Molykote AS880N (Part No. K0777YA010) or grease contained in the pad kit to the pad and pad shim.

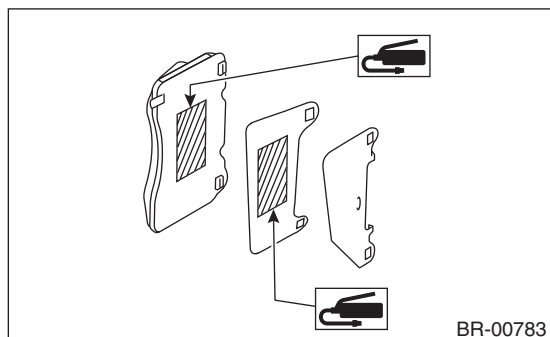

- 3) Install the pads to the caliper body.
- 4) Install the cross spring.
- 5) Install the pad pins.
- 6) Install the clips.

## 2. 16-INCH TYPE

1) Apply a thin coat of Molykote M7439 (Part No. 003602001) or grease contained in the pad kit to the pad clip.

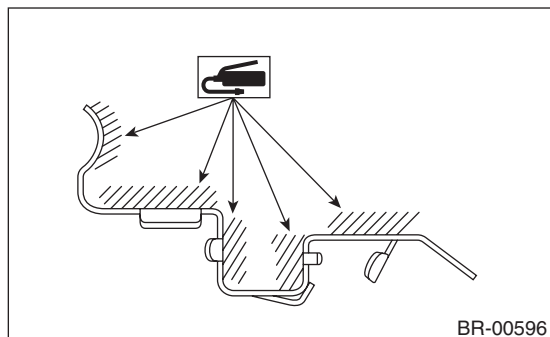

2) Apply a thin coat of Molykote AS880N (Part No. K0777YA010) or grease contained in the pad kit to both surfaces of the pad and inner shim.

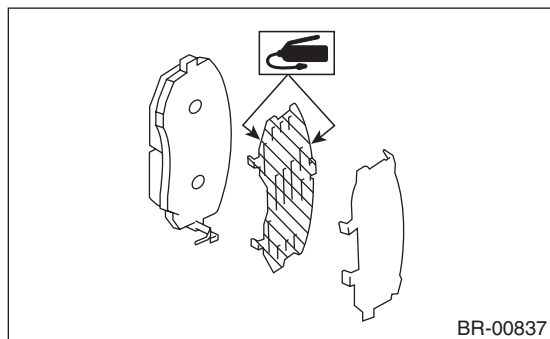

3) Install the pad to support.

### CAUTION:

- Be sure to install so that the pad return spring faces the input side of the direction of brake rotor rotation, as shown in the figure.
- Correctly install the pad return spring to the supporting surface of the pad clip as shown in the figure.
- If the pad return spring is deformed or damaged, replace the brake pad.

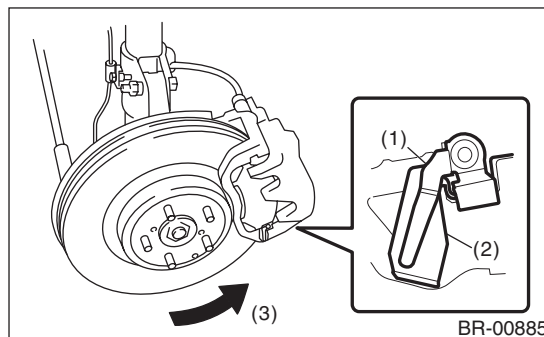

- (1) Pad return spring
- (2) Supporting surface of pad clip
- (3) Direction of brake rotor rotation

### NOTE:

Install the pad indicator in proper direction.

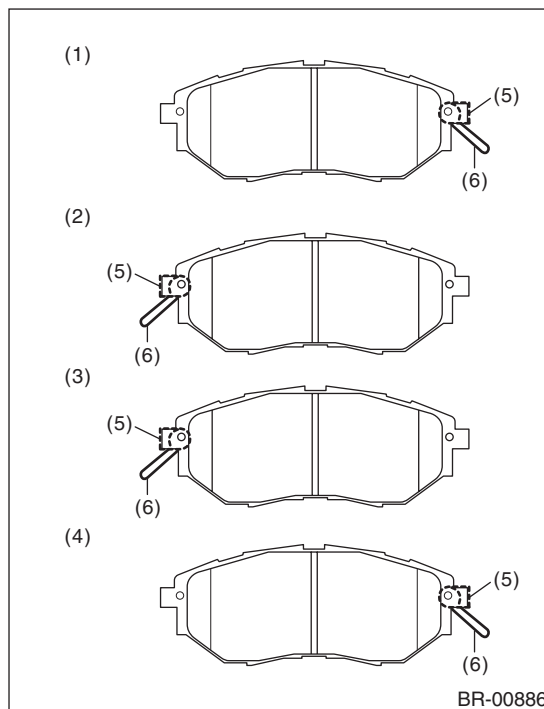

- (1) LH — IN
- (2) LH — OUT
- (3) RH — IN
- (4) RH — OUT
- (5) Pad indicator
- (6) Pad return spring

# Front Brake Pad

## BRAKE

---

4) Install the caliper body to the support.

### **Tightening torque:**

**27 N·m (2.75 kgf·m, 19.9 ft·lb)**

## **C: INSPECTION**

Check the pad thickness A.

- 17-inch type

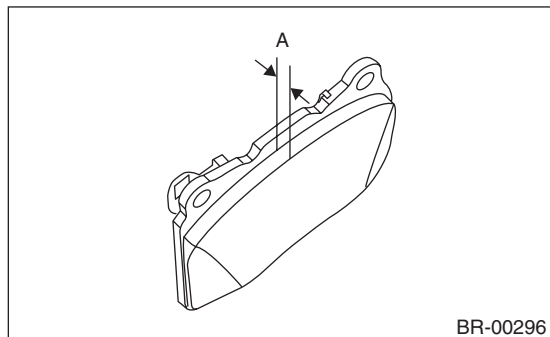

Pad thickness A mm (in)	Specification	8.9 (0.35)
	Wear limit	1.2 (0.047)

- 16-inch type

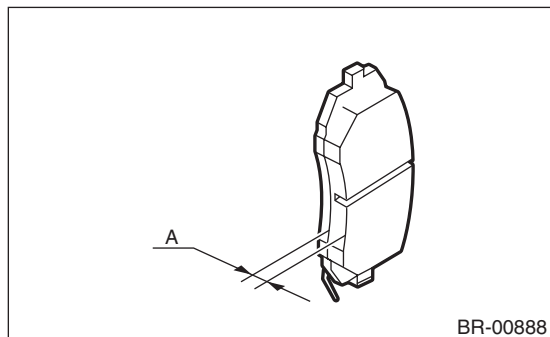

Pad thickness A mm (in)	Specification	11 (0.433)
	Wear limit	1.5 (0.059)

### **NOTE:**

- Always replace the pads of both wheels and both sides as a set.
- Replace the cross spring and pad pins if they are twisted or worn. (17-inch type)
- A wear indicator is installed on the outer disc brake pad. (17-inch type)
- Wear indicators are installed on the inner and outer disc brake pads. (16-inch type)
- If the pad is worn to the limit, the end of wear indicator contacts disc rotor, and a squeaking sound is heard as the wheel rotates. If the sound is heard, replace the pad.
- Replace the pad if there is oil or grease on it.

## 3. Front Disc Rotor

### A: REMOVAL

- 1) Lift up the vehicle, and then remove the front wheels.
- 2) Remove the caliper body assembly from housing, and suspend it from the strut using a wire.

#### CAUTION:

**Be careful not to stretch the brake hose.**

- 17-inch type

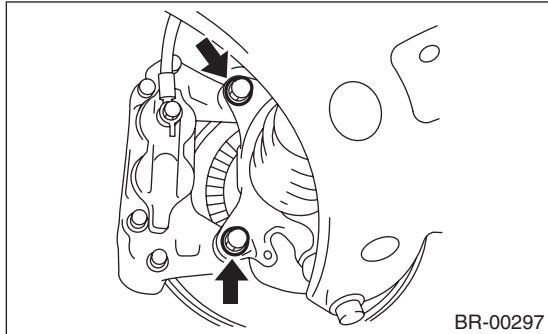

- 16-inch type

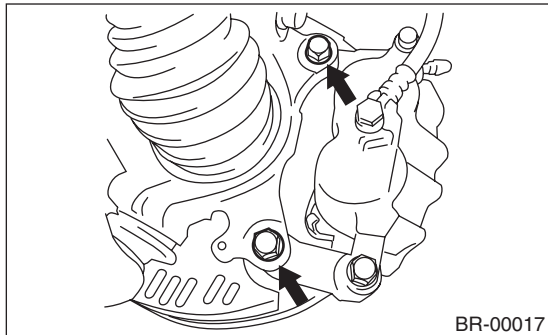

- 3) Remove the disc rotor.

#### NOTE:

If it is difficult to remove the disc rotor from the hub, drive an 8 mm bolt into the threaded section (B) of the rotor, then remove the rotor.

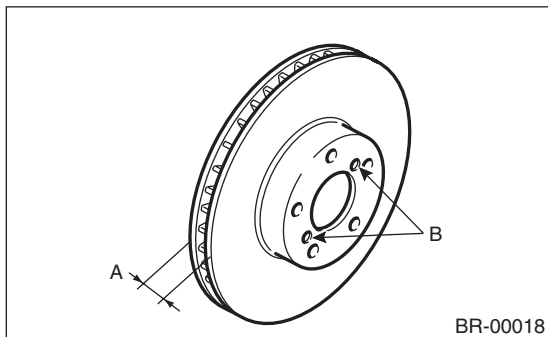

- 4) Remove mud and foreign matter from the caliper body assembly.

### B: INSTALLATION

- 1) Install the disc rotor.
- 2) Install the caliper body assembly to the housing.

#### Tightening torque:

**17-inch type**

**155 N·m (15.81 kgf·m, 114.3 ft·lb)**

**16-inch type**

**80 N·m (8.16 kgf·m, 59 ft·lb)**

- 3) Install the front wheels.

### C: INSPECTION

- 1) Check the front wheel bearing play and axle hub runout before the inspection of disc rotor runout limit. <Ref. to DS-17, INSPECTION, Front Axle.>
- 2) Secure the disc rotor by tightening the five wheel nuts.
- 3) Set a dial gauge 10 mm (0.39 in) inward from the disc rotor outer circumference. Rotate the disc rotor to check runout. If the disc rotor runout exceeds the limit, resurface the disc rotor. After grinding, check the thickness of the disc rotor according to the procedure in step 4).

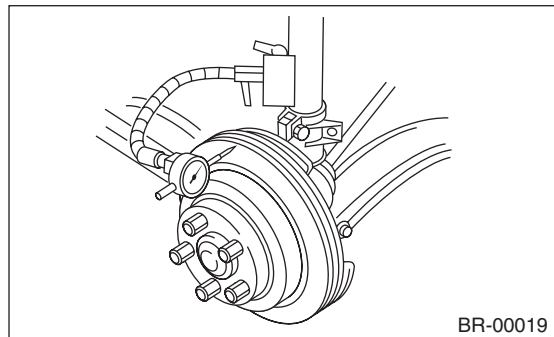

#### Disc rotor runout limit:

**17-inch type**

**0.075 mm (0.0030 in)**

**16-inch type**

**0.050 mm (0.0020 in)**

- 4) Set a micrometer 10 mm (0.39 in) inward from the disc rotor outer perimeter, and then measure the disc rotor thickness. If the thickness A of the disc rotor exceeds the service limit, replace with a new disc rotor.

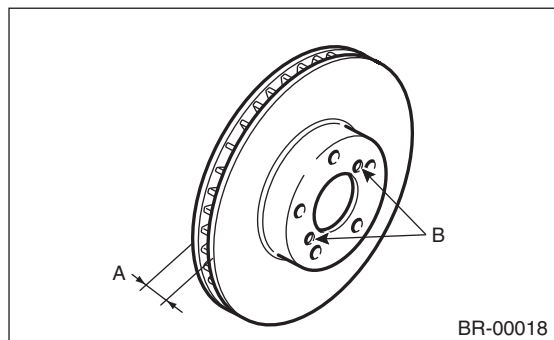

Disc rotor thickness A mm (in)	Specifica- tion	Limit	Disc rotor diameter
17-inch type	30 (1.18)	28 (1.10)	326 (12.83)
16-inch type	24 (0.94)	22 (0.87)	294 (11.57)

# Front Disc Brake Assembly

BRAKE

## 4. Front Disc Brake Assembly

### A: REMOVAL

#### 1. 17-INCH TYPE

##### CAUTION:

Do not allow brake fluid to come in contact with the painted surface of the vehicle body. If it does, wash off with water immediately and wipe away completely.

- 1) Lift up the vehicle, and then remove the front wheels.
- 2) Remove the union bolt (1) and brake hose from the caliper body.
- 3) Remove the mounting bolts (2) from the housing.

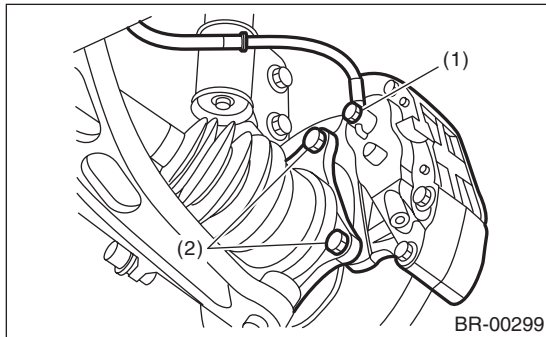

- 4) Remove mud and foreign matter from the caliper body assembly.

#### 2. 16-INCH TYPE

##### CAUTION:

Do not allow brake fluid to come in contact with the painted surface of the vehicle body. If it does, wash off with water and wipe away completely.

- 1) Lift up the vehicle, and then remove the front wheels.
- 2) Remove the union bolt, and disconnect the brake hose from the caliper body.

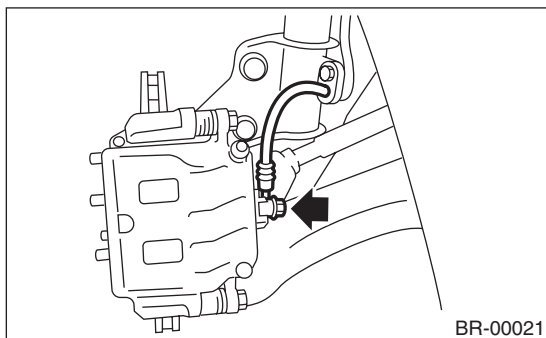

- 3) Remove the bolts which secure the caliper body.

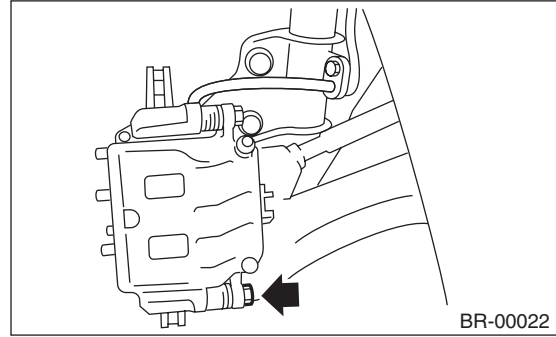

- 4) Raise the caliper body, and then move it toward vehicle center to separate it from the support.
- 5) Remove the brake pad, and then remove the support from the housing.

##### NOTE:

Remove the support only when replacing the rotor or support. It is not necessary to remove it when servicing the caliper body.

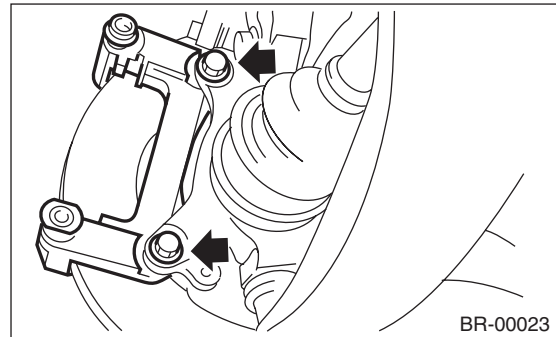

- 6) Remove mud and foreign matter from the caliper body and the support.

### B: INSTALLATION

#### 1. 17-INCH TYPE

- 1) Install the caliper body assembly to the housing.

##### Tightening torque:

**155 N·m (15.81 kgf-m, 114.3 ft-lb)**

- 2) Apply a thin coat of Molykote M7439 (Part No. 003602001) or grease contained in the pad kit to the side of the pad.

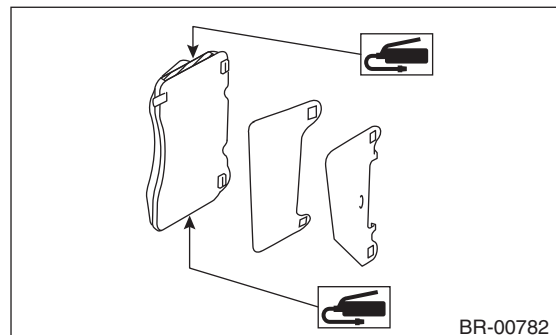

3) Apply a thin coat of Molykote AS880N (Part No. K0777YA010) or grease contained in the pad kit to the pad and pad shim.

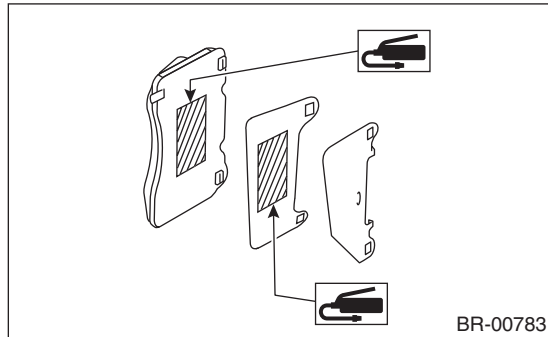

- 4) Install the pads to the caliper body.
- 5) Install the cross spring.
- 6) Install the pad pins.
- 7) Install the clips.
- 8) Connect the brake hose using a new brake hose gasket.

**Tightening torque:**

**18 N·m (1.84 kgf·m, 13.3 ft·lb)**

9) Bleed air from the brake system. <Ref. to BR-39, PROCEDURE, Air Bleeding.>

## 2. 16-INCH TYPE

1) Apply a thin coat of Molykote M7439 (Part No. 003602001) or the grease included with pad kit to the support.

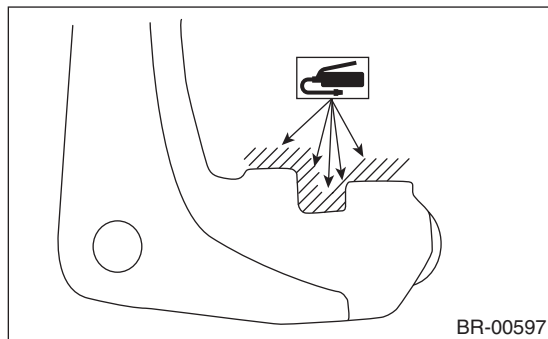

2) Install the support to the housing.

**Tightening torque:**

**80 N·m (8.16 kgf·m, 59 ft·lb)**

3) Apply a thin coat of Molykote M7439 (Part No. 003602001) or grease contained in the pad kit to the pad clip.

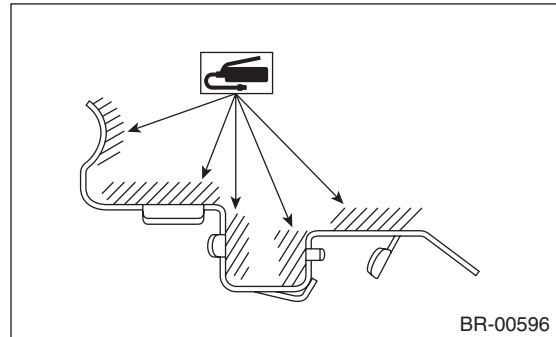

4) Apply a thin coat of Molykote AS880N (Part No. K0777YA010) or grease contained in the pad kit to both surfaces of the pad and inner shim.

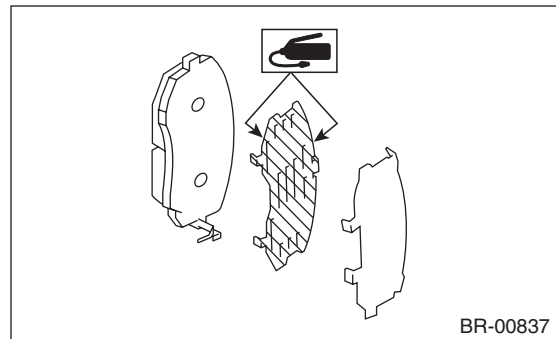

5) Install the pad to support.

**CAUTION:**

- Be sure to install so that the pad return spring faces the input side of the direction of brake rotor rotation, as shown in the figure.
- Correctly install the pad return spring to the supporting surface of the pad clip as shown in the figure.
- If the pad return spring is deformed or damaged, replace the brake pad.

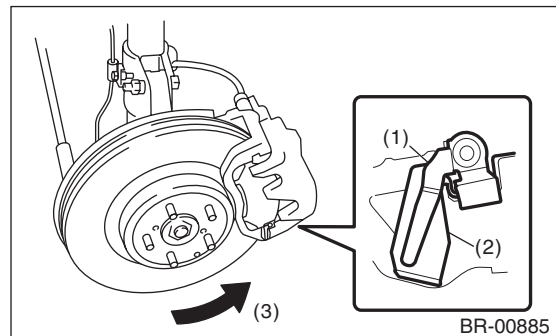

- (1) Pad return spring
- (2) Supporting surface of pad clip
- (3) Direction of brake rotor rotation



# Front Disc Brake Assembly

## BRAKE

### NOTE:

Install the pad indicator in proper direction.

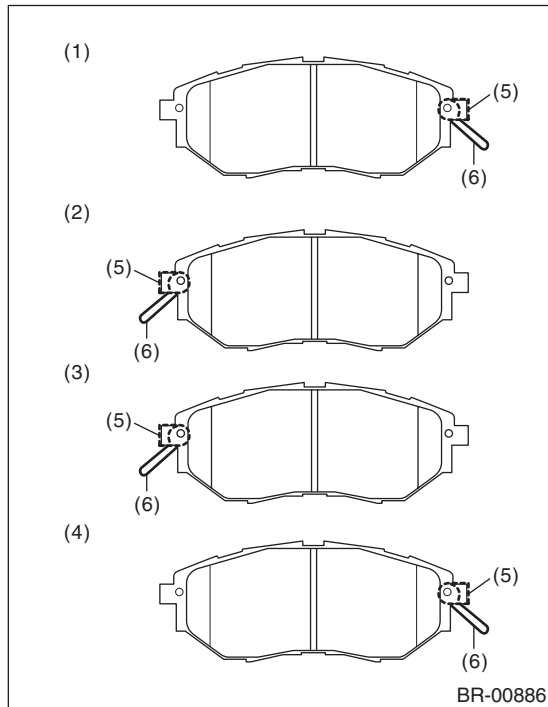

- (1) LH — IN
- (2) LH — OUT
- (3) RH — IN
- (4) RH — OUT
- (5) Pad indicator
- (6) Pad return spring

6) Install the caliper body to the support.

### **Tightening torque:**

**27 N·m (2.75 kgf·m, 19.9 ft·lb)**

7) Connect the brake hose using a new brake hose gasket.

### **Tightening torque:**

**18 N·m (1.84 kgf·m, 13.3 ft·lb)**

8) Bleed air from the brake system. <Ref. to BR-39, PROCEDURE, Air Bleeding.>

## C: DISASSEMBLY

### 1. 17-INCH TYPE

1) Remove mud and foreign matter from the caliper body.

### **CAUTION:**

**Be careful not to allow foreign matter to enter the brake hose connector.**

2) Remove the piston boots from each piston end.

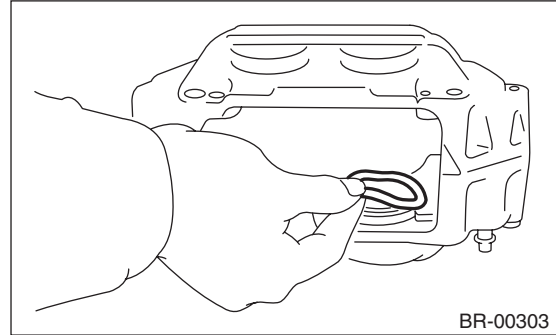

3) Place a wooden block in the caliper body as shown in the figure to prevent the piston from jumping out and being damaged.

4) Gradually apply compressed air via the brake hose installation hole to push the piston out.

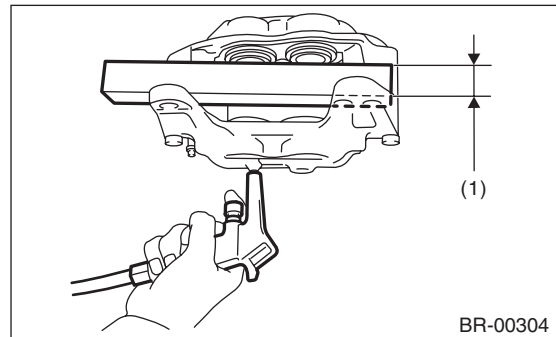

(1) Place a wooden block of 30 mm (1.18 in) width.

5) Remove the piston seal (1) from the caliper body cylinder.

### **CAUTION:**

**Do not damage the cylinder and piston seal groove.**

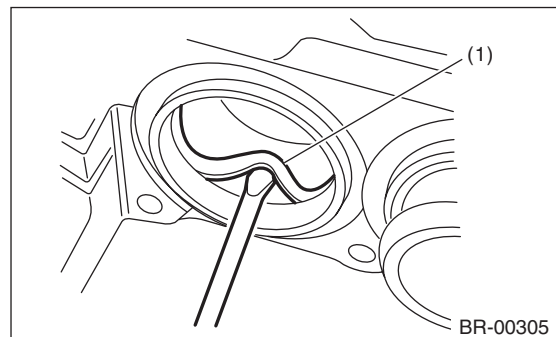

### 2. 16-INCH TYPE

1) Remove mud and foreign matter from the caliper body and the support.

### **CAUTION:**

**Be careful not to allow foreign matter to enter the brake hose connector.**

2) Place a wooden block in the caliper body as shown in the figure to prevent the piston from jumping out and being damaged.

3) Gradually apply compressed air via the brake hose installation hole to push the piston out.

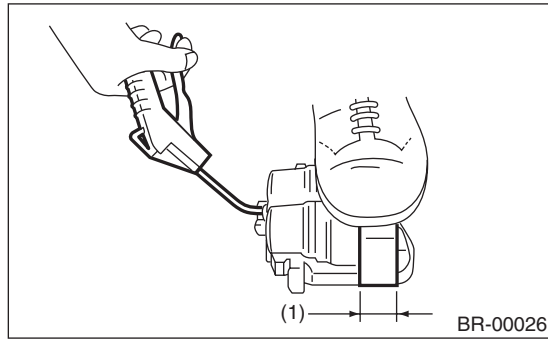

(1) Place a wooden block of 30 mm (1.18 in) width.

4) Remove the piston boot.

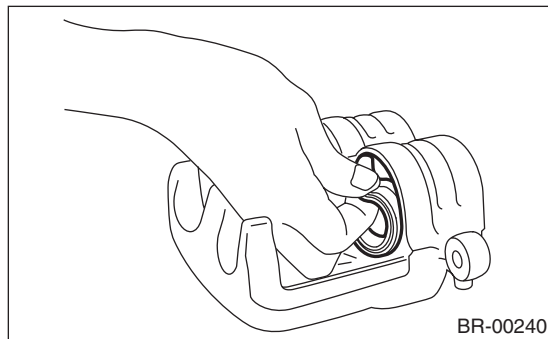

5) Remove the piston seal (1) from the caliper body cylinder.

**CAUTION:**  
Do not damage the cylinder and piston seal groove.

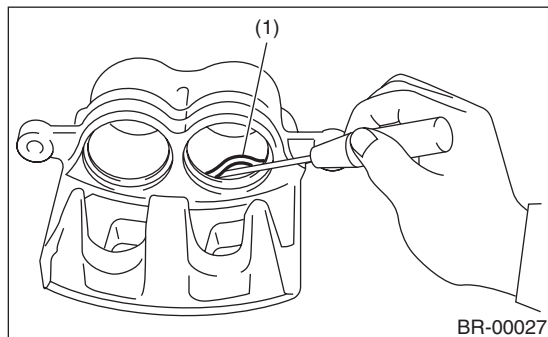

6) Remove the guide pin and boot from caliper body.

## D: ASSEMBLY

### 1. 17-INCH TYPE

- 1) Clean the inside of the caliper body using brake fluid.
- 2) Apply a coat of brake fluid to piston seal and install the piston seal to the caliper body groove.
- 3) Apply a coat of brake fluid to the inner surface of cylinder and the entire outer surface of the piston.

4) Apply NIGLUBE RX-2 (Part No. K0779AG102) or the piston kit grease to the boot, and install to the piston groove.

5) Insert the piston into the cylinder.

**CAUTION:**  
Do not force the piston into cylinder.

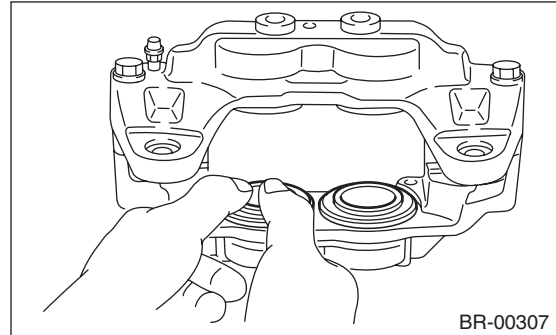

6) Position the boot in the grooves on cylinder and piston.

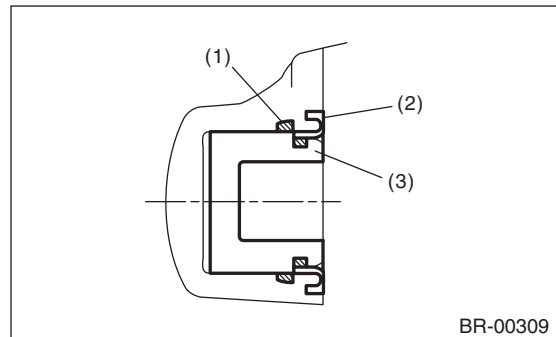

- (1) Piston seal
- (2) Piston boot
- (3) Piston

### 2. 16-INCH TYPE

- 1) Clean the inside of the caliper body using brake fluid.
- 2) Apply a coat of brake fluid to piston seal and install the piston seal to the caliper body groove.
- 3) Apply a coat of brake fluid to the inner surface of cylinder and the entire outer surface of the piston.
- 4) Apply grease contained in the piston seal kit to the boot, and install it to the groove at the end of the cylinder.

# Front Disc Brake Assembly

## BRAKE

5) Insert the piston into cylinder.

### CAUTION:

Do not force the piston into cylinder.

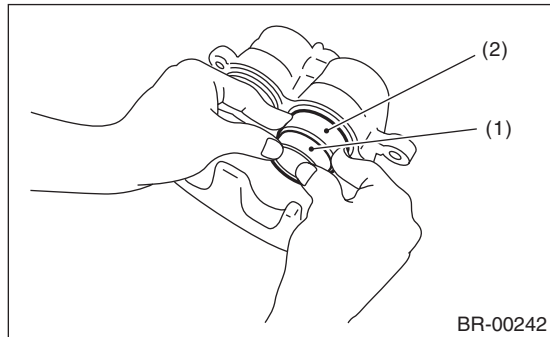

- (1) Piston
- (2) Piston boot

6) Position the boot in the grooves on cylinder and piston.

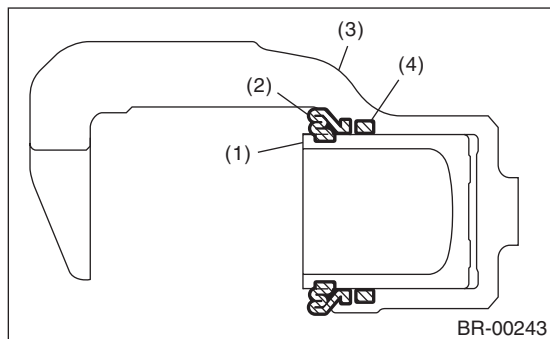

- (1) Piston
- (2) Piston boot
- (3) Caliper body
- (4) Piston seal

7) Apply a coat of the grease included with the piston kit to the lock pin and guide pin outer surface, cylinder inner surface, and boot grooves.

8) Insert the lock pin and guide pin boot into the support.

### CAUTION:

After inserting the pin into the given place, move the caliper by hand to make sure that it moves smoothly without obstacles or excessive friction.

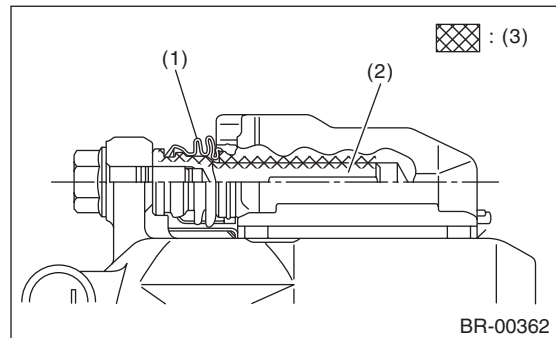

- (1) Pin boot
- (2) Lock pin or guide pin
- (3) Grease applied area

## E: INSPECTION

- 1) Repair or replace the faulty parts.
- 2) Check the caliper body and piston for uneven wear, damage or rust.
- 3) Check the rubber parts for damage or deterioration.

## 5. Rear Brake Pad

### A: REMOVAL

#### 1. 17-INCH TYPE

- 1) Lift up the vehicle, and then remove the rear wheels.
- 2) Remove clips (1).

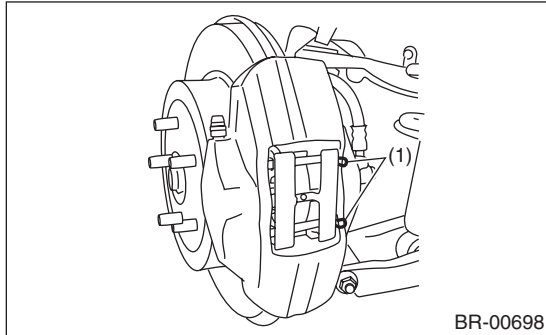

- 3) Remove the pad pins (1) and cross spring (2).

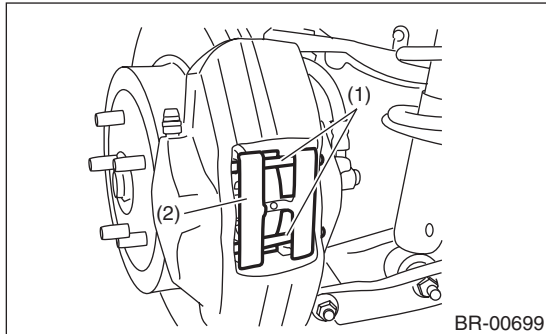

- 4) Spread apart the pads using a pair of wrenches and push back the piston.
- 5) Remove the pads.

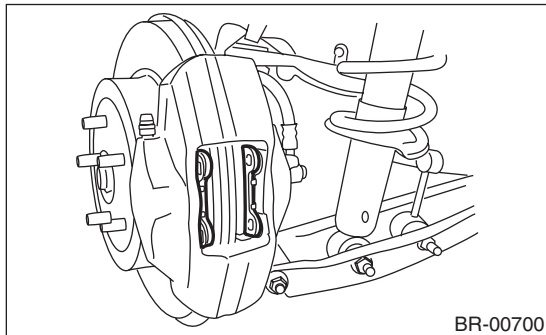

#### 2. 15-INCH TYPE

- 1) Lift up the vehicle, and then remove the rear wheels.

- 2) Remove the brake hose bracket.

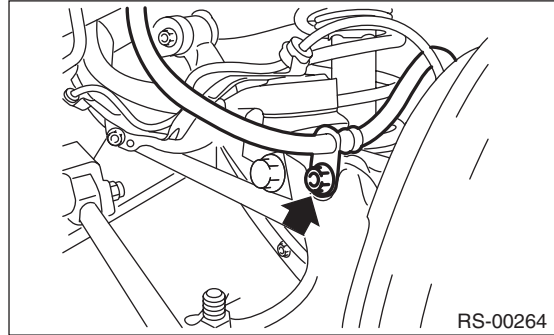

- 3) Remove the caliper bolt.

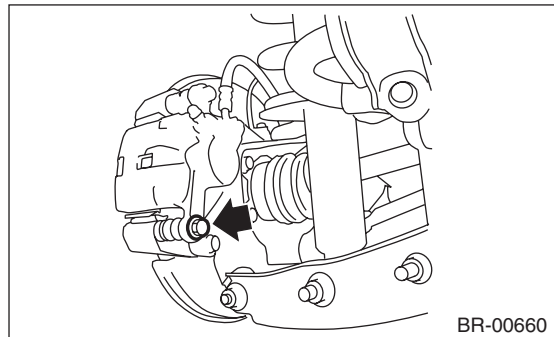

- 4) Raise the caliper body and support it.

#### NOTE:

Do not disconnect the brake hose from the caliper body.

- 5) Remove the pads.

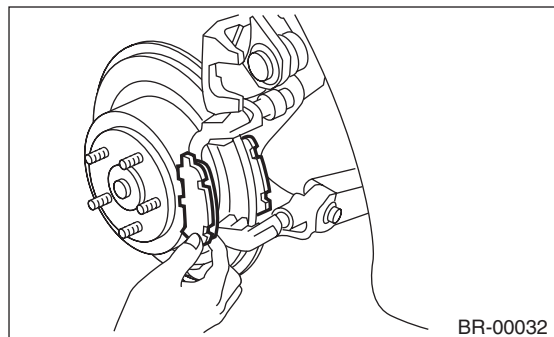

# Rear Brake Pad

BRAKE

## B: INSTALLATION

### 1. 17-INCH TYPE

1) Apply a thin coat of Molykote M7439 (Part No. 003602001) or grease contained in the pad kit to the side of the pad.

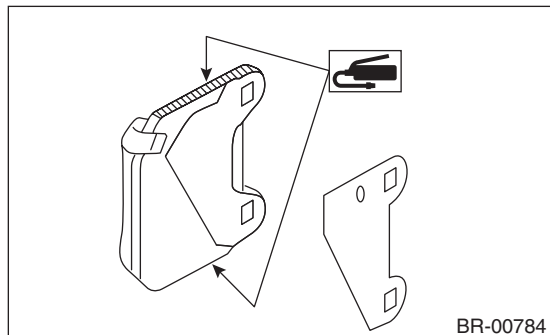

2) Apply a thin coat of Molykote AS880N (Part No. K0777YA010) or the grease contained in the pad kit to the contact surface between the pad and pad shim.

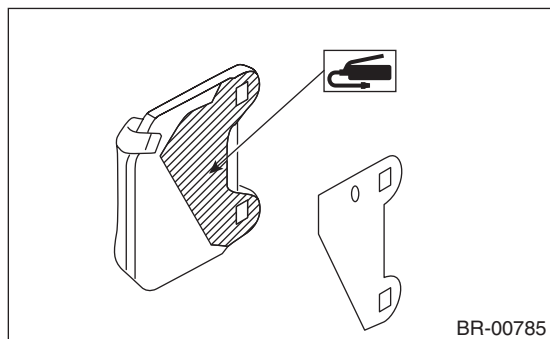

- 3) Install the pads to the caliper body.
- 4) Install the cross spring and pad pins.
- 5) Install the clips.

### 2. 15-INCH TYPE

1) Apply a thin coat of Molykote M7439 (Part No. 003602001) or grease contained in the pad kit to the pad clip.

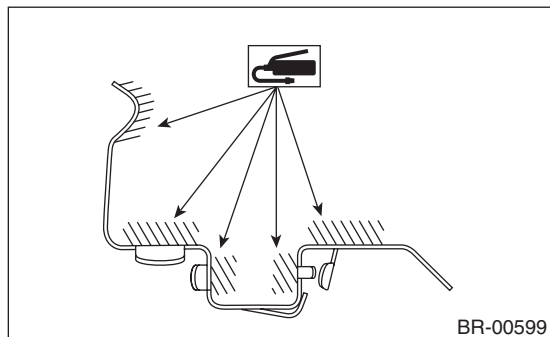

2) Apply a thin coat of Molykote AS880N (Part No. K0777YA010) or grease contained in the pad kit between the outer pad and shim.

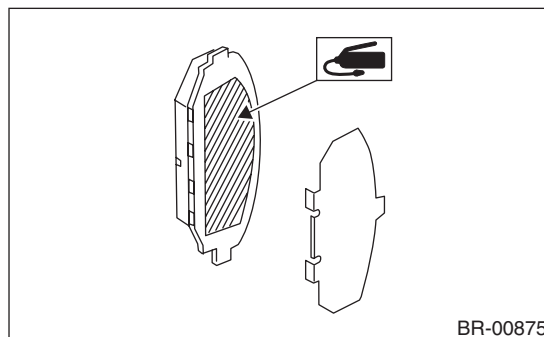

3) Apply a thin coat of Molykote AS880N (Part No. K0777YA010) or grease contained in the pad kit to both surfaces of the inner pad inner shim.

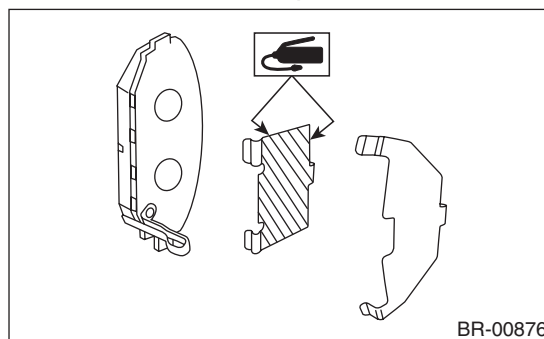

- 4) Install the pad to support.
- 5) Install the caliper body to the support.

**Tightening torque:**  
27 N·m (2.75 kgf·m, 19.9 ft·lb)

- 6) Install the brake hose bracket.

**Tightening torque:**  
33 N·m (3.36 kgf·m, 24.3 ft·lb)

## C: INSPECTION

Check the pad thickness A.

- 17-inch type

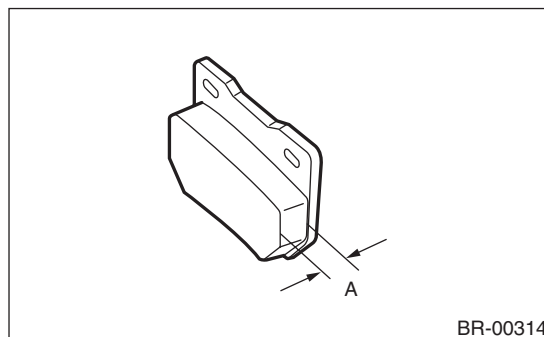

Pad thickness A mm (in)	Specification	9.0 (0.354)
	Wear limit	1.2 (0.047)

- 15-inch type

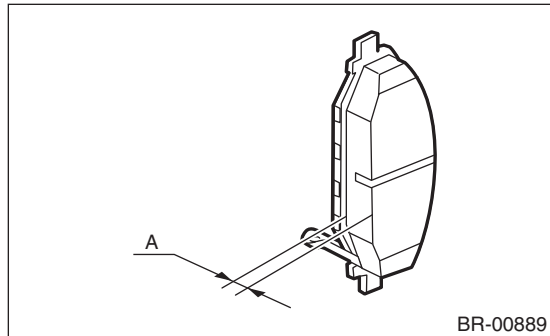

Pad thickness A mm (in)	Specification	9.0 (0.354)
	Wear limit	1.5 (0.059)

**NOTE:**

- Always replace the pads of both wheels and both sides as a set.
- Replace the cross spring and pad pins if they are twisted or worn. (17-inch type)
- A wear indicator is installed on the outer disc brake pad. (17-inch type)
- Wear indicators are installed on the inner and outer disc brake pads. (15-inch type)
- If the pad is worn to the limit, the end of wear indicator contacts disc rotor, and a squeaking sound is heard as the wheel rotates. If the sound is heard, replace the pad.
- Replace the pad if there is oil or grease on it.

## 6. Rear Disc Rotor

### A: REMOVAL

- 1) Lift up the vehicle, and then remove the rear wheels.
- 2) Release the parking brake.
- 3) Remove the brake hose bracket.

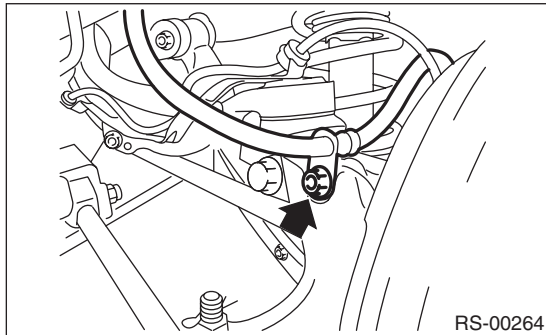

- 4) Remove the caliper body assembly from housing, and suspend it from the strut using a wire.

#### CAUTION:

Be careful not to stretch the brake hose.

- 17-inch type

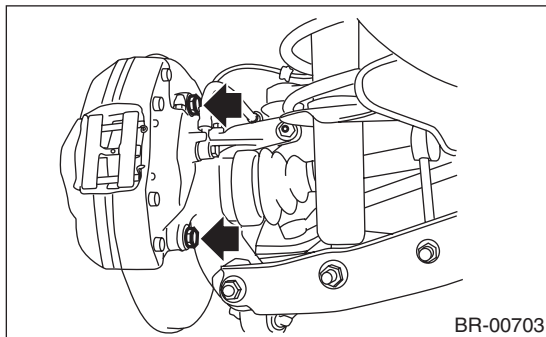

- 15-inch type

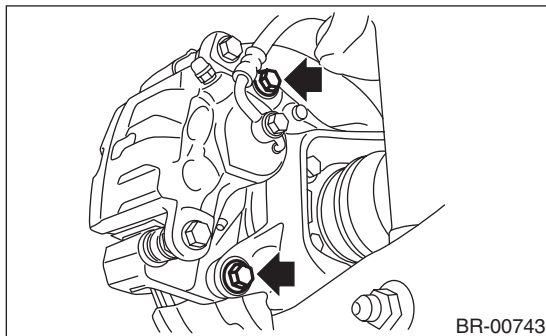

- 5) Remove the disc rotor.

#### NOTE:

If it is difficult to remove the disc rotor, perform the following two methods in order.

- (1) Turn the adjusting screw using a flat tip screwdriver until the brake shoe is far enough away to allow removal of the disc rotor.

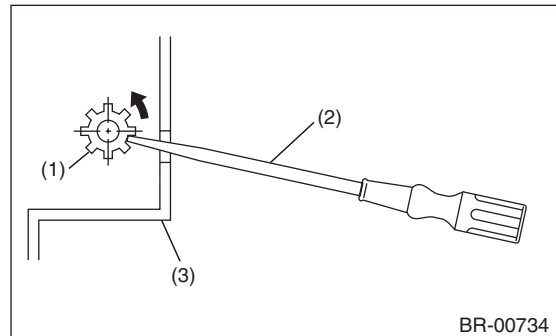

- (1) Adjusting screw
- (2) Flat tip screwdriver
- (3) Disc rotor

- (2) If it is difficult to remove the disc rotor from the hub, drive an 8 mm bolt into the threads B of the rotor, then remove the rotor.

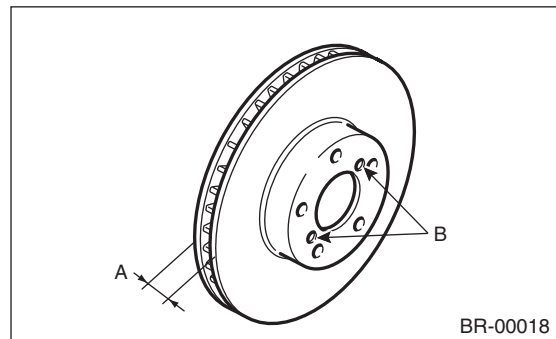

### B: INSTALLATION

- 1) Install each part in the reverse order of removal.

#### Tightening torque:

##### Brake hose bracket

**33 N·m (3.36 kgf-m, 24.3 ft-lb)**

##### Caliper body assembly (17-inch type)

**65 N·m (6.63 kgf-m, 47.9 ft-lb)**

##### Caliper body assembly (15-inch type)

**66 N·m (6.73 kgf-m, 48.7 ft-lb)**

- 2) Adjust the parking brake. <Ref. to PB-8, ADJUSTMENT, Parking Brake Assembly (Rear Disc Brake).>

### C: INSPECTION

- 1) Check the rear wheel bearing play and axle hub runout before inspecting the disc rotor runout. <Ref. to DS-26, INSPECTION, Rear Hub Unit Bearing.>
- 2) Secure the disc rotor by tightening the five wheel nuts.

3) Set a dial gauge 10 mm (0.39 in) inward from the disc rotor outer circumference. Rotate the disc rotor to check runout. If the disc rotor runout exceeds the limit, resurface the disc rotor. After grinding, check the thickness of the disc rotor according to the procedure in step 4).

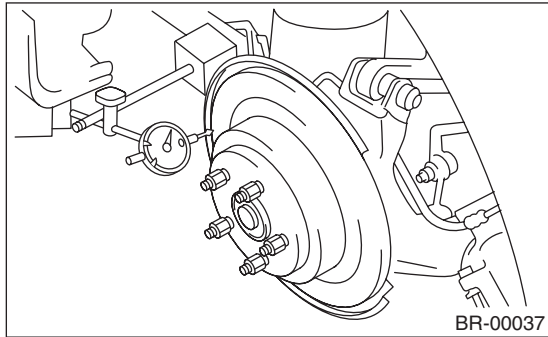

**Disc rotor runout limit:**

**17-inch type**

**0.070 mm (0.0028 in)**

**15-inch type**

**0.050 mm (0.0020 in)**

4) Set a micrometer 10 mm (0.39 in) inward from the disc rotor outer perimeter, and then measure the disc rotor thickness. If the thickness A of the disc rotor exceeds the service limit, replace with a new disc rotor.

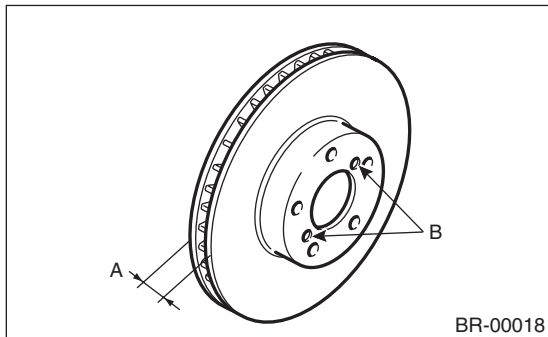

Disc rotor thickness A mm (in)	Specification	Limit	Disc rotor diameter
17-inch type	20 (0.79)	18 (0.71)	316 (12.44)
15-inch type	10 (0.39)	8.5 (0.335)	286 (11.26)



# Rear Disc Brake Assembly

## BRAKE

### 7. Rear Disc Brake Assembly

#### A: REMOVAL

##### 1. 17-INCH TYPE

###### CAUTION:

Do not allow brake fluid to come in contact with the painted surface of the vehicle body. If it does, wash off with water and wipe away completely.

- 1) Lift up the vehicle, and then remove the rear wheels.
- 2) Remove the union bolt and brake hose from the caliper body.
- 3) Remove the caliper body assembly.

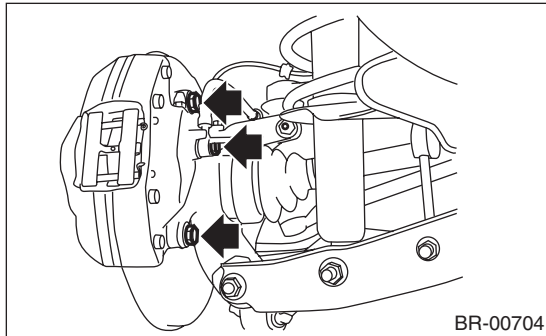

- 4) Remove mud and foreign matter from the caliper body assembly.

###### CAUTION:

Be careful not to allow foreign matter to enter the brake hose connector.

##### 2. 15-INCH TYPE

###### CAUTION:

Do not allow brake fluid to come in contact with the painted surface of the vehicle body. If it does, wash off with water and wipe away completely.

- 1) Lift up the vehicle, and then remove the rear wheels.
- 2) Remove the brake hose bracket.
- 3) Disconnect the brake hose.

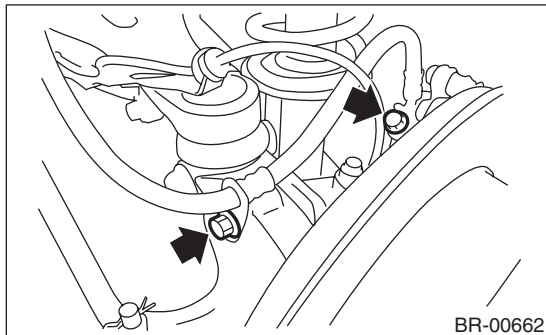

- 4) Remove the caliper mounting bolts.

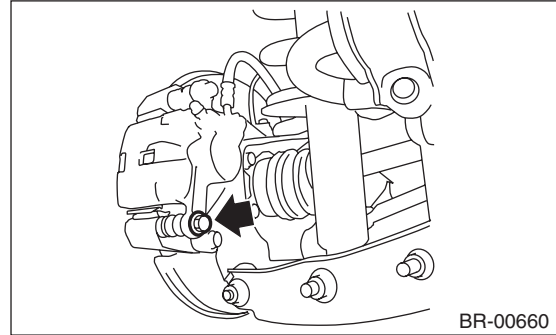

- 5) Raise the caliper body, and then move it toward vehicle center to separate it from the support.
- 6) Remove the brake pad, and then remove the support from the housing.

###### NOTE:

Remove the support only when replacing the rotor or support. It is not necessary to remove it when servicing the caliper body.

- 7) Remove mud and foreign matter from the caliper body and the support.

###### CAUTION:

Be careful not to allow foreign matter to enter the brake hose connector.

#### B: INSTALLATION

##### 1. 17-INCH TYPE

- 1) Install the caliper body to the housing.

###### Tightening torque:

**65 N·m (6.63 kgf·m, 47.9 ft·lb)**

- 2) Apply a thin coat of Molykote M7439 (Part No. 003602001) or grease contained in the pad kit to the side of the pad.

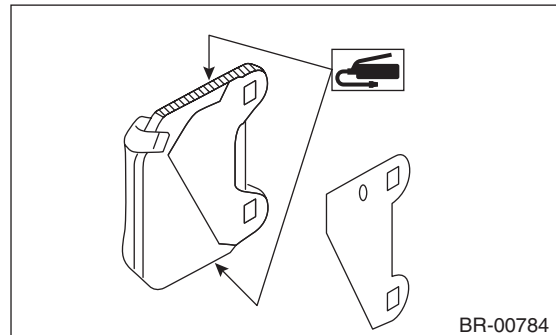

3) Apply a thin coat of Molykote AS880N (Part No. K0777YA010) or the grease contained in the pad kit to the contact surface between the pad and pad shim.

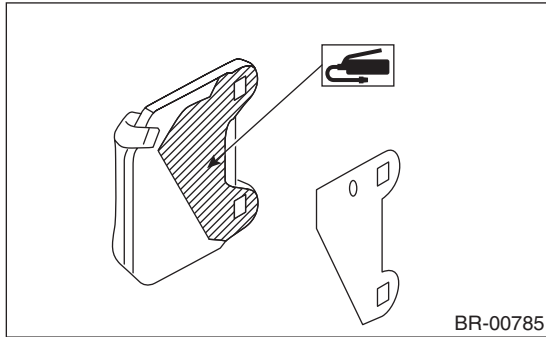

- 4) Install the pads to the caliper body.
- 5) Install the cross spring and pad pins.
- 6) Install the clips.
- 7) Connect the brake hose using a new brake hose gasket.

**Tightening torque:**

**18 N·m (1.84 kgf·m, 13.3 ft·lb)**

8) Bleed air from the brake system. <Ref. to BR-39, PROCEDURE, Air Bleeding.>

## 2. 15-INCH TYPE

1) Apply a thin coat of Molykote M7439 (Part No. 003602001) or the grease included with pad kit to the support.

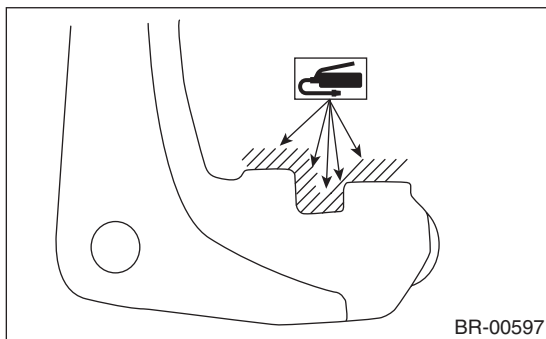

2) Install the support to the housing.

**Tightening torque:**

**66 N·m (6.73 kgf·m, 48.7 ft·lb)**

3) Apply a thin coat of Molykote M7439 (Part No. 003602001) or grease contained in the pad kit to the pad clip.

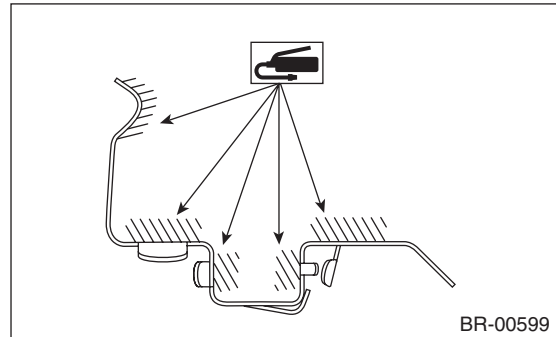

4) Apply a thin coat of Molykote AS880N (Part No. K0777YA010) or grease contained in the pad kit between the outer pad and shim.

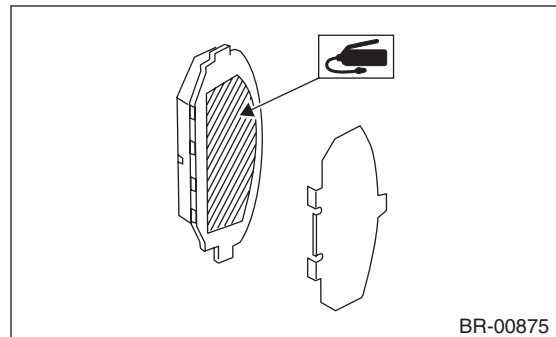

5) Apply a thin coat of Molykote AS880N (Part No. K0777YA010) or grease contained in the pad kit to both surfaces of the inner pad inner shim.

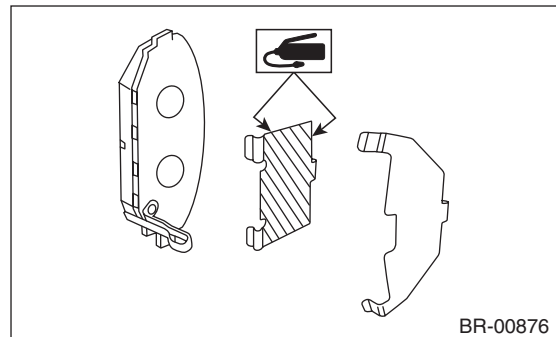

- 6) Install the pad to support.
- 7) Install the caliper body to the support.

**Tightening torque:**

**27 N·m (2.75 kgf·m, 19.9 ft·lb)**

8) Install the brake hose bracket.

**Tightening torque:**

**33 N·m (3.36 kgf·m, 24.3 ft·lb)**

9) Connect the brake hose using a new brake hose gasket.

**Tightening torque:**

**18 N·m (1.84 kgf·m, 13.3 ft·lb)**

10) Bleed air from the brake system. <Ref. to BR-39, PROCEDURE, Air Bleeding.>

# Rear Disc Brake Assembly

## BRAKE

### C: DISASSEMBLY

#### 1. 17-INCH TYPE

- 1) Remove the piston boots from each piston end.

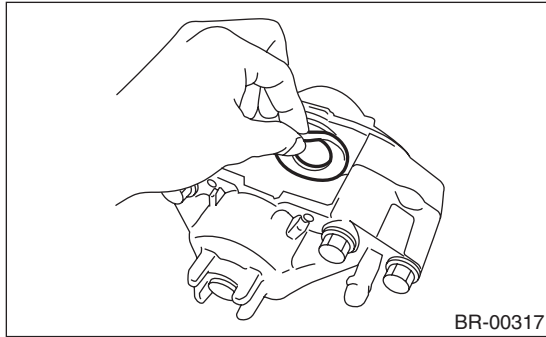

- 2) Place a wooden block in the caliper body as shown in the figure to prevent the piston from jumping out and being damaged.

- 3) Gradually apply compressed air via the brake hose installation hole to push the piston out.

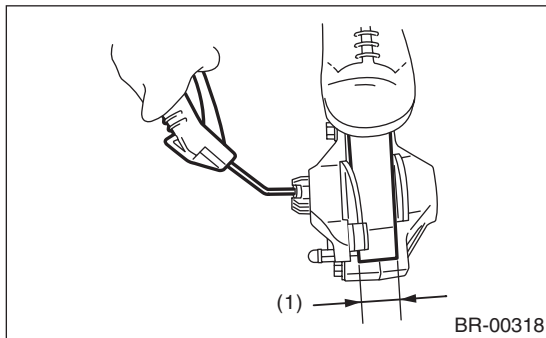

- (1) Place a wooden block of 20 mm (0.79 in) width.

- 4) Remove the piston seal from caliper body cylinder.

**CAUTION:**  
Do not damage the cylinder and piston seal groove.

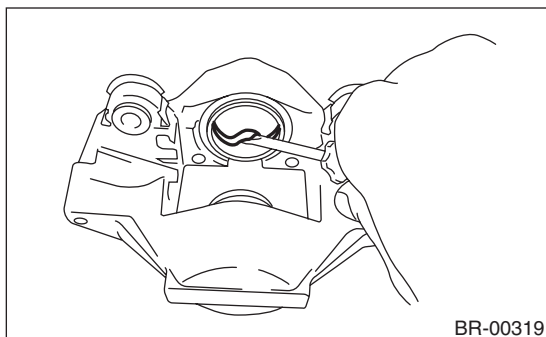

#### 2. 15-INCH TYPE

- 1) Remove the piston boot.

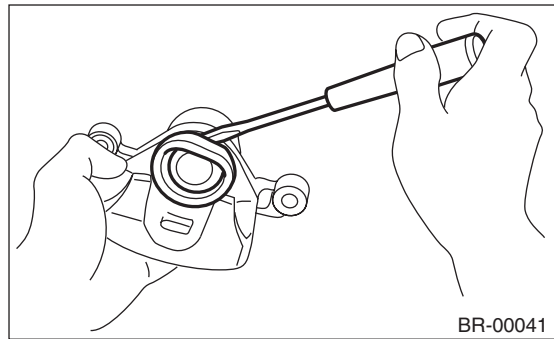

- 2) Place a wooden block in the caliper body as shown in the figure to prevent the piston from jumping out and being damaged.

- 3) Gradually apply compressed air via the brake hose installation hole to push the piston out.

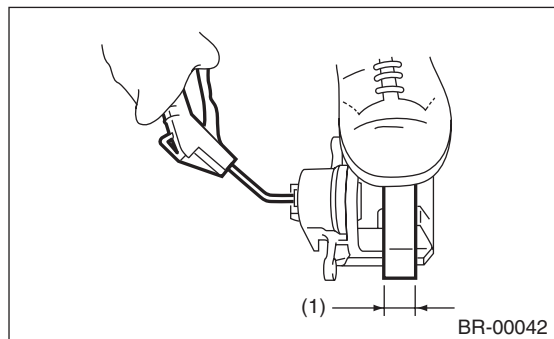

- (1) Place a wooden block of 30 mm (1.18 in) width.

- 4) Remove the piston seal from caliper body cylinder.

**CAUTION:**  
Do not damage the cylinder and piston seal groove.

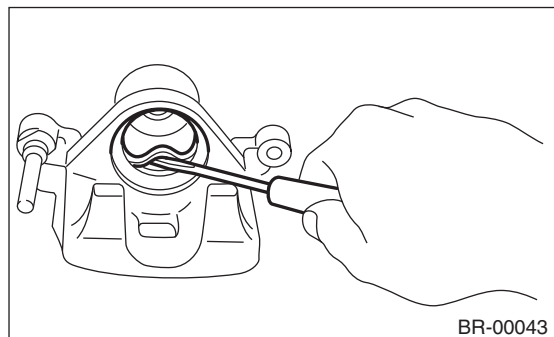

- 5) Remove the pin boot.

## D: ASSEMBLY

### 1. 17-INCH TYPE

- 1) Clean the inside of the caliper body using brake fluid.
- 2) Apply a coat of brake fluid to the piston seal and install in the caliper body groove.
- 3) Apply a coat of brake fluid to the inner surface and the entire outer surface of the cylinder.
- 4) Apply NIGLUBE RX-2 (Part No. K0779GA102) or the pad kit grease to the boot, and install to the piston groove.
- 5) Insert the piston into the cylinder.

**CAUTION:**

**Do not force the piston into cylinder.**

- 6) Position the boot in the grooves on piston and cylinder.

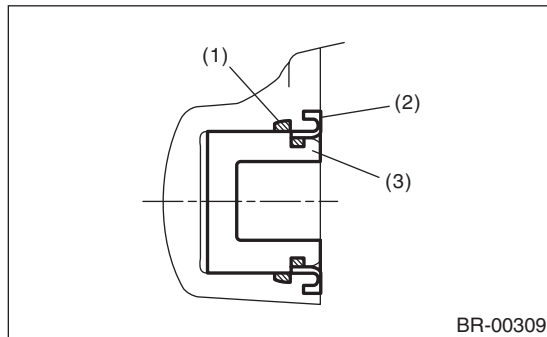

- (1) Piston seal
- (2) Piston boot
- (3) Piston

### 2. 15-INCH TYPE

- 1) Clean the inside of the caliper body using brake fluid.
- 2) Apply a coat of brake fluid to piston seal and install the piston seal to the caliper body groove.
- 3) Apply a coat of brake fluid to the inner surface of cylinder and the entire outer surface of the piston.
- 4) Apply grease contained in the piston seal kit to the boot, and install it to the groove at the end of the cylinder.
- 5) Insert the piston into cylinder.

**CAUTION:**

**Do not force the piston into cylinder.**

- 6) Position the boot in the grooves on piston and cylinder.

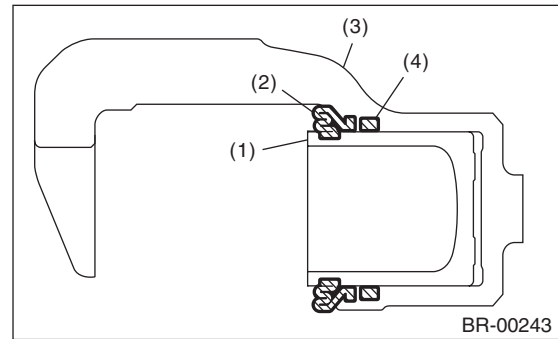

- (1) Piston
- (2) Piston boot
- (3) Caliper body
- (4) Piston seal

- 7) Apply grease contained in the piston seal kit to the cylinder inner surface, pin, bushing outer surface, and boot grooves.

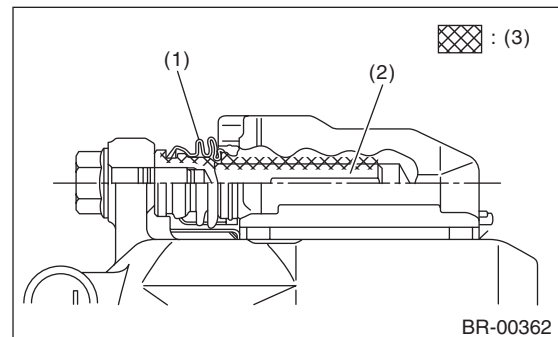

- (1) Pin boot
- (2) Lock pin or guide pin
- (3) Grease applied area

- 8) Insert the pin boot into the support.
- 9) Install the pin boot to the support, and then insert the pin into the specified position.

**CAUTION:**

**Insert the pin into specified position, and make sure that they slide and seat properly.**

## E: INSPECTION

- 1) Repair or replace the faulty parts.
- 2) Check the caliper body and piston for uneven wear, damage or rust.
- 3) Check the rubber parts for damage or deterioration.

# Master Cylinder

BRAKE

## 8. Master Cylinder

### A: REMOVAL

#### CAUTION:

Do not allow brake fluid to come in contact with the painted surface of the vehicle body. If it does, wash off with water and wipe away completely.

- 1) Drain brake fluid from the reservoir tank completely.
- 2) Disconnect the harness connector of the fluid level gauge.
- 3) Remove the brake pipe from the master cylinder.
- 4) Remove the master cylinder mounting nuts, and carefully remove the master cylinder from the brake booster.

### B: INSTALLATION

- 1) Replace the O-ring for the master cylinder with a new part.

#### CAUTION:

Be careful not to install the O-ring in the wrong location.

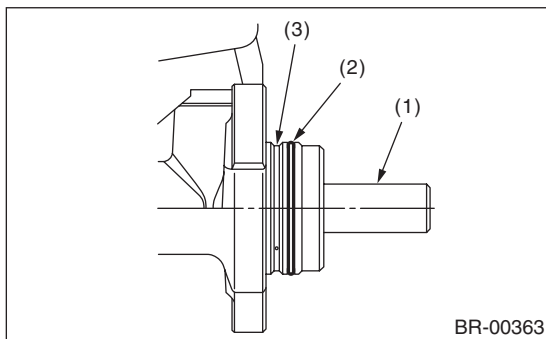

- (1) Primary piston
- (2) O-ring
- (3) Do not install the O-ring on this groove.

- 2) Install each part in the reverse order of removal.

#### Tightening torque:

**Master cylinder mounting nut**  
13 N·m (1.33 kgf·m, 9.6 ft·lb)

**Piping flare nut**  
15 N·m (1.53 kgf·m, 11.1 ft·lb)

#### CAUTION:

Be sure to use recommended brake fluid. <Ref. to BR-2, SPECIFICATION, General Description.>

- 3) Bleed air from the brake system. <Ref. to BR-39, PROCEDURE, Air Bleeding.>

### C: REPLACEMENT

- 1) Remove mud and dirt from the surface of brake master cylinder.

- 2) Secure the master cylinder in a vise.

#### CAUTION:

To avoid damaging the master cylinder, place between aluminum plates or other material when holding with a vise.

- 3) Remove the pin which secures the master cylinder and reservoir tank, then remove the reservoir tank and seal.

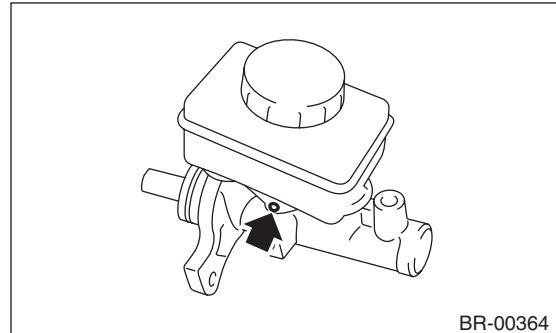

- 4) While pushing in the primary piston, remove the C-ring using pliers.

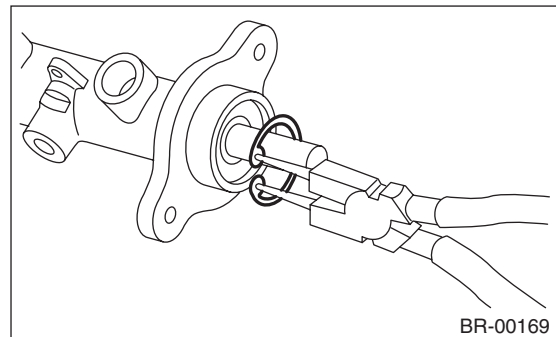

- 5) While pushing in the primary piston, remove the cylinder pin (1) from the port on the reservoir tank attachment location using a magnet pick-up tool.

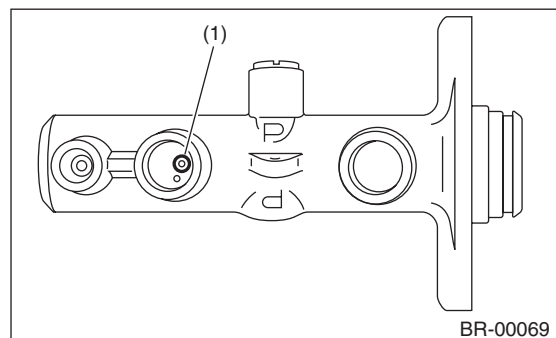

- 6) Extract the primary piston assembly and secondary piston assembly straight out while taking care not to scratch the inner surface of the cylinder.
- 7) Clean the inside of master cylinder with brake fluid. Check the inside of the cylinder for damage, deformation and wear. Replace the master cylinder as an assembly if faulty.
- 8) Apply brake fluid to the inner surface of master cylinder and piston assembly.

9) Make sure that the inner surface of master cylinder and the piston assembly are free of foreign matter. Install the primary piston assembly and the secondary piston assembly to master cylinder, while taking care not to scratch the master cylinder inner surface.

10) While pushing-in the primary piston, install the cylinder pin.

11) While pushing-in the primary piston, install the C-ring to the groove using pliers.

**CAUTION:**

**Make sure the C-ring is installed to the groove securely.**

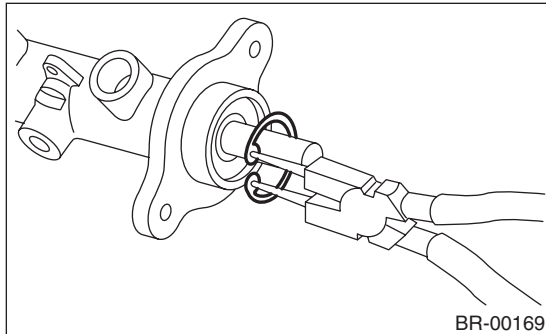

12) Install the seal (1) to reservoir tank.

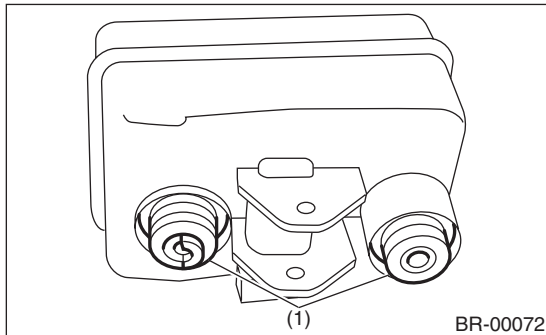

13) Install the reservoir tank to the master cylinder, and secure with pin.

14) Replace the O-ring for the master cylinder with a new part.

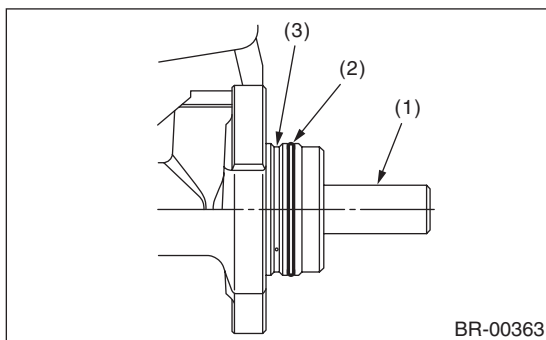

- (1) Primary piston
- (2) O-ring
- (3) Do not install the O-ring on this groove.

## D: INSPECTION

Inspect for brake fluid leakage from the master cylinder.

**NOTE:**

After replacing the piston kit, if a brake fluid leakage is found even though there is no damage or scratches on the inside of the cylinder, the master cylinder inner wall may be worn. In this case, replace the master cylinder as an assembly.

# Brake Booster

## BRAKE

### 9. Brake Booster

#### A: REMOVAL

1) Remove or disconnect the following parts in the engine compartment.

- (1) Disconnect the connector of brake fluid level gauge.
- (2) Remove the brake pipe from the master cylinder.
- (3) Remove the master cylinder installation nut.
- (4) Disconnect the vacuum hose from brake booster.

2) Remove the following parts from the pedal bracket.

- (1) Snap pin and clevis pin
- (2) Four brake booster installation nuts

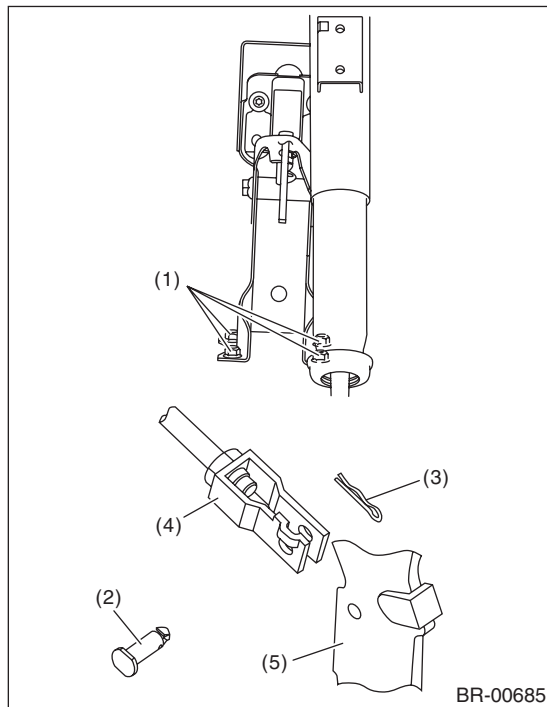

- (1) Nut
- (2) Clevis pin
- (3) Snap pin
- (4) Operating rod
- (5) Brake pedal

3) Remove the brake booster while avoiding the brake pipe.

#### CAUTION:

- Do not disassemble the brake booster.
- If external force (1) is applied from above when brake booster is placed in this position, the resin portion as indicated by "P" may become damaged.

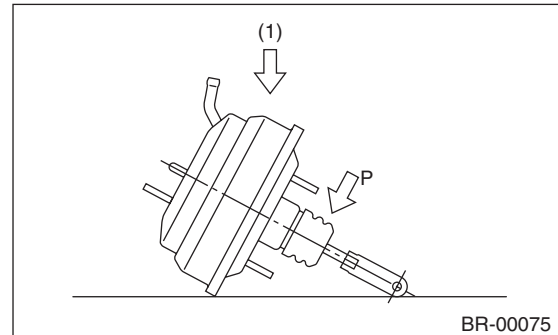

#### NOTE:

- Make sure that the booster shell and vacuum pipe are not subject to strong impacts.
- Be careful not to drop the brake booster. If the booster is dropped, replace it.
- Use special care when handling the operating rod. If excessive force is applied to the operating rod, the angle may change by  $\pm 3^\circ$ , and it may result in damage to power piston cylinder.
- Be careful when placing the brake booster on floor.
- Do not change the push rod length.

#### B: INSTALLATION

1) Check and adjust the operating rod of the brake booster.

**Specification L:**  
**136.3 mm (5.37 in)**

If it is out of specification, adjust it with the brake booster operating rod.

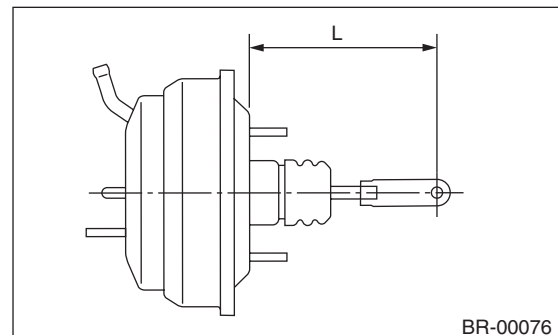

2) Mount the brake booster in position.



3) Install clevis pin and snap pin which secure the operating rod to the brake pedal.

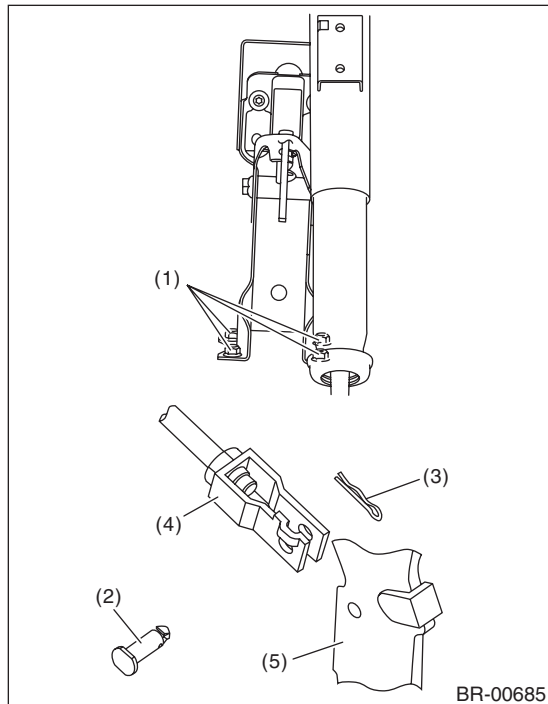

- (1) Nut
- (2) Clevis pin
- (3) Snap pin
- (4) Operating rod
- (5) Brake pedal

**NOTE:**

- Replace with a new clevis pin.
  - Apply NIGTIGHT LYW No. 2 grease to the clevis pin.
- 4) Connect the vacuum hose to the brake booster.  
 5) After replacing the O-ring, install the master cylinder to brake booster.

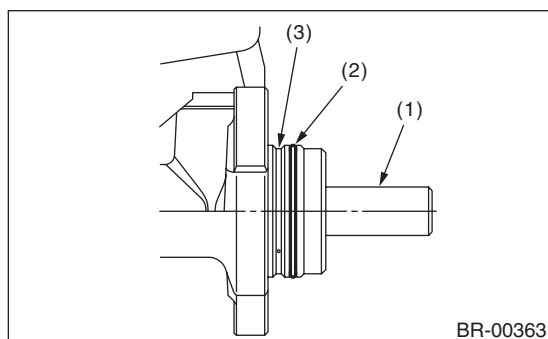

- (1) Primary piston
- (2) O-ring
- (3) Do not install the O-ring on this groove.

6) Connect the brake pipes to the master cylinder.  
 7) Connect the connector of the brake fluid level gauge.

8) Apply grease to the operating rod connecting pin to prevent it from wear.

9) Bleed air from the brake system. <Ref. to BR-39, PROCEDURE, Air Bleeding.>

10) Perform a road test to make sure the brakes do not drag.

## C: INSPECTION

**NOTE:**

On the model with brake assist mechanism, the following phenomena occur when the brake pedal is depressed. However, those are not malfunction but the phenomena that occur when the brake assist mechanism functions properly.

- Brake feel is soft when brake pedal is depressed hard or quicker than usual.
- ABS operating sound is heard when brake pedal is depressed hard or quicker than usual.

### 1. OPERATION CHECK (WITHOUT GAUGES)

**CAUTION:**

**When checking operation, be sure to apply the parking brake securely.**

- **Check without gauges**

This method can not determine exactly what part is defective. But it is possible to identify the outline of the defect by performing the check according to the following procedures.

- **Air tightness check**

Start the engine, and idle it for 1 to 2 minutes, then turn it OFF. Depress the brake pedal several times applying the normal pedal force. The pedal stroke should be the longest at the 1st depression, and it should become shorter at each successive depression. If no change occurs in the pedal height when pressed, the brake booster is faulty.

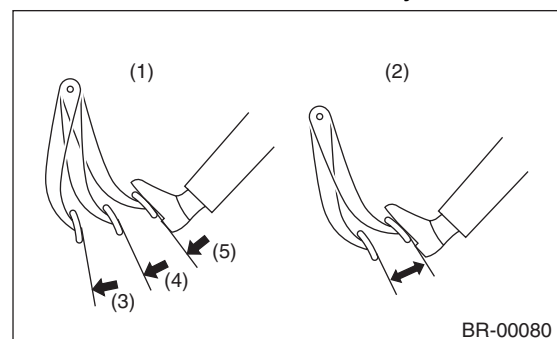

- (1) Normal
- (2) Not OK
- (3) 1st
- (4) 2nd
- (5) 3rd



# Brake Booster

## BRAKE

### NOTE:

- In case of defective operation, inspect the condition of the check valve and vacuum hose as well.
- Replace them if faulty, and perform the test again.
- If no improvement is observed, check precisely with gauges.

### • Check operation

1) While the engine is OFF, depress the brake pedal several times applying the same pedal force, to check for a change in pedal height.

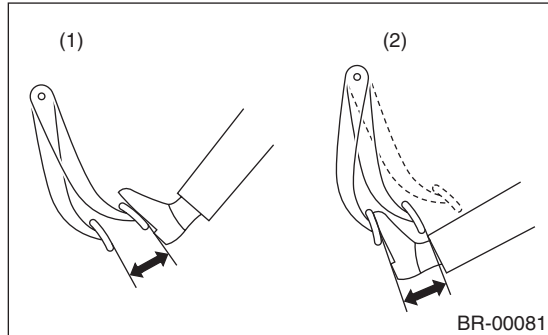

- (1) When engine is stopped  
(2) When engine is started

2) With the brake pedal depressed, start the engine.

3) As the engine starts, the brake pedal should move slowly toward the floor. If the pedal height does not change, the brake booster is faulty.

### NOTE:

If faulty, check precisely with gauges.

### • Loaded air tightness check

Depress the brake pedal while the engine is running, and turn the engine to OFF while the pedal is depressed. Keep the pedal depressed for 30 seconds. If the pedal height does not change, the function of brake booster is normal. If the pedal height increases, it is faulty.

### NOTE:

If faulty, check precisely with gauges.

## 2. OPERATION CHECK (WITH GAUGE)

### CAUTION:

When checking operation, be sure to apply the parking brake securely.

### • Check with gauge

Connect the gauge as shown in the figure. After bleeding air from the pressure gauge, perform each check.

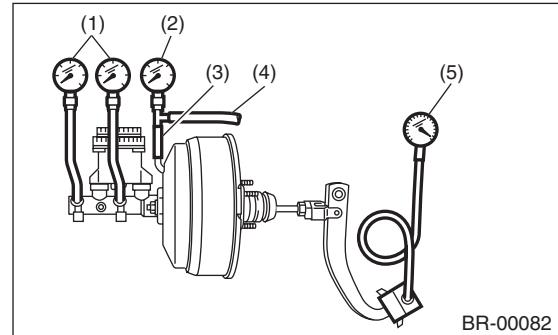

- (1) Pressure gauge  
(2) Vacuum gauge  
(3) Adapter hose  
(4) Vacuum hose  
(5) Pedal force gauge

### • Air tightness check

1) Start the engine and keep it running until vacuum pressure indicates point A of the vacuum gauge = 66.7 kPa (500 mmHg, 19.69 inHg). Do not depress the brake pedal at this time.

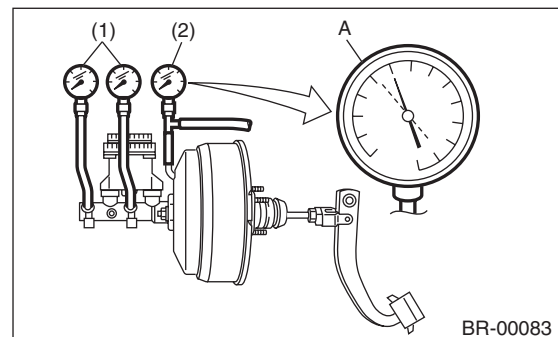

- (1) Pressure gauge  
(2) Vacuum gauge

2) Stop the engine and check the gauge. If the vacuum pressure drop within 15 seconds after stopping the engine is 3.3 kPa (25 mmHg, 0.98 inHg) or less, the function of brake booster is normal.

If faulty, the cause may be one of the following.

- Check valve malfunction
- Leak from vacuum hose
- Leak from shell joint section or stud bolt welded section
- Damaged diaphragm
- Leak from valve body seal and bearing section
- Leak from plate and seal assembly section
- Leak from poppet valve assembly section

• **Loaded air tightness check**

1) Start the engine and depress the brake pedal with a pedal force of 196 N (20 kgf, 44 lbf). Keep the engine running and keep the pedal pressed until a vacuum of point B = 66.7 kPa (500 mmHg, 19.69 inHg) is indicated on the vacuum gauge.

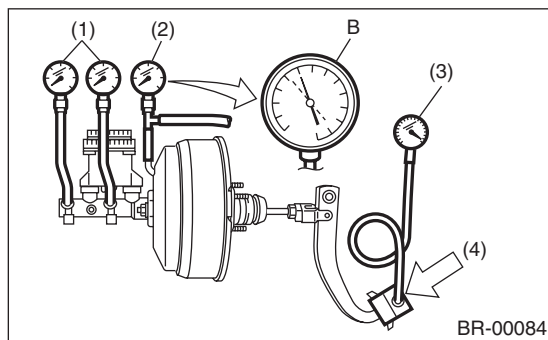

- (1) Pressure gauge
- (2) Vacuum gauge
- (3) Pedal force gauge
- (4) Depressed

2) Stop the engine and check the vacuum gauge. If the vacuum pressure drop within 15 seconds after stopping the engine is 3.3 kPa (25 mmHg, 0.98 inHg) or less, the function of brake booster is normal.

If defective, refer to "AIR TIGHTNESS CHECK".  
<Ref. to BR-35, INSPECTION, Brake Booster.>

3) If the brake booster is faulty, replace it with a new part.

• **Lack of boost action check**

Turn the engine OFF, and set the value of the vacuum gauge to "0". Then, check the fluid pressure when the brake pedal is depressed. The pressure must be greater than the specification listed.

• **Boosting action check**

Set the vacuum gauge reading to 66.7 kPa (500 mmHg, 19.69 inHg) with the engine running. Then, check the fluid pressure when the brake pedal is depressed. The pressure must be greater than the specification listed.

Brake pedal operation force N (kgf, lbf)		147 (15, 33)	294 (30, 66)
Fluid pressure kPa (kgf/cm <sup>2</sup> , psi)	6MT type	4,984 (51, 723)	10,249 (105, 1,486)
	5MT type	6,003 (61, 871)	11,273 (115, 1,635)

Brake pedal operation force N (kgf, lbf)	147 (15, 33)	294 (30, 66)
Fluid pressure kPa (kgf/cm <sup>2</sup> , psi)	545 (6, 79)	1,564 (16, 227)

## 10.Brake Fluid

### A: INSPECTION

1) Check that the amount of brake fluid is between the lines of "MIN" and "MAX". If out of the specified range, refill or drain the fluid. If the fluid level is close to "MIN", check the brake pad for wear and refill the fluid.

2) Check the fluid for discoloration. If the fluid is extremely discolored, replace with the new fluid.

### B: REPLACEMENT

#### CAUTION:

- Do not let brake fluid come into contact with the painted surface of the vehicle body. Wash away with water immediately and wipe off if it is spilled by accident.
- Avoid mixing brake fluid of different brands to prevent fluid performance from degrading.
- Be careful not to allow dirt or dust to enter the reservoir tank.

#### NOTE:

- During the operation, keep the reservoir tank filled with brake fluid to prevent entry of air.
- Operate the brake pedal slowly.
- For convenience and safety, perform the work with 2 people.
- The required amount of brake fluid is approximately 500 ml (16.9 US fl oz, 17.6 Imp fl oz) for the entire brake system.

1) Lift up the vehicle and set rigid racks at the specified locations, or keep the vehicle lifted.

2) Remove both the front and rear wheels.

3) Drain brake fluid from the reservoir tank.

4) Refill the reservoir tank with recommended brake fluid.

#### **Recommended brake fluid:**

**Refer to the "Specifications" in "General Description". <Ref. to BR-2, SPECIFICATION, General Description.>**

Perform the same procedure as for bleeding the brake line, until new brake fluid comes out from vinyl tube. <Ref. to BR-39, PROCEDURE, Air Bleeding.>

## 11. Air Bleeding

### A: PROCEDURE

#### CAUTION:

- Do not let brake fluid come into contact with the painted surface of the vehicle body. Wash away with water immediately and wipe off if it is spilled by accident.
- Avoid mixing brake fluid of different brands to prevent fluid performance from degrading.
- Be careful not to allow dirt or dust to enter the reservoir tank.

#### 1. MASTER CYLINDER

##### NOTE:

- When the master cylinder is disassembled or the reservoir tank is empty, bleed the master cylinder.
- If bleeding of the master cylinder is not necessary, omit the following procedures, and perform bleeding of the brake line. <Ref. to BR-39, BRAKE LINE, PROCEDURE, Air Bleeding.>

1) Fill the reservoir tank of the master cylinder with brake fluid.

##### NOTE:

While bleeding air, keep the reservoir tank filled with brake fluid to prevent entry of air.

- 2) Disconnect the brake line at primary and secondary sides.
- 3) Wrap the master cylinder with a plastic bag.
- 4) Depress the brake pedal slowly and hold it.

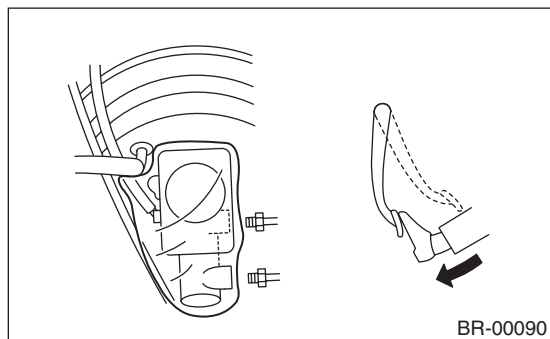

##### NOTE:

On the model with brake assist mechanism, the following phenomena occur when the brake pedal is depressed. However, those are not malfunction but the phenomena that occur when the brake assist mechanism functions properly.

- Brake feel is soft when brake pedal is depressed hard or quicker than usual.
- ABS operating sound is heard when brake pedal is depressed hard or quicker than usual.

- 5) Plug the outlet plug with your finger, and then release the brake pedal.

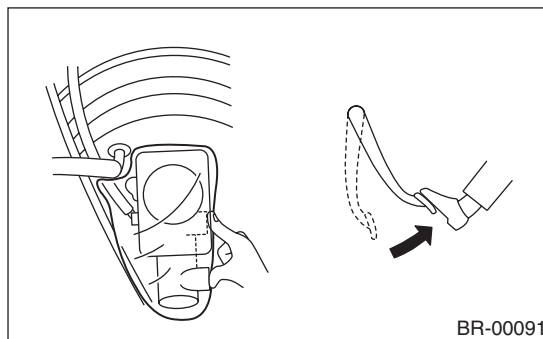

- 6) Repeat the step 4) and 5) several times.
- 7) Remove the plastic bag.
- 8) Install the brake pipe to the master cylinder.

#### **Tightening torque:**

**19 N·m (1.94 kgf-m, 14 ft-lb)**

- 9) Bleed air from the brake line. <Ref. to BR-39, BRAKE LINE, PROCEDURE, Air Bleeding.>

#### 2. BRAKE LINE

1) When the master cylinder is disassembled or the reservoir tank is empty, bleed the master cylinder before bleeding the brake line. <Ref. to BR-39, MASTER CYLINDER, PROCEDURE, Air Bleeding.>

- 2) Fill the reservoir tank of the master cylinder with brake fluid.

##### NOTE:

While bleeding air, keep the reservoir tank filled with brake fluid to prevent entry of air.

- 3) Attach one end of the vinyl tube to the air bleeder and the other end to the brake fluid container.
- 4) Depress the brake pedal several times, and hold it.

# Air Bleeding

## BRAKE

5) Loosen the air bleeder screw to drain brake fluid. Tighten the air bleeder quickly, and release the brake pedal.

### NOTE:

- Bleed air in order starting from the wheel cylinder farthest from the master cylinder.
- For calipers with two air bleeder screws, bleed air from the inner side first and then the outer side. Repeat this operation at least twice.

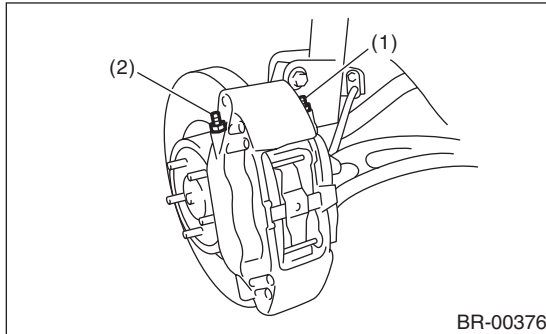

- (1) Inner side air bleeder screw  
(2) Outer side air bleeder screw

- 6) Repeat the steps 4) to 5) until there are no more air bubbles in the vinyl tube.  
7) Repeat the steps from 2) to 6) above to bleed air from each wheel.  
8) Securely tighten the air bleeder screws.

### Tightening torque:

#### 17-inch type

**20 N·m (2.04 kgf·m, 14.5 ft·lb)**

#### Excluding 17-inch type

**8 N·m (0.82 kgf·m, 5.9 ft·lb)**

- 9) Check that there are no brake fluid leaks in the entire system.  
10) Check the pedal stroke.

Run the engine at idle after warming up the engine, and depress the brake pedal with a force of 500 N (51 kgf, 112 lbf). Measure the distance between the brake pedal and steering wheel. Release the pedal, and measure the distance between pedal and steering wheel again.

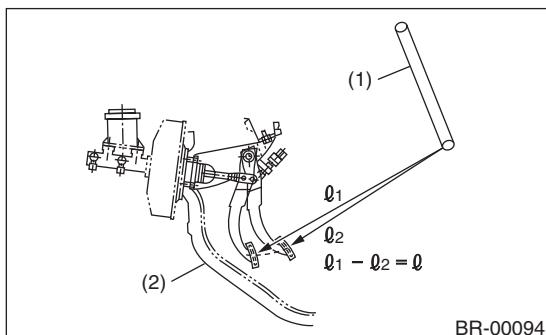

- (1) Steering wheel  
(2) Toe board

### Specification of pedal stroke:

**When depressing the pedal with a force of 500 N (51 kgf, 112 lbf).**

**95 mm (3.74 in) or less**

- 11) If the distance is more than specification, there is a possibility of air being caught in the brake line. Bleed the brake line of all air until the pedal stroke meets the specification.  
12) Operate the hydraulic control unit in the sequence control mode. <Ref. to VDC-14, ABS Sequence Control.>  
13) Check the pedal stroke again.  
14) If the distance is more than specification, there is a possibility of air being caught in the hydraulic unit. Repeat above steps 2) to 9) until the pedal stroke meets the specification.  
15) Fill the reservoir tank with brake fluid up to the "MAX" level.  
16) Test run the vehicle and ensure that the brakes operate normally.

## 12.Brake Hose

### A: REMOVAL

#### 1. FRONT BRAKE HOSE

- 1) Separate the brake pipe from brake hose using a flare nut wrench.
- 2) Remove the clamp, the strut mount bolts, and union bolt.

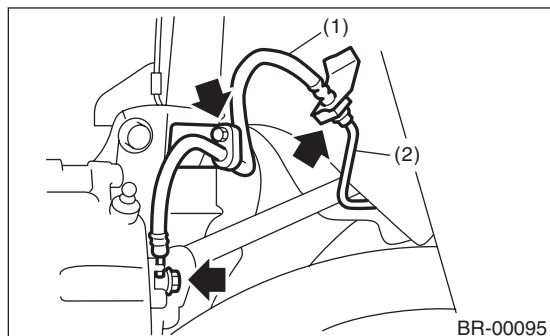

- (1) Brake hose
- (2) Brake pipe

#### 2. REAR BRAKE HOSE

- 1) Remove union bolt and brake hose bracket bolt.
- 17-inch type

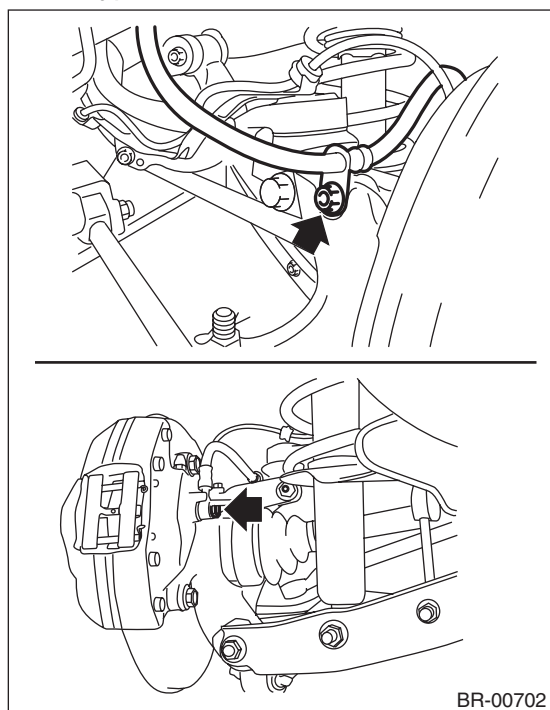

- 15-inch type

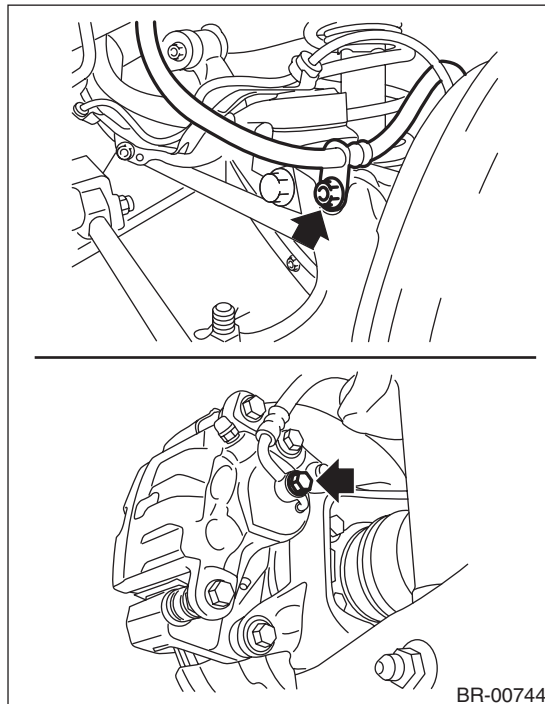

- 2) Separate the brake pipe from brake hose using a flare nut wrench.
- 3) Remove the clamp, and then remove the brake hose.

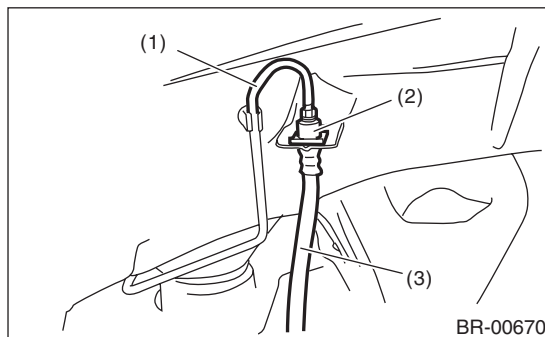

- (1) Brake pipe
- (2) Brake hose clamp
- (3) Brake hose

### B: INSTALLATION

#### 1. FRONT BRAKE HOSE

- 1) Secure the brake hose to strut mount.

**Tightening torque:**

**33 N·m (3.36 kgf·m, 24.3 ft·lb)**

- 2) Install the brake hose to the caliper using a new gasket.

**Tightening torque (union bolt):**

**18 N·m (1.84 kgf·m, 13.3 ft·lb)**

# Brake Hose

## BRAKE

3) Position the disc in straight position and route the brake hose through the hole in the bracket on the wheel apron side.

### CAUTION:

**Do not twist the brake hose.**

4) Temporarily tighten the flare nut which connects brake pipe and hose.

5) Secure the brake hose to wheel apron bracket with clamp.

6) Tighten the flare nut to the specified torque.

### **Tightening torque (brake pipe flare nut):**

**15 N·m (1.53 kgf-m, 11.1 ft-lb)**

7) Bleed air from the brake system. <Ref. to BR-39, PROCEDURE, Air Bleeding.>

## 2. REAR BRAKE HOSE

1) Route the brake hose through the hole of bracket, and lightly tighten the flare nut to connect brake pipe.

2) Insert the clamp to secure brake hose.

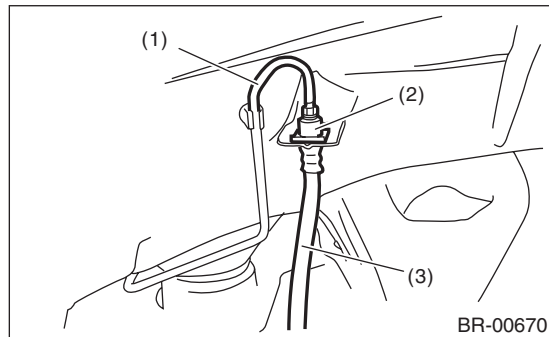

- (1) Brake pipe
- (2) Brake hose clamp
- (3) Brake hose

3) Install the brake hose bracket.

### **Tightening torque:**

**33 N·m (3.36 kgf-m, 24.3 ft-lb)**

4) Install the brake hose to rear brake caliper using a new gasket.

### **Tightening torque (union bolt):**

**18 N·m (1.84 kgf-m, 13.3 ft-lb)**

- 17-inch type

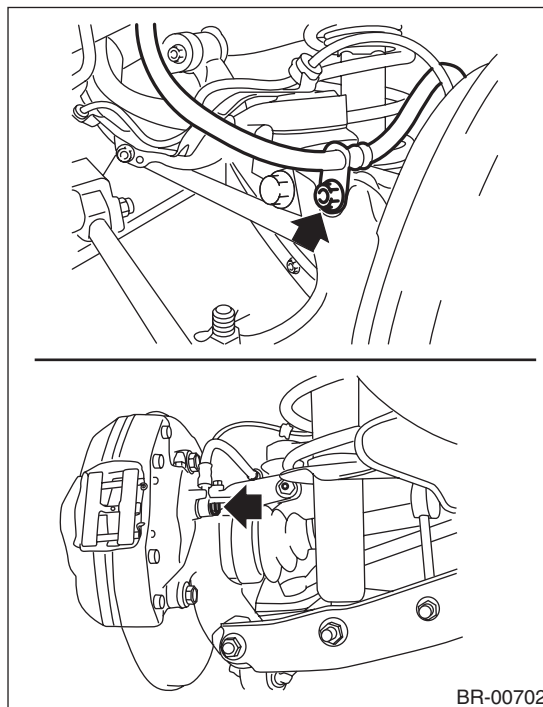

- 15-inch type

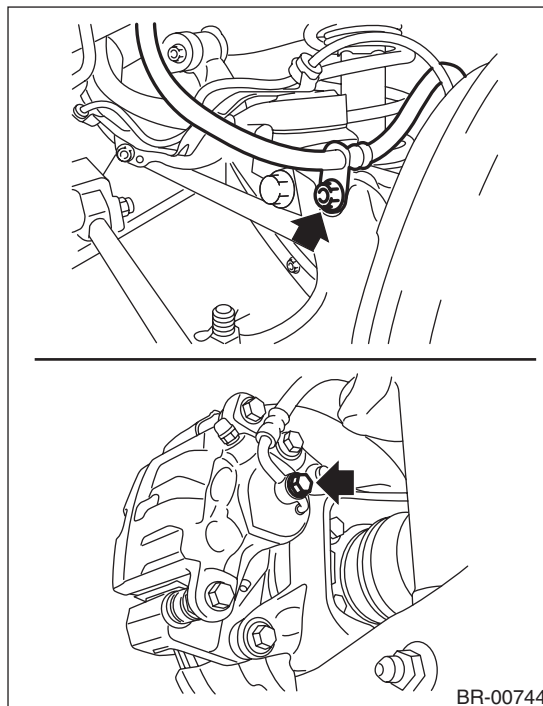

5) Tighten the flare nut to the specified torque.

### **Tightening torque (brake pipe flare nut):**

**15 N·m (1.53 kgf-m, 11.1 ft-lb)**

6) Bleed air from the brake system. <Ref. to BR-39, PROCEDURE, Air Bleeding.>

## C: INSPECTION

Make sure there are no cracks, breakage or damage on hoses. Check the joint for fluid leakage. If any cracks, breakage, damage or fluid leakage is found, repair or replace the hose.



## 13.Brake Pipe

### A: REMOVAL

#### CAUTION:

- Yellow connectors and harnesses with yellow tapes around them are the connectors and harnesses for the airbag system. Using a tester above such circuits may cause malfunction of airbag system. Follow the cautions for the airbag system in this case. <Ref. to AB-5, CAUTION, General Description.>
- Be careful not to damage the airbag system wiring harness when servicing the center brake pipe.
- When removing the brake pipe, do not bend.

#### NOTE:

The airbag system wiring harness is routed near the center brake pipe.

### B: INSTALLATION

#### CAUTION:

- Yellow connectors and harnesses with yellow tapes around them are the connectors and harnesses for the airbag system. Using a tester above such circuits may cause malfunction of airbag system. Follow the cautions for the airbag system in this case. <Ref. to AB-5, CAUTION, General Description.>
- Be careful not to damage the airbag system wiring harness when servicing the center brake pipe.
- When installing the brake pipe, do not bend.
- After installing the brake pipe and hose, perform air bleed.
- After installing the brake hoses, make sure that they do not contact the tires or suspension assembly, etc.

#### NOTE:

The airbag system wiring harness is routed near the center brake pipe.

#### **Brake pipe tightening torque:**

**Refer to "COMPONENT" of "General Description".**

**Front brake pipes & hoses: <Ref. to BR-9, FRONT BRAKE PIPES AND HOSES, COMPONENT, General Description.>**

**Center and rear brake pipes & hoses: <Ref. to BR-10, CENTER AND REAR BRAKE PIPES & HOSES, COMPONENT, General Description.>**

### C: INSPECTION

Make sure there are no cracks, breakage or damage on hoses. Check the joint for fluid leakage. If any cracks, breakage, damage or fluid leakage is found, repair or replace the pipes.

#### NOTE:

Use a mirror when inspecting back sides and other locations which are hard to see.



## 14. Brake Pedal

### A: REMOVAL

- 1) Remove the steering column. <Ref. to PS-15, REMOVAL, Steering Column.>
- 2) Disconnect the connector from the clutch switch.
- 3) Disconnect the connector from stop light switch.
- 4) Turn the stop light switch (1) counterclockwise and remove the stop light switch.

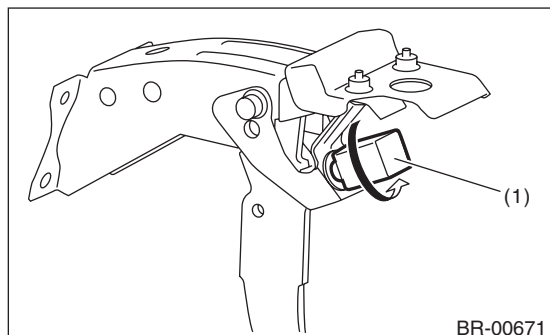

- 5) Remove the clevis pin which secures the pedal and operating rod.

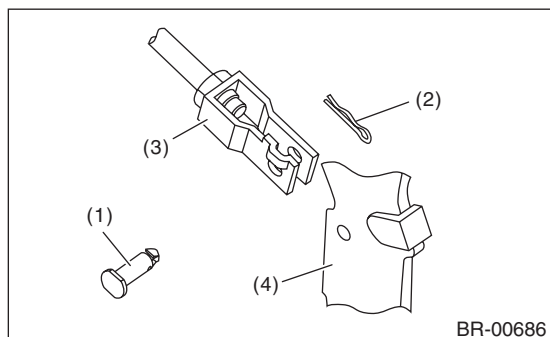

- (1) Clevis pin
- (2) Snap pin
- (3) Operating rod
- (4) Brake pedal

- 6) Remove the nut which secures the clutch master cylinder.
- 7) Remove the bolt and nut which secure the brake pedal bracket.

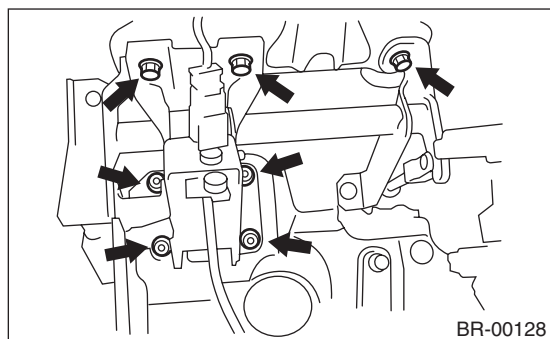

### B: INSTALLATION

#### CAUTION:

- Install the stop light switch according the following procedure.
- Do not install the stop light switch before step 2). Installing the stop light switch before step 2) may result in the switch falling off, remaining illuminated constantly, or an illumination fault.

- 1) Install the bolt and nut which secure the brake pedal bracket.

#### Tightening torque:

**18 N·m (1.84 kgf-m, 13.3 ft-lb)**

- 2) Install clevis pin and snap pin which secure the operating rod to the brake pedal.

#### NOTE:

- Replace with a new clevis pin.
- Apply NIGTIGHT LYW No. 2 grease to the clevis pin.

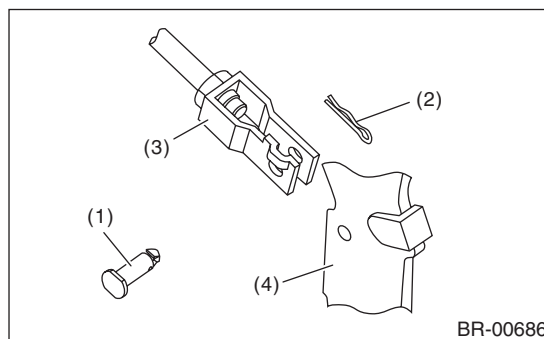

- (1) Clevis pin
- (2) Snap pin
- (3) Operating rod
- (4) Brake pedal

- 3) Make sure that the switch clip (gray) is securely installed to the brake pedal bracket.

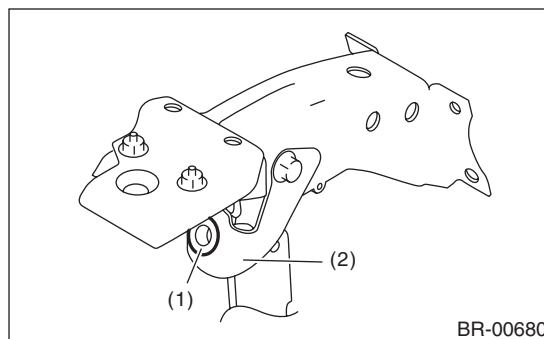

- (1) Switch clip
- (2) Brake pedal bracket

4) While pulling up the brake pedal, insert the stop light switch until it reaches the stopper (brown) at the brake pedal side. Turn the stop light switch clockwise and install the switch.

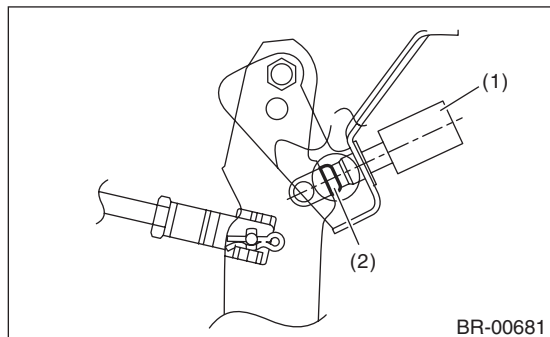

- (1) Stop light switch
- (2) Stopper

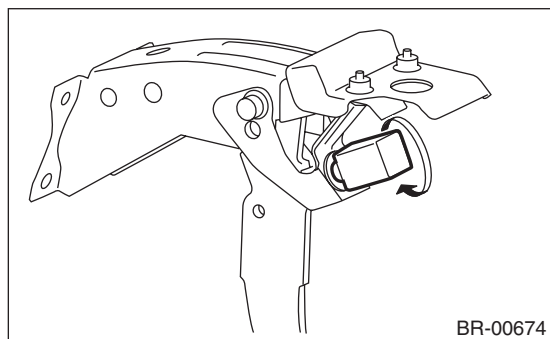

- 5) Connect the stop light switch connector.
- 6) Check that the brake light operate properly.
- 7) Check the brake pedal after installation. <Ref. to BR-45, INSPECTION, Brake Pedal.>

## C: INSPECTION

1) Move the brake pedal pads in a horizontal direction with a force of approx. 10 N (1 kgf, 2 lbf), and check that the pedal deflection is in the range of specifications.

### CAUTION:

**If excessive deflection is noted, replace with a new bushing.**

### Deflection of brake pedal:

#### Limit

**5.0 mm (0.197 in) or less**

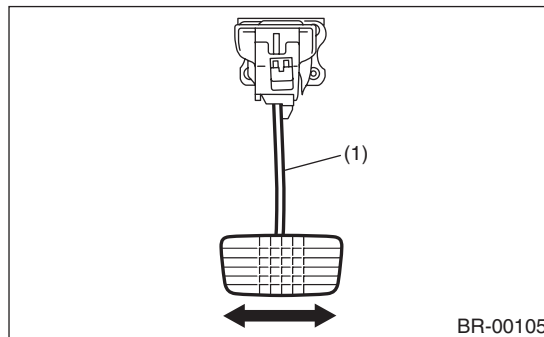

- (1) Brake pedal

2) Check the position of the pedal pad.

### Pedal height L:

**150 — 160 mm (5.91 — 6.29 in)**

### Brake pedal free play A:

**0.5 — 2 mm (0.020 — 0.079 in) [When pulling the brake pedal upward with a force of less than 10 N (1 kgf, 2 lbf).]**

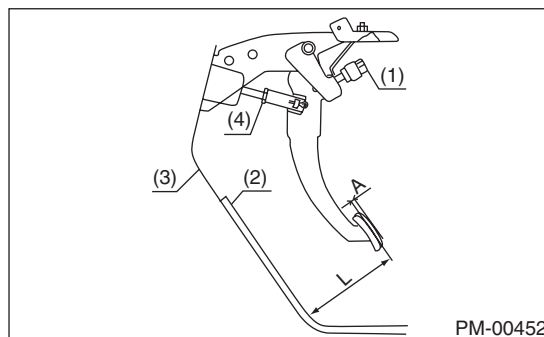

- (1) Stop light switch
- (2) Mat
- (3) Toe board
- (4) Brake booster operating rod

3) Adjust as follows, if the inspection result is not within the standard value.

- (1) Remove the stop light switch. <Ref. to BR-46, REMOVAL, Stop Light Switch.>
- (2) Loosen the lock nut of the brake booster operating rod, and rotate the rod to adjust the pedal height L to be within the standard value.
- (3) Tighten the lock nut.

### Tightening torque:

**22 N·m (2.24 kgf-m, 16.2 ft-lb)**

- (4) Install the stop light switch. <Ref. to BR-46, INSTALLATION, Stop Light Switch.>

# Stop Light Switch

## BRAKE

### 15. Stop Light Switch

#### A: REMOVAL

- 1) Disconnect the ground cable from battery.
- 2) Disconnect the stop light switch connector.
- 3) Turn the stop light switch (1) counterclockwise and remove the stop light switch.

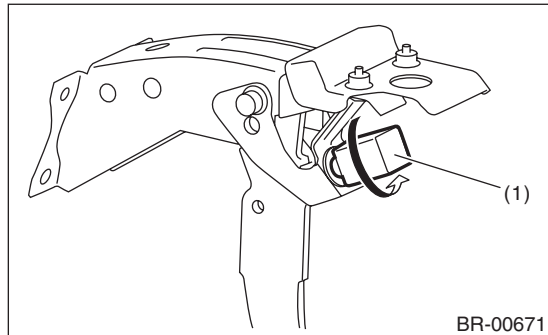

- When the stop light switch is not pressed sufficiently, the stop light will not illuminate.

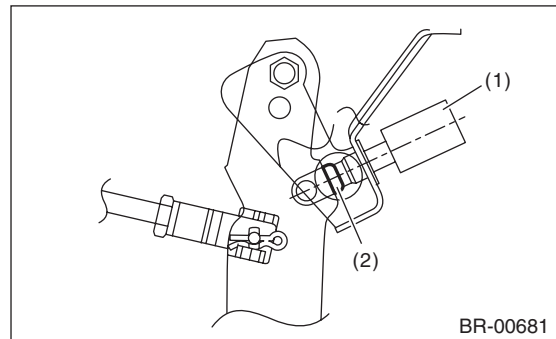

- (1) Stop light switch  
(2) Stopper

#### B: INSTALLATION

- 1) Make sure that the switch clip (gray) is securely installed to the brake pedal bracket.

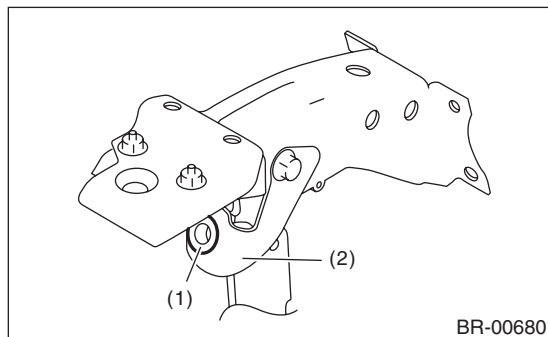

- (1) Switch clip  
(2) Brake pedal bracket

- 3) Turn the stop light switch clockwise and install the switch.

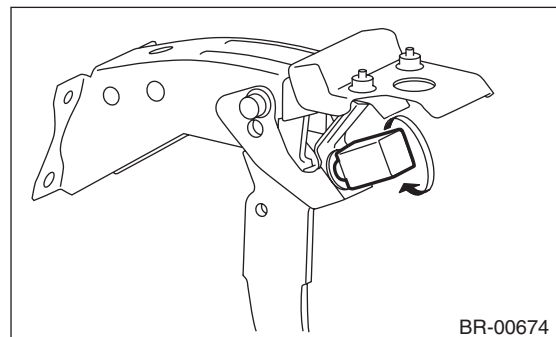

- 4) Pull up the brake pedal and make sure that play is 0.5 — 2 mm (0.020 — 0.079 in).
- 5) Connect the stop light switch connector.
- 6) Connect the battery ground terminal.
- 7) Check that the brake light operate properly.

- 2) While pulling up the brake pedal, insert the stop light switch until it reaches the stopper (brown) at the brake pedal side.

#### NOTE:

- When the stop light switch is inserted with the brake pedal not pulled up sufficiently, interference with the stop light switch may occur during brake pedal operation.

#### NOTE:

It is not necessary to check or adjust the clearance to the stop light switch because it is automatically adjusted at installation.

## C: INSPECTION

1) Measure the resistance between stop light switch terminals.

- 5 door model

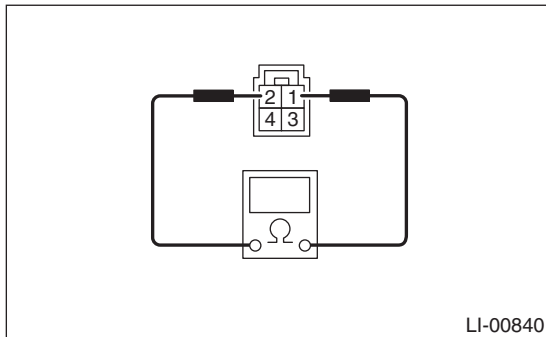

Switch	Pedal	Terminal No.	Standard
Stop light	Released	1 and 2	1 MΩ or more
	Depressed		Less than 1 Ω
	Released	3 and 4	Less than 1 Ω
	Depressed		1 MΩ or more

- 4 door model

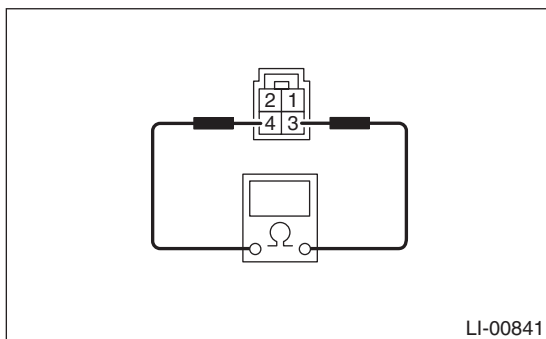

Switch	Pedal	Terminal No.	Standard
Stop light	Released	3 and 4	1 MΩ or more
	Depressed		Less than 1 Ω
	Released	1 and 2	Less than 1 Ω
	Depressed		1 MΩ or more

2) Replace the stop light switch if the inspection result is not within the standard value.

## 16.Hill Start Assist

### A: NOTE

For procedure and diagnosis procedure of each component in the hill start assist, refer to the respective section.

- VEHICLE DYNAMICS CONTROL (VDC): <Ref. to VDC-2, General Description.>
- VEHICLE DYNAMICS CONTROL (VDC) (DIAGNOSTICS): <Ref. to VDC(diag)-2, Basic Diagnostic Procedure.>

### B: OPERATION

#### 1. HILL START ASSIST OFF MODE (6 MT MODEL)

##### CAUTION:

- Hill start auxiliary function by brake force does not operate when turning the hill start assist function to OFF. Be sure to perform the hill start operation with parking brake.
- Hill start assist warning light always illuminates to inform that the hill start assist does not operate during hill start assist OFF mode.

- 1) Park the vehicle on a level surface, and apply the parking brake.
- 2) Stop the engine.
- 3) Restart the engine.
- 4) After restarting the engine, check that the ABS and VDC warning light go off and brake warning light illuminates.
- 5) Continue to push the VDC mode change switch with the engine starting condition.
- 6) VDC warning light & VDC multi mode indicator light illuminate to yellow from green, and after 8 seconds, VDC warning light & VDC multi mode indicator light go off.
- 7) Within 5 seconds after going off the VDC warning light & VDC multi mode indicator light, release the VDC mode change switch and push the VDC mode change switch once again within 2 seconds.
- 8) Hill start assist warning light illuminates.
- 9) Stop the engine.
- 10) Restart the engine.

##### NOTE:

- Hill start assist function can not be turned to OFF until restarting the engine.

- In case of wrong operation procedure, stop the engine and start from the step (1) again.

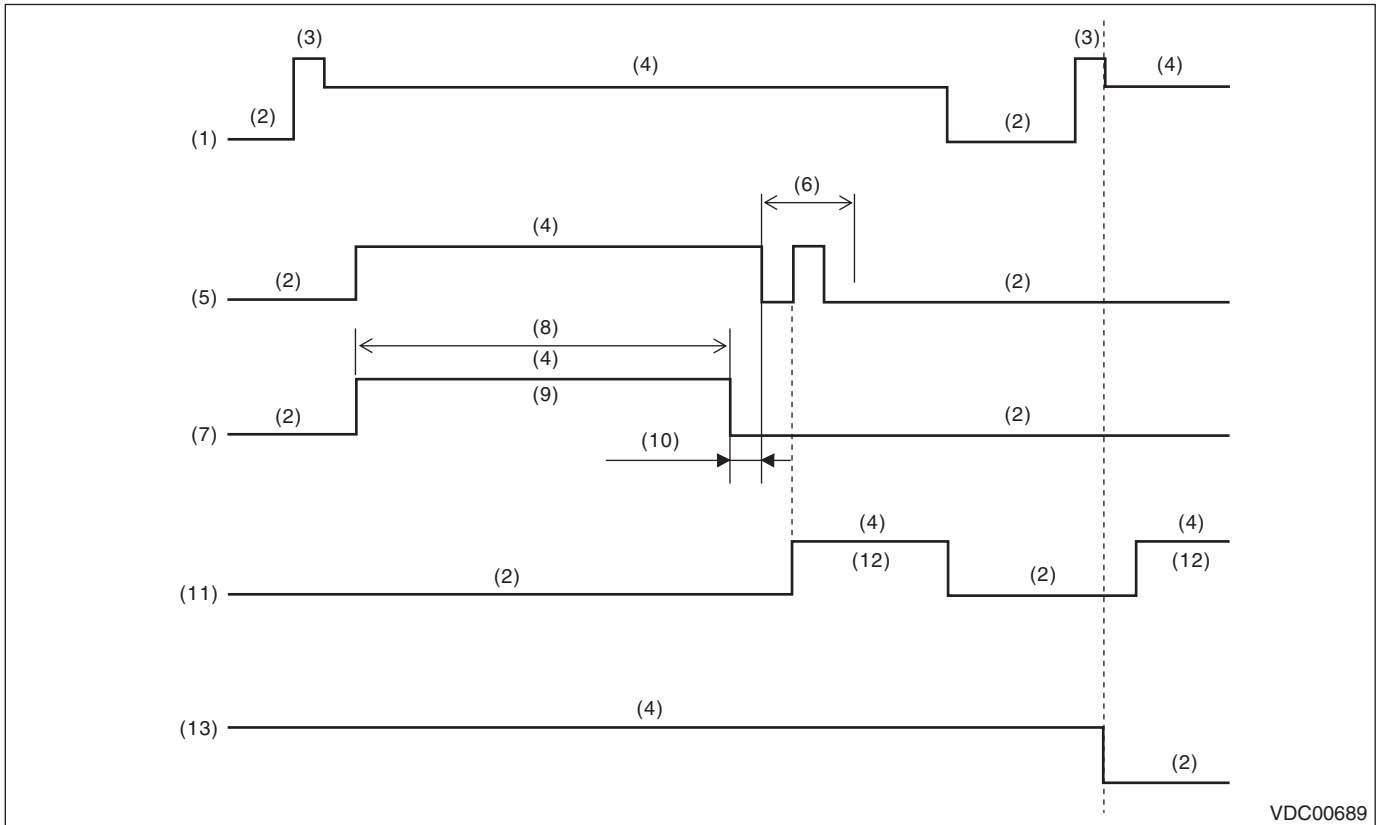

- |                            |  |   |
|----------------------------|--|---|
| (1) Ignition key           | (6) 2 seconds or less                                      | (11) Hill start assist warning light            |
| (2) OFF                    | (7) VDC warning light & VDC multi mode indicator light     | (12) Yellow illumination                        |
| (3) Start                  | (8) Approx. 8 seconds (until the (7) stops appearing)      | (13) Hill start assist function stops appearing |
| (4) ON                     | (9) Change to yellow illumination from green illumination. |   |
| (5) VDC mode change switch | (10) 5 seconds or less                                     |   |

## 2. RETURNING OF HILL START ASSIST OFF MODE (6 MT MODEL)

### NOTE:

Operation procedure for returning from the hill start assist OFF mode.

- 1) Park the vehicle on a level surface, and apply the parking brake.
- 2) Stop the engine.
- 3) Restart the engine.
- 4) After restarting the engine, check that the ABS and VDC warning light go off and brake warning light illuminates.
- 5) Continue to push the VDC mode change switch with the engine starting condition.
- 6) VDC warning light & VDC multi mode indicator light illuminate to yellow from green, and after 8 seconds, VDC warning light & VDC multi mode indicator light go off.
- 7) Within 5 seconds after going off the VDC warning light & VDC multi mode indicator light, release the VDC mode change switch and push the VDC mode change switch once again within 2 seconds.
- 8) Hill start assist warning light goes off.
- 9) Stop the engine.
- 10) Restart the engine.

### NOTE:

- Hill start assist function does not return until restarting the engine.
- In case of wrong operation procedure, stop the engine and start from the step (1) again.

# General Diagnostic Table

BRAKE

## 17. General Diagnostic Table

### A: INSPECTION

	Trouble and possible cause	Corrective action
<b>1. Insufficient braking</b>	(1) Fluid leakage from the hydraulic mechanism	Repair or replace. (cup, piston seal, piston boot, master cylinder piston kit, pipe or hose)
	(2) Entry of air into the hydraulic mechanism	Bleed air.
	(3) Wear, deteriorated surface material, water or fluid on lining	Replace, grind or clean.
	(4) Improper operation of master cylinder, disc caliper, brake booster or check valve	Repair or replace.
<b>2. Unstable or uneven braking</b>	(1) Fluid on lining or rotor	Correct the cause of fluid leakage, and clean or replace.
	(2) Rotor defective	Repair or replace the rotor.
	(3) Improper lining contact, deteriorated surface, deteriorated or worn lining material	Repair by grinding, or replace.
	(4) Deformed back plate	Repair or replace.
	(5) Overinflation of tires	Adjust the air pressure.
	(6) Defective wheel alignment	Adjust alignment.
	(7) Loose back plate or support installation bolt	Tighten to the specified torque.
	(8) Faulty wheel bearing	Replace.
	(9) Defective hydraulic system	Replace the cylinder, brake pipe or hose.
	(10) Unstable performance of the parking brake	Check, adjust or replace the rear brake and cable system.
<b>3. Excessive pedal stroke</b>	(1) Entry of air into the hydraulic mechanism	Bleed air.
	(2) Excessive play in the master cylinder push rod	Adjust.
	(3) Fluid leakage from the hydraulic mechanism	Repair or replace. (cup, piston seal, piston boot, master cylinder piston kit, pipe or hose)
	(4) Improper lining contact or worn lining	Repair or replace.
<b>4. Brake dragging or improper brake return</b>	(1) Insufficient pedal play	Adjust play.
	(2) Improper master cylinder return	Clean or replace the cylinder.
	(3) Clogged hydraulic system	Replace.
	(4) Improper return or adjustment of parking brake	Repair or adjust.
	(5) Weakened spring tension or breakage of shoe return spring	Replace the spring.
	(6) Improper disc caliper operation	Repair or replace.
	(7) Faulty wheel bearing	Replace.
<b>5. Brake noise (1) (creaking sound)</b>	(1) Hardened or deteriorated brake pad	Replace the pad.
	(2) Worn brake pad	Replace the pad.
	(3) Loose back plate or support installation bolt	Tighten to the specified torque.
	(4) Loose wheel bearing	Tighten to the specified torque.
	(5) Dirty rotor	Clean the rotor, or clean and replace brake assembly.
<b>6. Brake noise (2) (hissing sound)</b>	(1) Worn brake pad	Replace the pad.
	(2) Improperly installed pad	Correct or replace the pad.
	(3) Loose or bent rotor	Retighten or replace.
<b>7. Brake noise (3) (click sound)</b>	Excessively worn pad or support	Replace the pad or the support.

BR-50

Brought to you by Ebay Seller "SubaruManuals"

# PARKING BRAKE

# *PB*

---

	<b>Page</b>
1. General Description .....	2
2. Parking Brake Lever .....	4
3. Parking Brake Cable .....	5
4. Parking Brake Assembly (Rear Disc Brake) .....	6
5. General Diagnostic Table .....	9



# General Description

## PARKING BRAKE

### 1. General Description

#### A: SPECIFICATION

Model		Rear disc brake
Type		Mechanical, drum in disc rear brakes
Effective drum diameter	mm (in)	190 (7.48)
Lining dimensions (Length x Width x Thickness)	mm (in)	165.8 x 30.0 x 2.8 (6.53 x 1.181 x 0.11)
Clearance adjustment		Manual adjustment
Lever stroke	Notches/N (kgf, lbf)	7 — 8/200 (20.4, 45)

#### B: COMPONENT

##### 1. PARKING BRAKE (REAR DISC BRAKE)

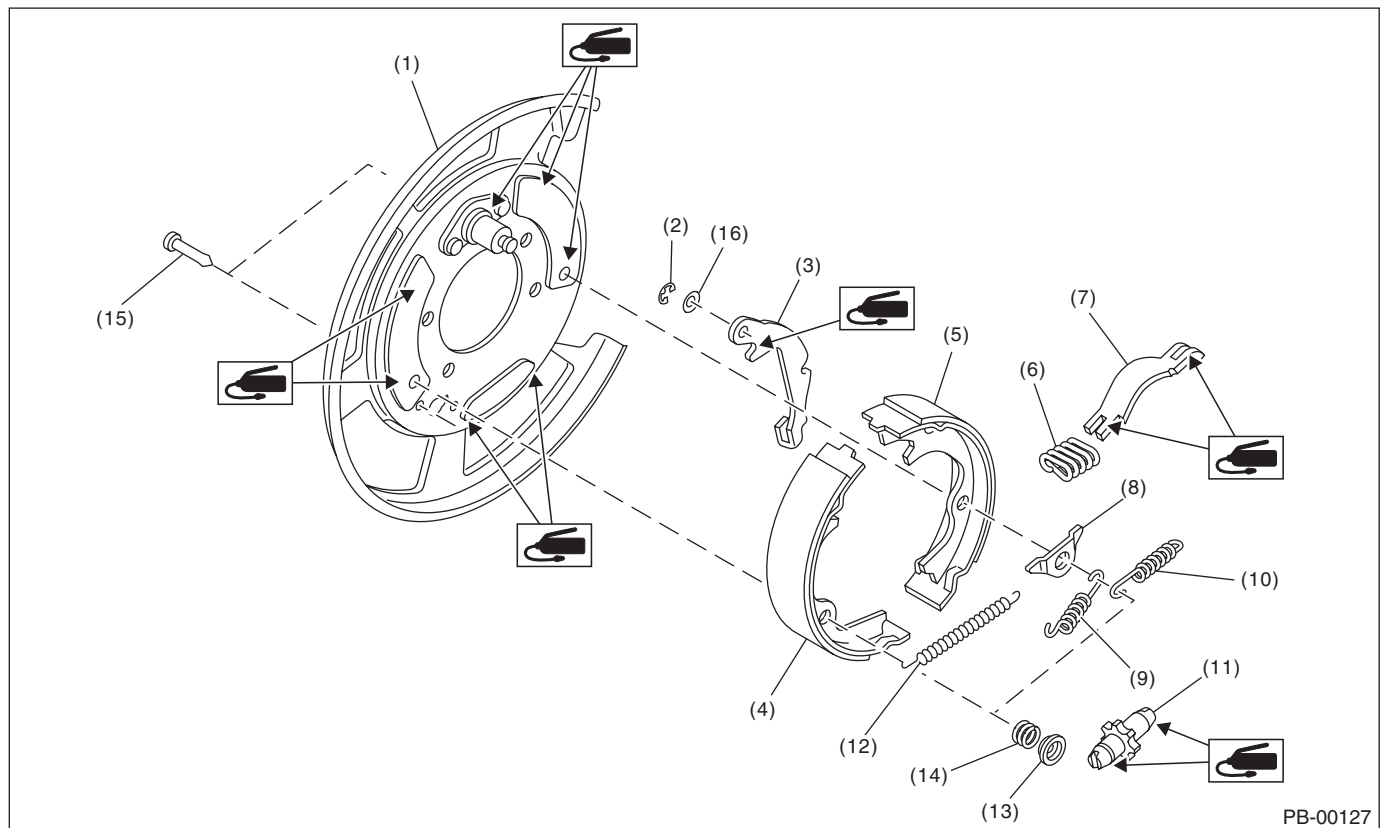

- |                                    |                              |                            |
|------------------------------------|------------------------------|----------------------------|
| (1) Back plate                     | (7) Strut                    | (13) Shoe hold-down cup    |
| (2) Retainer                       | (8) Shoe guide plate         | (14) Shoe hold-down spring |
| (3) Lever                          | (9) Primary return spring    | (15) Shoe hold-down pin    |
| (4) Parking brake shoe (primary)   | (10) Secondary return spring | (16) Wave washer           |
| (5) Parking brake shoe (secondary) | (11) Adjuster                |                            |
| (6) Strut spring                   | (12) Adjusting spring        |                            |

## 2. PARKING BRAKE LEVER & CABLE

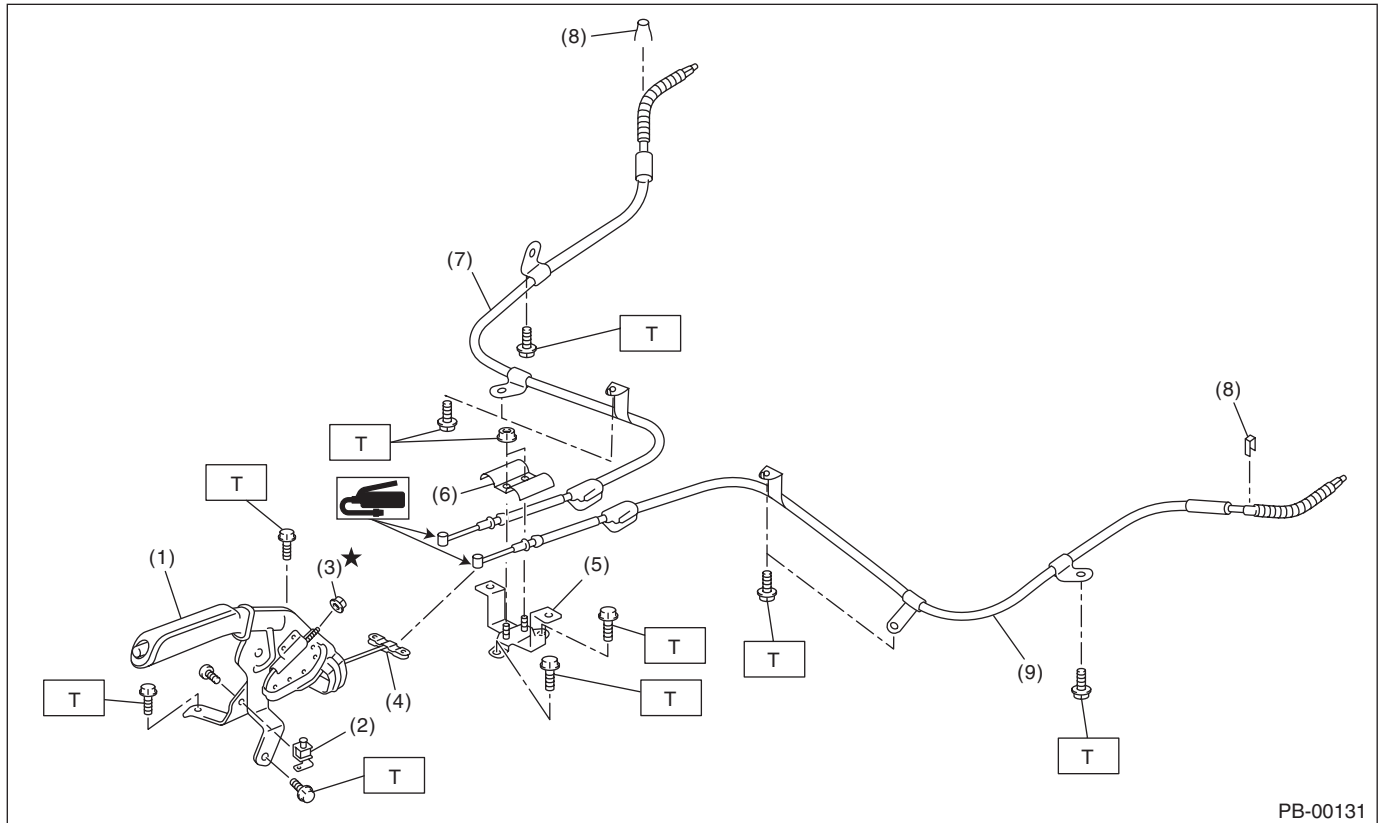

PB-00131

- |                                      |                            |                            |
|--------------------------------------|----------------------------|----------------------------|
| (1) Parking brake lever              | (5) Bracket                | (9) Parking brake cable LH |
| (2) Parking brake switch             | (6) Clamp                  |                            |
| (3) Adjusting nut (self-locking nut) | (7) Parking brake cable RH |                            |
| (4) Equalizer                        | (8) Clamp                  |                            |

**Tightening torque: N·m (kgf-m, ft-lb)**  
**T: 18 (1.84, 13.3)**

### C: CAUTION

- Wear appropriate work clothing, including a helmet, protective goggles and protective shoes when performing any work.
- Before removal, installation or disassembly, be sure to clarify the failure. Avoid unnecessary removal, installation, disassembly and replacement.
- Vehicle components are extremely hot after driving. Be wary of receiving burns from heated parts.
- Use SUBARU genuine grease etc. or equivalent. Do not mix grease etc. of different grades or manufacturers.
- Be sure to tighten fasteners including bolts and nuts to the specified torque.
- Place shop jacks or rigid racks at the specified points.
- Make sure grease does not come into contact with the parking shoes.

# Parking Brake Lever

## PARKING BRAKE

---

## 2. Parking Brake Lever

### A: REMOVAL

- 1) Set the wheel stoppers to tires.
- 2) Remove the console box. <Ref. to EI-51, REMOVAL, Console Box.>
- 3) Disconnect the parking brake switch connector.
- 4) Remove the parking cable adjusting nut (self-locking nut).
- 5) Remove the bolt, and then detach the parking brake lever.

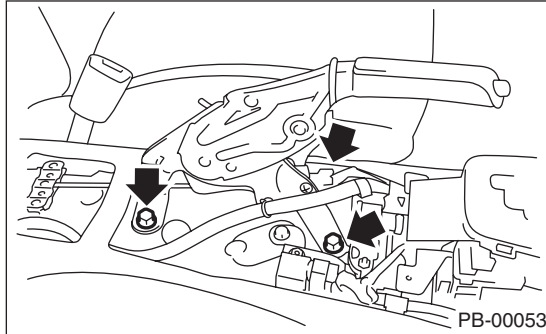

### B: INSTALLATION

- 1) Install each part in the reverse order of removal.

#### **Tightening torque:**

##### **Parking brake lever**

**18 N·m (1.84 kgf-m, 13.3 ft-lb)**

- 2) Install a new adjusting nut (self-locking nut).
- 3) Be sure to adjust the lever stroke. <Ref. to PB-4, ADJUSTMENT, Parking Brake Lever.>

### C: INSPECTION

- 1) Operate the parking brake lever 3 to 4 times and fully return the lever.
- 2) While slowly pulling the parking brake lever upward, count the notches.

#### **Lever stroke:**

**7 to 8 notches when pulled with a force of 200 N (20.4 kgf, 45 lbf)**

- 3) Adjust the parking brake if the inspection result is not within the standard value. <Ref. to PB-8, ADJUSTMENT, Parking Brake Assembly (Rear Disc Brake).>

### D: ADJUSTMENT

Adjust the parking lever stroke. <Ref. to PB-8, LEVER STROKE, ADJUSTMENT, Parking Brake Assembly (Rear Disc Brake).>

## 3. Parking Brake Cable

### A: REMOVAL

- 1) Remove the rear seat cushion. <Ref. to SE-13, REMOVAL, Rear Seat.>
- 2) Remove the console box. <Ref. to EI-51, REMOVAL, Console Box.>
- 3) Remove the parking cable adjusting nut (self-locking nut).
- 4) Remove the parking brake lever. <Ref. to PB-4, REMOVAL, Parking Brake Lever.>
- 5) Roll up the floor mat, remove the nuts, and then remove the clamps.

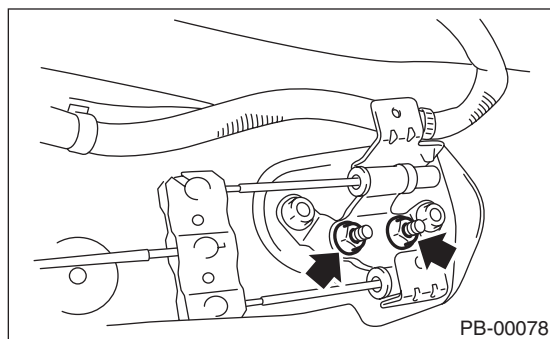

- 6) Remove the inner cable end (2) from the equalizer (1).

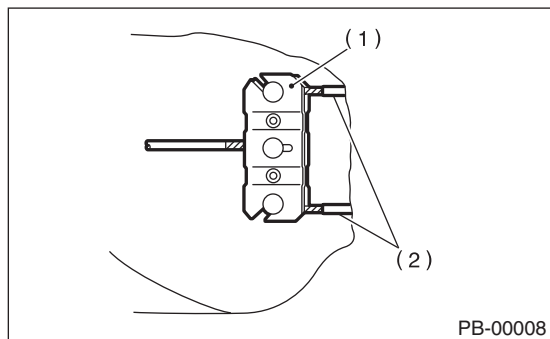

- 7) Lift up the vehicle, and then remove the rear wheels.
- 8) Remove the parking brake cable from rear brake. <Ref. to PB-6, REMOVAL, Parking Brake Assembly (Rear Disc Brake).>
- 9) Remove the clamp from the rear brake.
- 10) Remove the cable clamp from the rear arm bracket.

- 11) Remove the bolt and detach the cable clamp from the rear floor.

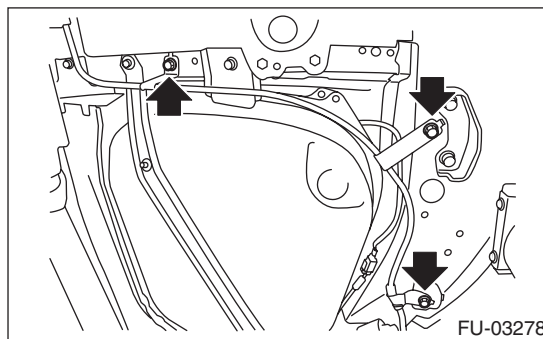

- 12) Remove the grommet from the rear floor, and remove the cable assembly.

### B: INSTALLATION

- 1) Install each part in the reverse order of removal.

#### NOTE:

Be sure to pass the cable through the tunnel in the cable guide.

#### Tightening torque:

##### Cable clamp

**18 N·m (1.84 kgf-m, 13.3 ft-lb)**

- 2) Be sure to adjust the lever stroke. <Ref. to PB-4, ADJUSTMENT, Parking Brake Lever.>

### C: INSPECTION

Check and replace the removed cable if damaged, rusty or faulty.

- 1) Check the cable for smooth operation.
- 2) Check the inner cable for damage and rust.
- 3) Check the outer cable for damage, bends and cracks.

# Parking Brake Assembly (Rear Disc Brake)

## PARKING BRAKE

### 4. Parking Brake Assembly (Rear Disc Brake)

#### A: REMOVAL

- 1) Release the parking brake.
- 2) Lift up the vehicle, and then remove the rear wheels.
- 3) Remove the bolts and then remove the brake hose bracket.

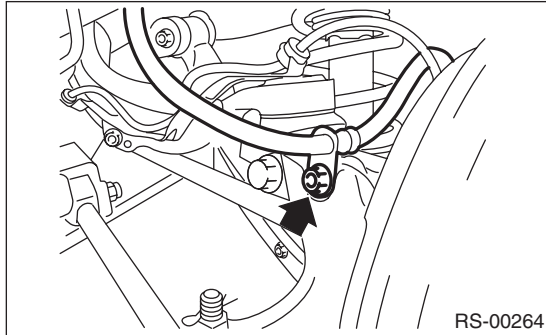

- 4) Remove the attachment bolts and remove the rear caliper body assembly.
- 17-inch type

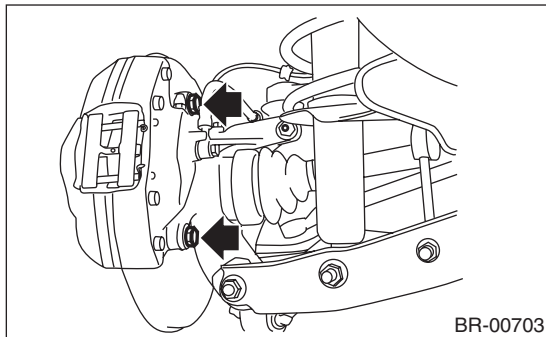

- 15-inch type

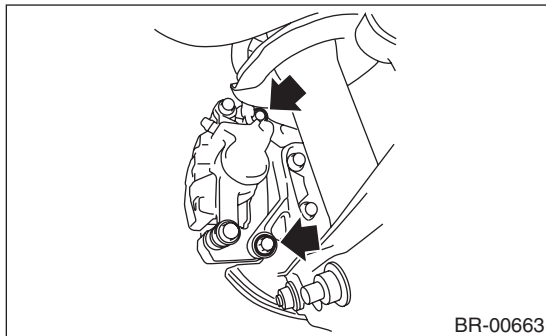

- 5) Suspend the rear caliper body assembly so that the brake hose is not stretched.
- 6) Remove the rear disc rotor.

#### NOTE:

If the disc rotor is difficult to remove, try the following two methods in order.

- (1) Turn the adjuster using a flat tip screwdriver until the brake shoe moves adequately away from the disc rotor.

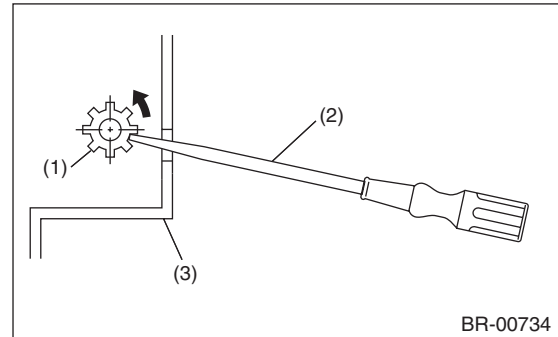

- (1) Adjuster
- (2) Flat tip screwdriver
- (3) Disc rotor

- (2) If disc rotor is seized on the hub, drive the disc rotor out by pushing two 8 mm bolts in holes B on the rotor.

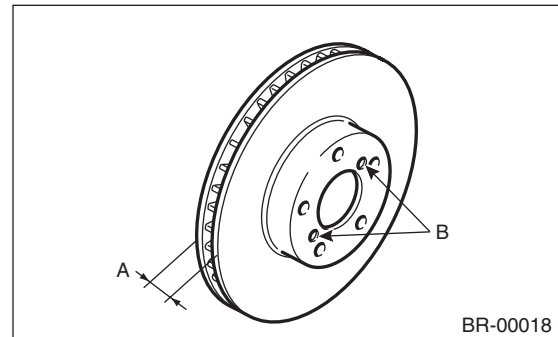

- 7) Remove the shoe return spring.

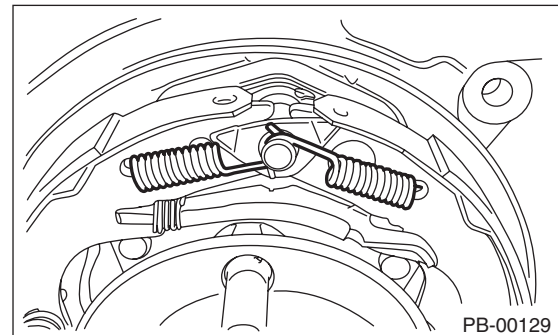

- 8) Remove the brake shoe cup and brake shoe spring, and remove the primary brake shoe.

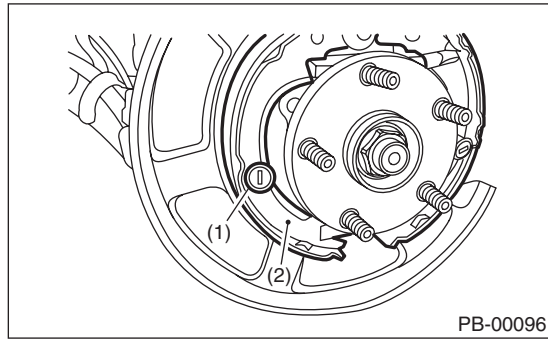

- (1) Brake shoe cup  
(2) Primary brake shoe

- 9) Remove the strut and strut spring.  
10) Remove the adjuster.  
11) Remove brake shoe cup and brake shoe spring, and remove the secondary brake shoe.  
12) Remove the parking brake cable from lever.

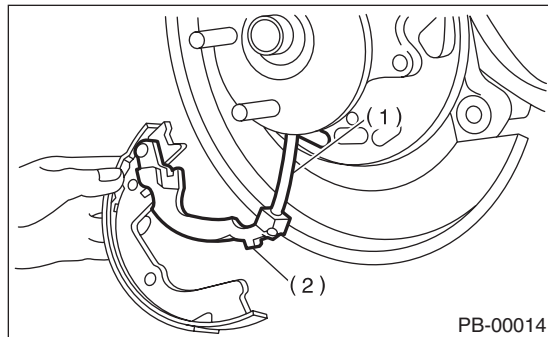

- (1) Parking brake cable  
(2) Lever

- 13) Remove a retainer from the secondary side brake shoe. Remove the lever from the brake shoe.

## B: INSTALLATION

### CAUTION:

Be sure the lining surface is free from brake fluid and grease.

- 1) Apply brake grease to the following locations.

### Brake grease:

#### Brake Grease (Part No. 003602002)

- Six contact surfaces of the brake shoe rim and back plate gasket
- Contact surface of the brake shoe and the anchor pin
- Contact surface of the parking brake lever and strut
- Contact surface of the brake shoe and adjuster
- Contact surface of the brake shoe and strut
- Contact surface of the lever and brake shoe

- 2) Install the wave washer and lever to the secondary side brake shoe pin, and lock the retainer securely.  
3) Install the parking brake cable to the lever.  
4) Install the adjuster and adjusting spring to the brake shoe.

### NOTE:

Install the adjuster with screw section on the direction side in the figure below.

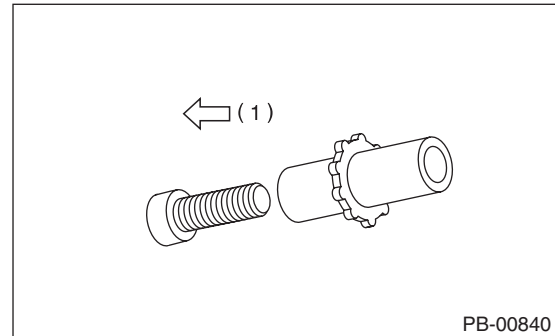

- (1) Left wheel: front side of vehicle, right wheel: rear side of vehicle

- 5) Check that the parking brake cable does not fall from the cable guide.  
6) Install the brake shoes to the back plate with shoe hold pins, brake shoe springs, and brake shoe cups.  
7) Install the strut and strut spring to the brake shoes.

### NOTE:

- Install the strut springs on front side of the vehicle.  
8) Install the return springs on the primary side first, and then the secondary side.  
9) Install the rear disc rotors and rear caliper body assembly.

### Tightening torque:

**Caliper body assembly (17-inch type)**

**65 N·m (6.63 kgf-m, 47.9 ft-lb)**

**Caliper body assembly (15-inch type)**

**66 N·m (6.73 kgf-m, 48.7 ft-lb)**

- 10) Install the brake hose bracket.

### Tightening torque:

**33 N·m (3.36 kgf-m, 24.3 ft-lb)**

- 11) Adjust the parking brake. <Ref. to PB-8, ADJUSTMENT, Parking Brake Assembly (Rear Disc Brake).>

- 12) If new brake shoes are replaced, drive the vehicle to break-in the parking brake lining.

(1) Drive the vehicle at approximately 35 km/h (22 MPH) or more.

(2) While pressing the parking brake lever button, pull the parking brake lever with a force of 150 N (15.3 kgf, 33.7 lbf).

# Parking Brake Assembly (Rear Disc Brake)

## PARKING BRAKE

(3) Drive the vehicle for about 200 m (0.12 mile) in this condition.

(4) Wait 5 to 10 minutes for the parking brake to cool down. Repeat steps (1) through (3) again.

(5) After breaking-in, re-adjust the parking brakes.

### C: INSPECTION

1) Measure the inner diameter of the disc rotor. If scoring or worn is found on the disc, replace the disc rotor.

#### **Disc rotor inner diameter:**

##### **Standard**

**190 mm (7.48 in)**

##### **Service limit**

**191 mm (7.52 in)**

2) Measure the lining thickness. If it exceeds the limit, replace the brake shoe.

#### **Lining thickness:**

##### **Standard**

**2.8 mm (0.11 in)**

##### **Service limit**

**1.5 mm (0.059 in)**

#### **NOTE:**

Replace the right and left brake shoe as a set.

### D: ADJUSTMENT

#### 1. SHOE CLEARANCE

1) Return the parking brake lever fully.

2) Loosen the adjusting nut, and make the cable free.

3) Remove the adjusting hole cover from the disc rotor.

4) Using a flat tip screwdriver, turn the adjuster in the direction of the arrow as shown in the figure to an extent that the disc rotor cannot be rotated by both hands.

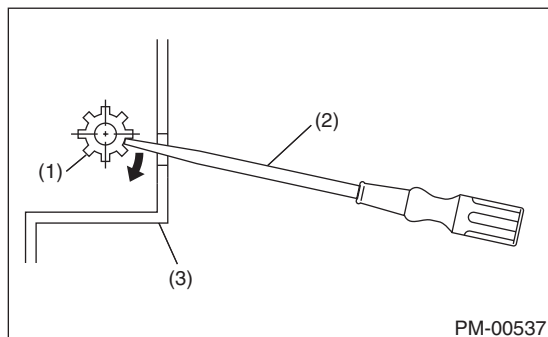

- (1) Adjuster
- (2) Flat tip screwdriver
- (3) Disc rotor

5) Loosen the adjuster by 5 notches in the opposite direction of the arrow.

#### **CAUTION:**

- Check there is no brake drag.
- If the return amount of adjuster is insufficient, be sure to loosen it by 5 notches to avoid dragging.

6) Install the adjusting hole cover to the disc rotor.

7) Adjust the parking lever stroke. <Ref. to PB-8, LEVER STROKE, ADJUSTMENT, Parking Brake Assembly (Rear Disc Brake).>

#### 2. LEVER STROKE

1) Adjust the shoe clearance before adjusting lever stroke. <Ref. to PB-8, SHOE CLEARANCE, ADJUSTMENT, Parking Brake Assembly (Rear Disc Brake).>

2) Remove the parking lever cover.

3) Pull the parking brake lever hard 3 to 5 times.

4) Turn the adjusting nut until the lever stroke is at the specified value.

#### **Lever stroke:**

**7 to 8 notches when pulled with a force of 200 N (20.4 kgf, 45 lbf)**

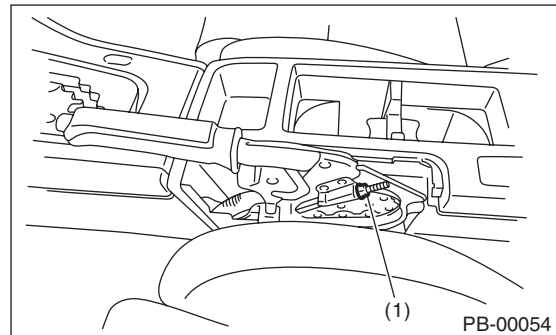

(1) Adjusting nut (self-locking nut)

5) Check there is no brake drag.

6) Install the parking lever cover.

## 5. General Diagnostic Table

### A: INSPECTION

Symptoms	Possible cause	Corrective action
Brake drag	Parking brake lever not adjusted correctly.	Adjust.
	Parking brake cable does not move.	Repair or replace.
	Parking brake shoe clearance is maladjusted.	Adjust.
	Return spring is faulty.	Replace.
Noise from brake	Return spring is faulty.	Replace.
	Shoe hold-down spring faulty.	Replace.



# General Diagnostic Table

PARKING BRAKE

---

# POWER ASSISTED SYSTEM (POWER STEERING)

# PS

---

	<b>Page</b>
1. General Description .....	2
2. Steering Wheel .....	12
3. Universal Joint .....	13
4. Steering Column .....	15
5. Steering Gearbox .....	17
6. Pipe Assembly .....	38
7. Oil Pump .....	44
8. Reservoir Tank .....	49
9. Power Steering Fluid .....	50
10. General Diagnostic Table .....	51

# General Description

## POWER ASSISTED SYSTEM (POWER STEERING)

### 1. General Description

#### A: SPECIFICATION

Model		STI model	Except for STI model
Whole system	Minimum turning radius	m (ft)	
	Steering angle	Inner wheel	5.5 (18)
		Outer wheel	36.6°±1.5°
	Steering wheel diameter	mm (in)	
Whole gear ratio (Turn, from lock to lock. Gearbox)	2.8		
Gearbox	Type	Rack and Pinion, Integral	
	Backlash	0 (Automatic adjusting)	
	Valve (Power steering system)	Rotary valve	
Pump (Power steering system)	Type	Vane pump	
	Oil tank	Installed on body	
	Specific output	cm <sup>3</sup> (cu in)/rev.	
	Relief pressure	8,300 — 9,000 (85 — 92, 1,203 — 1,305)	8,100 — 8,800 (83 — 90, 1,174 — 1,276)
	Hydraulic fluid control	Engine speed sensitive	
	Hydraulic fluid	ℓ (US qt, Imp qt)	
	RPM range	rpm	
Direction of rotation	Clockwise		
Hydraulic oil (Power steering system)	Capacity ℓ (US qt, Imp qt)	Oil tank	0.2 (0.2, 0.2)
		Whole system	0.7 (0.7, 0.6)

Steering wheel	Free play	mm (in)	17 (0.67)	
Steering shaft	Clearance between the steering wheel and column cover	mm (in)	2 — 4 (0.08 — 0.16)	
Steering gearbox (Power steering system)	Sliding resistance	N (kgf, lbf)	370 (38, 83) or less Difference between right and left sliding resistance: 20% or less	
	Rack shaft play in the radial direction	Right-turn steering	mm (in)	0.12 (0.005) or less
		Left-turn steering	mm (in)	0.3 (0.012) or less
	Input shaft play	In radial direction	mm (in)	0.26 (0.01) or less
		In axial direction	mm (in)	Without play
Rotational resistance	N (kgf, lbf)	Maximum allowable value: 11.3 (1.15, 2.54) or less Difference between right and left sliding resistance: 24%		
Oil pump (Power steering system)	Pulley shaft	Radial play	mm (in)	0.2 (0.008) or less
		Axial play	mm (in)	0.9 (0.035) or less
	Pulley	Ditch deflection	mm (in)	1.0 (0.039) or less
		Rotational resistance	N (kgf, lbf)	9.22 (0.94, 2.07) or less
Regular pressure (Unloaded)	kPa (kgf/cm <sup>2</sup> , psi)	981 (10, 142) or less		
Steering wheel effort (Power steering system)	At standstill with engine idling on paved road	N (kgf, lbf)	29.4 (3.0, 6.6) or less	
	At standstill with engine stalled on paved road	N (kgf, lbf)	294.2 (30, 66.1) or less	

Recommended power steering fluid
SUBARU ATF or DEXRON III

# General Description

POWER ASSISTED SYSTEM (POWER STEERING)

## B: COMPONENT

### 1. STEERING WHEEL AND COLUMN

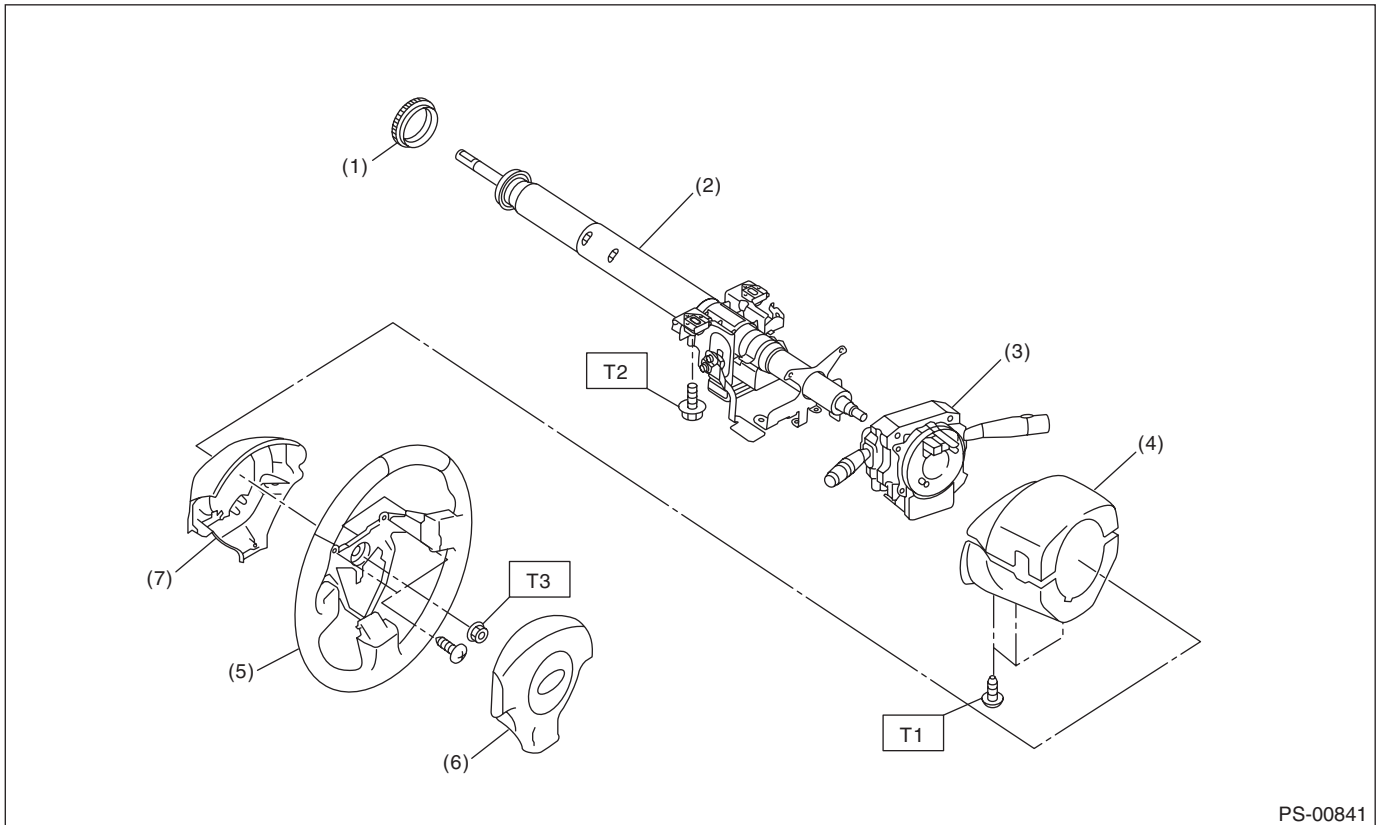

- |                             |                                |
|-----------------------------|--------------------------------|
| (1) Bushing                 | (5) Steering wheel             |
| (2) Steering shaft          | (6) Airbag module              |
| (3) Steering roll connector | (7) Steering wheel lower cover |
| (4) Column cover            |                                |

**Tightening torque: N·m (kgf·m, ft·lb)**

**T1: 1.2 (0.12, 0.9)**

**T2: 20 (2.0, 14.8)**

**T3: 39 (4.0, 28.8)**

# General Description

## POWER ASSISTED SYSTEM (POWER STEERING)

### 2. POWER ASSISTED SYSTEM

- Hose and tank

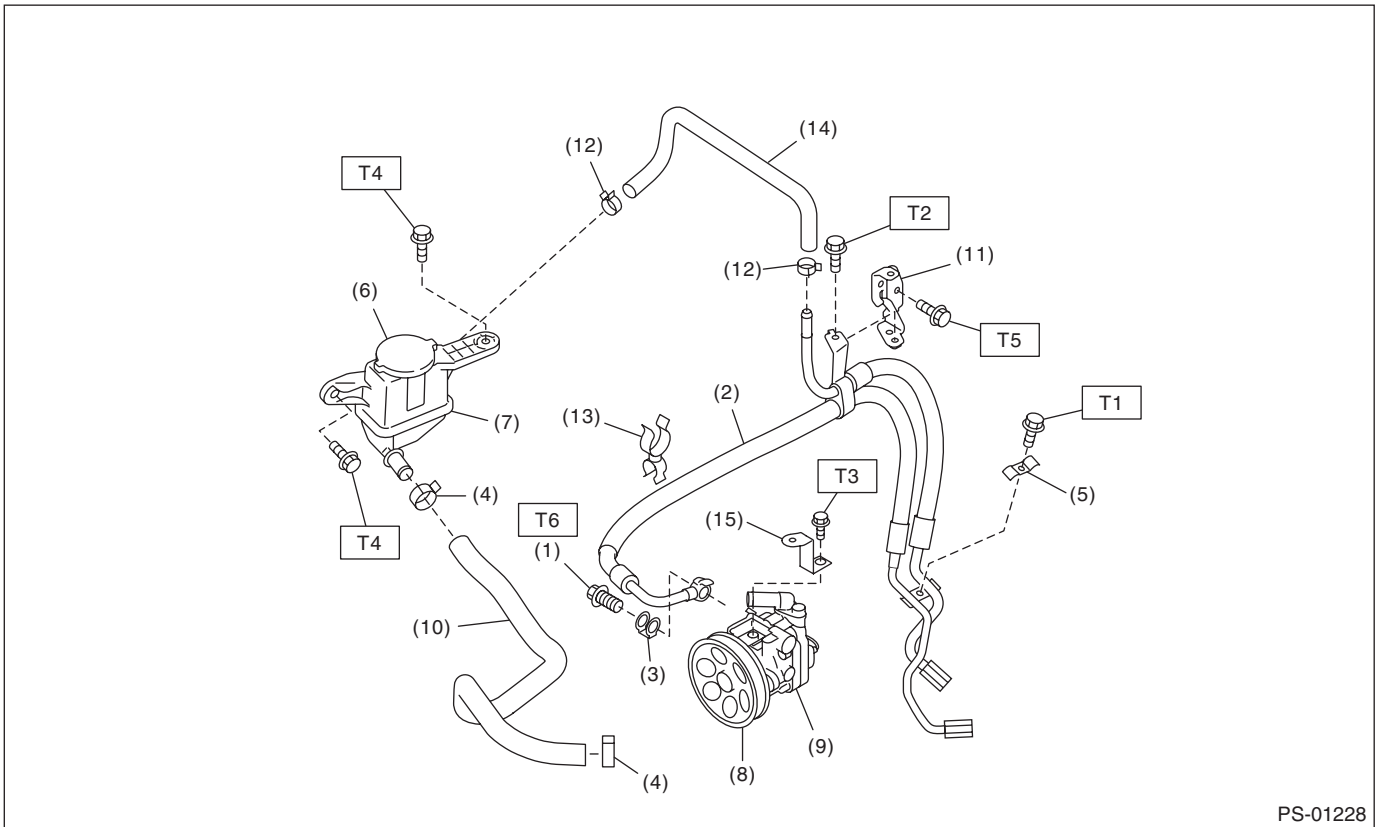

PS-01228

- |                     |                         |
|---------------------|-------------------------|
| (1) Eye bolt        | (9) Oil pump            |
| (2) Hose            | (10) Suction hose       |
| (3) Eye bolt gasket | (11) Hose bracket       |
| (4) Clip            | (12) Clip               |
| (5) Clamp E         | (13) Clip               |
| (6) Cap             | (14) Return hose        |
| (7) Reservoir tank  | (15) Belt cover bracket |
| (8) Pulley          |                         |

#### **Tightening torque: N·m (kgf-m, ft-lb)**

**T1: 7.5 (0.76, 5.5)**

**T2: 10 (1.0, 7.4)**

**T3: 11 (1.1, 8.1)**

**T4: 13 (1.3, 9.6)**

**T5: 18 (1.8, 13.3)**

**T6: 40 (4.1, 29.5)**

# General Description

## POWER ASSISTED SYSTEM (POWER STEERING)

### • Gearbox

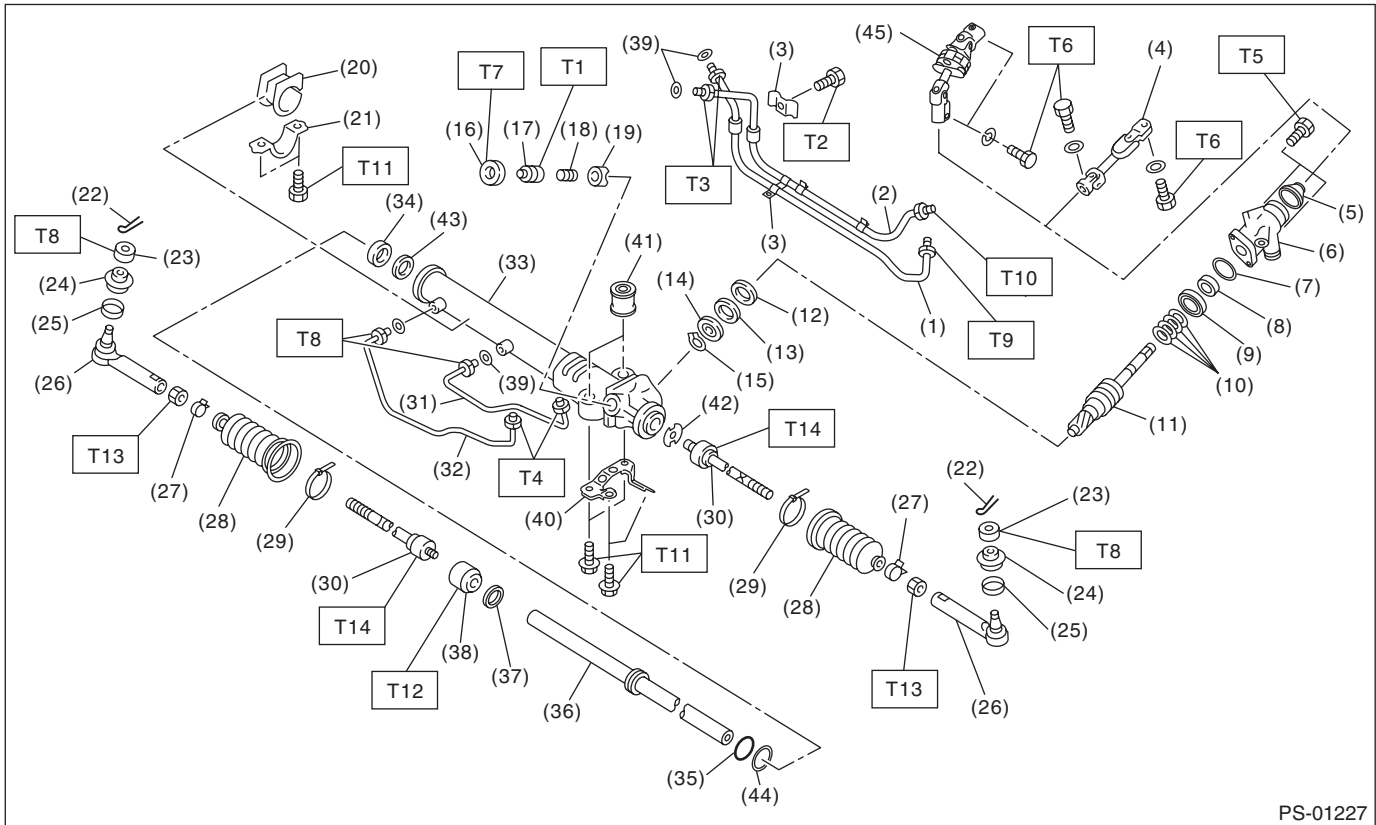

PS-01227

(1) Feed pipe	(21) Clamp	(41) Bushing
(2) Return pipe	(22) Cotter pin	(42) Lock washer
(3) Clamp plate	(23) Castle nut	(43) Back-up washer
(4) Universal joint (STI model)	(24) Dust cover	(44) O-ring
(5) Dust seal	(25) Clip	(45) Universal joint (except for STI model)
(6) Valve housing	(26) Tie-rod end	
(7) O-ring	(27) Clip	
(8) Oil seal	(28) Boot	
(9) Bushing	(29) Band	
(10) Seal ring	(30) Tie-rod	
(11) Pinion & valve ASSY	(31) Pipe B	
(12) Oil seal	(32) Pipe A	
(13) Back-up washer	(33) Steering body	
(14) Ball bearing	(34) Oil seal	
(15) Snap ring	(35) Piston ring	
(16) Lock nut	(36) Rack	
(17) Adjusting screw	(37) Oil seal	
(18) Spring	(38) Holder	
(19) Sleeve	(39) O-ring	
(20) Adapter	(40) Stiffener	

#### **Tightening torque:N-m (kgf-m, ft-lb)**

**T1: Tighten to 5.9 (0.6, 4.4), and loosen by 20 degrees.**

**T2: 9 (0.9, 6.6)**

**T3: 15 (1.5, 11.1)**

**T4: 17 (1.7, 12.5)**

**T5: 20 (2.0, 14.8)**

**T6: 24 (2.4, 17.7)**

**T7: 25 (2.5, 18.4)**

**T8: 27 (2.8, 19.9)**

**T9: 37 (3.8, 27.3)**

**T10: 29 (3.0, 21.4)**

**T11: 60 (6.1, 44.3)**

**T12: 70 (7.1, 51.6)**

**T13: 85 (8.7, 62.7)**

**T14: 95 (9.7, 70.1)**

**PS-5**

Brought to you by Ebay Seller "SubaruManuals"

# General Description

## POWER ASSISTED SYSTEM (POWER STEERING)

### 3. OIL PUMP

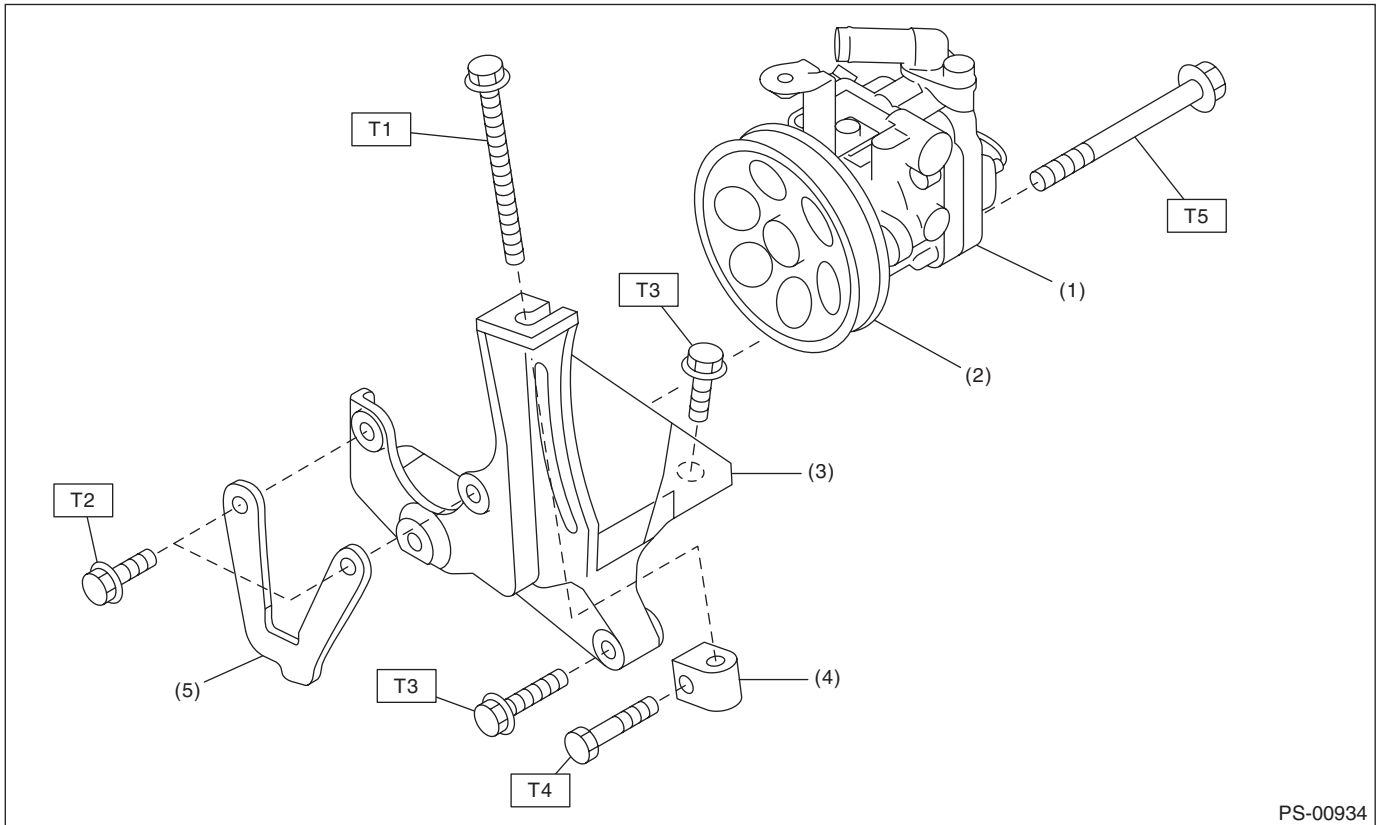

- (1) Oil pump
- (2) Pulley
- (3) Bracket
- (4) Belt tension nut
- (5) Washer plate

**Tightening torque: N·m (kgf·m, ft·lb)**

**T1: 8 (0.8, 5.9)**

**T2: 16 (1.6, 11.8)**

**T3: 22 (2.2, 16.2)**

**T4: 25 (2.5, 18.4)**

**T5: 48 (4.9, 35.4)**

### C: CAUTION

- Wear appropriate work clothing, including a helmet, protective goggles and protective shoes when performing any work.
- Before removal, installation or disassembly, be sure to clarify the failure. Avoid unnecessary removal, installation, disassembly and replacement.
- Vehicle components are extremely hot after driving. Be wary of receiving burns from heated parts.
- Use SUBARU genuine power steering fluid, grease etc. or equivalent. Do not mix fluid, grease etc. of different grades or manufacturers.
- Be sure to tighten fasteners including bolts and nuts to the specified torque.
- Place shop jacks or rigid racks at the specified points.
- Before securing a part on a vise, place cushioning material such as wooden blocks, aluminum plate or cloth between the part and the vise.

# General Description

POWER ASSISTED SYSTEM (POWER STEERING)

## D: PREPARATION TOOL

### 1. SPECIAL TOOL

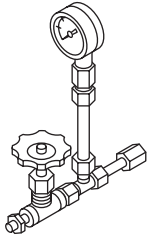
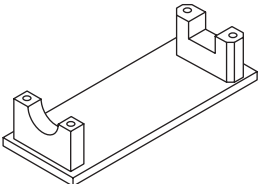
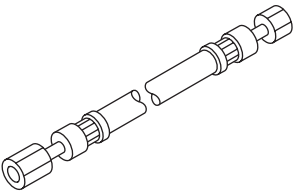
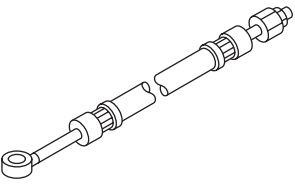
ILLUSTRATION	TOOL NUMBER	DESCRIPTION	REMARKS
 <p>ST-925711000</p>	925711000	PRESSURE GAUGE	Used for measuring oil pressure.
 <p>ST-926200000</p>	926200000	STAND	<ul style="list-style-type: none"> <li>Used when inspecting characteristic of gear-box assembly and disassembling it.</li> <li>Used together with BOSS D (34199AG000).</li> </ul>
 <p>ST34099AC010</p>	34099AC010	ADAPTER HOSE A	Used together with PRESSURE GAUGE (925711000).
 <p>ST34099AC020</p>	34099AC020	ADAPTER HOSE B	Used together with PRESSURE GAUGE (925711000).



## General Description

### POWER ASSISTED SYSTEM (POWER STEERING)

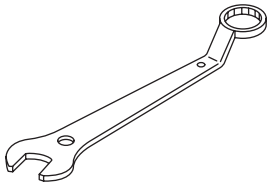
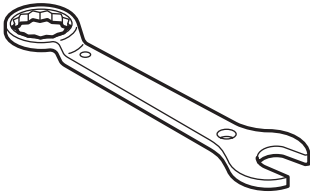
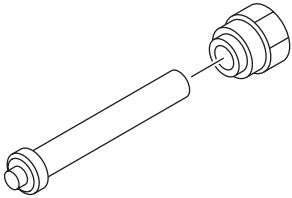
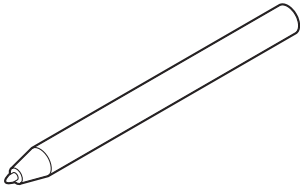
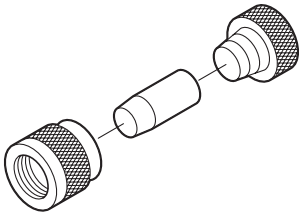
ILLUSTRATION	TOOL NUMBER	DESCRIPTION	REMARKS
 <p style="text-align: center;">ST-926230000</p>	926230000	SPANNER	For the lock nut when adjusting backlash of gearbox.
 <p style="text-align: center;">ST34099PA100</p>	34099PA100	SPANNER	Used when measuring the rotating resistance of gearbox assembly.
 <p style="text-align: center;">ST-926420000</p>	926420000	PLUG	When fluid leaks from pinion side of gearbox assembly, remove pipe B from valve housing, attach this tool and check fluid leaking points.
 <p style="text-align: center;">ST34099FA060</p>	34099FA060	PUNCH HOLDER	Used for crimping.
 <p style="text-align: center;">ST34199FE040</p>	34199FE040	INSTALLER A, B, C	<ul style="list-style-type: none"> <li>• Used for installing the oil seal to the rack assembly.</li> <li>• INSTALLER A: 34199FE070</li> <li>• INSTALLER B: 34199FE080</li> <li>• INSTALLER C: 34199FE090</li> </ul>

# General Description

## POWER ASSISTED SYSTEM (POWER STEERING)

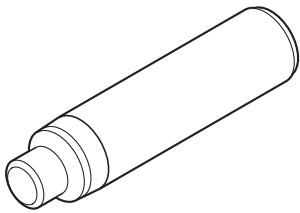
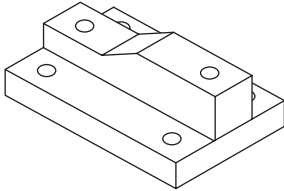
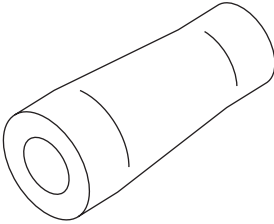
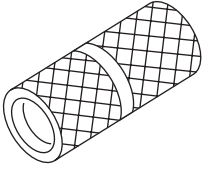
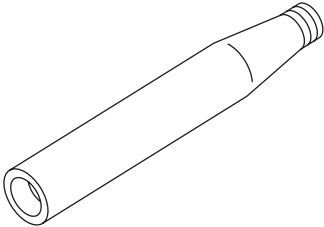
ILLUSTRATION	TOOL NUMBER	DESCRIPTION	REMARKS
 <p>ST34199XA030</p>	34199XA030	INSTALLER & REMOVER	Used for removing and installing the rack oil seal (outer and inner).
 <p>ST34199AG000</p>	34199AG000	BOSS D	<ul style="list-style-type: none"> <li>• Used when inspecting characteristic of gear-box assembly and disassembling it.</li> <li>• Used together with STAND (926200000).</li> </ul>
 <p>ST34199AG040</p>	34199AG040	GUIDE	Used for installing seal ring of rack.
 <p>ST34199AG070</p>	34199AG070	FORMER	Used for forming seal ring of pinion.
 <p>ST34199AG020</p>	34199AG020	GUIDE	Used for installing seal ring of pinion.

## General Description

### POWER ASSISTED SYSTEM (POWER STEERING)

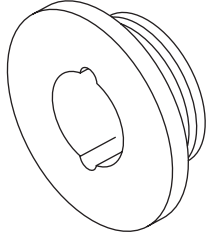
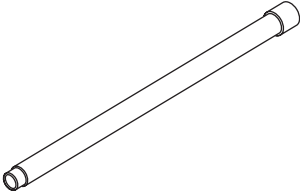
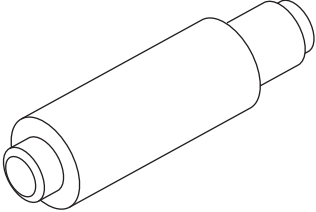
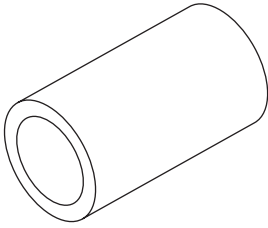
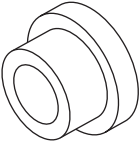
ILLUSTRATION	TOOL NUMBER	DESCRIPTION	REMARKS
 <p style="text-align: center;">ST34199AG060</p>	34199AG060	GUIDE G (26)	<ul style="list-style-type: none"> <li>• Used for forming seal ring of rack.</li> <li>• Used together with FORMER PISTON (34199AG080).</li> </ul>
 <p style="text-align: center;">ST34099PA010</p>	34099PA010	OIL SEAL REMOVER	Used for removing oil seal.
 <p style="text-align: center;">ST34199AG090</p>	34199AG090	INSTALLER & REMOVER	<ul style="list-style-type: none"> <li>• Used for installing oil seal of valve housing.</li> <li>• Used for installing ball bearing of valve housing.</li> <li>• Used for removing oil seal and ball bearing from valve housing.</li> </ul>
 <p style="text-align: center;">ST34199AG080</p>	34199AG080	FORMER PISTON	<ul style="list-style-type: none"> <li>• Used for forming seal ring of rack.</li> <li>• Used together with GUIDE G (26) (34199AG060).</li> </ul>
 <p style="text-align: center;">ST34199AG010</p>	34199AG010	INSTALLER	Used for pressing-fit oil seal of gearbox cylinder.

# General Description

POWER ASSISTED SYSTEM (POWER STEERING)

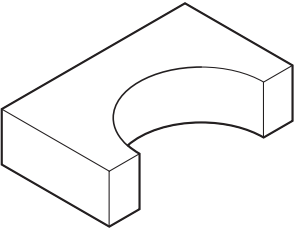
ILLUSTRATION	TOOL NUMBER	DESCRIPTION	REMARKS
 <p data-bbox="326 520 467 539">ST34199FE020</p>	34199FE020	BASE	Used for crimping.

# Steering Wheel

POWER ASSISTED SYSTEM (POWER STEERING)

## 2. Steering Wheel

### A: REMOVAL

- 1) Disconnect the ground cable from battery.
- 2) Set the tire to the straight-ahead position.
- 3) Remove the airbag module. <Ref. to AB-16, REMOVAL, Driver's Airbag Module.>

#### WARNING:

**Always refer to "Airbag System" before performing service on the airbag modules. <Ref. to AB-5, CAUTION, General Description.>**

- 4) Place alignment marks on the steering wheel and steering shaft.

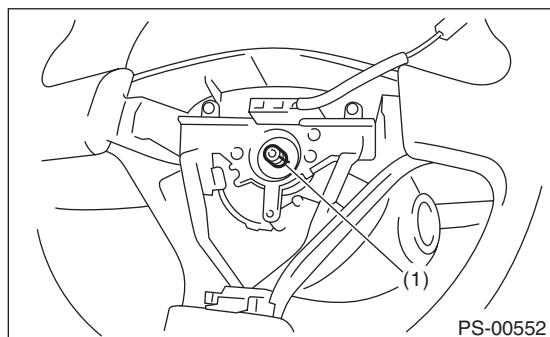

(1) Alignment mark

- 5) Remove the steering wheel nut, and then draw out the steering wheel from shaft using steering puller.

### B: INSTALLATION

#### WARNING:

**Always refer to "Airbag System" before performing service on the airbag modules. <Ref. to AB-5, CAUTION, General Description.>**

- 1) Align the center position of the roll connector. <Ref. to AB-28, ADJUSTMENT, Roll Connector.>
- 2) Install each part in the reverse order of removal.

#### CAUTION:

**Insert the roll connector guide pin into the guide hole on the lower end of the steering wheel surface. Avoid damaging the pin.**

#### NOTE:

Align the alignment marks on the steering wheel and steering shaft.

#### *Tightening torque:*

**39 N·m (4.0 kgf·m, 28.8 ft·lb)**

#### *Column cover-to-steering wheel clearance:*

**2 — 4 mm (0.08 — 0.16 in)**

### C: INSPECTION

- 1) Check the steering wheel for deformation. If the deformation is excessive, replace the steering wheel.
- 2) Check the splines on the steering wheel for damage. If the damage is excessive, replace the steering wheel.

# Universal Joint

POWER ASSISTED SYSTEM (POWER STEERING)

## 3. Universal Joint

### A: REMOVAL

- 1) Remove the steering wheel. <Ref. to PS-12, REMOVAL, Steering Wheel.>
- 2) Place alignment marks on universal joint.
- 3) Remove the universal joint bolt and remove the universal joint.

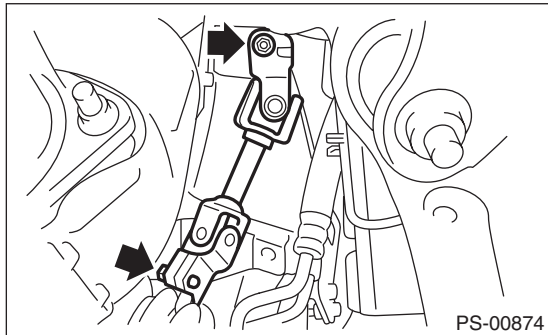

### B: INSTALLATION

- 1) Align the cutout portion (a) at serrated section of the column shaft (c) and yoke (b), then install the universal joint into column shaft.

#### CAUTION:

Be sure to align the protrusion section (a) of the column shaft side with the cutout (a) of the serration. If the protrusion is aligned with the other cutout (d), the universal joint bolt cannot be assembled.

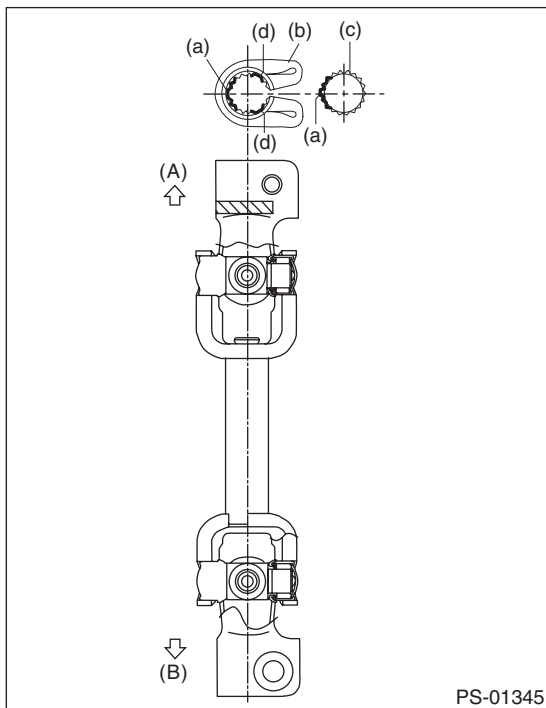

- (A) Column shaft side  
(B) Gearbox side

- 2) Install the universal joint to the serrations of gearbox assembly by matching alignment marks.
- 3) Tighten the bolts.

#### CAUTION:

Excessively large tightening torque of universal joint bolts may lead to heavy steering wheel operation.

#### Tightening torque:

24 N·m (2.4 kgf·m, 17.7 ft·lb)

Clearance between coupling of universal joint and turbo cover:

15 mm (0.59 in) or more

- 4) Align the center position of the roll connector. <Ref. to AB-28, ADJUSTMENT, Roll Connector.>
- 5) Install the steering wheel. <Ref. to PS-12, INSTALLATION, Steering Wheel.>

### C: INSPECTION

- 1) Check for wear, damage or any other faults. Replace as necessary

#### Service limit:

Universal joint play: 0 mm (0 in)

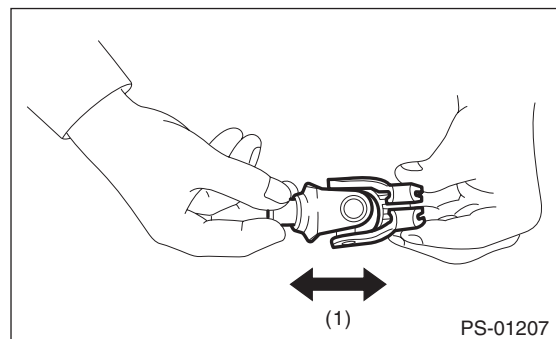

- (1) Play

- 2) Measure the swing torque of universal joint.

#### Service limit:

Maximum load: 3.8 N (0.39 kgf, 0.86 lbf) or less

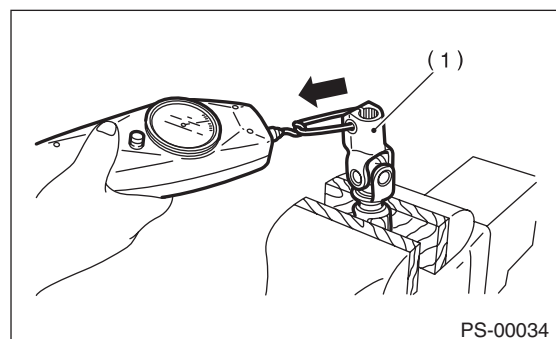

- (1) Yoke

# Universal Joint

POWER ASSISTED SYSTEM (POWER STEERING)

---

**Service limit:**

**Maximum load: 3.8 N (0.39 kgf, 0.86 lbf) or less**

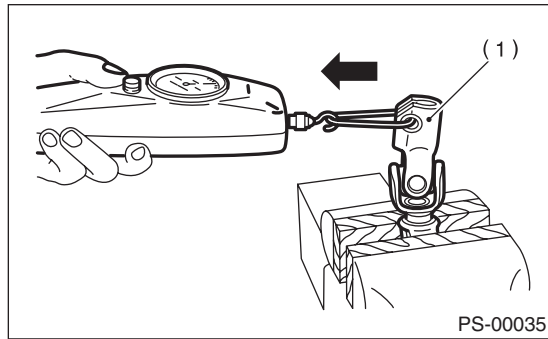

(1) Yoke

# Steering Column

POWER ASSISTED SYSTEM (POWER STEERING)

## 4. Steering Column

### A: REMOVAL

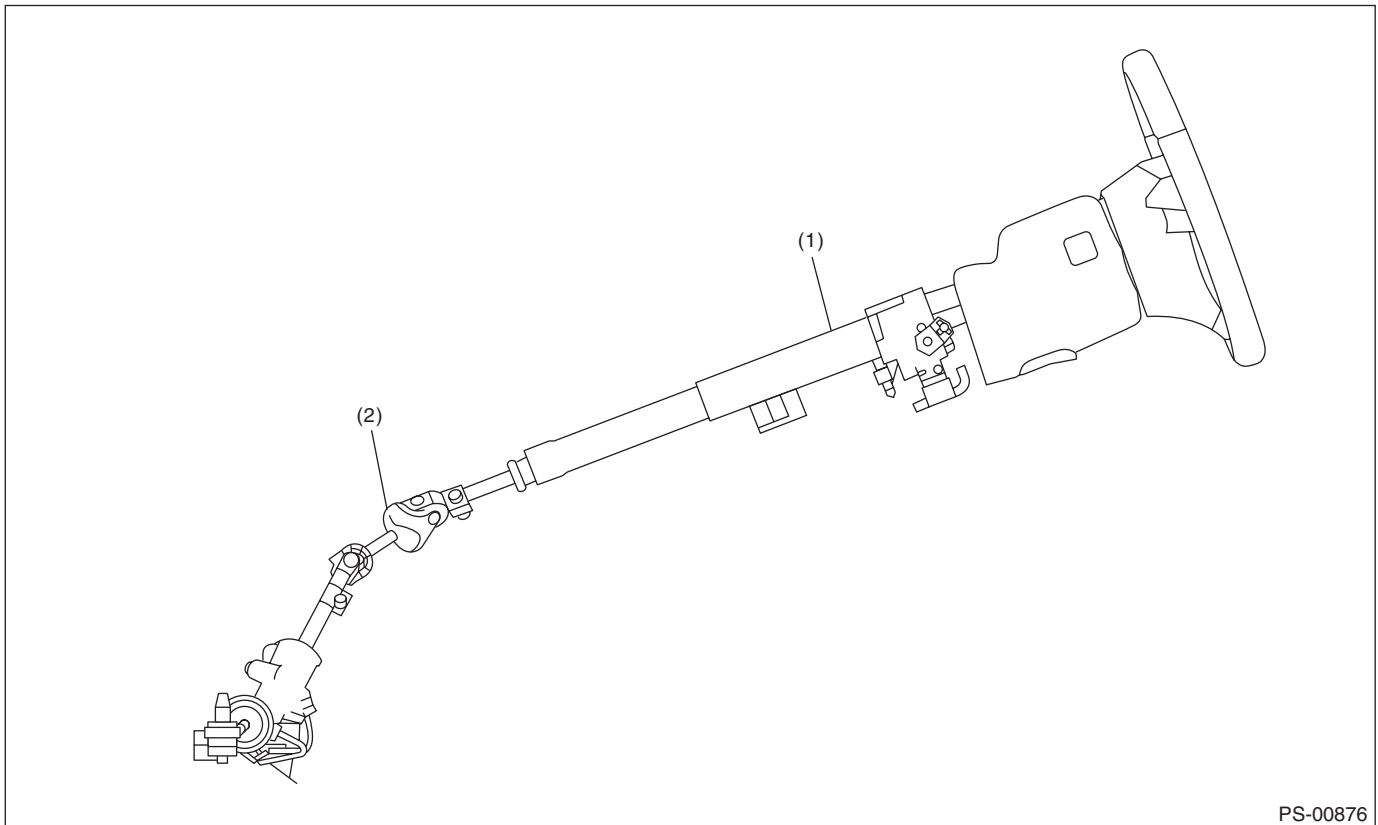

PS-00876

- (1) Tilt and telescopic steering column (2) Universal joint

- 1) Adjust the tilt position of the steering column to the highest position and lock the tilt lever.
- 2) Remove the steering wheel. <Ref. to PS-12, REMOVAL, Steering Wheel.>
- 3) Remove the universal joint. <Ref. to PS-13, REMOVAL, Universal Joint.>
- 4) Remove the instrument panel lower cover under.
- 5) Remove the instrument panel lower cover upper.
- 6) Remove the one screw which secures the column cover lower, and then remove the column cover lower.
- 7) Remove all connectors from the steering column.

- 8) Remove the two bolts under instrument panel securing the steering column.

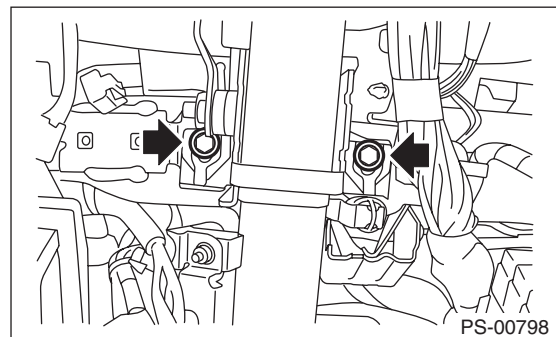

PS-00798



# Steering Column

## POWER ASSISTED SYSTEM (POWER STEERING)

9) Pull out the steering shaft assembly from the hole on toe board.

### CAUTION:

- Always remove the universal joint before removing the steering column installation bolt to avoid damage to the universal joint.
- Be sure to remove the universal joint before removing the parts, if the relative position between steering shaft and gearbox changes when removing steering shaft assembly or when lowering it and gearbox for servicing other parts.
- Do not loosen the tilt lever when the steering column is not secured to the vehicle.

## B: INSTALLATION

1) Install the grommet to the toe board.

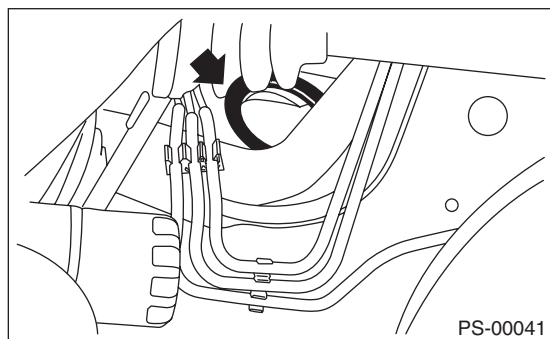

2) Insert the end of the steering shaft into the toe board grommet.

3) With the tilt lever secured, tighten the steering shaft mounting bolts under instrument panel.

### Tightening torque:

**20 N·m (2.0 kgf·m, 14.8 ft·lb)**

4) Connect all the connectors under the instrument panel.

5) Connect the airbag system connector at the harness spool.

### NOTE:

Make sure to apply double lock.

6) Install the instrument panel lower cover with tilt lever held in the lowered position.

7) Install the universal joint. <Ref. to PS-13, INSTALLATION, Universal Joint.>

8) Align the center position of the roll connector. <Ref. to AB-28, ADJUSTMENT, Roll Connector.>

9) Install the steering wheel. <Ref. to PS-12, INSTALLATION, Steering Wheel.>

### CAUTION:

Insert the roll connector guide pin into the guide hole on lower end of steering wheel surface to prevent damage.

## C: DISASSEMBLY

Remove the three screws securing the upper steering column covers, and the two screws securing the combination switch, and then remove related parts.

## D: ASSEMBLY

Insert the combination switch to the upper column shaft, and install the upper column cover. Then route the ignition key harness and combination switch harness between the column cover mounting bosses.

### CAUTION:

Do not overtorque the screw.

### Tightening torque:

**1.2 N·m (0.12 kgf·m, 0.9 ft·lb)**

## E: INSPECTION

### 1. BASIC INSPECTION

Measure the overall length of steering column. If not within specification, replace it.

**Standard: Overall length L**

**Tilt and telescopic column (measure while minimized)**

**818.6<sup>+1.5</sup><sub>-1.5</sub> mm (32.23<sup>+0.059</sup><sub>-0.059</sub> in)**

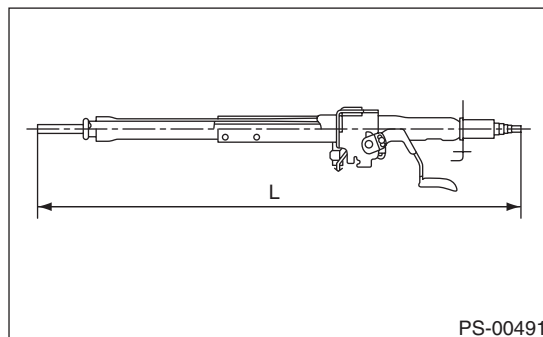

### 2. INSPECTION OF AIRBAG SYSTEM

Refer to "Airbag System" for airbag inspection procedure. <Ref. to AB-16, INSPECTION, Driver's Airbag Module.>

# Steering Gearbox

POWER ASSISTED SYSTEM (POWER STEERING)

## 5. Steering Gearbox

### A: REMOVAL

- 1) Set the vehicle on a lift.
- 2) Disconnect the ground cable from battery.
- 3) Loosen the front wheel nuts.
- 4) Lift up the vehicle, and then remove the front wheels.
- 5) Remove the under cover. <Ref. to EI-28, REMOVAL, Front Under Cover.>
- 6) Remove the front exhaust pipe assembly. <Ref. to EX(STI)-6, REMOVAL, Front Exhaust Pipe.>

#### WARNING:

**Be careful not to burn yourself because the exhaust pipe is hot.**

- 7) Remove the cotter pin and castle nut securing the tie-rod end.

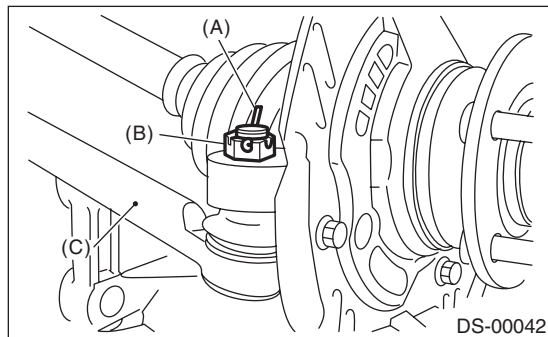

- (A) Cotter pin
- (B) Castle nut
- (C) Tie-rod end

- 8) Using a puller, remove the tie-rod.

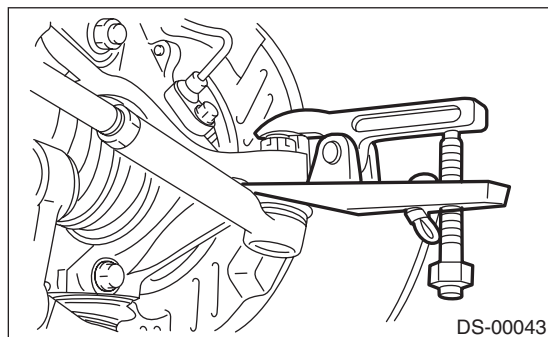

- 9) Remove the front crossmember support plate and front stabilizer. <Ref. to FS-17, REMOVAL, Front Stabilizer.>

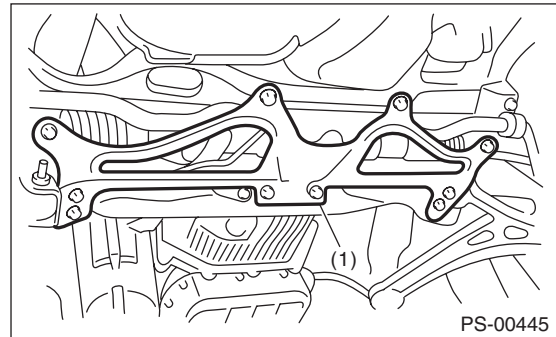

- (1) Front crossmember support plate

- 10) Remove the one pipe joint at the center of the gearbox, and connect the vinyl hose to the pipe and the joint. Discharge the fluid by turning the steering wheel fully clockwise and counterclockwise. Discharge the fluid similarly from other pipes.

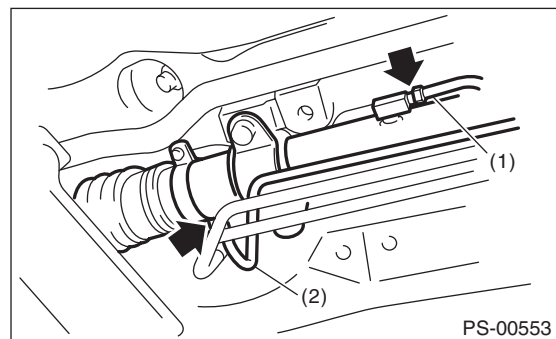

- (1) Pipe A
- (2) Pipe B

- 11) Remove the universal joint. <Ref. to PS-13, REMOVAL, Universal Joint.>

# Steering Gearbox

## POWER ASSISTED SYSTEM (POWER STEERING)

12) Disconnect the feed pipe from the pressure hose first, then disconnect the return pipe from the return hose.

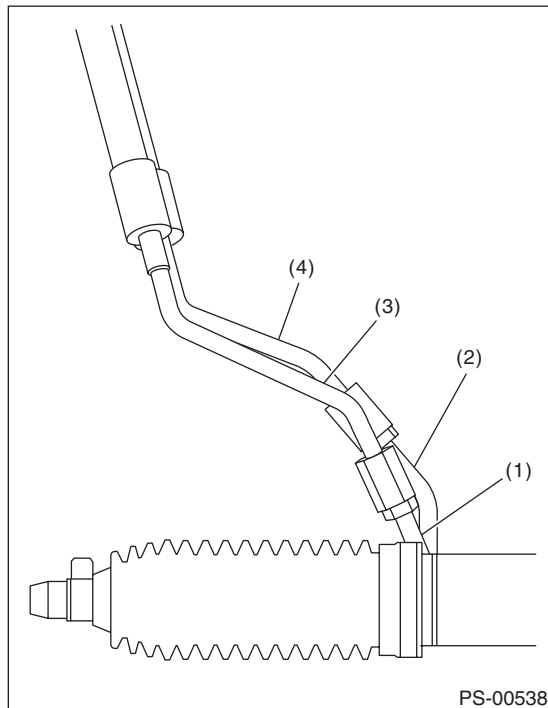

- (1) Feed pipe
- (2) Return pipe
- (3) Pressure hose
- (4) Return hose

13) Remove the clamp bolts securing the gearbox to the crossmember, and remove the clamp.

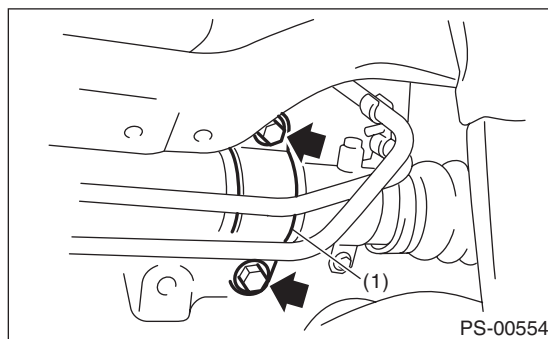

- (1) Clamp

14) Remove the bolts which secure the gearbox bracket, and remove the stiffener and gearbox.

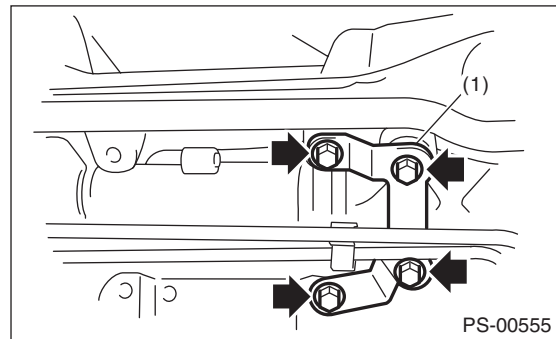

- (1) Stiffener

## B: INSTALLATION

1) Insert the gearbox into crossmember, being careful not to damage gearboot.

2) Install the gearbox and stiffener. Temporarily tighten the bolts.

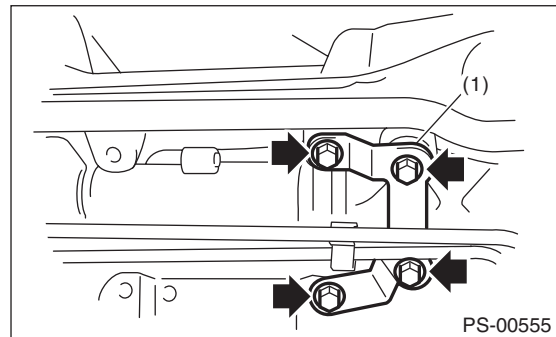

- (1) Stiffener

3) Insert bolts through the clamp to temporarily tighten the gearbox to the crossmember bracket.

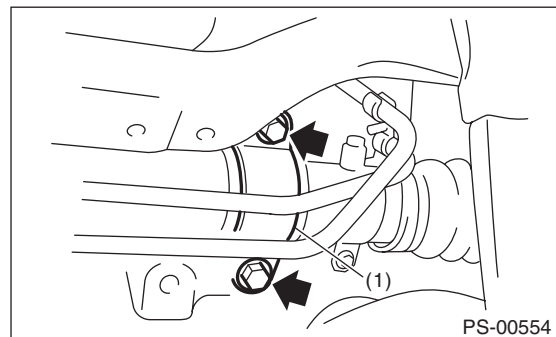

- (1) Clamp

4) Tighten the bolts temporarily holding the gearbox clamp and bracket together to the specified torque.

**Tightening torque:**

**60 N·m (6.1 kgf·m, 44.3 ft·lb)**

# Steering Gearbox

## POWER ASSISTED SYSTEM (POWER STEERING)

5) Connect the return pipe to the return hose and then connect the feed pipe to the pressure hose.

### **Tightening torque:**

**15 N·m (1.5 kgf·m, 11.1 ft·lb)**

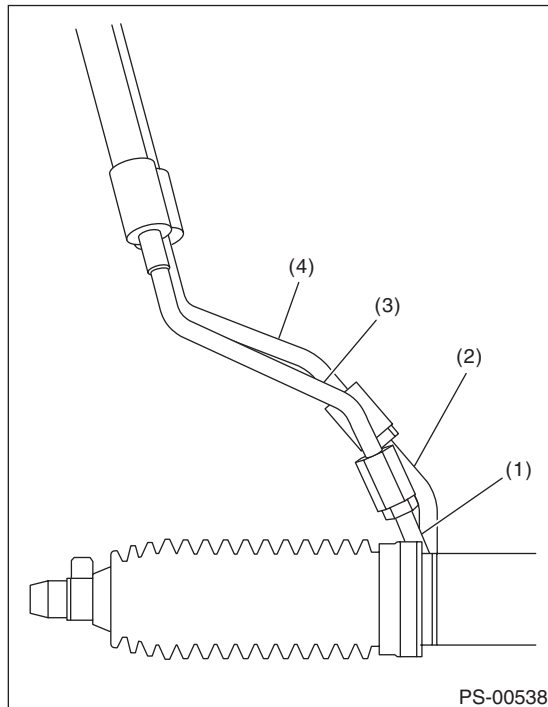

- (1) Feed pipe
- (2) Return pipe
- (3) Pressure hose
- (4) Return hose

6) Install the universal joint. <Ref. to PS-13, INSTALLATION, Universal Joint.>

7) Connect the tie-rod end and knuckle arm, and tighten with castle nut.

### **CAUTION:**

**When connecting, do not hit the cap at the bottom of tie-rod end with hammer.**

### **Castle nut tightening torque:**

**27 N·m (2.8 kgf·m, 19.9 ft·lb)**

8) After tightening the castle nut to the specified tightening torque, tighten it further within 60° until the cotter pin hole is aligned with slot in the nut. Fit the cotter pin into the nut, and then bend the pin to lock.

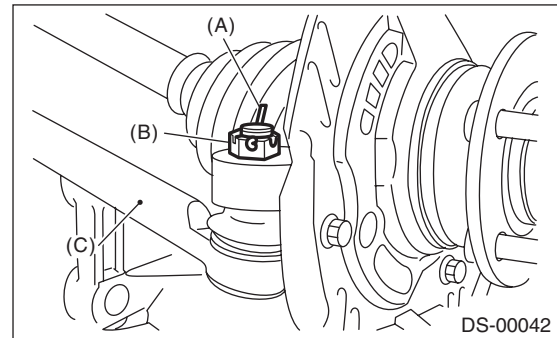

- (A) Cotter pin
- (B) Castle nut
- (C) Tie-rod end

9) Install the front stabilizer. <Ref. to FS-17, INSTALLATION, Front Stabilizer.>

10) Install the front crossmember support plate.

11) Install the front exhaust pipe assembly. <Ref. to EX(STI)-6, INSTALLATION, Front Exhaust Pipe.>

12) Install the under cover. <Ref. to EI-28, INSTALLATION, Front Under Cover.>

13) Install the front wheels.

14) Tighten the wheel nuts to the specified torque.

### **Tightening torque:**

**100 N·m (10.2 kgf·m, 73.8 ft·lb)**

15) Lower the vehicle.

16) Remove the steering wheel. <Ref. to PS-12, REMOVAL, Steering Wheel.>

17) Align the center position of the roll connector. <Ref. to AB-28, ADJUSTMENT, Roll Connector.>

18) Install the steering wheel. <Ref. to PS-12, INSTALLATION, Steering Wheel.>

19) Connect the battery ground terminal.

20) Pour fluid into the oil tank, and bleed air. <Ref. to PS-50, Power Steering Fluid.>

21) Check for fluid leaks.

22) Check the fluid level in oil tank.

# Steering Gearbox

## POWER ASSISTED SYSTEM (POWER STEERING)

23) After adjusting toe-in and steering angle, tighten the lock nut on tie-rod end.

### Tightening torque:

**85 N·m (8.7 kgf-m, 62.7 ft-lb)**

### NOTE:

When adjusting toe-in, hold the boot as shown to prevent it from being rotated or twisted. If it becomes twisted, straighten it.

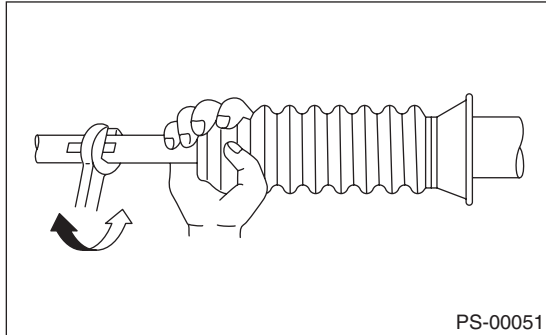

4) Remove the small clip from the boot using pliers, and then move the boot to tie-rod end side.

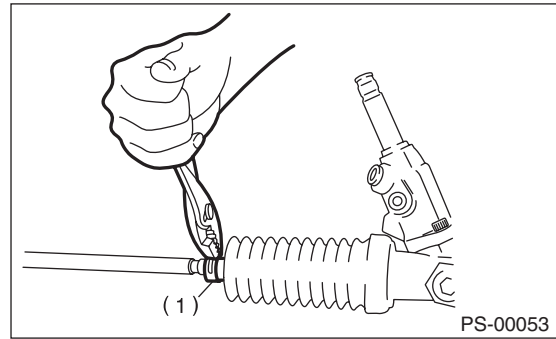

(1) Clip

5) Using a flat tip screwdriver, remove the band from boot.

### NOTE:

Replace the boot if there is damage, cracks or deterioration.

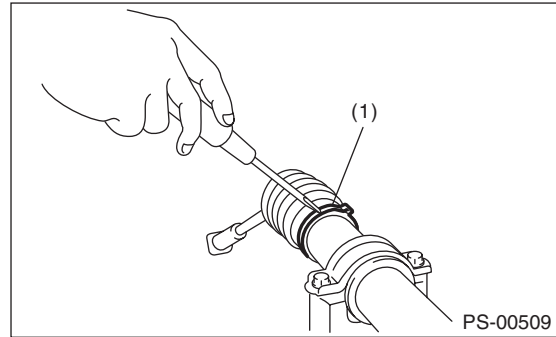

(1) Band

## C: DISASSEMBLY

### 1. RACK HOUSING ASSEMBLY

1) Disconnect the four pipes from gearbox.

### NOTE:

Remove the pipes C and D, which are fixed to clamp plate, as a unit.

2) Secure the gearbox removed from vehicle in a vise using ST.

### CAUTION:

**Secure the gearbox assembly in a vise using ST as shown. Do not affix the gearbox to the vice without this ST.**

ST1 926200000 STAND

ST2 34199AG000 BOSS D

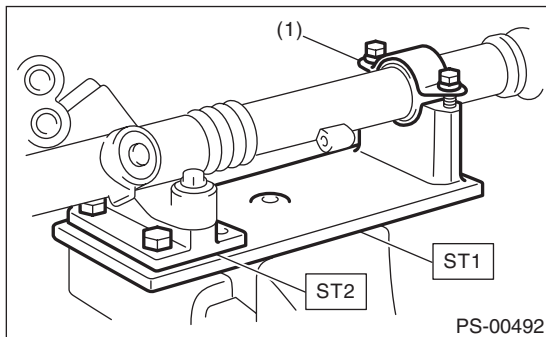

(1) Clamp

6) Using the ST, loosen the lock nut.

ST 926230000 SPANNER

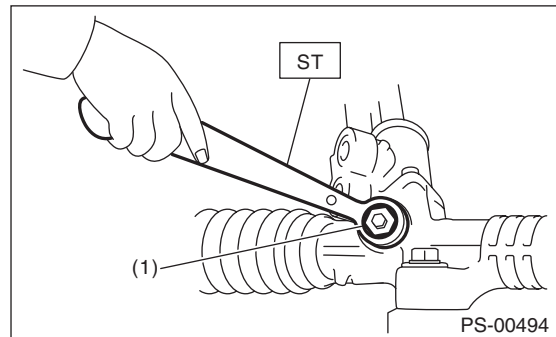

(1) Lock nut

3) Remove the tie-rod end and lock nut from gearbox.

# Steering Gearbox

POWER ASSISTED SYSTEM (POWER STEERING)

7) Tighten the adjusting screw until it can no longer be tightened.

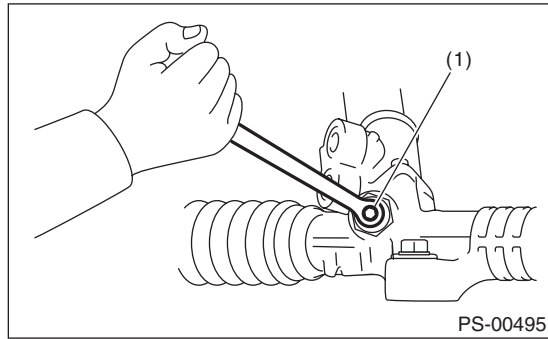

(1) Adjusting screw

8) Remove the tie-rod.

9) Loosen the adjusting screw, and remove the spring and sleeve.

10) Remove the two bolts securing valve assembly.

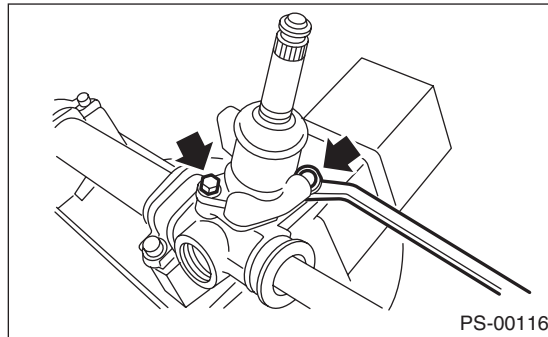

11) Carefully draw out the input shaft and remove the valve assembly.

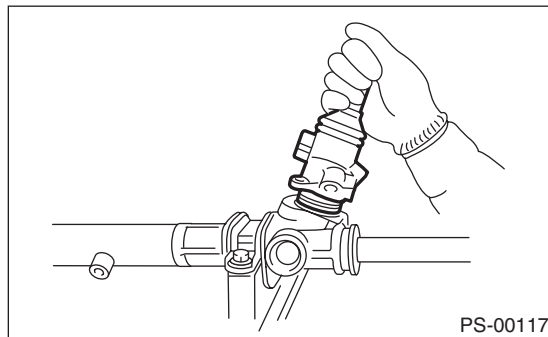

12) Using a drill, release the crimping of holder.

### CAUTION:

Make a hole of 2 mm (0.08 in) depth using a drill with 3 mm (0.12 in) diameter.

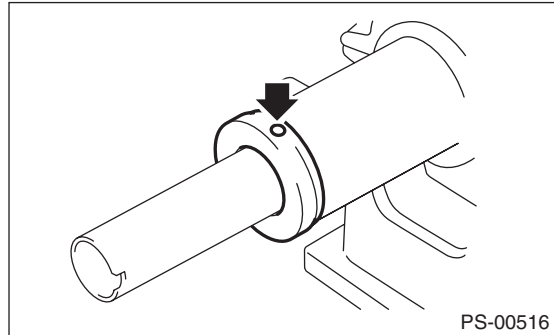

13) Remove the holder.

14) Attach the ST on the valve side of rack, and press out the outer side oil seal while taking care that the rack and the steering body inner surface do not come into contact with each other.

ST 34199XA030 INSTALLER & REMOVER

### NOTE:

Block the pipe connection of steering body to prevent fluid from flowing out.

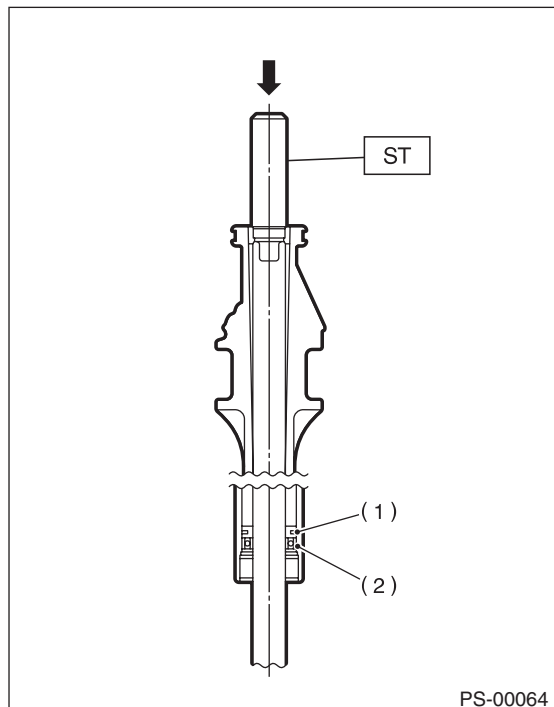

(1) Rack piston

(2) Outer side oil seal

# Steering Gearbox

## POWER ASSISTED SYSTEM (POWER STEERING)

15) Insert the ST from pinion housing side and remove the oil seal using a press.

ST 34099PA010 OIL SEAL REMOVER

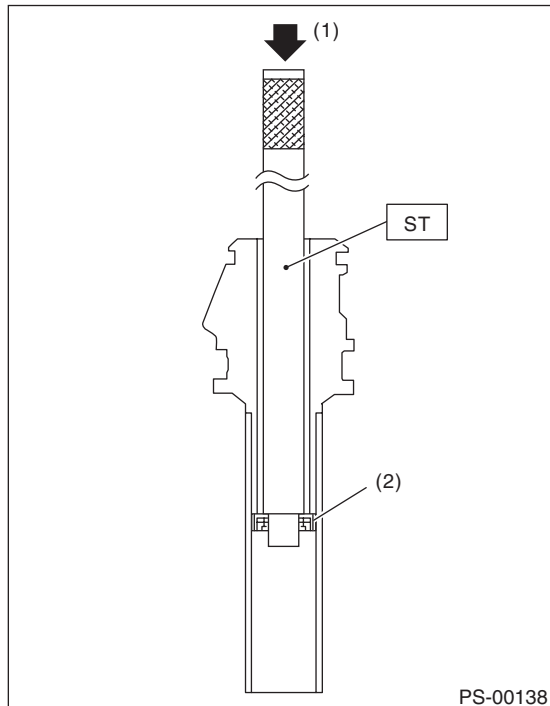

- (1) Press
- (2) Oil seal

16) Using a press, remove the bushing of gearbox installation portion.

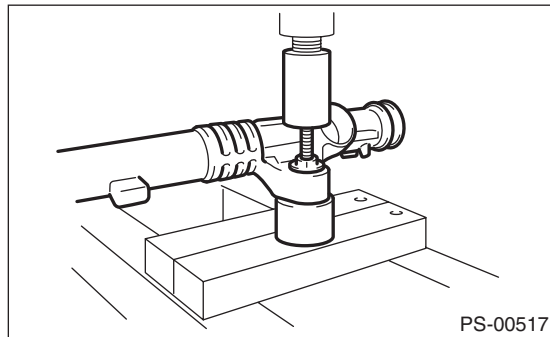

## 2. CONTROL VALVE

1) Disconnect the pipes A and B from gearbox.

2) Secure the gearbox removed from vehicle in a vise using ST.

### CAUTION:

**Secure the gearbox assembly in a vise using ST as shown. Do not affix the gearbox to the vice without this ST.**

ST1 926200000 STAND

ST2 34199AG000 BOSS D

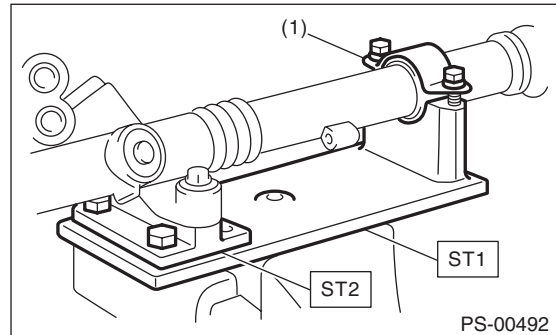

- (1) Clamp

3) Using the ST, loosen the lock nut.

ST 926230000 SPANNER

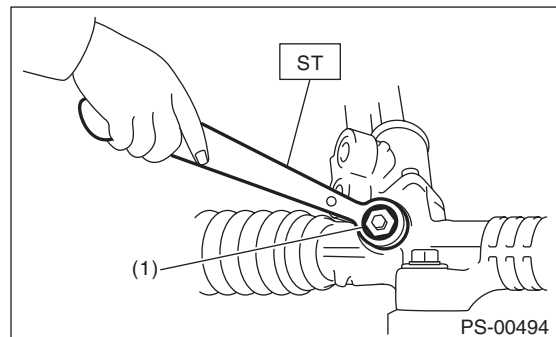

- (1) Lock nut

4) Loosen the adjusting screw, and remove the spring and sleeve.

5) Remove the two bolts securing valve assembly.

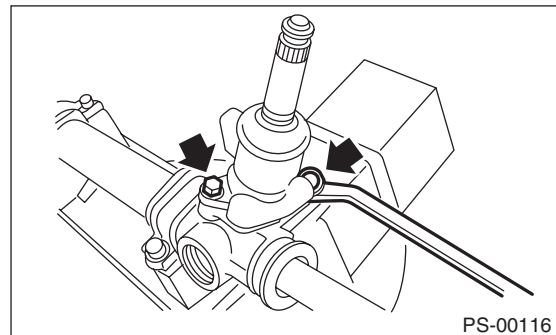



# Steering Gearbox

POWER ASSISTED SYSTEM (POWER STEERING)

6) Carefully draw out the input shaft and remove the valve assembly.

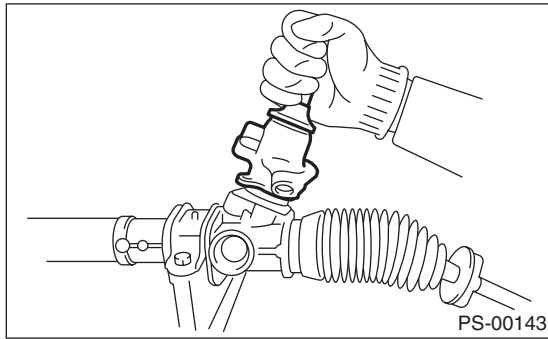

7) Put a vinyl tape around the spline portion, and slide the dust cover to remove.

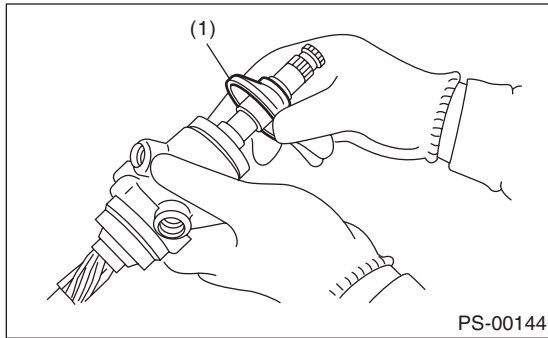

(1) Dust cover

8) Using a press, remove the pinion & valve assembly from valve housing.

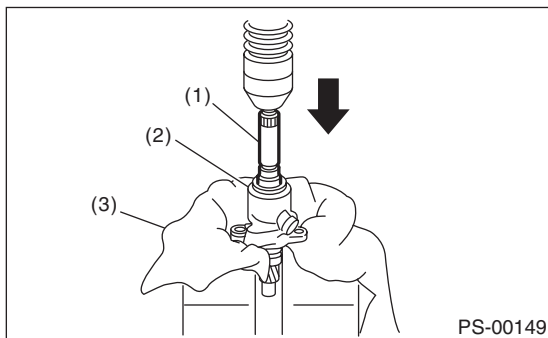

(1) Pinion & valve ASSY  
(2) Valve housing  
(3) Cloth

9) Using the ST and a press, remove the bushing and oil seal from the valve housing.

### CAUTION:

- Do not apply a force to the end surface of valve housing.
- Do not reuse the oil seal after removal.

ST 34199AG090 INSTALLER & REMOVER

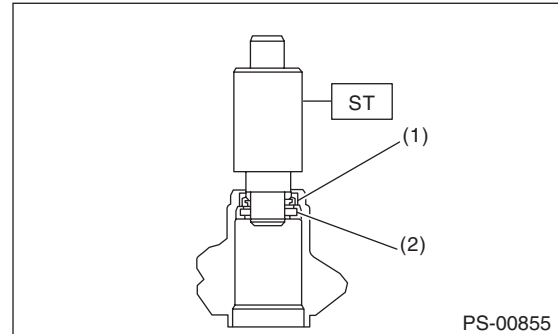

(1) Oil seal  
(2) Bushing

10) Using a snap ring pliers, remove the snap ring, valve, oil seal and back-up washer.

### CAUTION:

Be careful not to scratch the pinion and valve assembly.

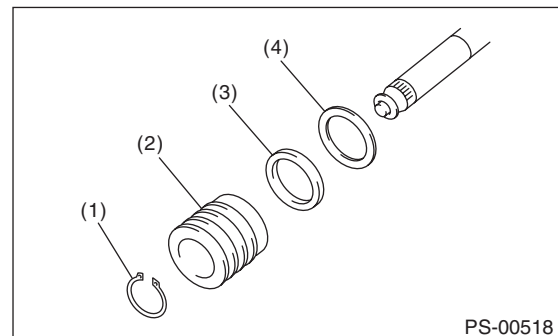

(1) Snap ring  
(2) Valve  
(3) Oil seal  
(4) Back-up ring



# Steering Gearbox

## POWER ASSISTED SYSTEM (POWER STEERING)

### D: ASSEMBLY

#### 1. RACK HOUSING ASSEMBLY

1) Using a press, install the bushing to gearbox installation portion.

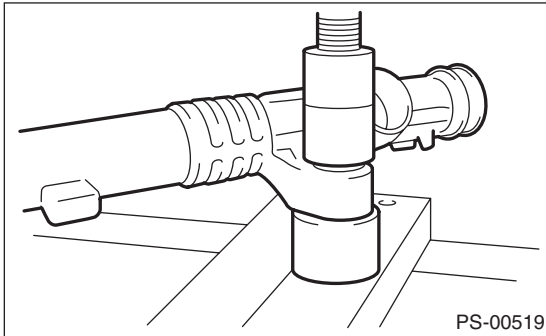

2) Insert the ST to rack.  
ST 34199AG040 GUIDE

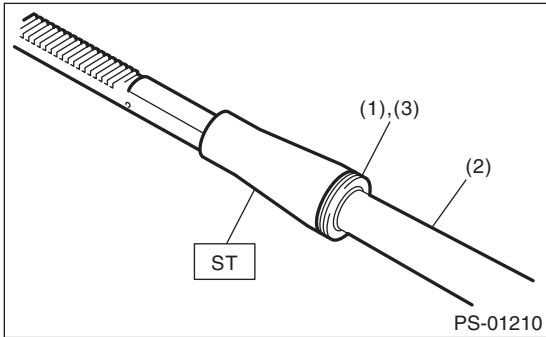

- (1) Seal ring
- (2) Rack
- (3) O-ring

3) Install the seal ring and O-ring to piston portion of rack.

4) Using the ST, form the seal ring properly.

ST1 34199AG080 FORMER PISTON

ST2 34199AG060 GUIDE G (26)

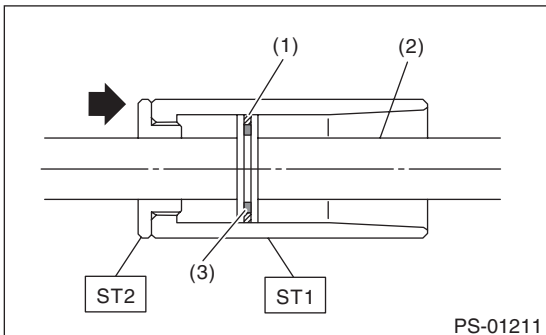

- (1) Seal ring
- (2) Rack
- (3) O-ring

5) Using the ST A and ST B, attach the oil seal to ST C.

ST 34199FE040 INSTALLER A, B, C

- INSTALLER A: 34199FE070
- INSTALLER B: 34199FE080
- INSTALLER C: 34199FE090

NOTE:

Face the oil seal in the direction as shown in the figure.

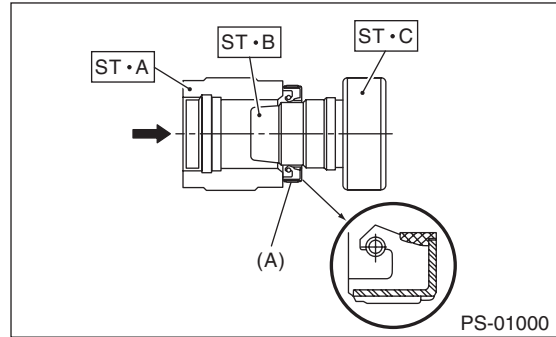

(A) Oil seal

6) Insert the ST C with oil seal assembled from the gear side of rack. Remove the oil seal from ST C near piston, and then remove the ST C from rack.

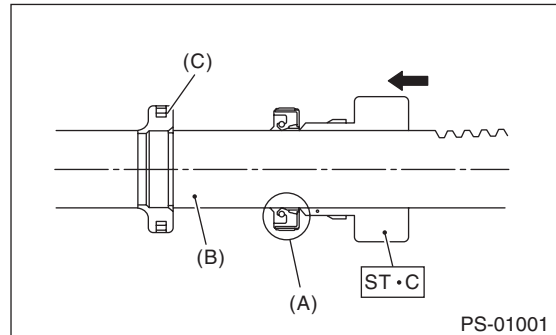

- (A) Oil seal
- (B) Rack
- (C) Piston

# Steering Gearbox

POWER ASSISTED SYSTEM (POWER STEERING)

7) Install the back-up washer from the gear side of rack.

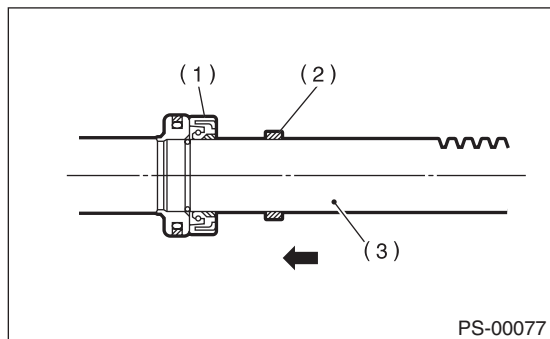

- (1) Oil seal
- (2) Back-up washer
- (3) Rack

8) Check the threaded end of holder and gearbox cylinder end for burrs, damage, etc. Correct if faulty.

9) Apply a coat of grease to the grooves in rack, sliding surface of sleeve and sealing surface of piston. Then insert the rack into steering body from cylinder side.

10) Temporarily tighten a new holder to the gearbox cylinder.

11) Put a mark at the specified position measured from the end surface of ST, as shown in the figure.

**Specified position:**

**15 mm (0.59 in)**

ST 34199XA030 INSTALLER & REMOVER

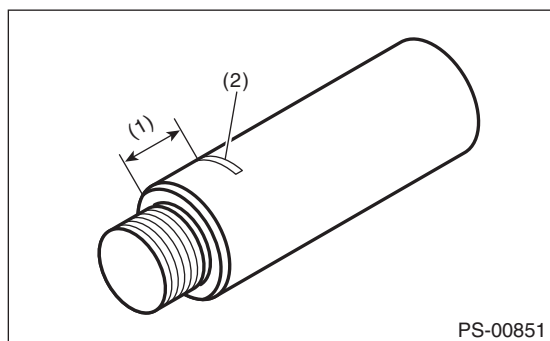

- (1) 15 mm (0.59 in) or 13.5 mm (0.53 in)
- (2) Place a mark

12) Set the ST to the end of rack.

ST 34199XA030 INSTALLER & REMOVER

13) Using a press, press-fit until the mark on the ST is aligned with the end surface of the holder.

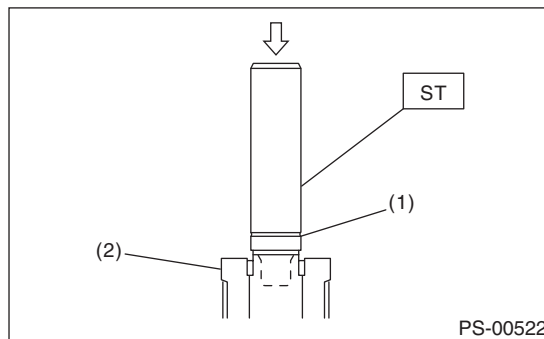

- (1) Mark
- (2) Holder

14) Remove the ST and holder.

15) Insert the outer side oil seal into the rack using the same procedure as steps 5) and 6).

ST 34199FE040 INSTALLER A, B, C

- INSTALLER A: 34199FE070
- INSTALLER B: 34199FE080
- INSTALLER C: 34199FE090

16) Put the ST and pipe through the rack, and press-fit the outer side oil seal using a press.

ST 34199AG010 INSTALLER

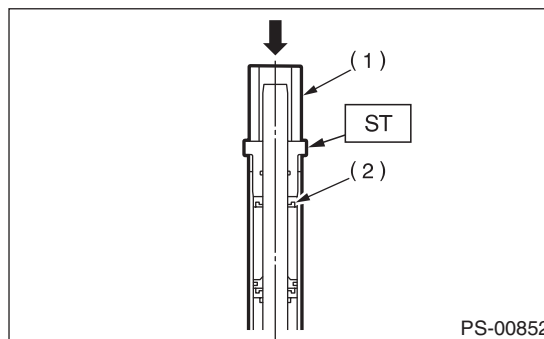

- (1) Pipe
- (2) Outer side oil seal

17) Secure the gearbox in a vise using ST.

ST1 926200000 STAND

ST2 34199AG000 BOSS D

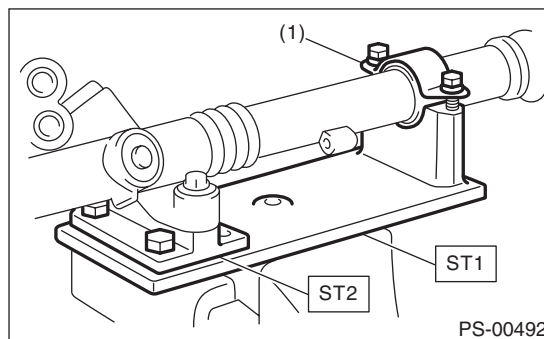

- (1) Clamp

# Steering Gearbox

## POWER ASSISTED SYSTEM (POWER STEERING)

18) Tighten the holder.

### **Tightening torque:**

**70 N·m (7.1 kgf·m, 51.6 ft·lb)**

19) Using the ST, crimp so that the diameter of punch hole is 2 — 2.5 mm (0.08 — 0.10 in) and is aligned to the position of 2 mm (0.08 in) from gearbox cylinder end surface.

ST1 34099FA060 PUNCH HOLDER

ST2 34199FE020 BASE

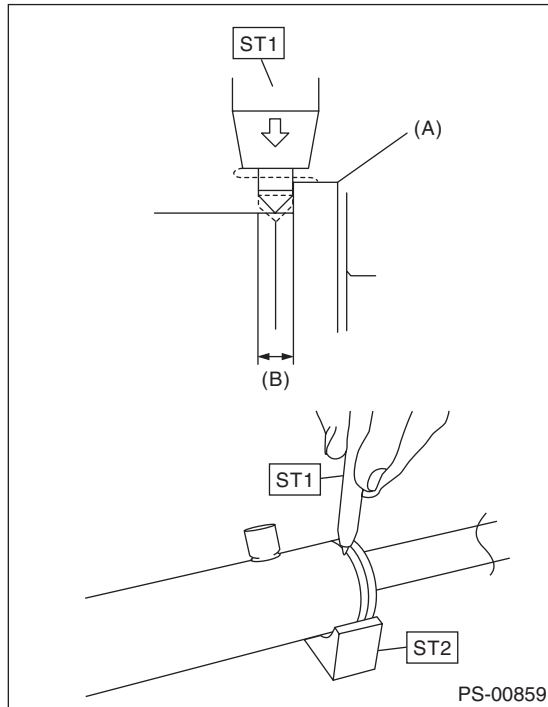

(A) Holder

(B) 2 mm (0.08 in)

20) Put a vinyl tape around the spline portion and apply genuine grease to the dust cover and install to valve assembly.

### **CAUTION:**

**Be sure to install the dust cover to groove of shaft.**

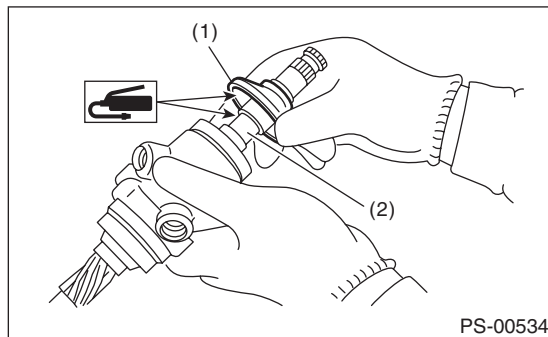

(1) Dust cover

(2) Groove

21) Apply the genuine grease to the pinion gear and bearing of valve assembly.

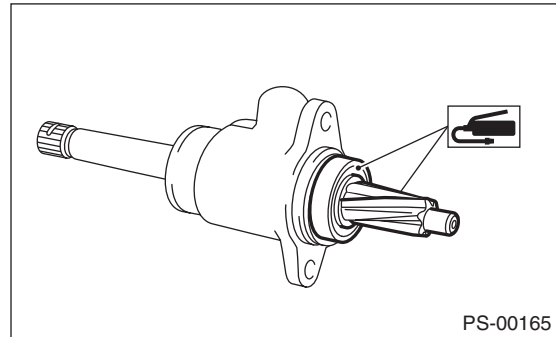

22) Install new O-ring to valve assembly. Insert the valve assembly into place while facing the rack teeth toward pinion.

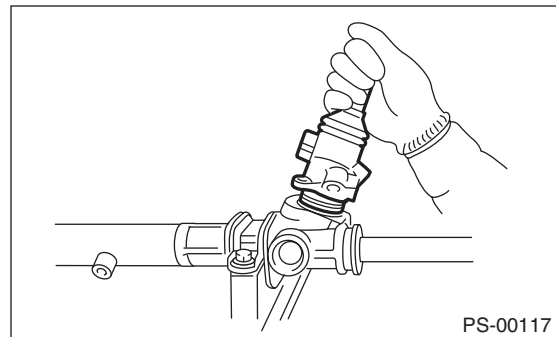

23) Tighten the bolts alternately to secure the valve assembly.

### **CAUTION:**

**Be sure to alternately tighten the bolts.**

### **Tightening torque:**

**20 N·m (2.0 kgf·m, 14.8 ft·lb)**

24) Temporarily tighten the tie-rod to the rack end, and then operate the rack from lock to lock for two or three times to make it fit in.

### **CAUTION:**

**Operating the rack from lock to lock without installing tie-rods may damage the oil seal. Always install the left and right tie-rods.**

25) Apply liquid gasket to 1/3 or more of entire perimeter of adjusting screw thread.

### **Liquid gasket:**

**THREE BOND 1102 or THREE BOND 1215**

# Steering Gearbox

POWER ASSISTED SYSTEM (POWER STEERING)

26) Apply a coat of grease to the sliding surface of sleeve and seating surface of spring, and then insert the sleeve into steering body.  
Charge the adjusting screw with grease, and then insert the spring into adjusting screw. Then install on the steering body.

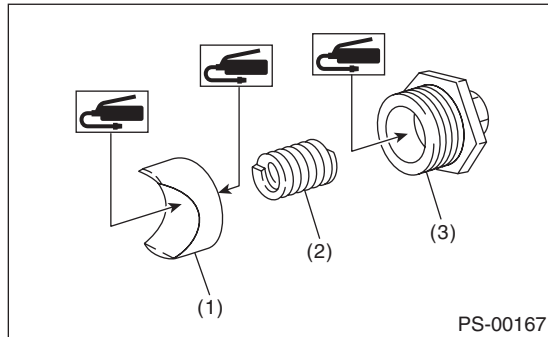

- (1) Sleeve
- (2) Spring
- (3) Adjusting screw

27) Tighten the adjusting screw to the specified torque, then loosen it.

### **Tightening torque:**

**25 N·m (2.5 kgf·m, 18.4 ft·lb)**

28) Tighten the adjusting screw to the specified torque, then loosen it within 20°.

### **Tightening torque:**

**5.9 N·m (0.6 kgf·m, 4.4 ft·lb)**

29) Remove the tie-rod.

30) Adjust the turning resistance of gearbox so that it is within specification using adjusting screw.  
<Ref. to PS-35, TURNING RESISTANCE OF GEARBOX, INSPECTION, Steering Gearbox.>

31) Attach the lock nut into adjusting screw, and while holding the adjusting screw with wrench, tighten the lock nut using ST.

ST 926230000 SPANNER

### **Tightening torque (lock nut):**

**25 N·m (2.5 kgf·m, 18.4 ft·lb)**

### **NOTE:**

Hold the adjusting screw with a wrench to prevent it from turning while tightening lock nut.

32) Extend the rack approx. 40 mm (1.57 in) from steering body.

33) Install the tie-rod and new lock washer into rack.

### **Tightening torque:**

**95 N·m (9.7 kgf·m, 70.1 ft·lb)**

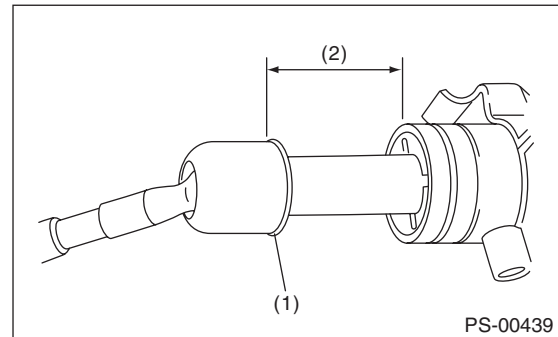

- (1) Lock washer
- (2) Approx. 40 mm (1.57 in)

34) Bend the lock washer and crimp it.

### **CAUTION:**

**Be careful not to scratch the rack when crimping lock washer.**

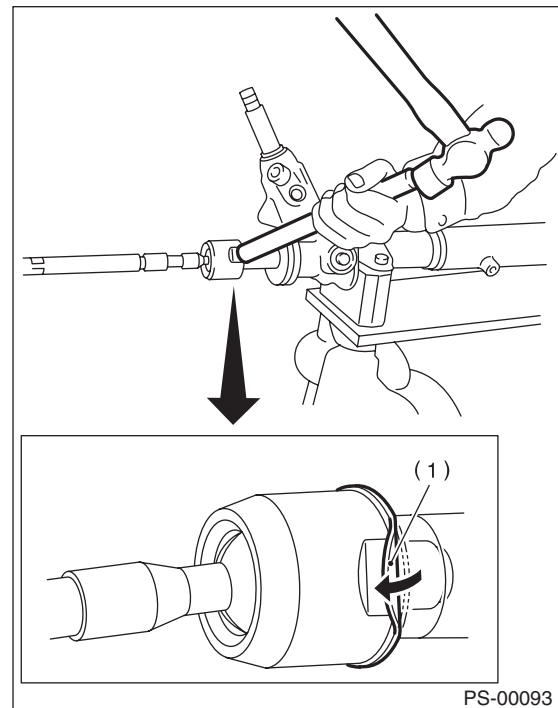

- (1) Lock washer

# Steering Gearbox

## POWER ASSISTED SYSTEM (POWER STEERING)

35) Apply a coat of grease to the tie-rod groove, and then install the boot to the housing.

### CAUTION:

Right side boot has groove for identification, be sure to install the right and left of boot.

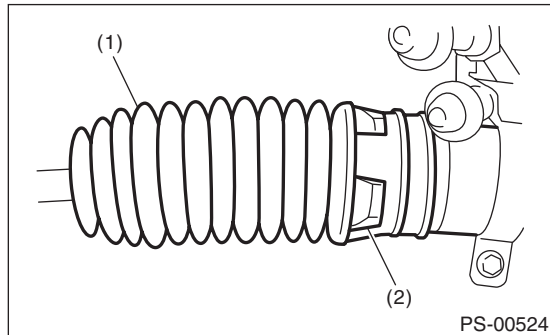

- (1) Right side boot
- (2) Groove for identification

### NOTE:

Make sure that the boot is installed without unusual inflation or deflation.

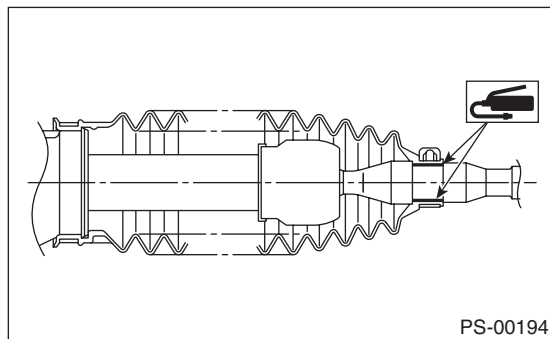

36) Install a new boot band. Using band clamp pliers, crimp it so that the clearance of crimping portion becomes 2 mm (0.079 in) or less.

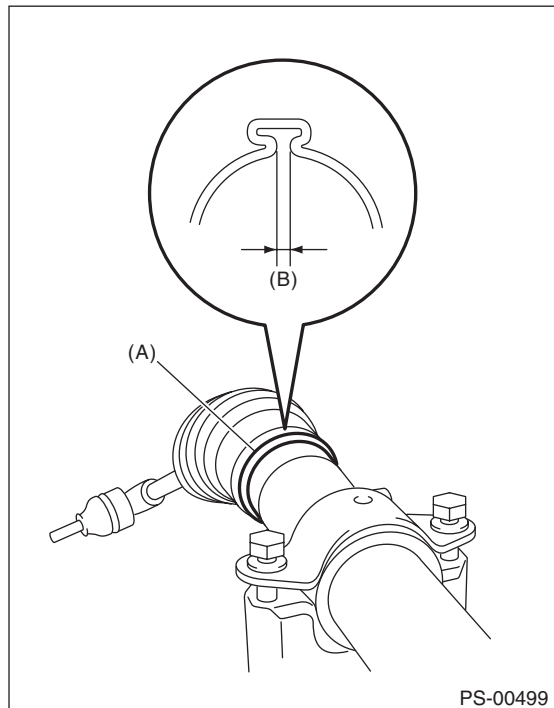

- (A) Boot band
- (B) 2 mm (0.079 in) or less

37) Fix the boot end with small clip.

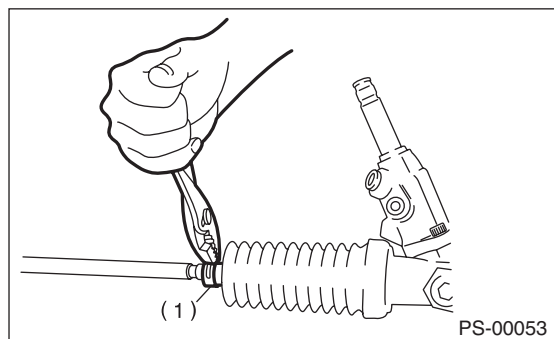

- (1) Clip

38) After installing, check that the boot end is installed to the groove of the tie-rod.

# Steering Gearbox

POWER ASSISTED SYSTEM (POWER STEERING)

39) If the tie-rod end has been removed, screw in lock nut and tie-rod end to the screwed portion of tie-rod, and tighten the lock nut temporarily in a position as shown in the figure.

**Installed tie-rod length L:**  
**28 mm (1.1 in)**

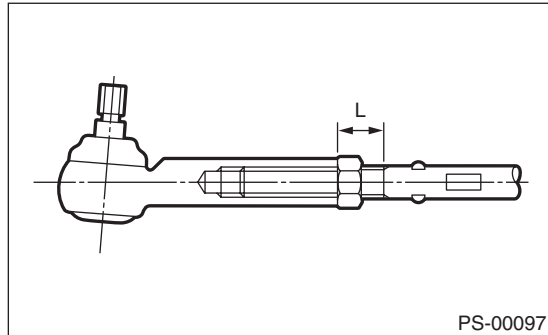

40) Inspect the gearbox as follows:  
"A" Holding the tie-rod end, repeat lock to lock several times as quickly as possible.  
"B" Holding the tie-rod end, turn it slowly at a radius several times as large as possible.  
Finally, make sure that the boot is installed in the specified position without inflating.

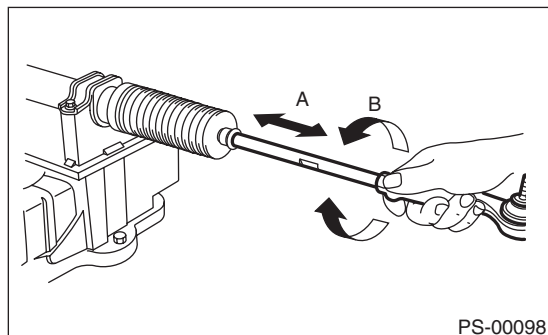

41) Remove the gearbox from ST.

ST1 926200000 STAND

ST2 34199AG000 BOSS D

42) Install the four pipes on gearbox.

(1) Connect the pipes A and B to the four pipe joints of gearbox.

**Tightening torque:**

**Refer to "COMPONENT" of "General Description". <Ref. to PS-4, POWER ASSISTED SYSTEM, COMPONENT, General Description.>**

(2) Connect the feed pipe and return pipe to the gearbox.

**Tightening torque:**

**Feed pipe: 37 N·m (3.8 kgf-m, 27.3 ft-lb)**

**Return pipe: 29 N·m (3.0 kgf-m, 21.4 ft-lb)**

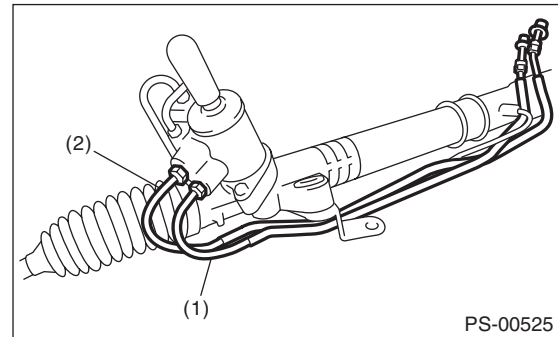

(1) Feed pipe

(2) Return pipe

## 2. CONTROL VALVE ASSEMBLY

**Specified steering grease:**

**VALIANT GREASE M2**

- 1) Clean all parts and tools before reassembling.
- 2) Apply a coat of specified power steering fluid to the inner wall of valve housing.

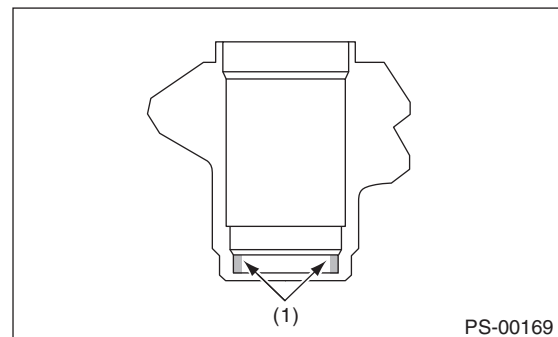

(1) Apply fluid.

3) Apply grease to the oil seal.

4) Verify the direction of oil seal.

5) Using the ST and a press, install the oil seal and the bushing in valve housing.

ST 34199AG090 INSTALLER & REMOVER

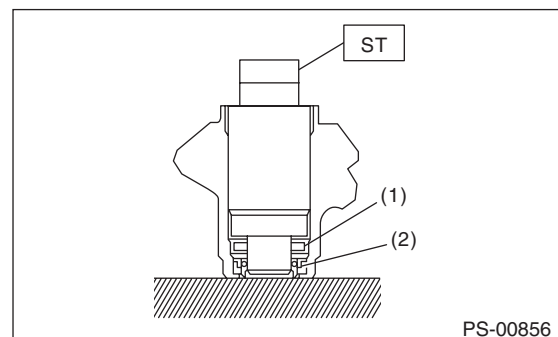

(1) Bushing

(2) Oil seal

# Steering Gearbox

## POWER ASSISTED SYSTEM (POWER STEERING)

- 6) Apply vinyl tape to the groove of pinion.
- 7) Install the wave washer and oil seal to pinion, and then remove the vinyl tape.

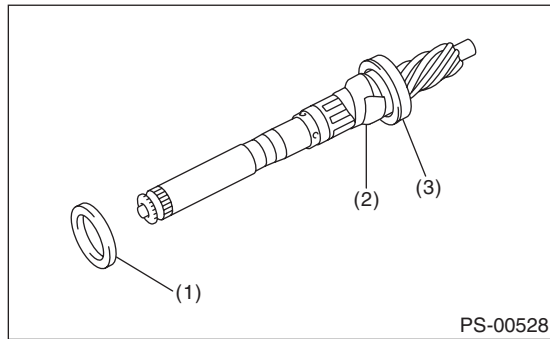

- (1) Oil seal
- (2) Vinyl tape
- (3) Wave washer

- 8) Attach the ST to pinion, and install the seal ring and O-ring.

ST 34199AG020 GUIDE

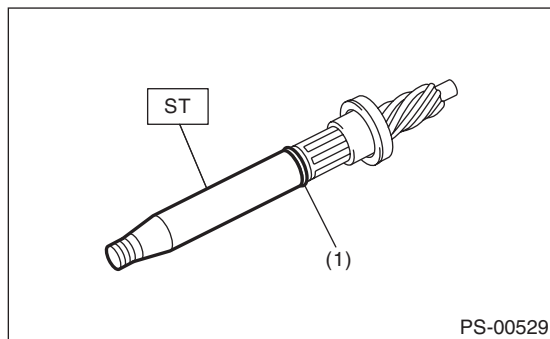

- (1) Seal ring and O-ring

- 9) Remove the ST GUIDE, and form the seal ring properly using ST FORMER.

ST 34199AG070 FORMER

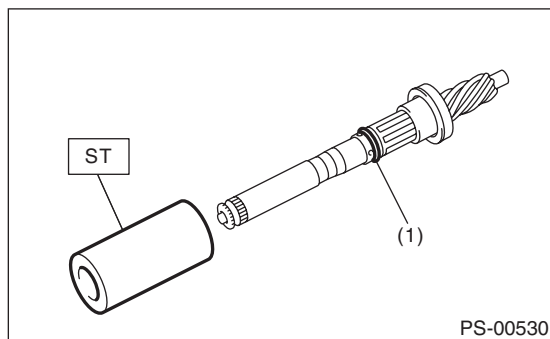

- (1) Seal ring

- 10) Put vinyl tape around pinion shaft spline to protect oil seal from damage.

- 11) Install the valve to pinion, and install the snap ring.

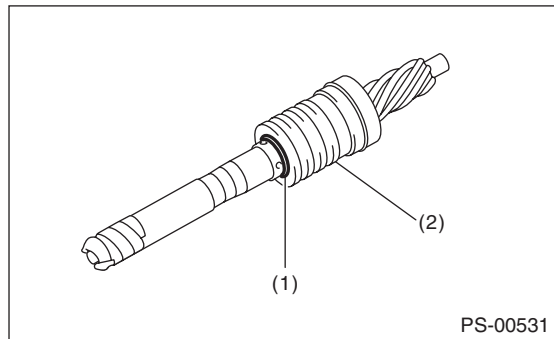

- (1) Snap ring
- (2) Valve

- 12) Attach the pinion & valve assembly into the valve housing.

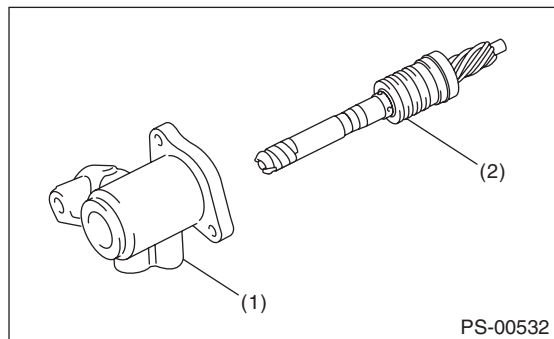

- (1) Valve housing
- (2) Pinion & valve ASSY

- 13) Using a press, push the outer race of bearing and press-fit the pinion & valve assembly into housing.

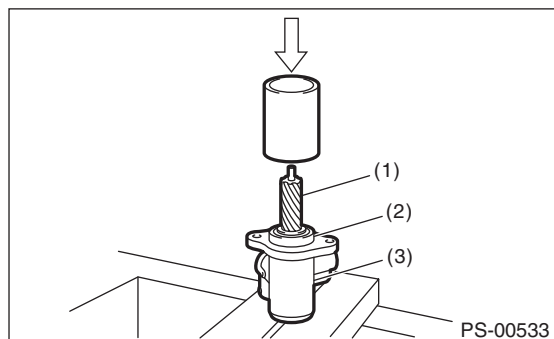

- (1) Pinion & valve ASSY
- (2) Bearing
- (3) Housing

- 14) Apply the specified grease to dust cover.



# Steering Gearbox

POWER ASSISTED SYSTEM (POWER STEERING)

15) Install the dust cover on valve assembly.

**CAUTION:**

Be sure to install the dust cover to groove of shaft.

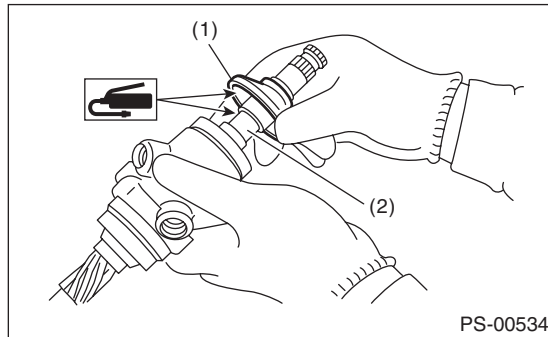

- (1) Dust cover
- (2) Groove

16) Apply the genuine grease to the pinion gear and bearing of valve assembly.

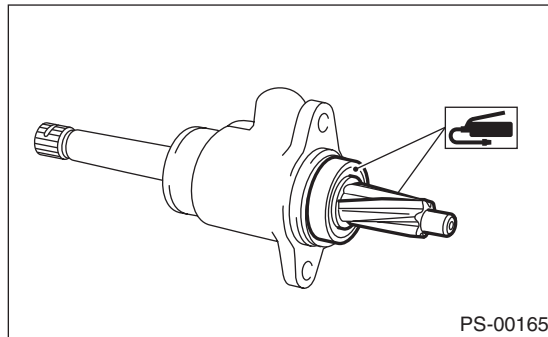

17) Install new O-ring to valve assembly.

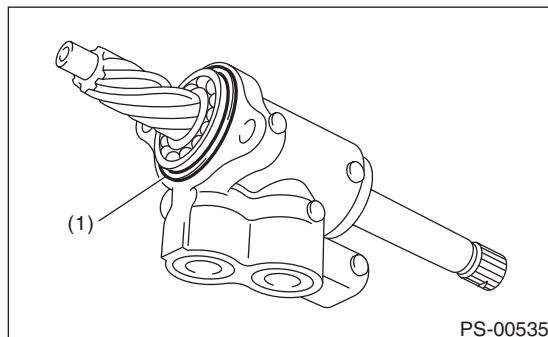

- (1) O-ring

18) Insert the valve assembly into place while facing the rack teeth toward pinion.

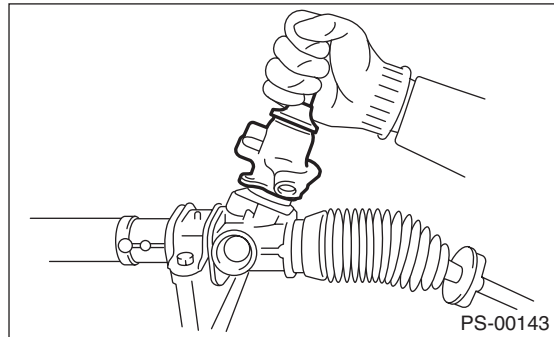

19) Tighten the bolts alternately to secure the valve assembly.

**CAUTION:**

Be sure to alternately tighten the bolts.

**Tightening torque:**

**20 N·m (2.0 kgf-m, 14.8 ft-lb)**

20) Apply liquid gasket to 1/3 or more of entire perimeter of adjusting screw thread.

**Liquid gasket:**

**THREE BOND 1102 or THREE BOND 1215**

21) Apply a coat of grease to the sliding surface of sleeve and seating surface of spring, and then insert the sleeve into steering body.

Charge the adjusting screw with grease, and then insert the spring into adjusting screw. Then install on the steering body.

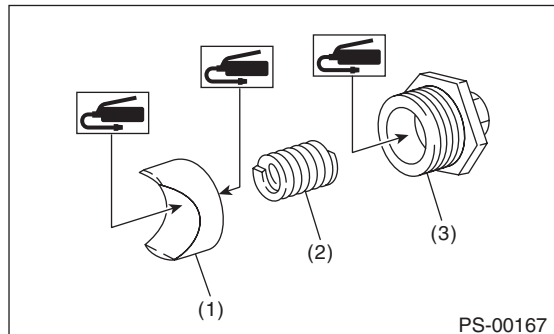

- (1) Sleeve
- (2) Spring
- (3) Adjusting screw

22) Tighten the adjusting screw to the specified torque, then loosen it.

**Tightening torque:**

**25 N·m (2.5 kgf-m, 18.4 ft-lb)**

23) Tighten the adjusting screw to the specified torque, then loosen it within 20°.

**Tightening torque:**

**5.9 N·m (0.6 kgf-m, 4.4 ft-lb)**



# Steering Gearbox

## POWER ASSISTED SYSTEM (POWER STEERING)

---

24) Adjust the turning resistance of gearbox so that it is within specification using adjusting screw.  
<Ref. to PS-35, TURNING RESISTANCE OF GEARBOX, INSPECTION, Steering Gearbox.>

25) Attach the lock nut into adjusting screw, and while holding the adjusting screw with wrench, tighten the lock nut using ST.

ST 926230000 SPANNER

**Tightening torque (lock nut):**

**25 N·m (2.5 kgf·m, 18.4 ft·lb)**

**NOTE:**

Hold the adjusting screw with a wrench to prevent it from turning while tightening lock nut.

26) Remove the gearbox from ST.

ST1 926200000 STAND

ST2 34199AG000 BOSS D

27) Install the four pipes on gearbox.

(1) Connect the pipes A and B to gearbox.

**Tightening torque:**

**Refer to "COMPONENT" of "General Description". <Ref. to PS-4, POWER ASSISTED SYSTEM, COMPONENT, General Description.>**

(2) Connect the feed pipe and return pipe to the gearbox.

**Tightening torque:**

**Feed pipe: 37 N·m (3.8 kgf·m, 27.3 ft·lb)**

**Return pipe: 29 N·m (3.0 kgf·m, 21.4 ft·lb)**

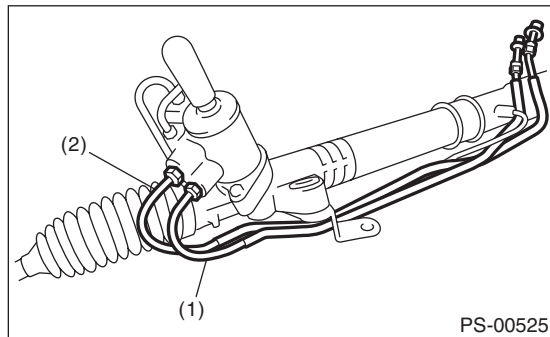

(1) Feed pipe

(2) Return pipe

# Steering Gearbox

POWER ASSISTED SYSTEM (POWER STEERING)

## E: INSPECTION

### 1. BASIC INSPECTION

1) Clean all the disassembled parts, and check for wear, damage or any other faults, then repair or replace as necessary.

2) When disassembling, check the inside of gearbox for water. If any water is found, carefully check the boot for damage, input shaft dust seal, adjusting screw and boot clips for poor sealing. If faulty, replace with new parts.

No.	Parts	Inspection	Corrective action
1	Input shaft	(1) Bent input shaft (2) Damage on serration	If the bend or damage is excessive, replace the entire gearbox.
2	Dust seal	(1) Crack or damage (2) Wear	If the outer wall slips, the lip is worn out or damage is found, replace it with a new part.
3	Rack and pinion	Poor mating of rack with pinion	(1) Adjust the backlash properly. By measuring the turning torque of the gearbox and sliding resistance of rack, check if the rack & pinion engage uniformly and smoothly with each other. (Refer to "Service limit".) (2) Pull out the entire rack to allow viewing of the teeth, and check for damage. Even if abnormality is found in either (1) or (2), replace the entire gearbox.
4	Gearbox unit	(1) Bending of the rack shaft (2) Bending of the cylinder portion (3) Crack or damage on the aluminum portion	Replace the gearbox with a new part.
		(4) Wear or damage on rack bushing	If the free play of rack shaft in radial direction is out of the specified range, replace the gearbox with new part. (Refer to "Service limit".)
		(5) Wear on input shaft bearing	If the free play of input shaft in radial and axial direction is out of the specified range, replace the gearbox with a new part. (Refer to "Service limit".)
5	Boot	Crack, damage or deterioration	Replace.
6	Tie-rod	(1) Looseness of ball joint (2) Bend of tie-rod	Replace.
7	Tie-rod end	Damage or deterioration of dust seal	Replace.
8	Adjusting screw spring	Deterioration	Replace.
9	Boot clip	Deterioration	Replace.
10	Sleeve	Damage	Replace.
11	Pipe	(1) Damage to flared surface (2) Damage to flare nut (3) Damage to pipe	Replace.

# Steering Gearbox

POWER ASSISTED SYSTEM (POWER STEERING)

## 2. SERVICE LIMIT

Make a measurements as follows. If it exceeds the specified service limits, adjust or replace.

### NOTE:

When making a measurement, vise the gearbox using ST. Never vise the gearbox by inserting aluminum plates etc. between vise and gearbox.

ST1 926200000 STAND  
ST2 34199AG000 BOSS D

### Rack shaft sliding resistance:

#### Limit

**370 N (38 kgf, 83 lbf) or less**

### Left/right differential of sliding resistance:

**20% or less**

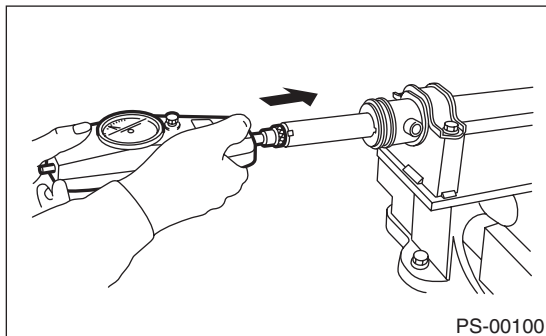
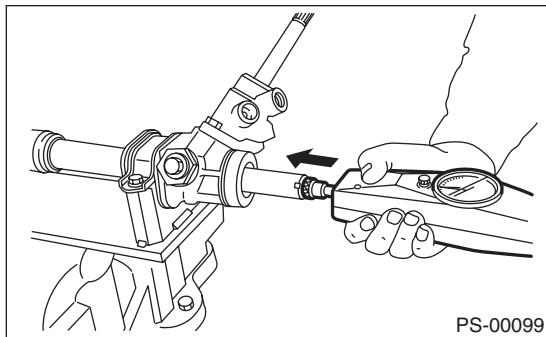

## 3. RACK SHAFT PLAY IN THE RADIAL DIRECTION

### Right-turn steering:

#### Service limit

**0.12 mm (0.005 in) or less**

#### Condition

##### Weighting point

**L1: 10 mm (0.39 in)**

**P: 98 N (10 kgf, 22 lb)**

##### Measuring point

**L2: 25 mm (0.98 in)**

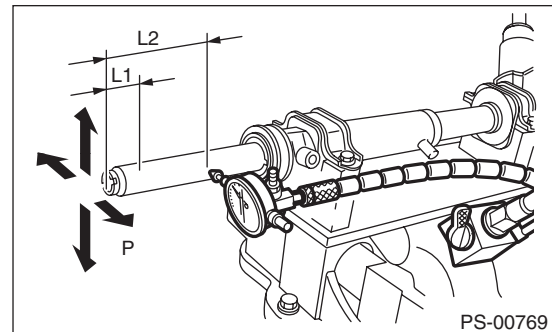

### Left-turn steering:

#### Service limit

**Direction ← →**

**0.3 mm (0.012 in) or less**

**Direction ← →**

**0.15 mm (0.0059 in) or less**

#### Condition

**L: 5 mm (0.20 in)**

**P: 98 N (10 kgf, 22 lbf)**

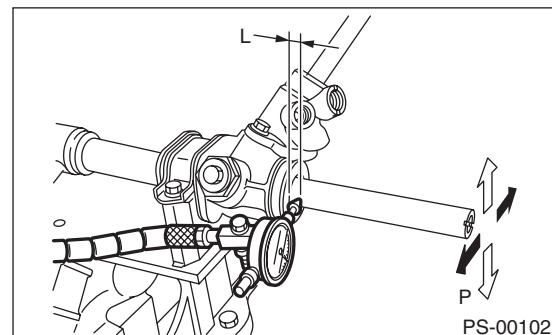

# Steering Gearbox

POWER ASSISTED SYSTEM (POWER STEERING)

## 4. INPUT SHAFT PLAY

*In radial direction:*

**Service limit**

**0.26 mm (0.01 in) or less**

**Condition**

**P: 98 N (10 kgf, 22 lb)**

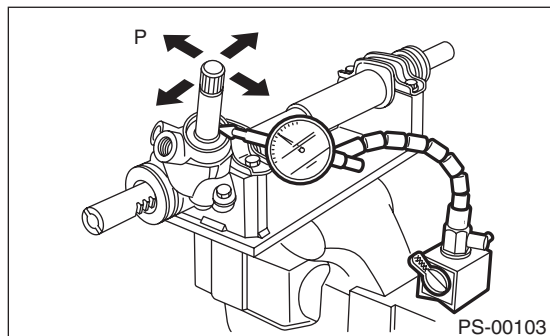

*In axial direction:*

**Without play**



## 5. TURNING RESISTANCE OF GEARBOX

Using the ST, measure the gearbox turning resistance.

ST 34099PA100 SPANNER

**Service limit:**

**Maximum allowable resistance:**

**11.3 N (1.15 kgf, 2.54 lb) or less.**

**Difference between right and left turning resistance:**

**24% or less**

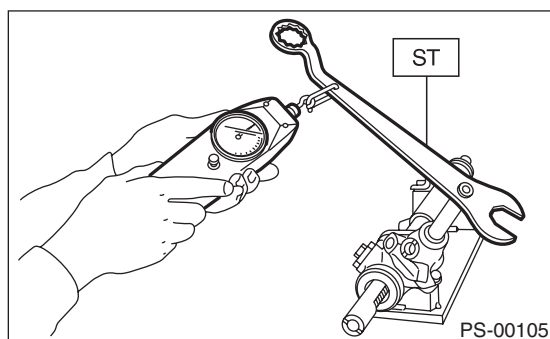

# Steering Gearbox

## POWER ASSISTED SYSTEM (POWER STEERING)

### 6. FLUID LEAKAGE

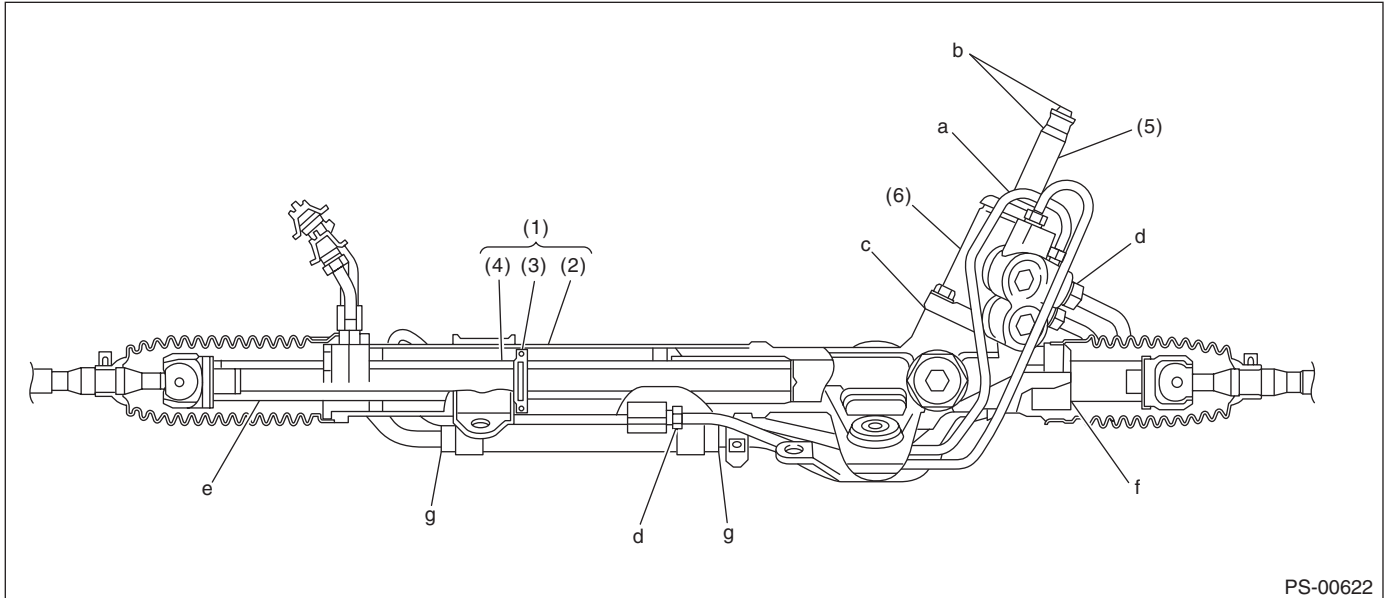

PS-00622

(1) Power cylinder

(3) Rack piston

(5) Input shaft

(2) Cylinder

(4) Rack axle

(6) Valve housing

1) Lift up the vehicle.

2) If a fluid leak is found, clean the fluid completely from the suspect area, and turn the steering wheel 30 to 40 times to the left and right from lock to lock, with the engine running, and check again for leaks immediately, and also after a few hours have passed.

3) Cause and solution for oil leakage from "a"

The oil seal is damaged. Replace the valve assembly or valve housing side oil seal assembly with a new part.

4) Cause and solution for oil leakage from "b"

The torsion bar O-ring is damaged. Replace the valve assembly with a new part.

5) Cause and solution for oil leakage from "c"

The oil seal is damaged. Replace the valve assembly or pinion side oil seal with a new part.

6) Cause and solution for oil leakage from "d"

The pipe is damaged. Replace the faulty pipe or O-ring.

7) Cause and solution for oil leakage from "g"

The hose is damaged. Replace the hose with a new part.

8) If leak is other than a, b, c, d or g, or if oil is leaking from gearbox, move the right and left boots toward tie-rod end side, respectively, with the gearbox mounted to the vehicle, and remove fluid from surrounding portions. Then, turn the steering wheel from lock to lock about 30 to 40 times with the engine running, then re-inspect the leaking area immediately after and several hours after this operation.

(1) Leakage from "e"

The cylinder seal is damaged. Replace the oil seal.

(2) Leakage from "f"

There are two possible causes. Perform the following step first. Remove the pipe assembly B from the valve housing, and close the circuit using ST.

ST 926420000 PLUG

Turn the steering wheel from lock to lock approx. 30 to 40 times with the engine running, then inspect the leaked portion immediately after and several hours after this operation.

• If leakage from "f" is noted again:

The oil seal of pinion and valve assembly is damaged. Replace the pinion & valve assembly with a new part. Or, replace the oil seal.

• If oil stops leaking from "f":

The oil seal of rack housing is damaged. Replace the oil seal and back-up washer.

## F: ADJUSTMENT

- 1) Adjust the front toe.  
 <Ref. to FS-12, FRONT WHEEL TOE-IN, INSPECTION, Wheel Alignment.>

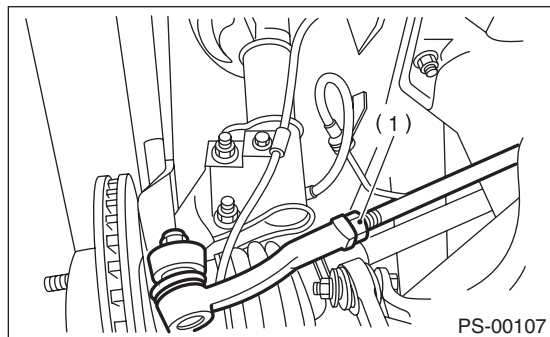

(1) Lock nut

- 2) Check the steering angle of the wheels.

### **Standard of steering angle:**

Inner wheel	Outer wheel
$36.6^{\circ} \pm 1.5^{\circ}$	$32.2^{\circ} \pm 1.5^{\circ}$

- 3) If the steering wheel spokes are not horizontal when wheels are set in the straight ahead position, or error is more than  $5^{\circ}$  on the periphery of the steering wheel, correctly re-install the steering wheel.

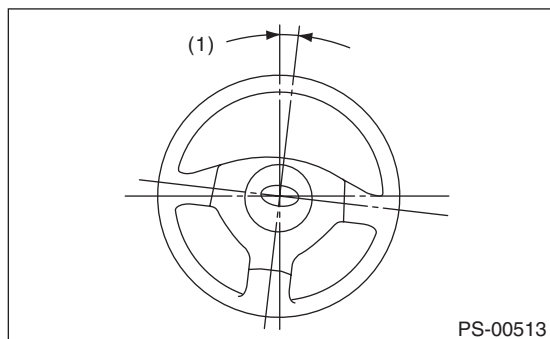

(1)  $5^{\circ}$  or less

- 4) If the steering wheel spokes are not horizontal with vehicle set in the straight ahead position after this adjustment, correct it by turning the right and left tie-rods in the opposite direction from each other by the same angle.

# Pipe Assembly

## POWER ASSISTED SYSTEM (POWER STEERING)

### 6. Pipe Assembly

#### A: REMOVAL

- 1) Disconnect the ground cable from battery.
- 2) Lift up the vehicle, and remove the front cross-member support plate.

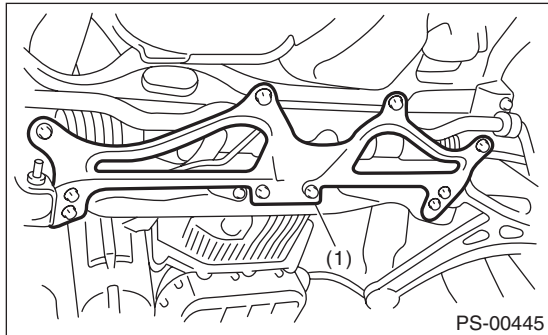

(1) Front crossmember support plate

- 3) Remove the one pipe joint at the center of the gearbox, and connect the vinyl hose to the pipe and the joint. Discharge the fluid by turning the steering wheel fully clockwise and counterclockwise. Discharge the fluid similarly from other pipes.

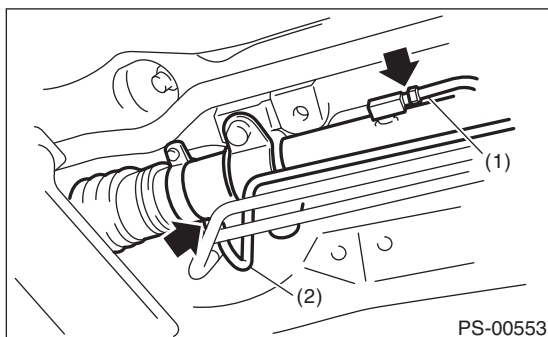

(1) Pipe A  
(2) Pipe B

- 4) Remove the clamp E from return hose and pressure hose.

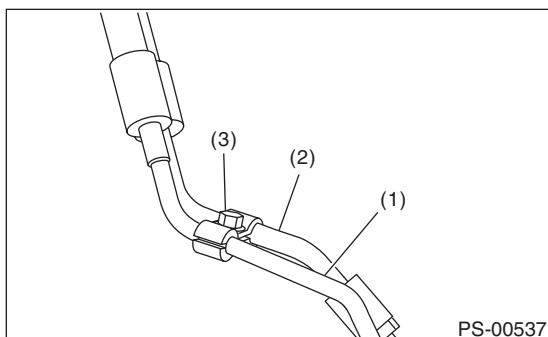

(1) Pressure hose  
(2) Return hose  
(3) Clamp E

- 5) Disconnect the return hose from return pipe and disconnect the pressure hose from feed pipe.

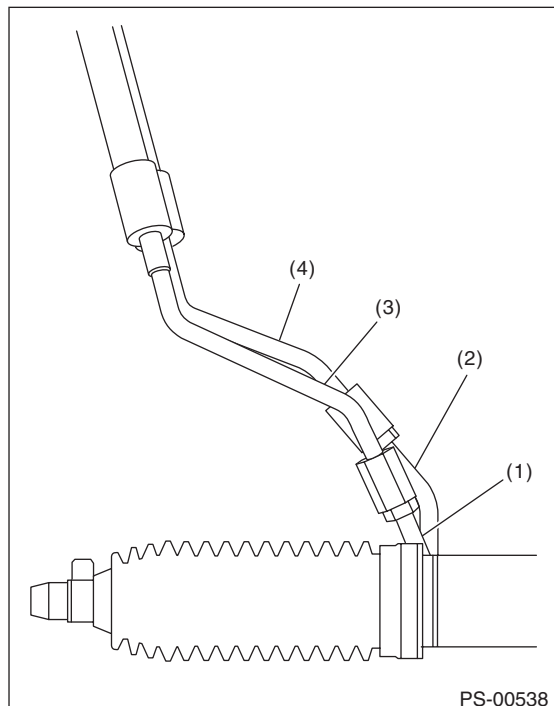

(1) Feed pipe  
(2) Return pipe  
(3) Pressure hose  
(4) Return hose

- 6) Remove the air intake duct.
  - Except for STI model: <Ref. to IN(w/o STI)-10, REMOVAL, Air Intake Duct.>
  - STI model: <Ref. to IN(STI)-10, REMOVAL, Air Intake Duct.>
- 7) Disconnect the suction hose and pressure hose from oil pump.

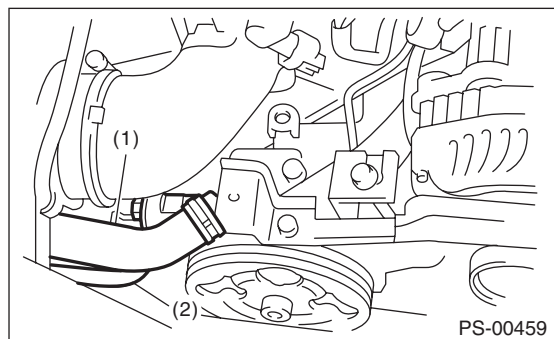

(1) Suction hose  
(2) Pressure hose

# Pipe Assembly

POWER ASSISTED SYSTEM (POWER STEERING)

8) Disconnect the suction hose and return hose from the reservoir tank.

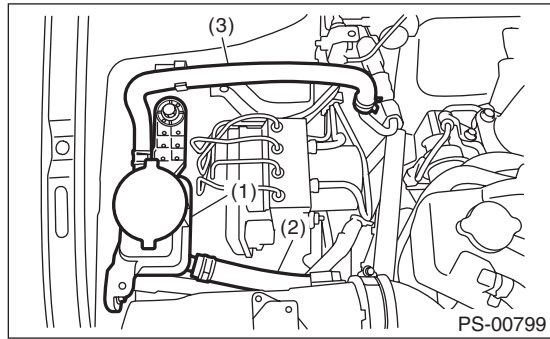

- (1) Reservoir tank
- (2) Suction hose
- (3) Return hose

2) Install the plastic clip to the pressure hose and suction hose.

### CAUTION:

Align the installation position of the plastic clip with the protector edge of the suction hose.

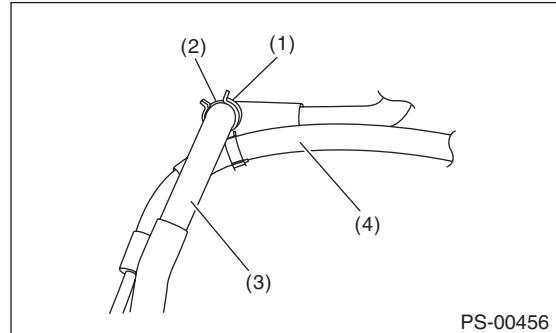

- (1) Plastic clip
- (2) Protector
- (3) Suction hose
- (4) Pressure hose

9) Remove the hose bracket and take out the hose assembly from vehicle.

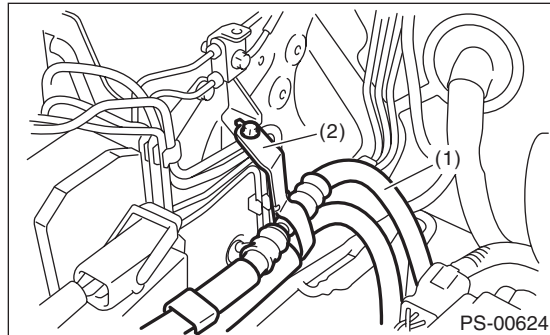

- (1) Hose ASSY
- (2) Hose bracket

3) Connect the suction hose and return hose to the reservoir tank.

### CAUTION:

Firmly insert the plastic clip of return hose to the bracket.

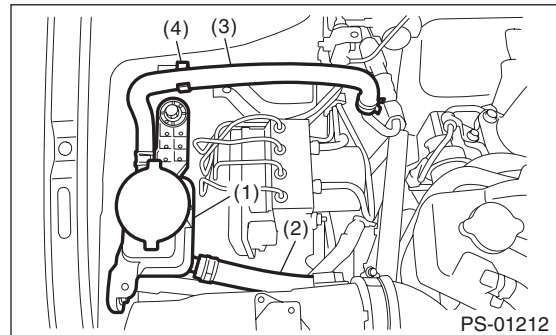

- (1) Reservoir tank
- (2) Suction hose
- (3) Return hose
- (4) Plastic clip

## B: INSTALLATION

1) Temporarily tighten the hose bracket bolt.

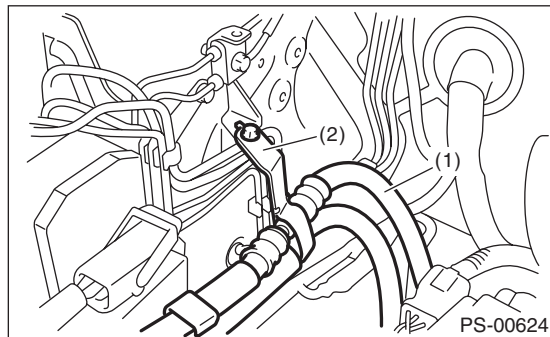

- (1) Hose ASSY
- (2) Hose bracket



# Pipe Assembly

## POWER ASSISTED SYSTEM (POWER STEERING)

4) Connect the suction hose and pressure hose to the oil pump. Tighten the eye bolt of pressure hose.

**Tightening torque:**

**40 N·m (4.1 kgf·m, 29.5 ft·lb)**

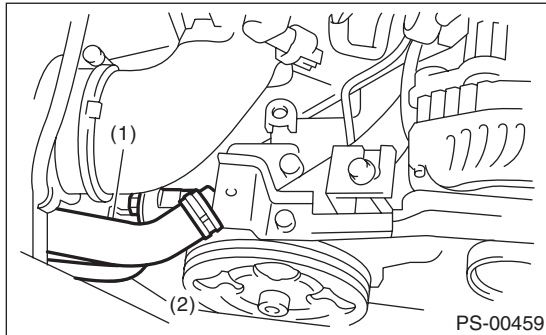

- (1) Suction hose
- (2) Pressure hose

**NOTE:**

Make sure that the character "8" on each clamp is positioned on the opposite side, as shown in the figure.

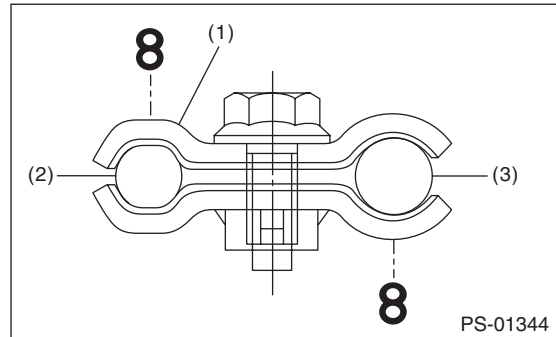

- (1) Clamp E
- (2) Pressure hose
- (3) Return hose

5) Temporarily connect the pressure hose to feed pipe and return hose to return pipe. Temporarily tighten the bolt of clamp E.

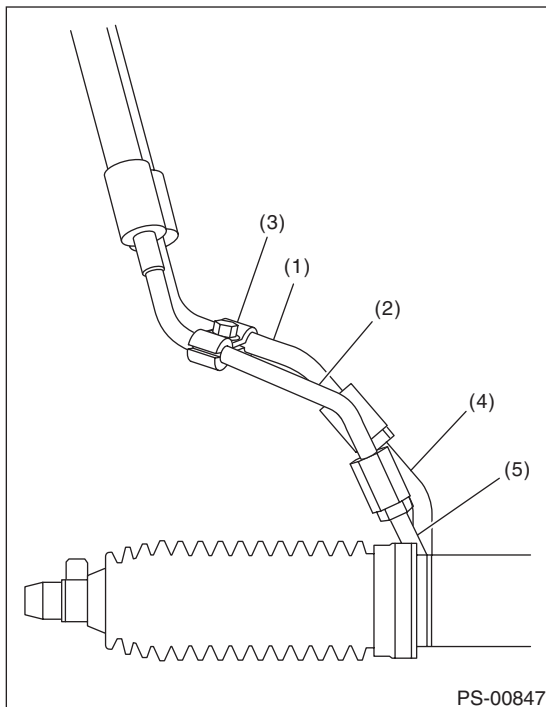

- (1) Return hose
- (2) Pressure hose
- (3) Clamp E
- (4) Return pipe
- (5) Feed pipe

6) Tighten clamp E.

**Tightening torque:**

**7.5 N·m (0.76 kgf·m, 5.5 ft·lb)**

7) Tighten the pressure hose to feed pipe and return hose to return pipe.

**Tightening torque:**

**15 N·m (1.5 kgf·m, 11.1 ft·lb)**

8) Connect pipes A and B to the four pipe joints of the gearbox.

**Tightening torque:**

**Refer to "COMPONENT" of "General Description". <Ref. to PS-4, POWER ASSISTED SYSTEM, COMPONENT, General Description.>**

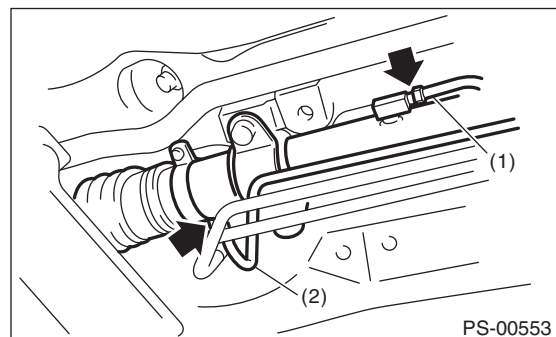

- (1) Pipe A
- (2) Pipe B

9) Install the front crossmember support plate and jack-up plate.

10) Lower the vehicle.

## Pipe Assembly

POWER ASSISTED SYSTEM (POWER STEERING)

11) Tighten the bolts which hold the hose bracket.

**Tightening torque:**

**10 N·m (1.0 kgf·m, 7.4 ft·lb)**

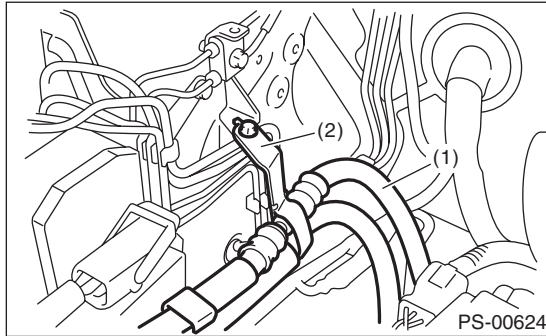

- (1) Hose ASSY
- (2) Hose bracket

12) Install the air intake duct.

- Except for STI model: <Ref. to IN(w/o STI)-10, INSTALLATION, Air Intake Duct.>
- STI model: <Ref. to IN(STI)-10, INSTALLATION, Air Intake Duct.>

13) Connect the battery ground terminal.

14) Fill with the specified fluid.

**CAUTION:**

**Never start the engine before filling with fluid; otherwise the vane pump may become seized.**

15) Finally, check the clearance between pipes or hoses as shown in the figure indicated in "General Diagnostic Table". <Ref. to PS-56, INSPECTION OF CLEARANCE, INSPECTION, General Diagnostic Table.>

# Pipe Assembly

POWER ASSISTED SYSTEM (POWER STEERING)

## C: INSPECTION

Check all disassembled parts for wear, damage or other problems. Repair or replace the defective parts as necessary.

Part	Maintenance parts	Corrective action
Pipe	<ul style="list-style-type: none"> <li>• O-ring fitting surface damage</li> <li>• Nut damage</li> <li>• Pipe damage</li> </ul>	Replace with a new part.
Hose	<ul style="list-style-type: none"> <li>• Flare surface damage</li> <li>• Flare nut damage</li> <li>• Outer surface cracks</li> <li>• Outer surface wear</li> <li>• Clip damage</li> <li>• End coupling or adapter deformation</li> </ul>	Replace with a new part.

### CAUTION:

**Although the surface layer materials of rubber hoses have excellent weathering resistance, heat resistance and resistance for low temperature brittleness, they are likely to be damaged chemically by brake fluid, battery electrolyte, engine oil and automatic transmission fluid and their service lives are to be very shortened. Wipe off hoses immediately if any of these come into contact with the hoses. Since resistances for heat or low temperature brittleness are gradually declining according to time accumulation of hot or cold conditions for the hoses and their service lives are shortening accordingly, it is necessary to perform careful inspection frequently when the vehicle is used in hot weather areas, cold weather areas and a driving condition in which many steering operations are required in short time.**

**Continuous discharge of the relief valve for 5 seconds or more will reduce the service lives of hoses, oil pump, fluid, etc., due to over heating.**

Trouble	Possible cause	Corrective action
Pressure hose burst	Excessive holding time of relief status	Instruct customers.
	Malfunction of the relief valve	Replace the oil pump.
	Poor cold characteristic of fluid	Replace fluid.
Disconnection of the return hose	Improper connection	Repair.
	Loosening of the clip	Replace the hose clip.
	Poor cold characteristic of fluid	Replace fluid.
Fluid slightly leaking out of hose	Wrong layout, tensioned	Replace the hose.
	Excessive play of engine due to deterioration of engine mounting rubber	Replace the parts if defective.
	Improper stop position of pitching stopper	Replace the parts if defective.
Crack on hose	Excessive holding time of relief status	Replace. Instruct customers.
	Power steering fluid, engine oil, electrolyte adhere on the hose surface	Replace. Be careful during service work.
	Too many uses in extremely cold weather	Replace. Instruct customers.

# Pipe Assembly

POWER ASSISTED SYSTEM (POWER STEERING)

**NOTE:**

There are conditions in which a fluid leak is diagnosed, but is not actually leaking. This is because the fluid spilt during the last maintenance was not completely wiped off. Be sure to wipe off spilt fluid thoroughly after maintenance.

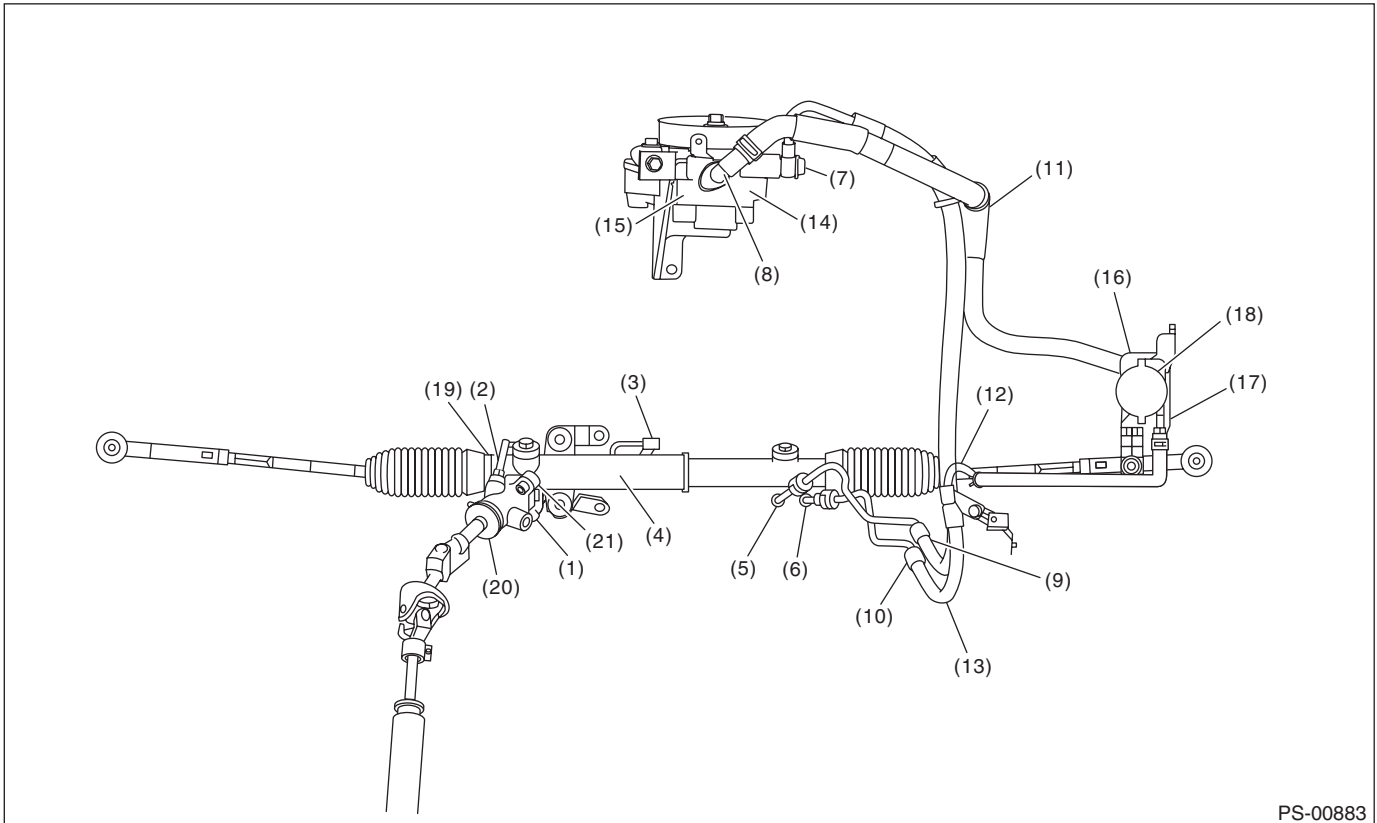

PS-00883

Fluid leaking area	Possible cause	Corrective action
Leakage from the connections of pipes and hoses, numbered (1) through (8) in the figure	Insufficient tightening of flare nut, adhesion of dirt, damage to flare or flare nut or eye bolt	Loosen and retighten. Replace if ineffective.
	Improper installation of hose or clamp	Replace.
	Damaged O-ring or gasket	Replace the O-ring, gasket pipe or hose with new part, if still no improvement, replace the gearbox or oil pump as well.
Leakage from hose (9) through (13) in the figure	Crack or damage in hose	Replace with a new part.
	Crack or damage in hose hardware	Replace with a new part.
Leakage from surrounding of aluminum portion of oil pump, (14) and (15) in the figure	Damaged O-ring	Replace the oil pump.
	Damaged gasket	Replace the oil pump.
Leakage from oil tank, (16) and (17) in the figure	Crack in oil tank	Replace the oil tank.
Leakage from filler neck of (18)	Damaged cap gasket	Replace the cap.
	Crack in root of filler neck	Replace the oil tank.
	Fluid level too high	Adjust the fluid level.
Leakage from power cylinder of gearbox area (19) in the figure	Damaged oil seal	Replace the oil seal.
Leakage from (20), (21) in the figure and control valve of gearbox	Damaged gasket or oil seal	Replace the problem parts.
	Damage in control valve	Replace the control valve.

# Oil Pump

## POWER ASSISTED SYSTEM (POWER STEERING)

### 7. Oil Pump

#### A: REMOVAL

- 1) Disconnect the ground cable from battery.
- 2) Remove the V-belts (front side belt).
  - Except for STI model: <Ref. to ME(w/o STI)-39, REMOVAL, V-belt.>
  - STI model: <Ref. to ME(STI)-40, REMOVAL, V-belt.>
- 3) Disconnect the connector from power steering pump switch.
- 4) Disconnect the pressure hose and suction hose from the oil pump.

#### CAUTION:

- Do not allow fluid to come into contact with the pulley belt.
- To prevent foreign matter from entering the hose and pipe, cover the open ends with clean cloth.

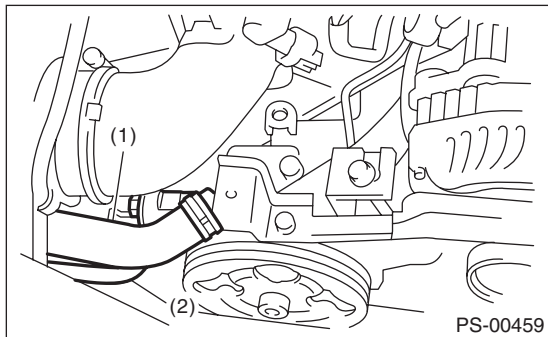

- (1) Suction hose
- (2) Pressure hose

- 5) Remove the installation bolt of the power steering pump bracket.

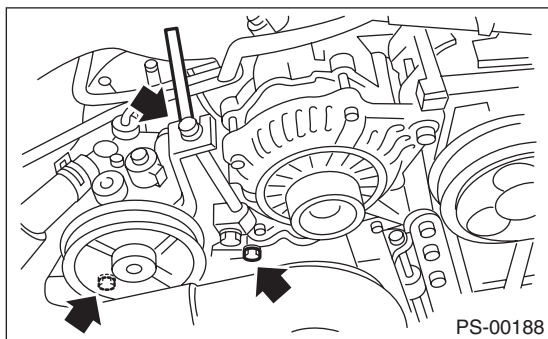

- 6) Place the oil pump bracket in a vise, and remove the two bolts from the front side of the oil pump.

#### CAUTION:

When securing the oil pump bracket in a vise, hold the oil pump bracket with the least possible force between two pieces of wood.

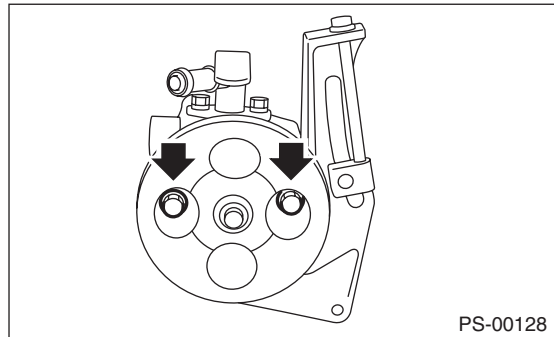

- 7) Remove the bolt from the rear side of oil pump.
- 8) Disassemble the oil pump and bracket by inserting a flat tip screwdriver as shown in the figure.

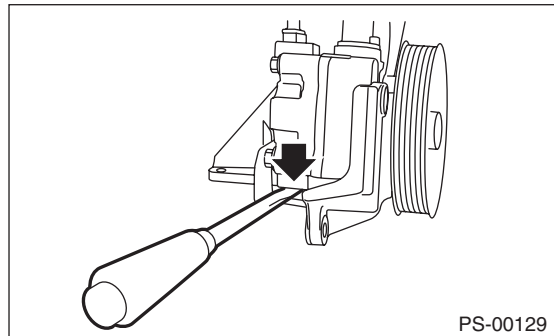

#### B: INSTALLATION

- 1) Install the oil pump to bracket.
- 2) Tighten the bolts which hold the oil pump to the bracket.

#### Tightening torque:

16 N·m (1.6 kgf·m, 11.8 ft·lb)

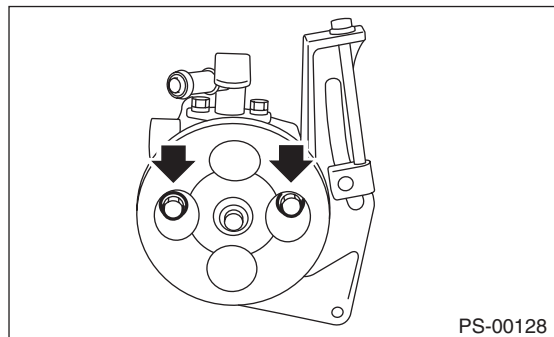

# Oil Pump

POWER ASSISTED SYSTEM (POWER STEERING)

## Tightening torque:

**48 N·m (4.9 kgf·m, 35.4 ft·lb)**

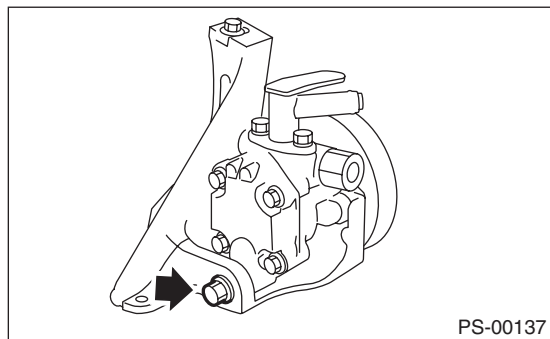

3) Attach the installation bolts of the power steering pump bracket.

## Tightening torque:

Refer to "COMPONENT" of "General Description". <Ref. to PS-6, OIL PUMP, COMPONENT, General Description.>

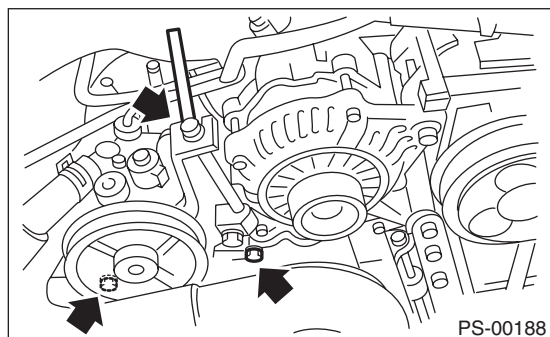

4) Connect the pressure hose and suction hose.

## CAUTION:

Be careful when installing; if the hose is twisted it may come into contact with other parts.

## Tightening torque:

### Eye bolt

**40 N·m (4.1 kgf·m, 29.5 ft·lb)**

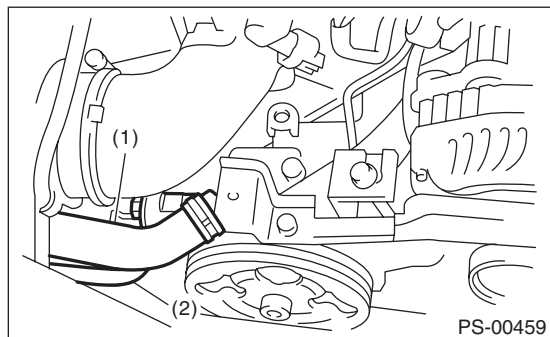

(1) Suction hose

(2) Pressure hose

5) Connect the power steering pump switch to the connector.

6) After installing the oil pump, fill the oil pump with fluid while rotating the pulley by hand and bleed the air from the oil pump.

## CAUTION:

Always fill the oil pump with the fluid to prevent abnormal noise and seizure of the oil pump.

7) Install the V-belts (front side belt).

- Except for STI model: <Ref. to ME(w/o STI)-39, INSTALLATION, V-belt.>

- STI model: <Ref. to ME(STI)-40, INSTALLATION, V-belt.>

8) Connect the battery ground terminal.

9) Fill with the specified power steering fluid. <Ref. to PS-50, Power Steering Fluid.>

## CAUTION:

Never start the engine before filling with fluid; otherwise the vane pump may become seized.

# Oil Pump

POWER ASSISTED SYSTEM (POWER STEERING)

## C: INSPECTION

### 1. BASIC INSPECTION

Perform the following inspection procedures and replace faulty parts.

No.	Parts	Inspection	Corrective action
1	Oil pump (Exterior)	(1) Crack, damage or oil leakage	Replace the oil pump with a new part.
		(2) Play of pulley shaft	Measure the radial play and axial play. If any of these exceeds the service limit, replace the oil pump with a new part.
2	Pulley	(1) Damage	Replace with a new part.
		(2) Bend	Measure the V groove deflection. If it exceeds the service limit, replace the oil pump with a new part.
3	Oil pump (Interior)	(1) Faulty or seized of vane pump	Check the rotating resistance of pulley. If it exceeds the service limit, replace the oil pump with a new part.
		(2) Bend in the shaft or damage to bearing	If the a string is wrapped on the pulley and rotated, and the oil pump emits a noise that is markedly different in tone and loudness from a sound of a new oil pump, replace the oil pump with a new part.
4	O-ring	Cracking or deterioration	Replace with a new part.
5	Bracket	Cracks	Replace with a new part.

### 2. SERVICE LIMIT

Make a measurements as follows. If it exceeds the service limit, replace with a new part.

#### CAUTION:

- When securing the oil pump in a vice, hold the oil pump with the least possible force between two pieces of wood.
- Do not set the outside of flow control valve or pulley on a vise; otherwise outside or pulley might be deformed. Select properly sized wood pieces.

1) Play of the pulley shaft

#### Condition:

**P:** When applying a force of 9.8 N (1.0 kgf, 2.2 lbf)

#### Service limit:

**Play in the radial direction (Direction ◀ ▶ )**  
**0.2 mm (0.008 in) or less**

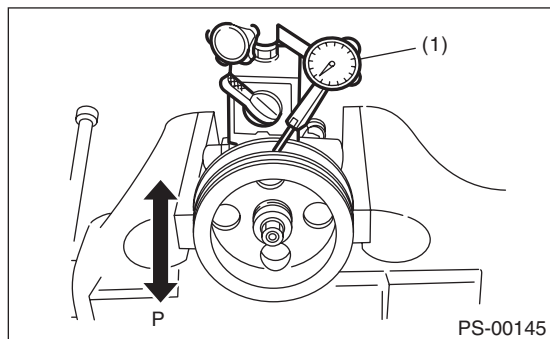

(1) Dial gauge

**Axial play (Direction ⇄ )**  
**0.9 mm (0.035 in) or less**

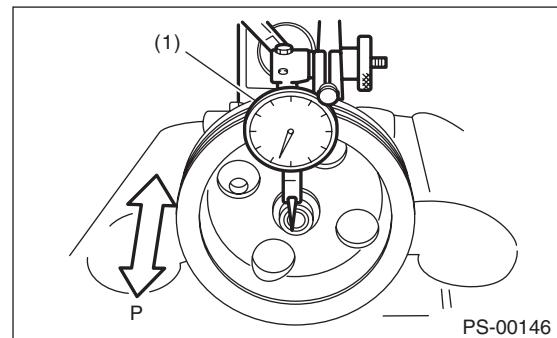

(1) Dial gauge



# Oil Pump

POWER ASSISTED SYSTEM (POWER STEERING)

## 2) Deflection of the pulley groove

### Service limit:

**1.0 mm (0.039 in) or less**

### NOTE:

Read the value on one surface of V groove, set the dial gauge on the other surface, and read the value of the dial gauge.

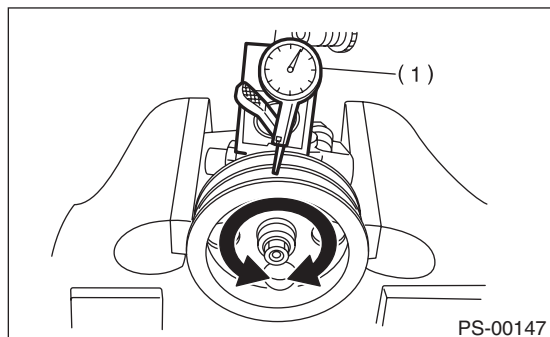

(1) Dial gauge

## 3) Rotating resistance of pulley

### Service limit:

**Maximum load: 9.22 N (0.94 kgf, 2.07 lbf) or less**

### NOTE:

- A rather higher value may be indicated when pulley starts turning.
- Measure the load during rotation to make a judgment.

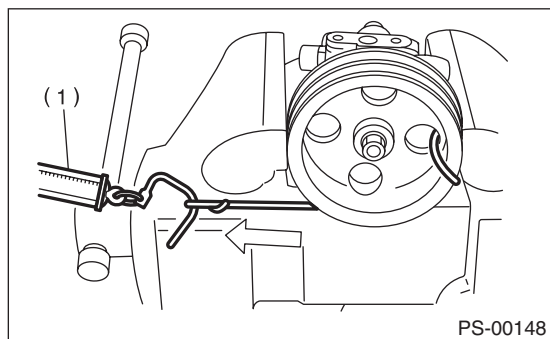

(1) Spring scale

## 3. HYDRAULIC PRESSURE

### NOTE:

- To measure hydraulic pressure correctly, be sure to complete all the items in "INSPECTION", prior to performing the measurement. <Ref. to PS-51, INSPECTION, General Diagnostic Table.>
- Do not leave the valve of pressure gauge closed or hold the steering wheel at lock for 5 seconds or more in any case, this can damage the oil pump.
- Before attaching a pressure gauge, place cloth at locations where fluid is expected to spill. Wipe off any spilt fluid completely after the measurement.

## 1) Regular pressure measurement

(1) Connect the ST1, ST2 and ST3.

ST1 925711000 PRESSURE GAUGE

ST2 34099AC020 ADAPTER HOSE B

ST3 34099AC010 ADAPTER HOSE A

(2) Remove the air intake duct.

• Except for STI model: <Ref. to IN(w/o STI)-10, REMOVAL, Air Intake Duct.>

• STI model: <Ref. to IN(STI)-10, REMOVAL, Air Intake Duct.>

(3) Disconnect the pressure hose from the pump.

(4) Using the gasket (Part No. 34621AC021) and bolt (Part No. 34620AC010), install the ST2 to pump instead of pressure hose.

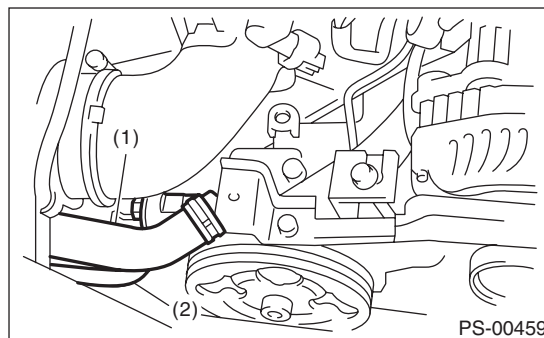

(1) Suction hose

(2) Pressure hose

(5) Attach the ST3 to the end of pressure hose which is removed from pump.

(6) Replenish power steering fluid up to the specified level.

(7) Open the valve, and start the engine.

(8) Measure the regular pressure.

ST1 925711000 PRESSURE GAUGE

ST2 34099AC020 ADAPTER HOSE B

ST3 34099AC010 ADAPTER HOSE A

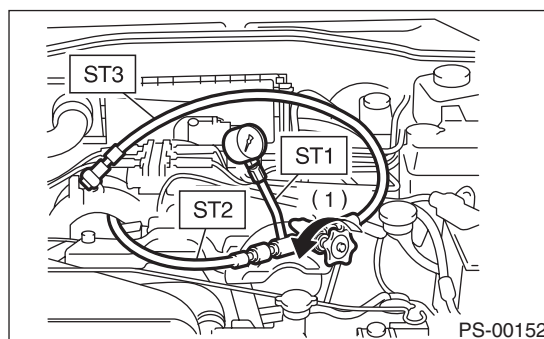

(1) Valve

### Service limit:

**981 kPa (10 kgf/cm<sup>2</sup>, 142 psi) or less**



# Oil Pump

## POWER ASSISTED SYSTEM (POWER STEERING)

(9) If it is not within the specification, replace the faulty part for the following problems. (Pipe or hose clogged, leaks from fluid line, and mixture of foreign matter in fluid line)

2) Measure the relief pressure.

- (1) Using the ST, measure the relief pressure.
- (2) Close the valve.
- (3) Measure the relief pressure.

ST1 925711000 PRESSURE GAUGE

ST2 34099AC020 ADAPTER HOSE B

ST3 34099AC010 ADAPTER HOSE A

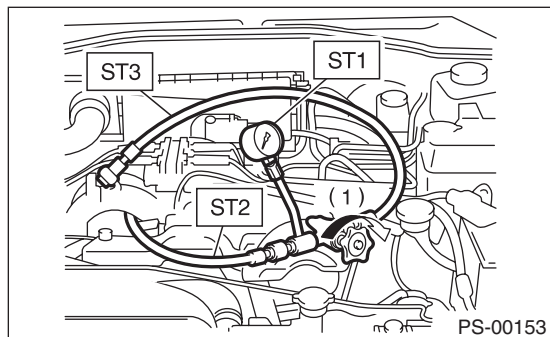

(1) Valve

**Service limit:**

**STI model**

**8,300 — 9,000 kPa (85 — 92 kgf/cm<sup>2</sup>, 1,203 — 1,305 psi)**

**Except for STI model**

**8,100 — 8,800 kPa (83 — 90 kgf/cm<sup>2</sup>, 1,174 — 1,276 psi)**

(4) If the torque is not within specified range, replace the oil pump.

3) Measure the working pressure.

- (1) Using the ST, measure the working pressure.
- (2) Open the valve.
- (3) Measure the working pressure of control valve by turning steering wheel from stop to stop.

ST1 925711000 PRESSURE GAUGE

ST2 34099AC020 ADAPTER HOSE B

ST3 34099AC010 ADAPTER HOSE A

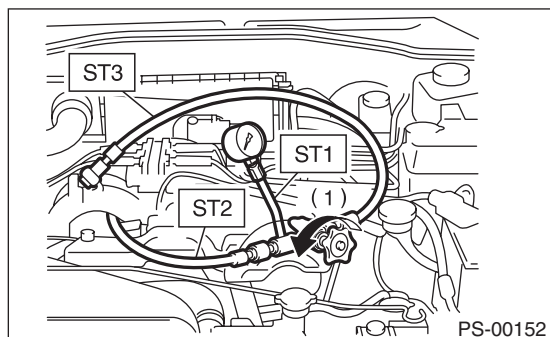

(1) Valve

**Service limit:**

**STI model**

**8,300 — 9,000 kPa (85 — 92 kgf/cm<sup>2</sup>, 1,203 — 1,305 psi)**

**Except for STI model**

**8,100 — 8,800 kPa (83 — 90 kgf/cm<sup>2</sup>, 1,174 — 1,276 psi)**

(4) If it is out of specification, measure the steering effort. <Ref. to PS-54, MEASUREMENT OF STEERING EFFORT, INSPECTION, General Diagnostic Table.>

If it is not within specification, replace the control valve itself or control valve and pinion as a single unit, using new parts.

## 8. Reservoir Tank

### A: REMOVAL

- 1) Drain fluid from the reservoir tank.
- 2) Disconnect the hose from reservoir tank.

#### CAUTION:

To prevent foreign matter from entering the hose and pipe, cover the open ends of them with clean cloth.

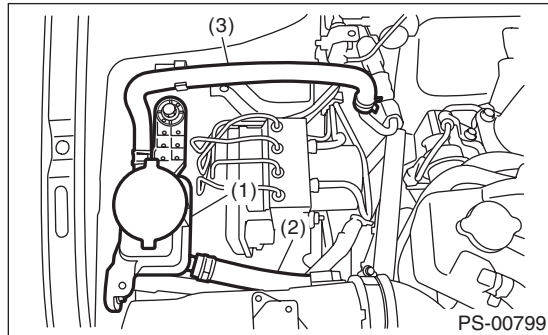

- (1) Reservoir tank
- (2) Suction hose
- (3) Return hose

- 3) Remove the reservoir tank from the body.

### B: INSTALLATION

- 1) Install the reservoir tank to the body.

#### Tightening torque:

**13 N·m (1.3 kgf·m, 9.6 ft·lb)**

- 2) Connect the hose to the reservoir tank.

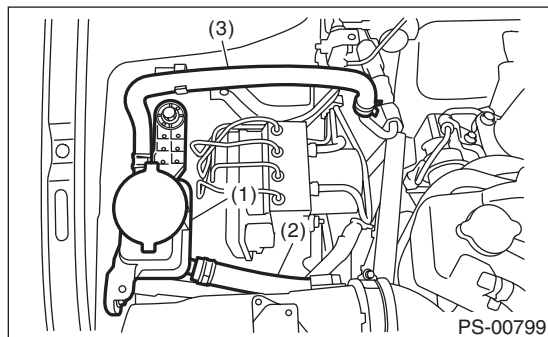

- (1) Reservoir tank
- (2) Suction hose
- (3) Return hose

- 3) Replenish power steering fluid up to the specified level. <Ref. to PS-50, INSPECTION, Power Steering Fluid.>

### C: INSPECTION

Check the reservoir tank for cracks, breakage or damage. If a failure is found, replace the reservoir tank.

# Power Steering Fluid

POWER ASSISTED SYSTEM (POWER STEERING)

## 9. Power Steering Fluid

### A: SPECIFICATION

Recommended power steering fluid
SUBARU ATF or DEXRON III

### B: INSPECTION

1) Check the power steering fluid for deterioration or contamination. If the fluid is highly deteriorated or contaminated, drain it and refill with new fluid.

2) Check the joints and units for oil leakage. If any oil leaks are found, repair or replace the applicable part.

3) Inspect the fluid level of reservoir tank with vehicle on level surface and engine stopped.

If the level is at "MIN." point or below, add fluid to keep the level in the specified range of the indicator. If at "MAX". point or above, drain fluid by using a syringe or the like.

(1) Check at power steering fluid temperature 20°C (68°F); read the fluid level on the "COLD" side.

(2) Check at power steering fluid temperature 80°C (176°F); read the fluid level on the "HOT" side.

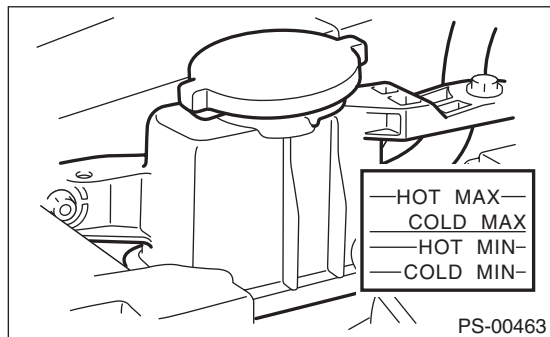

### C: REPLACEMENT

1) Lift up the vehicle.

2) Remove the crossmember support.

3) Remove the pipe joint in the center of gearbox, and connect the vinyl hose to the pipe and joint. Wipe fluid off while turning the steering wheel.

4) Add the specified fluid to reservoir tank at "MAX" level.

5) Continue to turn the steering wheel slowly from lock to lock until the bubbles stop appearing on oil surface while keeping the fluid at the level in the Step 4).

6) If the steering wheel is turned in a low fluid level condition, air will be sucked into the pipe. If air has entered, leave it for about half an hour and then repeat step 5) again.

7) Start the engine and let it idle.

8) Continue to turn the steering wheel slowly from lock to lock again until the bubbles stop appearing on oil surface, while keeping the fluid at the level in Step 4).

Normally bubbles will stop appearing after turning the steering wheel from lock to lock three times.

9) In case bubbles do not stop appearing in the tank, leave it for about half an hour and then repeat from step 4) again.

10) Lower the vehicle, and then idle the engine.

11) Continue to turn the steering wheel from lock to lock until the bubbles stop appearing and change of the fluid level is within 3 mm (0.12 in).

12) In case the following happens, leave it about half an hour and then perform step 8) to 11) again.

(1) The fluid level changes by 3 mm (0.12 in) or more.

(2) Bubbles remain on the upper surface of the fluid.

(3) Grinding noise is generated from oil pump.

13) Check the fluid leakage after turning steering wheel from lock to lock with engine running.

# General Diagnostic Table

POWER ASSISTED SYSTEM (POWER STEERING)

## 10. General Diagnostic Table

### A: INSPECTION

Trouble	Possible cause	Corrective action
<ul style="list-style-type: none"> <li>Steering effort is heavy in all ranges.</li> <li>Steering effort is heavy at stand still.</li> <li>Steering wheel vibrates when turning.</li> </ul>	1. Pulley belt <ul style="list-style-type: none"> <li>Unequal length of pulley belts</li> <li>Contact with oil or grease</li> <li>Looseness or damage of the pulley belt</li> <li>Poor uniformity of the pulley belt cross section</li> <li>Pulley belt touches to pulley bottom</li> <li>Poor revolution of pulleys (except oil pump pulley)</li> <li>Poor revolution of oil pump pulley</li> </ul>	Adjust or replace the faulty parts.
	2. Tire and wheel <ul style="list-style-type: none"> <li>Improper tire out of specifications*1</li> <li>Improper wheel out of specifications*1</li> <li>Tires not properly inflated</li> </ul>	Replace or reinflate the tire and wheel. Instruct customers.
	3. Fluid <ul style="list-style-type: none"> <li>Low fluid level</li> <li>Air entry in fluid</li> <li>Dust entry in fluid</li> <li>Fluid deterioration</li> <li>Inadequate warm up of fluid*2</li> </ul>	Refill the fluid, bleed air, replace or instruct customer.
	4. Idle speed <ul style="list-style-type: none"> <li>Lower idle speed</li> <li>Excessive drop of idle speed at start or when turning the steering wheel*3</li> </ul>	Adjust the idle speed or instruct customer.
	5. Measure the hydraulic pressure. <Ref. to PS-46, INSPECTION, Oil Pump.>	Replace the faulty parts.
	6. Measure the steering wheel effort. <Ref. to PS-54, MEASUREMENT OF STEERING EFFORT, INSPECTION, General Diagnostic Table.>	Adjust or replace the faulty parts.
	7. Fluid line <ul style="list-style-type: none"> <li>Folded hose</li> <li>Flattened pipe</li> </ul>	Replace the faulty parts.
<ul style="list-style-type: none"> <li>Vehicle leads to one side or the other.</li> <li>Returning force of steering wheel to center is poor.</li> <li>Steering wheel vibrates when turning.</li> </ul>	1. Tire and wheel <ul style="list-style-type: none"> <li>Flat tire</li> <li>Mixed use of different tires</li> <li>Mixed use of different wheels</li> <li>Abnormal wear of tire</li> <li>Unequal tread remaining</li> <li>Unequal pressure of tire</li> </ul>	Adjust, repair or replace the tire and wheel.
	2. Front alignment <ul style="list-style-type: none"> <li>Improper or unequal caster</li> <li>Improper or unequal toe-in</li> <li>Loose suspension connections</li> </ul>	Adjust or retighten.
	3. Others <ul style="list-style-type: none"> <li>Damaged joint assembly</li> <li>Unbalance of ground clearance</li> <li>Unbalance of load</li> </ul>	Replace or adjust the faulty parts, or instruct customer.
	4. Measure the steering wheel effort. <Ref. to PS-54, MEASUREMENT OF STEERING EFFORT, INSPECTION, General Diagnostic Table.>	Adjust or replace the faulty parts.

\*1 If the tires or wheels are wider than standard, the load to power steering system is increased. Accordingly, in a condition, for example before fluid warms-up, relief valve may work before reaching maximum turning angle. In this case, steering effort may be heavy. When the measured hydraulic pressure is normal, there is no abnormal thing.

\*2 In cold weather, steering effort may be heavy due to increased flow resistance of cold fluid. After warming-up engine, turn the steering wheel from stop to stop several times to warm up fluid. If steering effort reduces normally, function is normal.

\*3 In cold weather or with insufficient warm up of the engine, steering effort may be heavy due to excessive drop of idling when turning the steering wheel. In this case, start the vehicle with increasing engine speed than usual. If steering effort reduces normally, function is normal.

# General Diagnostic Table

## POWER ASSISTED SYSTEM (POWER STEERING)

### 1. NOISE AND VIBRATION

#### CAUTION:

**Do not keep the relief valve operated for five seconds or more at any time or inner parts of the oil pump may be damaged due to rapid increase of fluid temperature.**

#### NOTE:

- A screeching noise may be heard immediately after the engine start in extremely cold conditions. In this case, if the noise goes off during warm up there is no abnormal function in the system. This is due to the fluid characteristics in extremely cold condition.
- The oil pump normally makes a small whining noise due to its mechanism. Even if a noise is heard when steering wheel is turned at stand still, there is no abnormal function in the system provided that the noise eliminates when the vehicle is driving.
- When turning the steering wheel with the brake applied when the vehicle is parked, a screeching noise may be generated by the brake disc and pads. This is not a fault in the steering system.
- There may be a small vibration around the steering devices when turning the steering wheel at standstill, even though the component parts are operating properly.

Hydraulic systems are likely to generate this kind of vibration as well as working noise and fluid noise because of combined conditions, i.e., road surface and tire surface, engine speed and turning speed of steering wheel, fluid temperature and braking condition.

These conditions do not indicate a problem in the system.

Confirm vibration by applying the parking brake on a concrete surface and turning the steering wheel from slowly to rapidly, in steps.

Trouble	Possible cause	Corrective action
Hiss noise (continuous) While engine is running.	Relief valve emits operating sound when steering wheel is completely turned in either direction. (Do not keep this condition for 5 seconds or more.)	Normal
	Relief valve emits operating sound when steering wheel is not turned. This means that the relief valve is defective.	Replace the oil pump.
Rattling noise (intermittent) While engine is running.	Interference with adjacent parts	Check the clearance. Correct if necessary. <Ref. to PS-56, INSPECTION OF CLEARANCE, INSPECTION, General Diagnostic Table.>
	Loosened installation of oil pump, oil tank, pump bracket, gearbox or crossmember	Retighten.
	Loose oil pump pulley or other pulley(s)	Retighten.
	Looseness of linkage, play of steering, improper tightening (looseness) of suspension joint or steering column	Retighten or replace.
	Sound generates from the inside of gearbox or oil pump.	Replace faulty parts in the gearbox or oil pump.
Knocking When turning steering wheel in both directions with small angle repeatedly at engine ON or OFF.	Excessive backlash Loosened lock nut for adjusting backlash	Adjust and retighten.
	Insufficient tightening or play in the tie-rod or tie-rod end	Retighten or replace.
Grinding noise (continuous) While engine is running.	Air in vane pump	Inspect and retighten the fluid line connection. Refill the fluid and vent air.
	Vane pump seizing	Replace the oil pump.
	Oil pump pulley bearing seized	Replace the oil pump.
	Folded hose, flattened pipe	Replace.

# General Diagnostic Table

## POWER ASSISTED SYSTEM (POWER STEERING)

Trouble	Possible cause	Corrective action
Squeal, squeak (intermittent or continuous) While engine is running.	Improper adjustment of pulley belt Damaged or over tensioned pulley belt Unequal length of pulley belts	Adjust or replace.
	Runout or dirty V-groove surface of oil pump pulley	Clean or replace.
Sizzling noise (continuous) While engine is running.	Fluid aeration	Fix the faulty part causing aeration. Replace the fluid and vent air.
	Damaged pipe of gearbox	Replace the pipe.
	Faulty inside of hose or pipe Flattened hose or pipe	Repair or replace.
	Abnormal inside of oil tank	Replace.
	Removed oil tank cap	Install cap.
Whistle (continuous) While engine is running.	Faulty pipe of gearbox or faulty hose	Replace the faulty parts of the gearbox or the hose.
Whine or growl (intermittent or continuous) While engine is running. (with/without steering turned)	Looseness of oil pump, oil pump bracket attachment	Retighten.
	Fault inside of oil pump or hose	Replace the oil pump or hose, if the noise can be heard when vehicle is running as well as being stopped.
	Air conditioner compression whirling noise	Remove the power steering pulley belt and check.
Grinding noise (continuous) While engine is running. (with the steering turned)	Fault inside of gearbox	Replace the faulty parts of gearbox.
	Faulty steering shaft bearing	Apply grease or replace.
	Occurs when turning the steering wheel with brakes (service or parking) applied.	If the noise goes off when brake is released, it is normal.
Vibration While engine is running. (with/without steering turned)	Engine speed is too low.	Adjust, and notify customer.
	Air in vane pump	Repair faulty part Vent air.
	Damaged valve in oil pump or gearbox	Replace the faulty parts in gearbox and oil pump.
	Excessive play in steering, looseness of suspension parts	Retighten.

# General Diagnostic Table

## POWER ASSISTED SYSTEM (POWER STEERING)

### 2. MEASUREMENT OF STEERING EFFORT

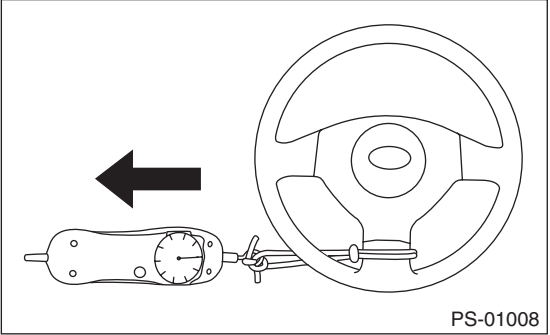
Step	Check	Yes	No
<p><b>1 CHECK STEERING EFFORT.</b>                      1) Stop the vehicle on paved road.                      2) Start the engine.                      3) Run the engine at idle.                      4) Install a spring scale on the steering wheel.                      5) Pull the spring scale at a right angle to the steering wheel, and measure both right and left steering wheel efforts.</p>  <p style="text-align: right;">PS-01008</p> <p><b>NOTE:</b>                      When turning the steering more quickly than necessary from a direction to the other direction at an engine speed of 2,000 rpm or higher, steering effort may be heavy. This is caused by flow characteristic of the fluid in the oil pump and is not a defect.</p>	Is the steering effort less than 29.4 N (3.0 kgf, 6.6 lbf)?	Steering effort is normal.	Go to step 2.
<p><b>2 CHECK STEERING EFFORT.</b>                      1) Stop the engine and lift up the vehicle.                      2) Pull the spring scale at a right angle to the steering wheel, and measure both right and left steering wheel efforts.</p>	Is the steering effort less than 14 N (1.4 kgf, 3.1 lbf)?	Go to step 3.	Perform the backlash adjustment.
<p><b>3 CHECK STEERING WHEEL EFFORT.</b>                      1) Remove the universal joint.                      2) Measure the steering wheel effort.</p>	Is the steering effort less than 2.26 N (0.23 kgf, 0.51 lbf)?	Go to step 4.	Replace the steering column.
<p><b>4 CHECK STEERING WHEEL EFFORT.</b>                      Measure the steering wheel effort.</p>	Is the difference of steering effort between right and left less than 20%?	Go to step 5.	Replace the steering column.
<p><b>5 CHECK UNIVERSAL JOINT.</b>                      Measure the swing torque of the joint (yoke of steering column side). &lt;Ref. to PS-13, INSPECTION, Universal Joint.&gt;</p>	Is the swing torque of the universal joint less than 7.3 N (0.74 kgf, 1.64 lbf)?	Go to step 6.	Replace the universal joint.
<p><b>6 CHECK UNIVERSAL JOINT.</b>                      Measure the swing torque of the joint (yoke of gearbox side). &lt;Ref. to PS-13, INSPECTION, Universal Joint.&gt;</p>	Is the swing torque of the universal joint less than 3.8 N (0.39 kgf, 0.86 lbf)?	Go to step 7.	Replace with a new part.
<p><b>7 CHECK FRONT WHEEL.</b>                      Check the front wheels.</p>	Does the front wheels have unsteady revolution or rattling, or does the brake drag?	Inspect, readjust and replace if necessary.	Go to step 8.
<p><b>8 CHECK TIE-ROD ENDS.</b>                      Remove the tie-rod ends from housing.</p>	Does the tie-rod ends have unsteady revolution or rattling?	Inspect and replace if necessary.	Go to step 9.
<p><b>9 CHECK GEARBOX.</b>                      Measure the rotating of gearbox.                      &lt;Ref. to PS-35, TURNING RESISTANCE OF GEARBOX, INSPECTION, Steering Gearbox.&gt;</p>	Is the turn resistance of the steering gearbox less than 11.3 N (1.15 kgf, 2.54 lbf)? Is the difference between the right and left rotational resistances less than 24%?	Steering effort is normal.	Readjust the backlash, and if ineffective, replace the faulty parts.

# General Diagnostic Table

POWER ASSISTED SYSTEM (POWER STEERING)

Step	Check	Yes	No
<b>10</b> <b>CHECK GEARBOX.</b> Measure the sliding of gearbox. <Ref. to PS-34, SERVICE LIMIT, INSPECTION, Steering Gearbox.>	Is the sliding resistance of the steering gearbox less than 370 N (38 kgf, 83 lbf)? Is the difference between the right and left sliding resistances less than 20%?	Steering effort is normal.	Readjust the backlash, and if ineffective, replace the faulty parts.



## General Diagnostic Table

### POWER ASSISTED SYSTEM (POWER STEERING)

#### 3. INSPECTION OF CLEARANCE

This table lists various clearances that must be correctly adjusted to ensure the normal vehicle driving without interfering noise, or any other faults.

Location	Minimum allowance mm (in)
(1) Crossmember to hose ASSY	3 (0.12)
(2) Front exhaust pipe to hose ASSY	15 (0.59)
(3) Front frame side to hose ASSY	10 (0.39)
(4) Turbo cover to hose ASSY	10 (0.39)
(5) Master cylinder to return hose	10 (0.39)
(6) Master cylinder to hose clip	10 (0.39)
(7) VDC H/U to hose ASSY	5 (0.20)
(8) Air cleaner to hose ASSY	5 (0.20)
(9) Air boot to hose ASSY	10 (0.39)
(10) Air cleaner hose to hose ASSY	10 (0.39)
(11) Blow-by hose to hose ASSY	8 (0.31)
(12) Over flow hose to hose ASSY	8 (0.31)
(13) Brake pipe to return hose	10 (0.39)
(14) Front suspension bracket to return hose	5 (0.20)
(15) Front wheel apron to return hose	5 (0.20)
(16) VDC H/U bracket to suction hose	5 (0.20)
(17) Air cleaner case to suction hose	5 (0.20)
(18) Air intake duct to suction hose	10 (0.39)
(19) Air duct to suction hose	10 (0.39)
(20) Front wheel apron to reservoir tank	5 (0.20)
(21) VDC H/U to reserve tank	5 (0.20)
(22) Valve housing to DOJ (MT model)	12 (0.47)
(23) Valve housing to crossmember (hole)	1 (0.04)
(24) Cannon mount to crossmember	There must be no contact
(25) Pipe to crossmember	5 (0.20)
(26) Pipe to stabilizer	15 (0.59)
(27) Pipe to exhaust pipe	18 (0.71)
(28) Tie-rod end to brake dust cover	2.5 (0.10)
(29) Universal joint coupling to turbo cover	15 (0.59)
(30) Universal joint column side yoke to master cylinder (closest point of approach when the universal joint turns by 360°)	5 (0.20)
(31) Universal joint coupling to ATF level gauge	10 (0.39)

# General Diagnostic Table

POWER ASSISTED SYSTEM (POWER STEERING)

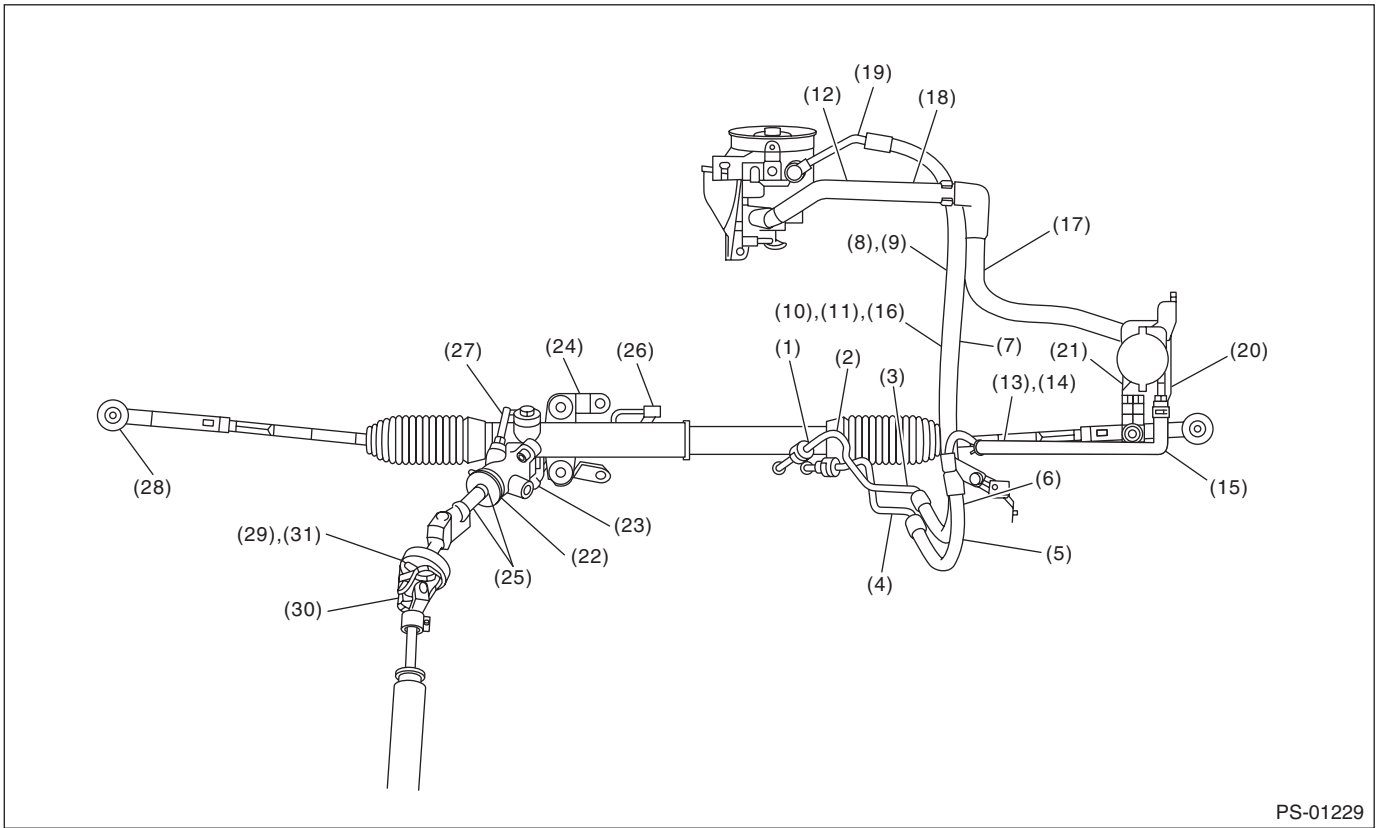

PS-01229

**PS-57**

Brought to you by Ebay Seller "SubaruManuals"

# General Diagnostic Table

POWER ASSISTED SYSTEM (POWER STEERING)

---

**BODY SECTION**

This service manual has been prepared to provide SUBARU service personnel with the necessary information and data for the correct maintenance and repair of SUBARU vehicles.

This manual includes the procedures for maintenance, disassembling, reassembling, inspection and adjustment of components and diagnostics for guidance of experienced mechanics.

Please peruse and utilize this manual fully to ensure complete repair work for satisfying our customers by keeping their vehicle in optimum condition. When replacement of parts during repair work is needed, be sure to use SUBARU genuine parts.

All information, illustration and specifications contained in this manual are based on the latest product information available at the time of publication approval.

<b>HVAC SYSTEM (HEATER, VENTILATOR AND A/C)</b>	<b>AC</b>
<b>HVAC SYSTEM (AUTO A/C) (DIAGNOSTICS)</b>	<b>AC(diag)</b>
<b>AIRBAG SYSTEM</b>	<b>AB</b>
<b>AIRBAG SYSTEM (DIAGNOSTICS)</b>	<b>AB(diag)</b>
<b>OCCUPANT DETECTION SYSTEM (DIAGNOSTICS)</b>	<b>OD(diag)</b>
<b>SEAT BELT SYSTEM</b>	<b>SB</b>
<b>LIGHTING SYSTEM</b>	<b>LI</b>
<b>WIPER AND WASHER SYSTEMS</b>	<b>WW</b>
<b>ENTERTAINMENT</b>	<b>ET</b>
<b>COMMUNICATION SYSTEM</b>	<b>COM</b>
<b>GLASS/WINDOWS/MIRRORS</b>	<b>GW</b>
<b>BODY STRUCTURE</b>	<b>BS</b>
<b>INSTRUMENTATION/DRIVER INFO</b>	<b>IDI</b>
<b>SEATS</b>	<b>SE</b>
<b>SECURITY AND LOCKS</b>	<b>SL</b>
<b>SUNROOF/T-TOP/CONVERTIBLE TOP (SUNROOF)</b>	<b>SR</b>
<b>EXTERIOR/INTERIOR TRIM</b>	<b>EI</b>

**BODY SECTION**

**EXTERIOR BODY PANELS**

**EB**

**CRUISE CONTROL SYSTEM**

**CC**

**CRUISE CONTROL SYSTEM  
(DIAGNOSTICS)**

**CC(diag)**

**IMMOBILIZER (DIAGNOSTICS)**

**IM(diag)**

**LAN SYSTEM (DIAGNOSTICS)**

**LAN(diag)**

# HVAC SYSTEM (HEATER, VENTILATOR AND A/C)

# AC

---

	<b>Page</b>
1. General Description .....	2
2. Air Conditioning System .....	18
3. Refrigerant Pressure with Manifold Gauge Set .....	19
4. Refrigerant Recovery Procedure .....	20
5. Refrigerant Charging Procedure .....	21
6. Refrigerant Leak Check .....	24
7. Compressor Oil .....	25
8. Blower Motor Unit Assembly .....	26
9. Blower Motor .....	27
10. Power Transistor (Auto A/C Model) .....	28
11. Blower Resistor (Manual A/C Model) .....	29
12. Heater Core .....	30
13. Control Unit (Manual A/C Model) .....	31
14. Control Unit (Auto A/C Model) .....	32
15. Compressor .....	33
16. Condenser .....	34
17. Heater and Cooling Unit .....	35
18. Evaporator .....	36
19. Hose and Pipe .....	40
20. Relay and Fuse .....	41
21. Pressure Switch (Triple Pressure Switch) .....	42
22. Ambient Sensor (Auto A/C Model) .....	43
23. Sunload Sensor (Auto A/C Model) .....	45
24. In-Vehicle Sensor (Auto A/C Model) .....	46
25. Air Vent Grille .....	48
26. Heater Duct .....	49
27. Heater Vent Duct .....	50
28. A/C Filter .....	51
29. General Diagnostic Table .....	52

# General Description

HVAC SYSTEM (HEATER, VENTILATOR AND A/C)

## 1. General Description

### A: SPECIFICATION

#### 1. HEATER SYSTEM

Item		Specifications	Condition
Heating capacity		5.0 kW (4,299 kcal/h, 17,059 BTU/h) or more	<ul style="list-style-type: none"> <li>Air flow control dial: FOOT</li> <li>Temperature adjustment dial: MAX HOT</li> <li>Temperature difference between hot water and inlet air: 65°C (149°F)</li> <li>Hot water flow rate: 360 ℓ (95.1 US gal, 79.2 Imp gal)/h</li> </ul>
Air flow rate		290 m <sup>3</sup> (10,243 cu ft)/h	FOOT mode (FRESH), MAX HOT at 12.5 V
Max air flow rate		480 m <sup>3</sup> (16,954 cu ft)/h	<ul style="list-style-type: none"> <li>Temperature adjustment dial: MAX COOL</li> <li>Fan speed control dial: Auto A/C model: 7th position Manual A/C model: 4th position</li> <li>FRESH/RECIRC switch: RECIRC</li> </ul>
Heater core size (height × length × width)		257.5 × 118.5 × 27 mm (10.1 × 4.67 × 1.06 in)	—
Blower motor	Type	Magnet motor 260 W or less	12 V
	Fan type and size (diameter × width)	Sirocco fan type 150 × 75 mm (5.91 × 2.95 in)	—

#### 2. A/C SYSTEM

Item		Specifications
Type of air conditioner		Reheat air-mix type
Cooling capacity		5.0 kW [at 480 m <sup>3</sup> (16,954 cu ft)/h] (4,299 kcal/h, 17,059 BTU/h)
Refrigerant		HFC-134a (CH <sub>2</sub> FCF <sub>3</sub> ) [0.5±0.05 kg (1.1±0.11 lb)]
Compressor	Type	Rotary fixed capacity (DVK-10R)
	Discharge	105 cc (6.41 cu in)/rev
	Max. permissible speed	7,700 rpm
Magnet clutch	Type	Dry, single-disc type
	Power consumption	38.8 W
	Type of belt	V-belt 4 PK
	Pulley dia. (effective dia.)	100 mm (3.9 in)
	Pulley ratio	1.32
Condenser	Type	Sub cool type
	Core face area	0.188 m <sup>2</sup> (2.002 sq ft)
	Core thickness	16 mm (0.63 in)
	Radiation area	4.5 m <sup>2</sup> (48.44 sq ft)
Expansion valve	Type	Block
Evaporator	Type	Dual-tank
	Dimensions (W × H × T)	290.1 × 172 × 39 mm (11.42 × 6.77 × 1.54 in)
Blower fan	Fan type	Sirocco fan
	Outer diameter × width	150 × 75 mm (5.91 × 2.95 in)
	Power consumption	260 W
Condenser fan (Sub fan)	Motor type	Magnet
	Power consumption	120 W
	Fan outer diameter	318.5 mm (12.5 in)

# General Description

HVAC SYSTEM (HEATER, VENTILATOR AND A/C)

Item		Specifications	
Radiator fan (Main fan)		Motor type	Magnet
		Power consumption	120 W
		Fan outer diameter	318.5 mm (12.5 in)
Idle speed	MPFI model	No load	700±100 rpm
		A/C ON	750±100 rpm
Triple switch (Pressure switch)	Low-pressure switch operating pressure	ON → OFF	177±25 kPa (1.80±0.25 kgf/cm <sup>2</sup> , 25.7±3.6 psi)
		OFF → ON	206±30 kPa (2.10±0.31 kgf/cm <sup>2</sup> , 29.9±4.3 psi)
	High-pressure switch operating pressure	ON → OFF	2,940±200 kPa (29.98±2.04 kgf/cm <sup>2</sup> , 426.3±29 psi)
		OFF → ON	2,350±200 kPa (24.00±2.04 kgf/cm <sup>2</sup> , 340.7±29.0 psi)
	Middle-pressure switch operating pressure	ON → OFF	1,470±120 kPa (14.99±1.22 kgf/cm <sup>2</sup> , 213.15±17.4 psi)
		OFF → ON	1,770±100 kPa (18.05±1.02 kgf/cm <sup>2</sup> , 256.65±14.5 psi)
Thermo-control amplifier working temperature		<p style="text-align: right;">AC-00601</p> <p>(1) ON (2) OFF (3) 1.5±0.3°C (34.7±0.5°F) (4) 1.0±0.5°C (33.8±0.9°F)</p>	



# General Description

HVAC SYSTEM (HEATER, VENTILATOR AND A/C)

## B: COMPONENT

### 1. HEATER COOLING UNIT

- Auto A/C model

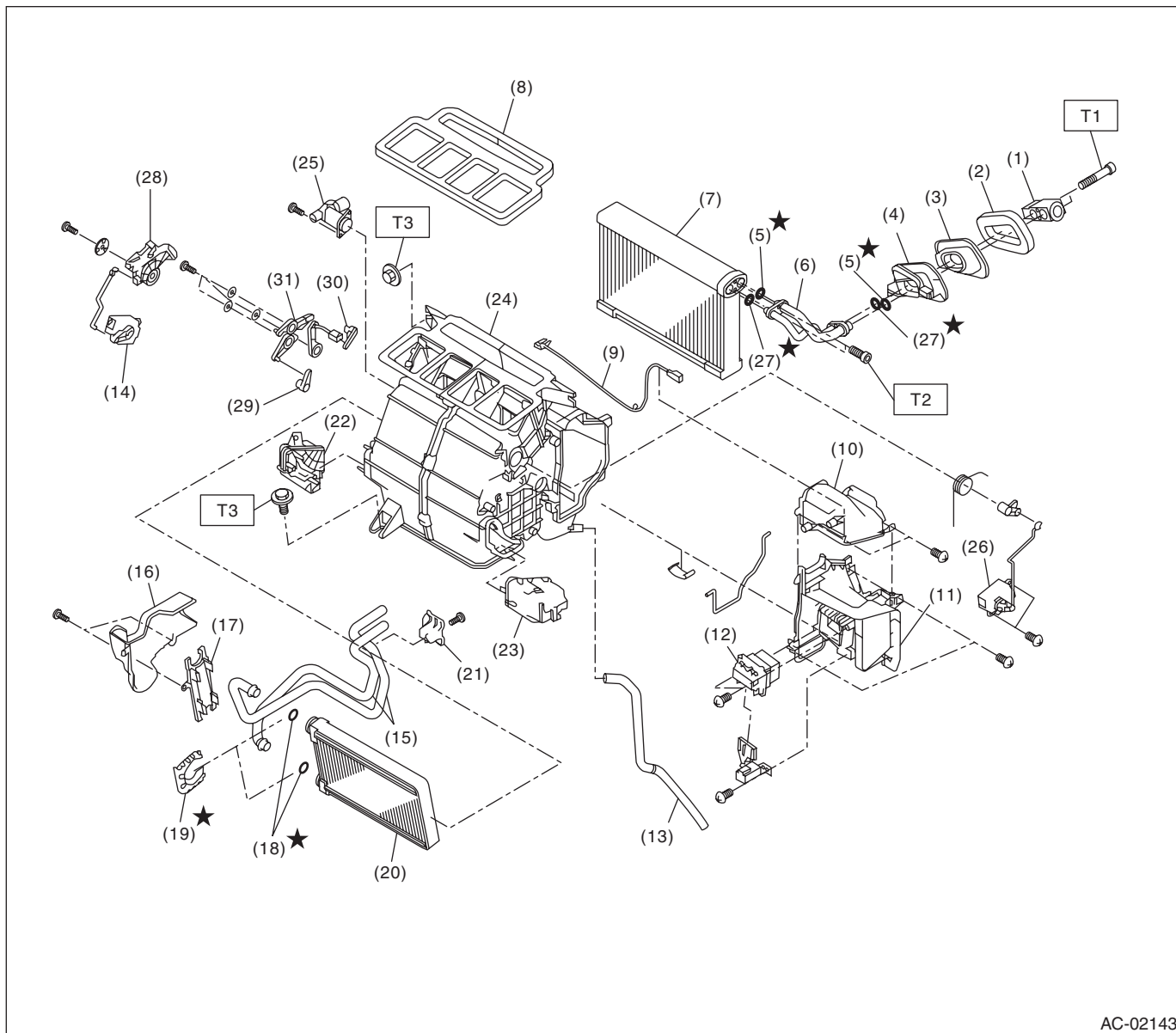

AC-02143

(1) Expansion valve	(13) Drain hose	(25) Aspirator
(2) Gasket	(14) Mode actuator	(26) Air mix actuator
(3) Grommet	(15) Heater core pipe	(27) O-ring
(4) Case	(16) Heater pipe cover	(28) Mode main lever
(5) O-ring	(17) Heater core cover	(29) Vent door link
(6) Evaporator pipe	(18) O-ring	(30) Defroster door link
(7) Evaporator	(19) Clamp	(31) Mode link
(8) Lining	(20) Heater core	
(9) Evaporator sensor	(21) Pipe clamp	
(10) Evaporator pipe cover	(22) Foot duct (LH)	
(11) Evaporator cover	(23) Foot duct (RH)	
(12) Power transistor	(24) Heater case	

**Tightening torque: N·m (kgf·m, ft·lb)**

**T1: 5.0 (0.51, 3.7)**

**T2: 6.7 (0.68, 4.9)**

**T3: 7.5 (0.76, 5.5)**

**AC-4**

Brought to you by Ebay Seller "SubaruManuals"

# General Description

HVAC SYSTEM (HEATER, VENTILATOR AND A/C)

• Manual A/C model

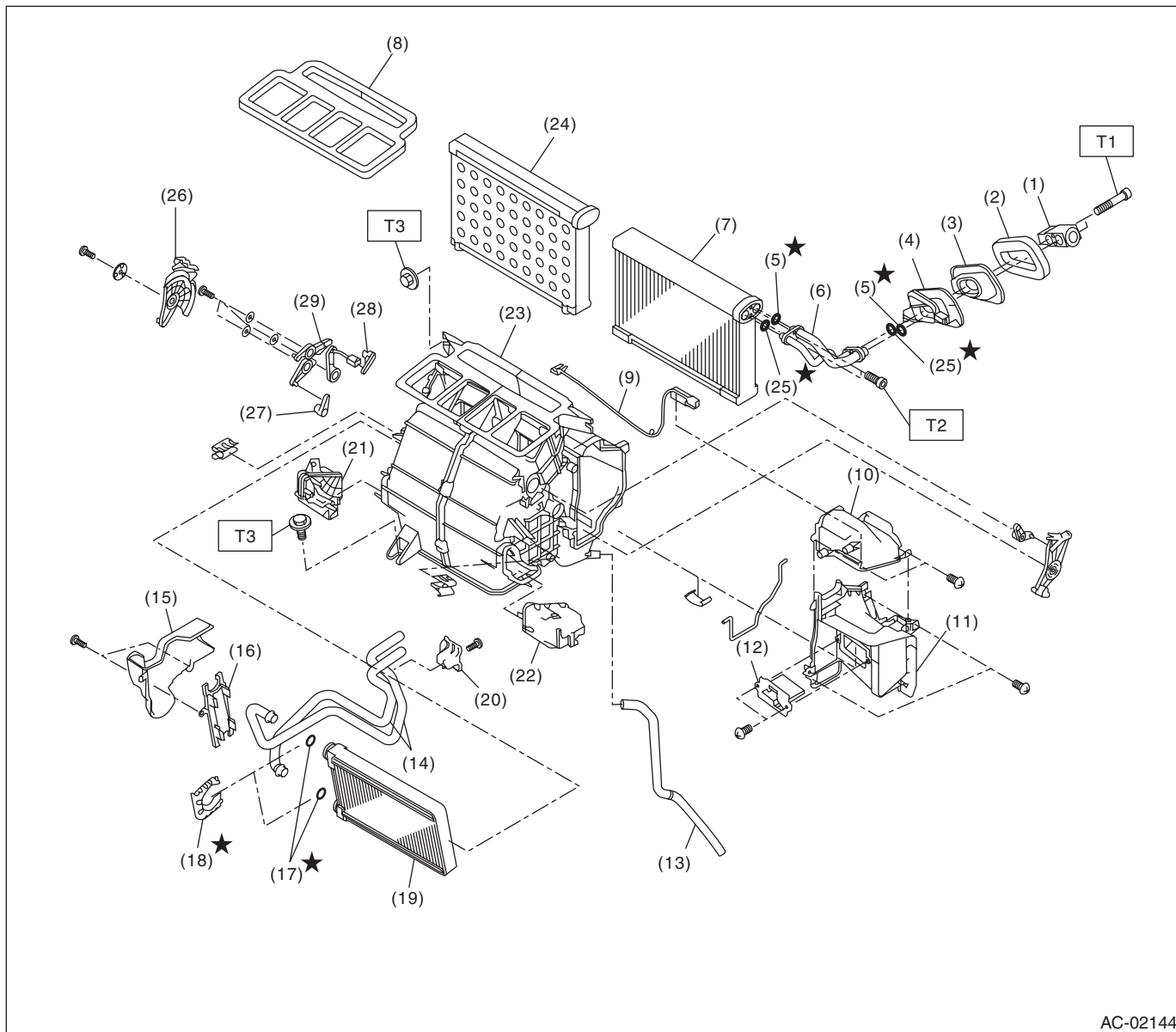

AC-02144

- |                            |                                |                          |
|----------------------------|--------------------------------|--------------------------|
| (1) Expansion valve        | (13) Drain hose                | (25) O-ring              |
| (2) Gasket                 | (14) Heater core pipe          | (26) Mode main lever     |
| (3) Grommet                | (15) Heater pipe cover         | (27) Vent door link      |
| (4) Case                   | (16) Heater core cover         | (28) Defroster door link |
| (5) O-ring                 | (17) O-ring                    | (29) Mode link           |
| (6) Evaporator pipe        | (18) Clamp                     |                          |
| (7) Evaporator             | (19) Heater core               |                          |
| (8) Lining                 | (20) Pipe clamp                |                          |
| (9) Thermostat             | (21) Foot duct (LH)            |                          |
| (10) Evaporator pipe cover | (22) Foot duct (RH)            |                          |
| (11) Evaporator cover      | (23) Heater case               |                          |
| (12) Resistor              | (24) Plate (model without A/C) |                          |

**Tightening torque: N·m (kgf·m, ft·lb)**

**T1: 5.0 (0.51, 3.7)**

**T2: 6.7 (0.68, 4.9)**

**T3: 7.5 (0.76, 5.5)**

**AC-5**

Brought to you by Ebay Seller "SubaruManuals"

# General Description

HVAC SYSTEM (HEATER, VENTILATOR AND A/C)

## 2. BLOWER MOTOR UNIT

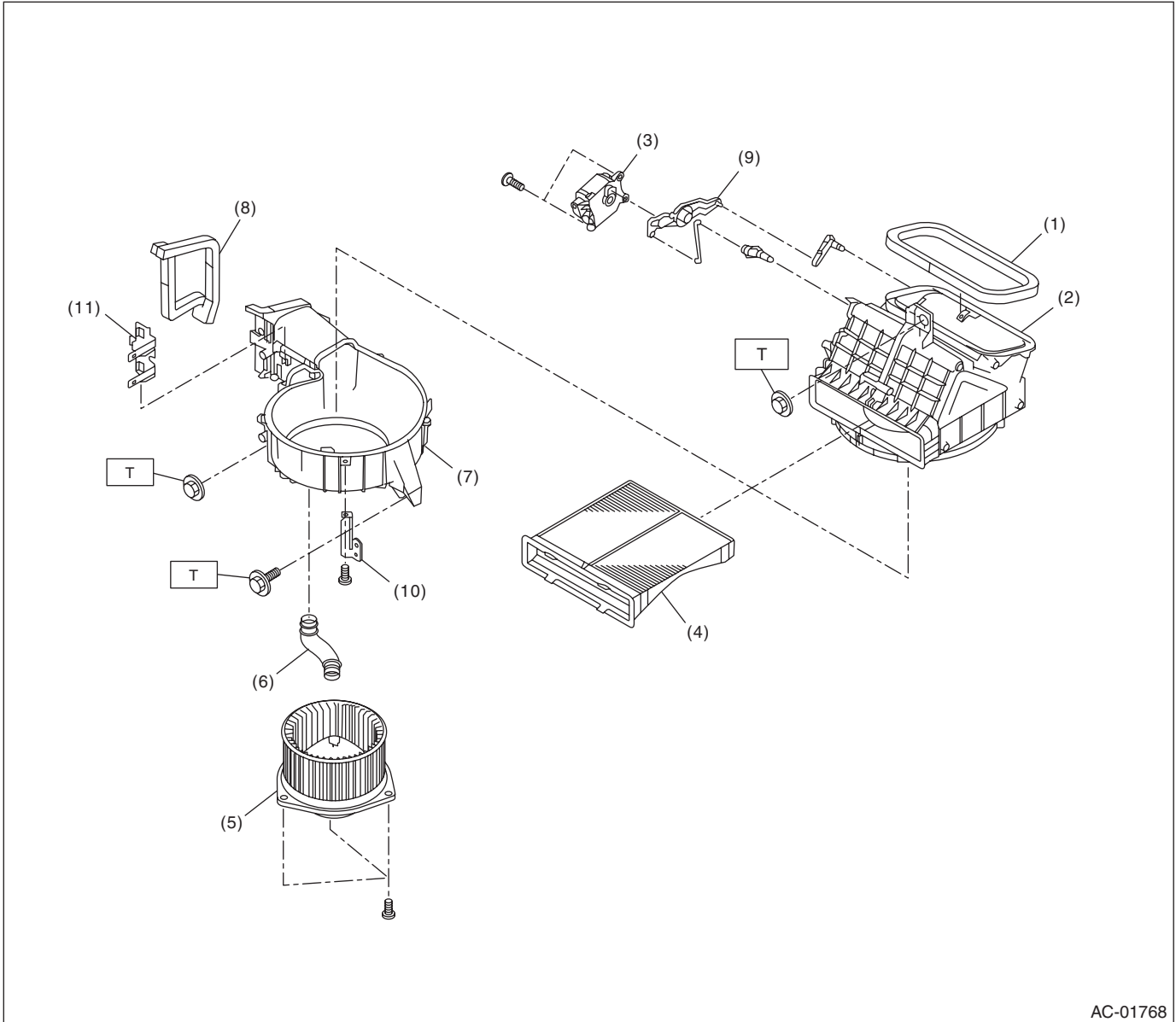

AC-01768

- |                          |                      |                           |
|--------------------------|----------------------|---------------------------|
| (1) Lining               | (6) Hose             | (11) Relay holder bracket |
| (2) Upper case           | (7) Lower case       |                           |
| (3) Intake door actuator | (8) Lining           |                           |
| (4) Filter               | (9) Intake door link |                           |
| (5) Blower motor ASSY    | (10) Relay bracket   |                           |

**Tightening torque: N·m (kgf·m, ft·lb)**

**T: 7.5 (0.76, 5.5)**

**AC-6**

Brought to you by Ebay Seller "SubaruManuals"

# General Description

HVAC SYSTEM (HEATER, VENTILATOR AND A/C)

## 3. CONTROL MODULE

- Auto A/C model

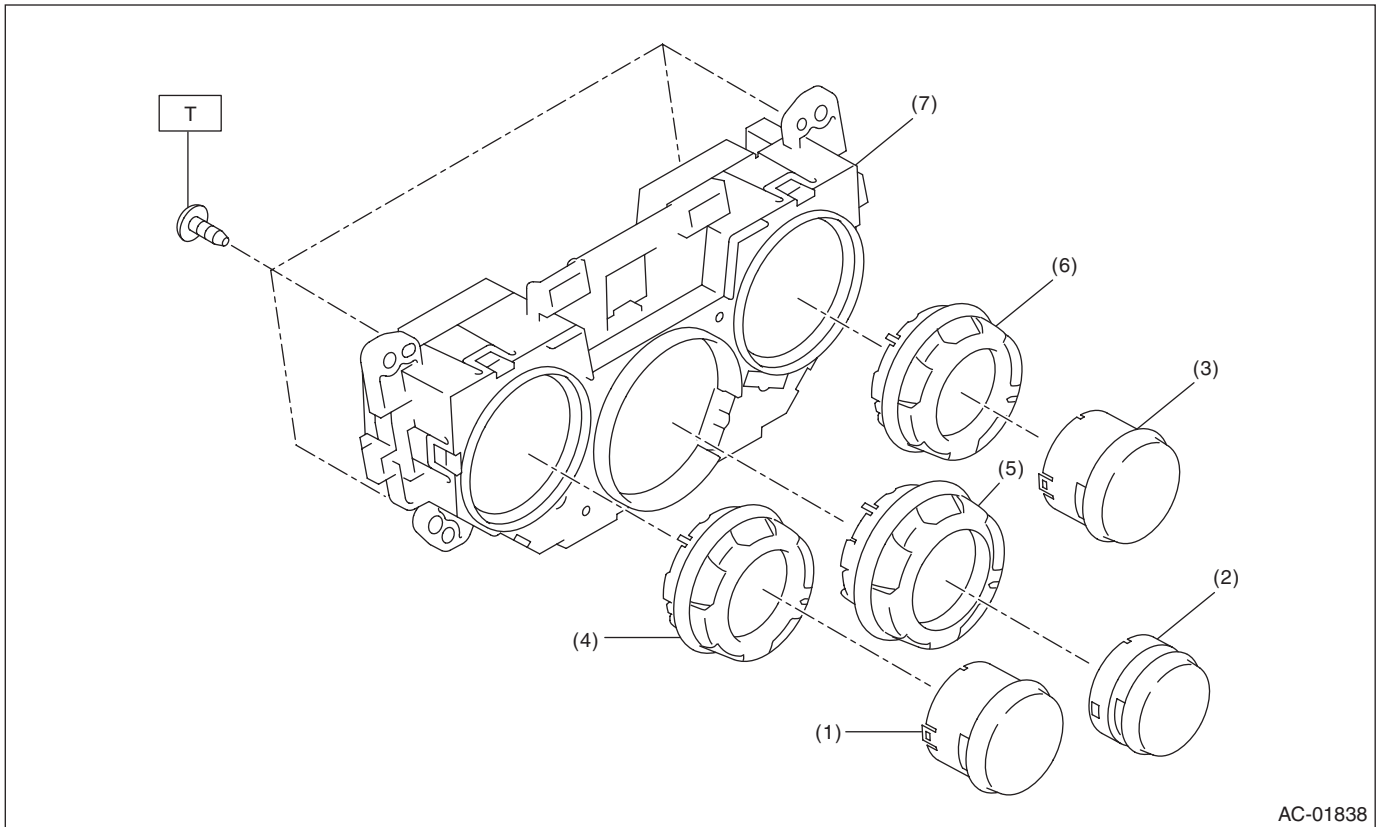

AC-01838

- |                                 |                              |
|---------------------------------|------------------------------|
| (1) FRESH/RECIRC switch         | (5) Air flow control dial    |
| (2) Rear window defogger switch | (6) Temperature control dial |
| (3) A/C switch                  | (7) Control case             |
| (4) Fan speed control dial      |                              |

**Tightening torque: N·m (kgf·m, ft·lb)**  
**T: 2 (0.20, 1.5)**

# General Description

## HVAC SYSTEM (HEATER, VENTILATOR AND A/C)

- Manual A/C model

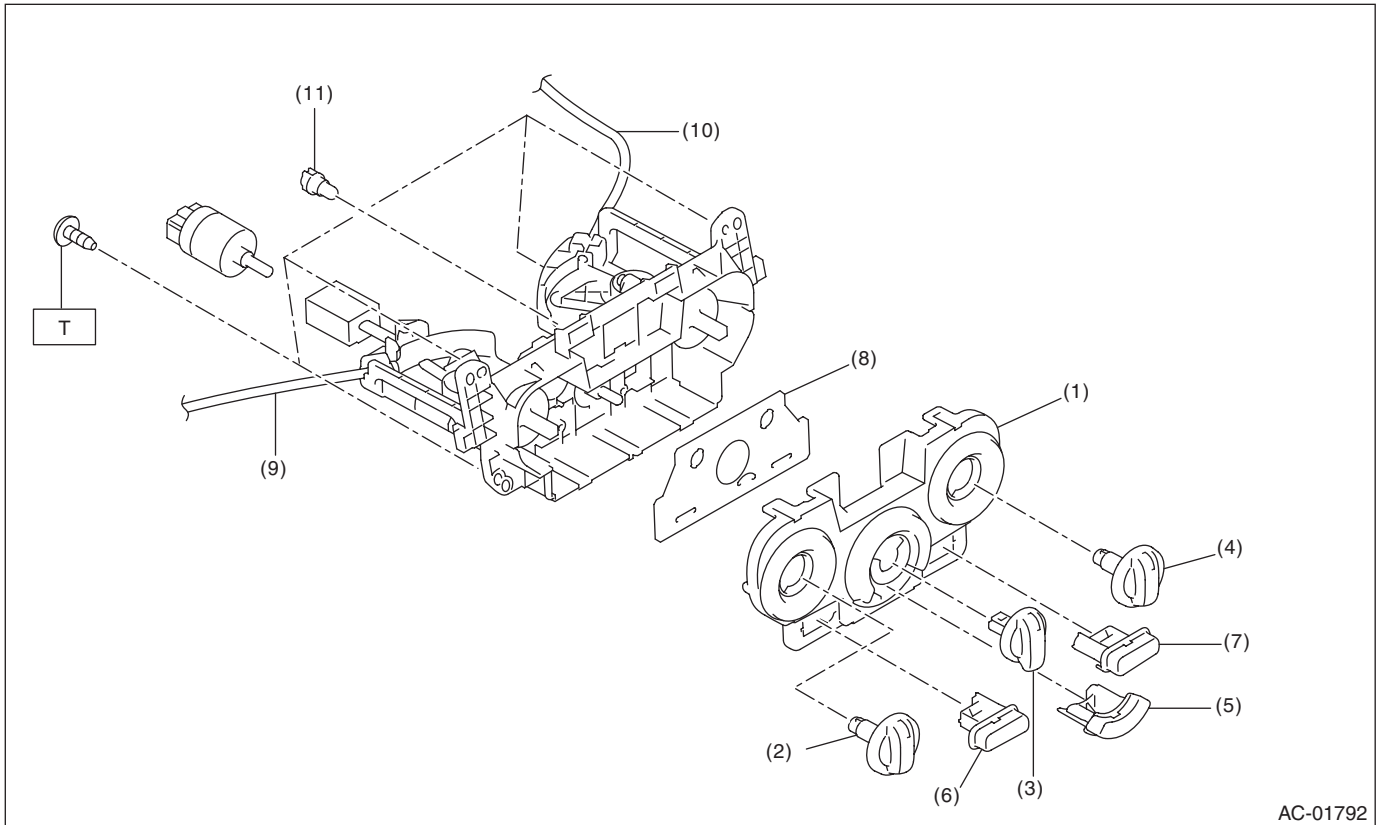

- |                              |                                 |            |
|------------------------------|---------------------------------|------------|
| (1) Panel                    | (6) Rear window defogger switch | (11) Valve |
| (2) Air flow control dial    | (7) FRESH/RECIRC switch         |            |
| (3) Fan speed control dial   | (8) Switch board                |            |
| (4) Temperature control dial | (9) Air flow control cable      |            |
| (5) A/C switch               | (10) Temperature control cable  |            |

---

**Tightening torque: N·m (kgf·m, ft·lb)**

**T: 2 (0.20, 1.5)**

---

# General Description

HVAC SYSTEM (HEATER, VENTILATOR AND A/C)

## 4. AIR CONDITIONING UNIT

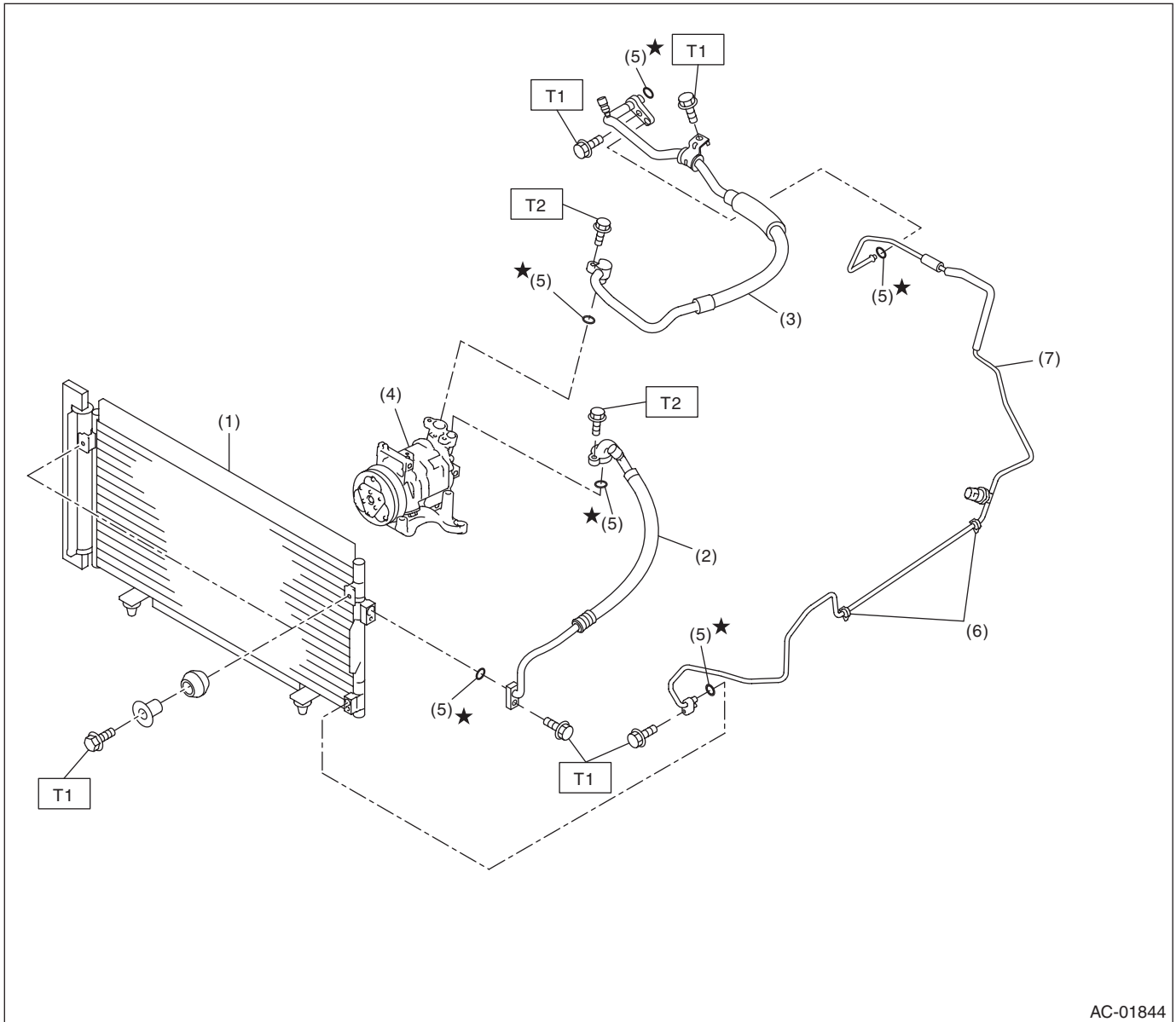

AC-01844

- |                          |            |
|--------------------------|------------|
| (1) Condenser            | (5) O-ring |
| (2) Hose (high pressure) | (6) Clamp  |
| (3) Hose (low pressure)  | (7) Pipe   |
| (4) Compressor           |            |

**Tightening torque: N·m (kgf·m, ft·lb)**

**T1: 7.5 (0.76, 5.5)**

**T2: 10 (1.02, 7.4)**

**AC-9**

Brought to you by Ebay Seller "SubaruManuals"

# General Description

HVAC SYSTEM (HEATER, VENTILATOR AND A/C)

## 5. COMPRESSOR

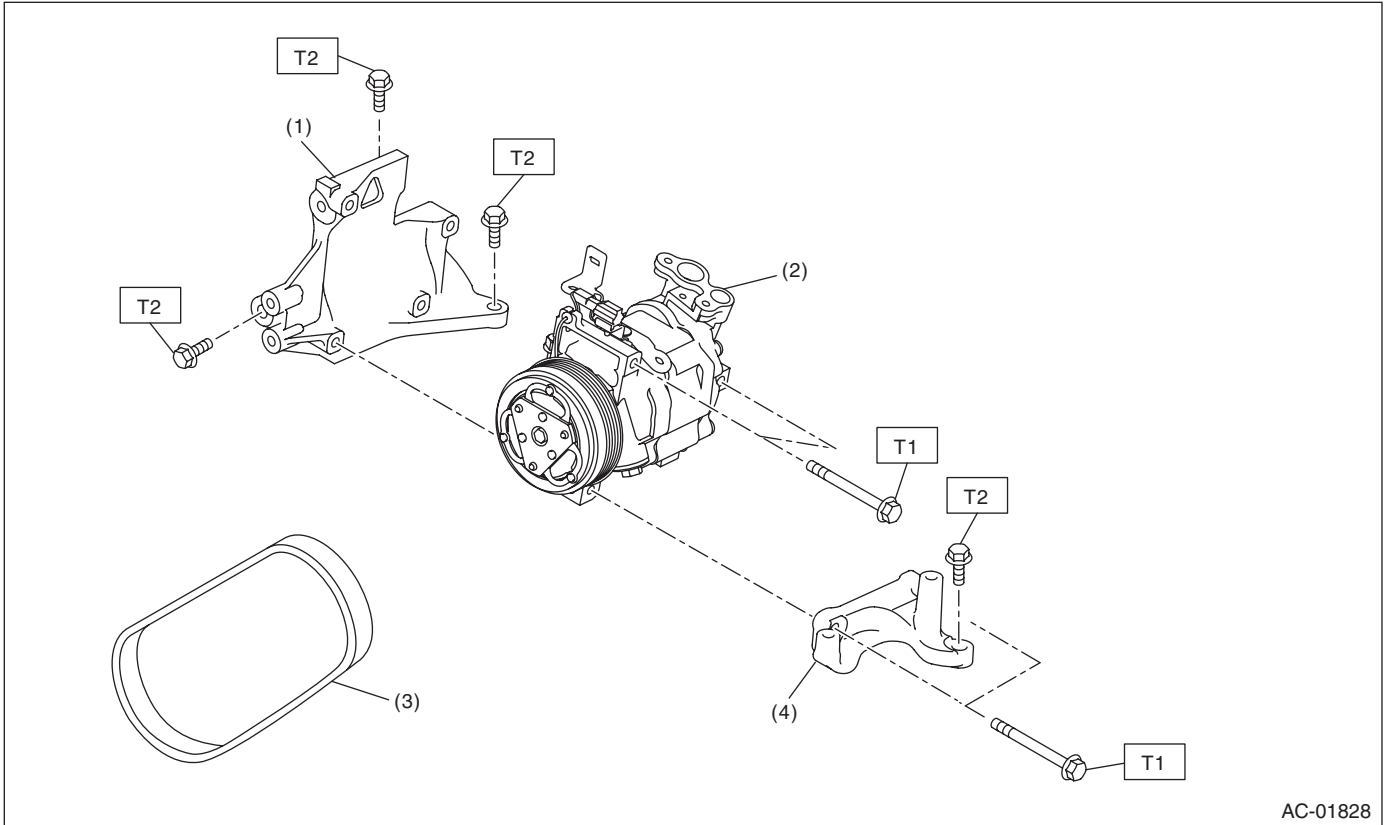

AC-01828

- (1) Compressor bracket
- (2) Compressor
- (3) V-belt
- (4) Compressor bracket

**Tightening torque: N·m (kgf·m, ft·lb)**

**T1: 26.5 (2.70, 19.5)**

**T2: 36 (3.67, 26.6)**

# General Description

HVAC SYSTEM (HEATER, VENTILATOR AND A/C)

## 6. HEATER DUCT

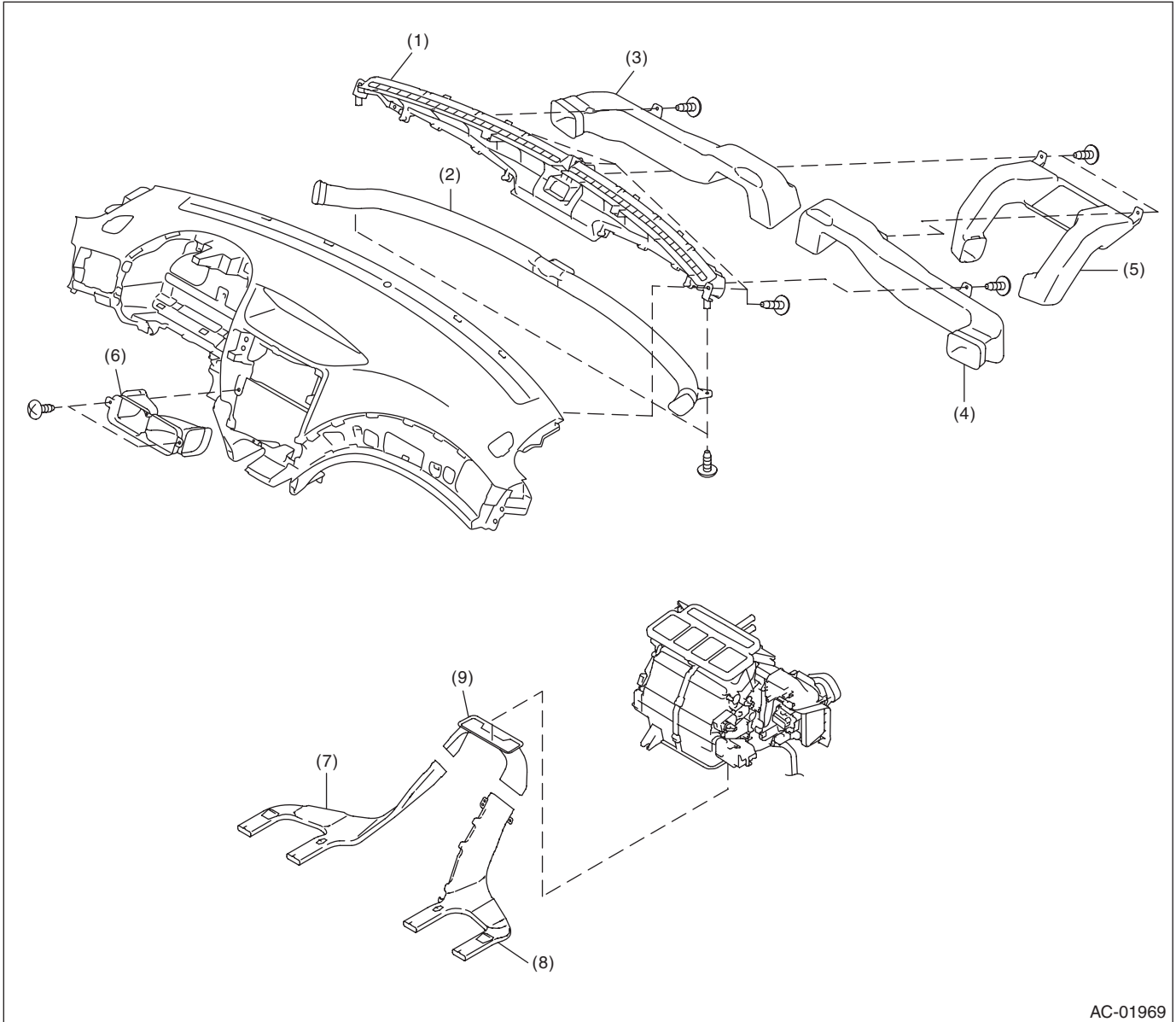

AC-01969

- (1) Front defroster nozzle
- (2) Side defroster duct
- (3) Side vent duct (LH)

- (4) Side vent duct (RH)
- (5) Center vent duct
- (6) Center vent duct front

- (7) Rear heater duct (LH)
- (8) Rear heater duct (RH)
- (9) Rear heater duct center



# General Description

## HVAC SYSTEM (HEATER, VENTILATOR AND A/C)

### C: CAUTION

- Before disassembling or reassembling parts, always disconnect the battery ground cable from battery. When replacing the audio, control module and other parts provided with memory functions, record the memory contents before disconnecting the battery ground cable. Otherwise, the memory is cleared.
- Reassemble the parts in the reverse order of disassembly procedure unless otherwise indicated.
- Adjust parts to the given specifications.
- Connect the connectors securely during reassembly.
- After reassembly, make sure that the functional parts operate normally.

### 1. HFC-134A A/C SYSTEM

- The cooling system components for the HFC-134a system such as the refrigerant and compressor oil are different from the conventional CFC-12 system components and they are incompatible with each other.
- Vehicles with the HFC-134a system can be identified by the label (A) attached to the vehicle. Before maintenance, check which A/C system is installed to the vehicle.

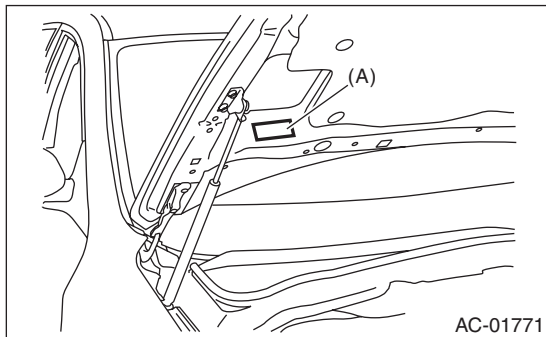

### 2. COMPRESSOR OIL

- HFC-134a compressor oil has no compatibility with that of CFC-12 system.
- Use only the manufacturer-authorized compressor oil for the HFC-134a system; only use DH-PR (ZXL200PG).
- Do not mix multiple compressor oils.

If CFC-12 compressor oil is used in the HFC-134a A/C system, the compressor may become stuck due to poor lubrication, or the refrigerant may leak due to swelling of rubber parts.

On the other hand, if HFC-134a compressor oil is used in a CFC-12 A/C system, the durability of the A/C system will be lowered.

- HFC-134a compressor oil is very hygroscopic. When replacing or installing/removing A/C parts, immediately isolate the oil from atmosphere using a plug or tape. In order to avoid moisture, store the oil in a container with its cap tightly closed.

### 3. REFRIGERANT

- CFC-12 refrigerant cannot be used in a HFC-134a A/C system. HFC-134a refrigerant, also cannot be used in a CFC-12 A/C system.
- If an incorrect or no refrigerant is used, it will result in poor lubrication and the compressor itself may be damaged.

### 4. HANDLING OF REFRIGERANT

- The refrigerant boils at approx.  $-30^{\circ}\text{C}$  ( $-22^{\circ}\text{F}$ ). When handling it, be sure to wear protective goggles and protective gloves. Direct contact of the refrigerant with skin may cause frostbite. If the refrigerant gets into your eye, avoid rubbing your eyes with your hands. Wash your eye with plenty of water, and receive medical treatment from an eye doctor.
- Do not heat a service can. If a service can is directly heated, or put into boiling water, the inside pressure will become extremely high. This may cause the can to explode. If a service can must be warmed up, use warm water of  $40^{\circ}\text{C}$  ( $104^{\circ}\text{F}$ ) or less.
- Do not drop or impact a service can. (Observe the precautions and operation procedure described on the refrigerant can.)
- When the engine is running, do not open the high-pressure valve of manifold gauge. The high-pressure gas will back-flow resulting in an explosion of the can.
- Provide good ventilation and do not work in a closed area.

# General Description

HVAC SYSTEM (HEATER, VENTILATOR AND A/C)

- In order to prevent global warming, avoid releasing HFC-134a into the atmosphere. Using a refrigerant recovery system, discharge and recycle the gas.

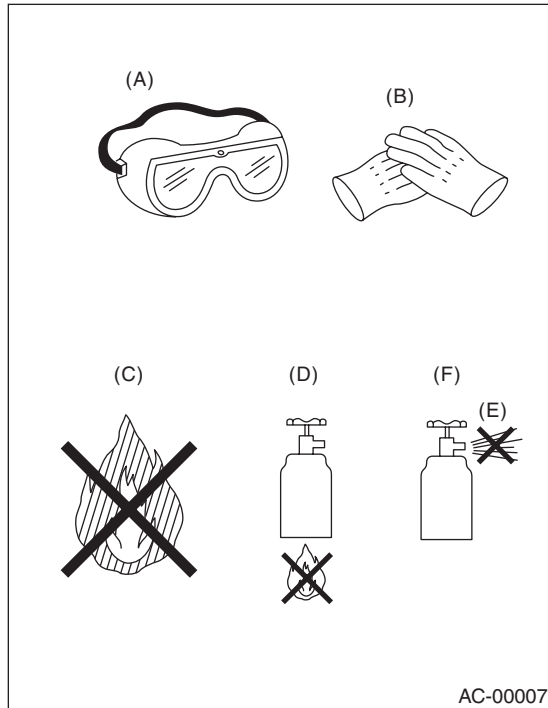

- (A) Goggles
- (B) Gloves
- (C) Avoid open flame
- (D) No direct heat on container
- (E) Do not discharge
- (F) Loosen

## 5. O-RING CONNECTIONS

- Always use a new O-ring.
- In order to keep the O-rings free of lint which will cause a refrigerant gas leak, perform work without using gloves or waste cloths.
- Apply compressor oil to O-rings to avoid sticking, before installation.
- Use a torque wrench to tighten the O-ring fittings. Over-tightening will result in damage of the O-ring and deformation of the pipe end.
- If the work is interrupted before completing pipe connections, recap the pipes, components and fittings with a plug or tape to prevent foreign matter from entering.

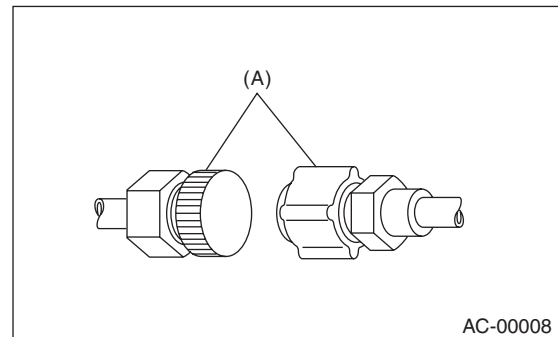

(A) Seal

- Visually check the surfaces and mating surfaces of O-rings, threads and connecting points. If a failure is found, replace the applicable parts.
- Install the O-rings straight against the pipe groove.

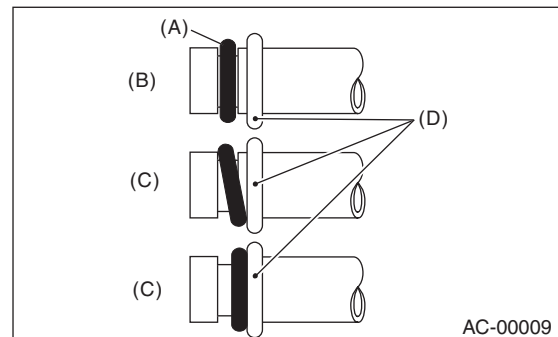

- (A) O-ring
- (B) OK
- (C) NG
- (D) Groove

## General Description

### HVAC SYSTEM (HEATER, VENTILATOR AND A/C)

---

- Use compressor oil specified in the service manual to lubricate the O-rings.

Apply oil to the top and sides of O-rings before installation.

Apply compressor oil to the pipe grooves.

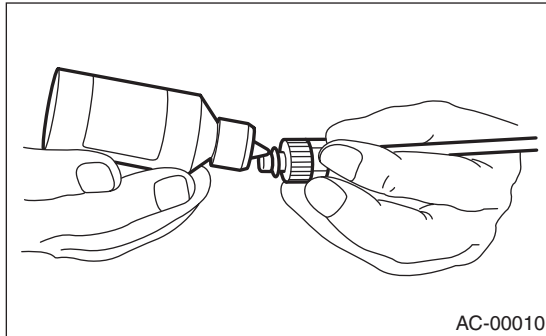

- After tightening, use a clean cloth to remove excess compressor oil from the connections and any oil which may have run on the vehicle body or other parts.
- If any leakage is suspected after tightening, do not tighten the connections further, but disconnect the connections, remove the O-rings, and check the O-rings, threads, and connections.

# General Description

HVAC SYSTEM (HEATER, VENTILATOR AND A/C)

## D: PREPARATION TOOL

### CAUTION:

When working on vehicles with a HFC-134a system, only use HFC-134a specified tools and parts. Do not mix CFC-12 tools and parts. If HFC-134a and CFC-12 refrigerant or compressor oil is mixed, it will result in poor lubrication and the compressor itself may be damaged.

In order to prevent the mixture of HFC-134a and CFC-12 parts and liquid, the type of tool and screw, and the replacement valves used are different. The gas leak detectors for the HFC-134a and CFC-12 systems must also not be interchanged.

	HFC-134a	CFC-12
Tool & screw type	Millimeter size	Inch size
Valve type	Quick joint type	Screw-in type

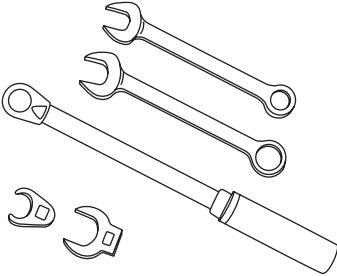
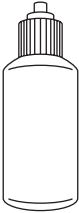
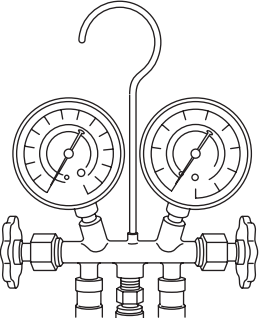
Illustration	Tools and Equipment
 <p>AC-00213</p>	<p><b>Wrench</b></p> <p>Various <b>WRENCHES</b> will be required to service any A/C system. 7 — 40 N·m (0.7 to 4.1 kgf-m, 5 to 30 ft-lb) torque wrench and various crow-foot wrenches will be needed. Open end or flare nut wrenches will be needed to hold the tube and hose fittings.</p>
 <p>AC-00012</p>	<p><b>Applicator bottle</b></p> <p>A small <b>APPLICATOR BOTTLE</b> is recommended to apply compressor oil to the various parts. It can be available at a hardware store.</p>
 <p>AC-00013</p>	<p><b>Manifold gauge set</b></p> <p>A <b>MANIFOLD GAUGE SET</b> (with hoses) is available at either a refrigerant supplier or an automotive equipment supplier.</p>

## General Description

### HVAC SYSTEM (HEATER, VENTILATOR AND A/C)

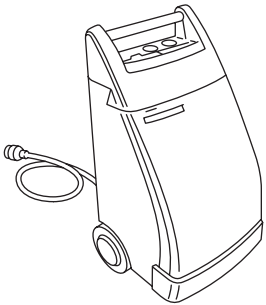
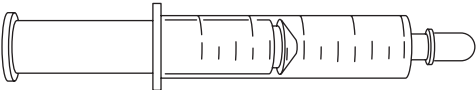
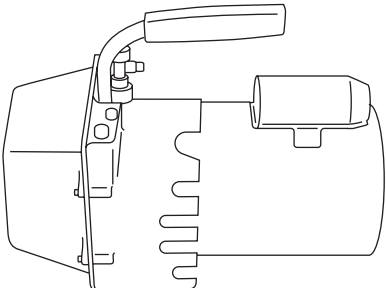
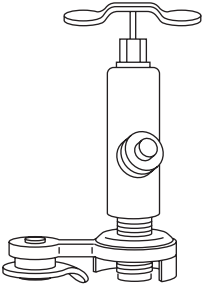
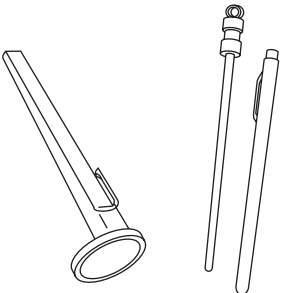
Illustration	Tools and Equipment
 <p style="text-align: right;">AC-00014</p>	<p>Refrigerant recovery system</p> <p>A <b>REFRIGERANT RECOVERY SYSTEM</b> is used for the recovery and recycling of A/C system refrigerant after contaminants and moisture have been removed from the refrigerant.</p>
 <p style="text-align: right;">AC-00015</p>	<p>Syringe</p> <p>A graduated plastic <b>SYRINGE</b> will be needed to add oil into the system again. A syringe can be available at a pharmacy or drug store.</p>
 <p style="text-align: right;">AC-00016</p>	<p>Vacuum pump</p> <p>A <b>VACUUM PUMP</b> is necessary (for a good working condition), and may be available at either a refrigerant supplier or an automotive equipment supplier.</p>
 <p style="text-align: right;">AC-00017</p>	<p>Can tap</p> <p>A <b>CAN TAP</b> for the 397 g (14 oz) can is available at an automotive equipment supplier.</p>
 <p style="text-align: right;">AC-00018</p>	<p>Thermometer</p> <p>A Pocket <b>THERMOMETER</b> is available at either a industrial hardware store or a refrigerant supplier.</p>

# General Description

HVAC SYSTEM (HEATER, VENTILATOR AND A/C)

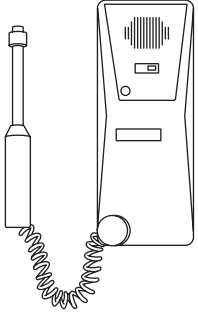
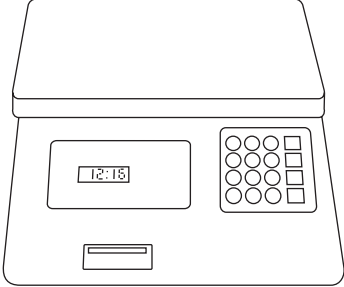
Illustration	Tools and Equipment
 <p>AC-00019</p>	<p>Electronic leak detector</p> <p>An <b>ELECTRONIC LEAK DETECTOR</b> can be available at either a specialty tool supplier or an A/C equipment supplier.</p>
 <p>AC-00020</p>	<p>Weight scale</p> <p>A <b>WEIGHT SCALE</b> such as an electronic charging scale or a bathroom scale with digital display will be needed, if a 13.6 kg (30 lb) refrigerant container is used.</p>

# Air Conditioning System

HVAC SYSTEM (HEATER, VENTILATOR AND A/C)

---

## 2. Air Conditioning System

### A: WIRING DIAGRAM

Refer to "Air Conditioning System" in the wiring diagram. <Ref. to WI-74, WIRING DIAGRAM, Air Conditioning System.>

### B: INSPECTION

Refer to "Basic Diagnostic Procedure" for "HVAC SYSTEM (AUTO A/C) (DIAGNOSTICS)" section. <Ref. to AC(diag)-2, Basic Diagnostic Procedure.>

### C: NOTE

For procedure of each component in the air conditioning system, refer to the respective section.

- Blower motor unit assembly: <Ref. to AC-26, Blower Motor Unit Assembly.>
- Blower motor: <Ref. to AC-27, Blower Motor.>
- Power transistor (auto A/C model): <Ref. to AC-28, Power Transistor (Auto A/C Model).>
- Blower resistor (manual A/C model): <Ref. to AC-29, Blower Resistor (Manual A/C Model).>
- Heater core: <Ref. to AC-30, Heater Core.>
- Control unit (manual A/C model): <Ref. to AC-31, Control Unit (Manual A/C Model).>
- Control unit (auto A/C model): <Ref. to AC-32, Control Unit (Auto A/C Model).>
- Compressor: <Ref. to AC-33, Compressor.>
- Condenser: <Ref. to AC-34, Condenser.>
- Heater and cooling unit: <Ref. to AC-35, Heater and Cooling Unit.>
- Evaporator: <Ref. to AC-36, Evaporator.>
- Hose & pipe: <Ref. to AC-40, Hose and Pipe.>
- Ambient sensor (auto A/C model): <Ref. to AC-43, Ambient Sensor (Auto A/C Model).>
- Sunload sensor (auto A/C model): <Ref. to AC-45, Sunload Sensor (Auto A/C Model).>
- In-vehicle sensor (auto A/C model): <Ref. to AC-46, In-Vehicle Sensor (Auto A/C Model).>

# Refrigerant Pressure with Manifold Gauge Set

HVAC SYSTEM (HEATER, VENTILATOR AND A/C)

## 3. Refrigerant Pressure with Manifold Gauge Set

### A: PROCEDURE

- 1) Place the vehicle in the shade and windless condition.
- 2) Open the front hood.
- 3) Connect the manifold gauge set.
- 4) Open the front windows and close all doors.
- 5) Increase the engine to 1,500 rpm.
- 6) Turn the A/C switch to ON.
- 7) Turn the temperature control dial to MAX COOL position.
- 8) Turn the FRESH/RECIRC switch to RECIRC position.
- 9) Turn the fan speed control dial to HI (MAX) position.
- 10) Read the gauge.

### Specification:

**Low pressure: 127 — 196 kPa (1.3 — 2.0 kg/cm<sup>2</sup>, 18 — 28 psi)**

**High pressure: 1,471 — 1,667 kPa (15 — 17 kg/cm<sup>2</sup>, 213 — 242 psi)**

**Ambient temperature: 30 — 35°C (86 — 95°F)**

### B: INSPECTION

Symptoms	Probable cause	Repair order
High-pressure side is unusually high.	<ul style="list-style-type: none"><li>• Defective condenser fan motor</li><li>• Clogged condenser fin</li><li>• Too much refrigerant</li><li>• Air inside the system</li><li>• Defective receiver dryer (condenser)</li></ul>	<ul style="list-style-type: none"><li>• Replace the fan motor.</li><li>• Clean the condenser fin.</li><li>• Discharge refrigerant.</li><li>• Replace the condenser.</li><li>• After evacuating again, charge an appropriate amount of refrigerant.</li></ul>
High-pressure side is unusually low.	<ul style="list-style-type: none"><li>• Defective compressor</li><li>• Not enough refrigerant</li><li>• Clogged expansion valve</li><li>• Expansion valve frozen temporarily by moisture.</li></ul>	<ul style="list-style-type: none"><li>• Replace the compressor.</li><li>• Check for leaks.</li><li>• Replace the expansion valve.</li><li>• Fully evacuate the expansion valve.</li></ul>
Low-pressure side is unusually high.	<ul style="list-style-type: none"><li>• Defective compressor</li><li>• Defective expansion valve</li><li>• Too much refrigerant</li></ul>	<ul style="list-style-type: none"><li>• Replace the compressor.</li><li>• Replace the expansion valve.</li><li>• Discharge refrigerant.</li></ul>
Low-pressure side is unusually low.	<ul style="list-style-type: none"><li>• Not enough refrigerant</li><li>• Clogged expansion valve</li><li>• Expansion valve frozen temporarily by moisture.</li><li>• Saturated receiver dryer (condenser)</li></ul>	<ul style="list-style-type: none"><li>• Check for leaks.</li><li>• Replace the expansion valve.</li><li>• Replace the condenser.</li></ul>



# Refrigerant Recovery Procedure

HVAC SYSTEM (HEATER, VENTILATOR AND A/C)

## 4. Refrigerant Recovery Procedure

### A: PROCEDURE

#### CAUTION:

- During operation, be sure to wear protective goggles and protective gloves.
- Connect the refrigerant recovery system with the manifold gauge set set to discharge the refrigerant from the A/C system and recycle the gas.
- When recycling the discharged refrigerant, keep service cans on hand. Because the recovery rate with the recovery system is approx. 90%, service cans are necessary to charge the refrigerant.
- Follow the detailed operation procedure described in the operation manual attached to the refrigerant recovery system.

- 1) Perform compressor oil return operation. <Ref. to AC-25, PROCEDURE, Compressor Oil.>
- 2) Stop the engine.
- 3) Make sure the valves on low/high pressure sides of manifold gauge set are fully closed.

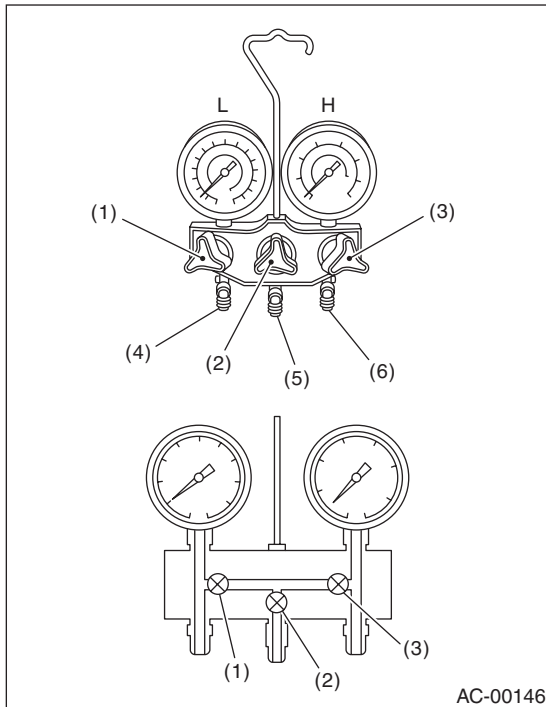

- L: Low pressure gauge
- H: High pressure gauge
- (1) Low pressure valve
- (2) Vacuum pump valve
- (3) High pressure valve
- (4) For low pressure
- (5) For vacuum pump
- (6) For high pressure

- 4) Install the low/high pressure hoses to the service ports on the low/high pressure sides of the vehicle respectively.

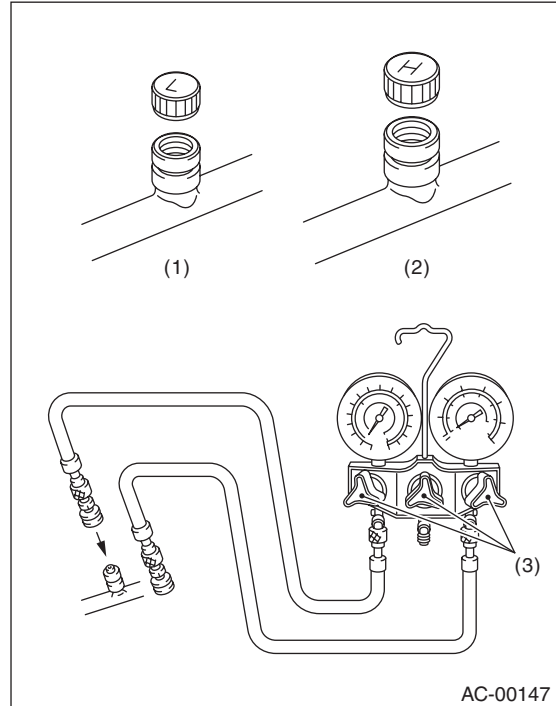

- (1) Low-pressure side service port
- (2) High-pressure side service port
- (3) Close

- 5) Connect the center hose to the refrigerant recovery system.
- 6) Follow the operation manual to activate the refrigerant recovery system.

# Refrigerant Charging Procedure

HVAC SYSTEM (HEATER, VENTILATOR AND A/C)

## 5. Refrigerant Charging Procedure

### A: PROCEDURE

#### CAUTION:

- While working, be sure to wear protective goggles and protective gloves.
- Air in the cycle can cause insufficient air conditioning, and water in the cycle can cause clogging in the cycle (icing) and rust. To remove this air and water content, use a vacuum pump to perform evacuation before filling with refrigerant. By making the inside of the cycle a vacuum, the water content will evaporate even at normal temperatures, and can be removed.

1) Close all valves of the manifold gauge.

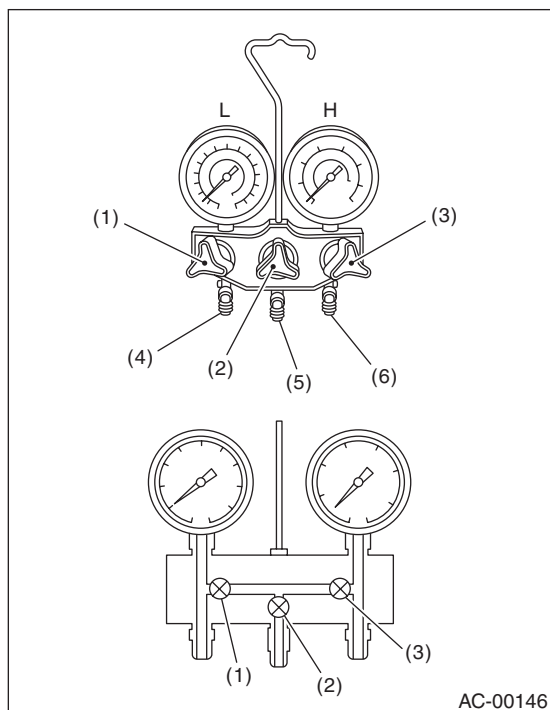

- L: Low pressure gauge
- H: High pressure gauge
- (1) Low pressure valve
- (2) Vacuum pump valve
- (3) High pressure valve
- (4) For low pressure
- (5) For vacuum pump
- (6) For high pressure

2) Attach the low pressure side and high pressure side hoses to the vehicle service port.

#### CAUTION:

Confirm that the connections are secure.

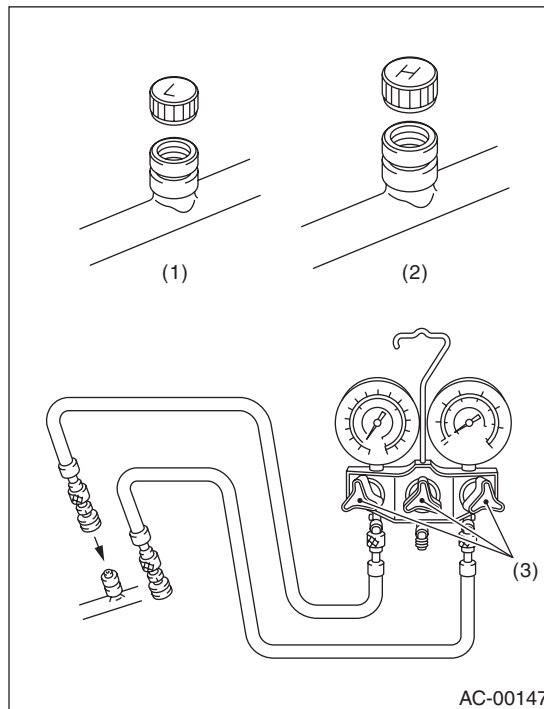

- (1) Low-pressure side service port
- (2) High-pressure side service port
- (3) Close

3) Connect the center manifold hose of the manifold gauge to the vacuum pump.

4) Operate the vacuum pump and open the low pressure and high pressure side valves. Next, open the center manifold hose valve, and begin evacuation.

#### CAUTION:

Make sure to perform evacuation using a vacuum pump.

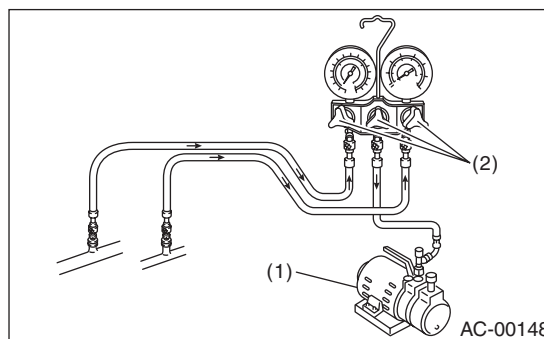

- (1) Vacuum pump
- (2) Open

# Refrigerant Charging Procedure

## HVAC SYSTEM (HEATER, VENTILATOR AND A/C)

5) Perform evacuation for 5 minutes or more, and when the low pressure gauge needle reaches  $-100.0$  kPa ( $-750$  mmHg,  $-29.5$  inHg) or higher, close the center manifold hose valve, and stop the vacuum pump.

6) Leave alone for 5 to 10 minutes after closing the low pressure side and high pressure side valves, and check whether there is any change in the low pressure gauge needle indication. If the needle position changes, this indicates a leak. Check the pipe and hose connections, and repair the location with the problem. In this case, repeat again from step 1).

7) If there is no leakage, continue evacuation for additional 20 to 30 minutes.

8) Close all valves and stop the vacuum pump.

9) Follow the can tap operation manual, install to the refrigerant can.

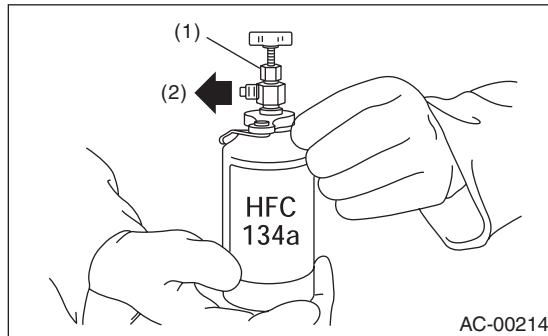

- (1) Tap valve
- (2) To the center manifold hose

10) Disconnect the center manifold hose from the vacuum pump, and connect the hose to the tap valve.

11) When a 13.6 kg (30 lb) refrigerant container is used, measure the amount of refrigerant with a refrigerant charging scale, and connect with the center manifold hose.

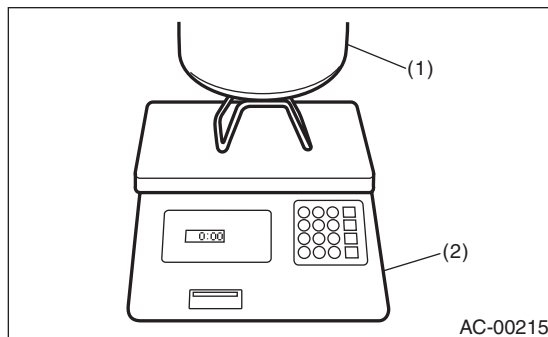

- (1) Refrigerant container (HFC-134a)
- (2) Weight scale

12) Open the valve on the HFC-134a source.

13) Loosen the center manifold hose connection on the manifold gauge for a few seconds (if there is a purge valve on the manifold gauge, push this instead) to allow the air in the center manifold hose to be bled by the refrigerant pressure.

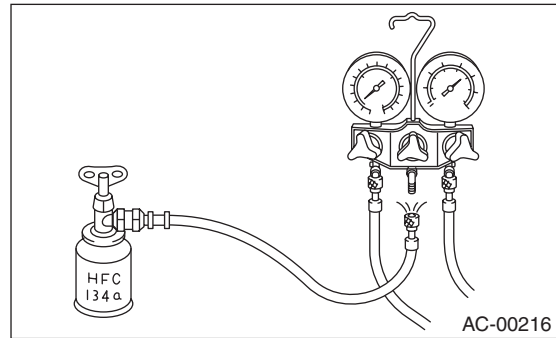

14) Open the high pressure side and low pressure side valves of the manifold gauge to fill with refrigerant.

### CAUTION:

**When filling with the engine running, do not open the high pressure side valve. Always fill from the low pressure side.**

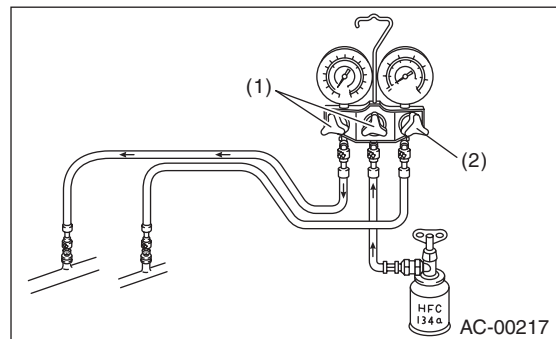

- (1) Open (low pressure)
- (2) Open (high pressure)

15) When the gauge needle reaches approximately 200 kPa (1,500 mmHg, 59.1 inHg), close all valves.

16) Using a leak tester, check for refrigerant leaks in the system.

17) After checking that there are no refrigerant leaks, fill with refrigerant up to the specified amount.

18) If the HFC-134a supply container becomes empty, close all valves, and close the can tap valve to replace the empty container. After replacing with a new HFC-134a supply container, perform air purge, and resume the filling operation.

19) If the refrigerant filling efficiency drops, close all valves.

20) Check that both the low pressure and high pressure valves are closed. Start the engine with the A/C switch OFF.

# Refrigerant Charging Procedure

HVAC SYSTEM (HEATER, VENTILATOR AND A/C)

---

21) To prevent damage to the compressor, push the A/C switch ON-OFF quickly a few times.

22) Set up the vehicle to the following status:

**CAUTION:**

**When filling with the engine running, do not open the high pressure side valve.**

**Always fill from the low pressure side valve.**

- A/C switch: ON
- Engine running at 1,500 rpm
- Fan speed control dial: HI
- Temperature control dial: MAX COOL
- FRESH/RECIRC switch: RECIRC
- Window: open

23) Open the low pressure side valve and fill with refrigerant up to the specified amount.

24) After filling with refrigerant, close all valves and disconnect the hose from the service port.

25) Attach the cap to the service port.

# Refrigerant Leak Check

HVAC SYSTEM (HEATER, VENTILATOR AND A/C)

## 6. Refrigerant Leak Check

### A: INSPECTION

1) Operate the A/C system for approx. 10 minutes, and check that the high-pressure side shows at least 690 kPa (7.03 kgf/cm<sup>2</sup>, 100 psi). Then stop the engine to start the leak test.

2) Starting from the connection between high-pressure pipe and evaporator, check the system for leaks along the high-pressure side through the compressor. The following items must be checked thoroughly.

- Check the joint and seam between pressure switch (triple pressure switch) and high-pressure pipe.
- Check the connections between condenser and pipes, and welded joints on the condenser.

#### NOTE:

The leak tester may detect the oil on the condenser fins as a leak.

- Check the joint between compressor and hoses.
- Check the machined area of the compressor and other joints on the compressor.
- Check the compressor shaft seal at the area near the center of compressor clutch pulley.

#### NOTE:

Some shaft seals will show a slight amount of leakage, about 3 g (0.1 oz) per year. This is not a problem.

3) Starting from the connection between low-pressure pipe and evaporator, check the system for leakage along the low-pressure side through the compressor. The following items must be checked thoroughly.

- Connection between 2 parts
- Connection between pipe and plate

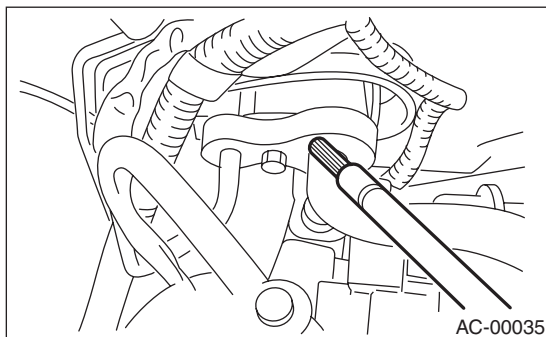

4) Visually check the rubber area of the flexible hose for cracks. Check the entire length of the flexible hose, especially the connection with the metal hose end.

#### CAUTION:

Carefully check the external surface of hoses and pipes at approx. 25 mm (0.98 in) per second.

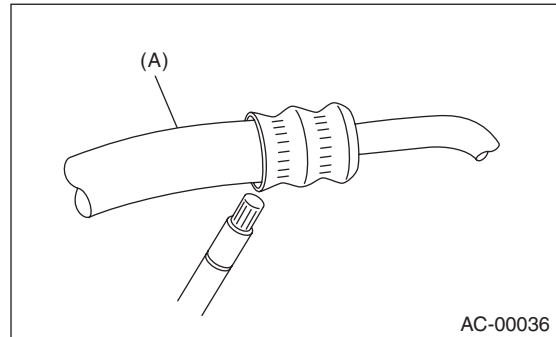

(A) Flexible hose

5) Disconnect the drain hose from the heater case, and check the hose end for at least 10 seconds.

After the test is finished, reconnect the drain hose.

6) Turn the ignition switch to the ON, and run the blower at high speed for approx. 1 minute. Stop the blower to check the ventilation grille on the instrument panel. While moving the tester closer to the grille, run the blower for 1 or 2 seconds, then stop it. Check the grille at that position for at least 10 seconds.

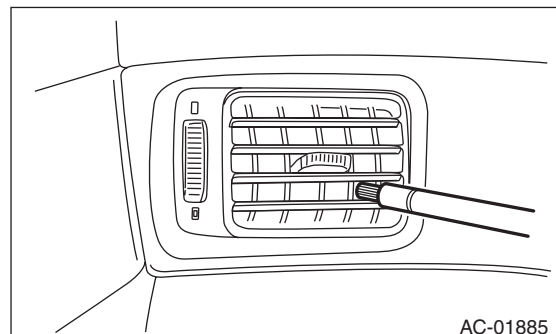

7) Check the valve in the service port.

8) Visually check the rubber seal in the service port cap.

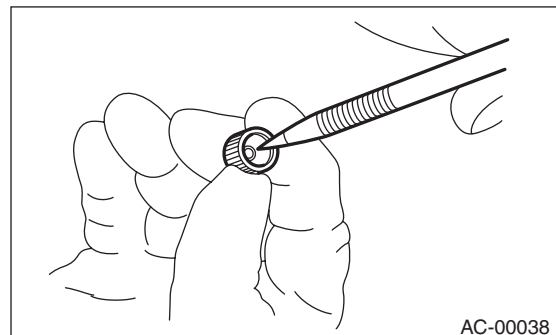

## 7. Compressor Oil

### A: PROCEDURE

**NOTE:**

Before making repairs, perform the oil return operation to return the compressor oil in circulation with the refrigerant to the compressor.

- 1) Increase the engine to 1,500 rpm.
- 2) Turn the A/C switch to ON.
- 3) Turn the temperature control dial to MAX COOL position.
- 4) Turn the FRESH/RECIRC switch to RECIRC position.
- 5) Turn the fan speed control dial to HI (MAX) position.
- 6) Leave in this condition for 10 minutes.

### B: REPLACEMENT

**NOTE:**

- If a component has been replaced, add an appropriate amount of compressor oil (same as the amount of remaining oil in removed component).
- When replacing the compressor, the new compressor will already have the specified amount of oil in it. Adjust the oil amount (so that the amount remains the same as that of the removed compressor) and install the new compressor.
- Since the hygroscopicity of compressor oil is high, perform this series of works quickly.

# Blower Motor Unit Assembly

HVAC SYSTEM (HEATER, VENTILATOR AND A/C)

---

## 8. Blower Motor Unit Assembly

### A: REMOVAL

- 1) Disconnect the ground cable from battery.
- 2) Remove the instrument panel lower. <Ref. to EI-54, INSTRUMENT PANEL LOWER, REMOVAL, Center Console.>
- 3) Remove the engine ECM protect cover.

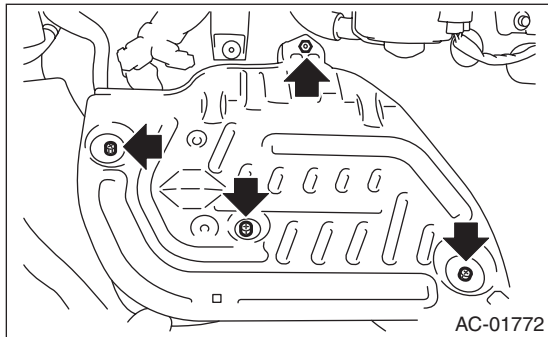

- 4) Disconnect the intake door actuator and blower motor harness connectors.
- 5) Remove the relay holder.
- 6) Remove the bolts and nuts to remove blower motor unit assembly.

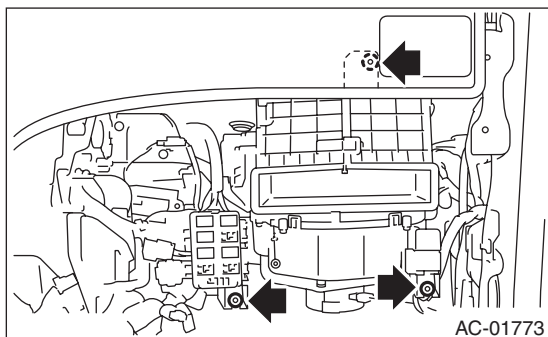

### B: INSTALLATION

Install each part in the reverse order of removal.

#### **Tightening torque:**

**Refer to "COMPONENT" of "General Description". <Ref. to AC-6, BLOWER MOTOR UNIT, COMPONENT, General Description.>**

## 9. Blower Motor

### A: REMOVAL

- 1) Disconnect the ground cable from battery.
- 2) Disconnect the blower motor connector.
- 3) Turn over the floor mat near the blower motor.
- 4) Remove the screws and detach the blower motor.

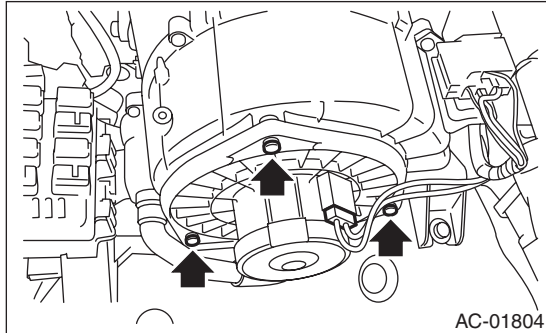

### B: INSTALLATION

Install each part in the reverse order of removal.

### C: INSPECTION

- 1) Disconnect the blower motor connector.
- 2) Connect the battery positive (+) terminal to terminal No. 2 of blower motor connector, and negative (-) terminal to terminal No. 1. Check that the blower motor rotates normally.

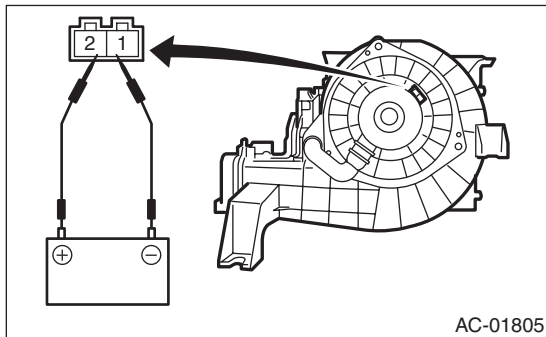

- 3) If the blower motor does not operate normally, replace the blower motor.



## Power Transistor (Auto A/C Model)

HVAC SYSTEM (HEATER, VENTILATOR AND A/C)

---

### 10. Power Transistor (Auto A/C Model)

#### A: REMOVAL

- 1) Remove the instrument panel lower. <Ref. to EI-54, INSTRUMENT PANEL LOWER, REMOVAL, Center Console.>
- 2) Disconnect the power transistor connector.
- 3) Remove the screws and remove the power transistor.

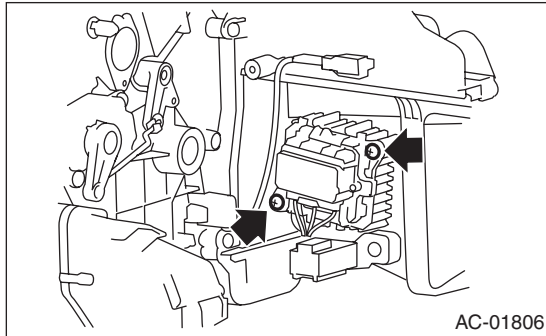

#### B: INSTALLATION

Install each part in the reverse order of removal.

## 11. Blower Resistor (Manual A/C Model)

### A: REMOVAL

- 1) Remove the instrument panel lower. <Ref. to EI-54, INSTRUMENT PANEL LOWER, REMOVAL, Center Console.>
- 2) Disconnect the blower resistor connector.
- 3) Remove the screw and remove the blower resistor.

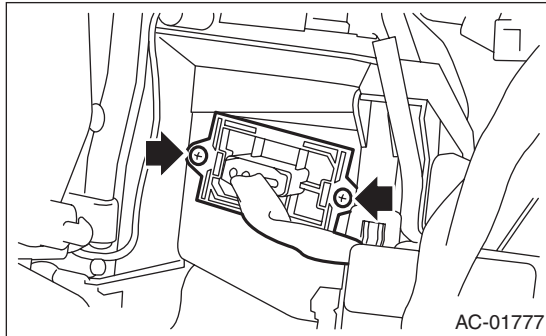

### B: INSTALLATION

Install each part in the reverse order of removal.

### C: INSPECTION

- 1) Disconnect the blower resistor connector.
- 2) Check the resistance between blower resistor terminals.

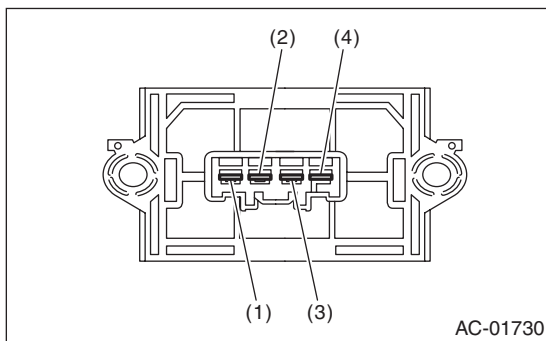

Terminal No.	Specification
4 and 3	Approx. 0.43 $\Omega$
4 and 2	Approx. 1.03 $\Omega$
4 and 1	Approx. 3.0 $\Omega$

- 3) Replace the blower resistor if the inspection result is not within the standard value.

# Heater Core

HVAC SYSTEM (HEATER, VENTILATOR AND A/C)

## 12.Heater Core

### A: REMOVAL

- 1) Remove the heater and cooling unit. <Ref. to AC-35, REMOVAL, Heater and Cooling Unit.>
- 2) Remove the screw and detach the heater pipe cover.

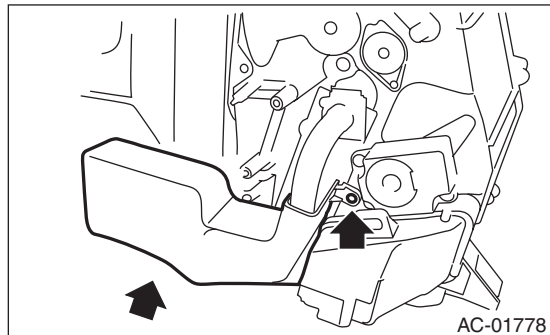

- 3) Remove the screw and detach the clamp.

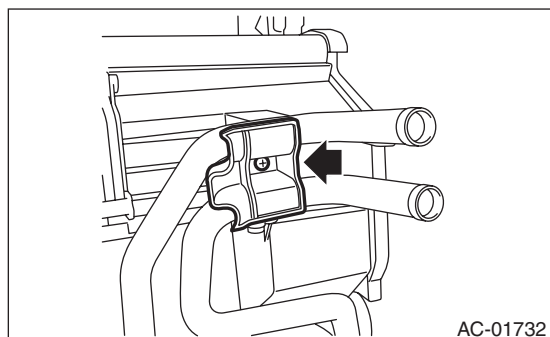

- 4) Remove the pipe clamp and pipe.

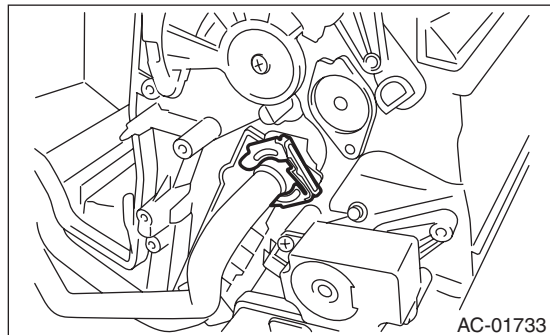

- 5) Remove the heater core cover.

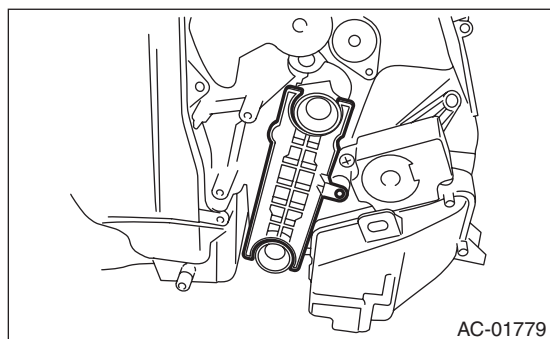

- 6) Remove the heater core.

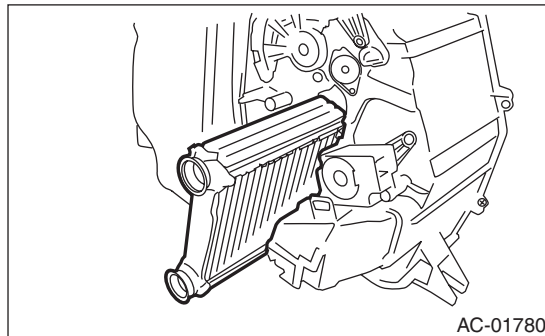

### B: INSTALLATION

#### CAUTION:

Replace O-rings and pipe clamps with new parts and install securely.

- 1) Install each part in the reverse order of removal.
- 2) Fill engine coolant.
  - Other than STI model: <Ref. to CO(w/o STI)-13, FILLING OF ENGINE COOLANT, REPLACEMENT, Engine Coolant.>
  - STI model: <Ref. to CO(STI)-13, FILLING OF ENGINE COOLANT, REPLACEMENT, Engine Coolant.>
- 3) Charge refrigerant. <Ref. to AC-21, PROCEDURE, Refrigerant Charging Procedure.>

## 13. Control Unit (Manual A/C Model)

### A: REMOVAL

- 1) Disconnect the ground cable from battery.
- 2) Remove the ornament panel. <Ref. to EI-52, ORNAMENT PANEL, REMOVAL, Center Console.>
- 3) Remove the control wires from both sides of the heater and cooling unit.

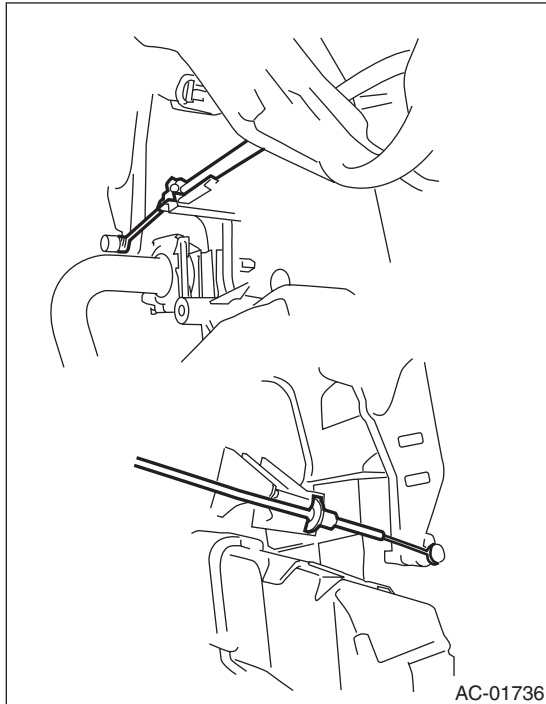

- 4) Remove the screws and claws, and remove the control module from the ornament panel.

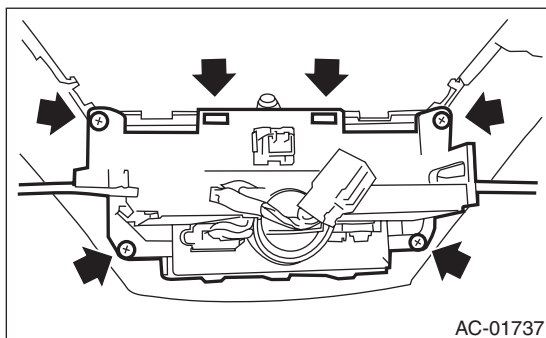

### B: INSTALLATION

#### CAUTION:

Securely assemble the plate at the end of the control wire to the heater case.

Install each part in the reverse order of removal.

#### Tightening torque:

Refer to "COMPONENT" of "General Description". <Ref. to AC-7, CONTROL MODULE, COMPONENT, General Description.>

## Control Unit (Auto A/C Model)

HVAC SYSTEM (HEATER, VENTILATOR AND A/C)

---

### 14. Control Unit (Auto A/C Model)

#### A: REMOVAL

- 1) Disconnect the ground cable from battery.
- 2) Remove the ornament panel. <Ref. to EI-52, ORNAMENT PANEL, REMOVAL, Center Console.>
- 3) Remove the screws and claws, and remove the control module from the ornament panel.

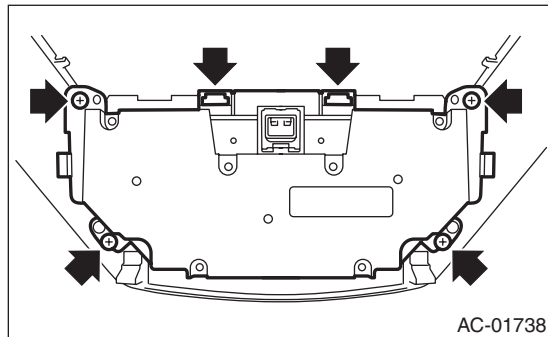

#### B: INSTALLATION

Install each part in the reverse order of removal.

##### ***Tightening torque:***

***Refer to "COMPONENT" of "General Description". <Ref. to AC-7, CONTROL MODULE, COMPONENT, General Description.>***

# Compressor

HVAC SYSTEM (HEATER, VENTILATOR AND A/C)

## 15. Compressor

### A: REMOVAL

- 1) Perform compressor oil return operation. <Ref. to AC-25, PROCEDURE, Compressor Oil.>
- 2) Turn the A/C switch to OFF and stop the engine.
- 3) Using the refrigerant recovery system, discharge refrigerant. <Ref. to AC-20, PROCEDURE, Refrigerant Recovery Procedure.>
- 4) Disconnect the ground cable from battery.
- 5) Remove the V-belts.
  - Other than STI model: <Ref. to ME(w/o STI)-39, REMOVAL, V-belt.>
  - STI model: <Ref. to ME(STI)-40, REMOVAL, V-belt.>
- 6) Remove the generator. <Ref. to SC(STI)-21, REMOVAL, Generator.>
- 7) Remove the bolt and remove the low-pressure hose and high-pressure hose.

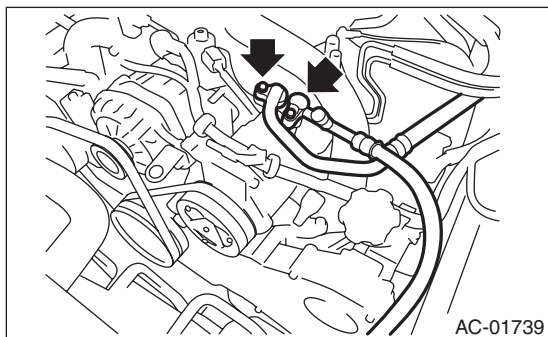

- 8) Disconnect the compressor connector.
- 9) Remove the bolts and remove the compressor bracket.

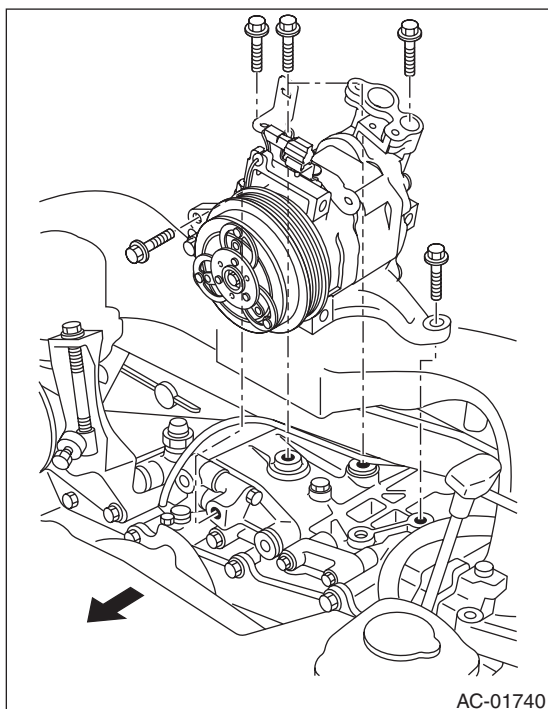

### NOTE:

Since the compressor cannot be removed by itself, remove with the compressor bracket as a unit.

- 10) Remove the bolts, then remove the bracket from the compressor.

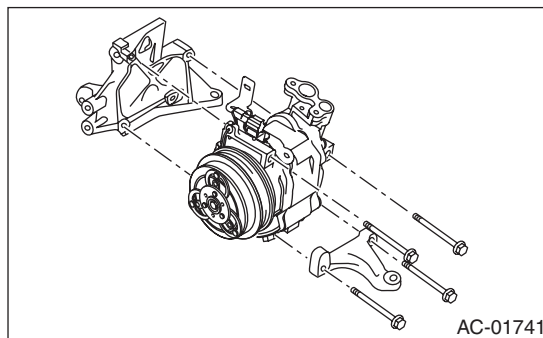

### B: INSTALLATION

- 1) Install each part in the reverse order of removal.
- 2) Replace the O-rings on low/high pressure hoses with new parts, and apply compressor oil.
- 3) After replacing the compressor, adjust the amount of the compressor oil. <Ref. to AC-25, PROCEDURE, Compressor Oil.>
- 4) Charge refrigerant. <Ref. to AC-21, PROCEDURE, Refrigerant Charging Procedure.>

### Tightening torque:

Refer to "COMPONENT" of "General Description".

- **Air conditioning unit:** <Ref. to AC-9, AIR CONDITIONING UNIT, COMPONENT, General Description.>
- **Compressor:** <Ref. to AC-10, COMPRESSOR, COMPONENT, General Description.>

### C: INSPECTION

#### 1. MAGNETIC CLUTCH CLEARANCE

- 1) Check the clearance of entire circumference around the drive plate and pulley.

#### Specification:

**0.3 — 0.6 mm (0.0118 — 0.0236 in)**

- 2) Replace the compressor if the inspection result is not within the standard value.

#### 2. MAGNETIC CLUTCH OPERATION

- 1) Disconnect the compressor connector.
- 2) Connect the battery positive (+) terminal to the terminal of the compressor connector and check the magnet clutch engagement.
- 3) If the magnet clutch does not operate normally, replace the compressor.

# Condenser

HVAC SYSTEM (HEATER, VENTILATOR AND A/C)

## 16. Condenser

### A: REMOVAL

- 1) Using the refrigerant recovery system, discharge refrigerant. <Ref. to AC-20, PROCEDURE, Refrigerant Recovery Procedure.>
- 2) Disconnect the ground cable from battery.
- 3) Disconnect the high pressure hose and pipe from the condenser.

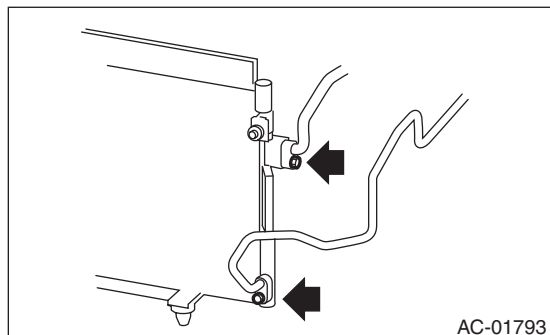

- 4) Remove the bolts and remove the radiator upper bracket.

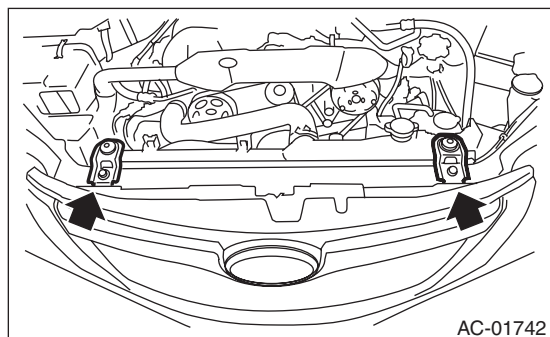

- 5) Remove the front bumper face. <Ref. to EI-31, FRONT BUMPER FACE, REMOVAL, Front Bumper.>
- 6) Remove the bolts, and lift the condenser to pull it out through space between the radiator and the radiator panel.

#### CAUTION:

- Be careful not to damage the condenser fins. If a damaged fin is found, repair it using a thin screwdriver.

- If the condenser is replaced, add an appropriate amount of compressor oil to the compressor. <Ref. to AC-25, REPLACEMENT, Compressor Oil.>

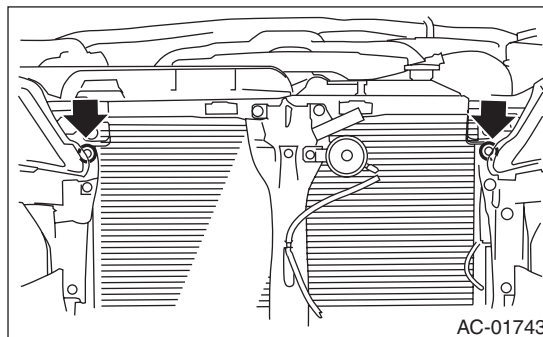

### B: INSTALLATION

#### CAUTION:

- Replace the O-rings on hoses or pipes with new parts, and then apply compressor oil.
- Confirm that lower guide (A) of condenser fits into holes on radiator panel.

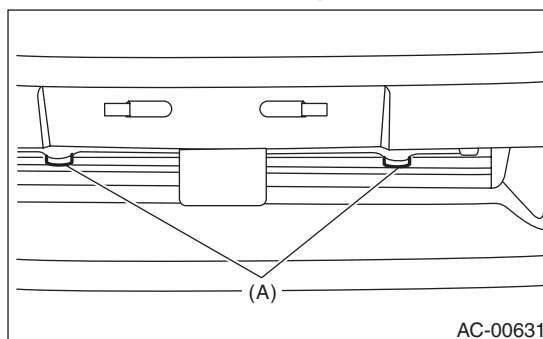

- 1) Install each part in the reverse order of removal.
- 2) Charge refrigerant. <Ref. to AC-21, PROCEDURE, Refrigerant Charging Procedure.>

#### Tightening torque:

Refer to "COMPONENT" of "General Description".

- Air conditioning unit: <Ref. to AC-9, AIR CONDITIONING UNIT, COMPONENT, General Description.>
  - Radiator & radiator fan: <Ref. to CO(STI)-4, RADIATOR AND RADIATOR FAN, COMPONENT, General Description.>
- 3) Adjust the fog light beam. (Model with fog light) <Ref. to LI-21, FOG LIGHT AIMING, ADJUSTMENT, Front Fog Light Assembly.>

### C: INSPECTION

- 1) Check to see that the condenser fins are not clogged with debris or insects. Blow with compressed air or flush fins with water as needed.
- 2) If any oil leak is found from the condenser, replace the condenser with a new part.



# Heater and Cooling Unit

HVAC SYSTEM (HEATER, VENTILATOR AND A/C)

## 17.Heater and Cooling Unit

### A: REMOVAL

- 1) Disconnect the ground cable from battery.
- 2) Using the refrigerant recovery system, discharge refrigerant. <Ref. to AC-20, PROCEDURE, Refrigerant Recovery Procedure.>
- 3) Drain coolant from the radiator.
  - Other than STI model: <Ref. to CO(w/o STI)-13, DRAINING OF ENGINE COOLANT, REPLACEMENT, Engine Coolant.>
  - STI model: <Ref. to CO(STI)-13, DRAINING OF ENGINE COOLANT, REPLACEMENT, Engine Coolant.>
- 4) Remove the bolts securing expansion valve and pipe in engine compartment. Release the heater hose clamps in engine compartment to remove the hoses.

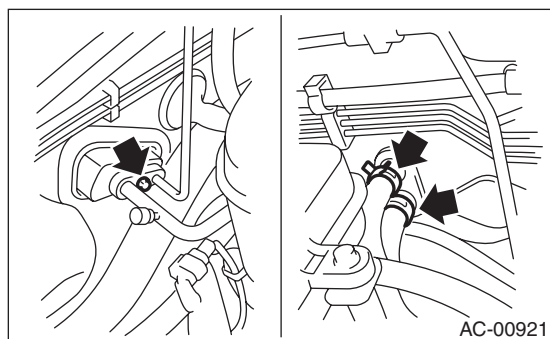

- 5) Remove the instrument panel. <Ref. to EI-55, REMOVAL, Instrument Panel Assembly.>
- 6) Remove the blower motor unit assembly. <Ref. to AC-26, REMOVAL, Blower Motor Unit Assembly.>
- 7) Disconnect the harness connectors of the actuator, thermo sensor and power transistor or blower resistor.
- 8) Remove the bolt and nuts and remove the heater and cooling unit.

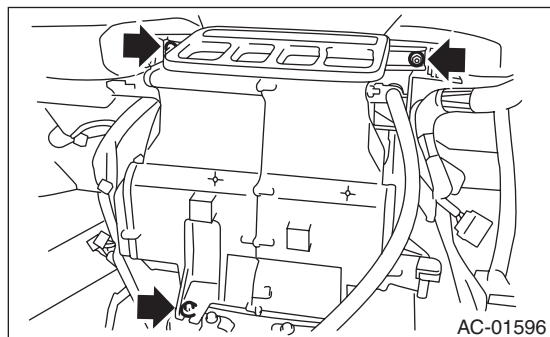

### B: INSTALLATION

- 1) Install each part in the reverse order of removal.
- 2) Fill engine coolant.
  - Other than STI model: <Ref. to CO(w/o STI)-13, FILLING OF ENGINE COOLANT, REPLACEMENT, Engine Coolant.>
  - STI model: <Ref. to CO(STI)-13, FILLING OF ENGINE COOLANT, REPLACEMENT, Engine Coolant.>
- 3) Charge refrigerant. <Ref. to AC-21, PROCEDURE, Refrigerant Charging Procedure.>

#### Tightening torque:

Refer to “**COMPONENT**” of “**General Description**”.

- **Heater cooling unit:** <Ref. to AC-4, HEATER COOLING UNIT, COMPONENT, General Description.>
- **Blower motor unit:** <Ref. to AC-6, BLOWER MOTOR UNIT, COMPONENT, General Description.>



# Evaporator

HVAC SYSTEM (HEATER, VENTILATOR AND A/C)

---

## 18. Evaporator

### A: REMOVAL

- 1) Disconnect the ground cable from battery.
- 2) Using the refrigerant recovery system, discharge refrigerant. <Ref. to AC-20, PROCEDURE, Refrigerant Recovery Procedure.>
- 3) Remove the bolt and detach the pipe from the expansion valve.

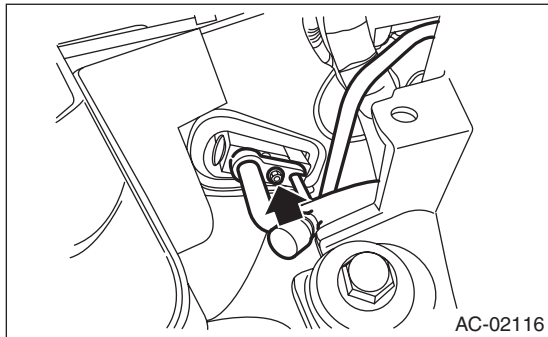

- 4) Remove the instrument panel lower. <Ref. to EI-54, INSTRUMENT PANEL LOWER, REMOVAL, Center Console.>
- 5) Remove the blower motor unit. <Ref. to AC-26, REMOVAL, Blower Motor Unit Assembly.>
- 6) Remove the screw and remove the evaporator pipe cover.

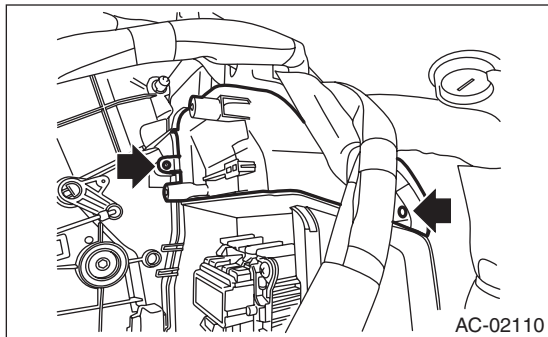

- 7) Remove the evaporator pipe mounting bolt, and evaporator cover mounting screw and clip.

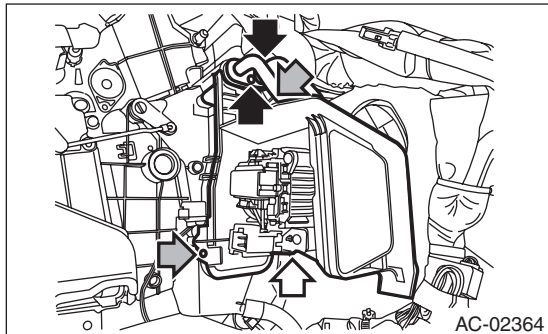

# Evaporator

HVAC SYSTEM (HEATER, VENTILATOR AND A/C)

8) Remove the evaporator cover and evaporator pipe.

**CAUTION:**

Since the evaporator cover and the evaporator pipe cannot be removed by itself, remove them as a unit.

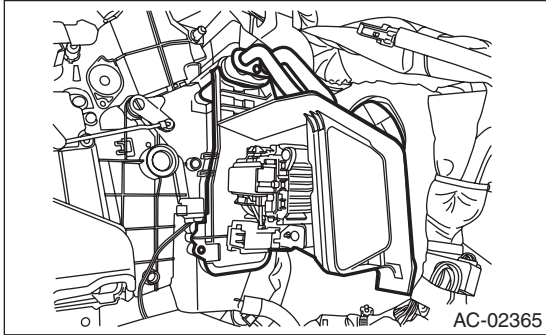

(1) Disengage the evaporator and the pipe.

(2) Remove the evaporator pipe with the evaporator cover.

9) Remove the evaporator.

**CAUTION:**

If the evaporator is replaced, add an appropriate amount of compressor oil to evaporator. <Ref. to AC-25, REPLACEMENT, Compressor Oil.>

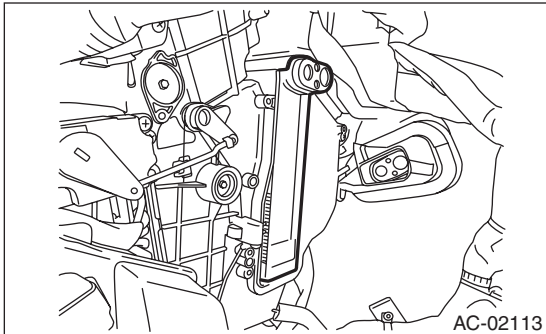

10) Remove the evaporator sensor from the evaporator.

# Evaporator

HVAC SYSTEM (HEATER, VENTILATOR AND A/C)

## B: INSTALLATION

### CAUTION:

- Make sure that the water seal packing on the cover attachment area is securely attached.
- Install the sensor in the location shown in the figures below.

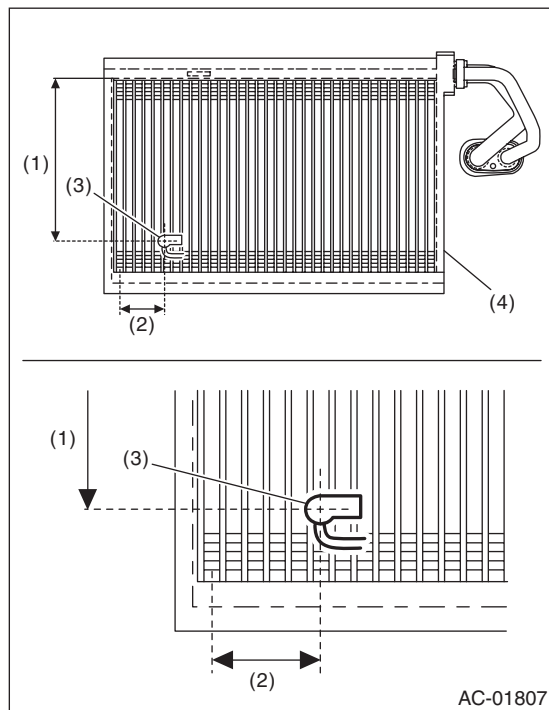

- (1) 148 mm (5.83 in) from the upper end of the fins
- (2) Sixth row fin from the left end
- (3) Sensor
- (4) Evaporator

- 1) Install each part in the reverse order of removal.
- 2) Charge refrigerant. <Ref. to AC-21, PROCEDURE, Refrigerant Charging Procedure.>

### Tightening torque:

Refer to "COMPONENT" of "General Description".

- Heater cooling unit: <Ref. to AC-4, HEATER COOLING UNIT, COMPONENT, General Description.>
- Blower motor unit: <Ref. to AC-6, BLOWER MOTOR UNIT, COMPONENT, General Description.>

# Evaporator

HVAC SYSTEM (HEATER, VENTILATOR AND A/C)

## C: INSPECTION

### 1. EVAPORATOR

- 1) Check the evaporator fin for dust. Blow with compressed air or flush fins with water as needed.
- 2) If any oil leak is found from the evaporator, replace the evaporator.

### 2. EVAPORATOR SENSOR

#### UNIT INSPECTION

**Preparation tool: Circuit tester**

- 1) Check the resistance between evaporator sensor terminals.

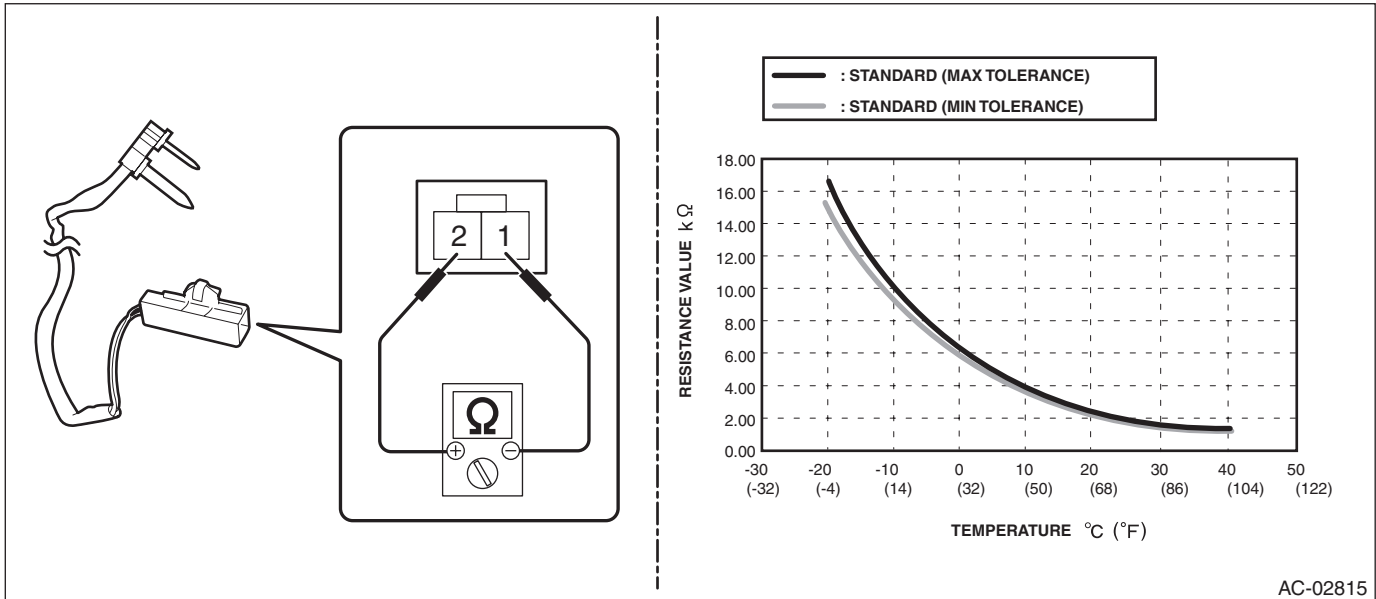

Terminal No.	Inspection conditions	Standard
1 — 2	-20°C	15.37 — 16.62 kΩ
	-15°C	12.09 — 12.87 kΩ
	-10°C	9.576 — 10.05 kΩ
	-5°C	7.636 — 7.899 kΩ
	0°C	6.132 — 6.256 kΩ
	5°C	4.891 — 5.057 kΩ
	10°C	3.928 — 4.113 kΩ
	15°C	3.174 — 3.366 kΩ
	20°C	2.581 — 2.77 kΩ
	25°C	2.111 — 2.292 kΩ
	30°C	1.737 — 1.907 kΩ
	35°C	1.437 — 1.595 kΩ
40°C	1.195 — 1.34 kΩ	

- 2) Replace the evaporator sensor if the inspection result is not within the standard value.

## 19.Hose and Pipe

### A: REMOVAL

**CAUTION:**

- When disconnecting hoses, do not apply excessive force.
- Seal the disconnected hose with a plug or vinyl tape to prevent foreign matter from entering.

- 1) Disconnect the ground cable from battery.
- 2) Using the refrigerant recovery system, discharge refrigerant. <Ref. to AC-20, PROCEDURE, Refrigerant Recovery Procedure.>
- 3) Remove the bolt and detach the hoses and pipes.

### B: INSTALLATION

**CAUTION:**

- Replace the O-rings with new parts.
- When connecting hoses, do not apply an excessive force to them. After installing, check that no torsion or excessive tension applied to the hoses.

- 1) Install each part in the reverse order of removal.
- 2) Charge refrigerant. <Ref. to AC-21, PROCEDURE, Refrigerant Charging Procedure.>

**Tightening torque:**

***Refer to "COMPONENT" of "General Description". <Ref. to AC-9, AIR CONDITIONING UNIT, COMPONENT, General Description.>***

### C: INSPECTION

Check the hoses for cracks, damage and expansion, and then replace it with a new part if defective.

# Relay and Fuse

HVAC SYSTEM (HEATER, VENTILATOR AND A/C)

## 20. Relay and Fuse

### A: LOCATION

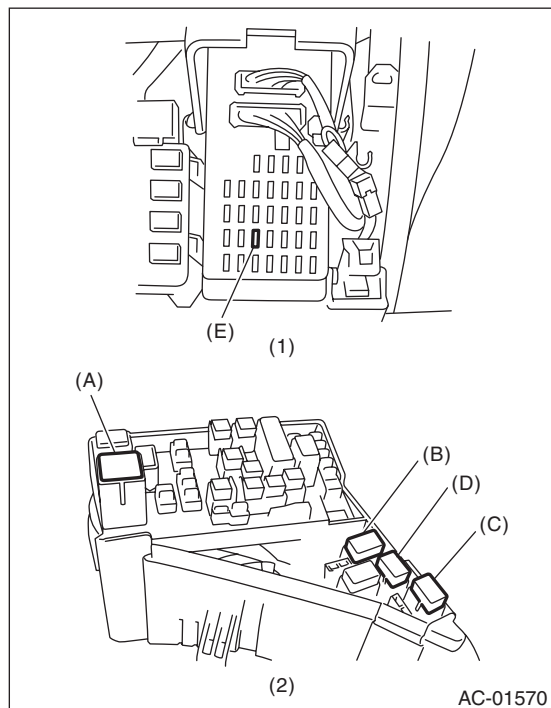

- (1) Joint box
- (2) Main fuse box

Main fan relay 1	(A)
Main fan relay 2	(B)
Sub fan relay	(C)
A/C relay	(D)
A/C Fuse	(E)

### B: INSPECTION

#### 1. FUSE

- 1) Remove the fuse and inspect visually.
- 2) If the fuse is blown out, replace the fuse.

#### 2. RELAY

- 1) Connect terminal No. 4 to the battery positive terminal and the terminal No. 3 to the battery negative terminal, and check the resistance value between the relay terminals.

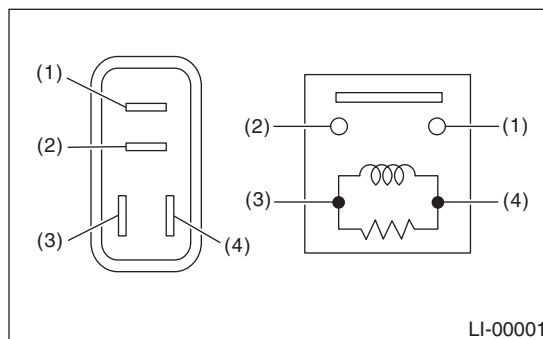

LI-00001

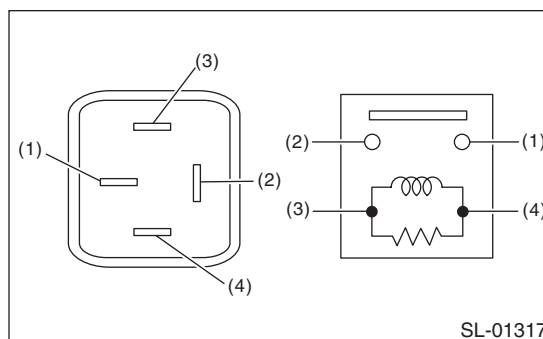

SL-01317

Continuity	Terminal No.	Specification
Yes	1 and 2	Less than 1 $\Omega$
None		1 M $\Omega$ or more

- 2) Replace the relay if the inspection result is not within the standard value.

# Pressure Switch (Triple Pressure Switch)

HVAC SYSTEM (HEATER, VENTILATOR AND A/C)

## 21. Pressure Switch (Triple Pressure Switch)

### A: INSPECTION

- 1) Connect the manifold gauge to the service valve on the high-pressure side.
- 2) Disconnect the pressure switch connector.
- 3) Start the air conditioner, and check the operating pressure of switch by turning the compressor (magnet clutch) to ON/OFF. Operation of each switch is as follows.

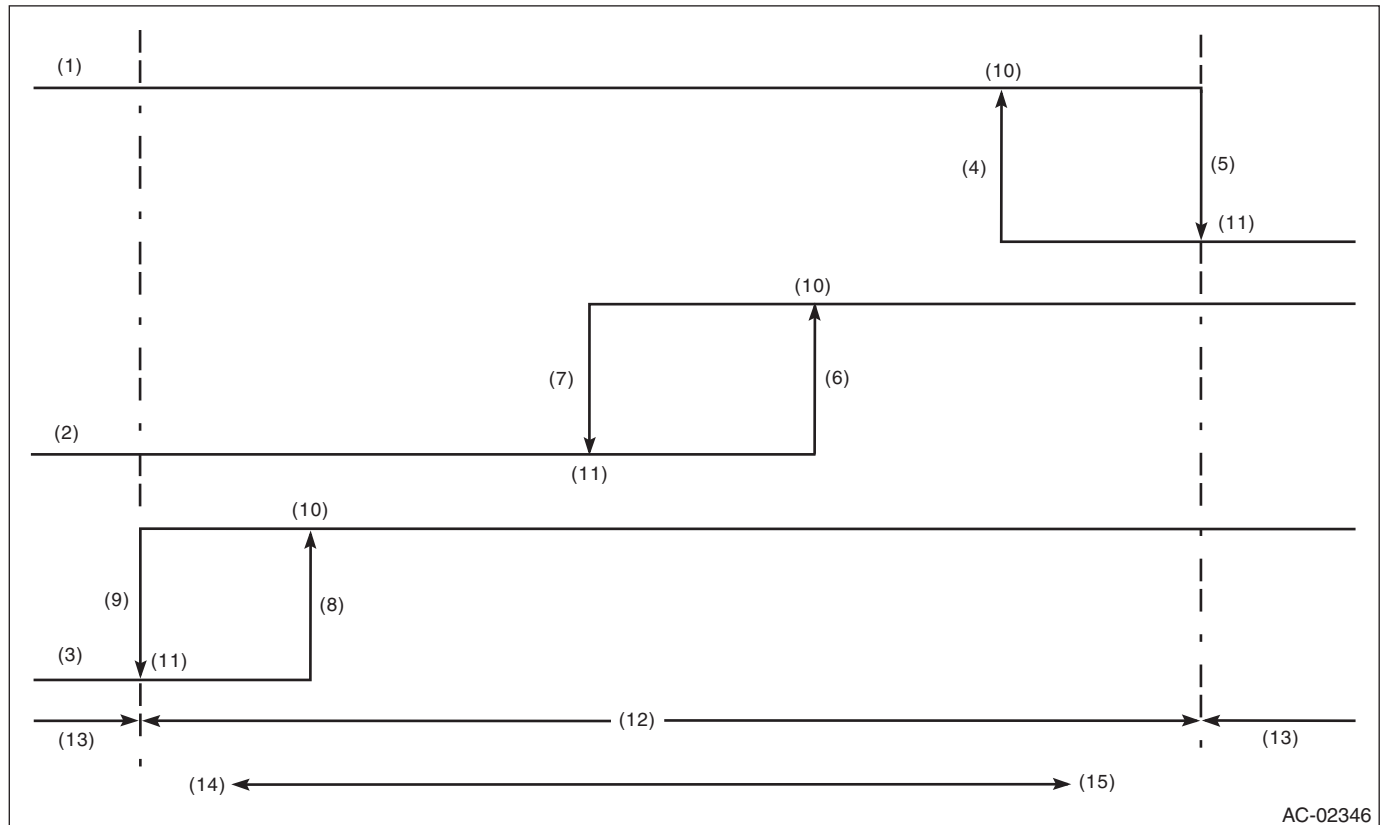

(1) High pressure switch	(6) 1,770±100 kPa (18.05±1.02 kg/cm <sup>2</sup> , 256.65±14.5 psi)	(11) OFF
(2) Middle pressure switch	(7) 1,470±120 kPa (14.99±1.22 kg/cm <sup>2</sup> , 213.15±17.4 psi)	(12) Operative range of compressor
(3) Low pressure switch	(8) 206±30 kPa (2.10±0.31 kg/cm <sup>2</sup> , 29.9±4.3 psi)	(13) Inoperative range of compressor
(4) 2,350±200 kPa (24.00±2.04 kg/cm <sup>2</sup> , 340.7±29.0 psi)	(9) 177±25 kPa (1.80±0.25 kg/cm <sup>2</sup> , 25.7±3.6 psi)	(14) Low pressure
(5) 2,940±200 kPa (29.98±2.04 kg/cm <sup>2</sup> , 426.3±29.0 psi)	(10) ON	(15) High pressure

#### NOTE:

- High pressure switch turns the compressor (magnet clutch) to OFF when the refrigerant pressure becomes extremely high to prevent the evaporator, air conditioner piping and expansion valve from getting damaged or frozen, etc.
- Middle pressure switch effectively controls the radiator fan output by judging high load/low load in normal range.
- The low pressure switch detects a refrigerant shortage and deactivates the compressor (magnet clutch) if the refrigerant pressure is abnormally low. (Because any further compressor operation in such a state may lead to compressor seizure)

AC-42

Brought to you by Ebay Seller "SubaruManuals"

## Ambient Sensor (Auto A/C Model)

HVAC SYSTEM (HEATER, VENTILATOR AND A/C)

### 22. Ambient Sensor (Auto A/C Model)

#### A: REMOVAL

- 1) Disconnect the ground cable from battery.
- 2) Disconnect the ambient sensor connector.
- 3) Remove the ambient sensor from the radiator lower panel.

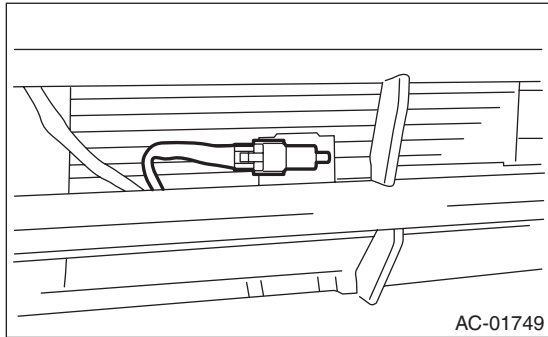

#### B: INSTALLATION

Install each part in the reverse order of removal.



# Ambient Sensor (Auto A/C Model)

HVAC SYSTEM (HEATER, VENTILATOR AND A/C)

## C: INSPECTION

**Preparation tool: Circuit tester**

- 1) Visually check the ambient sensor for dirt or damage, and clean or replace as necessary.
- 2) Check the resistance between ambient sensor terminals.

**CAUTION:**

During inspection, be careful not to touch the sensor end in order to avoid misjudgment due to body temperature.

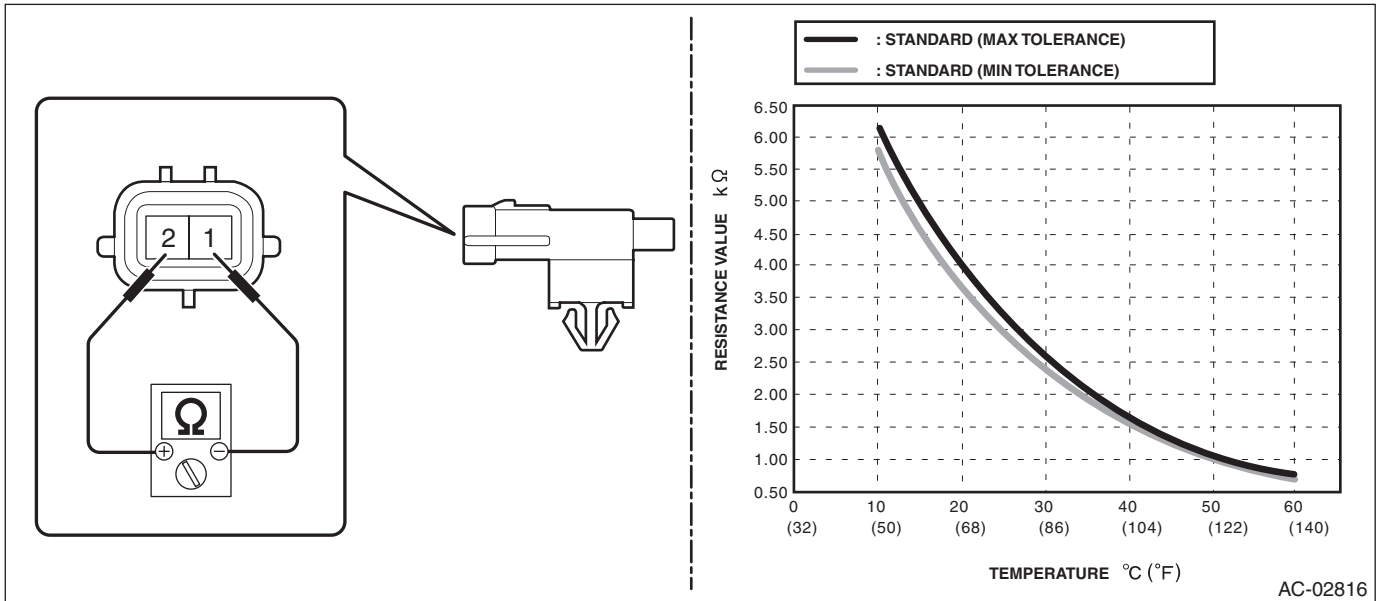

Terminal No.	Inspection conditions	Standard
1 — 2	10°C	5.82 — 6.18 kΩ
	15°C	4.58 — 4.87 kΩ
	20°C	3.64 — 3.86 kΩ
	25°C	2.91 — 3.09 kΩ
	30°C	2.35 — 2.49 kΩ
	35°C	1.9 — 2.02 kΩ
	40°C	1.56 — 1.65 kΩ
	45°C	1.28 — 1.36 kΩ
	50°C	1.06 — 1.12 kΩ
	55°C	0.88 — 0.93 kΩ
	60°C	0.74 — 0.78 kΩ

- 3) Replace the ambient sensor if the inspection result is not within the standard value.

### 23. Sunload Sensor (Auto A/C Model)

#### A: REMOVAL

- 1) Disconnect the ground cable from battery.
- 2) Remove the audio. (model with audio) <Ref. to ET-6, REMOVAL, Audio.>
- 3) Remove the navigation unit. (model with navigation) <Ref. to ET-14, PROCEDURE, Navigation Body.>
- 4) Push out the sunload sensor from the back side of the instrument panel.

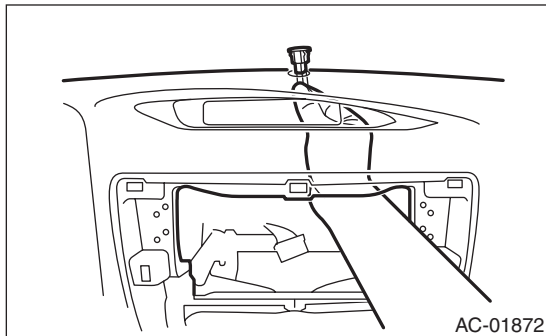

- 5) Disconnect the harness connector and remove the sunload sensor.

#### CAUTION:

Be careful not to damage the interior trims when removing the sensor.

#### B: INSTALLATION

Install each part in the reverse order of removal.

#### C: INSPECTION

Refer to "Sunload Sensor" of HVAC SYSTEM (AUTO A/C)(DIAGNOSTICS). <Ref. to AC(diag)-36, SUNLOAD SENSOR, Diagnostic Procedure for Sensors.>

## In-Vehicle Sensor (Auto A/C Model)

HVAC SYSTEM (HEATER, VENTILATOR AND A/C)

---

### 24. In-Vehicle Sensor (Auto A/C Model)

#### A: REMOVAL

##### CAUTION:

**Be careful not to damage the sensors and interior trims when removing.**

- 1) Disconnect the ground cable from battery.
- 2) Remove the instrument panel lower cover. <Ref. to EI-54, INSTRUMENT PANEL LOWER, REMOVAL, Center Console.>
- 3) Remove the screws.
- 4) Disconnect the in-vehicle sensor connector and aspirator hose, and remove the in-vehicle sensor from the instrument panel.

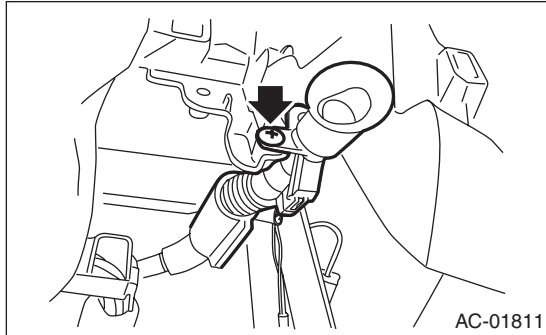

#### B: INSTALLATION

Install each part in the reverse order of removal.

# In-Vehicle Sensor (Auto A/C Model)

HVAC SYSTEM (HEATER, VENTILATOR AND A/C)

## C: INSPECTION

### UNIT INSPECTION

**Preparation tool: Circuit tester**

1) Check the resistance between in-vehicle sensor terminals.

#### CAUTION:

During inspection, be careful not to touch the sensor end in order to avoid misjudgment due to body temperature.

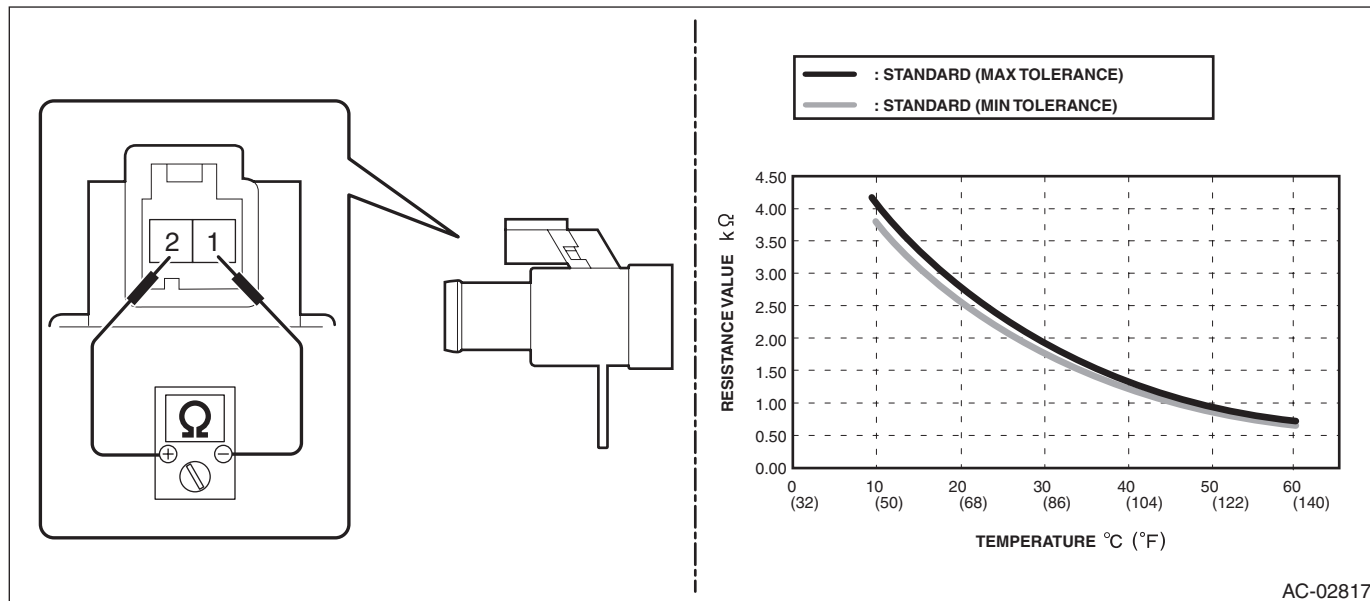

Terminal No.	Inspection conditions	Standard
1 — 2	10°C	3.772 — 4.101 kΩ
	15°C	3.096 — 3.338 kΩ
	20°C	2.556 — 2.734 kΩ
	25°C	2.121 — 2.251 kΩ
	30°C	1.756 — 1.878 kΩ
	35°C	1.462 — 1.574 kΩ
	40°C	1.223 — 1.326 kΩ
	45°C	1.028 — 1.122 kΩ
	50°C	0.868 — 0.954 kΩ
	55°C	0.736 — 0.814 kΩ
	60°C	0.627 — 0.698 kΩ

2) Replace the in-vehicle sensor if the inspection result is not within the standard value.

# Air Vent Grille

HVAC SYSTEM (HEATER, VENTILATOR AND A/C)

---

## 25. Air Vent Grille

### A: REMOVAL

#### 1. CENTER GRILLE

- 1) Insert a plastic remover into the slit at the bottom of the center panel, to lift the panel.
- 2) Remove the claws and resin hook and then remove the center panel.

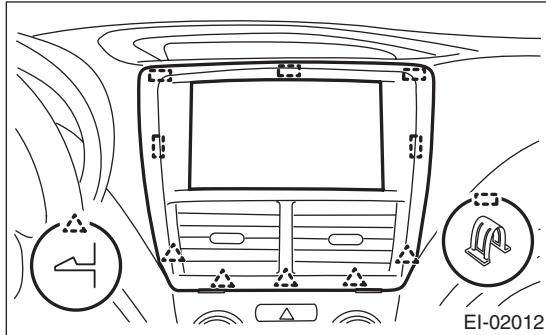

- 3) Remove the claws, and remove the air vent center grille from the center panel.

#### 2. SIDE GRILLE

- 1) Remove the ornament panel. <Ref. to EI-52, ORNAMENT PANEL, REMOVAL, Center Console.>
- 2) Remove the claws, and remove the air vent side grille.

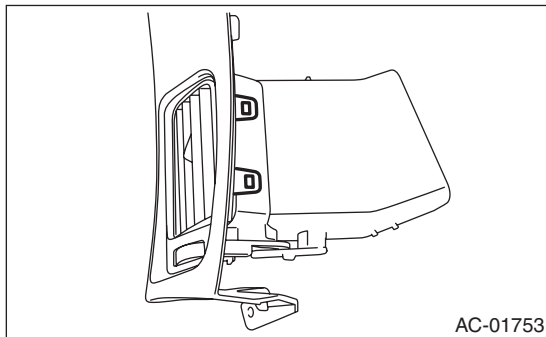

### B: INSTALLATION

Install each part in the reverse order of removal.

### C: INSPECTION

- 1) Check that the direction and amount of air can be adjusted smoothly, and if there is any faulty, replace the air vent grille.
- 2) Check that the adjustment can be maintained in each position, and if there is any faulty, replace the air vent grille.

## 26.Heater Duct

### A: REMOVAL

#### 1. REAR HEATER DUCT

- 1) Remove the heater and cooling unit. <Ref. to AC-35, REMOVAL, Heater and Cooling Unit.>
- 2) Remove the front seats. <Ref. to SE-6, REMOVAL, Front Seat.>
- 3) Remove the lower inner trim (front). <Ref. to EI-57, REMOVAL, Lower Inner Trim.>
- 4) Pull off the floor mat to remove the rear heater duct center (A) and rear heater duct LH, RH (B).

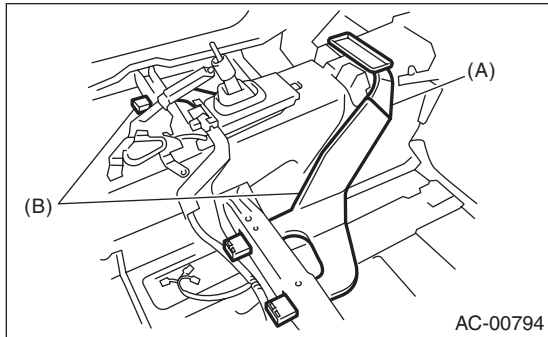

### B: INSTALLATION

Install each part in the reverse order of removal.

## Heater Vent Duct

HVAC SYSTEM (HEATER, VENTILATOR AND A/C)

---

### 27.Heater Vent Duct

#### A: REMOVAL

- 1) Remove the instrument panel. <Ref. to EI-55, REMOVAL, Instrument Panel Assembly.>
- 2) Remove the screws, and then remove the heater vent duct.

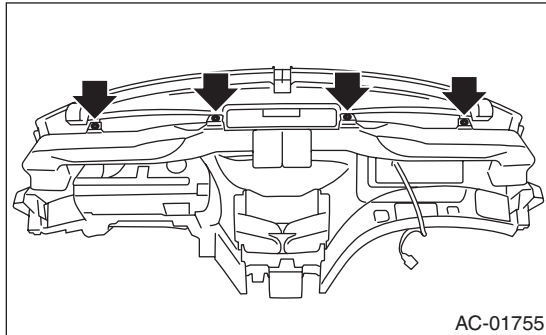

#### B: INSTALLATION

Install each part in the reverse order of removal.

## 28.A/C Filter

### A: REPLACEMENT

1) Remove the glove box damper.

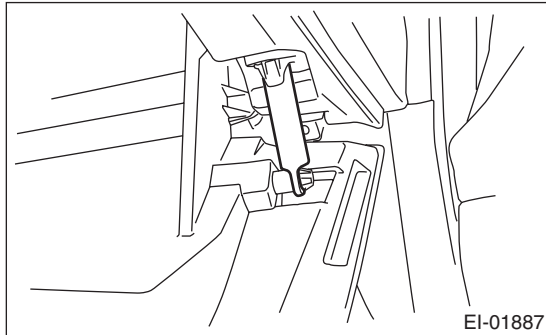

2) Remove the stoppers and pull the glove box lid assembly forward to remove.

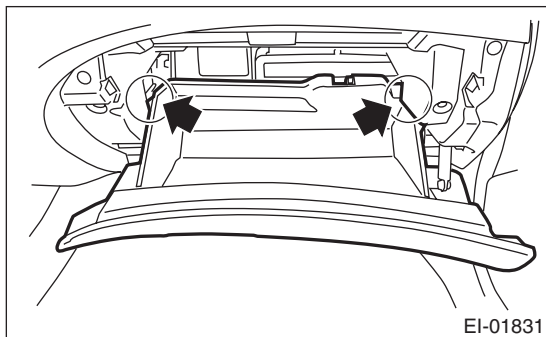

3) Pinch the tabs to release the lock and remove the A/C filter.

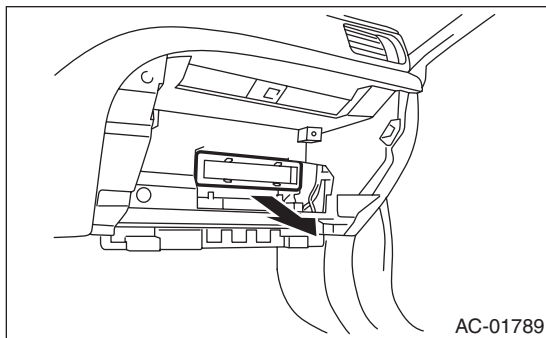

4) Install each part in the reverse order of removal.



## General Diagnostic Table

HVAC SYSTEM (HEATER, VENTILATOR AND A/C)

---

### 29. General Diagnostic Table

#### A: INSPECTION

Refer to "Diagnostics with Phenomenon" for "HVAC SYSTEM (AUTO A/C) (DIAGNOSTICS)" section. <Ref. to AC(diag)-38, INSPECTION, Diagnostics with Phenomenon.>

# HVAC SYSTEM (AUTO A/C) (DIAGNOSTICS)

# *AC(diag)*

---

	<b>Page</b>
1. Basic Diagnostic Procedure .....	2
2. General Description .....	3
3. Electrical Component Location .....	5
4. Auto A/C Control Module I/O Signal .....	7
5. Diagnostic Chart for Self-Diagnosis .....	9
6. Diagnostics for A/C System Malfunction .....	13
7. Diagnostic Procedure for Actuators .....	24
8. Diagnostic Procedure for Sensors .....	30
9. Diagnostics with Phenomenon .....	38

# Basic Diagnostic Procedure

HVAC SYSTEM (AUTO A/C) (DIAGNOSTICS)

## 1. Basic Diagnostic Procedure

### A: PROCEDURE

	Step	Check	Yes	No
1	<b>START INSPECTIONS.</b> 1) Perform the pre-inspection. <Ref. to AC(diag)-3, INSPECTION, General Description.> 2) Perform the self-diagnosis. <Ref. to AC(diag)-9, OPERATION, Diagnostic Chart for Self-Diagnosis.>	Does the self-diagnosis operate?	Go to step 2.	<Ref. to AC(diag)-13, A/C OR SELF-DIAGNOSIS SYSTEMS DO NOT OPERATE, Diagnostics for A/C System Malfunction.>
2	<b>IDENTIFY MALFUNCTION PART.</b> Identify the malfunction part with self-diagnosis.	Can the malfunction part be confirmed?	Repair the malfunctioning part in accordance with each diagnostic chart.	Go to step 3.
3	<b>CHECK COMPARTMENT TEMPERATURE.</b> 1) Turn the A/C switch to ON. 2) Turn the temperature control dial at maximum cool position. 3) Check the compartment temperature change.	Does the compartment temperature change?	Go to step 4.	<Ref. to AC-19, PROCEDURE, Refrigerant Pressure with Manifold Gauge Set.>
4	<b>CHECK A/C SYSTEM RESPONSE.</b> Change the temperature setting, and check the response of A/C system.	Does the A/C system respond quickly?	A/C system is normal.	<Ref. to AC(diag)-19, COMPARTMENT TEMPERATURE DOES NOT CHANGE, OR A/C SYSTEM DOES NOT RESPOND PROMPTLY, Diagnostics for A/C System Malfunction.>

# General Description

HVAC SYSTEM (AUTO A/C) (DIAGNOSTICS)

## 2. General Description

### A: CAUTION

- 1) Never connect the battery in reverse polarity.
  - Doing so may immediately damage the auto A/C control module.
- 2) Do not disconnect the battery terminals while the engine is running.
  - A large counter electromotive force will be generated in the generator, and this voltage may damage electronic parts such as auto A/C control module etc.
- 3) Before disconnecting the connectors of sensors and the auto A/C control module, be sure to turn off the ignition switch.
  - Auto A/C control module may be damaged.
- 4) Every A/C-related part is a precision part. Do not drop them.
- 5) Airbag system wiring harness is routed near the auto A/C control module and junction box.

### CAUTION:

- Do not use electrical test equipment on the airbag system wiring harness and connector.
- Be careful not to damage the airbag system wiring harness when servicing the auto A/C control module and junction box.

### B: INSPECTION

Before performing the diagnosis, check the following items which may cause problems in the A/C system.

#### 1. BATTERY

- 1) Measure the battery voltage and specific gravity of the electrolyte.

**Standard voltage:**

**12 V**

**Specific gravity:**

**1.260 or more**

- 2) Check the condition of the fuses for A/C system power supply and other fuses.
- 3) Check the condition of harness and harness connector connections.

#### 2. ASPIRATOR HOSE

- 1) Turn the ignition switch to ON, and press the A/C switch.
- 2) Turn the temperature control dial to maximum hot position.
- 3) Set the blow vents to the DEF position.
- 4) Turn the fan switch to "MAX" position.

- 5) Put a strip of paper close to the front side of in-vehicle sensor suction port (A) located in the instrument panel lower cover, and check that air is being sucked into the port by seeing the paper moving towards the port.

### NOTE:

Be careful not to let the paper get sucked into the port.

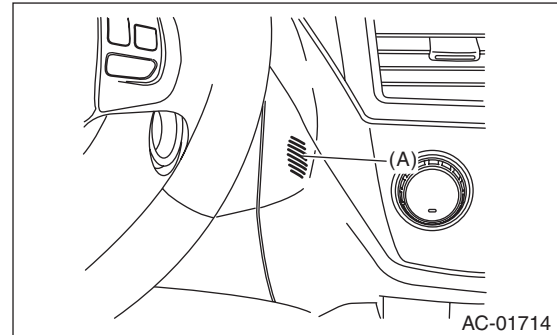

- 6) If the paper does not move at all, remove the instrument panel lower cover <Ref. to EI-49, REMOVAL, Instrument Panel Lower Cover.> and check for poor connection of the aspirator hose (A), in-vehicle sensor and heater unit, and repair them if necessary.

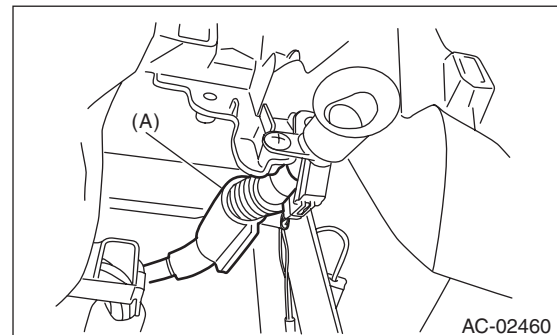

#### 3. A/C LINE

Check the connection for A/C line (A) and lower side high-pressure pipe.

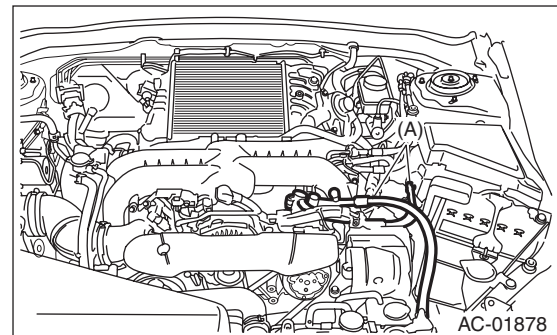

#### 4. CONTROL LINKAGE

- 1) Check the state of mode door linkage.
- 2) Check the state of air mix door linkage.
- 3) Check the state of intake door linkage.

## General Description

### HVAC SYSTEM (AUTO A/C) (DIAGNOSTICS)

#### 5. CONTROL SWITCHES

Start the engine and warm up completely.

##### 1) Inspection using switches

No.	Point to check	Switch operation	Judgment standard
1	Air flow control dial	Turn the dial to the right.	Outlet opening (mode) switches AUTO → VENT → BI-LEVEL → HEAT → DEF/HEAT → DEF each time turning the dial.
2	Fan speed control dial	Turn the dial to the right.	Each time the dial is turned, the fan speed switches OFF → AUTO → 1st → 2nd → 3rd → 4th → 5th → 6th → 7th.
3	FRESH/RECIRC switch	Press the FRESH/RECIRC switch.	Inlet opening switches RECIRC → FRESH → RECIRC each time pressing the switch. (LED illuminates at RECIRC)
		Set the air flow control dial and fan speed control dial to the AUTO position.	The system switches to AUTO.
4	A/C switch	Turn the A/C switch to ON with the fan speed control dial set to other than OFF position.	The LED lights and the compressor operates.
		Set the air flow control dial and fan speed control dial to the AUTO position.	The system switches to AUTO.
5	Auto function Operate in order from 1).	1) Set the following dial to AUTO. • Air flow control dial • Fan speed control dial 2) Turn the temperature control dial completely to the left, and set to the maximum cool position.	• Outlet air temperature: COOL • Fan speed: Max. • Outlet opening: VENT • Inlet opening: RECIRC • Compressor: AUTO
		3) Turn the temperature control dial to the right slowly up to the maximum hot position.	• Outlet air temperature: COOL → HOT • Fan speed: AUTO • Outlet opening: AUTO • Inlet opening: AUTO • Compressor: AUTO
		4) Turn the temperature control dial fully to the right, to the maximum hot position.	• Outlet air temperature: HOT • Fan speed: Max. • Outlet opening: HEAT • Inlet opening: FRESH • Compressor: AUTO
6	Defroster Interlock Function	Set the air flow control dial to the DEF or the DEF/HEAT position.	• Outlet air temperature: AUTO • Fan speed: AUTO • Outlet opening: DEF or DEF/HEAT • Inlet opening: FRESH • Compressor: ON
7	Rear defogger switch	Press the rear defogger switch.	LED illuminates.

##### 2) Inspection of compressor operation

No.	Point to check	Switch operation	Judgment standard
1	Compressor	1) Turn the A/C switch to ON. 2) Set the FAN switch between LO and HI.	Compressor: ON

##### 3) Inspection of illumination control

No.	Point to check	Switch operation	Judgment standard
1	Illumination	Turn the lighting switch to ON.	Illumination comes on. If the LED lights, the LED will dim.

# Electrical Component Location

HVAC SYSTEM (AUTO A/C) (DIAGNOSTICS)

## 3. Electrical Component Location

### A: LOCATION

#### 1. ENGINE COMPARTMENT

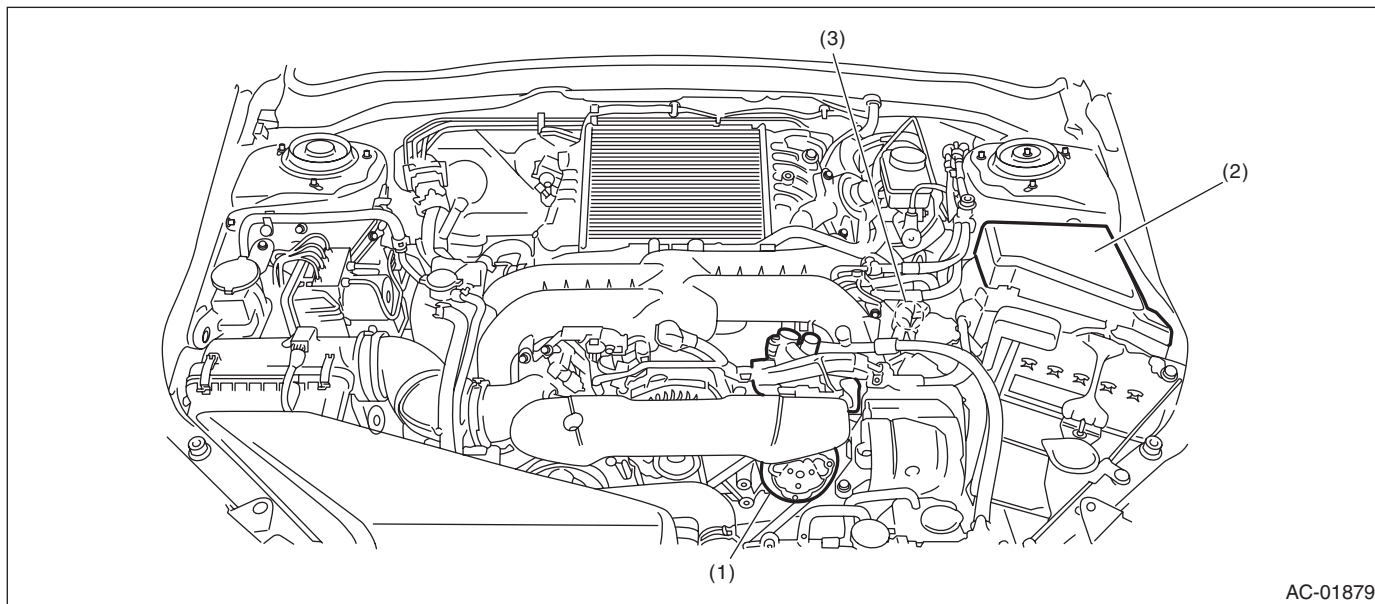

AC-01879

- (1) A/C compressor
- (2) A/C relay

- (3) Pressure switch

- (4) Ambient sensor

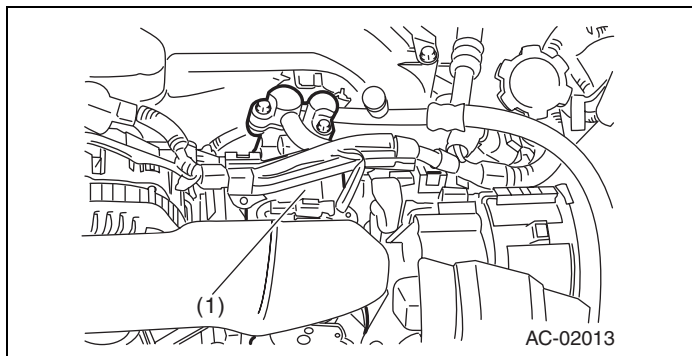

AC-02013

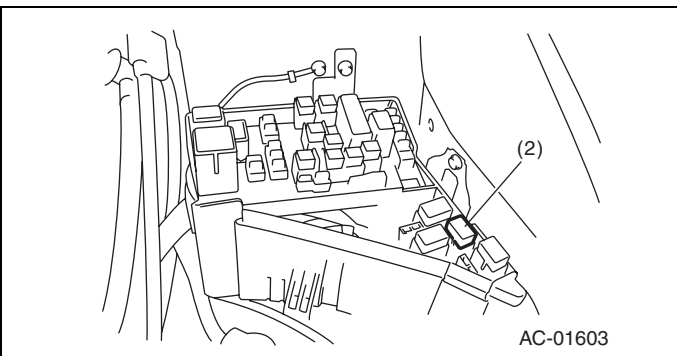

AC-01603

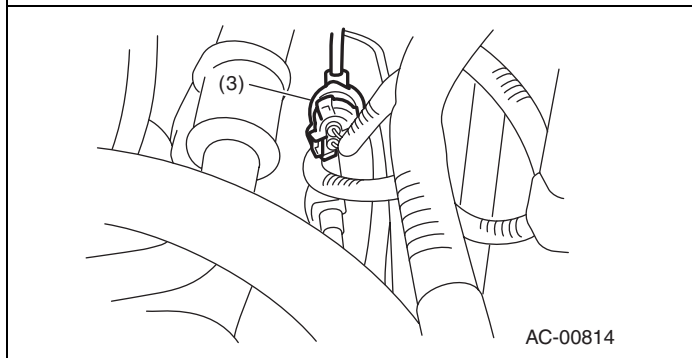

AC-00814

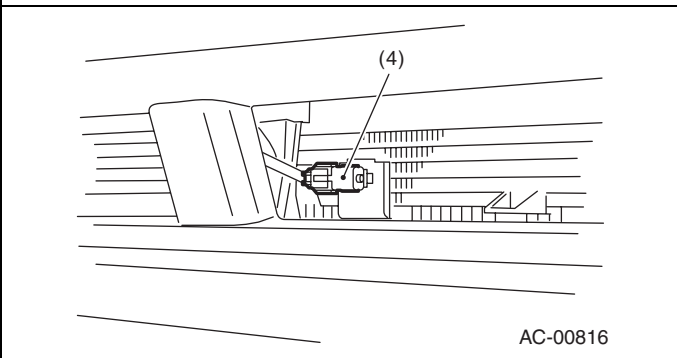

AC-00816

# Electrical Component Location

HVAC SYSTEM (AUTO A/C) (DIAGNOSTICS)

## 2. COMPARTMENT

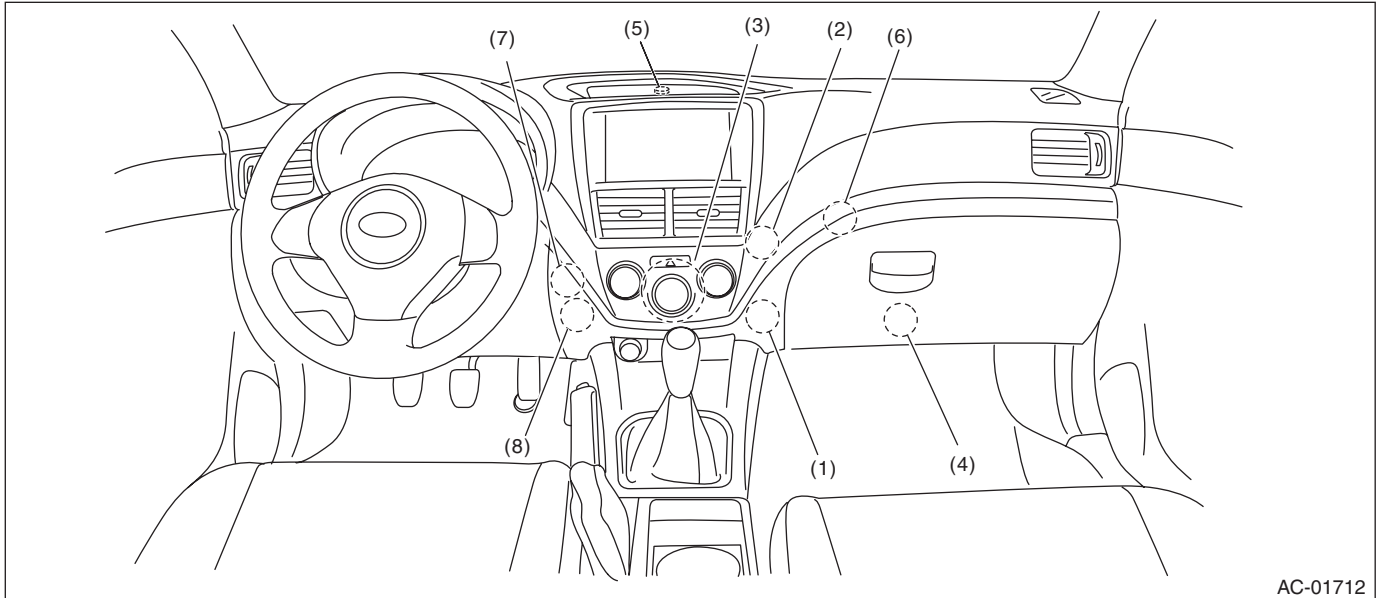

AC-01712

- |                             |                          |                        |
|-----------------------------|--------------------------|------------------------|
| (1) Evaporator sensor       | (4) Blower motor         | (7) Mode door actuator |
| (2) Air mix door actuator   | (5) Sunload sensor       | (8) In-vehicle sensor  |
| (3) Auto A/C control module | (6) Intake door actuator |                        |

# Auto A/C Control Module I/O Signal

HVAC SYSTEM (AUTO A/C) (DIAGNOSTICS)

## 4. Auto A/C Control Module I/O Signal

### A: ELECTRICAL SPECIFICATION

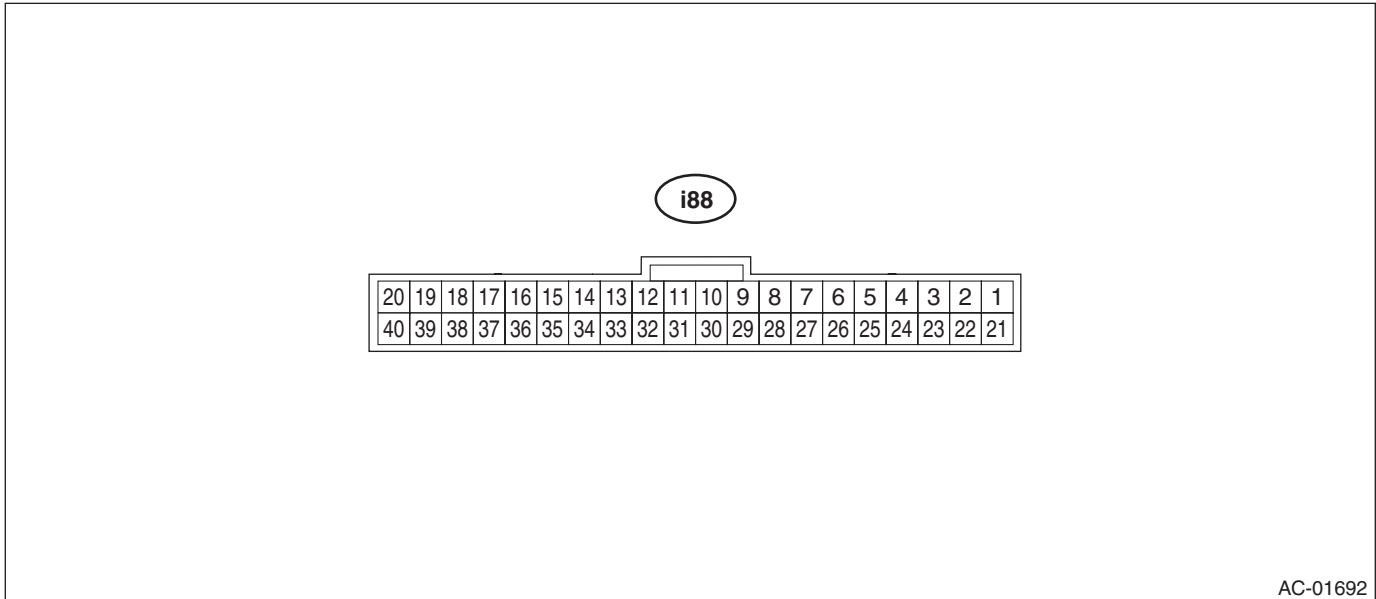

AC-01692

Terminal No.	Content	Measuring condition	Specification
1	Mode actuator # 4	Actuator operating	8 V or more
2	Mode actuator # 3	Actuator operating	8 V or more
3	Mode actuator # 2	Actuator operating	8 V or more
4	Mode actuator # 1	Actuator operating	8 V or more
6	Intake door actuator (FRESH)	FRESH mode	1 V or less
7	Intake door actuator (MIX)	MIX mode	1 V or less
8	Intake door actuator (RECIRC)	RECIRC mode	1 V or less
9	Blower fan ON signal	Blower fan is ON	1 V or less
11	A/C cut-off signal	A/C is cut off	1 V or less
14	GND for sensors	Always	1 V or less
15	ACC power supply	ACC ON	Battery voltage
16	Sunload sensor	Sunlight is contacting sensor	1 — 4 V
17	RECIRC sensor	Ignition switch ON	25°C: 2.5 V
18	Post evaporator sensor	Depends on temperature after the evaporator.	1 — 4.5 V
19	CAN Lo	Digital signal; can not be measured	—
20	CAN Hi	Digital signal; can not be measured	—
25	Air mix actuator #4	Air mix actuator is operating	8 V or more
26	Air mix actuator #3	Air mix actuator is operating	8 V or more
27	Air mix actuator #2	Air mix actuator is operating	8 V or more
28	Air mix actuator #1	Air mix actuator is operating	8 V or more
31	BATT	Always	Battery voltage
32	IGN	Ignition ON	Battery voltage
34	Ground	Always	1 V or less
36	A/C ON signal	A/C is operating	8 V or more
35	ILL-	Illumination ON (measure between 37 — 35)	Battery voltage
37	ILL+		
39	Rr defogger switch output	When the rear defogger switch is ON	1 V or less
40	Fan control signal	Ignition switch: ON, Blower switch: ON	8 V or more



# Auto A/C Control Module I/O Signal

HVAC SYSTEM (AUTO A/C) (DIAGNOSTICS)

---

## **B: WIRING DIAGRAM**

### **1. AIR CONDITIONER AUTO A/C MODEL**

<Ref. to WI-74, WIRING DIAGRAM, Air Conditioning System.>

# Diagnostic Chart for Self-Diagnosis

HVAC SYSTEM (AUTO A/C) (DIAGNOSTICS)

## 5. Diagnostic Chart for Self-Diagnosis

### A: OPERATION

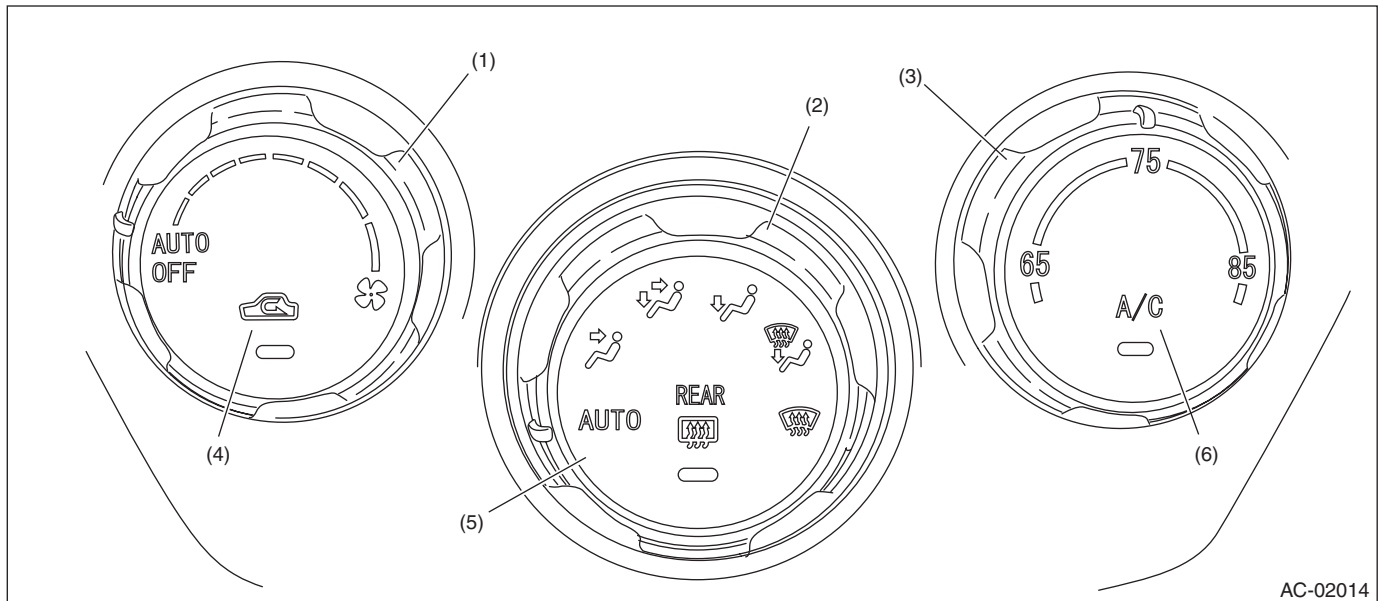

AC-02014

- |                           |                                 |                                 |
|---------------------------|---------------------------------|---------------------------------|
| (1) Fan dial              | (3) Temperature adjustment dial | (5) Rear window defogger switch |
| (2) Air flow control dial | (4) FRESH/RECIRC switch         | (6) A/C switch                  |

### 1. A/C CONTROL MODULE SELF-DIAGNOSIS

Step	Check	Yes	No
<b>1 SELECT SELF-DIAGNOSIS MODE IN THE CONTROL MODULE.</b> 1) Set the air flow control dial and fan dial to the AUTO position. 2) Start the engine with the A/C switch and the FRESH/RECIRC switch pressed.	Does the self-diagnosis mode operate?	Go to step 2.	<Ref. to AC(diag)-13, A/C OR SELF-DIAGNOSIS SYSTEMS DO NOT OPERATE, Diagnostics for A/C System Malfunction.>
<b>2 CHECK THE LIGHTING OF THE LED.</b> Make sure that all switch LEDs on the control module illuminate.	Do all LEDs blink eight times?	Go to step 3.	Replace the control module.
<b>3 CHECK SENSOR MALFUNCTION.</b> 1) Set the air flow control dial and fan dial to the AUTO position. 2) If the system has trouble for each sensor, the FRESH/RECIRC switch LED blinks or is turned off. 3) If the system has no malfunctions, the FRESH/RECIRC switch LED is illuminated.	Does the FRESH/RECIRC switch LED illuminate?	Go to step 5.	Go to step 4.
<b>4 CONFIRM MALFUNCTIONING SENSOR.</b> 1) Set the air flow control dial to AUTO. 2) Turn the fan dial to each mode position, and check each switch LED illumination according to sensor check table. <Ref. to AC(diag)-11, SENSOR CHECK TABLE, OPERATION, Diagnostic Chart for Self-Diagnosis.>	When turning the fan dial to each mode position, does the FRESH/RECIRC switch LED go off?	Go to step 5.	Repair the defective sensor. <Ref. to AC(diag)-30, Diagnostic Procedure for Sensors.>

# Diagnostic Chart for Self-Diagnosis

## HVAC SYSTEM (AUTO A/C) (DIAGNOSTICS)

Step	Check	Yes	No
<b>5 CHECK AIR MIX DOOR AND MODE DOOR POSITION SIGNALS.</b> 1) Set the air flow control dial to FACE. 2) Turn the fan dial to AUTO. 3) If there is a system malfunction in the air mix door signal or the mode door position signal, the FRESH/RECIRC switch LED goes off or blinks. 4) If the system has no malfunctions, the FRESH/RECIRC switch LED is illuminated.	Does the FRESH/RECIRC switch LED illuminate?	Go to step 8.	Go to step 6.
<b>6 CHECK AIR MIX DOOR POSITION DRIVE SIGNALS.</b> 1) Set the air flow control dial to FACE. 2) Place the fan dial in each position and then check each LED illumination conditions. <Ref. to AC(diag)-12, DRIVE SIGNAL CHECK TABLE, OPERATION, Diagnostic Chart for Self-Diagnosis.>	Do the LEDs illuminate in accordance with operation signal table?	Go to step 7.	Check the air mix door actuator circuit. <Ref. to AC(diag)-28, AIR MIX DOOR ACTUATOR, Diagnostic Procedure for Actuators.>
<b>7 CHECK MODE DOOR POSITION DRIVE SIGNAL.</b> 1) Press the A/C switch. 2) Place the fan dial in each position and then check each LED illumination conditions. <Ref. to AC(diag)-12, DRIVE SIGNAL CHECK TABLE, OPERATION, Diagnostic Chart for Self-Diagnosis.>	Do the LEDs illuminate in accordance with operation signal table?	Go to step 8.	Check the mode door actuator circuit. <Ref. to AC(diag)-26, MODE DOOR ACTUATOR, Diagnostic Procedure for Actuators.>
<b>8 CHECK OPERATION OF EACH ACTUATOR, BLOWER FAN AND COMPRESSOR CLUTCH.</b> 1) Set the air flow control dial to B/L. 2) Turn the fan dial from AUTO to 7th, and select operating modes. 3) Check the operation of each mode according to operating mode table. <Ref. to AC(diag)-12, OPERATING MODE TABLE, OPERATION, Diagnostic Chart for Self-Diagnosis.> <ul style="list-style-type: none"> <li>• FRESH/RECIRC door</li> <li>• Air flow control door</li> <li>• Air mix door</li> <li>• Blower fan</li> <li>• A/C compressor</li> </ul>	Does the operation of each mode match to operating mode table?	Turn the fan dial to OFF or the ignition switch to OFF in order to complete self-diagnosis.	Repair the malfunctioning part in accordance with each diagnostic chart.

# Diagnostic Chart for Self-Diagnosis

HVAC SYSTEM (AUTO A/C) (DIAGNOSTICS)

## 2. SENSOR CHECK TABLE

NOTE:

- When the sunload sensor check is performed indoors or in the shade, it could be diagnosed as having an open circuit. Always check the sunload sensor at a location exposed to direct sunlight.
- LED illuminates to warn the past malfunction if it was detected four times or more in the past.
- To clear the past malfunction, disconnect the ground cable from the battery, or press and hold the FRESH/RECIRC switch for five seconds or more when performing the self-diagnosis Step 3 to Step 7.

Air flow control dial position	Fan dial position	Sensor	No trouble	Short circuit	Open circuit	When currently malfunctioning	When having malfunctioned in the past
AUTO	AUTO	In-vehicle sensor	FRESH/RECIRC switch LED is turned off	FRESH/RECIRC switch LED blinks (Illuminates for 0.2 sec. ←→ turns off for 0.2 sec.)	FRESH/RECIRC switch LED blinks (Illuminates for 1 sec. ←→ turns off for 1 sec.)	Rear window defogger switch LED is turned off	Rear window defogger switch LED illuminates
	1st	Ambient sensor		FRESH/RECIRC switch LED blinks (Illuminates for 0.2 sec. ←→ turns off for 0.2 sec.)			
	2nd	Evaporator sensor		FRESH/RECIRC switch LED blinks (Illuminates for 0.2 sec. ←→ turns off for 0.2 sec.)			
	3rd	Engine coolant temperature sensor		—			
	4th	Sunload sensor		FRESH/RECIRC switch LED blinks (Illuminates for 0.2 sec. ←→ turns off for 0.2 sec.)			
	5th — 7th	CAN communication		—			

# Diagnostic Chart for Self-Diagnosis

HVAC SYSTEM (AUTO A/C) (DIAGNOSTICS)

## 3. OPERATING MODE TABLE

Operation	Fan dial position							
	AUTO	1st	2nd	3rd	4th	5th	6th	7th
Blower fan	4 V	4 V	4.9 V	5.9 V	7.0 V	8.3 V	9.8 V	14 V
FRESH/RECIRC door	RECIRC	RECIRC	MIX	FRESH	FRESH	FRESH	FRESH	FRESH
Air flow control door	FACE	FACE	FACE	B/L	HEAT	HEAT	D/H	DEF
Air mix door	0%	0%	0%	50%	50%	100%	100%	100%
A/C compressor	OFF	ON	ON	ON	ON	ON	ON	ON

## 4. DRIVE SIGNAL CHECK TABLE

NOTE:

- LED illuminates to warn the past malfunction if it was detected four times or more in the past.
- To clear the past malfunction, disconnect the ground cable from the battery, or press and hold the FRESH/RECIRC switch for five seconds or more when performing the self-diagnosis Step 3 to Step 7.

Air flow control dial position	Fan dial position	Drive signal to check	A/C switch LED	No trouble	Short circuit	Open circuit	When currently malfunctioning	When having malfunctioned in the past
FACE	AUTO	MIX #1	Blinking (Illuminates for 0.2 sec. ←→ turns off for 0.2 sec.)	FRESH/RECIRC switch LED is turned off	FRESH/RECIRC switch LED blinks (Illuminates for 0.2 sec. ←→ turns off for 0.2 sec.)	FRESH/RECIRC switch LED blinks (Illuminates for 1 sec. ←→ turns off for 1 sec.)	Rear window defogger switch LED is turned off	Rear window defogger switch LED illuminates
	1st	MIX #2						
	2nd	MIX #3						
	3rd — 7th	MIX #4						
	AUTO	MODE #1	Blinking (Illuminates for 1 sec. ←→ turns off for 1 sec.)					
	1st	MODE #2						
	2nd	MODE #3						
	3rd — 7th	MODE #4						

# Diagnostics for A/C System Malfunction

HVAC SYSTEM (AUTO A/C) (DIAGNOSTICS)

## 6. Diagnostics for A/C System Malfunction

### A: A/C OR SELF-DIAGNOSIS SYSTEMS DO NOT OPERATE

#### TROUBLE SYMPTOM:

- Set temperature is not indicated on the display, switch LEDs are faulty and switches do not operate.
- Self-diagnosis system does not operate.

#### WIRING DIAGRAM:

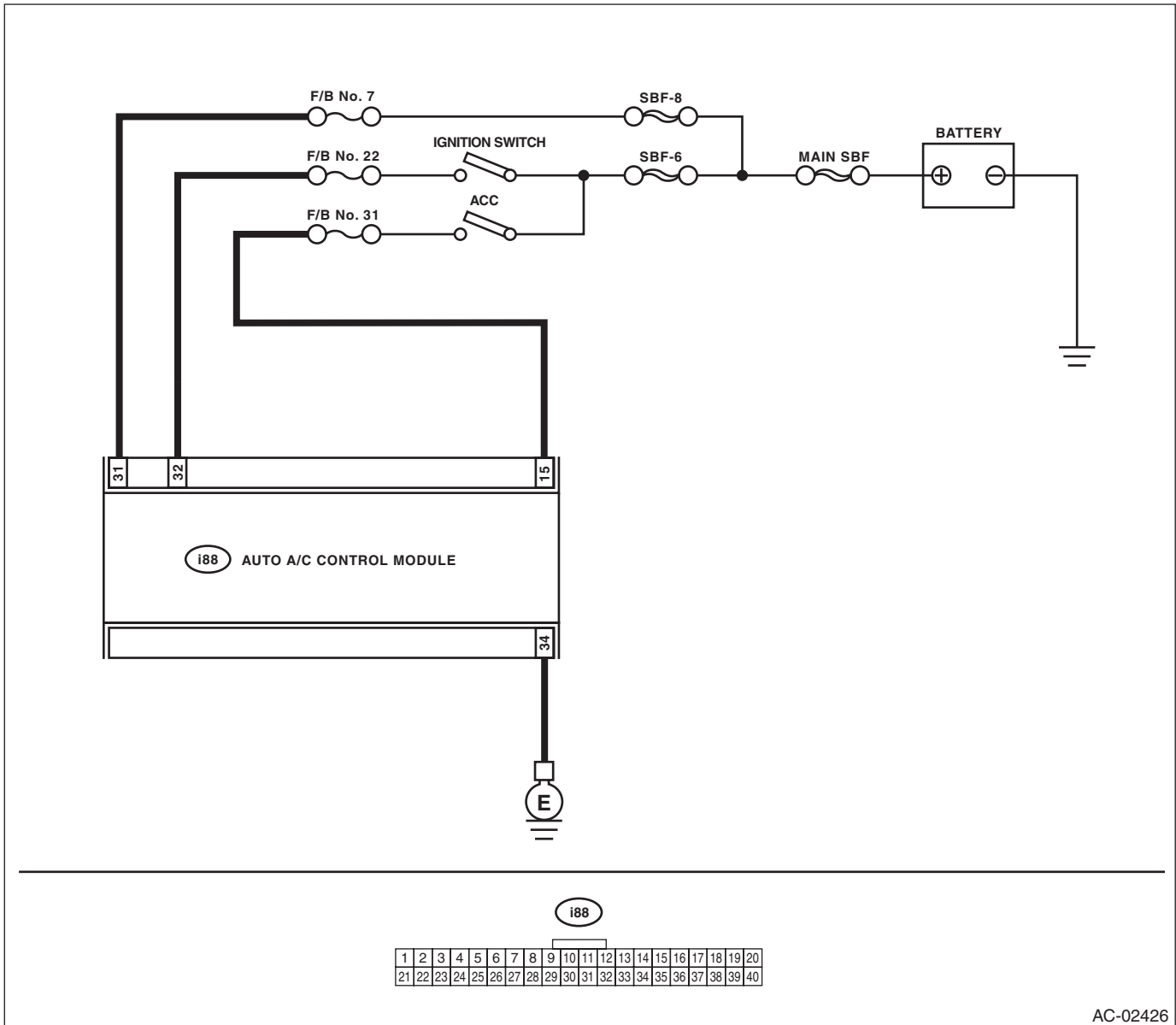

Step	Check	Yes	No
<b>1 CHECK FUSE.</b> 1) Turn the ignition switch to OFF. 2) Remove the fuse No. 7, No. 22 and No. 31 from fuse & relay box. 3) Check the condition of fuse.	Is the fuse blown out?	Replace the fuse.	Go to step 2.

## Diagnostics for A/C System Malfunction

### HVAC SYSTEM (AUTO A/C) (DIAGNOSTICS)

Step	Check	Yes	No
<b>2 CHECK A/C CONTROL MODULE POWER CIRCUIT.</b> 1) Remove the A/C control module. 2) Disconnect the A/C control module harness connector. 3) Turn the ignition switch to ACC, and measure the voltage between A/C control module harness connector terminal and chassis ground. <b>Connector &amp; terminal</b> <b>(i88) No. 15 (+) — Chassis ground (-):</b>	Is the voltage 10 V or more?	Go to step 3.	Check for open or short circuit in the harness between A/C control module and fuse.
<b>3 CHECK A/C CONTROL MODULE POWER CIRCUIT.</b> Measure the voltage between A/C control module harness connector terminal and chassis ground after turning the ignition switch to ON. <b>Connector &amp; terminal</b> <b>(i88) No. 32 (+) — Chassis ground (-):</b>	Is the voltage 10 V or more?	Go to step 4.	Check for open or short circuit in the harness between A/C control module and fuse.
<b>4 CHECK A/C CONTROL MODULE GROUND CIRCUIT.</b> Measure the resistance of harness between A/C control module and chassis ground after turning the ignition switch to OFF. <b>Connector &amp; terminal</b> <b>(i88) No. 34 — Chassis ground:</b>	Is the resistance less than 10 $\Omega$ ?	Go to step 5.	Repair the harness for ground line.
<b>5 CHECK FOR POOR CONTACT.</b> Check poor contact of auto A/C control module connector.	Is there poor contact of connector?	Repair the connector.	Replace the auto A/C control module. <Ref. to AC-32, REMOVAL, Control Unit (Auto A/C Model).>

# Diagnostics for A/C System Malfunction

HVAC SYSTEM (AUTO A/C) (DIAGNOSTICS)

## B: BLOWER MOTOR DOES NOT ROTATE

### TROUBLE SYMPTOM:

- Blower motor does not rotate.
- Blower motor does not change speeds.

### WIRING DIAGRAM:

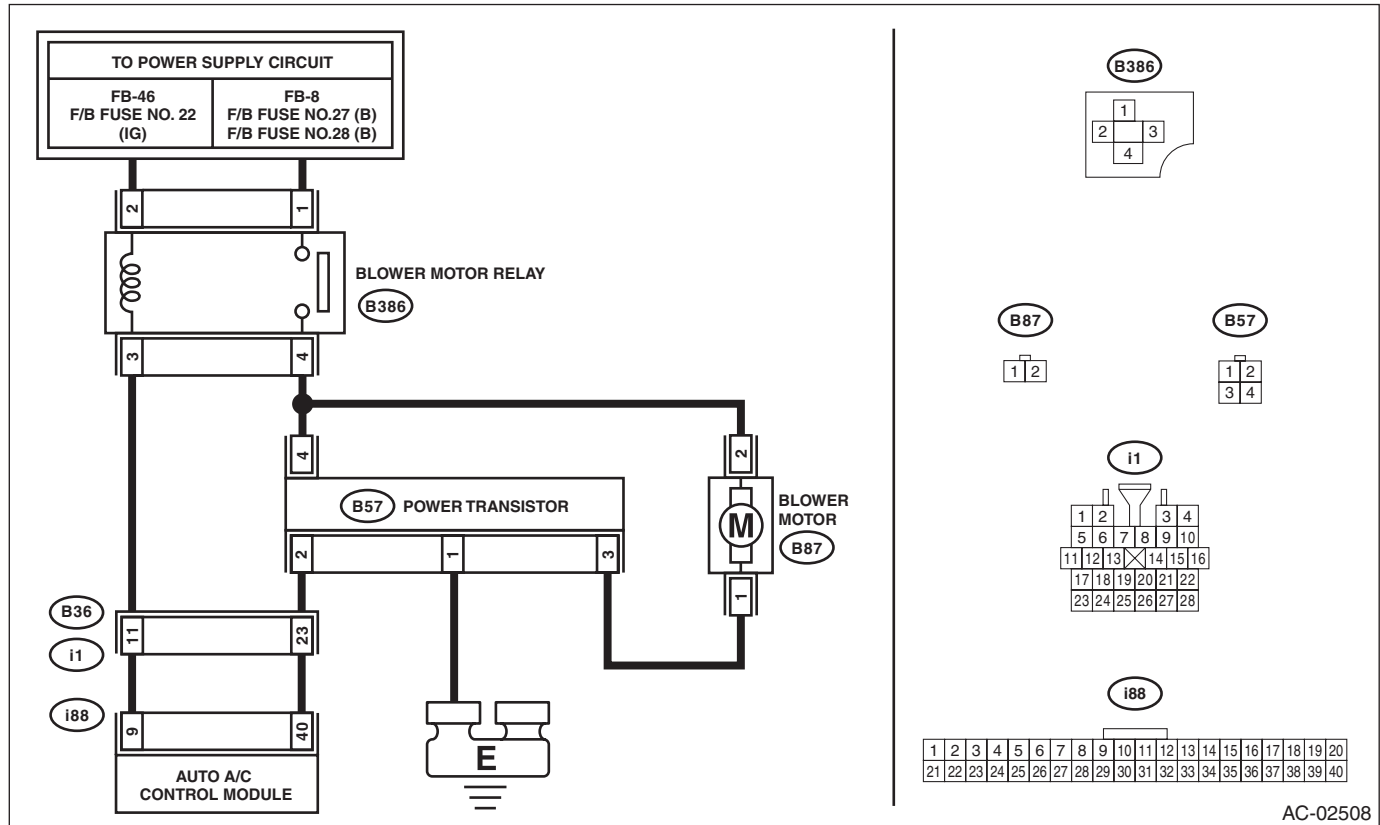

Step	Check	Yes	No
<b>1 CHECK FUSE.</b> 1) Remove fuse No. 22, 27 and 28 from fuse & relay box. 2) Check the condition of fuse.	Is any fuse blown out?	Replace the fuse.	Go to step 2.
<b>2 CHECK POWER SUPPLY OF BLOWER MOTOR RELAY.</b> 1) Turn the ignition switch to OFF. 2) Remove the blower motor relay. 3) Turn the ignition switch to ON. 4) Use a tester to measure the voltage between the blower motor relay connector and chassis ground. <b>Connector &amp; terminal</b> <b>(B386) No. 2 (+) — Chassis ground (-):</b>	Is the voltage 10 V or more?	Go to step 3.	Repair the open circuit of blower motor power supply line harness.
<b>3 CHECK BLOWER MOTOR RELAY.</b> 1) Turn the ignition switch to OFF. 2) Connect the battery positive terminal to the blower motor relay terminal No. 2, and the negative terminal to No. 3. 3) Using the tester, measure the resistance between terminals. <b>Connector &amp; terminal</b> <b>(Relay) No. 1 — No. 4:</b>	Is the resistance less than 1 Ω?	Go to step 4.	Replace the blower motor relay.



# Diagnostics for A/C System Malfunction

## HVAC SYSTEM (AUTO A/C) (DIAGNOSTICS)

Step	Check	Yes	No
<b>4 CHECK HARNESS.</b> 1) Remove the auto A/C control module. 2) Measure the resistance between auto A/C control module and relay using a tester. <b>Connector &amp; terminal</b> <b>(B386) No. 3 — (i88) No. 9:</b>	Is the resistance less than 1 $\Omega$ ?	Go to step 5.	Repair or replace the harness.
<b>5 CHECK BLOWER MOTOR POWER SUPPLY.</b> 1) Install the blower motor relay and auto A/C control module. 2) Turn the ignition switch to ON. 3) Turn the blower fan switch to ON. 4) Use a tester to measure the voltage between the blower motor and chassis ground. <b>Connector &amp; terminal</b> <b>(B87) No. 2 (+) — Chassis ground (-):</b>	Is the voltage 10 V or more?	Go to step 6.	Repair or replace the harness between relay and the blower motor.
<b>6 CHECK BLOWER MOTOR.</b> 1) Turn the ignition switch to OFF. 2) Disconnect the connector from blower motor. 3) Connect the battery positive terminal to the blower motor connector terminal No. 2, and the negative terminal to No. 1. 4) Make sure the blower motor runs.	Does the blower motor run?	Go to step 7.	Replace the blower motor. <Ref. to AC-27, REMOVAL, Blower Motor.>
<b>7 CHECK HARNESS.</b> 1) Disconnect the power transistor connector. 2) Disconnect the auto A/C control module connector. 3) Using the tester, measure the resistance between terminals of harness. <b>Connector &amp; terminal</b> <b>(B57) No. 1 — Chassis ground:</b> <b>(B57) No. 2 — (i88) No. 40:</b> <b>(B57) No. 3 — (B87) No. 1:</b> <b>(B57) No. 4 — (B87) No. 2:</b> <b>(B57) No. 4 — (B386) No. 5:</b>	Is the resistance less than 1 $\Omega$ ?	Go to step 8.	Repair or replace the harness.
<b>8 CHECK FAN CONTROL SIGNAL.</b> 1) Connect the disconnected connectors. 2) Turn the ignition switch to ON. 3) Change the fan speed control dial from 1st to 7th. 4) Measure the voltage between the power transistor and chassis ground using a tester. <b>Connector &amp; terminal</b> <b>(B57) No. 2 (+) — Chassis ground (-):</b>	Is the voltage approx. 10 V at 1st and approx. 1 V at 7th?	Replace the power transistor. <Ref. to AC-28, REMOVAL, Power Transistor (Auto A/C Model).>	Go to step 9.
<b>9 CHECK FOR POOR CONTACT.</b> Check poor contact of auto A/C control module connector.	Is there poor contact of connector?	Repair the connector.	Replace the auto A/C control module. <Ref. to AC-32, REMOVAL, Control Unit (Auto A/C Model).>

# Diagnostics for A/C System Malfunction

HVAC SYSTEM (AUTO A/C) (DIAGNOSTICS)

## C: BLOWER MOTOR TURNS AROUND EARLY

### TROUBLE SYMPTOM:

- The blower rotates even though the blower switch is not turned on.
- The blower motor continues to rotate at high speed. (Not adjustable.)

### WIRING DIAGRAM:

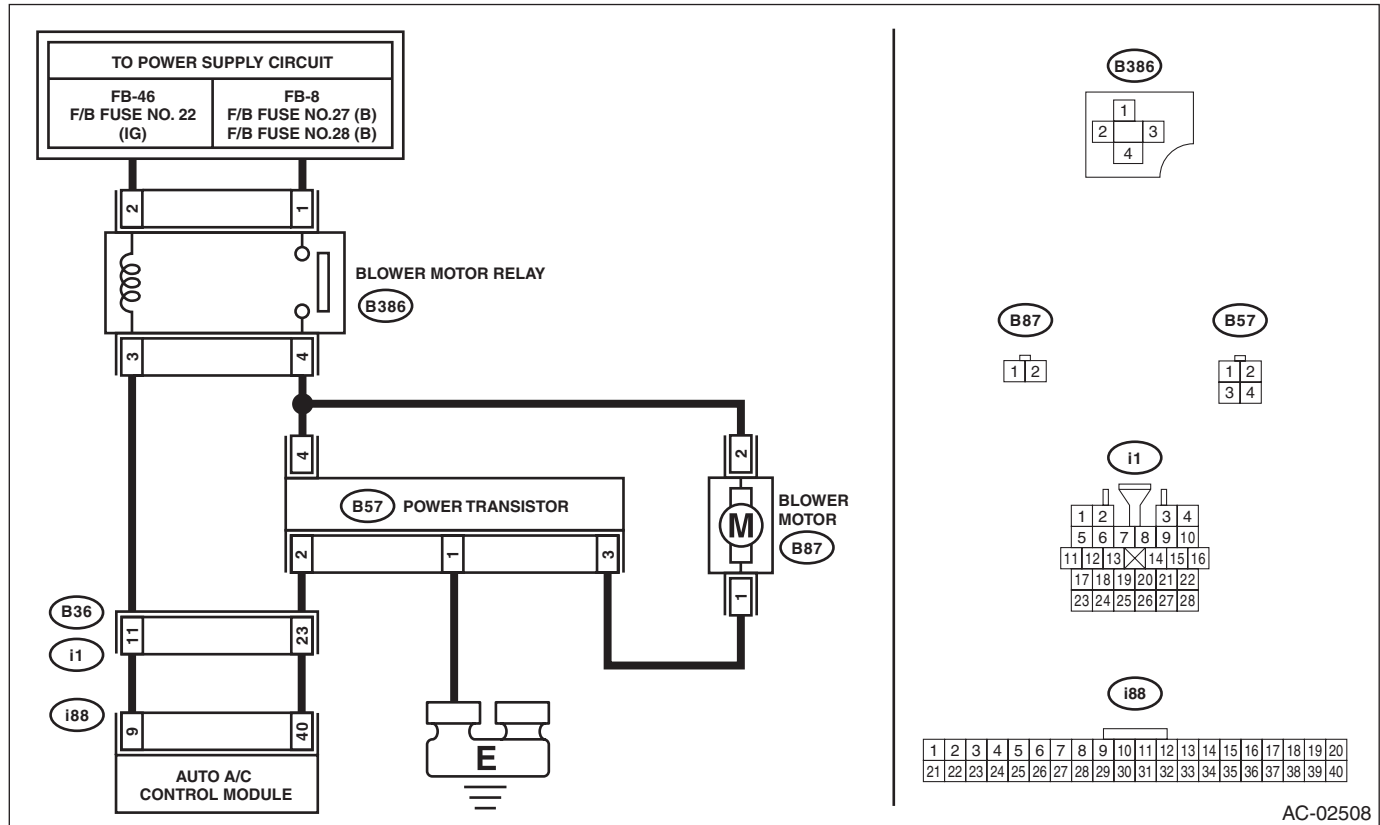

AC-02508

Step	Check	Yes	No
<b>1 CHECK BLOWER MOTOR CIRCUIT.</b> 1) Turn the ignition switch to OFF. 2) Disconnect the power transistor connector. 3) Use a tester to measure the resistance between the power transistor connector and chassis ground. <b>Connector &amp; terminal</b> <b>(B57) No. 3 — Chassis ground:</b>	Is there continuity?	Repair or replace the short circuit of the harness.	Go to step 2.
<b>2 CHECK HARNESS.</b> 1) Remove the auto A/C control module. 2) Use a tester to measure the resistance between the power transistor connector and chassis ground. <b>Connector &amp; terminal</b> <b>(B57) No. 2 — Chassis ground:</b>	Is there continuity?	Repair or replace the short circuit of the harness.	Go to step 3.
<b>3 CHECK POWER TRANSISTOR.</b> 1) Connect the disconnected connectors. 2) Turn the ignition switch to ON. 3) Use a tester to measure the voltage between the power transistor connector and chassis ground. <b>Connector &amp; terminal</b> <b>(B57) No. 2 (+) — Chassis ground (-):</b>	Is the voltage approx. 10 V when fan dial in 1st, and approx. 1 V when fan dial in 7th?	Replace the power transistor. <Ref. to AC-28, REMOVAL, Power Transistor (Auto A/C Model).>	Go to step 4.

## Diagnostics for A/C System Malfunction

### HVAC SYSTEM (AUTO A/C) (DIAGNOSTICS)

Step	Check	Yes	No
<b>4</b> <b>CHECK AUTO A/C CONTROL MODULE.</b> 1) Turn the fan dial OFF. 2) Disconnect the power transistor connector. 3) Use a tester to measure the resistance between the power transistor connector and chassis ground. <b>Connector &amp; terminal</b> <b>(B57) No. 2 — Chassis ground:</b>	When the fan dial is OFF and other than OFF, does the resistance change?	Replace the power transistor. <Ref. to AC-28, REMOVAL, Power Transistor (Auto A/C Model).>	Replace the auto A/C control module. <Ref. to AC-32, REMOVAL, Control Unit (Auto A/C Model).>

# Diagnostics for A/C System Malfunction

HVAC SYSTEM (AUTO A/C) (DIAGNOSTICS)

## D: COMPARTMENT TEMPERATURE DOES NOT CHANGE, OR A/C SYSTEM DOES NOT RESPOND PROMPTLY

### TROUBLE SYMPTOM:

- Compartment temperature does not change. (Cold air does not come out.)
- A/C system does not respond. (Response is extremely slow)

### WIRING DIAGRAM:

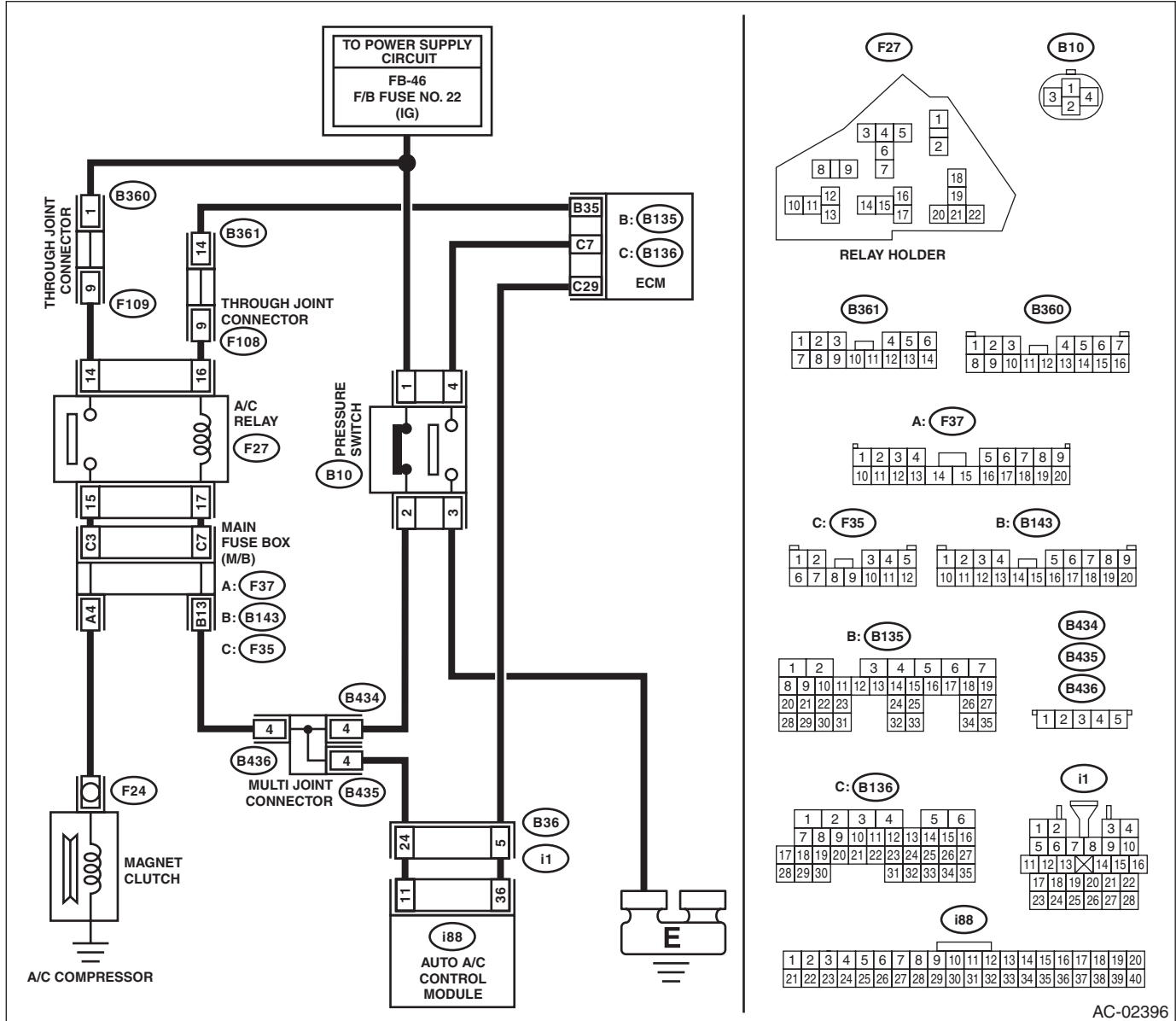

AC-02396

# Diagnostics for A/C System Malfunction

## HVAC SYSTEM (AUTO A/C) (DIAGNOSTICS)

Step	Check	Yes	No
<b>1 CHECK FUSE.</b> 1) Turn the ignition switch to OFF. 2) Remove the fuse No. 22 from fuse & relay box. 3) Check the condition of fuse.	Is the fuse blown out?	Replace the fuse.	Go to step 2.
<b>2 CHECK SIGNAL TO A/C RELAY AND AUTO A/C CONTROL MODULE.</b> 1) Disconnect the A/C relay and auto A/C control module harness connector. 2) Turn the ignition switch to ON. 3) Measure the voltage between A/C relay connector terminal and chassis ground. 4) Measure the voltage between auto A/C control module harness connector terminal and chassis ground. <b>Connector &amp; terminal</b> <b>(F27) No. 17 (+) — Chassis ground (-):</b> <b>(i88) No. 11 (+) — Chassis ground (-):</b>	Is the voltage 10 V or more?	Go to step 5.	Go to step 3.
<b>3 CHECK POWER SUPPLY FOR PRESSURE SWITCH.</b> 1) Turn the ignition switch to OFF. 2) Disconnect the pressure switch harness connector. 3) Turn the ignition switch to ON. 4) Measure the voltage between pressure switch harness connector terminal and chassis ground. <b>Connector &amp; terminal</b> <b>(B10) No. 2 (+) — Chassis ground (-):</b>	Is the voltage 10 V or more?	Go to step 4.	Check for open or short circuit in the harness between fuse and pressure switch.
<b>4 CHECK HARNESS BETWEEN PRESSURE SWITCH AND A/C RELAY, AUTO A/C CONTROL MODULE.</b> 1) Turn the ignition switch to OFF. 2) Measure the resistance of harness between pressure switch connector and A/C relay connector. 3) Measure the resistance of harness between pressure switch connector and auto A/C control module connector. <b>Connector &amp; terminal</b> <b>(B10) No. 2 — (F27) No. 17:</b> <b>(B10) No. 2 — (i88) No. 11:</b>	Is the resistance less than 1 $\Omega$ ?	Check the pressure switch. <Ref. to AC-42, INSPECTION, Pressure Switch (Triple Pressure Switch).>	Repair the harness.
<b>5 CHECK POWER SUPPLY FOR A/C RELAY.</b> Measure the voltage between A/C relay connector terminal and chassis ground. <b>Connector &amp; terminal</b> <b>(F27) No. 14 (+) — Chassis ground (-):</b>	Is the voltage 10 V or more?	Go to step 6.	Check open or short circuit of harness between fuse and A/C relay.
<b>6 CHECK A/C RELAY.</b> Check the A/C relay. <Ref. to AC-41, INSPECTION, Relay and Fuse.>	Is the A/C relay normal?	Go to step 7.	Replace the A/C relay.

# Diagnostics for A/C System Malfunction

HVAC SYSTEM (AUTO A/C) (DIAGNOSTICS)

Step	Check	Yes	No
<p><b>7 CHECK A/C ON SIGNAL.</b>                      1) Turn the ignition switch to OFF.                      2) Connect the A/C relay and all disconnected connectors.                      3) Start the engine and turn the A/C switch to ON.                      4) Turn the temperature control dial at maximum cool position.                      5) Measure the voltage between auto A/C control module harness connector terminal and chassis ground.  <b>Connector &amp; terminal</b>  <b>(i88) No. 36 (+) — Chassis ground (-):</b></p>	Is the voltage 5.5 V or more?	Go to step 8.	Replace the auto A/C control module. <Ref. to AC-32, REMOVAL, Control Unit (Auto A/C Model).>
<p><b>8 CHECK HARNESS BETWEEN AUTO A/C CONTROL MODULE AND ECM.</b>                      1) Turn the ignition switch to OFF.                      2) Disconnect the harness connector of auto A/C control module and ECM.                      3) Measure the resistance of harness between auto A/C control module connector and ECM connector.  <b>Connector &amp; terminal</b>  <b>(i88) No. 36 — (B136) No. 29:</b></p>	Is the resistance less than 1 Ω?	Go to step 9.	Repair the harness.
<p><b>9 CHECK MAGNET CLUTCH ON SIGNAL.</b>                      1) Stop the engine and turn the A/C switch to OFF.                      2) Turn the ignition switch to ON.                      3) Measure the voltage between ECM connector terminal and chassis ground.  <b>Connector &amp; terminal</b>  <b>(B135) No. 35 (+) — Chassis ground (-):</b></p>	Is the voltage 10 V or more?	Go to step 10.	Check for open or short circuit in the harness between A/C relay and ECM.
<p><b>10 CHECK MAGNET CLUTCH ON SIGNAL.</b>                      1) Start the engine and turn the A/C switch to ON.                      2) Turn the temperature control dial at maximum cool position.                      3) Measure the voltage between ECM connector terminal and chassis ground.  <b>Connector &amp; terminal</b>  <b>(B135) No. 35 (+) — Chassis ground (-):</b></p>	Is the voltage 0 V?	Go to step 11.	Replace the ECM. <Ref. to FU(STI)-59, REMOVAL, Engine Control Module (ECM).> <Ref. to FU(w/o STI)-58, REMOVAL, Engine Control Module (ECM).>
<p><b>11 CHECK POWER SUPPLY FOR MAGNET CLUTCH.</b>                      1) Stop the engine and turn the A/C switch to OFF.                      2) Disconnect the harness connector of magnet clutch.                      3) Start the engine and turn the A/C switch to ON.                      4) Turn the temperature control dial at maximum cool position.                      5) Measure the voltage between magnet clutch harness connector terminal and chassis ground.  <b>Connector &amp; terminal</b>  <b>(F24) No. 1 (+) — Chassis ground (-):</b></p>	Is the voltage 10 V or more?	Inspect the compressor. <Ref. to AC-33, INSPECTION, Compressor.>	Check for open or short circuit in the harness between A/C relay and magnet clutch.

# Diagnostics for A/C System Malfunction

HVAC SYSTEM (AUTO A/C) (DIAGNOSTICS)

## E: FRESH/RECIRC SWITCH LIGHT IS BLINKING

### TROUBLE SYMPTOM:

FRESH/RECIRC switch indicator blinks when the ignition switch is turned from OFF to ON.

### NOTE:

When the ignition switch is turned from OFF to ON immediately after the reconnection of the battery or when the battery power supply voltage is low (battery voltage: 9 V or less), the indicator may blink. Throughout this blinking period, the system recognizes the specified position of the air mix door actuator and mode door actuator. So, this is not a malfunction. (number of blinking: 12 at 0.5 second intervals)

### WIRING DIAGRAM:

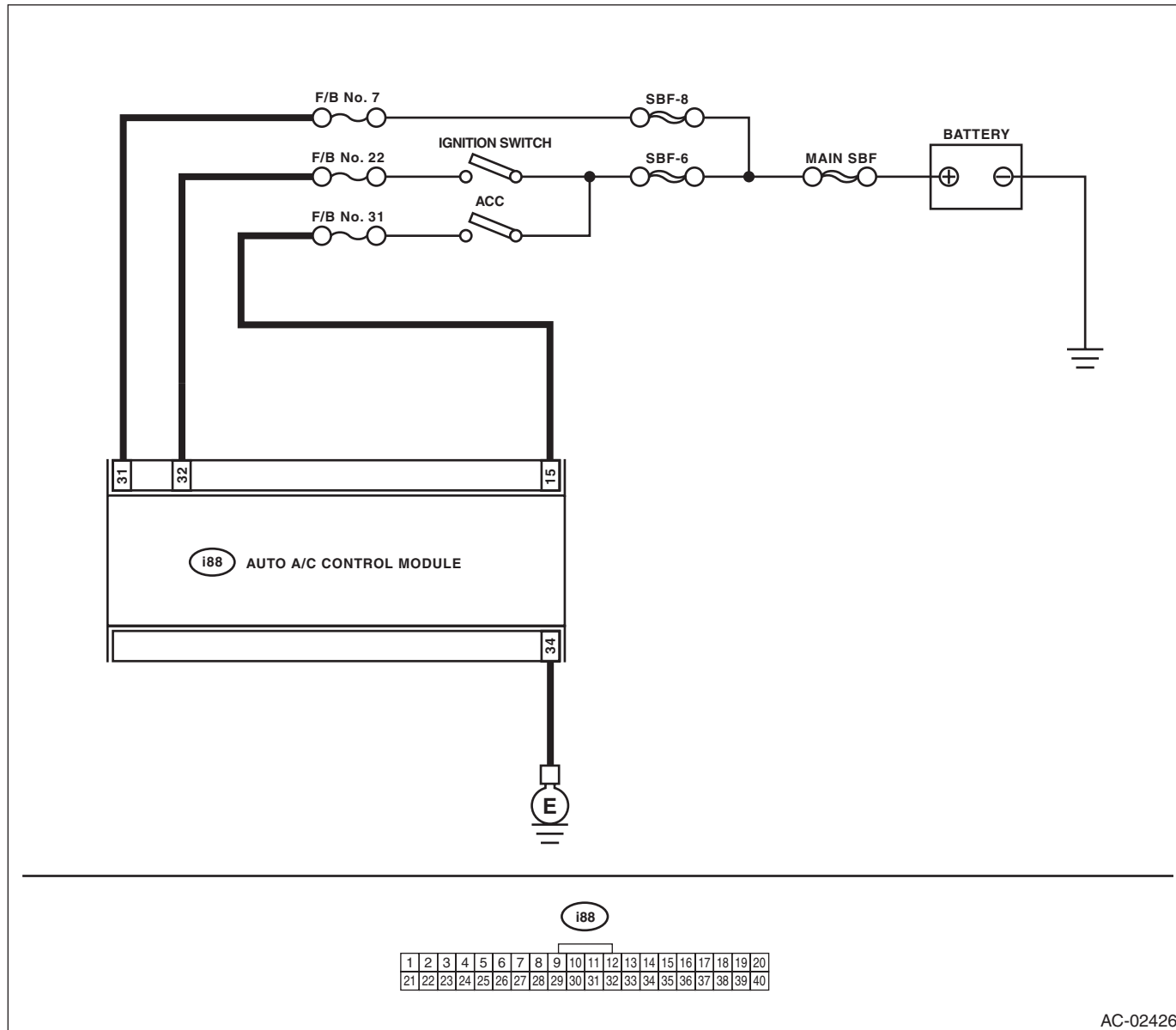

Step	Check	Yes	No
1	<b>CHECK INDICATOR BLINKING.</b> Turn the ignition switch to ON.	Go to step 2.	System is normal.
2	<b>CHECK INDICATOR BLINKING.</b> 1) Turn the ignition switch to OFF and wait for 3 minutes. 2) Turn the ignition switch to ON again.	Go to step 3.	System is normal.

# Diagnostics for A/C System Malfunction

HVAC SYSTEM (AUTO A/C) (DIAGNOSTICS)

Step	Check	Yes	No
<b>3</b> <b>CHECK AUTO A/C CONTROL MODULE POWER CIRCUIT.</b> 1) Turn the ignition switch to OFF. 2) Disconnect the auto A/C control module harness connector. 3) Measure the voltage between auto A/C control module and chassis ground after turning the ignition switch to the ON position. <b>Connector &amp; terminal</b> <b>(i88) No. 31 (+) — Chassis ground (-):</b>	Is the voltage 9 V or less?	Check the harness for open or short circuit. Check the battery condition.	System is normal.



# Diagnostic Procedure for Actuators

HVAC SYSTEM (AUTO A/C) (DIAGNOSTICS)

## 7. Diagnostic Procedure for Actuators

### A: INTAKE DOOR ACTUATOR

#### TROUBLE SYMPTOM:

FRESH/RECIRC mode is not changed.

#### WIRING DIAGRAM:

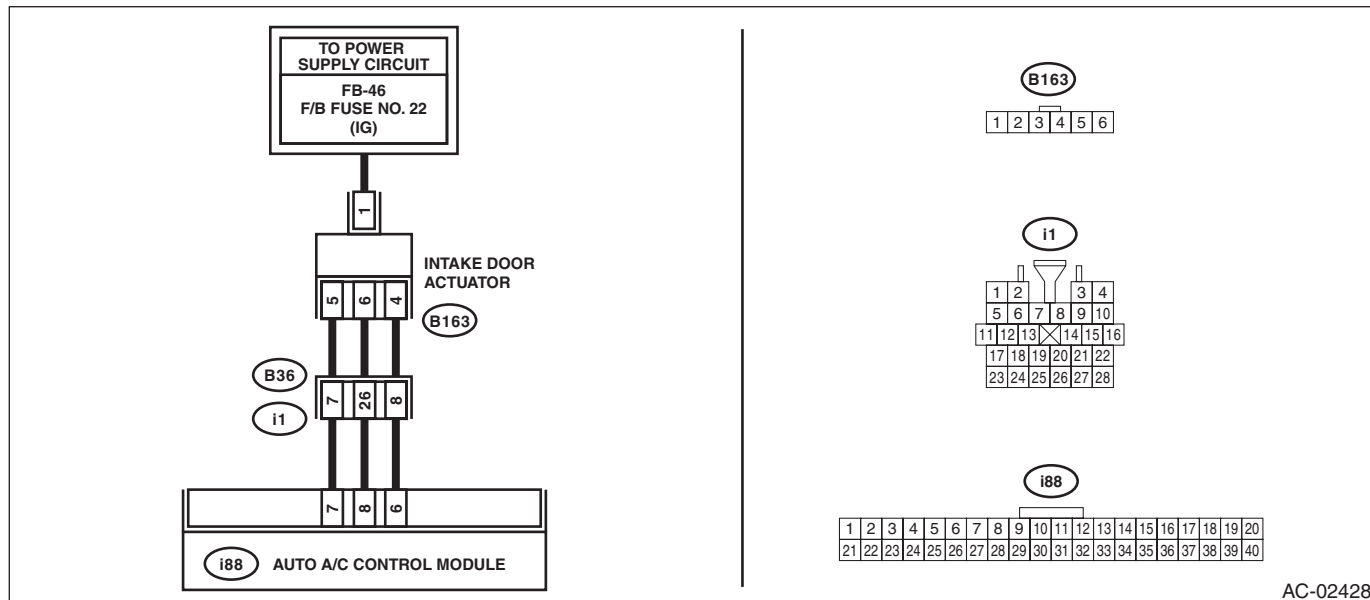

AC-02428

Step	Check	Yes	No
<b>1</b> <b>CHECK POWER SUPPLY FOR INTAKE DOOR ACTUATOR.</b> 1) Turn the ignition switch to OFF. 2) Disconnect the intake door actuator connector. 3) Turn the ignition switch to ON. 4) Measure the voltage between intake door actuator connector and chassis ground. <b>Connector &amp; terminal</b> <b>(B163) No. 1 (+) — Chassis ground (-):</b>	Is the voltage approx. 10 V or more?	Go to step 2.	Check for open or short circuit in the harness between intake door actuator and fuse.
<b>2</b> <b>CHECK HARNESS BETWEEN AUTO A/C CONTROL MODULE AND INTAKE DOOR ACTUATOR.</b> 1) Turn the ignition switch to OFF. 2) Disconnect the auto A/C control module connector. 3) Measure the resistance between intake door actuator connector and auto A/C control module connector. <b>Connector &amp; terminal</b> <b>(i88) No. 8 — (B163) No. 6:</b> <b>(i88) No. 7 — (B163) No. 5:</b> <b>(i88) No. 6 — (B163) No. 4:</b>	Is the resistance less than 1 Ω?	Go to step 3.	Repair the harness between auto A/C control module and intake door actuator.
<b>3</b> <b>CHECK OPERATION OF INTAKE DOOR ACTUATOR.</b> 1) Connect the intake door actuator connector. 2) Ground the auto A/C control module connector with a suitable wire. 3) Turn the ignition switch to ON, and check the operation of intake door actuator. <b>Connector &amp; terminal</b> <b>(i88) No. 6 — Chassis ground:</b>	Does the actuator move to the FRESH side?	Go to step 4.	Replace the intake door actuator.

# Diagnostic Procedure for Actuators

HVAC SYSTEM (AUTO A/C) (DIAGNOSTICS)

Step	Check	Yes	No
<p><b>4</b>     <b>CHECK OPERATION OF INTAKE DOOR ACTUATOR.</b> 1) Turn the ignition switch to OFF. 2) Ground the auto A/C control module connector with a suitable wire. 3) Turn the ignition switch to ON, and check the operation of intake door actuator. <b>Connector &amp; terminal:</b> <b>(i88) No. 8 — Chassis ground:</b></p>	<p>Does the actuator move to the RECIRC side?</p>	<p>Replace the auto A/C control module. &lt;Ref. to AC-32, REMOVAL, Control Unit (Auto A/C Model).&gt;</p>	<p>Replace the intake door actuator.</p>

# Diagnostic Procedure for Actuators

HVAC SYSTEM (AUTO A/C) (DIAGNOSTICS)

## B: MODE DOOR ACTUATOR

### TROUBLE SYMPTOM:

Air flow outlet is not changed.

### WIRING DIAGRAM:

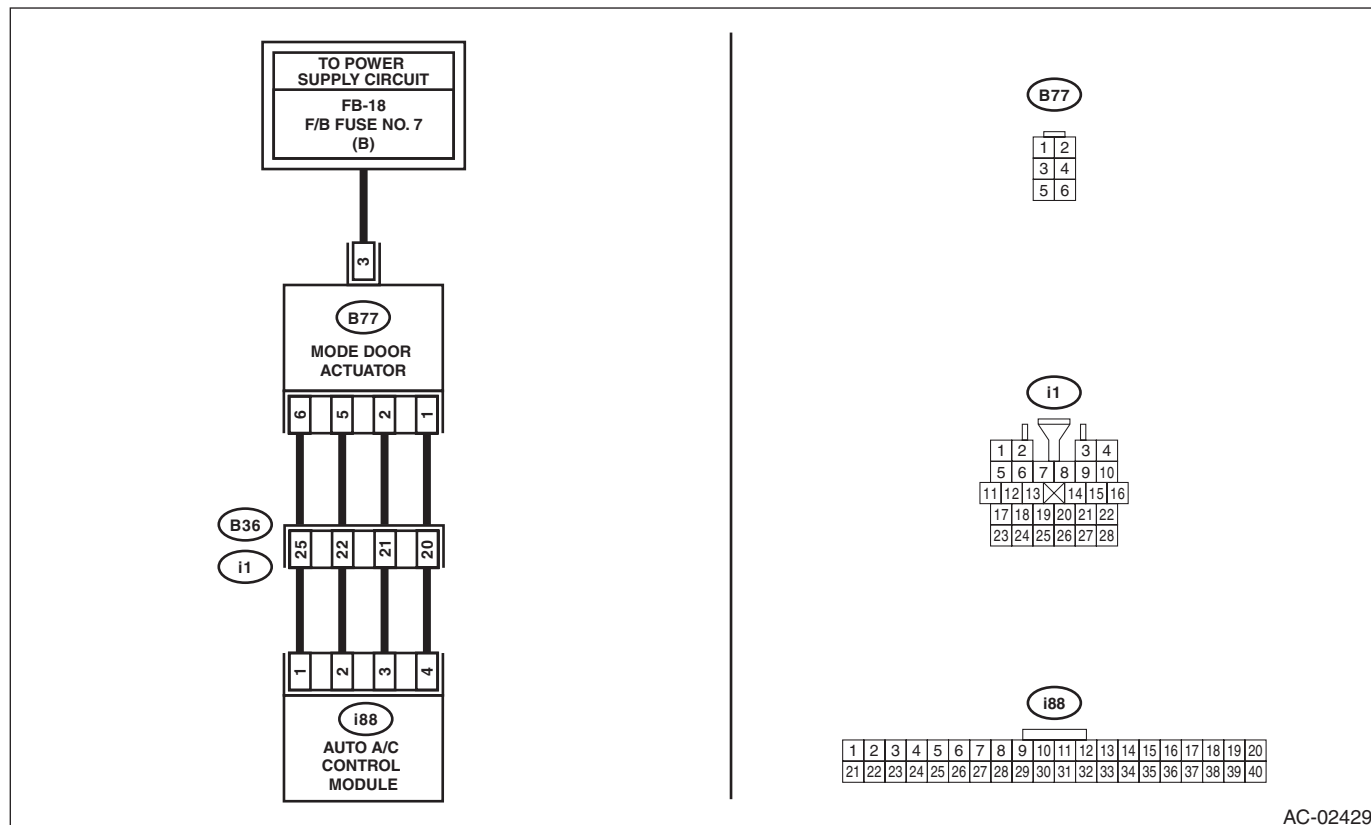

AC-02429

Step	Check	Yes	No
<b>1 CHECK POWER SUPPLY FOR MODE DOOR ACTUATOR.</b> 1) Turn the ignition switch to OFF. 2) Disconnect the mode door actuator connector. 3) Turn the ignition switch to ON. 4) Measure the voltage between the mode door actuator connector terminal and chassis ground. <i>Connector &amp; terminal</i> <i>(B77) No. 3 (+) — Chassis ground (-):</i>	Is the voltage approx. 10 V or more?	Go to step 2.	Check the DC power supply circuit.
<b>2 CHECK MODE DOOR ACTUATOR.</b> 1) Turn the ignition switch to OFF. 2) Measure the resistance between mode door actuator terminals using a tester. <i>Connector &amp; terminal</i> <i>(B77) No. 3 — No. 1:</i> <i>(B77) No. 3 — No. 2:</i> <i>(B77) No. 3 — No. 5:</i> <i>(B77) No. 3 — No. 6:</i>	Is the resistance 80 — 100 Ω?	Go to step 3.	Replace the mode door actuator.

# Diagnostic Procedure for Actuators

HVAC SYSTEM (AUTO A/C) (DIAGNOSTICS)

Step	Check	Yes	No
<p><b>3</b></p> <p><b>CHECK HARNESS BETWEEN AUTO A/C CONTROL MODULE AND MODE DOOR ACTUATOR.</b></p> <p>1) Disconnect the auto A/C control module connector.</p> <p>2) Measure the resistance between auto A/C control module and mode door actuator connector.</p> <p><b>Connector &amp; terminal</b>  <b>(B77) No. 1 — (i88) No. 4:</b>  <b>(B77) No. 2 — (i88) No. 3:</b>  <b>(B77) No. 5 — (i88) No. 2:</b>  <b>(B77) No. 6 — (i88) No. 1:</b></p>	<p>Is the resistance less than 1 <math>\Omega</math>?</p>	<p>Go to step 4.</p>	<p>Repair the harness between auto A/C control module and mode door actuator.</p>
<p><b>4</b></p> <p><b>CHECK FOR POOR CONTACT.</b>            Check poor contact of auto A/C control module and connector.</p>	<p>Is there poor contact of connector?</p>	<p>Repair the connector.</p>	<p>Replace the auto A/C control module. &lt;Ref. to AC-32, REMOVAL, Control Unit (Auto A/C Model).&gt;</p>

# Diagnostic Procedure for Actuators

HVAC SYSTEM (AUTO A/C) (DIAGNOSTICS)

## C: AIR MIX DOOR ACTUATOR

### TROUBLE SYMPTOM:

Outlet air temperature does not change.

### WIRING DIAGRAM:

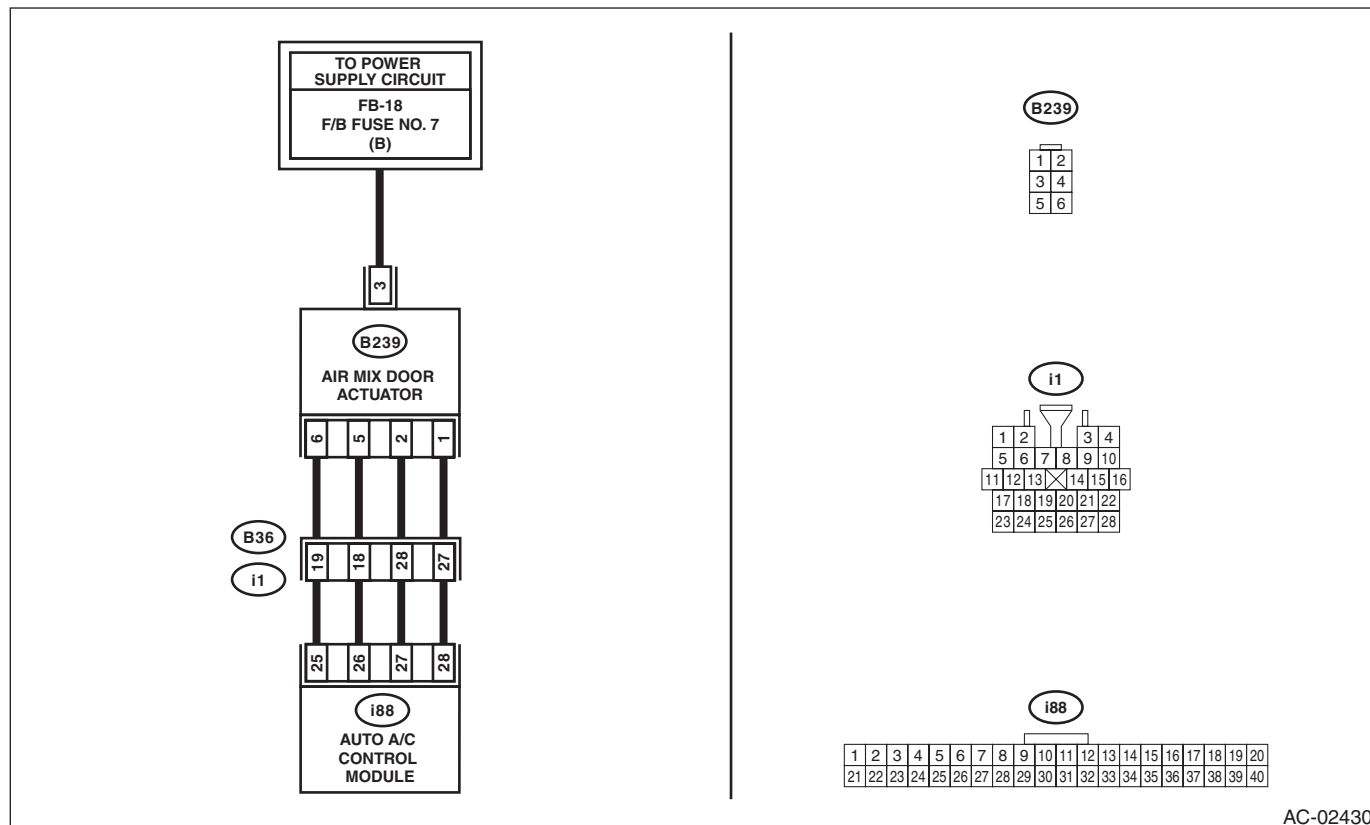

AC-02430

Step	Check	Yes	No
<b>1 CHECK POWER SUPPLY OF AIR MIX DOOR ACTUATOR.</b> 1) Turn the ignition switch to OFF. 2) Disconnect the air mix door actuator connector. 3) Turn the ignition switch to ON. 4) Measure the voltage between the air mix door actuator connector terminal and chassis ground. <i>Connector &amp; terminal</i> <i>(B239) No. 3 (+) — Chassis ground (-):</i>	Is the voltage approx. 10 V or more?	Go to step 2.	Check the DC power supply circuit.
<b>2 CHECK AIR MIX DOOR ACTUATOR.</b> 1) Turn the ignition switch to OFF. 2) Measure the resistance between air mix door actuator terminals using a tester. <i>Connector &amp; terminal</i> <i>(B239) No. 3 — No. 1:</i> <i>(B239) No. 3 — No. 2:</i> <i>(B239) No. 3 — No. 5:</i> <i>(B239) No. 3 — No. 6:</i>	Is the resistance 80 — 100 Ω?	Go to step 3.	Replace the air mix door actuator.

# Diagnostic Procedure for Actuators

HVAC SYSTEM (AUTO A/C) (DIAGNOSTICS)

Step	Check	Yes	No
<b>3</b> <b>CHECK HARNESS BETWEEN AUTO A/C CONTROL MODULE AND AIR MIX DOOR ACTUATOR.</b> 1) Disconnect the auto A/C control module connector. 2) Measure the resistance between auto A/C control module and air mix door actuator connector. <b>Connector &amp; terminal</b> <i>(B239) No. 1 — (i88) No. 28:</i> <i>(B239) No. 2 — (i88) No. 27:</i> <i>(B239) No. 5 — (i88) No. 26:</i> <i>(B239) No. 6 — (i88) No. 25:</i>	Is the resistance less than 1 $\Omega$ ?	Go to step 4.	Repair the harness between auto A/C control module and air mix door actuator.
<b>4</b> <b>CHECK FOR POOR CONTACT.</b> Check poor contact of auto A/C control module and connector.	Is there poor contact of connector?	Repair the connector.	Replace the auto A/C control module. <Ref. to AC-32, REMOVAL, Control Unit (Auto A/C Model).>

# Diagnostic Procedure for Sensors

HVAC SYSTEM (AUTO A/C) (DIAGNOSTICS)

## 8. Diagnostic Procedure for Sensors

### A: AMBIENT SENSOR

#### TROUBLE SYMPTOM:

- Fan speed is not switched when the fan dial is in AUTO position.
- Failure related to the ambient sensor is indicated in self-diagnosis.

#### WIRING DIAGRAM:

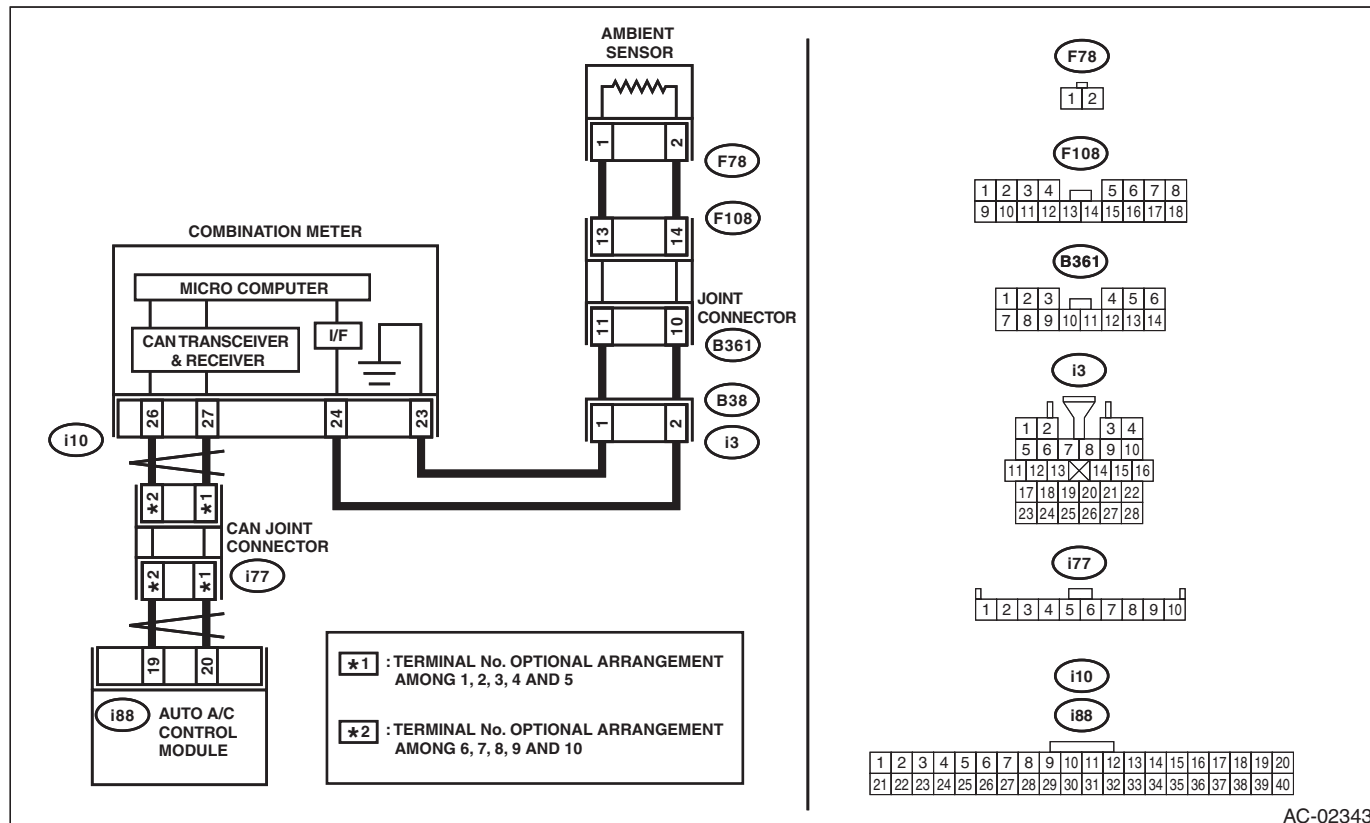

AC-02343

Step	Check	Yes	No
<b>1 CHECK AMBIENT SENSOR.</b> Perform the inspection of ambient sensor unit. <Ref. to AC-44, INSPECTION, Ambient Sensor (Auto A/C Model).>	Is the ambient sensor operating properly?	Go to step 2.	Replace the ambient sensor. <Ref. to AC-43, REMOVAL, Ambient Sensor (Auto A/C Model).>
<b>2 CHECK INPUT SIGNAL FOR AMBIENT SENSOR.</b> 1) Turn the ignition to ON. 2) Measure the voltage between connector (F78) terminals. <b>Connector &amp; terminal (F78) No. 2 (+) — No. 1 (-):</b>	Is the voltage approx. 5 V?	Go to step 6.	Go to step 3.

# Diagnostic Procedure for Sensors

HVAC SYSTEM (AUTO A/C) (DIAGNOSTICS)

Step	Check	Yes	No
<b>3 CHECK COMBINATION METER OUTPUT SIGNAL.</b> 1) Turn the ignition switch to OFF. 2) Pull out the combination meter. 3) Disconnect the connector from ambient sensor. 4) Turn the ignition switch to ON. 5) Measure the voltage between the combination meter connector terminals. <i>Connector &amp; terminal (i10) No. 24 (+) — No. 23 (-):</i>	Is the voltage approx. 5 V?	Go to step 4.	Replace the combination meter. <Ref. to IDI-16, REMOVAL, Combination Meter.>
<b>4 CHECK HARNESS CONNECTOR BETWEEN COMBINATION METER AND AMBIENT SENSOR.</b> 1) Turn the ignition switch to OFF. 2) Disconnect the connector from the combination meter. 3) Measure the resistance of harness between combination meter and ambient sensor. <i>Connector &amp; terminal (F78) No. 2 — (i10) No. 24:</i>	Is the resistance less than 1 $\Omega$ ?	Go to step 5.	Repair the open circuit of the harness between the combination meter and ambient sensor.
<b>5 CHECK HARNESS CONNECTOR BETWEEN COMBINATION METER AND AMBIENT SENSOR.</b> Measure the resistance of harness between combination meter and ambient sensor. <i>Connector &amp; terminal (F78) No. 1 — (i10) No. 23:</i>	Is the resistance less than 1 $\Omega$ ?	Replace the combination meter. <Ref. to IDI-16, REMOVAL, Combination Meter.>	Repair the open circuit of the harness between the combination meter and ambient sensor.
<b>6 CHECK HARNESS CONNECTOR BETWEEN COMBINATION METER AND AUTO A/C CONTROL MODULE.</b> 1) Turn the ignition switch to OFF. 2) Disconnect the connector from the combination meter. 3) Disconnect the auto A/C control module connector. 4) Measure the resistance of harness between the combination meter and auto A/C control module. <i>Connector &amp; terminal (i88) No. 19 — (i10) No. 26:</i>	Is the resistance less than 1 $\Omega$ ?	Go to step 7.	Repair the open circuit in the harness between the combination meter and auto A/C control module. <Ref. to LAN(diag)-6, LAN SYSTEM, CAUTION, General Description.>
<b>7 CHECK HARNESS CONNECTOR BETWEEN COMBINATION METER AND AUTO A/C CONTROL MODULE.</b> Measure the resistance of harness between the combination meter and auto A/C control module. <i>Connector &amp; terminal (i88) No. 20 — (i10) No. 27:</i>	Is the resistance less than 1 $\Omega$ ?	Go to step 8.	Repair the open circuit in the harness between the combination meter and auto A/C control module. <Ref. to LAN(diag)-6, LAN SYSTEM, CAUTION, General Description.>
<b>8 CHECK FOR POOR CONTACT.</b> Check poor contact of auto A/C control module connector.	Is there poor contact of connector?	Repair the connector.	Replace the auto A/C control module. <Ref. to AC-32, REMOVAL, Control Unit (Auto A/C Model).>



# Diagnostic Procedure for Sensors

HVAC SYSTEM (AUTO A/C) (DIAGNOSTICS)

## B: IN-VEHICLE SENSOR

### TROUBLE SYMPTOM:

- Blower fan speed, air flow outlet and FRESH/RECIRC do not change after turning the AUTO switch to ON.
- Failure related to the in-vehicle sensor is indicated in self-diagnosis.

### WIRING DIAGRAM:

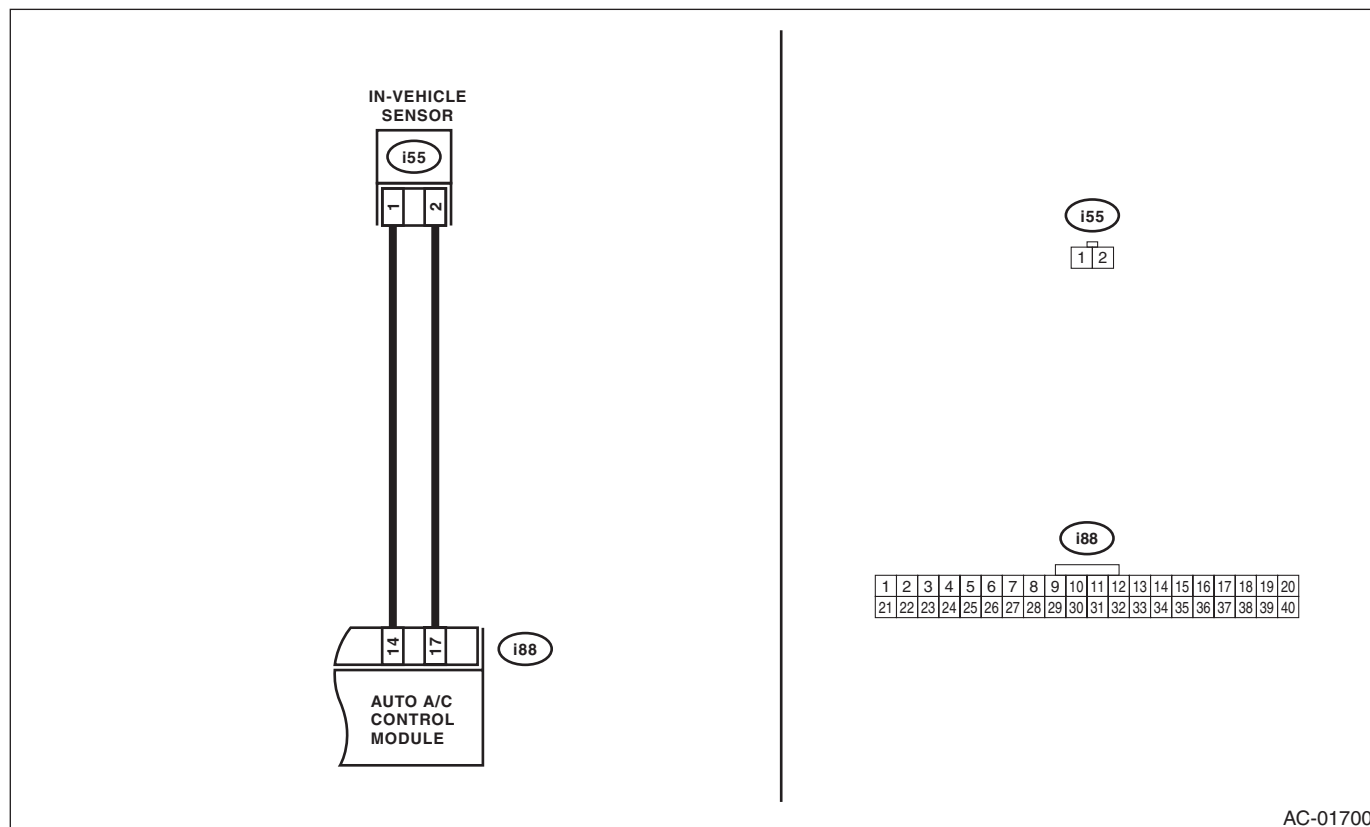

AC-01700

Step	Check	Yes	No
<b>1 CHECK IN-VEHICLE SENSOR.</b> Perform the inspection of in-vehicle sensor unit. <Ref. to AC-47, INSPECTION, In-Vehicle Sensor (Auto A/C Model).>	Is the in-vehicle sensor normal?	Go to step 2.	Replace the in-vehicle sensor. <Ref. to AC-46, REMOVAL, In-Vehicle Sensor (Auto A/C Model).>
<b>2 CHECK INPUT SIGNAL FOR IN-VEHICLE SENSOR.</b> 1) Turn the ignition switch to ON. 2) Measure the voltage between in-vehicle sensor harness connector terminals. <b>Connector &amp; terminal</b> <i>(i55) No. 2 (+) — No. 1 (-):</i>	Is the voltage approx. 5 V?	Go to step 6.	Go to step 3.
<b>3 CHECK AUTO A/C CONTROL MODULE OUTPUT SIGNAL.</b> 1) Turn the ignition switch to OFF. 2) Remove the auto A/C control module. 3) Turn the ignition switch to ON. 4) Measure the voltage between connector terminals of auto A/C control module. <b>Connector &amp; terminal</b> <i>(i88) No. 17 (+) — (i88) No. 14 (-):</i>	Is the voltage approx. 5 V?	Go to step 4.	Go to step 6.

# Diagnostic Procedure for Sensors

HVAC SYSTEM (AUTO A/C) (DIAGNOSTICS)

Step	Check	Yes	No
<b>4</b> <b>CHECK HARNESS BETWEEN AUTO A/C CONTROL MODULE AND IN-VEHICLE SENSOR.</b> 1) Turn the ignition switch to OFF. 2) Disconnect the connector from the auto A/C control module. 3) Measure the resistance of harness between auto A/C control module and in-vehicle sensor. <b>Connector &amp; terminal</b> <i>(i55) No. 2 — (i88) No. 17:</i>	Is the resistance less than 1 $\Omega$ ?	Go to step 5.	Repair the harness between auto A/C control module and in-vehicle sensor.
<b>5</b> <b>CHECK HARNESS BETWEEN AUTO A/C CONTROL MODULE AND IN-VEHICLE SENSOR.</b> Measure the resistance of harness between auto A/C control module and in-vehicle sensor. <b>Connector &amp; terminal</b> <i>(i55) No. 1 — (i88) No. 14:</i>	Is the resistance less than 1 $\Omega$ ?	Go to step 6.	Repair the harness between auto A/C control module and in-vehicle sensor.
<b>6</b> <b>CHECK FOR POOR CONTACT.</b> Check poor contact of auto A/C control module connector.	Is there poor contact of connector?	Repair the connector.	Replace the auto A/C control module. <Ref. to AC-32, REMOVAL, Control Unit (Auto A/C Model).>

# Diagnostic Procedure for Sensors

HVAC SYSTEM (AUTO A/C) (DIAGNOSTICS)

## C: EVAPORATOR SENSOR

### WIRING DIAGRAM:

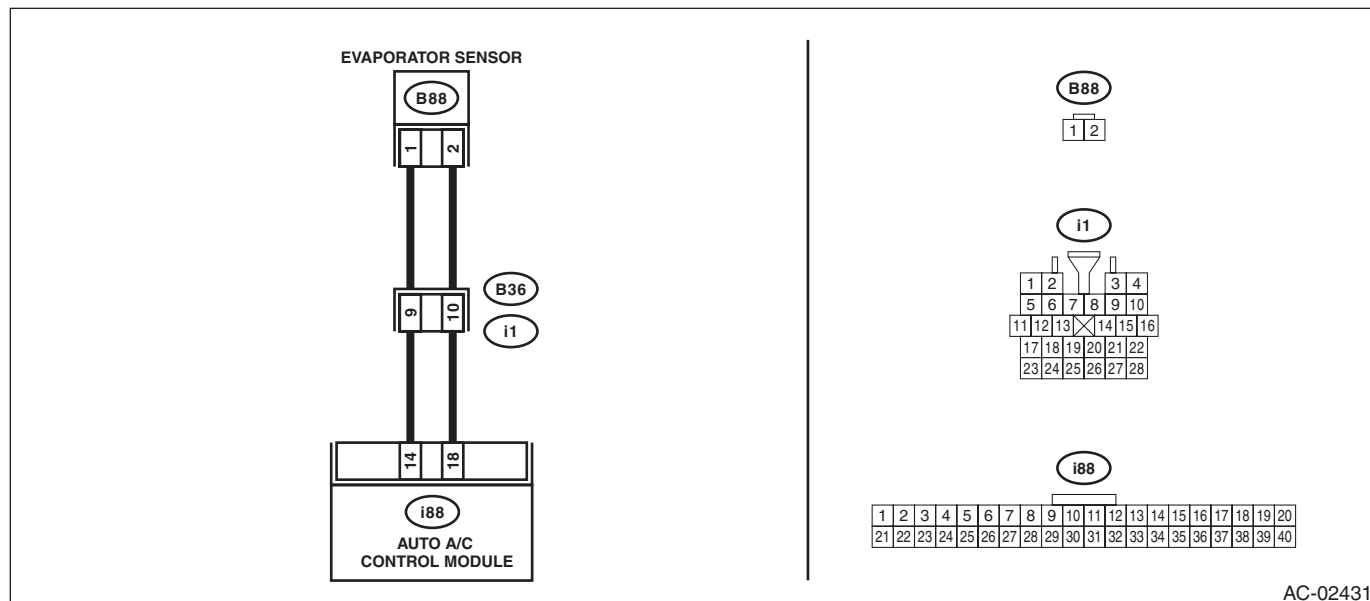

AC-02431

Step	Check	Yes	No
<b>1 CHECK EVAPORATOR SENSOR.</b> Perform the inspection of evaporator sensor unit. <Ref. to AC-39, EVAPORATOR SENSOR, INSPECTION, Evaporator.>	Is the evaporator sensor normal?	Go to step 2.	Replace the evaporator sensor. <Ref. to AC-36, REMOVAL, Evaporator.>
<b>2 CHECK INPUT SIGNAL FOR EVAPORATOR SENSOR.</b> 1) Turn the ignition switch to ON. 2) Measure the voltage between connector (B88) terminals. <b>Connector &amp; terminal</b> <b>(B88) No. 2 (+) — No. 1 (-):</b>	Is the voltage approx. 5 V?	Go to step 6.	Go to step 3.
<b>3 CHECK AUTO A/C CONTROL MODULE OUTPUT SIGNAL.</b> 1) Turn the ignition switch to OFF. 2) Remove the auto A/C control module. 3) Turn the ignition switch to ON. 4) Measure the voltage between connector terminals of auto A/C control module. <b>Connector &amp; terminal</b> <b>(i88) No. 18 (+) — (i88) No. 14 (-):</b>	Is the voltage approx. 5 V?	Go to step 4.	Go to step 6.
<b>4 CHECK HARNESS CONNECTOR BETWEEN AUTO A/C CONTROL MODULE AND EVAPORATOR SENSOR.</b> 1) Turn the ignition switch to OFF. 2) Disconnect the connector from the auto A/C control module. 3) Measure the resistance of harness between auto A/C control module and evaporator sensor. <b>Connector &amp; terminal</b> <b>(B88) No. 2 — (i88) No. 18:</b>	Is the resistance less than 1 $\Omega$ ?	Go to step 5.	Repair the open circuit of harness between auto A/C control module and evaporator sensor.

# Diagnostic Procedure for Sensors

HVAC SYSTEM (AUTO A/C) (DIAGNOSTICS)

Step	Check	Yes	No
<b>5</b> <b>CHECK HARNESS CONNECTOR BETWEEN AUTO A/C CONTROL MODULE AND EVAPORATOR SENSOR.</b> Measure the resistance of harness between auto A/C control module and evaporator sensor. <b>Connector &amp; terminal</b> <b>(B88) No. 1 — (i88) No. 14:</b>	Is the resistance less than 1 $\Omega$ ?	Go to step 6.	Repair the open circuit of harness between auto A/C control module and evaporator sensor.
<b>6</b> <b>CHECK FOR POOR CONTACT.</b> Check poor contact of auto A/C control module connector.	Is there poor contact of connector?	Repair the connector.	Replace the auto A/C control module. <Ref. to AC-32, REMOVAL, Control Unit (Auto A/C Model).>

# Diagnostic Procedure for Sensors

HVAC SYSTEM (AUTO A/C) (DIAGNOSTICS)

## D: SUNLOAD SENSOR

### TROUBLE SYMPTOM:

- Sensor identifies that sunlight is at maximum. Then, A/C system is controlled to COOL side.
- Sensor identifies that sunlight is at minimum. Then, A/C system is controlled to HOT side.

### NOTE:

When the sunload sensor check is performed indoors or in the shade, it could be diagnosed as having an open circuit. Always check the sunload sensor with the sun shining on it.

### WIRING DIAGRAM:

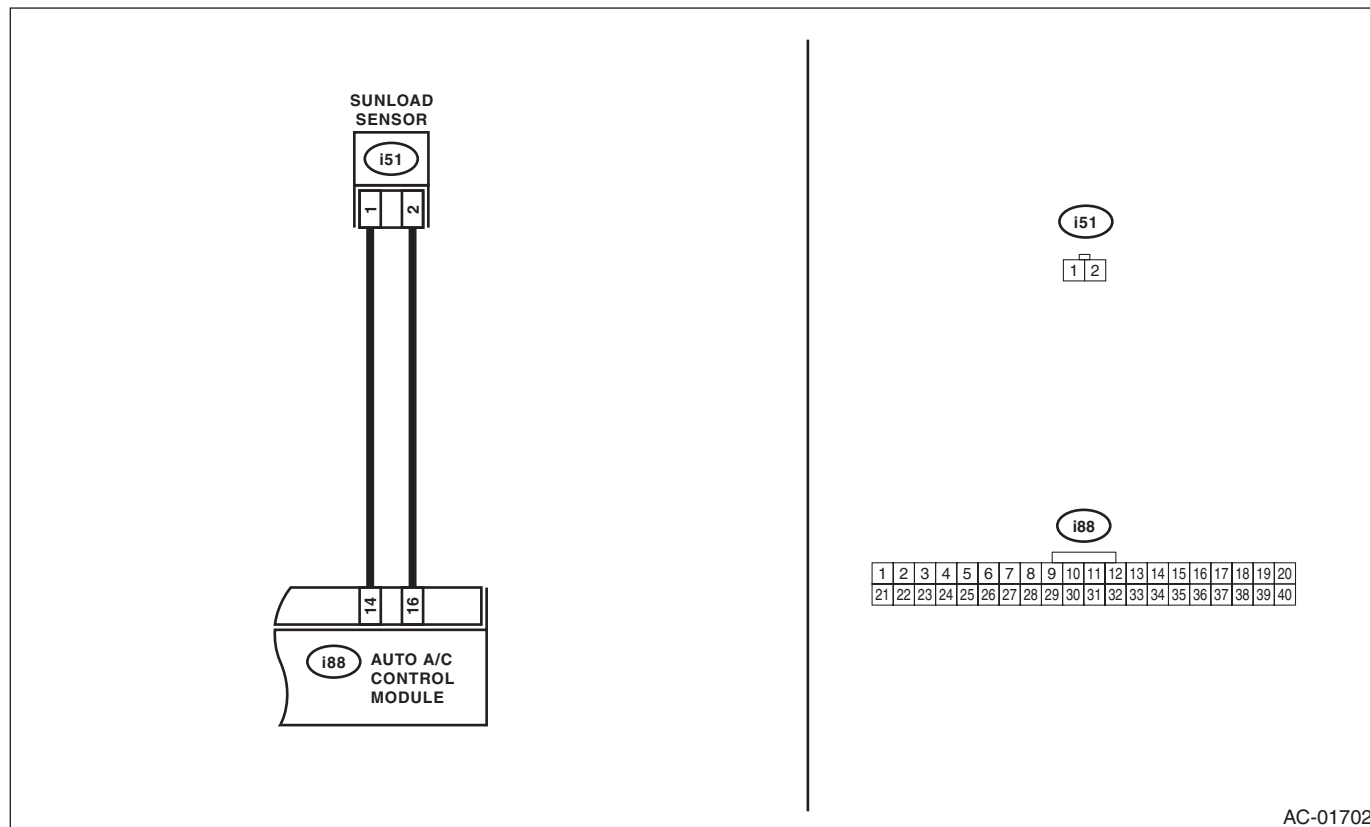

AC-01702

Step	Check	Yes	No
<b>1 CHECK POWER SUPPLY VOLTAGE FOR SUNLOAD SENSOR.</b> 1) Turn the ignition switch to OFF. 2) Disconnect the connector from sunload sensor. 3) Turn the ignition switch to ON. 4) Measure the power supply voltage for sunload sensor. <i>Connector &amp; terminal</i> <i>(i51) No. 2 (+) — No. 1 (-):</i>	Is the voltage approx. 5 V?	Go to step 4.	Go to step 2.
<b>2 CHECK HARNESS CONNECTOR BETWEEN AUTO A/C CONTROL MODULE AND SUNLOAD SENSOR.</b> 1) Turn the ignition switch to OFF. 2) Disconnect the connector from the auto A/C control module. 3) Measure the resistance of the harness between the auto A/C control module and sunload sensor. <i>Connector &amp; terminal</i> <i>(i51) No. 2 — (i88) No. 16:</i>	Is the resistance less than 1 Ω?	Go to step 3.	Repair the harness between auto A/C control module and sunload sensor.

# Diagnostic Procedure for Sensors

HVAC SYSTEM (AUTO A/C) (DIAGNOSTICS)

Step	Check	Yes	No
<b>3</b> <b>CHECK HARNESS CONNECTOR BETWEEN AUTO A/C CONTROL MODULE AND SUNLOAD SENSOR.</b> Measure the resistance of the harness between the auto A/C control module and sunload sensor. <i>Connector &amp; terminal</i> <i>(i51) No. 1 — (i88) No. 14:</i>	Is the resistance less than 1 $\Omega$ ?	Go to step 4.	Repair the harness between auto A/C control module and sunload sensor.
<b>4</b> <b>CHECK INPUT VOLTAGE FOR AUTO A/C CONTROL MODULE.</b> 1) Connect the connectors of sunload sensor and auto A/C control module. 2) Turn the ignition switch to ON. 3) Measure the voltage between connector terminals of auto A/C control module. <i>Connector &amp; terminal</i> <i>(i88) No. 16 (+) — (i88) No. 14 (-):</i>	Is the voltage between approx. 1.0 — 4.0 V?	Go to step 5.	Replace the sunload sensor. <Ref. to AC-45, REMOVAL, Sunload Sensor (Auto A/C Model).>
<b>5</b> <b>CHECK FOR POOR CONTACT.</b> Check poor contact of auto A/C control module connector.	Is there poor contact of connector?	Repair the connector.	Replace the auto A/C control module. <Ref. to AC-32, REMOVAL, Control Unit (Auto A/C Model).>

## Diagnostics with Phenomenon

HVAC SYSTEM (AUTO A/C) (DIAGNOSTICS)

### 9. Diagnostics with Phenomenon

#### A: INSPECTION

Symptoms	Faulty parts
A/C system fails to operate.	<ul style="list-style-type: none"> <li>• Fuse (F/B No. 7, 22, 31)</li> <li>• Connector (Poor contact)</li> <li>• Ground</li> <li>• Auto A/C control module</li> <li>• Blower fan motor</li> <li>• Blower fan relay</li> <li>• A/C relay</li> <li>• Compressor (Magnet clutch)</li> <li>• Evaporator sensor</li> <li>• ECM</li> </ul>
Fuse is blown out.	<ul style="list-style-type: none"> <li>• Fuse (F/B No. 7, 22, 31)</li> <li>• Connector (Poor contact)</li> </ul>
Illumination cannot dim.	<ul style="list-style-type: none"> <li>• Fuse (F/B No. 7, 22, 31)</li> <li>• Connector (Poor contact)</li> <li>• Auto A/C control module</li> </ul>
Blower fan does not rotate or fan speed cannot be controlled.	<ul style="list-style-type: none"> <li>• Fuse (F/B No. 7, 22, 31)</li> <li>• Connector (Poor contact)</li> <li>• Ground</li> <li>• Auto A/C control module</li> <li>• Blower fan motor</li> <li>• Blower fan relay</li> <li>• Power transistor</li> </ul>
Unable to switch suction vents.	<ul style="list-style-type: none"> <li>• Connector (Poor contact)</li> <li>• Auto A/C control module</li> <li>• Intake door actuator</li> </ul>
Unable to switch vents.	<ul style="list-style-type: none"> <li>• Connector (Poor contact)</li> <li>• Auto A/C control module</li> <li>• Mode door actuator</li> </ul>
Compartment temperature does not rise. (Warm air does not come out.)	<ul style="list-style-type: none"> <li>• Connector (Poor contact)</li> <li>• Auto A/C control module</li> <li>• Air mix door actuator</li> <li>• In-vehicle sensor, ambient sensor, evaporator sensor and sunload sensor</li> <li>• In-vehicle sensor aspirator hose</li> </ul>
Compartment temperature does not lower. (Cold air does not come out.)	<ul style="list-style-type: none"> <li>• Connector (Poor contact)</li> <li>• Auto A/C control module</li> <li>• Air mix door actuator</li> <li>• A/C relay</li> <li>• Compressor (Magnet clutch)</li> <li>• Radiator fan motor</li> <li>• Radiator fan relay</li> <li>• In-vehicle sensor, ambient sensor, evaporator sensor and sunload sensor</li> <li>• In-vehicle sensor aspirator hose</li> </ul>
Compartment temperature is higher or lower than setting temperature.	<ul style="list-style-type: none"> <li>• Auto A/C control module</li> <li>• Air mix door actuator</li> <li>• In-vehicle sensor, ambient sensor, evaporator sensor and sunload sensor</li> <li>• In-vehicle sensor aspirator hose</li> </ul>
Compartment temperature does not quickly respond to setting temperature.	<ul style="list-style-type: none"> <li>• Air mix door actuator</li> <li>• In-vehicle sensor, ambient sensor, evaporator sensor and sunload sensor</li> <li>• In-vehicle sensor aspirator hose</li> </ul>
Radiator fan does not rotate during A/C operation.	<ul style="list-style-type: none"> <li>• Radiator fan motor</li> <li>• Radiator fan relay</li> <li>• ECM</li> </ul>

# AIRBAG SYSTEM

# AB

---

	<b>Page</b>
1. General Description .....	2
2. Airbag Connector .....	9
3. Inspection Locations after a Collision .....	13
4. Driver's Airbag Module .....	16
5. Passenger's Airbag Module .....	17
6. Side Airbag Module .....	18
7. Curtain Airbag Module .....	20
8. Airbag Control Module .....	22
9. Front Sub Sensor .....	23
10. Side Airbag Sensor .....	24
11. Curtain Airbag Sensor .....	25
12. Satellite Safing Sensor .....	26
13. Roll Connector .....	27



# General Description

## AIRBAG SYSTEM

### 1. General Description

#### A: COMPONENT

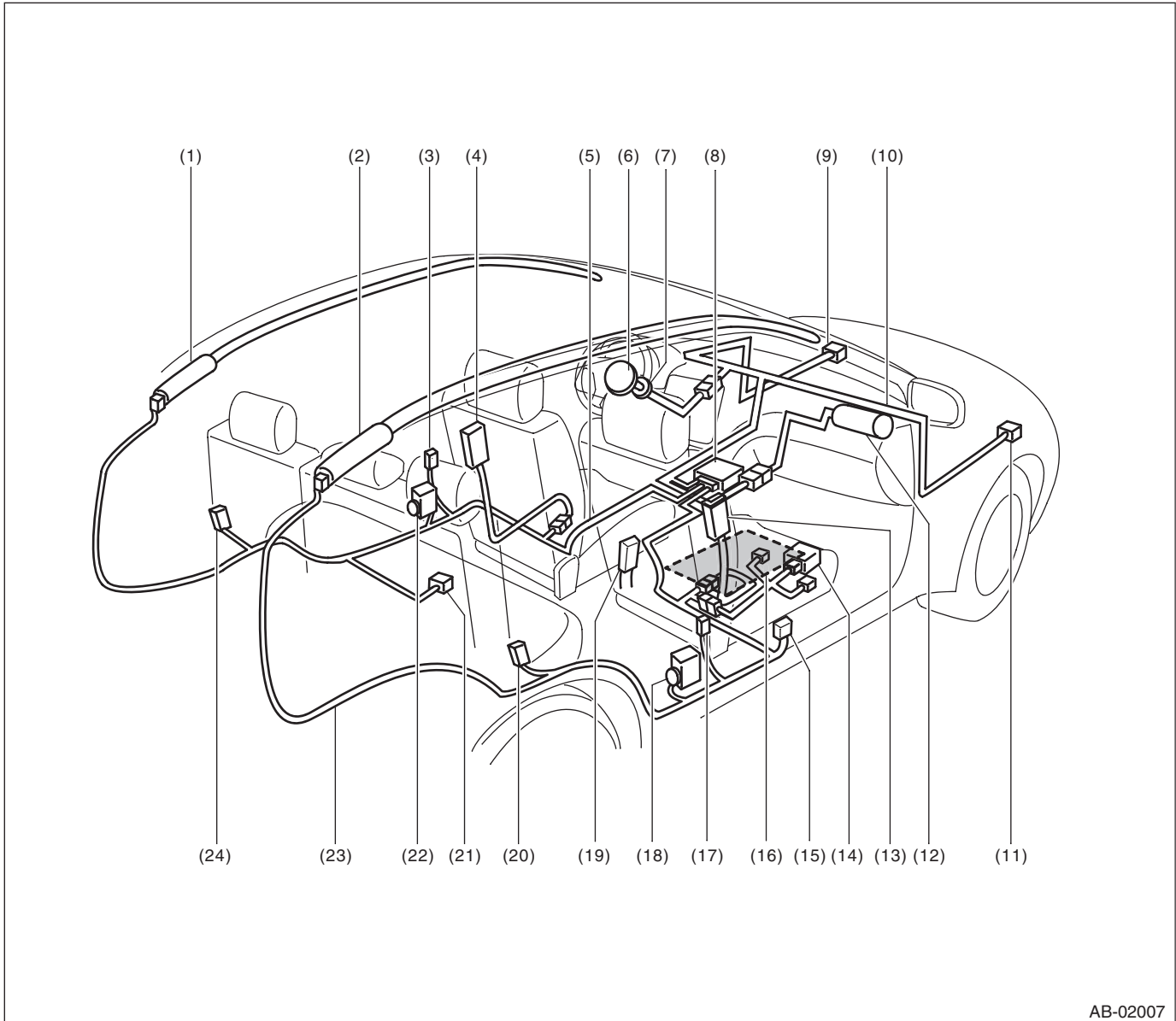

AB-02007

- |  |   |   |
|--|---|---|
| (1) Curtain airbag module LH                                     | (9) Front sub sensor LH   | (17) Side airbag sensor RH  |
| (2) Curtain airbag module RH                                     | (10) Front airbag harness (integrated with bulkhead wiring harness) | (18) Seat belt pretensioner RH                                    |
| (3) Side airbag sensor LH  | (11) Front sub sensor RH  | (19) Buckle switch RH   |
| (4) Side airbag module LH  | (12) Airbag module ASSY (passenger)                                 | (20) Curtain airbag sensor RH                                     |
| (5) Airbag rear harness LH (integrated with rear wiring harness) | (13) Side airbag module RH  | (21) Satellite safing sensor                                      |
| (6) Airbag module ASSY (driver)                                  | (14) Occupant detection control module                              | (22) Seat belt pretensioner LH                                    |
| (7) Combination switch ASSY with roll connector                  | (15) Belt tension sensor  | (23) Airbag rear harness RH (integrated with rear wiring harness) |
| (8) Airbag control module  | (16) Occupant detection sensor                                      | (24) Curtain airbag sensor LH                                     |

## 1. DRIVER'S AIRBAG MODULE

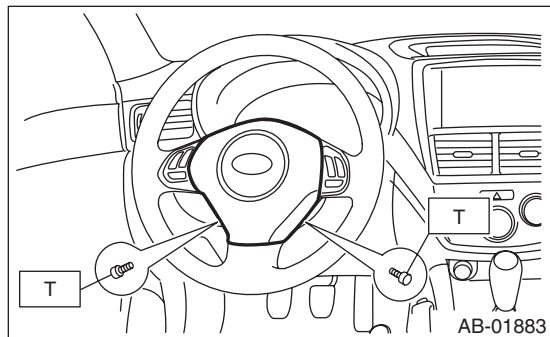

**Tightening torque:**  
**10 N·m (1.02 kgf·m, 7.4 ft·lb)**

## 2. PASSENGER'S AIRBAG MODULE

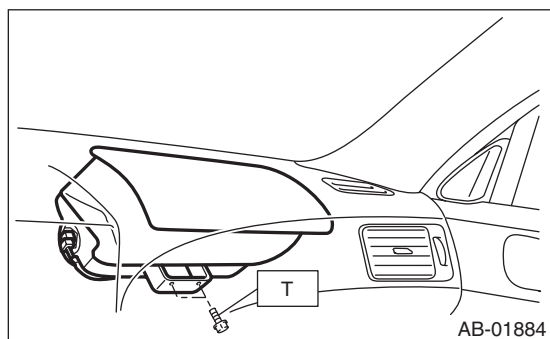

**Tightening torque:**  
**7.5 N·m (0.76 kgf·m, 5.5 ft·lb)**

## 3. SIDE AIRBAG MODULE

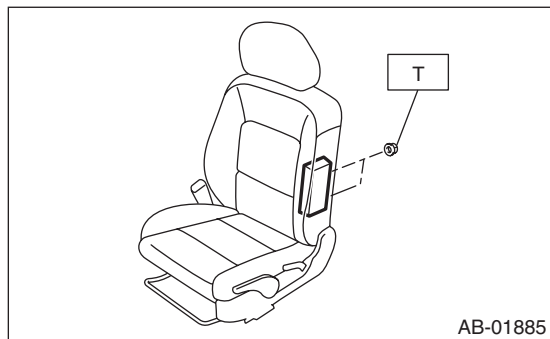

**Tightening torque:**  
**6 N·m (0.61 kgf·m, 4.4 ft·lb)**

## 4. CURTAIN AIRBAG MODULE

- 5 door model

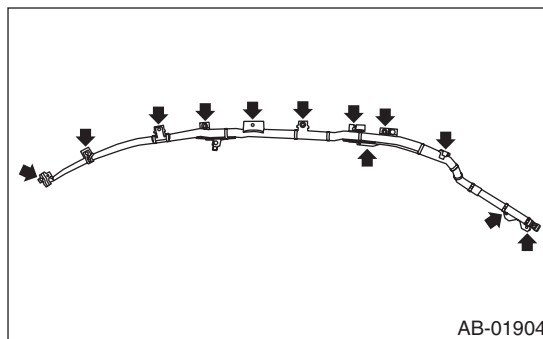

- 4 door model

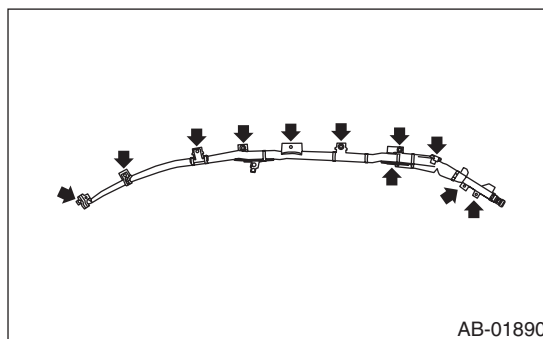

**Tightening torque:**  
**7.5 N·m (0.76 kgf·m, 5.5 ft·lb)**

## 5. AIRBAG CONTROL MODULE

**CAUTION:**  
**Do not reuse mounting bolts and nuts.**

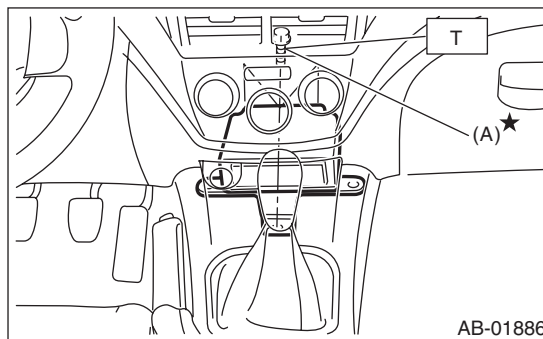

(A) Bolt

**Tightening torque:**  
**25 N·m (2.55 kgf·m, 18.4 ft·lb)**

# General Description

## AIRBAG SYSTEM

### 6. FRONT SUB SENSOR

#### CAUTION:

Do not reuse mounting bolts and nuts.

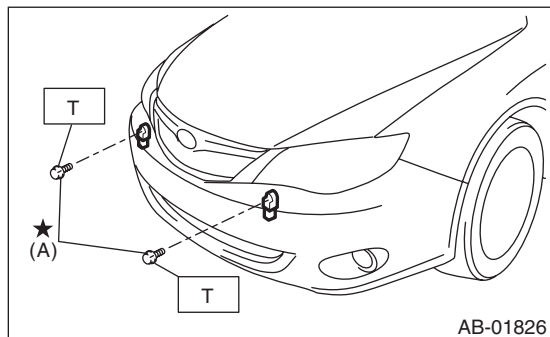

(A) Bolt

#### Tightening torque:

13 N-m (1.33 kgf-m, 9.6 ft-lb)

### 7. SIDE AIRBAG SENSOR

#### CAUTION:

Do not reuse mounting bolts and nuts.

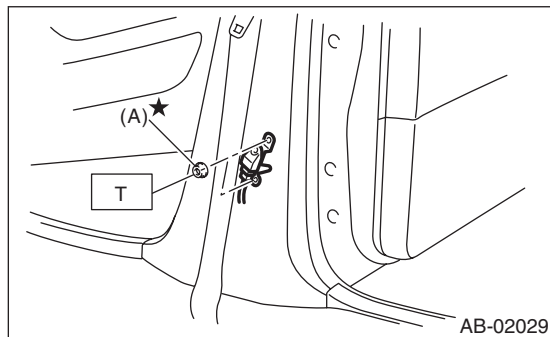

(A) Nut

#### Tightening torque:

7.5 N-m (0.76 kgf-m, 5.5 ft-lb)

### 8. CURTAIN AIRBAG SENSOR

#### CAUTION:

Do not reuse mounting bolts and nuts.

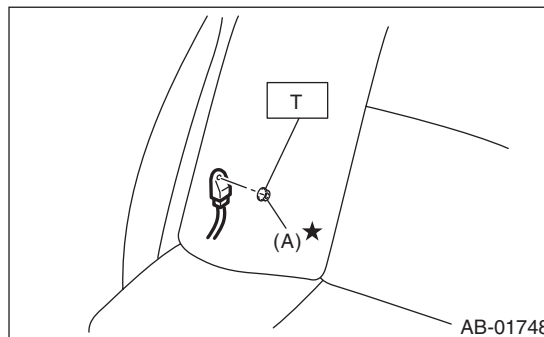

(A) Nut

#### Tightening torque:

7.5 N-m (0.76 kgf-m, 5.5 ft-lb)

### 9. SATELLITE SAFING SENSOR

#### CAUTION:

Do not reuse mounting bolts and nuts.

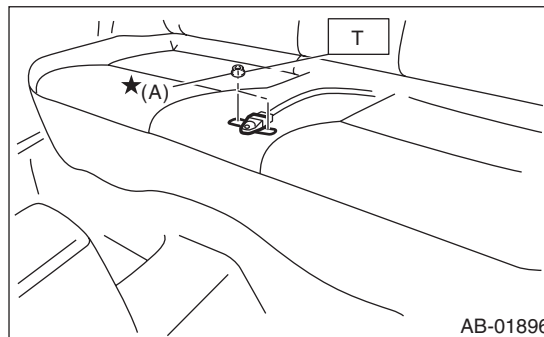

(A) Nut

#### Tightening torque:

7.5 N-m (0.76 kgf-m, 5.5 ft-lb)

### 10. STEERING ROLL CONNECTOR

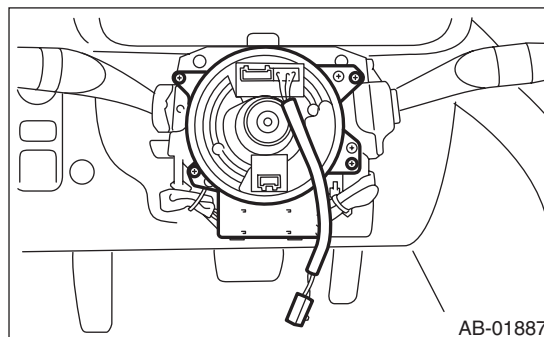

## 11. AIRBAG HARNESS

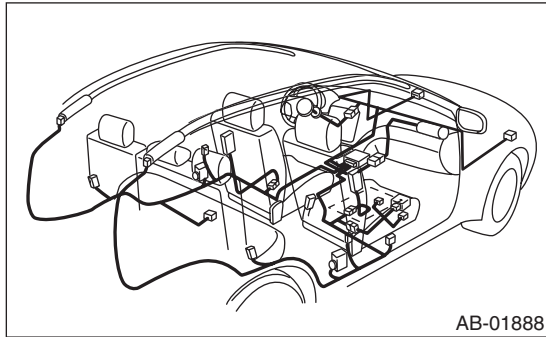

### B: CAUTION

- When servicing a vehicle, be sure to turn the ignition switch to OFF, disconnect the ground cable from battery, and wait for 60 seconds or more before starting work.
- The airbag system is fitted with a backup power supply. After disconnecting the battery ground cable, the airbag may operate if you do not wait for 60 seconds or more before starting the service of airbag system.

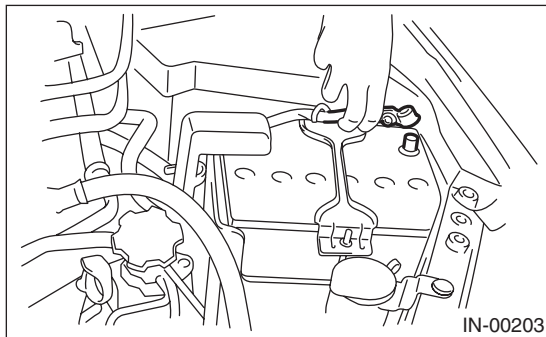

- If the airbag warning light illuminates, check or repair the vehicle immediately to prevent it from airbag system malfunction.
- If any of the airbag sensors, airbag module, airbag control module, pretensioner, harness or satellite safing sensor cover is deformed or damaged, replace with new parts.

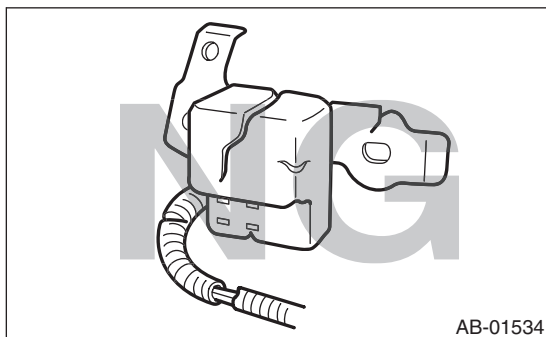

- When checking the airbag system, be sure to use a digital circuit tester. Use of an analog circuit tester may cause the airbag to activate erroneously due to a minimal current inside tester.

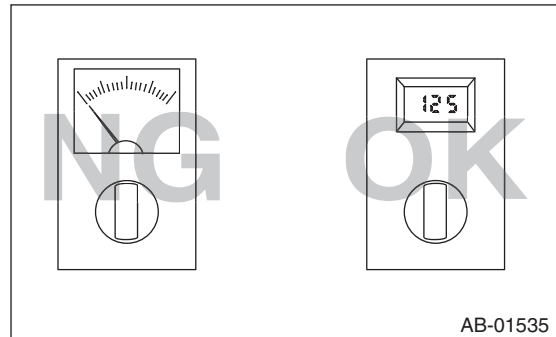

- When checking, use a test harness (1). Damage to connector terminal causes malfunction. Do not directly put the tester probe on airbag connector terminal.

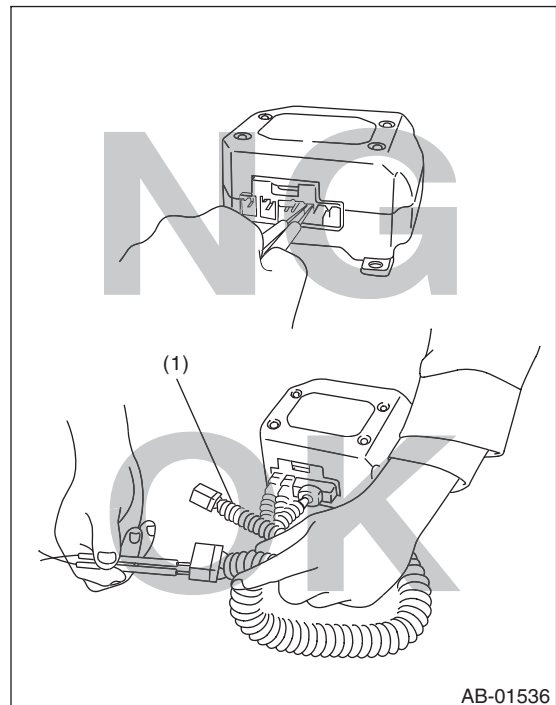

- Do not allow water or oil to come in contact with the connector terminals. Also, do not touch the connector terminals.

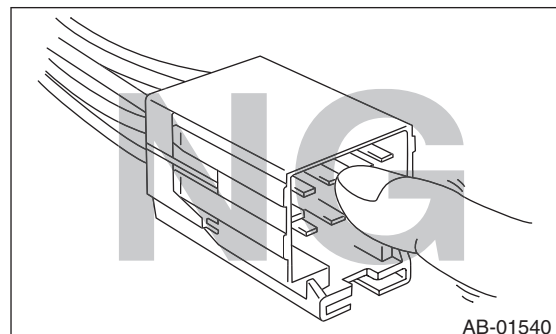

## General Description

### AIRBAG SYSTEM

- Do not check continuity of the airbag modules for driver's side, passenger's side and curtain, or the pretensioner.

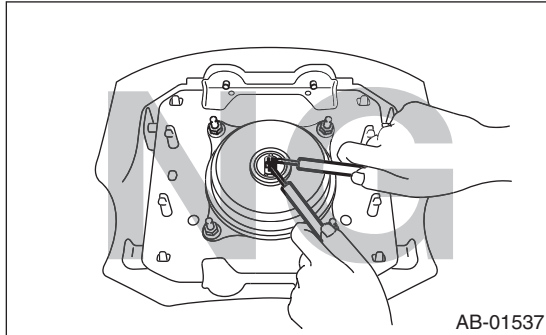

- If damage, open circuit or rust is found on airbag system wiring harness, do not use a soldering equipment to repair. Replace the faulty harness with a new genuine part.

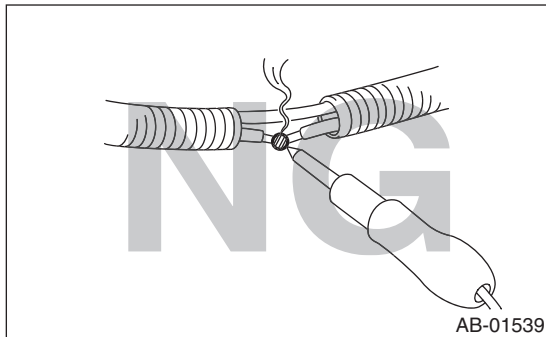

- Install the wiring harness securely with the specified clips to avoid interference or tangled with other parts.

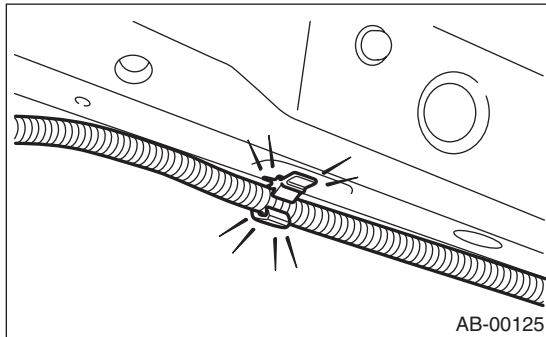

- When painting or performing sheet metal work on the front part of the vehicle, including the front wheel apron, front fender and front side frame, remove the front sub sensors and wiring harness of airbag system.

- When painting or performing sheet metal work on the side of the vehicle including the side sill, center pillar and front and rear doors, or on the rear floor pan or around the rear crossmember, remove the side airbag sensors, curtain airbag sensor, satellite safing sensor and wiring harness of the airbag system.

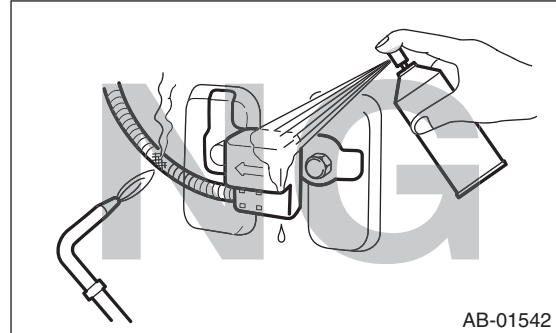

- Do not use the airbag or pretensioner parts from other vehicles. Always replace the defective parts with new parts.
- Never reuse any activated airbag module and pretensioner.
- Do not discard undeployed airbag or pretensioner.
- When airbag control module, front sub sensor, side airbag sensor, curtain airbag sensor and satellite safing sensor are removed, do not reuse the bolts and nuts of them. Always replace with the specified new bolts and nuts.

- Do not drop each airbag module, airbag control module and each sensor, or store these parts under high temperature of 85°C (185°F) or more, or let water, oil or grease get on them; the internal parts may be damaged or the reliability may be decreased.

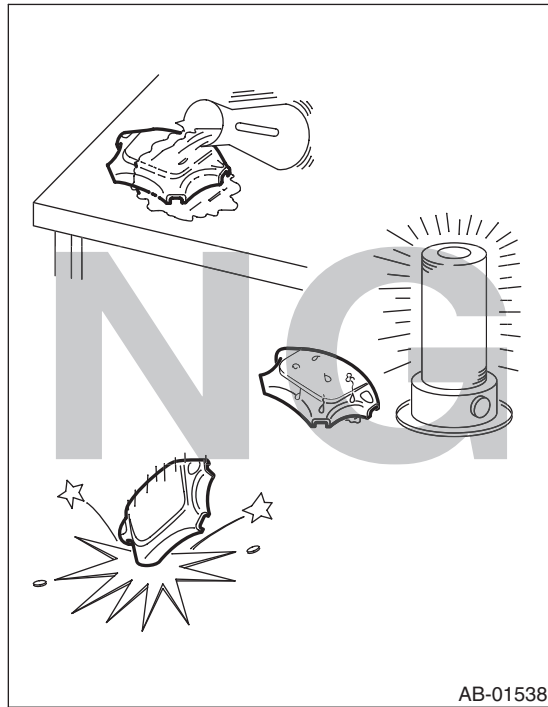

AB-01538

- After removing each parts of the airbag system, keep them with the pad side facing upward on a dry, clean and flat surface away from heat, light sources, moisture and dust.

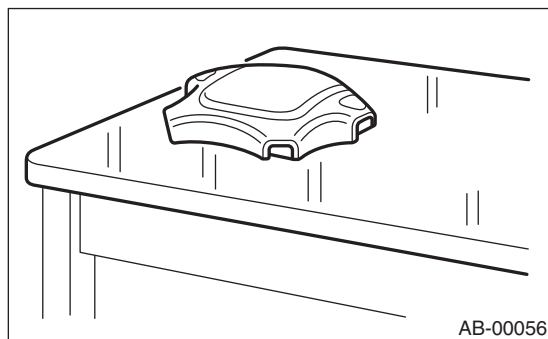

AB-00056

- Do not disassemble driver's airbag module, passenger's airbag module, side or curtain airbag modules, or pretensioner.

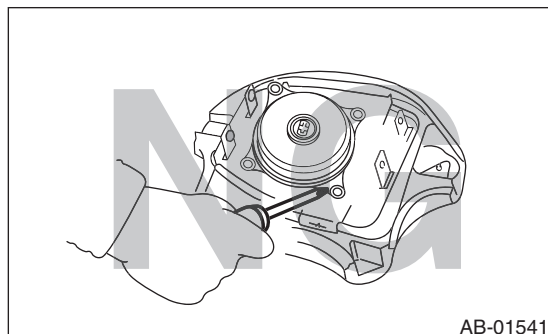

AB-01541

- When attaching the steering wheel and steering roll connector, be sure to adjust the steering roll connector.
- The removed front seat with airbag module must be kept at least 200 mm (8 in) away from walls and other objects.

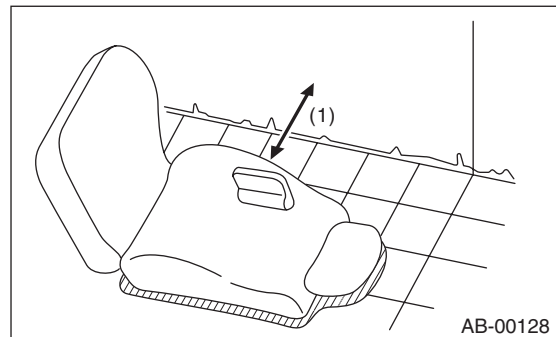

AB-00128

(1) 200 mm (8 in) or more

- When storing a removed airbag module, do not place it with the pad side facing downward. Do not place any objects on the airbag module. Do not pile up the airbag module. If the pad of the airbag module is in contact with other objects, it may cause a serious accident if the airbag accidentally operates.
  - Driver's airbag module

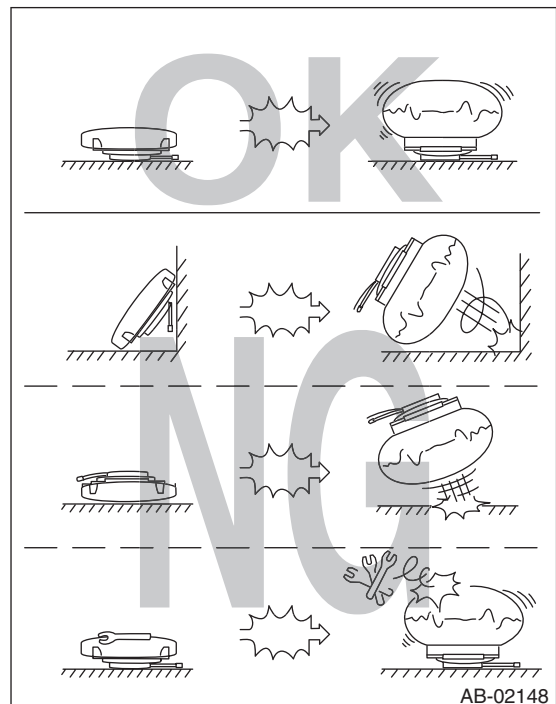

AB-02148

# General Description

## AIRBAG SYSTEM

- Passenger's airbag module and side airbag module

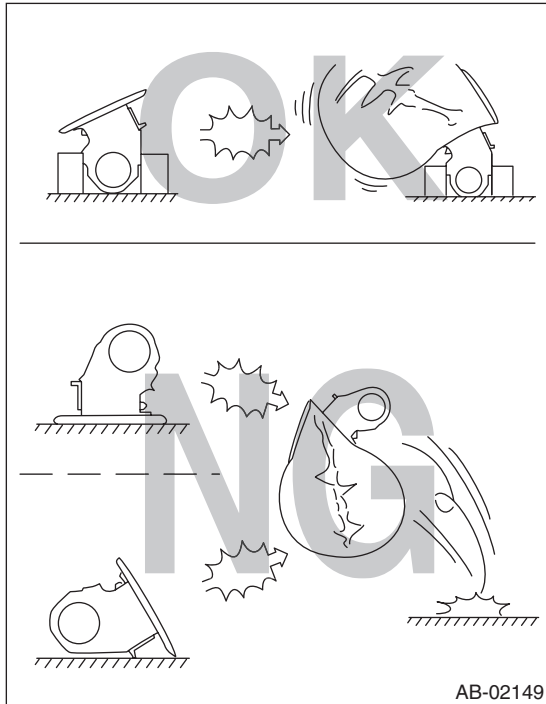

## C: PREPARATION TOOL

### 1. GENERAL TOOL

TOOL NAME	REMARKS
TORX® T30	Used for removal/installation of drivers airbag module

## 2. Airbag Connector

### A: PROCEDURE

#### 1. POWER SUPPLY

1) How to disconnect:

**CAUTION:**

**When pulling the slide lock or disconnecting connector, be sure to hold the connector, not the harness.**

Press the lock (A), and then disconnect the connector.

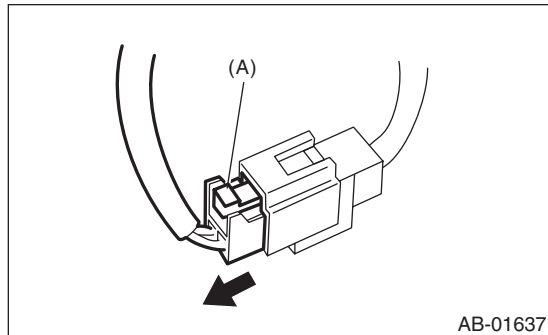

2) How to connect:

**CAUTION:**

**Be sure to insert the connector in until it is locked. Then pull it gently to make sure that it is locked.**

Holding the connector, push it in securely until a clicking sound is heard.

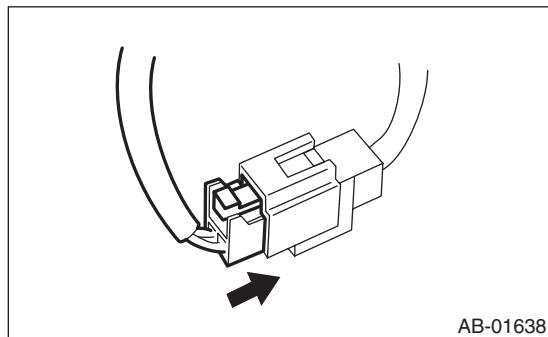

#### 2. AIRBAG CONTROL MODULE

1) How to disconnect:

**CAUTION:**

**When disconnecting connector, be sure to hold the connector, not the harness.**

Press the lock lever plate (A) and pull out the lock lever.

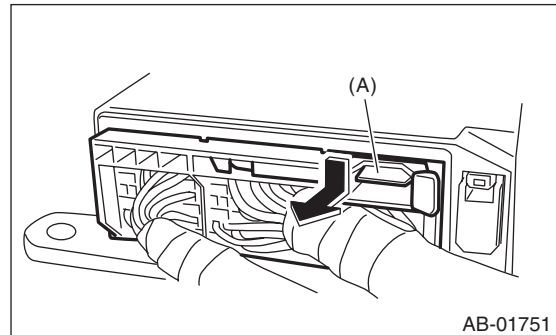

2) How to connect:

**CAUTION:**

**Be sure to insert the connector in until it is locked. Then pull it gently to make sure that it is locked.**

Insert the connector and push the lock lever in securely.

#### 3. DRIVER'S AIRBAG MODULE (BETWEEN AIRBAG MAIN HARNESS AND ROLL CONNECTOR) AND PASSENGER'S AIRBAG MODULE

1) How to disconnect:

**CAUTION:**

**When pulling the slide lock or disconnecting connector, be sure to hold the connector, not the harness.**

(1) Push the slide lock (A) in the direction of arrow.

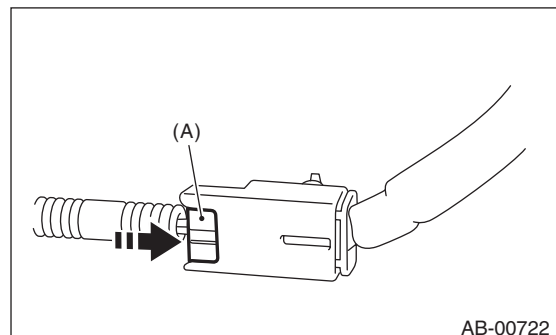



# Airbag Connector

## AIRBAG SYSTEM

(2) With the slide lock pushed, disconnect the connector.

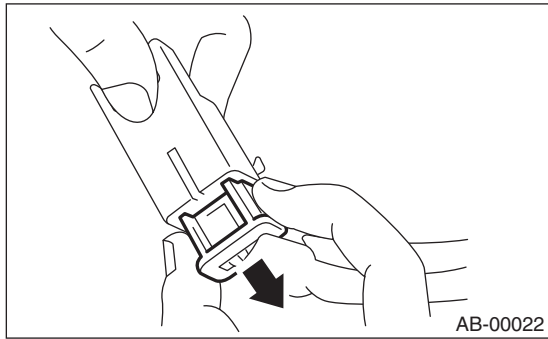

2) How to connect:

### CAUTION:

Be sure to insert the connector in until it is locked. Then pull it gently to make sure that it is locked.

Holding the connector, push it in securely until a clicking sound is heard.

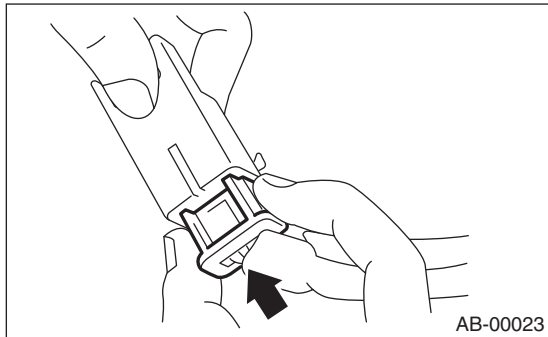

## 4. DRIVER'S AIRBAG MODULE, CURTAIN AIRBAG MODULE AND PRETENSIONER

1) How to disconnect:

(1) Using a flat tip screwdriver, pry the push lock upward to unlock.

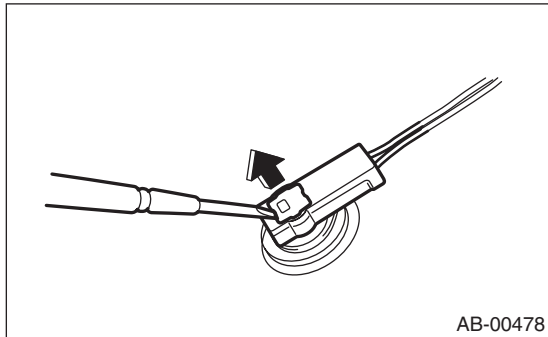

(2) Pull the connector to disconnect from the driver's airbag module assembly or the retractor assembly.

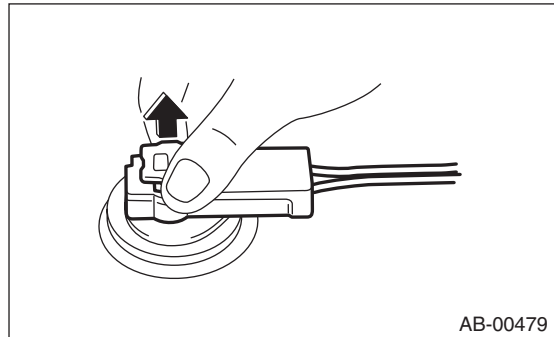

2) How to connect:

### CAUTION:

• Be sure to insert the connector in until it is locked.

• Press in the push lock securely. Then pull it gently to make sure that it is locked.

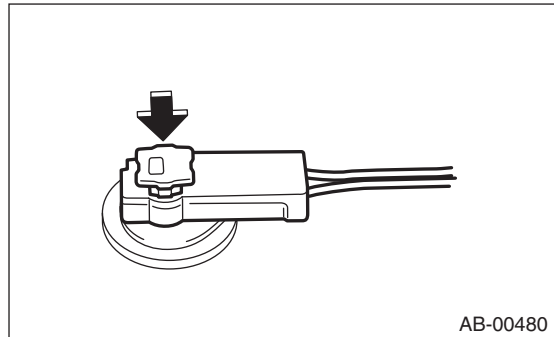

Connect the connector in the reverse order of disconnecting. At this time, be sure to insert until a clicking sound is heard.

## 5. SIDE AIRBAG SENSOR AND CURTAIN AIRBAG SENSOR

1) How to disconnect:

### CAUTION:

When pulling the slide lock or disconnecting connector, be sure to hold the connector, not the harness.

(1) Push the lock arm.

(2) Holding outer part, pull it one step in the direction of arrow.

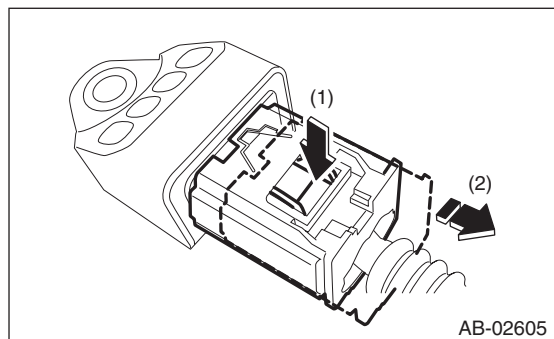

- (3) Push the lock arm again.
- (4) Holding outer part, pull it in the direction of arrow to disconnect the connector.

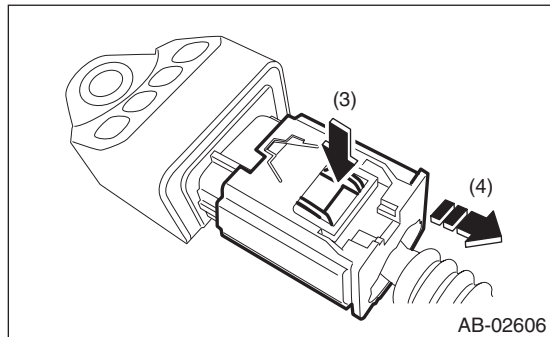

2) How to connect:

**CAUTION:**

**Be sure to insert the connector in until it is locked. Then pull it gently to make sure that it is locked.**

Holding the connector, push it in securely until a clicking sound is heard.

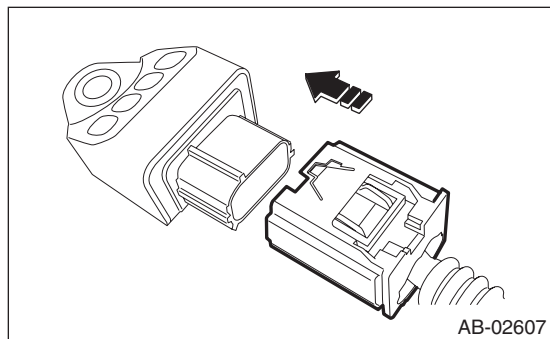

## 6. SATELLITE SAFING SENSOR

1) How to disconnect:

**CAUTION:**

**When pulling the slide lock or disconnecting connector, be sure to hold the connector, not the harness.**

Holding outer part (A), pull it in the direction of arrow.

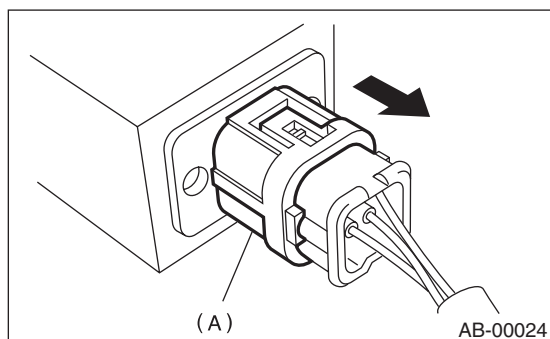

2) How to connect:

**CAUTION:**

- Outer side (A) moves back, and so do not touch the outer part.

- **Be sure to insert the connector in until it is locked. Then pull it gently to make sure that it is locked.**

Holding the connector, push it in securely until a clicking sound is heard.

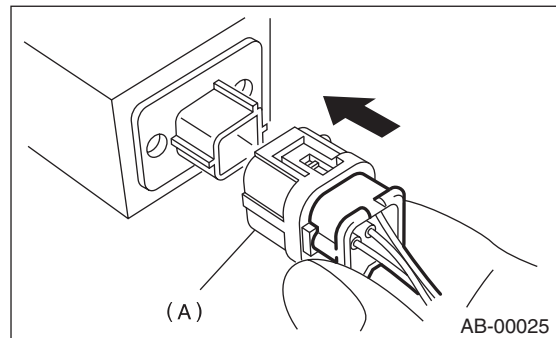

## 7. SIDE AIRBAG MODULE

1) How to disconnect:

**CAUTION:**

**When pulling the slide lock or disconnecting connector, be sure to hold the connector, not the harness.**

(1) Move the slide lock (A) in the direction of arrow and hold it.

(2) While holding the slide lock (A), pull the connector (B) in the direction of arrow.

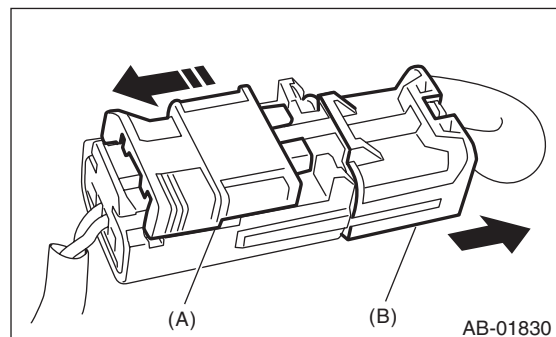

2) How to connect:

**CAUTION:**

**Be sure to insert the connector in until it is locked. Then pull it gently to make sure that it is locked.**

Holding the connector, push it in securely until a clicking sound is heard.

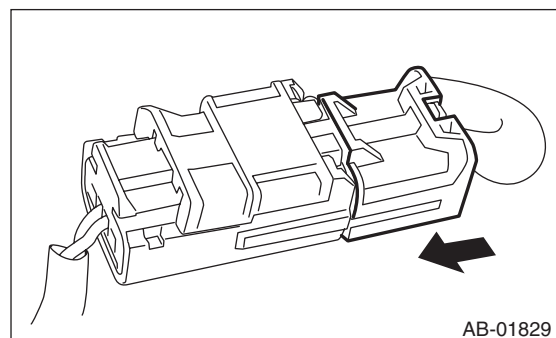

# Airbag Connector

## AIRBAG SYSTEM

### 8. BUCKLE SWITCH RH

1) How to disconnect:

#### CAUTION:

**When pulling the slide lock or disconnecting connector, be sure to hold the connector, not the harness.**

(1) Move the slide lock (A) in the direction of arrow and hold it.

(2) While holding the slide lock (A), pull the connector (B) in the direction of arrow.

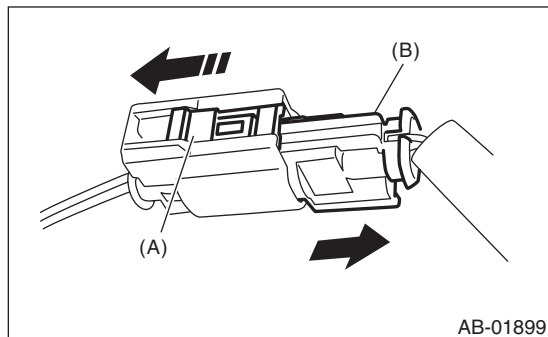

2) How to connect:

#### CAUTION:

**Be sure to insert the connector in until it is locked. Then pull it gently to make sure that it is locked.**

Holding the connector, push it in securely until a clicking sound is heard.

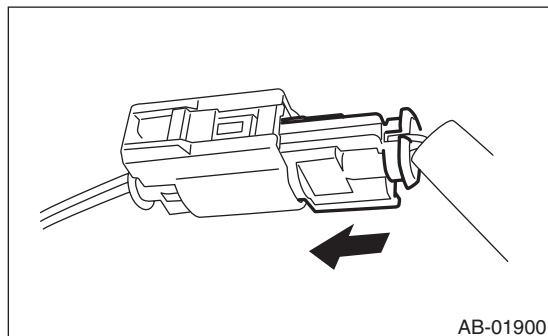

### 9. FRONT SUB SENSOR

1) How to disconnect:

#### CAUTION:

**When pulling the slide lock or disconnecting connector, be sure to hold the connector, not the harness.**

(1) Push the lock arm.

(2) Holding outer part, pull it one step in the direction of arrow.

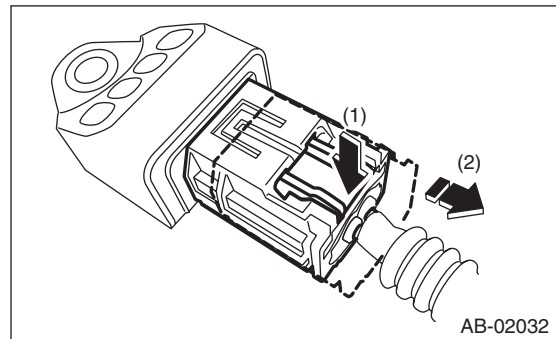

(3) Push the lock arm again.

(4) Holding outer part, pull it in the direction of arrow to disconnect the connector.

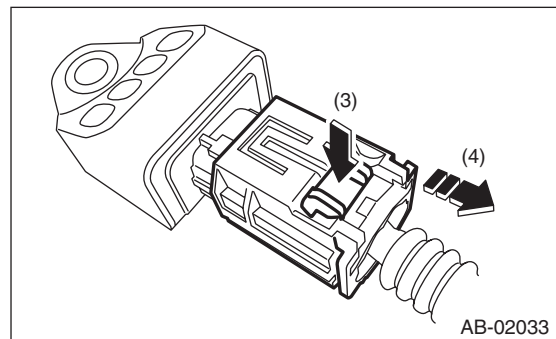

2) How to connect:

#### CAUTION:

**Be sure to insert the connector in until it is locked. Then pull it gently to make sure that it is locked.**

Holding the connector, push it in securely until a clicking sound is heard.

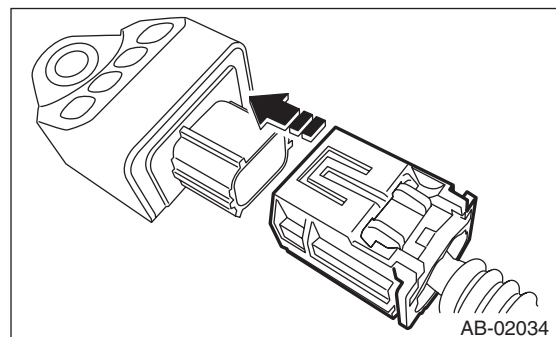

### 10. OCCUPANT DETECTION SYSTEM (BETWEEN AIRBAG REAR HARNESS AND SEAT HARNESS) AND BELT TENSION SENSOR

Refer to the occupant detection system section.  
<Ref. to OD(diag)-11, OCCUPANT DETECTION SYSTEM (BETWEEN AIRBAG REAR HARNESS AND SEAT HARNESS) AND BELT TENSION SENSOR, PROCEDURE, Airbag Connector.>

## 3. Inspection Locations after a Collision

### A: REPLACEMENT

Replace the following parts if the airbag has been activated.

#### 1. FRONT COLLISION

- 1) Driver's airbag module
- 2) Passenger's airbag module
- 3) Driver's seat belt (pretensioner)
- 4) Passenger's seat belt (pretensioner)
- 5) Airbag control module
- 6) Front sub sensor
- 7) Roll connector
- 8) Passenger's side seat cushion pad and frame assembly
- 9) Instrument panel (for integrating with passenger's airbag module)

#### 2. SIDE COLLISION

- 1) Airbag control module
- 2) Satellite safing sensor
- 3) Satellite safing sensor cover
- 4) Side airbag module (operating side seat backrest)
- 5) Side airbag sensor (operating side)
- 6) Curtain airbag module (operating side)
- 7) Curtain airbag sensor (operating side)

#### 3. INSPECTION OF OTHER PARTS

Check for the following parts, and replace the damaged parts with new parts.

- 1) Steering wheel and steering shaft

Check the steering shaft for mounting conditions and deflection of front and rear, upward and downward directions, and deflection of front and rear direction with tilt lever released. (After a collision, absorbing part of steering shaft may have been operated.)

2) Check the direct type connector of driver's airbag module, curtain airbag module, pretensioner, etc. for damage, and also check each harness for pinch and connector damage. Replace the main harness as a unit if damage is found.

3) Check the seat cushion, backrest, seat rail and headrest for installing condition and play.

4) For the passenger's seat, replace the seat cushion pad frame assembly with a new part if the seat cushion frame assembly is deformed or cracked.

5) If there are tears or loosening in the passenger side seat cushion cover, it may interfere with the proper operation of the passenger detection system. Replace with a new cushion cover.

6) Be sure to perform the system calibration for the occupant detection system after removing or replacing the passenger seat cushion cover. Failure to do so may cause improper operation of the occupant detection system. <Ref. to OD(diag)-14, SYSTEM CALIBRATION (REZEROING), OPERATION, Subaru Select Monitor.>

7) Use the Subaru Select Monitor to check whether the front right seat belt buckle switch is operating normally.

### B: INSPECTION

If the vehicle is involved in a collision, even if it is a slight collision, be sure to check the following systems.

#### 1. DRIVER'S AIRBAG MODULE

1) Check for the following, and replace the damaged parts with new parts.

- Airbag module is cracked or deformed.
- Harness and/or connector is cracked, deformed or open.
- Harness wire is exposed.
- The module surface is fouled with grease, oil, water or cleaning solvent.

2) When installing a new driver's airbag module, check for the following, and replace the damaged parts with new parts.

- The steering wheel is in the way, making it difficult to install the airbag module.
- The clearance between the driver's airbag module and steering wheel is not constant.
- When steering wheel deformation in axial and vertical directions exceed limits.

#### Standard:

**Axial deflection A (deflection of steering wheel)**

**Less than 6 mm (0.24 in)**

**Vertical deflection L (runout of steering wheel)**

**Less than 17 mm (0.68 in)**

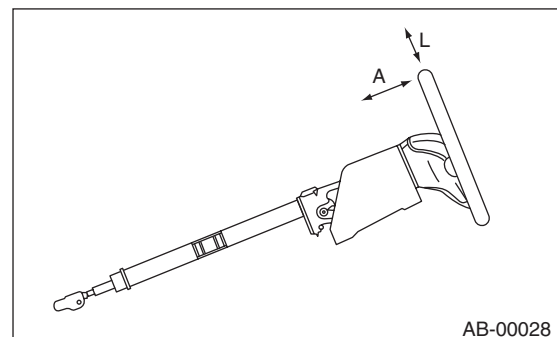

# Inspection Locations after a Collision

## AIRBAG SYSTEM

### 2. PASSENGER'S AIRBAG MODULE

Check for the following, and replace the damaged parts with new parts.

- Airbag module is cracked or deformed.
- Harness and/or connector is cracked, deformed or open.
- Harness wire is exposed.
- Mounting bracket is cracked or deformed.

### 3. SIDE AIRBAG MODULE

Check for the following, and replace the damaged parts with new parts.

- Front seat, airbag module and mounting bracket are damaged or deformed.
- Harness and/or connector is cracked, deformed or open.
- Harness wire is exposed.

### 4. CURTAIN AIRBAG MODULE

Check for the following, and replace the damaged parts with new parts.

- Airbag cover is scratched or torn.
- Harness and/or connector is cracked, deformed or open.
- Harness wire is exposed.
- Mounting bracket and securing clip are cracked or deformed.

### 5. AIRBAG CONTROL MODULE

Check for the following, and replace the damaged parts with new parts.

- Control module is cracked or deformed.
- Mounting bracket is cracked or deformed.
- Connector is scratched, cracked or deformed.
- Airbag has been activated.
- Side airbag has been activated.
- Curtain airbag has been activated.

### 6. FRONT SUB SENSOR

If the section of vehicle as shown in the figure is damaged, check the following items and replace the damaged parts with new parts.

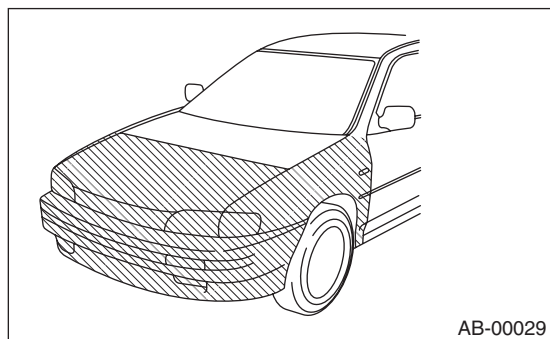

- Front sub sensor is cracked or deformed.
- Connector is scratched, cracked or deformed.
- Airbag has been activated.

### 7. SATELLITE SAFING SENSOR, SIDE AIRBAG SENSOR AND CURTAIN AIRBAG SENSOR

If the section of vehicle as shown in the figure is damaged, check the following items and replace the damaged parts with new parts.

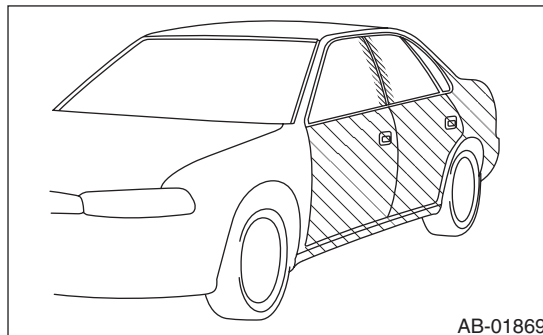

- Satellite safing sensor, side airbag sensor and curtain airbag sensor are cracked or deformed.
- Mounting bracket is cracked or deformed.
- Satellite safing sensor cover is cracked or deformed.
- Connector is scratched, cracked or deformed.
- Side airbag or curtain airbag has been activated. (operating side)

### 8. ROLL CONNECTOR

Check for the following, and replace the damaged parts such as cracks, deformation, etc. with new parts.

- Combination switch
- Steering roll connector

### 9. STEERING SHAFT

Measure the overall length of steering column. If the length is not within the specification, the steering column may be damaged. Replace it with a new part.

**Standard: Overall length L**

**Tilt and telescopic column (measure while minimized)**

$$818.6^{+1.5}_{-1.5} \text{ mm } (32.23^{+0.059}_{-0.059} \text{ in})$$

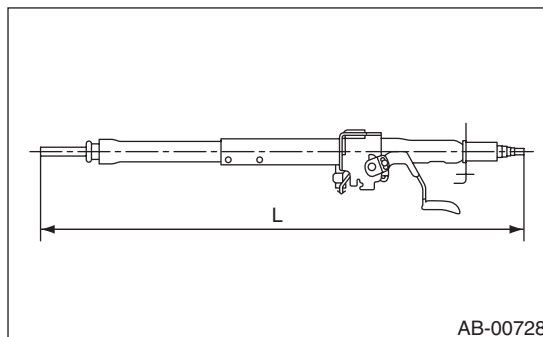

## 10.PASSENGER'S SEAT

1) Check for the following, and replace the damaged parts with new parts.

- Seat belt buckle body or bracket is scratched, cracked or deformed.
- Backrest frame for crack or deformation
- Headrest for deformation or play
- If the seat cushion cover and seat backrest cover is scratched or coming loose, replace with a new cover and readjust the system. <Ref. to OD(diag)-14, SYSTEM CALIBRATION (REZEROING), OPERATION, Subaru Select Monitor.>

### **CAUTION:**

**If any of the following applies, replace the seat cushion pad and frame assembly. Do not disassemble.**

- **Cracks or deformation found in the seat cushion frame or seat cushion pad.**
- **Scratches, cracks, or deformation found on the passenger detection system pressure sensor hoses or passenger detection control module, or attachment brackets of the control module.**
- **Harness and/or connector is cracked, deformed or open. Harness wire is exposed.**

2) After checking the installing condition of passenger's seat, perform the system calibration of occupant detection system. <Ref. to OD(diag)-14, SYSTEM CALIBRATION (REZEROING), OPERATION, Subaru Select Monitor.>

## 11.BELT TENSION SENSOR

Check for the following, and replace the damaged parts with new parts.

- Belt tension sensor is scratched, cracked, or deformed.
- Harness and/or connector is cracked, deformed or open. Harness wire is exposed.



### 4. Driver's Airbag Module

#### A: REMOVAL

##### CAUTION:

Refer to "CAUTION" of "General Description" before handling the airbag module. <Ref. to AB-5, CAUTION, General Description.>

- 1) Position the front wheels straight ahead. (After moving a vehicle 5 m (16 ft) or more with front wheels positioned straight ahead, make sure that the vehicle moves straight ahead.)
- 2) Turn the ignition switch to OFF.
- 3) Disconnect the ground cable from battery and wait for at least 60 seconds before starting work.
- 4) Using TORX® bit T30 (1), remove the two TORX® bolts on the side of the steering wheel.

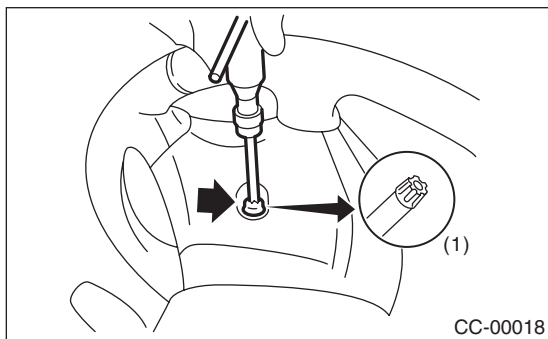

- 5) Disconnect the horn harness.
- 6) Disconnect the airbag connector on the back of airbag module, and then remove the airbag module. <Ref. to AB-9, PROCEDURE, Airbag Connector.>

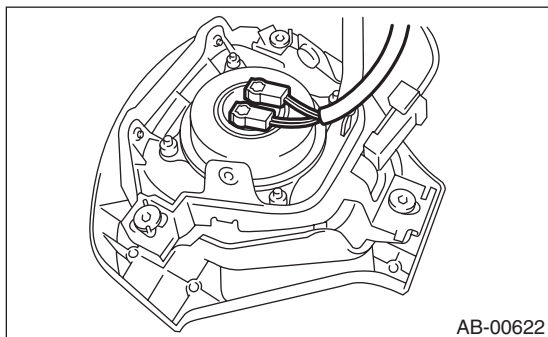

- 7) For handling of the removed airbag module, refer to "CAUTION". <Ref. to AB-5, CAUTION, General Description.>

#### B: INSTALLATION

##### CAUTION:

- Refer to "CAUTION" of "General Description" before handling the airbag module. <Ref. to AB-5, CAUTION, General Description.>
  - Do not allow harness and connectors to interfere or get tangled up with other parts.
- Install each part in the reverse order of removal.

##### Tightening torque:

10 N·m (1.02 kgf-m, 7.4 ft-lb)

#### C: INSPECTION

##### CAUTION:

- Refer to "CAUTION" of "General Description" before handling the airbag module. <Ref. to AB-5, CAUTION, General Description.>
  - Do not allow harness and connectors to interfere or get tangled up with other parts.
- Check for the following, and replace the damaged parts with new parts. <Ref. to AB-13, DRIVER'S AIRBAG MODULE, INSPECTION, Inspection Locations after a Collision.>

- Airbag module
- Harness
- Connector
- Mounting bracket

## 5. Passenger's Airbag Module

### A: REMOVAL

#### CAUTION:

Refer to "CAUTION" of "General Description" before handling the airbag module. <Ref. to AB-5, CAUTION, General Description.>

- 1) Turn the ignition switch to OFF.
- 2) Disconnect the ground cable from battery and wait for at least 60 seconds before starting work.
- 3) Remove the instrument panel. <Ref. to EI-55, REMOVAL, Instrument Panel Assembly.>
- 4) Remove the claws, and remove the passenger's airbag module.

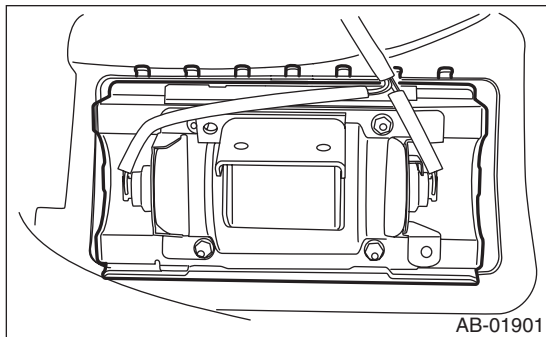

- 5) For handling of the removed airbag module, refer to "CAUTION". <Ref. to AB-5, CAUTION, General Description.>

### B: INSTALLATION

#### CAUTION:

Do not allow harness and connectors to interfere or get tangled up with other parts.

Install each part in the reverse order of removal.

#### *Tightening torque:*

*7.5 N·m (0.76 kgf-m, 5.5 ft-lb)*

### C: INSPECTION

#### CAUTION:

Refer to "CAUTION" of "General Description" before handling the airbag module. <Ref. to AB-5, CAUTION, General Description.>

Check for the following, and replace the damaged parts with new parts. <Ref. to AB-14, PASSENGER'S AIRBAG MODULE, INSPECTION, Inspection Locations after a Collision.>

- Airbag module
- Harness
- Connector
- Mounting bracket



# Side Airbag Module

## AIRBAG SYSTEM

### 6. Side Airbag Module

#### A: REMOVAL

##### CAUTION:

- Refer to “CAUTION” of “General Description” before handling the airbag module. <Ref. to AB-5, CAUTION, General Description.>
- Make sure how the harnesses of the side airbag are routed before assembling to avoid misarranging. Assembling with harnesses improperly routed may cause the harness to get caught and short out.

##### NOTE:

Remove the passenger's side by referring to driver's side.

- 1) Turn the ignition switch to OFF.
- 2) Disconnect the ground cable from battery and wait for at least 60 seconds before starting work.
- 3) Remove the front seat from vehicle. <Ref. to SE-6, REMOVAL, Front Seat.>
- 4) Remove the side airbag harness from the harness holder on the backside of seat cushion assembly.
- 5) Remove the side airbag harness from backrest frame assembly.
- 6) Remove the plastic fastener at the back side (bottom) of backrest.

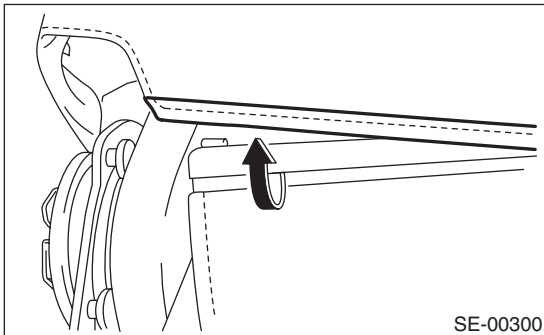

- 7) Open the fastener at the rear side of backrest.

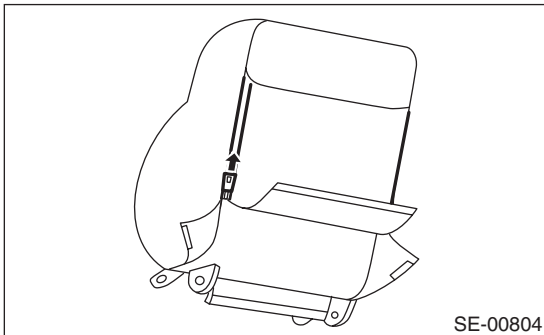

- 8) Remove the hog rings of backrest cover.

##### CAUTION:

Be careful not to tear the vinyl inside the seat when removing the hog rings. If torn, replace with a new part.

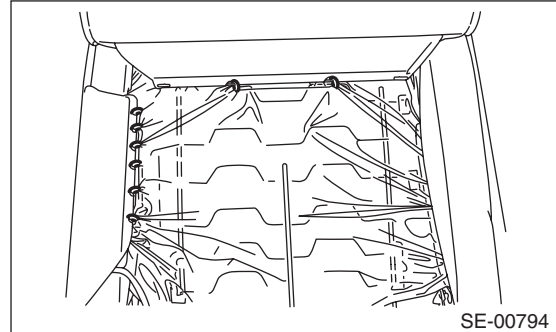

- 9) Remove the pad (A), and remove the mounting nut from the side airbag module.

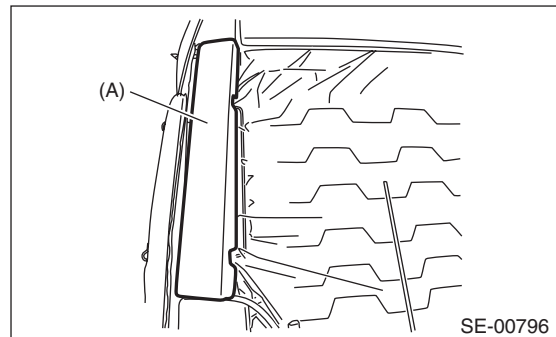

- 10) Remove the side airbag harness from backrest frame assembly.

#### B: INSTALLATION

##### CAUTION:

- Refer to “CAUTION” of “General Description” before handling the airbag module. <Ref. to AB-5, CAUTION, General Description.>
- Make sure how the harnesses of the side airbag are routed before assembling to avoid misarranging. Assembling with harnesses improperly routed may cause the harness to get caught and short out.
- Be sure to perform the system calibration for occupant detection system after passenger's seat installation. <Ref. to OD(diag)-14, SYSTEM CALIBRATION (REZEROING), OPERATION, Subaru Select Monitor.>

- 1) Make sure that there is no foreign matter on side airbag module.

2) Install the side airbag module to backrest frame assembly.

**CAUTION:**

**When installing the side airbag module assembly, be sure to put the side airbag module between backrest cover and airbag guide cloth.**

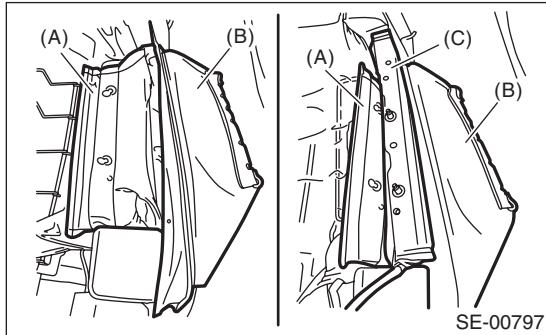

- (A) Airbag guide cloth
- (B) Backrest cover
- (C) Side airbag module ASSY

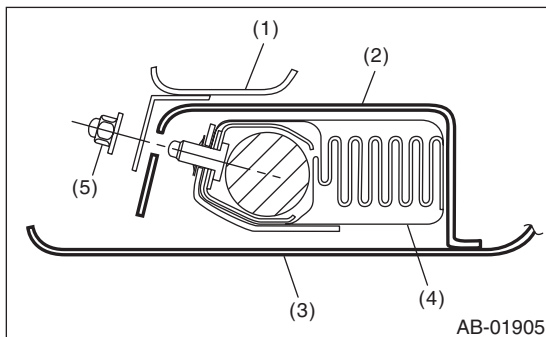

- (1) Backrest frame ASSY
- (2) Airbag guide cloth
- (3) Backrest cover
- (4) Side airbag module ASSY
- (5) Hexagon cap nut

**Besides, when the backrest cover is not installed securely, the side airbag module may not be activated properly, therefore keep strictly to the following procedure.**

- Be careful not to stain or damage the backrest cover during assembly.
- Do not reuse hog rings.
- Secure the hog ring using hog ring pliers.
- Install the hog rings to the specified points securely and make sure that no wrinkle or twisting on backrest cover.

**Tightening torque:**

**6.0 N·m (0.61 kgf·m, 4.4 ft·lb)**

- 3) Install the side airbag harness to backrest frame assembly.
- 4) Install the backrest cover.

5) Install the side airbag harness to the clip of the slide rail IN.

6) Recline the seat or slide it backward and forward, and check there is no contact between the seat backrest assembly, cushion cover assembly and side airbag harness.

**C: INSPECTION**

**CAUTION:**

**Refer to “CAUTION” of “General Description” before handling the airbag module. <Ref. to AB-5, CAUTION, General Description.>**

Check for the following, and replace damaged parts with new parts. <Ref. to AB-14, SIDE AIRBAG MODULE, INSPECTION, Inspection Locations after a Collision.>

1) With side collision (when side airbag is activated)

- Side airbag module assembly
- Satellite safing sensor
- Side airbag sensor
- Curtain airbag sensor
- Backrest pad assembly
- Backrest frame assembly
- Backrest cover assembly

2) When damage is found by visual check

- Headrest assembly
- Headrest lock bushing
- Outer slide rail
- Inner slide rail
- Seat hinge cover
- Seat lifter lever
- Reclining lever
- Side airbag harness and connector on body side
- Satellite safing sensor cover

3) With side collision (when side airbag is not activated)

Check the seat, airbag module, sensor visually, and then replace them with new parts if damaged or cracked.

Specially inspect the damage of airbag module body, mounting bracket and harness connector.

4) Without side collision (dirt and damage of cover)  
Replace the corresponding part with a new part.

# Curtain Airbag Module

## AIRBAG SYSTEM

### 7. Curtain Airbag Module

#### A: REMOVAL

##### CAUTION:

Refer to "CAUTION" of "General Description" before handling the airbag module. <Ref. to AB-5, CAUTION, General Description.>

- 1) Turn the ignition switch to OFF.
  - 2) Disconnect the ground cable from battery and wait for at least 60 seconds before starting work.
  - 3) Remove the rear quarter trim. <Ref. to EI-60, REMOVAL, Rear Quarter Trim.>
  - 4) Disconnect the curtain airbag module connector.
- 5 door model

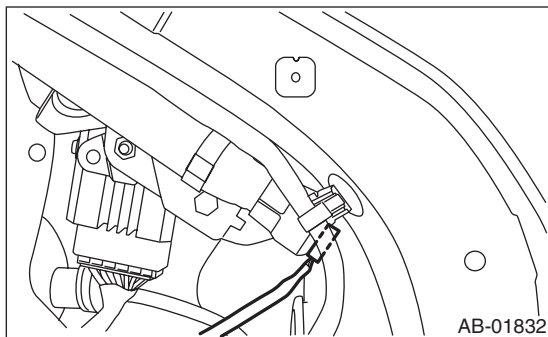

- 4 door model

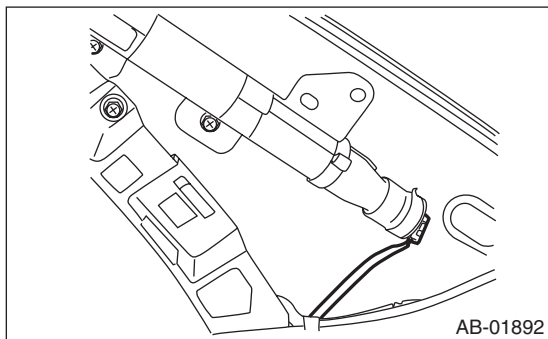

- 5) Remove the roof trim. <Ref. to EI-66, REMOVAL, Roof Trim.>
- 6) Remove the airbag guide from the front pillar.

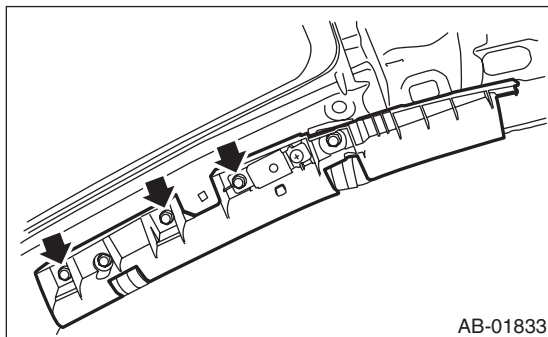

- 7) Remove the bolt, and remove the curtain airbag module.

##### CAUTION:

- Be careful not to damage the curtain airbag module during removal.
- Never open the curtain airbag module before activation. Never reuse the deployed curtain airbag module.
- 5 door model

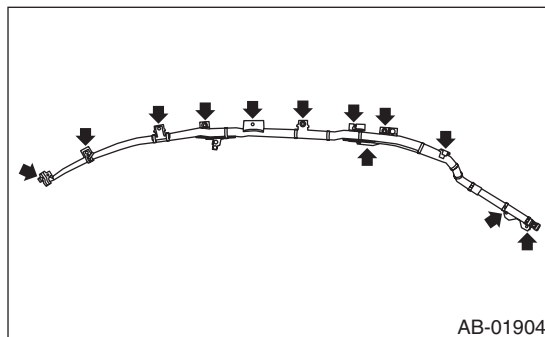

- 4 door model

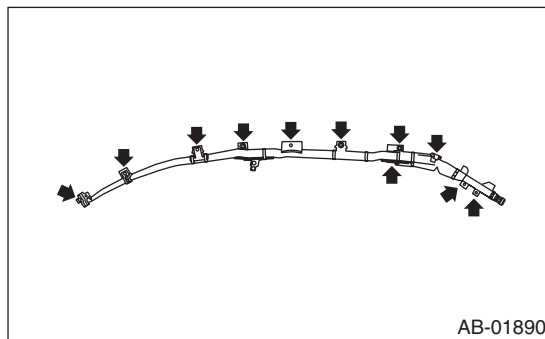

#### B: INSTALLATION

##### CAUTION:

- Refer to "CAUTION" of "General Description" before handling the airbag module. <Ref. to AB-5, CAUTION, General Description.>
- When installing the curtain airbag module, install a specified part at specified place.
- Be careful not to damage the curtain airbag module during installation.
- Never open the curtain airbag module before activation. Never reuse the deployed curtain airbag module.
- Make sure that there are no foreign matter on airbag module.

Install each part in the reverse order of removal.

##### Tightening torque:

7.5 N·m (0.76 kgf·m, 5.5 ft·lb)

## C: INSPECTION

### CAUTION:

Refer to “CAUTION” of “General Description” before handling the airbag module. <Ref. to AB-5, CAUTION, General Description.>

Check for the following, and replace the damaged parts with new parts. <Ref. to AB-14, CURTAIN AIRBAG MODULE, INSPECTION, Inspection Locations after a Collision.>

1) With side collision (when curtain airbag is activated)

- Curtain airbag module assembly
- Satellite safing sensor
- Curtain airbag sensor
- Roof trim
- Front pillar upper trim
- Center pillar upper trim
- Rear quarter pillar trim
- Airbag guide

2) When damage is found by visual check

- Assist grip
- Assist grip bracket
- Curtain airbag harness and connector on body side.
- Satellite safing sensor cover

3) With side collision (when curtain airbag is not activated)

Check the roof trim, pillar trim, airbag module and sensor visually, and then replace them with new parts if damaged or cracked.

Specially inspect the damage of airbag module body, mounting bracket and harness connector.

4) Without side collision (dirt and damage of cover)

Replace the corresponding part with a new part.

# Airbag Control Module

AIRBAG SYSTEM

## 8. Airbag Control Module

### A: REMOVAL

#### CAUTION:

- Do not disassemble the airbag control module.
- If the airbag control module is deformed or if the damage from water is suspected, replace the airbag control module with a new part.
- Do not drop the airbag control module.
- After removal, keep the airbag control module on a dry, clean surface away from moisture, heat and dust.

- 1) Turn the ignition switch to OFF.
- 2) Disconnect the ground cable from battery and wait for at least 60 seconds before starting work.
- 3) Remove the console box. <Ref. to EI-51, REMOVAL, Console Box.>
- 4) Remove the center panel. <Ref. to EI-52, CENTER PANEL, REMOVAL, Center Console.>
- 5) Remove the console front panel. <Ref. to EI-52, CONSOLE FRONT PANEL, REMOVAL, Center Console.>
- 6) Remove the audio.
- 7) Remove the heater duct.

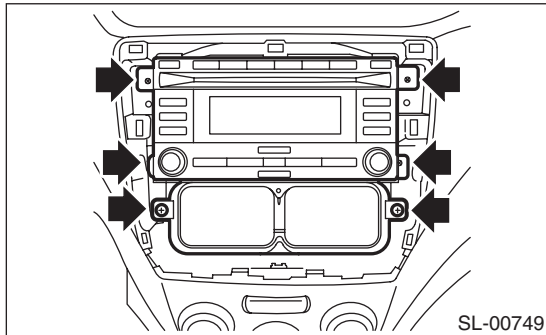

- 8) Disconnect the connector from airbag control module.
- 9) Remove the three bolts and remove airbag control module.

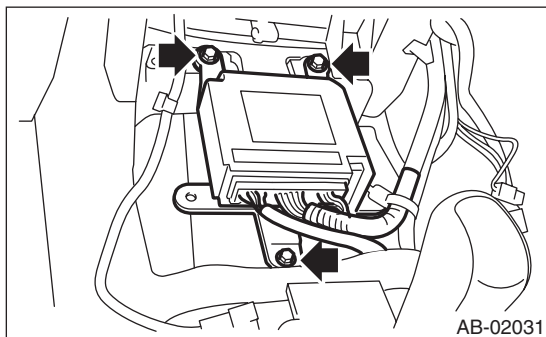

### B: INSTALLATION

#### CAUTION:

- Do not reuse the bolt and nut. Always replace with the specified new bolts and nuts.

• Before installing the audio, make sure that the heater duct is securely connected.

Install each part in the reverse order of removal.

#### Tightening torque:

25 N·m (2.55 kgf-m, 18.4 ft-lb)

### C: INSPECTION

Check for the following, and replace the damaged parts with new parts.

- Control module, connector, and mounting bracket are damaged.
- Airbag has been activated.
- Side airbag has been activated.
- Curtain airbag has been activated.

## 9. Front Sub Sensor

### A: REMOVAL

- 1) Turn the ignition switch to OFF.
- 2) Disconnect the ground cable from battery and wait for at least 60 seconds before starting work.
- 3) Remove the front bumper face. <Ref. to EI-31, FRONT BUMPER FACE, REMOVAL, Front Bumper.>
- 4) Remove the headlight assembly. <Ref. to LI-15, REMOVAL, Headlight Assembly.>
- 5) Remove the bolt, and then detach the front sub sensor.

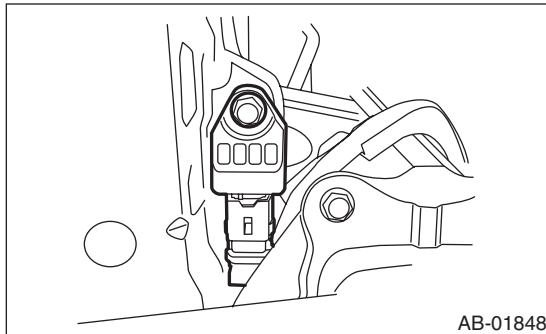

- 6) Disconnect the connector from front sub sensor.

### B: INSTALLATION

#### CAUTION:

- Do not reuse the bolt and nut.  
Always replace with the specified new bolts and nuts.
  - When installing the sensor, insert the set pin on the backside of the sensor into the hole on the body side securely.
  - After the installation of headlight assembly, be sure to perform headlight beam adjustment.
- Install each part in the reverse order of removal.

#### *Tightening torque:*

**13 N·m (1.33 kgf·m, 9.6 ft·lb)**

### C: INSPECTION

Check for the following, and replace the damaged parts with new parts.

- Front sub sensor or connector is damaged.
- Airbag has been activated.

## 10.Side Airbag Sensor

### A: REMOVAL

- 1) Turn the ignition switch to OFF.
- 2) Disconnect the ground cable from battery and wait for at least 60 seconds before starting work.
- 3) Remove the front outer seat belt. <Ref. to SB-18, OUTER SEAT BELT ASSEMBLY, REMOVAL, Front Seat Belt.>
- 4) Remove the nuts and then remove the side airbag sensor.

#### CAUTION:

- Do not separate the side airbag sensor and bracket. It cause the airbag system malfunction.
- If the sensor is removed from the bracket, be sure to replace with a new part.

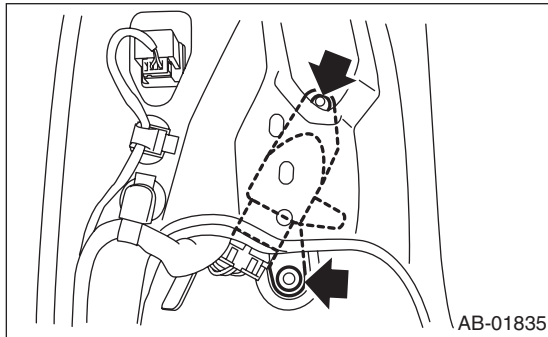

- 5) Disconnect the airbag connector.

### B: INSTALLATION

#### CAUTION:

- Do not reuse the bolt and nut.**  
**Always replace with the specified new bolts and nuts.**  
Install each part in the reverse order of removal.

#### *Tightening torque:*

**7.5 N·m (0.76 kgf-m, 5.5 ft-lb)**

### C: INSPECTION

Check for the following, and replace the damaged parts with new parts.

- The bracket or connector of side airbag sensor is damaged.
- Side airbag has been activated.

## 11. Curtain Airbag Sensor

### A: REMOVAL

- 1) Turn the ignition switch to OFF.
- 2) Disconnect the ground cable from battery and wait for at least 60 seconds before starting work.
- 3) Remove the rear seat. <Ref. to SE-13, REMOVAL, Rear Seat.>
- 4) Remove the nuts and then remove the curtain airbag sensor.

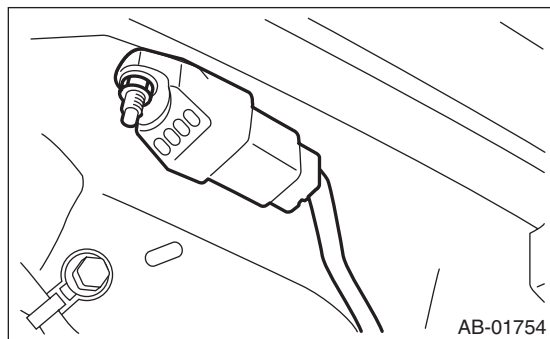

- 5) Disconnect the airbag connector.

### B: INSTALLATION

#### CAUTION:

- Do not reuse the bolt and nut.  
Always use new bolts and nuts for them.
- When installing the sensor, insert the set pin on the backside of the sensor into the hole on the body side securely.

Install in the reverse order of removal.

#### *Tightening torque:*

*7.5 N·m (0.76 kgf-m, 5.5 ft-lb)*

### C: INSPECTION

Check for the following, and replace the damaged parts with new parts.

- Curtain airbag sensor or connector is damaged.
- Curtain airbag has been activated.



## 12. Satellite Safing Sensor

### A: REMOVAL

- 1) Turn the ignition switch to OFF.
- 2) Disconnect the ground cable from battery and wait for at least 60 seconds before starting work.
- 3) Remove the rear seat cushion. <Ref. to SE-13, REMOVAL, Rear Seat.>
- 4) Remove the satellite safing sensor cover.

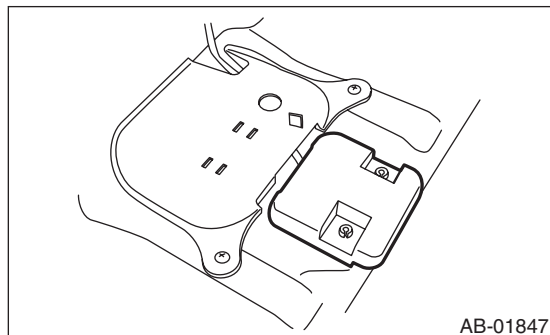

- 5) Remove the nut, and remove the satellite safing sensor.

#### CAUTION:

- Do not separate the satellite safing sensor and bracket. It cause the airbag system malfunction.
- If the sensor is removed from the bracket, be sure to replace with a new part.

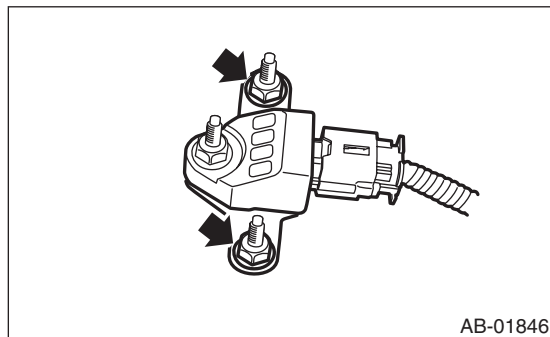

- 6) Disconnect the airbag connector.

### B: INSTALLATION

#### CAUTION:

- Do not reuse the bolt and nut. Always replace with the specified new bolts and nuts.
- When installing the satellite safing sensor cover, push the cover securely until it contacts the floor panel.
- If the satellite safing sensor cover is too loose at its mounting portion to remove easily, replace with a new satellite safing sensor cover.
- After installing the satellite safing sensor cover, make sure that the sensor harness does not get caught.

Install each part in the reverse order of removal.

#### Tightening torque:

*7.5 N·m (0.76 kgf·m, 5.5 ft·lb)*

### C: INSPECTION

Check for the following, and replace the damaged parts with new parts.

- Mounting bracket or connector of satellite safing sensor is damaged.
- The satellite safing sensor cover is damaged
- Side airbag or curtain airbag has been activated.

## 13. Roll Connector

### A: REMOVAL

- 1) Turn the ignition switch to OFF.
- 2) Disconnect the ground cable from battery and wait for at least 60 seconds before starting work.
- 3) Remove the driver's airbag module. <Ref. to AB-16, Driver's Airbag Module.>
- 4) Remove the steering wheel. <Ref. to PS-12, REMOVAL, Steering Wheel.>
- 5) Remove the steering column cover.
- 6) Disconnect the airbag connector next to the steering shaft. <Ref. to AB-9, DRIVER'S AIRBAG MODULE (BETWEEN AIRBAG MAIN HARNESS AND ROLL CONNECTOR) AND PASSENGER'S AIRBAG MODULE, PROCEDURE, Airbag Connector.>
- 7) Remove the screws, and then remove the roll connector.

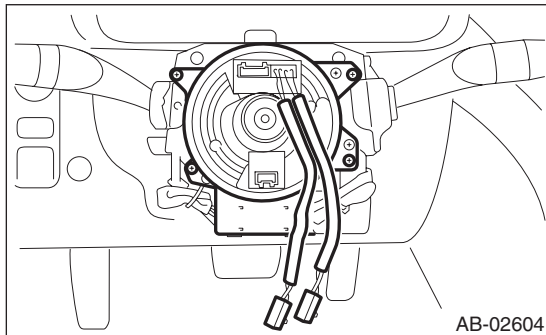

### B: INSTALLATION

- 1) Install each part in the reverse order of removal.
- 2) Before installing steering wheel, be sure to adjust the direction of roll connector with steering. <Ref. to AB-28, ADJUSTMENT, Roll Connector.>

### C: INSPECTION

#### 1. VISUAL INSPECTION

Check for the following, and replace the damaged parts with new parts.

- Combination switch is cracked or deformed.
- Roll connector is cracked or deformed.

#### 2. UNIT INSPECTION OF ROLL CONNECTOR

##### CAUTION:

- **Do not rotate the roll connector to more than the specified number of turns. Otherwise, the roll connector internal wire may be broken.**
- **When determining the end stop, rotate the connector slowly without applying excessive force. Applying excessive force at the end stop may break the internal wire.**

- 1) Adjust the roll connector. <Ref. to AB-28, ADJUSTMENT, Roll Connector.>
- 2) Set the roll connector to the central position.
- 3) Connect the test harness to the airbag module connectors (black) and (orange).

##### PREPARATION TOOL:

**Test harness N (98299SA000)**

**Test harness Q (98299SA040)**

Airbag module connector (black) — Test harness (1N)

Airbag module connector (orange) — Test harness (1Q)

- 4) With the following conditions, check the resistance between the test harness connector terminals.

- Perform the check with the roll connector centered (front wheels direct straightforward).
- Rotate the roll connector counterclockwise from the center (front wheels direct straightforward) to an end stop. Then, perform the check while rotating it clockwise to approximately 3.25 turns.

##### Preparation tool: Circuit tester

Terminal No.	Inspection conditions	Standard value
(2N) No. 1 and (2N) No. 2	Always	Less than 1 Ω
(2Q) No. 1 and (2Q) No. 2	Always	Less than 1 Ω

##### NOTE:

Terminals are designed to be shorted as the connection between airbag main harness and roll connector is disconnected.

- 5) Replace the roll connector with a new part if the inspection result is not within the standard value.

# Roll Connector

AIRBAG SYSTEM

---

## D: ADJUSTMENT

### CAUTION:

- Do not rotate the roll connector to more than the specified number of turns. Otherwise, the roll connector internal wire may be broken.
- When determining the end stop, rotate the connector slowly without applying excessive force. Applying excessive force at the end stop may break the internal wire.

1) Check that front wheels are positioned in straight ahead direction.

2) Turn the roll connector pin (A) clockwise until it stops.

3) Turn the roll connector pins (A) approx. 3.25 turns in the counterclockwise direction until “▲” marks are aligned.

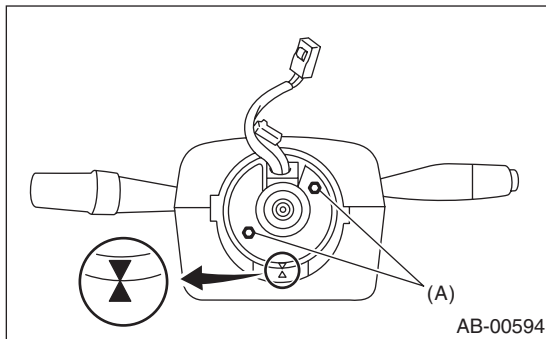

# AIRBAG SYSTEM (DIAGNOSTICS)

# *AB(diag)*

---

	<b>Page</b>
1. Basic Diagnostic Procedure .....	2
2. Check List for Interview .....	3
3. General Description .....	4
4. Electrical Component Location .....	21
5. Airbag Connector .....	23
6. Airbag Control Module I/O Signal .....	24
7. Subaru Select Monitor .....	26
8. Read Diagnostic Trouble Code (DTC) .....	31
9. Inspection Mode .....	32
10. Clear Memory Mode .....	33
11. Airbag Warning Light Illumination Pattern .....	34
12. Airbag Warning Light Failure .....	35
13. List of Diagnostic Trouble Code (DTC) .....	39
14. Diagnostic Chart with Trouble Code .....	48

# Basic Diagnostic Procedure

## AIRBAG SYSTEM (DIAGNOSTICS)

### 1. Basic Diagnostic Procedure

#### A: PROCEDURE

	Step	Check	Yes	No
1	<b>CHECK WARNING LIGHT.</b> Check whether the airbag warning light in the combination meter is lit.	Does the airbag warning light illuminate?	Go to step 2.	Perform the diagnosis according to phenomenon of the problem.
2	<b>READ DTC.</b> 1) Turn the ignition switch to OFF. 2) Connect the Subaru Select Monitor to data link connector. 3) Turn the ignition switch to ON and run the Subaru Select Monitor. 4) Read the DTC. <Ref. to AB(diag)-31, OPERATION, Read Diagnostic Trouble Code (DTC).> NOTE: If the communication function of the Subaru Select Monitor cannot be executed properly, check the communication circuit. <Ref. to AB(diag)-28, COMMUNICATION FOR INITIALIZING IMPOSSIBLE, INSPECTION, Subaru Select Monitor.> 5) Record all DTCs and freeze frame data.	Is DTC displayed?	Go to step 3.	Go to "Airbag Warning Light Failure" <Ref. to AB(diag)-35, Airbag Warning Light Failure.>.
3	<b>PERFORM DIAGNOSIS.</b> 1) Determine the possible cause from "List of Diagnostic Trouble Code (DTC)" <Ref. to AB(diag)-39, List of Diagnostic Trouble Code (DTC).>. 2) Inspect the DTC using "List of Diagnostic Trouble Code (DTC)". 3) Repair the trouble cause. 4) Perform the Clear Memory Mode. <Ref. to AB(diag)-33, Clear Memory Mode.> 5) Perform the Inspection Mode. <Ref. to AB(diag)-32, Inspection Mode.> 6) Read any other DTCs displayed.	Is DTC displayed?	Perform the procedure 1) to 5) in step 3.	Finish the diagnosis.



# General Description

## AIRBAG SYSTEM (DIAGNOSTICS)

### 3. General Description

#### A: CAUTION

- When servicing a vehicle, be sure to turn the ignition switch to OFF, disconnect the ground cable from battery, and wait for 60 seconds or more before starting work.
- The airbag system is fitted with a backup power supply. After disconnecting the battery ground cable, the airbag may deploy if you do not wait for 60 seconds or more before starting airbag system servicing.

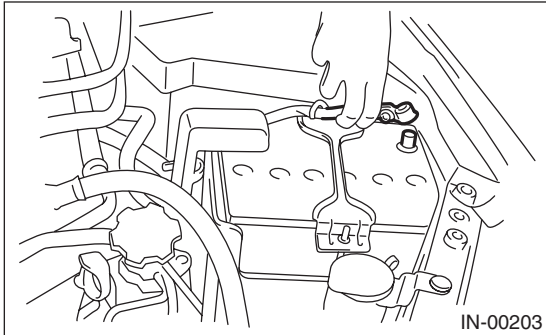

- If sensors, airbag module, airbag control module, pretensioner or harness is deformed or damaged, replace with new parts.

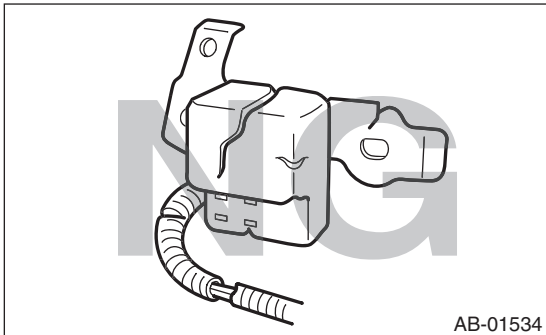

- Do not use the airbag system and pretensioners on other vehicles. When replacing parts, be sure to replace them with new parts.
- When checking the airbag system, be sure to use a digital circuit tester. Use of an analog circuit tester may cause the airbag to activate erroneously due to a minimal current inside tester.

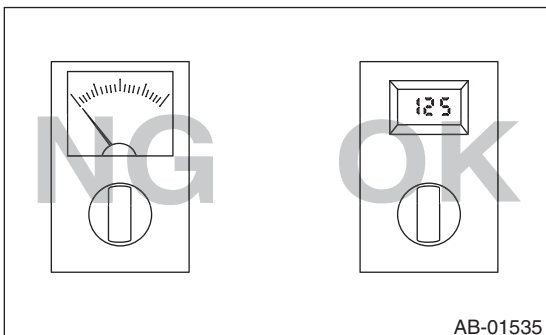

- When checking, use a test harness (1). Damage to connector terminal causes malfunction. Do not directly put the tester probe on airbag connector terminal.

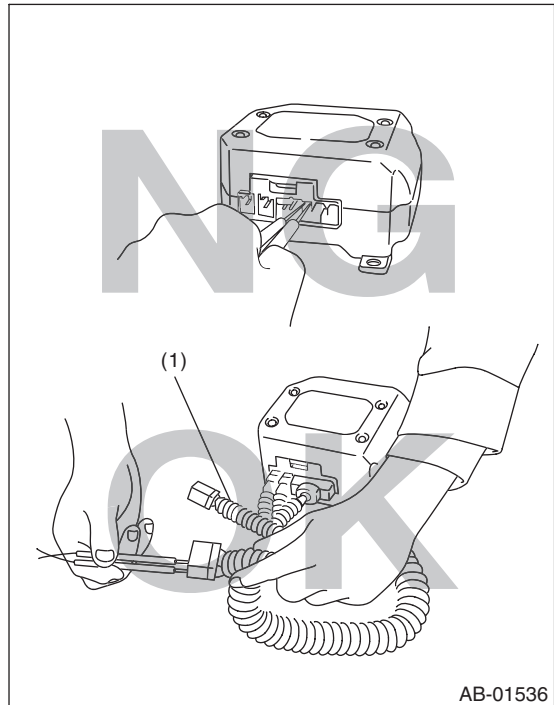

- Do not drop any airbag component, store them under high temperature of 85°C (185°F) or more, or let water, oil or grease get on them; the internal parts may be damaged or the reliability may be greatly lowered.

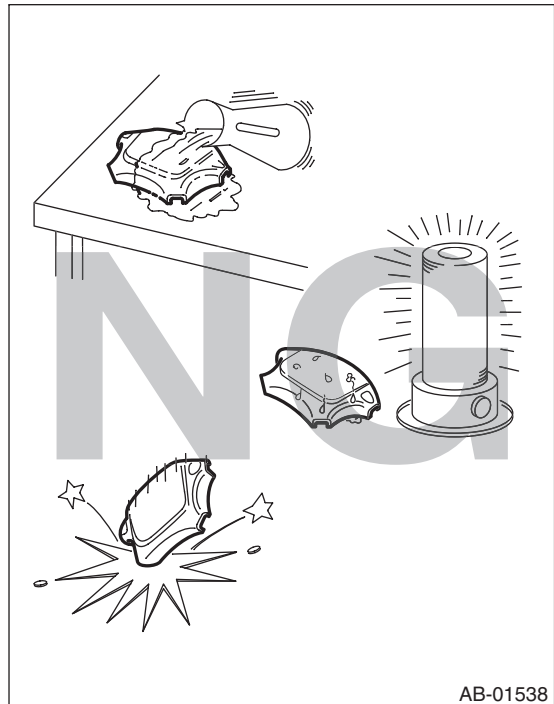

# General Description

## AIRBAG SYSTEM (DIAGNOSTICS)

- If damage, open circuit or rust is found on airbag system wiring harness, do not use a soldering equipment to repair. Replace the faulty harness with a new genuine part.

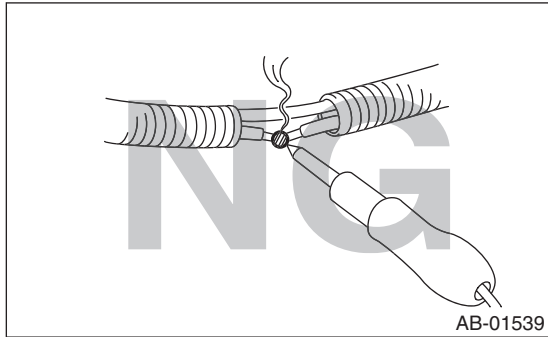

- Install the wiring harness securely with the specified clips to avoid interference or tangled with other parts.

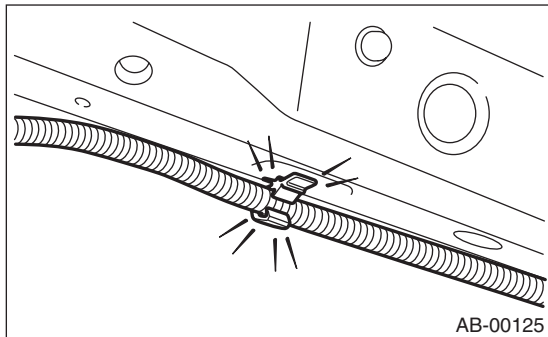

- Do not allow water or oil to come in contact with the connector terminals. Also, do not touch the connector terminals.

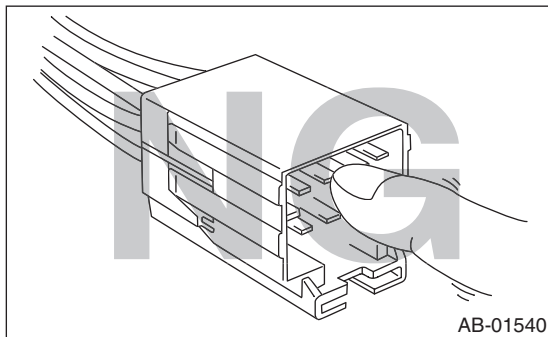

- Do not disassemble driver's airbag module, passenger's airbag module, side or curtain airbag modules, or pretensioner.

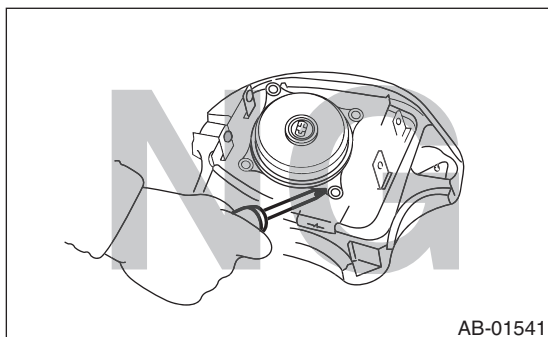

- The airbag module cannot be used again if deployed once.
- After removal, keep the airbag module with the pad side facing upward on a dry, clean and flat surface away from heat, light sources, moisture and dust.

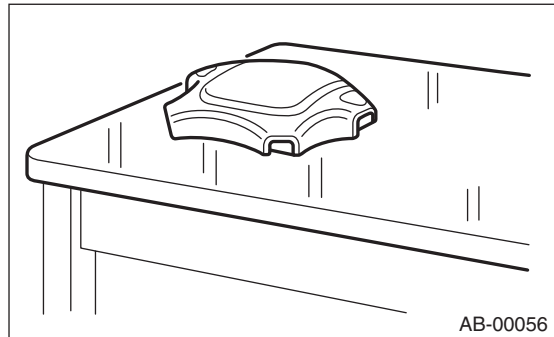

- Do not check continuity of the airbag modules for driver's side, passenger's side and curtain, or the pretensioner.

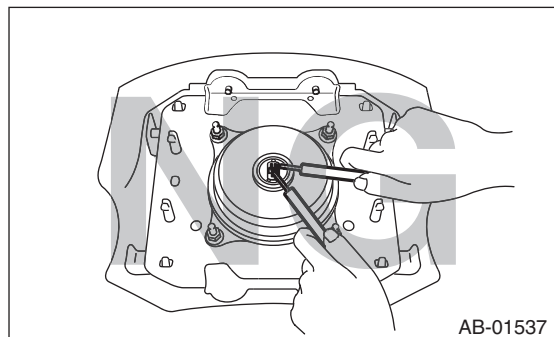

- The removed front seat with airbag module must be kept at least 200 mm (8 in) away from walls and other objects.

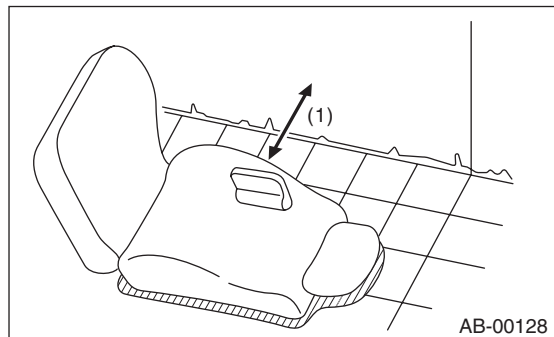

(1) 200 mm (8 in) or more

- When painting or performing sheet metal work on the front part of the vehicle, including the front wheel apron, front fender and front side frame, remove the front sub sensors and wiring harness of airbag system.



## General Description

### AIRBAG SYSTEM (DIAGNOSTICS)

---

- When painting or repairing sheet metal work on the side of the vehicle, including the side sill, center pillar, front and rear doors, rear crossmember and rear floor pan, remove the side airbag sensors, curtain airbag sensor, satellite safing sensor and wiring harness of the airbag system.

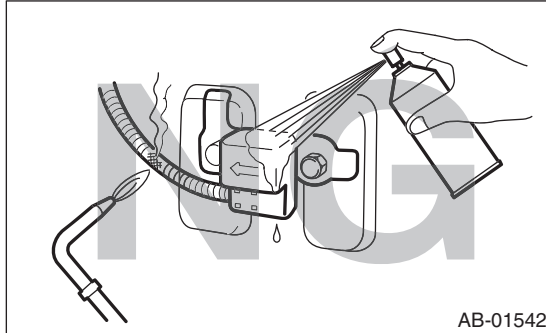

- Do not discard undeployed airbag module. They could easily cause a serious accident if accidentally deployed.

# General Description

## AIRBAG SYSTEM (DIAGNOSTICS)

- When storing a removed airbag module, do not place it with the pad side facing downward. Do not place any objects on the airbag module. Do not pile up the airbag module. If the airbag inflates for some reason when an airbag module pad is touching other objects, it may cause serious accident.

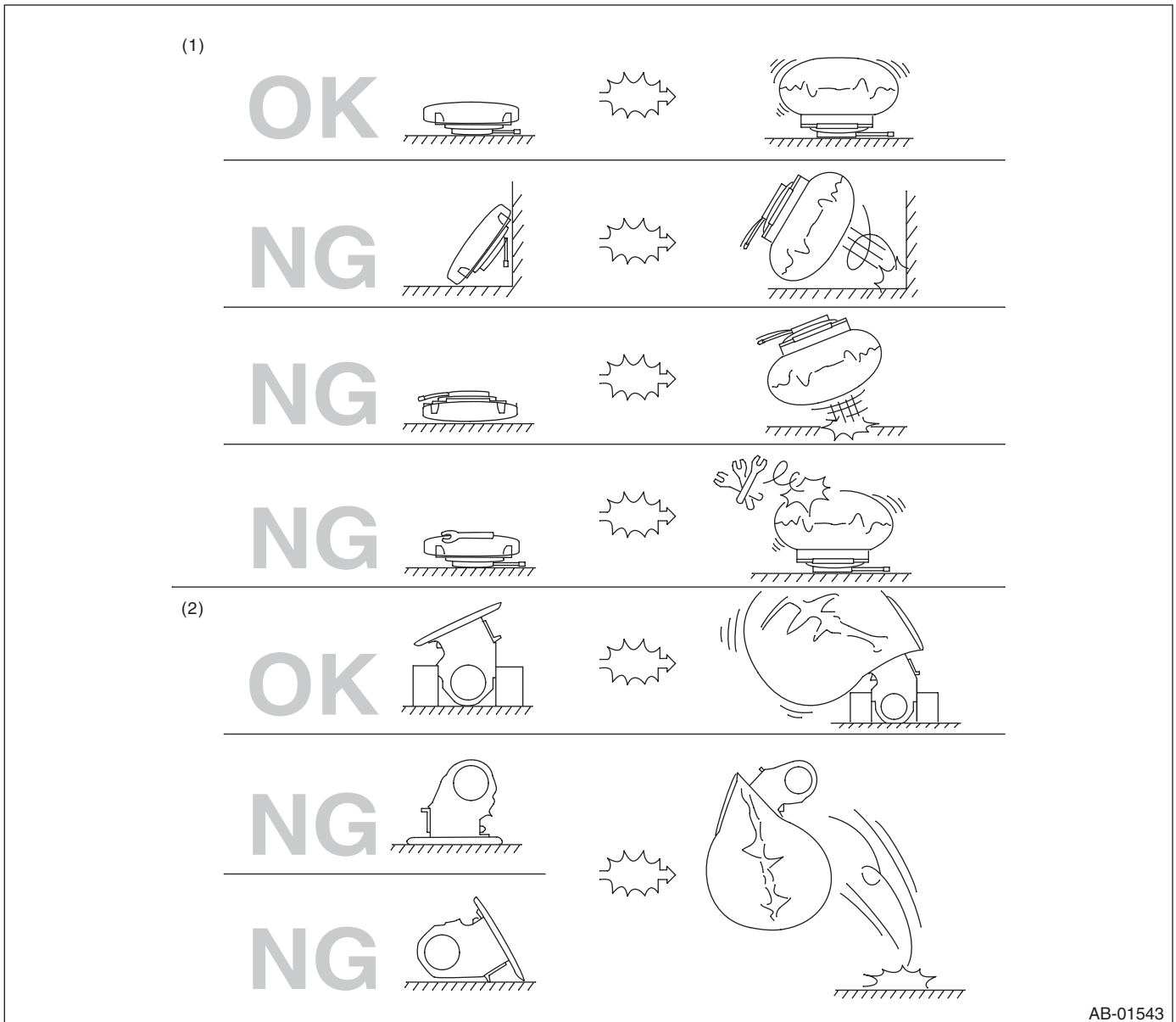

AB-01543

(1) Driver's airbag module

(2) Passenger's airbag module

## B: INSPECTION

Measure the battery voltage and check electrolyte.

**Standard voltage: 12 V**

**Specific gravity: 1.260 or more**

**AB(diag)-7**

Brought to you by Ebay Seller "SubaruManuals"

# General Description

AIRBAG SYSTEM (DIAGNOSTICS)

## C: PREPARATION TOOL

### CAUTION:

To measure the voltage and resistance of airbag system component, be sure to use the specified test harness.

### 1. SPECIAL TOOL

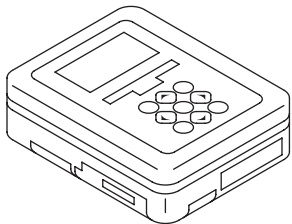
ILLUSTRATION	TOOL NUMBER	DESCRIPTION	REMARKS
 <p>ST1B022XU0</p>	1B022XU0	SUBARU SELECT MONITOR III KIT	Used for troubleshooting the electrical system.

### • TEST HARNESS H

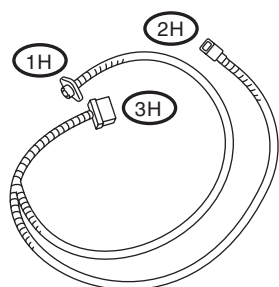
ILLUSTRATION	TOOL NUMBER	DESCRIPTION	REMARKS
 <p>ST98299FA030</p>	98299FA030	TEST HARNESS H	Used when measuring voltage and resistance of front sub sensor and satellite safing sensor.

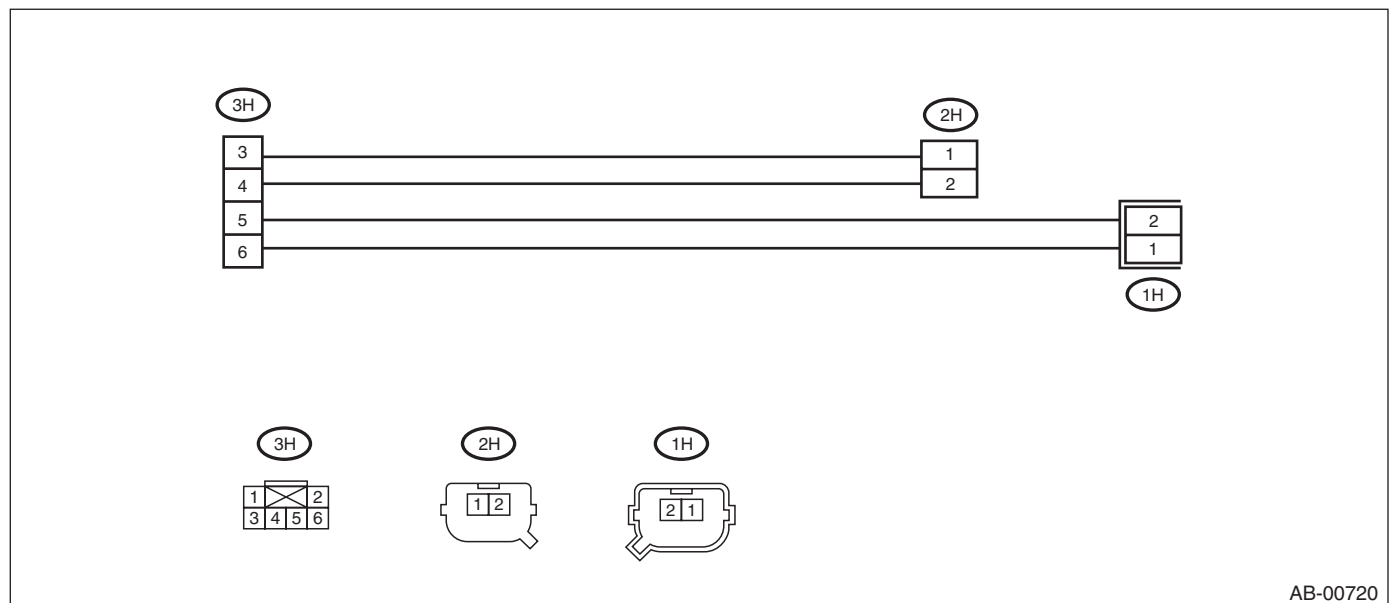

AB-00720

# General Description

AIRBAG SYSTEM (DIAGNOSTICS)

- TEST HARNESS N

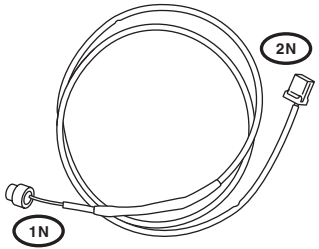
ILLUSTRATION	TOOL NUMBER	DESCRIPTION	REMARKS
 <p>ST98299SA000</p>	98299SA000	TEST HARNESS N	Used when measuring voltage and resistance of driver's airbag module, seat belt pretensioner and curtain airbag module.

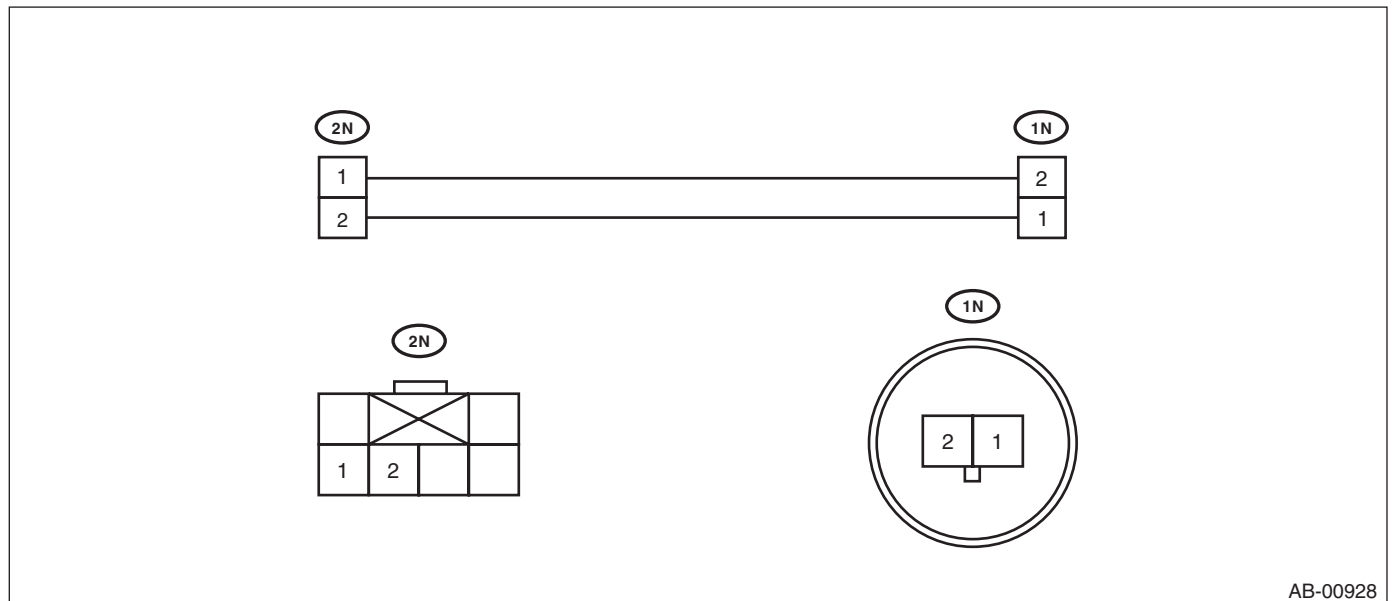

# General Description

## AIRBAG SYSTEM (DIAGNOSTICS)

- TEST HARNESS P

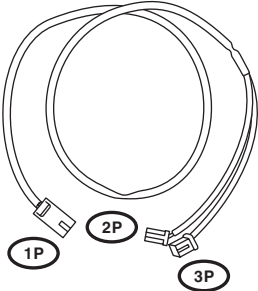
ILLUSTRATION	TOOL NUMBER	DESCRIPTION	REMARKS
 <p>ST98299SA020</p>	98299SA020	TEST HARNESS P	Used when measuring voltage and resistance of driver's airbag module and passenger's airbag module.

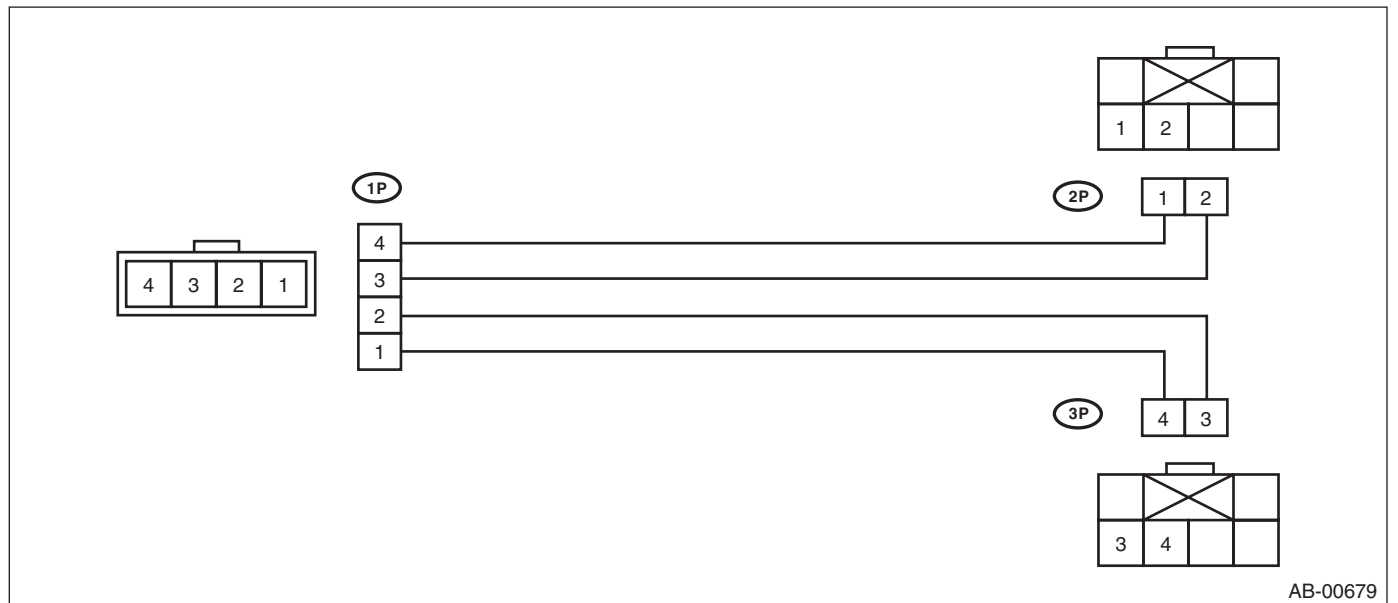

# General Description

AIRBAG SYSTEM (DIAGNOSTICS)

- TEST HARNESS Q

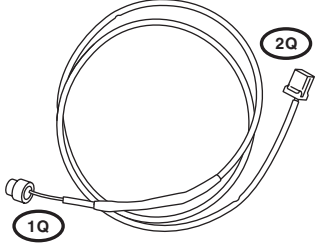
ILLUSTRATION	TOOL NUMBER	DESCRIPTION	REMARKS
 <p>ST98299SA040</p>	98299SA040	TEST HARNESS Q	Used when measuring voltage and resistance of driver's airbag module.

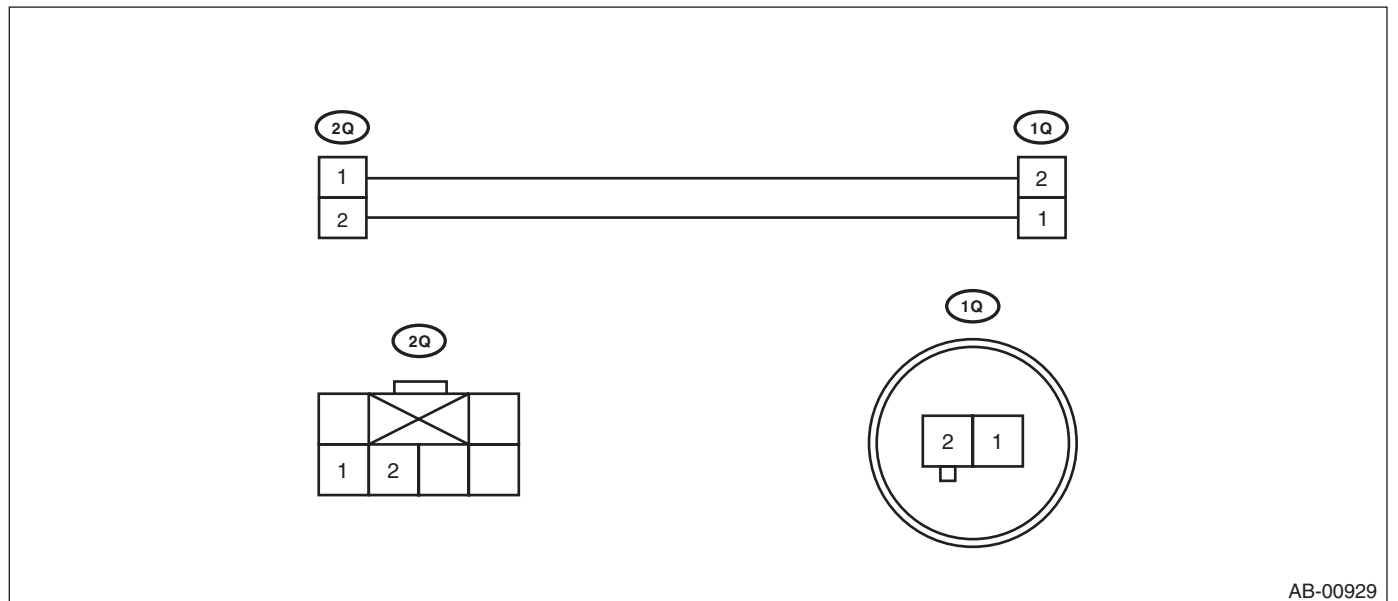

AB-00929

# General Description

## AIRBAG SYSTEM (DIAGNOSTICS)

- TEST HARNESS V

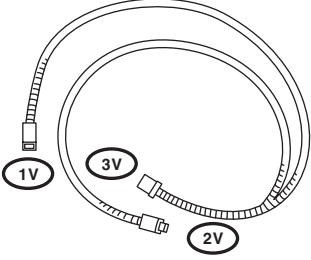
ILLUSTRATION	TOOL NUMBER	DESCRIPTION	REMARKS
 <p>ST98299AG010</p>	98299AG010	TEST HARNESS V	Used when measuring voltage and resistance of side airbag sensor and curtain airbag sensor.

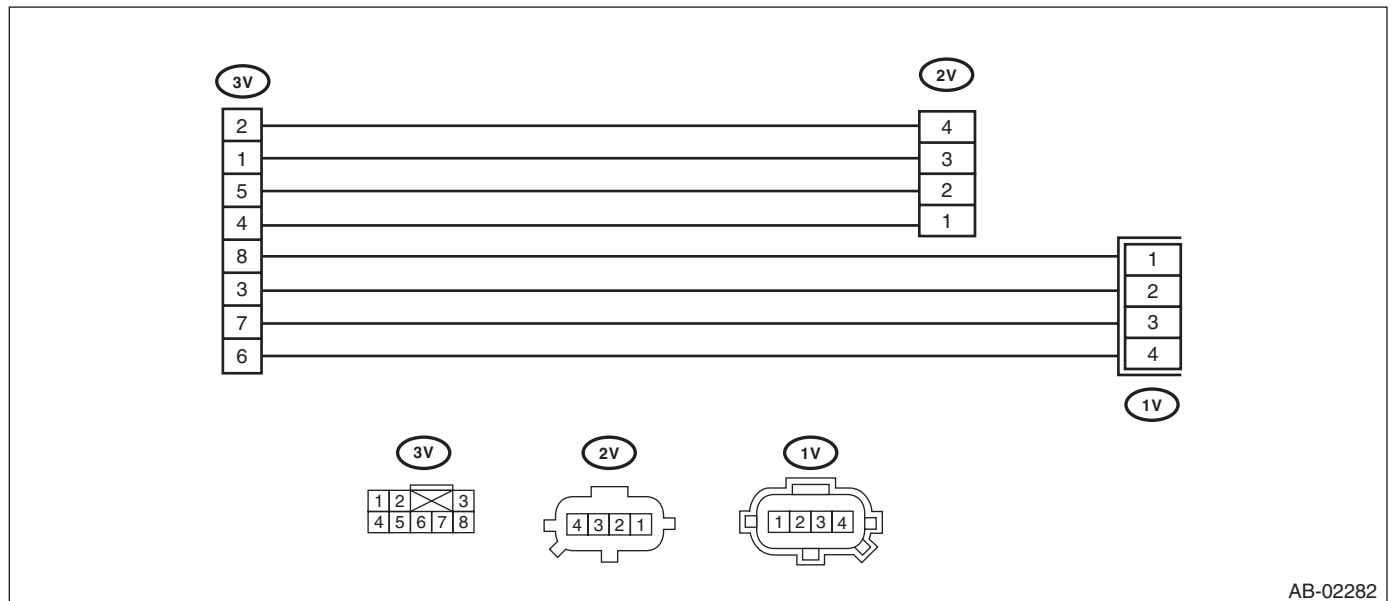

# General Description

AIRBAG SYSTEM (DIAGNOSTICS)

## • AIRBAG RESISTOR

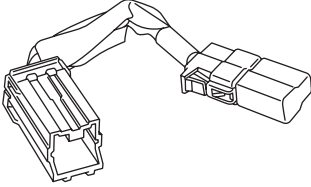
ILLUSTRATION	TOOL NUMBER	DESCRIPTION	REMARKS
 ST98299PA040	98299PA040	AIRBAG RESISTOR	Used in replacement of airbag module for which resistance value is same as airbag module.

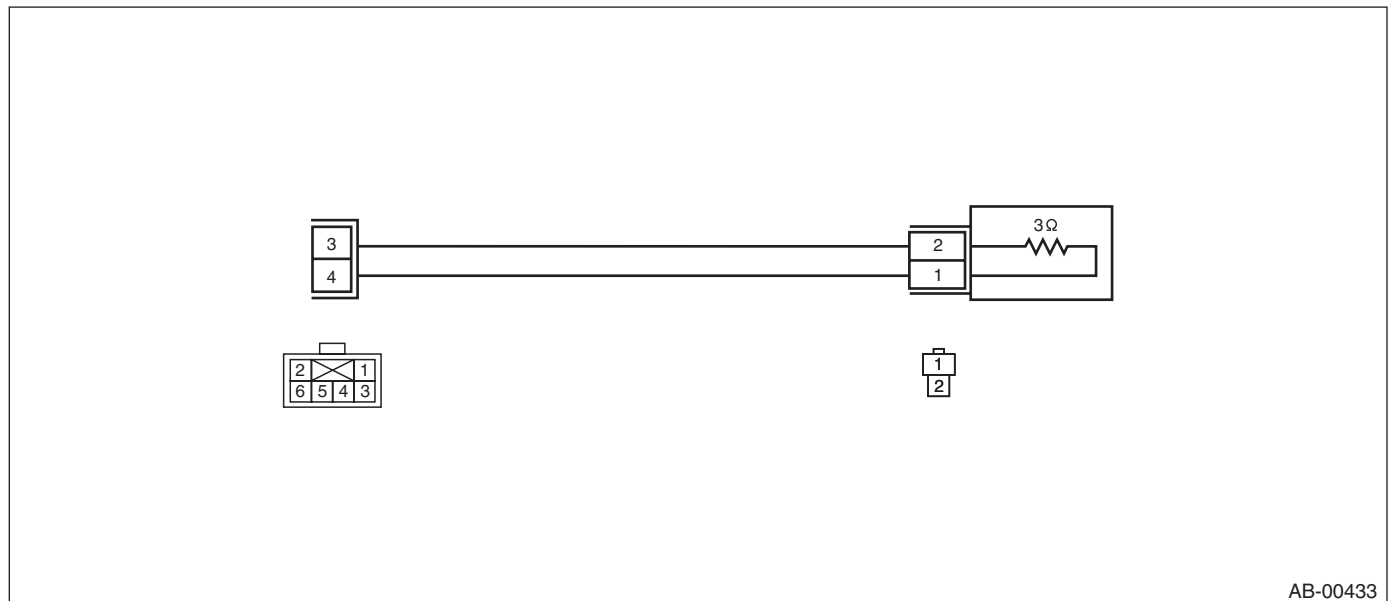

AB-00433



## General Description

### AIRBAG SYSTEM (DIAGNOSTICS)

- TEST HARNESS AG

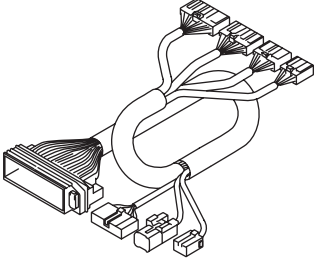
ILLUSTRATION	TOOL NUMBER	DESCRIPTION	REMARKS
 <p>ST98299AG070</p>	98299AG070	TEST HARNESS AG	Used together with test harness AH when measuring voltage and resistance of the airbag control module.

# General Description

## AIRBAG SYSTEM (DIAGNOSTICS)

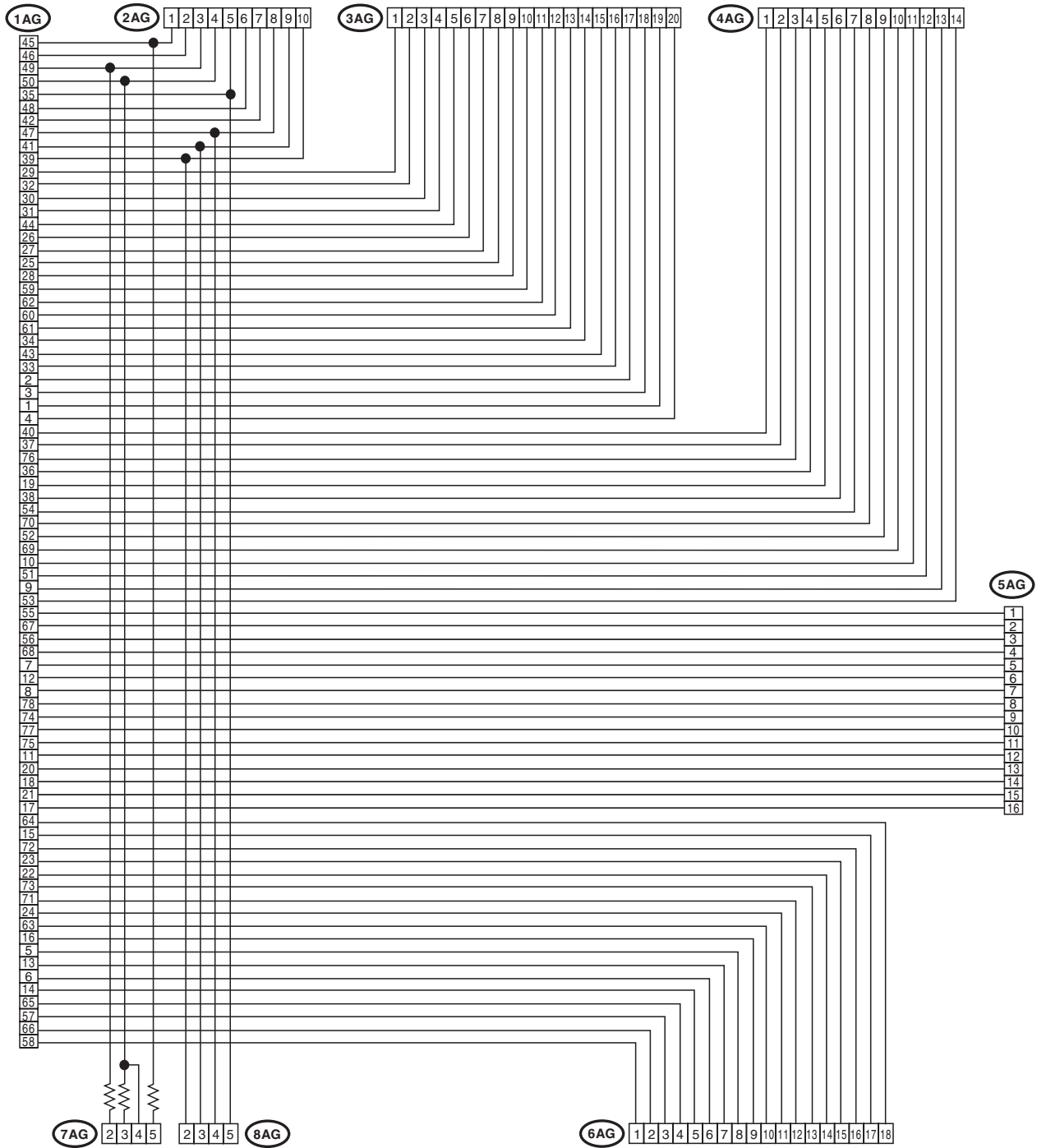

AB-01902

# General Description

## AIRBAG SYSTEM (DIAGNOSTICS)

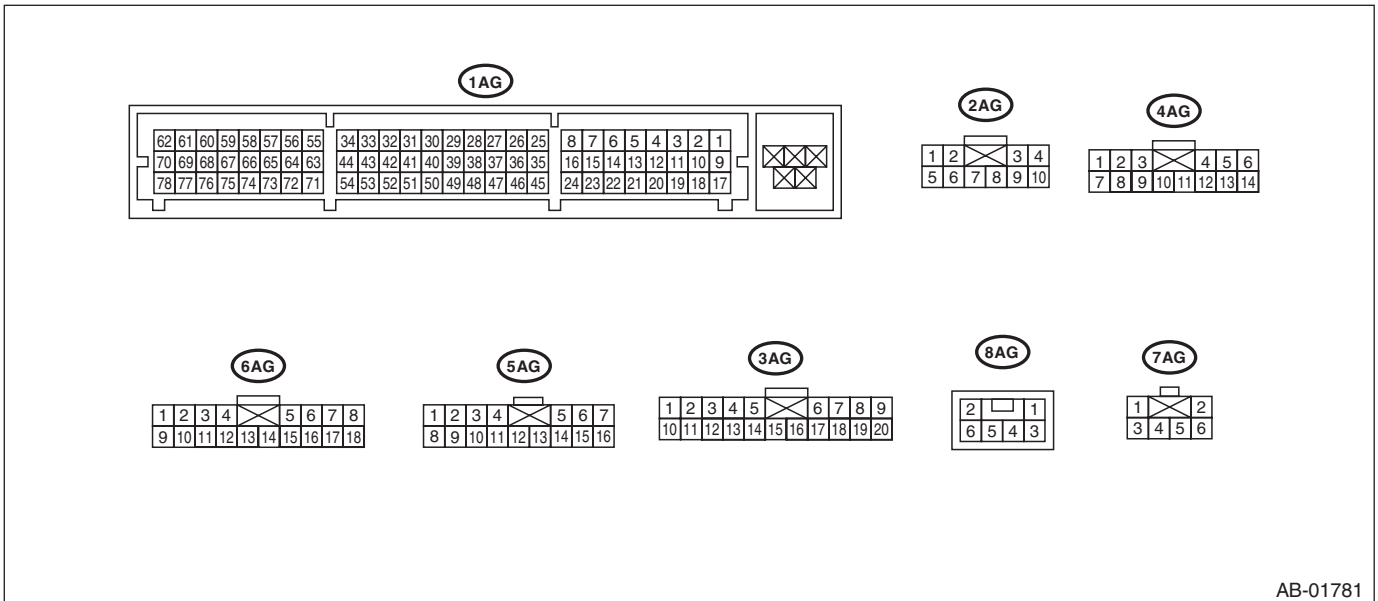

# General Description

- TEST HARNESS AH

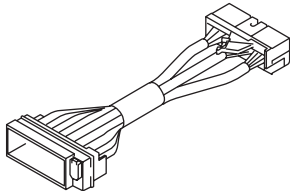
ILLUSTRATION	TOOL NUMBER	DESCRIPTION	REMARKS
 <p>ST98299AG080</p>	98299AG080	TEST HARNESS AH	Used together with test harness AG when measuring voltage and resistance of the airbag control module.

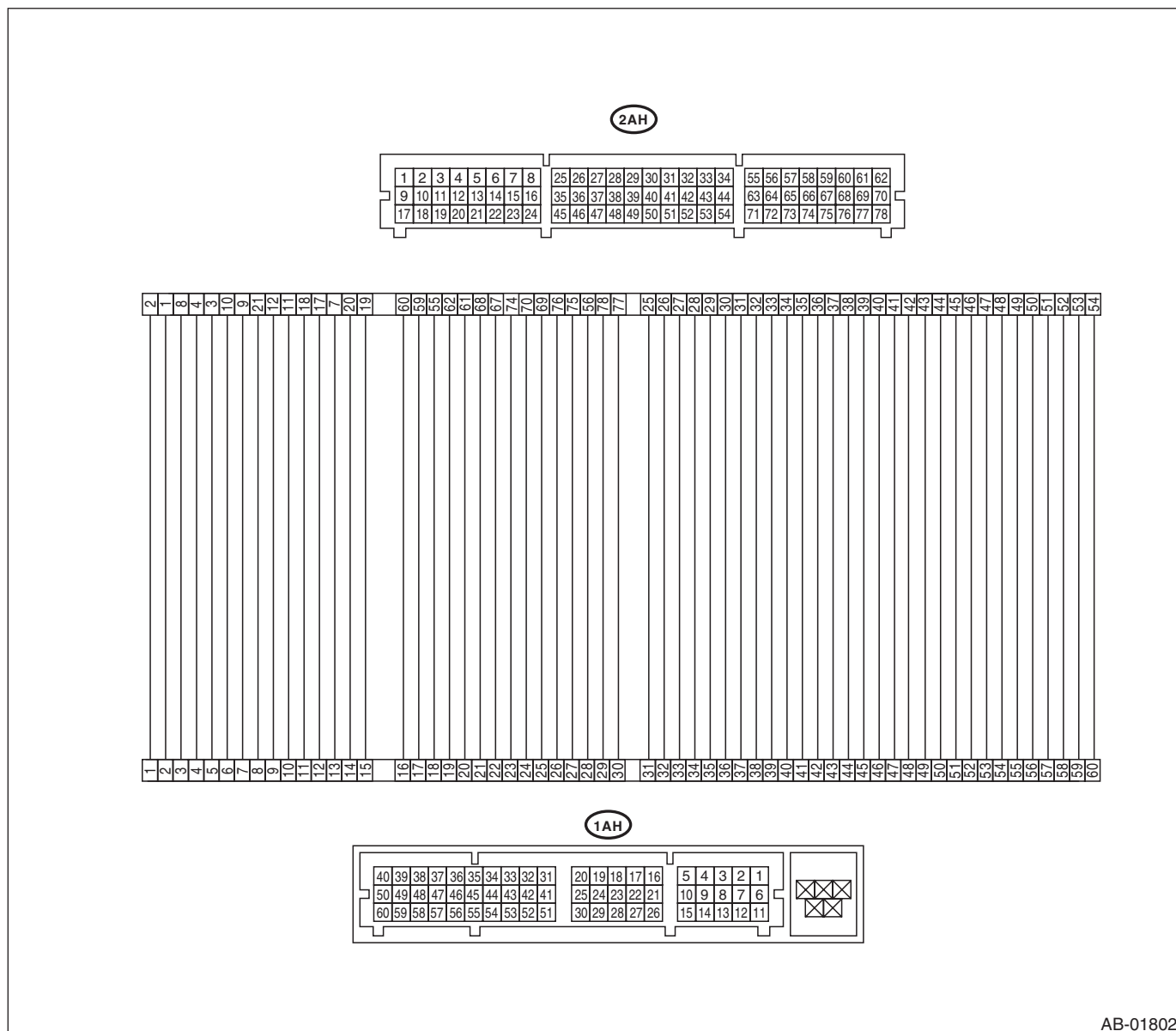

AB-01802

# General Description

## AIRBAG SYSTEM (DIAGNOSTICS)

### • TEST HARNESS AI

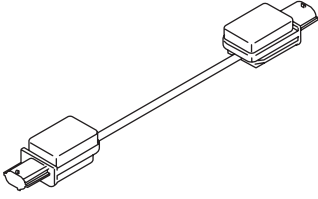
ILLUSTRATION	TOOL NUMBER	DESCRIPTION	REMARKS
 <p>ST98299AG090</p>	98299AG090	TEST HARNESS AI	<ul style="list-style-type: none"> <li>Used for diagnoses of side airbag sensor and curtain airbag sensor.</li> <li>Used together with test harness V.</li> </ul>

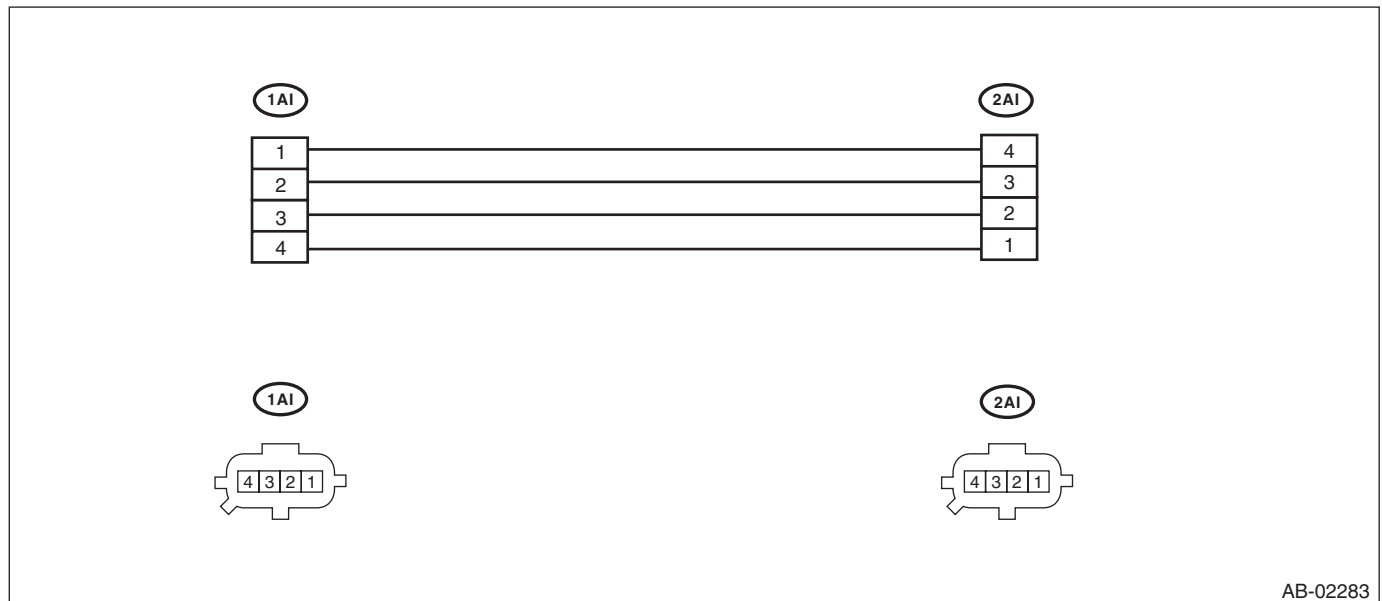

# General Description

- TEST HARNESS AJ

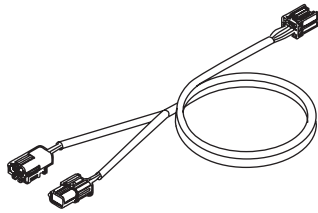
ILLUSTRATION	TOOL NUMBER	DESCRIPTION	REMARKS
 <p>ST98299FG000</p>	98299FG000	TEST HARNESS AJ	Used when measuring power supply and resistance of side airbag harness.

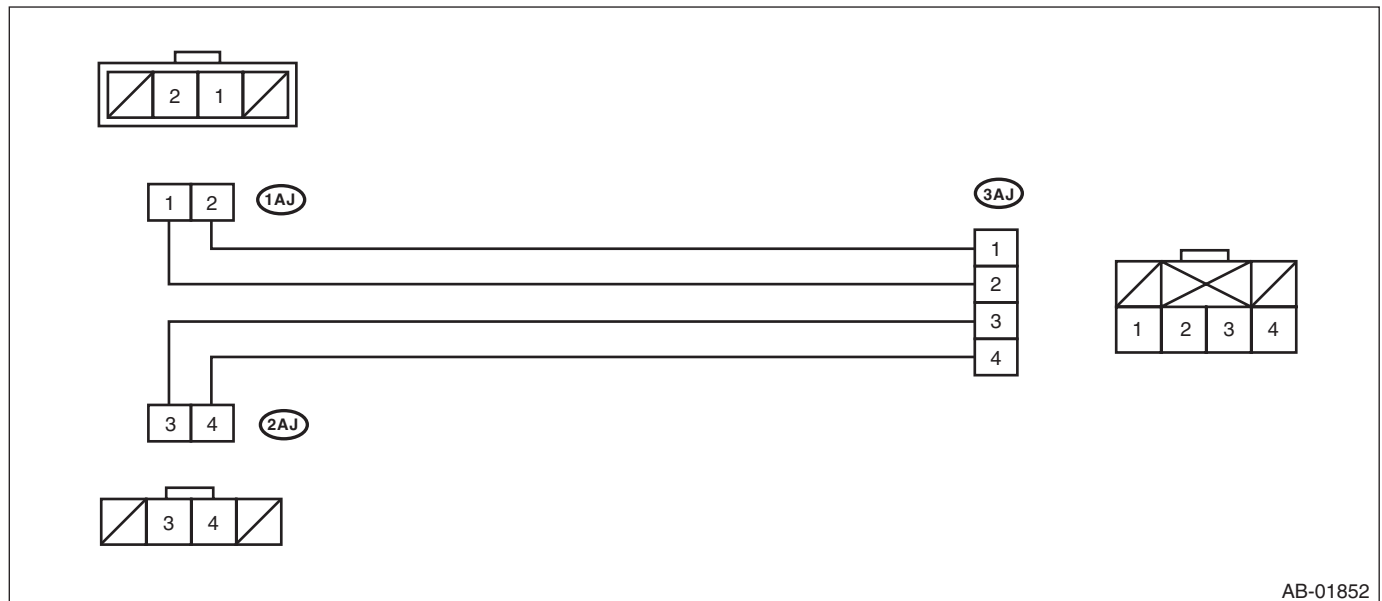

AB-01852

# General Description

## AIRBAG SYSTEM (DIAGNOSTICS)

- TEST HARNESS AB

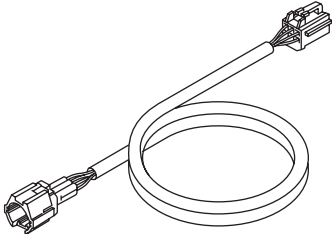
ILLUSTRATION	TOOL NUMBER	DESCRIPTION	REMARKS
 <p>ST98299XA000</p>	98299XA000	TEST HARNESS AB	Used when measuring voltage and resistance of occupant detection system.

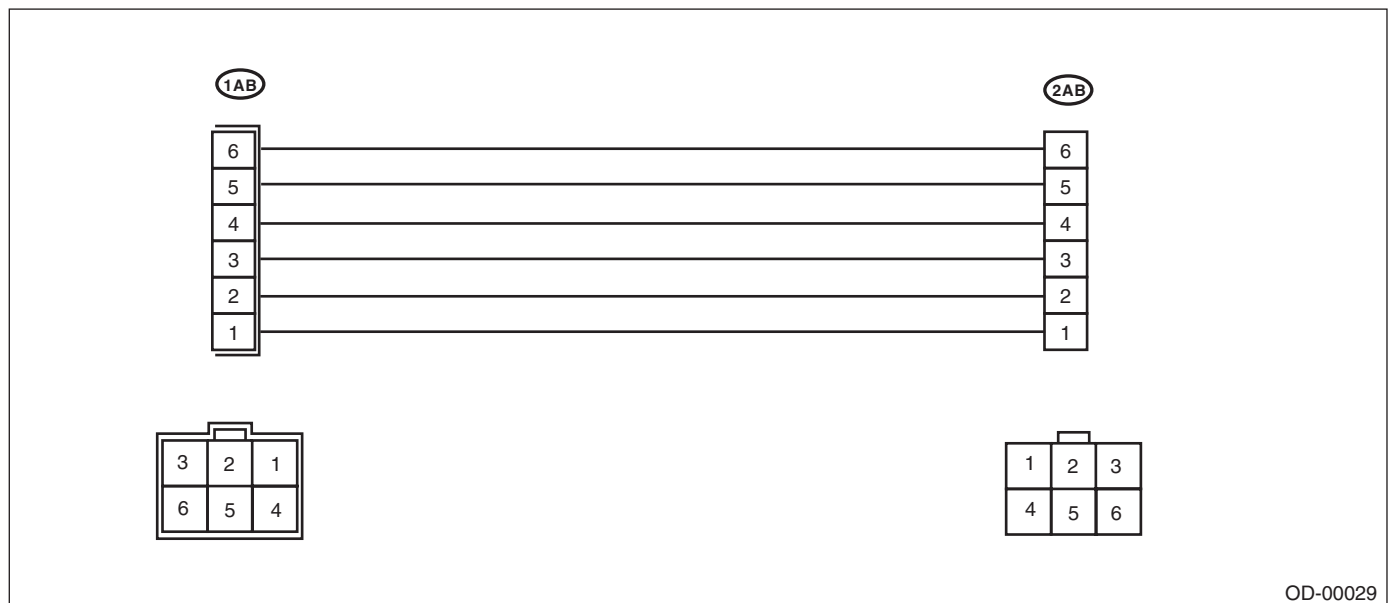

## 2. GENERAL TOOL

TOOL NAME	REMARKS
Circuit tester	Used for measuring resistance, voltage and current.
Oscilloscope	Used for measuring the sensor.

# Electrical Component Location

AIRBAG SYSTEM (DIAGNOSTICS)

## 4. Electrical Component Location

### A: LOCATION

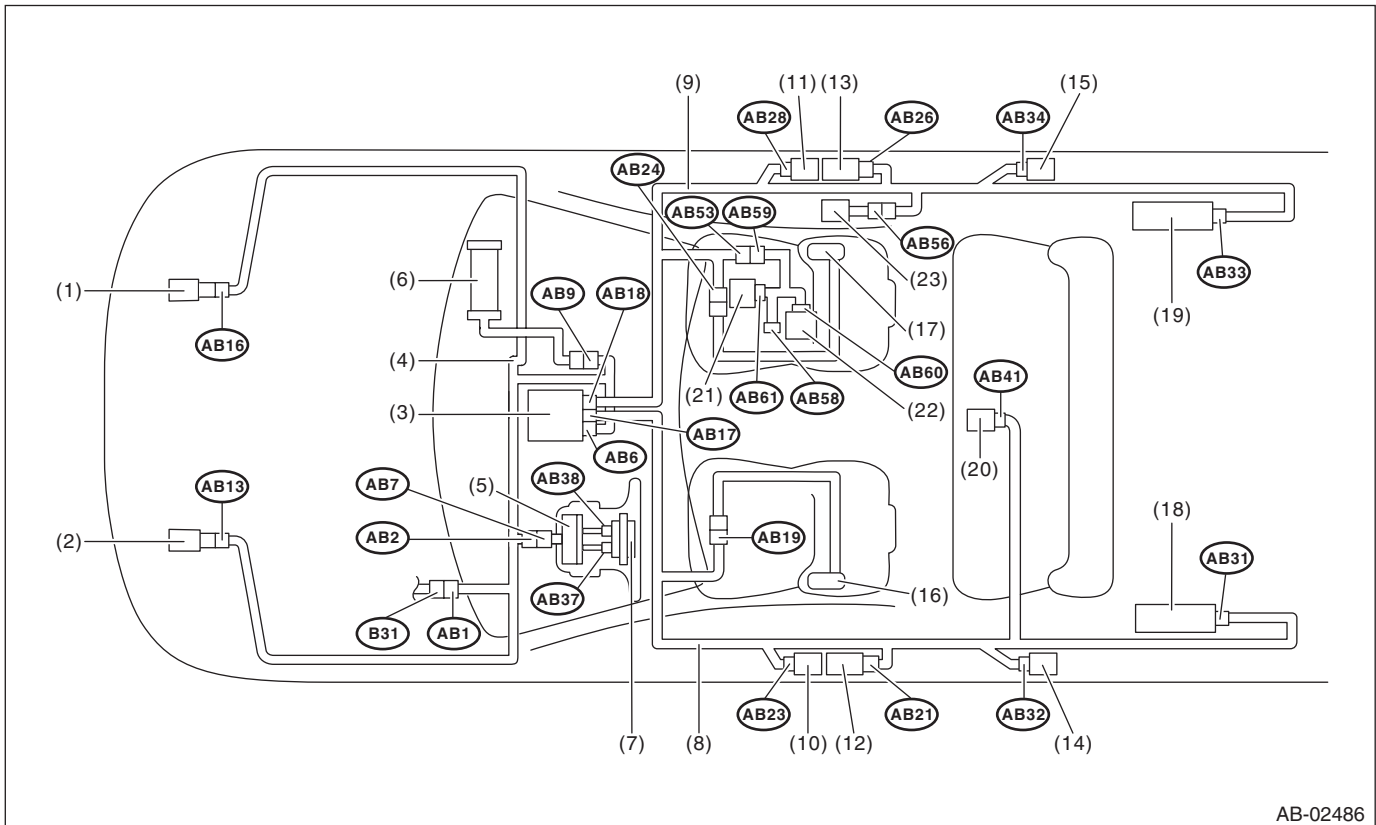

AB-02486

- |   |                                  |  |
|---|----------------------------------|--|
| (1) Front sub sensor (RH)                     | (9) Airbag rear harness (RH)     | (17) Side airbag inflator (RH)         |
| (2) Front sub sensor (LH)                     | (10) Side airbag sensor (LH)     | (18) Curtain airbag inflator (LH)      |
| (3) Airbag control module                     | (11) Side airbag sensor (RH)     | (19) Curtain airbag inflator (RH)      |
| (4) Airbag main harness<br>(bulkhead harness) | (12) Seat belt pretensioner (LH) | (20) Satellite safing sensor           |
| (5) Roll connector                            | (13) Seat belt pretensioner (RH) | (21) Occupant detection control module |
| (6) Passenger's airbag inflator               | (14) Curtain airbag sensor (LH)  | (22) Buckle switch (RH)                |
| (7) Driver's airbag inflator                  | (15) Curtain airbag sensor (RH)  | (23) Belt tension sensor               |
| (8) Airbag rear harness (LH)                  | (16) Side airbag inflator (LH)   |  |

**AB(diag)-21**

Brought to you by Ebay Seller "SubaruManuals"



# Electrical Component Location

## AIRBAG SYSTEM (DIAGNOSTICS)

Connector No.	(AB1)	(AB2)	(AB6)	(AB7)	(AB9)	(AB13)	(AB16)	(AB17)	(AB18)	(AB19)	(AB21)	(AB23)
Pin	6	4	30	4	4	2	2	15	15	4	2	4
Color	White	Yellow	Yellow	Yellow	Yellow	Yellow	Yellow	Yellow	Yellow	Yellow	Black	Yellow
Male/Female	Male	Female	Female	Male	Female	Female	Female	Female	Female	Female	Female	Female
Connector No.	(AB24)	(AB26)	(AB28)	(AB31)	(AB32)	(AB33)	(AB34)	(AB37)	(AB38)	(AB41)	(AB53)	(AB56)
Pin	4	2	4	2	4	2	4	2	2	2	6	3
Color	Yellow	Black	Yellow	Black	Yellow	Black	Yellow	Orange	Black	Yellow	Gray	Brown
Male/Female	Female	Female	Female	Female	Female	Female	Female	Female	Female	Female	Female	Female
Connector No.	(AB58)	(AB59)	(AB60)	(AB61)	(AB62)							
Pin	3	6	2	18	3							
Color	Gray	Gray	Yellow	Black	Brown							
Male/Female	Female	Female	Female	Female	Female							

## 5. Airbag Connector

### A: PROCEDURE

For detailed operation procedure, refer to the "Airbag Connector" in AB section. <Ref. to AB-9, Airbag Connector.>

# Airbag Control Module I/O Signal

AIRBAG SYSTEM (DIAGNOSTICS)

## 6. Airbag Control Module I/O Signal

### A: ELECTRICAL SPECIFICATION

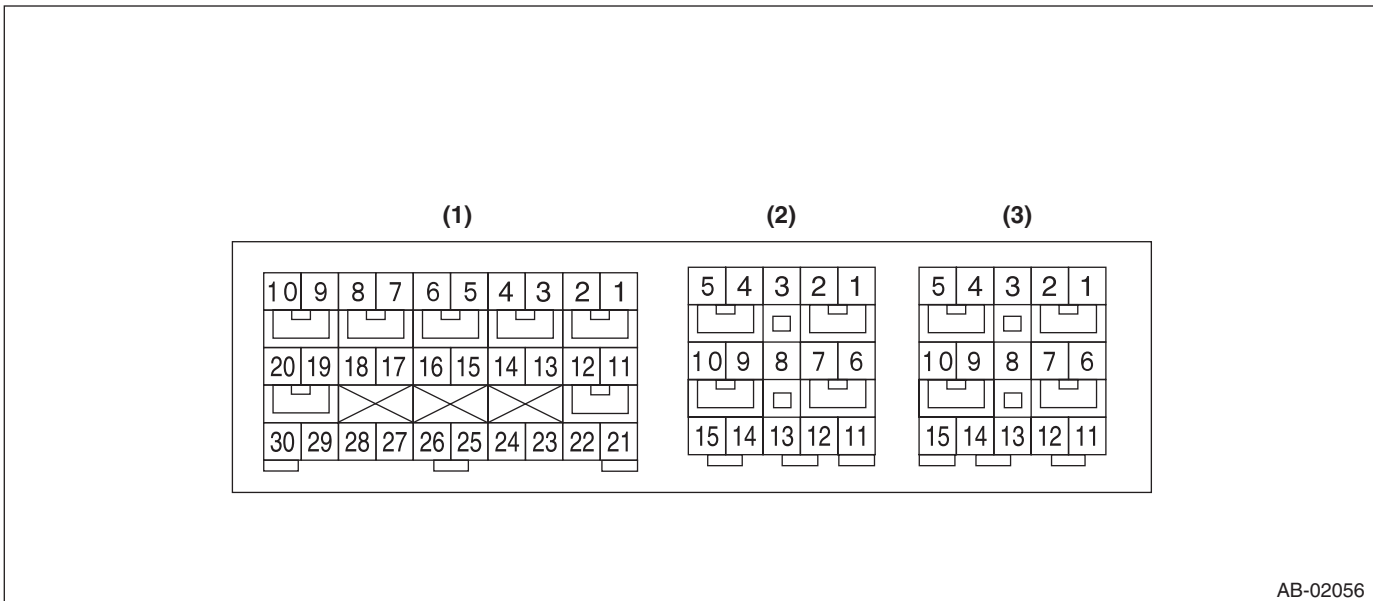

AB-02056

- Terminal numbers in airbag control module connector are shown in the figure.
- The airbag warning light illuminates when the connector is removed from the airbag control module.

Item		Control module terminal No.
Data link connector		(1) — 16
Combination meter		(1) — 11
Ignition power supply	Dedicated fuse	(1) — 21
Passenger's airbag module level one	+	(1) — 4
	-	(1) — 3
Passenger's airbag module level two	+	(1) — 1
	-	(1) — 2
Driver's airbag module level one	+	(1) — 5
	-	(1) — 6
Driver's airbag module level two	+	(1) — 8
	-	(1) — 7
Front sub sensor LH	+	(1) — 30
	-	(1) — 28
Front sub sensor RH	+	(1) — 29
	-	(1) — 27
Ground line (GND)		(1) — 25
		(1) — 26
Passenger's airbag OFF indicator		(1) — 17
Passenger's airbag ON indicator		(1) — 23
Passenger's seat belt warning light (integrated module)		(1) — 15
Side airbag sensor LH Curtain airbag sensor LH	+	(2) — 8
	-	(2) — 15
Side airbag module LH	+	(2) — 9
	-	(2) — 10
Curtain airbag module LH	+	(2) — 7
	-	(2) — 6
Seat belt pretensioner LH	+	(2) — 2
	-	(2) — 1

# Airbag Control Module I/O Signal

AIRBAG SYSTEM (DIAGNOSTICS)

Item		Control module terminal No.
Satellite safing sensor	+	(2) — 11
	-	(2) — 12
Seat belt pretensioner RH	+	(3) — 4
	-	(3) — 5
Side airbag sensor RH Curtain airbag sensor RH	+	(3) — 8
	-	(3) — 11
Side airbag module RH	+	(3) — 7
	-	(3) — 6
Curtain airbag module RH	+	(3) — 9
	-	(3) — 10
Occupant detection control module	+	(3) — 12
	-	(3) — 13

## B: WIRING DIAGRAM

Refer to the WI section wiring diagram. <Ref. to WI-82, WIRING DIAGRAM, Airbag System.>

# Subaru Select Monitor

## AIRBAG SYSTEM (DIAGNOSTICS)

### 7. Subaru Select Monitor

#### A: OPERATION

##### 1. READ DIAGNOSTIC TROUBLE CODE (DTC)

When malfunction of airbag system occurs, the DTC stored in airbag control module will be read out.

1) Prepare the Subaru Select Monitor kit. <Ref. to AB(diag)-8, SPECIAL TOOL, PREPARATION TOOL, General Description.>

2) Connect the diagnosis cable to Subaru Select Monitor.

3) Connect the Subaru Select Monitor to data link connector.

(1) Data link connector is located in the lower portion of instrument panel (on the driver's side).

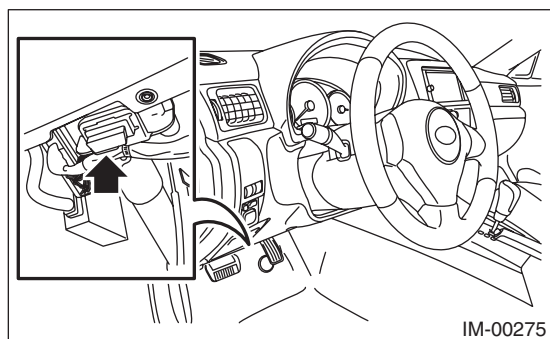

(2) Connect the diagnosis cable to data link connector.

#### CAUTION:

**Do not connect the scan tools other than the Subaru Select Monitor.**

4) Turn the ignition switch to ON and run the Subaru Select Monitor.

5) On «Main Menu» display, select {Each System Check}.

6) On «System Selection Menu» display, select {Airbag System}.

7) After {Airbag System} is displayed, select [OK].

8) Select the {Diagnostic Code(s) Display} in «Airbag System».

#### NOTE:

- For details concerning the operation procedure, refer to “PC application help for Subaru Select Monitor”.

- For details concerning DTCs, refer to List of Diagnostic Trouble Code (DTC). <Ref. to AB(diag)-39, List of Diagnostic Trouble Code (DTC).>

##### 2. CLEAR MEMORY MODE

Clear the DTC stored in the airbag control module after repairing the airbag system. (After the breakdown is recovered, the breakdown code for completed recoveries are read out when the next breakdown occurs if the memory clear work is not performed.)

1) On «Main Menu» display, select {Each System Check}.

2) On «System Selection Menu» display, select {Airbag System}.

3) Select the {Clear Memory} in «Airbag System».

4) When the “Clear Memory?” is shown on the screen, select [OK].

5) When “Done” is displayed, end the Subaru Select Monitor.

#### NOTE:

For detailed operation procedures, refer to “PC application help for Subaru Select Monitor”.

### 3. DISPLAY OF STATUS INFORMATION

Check the operating condition of each sensor in the event of malfunction in the seat belt buckle switch, or when the seat belt buckle switch has been replaced.

- 1) On «Main Menu» display, select {Each System Check}.
- 2) On «System Selection Menu» display, select {Airbag System}.
- 3) On «Airbag System» display, select {Status Data}.

The following table is for support data.

Item	Display
Seat position sensor LH	— <sup>*2</sup>
Seat position sensor RH	— <sup>*2</sup>
Seat belt buckle switch LH	— <sup>*6</sup>
Seat belt buckle switch RH	Equipped <sup>*3</sup> /Unequipped <sup>*4</sup> /Other <sup>*5</sup> /Initial setting <sup>*1</sup> /— <sup>*6</sup>
Passenger's airbag control status	ON <sup>*7</sup> /OFF <sup>*8</sup> /Initial setting <sup>*1</sup>

\*1: Displayed when it is initial.

\*2: Seat position sensor not supported

\*3: Seat belt fastened

\*4: Seat belt not fastened

\*5: Displayed when data other than belt fastened or not fastened, such as breakdowns is input.

\*6: Seat belt buckle switch not supported

\*7: Passenger's airbag operating state

\*8: Passenger's airbag non-operating state

**NOTE:**

For detailed operation procedures, refer to "PC application help for Subaru Select Monitor".

# Subaru Select Monitor

## AIRBAG SYSTEM (DIAGNOSTICS)

### B: INSPECTION

#### 1. COMMUNICATION FOR INITIALIZING IMPOSSIBLE

##### DETECTING CONDITION:

Defective harness connector

##### TROUBLE SYMPTOM:

Communication is impossible between the airbag control module and the Subaru Select Monitor.

##### WIRING DIAGRAM:

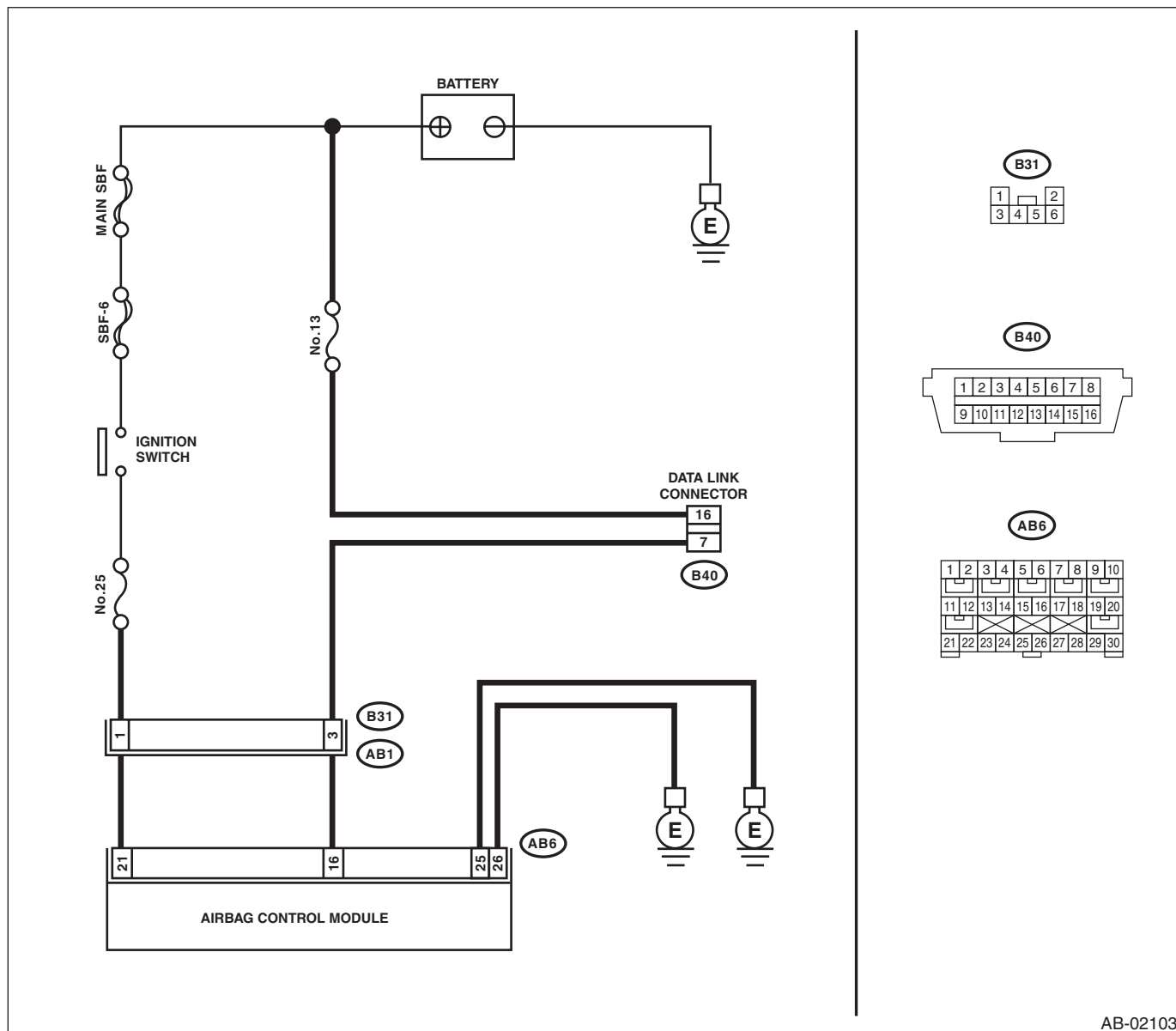

AB-02103

Step	Check	Yes	No
1	<b>CHECK IGNITION SWITCH.</b>	Go to step 2.	Turn the ignition switch to ON, and select the airbag mode using the Subaru Select Monitor.
2	<b>CHECK BATTERY.</b> 1) Turn the ignition switch to OFF. 2) Measure the battery voltage.	Go to step 3.	Charge or replace the battery.

AB(diag)-28

Brought to you by Ebay Seller "SubaruManuals"

# Subaru Select Monitor

## AIRBAG SYSTEM (DIAGNOSTICS)

Step	Check	Yes	No	
<b>3</b>	<b>CHECK BATTERY TERMINAL.</b>	Is there poor contact at battery terminal?	Repair or tighten the battery terminal.	Go to step 4.
<b>4</b>	<b>CHECK SUBARU SELECT MONITOR COMMUNICATION.</b> 1) Turn the ignition switch to ON. 2) Using the Subaru Select Monitor, check whether communication to other systems can be executed normally.	Is the system name displayed on Subaru Select Monitor?	Go to step 11.	Go to step 5.
<b>5</b>	<b>CHECK SUBARU SELECT MONITOR.</b>	Is Subaru Select Monitor powered on?	Go to step 7.	Go to step 6.
<b>6</b>	<b>CHECK FUSE.</b> Remove fuse No. 13 from the fuse & relay box, and perform visual inspection.	Is the fuse OK?	Repair the harness between the battery and the data link connector.	Replace the fuse. If the fuse is blown out again, check the power supply circuit.
<b>7</b>	<b>CHECK AIRBAG CONTROL MODULE CONNECTOR.</b> 1) Turn the ignition switch to OFF, disconnect the battery ground cable, and wait for 60 seconds or more. 2) Confirm that the connectors of airbag control module (AB6, AB17, AB18) are securely connected.	Is the connector of the airbag control module securely connected?	Go to step 8.	Connect the connector of the airbag control module.
<b>8</b>	<b>CHECK SUBARU SELECT MONITOR COMMUNICATION.</b> 1) Disconnect the airbag control module connector. 2) Connect the battery ground terminal. 3) Turn the ignition switch to ON. 4) Check whether communication to other systems can be executed normally.	Is the system name displayed on Subaru Select Monitor?	Replace the airbag control module. <Ref. to AB-22, Airbag Control Module.>	Go to step 9.
<b>9</b>	<b>CHECK HARNESS CONNECTOR BETWEEN EACH CONTROL MODULE AND DATA LINK CONNECTOR.</b> 1) Turn the ignition switch to OFF. 2) Disconnect the airbag control module, VDCCM&H/U, body integrated unit, ECM, and TCM. 3) Measure the resistance between data link connector and chassis ground. <b>Connector &amp; terminal</b> <b>(B40) No. 7 — Chassis ground:</b>	Is the resistance 1 MΩ or more?	Go to step 10.	Repair the harness and connector between each control module and data link connector. (Replace the entire harness if repair is necessary for airbag harness.)
<b>10</b>	<b>CHECK OUTPUT SIGNAL TO THE AIRBAG CONTROL MODULE.</b> 1) Turn the ignition switch to ON in the condition of step 9. 2) Measure the voltage between data link connector and chassis ground. <b>Connector &amp; terminal</b> <b>(B40) No. 7 (+) — Chassis ground (-):</b>	Is the voltage less than 1 V?	Repair each control module.	Repair the harness and connector between each control module and data link connector. (Replace the entire harness if repair is necessary for airbag harness.)
<b>11</b>	<b>CHECK FUSE.</b> Remove fuse No. 25 from the fuse & relay box, and perform visual inspection.	Is the fuse OK?	Go to step 12.	Replace the fuse. If the fuse is blown out again, check the power supply circuit.



# Subaru Select Monitor

## AIRBAG SYSTEM (DIAGNOSTICS)

Step	Check	Yes	No
<b>12 CHECK AIRBAG CONTROL MODULE CONNECTOR.</b> 1) Turn the ignition switch to OFF, disconnect the battery ground cable, and wait for 60 seconds or more. 2) Confirm that the connectors of airbag control module (AB6, AB17, AB18) are securely connected.	Is the connector of the airbag control module securely connected?	Go to step 13.	Connect the connector of the airbag control module.
<b>13 CHECK THE HARNESS BETWEEN THE AIRBAG CONTROL MODULE AND DATA LINK CONNECTOR.</b> 1) Disconnect the connectors (AB6, AB17, AB18) from airbag control module. 2) Connect the connector (1AH) in the test harness AH to the connectors (AB6, AB17, AB18). 3) Connect the connector (2AH) in the test harness AH and the connector (1AG) in the test harness AG. 4) Measure the resistance between connector (4AG) in the test harness AG and the data link connector. <i>Connector &amp; terminal (4AG) No. 1 — (B40) No. 7:</i>	Is the resistance less than 10 $\Omega$ ?	Go to step 14.	Repair the harness between the airbag control module and the data link connector. Or replace the airbag main harness along with the bulkhead harness.
<b>14 CHECK POWER SUPPLY CIRCUIT.</b> 1) Turn the ignition switch to ON. 2) Measure the voltage between connector (2AG) in the test harness AG and chassis ground. <i>Connector &amp; terminal (2AG) No. 1 (+) — Chassis ground (-):</i>	Is the voltage 10 V or more?	Go to step 15.	Repair the harness between the airbag control module and the battery. Or replace the airbag main harness along with the bulkhead harness.
<b>15 CHECK BETWEEN AIRBAG CONTROL MODULE AND CHASSIS GROUND.</b> 1) Turn the ignition switch to OFF. 2) Measure the resistance between connector (2AG) in the test harness AG and chassis ground. <i>Connector &amp; terminal (2AG) No. 4 — Chassis ground: (2AG) No. 3 — Chassis ground:</i>	Is the resistance less than 10 $\Omega$ ?	Go to step 16.	Repair the harness between the airbag control module and the chassis ground. Or replace the airbag main harness along with the bulkhead harness.
<b>16 CHECK POOR CONTACT OF CONNECTOR.</b>	Is there poor contact of the control module power supply, ground circuit and data link connector?	Repair the connector. (Replace the harness instead of repairing the airbag system connector.)	Replace the airbag control module. <Ref. to AB-22, REMOVAL, Airbag Control Module.>

### 8. Read Diagnostic Trouble Code (DTC)

#### A: OPERATION

For details about reading of DTCs, refer to “Subaru Select Monitor”. <Ref. to AB(diag)-26, Subaru Select Monitor.>

### **9. Inspection Mode**

#### **A: PROCEDURE**

Recreate the circumstance by referring to the conditions described in the checklist.

## 10. Clear Memory Mode

### A: OPERATION

- Clear the memory in the following steps after the malfunction is repaired.
- For details concerning DTC clear operation, refer to "Subaru Select Monitor". <Ref. to AB(diag)-26, Subaru Select Monitor.>

# Airbag Warning Light Illumination Pattern

AIRBAG SYSTEM (DIAGNOSTICS)

---

## 11. Airbag Warning Light Illumination Pattern

### A: INSPECTION

Turn the ignition switch to ON, and confirm that the airbag warning light remains on for approx. 6 seconds then turns off afterwards.

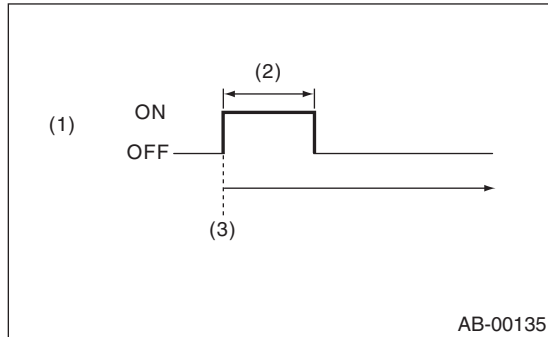

- (1) Airbag warning light
- (2) Approx. 6 sec.
- (3) Ignition switch ON

## Airbag Warning Light Failure

### A: AIRBAG WARNING LIGHT REMAINS ON

#### DETECTING CONDITION:

- Airbag warning light is faulty.
- Airbag control module to airbag warning light circuit is shorted or open.
- Grounding circuit is faulty.
- Airbag control module is faulty.
- Connector connection is improper.
- Connections of (AB6, AB17, AB18) to airbag control module are improper.

#### CAUTION:

- Before diagnosing the airbag system, be sure to turn the ignition switch to OFF, disconnect the ground cable from battery, and wait 60 seconds or more before starting to work.
- When replacing the airbag module, seat belt pretensioner, roll connector, control module and sensor, reconnect each part and check that the warning light operates properly.
- When inspecting the airbag main harness, disconnect the airbag module connectors of the driver's and passenger's seats for safety.
- When inspecting the airbag rear harness, disconnect the side airbag module connector, curtain airbag module connector and seat belt pretensioner connector for safety reasons.

#### WIRING DIAGRAM:

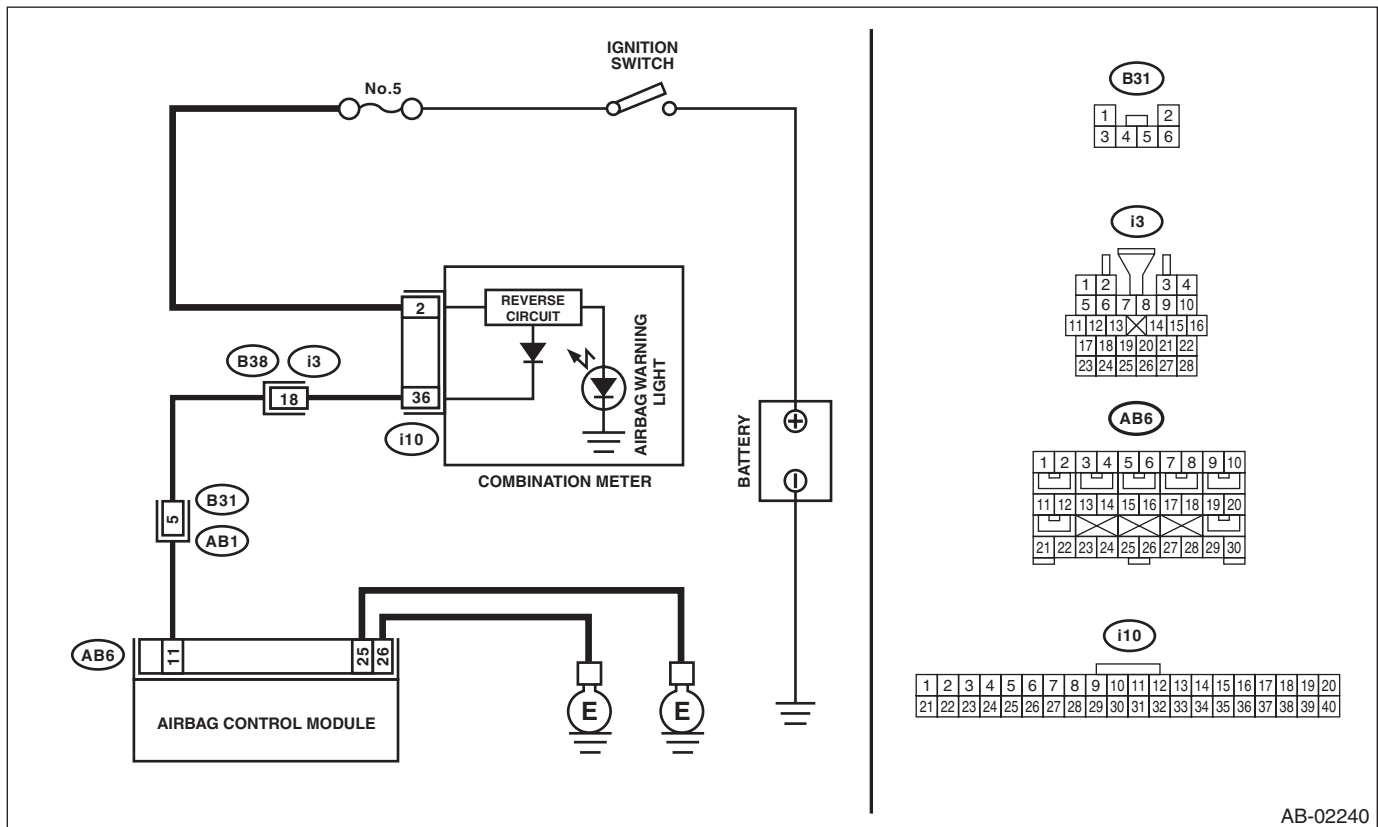

AB-02240

Step	Check	Yes	No
1 <b>READ DTC.</b> Read the DTC. <Ref. to AB(diag)-26, READ DIAGNOSTIC TROUBLE CODE (DTC), OPERATION, Subaru Select Monitor.>	Is DTC displayed?	Go to step 2.	Go to step 3.
2 <b>CHECK DTC.</b>	Is the displayed DTC 2D?	Go to step 3.	Perform the diagnosis according to DTC.

# Airbag Warning Light Failure

## AIRBAG SYSTEM (DIAGNOSTICS)

Step	Check	Yes	No
<b>3 CHECK FOR POOR CONTACT.</b> 1) Turn the ignition switch to OFF, disconnect the battery ground cable, and wait for 60 seconds or more. 2) Check that the airbag control module and the connectors (AB6, AB17, AB18) are securely connected.	Are there poor contact of connectors (AB6, AB17, AB18)?	If the faulty connector contact remains, replace the airbag main harness along with body harness or replace the airbag control module. <Ref. to AB-22, Airbag Control Module.>	Go to step 4.
<b>4 CHECK AIRBAG MAIN HARNESS.</b> 1) Remove the instrument panel lower cover and disconnect the connectors (AB7) and (AB2). 2) Remove the console front panel and disconnect the connector (AB9). 3) Disconnect the connectors (AB6, AB17, AB18) from the airbag control module, and connect the connector (1AH) in the test harness AH. 4) Connect the connector (2AH) in the test harness AH and the connector (1AG) in the test harness AG. 5) Connect the battery ground terminal and turn the ignition switch to ON. 6) Connect the connectors (7AG) and (8AG) in the test harness AG. NOTE: After the fault has been cleared, disconnect the connectors (7AG) and (8AG).	Does the airbag warning light go off?	Go to step 5.	Go to step 6.
<b>5 CHECK GROUND CIRCUIT.</b> Measure the resistance between connector (2AG) in the test harness AG and chassis ground. <i>Connector &amp; terminal</i> <i>(2AG) No. 4 — Chassis ground:</i> <i>(2AG) No. 3 — Chassis ground:</i>	Is the resistance less than 10 $\Omega$ ?	Replace the airbag control module. <Ref. to AB-22, Airbag Control Module.>	Repair the chassis ground circuit.
<b>6 CHECK AIRBAG MAIN HARNESS AND BULKHEAD HARNESS.</b> 1) Disconnect the connectors (7AG) and (8AG). 2) Remove the combination meter. 3) Measure the resistance between the combination meter connector and test harness AG connector (2AG). <i>Connector &amp; terminal</i> <i>(2AG) No. 5 — (i10) No. 36:</i>	Is the resistance less than 10 $\Omega$ ?	Check the combination meter.	Go to step 7.
<b>7 CHECK POOR CONTACT OF CONNECTOR.</b> 1) Turn the ignition switch to OFF, disconnect the battery ground terminal, and wait 60 seconds or more. 2) Confirm that the connectors between the airbag control module and the combination meter are securely connected.	Is there poor contact of connector?	Repair the bulkhead harness or replace the airbag main harness along with body harness.	Go to step 8.
<b>8 CHECK AIRBAG MAIN HARNESS.</b> Check the airbag main harness for defect.	Is there any defect in the airbag main harness?	Replace the airbag main harness along with bulkhead harness.	Repair the bulkhead harness.

# Airbag Warning Light Failure

## B: AIRBAG WARNING LIGHT REMAINS OFF

### DETECTING CONDITION:

- Fuse No. 5 (in fuse & relay box) is blown out.
- Body harness circuit is open.
- Airbag warning light is faulty.
- Airbag main harness is faulty.
- Airbag control module is faulty.

### CAUTION:

- Before diagnosing the airbag system, be sure to turn the ignition switch to OFF, disconnect the ground cable from battery, and wait 60 seconds or more before starting to work.
- When replacing the airbag module, seat belt pretensioner, roll connector, control module and sensor, reconnect each part and check that the warning light operates properly.
- When inspecting the airbag main harness, disconnect the airbag module connectors of the driver's and passenger's seats for safety.
- When inspecting the airbag rear harness, disconnect the side airbag module connector, curtain airbag module connector and seat belt pretensioner connector for safety reasons.

### WIRING DIAGRAM:

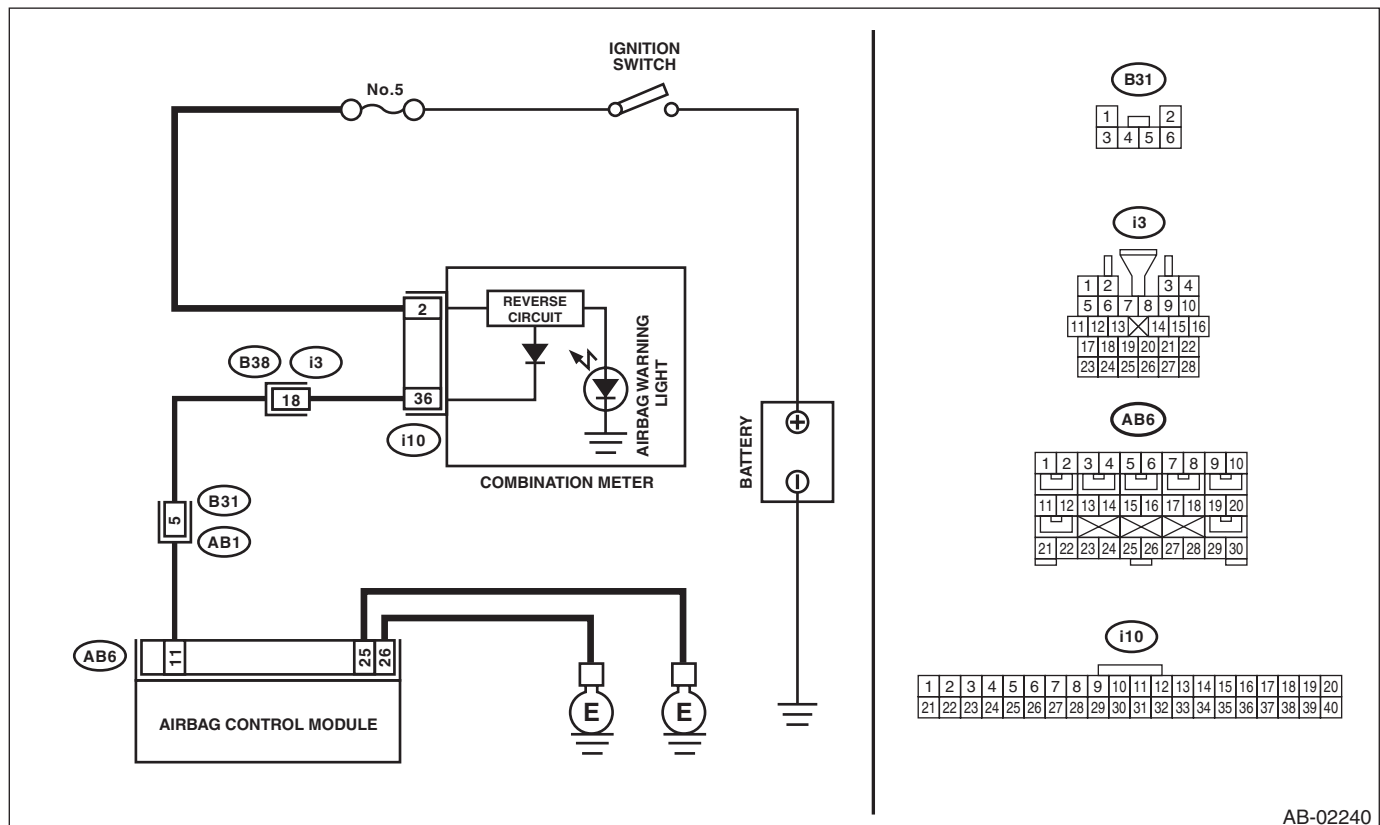

AB-02240

Step	Check	Yes	No
1	<b>CHECK COMBINATION METER.</b> Turn the ignition switch to ON, and confirm that warning lights of combination meter illuminate.	Go to step 2.	Check the combination meter.
2	<b>CHECK DTC.</b> Read the DTC. <Ref. to AB(diag)-26, READ DIAGNOSTIC TROUBLE CODE (DTC), OPERATION, Subaru Select Monitor.>	Perform the diagnosis according to DTC.	Go to step 3.
3	<b>CHECK FUSE.</b> Remove fuse No. 5 from the fuse & relay box, and perform visual inspection.	Go to step 4.	Replace the fuse. If the fuse is blown out again, go to step 4.



## Airbag Warning Light Failure

### AIRBAG SYSTEM (DIAGNOSTICS)

Step	Check	Yes	No
<b>4</b> <b>CHECK AIRBAG WARNING LIGHT CIRCUIT (IN COMBINATION METER).</b> 1) Turn the ignition switch to OFF, disconnect the battery ground cable, and wait for 60 seconds or more. 2) Disconnect the connectors (AB1) and (B31). 3) Connect the battery ground terminal and turn the ignition switch to ON.	Does airbag warning light illuminate?	Go to step 5.	Check the combination meter.
<b>5</b> <b>CHECK AIRBAG MAIN HARNESS.</b> 1) Turn the ignition switch to OFF, disconnect the battery ground cable, and wait for 60 seconds or more. 2) Connect the connector (AB1) and (B31). 3) Disconnect the connectors (AB6, AB17, AB18) from airbag control module. 4) Connect the battery ground terminal and turn the ignition switch to ON.	Does airbag warning light illuminate?	Replace the airbag control module. <Ref. to AB-22, Airbag Control Module.>	Replace the airbag main harness along with bulkhead harness.

# List of Diagnostic Trouble Code (DTC)

AIRBAG SYSTEM (DIAGNOSTICS)

## 13. List of Diagnostic Trouble Code (DTC)

### A: LIST

DTC	Item	Content of diagnosis	Reference
11	Driver's Airbag failure	<ul style="list-style-type: none"> <li>• Airbag main harness circuit is shorted to ground.</li> <li>• Airbag module harness (driver's side) circuit is shorted to ground.</li> <li>• Roll connector circuit is shorted to ground.</li> <li>• Driver's airbag module is faulty.</li> <li>• Airbag control module is faulty.</li> </ul>	<Ref. to AB(diag)-48, DTC 11 DRIVER'S AIRBAG FAILURE, Diagnostic Chart with Trouble Code.>
12	Passenger's Airbag failure	<ul style="list-style-type: none"> <li>• Airbag main harness circuit is shorted to ground.</li> <li>• Airbag module harness (passenger's side) circuit is shorted to ground.</li> <li>• Passenger's airbag module is faulty.</li> <li>• Airbag control module is faulty.</li> </ul>	<Ref. to AB(diag)-51, DTC 12 PASSENGER'S AIRBAG FAILURE, Diagnostic Chart with Trouble Code.>
15	Driver's Airbag failure	<ul style="list-style-type: none"> <li>• Airbag main harness circuit is shorted to power supply.</li> <li>• Airbag module harness circuit (driver's side) is shorted to power supply.</li> <li>• Roll connector is shorted to power supply.</li> <li>• Driver's airbag module is faulty.</li> <li>• Airbag control module is faulty.</li> </ul>	<Ref. to AB(diag)-53, DTC 15 DRIVER'S AIRBAG FAILURE, Diagnostic Chart with Trouble Code.>
16	Passenger's Airbag failure	<ul style="list-style-type: none"> <li>• Airbag main harness circuit is shorted to power supply.</li> <li>• Airbag module harness (passenger's side) circuit is shorted to power supply.</li> <li>• Passenger's airbag module is faulty.</li> <li>• Airbag control module is faulty.</li> </ul>	<Ref. to AB(diag)-56, DTC 16 PASSENGER'S AIRBAG FAILURE, Diagnostic Chart with Trouble Code.>
1A	Driver's Airbag failure	<ul style="list-style-type: none"> <li>• Airbag main harness circuit is shorted.</li> <li>• Airbag module harness (driver's side) circuit is shorted.</li> <li>• Roll connector circuit is shorted.</li> <li>• Driver's airbag module is faulty.</li> <li>• Airbag control module is faulty.</li> </ul>	<Ref. to AB(diag)-58, DTC 1A DRIVER'S AIRBAG FAILURE, Diagnostic Chart with Trouble Code.>
1B	Passenger's Airbag failure	<ul style="list-style-type: none"> <li>• Airbag main harness circuit is shorted.</li> <li>• Airbag module harness circuit (passenger's side) is shorted.</li> <li>• Passenger's airbag module is faulty.</li> <li>• Airbag control module is faulty.</li> </ul>	<Ref. to AB(diag)-61, DTC 1B PASSENGER'S AIRBAG FAILURE, Diagnostic Chart with Trouble Code.>
1D	Driver's Airbag failure	<ul style="list-style-type: none"> <li>• Airbag main harness circuit is open.</li> <li>• Airbag module harness circuit (driver's side) is open.</li> <li>• Roll connector circuit is open.</li> <li>• Driver's airbag module is faulty.</li> <li>• Airbag control module is faulty.</li> </ul>	<Ref. to AB(diag)-63, DTC 1D DRIVER'S AIRBAG FAILURE, Diagnostic Chart with Trouble Code.>
1E	Passenger's Airbag failure	<ul style="list-style-type: none"> <li>• Airbag main harness circuit is open.</li> <li>• Airbag module harness circuit (passenger's side) is open.</li> <li>• Passenger's airbag module is faulty.</li> <li>• Airbag control module is faulty.</li> </ul>	<Ref. to AB(diag)-66, DTC 1E PASSENGER'S AIRBAG FAILURE, Diagnostic Chart with Trouble Code.>
21	Airbag ECU failure	Airbag control module is faulty.	<Ref. to AB(diag)-68, DTC 21 AIRBAG ECM FAILURE, Diagnostic Chart with Trouble Code.>

## List of Diagnostic Trouble Code (DTC)

### AIRBAG SYSTEM (DIAGNOSTICS)

DTC	Item	Content of diagnosis	Reference
22	Front Airbag: Firing output	Front airbag module and seat belt pretensioner (LH/RH) are inflated.	<Ref. to AB(diag)-68, DTC 22 FRONT AIRBAG FIRING OUTPUT, Diagnostic Chart with Trouble Code.>
26	Passenger's Airbag indicator failure	<ul style="list-style-type: none"> <li>• Passenger's airbag indicator is faulty.</li> <li>• Airbag control module is faulty.</li> <li>• Airbag main harness circuit is open, shorted or shorted to ground.</li> <li>• Body harness circuit is open.</li> </ul>	<Ref. to AB(diag)-69, DTC 26 PASSENGER'S AIRBAG INDICATOR FAILURE, Diagnostic Chart with Trouble Code.>
27	ODS Communication error	<ul style="list-style-type: none"> <li>• Occupant detection control module communication is faulty.</li> <li>• Airbag rear harness circuit is open, shorted, shorted to ground or shorted to power supply.</li> <li>• Occupant detection harness is faulty.</li> <li>• Airbag control module is faulty.</li> <li>• Occupant detection system is faulty.</li> </ul>	<Ref. to AB(diag)-71, DTC 27 ODS COMMUNICATION ERROR, Diagnostic Chart with Trouble Code.>
29	ODS failure	<ul style="list-style-type: none"> <li>• Occupant detection sensor is faulty.</li> <li>• Occupant detection control module is faulty.</li> <li>• Occupant detection harness is faulty.</li> <li>• Fuse is blown.</li> </ul>	<Ref. to OD(diag)-25, DTC 29 ODS FAILURE, Diagnostic Procedure with Diagnostic Trouble Code (DTC).>
2A	ODS Calibration error	<ul style="list-style-type: none"> <li>• Occupant detection control module is faulty.</li> <li>• Calibration of occupant detection control module is initial setting or faulty.</li> </ul>	<Ref. to OD(diag)-22, DTC 2A ODS CALIBRATION ERROR, Diagnostic Procedure with Diagnostic Trouble Code (DTC).>
2B	ODS System wrong parts	<ul style="list-style-type: none"> <li>• Specification of occupant detection control module is improper.</li> <li>• Occupant detection control module is faulty.</li> </ul>	<Ref. to OD(diag)-22, DTC 2B ODS SYSTEM WRONG PARTS, Diagnostic Procedure with Diagnostic Trouble Code (DTC).>
2C	Belt tension Sensor failure	<ul style="list-style-type: none"> <li>• Passenger's seat belt tension sensor is faulty.</li> <li>• Airbag rear harness circuit is open or shorted.</li> <li>• Occupant detection system is faulty.</li> <li>• Occupant detection harness is faulty.</li> </ul>	<Ref. to OD(diag)-23, DTC 2C BELT TENSION SENSOR FAILURE, Diagnostic Procedure with Diagnostic Trouble Code (DTC).>
2D	Airbag warning light circuit failure	<ul style="list-style-type: none"> <li>• Airbag warning light is faulty.</li> <li>• Open or short circuit in harness between airbag control module and airbag warning light.</li> <li>• Poor contact of airbag main harness and instrument panel harness.</li> <li>• Ground circuit is faulty.</li> <li>• Airbag control module is faulty.</li> </ul>	<Ref. to AB(diag)-73, DTC 2D AIRBAG WARNING INDICATOR FAILURE, Diagnostic Chart with Trouble Code.>
33	FrontSubSensor RH failure	Front sub sensor (RH) is faulty.	<Ref. to AB(diag)-73, DTC 33 FRONT SUB SENSOR RH FAILURE, Diagnostic Chart with Trouble Code.>
34	FrontSubSensor LH failure	Front sub sensor (LH) is faulty.	<Ref. to AB(diag)-73, DTC 34 FRONT SUB SENSOR LH FAILURE, Diagnostic Chart with Trouble Code.>

# List of Diagnostic Trouble Code (DTC)

## AIRBAG SYSTEM (DIAGNOSTICS)

DTC	Item	Content of diagnosis	Reference
37	Buckle Switch RH failure	<ul style="list-style-type: none"> <li>• Passenger's buckle switch circuit is open, shorted or shorted to ground.</li> <li>• Occupant detection system is faulty.</li> <li>• Occupant detection harness is faulty.</li> </ul>	<Ref. to OD(diag)-26, DTC 37 BUCKLE SWITCH RH FAILURE, Diagnostic Procedure with Diagnostic Trouble Code (DTC).>
39	Seatbelt Warning failure	<ul style="list-style-type: none"> <li>• Airbag control module is faulty.</li> <li>• Body integrated unit is faulty.</li> <li>• Harness circuits between body integrated unit and airbag control module are open, shorted or shorted to ground.</li> </ul>	<Ref. to AB(diag)-74, DTC 39 SEAT BELT WARNING FAILURE, Diagnostic Chart with Trouble Code.>
3A	Front Sub Sensor RH false installation	<ul style="list-style-type: none"> <li>• Front sensor (RH) is misinstalled.</li> <li>• Airbag control module is faulty.</li> </ul>	<Ref. to AB(diag)-76, DTC 3A FRONT SUB SENSOR RH FALSE INSTALLATION, Diagnostic Chart with Trouble Code.>
3B	Front Sub Sensor LH false installation	<ul style="list-style-type: none"> <li>• Front sensor (LH) is misinstalled.</li> <li>• Airbag control module is faulty.</li> </ul>	<Ref. to AB(diag)-76, DTC 3B FRONT SUB SENSOR LH FALSE INSTALLATION, Diagnostic Chart with Trouble Code.>
3C	Satellite Sensor Bus failure	Satellite safing sensor is faulty.	<Ref. to AB(diag)-76, DTC 3C SATELLITE SENSOR BUS FAILURE, Diagnostic Chart with Trouble Code.>
3D	Satellite Sensor false installation	<ul style="list-style-type: none"> <li>• Satellite safing sensor is misinstalled.</li> <li>• Airbag control module is faulty.</li> </ul>	<Ref. to AB(diag)-76, DTC 3D SATELLITE SENSOR FALSE INSTALLATION, Diagnostic Chart with Trouble Code.>
41	Side Airbag RH failure	<ul style="list-style-type: none"> <li>• Side airbag harness (RH) circuit is shorted to ground.</li> <li>• Side airbag module (RH) is faulty.</li> <li>• Airbag control module is faulty.</li> </ul>	<Ref. to AB(diag)-77, DTC 41 SIDE AIRBAG RH FAILURE, Diagnostic Chart with Trouble Code.>
42	Side Airbag LH failure	<ul style="list-style-type: none"> <li>• Side airbag harness (LH) circuit is shorted to ground.</li> <li>• Side airbag module (LH) is faulty.</li> <li>• Airbag control module is faulty.</li> </ul>	<Ref. to AB(diag)-79, DTC 42 SIDE AIRBAG LH FAILURE, Diagnostic Chart with Trouble Code.>
45	Side Airbag RH failure	<ul style="list-style-type: none"> <li>• Side airbag harness (RH) circuit is shorted to power supply.</li> <li>• Side airbag module (RH) is faulty.</li> <li>• Airbag control module is faulty.</li> </ul>	<Ref. to AB(diag)-81, DTC 45 SIDE AIRBAG RH FAILURE, Diagnostic Chart with Trouble Code.>
46	Side Airbag LH failure	<ul style="list-style-type: none"> <li>• Side airbag harness (LH) circuit is shorted to power supply.</li> <li>• Side airbag module (LH) is faulty.</li> <li>• Airbag control module is faulty.</li> </ul>	<Ref. to AB(diag)-83, DTC 46 SIDE AIRBAG LH FAILURE, Diagnostic Chart with Trouble Code.>
4A	Side Airbag RH failure	<ul style="list-style-type: none"> <li>• Side airbag harness (RH) circuit is shorted.</li> <li>• Side airbag module (RH) is faulty.</li> <li>• Airbag control module is faulty.</li> </ul>	<Ref. to AB(diag)-85, DTC 4A SIDE AIRBAG RH FAILURE, Diagnostic Chart with Trouble Code.>

**AB(diag)-41**

Brought to you by Ebay Seller "SubaruManuals"

## List of Diagnostic Trouble Code (DTC)

### AIRBAG SYSTEM (DIAGNOSTICS)

DTC	Item	Content of diagnosis	Reference
4B	Side Airbag LH failure	<ul style="list-style-type: none"> <li>Side airbag harness (LH) circuit is shorted.</li> <li>Side airbag module (LH) is faulty.</li> <li>Airbag control module is faulty.</li> </ul>	<Ref. to AB(diag)-87, DTC 4B SIDE AIRBAG LH FAILURE, Diagnostic Chart with Trouble Code.>
4D	Side Airbag RH failure	<ul style="list-style-type: none"> <li>Side airbag harness (RH) circuit is open.</li> <li>Side airbag module (RH) is faulty.</li> <li>Airbag control module is faulty.</li> </ul>	<Ref. to AB(diag)-89, DTC 4D SIDE AIRBAG RH FAILURE, Diagnostic Chart with Trouble Code.>
4E	Side Airbag LH failure	<ul style="list-style-type: none"> <li>Side airbag harness (LH) circuit is open.</li> <li>Side airbag module (LH) is faulty.</li> <li>Airbag control module is faulty.</li> </ul>	<Ref. to AB(diag)-91, DTC 4E SIDE AIRBAG LH FAILURE, Diagnostic Chart with Trouble Code.>
53	Side Airbag Sensor RH failure	Side airbag sensor (RH) is faulty.	<Ref. to AB(diag)-93, DTC 53 SIDE AIRBAG SENSOR RH FAILURE, Diagnostic Chart with Trouble Code.>
54	Side Airbag Sensor LH failure	Side airbag sensor (LH) is faulty.	<Ref. to AB(diag)-93, DTC 54 SIDE AIRBAG SENSOR LH FAILURE, Diagnostic Chart with Trouble Code.>
55	Side/Curtain Airbag: Firing output	<ul style="list-style-type: none"> <li>Side airbag module and curtain airbag module are deployed.</li> <li>Curtain airbag module is deployed.</li> </ul>	<Ref. to AB(diag)-93, DTC 55 SIDE CURTAIN AIRBAG FIRING OUTPUT, Diagnostic Chart with Trouble Code.>
58	Curtain Airbag Sensor RH failure	Curtain airbag sensor (RH) is faulty.	<Ref. to AB(diag)-93, DTC 58 CURTAIN AIRBAG SENSOR RH FAILURE, Diagnostic Chart with Trouble Code.>
59	Curtain Airbag Sensor LH failure	Curtain airbag sensor (LH) is faulty.	<Ref. to AB(diag)-93, DTC 59 CURTAIN AIRBAG SENSOR LH FAILURE, Diagnostic Chart with Trouble Code.>
5A	Side Airbag Sensor RH false installation	<ul style="list-style-type: none"> <li>Side airbag sensor (RH) is misinstalled.</li> <li>Airbag control module is faulty.</li> </ul>	<Ref. to AB(diag)-94, DTC 5A SIDE AIRBAG SENSOR RH FALSE INSTALLATION, Diagnostic Chart with Trouble Code.>
5B	Side Airbag Sensor LH false installation	<ul style="list-style-type: none"> <li>Side airbag sensor (LH) is misinstalled.</li> <li>Airbag control module is faulty.</li> </ul>	<Ref. to AB(diag)-94, DTC 5B SIDE AIRBAG SENSOR LH FALSE INSTALLATION, Diagnostic Chart with Trouble Code.>
5C	Curtain Airbag Sensor RH false installation	<ul style="list-style-type: none"> <li>Curtain airbag sensor (RH) is misinstalled.</li> <li>Airbag control module is faulty.</li> </ul>	<Ref. to AB(diag)-94, DTC 5C CURTAIN AIRBAG SENSOR RH FALSE INSTALLATION, Diagnostic Chart with Trouble Code.>

# List of Diagnostic Trouble Code (DTC)

## AIRBAG SYSTEM (DIAGNOSTICS)

DTC	Item	Content of diagnosis	Reference
5D	Curtain Airbag Sensor LH false installation	<ul style="list-style-type: none"> <li>• Curtain airbag sensor (LH) is misinstalled.</li> <li>• Airbag control module is faulty.</li> </ul>	<Ref. to AB(diag)-94, DTC 5D CURTAIN AIRBAG SENSOR LH FALSE INSTALLATION, Diagnostic Chart with Trouble Code.>
61	Belt Pretensioner RH failure	<ul style="list-style-type: none"> <li>• Seat belt pretensioner (RH) circuit is shorted to ground.</li> <li>• Pretensioner (RH) is faulty.</li> <li>• Pretensioner harness (RH) is shorted to ground.</li> <li>• Airbag control module is faulty.</li> </ul>	<Ref. to AB(diag)-95, DTC 61 BELT PRETENSIONER RH FAILURE, Diagnostic Chart with Trouble Code.>
62	Belt Pretensioner LH failure	<ul style="list-style-type: none"> <li>• Seat belt pretensioner (LH) circuit is shorted to ground.</li> <li>• Pretensioner (LH) is faulty.</li> <li>• Pretensioner harness (LH) is shorted to ground.</li> <li>• Airbag control module is faulty.</li> </ul>	<Ref. to AB(diag)-97, DTC 62 BELT PRETENSIONER LH FAILURE, Diagnostic Chart with Trouble Code.>
65	Belt Pretensioner RH failure	<ul style="list-style-type: none"> <li>• Seat belt pretensioner (RH) circuit is shorted to power supply.</li> <li>• Pretensioner (RH) is faulty.</li> <li>• Pretensioner harness (RH) is shorted to power supply.</li> <li>• Airbag control module is faulty.</li> </ul>	<Ref. to AB(diag)-99, DTC 65 BELT PRETENSIONER RH FAILURE, Diagnostic Chart with Trouble Code.>
66	Belt Pretensioner LH failure	<ul style="list-style-type: none"> <li>• Seat belt pretensioner (LH) circuit is shorted to power supply.</li> <li>• Pretensioner (LH) is faulty.</li> <li>• Pretensioner harness (LH) is shorted to power supply.</li> <li>• Airbag control module is faulty.</li> </ul>	<Ref. to AB(diag)-101, DTC 66 BELT PRETENSIONER LH FAILURE, Diagnostic Chart with Trouble Code.>
6A	Belt Pretensioner RH failure	<ul style="list-style-type: none"> <li>• Seat belt pretensioner (RH) circuit is shorted.</li> <li>• Pretensioner (RH) is faulty.</li> <li>• Pretensioner harness (RH) is shorted.</li> <li>• Airbag control module is faulty.</li> </ul>	<Ref. to AB(diag)-103, DTC 6A BELT PRETENSIONER RH FAILURE, Diagnostic Chart with Trouble Code.>
6B	Belt Pretensioner LH failure	<ul style="list-style-type: none"> <li>• Seat belt pretensioner (LH) circuit is shorted.</li> <li>• Pretensioner (LH) is faulty.</li> <li>• Pretensioner harness (LH) is shorted.</li> <li>• Airbag control module is faulty.</li> </ul>	<Ref. to AB(diag)-105, DTC 6B BELT PRETENSIONER LH FAILURE, Diagnostic Chart with Trouble Code.>
6D	Belt Pretensioner RH failure	<ul style="list-style-type: none"> <li>• Seat belt pretensioner (RH) circuit is open.</li> <li>• Pretensioner (RH) is faulty.</li> <li>• Pretensioner harness (RH) is open.</li> <li>• Airbag control module is faulty.</li> </ul>	<Ref. to AB(diag)-107, DTC 6D BELT PRETENSIONER RH FAILURE, Diagnostic Chart with Trouble Code.>
6E	Belt Pretensioner LH failure	<ul style="list-style-type: none"> <li>• Seat belt pretensioner (LH) circuit is open.</li> <li>• Pretensioner harness (LH) is open.</li> <li>• Airbag control module is faulty.</li> </ul>	<Ref. to AB(diag)-109, DTC 6E BELT PRETENSIONER LH FAILURE, Diagnostic Chart with Trouble Code.>
71	Driver's Airbag failure	<ul style="list-style-type: none"> <li>• Airbag main harness circuit is shorted to ground.</li> <li>• Airbag module harness (driver's side) circuit is shorted to ground.</li> <li>• Roll connector circuit is shorted to ground.</li> <li>• Driver's airbag module is faulty.</li> <li>• Airbag control module is faulty.</li> </ul>	<Ref. to AB(diag)-111, DTC 71 DRIVER'S AIRBAG FAILURE, Diagnostic Chart with Trouble Code.>
72	Passenger's Airbag failure	<ul style="list-style-type: none"> <li>• Airbag main harness circuit is shorted to ground.</li> <li>• Airbag module harness (passenger's side) circuit is shorted to ground.</li> <li>• Passenger's airbag module is faulty.</li> <li>• Airbag control module is faulty.</li> </ul>	<Ref. to AB(diag)-114, DTC 72 PASSENGER'S AIRBAG FAILURE, Diagnostic Chart with Trouble Code.>

**AB(diag)-43**

Brought to you by Ebay Seller "SubaruManuals"

## List of Diagnostic Trouble Code (DTC)

### AIRBAG SYSTEM (DIAGNOSTICS)

DTC	Item	Content of diagnosis	Reference
75	Driver's Airbag failure	<ul style="list-style-type: none"> <li>• Airbag main harness circuit is shorted to power supply.</li> <li>• Airbag module harness circuit (driver's side) is shorted to power supply.</li> <li>• Roll connector circuit is shorted to power supply.</li> <li>• Driver's airbag module is faulty.</li> <li>• Airbag control module is faulty.</li> </ul>	<Ref. to AB(diag)-116, DTC 75 DRIVER'S AIRBAG FAILURE, Diagnostic Chart with Trouble Code.>
76	Passenger's Airbag failure	<ul style="list-style-type: none"> <li>• Airbag main harness circuit is shorted to power supply.</li> <li>• Airbag module harness (passenger's side) circuit is shorted to power supply.</li> <li>• Passenger's airbag module is faulty.</li> <li>• Airbag control module is faulty.</li> </ul>	<Ref. to AB(diag)-119, DTC 76 PASSENGER'S AIRBAG FAILURE, Diagnostic Chart with Trouble Code.>
7A	Driver's Airbag failure	<ul style="list-style-type: none"> <li>• Airbag main harness circuit is shorted.</li> <li>• Airbag module harness (driver's side) circuit is shorted.</li> <li>• Roll connector circuit is shorted to power supply.</li> <li>• Driver's airbag module is faulty.</li> <li>• Airbag control module is faulty.</li> </ul>	<Ref. to AB(diag)-121, DTC 7A DRIVER'S AIRBAG FAILURE, Diagnostic Chart with Trouble Code.>
7B	Passenger's Airbag failure	<ul style="list-style-type: none"> <li>• Airbag main harness circuit is shorted.</li> <li>• Airbag module harness circuit (passenger's side) is shorted.</li> <li>• Passenger's airbag module is faulty.</li> <li>• Airbag control module is faulty.</li> </ul>	<Ref. to AB(diag)-124, DTC 7B PASSENGER'S AIRBAG FAILURE, Diagnostic Chart with Trouble Code.>
7D	Driver's Airbag failure	<ul style="list-style-type: none"> <li>• Airbag main harness circuit is open.</li> <li>• Airbag module harness circuit (driver's side) is open.</li> <li>• Roll connector circuit is open.</li> <li>• Driver's airbag module is faulty.</li> <li>• Airbag control module is faulty.</li> </ul>	<Ref. to AB(diag)-126, DTC 7D DRIVER'S AIRBAG FAILURE, Diagnostic Chart with Trouble Code.>
7E	Passenger's Airbag failure	<ul style="list-style-type: none"> <li>• Airbag main harness circuit is open.</li> <li>• Airbag module harness circuit (passenger's side) is open.</li> <li>• Passenger's airbag module is faulty.</li> <li>• Airbag control module is faulty.</li> </ul>	<Ref. to AB(diag)-129, DTC 7E PASSENGER'S AIRBAG FAILURE, Diagnostic Chart with Trouble Code.>
91	Curtain Airbag RH failure	<ul style="list-style-type: none"> <li>• Curtain airbag harness (RH) circuit is shorted to ground.</li> <li>• Curtain airbag module (RH) is faulty.</li> <li>• Airbag control module is faulty.</li> </ul>	<Ref. to AB(diag)-131, DTC 91 CURTAIN AIRBAG MODULE RH FAILURE, Diagnostic Chart with Trouble Code.>
92	Curtain Airbag LH failure	<ul style="list-style-type: none"> <li>• Curtain airbag harness (LH) circuit is shorted to ground.</li> <li>• Curtain airbag module (LH) is faulty.</li> <li>• Airbag control module is faulty.</li> </ul>	<Ref. to AB(diag)-133, DTC 92 CURTAIN AIRBAG MODULE LH FAILURE, Diagnostic Chart with Trouble Code.>
95	Curtain Airbag RH failure	<ul style="list-style-type: none"> <li>• Curtain airbag harness (RH) is shorted to power supply.</li> <li>• Curtain airbag module (RH) is faulty.</li> <li>• Airbag control module is faulty.</li> </ul>	<Ref. to AB(diag)-135, DTC 95 CURTAIN AIRBAG MODULE RH FAILURE, Diagnostic Chart with Trouble Code.>
96	Curtain Airbag LH failure	<ul style="list-style-type: none"> <li>• Curtain airbag harness (LH) is shorted to power supply.</li> <li>• Curtain airbag module (LH) is faulty.</li> <li>• Airbag control module is faulty.</li> </ul>	<Ref. to AB(diag)-137, DTC 96 CURTAIN AIRBAG MODULE LH FAILURE, Diagnostic Chart with Trouble Code.>

# List of Diagnostic Trouble Code (DTC)

## AIRBAG SYSTEM (DIAGNOSTICS)

DTC	Item	Content of diagnosis	Reference
9A	Curtain Airbag RH failure	<ul style="list-style-type: none"> <li>• Curtain airbag harness (RH) circuit is shorted.</li> <li>• Curtain airbag module (RH) is faulty.</li> <li>• Airbag control module is faulty.</li> </ul>	<Ref. to AB(diag)-139, DTC 9A CURTAIN AIRBAG MODULE RH FAILURE, Diagnostic Chart with Trouble Code.>
9B	Curtain Airbag LH failure	<ul style="list-style-type: none"> <li>• Curtain airbag harness (LH) circuit is shorted.</li> <li>• Curtain airbag module (LH) is faulty.</li> <li>• Airbag control module is faulty.</li> </ul>	<Ref. to AB(diag)-141, DTC 9B CURTAIN AIRBAG MODULE LH FAILURE, Diagnostic Chart with Trouble Code.>
9D	Curtain Airbag RH failure	<ul style="list-style-type: none"> <li>• Curtain airbag harness (RH) circuit is open.</li> <li>• Curtain airbag module (RH) is faulty.</li> <li>• Airbag control module is faulty.</li> </ul>	<Ref. to AB(diag)-143, DTC 9D CURTAIN AIRBAG MODULE RH FAILURE, Diagnostic Chart with Trouble Code.>
9E	Curtain Airbag LH failure	<ul style="list-style-type: none"> <li>• Curtain airbag harness (LH) circuit is open.</li> <li>• Curtain airbag module (LH) is faulty.</li> <li>• Airbag control module is faulty.</li> </ul>	<Ref. to AB(diag)-145, DTC 9E CURTAIN AIRBAG MODULE LH FAILURE, Diagnostic Chart with Trouble Code.>
A1	Front sensor Bus communication error	<ul style="list-style-type: none"> <li>• Open or short circuit in harness between airbag control module and front sub sensor.</li> <li>• Front sub sensor is faulty.</li> <li>• Airbag control module is faulty.</li> </ul>	<Ref. to AB(diag)-147, DTC A1 FRONT SENSOR BUS COMMUNICATION ERROR, Diagnostic Chart with Trouble Code.>
E3 E4	Front Sensor Bus RH Communication error	<ul style="list-style-type: none"> <li>• Open or short circuit in harness (RH) between airbag control module and front sub sensor.</li> <li>• Front sub sensor (RH) is faulty.</li> <li>• Airbag control module is faulty.</li> </ul>	<Ref. to AB(diag)-149, DTC E3 FRONT SENSOR BUS RH COMMUNICATION ERROR, Diagnostic Chart with Trouble Code.> <Ref. to AB(diag)-149, DTC E4 FRONT SENSOR BUS RH COMMUNICATION ERROR, Diagnostic Chart with Trouble Code.>
E7 E8	Front Sensor Bus LH Communication error	<ul style="list-style-type: none"> <li>• Open or short circuit in harness (LH) between airbag control module and front sub sensor.</li> <li>• Front sub sensor (LH) is faulty.</li> <li>• Airbag control module is faulty.</li> </ul>	<Ref. to AB(diag)-150, DTC E7 FRONT SENSOR BUS LH COMMUNICATION ERROR, Diagnostic Chart with Trouble Code.> <Ref. to AB(diag)-152, DTC E8 FRONT SENSOR BUS LH COMMUNICATION ERROR, Diagnostic Chart with Trouble Code.>
E9	Side Sensor Bus RH Communication error	<ul style="list-style-type: none"> <li>• Open or short circuit in harness (RH) between airbag control module and curtain airbag sensor.</li> <li>• Side airbag sensor (RH) is faulty.</li> <li>• Curtain airbag sensor (RH) is faulty.</li> <li>• Airbag control module is faulty.</li> </ul>	<Ref. to AB(diag)-152, DTC E9 SIDE SENSOR BUS RH COMMUNICATION ERROR, Diagnostic Chart with Trouble Code.>



## List of Diagnostic Trouble Code (DTC)

### AIRBAG SYSTEM (DIAGNOSTICS)

DTC	Item	Content of diagnosis	Reference
EB EC	Side Sensor Bus RH Communication error	<ul style="list-style-type: none"> <li>• Open or short circuit in harness (RH) between airbag control module and side airbag sensor.</li> <li>• Side airbag sensor (RH) is faulty.</li> <li>• Airbag control module is faulty.</li> </ul>	<Ref. to AB(diag)-152, DTC EB SIDE SENSOR BUS RH COMMUNICATION ERROR, Diagnostic Chart with Trouble Code.> <Ref. to AB(diag)-153, DTC EC SIDE SENSOR BUS RH COMMUNICATION ERROR, Diagnostic Chart with Trouble Code.>
ED EE	Side Sensor Bus RH Communication error	<ul style="list-style-type: none"> <li>• Open or short circuit in harness (RH) between airbag control module and curtain airbag sensor.</li> <li>• Side airbag sensor (RH) is faulty.</li> <li>• Curtain airbag sensor (RH) is faulty.</li> <li>• Airbag control module is faulty.</li> </ul>	<Ref. to AB(diag)-155, DTC ED SIDE SENSOR BUS RH COMMUNICATION ERROR, Diagnostic Chart with Trouble Code.> <Ref. to AB(diag)-156, DTC EE SIDE SENSOR BUS RH COMMUNICATION ERROR, Diagnostic Chart with Trouble Code.>
F1	Side Sensor Bus LH Communication error	<ul style="list-style-type: none"> <li>• Open or short circuit in harness (LH) between airbag control module and curtain airbag sensor.</li> <li>• Side airbag sensor (LH) is faulty.</li> <li>• Curtain airbag sensor (LH) is faulty.</li> <li>• Airbag control module is faulty.</li> </ul>	<Ref. to AB(diag)-159, DTC F1 SIDE SENSOR BUS LH COMMUNICATION ERROR, Diagnostic Chart with Trouble Code.>
F3 F4	Side Sensor Bus LH Communication error	<ul style="list-style-type: none"> <li>• Open or short circuit in harness (LH) between airbag control module and side airbag sensor.</li> <li>• Side airbag sensor (LH) is faulty.</li> <li>• Airbag control module is faulty.</li> </ul>	<Ref. to AB(diag)-159, DTC F3 SIDE SENSOR BUS LH COMMUNICATION ERROR, Diagnostic Chart with Trouble Code.> <Ref. to AB(diag)-160, DTC F4 SIDE SENSOR BUS LH COMMUNICATION ERROR, Diagnostic Chart with Trouble Code.>
F5 F6	Side Sensor Bus LH Communication error	<ul style="list-style-type: none"> <li>• Open or short circuit in harness (LH) between airbag control module and curtain airbag sensor.</li> <li>• Side airbag sensor (LH) is faulty.</li> <li>• Curtain airbag sensor (LH) is faulty.</li> <li>• Airbag control module is faulty.</li> </ul>	<Ref. to AB(diag)-162, DTC F5 SIDE SENSOR BUS LH COMMUNICATION ERROR, Diagnostic Chart with Trouble Code.> <Ref. to AB(diag)-163, DTC F6 SIDE SENSOR BUS LH COMMUNICATION ERROR, Diagnostic Chart with Trouble Code.>

# List of Diagnostic Trouble Code (DTC)

AIRBAG SYSTEM (DIAGNOSTICS)

DTC	Item	Content of diagnosis	Reference
F7 F8 F9 FA	Satellite Sensor Bus Communication error	<ul style="list-style-type: none"><li>• Open or short circuit in harness between airbag control module and satellite safing sensor.</li><li>• Satellite safing sensor is faulty.</li><li>• Airbag control module is faulty.</li></ul>	<Ref. to AB(diag)-166, DTC F7 SATELLITE SENSOR BUS COMMUNICATION ERROR, Diagnostic Chart with Trouble Code.> <Ref. to AB(diag)-166, DTC F8 SATELLITE SENSOR BUS COMMUNICATION ERROR, Diagnostic Chart with Trouble Code.> <Ref. to AB(diag)-166, DTC F9 SATELLITE SENSOR BUS COMMUNICATION ERROR, Diagnostic Chart with Trouble Code.> <Ref. to AB(diag)-167, DTC FA SATELLITE SENSOR BUS COMMUNICATION ERROR, Diagnostic Chart with Trouble Code.>

# Diagnostic Chart with Trouble Code

AIRBAG SYSTEM (DIAGNOSTICS)

## 14. Diagnostic Chart with Trouble Code

### A: DTC 11 DRIVER'S AIRBAG FAILURE

#### DTC DETECTING CONDITION:

- Airbag main harness circuit is shorted to ground.
- Airbag module harness (driver's side) circuit is shorted to ground.
- Roll connector circuit is shorted to ground.
- Driver's airbag module is faulty.
- Airbag control module is faulty.

#### CAUTION:

- Before diagnosing the airbag system, be sure to turn the ignition switch to OFF, disconnect the ground cable from battery, and wait 60 seconds or more before starting to work.
- When replacing the airbag module, seat belt pretensioner, roll connector, control module and sensor, reconnect each part and check that the warning light operates properly.
- When inspecting the airbag main harness, disconnect the airbag module connectors of the driver's and passenger's seats for safety.
- When inspecting the airbag rear harness, disconnect the side airbag module connector, curtain airbag module connector and seat belt pretensioner connector for safety reasons.

#### NOTE:

Prior to starting work, prepare two AIRBAG RESISTORS (98299PA040).

#### WIRING DIAGRAM:

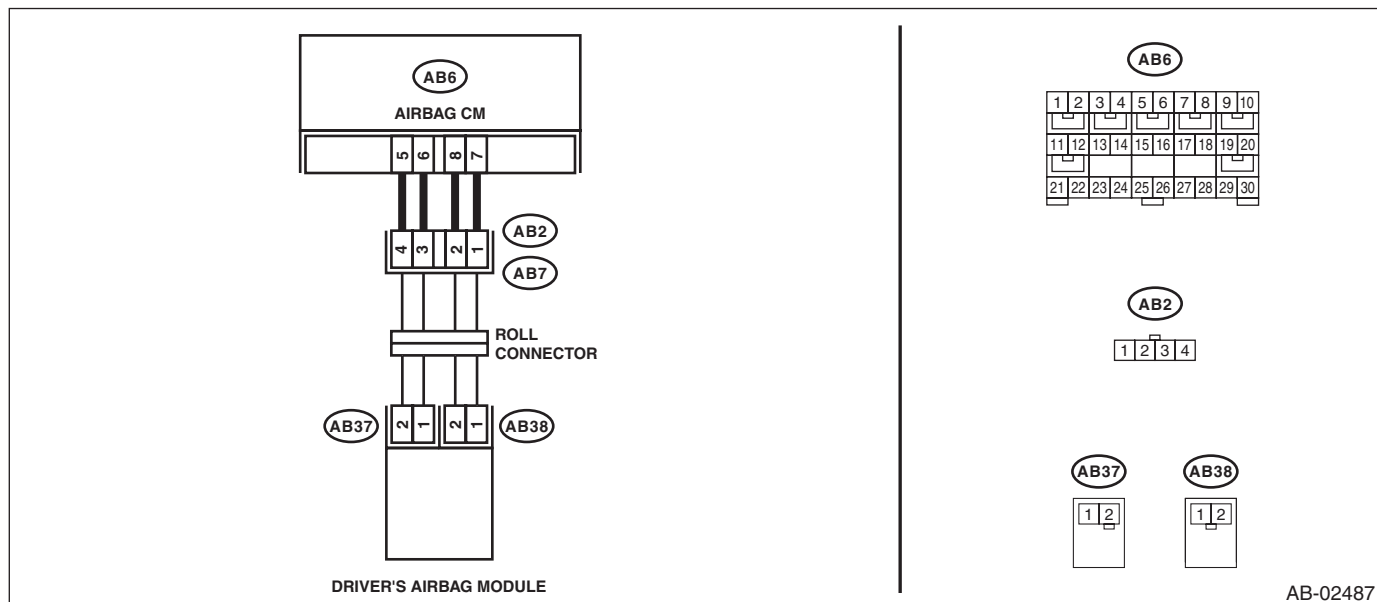

Step	Check	Yes	No
1	<p><b>CHECK POOR CONTACT OF CONNECTORS.</b></p> <p>Check for poor contact of the connectors between the airbag control module and the driver's airbag module.</p>	Is there poor contact?	<p>Replace the airbag harness.</p> <p>Go to step 2.</p>

# Diagnostic Chart with Trouble Code

AIRBAG SYSTEM (DIAGNOSTICS)

Step	Check	Yes	No
<p><b>2 CHECK DRIVER'S AIRBAG MODULE.</b></p> <ol style="list-style-type: none"> <li>1) Turn the ignition switch to OFF, disconnect the battery ground cable, and wait for 60 seconds or more.</li> <li>2) Remove the driver's airbag module.</li> <li>3) Connect the connector (1N) in the test harness N to the connector (AB38).</li> <li>4) Connect the airbag resistor to the connector (2N) of test harness N.</li> <li>5) Connect the connector (1Q) in the test harness Q to connector (AB37).</li> <li>6) Connect the airbag resistor to the connector (2Q) in the test harness Q.</li> <li>7) Connect the battery ground terminal and turn the ignition switch to ON.</li> </ol>	Does the airbag warning light illuminate for six seconds and go off?	Replace the driver's airbag module. <Ref. to AB-16, Driver's Airbag Module.>	Go to step 3.
<p><b>3 CHECK ROLL CONNECTOR.</b></p> <ol style="list-style-type: none"> <li>1) Turn the ignition switch to OFF, disconnect the battery ground cable, and wait for 60 seconds or more.</li> <li>2) Disconnect the test harness N from connector (AB38).</li> <li>3) Disconnect the test harness Q from connector (AB37).</li> <li>4) Remove the instrument panel lower cover and disconnect the connector (AB7) from (AB2).</li> <li>5) Connect the connector (1P) in the test harness P to connector (AB2).</li> <li>6) Connect the airbag resistor to the connectors (2P) and (3P) of test harness P.</li> <li>7) Connect the battery ground terminal and turn the ignition switch to ON.</li> </ol>	Does the airbag warning light illuminate for six seconds and go off?	Replace the roll connector. <Ref. to AB-27, Roll Connector.>	Go to step 4.
<p><b>4 CHECK AIRBAG MAIN HARNESS (DRIVER'S AIRBAG HARNESS).</b></p> <ol style="list-style-type: none"> <li>1) Turn the ignition switch to OFF, disconnect the battery ground cable, and wait for 60 seconds or more.</li> <li>2) Disconnect the airbag resistor from the connectors (2P) and (3P) of test harness P.</li> <li>3) Remove the console front panel and disconnect the connector (AB9).</li> <li>4) Disconnect the connectors (AB6, AB17, AB18) from the airbag control module, and connect the connector (1AH) in the test harness AH.</li> <li>5) Connect the connector (2AH) in the test harness AH and the connector (1AG) in the test harness AG.</li> <li>6) Measure the resistance between connector (3AG) in the test harness AG and chassis ground.</li> </ol> <p><b>Connector &amp; terminal</b>  <b>(3AG) No. 1 — Chassis ground:</b>  <b>(3AG) No. 3 — Chassis ground:</b></p>	Is the resistance 1 MΩ or more?	Go to step 5.	Replace the airbag main harness along with body harness.
<p><b>5 CHECK AIRBAG CONTROL MODULE.</b></p> <ol style="list-style-type: none"> <li>1) Connect all connectors.</li> <li>2) Clear the memory.</li> <li>3) Perform the Inspection Mode.</li> <li>4) Read the DTC.</li> </ol>	Is the same DTC displayed?	Replace the airbag control module. <Ref. to AB-22, Airbag Control Module.>	Go to step 6.

# Diagnostic Chart with Trouble Code

## AIRBAG SYSTEM (DIAGNOSTICS)

Step	Check	Yes	No
6 <b>CHECK FOR ANY OTHER DTC ON DISPLAY.</b>	Is any other DTC displayed?	Check DTC using "List of Diagnostic Trouble Code (DTC)". <Ref. to AB(diag)-39, List of Diagnostic Trouble Code (DTC).>	Finish the diagnosis.

# Diagnostic Chart with Trouble Code

AIRBAG SYSTEM (DIAGNOSTICS)

## B: DTC 12 PASSENGER'S AIRBAG FAILURE

### DTC DETECTING CONDITION:

- Airbag main harness circuit is shorted to ground.
- Airbag module harness (passenger's side) circuit is shorted to ground.
- Passenger's airbag module is faulty.
- Airbag control module is faulty.

### CAUTION:

- Before diagnosing the airbag system, be sure to turn the ignition switch to OFF, disconnect the ground cable from battery, and wait 60 seconds or more before starting to work.
- When replacing the airbag module, seat belt pretensioner, roll connector, control module and sensor, reconnect each part and check that the warning light operates properly.
- When inspecting the airbag main harness, disconnect the airbag module connectors of the driver's and passenger's seats for safety.
- When inspecting the airbag rear harness, disconnect the side airbag module connector, curtain airbag module connector and seat belt pretensioner connector for safety reasons.

### NOTE:

Prior to starting work, prepare two AIRBAG RESISTORS (98299PA040).

### WIRING DIAGRAM:

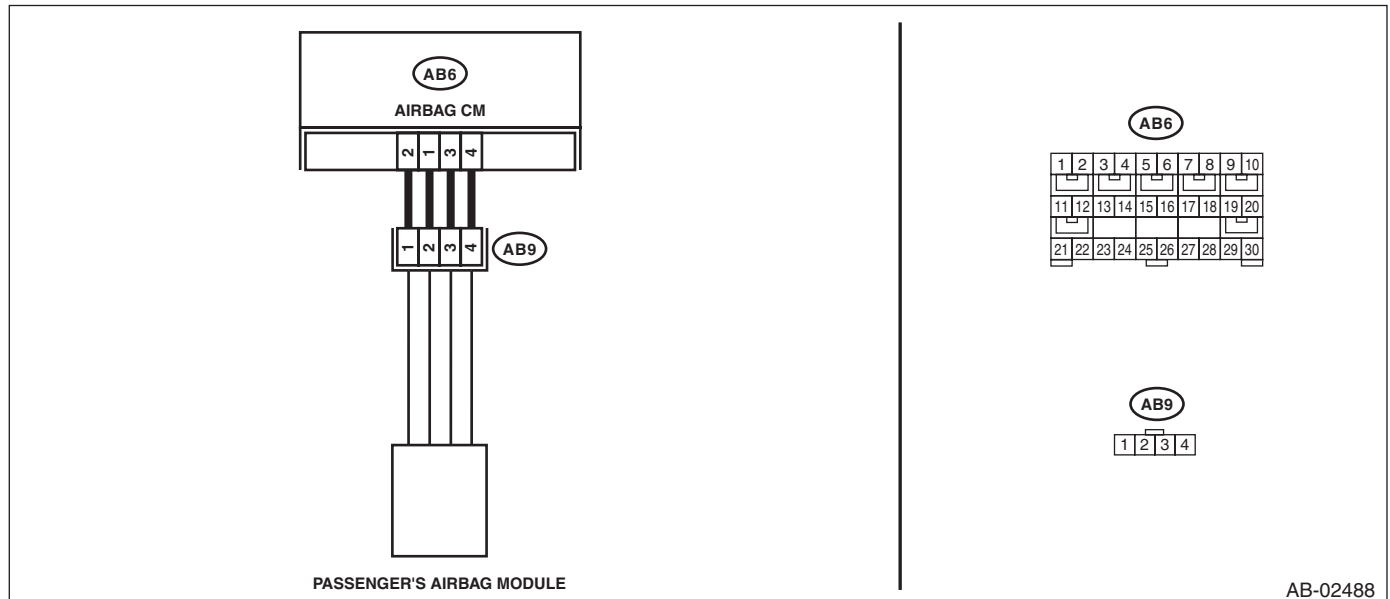

Step	Check	Yes	No
<b>1 CHECK POOR CONTACT OF CONNECTORS.</b> Check for poor contact of the connectors between the airbag control module and the passenger's airbag module.	Is there poor contact?	Replace the airbag harness.	Go to step 2.
<b>2 CHECK PASSENGER'S AIRBAG MODULE.</b> 1) Turn the ignition switch to OFF, disconnect the battery ground cable, and wait for 60 seconds or more. 2) Remove the console front panel and disconnect the connector (AB9). 3) Connect the connector (1P) in the test harness P to connector (AB9). 4) Connect the airbag resistor to the connectors (2P) and (3P) of test harness P. 5) Connect the battery ground terminal and turn the ignition switch to ON.	Does the airbag warning light illuminate for six seconds and go off?	Replace the passenger's airbag module. <Ref. to AB-17, Passenger's Airbag Module.>	Go to step 3.

# Diagnostic Chart with Trouble Code

## AIRBAG SYSTEM (DIAGNOSTICS)

Step	Check	Yes	No
<b>3 CHECK AIRBAG MAIN HARNESS (PASSENGER'S AIRBAG HARNESS).</b> 1) Turn the ignition switch to OFF, disconnect the battery ground cable, and wait for 60 seconds or more. 2) Disconnect the airbag resistor from the connectors (2P) and (3P) of test harness P. 3) Remove the instrument panel lower cover and disconnect the connector (AB7) from (AB2). 4) Disconnect the connectors (AB6, AB17, AB18) from the airbag control module, and connect the connector (1AH) in the test harness AH. 5) Connect the connector (2AH) in the test harness AH and the connector (1AG) in the test harness AG. 6) Measure the resistance between connector (3AG) in the test harness AG and chassis ground. <i><b>Connector &amp; terminal</b></i> <i><b>(3AG) No. 9 — Chassis ground:</b></i> <i><b>(3AG) No. 7 — Chassis ground:</b></i>	Is the resistance 1 MΩ or more?	Go to step 4.	Replace the airbag main harness along with body harness.
<b>4 CHECK AIRBAG CONTROL MODULE.</b> 1) Connect all connectors. 2) Clear the memory. 3) Perform the Inspection Mode. 4) Read the DTC.	Is the same DTC displayed?	Replace the airbag control module. <Ref. to AB-22, Airbag Control Module.>	Go to step 5.
<b>5 CHECK FOR ANY OTHER DTC ON DISPLAY.</b>	Is any other DTC displayed?	Check DTC using "List of Diagnostic Trouble Code (DTC)". <Ref. to AB(diag)-39, List of Diagnostic Trouble Code (DTC).>	Finish the diagnosis.

# Diagnostic Chart with Trouble Code

AIRBAG SYSTEM (DIAGNOSTICS)

## C: DTC 15 DRIVER'S AIRBAG FAILURE

### DTC DETECTING CONDITION:

- Airbag main harness circuit (driver's side) is shorted to power supply.
- Airbag module harness circuit (driver's side) is shorted to power supply.
- Roll connector is shorted to power supply.
- Driver's airbag module is faulty.
- Airbag control module is faulty.

### CAUTION:

- Before diagnosing the airbag system, be sure to turn the ignition switch to OFF, disconnect the ground cable from battery, and wait 60 seconds or more before starting to work.
- When replacing the airbag module, seat belt pretensioner, roll connector, control module and sensor, reconnect each part and check that the warning light operates properly.
- When inspecting the airbag main harness, disconnect the airbag module connectors of the driver's and passenger's seats for safety.
- When inspecting the airbag rear harness, disconnect the side airbag module connector, curtain airbag module connector and seat belt pretensioner connector for safety reasons.

### NOTE:

Prior to starting work, prepare two AIRBAG RESISTORS (98299PA040).

### WIRING DIAGRAM:

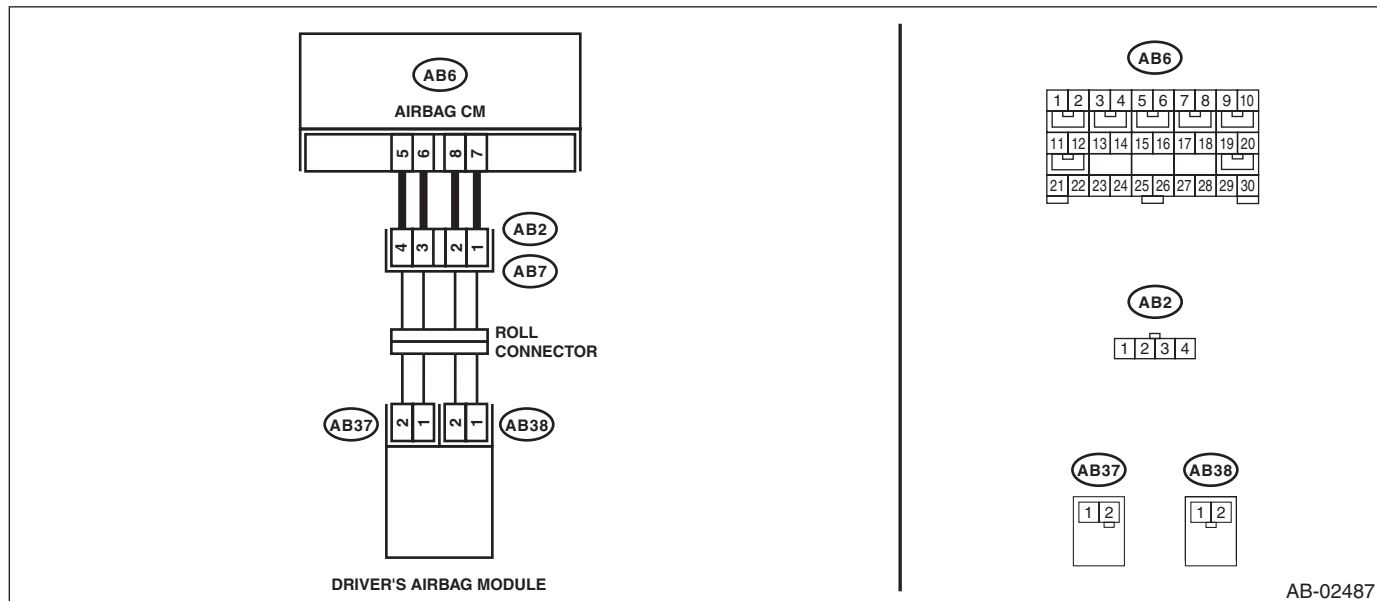

Step	Check	Yes	No
1	<p><b>CHECK POOR CONTACT OF CONNECTORS.</b></p> <p>Check for poor contact of the connectors between the airbag control module and the driver's airbag module.</p>	Is there poor contact?	<p>Replace the airbag harness.</p> <p>Go to step 2.</p>



## Diagnostic Chart with Trouble Code

### AIRBAG SYSTEM (DIAGNOSTICS)

Step	Check	Yes	No
<b>2 CHECK DRIVER'S AIRBAG MODULE.</b> 1) Turn the ignition switch to OFF, disconnect the battery ground cable, and wait for 60 seconds or more. 2) Remove the driver's airbag module. 3) Connect the connector (AB38) to the connector (1N) in the test harness N. 4) Connect the airbag resistor to the connector (2N) of test harness N. 5) Connect the connector (1Q) in the test harness Q to connector (AB37). 6) Connect the airbag resistor to the connector (2Q) in the test harness Q. 7) Connect the battery ground terminal and turn the ignition switch to ON.	Does the airbag warning light illuminate for six seconds and go off?	Replace the driver's airbag module. <Ref. to AB-16, Driver's Airbag Module.>	Go to step 3.
<b>3 CHECK ROLL CONNECTOR.</b> 1) Turn the ignition switch to OFF, disconnect the battery ground cable, and wait for 60 seconds or more. 2) Disconnect the test harness N from connector (AB38). 3) Disconnect the test harness Q from connector (AB37). 4) Remove the instrument panel lower cover and disconnect the connector (AB7) from (AB2). 5) Connect the connector (1P) in the test harness P to connector (AB2). 6) Connect the airbag resistor to the connectors (2P) and (3P) of test harness P. 7) Connect the battery ground terminal and turn the ignition switch to ON.	Does the airbag warning light illuminate for six seconds and go off?	Replace the roll connector. <Ref. to AB-27, Roll Connector.>	Go to step 4.
<b>4 CHECK AIRBAG MAIN HARNESS (DRIVER'S AIRBAG HARNESS).</b> 1) Turn the ignition switch to OFF, disconnect the battery ground cable, and wait for 60 seconds or more. 2) Disconnect the airbag resistor from the connectors (2P) and (3P) of test harness P. 3) Remove the console front panel and disconnect the connector (AB9). 4) Disconnect the connectors (AB6, AB17, AB18) from the airbag control module, and connect the connector (1AH) in the test harness AH. 5) Connect the connector (2AH) in the test harness AH and the connector (1AG) in the test harness AG. 6) Connect the battery ground terminal and turn the ignition switch to ON. 7) Measure the voltage between connector (3AG) in the test harness AG and chassis ground.  <b>Connector &amp; terminal</b> <b>(3AG) No. 3 (+) — Chassis ground (-):</b> <b>(3AG) No. 1 (+) — Chassis ground (-):</b>	Is the voltage less than 1 V?	Go to step 5.	Replace the airbag main harness along with body harness.

# Diagnostic Chart with Trouble Code

AIRBAG SYSTEM (DIAGNOSTICS)

Step	Check	Yes	No
<b>5</b> <b>CHECK AIRBAG CONTROL MODULE.</b> 1) Connect all connectors. 2) Clear the memory. 3) Perform the Inspection Mode. 4) Read the DTC.	Is the same DTC displayed?	Replace the airbag control module. <Ref. to AB-22, Airbag Control Module.>	Go to step <b>6</b> .
<b>6</b> <b>CHECK FOR ANY OTHER DTC ON DISPLAY.</b>	Is any other DTC displayed?	Check DTC using "List of Diagnostic Trouble Code (DTC)". <Ref. to AB(diag)-39, List of Diagnostic Trouble Code (DTC).>	Finish the diagnosis.

# Diagnostic Chart with Trouble Code

## AIRBAG SYSTEM (DIAGNOSTICS)

### D: DTC 16 PASSENGER'S AIRBAG FAILURE

#### DTC DETECTING CONDITION:

- Airbag main harness circuit (passenger's side) is shorted to power supply.
- Airbag module harness circuit (passenger's side) is shorted to power supply.
- Passenger's airbag module is faulty.
- Airbag control module is faulty.

#### CAUTION:

- Before diagnosing the airbag system, be sure to turn the ignition switch to OFF, disconnect the ground cable from battery, and wait 60 seconds or more before starting to work.
- When replacing the airbag module, seat belt pretensioner, roll connector, control module and sensor, reconnect each part and check that the warning light operates properly.
- When inspecting the airbag main harness, disconnect the airbag module connectors of the driver's and passenger's seats for safety.
- When inspecting the airbag rear harness, disconnect the side airbag module connector, curtain airbag module connector and seat belt pretensioner connector for safety reasons.

#### NOTE:

Prior to starting work, prepare two AIRBAG RESISTORS (98299PA040).

#### WIRING DIAGRAM:

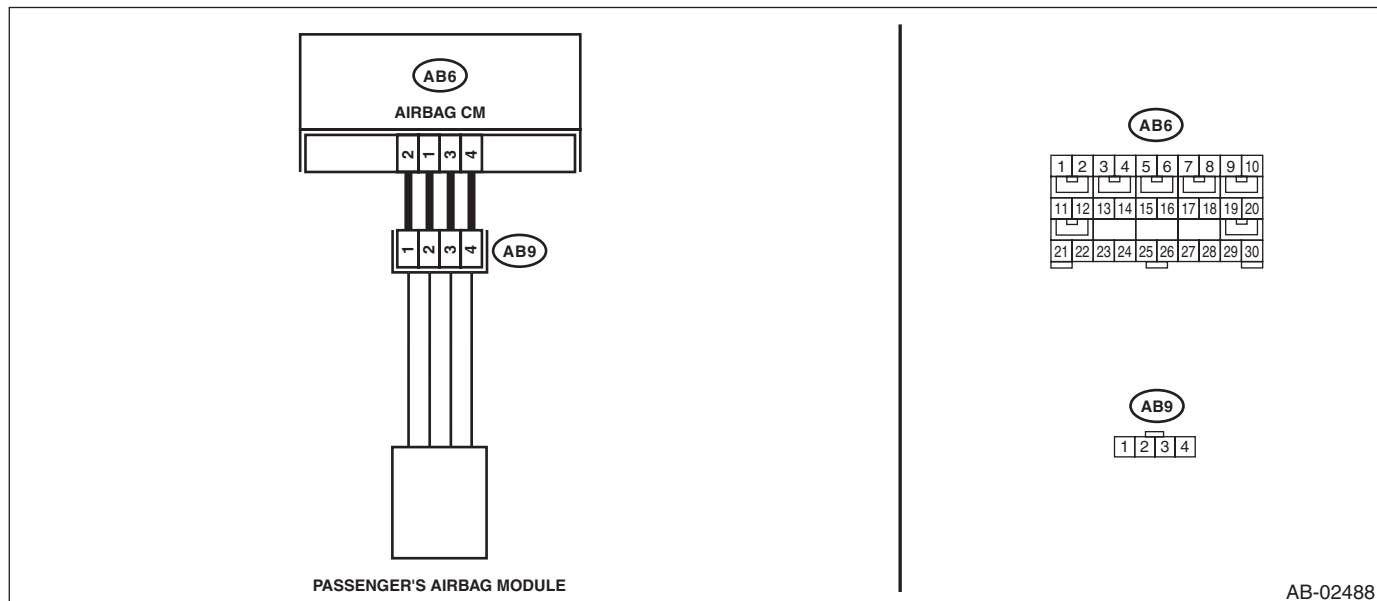

Step	Check	Yes	No
<b>1 CHECK POOR CONTACT OF CONNECTORS.</b> Check for poor contact of the connectors between the airbag control module and the passenger's airbag module.	Is there poor contact?	Replace the airbag harness along with chassis harness.	Go to step 2.
<b>2 CHECK PASSENGER'S AIRBAG MODULE.</b> 1) Turn the ignition switch to OFF, disconnect the battery ground cable, and wait for 60 seconds or more. 2) Remove the console front panel and disconnect the connector (AB9). 3) Connect the connector (1P) in the test harness P to connector (AB9). 4) Connect the airbag resistor to the connectors (2P) and (3P) of test harness P. 5) Connect the battery ground terminal and turn the ignition switch to ON.	Does the airbag warning light illuminate for six seconds and go off?	Replace the passenger's airbag module. <Ref. to AB-17, Passenger's Airbag Module.>	Go to step 3.

# Diagnostic Chart with Trouble Code

AIRBAG SYSTEM (DIAGNOSTICS)

Step	Check	Yes	No
<b>3 CHECK AIRBAG MAIN HARNESS (PASSENGER'S AIRBAG HARNESS).</b> 1) Turn the ignition switch to OFF, disconnect the battery ground cable, and wait for 60 seconds or more. 2) Disconnect the airbag resistor from the connectors (2P) and (3P) of test harness P. 3) Remove the instrument panel lower cover and disconnect the connector (AB7) from (AB2). 4) Disconnect the connectors (AB6, AB17, AB18) from the airbag control module, and connect the connector (1AH) in the test harness AH. 5) Connect the connector (2AH) in the test harness AH and the connector (1AG) in the test harness AG. 6) Connect the battery ground terminal and turn the ignition switch to ON. 7) Measure the voltage between connector (3AG) in the test harness AG and chassis ground.  <b>Connector &amp; terminal</b> <b>(3AG) No. 9 (+) — Chassis ground (-):</b> <b>(3AG) No. 7 (+) — Chassis ground (-):</b>	Is the voltage less than 1 V?	Go to step 4.	Replace the airbag main harness along with body harness.
<b>4 CHECK AIRBAG CONTROL MODULE.</b> 1) Connect all connectors. 2) Clear the memory. 3) Perform the Inspection Mode. 4) Read the DTC.	Is the same DTC displayed?	Replace the airbag control module. <Ref. to AB-22, Airbag Control Module.>	Go to step 5.
<b>5 CHECK FOR ANY OTHER DTC ON DISPLAY.</b>	Is any other DTC displayed?	Check DTC using "List of Diagnostic Trouble Code (DTC)". <Ref. to AB(diag)-39, List of Diagnostic Trouble Code (DTC).>	Finish the diagnosis.

# Diagnostic Chart with Trouble Code

## AIRBAG SYSTEM (DIAGNOSTICS)

### E: DTC 1A DRIVER'S AIRBAG FAILURE

#### DTC DETECTING CONDITION:

- Airbag main harness circuit is shorted.
- Airbag module harness (driver's side) circuit is shorted.
- Roll connector circuit is shorted.
- Driver's airbag module is faulty.
- Airbag control module is faulty.

#### CAUTION:

- Before diagnosing the airbag system, be sure to turn the ignition switch to OFF, disconnect the ground cable from battery, and wait 60 seconds or more before starting to work.
- When replacing the airbag module, seat belt pretensioner, roll connector, control module and sensor, reconnect each part and check that the warning light operates properly.
- When inspecting the airbag main harness, disconnect the airbag module connectors of the driver's and passenger's seats for safety.
- When inspecting the airbag rear harness, disconnect the side airbag module connector, curtain airbag module connector and seat belt pretensioner connector for safety reasons.

#### NOTE:

Prior to starting work, prepare two AIRBAG RESISTORS (98299PA040).

#### WIRING DIAGRAM:

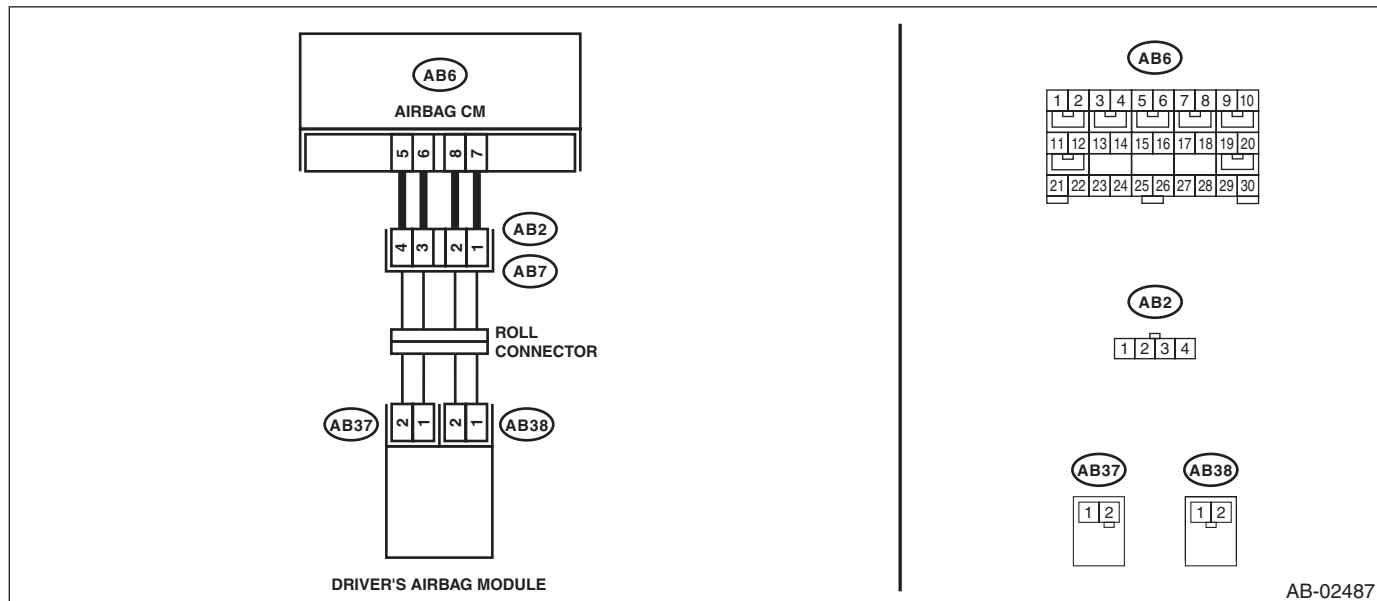

Step	Check	Yes	No
1	<p><b>CHECK POOR CONTACT OF CONNECTORS.</b></p> <p>Check for poor contact of the connectors between the airbag control module and the driver's airbag module.</p>	Is there poor contact?	<p>Replace the airbag harness.</p> <p>Go to step 2.</p>

# Diagnostic Chart with Trouble Code

AIRBAG SYSTEM (DIAGNOSTICS)

Step	Check	Yes	No
<b>2 CHECK DRIVER'S AIRBAG MODULE.</b> 1) Turn the ignition switch to OFF, disconnect the battery ground cable, and wait for 60 seconds or more. 2) Remove the driver's airbag module. 3) Connect the connector (1N) in the test harness N to the connector (AB38). 4) Connect the airbag resistor to the connector (2N) of test harness N. 5) Connect the connector (1Q) in the test harness Q to connector (AB37). 6) Connect the airbag resistor to the connector (2Q) in the test harness Q. 7) Connect the battery ground terminal and turn the ignition switch to ON.	Does the airbag warning light illuminate for 6 seconds and go off?	Replace the driver's airbag module. <Ref. to AB-16, Driver's Airbag Module.>	Go to step 3.
<b>3 CHECK ROLL CONNECTOR.</b> 1) Turn the ignition switch to OFF, disconnect the battery ground cable, and wait for 60 seconds or more. 2) Disconnect the test harness N from connector (AB38). 3) Disconnect the test harness Q from connector (AB37). 4) Remove the instrument panel lower cover and disconnect the connector (AB7) from (AB2). 5) Connect the connector (1P) in the test harness P to connector (AB2). 6) Connect the airbag resistor to the connectors (2P) and (3P) of test harness P. 7) Connect the battery ground terminal and turn the ignition switch to ON.	Does the airbag warning light illuminate for six seconds and go off?	Replace the roll connector. <Ref. to AB-27, Roll Connector.>	Go to step 4.
<b>4 CHECK AIRBAG MAIN HARNESS (DRIVER'S AIRBAG HARNESS).</b> 1) Turn the ignition switch to OFF, disconnect the battery ground cable, and wait for 60 seconds or more. 2) Disconnect the airbag resistor from the connectors (2P) and (3P) of test harness P. 3) Remove the console front panel and disconnect the connector (AB9). 4) Disconnect the connectors (AB6, AB17, AB18) from the airbag control module, and connect the connector (1AH) in the test harness AH. 5) Connect the connector (2AH) in the test harness AH and the connector (1AG) in the test harness AG. 6) Measure the resistance between connector (3AG) terminals in test harness AG. <b>Connector &amp; terminal</b> <b>(3AG) No. 1 — (3AG) No. 3:</b>	Is the resistance 1 MΩ or more?	Go to step 5.	Replace the airbag main harness along with body harness.
<b>5 CHECK AIRBAG CONTROL MODULE.</b> 1) Connect all connectors. 2) Clear the memory. 3) Perform the Inspection Mode. 4) Read the DTC.	Is the same DTC displayed?	Replace the airbag control module. <Ref. to AB-22, Airbag Control Module.>	Go to step 6.

# Diagnostic Chart with Trouble Code

## AIRBAG SYSTEM (DIAGNOSTICS)

Step	Check	Yes	No
6 <b>CHECK FOR ANY OTHER DTC ON DISPLAY.</b>	Is any other DTC displayed?	Check DTC using "List of Diagnostic Trouble Code (DTC)". <Ref. to AB(diag)-39, List of Diagnostic Trouble Code (DTC).>	Finish the diagnosis.

# Diagnostic Chart with Trouble Code

AIRBAG SYSTEM (DIAGNOSTICS)

## F: DTC 1B PASSENGER'S AIRBAG FAILURE

### DTC DETECTING CONDITION:

- Airbag main harness circuit is shorted.
- Airbag module harness (passenger's side) circuit is shorted.
- Passenger's airbag module is faulty.
- Airbag control module is faulty.

### CAUTION:

- Before diagnosing the airbag system, be sure to turn the ignition switch to OFF, disconnect the ground cable from battery, and wait 60 seconds or more before starting to work.
- When replacing the airbag module, seat belt pretensioner, roll connector, control module and sensor, reconnect each part and check that the warning light operates properly.
- When inspecting the airbag main harness, disconnect the airbag module connectors of the driver's and passenger's seats for safety.
- When inspecting the airbag rear harness, disconnect the side airbag module connector, curtain airbag module connector and seat belt pretensioner connector for safety reasons.

### NOTE:

Prior to starting work, prepare two AIRBAG RESISTORS (98299PA040).

### WIRING DIAGRAM:

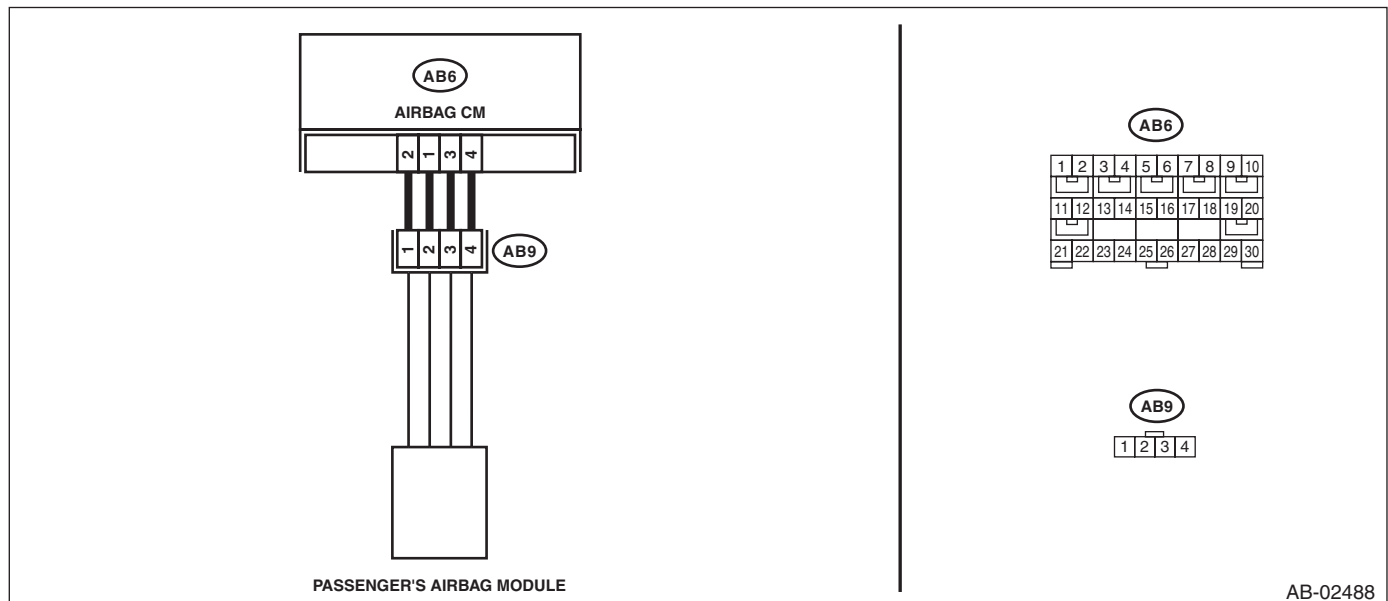

Step	Check	Yes	No
<b>1 CHECK POOR CONTACT OF CONNECTORS.</b> Check for poor contact of the connectors between the airbag control module and the passenger's airbag module.	Is there poor contact?	Replace the airbag harness.	Go to step 2.
<b>2 CHECK PASSENGER'S AIRBAG MODULE.</b> 1) Turn the ignition switch to OFF, disconnect the battery ground cable, and wait for 60 seconds or more. 2) Remove the console front panel and disconnect the connector (AB9). 3) Connect the connector (1P) in the test harness P to connector (AB9). 4) Connect the airbag resistor to the connectors (2P) and (3P) of test harness P. 5) Connect the battery ground terminal and turn the ignition switch to ON.	Does the airbag warning light illuminate for 6 seconds and go off?	Replace the passenger's airbag module. <Ref. to AB-17, Passenger's Airbag Module.>	Go to step 3.



# Diagnostic Chart with Trouble Code

## AIRBAG SYSTEM (DIAGNOSTICS)

Step	Check	Yes	No
<b>3 CHECK AIRBAG MAIN HARNESS (PASSENGER'S AIRBAG HARNESS).</b> 1) Turn the ignition switch to OFF, disconnect the battery ground cable, and wait for 60 seconds or more. 2) Disconnect the airbag resistor from the connectors (2P) and (3P) of test harness P. 3) Remove the instrument panel lower cover and column cover, and disconnect the connector (AB7) from (AB2). 4) Disconnect the connectors (AB6, AB17, AB18) from the airbag control module, and connect the connector (1AH) in the test harness AH. 5) Connect the connector (2AH) in the test harness AH and the connector (1AG) in the test harness AG. 6) Measure the resistance between connector (3AG) terminals in test harness AG. <b>Connector &amp; terminal (3AG) No. 7 — (3AG) No. 9:</b>	Is the resistance 1 MΩ or more?	Go to step 4.	Replace the airbag main harness along with body harness.
<b>4 CHECK AIRBAG CONTROL MODULE.</b> 1) Connect all connectors. 2) Clear the memory. 3) Perform the Inspection Mode. 4) Read the DTC.	Is the same DTC displayed?	Replace the airbag control module. <Ref. to AB-22, Airbag Control Module.>	Go to step 5.
<b>5 CHECK FOR ANY OTHER DTC ON DISPLAY.</b>	Is any other DTC displayed?	Check DTC using "List of Diagnostic Trouble Code (DTC)". <Ref. to AB(diag)-39, List of Diagnostic Trouble Code (DTC).>	Finish the diagnosis.

# Diagnostic Chart with Trouble Code

AIRBAG SYSTEM (DIAGNOSTICS)

## G: DTC 1D DRIVER'S AIRBAG FAILURE

### DTC DETECTING CONDITION:

- Airbag main harness circuit is open.
- Airbag module harness (driver's side) circuit is open.
- Roll connector circuit is open.
- Driver's airbag module is faulty.
- Airbag control module is faulty.

### CAUTION:

- Before diagnosing the airbag system, be sure to turn the ignition switch to OFF, disconnect the ground cable from battery, and wait 60 seconds or more before starting to work.
- When replacing the airbag module, seat belt pretensioner, roll connector, control module and sensor, reconnect each part and check that the warning light operates properly.
- When inspecting the airbag main harness, disconnect the airbag module connectors of the driver's and passenger's seats for safety.
- When inspecting the airbag rear harness, disconnect the side airbag module connector, curtain airbag module connector and seat belt pretensioner connector for safety reasons.

### NOTE:

Prior to starting work, prepare two AIRBAG RESISTORS (98299PA040).

### WIRING DIAGRAM:

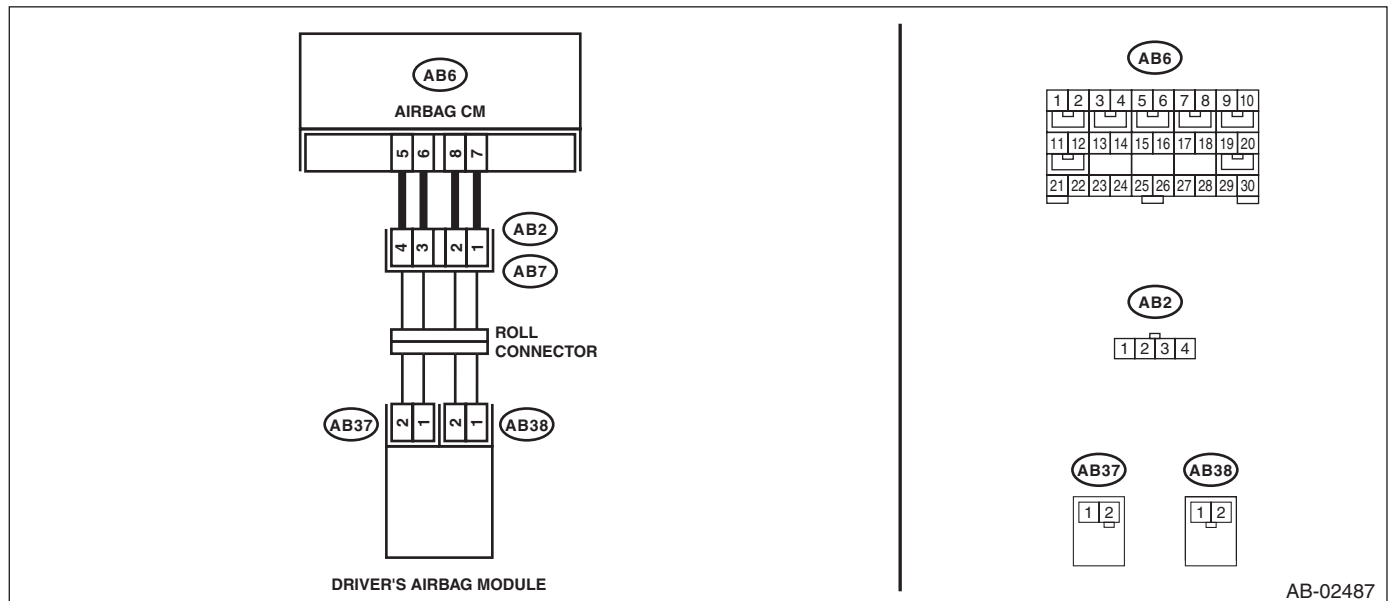

Step	Check	Yes	No
1	<p><b>CHECK POOR CONTACT OF CONNECTORS.</b></p> <p>Check for poor contact of the connectors between the airbag control module and the driver's airbag module.</p>	Is there poor contact?	<p>Replace the airbag harness.</p> <p>Go to step 2.</p>

## Diagnostic Chart with Trouble Code

### AIRBAG SYSTEM (DIAGNOSTICS)

Step	Check	Yes	No
<b>2 CHECK DRIVER'S AIRBAG MODULE.</b> 1) Turn the ignition switch to OFF, disconnect the battery ground cable, and wait for 60 seconds or more. 2) Remove the driver's airbag module. 3) Connect the connector (1N) in the test harness N to the connector (AB38). 4) Connect the airbag resistor to the connector (2N) of test harness N. 5) Connect the connector (1Q) in the test harness Q to connector (AB37). 6) Connect the airbag resistor to the connector (2Q) in the test harness Q. 7) Connect the battery ground terminal and turn the ignition switch to ON.	Does the airbag warning light illuminate for 6 seconds and go off?	Replace the driver's airbag module. <Ref. to AB-16, Driver's Airbag Module.>	Go to step 3.
<b>3 CHECK ROLL CONNECTOR.</b> 1) Turn the ignition switch to OFF, disconnect the battery ground cable, and wait for 60 seconds or more. 2) Disconnect the connector (1N) in the test harness N from the connector (AB38). 3) Disconnect the test harness Q from connector (AB37). 4) Remove the instrument panel lower cover and disconnect the connector (AB7) from (AB2). 5) Connect the connector (1P) in the test harness P to connector (AB2). 6) Connect the airbag resistor to the connectors (2P) and (3P) of test harness P. 7) Connect the battery ground terminal and turn the ignition switch to ON.	Does the airbag warning light illuminate for 6 seconds and go off?	Replace the roll connector. <Ref. to AB-27, Roll Connector.>	Go to step 4.
<b>4 CHECK AIRBAG MAIN HARNESS (DRIVER'S AIRBAG HARNESS).</b> 1) Turn the ignition switch to OFF, disconnect the battery ground cable, and wait for 60 seconds or more. 2) Disconnect the airbag resistor from the connectors (2P) and (3P) of test harness P. 3) Remove the console front panel and disconnect the connector (AB9). 4) Disconnect the connectors (AB6, AB17, AB18) from the airbag control module, and connect the connector (1AH) in the test harness AH. 5) Connect the connector (2AH) in the test harness AH and the connector (1AG) in the test harness AG. 6) Measure the resistance between connector (3AG) of test harness AG and connector (2P) of test harness P.  <i>Connector &amp; terminal</i> <i>(3AG) No. 1 — (2P) No. 1:</i> <i>(3AG) No. 3 — (2P) No. 2:</i>	Is the resistance less than 10 $\Omega$ ?	Go to step 5.	Replace the airbag main harness along with body harness.
<b>5 CHECK AIRBAG CONTROL MODULE.</b> 1) Connect all connectors. 2) Clear the memory. 3) Perform the Inspection Mode. 4) Read the DTC.	Is the same DTC displayed?	Replace the airbag control module. <Ref. to AB-22, Airbag Control Module.>	Go to step 6.

# Diagnostic Chart with Trouble Code

AIRBAG SYSTEM (DIAGNOSTICS)

Step	Check	Yes	No
6 <b>CHECK FOR ANY OTHER DTC ON DISPLAY.</b>	Is any other DTC displayed?	Check DTC using "List of Diagnostic Trouble Code (DTC)". <Ref. to AB(diag)-39, List of Diagnostic Trouble Code (DTC).>	Finish the diagnosis.

# Diagnostic Chart with Trouble Code

## AIRBAG SYSTEM (DIAGNOSTICS)

### H: DTC 1E PASSENGER'S AIRBAG FAILURE

#### DTC DETECTING CONDITION:

- Airbag main harness circuit is open.
- Airbag module harness (passenger's side) circuit is open.
- Passenger's airbag module is faulty.
- Airbag control module is faulty.

#### CAUTION:

- Before diagnosing the airbag system, be sure to turn the ignition switch to OFF, disconnect the ground cable from battery, and wait 60 seconds or more before starting to work.
- When replacing the airbag module, seat belt pretensioner, roll connector, control module and sensor, reconnect each part and check that the warning light operates properly.
- When inspecting the airbag main harness, disconnect the airbag module connectors of the driver's and passenger's seats for safety.
- When inspecting the airbag rear harness, disconnect the side airbag module connector, curtain airbag module connector and seat belt pretensioner connector for safety reasons.

#### NOTE:

Prior to starting work, prepare two AIRBAG RESISTORS (98299PA040).

#### WIRING DIAGRAM:

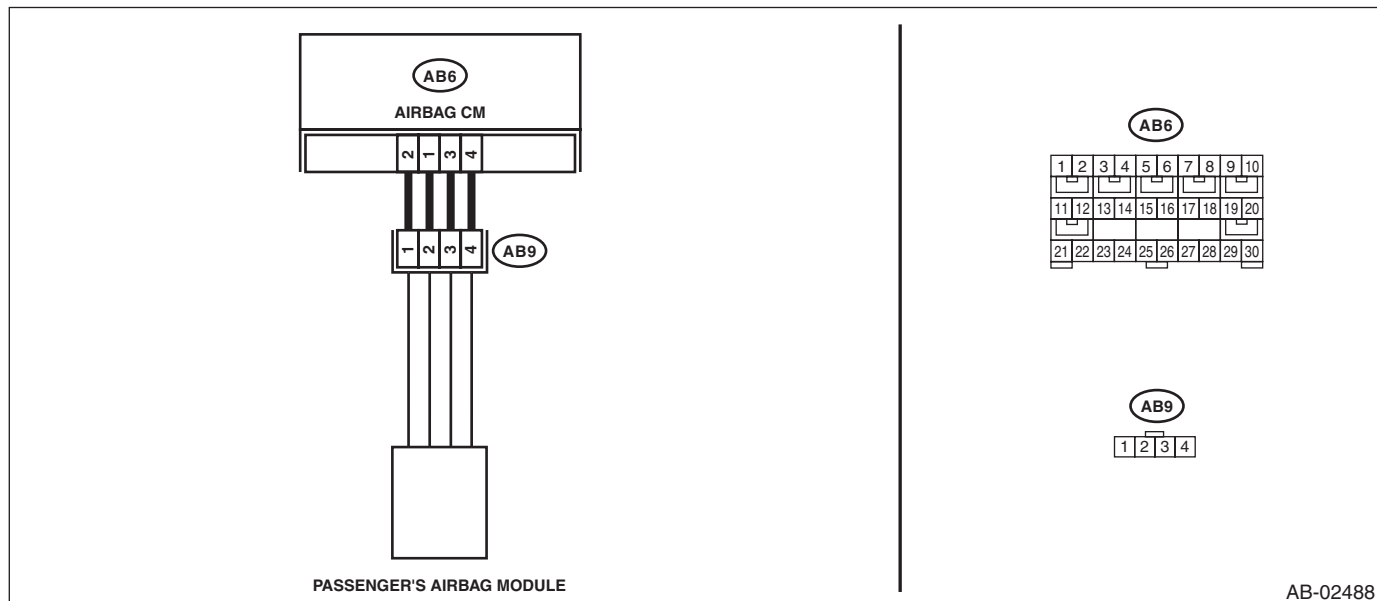

Step	Check	Yes	No
<b>1 CHECK POOR CONTACT OF CONNECTORS.</b> Check for poor contact of the connectors between the airbag control module and the passenger's airbag module.	Is there poor contact?	Replace the airbag harness.	Go to step 2.
<b>2 CHECK PASSENGER'S AIRBAG MODULE.</b> 1) Turn the ignition switch to OFF, disconnect the battery ground cable, and wait for 60 seconds or more. 2) Remove the console front panel and disconnect the connector (AB9). 3) Connect the connector (1P) in the test harness P to connector (AB9). 4) Connect the airbag resistor to the connectors (2P) and (3P) of test harness P. 5) Connect the battery ground terminal and turn the ignition switch to ON.	Does the airbag warning light illuminate for 6 seconds and go off?	Replace the passenger's airbag module. <Ref. to AB-17, Passenger's Airbag Module.>	Go to step 3.

# Diagnostic Chart with Trouble Code

AIRBAG SYSTEM (DIAGNOSTICS)

Step	Check	Yes	No
<b>3 CHECK AIRBAG MAIN HARNESS (PASSENGER'S AIRBAG HARNESS).</b> 1) Turn the ignition switch to OFF, disconnect the battery ground cable, and wait for 60 seconds or more. 2) Disconnect the airbag resistor from the connectors (2P) and (3P) of test harness P. 3) Remove the instrument panel lower cover and column cover, and disconnect the connector (AB7) from (AB2). 4) Disconnect the connectors (AB6, AB17, AB18) from the airbag control module, and connect the connector (1AH) in the test harness AH. 5) Connect the connector (2AH) in the test harness AH and the connector (1AG) in the test harness AG. 6) Measure the resistance between connector (3AG) of test harness AG and connector (2P) of test harness P. <i><b>Connector &amp; terminal</b></i> <i><b>(3AG) No. 9 — (2P) No. 1:</b></i> <i><b>(3AG) No. 7 — (2P) No. 2:</b></i>	Is the resistance less than 10 $\Omega$ ?	Go to step 4.	Replace the airbag main harness along with body harness.
<b>4 CHECK AIRBAG CONTROL MODULE.</b> 1) Connect all connectors. 2) Clear the memory. 3) Perform the Inspection Mode. 4) Read the DTC.	Is the same DTC displayed?	Replace the airbag control module. <Ref. to AB-22, Airbag Control Module.>	Go to step 5.
<b>5 CHECK FOR ANY OTHER DTC ON DISPLAY.</b>	Is any other DTC displayed?	Check DTC using "List of Diagnostic Trouble Code (DTC)". <Ref. to AB(diag)-39, List of Diagnostic Trouble Code (DTC).>	Finish the diagnosis.

# Diagnostic Chart with Trouble Code

AIRBAG SYSTEM (DIAGNOSTICS)

---

## I: DTC 21 AIRBAG ECM FAILURE

### DTC DETECTING CONDITION:

Airbag control module is faulty.

### CAUTION:

- Before diagnosing the airbag system, be sure to turn the ignition switch to OFF, disconnect the ground cable from battery, and wait 60 seconds or more before starting to work.
- When replacing the airbag module, seat belt pretensioner, roll connector, control module and sensor, reconnect each part and check that the warning light operates properly.

Step	Check	Yes	No
1 <b>CHECK IF DTC 21 IS INDICATED.</b> Read the DTC. <Ref. to AB(diag)-26, READ DIAGNOSTIC TROUBLE CODE (DTC), OPERATION, Subaru Select Monitor.>	Does the Subaru Select Monitor display DTC21?	Replace the airbag control module. <Ref. to AB-22, Airbag Control Module.>	Perform the Clear Memory Mode. <Ref. to AB(diag)-26, CLEAR MEMORY MODE, OPERATION, Subaru Select Monitor.>

## J: DTC 22 FRONT AIRBAG FIRING OUTPUT

### DTC DETECTING CONDITION:

This DTC is indicated when the front airbag module and the pretensioner are deployed.

Once this DTC is displayed, the memory cannot be cleared. Therefore replace the following parts.

- Airbag control module <Ref. to AB-22, Airbag Control Module.>
- Driver's airbag module <Ref. to AB-16, Driver's Airbag Module.>
- Passenger's airbag module <Ref. to AB-17, Passenger's Airbag Module.>
- Front sub sensor of both sides. <Ref. to AB-23, Front Sub Sensor.>
- Front outer seat belt with pretensioner of both sides. <Ref. to SB-18, Front Seat Belt.>
- Steering roll connector <Ref. to AB-27, Roll Connector.>
- Occupant detection system (passenger's seat cushion & frame assembly) <Ref. to SE-6, Front Seat.>

# Diagnostic Chart with Trouble Code

AIRBAG SYSTEM (DIAGNOSTICS)

## K: DTC 26 PASSENGER'S AIRBAG INDICATOR FAILURE

### DTC DETECTING CONDITION:

- Passenger's airbag indicator is faulty.
- Airbag control module is faulty.
- Airbag main harness circuit is open or shorted.
- Body harness circuit is open.

### CAUTION:

- Before diagnosing the airbag system, be sure to turn the ignition switch to OFF, disconnect the ground cable from battery, and wait 60 seconds or more before starting to work.
- When replacing the airbag module, seat belt pretensioner, roll connector, control module and sensor, reconnect each part and check that the warning light operates properly.
- When inspecting the airbag main harness, disconnect the airbag module connectors of the driver's and passenger's seats for safety.
- When inspecting the airbag rear harness, disconnect the side airbag module connector, curtain airbag module connector and seat belt pretensioner connector for safety reasons.

### WIRING DIAGRAM:

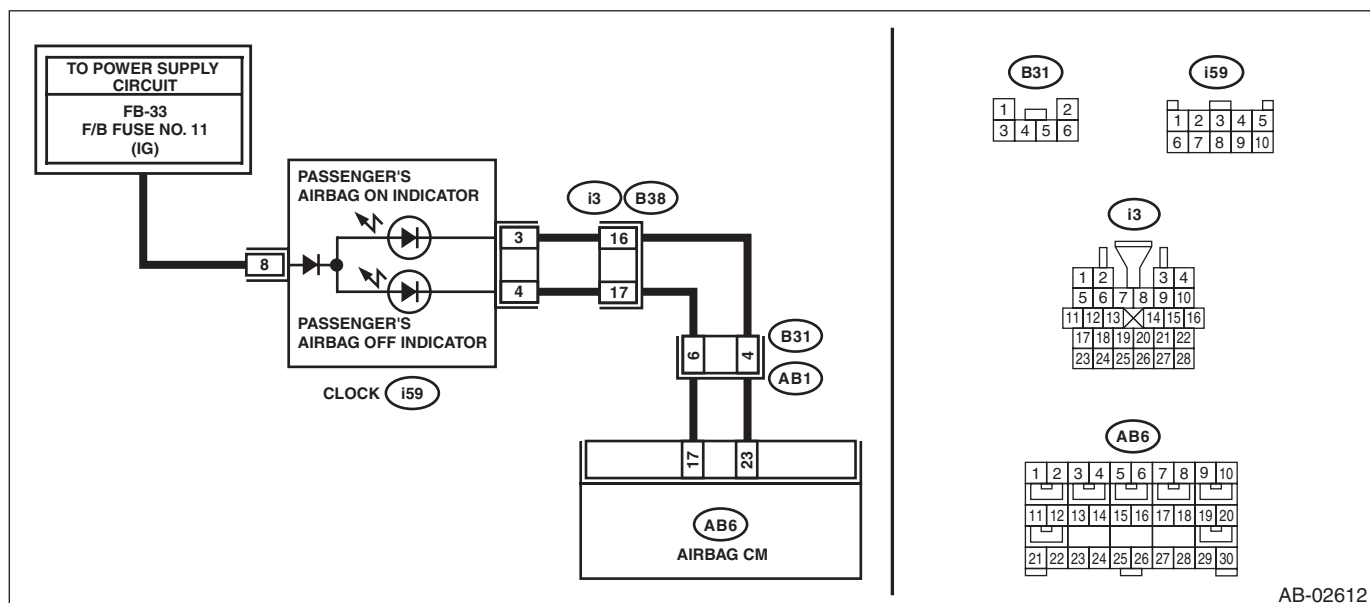

AB-02612

Step	Check	Yes	No
<b>1 CHECK FOR POOR CONTACT.</b> 1) Turn the ignition switch to OFF, disconnect the battery ground cable, and wait for 60 seconds or more. 2) Check that the connector between the airbag control module and the clock is securely connected.	Is there poor contact of any connector?	Repair the bulk-head harness. Or replace the airbag main harness along with body harness.	Go to step 2.
<b>2 CHECK AIRBAG MAIN HARNESS.</b> 1) Disconnect the connectors (AB6, AB17, AB18) from airbag control module. 2) Connect the battery ground terminal and turn the ignition switch to ON.  NOTE: Neither of ON/OFF illuminates when it is normal.	Does the passenger's airbag indicator illuminate?	Go to step 3.	Go to step 4.



# Diagnostic Chart with Trouble Code

## AIRBAG SYSTEM (DIAGNOSTICS)

Step	Check	Yes	No
<b>3</b> <b>CHECK AIRBAG MAIN HARNESS.</b> 1) Turn the ignition switch to OFF. 2) Remove the clock and disconnect the connector (i59). 3) Disconnect the connectors (AB6, AB17, AB18) from the airbag control module, and connect the connector (1AH) in the test harness AH. 4) Connect the connector (2AH) in the test harness AH and the connector (1AG) in the test harness AG. 5) Measure the resistance between connector (2AG) in the test harness AG and chassis ground. <b>Connector &amp; terminal</b> <b>(2AG) No. 9 — (2AG) No. 8:</b> <b>(2AG) No. 9 — Chassis ground:</b> <b>(2AG) No. 8 — Chassis ground:</b>	Is the resistance 1 MΩ or more?	Replace the clock. <Ref. to IDI-21, REMOVAL, Clock.>	Repair the bulk-head harness. Or replace the airbag main harness along with body harness.
<b>4</b> <b>CHECK AIRBAG MAIN HARNESS.</b> 1) Turn the ignition switch to OFF. 2) Disconnect the connectors (AB6, AB17, AB18) from the airbag control module, and connect the connector (1AH) in the test harness AH. 3) Connect the connector (2AH) in the test harness AH and the connector (1AG) in the test harness AG. 4) Connect the connectors (7AG) and (8AG) in the test harness AG. 5) Connect the battery ground terminal and turn the ignition switch to ON.	Does the passenger's airbag indicator illuminate?	Replace the airbag control module. <Ref. to AB-22, Airbag Control Module.>	Go to step 5.
<b>5</b> <b>CHECK AIRBAG MAIN HARNESS.</b> 1) Turn the ignition switch to OFF. 2) Remove the clock, and disconnect the connector (i59). 3) Measure the resistance between connector (2AG) in the test harness AG and connector (i59). <b>Connector &amp; terminal</b> <b>(2AG) No. 9 — (i59) No. 4:</b> <b>(2AG) No. 8 — (i59) No. 3:</b>	Is the resistance less than 10 Ω?	Go to step 6.	Repair the bulk-head harness. Or replace the airbag main harness along with body harness.
<b>6</b> <b>CHECK BODY HARNESS.</b> 1) Turn the ignition switch to ON. 2) Measure the voltage between connector (i59) and chassis ground. <b>Connector &amp; terminal</b> <b>(i59) No. 8 (+) — Chassis ground (-):</b>	Is the voltage 10 V or more?	Replace the clock. <Ref. to IDI-21, REMOVAL, Clock.>	Check the power supply circuit of the clock.

# Diagnostic Chart with Trouble Code

AIRBAG SYSTEM (DIAGNOSTICS)

## L: DTC 27 ODS COMMUNICATION ERROR

### DTC DETECTING CONDITION:

- Communication to the occupant detection control module is faulty.
- Airbag rear harness circuit is open, shorted, shorted to ground or shorted to power supply.
- Occupant detection harness (seat harness) is faulty.
- Occupant detection system is faulty.
- Airbag control module is faulty.

### CAUTION:

- Before diagnosing the airbag system, be sure to turn the ignition switch to OFF, disconnect the ground cable from battery, and wait 60 seconds or more before starting to work.
- When replacing the airbag module, seat belt pretensioner, roll connector, control module and sensor, reconnect each part and check that the warning light operates properly.
- When inspecting the airbag rear harness, disconnect the side airbag module connector, curtain airbag module connector and seat belt pretensioner connector for safety reasons.

### WIRING DIAGRAM:

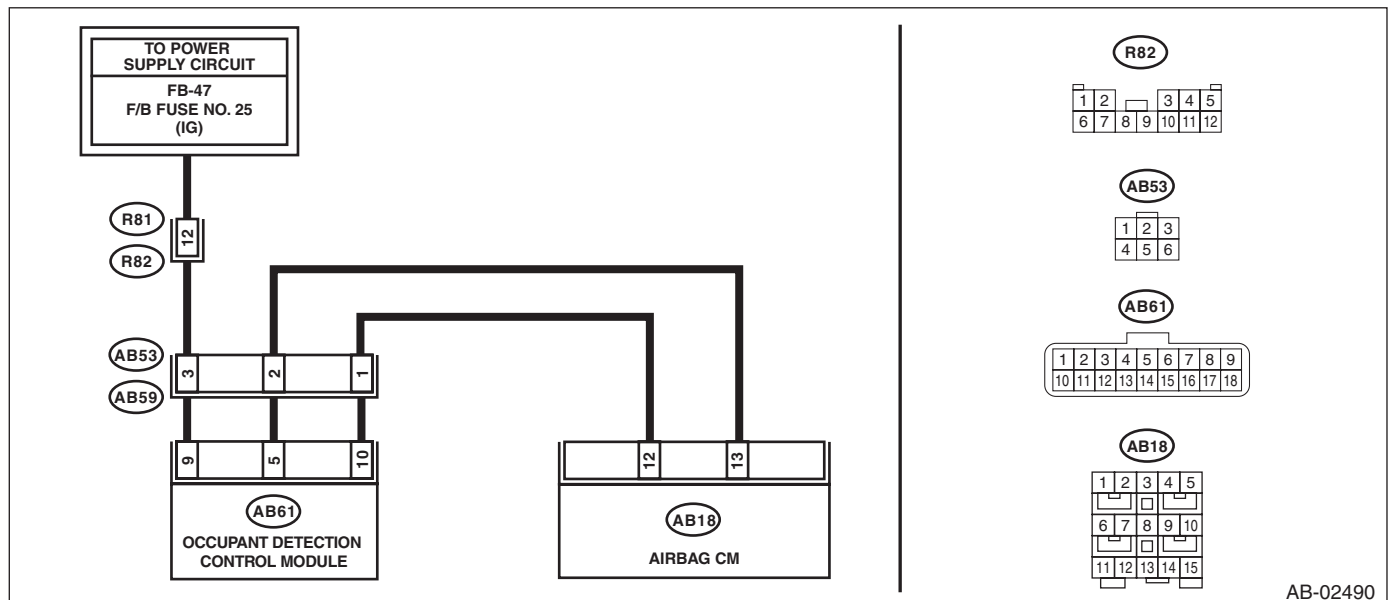

AB-02490

Step	Check	Yes	No
<b>1</b> <b>CHECK POOR CONTACT OF CONNECTORS.</b> Check for poor contact of the connectors between the airbag control module and the occupant detection control module.	Is there poor contact?	Reconnect the connector. If defective is not improved, replace the airbag rear harness along with the body harness or the occupant detection harness (seat harness).	Go to step 2.

## Diagnostic Chart with Trouble Code

### AIRBAG SYSTEM (DIAGNOSTICS)

Step	Check	Yes	No
<p><b>2</b>      <b>CHECK AIRBAG REAR HARNESS.</b>                      1) Turn the ignition switch to OFF, disconnect the battery ground cable, and wait for 60 seconds or more.                      2) Disconnect the connectors (AB59) and (AB53) under the passenger's seat.                      3) Disconnect the connectors (AB6, AB17, AB18) from the airbag control module, and connect the connector (1AH) in the test harness AH.                      4) Connect the connector (2AH) in the test harness AH and the connector (1AG) in the test harness AG.                      5) Connect the connector (1AB) in the test harness AB to the connector (AB53).                      6) Measure the resistance between connector (5AG) in the test harness AG and connector (2AB) in the test harness AB.</p> <p style="text-align: center;"><b>Connector &amp; terminal</b>  <b>(5AG) No. 5 — (2AB) No. 2:</b>  <b>(5AG) No. 16 — (2AB) No. 1:</b></p>	Is the resistance less than 10 Ω?	Go to step 3.	Replace the airbag rear harness along with body harness.
<p><b>3</b>      <b>CHECK AIRBAG REAR HARNESS.</b>                      Measure the resistance between connector (5AG) in the test harness AG and chassis ground.</p> <p style="text-align: center;"><b>Connector &amp; terminal</b>  <b>(5AG) No. 5 — Chassis ground:</b>  <b>(5AG) No. 16 — Chassis ground:</b>  <b>(5AG) No. 5 — (5AG) No. 16:</b></p>	Is the resistance less than 1 MΩ?	Go to step 4.	Replace the airbag rear harness along with body harness.
<p><b>4</b>      <b>CHECK OCCUPANT DETECTION HARNESS.</b>                      1) Turn the ignition switch to ON.                      2) Measure the voltage between connector (2AB) in the test harness AB and chassis ground.</p> <p style="text-align: center;"><b>Connector &amp; terminal</b>  <b>(2AB) No. 3 (+) — Chassis ground (-):</b></p>	Is the voltage 9 V or more?	Replace the occupant detection harness (seat harness). If defective is not improved, replace the occupant detection system (seat cushion & frame assembly), and then the airbag control module in this order.	Check the battery voltage and fuse. If there is no fault, replace the airbag rear harness together with body harness.

# Diagnostic Chart with Trouble Code

AIRBAG SYSTEM (DIAGNOSTICS)

## **M: DTC 29 ODS FAILURE**

NOTE:

Refer to "Occupant Detection System" for details on DTC 29. <Ref. to OD(diag)-25, DTC 29 ODS FAILURE, Diagnostic Procedure with Diagnostic Trouble Code (DTC).>

## **N: DTC 2A ODS CALIBRATION ERROR**

NOTE:

Refer to "Occupant Detection System" for details on DTC 2A. <Ref. to OD(diag)-22, DTC 2A ODS CALIBRATION ERROR, Diagnostic Procedure with Diagnostic Trouble Code (DTC).>

## **O: DTC 2B ODS SYSTEM WRONG PARTS**

NOTE:

Refer to "Occupant Detection System" for details on DTC 2B. <Ref. to OD(diag)-22, DTC 2B ODS SYSTEM WRONG PARTS, Diagnostic Procedure with Diagnostic Trouble Code (DTC).>

## **P: DTC 2C BELT TENSION SENSOR FAILURE**

NOTE:

Refer to "Occupant Detection System" for details on DTC 2C. <Ref. to OD(diag)-23, DTC 2C BELT TENSION SENSOR FAILURE, Diagnostic Procedure with Diagnostic Trouble Code (DTC).>

## **Q: DTC 2D AIRBAG WARNING INDICATOR FAILURE**

**DTC DETECTING CONDITION:**

- Airbag warning light is faulty.
- Harness between airbag control module and airbag warning light is shorted or open.
- Connection of airbag main harness and instrument panel harness is improper.
- Grounding circuit is faulty.
- Airbag control module is faulty.

NOTE:

For the diagnostic procedure, refer to "Airbag Warning Light Failure". <Ref. to AB(diag)-35, Airbag Warning Light Failure.>

## **R: DTC 33 FRONT SUB SENSOR RH FAILURE**

**DTC DETECTING CONDITION:**

Front sub sensor (RH) is faulty.

If DTC 33 is displayed, the circuit within the front sub sensor (RH) is faulty.

Replace the front sub sensor (RH). <Ref. to AB-23, Front Sub Sensor.>

## **S: DTC 34 FRONT SUB SENSOR LH FAILURE**

**DTC DETECTING CONDITION:**

Front sub sensor (LH) is faulty.

If DTC 34 is displayed, the circuit within the front sub sensor (LH) is faulty.

Replace the front sub sensor (LH). <Ref. to AB-23, Front Sub Sensor.>

## **T: DTC 37 BUCKLE SWITCH RH FAILURE**

NOTE:

Refer to "Occupant Detection System" for details on DTC 37. <Ref. to OD(diag)-26, DTC 37 BUCKLE SWITCH RH FAILURE, Diagnostic Procedure with Diagnostic Trouble Code (DTC).>

# Diagnostic Chart with Trouble Code

## AIRBAG SYSTEM (DIAGNOSTICS)

### U: DTC 39 SEAT BELT WARNING FAILURE

#### DTC DETECTING CONDITION:

- Airbag control module is faulty.
- Body integrated unit is faulty.
- Harness circuits between body integrated unit and airbag control module are open, shorted or shorted to ground.

#### CAUTION:

- Before diagnosing the airbag system, be sure to turn the ignition switch to OFF, disconnect the ground cable from battery, and wait 60 seconds or more before starting to work.
- When replacing the airbag module, seat belt pretensioner, roll connector, control module and sensor, reconnect each part and check that the warning light operates properly.
- When inspecting the airbag main harness, disconnect the airbag module connectors of the driver's and passenger's seats for safety.

#### WIRING DIAGRAM:

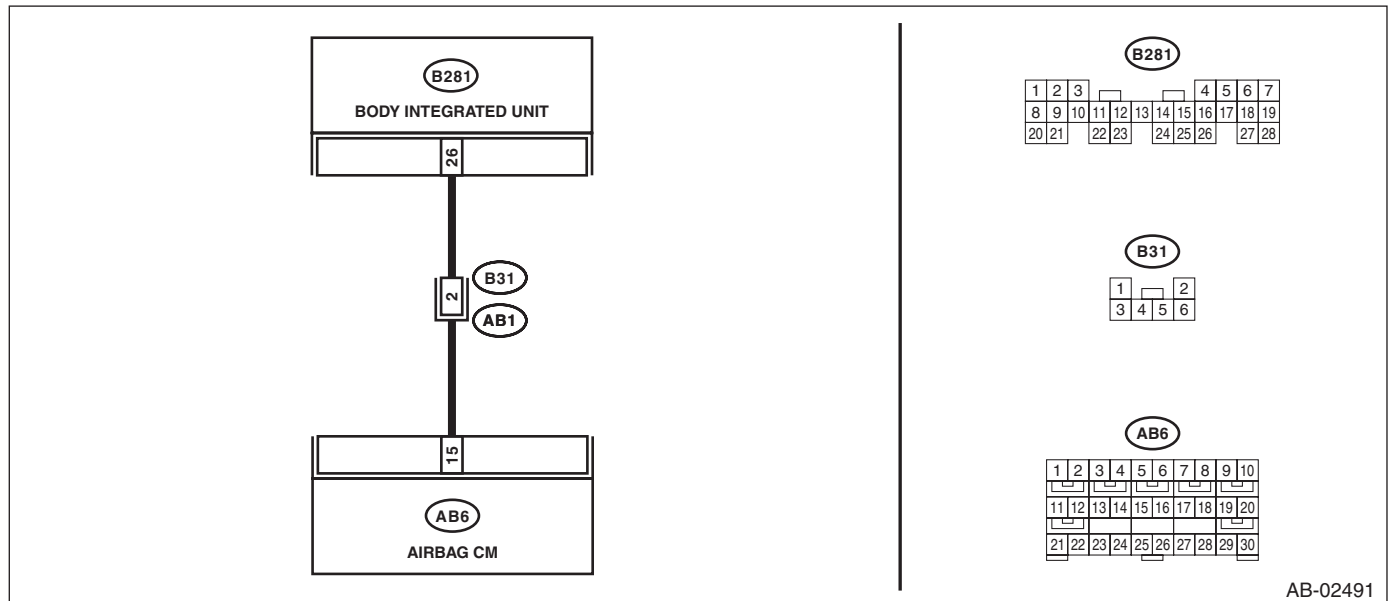

Step	Check	Yes	No
<b>1</b> <b>CHECK AIRBAG HARNESS.</b> 1) Turn the ignition switch to OFF, disconnect the battery ground cable, and wait for 60 seconds or more. 2) Disconnect the connectors (AB6, AB17, AB18) from airbag control module. 3) Connect the battery ground terminal and turn the ignition switch to ON.	Does the passenger's seat belt warning light blink for 6 seconds and go off?	Go to step 3.	Go to step 2.
<b>2</b> <b>CHECK AIRBAG HARNESS.</b> 1) Turn the ignition switch to OFF. 2) Disconnect the connectors (AB6, AB17, AB18) from the airbag control module, and connect the connector (1AH) in the test harness AH. 3) Connect the connector (2AH) in the test harness AH and the connector (1AG) in the test harness AG. 4) Measure the resistance between connector (2AG) in the test harness AG and chassis ground. <b>Connector &amp; terminal</b> <b>(2AG) No. 10 — Chassis ground:</b>	Is the resistance 1 MΩ or more?	Replace the body integrated unit.	Repair the bulk-head harness. Or replace the airbag main harness along with body harness.

# Diagnostic Chart with Trouble Code

AIRBAG SYSTEM (DIAGNOSTICS)

Step	Check	Yes	No
<b>3</b> <b>CHECK AIRBAG HARNESS.</b> 1) Turn the ignition switch to OFF. 2) Disconnect the connectors (AB6, AB17, AB18) from the airbag control module, and connect the connector (1AH) in the test harness AH. 3) Connect the connector (2AH) in the test harness AH and the connector (1AG) in the test harness AG. 4) Connect the connectors (7AG) and (8AG) in the test harness AG. 5) Turn the ignition switch to ON.	Does the passenger's seat belt warning light blink for 6 seconds, then repeatedly light and go off?	Replace the airbag control module. <Ref. to AB-22, Airbag Control Module.>	Go to step 4.
<b>4</b> <b>CHECK AIRBAG HARNESS.</b> 1) Turn the ignition switch to OFF. 2) Disconnect the connectors (7AG) and (8AG) in the test harness AG in the condition of step 3. 3) Disconnect the connector (B281) from body integrated unit. 4) Measure the resistance between connector (2AG) in the test harness AG and connector (B281). <b>Connector &amp; terminal</b> <b>(2AG) No. 10 — (B281) No. 26:</b>	Is the resistance less than 10 Ω?	Replace the body integrated unit.	Repair the bulk-head harness. Or replace the airbag main harness along with body harness.

# Diagnostic Chart with Trouble Code

## AIRBAG SYSTEM (DIAGNOSTICS)

### V: DTC 3A FRONT SUB SENSOR RH FALSE INSTALLATION

#### DTC DETECTING CONDITION:

Front sub sensor (RH) is misinstalled.

Step	Check	Yes	No
<b>1</b> <b>REPLACE FRONT SUB SENSOR.</b> 1) Turn the ignition switch to OFF, disconnect the battery ground cable, and wait for 60 seconds or more. 2) Replace the front sub sensor (RH) with a genuine sensor. <Ref. to AB-23, REMOVAL, Front Sub Sensor.>	Does the warning light go off?	Finish the diagnosis.	Replace the airbag control module. <Ref. to AB-22, REMOVAL, Airbag Control Module.>

### W: DTC 3B FRONT SUB SENSOR LH FALSE INSTALLATION

#### DTC DETECTING CONDITION:

Front sub sensor (LH) is misinstalled.

Step	Check	Yes	No
<b>1</b> <b>REPLACE FRONT SUB SENSOR.</b> 1) Turn the ignition switch to OFF, disconnect the battery ground cable, and wait for 60 seconds or more. 2) Replace the front sub sensor (LH) with a genuine sensor. <Ref. to AB-23, REMOVAL, Front Sub Sensor.>	Does the warning light go off?	Finish the diagnosis.	Replace the airbag control module. <Ref. to AB-22, REMOVAL, Airbag Control Module.>

### X: DTC 3C SATELLITE SENSOR BUS FAILURE

#### DTC DETECTING CONDITION:

Satellite safing sensor is faulty.

Step	Check	Yes	No
<b>1</b> <b>REPLACE SATELLITE SAFING SENSOR.</b> 1) Turn the ignition switch to OFF, disconnect the battery ground cable, and wait for 60 seconds or more. 2) Replace the satellite safing sensor with a genuine sensor. <Ref. to AB-26, REMOVAL, Satellite Safing Sensor.>	Does the warning light go off?	Finish the diagnosis.	Replace the airbag control module. <Ref. to AB-22, REMOVAL, Airbag Control Module.>

### Y: DTC 3D SATELLITE SENSOR FALSE INSTALLATION

#### DTC DETECTING CONDITION:

Satellite safing sensor is misinstalled.

Step	Check	Yes	No
<b>1</b> <b>REPLACE SATELLITE SAFING SENSOR.</b> 1) Turn the ignition switch to OFF, disconnect the battery ground cable, and wait for 60 seconds or more. 2) Replace the satellite safing sensor with a genuine sensor. <Ref. to AB-26, REMOVAL, Satellite Safing Sensor.>	Does the warning light go off?	Finish the diagnosis.	Replace the airbag control module. <Ref. to AB-22, REMOVAL, Airbag Control Module.>

# Diagnostic Chart with Trouble Code

AIRBAG SYSTEM (DIAGNOSTICS)

## Z: DTC 41 SIDE AIRBAG RH FAILURE

### DTC DETECTING CONDITION:

- Side airbag harness (RH) circuit is shorted to ground.
- Side airbag module (RH) is faulty.
- Airbag control module is faulty.

### CAUTION:

- Before diagnosing the airbag system, be sure to turn the ignition switch to OFF, disconnect the ground cable from battery, and wait 60 seconds or more before starting to work.
- When replacing the airbag module, seat belt pretensioner, roll connector, control module and sensor, reconnect each part and check that the warning light operates properly.
- When inspecting the airbag main harness, disconnect the airbag module connectors of the driver's and passenger's seats for safety.
- When inspecting the airbag rear harness, disconnect the side airbag module connector, curtain airbag module connector and seat belt pretensioner connector for safety reasons.

### WIRING DIAGRAM:

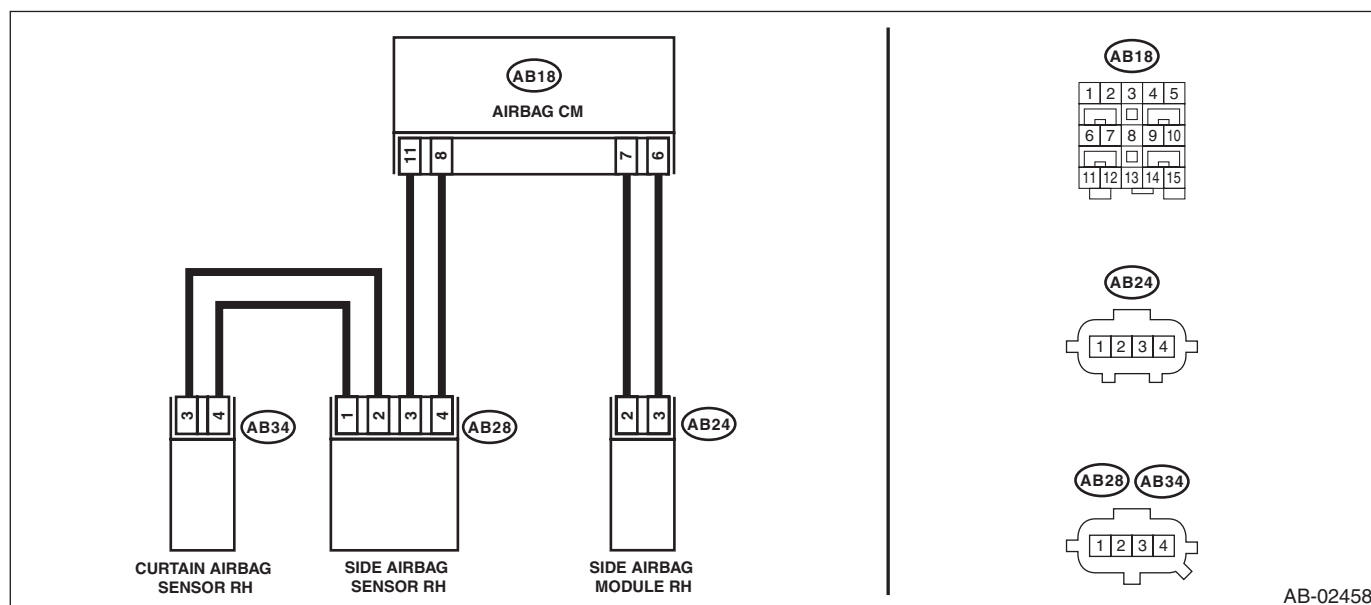

Step	Check	Yes	No
<b>1 CHECK POOR CONTACT OF CONNECTORS.</b> Check for poor contact of the connectors between the airbag control module, side airbag module RH and the side airbag sensor RH.	Is there poor contact?	Replace the airbag rear harness along with body harness.	Go to step 2.
<b>2 CHECK SIDE AIRBAG MODULE.</b> 1) Turn the ignition switch to OFF, disconnect the battery ground cable, and wait for 60 seconds or more. 2) Disconnect the connector (AB24), and connect the connector (1AJ) in test harness AJ to connector (AB24). 3) Connect the airbag resistor to the test harness AJ connector (3AJ). 4) Connect the battery ground terminal and turn the ignition switch to ON.	Does the airbag warning light illuminate for six seconds and go off?	Replace the side airbag module (RH). <Ref. to AB-18, REMOVAL, Side Airbag Module.>	Go to step 3.



# Diagnostic Chart with Trouble Code

## AIRBAG SYSTEM (DIAGNOSTICS)

Step	Check	Yes	No
<b>3 CHECK AIRBAG REAR HARNESS (SIDE AIRBAG MODULE HARNESS RH).</b> 1) Turn the ignition switch to OFF, disconnect the battery ground cable, and wait for 60 seconds or more. 2) Disconnect the connector (AB26) from seat belt pretensioner (RH). 3) Disconnect the connector (AB33) from curtain airbag module (RH). 4) Disconnect the airbag resistor from test harness AJ. 5) Disconnect the connectors (AB6, AB17, AB18) from airbag control module. 6) Connect the connector (1AH) in the test harness AH to the connectors (AB6, AB17, AB18). 7) Connect the connector (2AH) in the test harness AH and the connector (1AG) in the test harness AG. 8) Measure the resistance between connector (4AG) in the test harness AG and chassis ground. <i><b>Connector &amp; terminal</b></i> <i><b>(4AG) No. 11 — Chassis ground:</b></i> <i><b>(4AG) No. 13 — Chassis ground:</b></i>	Is the resistance 1 MΩ or more?	Go to step 4.	Replace the airbag rear harness along with body harness.
<b>4 CHECK AIRBAG CONTROL MODULE.</b> 1) Connect all connectors. 2) Clear the memory. 3) Perform the Inspection Mode. 4) Read the DTC.	Is the same DTC displayed?	Replace the airbag control module. <Ref. to AB-22, Airbag Control Module.>	Go to step 5.
<b>5 CHECK FOR ANY OTHER DTC ON DISPLAY.</b>	Is any other DTC displayed?	Check DTC using "List of Diagnostic Trouble Code (DTC)". <Ref. to AB(diag)-39, List of Diagnostic Trouble Code (DTC).>	Finish the diagnosis.

# Diagnostic Chart with Trouble Code

AIRBAG SYSTEM (DIAGNOSTICS)

## AA:DTC 42 SIDE AIRBAG LH FAILURE

### DTC DETECTING CONDITION:

- Side airbag harness (LH) circuit is shorted to ground.
- Side airbag module (LH) is faulty.
- Airbag control module is faulty.

### CAUTION:

- Before diagnosing the airbag system, be sure to turn the ignition switch to OFF, disconnect the ground cable from battery, and wait 60 seconds or more before starting to work.
- When replacing the airbag module, seat belt pretensioner, roll connector, control module and sensor, reconnect each part and check that the warning light operates properly.
- When inspecting the airbag main harness, disconnect the airbag module connectors of the driver's and passenger's seats for safety.
- When inspecting the airbag rear harness, disconnect the side airbag module connector, curtain airbag module connector and seat belt pretensioner connector for safety reasons.

### WIRING DIAGRAM:

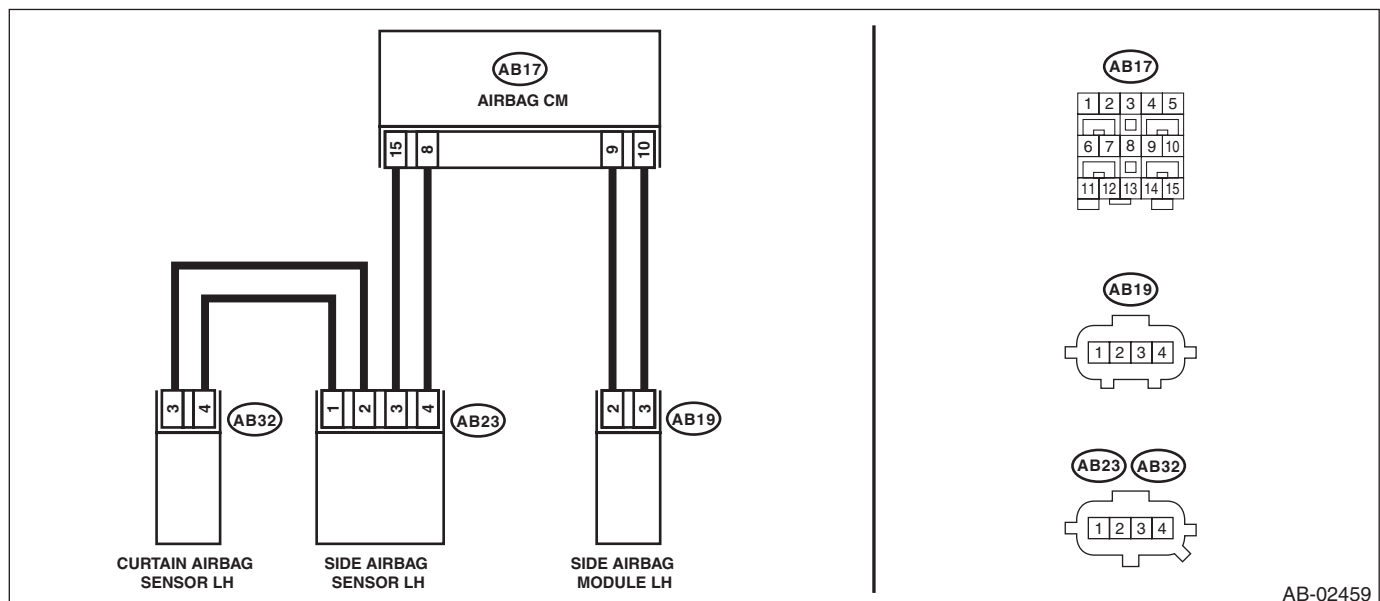

AB-02459

Step	Check	Yes	No
<b>1 CHECK POOR CONTACT OF CONNECTORS.</b> Check for poor contact of the connectors between the airbag control module, side airbag module LH and the side airbag sensor LH.	Is there poor contact?	Replace the airbag rear harness along with body harness.	Go to step 2.
<b>2 CHECK SIDE AIRBAG MODULE.</b> 1) Turn the ignition switch to OFF, disconnect the battery ground cable, and wait for 60 seconds or more. 2) Disconnect the connector (AB19), and connect the connector (1AJ) in test harness AJ to connector (AB19). 3) Connect the airbag resistor to the test harness AJ connector (3AJ). 4) Connect the battery ground terminal and turn the ignition switch to ON.	Does the airbag warning light illuminate for six seconds and go off?	Replace the side airbag module (LH). <Ref. to AB-18, REMOVAL, Side Airbag Module.>	Go to step 3.

# Diagnostic Chart with Trouble Code

## AIRBAG SYSTEM (DIAGNOSTICS)

Step	Check	Yes	No
<b>3 CHECK AIRBAG REAR HARNESS (SIDE AIRBAG MODULE HARNESS LH).</b> 1) Turn the ignition switch to OFF, disconnect the battery ground cable, and wait for 60 seconds or more. 2) Disconnect the connector (AB21) from seat belt pretensioner (LH). 3) Disconnect the connector (AB31) from curtain airbag module (LH). 4) Disconnect the airbag resistor from test harness. 5) Disconnect the connectors (AB6, AB17, AB18) from airbag control module. 6) Connect the connector (1AH) in the test harness AH to the connectors (AB6, AB17, AB18). 7) Connect the connector (2AH) in the test harness AH and the connector (1AG) in the test harness AG. 8) Measure the resistance between connector (4AG) in the test harness AG and chassis ground. <i><b>Connector &amp; terminal</b></i> <i><b>(4AG) No. 8 — Chassis ground:</b></i> <i><b>(4AG) No. 10 — Chassis ground:</b></i>	Is the resistance 1 MΩ or more?	Go to step 4.	Replace the airbag rear harness along with body harness.
<b>4 CHECK AIRBAG CONTROL MODULE.</b> 1) Connect all connectors. 2) Clear the memory. 3) Perform the Inspection Mode. 4) Read the DTC.	Is the same DTC displayed?	Replace the airbag control module. <Ref. to AB-22, Airbag Control Module.>	Go to step 5.
<b>5 CHECK FOR ANY OTHER DTC ON DISPLAY.</b>	Is any other DTC displayed?	Check DTC using "List of Diagnostic Trouble Code (DTC)". <Ref. to AB(diag)-39, List of Diagnostic Trouble Code (DTC).>	Finish the diagnosis.

# Diagnostic Chart with Trouble Code

AIRBAG SYSTEM (DIAGNOSTICS)

## AB:DTC 45 SIDE AIRBAG RH FAILURE

### DTC DETECTING CONDITION:

- Side airbag harness (RH) is shorted to power supply.
- Side airbag module (RH) is faulty.
- Airbag control module is faulty.

### CAUTION:

- Before diagnosing the airbag system, be sure to turn the ignition switch to OFF, disconnect the ground cable from battery, and wait 60 seconds or more before starting to work.
- When replacing the airbag module, seat belt pretensioner, roll connector, control module and sensor, reconnect each part and check that the warning light operates properly.
- When inspecting the airbag main harness, disconnect the airbag module connectors of the driver's and passenger's seats for safety.
- When inspecting the airbag rear harness, disconnect the side airbag module connector, curtain airbag module connector and seat belt pretensioner connector for safety reasons.

### WIRING DIAGRAM:

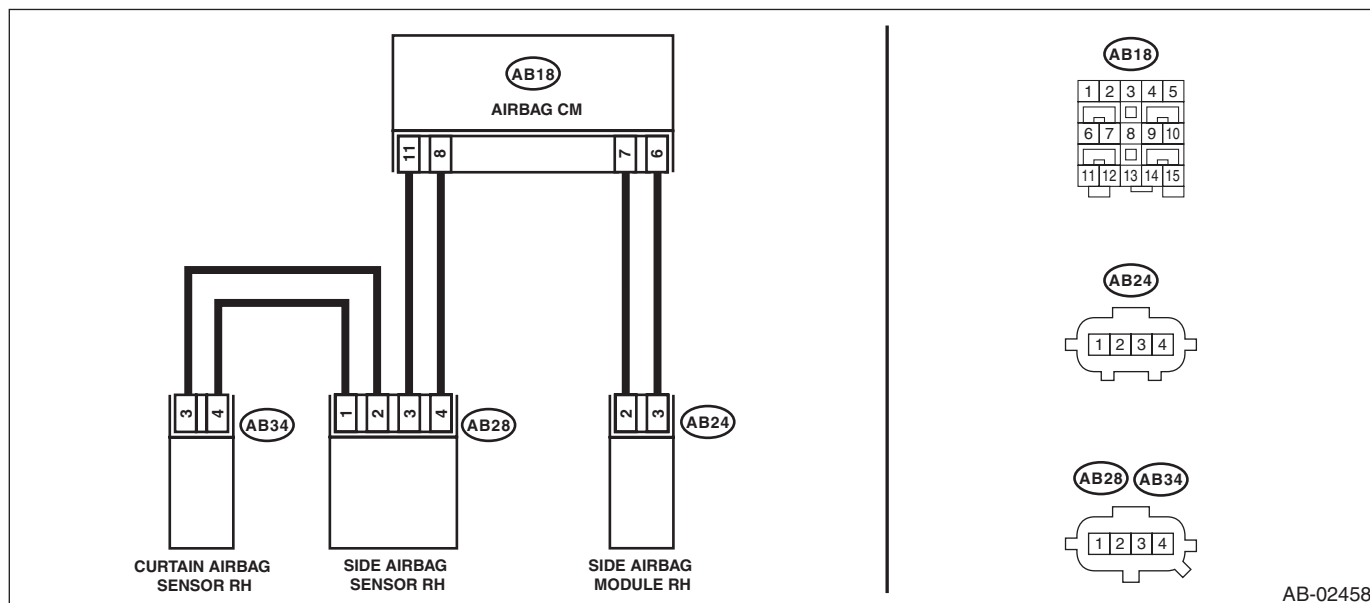

AB-02458

Step	Check	Yes	No
<b>1 CHECK POOR CONTACT OF CONNECTORS.</b> Check for poor contact of the connectors between the airbag control module, side airbag module RH and the side airbag sensor RH.	Is there poor contact?	Replace the airbag rear harness along with body harness.	Go to step 2.
<b>2 CHECK SIDE AIRBAG MODULE.</b> 1) Turn the ignition switch to OFF, disconnect the battery ground cable, and wait for 60 seconds or more. 2) Disconnect the connector (AB24), and connect the connector (1AJ) in test harness AJ to connector (AB24). 3) Connect the airbag resistor to the test harness AJ connector (3AJ). 4) Connect the battery ground terminal and turn the ignition switch to ON.	Does the airbag warning light illuminate for six seconds and go off?	Replace the side airbag module (RH). <Ref. to AB-18, REMOVAL, Side Airbag Module.>	Go to step 3.

# Diagnostic Chart with Trouble Code

## AIRBAG SYSTEM (DIAGNOSTICS)

Step	Check	Yes	No
<b>3 CHECK AIRBAG REAR HARNESS (SIDE AIRBAG MODULE HARNESS RH).</b> 1) Turn the ignition switch to OFF, disconnect the battery ground cable, and wait for 60 seconds or more. 2) Disconnect the connector (AB26) from seat belt pretensioner (RH). 3) Disconnect the connector (AB33) from curtain airbag module (RH). 4) Disconnect the airbag resistor from test harness. 5) Disconnect the connectors (AB6, AB17, AB18) from airbag control module. 6) Connect the connector (1AH) in the test harness AH to the connectors (AB6, AB17, AB18). 7) Connect the connector (2AH) in the test harness AH and the connector (1AG) in the test harness AG. 8) Connect the battery ground terminal and turn the ignition switch to ON. 9) Measure the voltage between connector (4AG) in the test harness AG and chassis ground.  <b>Connector &amp; terminal</b> <b>(4AG) No. 11 (+) — Chassis ground (-):</b> <b>(4AG) No. 13 (+) — Chassis ground (-):</b>	Is the voltage less than 1 V?	Go to step 4.	Replace the airbag rear harness along with body harness.
<b>4 CHECK AIRBAG CONTROL MODULE.</b> 1) Connect all connectors. 2) Clear the memory. 3) Perform the Inspection Mode. 4) Read the DTC.	Is the same DTC displayed?	Replace the airbag control module. <Ref. to AB-22, Airbag Control Module.>	Go to step 5.
<b>5 CHECK FOR ANY OTHER DTC ON DISPLAY.</b>	Is any other DTC displayed?	Check DTC using "List of Diagnostic Trouble Code (DTC)". <Ref. to AB(diag)-39, List of Diagnostic Trouble Code (DTC).>	Finish the diagnosis.

# Diagnostic Chart with Trouble Code

AIRBAG SYSTEM (DIAGNOSTICS)

## AC:DTC 46 SIDE AIRBAG LH FAILURE

### DTC DETECTING CONDITION:

- Side airbag harness (LH) is shorted to power supply.
- Side airbag module (LH) is faulty.
- Airbag control module is faulty.

### CAUTION:

- Before diagnosing the airbag system, be sure to turn the ignition switch to OFF, disconnect the ground cable from battery, and wait 60 seconds or more before starting to work.
- When replacing the airbag module, seat belt pretensioner, roll connector, control module and sensor, reconnect each part and check that the warning light operates properly.
- When inspecting the airbag main harness, disconnect the airbag module connectors of the driver's and passenger's seats for safety.
- When inspecting the airbag rear harness, disconnect the side airbag module connector, curtain airbag module connector and seat belt pretensioner connector for safety reasons.

### WIRING DIAGRAM:

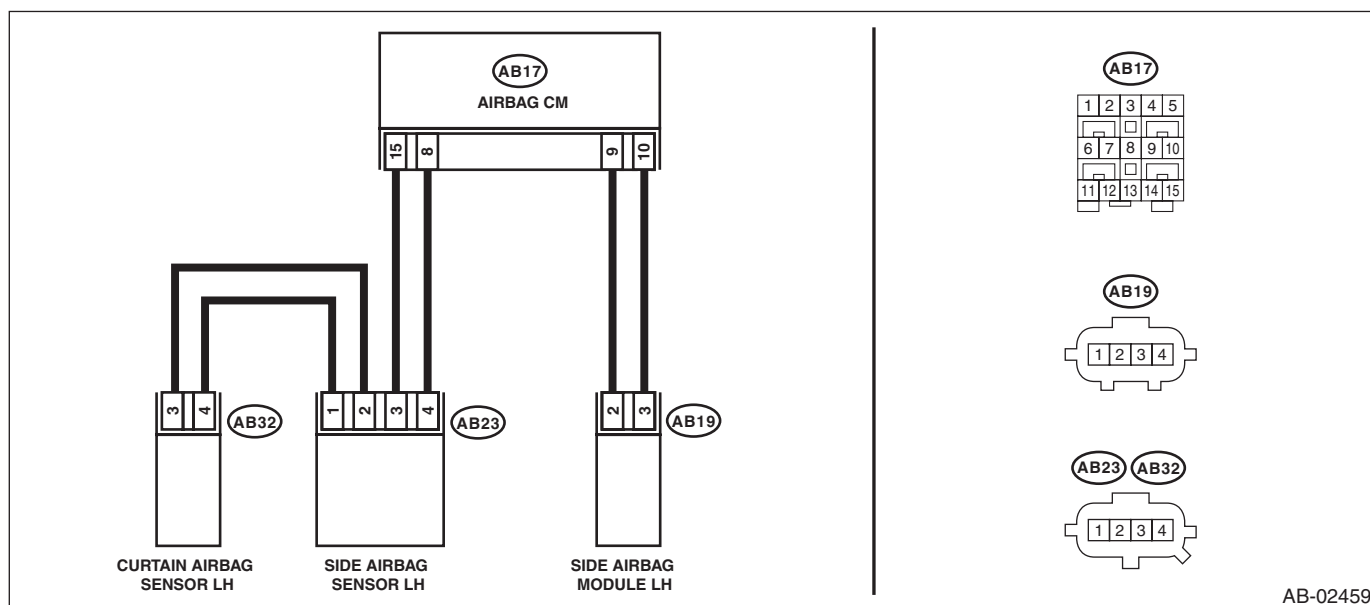

AB-02459

Step	Check	Yes	No
<b>1 CHECK POOR CONTACT OF CONNECTORS.</b> Check for poor contact of the connectors between the airbag control module, side airbag module LH and the side airbag sensor LH.	Is there poor contact?	Replace the airbag rear harness along with body harness.	Go to step 2.
<b>2 CHECK SIDE AIRBAG MODULE.</b> 1) Turn the ignition switch to OFF, disconnect the battery ground cable, and wait for 60 seconds or more. 2) Disconnect the connector (AB19), and connect the connector (1AJ) in test harness AJ to connector (AB19). 3) Connect the airbag resistor to the test harness AJ connector (3AJ). 4) Connect the battery ground terminal and turn the ignition switch to ON.	Does the airbag warning light illuminate for six seconds and go off?	Replace the side airbag module (LH). <Ref. to AB-18, REMOVAL, Side Airbag Module.>	Go to step 3.

# Diagnostic Chart with Trouble Code

## AIRBAG SYSTEM (DIAGNOSTICS)

Step	Check	Yes	No
<b>3 CHECK AIRBAG REAR HARNESS (SIDE AIRBAG MODULE HARNESS LH).</b> 1) Turn the ignition switch to OFF, disconnect the battery ground cable, and wait for 60 seconds or more. 2) Disconnect the connector (AB21) from seat belt pretensioner (LH). 3) Disconnect the connector (AB31) from curtain airbag module (LH). 4) Disconnect the airbag resistor from test harness. 5) Disconnect the connectors (AB6, AB17, AB18) from airbag control module. 6) Connect the connector (1AH) in the test harness AH to the connectors (AB6, AB17, AB18). 7) Connect the connector (2AH) in the test harness AH and the connector (1AG) in the test harness AG. 8) Connect the battery ground terminal and turn the ignition switch to ON. 9) Measure the voltage between connector (4AG) in the test harness AG and chassis ground.  <b>Connector &amp; terminal</b> <b>(4AG) No. 8 (+) — Chassis ground (-):</b> <b>(4AG) No. 10 (+) — Chassis ground (-):</b>	Is the voltage less than 1 V?	Go to step 4.	Replace the airbag rear harness along with body harness.
<b>4 CHECK AIRBAG CONTROL MODULE.</b> 1) Connect all connectors. 2) Clear the memory. 3) Perform the Inspection Mode. 4) Read the DTC.	Is the same DTC displayed?	Replace the airbag control module. <Ref. to AB-22, Airbag Control Module.>	Go to step 5.
<b>5 CHECK FOR ANY OTHER DTC ON DISPLAY.</b>	Is any other DTC displayed?	Check DTC using "List of Diagnostic Trouble Code (DTC)". <Ref. to AB(diag)-39, List of Diagnostic Trouble Code (DTC).>	Finish the diagnosis.

# Diagnostic Chart with Trouble Code

AIRBAG SYSTEM (DIAGNOSTICS)

## AD:DTC 4A SIDE AIRBAG RH FAILURE

### DTC DETECTING CONDITION:

- Side airbag harness (RH) circuit is shorted.
- Side airbag module (RH) is faulty.
- Airbag control module is faulty.

### CAUTION:

- Before diagnosing the airbag system, be sure to turn the ignition switch to OFF, disconnect the ground cable from battery, and wait 60 seconds or more before starting to work.
- When replacing the airbag module, seat belt pretensioner, roll connector, control module and sensor, reconnect each part and check that the warning light operates properly.
- When inspecting the airbag main harness, disconnect the airbag module connectors of the driver's and passenger's seats for safety.
- When inspecting the airbag rear harness, disconnect the side airbag module connector, curtain airbag module connector and seat belt pretensioner connector for safety reasons.

### WIRING DIAGRAM:

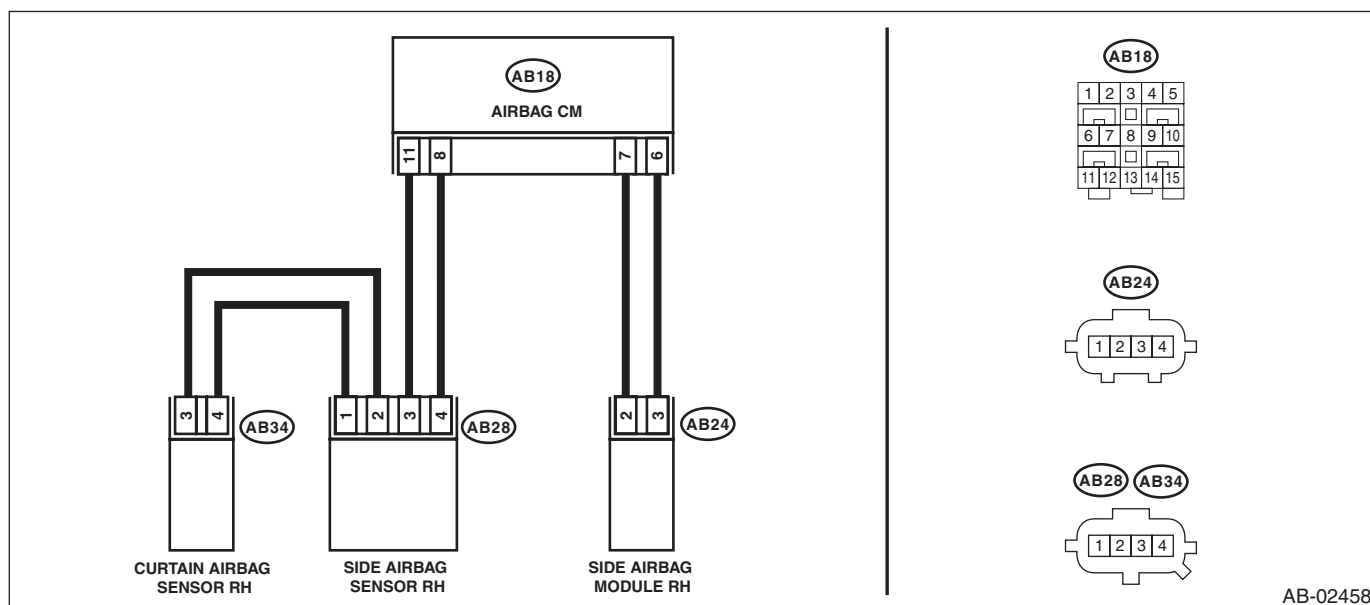

Step	Check	Yes	No
<b>1 CHECK POOR CONTACT OF CONNECTORS.</b> Check for poor contact of the connectors between the airbag control module, side airbag module RH and the side airbag sensor RH.	Is there poor contact?	Replace the airbag rear harness along with body harness.	Go to step 2.
<b>2 CHECK SIDE AIRBAG MODULE.</b> 1) Turn the ignition switch to OFF, disconnect the battery ground cable, and wait for 60 seconds or more. 2) Disconnect the connector (AB24) from the side airbag module (RH), and connect the connector (1AJ) in the test harness AJ to connector (AB24). 3) Connect the airbag resistor to the test harness AJ connector (3AJ). 4) Connect the battery ground terminal and turn the ignition switch to ON.	Does the airbag warning light illuminate for 6 seconds and go off?	Replace the side airbag module (RH). <Ref. to AB-18, REMOVAL, Side Airbag Module.>	Go to step 3.



## Diagnostic Chart with Trouble Code

### AIRBAG SYSTEM (DIAGNOSTICS)

Step	Check	Yes	No
<b>3 CHECK AIRBAG REAR HARNESS (SIDE AIRBAG MODULE HARNESS RH).</b> 1) Turn the ignition switch to OFF, disconnect the battery ground cable, and wait for 60 seconds or more. 2) Disconnect the connector (AB26) from seat belt pretensioner (RH). 3) Disconnect the connector (AB33) from curtain airbag module (RH). 4) Disconnect the airbag resistor from test harness AJ. 5) Disconnect the connectors (AB6, AB17, AB18) from airbag control module. 6) Connect the connector (1AH) in the test harness AH to the connectors (AB6, AB17, AB18). 7) Connect the connector (2AH) in the test harness AH and the connector (1AG) in the test harness AG. 8) Measure the resistance between connector (4AG) terminals in test harness AG. <b>Connector &amp; terminal (4AG) No. 11 — (4AG) No. 13:</b>	Is the resistance 1 MΩ or more?	Go to step 4.	Replace the airbag rear harness along with body harness.
<b>4 CHECK AIRBAG CONTROL MODULE.</b> 1) Connect all connectors. 2) Clear the memory. 3) Perform the Inspection Mode. 4) Read the DTC.	Is the same DTC displayed?	Replace the airbag control module. <Ref. to AB-22, Airbag Control Module.>	Go to step 5.
<b>5 CHECK FOR ANY OTHER DTC ON DISPLAY.</b>	Is any other DTC displayed?	Check DTC using "List of Diagnostic Trouble Code (DTC)". <Ref. to AB(diag)-39, List of Diagnostic Trouble Code (DTC).>	Finish the diagnosis.

# Diagnostic Chart with Trouble Code

AIRBAG SYSTEM (DIAGNOSTICS)

## AE:DTC 4B SIDE AIRBAG LH FAILURE

### DTC DETECTING CONDITION:

- Side airbag harness (LH) circuit is shorted.
- Side airbag module (LH) is faulty.
- Airbag control module is faulty.

### CAUTION:

- Before diagnosing the airbag system, be sure to turn the ignition switch to OFF, disconnect the ground cable from battery, and wait 60 seconds or more before starting to work.
- When replacing the airbag module, seat belt pretensioner, roll connector, control module and sensor, reconnect each part and check that the warning light operates properly.
- When inspecting the airbag main harness, disconnect the airbag module connectors of the driver's and passenger's seats for safety.
- When inspecting the airbag rear harness, disconnect the side airbag module connector, curtain airbag module connector and seat belt pretensioner connector for safety reasons.

### WIRING DIAGRAM:

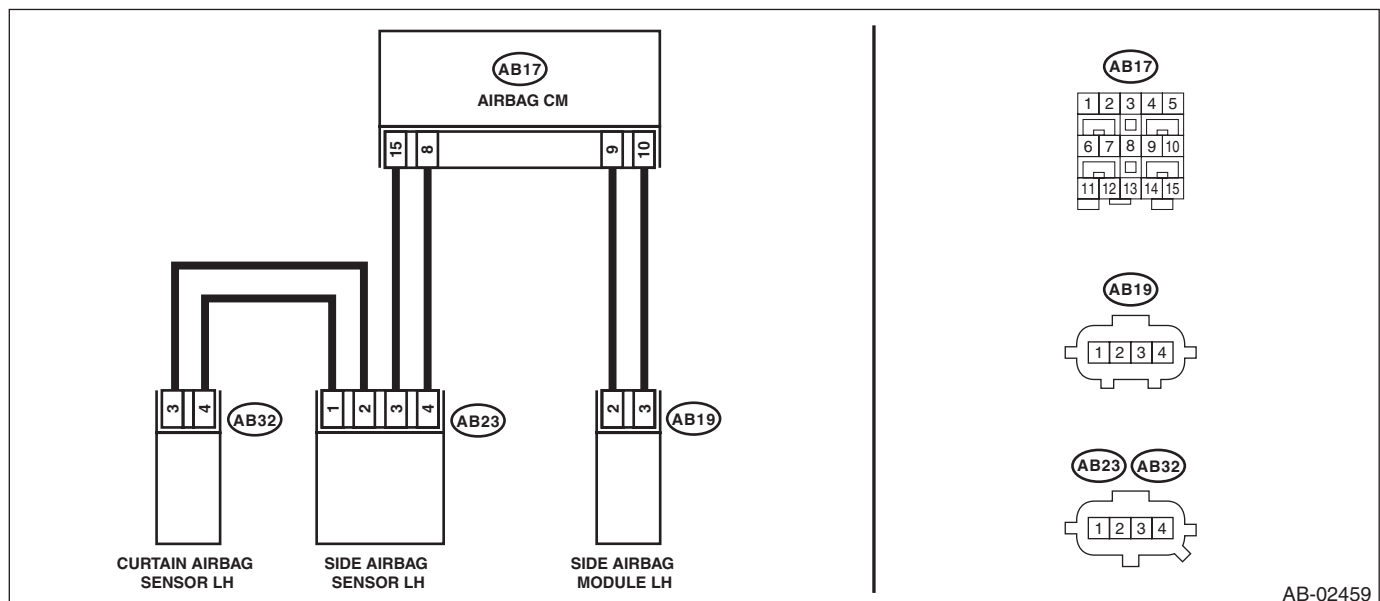

AB-02459

Step	Check	Yes	No
<b>1 CHECK POOR CONTACT OF CONNECTORS.</b> Check for poor contact of the connectors between the airbag control module, side airbag module LH and the side airbag sensor LH.	Is there poor contact?	Replace the airbag rear harness along with body harness.	Go to step 2.
<b>2 CHECK SIDE AIRBAG MODULE.</b> 1) Turn the ignition switch to OFF, disconnect the battery ground cable, and wait for 60 seconds or more. 2) Disconnect the connector (AB19) from the side airbag module (LH), and connect the connector (1AJ) in test harness AJ to the connector (AB19). 3) Connect the airbag resistor to the test harness AJ connector (3AJ). 4) Connect the battery ground terminal and turn the ignition switch to ON.	Does the airbag warning light illuminate for 6 seconds and go off?	Replace the side airbag module (LH). <Ref. to AB-18, REMOVAL, Side Airbag Module.>	Go to step 3.

# Diagnostic Chart with Trouble Code

## AIRBAG SYSTEM (DIAGNOSTICS)

Step	Check	Yes	No
<b>3 CHECK AIRBAG REAR HARNESS (SIDE AIRBAG MODULE HARNESS LH).</b> 1) Turn the ignition switch to OFF, disconnect the battery ground cable, and wait for 60 seconds or more. 2) Disconnect the connector (AB21) from seat belt pretensioner (LH). 3) Disconnect the connector (AB31) from curtain airbag module (LH). 4) Disconnect the airbag resistor from test harness AJ. 5) Disconnect the connectors (AB6, AB17, AB18) from airbag control module. 6) Connect the connector (1AH) in the test harness AH to the connectors (AB6, AB17, AB18). 7) Connect the connector (2AH) in the test harness AH and the connector (1AG) in the test harness AG. 8) Measure the resistance between connector (4AG) terminals in test harness AG. <b>Connector &amp; terminal (4AG) No. 8 — (4AG) No. 10:</b>	Is the resistance 1 MΩ or more?	Go to step 4.	Replace the airbag rear harness along with body harness.
<b>4 CHECK AIRBAG CONTROL MODULE.</b> 1) Connect all connectors. 2) Clear the memory. 3) Perform the Inspection Mode. 4) Read the DTC.	Is the same DTC displayed?	Replace the airbag control module. <Ref. to AB-22, Airbag Control Module.>	Go to step 5.
<b>5 CHECK FOR ANY OTHER DTC ON DISPLAY.</b>	Is any other DTC displayed?	Check DTC using "List of Diagnostic Trouble Code (DTC)". <Ref. to AB(diag)-39, List of Diagnostic Trouble Code (DTC).>	Finish the diagnosis.

# Diagnostic Chart with Trouble Code

AIRBAG SYSTEM (DIAGNOSTICS)

## AF:DTC 4D SIDE AIRBAG RH FAILURE

### DTC DETECTING CONDITION:

- Side airbag harness (RH) circuit is open.
- Side airbag module (RH) is faulty.
- Airbag control module is faulty.

### CAUTION:

- Before diagnosing the airbag system, be sure to turn the ignition switch to OFF, disconnect the ground cable from battery, and wait 60 seconds or more before starting to work.
- When replacing the airbag module, seat belt pretensioner, roll connector, control module and sensor, reconnect each part and check that the warning light operates properly.
- When inspecting the airbag main harness, disconnect the airbag module connectors of the driver's and passenger's seats for safety.
- When inspecting the airbag rear harness, disconnect the side airbag module connector, curtain airbag module connector and seat belt pretensioner connector for safety reasons.

### WIRING DIAGRAM:

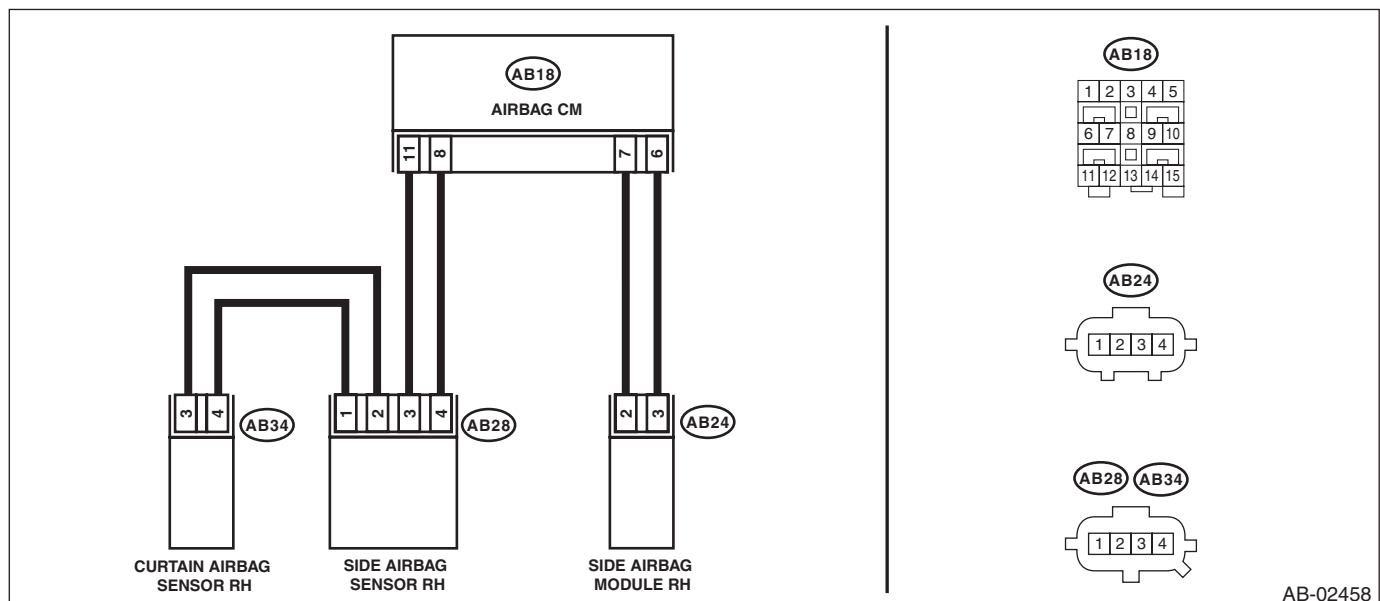

AB-02458

Step	Check	Yes	No
<b>1 CHECK POOR CONTACT OF CONNECTORS.</b> Check for poor contact of the connectors between the airbag control module, side airbag module RH and the side airbag sensor RH.	Is there poor contact?	Replace the airbag rear harness along with body harness.	Go to step 2.
<b>2 CHECK SIDE AIRBAG MODULE.</b> 1) Turn the ignition switch to OFF, disconnect the battery ground cable, and wait for 60 seconds or more. 2) Disconnect the connector (AB24) from the side airbag module (RH), and connect the connector (1AJ) in the test harness AJ to connector (AB24). 3) Connect the airbag resistor to the test harness AJ connector (3AJ). 4) Connect the battery ground terminal and turn the ignition switch to ON.	Does the airbag warning light illuminate for 6 seconds and go off?	Replace the side airbag module (RH). <Ref. to AB-18, REMOVAL, Side Airbag Module.>	Go to step 3.

# Diagnostic Chart with Trouble Code

## AIRBAG SYSTEM (DIAGNOSTICS)

Step	Check	Yes	No
<b>3 CHECK AIRBAG REAR HARNESS (SIDE AIRBAG MODULE HARNESS RH).</b> 1) Turn the ignition switch to OFF, disconnect the battery ground cable, and wait for 60 seconds or more. 2) Disconnect the connector (AB26) from seat belt pretensioner (RH). 3) Disconnect the connector (AB33) from curtain airbag module (RH). 4) Disconnect the airbag resistor from test harness AJ. 5) Disconnect the connectors (AB6, AB17, AB18) from airbag control module. 6) Connect the connector (1AH) in the test harness AH to the connectors (AB6, AB17, AB18). 7) Connect the connector (2AH) in the test harness AH and the connector (1AG) in the test harness AG. 8) Measure the resistance between the test harness AG connector (4AG) and the test harness AJ connector (3AJ). <b>Connector &amp; terminal</b> <b>(4AG) No. 11 — (3AJ) No. 1:</b> <b>(4AG) No. 13 — (3AJ) No. 2:</b>	Is the resistance less than 10 Ω?	Go to step 4.	Replace the airbag rear harness along with body harness.
<b>4 CHECK AIRBAG CONTROL MODULE.</b> 1) Connect all connectors. 2) Clear the memory. 3) Perform the Inspection Mode. 4) Read the DTC.	Is the same DTC displayed?	Replace the airbag control module. <Ref. to AB-22, Airbag Control Module.>	Go to step 5.
<b>5 CHECK FOR ANY OTHER DTC ON DISPLAY.</b>	Is any other DTC displayed?	Check DTC using "List of Diagnostic Trouble Code (DTC)". <Ref. to AB(diag)-39, List of Diagnostic Trouble Code (DTC).>	Finish the diagnosis.

# Diagnostic Chart with Trouble Code

AIRBAG SYSTEM (DIAGNOSTICS)

## AG:DTC 4E SIDE AIRBAG LH FAILURE

### DTC DETECTING CONDITION:

- Side airbag harness (LH) circuit is open.
- Side airbag module (LH) is faulty.
- Airbag control module is faulty.

### CAUTION:

- Before diagnosing the airbag system, be sure to turn the ignition switch to OFF, disconnect the ground cable from battery, and wait 60 seconds or more before starting to work.
- When replacing the airbag module, seat belt pretensioner, roll connector, control module and sensor, reconnect each part and check that the warning light operates properly.
- When inspecting the airbag main harness, disconnect the airbag module connectors of the driver's and passenger's seats for safety.
- When inspecting the airbag rear harness, disconnect the side airbag module connector, curtain airbag module connector and seat belt pretensioner connector for safety reasons.

### WIRING DIAGRAM:

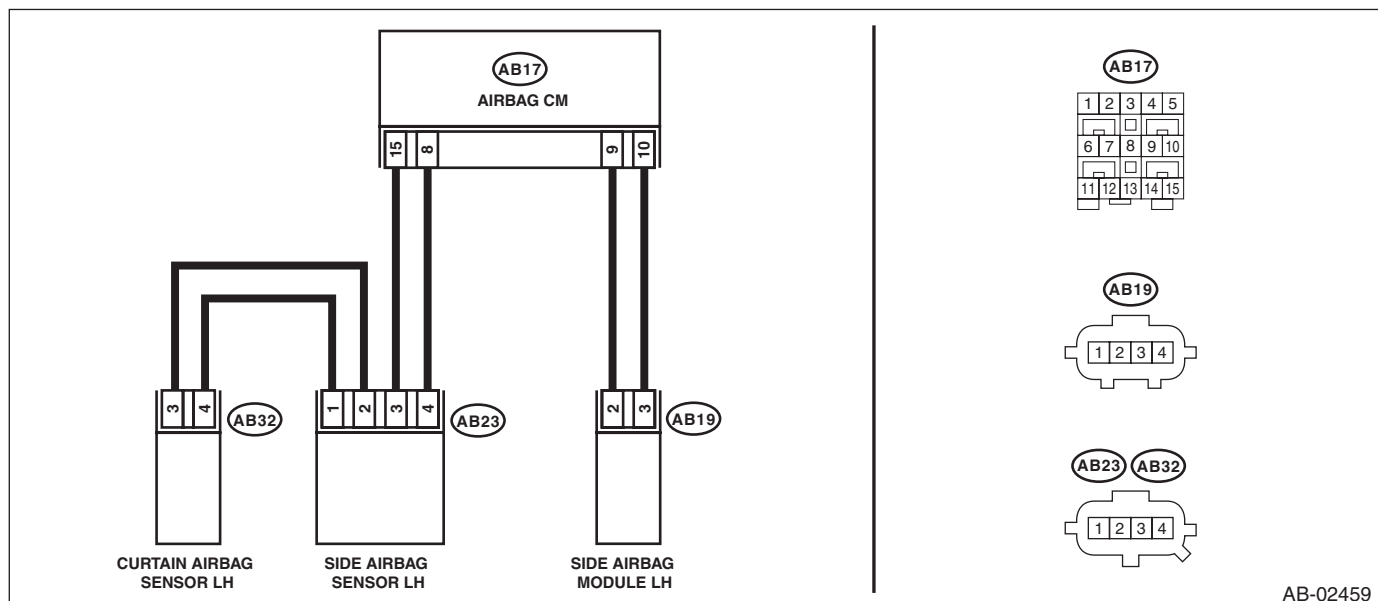

AB-02459

Step	Check	Yes	No
<b>1 CHECK POOR CONTACT OF CONNECTORS.</b> Check for poor contact of the connectors between the airbag control module, side airbag module LH and the side airbag sensor LH.	Is there poor contact?	Replace the airbag rear harness along with body harness.	Go to step 2.
<b>2 CHECK SIDE AIRBAG MODULE.</b> 1) Turn the ignition switch to OFF, disconnect the battery ground cable, and wait for 60 seconds or more. 2) Disconnect the connector (AB19) from the side airbag module (LH), and connect the connector (1AJ) in test harness AJ to the connector (AB19). 3) Connect the airbag resistor to the test harness AJ connector (3AJ). 4) Connect the battery ground terminal and turn the ignition switch to ON.	Does the airbag warning light illuminate for 6 seconds and go off?	Replace the side airbag module (LH). <Ref. to AB-18, REMOVAL, Side Airbag Module.>	Go to step 3.

# Diagnostic Chart with Trouble Code

## AIRBAG SYSTEM (DIAGNOSTICS)

Step	Check	Yes	No
<b>3 CHECK AIRBAG REAR HARNESS (SIDE AIRBAG MODULE HARNESS LH).</b> 1) Turn the ignition switch to OFF, disconnect the battery ground cable, and wait for 60 seconds or more. 2) Disconnect the connector (AB21) from seat belt pretensioner (LH). 3) Disconnect the connector (AB31) from curtain airbag module (LH). 4) Disconnect the airbag resistor from test harness AJ. 5) Disconnect the connectors (AB6, AB17, AB18) from airbag control module. 6) Connect the connector (1AH) in the test harness AH to the connectors (AB6, AB17, AB18). 7) Connect the connector (2AH) in the test harness AH and the connector (1AG) in the test harness AG. 8) Measure the resistance between the test harness AG connector (4AG) and the test harness AJ connector (3AJ). <b>Connector &amp; terminal</b> <b>(4AG) No. 8 — (3AJ) No. 2:</b> <b>(4AG) No. 10 — (3AJ) No. 1:</b>	Is the resistance less than 10 $\Omega$ ?	Go to step 4.	Replace the airbag rear harness along with body harness.
<b>4 CHECK AIRBAG CONTROL MODULE.</b> 1) Connect all connectors. 2) Clear the memory. 3) Perform the Inspection Mode. 4) Read the DTC.	Is the same DTC displayed?	Replace the airbag control module. <Ref. to AB-22, Airbag Control Module.>	Go to step 5.
<b>5 CHECK FOR ANY OTHER DTC ON DISPLAY.</b>	Is any other DTC displayed?	Check DTC using "List of Diagnostic Trouble Code (DTC)". <Ref. to AB(diag)-39, List of Diagnostic Trouble Code (DTC).>	Finish the diagnosis.

## **AH:DTC 53 SIDE AIRBAG SENSOR RH FAILURE**

### **DTC DETECTING CONDITION:**

Side airbag sensor (RH) is faulty.

When DTC 53 is displayed, the circuit within the side airbag sensor (RH) is faulty.

Replace the side airbag sensor (RH). <Ref. to AB-24, Side Airbag Sensor.>

## **AI: DTC 54 SIDE AIRBAG SENSOR LH FAILURE**

### **DTC DETECTING CONDITION:**

Side airbag sensor (LH) is faulty.

When DTC 54 is displayed, the circuit within the side airbag sensor (LH) is faulty.

Replace the side airbag sensor (LH). <Ref. to AB-24, Side Airbag Sensor.>

## **AJ:DTC 55 SIDE CURTAIN AIRBAG FIRING OUTPUT**

This DTC is displayed when the side airbag module and curtain airbag module are deployed.

Once this DTC is displayed, the memory cannot be cleared. Replace the following parts.

- Airbag control module <Ref. to AB-22, Airbag Control Module.>
- Side airbag module (operating side) <Ref. to AB-18, Side Airbag Module.>
- Side airbag sensor (operating side) <Ref. to AB-24, Side Airbag Sensor.>
- Curtain airbag module (operating side) <Ref. to AB-20, Curtain Airbag Module.>
- Curtain airbag sensor (operating side) <Ref. to AB-25, Curtain Airbag Sensor.>
- Satellite safing sensor <Ref. to AB-26, Satellite Safing Sensor.>

## **AK:DTC 58 CURTAIN AIRBAG SENSOR RH FAILURE**

### **DTC DETECTING CONDITION:**

Curtain airbag sensor (RH) is faulty.

If DTC 58 is displayed, the circuit within the curtain airbag sensor (RH) is faulty.

Replace the curtain airbag sensor (RH). <Ref. to AB-25, Curtain Airbag Sensor.>

## **AL:DTC 59 CURTAIN AIRBAG SENSOR LH FAILURE**

### **DTC DETECTING CONDITION:**

Curtain airbag sensor (LH) is faulty.

If DTC 59 is displayed, the circuit within the curtain airbag sensor (LH) is faulty.

Replace the curtain airbag sensor (LH). <Ref. to AB-25, Curtain Airbag Sensor.>



# Diagnostic Chart with Trouble Code

## AIRBAG SYSTEM (DIAGNOSTICS)

### AM:DTC 5A SIDE AIRBAG SENSOR RH FALSE INSTALLATION

#### DTC DETECTING CONDITION:

Side airbag sensor RH is misinstalled.

Step	Check	Yes	No
<b>1</b> <b>REPLACE SIDE AIRBAG SENSOR (RH).</b> 1) Turn the ignition switch to OFF, disconnect the battery ground cable, and wait for 60 seconds or more. 2) Replace the side A/B sensor (RH) with a genuine sensor. <Ref. to AB-24, REMOVAL, Side Airbag Sensor.>	Does the warning light go off?	Finish the diagnosis.	Replace the airbag control module. <Ref. to AB-22, REMOVAL, Airbag Control Module.>

### AN:DTC 5B SIDE AIRBAG SENSOR LH FALSE INSTALLATION

#### DTC DETECTING CONDITION:

Side airbag sensor LH is misinstalled.

Step	Check	Yes	No
<b>1</b> <b>REPLACE SIDE AIRBAG SENSOR (LH).</b> 1) Turn the ignition switch to OFF, disconnect the battery ground cable, and wait for 60 seconds or more. 2) Replace the side A/B sensor (LH) with a genuine sensor. <Ref. to AB-24, REMOVAL, Side Airbag Sensor.>	Does the warning light go off?	Finish the diagnosis.	Replace the airbag control module. <Ref. to AB-22, REMOVAL, Airbag Control Module.>

### AO:DTC 5C CURTAIN AIRBAG SENSOR RH FALSE INSTALLATION

#### DTC DETECTING CONDITION:

Curtain airbag sensor RH is misinstalled.

Step	Check	Yes	No
<b>1</b> <b>REPLACE CURTAIN AIRBAG SENSOR (RH).</b> 1) Turn the ignition switch to OFF, disconnect the battery ground cable, and wait for 60 seconds or more. 2) Replace the curtain A/B sensor (RH) with a genuine sensor. <Ref. to AB-25, REMOVAL, Curtain Airbag Sensor.>	Does the warning light go off?	Finish the diagnosis.	Replace the airbag control module. <Ref. to AB-22, REMOVAL, Airbag Control Module.>

### AP:DTC 5D CURTAIN AIRBAG SENSOR LH FALSE INSTALLATION

#### DTC DETECTING CONDITION:

Curtain airbag sensor LH is misinstalled.

Step	Check	Yes	No
<b>1</b> <b>REPLACE CURTAIN AIRBAG SENSOR (LH).</b> 1) Turn the ignition switch to OFF, disconnect the battery ground cable, and wait for 60 seconds or more. 2) Replace the curtain A/B sensor (LH) with a genuine sensor. <Ref. to AB-25, REMOVAL, Curtain Airbag Sensor.>	Does the warning light go off?	Finish the diagnosis.	Replace the airbag control module. <Ref. to AB-22, REMOVAL, Airbag Control Module.>

# Diagnostic Chart with Trouble Code

AIRBAG SYSTEM (DIAGNOSTICS)

## AQ:DTC 61 BELT PRETENSIONER RH FAILURE

### DTC DETECTING CONDITION:

- Seat belt pretensioner (RH) circuit is shorted to ground.
- Pretensioner (RH) is faulty.
- Pretensioner harness (RH) is faulty.
- Airbag control module is faulty.

### CAUTION:

- Before diagnosing the airbag system, be sure to turn the ignition switch to OFF, disconnect the ground cable from battery, and wait 60 seconds or more before starting to work.
- When replacing the airbag module, seat belt pretensioner, roll connector, control module and sensor, reconnect each part and check that the warning light operates properly.
- When inspecting the airbag main harness, disconnect the airbag module connectors of the driver's and passenger's seats for safety.
- When inspecting the airbag rear harness, disconnect the side airbag module connector, curtain airbag module connector and seat belt pretensioner connector for safety reasons.

### WIRING DIAGRAM:

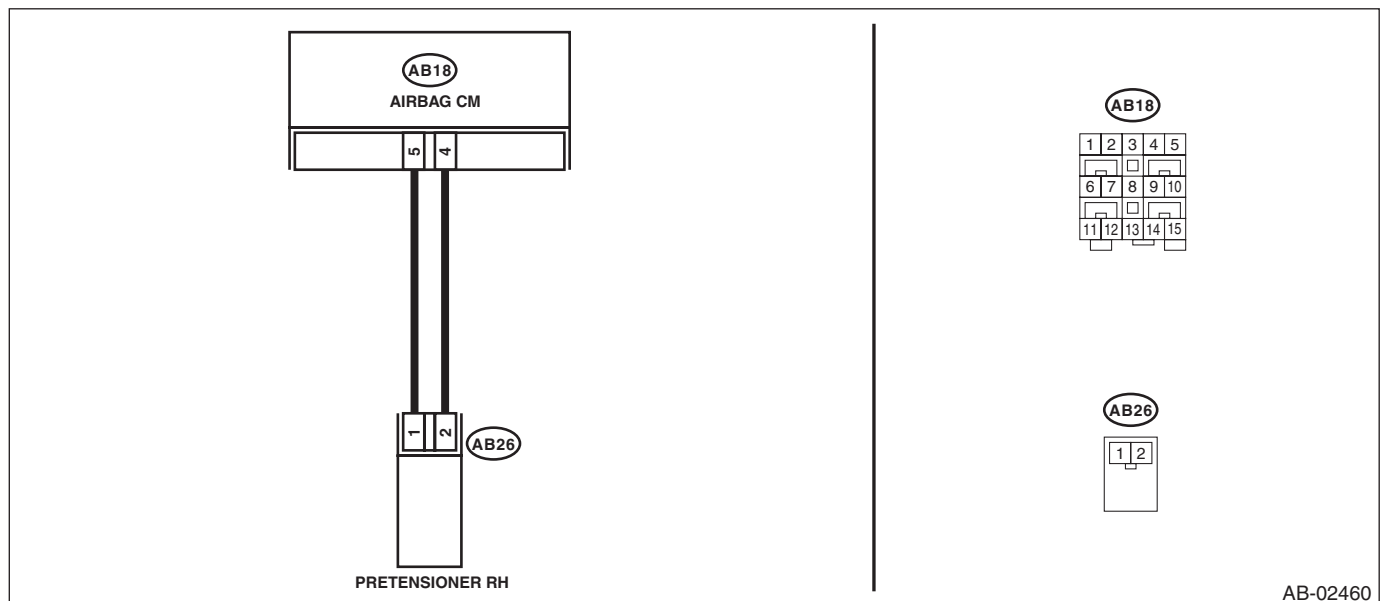

AB-02460

Step	Check	Yes	No
<b>1</b> <b>CHECK POOR CONTACT OF CONNECTORS.</b> Check for poor contact of the connectors between the airbag control module and the seat belt pretensioner RH.	Is there poor contact?	Replace the airbag rear harness along with body harness.	Go to step 2.
<b>2</b> <b>CHECK SEAT BELT PRETENSIONER.</b> 1) Turn the ignition switch to OFF, disconnect the battery ground cable, and wait for 60 seconds or more. 2) Disconnect the connector (AB26) from seat belt pretensioner (RH). 3) Connect the connector (1N) in the test harness N to the connector (AB26). 4) Connect the airbag resistor to the connector (2N) of test harness N. 5) Connect the battery ground terminal and turn the ignition switch to ON.	Does the airbag warning light illuminate for six seconds and go off?	Replace the seat belt pretensioner (RH). <Ref. to SB-18, Front Seat Belt.>	Go to step 3.

# Diagnostic Chart with Trouble Code

## AIRBAG SYSTEM (DIAGNOSTICS)

Step	Check	Yes	No
<b>3</b> <b>CHECK AIRBAG REAR HARNESS (PRE-TENSIONER HARNESS RH).</b> 1) Turn the ignition switch to OFF, disconnect the battery ground cable, and wait for 60 seconds or more. 2) Disconnect the airbag resistor from the connector (2N) of test harness N. 3) Disconnect connector (AB24) from side airbag module (RH). 4) Disconnect the connector (AB33) from curtain airbag module (RH). 5) Disconnect the connectors (AB6, AB17, AB18) from airbag control module. 6) Connect the connector (1AH) in the test harness AH to the connectors (AB18, AB17, AB6). 7) Connect the connector (2AH) in the test harness AH and the connector (1AG) in the test harness AG. 8) Measure the resistance between connector (3AG) in the test harness AG and chassis ground. <i><b>Connector &amp; terminal</b></i> <i><b>(3AG) No. 18 — Chassis ground:</b></i> <i><b>(3AG) No. 20 — Chassis ground:</b></i>	Is the resistance 1 MΩ or more?	Go to step 4.	Replace the airbag rear harness along with body harness.
<b>4</b> <b>CHECK AIRBAG CONTROL MODULE.</b> 1) Connect all connectors. 2) Clear the memory. 3) Perform the Inspection Mode. 4) Read the DTC.	Is the same DTC displayed?	Replace the airbag control module. <Ref. to AB-22, Airbag Control Module.>	Go to step 5.
<b>5</b> <b>CHECK FOR ANY OTHER DTC ON DISPLAY.</b>	Is any other DTC displayed?	Check DTC using "List of Diagnostic Trouble Code (DTC)". <Ref. to AB(diag)-39, List of Diagnostic Trouble Code (DTC).>	Finish the diagnosis.

# Diagnostic Chart with Trouble Code

AIRBAG SYSTEM (DIAGNOSTICS)

## AR:DTC 62 BELT PRETENSIONER LH FAILURE

### DTC DETECTING CONDITION:

- Seat belt pretensioner (LH) circuit is shorted to ground.
- Pretensioner (LH) is faulty.
- Pretensioner harness (LH) is faulty.
- Airbag control module is faulty.

### CAUTION:

- Before diagnosing the airbag system, be sure to turn the ignition switch to OFF, disconnect the ground cable from battery, and wait 60 seconds or more before starting to work.
- When replacing the airbag module, seat belt pretensioner, roll connector, control module and sensor, reconnect each part and check that the warning light operates properly.
- When inspecting the airbag main harness, disconnect the airbag module connectors of the driver's and passenger's seats for safety.
- When inspecting the airbag rear harness, disconnect the side airbag module connector, curtain airbag module connector and seat belt pretensioner connector for safety reasons.

### WIRING DIAGRAM:

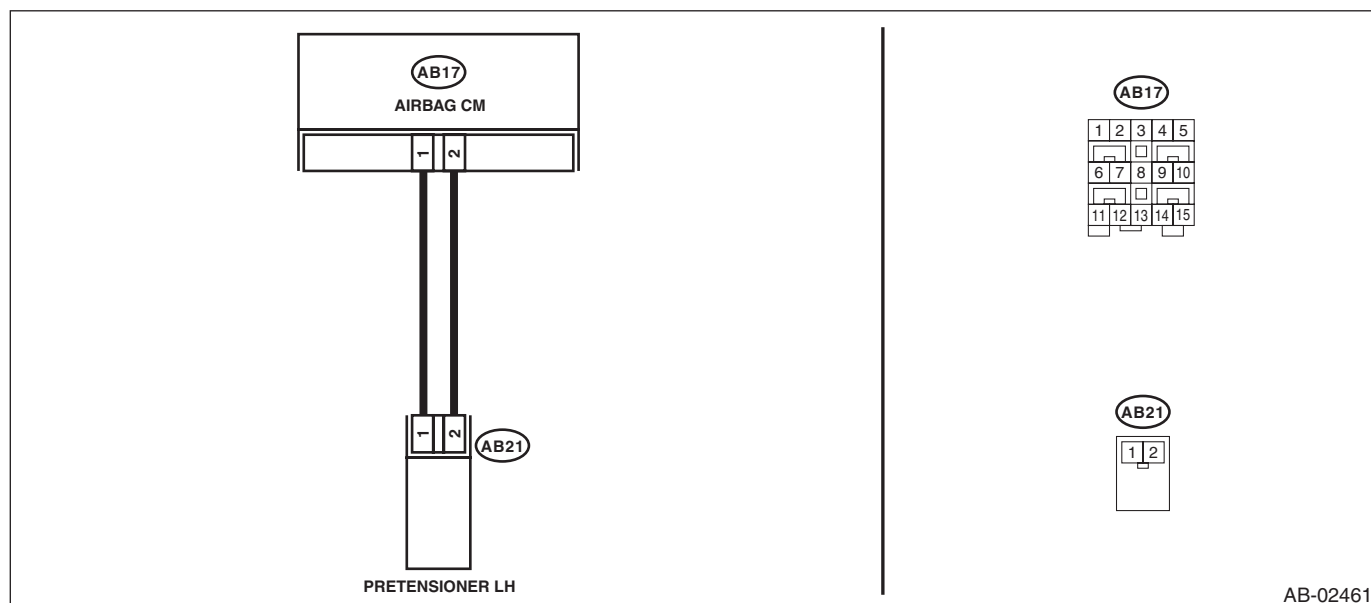

Step	Check	Yes	No
<b>1 CHECK POOR CONTACT OF CONNECTORS.</b> Check for poor contact of the connectors between the airbag control module and the seat belt pretensioner LH.	Is there poor contact?	Replace the airbag rear harness along with body harness.	Go to step 2.
<b>2 CHECK SEAT BELT PRETENSIONER.</b> 1) Turn the ignition switch to OFF, disconnect the battery ground cable, and wait for 60 seconds or more. 2) Disconnect the connector (AB21) from seat belt pretensioner (LH). 3) Connect the connector (1N) in the test harness N to the connector (AB21). 4) Connect the airbag resistor to the connector (2N) of test harness N. 5) Connect the battery ground terminal and turn the ignition switch to ON.	Does the airbag warning light illuminate for six seconds and go off?	Replace the seat belt pretensioner (LH). <Ref. to SB-18, Front Seat Belt.>	Go to step 3.

# Diagnostic Chart with Trouble Code

## AIRBAG SYSTEM (DIAGNOSTICS)

Step	Check	Yes	No
<b>3 CHECK AIRBAG REAR HARNESS (PRE-TENSIONER HARNESS LH).</b> 1) Turn the ignition switch to OFF, disconnect the battery ground cable, and wait for 60 seconds or more. 2) Disconnect the airbag resistor from the connector (2N) of test harness N. 3) Disconnect connector (AB19) from side airbag module (LH). 4) Disconnect the connector (AB31) from curtain airbag module (LH). 5) Disconnect the connectors (AB6, AB17, AB18) from airbag control module. 6) Connect the connector (1AH) in the test harness AH to the connectors (AB6, AB17, AB18). 7) Connect the connector (2AH) in the test harness AH and the connector (1AG) in the test harness AG. 8) Measure the resistance between connector (3AG) in the test harness AG and chassis ground. <b>Connector &amp; terminal</b> <b>(3AG) No. 10 — Chassis ground:</b> <b>(3AG) No. 12 — Chassis ground:</b>	Is the resistance 1 MΩ or more?	Go to step 4.	Replace the airbag rear harness along with body harness.
<b>4 CHECK AIRBAG CONTROL MODULE.</b> 1) Connect all connectors. 2) Clear the memory. 3) Perform the Inspection Mode. 4) Read the DTC.	Is the same DTC displayed?	Replace the airbag control module. <Ref. to AB-22, Airbag Control Module.>	Go to step 5.
<b>5 CHECK FOR ANY OTHER DTC ON DISPLAY.</b>	Is any other DTC displayed?	Check DTC using "List of Diagnostic Trouble Code (DTC)". <Ref. to AB(diag)-39, List of Diagnostic Trouble Code (DTC).>	Finish the diagnosis.

# Diagnostic Chart with Trouble Code

AIRBAG SYSTEM (DIAGNOSTICS)

## AS:DTC 65 BELT PRETENSIONER RH FAILURE

### DTC DETECTING CONDITION:

- Seat belt pretensioner (RH) circuit is shorted to power supply.
- Pretensioner (RH) is faulty.
- Pretensioner harness (RH) is faulty.
- Airbag control module is faulty.

### CAUTION:

- Before diagnosing the airbag system, be sure to turn the ignition switch to OFF, disconnect the ground cable from battery, and wait 60 seconds or more before starting to work.
- When replacing the airbag module, seat belt pretensioner, roll connector, control module and sensor, reconnect each part and check that the warning light operates properly.
- When inspecting the airbag main harness, disconnect the airbag module connectors of the driver's and passenger's seats for safety.
- When inspecting the airbag rear harness, disconnect the side airbag module connector, curtain airbag module connector and seat belt pretensioner connector for safety reasons.

### WIRING DIAGRAM:

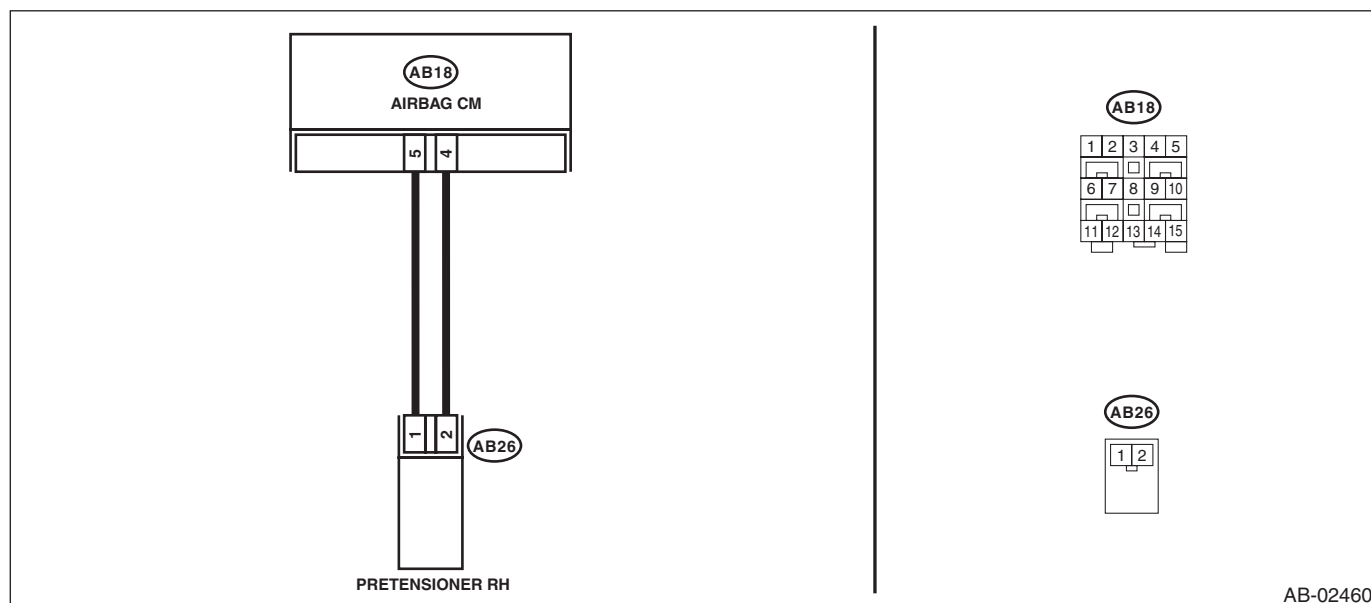

Step	Check	Yes	No
<b>1</b> <b>CHECK POOR CONTACT OF CONNECTORS.</b> Check for poor contact of the connectors between the airbag control module and the seat belt pretensioner RH.	Is there poor contact?	Replace the airbag rear harness along with body harness.	Go to step 2.
<b>2</b> <b>CHECK SEAT BELT PRETENSIONER.</b> 1) Turn the ignition switch to OFF, disconnect the battery ground cable, and wait for 60 seconds or more. 2) Disconnect the connector (AB26) from seat belt pretensioner (RH). 3) Connect the connector (1N) in the test harness N to the connector (AB26). 4) Connect the airbag resistor to the connector (2N) of test harness N. 5) Connect the battery ground terminal and turn the ignition switch to ON.	Does the airbag warning light illuminate for six seconds and go off?	Replace the seat belt pretensioner (RH). <Ref. to SB-18, Front Seat Belt.>	Go to step 3.

## Diagnostic Chart with Trouble Code

### AIRBAG SYSTEM (DIAGNOSTICS)

Step	Check	Yes	No
<b>3 CHECK AIRBAG REAR HARNESS (PRE-TENSIONER HARNESS RH).</b> 1) Turn the ignition switch to OFF, disconnect the battery ground cable, and wait for 60 seconds or more. 2) Disconnect the airbag resistor from the connector (2N) of test harness N. 3) Disconnect connector (AB24) from side airbag module (RH). 4) Disconnect the connector (AB33) from curtain airbag module (RH). 5) Disconnect the connectors (AB6, AB17, AB18) from airbag control module. 6) Connect the connector (1AH) in the test harness AH to the connectors (AB6, AB17, AB18). 7) Connect the connector (2AH) in the test harness AH and the connector (1AG) in the test harness AG. 8) Connect the battery ground terminal and turn the ignition switch to ON. 9) Measure the voltage between connector (3AG) in the test harness AG and chassis ground.  <b>Connector &amp; terminal</b> <b>(3AG) No. 20 (+) — Chassis ground (-):</b> <b>(3AG) No. 18 (+) — Chassis ground (-):</b>	Is the voltage less than 1 V?	Go to step 4.	Replace the airbag rear harness along with body harness.
<b>4 CHECK AIRBAG CONTROL MODULE.</b> 1) Connect all connectors. 2) Clear the memory. 3) Perform the Inspection Mode. 4) Read the DTC.	Is the same DTC displayed?	Replace the airbag control module. <Ref. to AB-22, Airbag Control Module.>	Go to step 5.
<b>5 CHECK FOR ANY OTHER DTC ON DISPLAY.</b>	Is any other DTC displayed?	Check DTC using "List of Diagnostic Trouble Code (DTC)". <Ref. to AB(diag)-39, List of Diagnostic Trouble Code (DTC).>	Finish the diagnosis.

# Diagnostic Chart with Trouble Code

AIRBAG SYSTEM (DIAGNOSTICS)

## AT:DTC 66 BELT PRETENSIONER LH FAILURE

### DTC DETECTING CONDITION:

- Seat belt pretensioner (LH) circuit is shorted to power supply.
- Pretensioner (LH) is faulty.
- Pretensioner harness (LH) is faulty.
- Airbag control module is faulty.

### CAUTION:

- Before diagnosing the airbag system, be sure to turn the ignition switch to OFF, disconnect the ground cable from battery, and wait 60 seconds or more before starting to work.
- When replacing the airbag module, seat belt pretensioner, roll connector, control module and sensor, reconnect each part and check that the warning light operates properly.
- When inspecting the airbag main harness, disconnect the airbag module connectors of the driver's and passenger's seats for safety.
- When inspecting the airbag rear harness, disconnect the side airbag module connector, curtain airbag module connector and seat belt pretensioner connector for safety reasons.

### WIRING DIAGRAM:

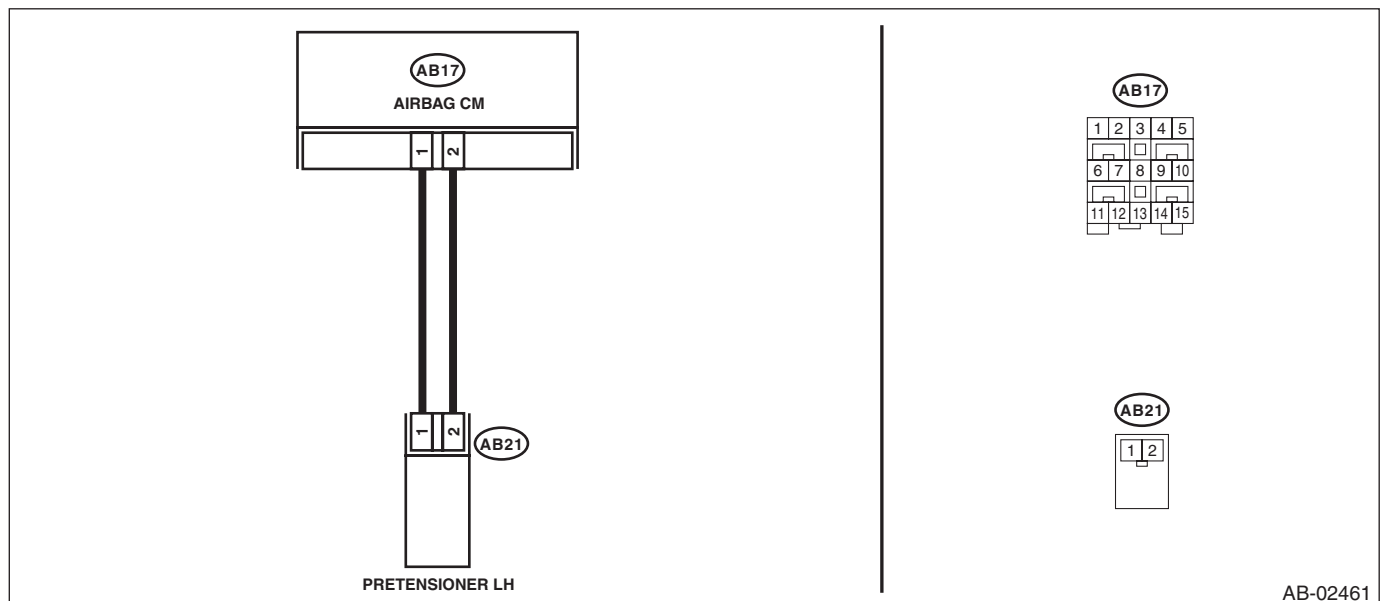

AB-02461

Step	Check	Yes	No
<b>1 CHECK POOR CONTACT OF CONNECTORS.</b> Check for poor contact of the connectors between the airbag control module and the seat belt pretensioner LH.	Is there poor contact?	Replace the airbag rear harness along with body harness.	Go to step 2.
<b>2 CHECK SEAT BELT PRETENSIONER.</b> 1) Turn the ignition switch to OFF, disconnect the battery ground cable, and wait for 60 seconds or more. 2) Disconnect the connector (AB21) from seat belt pretensioner (LH). 3) Connect the connector (1N) in the test harness N to the connector (AB21). 4) Connect the airbag resistor to the connector (2N) of test harness N. 5) Connect the battery ground terminal and turn the ignition switch to ON.	Does the airbag warning light illuminate for six seconds and go off?	Replace the seat belt pretensioner (LH). <Ref. to SB-18, Front Seat Belt.>	Go to step 3.



# Diagnostic Chart with Trouble Code

## AIRBAG SYSTEM (DIAGNOSTICS)

Step	Check	Yes	No
<b>3 CHECK AIRBAG REAR HARNESS (PRE-TENSIONER HARNESS LH).</b> 1) Turn the ignition switch to OFF, disconnect the battery ground cable, and wait for 60 seconds or more. 2) Disconnect the airbag resistor from the connector (2N) of test harness N. 3) Disconnect connector (AB19) from side airbag module (LH). 4) Disconnect the connector (AB31) from curtain airbag module (LH). 5) Disconnect the connectors (AB6, AB17, AB18) from airbag control module. 6) Connect the connector (1AH) in the test harness AH to the connectors (AB6, AB17, AB18). 7) Connect the connector (2AH) in the test harness AH and the connector (1AG) in the test harness AG. 8) Connect the battery ground terminal and turn the ignition switch to ON. 9) Measure the voltage between connector (3AG) in the test harness AG and chassis ground.  <b>Connector &amp; terminal</b> <b>(3AG) No. 10 (+) — Chassis ground (-):</b> <b>(3AG) No. 12 (+) — Chassis ground (-):</b>	Is the voltage less than 1 V?	Go to step 4.	Replace the airbag rear harness along with body harness.
<b>4 CHECK AIRBAG CONTROL MODULE.</b> 1) Connect all connectors. 2) Clear the memory. 3) Perform the Inspection Mode. 4) Read the DTC.	Is the same DTC displayed?	Replace the airbag control module. <Ref. to AB-22, Airbag Control Module.>	Go to step 5.
<b>5 CHECK FOR ANY OTHER DTC ON DISPLAY.</b>	Is any other DTC displayed?	Check DTC using "List of Diagnostic Trouble Code (DTC)". <Ref. to AB(diag)-39, List of Diagnostic Trouble Code (DTC).>	Finish the diagnosis.

# Diagnostic Chart with Trouble Code

AIRBAG SYSTEM (DIAGNOSTICS)

## AU:DTC 6A BELT PRETENSIONER RH FAILURE

### DTC DETECTING CONDITION:

- Seat belt pretensioner (RH) circuit is shorted.
- Pretensioner (RH) is faulty.
- Pretensioner harness (RH) is faulty.
- Airbag control module is faulty.

### CAUTION:

- Before diagnosing the airbag system, be sure to turn the ignition switch to OFF, disconnect the ground cable from battery, and wait 60 seconds or more before starting to work.
- When replacing the airbag module, seat belt pretensioner, roll connector, control module and sensor, reconnect each part and check that the airbag warning light operates properly.
- When inspecting the airbag main harness, disconnect the airbag module connectors of the driver's and passenger's seats for safety.
- When inspecting the airbag rear harness, disconnect the side airbag module connector, curtain airbag module connector and seat belt pretensioner connector for safety reasons.

### WIRING DIAGRAM:

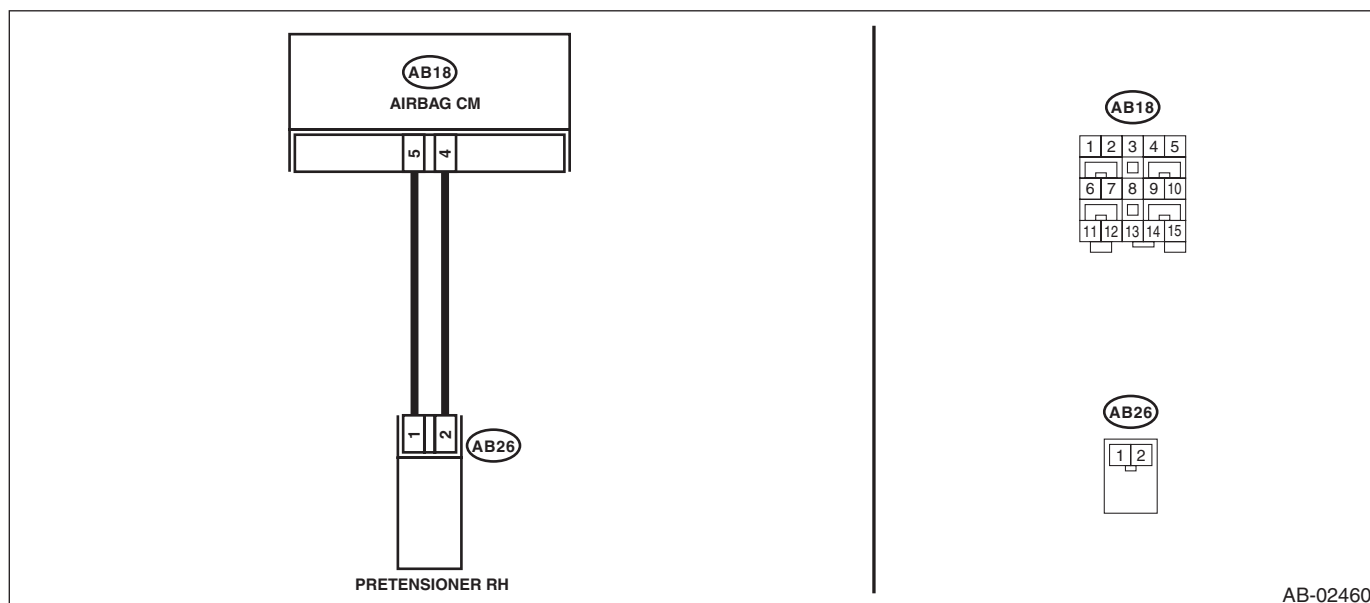

AB-02460

Step	Check	Yes	No
<b>1 CHECK POOR CONTACT OF CONNECTORS.</b> Check for poor contact of the connectors between the airbag control module and the seat belt pretensioner RH.	Is there poor contact?	Replace the airbag rear harness along with body harness.	Go to step 2.
<b>2 CHECK SEAT BELT PRETENSIONER.</b> 1) Turn the ignition switch to OFF, disconnect the battery ground cable, and wait for 60 seconds or more. 2) Disconnect the connector (AB26) from seat belt pretensioner (RH). 3) Connect the connector (1N) in the test harness N to the connector (AB26). 4) Connect the airbag resistor to the connector (2N) of test harness N. 5) Connect the battery ground terminal and turn the ignition switch to ON.	Does the airbag warning light illuminate for 6 seconds and go off?	Replace the seat belt pretensioner (RH). <Ref. to SB-18, Front Seat Belt.>	Go to step 3.

## Diagnostic Chart with Trouble Code

### AIRBAG SYSTEM (DIAGNOSTICS)

Step	Check	Yes	No
<b>3 CHECK AIRBAG REAR HARNESS (PRE-TENSIONER HARNESS RH).</b> 1) Turn the ignition switch to OFF, disconnect the battery ground cable, and wait for 60 seconds or more. 2) Disconnect the airbag resistor from test harness N. 3) Disconnect connector (AB24) from side airbag module (RH). 4) Disconnect the connector (AB33) from curtain airbag module (RH). 5) Disconnect the connectors (AB6, AB17, AB18) from airbag control module. 6) Connect the connector (1AH) in the test harness AH to the connectors (AB6, AB17, AB18). 7) Connect the connector (2AH) in the test harness AH and the connector (1AG) in the test harness AG. 8) Measure the resistance between connector (3AG) terminals in test harness AG. <b>Connector &amp; terminal (3AG) No. 18 — (3AG) No. 20:</b>	Is the resistance 1 MΩ or more?	Go to step 4.	Replace the airbag rear harness along with body harness.
<b>4 CHECK AIRBAG CONTROL MODULE.</b> 1) Connect all connectors. 2) Clear the memory. 3) Perform the Inspection Mode. 4) Read the DTC.	Is the same DTC displayed?	Replace the airbag control module. <Ref. to AB-22, Airbag Control Module.>	Go to step 5.
<b>5 CHECK FOR ANY OTHER DTC ON DISPLAY.</b>	Is any other DTC displayed?	Check DTC using "List of Diagnostic Trouble Code (DTC)". <Ref. to AB(diag)-39, List of Diagnostic Trouble Code (DTC).>	Finish the diagnosis.

# Diagnostic Chart with Trouble Code

AIRBAG SYSTEM (DIAGNOSTICS)

## AV:DTC 6B BELT PRETENSIONER LH FAILURE

### DTC DETECTING CONDITION:

- Seat belt pretensioner (LH) circuit is shorted.
- Pretensioner (LH) is faulty.
- Pretensioner harness (LH) is faulty.
- Airbag control module is faulty.

### CAUTION:

- Before diagnosing the airbag system, be sure to turn the ignition switch to OFF, disconnect the ground cable from battery, and wait 60 seconds or more before starting to work.
- When replacing the airbag module, seat belt pretensioner, roll connector, control module and sensor, reconnect each part and check that the airbag warning light operates properly.
- When inspecting the airbag main harness, disconnect the airbag module connectors of the driver's and passenger's seats for safety.
- When inspecting the airbag rear harness, disconnect the side airbag module connector, curtain airbag module connector and seat belt pretensioner connector for safety reasons.

### WIRING DIAGRAM:

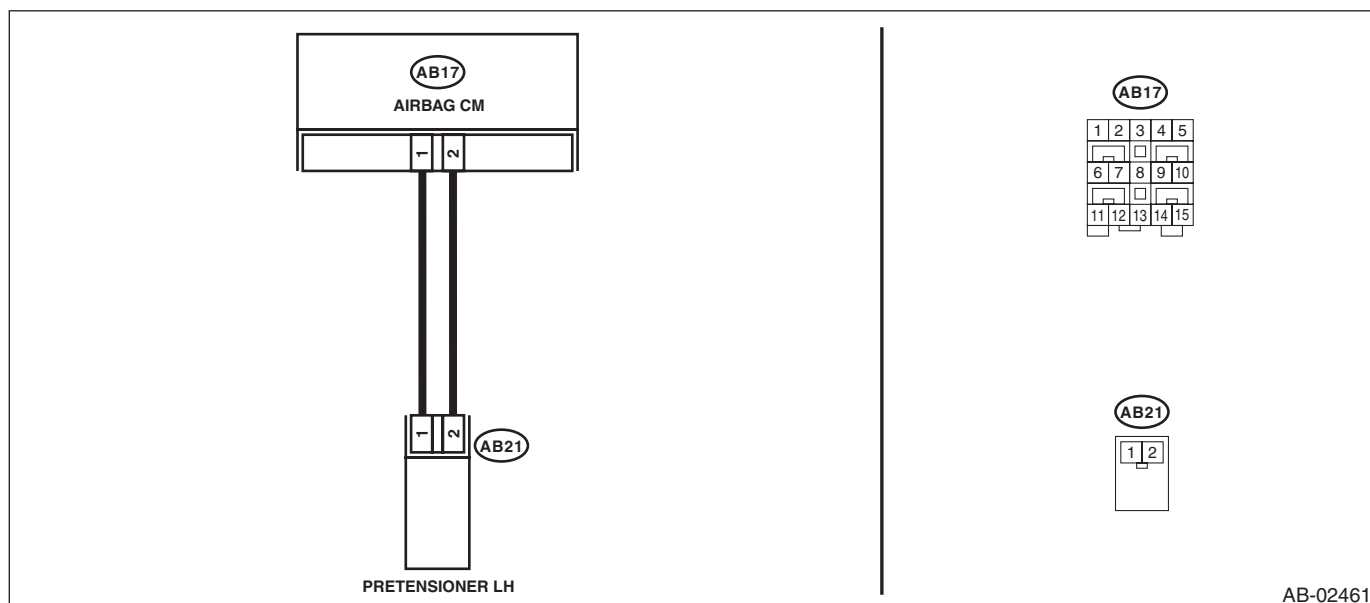

AB-02461

Step	Check	Yes	No
<b>1 CHECK POOR CONTACT OF CONNECTORS.</b> Check for poor contact of the connectors between the airbag control module and the seat belt pretensioner LH.	Is there poor contact?	Replace the airbag rear harness along with body harness.	Go to step 2.
<b>2 CHECK SEAT BELT PRETENSIONER.</b> 1) Turn the ignition switch to OFF, disconnect the battery ground cable, and wait for 60 seconds or more. 2) Disconnect the connector (AB21) from seat belt pretensioner (LH). 3) Connect the connector (1N) in the test harness N to the connector (AB21). 4) Connect the airbag resistor to the connector (2N) of test harness N. 5) Connect the battery ground terminal and turn the ignition switch to ON.	Does the airbag warning light illuminate for 6 seconds and go off?	Replace the seat belt pretensioner (LH). <Ref. to SB-18, Front Seat Belt.>	Go to step 3.

## Diagnostic Chart with Trouble Code

### AIRBAG SYSTEM (DIAGNOSTICS)

Step	Check	Yes	No
<b>3 CHECK AIRBAG REAR HARNESS (PRE-TENSIONER HARNESS LH).</b> 1) Turn the ignition switch to OFF, disconnect the battery ground cable, and wait for 60 seconds or more. 2) Disconnect the airbag resistor from the connector (2N) of test harness N. 3) Disconnect connector (AB19) from side airbag module (LH). 4) Disconnect the connector (AB31) from curtain airbag module (LH). 5) Disconnect the connectors (AB6, AB17, AB18) from airbag control module. 6) Connect the connector (1AH) in the test harness AH to the connectors (AB6, AB17, AB18). 7) Connect the connector (2AH) in the test harness AH and the connector (1AG) in the test harness AG. 8) Measure the resistance between connector (3AG) terminals in test harness AG. <b>Connector &amp; terminal (3AG) No. 10 — (3AG) No. 12:</b>	Is the resistance 1 MΩ or more?	Go to step 4.	Replace the airbag rear harness along with body harness.
<b>4 CHECK AIRBAG CONTROL MODULE.</b> 1) Connect all connectors. 2) Clear the memory. 3) Perform the Inspection Mode. 4) Read the DTC.	Is the same DTC displayed?	Replace the airbag control module. <Ref. to AB-22, Airbag Control Module.>	Go to step 5.
<b>5 CHECK FOR ANY OTHER DTC ON DISPLAY.</b>	Is any other DTC displayed?	Check DTC using "List of Diagnostic Trouble Code (DTC)". <Ref. to AB(diag)-39, List of Diagnostic Trouble Code (DTC).>	Finish the diagnosis.

# Diagnostic Chart with Trouble Code

AIRBAG SYSTEM (DIAGNOSTICS)

## AW:DTC 6D BELT PRETENSIONER RH FAILURE

### DTC DETECTING CONDITION:

- Seat belt pretensioner (RH) circuit is open.
- Pretensioner (RH) is faulty.
- Pretensioner harness (RH) is faulty.
- Airbag control module is faulty.

### CAUTION:

- Before diagnosing the airbag system, be sure to turn the ignition switch to OFF, disconnect the ground cable from battery, and wait 60 seconds or more before starting to work.
- When replacing the airbag module, seat belt pretensioner, roll connector, control module and sensor, reconnect each part and check that the airbag warning light operates properly.
- When inspecting the airbag main harness, disconnect the airbag module connectors of the driver's and passenger's seats for safety.
- When inspecting the airbag rear harness, disconnect the side airbag module connector, curtain airbag module connector and seat belt pretensioner connector for safety reasons.

### WIRING DIAGRAM:

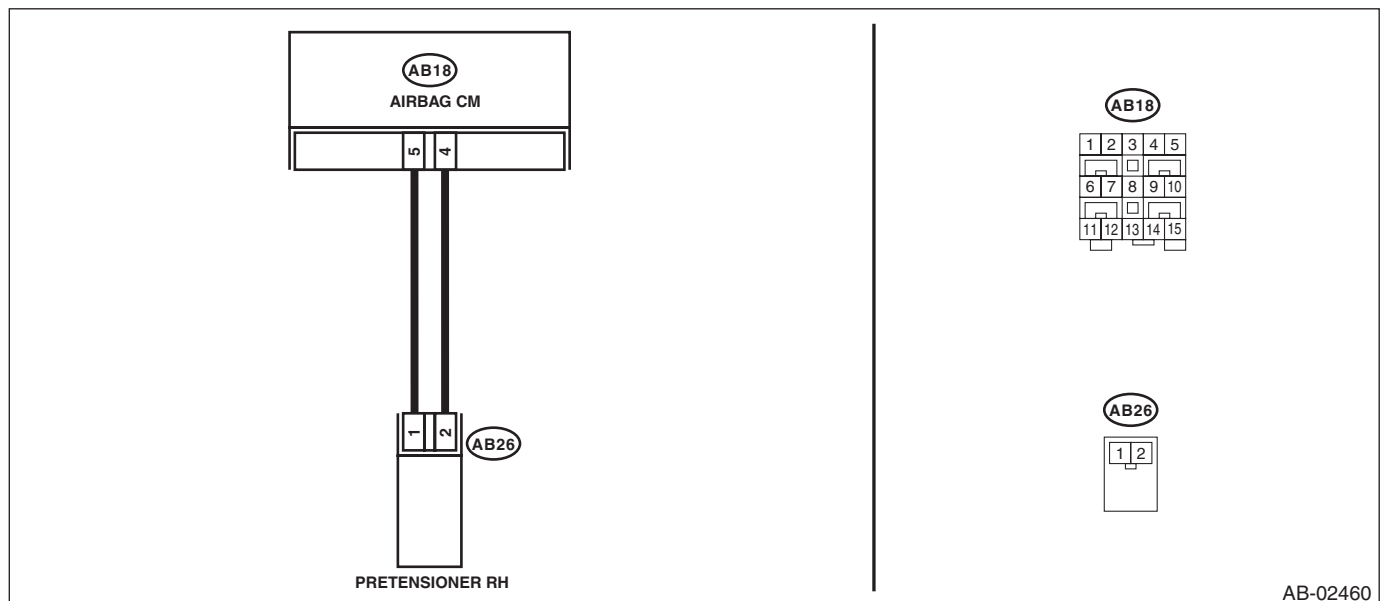

Step	Check	Yes	No
<b>1 CHECK POOR CONTACT OF CONNECTORS.</b> Check for poor contact of the connectors between the airbag control module and the seat belt pretensioner RH.	Is there poor contact?	Replace the airbag rear harness along with body harness.	Go to step 2.
<b>2 CHECK SEAT BELT PRETENSIONER.</b> 1) Turn the ignition switch to OFF, disconnect the battery ground cable, and wait for 60 seconds or more. 2) Disconnect the connector (AB26) from seat belt pretensioner (RH). 3) Connect the connector (1N) in the test harness N to the connector (AB26). 4) Connect the airbag resistor to the connector (2N) of test harness N. 5) Connect the battery ground terminal and turn the ignition switch to ON.	Does the airbag warning light illuminate for 6 seconds and go off?	Replace the seat belt pretensioner (RH). <Ref. to SB-18, Front Seat Belt.>	Go to step 3.

# Diagnostic Chart with Trouble Code

## AIRBAG SYSTEM (DIAGNOSTICS)

Step	Check	Yes	No
<b>3 CHECK AIRBAG REAR HARNESS (PRE-TENSIONER HARNESS RH).</b> 1) Turn the ignition switch to OFF, disconnect the battery ground cable, and wait for 60 seconds or more. 2) Disconnect the airbag resistor from the connector (2N) of test harness N. 3) Disconnect connector (AB24) from side airbag module (RH). 4) Disconnect the connector (AB33) from curtain airbag module (RH). 5) Disconnect the connectors (AB6, AB17, AB18) from airbag control module. 6) Connect the connector (1AH) in the test harness AH to the connectors (AB6, AB17, AB18). 7) Connect the connector (2AH) in the test harness AH and the connector (1AG) in the test harness AG. 8) Measure the resistance between connector (3AG) in the test harness AG and connector (2N) in the test harness N. <b>Connector &amp; terminal</b> <b>(3AG) No. 18 — (2N) No. 1:</b> <b>(3AG) No. 20 — (2N) No. 2:</b>	Is the resistance less than 10 $\Omega$ ?	Go to step 4.	Replace the airbag rear harness along with body harness.
<b>4 CHECK AIRBAG CONTROL MODULE.</b> 1) Connect all connectors. 2) Clear the memory. 3) Perform the Inspection Mode. 4) Read the DTC.	Is the same DTC displayed?	Replace the airbag control module. <Ref. to AB-22, Airbag Control Module.>	Go to step 5.
<b>5 CHECK FOR ANY OTHER DTC ON DISPLAY.</b>	Is any other DTC displayed?	Check DTC using "List of Diagnostic Trouble Code (DTC)". <Ref. to AB(diag)-39, List of Diagnostic Trouble Code (DTC).>	Finish the diagnosis.

# Diagnostic Chart with Trouble Code

AIRBAG SYSTEM (DIAGNOSTICS)

## AX:DTC 6E BELT PRETENSIONER LH FAILURE

### DTC DETECTING CONDITION:

- Seat belt pretensioner (LH) circuit is open.
- Pretensioner (LH) is faulty.
- Pretensioner harness (LH) is faulty.
- Airbag control module is faulty.

### CAUTION:

- Before diagnosing the airbag system, be sure to turn the ignition switch to OFF, disconnect the ground cable from battery, and wait 60 seconds or more before starting to work.
- When replacing the airbag module, seat belt pretensioner, roll connector, control module and sensor, reconnect each part and check that the airbag warning light operates properly.
- When inspecting the airbag main harness, disconnect the airbag module connectors of the driver's and passenger's seats for safety.
- When inspecting the airbag rear harness, disconnect the side airbag module connector, curtain airbag module connector and seat belt pretensioner connector for safety reasons.

### WIRING DIAGRAM:

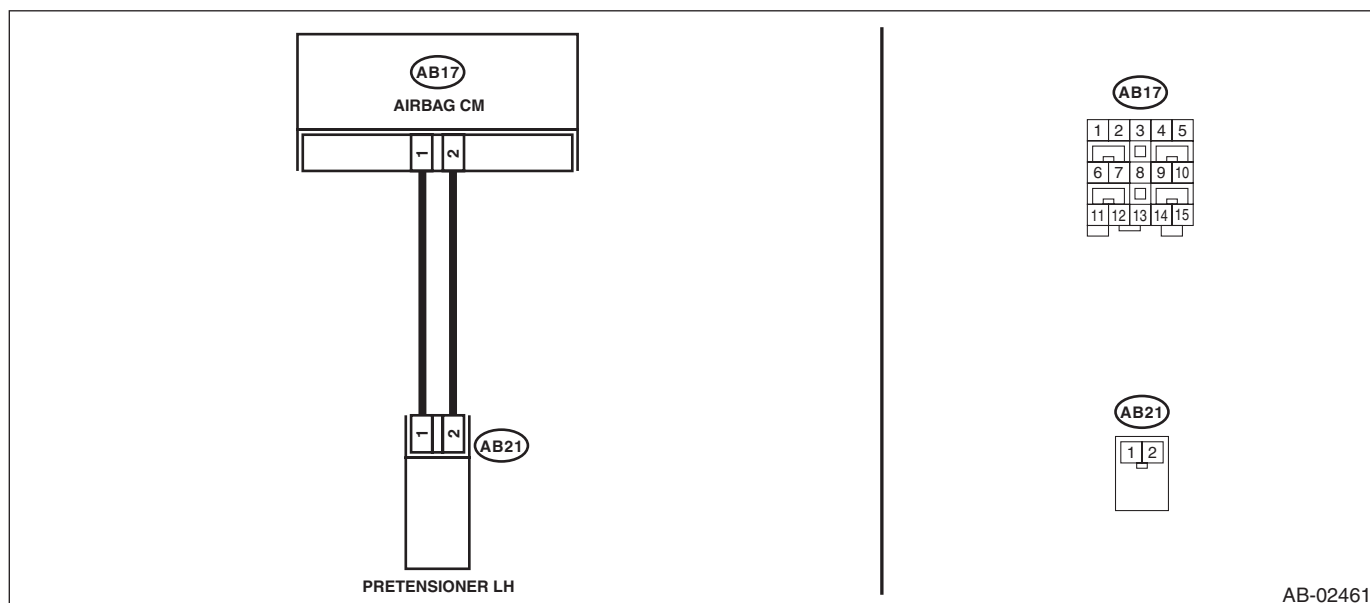

AB-02461

Step	Check	Yes	No
<b>1 CHECK POOR CONTACT OF CONNECTORS.</b> Check for poor contact of the connectors between the airbag control module and the seat belt pretensioner LH.	Is there poor contact?	Replace the airbag rear harness along with body harness.	Go to step 2.
<b>2 CHECK SEAT BELT PRETENSIONER.</b> 1) Turn the ignition switch to OFF, disconnect the battery ground cable, and wait for 60 seconds or more. 2) Disconnect the connector (AB21) from seat belt pretensioner (LH). 3) Connect the connector (1N) in the test harness N to the connector (AB21). 4) Connect the airbag resistor to the connector (2N) of test harness N. 5) Connect the battery ground terminal and turn the ignition switch to ON.	Does the airbag warning light illuminate for 6 seconds and go off?	Replace the seat belt pretensioner (LH). <Ref. to SB-18, Front Seat Belt.>	Go to step 3.



# Diagnostic Chart with Trouble Code

## AIRBAG SYSTEM (DIAGNOSTICS)

Step	Check	Yes	No
<b>3 CHECK AIRBAG REAR HARNESS (PRE-TENSIONER HARNESS LH).</b> 1) Turn the ignition switch to OFF, disconnect the battery ground cable, and wait for 60 seconds or more. 2) Disconnect the airbag resistor from the connector (2N) of test harness N. 3) Disconnect connector (AB19) from side airbag module (LH). 4) Disconnect the connector (AB31) from curtain airbag module (LH). 5) Disconnect the connectors (AB6, AB17, AB18) from airbag control module. 6) Connect the connector (1AH) in the test harness AH to the connectors (AB6, AB17, AB18). 7) Connect the connector (2AH) in the test harness AH and the connector (1AG) in the test harness AG. 8) Measure the resistance between connector (3AG) in the test harness AG and connector (2N) in the test harness N. <b>Connector &amp; terminal</b> <b>(3AG) No. 10 — (2N) No. 2:</b> <b>(3AG) No. 12 — (2N) No. 1:</b>	Is the resistance less than 10 $\Omega$ ?	Go to step 4.	Replace the airbag rear harness along with body harness.
<b>4 CHECK AIRBAG CONTROL MODULE.</b> 1) Connect all connectors. 2) Clear the memory. 3) Perform the Inspection Mode. 4) Read the DTC.	Is the same DTC displayed?	Replace the airbag control module. <Ref. to AB-22, Airbag Control Module.>	Go to step 5.
<b>5 CHECK FOR ANY OTHER DTC ON DISPLAY.</b>	Is any other DTC displayed?	Check DTC using "List of Diagnostic Trouble Code (DTC)". <Ref. to AB(diag)-39, List of Diagnostic Trouble Code (DTC).>	Finish the diagnosis.

# Diagnostic Chart with Trouble Code

AIRBAG SYSTEM (DIAGNOSTICS)

## AJ:DTC 71 DRIVER'S AIRBAG FAILURE

### DTC DETECTING CONDITION:

- Airbag main harness circuit is shorted to ground.
- Airbag module harness (driver's side) circuit is shorted to ground.
- Roll connector circuit is shorted to ground.
- Driver's airbag module is faulty.
- Airbag control module is faulty.

### CAUTION:

- Before diagnosing the airbag system, be sure to turn the ignition switch to OFF, disconnect the ground cable from battery, and wait 60 seconds or more before starting to work.
- When replacing the airbag module, seat belt pretensioner, roll connector, control module and sensor, reconnect each part and check that the warning light operates properly.
- When inspecting the airbag main harness, disconnect the airbag module connectors of the driver's and passenger's seats for safety.
- When inspecting the airbag rear harness, disconnect the side airbag module connector, curtain airbag module connector and seat belt pretensioner connector for safety reasons.

### NOTE:

Prior to starting work, prepare two AIRBAG RESISTORS (98299PA040).

### WIRING DIAGRAM:

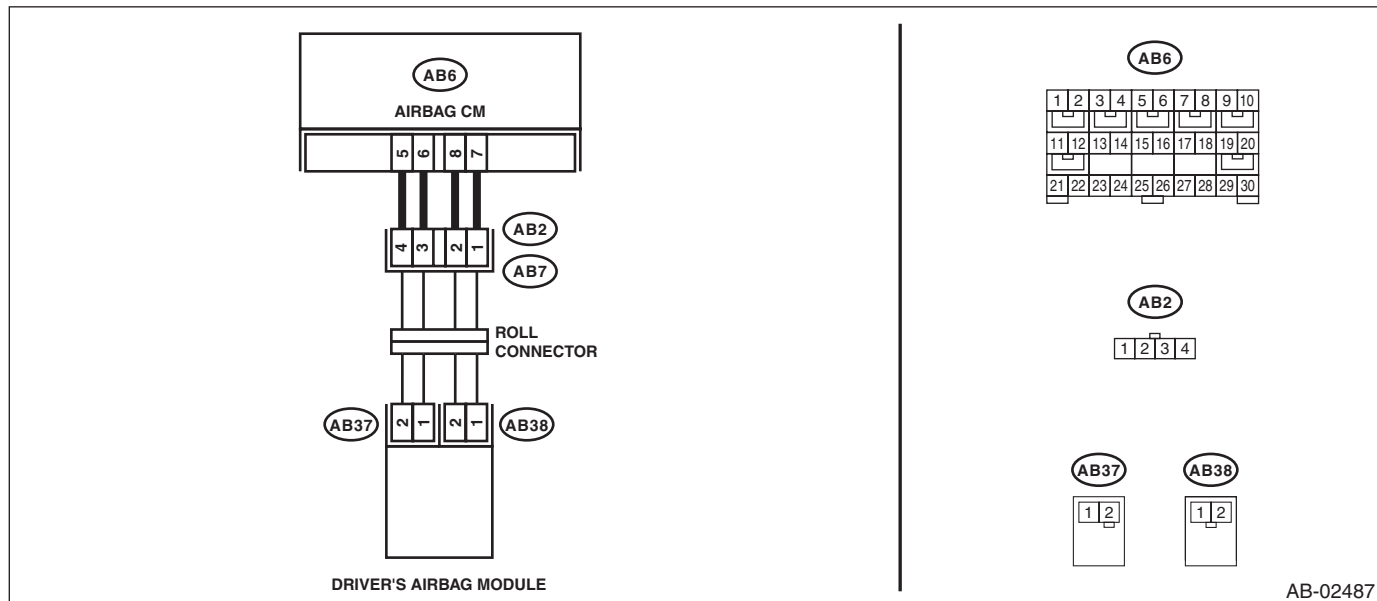

	Step	Check	Yes	No
1	<b>CHECK POOR CONTACT OF CONNECTORS.</b> Check for poor contact of the connectors between the airbag control module and the driver's airbag module.	Is there poor contact?	Replace the airbag main harness along with body harness.	Go to step 2.

## Diagnostic Chart with Trouble Code

### AIRBAG SYSTEM (DIAGNOSTICS)

Step	Check	Yes	No
<b>2 CHECK DRIVER'S AIRBAG MODULE.</b> 1) Turn the ignition switch to OFF, disconnect the battery ground cable, and wait for 60 seconds or more. 2) Remove the driver's airbag module. 3) Connect the connector (1N) in the test harness N to the connector (AB38). 4) Connect the airbag resistor to the connector (2N) of test harness N. 5) Connect the connector (1Q) in the test harness Q to connector (AB37). 6) Connect the airbag resistor to the connector (2Q) in the test harness Q. 7) Connect the battery ground terminal and turn the ignition switch to ON.	Does the airbag warning light illuminate for six seconds and go off?	Replace the driver's airbag module. <Ref. to AB-16, Driver's Airbag Module.>	Go to step 3.
<b>3 CHECK ROLL CONNECTOR.</b> 1) Turn the ignition switch to OFF, disconnect the battery ground cable, and wait for 60 seconds or more. 2) Disconnect the test harness N from connector (AB38). 3) Disconnect the test harness Q from connector (AB37). 4) Remove the instrument panel lower cover and disconnect the connector (AB7) from (AB2). 5) Connect the connector (1P) in the test harness P to connector (AB2). 6) Connect the airbag resistor to the connectors (2P) and (3P) of test harness P. 7) Connect the battery ground terminal and turn the ignition switch to ON.	Does the airbag warning light illuminate for six seconds and go off?	Replace the roll connector. <Ref. to AB-27, Roll Connector.>	Go to step 4.
<b>4 CHECK AIRBAG MAIN HARNESS (DRIVER'S AIRBAG HARNESS).</b> 1) Turn the ignition switch to OFF, disconnect the battery ground cable, and wait for 60 seconds or more. 2) Disconnect the airbag resistor from the connectors (2P) and (3P) of test harness P. 3) Remove the console front panel and disconnect the connector (AB9). 4) Disconnect the connectors (AB6, AB17, AB18) from the airbag control module, and connect the connector (1AH) in the test harness AH. 5) Connect the connector (2AH) in the test harness AH and the connector (1AG) in the test harness AG. 6) Measure the resistance between connector (3AG) in the test harness AG and chassis ground.  <i>Connector &amp; terminal</i> <i>(3AG) No. 2 — Chassis ground:</i> <i>(3AG) No. 4 — Chassis ground:</i>	Is the resistance 1 MΩ or more?	Go to step 5.	Replace the airbag main harness along with body harness.
<b>5 CHECK AIRBAG CONTROL MODULE.</b> 1) Connect all connectors. 2) Clear the memory. 3) Perform the Inspection Mode. 4) Read the DTC.	Is the same DTC displayed?	Replace the airbag control module. <Ref. to AB-22, Airbag Control Module.>	Go to step 6.

# Diagnostic Chart with Trouble Code

AIRBAG SYSTEM (DIAGNOSTICS)

Step	Check	Yes	No
6 <b>CHECK FOR ANY OTHER DTC ON DISPLAY.</b>	Is any other DTC displayed?	Check DTC using "List of Diagnostic Trouble Code (DTC)". <Ref. to AB(diag)-39, List of Diagnostic Trouble Code (DTC).>	Finish the diagnosis.

# Diagnostic Chart with Trouble Code

## AIRBAG SYSTEM (DIAGNOSTICS)

### AZ:DTC 72 PASSENGER'S AIRBAG FAILURE

#### DTC DETECTING CONDITION:

- Airbag main harness circuit is shorted to ground.
- Airbag module harness (passenger's side) circuit is shorted to ground.
- Passenger's airbag module is faulty.
- Airbag control module is faulty.

#### CAUTION:

- **Before diagnosing the airbag system, be sure to turn the ignition switch to OFF, disconnect the ground cable from battery, and wait 60 seconds or more before starting to work.**
- **When replacing the airbag module, seat belt pretensioner, roll connector, control module and sensor, reconnect each part and check that the warning light operates properly.**
- **When inspecting the airbag main harness, disconnect the airbag module connectors of the driver's and passenger's seats for safety.**
- **When inspecting the airbag rear harness, disconnect the side airbag module connector, curtain airbag module connector and seat belt pretensioner connector for safety reasons.**

#### NOTE:

Prior to starting work, prepare two AIRBAG RESISTORS (98299PA040).

#### WIRING DIAGRAM:

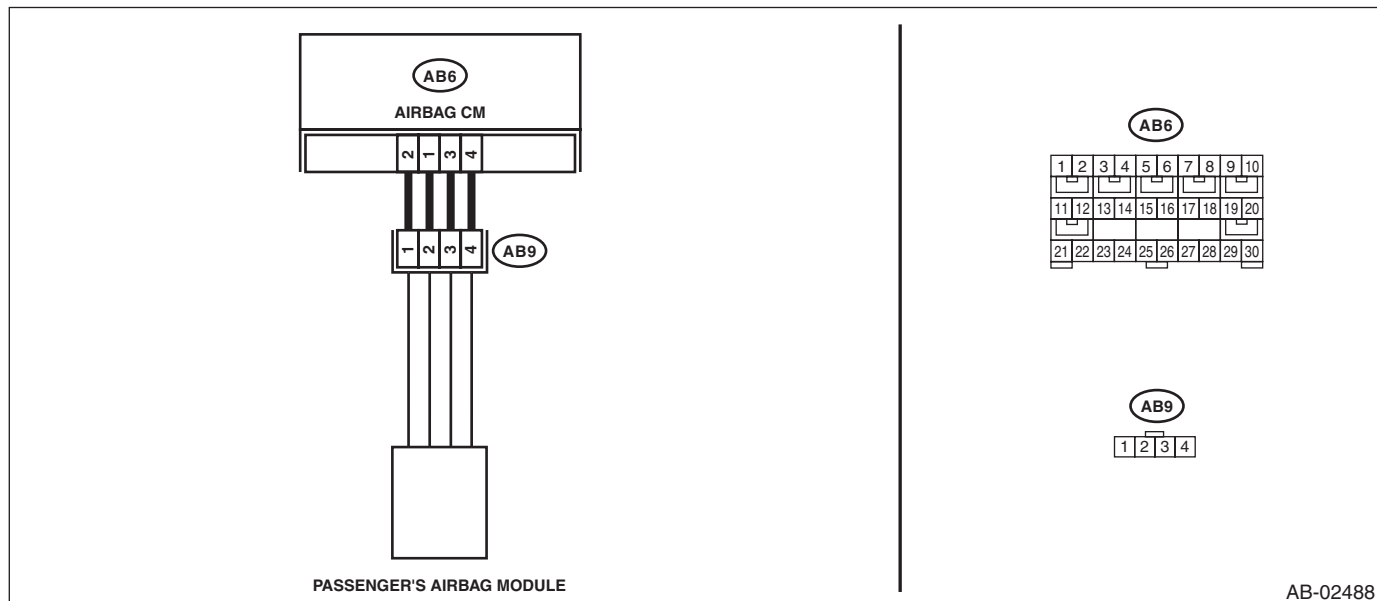

Step	Check	Yes	No
<b>1 CHECK POOR CONTACT OF CONNECTORS.</b> Check for poor contact of the connectors between the airbag control module and the passenger's airbag module.	Is there poor contact?	Replace the airbag main harness along with body harness.	Go to step 2.
<b>2 CHECK PASSENGER'S AIRBAG MODULE.</b> 1) Turn the ignition switch to OFF, disconnect the battery ground cable, and wait for 60 seconds or more. 2) Remove the console front panel and disconnect the connector (AB9). 3) Connect the connector (1P) in the test harness P to connector (AB9). 4) Connect the airbag resistor to the connectors (2P) and (3P) of test harness P. 5) Connect the battery ground terminal and turn the ignition switch to ON.	Does the airbag warning light illuminate for six seconds and go off?	Replace the passenger's airbag module. <Ref. to AB-17, Passenger's Airbag Module.>	Go to step 3.

# Diagnostic Chart with Trouble Code

AIRBAG SYSTEM (DIAGNOSTICS)

Step	Check	Yes	No
<b>3 CHECK AIRBAG MAIN HARNESS (PASSENGER'S AIRBAG HARNESS).</b> 1) Turn the ignition switch to OFF, disconnect the battery ground cable, and wait for 60 seconds or more. 2) Disconnect the airbag resistor from the connectors (2P) and (3P) of test harness P. 3) Remove the instrument panel lower cover and disconnect the connector (AB7) from (AB2). 4) Disconnect the connectors (AB6, AB17, AB18) from the airbag control module, and connect the connector (1AH) in the test harness AH. 5) Connect the connector (2AH) in the test harness AH and the connector (1AG) in the test harness AG. 6) Measure the resistance between connector (3AG) in the test harness AG and chassis ground. <i><b>Connector &amp; terminal</b></i> <i><b>(3AG) No. 6 — Chassis ground:</b></i> <i><b>(3AG) No. 8 — Chassis ground:</b></i>	Is the resistance 1 MΩ or more?	Go to step 4.	Replace the airbag main harness along with body harness.
<b>4 CHECK AIRBAG CONTROL MODULE.</b> 1) Connect all connectors. 2) Clear the memory. 3) Perform the Inspection Mode. 4) Read the DTC.	Is the same DTC displayed?	Replace the airbag control module. <Ref. to AB-22, Airbag Control Module.>	Go to step 5.
<b>5 CHECK FOR ANY OTHER DTC ON DISPLAY.</b>	Is any other DTC displayed?	Check DTC using "List of Diagnostic Trouble Code (DTC)". <Ref. to AB(diag)-39, List of Diagnostic Trouble Code (DTC).>	Finish the diagnosis.

# Diagnostic Chart with Trouble Code

## AIRBAG SYSTEM (DIAGNOSTICS)

### BA:DTC 75 DRIVER'S AIRBAG FAILURE

#### DTC DETECTING CONDITION:

- Airbag main harness circuit (driver's side) is shorted to power supply.
- Airbag module harness circuit (driver's side) is shorted to power supply.
- Roll connector is shorted to power supply.
- Driver's airbag module is faulty.
- Airbag control module is faulty.

#### CAUTION:

- Before diagnosing the airbag system, be sure to turn the ignition switch to OFF, disconnect the ground cable from battery, and wait 60 seconds or more before starting to work.
- When replacing the airbag module, seat belt pretensioner, roll connector, control module and sensor, reconnect each part and check that the warning light operates properly.
- When inspecting the airbag main harness, disconnect the airbag module connectors of the driver's and passenger's seats for safety.
- When inspecting the airbag rear harness, disconnect the side airbag module connector, curtain airbag module connector and seat belt pretensioner connector for safety reasons.

#### NOTE:

Prior to starting work, prepare two AIRBAG RESISTORS (98299PA040).

#### WIRING DIAGRAM:

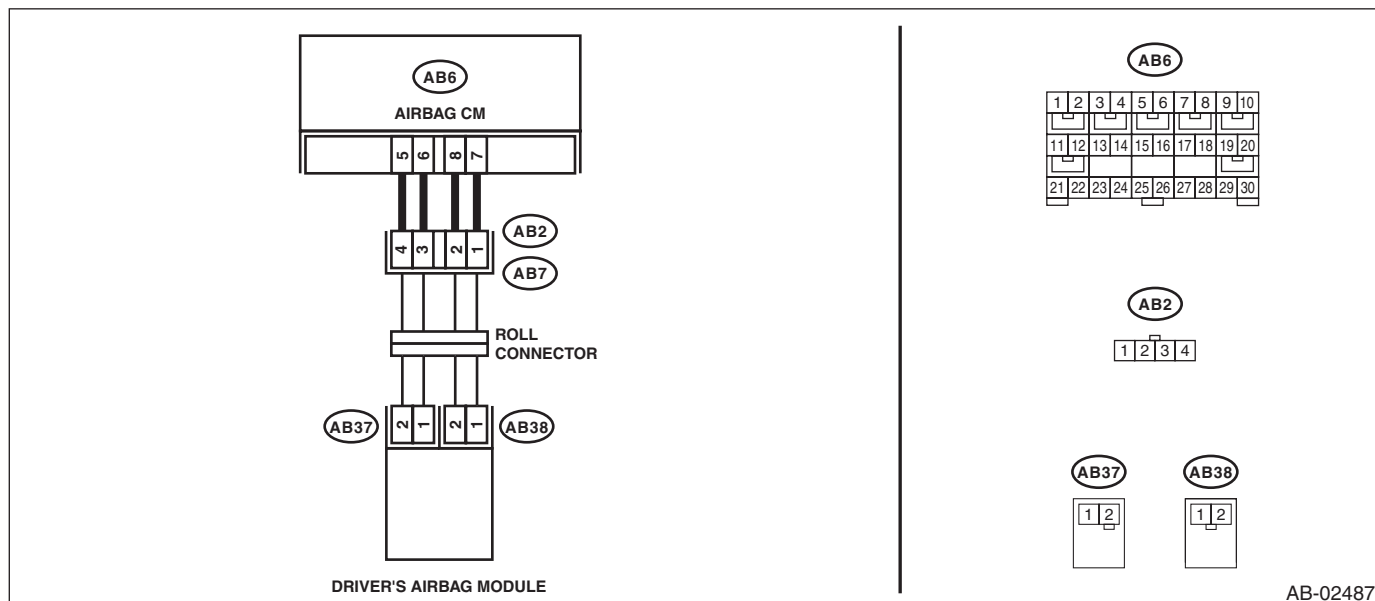

Step	Check	Yes	No
1	<p><b>CHECK POOR CONTACT OF CONNECTORS.</b></p> <p>Check for poor contact of the connectors between the airbag control module and the driver's airbag module.</p>	Is there poor contact?	<p>Replace the airbag main harness along with body harness.</p> <p>Go to step 2.</p>

# Diagnostic Chart with Trouble Code

AIRBAG SYSTEM (DIAGNOSTICS)

Step	Check	Yes	No
<p><b>2</b></p> <p><b>CHECK DRIVER'S AIRBAG MODULE.</b></p> <ol style="list-style-type: none"> <li>1) Turn the ignition switch to OFF, disconnect the battery ground cable, and wait for 60 seconds or more.</li> <li>2) Remove the driver's airbag module.</li> <li>3) Connect the connector (AB38) to the connector (1N) in the test harness N.</li> <li>4) Connect the airbag resistor to the connector (2N) of test harness N.</li> <li>5) Connect the connector (1Q) in the test harness Q to connector (AB37).</li> <li>6) Connect the airbag resistor to the connector (2Q) in the test harness Q.</li> <li>7) Connect the battery ground terminal and turn the ignition switch to ON.</li> </ol>	<p>Does the airbag warning light illuminate for six seconds and go off?</p>	<p>Replace the driver's airbag module. &lt;Ref. to AB-16, Driver's Airbag Module.&gt;</p>	<p>Go to step 3.</p>
<p><b>3</b></p> <p><b>CHECK ROLL CONNECTOR.</b></p> <ol style="list-style-type: none"> <li>1) Turn the ignition switch to OFF, disconnect the battery ground cable, and wait for 60 seconds or more.</li> <li>2) Disconnect the test harness N from connector (AB38).</li> <li>3) Disconnect the test harness Q from connector (AB37).</li> <li>4) Remove the instrument panel lower cover and disconnect the connector (AB7) from (AB2).</li> <li>5) Connect the connector (1P) in the test harness P to connector (AB2).</li> <li>6) Connect the airbag resistor to the connectors (2P) and (3P) of test harness P.</li> <li>7) Connect the battery ground terminal and turn the ignition switch to ON.</li> </ol>	<p>Does the airbag warning light illuminate for six seconds and go off?</p>	<p>Replace the roll connector. &lt;Ref. to AB-27, Roll Connector.&gt;</p>	<p>Go to step 4.</p>
<p><b>4</b></p> <p><b>CHECK AIRBAG MAIN HARNESS (DRIVER'S AIRBAG HARNESS).</b></p> <ol style="list-style-type: none"> <li>1) Turn the ignition switch to OFF, disconnect the battery ground cable, and wait for 60 seconds or more.</li> <li>2) Disconnect the airbag resistor from the connectors (2P) and (3P) of test harness P.</li> <li>3) Remove the console front panel and disconnect the connector (AB9).</li> <li>4) Disconnect the connectors (AB6, AB17, AB18) from the airbag control module, and connect the connector (1AH) in the test harness AH.</li> <li>5) Connect the connector (2AH) in the test harness AH and the connector (1AG) in the test harness AG.</li> <li>6) Connect the battery ground terminal and turn the ignition switch to ON.</li> <li>7) Measure the voltage between connector (3AG) in the test harness AG and chassis ground.</li> </ol> <p><b>Connector &amp; terminal</b>  <b>(3AG) No. 2 (+) — Chassis ground (-):</b>  <b>(3AG) No. 4 (+) — Chassis ground (-):</b></p>	<p>Is the voltage less than 1 V?</p>	<p>Go to step 5.</p>	<p>Replace the airbag main harness along with body harness.</p>



# Diagnostic Chart with Trouble Code

## AIRBAG SYSTEM (DIAGNOSTICS)

Step	Check	Yes	No
<b>5</b> <b>CHECK AIRBAG CONTROL MODULE.</b> 1) Connect all connectors. 2) Clear the memory. 3) Perform the Inspection Mode. 4) Read the DTC.	Is the same DTC displayed?	Replace the airbag control module. <Ref. to AB-22, Airbag Control Module.>	Go to step <b>6</b> .
<b>6</b> <b>CHECK FOR ANY OTHER DTC ON DISPLAY.</b>	Is any other DTC displayed?	Check DTC using "List of Diagnostic Trouble Code (DTC)". <Ref. to AB(diag)-39, List of Diagnostic Trouble Code (DTC).>	Finish the diagnosis.

# Diagnostic Chart with Trouble Code

AIRBAG SYSTEM (DIAGNOSTICS)

## BB:DTC 76 PASSENGER'S AIRBAG FAILURE

### DTC DETECTING CONDITION:

- Airbag main harness circuit (passenger's side) is shorted to power supply.
- Airbag module harness circuit (passenger's side) is shorted to power supply.
- Passenger's airbag module is faulty.
- Airbag control module is faulty.

### CAUTION:

- Before diagnosing the airbag system, be sure to turn the ignition switch to OFF, disconnect the ground cable from battery, and wait 60 seconds or more before starting to work.
- When replacing the airbag module, seat belt pretensioner, roll connector, control module and sensor, reconnect each part and check that the warning light operates properly.
- When inspecting the airbag main harness, disconnect the airbag module connectors of the driver's and passenger's seats for safety.
- When inspecting the airbag rear harness, disconnect the side airbag module connector, curtain airbag module connector and seat belt pretensioner connector for safety reasons.

### NOTE:

Prior to starting work, prepare two AIRBAG RESISTORS (98299PA040).

### WIRING DIAGRAM:

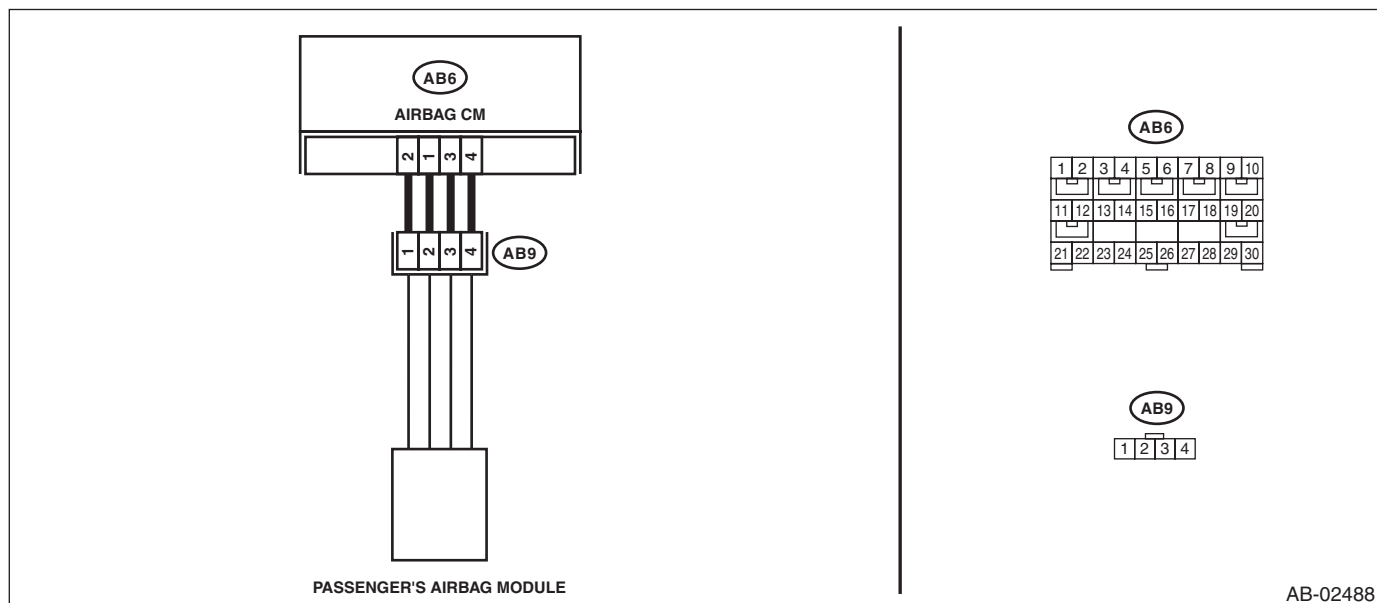

Step	Check	Yes	No
<b>1 CHECK POOR CONTACT OF CONNECTORS.</b> Check for poor contact of the connectors between the airbag control module and the passenger's airbag module.	Is there poor contact?	Replace the airbag main harness along with body harness.	Go to step 2.
<b>2 CHECK PASSENGER'S AIRBAG MODULE.</b> 1) Turn the ignition switch to OFF, disconnect the battery ground cable, and wait for 60 seconds or more. 2) Remove the console front panel and disconnect the connector (AB9). 3) Connect the connector (1P) in the test harness P to connector (AB9). 4) Connect the airbag resistor to the connectors (2P) and (3P) of test harness P. 5) Connect the battery ground terminal and turn the ignition switch to ON.	Does the airbag warning light illuminate for six seconds and go off?	Replace the passenger's airbag module. <Ref. to AB-17, Passenger's Airbag Module.>	Go to step 3.

## Diagnostic Chart with Trouble Code

### AIRBAG SYSTEM (DIAGNOSTICS)

Step	Check	Yes	No
<b>3 CHECK AIRBAG MAIN HARNESS (PASSENGER'S AIRBAG HARNESS).</b> 1) Turn the ignition switch to OFF, disconnect the battery ground cable, and wait for 60 seconds or more. 2) Disconnect the airbag resistor from the connectors (2P) and (3P) of test harness P. 3) Remove the instrument panel lower cover and disconnect the connector (AB7) from (AB2). 4) Disconnect the connectors (AB6, AB17, AB18) from the airbag control module, and connect the connector (1AH) in the test harness AH. 5) Connect the connector (2AH) in the test harness AH and the connector (1AG) in the test harness AG. 6) Measure the voltage between connector (3AG) in the test harness AG and chassis ground. <i><b>Connector &amp; terminal</b></i> <i><b>(3AG) No. 6 (+) — Chassis ground (-):</b></i> <i><b>(3AG) No. 8 (+) — Chassis ground (-):</b></i>	Is the voltage less than 1 V?	Go to step 4.	Replace the airbag main harness along with body harness.
<b>4 CHECK AIRBAG CONTROL MODULE.</b> 1) Connect all connectors. 2) Clear the memory. 3) Perform the Inspection Mode. 4) Read the DTC.	Is the same DTC displayed?	Replace the airbag control module. <Ref. to AB-22, Airbag Control Module.>	Go to step 5.
<b>5 CHECK FOR ANY OTHER DTC ON DISPLAY.</b>	Is any other DTC displayed?	Check DTC using "List of Diagnostic Trouble Code (DTC)". <Ref. to AB(diag)-39, List of Diagnostic Trouble Code (DTC).>	Finish the diagnosis.

# Diagnostic Chart with Trouble Code

AIRBAG SYSTEM (DIAGNOSTICS)

## BC:DTC 7A DRIVER'S AIRBAG FAILURE

### DTC DETECTING CONDITION:

- Airbag main harness circuit is shorted.
- Airbag module harness (driver's side) circuit is shorted.
- Roll connector circuit is shorted.
- Driver's airbag module is faulty.
- Airbag control module is faulty.

### CAUTION:

- Before diagnosing the airbag system, be sure to turn the ignition switch to OFF, disconnect the ground cable from battery, and wait 60 seconds or more before starting to work.
- When replacing the airbag module, seat belt pretensioner, roll connector, control module and sensor, reconnect each part and check that the warning light operates properly.
- When inspecting the airbag main harness, disconnect the airbag module connectors of the driver's and passenger's seats for safety.
- When inspecting the airbag rear harness, disconnect the side airbag module connector, curtain airbag module connector and seat belt pretensioner connector for safety reasons.

### NOTE:

Prior to starting work, prepare two AIRBAG RESISTORS (98299PA040).

### WIRING DIAGRAM:

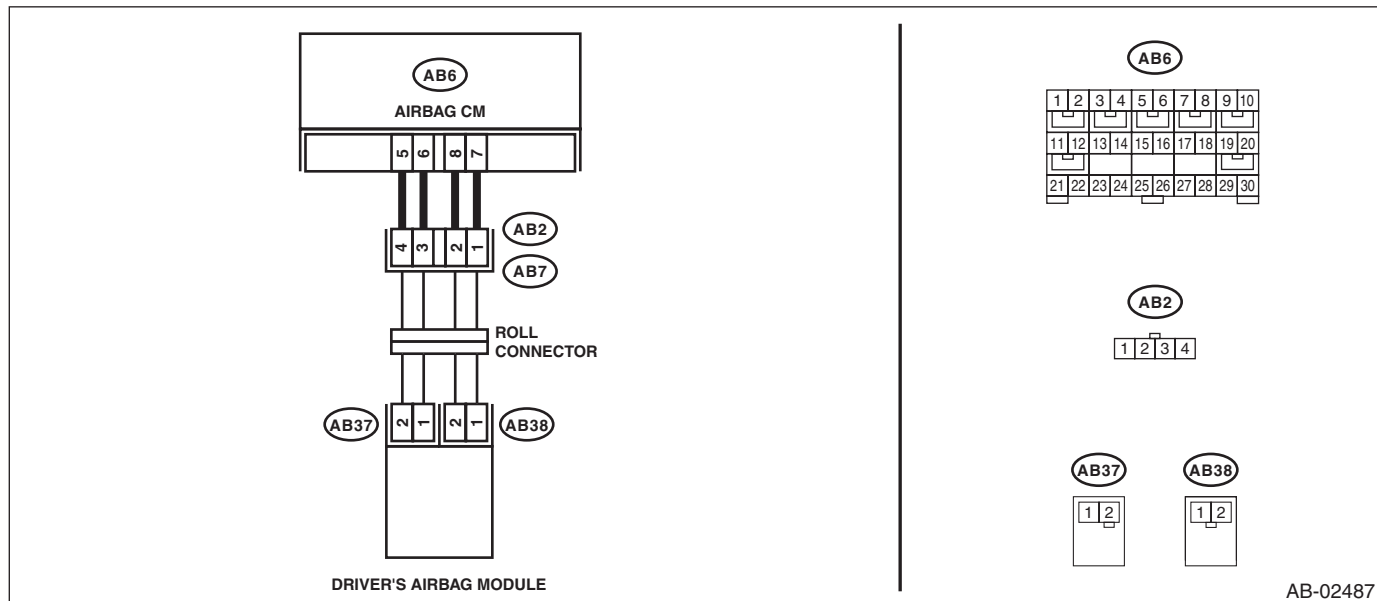

	Step	Check	Yes	No
1	<b>CHECK POOR CONTACT OF CONNECTORS.</b> Check for poor contact of the connectors between the airbag control module and the driver's airbag module.	Is there poor contact?	Replace the airbag harness.	Go to step 2.

## Diagnostic Chart with Trouble Code

### AIRBAG SYSTEM (DIAGNOSTICS)

Step	Check	Yes	No
<b>2 CHECK DRIVER'S AIRBAG MODULE.</b> 1) Turn the ignition switch to OFF, disconnect the battery ground cable, and wait for 60 seconds or more. 2) Remove the driver's airbag module. 3) Connect the connector (1N) in the test harness N to the connector (AB38). 4) Connect the airbag resistor to the connector (2N) of test harness N. 5) Connect the connector (1Q) in the test harness Q to connector (AB37). 6) Connect the airbag resistor to the connector (2Q) in the test harness Q. 7) Connect the battery ground terminal and turn the ignition switch to ON.	Does the airbag warning light illuminate for six seconds and go off?	Replace the driver's airbag module. <Ref. to AB-16, Driver's Airbag Module.>	Go to step 3.
<b>3 CHECK ROLL CONNECTOR.</b> 1) Turn the ignition switch to OFF, disconnect the battery ground cable, and wait for 60 seconds or more. 2) Disconnect the test harness N from connector (AB38). 3) Disconnect the test harness Q from connector (AB37). 4) Remove the instrument panel lower cover and disconnect the connector (AB7) from (AB2). 5) Connect the connector (1P) in the test harness P to connector (AB2). 6) Connect the airbag resistor to the connectors (2P) and (3P) of test harness P. 7) Connect the battery ground terminal and turn the ignition switch to ON.	Does the airbag warning light illuminate for six seconds and go off?	Replace the roll connector. <Ref. to AB-27, Roll Connector.>	Go to step 4.
<b>4 CHECK AIRBAG MAIN HARNESS (DRIVER'S AIRBAG HARNESS).</b> 1) Turn the ignition switch to OFF, disconnect the battery ground cable, and wait for 60 seconds or more. 2) Disconnect the airbag resistor from the connectors (2P) and (3P) of test harness P. 3) Remove the console front panel and disconnect the connector (AB9). 4) Disconnect the connectors (AB6, AB17, AB18) from the airbag control module, and connect the connector (1AH) in the test harness AH. 5) Connect the connector (2AH) in the test harness AH and the connector (1AG) in the test harness AG. 6) Measure the resistance between connector (3AG) terminals in test harness AG. <b>Connector &amp; terminal</b> <b>(3AG) No. 2 — (3AG) No. 4:</b>	Is the resistance 1 MΩ or more?	Go to step 5.	Replace the airbag main harness along with body harness.
<b>5 CHECK AIRBAG CONTROL MODULE.</b> 1) Connect all connectors. 2) Clear the memory. 3) Perform the Inspection Mode. 4) Read the DTC.	Is the same DTC displayed?	Replace the airbag control module. <Ref. to AB-22, Airbag Control Module.>	Go to step 6.

# Diagnostic Chart with Trouble Code

AIRBAG SYSTEM (DIAGNOSTICS)

Step	Check	Yes	No
6 <b>CHECK FOR ANY OTHER DTC ON DISPLAY.</b>	Is any other DTC displayed?	Check DTC using "List of Diagnostic Trouble Code (DTC)". <Ref. to AB(diag)-39, List of Diagnostic Trouble Code (DTC).>	Finish the diagnosis.

# Diagnostic Chart with Trouble Code

AIRBAG SYSTEM (DIAGNOSTICS)

## BD:DTC 7B PASSENGER'S AIRBAG FAILURE

### DTC DETECTING CONDITION:

- Airbag main harness circuit is shorted.
- Airbag module harness (passenger's side) circuit is shorted.
- Passenger's airbag module is faulty.
- Airbag control module is faulty.

### CAUTION:

- Before diagnosing the airbag system, be sure to turn the ignition switch to OFF, disconnect the ground cable from battery, and wait 60 seconds or more before starting to work.
- When replacing the airbag module, seat belt pretensioner, roll connector, control module and sensor, reconnect each part and check that the warning light operates properly.
- When inspecting the airbag main harness, disconnect the airbag module connectors of the driver's and passenger's seats for safety.
- When inspecting the airbag rear harness, disconnect the side airbag module connector, curtain airbag module connector and seat belt pretensioner connector for safety reasons.

### NOTE:

Prior to starting work, prepare two AIRBAG RESISTORS (98299PA040).

### WIRING DIAGRAM:

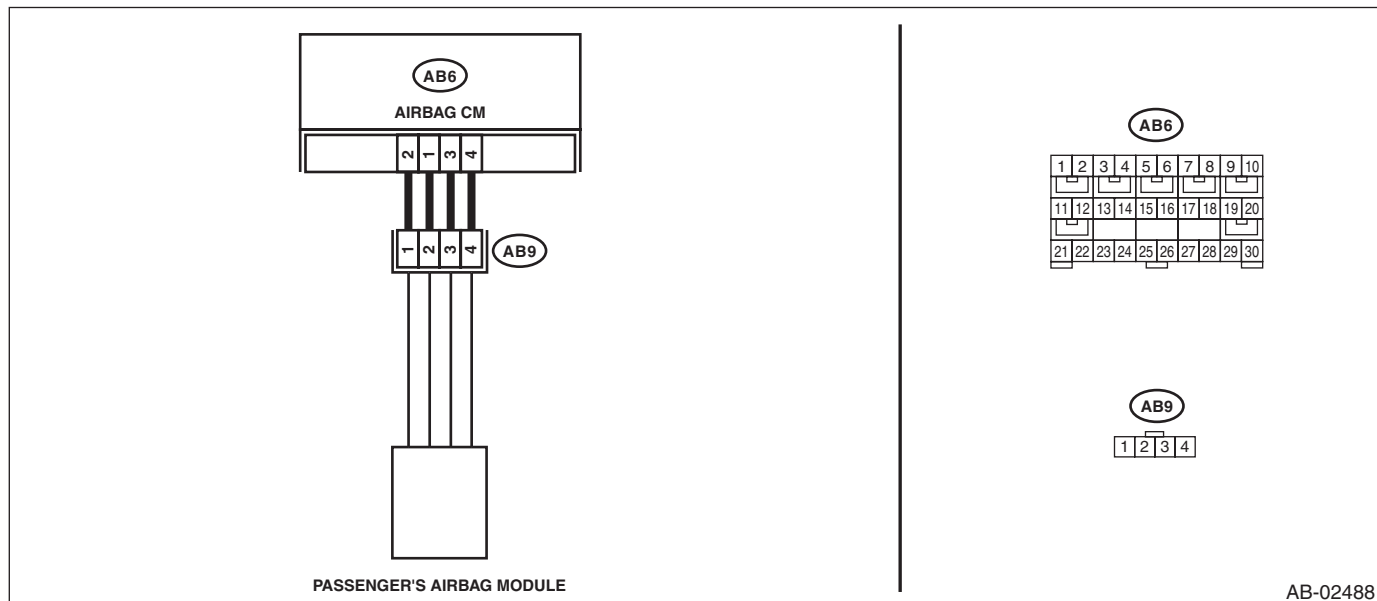

Step	Check	Yes	No
<b>1 CHECK POOR CONTACT OF CONNECTORS.</b> Check for poor contact of the connectors between the airbag control module and the passenger's airbag module.	Is there poor contact?	Replace the airbag harness.	Go to step 2.
<b>2 CHECK PASSENGER'S AIRBAG MODULE.</b> 1) Turn the ignition switch to OFF, disconnect the battery ground cable, and wait for 60 seconds or more. 2) Remove the console front panel and disconnect the connector (AB9). 3) Connect the connector (1P) in the test harness P to connector (AB9). 4) Connect the airbag resistor to the connectors (2P) and (3P) of test harness P. 5) Connect the battery ground terminal and turn the ignition switch to ON.	Does the airbag warning light illuminate for six seconds and go off?	Replace the passenger's airbag module. <Ref. to AB-17, Passenger's Airbag Module.>	Go to step 3.

# Diagnostic Chart with Trouble Code

AIRBAG SYSTEM (DIAGNOSTICS)

Step	Check	Yes	No
<b>3 CHECK AIRBAG MAIN HARNESS (PASSENGER'S AIRBAG HARNESS).</b> 1) Turn the ignition switch to OFF, disconnect the battery ground cable, and wait for 60 seconds or more. 2) Disconnect the airbag resistor from the connectors (2P) and (3P) of test harness P. 3) Remove the instrument panel lower cover and column cover, and disconnect the connector (AB7) from (AB2). 4) Disconnect the connectors (AB6, AB17, AB18) from the airbag control module, and connect the connector (1AH) in the test harness AH. 5) Connect the connector (2AH) in the test harness AH and the connector (1AG) in the test harness AG. 6) Measure the resistance between connector (3AG) terminals in test harness AG. <b>Connector &amp; terminal (3AG) No. 6 — (3AG) No. 8:</b>	Is the resistance 1 MΩ or more?	Go to step 4.	Replace the airbag main harness along with body harness.
<b>4 CHECK AIRBAG CONTROL MODULE.</b> 1) Connect all connectors. 2) Clear the memory. 3) Perform the Inspection Mode. 4) Read the DTC.	Is the same DTC displayed?	Replace the airbag control module. <Ref. to AB-22, Airbag Control Module.>	Go to step 5.
<b>5 CHECK FOR ANY OTHER DTC ON DISPLAY.</b>	Is any other DTC displayed?	Check DTC using "List of Diagnostic Trouble Code (DTC)". <Ref. to AB(diag)-39, List of Diagnostic Trouble Code (DTC).>	Finish the diagnosis.



# Diagnostic Chart with Trouble Code

## AIRBAG SYSTEM (DIAGNOSTICS)

### BE:DTC 7D DRIVER'S AIRBAG FAILURE

#### DTC DETECTING CONDITION:

- Airbag main harness circuit is open.
- Airbag module harness (driver's side) circuit is open.
- Roll connector circuit is open.
- Driver's airbag module is faulty.
- Airbag control module is faulty.

#### CAUTION:

- Before diagnosing the airbag system, be sure to turn the ignition switch to OFF, disconnect the ground cable from battery, and wait 60 seconds or more before starting to work.
- When replacing the airbag module, seat belt pretensioner, roll connector, control module and sensor, reconnect each part and check that the warning light operates properly.
- When inspecting the airbag main harness, disconnect the airbag module connectors of the driver's and passenger's seats for safety.
- When inspecting the airbag rear harness, disconnect the side airbag module connector, curtain airbag module connector and seat belt pretensioner connector for safety reasons.

#### NOTE:

Prior to starting work, prepare two AIRBAG RESISTORS (98299PA040).

#### WIRING DIAGRAM:

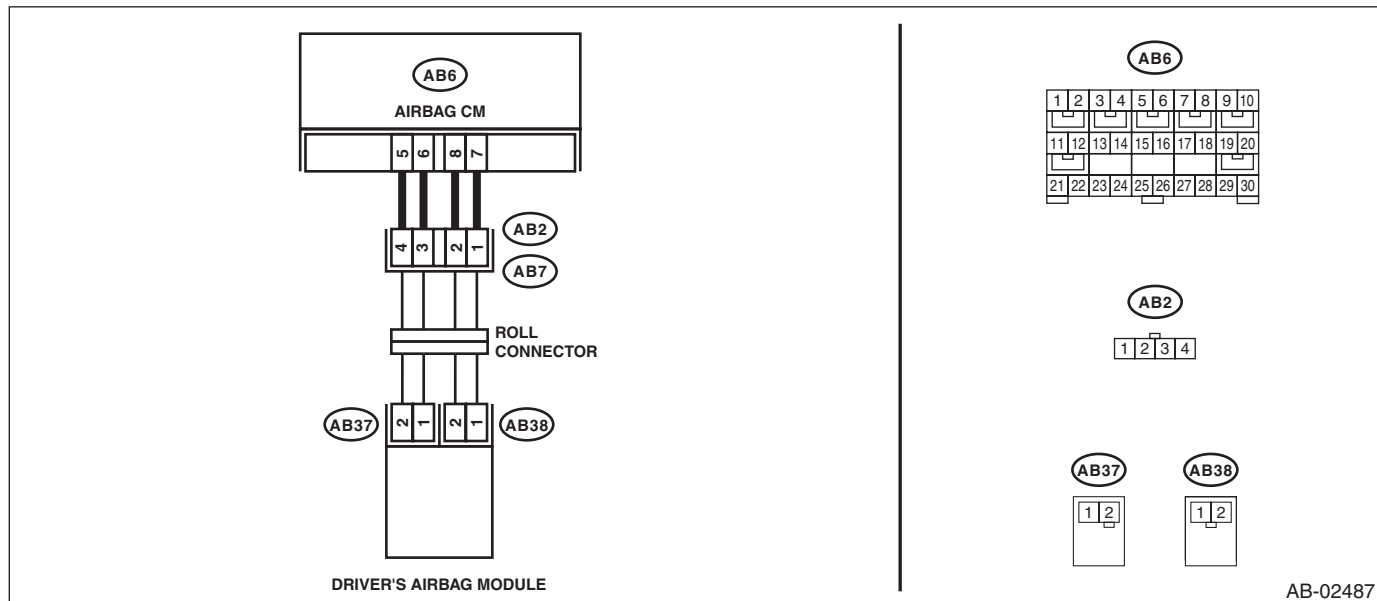

Step	Check	Yes	No
1	<p><b>CHECK POOR CONTACT OF CONNECTORS.</b> Check for poor contact of the connectors between the airbag control module and the driver's airbag module.</p>	Is there poor contact?	<p>Replace the airbag harness.</p> <p>Go to step 2.</p>

# Diagnostic Chart with Trouble Code

AIRBAG SYSTEM (DIAGNOSTICS)

Step	Check	Yes	No
<p><b>2 CHECK DRIVER'S AIRBAG MODULE.</b></p> <ol style="list-style-type: none"> <li>1) Turn the ignition switch to OFF, disconnect the battery ground cable, and wait for 60 seconds or more.</li> <li>2) Remove the driver's airbag module.</li> <li>3) Connect the connector (1N) in the test harness N to the connector (AB38).</li> <li>4) Connect the airbag resistor to the connector (2N) of test harness N.</li> <li>5) Connect the connector (1Q) in the test harness Q to connector (AB37).</li> <li>6) Connect the airbag resistor to the connector (2Q) in the test harness Q.</li> <li>7) Connect the battery ground terminal and turn the ignition switch to ON.</li> </ol>	Does the airbag warning light illuminate for six seconds and go off?	Replace the driver's airbag module. <Ref. to AB-16, Driver's Airbag Module.>	Go to step 3.
<p><b>3 CHECK ROLL CONNECTOR.</b></p> <ol style="list-style-type: none"> <li>1) Turn the ignition switch to OFF, disconnect the battery ground cable, and wait for 60 seconds or more.</li> <li>2) Disconnect the test harness N from connector (AB38).</li> <li>3) Disconnect the test harness Q from connector (AB37).</li> <li>4) Remove the instrument panel lower cover and disconnect the connector (AB7) from (AB2).</li> <li>5) Connect the connector (1P) in the test harness P to connector (AB2).</li> <li>6) Connect the airbag resistor to the connectors (2P) and (3P) of test harness P.</li> <li>7) Connect the battery ground terminal and turn the ignition switch to ON.</li> </ol>	Does the airbag warning light illuminate for six seconds and go off?	Replace the roll connector. <Ref. to AB-27, Roll Connector.>	Go to step 4.
<p><b>4 CHECK AIRBAG MAIN HARNESS (DRIVER'S AIRBAG HARNESS).</b></p> <ol style="list-style-type: none"> <li>1) Turn the ignition switch to OFF, disconnect the battery ground cable, and wait for 60 seconds or more.</li> <li>2) Disconnect the airbag resistor from the connectors (2P) and (3P) of test harness P.</li> <li>3) Remove the console front panel and disconnect the connector (AB9).</li> <li>4) Disconnect the connectors (AB6, AB17, AB18) from the airbag control module, and connect the connector (1AH) in the test harness AH.</li> <li>5) Connect the connector (2AH) in the test harness AH and the connector (1AG) in the test harness AG.</li> <li>6) Measure the resistance between connector (3AG) of test harness AG and connector (3P) of test harness P.</li> </ol> <p style="margin-left: 20px;"><b>Connector &amp; terminal</b> (3AG) No. 2 — (3P) No. 3: (3AG) No. 4 — (3P) No. 4:</p>	Is the resistance less than 10 $\Omega$ ?	Go to step 5.	Replace the airbag main harness along with body harness.
<p><b>5 CHECK AIRBAG CONTROL MODULE.</b></p> <ol style="list-style-type: none"> <li>1) Connect all connectors.</li> <li>2) Clear the memory.</li> <li>3) Perform the Inspection Mode.</li> <li>4) Read the DTC.</li> </ol>	Is the same DTC displayed?	Replace the airbag control module. <Ref. to AB-22, Airbag Control Module.>	Go to step 6.

# Diagnostic Chart with Trouble Code

## AIRBAG SYSTEM (DIAGNOSTICS)

Step	Check	Yes	No
6 <b>CHECK FOR ANY OTHER DTC ON DISPLAY.</b>	Is any other DTC displayed?	Check DTC using "List of Diagnostic Trouble Code (DTC)". <Ref. to AB(diag)-39, List of Diagnostic Trouble Code (DTC).>	Finish the diagnosis.

# Diagnostic Chart with Trouble Code

AIRBAG SYSTEM (DIAGNOSTICS)

## BF:DTC 7E PASSENGER'S AIRBAG FAILURE

### DTC DETECTING CONDITION:

- Airbag main harness circuit is open.
- Airbag module harness (passenger's side) circuit is open.
- Passenger's airbag module is faulty.
- Airbag control module is faulty.

### CAUTION:

- Before diagnosing the airbag system, be sure to turn the ignition switch to OFF, disconnect the ground cable from battery, and wait 60 seconds or more before starting to work.
- When replacing the airbag module, seat belt pretensioner, roll connector, control module and sensor, reconnect each part and check that the warning light operates properly.
- When inspecting the airbag main harness, disconnect the airbag module connectors of the driver's and passenger's seats for safety.
- When inspecting the airbag rear harness, disconnect the side airbag module connector, curtain airbag module connector and seat belt pretensioner connector for safety reasons.

### NOTE:

Prior to starting work, prepare two AIRBAG RESISTORS (98299PA040).

### WIRING DIAGRAM:

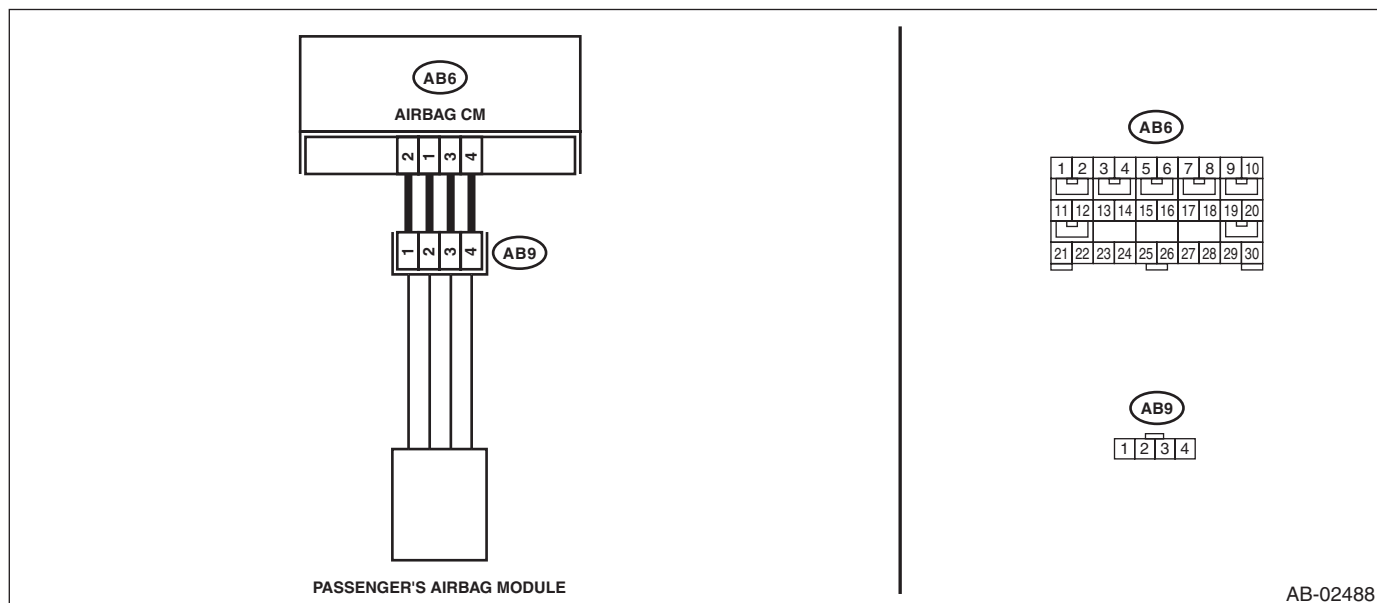

Step	Check	Yes	No
<b>1 CHECK POOR CONTACT OF CONNECTORS.</b> Check for poor contact of the connectors between the airbag control module and the passenger's airbag module.	Is there poor contact?	Replace the airbag harness.	Go to step 2.
<b>2 CHECK PASSENGER'S AIRBAG MODULE.</b> 1) Turn the ignition switch to OFF, disconnect the battery ground cable, and wait for 60 seconds or more. 2) Remove the console front panel and disconnect the connector (AB9). 3) Connect the connector (1P) in the test harness P to connector (AB9). 4) Connect the airbag resistor to the connectors (2P) and (3P) of test harness P. 5) Connect the battery ground terminal and turn the ignition switch to ON.	Does the airbag warning light illuminate for six seconds and go off?	Replace the passenger's airbag module. <Ref. to AB-17, Passenger's Airbag Module.>	Go to step 3.

# Diagnostic Chart with Trouble Code

## AIRBAG SYSTEM (DIAGNOSTICS)

Step	Check	Yes	No
<b>3 CHECK AIRBAG MAIN HARNESS (PASSENGER'S AIRBAG HARNESS).</b> 1) Turn the ignition switch to OFF, disconnect the battery ground cable, and wait for 60 seconds or more. 2) Disconnect the airbag resistor from the connectors (2P) and (3P) of test harness P. 3) Remove the instrument panel lower cover and column cover, and disconnect the connector (AB7) from (AB2). 4) Disconnect the connectors (AB6, AB17, AB18) from the airbag control module, and connect the connector (1AH) in the test harness AH. 5) Connect the connector (2AH) in the test harness AH and the connector (1AG) in the test harness AG. 6) Measure the resistance between connector (3AG) of test harness AG and connector (3P) of test harness P. <b>Connector &amp; terminal</b> <b>(3AG) No. 6 — (3P) No. 4:</b> <b>(3AG) No. 8 — (3P) No. 3:</b>	Is the resistance less than 10 $\Omega$ ?	Go to step 4.	Replace the airbag main harness along with body harness.
<b>4 CHECK AIRBAG CONTROL MODULE.</b> 1) Connect all connectors. 2) Clear the memory. 3) Perform the Inspection Mode. 4) Read the DTC.	Is the same DTC displayed?	Replace the airbag control module. <Ref. to AB-22, Airbag Control Module.>	Go to step 5.
<b>5 CHECK FOR ANY OTHER DTC ON DISPLAY.</b>	Is any other DTC displayed?	Check DTC using "List of Diagnostic Trouble Code (DTC)". <Ref. to AB(diag)-39, List of Diagnostic Trouble Code (DTC).>	Finish the diagnosis.

# Diagnostic Chart with Trouble Code

AIRBAG SYSTEM (DIAGNOSTICS)

## BG:DTC 91 CURTAIN AIRBAG MODULE RH FAILURE

### DTC DETECTING CONDITION:

- Curtain airbag harness (RH) circuit is shorted to ground.
- Curtain airbag module (RH) is faulty.
- Airbag control module is faulty.

### CAUTION:

- Before diagnosing the airbag system, be sure to turn the ignition switch to OFF, disconnect the ground cable from battery, and wait 60 seconds or more before starting to work.
- When replacing the airbag module, seat belt pretensioner, roll connector, control module and sensor, reconnect each part and check that the warning light operates properly.
- When inspecting the airbag main harness, disconnect the airbag module connectors of the driver's and passenger's seats for safety.
- When inspecting the airbag rear harness, disconnect the side airbag module connector, curtain airbag module connector and seat belt pretensioner connector for safety reasons.

### WIRING DIAGRAM:

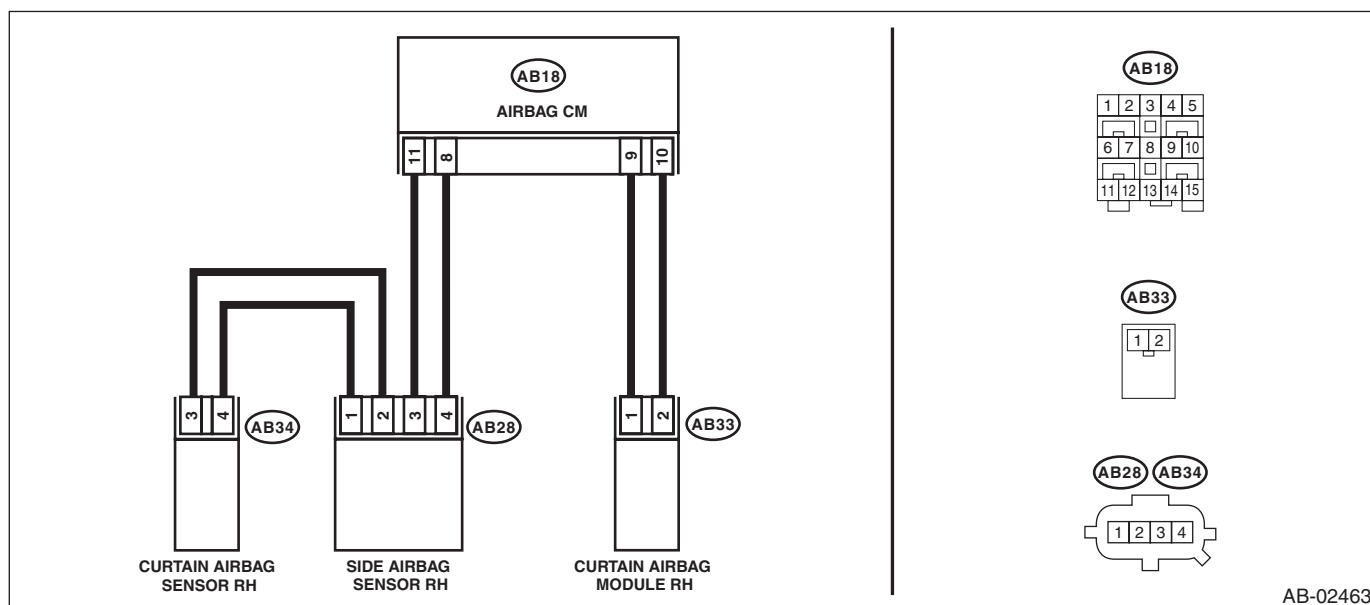

AB-02463

Step	Check	Yes	No
<b>1 CHECK POOR CONTACT OF CONNECTORS.</b> Check for poor contact of the connectors between the airbag control module, curtain airbag module RH and the curtain airbag sensor RH.	Is there poor contact?	Replace the airbag rear harness along with body harness.	Go to step 2.
<b>2 CHECK CURTAIN AIRBAG MODULE.</b> 1) Turn the ignition switch to OFF, disconnect the battery ground cable, and wait for 60 seconds or more. 2) Disconnect the connector (AB33), and connect the connector (1N) in test harness N to connector (AB33). 3) Connect the airbag resistor to the connector (2N) of test harness N. 4) Connect the battery ground terminal and turn the ignition switch to ON.	Does the airbag warning light illuminate for six seconds and go off?	Replace the curtain airbag module (RH). <Ref. to AB-20, Curtain Airbag Module.>	Go to step 3.

# Diagnostic Chart with Trouble Code

## AIRBAG SYSTEM (DIAGNOSTICS)

Step	Check	Yes	No
<b>3 CHECK AIRBAG REAR HARNESS (CURRENT AIRBAG MODULE HARNESS RH).</b> 1) Turn the ignition switch to OFF, disconnect the battery ground cable, and wait for 60 seconds or more. 2) Disconnect the connector (AB26) from seat belt pretensioner (RH). 3) Disconnect connector (AB24) from side airbag module (RH). 4) Disconnect the airbag resistor from test harness N. 5) Disconnect the connectors (AB6, AB17, AB18) from airbag control module. 6) Connect the connector (1AH) in the test harness AH to the connectors (AB6, AB17, AB18). 7) Connect the connector (2AH) in the test harness AH and the connector (1AG) in the test harness AG. 8) Measure the resistance between connector (5AG) in the test harness AG and chassis ground. <b>Connector &amp; terminal</b> <b>(5AG) No. 6 — Chassis ground:</b> <b>(5AG) No. 12 — Chassis ground:</b>	Is the resistance 1 MΩ or more?	Go to step 4.	Replace the airbag rear harness along with body harness.
<b>4 CHECK AIRBAG CONTROL MODULE.</b> 1) Connect all connectors. 2) Clear the memory. 3) Perform the Inspection Mode. 4) Read the DTC.	Is the same DTC displayed?	Replace the airbag control module. <Ref. to AB-22, Airbag Control Module.>	Go to step 5.
<b>5 CHECK FOR ANY OTHER DTC ON DISPLAY.</b>	Is any other DTC displayed?	Check DTC using "List of Diagnostic Trouble Code (DTC)". <Ref. to AB(diag)-39, List of Diagnostic Trouble Code (DTC).>	Finish the diagnosis.

# Diagnostic Chart with Trouble Code

AIRBAG SYSTEM (DIAGNOSTICS)

## BH:DTC 92 CURTAIN AIRBAG MODULE LH FAILURE

### DTC DETECTING CONDITION:

- Curtain airbag harness (LH) circuit is shorted to ground.
- Curtain airbag module (LH) is faulty.
- Airbag control module is faulty.

### CAUTION:

- Before diagnosing the airbag system, be sure to turn the ignition switch to OFF, disconnect the ground cable from battery, and wait 60 seconds or more before starting to work.
- When replacing the airbag module, seat belt pretensioner, roll connector, control module and sensor, reconnect each part and check that the warning light operates properly.
- When inspecting the airbag main harness, disconnect the airbag module connectors of the driver's and passenger's seats for safety.
- When inspecting the airbag rear harness, disconnect the side airbag module connector, curtain airbag module connector and seat belt pretensioner connector for safety reasons.

### WIRING DIAGRAM:

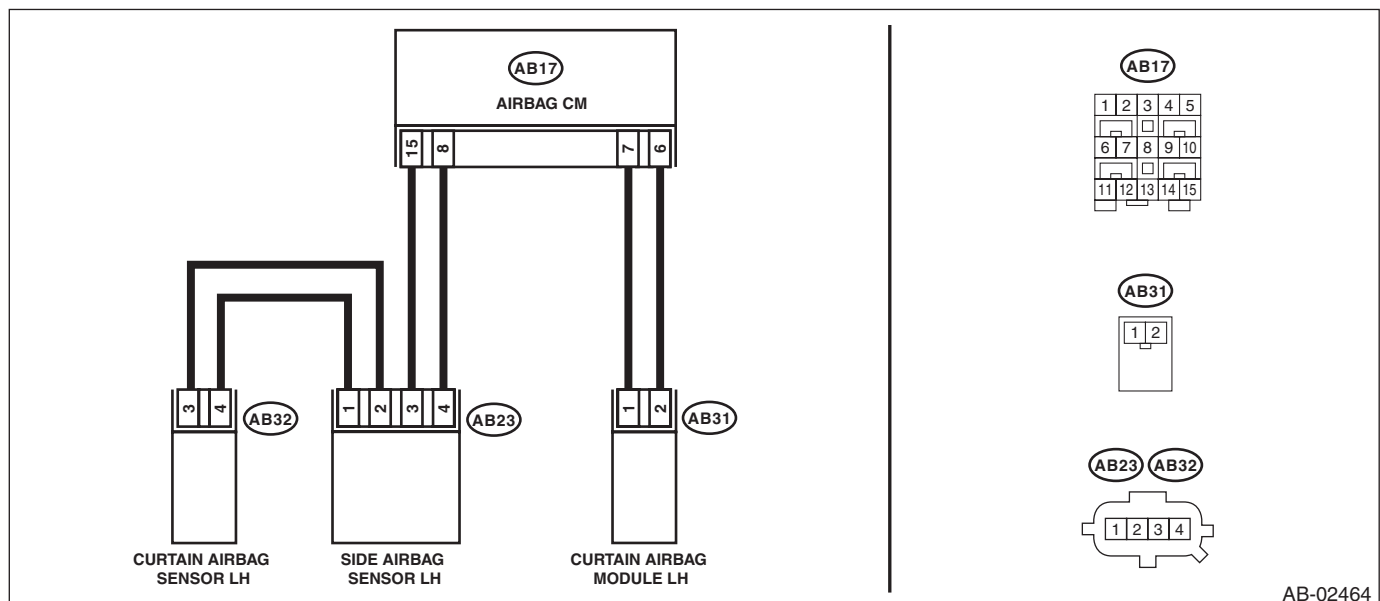

AB-02464

Step	Check	Yes	No
<b>1 CHECK POOR CONTACT OF CONNECTORS.</b> Check for poor contact of the connectors between the airbag control module, curtain airbag module LH and the curtain airbag sensor LH.	Is there poor contact?	Replace the airbag rear harness along with body harness.	Go to step 2.
<b>2 CHECK CURTAIN AIRBAG MODULE.</b> 1) Turn the ignition switch to OFF, disconnect the battery ground cable, and wait for 60 seconds or more. 2) Disconnect the connector (AB31), and connect the connector (1N) in test harness N to connector (AB31). 3) Connect the airbag resistor to the connector (2N) of test harness N. 4) Connect the battery ground terminal and turn the ignition switch to ON.	Does the airbag warning light illuminate for six seconds and go off?	Replace the curtain airbag module (LH). <Ref. to AB-20, Curtain Airbag Module.>	Go to step 3.

AB(diag)-133

Brought to you by Ebay Seller "SubaruManuals"



# Diagnostic Chart with Trouble Code

## AIRBAG SYSTEM (DIAGNOSTICS)

Step	Check	Yes	No
<b>3</b> <b>CHECK AIRBAG REAR HARNESS (CURRENT AIRBAG MODULE HARNESS LH).</b> 1) Turn the ignition switch to OFF, disconnect the battery ground cable, and wait for 60 seconds or more. 2) Disconnect the connector (AB21) from seat belt pretensioner (LH). 3) Disconnect connector (AB19) from side airbag module (LH). 4) Disconnect the airbag resistor from test harness N. 5) Disconnect the connectors (AB6, AB17, AB18) from airbag control module. 6) Connect the connector (1AH) in the test harness AH to the connectors (AB6, AB17, AB18). 7) Connect the connector (2AH) in the test harness AH and the connector (1AG) in the test harness AG. 8) Measure the resistance between connector (5AG) in the test harness AG and chassis ground. <i><b>Connector &amp; terminal</b></i> <i><b>(5AG) No. 2 — Chassis ground:</b></i> <i><b>(5AG) No. 4 — Chassis ground:</b></i>	Is the resistance 1 MΩ or more?	Go to step 4.	Replace the airbag rear harness along with body harness.
<b>4</b> <b>CHECK AIRBAG CONTROL MODULE.</b> 1) Connect all connectors. 2) Clear the memory. 3) Perform the Inspection Mode. 4) Read the DTC.	Is the same DTC displayed?	Replace the airbag control module. <Ref. to AB-22, Airbag Control Module.>	Go to step 5.
<b>5</b> <b>CHECK FOR ANY OTHER DTC ON DISPLAY.</b>	Is any other DTC displayed?	Check DTC using "List of Diagnostic Trouble Code (DTC)". <Ref. to AB(diag)-39, List of Diagnostic Trouble Code (DTC).>	Finish the diagnosis.

# Diagnostic Chart with Trouble Code

AIRBAG SYSTEM (DIAGNOSTICS)

## BI: DTC 95 CURTAIN AIRBAG MODULE RH FAILURE

### DTC DETECTING CONDITION:

- Curtain airbag harness (RH) is shorted to power supply.
- Curtain airbag module (RH) is faulty.
- Airbag control module is faulty.

### CAUTION:

- Before diagnosing the airbag system, be sure to turn the ignition switch to OFF, disconnect the ground cable from battery, and wait 60 seconds or more before starting to work.
- When replacing the airbag module, seat belt pretensioner, roll connector, control module and sensor, reconnect each part and check that the warning light operates properly.
- When inspecting the airbag main harness, disconnect the airbag module connectors of the driver's and passenger's seats for safety.
- When inspecting the airbag rear harness, disconnect the side airbag module connector, curtain airbag module connector and seat belt pretensioner connector for safety reasons.

### WIRING DIAGRAM:

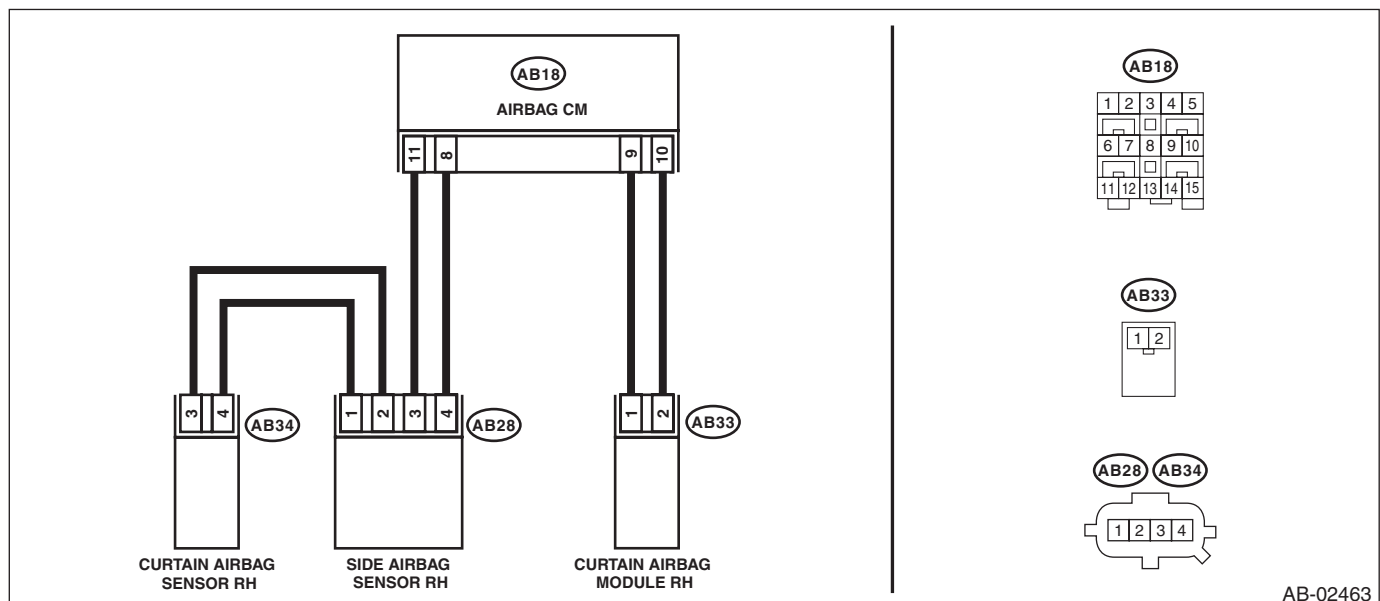

AB-02463

Step	Check	Yes	No
<b>1 CHECK POOR CONTACT OF CONNECTORS.</b> Check for poor contact of the connectors between the airbag control module, curtain airbag module RH and the curtain airbag sensor RH.	Is there poor contact?	Replace the airbag rear harness along with body harness.	Go to step 2.
<b>2 CHECK CURTAIN AIRBAG MODULE.</b> 1) Turn the ignition switch to OFF, disconnect the battery ground cable, and wait for 60 seconds or more. 2) Disconnect the connector (AB33), and connect the connector (1N) in test harness N to connector (AB33). 3) Connect the airbag resistor to the connector (2N) of test harness N. 4) Connect the battery ground terminal and turn the ignition switch to ON.	Does the airbag warning light illuminate for six seconds and go off?	Replace the curtain airbag module (RH). <Ref. to AB-20, Curtain Airbag Module.>	Go to step 3.

AB(diag)-135

Brought to you by Ebay Seller "SubaruManuals"

# Diagnostic Chart with Trouble Code

## AIRBAG SYSTEM (DIAGNOSTICS)

Step	Check	Yes	No
<b>3 CHECK AIRBAG REAR HARNESS (CURTAIN AIRBAG MODULE HARNESS RH).</b> 1) Turn the ignition switch to OFF, disconnect the battery ground cable, and wait for 60 seconds or more. 2) Disconnect the connector (AB26) from seat belt pretensioner (RH). 3) Disconnect connector (AB24) from side airbag module (RH). 4) Disconnect the airbag resistor from test harness N. 5) Disconnect the connectors (AB6, AB17, AB18) from airbag control module. 6) Connect the connector (1AH) in the test harness AH to the connectors (AB6, AB17, AB18). 7) Connect the connector (2AH) in the test harness AH and the connector (1AG) in the test harness AG. 8) Connect the battery ground terminal and turn the ignition switch to ON. 9) Measure the voltage between connector (5AG) in the test harness AG and chassis ground.  <b>Connector &amp; terminal</b> <b>(5AG) No. 6 (+) — Chassis ground (-):</b> <b>(5AG) No. 12 (+) — Chassis ground (-):</b>	Is the voltage less than 1 V?	Go to step 4.	Replace the airbag rear harness along with body harness.
<b>4 CHECK AIRBAG CONTROL MODULE.</b> 1) Connect all connectors. 2) Clear the memory. 3) Perform the Inspection Mode. 4) Read the DTC.	Is the same DTC displayed?	Replace the airbag control module. <Ref. to AB-22, Airbag Control Module.>	Go to step 5.
<b>5 CHECK FOR ANY OTHER DTC ON DISPLAY.</b>	Is any other DTC displayed?	Check DTC using "List of Diagnostic Trouble Code (DTC)". <Ref. to AB(diag)-39, List of Diagnostic Trouble Code (DTC).>	Finish the diagnosis.

# Diagnostic Chart with Trouble Code

AIRBAG SYSTEM (DIAGNOSTICS)

## BJ:DTC 96 CURTAIN AIRBAG MODULE LH FAILURE

### DTC DETECTING CONDITION:

- Curtain airbag harness (LH) is shorted to power supply.
- Curtain airbag module (LH) is faulty.
- Airbag control module is faulty.

### CAUTION:

- Before diagnosing the airbag system, be sure to turn the ignition switch to OFF, disconnect the ground cable from battery, and wait 60 seconds or more before starting to work.
- When replacing the airbag module, seat belt pretensioner, roll connector, control module and sensor, reconnect each part and check that the warning light operates properly.
- When inspecting the airbag main harness, disconnect the airbag module connectors of the driver's and passenger's seats for safety.
- When inspecting the airbag rear harness, disconnect the side airbag module connector, curtain airbag module connector and seat belt pretensioner connector for safety reasons.

### WIRING DIAGRAM:

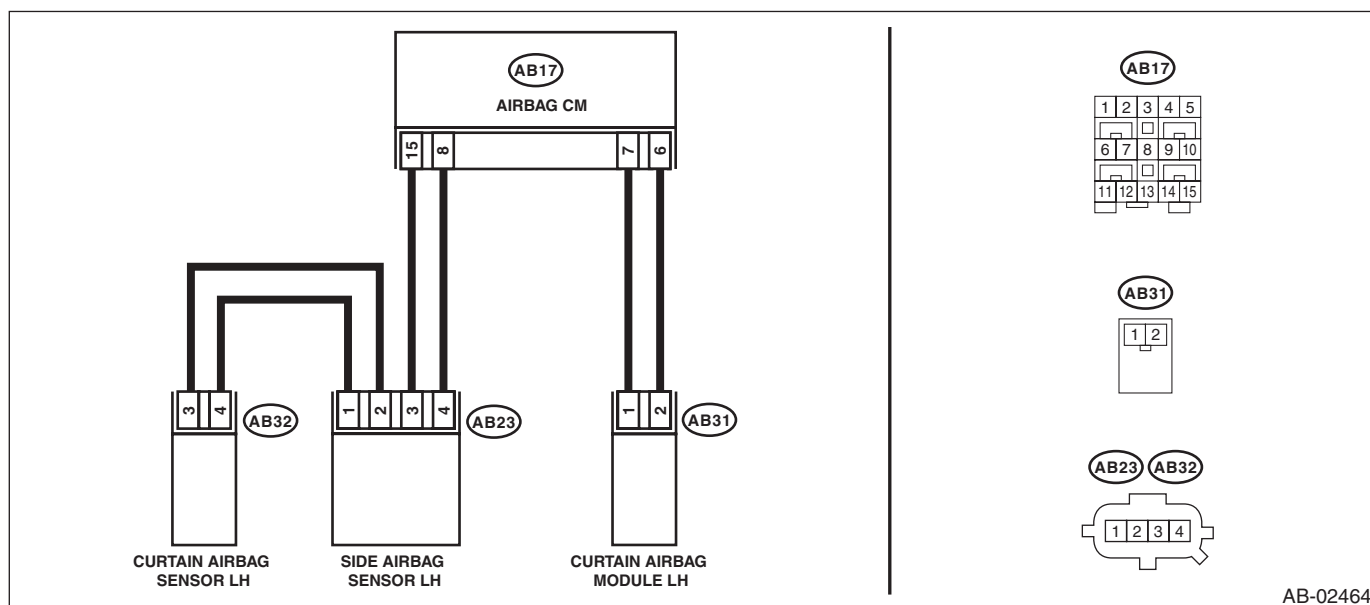

AB-02464

Step	Check	Yes	No
<b>1 CHECK POOR CONTACT OF CONNECTORS.</b> Check for poor contact of the connectors between the airbag control module, curtain airbag module LH and the curtain airbag sensor LH.	Is there poor contact?	Replace the airbag rear harness along with body harness.	Go to step 2.
<b>2 CHECK CURTAIN AIRBAG MODULE.</b> 1) Turn the ignition switch to OFF, disconnect the battery ground cable, and wait for 60 seconds or more. 2) Disconnect the connector (AB31), and connect the connector (1N) in test harness N to connector (AB31). 3) Connect the airbag resistor to the connector (2N) of test harness N. 4) Connect the battery ground terminal and turn the ignition switch to ON.	Does the airbag warning light illuminate for six seconds and go off?	Replace the curtain airbag module (LH). <Ref. to AB-20, Curtain Airbag Module.>	Go to step 3.

## Diagnostic Chart with Trouble Code

### AIRBAG SYSTEM (DIAGNOSTICS)

Step	Check	Yes	No
<b>3 CHECK AIRBAG REAR HARNESS (CURTAIN AIRBAG MODULE HARNESS LH).</b> 1) Turn the ignition switch to OFF, disconnect the battery ground cable, and wait for 60 seconds or more. 2) Disconnect the connector (AB21) from seat belt pretensioner (LH). 3) Disconnect connector (AB19) from side airbag module (LH). 4) Disconnect the airbag resistor from test harness N. 5) Disconnect the connectors (AB6, AB17, AB18) from airbag control module. 6) Connect the connector (1AH) in the test harness AH to the connectors (AB6, AB17, AB18). 7) Connect the connector (2AH) in the test harness AH and the connector (1AG) in the test harness AG. 8) Connect the battery ground terminal and turn the ignition switch to ON. 9) Measure the voltage between connector (5AG) in the test harness AG and chassis ground.  <b>Connector &amp; terminal</b> <b>(5AG) No. 2 (+) — Chassis ground (-):</b> <b>(5AG) No. 4 (+) — Chassis ground (-):</b>	Is the voltage less than 1 V?	Go to step 4.	Replace the airbag rear harness along with body harness.
<b>4 CHECK AIRBAG CONTROL MODULE.</b> 1) Connect all connectors. 2) Clear the memory. 3) Perform the Inspection Mode. 4) Read the DTC.	Is the same DTC displayed?	Replace the airbag control module. <Ref. to AB-22, Airbag Control Module.>	Go to step 5.
<b>5 CHECK FOR ANY OTHER DTC ON DISPLAY.</b>	Is any other DTC displayed?	Check DTC using "List of Diagnostic Trouble Code (DTC)". <Ref. to AB(diag)-39, List of Diagnostic Trouble Code (DTC).>	Finish the diagnosis.

# Diagnostic Chart with Trouble Code

AIRBAG SYSTEM (DIAGNOSTICS)

## BK:DTC 9A CURTAIN AIRBAG MODULE RH FAILURE

### DTC DETECTING CONDITION:

- Curtain airbag harness (RH) circuit is shorted.
- Curtain airbag module (RH) is faulty.
- Airbag control module is faulty.

### CAUTION:

- Before diagnosing the airbag system, be sure to turn the ignition switch to OFF, disconnect the ground cable from battery, and wait 60 seconds or more before starting to work.
- When replacing the airbag module, seat belt pretensioner, roll connector, control module and sensor, reconnect each part and check that the warning light operates properly.
- When inspecting the airbag main harness, disconnect the airbag module connectors of the driver's and passenger's seats for safety.
- When inspecting the airbag rear harness, disconnect the side airbag module connector, curtain airbag module connector and seat belt pretensioner connector for safety reasons.

### WIRING DIAGRAM:

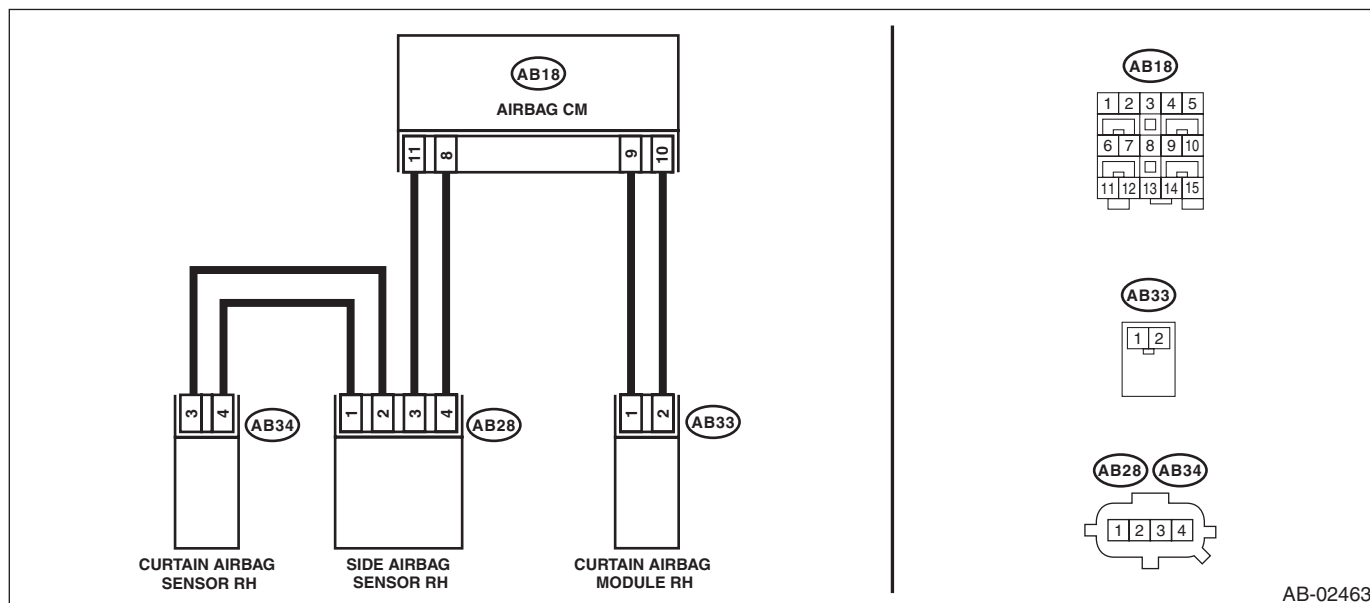

AB-02463

Step	Check	Yes	No
<b>1 CHECK POOR CONTACT OF CONNECTORS.</b> Check for poor contact of the connectors between the airbag control module, curtain airbag module RH and the curtain airbag sensor RH.	Is there poor contact?	Replace the airbag rear harness along with body harness.	Go to step 2.
<b>2 CHECK CURTAIN AIRBAG MODULE.</b> 1) Turn the ignition switch to OFF, disconnect the battery ground cable, and wait for 60 seconds or more. 2) Disconnect the connector (AB33) from curtain airbag module (RH). 3) Connect the connector (1N) in the test harness N to the connector (AB33). 4) Connect the airbag resistor to the connector (2N) of test harness N. 5) Connect the battery ground terminal and turn the ignition switch to ON.	Does the airbag warning light illuminate for 6 seconds and go off?	Replace the curtain airbag module (RH). <Ref. to AB-20, Curtain Airbag Module.>	Go to step 3.

# Diagnostic Chart with Trouble Code

## AIRBAG SYSTEM (DIAGNOSTICS)

Step	Check	Yes	No
<b>3 CHECK AIRBAG REAR HARNESS (CURTAIN AIRBAG MODULE HARNESS RH).</b> 1) Turn the ignition switch to OFF, disconnect the battery ground cable, and wait for 60 seconds or more. 2) Disconnect the connector (AB26) from seat belt pretensioner (RH). 3) Disconnect connector (AB24) from side airbag module (RH). 4) Disconnect the airbag resistor from test harness N. 5) Disconnect the connectors (AB6, AB17, AB18) from airbag control module. 6) Connect the connector (1AH) in the test harness AH to the connectors (AB6, AB17, AB18). 7) Connect the connector (2AH) in the test harness AH and the connector (1AG) in the test harness AG. 8) Measure the resistance between connector (5AG) terminals in test harness AG. <b>Connector &amp; terminal (5AG) No. 6 — (5AG) No. 12:</b>	Is the resistance 1 MΩ or more?	Go to step 4.	Replace the airbag rear harness along with body harness.
<b>4 CHECK AIRBAG CONTROL MODULE.</b> 1) Connect all connectors. 2) Clear the memory. 3) Perform the Inspection Mode. 4) Read the DTC.	Is the same DTC displayed?	Replace the airbag control module. <Ref. to AB-22, Airbag Control Module.>	Go to step 5.
<b>5 CHECK FOR ANY OTHER DTC ON DISPLAY.</b>	Is any other DTC displayed?	Check DTC using "List of Diagnostic Trouble Code (DTC)". <Ref. to AB(diag)-39, List of Diagnostic Trouble Code (DTC).>	Finish the diagnosis.

# Diagnostic Chart with Trouble Code

AIRBAG SYSTEM (DIAGNOSTICS)

## BL:DTC 9B CURTAIN AIRBAG MODULE LH FAILURE

### DTC DETECTING CONDITION:

- Curtain airbag harness (LH) circuit is shorted.
- Curtain airbag module (LH) is faulty.
- Airbag control module is faulty.

### CAUTION:

- Before diagnosing the airbag system, be sure to turn the ignition switch to OFF, disconnect the ground cable from battery, and wait 60 seconds or more before starting to work.
- When replacing the airbag module, seat belt pretensioner, roll connector, control module and sensor, reconnect each part and check that the warning light operates properly.
- When inspecting the airbag main harness, disconnect the airbag module connectors of the driver's and passenger's seats for safety.
- When inspecting the airbag rear harness, disconnect the side airbag module connector, curtain airbag module connector and seat belt pretensioner connector for safety reasons.

### WIRING DIAGRAM:

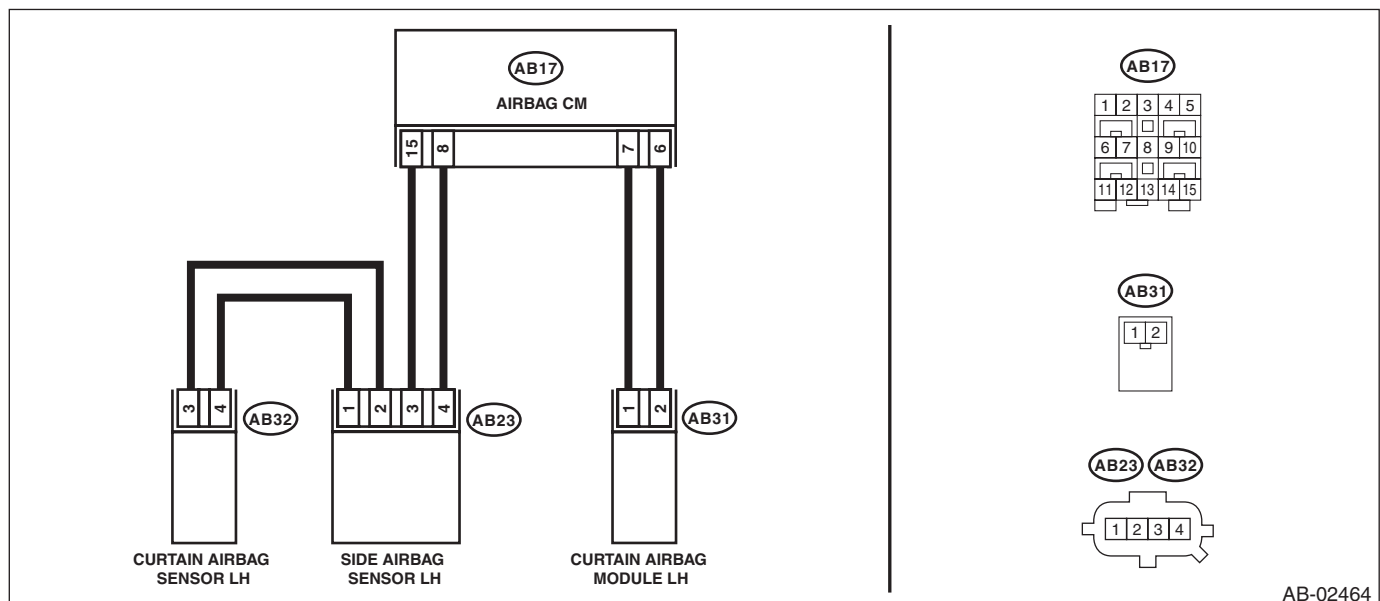

AB-02464

Step	Check	Yes	No
<b>1 CHECK POOR CONTACT OF CONNECTORS.</b> Check for poor contact of the connectors between the airbag control module, curtain airbag module LH and the curtain airbag sensor LH.	Is there poor contact?	Replace the airbag rear harness along with body harness.	Go to step 2.
<b>2 CHECK CURTAIN AIRBAG MODULE.</b> 1) Turn the ignition switch to OFF, disconnect the battery ground cable, and wait for 60 seconds or more. 2) Disconnect the connector (AB31) from curtain airbag module (LH). 3) Connect the connector (1N) in the test harness N to the connector (AB31). 4) Connect the airbag resistor to the connector (2N) of test harness N. 5) Connect the battery ground terminal and turn the ignition switch to ON.	Does the airbag warning light illuminate for 6 seconds and go off?	Replace the curtain airbag module (LH). <Ref. to AB-20, Curtain Airbag Module.>	Go to step 3.

AB(diag)-141

Brought to you by Ebay Seller "SubaruManuals"



## Diagnostic Chart with Trouble Code

### AIRBAG SYSTEM (DIAGNOSTICS)

Step	Check	Yes	No
<b>3 CHECK AIRBAG REAR HARNESS (CURTAIN AIRBAG MODULE HARNESS LH).</b> 1) Turn the ignition switch to OFF, disconnect the battery ground cable, and wait for 60 seconds or more. 2) Disconnect the connector (AB21) from seat belt pretensioner (LH). 3) Disconnect connector (AB19) from side airbag module (LH). 4) Disconnect the airbag resistor from test harness N. 5) Disconnect the connectors (AB6, AB17, AB18) from airbag control module. 6) Connect the connector (1AH) in the test harness AH to the connectors (AB6, AB17, AB18). 7) Connect the connector (2AH) in the test harness AH and the connector (1AG) in the test harness AG. 8) Measure the resistance between connector (5AG) terminals in test harness AG. <b>Connector &amp; terminal (5AG) No. 2 — (5AG) No. 4:</b>	Is the resistance 1 MΩ or more?	Go to step 4.	Replace the airbag rear harness along with body harness.
<b>4 CHECK AIRBAG CONTROL MODULE.</b> 1) Connect all connectors. 2) Clear the memory. 3) Perform the Inspection Mode. 4) Read the DTC.	Is the same DTC displayed?	Replace the airbag control module. <Ref. to AB-22, Airbag Control Module.>	Go to step 5.
<b>5 CHECK FOR ANY OTHER DTC ON DISPLAY.</b>	Is any other DTC displayed?	Check DTC using "List of Diagnostic Trouble Code (DTC)". <Ref. to AB(diag)-39, List of Diagnostic Trouble Code (DTC).>	Finish the diagnosis.

# Diagnostic Chart with Trouble Code

AIRBAG SYSTEM (DIAGNOSTICS)

## BM:DTC 9D CURTAIN AIRBAG MODULE RH FAILURE

### DTC DETECTING CONDITION:

- Curtain airbag harness (RH) circuit is open.
- Curtain airbag module (RH) is faulty.
- Airbag control module is faulty.

### CAUTION:

- Before diagnosing the airbag system, be sure to turn the ignition switch to OFF, disconnect the ground cable from battery, and wait 60 seconds or more before starting to work.
- When replacing the airbag module, seat belt pretensioner, roll connector, control module and sensor, reconnect each part and check that the warning light operates properly.
- When inspecting the airbag main harness, disconnect the airbag module connectors of the driver's and passenger's seats for safety.
- When inspecting the airbag rear harness, disconnect the side airbag module connector, curtain airbag module connector and seat belt pretensioner connector for safety reasons.

### WIRING DIAGRAM:

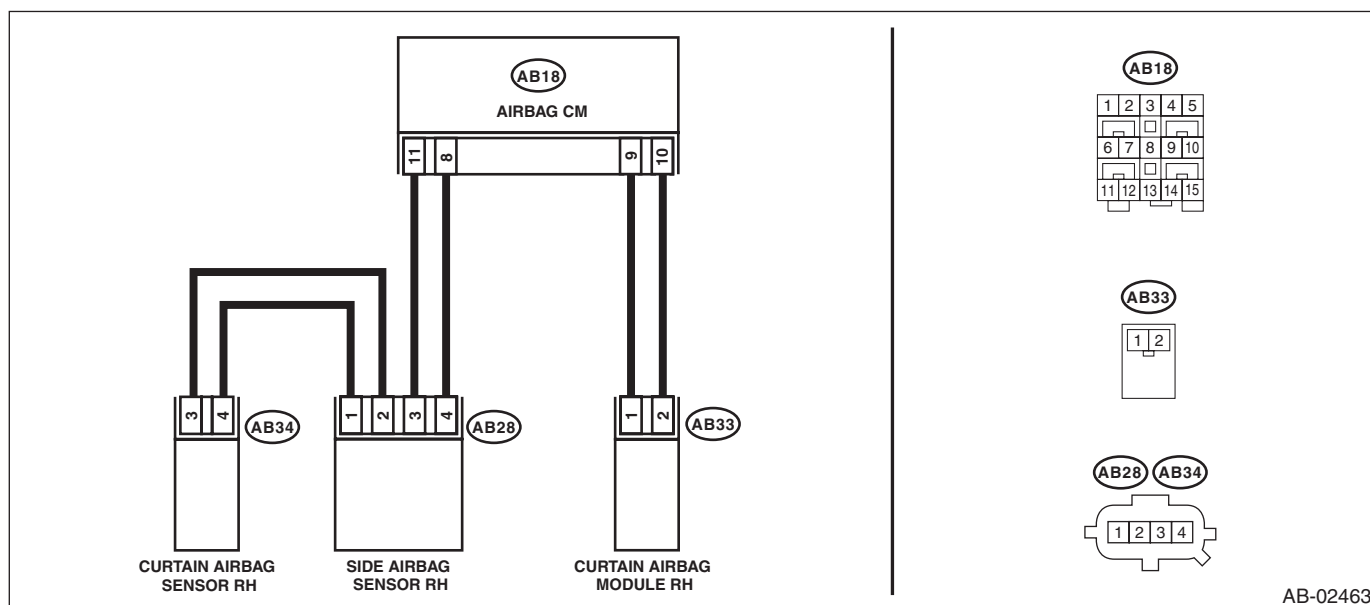

AB-02463

Step	Check	Yes	No
<b>1 CHECK POOR CONTACT OF CONNECTORS.</b> Check for poor contact of the connectors between the airbag control module, curtain airbag module RH and the curtain airbag sensor RH.	Is there poor contact?	Replace the airbag rear harness along with body harness.	Go to step 2.
<b>2 CHECK CURTAIN AIRBAG MODULE.</b> 1) Turn the ignition switch to OFF, disconnect the battery ground cable, and wait for 60 seconds or more. 2) Disconnect the connector (AB33) from curtain airbag module (RH). 3) Connect the connector (1N) in the test harness N to the connector (AB33). 4) Connect the airbag resistor to the connector (2N) of test harness N. 5) Connect the battery ground terminal and turn the ignition switch to ON.	Does the airbag warning light illuminate for 6 seconds and go off?	Replace the curtain airbag module (RH). <Ref. to AB-20, Curtain Airbag Module.>	Go to step 3.

## Diagnostic Chart with Trouble Code

### AIRBAG SYSTEM (DIAGNOSTICS)

Step	Check	Yes	No
<b>3 CHECK AIRBAG REAR HARNESS (CURRENT AIRBAG MODULE HARNESS RH).</b> 1) Turn the ignition switch to OFF, disconnect the battery ground cable, and wait for 60 seconds or more. 2) Disconnect the connector (AB26) from seat belt pretensioner (RH). 3) Disconnect connector (AB24) from side airbag module (RH). 4) Disconnect the airbag resistor from test harness N. 5) Disconnect the connectors (AB6, AB17, AB18) from airbag control module. 6) Connect the connector (1AH) in the test harness AH to the connectors (AB6, AB17, AB18). 7) Connect the connector (2AH) in the test harness AH and the connector (1AG) in the test harness AG. 8) Measure the resistance between connector (5AG) in the test harness AG and connector (2N) in the test harness N. <b>Connector &amp; terminal</b> <b>(5AG) No. 6 — (2N) No. 2:</b> <b>(5AG) No. 12 — (2N) No. 1:</b>	Is the resistance less than 10 $\Omega$ ?	Go to step 4.	Replace the airbag rear harness along with body harness.
<b>4 CHECK AIRBAG CONTROL MODULE.</b> 1) Connect all connectors. 2) Clear the memory. 3) Perform the Inspection Mode. 4) Read the DTC.	Is the same DTC displayed?	Replace the airbag control module. <Ref. to AB-22, Airbag Control Module.>	Go to step 5.
<b>5 CHECK FOR ANY OTHER DTC ON DISPLAY.</b>	Is any other DTC displayed?	Check DTC using "List of Diagnostic Trouble Code (DTC)". <Ref. to AB(diag)-39, List of Diagnostic Trouble Code (DTC).>	Finish the diagnosis.

# Diagnostic Chart with Trouble Code

AIRBAG SYSTEM (DIAGNOSTICS)

## BN:DTC 9E CURTAIN AIRBAG MODULE LH FAILURE

### DTC DETECTING CONDITION:

- Curtain airbag harness (LH) circuit is open.
- Curtain airbag module (LH) is faulty.
- Airbag control module is faulty.

### CAUTION:

- Before diagnosing the airbag system, be sure to turn the ignition switch to OFF, disconnect the ground cable from battery, and wait 60 seconds or more before starting to work.
- When replacing the airbag module, seat belt pretensioner, roll connector, control module and sensor, reconnect each part and check that the warning light operates properly.
- When inspecting the airbag main harness, disconnect the airbag module connectors of the driver's and passenger's seats for safety.
- When inspecting the airbag rear harness, disconnect the side airbag module connector, curtain airbag module connector and seat belt pretensioner connector for safety reasons.

### WIRING DIAGRAM:

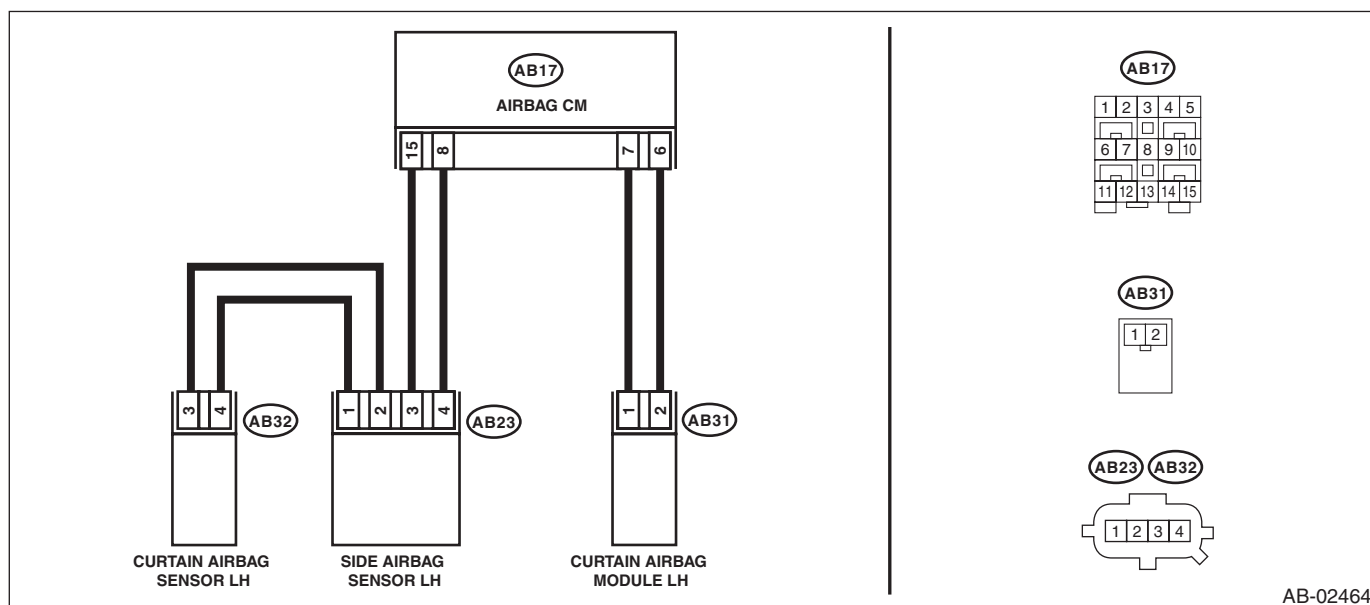

AB-02464

Step	Check	Yes	No
<b>1 CHECK POOR CONTACT OF CONNECTORS.</b> Check for poor contact of the connectors between the airbag control module, curtain airbag module LH and the curtain airbag sensor LH.	Is there poor contact?	Replace the airbag rear harness along with body harness.	Go to step 2.
<b>2 CHECK CURTAIN AIRBAG MODULE.</b> 1) Turn the ignition switch to OFF, disconnect the battery ground cable, and wait for 60 seconds or more. 2) Disconnect the connector (AB31) from curtain airbag module (LH). 3) Connect the connector (1N) in the test harness N to the connector (AB31). 4) Connect the airbag resistor to the connector (2N) of test harness N. 5) Connect the battery ground terminal and turn the ignition switch to ON.	Does the airbag warning light illuminate for 6 seconds and go off?	Replace the curtain airbag module (LH). <Ref. to AB-20, Curtain Airbag Module.>	Go to step 3.

# Diagnostic Chart with Trouble Code

## AIRBAG SYSTEM (DIAGNOSTICS)

Step	Check	Yes	No
<b>3 CHECK AIRBAG REAR HARNESS (CURRENT AIRBAG MODULE HARNESS LH).</b> 1) Turn the ignition switch to OFF, disconnect the battery ground cable, and wait for 60 seconds or more. 2) Disconnect the connector (AB21) from seat belt pretensioner (LH). 3) Disconnect connector (AB19) from side airbag module (LH). 4) Disconnect the airbag resistor from test harness N. 5) Disconnect the connectors (AB6, AB17, AB18) from airbag control module. 6) Connect the connector (1AH) in the test harness AH to the connectors (AB6, AB17, AB18). 7) Connect the connector (2AH) in the test harness AH and the connector (1AG) in the test harness AG. 8) Measure the resistance between connector (5AG) in the test harness AG and connector (2N) in the test harness N. <b>Connector &amp; terminal</b> <b>(5AG) No. 2 — (2N) No. 2:</b> <b>(5AG) No. 4 — (2N) No. 1:</b>	Is the resistance less than 10 $\Omega$ ?	Go to step 4.	Replace the airbag rear harness along with body harness.
<b>4 CHECK AIRBAG CONTROL MODULE.</b> 1) Connect all connectors. 2) Clear the memory. 3) Perform the Inspection Mode. 4) Read the DTC.	Is the same DTC displayed?	Replace the airbag control module. <Ref. to AB-22, Airbag Control Module.>	Go to step 5.
<b>5 CHECK FOR ANY OTHER DTC ON DISPLAY.</b>	Is any other DTC displayed?	Check DTC using "List of Diagnostic Trouble Code (DTC)". <Ref. to AB(diag)-39, List of Diagnostic Trouble Code (DTC).>	Finish the diagnosis.

# Diagnostic Chart with Trouble Code

AIRBAG SYSTEM (DIAGNOSTICS)

## BO:DTC A1 FRONT SENSOR BUS COMMUNICATION ERROR

### DTC DETECTING CONDITION:

- Harness between airbag control module and front sub sensor is open or shorted.
- Front sub sensor is faulty.
- Airbag control module is faulty.

### CAUTION:

- Before diagnosing the airbag system, be sure to turn the ignition switch to OFF, disconnect the ground cable from battery, and wait 60 seconds or more before starting to work.
- When replacing the airbag module, seat belt pretensioner, roll connector, control module and sensor, reconnect each part and check that the warning light operates properly.
- When inspecting the airbag main harness, disconnect the airbag module connectors and seat belt pretensioner connectors of the driver's and passenger's seats for safety reasons.

### WIRING DIAGRAM:

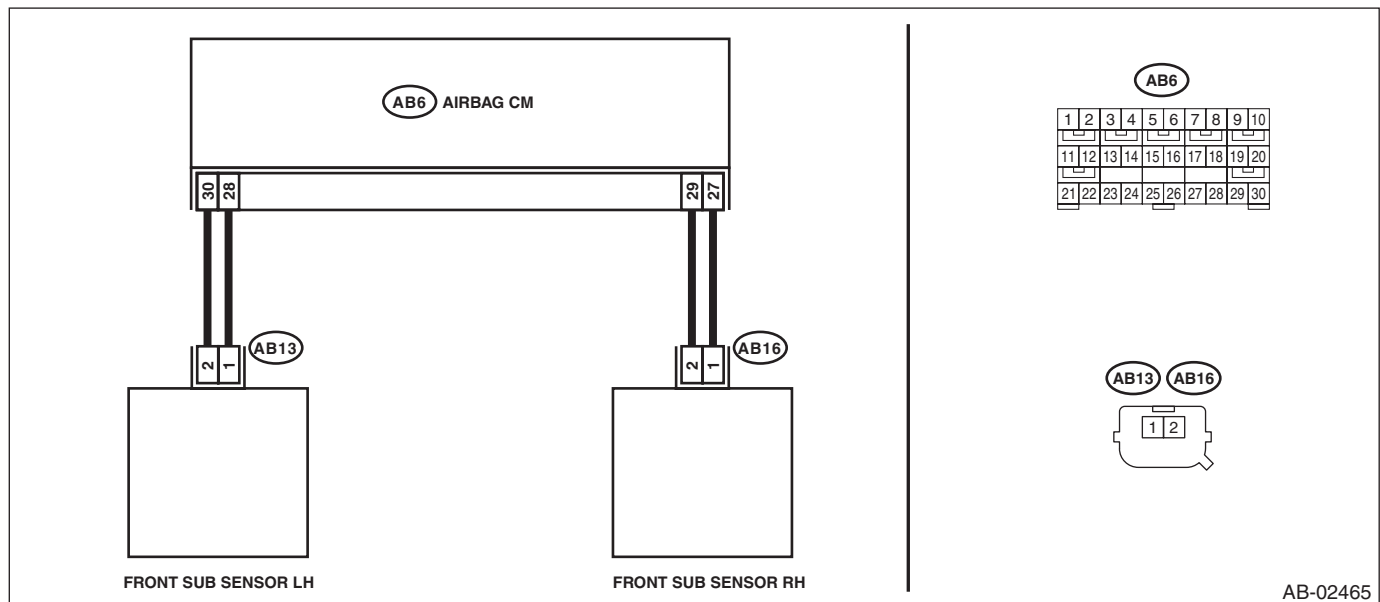

Step	Check	Yes	No
1	<b>CHECK POOR CONTACT OF CONNECTORS.</b> Check for poor contact of the connectors between the airbag control module and the front sub sensor.	Is there poor contact?	Replace the airbag main harness along with body harness.  Go to step 2.

# Diagnostic Chart with Trouble Code

## AIRBAG SYSTEM (DIAGNOSTICS)

Step	Check	Yes	No
<p><b>2 CHECK AIRBAG MAIN HARNESS (FRONT SENSOR BUS LH).</b></p> <p>1) Turn the ignition switch to OFF, disconnect the battery ground cable, and wait for 60 seconds or more.</p> <p>2) Remove the instrument panel lower cover and column cover, and disconnect the connectors (AB7) and (AB2).</p> <p>3) Remove the console front panel and disconnect the connector (AB9).</p> <p>4) Disconnect the connectors (AB6, AB17, AB18) from airbag control module.</p> <p>5) Connect the connector (1AH) in the test harness AH to the connectors (AB6, AB17, AB18).</p> <p>6) Connect the connector (2AH) in the test harness AH and the connector (1AG) in the test harness AG.</p> <p>7) Disconnect the connector (AB13) from the front sub sensor (LH), and then connect the connector (1H) in the test harness H to connector (AB13).</p> <p>8) Measure the resistance between connector (4AG) in the test harness AG and connector (3H) in the test harness H.</p> <p><b>Connector &amp; terminal</b>  <b>(4AG) No. 7 — (3H) No. 5:</b>  <b>(4AG) No. 9 — (3H) No. 6:</b></p>	<p>Is the resistance less than 10 <math>\Omega</math>?</p>	<p>Go to step 3.</p>	<p>Replace the airbag main harness along with body harness.</p>
<p><b>3 CHECK AIRBAG MAIN HARNESS (FRONT SENSOR BUS LH).</b></p> <p>Measure the resistance between connector (4AG) in the test harness AG and chassis ground, and the resistance between connector (4AG) terminals in the test harness AG.</p> <p><b>Connector &amp; terminal</b>  <b>(4AG) No. 7 — Chassis ground:</b>  <b>(4AG) No. 9 — Chassis ground:</b>  <b>(4AG) No. 7 — (4AG) No. 9:</b></p>	<p>Is the resistance 1 M<math>\Omega</math> or more?</p>	<p>Go to step 4.</p>	<p>Replace the airbag main harness along with body harness.</p>
<p><b>4 CHECK AIRBAG MAIN HARNESS (FRONT SENSOR BUS RH).</b></p> <p>1) Disconnect the connector (1H) in the test harness H from connector (AB13).</p> <p>2) Disconnect the connector (AB16) from the front sub sensor (RH), and then connect the connector (1H) in the test harness H to connector (AB16).</p> <p>3) Measure the resistance between connector (4AG) in the test harness AG and connector (3H) in the test harness H.</p> <p><b>Connector &amp; terminal</b>  <b>(4AG) No. 14 — (3H) No. 5:</b>  <b>(4AG) No. 12 — (3H) No. 6:</b></p>	<p>Is the resistance less than 10 <math>\Omega</math>?</p>	<p>Go to step 5.</p>	<p>Replace the airbag main harness along with body harness.</p>

# Diagnostic Chart with Trouble Code

AIRBAG SYSTEM (DIAGNOSTICS)

Step	Check	Yes	No
<b>5 CHECK AIRBAG MAIN HARNESS (FRONT SENSOR BUS RH).</b> Measure the resistance between connector (4AG) in the test harness AG and chassis ground, and the resistance between connector (4AG) terminals in the test harness AG. <b>Connector &amp; terminal</b> <b>(4AG) No. 12 — Chassis ground:</b> <b>(4AG) No. 14 — Chassis ground:</b> <b>(4AG) No. 12 — (4AG) No. 14:</b>	Is the resistance 1 MΩ or more?	Go to step 6.	Replace the airbag main harness along with body harness.
<b>6 CHECK AIRBAG CONTROL MODULE.</b> 1) Connect all connectors. 2) Clear the memory. 3) Perform the Inspection Mode. 4) Read the DTC.	Is the same DTC displayed?	Replace the front sub sensor (LH) and front sub sensor (RH). <Ref. to AB-23, REMOVAL, Front Sub Sensor.> Replace the airbag control module if not operating normally even after replacing the sensor. <Ref. to AB-22, REMOVAL, Airbag Control Module.>	Go to step 7.
<b>7 CHECK FOR ANY OTHER DTC ON DISPLAY.</b>	Is any other DTC displayed?	Check DTC using "List of Diagnostic Trouble Code". <Ref. to AB(diag)-39, List of Diagnostic Trouble Code (DTC).>	Finish the diagnosis.

## BP:DTC E3 FRONT SENSOR BUS RH COMMUNICATION ERROR

NOTE:

Refer to DTC A1 for DTC E3. <Ref. to AB(diag)-147, DTC A1 FRONT SENSOR BUS COMMUNICATION ERROR, Diagnostic Chart with Trouble Code.>

## BQ:DTC E4 FRONT SENSOR BUS RH COMMUNICATION ERROR

NOTE:

Refer to DTC A1 for DTC E4. <Ref. to AB(diag)-147, DTC A1 FRONT SENSOR BUS COMMUNICATION ERROR, Diagnostic Chart with Trouble Code.>



# Diagnostic Chart with Trouble Code

AIRBAG SYSTEM (DIAGNOSTICS)

## BR:DTC E7 FRONT SENSOR BUS LH COMMUNICATION ERROR

### DTC DETECTING CONDITION:

- Open or short circuit in harness of front sensor bus (LH).
- Front sub sensor (LH) is faulty.
- Airbag control module is faulty.

### CAUTION:

- Before diagnosing the airbag system, be sure to turn the ignition switch to OFF, disconnect the ground cable from battery, and wait 60 seconds or more before starting to work.
- When replacing the airbag module, seat belt pretensioner, roll connector, control module and sensor, reconnect each part and check that the warning light operates properly.
- When inspecting the airbag main harness, disconnect the airbag module connectors and seat belt pretensioner connectors of the driver's and passenger's seats for safety reasons.

### WIRING DIAGRAM:

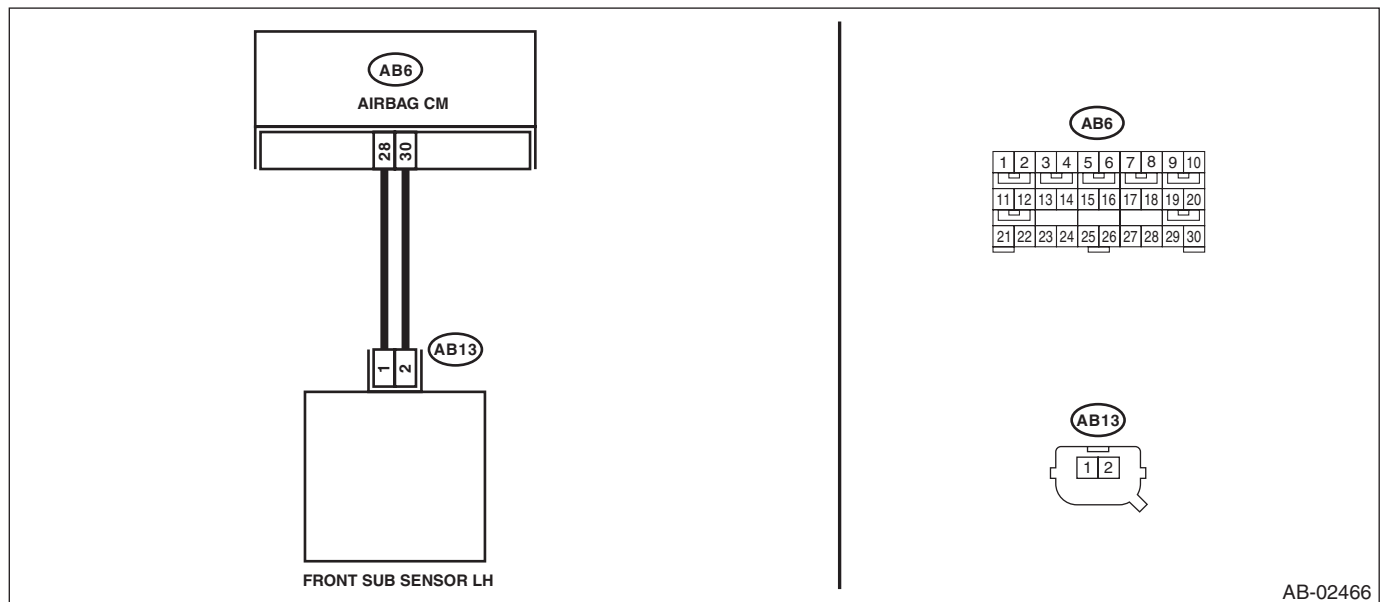

Step	Check	Yes	No
<b>1</b> <b>CHECK POOR CONTACT OF CONNECTORS.</b> Check for poor contact of the connectors (AB6, AB13) between the airbag control module and the front sub sensor (LH).	Is there poor contact?	Replace the airbag main harness along with body harness.	Go to step 2.

# Diagnostic Chart with Trouble Code

AIRBAG SYSTEM (DIAGNOSTICS)

Step	Check	Yes	No
<p><b>2 CHECK AIRBAG MAIN HARNESS (FRONT SENSOR BUS LH).</b></p> <p>1) Turn the ignition switch to OFF, disconnect the battery ground cable, and wait for 60 seconds or more.</p> <p>2) Remove the instrument panel lower cover and column cover, and disconnect the connectors (AB7) and (AB2).</p> <p>3) Remove the console front panel and disconnect the connector (AB9).</p> <p>4) Disconnect the connectors (AB6, AB17, AB18) from airbag control module.</p> <p>5) Connect the connector (1AH) in the test harness AH to the connectors (AB6, AB17, AB18).</p> <p>6) Connect the connector (2AH) in the test harness AH and the connector (1AG) in the test harness AG.</p> <p>7) Disconnect the connector (AB13) from the front sub sensor (LH), and then connect the connector (1H) in the test harness H to connector (AB13).</p> <p>8) Measure the resistance between connector (4AG) in the test harness AG and connector (3H) in the test harness H.</p> <p><b>Connector &amp; terminal</b>  <b>(4AG) No. 7 — (3H) No. 5:</b>  <b>(4AG) No. 9 — (3H) No. 6:</b></p>	<p>Is the resistance less than 10 <math>\Omega</math>?</p>	<p>Go to step 3.</p>	<p>Replace the airbag main harness along with body harness.</p>
<p><b>3 CHECK AIRBAG MAIN HARNESS (FRONT SENSOR BUS LH).</b></p> <p>Measure the resistance between connector (4AG) in the test harness AG and chassis ground, and the resistance between connector (4AG) terminals in the test harness AG.</p> <p><b>Connector &amp; terminal</b>  <b>(4AG) No. 7 — Chassis ground:</b>  <b>(4AG) No. 9 — Chassis ground:</b>  <b>(4AG) No. 7 — (4AG) No. 9:</b></p>	<p>Is the resistance 1 M<math>\Omega</math> or more?</p>	<p>Go to step 4.</p>	<p>Replace the airbag main harness along with body harness.</p>
<p><b>4 CHECK AIRBAG CONTROL MODULE.</b></p> <p>1) Connect all connectors.</p> <p>2) Clear the memory.</p> <p>3) Perform the Inspection Mode.</p> <p>4) Read the DTC.</p>	<p>Is the same DTC displayed?</p>	<p>Replace the front sub sensor (LH). &lt;Ref. to AB-23, REMOVAL, Front Sub Sensor.&gt;                      Replace the airbag control module if not operating normally even after replacing the sensor. &lt;Ref. to AB-22, REMOVAL, Airbag Control Module.&gt;</p>	<p>Go to step 5.</p>
<p><b>5 CHECK FOR ANY OTHER DTC ON DISPLAY.</b></p>	<p>Is any other DTC displayed?</p>	<p>Check DTC using "List of Diagnostic Trouble Code". &lt;Ref. to AB(diag)-39, LIST, List of Diagnostic Trouble Code (DTC).&gt;</p>	<p>Finish the diagnosis.</p>

## Diagnostic Chart with Trouble Code

AIRBAG SYSTEM (DIAGNOSTICS)

---

### **BS:DTC E8 FRONT SENSOR BUS LH COMMUNICATION ERROR**

NOTE:

Refer to DTC E7 for DTC E8. <Ref. to AB(diag)-150, DTC E7 FRONT SENSOR BUS LH COMMUNICATION ERROR, Diagnostic Chart with Trouble Code.>

### **BT:DTC E9 SIDE SENSOR BUS RH COMMUNICATION ERROR**

NOTE:

Refer to DTC EC for details on DTC E9. <Ref. to AB(diag)-153, DTC EC SIDE SENSOR BUS RH COMMUNICATION ERROR, Diagnostic Chart with Trouble Code.>

### **BU:DTC EB SIDE SENSOR BUS RH COMMUNICATION ERROR**

NOTE:

Refer to DTC EC for details on DTC EB. <Ref. to AB(diag)-153, DTC EC SIDE SENSOR BUS RH COMMUNICATION ERROR, Diagnostic Chart with Trouble Code.>

# Diagnostic Chart with Trouble Code

AIRBAG SYSTEM (DIAGNOSTICS)

## BV:DTC EC SIDE SENSOR BUS RH COMMUNICATION ERROR

### DTC DETECTING CONDITION:

- Open or short circuit in harness of side sensor bus (RH).
- Side airbag sensor (RH) and curtain airbag sensor (RH) are faulty.
- Airbag control module is faulty.

### CAUTION:

- Before diagnosing the airbag system, be sure to turn the ignition switch to OFF, disconnect the ground cable from battery, and wait approx. 60 seconds or more before starting to work.
- When replacing the airbag module, seat belt pretensioner, roll connector, control module and sensor, reconnect each part and check that the warning light operates properly.
- When inspecting the airbag main harness, disconnect the airbag module connectors and seat belt pretensioners of the driver's and passenger's seats for safety reasons.
- When inspecting the airbag rear harness, disconnect the side airbag module connector, curtain airbag module connector and seat belt pretensioner connector for safety reasons.

### WIRING DIAGRAM:

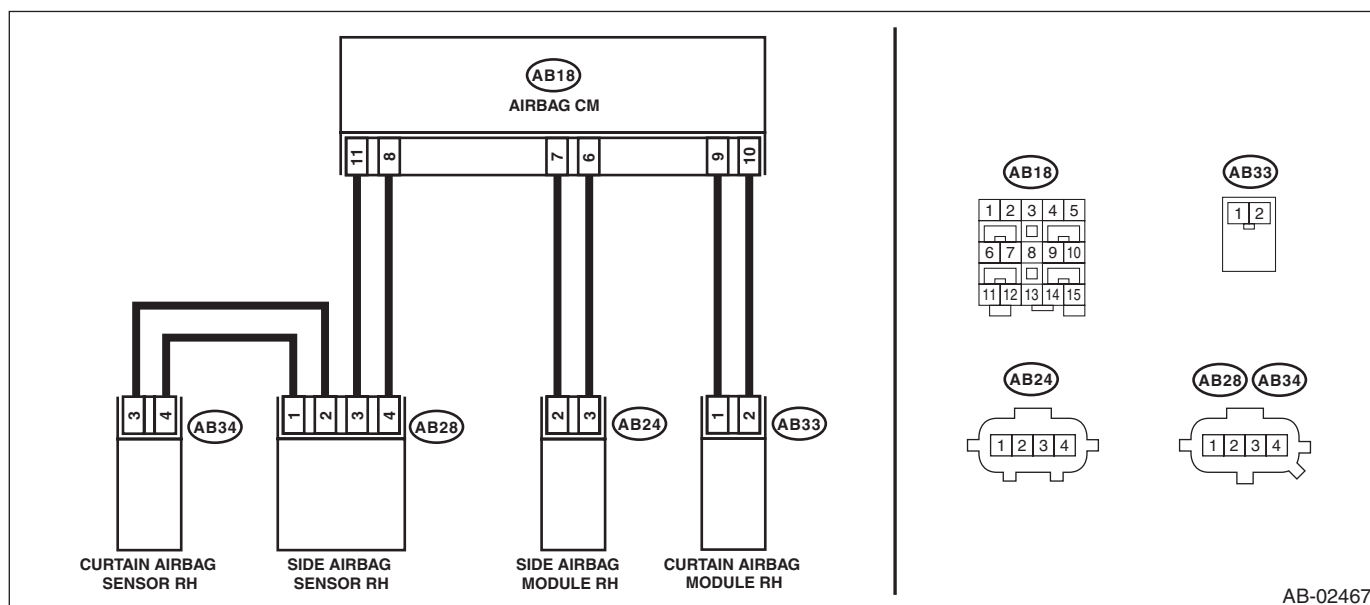

Step	Check	Yes	No
<b>1</b> <b>CHECK POOR CONTACT OF CONNECTORS.</b> Check for poor contact of the connectors (AB18, AB28, AB34) between the airbag control module and the curtain airbag sensor (RH).	Is there poor contact?	Replace the airbag rear harness along with body harness.	Go to step 2.

## Diagnostic Chart with Trouble Code

### AIRBAG SYSTEM (DIAGNOSTICS)

Step	Check	Yes	No
<p><b>2</b></p> <p><b>CHECK AIRBAG REAR HARNESS (BETWEEN AIRBAG CONTROL MODULE AND SIDE AIRBAG SENSOR RH).</b></p> <p>1) Turn the ignition switch to OFF, disconnect the battery ground cable, and wait for 60 seconds or more.</p> <p>2) Disconnect the connector (AB26) from seat belt pretensioner (RH).</p> <p>3) Disconnect the connector (AB33) from curtain airbag module (RH).</p> <p>4) Disconnect connector (AB24) of the side airbag module (RH).</p> <p>5) Disconnect the connectors (AB6, AB17, AB18) from airbag control module.</p> <p>6) Connect the connector (1AH) in the test harness AH to the connectors (AB6, AB17, AB18).</p> <p>7) Connect the connector (2AH) in the test harness AH and the connector (1AG) in the test harness AG.</p> <p>8) Disconnect the connector (AB28) from side airbag sensor (RH), and connect the connector (2V) in test harness V to connector (AB28).</p> <p>9) Measure the resistance between connector (5AG) in the test harness AG and connector (3V) in the test harness V.</p> <p><b>Connector &amp; terminal</b>  <b>(5AG) No. 14 — (3V) No. 1:</b>  <b>(5AG) No. 15 — (3V) No. 2:</b></p>	<p>Is the resistance less than 10 <math>\Omega</math>?</p>	<p>Go to step 3.</p>	<p>Replace the airbag rear harness along with body harness.</p>
<p><b>3</b></p> <p><b>CHECK AIRBAG REAR HARNESS (BETWEEN AIRBAG CONTROL MODULE AND SIDE AIRBAG SENSOR RH).</b></p> <p>Measure the resistance between test harness AG connectors (5AG) and chassis ground, and the resistance between connectors (5AG) of the test harness AG.</p> <p><b>Connector &amp; terminal</b>  <b>(5AG) No. 14 — Chassis ground:</b>  <b>(5AG) No. 15 — Chassis ground:</b>  <b>(5AG) No. 14 — (5AG) No. 15:</b></p>	<p>Is the resistance 1 M<math>\Omega</math> or more?</p>	<p>Go to step 4.</p>	<p>Replace the airbag rear harness along with body harness.</p>
<p><b>4</b></p> <p><b>CHECK AIRBAG REAR HARNESS (BETWEEN SIDE AIRBAG SENSOR AND CURTAIN AIRBAG SENSOR RH).</b></p> <p>1) Disconnect the connector (2V) in the test harness V from the connector (AB28) of side airbag sensor (RH).</p> <p>2) Connect the connector (AB28) of side airbag sensor (RH) and the connector (1AI) in the test harness AI.</p> <p>3) Connect the connector (2AI) in the test harness AI and the connector (1V) in the test harness V.</p> <p>4) Disconnect the connector (AB34) from curtain airbag sensor (RH), and connect the connector (2V) in test harness V to connector (AB34).</p> <p>5) Measure the resistance between connector (3V) terminals in the test harness V.</p> <p><b>Connector &amp; terminal</b>  <b>(3V) No. 2 — (3V) No. 6:</b>  <b>(3V) No. 1 — (3V) No. 7:</b></p>	<p>Is the resistance less than 10 <math>\Omega</math>?</p>	<p>Go to step 5.</p>	<p>Replace the airbag rear harness along with body harness.</p>

# Diagnostic Chart with Trouble Code

AIRBAG SYSTEM (DIAGNOSTICS)

Step	Check	Yes	No
<b>5 CHECK AIRBAG REAR HARNESS (BETWEEN SIDE AIRBAG SENSOR AND CURTAIN AIRBAG SENSOR RH).</b> Measure the resistance between connector (3V) in test harness V and chassis ground, and the resistance between connector (3V) in test harness V. <i>Connector &amp; terminal</i> <i>(3V) No. 2 — Chassis ground:</i> <i>(3V) No. 1 — Chassis ground:</i> <i>(3V) No. 2 — (3V) No. 1:</i>	Is the resistance 1 MΩ or more?	Go to step 6.	Replace the airbag rear harness along with body harness.
<b>6 CHECK AIRBAG CONTROL MODULE.</b> 1) Connect all connectors. 2) Clear the memory. 3) Perform the Inspection Mode. 4) Read the DTC.	Is the same DTC displayed?	Go to step 7.	Go to step 8.
<b>7 REPLACE SIDE AIRBAG SENSOR (RH) AND CHECK AIRBAG CONTROL MODULE AFTER REPLACEMENT.</b> 1) Turn the ignition switch to OFF, disconnect the battery ground cable, and wait for 60 seconds or more. 2) Replace the side airbag sensor (RH). <Ref. to AB-24, REMOVAL, Side Airbag Sensor.> 3) Connect all connectors. 4) Clear the memory. 5) Perform the Inspection Mode. 6) Read the DTC.	Is the system normal?	Go to step 8.	Replace the curtain airbag sensor (RH). <Ref. to AB-25, REMOVAL, Curtain Airbag Sensor.> Replace the airbag control module if not operating normally even after replacing the sensor. <Ref. to AB-22, REMOVAL, Airbag Control Module.>
<b>8 CHECK FOR ANY OTHER DTC ON DISPLAY.</b>	Is any other DTC displayed?	Check DTC using "List of Diagnostic Trouble Code (DTC)". <Ref. to AB(diag)-39, List of Diagnostic Trouble Code (DTC).>	Finish the diagnosis.

## BW:DTC ED SIDE SENSOR BUS RH COMMUNICATION ERROR

**NOTE:**

Refer to DTC EE for details on DTC ED. <Ref. to AB(diag)-156, DTC EE SIDE SENSOR BUS RH COMMUNICATION ERROR, Diagnostic Chart with Trouble Code.>

# Diagnostic Chart with Trouble Code

AIRBAG SYSTEM (DIAGNOSTICS)

## BX:DTC EE SIDE SENSOR BUS RH COMMUNICATION ERROR

### DTC DETECTING CONDITION:

- Open or short circuit in harness of side sensor bus (RH).
- Side airbag sensor (RH) or curtain airbag sensor (RH) are faulty.
- Airbag control module is faulty.

### CAUTION:

- Before diagnosing the airbag system, be sure to turn the ignition switch to OFF, disconnect the ground cable from battery, and wait approx. 60 seconds or more before starting to work.
- When replacing the airbag module, seat belt pretensioner, roll connector, control module and sensor, reconnect each part and check that the warning light operates properly.
- When inspecting the airbag main harness, disconnect the airbag module connectors and seat belt pretensioners of the driver's and passenger's seats for safety reasons.
- When inspecting the airbag rear harness, disconnect the side airbag module connector, curtain airbag module connector and seat belt pretensioner connector for safety reasons.

### WIRING DIAGRAM:

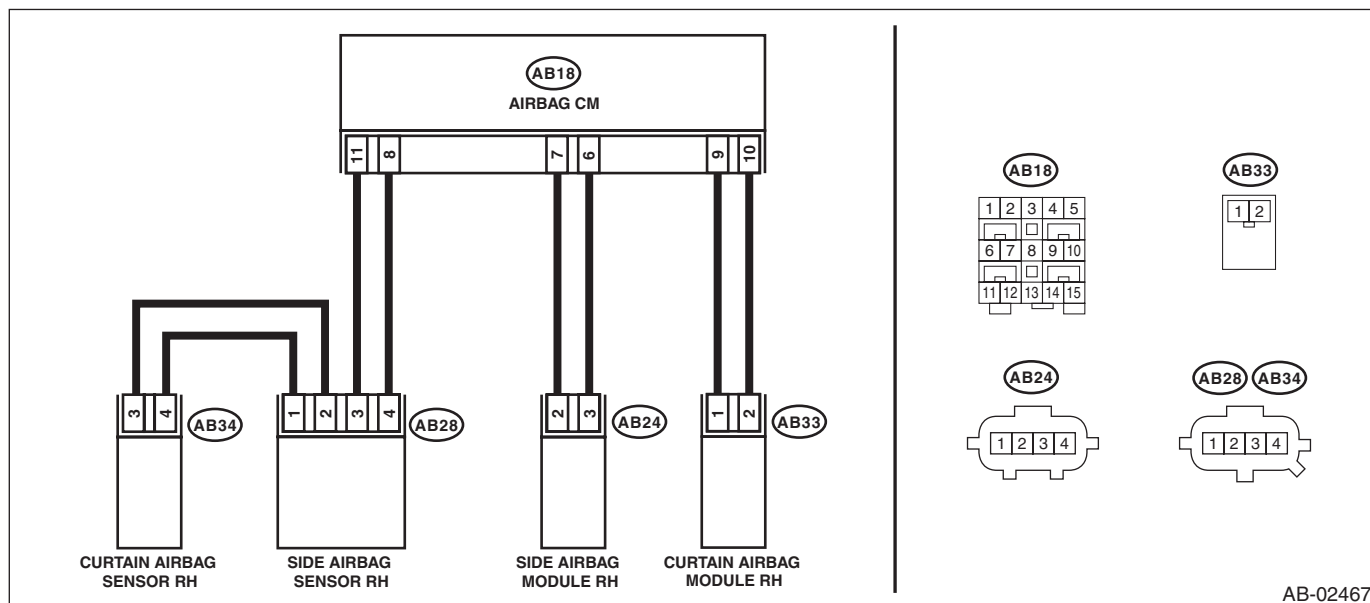

Step	Check	Yes	No
<b>1</b> <b>CHECK POOR CONTACT OF CONNECTORS.</b> Check for poor contact of the connectors (AB18, AB28, AB34) between the airbag control module and the curtain airbag sensor (RH).	Is there poor contact?	Replace the airbag rear harness along with body harness.	Go to step 2.

# Diagnostic Chart with Trouble Code

AIRBAG SYSTEM (DIAGNOSTICS)

Step	Check	Yes	No
<p><b>2</b></p> <p><b>CHECK AIRBAG REAR HARNESS (BETWEEN SIDE AIRBAG SENSOR (RH) AND CURTAIN AIRBAG SENSOR (RH)).</b></p> <p>1) Turn the ignition switch to OFF, disconnect the battery ground cable, and wait for 60 seconds or more.</p> <p>2) Disconnect the connector (AB26) from seat belt pretensioner (RH).</p> <p>3) Disconnect the connector (AB33) from curtain airbag module (RH).</p> <p>4) Disconnect connector (AB24) of the side airbag module (RH).</p> <p>5) Disconnect connector (AB28) from side airbag sensor (RH).</p> <p>6) Connect the connector (AB28) of side airbag sensor (RH) and the connector (1A1) in the test harness A1.</p> <p>7) Connect the connector (2A1) in the test harness A1 and the connector (1V) in the test harness V.</p> <p>8) Disconnect the connector (AB34) from curtain airbag sensor (RH), and connect the connector (2V) in test harness V to connector (AB34).</p> <p>9) Measure the resistance between connector (3V) terminals in the test harness V.</p> <p><b>Connector &amp; terminal</b>  <b>(3V) No. 2 — (3V) No. 6:</b>  <b>(3V) No. 1 — (3V) No. 7:</b></p>	<p>Is the resistance less than 10 Ω?</p>	<p>Go to step 3.</p>	<p>Replace the airbag rear harness along with body harness.</p>
<p><b>3</b></p> <p><b>CHECK AIRBAG REAR HARNESS (BETWEEN SIDE AIRBAG SENSOR AND CURTAIN AIRBAG SENSOR RH).</b></p> <p>Measure the resistance between connector (3V) in test harness V and chassis ground, and the resistance between connector (3V) in test harness V.</p> <p><b>Connector &amp; terminal</b>  <b>(3V) No. 2 — Chassis ground:</b>  <b>(3V) No. 1 — Chassis ground:</b>  <b>(3V) No. 2 — (3V) No. 1:</b></p>	<p>Is the resistance 1 MΩ or more?</p>	<p>Go to step 4.</p>	<p>Replace the airbag rear harness along with body harness.</p>



# Diagnostic Chart with Trouble Code

## AIRBAG SYSTEM (DIAGNOSTICS)

Step	Check	Yes	No
<p><b>4 CHECK AIRBAG REAR HARNESS (BETWEEN AIRBAG CONTROL MODULE AND SIDE AIRBAG SENSOR (RH)).</b></p> <p>1) Disconnect the connectors (AB6, AB17, AB18) from airbag control module.</p> <p>2) Connect the connector (1AH) in the test harness AH to the connectors (AB17, AB6, AB18).</p> <p>3) Connect the connector (2AH) in the test harness AH and the connector (1AG) in the test harness AG.</p> <p>4) Disconnect the connector (AB28) in the side airbag sensor (RH) from the connector (1AI) in the test harness AI.</p> <p>5) Disconnect the connector (2AI) in the test harness AI from the connector (1V) in the test harness V.</p> <p>6) Connect the connector (AB28) of side airbag sensor (RH) and the connector (2V) in the test harness V.</p> <p>7) Measure the resistance between connector (5AG) in the test harness AG and connector (3V) in the test harness V.</p> <p><b>Connector &amp; terminal</b>  <b>(5AG) No. 14 — (3V) No. 1:</b>  <b>(5AG) No. 15 — (3V) No. 2:</b></p>	Is the resistance less than 10 Ω?	Go to step 5.	Replace the airbag rear harness along with body harness.
<p><b>5 CHECK AIRBAG REAR HARNESS (BETWEEN AIRBAG CONTROL MODULE AND SIDE AIRBAG SENSOR RH).</b></p> <p>Measure the resistance between connector (5AG) in the test harness AG and chassis ground, and the resistance between connector (5AG) terminals in the test harness AG.</p> <p><b>Connector &amp; terminal</b>  <b>(5AG) No. 14 — Chassis ground:</b>  <b>(5AG) No. 15 — Chassis ground:</b>  <b>(5AG) No. 14 — (5AG) No. 15:</b></p>	Is the resistance 1 MΩ or more?	Go to step 6.	Replace the airbag rear harness along with body harness.
<p><b>6 CHECK AIRBAG CONTROL MODULE.</b></p> <p>1) Connect all connectors.</p> <p>2) Clear the memory.</p> <p>3) Perform the Inspection Mode.</p> <p>4) Read the DTC.</p>	Is the same DTC displayed?	Go to step 7.	Go to step 8.
<p><b>7 REPLACE SIDE AIRBAG SENSOR (RH) AND CHECK AIRBAG CONTROL MODULE AFTER REPLACEMENT.</b></p> <p>1) Turn the ignition switch to OFF, disconnect the battery ground cable, and wait for 60 seconds or more.</p> <p>2) Replace the side airbag sensor (RH). &lt;Ref. to AB-24, REMOVAL, Side Airbag Sensor.&gt;</p> <p>3) Connect all connectors.</p> <p>4) Clear the memory.</p> <p>5) Perform the Inspection Mode.</p> <p>6) Read the DTC.</p>	Is the system normal?	Go to step 8.	Replace the curtain airbag sensor (RH). <Ref. to AB-25, REMOVAL, Curtain Airbag Sensor.> Replace the airbag control module if not operating normally even after replacing the sensor. <Ref. to AB-22, REMOVAL, Airbag Control Module.>

# Diagnostic Chart with Trouble Code

AIRBAG SYSTEM (DIAGNOSTICS)

Step	Check	Yes	No
8 <b>CHECK FOR ANY OTHER DTC ON DISPLAY.</b>	Is any other DTC displayed?	Check DTC using "List of Diagnostic Trouble Code (DTC)". <Ref. to AB(diag)-39, List of Diagnostic Trouble Code (DTC).>	Finish the diagnosis.

## **BY:DTC F1 SIDE SENSOR BUS LH COMMUNICATION ERROR**

NOTE:

Refer to DTC F4 for details on DTC F1. <Ref. to AB(diag)-160, DTC F4 SIDE SENSOR BUS LH COMMUNICATION ERROR, Diagnostic Chart with Trouble Code.>

## **BZ:DTC F3 SIDE SENSOR BUS LH COMMUNICATION ERROR**

NOTE:

Refer to DTC F4 for details on DTC F3. <Ref. to AB(diag)-160, DTC F4 SIDE SENSOR BUS LH COMMUNICATION ERROR, Diagnostic Chart with Trouble Code.>

# Diagnostic Chart with Trouble Code

## AIRBAG SYSTEM (DIAGNOSTICS)

### CA:DTC F4 SIDE SENSOR BUS LH COMMUNICATION ERROR

#### DTC DETECTING CONDITION:

- Open or short circuit in harness of side sensor bus (LH).
- Side airbag sensor (LH) and curtain airbag sensor (LH) are faulty.
- Airbag control module is faulty.

#### CAUTION:

- Before diagnosing the airbag system, be sure to turn the ignition switch to OFF, disconnect the ground cable from battery, and wait approx. 60 seconds or more before starting to work.
- When replacing the airbag module, seat belt pretensioner, roll connector, control module and sensor, reconnect each part and check that the warning light operates properly.
- When inspecting the airbag main harness, disconnect the airbag module connectors and seat belt pretensioners of the driver's and passenger's seats for safety reasons.
- When inspecting the airbag rear harness, disconnect the side airbag module connector, curtain airbag module connector and seat belt pretensioner connector for safety reasons.

#### WIRING DIAGRAM:

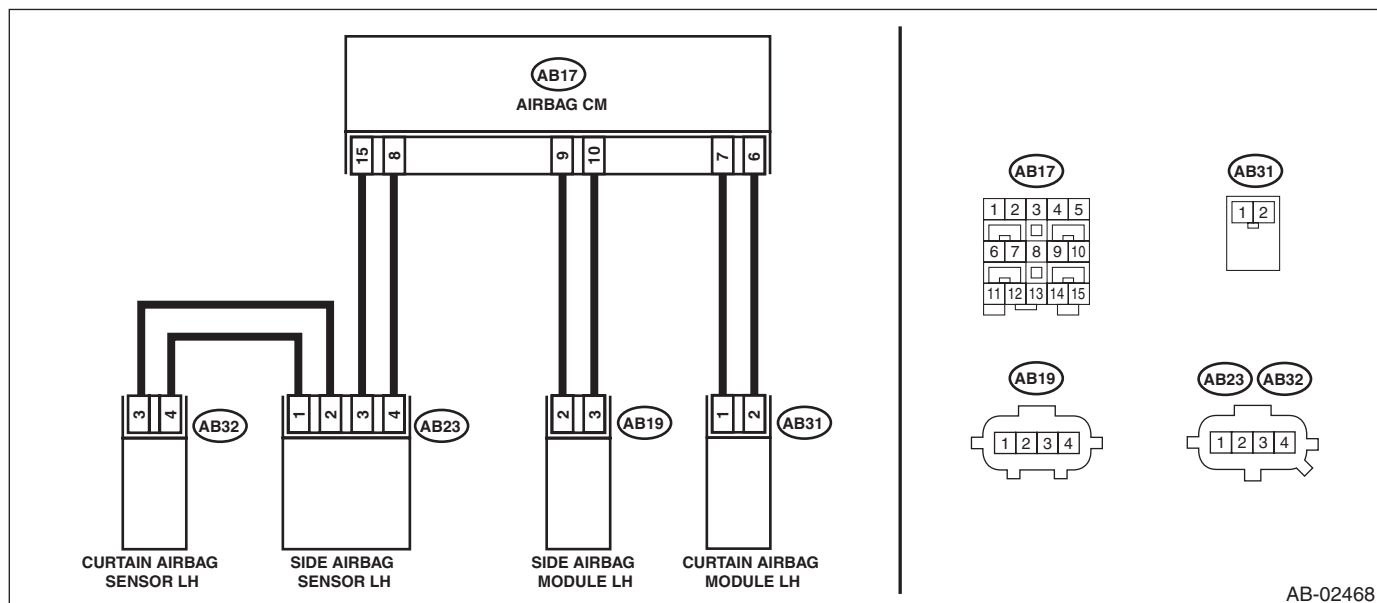

Step	Check	Yes	No
<b>1</b> <b>CHECK POOR CONTACT OF CONNECTORS.</b> Check for poor contact of the connectors (AB17, AB23, AB32) between the airbag control module and the curtain airbag sensor (LH).	Is there poor contact?	Replace the airbag rear harness along with body harness.	Go to step 2.

# Diagnostic Chart with Trouble Code

AIRBAG SYSTEM (DIAGNOSTICS)

Step	Check	Yes	No
<p><b>2 CHECK AIRBAG REAR HARNESS (BETWEEN AIRBAG CONTROL MODULE AND SIDE AIRBAG SENSOR LH).</b></p> <p>1) Turn the ignition switch to OFF, disconnect the battery ground cable, and wait for 60 seconds or more.</p> <p>2) Disconnect the connector (AB21) from seat belt pretensioner (LH).</p> <p>3) Disconnect the connector (AB31) from curtain airbag module (LH).</p> <p>4) Disconnect connector (AB19) of the side airbag module (LH).</p> <p>5) Disconnect the connectors (AB17, AB6, AB18) from airbag control module.</p> <p>6) Connect the connector (1AH) in the test harness AH to the connectors (AB17, AB6, AB18).</p> <p>7) Connect the connector (2AH) in the test harness AH and the connector (1AG) in the test harness AG.</p> <p>8) Disconnect the connector (AB23) from side airbag sensor (LH), and connect the connector (2V) in test harness V to connector (AB23).</p> <p>9) Measure the resistance between connector (5AG) in the test harness AG and connector (3V) in the test harness V.</p> <p><b>Connector &amp; terminal</b>  <b>(5AG) No. 9 — (3V) No. 2:</b>  <b>(5AG) No. 10 — (3V) No. 1:</b></p>	<p>Is the resistance less than 10 <math>\Omega</math>?</p>	<p>Go to step 3.</p>	<p>Replace the airbag rear harness along with body harness.</p>
<p><b>3 CHECK AIRBAG REAR HARNESS (BETWEEN AIRBAG CONTROL MODULE AND SIDE AIRBAG SENSOR LH).</b></p> <p>Measure the resistance between connector (5AG) in the test harness AG and chassis ground, and the resistance between connector (5AG) terminals in the test harness AG.</p> <p><b>Connector &amp; terminal</b>  <b>(5AG) No. 9 — Chassis ground:</b>  <b>(5AG) No. 10 — Chassis ground:</b>  <b>(5AG) No. 9 — (5AG) No. 10:</b></p>	<p>Is the resistance 1 M<math>\Omega</math> or more?</p>	<p>Go to step 4.</p>	<p>Replace the airbag rear harness along with body harness.</p>
<p><b>4 CHECK AIRBAG REAR HARNESS (BETWEEN SIDE AIRBAG SENSOR LH AND CURTAIN AIRBAG SENSOR LH).</b></p> <p>1) Disconnect the connector (2V) in the test harness V from the connector (AB23) of side airbag sensor (LH).</p> <p>2) Connect the connector (AB23) of side airbag sensor (LH) and the connector (1AI) in the test harness AI.</p> <p>3) Connect the connector (2AI) in the test harness AI and the connector (1V) in the test harness V.</p> <p>4) Disconnect the connector (AB32) from curtain airbag sensor (LH), and connect the connector (2V) in test harness V to connector (AB32).</p> <p>5) Measure the resistance between connector (3V) terminals in the test harness V.</p> <p><b>Connector &amp; terminal</b>  <b>(3V) No. 2 — (3V) No. 6:</b>  <b>(3V) No. 1 — (3V) No. 7:</b></p>	<p>Is the resistance less than 10 <math>\Omega</math>?</p>	<p>Go to step 5.</p>	<p>Replace the airbag rear harness along with body harness.</p>

# Diagnostic Chart with Trouble Code

## AIRBAG SYSTEM (DIAGNOSTICS)

Step	Check	Yes	No
<b>5 CHECK AIRBAG REAR HARNESS (BETWEEN SIDE AIRBAG SENSOR LH AND CURTAIN AIRBAG SENSOR LH).</b> Measure the resistance between connector (3V) in test harness V and chassis ground, and the resistance between connector (3V) in test harness V. <i>Connector &amp; terminal</i> <i>(3V) No. 2 — Chassis ground:</i> <i>(3V) No. 1 — Chassis ground:</i> <i>(3V) No. 2 — (3V) No. 1:</i>	Is the resistance 1 MΩ or more?	Go to step 6.	Replace the airbag rear harness along with body harness.
<b>6 CHECK AIRBAG CONTROL MODULE.</b> 1) Connect all connectors. 2) Clear the memory. 3) Perform the Inspection Mode. 4) Read the DTC.	Is the same DTC displayed?	Go to step 7.	Go to step 8.
<b>7 REPLACE SIDE AIRBAG SENSOR (LH) AND CHECK AIRBAG CONTROL MODULE AFTER REPLACEMENT.</b> 1) Turn the ignition switch to OFF, disconnect the battery ground cable, and wait for 60 seconds or more. 2) Replace the side airbag sensor (LH). <Ref. to AB-24, REMOVAL, Side Airbag Sensor.> 3) Connect all connectors. 4) Clear the memory. 5) Perform the Inspection Mode. 6) Read the DTC.	Is the system normal?	Go to step 8.	Replace the curtain airbag sensor (LH). <Ref. to AB-25, REMOVAL, Curtain Airbag Sensor.> Replace the airbag control module if not operating normally even after replacing the sensor. <Ref. to AB-22, REMOVAL, Airbag Control Module.>
<b>8 CHECK FOR ANY OTHER DTC ON DISPLAY.</b>	Is any other DTC displayed?	Check DTC using "List of Diagnostic Trouble Code (DTC)". <Ref. to AB(diag)-39, List of Diagnostic Trouble Code (DTC).>	Finish the diagnosis.

### CB:DTC F5 SIDE SENSOR BUS LH COMMUNICATION ERROR

**NOTE:**

Refer to DTC F6 for details on DTC F5. <Ref. to AB(diag)-163, DTC F6 SIDE SENSOR BUS LH COMMUNICATION ERROR, Diagnostic Chart with Trouble Code.>

# Diagnostic Chart with Trouble Code

AIRBAG SYSTEM (DIAGNOSTICS)

## CC:DTC F6 SIDE SENSOR BUS LH COMMUNICATION ERROR

### DTC DETECTING CONDITION:

- Open or short circuit in harness of side sensor bus (LH).
- Side airbag sensor (LH) or curtain airbag sensor (LH) are faulty.
- Airbag control module is faulty.

### CAUTION:

- Before diagnosing the airbag system, be sure to turn the ignition switch to OFF, disconnect the ground cable from battery, and wait 60 seconds or more before starting to work.
- When replacing the airbag module, seat belt pretensioner, roll connector, control module and sensor, reconnect each part and check that the warning light operates properly.
- When inspecting the airbag main harness, disconnect the airbag module connectors and seat belt pretensioners of the driver's and passenger's seats for safety reasons.
- When inspecting the airbag rear harness, disconnect the side airbag module connector, curtain airbag module connector and seat belt pretensioner connector for safety reasons.

### WIRING DIAGRAM:

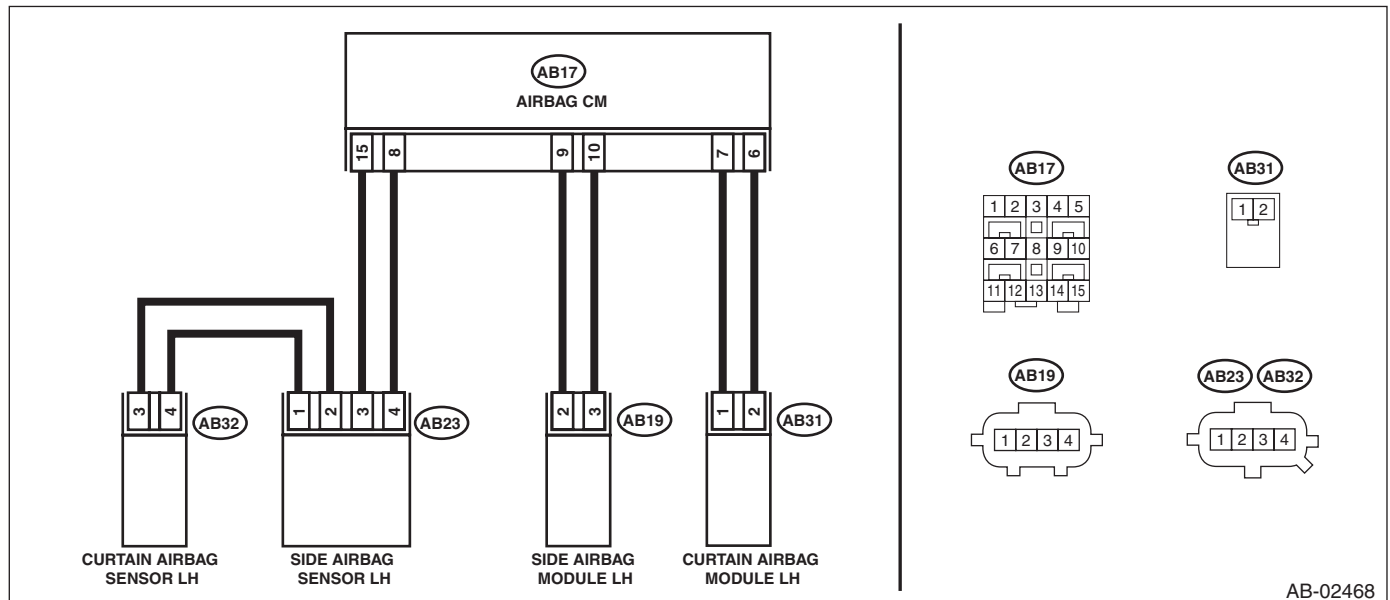

Step	Check	Yes	No
<b>1 CHECK POOR CONTACT OF CONNECTORS.</b> Check for poor contact of the connectors (AB17, AB23, AB32) between the airbag control module and the curtain airbag sensor (LH).	Is there poor contact?	Replace the airbag rear harness along with body harness.	Go to step 2.

## Diagnostic Chart with Trouble Code

### AIRBAG SYSTEM (DIAGNOSTICS)

Step	Check	Yes	No
<p><b>2</b></p> <p><b>CHECK AIRBAG REAR HARNESS (BETWEEN SIDE AIRBAG SENSOR LH AND CURTAIN AIRBAG SENSOR LH).</b></p> <p>1) Turn the ignition switch to OFF, disconnect the battery ground cable, and wait for 60 seconds or more.</p> <p>2) Disconnect the connector (AB21) from seat belt pretensioner (LH).</p> <p>3) Disconnect the connector (AB31) from curtain airbag module (LH).</p> <p>4) Disconnect connector (AB19) of the side airbag module (LH).</p> <p>5) Disconnect the connector (AB23) in the side airbag sensor (LH).</p> <p>6) Connect the connector (AB23) of side airbag sensor (LH) and the connector (1AI) in the test harness AI.</p> <p>7) Connect the connector (2AI) in the test harness AI and the connector (1V) in the test harness V.</p> <p>8) Disconnect the connector (AB32) from curtain airbag sensor (LH), and connect to the connector (2V) in test harness V.</p> <p>9) Measure the resistance between connector (3V) terminals in the test harness V.</p> <p><b>Connector &amp; terminal</b>  <b>(3V) No. 2 — (3V) No. 6:</b>  <b>(3V) No. 1 — (3V) No. 7:</b></p>	<p>Is the resistance less than 10 <math>\Omega</math>?</p>	<p>Go to step 3.</p>	<p>Replace the airbag rear harness along with body harness.</p>
<p><b>3</b></p> <p><b>CHECK AIRBAG REAR HARNESS (BETWEEN SIDE AIRBAG SENSOR AND CURTAIN AIRBAG SENSOR LH).</b></p> <p>Measure the resistance between connector (3V) in test harness V and chassis ground, and the resistance between connector (3V) in test harness V.</p> <p><b>Connector &amp; terminal</b>  <b>(3V) No. 1 — Chassis ground:</b>  <b>(3V) No. 2 — Chassis ground:</b>  <b>(3V) No. 1 — (3V) No. 2:</b></p>	<p>Is the resistance 1 M<math>\Omega</math> or more?</p>	<p>Go to step 4.</p>	<p>Replace the airbag rear harness along with body harness.</p>

# Diagnostic Chart with Trouble Code

AIRBAG SYSTEM (DIAGNOSTICS)

Step	Check	Yes	No
<p><b>4 CHECK AIRBAG REAR HARNESS (BETWEEN AIRBAG CONTROL MODULE AND SIDE AIRBAG SENSOR LH).</b></p> <p>1) Disconnect the connectors (AB6, AB17, AB18) from airbag control module.</p> <p>2) Connect the connector (1AH) in the test harness AH to the connectors (AB17, AB6, AB18).</p> <p>3) Connect the connector (2AH) in the test harness AH and the connector (1AG) in the test harness AG.</p> <p>4) Disconnect the connector (AB23) in the side airbag sensor (LH) from the connector (1AI) in the test harness AI.</p> <p>5) Disconnect the connector (2AI) in the test harness AI from the connector (1V) in the test harness V.</p> <p>6) Connect the connector (2V) in the test harness V to the connector (AB23).</p> <p>7) Measure the resistance between connector (5AG) in the test harness AG and connector (3V) in the test harness V.</p> <p><b>Connector &amp; terminal</b>  <b>(5AG) No. 9 — (3V) No. 2:</b>  <b>(5AG) No. 10 — (3V) No. 1:</b></p>	<p>Is the resistance less than 10 Ω?</p>	<p>Go to step 5.</p>	<p>Replace the airbag rear harness along with body harness.</p>
<p><b>5 CHECK AIRBAG REAR HARNESS (BETWEEN SIDE AIRBAG SENSOR LH AND CURTAIN AIRBAG SENSOR LH).</b></p> <p>Measure the resistance between connector (3V) in test harness V and chassis ground, and the resistance between connector (5AG) terminals in test harness AG.</p> <p><b>Connector &amp; terminal</b>  <b>(5AG) No. 9 — Chassis ground:</b>  <b>(5AG) No. 10 — Chassis ground:</b>  <b>(5AG) No. 9 — (5AG) No. 10:</b></p>	<p>Is the resistance 1 MΩ or more?</p>	<p>Go to step 6.</p>	<p>Replace the airbag rear harness along with body harness.</p>
<p><b>6 CHECK AIRBAG CONTROL MODULE.</b></p> <p>1) Connect all connectors.</p> <p>2) Clear the memory.</p> <p>3) Perform the Inspection Mode.</p> <p>4) Read the DTC.</p>	<p>Is the same DTC displayed?</p>	<p>Go to step 7.</p>	<p>Go to step 8.</p>
<p><b>7 REPLACE SIDE AIRBAG SENSOR (LH) AND CHECK AIRBAG CONTROL MODULE AFTER REPLACEMENT.</b></p> <p>1) Turn the ignition switch to OFF, disconnect the battery ground cable, and wait for 60 seconds or more.</p> <p>2) Replace the side airbag sensor (LH). &lt;Ref. to AB-24, REMOVAL, Side Airbag Sensor.&gt;</p> <p>3) Connect all connectors.</p> <p>4) Clear the memory.</p> <p>5) Perform the Inspection Mode.</p> <p>6) Read the DTC.</p>	<p>Is the system normal?</p>	<p>Go to step 8.</p>	<p>Replace the curtain airbag sensor (LH). &lt;Ref. to AB-25, REMOVAL, Curtain Airbag Sensor.&gt; Replace the airbag control module if not operating normally even after replacing the sensor. &lt;Ref. to AB-22, REMOVAL, Airbag Control Module.&gt;</p>



# Diagnostic Chart with Trouble Code

## AIRBAG SYSTEM (DIAGNOSTICS)

Step	Check	Yes	No
<b>8</b> <b>CHECK FOR ANY OTHER DTC ON DISPLAY.</b>	Is any other DTC displayed?	Check DTC using "List of Diagnostic Trouble Code (DTC)". <Ref. to AB(diag)-39, List of Diagnostic Trouble Code (DTC).>	Finish the diagnosis.

### **CD:DTC F7 SATELLITE SENSOR BUS COMMUNICATION ERROR**

**NOTE:**

Refer to DTC FA for details on DTC F7. <Ref. to AB(diag)-167, DTC FA SATELLITE SENSOR BUS COMMUNICATION ERROR, Diagnostic Chart with Trouble Code.>

### **CE:DTC F8 SATELLITE SENSOR BUS COMMUNICATION ERROR**

**NOTE:**

Refer to DTC FA for details on DTC F8. <Ref. to AB(diag)-167, DTC FA SATELLITE SENSOR BUS COMMUNICATION ERROR, Diagnostic Chart with Trouble Code.>

### **CF:DTC F9 SATELLITE SENSOR BUS COMMUNICATION ERROR**

**NOTE:**

Refer to DTC FA for details on DTC F9. <Ref. to AB(diag)-167, DTC FA SATELLITE SENSOR BUS COMMUNICATION ERROR, Diagnostic Chart with Trouble Code.>

# Diagnostic Chart with Trouble Code

AIRBAG SYSTEM (DIAGNOSTICS)

## CG:DTC FA SATELLITE SENSOR BUS COMMUNICATION ERROR

### DTC DETECTING CONDITION:

- Open or short circuit in harness of satellite safing sensor.
- Satellite safing sensor is faulty.
- Airbag control module is faulty.

### CAUTION:

- Before diagnosing the airbag system, be sure to turn the ignition switch to OFF, disconnect the ground cable from battery, and wait 60 seconds or more before starting to work.
- When replacing the airbag module, seat belt pretensioner, roll connector, control module and sensor, reconnect each part and check that the warning light operates properly.
- When inspecting the airbag main harness, disconnect the airbag module connectors and seat belt pretensioners of the driver's and passenger's seats for safety reasons.
- When inspecting the airbag rear harness, disconnect the side airbag module connector, curtain airbag module connector and seat belt pretensioner connector for safety reasons.

### WIRING DIAGRAM:

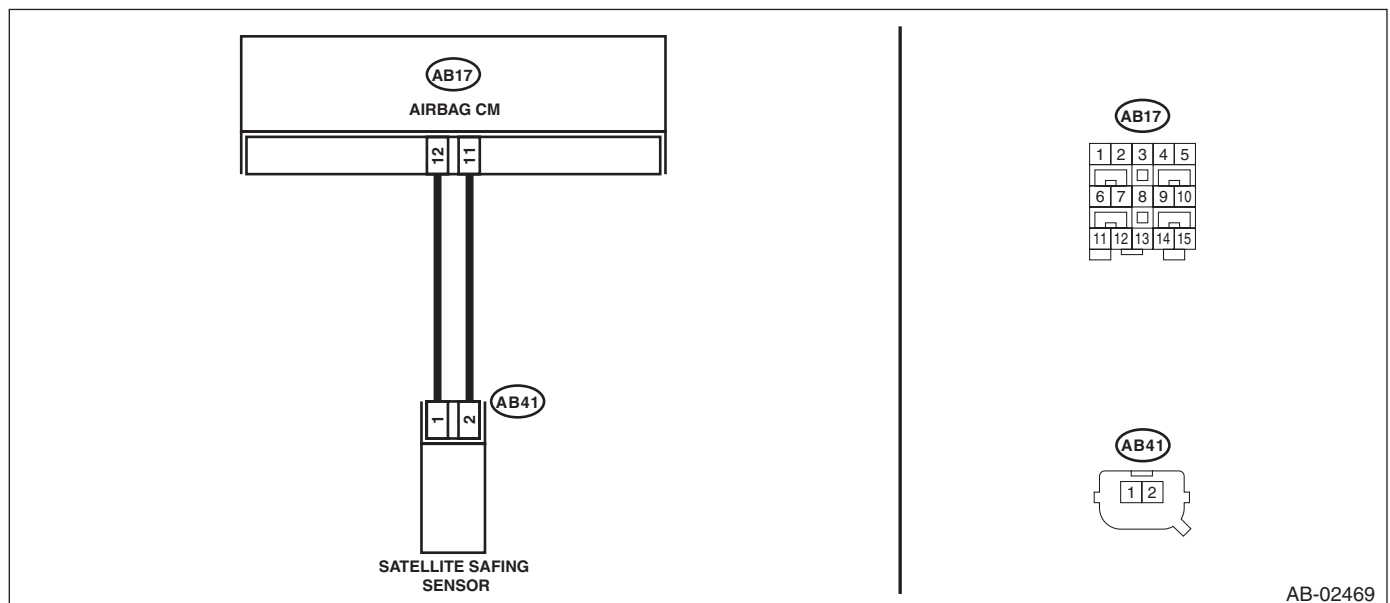

AB-02469

Step	Check	Yes	No
<b>1</b> <b>CHECK POOR CONTACT OF CONNECTORS.</b> Check for poor contact of the connectors (AB17, AB41) between the airbag control module and the satellite safing sensor.	Is there poor contact?	Replace the airbag rear harness along with body harness.	Go to step 2.

# Diagnostic Chart with Trouble Code

## AIRBAG SYSTEM (DIAGNOSTICS)

Step	Check	Yes	No
<p><b>2</b>      <b>CHECK AIRBAG REAR HARNESS (BETWEEN AIRBAG CONTROL MODULE AND SATELLITE SAFING SENSOR).</b></p> <p>1) Turn the ignition switch to OFF, disconnect the battery ground cable, and wait for 60 seconds or more.</p> <p>2) Disconnect the connectors (AB21, AB26) from seat belt pretensioner.</p> <p>3) Disconnect the connectors (AB31, AB33) from curtain airbag module.</p> <p>4) Disconnect connectors (AB19) and (AB24) from the side airbag module.</p> <p>5) Disconnect the connectors (AB17, AB6, AB18) from airbag control module.</p> <p>6) Connect the connector (1AH) in the test harness AH to the connectors (AB17, AB6, AB18).</p> <p>7) Connect the connector (2AH) in the test harness AH and the connector (1AG) in the test harness AG.</p> <p>8) Disconnect the connector (AB41) from the satellite safing sensor and connect to the test harness H connector (1H).</p> <p>9) Measure the resistance between connectors (5AG) and (4AG) in the test harness AG and connector (3H) in the test harness H.</p> <p><b>Connector &amp; terminal</b>  <b>(4AG) No. 3 — (3H) No. 5:</b>  <b>(5AG) No. 11 — (3H) No. 6:</b></p>	<p>Is the resistance less than 10 <math>\Omega</math>?</p>	<p>Go to step 3.</p>	<p>Replace the airbag rear harness along with body harness.</p>
<p><b>3</b>      <b>CHECK AIRBAG REAR HARNESS (BETWEEN AIRBAG CONTROL MODULE AND SATELLITE SAFING SENSOR).</b></p> <p>Measure the resistance between connector (5AG) in the test harness AG and chassis ground, and the resistance between connector (5AG) terminals in the test harness AG.</p> <p><b>Connector &amp; terminal</b>  <b>(4AG) No. 3 — Chassis ground:</b>  <b>(5AG) No. 11 — Chassis ground:</b>  <b>(4AG) No. 3 — (5AG) No. 11:</b></p>	<p>Is the resistance 1 M<math>\Omega</math> or more?</p>	<p>Go to step 4.</p>	<p>Replace the airbag rear harness along with body harness.</p>
<p><b>4</b>      <b>CHECK AIRBAG CONTROL MODULE.</b></p> <p>1) Connect all connectors.</p> <p>2) Clear the memory.</p> <p>3) Perform the Inspection Mode.</p> <p>4) Read the DTC.</p>	<p>Is the same DTC displayed?</p>	<p>Replace the satellite safing sensor.          &lt;Ref. to AB-26, REMOVAL, Satellite Safing Sensor.&gt; Replace the airbag control module if not operating normally even after replacing the sensor.          &lt;Ref. to AB-22, REMOVAL, Airbag Control Module.&gt;</p>	<p>Go to step 5.</p>
<p><b>5</b>      <b>CHECK FOR ANY OTHER DTC ON DISPLAY.</b></p>	<p>Is any other DTC displayed?</p>	<p>Check DTC using "List of Diagnostic Trouble Code (DTC)". &lt;Ref. to AB(diag)-39, List of Diagnostic Trouble Code (DTC).&gt;</p>	<p>Finish the diagnosis.</p>

# OCCUPANT DETECTION SYSTEM (DIAGNOSTICS)

## *OD(diag)*

---

	<b>Page</b>
1. Basic Diagnostic Procedure .....	2
2. Check List for Interview .....	3
3. General Description .....	4
4. Electrical Component Location .....	10
5. Airbag Connector .....	11
6. Control Module I/O Signal .....	12
7. Subaru Select Monitor .....	13
8. Read Diagnostic Trouble Code (DTC) .....	16
9. Inspection Mode .....	17
10. Clear Memory Mode .....	18
11. Airbag Warning Light Illumination Pattern .....	19
12. Passenger's Airbag ON/OFF Indicator Light Illumination Pattern .....	20
13. List of Diagnostic Trouble Code (DTC) .....	21
14. Diagnostic Procedure with Diagnostic Trouble Code (DTC) .....	22

# Basic Diagnostic Procedure

## OCCUPANT DETECTION SYSTEM (DIAGNOSTICS)

### 1. Basic Diagnostic Procedure

#### A: PROCEDURE

	Step	Check	Yes	No
1	<b>CHECK WARNING LIGHT.</b> Check whether the airbag warning light in the combination meter is lit.	Does the airbag warning light illuminate?	Go to step 2.	Perform the diagnosis according to phenomenon of the problem.
2	<b>READ DTC.</b> 1) Turn the ignition switch to OFF. 2) Connect the Subaru Select Monitor to data link connector. 3) Turn the ignition switch to ON and run the Subaru Select Monitor. 4) Read the DTC. <Ref. to OD(diag)-16, OPERATION, Read Diagnostic Trouble Code (DTC).> NOTE: If the communication function of the Subaru Select Monitor cannot be executed properly, check the communication circuit. <Ref. to AB(diag)-28, COMMUNICATION FOR INITIALIZING IMPOSSIBLE, INSPECTION, Subaru Select Monitor.> 5) Record all DTCs and freeze frame data.	Is DTC displayed?	Go to step 3.	Go to "Airbag Warning Light Failure" <Ref. to AB(diag)-35, Airbag Warning Light Failure.>.
3	<b>PERFORM DIAGNOSIS.</b> 1) Determine the possible cause from "List of Diagnostic Trouble Code (DTC)" <Ref. to OD(diag)-21, List of Diagnostic Trouble Code (DTC).>. 2) Inspect the DTC using "List of Diagnostic Trouble Code (DTC)". 3) Repair the trouble cause. 4) Perform the Clear Memory Mode. <Ref. to OD(diag)-18, Clear Memory Mode.> 5) Perform the Inspection Mode. <Ref. to OD(diag)-17, Inspection Mode.> 6) Read any other DTCs displayed.	Is DTC displayed?	Perform the procedure 1) to 5) in step 3.	Finish the diagnosis.

## Check List for Interview

OCCUPANT DETECTION SYSTEM (DIAGNOSTICS)

### 2. Check List for Interview

#### A: CHECK

Customer's Name		Inspector's Name	
Date Vehicle Brought in	/ /	Registration No.	
Odometer reading	km miles	V.I.N.	
Date Problem Occurred	/ /	Registration Year	/ /
Weather	<input type="checkbox"/> Fine <input type="checkbox"/> Cloudy <input type="checkbox"/> Rainy <input type="checkbox"/> Snowy <input type="checkbox"/> Others:		
Temperature	°C (°F)		
Road Condition	<input type="checkbox"/> Flat road <input type="checkbox"/> Uphill <input type="checkbox"/> Downhill <input type="checkbox"/> Gravel road <input type="checkbox"/> Others:		
Vehicle Operation	<input type="checkbox"/> Starting <input type="checkbox"/> Idling <input type="checkbox"/> Driving <input type="checkbox"/> Constant speed <input type="checkbox"/> Accelerating <input type="checkbox"/> Decelerating <input type="checkbox"/> Turning <input type="checkbox"/> Others:		
Details of Problem			
Airbag Warning Light Operation	<input type="checkbox"/> Normal (After turning the ignition switch to ON, illuminates for 6 seconds then goes off.) <input type="checkbox"/> Remains ON <input type="checkbox"/> Remains OFF		
Passengers airbag ON/OFF indicator operation	<input type="checkbox"/> Normal (After turning the ignition switch to ON, illuminates for 6 seconds then goes off for 2 seconds; Lights ON (adult) or OFF (children/unoccupied).) <input type="checkbox"/> Both remain ON <input type="checkbox"/> Both remain OFF		
DTC output	<input type="checkbox"/> OK code <input type="checkbox"/> DTC: (Code:                    )		

## General Description

### OCCUPANT DETECTION SYSTEM (DIAGNOSTICS)

---

### 3. General Description

#### A: CAUTION

1) If the seat cushion cover is removed or replaced, make sure to perform passenger detection system adjustment after installing the seat to the vehicle. <Ref. to OD(diag)-14, SYSTEM CALIBRATION (REZEROING), OPERATION, Subaru Select Monitor.>

Failure to do so may cause improper operation of the occupant detection system.

2) The passenger detection system (passenger seat only) control unit and the passenger detection sensor are fixed to the seat cushion frame. Never remove the passenger detection control unit or the pressure sensor from the seat cushion frame.

3) Do not replace the seat cushion pad by itself. Always replace the seat cushion pad and frame assembly as a set. The seat cushion pad and cushion frame are adjusted as a set at the time of manufacture. If cushion pads and cushion frames are combined from those of other vehicles or other sets, the passenger detection system may not operate properly.

4) If the seat cushion cover is removed, make sure to replace the hang wire on the seat cushion side with a new wire.

5) Never connect the battery in reverse polarity. Occupant detection system may be destroyed instantly.

6) Do not disconnect the battery terminals while the engine is running.

A large counter electromotive force will be generated in the generator, and this voltage may damage electronic parts such as occupant detection control module.

7) Before disconnecting the connectors of each sensor and control module, be sure to turn the ignition switch to OFF and wait for 60 seconds or more. Occupant detection control module may be damaged.

8) Every occupant detection system-related part is a precision part. Do not drop them.

#### CAUTION:

- Do not use electrical test equipment on wiring harness and connector circuits of the airbag system.
- Be careful not to damage the airbag system wiring harness when servicing the occupant detection system.
- Refer to CAUTION in Airbag System when repairing the occupant detection system. <Ref. to AB(diag)-4, CAUTION, General Description.>

#### B: INSPECTION

Measure the battery voltage and check electrolyte.

##### **Standard voltage:**

**12 V**

##### **Specific gravity:**

**1.260 or more**

##### **Fluid level:**

**Between the upper level and lower level**

# General Description

OCCUPANT DETECTION SYSTEM (DIAGNOSTICS)

## C: PREPARATION TOOL

### CAUTION:

To measure the voltage and resistance of airbag system and occupant detection system components, be sure to use the specified test harness.

### 1. SPECIAL TOOL

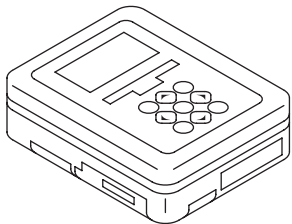
ILLUSTRATION	TOOL NUMBER	DESCRIPTION	REMARKS
 <p>ST1B022XU0</p>	1B022XU0	SUBARU SELECT MONITOR III KIT	Used for troubleshooting the electrical system.

### • TEST HARNESS Y

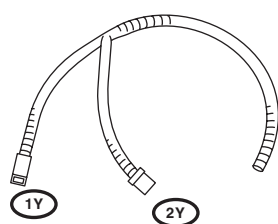
ILLUSTRATION	TOOL NUMBER	DESCRIPTION	REMARKS
 <p>ST98299AG040</p>	98299AG040	TEST HARNESS Y	Used for troubleshooting seat belt buckle switch.

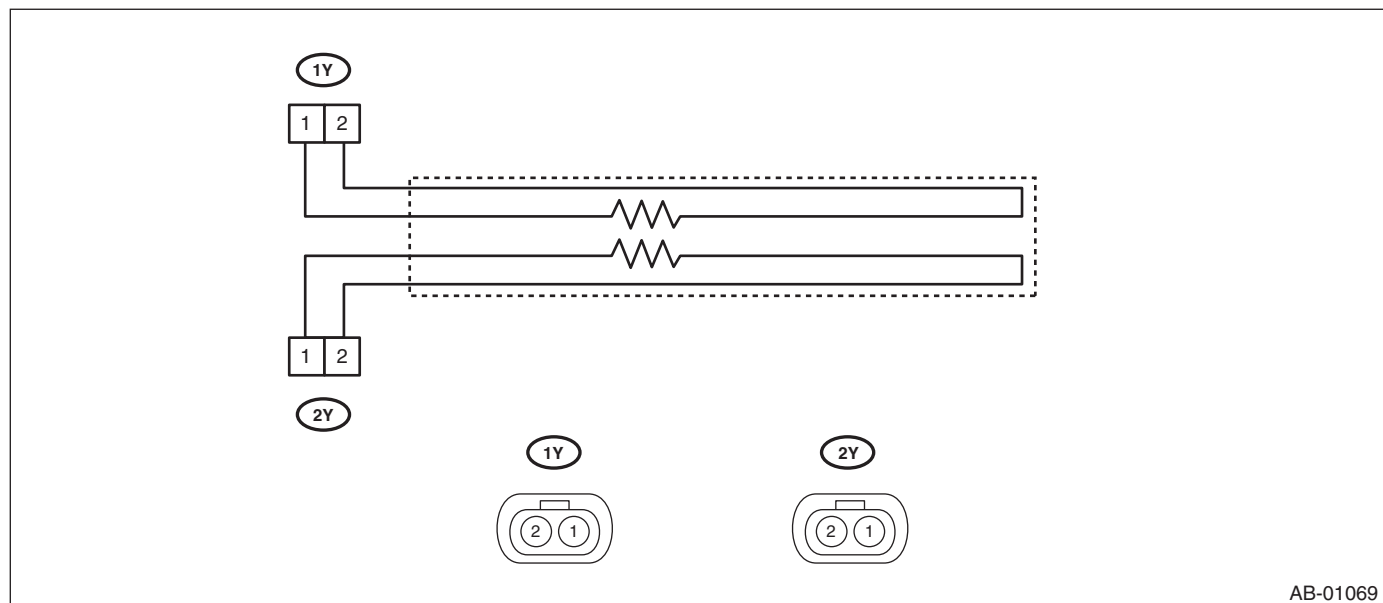

AB-01069



# General Description

## OCCUPANT DETECTION SYSTEM (DIAGNOSTICS)

- TEST HARNESS AB

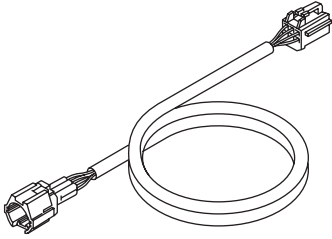
ILLUSTRATION	TOOL NUMBER	DESCRIPTION	REMARKS
 <p>ST98299XA000</p>	98299XA000	TEST HARNESS AB	Used when measuring voltage and resistance of occupant detection system.

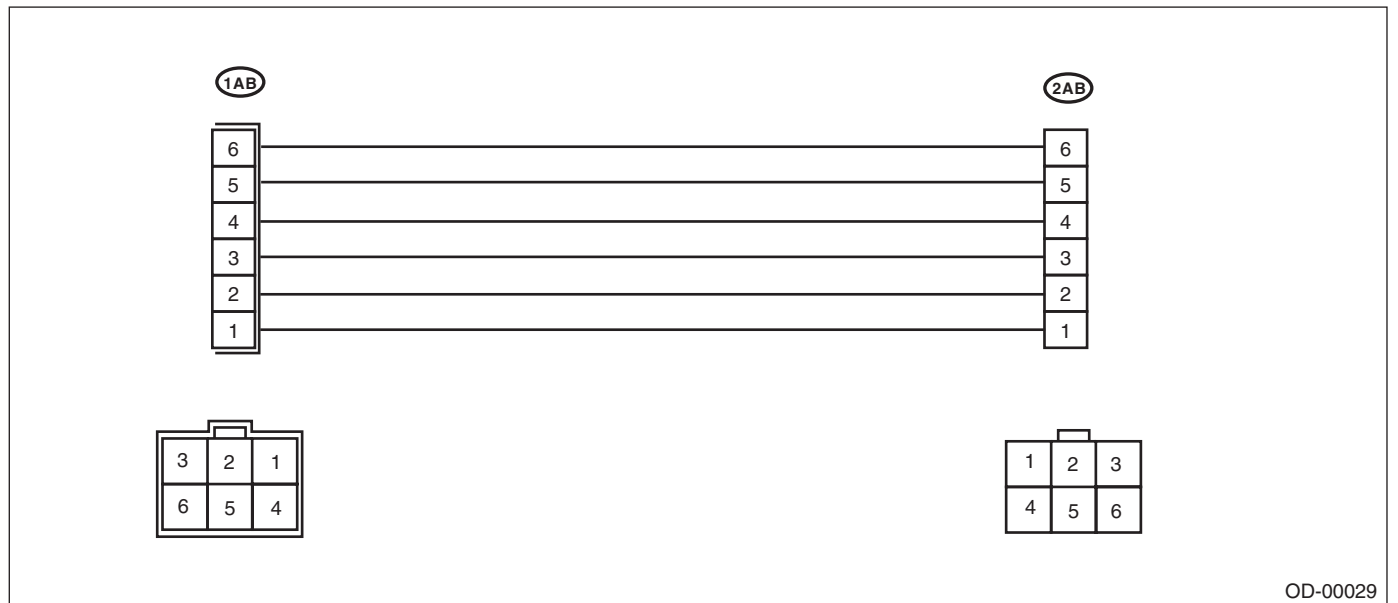

OD-00029

# General Description

## OCCUPANT DETECTION SYSTEM (DIAGNOSTICS)

- TEST HARNESS AE

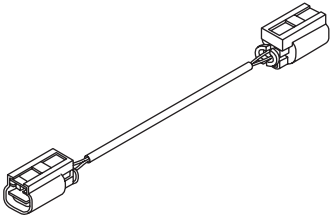
ILLUSTRATION	TOOL NUMBER	DESCRIPTION	REMARKS
 ST98299XA030	98299XA030	TEST HARNESS AE	TEST HARNESS Y adapter harness. Used for troubleshooting seat belt buckle switch.

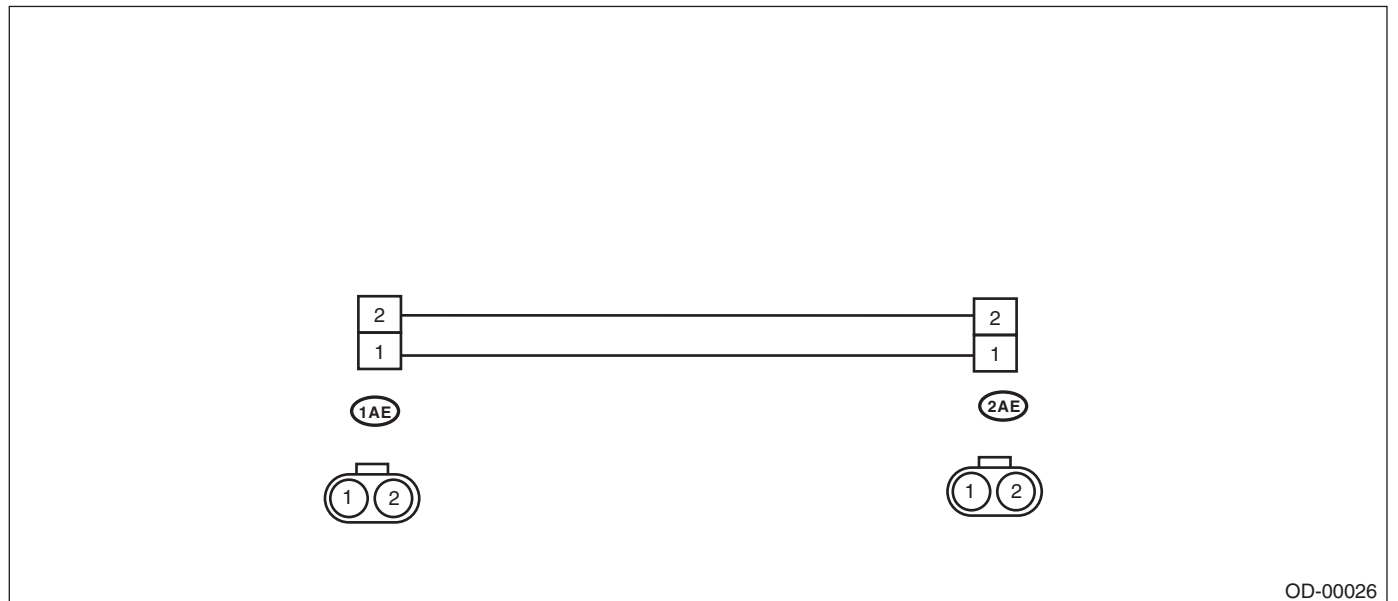

# General Description

## OCCUPANT DETECTION SYSTEM (DIAGNOSTICS)

### • TEST HARNESS AC

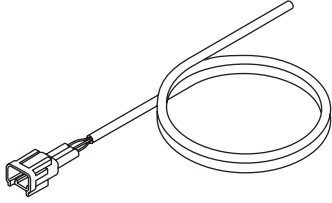
ILLUSTRATION	TOOL NUMBER	DESCRIPTION	REMARKS
 ST98299XA010	98299XA010	TEST HARNESS AC	Used for troubleshooting seat belt tension sensor.

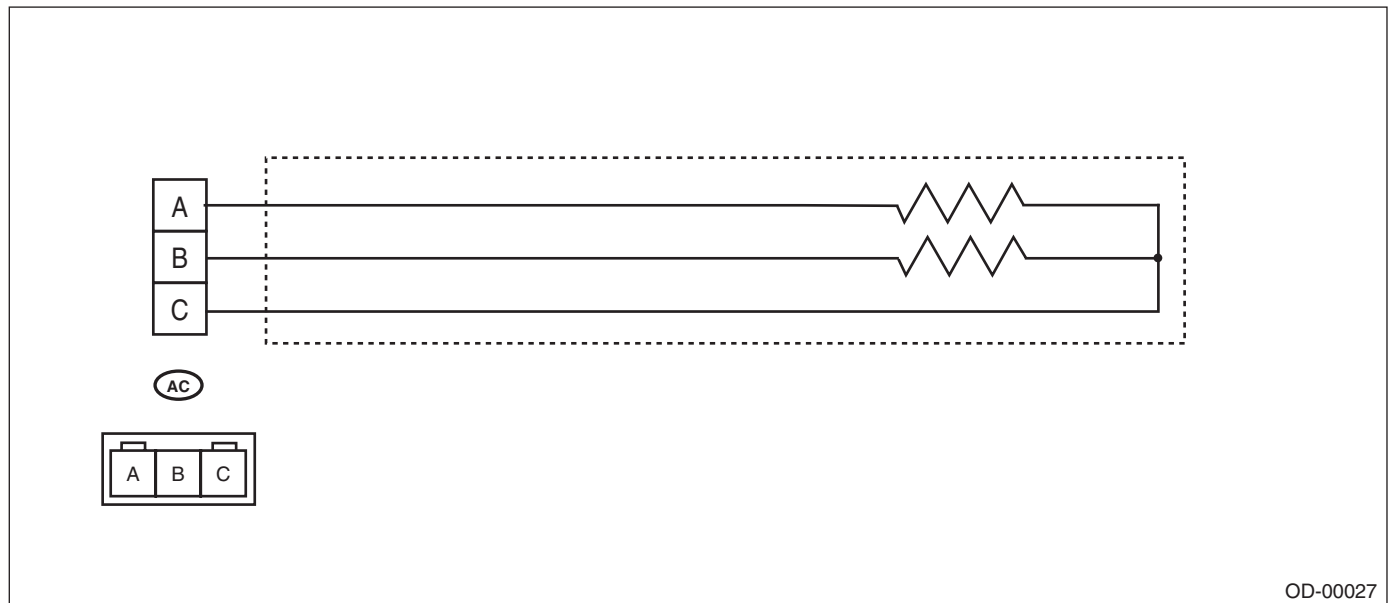

# General Description

OCCUPANT DETECTION SYSTEM (DIAGNOSTICS)

## • TEST HARNESS AD

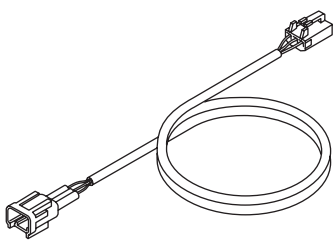
ILLUSTRATION	TOOL NUMBER	DESCRIPTION	REMARKS
 <p>ST98299XA020</p>	98299XA020	TEST HARNESS AD	Used when measuring voltage and resistance of the seat belt tension sensor.

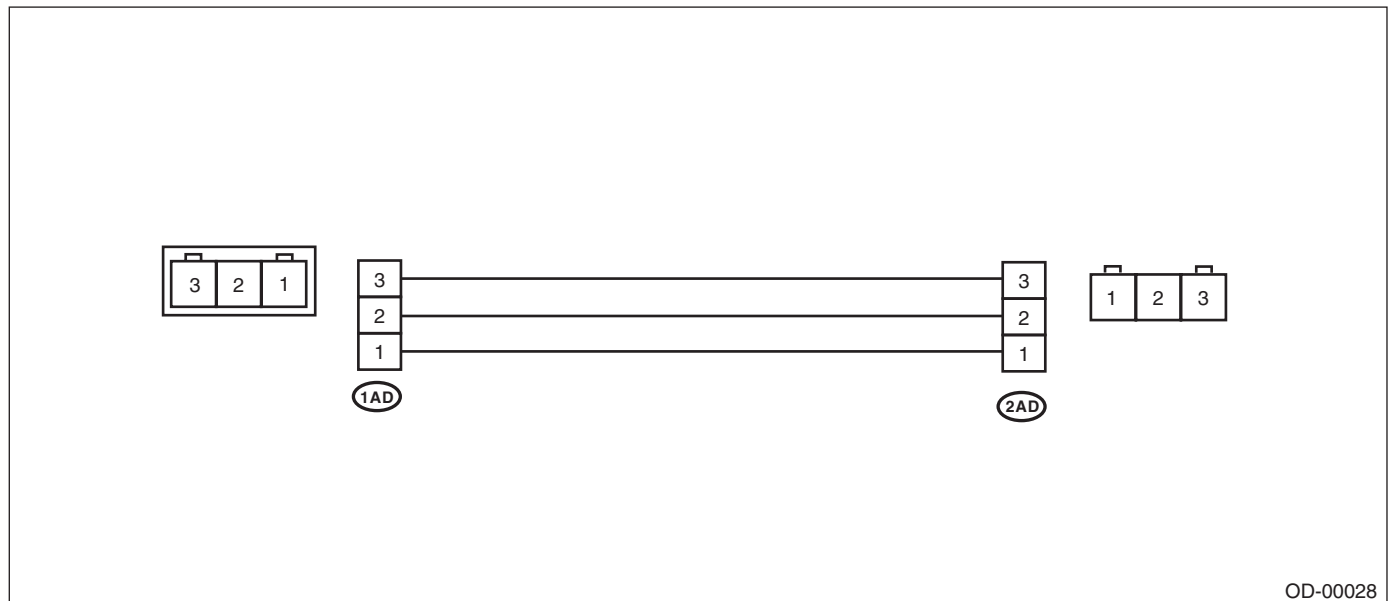

## 2. GENERAL TOOL

TOOL NAME	REMARKS
Circuit tester	Used for measuring resistance, voltage and current.

# Electrical Component Location

## OCCUPANT DETECTION SYSTEM (DIAGNOSTICS)

### 4. Electrical Component Location

#### A: LOCATION

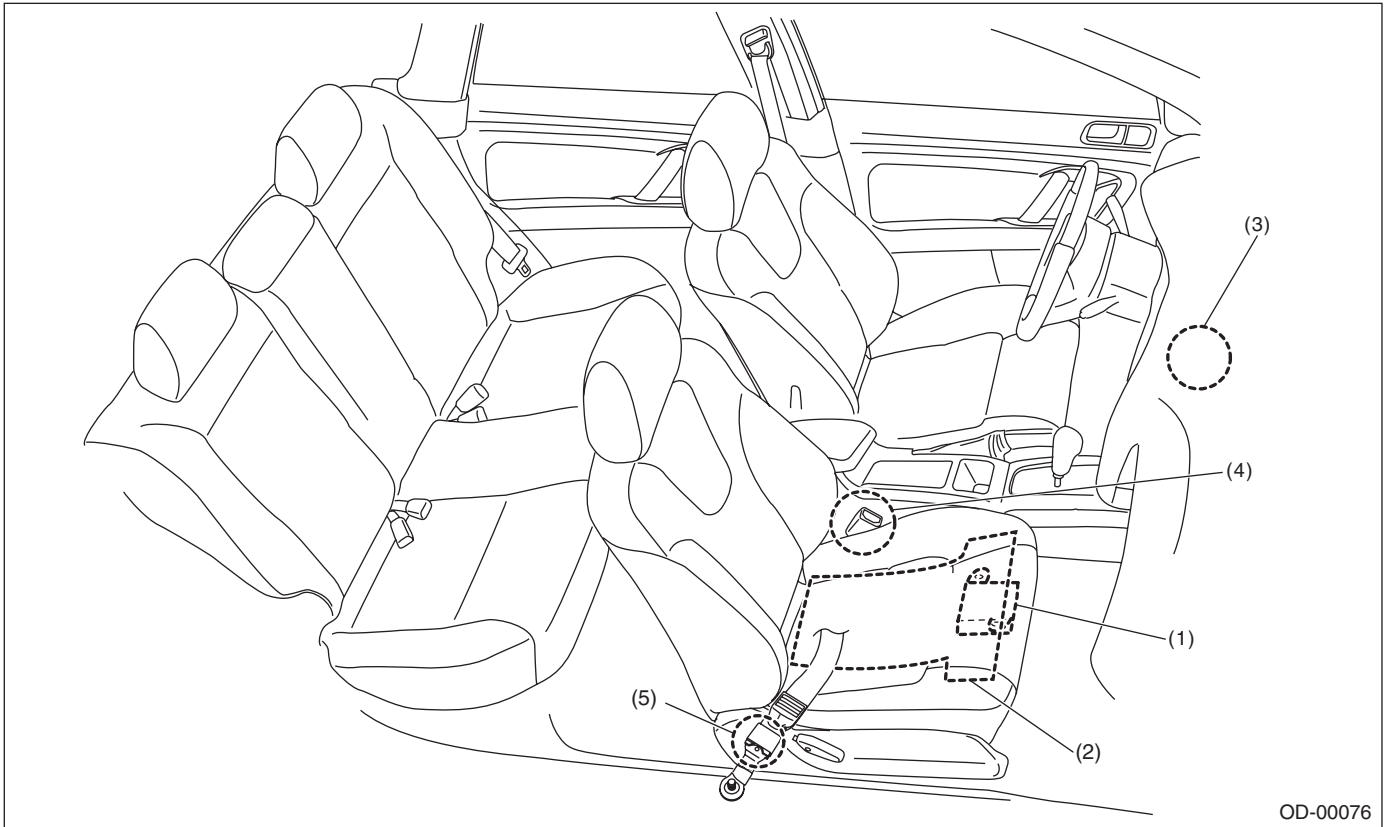

- (1) Occupant detection control module
- (2) Occupant detection sensor
- (3) Airbag ON/OFF indicator light
- (4) Buckle switch (passenger's seat)
- (5) Seat belt tension sensor

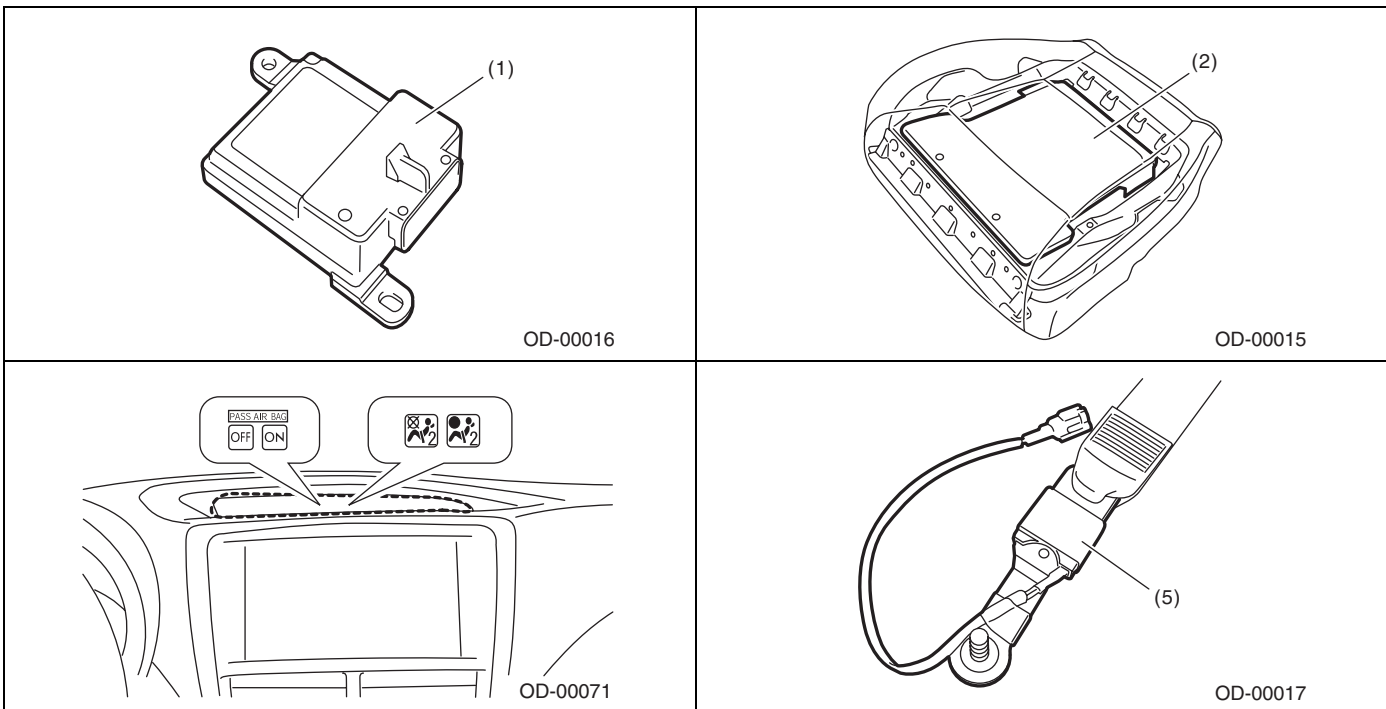

## 5. Airbag Connector

### A: PROCEDURE

#### 1. OCCUPANT DETECTION SYSTEM (BETWEEN AIRBAG REAR HARNESS AND SEAT HARNESS) AND BELT TENSION SENSOR

1) How to disconnect:

Press the lock arm (A) and disconnect the connector.

#### CAUTION:

**When pulling the slide lock or disconnecting connector, be sure to hold the connector, not the harness.**

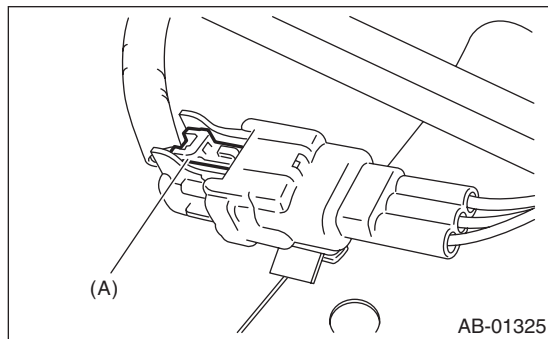

2) How to connect:

Holding the connector, push it in securely until a clicking sound is heard.

#### CAUTION:

**Be sure to insert the connector in until it is locked. Then pull it gently to make sure that it is locked.**

#### 2. AIRBAG CONTROL MODULE

Refer to the airbag system section. <Ref. to AB-9, AIRBAG CONTROL MODULE, PROCEDURE, Airbag Connector.>

#### 3. BUCKLE SWITCH RH

Refer to the airbag system section. <Ref. to AB-12, BUCKLE SWITCH RH, PROCEDURE, Airbag Connector.>

## Control Module I/O Signal

OCCUPANT DETECTION SYSTEM (DIAGNOSTICS)

### 6. Control Module I/O Signal

#### A: ELECTRICAL SPECIFICATION

##### CAUTION:

Never remove the occupant detection control module, occupant detection sensor or seat frame because they are integrated into one unit.

Terminal name	Terminal No.	Input/Output value	Remarks	
IG – power supply	9	9 — 16 V	When ignition switch ON	
Airbag control module communication (COM)	10	Open collector terminal	Communication line	
Airbag control module communication (GND)	5	0 V	Ground	
Belt tension sensor	(Vcc)	4	0 — 5 V	Belt tension sensor power supply
	(Vout)	16	0.5 — 4.5 V	Sensor output voltage
	(GND)	14	0 V	Sensor ground
Occupant detection sensor	(Vcc)	6	0 — 5 V	Pressure sensor power supply
	(Vout)	7	0.5 — 4.5 V	Sensor output voltage
	(GND)	15	0 V	Sensor ground
Buckle switch	1	0 — IG voltage	Ignition voltage when switch ON	
Buckle switch (GND)	2	0 V	Switch ground	

#### B: WIRING DIAGRAM

Refer to the electrical wiring diagram. <Ref. to WI-87, WIRING DIAGRAM, Occupant Detection System.>

## 7. Subaru Select Monitor

### A: OPERATION

#### 1. READ DIAGNOSTIC TROUBLE CODE (DTC)

When malfunction of the airbag system and the occupant detection system occur, the DTC stored in airbag control module will be read out.

Refer to the READ DIAGNOSTIC TROUBLE CODE (DTC) of the Airbag system (diagnostics). <Ref. to AB(diag)-26, READ DIAGNOSTIC TROUBLE CODE (DTC), OPERATION, Subaru Select Monitor.>

NOTE:

- For detailed operation procedures, refer to “PC application help for Subaru Select Monitor”.
- For details concerning DTCs, refer to the List of Diagnostic Trouble Code (Airbag system, Occupant detection system). <Ref. to AB(diag)-39, List of Diagnostic Trouble Code (DTC).> <Ref. to OD(diag)-21, List of Diagnostic Trouble Code (DTC).>

#### 2. DISPLAY OF STATUS INFORMATION

Check the operating condition of each sensor in the event of malfunction in the seat belt buckle switch and seat position sensor, or when the seat belt buckle switch and seat position sensor has been replaced.

- 1) On «Main Menu» display, select {Each System Check}.
- 2) On «System Selection Menu» display, select {Airbag System}.
- 3) Select the {Status Data} in «Airbag System».

The following table is for support data.

Item	Display Contents
Seat position sensor LH	— <sup>*2</sup>
Seat position sensor RH	— <sup>*2</sup>
Seat belt buckle switch LH	— <sup>*6</sup>
Seat belt buckle switch RH	Equipped <sup>*3</sup> /Unequipped <sup>*4</sup> /Other <sup>*5</sup> /Initial setting <sup>*1</sup> /— <sup>*6</sup>
Passenger's airbag control status	ON <sup>*7</sup> /OFF <sup>*8</sup> /Initial Setting <sup>*1</sup>

\*1: Displayed when it is initial.

\*2: Seat position sensor not supported

\*3: Seat belt fastened

\*4: Seat belt not fastened

\*5: Displayed when data other than belt fastened or not fastened, such as breakdowns is input.

\*6: Seat belt buckle switch not supported

\*7: Passenger's airbag operating state

\*8: Passenger's airbag non-operating state

NOTE:

For details concerning the operation procedure, refer to “PC application help for Subaru Select Monitor”.



# Subaru Select Monitor

## OCCUPANT DETECTION SYSTEM (DIAGNOSTICS)

### 3. CLEAR MEMORY MODE

Clear the DTC stored in the airbag control module after repairing the airbag system and occupant detection system. (After the breakdown is recovered, the breakdown code for completed recoveries are read out when the next breakdown occurs if the memory clear work is not performed.)

- 1) On «Main Menu» display, select {Each System Check}.
- 2) On «System Selection Menu» display, select {Airbag System}.
- 3) Select {Clear Memory} in {Airbag System} menu screen.
- 4) When the “Clear Memory?” is shown on the screen, select [OK].
- 5) When Done is displayed, terminate the Subaru Select Monitor and turn the ignition switch to OFF.

#### NOTE:

For details concerning the operation procedure, refer to “PC application help for Subaru Select Monitor”.

### 4. SYSTEM CALIBRATION (REZEROING)

#### NOTE:

When replacing the occupant detection system, or removing and disassembling the passenger's seat, always perform the system calibration after installing a seat in the vehicle.

#### CAUTION:

**When the trouble occurs in the system during calibration process, “Occupant detection calibration failure” is detected in the DTC 2A of the airbag system and the airbag warning light lights. In this case, after turning the ignition switch to OFF once, redo the system calibration (Rezeroing), or after clearing the cause of the failure, perform the system calibration again.**

- 1) Park empty vehicle on a level surface.
- 2) On «Main Menu» display, select {Each System Check}.
- 3) On «System Selection Menu» display, select {Occupant Detection System}.
- 4) On the {Occupant Detection System} display, select {Rezeroing}.
- 5) When «See service manual. And check vehicle condition for successfully completing the rezeroing.» is displayed, check the following to adjust the condition of the vehicle.
  - Adjust the seat backrest to be fully upright. (For models with power seats, press the power seat button until the backrest comes to a stop.)
  - Adjust the seat slide position all the way back. (For models with power seats, press the power seat button until the seat slide does not move any further.)

- Do not place anything on the top of the seat cushion.
  - Sit on the seat cushion to smooth the seat surface.
  - Check that the passenger's seat belt is not inserted into the buckle, not tense or not stuck.
  - Check that ambient temperature is in a range from 0 to 40°C (32 to 104°F).
- 6) When the «Re-zeroing Adjust the passenger seat to the condition shown in service manual» is displayed, slide the passenger seat all the way to the back, check that the backrest is adjusted to all the way up, and select the [OK].

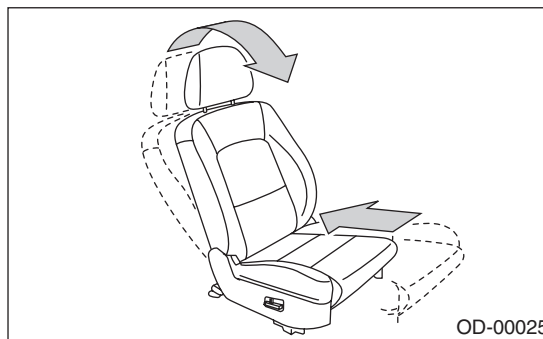

- 7) When the «Re-zeroing Unbelt the Passenger seatbelt Continue: OK, Quit: NO» is displayed, make sure the passenger's seatbelt is disconnected from the buckle and select the [OK].
- 8) When the «Re-zeroing Empty the passenger seat Continue: OK, Quit: NO» is displayed, make sure that the passenger's seat is empty, airbag OFF indicator illuminates and airbag ON indicator does not illuminate, and select the [OK].

#### NOTE:

- After selecting the [OK], «In process...Please wait for a while without touching vehicle» is displayed. Do not touch or rock the vehicle while the message is displayed.
  - During the system calibration process, if the «Re-zeroing is unsuccessful See service manual Press “OK” to END» is displayed, go to step 10).
- 9) When the re-zeroing is ended normally, the «Re-zeroing is successfully completed Press “OK” to END» is displayed. And then turn the ignition switch to OFF to finish the diagnosis.

10) During the system calibration process, if «Re-zeroing is unsuccessful See service manual Press “OK” to END» is displayed, turn the ignition switch to OFF once and turn it ON again, then read the DTC of the airbag system. <Ref. to AB(diag)-26, READ DIAGNOSTIC TROUBLE CODE (DTC), OPERATION, Subaru Select Monitor.>

When DTC is input, fix the fault and then perform the system calibration. When DTC is not input, check the seat and vehicle status and then perform the system calibration again. <Ref. to OD(diag)-14, SYSTEM CALIBRATION (REZEROING), OPERATION, Subaru Select Monitor.>

### NOTE:

When the re-zeroing is unsuccessful, there could be occupant detection system failure or improper seat and vehicle status. When the airbag warning light illuminates, read the DTC of the airbag system, and perform the diagnosis while referring to List of Diagnostic Trouble Code (DTC). <Ref. to AB(diag)-26, READ DIAGNOSTIC TROUBLE CODE (DTC), OPERATION, Subaru Select Monitor.> <Ref. to AB(diag)-39, LIST, List of Diagnostic Trouble Code (DTC).>

## **B: INSPECTION**

### **1. COMMUNICATION FOR INITIALIZING IMPOSSIBLE**

#### **DETECTING CONDITION:**

Defective harness connector

#### **TROUBLE SYMPTOM:**

Communication is impossible between the airbag control module and the Subaru Select Monitor.

Refer to “COMMUNICATION FOR INITIALIZING IMPOSSIBLE” in the Airbag system (diagnostics). <Ref. to AB(diag)-28, COMMUNICATION FOR INITIALIZING IMPOSSIBLE, INSPECTION, Subaru Select Monitor.>

### **2. WITHOUT DTC**

#### **DETECTING CONDITION:**

- Defective combination meter
- Open circuit of harness

#### **TROUBLE SYMPTOM:**

- Airbag warning light remains ON.
- “No diagnostic Code Present” will be displayed on the Subaru Select Monitor.

### NOTE:

- For detailed operation procedures, refer to “Airbag Warning Light Failure”. <Ref. to AB(diag)-35, Airbag Warning Light Failure.>
- When the airbag warning light is OFF and “No diagnostic Code Present” is displayed on Subaru Select Monitor, the system is operating properly.

## Read Diagnostic Trouble Code (DTC)

OCCUPANT DETECTION SYSTEM (DIAGNOSTICS)

---

### 8. Read Diagnostic Trouble Code (DTC)

#### A: OPERATION

For details on reading DTCs, refer to “Airbag System (Diagnostics) Subaru Select Monitor”. <Ref. to AB(diag)-26, Subaru Select Monitor.>

## 9. Inspection Mode

### A: PROCEDURE

Recreate the circumstance by referring to the conditions described in the checklist.

## Clear Memory Mode

OCCUPANT DETECTION SYSTEM (DIAGNOSTICS)

---

### 10. Clear Memory Mode

#### A: OPERATION

- Clear the memory in the following steps after the malfunction is repaired.
- For details to clear the DTC, refer to “Airbag System (Diagnostics) Subaru Select Monitor”. <Ref. to AB(diag)-26, Subaru Select Monitor.>

## 11. Airbag Warning Light Illumination Pattern

### A: INSPECTION

Turn the ignition switch to ON, and confirm that the airbag warning light remains on for approx. 6 seconds then turns off afterwards.

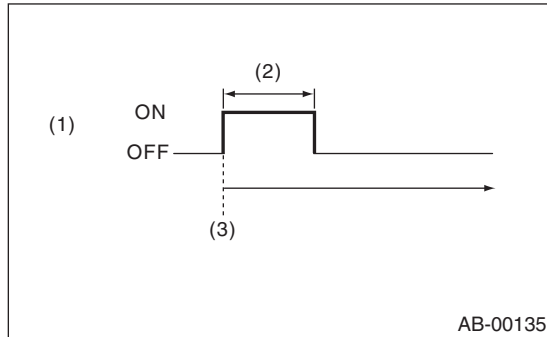

- (1) Airbag warning light
- (2) Approx. 6 sec.
- (3) Ignition switch ON

# Passenger's Airbag ON/OFF Indicator Light Illumination Pattern

OCCUPANT DETECTION SYSTEM (DIAGNOSTICS)

## 12. Passenger's Airbag ON/OFF Indicator Light Illumination Pattern

### A: INSPECTION

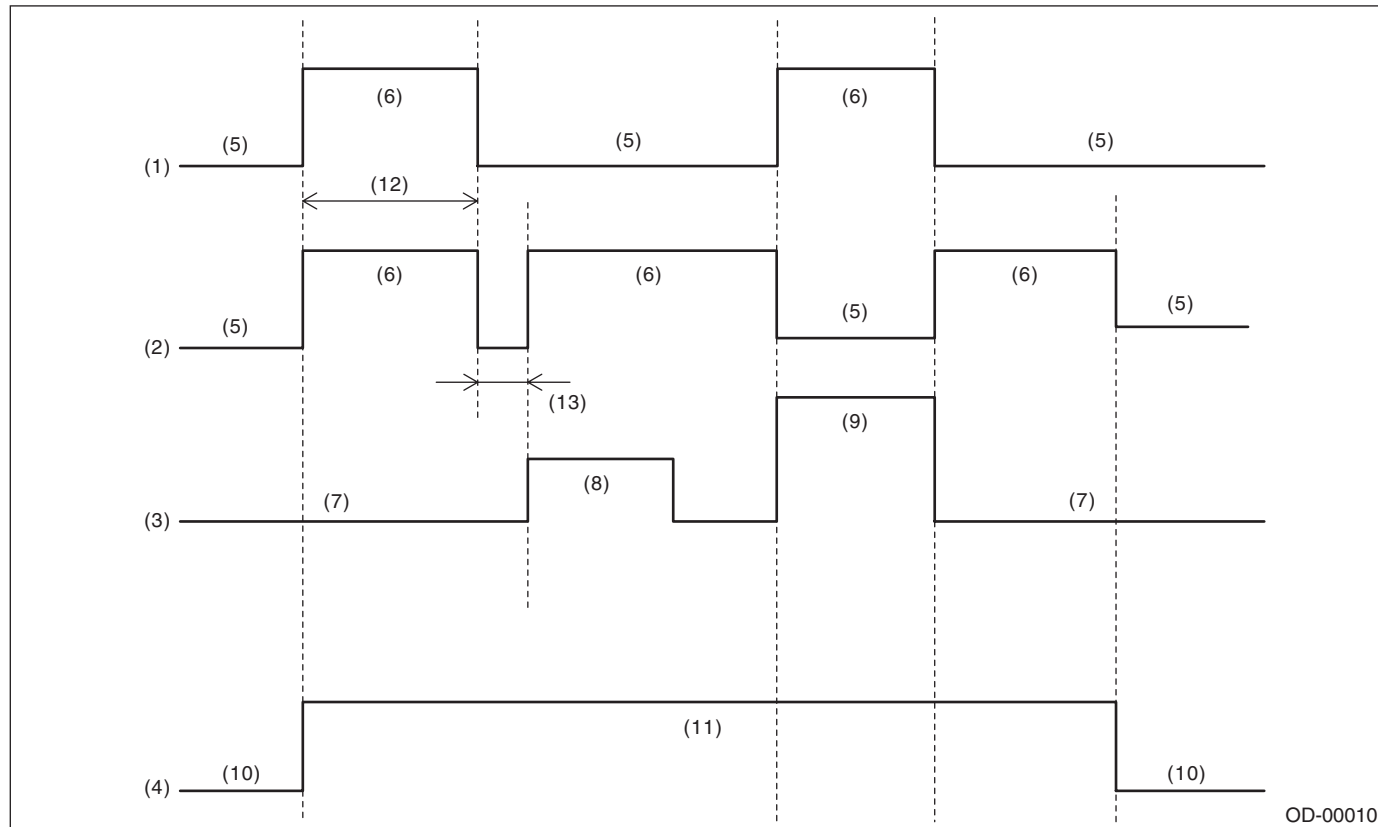

OD-00010

- |  |              |                     |
|--|--------------|---------------------|
| (1) Passenger's airbag ON indicator light  | (6) Light ON | (10) OFF            |
| (2) Passenger's airbag OFF indicator light | (7) Empty    | (11) ON             |
| (3) Occupant seating                       | (8) Child    | (12) Approx. 6 sec. |
| (4) Ignition switch                        | (9) Adult    | (13) Approx. 2 sec. |
| (5) Light OFF                              |              |                     |

# List of Diagnostic Trouble Code (DTC)

OCCUPANT DETECTION SYSTEM (DIAGNOSTICS)

## 13. List of Diagnostic Trouble Code (DTC)

### A: LIST

DTC	Item	Content of diagnosis	Reference
2A	ODS Calibration error	System calibration (Rezeroing) was not completed normally.	<Ref. to OD(diag)-22, DTC 2A ODS CALIBRATION ERROR, Diagnostic Procedure with Diagnostic Trouble Code (DTC).>
2B	ODS System wrong parts	<ul style="list-style-type: none"> <li>• Wrong airbag control module is installed.</li> <li>• Wrong occupant detection system is installed.</li> <li>• Occupant detection system is faulty.</li> </ul>	<Ref. to OD(diag)-22, DTC 2B ODS SYSTEM WRONG PARTS, Diagnostic Procedure with Diagnostic Trouble Code (DTC).>
2C	Belt tension Sensor failure	<ul style="list-style-type: none"> <li>• Passenger's seat belt tension sensor is faulty.</li> <li>• Airbag rear harness circuit is open or shorted.</li> <li>• Occupant detection system is faulty.</li> <li>• Occupant detection harness is faulty.</li> </ul>	<Ref. to OD(diag)-23, DTC 2C BELT TENSION SENSOR FAILURE, Diagnostic Procedure with Diagnostic Trouble Code (DTC).>
27	ODS Communication error	<ul style="list-style-type: none"> <li>• Occupant detection control module and airbag control module communication is faulty.</li> <li>• Airbag rear harness circuit is open, shorted, shorted to ground or shorted to power supply.</li> <li>• Occupant detection harness is faulty.</li> <li>• Occupant detection system is faulty.</li> <li>• Airbag control module is faulty.</li> </ul>	<Ref. to OD(diag)-24, DTC 27 ODS COMMUNICATION ERROR, Diagnostic Procedure with Diagnostic Trouble Code (DTC).>
29	ODS failure	<ul style="list-style-type: none"> <li>• Occupant detection sensor is faulty.</li> <li>• Occupant detection control module is faulty.</li> <li>• Occupant detection harness is faulty.</li> <li>• Fuse No. 25 (in joint box) is blown.</li> </ul>	<Ref. to OD(diag)-25, DTC 29 ODS FAILURE, Diagnostic Procedure with Diagnostic Trouble Code (DTC).>
37	Buckle Switch RH failure	<ul style="list-style-type: none"> <li>• Passenger's buckle switch circuit is open, shorted or shorted to ground.</li> <li>• Occupant detection system is faulty.</li> <li>• Occupant detection harness is faulty.</li> </ul>	<Ref. to OD(diag)-26, DTC 37 BUCKLE SWITCH RH FAILURE, Diagnostic Procedure with Diagnostic Trouble Code (DTC).>



# Diagnostic Procedure with Diagnostic Trouble Code (DTC)

OCCUPANT DETECTION SYSTEM (DIAGNOSTICS)

## 14. Diagnostic Procedure with Diagnostic Trouble Code (DTC)

### A: DTC 2A ODS CALIBRATION ERROR

#### DTC DETECTING CONDITION:

System calibration (Rezeroing) was not completed properly.

	Step	Check	Yes	No
1	<b>PERFORM RE-ZEROING.</b> Perform system calibration using the Subaru Select Monitor. <Ref. to OD(diag)-14, SYSTEM CALIBRATION (REZEROING), OPERATION, Subaru Select Monitor.>	Did the system calibration complete properly?	Finish the diagnosis.	Follow the system calibration procedures. <Ref. to OD(diag)-14, SYSTEM CALIBRATION (REZEROING), OPERATION, Subaru Select Monitor.>

### B: DTC 2B ODS SYSTEM WRONG PARTS

#### DTC DETECTING CONDITION:

- Wrong airbag control module is installed.
- Wrong occupant detection system is installed.

	Step	Check	Yes	No
1	<b>CHECK OCCUPANT DETECTION SYSTEM.</b> 1) Turn the ignition switch to OFF, disconnect the battery ground cable, and wait for 60 seconds or more. 2) Replace the passenger's seat cushion pad frame assembly. <Ref. to SE-6, REMOVAL, Front Seat.> <Ref. to SE-8, PASSENGER'S SEAT, DISASSEMBLY, Front Seat.> 3) Connect the ground cable to battery. 4) Connect Subaru Select Monitor to the vehicle and perform the system calibration. <Ref. to OD(diag)-14, SYSTEM CALIBRATION (REZEROING), OPERATION, Subaru Select Monitor.>	Did the system calibration complete properly?	Finish the diagnosis.	Go to step 2.
2	<b>CHECK AIRBAG CONTROL SYSTEM.</b> 1) Turn the ignition switch to OFF, disconnect the battery ground cable, and wait for 60 seconds or more. 2) Replace the airbag control module. <Ref. to AB-22, REMOVAL, Airbag Control Module.> 3) Connect the ground cable to battery. 4) Connect Subaru Select Monitor to the vehicle and perform the system calibration. <Ref. to OD(diag)-14, SYSTEM CALIBRATION (REZEROING), OPERATION, Subaru Select Monitor.>	Did the system calibration complete properly?	Finish the diagnosis.	Check between the occupant detection control module and airbag control module.

# Diagnostic Procedure with Diagnostic Trouble Code (DTC)

OCCUPANT DETECTION SYSTEM (DIAGNOSTICS)

## C: DTC 2C BELT TENSION SENSOR FAILURE

### DTC DETECTING CONDITION:

- Passenger's seat belt tension sensor is faulty.
- Airbag main harness circuit is open or shorted.
- Occupant detection control module is faulty.

### WIRING DIAGRAM:

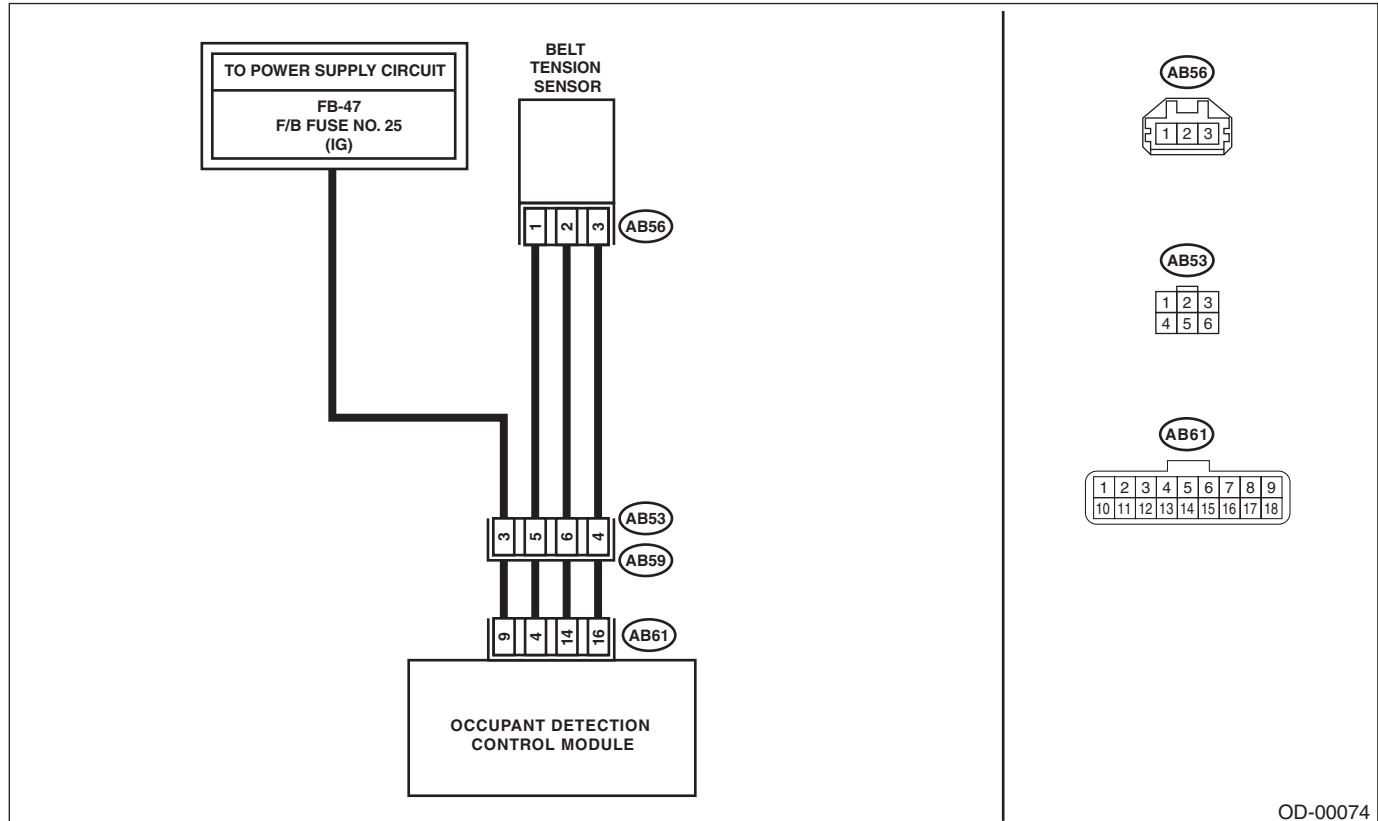

Step	Check	Yes	No
<b>1 CHECK POOR CONTACT OF CONNECTORS.</b> Check for poor contact of the connectors between the occupant detection control module and belt tension sensor.	Is there poor contact?	Reconnect the connector. If the fault is not fixed, replace the airbag harness.	Go to step 2.
<b>2 CHECK BELT TENSION SENSOR.</b> 1) Turn the ignition switch to OFF, disconnect the battery ground cable, and wait for 60 seconds or more. 2) Disconnect the belt tension sensor connector (AB56) from the airbag harness. 3) Connect the test harness AC to the connector (AB56). 4) Connect the battery ground terminal and turn the ignition switch to ON.	Does the airbag warning light illuminate for approximately 6 seconds and go off?	Replace the seat belt out. <Ref. to SB-18, OUTER SEAT BELT ASSEMBLY, REMOVAL, Front Seat Belt.>	Go to step 3.

# Diagnostic Procedure with Diagnostic Trouble Code (DTC)

## OCCUPANT DETECTION SYSTEM (DIAGNOSTICS)

	Step	Check	Yes	No
3	<p><b>CHECK AIRBAG HARNESS.</b></p> <p>1) Turn the ignition switch to OFF, disconnect the battery ground cable, and wait for 60 seconds or more.</p> <p>2) Disconnect the test harness AC from the belt tension sensor connector (AB56).</p> <p>3) Connect the test harness AD (1AD) to the connector (AB56).</p> <p>4) Disconnect the airbag harness connector (AB53), and connect connector (1AB) of test harness AB.</p> <p>5) Measure the resistance between test harness terminals.</p> <p><b>Connector &amp; terminal</b>  <b>(2AB) No. 5 — (2AD) No. 1:</b>  <b>(2AB) No. 4 — (2AD) No. 3:</b>  <b>(2AB) No. 6 — (2AD) No. 2:</b></p>	Is the resistance less than 10 Ω?	Go to step 4.	Replace the airbag harness along with chassis harness.
4	<p><b>CHECK AIRBAG HARNESS.</b></p> <p>Measure the resistance between test harness terminals, and between test harness terminal and chassis ground.</p> <p><b>Connector &amp; terminal</b>  <b>(2AB) No. 4 — (2AD) No. 1:</b>  <b>(2AB) No. 4 — (2AD) No. 2:</b>  <b>(2AB) No. 4 — chassis ground:</b>  <b>(2AB) No. 5 — (2AD) No. 2:</b>  <b>(2AB) No. 5 — chassis ground:</b></p>	Is the resistance 1 MΩ or more?	Go to step 5.	Replace the airbag harness along with chassis harness.
5	<p><b>CHECK AIRBAG HARNESS.</b></p> <p>1) Connect the battery ground terminal and turn the ignition switch to ON.</p> <p>2) Measure the voltage between test harness and chassis ground.</p> <p><b>Connector &amp; terminal</b>  <b>(2AD) No. 1 (+) — Chassis ground (-):</b>  <b>(2AD) No. 3 (+) — Chassis ground (-):</b></p>	Is the voltage 1 V or less?	Replace the airbag harness along with chassis harness.	Check the seat harness, and if any fault is found, replace the seat harness. If no fault is found in the seat harness, replace the seat cushion frame assembly. <Ref. to SE-8, PASSENGER'S SEAT, DISASSEMBLY, Front Seat.>

### D: DTC 27 ODS COMMUNICATION ERROR

Perform the diagnosis following diagnostic procedures for the airbag system. <Ref. to AB(diag)-71, DTC 27 ODS COMMUNICATION ERROR, Diagnostic Chart with Trouble Code.>

# Diagnostic Procedure with Diagnostic Trouble Code (DTC)

OCCUPANT DETECTION SYSTEM (DIAGNOSTICS)

## E: DTC 29 ODS FAILURE

### DTC DETECTING CONDITION:

- Occupant detection sensor is faulty.
- Occupant detection control module is faulty.
- Occupant detection harness is faulty.
- Rear airbag harness is faulty.
- Fuse No. 25 (in joint box) is blown.

	Step	Check	Yes	No
1	<b>CHECK POOR CONTACT OF CONNECTORS.</b> Check for poor contact of the connectors between the occupant detection control module and airbag control module.	Is there poor contact?	Reconnect the connector. If the fault is not fixed, replace the airbag harness.	Go to step 2.
2	<b>CHECK DTC.</b> Read diagnostic trouble code (DTC) for the airbag system.	Is "2C Belt Tension Sensor failure" or "37 Buckle Switch failure" displayed in the diagnostics code?	Perform the diagnosis according to each DTC.	Check the seat harness, and if any fault is found, replace the seat harness. If the fault is not fixed, replace the occupant detection system. <Ref. to SE-8, PASSENGER'S SEAT, DISASSEMBLY, Front Seat.>

# Diagnostic Procedure with Diagnostic Trouble Code (DTC)

## OCCUPANT DETECTION SYSTEM (DIAGNOSTICS)

### F: DTC 37 BUCKLE SWITCH RH FAILURE

#### DTC DETECTING CONDITION:

- Passenger's buckle switch circuit is open, shorted or shorted to ground.
- Seat harness circuit is open, shorted or shorted to ground.
- Occupant detection control module is faulty.

#### WIRING DIAGRAM:

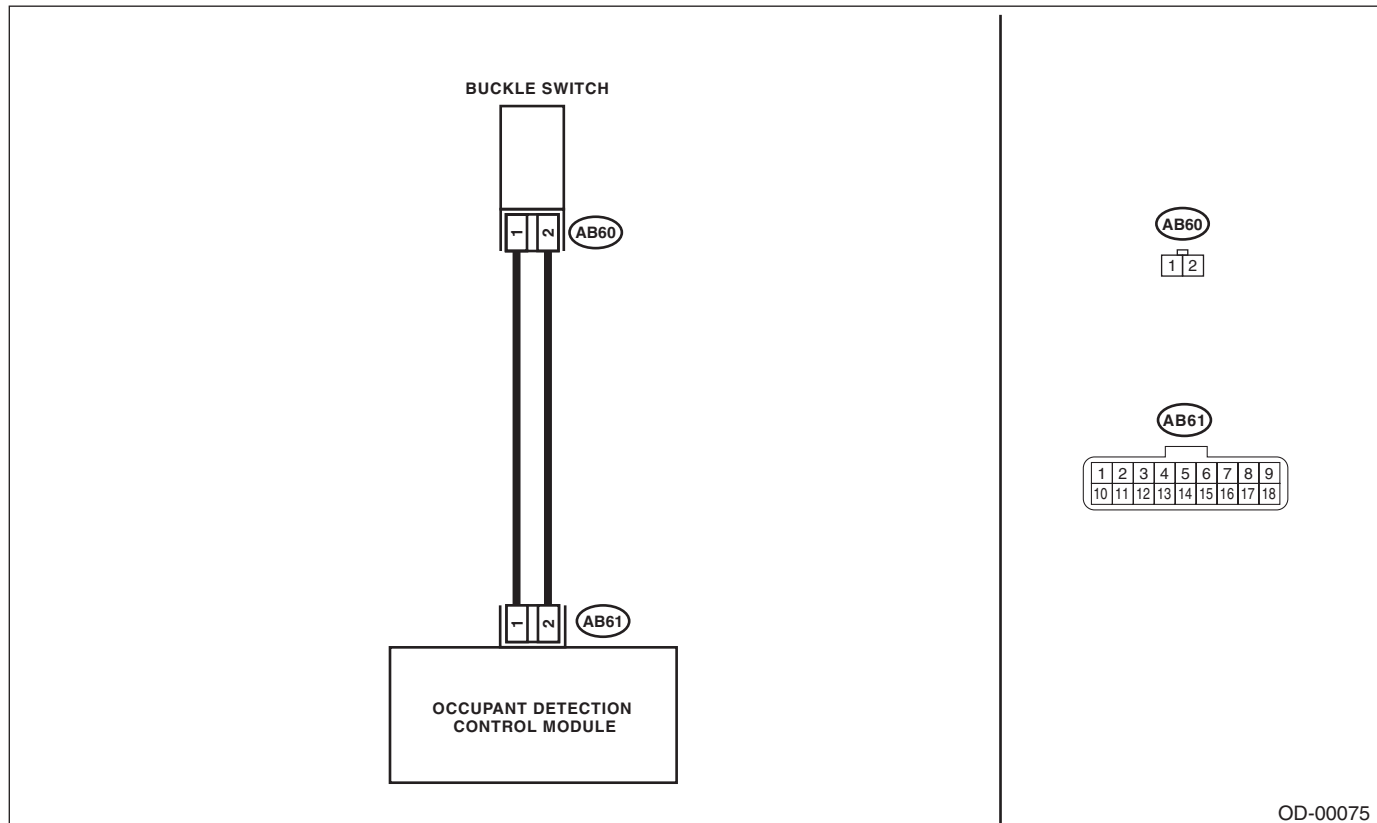

OD-00075

Step	Check	Yes	No
<b>1 CHECK POOR CONTACT OF CONNECTORS.</b> Check for poor contact of the connectors between the occupant detection control module and buckle switch.	Is there poor contact?	Reconnect the connector. If the fault is not fixed, replace the airbag harness.	Go to step 2.
<b>2 CHECK BUCKLE SWITCH.</b> 1) Turn the ignition switch to OFF, disconnect the battery ground terminal, and wait for 60 seconds. 2) Disconnect the buckle switch connector (AB60). 3) Connect the test harness AE and test harness Y to buckle switch connector (AB60). 4) Connect the battery ground terminal and turn the ignition switch to ON.	Does the airbag warning light illuminate for 6 seconds and go off?	Replace the buckle switch. <Ref. to SB-18, INNER SEAT BELT ASSEMBLY, REMOVAL, Front Seat Belt.>	Check the seat harness, and if any fault is found, replace the seat harness. If the fault is not fixed, replace the occupant detection system.

# SEAT BELT SYSTEM

# SB

---

	<b>Page</b>
1. General Description .....	2
2. Pretensioner Connector .....	12
3. Inspection Locations after a Collision .....	13
4. Seat Belt Warning System .....	14
5. Front Seat Belt .....	18
6. Rear Seat Belt .....	20

# General Description

## SEAT BELT SYSTEM

### 1. General Description

#### A: COMPONENT

#### 1. FRONT SEAT BELT

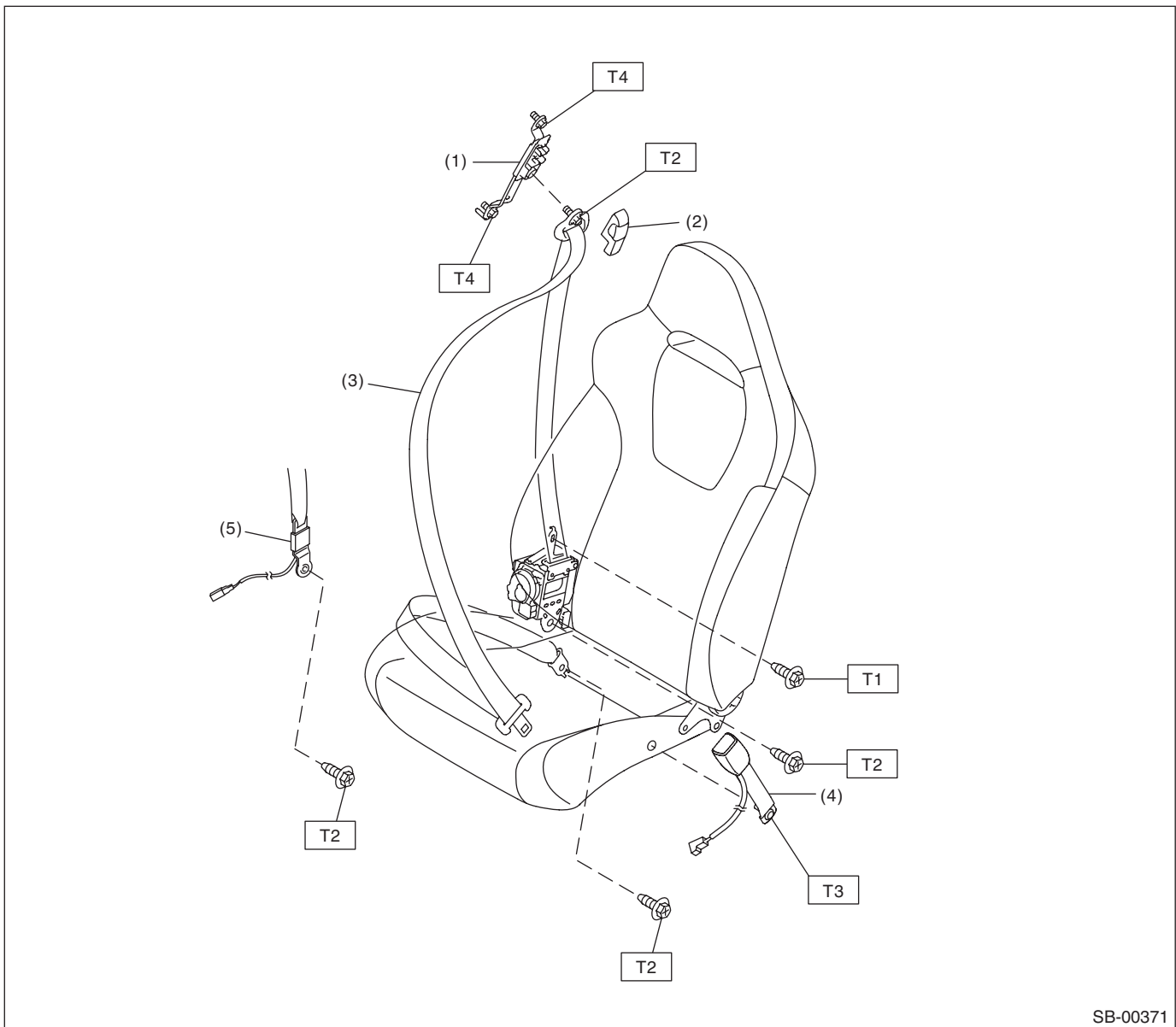

(1) Adjustable anchor ASSY

(2) Anchor cover

(3) Outer belt ASSY

(4) Inner seat belt ASSY

(5) Belt tension sensor  
(passenger's side only)

**Tightening torque: N·m (kgf·m, ft·lb)**

**T1: 7.5 (0.76, 5.5)**

**T2: 30 (3.1, 22.1)**

**T3: 38 (3.9, 28.0)**

**T4: 53 (5.4, 39.1)**

## 2. REAR SEAT BELT

5 door model

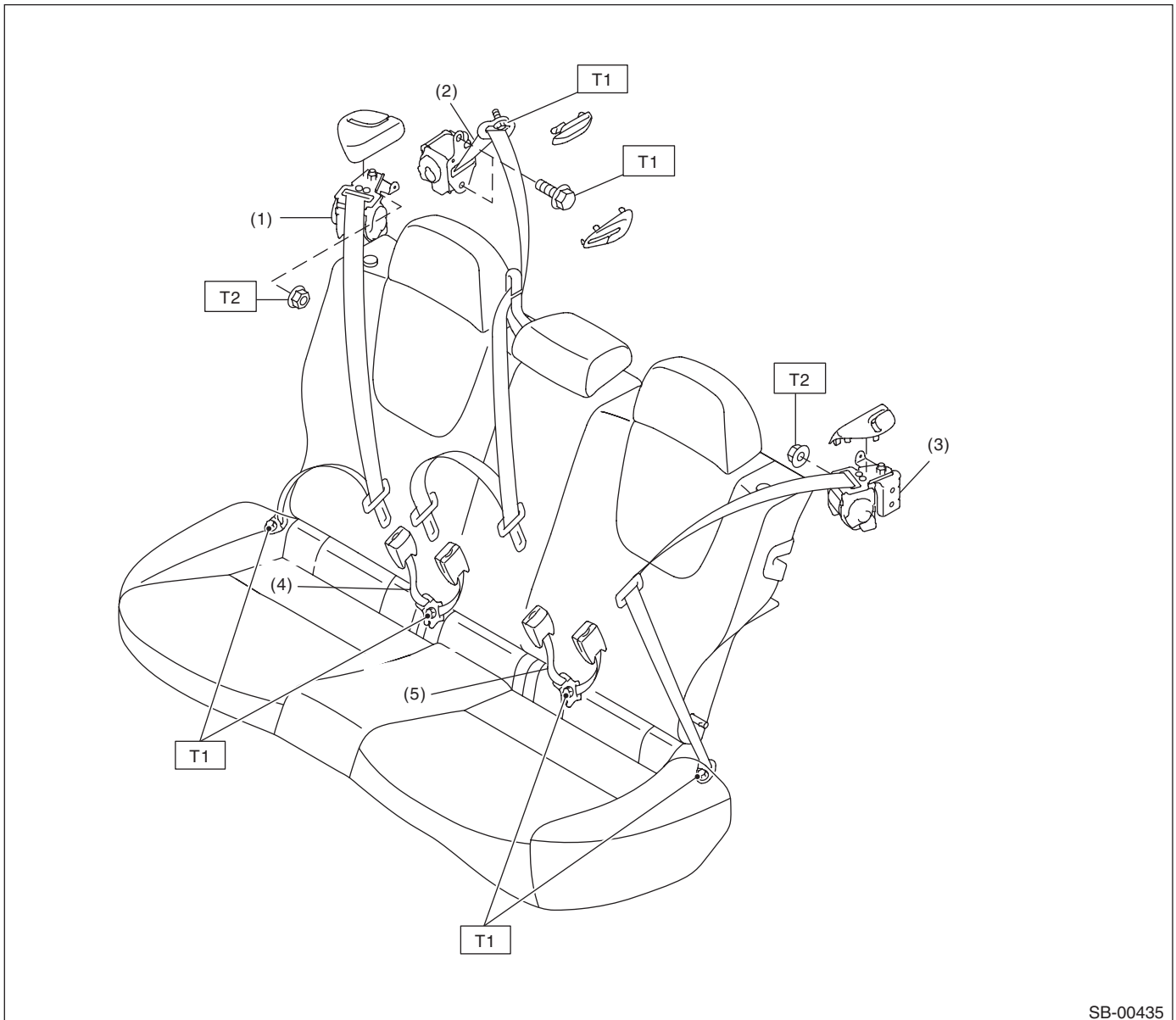

SB-00435

- |                                    |                              |
|------------------------------------|------------------------------|
| (1) Outer seat belt ASSY RH        | (4) Center seat belt ASSY RH |
| (2) Shoulder seat belt center ASSY | (5) Center seat belt ASSY LH |
| (3) Outer seat belt ASSY LH        |                              |

**Tightening torque: N·m (kgf·m, ft·lb)**

**T1: 30 (3.1, 22.1)**

**T2: 53 (5.4, 39.1)**



# General Description

## SEAT BELT SYSTEM

### 4 door model

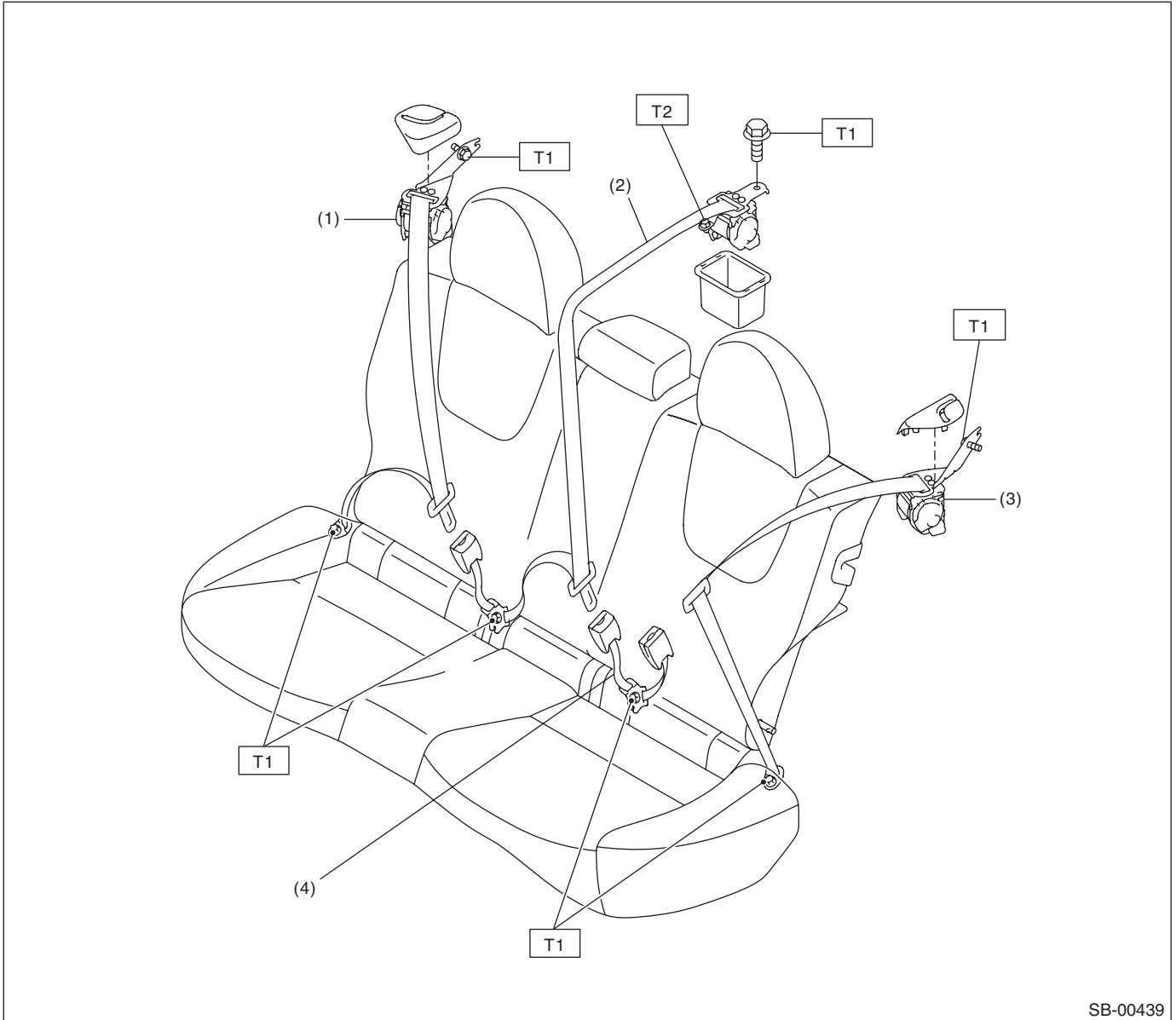

SB-00439

- |                                    |                              |
|------------------------------------|------------------------------|
| (1) Outer seat belt ASSY RH        | (3) Outer seat belt ASSY LH  |
| (2) Shoulder seat belt center ASSY | (4) Center seat belt ASSY LH |

**Tightening torque: N-m (kgf-m, ft-lb)**

**T1: 30 (3.1, 22.1)**

**T2: 53 (5.4, 39.1)**

## B: CAUTION

- Before starting the work, turn the ignition switch to OFF, disconnect the battery ground cable and wait for 60 seconds or more.
- The pretensioner system has a back-up power supply. Be aware that the pretensioner might deploy if you do not wait for 60 seconds or more before starting work.
- Do not drop or apply any impact to the pretensioner.
- If oil, grease or water gets on the pretensioner, wipe it off immediately with a dry cloth.
- Do not expose the pretensioner to high temperature or flame.
- Do not allow current to flow through or voltage to reach the pretensioner. Do not use a circuit tester to check resistance of the pretensioner.
- Do not disassemble or attempt to repair the pretensioner. If it is dented, cracked or deformed, replace it with a new part.
- Do not use the airbag or pretensioner parts from other vehicles. Always replace parts with new parts.
- When handling a seat belt with deployed pretensioner, wear gloves and goggles. Wash your hands afterwards.
- Do not reuse a seat belt with deployed pretensioner.

## C: PREPARATION TOOL

### 1. SPECIAL TOOL

- SUBARU SELECT MONITOR

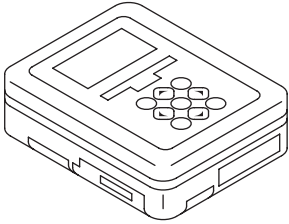
ILLUSTRATION	TOOL NUMBER	DESCRIPTION	REMARKS
 <p style="text-align: center;">ST1B022XU0</p>	1B022XU0	SUBARU SELECT MONITOR III KIT	Used for setting of each function and troubleshooting for electrical system.

# General Description

## SEAT BELT SYSTEM

- TEST HARNESS AB

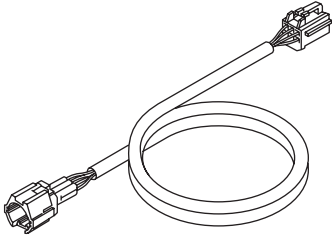
ILLUSTRATION	TOOL NUMBER	DESCRIPTION	REMARKS
 <p style="text-align: center;">ST98299XA000</p>	98299XA000	TEST HARNESS AB	Used when measuring voltage and resistance of occupant detection system.

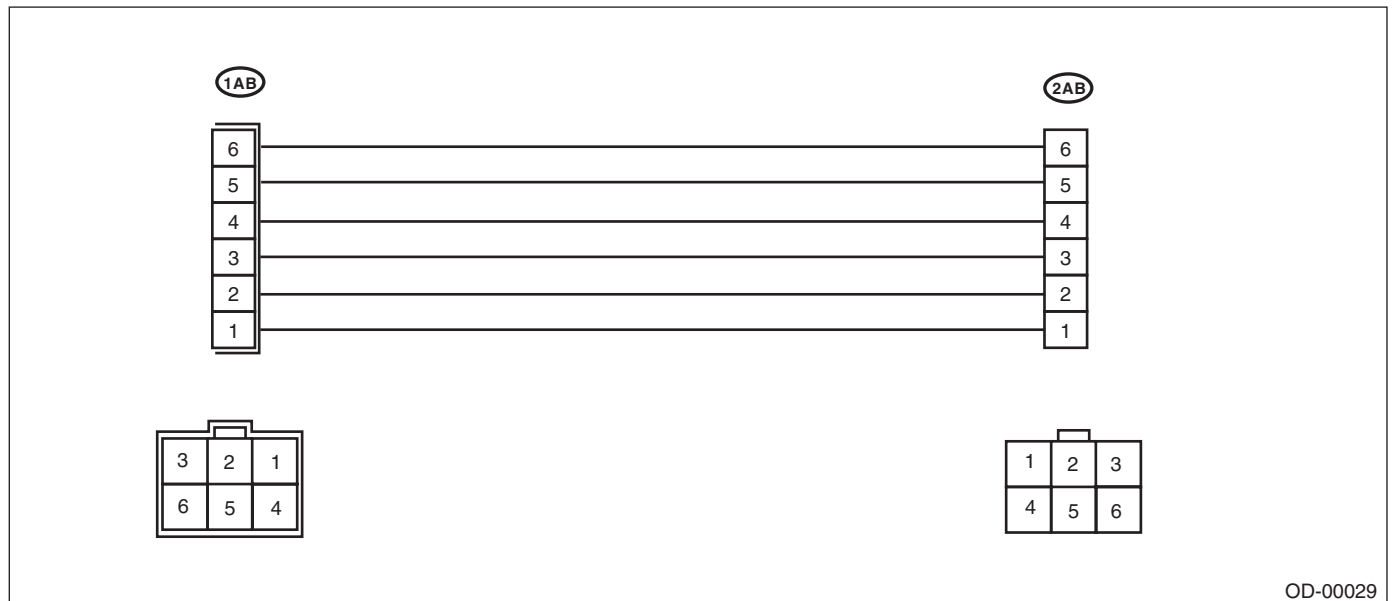

# General Description

SEAT BELT SYSTEM

## • TEST HARNESS AE

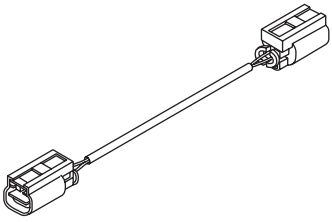
ILLUSTRATION	TOOL NUMBER	DESCRIPTION	REMARKS
 ST98299XA030	98299XA030	TEST HARNESS AE	<ul style="list-style-type: none"><li>• Used for diagnosing seat belt tension sensor.</li><li>• Used together with test harness Y.</li></ul>

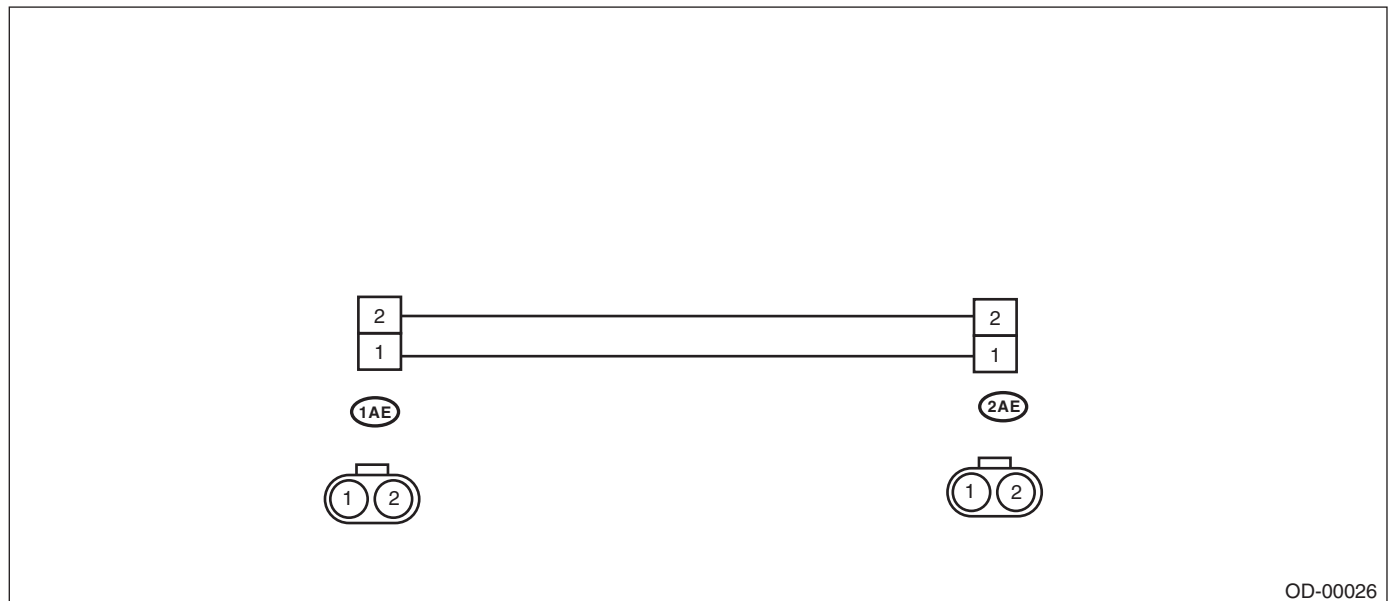

# General Description

## SEAT BELT SYSTEM

### • TEST HARNESS AG

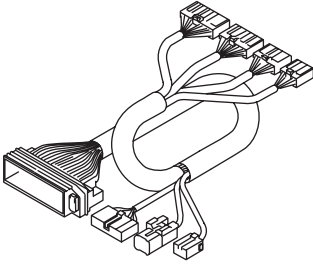
ILLUSTRATION	TOOL NUMBER	DESCRIPTION	REMARKS
 <p>ST98299AG070</p>	98299AG070	TEST HARNESS AG	Used when measuring voltage and resistance of airbag control module.

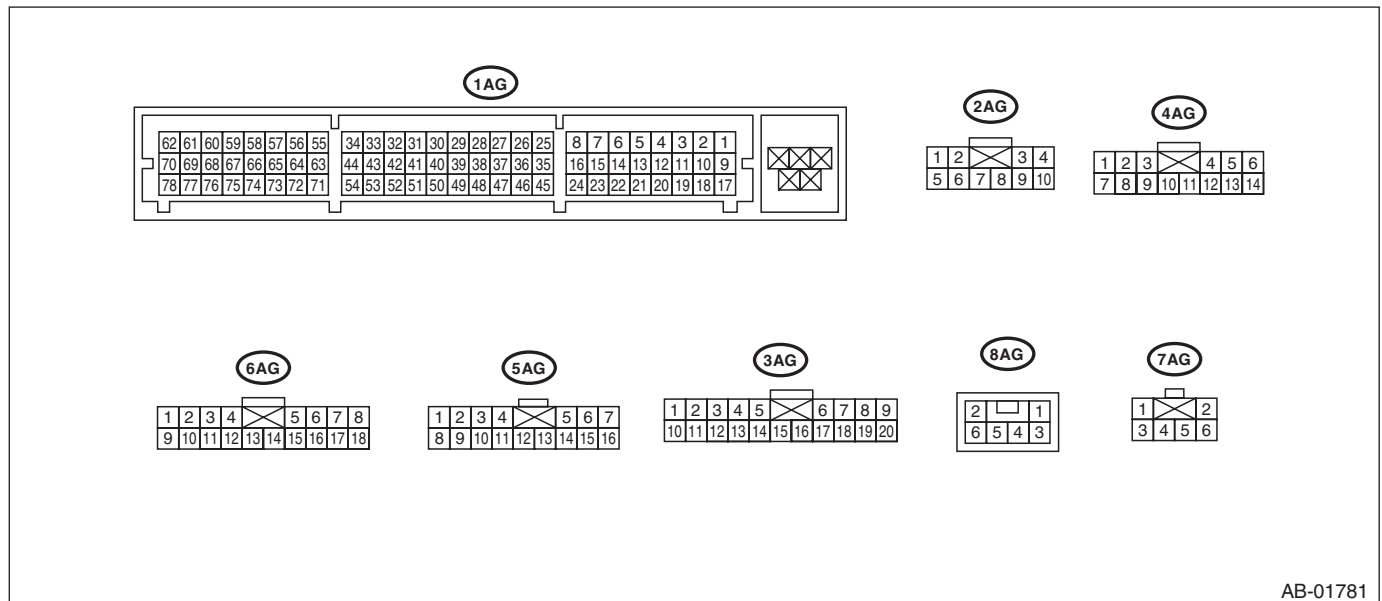

AB-01781

# General Description

## SEAT BELT SYSTEM

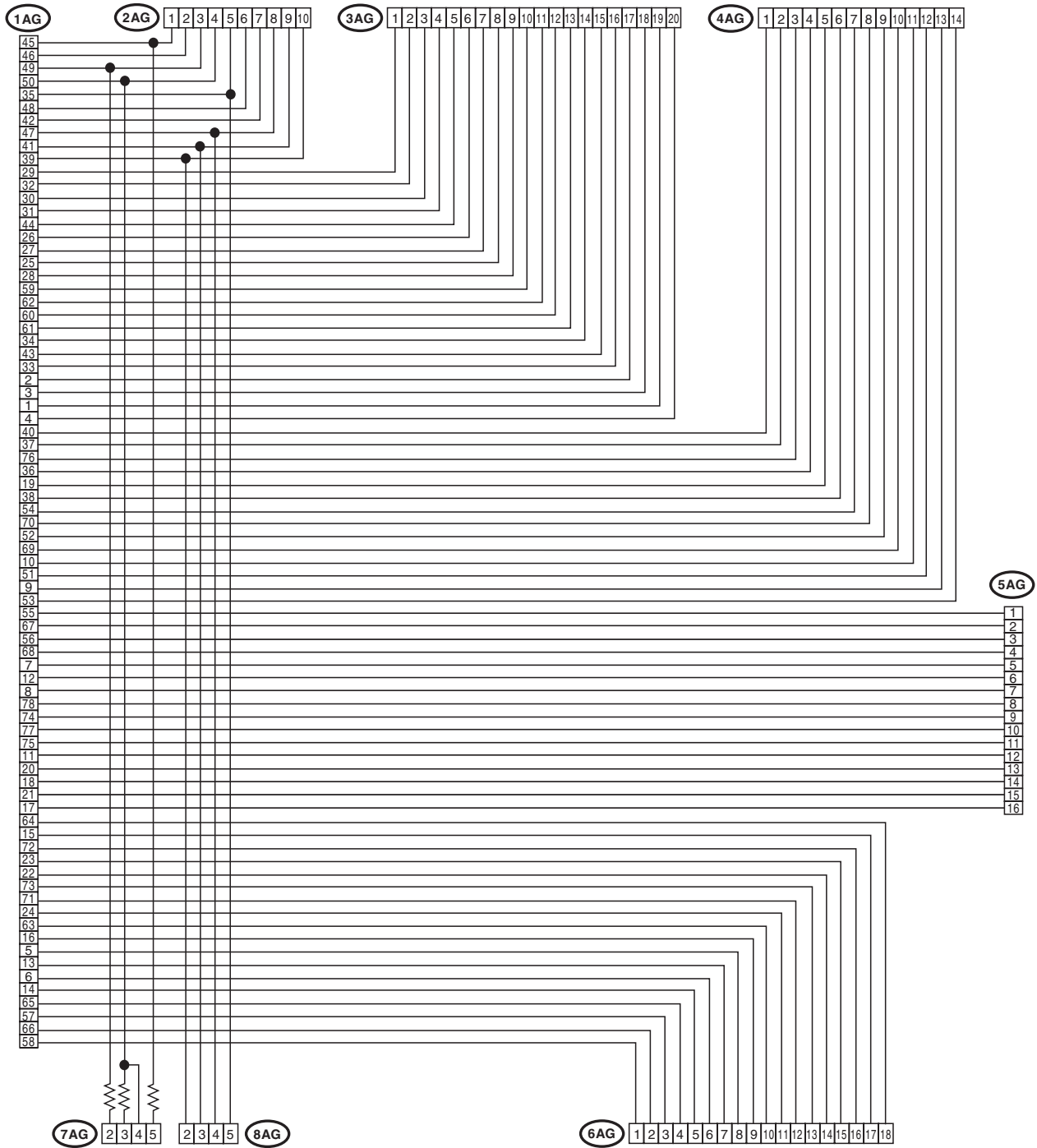

AB-01902

SB-9

Brought to you by Ebay Seller "SubaruManuals"

# General Description

## SEAT BELT SYSTEM

- TEST HARNESS Y

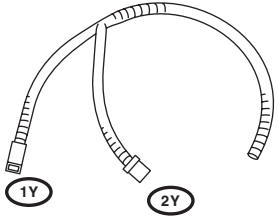
ILLUSTRATION	TOOL NUMBER	DESCRIPTION	REMARKS
 <p>ST98299AG040</p>	98299AG040	TEST HARNESS Y	Used for troubleshooting seat belt buckle switch.

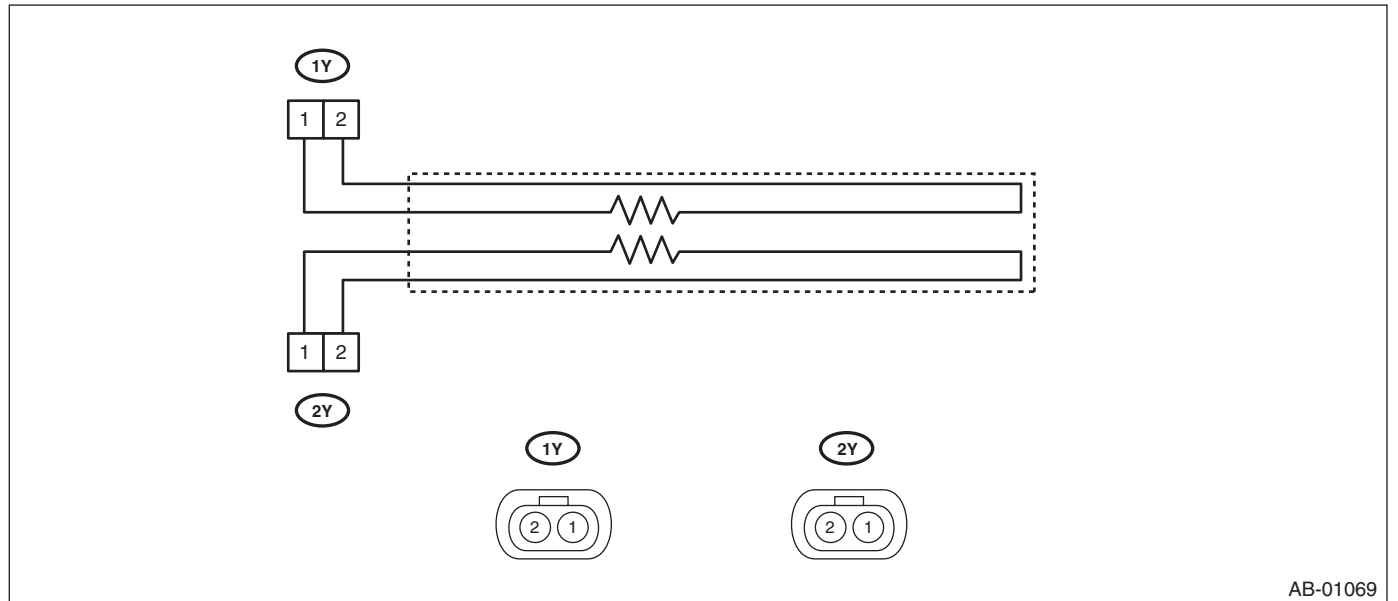

# General Description

SEAT BELT SYSTEM

## • AIRBAG RESISTOR

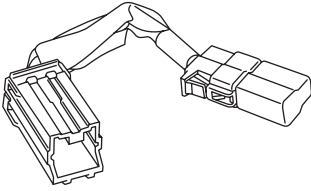
ILLUSTRATION	TOOL NUMBER	DESCRIPTION	REMARKS
 <p>ST98299PA040</p>	98299PA040	AIRBAG RESISTOR	Used in replacement of airbag module for which resistance value is same as airbag module. Two STs are required for diagnosis of two-stage inflator type airbag module.

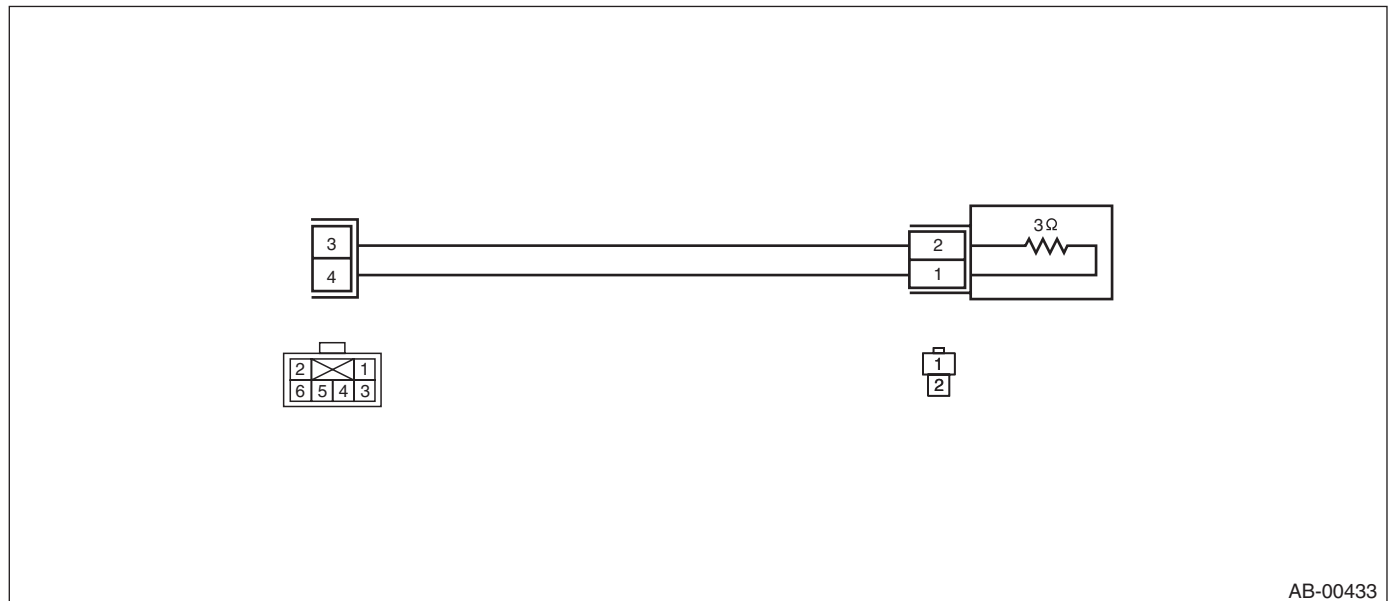

## 2. GENERAL TOOL

TOOL NAME	REMARKS
TORX® T50	Used for removing and installing the inner seat belt assembly.
Circuit tester	Used for measuring resistance and voltage.



# Pretensioner Connector

SEAT BELT SYSTEM

---

## 2. Pretensioner Connector

### A: PROCEDURE

Refer to "Airbag Connector" of Airbag section for the connectors of the seat belt pretensioners and buckle switch RH. <Ref. to AB-9, PROCEDURE, Airbag Connector.>

## 3. Inspection Locations after a Collision

### A: INSPECTION

Refer to "Inspection Locations after a Collision" of Airbag section. <Ref. to AB-13, Inspection Locations after a Collision.>

# Seat Belt Warning System

SEAT BELT SYSTEM

## 4. Seat Belt Warning System

### A: WIRING DIAGRAM

Refer to "Seat Belt Warning System" in the wiring diagram. <Ref. to WI-86, WIRING DIAGRAM, Seat Belt Warning System.>

### B: INSPECTION

#### CAUTION:

- Before diagnosing the airbag system, be sure to turn the ignition switch to OFF, disconnect the ground cable from battery, and wait 60 seconds or more before starting to work.
- When replacing the airbag module, seat belt pretensioner, roll connector, control module and sensor, reconnect each part and check that the warning light operates properly.
- When inspecting the airbag main harness, disconnect the airbag module connectors of the driver's and passenger's seats for safety.
- When inspecting the airbag rear harness, disconnect the side airbag module connector, curtain airbag module connector and seat belt pretensioner connector for safety reasons.

#### TROUBLE SYMPTOM:

- Driver's side seat belt warning light does not illuminate or it remains illuminating.
- Warning buzzer does not beep.

Step	Check	Yes	No
<b>1 CHECK CURRENT SETTINGS.</b> 1) Prepare the Subaru Select Monitor. 2) Turn the ignition switch to ON (engine OFF) and run the "PC application for Subaru Select Monitor". 3) Select the "current data display" and read the data of the "belt warning switch".	Is the belt warning display ON?	Go to step 2.	Turn the belt warning ON with unit customization.
<b>2 CHECK CURRENT DATA.</b> 1) Select the "current data display" and read the data of the "IG power supply voltage". 2) Turn the ignition switch ON ↔ OFF.	Does the voltage change between 9 V or higher ↔ less than 1.5 V, according to the ignition switch ON ↔ OFF operation?	Go to step 3.	Check the ignition switch circuit.
<b>3 CHECK FUNCTION.</b> 1) Sit on the driver's seat and passenger's seat and disconnect the seat belts of the both. 2) Turn the ignition switch to ON (engine OFF). 3) Check if the driver's seat belt warning light in the combination meter and the passenger's seat belt warning light in the clock unit illuminate, and if the warning buzzer sounds.	Do the driver's warning light and passenger's warning light blink and the buzzer sound while blinking?	Go to step 4.	<ul style="list-style-type: none"> <li>• Malfunction of the driver's seat belt warning light → Go to step 10.</li> <li>• Malfunction of the passenger's seat belt warning light → Go to step 16.</li> <li>• The buzzer does not sound → Go to step 6.</li> </ul>
<b>4 CHECK FUNCTION.</b> 1) Wait until the buzzer stops sounding in step 3. (for approximately six seconds after starting sounding) 2) Connect and disconnect the seat belts of the driver's and passenger's. 3) Check if the driver's seat belt warning light in the combination meter and the passenger's seat belt warning light in the clock unit illuminate, and if the warning buzzer sounds.	Do the seat belts warning light illuminate ↔ go off according to the operation?	Go to step 5.	<ul style="list-style-type: none"> <li>• Malfunction of the driver's seat belt warning light → Go to step 6.</li> <li>• Malfunction of the passenger's seat belt warning light → Go to step 12.</li> </ul>

# Seat Belt Warning System

SEAT BELT SYSTEM

Step	Check	Yes	No
<b>5 CHECK FUNCTION.</b> 1) Wait until the buzzer stops sounding in step 3. (for approximately six seconds after starting sounding) 2) Start the engine, and set the vehicle speed at 15 km/h (9 MPH) or more. 3) Check the seat belt warning lights of the driver's and the passenger's, and if the warning buzzer sounds.	Do the driver's warning light and passenger's warning light blink and the buzzer sound while blinking?	Seat belt warning system is normal.	Go to step 19.
<b>6 CHECK CURRENT DATA.</b> 1) Select the "current data display" and read the data of the seat belt switch of the driver's. 2) Fasten and detach the driver's side seat belt buckle, and read the data of the seat belt switch. <Ref. to LAN(diag)-31, OPERATION, Read Current Data.>	Does the seat belt switch display turn ON ←→ OFF according to the operation of the seat belt buckle?	Go to step 10.	Go to step 7.
<b>7 CHECK HARNESS.</b> 1) Disconnect the negative terminal from the battery, and wait for 60 seconds or more. 2) Disconnect the connector of body integrated unit and the seat belt buckle switch. 3) Check for a short circuit to battery, open circuit or short circuit to ground between the body integrated unit and the driver's seat belt buckle switch.  <i>Connector &amp; terminal (B281) No. 16 — (R107) No. 3:</i>	Is the harness normal?	Go to step 8.	Repair or replace the harness.
<b>8 CHECK HARNESS.</b> Measure the resistance between the driver's seat belt buckle switch and chassis ground.  <i>Connector &amp; terminal (R107) No. 1 — Chassis ground:</i>	Is the resistance less than 10 Ω?	Go to step 9.	Repair or replace the harness.
<b>9 CHECK DRIVER'S SEAT BELT BUCKLE SWITCH LH.</b> Measure the resistance between the connector terminals of the driver's seat belt switch when the driver's seat belt is fastened and detached.  <i>Connector &amp; terminal (R107) No. 1 — (R107) No. 3:</i>	Is the resistance when the belt is fastened 1 MΩ or more, and less than 10 Ω when the belt is detached?	Replace the body integrated unit. <Ref. to SL-48, REMOVAL, Body Integrated Unit.>	Replace the driver's side inner belt assembly. <Ref. to SB-18, INNER SEAT BELT ASSEMBLY, REMOVAL, Front Seat Belt.>
<b>10 CHECK DTC.</b> Read the DTC using Subaru Select Monitor.	Is any CAN-related body system DTC detected?	Check the CAN system according to the DTC.	Go to step 11.
<b>11 CHECK COMBINATION METER.</b> Perform the self-diagnosis of combination meter. <Ref. to IDI-5, SELF-DIAGNOSIS, INSPECTION, Combination Meter System.>	At the start of combination meter self diagnosis, did the buzzer sound and the seat belt warning light illuminate?	Replace the body integrated unit or the combination meter. Or replace both. It may be due to the transmission failure of the body integrated unit or the reception failure of the combination meter.	Replace the combination meter. <Ref. to IDI-16, REMOVAL, Combination Meter.>

# Seat Belt Warning System

## SEAT BELT SYSTEM

Step	Check	Yes	No
<b>12 CHECK CURRENT DATA.</b> 1) Sit in the passenger's seat. 2) Select "Current Data Display" and display the data of "P seatbelt SW input". 3) Fasten and detach the passenger's side seat belt buckle, and read the data of the seat belt switch. <Ref. to LAN(diag)-31, OPERATION, Read Current Data.>	Does the seat belt switch display turn ON ←→ OFF according to the operation of the seat belt buckle?	Go to step 16.	Go to step 13.
<b>13 CHECK AIRBAG SYSTEM AND OCCUPANT DETECTION SYSTEM.</b> Perform the check in accordance with the diagnostic procedure DTC 27 of the airbag system. <Ref. to AB(diag)-71, DTC 27 ODS COMMUNICATION ERROR, Diagnostic Chart with Trouble Code.>	Is there any problem on the inspection result?	Go to step 14.	Replace with new parts according to DTC 27.
<b>14 CHECK BUCKLE SWITCH RH.</b> Perform the check in accordance with the diagnostic procedure DTC 37 of the occupant detection system. <Ref. to OD(diag)-26, DTC 37 BUCKLE SWITCH RH FAILURE, Diagnostic Procedure with Diagnostic Trouble Code (DTC).>	Is there any problem on the inspection result?	Go to step 15.	Replace with new parts according to DTC 37.
<b>15 CHECK AIRBAG CONTROL MODULE AND BODY INTEGRATED UNIT.</b> Check the airbag control module, occupant detection sensor and seat belt buckle switch RH. Perform the check in accordance with the diagnostic procedure DTC 39 of the airbag system. <Ref. to AB(diag)-74, DTC 39 SEAT BELT WARNING FAILURE, Diagnostic Chart with Trouble Code.>	Is there any problem on the inspection result?	Replace the body integrated unit. <Ref. to SL-48, REMOVAL, Body Integrated Unit.>	Replace with new parts according to DTC 39.
<b>16 CHECK HARNESS.</b> 1) Disconnect the clock connector. 2) Turn the ignition switch to ON. 3) Measure the voltage between body integrated unit and clock. <b>Connector &amp; terminal</b> <b>(i59) No. 8 (+) — Chassis ground (-):</b>	Is the voltage 10 V or more?	Go to step 17.	Repair or replace the harness.
<b>17 CHECK HARNESS.</b> 1) Turn the ignition switch to ON. 2) Disconnect the connector of body integrated unit. 3) Check for battery short and open circuits, and short to ground between the body integrated unit and clock. <b>Connector &amp; terminal</b> <b>(i84) No. 25 — (i59) No. 2:</b>	Is the harness normal?	Go to step 18.	Repair or replace the harness.
<b>18 CHECK CLOCK.</b> 1) Connect the clock connector. 2) Turn the ignition switch to ON. 3) Use an appropriate wiring harness to create a short between the body integrated unit and clock. <b>Connector &amp; terminal</b> <b>(i84) No. 25 — Chassis ground:</b> <b>(i59) No. 2 — Chassis ground:</b>	Does passenger's seat belt warning light in the clock illuminate?	Replace the body integrated unit. <Ref. to SL-48, REMOVAL, Body Integrated Unit.>	Replace the clock. <Ref. to IDI-21, REMOVAL, Clock.>
<b>19 CHECK DTC.</b> Read the DTCs for all systems using the Subaru Select Monitor.	Is a DTC detected?	Perform a check according to the DTC.	Go to step 20.

# Seat Belt Warning System

SEAT BELT SYSTEM

Step	Check	Yes	No
<b>20</b> <b>CHECK CURRENT DATA.</b> Select "Current Data Display" and read the data of the "Front Wheel Speed". <Ref. to LAN(diag)-31, OPERATION, Read Current Data.>	Does the data display the wheel speed data correctly?	Go to step 11.	Check the following items. <ul style="list-style-type: none"><li>• LAN system &lt;Ref. to LAN(diag)-61, DTC U1223 CAN-HS VDC/ABS NO-RECEIVE DATA, Diagnostic Procedure with Diagnostic Trouble Code (DTC).&gt;</li><li>• VDC &lt;Ref. to VDC(diag)-2, Basic Diagnostic Procedure.&gt;</li></ul>

# Front Seat Belt

## SEAT BELT SYSTEM

### 5. Front Seat Belt

#### A: REMOVAL

##### 1. OUTER SEAT BELT ASSEMBLY

###### CAUTION:

- Do not drop or subject the pretensioner to any impact.
- Since the pretensioner and bracket are integrated as a unit, do not disassemble them.

1) Before starting the work, turn the ignition switch to OFF, disconnect the battery ground cable, and wait for 60 seconds or more.

2) Tilt the backrest forward and move the seat to the front most position.

3) Remove the center pillar lower trim. <Ref. to EI-57, REMOVAL, Lower Inner Trim.>

4) Remove the anchor cover (A).

5) Loosen the shoulder anchor bolt (B), and then detach the shoulder anchor from center pillar.

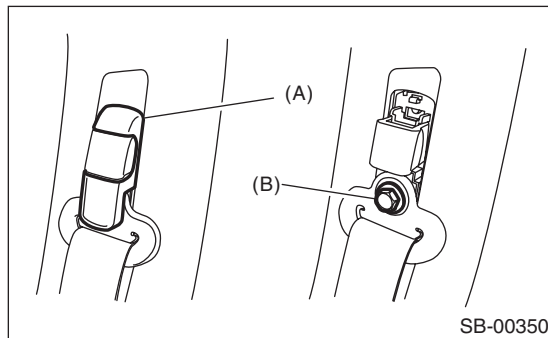

6) Disconnect the connector of the belt tension sensor on passenger's seat.

7) Turn over the floor mat and disconnect the pretensioner connector (A).

8) Remove the bolts, then remove the front outer belt.

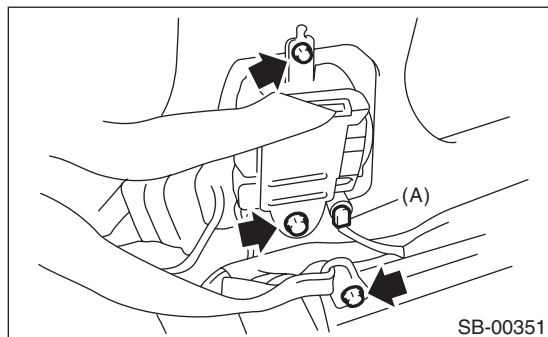

9) Remove the center pillar upper trim. <Ref. to EI-59, REMOVAL, Upper Inner Trim.>

10) Remove the bolts and then remove adjustable anchor assembly.

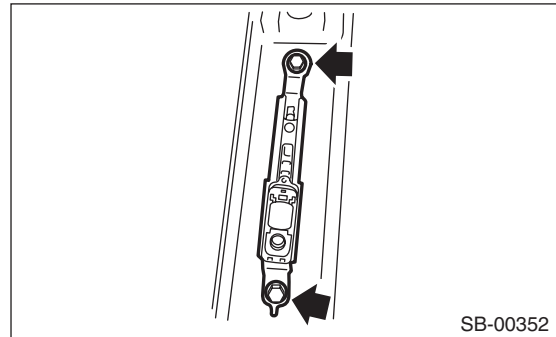

##### 2. INNER SEAT BELT ASSEMBLY

1) Turn the ignition switch to OFF, disconnect the battery ground cable, and wait for 60 seconds or more.

2) Remove the front seats. <Ref. to SE-6, REMOVAL, Front Seat.>

3) Disconnect the seat belt warning light connector under the seat.

4) Remove the seat belt harness from the harness holder on the backside of seat cushion assembly.

5) Remove the TORX® bolt, and then remove the inner seat belt assembly.

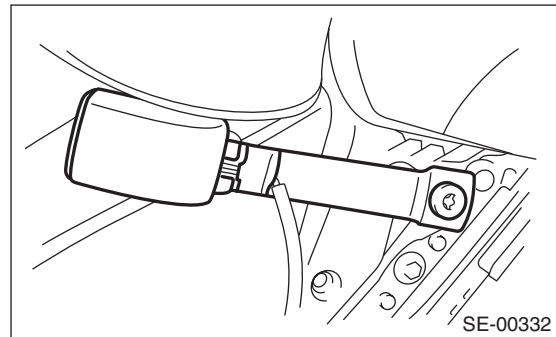

#### B: INSTALLATION

###### CAUTION:

- Before installation, make sure that the correct part is used.
  - Be careful not to twist the seat belts during installation.
  - Check that there is no pinching of the seat belt harness. Wrong harness routing may cause the harness short from pinch.
- Install each part in the reverse order of removal.

###### Tightening torque:

**Seat belt:** <Ref. to SB-2, FRONT SEAT BELT, COMPONENT, General Description.>

**Upper inner trim:** 7.5 N·m (0.76 kgf·m, 5.5 ft·lb)

## **C: INSPECTION**

Check for the following, and replace with new parts if necessary.

- Pretensioner is cracked or deformed.
- Seat belt is slackened, bent or worn.
- Seat belt is abnormally wound or extended.
- Inner seat belt assembly is deformed or damaged.
- Seat belt buckle cannot be engaged properly.



# Rear Seat Belt

## SEAT BELT SYSTEM

### 6. Rear Seat Belt

#### A: REMOVAL

##### 1. OUTER SEAT BELT ASSEMBLY RH & LH

- 1) Remove the luggage floor mat.
- 2) Remove the rear seat cushion. <Ref. to SE-13, REMOVAL, Rear Seat.>
- 3) Remove the seat belt lower anchor bolt.

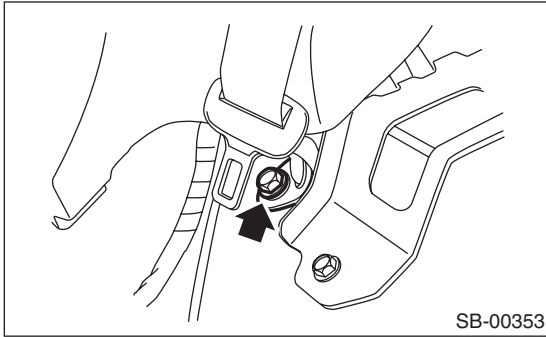

- 4) Remove the rear quarter trim. <Ref. to EI-60, REMOVAL, Rear Quarter Trim.>
- 5) Remove the outer seat belt assembly.

- 5 door model
- Remove the nut.

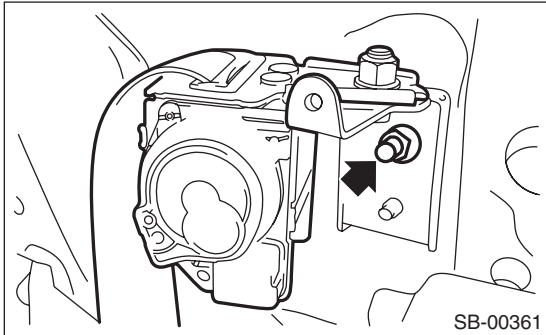

**CAUTION:**  
Do not remove the bolt and nut securing the retractor and bracket.

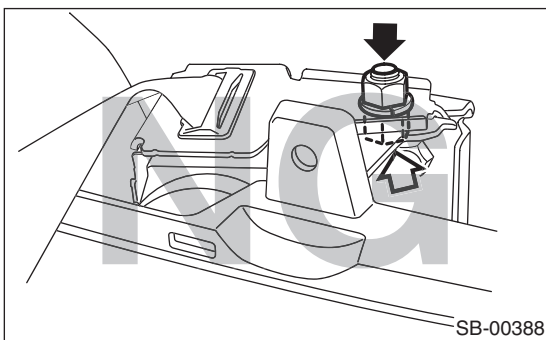

- 4 door model
- Remove the bolt.

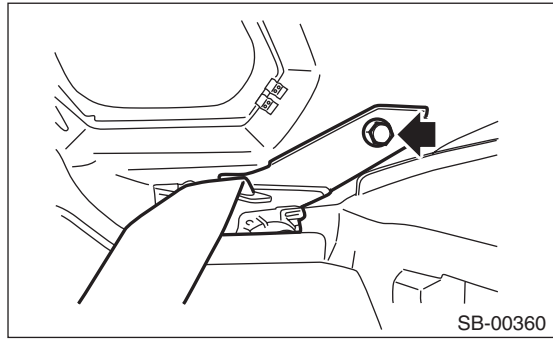

##### 2. SHOULDER SEAT BELT CENTER ASSEMBLY (5 DOOR MODEL)

- 1) Remove the shoulder anchor bolt cover (A).
- 2) Remove the shoulder anchor bolt (B) and remove the shoulder anchor from the quarter pillar.

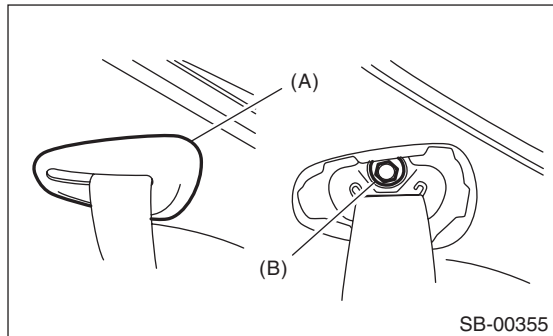

- 3) Remove the rear quarter trim. <Ref. to EI-60, REMOVAL, Rear Quarter Trim.>
- 4) Remove the bolts, and then detach the outer belt center assembly.

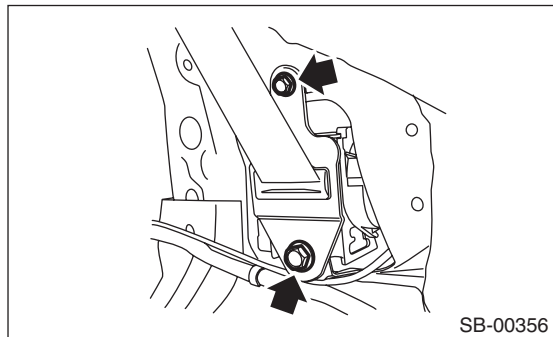

### 3. SHOULDER SEAT BELT CENTER ASSEMBLY (4 DOOR MODEL)

- 1) Remove the rear seat. <Ref. to SE-13, REMOVAL, Rear Seat.>
- 2) Remove the rear quarter trim. <Ref. to EI-60, REMOVAL, Rear Quarter Trim.>
- 3) Remove the rear shelf trim. <Ref. to EI-62, REMOVAL, Rear Shelf Trim.>
- 4) Remove the bolts, then remove the shoulder seat belt assembly.

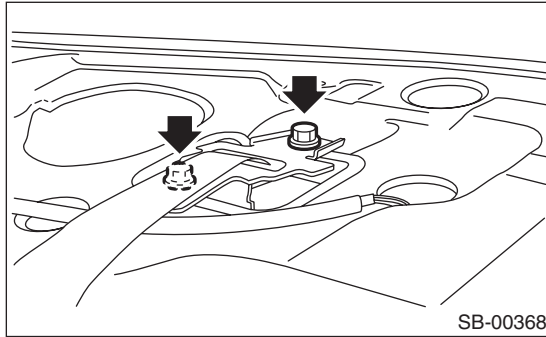

- 5) Remove the seat belt lower anchor bolt.

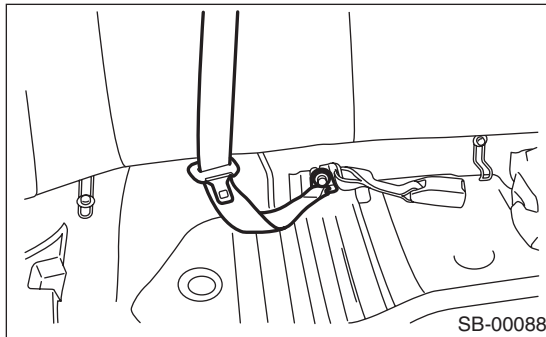

### 4. CENTER SEAT BELT ASSEMBLY

- 1) Remove the rear seat cushion.
- 2) Remove the bolts, then remove the center seat belt assembly.

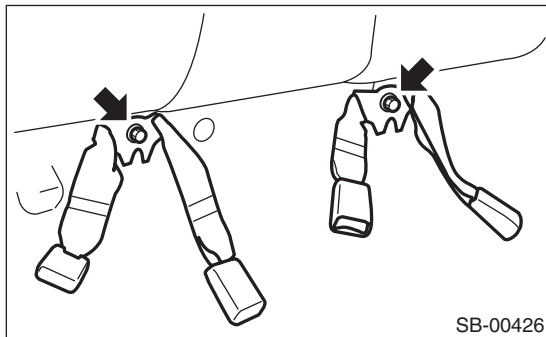

### B: INSTALLATION

#### CAUTION:

- During installation, make sure that the seat belts are not twisted.
- After installation, make sure that the seat belts are smoothly extended and wound.
- Make sure that the center seat belt is securely installed.

- 1) Install each part in the reverse order of removal.

#### Tightening torque:

Refer to "COMPONENT" of "General Description". <Ref. to SB-3, REAR SEAT BELT, COMPONENT, General Description.>

- 2) Turn the seat belt as shown in the figure.
  - LH side

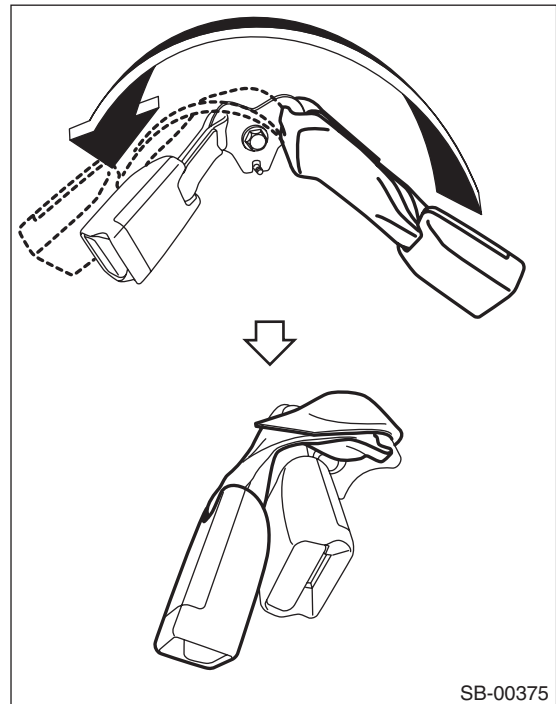

# Rear Seat Belt

## SEAT BELT SYSTEM

- RH side (5 door model only)

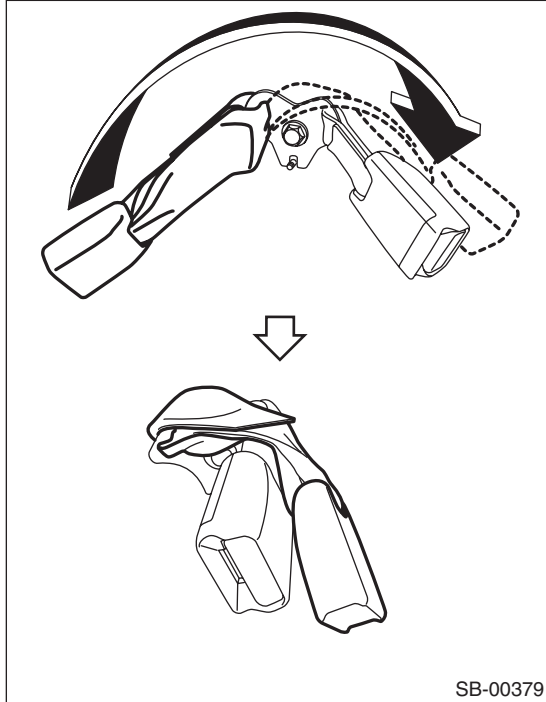

## C: INSPECTION

Check for the following, and replace with new parts if necessary.

- Seat belt is slackened, bent or worn.
- Seat belt is abnormally wound or extended.
- Inner seat belt is deformed or damaged.
- Seat belt buckle cannot be engaged properly.

3) Install the seat cushion and pull out the center seat belt assembly.

- 5 door model

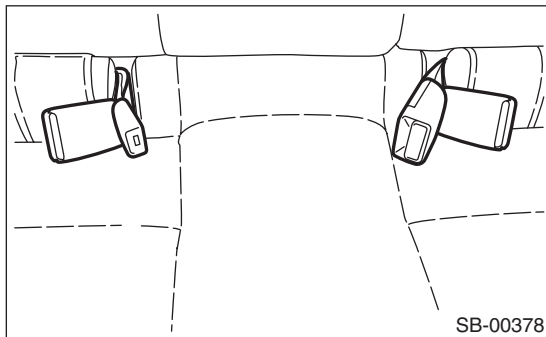

- 4 door model

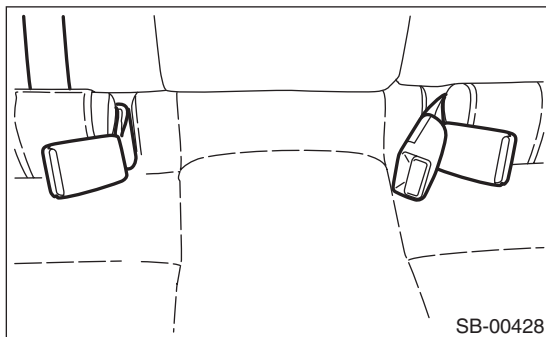

# LIGHTING SYSTEM

# LI

---

	<b>Page</b>
1. General Description .....	2
2. Headlight and Tail Light System .....	4
3. Day Time Running Light System .....	5
4. Front Fog Light System .....	6
5. Turn Signal Light and Hazard Light System .....	7
6. Back-up Light System .....	8
7. Stop Light System .....	9
8. Room Light System .....	10
9. Combination Switch (Light) .....	11
10. Headlight Beam Leveler System .....	13
11. Combination Base Switch Assembly .....	14
12. Headlight Assembly .....	15
13. Headlight Bulb .....	17
14. Front Turn Signal Light Bulb .....	19
15. Front Side Marker Light Bulb .....	20
16. Front Fog Light Assembly .....	21
17. Front Fog Light Bulb .....	23
18. Side Turn Signal Light Assembly .....	24
19. Rear Combination Light Assembly .....	25
20. Tail/Stop Light Bulb .....	26
21. Rear Turn Signal Light Bulb .....	27
22. Rear Side Marker Light Bulb .....	28
23. Rear Finisher Light Assembly .....	29
24. Back-up Light Bulb .....	30
25. License Plate Light .....	31
26. High-mounted Stop Light .....	32
27. Spot Map Light .....	33
28. Room Light .....	34
29. Luggage Room Light .....	35
30. Trunk Room Light .....	36
31. Ignition Switch Illumination .....	37
32. Day Time Running Resistor .....	39
33. Reflex Reflector .....	40
34. Door Switch .....	41

# General Description

## LIGHTING SYSTEM

### 1. General Description

#### A: SPECIFICATION

Headlight	Low beam (halogen type)	12 V — 55 W
	Low beam (HID type)	12 V — 35 W
	High beam	12 V — 60 W
Front turn signal/front side marker light		12 V — 27 / 8 W
Front fog light		12 V — 51 W
Side turn signal light		12 V — 1.4 W (LED)
Rear combination light (4 door model)	Tail/stop light	12 V — 5 / 21 W
	Turn signal light	12 V — 21 W
	Back-up light	12 V — 16 W
Rear combination light (5 door model)	Tail/stop light	12 V — 0.3 W (LED)/12 V — 4.8 W (LED)
	Turn signal light	12 V — 21 W
	Side marker light	12 V — 5 W
Back-up light (5 door model)		12 V — 21 W
License plate light		12 V — 5 W
High-mounted stop light	4 door model (standard type)	12 V — 21 W
	4 door model (with built-in rear spoiler type)	12 V — 1.2 W (LED)
	5 door model	12 V — 1.2 W (LED)
Room light		12 V — 8 W
Spot map light		12 V — 8 W
Luggage room light		12 V — 5 W
Trunk room light		12 V — 5 W

#### B: CAUTION

- Before disassembling or reassembling parts, always disconnect the battery ground cable from battery. When replacing the audio, control module and other parts provided with memory functions, record the memory contents before disconnecting the battery ground cable. Otherwise, the memory is cleared.
- Reassemble the parts in the reverse order of disassembly procedure unless otherwise indicated.
- Connect the connectors securely during reassembly.
- After reassembly, make sure that the functional parts operate normally.
- Yellow connectors and harnesses with yellow tapes around them are the connectors and harnesses for the airbag system. Using a tester above such circuits may cause malfunction of airbag system. Follow the cautions for the airbag system in this case. <Ref. to AB-5, CAUTION, General Description.>
- Be careful not to damage the airbag system wiring harness when servicing electrical parts and switches.

## C: PREPARATION TOOL

### 1. SPECIAL TOOL

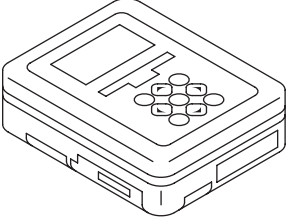
ILLUSTRATION	TOOL NUMBER	DESCRIPTION	REMARKS
 <p style="text-align: center; margin-top: 10px;">ST1B022XU0</p>	1B022XU0	SUBARU SELECT MONITOR III KIT	Used for troubleshooting the electrical system.

### 2. GENERAL TOOL

TOOL NAME	REMARKS
Circuit tester	Used for measuring resistance and voltage.

# Headlight and Tail Light System

## LIGHTING SYSTEM

### 2. Headlight and Tail Light System

#### A: WIRING DIAGRAM

##### 1. HALOGEN TYPE HEADLIGHT

Refer to "Headlight System" in WI section. <Ref. to WI-90, WIRING DIAGRAM, Headlight System.>

##### 2. HID TYPE HEADLIGHT

Refer to "Headlight System" in WI section. <Ref. to WI-90, WIRING DIAGRAM, Headlight System.>

##### 3. CLEARANCE LIGHT AND ILLUMINATION LIGHT

Refer to "Clearance Light and Illumination Light System" in WI section. <Ref. to WI-98, WIRING DIAGRAM, Clearance Light and Illumination Light System.>

#### B: INSPECTION

##### 1. LIGHTING SWITCH

Measure the resistance between lighting switch terminals. <Ref. to LI-11, INSPECTION, Combination Switch (Light).>

##### 2. DIMMER AND PASSING SWITCH

Measure the resistance between dimmer & passing switch terminals. <Ref. to LI-11, INSPECTION, Combination Switch (Light).>

##### 3. HEADLIGHT RELAY

1) Connect terminal No. 4 to the battery positive terminal and the terminal No. 3 to the battery negative terminal, and check the resistance value between the headlight relay terminals.

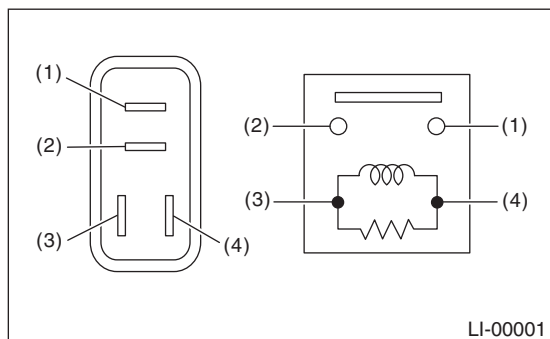

Continuity	Terminal No.	Specification
Yes	1 and 2	Less than 1 Ω
No		1 MΩ or more

2) Replace the headlight relay if the inspection result is not within the standard value.

#### 4. TAIL AND ILLUMINATION RELAY

1) Connect terminal No. 4 to the battery positive terminal and terminal No. 3 to the battery ground terminal, and check the resistance between tail and illumination relay terminals.

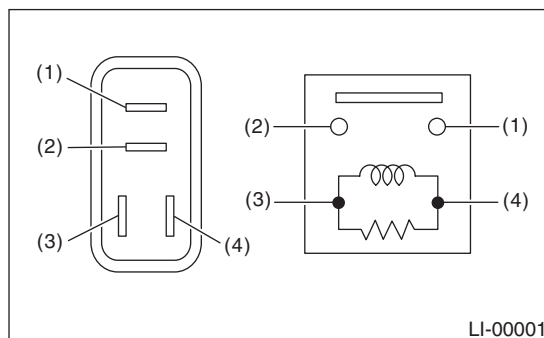

Continuity	Terminal No.	Specification
Yes	1 and 2	Less than 1 Ω
No		1 MΩ or more

2) If the result of the inspection is not at the standard value, replace the tail & illumination relay.

#### C: NOTE

For operation procedures of each component of the headlight system, refer to the respective section.

- Headlight Assembly: <Ref. to LI-15, Headlight Assembly.>
- Headlight bulb: <Ref. to LI-17, Headlight Bulb.>
- Combination switch (light): <Ref. to LI-11, Combination Switch (Light).>
- Combination base switch: <Ref. to LI-14, Combination Base Switch Assembly.>
- License plate light: <Ref. to LI-31, License Plate Light.>
- Front side marker light bulb: <Ref. to LI-20, Front Side Marker Light Bulb.>
- Rear combination light assembly: <Ref. to LI-25, Rear Combination Light Assembly.>
- Rear finisher light assembly: <Ref. to LI-29, Rear Finisher Light Assembly.>
- Tail light/stop light bulb: <Ref. to LI-26, Tail/Stop Light Bulb.>
- Rear side marker light bulb: <Ref. to LI-28, Rear Side Marker Light Bulb.>

## 3. Day Time Running Light System

### A: WIRING DIAGRAM

Refer to "Headlight System" in WI section. <Ref. to WI-90, WIRING DIAGRAM, Headlight System.>

### B: INSPECTION

#### 1. DAYTIME RUNNING LIGHT MODULE CHECK

Step	Check	Yes	No
<b>1 CHECK DTC.</b> 1) Connect the Subaru Select Monitor. 2) Read the DTC of the integrated unit.	Is DTC displayed?	Perform the diagnosis according to DTC.	Go to step 2.
<b>2 CHECK INPUT SIGNAL.</b> 1) Display the current data of the integrated unit. 2) Check the following input signals. (1) Parking brake switch (2) Shift position (3) Light 2	Is the input signal normal?	Go to step 3.	Check the defective part.
<b>3 CHECK RELAY.</b> Check the daytime running light relay.	Is the relay OK?	Go to step 4.	Replace the relay.
<b>4 CHECK HARNESS.</b>	Is the harness normal?	Replace the integrated unit.	Repair the harness.

#### 2. DAYTIME RUNNING LIGHT RELAY

1) Check the resistance between the daytime running relay terminals when connecting terminal No. 3 to the battery positive terminal and terminal No. 5 to the battery ground terminal.

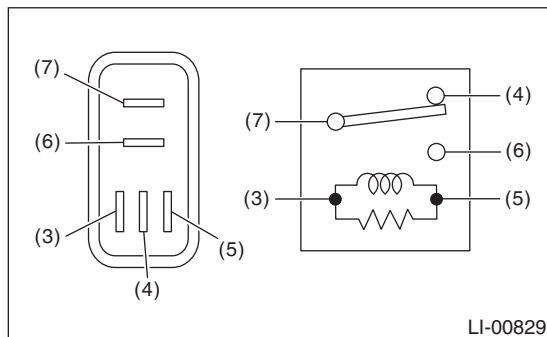

Continuity	Terminal No.	Specification
Yes	7 and 6	Less than 1 Ω
No		1 MΩ or more
Yes	7 and 4	1 MΩ or more
No		Less than 1 Ω

2) Replace the daytime running light relay if the inspection result is not within the standard value.



## 4. Front Fog Light System

### A: WIRING DIAGRAM

Refer to "Front Fog Light System" in WI section.  
 <Ref. to WI-94, WIRING DIAGRAM, Front Fog Light System.>

### B: INSPECTION

#### 1. FRONT FOG LIGHT SWITCH

Measure the resistance between front fog light switch terminals. <Ref. to LI-11, INSPECTION, Combination Switch (Light).>

#### 2. FRONT FOG LIGHT RELAY

1) Connect terminal No. 4 to the battery positive terminal and the terminal No. 3 to the battery negative terminal, and check the resistance value between the front fog light relay terminals.

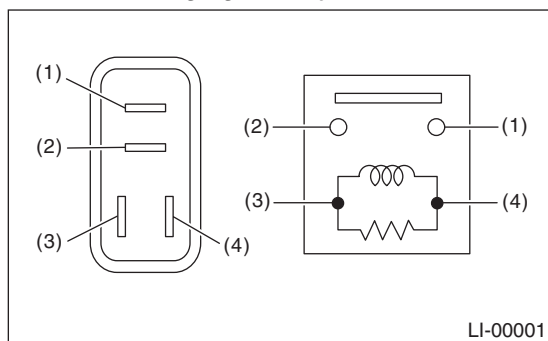

Continuity	Terminal No.	Specification
Yes	1 and 2	Less than 1 Ω
No		1 MΩ or more

2) If the result of the inspection is not at the standard value, replace the front fog light relay.

### C: NOTE

For operation procedures of each component of the front fog light system, refer to the respective section.

- Front fog light assembly: <Ref. to LI-21, Front Fog Light Assembly.>
- Front fog light bulb: <Ref. to LI-23, Front Fog Light Bulb.>
- Combination switch (light): <Ref. to LI-11, Combination Switch (Light).>
- Combination base switch: <Ref. to LI-14, Combination Base Switch Assembly.>

## 5. Turn Signal Light and Hazard Light System

### A: WIRING DIAGRAM

Refer to "Turn Signal Light and Hazard Light System" in WI section. <Ref. to WI-103, WIRING DIAGRAM, Turn Signal Light and Hazard Light System.>

### B: INSPECTION

#### 1. TURN SIGNAL SWITCH

Measure the resistance between turn signal switch terminals. <Ref. to LI-11, INSPECTION, Combination Switch (Light).>

#### 2. HAZARD SWITCH

1) Measure the resistance between hazard switch terminals.

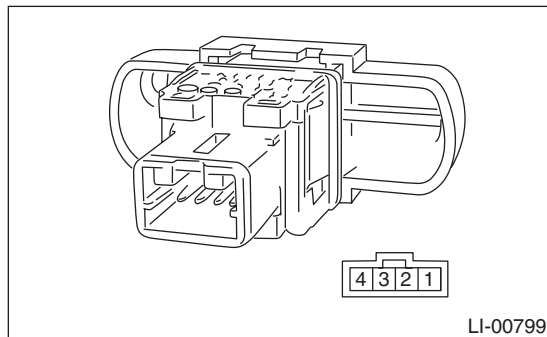

LI-00799

Switch position	Terminal No.	Specification
OFF	2 and 3	1 MΩ or more
ON		Less than 1 Ω

2) If the result of the inspection is not at the standard value, replace the hazard switch.

### 3. TURN SIGNAL AND HAZARD MODULE

1) Connect the battery and turn signal light bulb to the module. The module is properly functioning if it blinks when power is supplied to the circuit.

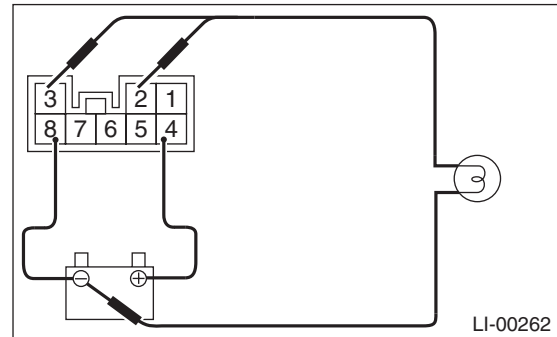

2) Replace the turn signal & hazard module if it is found defective.

### C: NOTE

For operation procedures of each component of the turn signal and hazard light system, refer to the respective sections.

- Rear combination light assembly: <Ref. to LI-25, Rear Combination Light Assembly.>
- Side turn signal light assembly: <Ref. to LI-24, Side Turn Signal Light Assembly.>
- Front turn signal light bulb: <Ref. to LI-19, Front Turn Signal Light Bulb.>
- Rear turn signal light bulb: <Ref. to LI-27, Rear Turn Signal Light Bulb.>
- Combination switch (light): <Ref. to LI-11, Combination Switch (Light).>
- Combination base switch: <Ref. to LI-14, Combination Base Switch Assembly.>

## 6. Back-up Light System

### A: WIRING DIAGRAM

Refer to "Back-up Light System" in WI section.  
 <Ref. to WI-95, WIRING DIAGRAM, Back-up Light System.>

### B: INSPECTION

#### 1. BACK-UP LIGHT SWITCH

1) Measure the resistance between back-up light switch terminals.

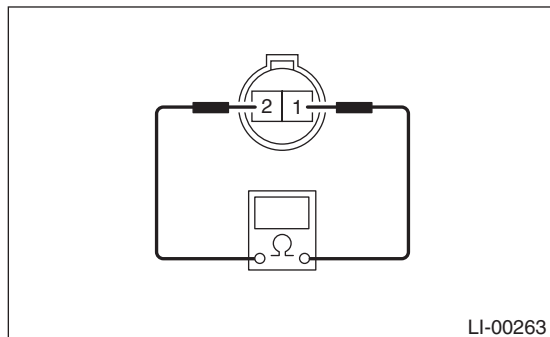

Switch position	Terminal No.	Specification
When shift lever is set in reverse position	1 and 2	Less than 1 Ω
Other positions		1 MΩ or more

2) Replace the back-up light switch if the inspection result is not within the standard value.

### C: NOTE

For operation procedures of each component of the back-up light system, refer to the respective section.

- Rear combination light assembly: <Ref. to LI-25, Rear Combination Light Assembly.>
- Back-up light bulb: <Ref. to LI-30, Back-up Light Bulb.>

## 7. Stop Light System

### A: WIRING DIAGRAM

Refer to "Stop Light System" in WI section. <Ref. to WI-96, WIRING DIAGRAM, Stop Light System.>

### B: INSPECTION

#### 1. STOP LIGHT SWITCH

1) Measure the resistance between stop light switch terminals.

- 5 door model

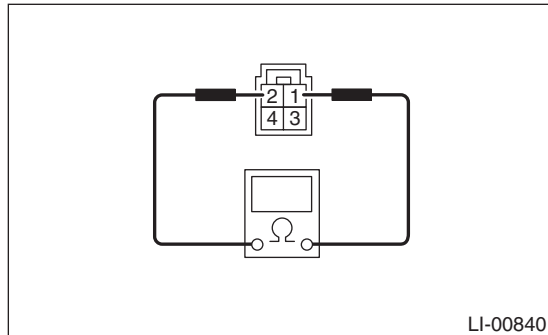

- 4 door model

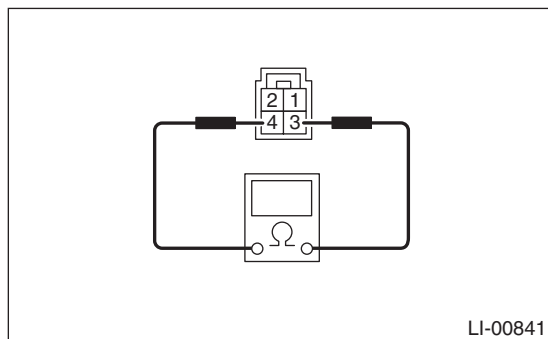

Switch position	Terminal No.	Specification
When brake pedal is depressed	5 door model: 1 and 2	Less than 1 $\Omega$
When brake pedal is released	4 door model: 3 and 4	

2) Replace the stop light switch if the inspection result is not within the standard value.

### C: NOTE

For operation procedures of each component of the stop light system, refer to the respective section.

- Rear combination light assembly: <Ref. to LI-25, Rear Combination Light Assembly.>
- Tail light/stop light bulb: <Ref. to LI-26, Tail/Stop Light Bulb.>
- High-mounted stop light: <Ref. to LI-32, High-mounted Stop Light.>

# Room Light System

## LIGHTING SYSTEM

### 8. Room Light System

#### A: WIRING DIAGRAM

Refer to "Interior Light System" in WI section. <Ref. to WI-106, WIRING DIAGRAM, Interior Light System.>

#### B: INSPECTION

##### 1. DOOR SWITCH

1) Measure the resistance between door switch terminals.

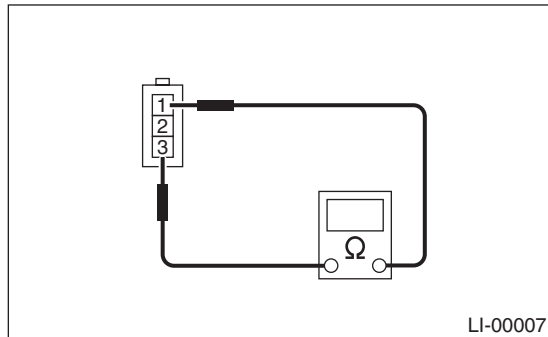

Switch position	Terminal No.	Specification
When door is opened	1 and 3	Less than 1 $\Omega$
When door is closed		1 M $\Omega$ or more

2) Replace the door switch if the inspection result is not within the standard value.

##### 2. REAR GATE LATCH SWITCH

1) Measure the resistance between rear gate latch switch terminals.

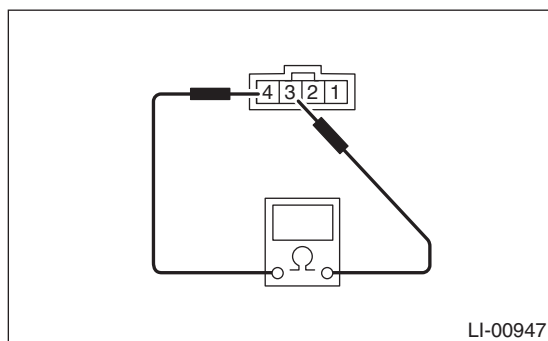

Switch position	Terminal No.	Standard value
When rear gate is opened	3 and 4	Less than 1 $\Omega$
When rear gate is closed		1 M $\Omega$ or more

2) If the inspection result is not within the standard value, replace the rear gate latch and actuator assembly.

##### 3. TRUNK LID LATCH SWITCH

1) Measure the resistance between trunk lid latch switch terminals.

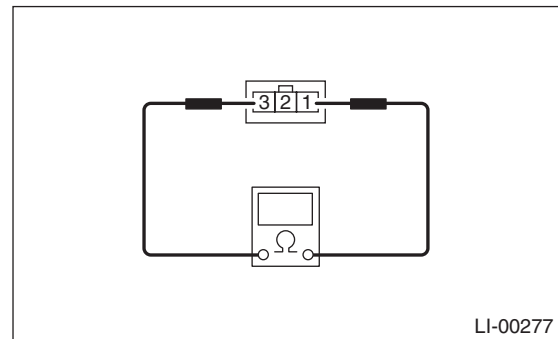

Switch position	Terminal No.	Standard value
When trunk lid is opened	1 and 3	Less than 1 $\Omega$
When trunk lid is closed		1 M $\Omega$ or more

2) If the inspection result is not within the standard value, replace the trunk lid latch and actuator assembly.

#### C: NOTE

For operation procedures of each component of the room light system, refer to the respective section.

- Spot map light: <Ref. to LI-33, Spot Map Light.>
- Room light: <Ref. to LI-34, Room Light.>
- Luggage room light: <Ref. to LI-35, Luggage Room Light.>
- Trunk room light: <Ref. to LI-36, Trunk Room Light.>
- Door switch: <Ref. to LI-41, Door Switch.>
- Ignition switch illumination: <Ref. to LI-37, Ignition Switch Illumination.>

## 9. Combination Switch (Light)

### A: REMOVAL

- 1) Disconnect the ground cable from battery.
- 2) Remove the screws and remove the steering column cover lower.

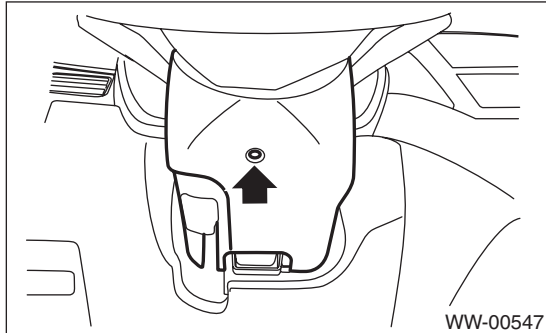

- 3) Remove the harness cover lock.
- 4) Remove the screws and detach the knee protector.

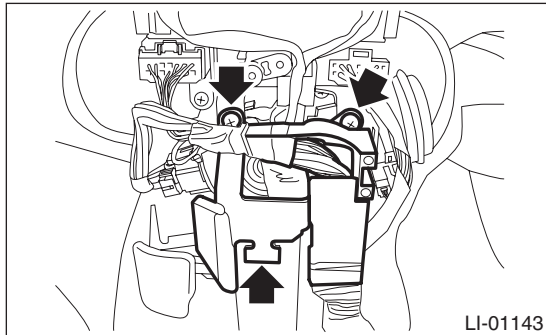

- 5) Remove the mounting screws of steering column cover upper.

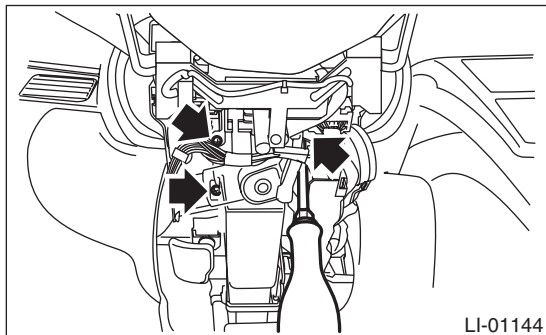

- 6) Disconnect the connector from combination switch.

- 7) Remove the screws which secure the switch, then remove the combination switch.

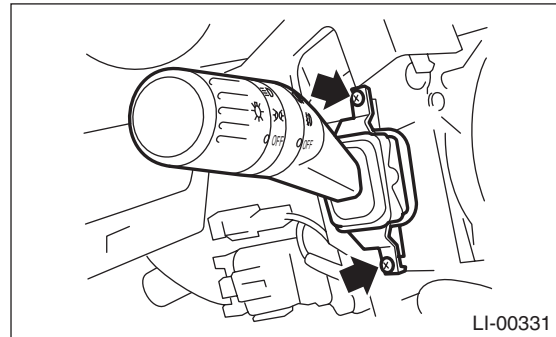

### B: INSTALLATION

Install each part in the reverse order of removal.

### C: INSPECTION

- 1) Disconnect the combination switch connector.
- 2) Check the resistance between combination switch terminals.

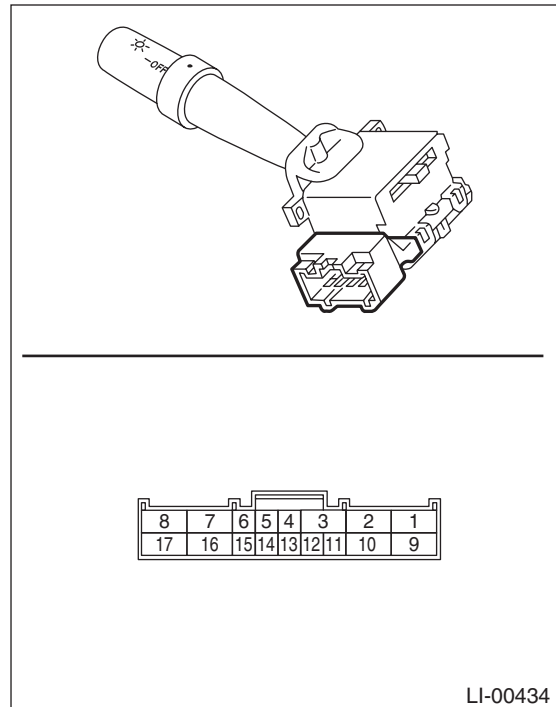

# Combination Switch (Light)

## LIGHTING SYSTEM

---

3) Replace the combination switch (light) if the inspection result of each switch is not within the standard value.

### 1. LIGHTING SWITCH

Switch position	Terminal No.	Standard value
OFF	—	1 M $\Omega$ or more
Tail	14 and 16	Less than 1 $\Omega$
Head	13, 14 and 16	Less than 1 $\Omega$

### 2. DIMMER & PASSING SWITCH

Switch position	Terminal No.	Standard value
Passing	7, 8 and 16	Less than 1 $\Omega$
High beam	7 and 16	Less than 1 $\Omega$

### 3. TURN SIGNAL SWITCH

Switch position	Terminal No.	Standard value
Left	1 and 2	Less than 1 $\Omega$
Neutral	—	1 M $\Omega$ or more
Right	3 and 2	Less than 1 $\Omega$

### 4. FRONT FOG LIGHT SWITCH

Switch position	Terminal No.	Standard value
OFF	11 and 10	1 M $\Omega$ or more
ON		Less than 1 $\Omega$

## 10. Headlight Beam Leveler System

### A: WIRING DIAGRAM

Refer to "Headlight Beam Leveler System" in WI section. <Ref. to WI-93, WIRING DIAGRAM, Headlight Beam Leveler System.>

### B: INSPECTION

#### 1. HEADLIGHT BEAM LEVELER ACTUATOR

- 1) Turn on the headlight beam.
- 2) Change the switch position in the order of 0 → 1 → 2 → 3 → 4 → 5, and check that the headlight beam position is lowered.

#### 2. HEADLIGHT BEAM LEVELER SWITCH

- 1) Connect the circuit tester to the battery and headlight beam leveler switch connector.
- 2) Check the voltage at each switch position.

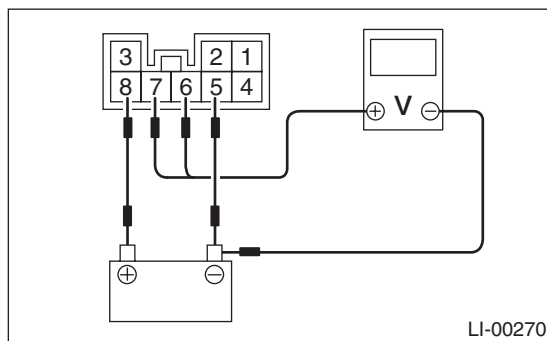

Switch position	Terminal No.	Standard value
0	6, 7 (+) and battery (-)	84 — 89% of battery voltage
1		67 — 73% of battery voltage
2		51 — 57% of battery voltage
3		36 — 41% of battery voltage
4		21 — 26% of battery voltage
5		7 — 10% of battery voltage

- 3) Replace the headlight beam leveler switch if the inspection result is not within the standard value.



# Combination Base Switch Assembly

LIGHTING SYSTEM

## 11. Combination Base Switch Assembly

### A: REMOVAL

1) Remove the driver's airbag module. <Ref. to AB-16, REMOVAL, Driver's Airbag Module.>

#### WARNING:

Before handling the airbag module, refer to "CAUTION" of "General Description" in the "AB" section. <Ref. to AB-5, CAUTION, General Description.>

2) Remove the steering wheel. <Ref. to PS-12, REMOVAL, Steering Wheel.>

3) Remove the combination switch.

- Combination switch (light): <Ref. to LI-11, REMOVAL, Combination Switch (Light).>

- Combination switch (wiper): <Ref. to WW-7, REMOVAL, Combination Switch (Wiper).>

4) Remove the screws, and then remove the roll connector.

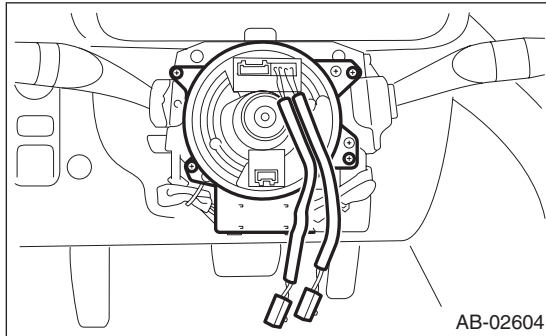

5) Remove the screws, disconnect the harness connector and remove the combination base switch assembly.

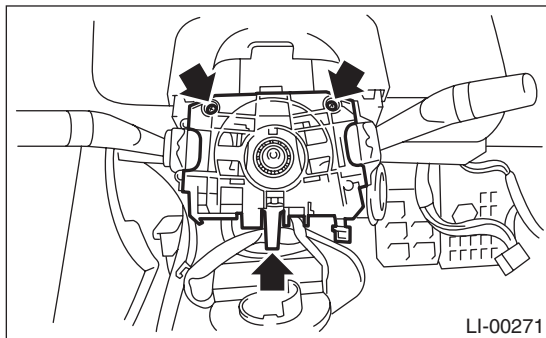

### B: INSTALLATION

1) Before installing steering wheel, be sure to adjust the direction of roll connector with steering. <Ref. to AB-28, ADJUSTMENT, Roll Connector.>

2) Install each part in the reverse order of removal.

### C: INSPECTION

#### 1. COMBINATION BASE SWITCH ASSEMBLY

Inspect the combination base switch assembly and roll connector for cracks or deformation. If any damage is found, replace with a new part.

## 12. Headlight Assembly

### A: REMOVAL

**WARNING:**

Because the headlight system uses high voltage, be careful not to perform work with wet hands. There is a possibility of electrical shock.

**CAUTION:**

The HID headlight uses very high voltages for the lighting circuit. Make sure that the power is turned OFF before working.

- 1) Disconnect the ground cable from battery.
- 2) Remove the clips and remove the air intake duct. (When removing the headlight RH)

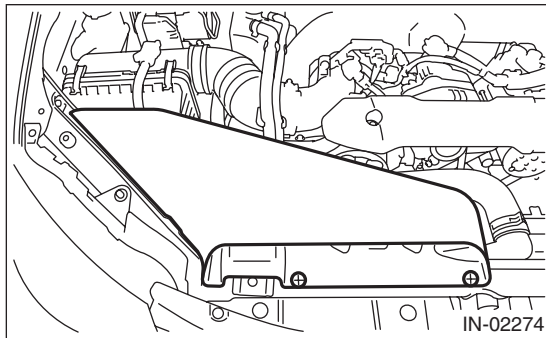

- 3) Remove the front bumper face. <Ref. to EI-31, FRONT BUMPER FACE, REMOVAL, Front Bumper.>

- 4) Disconnect harness connectors.
- 5) Remove the bolts and clips, and remove the headlight assembly.

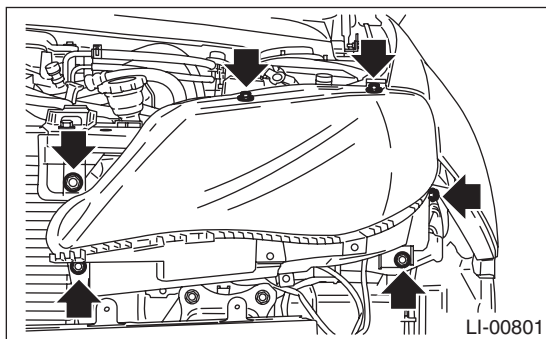

### B: INSTALLATION

- 1) Install each part in the reverse order of removal.

**Tightening torque:**

**7.5 N·m (0.76 kgf·m, 5.5 ft·lb)**

- 2) Adjust the headlight beam and fog light beam.
  - Adjust the headlight beam. <Ref. to LI-16, HEADLIGHT BEAM ADJUSTMENT, ADJUSTMENT, Headlight Assembly.>
  - Adjust the fog light beam. (Model with fog light) <Ref. to LI-21, FOG LIGHT AIMING, ADJUSTMENT, Front Fog Light Assembly.>

### C: DISASSEMBLY

#### 1. HID HEADLIGHT BALLAST

**WARNING:**

Because the headlight system uses high voltage, be careful not to perform work with wet hands. There is a possibility of electrical shock.

**CAUTION:**

The HID headlight uses very high voltages for the lighting circuit. Make sure that the power is turned OFF before working.

Do not leave the headlight without the ballast for a long time. Dust, moisture, etc. entering the headlight may affect its performance.

- 1) Disconnect the ground cable from battery.
- 2) Remove the headlight assembly. <Ref. to LI-15, REMOVAL, Headlight Assembly.>
- 3) Remove the back cover.

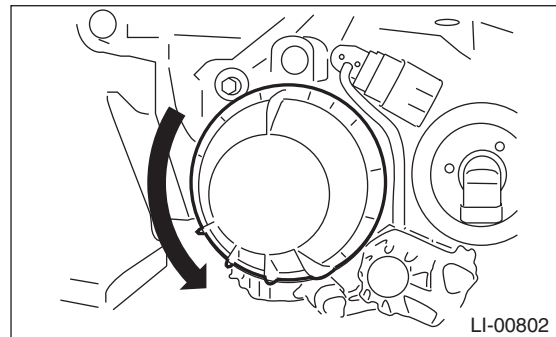

- 4) Disconnect the bulb connector.

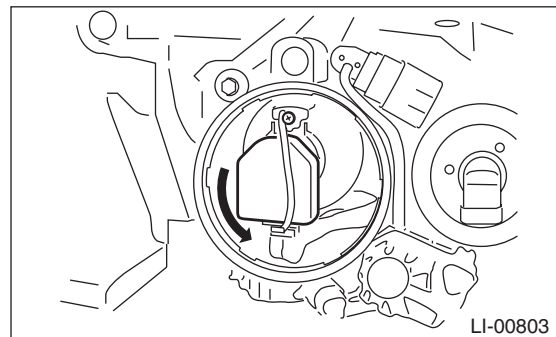

- 5) Remove the harness connector and screws to pull out the ballast.

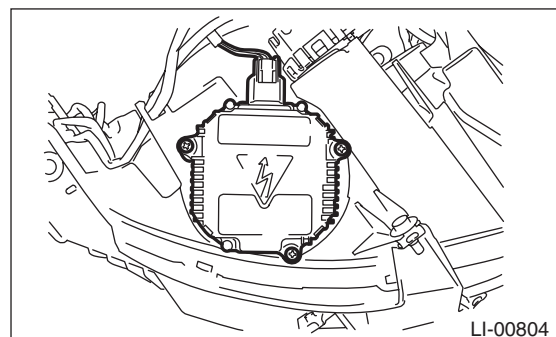

# Headlight Assembly

## LIGHTING SYSTEM

6) Remove the harness connector and screws on the back to remove the headlight ballast.

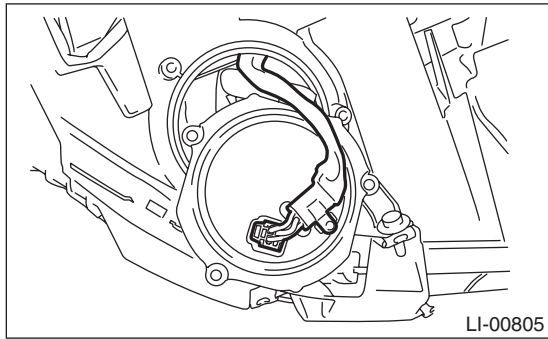

LI-00805

## D: ASSEMBLY

### 1. HID HEADLIGHT BALLAST

#### CAUTION:

- When installing the ballast cover, be sure to install the gasket.
- After installing the ballast to the vehicle, be sure to perform beam adjustment.

Assemble each part in the reverse order of disassembly.

#### Tightening torque:

**1.3 N·m (0.13 kgf·m, 0.96 ft·lb)**

#### NOTE:

Adjust the projector lens to near the center of the extension opening before installing the ballast. This makes the beam adjustment work easier.

## E: ADJUSTMENT

### 1. HEADLIGHT BEAM ADJUSTMENT

#### CAUTION:

Turn off the light before adjusting the headlight beam level. If it is necessary to inspect the beam level, do not keep the light on for two minutes or more.

1) Before checking the headlight beam level, be sure of the following:

- The area around the headlight has not sustained any scratches, damage or other type of deformation.
- Vehicle is parked on a level surface.
- The inflation pressure of tires is correct.
- Vehicle's fuel tank is fully filled.

2) For vehicle with a manual leveler, set the headlight beam leveler switch to the "0" position.

3) Bounce the vehicle several times to normalize the suspension.

4) Make certain that someone is seated in the driver's seat.

5) Measure the distance between the low beam bulb centers and the height of the bulb center.

6) Turn the headlights on and then adjust the low beam pattern.

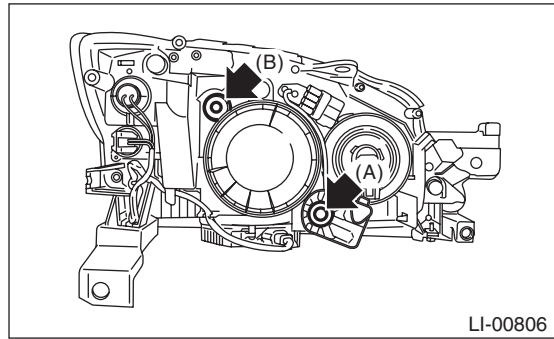

LI-00806

(1) Adjust the vertical beam level (A).

(2) Adjust the horizontal beam level (B).

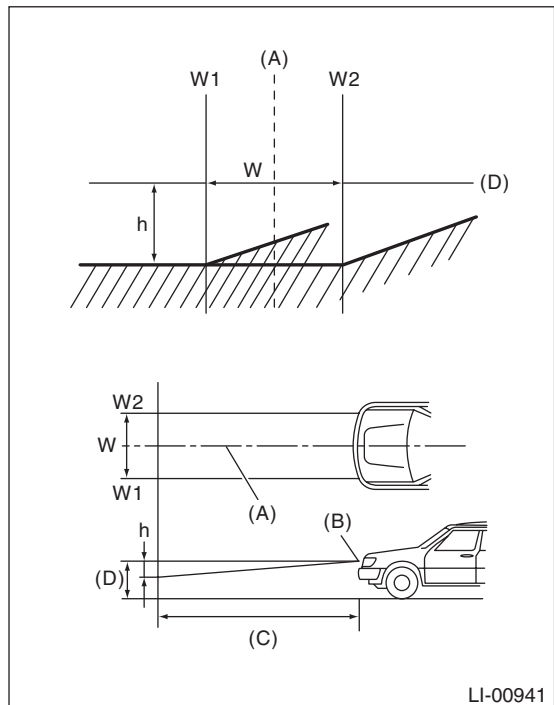

LI-00941

(A) Vehicle center

(B) Bulb center marking

(C) 3 m (10 ft)

(D) Height of headlight center

W mm (in)	h mm (in) at 3 m (10 ft)
1,160 (45.67)	30 (1.18)

## 13. Headlight Bulb

### A: REMOVAL

#### 1. HIGH BEAM & HALOGEN TYPE LOW BEAM

**WARNING:**

Because the headlight system uses high voltage, be careful not to perform work with wet hands. There is a possibility of electrical shock.

**CAUTION:**

- Because the halogen bulb operates at a high temperature, dirt and oil on the bulb surface reduces the bulb's service life. Hold the flange portion when replacing the bulb. Never touch the glass portion.
- Do not leave the headlight without a bulb for a long time. Dust, moisture, etc. entering the headlight may affect its performance.

- 1) Disconnect the ground cable from battery.
- 2) Remove the clips and remove the air intake duct. (When removing the headlight bulb RH)

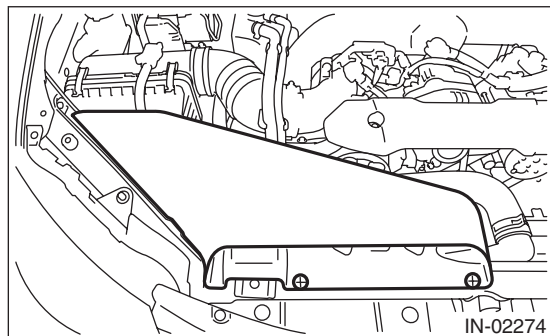

- 3) Remove the battery cover. (When removing the headlight bulb LH)
- 4) Tilt the washer tank filler neck. (When removing the headlight bulb LH)
- 5) Disconnect the bulb connector.
- 6) Remove the bulb assembly (A) then remove the high beam. To remove the low beam, remove the back cover (B), and then go to step 7.

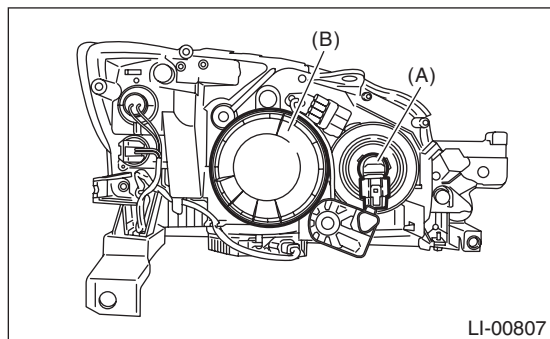

- 7) Remove the bulb connector and retaining spring (A), and remove the bulb.

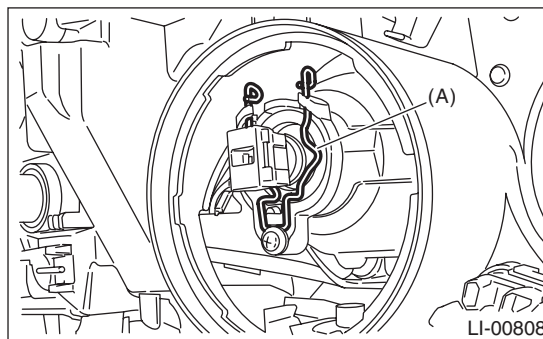

#### 2. HID TYPE LOW BEAM

**WARNING:**

Because the headlight system uses high voltage, be careful not to perform work with wet hands. There is a possibility of electrical shock.

**CAUTION:**

- Because the HID lighting circuit uses high voltage, be sure to confirm that the power supply is turned off before operation.
- When replacing bulb, hold the flange area. Be careful not to touch the glass area.
- Do not leave the headlight without a bulb for a long time. Dust, moisture, etc. entering the headlight may affect its performance.

- 1) Disconnect the ground cable from battery.
- 2) Remove the headlight assembly. <Ref. to LI-15, REMOVAL, Headlight Assembly.>
- 3) Remove the back cover.

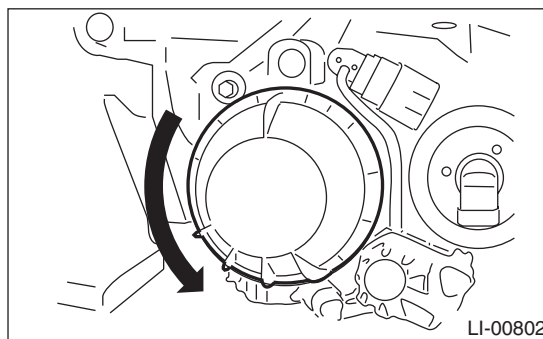

- 4) Disconnect the bulb connector.

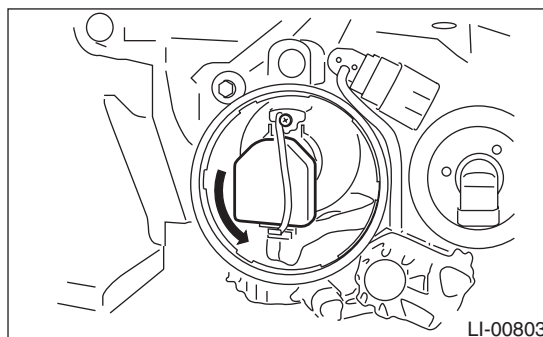

# Headlight Bulb

## LIGHTING SYSTEM

5) Remove the retaining spring of bulb, and remove the bulb.

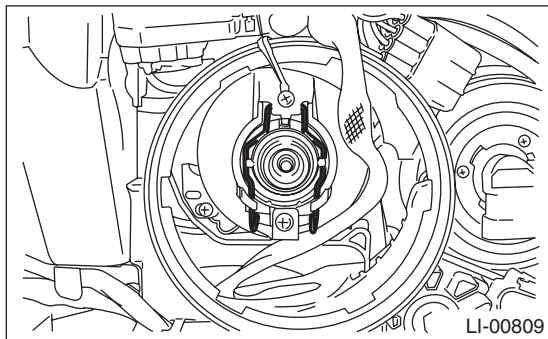

### B: INSTALLATION

Install each part in the reverse order of removal.

### C: INSPECTION

#### 1. HALOGEN TYPE

##### WARNING:

Because the headlight system uses high voltage, be careful not to perform work with wet hands. There is a possibility of electrical shock.

##### CAUTION:

- Because the halogen bulb operates at a high temperature, dirt and oil on the bulb surface reduces the bulb's service life. Hold the flange portion when replacing the bulb. Never touch the glass portion.

- Do not leave the headlight without a bulb for a long time. Dust, moisture, etc. entering the headlight may affect its performance.

- 1) Visually check the bulb for blow out.
- 2) Check the bulb specification. <Ref. to LI-2, SPECIFICATION, General Description.>
- 3) Replace the bulb if it is found defective.

#### 2. HID TYPE

##### WARNING:

Because the headlight system uses high voltage, be careful not to perform work with wet hands. There is a possibility of electrical shock.

##### CAUTION:

- When lit (lighting switch is ON), do not touch the harness, light internals, or metal parts of the light.

- When performing a lighting test, make sure that the headlight is mounted on the vehicle, and the power supply is connected to the connector on the vehicle's side.

- 1) Check the bulb specification. <Ref. to LI-2, SPECIFICATION, General Description.>
- 2) Install the factory HID bulb to check whether it lights properly.

3) If it fails to illuminate normally, replace the bulb with a new part.

4) Inspect the HID ballast.

Inspect the ballast in the following manner, and determine whether or not to reuse.

(1) Perform cold starts (light the headlight after turning off for 10 minutes or more), and hot starts (light the headlight for 15 minutes or more, then turn off for 1 minute and relight) several times, to make sure that the headlight lights properly.

(2) Monitor the lighting condition right after a cold start up to a stable state (approx. 5 min.), to see if there are any unstable conditions such as flickering.

(3) Install bulbs with the same number of operating hours on both headlights, and light for approximately 30 minutes. Check for whether there is a difference in brightness on the right and left sides.

5) Replace the ballast if it is found defective.



## 14. Front Turn Signal Light Bulb

### A: REMOVAL

- 1) When removing the turn signal light bulb, fully turn the steering wheels to opposite direction from the turn signal light bulb to remove.
- 2) Disconnect the ground cable from battery.
- 3) Turn the mud guard inward.
- 4) Turn socket (A) from the wheel arch, and remove the front turn signal light bulb.

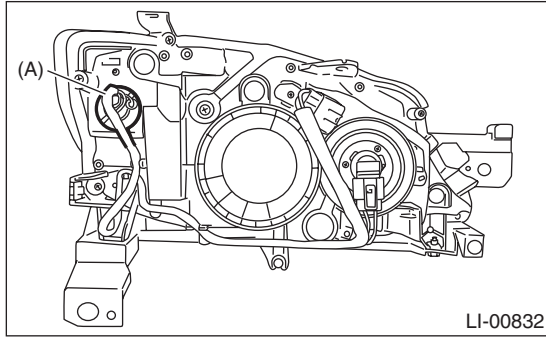

### B: INSTALLATION

Install each part in the reverse order of removal.

### C: INSPECTION

- 1) Visually check the bulb for blow out.
- 2) Check the bulb specification. <Ref. to LI-2, SPECIFICATION, General Description.>
- 3) Replace the bulb if it is found defective.

# Front Side Marker Light Bulb

## LIGHTING SYSTEM

---

### 15. Front Side Marker Light Bulb

#### A: REMOVAL

- 1) When removing the front side marker light bulb, fully turn the steering wheel in the opposite direction from the front side marker light bulb to be removed.
- 2) Disconnect the ground cable from battery.
- 3) Turn the mud guard inward.
- 4) Turn socket (A) from the wheel arch, and remove the front side marker light bulb.

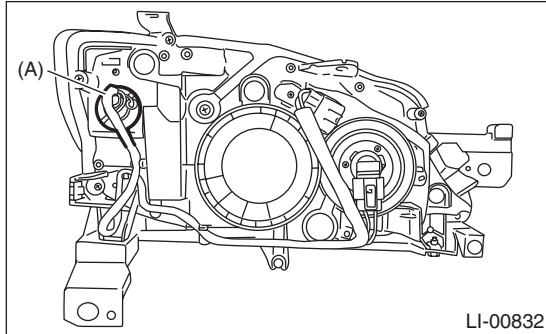

#### B: INSTALLATION

Install each part in the reverse order of removal.

#### C: INSPECTION

- 1) Visually check the bulb for blow out.
- 2) Check the bulb specification. <Ref. to LI-2, SPECIFICATION, General Description.>
- 3) Replace the bulb if it is found defective.

## 16. Front Fog Light Assembly

### A: REMOVAL

- 1) Disconnect the ground cable from battery.
- 2) Remove the screw and clips, and turn over the mud guard.

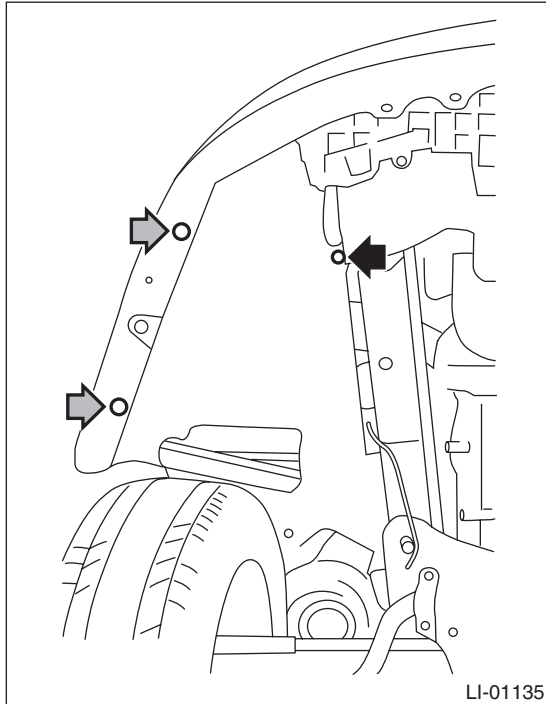

- 3) Disconnect the bulb connector.
- 4) Remove the bolts, then remove the fog light assembly.

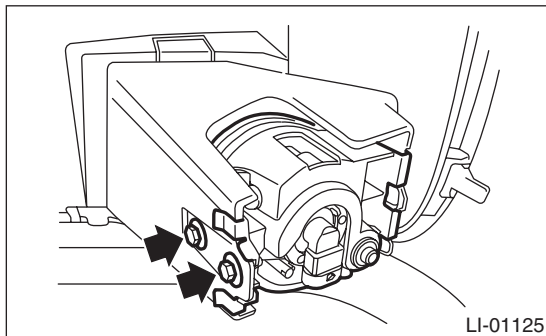

#### NOTE:

Remove the bracket as required.

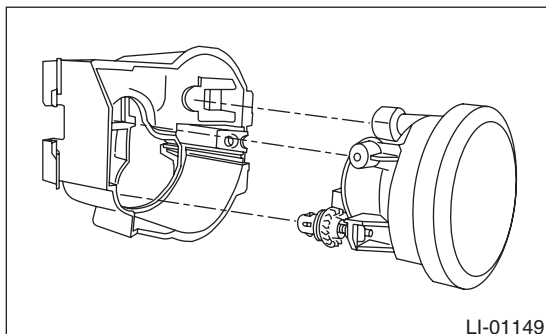

### B: INSTALLATION

- 1) Install each part in the reverse order of removal.

#### Tightening torque:

**7.5 N·m (0.76 kgf-m, 5.5 ft-lb)**

- 2) Adjust the fog light beam. <Ref. to LI-21, FOG LIGHT AIMING, ADJUSTMENT, Front Fog Light Assembly.>

### C: ADJUSTMENT

#### 1. FOG LIGHT AIMING

- 1) Before checking the fog light beam level, be sure of the following:
  - The area around the fog light has not sustained any accident, damage or other type of deformation.
  - Vehicle is parked on a level surface.
  - The inflation pressure of tires is correct.
  - Vehicle's fuel tank is fully filled.
- 2) Bounce the vehicle several times to normalize the suspension.
- 3) Make certain that someone is seated in the driver's seat.
- 4) Remove the clips and turn over the mud guard.

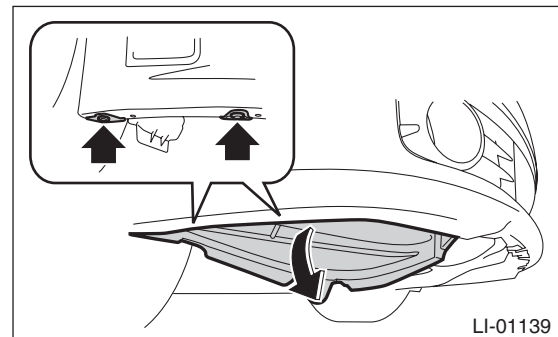



# Front Fog Light Assembly

## LIGHTING SYSTEM

5) Adjust the front fog light pattern by inserting a Philips screwdriver to the adjusting hole (1).

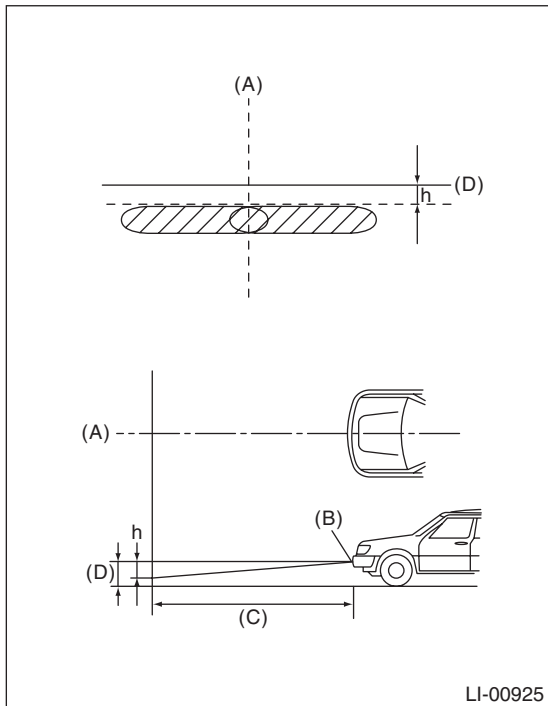
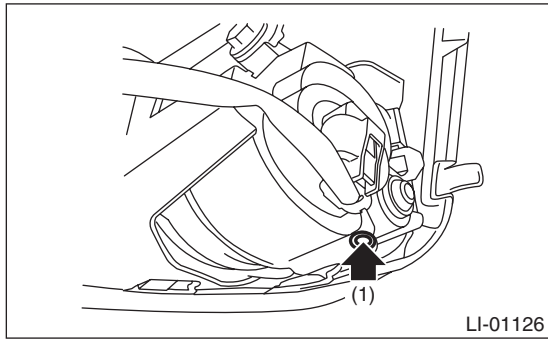

- (A) Vehicle center
- (B) Bulb center marking
- (C) 3 m (10 ft)
- (D) Height of fog light center

h mm (in) at 3 m (10 ft)
60 (2.38)

## 17. Front Fog Light Bulb

### A: REMOVAL

- 1) Disconnect the ground cable from battery.
- 2) Remove the clips and turn over the mud guard.

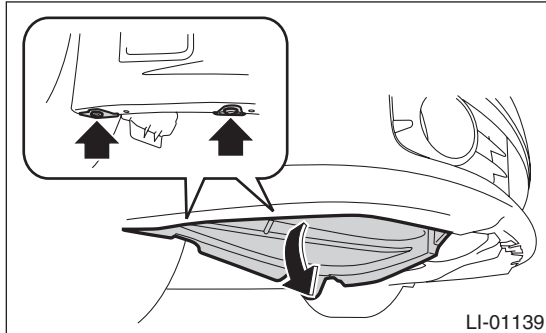

- 3) Disconnect the bulb connector.
- 4) Rotate the bulb then detach the fog light bulb.

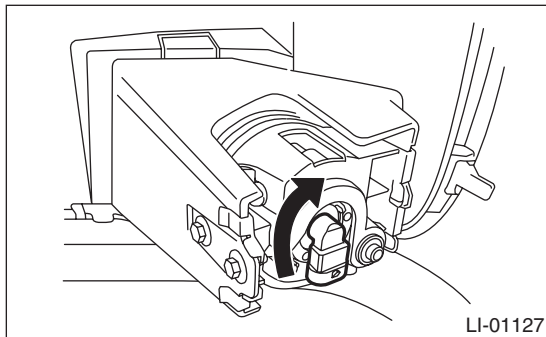

### B: INSTALLATION

#### CAUTION:

**Align the bulb tabs with the fog light securely, push the bulb fully, and then rotate it.**

Install each part in the reverse order of removal.

### C: INSPECTION

- 1) Visually check the bulb for blow out.
- 2) Check the bulb specification. <Ref. to LI-2, SPECIFICATION, General Description.>
- 3) Replace the bulb if it is found defective.

# Side Turn Signal Light Assembly

LIGHTING SYSTEM

---

## 18. Side Turn Signal Light Assembly

### A: REMOVAL

- 1) Disconnect the ground cable from battery.
- 2) Remove the mirror. <Ref. to GW-17, REPLACEMENT, Outer Mirror.>
- 3) Remove the scalp cap. <Ref. to GW-15, REPLACEMENT, Scalp Cap.>
- 4) Remove the screws.

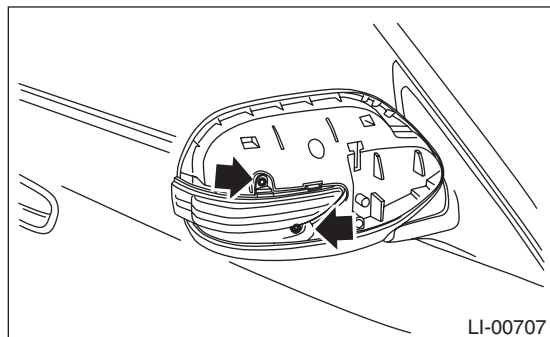

- 5) Disconnect the harness connector and remove the side turn signal light assembly.

### B: INSTALLATION

Install each part in the reverse order of removal.

### C: INSPECTION

- 1) Install the side turn signal light assembly and check that it blinks normally.
- 2) If it fails to blink normally, replace the side turn signal light assembly with a new part.

#### NOTE:

Since LED (Light Emitting Diode) is used for the side turn signal light, replace the side turn signal light assembly if the LED burns out.

## 19. Rear Combination Light Assembly

### A: REMOVAL

#### 1. 4 DOOR MODEL

- 1) Disconnect the ground cable from battery.
- 2) Remove the trunk room side trim. <Ref. to EI-63, REMOVAL, Trunk Room Trim.>
- 3) Disconnect the rear combination light connector.
- 4) Remove the nuts and detach the rear combination light.

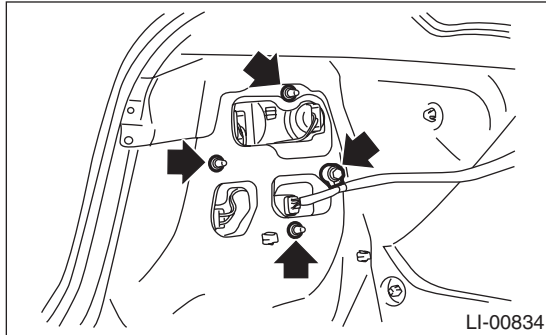

#### 2. 5 DOOR MODEL

- 1) Disconnect the ground cable from battery.
- 2) Remove the bolts, and then detach the rear combination light by pulling it to the rear side of vehicle.

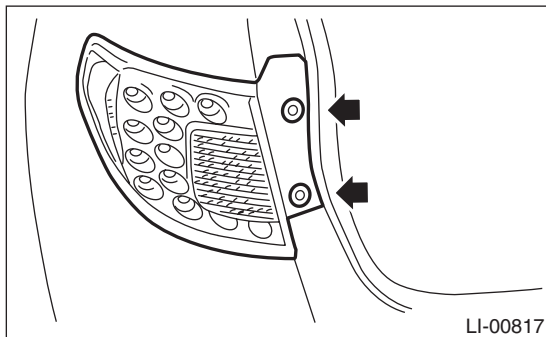

- 3) Disconnect the harness connector and remove the rear combination light.

### B: INSTALLATION

Install each part in the reverse order of removal.

#### Tightening torque:

##### 4 door model

**4.5 N·m (0.46 kgf-m, 3.3 ft-lb)**

##### 5 door model

**7.5 N·m (0.76 kgf-m, 5.5 ft-lb)**

### C: INSPECTION

#### 1. 4 DOOR MODEL

- 1) Visually check the bulb for blow out.
- 2) Check the bulb specification. <Ref. to LI-2, SPECIFICATION, General Description.>
- 3) Replace the bulb if it is found defective.

#### 2. 5 DOOR MODEL

- 1) Install the rear combination light assembly and check that it blinks normally.
- 2) If it fails to blink normally, replace the rear combination light assembly with a new part.

#### NOTE:

Since LED (Light Emitting Diode) is used for the tail light/stop light bulb, replace the rear combination light assembly if the LED burns out.

## 20. Tail/Stop Light Bulb

### A: REMOVAL

#### 1. 4 DOOR MODEL

- 1) Disconnect the ground cable from battery.
- 2) Remove the trunk room side trim cover. <Ref. to EI-63, REMOVAL, Trunk Room Trim.>
- 3) Turn the socket and remove the bulb.

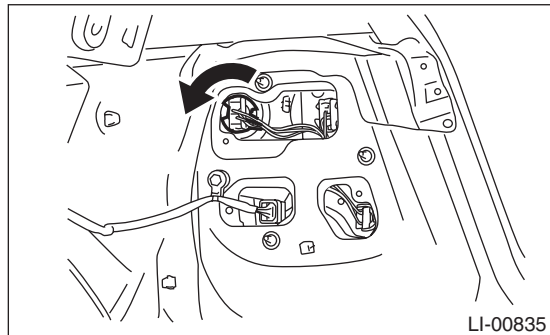

#### 2. 5 DOOR MODEL

The tail light/stop light bulbs use LEDs (Light Emitting Diode) can not removed.

### B: INSTALLATION

Install each part in the reverse order of removal.

### C: INSPECTION

#### 1. 4 DOOR MODEL

- 1) Visually check the bulb for blow out.
- 2) Check the bulb specification. <Ref. to LI-2, SPECIFICATION, General Description.>
- 3) Replace the bulb if it is found defective.

#### 2. 5 DOOR MODEL

#### NOTE:

Since LED (Light Emitting Diode) is used for the tail light/stop light bulb, replace the rear combination light assembly if the LED burns out.

## 21. Rear Turn Signal Light Bulb

### A: REMOVAL

#### 1. 4 DOOR MODEL

- 1) Disconnect the ground cable from battery.
- 2) Remove the trunk room side trim cover. <Ref. to EI-63, REMOVAL, Trunk Room Trim.>
- 3) Turn the socket and remove the bulb.

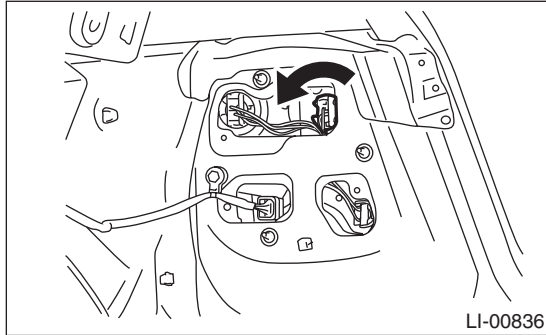

#### 2. 5 DOOR MODEL

- 1) Remove the rear combination light assembly. <Ref. to LI-25, 5 DOOR MODEL, REMOVAL, Rear Combination Light Assembly.>
- 2) Turn the socket and remove the bulb.

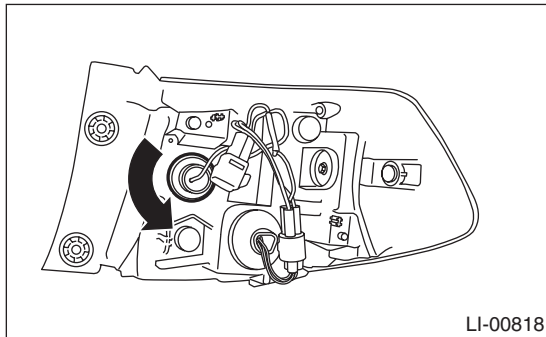

### B: INSTALLATION

Install each part in the reverse order of removal.

### C: INSPECTION

- 1) Visually check the bulb for blow out.
- 2) Check the bulb specification. <Ref. to LI-2, SPECIFICATION, General Description.>
- 3) Replace the bulb if it is found defective.

# Rear Side Marker Light Bulb

LIGHTING SYSTEM

---

## 22.Rear Side Marker Light Bulb

### A: REMOVAL

NOTE:

Equipped with 5 door model only.

- 1) Remove the rear combination light assembly.  
<Ref. to LI-25, 5 DOOR MODEL, REMOVAL, Rear Combination Light Assembly.>
- 2) Turn the socket and remove the bulb.

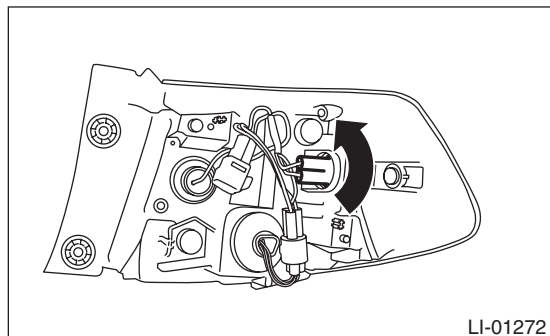

### B: INSTALLATION

Install each part in the reverse order of removal.

### C: INSPECTION

- 1) Visually check the bulb for blow out.
- 2) Check the bulb specification. <Ref. to LI-2, SPECIFICATION, General Description.>
- 3) Replace the bulb if it is found defective.

## 23. Rear Finisher Light Assembly

### A: REMOVAL

- 1) Disconnect the ground cable from battery.
- 2) Remove the rear gate trim. <Ref. to EI-69, REMOVAL, Rear Gate Trim.>
- 3) Disconnect the rear finisher light connector.
- 4) Remove the nuts, and then remove the rear finisher light assembly.

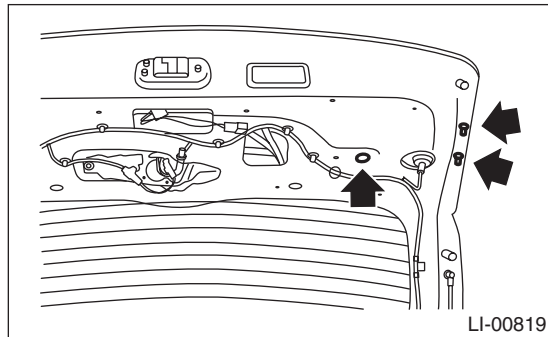

### B: INSTALLATION

Install each part in the reverse order of removal.

#### ***Tightening torque:***

***4.5 N·m (0.46 kgf·m, 3.3 ft·lb)***



## 24. Back-up Light Bulb

### A: REMOVAL

#### 1. 4 DOOR MODEL

- 1) Disconnect the ground cable from battery.
- 2) Remove the trunk room side trim cover. <Ref. to EI-63, REMOVAL, Trunk Room Trim.>
- 3) Turn the socket and remove the bulb.

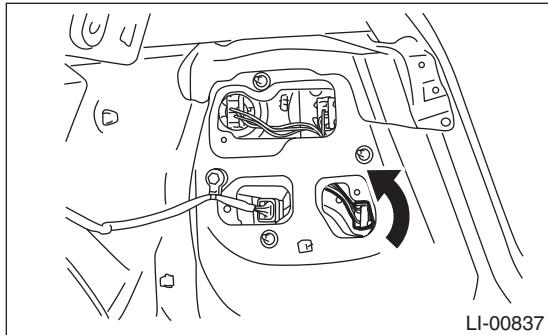

#### 2. 5 DOOR MODEL

- 1) Disconnect the ground cable from battery.
- 2) Remove the bulb inspection cover of the rear gate trim.
- 3) Turn the socket and remove the bulb.

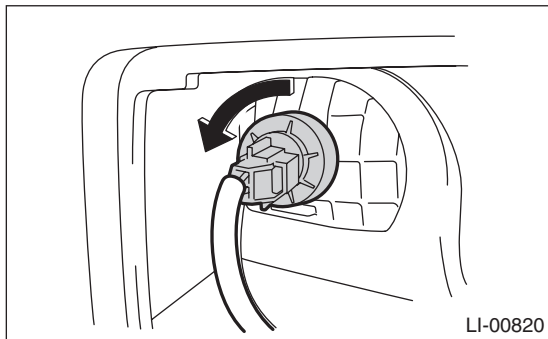

### B: INSTALLATION

Install each part in the reverse order of removal.

### C: INSPECTION

- 1) Visually check the bulb for blow out.
- 2) Check the bulb specification. <Ref. to LI-2, SPECIFICATION, General Description.>
- 3) Replace the bulb if it is found defective.

## 25. License Plate Light

### A: REMOVAL

#### 1. 4 DOOR MODEL

- 1) Disconnect the ground cable from battery.
- 2) Remove the license plate light mounting screw (A) and then remove the lens.

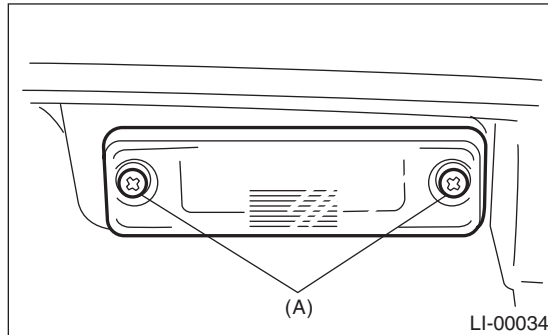

- 3) Remove the bulb.
- 4) Remove the trunk lid garnish. <Ref. to EI-73, REMOVAL, Trunk Lid Garnish.>
- 5) Remove the license plate light assembly harness.

#### 2. 5 DOOR MODEL

- 1) Disconnect the ground cable from battery.
- 2) Remove the license plate light while pushing it to the left and pulling it.

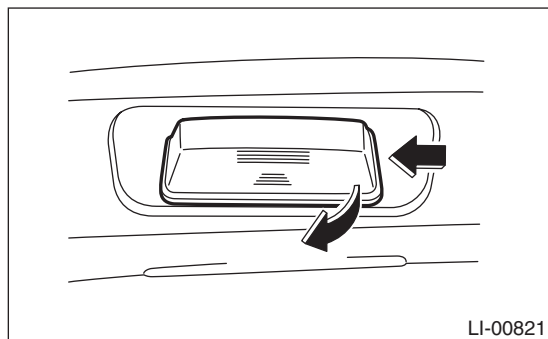

- 3) Disconnect the harness connector, and remove the socket (A).

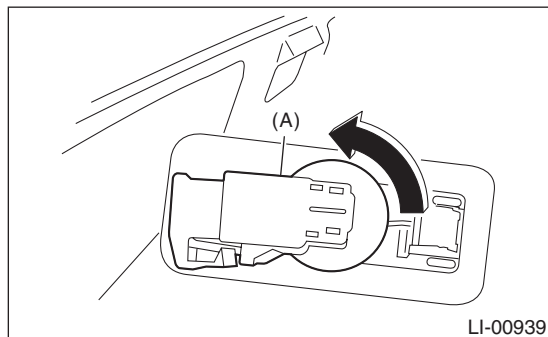

- 4) Remove the bulb.

### B: INSTALLATION

Install each part in the reverse order of removal.

### C: INSPECTION

- 1) Visually check the bulb for blow out.
- 2) Check the bulb specification. <Ref. to LI-2, SPECIFICATION, General Description.>
- 3) Replace the bulb if it is found defective.

# High-mounted Stop Light

## LIGHTING SYSTEM

### 26. High-mounted Stop Light

#### A: REMOVAL

##### 1. 4 DOOR MODEL (STANDARD TYPE)

- 1) Disconnect the ground cable from battery.
- 2) Disconnect the high-mounted stop light connector.
- 3) Loosen the bolt, and remove the high-mounted stop light assembly.

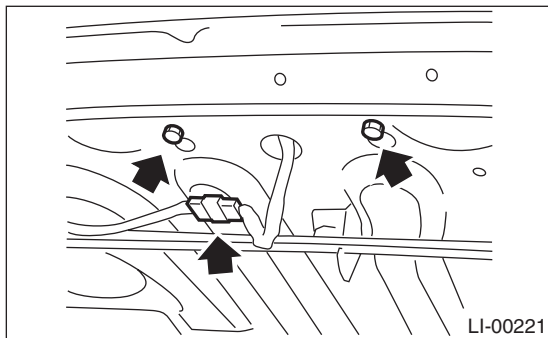

- 4) Remove the high-mounted stop light assembly cover.
- 5) Turn the socket and remove the bulb.

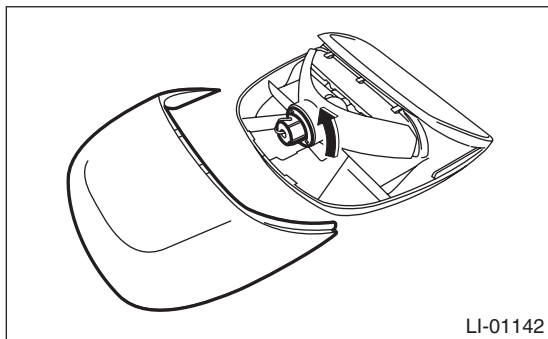

##### 2. 4 DOOR MODEL (WITH BUILT-IN REAR SPOILER)

- 1) Disconnect the ground cable from battery.
- 2) Detach the rear spoiler. <Ref. to EI-42, REMOVAL, Rear Spoiler.>
- 3) Remove the screw, and remove the high-mounted stop light.

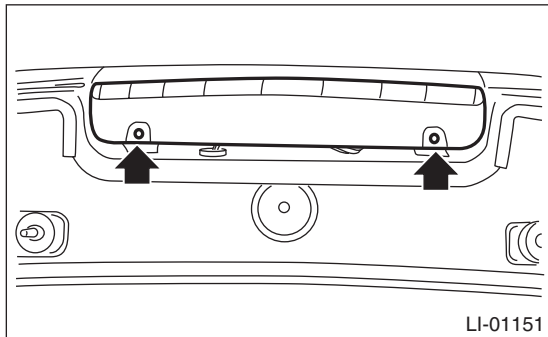

##### 3. 5 DOOR MODEL

- 1) Disconnect the ground cable from battery.
- 2) Remove the roof spoiler. <Ref. to EI-41, REMOVAL, Roof Spoiler.>
- 3) Remove the caps and screws, then remove the high-mounted stop light.

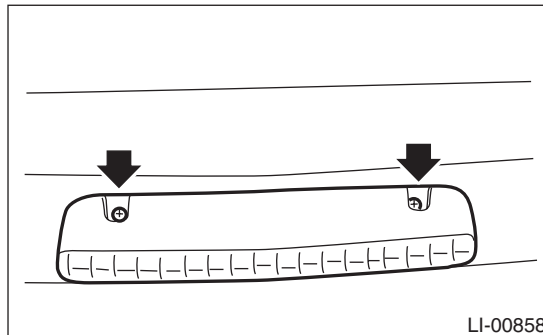

#### B: INSTALLATION

Install each part in the reverse order of removal.

##### Tightening torque:

**4 door model (standard type)**  
**7.5 N·m (0.76 kgf·m, 5.5 ft·lb)**

#### C: INSPECTION

##### 1. 4 DOOR MODEL (STANDARD TYPE)

- 1) Visually check the bulb for blow out.
- 2) Check the bulb specification. <Ref. to LI-2, SPECIFICATION, General Description.>
- 3) Replace the bulb if it is found defective.

##### 2. EXCEPT FOR 4 DOOR MODEL (STANDARD TYPE)

- 1) Install the high-mounted stop light to test if it illuminates normally.
- 2) If it fails to illuminate normally, replace the high-mounted stop light with a new part.

##### NOTE:

Since LED (Light Emitting Diode) is used for the high-mounted stop light, replace the high-mounted stop light assembly if the LED burns out.

## 27. Spot Map Light

### A: REMOVAL

- 1) Disconnect the ground cable from battery.
- 2) Remove the lens (A) and spot map light mounting screws (B).

- Model without sunroof

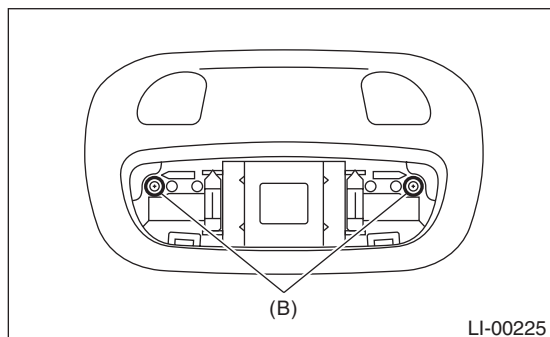
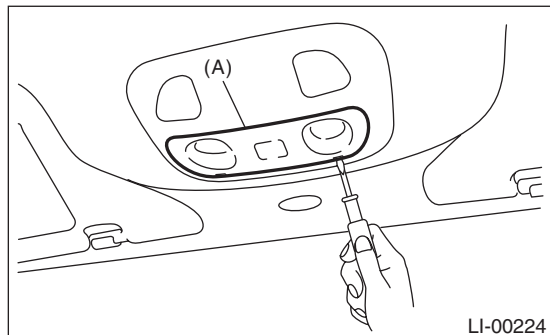

- Model with sunroof

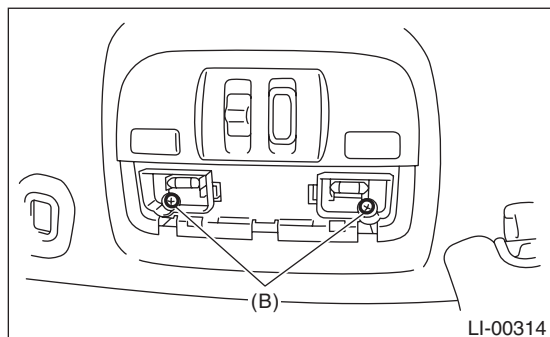
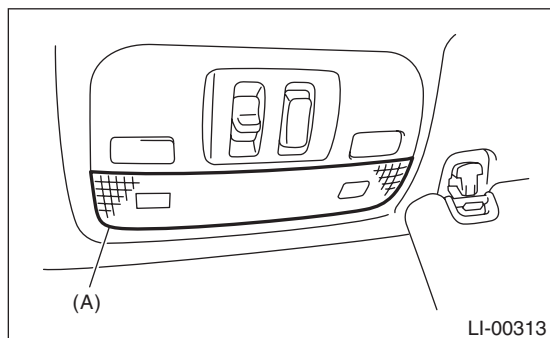

- 3) Disconnect the harness connectors and remove the spot map light.
- 4) Remove the bulb.

### B: INSTALLATION

Install each part in the reverse order of removal.

### C: INSPECTION

#### 1. SPOT MAP LIGHT BULB

- 1) Visually check the bulb for blow out.
- 2) Check the bulb specification. <Ref. to LI-2, SPECIFICATION, General Description.>
- 3) Replace the bulb if it is found defective.

#### 2. SPOT MAP LIGHT SWITCH

- 1) Remove the spot map light.
- 2) Check the resistance of spot map light.

- Model without sunroof

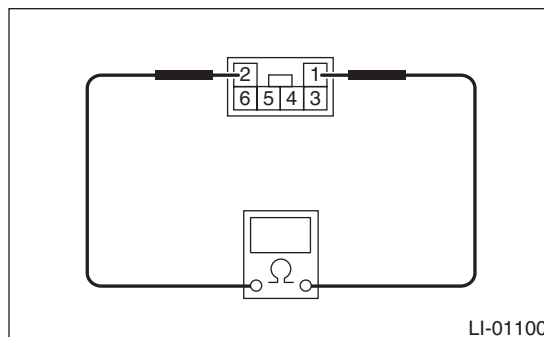

- Model with sunroof

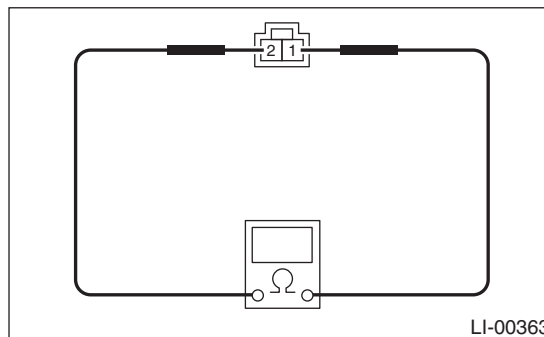

Switch position	Terminal No.	Standard value
OFF	1 and 2	1 MΩ or more
ON	1 and 2	18±5.4 Ω

- 3) Replace the spot map light if the inspection result is not within the standard value.

# Room Light

## LIGHTING SYSTEM

### 28. Room Light

#### A: REMOVAL

- 1) Disconnect the ground cable from battery.
- 2) Remove the lens (A) and room light mounting screws (B).

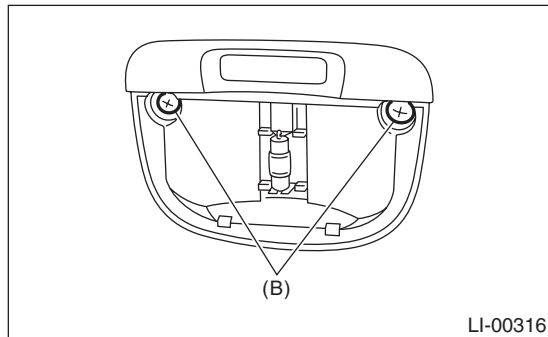
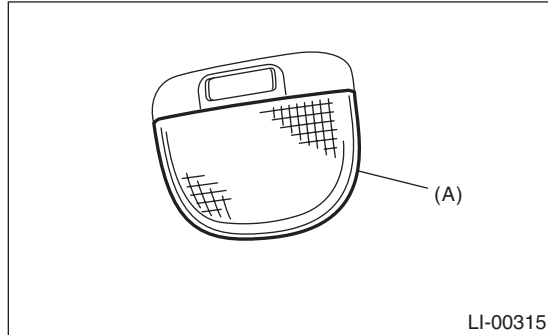

- 3) Disconnect the harness connector and remove the room light.
- 4) Remove the bulb.

#### B: INSTALLATION

Install each part in the reverse order of removal.

#### C: INSPECTION

##### 1. ROOM LIGHT BULB

- 1) Visually check the bulb for blow out.
- 2) Check the bulb specification. <Ref. to LI-2, SPECIFICATION, General Description.>
- 3) Replace the bulb if it is found defective.

##### 2. ROOM LIGHT SWITCH

- 1) Remove the room light.
- 2) Measure the resistance between room light switch terminals.

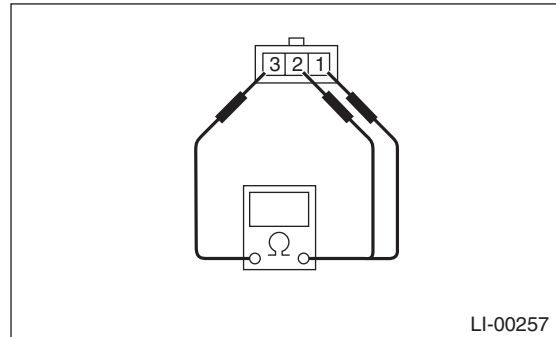

Switch position	Terminal No.	Standard value
OFF	—	1 MΩ or more
ON	1 and 3	1.5±0.5 Ω
DOOR	2 and 3	1.5±0.5 Ω

- 3) Connect terminal No. 3 to the battery positive terminal and terminal No. 1 and No. 2 to the battery ground terminal, and check room light operation.

Switch position	Light status
OFF	Light OFF
ON	Light ON
DOOR	Light ON

- 4) Replace the room light if it is found defective.

## 29. Luggage Room Light

### A: REMOVAL

- 1) Disconnect the ground cable from battery.
- 2) Insert a flat tip screwdriver into the edge of the luggage room light body to remove the luggage room light.

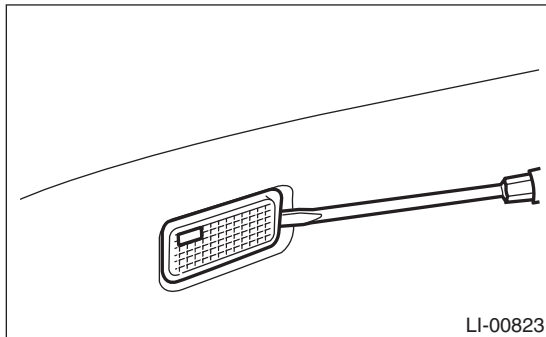

- 3) Disconnect the harness connector and remove the luggage room light.
- 4) Remove bulb (A).

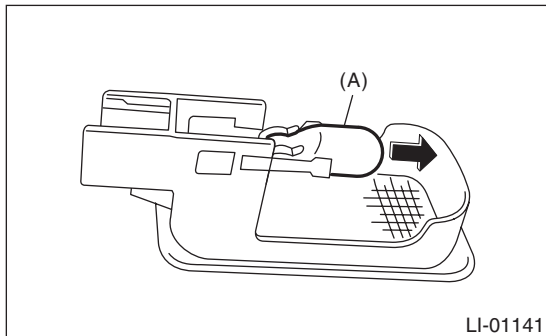

### B: INSTALLATION

Install each part in the reverse order of removal.

### C: INSPECTION

#### 1. LUGGAGE ROOM LIGHT BULB

- 1) Visually check the bulb for blow out.
- 2) Check the bulb specification. <Ref. to LI-2, SPECIFICATION, General Description.>
- 3) Replace the bulb if it is found defective.

#### 2. LUGGAGE ROOM LIGHT SWITCH

- 1) Remove the luggage room light.
- 2) Measure the resistance between luggage room light switch terminals.

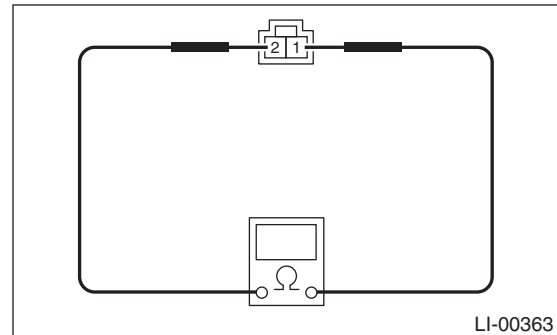

Switch position	Terminal No.	Standard value
OFF	1 and 2	1 MΩ or more
ON		Less than 1 Ω

- 3) Replace the luggage room light if the inspection result is not within the standard value.

# Trunk Room Light

## LIGHTING SYSTEM

---

### 30.Trunk Room Light

#### A: REMOVAL

- 1) Disconnect the ground cable from battery.
- 2) Turn the trunk room light counterclockwise 60° to remove it and disconnect the harness connector.

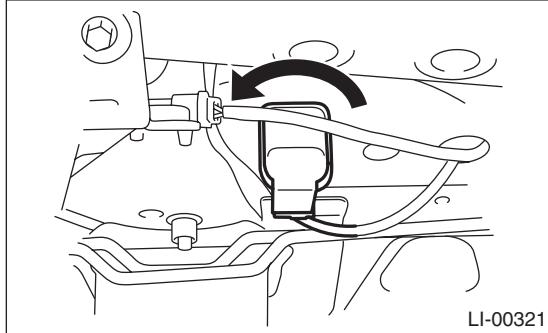

- 3) Remove bulb (A).

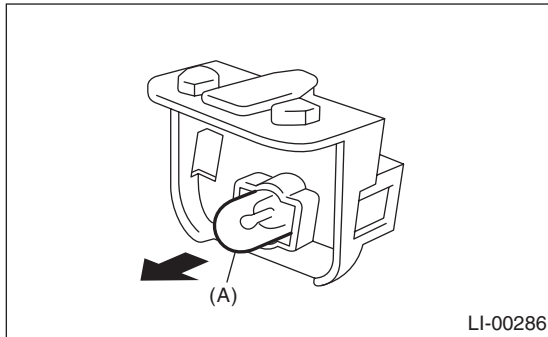

#### B: INSTALLATION

Install each part in the reverse order of removal.

#### C: INSPECTION

##### 1. TRUNK ROOM LIGHT BULB

- 1) Visually check the bulb for blow out.
- 2) Check the bulb specification. <Ref. to LI-2, SPECIFICATION, General Description.>
- 3) Replace the bulb if it is found defective.

## 31. Ignition Switch Illumination

### A: REMOVAL

- 1) Disconnect the ground cable from battery.
- 2) Remove the screws and remove the steering column cover lower.

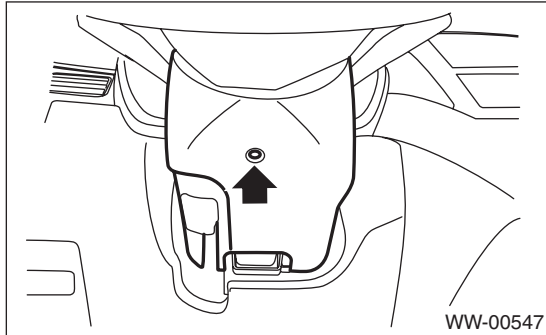

- 3) Remove the harness cover lock.
- 4) Remove the screws and detach the knee protector.

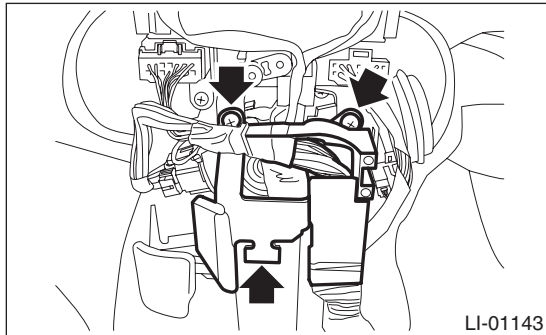

- 5) Remove the screws and remove the steering column cover upper.

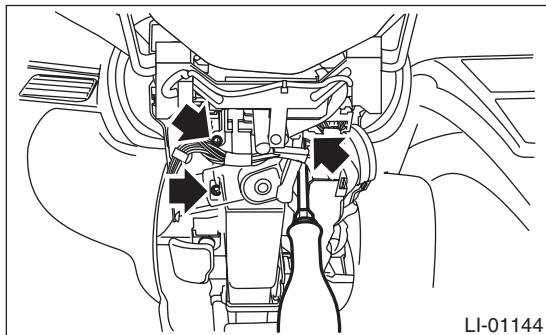

- 6) Remove the instrument panel lower cover. <Ref. to EI-49, REMOVAL, Instrument Panel Lower Cover.>
- 7) Disconnect the ignition switch illumination connector (A).

- 8) Turn the ignition switch illumination connector to the left and remove it.

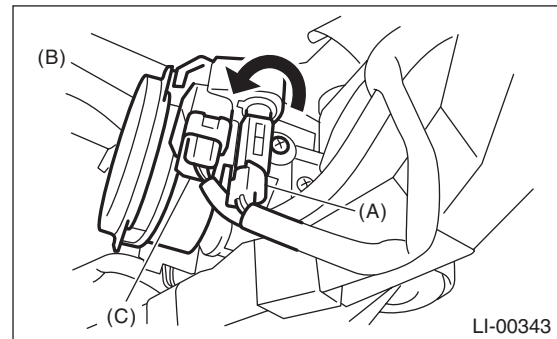

- (A) Ignition switch illumination connector
- (B) Ignition switch illumination
- (C) Immobilizer antenna connector

### B: INSTALLATION

Install each part in the reverse order of removal.



# Ignition Switch Illumination

LIGHTING SYSTEM

## C: INSPECTION

	Step	Check	Yes	No
1	<b>CHECK THE IGNITION SWITCH ILLUMINATION.</b> Make sure the ignition switch illumination illuminates when driver's side door is open.	Does the ignition switch illumination illuminate?	Ignition switch illumination is normal.	Go to step 2.
2	<b>CHECK THE IGNITION SWITCH ILLUMINATION.</b> Make sure the ignition switch illumination blinks when the ignition switch is turned to ON.	Does the ignition switch illumination blink?	Check the function setting of body integrated unit. <Ref. to LAN(diag)-2, Basic Diagnostic Procedure.>	Check the ignition switch illumination circuit. <Ref. to SL-25, CHECK IGNITION SWITCH ILLUMINATION, INSPECTION, Keyless Entry System.>

## 32. Day Time Running Resistor

### A: REMOVAL

- 1) Remove the front bumper face. <Ref. to EI-31, FRONT BUMPER FACE, REMOVAL, Front Bumper.>
- 2) Disconnect the harness connector.
- 3) Remove the bolt, and remove the daytime running resistor.

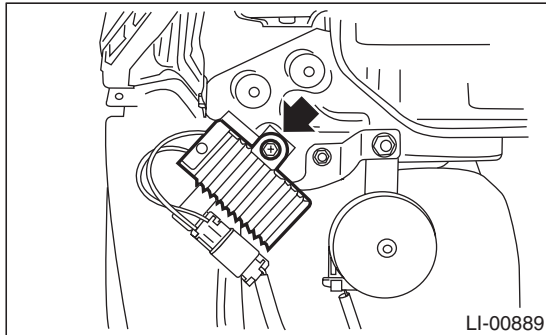

### B: INSTALLATION

- 1) Install each part in the reverse order of removal.

#### **Tightening torque:**

**7.5 N·m (0.76 kgf·m, 5.5 ft·lb)**

- 2) Adjust the fog light beam. (Model with fog light)  
<Ref. to LI-21, FOG LIGHT AIMING, ADJUSTMENT, Front Fog Light Assembly.>

# Reflex Reflector

LIGHTING SYSTEM

---

## 33. Reflex Reflector

### A: REMOVAL

Remove the reflex reflector by pressing the claw of the reflex reflector from the backside of bumper.

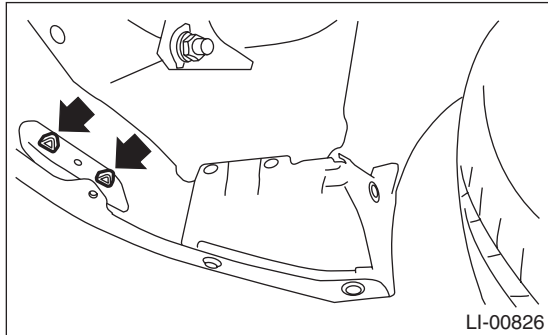

### B: INSTALLATION

Install each part in the reverse order of removal.

## 34. Door Switch

### A: REMOVAL

- 1) Disconnect the ground cable from battery.
- 2) Remove the screw, and pull out the door switch.

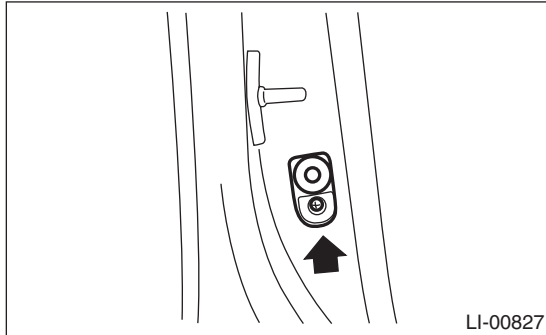

- 3) Disconnect the harness connector and remove the door switch.

### B: INSTALLATION

Install each part in the reverse order of removal.

### C: INSPECTION

Refer to the door switch inspection of the room light system. <Ref. to LI-10, DOOR SWITCH, INSPECTION, Room Light System.>

# Door Switch

LIGHTING SYSTEM

---

**LI-42**

Brought to you by Ebay Seller "SubaruManuals"

# WIPER AND WASHER SYSTEMS



---

	<b>Page</b>
1. General Description .....	2
2. Wiper and Washer System .....	6
3. Combination Switch (Wiper) .....	7
4. Wiper Blade .....	11
5. Washer Tank and Motor .....	14
6. Front Wiper Arm .....	15
7. Front Wiper Motor and Link .....	16
8. Front Washer Nozzle .....	18
9. Rear Wiper Arm .....	19
10. Rear Wiper Motor .....	20
11. Rear Washer .....	21

# General Description

## WIPER AND WASHER SYSTEMS

### 1. General Description

#### A: SPECIFICATION

Front wiper motor	Input	12 V — 72 W or less
Rear wiper motor	Input	12 V — 42 W or less
Front washer motor	Pump type	Centrifugal
	Input	12 V — 36 W or less
Rear washer motor	Pump type	Centrifugal
	Input	12 V — 36 W or less

#### B: COMPONENT

##### 1. FRONT WIPER

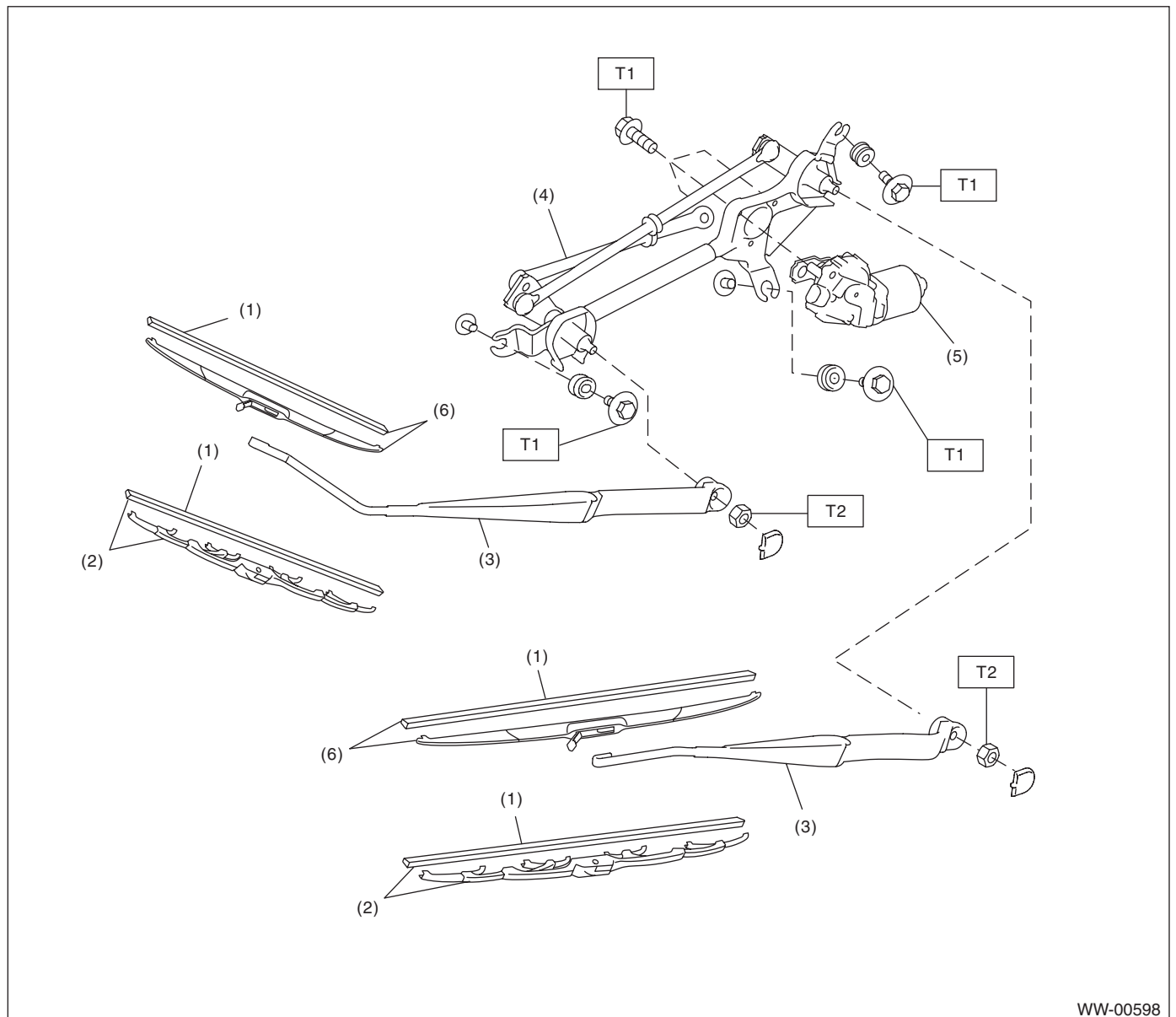

WW-00598

- |                               |                               |
|-------------------------------|-------------------------------|
| (1) Wiper rubber              | (4) Wiper link                |
| (2) Wiper blade ASSY (type A) | (5) Wiper motor               |
| (3) Wiper arm                 | (6) Wiper blade ASSY (type B) |

**Tightening torque: N·m (kgf·m, ft·lb)**

**T1: 6.0 (0.61, 4.4)**

**T2: 22 (2.24, 16.2)**

**WW-2**

Brought to you by Ebay Seller "SubaruManuals"

## 2. REAR WIPER

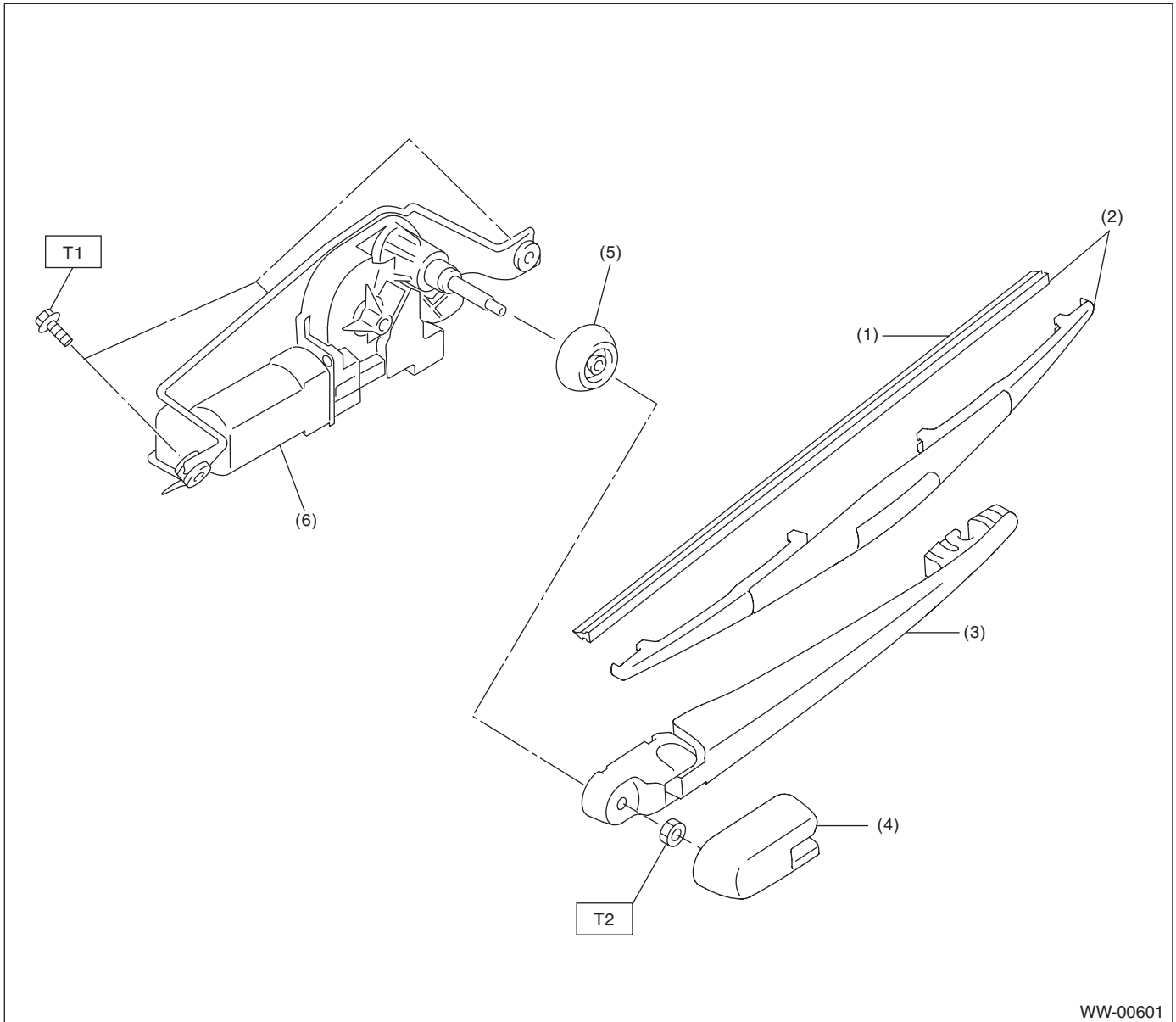

WW-00601

- (1) Wiper rubber
- (2) Wiper blade ASSY
- (3) Wiper arm

- (4) Wiper arm cover
- (5) Pivot cap
- (6) Wiper motor

**Tightening torque: N·m (kgf-m, ft-lb)**

**T1: 6.0 (0.61, 4.4)**

**T2: 8.0 (0.82, 5.9)**



# General Description

## WIPER AND WASHER SYSTEMS

### 3. WASHER TANK

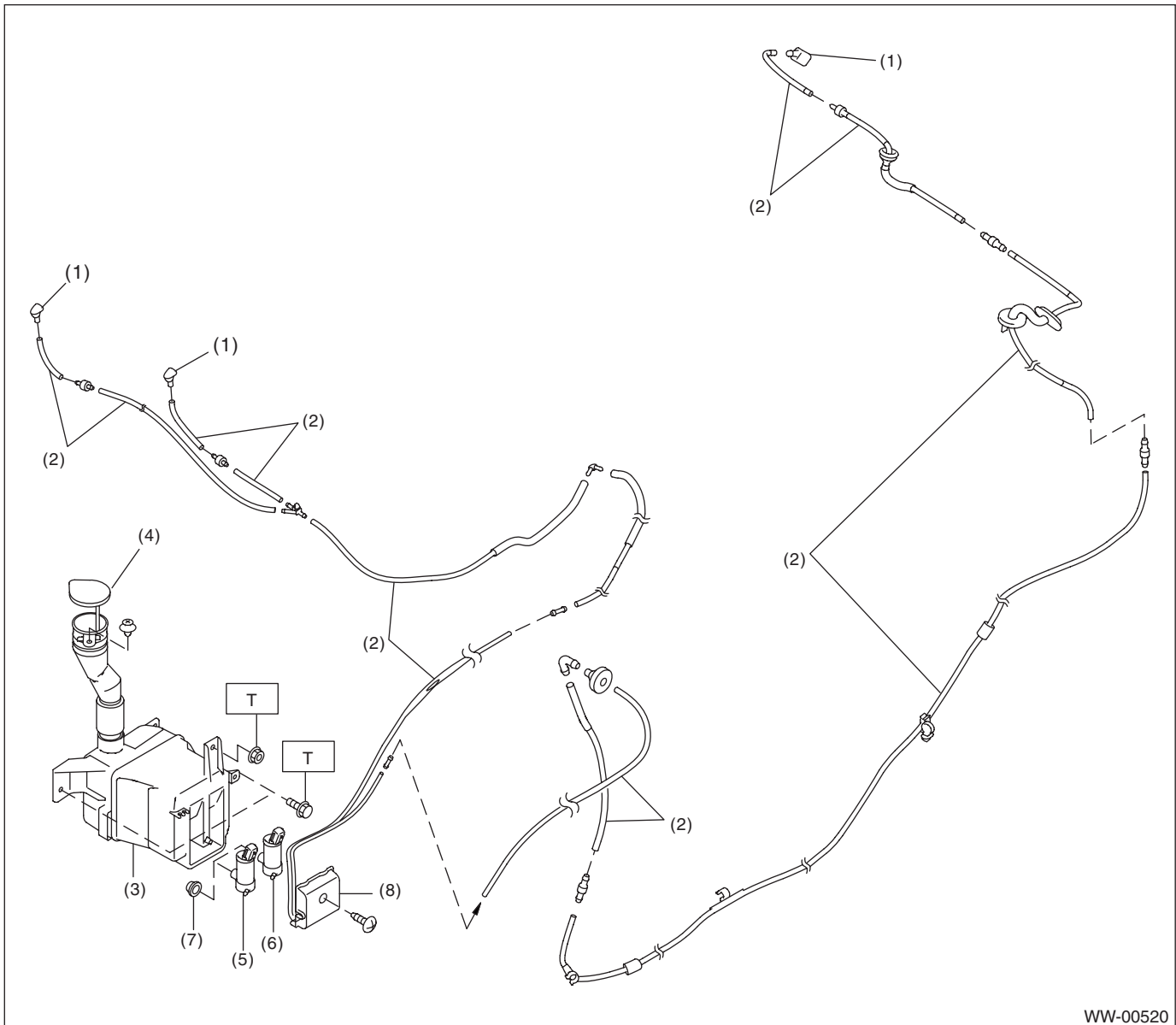

WW-00520

- |                                   |                        |
|-----------------------------------|------------------------|
| (1) Washer nozzle                 | (5) Front washer motor |
| (2) Washer hose                   | (6) Rear washer motor  |
| (3) Washer tank                   | (7) Grommet            |
| (4) Washer tank cap & level gauge | (8) Washer motor cover |

**Tightening torque: N·m (kgf·m, ft·lb)**

**T: 6.0 (0.61, 4.4)**

### C: CAUTION

- Connect the connectors and hoses securely during reassembly.
- After reassembly, make sure that the functional parts operate normally.
- Be careful with the airbag system wiring harness which passes near electrical parts and switches.
- Yellow connectors and harnesses with yellow tapes around them are the connectors and harnesses for the airbag system. Using a tester above such circuits may cause malfunction of airbag system. Follow the cautions for the airbag system in this case. <Ref. to AB-5, CAUTION, General Description.>
- Care must be taken when connecting the hose to the pipe so that no bending, jamming, etc. are caused.
- If even a small amount of silicon oil or grease enters tank and washer fluid passages, an oil film will be formed on the glass and will cause the wiper to chatter and judder. Make sure that no oil comes into contact with the system.

**WW-4**

Brought to you by Ebay Seller "SubaruManuals"

# General Description

WIPER AND WASHER SYSTEMS

## D: PREPARATION TOOL

### 1. SPECIAL TOOL

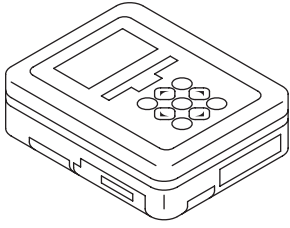
ILLUSTRATION	TOOL NUMBER	DESCRIPTION	REMARKS
 ST1B022XU0	1B022XU0	SUBARU SELECT MONITOR III KIT	Used for setting of each function and trouble-shooting for electrical system.

### 2. GENERAL TOOL

TOOL NAME	REMARKS
Circuit tester	Used for checking voltage and continuity.

# Wiper and Washer System

## WIPER AND WASHER SYSTEMS

## 2. Wiper and Washer System

### A: WIRING DIAGRAM

#### 1. WIPER AND WASHER (FRONT)

Refer to "Front Wiper and Washer System" in the wiring diagram. <Ref. to WI-109, WIRING DIAGRAM, Front Wiper and Washer System.>

#### 2. WIPER AND WASHER (REAR)

Refer to "Rear Wiper and Washer System" in the wiring diagram. <Ref. to WI-110, WIRING DIAGRAM, Rear Wiper and Washer System.>

### B: INSPECTION

Symptoms	Repair order
Wiper and washers do not operate.	1. Wiper fuse 2. Combination switch 3. Wiper motor assembly 4. Wiring harness
Wipers do not operate in LO or HI.	1. Combination switch 2. Wiper motor assembly 3. Wiring harness
Wipers do not operate in INT.	1. Combination switch 2. Wiper motor assembly 3. Wiring harness
Washer motor does not operate.	1. Washer switch 2. Washer motor 3. Wiring harness
Wipers do not operate when washer switch is ON.	1. Wiper motor assembly 2. Wiring harness
Washer fluid spray does not operate properly.	1. Washer motor 2. Washer hose and nozzle

### C: NOTE

For procedure of each component of the wiper and washer system, refer to the respective sections.

- Combination switch (Wiper): <Ref. to WW-7, Combination Switch (Wiper).>
- Wiper blade: <Ref. to WW-11, Wiper Blade.>
- Front wiper arm: <Ref. to WW-15, Front Wiper Arm.>
- Front wiper motor and link: <Ref. to WW-16, Front Wiper Motor and Link.>
- Rear wiper arm: <Ref. to WW-19, Rear Wiper Arm.>
- Rear wiper motor: <Ref. to WW-20, Rear Wiper Motor.>
- Washer tank and motor: <Ref. to WW-14, Washer Tank and Motor.>
- Front washer nozzle: <Ref. to WW-18, Front Washer Nozzle.>
- Rear washer nozzle: <Ref. to WW-21, Rear Washer.>

## 3. Combination Switch (Wiper)

### A: REMOVAL

- 1) Disconnect the ground cable from battery.
- 2) Remove the screws and remove the steering column cover lower.

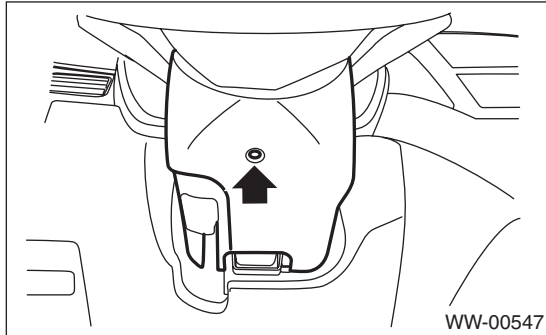

- 3) Remove the harness cover lock.
- 4) Remove the screws and detach the knee protector.

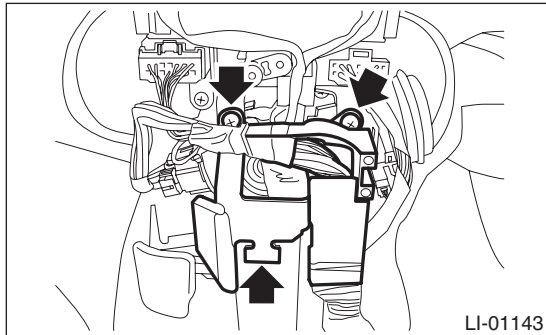

- 5) Remove the mounting screws of steering column cover upper.

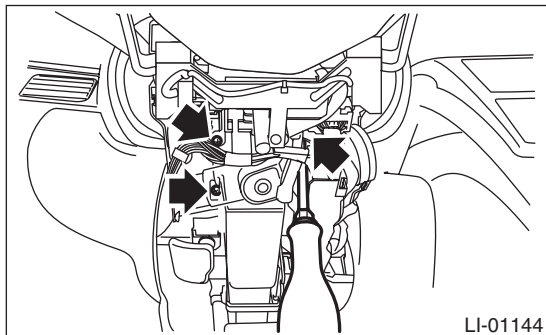

- 6) Disconnect the connector from wiper switch.

- 7) Remove the screws and then remove the wiper switch.

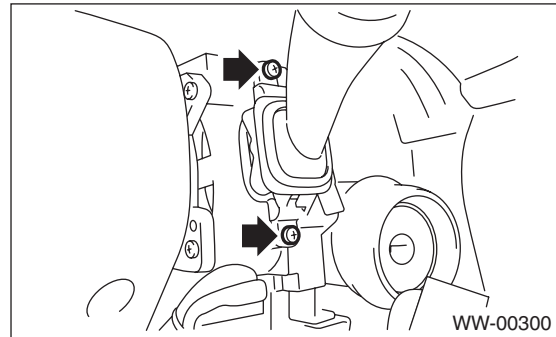

### B: INSTALLATION

Install each part in the reverse order of removal.

# Combination Switch (Wiper)

## WIPER AND WASHER SYSTEMS

### C: INSPECTION

- Inspect the continuity between each connector terminal.

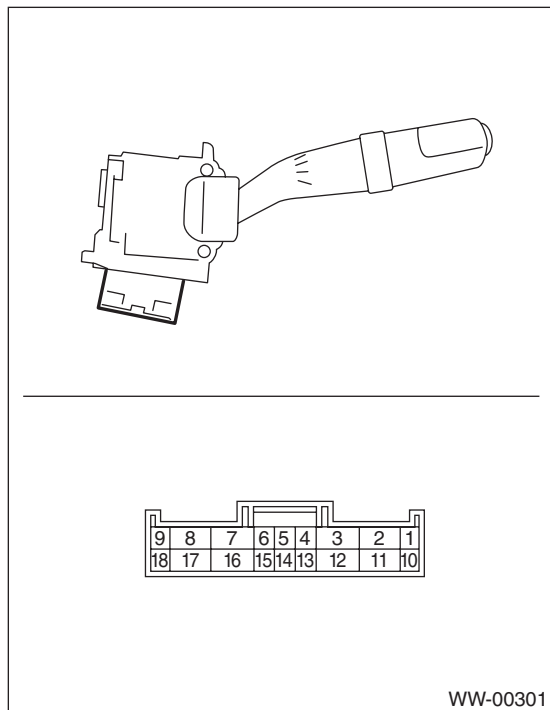

	Switch position	Terminal No.	Standard
Front	OFF	7 and 16	Less than 1 Ω
	INT	7 and 16	Less than 1 Ω
	LO	7 and 17	Less than 1 Ω
	HI	8 and 17	Less than 1 Ω
	Washer ON	2 and 11	Less than 1 Ω
Rear	OFF	2 and 10 10 and 12 2 and 12	1 MΩ or more
	INT	2 and 13	Less than 1 Ω
	ON	2 and 10	Less than 1 Ω
	Washer ON	2 and 12	Less than 1 Ω

Replace the switch if the inspection result is not within the standard value.

#### 1. FRONT WIPER

1) Check with Subaru Select Monitor

When the front wiper switch is operated, check the input signal using the Subaru Select Monitor.

- Prepare the Subaru Select Monitor kit.
- Turn the ignition switch to ON.
- On «System Selection Menu» display, select {Integ. unit mode}.
- Display the {Current Data Display & Save}, and select {Fr wiper input}.

(5) Check the input signal when the front wiper switch is set to LO or HI.

Does the input signal change between ON ←→ OFF correctly?

- Yes → Finish the diagnosis.
- No →
  - Check the harness.
  - Check the wiper motor.
  - Check ACC input voltage of body integrated unit.

#### Connector & terminal

**(B281) No. 5 (+) — Chassis ground (-):**

4. Replace the body integrated unit. <Ref. to SL-48, Body Integrated Unit.>

2) Check the intermittent operation (inspection of the wiper switch alone)

(1) Set the voltage meter between terminal No. 7 (+) and No. 2 (-).

(2) Connect the battery to connector. (terminal No. 17 (+), terminal No. 2 & 16 (-))

(3) Turn the front wiper switch to INT.

(4) Connect the battery (+) to the terminal No. 16 for 5 seconds.

(5) Connect the battery (-) to the terminal No. 16, and check the voltage between terminal No. 7 — No. 2 when performing the intermittent operation.

(6) Perform step (1) to (5) above when intermittent control switch is in MIN and MAX, and replace the switch if the operation is not as specified.

#### Intermittent stationary time

**MIN: Approx. 4 seconds**

**MAX: Approx. 19 seconds**

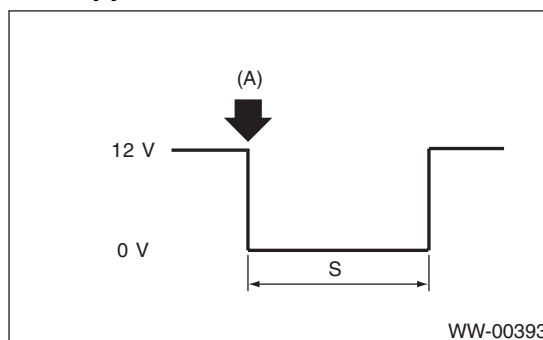

(A): Connect the battery (-) to the terminal No. 16.

S: Intermittent downtime (sec.)

# Combination Switch (Wiper)

## 2. REAR WIPER

### 1) Check with Subaru Select Monitor

	Step	Check	Yes	No
1	<b>CHECK INPUT OF REAR WIPER SWITCH.</b> Check the input from body integrated unit using the Subaru Select Monitor. 1) Prepare the Subaru Select Monitor kit. 2) Turn the ignition switch to ON. 3) On «System Selection Menu» display, select {Integ. unit mode}. 4) Select {Current Data Display & Save}. 5) Check the input of the rear wiper switch.	Is the input normal?	Go to step 4.	Go to step 2.
2	<b>CHECK HARNESS.</b> 1) Turn the ignition switch to OFF, disconnect the ground cable from battery. 2) Disconnect the connector of body integrated unit. 3) Disconnect the connector from wiper switch. 4) Measure the resistance between body integrated unit and wiper switch, and between wiper switch and chassis ground. <b>Connector &amp; terminal</b> <b>(B281) No. 18 — (B70) No. 10:</b> <b>(B281) No. 27 — (B70) No. 13:</b> <b>(B281) No. 28 — (B70) No. 12:</b> <b>(B70) No. 8 — Chassis ground:</b>	Is the resistance less than 10 Ω?	Go to step 3.	Repair the harness between body integrated unit and wiper switch, and between wiper switch and chassis ground.
3	<b>CHECK INPUT VOLTAGE OF BODY INTEGRATED UNIT.</b> 1) Connect the ground cable to battery. 2) Turn the ignition switch to ACC. 3) Check the input voltage of body integrated unit. <b>Connector &amp; terminal</b> <b>(B280) No. 7 (+) — Chassis ground (-):</b>	Is the voltage 10 V or more?	Go to step 4.	Check the harness and fuse.
4	<b>CHECK OUTPUT OF BODY INTEGRATED UNIT.</b> When the rear wiper switch is operated, check the output using the Subaru Select Monitor. 1) Turn the ignition switch to ON. 2) Operate the rear wiper switch and set to each position of ON and INT. 3) At this time, check the body integrated unit output.	When set to ON, is ON output continuous? When set to INT, is ON/OFF output repeated? (4 door model: INT OFF time (when vehicle parked): 3 seconds; 5 door model: INT OFF time (when vehicle parked): 12 seconds)	Check the rear wiper motor circuit.	Replace the body integrated unit. <Ref. to SL-48, Body Integrated Unit.>

# Combination Switch (Wiper)

## WIPER AND WASHER SYSTEMS

### 2) Check rear wiper motor circuit

Step	Check	Yes	No
<b>1 CHECK POWER SUPPLY CIRCUIT OF THE REAR WIPER MOTOR.</b> 1) Disconnect the harness connector of the rear wiper motor. 2) Turn the ignition switch to ACC. 3) Measure the voltage between the rear wiper motor harness connector terminal and chassis ground. <b>Connector &amp; terminal</b> <b>(D43) No. 3 (+) — Chassis ground (-):</b>	Is the voltage 10 V or more?	Go to step 2.	<ul style="list-style-type: none"> <li>• Check the fuse (No. 23 in fuse &amp; relay box).</li> <li>• Check the fusible link (No. 7 in main fuse box).</li> </ul>
<b>2 CHECK GROUND CIRCUIT OF REAR WIPER MOTOR.</b> 1) Turn the ignition switch to OFF. 2) Measure the resistance between the rear wiper motor harness connector terminal and chassis ground. <b>Connector &amp; terminal</b> <b>(D43) No. 4 — Chassis ground:</b>	Is the resistance less than 10 $\Omega$ ?	Go to step 3.	Repair the open circuit of the rear wiper motor ground circuit.
<b>3 CHECK HARNESS BETWEEN BODY INTEGRATED UNIT AND REAR WIPER MOTOR.</b> 1) Turn the ignition switch to OFF. 2) Disconnect the harness connector of body integrated unit. 3) Disconnect the harness connector of the rear wiper motor. 4) Measure the resistance between the harness connector terminals of the body integrated unit and rear wiper motor. <b>Connector &amp; terminal</b> <b>(B279) No. 8 — (D43) No. 1:</b> <b>(B279) No. 9 — (D43) No. 2:</b>	Is the resistance less than 10 $\Omega$ ?	Go to step 4.	Repair the open circuit of the harness between body integrated unit and rear wiper motor.
<b>4 CHECK INPUT VOLTAGE OF BODY INTEGRATED UNIT.</b> 1) Turn the ignition switch to ACC. 2) Check the input voltage of body integrated unit. <b>Connector &amp; terminal</b> <b>(B279) No. 21 (+) — Chassis ground (-):</b>	Is the voltage 10 V or more?	Go to step 5.	Check the harness and fuse.
<b>5 CHECK OUTPUT OF BODY INTEGRATED UNIT.</b> 1) Connect the harness connector of body integrated unit. 2) Disconnect the connector of the rear wiper motor. 3) Turn the ignition switch to ACC. 4) Measure the voltage between rear wiper motor connector and chassis ground. <b>Connector &amp; terminal</b> <b>(D43) No. 2 (+) — Chassis ground (-):</b>	Is the voltage less than 1.5 V when the rear wiper switch is OFF, and is the voltage 10 V or more when the rear wiper switch is ON?	Go to step 6.	Replace the body integrated unit. <Ref. to SL-48, Body Integrated Unit.>
<b>6 CHECK OPERATION OF REAR WIPER MOTOR.</b> 1) Remove the rear wiper motor. 2) Check the rear wiper motor. <Ref. to WW-20, INSPECTION, Rear Wiper Motor.>	Does the rear wiper motor rotate normally?	End.	Replace the rear wiper motor.

## 4. Wiper Blade

### A: REMOVAL

#### 1. FRONT

##### Type A

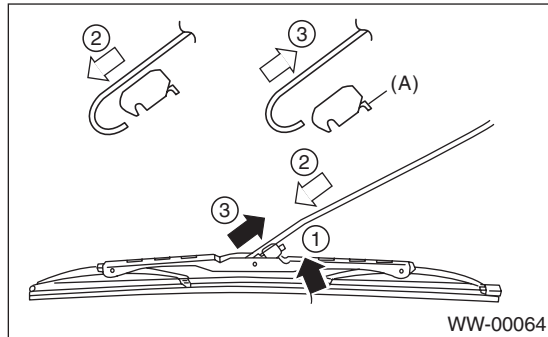

- 1) While pushing the locking clip (A), push in the arm to the blade assembly side. (arrow mark 2)
- 2) Pull the arm while lifting the arm (arrow mark 3), and then remove the blade assembly from the arm.

##### Type B

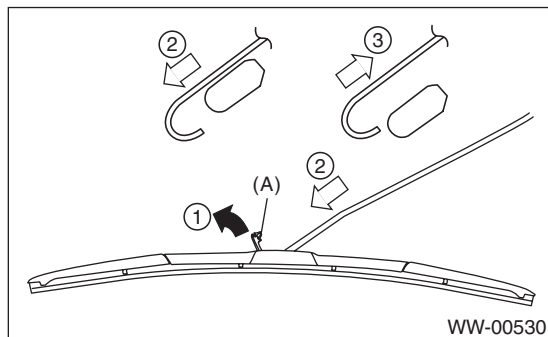

- 1) Pull up the locking clip (A) and then push the arm to blade assembly side. (arrow mark 2)
- 2) Pull the arm while lifting the arm (arrow mark 3), and then remove the blade assembly from the arm.

#### 2. REAR

Turn the blade in the direction of arrow (A) and remove it from arm.

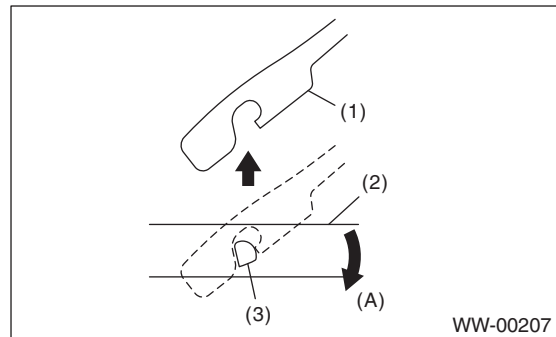

(A) Turn the wiper blade.

- (1) Wiper arm
- (2) Wiper blade
- (3) Wiper blade attachment section

### B: INSTALLATION

- 1) Install each part in the reverse order of removal.
- 2) Confirm that the clip is locked securely.

### C: DISASSEMBLY

#### 1. FRONT

Pull side (A) of the wiper rubber stopper and remove the rubber from the blade assembly.

- Type A

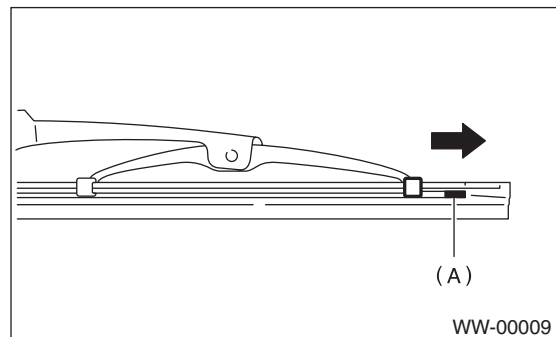

- Type B

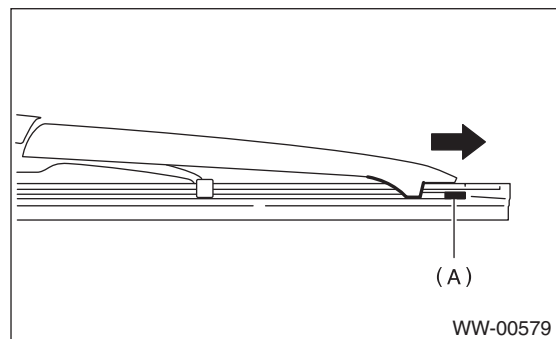



# Wiper Blade

## WIPER AND WASHER SYSTEMS

### 2. REAR

Pull the wiper rubber top slightly from stopper (A) and pull out completely.

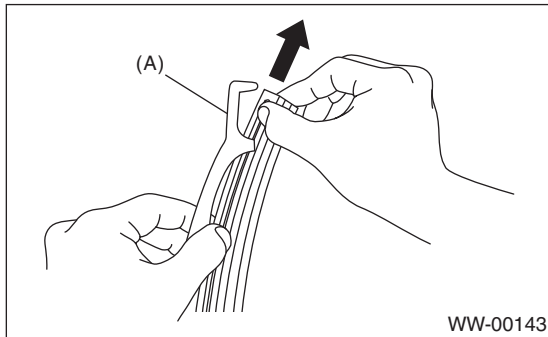

### D: ASSEMBLY

#### 1. FRONT

1) Insert the wiper rubber onto the blade so that the stopper is in the position shown in the figure.

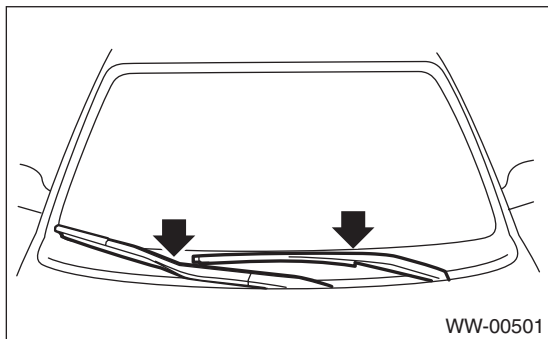

2) Make sure the wiper rubber is securely fastened to the pull stopper (A).

- Type A

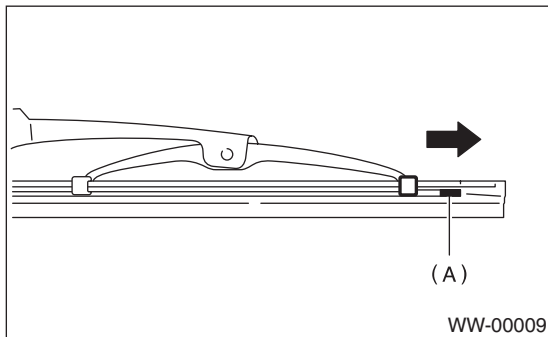

- Type B

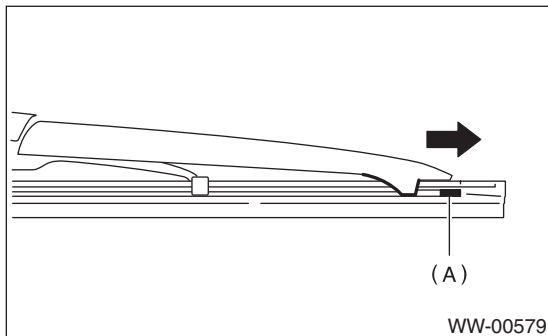

### 2. REAR

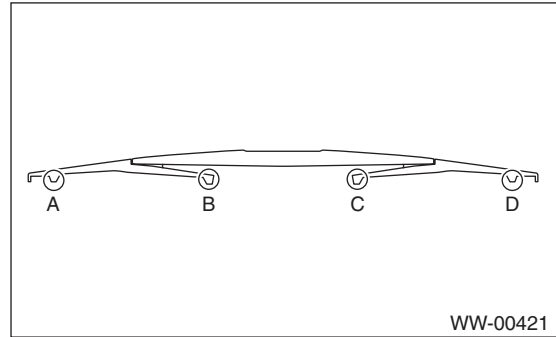

1) Insert the wiper rubber into claw (B).

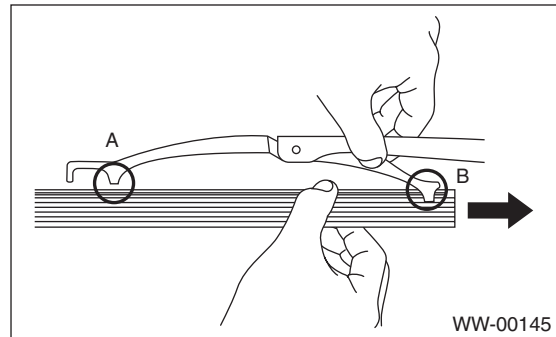

2) Insert the wiper rubber until its top end protrudes approx. 20 mm (0.79 in) from stopper (D).

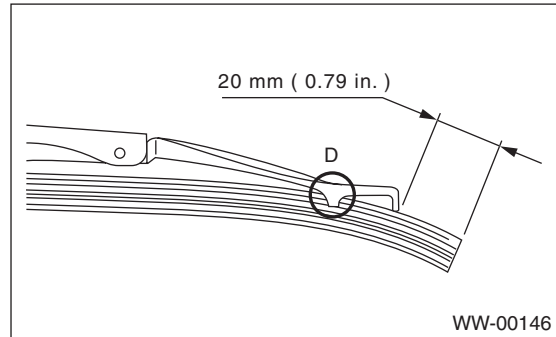

3) Insert the wiper rubber into claw (A).

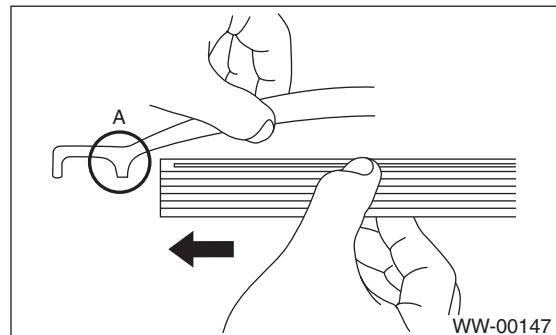

## **E: INSPECTION**

1) When the wiper does not operate properly, inspect the following item.

- Make sure the movable part of blade assembly moves smoothly.
- Make sure the wiper rubber is not deformed or damaged.

2) Replace with a new part if damage is found.

# Washer Tank and Motor

## WIPER AND WASHER SYSTEMS

### 5. Washer Tank and Motor

#### A: REMOVAL

- 1) Open the front hood.
- 2) Disconnect the ground cable from battery.
- 3) Remove the front bumper face. <Ref. to EI-31, FRONT BUMPER FACE, REMOVAL, Front Bumper.>
- 4) Remove the duct clip.

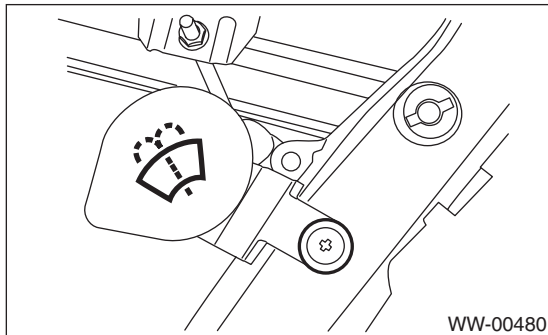

- 5) Disconnect the connector.

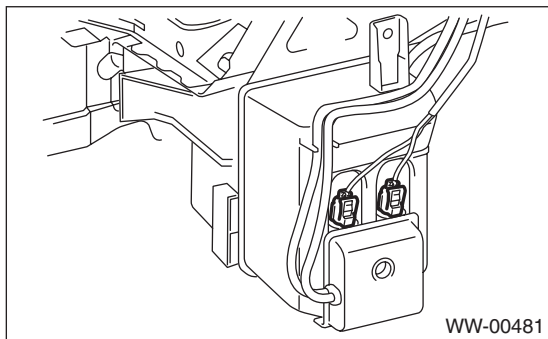

- 6) Remove the screws and detach the cover.

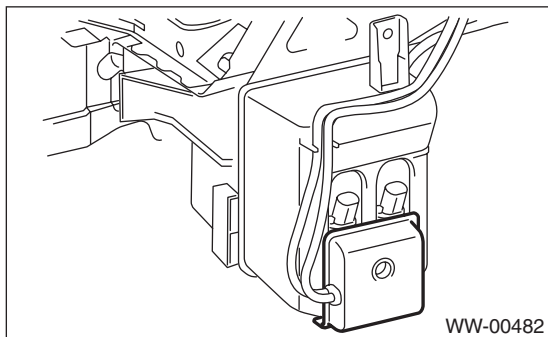

- 7) Disconnect the hoses.

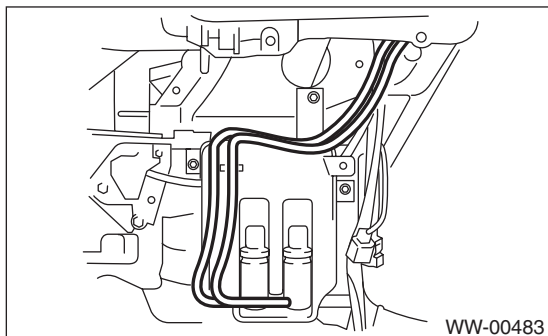

- 8) Remove the bolts and nuts and remove the washer tank.

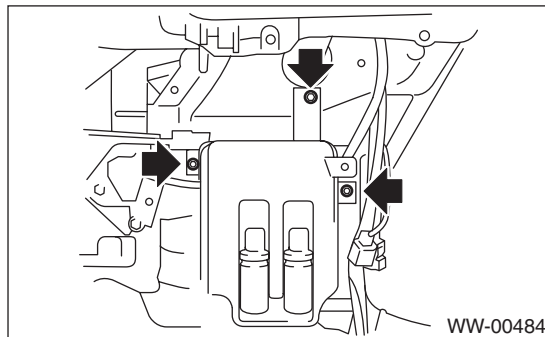

#### B: INSTALLATION

Install each part in the reverse order of removal.

#### Tightening torque:

**6.0 N-m (0.61 kgf-m, 4.4 ft-lb)**

#### C: DISASSEMBLY

Pull out the washer motor from the tank.

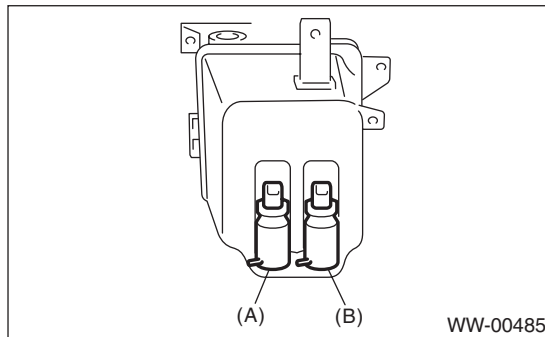

- (A) Front
- (B) Rear

#### D: ASSEMBLY

- 1) Assemble each part in the reverse order of disassembly.
- 2) Confirm that water does not leak from installation area of motor.

#### E: INSPECTION

Apply battery voltage to the connector terminal of the washer motor and make sure the motor operates.

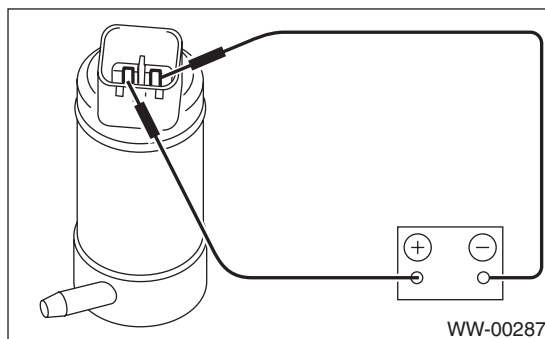

## 6. Front Wiper Arm

### A: REMOVAL

- 1) Open the front hood.
- 2) Remove the cap.
- 3) Remove the nut and remove the arm.

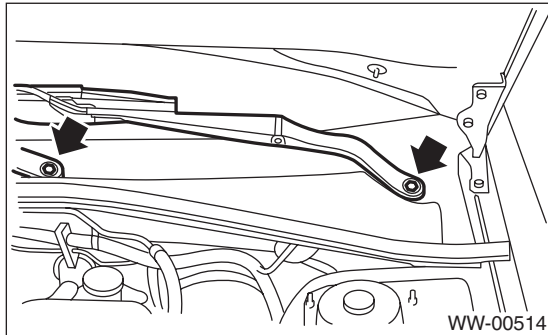

### B: INSTALLATION

- 1) Install each part in the reverse order of removal.
- 2) Operate the wiper once.
- 3) Align the wiper blade to ceramic print point mark (A) of front window panel.

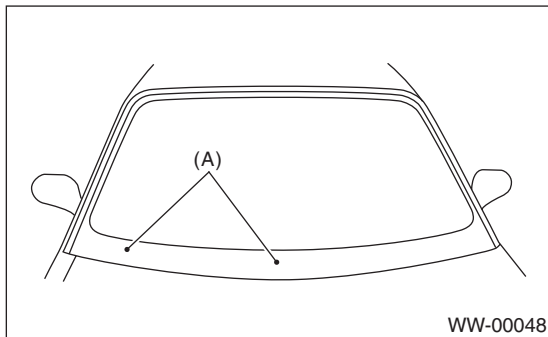

#### **Tightening torque:**

Refer to "COMPONENT" of "General Description". <Ref. to WW-2, FRONT WIPER, COMPONENT, General Description.>

### C: ADJUSTMENT

Operate the wiper once. Align the wiper blade to ceramic print point mark (A) of front window panel.

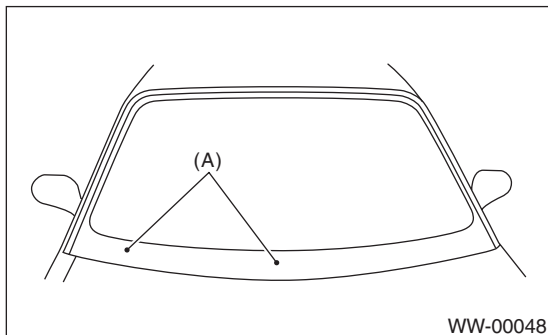

# Front Wiper Motor and Link

## WIPER AND WASHER SYSTEMS

### 7. Front Wiper Motor and Link

#### A: REMOVAL

- 1) Disconnect the ground cable from the battery.
- 2) Remove the cowl panel. <Ref. to EI-40, REMOVAL, Cowl Panel.>
- 3) Disconnect the connector of motor.
- 4) Remove the bolt, and then remove the wiper link.

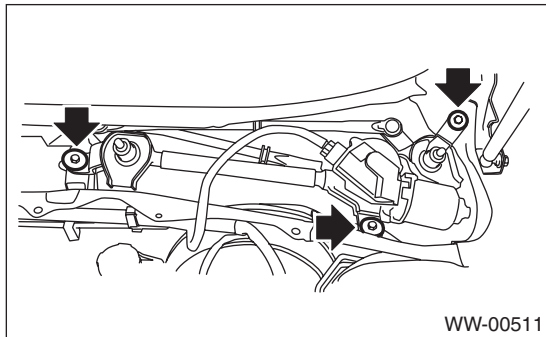

- 5) Remove the bolts and nuts and remove the motor.

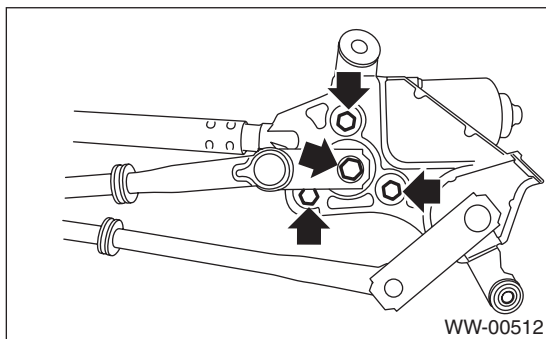

#### B: INSTALLATION

- 1) Connect the battery ground terminal.
- 2) To confirm that the motor is at the auto stop position, connect the harness to the motor and turn the wiper switch to ON/OFF once.
- 3) Disconnect the ground cable from battery.
- 4) Tighten the nut where rod (A) and link plate (B) is aligned in a straight line.

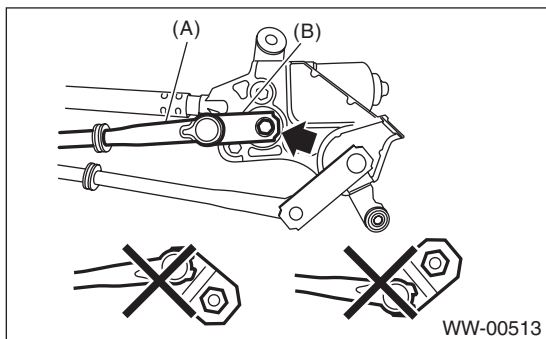

- 5) Install each part in the reverse order of removal.

#### Tightening torque:

Refer to "COMPONENT" of "General Description". <Ref. to WW-2, FRONT WIPER, COMPONENT, General Description.>

#### C: INSPECTION

- 1) When the battery is connected to the terminal of connectors as shown in the figure, confirm that the motor operates at low speed.

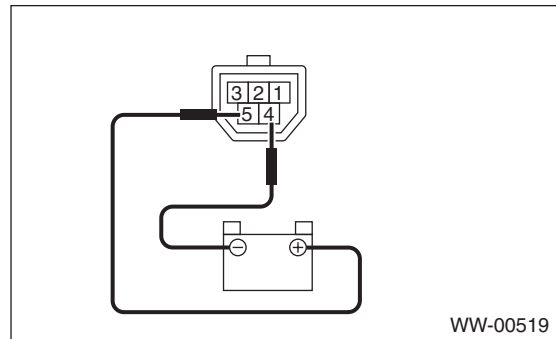

- 2) When the battery is connected to the terminal of connectors as shown in the figure, confirm that the wiper motor operates at high speed.

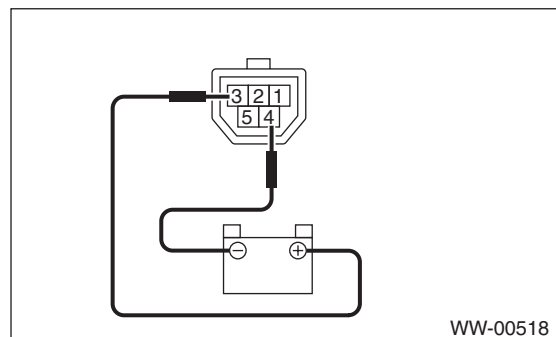

- 3) Connect the battery to terminals of the connector, and remove the terminal connection with motor rotating at low speed, and stop the wiper motor in mid-operation.

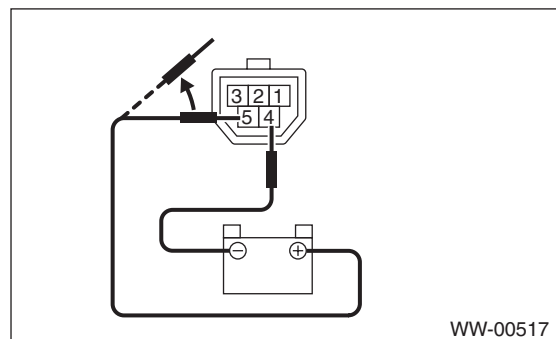

## Front Wiper Motor and Link

4) Connect the battery and confirm that the motor stops at the automatic stop position after the motor operates at low speed again.

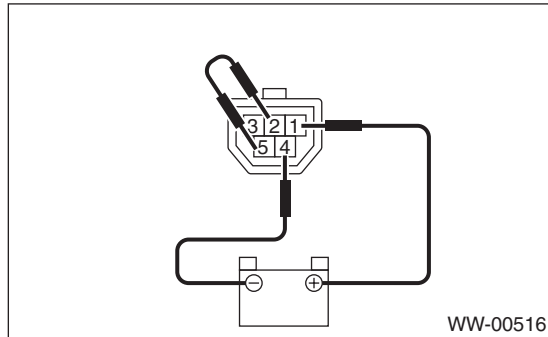

# Front Washer Nozzle

## WIPER AND WASHER SYSTEMS

### 8. Front Washer Nozzle

#### A: REMOVAL

- 1) Remove the washer hose from the washer nozzle.
- 2) Open the clips on the underside of the front hood with a thin screwdriver or other tool, and remove the washer nozzle.

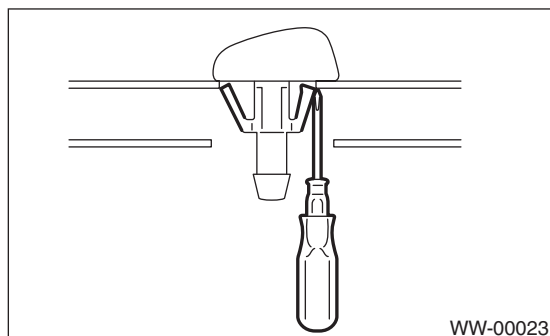

#### B: INSTALLATION

Install each part in the reverse order of removal.

#### C: INSPECTION

##### 1. VISUAL CHECK

Check the following items, if a failure is found replace the parts.

- Make sure the nozzle and hose are not clogged.
- Make sure the hose is not bent.

##### 2. SPRAY POSITION CHECK

- 1) Turn the wiper switch to OFF position.
- 2) While the vehicle is at a standstill, make sure that the washer injection position is as shown in the figure.
- 3) After check, if the spray position is largely different from the position, replace with a new washer nozzle.

##### **Spray position:**

**A: 250 mm (9.84 in)**

**B: 315 mm (12.4 in)**

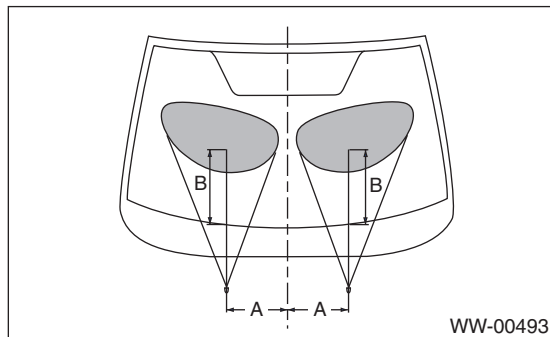

## 9. Rear Wiper Arm

### A: REMOVAL

- 1) Detach the wiper arm cover (A).

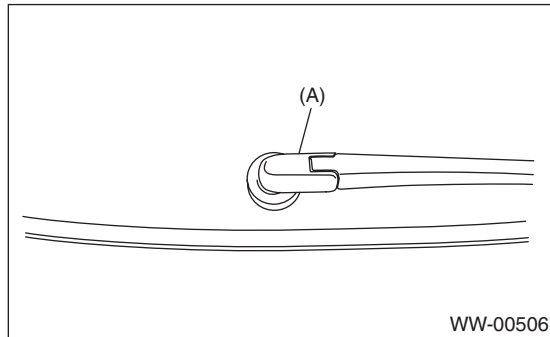

- 2) Remove the nut and remove the wiper arm.

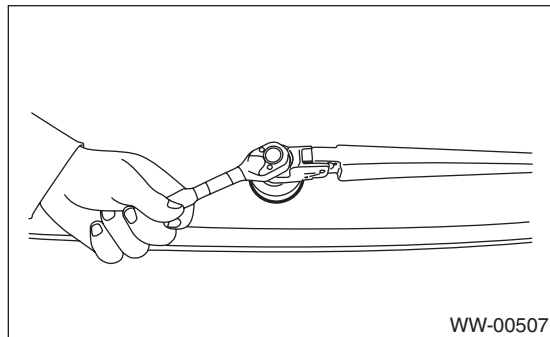

### B: INSTALLATION

- 1) Install each part in the reverse order of removal.
- 2) Operate the rear wiper once.
- 3) Align the blade with the marking (A) of the glass.

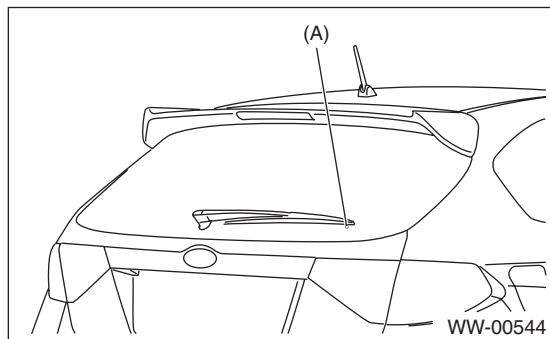

#### Tightening torque:

Refer to "COMPONENT" of "General Description". <Ref. to WW-3, REAR WIPER, COMPONENT, General Description.>

### C: ADJUSTMENT

- 1) Operate the rear wiper once.
- 2) Align the blade with the marking (A) of the glass.

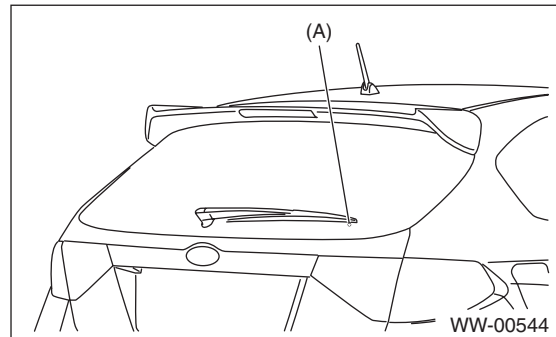



# Rear Wiper Motor

## WIPER AND WASHER SYSTEMS

### 10. Rear Wiper Motor

#### A: REMOVAL

- 1) Disconnect the ground cable from the battery.
- 2) Remove the rear wiper arm. <Ref. to WW-19, REMOVAL, Rear Wiper Arm.>
- 3) Remove the rear gate lower trim. <Ref. to EI-69, REMOVAL, Rear Gate Trim.>
- 4) Disconnect the harness connector of wiper motor assembly.
- 5) Remove the bolt, and then remove the wiper motor assembly.

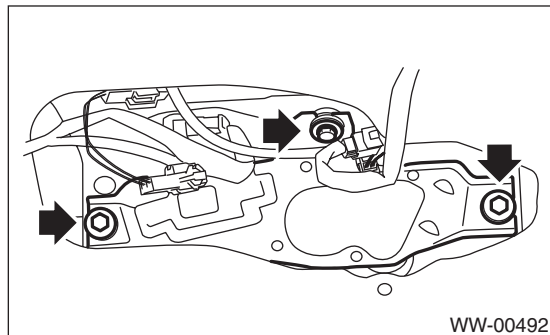

#### B: INSTALLATION

- 1) Install each part in the reverse order of removal.
- 2) Make sure that the pivot cap with the round mark facing up, as shown in the figure.

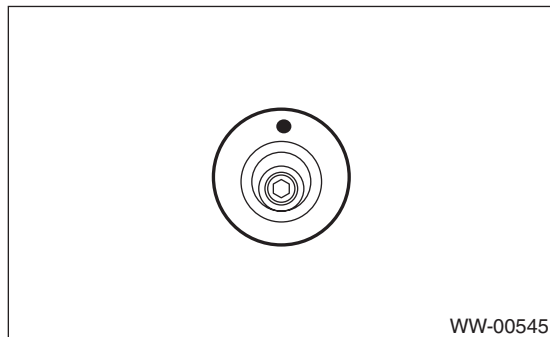

#### Tightening torque:

Refer to "COMPONENT" of "General Description". <Ref. to WW-3, REAR WIPER, COMPONENT, General Description.>

#### C: INSPECTION

- 1) Connect the battery to the wiper motor connector and confirm that wiper motor operates.

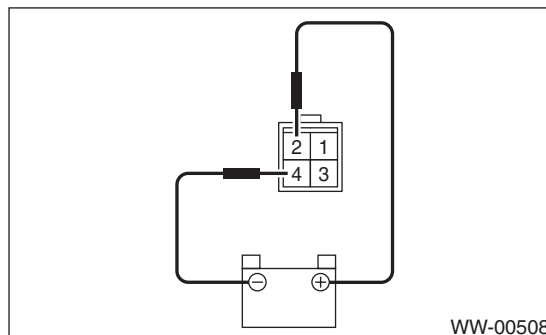

- 2) Connect the battery to terminals of the connector, and remove the terminal connection with motor rotating, and stop the wiper motor in mid-operation.

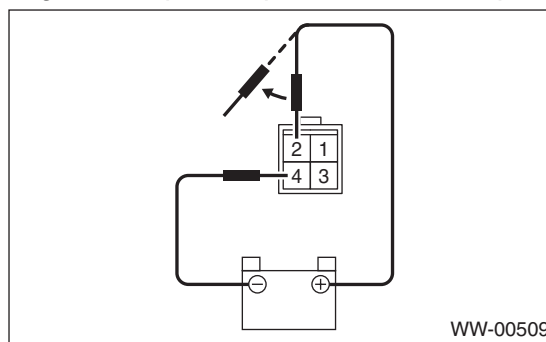

- 3) Connect the battery and confirm that the motor stops at the automatic stop position after the motor operates at low speed again.

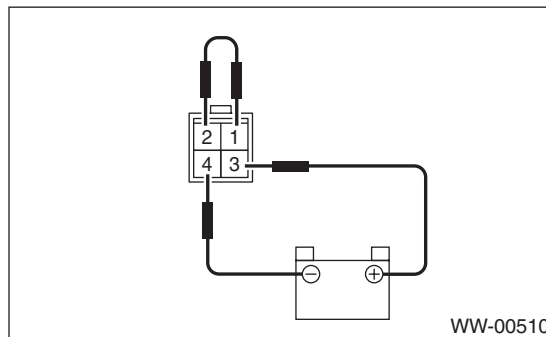

## 11.Rear Washer

### A: REMOVAL

- 1) Remove the high-mounted stop light. <Ref. to LI-32, REMOVAL, High-mounted Stop Light.>
- 2) Remove the washer hose from the washer nozzle.
- 3) Push the claw of the nozzle from the reverse side of roof spoiler with a flat tip screwdriver or equivalent, and remove the washer nozzle.

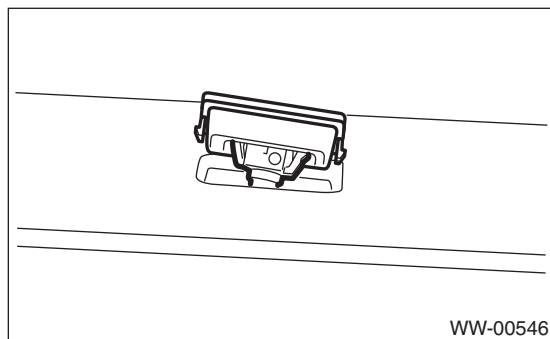

### B: INSTALLATION

Install each part in the reverse order of removal.

### C: INSPECTION

#### 1. VISUAL CHECK

Check the following items, if a failure is found replace the parts.

- Make sure the nozzle and hose are not clogged.
- Make sure the hose is not bent.

#### 2. SPRAY POSITION CHECK

- 1) Turn the wiper switch to OFF position.
- 2) While the vehicle is at a standstill, make sure that the washer injection position is as shown in the figure.
- 3) After check, if the spray position is largely different from the position, replace with a new washer nozzle.

#### **Spray position:**

**A: 140 mm (5.5 in)**

**B: 70°**

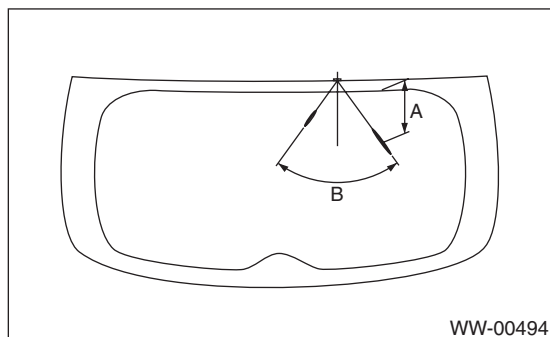

# Rear Washer

WIPER AND WASHER SYSTEMS

---

**WW-22**

Brought to you by Ebay Seller "SubaruManuals"

# ENTERTAINMENT

# *ET*

---

	<b>Page</b>
1. General Description .....	2
2. Audio System .....	3
3. Navigation System .....	4
4. Audio .....	6
5. Front Speaker .....	7
6. Tweeter .....	8
7. Rear Speaker .....	9
8. Antenna .....	10
9. Steering Satellite Switch .....	11
10. Steering Switch .....	13
11. Navigation Body .....	14
12. GPS Antenna .....	15
13. Front Accessory Power Supply Socket .....	16
14. Rear Accessory Power Supply Socket .....	17
15. AUX Input Terminal .....	18
16. Microphone .....	19

# General Description

ENTERTAINMENT

---

## 1. General Description

### A: CAUTION

- Before disassembling or reassembling parts, always disconnect the battery ground cable from battery. When replacing the audio, control module and other parts provided with memory functions, record the memory contents before disconnecting the battery ground cable. Otherwise, the memory is cleared.
- Reassemble the parts in the reverse order of disassembly procedure unless otherwise indicated.
- Adjust parts to the given specifications.
- Connect the connectors securely during reassembly.
- After reassembly, make sure that the functional parts operate normally.

### B: PREPARATION TOOL

#### 1. GENERAL TOOL

TOOL NAME	REMARKS
Circuit tester	Used for measuring resistance and voltage.

## 2. Audio System

### A: WIRING DIAGRAM

#### 1. AUDIO

Refer to "Audio System" in the wiring diagram. <Ref. to WI-113, WIRING DIAGRAM, Audio System.>

### B: INSPECTION

Symptom	Repair order
No power coming in. (No display and no sound from speakers)	<ol style="list-style-type: none"> <li>1. Check the fuse and power supply for audio.</li> <li>2. Check the audio ground.</li> <li>3. Remove the audio for repair.</li> </ol>
A specific speaker does not operate.	<ol style="list-style-type: none"> <li>1. Check the speaker.</li> <li>2. Check the output circuit between audio and speaker.</li> </ol>
Audio generates noise with engine is running.	<ol style="list-style-type: none"> <li>1. Check the audio ground.</li> <li>2. Check the generator.</li> <li>3. Check the ignition coil.</li> <li>4. Remove the audio for repair.</li> </ol>
Volume is low in AM and FM modes or interference noise occurs.	<ol style="list-style-type: none"> <li>1. Check the antenna.</li> <li>2. Check the audio ground.</li> <li>3. Remove the audio for repair.</li> </ol>

### C: NOTE

For procedure of each component in the audio system, refer to the respective sections.

- Audio unit: <Ref. to ET-6, Audio.>
- Front speaker: <Ref. to ET-7, Front Speaker.>
- Tweeter: <Ref. to ET-8, Tweeter.>
- Rear speaker: <Ref. to ET-9, Rear Speaker.>
- Antenna: <Ref. to ET-10, Antenna.>
- Steering satellite switch: <Ref. to ET-11, Steering Satellite Switch.>
- Steering switch: <Ref. to ET-13, Steering Switch.>
- AUX input terminal: <Ref. to ET-18, AUX Input Terminal.>
- Microphone: <Ref. to ET-19, Microphone.>

## 3. Navigation System

### A: WIRING DIAGRAM

Refer to "Navigation System" in the wiring diagram. <Ref. to WI-123, WIRING DIAGRAM, Navigation System.>

### B: INSPECTION

**NOTE:**

If no problems are found in "CHECK NAVIGATION OPERATION", "CHECK CONNECTION" and "CHECK EACH VEHICLE SIGNAL" as described below, check the navigation system circuit. <Ref. to WI-123, WIRING DIAGRAM, Navigation System.>

#### 1. CHECK THE OPERATION OF THE NAVIGATION

Start the engine, and then inspect that the opening screen is displayed.

Standard value: The opening screen should be displayed.

OK: Normal

NG: If the screen is not displayed, check that the map disc is inserted correctly. Or, check the connection of the power supply connector at the backside of the navigation unit. If there are no problems in the connecting lines or the lines were repaired, check that the opening screen is displayed.

At this point, if the display is not viewable, the unit is defective.

#### 2. CHECK EACH CONNECTION

1) With the main power OFF, press and hold the button (c) for 3 seconds or more while pressing the buttons (a) and (b) simultaneously.

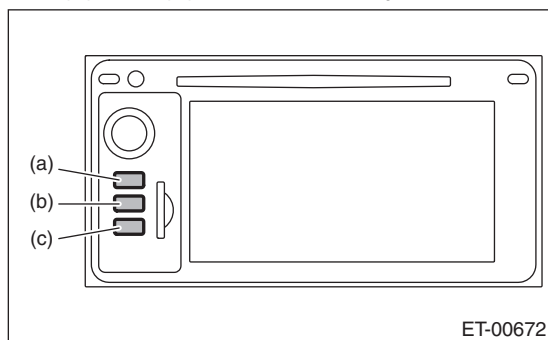

ET-00672

**NOTE:**

Pressing the button (a) for 3 seconds or more, or turning the ignition switch from ACC OFF to ON position can exit the diagnostic mode.

2) Line Diag screen is displayed.

3) Check the connection status for each item listed in "Connectivity Check" displayed on the left of the screen.

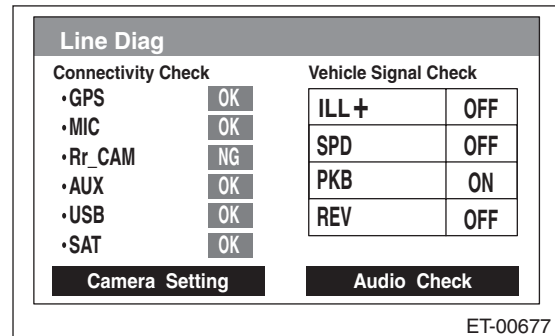

ET-00677

OK: Each connection device is connected properly.  
NG: No connection or abnormal connection is detected.

4) Check the connection status of the connector. If there are no problems, the connection device or unit could be faulty.

#### 3. CHECK EACH VEHICLE SIGNAL

1) With the main power OFF, press and hold the button (c) for 3 seconds or more while pressing the buttons (a) and (b) simultaneously.

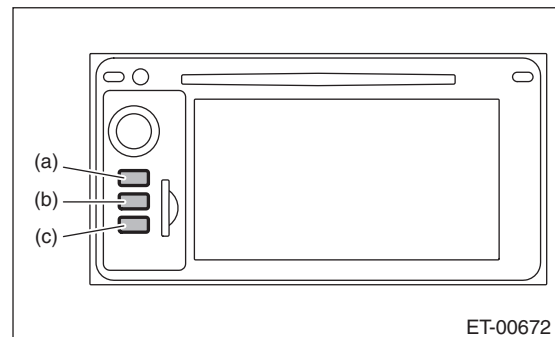

ET-00672

**NOTE:**

Pressing the button (a) for 3 seconds or more, or turning the ignition switch from ACC OFF to ON position can exit the diagnostic mode.

2) Line Diag screen is displayed.

3) Check the connection status for each item listed in "Vehicle Signal Check" displayed on the right of the screen.

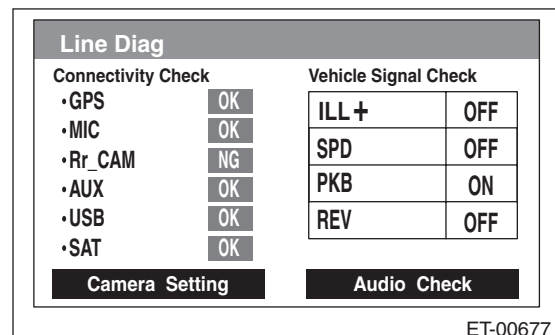

ET-00677

## • CHECK ILLUMINATION

### NOTE:

Before starting inspections, turn the ignition switch to ON.

1) Turn the lighting switch to level 1.

Make sure that the bright switch is not turned ON at this time.

2) Make sure that "ON" lights in ILL+ and then the screen becomes dim.

ON: Normal.

OFF: Abnormal. Check the signal line connector. If there are no problems, the unit could be faulty.

## • CHECK SPEED SENSOR

### NOTE:

- Before starting inspections, check the safety around the vehicle.

- Lift up the vehicle as necessary.

- When the diagnostic trouble code is input in the VDCCM, perform the Clear Memory operation.

1) Drive the vehicle at 9 km/h (6 mph) or more.

2) Check that "ON" is displayed in SPD.

ON: Normal.

OFF: Vehicle speed is less than 7 km/h (4 mph), or malfunction is detected in the signal line. Check the signal line connector. If there are no problems, the unit could be faulty.

## • CHECK PARKING BRAKE SIGNAL

1) Pull parking brake lever.

2) Check that "ON" is displayed in PKB.

ON: Normal.

OFF: Abnormal. Check the signal line connector. If there are no problems, the unit could be faulty.

## • CHECK BACK SENSOR

### NOTE:

Before starting inspections, check the safety around the rear end of the vehicle and then turn the ignition switch to ON.

1) Pull the parking brake and depress the brake, then put the gear in reverse.

2) Make sure that "ON" is displayed in REV.

ON: Normal.

OFF: Abnormal. Check the signal line connector. If there are no problems, the unit could be faulty.

## C: NOTE

For procedure of each component in the navigation system, refer to the respective section.

- Navigation unit: <Ref. to ET-14, Navigation Body.>

- GPS antenna: <Ref. to ET-15, GPS Antenna.>



### 4. Audio

#### A: REMOVAL

- 1) Disconnect the ground cable from battery.
- 2) Remove the center panel. <Ref. to EI-52, CENTER PANEL, REMOVAL, Center Console.>
- 3) Remove the screws, and partially pull the audio out from center console.

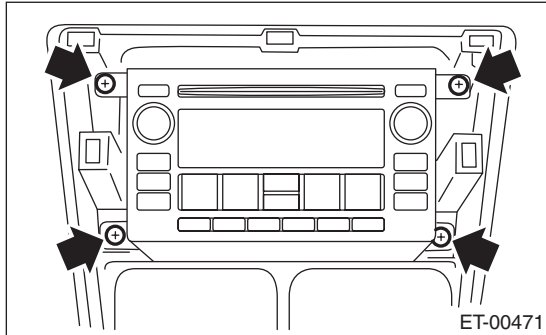

- 4) Disconnect the harness connectors and antenna feeder cord.
- 5) Remove the audio.
- 6) Remove the screws and detach the satellite radio unit.

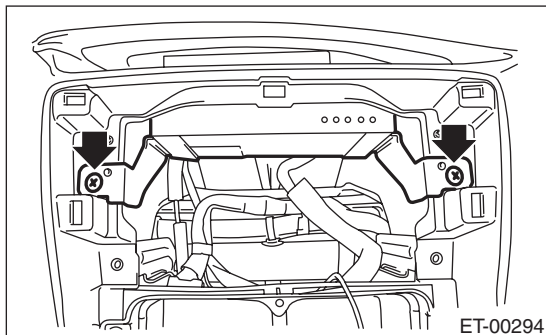

#### B: INSTALLATION

Install each part in the reverse order of removal.

## 5. Front Speaker

### A: REMOVAL

- 1) Disconnect the ground cable from battery.
- 2) Remove the front door trim. <Ref. to EI-45, FRONT DOOR, REMOVAL, Door Trim.>
- 3) Remove the mounting screw of the front speaker.

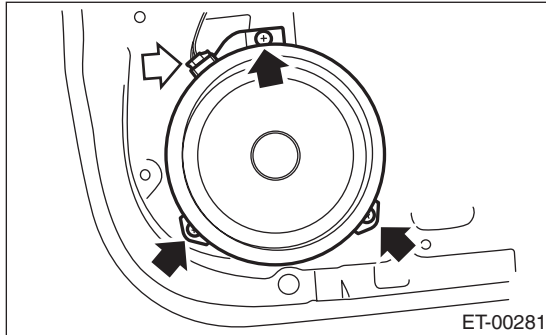

- 4) Disconnect the harness connector and remove the front speaker.

### B: INSTALLATION

Install each part in the reverse order of removal.

## 6. Tweeter

### A: REMOVAL

- 1) Disconnect the ground cable from battery.
- 2) Remove the front door gusset cover. <Ref. to EI-45, FRONT DOOR, REMOVAL, Door Trim.>
- 3) Disconnect the harness connector.
- 4) Remove the screws and detach the tweeter.

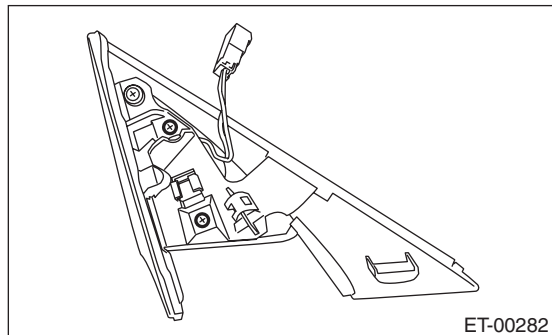

### B: INSTALLATION

Install each part in the reverse order of removal.

## 7. Rear Speaker

### A: REMOVAL

- 1) Disconnect the ground cable from battery.
- 2) Remove the rear door trim. <Ref. to EI-46, REAR DOOR, REMOVAL, Door Trim.>
- 3) Remove the mounting screw of the rear speaker.

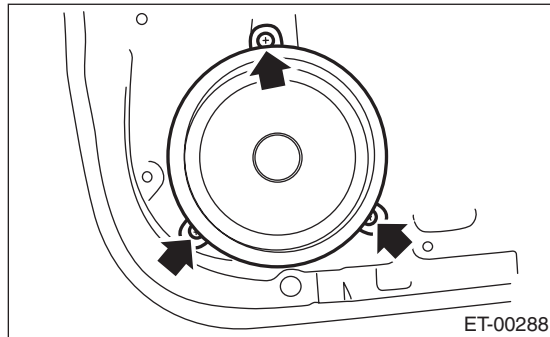

- 4) Disconnect the harness connector and remove the rear speaker.

### B: INSTALLATION

Install each part in the reverse order of removal.

## 8. Antenna

### A: REMOVAL

#### 1. ROOF ANTENNA

- 1) Remove the roof trim. <Ref. to EI-66, REMOVAL, Roof Trim.>
- 2) Disconnect the harness connector and terminal, and remove the mounting nut (A).

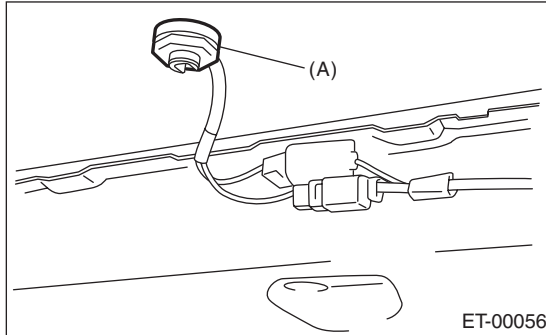

- 3) Pull out the antenna from the roof top.

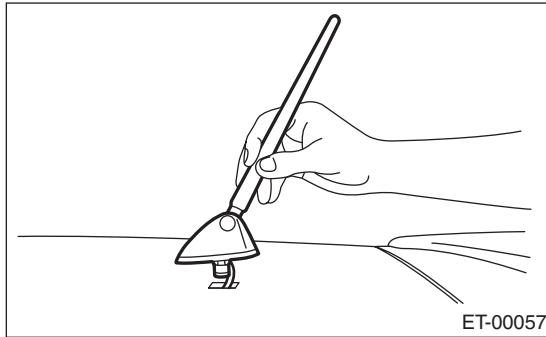

#### 2. FEEDER CORD

- 1) Remove the roof trim. <Ref. to EI-66, REMOVAL, Roof Trim.>
- 2) Remove the feeder cord from the roof trim.

### B: INSTALLATION

Install each part in the reverse order of removal.

#### NOTE:

For how to attach the feeder cord, refer to the "Roof Trim" section. <Ref. to EI-68, INSTALLATION, Roof Trim.>

### C: INSPECTION

Check for cracks or damages.

If any cracks or damages, replace the antenna.

## 9. Steering Satellite Switch

### A: REMOVAL

**WARNING:**

Before servicing, be sure to read the notes in the "AB" section for proper handling of the driver's airbag module. <Ref. to AB-5, CAUTION, General Description.>

- 1) Set the front wheels in straight ahead position.
- 2) Turn the ignition switch to OFF.
- 3) Disconnect the ground cable from battery and wait for at least 60 seconds before starting work.
- 4) Using TORX® bit T30 (1), loosen two TORX® bolts which secure the driver's airbag module.

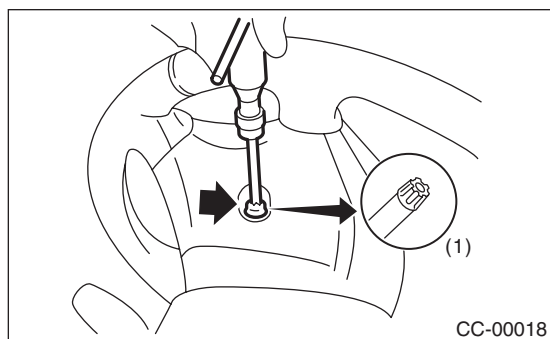

- 5) Disconnect the airbag module connector on back of the airbag module. <Ref. to AB-9, PROCEDURE, Airbag Connector.>
- 6) Remove the steering wheel. <Ref. to PS-12, REMOVAL, Steering Wheel.>
- 7) Remove the screws to remove the lower cover from steering wheel.

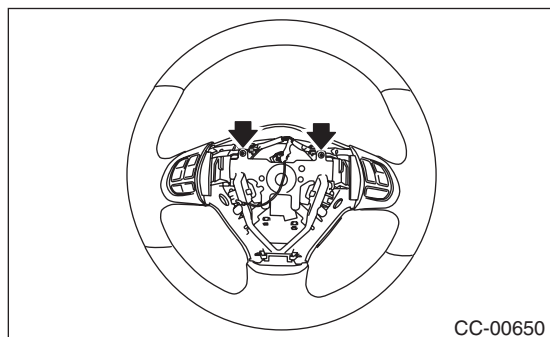

- 8) Loosen the screws on the backside of the steering wheel and remove the satellite switch.

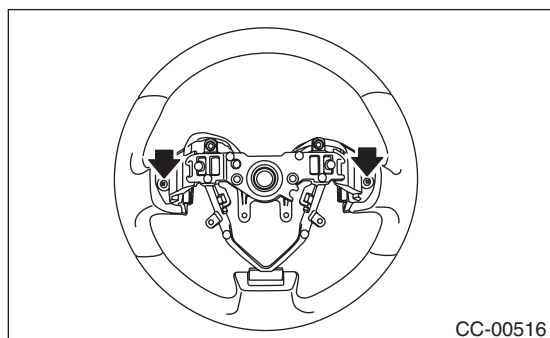

### B: INSTALLATION

Install each part in the reverse order of removal.

### C: INSPECTION

- 1) Remove the airbag module from the steering wheel. <Ref. to AB-16, REMOVAL, Driver's Airbag Module.>
- 2) Check the resistance between satellite switch connector terminals.
  - Model with normal audio and navigation

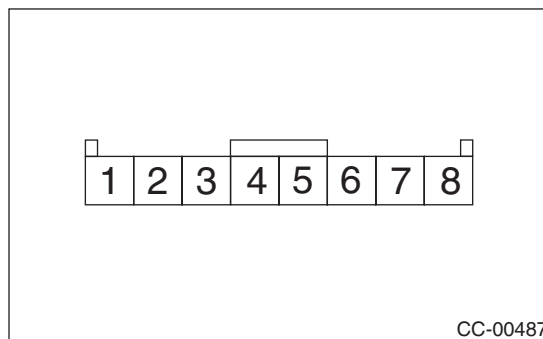

Switch	Position	Terminal No.	Standard
Mute Volume (+) Volume (-) Mode SEEK (∧) SEEK (∨)	All OFF	4 and 5	Approx. 4.7 kΩ
Mute	ON	4 and 5	Approx. 22 Ω
Volume (+)	ON	4 and 5	Approx. 90 Ω
Volume (-)	ON	4 and 5	Approx. 200 Ω
Mode	ON	4 and 5	Approx. 360 Ω
Preset CH UP/ SEEK (∧)	ON	4 and 5	Approx. 690 Ω
Preset CH DOWN/SEEK (∨)	ON	4 and 5	Approx. 1.5 kΩ

# Steering Satellite Switch

## ENTERTAINMENT

- Model with premium audio (Bluetooth applicable) and model with navigation

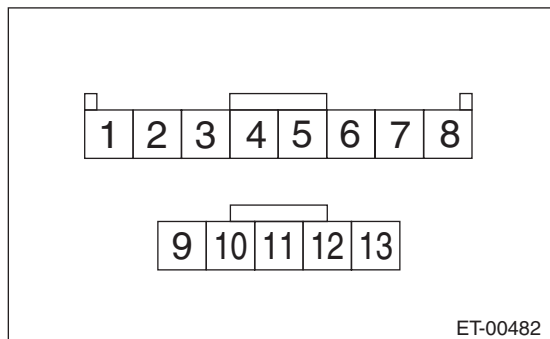

Switch	Position	Terminal No.	Standard
Volume (+) Volume (-) Mode SEEK (∧) SEEK (∨)	All OFF	4 and 5 5 and 11	Approx. 100 kΩ
Volume (+)	ON	4 and 5	Approx. 1010 Ω
Volume (-)	ON	4 and 5	Approx. 3.21 kΩ
Mode	ON	5 and 11	Less than 1 Ω
SEEK (∧)	ON	4 and 5	Less than 1 Ω
SEEK (∨)	ON	4 and 5	Approx. 330 Ω

3) Replace the satellite switch if the inspection result is not within the standard value.

## 10. Steering Switch

### A: REMOVAL

- 1) Set the front wheels in straight ahead position.
- 2) Turn the ignition switch to OFF.
- 3) Disconnect the ground cable from battery and wait for at least 60 seconds before starting work.
- 4) Using TORX® bit T30 (1), loosen two TORX® bolts which secure the driver's airbag module.

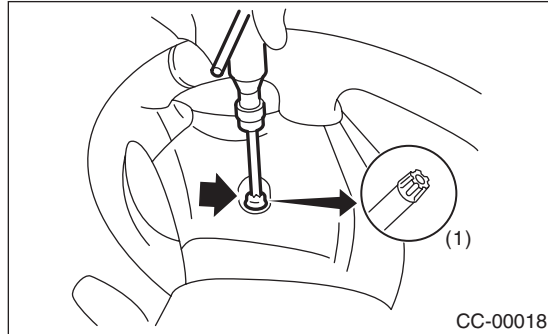

- 5) Disconnect the airbag module connector on back of the airbag module. <Ref. to AB-9, PROCEDURE, Airbag Connector.>

- 6) Remove the steering wheel.
- 7) Remove the screws, disconnect the steering switch connector, and remove the lower cover from steering wheel.

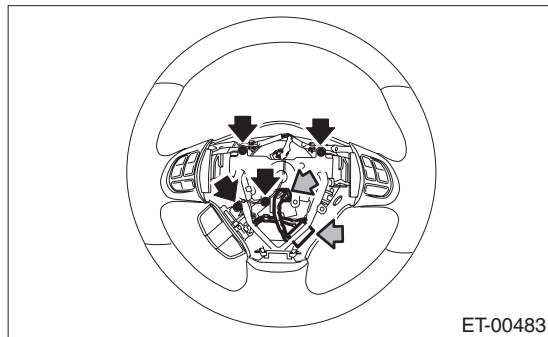

- 8) Remove the screws and remove the steering switch.

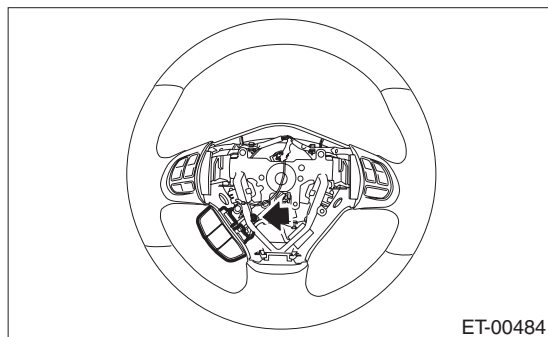

### B: INSTALLATION

Install each part in the reverse order of removal.

### C: INSPECTION

- 1) Remove the airbag module from the steering wheel. <Ref. to AB-16, REMOVAL, Driver's Airbag Module.>
- 2) Connect the tester as shown in the figure, then check resistance between terminals when each switch is pressed.

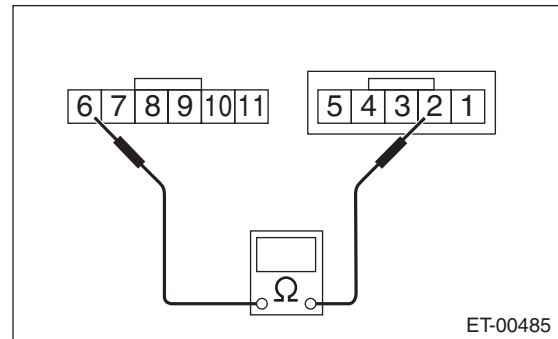

Switch	Resistance
No switch pressed	1 MΩ or more
HOOK ON	Approx. 330 Ω
HOOK OFF	Approx. 1010 Ω
TALK	Approx. 3.21 kΩ

- 3) If internal resistance is out of specification shown in the above table, replace the steering switch.



### **11.Navigation Body**

#### **A: PROCEDURE**

For the removal and installation operation procedures of navigation unit, refer to the removal and installation procedures of the audio unit. <Ref. to ET-6, Audio.>

## 12. GPS Antenna

### A: REMOVAL

- 1) Disconnect the ground cable from the battery.
- 2) Remove the center panel. <Ref. to EI-52, CENTER PANEL, REMOVAL, Center Console.>
- 3) Remove the navigation unit. <Ref. to ET-14, PROCEDURE, Navigation Body.>
- 4) Disconnect the connector (green) of GPS antenna.

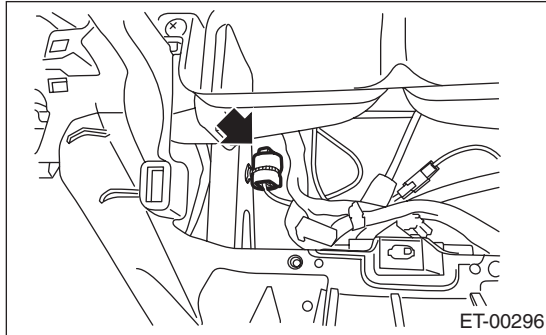

#### NOTE:

Attach a string of about 50 cm in length, etc. to the GPS antenna for easy installation work.

5) Remove the combination meter assembly. <Ref. to IDI-16, REMOVAL, Combination Meter.>

6) Remove the screw and harness clamp to remove the GPS antenna.

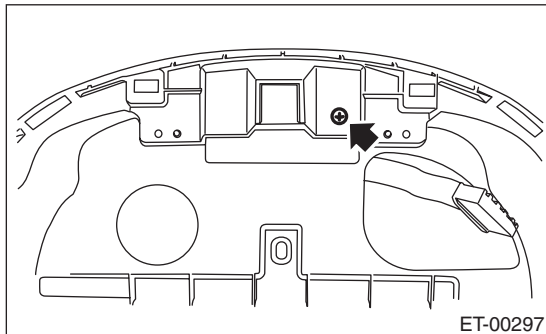

#### NOTE:

When the GPS antenna harness connector is pulled out, remove the string attached to the connector in step 4).

### B: INSTALLATION

Install each part in the reverse order of removal.

# Front Accessory Power Supply Socket

ENTERTAINMENT

---

## 13. Front Accessory Power Supply Socket

### A: WIRING DIAGRAM

Refer to "Front Accessory Power Supply Socket System" in the wiring diagram. <Ref. to WI-121, WIRING DIAGRAM, Front Accessory Power Supply Socket System.>

### B: REMOVAL

- 1) Disconnect the ground cable from battery.
- 2) Remove the instrument panel lower. <Ref. to EI-54, INSTRUMENT PANEL LOWER, REMOVAL, Center Console.>
- 3) Disconnect the harness connectors and remove the front accessory power supply socket.

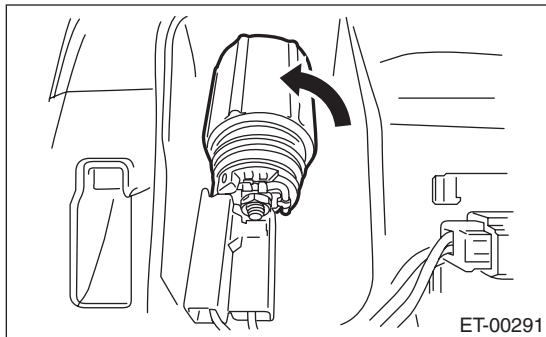

### C: INSTALLATION

Install each part in the reverse order of removal.

## 14. Rear Accessory Power Supply Socket

### A: WIRING DIAGRAM

Refer to "Rear Accessory Power Supply Socket System" in the wiring diagram. <Ref. to WI-122, WIRING DIAGRAM, Rear Accessory Power Supply Socket System.>

### B: REMOVAL

- 1) Disconnect the ground cable from battery.
- 2) Remove the console box. <Ref. to EI-51, REMOVAL, Console Box.>
- 3) Disconnect the harness connector, and remove the claws (two) in accessory power supply socket.
- 4) Pull the accessory power supply socket out to remove.

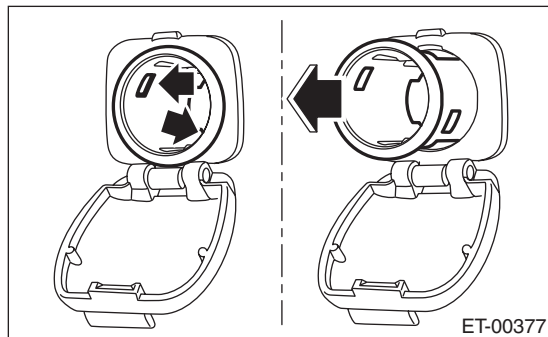

### C: INSTALLATION

Install each part in the reverse order of removal.

## 15.AUX Input Terminal

### A: REMOVAL

- 1) Disconnect the ground cable from battery.
- 2) Remove the console box. <Ref. to EI-51, REMOVAL, Console Box.>
- 3) Disconnect the harness connector.
- 4) Disengage four claws, and remove the AUX input terminal by pushing it into the console box.

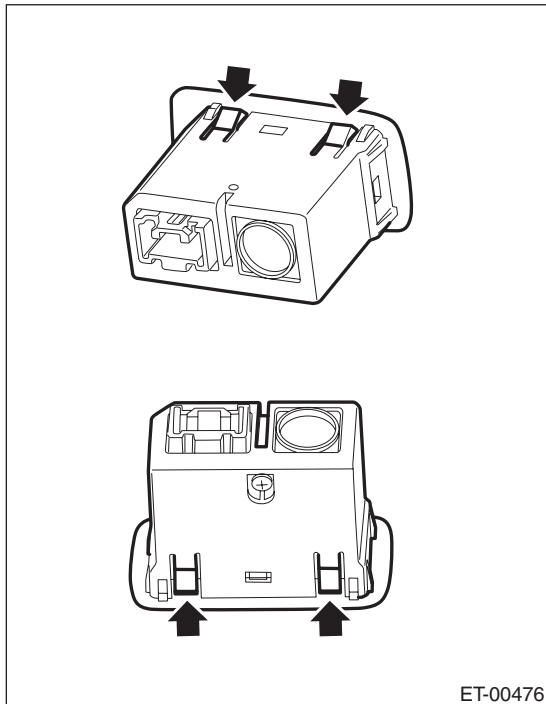
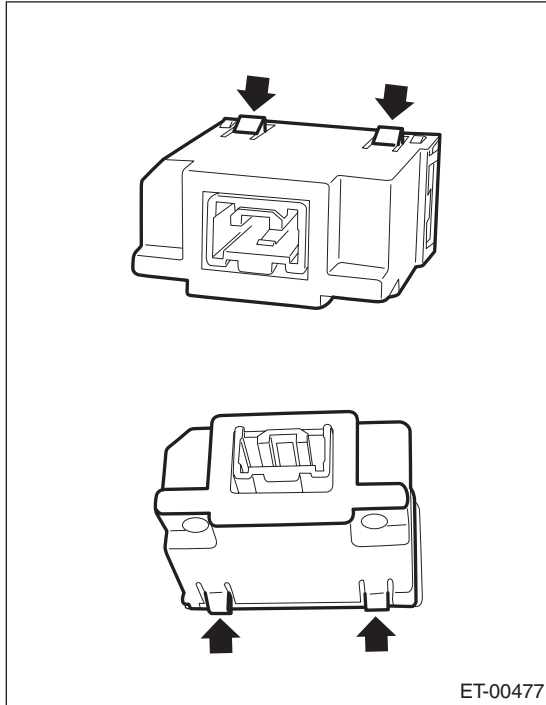

### B: INSTALLATION

Install each part in the reverse order of removal.

## 16. Microphone

### A: PROCEDURE

Refer to "Spot Map Light" for removal and installation procedures of microphone. <Ref. to LI-33, Spot Map Light.>

### B: INSPECTION

- 1) Check the connection status of the microphone.
- 2) Replace the spot map light assembly if the microphone is found defective. <Ref. to LI-33, REMOVAL, Spot Map Light.>

# Microphone

ENTERTAINMENT

---

**ET-20**

Brought to you by Ebay Seller "SubaruManuals"

# COMMUNICATION SYSTEM

# COM

---

	<b>Page</b>
1. General Description .....	2
2. Horn System .....	3
3. Horn .....	4
4. Horn Switch .....	5



# General Description

COMMUNICATION SYSTEM

## 1. General Description

### A: COMPONENT

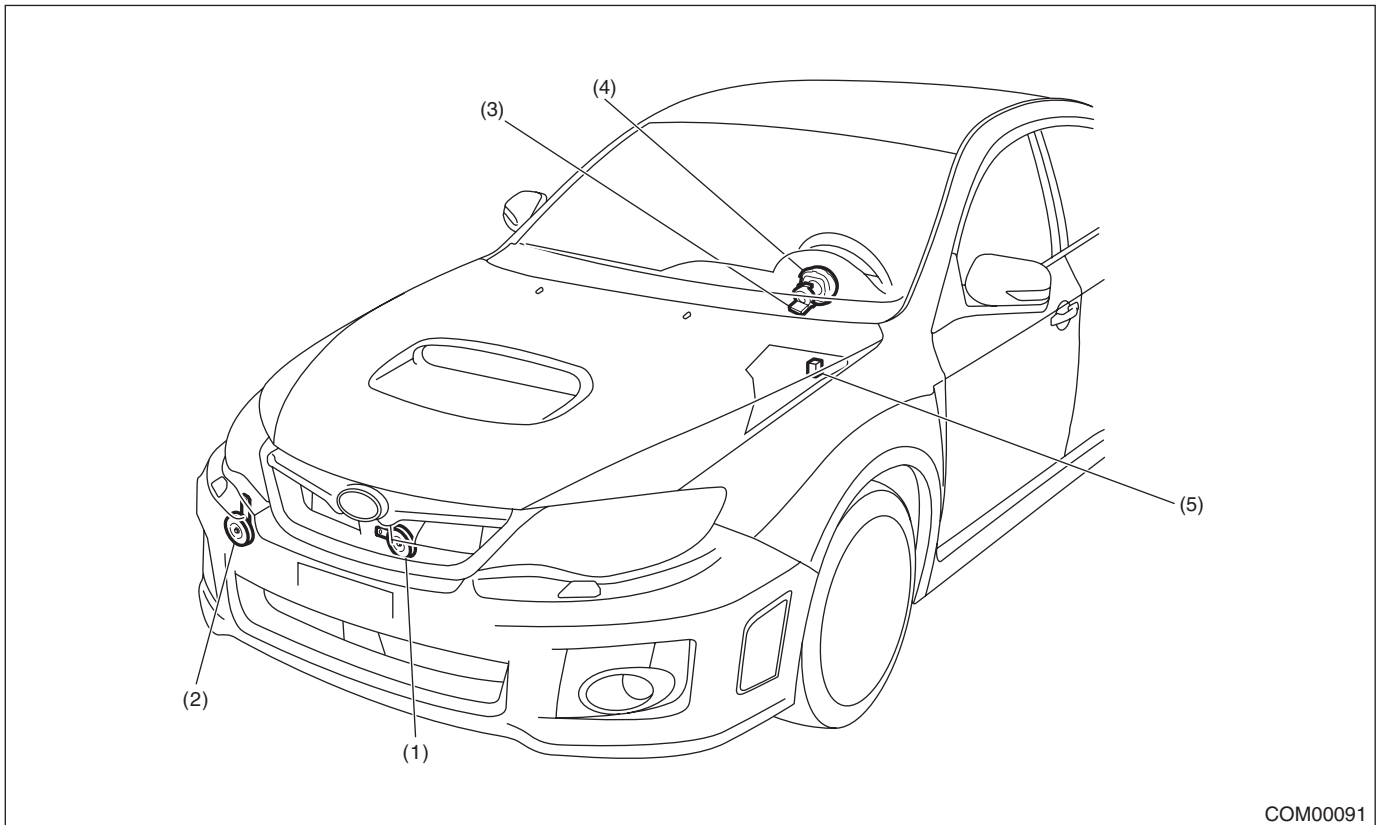

COM00091

- |                  |   |                |
|------------------|---|----------------|
| (1) Lo side horn | (3) Roll connector                            | (5) Horn relay |
| (2) Hi side horn | (4) Horn switch (Driver's airbag module ASSY) |                |

### B: CAUTION

- Before disassembling or reassembling parts, always disconnect the battery ground cable from battery. When replacing the audio, control module and other parts provided with memory functions, record the memory contents before disconnecting the battery ground cable. Otherwise, the memory is cleared.
- Reassemble the parts in the reverse order of disassembly procedure unless otherwise indicated.
- Connect the connectors securely during reassembly.
- After reassembly, make sure that the functional parts operate normally.
- Yellow connectors and harnesses with yellow tapes around them are the connectors and harnesses for the airbag system. Using a tester above such circuits may cause malfunction of airbag system. Follow the cautions for the airbag system in this case. <Ref. to AB-5, CAUTION, General Description.>
- Be careful not to damage the airbag system wiring harness when servicing electrical parts and switches.

### C: PREPARATION TOOL

#### 1. GENERAL TOOL

TOOL NAME	REMARKS
Circuit tester	Used for measuring resistance and voltage.
TORX® T30	Used for removal/installation of drivers airbag module

COM-2

Brought to you by Ebay Seller "SubaruManuals"

## 2. Horn System

### A: WIRING DIAGRAM

Refer to "Horn System" in the wiring diagram. <Ref. to WI-129, WIRING DIAGRAM, Horn System.>

### B: INSPECTION

Symptoms	Inspection steps
Horn does not sound	1. Check the fuse.
	2. Check the horn relay.
	3. Check the role connector.
	4. Check the horn switch.
	5. Check the horn assembly.
	6. Check the harness.

### 1. HORN RELAY

1) Connect terminal No. 4 to the battery positive terminal and the terminal No. 3 to the battery negative terminal, and check the resistance value between the horn relay terminals.

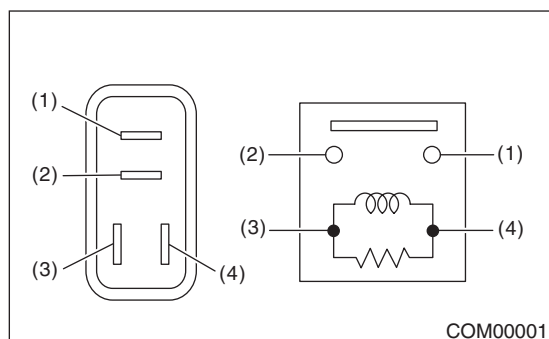

Continuity	Terminal No.	Standard value
Yes	1 and 2	Less than 1 Ω
None		1 MΩ or more

2) Replace the horn relay if the inspection result is not within the standard value.

### C: NOTE

For procedure of each component in the horn system, refer to the respective section.

- Horn assembly: <Ref. to COM-4, Horn.>
- Horn switch: <Ref. to COM-5, Horn Switch.>

### 3. Horn

#### A: REMOVAL

- 1) Disconnect the ground cable from battery.
- 2) Remove the front bumper face. <Ref. to EI-31, FRONT BUMPER FACE, REMOVAL, Front Bumper.>
- 3) Disconnect the harness connector.
- 4) Remove the horn bracket mounting bolt, and remove the horn assembly.

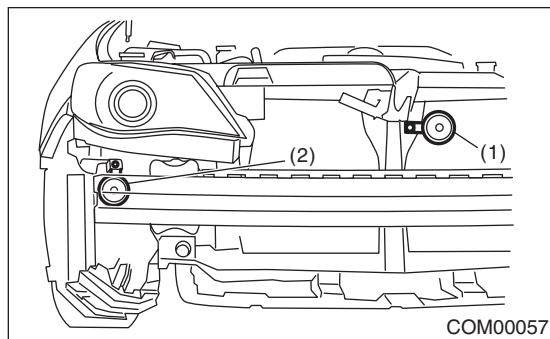

- (1) Lo side horn  
(2) Hi side horn

#### B: INSTALLATION

- 1) Install each part in the reverse order of removal.

##### **Tightening torque:**

**Lo side: 18 N·m (1.84 kgf-m, 13.3 ft-lb)**

**Hi side: 13 N·m (1.33 kgf-m, 9.6 ft-lb)**

- 2) Adjust the fog light beam. (Model with fog light)  
<Ref. to LI-21, FOG LIGHT AIMING, ADJUSTMENT, Front Fog Light Assembly.>

#### C: INSPECTION

- 1) Remove the horn. <Ref. to COM-4, REMOVAL, Horn.>
- 2) Check the horn sounds when applying the battery voltage to the horn assembly.

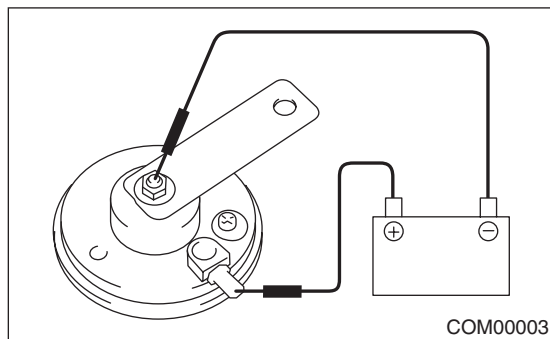

- 3) If it does not operate normally, replace the horn assembly.

## 4. Horn Switch

### A: REMOVAL

**CAUTION:**

Before handling the airbag module, refer to "CAUTION" of "General Description" in "AIRBAG SYSTEM". <Ref. to AB-5, CAUTION, General Description.>

**NOTE:**

Horn switch is a unit with the driver's airbag module.

- 1) Disconnect the ground cable from battery and wait for at least 60 seconds before starting work.
- 2) Remove the driver's airbag module. <Ref. to AB-16, REMOVAL, Driver's Airbag Module.>

### B: INSTALLATION

**CAUTION:**

- Before handling the airbag module, refer to "CAUTION" of "General Description" in "AIRBAG SYSTEM". <Ref. to AB-5, CAUTION, General Description.>

- Do not allow harness and connectors to interfere or get tangled up with other parts.

- 1) Install the driver's airbag module. <Ref. to AB-16, INSTALLATION, Driver's Airbag Module.>
- 2) Install each part in the reverse order of removal.

### C: INSPECTION

- 1) Remove the horn switch. <Ref. to COM-5, REMOVAL, Horn Switch.>
- 2) Check the resistance between horn switch terminal and airbag module bracket.

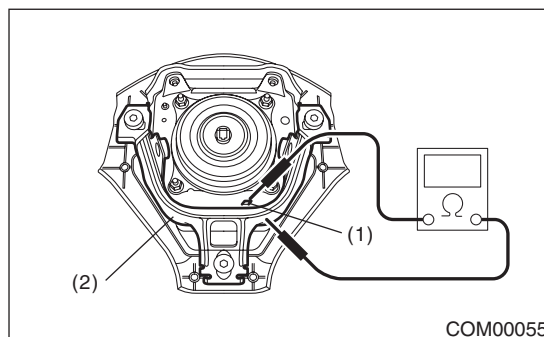

- (1) Horn switch terminal
- (2) Airbag module bracket

Switch position	Terminal No.	Standard value
The airbag module bracket being pushed	Horn switch terminal and airbag module bracket	Less than 1 Ω
The airbag module bracket being separated		1 MΩ or more

- 3) Replace the driver's airbag module if the inspection result is not within the standard value.

# Horn Switch

COMMUNICATION SYSTEM

---

**COM-6**

Brought to you by Ebay Seller "SubaruManuals"

# GLASS/WINDOWS/MIRRORS

# GW

---

	<b>Page</b>
1. General Description .....	2
2. Power Window System .....	8
3. Power Window Control Switch .....	9
4. Front Door Glass .....	12
5. Front Regulator and Motor Assembly .....	13
6. Remote Control Mirror System .....	14
7. Scalp Cap .....	15
8. Outer Mirror Assembly .....	16
9. Outer Mirror .....	17
10. Remote Control Mirror Switch .....	18
11. Rear Door Glass .....	19
12. Rear Regulator and Motor Assembly .....	20
13. Windshield Glass .....	21
14. Rear Gate Glass .....	26
15. Rear Window Glass .....	30
16. Rear Window Defogger System .....	32
17. Rear Quarter Glass .....	34
18. Rearview Mirror .....	37
19. Wiper Deicer System .....	38

# General Description

GLASS/WINDOWS/MIRRORS

## 1. General Description

### A: COMPONENT

#### 1. FIXED GLASS (5 DOOR MODEL)

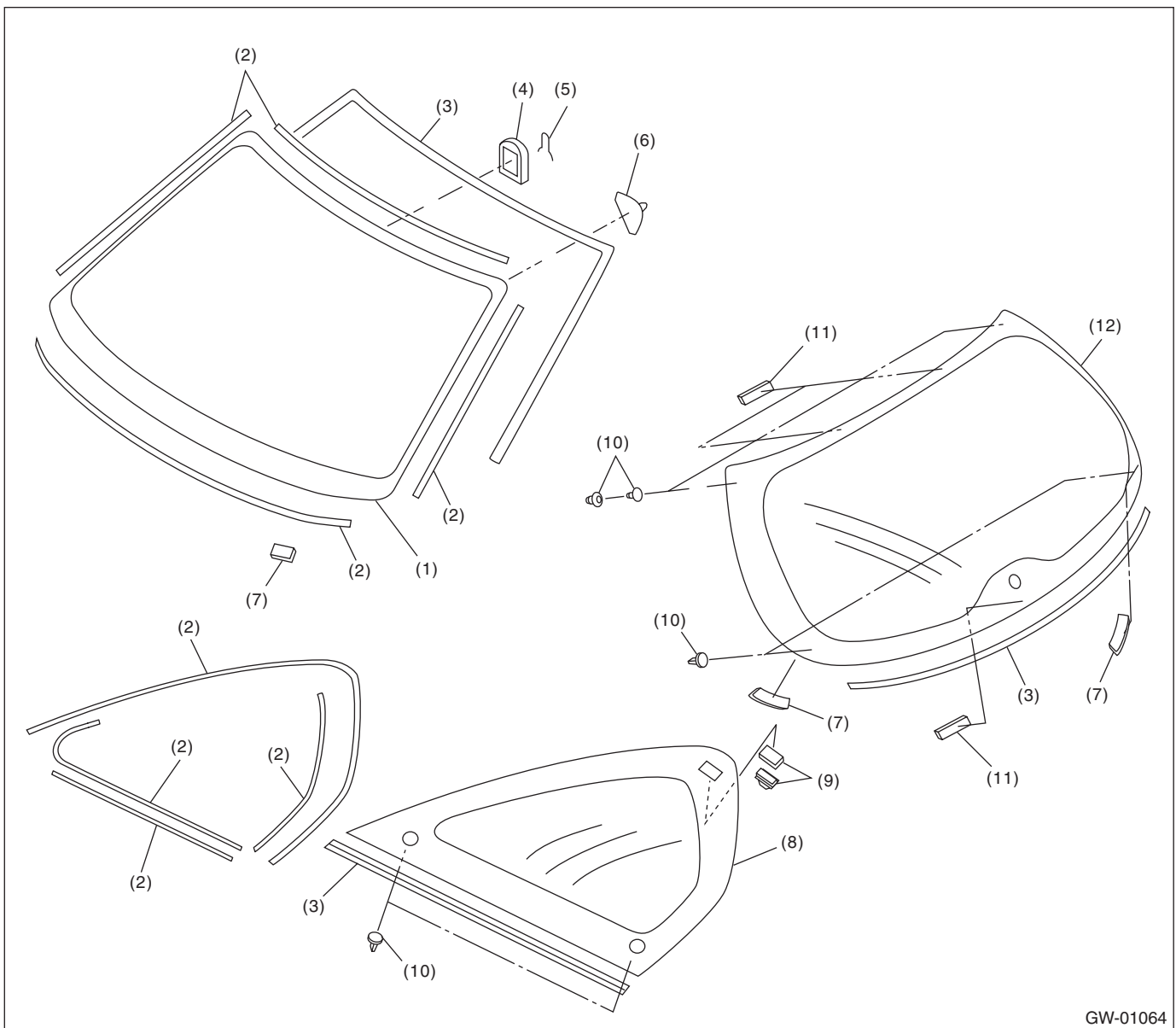

GW-01064

- (1) Windshield glass
- (2) Dam rubber
- (3) Molding
- (4) Rearview mirror mount

- (5) Spring
- (6) Locating pin
- (7) Seal
- (8) Rear quarter glass

- (9) Fastener
- (10) Locating pin
- (11) Spacer
- (12) Rear gate glass

GW-2

Brought to you by Ebay Seller "SubaruManuals"

## 2. FIXED GLASS (4 DOOR MODEL)

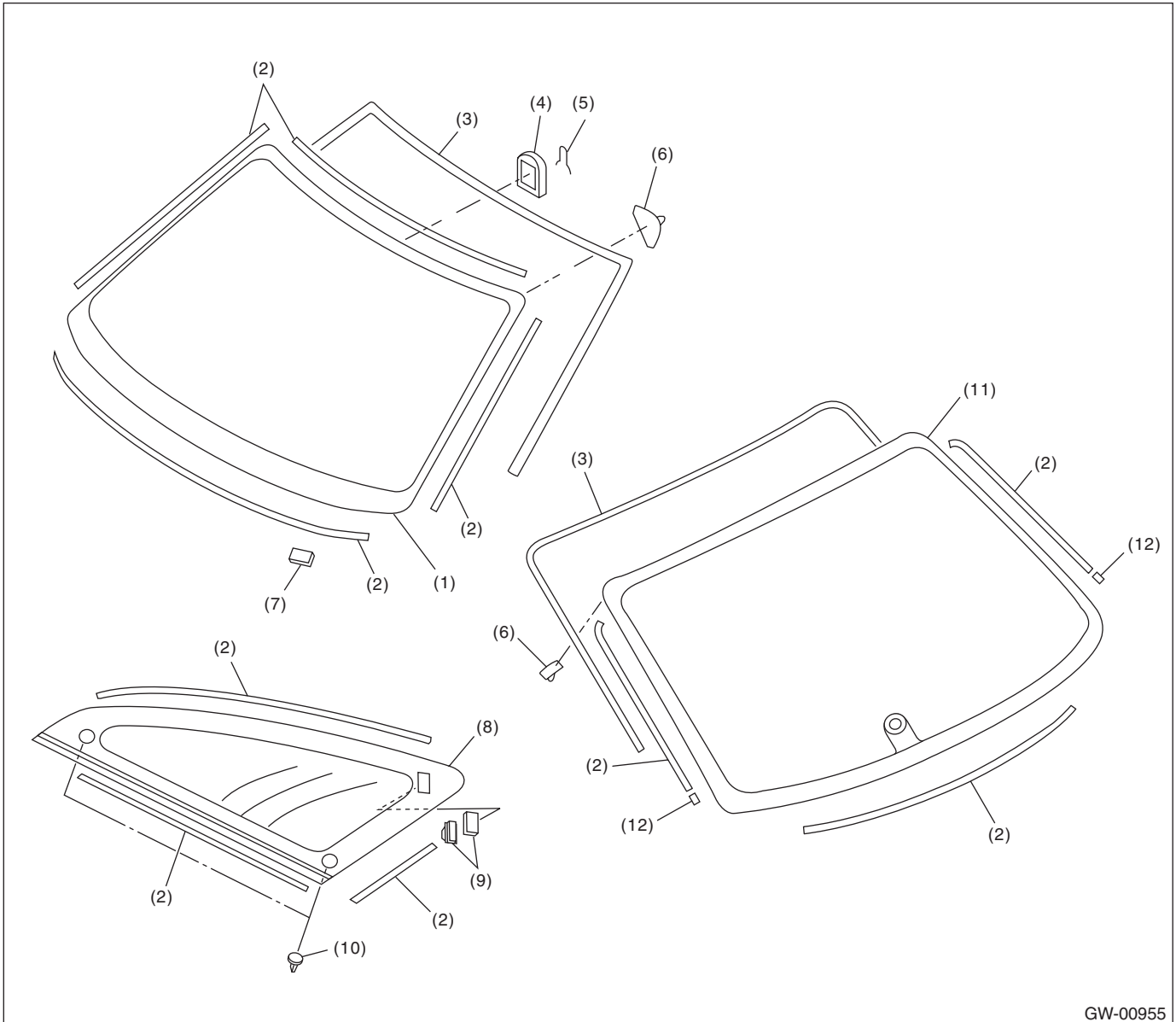

GW-00955

- |                           |                        |                        |
|---------------------------|------------------------|------------------------|
| (1) Windshield glass      | (5) Spring             | (9) Fastener           |
| (2) Dam rubber            | (6) Locating pin       | (10) Locating pin      |
| (3) Molding               | (7) Seal               | (11) Rear window glass |
| (4) Rearview mirror mount | (8) Rear quarter glass | (12) Spacer            |



# General Description

GLASS/WINDOWS/MIRRORS

## 3. FRONT DOOR GLASS

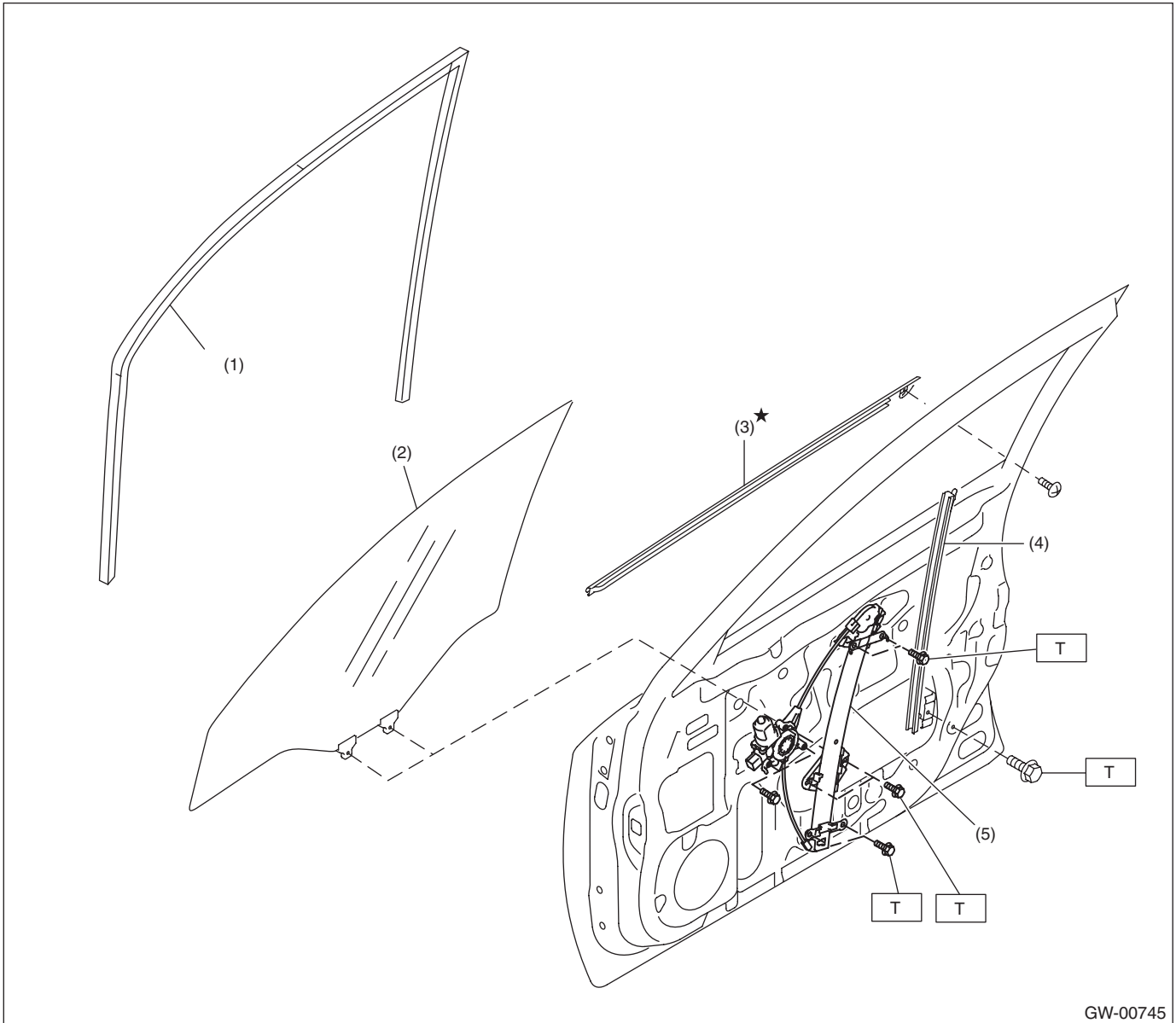

- (1) Glass run rubber
- (2) Glass
- (3) Weather strip outer

- (4) Door sash
- (5) Regulator & motor ASSY

**Tightening torque: N·m (kgf·m, ft·lb)**

**T: 7.5 (0.76, 5.5)**

## 4. REAR DOOR GLASS

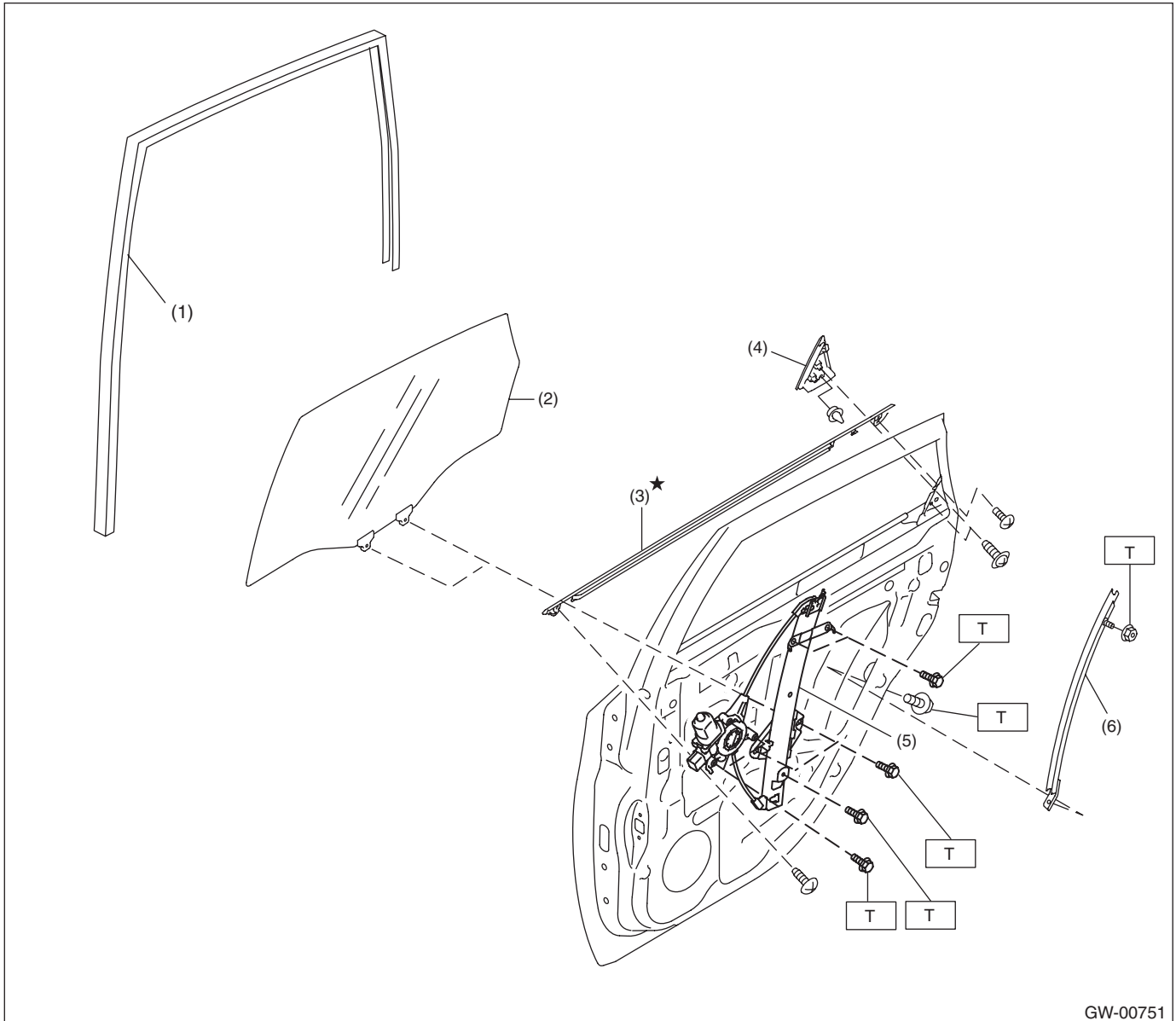

GW-00751

- |                         |                             |
|-------------------------|-----------------------------|
| (1) Glass run rubber    | (4) Rear outer gusset cover |
| (2) Glass               | (5) Regulator & motor ASSY  |
| (3) Weather strip outer | (6) Door sash               |

**Tightening torque: N·m (kgf·m, ft·lb)**

**T: 7.5 (0.76, 5.5)**

# General Description

## GLASS/WINDOWS/MIRRORS

### 5. MIRROR

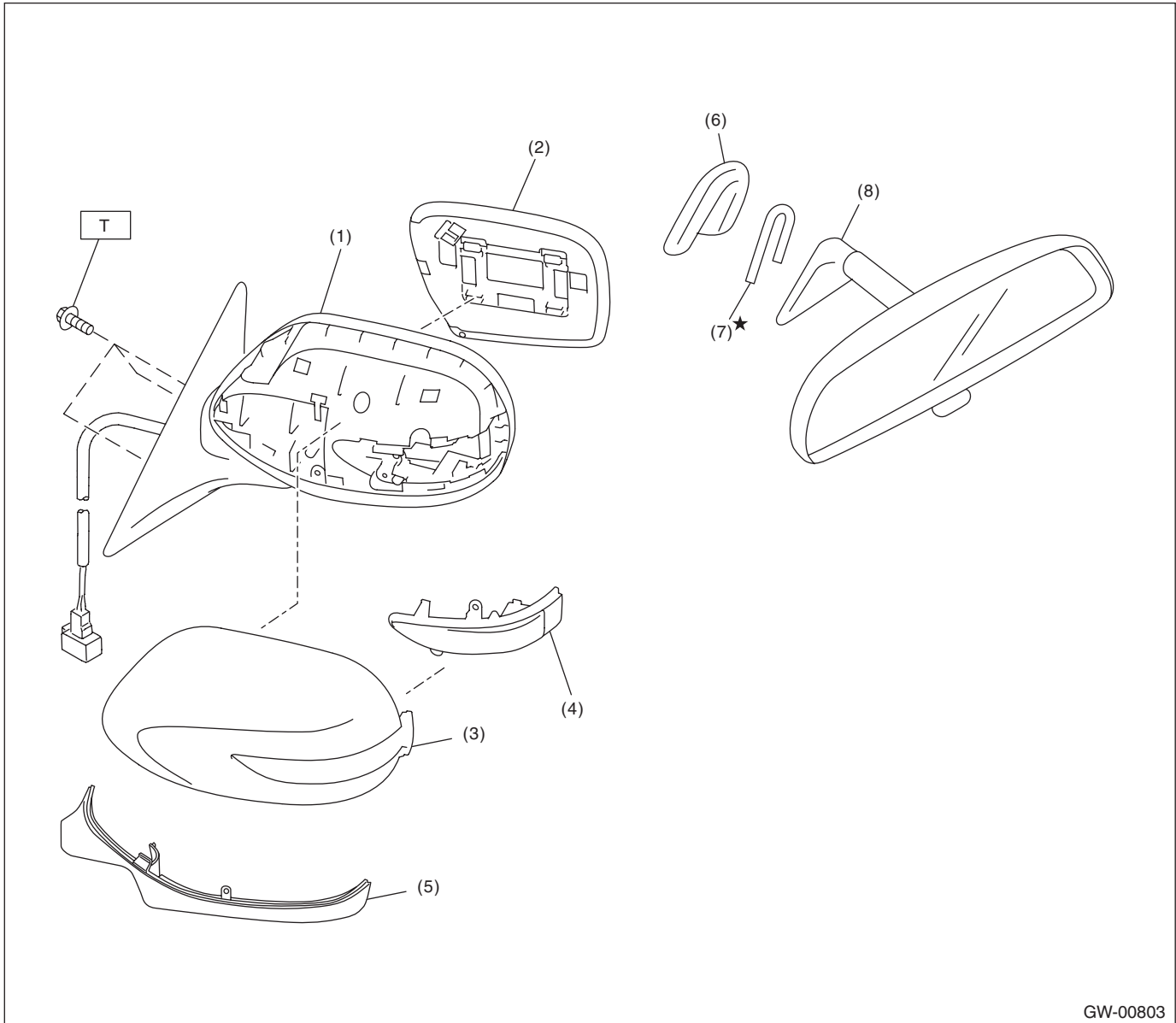

GW-00803

- |                                 |                              |
|---------------------------------|------------------------------|
| (1) Outer mirror case ASSY      | (5) Outer mirror lower cover |
| (2) Mirror                      | (6) Mount                    |
| (3) Scalp cap                   | (7) Spring                   |
| (4) Side turn signal light ASSY | (8) Rearview mirror ASSY     |

**Tightening torque: N·m (kgf·m, ft·lb)**

**T: 4.5 (0.46, 3.3)**

### B: CAUTION

- Before disassembling or reassembling parts, always disconnect the battery ground cable from battery. When replacing the audio, control module and other parts provided with memory functions, record the memory contents before disconnecting the battery ground cable. Otherwise, the memory is cleared.
- Avoid impact and damage to the glass.
- Reassemble the parts in the reverse order of disassembly procedure unless otherwise indicated.
- Connect the connectors securely during reassembly.
- After reassembly, make sure that the functional parts operate normally.

## C: PREPARATION TOOL

### 1. SPECIAL TOOL

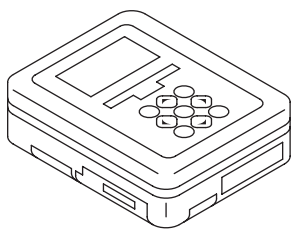
ILLUSTRATION	TOOL NUMBER	DESCRIPTION	REMARKS
 ST1B022XU0	1B022XU0	SUBARU SELECT MONITOR III KIT	Used for setting of each function and trouble-shooting for electrical system.

### 2. GENERAL TOOL

TOOL NAME	REMARKS
Circuit tester	Used for measuring resistance and voltage.
Piano wire	Used for removing the window glass.
Cutter knife	Used for removing the window glass.
Windshield glass knife	Used for removing the window glass.

# Power Window System

GLASS/WINDOWS/MIRRORS

## 2. Power Window System

### A: WIRING DIAGRAM

Refer to "Power Window System" in the wiring diagram. <Ref. to WI-130, WIRING DIAGRAM, Power Window System.>

### B: INSPECTION

Symptoms	Repair order
All power windows do not operate.	1. Check the fuse (SBF-4). 2. Check the power window circuit breaker. 3. Check the power window relay. 4. Check the wiring harness.
Particular window does not operate.	1. Check the power window main switch. 2. Check the power window sub-switch. 3. Check the power window motor. 4. Check the wiring harness.
"Window Lock" does not operate.	Check the power window main switch.
Driver's side window moves slightly (approx. 20 mm (0.79 in)).	1. Check the power window motor. 2. Check the power window main switch. 3. Check the wiring harness.
Driver's side window moves slightly (approx. 50 mm (1.97 in)). (This status is not a failure.)	Perform reset operation A. <Ref. to GW-8, RESET OPERATION A, INSPECTION, Power Window System.>
Driver's side window does not close completely. (Using AUTO UP allows the window to fully close first and then move in reverse resulting in slightly opening.)	Perform reset operation B. <Ref. to GW-8, RESET OPERATION B, INSPECTION, Power Window System.>

### 1. RESET OPERATION A

- 1) Sit in the driver's seat and close the door.
- 2) Turn the ignition switch to ON.
- 3) Operate the power window main switch to open the window glass halfway.
- 4) Operate the power window main switch to "UP" direction to fully close the driver's side window glass.
- 5) While the window glass is fully closed, hold down the power window switch to "UP" direction for one second.
- 6) Operate the power window main switch to "AUTO DOWN" direction to check whether the window fully opens properly. If the window does not fully open properly, repeat steps 1) to 6).

### 2. RESET OPERATION B

- 1) Sit in the driver's seat and close the door.
- 2) Turn the ignition switch to ON.
- 3) Perform "AUTO UP" operation for the driver's side window glass, by fully pulling up the power window main switch to cause the reverse operation (in reverse operation, the window is repeatedly fully closed and then reversed to open it slightly) 10 times in row.
- 4) Check that the "AUTO UP" does not operate.
- 5) Perform reset operation A.
- 6) Check that the window operates properly by operating the "AUTO UP" and "AUTO DOWN" switch. If the window does not fully open/close properly, repeat steps 1) to 6).

### C: NOTE

For procedure of each component in the power window system, refer to the respective section.

- Power window control switch: <Ref. to GW-9, Power Window Control Switch.>
- Front door glass: <Ref. to GW-12, Front Door Glass.>
- Front regulator and motor assembly: <Ref. to GW-13, Front Regulator and Motor Assembly.>
- Rear door glass: <Ref. to GW-19, Rear Door Glass.>
- Rear regulator and motor assembly: <Ref. to GW-20, Rear Regulator and Motor Assembly.>

## 3. Power Window Control Switch

### A: REMOVAL

#### 1. MAIN SWITCH

- 1) Disconnect the ground cable from battery.
- 2) Remove the power window switch panel.

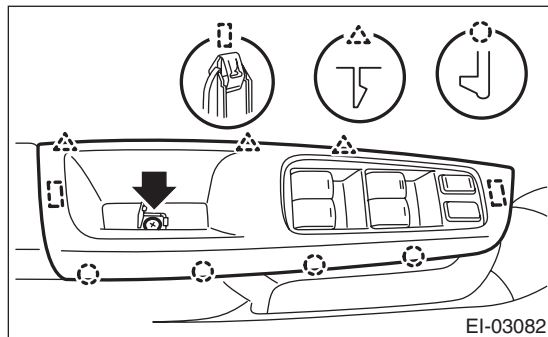

- (1) Open the cover and remove the screws.
- (2) Lift up the tip of switch panel by using a plastic remover.

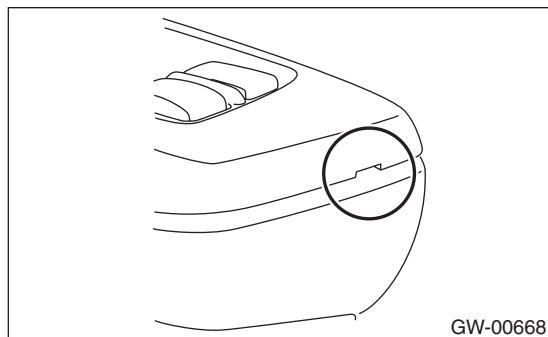

- (3) Disengage the end face tabs by using a plastic remover.

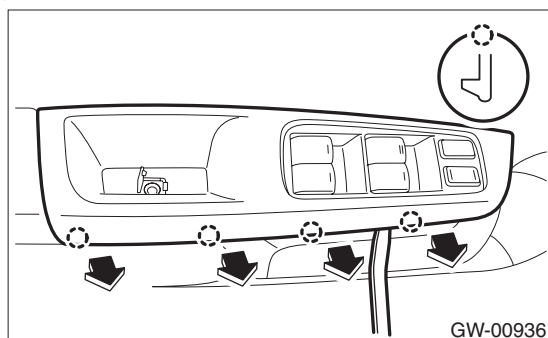

- (4) Remove the power window switch panel.
- 3) Disconnect the main switch connector.
- 4) Remove the screws to remove the power window main switch assembly.

#### 2. SUB-SWITCH

- 1) Disconnect the ground cable from battery.
- 2) Remove the power window switch panel.

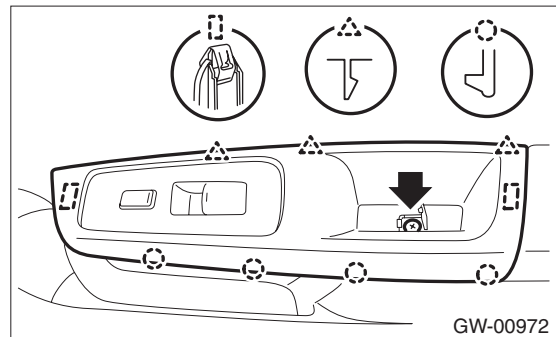

- (1) Open the cover and remove the screws.
- (2) Lift up the tip of switch panel by using a plastic remover.

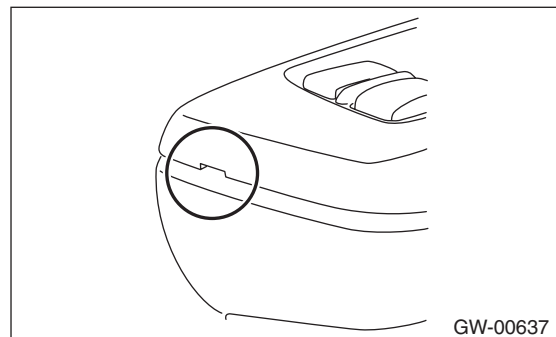

- (3) Disengage the end face tabs by using a plastic remover.

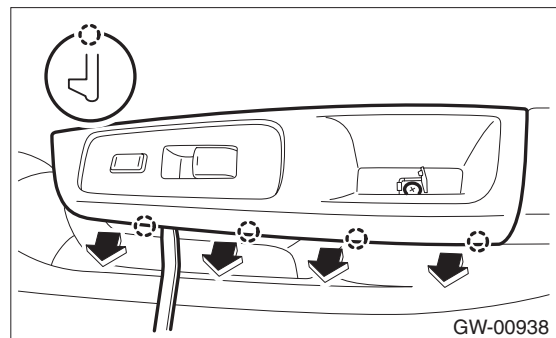

- (4) Remove the power window switch panel.
- 3) Disconnect the power window sub-switch connector.
- 4) Remove the screws to remove the power window sub-switch assembly.

# Power Window Control Switch

GLASS/WINDOWS/MIRRORS

## B: INSTALLATION

### CAUTION:

After installation of main switch, always perform the reset operation A (initial setting).

Failure to do so may cause the improper activation of auto-reverse operation for pinching hazard prevention. <Ref. to GW-8, RESET OPERATION A, INSPECTION, Power Window System.>

Install each part in the reverse order of removal.

## C: INSPECTION

### 1. MAIN SWITCH

- Driver's seat

### CAUTION:

Since the driver's side power window switch is controlled by CPU, do not check continuity for switch alone with the circuit tester. Performing continuity check with circuit tester may damage the driver's side power window switch circuit.

Check output from the power window main switch to driver's side motor using the oscilloscope function in the Subaru Select Monitor.

- 1) Disconnect the ground cable from battery.
- 2) Remove the power window main switch. <Ref. to GW-9, REMOVAL, Power Window Control Switch.>
- 3) Connect the battery and the Subaru Select Monitor to the power window main switch connector.

### CAUTION:

Never mix up the terminals when connecting the power window main switch connector and battery. If connected to a wrong terminal, the power window main switch may be damaged.

### NOTE:

- When the battery is connected to the power window main switch, the letters "AUTO" on the driver's side knob illuminates.
- For detailed procedures, refer to "Subaru Select Monitor Operation Manual".

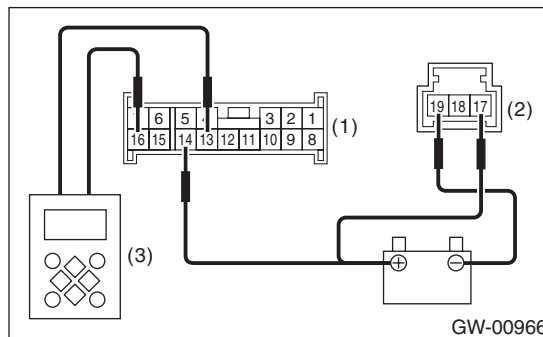

- (1) Power window main switch connector (16 poles)
- (2) Power window main switch connector (3 poles)
- (3) Subaru Select Monitor

- 4) Operate the driver's side power window switch knob and check the output.

### NOTE:

Since output time during window UP operation is extremely short, it cannot be checked without using a measuring instrument such as oscilloscope. Output is constantly produced while the knob is operated for window DOWN operation.

Switch knob position	Output time	Standard
AUTO UP	150 ms	Battery voltage
UP		
OFF	—	0 V
DOWN	During switch knob operation	Battery voltage
AUTO DOWN	Approx. 300 ms	

5) Replace the power window main switch if the inspection result is not within the standard value.

• **Except for driver's seat**

1) Check the resistance between switch terminals.

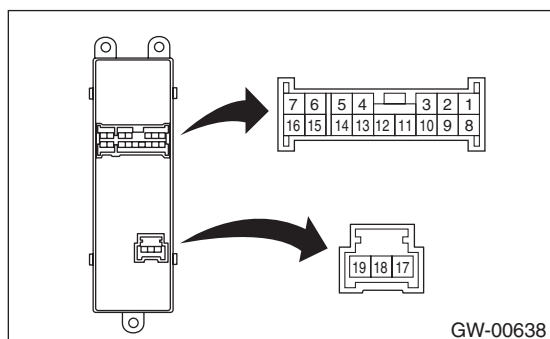

GW-00638

	Switch position	Terminal No.	Standard
Passenger's seat	UP	14 and 8 12 and 19	Less than 1 Ω
	OFF	14 and 12 14 and 8	1 MΩ or more
		8 and 12 8 and 19 12 and 19	Less than 1 Ω
	DOWN	14 and 12 8 and 19	Less than 1 Ω
Rear LH	UP	14 and 7 5 and 19	Less than 1 Ω
	OFF	14 and 7 14 and 5	1 MΩ or more
		19 and 7 19 and 5 7 and 5	Less than 1 Ω
DOWN	14 and 5 7 and 19	Less than 1 Ω	
Rear RH	UP	14 and 1 3 and 19	Less than 1 Ω
	OFF	14 and 1 14 and 3	1 MΩ or more
		19 and 3 19 and 1 3 and 1	Less than 1 Ω
DOWN	14 and 3 1 and 19	Less than 1 Ω	

2) Replace the power window main switch if the inspection result is not within the standard value.

## 2. SUB-SWITCH

1) Remove the sub-switch. <Ref. to GW-9, SUB-SWITCH, REMOVAL, Power Window Control Switch.>

2) Check the resistance between sub-switch terminals.

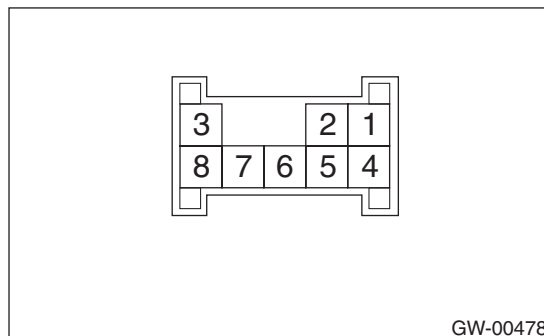

GW-00478

	Switch position	Terminal No.	Standard
Passenger seat, rear	UP	4 and 5 6 and 7	Less than 1 Ω
	OFF	7 and 4 8 and 4	1 MΩ or more
		5 and 8 6 and 7	Less than 1 Ω
	DOWN	4 and 6 5 and 8	Less than 1 Ω

3) Replace the power window sub-switch if the inspection result is not within the standard value.



## 4. Front Door Glass

### A: REMOVAL

- 1) Remove the front door trim. <Ref. to EI-45, FRONT DOOR, REMOVAL, Door Trim.>
- 2) Remove the sealing cover. <Ref. to EB-21, REMOVAL, Front Sealing Cover.>
- 3) Operate the power window switch to move the glass, and remove the bolts.

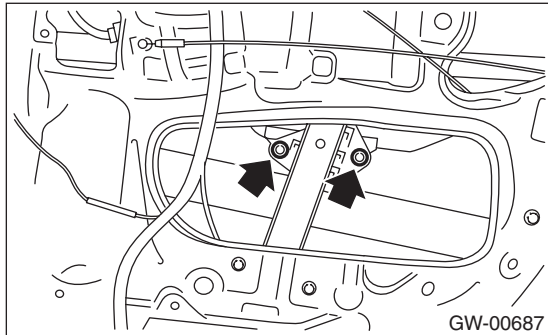

- 4) Tilt the door glass forward and remove the door glass from the glass run rubber.
- 5) Remove the door glass while tilting.

### CAUTION:

**Avoid impact and damage to the glass.**

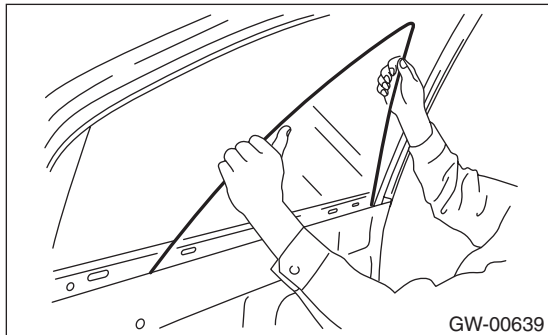

### B: INSTALLATION

#### CAUTION:

**Make sure that the glass run rubber is placed securely in door frame and sash.**

Install each part in the reverse order of removal.

#### *Tightening torque:*

*Refer to "COMPONENT" of "General Description". <Ref. to GW-4, FRONT DOOR GLASS, COMPONENT, General Description.>*

## 5. Front Regulator and Motor Assembly

### A: REMOVAL

- 1) Remove the front door glass. <Ref. to GW-12, REMOVAL, Front Door Glass.>
- 2) Disconnect the motor connector.
- 3) Remove the bolts, and then remove the front regulator and motor assembly.

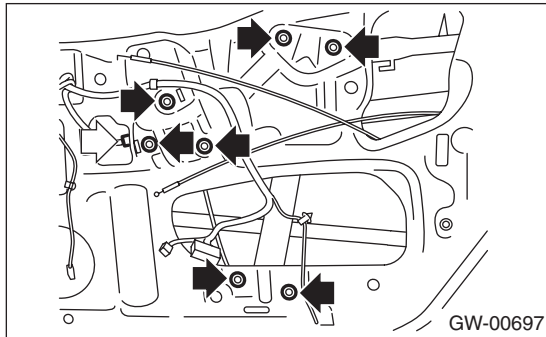

### B: INSTALLATION

Install each part in the reverse order of removal.

#### **Tightening torque:**

**Refer to "COMPONENT" of "General Description". <Ref. to GW-4, FRONT DOOR GLASS, COMPONENT, General Description.>**

### C: INSPECTION

- 1) Disconnect the motor connector.
- 2) Apply battery voltage between the motor connector terminals and check the motor operation. Check to ensure that the motor rotates in reverse direction when the terminal to which battery voltage is applied is changed.
- 3) If the inspection results in improper operation, replace the front regulator and motor assembly.

# Remote Control Mirror System

GLASS/WINDOWS/MIRRORS

---

## 6. Remote Control Mirror System

### A: WIRING DIAGRAM

Refer to "Remote Control Mirror System" in the wiring diagram. <Ref. to WI-134, WIRING DIAGRAM, Remote Control Mirror System.>

### B: INSPECTION

Symptoms	Repair order
All function does not operate.	<ol style="list-style-type: none"><li>1. Check the fuse.</li><li>2. Check the remote control mirror switch.</li><li>3. Check the wiring harness.</li></ol>
One side of the mirror motor does not operate.	<ol style="list-style-type: none"><li>1. Check the remote control mirror switch.</li><li>2. Check the mirror motor.</li><li>3. Check the wiring harness.</li></ol>
Mirror heater does not operate.	<ol style="list-style-type: none"><li>1. Check the defogger switch.</li><li>2. Check the mirror heater.</li><li>3. Check the wiring harness.</li></ol>

#### NOTE:

The mirror heater operates with the rear window defogger at the same time. Refer to "INSPECTION" of "Rear Window Defogger System" for details. <Ref. to GW-32, INSPECTION, Rear Window Defogger System.>

### C: NOTE

For procedure of each component in the remote control mirror system, refer to the respective section.

- Scalp cap: <Ref. to GW-15, Scalp Cap.>
- Outer mirror assembly: <Ref. to GW-16, Outer Mirror Assembly.>
- Outer mirror: <Ref. to GW-17, Outer Mirror.>
- Remote control mirror switch: <Ref. to GW-18, Remote Control Mirror Switch.>

## 7. Scalp Cap

### A: REPLACEMENT

- 1) Remove the mirror. <Ref. to GW-17, REPLACEMENT, Outer Mirror.>
- 2) Press-in the clips (A) from inside of outer mirror.

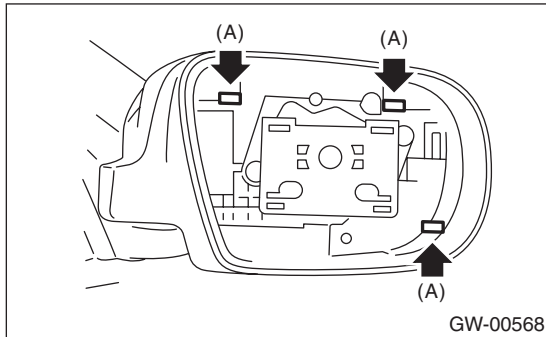

- 3) Pull the scalp cap away from the outer mirror, release upper side clips (A), and then remove the scalp cap.

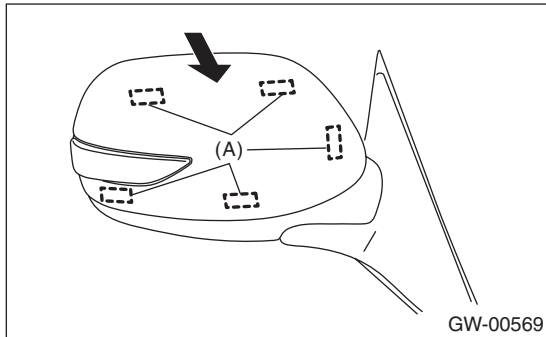

- 4) Install the scalp cap securely.

# Outer Mirror Assembly

GLASS/WINDOWS/MIRRORS

## 8. Outer Mirror Assembly

### A: REMOVAL

- 1) Remove the front door trim. <Ref. to EI-45, FRONT DOOR, REMOVAL, Door Trim.>
- 2) Disconnect the outer mirror connector.
- 3) Remove the bolts to remove outer mirror assembly.

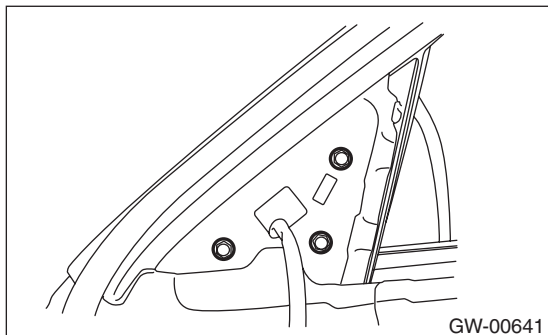

### B: INSTALLATION

Install each part in the reverse order of removal.

#### Tightening torque:

**4.5 N·m (0.46 kgf·m, 3.3 ft·lb)**

### C: INSPECTION

- 1) Disconnect the outer mirror connector.
- 2) Apply battery voltage between the outer mirror connector terminals and check the mirror operation.

- Model without mirror heater

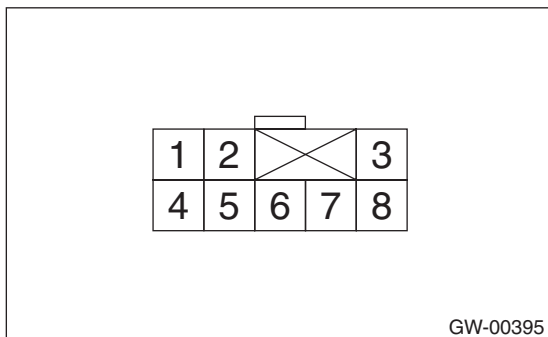

Switch position	Terminal No.
OFF	—
UP	6 (+) and 3 (-)
DOWN	3 (+) and 6 (-)
LEFT	7 (+) and 3 (-)
RIGHT	3 (+) and 7 (-)

- Model with mirror heater

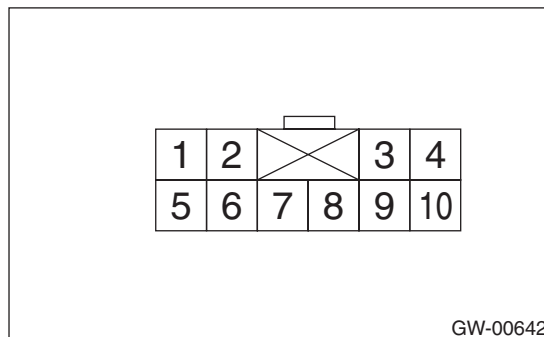

Switch position	Terminal No.
OFF	—
UP	7 (+) and 3 (-)
DOWN	3 (+) and 7 (-)
LEFT	8 (+) and 3 (-)
RIGHT	3 (+) and 8 (-)

- 3) If it does not operate normally, replace the outer mirror assembly.

## 9. Outer Mirror

### A: REPLACEMENT

#### CAUTION:

- When removing the mirror, be careful not to damage the back surface of mirror with a flat tip screwdriver.
  - When installing the mirror, insert the hooks and clips securely.
- 1) Face the mirror upward.
  - 2) Disconnect the ground cable from battery. (Model with mirror heater)
  - 3) Use a flat tip screwdriver to remove clips (A).
  - 4) Lift the lower mirror up to remove hooks (B).

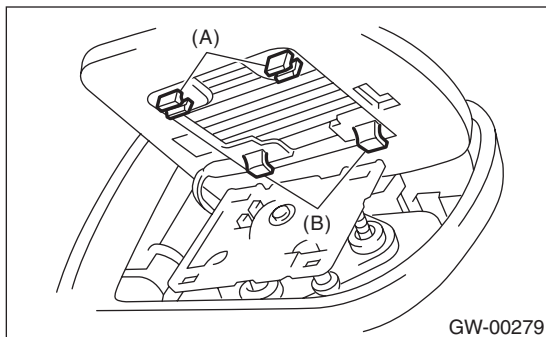

- 5) Disconnect the mirror heater connector from side of the mirror. (Model with mirror heater)

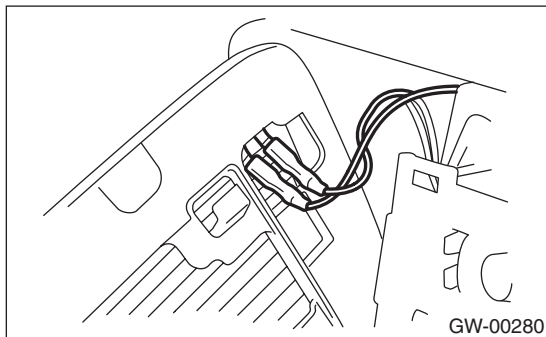

- 6) Catch the hooks (B) and install clips (A).

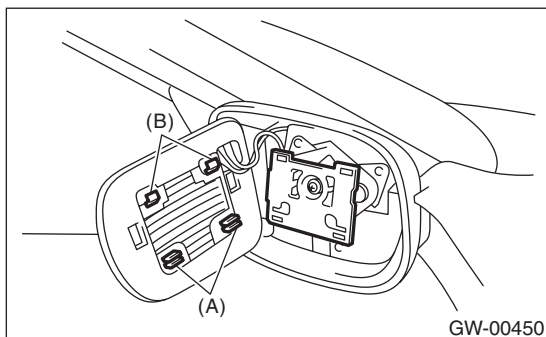

## 10. Remote Control Mirror Switch

### A: REMOVAL

- 1) Remove the instrument panel lower cover. <Ref. to EI-49, REMOVAL, Instrument Panel Lower Cover.>
- 2) Remove the remote control mirror switch from instrument panel lower cover.

### B: INSTALLATION

Install each part in the reverse order of removal.

### C: INSPECTION

- 1) Disconnect the remote control mirror switch connector.
- 2) Check the resistance between remote control mirror switch terminals.

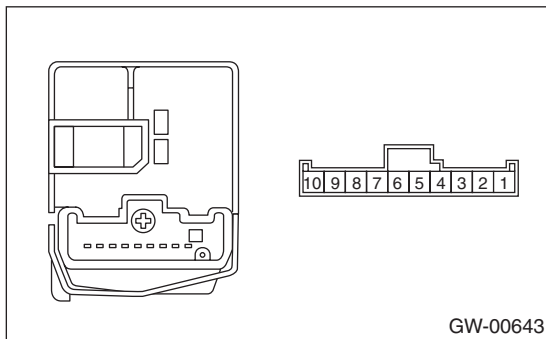

- Switch the change over switch to the right side.

Switch position	Terminal No.	Standard value
OFF	—	1 M $\Omega$ or more
UP	8 and 3, 6 and 7	Less than 1 $\Omega$
DOWN	8 and 6, 3 and 7	Less than 1 $\Omega$
LEFT	8 and 2, 6 and 7	Less than 1 $\Omega$
RIGHT	8 and 6, 2 and 7	Less than 1 $\Omega$

- Switch the change over switch to the left side.

Switch position	Terminal No.	Standard value
OFF	—	1 M $\Omega$ or more
UP	8 and 4, 6 and 7	Less than 1 $\Omega$
DOWN	8 and 6, 4 and 7	Less than 1 $\Omega$
LEFT	8 and 5, 6 and 7	Less than 1 $\Omega$
RIGHT	8 and 6, 5 and 7	Less than 1 $\Omega$

- 3) Replace the remote control mirror switch if the inspection result is not within the standard value.

## 11. Rear Door Glass

### A: REMOVAL

- 1) Remove the rear door trim. <Ref. to EI-46, REAR DOOR, REMOVAL, Door Trim.>
- 2) Remove the sealing cover. <Ref. to EB-24, REMOVAL, Rear Sealing Cover.>
- 3) Operate the power window switch to move the glass, and remove the bolts.

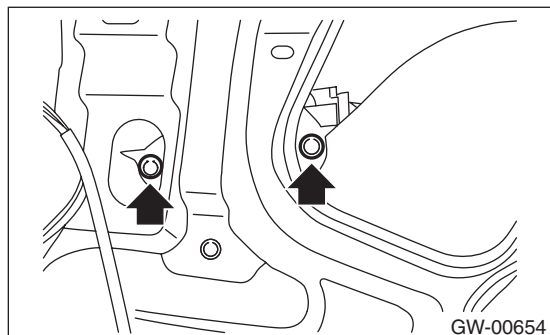

- 4) Remove the glass from the carrier plate, and while holding the glass, lower the carrier plate alone to the lowest position.

#### CAUTION:

Without the carrier plate lowered to the bottom most position, do not lower the glass by itself to the lowest position within the door panel. The glass may come off of the sash, and become damaged.

- 5) Lower the glass slowly to the bottom most position in the door panel.
- 6) Remove the bolts and nuts, and then remove the sash. (Remove the upper attachment point first.)

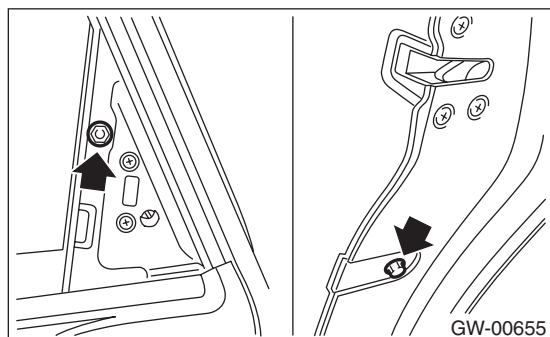

- 7) Remove the glass run rubber.
- 8) Remove the door glass while tilting.

#### CAUTION:

Avoid impact and damage to the glass.

### B: INSTALLATION

#### CAUTION:

Make sure that the glass run rubber is placed securely in door frame and sash.

Install each part in the reverse order of removal.

#### Tightening torque:

Refer to "COMPONENT" of "General Description". <Ref. to GW-5, REAR DOOR GLASS, COMPONENT, General Description.>



# Rear Regulator and Motor Assembly

GLASS/WINDOWS/MIRRORS

---

## 12. Rear Regulator and Motor Assembly

### A: REMOVAL

- 1) Remove the rear door glass. <Ref. to GW-19, REMOVAL, Rear Door Glass.>
- 2) Disconnect the motor connector.
- 3) Remove the bolts, and then remove the rear regulator and motor assembly.

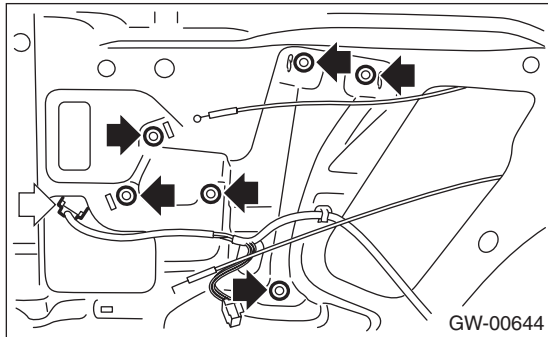

### B: INSTALLATION

Install each part in the reverse order of removal.

#### **Tightening torque:**

**Refer to "COMPONENT" of "General Description". <Ref. to GW-5, REAR DOOR GLASS, COMPONENT, General Description.>**

### C: INSPECTION

- 1) Disconnect the motor connector.
- 2) Apply battery voltage between the motor connector terminals and check the motor operation. Check to ensure that the motor rotates in reverse direction when the terminal to which battery voltage is applied is changed.
- 3) If the inspection results in improper operation, replace the rear regulator and motor assembly.

## 13. Windshield Glass

### A: REMOVAL

#### 1. WHEN USING WINDSHIELD GLASS KNIFE

##### CAUTION:

Apply protective tape, etc, and be careful that the inner and outer components of the vehicle are not damaged.

- 1) Disconnect the ground cable from battery. (Model with wiper deicer)
- 2) Remove the front pillar upper trim. <Ref. to EI-59, REMOVAL, Upper Inner Trim.>
- 3) Disconnect the wiper deicer connector. (Model with wiper deicer)
- 4) Remove the cowl panel. <Ref. to EI-40, REMOVAL, Cowl Panel.>
- 5) Remove the glass molding.
- 6) Tape the body side of the circumference of windshield glass for protection.
- 7) Apply sufficient amount of soapy water to the adhesive part.
- 8) Make a slit using a cutter knife to make it easier to insert the windshield glass knife.
- 9) Insert the windshield glass knife into adhesive part.

10) While holding the knife edge and windshield glass edge at a right angle, move the windshield glass knife in parallel to the windshield glass edge along the surface and edge of windshield glass to cut the adhesive part.

##### NOTE:

- Do not twist the windshield glass knife.
- Cutting of adhesive part shall be started with wider gap between windshield glass and body.

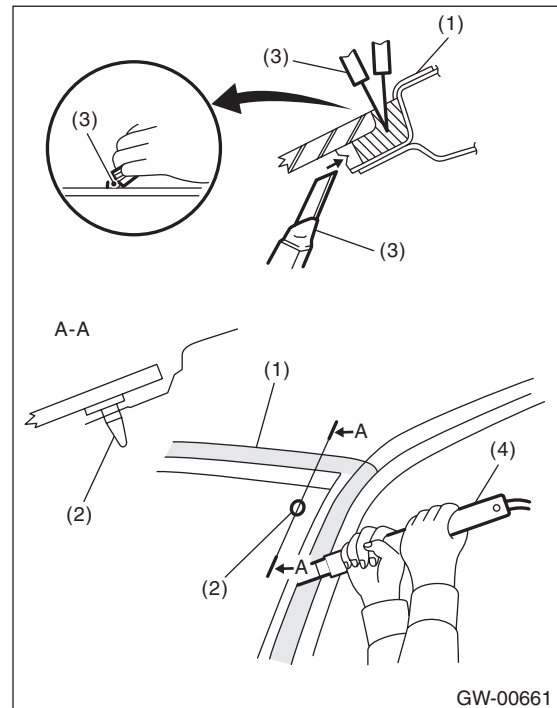

- (1) Tape for protection
- (2) Locating pin
- (3) Cutter knife
- (4) Windshield glass knife

- The locating pins are bonded to the corners of glass. Use piano wire to disconnect the pins.

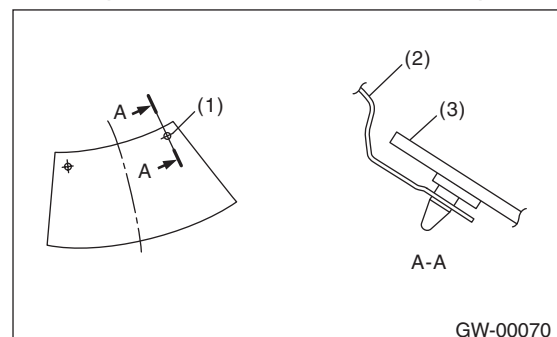

- (1) Locating pin
- (2) Body panel
- (3) Windshield glass

# Windshield Glass

GLASS/WINDOWS/MIRRORS

## 2. WHEN USING PIANO WIRE

### CAUTION:

- Do not tightly pull the piano wire against the windshield glass edge.
- Apply protective tape, etc, and be careful that the inner and outer components of the vehicle are not damaged.
- Do not cross piano wires. Otherwise they may be cut.

- 1) Disconnect the ground cable from battery. (Model with wiper deicer)
- 2) Remove the front pillar upper trim. <Ref. to EI-59, REMOVAL, Upper Inner Trim.>
- 3) Disconnect the wiper deicer connector. (Model with wiper deicer)
- 4) Remove the cowl panel. <Ref. to EI-40, REMOVAL, Cowl Panel.>
- 5) Remove the glass molding.
- 6) Tape the body side of the circumference of windshield glass for protection.
- 7) Make a hole in the adhesive part using drill or cutter knife.
- 8) Pass the piano wire through the hole, and attach both the wire ends securely to pieces of wood.

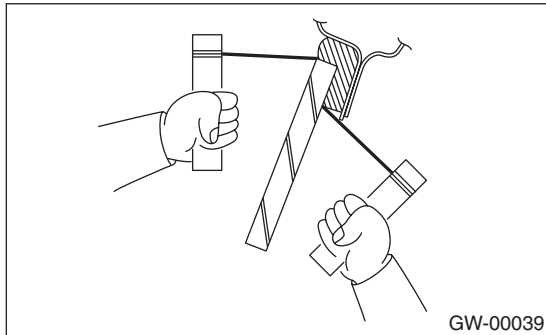

- 9) Pull the wire ends alternately to cut off the adhesive part.

## B: INSTALLATION

- 1) Fabricate the cartridge nozzle tip as shown and set the sealant gun with the adhesive.

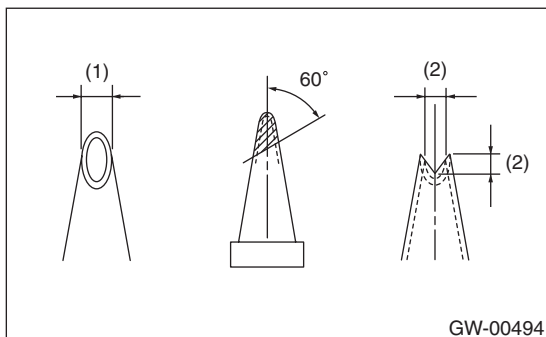

- (1) 10 mm (0.39 in)
- (2) 8 mm (0.31 in)

- 2) Clean the external circumference of windshield glass with alcohol or white gasoline.
- 3) Remove the adhesive layer on the body using cutter knife to obtain smooth face of 2 mm (0.08 in) thick.

### CAUTION:

Be careful not to damage the body and paint surface.

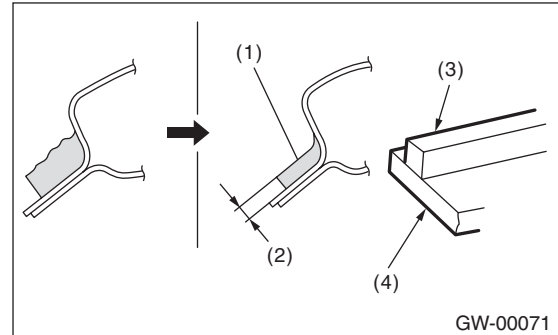

- (1) Adhesive
- (2) 2 mm (0.08 in)
- (3) Dam rubber
- (4) Glass

- 4) Clean the body with alcohol or white gasoline to eliminate cutting powder, dust and dirt completely from body.
- 5) Install the dam rubber.

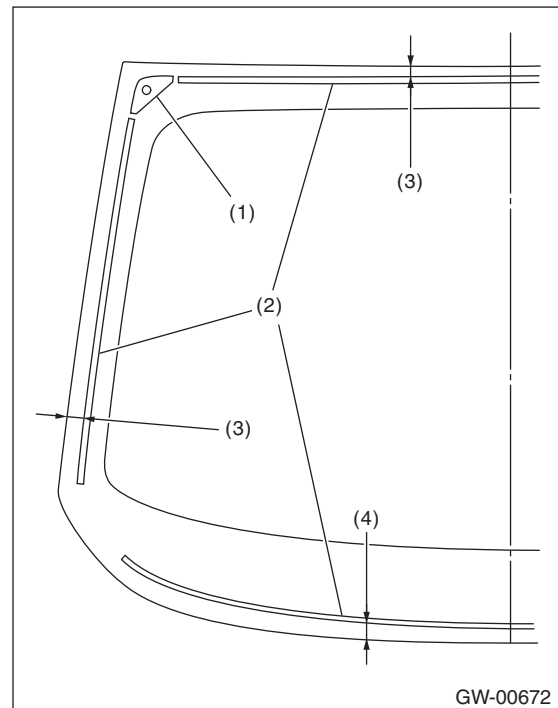

- (1) Locating pin
- (2) Dam rubber
- (3) 11 mm (0.43 in)
- (4) 14.5 mm (0.57 in)

GW-22

Brought to you by Ebay Seller "SubaruManuals"

6) Apply the seal to the glass. (driver's side only)

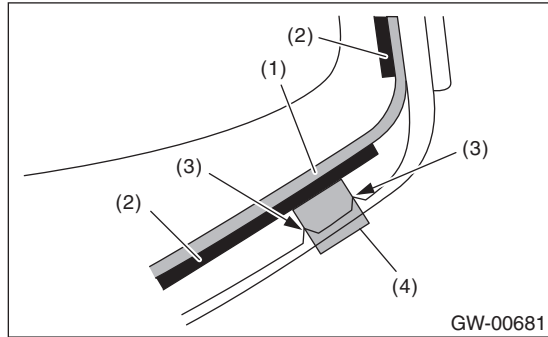

- (1) Adhesive
- (2) Dam rubber
- (3) Ceramic print cutout portion
- (4) Seal

**NOTE:**

Apply the sticker between the cut out (3) at the ceramic print on the bottom part of the glass (driver's side).

Attach the seal and dam rubber so that there are no gap by pressing on them.

7) Install the molding to the glass.

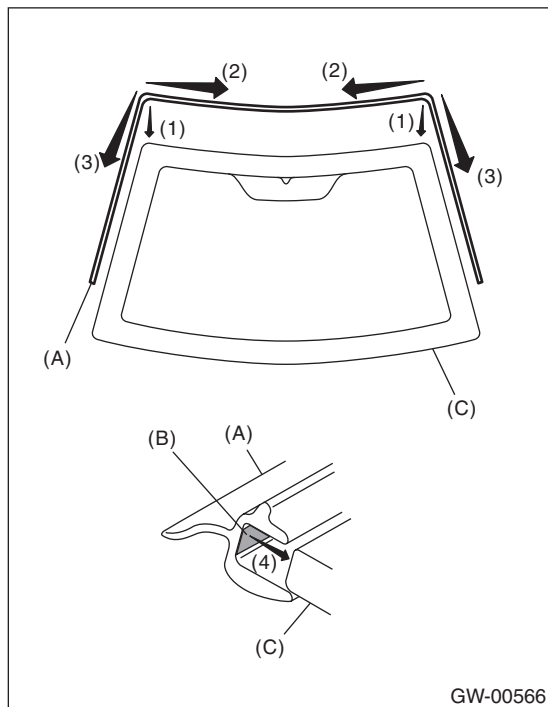

- (1) Align the molding (A) with both ends of the upper edge of the windshield glass (C).
- (2) Install the molding from both corners of the upper edge toward the center.
- (3) Install the molding from both corners of the upper edge toward the lower side.
- (4) Apply the double-sided tapes (B) of the molding uniformly on both sides of the glass.

8) Apply the primer to the adhesive surface of glass side and body side using sponge.

**Glass primer:**

**Dow Automotive's  
ESSEX U-401, U-402 or equivalent**

**Painted surface primer:**

**Dow Automotive's  
ESSEX U-413 or equivalent**

**NOTE:**

- Primer once attached to the painted surface of the body and internal trim is hard to wipe off. Mask the circumference of such area.
- Let primer dry for about ten minutes before installing the glass.
- Do not touch the surface coated with primer.

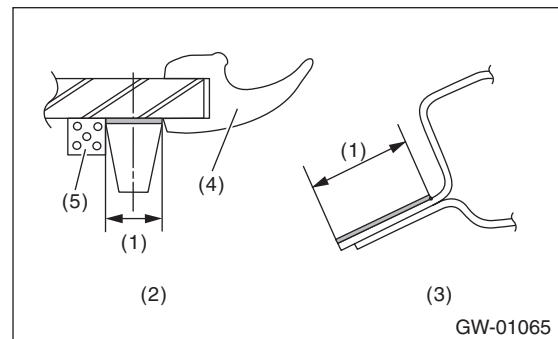

- (1) Application of primer
- (2) Glass side
- (3) Body side
- (4) Molding
- (5) Dam rubber

# Windshield Glass

## GLASS/WINDOWS/MIRRORS

9) Apply adhesive to the glass end surface as shown.

### Adhesive:

**Dow Automotive's  
ESSEX U-400HV or equivalent**

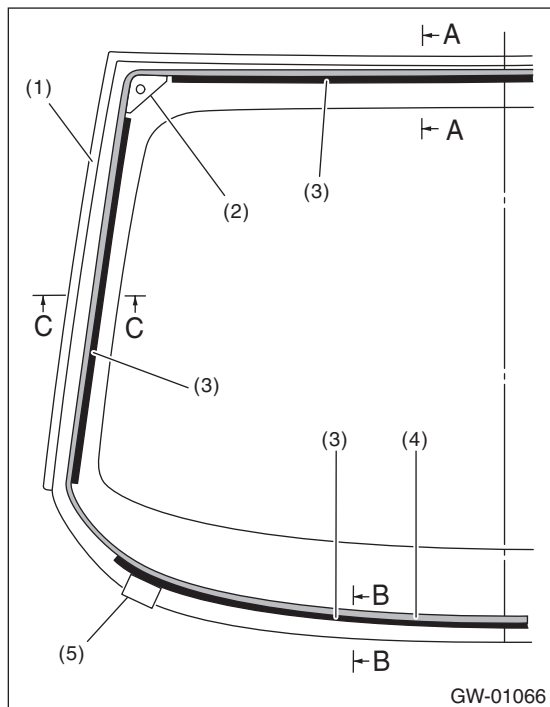

- (1) Molding
- (2) Locating pin
- (3) Dam rubber
- (4) Adhesive
- (5) Seal (driver's side only)

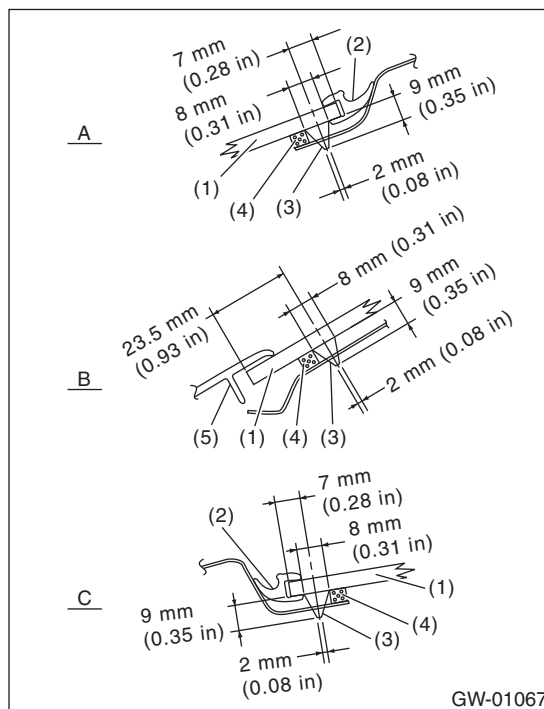

- A Upper end
- B Lower end
- C Side end

- (1) Glass
- (2) Molding
- (3) Adhesive
- (4) Dam rubber
- (5) Cowl panel

10) Fit the locating pins to vehicle body using suction rubber cup to install the windshield glass.

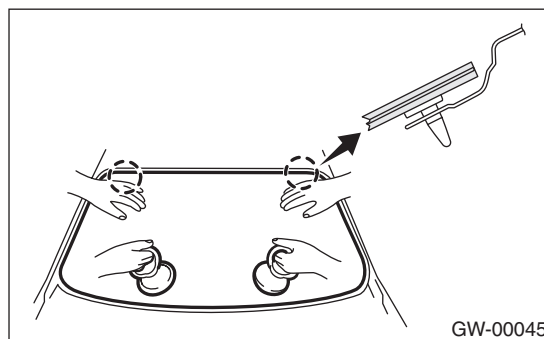

11) Lightly press the windshield glass for tight fit.  
12) Make flush the adhesive surface jugged out using spatula.

13) After completion of all work, allow the vehicle to stand for about 24 hours.

**NOTE:**

- When door is opened/closed after glass is bonded, always lower the door glass first, and then open/close it carefully.
- Move the vehicle slowly.
- For minimum drying time and vehicle standing time before driving after bonding, follow instructions or instruction manual from the adhesive manufacturer.

14) After curing of adhesive, pour the water on external surface of vehicle to check that there are no water leaks.

**NOTE:**

When a vehicle is returned to the user, tell him or her that the vehicle should not be subjected to heavy impact for at least three days.

15) Install the cowl panel. <Ref. to EI-40, INSTALLATION, Cowl Panel.>

16) Connect the wiper deicer connector. (Models with wiper deicer)

17) Install the front pillar upper trim. <Ref. to EI-59, INSTALLATION, Upper Inner Trim.>

# Rear Gate Glass

GLASS/WINDOWS/MIRRORS

## 14. Rear Gate Glass

### A: REMOVAL

- 1) Remove the roof spoiler. <Ref. to EI-41, REMOVAL, Roof Spoiler.>
- 2) Remove the rear wiper motor. <Ref. to WW-20, REMOVAL, Rear Wiper Motor.>
- 3) Disconnect the connectors from rear defogger terminal.
- 4) Remove the rear gate glass in the same procedure as for windshield glass. <Ref. to GW-21, REMOVAL, Windshield Glass.>

### B: INSTALLATION

- 1) Apply the primer to the glass and body sides in the same procedure as for windshield glass. <Ref. to GW-22, INSTALLATION, Windshield Glass.>
- 2) Fabricate the cartridge nozzle tip as shown and set the sealant gun with the adhesive.

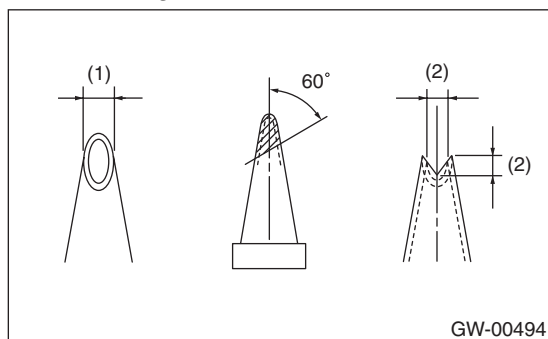

- (1) 10 mm (0.39 in)
- (2) 8 mm (0.31 in)

- 3) Install the molding.

- 4) Apply adhesive in the same procedure as for windshield glass. <Ref. to GW-22, INSTALLATION, Windshield Glass.>

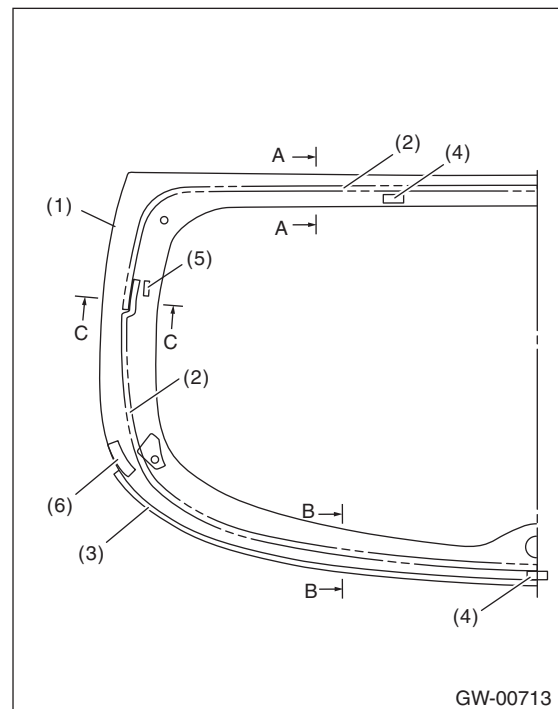

- (1) Glass
- (2) Adhesive
- (3) Molding
- (4) Spacer
- (5) Heat wire terminal
- (6) Seal

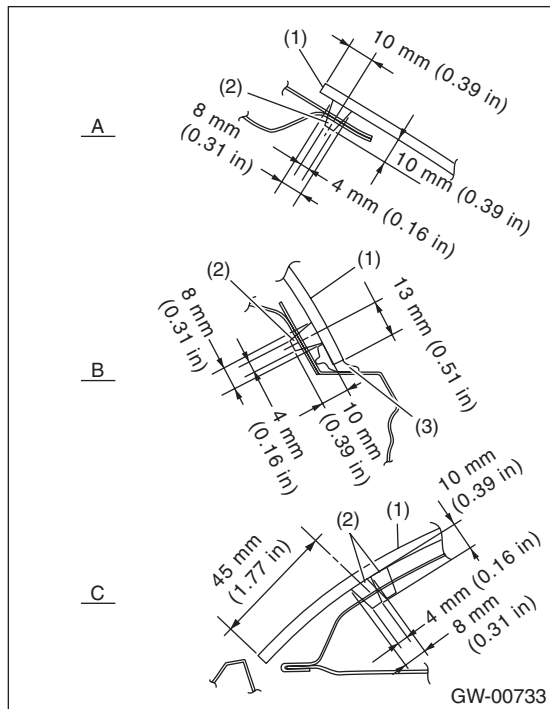

- A Upper end
- B Lower end
- C Side end

- (1) Glass
- (2) Adhesive
- (3) Molding

5) Insert the glass locating pin into the hole on rear gate panel and push on the area around the locating pin to secure it.

**NOTE:**

Insert the locating pin into the lower hole of the rear gate panel.

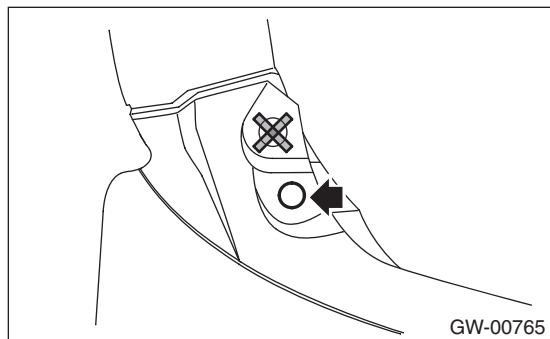

- 6) Push lightly all around the locating pin to seal it.
- 7) After completion of all work, allow the vehicle to stand for about 24 hours.

**NOTE:**

- When door is opened/closed after glass is bonded, always lower the door glass first, and then open/close it carefully.
- Move the vehicle slowly.
- For minimum drying time and vehicle standing time before driving after bonding, follow instructions or instruction manual from the adhesive manufacturer.

8) Connect the rear defogger terminals.

9) Install the rear wiper motor. <Ref. to WW-20, INSTALLATION, Rear Wiper Motor.>

10) Install the roof spoiler. <Ref. to EI-41, INSTALLATION, Roof Spoiler.>

11) After curing of adhesive, pour the water on external surface of vehicle to check that there are no water leaks.

**NOTE:**

When a vehicle is returned to the user, tell him or her that the vehicle should not be subjected to heavy impact for at least three days.



# Rear Gate Glass

## GLASS/WINDOWS/MIRRORS

### C: REPLACEMENT

When replacing only the molding, perform work according to the following procedures. (when reusing the rear gate glass)

- 1) Remove the rear gate glass from the vehicle. <Ref. to GW-26, REMOVAL, Rear Gate Glass.>
- 2) From the removed rear gate glass, completely remove the adhesive and molding.
- 3) Check the silver print (1) (2) (3) (4) of the rear gate glass on the passenger room side surface.

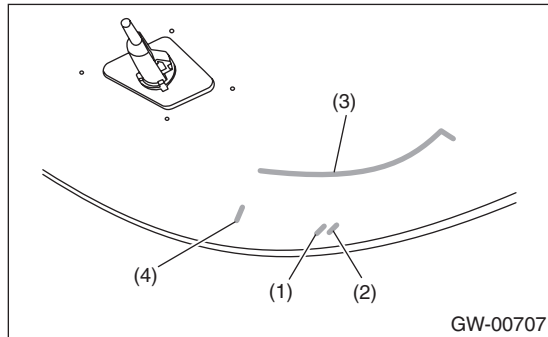

- 4) Degrease the rear gate glass (passenger room side) molding adhesive surface (A) with a primer.

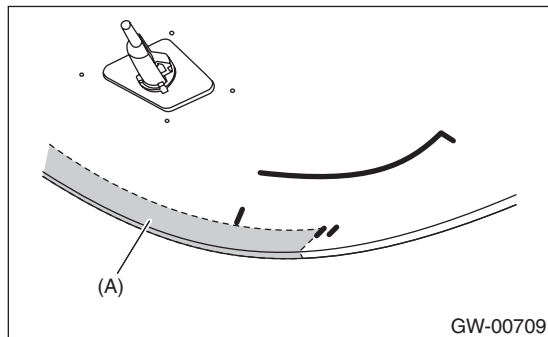

- 5) Remove the backing paper of the molding, and match the silver print (1) and the end of the molding.

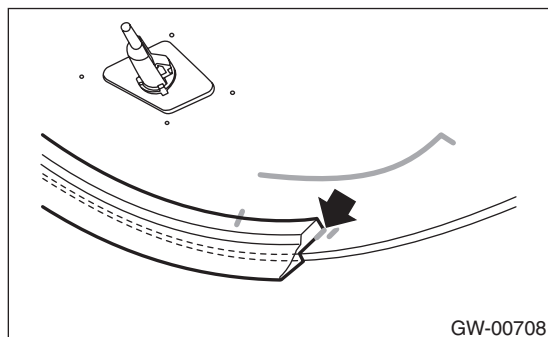

- 6) Match the corner of the molding to the corner of the glass end surface, and adhere the molding to be within the silver print (1) on both sides.

#### CAUTION:

- Apply the molding without pulling it, and while applying pressure.
- After applying, push on the molding lightly to affix securely.
- Temporarily mount the glass, and make sure that there are no gaps between the molding and the rear gate panel.

#### NOTE:

When application of the molding is finished, if there is protrusion from the silver print (1) on the other side, cut with a razor blade so that the left and right are symmetric, and so that it fits between the silver print (1) and (2).

- 7) Degrease the rear gate glass seal adhesion surface (B) with primer.

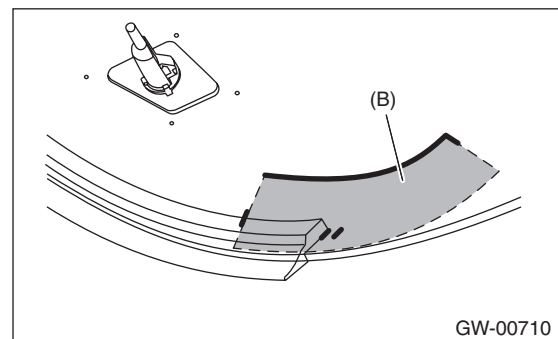

8) Remove the backing sheet of the sticker, and apply the sealer based on the positions of the silver print (3) and (4) of the rear gate glass (passenger room side).

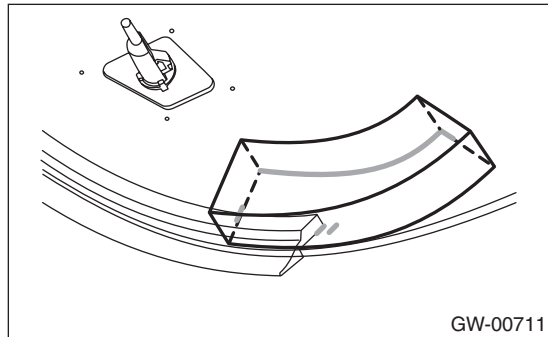

**CAUTION:**

- Because the seal is applied on top of the molding, make sure to apply so that there is no gap at side face (C) of the molding.
- Apply so that the end of the seal does not protrude from the end of the glass. If it protrudes from the glass, reapply.

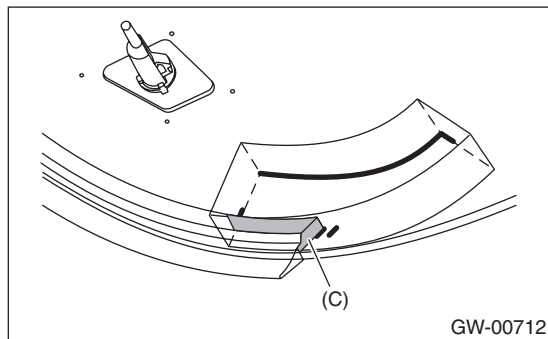

# Rear Window Glass

GLASS/WINDOWS/MIRRORS

## 15. Rear Window Glass

### A: REMOVAL

- 1) Disconnect the ground cable from battery.
- 2) Remove the rear wiper motor. <Ref. to WW-20, REMOVAL, Rear Wiper Motor.>
- 3) Disconnect the connectors from rear defogger terminal.
- 4) Remove the rear window glass in the same procedure as for windshield glass. <Ref. to GW-21, REMOVAL, Windshield Glass.>

### B: INSTALLATION

- 1) Apply the primer to the glass and body sides in the same procedure as for windshield glass. <Ref. to GW-22, INSTALLATION, Windshield Glass.>
- 2) Fabricate the cartridge nozzle tip as shown and set the sealant gun with the adhesive.

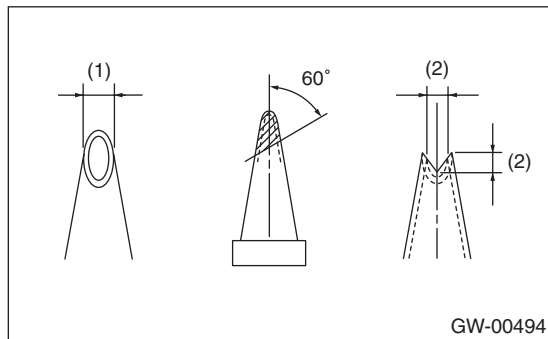

- (1) 10 mm (0.39 in)
- (2) 8 mm (0.31 in)

- 3) Apply adhesive with the dam rubber installed in the same procedure as for windshield glass. <Ref. to GW-22, INSTALLATION, Windshield Glass.>

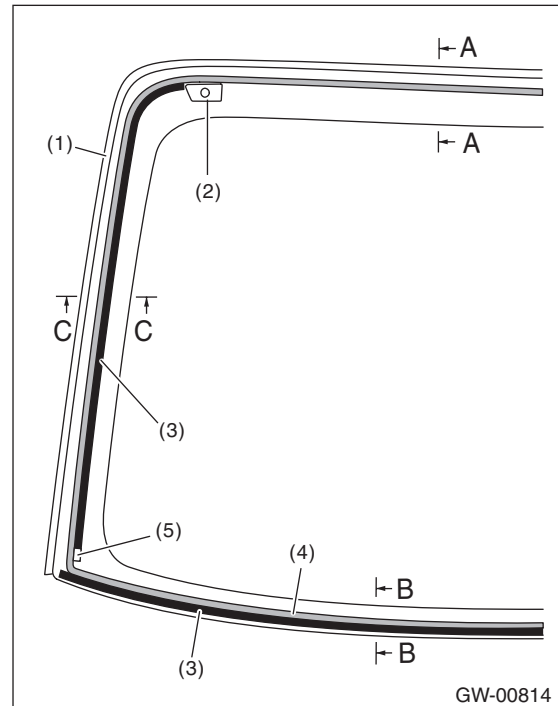

- (1) Molding
- (2) Locating pin (adhered)
- (3) Dam rubber
- (4) Adhesive
- (5) Spacer

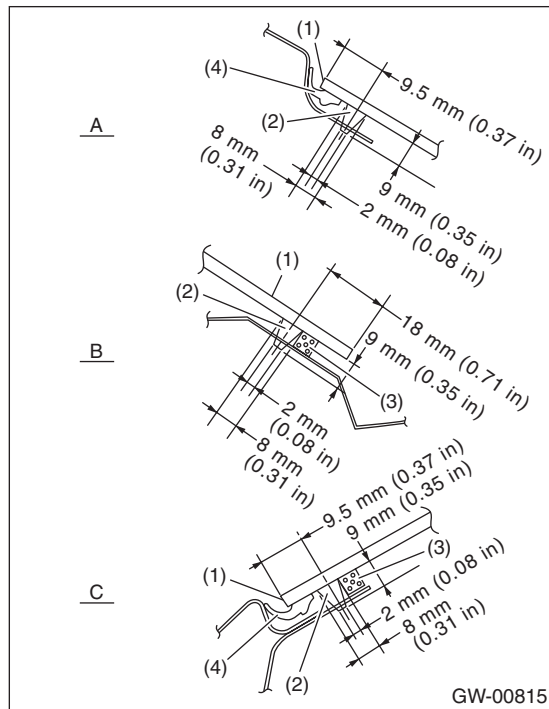

- A Upper end
- B Lower end
- C Side end

- (1) Glass
- (2) Adhesive
- (3) Dam rubber
- (4) Molding

4) Install the glass in the same procedure as for windshield glass. <Ref. to GW-22, INSTALLATION, Windshield Glass.>

5) After completion of all work, allow the vehicle to stand for about 24 hours.

**NOTE:**

- When door is opened/closed after glass is bonded, always lower the door glass first, and then open/close it carefully.
- Move the vehicle slowly.
- For minimum drying time and vehicle standing time before driving after bonding, follow instructions or instruction manual from the adhesive manufacturer.

6) Connect the rear defogger terminals.

7) Install the rear wiper motor. <Ref. to WW-20, INSTALLATION, Rear Wiper Motor.>

8) After curing of adhesive, pour the water on external surface of vehicle to check that there are no water leaks.

**NOTE:**

When a vehicle is returned to the user, tell him or her that the vehicle should not be subjected to heavy impact for at least three days.

# Rear Window Defogger System

GLASS/WINDOWS/MIRRORS

## 16. Rear Window Defogger System

### A: WIRING DIAGRAM

Refer to "Rear Defogger System" in the wiring diagram. <Ref. to WI-135, WIRING DIAGRAM, Rear Defogger System.>

### B: INSPECTION

#### 1. SYSTEM INSPECTION

Symptom	Repair order
Rear window defogger does not operate.	<ol style="list-style-type: none"> <li>1. Check the fuse.</li> <li>2. Check the rear defogger relay.</li> <li>3. Check the rear defogger switch.</li> <li>4. Check the heat wire.</li> <li>5. Check the wiring harness.</li> <li>6. Check body integrated unit.</li> </ol>

#### NOTE:

Rear window defogger system can be customized on the Subaru Select Monitor, when the body integrated unit customize setting {A/C ECM setting} is "support".

System name	Initial setting	Customize setting
Rr defogger op. mode	OFF after 15 min.	Repeat 15 min. operation and 2 min. stop.

#### 2. CHECK WITH SUBARU SELECT MONITOR

#### CAUTION:

**Check whether the "Rr defogger op. mode" setting is in initial setting or customize setting before performing inspection.**

1) Check the input signal when the rear window defogger switch is operated using Subaru Select Monitor.

(1) Prepare the Subaru Select Monitor. <Ref. to GW-7, PREPARATION TOOL, General Description.>

(2) Turn the ignition switch to ON (engine OFF) and run the "PC application for Subaru Select Monitor".

(3) On «System Selection Menu» display, select {Integ. unit mode}.

(4) Select the {Rr defogger output} on {Current Data Display & Save}.

(5) Check the displayed data (ON/OFF) by operating the rear window defogger switch.

2) Check the operation with rear window defogger switch ON.

- When customize setting is set as "Continuous", it is normal if the 15-minute operation and 2-minute stop repeats.

- When customize setting is "Normal", it is normal if the operation lasts for 15 minutes and then turns OFF.

3) When the operation in 2) above fails, replace the body integrated unit.

#### 3. HEAT WIRE INSPECTION

#### CAUTION:

**When wiping off the stain on glass with cloth, use a dry and soft cloth and move it in the direction of the heat wire extension to avoid damage to the heat wire.**

1) Prepare the following checking items.

- Liquid crystal thermograph sheet (approximate size: 300 × 300 mm (11.8 × 11.8 in) and thermal temperature: 35 — 40°C (95 — 104°F))

- Aluminum foil

2) Turn the ignition switch to ON.

3) Turn the defogger switch to ON.

4) Push the liquid crystal thermograph sheet from the outside of the rear glass.

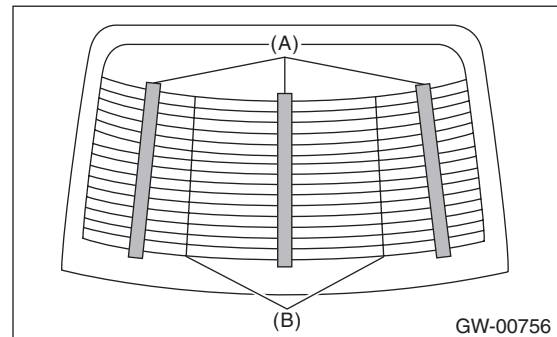

(A) Liquid crystal thermograph sheet

(B) Separate line

#### NOTE:

Use the liquid crystal thermograph sheet every range it is separated with the separate line.

5) Determine the faulty heat wire by checking the color of the liquid crystal thermograph sheet.

Liquid crystal thermograph sheet	Criteria
Change occurred (red → blue)	Normal
No change (black)	Open

#### NOTE:

- Check from the inside of the glass if the liquid crystal thermograph sheet does not change.

- The time for the color change may differ depends on the surface temperature of the glass.

6) Wrap a piece of aluminum foil around the tip of tester probe and press it against the heat wire with your finger.

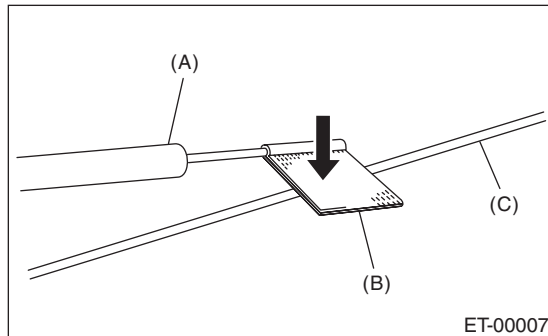

- (A) Tester probe
- (B) Aluminum foil
- (C) Heat wire

7) To both ends of the section that has been found to include an open in the step 5), apply the tester positive (+) probe and the negative (-) probe.

8) Move the tester probe on the negative (-) side slowly along the heat wire. If voltage changes from zero to several volts during movement of tester probe, heat wire is open at the voltage change point.

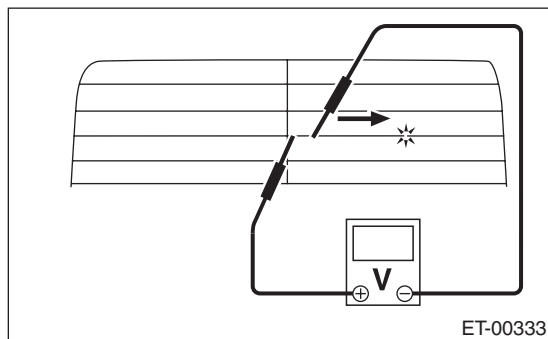

9) Repair the heat wire that determines the place of the open circuit. <Ref. to GW-33, REPAIR, Rear Window Defogger System.>

## C: REPAIR

- 1) Clean the broken portion with alcohol or white gasoline.
- 2) Mask both side of wire with masking tape.
- 3) Apply the conductive silver composition to the broken portion.

### Conductive silver composition:

**Permatex's  
QUICK GRID**

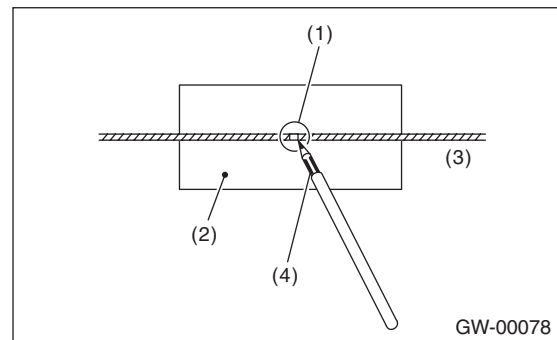

- (1) Broken portion
- (2) Masking tape
- (3) Broken wire
- (4) Conductive silver composition

- 4) Dry using a dryer after applying the composition.
- 5) After repair, check the wire.

# Rear Quarter Glass

GLASS/WINDOWS/MIRRORS

## 17.Rear Quarter Glass

### A: REMOVAL

- 1) Disconnect the ground cable from battery.
- 2) Remove the rear quarter trim.
  - 5 door model: <Ref. to EI-60, 5 DOOR MODEL, REMOVAL, Rear Quarter Trim.>
  - 4 door model: <Ref. to EI-61, 4 DOOR MODEL, REMOVAL, Rear Quarter Trim.>
- 3) Remove the rear quarter glass in the same procedure as for windshield glass. <Ref. to GW-21, REMOVAL, Windshield Glass.>

### B: INSTALLATION

#### 1. 5 DOOR MODEL

- 1) Mount the fastener on the vehicle body.
- 2) Apply the primer to the glass and body sides in the same procedure as for windshield glass. <Ref. to GW-22, INSTALLATION, Windshield Glass.>

#### CAUTION:

**Do not allow the primer to come in contact with the molding during the application of the primer.**

- 3) Fabricate the cartridge nozzle tip as shown and set the sealant gun with the adhesive.

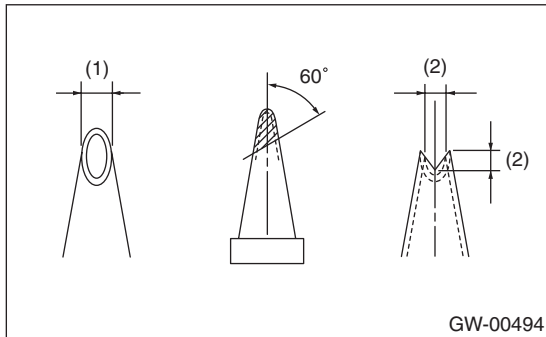

- (1) 10 mm (0.39 in)
- (2) 8 mm (0.31 in)

- 4) Apply adhesive with the dam rubber installed in the same procedure as for windshield glass. <Ref. to GW-22, INSTALLATION, Windshield Glass.>

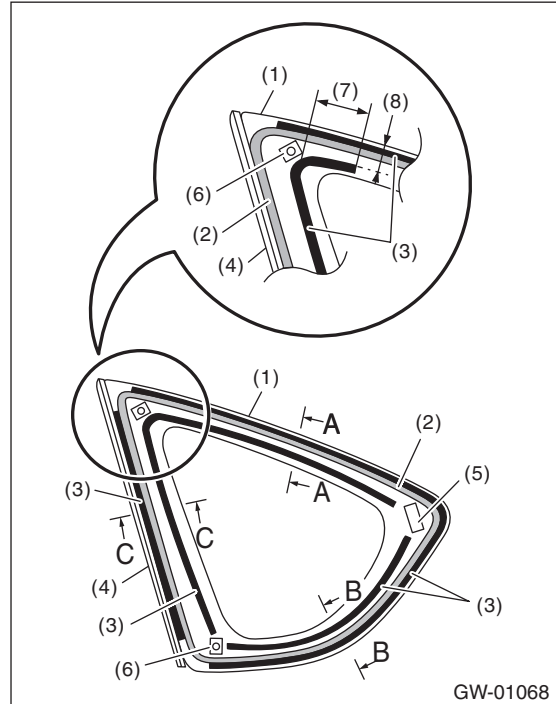

- (1) Glass
- (2) Adhesive
- (3) Dam rubber
- (4) Molding
- (5) Fastener
- (6) Clip
- (7) 66 mm (2.60 in)
- (8) 17 mm (0.61 in)

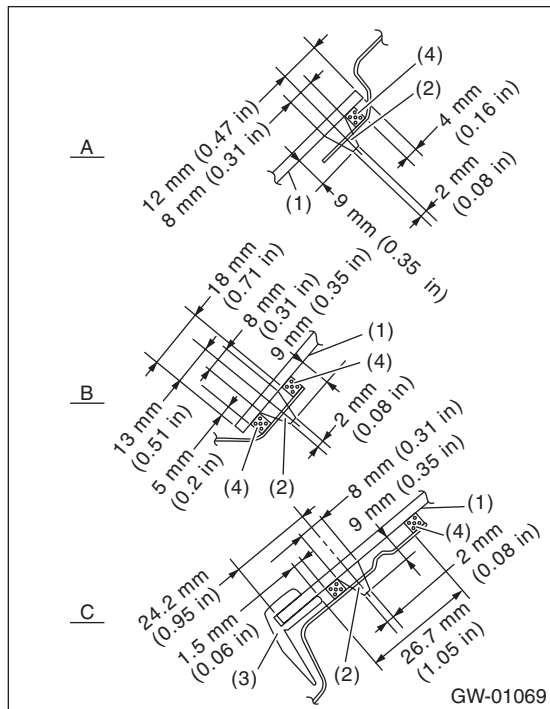

- A Upper end
- B Lower end
- C Front end

- (1) Glass
- (2) Adhesive
- (3) Molding
- (4) Dam rubber

5) Insert the glass locating pin into the hole on side panel and push on the area around the locating pin to secure it.

Then push lightly all around the locating pin to seal it.

6) After completion of all work, allow the vehicle to stand for about 24 hours.

**NOTE:**

- When door is opened/closed after glass is bonded, always lower the door glass first, and then open/close it carefully.
- Move the vehicle slowly.
- For minimum drying time and vehicle standing time before driving after bonding, follow instructions or instruction manual from the adhesive manufacturer.

7) After curing of adhesive, pour the water on external surface of vehicle to check that there are no water leaks.

**NOTE:**

When a vehicle is returned to the user, tell him or her that the vehicle should not be subjected to heavy impact for at least three days.

8) Install the rear quarter trim. <Ref. to EI-61, INSTALLATION, Rear Quarter Trim.>

**2. 4 DOOR MODEL**

- 1) Mount the fastener on the vehicle body.
- 2) Apply the primer to the glass and body sides in the same procedure as for windshield glass. <Ref. to GW-22, INSTALLATION, Windshield Glass.>
- 3) Fabricate the cartridge nozzle tip as shown and set the sealant gun with the adhesive.

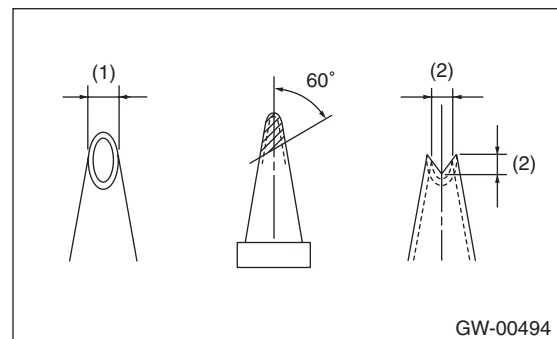

- (1) 10 mm (0.39 in)
- (2) 8 mm (0.31 in)



## Rear Quarter Glass

### GLASS/WINDOWS/MIRRORS

4) Apply adhesive with the dam rubber installed in the same procedure as for windshield glass. <Ref. to GW-22, INSTALLATION, Windshield Glass.>

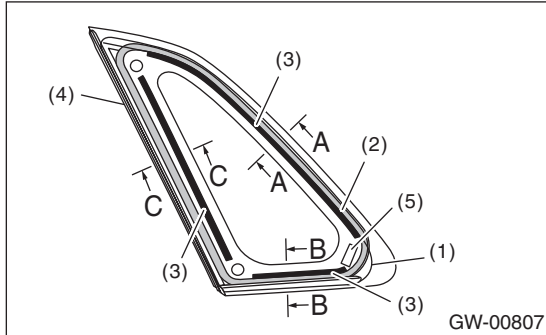

- (1) Glass
- (2) Adhesive
- (3) Dam rubber
- (4) Molding
- (5) Fastener

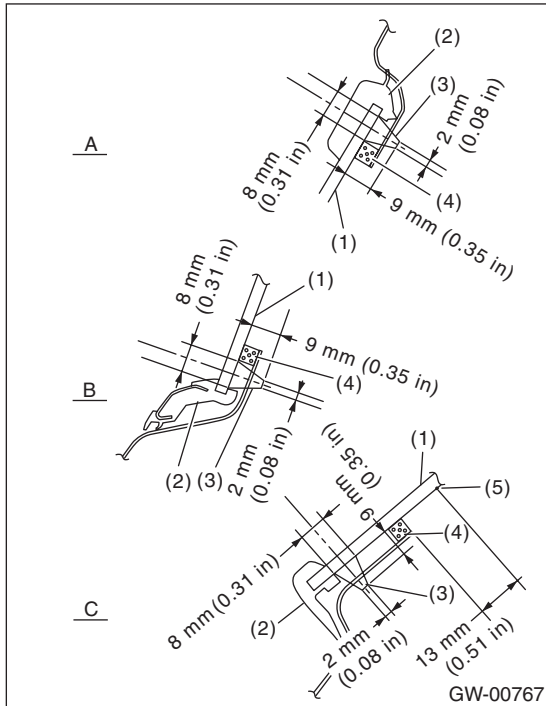

- A Upper end
- B Lower end
- C Front end

- (1) Glass
- (2) Molding
- (3) Adhesive
- (4) Dam rubber
- (5) Ceramic line edge

5) Insert the glass locating pin into the hole on side panel and push on the area around the locating pin to secure it. Then push lightly all around the locating pin to seal it.

6) After completion of all work, allow the vehicle to stand for about 24 hours.

#### NOTE:

- When door is opened/closed after glass is bonded, always lower the door glass first, and then open/close it carefully.
- Move the vehicle slowly.
- For minimum drying time and vehicle standing time before driving after bonding, follow instructions or instruction manual from the adhesive manufacturer.

7) After curing of adhesive, pour the water on external surface of vehicle to check that there are no water leaks.

#### NOTE:

When a vehicle is returned to the user, tell him or her that the vehicle should not be subjected to heavy impact for at least three days.

8) Install the rear quarter trim. <Ref. to EI-61, INSTALLATION, Rear Quarter Trim.>

## 18. Rearview Mirror

### A: REMOVAL

#### CAUTION:

- Never reuse the spring. When the rearview mirror assembly is removed from the mirror base, fixed force will decline and the rearview mirror assembly may come off.
- Be careful not to damage the mirror surface and windshield glass.

#### NOTE:

Never reuse the spring. Prepare a new spring before removal.

- 1) Turn the mirror base 90° clockwise or counterclockwise to remove it.

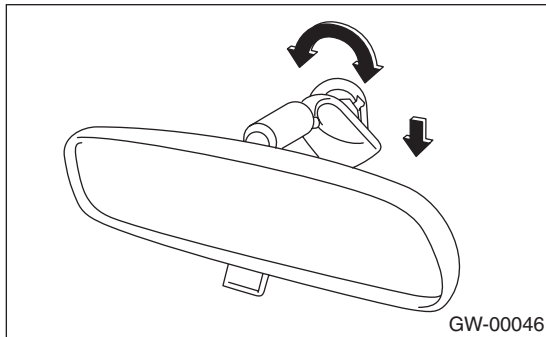

- 2) Remove the spring from the mirror base.

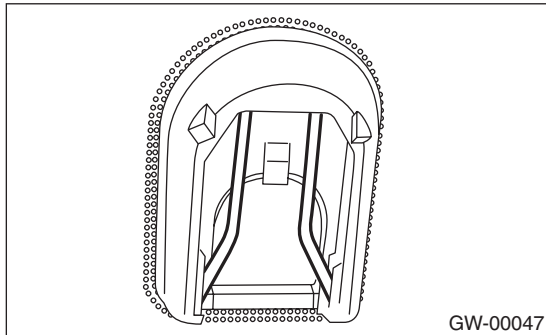

- 3) When the mirror base is damaged, use a piano wire, spatula, etc. to remove.

### B: INSTALLATION

Install each part in the reverse order of removal.

#### NOTE:

If the mirror base is removed, install it in the following procedure.

1. Clean the old adhesive completely.
2. Align the mirror base with the mark on the windshield glass to install it.
3. Make sure the mirror base is securely attached and then install the spring to it.

#### Adhesive

**REPAIR KIT IN MR (Part No. 65029FC000) or equivalent**

### C: INSPECTION

Check the mirror, mirror base and spring for damage, and replace if defective.

# Wiper Deicer System

GLASS/WINDOWS/MIRRORS

## 19. Wiper Deicer System

### A: WIRING DIAGRAM

Refer to "Wiper Deicer System" in the wiring diagram. <Ref. to WI-112, WIRING DIAGRAM, Wiper Deicer System.>

### B: INSPECTION

#### 1. SYSTEM INSPECTION

NOTE:

- The wiper deicer does not operate when the ambient temperature becomes 5°C (41°F) or more.
- The wiper deicer operates with the rear window defogger at the same time.
- It is possible to perform a forced operation if you keep holding the rear window defogger switch for 3 seconds or more.

Symptoms	Inspection order
Wiper deicer does not operate.	<ol style="list-style-type: none"><li>1. Check the fuse.</li><li>2. Check the wiper deicer relay.</li><li>3. Check the rear defogger switch.</li><li>4. Check the heat wire.</li><li>5. Check the wiring harness.</li><li>6. Check body integrated unit.</li></ol>

NOTE:

- Wiper deicer system can be customized using the Subaru Select Monitor, when the customize setting {A/C ECM setting} of the body integrated unit is set to With.
- Set the system using the Rr Defogger op. mode, and setting will be the same as rear defogger system setting.

System name	Initial setting	Customize setting
Rr defogger op. mode	OFF after 15 min.	Continuous operation*

\*: When one of the following conditions occurs, continuous operation is suspended and turned off after 15 minutes.

- Ambient temperature at 5°C (41°F) or more continues for 10 seconds.
- Malfunction occurs on ambient sensor.
- Vehicle speed of 15 km/h (9 MPH) or less continues 15 minutes (OFF when conditions are met)
- Malfunction occurs in CAN communication.
- Battery voltage remains at 10 V or less for 30 seconds.
- SI-DRIVE [I] mode driving continues for 10 seconds.

#### 2. CHECK WITH SUBARU SELECT MONITOR

CAUTION:

Before performing the inspection, check the following settings.

- Wiper deicer setting → "support". If "no support", set to "support" using customize setting.
- "Rr defogger op. mode" setting → Initial setting or customize setting

1) Check the input signal when the rear window defogger switch is operated using Subaru Select Monitor.

(1) Prepare the Subaru Select Monitor. <Ref. to GW-7, PREPARATION TOOL, General Description.>

(2) Turn the ignition switch to ON (engine OFF) and run the "PC application for Subaru Select Monitor".

(3) On «System Selection Menu» display, select {Integ. unit mode}.

(4) Select the {wiper deicer output} on {Current Data Display & Save}.

(5) Check the displayed data (ON/OFF) by operating the rear window defogger switch.

2) Check the operation with rear window defogger switch ON.

- When customize setting is "Continuous", it is normal if the operation lasts without any termination conditions.

- When customize setting is "Normal", it is normal if the operation lasts for 15 minutes and then turns OFF.

3) When the operation in 2) above fails, replace the body integrated unit.

#### 3. HEAT WIRE INSPECTION

For operation procedures, refer to "HEAT WIRE INSPECTION" of "Rear Window Defogger System". <Ref. to GW-32, HEAT WIRE INSPECTION, INSPECTION, Rear Window Defogger System.>

NOTE:

Heat wire inspection needs removing/installing procedure of instrument panel assembly.

### C: REPAIR

For operation procedures, refer to "REPAIR" of "Rear Window Defogger System". <Ref. to GW-33, REPAIR, Rear Window Defogger System.>

NOTE:

Heat wire repair needs removing/installing procedure of instrument panel assembly.

# BODY STRUCTURE

# *BS*

---

	Page
1. General Description .....	2

# General Description

BODY STRUCTURE

---

## 1. General Description

### A: SPECIFICATION

Refer to "IMPREZA Body Repair Manual" for general description of body structure, reference points and reference dimensions.

# INSTRUMENTATION/DRIVER INFO

***IDI***

---

	<b>Page</b>
1. General Description .....	2
2. Combination Meter System .....	5
3. Clock System .....	13
4. Combination Meter .....	16
5. Speedometer .....	17
6. Tachometer .....	18
7. Fuel Gauge .....	19
8. Engine Coolant Temperature Gauge .....	20
9. Clock .....	21

# General Description

INSTRUMENTATION/DRIVER INFO

## 1. General Description

### A: SPECIFICATION

Except for STI model

- Combination meter

Meter, display	Operation method, display method	Drive control	When checking the indicator needle operation/needle reading operation
Speedometer	Stepping motor type	Combination meter	Light ON
Tachometer			
Engine coolant temperature gauge			
Fuel gauge	LED	Combination meter	On/Off
ABS warning light			
Seat belt warning light			
Door open warning light			
Tire pressure warning light			
Hill start assist warning light			
VDC warning light/VDC operation indicator light			
VDC OFF indicator light			
HI-beam indicator light			
Cruise indicator light			
Cruise set indicator light			
Front fog light indicator light			
Light illumination indicator light			
Malfunction indicator light			
Meter illumination back light			
LCD back light			
Fuel level warning light			
Malfunction indicator light			
Oil pressure warning light			
Airbag warning light			
Charge warning light			
Turn signal indicator light			
Security/immobilizer indicator light			
Brake fluid/parking brake warning light	Combination meter/ brake fluid level switch	On/Turns on or off according to module control	
Odo/Trip indicator	LCD	Combination meter	—

- Clock

Display	Display method
Average fuel economy/instantaneous fuel economy (except for U4 model), average fuel economy/blank display (U4 model), ambient temperature, current time, trouble warning light	VFD
Passenger's airbag ON indicator	LED
Passenger's airbag OFF indicator	
Passenger' seat belt warning light	

# General Description

INSTRUMENTATION/DRIVER INFO

## STI model

- Combination meter

Meter, display	Operation method, display method	Drive control	When checking the indicator needle operation/needle reading operation
Speedometer	Stepping motor type	Combination meter	Light ON
Tachometer			
Engine coolant temperature gauge			
Fuel gauge			
ABS warning light	LED	Combination meter	On/Off
Seat belt warning light			
Door open warning light			
Tire pressure warning light			
Hill start assist warning light			
HI-beam indicator light			
[I] Indicator light			
[S] Indicator light			
[S#] Indicator light			
AUTO [-] indicator light			
AUTO [+] indicator light			
AUTO indicator light			
REV indicator light			
Shift-up indicator light			
Cruise indicator light			
Cruise set indicator light			
Front fog light indicator light			
Light illumination indicator light			
Oil pressure warning light			
Meter illumination back light			
LCD back light			
VDC warning light/VDC indicator light (yellow)			
VDC OFF (yellow)/VDC traction mode indicator light (green)			
Fuel level warning light			
Malfunction indicator light		ECM	Turns on or off according to module control
Oil pressure warning light		Oil pressure switch	
Airbag warning light		Airbag CM	
Charge warning light		Generator	
Rear differential oil temperature warning light		Rear differential oil temperature switch	
Turn signal indicator light		Turn signal and hazard unit	
Security/immobilizer indicator light		Body integrated unit	
Brake fluid/parking brake warning light		Combination meter/brake fluid level switch	On/Turns on or off according to module control
Odo/Trip indicator		LCD	Combination meter
DCCD torque indicator			
REV indicator			



## General Description

### INSTRUMENTATION/DRIVER INFO

- Clock

Display	Display method
Average fuel economy/instantaneous fuel economy (except for U4 model), average fuel economy/blank display (U4 model), ambient temperature, current time, trouble warning light	VFD
Passenger's airbag ON indicator	LED
Passenger's airbag OFF indicator	
Passenger' seat belt warning light	

### B: CAUTION

- Before disassembling or reassembling parts, always disconnect the battery ground cable from battery. When replacing the audio, control module and other parts provided with memory functions, record the memory contents before disconnecting the battery ground cable. Otherwise, the memory is cleared.
- Reassemble the parts in the reverse order of disassembly procedure unless otherwise indicated.
- Use gloves to avoid damage and getting fingerprints on the glass surface and meter surfaces.
- Do not apply an excessive force on the printed circuit.
- Do not drop or otherwise apply impact.
- Connect the connectors securely during reassembly.
- After reassembly, make sure that the functional parts operate normally.
- When the combination meter has been replaced, be sure to perform the registration of immobilizer.

### C: PREPARATION TOOL

#### 1. SPECIAL TOOL

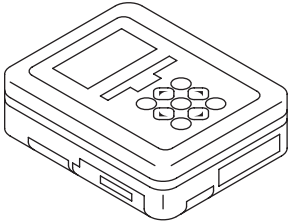
ILLUSTRATION	TOOL NUMBER	DESCRIPTION	REMARKS
 ST1B022XU0	1B022XU0	SUBARU SELECT MONITOR III KIT	Used for troubleshooting the electrical system.

#### 2. GENERAL TOOL

TOOL NAME	REMARKS
Circuit tester	Used for measuring resistance and voltage.

## 2. Combination Meter System

### A: WIRING DIAGRAM

Refer to "Combination Meter System" in WI section. <Ref. to WI-136, WIRING DIAGRAM, Combination Meter System.>

### B: INSPECTION

#### 1. SELF-DIAGNOSIS

The self-diagnosis (checking of each meter, warning light, indicator light, illumination, LCD) of combination meter can be performed in the following procedure.

#### CAUTION:

**Perform the steps described in 2) through 4) within 10 seconds.**

- 1) Within 3 seconds after turning the ignition switch to ON, set the lighting switch to tail light or headlight position.
- 2) Press the odo/trip meter knob three times.
- 3) Turn the lighting switch to OFF, and press the odo/trip meter knob three times.
- 4) Set the lighting switch to tail light or headlight position again, and press the odo/trip meter knob three times.

#### NOTE:

- When pressing the odo/trip meter knob four times, the display changes to DTC display mode. <Ref. to IDI-12, DTC DISPLAY MODE, INSPECTION, Combination Meter System.>
  - Warning light, indicator light, and LCD display checks are performed when self-diagnosis is performed. After this, every time the odo/trip meter knob is pressed, the buzzer will sound for 0.5 seconds, and operation checks for meter operation, meter readings, and the LCD are performed in this order. Turn the ignition switch to OFF to cancel the self-diagnosis function.
  - The self-diagnosis function is not canceled if the engine is started during diagnosis. However, the self-diagnosis function is canceled automatically for safety when you start to drive the vehicle.
- 5) Go to "Check meter indicator operation".

Check meter operation, warning light, indicator light, and LCD.

Meter indicator	LCD display, illumination	Warning light, indicator light
MIN indication ↓ MAX indication	ILL1 (Min. brightness) ↓(Display for one second for each level) ILL6 (Max. brightness)	*1, *2, *3
MAX indication ↓ MIN indication	ILL6 (Max. brightness) ↓(Display for one second for each level) ILL1 (Min. brightness)	

\*1: Warning lights and indicator lights controlled by the meter drive circuit are illuminated. <Ref. to IDI-2, SPECIFICATION, General Description.>

\*2: Warning lights and indicator lights controlled by other module are turned on/off according to the module control. <Ref. to IDI-2, SPECIFICATION, General Description.>

\*3: VDC multi mode indicator light (VDC warning light/VDC indicator light and VDC OFF indicator light) illuminates in yellow. (STI model)

- 6) Press the odo/trip meter knob once.

# Combination Meter System

## INSTRUMENTATION/DRIVER INFO

7) Go to "Meter Indicator Needle Indication Check".  
Check meter operation, warning light, indicator light, and LCD.

**NOTE:**

- The meter indicator needle will switch every 1.5 seconds.
- ILL indication illuminates at the same brightness as when entering "Meter Indicator Needle Indication Check".

Speedometer (km/h)	Tachometer (rpm)	Fuel gauge	Engine coolant temperature gauge	Fuel level warning light	Warning light, indicator light
0	0	Lowest point	Lowest point	Light ON	*1, *2, *3
0	0	E	C	Light ON	
40	1000	1/2	1/2	Light OFF	
100	4000	F	H	Light OFF	
40	1000	1/2	1/2	Light OFF	
0	0	E	C	Light ON	

\*1: Warning lights and indicator lights controlled by the meter drive circuit turn off. <Ref. to IDI-2, SPECIFICATION, General Description.>

\*2: Warning lights and indicator lights controlled by other module are turned on/off according to the module control. <Ref. to IDI-2, SPECIFICATION, General Description.>

\*3: VDC multi mode indicator light (VDC traction indicator light) illuminates to green. (STI model)

8) Press the odo/trip meter knob once.

9) Go to "Check LCD display".

Check the LCD.

**NOTE:**

- Warning lights and indicator lights controlled by the meter drive circuit turn off. <Ref. to IDI-2, SPECIFICATION, General Description.>
- Warning lights and indicator lights controlled by other module are turned on/off according to the module control. <Ref. to IDI-2, SPECIFICATION, General Description.>
- The meter indication remains at the same level as "Meter Indicator Needle Indication Check".
- ILL indication illuminates at ILL6 level (max. brightness).
- Except for STI model

Illuminating order	1	2	3	4	5	6	7	8	9	10	11	12	Go back to 1 and repeat.
ODO, TRIP A/B	All lights ON	All lights OFF	ODO	All lights OFF	TRIP A	All lights OFF	TRIP B	All lights OFF	REV.	All lights OFF	TRIP A	All lights OFF	
Odo/trip meter	88888.8	111111	22222.2	333333	44444.4	555555	66666.6	777777	88888.8	999999	00000.0	888888	

- STI model

Illuminating order	1	2	3	4	5	6	7	8	9	10	11	12	13	Go back to 1 and repeat.
ODO, TRIP A/B, REV.	All lights ON	All lights OFF	ODO	All lights OFF	TRIP A	All lights OFF	TRIP B	All lights OFF	REV.	All lights OFF	TRIP A	All lights OFF	TRIP B	
Odo/trip meter	88888.8	111111	22222.2	333333	44444.4	555555	66666.6	777777	88888.8	999999	00000.0	888888	88888.8	
DCCD torque indicator													All lights OFF	

# Combination Meter System

INSTRUMENTATION/DRIVER INFO

## 2. SYMPTOM CHART

### CAUTION:

When measuring the voltage and resistance of each control module or sensor, use a tapered pin with a diameter of less than 0.64 mm (0.025 in) in order to avoid poor contact. Do not insert the pin more than 2 mm (0.08 in).

Symptoms	Repair order	Note
Combination meter assembly does not operate.	1. Power supply 2. Ground circuit 3. Combination meter	<Ref. to IDI-7, CHECK POWER SUPPLY AND GROUND CIRCUIT, INSPECTION, Combination Meter System.>
Speedometer does not operate.	1. VDC C/M 2. Harness 3. Combination meter	<Ref. to IDI-8, CHECK VDC CONTROL MODULE, INSPECTION, Combination Meter System.>
Tachometer does not operate.	1. ECM 2. Harness 3. Combination meter	<Ref. to IDI-8, CHECK ENGINE CONTROL MODULE (ECM), INSPECTION, Combination Meter System.>
Fuel gauge does not operate.	1. Communication circuit 2. Harness 3. Body integrated unit 4. Fuel level sensor 5. Combination meter	<Ref. to IDI-9, CHECK FUEL LEVEL SENSOR, INSPECTION, Combination Meter System.>
Engine coolant temperature gauge does not operate.	1. Communication circuit 2. Engine coolant temperature sensor 3. Harness 4. Combination meter	<Ref. to IDI-10, CHECK ENGINE COOLANT TEMPERATURE SENSOR, INSPECTION, Combination Meter System.>
Warning buzzer for key left in ignition does not sound.	1. Communication circuit 2. Combination meter	<Ref. to IDI-11, CHECK KEY WARNING SWITCH ALARM, INSPECTION, Combination Meter System.>

## 3. CHECK POWER SUPPLY AND GROUND CIRCUIT

Step	Check	Yes	No
<b>1 CHECK POWER SUPPLY FOR COMBINATION METER.</b> 1) Remove the combination meter. <Ref. to IDI-16, REMOVAL, Combination Meter.> 2) Measure the voltage between combination meter connector and chassis ground. <b>Connector &amp; terminal</b> <i>(i10) No. 1 (+) — Chassis ground (-):</i>	Is the voltage 10 V or more?	Go to step 2.	Check the harness for open or short between the fuse and combination meter.
<b>2 CHECK POWER SUPPLY FOR COMBINATION METER.</b> 1) Turn the ignition switch to ON. 2) Measure the voltage between combination meter connector and chassis ground. <b>Connector &amp; terminal</b> <i>(i10) No. 2 (+) — Chassis ground (-):</i>	Is the voltage 10 V or more?	Go to step 3.	Check the harness for open or short between the ignition switch and combination meter.
<b>3 CHECK GROUND CIRCUIT OF COMBINATION METER.</b> 1) Turn the ignition switch to OFF. 2) Measure the resistance of harness between combination meter connector and body ground. <b>Connector &amp; terminal</b> <i>(i10) No. 21 — Chassis ground:</i> <i>(i10) No. 22 — Chassis ground:</i>	Is the resistance less than 10 $\Omega$ ?	Replace the meter case assembly.	Repair or replace the harness.

# Combination Meter System

INSTRUMENTATION/DRIVER INFO

## 4. CHECK VDC CONTROL MODULE

Step	Check	Yes	No
<b>1 CHECK VEHICLE SPEED SIGNAL.</b> 1) Remove the combination meter mounting screws. 2) Lift up the vehicle and support it with rigid racks. 3) Drive the vehicle faster than 10 km/h (6 MPH). <b>WARNING:</b> <b>Be careful not to get caught in the running wheels.</b> 4) Measure the voltage between combination meter connector and chassis ground. <b>Connector &amp; terminal</b> <b>(i10) No. 31 (+) — Chassis ground (-):</b>	Is the voltage less than 1 V $\leftrightarrow$ 5 V or more?	Replace the meter case assembly.	Go to step 2.
<b>2 CHECK HARNESS BETWEEN VDC CONTROL MODULE AND COMBINATION METER.</b> 1) Turn the ignition switch to OFF. 2) Disconnect the VDC control unit connector and the combination meter connector. 3) Measure the resistance between the VDC control module connector and the combination meter connector. <b>Connector &amp; terminal</b> <b>(B310) No. 33 — (i10) No. 31:</b>	Is the resistance less than 10 $\Omega$ ?	Check VDC control module. <Ref. to VDC(diag)-2, Basic Diagnostic Procedure.>	Repair or replace the harness.

## 5. CHECK ENGINE CONTROL MODULE (ECM)

Step	Check	Yes	No
<b>1 CHECK ECM SIGNAL.</b> 1) Start the engine. 2) Measure the voltage between ECM connector and chassis ground. <b>Connector &amp; terminal</b> <b>(B135) No. 15 (+) — Chassis ground (-):</b>	Is the voltage 0 $\leftrightarrow$ 14 V or more?	Go to step 2.	Inspect the ECM. <Ref. to EN(H4DOTC)(diag)-2, Basic Diagnostic Procedure.>
<b>2 CHECK HARNESS BETWEEN COMBINATION METER AND ECM.</b> 1) Turn the ignition switch to OFF. 2) Disconnect the ECM connector and combination meter connector. 3) Measure the resistance between the ECM connector and the combination meter connector. <b>Connector &amp; terminal</b> <b>(B135) No. 15 — (i10) No. 32:</b>	Is the resistance less than 10 $\Omega$ ?	Replace the meter case assembly.	Repair or replace the harness.

# Combination Meter System

INSTRUMENTATION/DRIVER INFO

## 6. CHECK FUEL LEVEL SENSOR

	Step	Check	Yes	No
1	<b>CHECK COMBINATION METER.</b> 1) Drain fuel. 2) Check the indication status of the fuel gauge in the combination meter.	Does the fuel gauge needle indicate EMPTY and is the low fuel warning light blinking?	Go to step 4.	Go to step 2.
2	<b>CHECK COMBINATION METER.</b> Perform the self-diagnosis of combination meter. <Ref. to IDI-5, SELF-DIAGNOSIS, INSPECTION, Combination Meter System.>	Is it operating normally?	Go to step 3.	Replace the meter case assembly.
3	<b>CHECK DIAGNOSTIC TROUBLE CODE (DTC).</b> 1) Prepare the Subaru Select Monitor kit. 2) Turn the ignition switch to ON (engine OFF) and run the "PC application for Subaru Select Monitor". 3) On «System Selection Menu» display, select {Integ. unit mode}. 4) Select the {Diagnostic Code(s) Display}.	Is DTC being displayed?	Perform the diagnosis according to DTC. <Ref. to LAN(diag)-33, LIST, List of Diagnostic Trouble Code (DTC).>	Go to step 4.
4	<b>CHECK HARNESS.</b> 1) Disconnect the body integrated unit connector. 2) Measure the resistance between body integrated unit connector and chassis ground. <i><b>Connector &amp; terminal</b></i> <i><b>(B281) No. 7 — Chassis ground:</b></i>	Is the resistance 2 — 96 Ω?	Go to step 5. If the step 1 is "Yes", Go to step 9.	Repair or replace the harness.
5	<b>CHECK COMMUNICATION BETWEEN BODY INTEGRATED UNIT AND COMBINATION METERS.</b> 1) Remove the fuel sub level sensor. • Except for STI model: <Ref. to FU(w/o STI)-82, REMOVAL, Fuel Sub Level Sensor.> • STI model: <Ref. to FU(STI)-83, REMOVAL, Fuel Sub Level Sensor.> 2) Short the fuel sub level sensor connector terminal to the chassis ground with approx. 100 Ω resistance. 3) Turn the ignition switch to ON. <i><b>Connector &amp; terminal</b></i> <i><b>(R59) No. 1 — Chassis ground:</b></i>	Does the meter needle indicate EMPTY?	Go to step 7.	Go to step 6.
6	<b>CHECK BODY INTEGRATED UNIT.</b> 1) Retain the condition in step 5. 2) On {Integ. unit mode}, select {Fuel level resistance} using the Subaru Select Monitor.	Is the resistance displayed as approx. 100 Ω?	Go to step 11.	Replace the body integrated unit. <Ref. to SL-48, Body Integrated Unit.>
7	<b>CHECK COMMUNICATION BETWEEN BODY INTEGRATED UNIT AND COMBINATION METERS.</b> 1) Remove the fuel sub level sensor. • Except for STI model: <Ref. to FU(w/o STI)-82, REMOVAL, Fuel Sub Level Sensor.> • STI model: <Ref. to FU(STI)-83, REMOVAL, Fuel Sub Level Sensor.> 2) Short the fuel sub level sensor connector terminal to the chassis ground with approx. 2 Ω to 6 Ω resistance. 3) Turn the ignition switch to ON. <i><b>Connector &amp; terminal</b></i> <i><b>(R59) No. 1 — Chassis ground:</b></i>	Does the meter needle indicate FULL?	Go to step 9.	Go to step 8.

# Combination Meter System

## INSTRUMENTATION/DRIVER INFO

	Step	Check	Yes	No
8	<b>CHECK BODY INTEGRATED UNIT.</b> 1) Retain the condition in step 7. 2) On {Integ. unit mode}, select {Fuel level resistance} using the Subaru Select Monitor.	Is the resistance 2 — 6 Ω?	Go to step 11.	Replace the body integrated unit. <Ref. to SL-48, Body Integrated Unit.>
9	<b>CHECK FUEL SUB LEVEL SENSOR.</b> 1) Remove the fuel sub level sensor. • Except for STI model: <Ref. to FU(w/o STI)-82, REMOVAL, Fuel Sub Level Sensor.> • STI model: <Ref. to FU(STI)-83, REMOVAL, Fuel Sub Level Sensor.> 2) Measure the resistance between the fuel sub level sensor connector terminals when the float is in FULL and EMPTY position. <b>Connector &amp; terminal (R59) No. 1 — No. 2:</b>	Is the resistance 1.0 to 2.5 Ω (FULL) and 61 to 63 Ω (EMPTY)?	Go to step 10.	Replace the fuel sub level sensor.
10	<b>CHECK FUEL LEVEL SENSOR.</b> 1) Remove the fuel level sensor. • Except for STI model: <Ref. to FU(w/o STI)-81, REMOVAL, Fuel Level Sensor.> • STI model: <Ref. to FU(STI)-82, REMOVAL, Fuel Level Sensor.> 2) Measure the resistance between the fuel level sensor connector terminals when the float is in FULL and EMPTY position. <b>Connector &amp; terminal (R58) No. 1 — No. 4:</b>	Is the resistance 1.0 to 3.0 Ω (FULL) and 31 to 33 Ω (EMPTY)?	Check the connection status of the harness and connector that may have a temporary poor contact.	Replace the fuel level sensor.
11	<b>CHECK COMBINATION METER OPERATION.</b> 1) Remove the combination meter. 2) Attach the combination meter to another vehicle on which the fuel gauge operates normally to check its operation.	Is the fuel gauge normal?	Replace the body integrated unit. <Ref. to SL-48, Body Integrated Unit.>	Replace the meter case assembly.

## 7. CHECK ENGINE COOLANT TEMPERATURE SENSOR

	Step	Check	Yes	No
1	<b>CHECK DIAGNOSTIC TROUBLE CODE (DTC).</b> 1) Prepare the Subaru Select Monitor kit. 2) Turn the ignition switch to ON (engine OFF) and run the "PC application for Subaru Select Monitor". 3) On «System Selection Menu» display, select {Integ. unit mode}. 4) Select the {Diagnostic Code(s) Display}.	Is DTC being displayed?	Perform the diagnosis according to DTC. <Ref. to LAN(diag)-33, LIST, List of Diagnostic Trouble Code (DTC).>	Go to step 2.

# Combination Meter System

INSTRUMENTATION/DRIVER INFO

Step	Check	Yes	No
<b>2 CHECK ENGINE COOLANT TEMPERATURE SENSOR.</b> Check the engine coolant temperature sensor. <Ref. to EN(H4DOTC)(diag)-2, Basic Diagnostic Procedure.>	Is the engine coolant temperature sensor OK?	Replace the meter case assembly.	Replace the engine coolant temperature sensor. • Except for STI model: <Ref. to FU(w/o STI)-35, REMOVAL, Engine Coolant Temperature Sensor.> • STI model: <Ref. to FU(STI)-34, REMOVAL, Engine Coolant Temperature Sensor.>

## 8. CHECK KEY WARNING SWITCH ALARM

Step	Check	Yes	No
<b>1 CHECK KEY WARNING SWITCH ALARM.</b> 1) Insert the key into ignition key lock. 2) Open the driver's side door.	Does the buzzer sound from the meter?	Normal	Go to step 2.
<b>2 CHECK COMMUNICATION STATUS.</b> 1) Prepare the Subaru Select Monitor. 2) On «System Selection Menu» display, select {Integ. unit mode}. 3) On {Current Data Display & Save}, select {Key-lock warning SW}. 4) Insert and remove the key.	Does the display change between ON ←→ OFF?	Go to step 3.	Check the ignition switch circuit. <Ref. to SL-42, INSPECTION, Ignition Key Lock.>
<b>3 CHECK COMMUNICATION STATUS.</b> 1) On {Current Data Display & Save}, select {Driver's door SW input}. 2) Open and close the door.	Does the display change between ON ←→ OFF?	Go to step 4.	Check the door switch circuit. <Ref. to SL-19, CHECK DOOR SWITCH, INSPECTION, Keyless Entry System.>
<b>4 CHECK DIAGNOSTIC TROUBLE CODE (DTC).</b> 1) Turn the ignition switch to ON (engine OFF) and run the "PC application for Subaru Select Monitor". 2) On «System Selection Menu» display, select {Integ. unit mode}. 3) Select the {Diagnostic Code(s) Display}.	Is DTC being displayed?	Perform the diagnosis according to DTC. <Ref. to LAN(diag)-33, LIST, List of Diagnostic Trouble Code (DTC).>	Go to step 5.
<b>5 CHECK COMBINATION METER.</b> Perform the self-diagnosis of combination meter. <Ref. to IDI-5, SELF-DIAGNOSIS, INSPECTION, Combination Meter System.>	Did the buzzer sound?	Go to step 6.	Replace the meter case assembly.
<b>6 CHECK COMBINATION METER.</b> 1) Remove the combination meter. 2) Attach the buzzer to another vehicle on which the buzzer operates normally to check its operation.	Did the buzzer sound?	Replace the body integrated unit. <Ref. to SL-48, Body Integrated Unit.>	Replace the meter case assembly.



# Combination Meter System

## INSTRUMENTATION/DRIVER INFO

### 9. DTC DISPLAY MODE

The combination meter DTC can be displayed according to the following procedure.

#### CAUTION:

**Perform the steps described in 2) through 4) within 10 seconds.**

- 1) Within 3 seconds after turning the ignition switch to ON, set the lighting switch to tail light or headlight position.
- 2) Press the odo/trip meter knob four times.
- 3) Turn the lighting switch to OFF, and press the odo/trip meter knob four times.
- 4) Set the lighting switch to tail light or headlight position again, and press the odo/trip meter knob four times.
- 5) Go to "DTC display mode".

When the DTC display mode operates, the display is changed every 3 seconds or {ECM}, {TCM}, {ABS/VDC} is displayed cyclically in this order for every press of the trip knob. DTC is displayed in the following table according to type of control module, receiving DTC, DTC detected or No DTC.

Control module	Condition	Display
ECM	Receiving DTC	Trip "A" + "P (Blink)"
	DTC detected	Trip "A" + "P xxxx"
	No DTC	Trip "A" + "P ----"
TCM	Receiving DTC	Trip "B" + "P (Blink)"
	DTC detected	Trip "B" + "P xxxx"
	No DTC	Trip "B" + "P ----"
ABS/VDCCM	Receiving DTC	Trip "A" + "C (Blink)"
	DTC detected	Trip "A" + "C xxxx"
	No DTC	Trip "A" + "C ----"
When CAN communication error is occurred	—	"-----"

#### NOTE:

- When the engine starts during diagnosis, the self-diagnosis function is not cancelled, however, once ignition switch is turned OFF or the vehicle is driven, the DTC display mode is cancelled automatically for safety.
- When the DTC of individual control modules changes in status from current trouble to past trouble, and the trouble is fixed, the DTC will no longer appear in the combination meter if the engine is started three times or more. In this case, read the DTC using the Subaru Select Monitor.
- Because the MT model is not equipped with a TCM, only "Receiving DTC" is displayed.

#### C: NOTE

For procedure of each component in the combination meter system, refer to the respective section.

- Combination meter: <Ref. to IDI-16, Combination Meter.>
- Speedometer: <Ref. to IDI-17, Speedometer.>
- Tachometer: <Ref. to IDI-18, Tachometer.>
- Fuel gauge: <Ref. to IDI-19, Fuel Gauge.>
- Engine coolant temperature gauge: <Ref. to IDI-20, Engine Coolant Temperature Gauge.>

## 3. Clock System

### A: WIRING DIAGRAM

Refer to "Clock System" in WI section. <Ref. to WI-147, WIRING DIAGRAM, Clock System.>

### B: INSPECTION

#### 1. SYMPTOM CHART

Symptoms	Repair order	Index
No display is shown.	<ol style="list-style-type: none"> <li>1. Power supply</li> <li>2. Ground circuit</li> <li>3. Communication circuit harness</li> <li>4. Clock body</li> </ol>	<Ref. to IDI-13, CHECK POWER SUPPLY AND GROUND CIRCUIT AND COMMUNICATION CIRCUIT, INSPECTION, Clock System.>
Ambient air temperature/fuel economy displays do not appear.	<ol style="list-style-type: none"> <li>1. Power supply</li> <li>2. Ground circuit</li> <li>3. Communication circuit harness</li> <li>4. Clock body</li> </ol>	<Ref. to IDI-14, CHECK CLOCK SYSTEM COMMUNICATION CIRCUIT, INSPECTION, Clock System.>
Only ambient air temperature display is not displayed.	<ol style="list-style-type: none"> <li>1. Power supply</li> <li>2. Harness</li> <li>3. Ambient sensor</li> <li>4. Communication circuit</li> <li>5. Clock body</li> </ol>	<Ref. to IDI-14, CHECK AMBIENT TEMPERATURE METER SYSTEM COMMUNICATION CIRCUIT, INSPECTION, Clock System.>
Only fuel economy display is not displayed.	<ol style="list-style-type: none"> <li>1. Setting</li> <li>2. Communication circuit</li> <li>3. Clock body</li> </ol>	<Ref. to IDI-15, CHECK COMMUNICATION CIRCUIT OF FUEL ECONOMY SYSTEM, INSPECTION, Clock System.>

#### 2. CHECK POWER SUPPLY AND GROUND CIRCUIT AND COMMUNICATION CIRCUIT

Step	Check	Yes	No
<b>1 CHECK POWER SUPPLY.</b> 1) Disconnect the clock connector. 2) Measure the voltage between clock connector and chassis ground. <i>Connector &amp; terminal</i> <i>(i59) No. 10 (+) — Chassis ground (-):</i>	Is the voltage 10 V or more?	Go to step 2.	Check the harness for a open or short between the fuse and clock.
<b>2 CHECK GROUND CIRCUIT.</b> Measure the resistance between the clock connector and chassis ground. <i>Connector &amp; terminal</i> <i>(i59) No. 6 — Chassis ground:</i>	Is the resistance less than 10 Ω?	Go to step 3.	Repair or replace the harness.
<b>3 CHECK HARNESS BETWEEN CLOCK AND COMBINATION METER.</b> 1) Disconnect the combination meter connector. 2) Measure the resistance between the clock connector and combination meter connector. <i>Connector &amp; terminal</i> <i>(i59) No. 5 — (i10) No. 29:</i>	Is the resistance less than 10 Ω?	Go to step 4.	Repair or replace the harness.
<b>4 CHECK CLOCK.</b> 1) Remove the clock. 2) Attach the clock to another vehicle on which the clock operates normally to check its operation.	Is clock normal?	Replace the meter case assembly.	Replace the clock body.

# Clock System

INSTRUMENTATION/DRIVER INFO

## 3. CHECK CLOCK SYSTEM COMMUNICATION CIRCUIT

Step	Check	Yes	No
<b>1 CHECK POWER SUPPLY.</b> 1) Disconnect the clock connector. 2) Measure the voltage between clock connector and chassis ground. <i>Connector &amp; terminal</i> <i>(i59) No. 8 (+) — Chassis ground (-):</i>	Is the voltage 10 V or more?	Go to step 2.	Repair or replace the harness.
<b>2 CHECK GROUND CIRCUIT.</b> Measure the resistance between the clock connector and chassis ground. <i>Connector &amp; terminal</i> <i>(i59) No. 6 — Chassis ground:</i>	Is the resistance less than 10 $\Omega$ ?	Go to step 3.	Repair or replace the harness.
<b>3 CHECK HARNESS BETWEEN CLOCK AND COMBINATION METER.</b> 1) Disconnect the combination meter connector. 2) Measure the resistance between the clock connector and combination meter connector. <i>Connector &amp; terminal</i> <i>(i59) No. 5 — (i10) No. 29:</i>	Is the resistance less than 10 $\Omega$ ?	Go to step 4.	Repair or replace the harness.
<b>4 CHECK CLOCK.</b> 1) Remove the clock. 2) Attach the clock to another vehicle on which the clock operates normally to check its operation.	Is clock normal?	Replace the meter case assembly.	Replace the clock body.

## 4. CHECK AMBIENT TEMPERATURE METER SYSTEM COMMUNICATION CIRCUIT

Step	Check	Yes	No
<b>1 CHECK AMBIENT SENSOR POWER SUPPLY.</b> 1) Disconnect the ambient sensor connector. 2) Turn the ignition switch to ON. 3) Measure the voltage between the ambient sensor connector and chassis ground. <i>Connector &amp; terminal</i> <i>(F78) No. 2 (+) — Chassis ground (-):</i>	Is the voltage 4 V or more?	Go to step 2.	Check the harness for a open or short between the fuse and clock.
<b>2 CHECK HARNESS BETWEEN AMBIENT SENSOR AND COMBINATION METER.</b> 1) Disconnect the combination meter connector. 2) Measure the resistance between the ambient sensor connector and the combination meter connector. <i>Connector &amp; terminal</i> <i>(F78) No. 1 — (i10) No. 23:</i> <i>(F78) No. 2 — (i10) No. 24:</i>	Is the resistance less than 10 $\Omega$ ?	Go to step 3.	Repair or replace the harness.
<b>3 CHECK AMBIENT SENSOR.</b> 1) Remove the ambient sensor. <Ref. to AC-43, REMOVAL, Ambient Sensor (Auto A/C Model).> 2) Check the ambient sensor. <Ref. to AC(diag)-30, AMBIENT SENSOR, Diagnostic Procedure for Sensors.>	Is the ambient sensor operating properly?	Go to step 4.	Replace the ambient sensor.

# Clock System

INSTRUMENTATION/DRIVER INFO

Step	Check	Yes	No
<b>4 CHECK AMBIENT TEMPERATURE DISPLAY.</b> 1) Connect the combination meter connector. 2) Install the 3 Ω resistance to ambient sensor connector terminal. 3) Turn the ignition switch to ON. <b>Connector &amp; terminal</b> <b>(F78) No. 1 — (F78) No. 2:</b>	Does the ambient temperature display 25°C (77°F)?	Repair the poor contact between the ambient sensor and harness connector.	Go to step 5.
<b>5 CHECK AMBIENT TEMPERATURE OUTPUT DATA.</b> 1) Prepare the Subaru Select Monitor kit. 2) Turn the ignition switch to ON (engine OFF) and run the "PC application for Subaru Select Monitor". 3) On «System Selection Menu» display, select {Integ. unit mode}. 4) Select {Ambient Temperature}.	Does the ambient temperature display 25°C (77°F)?	Go to step 6.	Replace the meter case assembly. <Ref. to IDI-16, Combination Meter.>
<b>6 CHECK CLOCK.</b> 1) Remove the clock. 2) Attach the ambient temperature display to another vehicle on which the ambient temperature display operates normally to check its operation.	Does the ambient temperature display 25°C (77°F)?	Replace the clock body.	Replace the meter case assembly.

## 5. CHECK COMMUNICATION CIRCUIT OF FUEL ECONOMY SYSTEM

Step	Check	Yes	No
<b>1 CHECK FUEL ECONOMY DISPLAY OFF MODE.</b> Hold down the button "+" on the clock for 5 seconds or more.	Does the fuel economy display part blink?	Go to step 2.	Go to step 3.
<b>2 CHECK FUEL ECONOMY DISPLAY OFF MODE.</b> Turn the ignition switch to ON.	Is fuel economy displayed?	Clock is normal.	Go to step 3.
<b>3 CHECK DIAGNOSTIC TROUBLE CODE (DTC).</b> 1) Prepare the Subaru Select Monitor kit. 2) Turn the ignition switch to ON (engine OFF) and run the "PC application for Subaru Select Monitor". 3) On «System Selection Menu» display, select {Integ. unit mode}. 4) Select the {Diagnostic Code(s) Display}.	Is DTC detected?	Go to step 4.	Replace the meter case assembly.
<b>4 CHECK CLOCK.</b> 1) Remove the clock. 2) Attach the fuel economy display to another vehicle on which the fuel economy display operates normally to check its operation.	Is the fuel economy display correct?	Replace the clock body.	Replace the meter case assembly.

### C: NOTE

For procedure of each component in the clock system, refer to the respective section.

- Clock: <Ref. to IDI-21, Clock.>

# Combination Meter

INSTRUMENTATION/DRIVER INFO

## 4. Combination Meter

### A: REMOVAL

- 1) Disconnect the ground cable from battery.
- 2) Set the tilt steering at the lowest position. For steering wheel with telescopic system, pull the steering.
- 3) Remove the plastic hook (A), and detach the meter visor.

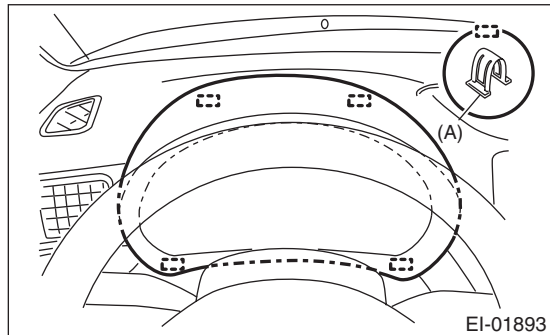

- 4) Remove the screws of the combination meter, and pull on the meter while tipping it towards yourself.

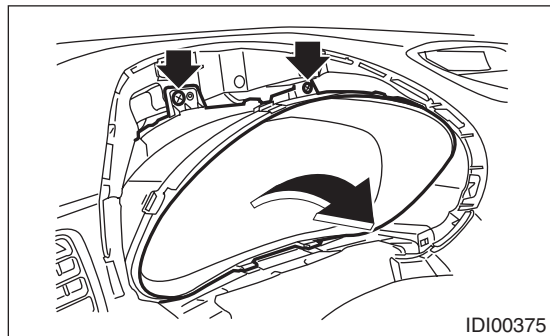

- 5) Disconnect the connector in the rear side of combination meter to remove meter.

### CAUTION:

- Be careful not to damage the meter or instrument panel.
- Pay particular attention to avoid damaging the meter glass.

### B: INSTALLATION

#### CAUTION:

- Make sure the electrical connector is connected securely.
- Make sure that each meter operates normally.
- When the combination meter has been replaced, be sure to perform the registration of immobilizer.

Install each part in the reverse order of removal.

## C: DISASSEMBLY

### 1. DISASSEMBLY OF COMBINATION METER

#### CAUTION:

- Use gloves to avoid damage and getting fingerprints on the glass surface and meter surfaces.
- Be careful not to apply excessive force to the trip knob.
- Be sure not to touch the meter indicator needle.

Disengage the tabs (A), and remove the meter glass assembly (B) and meter visor (C) from the meter case assembly (D).

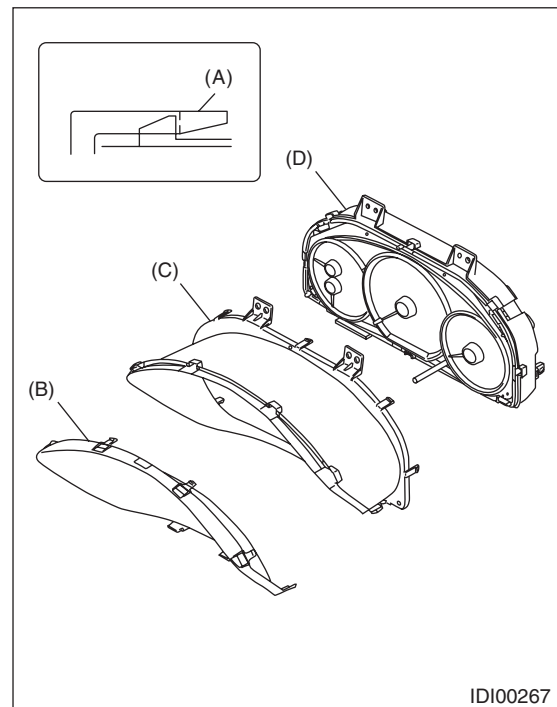

### 2. BULB REPLACEMENT

LEDs are used for all of warning lights and indicator lights of combination meters, replace the meter case assembly if faulty.

## D: ASSEMBLY

Assemble each part in the reverse order of disassembly.

## 5. Speedometer

### A: SPECIFICATION

Since the meter case assembly cannot be disassembled, do not remove or inspect the speedometer alone. (Do not remove the cover on the back surface.)

## 6. Tachometer

### A: SPECIFICATION

Since the meter case assembly cannot be disassembled, do not remove or inspect the tachometer alone. (Do not remove the cover on the back surface.)

## 7. Fuel Gauge

### A: SPECIFICATION

Since the meter case assembly cannot be disassembled, do not remove or inspect the fuel gauge alone. (Do not remove the cover on the back surface.)



# Engine Coolant Temperature Gauge

INSTRUMENTATION/DRIVER INFO

---

## 8. Engine Coolant Temperature Gauge

### A: SPECIFICATION

Since the meter case assembly cannot be disassembled, do not remove or inspect the engine coolant temperature gauge alone. (Do not remove the cover on the back surface.)

## 9. Clock

### A: REMOVAL

- 1) Disconnect the ground cable from battery.
- 2) Remove the audio. (model with audio) <Ref. to ET-6, REMOVAL, Audio.>
- 3) Remove the navigation unit. (model with navigation) <Ref. to ET-14, PROCEDURE, Navigation Body.>
- 4) Reach through the audio space to release the tabs from the bracket behind the instrument panel.

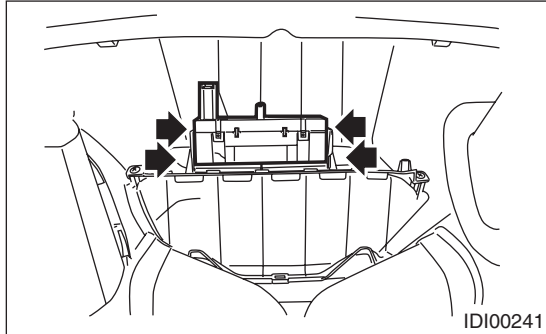

- 5) Disconnect the harness connector and remove the clock.

### B: INSTALLATION

Install each part in the reverse order of removal.

# Clock

INSTRUMENTATION/DRIVER INFO

---

**IDI-22**

Brought to you by Ebay Seller "SubaruManuals"

# SEATS

# SE

---

	<b>Page</b>
1. General Description .....	2
2. Front Seat .....	6
3. Rear Seat .....	13
4. Seat Heater System .....	17

# General Description

## SEATS

### 1. General Description

#### A: COMPONENT

#### 1. FRONT SEAT LH

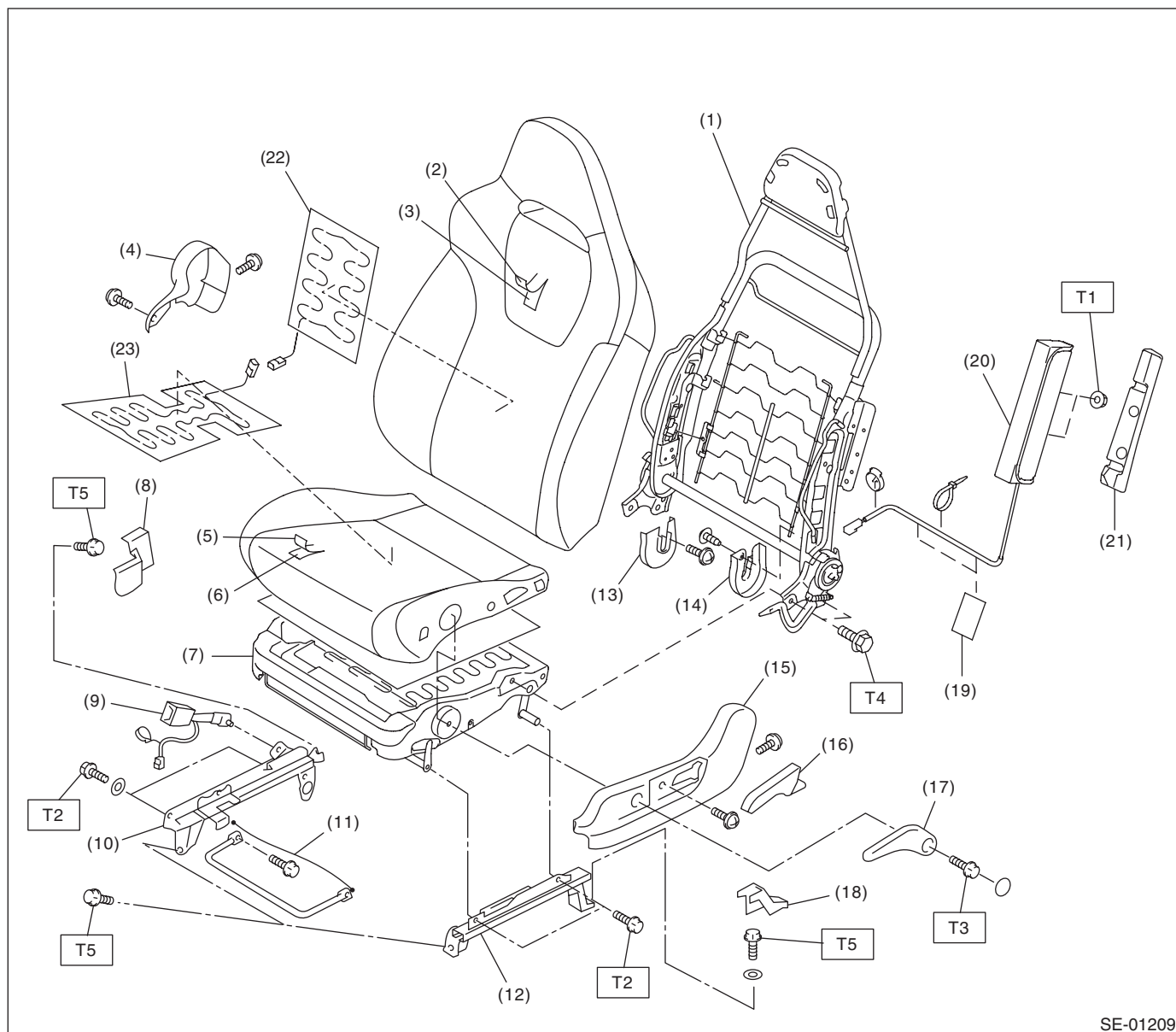

SE-01209

(1) Backrest frame ASSY	(11) Connecting cable	(21) Pad
(2) Backrest cover	(12) Slide rail outside	(22) Seat heater module (backrest)
(3) Backrest pad	(13) Seat hinge inner cover RH	(23) Seat heater module (seat cushion)
(4) Seat side cover inside	(14) Seat hinge inner cover LH	
(5) Seat cushion cover	(15) Seat side cover outside	
(6) Seat cushion pad	(16) Reclining lever cover	
(7) Seat cushion frame ASSY	(17) Lifter lever	
(8) Rear bolt cover inside	(18) Rear bolt cover outside	
(9) Inner seat belt ASSY	(19) Tape	
(10) Slide rail inside	(20) Side airbag module	

#### **Tightening torque:N-m (kgf-m, ft-lb)**

**T1: 6.0 (0.61, 4.4)**

**T2: 9.8 (1.0, 7.2)**

**T3: 17.6 (1.79, 13.0)**

**T4: 52 (5.30, 38.4)**

**T5: 53 (5.40, 39.1)**

## 2. FRONT SEAT RH

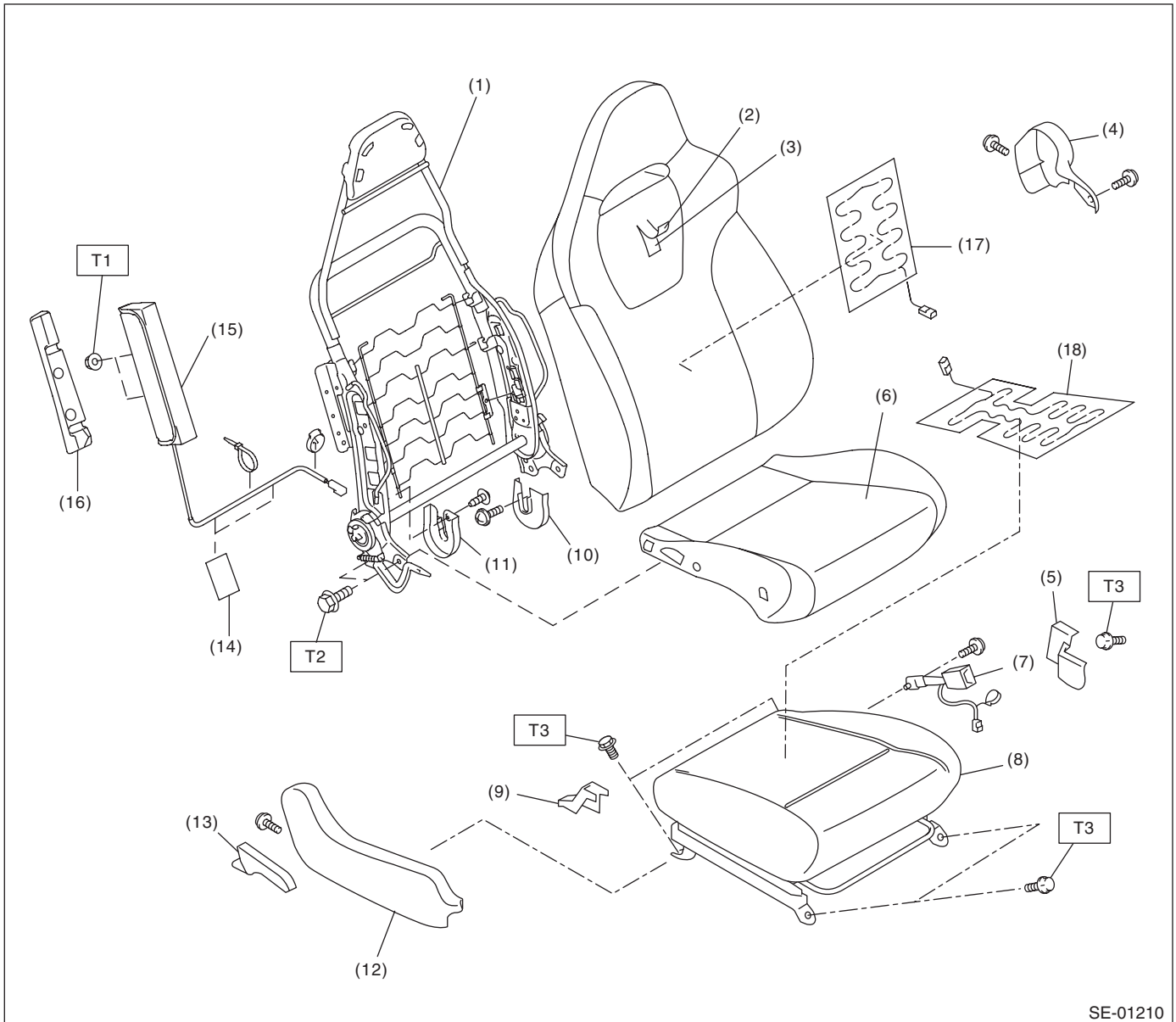

SE-01210

- |                                     |                              |  |
|-------------------------------------|------------------------------|--|
| (1) Backrest frame ASSY             | (9) Rear bolt cover outside  | (17) Seat heater module (backrest)     |
| (2) Backrest cover                  | (10) Hinge inner cover LH    | (18) Seat heater module (seat cushion) |
| (3) Backrest pad                    | (11) Hinge inner cover RH    |  |
| (4) Seat side cover inside          | (12) Seat side cover outside |  |
| (5) Rear bolt cover inside          | (13) Reclining lever         |  |
| (6) Seat cushion cover              | (14) Tape                    |  |
| (7) Inner seat belt ASSY            | (15) Side airbag module      |  |
| (8) Seat cushion pad and frame ASSY | (16) Pad                     |  |

**Tightening torque: N·m (kgf-m, ft-lb)**

**T1: 6.0 (0.61, 4.4)**

**T2: 52 (5.30, 38.4)**

**T3: 53 (5.40, 39.1)**

# General Description

## SEATS

### 3. REAR SEAT

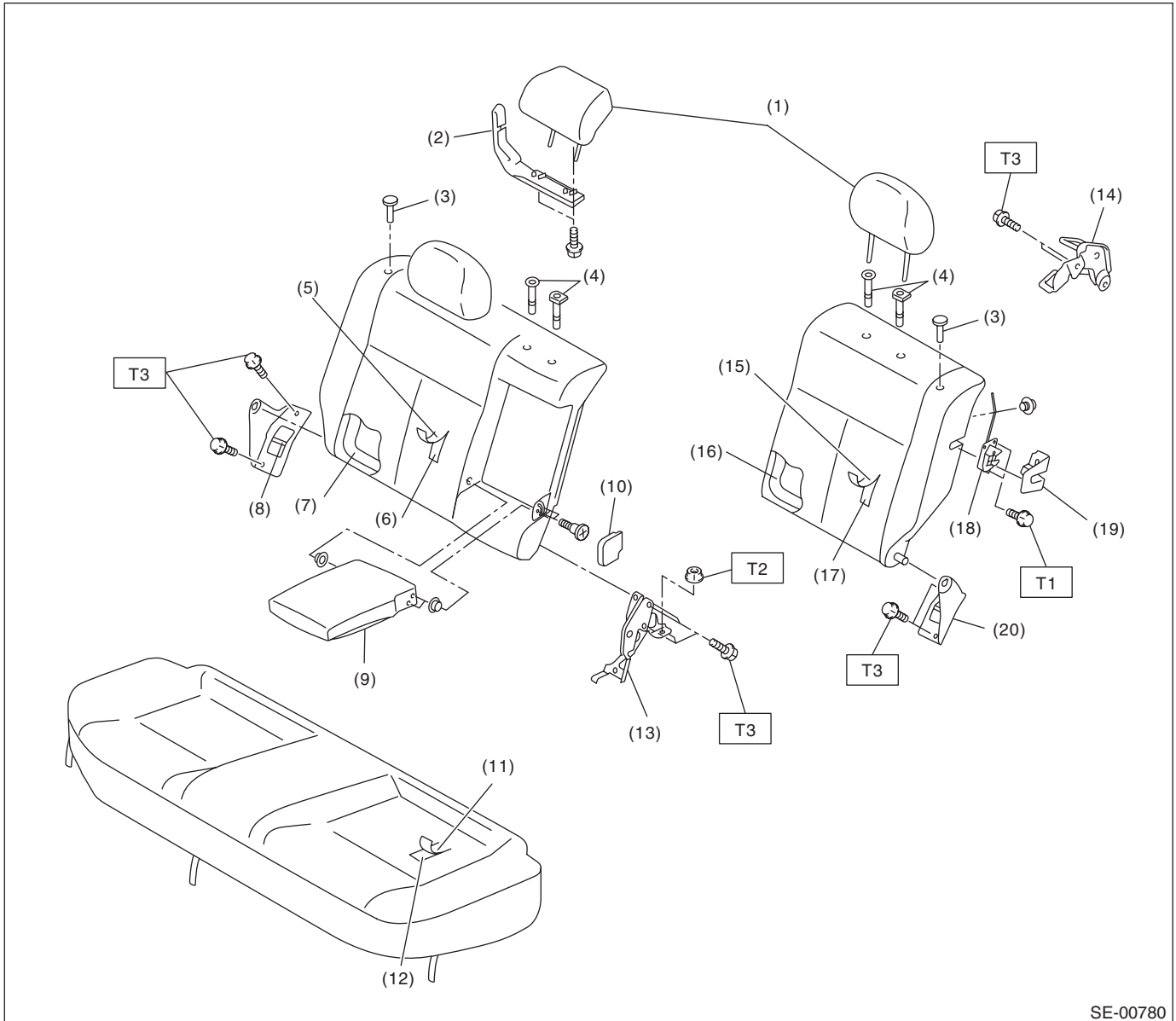

SE-00780

- |                       |                          |                                |
|-----------------------|--------------------------|--------------------------------|
| (1) Headrest          | (10) Armrest hinge cover | (19) Seat backrest latch cover |
| (2) Seat belt guide   | (11) Seat cushion cover  | (20) Hinge ASSY LH             |
| (3) Backrest knob     | (12) Seat cushion pad    |                                |
| (4) Headrest bushing  | (13) Hinge ASSY center   |                                |
| (5) Backrest cover RH | (14) Striker             |                                |
| (6) Backrest pad RH   | (15) Backrest cover LH   |                                |
| (7) Backrest frame RH | (16) Backrest frame LH   |                                |
| (8) Hinge ASSY RH     | (17) Backrest pad LH     |                                |
| (9) Armrest ASSY      | (18) Seat back latch     |                                |

---

**Tightening torque: N·m (kgf·m, ft·lb)**

**T1: 17.6 (1.79, 13.0)**

**T2: 24.5 (2.49, 18.1)**

**T3: 33 (3.36, 24.3)**

---

## B: CAUTION

- If the seat cushion cover is removed or replaced, make sure to perform passenger detection system adjustment after installing the seat to the vehicle. <Ref. to OD(diag)-14, SYSTEM CALIBRATION (REZEROING), OPERATION, Subaru Select Monitor.>

If system adjustment is not performed, the occupant detection system may not function properly.

- The passenger detection system (passenger seat only) control unit and the passenger detection sensor are fixed to the seat cushion frame. Never remove the passenger detection control unit or the pressure sensor from the seat cushion frame.
- Do not replace the seat cushion pad by itself. Always replace the seat cushion pad and frame assembly as a set. The seat cushion pad and cushion frame are adjusted as a set at the time of manufacture. If cushion pads and cushion frames are combined from those of other vehicles or other sets, the passenger detection system may not operate properly.
- If the seat cushion cover is removed, make sure to replace the hang wire on the seat cushion side with a new wire.
- When removing the front seat, follow cautions given in the airbag section. <Ref. to AB-5, CAUTION, General Description.>

## C: PREPARATION TOOL

### 1. GENERAL TOOL

TOOL NAME	REMARKS
Long nose plier	Used for removing the hog ring.
Hog ring pliers	Used for installing the hog ring.
TORX® T50	Used for removing and installing the inner seat belt assembly.
Circuit tester	Used for measuring resistance and voltage.



## 2. Front Seat

### A: REMOVAL

**CAUTION:**

The airbag system is fitted with a backup power supply. After disconnecting the battery ground cable, the airbag may operate if you do not wait for 60 seconds before starting the service of airbag system.

#### 1. DRIVER'S SEAT

- 1) Disconnect the ground cable from battery, and wait for 60 seconds or more before starting work.
- 2) Remove the slide rail installing bolt.
  - (1) Tilt the backrest forward and move the seat to the front most position.
  - (2) Remove the rear bolt cover at the rear side of the slide rail and remove the bolt.
  - (3) Move the seat to the rearmost position, and remove the bolt on the front side of the slide rail.
- 3) Disconnect the connector under the seat.

**CAUTION:**

Disconnect the ground cable from battery, and wait 60 seconds before disconnecting the connector.

- Seat belt buckle switch connector
  - Side airbag connector
  - Seat heater connector (model with seat heater)
- 4) Remove the front seat from vehicle.

#### 2. PASSENGER'S SEAT

**CAUTION:**

Refer to "CAUTION" of "General Description" for "AIRBAG SYSTEM" section before starting the work. <Ref. to SE-5, CAUTION, General Description.>

- 1) Disconnect the ground cable from battery, and wait for 60 seconds or more before starting work.
- 2) Tilt the backrest forward, and move the seat forward.
- 3) Remove the rear bolt cover, and then remove the rear side of slide rail.
- 4) Move the seat backward, remove the front bolt cover, and then remove the bolt at the front side of slide rail.
- 5) Disconnect all the connectors of connector holder in the backside of seat cushion.
  - Harness connector of occupant detection control module
  - Side airbag connector
  - Seat heater connector (model with seat heater)
- 6) Remove the seat from vehicle.

### B: INSTALLATION

Install each part in the reverse order of removal.

**NOTE:**

Tighten the slide rail installing bolt gradually in several steps to the specified torque in the order as shown in the figure.

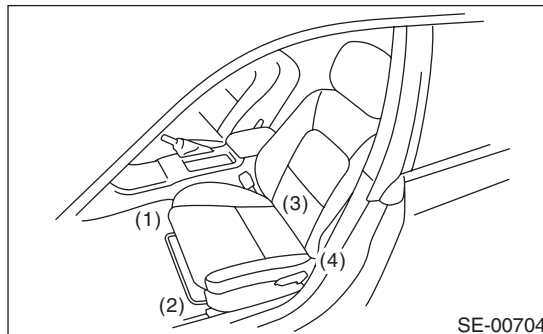

**Tightening torque:**

Refer to "COMPONENT" of "General Description". <Ref. to SE-2, FRONT SEAT LH, COMPONENT, General Description.>

### C: DISASSEMBLY

- 1) Remove the seat from vehicle. <Ref. to SE-6, REMOVAL, Front Seat.>
- 2) Remove the seat lifter cover using a flat tip screwdriver and loosen the inner bolt to remove the seat lifter lever.

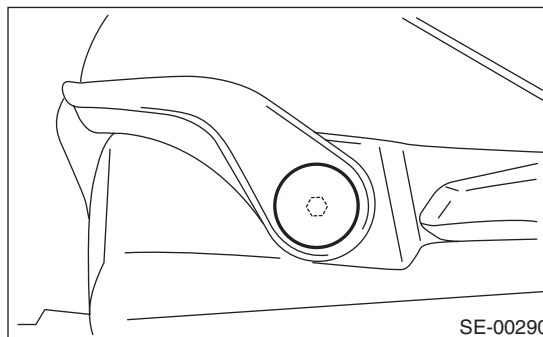

- 3) Disengage the tab on the backside while pulling the reclining lever, and remove the reclining lever cover.

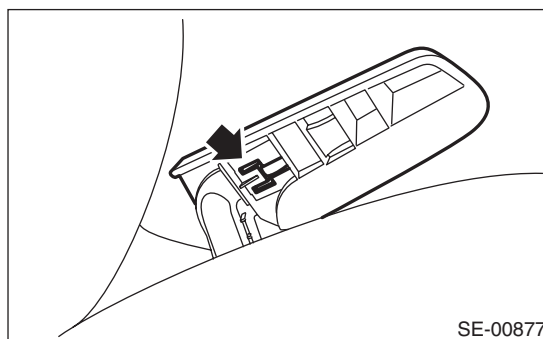

4) Remove screws (A) and clips (B), and then detach the seat side cover outside.

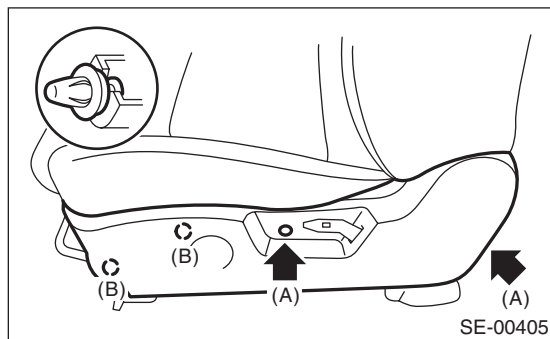

5) Remove the TORX® bolt, and then remove the inner seat belt assembly.

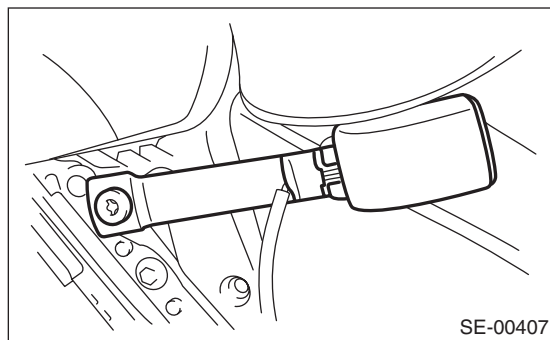

6) Remove the screws and detach the seat side cover inside.

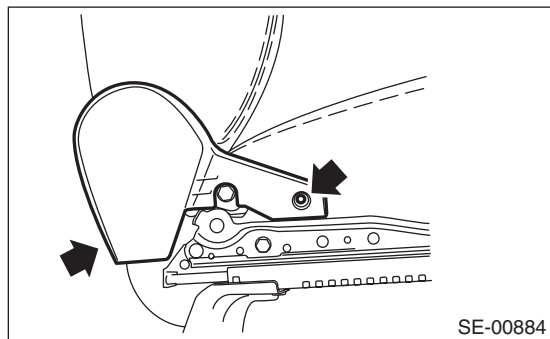

7) Remove the bolts from reclining hinge of both sides.

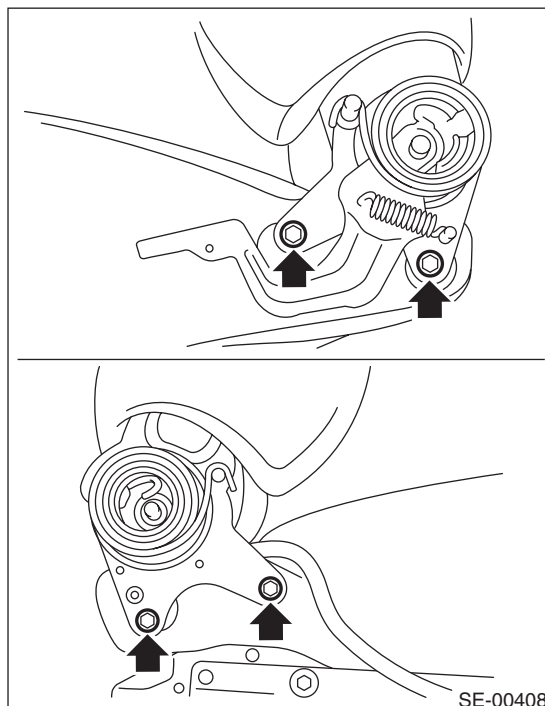

8) Remove the plastic fastener at the back side (bottom) of backrest.

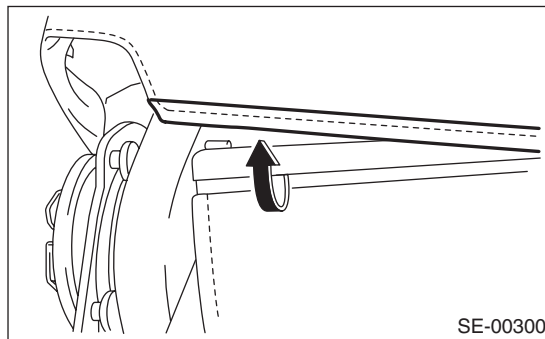

9) Open the fastener at the rear side of backrest.

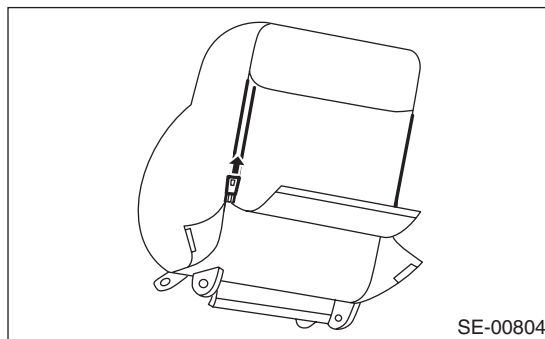

# Front Seat

## SEATS

10) Remove the hog rings of backrest cover.

### CAUTION:

Be careful not to tear the vinyl inside the seat when removing the hog rings.  
If torn, replace with a new part.

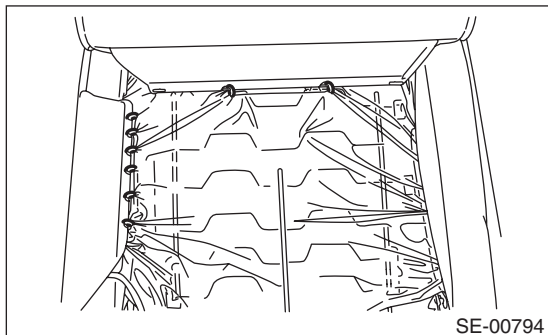

11) Remove the pad (A), and remove the mounting nut from the side airbag module.

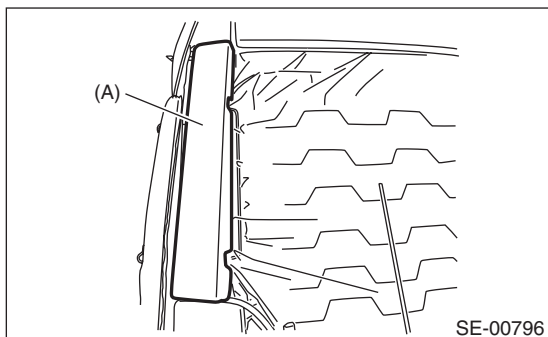

12) Remove the fastener (a) at the backrest hole.

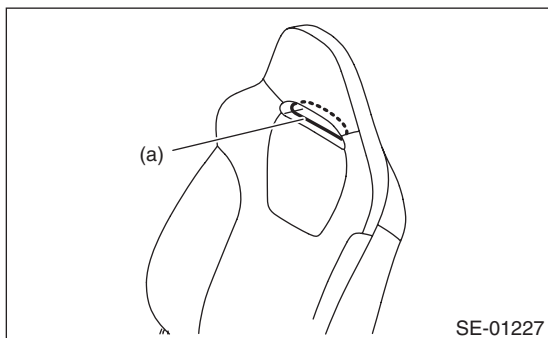

13) Pull out the backrest frame.

14) Remove all the hog rings at front of seat back, and then remove the seat back cover from seat backrest.

15) Remove the plastic hooks (A) of the seat cushion cover, and then remove the seat cushion frame assembly.

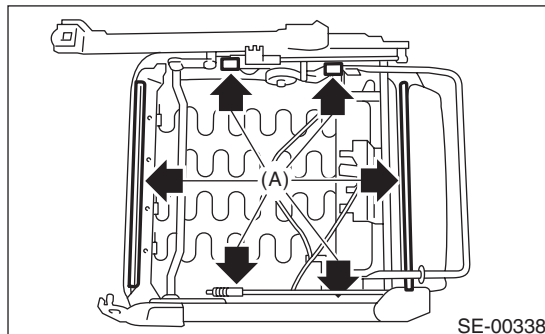

16) Remove all the hog rings, and then remove the seat cushion cover from seat cushion pad.

17) Remove the bolts on the side of seat cushion assembly, and then remove the slide rail.

### CAUTION:

Do not reuse the removed bolts because they are coated with the thread lock material. Always use new bolts during assembly.

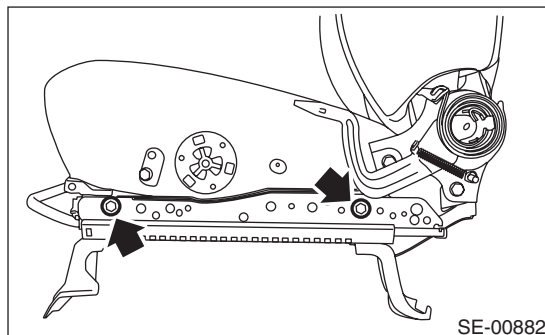

## 2. PASSENGER'S SEAT

### CAUTION:

• If the seat cushion cover is removed or replaced, make sure to perform passenger detection system adjustment after installing the seat to the vehicle. <Ref. to OD(diag)-14, SYSTEM CALIBRATION (REZEROING), OPERATION, Subaru Select Monitor.>

Failure to do so may cause improper activation of passenger's airbag.

• The passenger detection system (passenger seat only) control unit, passenger detection sensor, seat cushion pad and seat cushion frame are considered as a single seat cushion pad and frame assembly. Never remove the passenger detection control unit or the pressure sensor from the seat cushion frame.

• If the seat cushion cover is removed, make sure to replace the hang wire on the seat cushion side with a new wire.

- 1) Remove the seat from vehicle. <Ref. to SE-6, PASSENGER'S SEAT, REMOVAL, Front Seat.>
- 2) Refer to the disassembly procedures for the driver's seat.

## D: ASSEMBLY

### CAUTION:

**When installing the side airbag module assembly, be sure to put the side airbag module between backrest cover and airbag guide cloth.**

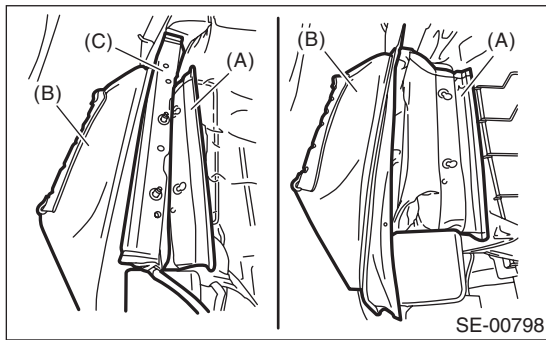

- (A) Airbag guide cloth
- (B) Backrest cover
- (C) Side airbag module ASSY

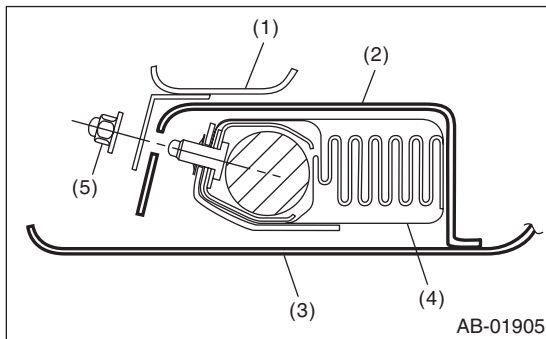

- (1) Backrest frame ASSY
- (2) Airbag guide cloth
- (3) Backrest cover
- (4) Side airbag module ASSY
- (5) Hexagon cap nut

**Besides, if the backrest cover is not installed securely, the side airbag module may not be activated properly, therefore keep strictly to the following procedures.**

- Be careful not to stain or damage the backrest cover during assembly.
- Do not reuse hog rings.
- Secure the hog ring using hog ring pliers.
- Install the hog rings to the specified points securely and make sure that there is no wrinkle or twisting on backrest cover.

- 1) Make sure that there is no foreign matter on side airbag module.
- 2) Assemble the seat cover.
  - (1) Adjust so that the left and right clearances between wire and seat pad become equal, and mark the seat pad.

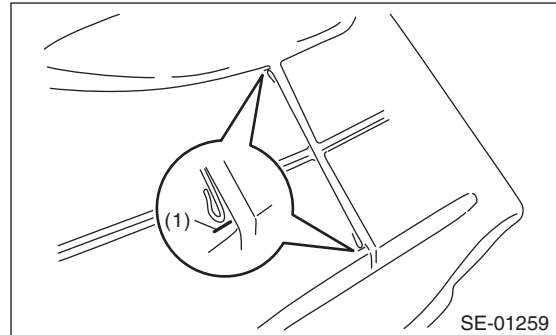

(1) Marking

- (2) Mark the center of the wire on the pad side to which the hog ring is attached.

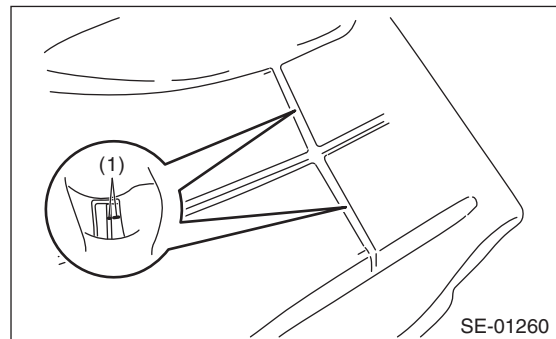

(1) Marking

- (3) Insert the wire into the seat cover, and align the wire with the position marked in step 1).

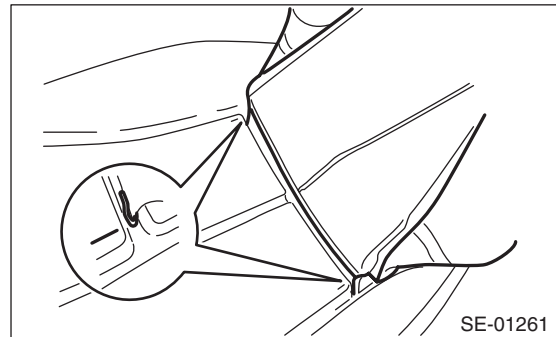

SE-01261

# Front Seat

## SEATS

(4) Mark the wire on the seat cover side according to the markings on the seat pad.

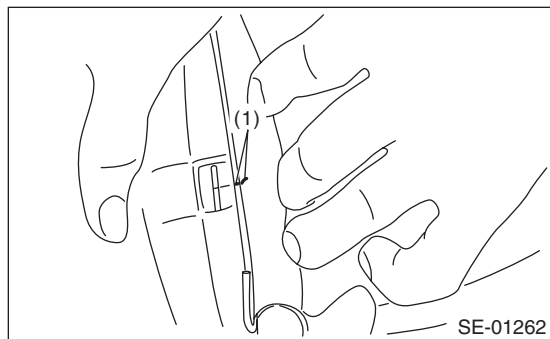

(1) Marking

(5) Perform steps 1) — 4) to all sections to which the hog rings are attached.

(6) Make sure that all hog rings (A) are attached securely.

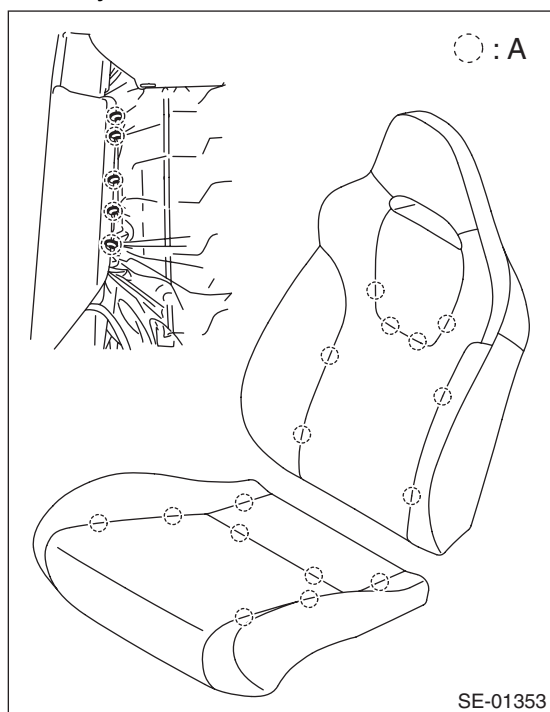

3) Hereafter, assemble each part in the reverse order of disassembly.

### Tightening torque:

Refer to "COMPONENT" of "General Description". <Ref. to SE-2, FRONT SEAT LH, COMPONENT, General Description.>

## 1. DRIVER'S SEAT

### NOTE:

• When installing the inner seat belt assembly, follow the procedures described in the seat belt section. <Ref. to SB-18, INSTALLATION, Front Seat Belt.>

• Install the backrest assembly and seat cushion assembly in the following procedure.

- 1) Temporarily tighten the reclining hinge bolts.
- 2) Place the backrest in the most upright position.
- 3) Tighten the reclining hinge bolts (1) through (4) in order, in two or three steps by gradually increasing the torque until they reach the specified torque.

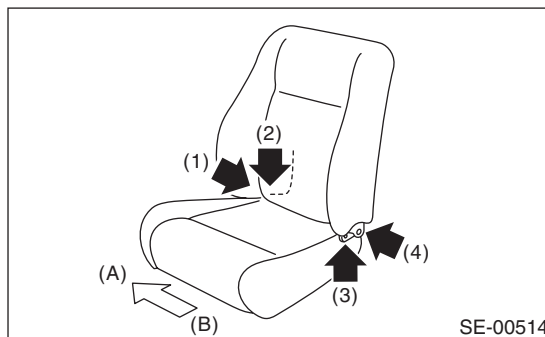

(A) Vehicle inside

(B) Vehicle outside

### Tightening torque:

Refer to "COMPONENT" of "General Description". <Ref. to SE-2, FRONT SEAT LH, COMPONENT, General Description.>

4) Assemble each part in the reverse order of disassembly.

5) If any wrinkles are found after the assembly of the seat cover, finish the seat cover with iron.

- (1) Place the wet towel on wrinkles.



- (2) Touch up with warm iron.

### CAUTION:

Keep moving the iron, otherwise the seat cover surface can be damaged.

**NOTE:**

This method is available for genuine leather, synthetic leather, cloth, etc.

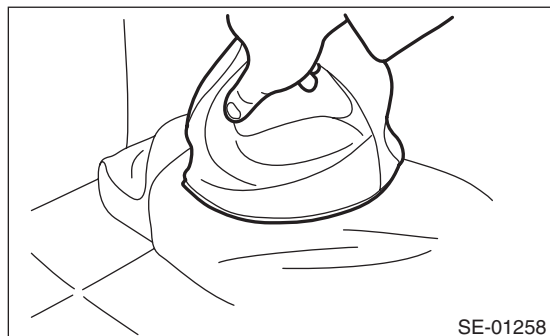

## 2. PASSENGER'S SEAT

**CAUTION:**

Make sure to adhere to the following rules when assembling the passenger seat. Improper work procedures can cause the occupant detection system to not operate properly.

- If the seat cushion cover is removed or replaced, make sure to perform occupant detection system adjustment after installing the seat. <Ref. to OD(diag)-14, SYSTEM CALIBRATION (REZEROING), OPERATION, Subaru Select Monitor.>

Failure to do so may prevent the passenger's airbag from operating properly.

- The occupant detection system (passenger seat only) control module, occupant detection sensor, seat cushion pad and seat cushion frame are considered as a single seat cushion pad and frame assembly. Never remove the occupant detection control module or the occupant detection sensor from the seat cushion frame.

- If the seat cushion cover is removed, make sure to replace the hang wire on the seat cushion side with a new wire.

- Make sure to install the hog rings/clips to the specified locations. Do not reuse hog rings.

1) Assemble the seat cushion in the reverse order of disassembly.

2) Assemble the backrest in the reverse order of disassembly.

3) When installing the backrest assembly to the seat cushion assembly, fill the gap in the front side of slide rail LH and in the rear side of slide rail RH with cloth etc. in order to stabilize the seat cushion assembly.

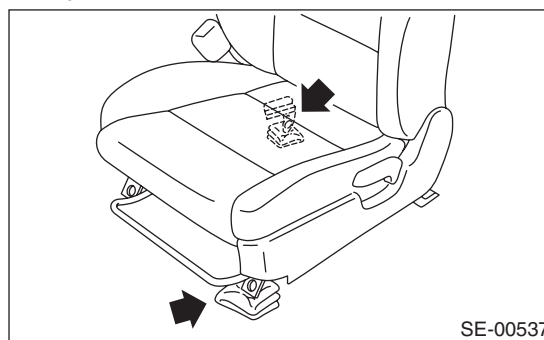

4) Temporarily tighten the reclining hinge bolts in the order of (1) through (4) to an extent that the seat backrest assembly is not held securely.

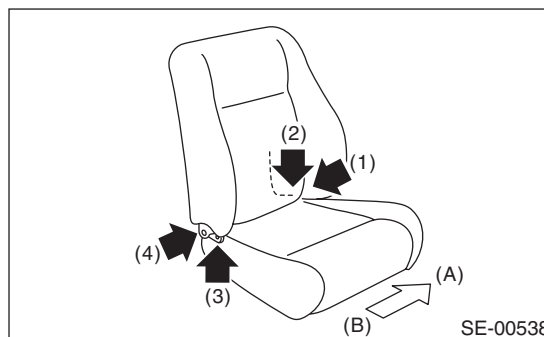

- (A) Vehicle inside
- (B) Vehicle outside

**Tightening torque:**

Refer to "COMPONENT" of "General Description". <Ref. to SE-2, FRONT SEAT LH, COMPONENT, General Description.>

5) Use the reclining lever to place the backrest in the most upright position, and check the first lock position of recliner.

6) Hold the seat cushion assembly securely, and tighten the reclining hinge bolts in the order described above until they reach the specified torque.

**CAUTION:**

Do not touch the backrest assembly when tightening the reclining hinge bolts.

7) Assemble each harness, inner belt assembly and each cover in the reverse order of removal.

8) Install the seat assembly.



## Front Seat

### SEATS

---

9) If any wrinkles are found after the assembly of the seat cover, finish the seat cover with iron.

(1) Place the wet towel on wrinkles.

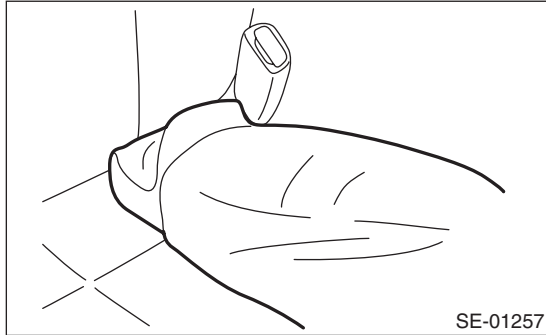

(2) Touch up with warm iron.

#### **CAUTION:**

**Keep moving the iron, otherwise the seat cover surface can be damaged.**

#### **NOTE:**

This method is available for genuine leather, synthetic leather, cloth, etc.

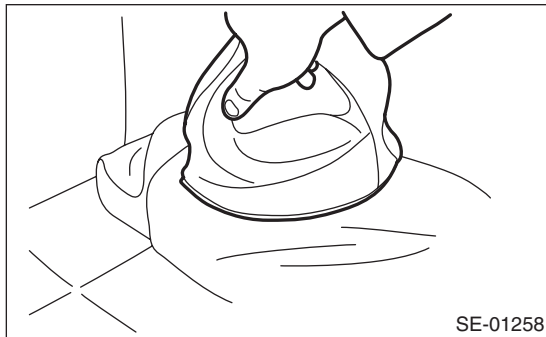

#### **E: INSPECTION**

Check that no tear or fray on the backrest cover and seat cushion cover.

#### **NOTE:**

For model with side airbag, if the door side of the backrest cover is torn or frayed, the side airbag may not be deployed properly. In this case, replace the backrest cover.

### 3. Rear Seat

#### A: REMOVAL

##### CAUTION:

- Airbag system satellite safing sensor is located in the lower of the rear seat cushion center. Read the cautions and warnings described in "AIRBAG SYSTEM" section before removing the rear seat. <Ref. to AB-5, CAUTION, General Description.>
- The airbag system is fitted with a backup power supply. After disconnecting the battery ground cable, the airbag may operate if you do not wait for 60 seconds before starting the service of airbag system.

- 1) Disconnect the ground cable from battery, and wait for 60 seconds or more before starting work.
- 2) Remove the rear seat cushion.

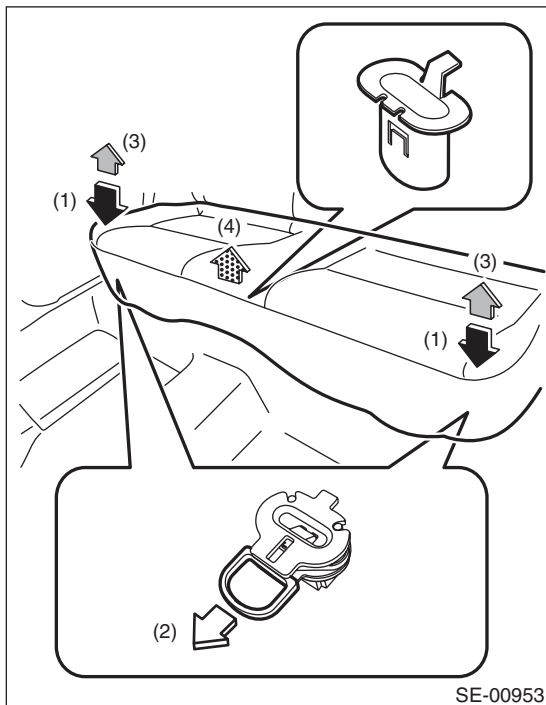

- (1) Push the corners of the seat cushion from above.
- (2) While pushing the corners of the seat cushion from above, pull the knob of the seat cushion hook towards yourself.
- (3) While pulling the knob towards yourself, disconnect the hooks by lifting up the seat cushion.
- (4) Pull up the front center part of the seat cushion and disconnect the center hook.

##### CAUTION:

If the center hook is disconnected from the vehicle body, replace the hook with the new part to prevent the decline of the fixed force of the seat.

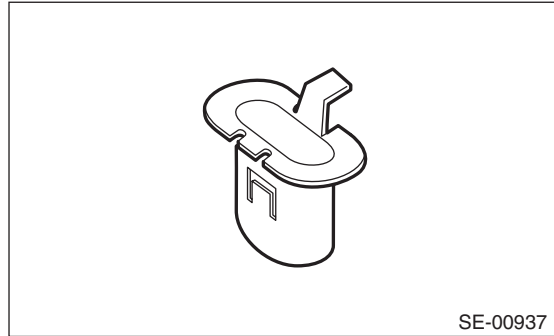

- (5) Remove the hook (A) by pushing it back while lifting the front side of the seat cushion, and remove the seat cushion.

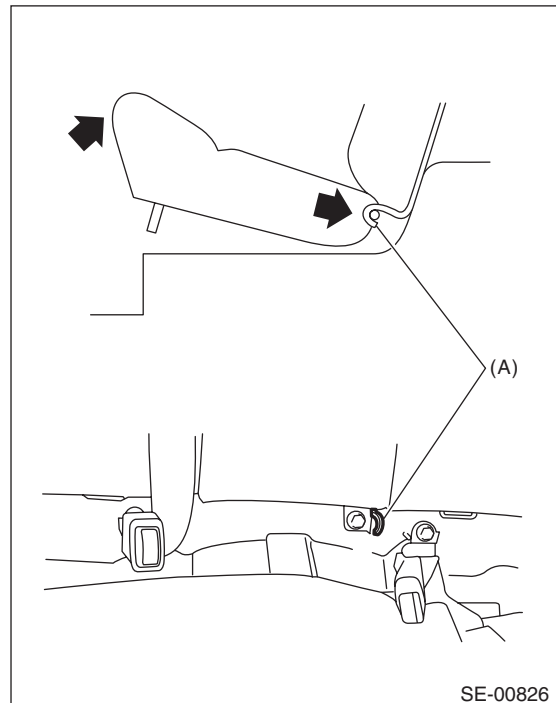

- 3) Remove the headrest, and then tilt the backrest forward.
- 4) Remove the luggage floor mat. (5 door model)
- 5) Turn over the mat to remove the bolt.

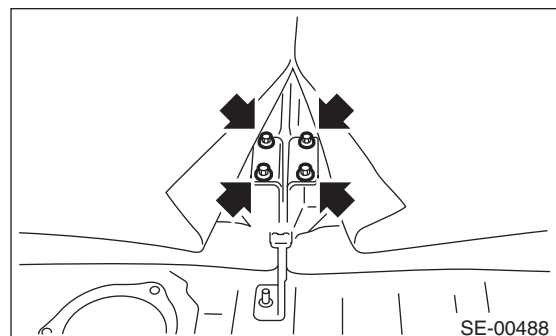



# Rear Seat

## SEATS

6) Remove the backrest from the hinge assembly LH (hinge assembly RH).

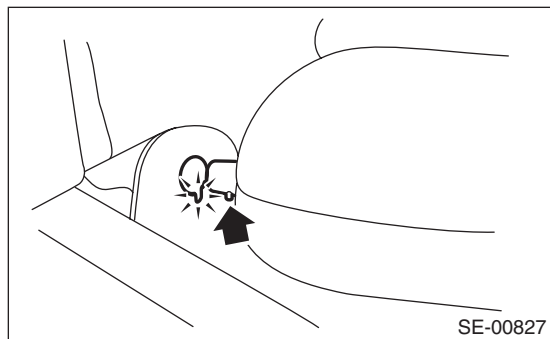

### NOTE:

The backrests cannot be detached while pin positions of the hinge assembly and backrests are not aligned.

## B: INSTALLATION

### CAUTION:

If the center hook is disconnected from the vehicle body, replace the hook with the new part to prevent the decline of the fixed force of the seat.

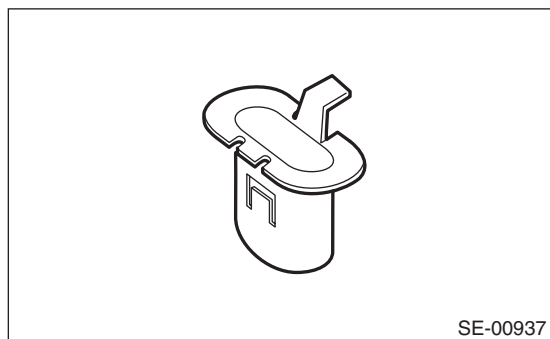

Install each part in the reverse order of removal.

### Tightening torque:

Refer to "COMPONENT" of "General Description". <Ref. to SE-4, REAR SEAT, COMPONENT, General Description.>

## C: DISASSEMBLY

1) Remove the rear seat. <Ref. to SE-13, REMOVAL, Rear Seat.>

2) Remove the armrest hinge cover in the direction of arrow (black), and loosen the screws to remove the armrest.

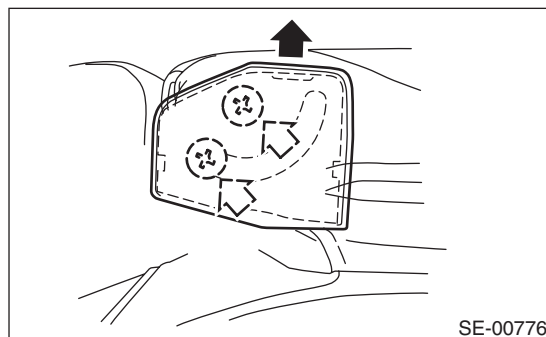

### NOTE:

The armrests cannot be detached while the backrest assembly RH and armrest side pin positions are not aligned.

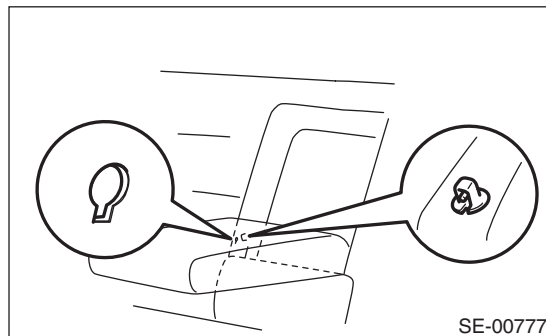

3) Remove the backrest knob. (screw-in type)

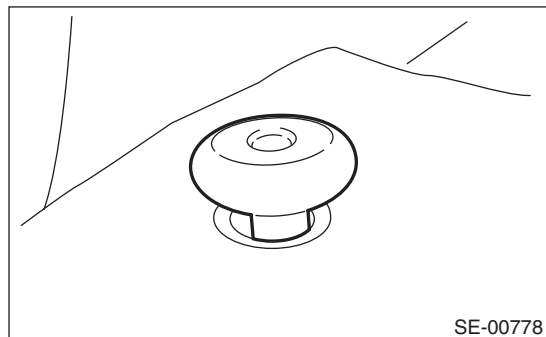

4) Remove the seat back latch cover.

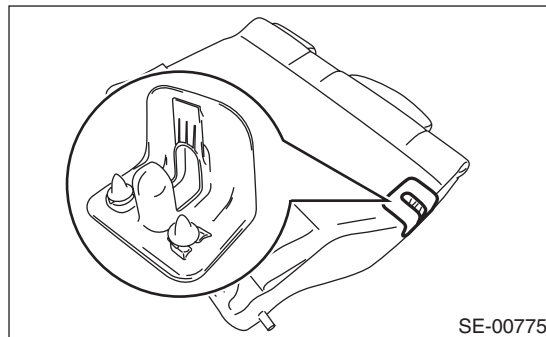

5) Peel the backrest cover, and remove the hog rings.

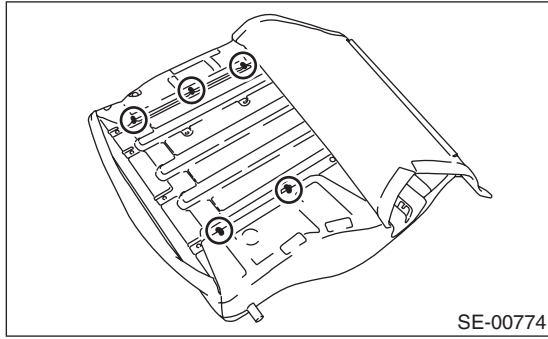

6) Remove all the hog rings which fix the backrest frame and backrest pad.

7) Remove the headrest bushing.

8) Remove the backrest pad and backrest cover from the backrest frame.

9) Disassemble the backrest assembly LH following the procedures described above.

10) Remove all the hog rings of the seat cushion, and separate the seat cushion cover and seat cushion pad.

11) Open the plastic fastener, and then remove the headrest cover from the headrest.

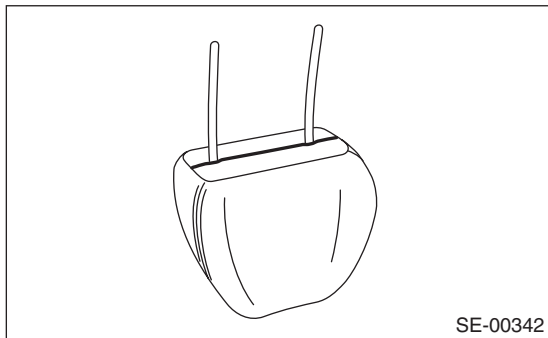

12) Remove the plastic fastener and hog rings, and then remove the armrest cover.

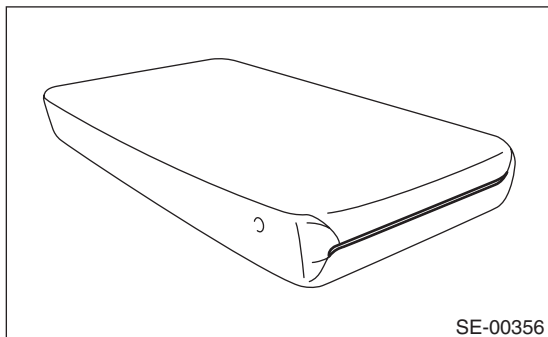

## D: ASSEMBLY

### CAUTION:

- Do not reuse hog rings.
- Secure the hog ring using hog ring pliers.
- Install the hog rings to the specified points securely and make sure that there is no wrinkle or twisting on backrest cover.

1) Assemble the seat cover in the same manner as the front seat. <Ref. to SE-9, ASSEMBLY, Front Seat.>

2) Make sure that all hog rings (A) are attached securely.

- Backrest (model without armrest)

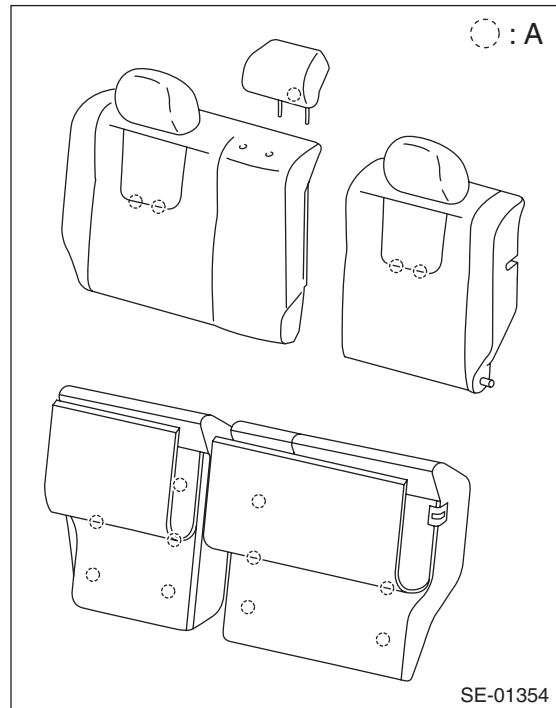

# Rear Seat

## SEATS

- Backrest (model with armrest)

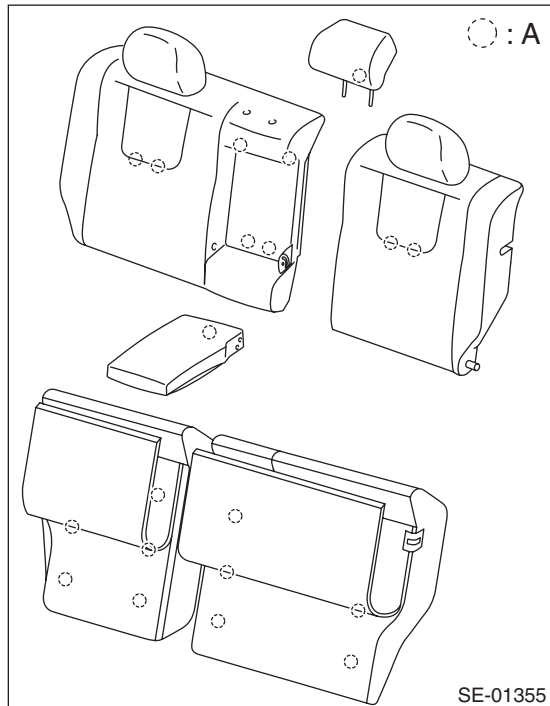

- Seat cushion (leather seat)

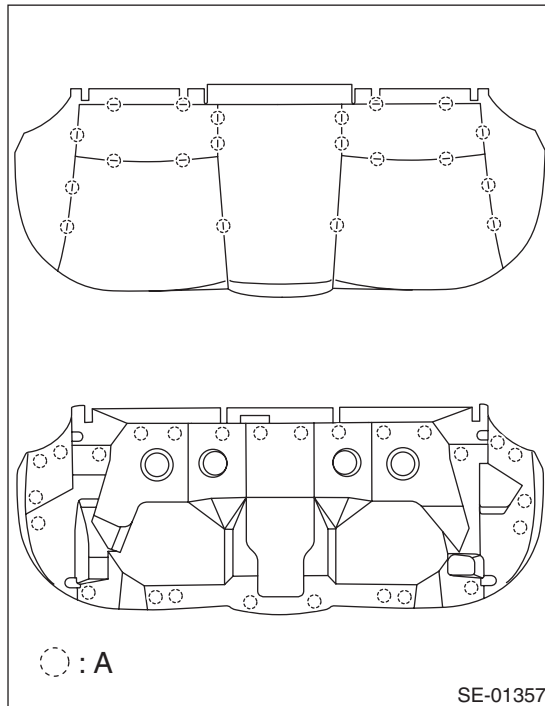

- Seat cushion (fabric seat)

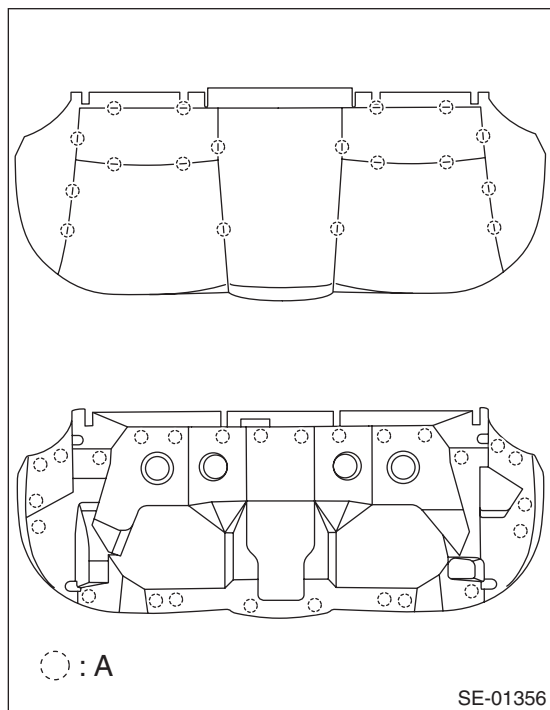

3) Assemble each part in the reverse order of disassembly.

### NOTE:

- Do not contaminate or damage the cover.
- While installing the hog rings, prevent the seat from getting wrinkled.

## 4. Seat Heater System

### A: REMOVAL

#### 1. SEAT HEATER MODULE

- 1) Remove the front seats. <Ref. to SE-6, REMOVAL, Front Seat.>
- 2) Remove the backrest cover of front seat and seat cushion cover. <Ref. to SE-6, DISASSEMBLY, Front Seat.>
- 3) Remove the seat heater module.

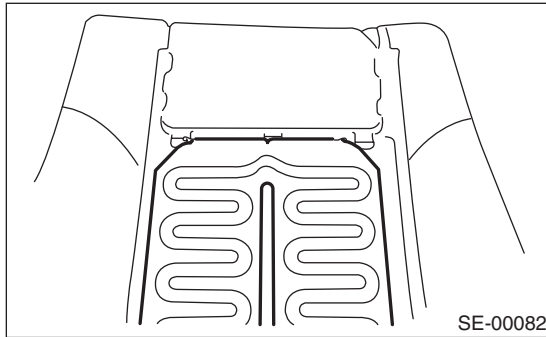

#### 2. SEAT HEATER SWITCH

- 1) Remove the console box. <Ref. to EI-51, REMOVAL, Console Box.>
- 2) Remove the seat heater switch from the console box.

### B: INSTALLATION

Install each part in the reverse order of removal.

### C: INSPECTION

#### 1. WIRING DIAGRAM

Refer to "Seat Heater System" in the wiring diagram. <Ref. to WI-88, WIRING DIAGRAM, Seat Heater System.>

## 2. DIAGNOSTIC CHART

- STI model

Symptoms	Repair order
Seat heater does not operate.	1. Check the fuse. <Ref. to SE-17, CHECK SEAT HEATER FUSE, INSPECTION, Seat Heater System.>
	2. Check the seat heater system power supply and ground circuit. <Ref. to SE-18, CHECK POWER SUPPLY AND GROUND CIRCUIT, INSPECTION, Seat Heater System.>
	3. Check the thermistor circuit. <Ref. to SE-18, CHECK THERMISTOR CIRCUIT, INSPECTION, Seat Heater System.>
	4. Check the seat heater switch circuit. <Ref. to SE-18, CHECK SEAT HEATER SWITCH, INSPECTION, Seat Heater System.>
	5. Check the seat heater module. <Ref. to SE-18, CHECK SEAT HEATER MODULE, INSPECTION, Seat Heater System.>

- Except for STI model

Symptoms	Repair order
Seat heater does not operate.	1. Check the fuse. <Ref. to SE-17, CHECK SEAT HEATER FUSE, INSPECTION, Seat Heater System.>
	2. Check the seat heater system power supply and ground circuit. <Ref. to SE-19, CHECK POWER SUPPLY AND GROUND CIRCUIT, INSPECTION, Seat Heater System.>
	3. Check the seat heater switch circuit. <Ref. to SE-19, SEAT HEATER SWITCH, INSPECTION, Seat Heater System.>
	4. Check the seat heater module. <Ref. to SE-18, CHECK SEAT HEATER MODULE, INSPECTION, Seat Heater System.>

## 3. CHECK SEAT HEATER FUSE

Remove the seat heater fuse, and then visually check.

Is the fuse blown out?

- Yes → Replace the fuse.
- No → Check the power supply and ground circuit.

# Seat Heater System

## SEATS

### 4. CHECK POWER SUPPLY AND GROUND CIRCUIT

- 1) Check power supply circuit.
  - (1) Disconnect the connector of seat heater switch.
  - (2) Turn the ignition switch to ON.
  - (3) Measure the voltage between harness connector terminal and chassis ground.

#### Connector & terminal

##### (AD8) No. 12 (+) — Chassis ground (-):

Is the voltage 12 V or more?

- Yes → Go to symptom 2.
- No → Check the harness between the seat heater switch and fuse.

- 2) Check ground circuit.

Measure the resistance between harness connector terminal and chassis ground.

#### Connector & terminal

##### (AD8) No. 2 — Chassis ground:

Is the resistance less than 10 Ω?

- Yes → Go to symptom 3.
- No → Repair the harness.

- 3) Check ground circuit.

Measure the resistance between seat heater switch terminals.

#### Connector & terminal

##### (AD8) No. 1 — (AD8) No. 2:

##### (AD8) No. 3 — (AD8) No. 2:

Is the resistance less than 10 Ω?

- Yes → The power supply and ground circuit are normal.
- No → Replace the seat heater switch.

### 5. CHECK THERMISTOR CIRCUIT

Measure the resistance between harness connector terminals.

#### Connector & terminal

##### Check LHD side

##### (AD8) No. 8 — (AD8) No. 3:

##### Check RHD side

##### (AD8) No. 6 — (AD8) No. 1:

Is the resistance between 1 kΩ and 200 kΩ?

- Yes → Thermistor circuit is normal
- No → Harness faulty or thermistor faulty

### 6. CHECK SEAT HEATER SWITCH

- 1) Check thermistor output voltage.
  - (1) Connect the seat heater switch connector.
  - (2) Turn the ignition switch to ON.
  - (3) Measure the voltage between the seat heater switch and chassis ground.

#### Connector & terminal:

##### LHD side seat

##### (AD8) No. 8 (+) — Chassis ground (-):

##### RHD side seat

##### (AD8) No. 6 (+) — Chassis ground (-):

Is the voltage 1.5 V or more?

- Yes → Go to symptom 2.
- No → Replace the seat heater switch.

- 2) Check output voltage.

(1) Turn the ignition switch to ON.

(2) Measure the voltage between the seat heater switch and chassis ground when turning the switch to a position other than OFF.

#### Connector & terminal:

##### LHD side seat

##### (AD8) No. 9 (+) — Chassis ground (-):

##### RHD side seat

##### (AD8) No. 7 (+) — Chassis ground (-):

Does the voltage repeat 12 V ↔ 0 V?

- Yes → The harness or thermistor is faulty, or the heater has an open circuit.
- No → Replace the seat heater switch.

### 7. CHECK SEAT HEATER MODULE

- 1) Disconnect the seat heater module connector, and check the continuity between terminals of connector.

#### Connector & terminal

##### No. 1 — No. 3:

##### No. 1 — No. 4:

##### No. 3 — No. 4:

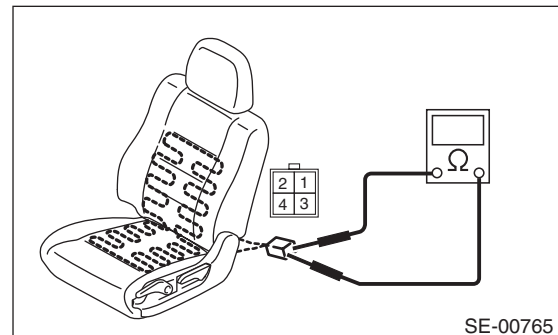

Is there continuity between connector terminals?

- **Continuity exists.** →

Seat heater module is normal. If there is a malfunction, check the seat heater switch and vehicle body side harness.

- **Continuity does not exist.** →  
**No. 1 — No. 3:** → Go to step 2).  
**No. 1 — No. 4:** → Go to step 2).  
**No. 3 — No. 4:** → Replace the seat heater module of seat cushion side.
- 2) Disconnect the seat heater module of backrest side, and check the continuity between connector terminals of the seat heater module unit of backrest side.

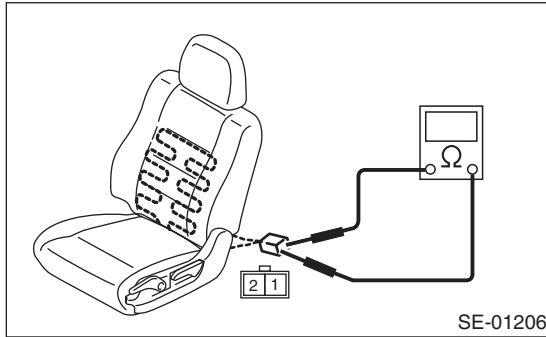

Is there continuity between connector terminals?

- **Continuity exists.** →  
 Replace the seat heater module of seat cushion side.
- **Continuity does not exist.** →  
 Replace the seat heater module of backrest side.

## 8. CHECK POWER SUPPLY AND GROUND CIRCUIT

- 1) Check power supply circuit.
  - (1) Disconnect the connector of seat heater switch.
  - (2) Turn the ignition switch to ON.
  - (3) Measure the voltage between harness connector terminal and chassis ground.

### Connector & terminal

**(R42) No. 2 (+) — Chassis ground (-):**

**(R43) No. 2 (+) — Chassis ground (-):**

Is the voltage 12 V or more?

- Yes → Go to symptom 2.
- No → Check the harness between the seat heater switch and fuse.

- 2) Check ground circuit.

Measure the resistance between harness connector terminal and chassis ground.

### Connector & terminal

**(R42) No. 3 — Chassis ground:**

**(R43) No. 3 — Chassis ground:**

Is the resistance less than 10 Ω?

- Yes → Go to symptom 3.
- No → Repair the harness.

- 3) Check ground circuit.

Measure the resistance between seat heater switch terminals.

### Connector & terminal

**(R42) No. 2 — (R42) No. 3:**

**(R43) No. 2 — (R43) No. 3:**

Is the resistance less than 10 Ω?

- Yes → The power supply and ground circuit are normal.
- No → Replace the seat heater switch.

## 9. SEAT HEATER SWITCH

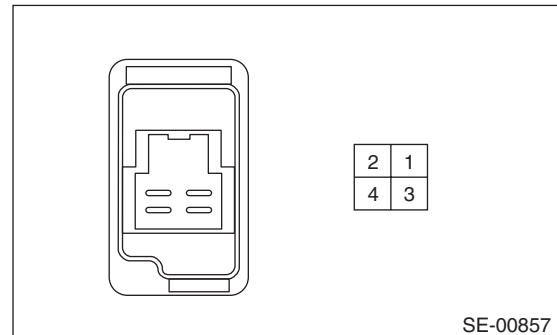

- 1) Inspect the continuity between the seat heater switch terminals.

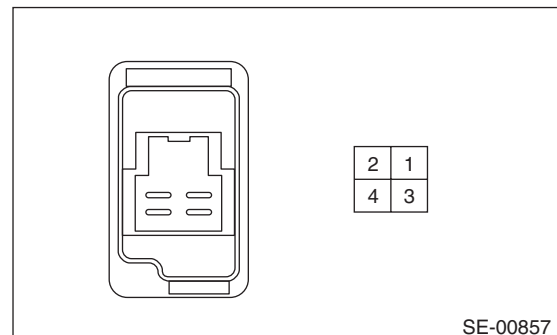

### Connector & terminal

**HI**

**No. 2 — No. 1:**

**No. 2 — No. 3:**

**No. 1 — No. 3:**

**No. 4 — No. 3:**

**LOW**

**No. 2 — No. 4:**

**No. 2 — No. 3:**

**No. 4 — No. 3:**

- 2) If no continuity exists, replace the seat heater switch with a new part.

# Seat Heater System

SEATS

---

# SECURITY AND LOCKS

# SL

---

	<b>Page</b>
1. General Description .....	2
2. Door Lock Control System .....	8
3. Keyless Entry System .....	13
4. Security System .....	26
5. Front Inner Remote .....	30
6. Front Outer Handle .....	31
7. Front Door Latch and Door Lock Actuator Assembly .....	32
8. Rear Inner Remote .....	33
9. Rear Outer Handle .....	34
10. Rear Door Latch and Door Lock Actuator Assembly .....	35
11. Rear Gate Opener Button .....	36
12. Rear Gate Latch and Actuator Assembly .....	37
13. Trunk Lid Latch and Actuator Assembly .....	38
14. Front Hood Lock Assembly .....	39
15. Remote Openers .....	40
16. Ignition Key Lock .....	42
17. Key Lock Cylinders .....	43
18. Security Control Module .....	44
19. Impact Sensor .....	45
20. Keyless Entry Control Module .....	46
21. Keyless Buzzer .....	47
22. Body Integrated Unit .....	48
23. Transmitter .....	49
24. Immobilizer Control Module .....	51
25. Immobilizer Antenna .....	52



# General Description

## SECURITY AND LOCKS

### 1. General Description

#### A: COMPONENT

#### 1. DOOR LOCK ASSEMBLY

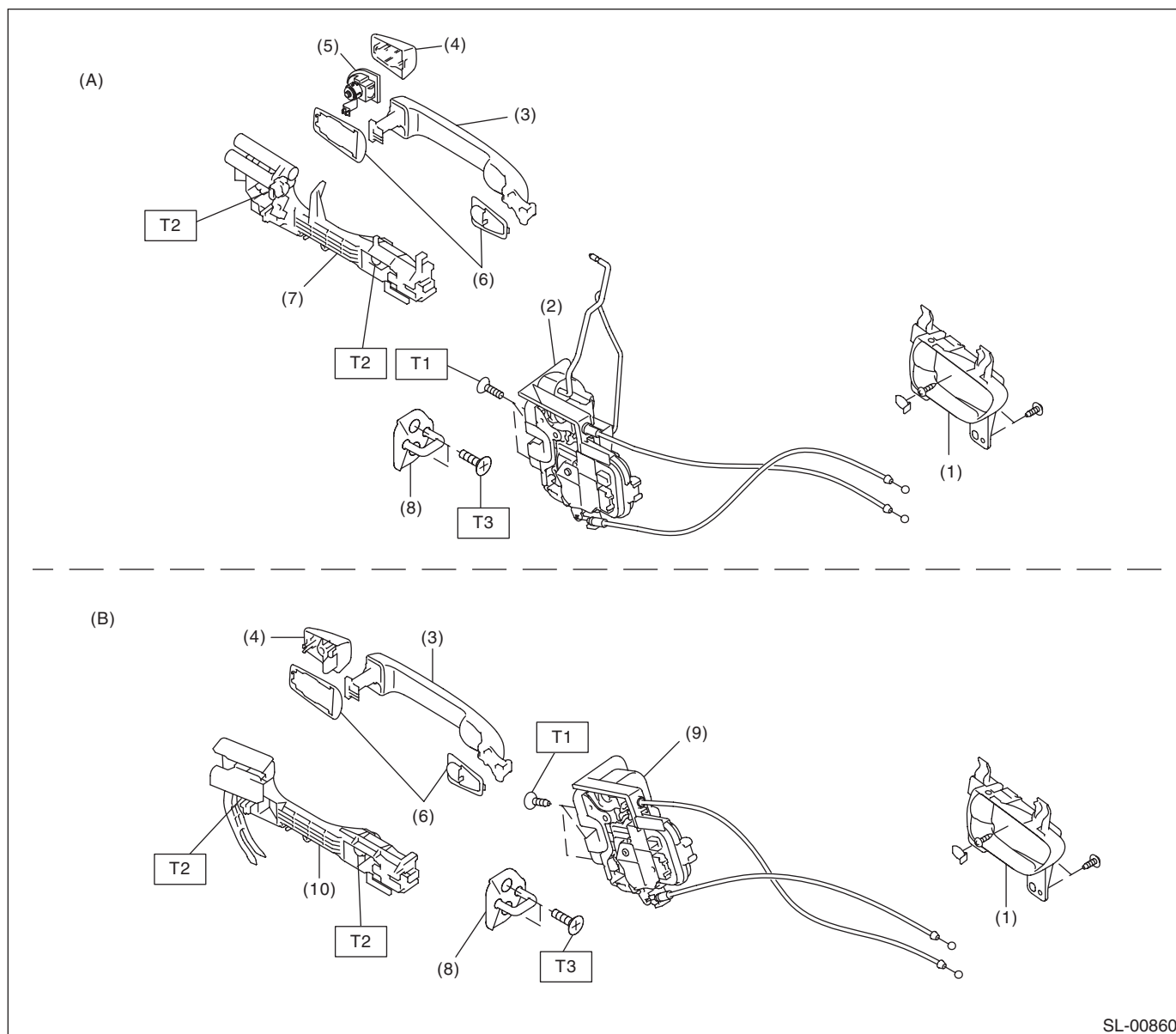

(A) Front

(B) Rear

- |  |   |
|--|---|
| (1) Inner remote ASSY                            | (6) Door outer handle spacer                    |
| (2) Front door latch and door lock actuator ASSY | (7) Front door outer handle frame ASSY          |
| (3) Door outer handle                            | (8) Striker                                     |
| (4) Door outer handle cover                      | (9) Rear door latch and door lock actuator ASSY |
| (5) Key cylinder (driver's side only)            | (10) Rear door outer handle frame ASSY          |

**Tightening torque: N·m (kgf·m, ft·lb)**

**T1: 6.5 (0.66, 4.8)**

**T2: 7.5 (0.76, 5.5)**

**T3: 18 (1.84, 13.3)**

## 2. REAR GATE LOCK AND TRUNK LID

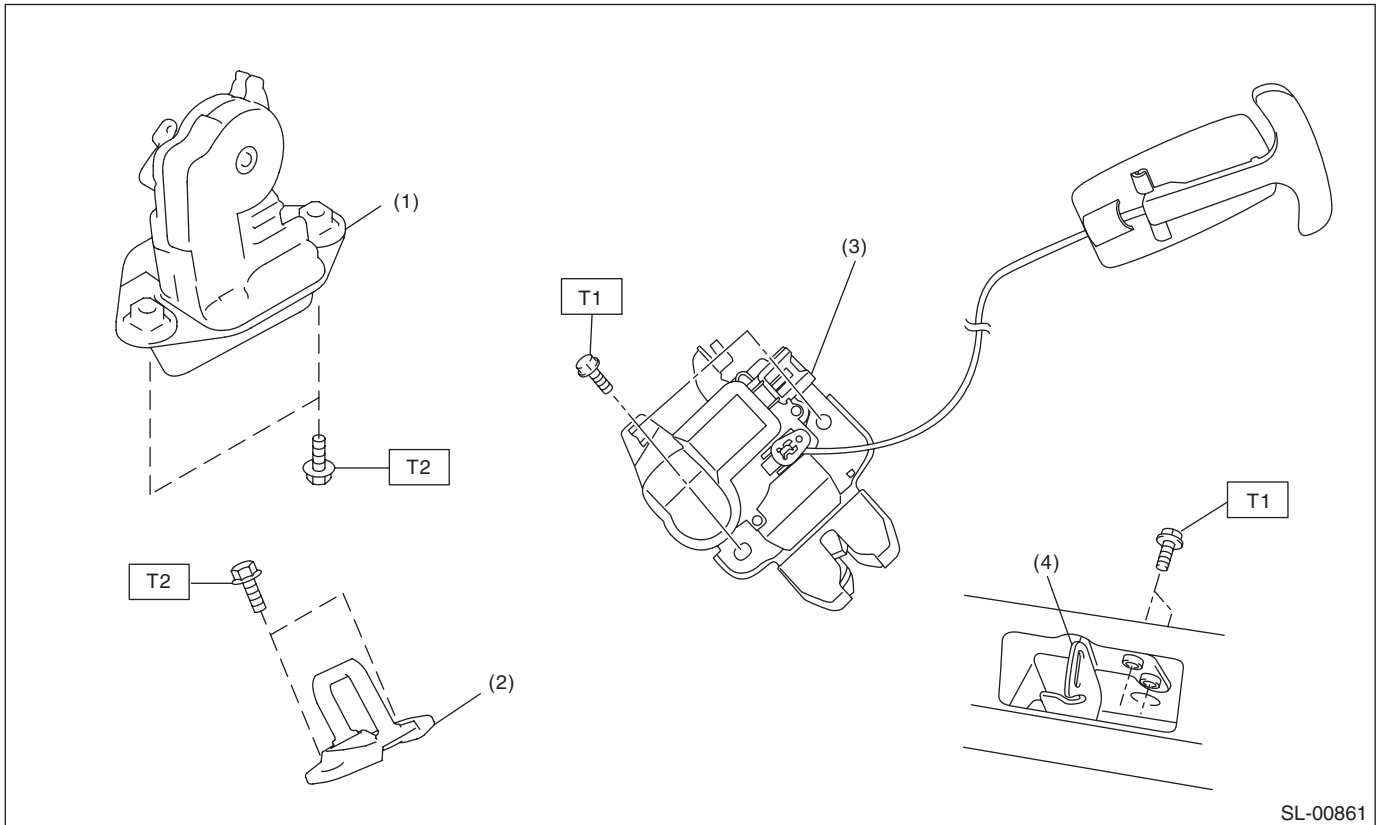

- (1) Rear gate latch and actuator ASSY
- (2) Rear gate striker

- (3) Trunk lid latch and actuator ASSY
- (4) Trunk lid striker

**Tightening torque: N·m (kgf-m, ft-lb)**

**T1: 7.5 (0.76, 5.5)**

**T2: 25 (2.55, 18.4)**

# General Description

## SECURITY AND LOCKS

### 3. FRONT HOOD LOCK AND REMOTE OPENERS

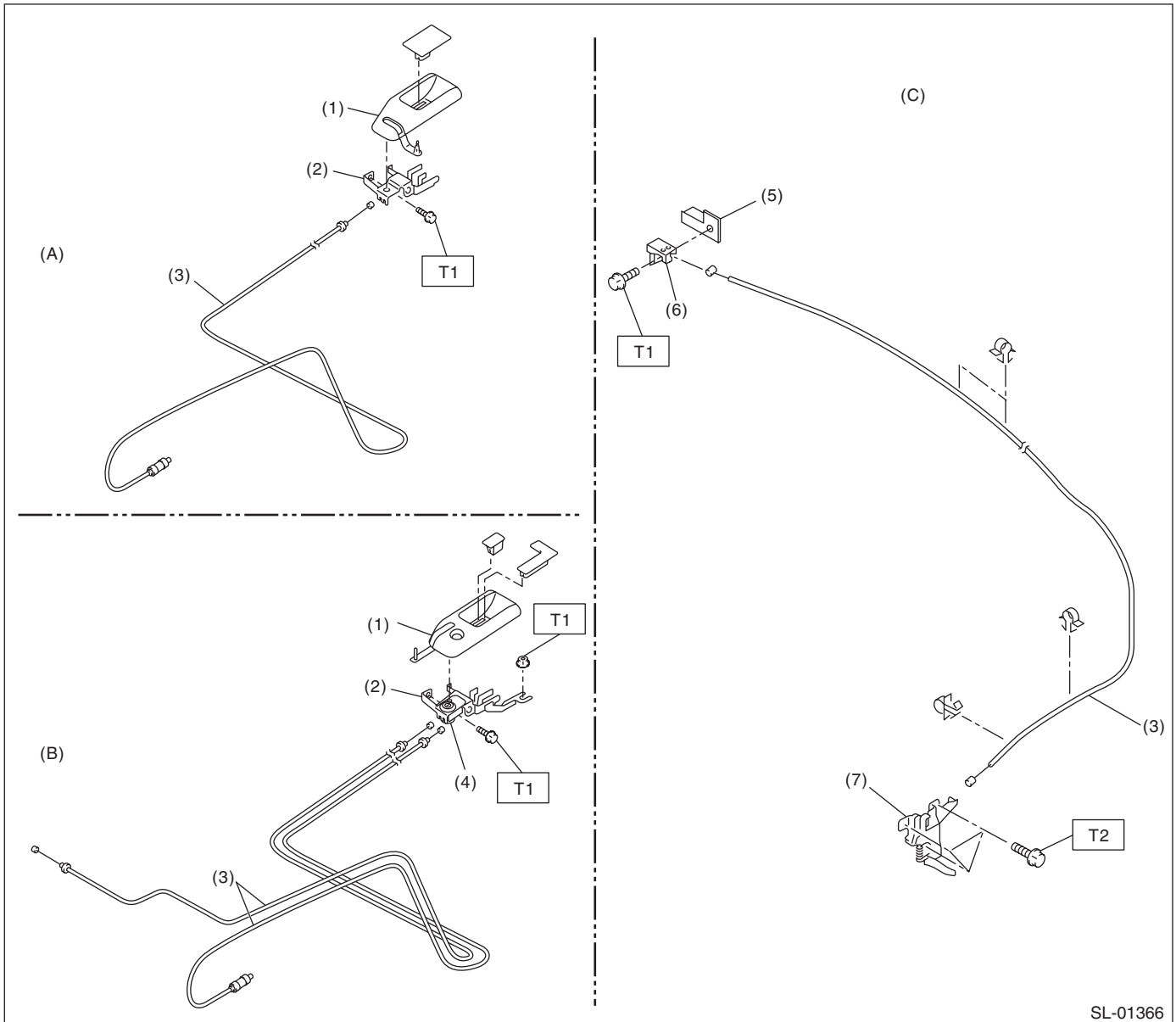

SL-01366

(A) Fuel lock release

(B) Fuel and trunk lock release

(C) Hood lock release

- (1) Cover
- (2) Pull handle ASSY
- (3) Cable
- (4) Key cylinder

- (5) Lever ASSY bracket
- (6) Lever ASSY
- (7) Front hood lock ASSY

**Tightening torque: N·m (kgf·m, ft·lb)**

**T1: 7.5 (0.76, 5.5)**

**T2: 33 (3.36, 24.2)**

### 4. KEYLESS ENTRY SYSTEM

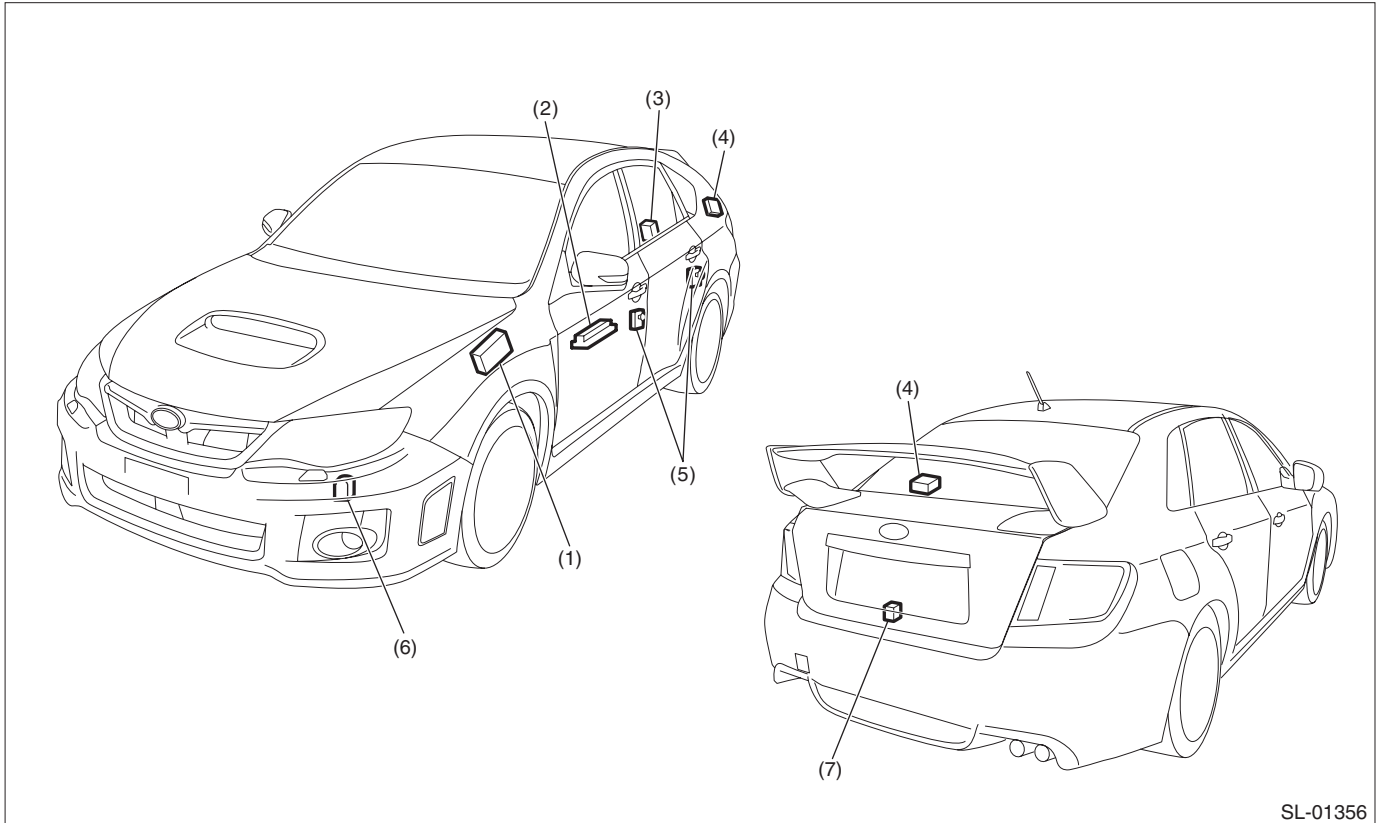

SL-01356

- |   |                                  |   |
|---|----------------------------------|---|
| (1) Body integrated unit                  | (4) Keyless entry control module | (7) Trunk lid latch switch (4 door model) |
| (2) Power window main switch              | (5) Door switch                  |   |
| (3) Rear gate latch switch (5 door model) | (6) Keyless buzzer               |   |

# General Description

## SECURITY AND LOCKS

### 5. SECURITY SYSTEM

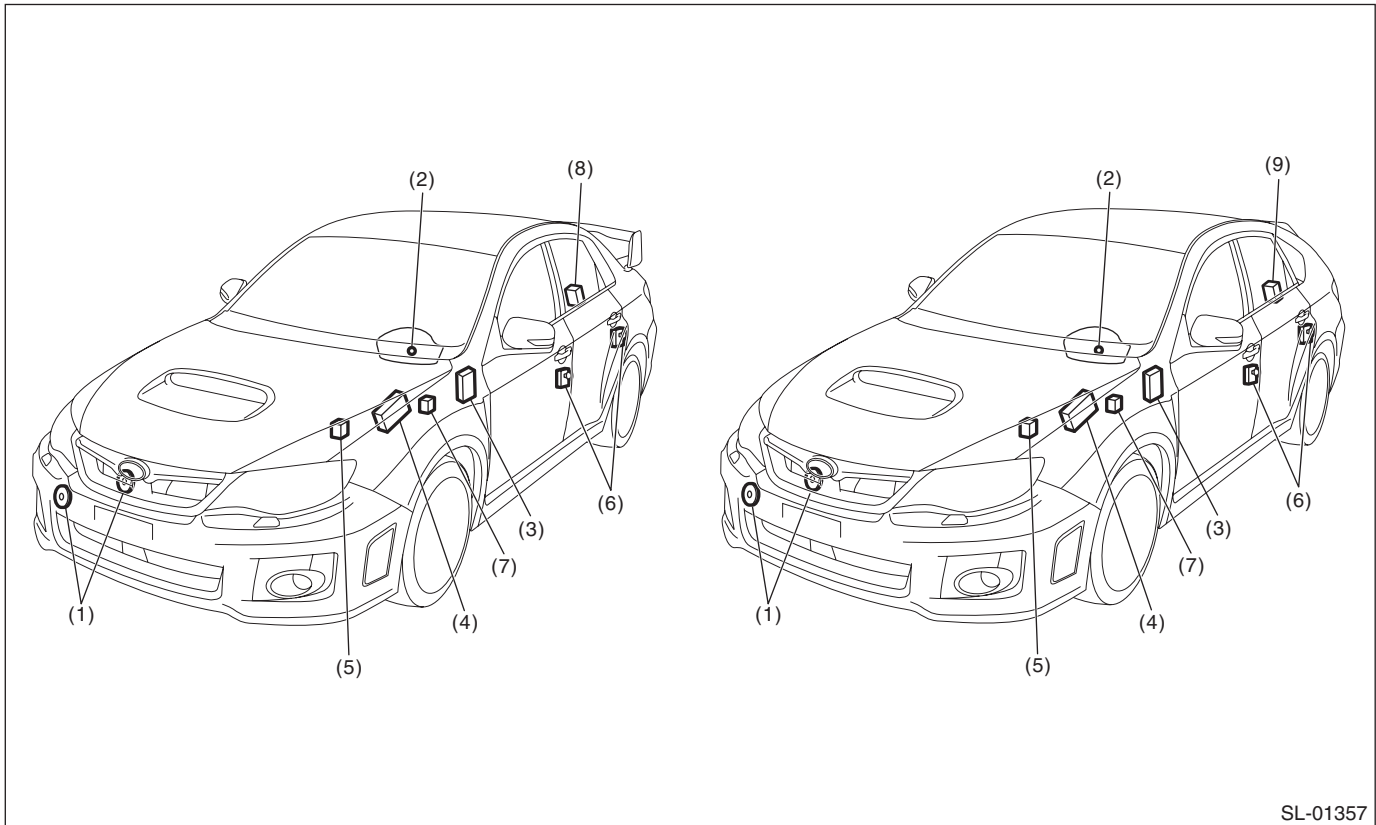

SL-01357

- |   |                                   |   |
|---|-----------------------------------|---|
| (1) Horn  | (4) Body integrated unit          | (7) Turn signal and hazard module         |
| (2) Security indicator light (in combination meter)                     | (5) Horn relay (in main fuse box) | (8) Trunk lid latch switch (4 door model) |
| (3) Impact sensor (driver's seat instrument panel side) (dealer option) | (6) Door switch                   | (9) Rear gate latch switch (5 door model) |

### B: CAUTION

- Before disassembling or reassembling parts, always disconnect the battery ground cable from battery. When replacing the audio, control module and other parts provided with memory functions, record the memory contents before disconnecting the battery ground cable. Otherwise, the memory is cleared.
- When performing a check after disconnecting the battery or restoring from a dead battery condition, perform the check after turning the ignition to ON and OFF, then opening and closing the driver's side door a few times.
- Reassemble the parts in the reverse order of disassembly procedure unless otherwise indicated.
- Connect the connectors securely during reassembly.
- After reassembly, make sure that the functional parts operate normally.
- If any immobilizer related part has been replaced, make sure to register the immobilizer.
- Do not use any electrical test equipment on the airbag system wiring harnesses and connector circuits.
- Be careful not to damage the airbag system wiring harness when servicing the ignition key cylinder.

## C: PREPARATION TOOL

### 1. SPECIAL TOOL

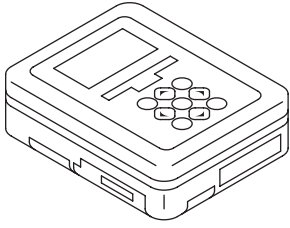
ILLUSTRATION	TOOL NUMBER	DESCRIPTION	REMARKS
 <p style="text-align: center; margin-top: 10px;">ST1B022XU0</p>	1B022XU0	SUBARU SELECT MONITOR III KIT	Used for troubleshooting the electrical system.

### 2. GENERAL TOOL

TOOL NAME	REMARKS
Circuit tester	Used for measuring resistance and voltage.
Drill	Used for replacing ignition key lock.
TORX® T30	Used for removing and installing the door outer handle.
Clip remover	Used for removing trim clip

# Door Lock Control System

## SECURITY AND LOCKS

## 2. Door Lock Control System

### A: WIRING DIAGRAM

Refer to "Keyless Entry System" in WI section. <Ref. to WI-159, WIRING DIAGRAM, Keyless Entry System.>

### B: ELECTRICAL SPECIFICATION

#### 1. BODY INTEGRATED UNIT

Refer to the Control Module I/O Signal of the LAN SYSTEM (DIAGNOSTICS) section. <Ref. to LAN(diag)-10, ELECTRICAL SPECIFICATION, Control Module I/O Signal.>

### C: INSPECTION

#### 1. SYMPTOM CHART

Symptom	Repair order	Index
The door lock control system does not operate.	1. Remove and visually inspect the following fuses. <ul style="list-style-type: none"><li>• No. 3 (in fuse &amp; relay box)</li><li>• No. 7 (in fuse &amp; relay box)</li><li>• No. 8 (in main fuse box)</li></ul>	If the fuse is blown out, replace the fuse with a new part. When there is no defective with the fuse, check the power supply and ground circuit. <Ref. to SL-9, CHECK POWER SUPPLY AND GROUND CIRCUIT, INSPECTION, Door Lock Control System.>
	2. Check the power supply and ground circuit for body integrated unit.	<Ref. to SL-9, CHECK POWER SUPPLY AND GROUND CIRCUIT, INSPECTION, Door Lock Control System.>
	3. Check the door lock switch and the circuit.	<Ref. to SL-9, CHECK DOOR LOCK SWITCH, INSPECTION, Door Lock Control System.>
	4. Check the rear gate opener button and the circuit.	<Ref. to SL-10, CHECK REAR GATE OPENER BUTTON CIRCUIT, INSPECTION, Door Lock Control System.>
	5. Check the door lock actuator and the circuit.	<Ref. to SL-11, CHECK DOOR LOCK ACTUATOR AND CIRCUIT, INSPECTION, Door Lock Control System.>
A specific door lock actuator does not operate.	Check the door lock actuator and circuit.	<Ref. to SL-11, CHECK DOOR LOCK ACTUATOR AND CIRCUIT, INSPECTION, Door Lock Control System.>

## 2. CHECK POWER SUPPLY AND GROUND CIRCUIT

Step	Check	Yes	No
<b>1 CHECK POWER SUPPLY.</b> 1) Disconnect the harness connector of body integrated unit. 2) Measure the voltage between harness connector terminal and chassis ground. <i>Connector &amp; terminal</i> <i>(i84) No. 34 (+) — Chassis ground (-):</i> <i>(B280) No. 6 (+) — Chassis ground (-):</i> <i>(B281) No. 2 (+) — Chassis ground (-):</i>	Is the voltage 9 V or more?	Go to step 2.	Check the harness for open or short circuit between body integrated unit and fuse.
<b>2 CHECK GROUND CIRCUIT.</b> Measure the resistance between harness connector terminal and chassis ground. <i>Connector &amp; terminal</i> <i>(i84) No. 28 — Chassis ground:</i> <i>(B280) No. 17 — Chassis ground:</i> <i>(B281) No. 20 — Chassis ground:</i> <i>(B279) No. 27 — Chassis ground:</i>	Is the resistance less than 10 Ω?	The power supply and ground circuit are OK.	Repair or replace the harness.

## 3. CHECK DOOR LOCK SWITCH

Step	Check	Yes	No
<b>1 CHECK DOOR LOCK SWITCH.</b> 1) Prepare the Subaru Select Monitor kit. 2) Turn the ignition switch to ON (engine OFF) and run the "PC application for Subaru Select Monitor". 3) On «System Selection Menu» display, select {Integ. unit mode}. 4) Select the {Current Data Display & Save}. 5) Select the {Manual lock SW input}.	Does the display switch between OFF ←→ ON when each door lock switch is moved to LOCK?	Go to step 2.	Go to step 3.
<b>2 CHECK DOOR LOCK SWITCH.</b> From the condition in step 1), operate each door lock switch (driver's and passenger's) in the UNLOCK direction.	Does the display switch between OFF ←→ ON?	The door lock switch is OK.	Go to step 4.
<b>3 CHECK DOOR LOCK SWITCH.</b> 1) Disconnect the door lock switch harness connector. 2) Check the continuity when the door lock switch is operated to the LOCK direction. <i>Connector &amp; terminal</i> <i>Driver's side:</i> <i>(D7) No. 10 — (D102) No. 3:</i> <i>Passenger's side:</i> <i>(D125) No. 4 — (D125) No. 5:</i>	Did the indicator change from "No continuity" (1 MΩ or more) to "Continuity exists" (less than 10 Ω)?	Go to step 4.	Replace the power window main switch or door lock switch. <Ref. to GW-9, Power Window Control Switch.>
<b>4 CHECK DOOR LOCK SWITCH.</b> Check the continuity when the door lock switch is operated to the UNLOCK direction. <i>Connector &amp; terminal</i> <i>Driver's side:</i> <i>(D7) No. 2 — (D102) No. 3:</i> <i>Passenger's side:</i> <i>(D125) No. 2 — (D125) No. 5:</i>	Did the indicator change from "No continuity" (1 MΩ or more) to "Continuity exists" (less than 10 Ω)?	Go to step 5.	Replace the power window main switch or door lock switch. <Ref. to GW-9, Power Window Control Switch.>



# Door Lock Control System

## SECURITY AND LOCKS

Step	Check	Yes	No
<b>5 CHECK HARNESS.</b> Use a tester to measure the resistance between the door lock switch harness connector and chassis ground. <b>Connector &amp; terminal</b> <b>Driver's side:</b> (D102) No. 3 — Chassis ground: <b>Passenger's side:</b> (D125) No. 5 — Chassis ground:	Is the resistance less than 10 Ω?	Go to step 6.	Repair or replace the harness.
<b>6 CHECK HARNESS.</b> 1) Disconnect the harness connector of body integrated unit. 2) Measure the resistance between the body integrated unit and door lock switch. <b>Connector &amp; terminal</b> <b>Driver's side:</b> (D7) No. 10 — (i84) No. 15: (D7) No. 2 — (i84) No. 29: <b>Passenger's side:</b> (D125) No. 4 — (i84) No. 15: (D125) No. 2 — (i84) No. 29:	Is the resistance less than 10 Ω?	Replace the body integrated unit. <Ref. to SL-48, Body Integrated Unit.>	Repair or replace the harness.

### 4. CHECK REAR GATE OPENER BUTTON CIRCUIT

Step	Check	Yes	No
<b>1 CHECK REAR GATE OPENER BUTTON.</b> 1) Prepare the Subaru Select Monitor kit. 2) Turn the ignition switch to ON (engine OFF) and run the "PC application for Subaru Select Monitor". 3) On «System Selection Menu» display, select {Integ. unit mode}. 4) Select the {Current Data Display & Save}. 5) Select the {Rear gate/Trunk release switch}.	Is the display change to OFF ←→ ON, when the rear gate opener button is operated?	Rear gate opener button is normal.	Go to step 2.
<b>2 CHECK HARNESS.</b> Check the harness between the body integrated unit and rear gate opener button. <b>Connector &amp; terminal</b> (B281) No. 24 — (D47) No. 1:	Is harness normal?	Go to step 3.	Repair or replace the harness.
<b>3 CHECK HARNESS.</b> Measure the resistance between the rear gate opener button and chassis ground. <b>Connector &amp; terminal</b> (D47) No. 2 — Chassis ground:	Is the resistance less than 10 Ω?	Go to step 4.	Repair or replace the harness.
<b>4 CHECK REAR GATE OPENER BUTTON.</b> Measure the resistance between connector terminals when the rear gate opener button is pressed, and when it is released. <b>Connector &amp; terminal</b> (D47) No. 1 — (D47) No. 2:	Is the resistance less than 10 Ω when the switch is pressed and 1 MΩ or more when not pressed?	Replace the body integrated unit. <Ref. to SL-48, Body Integrated Unit.>	Replace the rear gate opener button. <Ref. to SL-36, Rear Gate Opener Button.>

## 5. CHECK DOOR LOCK ACTUATOR AND CIRCUIT

Step	Check	Yes	No
<p><b>1 CHECK HARNESS (DOOR LOCK).</b>                      1) Disconnect the body integrated unit connector and each door lock actuator.                      2) Check the harness between body integrated unit and each door lock actuator.  <b>Connector &amp; terminal</b>  <i>(i84) No. 7 — (D72) No. 1: (front door LH)</i>  <i>(i84) No. 7 — (D18) No. 1: (front door RH)</i>  <i>(i84) No. 7 — (D26) No. 1: (rear door LH)</i>  <i>(i84) No. 7 — (D32) No. 1: (rear door RH)</i></p>	Is harness normal?	Go to step 2.	Repair or replace the harness.
<p><b>2 CHECK HARNESS (DOOR UNLOCK).</b>                      Check the harness between body integrated unit and each door lock actuator.  <b>Connector &amp; terminal</b>  <i>(i84) No. 23 — (D72) No. 2: (front door LH)</i>  <i>(i84) No. 8 — (D18) No. 2: (front door RH)</i>  <i>(i84) No. 8 — (D26) No. 2: (rear door LH)</i>  <i>(i84) No. 8 — (D32) No. 2: (rear door RH)</i></p>	Is harness normal?	Go to step 3.	Repair or replace the harness.
<p><b>3 CHECK HARNESS (TRUNK OR REAR GATE UNLOCK).</b>                      Check the harness between body integrated unit and trunk lid lock actuator or rear gate lock actuator.  <b>Connector &amp; terminal</b>  <i>(i84) No. 22 — (R186) No. 2: (4 door model)</i>  <i>(i84) No. 22 — (D46) No. 1: (5 door model)</i></p>	Is harness normal?	Go to step 4.	Repair or replace the harness.
<p><b>4 CHECK HARNESS (TRUNK OR REAR GATE UNLOCK).</b>                      Measure the resistance between the trunk lid lock actuator or rear gate lock actuator and chassis ground.  <b>Connector &amp; terminal</b>  <i>(R186) No. 1 — Chassis ground: (4 door model)</i>  <i>(D46) No. 2 — Chassis ground: (5 door model)</i></p>	Is the resistance less than 10 Ω?	Go to step 5.	Repair or replace the harness.
<p><b>5 CHECK BODY INTEGRATED UNIT OUTPUT SIGNAL.</b>                      Measure the voltage between terminals of the body integrated unit connector when operating the door lock switch to LOCK direction.  <b>Connector &amp; terminal</b>  <i>Except for front door LH</i>  <i>(i84) No. 7 (+) — (i84) No. 8 (-):</i>  <b>Front door LH</b>  <i>(i84) No. 7 (+) — (i84) No. 23 (-):</i></p>	Does the voltage change from less than 1 V → 9 V or more? (During lock output)	Go to step 6.	Replace the body integrated unit. <Ref. to SL-48, Body Integrated Unit.>
<p><b>6 CHECK BODY INTEGRATED UNIT OUTPUT SIGNAL.</b>                      Measure the voltage between terminals of the body integrated unit connector when operating the door lock switch to UNLOCK direction.  <b>Connector &amp; terminal</b>  <i>Except for front door LH</i>  <i>(i84) No. 8 (+) — (i84) No. 7 (-):</i>  <b>Front door LH</b>  <i>(i84) No. 23 (+) — (i84) No. 7 (-):</i></p>	Does the voltage change from less than 1 V → 9 V or more? (During unlock output)	Go to step 7.	Replace the body integrated unit. <Ref. to SL-48, Body Integrated Unit.>

# Door Lock Control System

## SECURITY AND LOCKS

Step	Check	Yes	No
<b>7</b> <b>CHECK BODY INTEGRATED UNIT OUTPUT SIGNAL.</b> Measure the voltage between body integrated unit and chassis ground when operating the rear gate opener button. <i><b>Connector &amp; terminal (i84) No. 22 (+) — Chassis ground (-):</b></i>	Does the voltage change from less than 1 V → 9 V or more? (During unlock output)	Go to step <b>8</b> .	Replace the body integrated unit. <Ref. to SL-48, Body Integrated Unit.>
<b>8</b> <b>CHECK DOOR LOCK ACTUATOR.</b> Check the door lock actuator. <ul style="list-style-type: none"> <li>• Front door lock actuator: &lt;Ref. to SL-32, INSPECTION, Front Door Latch and Door Lock Actuator Assembly.&gt;</li> <li>• Rear door lock actuator: &lt;Ref. to SL-35, INSPECTION, Rear Door Latch and Door Lock Actuator Assembly.&gt;</li> </ul>	Is the door lock actuator OK?	Go to step <b>9</b> .	Replace the door latch and door lock actuator assembly.
<b>9</b> <b>CHECK TRUNK LID LOCK ACTUATOR OR REAR GATE LOCK ACTUATOR.</b> <ul style="list-style-type: none"> <li>• Trunk lid lock actuator: &lt;Ref. to SL-38, INSPECTION, Trunk Lid Latch and Actuator Assembly.&gt;</li> <li>• Rear gate lock actuator: &lt;Ref. to SL-37, INSPECTION, Rear Gate Latch and Actuator Assembly.&gt;</li> </ul>	Is trunk lid lock actuator or rear gate lock actuator normal?	Check the connection status of the harness and connector that may have a temporary poor contact.	Replace the trunk lid latch and actuator assembly or rear gate latch and actuator assembly.

## 3. Keyless Entry System

### A: WIRING DIAGRAM

Refer to “Keyless Entry System” in WI section. <Ref. to WI-159, WIRING DIAGRAM, Keyless Entry System.>

### B: ELECTRICAL SPECIFICATION

#### 1. KEYLESS ENTRY CONTROL MODULE

- Model without tire pressure monitoring system

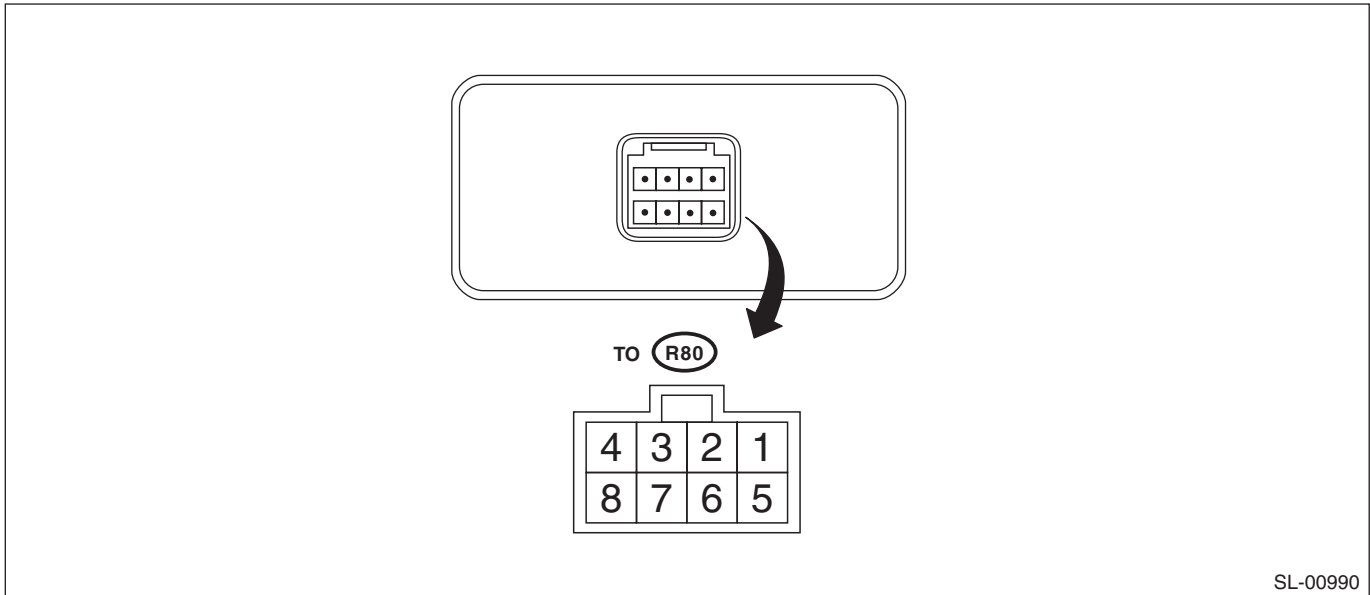

SL-00990

Terminal No.	Item	Measuring condition	Standard
3 (U-ART com.)	—	Cannot be measured	—
4 (+B) ↔ Chassis ground	Voltage	Always	10 — 14 V
7 (GND) ↔ Chassis ground	Resistance	Always	Less than 1 Ω

# Keyless Entry System

## SECURITY AND LOCKS

- Model with tire pressure monitoring system

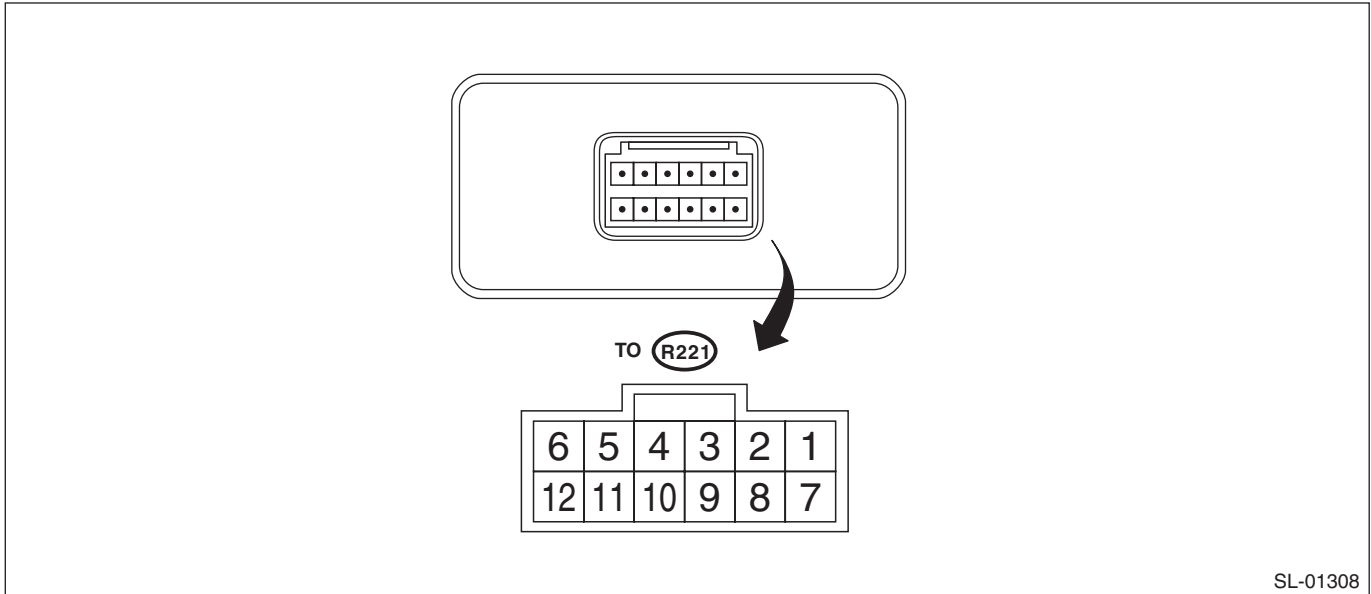

Terminal No.	Item	Measuring condition	Standard
2 ↔ Chassis ground	Voltage	Tire pressure warning light: Not illuminated → Illuminated	0 V → 10 — 14 V
3 ↔ Chassis ground	Waveform	Speedometer	Pulse generation
4 (IG) ↔ Chassis ground	Resistance	IG OFF → ON	0 V → 10 — 14 V
5 (GND) ↔ Chassis ground	Resistance	Always	Less than 1 Ω
6(+B) ↔ Chassis ground	Voltage	Always	10 — 14 V
11 (U-ART com.)	—	Cannot be measured	—
12 (SSM communication)	—	Cannot be measured	—

## 2. BODY INTEGRATED UNIT

Refer to the Control Module I/O Signal of the LAN SYSTEM (DIAGNOSTICS) section. <Ref. to LAN(diag)-10, ELECTRICAL SPECIFICATION, Control Module I/O Signal.>

## C: INSPECTION

### 1. SYMPTOM CHART

Symptoms	Repair order	Reference
None of the functions of the keyless entry system operate.	1. Check the keyless transmitter battery.	<Ref. to SL-17, CHECK KEYLESS TRANSMITTER BATTERY AND FUNCTION, INSPECTION, Keyless Entry System.>
	2. Remove and visually inspect the following fuses. <ul style="list-style-type: none"> <li>• No. 3 (in fuse &amp; relay box)</li> <li>• No. 7 (in fuse &amp; relay box)</li> </ul>	If the fuse is blown out, replace the fuse with a new part. When there is no defective with the fuse, check the power supply and ground circuit. <Ref. to SL-9, CHECK POWER SUPPLY AND GROUND CIRCUIT, INSPECTION, Door Lock Control System.>
	3. Check the keyless entry control module.	<Ref. to SL-18, CHECK KEYLESS ENTRY CONTROL MODULE, INSPECTION, Keyless Entry System.>
	4. Check the power supply and ground circuit for body integrated unit.	<Ref. to SL-18, CHECK BODY INTEGRATED UNIT POWER SUPPLY AND GROUND CIRCUIT, INSPECTION, Keyless Entry System.>
	5. Check the key warning switch.	<Ref. to SL-20, CHECK KEY WARNING SWITCH, INSPECTION, Keyless Entry System.>
	6. Check the door switch.	<Ref. to SL-19, CHECK DOOR SWITCH, INSPECTION, Keyless Entry System.>
	7. Check the body integrated unit.	<Ref. to LAN(diag)-2, Basic Diagnostic Procedure.>
The keyless transmitter cannot be registered.	1. Check the keyless transmitter battery.	<Ref. to SL-17, CHECK KEYLESS TRANSMITTER BATTERY AND FUNCTION, INSPECTION, Keyless Entry System.>
	2. Check the key warning switch.	<Ref. to SL-20, CHECK KEY WARNING SWITCH, INSPECTION, Keyless Entry System.>
	3. Check the door lock switch signal.	<Ref. to SL-24, CHECK DOOR LOCK SWITCH, INSPECTION, Keyless Entry System.>
	4. Check the body integrated unit.	<Ref. to LAN(diag)-2, Basic Diagnostic Procedure.>

# Keyless Entry System

## SECURITY AND LOCKS

Symptoms	Repair order	Reference
Door lock or unlock does not operate. <b>NOTE:</b> If the door lock control system does not operate when using the door lock switch, check the door lock control system. <Ref. to SL-8, INSPECTION, Door Lock Control System.>	1. Check the keyless transmitter battery.	<Ref. to SL-17, CHECK KEYLESS TRANSMITTER BATTERY AND FUNCTION, INSPECTION, Keyless Entry System.>
	2. Check the keyless entry control module.	<Ref. to SL-18, CHECK KEYLESS ENTRY CONTROL MODULE, INSPECTION, Keyless Entry System.>
	3. Check the key warning switch.	<Ref. to SL-20, CHECK KEY WARNING SWITCH, INSPECTION, Keyless Entry System.>
	4. Check the door switch.	<Ref. to SL-19, CHECK DOOR SWITCH, INSPECTION, Keyless Entry System.>
	5. Check the body integrated unit.	<Ref. to LAN(diag)-2, Basic Diagnostic Procedure.>
Trunk lid unlock does not operate. (4 door model)	1. Check the keyless transmitter battery.	<Ref. to SL-17, CHECK KEYLESS TRANSMITTER BATTERY AND FUNCTION, INSPECTION, Keyless Entry System.>
	2. Check the keyless entry control module.	<Ref. to SL-18, CHECK KEYLESS ENTRY CONTROL MODULE, INSPECTION, Keyless Entry System.>
	3. Check the key warning switch.	<Ref. to SL-20, CHECK KEY WARNING SWITCH, INSPECTION, Keyless Entry System.>
	4. Check the trunk lid lock actuator.	<Ref. to SL-23, CHECK TRUNK LID LOCK ACTUATOR, INSPECTION, Keyless Entry System.>
	5. Check the body integrated unit.	<Ref. to LAN(diag)-2, Basic Diagnostic Procedure.>
Buzzer and hazard light do not operate.	1. Check the buzzer operation.	<Ref. to SL-23, CHECK KEYLESS BUZZER, INSPECTION, Keyless Entry System.>
	2. Check the hazard light operation.	<Ref. to SL-22, CHECK HAZARD LIGHT OPERATION, INSPECTION, Keyless Entry System.>
	3. Check the body integrated unit.	<Ref. to LAN(diag)-2, Basic Diagnostic Procedure.>
Room light does not operate.	1. Check the room light operation.	<Ref. to SL-21, CHECK ROOM LIGHT OPERATION, INSPECTION, Keyless Entry System.>
	2. Check the body integrated unit.	<Ref. to LAN(diag)-2, Basic Diagnostic Procedure.>
Ignition switch illumination does not operate.	1. Check the ignition switch illumination.	<Ref. to SL-25, CHECK IGNITION SWITCH ILLUMINATION, INSPECTION, Keyless Entry System.>
	2. Check the body integrated unit.	<Ref. to LAN(diag)-2, Basic Diagnostic Procedure.>

## 2. CHECK KEYLESS TRANSMITTER BATTERY AND FUNCTION

**CAUTION:**

**Be sure to reset keyless transmitter of other vehicles registered to the inspection target vehicle, and vehicles to which keyless transmitters were registered for inspection, to the condition before performing the inspection. (Re-register the keyless transmitters.)**

Step	Check	Yes	No
<b>1</b> <b>CHECK KEYLESS TRANSMITTER BATTERY.</b> 1) Remove the battery from the keyless transmitter. <Ref. to SL-49, REMOVAL, Transmitter.> 2) Check the battery voltage. <Ref. to SL-49, INSPECTION, Transmitter.>	Is the voltage 2.5 V or more?	Go to step 2.	Replace the keyless transmitter battery. <Ref. to SL-49, Transmitter.>
<b>2</b> <b>CHECK KEYLESS TRANSMITTER.</b> Register the keyless transmitter which operates normally on other vehicles to the inspection target vehicle. <Ref. to SL-49, REGISTRATION OF KEYLESS TRANSMITTER WITH SUBARU SELECT MONITOR, REPLACEMENT, Transmitter.> 1) Close all the doors and rear gate (5 door model) or trunk lid (4 door model) of the inspection target vehicle. 2) Using the keyless transmitter, lock and unlock the doors and rear gate of vehicle. For the 4 door model, unlock the trunk lid.	Can the check vehicle be locked and unlocked properly?	Go to step 3.	Due to vehicle malfunction, continue the keyless entry system diagnosis.
<b>3</b> <b>CHECK KEYLESS TRANSMITTER.</b> Register the keyless transmitter of the inspected vehicle to another vehicle whose keyless system operates normally. <Ref. to SL-49, REGISTRATION OF KEYLESS TRANSMITTER WITH SUBARU SELECT MONITOR, REPLACEMENT, Transmitter.>	Is the keyless transmitter registered correctly?	Go to step 4.	Replace the keyless transmitter. <Ref. to SL-49, REGISTRATION OF KEYLESS TRANSMITTER WITH SUBARU SELECT MONITOR, REPLACEMENT, Transmitter.>
<b>4</b> <b>CHECK KEYLESS TRANSMITTER.</b> Check the registered keyless transmitter. 1) Close all the doors and rear gate of the vehicle which keyless system operates normally. 2) Using the keyless transmitter, lock and unlock the doors and rear gate of vehicle. For the 4 door model, unlock the trunk lid.	Can lock, unlock of doors and unlock of the trunk lid be performed properly on the vehicle?	Keyless transmitter is OK.	Replace the keyless transmitter. <Ref. to SL-49, REGISTRATION OF KEYLESS TRANSMITTER WITH SUBARU SELECT MONITOR, REPLACEMENT, Transmitter.>



# Keyless Entry System

## SECURITY AND LOCKS

### 3. CHECK KEYLESS ENTRY CONTROL MODULE

Step	Check	Yes	No
<b>1 CHECK DIAGNOSTIC TROUBLE CODE (DTC).</b> 1) Prepare the Subaru Select Monitor kit. 2) Turn the ignition switch to ON (engine OFF) and run the "PC application for Subaru Select Monitor". 3) On «System Selection Menu» display, select {Integ. unit mode}. 4) Select the {Diagnostic Code(s) Display}.	Is DTC B1500 "Keyless UART com. Malfunction" displayed?	Go to step 2.	Keyless entry control module is normal.
<b>2 CHECK POWER SUPPLY.</b> 1) Disconnect the keyless entry control module harness connector. 2) Measure the voltage between harness connector terminal and chassis ground. <b>Connector &amp; terminal</b> <b>Model without tire pressure monitoring system:</b> <b>(R80) No. 4 (+) — Chassis ground (-):</b> <b>Model with tire pressure monitoring system:</b> <b>(R221) No. 6 (+) — Chassis ground (-):</b>	Is the voltage 10 V or more?	Go to step 3.	Check the harness for open circuits and shorts between the keyless entry control module and fuse.
<b>3 CHECK GROUND CIRCUIT.</b> Measure the resistance between harness connector terminal and chassis ground. <b>Connector &amp; terminal</b> <b>Model without tire pressure monitoring system:</b> <b>(R80) No. 7 — Chassis ground:</b> <b>Model with tire pressure monitoring system:</b> <b>(R221) No. 5 — Chassis ground:</b>	Is the resistance less than 10 $\Omega$ ?	Go to step 4.	Repair or replace the harness.
<b>4 CHECK KEYLESS ENTRY CONTROL MODULE CIRCUIT.</b> 1) Disconnect the harness connector of body integrated unit. 2) Measure the resistance between harness connector terminals. <b>Connector &amp; terminal</b> <b>Model without tire pressure monitoring system:</b> <b>(i84) No. 24 — (R80) No. 3:</b> <b>Model with tire pressure monitoring system:</b> <b>(i84) No. 24 — (R221) No. 11:</b>	Is the resistance less than 10 $\Omega$ ?	Replace the keyless entry control module. <Ref. to SL-46, Keyless Entry Control Module.>	Repair or replace the harness.

### 4. CHECK BODY INTEGRATED UNIT POWER SUPPLY AND GROUND CIRCUIT

Refer to the INSPECTION of POWER SUPPLY AND GROUND CIRCUIT of the Door Lock Control System for detailed procedures. <Ref. to SL-9, CHECK POWER SUPPLY AND GROUND CIRCUIT, INSPECTION, Door Lock Control System.>

## 5. CHECK DOOR SWITCH

Step	Check	Yes	No
<p><b>1</b></p> <p><b>CHECK INPUT CIRCUIT.</b></p> <p>1) Prepare the Subaru Select Monitor kit.</p> <p>2) Turn the ignition switch to ON (engine OFF) and run the "PC application for Subaru Select Monitor".</p> <p>3) On «System Selection Menu» display, select {Integ. unit mode}.</p> <p>4) Select the {Current Data Display}.</p> <p>5) Select the {Driver's door SW input}, {P-door SW input}, {Rear right door SW input}, {Rear left door SW input}, and {R Gate SW input}.</p>	<p>Does the display switch between OFF ↔ ON when each door, rear gate or trunk lid is opened/closed?</p>	<p>The door switches, trunk lid latch switch or rear gate latch switch circuit are normal.</p>	<p>Go to step 2.</p>
<p><b>2</b></p> <p><b>CHECK HARNESS.</b></p> <p>1) Disconnect the harness connector of body integrated unit.</p> <p>2) Disconnect the door switch harness connector that the display does not change.</p> <p>3) Check the harness between body integrated unit terminal and defective door switch terminal.</p> <p><b>Connector &amp; terminal</b></p> <p><b>Front door RH</b> (i84) No. 32 — (R12) No. 1:</p> <p><b>Front door LH</b> (i84) No. 19 — (R9) No. 1:</p> <p><b>Rear door RH</b> (i84) No. 6 — (R16) No. 1:</p> <p><b>Rear door LH</b> (i84) No. 20 — (R22) No. 1:</p> <p><b>Trunk lid latch switch</b> (i84) No. 33 — (R186) No. 3:</p> <p><b>Rear gate latch switch</b> (i84) No. 33 — (D46) No. 3:</p>	<p>Is harness normal?</p>	<p>Go to step 3.</p>	<p>Repair or replace the harness.</p>
<p><b>3</b></p> <p><b>CHECK HARNESS.</b></p> <p>Measure the resistance between defective door switch, trunk lid latch switch or rear gate latch switch terminals and chassis ground.</p> <p><b>Connector &amp; terminal</b></p> <p><b>Front door RH</b> (R12) No. 3 — Chassis ground:</p> <p><b>Front door LH</b> (R9) No. 3 — Chassis ground:</p> <p><b>Rear door RH</b> (R16) No. 3 — Chassis ground:</p> <p><b>Rear door LH</b> (R22) No. 3 — Chassis ground:</p> <p><b>Trunk lid latch switch</b> (R186) No. 1 — Chassis ground:</p> <p><b>Rear gate latch switch</b> (D46) No. 4 — Chassis ground:</p>	<p>Is the resistance less than 10 Ω?</p>	<p>Go to step 4.</p>	<p>Repair or replace the harness.</p>

# Keyless Entry System

## SECURITY AND LOCKS

Step	Check	Yes	No
<b>4 CHECK DOOR SWITCH.</b> Measure the resistance between terminals of faulty door switch, trunk lid switch or rear gate latch switch. <i>Connector &amp; terminal</i> (R12) Front RH door switch No. 1 — No. 3: (R9) Front LH door switch No. 1 — No. 3: (R16) Rear RH door switch No. 1 — No. 3: (R22) Rear LH door switch No. 1 — No. 3: Trunk lid latch switch (R186) No. 1 — No. 3: Rear gate latch switch (D46) No. 3 — No. 4:	Is the resistance 1 M $\Omega$ or more when the door switch is pushed, or the trunk lid or rear gate is closed?	Go to step 5.	Replace the following parts if defective. <ul style="list-style-type: none"> <li>• Door switch</li> <li>• Trunk lid latch and actuator ASSY</li> <li>• Rear gate latch and actuator ASSY</li> </ul>
<b>5 CHECK DOOR SWITCH.</b> Measure the resistance between terminals of faulty door switch, trunk lid switch or rear gate latch switch. <i>Connector &amp; terminal</i> (R12) Front RH door switch No. 1 — No. 3: (R9) Front LH door switch No. 1 — No. 3: (R16) Rear RH door switch No. 1 — No. 3: (R22) Rear LH door switch No. 1 — No. 3: Trunk lid switch (R186) No. 1 — No. 3: Rear gate latch switch (D46) No. 3 — No. 4:	Is the resistance less than 10 $\Omega$ when door switch is released, or the trunk lid or rear gate is opened?	Replace the body integrated unit. <Ref. to SL-48, Body Integrated Unit.>	Replace the following parts if defective. <ul style="list-style-type: none"> <li>• Door switch</li> <li>• Trunk lid latch and actuator ASSY</li> <li>• Rear gate latch and actuator ASSY</li> </ul>

## 6. CHECK KEY WARNING SWITCH

Step	Check	Yes	No
<b>1 CHECK KEY WARNING SWITCH.</b> 1) Prepare the Subaru Select Monitor kit. 2) Run the "PC application for Subaru Select Monitor". 3) On «System Selection Menu» display, select {Integ. unit mode}. 4) Select {Current Data Display & Save}. 5) Select the {key-lock warning SW}.	Is the normal input signal displayed when the key is inserted in/removed from the ignition switch?	The key warning switch is OK.	Go to step 2.
<b>2 CHECK FUSE.</b> Remove and visually check fuse No. 14 (in the main fuse box).	Is the fuse blown out?	Replace the fuse with a new part.	Go to step 3.
<b>3 CHECK KEY WARNING SWITCH CIRCUIT.</b> 1) Disconnect the harness connector of body integrated unit. 2) Insert the key into ignition switch. (LOCK position) 3) Measure the voltage between harness connector terminal and chassis ground. <i>Connector &amp; terminal</i> (B279) No. 2 (+) — Chassis ground (-):	Is the voltage 9 V or more?	Go to step 4.	Go to step 5.

# Keyless Entry System

## SECURITY AND LOCKS

Step	Check	Yes	No
<b>4 CHECK KEY WARNING SWITCH CIRCUIT.</b> 1) Remove the key from ignition switch. 2) Measure the voltage between harness connector terminal and chassis ground. <b>Connector &amp; terminal</b> <b>(B279) No. 2 (+) — Chassis ground (-):</b>	Is the voltage 1.5 V?	Replace the body integrated unit. <Ref. to SL-48, Body Integrated Unit.>	Go to step 5.
<b>5 CHECK KEY WARNING SWITCH.</b> 1) Disconnect the key warning switch harness connector. 2) Insert the key into ignition switch. (LOCK position) 3) Measure the resistance between key warning switch terminals. <b>Connector &amp; terminal</b> <b>(B350) No. 3 — No. 4:</b>	Is the resistance less than 1 Ω?	Go to step 6.	Replace the key warning switch.
<b>6 CHECK KEY WARNING SWITCH.</b> 1) Remove the key from ignition switch. 2) Measure the resistance between key warning switch terminals. <b>Connector &amp; terminal</b> <b>(B350) No. 3 — No. 4:</b>	Is the resistance 1 MΩ or more?	Check the following: • Harness for open circuits and shorts between the key warning switch and fuse. • Harness for open or short between the body integrated unit and key warning switch	Replace the key warning switch.

## 7. CHECK ROOM LIGHT OPERATION

Step	Check	Yes	No
<b>1 CHECK ROOM LIGHT OPERATION.</b> Make sure the room light illuminates when the room light switch is ON, and goes off when the switch is OFF.	Does the room light illuminate or go off?	Go to step 2.	Check the room light circuit. <Ref. to LI-34, INSPECTION, Room Light.>
<b>2 CHECK ROOM LIGHT OPERATION.</b> 1) Turn the room light switch to the "DOOR" position. 2) Open/close any door (other than trunk).	Does the room light illuminate ←→ go off (including off delay) when the door is opened and closed?	Go to step 3.	Go to step 4.
<b>3 CHECK KEYLESS ENTRY OPERATION.</b> Press the LOCK/UNLOCK button of the keyless transmitter.	Does it operate properly?	The room light is normal.	Check keyless entry system. <Ref. to SL-15, SYMPTOM CHART, INSPECTION, Keyless Entry System.>
<b>4 CHECK ROOM LIGHT.</b> 1) Disconnect the room light connector. 2) Check the room light. <Ref. to LI-34, INSPECTION, Room Light.>	Is room light normal?	Go to step 5.	Replace the bulb or room light assembly.
<b>5 CHECK HARNESS.</b> 1) Disconnect the connector of body integrated unit. 2) Check the harness between body integrated unit connector and room light connector. <b>Connector &amp; terminal</b> <b>(B279) No. 5 — (R52) No. 2:</b>	Is harness normal?	Go to step 6.	Repair or replace the harness.

# Keyless Entry System

## SECURITY AND LOCKS

	Step	Check	Yes	No
6	<b>CHECK HARNESS.</b> Measure the voltage between room light harness connector terminal and chassis ground. <b>Connector &amp; terminal</b> <b>(R52) No. 3 (+) — Chassis ground (-):</b>	Is the voltage 10 V or more?	Replace the body integrated unit. <Ref. to SL-48, Body Integrated Unit.>	Repair or replace the harness.

### 8. CHECK HAZARD LIGHT OPERATION

	Step	Check	Yes	No
1	<b>CHECK HAZARD LIGHT OPERATION.</b> Make sure the hazard light blinks when hazard switch is turned to ON.	Does the hazard light blink?	Go to step 2.	Check the hazard light circuit.
2	<b>CHECK OUTPUT TO HAZARD LIGHT.</b> 1) Turn the ignition switch to OFF. 2) Disconnect the connector of key warning switch. 3) Prepare the Subaru Select Monitor kit. 4) Turn the ignition switch to ON (engine OFF) and run the "PC application for Subaru Select Monitor". 5) On «System Selection Menu» display, select {Integ. unit mode}. 6) Select {Integ. Unit customizing}. 7) Check {Emergency light setup}, and then switch to ON setting if necessary. 8) Select the {Current Data Display & Save}. 9) Select the {Hazard Output}. 10) Remove the key from ignition switch.	Is output signal present when operating the transmitter LOCK/UNLOCK button?	The hazard light operation circuit is OK.	Go to step 3.
3	<b>CHECK HARNESS BETWEEN HAZARD LIGHT AND BODY INTEGRATED UNIT.</b> 1) Disconnect the body integrated unit connector and turn signal & hazard module connector. 2) Measure the resistance between body integrated unit connector and turn signal & hazard unit connector. <b>Connector &amp; terminal</b> <b>(B281) No. 22 — (B32) No. 8:</b>	Is the resistance less than 10 $\Omega$ ?	Check body integrated unit. <Ref. to LAN(diag)-2, Basic Diagnostic Procedure.>	Repair or replace the harness.

## 9. CHECK TRUNK LID LOCK ACTUATOR

Step	Check	Yes	No
<b>1 CHECK UNLOCK OPERATION OF TRUNK ALONE.</b> By using the keyless transmitter, perform the UNLOCK operation of trunk alone.	Does answer-back occur?	Go to step 3.	Go to step 2.
<b>2 CHECK KEYLESS ENTRY SYSTEM CIRCUIT.</b> 1) Remove the keyless entry control module from the vehicle with faults. 2) Install the keyless control module that was removed to the other vehicle which is working normally. 3) Perform the UNLOCK operation by using the keyless transmitter of vehicle with faults.	Does UNLOCK occur?	Check body integrated unit. <Ref. to SL-48, Body Integrated Unit.>	Check the following: • Keyless entry control module • Transmitter
<b>3 CHECK HARNESS.</b> 1) Disconnect the body integrated unit connector and trunk lid lock actuator connector. 2) Check the harness between body integrated unit connector and trunk lid lock actuator connector.  <i>Connector &amp; terminal (i84) No. 22 — (R186) No. 2:</i>	Is harness normal?	Go to step 4.	Repair or replace the harness.
<b>4 CHECK HARNESS.</b> Measure the resistance between the trunk lid lock actuator connector and chassis ground.  <i>Connector &amp; terminal (R186) No. 1 — Chassis ground:</i>	Is the resistance less than 10 Ω?	Go to step 5.	Repair or replace the harness.
<b>5 CHECK TRUNK LID LOCK ACTUATOR.</b> Check the trunk lid lock actuator. <Ref. to SL-38, Trunk Lid Latch and Actuator Assembly.>	Is trunk lid lock actuator normal?	Replace the body integrated unit. <Ref. to SL-48, Body Integrated Unit.>	Replace the trunk lid latch & actuator assembly.

## 10. CHECK KEYLESS BUZZER

Step	Check	Yes	No
<b>1 CHECK FUNCTION.</b> Using the Subaru Select Monitor, check {Buzzer beeping setup}. <Ref. to LAN(diag)-20, CONFIRM CURRENT SETTING, OPERATION, Subaru Select Monitor.>	Is it ON?	Go to step 2.	Change the setting to ON. <Ref. to LAN(diag)-24, USER CUSTOMIZING, OPERATION, Subaru Select Monitor.>
<b>2 CHECK OUTPUT TO KEYLESS BUZZER.</b> 1) Remove the key from ignition switch. 2) Display the {Keyless Buzzer Output} of the body integrated unit using the Subaru Select Monitor. <Ref. to LAN(diag)-14, READ DIAGNOSTIC TROUBLE CODE (DTC), OPERATION, Subaru Select Monitor.> 3) Press the LOCK/UNLOCK button of the keyless transmitter.  NOTE: Due to the screen refresh timing of the Subaru Select Monitor, repeat the operation a few times to confirm, as there may be no change of OFF → ON at first.	Does display change from OFF → ON?	Go to step 3.	Replace the body integrated unit. <Ref. to SL-48, Body Integrated Unit.>

# Keyless Entry System

## SECURITY AND LOCKS

Step	Check	Yes	No
<b>3 CHECK KEYLESS BUZZER.</b> 1) Remove the keyless buzzer. 2) Install the keyless buzzer to another vehicle which operates keyless buzzer normally, check the buzzer sounds.	Does the keyless buzzer sound?	Go to step 4.	Replace the keyless buzzer.
<b>4 CHECK HARNESS.</b> 1) Disconnect the harness connector of body integrated unit. 2) Disconnect the keyless buzzer harness connector. 3) Measure the resistance between harness connector terminals. <b>Connector &amp; terminal</b> <b>(B279) No. 24 — (B164) No. 1:</b>	Is the resistance less than 10 $\Omega$ ?	Go to step 5.	Repair or replace the harness.
<b>5 CHECK HARNESS.</b> Measure the resistance between the keyless buzzer harness connector and chassis ground. <b>Connector &amp; terminal</b> <b>(B164) No. 2 — Chassis ground:</b>	Is the resistance less than 10 $\Omega$ ?	Replace the body integrated unit. <Ref. to SL-48, Body Integrated Unit.>	Repair or replace the harness.

### 11.CHECK DOOR LOCK ACTUATOR AND CIRCUIT

For diagnostic procedures, refer to the INSPECTION of DOOR LOCK ACTUATOR & CIRCUIT of the Door Lock Control System. <Ref. to SL-11, CHECK DOOR LOCK ACTUATOR AND CIRCUIT, INSPECTION, Door Lock Control System.>

### 12.CHECK DOOR LOCK SWITCH

For operation procedure, refer to the door lock switch inspection of the door lock control system. <Ref. to SL-9, CHECK DOOR LOCK SWITCH, INSPECTION, Door Lock Control System.>

## 13.CHECK IGNITION SWITCH ILLUMINATION

Step	Check	Yes	No
<b>1</b> <b>CHECK IGNITION CIRCUIT.</b> Check the ignition circuit.	Is the circuit normal?	Go to step 2.	Repair or replace.
<b>2</b> <b>CHECK DOOR SWITCH CIRCUIT.</b> Inspect door switch circuit.	Is the circuit normal?	Go to step 3.	Repair or replace.
<b>3</b> <b>CHECK FUSE.</b> Remove and visually check fuse No. 14 (in the main fuse box).	Is the fuse blown out?	Replace the fuse with a new part.	Go to step 4.
<b>4</b> <b>CHECK HARNESS.</b> 1) Disconnect the ignition switch illumination harness connector. 2) Measure the voltage between harness connector terminal and chassis ground. <b>Connector &amp; terminal</b> <b>(B224) No. 2 (+) — Chassis ground (-):</b>	Is the voltage 10 V or more?	Go to step 5.	Check the harness for open or short circuits between the ignition switch illumination and fuse.
<b>5</b> <b>CHECK IGNITION SWITCH ILLUMINATION CIRCUIT.</b> 1) Disconnect the body integrated unit connector. 2) Check the harness between body integrated unit connector and ignition switch illumination connector. <b>Connector &amp; terminal</b> <b>(B281) No. 23 — (B224) No. 1:</b>	Is harness normal?	Go to step 6.	Check the harness for open circuits and shorts between the body integrated unit and ignition switch illumination.
<b>6</b> <b>CHECK IGNITION SWITCH ILLUMINATION BULB.</b> Apply battery voltage to the bulb.	Does the bulb illuminate?	Replace the body integrated unit. <Ref. to SL-48, Body Integrated Unit.>	Replace the ignition switch illumination bulb. <Ref. to LI-37, REMOVAL, Ignition Switch Illumination.>



# Security System

## SECURITY AND LOCKS

### 4. Security System

#### A: WIRING DIAGRAM

Refer to "Security System" in WI section. <Ref. to WI-154, WIRING DIAGRAM, Security System.>

#### B: ELECTRICAL SPECIFICATION

##### 1. BODY INTEGRATED UNIT

Refer to the Control Module I/O Signal of the LAN SYSTEM (DIAGNOSTICS) section. <Ref. to LAN(diag)-10, ELECTRICAL SPECIFICATION, Control Module I/O Signal.>

#### C: INSPECTION

##### 1. BASIC DIAGNOSTIC PROCEDURE

Step	Check	Yes	No
1 <b>INITIAL CHECK.</b> Check keyless entry system.	Does the keyless entry system operate normally?	Go to step 2.	Check keyless entry system. <Ref. to SL-15, INSPECTION, Keyless Entry System.>
2 <b>CHECK SECURITY ON/OFF SETTING.</b> 1) Press the LOCK button of the keyless transmitter. 2) Check the security indicator light blinking patterns.	Is the security indicator light blinking patterns as follows? / When monitoring lag is set to 0 seconds: flashes twice within 0.5 seconds, in 2 second intervals / When monitoring lag is set to 30 seconds: flashes 3 times within 1 second, in 0.4 second intervals	Go to step 5.	Go to step 3.
3 <b>CHANGE SETTING OF SECURITY SYSTEM.</b> Change the setting of security system to ON. <Ref. to SL-28, SECURITY SYSTEM ON/OFF SETTING, INSPECTION, Security System.>	Is setting change completed correctly?	Go to step 4.	<ul style="list-style-type: none"><li>• Check the ignition switch circuit. &lt;Ref. to SL-29, CHECK IGNITION SWITCH CIRCUIT, INSPECTION, Security System.&gt;</li><li>• Check the door lock switch circuit. &lt;Ref. to SL-24, CHECK DOOR LOCK SWITCH, INSPECTION, Keyless Entry System.&gt;</li></ul>
4 <b>CHECK SETTING CHANGE OF SECURITY SYSTEM.</b> 1) Remove the key from ignition switch, and then close all doors. 2) Press the LOCK button of the keyless transmitter. 3) Check the security indicator light blinking patterns.	Is the security indicator light blinking patterns as follows? / When monitoring lag is set to 0 seconds: flashes twice within 0.5 seconds, in 2 second intervals / When monitoring lag is set to 30 seconds: flashes 3 times within 1 second, in 0.4 second intervals	Go to step 5.	Check the security indicator light circuit. <Ref. to SL-28, CHECK SECURITY INDICATOR LIGHT CIRCUIT, INSPECTION, Security System.>
5 <b>CHECK SECURITY SYSTEM OPERATION.</b> Press the LOCK button of keyless transmitter, and wait for 30 seconds.	Does the security indicator light blink twice within 0.5 seconds in 2 second intervals?	Go to step 6.	Replace the body integrated unit. <Ref. to SL-48, Body Integrated Unit.>

# Security System

## SECURITY AND LOCKS

Step	Check	Yes	No
<b>6</b> <b>CHECK SECURITY ALARM OPERATION.</b> 1) Unlock all doors using the door lock switch on driver's door. 2) Open any door, trunk lid or rear gate.	Does the security alarm operate when opening any door, trunk lid, or rear gate?	Go to step 7.	Check the door switch, trunk lid switch or rear gate latch switch. <Ref. to SL-19, CHECK DOOR SWITCH, INSPECTION, Keyless Entry System.>
<b>7</b> <b>CHECK SECURITY ALARM OPERATION.</b> Check the security alarm operation.	Do all security alarms operate? / Horn sound / Hazard lights flash / Security indicator light illuminates	Go to step 8.	<ul style="list-style-type: none"> <li>• Check the horn. &lt;Ref. to SL-29, CHECK HORN, INSPECTION, Security System.&gt;</li> <li>• Check the hazard light. &lt;Ref. to SL-22, CHECK HAZARD LIGHT OPERATION, INSPECTION, Keyless Entry System.&gt;</li> </ul>
<b>8</b> <b>CHECK SECURITY ALARM CANCEL OPERATION.</b> Press any button of transmitter while the security alarm is operating. Or turn the ignition switch to ON.	Do all security alarms stop? / Horn / Hazard lights	Go to step 9.	Check the ignition switch circuit. <Ref. to SL-29, CHECK IGNITION SWITCH CIRCUIT, INSPECTION, Security System.>
<b>9</b> <b>CHECK SECURITY SYSTEM CONDITION MEMORY.</b> Check that the system functions properly even when the battery is not connected temporarily. <Ref. to SL-28, CHECK SECURITY SYSTEM CONDITION MEMORY, INSPECTION, Security System.>	Does the system function properly when the battery is not connected temporarily?	Go to step 10.	Replace the body integrated unit. <Ref. to SL-48, Body Integrated Unit.>
<b>10</b> <b>CHECK IMPACT SENSOR (DEALER OPTION).</b> Check the sensibility of impact sensor. <Ref. to SL-45, CHECK IMPACT SENSOR, ADJUSTMENT, Impact Sensor.>	Is the sensibility set properly?	Press the UNLOCK button of keyless transmitter, and finish the diagnosis.	Adjust the sensitivity. <Ref. to SL-45, IMPACT SENSITIVITY ADJUSTMENT, ADJUSTMENT, Impact Sensor.>

**NOTE:**

If the horn sounds when the security is turned on (monitor condition) using the keyless transmitter, check the function setting of the body integrated unit. As a cause, it is possible that the impact sensor present (ON) / not present (OFF) setting is set to ON in the customization function though there is no impact sensor. <Ref. to LAN(diag)-2, Basic Diagnostic Procedure.>

# Security System

## SECURITY AND LOCKS

---

### 2. CHECK SECURITY SYSTEM CONDITION MEMORY

- 1) Pull out the key from the ignition switch, or turn the ignition to OFF.
- 2) Close all the doors, trunk lid or rear gate.
- 3) Open the front hood.
- 4) Press the LOCK button of the keyless transmitter.

#### NOTE:

Wait until the security indicator light blinks twice within 0.5 seconds at 2 second intervals.

If the 30 second monitoring lag has been set, wait for 30 seconds.

- 5) Disconnect the ground cable from battery.
- 6) Connect the battery ground terminal.
- 7) Check that the security indicator light blinks twice within 0.5 seconds at 2 second intervals. When it does not blink, replace the body integrated unit.

### 3. SECURITY SYSTEM ON/OFF SETTING

- 1) Close all doors, trunk lid or rear gate, and sit down on the driver seat. Press the UNLOCK button of the keyless transmitter.
- 2) Turn the ignition switch to ON.
- 3) Push the centralized door lock switch down and open the driver's side door at the same time, and hold in this condition for 10 seconds. (Keep the central door unlock switch pressed down.)
- 4) If the security system is ON, it will turn OFF. If OFF, it will turn ON.

Setting	Horn activation	Meter display
ON → OFF	Twice	[AL_OF]
OFF → ON	Once	[AL_ON]

### 4. CHECK DOOR SWITCH

For operation procedure, refer to the door switch inspection of the keyless entry system. <Ref. to SL-19, CHECK DOOR SWITCH, INSPECTION, Keyless Entry System.>

### 5. CHECK SECURITY INDICATOR LIGHT CIRCUIT

For operation procedures, refer to the "SECURITY INDICATOR" of "IMMOBILIZER (DIAGNOSTICS)". <Ref. to IM(diag)-11, CHECK SECURITY INDICATOR LIGHT CIRCUIT, INSPECTION, Diagnostics Chart for Security Indicator Light.>

## 6. CHECK HORN

Step	Check	Yes	No
<b>1 CHECK HORN OPERATION.</b> Check the horn sounds when the horn switch is pushed.	Does the horn sound?	Go to step 2.	Check the horn circuit.
<b>2 CHECK OUTPUT TO HORN RELAY.</b> 1) Connect the Subaru Select Monitor Kit. 2) Turn the ignition switch to ON (engine OFF) and run the "PC application for Subaru Select Monitor". 3) On «System Selection Menu» display, select {Integ. unit mode}. 4) Select {Function check}. 5) Select {Horn Output} and execute.	Does the horn sound?	Horn circuit is OK.	Go to step 3.
<b>3 CHECK HORN RELAY CIRCUIT.</b> 1) Turn the ignition switch to OFF. 2) Disconnect the harness connector of body integrated unit. 3) Disconnect the main fuse box harness connector (B186). 4) Measure the resistance between harness connector terminals. <i><b>Connector &amp; terminal</b></i> <i><b>(B279) No. 29 — (B186) No. 1:</b></i>	Is the resistance less than 10 Ω?	Check body integrated unit. <Ref. to LAN(diag)-2, Basic Diagnostic Procedure.>	Repair or replace the harness.

## 7. CHECK HAZARD LIGHT OPERATION

For operation procedure, refer to the hazard light inspection of the keyless entry system. <Ref. to SL-22, CHECK HAZARD LIGHT OPERATION, INSPECTION, Keyless Entry System.>

## 8. CHECK IGNITION SWITCH CIRCUIT

Step	Check	Yes	No
<b>1 CHECK IGNITION SWITCH VOLTAGE.</b> 1) Prepare the Subaru Select Monitor kit. 2) Turn the ignition switch to ON (engine OFF) and run the "PC application for Subaru Select Monitor". 3) On «System Selection Menu» display, select {Integ. unit mode}. 4) Select the {Current Data Display & Save}. 5) Select the {BATT voltage} and {IG power supply voltage}.	Is the {IG power supply voltage} within ±1 V against {BATT voltage}?	The ignition switch input circuit is OK.	Go to step 2.
<b>2 CHECK IGNITION SWITCH CIRCUIT.</b> 1) Turn the ignition switch to OFF. 2) Disconnect the harness connector of body integrated unit. 3) Turn the ignition switch to ON. 4) Measure the voltage between harness connector terminal and chassis ground. <i><b>Connector &amp; terminal</b></i> <i><b>(B280) No. 1 (+) — Chassis ground (-):</b></i>	Is the voltage 10 V or more?	Check body integrated unit. <Ref. to LAN(diag)-2, Basic Diagnostic Procedure.>	Check the harness for open or short circuit between body integrated unit and fuse.

### 5. Front Inner Remote

#### A: REMOVAL

- 1) Remove the front door trim. <Ref. to EI-45, REMOVAL, Door Trim.>
- 2) Remove the cable from the cable holder.
- 3) Remove the screws, and remove the inner remote handle.

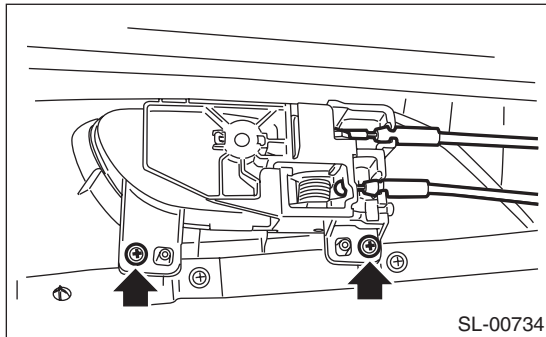

#### B: INSTALLATION

Install each part in the reverse order of removal.

#### C: INSPECTION

- Check if the front remote handle operates normally.
- If the lever is faulty, replace the front inner remote handle.
  - If the cable is deformed, replace the front door latch and door lock actuator assembly.

## 6. Front Outer Handle

### A: REMOVAL

- 1) Raise the front door glass to the top position.
- 2) Remove the front door trim. <Ref. to EI-45, REMOVAL, Door Trim.>
- 3) Remove the sealing cover. <Ref. to EB-21, REMOVAL, Front Sealing Cover.>
- 4) Remove the rod clamp.
- 5) Remove the plug at the rear of the door panel, and loosen the TORX® bolt (1).

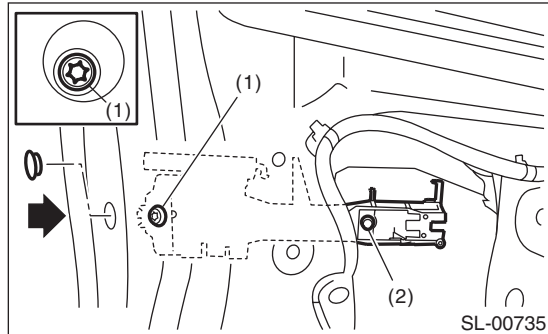

- 6) Remove the door outer handle cover.
- 7) Move the front outer handle towards the rear, and remove the front outer handle.

### CAUTION:

**Do not apply excessive force to remove the handle from the door panel. The door panel may become deformed.**

- 8) Remove the outer side spacer.
- 9) Loosen TORX® bolt (2).
- 10) Remove the frame assembly from inside the door panel.

### B: INSTALLATION

Install each part in the reverse order of removal.

#### *Tightening torque:*

**Refer to "COMPONENT" of "General Description". <Ref. to SL-2, DOOR LOCK ASSEMBLY, COMPONENT, General Description.>**

### C: INSPECTION

Check if the front outer handle operates normally.

- If the lever is faulty, replace the front outer handle.
- If the rod is deformed, replace the front door latch and door lock actuator assembly.

# Front Door Latch and Door Lock Actuator Assembly

## SECURITY AND LOCKS

### 7. Front Door Latch and Door Lock Actuator Assembly

#### A: REMOVAL

- 1) Raise the front door glass to the top position.
- 2) Disconnect the ground cable from battery.
- 3) Remove the front door trim. <Ref. to EI-45, REMOVAL, Door Trim.>
- 4) Remove the sealing cover. <Ref. to EB-21, REMOVAL, Front Sealing Cover.>
- 5) Remove the glass run rubber (A) partially.

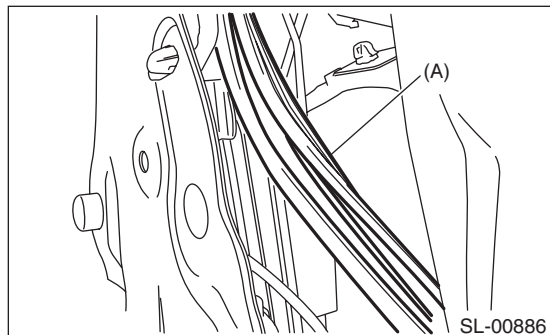

- 6) Remove the bolts, and then remove the door sash.
- 7) Remove the rod from the outer handle rod clamp.
- 8) Disconnect the door lock actuator connector.
- 9) Remove the screws, and remove the front door latch & door lock actuator assembly.

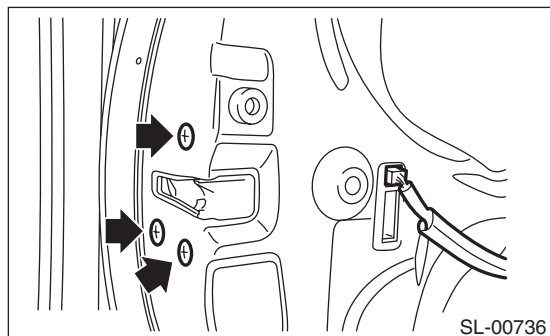

#### B: INSTALLATION

Install each part in the reverse order of removal.

#### Tightening torque:

Refer to "COMPONENT" of "General Description". <Ref. to SL-2, DOOR LOCK ASSEMBLY, COMPONENT, General Description.>

#### C: INSPECTION

##### 1. DOOR LATCH

Check if the front door latch operates normally.

- If the cable or rod is faulty, replace the front door latch and door lock actuator assembly.

##### 2. LOCK ACTUATOR

- 1) Disconnect the door lock actuator harness connector.
- 2) Connect the battery to door lock actuator terminals.

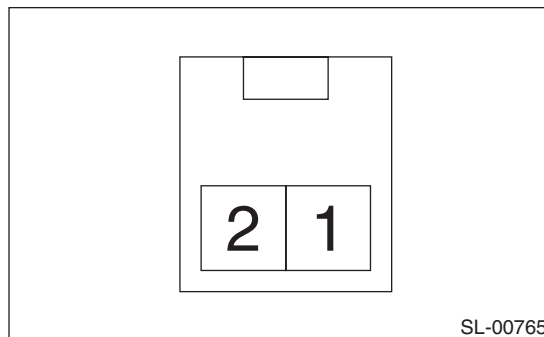

Actuator operation	Terminals	
	No. 1	No. 2
Lock → Unlock	-	+
Unlock → Lock	+	-

- 3) If the actuator does not operate normally, replace the front door latch and door lock actuator assembly.

## 8. Rear Inner Remote

### A: REMOVAL

Refer to "Front Inner Remote" for the removal procedure. <Ref. to SL-30, REMOVAL, Front Inner Remote.>

### B: INSTALLATION

Install each part in the reverse order of removal.

### C: INSPECTION

Check if the rear remote handle operates normally.

- If the lever is faulty, replace the rear inner remote handle.
- If the cable is deformed, replace the rear door latch and door lock actuator assembly.



# Rear Outer Handle

## SECURITY AND LOCKS

### 9. Rear Outer Handle

#### A: REMOVAL

- 1) Raise the rear door glass to the top position.
- 2) Remove the rear door trim. <Ref. to EI-45, REMOVAL, Door Trim.>
- 3) Remove the sealing cover. <Ref. to EB-24, REMOVAL, Rear Sealing Cover.>
- 4) Remove the screws, and move aside the rear door latch and door lock actuator assembly.

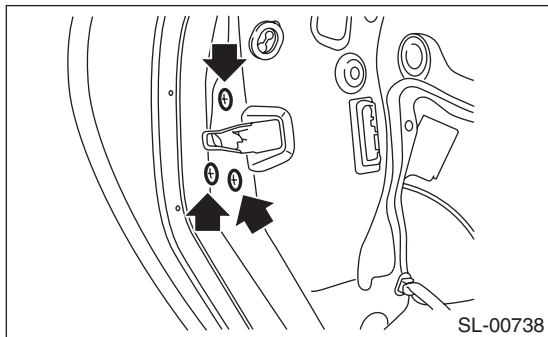

- 5) Remove the child protector cover, and loosen the TORX® bolt.

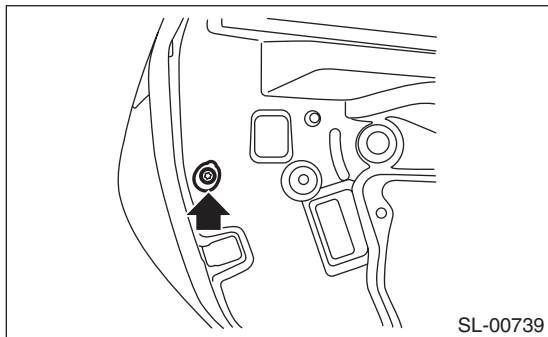

- 6) Remove the outer handle cover.
- 7) Move the rear outer handle towards the rear, and remove the rear outer handle.

#### CAUTION:

**Do not apply excessive force to remove the handle from the door panel. The door panel may become deformed.**

- 8) Remove the outer spacer, and remove the frame assembly from the inner side.
- 9) Remove the TORX® bolt.

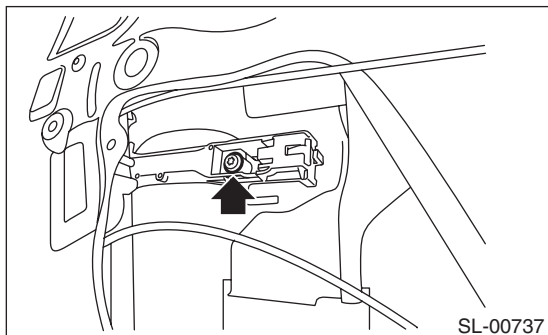

- 10) Remove the frame assembly from inside the door panel.

#### B: INSTALLATION

Install each part in the reverse order of removal.

#### Tightening torque:

*Refer to "COMPONENT" of "General Description". <Ref. to SL-2, DOOR LOCK ASSEMBLY, COMPONENT, General Description.>*

#### C: INSPECTION

Check if the rear outer handle operates normally.

- If the lever is faulty, replace the rear outer handle.
- If the rod is deformed, replace the rear door latch and door lock actuator assembly.

## 10. Rear Door Latch and Door Lock Actuator Assembly

### A: REMOVAL

- 1) Disconnect the ground cable from battery.
- 2) Remove the rear door trim. <Ref. to EI-45, REMOVAL, Door Trim.>
- 3) Remove the wire from the rear inner remote. <Ref. to SL-33, REMOVAL, Rear Inner Remote.>
- 4) Remove the sealing cover. <Ref. to EB-24, REMOVAL, Rear Sealing Cover.>
- 5) Remove the rear door glass. <Ref. to GW-19, REMOVAL, Rear Door Glass.>
- 6) Disconnect the door lock actuator connector.
- 7) Remove the screws, and remove the rear door latch and door lock actuator assembly.

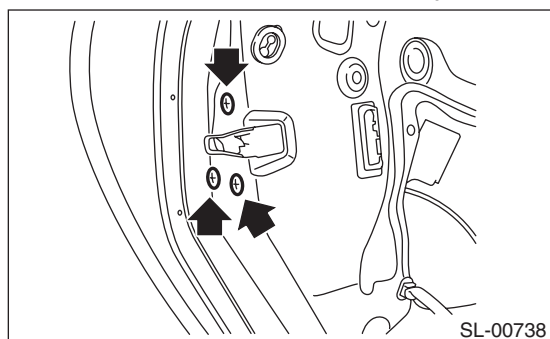

### B: INSTALLATION

Install each part in the reverse order of removal.

#### Tightening torque:

Refer to "COMPONENT" of "General Description". <Ref. to SL-2, DOOR LOCK ASSEMBLY, COMPONENT, General Description.>

#### NOTE:

Make sure the child safety lock works correctly after installation.

### C: INSPECTION

#### 1. DOOR LATCH

Check if the rear door latch operates normally.

- If the cable or rod is faulty, replace the rear door latch and door lock actuator assembly.

#### 2. LOCK ACTUATOR

- 1) Disconnect the ground cable from battery.
- 2) Disconnect the door lock actuator harness connector.
- 3) Connect the battery to door lock actuator terminals.

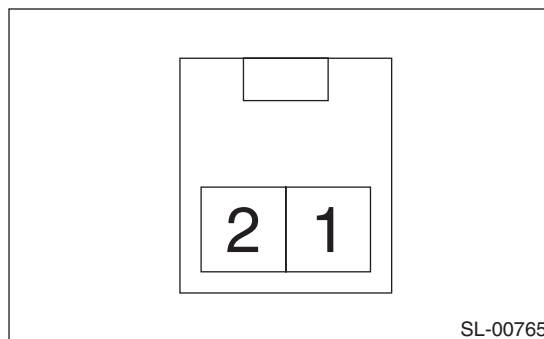

Actuator operation	Terminals	
	No. 1	No. 2
Lock → Unlock	-	+
Unlock → Lock	+	-

- 4) If the actuator does not operate normally, replace the rear door latch & door lock actuator assembly.

# Rear Gate Opener Button

## SECURITY AND LOCKS

### 11.Rear Gate Opener Button

#### A: REMOVAL

- 1) Disconnect the ground cable from battery.
- 2) Remove the rear gate trim. <Ref. to EI-69, REMOVAL, Rear Gate Trim.>
- 3) Remove the rear gate garnish. <Ref. to EI-72, REMOVAL, Rear Gate Garnish.>
- 4) Disconnect the harness connector of the rear gate opener button.
- 5) Hold down the rear gate opener button hook, and remove the rear gate opener button.

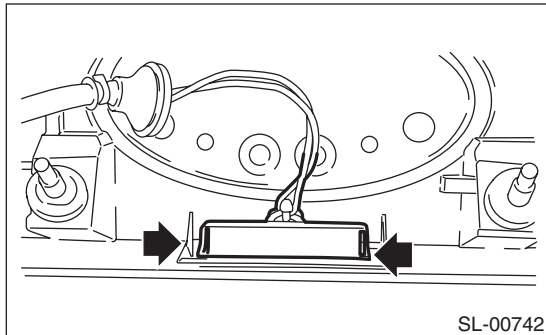

#### B: INSTALLATION

##### CAUTION:

**Make sure that the harness grommet is securely installed.**

**If not properly installed, this may cause leaks.**

Install each part in the reverse order of removal.

#### C: INSPECTION

- 1) Disconnect the rear gate opener button harness connector.
- 2) Check the resistance between rear gate opener button connector terminals.

Switch	Terminal No.	Standard
Open	1 and 2	Less than 1 $\Omega$
Close		1 M $\Omega$ or more

- 3) Replace the rear gate opener button if the inspection result is not within the standard value.

## 12. Rear Gate Latch and Actuator Assembly

### A: REMOVAL

- 1) Disconnect the ground cable from battery.
- 2) Remove the rear gate trim. <Ref. to EI-69, REMOVAL, Rear Gate Trim.>
- 3) Remove the bolt.

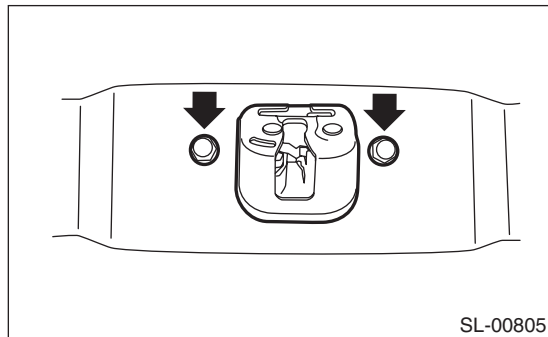

- 4) Disconnect the harness connector, and remove the rear gate latch and actuator assembly.

### B: INSTALLATION

Install each part in the reverse order of removal.

#### Tightening torque:

Refer to "COMPONENT" of "General Description". <Ref. to SL-3, REAR GATE LOCK AND TRUNK LID, COMPONENT, General Description.>

### C: INSPECTION

#### 1. REAR GATE LATCH

Check if the rear gate latch operates normally.

- If latch deformation, abnormal wear, or unsmooth lock operation is observed, replace the rear gate latch & actuator assembly.

#### 2. LOCK ACTUATOR

- 1) Disconnect the connector of rear gate latch and actuator assembly.
- 2) Connect the battery to the lock actuator terminals.

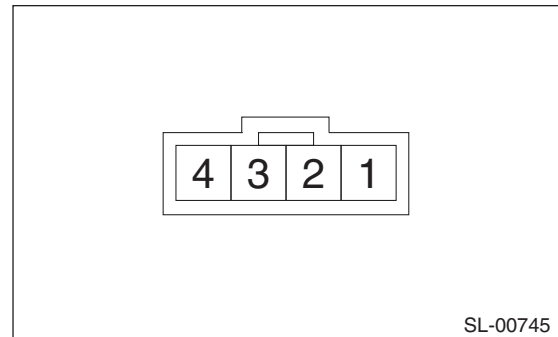

Actuator operation	Terminals	
	No. 1	No. 2
Lock → Unlock	+	-

- 3) If the actuator does not operate normally, replace the rear gate latch & actuator assembly.

# Trunk Lid Latch and Actuator Assembly

## SECURITY AND LOCKS

### 13. Trunk Lid Latch and Actuator Assembly

#### A: REMOVAL

- 1) Disconnect the ground cable from battery.
- 2) Disconnect the harness connector to remove the trunk opener cable.
- 3) Remove the bolts, and remove the trunk lid latch & actuator assembly.

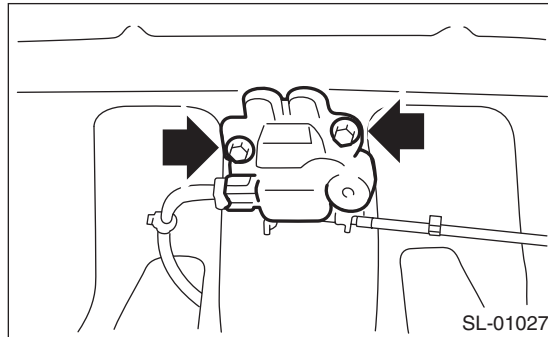

#### B: INSTALLATION

Install each part in the reverse order of removal.

##### **Tightening torque:**

**Refer to "COMPONENT" of "General Description". <Ref. to SL-3, REAR GATE LOCK AND TRUNK LID, COMPONENT, General Description.>**

##### **NOTE:**

Apply grease to the movable part.

#### C: INSPECTION

##### 1. TRUNK LID LATCH

Check if the trunk lid latch operates normally.

- If latch deformation, abnormal wear, or unsmooth lock operation is observed, replace the rear gate latch & actuator assembly.

##### 2. LOCK ACTUATOR

- 1) Disconnect the connector of trunk lid latch and actuator assembly.
- 2) Connect the battery to the lock actuator terminals.

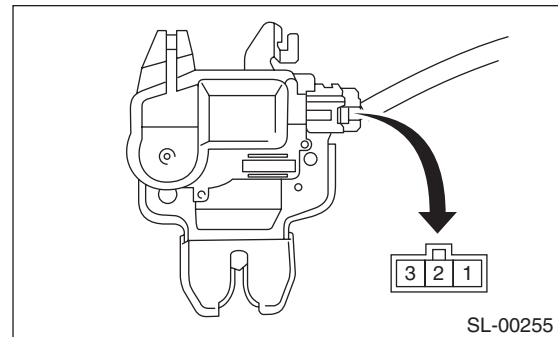

Actuator operation	Terminals	
	No. 1	No. 2
Lock → Unlock	-	+

- 3) If the actuator does not operate normally, replace the trunk lid latch & actuator assembly

## 14. Front Hood Lock Assembly

### A: REMOVAL

- 1) Open the front hood.
- 2) Remove the front bumper face. <Ref. to EI-31, FRONT BUMPER FACE, REMOVAL, Front Bumper.>
- 3) Remove the bolts, and then detach the front hood lock assembly.
- 4) Remove the release cable from the lock assembly.

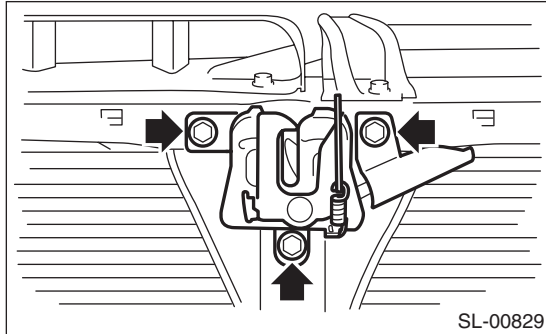

### B: INSTALLATION

- 1) Install each part in the reverse order of removal.

#### **Tightening torque:**

**Refer to "COMPONENT" of "General Description". <Ref. to SL-4, FRONT HOOD LOCK AND REMOTE OPENERS, COMPONENT, General Description.>**

#### **NOTE:**

- Apply grease to the movable part.
- 2) Adjust the fog light beam. (Model with fog light)  
<Ref. to LI-21, FOG LIGHT AIMING, ADJUSTMENT, Front Fog Light Assembly.>

### C: ADJUSTMENT

- 1) Loosen the bolt, and adjust the lock assembly while moving it up and down.

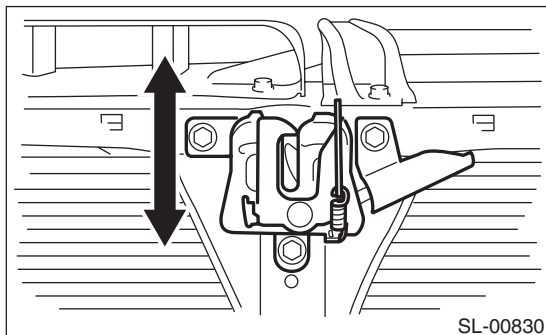

- 2) After adjustment, tighten the bolts securely.

### D: INSPECTION

Check if the front hood lock assembly operates normally.

- If latch deformation, abnormal wear, or unsmooth lock operation is observed, replace the front hood lock assembly.

# Remote Openers

## SECURITY AND LOCKS

### 15. Remote Openers

#### A: REMOVAL

##### 1. FRONT HOOD OPENER

- 1) Remove the cable from the front hood lock.
- 2) Remove the bolt, and then detach the opener lever.

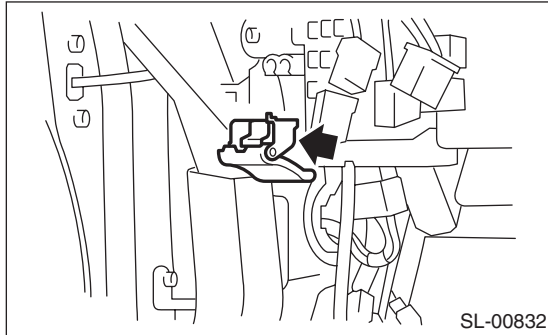

##### 2. TRUNK LID OPENER

- 1) Remove the rear seat. <Ref. to SE-13, REMOVAL, Rear Seat.>
- 2) Remove the lower inner trim, rear quarter trim and floor mat on the driver's side. Remove the clip holding the cable.
- 3) Remove the opener lever and detach the cover.
- 4) Remove the bolt and nut, and then detach the pull handle assembly.

- 5) Remove the cable from pull handle assembly.

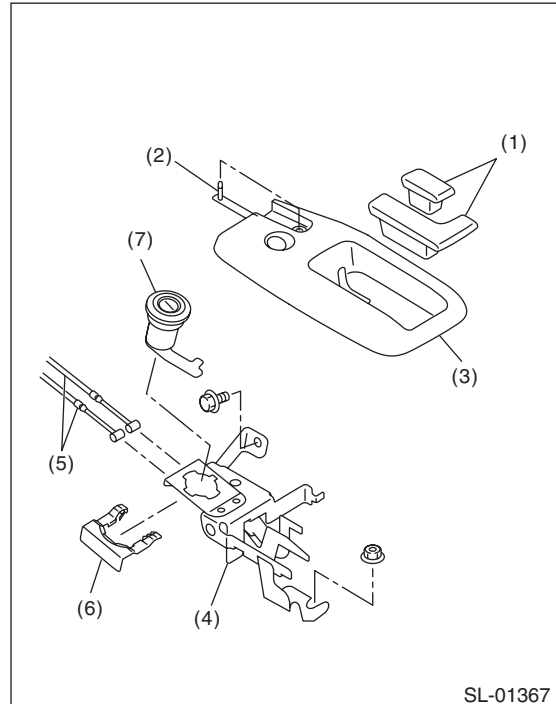

- (1) Opener lever
- (2) Pin
- (3) Front cover
- (4) Pull handle ASSY
- (5) Cable
- (6) Clamp
- (7) Key cylinder

- 6) Remove the trunk lid latch & actuator assembly from the trunk lid. <Ref. to SL-38, REMOVAL, Trunk Lid Latch and Actuator Assembly.>
- 7) Remove the cable from the trunk lid latch & actuator assembly.

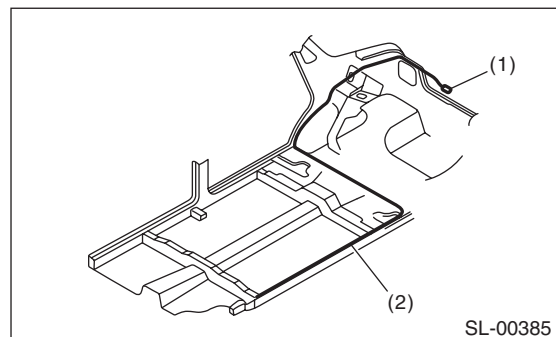

- (1) Trunk lid latch and actuator ASSY
- (2) Cable

## 3. FUEL FILLER LID OPENER

### 5 door model

- 1) Remove the rear seat. <Ref. to SE-13, REMOVAL, Rear Seat.>
- 2) Remove the lower inner trim, rear quarter trim and floor mat on the driver's side. Remove the clip holding the cable.
- 3) Remove the opener lever and detach the cover.
- 4) Remove the bolts, then remove the pull handle assembly.
- 5) Remove the cable from pull handle assembly.

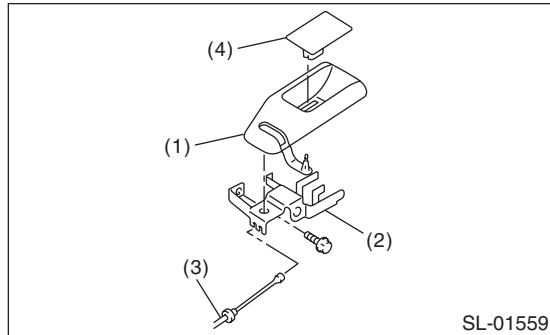

- (1) Cover
- (2) Pull handle ASSY
- (3) Cable
- (4) Opener lever

- 6) Rotate the fuel lock inside the quarter panel to 90° and remove. (Either right or left turn)

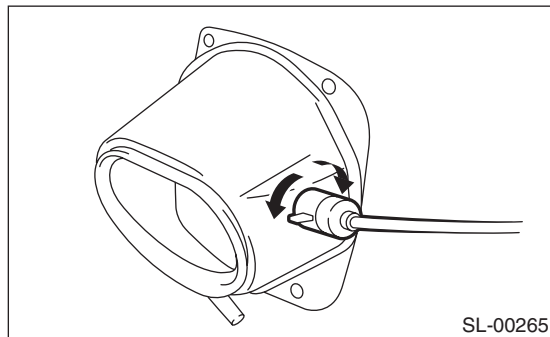

### 4 door model

Refer to the trunk lid opener. <Ref. to SL-40, TRUNK LID OPENER, REMOVAL, Remote Openers.>

## B: INSTALLATION

Install each part in the reverse order of removal.

## C: INSPECTION

Check if the front hood, trunk lid and fuel flap operate normally.



# Ignition Key Lock

## SECURITY AND LOCKS

### 16. Ignition Key Lock

#### A: REPLACEMENT

- 1) Disconnect the ground cable from battery.
- 2) Remove the steering column. <Ref. to PS-15, REMOVAL, Steering Column.>
- 3) Secure the steering column in a vise. Remove the bolt with a drill.

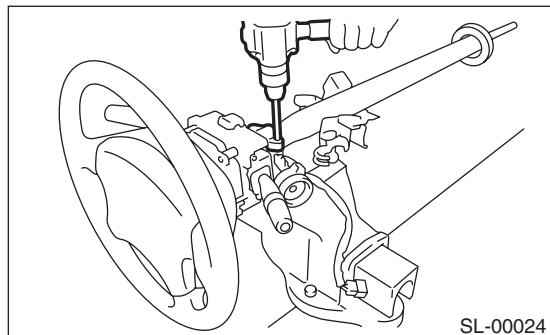

- 4) Remove the ignition key lock.
- 5) Use new bolts. Tighten the bolt until the bolt head is broken (bolt head wrenched off).

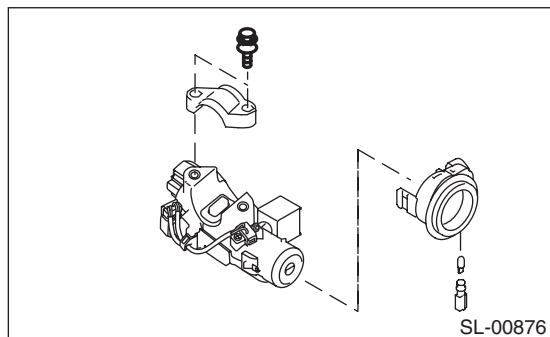

#### B: INSPECTION

- 1) Remove the instrument panel lower cover.
- 2) Remove the lower column cover.
- 3) Unfasten the fixing clip which secures harness, and then disconnect the connector of the ignition switch from body harness.
- 4) Turn the ignition key plate to each position and check the resistance between ignition connector terminals.

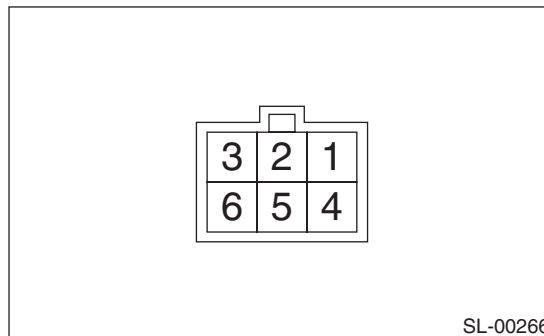

Switch position	Terminal No.	Standard
LOCK	—	—
ACC	3 and 5	Less than 1 $\Omega$
ON	3 and 1 and 4 3 and 5	Less than 1 $\Omega$
ST	3 and 2 3 and 1 and 6	Less than 1 $\Omega$

- 5) Replace the ignition switch if the inspection result is not within the standard value.

## 17. Key Lock Cylinders

### A: REPLACEMENT

#### 1. FRONT DOOR

- 1) Raise the front door glass to the top position.
- 2) Remove the front door trim. <Ref. to EI-45, REMOVAL, Door Trim.>
- 3) Remove the sealing cover. <Ref. to EB-21, REMOVAL, Front Sealing Cover.>
- 4) Remove the rod clamp.
- 5) Remove the plug to the rear of the door panel.
- 6) Loosen TORX® bolt (1).

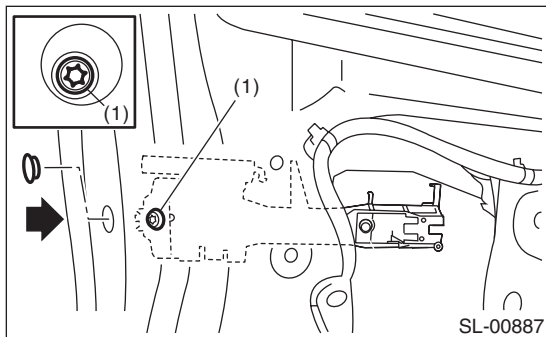

SL-00887

- 7) Remove the key cylinder along with the handle cover.
- 8) Remove the key cylinder from the cover, and replace the key cylinder.

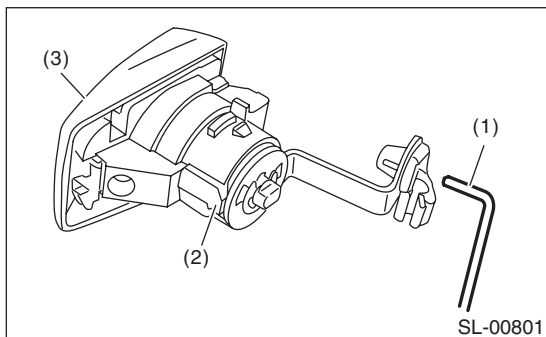

SL-00801

- (1) Latch connection rod
- (2) Key cylinder
- (3) Door outer handle cover

#### 2. GLOVE BOX LID

- 1) Remove the glove box damper.

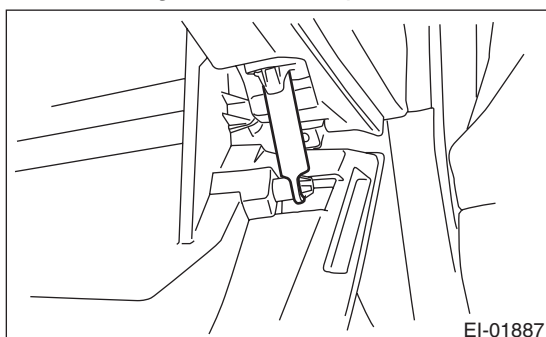

EI-01887

- 2) Remove the stoppers and pull the glove box lid assembly forward to remove.

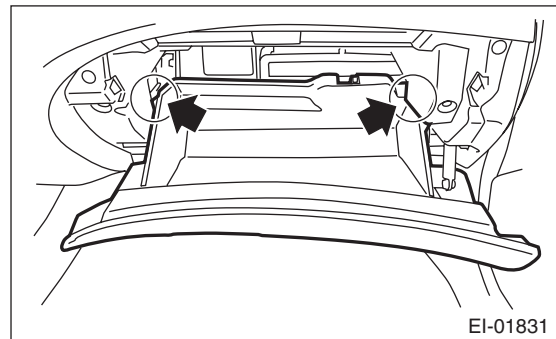

EI-01831

- 3) Pull up the lock knob with the key cylinder in UNLOCK.

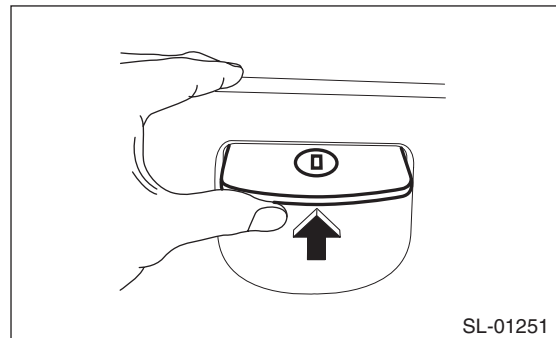

SL-01251

- 4) Insert the key while holding the condition of step 3), and pull out the key in LOCK status.

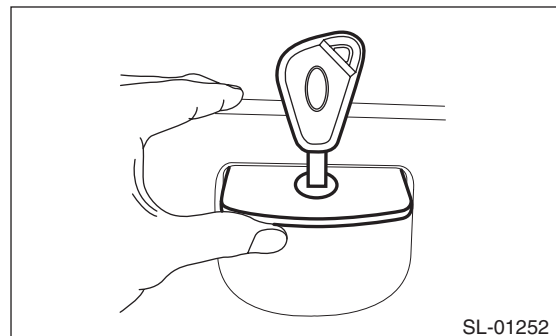

SL-01252

- 5) Remove the key cylinder from lock knob while pushing in the metal plate, and replace the key cylinder.

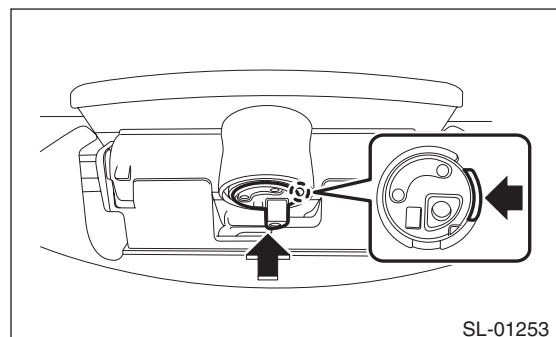

SL-01253

### **18.Security Control Module**

#### **A: NOTE**

The control of security system is carried out in body integrated unit. Refer to the section on the body integrated unit for the work procedures.

- Removal: <Ref. to SL-48, REMOVAL, Body Integrated Unit.>
- Installation: <Ref. to SL-48, INSTALLATION, Body Integrated Unit.>

## 19. Impact Sensor

### A: REMOVAL

- 1) Remove the key from ignition switch.
- 2) Close all the doors, trunk lid and rear gate.
- 3) Press the UNLOCK button of the keyless transmitter.
- 4) Disconnect the ground cable from battery.
- 5) Remove the impact sensor.
- 6) Change the setting of impact sensor using Subaru Select Monitor.

### B: INSTALLATION

- 1) Remove the key from ignition switch.
- 2) Close all the doors, trunk lid and rear gate.
- 3) Press the UNLOCK button of the keyless transmitter.
- 4) Disconnect the ground cable from battery.
- 5) Install the impact sensor.
- 6) Change the setting of impact sensor using Subaru Select Monitor.

### C: OPERATION

#### 1. IMPACT SENSOR SETTING USING SUBARU SELECT MONITOR

- 1) Connect the Subaru Select Monitor to the data link connector.
- 2) Turn the ignition switch to ON.
- 3) On the "System Selection Menu", select {Integ. unit mode}.
- 4) Select {ECM customizing}.
- 5) Make a impact monitor setting.
  - When installing: ON
  - When removing: OFF
- 6) Make a impact monitor ON/OFF setting.
  - When installing: ON
  - When removing: OFF
- 7) Turn the ignition switch to OFF, and then remove the Subaru Select Monitor.

### D: ADJUSTMENT

#### 1. CHECK IMPACT SENSOR

- 1) Remove the key from ignition switch.
- 2) Close all the windows.
- 3) Close all the doors and the rear gate. Leave open the front hood.
- 4) Press the LOCK button of the keyless transmitter from outside of vehicle.
- 5) Check that the security indicator light blinks twice within 0.5 seconds in 2 second cycles after 30 seconds.

- 6) Hit all windows with the palm with force repeatedly, to check for whether the security alarm operates. Lift up the front hood approx. 12 cm (4.7 in) or more, and then drop it off to check the operation of security alarm.
- 7) If NG, adjust the impact sensitivity.

#### 2. IMPACT SENSITIVITY ADJUSTMENT

- 1) Connect the Subaru Select Monitor to the data link connector.
- 2) Turn the ignition switch to ON.
- 3) On the "System Selection Menu", select {Impact Sensor}.
- 4) Make a {Sensitivity Adjustment Mode}.
  - Sensitivity can be adjusted in 11 levels (0 to 10).
  - Initial setting is 5.
  - Smaller number means more sensitive.
  - Larger number means less sensitive.
- 5) Turn the ignition switch to OFF, and then remove the Subaru Select Monitor.

#### NOTE:

- Set the sensor so as not to let the alarm on normal vibration (reclining to the door, hit the ball and etc.).
- Set the sensor to operate the alarm with hitting the door or window glass, etc. continuously like a mayhem by robbery.
- Even if there is no burglary attempt, if there is vibration (road construction, elevated parking lots, passage of trains or boarding of ferries), the alarm can be triggered. Because of this, ask the customer about their parking conditions, and set an appropriate sensitivity level after discussion.
- The impact sensitivity can also be adjusted on the manufacturer's optional display, and it can be set in 11 levels from 0 to 10. The sensitivity is set to 5 by default. (Unlike the specification of the Subaru Select Monitor, the setting becomes duller as the setting value becomes smaller, and more sensitive as the number becomes larger.)
- If the sensitivity setting was not performed properly, a buzzer will sound four times. In this case, check the following:
  - Is there an error in CAN communication?
  - Is there an open circuit in the harness between the body integrated unit and the impact sensor?
  - Is there a malfunction in the display, body integrated unit or impact sensor?

## 20. Keyless Entry Control Module

### A: REMOVAL

#### 1. 5 DOOR MODEL

- 1) Disconnect the ground cable from battery.
- 2) Remove the left rear quarter trim. <Ref. to EI-60, REMOVAL, Rear Quarter Trim.>
- 3) Disconnect the keyless entry control module connector.
- 4) Remove the bolt and then remove the keyless entry control module.

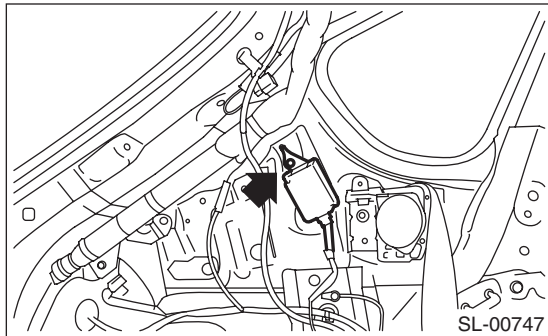

#### 2. 4 DOOR MODEL

- 1) Disconnect the ground cable from battery.
- 2) Remove the rear shelf trim. <Ref. to EI-62, REMOVAL, Rear Shelf Trim.>
- 3) Disconnect the keyless entry control module connector.
- 4) Remove the bolt and then remove the keyless entry control module.

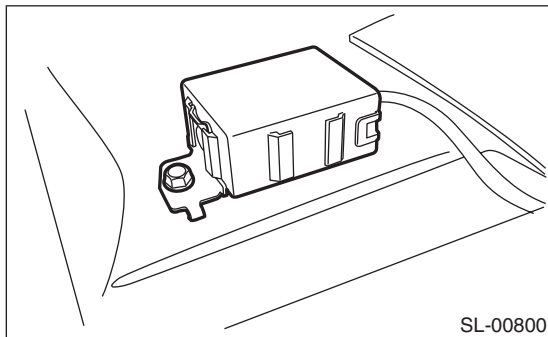

### B: INSTALLATION

Install each part in the reverse order of removal.

#### *Tightening torque:*

**Keyless entry control module: 13 N·m (1.33 kgf-m, 9.6 ft-lb)**

## 21. Keyless Buzzer

### A: REMOVAL

- 1) Disconnect the ground cable from the battery.
- 2) Turn over the left front mud guard.
- 3) Remove the bolt, and then remove the keyless buzzer.

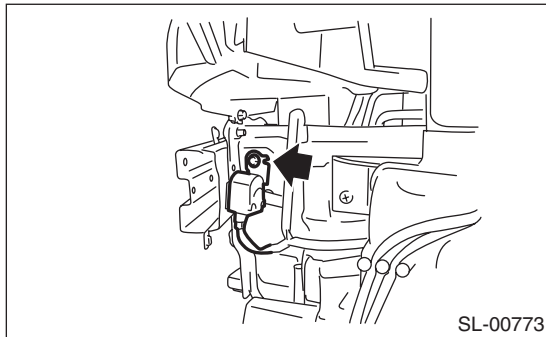

### B: INSTALLATION

Install each part in the reverse order of removal.

#### *Tightening torque:*

***Keyless buzzer: 7.5 N·m (0.76 kgf-m, 5.5 ft-lb)***

### C: INSPECTION

Using the Subaru Select Monitor, perform forced operation of the keyless buzzer. <Ref. to LAN(di-ag)-25, FUNCTION CHECK, OPERATION, Subaru Select Monitor.>

#### NOTE:

If it does not sound, replace the buzzer.

## 22. Body Integrated Unit

### A: NOTE

#### 1. WHEN REPLACING THE BODY INTEGRATED UNIT

- 1) Check and record the current setting. <Ref. to LAN(diag)-20, CONFIRM CURRENT SETTING, OPERATION, Subaru Select Monitor.>
- 2) Prepare the following.
  - Security ID plate
  - Required number of registered immobilizer keys or new (not registered) immobilizer keys.

#### 2. AFTER REPLACING THE BODY INTEGRATED UNIT

- 1) Register the immobilizer. For detailed operation procedures, refer to "PC application help for Subaru Select Monitor".
- 2) Set the current settings as recorded.

### B: REMOVAL

- 1) Disconnect the ground cable from battery.
- 2) Remove the driver's side instrument panel lower cover. <Ref. to EI-55, REMOVAL, Instrument Panel Assembly.>
- 3) Remove the knee guard panel.
- 4) Disconnect the connector of body integrated unit.

#### CAUTION:

**Be careful to keep water and other foreign materials away from body integrated unit.**

- 5) Remove the mounting bolt for the body integrated unit bracket, and remove the body integrated unit.

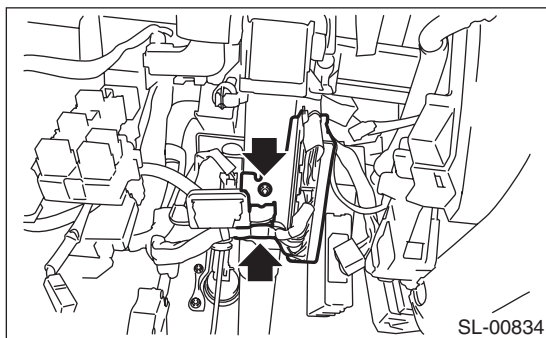

### C: INSTALLATION

Install each part in the reverse order of removal.

#### Tightening torque:

**Body integrated unit: 7.5 N·m (0.76 kgf-m, 5.5 ft-lb)**

#### NOTE:

Make sure that there are no differences from the contents of the current settings after installation. <Ref. to LAN(diag)-20, CONFIRM CURRENT SETTING, OPERATION, Subaru Select Monitor.>

## 23. Transmitter

### A: REMOVAL

#### 1. TRANSMITTER BATTERY

**CAUTION:**

To prevent static electricity damage to the keyless transmitter printed circuit board, touch the steel area of building with hand to discharge static electricity carried on body or clothes before disassembling the keyless transmitter.

Remove the battery (1) from the transmitter.

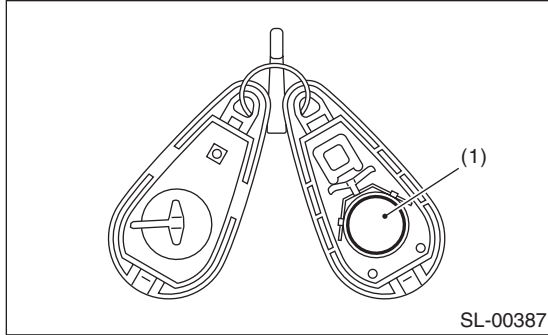

### B: INSTALLATION

Install each part in the reverse order of removal.

### C: INSPECTION

#### 1. TRANSMITTER BATTERY

1) Check the voltage between the transmitter battery (+) terminal and (-) terminal.

**NOTE:**

Battery discharge occurs during the inspection. Complete the measurement within 5 seconds.

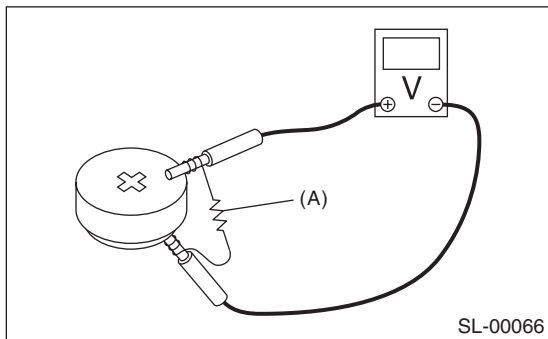

(A) Resistance 47  $\Omega$

Tester connection		Standard
(+)	(-)	
Battery Positive terminal	Battery Ground terminal	2.5 — 3.0 V

2) Replace the battery if the inspection result is not within the standard value. (Use CR2025 or equivalent.)

### D: REPLACEMENT

#### 1. REGISTRATION OF KEYLESS TRANSMITTER WITH SUBARU SELECT MONITOR

**NOTE:**

- A maximum of four keyless transmitter can be registered for each individual vehicle.
  - When replacing or adding the keyless transmitter, new registration of transmitter is necessary.
- 1) Prepare the Subaru Select Monitor kit. <Ref. to SL-7, SPECIAL TOOL, PREPARATION TOOL, General Description.>

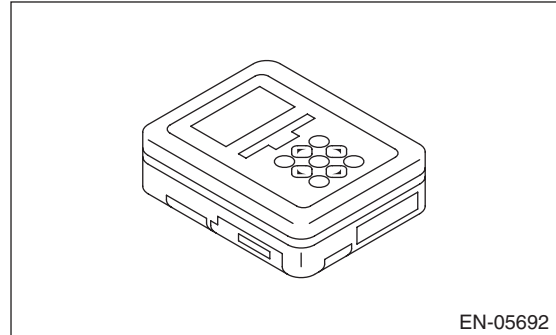

2) Prepare PC with Subaru Select Monitor installed.

3) Connect the USB cable to SDI (Subaru Diagnosis Interface) and USB port on the personal computer (dedicated port for the Subaru Select Monitor).

**NOTE:**

The dedicated port for the Subaru Select Monitor means the USB port which was used to install the Subaru Select Monitor.

4) Connect the diagnosis cable to SDI.

5) Connect SDI to data link connector located in the lower portion of the instrument panel (on the driver's side).

**CAUTION:**

Do not connect scan tools other than the Subaru Select Monitor.

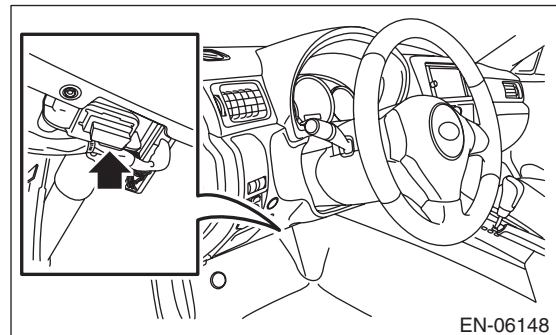

6) Start the PC.

7) Turn the ignition switch to ON (engine OFF) and run the "PC application for Subaru Select Monitor".



# Transmitter

## SECURITY AND LOCKS

---

8) On the «Main Menu» of the Subaru Select Monitor, select the {Each System Check} → {Integ. unit mode} → {Keyless ID registration}.

9) Input the 8-digit ID number attached to the tag plate of the transmitter or inside the transmitter, from left to right. Press the [OK] key.

10) The ID number you have entered will be shown. Make sure that the ID number shown is the same as that of plastic bag or inside of transmitter.

11) Press the [OK] key if the ID number is correct. Press the [EXIT] key if incorrect, to return to the step 3) and enter the ID number again.

12) «ID is being registered...» is displayed and registration starts.

13) «ID registration completed » will be displayed when the registration process is done.

14) To exit, select «Quit: NO» to return to {Keyless ID registration}. If there are additional keyless transmitters to be registered, select «The following are registered: OK» to return to the step 4).

### NOTE:

- If the registration fails, «ID cannot register. Try again.» will be shown. Select the [OK] key to return to the {Keyless ID registration}. Retry starting from the step 3).
- «Quit: NO» is shown on the Subaru Select Monitor when fourth keyless transmitter has been registered. Select the [NO] key to return to {Keyless ID registration}.

## 24. Immobilizer Control Module

### A: NOTE

The control of immobilizer system is carried out in body integrated unit. Refer to the section on the body integrated unit for the work procedures.

- Removal: <Ref. to SL-48, REMOVAL, Body Integrated Unit.>
- Installation: <Ref. to SL-48, INSTALLATION, Body Integrated Unit.>

# Immobilizer Antenna

## SECURITY AND LOCKS

### 25. Immobilizer Antenna

#### A: REMOVAL

- 1) Disconnect the ground cable from battery.
- 2) Remove the screws and remove the steering column cover lower.

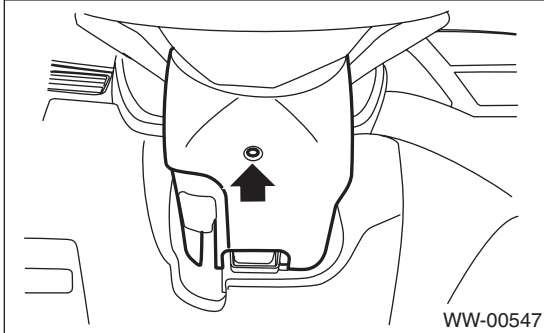

- 3) Remove the harness cover lock.
- 4) Remove the screws and detach the knee protector.

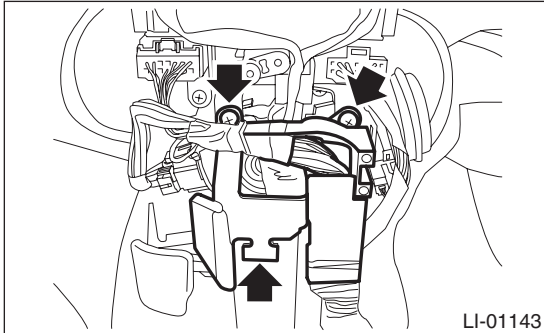

- 5) Remove the screws and remove the steering column cover upper.

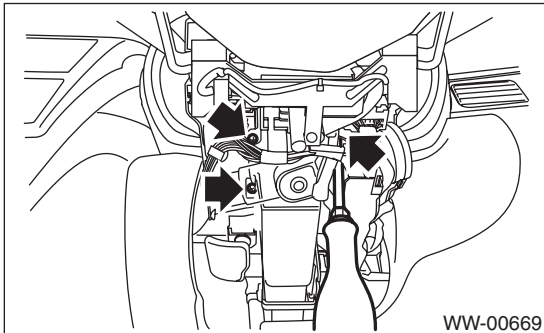

- 6) Remove the instrument panel lower cover. <Ref. to EI-49, REMOVAL, Instrument Panel Lower Cover.>
- 7) Disconnect the immobilizer antenna connector (A) and ignition switch lighting connector (B).
- 8) Loosen the screw and release the lock (D) at opposite side using flat tip screwdriver (1), and then detach the immobilizer antenna (C).

#### CAUTION:

Do not apply excessive force to remove the immobilizer antenna and lock. Otherwise they may be broken because those parts are the products made of a plastic.

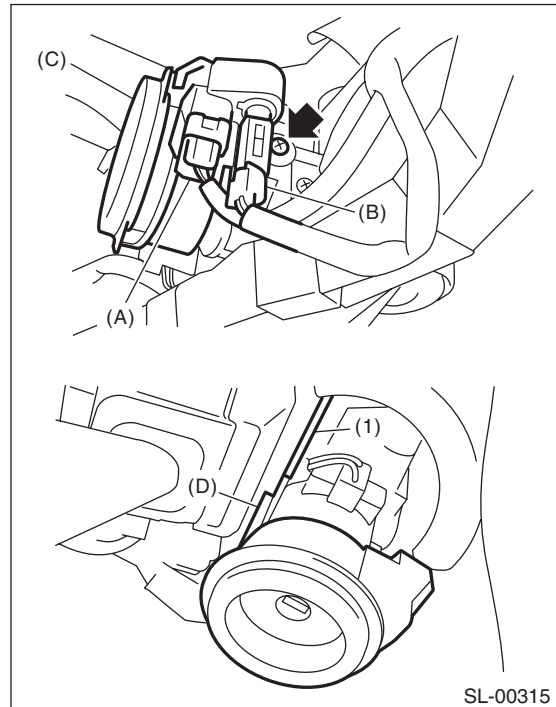

#### B: INSTALLATION

Install each part in the reverse order of removal.

# SUNROOF/T-TOP/CONVERTIBLE TOP (SUNROOF)

# SR

---

	<b>Page</b>
1. General Description .....	2
2. Sunroof Control System .....	4
3. Glass Lid .....	5
4. Sunroof Assembly .....	6
5. Sunroof Motor .....	7
6. Sunroof Switch .....	8
7. Sunshade .....	9

# General Description

SUNROOF/T-TOP/CONVERTIBLE TOP (SUNROOF)

## 1. General Description

### A: COMPONENT

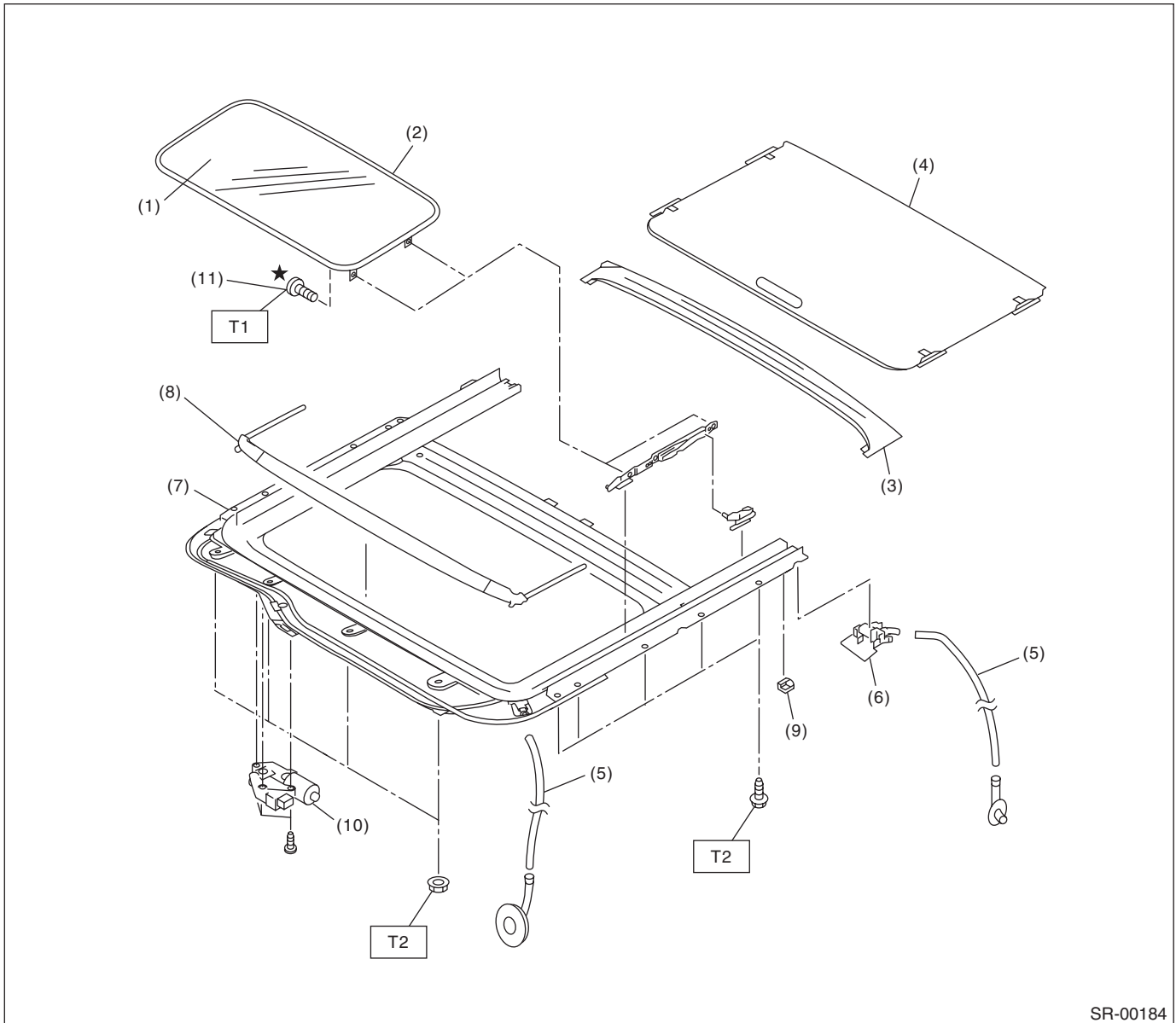

- |                   |                   |
|-------------------|-------------------|
| (1) Glass lid     | (7) Frame ASSY    |
| (2) Weather strip | (8) Deflector     |
| (3) Drip rail     | (9) Shade stopper |
| (4) Sunshade      | (10) Motor ASSY   |
| (5) Drain tube    | (11) TORX® bolt   |
| (6) Drain holder  |                   |

**Tightening torque: N·m (kgf·m, ft·lb)**

**T1: 4.5 (0.46, 3.3)**

**T2: 6.0 (0.61, 4.3)**

**SR-2**

Brought to you by Ebay Seller "SubaruManuals"

## General Description

SUNROOF/T-TOP/CONVERTIBLE TOP (SUNROOF)

---

### B: CAUTION

- Before disassembling or reassembling parts, always disconnect the battery ground cable from battery. When replacing the audio, control module and other parts provided with memory functions, record the memory contents before disconnecting the battery ground cable. Otherwise, the memory is cleared.
- Reassemble the parts in the reverse order of disassembly unless otherwise indicated.
- Adjust parts to the given specifications.
- Connect the connectors securely during reassembly.
- After reassembly, make sure that the functional parts operate normally.

### C: PREPARATION TOOL

#### 1. GENERAL TOOL

TOOL NAME	REMARKS
Circuit tester	Used for measuring resistance and voltage.
TORX® T25	Used for removing and installing the glass lid.
Hexagon wrench	Used for forcedly driving the sunroof motor.

# Sunroof Control System

SUNROOF/T-TOP/CONVERTIBLE TOP (SUNROOF)

## 2. Sunroof Control System

### A: WIRING DIAGRAM

Refer to "Sunroof Control System" in the wiring diagram. <Ref. to WI-153, WIRING DIAGRAM, Sunroof Control System.>

### B: INSPECTION

Symptom	Inspection order
Water leakage	<ol style="list-style-type: none"><li>1. Check roof panel and glass lid for improper or poor sealing.</li><li>2. Check drain tube for clogging.</li><li>3. Check sunroof frame seal and body for improper fit.</li></ol>
Booming noise, wind noise and other noise	<ol style="list-style-type: none"><li>1. Check glass lid and roof panel for improper clearance.</li><li>2. Check sunshade and roof trim for improper clearance.</li></ol>
Abnormal motor noise	<ol style="list-style-type: none"><li>1. Check installing part of motor for looseness.</li><li>2. Check gears and bearings for wear.</li><li>3. Check cable for wear.</li><li>4. Check cable pipe for deformities.</li></ol>
Failure of sunroof (Motor operates properly.)	<ol style="list-style-type: none"><li>1. Check guide rail for foreign particles.</li><li>2. Check guide rail for improper installation.</li><li>3. Check parts for mutual interference.</li><li>4. Check cable slider for improper clinching.</li><li>5. Check cable for improper installation.</li></ol>
Motor does not rotate or rotate improperly.	<ol style="list-style-type: none"><li>1. Check fuse for blown out.</li><li>2. Check switch for improper function.</li><li>3. Check motor for incorrect terminal voltage.</li><li>4. Check the relay for improper operation.</li><li>5. Check poor grounding system.</li><li>6. Check harness for open or short and terminals for poor connections.</li></ol>
Failure turn of glass lid	Check guide rail for foreign particles.

- Failure turn of glass lid while driving rough road.

Glass lid has auto-reverse function. When specified or more force is applied to the glass lid, the lid turns back and stops. When operating the glass lid (open or close) while driving the rough road, the lid judges vibration as a force and may causes failure turns. When the failure turn is occurred, need to perform the initialize operation with following procedure.

### 1. INITIALIZE OPERATION

- 1) Tilt up the glass lid.
- 2) Release the switch once, and press the tilt up switch again for 15 seconds.
- 3) When the glass lid is raised a little and returned to tilt up position, release the switch for the moment. (Initialization of position detecting function)
- 4) Holding down the tilt up switch again within 5 seconds from releasing the switch will automatically perform the tilt down → slide open → slide close operation. (When 5 seconds or more pass, the position detecting function is cancelled.)
- 5) Initialize operation is completed.

### C: NOTE

For procedure of each component in the sunroof control system, refer to the respective section.

- Glass lid: <Ref. to SR-5, Glass Lid.>
- Sunroof assembly: <Ref. to SR-6, Sunroof Assembly.>
- Sunroof motor: <Ref. to SR-7, Sunroof Motor.>
- Sunroof switch: <Ref. to SR-8, Sunroof Switch.>
- Sunshade: <Ref. to SR-9, Sunshade.>

# Glass Lid

SUNROOF/T-TOP/CONVERTIBLE TOP (SUNROOF)

## 3. Glass Lid

### A: REMOVAL

- 1) Open the sunshade.
- 2) Remove the TORX® bolt, and then remove the glass lid carefully.

#### CAUTION:

- The thread locker is applied to the TORX® bolts, so use the new parts once they are removed.
- Be careful not to damage the glass lid.

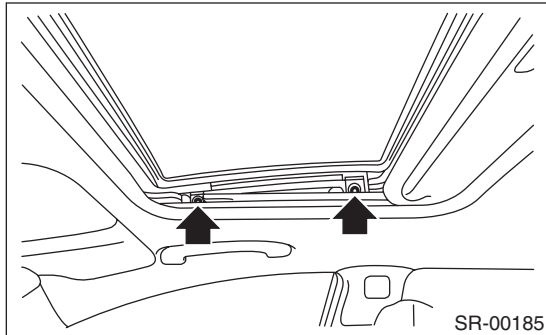

### B: INSTALLATION

Install each part in the reverse order of removal.

#### Tightening torque:

Refer to "COMPONENT" of "General Description". <Ref. to SR-2, COMPONENT, General Description.>

### C: ADJUSTMENT

- 1) Open the sunshade.
- 2) Loosen the glass lid mounting TORX® bolts (A), and then adjust the height by moving the lid side.

*Difference in height between glass lid and roof panel L:*

*0.75±1.0 mm (0.03±0.04 in)*

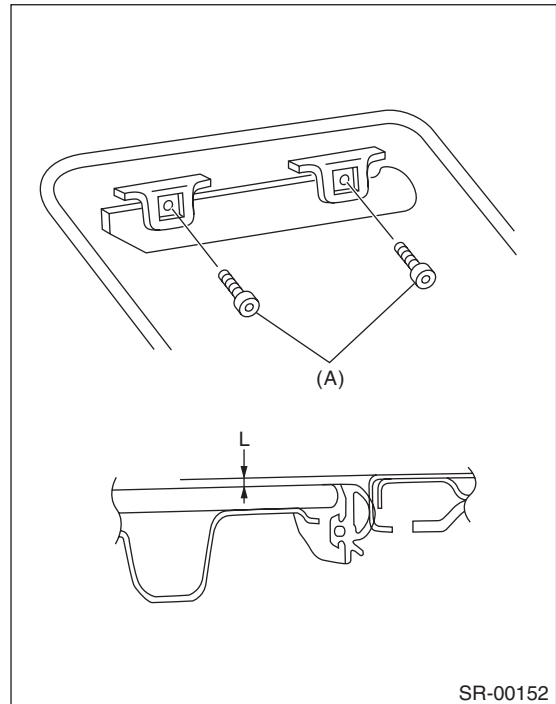

### D: FORCED DRIVE

#### CAUTION:

After a forced operation, make sure to perform an initialize operation. <Ref. to SR-4, INSPECTION, Sunroof Control System.>

#### NOTE:

If the glass lid does not operate or is not supplied with power, move the glass lid using the hexagon wrench.

- 1) Remove the spot map light. <Ref. to LI-33, REMOVAL, Spot Map Light.>
  - 2) Insert the hexagon wrench securely until it touches the motor shaft end.
  - 3) Turn the hexagon wrench, and move the glass lid.
- Turning right, the glass lid open.
  - Turning left, the glass lid close.

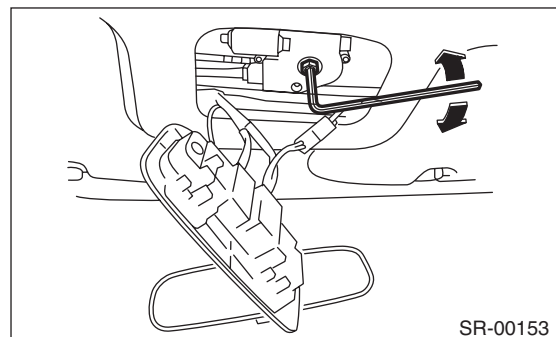



# Sunroof Assembly

SUNROOF/T-TOP/CONVERTIBLE TOP (SUNROOF)

## 4. Sunroof Assembly

### A: REMOVAL

#### CAUTION:

When removing the clip, use great care not to damage the roof trim.

- 1) Disconnect the ground cable from battery.
- 2) Remove the roof trim. <Ref. to EI-66, REMOVAL, Roof Trim.>
- 3) Disconnect the harness connector of sunroof motor.
- 4) Remove the glass lid. <Ref. to SR-5, REMOVAL, Glass Lid.>
- 5) Remove the four drain tubes from frame assembly.
- 6) Remove the assist rail bracket (front) (A) and assist rail bracket (rear) (B).

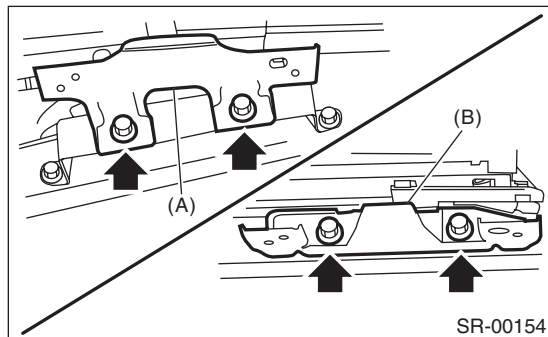

- 7) Remove the curtain airbag module. (model with curtain airbag module) <Ref. to AB-20, REMOVAL, Curtain Airbag Module.>
- 8) Remove the bolts and nuts and remove the frame assembly.

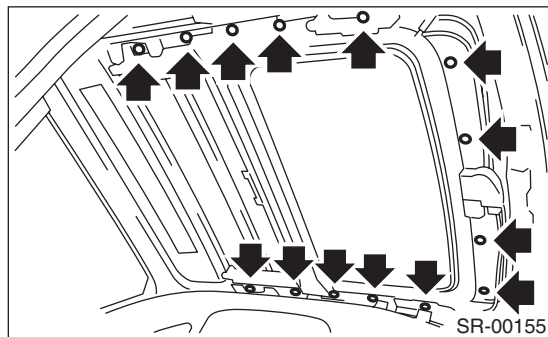

### B: INSTALLATION

#### CAUTION:

Be careful not to snag the harness.

Install each part in the reverse order of removal.

#### Tightening torque:

Refer to "COMPONENT" of "General Description". <Ref. to SR-2, COMPONENT, General Description.>

#### NOTE:

- Be sure to connect the harness connector.
- When installing the drain tube, insert it securely into drain pipe.

#### Length A:

15 mm (0.59 in) or more

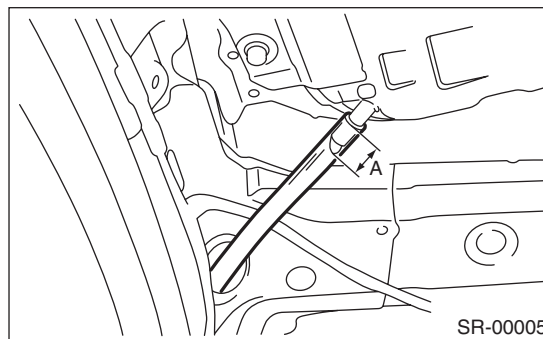

### C: DISASSEMBLY

- 1) Remove the sunroof motor. <Ref. to SR-7, REMOVAL, Sunroof Motor.>
- 2) Remove the sunshade. <Ref. to SR-9, REMOVAL, Sunshade.>

### D: ASSEMBLY

Assemble each part in the reverse order of disassembly.

## 5. Sunroof Motor

### A: REMOVAL

**CAUTION:**

Never rotate the motor assembly after removing it.

- 1) Completely close the glass lid.
- 2) Disconnect the ground cable from battery.
- 3) Remove the spot map light. <Ref. to LI-33, REMOVAL, Spot Map Light.>
- 4) Remove the motor assembly.

**CAUTION:**

When removing the motor assembly, secure the cable wires to prevent moves.

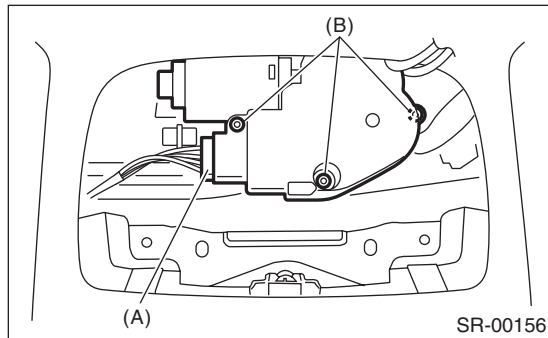

- (1) Disconnect the sunroof motor connector (A).
- (2) Remove the screws (B) to remove motor assembly.

### B: INSTALLATION

**CAUTION:**

When installing the motor assembly, be careful not to move the sunroof cable.

- 1) Install each part in the reverse order of removal.
- 2) Perform the initialize operation of motor. <Ref. to SR-4, INITIALIZE OPERATION, INSPECTION, Sunroof Control System.>
- 3) Check the operation of sunroof with following table below.

Operation	Switch position
(1) Glass lid closes completely.	Close
(2) Glass lid tilt up to the top position.	Tilt up
(3) Glass lid closes completely.	Tilt down
(4) Glass lid opens completely.	Open
(5) Glass lid closes completely.	Close

### C: INSPECTION

**CAUTION:**

Do not place objects in the way to check the auto-reverse mechanism.

- 1) Open the glass lid.
- 2) Forcefully push the glass lid in the opening direction while auto-closing, to check whether the window auto-reverse mechanism functions.
- 3) Check whether the window auto-reverse mechanism operates and the glass lid moves back to fully open position.

# Sunroof Switch

SUNROOF/T-TOP/CONVERTIBLE TOP (SUNROOF)

## 6. Sunroof Switch

### A: REMOVAL

- 1) Disconnect the ground cable from battery.
- 2) Remove the lens (A) and screws (B) of the spot map light.

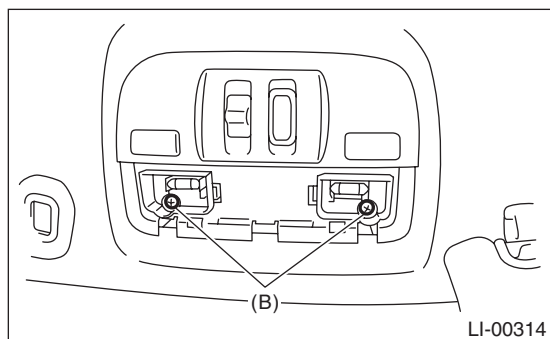
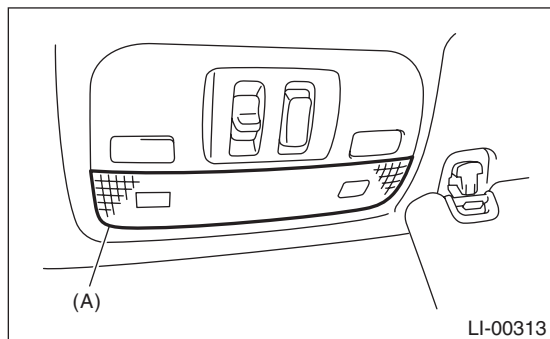

- 3) Disconnect the harness connectors and remove the spot map light.
- 4) Remove the screws and remove the sunroof switch bracket from the spot map light.

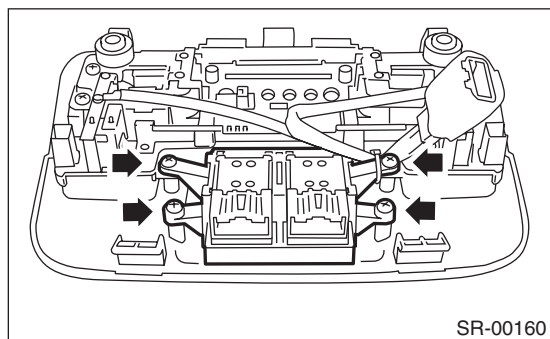

- 5) Remove the sunroof switch from the bracket.

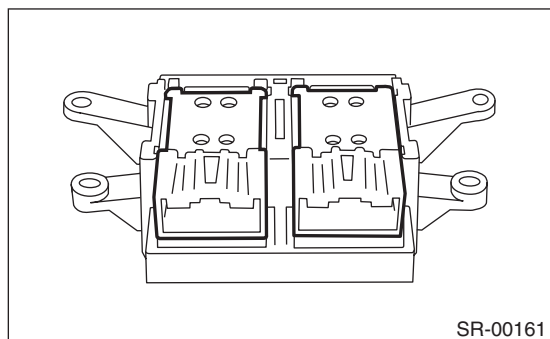

### B: INSTALLATION

Install each part in the reverse order of removal.

### C: INSPECTION

- 1) Remove the spot map light. <Ref. to LI-33, REMOVAL, Spot Map Light.>
- 2) Check the resistance between sunroof switch terminals.

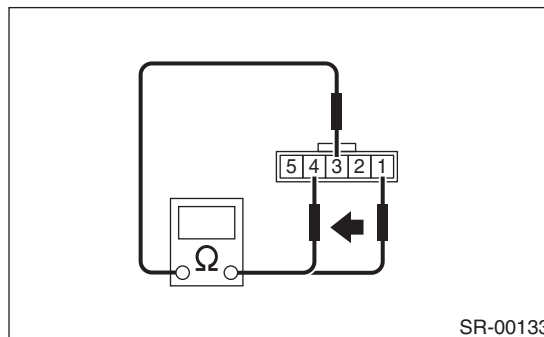

Switch position	Terminal No.	Standard	Connector No.
Open	1 and 3	Less than 1 Ω	R128
Close	3 and 4	Less than 1 Ω	
Tilt up	1 and 3	less than 1 Ω	R187
Tilt down	3 and 4	Less than 1 Ω	

- 3) Replace the sunroof switch if the inspection result is not within the standard value.

#### NOTE:

If the glass lid does not operate or is not supplied with power, move the glass lid using the hexagon wrench. <Ref. to SR-5, FORCED DRIVE, Glass Lid.>

# Sunshade

SUNROOF/T-TOP/CONVERTIBLE TOP (SUNROOF)

## 7. Sunshade

### A: REMOVAL

- 1) Remove the sunroof assembly. <Ref. to SR-6, REMOVAL, Sunroof Assembly.>
- 2) Remove the screws, and remove the drip rail.

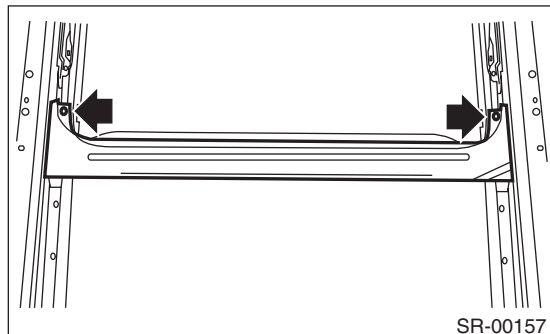

- 3) Remove the sunshade.

### CAUTION:

Being careful not to damage the shade knob, pull out it while bending the sunshade.

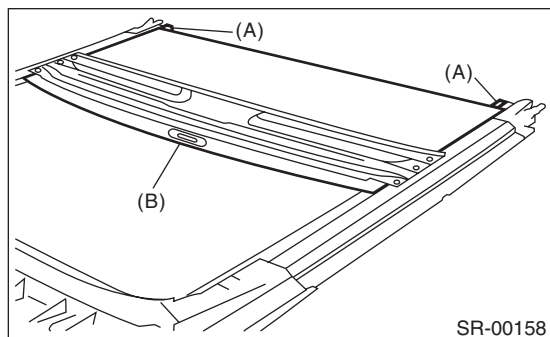

- (1) Remove the shade stopper (A).
- (2) Pull out the sunshade (B) from the frame assembly.

### B: INSTALLATION

Install each part in the reverse order of removal.

### C: INSPECTION

#### 1. CHECK FOR MOVING LOAD OF SUNSHADE

- 1) Attach a spring scale to sunshade edge using a cloth.

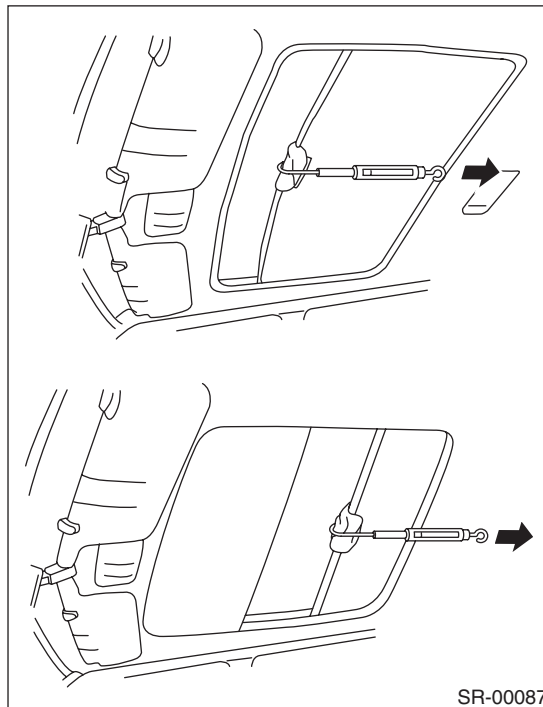

- 2) Pull the spring scale to measure moving load of the sunshade.

#### Moving load of sunshade:

##### Standard value

$18.0 \pm 5.0 \text{ N}$  ( $1.8 \pm 0.5 \text{ kgf}$ ,  $13 \pm 3.7 \text{ lbf}$ )

#### NOTE:

Moving load is larger at the beginning of pulling a spring scale, so take a spring scale reading while sunshade sliding smoothly.

- 3) If moving load exceeds specifications, check the glass lid, sunshade and frame assembly for improper installation.

# Sunshade

SUNROOF/T-TOP/CONVERTIBLE TOP (SUNROOF)

---

**SR-10**

Brought to you by Ebay Seller "SubaruManuals"

# EXTERIOR/INTERIOR TRIM



---

	<b>Page</b>
1. General Description .....	2
2. Front Grille .....	26
3. Front Hood Grille .....	27
4. Front Under Cover .....	28
5. Fuel Tank Protector .....	29
6. Mud Guard .....	30
7. Front Bumper .....	31
8. Rear Bumper .....	38
9. Cowl Panel .....	40
10. Roof Spoiler .....	41
11. Rear Spoiler .....	42
12. Side Sill Spoiler .....	43
13. Roof Molding .....	44
14. Door Trim .....	45
15. Instrument Panel Lower Cover .....	49
16. Glove Box .....	50
17. Console Box .....	51
18. Center Console .....	52
19. Instrument Panel Assembly .....	55
20. Lower Inner Trim .....	57
21. Upper Inner Trim .....	59
22. Rear Quarter Trim .....	60
23. Rear Shelf Trim .....	62
24. Trunk Room Trim .....	63
25. Sun Visor .....	64
26. Assist Grip .....	65
27. Roof Trim .....	66
28. Rear Gate Trim .....	69
29. Floor Mat .....	71
30. Rear Gate Garnish .....	72
31. Trunk Lid Garnish .....	73
32. Heat Shield Cover .....	74
33. Ornament .....	75

# General Description

EXTERIOR/INTERIOR TRIM

## 1. General Description

### A: COMPONENT

#### 1. FRONT GRILLE

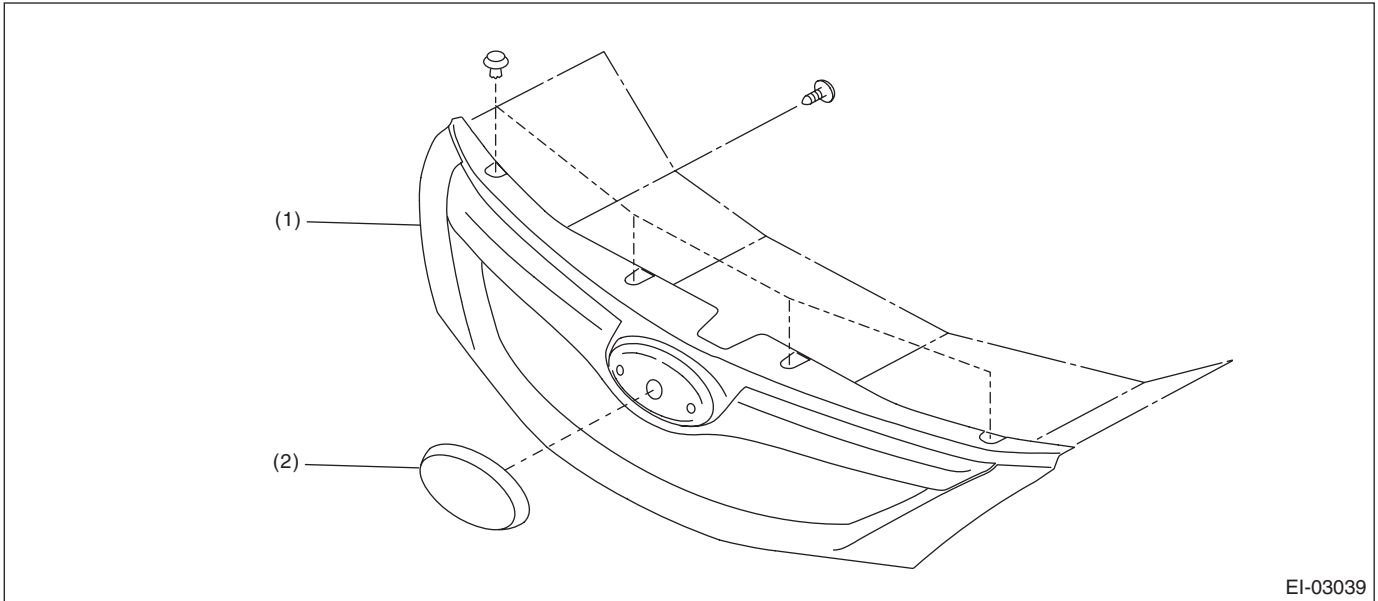

(1) Front grille ASSY

(2) Front grille emblem

#### 2. UNDER COVER

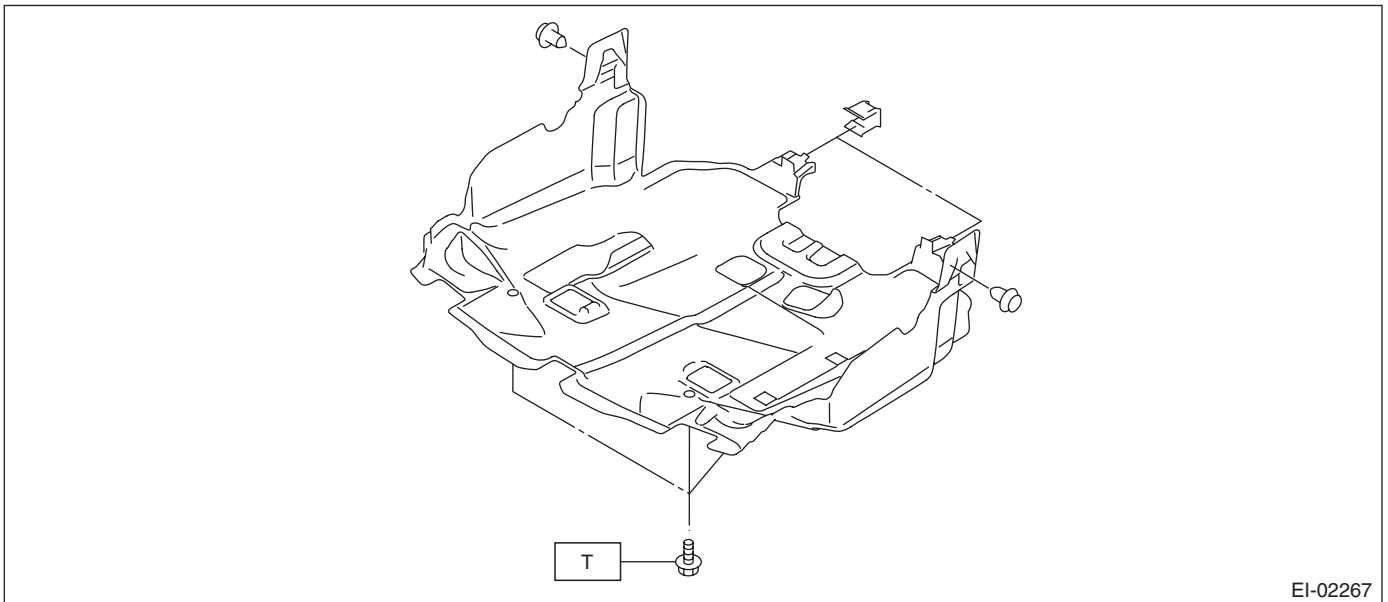

**Tightening torque: N·m (kgf-m, ft-lb)**

**T: 18 (1.84, 13.3)**

## 3. UNDER PROTECTOR

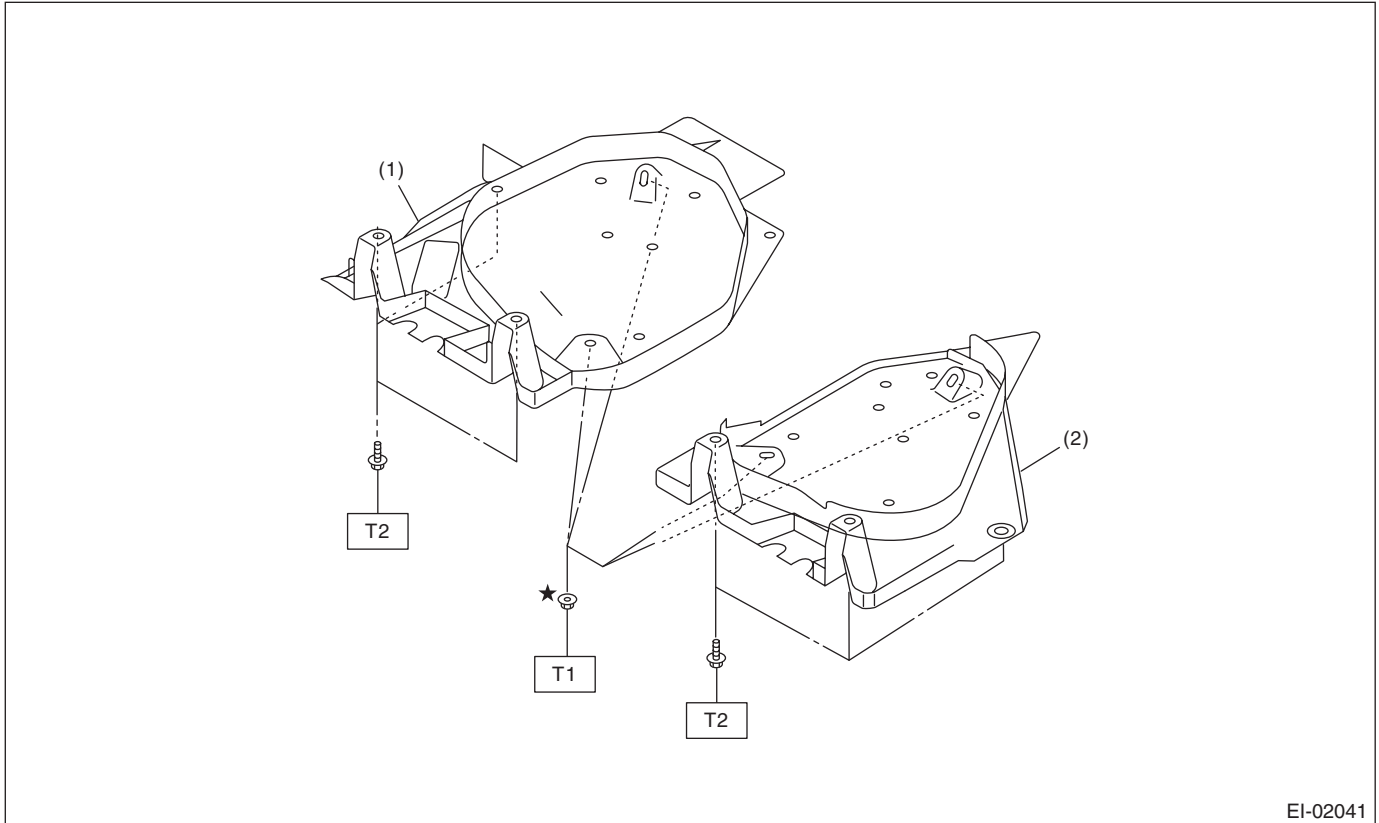

(1) Fuel tank protector RH

(2) Fuel tank protector LH

**Tightening torque: N·m (kgf·m, ft·lb)**

**T1: 9 (0.92, 6.6)**

**T2: 18 (1.84, 13.3)**



# General Description

EXTERIOR/INTERIOR TRIM

## 4. FRONT HOOD GRILLE

Except for STI model

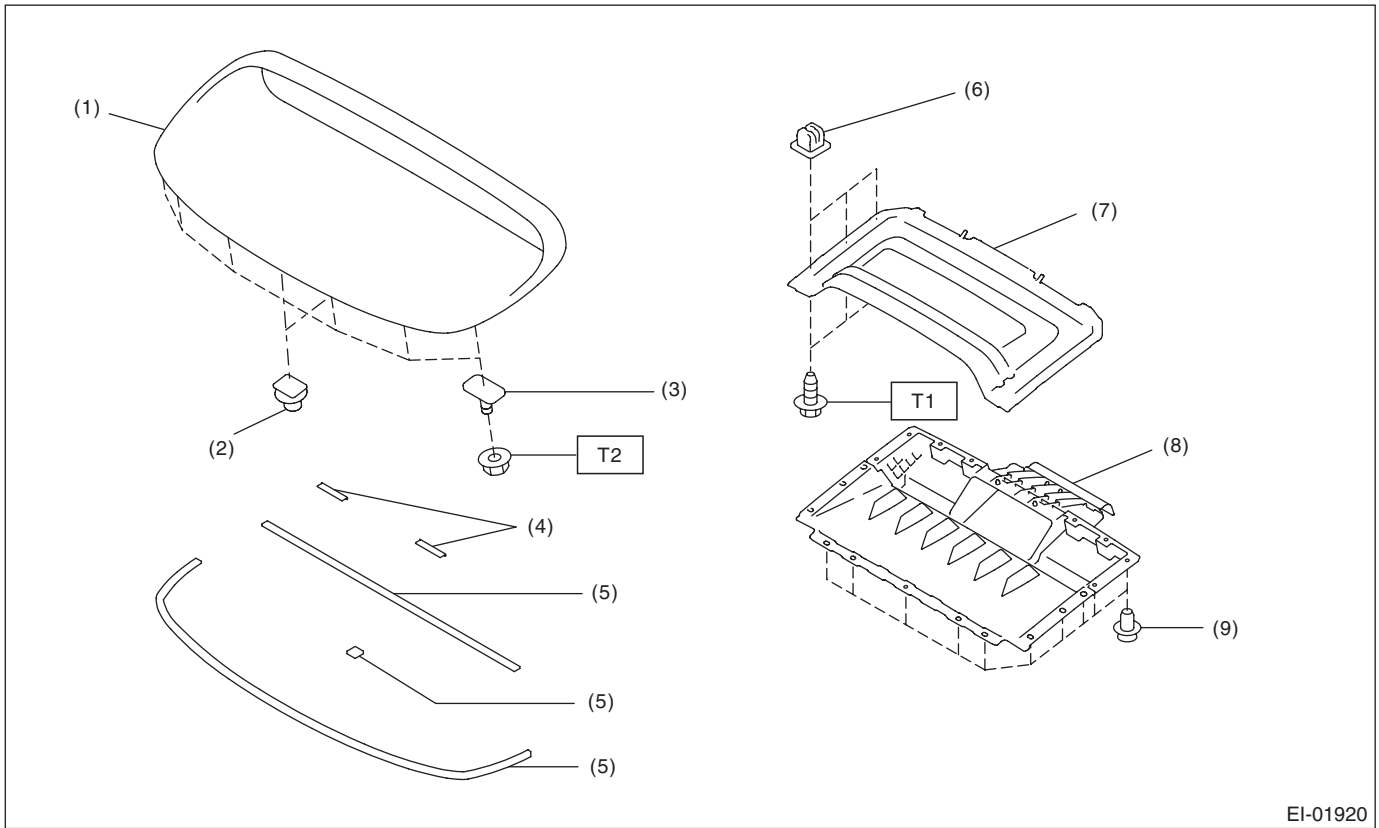

- |                       |                     |
|-----------------------|---------------------|
| (1) Front hood grille | (6) Grommet         |
| (2) Clip anchor       | (7) Hood duct       |
| (3) Bolt              | (8) Hood duct inner |
| (4) Protector         | (9) Clip            |
| (5) Packing           |                     |

**Tightening torque: N·m (kgf·m, ft·lb)**  
**T1: 1.0 (0.1, 0.7)**  
**T2: 4.5 (0.46, 3.3)**

# General Description

EXTERIOR/INTERIOR TRIM

## STI model

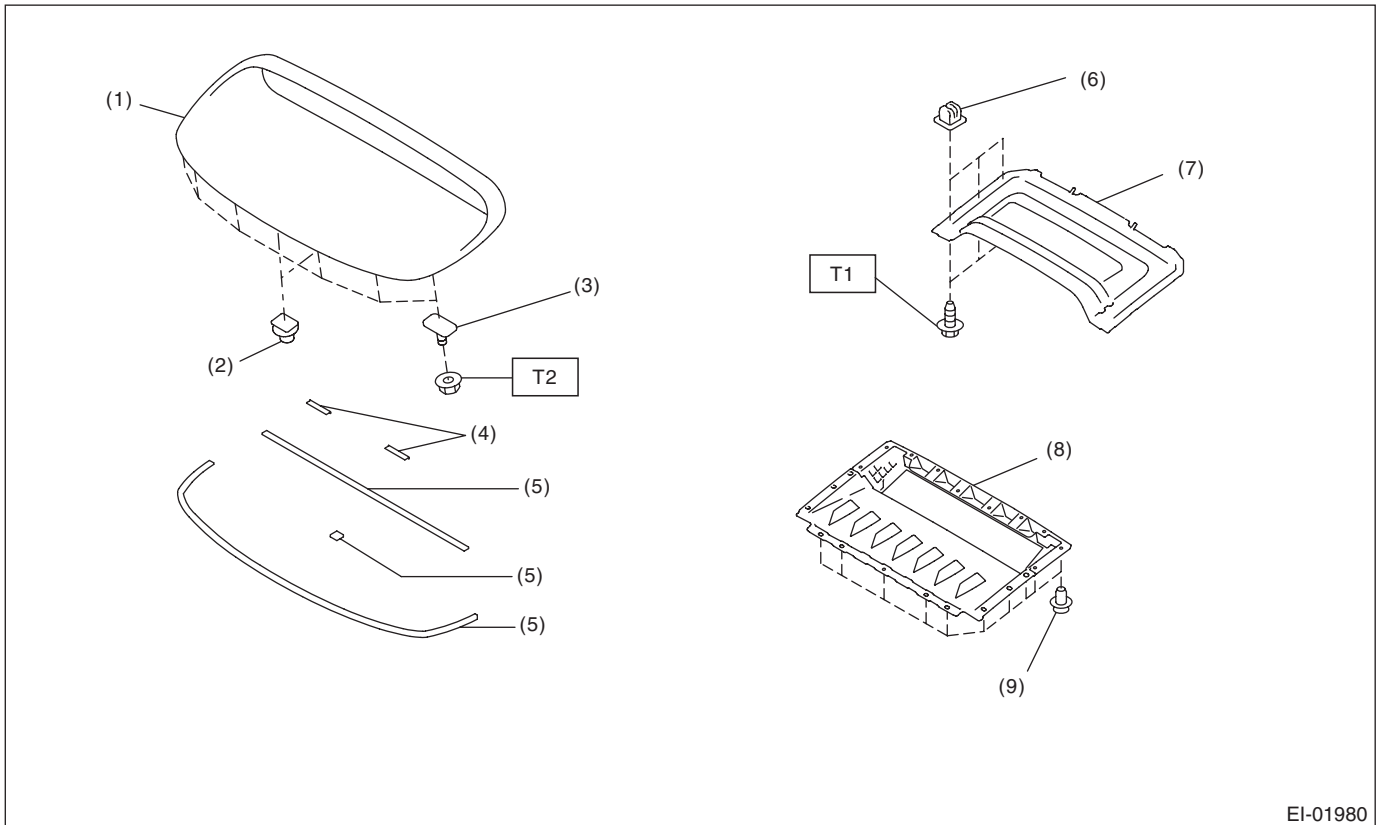

- |                       |                     |
|-----------------------|---------------------|
| (1) Front hood grille | (6) Grommet         |
| (2) Clip anchor       | (7) Hood duct       |
| (3) Bolt              | (8) Hood duct inner |
| (4) Protector         | (9) Clip            |
| (5) Packing           |                     |

**Tightening torque: N·m (kgf·m, ft·lb)**

**T1: 1.0 (0.1, 0.7)**

**T2: 4.5 (0.46, 3.3)**

# General Description

EXTERIOR/INTERIOR TRIM

## 5. FRONT BUMPER

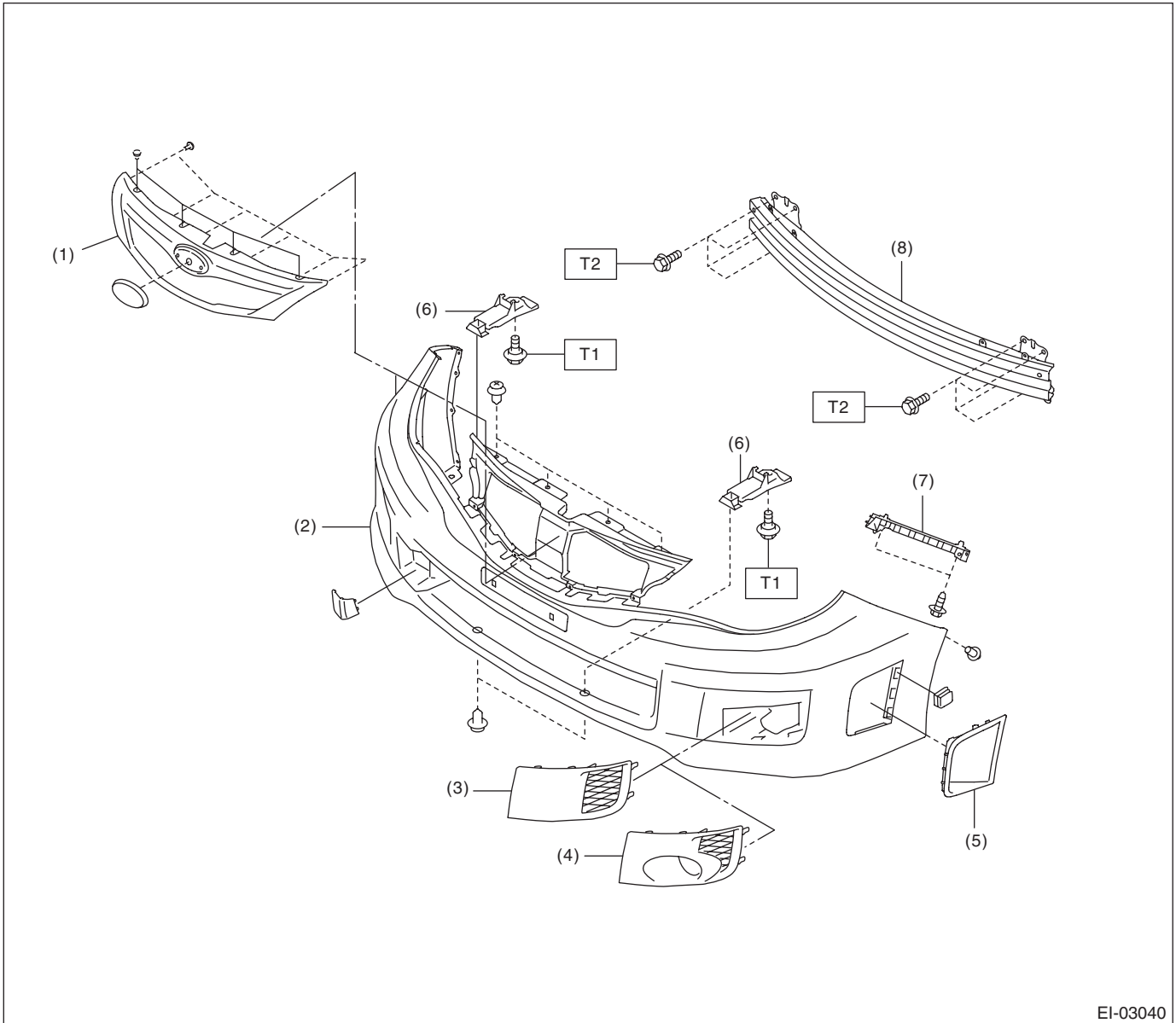

EI-03040

- (1) Front grille ASSY
- (2) Bumper face
- (3) Front cover
- (4) Fog light cover

- (5) Side cover
- (6) Front bracket center lower
- (7) Front side bracket
- (8) Bumper beam reinforcement

**Tightening torque: N·m (kgf·m, ft·lb)**

**T1: 7.5 (0.76, 5.5)**

**T2: 32 (3.26, 23.6)**

## 6. REAR BUMPER

5 door model

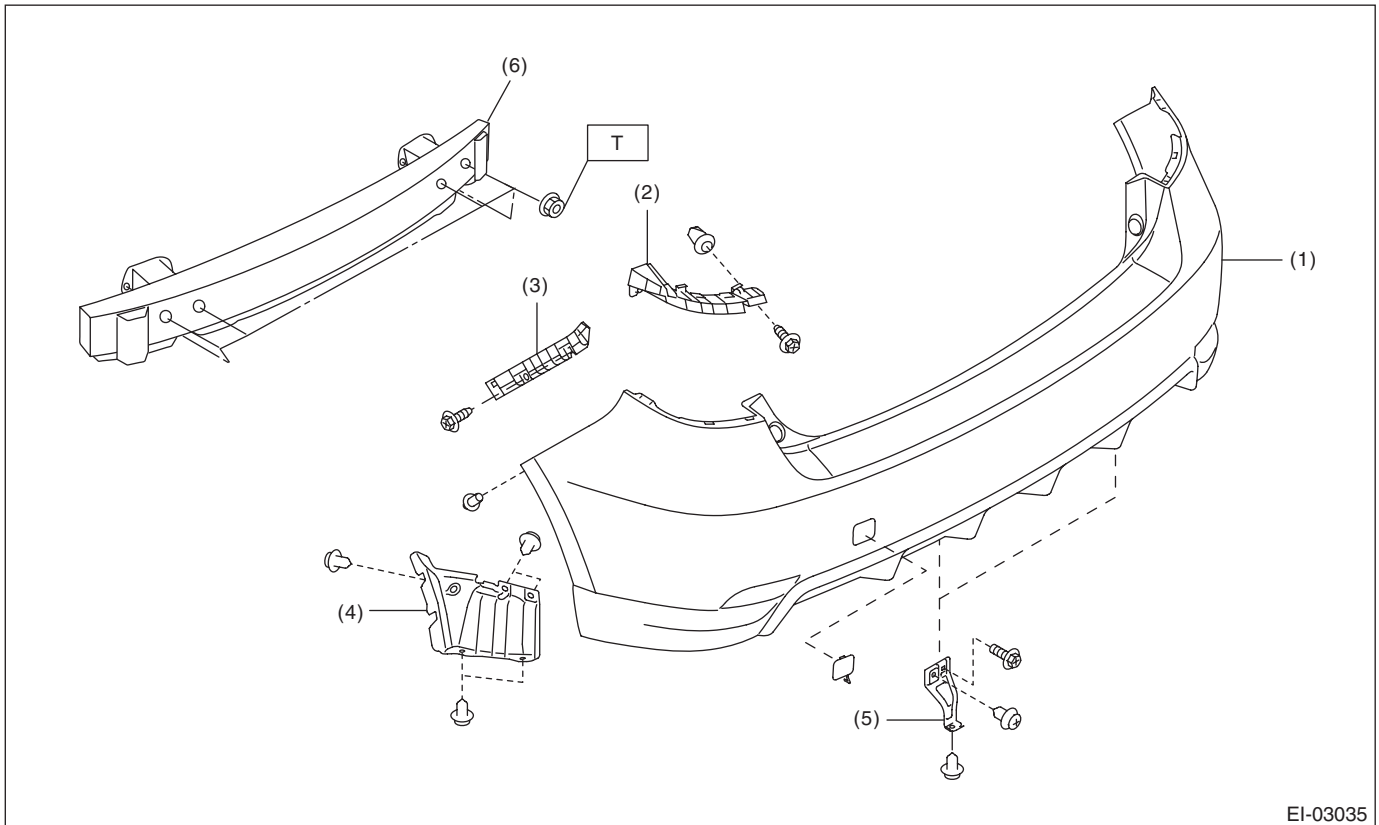

EI-03035

- |                         |                               |
|-------------------------|-------------------------------|
| (1) Bumper face         | (4) Rear side cover lower     |
| (2) Rear bracket corner | (5) Lower bracket             |
| (3) Rear side bracket   | (6) Bumper beam reinforcement |

**Tightening torque: N·m (kgf·m, ft·lb)**

**T: 45 (4.59, 33.2)**

# General Description

## EXTERIOR/INTERIOR TRIM

### 4 door model

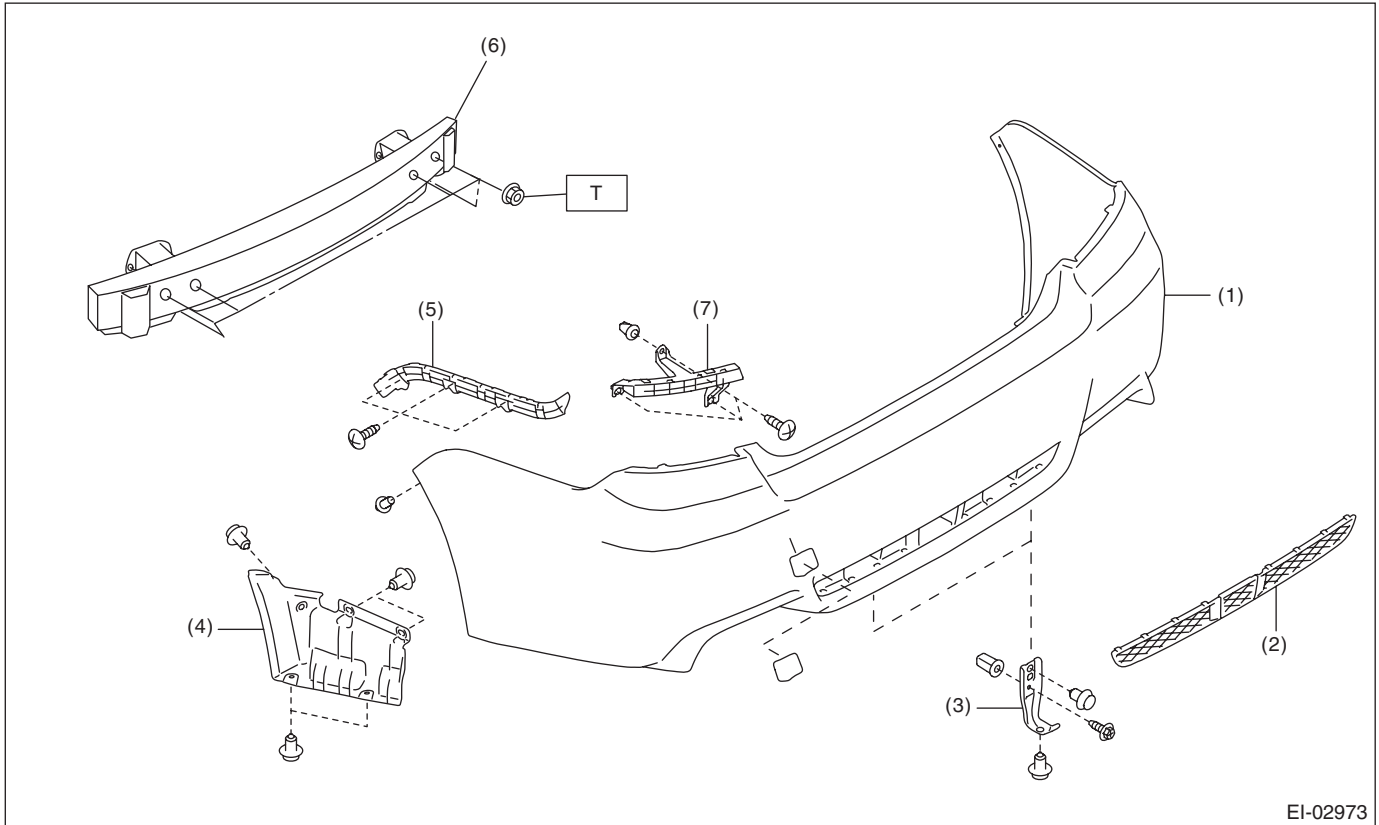

- |                           |                               |
|---------------------------|-------------------------------|
| (1) Bumper face           | (5) Rear side bracket         |
| (2) Cover bumper rear     | (6) Bumper beam reinforcement |
| (3) Lower bracket         | (7) Rear bracket corner       |
| (4) Rear side cover lower |                               |

**Tightening torque: N·m (kgf·m, ft·lb)**  
**T: 45 (4.59, 33.2)**

### 7. MUD GUARD

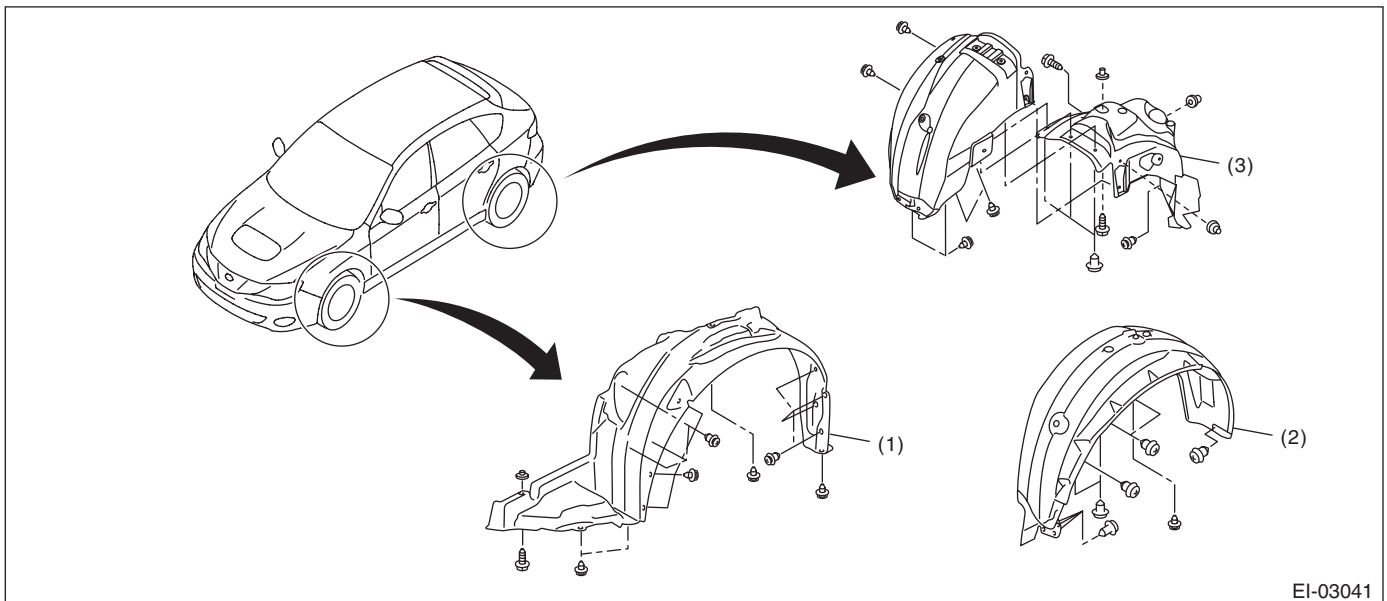

- |                     |                       |                       |
|---------------------|-----------------------|-----------------------|
| (1) Front mud guard | (2) Rear mud guard LH | (3) Rear mud guard RH |
|---------------------|-----------------------|-----------------------|

## 8. COWL PANEL

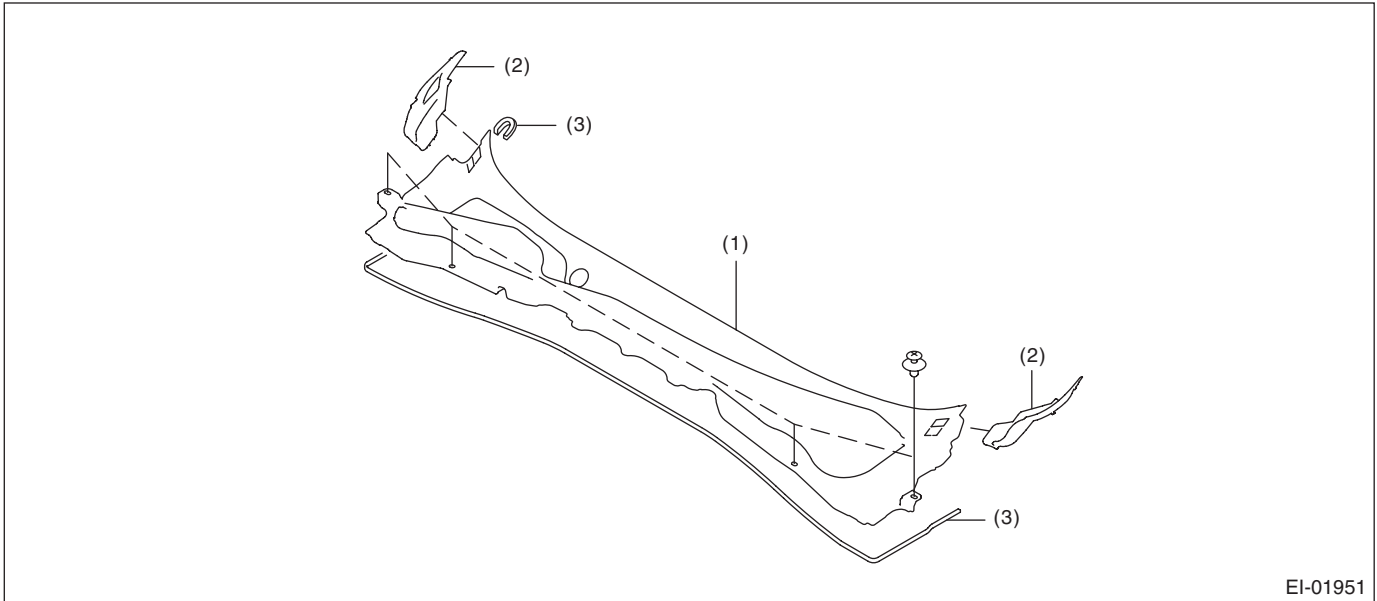

EI-01951

(1) Cowl panel

(2) Cowl panel side

(3) Gasket

## 9. ROOF SPOILER

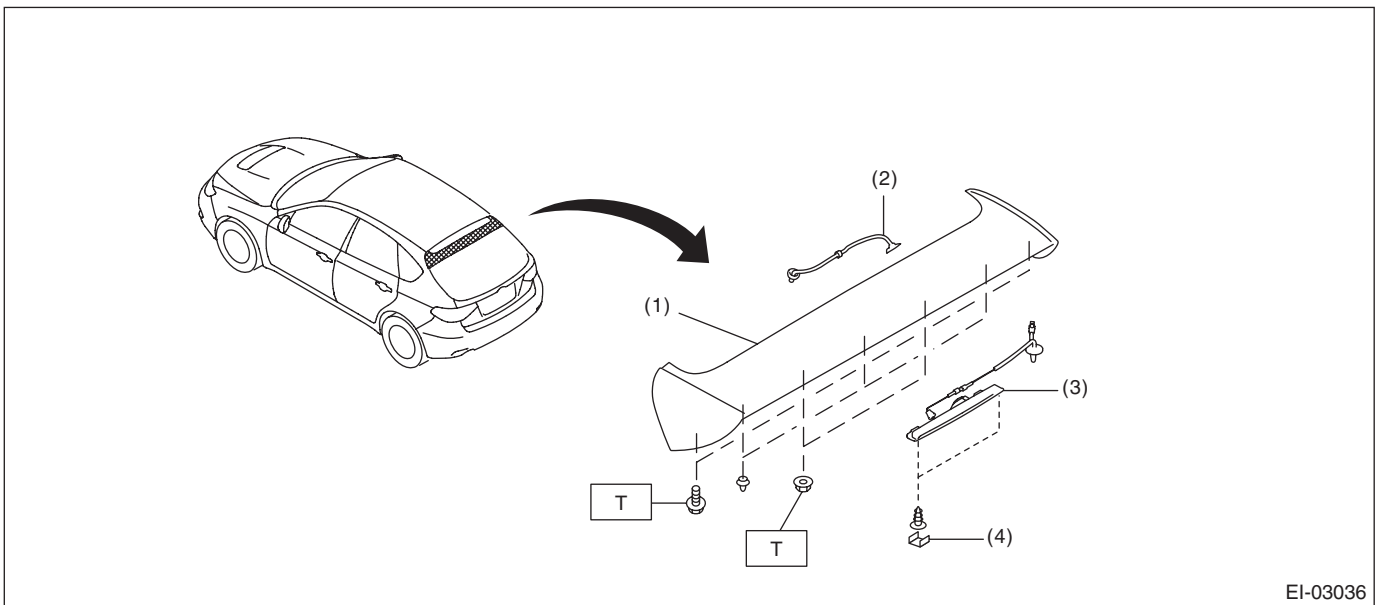

EI-03036

(1) Roof spoiler

(2) Washer nozzle

(3) High-mounted stop light

(4) Cap

**Tightening torque: N·m (kgf·m, ft·lb)**

**T: 7.5 (0.76, 5.5)**

# General Description

EXTERIOR/INTERIOR TRIM

## 10.REAR SPOILER

Except for STI model

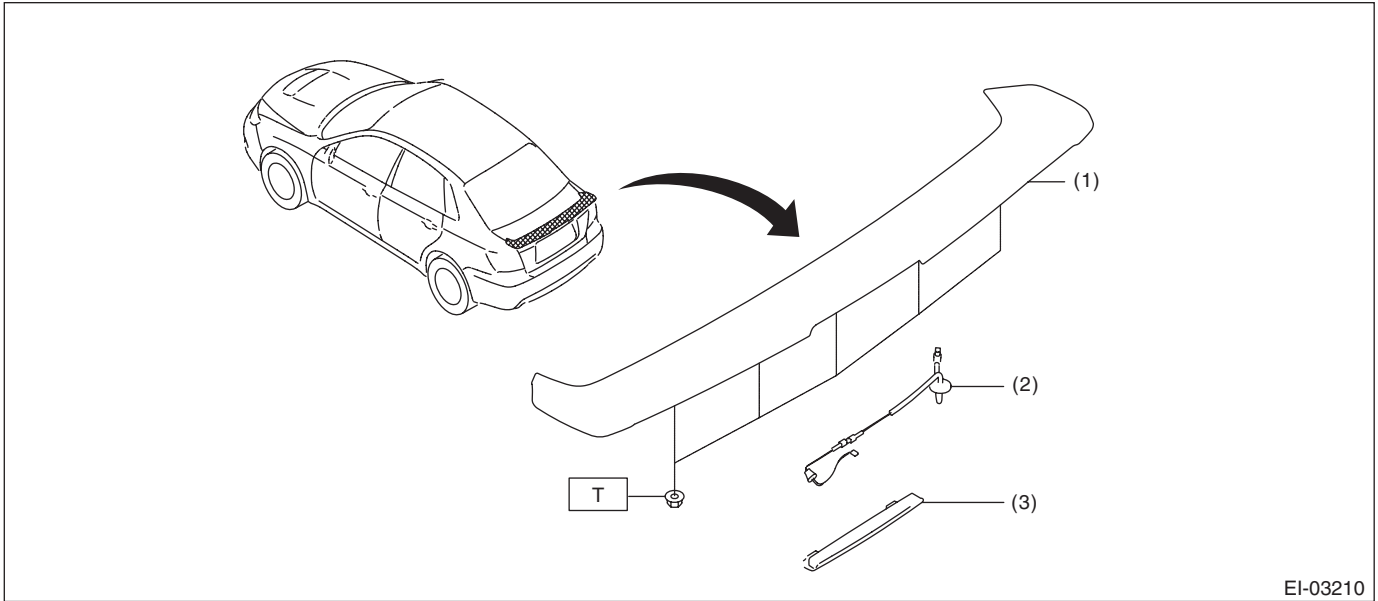

EI-03210

(1) Rear spoiler

(3) High-mounted stop light

(2) High mounted stop light harness

**Tightening torque:N-m (kgf-m, ft-lb)**

**T: 7.5 (0.76, 5.5)**

## STI model

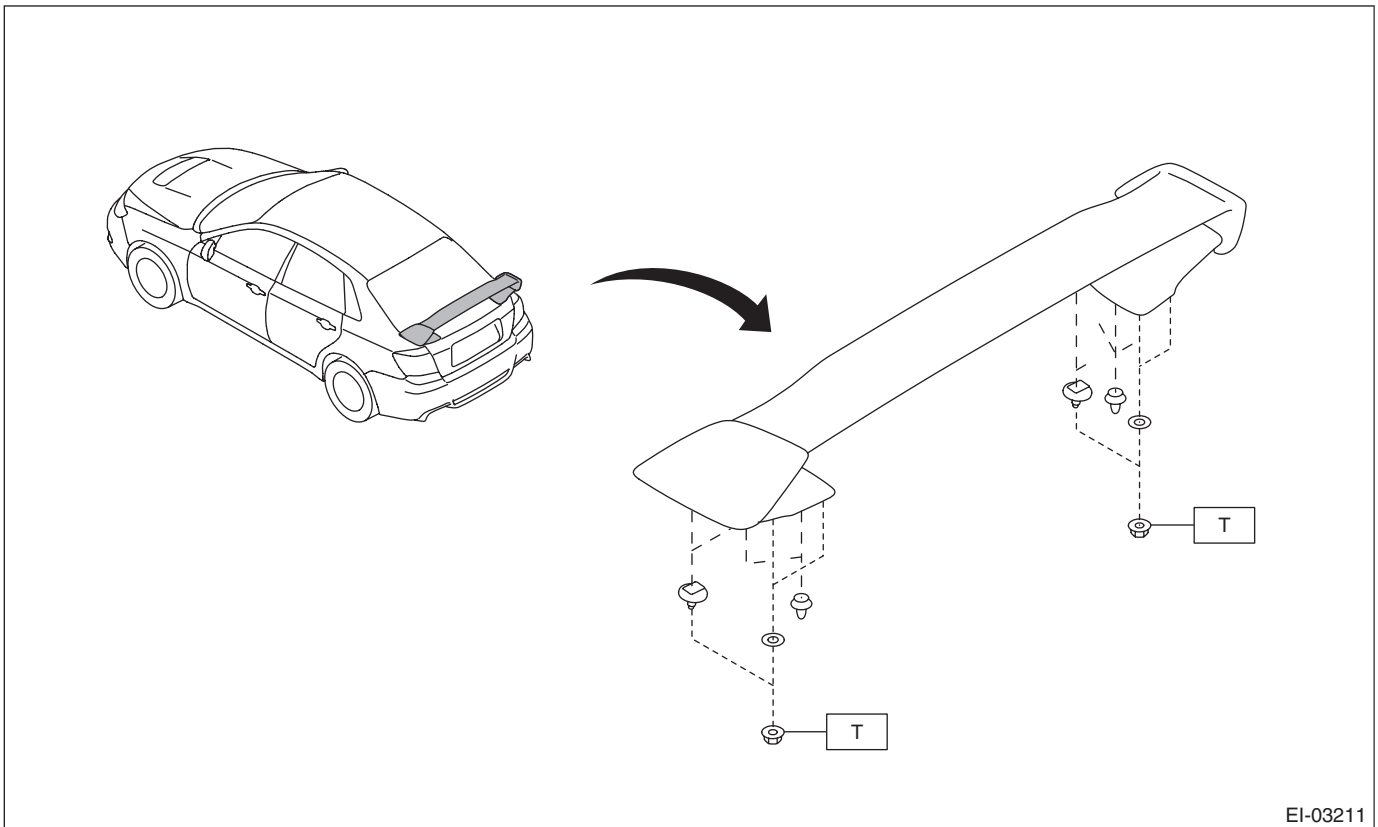

EI-03211

**Tightening torque:N-m (kgf-m, ft-lb)**

**T: 7.5 (0.76, 5.5)**

EI-10

Brought to you by Ebay Seller "SubaruManuals"

## 11.SIDE SILL SPOILER

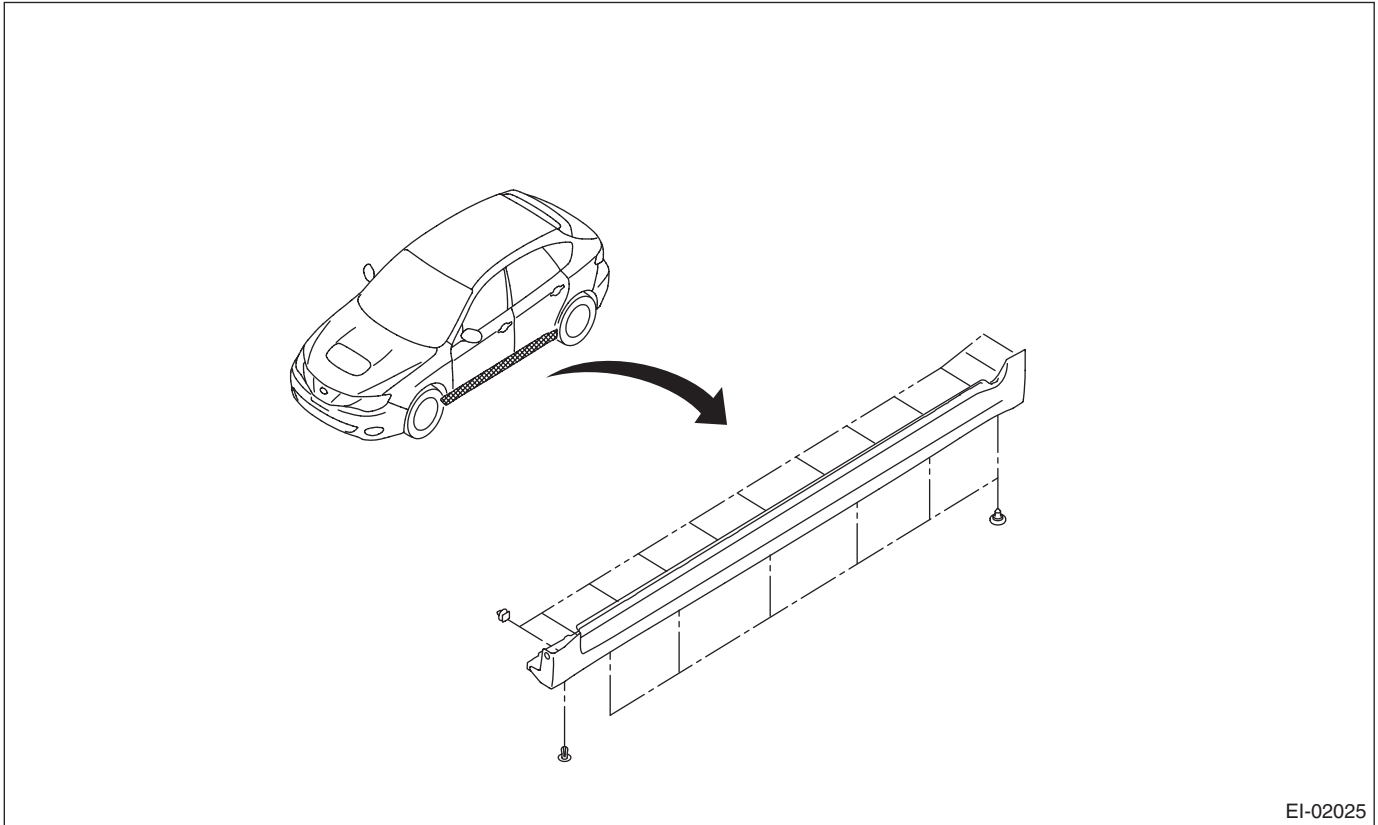

EI-02025

## 12.ROOF MOLDING

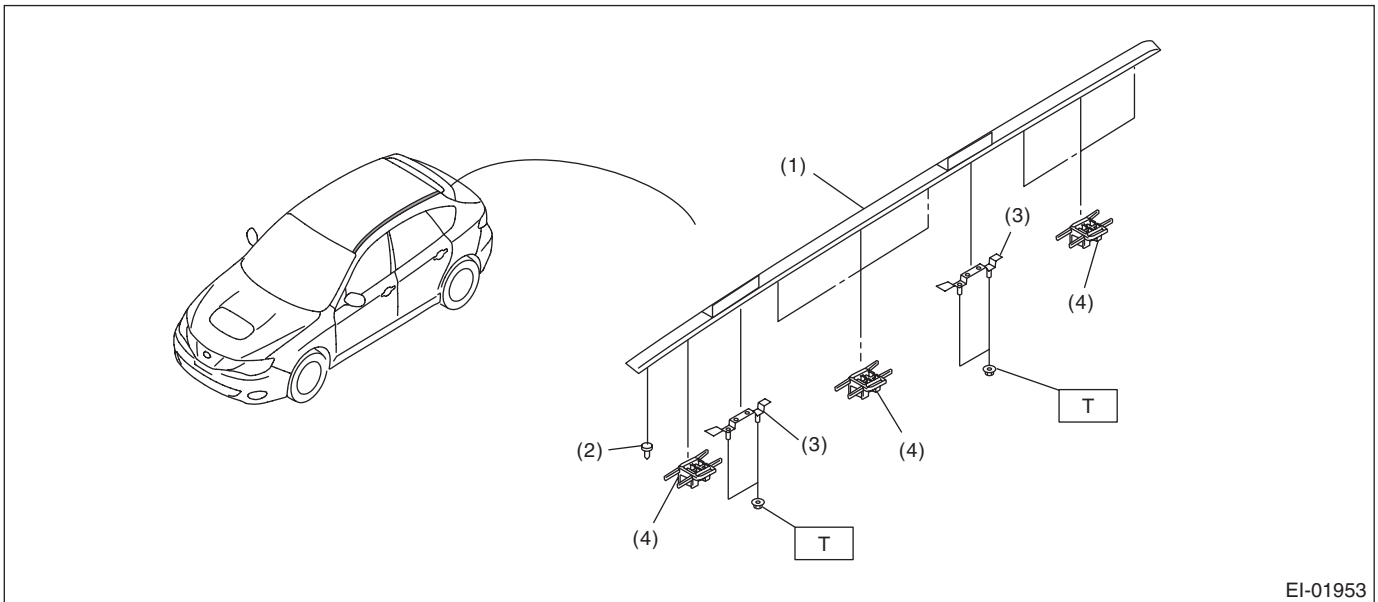

EI-01953

- (1) Roof molding
- (2) Rivet

- (3) Roof carrier attachment bracket
- (4) Clip

**Tightening torque: N·m (kgf·m, ft·lb)**  
**T: 7.5 (0.76, 5.5)**



# General Description

EXTERIOR/INTERIOR TRIM

## 13. REAR GATE GARNISH

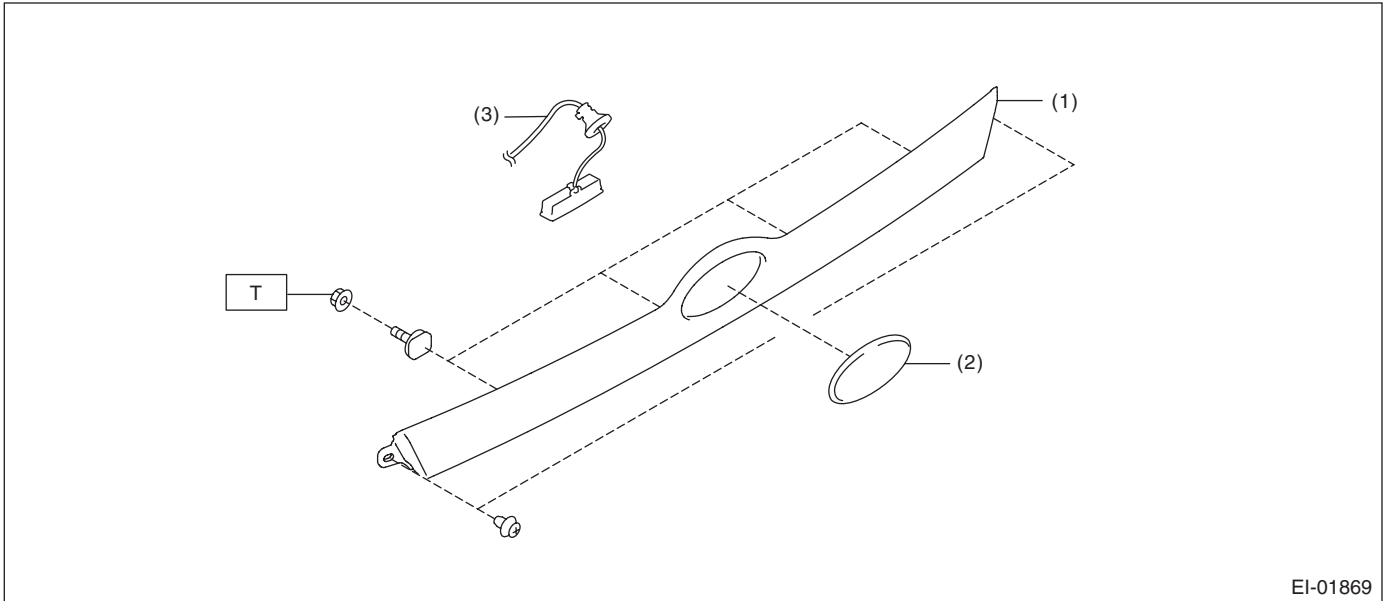

EI-01869

- (1) Rear gate garnish
- (2) Ornament

- (3) Rear gate opener button harness

**Tightening torque: N·m (kgf·m, ft·lb)**

**T: 4.5 (0.46, 3.3)**

## 14. TRUNK LID GARNISH

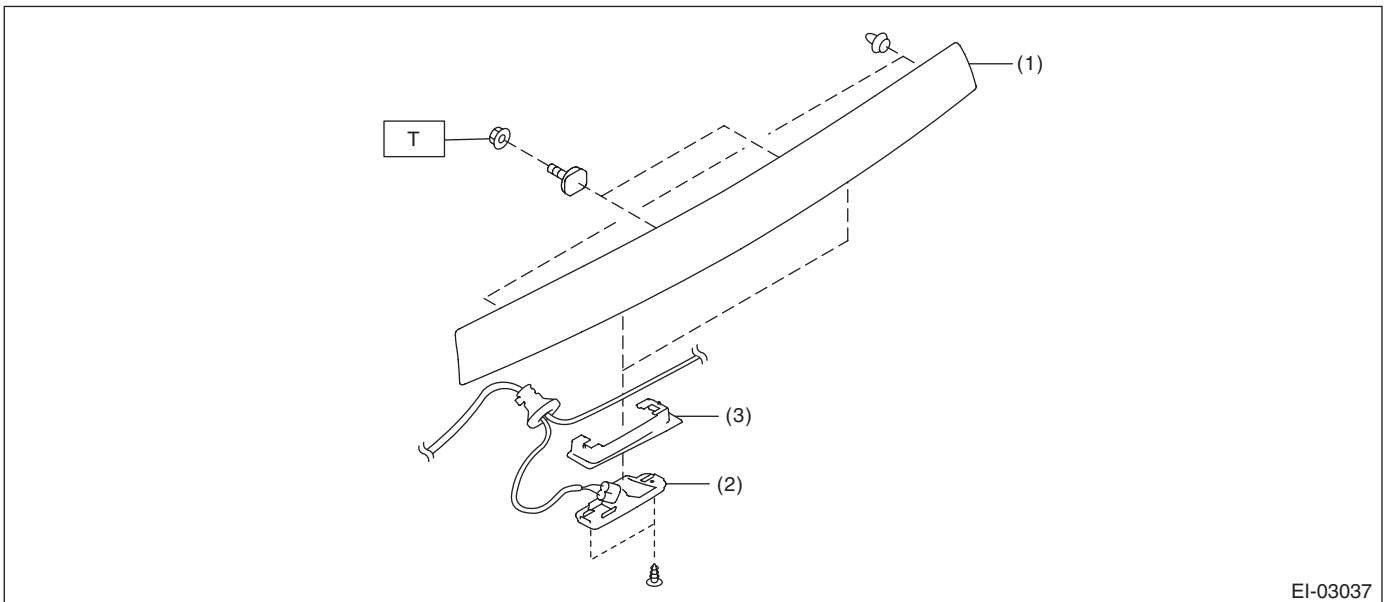

EI-03037

- (1) Trunk lid garnish
- (2) License light ASSY

- (3) License light bracket

**Tightening torque: N·m (kgf·m, ft·lb)**

**T: 4.5 (0.46, 3.3)**

## 15.DOOR TRIM

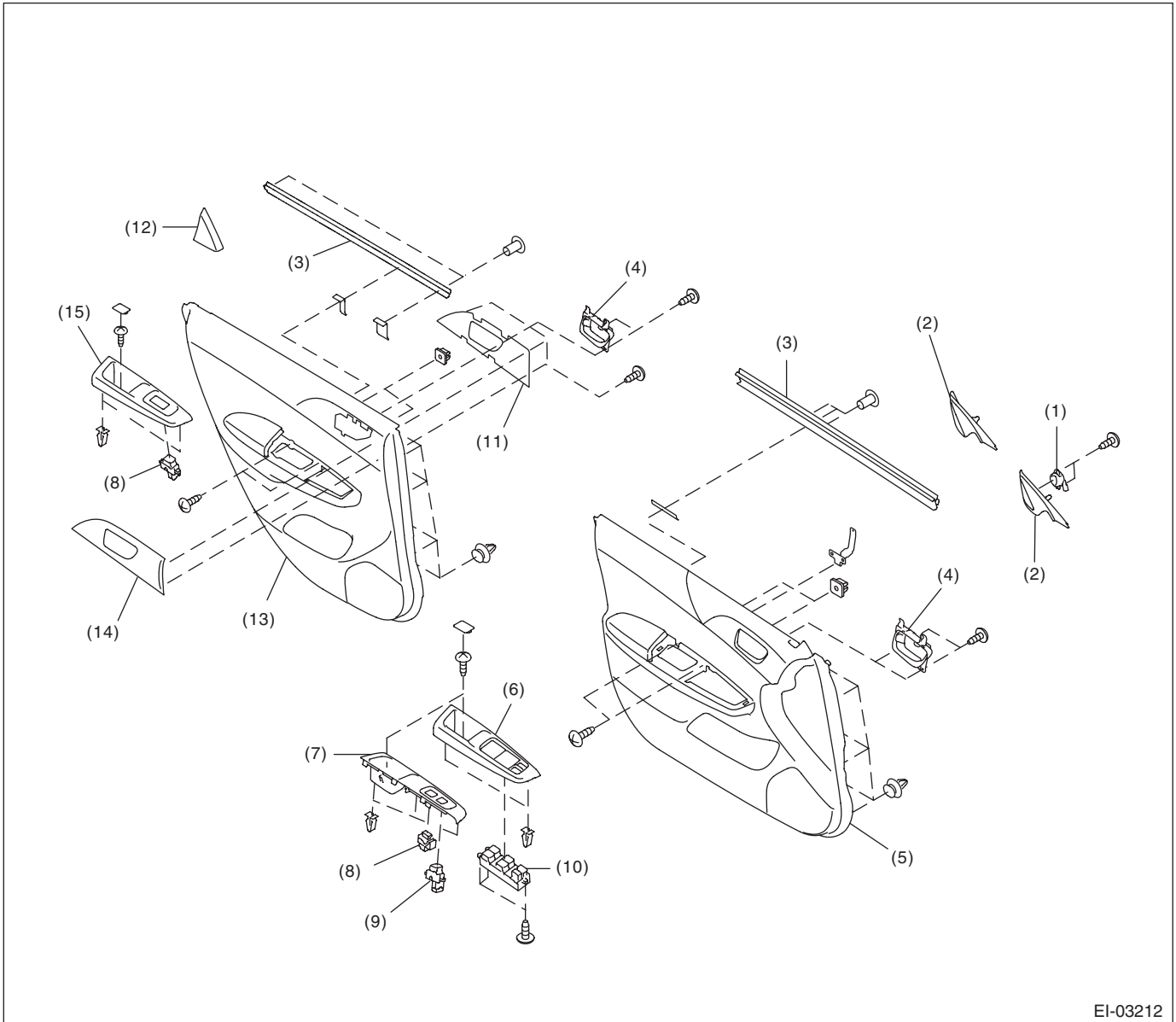

EI-03212

- |                         |                                    |                                     |
|-------------------------|------------------------------------|-------------------------------------|
| (1) Tweeter             | (6) Power window switch panel LH   | (11) Rear door ornament board       |
| (2) Gusset cover front  | (7) Power window switch panel RH   | (12) Gusset cover rear              |
| (3) Upper weather strip | (8) Power window sub-switch        | (13) Rear door trim                 |
| (4) Inner remote        | (9) Door lock switch               | (14) Rear door ornament panel       |
| (5) Front door trim     | (10) Power window main switch ASSY | (15) Power window switch panel rear |

# General Description

EXTERIOR/INTERIOR TRIM

## 16. CONSOLE BOX

Except for STI model

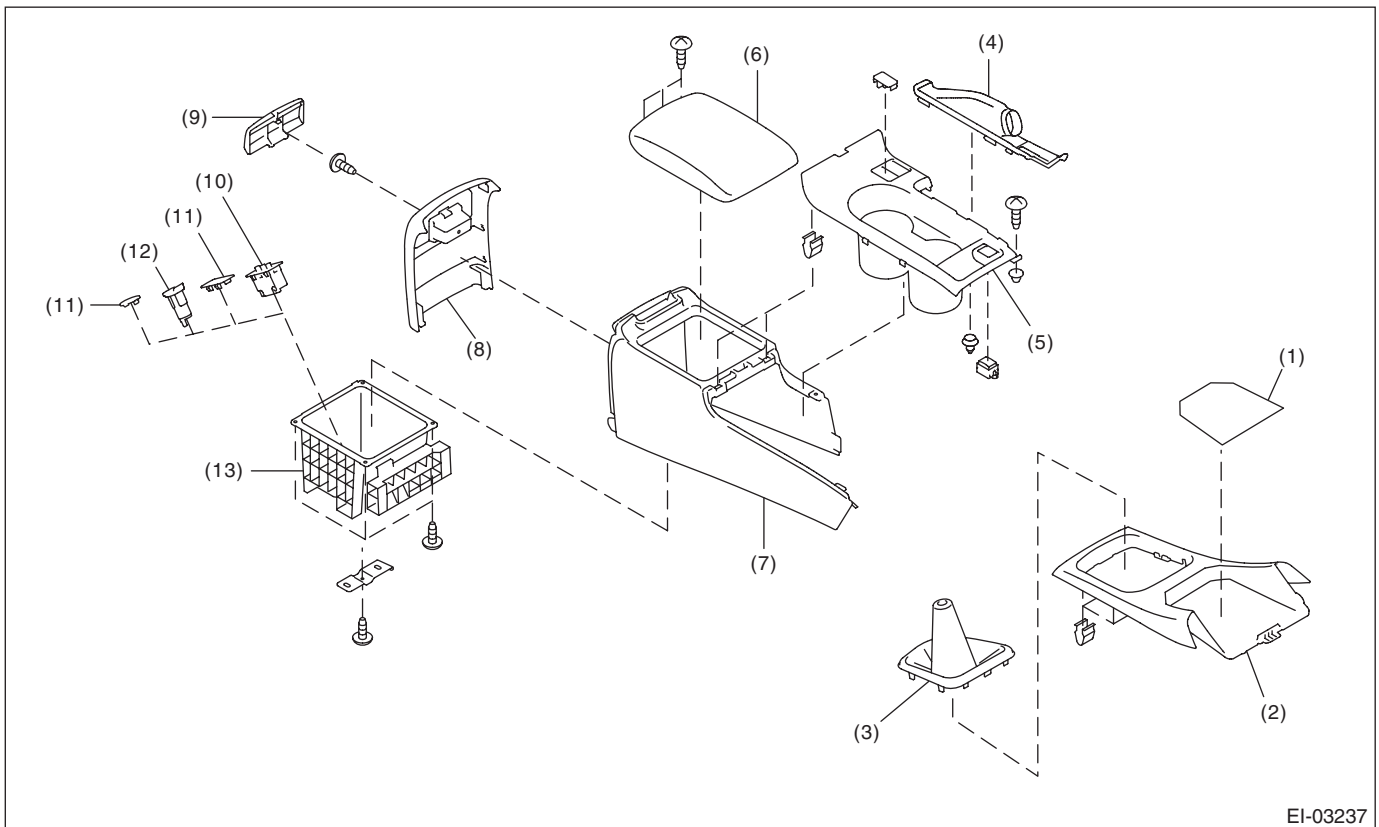

EI-03237

- |                              |                           |                                    |
|------------------------------|---------------------------|------------------------------------|
| (1) Console front mat        | (6) Upper lid             | (11) Cap                           |
| (2) Console front panel      | (7) Console box outer     | (12) Accessory power supply socket |
| (3) Shift boot               | (8) Console box end cover | (13) Console pocket                |
| (4) Parking brake lever boot | (9) Console box end cap   |                                    |
| (5) Console cover            | (10) AUX input terminal   |                                    |

## STI model

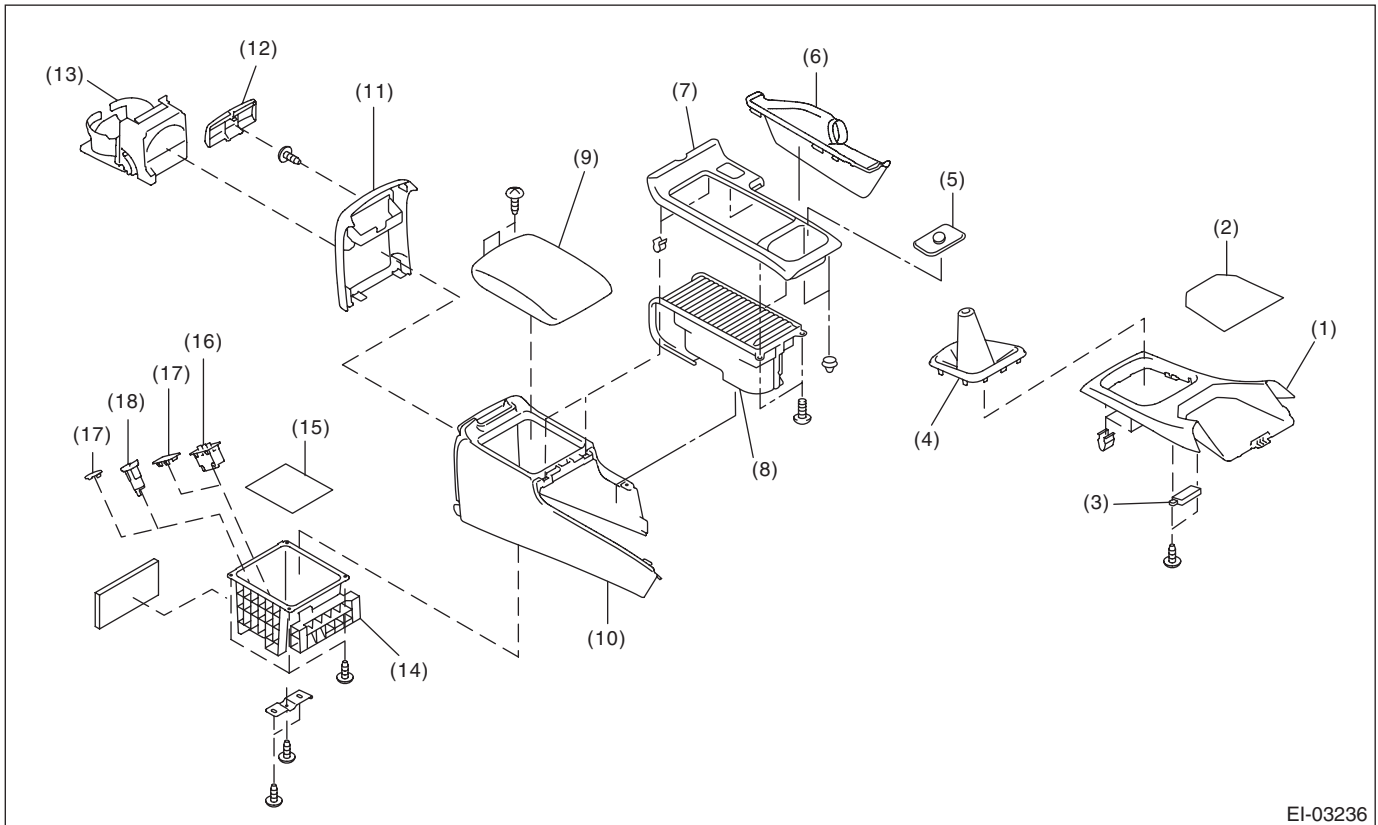

EI-03236

- |                              |                            |                                    |
|------------------------------|----------------------------|------------------------------------|
| (1) Console front panel      | (7) Console cover          | (13) Rear cup holder               |
| (2) Console front mat        | (8) Cup holder ASSY        | (14) Console pocket                |
| (3) Illumination ASSY        | (9) Upper lid              | (15) Console mat                   |
| (4) Shift boot               | (10) Console box outer     | (16) AUX input terminal            |
| (5) SI-drive switch          | (11) Console box end cover | (17) Cap                           |
| (6) Parking brake lever boot | (12) Console box end cap   | (18) Accessory power supply socket |

# General Description

EXTERIOR/INTERIOR TRIM

## 17. INSTRUMENT PANEL

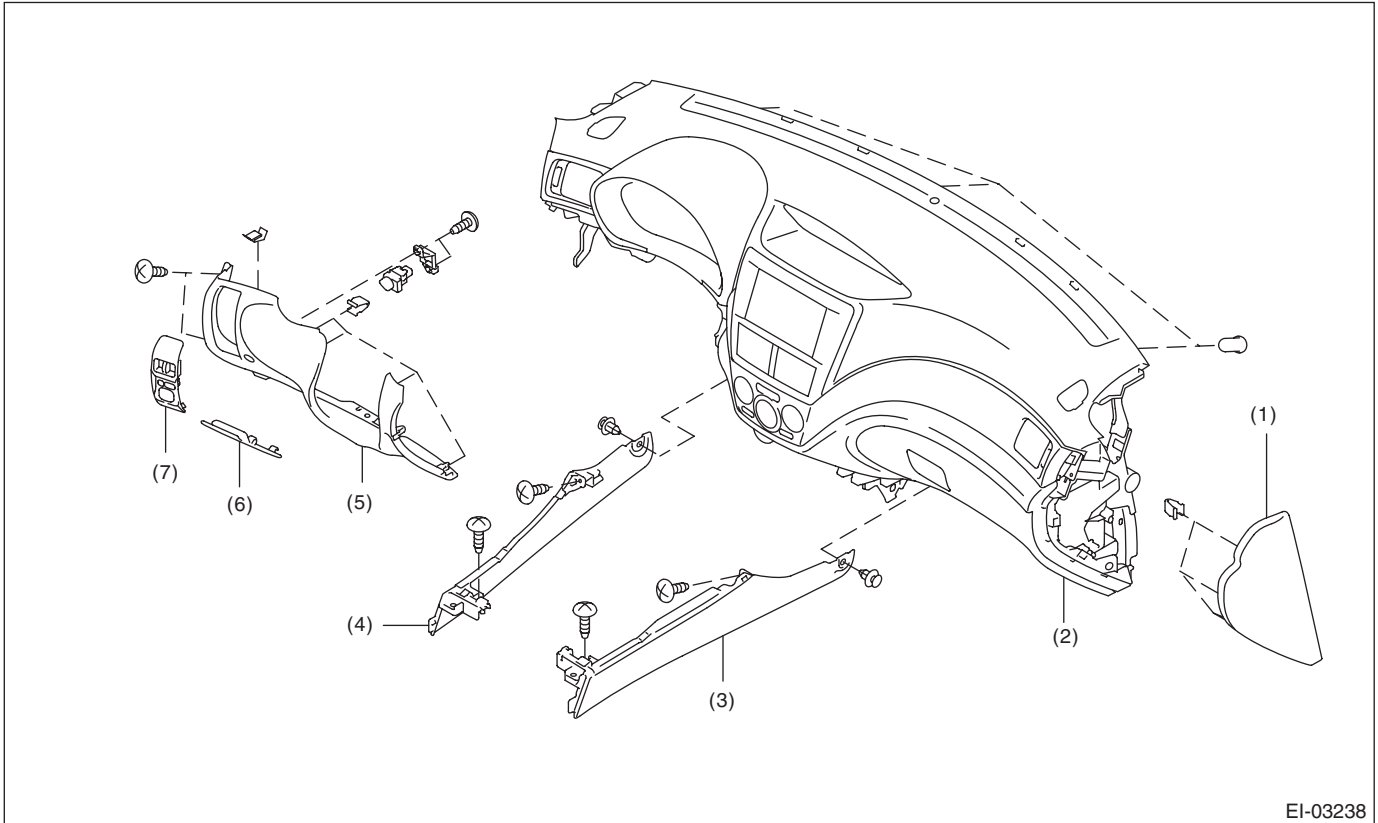

EI-03238

- |                                 |                                  |                       |
|---------------------------------|----------------------------------|-----------------------|
| (1) Instrument panel side cover | (4) Console side panel LH        | (7) Switch panel ASSY |
| (2) Instrument panel ASSY       | (5) Instrument panel lower cover |                       |
| (3) Console side panel RH       | (6) Fuse box lid                 |                       |

# General Description

EXTERIOR/INTERIOR TRIM

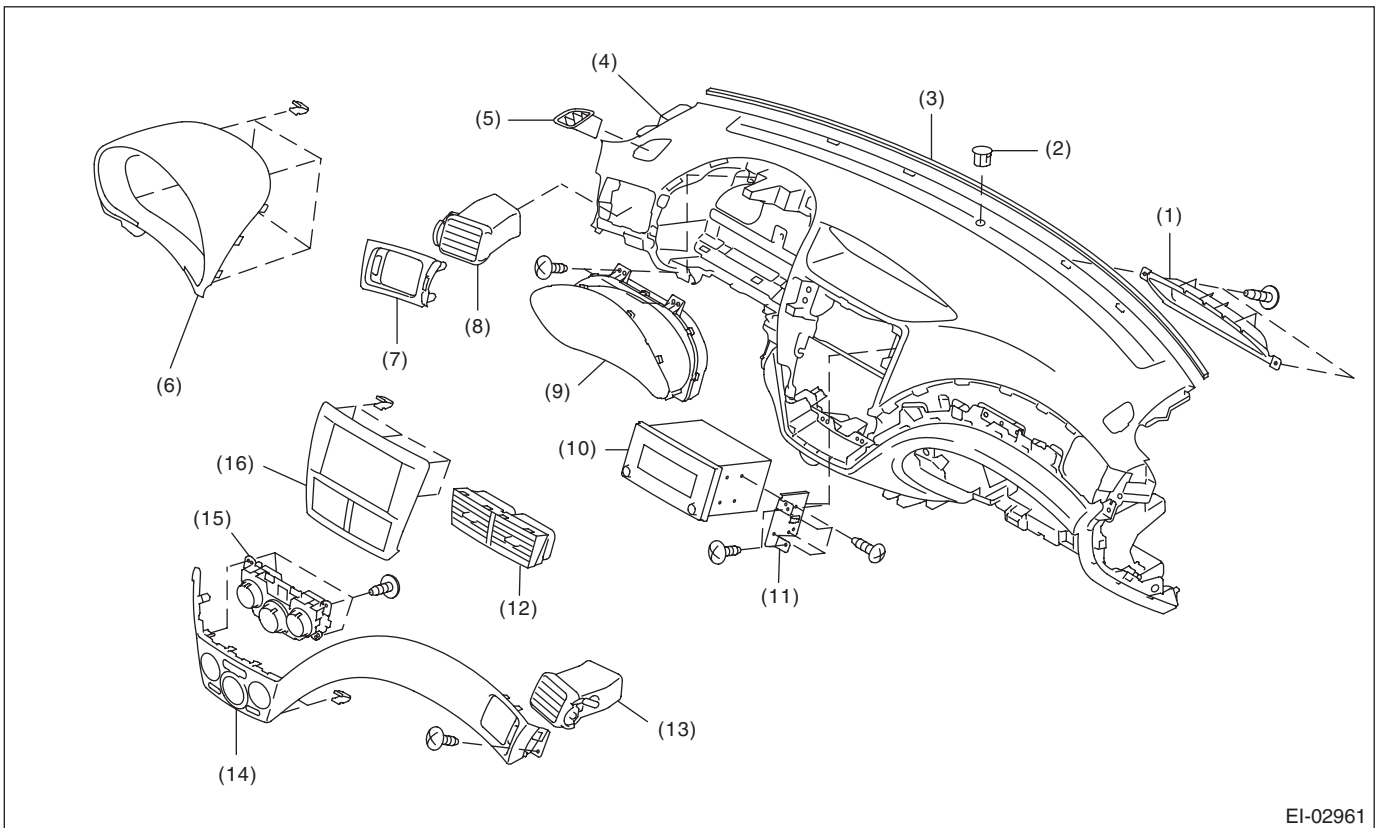

EI-02961

- |                           |                             |                              |
|---------------------------|-----------------------------|------------------------------|
| (1) Clock panel           | (7) Ornament panel LH       | (13) Air vent side grille RH |
| (2) Sunload sensor        | (8) Air vent side grille LH | (14) Ornament panel RH       |
| (3) Cushion               | (9) Combination meter ASSY  | (15) Control module          |
| (4) Instrument panel ASSY | (10) Audio                  | (16) Center panel            |
| (5) Defroster side grille | (11) Audio bracket          |                              |
| (6) Meter visor ASSY      | (12) Air vent grille CTR    |                              |

# General Description

## EXTERIOR/INTERIOR TRIM

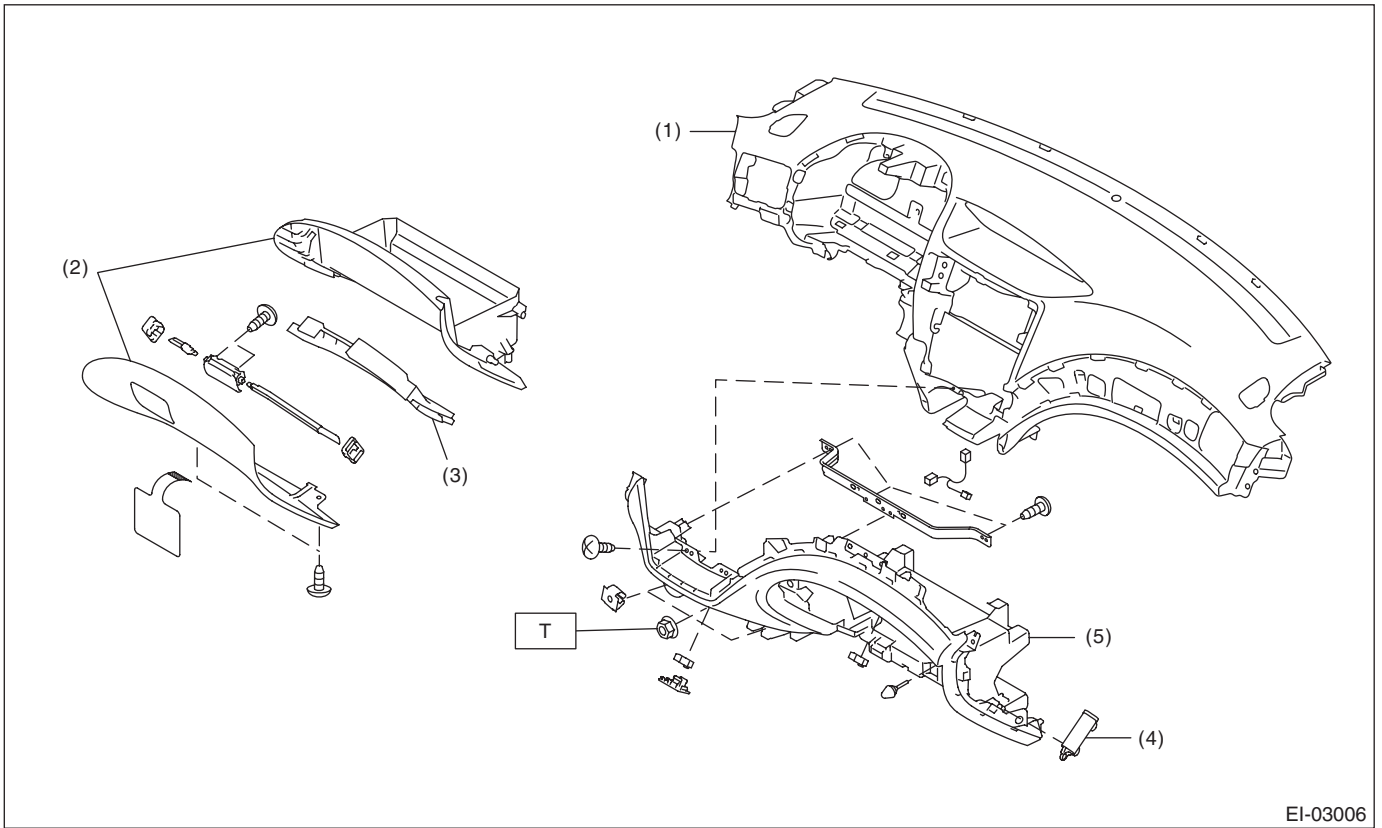

EI-03006

- |   |                            |
|---|----------------------------|
| (1) Instrument panel pad and frame ASSY | (4) Glove box damper       |
| (2) Glove box lid ASSY                  | (5) Instrument panel lower |
| (3) Glove box pad                       |                            |

**Tightening torque: N·m (kgf·m, ft·lb)**

**T: 7.5 (0.76, 5.5)**

# General Description

EXTERIOR/INTERIOR TRIM

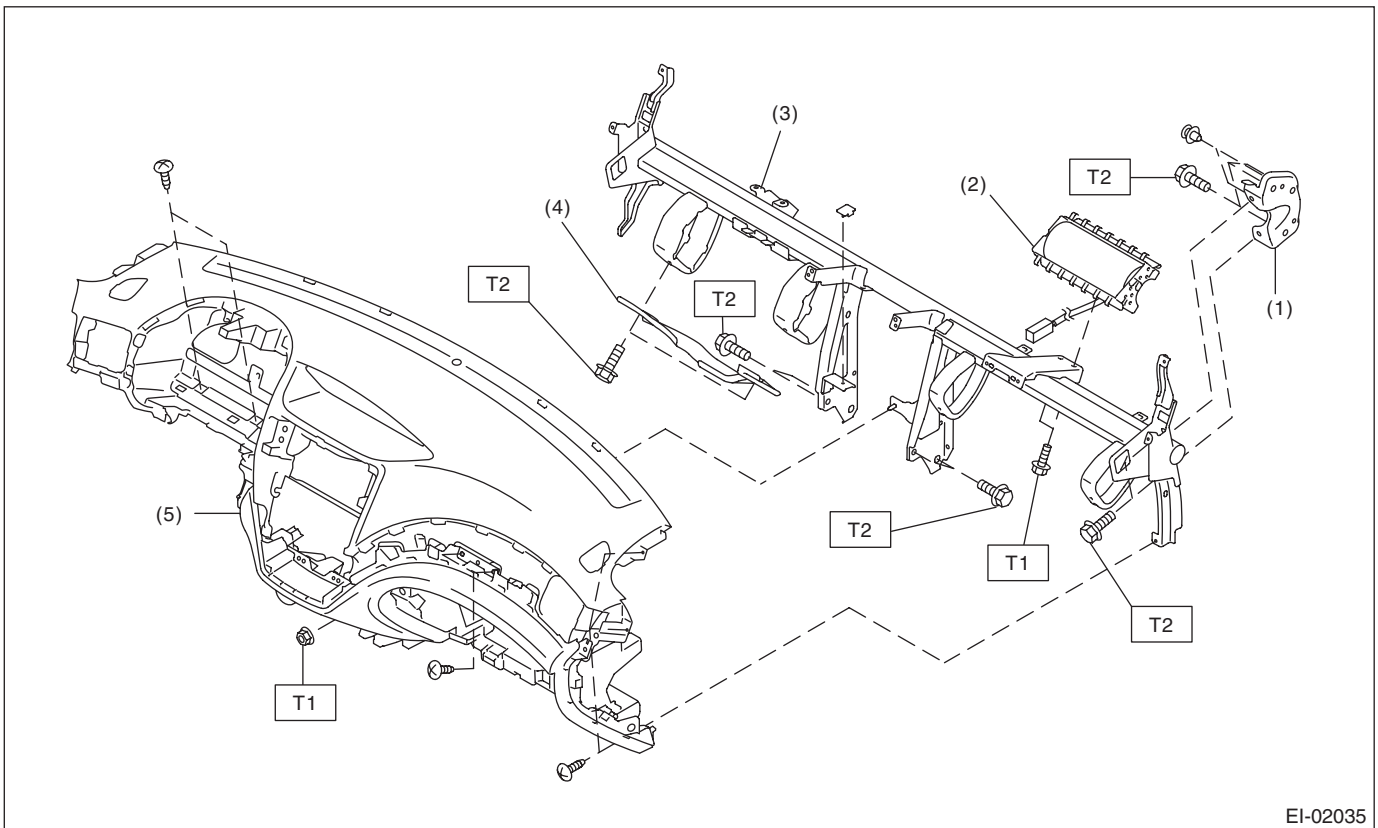

EI-02035

- |                                    |                           |
|------------------------------------|---------------------------|
| (1) Steering support beam bracket  | (4) Knee guard panel      |
| (2) Passenger's airbag module ASSY | (5) Instrument panel ASSY |
| (3) Steering support beam ASSY     |                           |

**Tightening torque: N·m (kgf·m, ft·lb)**

**T1: 7.5 (0.76, 5.5)**

**T2: 25 (2.55, 18.4)**



# General Description

## EXTERIOR/INTERIOR TRIM

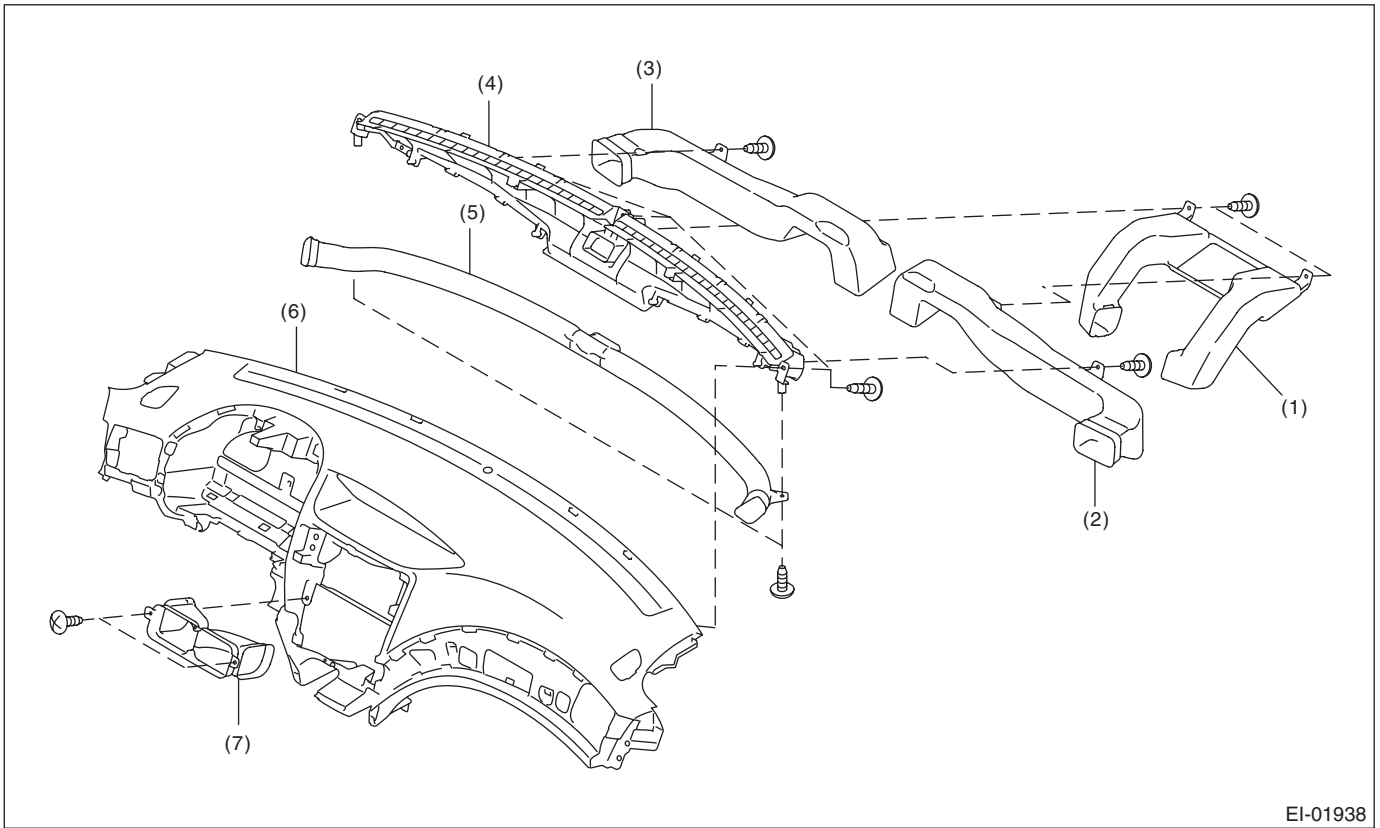

EI-01938

- |                       |   |                            |
|-----------------------|---|----------------------------|
| (1) Center vent duct  | (4) Defroster nozzle ASSY               | (7) Center vent duct front |
| (2) Side vent duct RH | (5) Side defroster                      |                            |
| (3) Side vent duct LH | (6) Instrument panel pad and frame ASSY |                            |

## 18.INNER TRIM (5 DOOR MODEL)

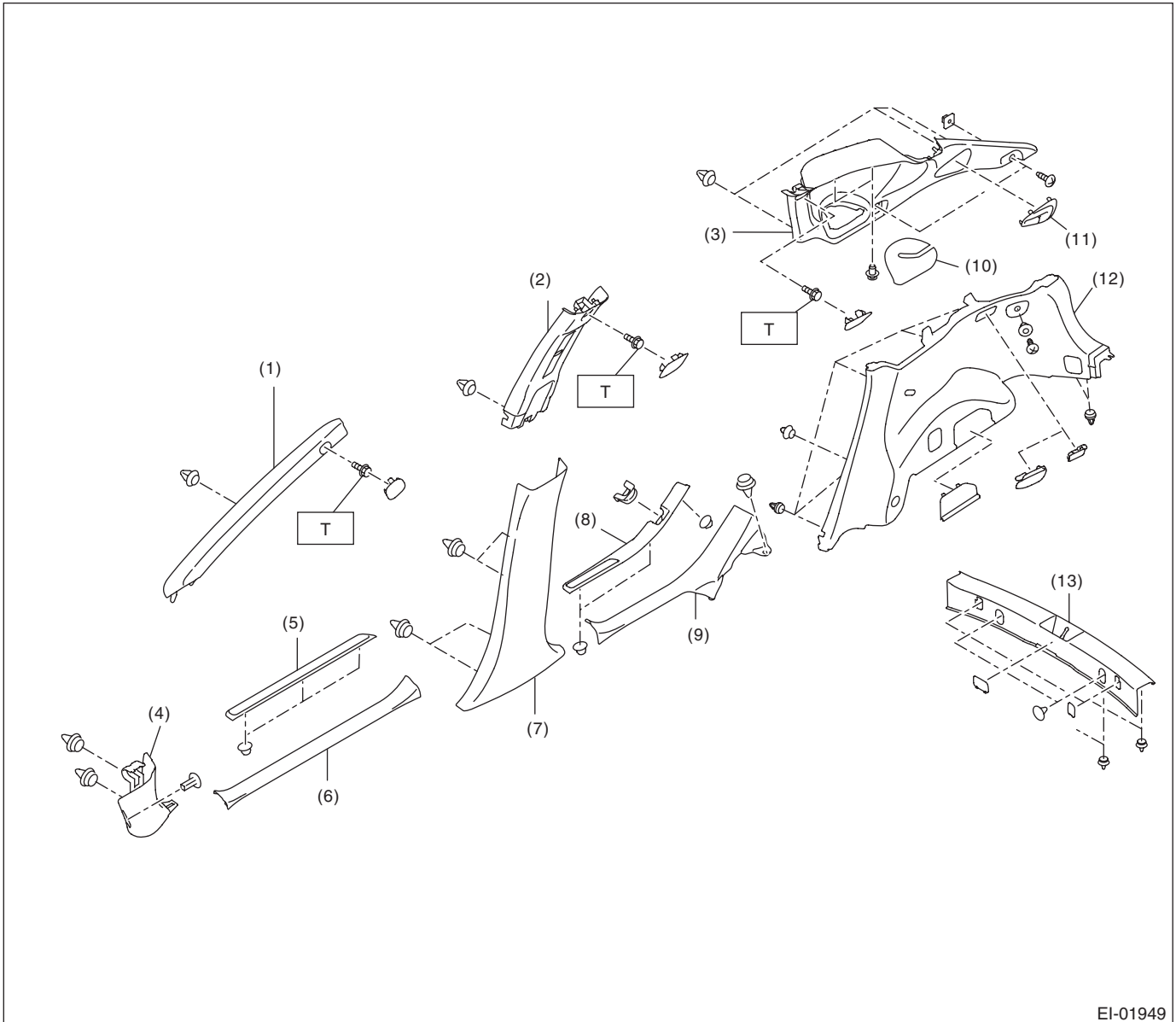

EI-01949

- |                               |                              |                              |
|-------------------------------|------------------------------|------------------------------|
| (1) Front pillar upper trim   | (7) Center pillar lower trim | (12) Rear quarter lower trim |
| (2) Center pillar upper trim  | (8) Rear outside scuff plate | (13) Luggage room end cover  |
| (3) Rear quarter upper trim   | (9) Rear inside scuff plate  |                              |
| (4) Front pillar lower trim   | (10) Side seat belt cover    |                              |
| (5) Front outside scuff plate | (11) Center seat belt cover  |                              |
| (6) Front inside scuff plate  |                              |                              |

**Tightening torque: N·m (kgf·m, ft·lb)**

**T: 7.5 (0.76, 5.5)**

# General Description

## EXTERIOR/INTERIOR TRIM

### 19.INNER TRIM (4 DOOR MODEL)

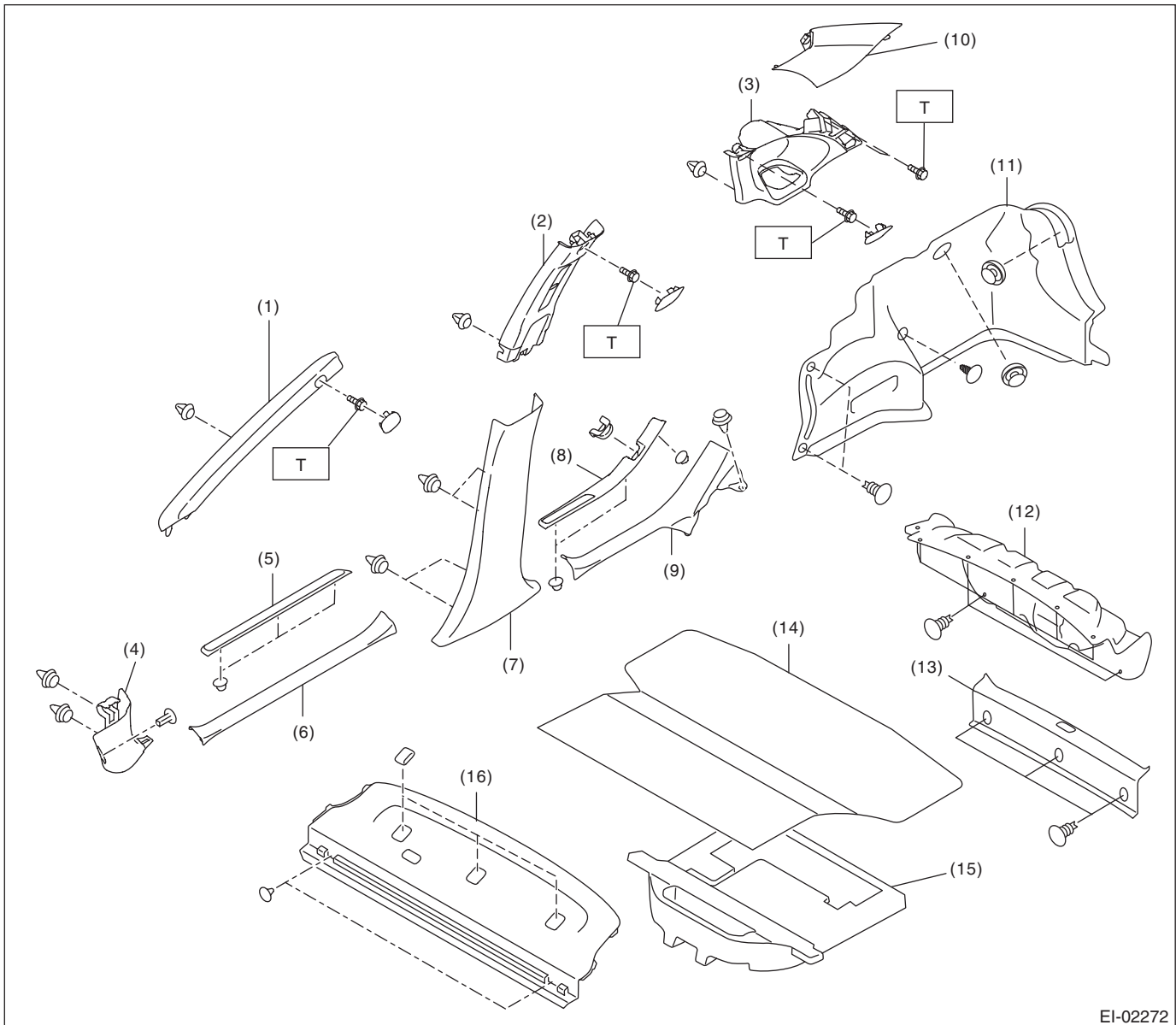

EI-02272

- |                               |                               |                      |
|-------------------------------|-------------------------------|----------------------|
| (1) Front pillar upper trim   | (8) Rear outside scuff plate  | (14) Trunk room mat  |
| (2) Center pillar upper trim  | (9) Rear inside scuff plate   | (15) Sub trunk box   |
| (3) Quarter upper trim, front | (10) Quarter upper trim, rear | (16) Rear shelf trim |
| (4) Front pillar lower trim   | (11) Quarter lower trim       |                      |
| (5) Front outside scuff plate | (12) Trunk lid trim           |                      |
| (6) Front inside scuff plate  | (13) Trunk room end cover     |                      |
| (7) Center pillar lower trim  |                               |                      |

---

**Tightening torque: N·m (kgf·m, ft·lb)**  
**T: 7.5 (0.76, 5.5)**

---

## 20. REAR GATE TRIM

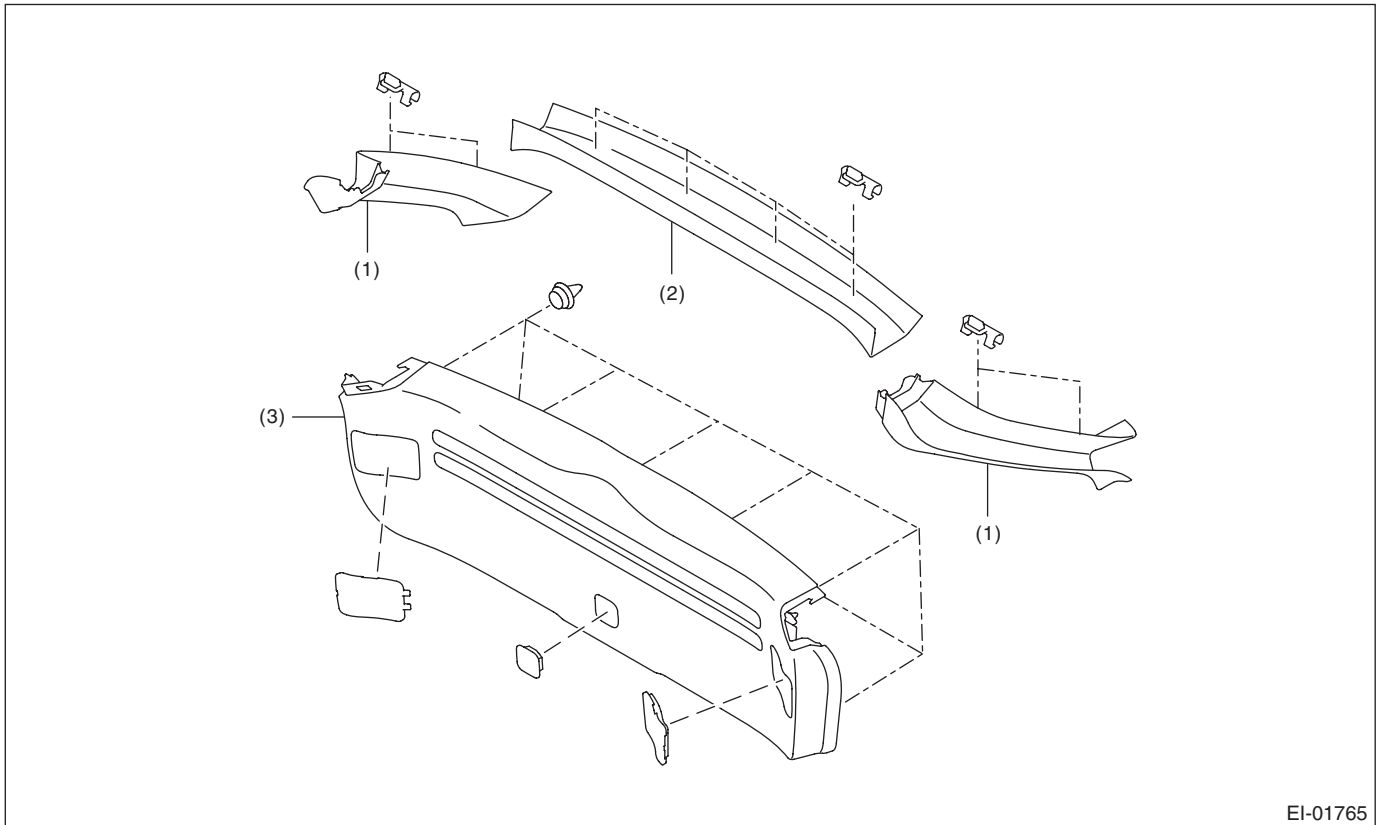

EI-01765

(1) Rear gate pillar trim

(2) Rear gate upper trim

(3) Rear gate lower trim

## 21. ROOF TRIM

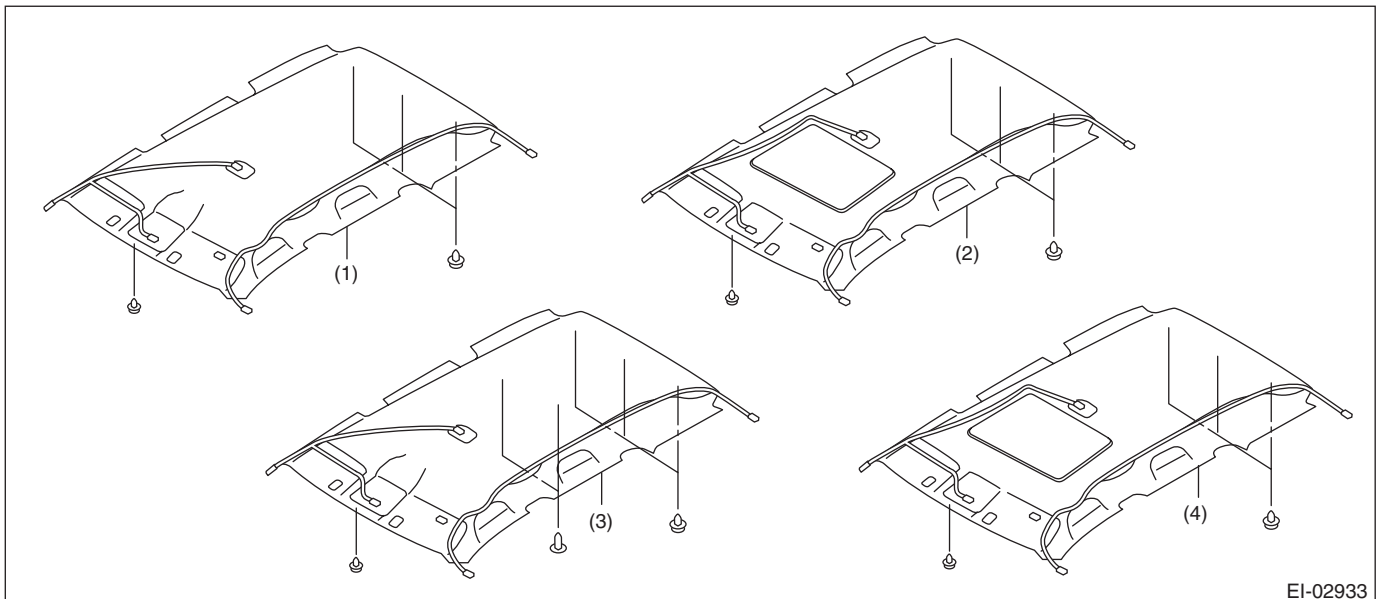

EI-02933

(1) Model without sunroof (5 door model)

(3) Model without sunroof (4 door model)

(4) Model with sunroof (4 door model)

(2) Model with sunroof (5 door model)

# General Description

EXTERIOR/INTERIOR TRIM

## 22.ROOM INNER PARTS

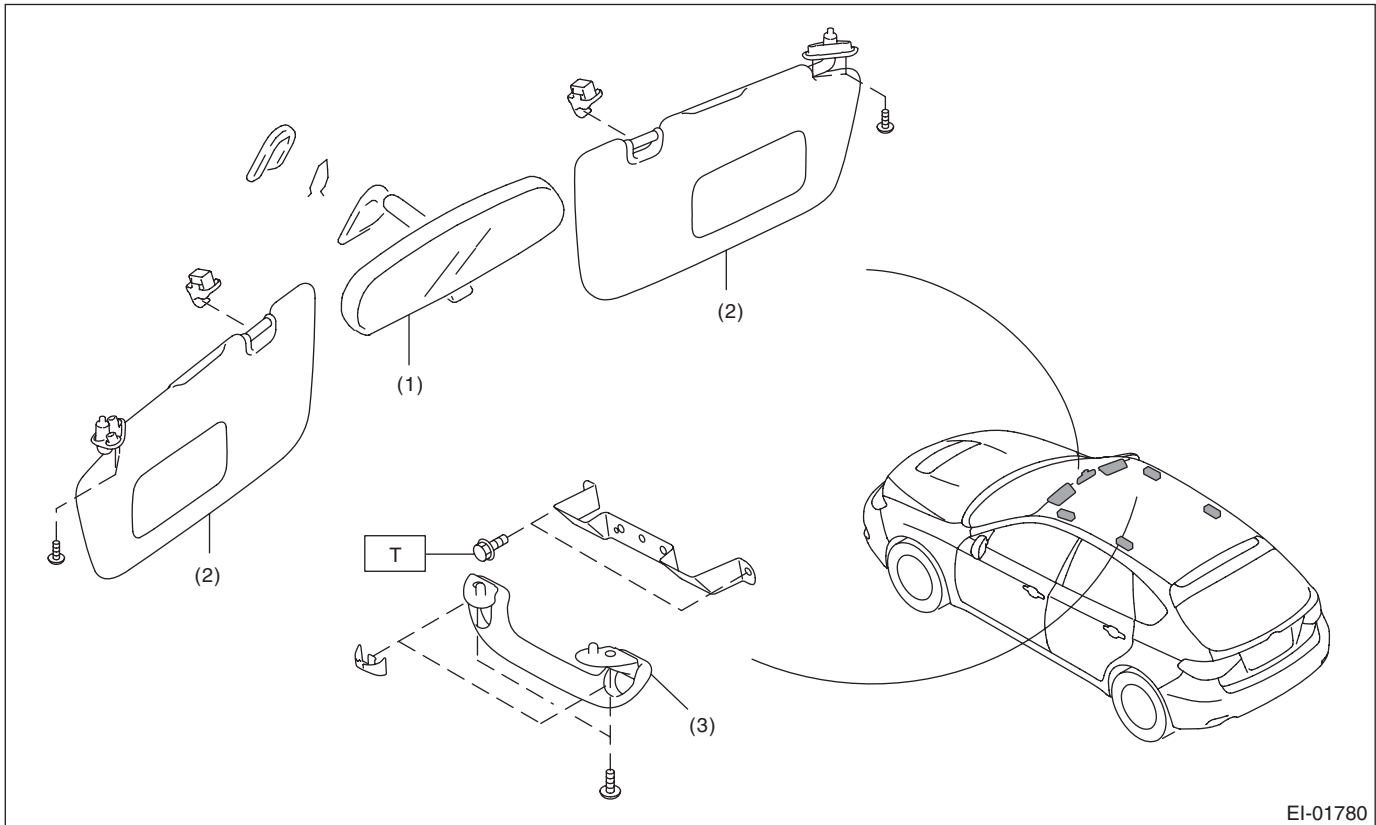

EI-01780

- (1) Room mirror
- (2) Sun visor
- (3) Assist grip

**Tightening torque: N·m (kgf·m, ft·lb)**  
**T: 7.5 (0.76, 5.5)**

## 23.HEAT SHIELD COVER

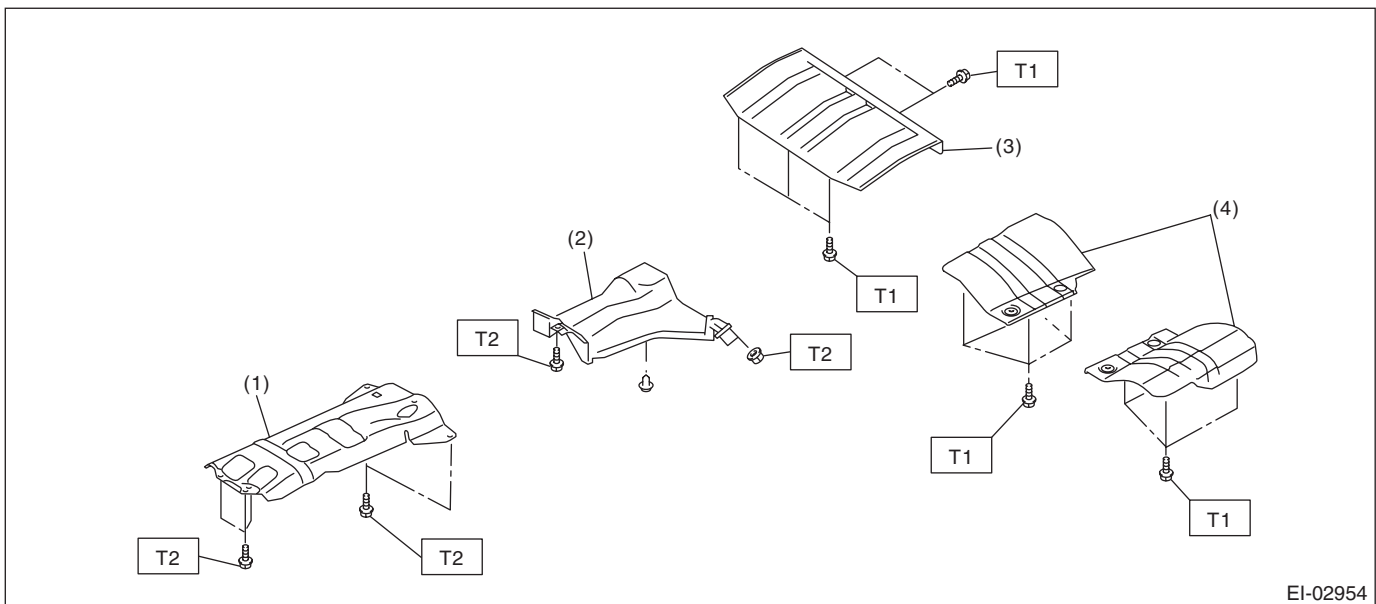

EI-02954

- (1) Front heat shield cover
- (2) Center heat shield cover
- (3) Rear heat shield cover (5 door model)
- (4) Rear heat shield cover (4 door model)

**Tightening torque:N·m (kgf·m, ft·lb)**  
**T1: 10 (1.02, 7.4)**  
**T2: 18 (1.84, 13.3)**

# General Description

EXTERIOR/INTERIOR TRIM

## B: PREPARATION TOOL

TOOL NAME	REMARKS
Clip remover	Used for removing trim. <ul style="list-style-type: none"><li>• KTC AP201-10A</li><li>• KTC AP201-N</li><li>• KTC AP203-10A</li><li>• KTC AP20L-10B</li></ul> Or equivalent.
Clip clamp pliers	Used for removal of various clips and clamps. <ul style="list-style-type: none"><li>• KTC CCP-190</li></ul> Or equivalent.

# Front Grille

EXTERIOR/INTERIOR TRIM

---

## 2. Front Grille

### A: REMOVAL

1) Remove the front bumper face. <Ref. to EI-31, FRONT BUMPER FACE, REMOVAL, Front Bumper.>

2) Remove the screws from the reverse side of the bumper face, and remove the front grille assembly.

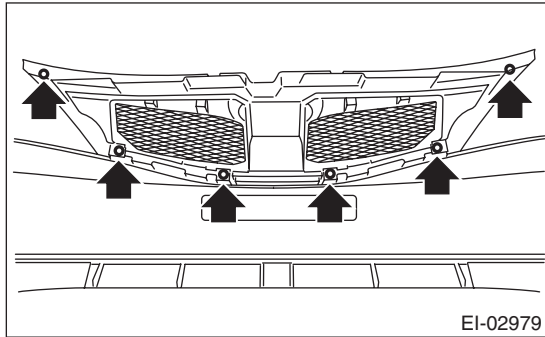

### B: INSTALLATION

Install each part in the reverse order of removal.

## 3. Front Hood Grille

### A: REMOVAL

- 1) Open the front hood.
- 2) Remove the front hood insulator. <Ref. to EB-15, FRONT HOOD INSULATOR, REMOVAL, Front Hood.>
- 3) Remove screws (A) and clips (B), and remove the hood duct assembly.
  - Except for STI model

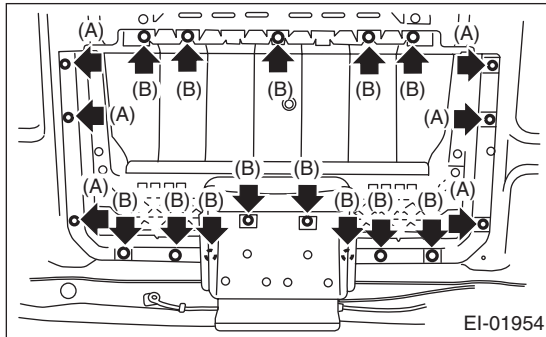

- STI model

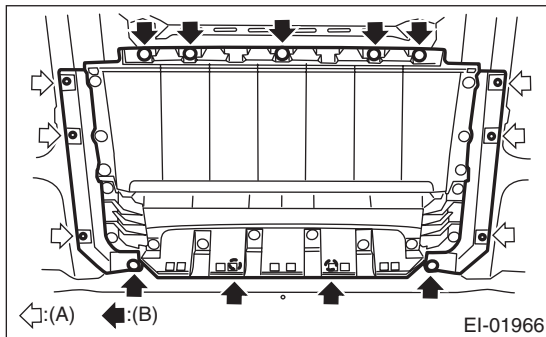

- 4) Remove the nuts (A) and clips (B), and remove the front hood grille.

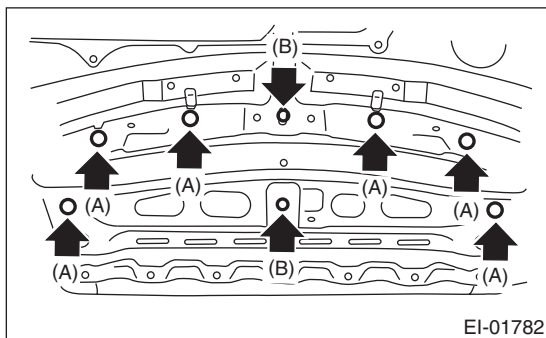

### B: INSTALLATION

Install each part in the reverse order of removal.

#### NOTE:

Insert the hooks (B) of the front hood duct into holes (A) of the front hood.

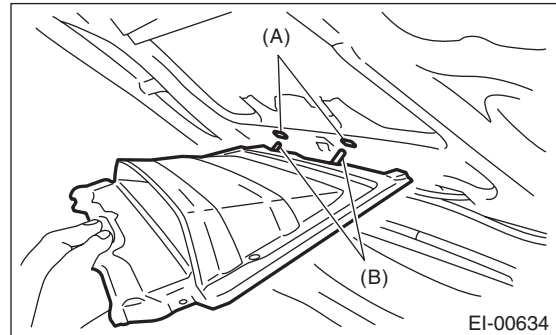

#### Tightening torque:

Refer to "COMPONENT" of "General Description". <Ref. to EI-4, FRONT HOOD GRILLE, COMPONENT, General Description.>



## Front Under Cover

EXTERIOR/INTERIOR TRIM

---

### 4. Front Under Cover

#### A: REMOVAL

- 1) Lift up the vehicle
- 2) Remove clips (A), (C) in front fender and bolts (B), then remove the front under cover.

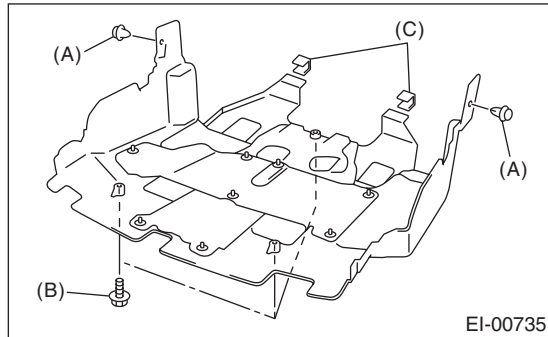

#### B: INSTALLATION

Install each part in the reverse order of removal.

**Tightening torque:**

**18 N·m (1.84 kgf-m, 13.3 ft-lb)**

## 5. Fuel Tank Protector

### A: REMOVAL

- 1) Lift up the vehicle.
- 2) Remove the bolts (A) and nuts (B), and then remove the fuel tank protector.

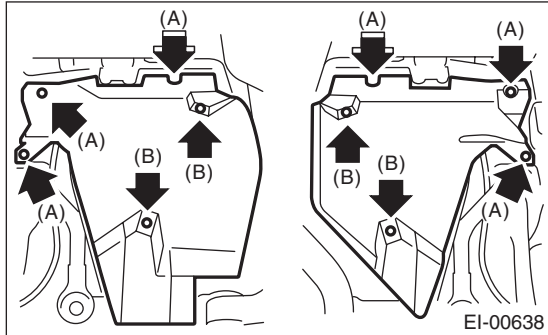

### B: INSTALLATION

#### CAUTION:

**Do not reuse the nut (self locking nut). Always replace with a new part.**

Install each part in the reverse order of removal.

#### *Tightening torque:*

*Refer to "COMPONENT" of "General Description". <Ref. to EI-3, UNDER PROTECTOR, COMPONENT, General Description.>*

## 6. Mud Guard

### A: REMOVAL

#### 1. FRONT MUD GUARD

- 1) Lift up the vehicle.
- 2) Remove the front wheels.
- 3) Remove the screws and clips to remove the mud guard.

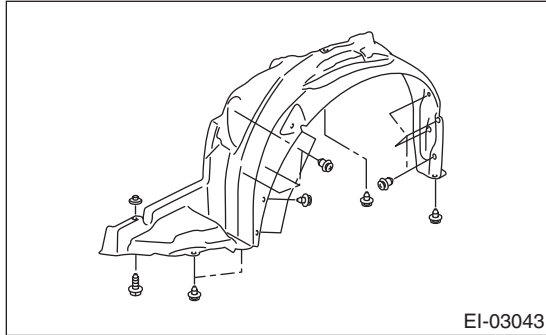

#### 2. REAR MUD GUARD

- 1) Lift up the vehicle.
- 2) Remove the rear wheels.
- 3) Remove the screws and clips to remove the mud guard.

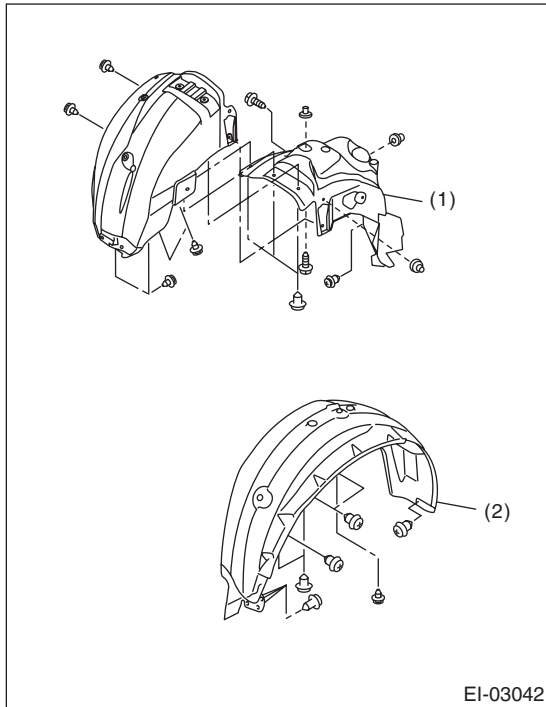

- (1) Rear mud guard RH
- (2) Rear mud guard LH

### B: INSTALLATION

Install each part in the reverse order of removal.

## 7. Front Bumper

### A: REMOVAL

#### 1. FRONT BUMPER FACE

- 1) Disconnect the ground cable from battery.
- 2) Remove the clip of the front grille.

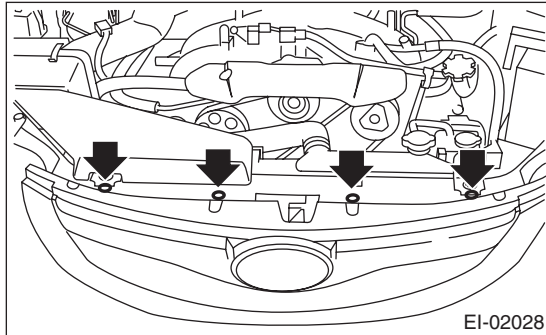

- 3) Remove the clip that secures the front mud guard and front bumper.

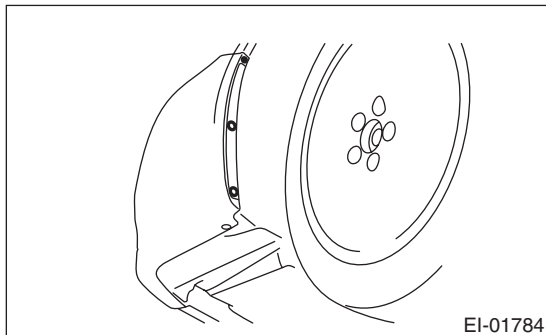

- 4) Remove the clips at the lower side of bumper.

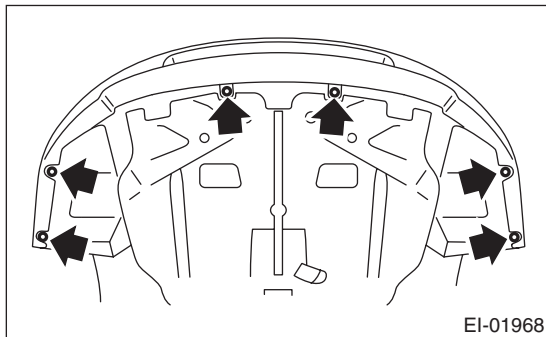

- 5) Disconnect the fog light connector. (model with fog light)

- 6) Detach the flange sections on the bumper face side from guide bracket (A).

**CAUTION:**

**Do not pull forcibly. It may damage the flange sections of the bumper face.**

**NOTE:**

It is easier to detach them from the fender side in the order from (1) to (3), while pulling up the bumper face to the direction of arrow (B) (upward).

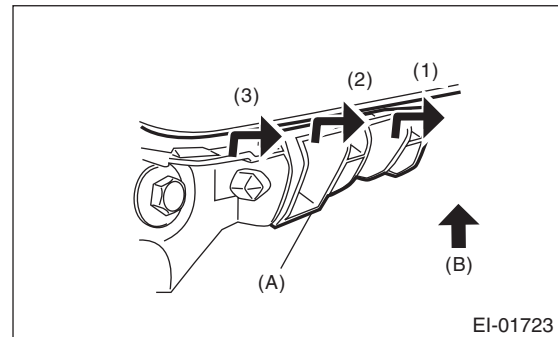

- 7) Remove the bumper face from vehicle body.
- 8) Remove the front grille from bumper face. <Ref. to EI-26, REMOVAL, Front Grille.>
- 9) Remove the fog light from bumper face. <Ref. to LI-21, REMOVAL, Front Fog Light Assembly.>
- 10) Remove the side cover from bumper face.

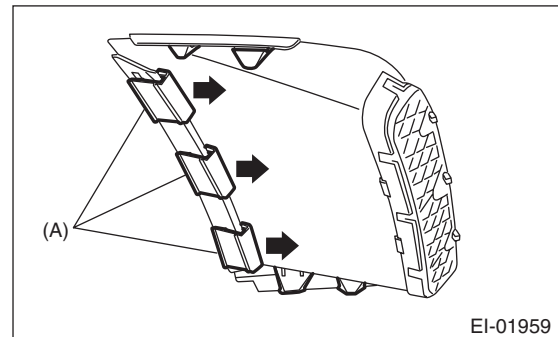

- (1) Remove clips (A).
- (2) Remove the upper and lower claws.

# Front Bumper

EXTERIOR/INTERIOR TRIM

## 2. FRONT BUMPER BEAM ASSEMBLY

- 1) Disconnect the ground cable from battery.
- 2) Remove the front bumper face. <Ref. to EI-31, FRONT BUMPER FACE, REMOVAL, Front Bumper.>
- 3) Remove the bolts, and remove the bumper beam assembly from vehicle body.

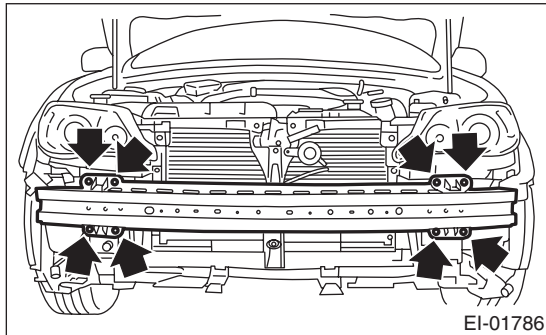

### NOTE:

After all bolts are removed, raise the whole bumper beam a little to remove it from vehicle body.

## B: INSTALLATION

- 1) Install each part in the reverse order of removal.

### NOTE:

Fit the bumper face to the gap (B) between the guide bracket (A) and fender securely.

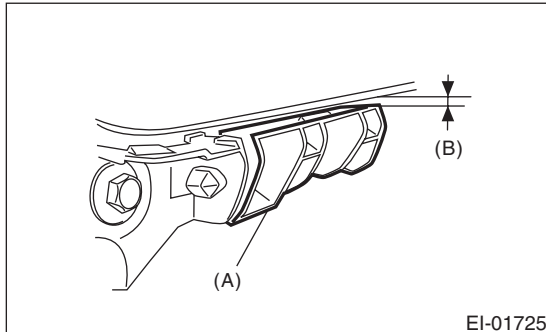

### Tightening torque:

Refer to "COMPONENT" of "General Description". <Ref. to EI-6, FRONT BUMPER, COMPONENT, General Description.>

- 2) Adjust the fog light beam. (model with fog light)  
<Ref. to LI-21, FOG LIGHT AIMING, ADJUSTMENT, Front Fog Light Assembly.>

## C: REPAIR

### 1. COATING METHOD FOR PP BUMPER

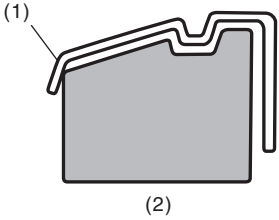
Process No.	Process name	Job contents	
1	Bumper installation	Place the bumper on a paint worktable as required. Use the paint worktable conforming to inner shape of bumper if possible.	 <p style="text-align: right;">EI-00234</p>
2	Masking	Mask specified part (black base) with masking tape. Use masking tape for PP.	
3	Degreasing/cleaning	Clean all parts to be painted with white gasoline, normal alcohol, etc. to remove dirt, oil, fat, etc.	
4	Primer paint	Apply primer to all parts to be painted, using spray gun. Use primer (clear).	
5	Drying	Dry at normal temperature [10 to 15 min. at 20°C (68°F)]. In half-dried condition, PP primer paint is dissolved by solvent, e.g. thinner, etc. Therefore, if dust or dirt must be removed, use ordinary alcohol etc.	
6	Top coat paint (I)	Non-colored	Metallic paint
		Use section (block) paint for top coat. For paint/hardener mixture, observe the specifications recommended by the manufacturers. <ul style="list-style-type: none"> <li>• Viscosity: 10 — 13 sec./20°C (68°F)</li> <li>• Film thickness: 35 — 45 μ</li> <li>• Spraying pressure: 245 — 343 kPa (2.5 — 3.5 kgf/cm<sup>2</sup>, 36 — 50 psi)</li> </ul>	Use section (block) paint for top coat. For paint/hardener mixture, observe the specifications recommended by the manufacturers. <ul style="list-style-type: none"> <li>• Viscosity: 10 — 13 sec./20°C (68°F)</li> <li>• Film thickness: 15 — 20 μ</li> <li>• Spraying pressure: 245 — 343 kPa (2.5 — 3.5 kgf/cm<sup>2</sup>, 36 — 50 psi)</li> </ul>
7	Drying	Not required.	Dry at normal temperature [at least 10 min. at 20°C (68°F)]. In half-dried condition, avoid dust, dirt.
8	Top coat paint (II)	Not required.	Apply a clear coat to parts with top coat paint (I), three times at 5 — 7 minute intervals. For paint/hardener mixture, observe the specifications recommended by the manufacturers. <ul style="list-style-type: none"> <li>• Viscosity: 14 — 16 sec./20°C (68°F)</li> <li>• Film thickness: 25 — 30 μ</li> <li>• Spraying pressure: 245 — 343 kPa (2.5 — 3.5 kgf/cm<sup>2</sup>, 36 — 50 psi)</li> </ul>
9	Drying	60°C (140°F), 60 min. or 80°C (176°F), 30 min. If the temperature is higher than 80°C (176°F), PP may be deformed. Keep maximum temperature at 80°C (176°F) or less.	
10	Inspection	Check paint.	
11	Removal of masking	Remove the masking tape applied in procedure 2.	

# Front Bumper

EXTERIOR/INTERIOR TRIM

## 2. REPAIR INSTRUCTIONS FOR COLORED PP BUMPER

### NOTE:

All PP bumpers are provided with a grained surface, and if the surface is damaged, it cannot normally be restored to its former condition. Damages limited to the shallow scratches that cause only a change in the luster of the base material or coating, can be almost fully restored. Before repairing a damaged area, explain this point to the customer and obtain an understanding about the matter.

Repair methods are outlined below, based on a classification of the extent of damage.

1) Minor damage causing only a change in the luster of the bumper due to a light touch  
Almost restorable.

Process No.	Process name	Job contents	
1	Cleaning	Clean the area to be repaired using water.	
2	Sanding	Grind the repairing area with #500 sand paper in a "feathering" motion.	
3	Finish	Resin section	Coated section
		Repeatedly apply wax to the affected area using soft cloth (such as flannel). Recommended wax: Tire wax or equivalent	Perform either the same procedures as for the resin section or process No. 18 and subsequent in section 3), depending on the degree and nature of damage.
		Polish the waxed area with clean cloth after 5 — 10 minutes.	

2) Deep damage caused by scratching with fences etc.

A dent cannot be repaired but a whitened or swelled part can be removed.

Process No.	Process name	Job contents	
1	Cleaning	Clean the damaged area with water.	
2	Removal of damaged area	Cut off protruding area, if any, due to collision, using a putty knife.	
3	Sanding	Grind the affected area with #100 — #500 sand paper.	
4	Finish	Resin section	Coated section
		Same as process No. 3 in section 1).	Perform process No. 12 and subsequent operations in section 3).

# Front Bumper

EXTERIOR/INTERIOR TRIM

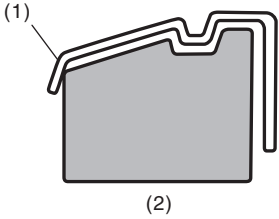
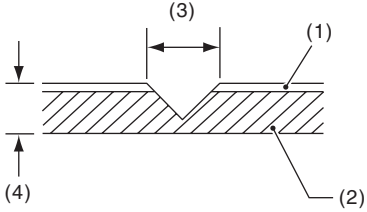
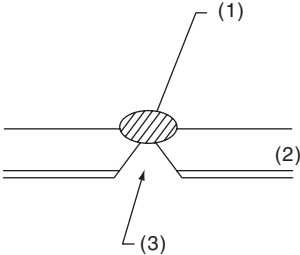

3) Deep damage such as a break or hole that requires filling  
 Much of the peripheral grained surface must be sacrificed for repair. The degree of restoration is not really worth the expense. (The surface, however, will become almost flush with adjacent areas.)

Process No.	Process name	Job contents
1	Bumper removal	Remove the bumper as required.
2	Removal of parts	Remove the parts built into bumper as required.
3	Bumper placement	<p>Place the bumper on a paint worktable as required.                      It is recommended to use the paint worktable conforming to internal shape of bumper.</p>  <p style="text-align: right;">EI-00234</p>
4	Surface preparation	Remove dust, oil, etc. from areas to be repaired and surrounding areas, using a suitable solvent (white gasoline or alcohol, etc.).
5	Cutting	<p>If the damage is a crack or a hole, cut a guide slit of 20 to 30 mm (0.79 to 1.18 in) in length along the crack or hole up to the bumper base surface. Next, use a knife or grinder to carve a V-shaped groove in the area for repair.</p>  <p style="text-align: right;">EI-00235</p>
6	Sanding (I)	Grind beveled surface with sand paper (#40 — #60) to smooth finish.
7	Cleaning	Clean the sanded surface with the same solvent as used in process No. 4.
8	Temporary welding	<p>Grind the side just opposite the beveled area with sand paper (#40 — #60) and clean using a solvent.                      Temporarily spot-weld the side, using PP welding rod and heater gun.</p>  <p style="text-align: right;">EI-00236</p>
<p>(1) Welded point (Use heater gun and PP welding rod)                      (2) PP base surface                      (3) Beveled section</p> <p>NOTE:</p> <ul style="list-style-type: none"> <li>Do not melt welding rod until it flows out. This results in reduced strength.</li> <li>Leave the welded spot unattended until it cools completely.</li> </ul>		

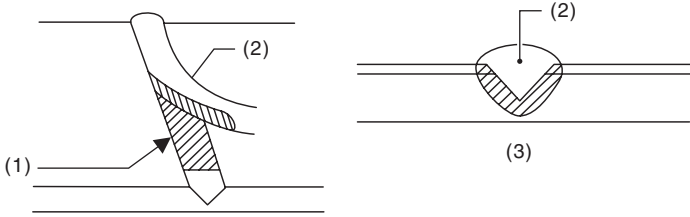

# Front Bumper

## EXTERIOR/INTERIOR TRIM

Process No.	Process name	Job contents
9	Welding	<p>Using a heater gun and PP welding rod, weld the beveled spot while melting both the rod and damaged area.</p>  <p>(1) Welding rod (2) Melt hatched area (3) Section</p> <p>NOTE:</p> <ul style="list-style-type: none"> <li>• Melt the sections indicated by hatched area.</li> <li>• Do not melt the welding rod until it flows out, in order to provide strength.</li> <li>• Always keep the heater gun 1 to 2 cm (0.4 to 0.8 in) away from the welding spot.</li> <li>• Leave the welded spot unattended until it cools completely.</li> </ul> <p style="text-align: right;">EI-00237</p>
10	Sanding (II)	<p>Remove excess part of weld with a putty knife. If a drill or disc wheel is used instead of the knife, operate it at a rate lower than 1,500 rpm and grind the excess part little by little. A higher rpm will cause the PP substrate to melt from the heat.</p>  <p style="text-align: right;">EI-00042</p> <p>Sand the welded spot smooth with #240 sand paper.</p>
11	Masking	Mask the black substrate section using masking tape.
12	Cleaning/degreasing	Completely clean the entire coated area, using solvent similar to that used in process No. 4.
13	Primer coating	<p>Apply a coat of primer for bumpers to the repaired surface and its surrounding areas. Mask these areas, if necessary.</p> <p>NOTE: Be sure to apply a coat of primer using a spray gun at a pressure of 245 — 343 kPa (2.5 — 3.5 kgf/cm<sup>2</sup>, 36 — 50 psi).</p>
14	Leave unattended	<p>Leave the repaired area unattended at 20°C (68°F) for 10 to 15 minutes until primer is half-dry.</p> <p>NOTE: If dirt or dust comes in contact with the coated area, wipe it off with a cloth dampened with alcohol. (Do not use thinner since the coated area tends to melt.)</p>
15	Surfacer coating	<p>Apply a coat of surfacer for PP bumpers to the repaired area two or three times at an interval of 3 — 5 minutes.</p> <p>For surfacer/hardener mixture, viscosity and paint thickness, observe the specifications of the surfacers to be used.</p>
16	Drying	Allow the coated surface to dry for 20 minutes at 20°C (68°F) [or 30 minutes at 60°C (140°F)].
17	Sanding (III)	Sand the coated surface and its surrounding areas using #400 sand paper and water.
18	Cleaning/degreasing	Same as process No. 12.

# Front Bumper

EXTERIOR/INTERIOR TRIM

Process No.	Process name	Job contents	
		Non-colored	Metallic paint
19	Top coat (I)	<p>Use a "block" coating method. For paint/hardener mixture, observe the specifications recommended by the manufacturers.</p> <ul style="list-style-type: none"> <li>• Viscosity: 11 — 13 sec./20°C (68°F)</li> <li>• Coating film thickness: 40 — 50 μ</li> <li>• Spraying pressure: 245 — 343 kPa (2.5 — 3.5 kgf/cm<sup>2</sup>, 36 — 50 psi)</li> </ul>	<p>Use a "block" coating method. For paint/hardener mixture, observe the specifications recommended by the manufacturers.</p> <ul style="list-style-type: none"> <li>• Viscosity: 11 — 13 sec./20°C (68°F)</li> <li>• Coating film thickness: 20 — 30 μ</li> <li>• Spraying pressure: 245 — 343 kPa (2.5 — 3.5 kgf/cm<sup>2</sup>, 36 — 50 psi)</li> </ul>
20	Leave unattended	Not required.	<p>Leave unattended at 20°C (68°F) for at least 10 minutes until the topcoated area is half-dry.</p> <p>NOTE: Be careful to keep dust or dirt from coming in contact with the affected area.</p>
21	Top coat (II)	Not required.	<p>Apply a clear coat three times at an interval of 3 to 5 minutes. For paint/hardener mixture, observe the specifications recommended by the manufacturers.</p> <ul style="list-style-type: none"> <li>• Viscosity: 10 — 13 sec./20°C (68°F)</li> <li>• Coating film thickness: 20 — 30 μ</li> <li>• Spraying pressure: 245 — 343 kPa (2.5 — 3.5 kgf/cm<sup>2</sup>, 36 — 50 psi)</li> </ul>
22	Drying	<p>Allow the coated surface to dry for two hours at 20°C (68°F) or 30 minutes at 60°C (140°F).</p> <p>NOTE: Do not allow the temperature to exceed 80°C (176°F) since this will deform the PP substrate.</p>	
23	Inspection	Carefully check the condition of the repaired area.	
24	Removal of masking	Remove the masking tape applied in process No. 11 and 13.	
25	Parts installation	Install parts on the bumper in reverse order of removal.	
26	Bumper installation	Install the bumper.	

# Rear Bumper

EXTERIOR/INTERIOR TRIM

## 8. Rear Bumper

### A: REMOVAL

#### 1. REAR BUMPER FACE

1) Remove the clips inside the wheel housing.

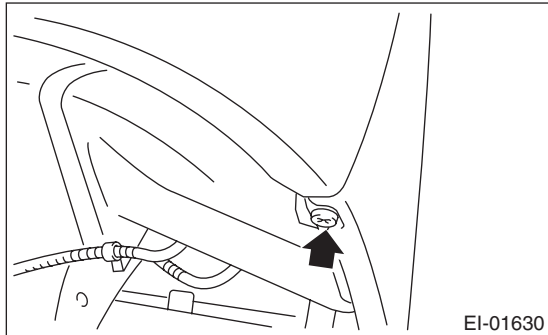

2) Remove the clips on the lower side of rear bumper.

- 5 door model

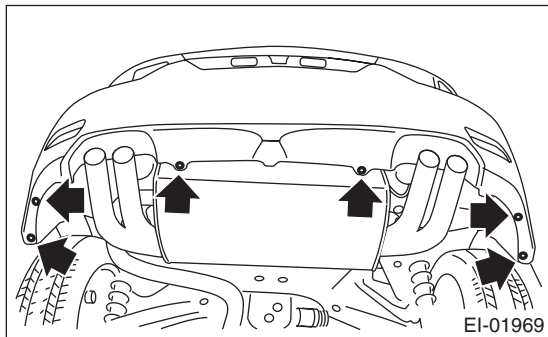

- 4 door model

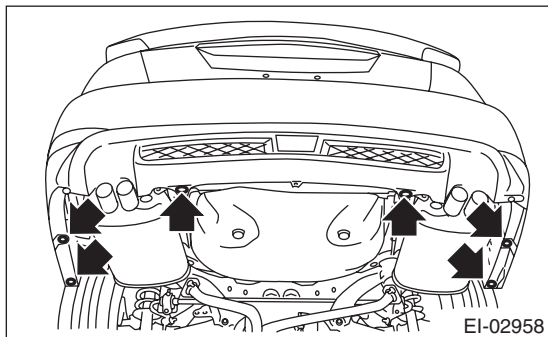

3) Remove the rear bumper from vehicle body.

#### CAUTION:

Do not pull with an excessive force. Otherwise the bracket installation area may be damaged.

- 5 door model

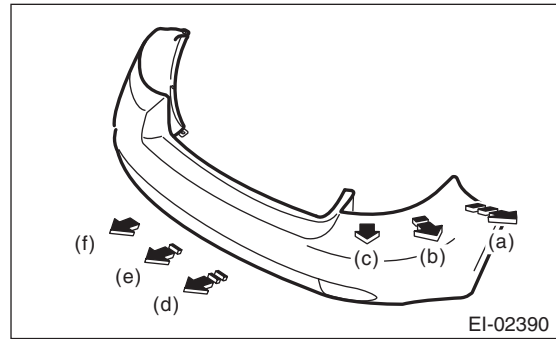

- 4 door model

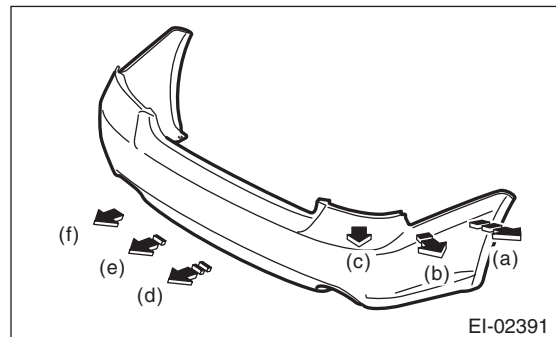

(1) Detach from the fender side in order from (a) to (c) while pulling up on the bumper face and twisting it towards you. (Both sides)

(2) Lifting the center of bumper face upward, detach in the order from (d) to (f).

4) Remove the reflector. (5 door model)

#### 2. REAR BUMPER BEAM ASSEMBLY

1) Remove the rear bumper face. <Ref. to EI-38, REAR BUMPER FACE, REMOVAL, Rear Bumper.>

2) Remove the nuts, and remove the bumper beam assembly from the vehicle body.

- 5 door model

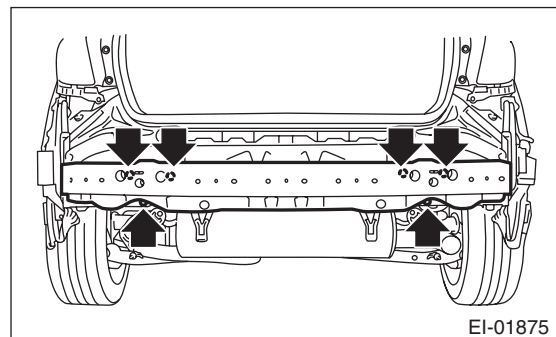

- 4 door model

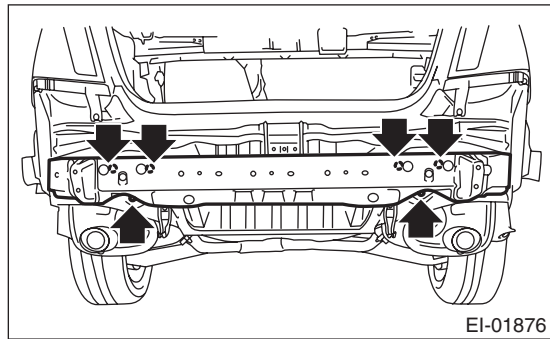

**NOTE:**

After all nuts have been removed, lift the whole bumper beam slightly while detaching it from the vehicle body.

### 3. REAR BUMPER BRACKET

Remove the rear bumper face from vehicle body, and remove each bumper bracket.

- Corner bracket

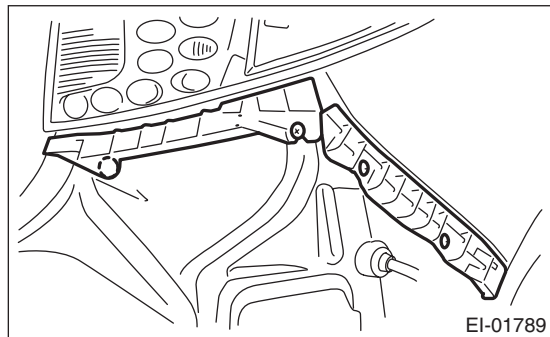

- Lower bracket

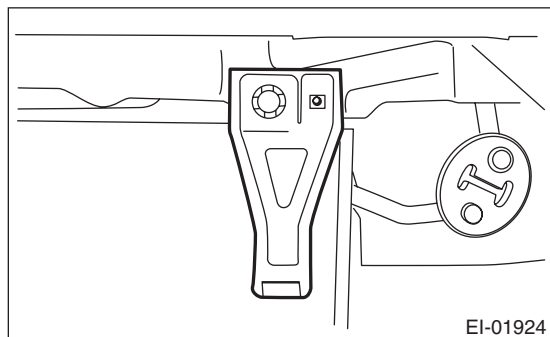

## B: INSTALLATION

Install each part in the reverse order of removal.

**NOTE:**

If the bumper face comes off easily from the beam upper rear, adjust the hook of the bracket side.

**Tightening torque:**

Refer to "**COMPONENT**" of "**General Description**". <Ref. to EI-7, REAR BUMPER, COMPONENT, General Description.>

## C: REPAIR

Refer to the description for front bumper repair. <Ref. to EI-33, REPAIR, Front Bumper.>

# Cowl Panel

EXTERIOR/INTERIOR TRIM

## 9. Cowl Panel

### A: REMOVAL

- 1) Open the front hood.
- 2) Remove the wiper arm. <Ref. to WW-15, REMOVAL, Front Wiper Arm.>
- 3) Detach the tabs and remove the cowl panel side.

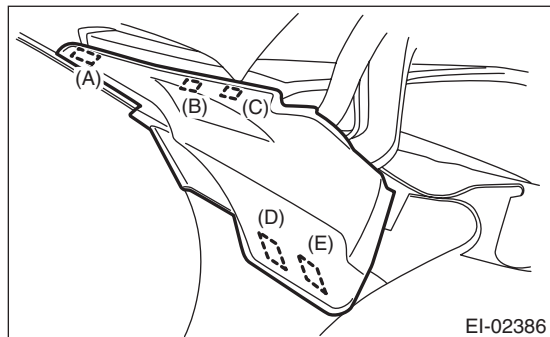

- (1) Detach tabs (A), (B), and (C) from the vehicle exterior.
  - (2) Detach tabs (D) and (E).
- 4) Remove the clips (A) and (B), and remove the cowl panel.

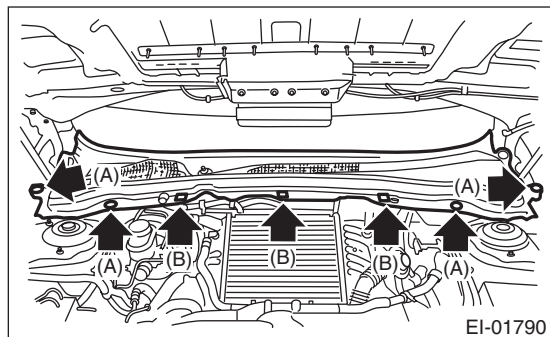

### CAUTION:

When removing clip (B), push the claws of the clips from the left and right to remove. Be careful because the clip can be damaged if you pull unnecessarily hard on them.

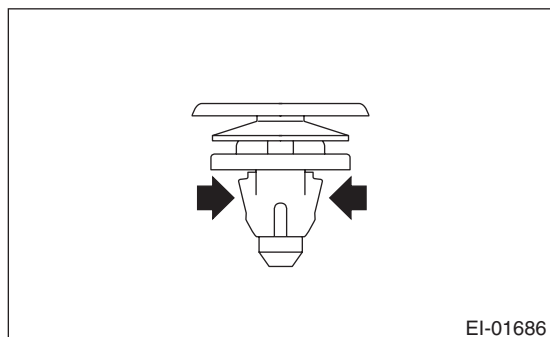

### B: INSTALLATION

Install each part in the reverse order of removal.

#### NOTE:

Hook the claw of the cowl panel on the lower end of the windshield.

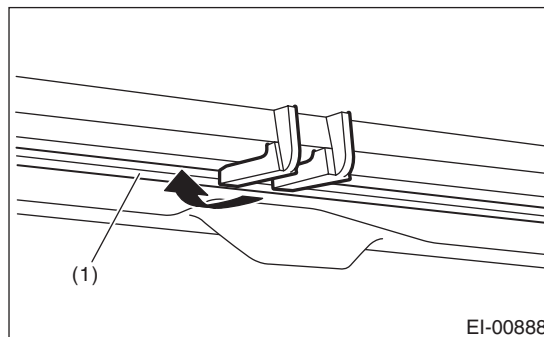

- (1) Windshield cross section

## 10. Roof Spoiler

### A: REMOVAL

- 1) Disconnect the ground cable from battery.
- 2) Remove the rear gate trim. <Ref. to EI-69, REMOVAL, Rear Gate Trim.>
- 3) Disconnect the connector of high-mounted stop light and the washer hose of rear washer.
- 4) Remove the bolts and nuts.

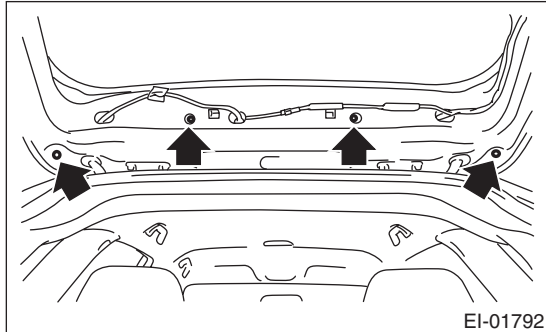

- 5) Remove the clips, and remove the roof spoiler.

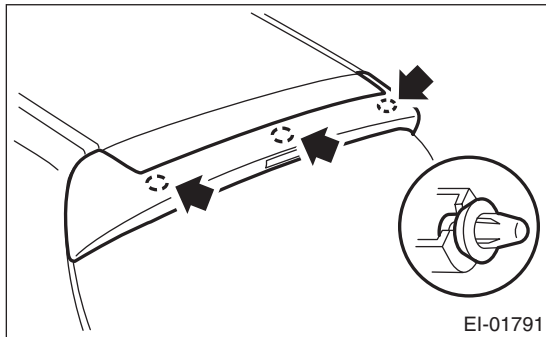

### B: INSTALLATION

#### CAUTION:

- Improper installing may cause the water leakage, make sure the harness grommet is installed securely.
  - Check that there is no foreign matter in roof spoiler between the high-mounted stop light harness or washer hose, it may cause washer defective and improper installation of spoiler.
- Install each part in the reverse order of removal.

#### *Tightening torque:*

*7.5 N·m (0.76 kgf-m, 5.5 ft-lb)*

## 11. Rear Spoiler

### A: REMOVAL

#### 1. SMALL TYPE

- 1) Disconnect the ground cable from battery.
- 2) Open the trunk lid.
- 3) Remove the high mount stop light connector (A).
- 4) Remove the rear spoiler attachment nut (B) and clip (C), and remove the rear spoiler.

#### CAUTION:

- When removing the nut, be careful not to drop the nut inside the trunk lid panel.
- Be careful not to cause damage during removal and installation.

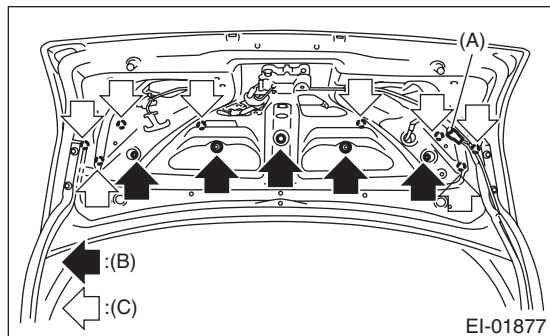

#### 2. LARGE TYPE

- 1) Disconnect the ground cable from battery.
- 2) Open the trunk lid.
- 3) Remove the clips and the trunk lid trim.
- 4) Remove the rear spoiler attachment nut (a) and clip (b), and remove the rear spoiler.

#### CAUTION:

- When removing the nut, be careful not to drop the nut inside the trunk lid panel.
- Be careful not to damage the vehicle body during removal and installation.

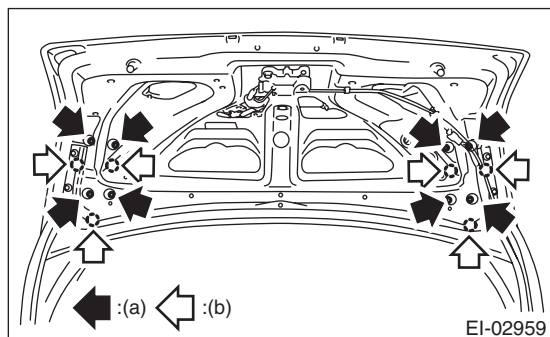

### B: INSTALLATION

#### CAUTION:

Improper installing may cause the water leakage, make sure the harness grommet is installed securely.

- 1) Install each part in the reverse order of removal.
- 2) Clean the trunk lid and spoiler attachment surface before installation.

#### Tightening torque:

7.5 N·m (0.76 kgf·m, 5.5 ft·lb)

## 12.Side Sill Spoiler

### A: REMOVAL

Remove the clip, and side spoiler.

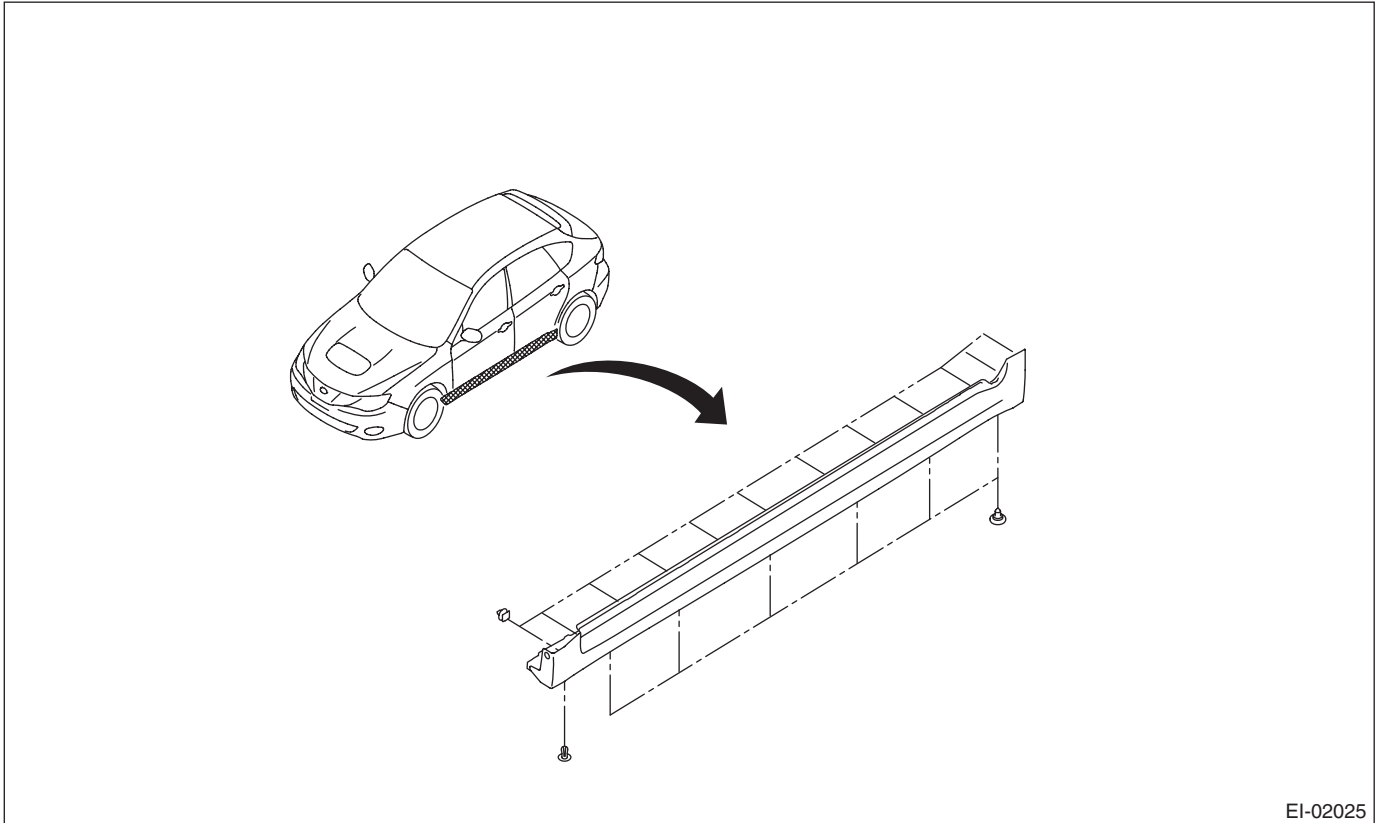

EI-02025

### B: INSTALLATION

Install each part in the reverse order of removal.



# Roof Molding

EXTERIOR/INTERIOR TRIM

## 13. Roof Molding

### A: REMOVAL

1) Peel the end of the roof molding, and slide the inner clip in the direction of the arrow using a flat tip screwdriver, to remove the clip from the stud on the vehicle side.

Right side: Slide towards the front of the vehicle.  
Left side: Slide towards the rear of the vehicle.

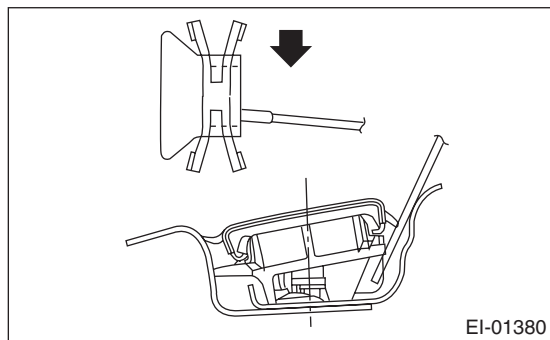
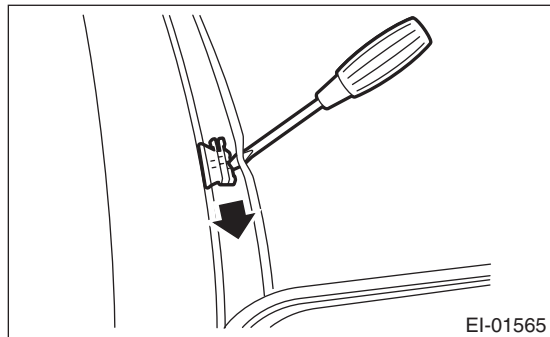

2) Pull up the roof molding upward, and remove from the vehicle.

3) Remove the roof trim. <Ref. to EI-66, REMOVAL, Roof Trim.>

4) Remove the nut, and remove the roof carrier bracket.

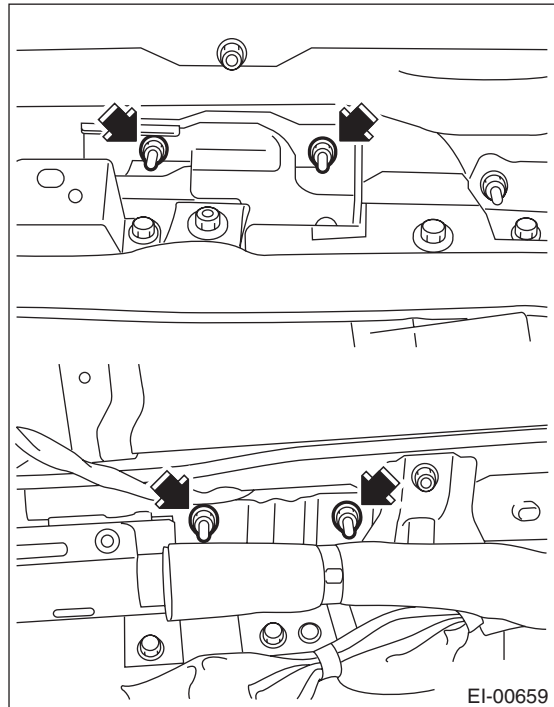

### B: INSTALLATION

#### CAUTION:

**Always replace clips that were damaged during removal of the roof molding.**

1) Install the roof carrier bracket.

#### Tightening torque:

**7.5 N·m (0.76 kgf·m, 5.5 ft·lb)**

2) Remove the clips from the roof molding, and attach to the studs on the vehicle.

3) Push the front end of the roof molding against the front window, and attach the forward positioning clip onto the rivet on the body.

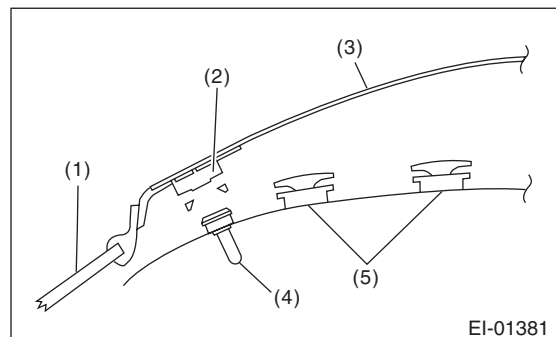

- (1) Windshield
- (2) Positioning clip
- (3) Roof molding
- (4) Rivet
- (5) Clip

4) While pushing down the roof molding from above, connect the roof molding and the clip.

## 14. Door Trim

### A: REMOVAL

#### 1. FRONT DOOR

- 1) Disconnect the ground cable from battery.
- 2) Remove the gusset cover.
  - (1) Pull the gusset cover backward to detach the claws (A) on the backside of the gusset cover.

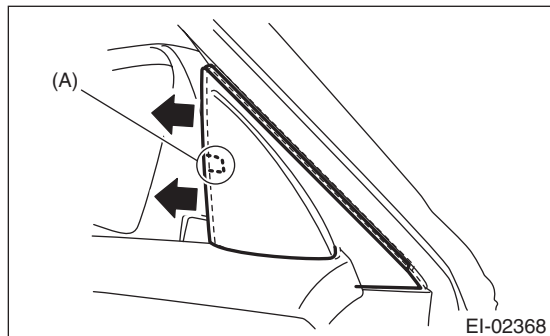

- (2) Insert a plastic remover into the position shown in the figure while retaining the condition in step (1), and lift up the gusset cover.

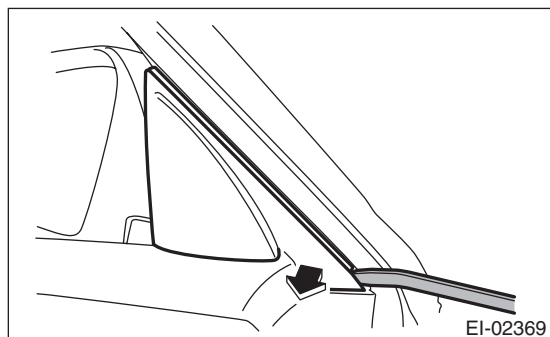

- (3) Remove the gusset cover in the direction of the arrow to detach the clip section (B), and disconnect the connector.

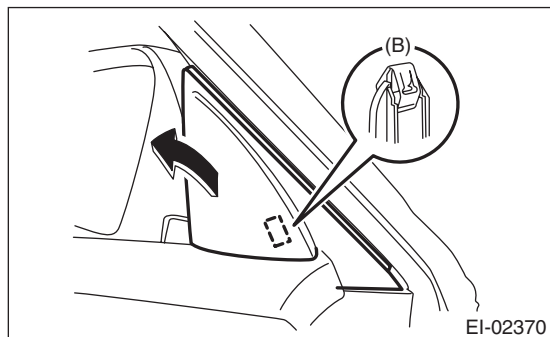

- 3) Open the cover of the inner remote section, and remove the screws.

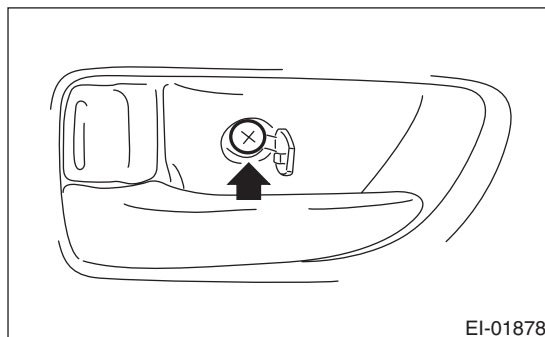

- 4) Remove the power window switch panel.

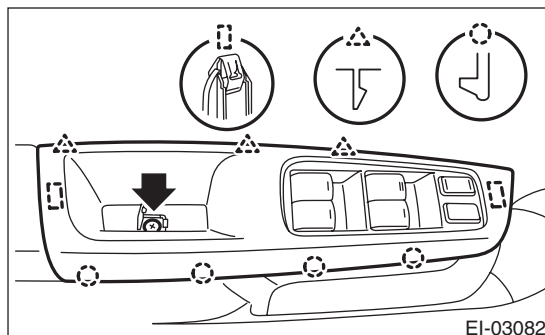

- (1) Open the cover and remove the screws.
- (2) Lift up the tip of switch panel by using a plastic remover.

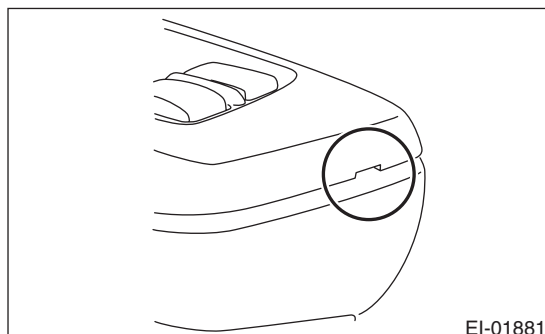

- (3) Remove the side claws by using a plastic remover.

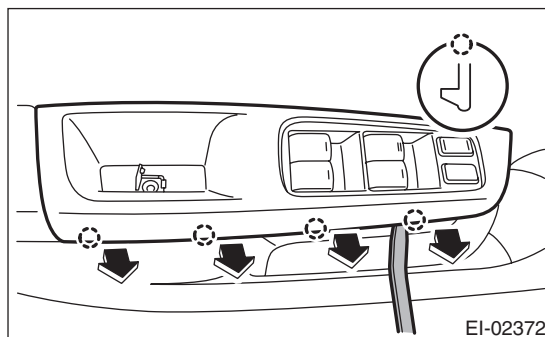

- (4) Disconnect the harness connector, and remove the power window switch panel.

# Door Trim

## EXTERIOR/INTERIOR TRIM

5) Remove the door trim screws.

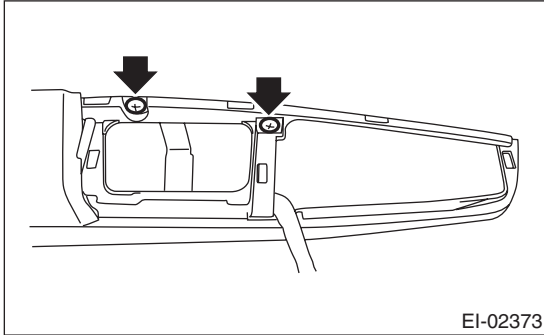

6) Remove the door trim.

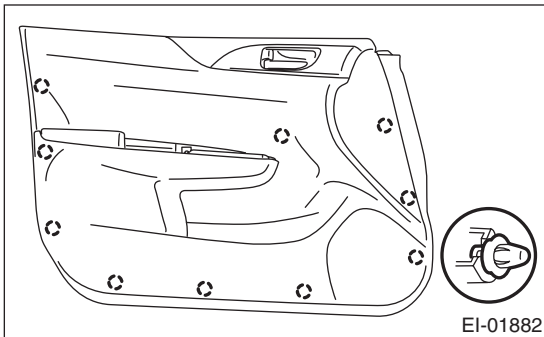

(1) Remove the clips, then lift the door trim.

### NOTE:

Insert a plastic clip remover into the slit at the bottom of the door trim, to lift the door trim.

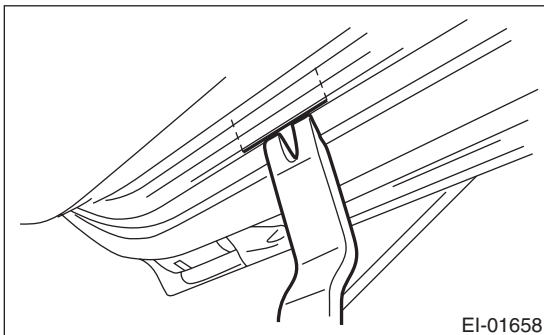

(2) Remove the cable (1) and (2) from the cable holder of inner remote.

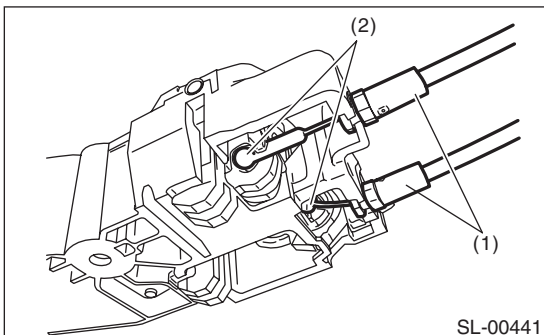

(3) Remove the door trim.

## 2. REAR DOOR

1) Disconnect the ground cable from battery.

2) Remove the gusset cover.

(1) Push gusset cover in direction of vehicle front to detach the claws (A) on the backside of the gusset cover.

### CAUTION:

Be careful not to damage the claws (A).

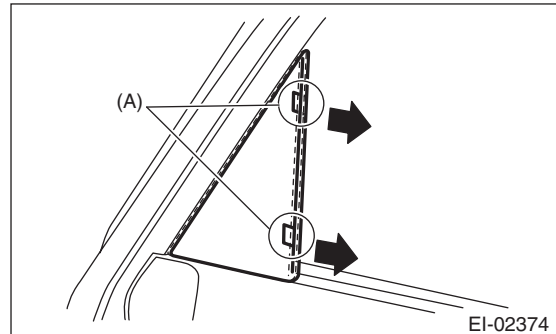

(2) Insert a plastic remover into the position shown in the figure while retaining the condition in step (1), and lift up the gusset cover.

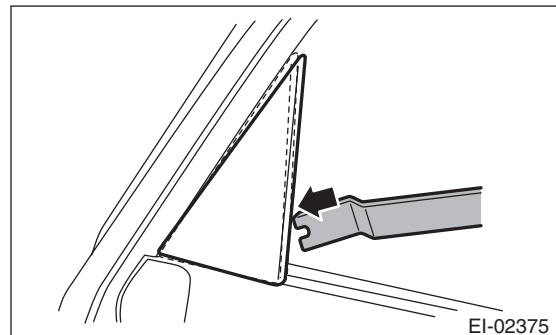

(3) Remove the gusset cover in the direction of the arrow to detach the clip section.

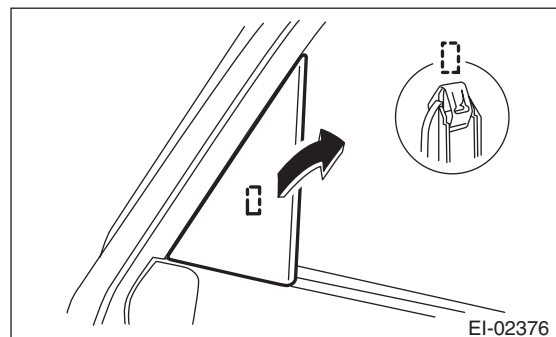

# Door Trim

EXTERIOR/INTERIOR TRIM

3) Open the cover of the inner remote section, and remove the screws.

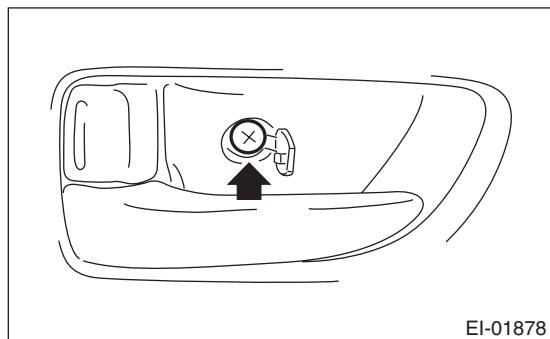

4) Remove the power window switch panel.

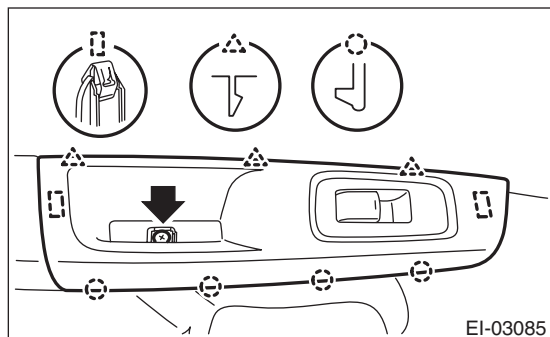

(1) Open the cover and remove the screws.  
(2) Lift up the tip of switch panel by using a plastic remover.

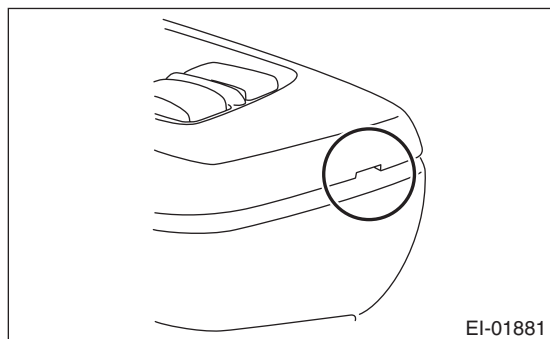

(3) Remove the side claws by using a plastic remover.

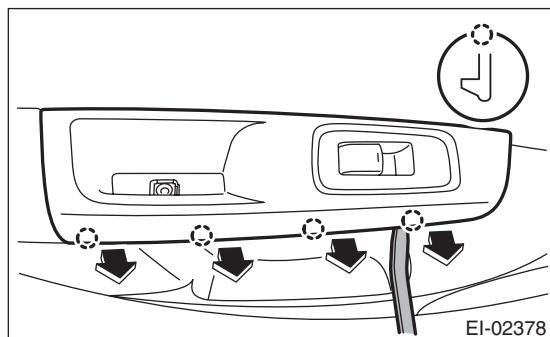

(4) Disconnect the harness connector, and remove the power window switch panel.

5) Remove the door trim screws.

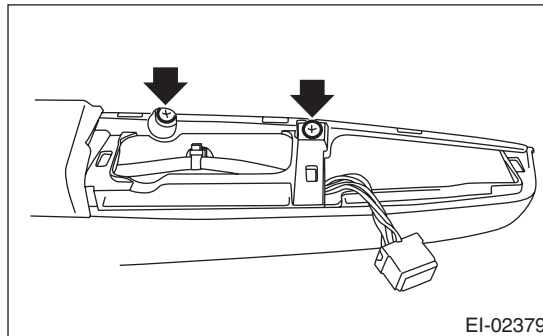

6) Remove the door trim.

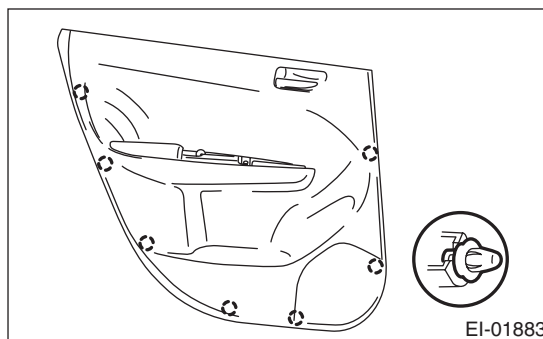

(1) Remove the clips, then lift the door trim.

**NOTE:**  
Insert a plastic clip remover into the slit at the bottom of the door trim, to lift the door trim.

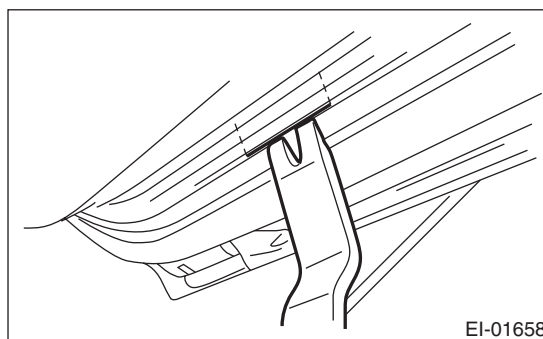

(2) Attach the protective tape (a) to the front door sash.

(3) Remove the door trim by rotating it around the trim tip part (b).

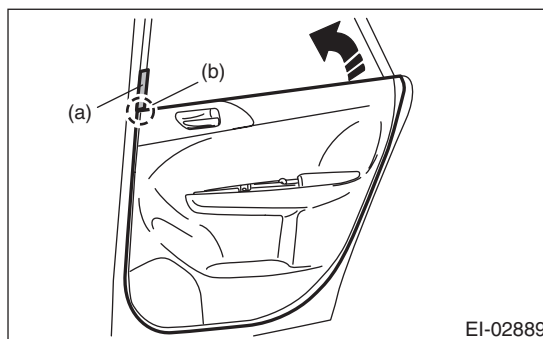

## Door Trim

### EXTERIOR/INTERIOR TRIM

---

(4) Remove the cable (1) and (2) from the cable holder of inner remote.

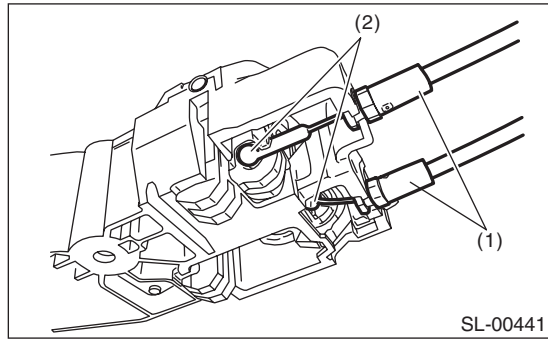

(5) Remove the door trim.

### **B: INSTALLATION**

Install each part in the reverse order of removal.

## 15. Instrument Panel Lower Cover

### A: REMOVAL

- 1) Disconnect the ground cable from battery.
- 2) Remove the plastic hook (A), and remove the instrument panel side cover LH.

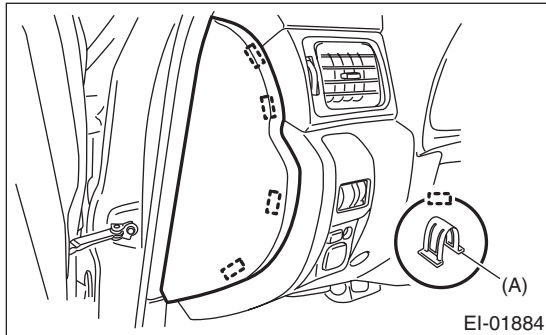

- 3) Remove the screws.

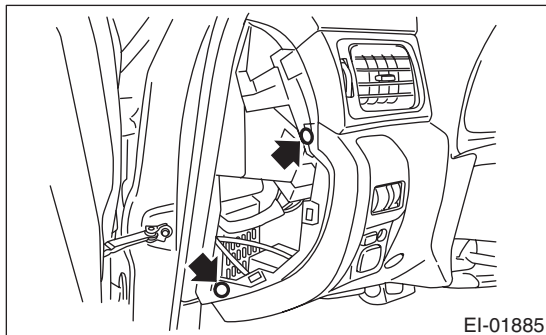

- 4) Remove plastic hook (A), disconnect connectors and remove the instrument panel lower cover.

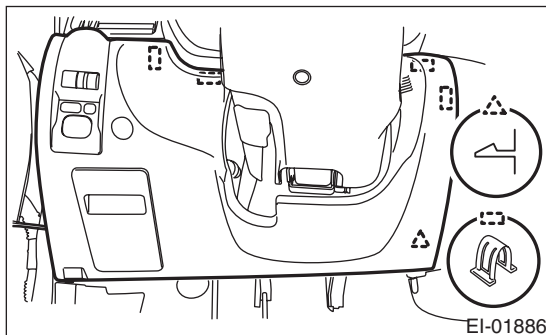

### B: INSTALLATION

Install each part in the reverse order of removal.

# Glove Box

EXTERIOR/INTERIOR TRIM

## 16. Glove Box

### A: REMOVAL

NOTE:

Refer to "Security and Locks" section for key cylinder replacement. <Ref. to SL-43, GLOVE BOX LID, REPLACEMENT, Key Lock Cylinders.>

- 1) Disconnect the ground cable from battery.
- 2) Remove the glove box damper.

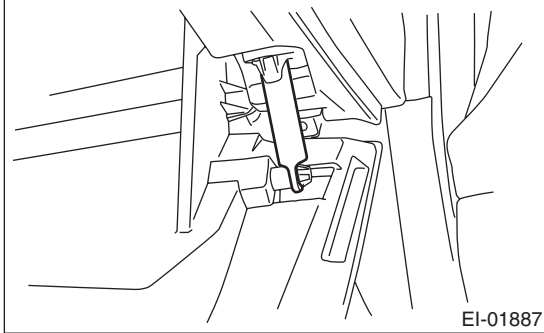

- 3) Remove the stoppers and pull the glove box lid assembly forward to remove.

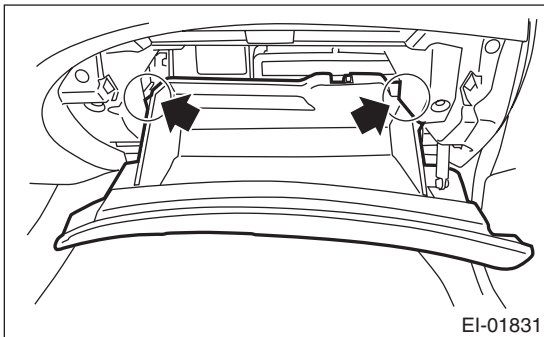

- 4) Remove the instrument panel lower. <Ref. to EI-54, INSTRUMENT PANEL LOWER, REMOVAL, Center Console.>

### B: INSTALLATION

Install each part in the reverse order of removal.

## 17. Console Box

### A: REMOVAL

- 1) Disconnect the ground cable from the battery.
- 2) Remove the parking brake lever boot.

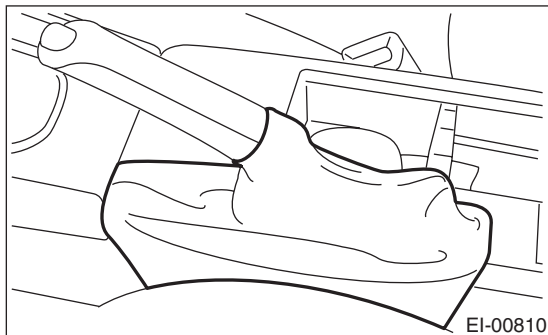

- 3) Remove the bolt (A), screw (B) and clip (C).

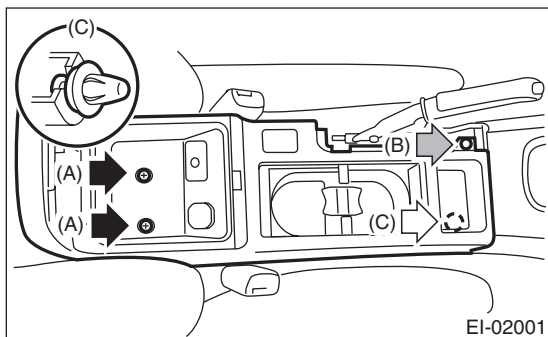

- 4) Disconnect the connector, and remove the console box.

### B: INSTALLATION

Install each part in the reverse order of removal.



# Center Console

EXTERIOR/INTERIOR TRIM

## 18.Center Console

### A: REMOVAL

#### 1. CENTER PANEL

- 1) Insert the lower slit of center panel to plastic clip remover and then lift up the panel.
- 2) Remove the claws and plastic hook and then remove the center panel.

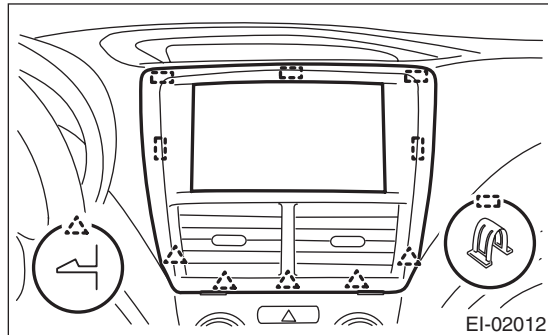

#### 2. CONSOLE FRONT PANEL

- 1) Remove the console box. <Ref. to EI-51, REMOVAL, Console Box.>
- 2) Remove the shift knob.
- 3) Remove the console front panel.

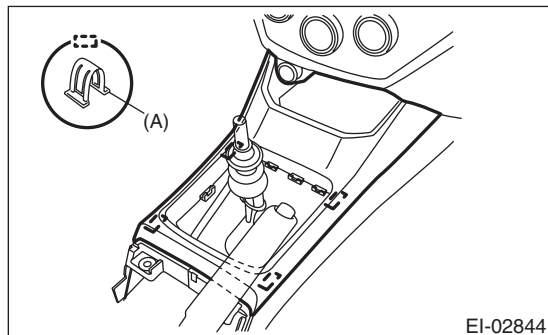

- (1) Remove the resin hook (A), and then lift up the console front panel.
- (2) Disconnect the connector and then remove the console front panel.

#### NOTE:

When removing the console front panel, pull it in the direction of the rear vehicle.

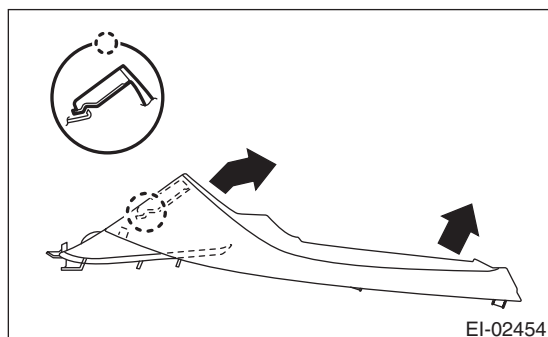

- 4) Remove the clips and screws, and remove the console side cover.

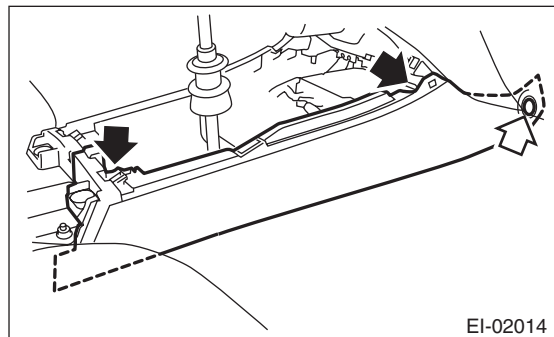
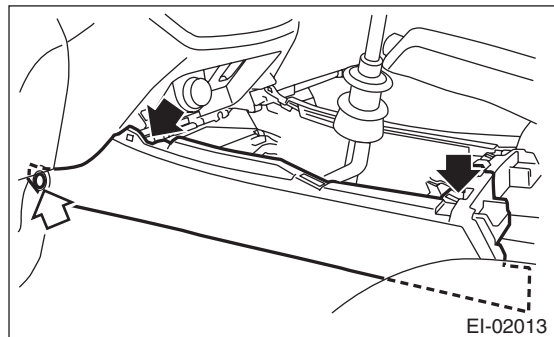

#### NOTE:

Pull towards the rear of the vehicle to remove.

#### 3. ORNAMENT PANEL

##### • Driver's side

- 1) Remove the plastic hook (A), and remove the instrument panel side cover LH.

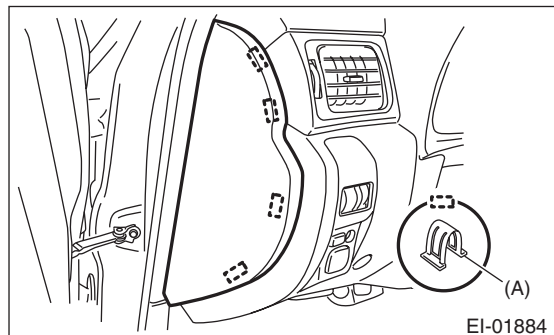

- 2) Remove the plastic hook (A), and detach the meter visor.

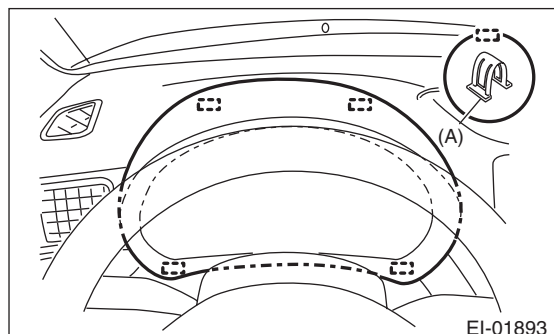

**NOTE:**

Remove the plastic hook on the bottom side of the meter visor by pulling it.

3) Detach the screw and the claw to take out ornament panel LH.

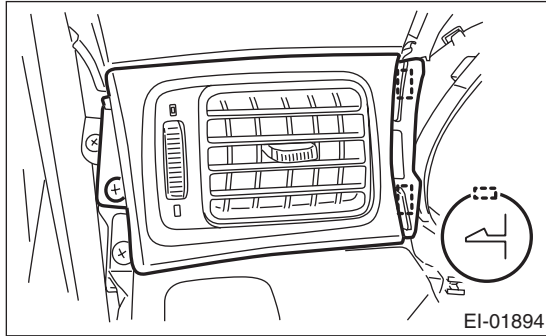

**• Passenger's side**

1) Remove the instrument panel lower cover. <Ref. to EI-49, REMOVAL, Instrument Panel Lower Cover.>

2) Remove the plastic hook (A), and detach the meter visor.

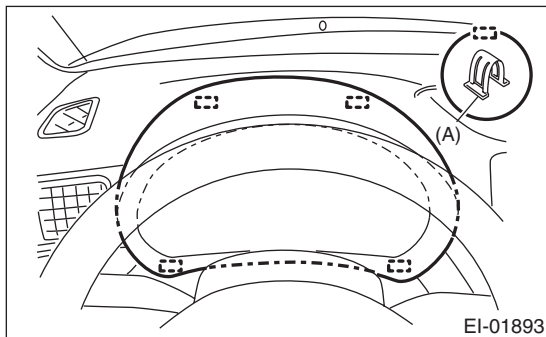

**NOTE:**

Remove the plastic hook on the bottom side of the meter visor by pulling it.

3) Insert a plastic clip remover into the slit at the bottom of the center panel, to lift the panel.

4) Remove the claws and resin hook and then remove the center panel.

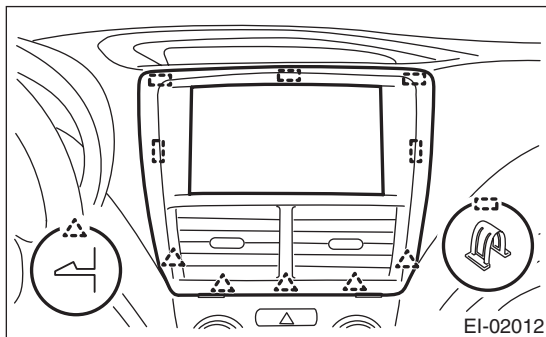

5) Detach the plastic hook (A), and remove the instrument panel side cover RH.

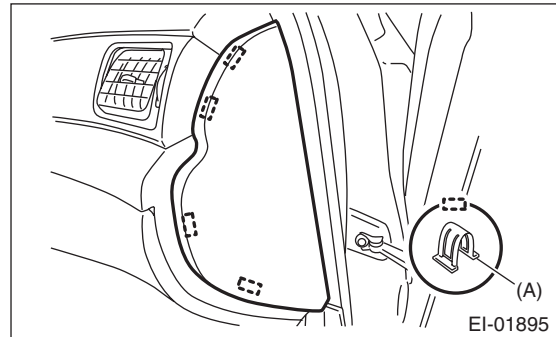

6) Detach the screws and the plastic hooks to remove ornament panel RH.

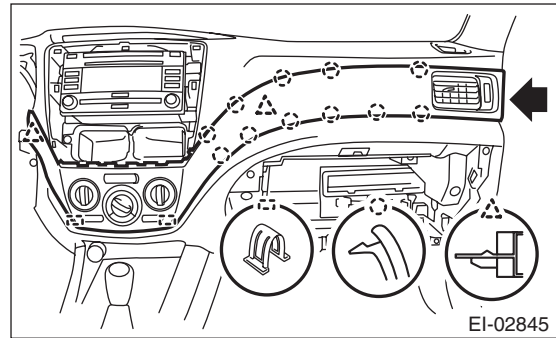

7) Disconnect connectors.

# Center Console

## EXTERIOR/INTERIOR TRIM

### 4. INSTRUMENT PANEL LOWER

- 1) Remove the console box. <Ref. to EI-51, REMOVAL, Console Box.>
- 2) Remove the center panel. <Ref. to EI-52, CENTER PANEL, REMOVAL, Center Console.>
- 3) Remove the console front panel. <Ref. to EI-52, CONSOLE FRONT PANEL, REMOVAL, Center Console.>
- 4) Remove ornament panel RH. <Ref. to EI-52, ORNAMENT PANEL, REMOVAL, Center Console.>
- 5) Remove the instrument panel lower cover. <Ref. to EI-49, REMOVAL, Instrument Panel Lower Cover.>
- 6) Remove the glove box lid. <Ref. to EI-49, REMOVAL, Instrument Panel Lower Cover.>
- 7) Remove the screws and nuts, and remove the instrument panel lower.

#### NOTE:

The screws indicated with the white arrows are tightened from the opposing side.

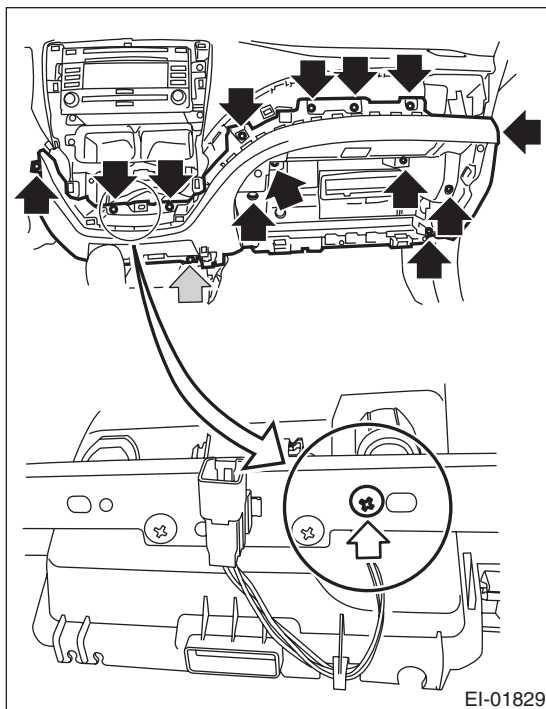

### B: INSTALLATION

Install each part in the reverse order of removal.

#### *Tightening torque:*

**7.5 N·m (7.6 kgf-m, 5.5 ft-lb)**

## 19. Instrument Panel Assembly

### A: REMOVAL

#### CAUTION:

Be careful not to damage the airbag system harness when servicing the instrument panel. Damage may cause the system to malfunction.

- 1) Disconnect the ground cable from battery.
- 2) Remove the front pillar upper trim. <Ref. to EI-59, REMOVAL, Upper Inner Trim.>
- 3) Remove the plastic hook (A), and remove the instrument panel side cover LH.

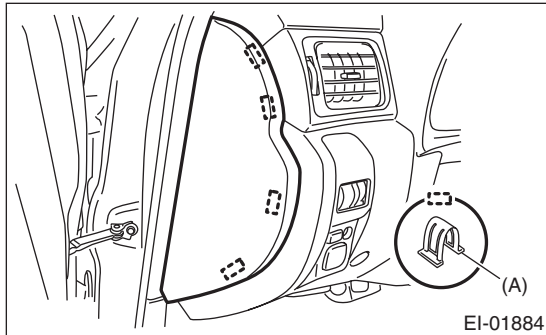

- 4) Detach the plastic hook (A), and remove the instrument panel side cover RH.

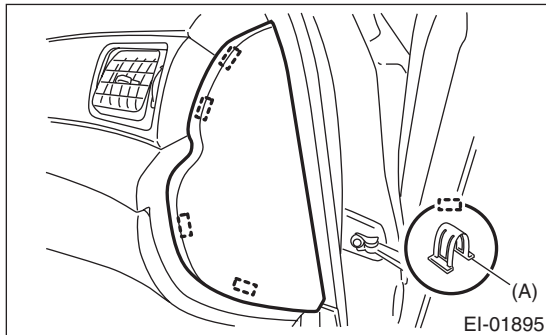

- 5) Remove the console box. <Ref. to EI-51, REMOVAL, Console Box.>
- 6) Remove the console front panel. <Ref. to EI-52, CONSOLE FRONT PANEL, REMOVAL, Center Console.>
- 7) Remove the instrument panel lower cover. <Ref. to EI-49, REMOVAL, Instrument Panel Lower Cover.>
- 8) Remove the steering shaft assembly. <Ref. to PS-15, REMOVAL, Steering Column.>
- 9) Disconnect connectors.

#### NOTE:

To make reassembly easier, place matching markings on connectors as necessary.

- 10) Remove the bolts and fuse box on the driver's side.

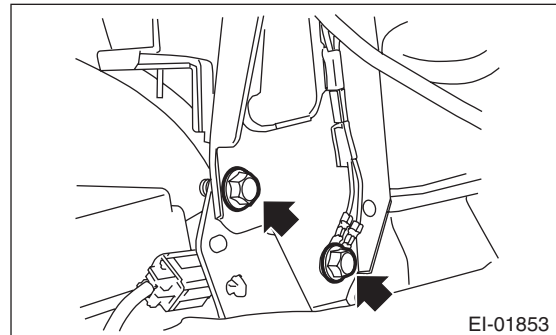
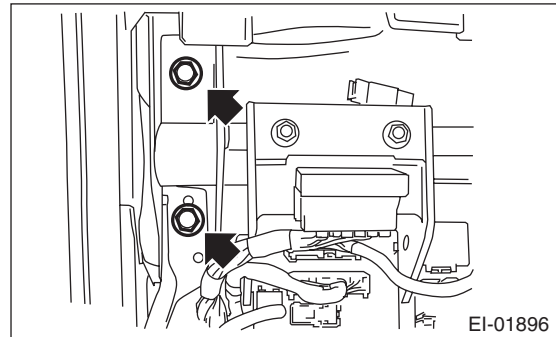

- 11) Remove the bolts on the passenger's side.

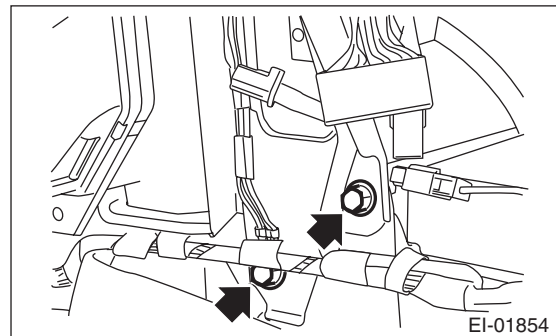
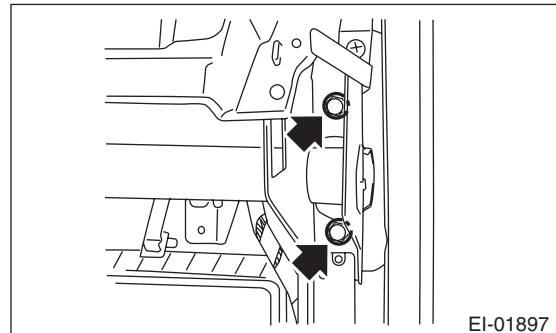

- 12) Make sure that the connectors are disconnected, and remove the instrument panel from the vehicle.

#### CAUTION:

When taking the instrument panel out of the vehicle, be careful not to damage the vehicle. Perform this work by a group of two persons or more.

# Instrument Panel Assembly

## EXTERIOR/INTERIOR TRIM

13) Remove the steering support beam bracket.

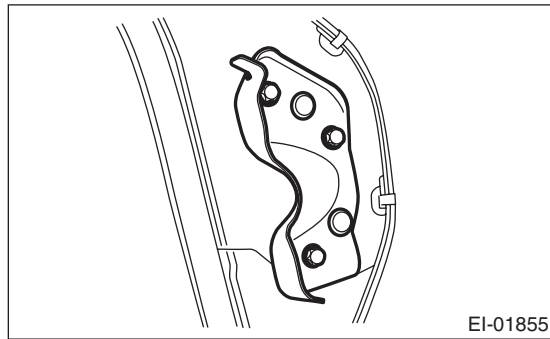

### B: INSTALLATION

- 1) Insert the matching pins (three locations) on the body side into the instrument panel assembly.
- 2) Check that the matching pins are inserted securely, and then route the harness.
- 3) Install each part in the reverse order of removal.

#### **Tightening torque:**

**Steering support beam & steering support beam bracket: 25 N·m (2.55 kgf·m, 18.4 ft·lb)**

**Steering shaft: <Ref. to PS-3, STEERING WHEEL AND COLUMN, COMPONENT, General Description.>**

**Instrument panel lower: 7.5 N·m (0.76 kgf·m, 5.5 ft·lb)**

### C: DISASSEMBLY

- 1) Remove the combination meter assembly. <Ref. to IDI-16, REMOVAL, Combination Meter.>
- 2) Remove the audio. <Ref. to ET-6, REMOVAL, Audio.>
- 3) Remove the GPS antenna. <Ref. to ET-15, REMOVAL, GPS Antenna.>
- 4) Remove the heater vent duct. <Ref. to AC-50, REMOVAL, Heater Vent Duct.>
- 5) Remove the bolts securing the passenger's side airbag module to the steering support beam.

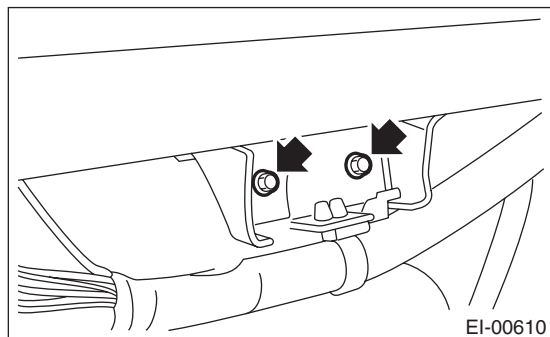

6) Remove the claws, and remove the passenger's airbag module.

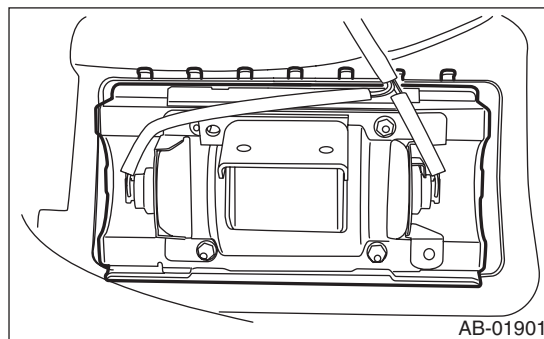

### D: ASSEMBLY

#### **CAUTION:**

**Be careful with the wiring harness routing during installation. When installing to the vehicle body, pinching the wiring harness may cause open circuits and shorts.**

Attach each part in the reverse order of disassembly, until the instrument panel assembly is formed.

#### **NOTE:**

Method of installing insulator

- Adhesive

Use polyurethane adhesive. When assembling the instrument panel assembly, wait until the adhesive has evaporated to prevent filling of the smell in the compartment.

- Double-sided tape

Use commercial double-sided tape. (Use strong double-sided adhesive tape.)

#### **Tightening torque:**

**Instrument panel lower: 7.5 N·m (0.76 kgf·m, 5.5 ft·lb)**

**Passenger's airbag module: 7.5 N·m (0.76 kgf·m, 5.5 ft·lb)**

## 20. Lower Inner Trim

### A: REMOVAL

1) Remove the hook, and remove the inside scuff plate.

**CAUTION:**

Do not pull with excessive force. Doing so may damage the scuff plate.

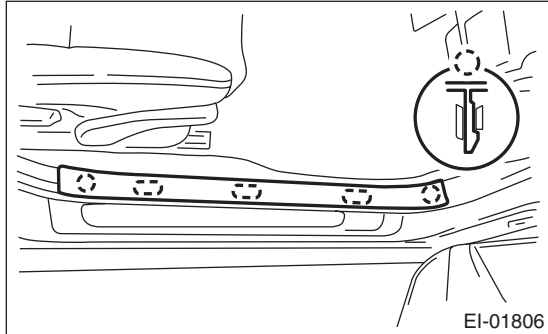

**NOTE:**

It is easier to remove the weather strip and pull off the floor mat to detach the claw of scuff plate from the backside.

2) Remove the weather strip (A), and remove the outside scuff plate.

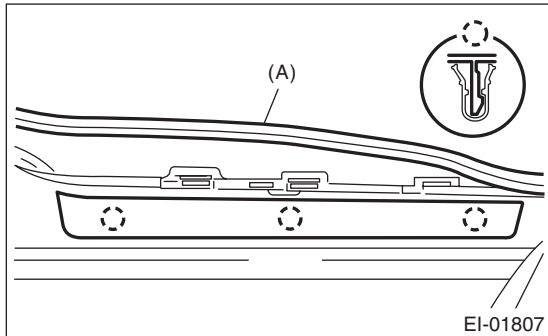

3) Remove clip (A), and remove the front pillar lower trim.

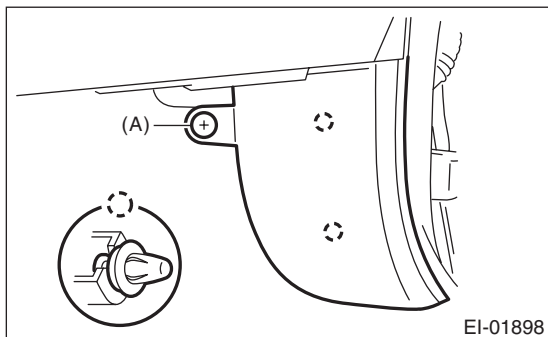

4) Remove the rear seat cushion. <Ref. to SE-13, REMOVAL, Rear Seat.>

5) Remove clip (A), and remove the inside scuff plate.

**CAUTION:**

Do not pull with excessive force. Doing so may damage the scuff plate.

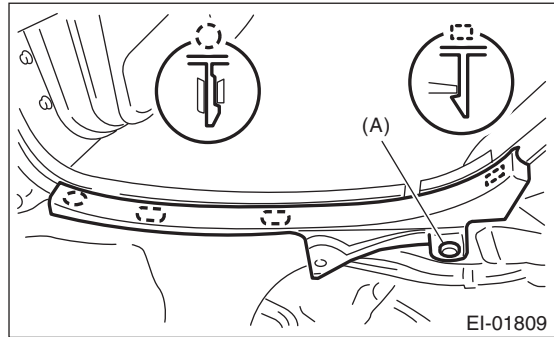

**NOTE:**

- It is easier to remove the weather strip to detach the claw of scuff plate from the backside of floor mat.

- It is easier to detach the tip claw of scuff plate using a clip remover.

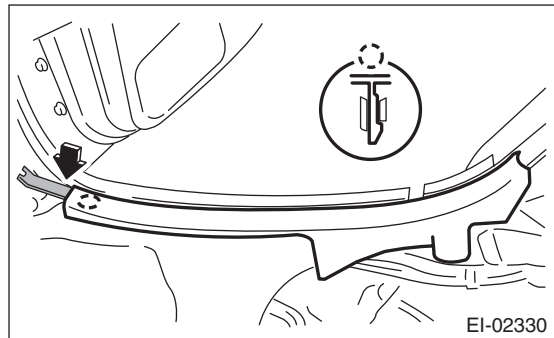

6) Remove weather strip (A) and door catcher cover (B), then remove the outside scuff plate.

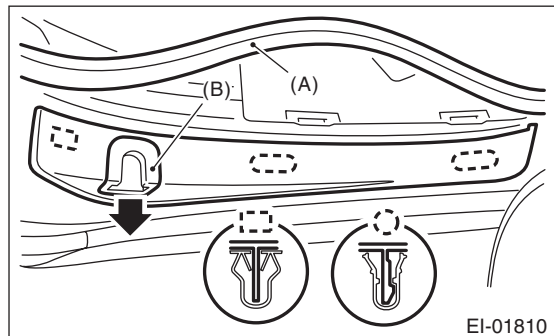

7) Remove the clips of the center pillar lower trim.

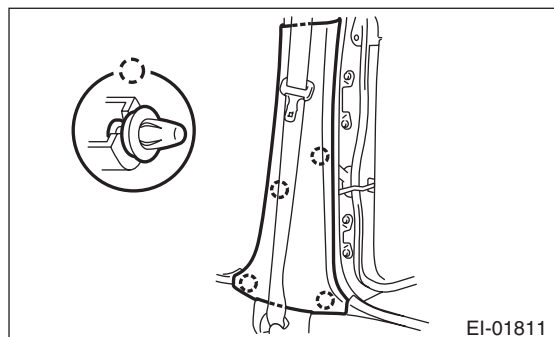



## Lower Inner Trim

### EXTERIOR/INTERIOR TRIM

---

8) Spread the lower trim outwards to remove the claw, and pull on the upper trim to remove.

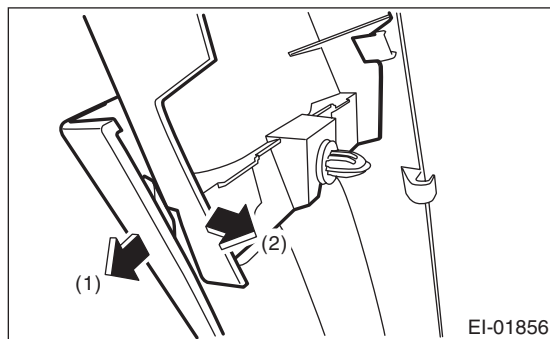

### **B: INSTALLATION**

Install each part in the reverse order of removal.

## 21. Upper Inner Trim

### A: REMOVAL

1) Remove the cap (B) on the upper side of the pillar trim, and remove the bolt.

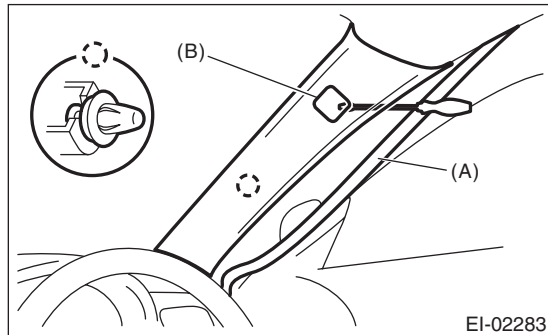

#### NOTE:

Remove the molding (A), and remove the cap from the backside of pillar trim not to damage the trim.

2) Remove the front pillar upper trim.

3) Remove the front inside scuff plate, rear inside scuff plate and center pillar lower trim. <Ref. to EI-57, REMOVAL, Lower Inner Trim.>

4) Remove anchor bolt cover (A).

5) Loosen the shoulder anchor bolt (B), and then detach the shoulder anchor from center pillar.

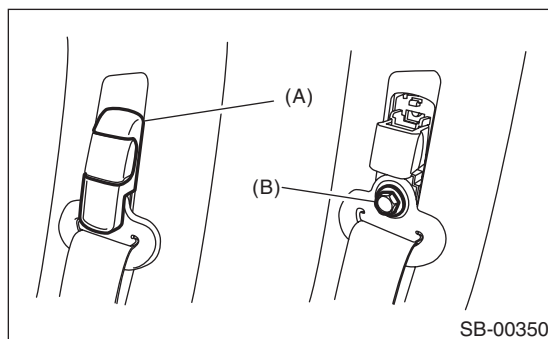

6) Remove the cap (B) on the upper side of the pillar trim, and remove the bolt.

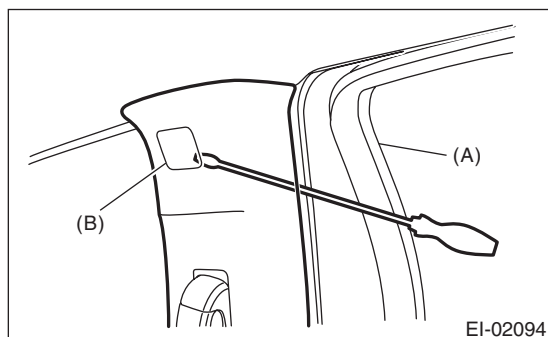

#### NOTE:

Remove the molding (A), and remove the cap from the backside of pillar trim not to damage the trim.

7) Pull and remove the upper trim clip section of the center pillar along with the lower trim.



8) Spread the lower trim outwards to remove the claw, and pull on the upper trim to remove.

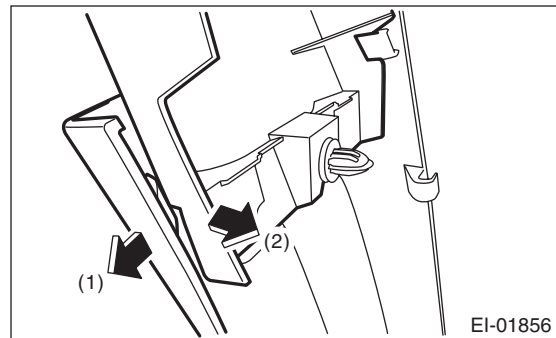

### B: INSTALLATION

Install each part in the reverse order of removal.

#### Tightening torque

Refer to "COMPONENT" of "General Description".

Upper inner trim: <Ref. to EI-21, INNER TRIM (5 DOOR MODEL), COMPONENT, General Description.>

Seat belt anchor: <Ref. to SB-2, FRONT SEAT BELT, COMPONENT, General Description.>



# Rear Quarter Trim

EXTERIOR/INTERIOR TRIM

## 22.Rear Quarter Trim

### A: REMOVAL

#### 1. 5 DOOR MODEL

- 1) Remove the rear seat. <Ref. to SE-13, REMOVAL, Rear Seat.>
- 2) Remove the seat belt lower anchor bolt.

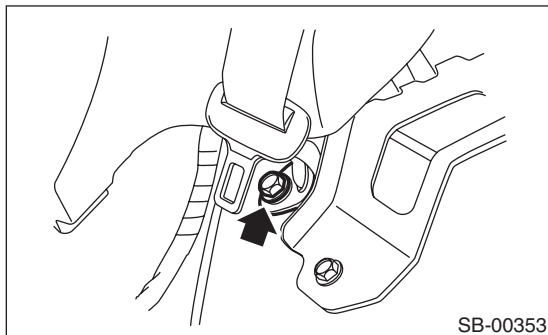

- 3) Remove the cap (B) on the upper side of the rear quarter pillar front trim, and remove the bolt inside.

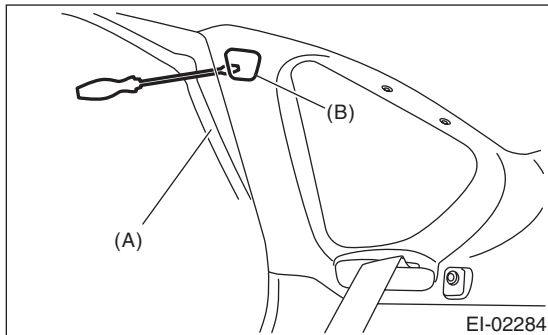

#### NOTE:

Remove the molding (A), and remove the cap from the backside of pillar trim not to damage the trim.

- 4) Remove the side belt cover (C).
- 5) Remove center belt cover (D), and remove the anchor bolt inside.

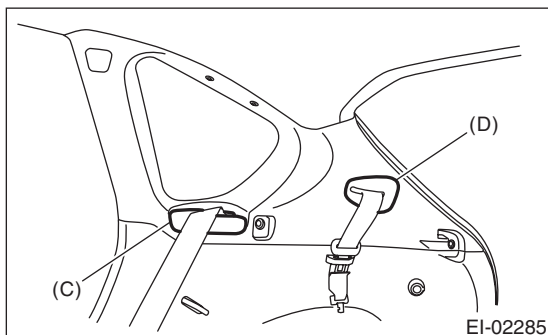

- 6) Remove the clips and screws, and remove the rear quarter upper trim.

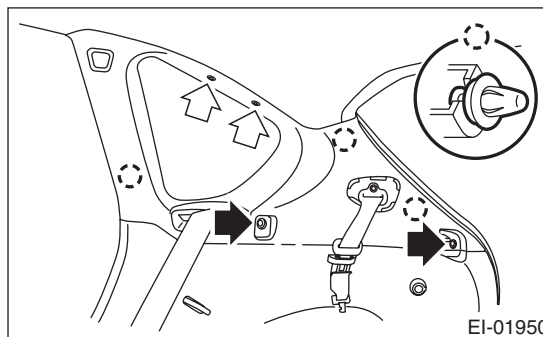

- 7) Remove the luggage floor end cover.

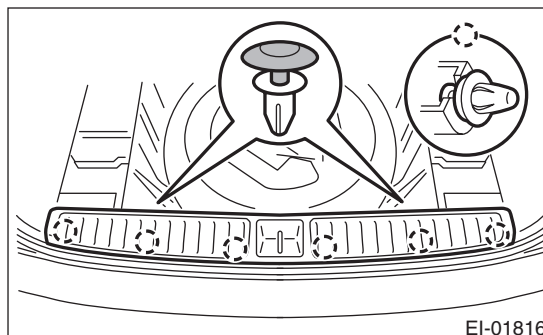

- 8) Remove the bolts, and remove the rear quarter lower trim.

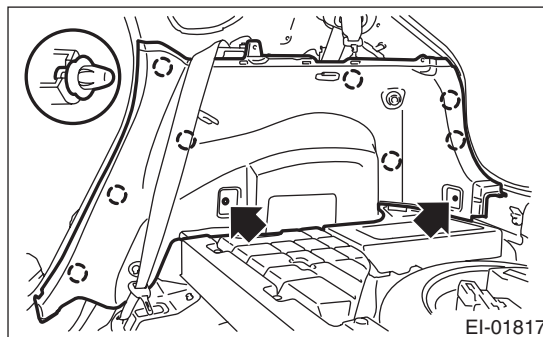

## 2. 4 DOOR MODEL

- 1) Remove the rear seat. <Ref. to SE-13, REMOVAL, Rear Seat.>
- 2) Remove the inside scuff plate. <Ref. to EI-57, REMOVAL, Lower Inner Trim.>
- 3) Peel the trim, and use a screwdriver, etc. to press claw (A) of the metal clip, to remove the quarter upper trim.

### CAUTION:

If the metal clip comes off or becomes damaged, replace both the quarter upper trim rear and metal clips.

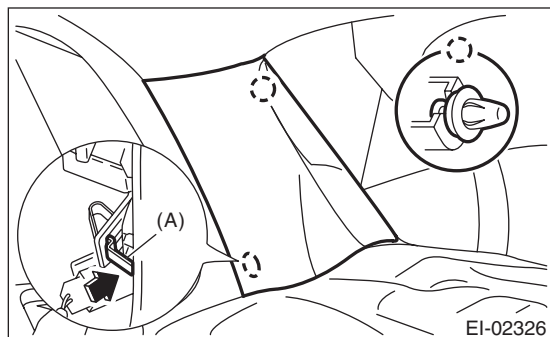

- 4) Remove the seat belt lower anchor bolt.

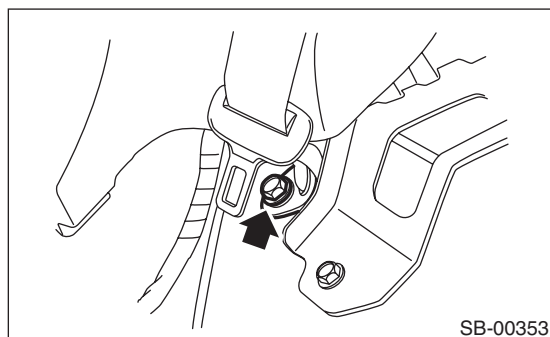

- 5) Remove the cap (B) on the upper side of the rear quarter trim, and remove the bolt inside.

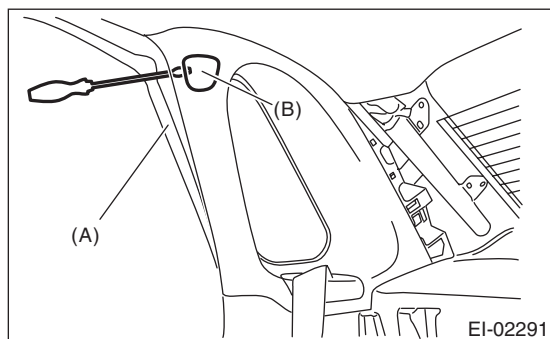

### NOTE:

Remove the molding (A), and remove the cap from the backside of pillar trim not to damage the trim.

- 6) Remove side belt cover (A).

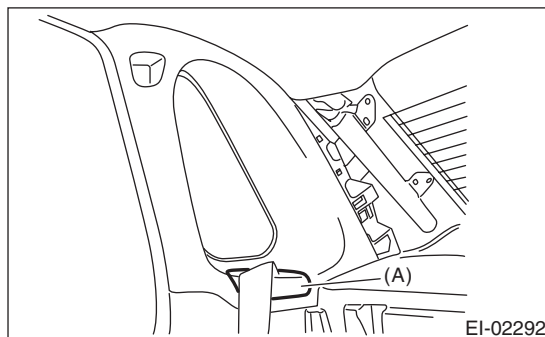

- 7) Remove the bolts and clips, and remove the quarter upper trim front.

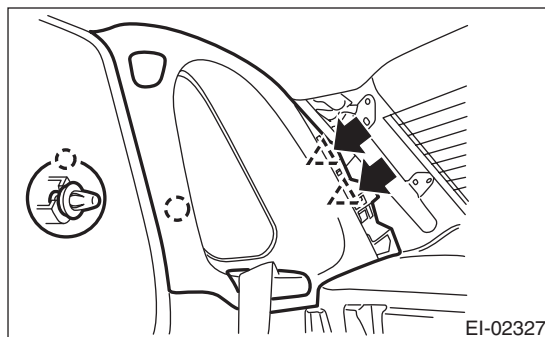

- 8) Remove the rear seat. <Ref. to SE-13, REMOVAL, Rear Seat.>

- 9) Remove the clip of the trunk room side trim.

- 10) Remove the clips, then remove the quarter lower trim.

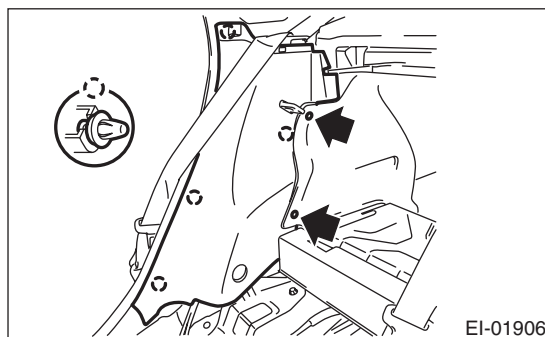

## B: INSTALLATION

Install each part in the reverse order of removal.

### Tightening torque

Refer to "COMPONENT" of "General Description".

Rear quarter upper trim: <Ref. to EI-21, INNER TRIM (5 DOOR MODEL), COMPONENT, General Description.>

Seat belt anchor: <Ref. to SB-3, REAR SEAT BELT, COMPONENT, General Description.>

# Rear Shelf Trim

EXTERIOR/INTERIOR TRIM

## 23.Rear Shelf Trim

### A: REMOVAL

- 1) Disconnect the ground cable from battery.
- 2) Remove the rear quarter trim. <Ref. to EI-61, 4 DOOR MODEL, REMOVAL, Rear Quarter Trim.>
- 3) Remove the seat belt center anchor lower bolt.  
(3-point type belt only)

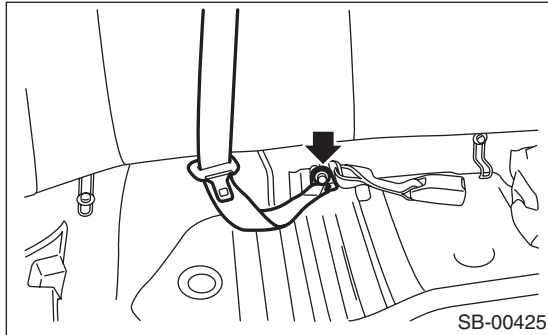

- 4) Remove the high-mounted stop light. <Ref. to LI-32, 4 DOOR MODEL (STANDARD TYPE), REMOVAL, High-mounted Stop Light.>
- 5) Remove the clips, and remove the rear shelf trim.

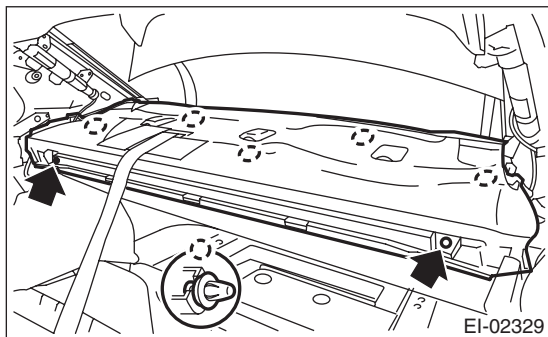

### B: INSTALLATION

Install each part in the reverse order of removal.

## 24. Trunk Room Trim

### A: REMOVAL

- 1) Remove the rear seat backrest. <Ref. to SE-13, REMOVAL, Rear Seat.>
- 2) Remove the trunk room mat.
- 3) Remove the clips, and then remove the trunk room rear trim.

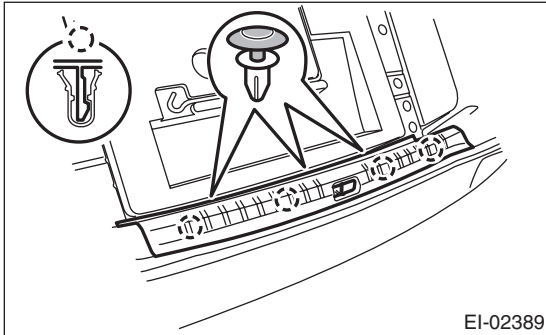

- 4) Remove the clips, and remove the trunk side trim.

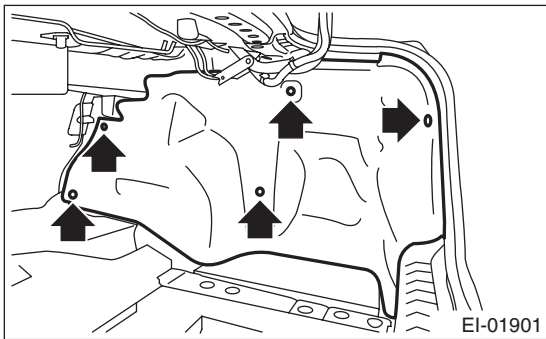

### B: INSTALLATION

Install each part in the reverse order of removal.

## 25.Sun Visor

### A: REMOVAL

1) Remove the screws and detach the sun visor.

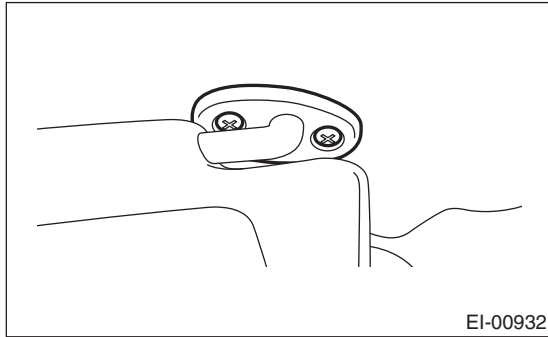

2) Disconnect the connector. (Model with vanity mirror light)

3) While pressing the (A) on the both side using flat tip screwdriver, pull the sun visor hook to remove it.

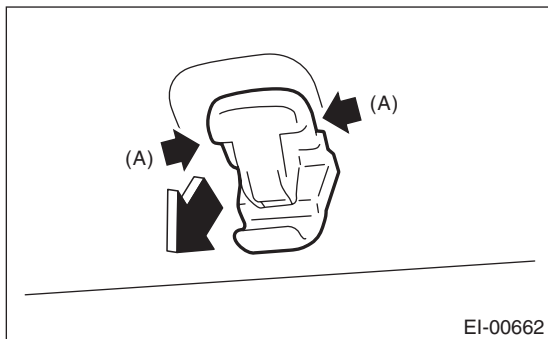

### B: INSTALLATION

Install each part in the reverse order of removal.

## 26. Assist Grip

### A: REMOVAL

- 1) Remove the screw cover, and remove the screw inside.
- 2) Pull the left side of assist grip, and rotate the right side of it counterclockwise to remove.

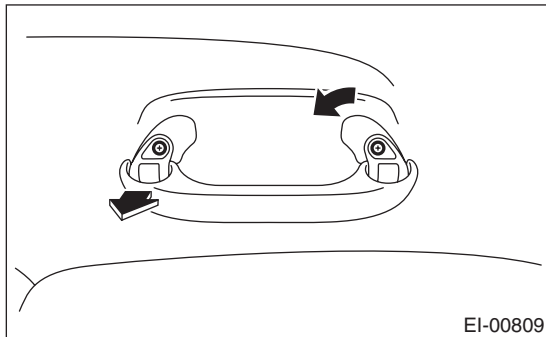

- 3) Remove the roof trim. <Ref. to EI-66, REMOVAL, Roof Trim.>
- 4) Remove the bolts, and remove the assist grip bracket.

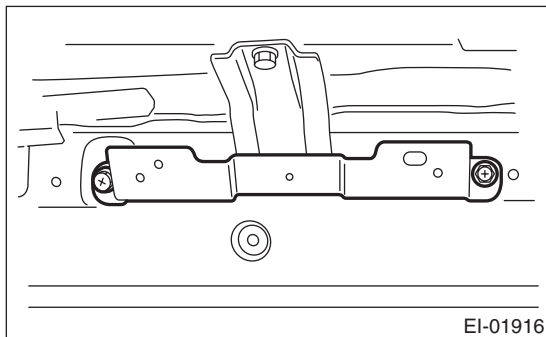

### B: INSTALLATION

Install each part in the reverse order of removal.

#### ***Tightening torque***

***7.5 N·m (0.76 kgf-m, 5.5 ft-lb)***

# Roof Trim

EXTERIOR/INTERIOR TRIM

## 27. Roof Trim

### A: REMOVAL

#### 1. 5 DOOR MODEL

- 1) Disconnect the ground cable from battery.
- 2) Remove the spot map light. <Ref. to LI-33, REMOVAL, Spot Map Light.>
- 3) Remove the room light. <Ref. to LI-34, REMOVAL, Room Light.>
- 4) Remove the sun visor. <Ref. to EI-64, REMOVAL, Sun Visor.>
- 5) Remove the assist grip. <Ref. to EI-65, REMOVAL, Assist Grip.>
- 6) Remove the upper inner trim. <Ref. to EI-59, REMOVAL, Upper Inner Trim.>
- 7) Remove the rear quarter trim. <Ref. to EI-60, REMOVAL, Rear Quarter Trim.>
- 8) Disconnect the harness connectors of the right and left front pillars, and the rear quarter (LH).
- 9) Remove the sunroof opening trim. (model with sunroof)

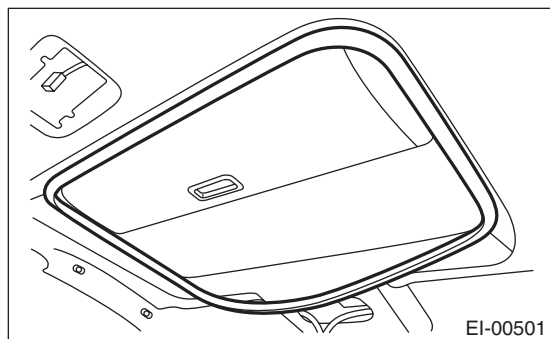

- 10) Remove the clips, and then remove the roof trim.

#### CAUTION:

**Do not remove the roof end trim with excessive force. Otherwise the roof trim may become damaged. Roof trim and roof end trim are fastened by rivets.**

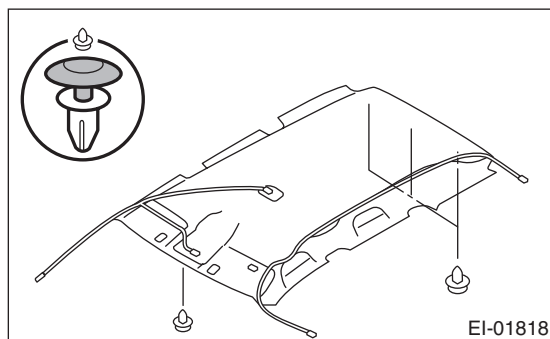

#### 2. 4 DOOR MODEL

#### CAUTION:

**When taking the roof trim out of the vehicle, be careful not to damage the room inner trim. Perform this work with 3 persons.**

- 1) Disconnect the ground cable from battery.
- 2) Apply protective tape, etc. to prevent damage to the face of the instrument panel.
- 3) Remove the spot map light. <Ref. to LI-33, REMOVAL, Spot Map Light.>
- 4) Remove the room light. <Ref. to LI-34, REMOVAL, Room Light.>
- 5) Remove the sun visor. <Ref. to EI-64, REMOVAL, Sun Visor.>
- 6) Remove the assist grip. <Ref. to EI-65, REMOVAL, Assist Grip.>
- 7) Remove the upper inner trim. <Ref. to EI-59, REMOVAL, Upper Inner Trim.>
- 8) Remove the rear quarter trim. <Ref. to EI-60, REMOVAL, Rear Quarter Trim.>
- 9) Disconnect the harness connectors of the right and left front pillars, and the rear quarter (LH).
- 10) Remove the console front panel. <Ref. to EI-52, CONSOLE FRONT PANEL, REMOVAL, Center Console.>

# Roof Trim

EXTERIOR/INTERIOR TRIM

- 11) Remove the steering wheel. <Ref. to PS-12, REMOVAL, Steering Wheel.>
- 12) Remove the passenger's side door trim. <Ref. to EI-45, REMOVAL, Door Trim.>
- 13) Remove the passenger's side door checker.

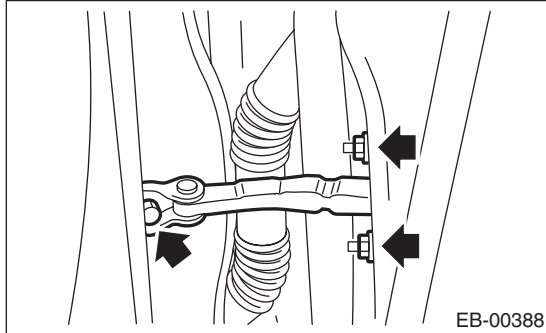

- 14) Fully recline the front seat.
- 15) Remove the sunroof opening trim. (model with sunroof)

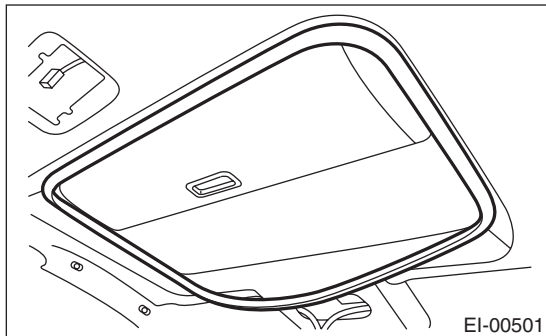

- 16) Remove the clips, and then remove the roof trim.

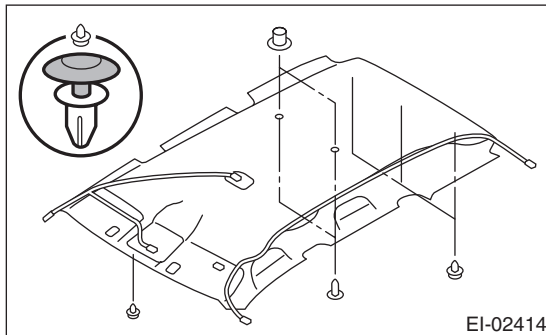

- 17) Open the passenger's side door all the way, and maintain at that position.
- 18) Take out the roof trim from the passenger's side opening.

## NOTE:

Rotate the roof trim to go through the gap between the front accessory socket and airbag control unit.



# Roof Trim

EXTERIOR/INTERIOR TRIM

## B: INSTALLATION

1) Apply the roof cord and feeder cord along the mark-off line of the roof trim.

### CAUTION:

Route and apply each cord so that they pass over the mark-off line. If not doing so, the cord may interfere, thus preventing normal deployment of the curtain airbag when necessary.

### Tape:

*Use the tape contained in the roof trim replacement parts.*

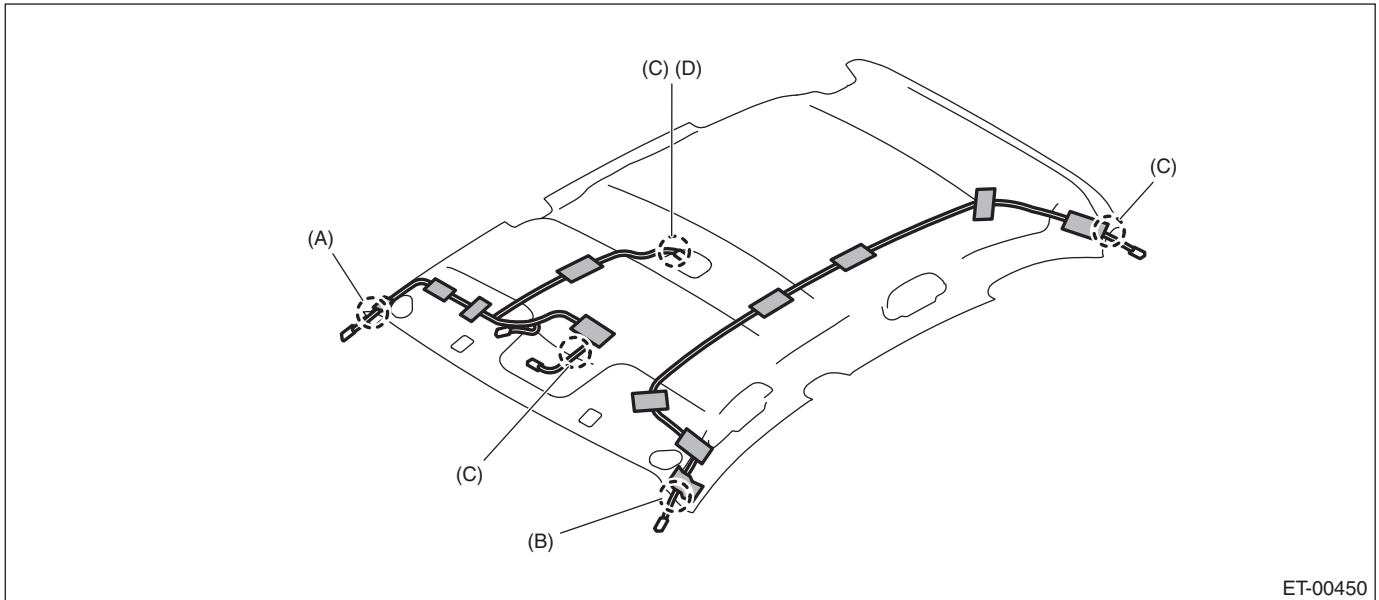

ET-00450

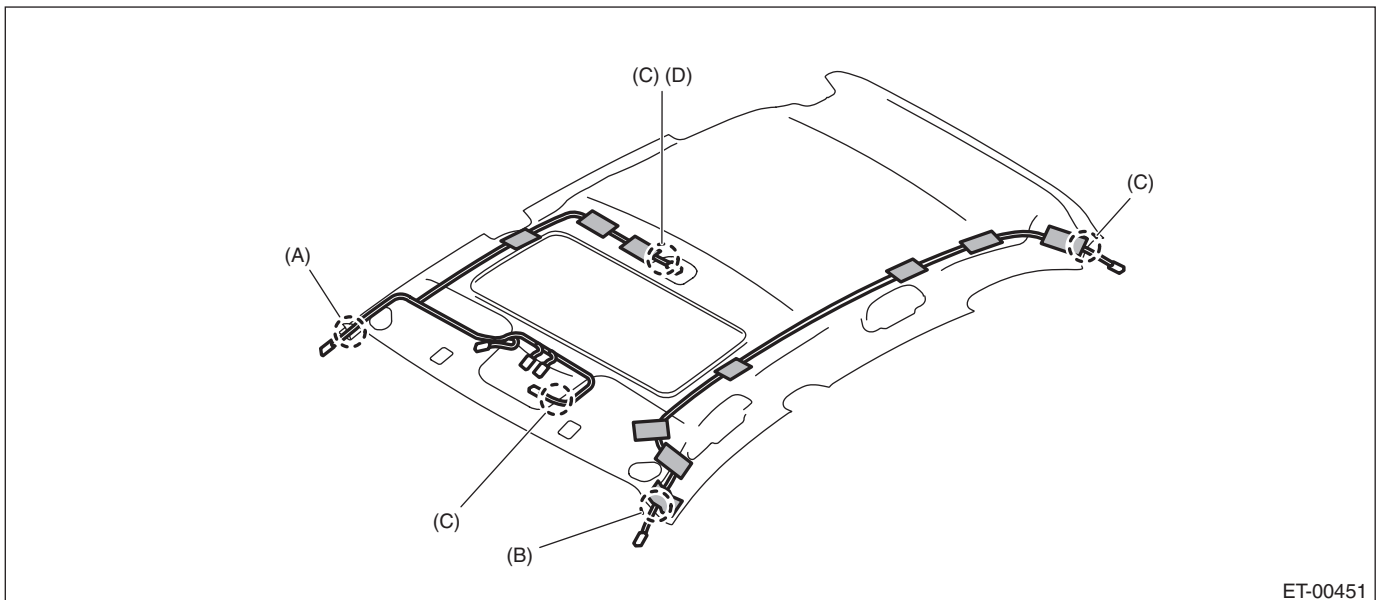

ET-00451

- (A) Align the end of roof cord white tape and the end of roof trim, and route the cord along the mark-off line of roof trim, and then affix with tape.
- (B) Align the end of feeder cord white tape and the end of roof trim, and route the cord along the mark-off line of roof trim, and then affix with tape.
- (C) Align the marking to the roof trim terminal end, and affix with tape.
- (D) Affix the roof cord end to the patch area of room light.

2) Install each part in the reverse order of removal.

EI-68

Brought to you by Ebay Seller "SubaruManuals"

## 28.Rear Gate Trim

### A: REMOVAL

#### CAUTION:

When detaching the rear gate upper trim and pillar trim, do not pull these parts with excessive force. Pulling with excessive force may damage the trim.

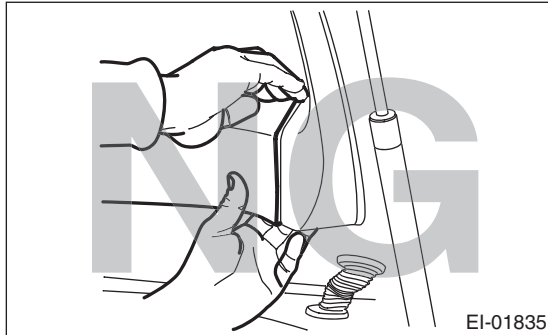

1) Remove the clips, and remove the rear gate upper trim.

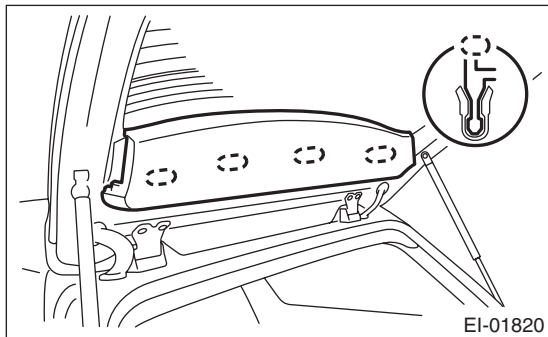

#### CAUTION:

When removing trim, make sure to follow the procedures below. Applying excessive force when removing may damage the trim. Remove the trim claws using a flat tip screwdriver (1) or clip remover (2).

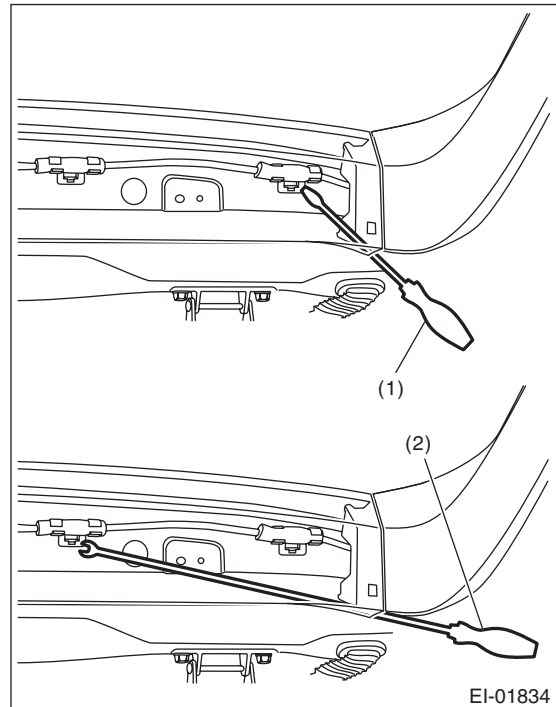

1. Remove the trim claws using a flat tip screwdriver (1).
2. Use a clip remover (2) to detach the claws of the trim.

#### Tools used

**Flat tip screwdriver:** Those with a shaft length of around 100 mm

**Clip remover:** KTC AP20L-10B

# Rear Gate Trim

## EXTERIOR/INTERIOR TRIM

2) Use a flat tip screwdriver to detach the claws of the trim, and remove the rear gate pillar trim.

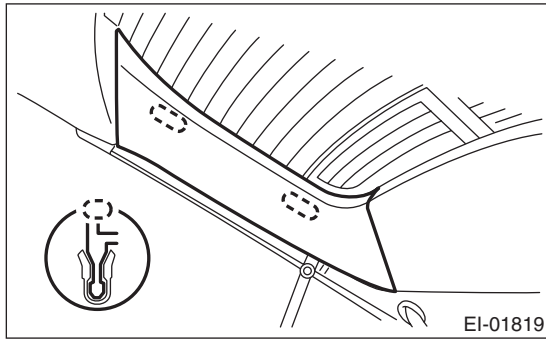

### CAUTION:

When removing trim, make sure to follow the procedures below. Applying excessive force when removing may damage the trim.

1. Insert a flat tip screwdriver (1) as shown in the figure, and then remove the trim claws.

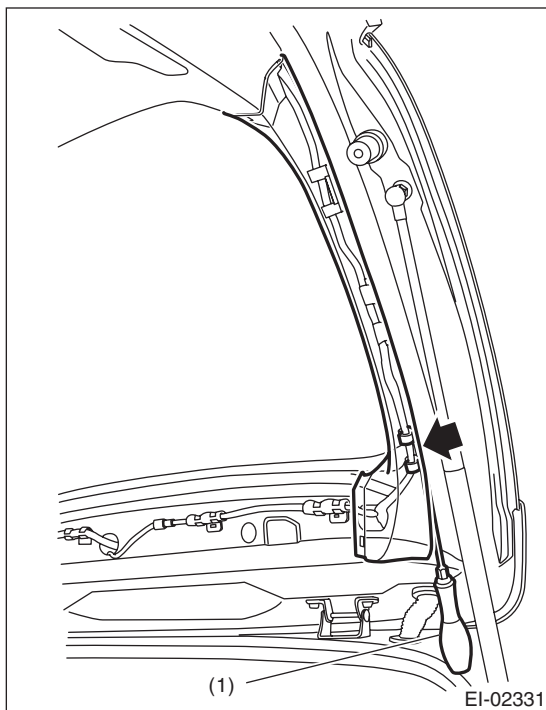

2. Insert a flat tip screwdriver (2) as shown in the figure, to detach the claws of the trim.

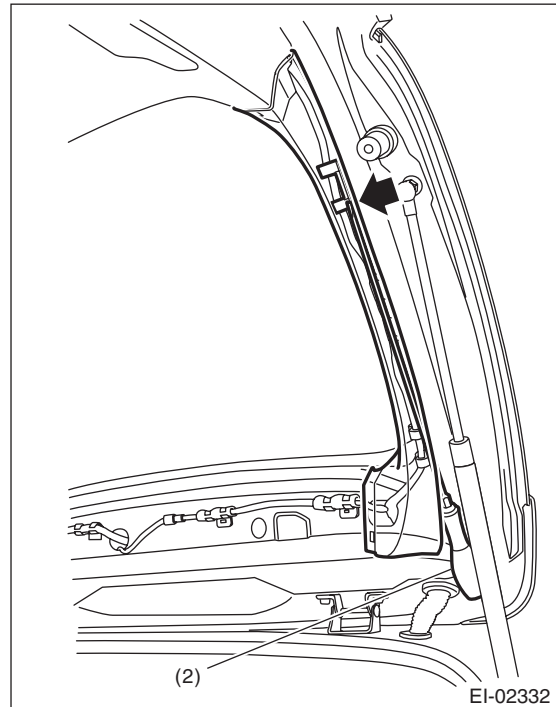

### Tools used

*Flat tip screwdriver (1): Axle length 100 mm*

*Flat tip screwdriver (2): Axle length 290 mm*

3) Remove the clips, and then remove the rear gate lower trim.

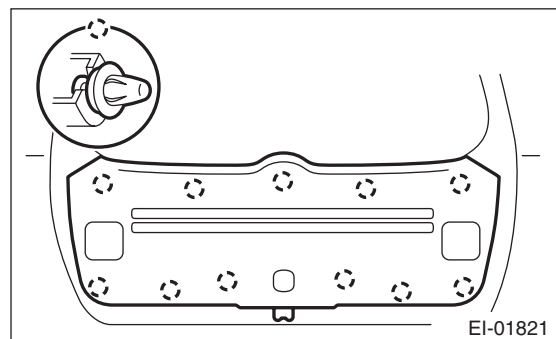

## B: INSTALLATION

Install each part in the reverse order of removal.

## 29. Floor Mat

### A: REMOVAL

- 1) Remove the front seats. <Ref. to SE-6, REMOVAL, Front Seat.>
- 2) Remove the rear seat cushion. <Ref. to SE-13, REMOVAL, Rear Seat.>
- 3) Remove the console box. <Ref. to EI-51, Console Box.>
- 4) Remove the console side panel. <Ref. to EI-52, REMOVAL, Center Console.>
- 5) Remove the lower inner trim. <Ref. to EI-57, REMOVAL, Lower Inner Trim.>
- 6) Remove the fuel filler lid opener. <Ref. to SL-41, FUEL FILLER LID OPENER, REMOVAL, Remote Openers.>
- 7) Remove the clips from the floor mat.
- 8) Remove the mat hook on both sides.
- 9) Remove the mat from toe board area.
- 10) Remove the mat from rear heater duct.
- 11) Roll the mat, and then take it out of opened rear door.

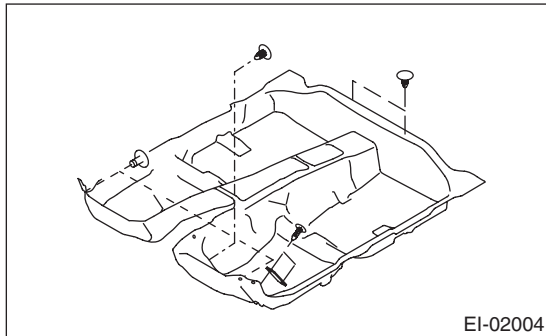

### B: INSTALLATION

Install each part in the reverse order of removal.

#### NOTE:

- Secure the mat firmly with hook and clip.
- Insert the mat edge firmly into the groove of side sill cover.

## 30.Rear Gate Garnish

### A: REMOVAL

- 1) Remove the rear gate trim. <Ref. to EI-69, REMOVAL, Rear Gate Trim.>
- 2) Remove the rear wiper motor. <Ref. to WW-20, Rear Wiper Motor.>
- 3) Remove the rear finisher light. <Ref. to LI-29, REMOVAL, Rear Finisher Light Assembly.>
- 4) Disconnect the connector of rear gate opener button.
- 5) Remove the nuts.

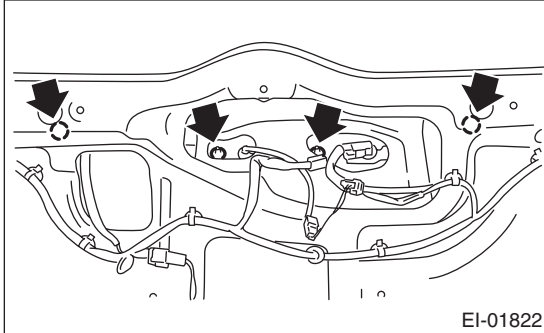

- 6) Remove the clips, and remove the rear gate garnish.

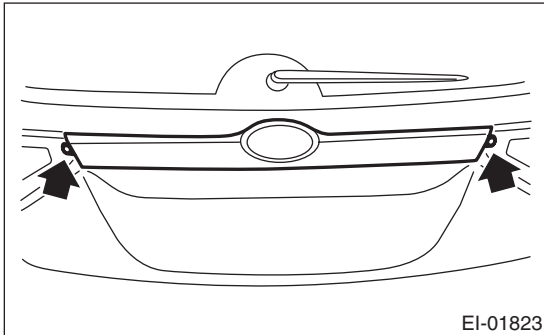

### B: INSTALLATION

#### CAUTION:

**Make sure that the harness grommet is securely installed.**

**If not properly installed, this may cause leaks.**

Install each part in the reverse order of removal.

#### **Tightening torque:**

**4.5 N·m (0.46 kgf-m, 3.3 ft-lb)**

## 31. Trunk Lid Garnish

### A: REMOVAL

1) Remove the nut in the upper part of the trunk lid garnish.

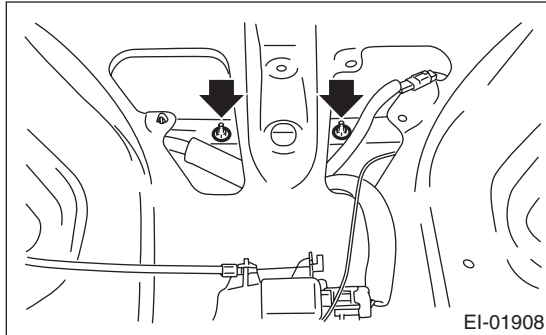

2) Disconnect the license plate light harness connector.

3) Remove the clips and the trunk lid garnish.

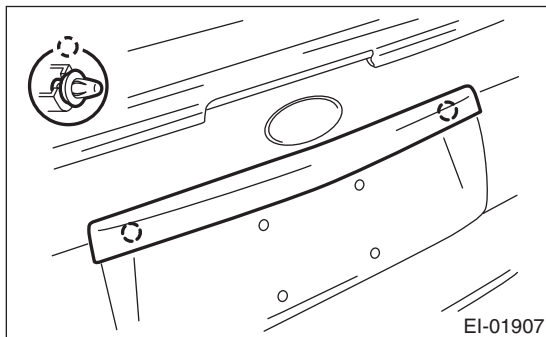

### B: INSTALLATION

Install each part in the reverse order of removal.

**Tightening torque:**

**4.5 N·m (0.46 kgf·m, 3.3 ft·lb)**

# Heat Shield Cover

EXTERIOR/INTERIOR TRIM

## 32. Heat Shield Cover

### A: REMOVAL

#### 1. FRONT HEAT SHIELD COVER

- 1) Disconnect the ground cable from battery.
- 2) Disconnect the connector from oxygen (A/F) sensor. <Ref. to EX(STI)-8, REMOVAL, Center Exhaust Pipe.>
- 3) Remove the exhaust pipe. <Ref. to EX(STI)-13, REMOVAL, Rear Exhaust Pipe.>
- 4) Remove the four bolts to remove the front heat shield cover.

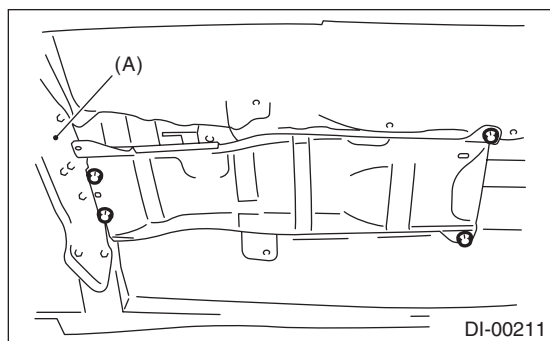

(A) Transmission mount

#### 2. CENTER HEAT SHIELD COVER

- 1) Remove the rear exhaust pipe. <Ref. to EX(STI)-13, REMOVAL, Rear Exhaust Pipe.>
- 2) Remove the propeller shaft. <Ref. to DS-11, REMOVAL, Propeller Shaft.>
- 3) Remove the bolt (A), nut (B) and clip (C) to remove center heat shield cover.

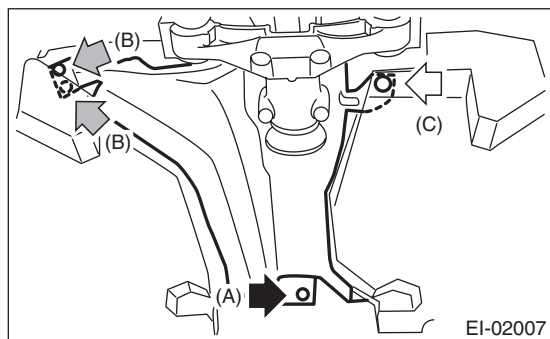

#### 3. REAR HEAT SHIELD COVER

- 1) Remove the muffler. <Ref. to EX(STI)-15, REMOVAL, Muffler.>
  - 2) Remove the bolts, and remove the rear heat shield cover.
- 5 door model

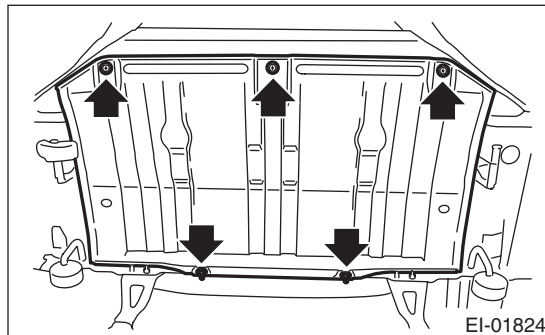

- 4 door model

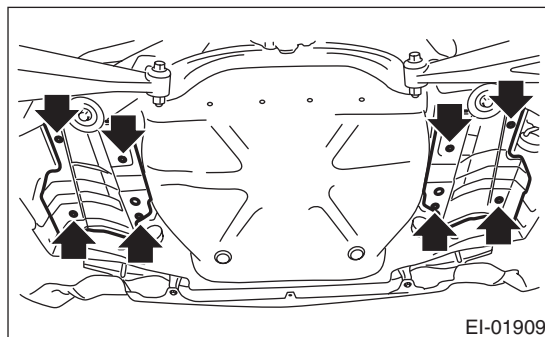

### B: INSTALLATION

Install each part in the reverse order of removal.

#### Tightening torque:

Refer to "COMPONENT" of "General Description". <Ref. to EI-24, HEAT SHIELD COVER, COMPONENT, General Description.>

## 33.Ornament

### A: INSTALLATION

#### 1. LETTER MARK

Adhere the letter mark according to the following position.

- 5 door model

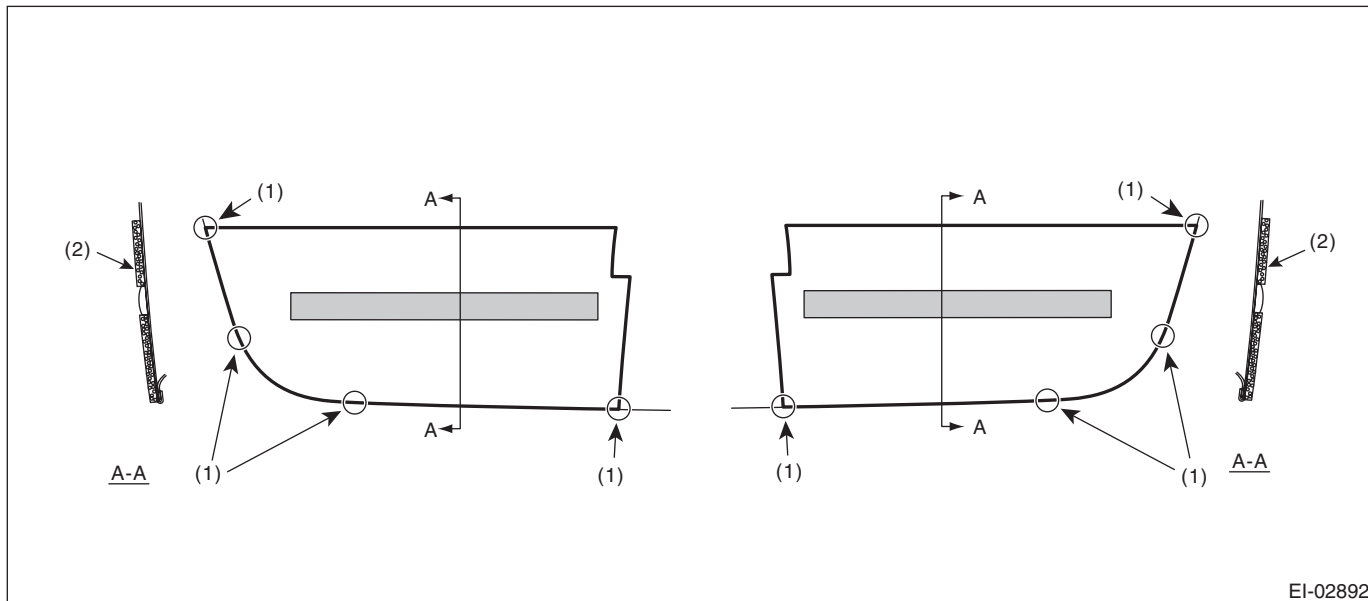

- (1) Match the end of the application tape to the end of the rear gate panel.
- (2) Application tape

- 4 door model

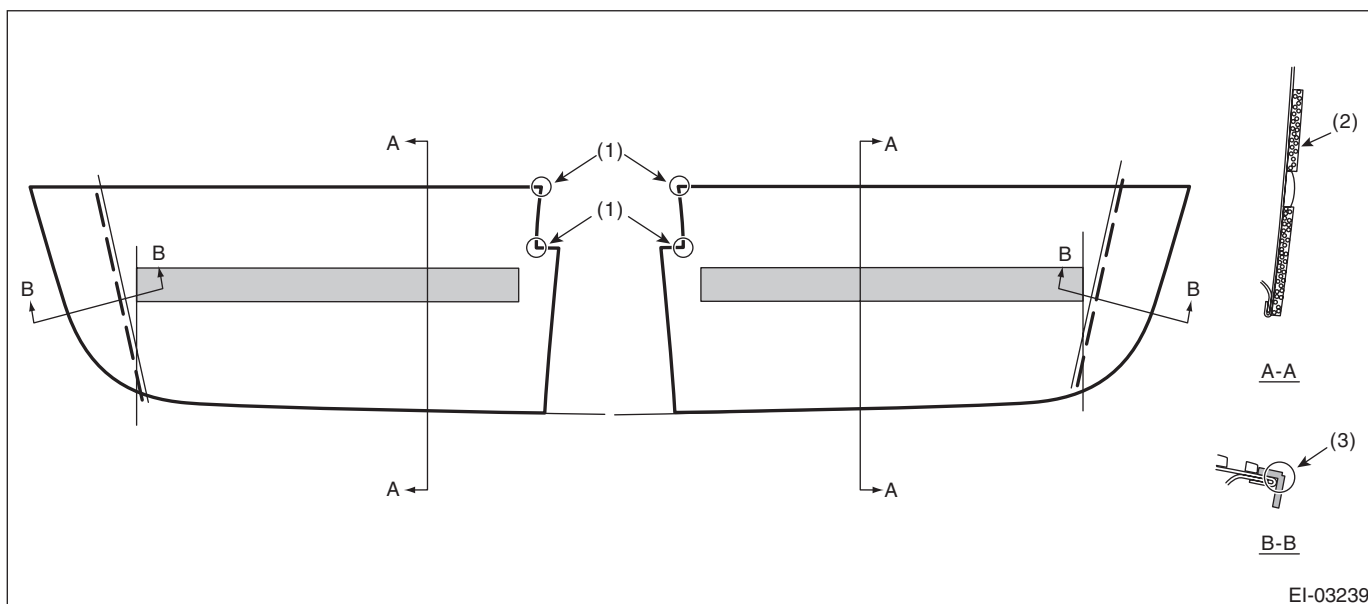

- (1) Match the end of the application tape to the end of the trunk lid garnish.
- (2) Application tape
- (3) Bend the slit of the application tape to fit along the end of the trunk panel.



# Ornament

EXTERIOR/INTERIOR TRIM

---

# EXTERIOR BODY PANELS

# EB

---

	<b>Page</b>
1. General Description .....	2
2. Front Hood .....	15
3. Front Fender .....	17
4. Front Performance Stay .....	18
5. Front Door .....	19
6. Front Sealing Cover .....	21
7. Rear Door .....	22
8. Rear Sealing Cover .....	24
9. Door Sash Tape .....	25
10. Rear Gate .....	30
11. Trunk Lid .....	33
12. Protector Tape .....	35

# General Description

## EXTERIOR BODY PANELS

### 1. General Description

#### A: SPECIFICATION

##### 1. FRONT

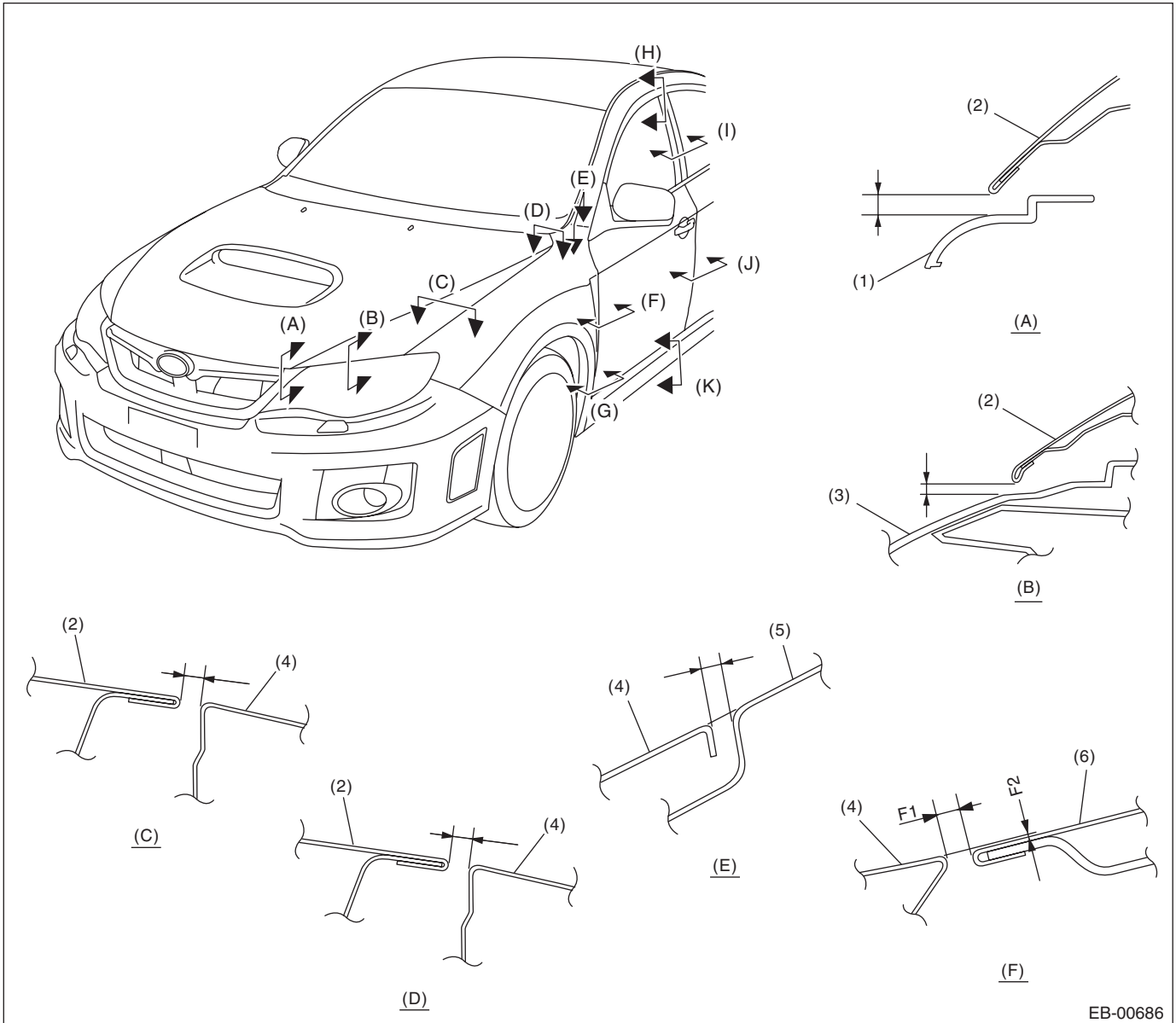

EB-00686

# General Description

## EXTERIOR BODY PANELS

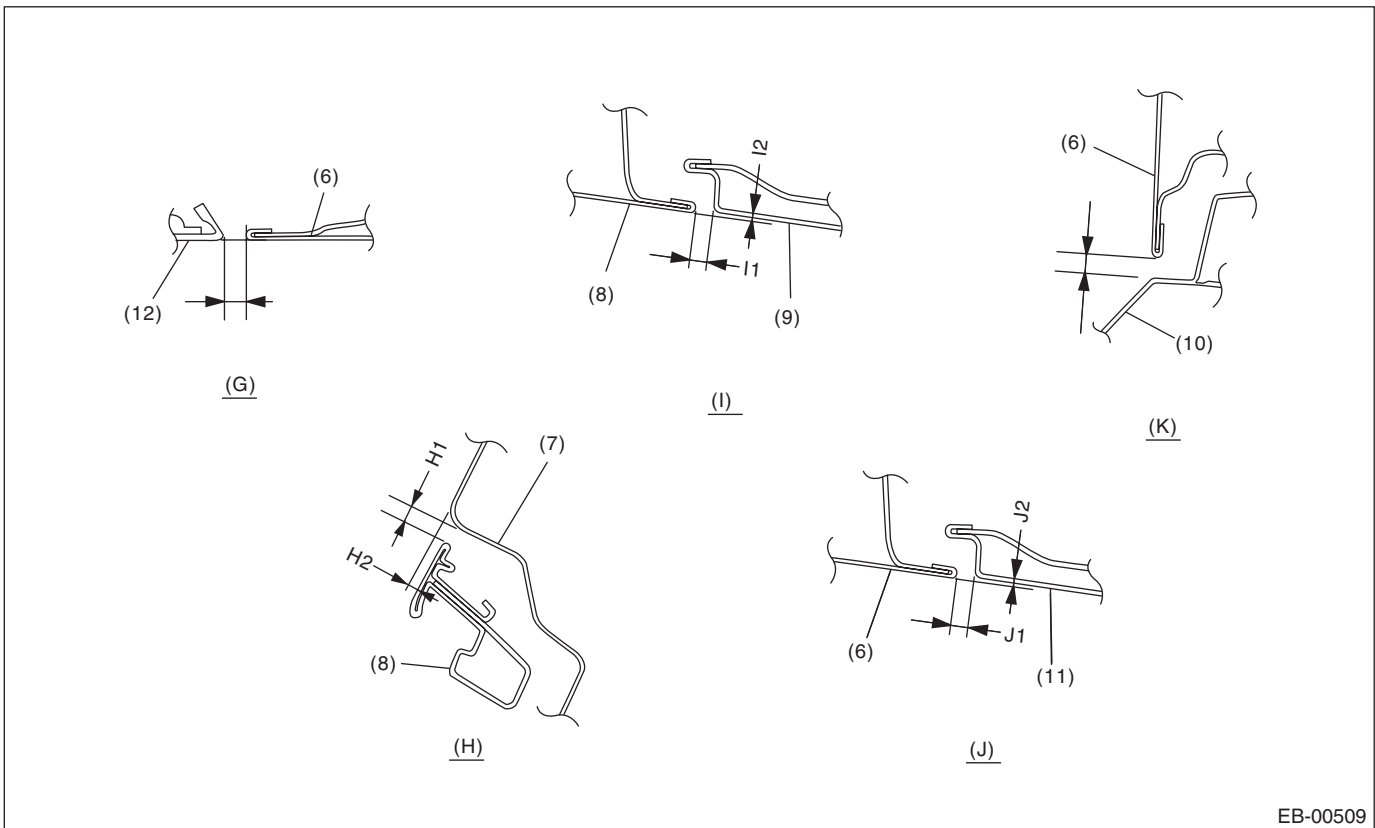

EB-00509

- |                        |                        |                        |
|------------------------|------------------------|------------------------|
| (1) Front grille       | (5) Front pillar panel | (9) Rear door sash     |
| (2) Front hood panel   | (6) Front door panel   | (10) Side sill spoiler |
| (3) Headlight          | (7) Roof panel         | (11) Rear door panel   |
| (4) Front fender panel | (8) Front door sash    | (12) Fender garnish    |

Section	Part	Standard
(A)	Front hood panel to Front grille	6.0±1.0 mm (0.24±0.04 in)
(B)	Front hood panel to Headlight	6.0±1.0 mm (0.24±0.04 in)
(C)	Front hood panel to Front fender panel	3.5±1.0 mm (0.14±0.04 in)
(D)	Front hood panel to Front fender panel (Rear end only)	4.8+0.7, -1.0 mm (0.19+0.03, -0.04 in)
(E)	Front fender panel to Front pillar panel	3.0±1.0 mm (0.12±0.04 in)
(F)	Front fender panel to Front door panel	F1: 4.0±1.0 mm (0.16±0.04 in) F2: 0+1.0, -0.5 mm (0+0.04, -0.02 in) (Make sure that the fender panel is slightly outside of the door panel)
(G)	Fender garnish to Front door panel	4.0±1.0 mm (0.16±0.04 in)
(H)	Roof panel to Front door sash	H1: 5.0±1.0 mm (0.20±0.04 in) H2: 3.8±1.0 mm (0.15±0.04 in)
(I)	Front door sash to Rear door sash	I1: 5.5±1.0 mm (0.22±0.04 in) I2: 0+1.0, -0.5 mm (0+0.04, -0.02 in) (Make sure that the front door side is slightly outside of the rear door side)
(J)	Front door panel to Rear door panel	J1: 4.5±1.0 mm (0.18±0.04 in) J2: 0+1.0, -0.5 mm (0+0.04, -0.02 in) (Make sure that the front door side is slightly outside of the rear door side)
(K)	Front door panel to Side sill spoiler	6.0±1.0 mm (0.24±0.04 in)

### NOTE:

For surface level gap between sunroof glass lid and roof panel, refer to "SUNROOF" section. <Ref. to SR-5, ADJUSTMENT, Glass Lid.>

# General Description

## EXTERIOR BODY PANELS

### 2. REAR

#### 5 DOOR MODEL

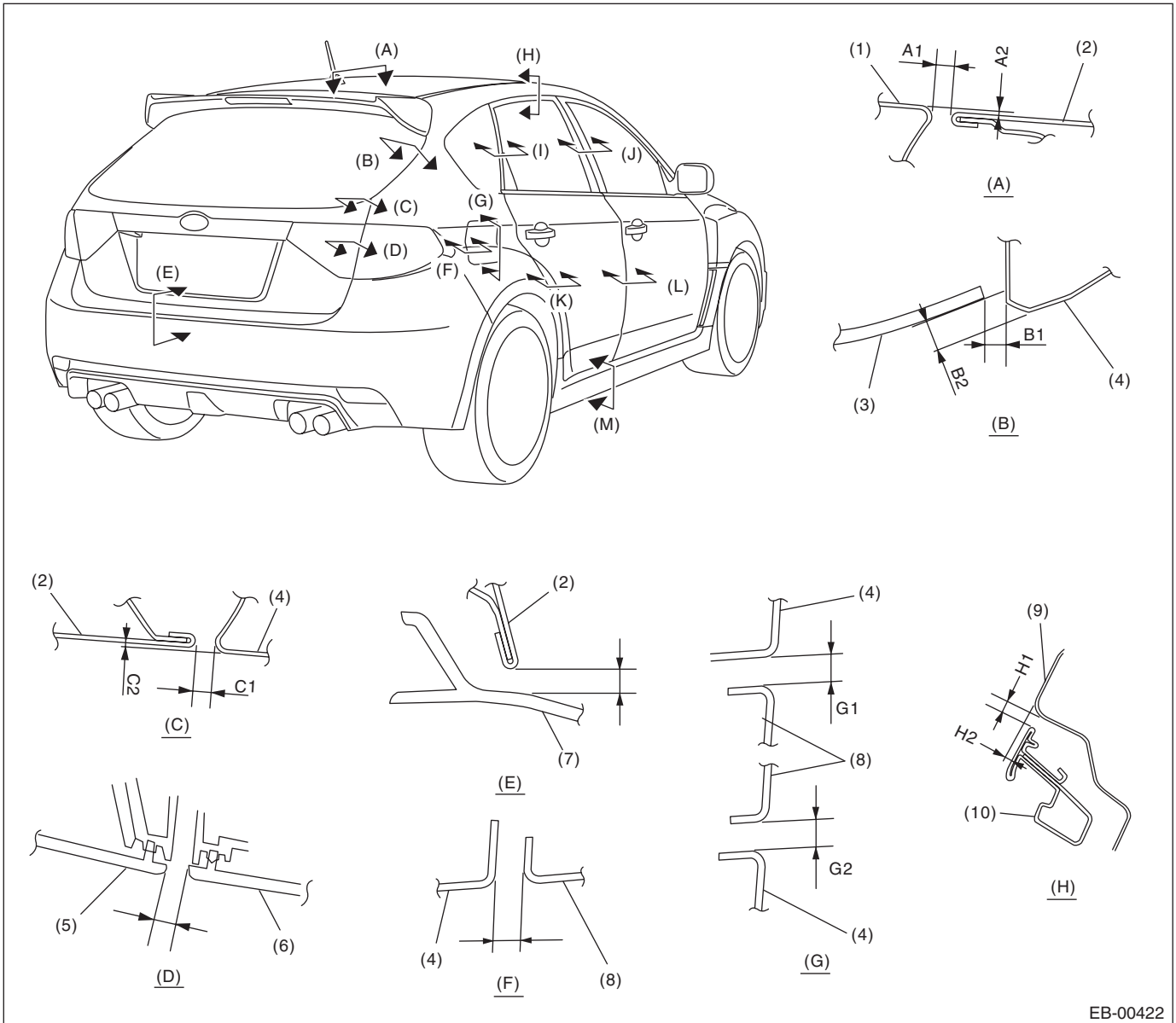

EB-00422

# General Description

## EXTERIOR BODY PANELS

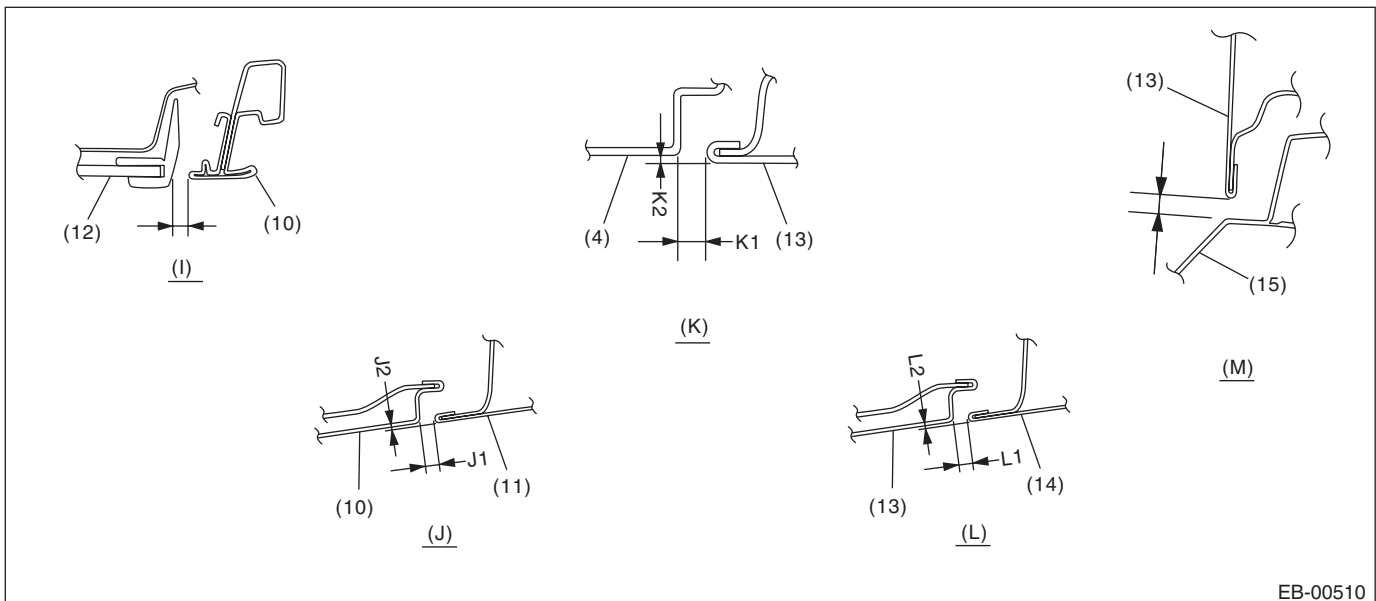

EB-00510

- |                         |                            |                         |
|-------------------------|----------------------------|-------------------------|
| (1) Roof panel          | (6) Rear combination light | (11) Front door sash    |
| (2) Rear gate panel     | (7) Rear bumper            | (12) Rear quarter glass |
| (3) Rear gate glass     | (8) Fuel filler lid        | (13) Rear door panel    |
| (4) Rear quarter panel  | (9) Roof panel             | (14) Front door panel   |
| (5) Rear finisher light | (10) Rear door sash        | (15) Side sill spoiler  |

Section	Part	Standard value
(A)	Roof panel to Rear gate panel	A1: 6.0+1.0-0.5 mm (0.24+0.04-0.02 in) A2: 1.0±1.0 mm (0.04±0.04 in)
(B)	Rear gate glass to Rear quarter panel	B1: 5.0±1.5 mm (0.20±0.06 in) B2: 6.7±1.5 mm (0.26±0.06 in)
(C)	Rear gate panel to Rear quarter panel	C1: 4.6±1.0 mm (0.18±0.04 in) C2: 0.5±1.0 mm (0.02±0.04 in)
(D)	Rear combination light to Rear finisher light	5.0±1.0 mm (0.20±0.04 in)
(E)	Rear gate panel to Rear bumper	8.0±1.0 mm (0.31±0.04 in)
(F)	Rear quarter panel to Fuel filler lid	3.5±0.5 mm (0.14±0.02 in)
(G)	Rear quarter panel to Fuel filler lid	G1: 3.5±0.5 mm (0.14±0.02 in) G2: 3.5±0.5 mm (0.14±0.02 in)
(H)	Roof panel to Rear door sash	H1: 5.0±1.0 mm (0.20±0.04 in) H2: 3.8±1.0 mm (0.15±0.04 in)
(I)	Rear door sash to Rear quarter glass molding	7.0±1.0 mm (0.28±0.04 in)
(J)	Rear door sash to Front door sash	J1: 5.5±1.0 mm (0.22±0.04 in) J2: 0+1.0, -0.5 mm (0+0.04, -0.02 in) (Make sure that the front door side is slightly outside of the rear door side)
(K)	Rear door panel to Rear quarter panel	K1: 4.0±1.0 mm (0.16±0.04 in) K2: 0+1.0, -0.5 mm (0+0.04, -0.02 in) (Make sure that the rear door panel is slightly outside of the quarter panel)
(L)	Front door panel to Rear door panel	L1: 4.5±1.0 mm (0.18±0.04 in) L2: 0+1.0, -0.5 mm (0+0.04, -0.02 in) (Make sure that the front door side is slightly outside of the rear door side)
(M)	Rear door panel to Side sill spoiler	6.0±1.0 mm (0.24±0.04 in)

### NOTE:

For surface level gap between sunroof glass lid and roof panel, refer to "SUNROOF" section. <Ref. to SR-5, ADJUSTMENT, Glass Lid.>

# General Description

## EXTERIOR BODY PANELS

### 4 door model

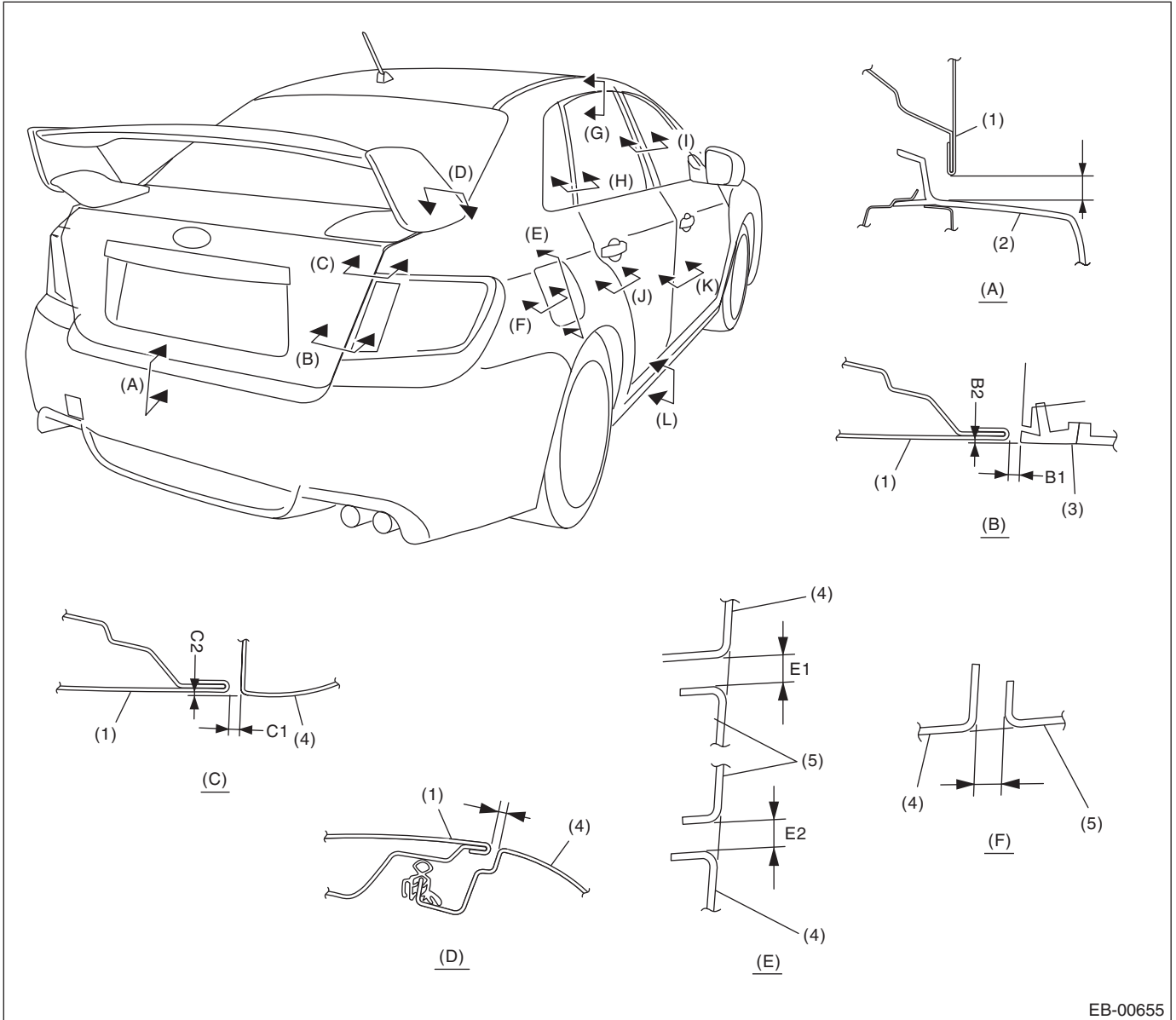

EB-00655

# General Description

## EXTERIOR BODY PANELS

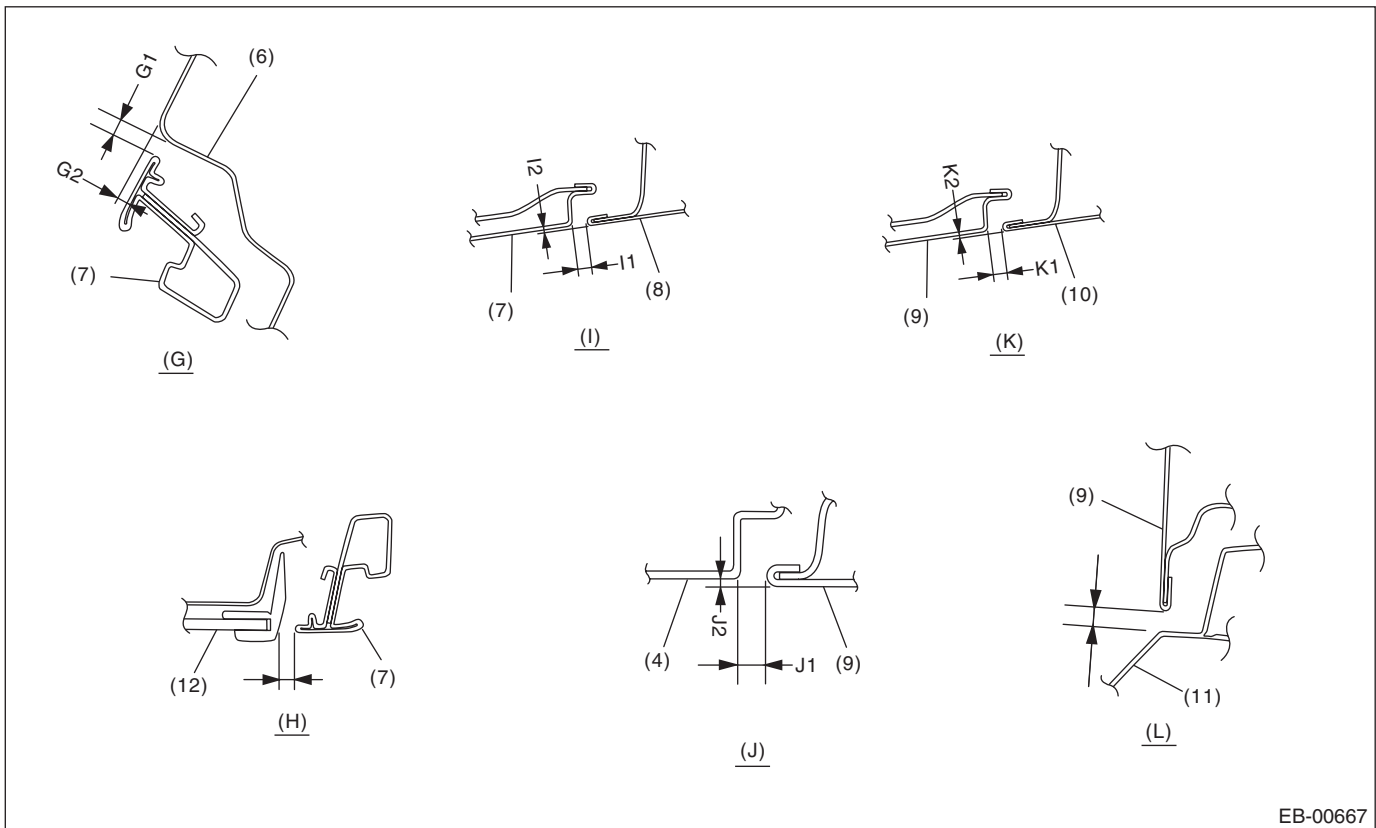

EB-00667

- |                            |                     |                         |
|----------------------------|---------------------|-------------------------|
| (1) Trunk panel            | (5) Fuel filler lid | (9) Rear door panel     |
| (2) Rear bumper            | (6) Roof panel      | (10) Front door panel   |
| (3) Rear combination light | (7) Rear door sash  | (11) Side sill spoiler  |
| (4) Rear quarter panel     | (8) Front door sash | (12) Rear quarter glass |

Section	Part	Standard value
(A)	Trunk panel to Rear bumper face	9.0±1.0 mm (0.35±0.04 in)
(B)	Trunk panel to Rear combination light	B1: 3.5±1.0 mm (0.14±0.04 in) B2: 0.5±1.0 mm (0.02±0.04 in)
(C)	Trunk panel to Rear quarter panel	C1: 3.5±1.0 mm (0.14±0.04 in) C2: 0.5±0.7 mm (0.02±0.03 in)
(D)	Trunk panel to Rear quarter panel	3.5±1.0 mm (0.14±0.04 in)
(E)	Rear quarter panel to Fuel filler lid	E1: 3.5±0.5 mm (0.14±0.02 in) E2: 3.5±0.5 mm (0.14±0.02 in)
(F)	Rear quarter panel to Fuel filler lid	3.5±0.5 mm (0.14±0.02 in)
(G)	Roof panel to Rear door sash	G1: 5.0±1.0 mm (0.20±0.04 in) G2: 3.8±1.0 mm (0.15±0.04 in)
(H)	Rear door sash to Rear quarter glass	7.0±1.0 mm (0.28±0.04 in)
(I)	Rear door sash to Front door sash	I1: 5.5±1.0 mm (0.22±0.04 in) I2: 0+1.0, -0.5 mm (0+0.04, -0.02 in) (Make sure that the front door side is slightly outside of the rear door side)
(J)	Rear door panel to Rear quarter panel	J1: 4.0±1.0 mm (0.16±0.04 in) J2: 0+1.0, -0.5 mm (0+0.04, -0.02 in) (Make sure that the rear door panel is slightly outside of the rear quarter panel)
(K)	Front door panel to Rear door panel	K1: 4.5±1.0 mm (0.18±0.04 in) K2: 0+1.0, -0.5 mm (0+0.04, -0.02 in) (Make sure that the front door side is slightly outside of the rear door side)
(L)	Rear door panel to Side sill spoiler	6.0±1.0 mm (0.24±0.04 in)



# General Description

## EXTERIOR BODY PANELS

### NOTE:

For surface level gap between sunroof glass lid and roof panel, refer to "SUNROOF" section. <Ref. to SR-5, ADJUSTMENT, Glass Lid.>

## B: COMPONENT

### 1. FRONT HOOD

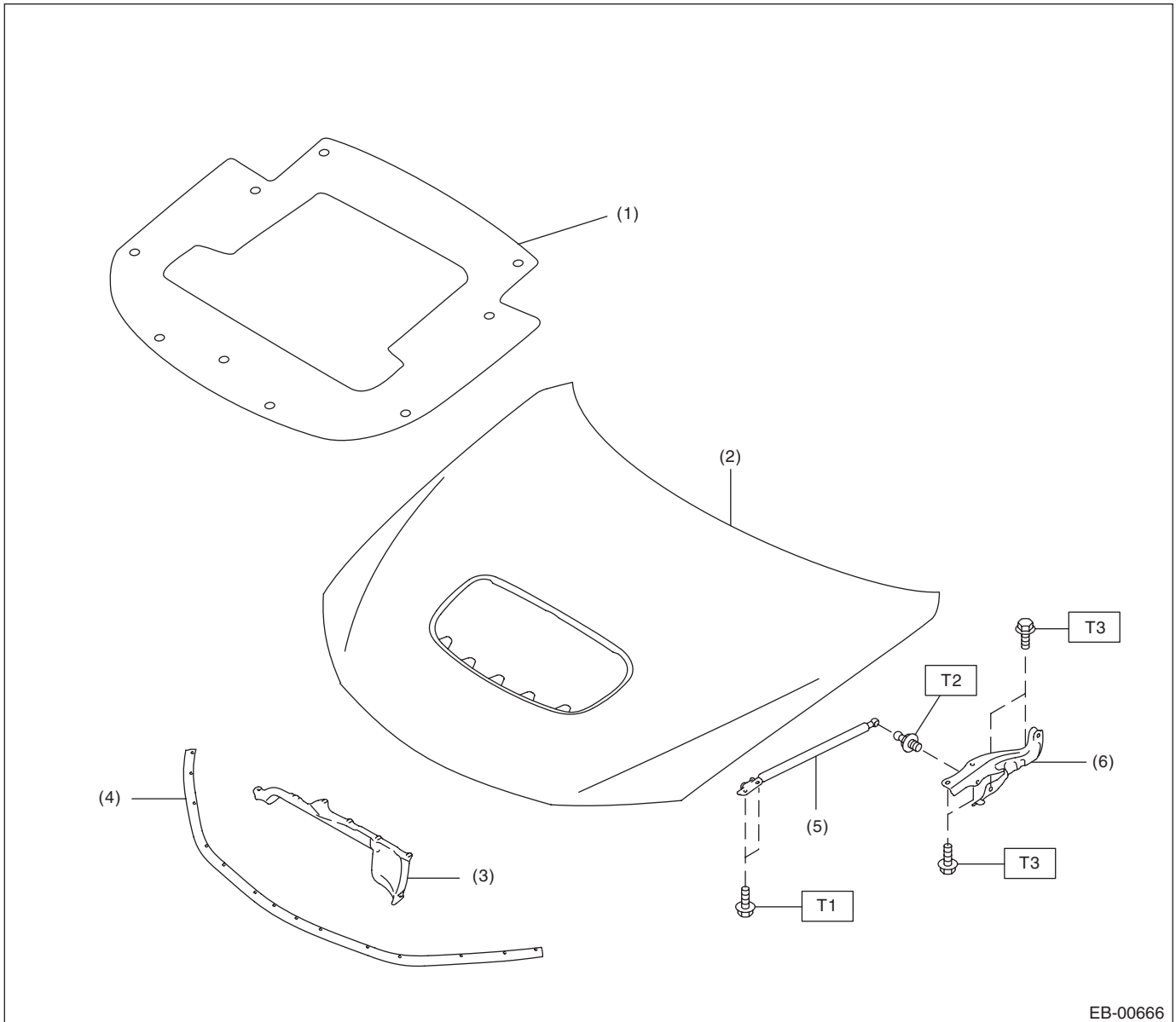

- |                           |                        |
|---------------------------|------------------------|
| (1) Insulator             | (4) Seal (front panel) |
| (2) Front hood panel ASSY | (5) Damper stay        |
| (3) Seal (intake duct)    | (6) Hinge              |

**Tightening torque: N·m (kgf·m, ft·lb)**

**T1: 7.5 (0.76, 5.5)**

**T2: 20 (2.04, 14.8)**

**T3: 25 (2.55, 18.4)**

## 2. FRONT FENDER

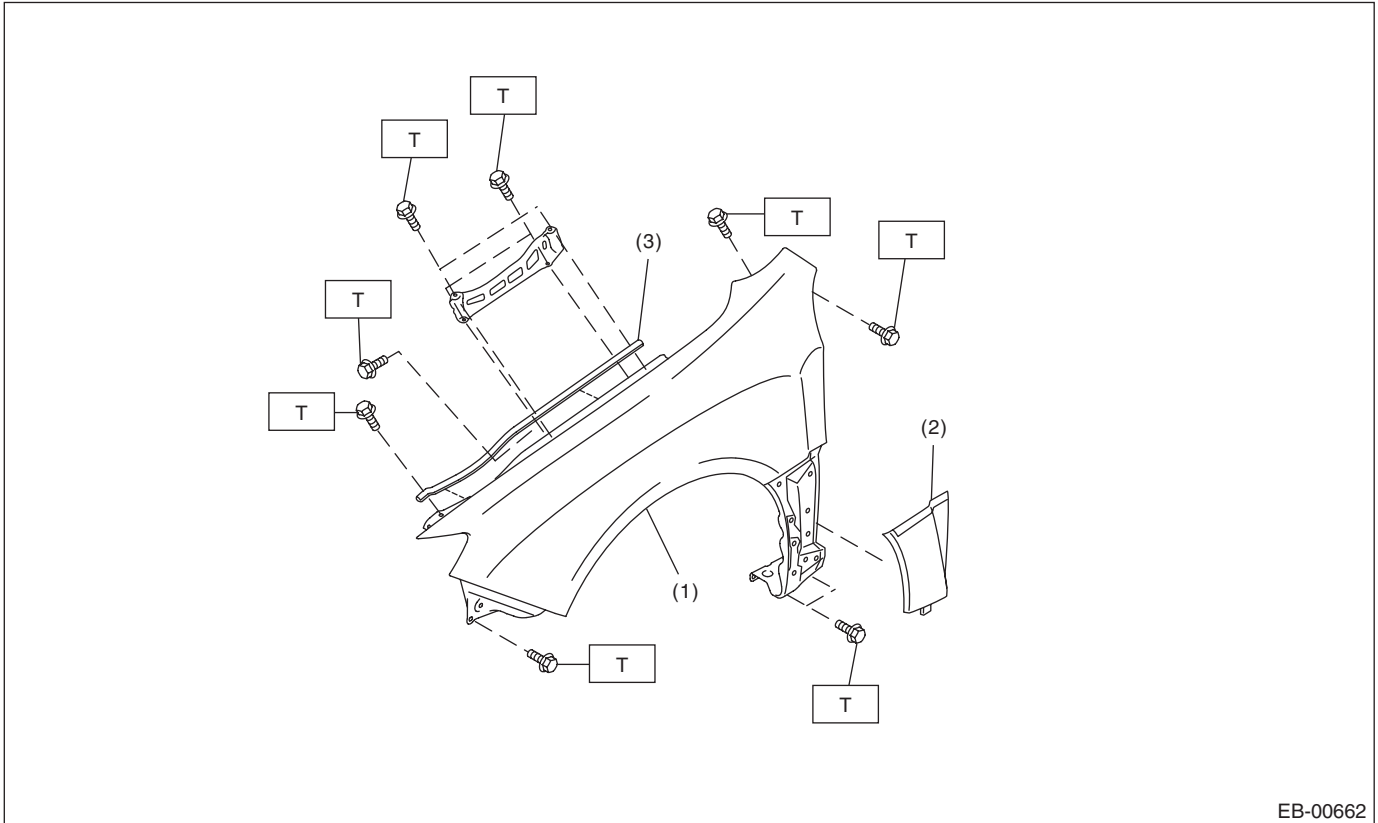

EB-00662

- (1) Front fender panel
- (2) Front fender garnish

- (3) Protector

**Tightening torque: N·m (kgf·m, ft·lb)**  
**T: 7.5 (0.76, 5.5)**

# General Description

## EXTERIOR BODY PANELS

### 3. FRONT DOOR

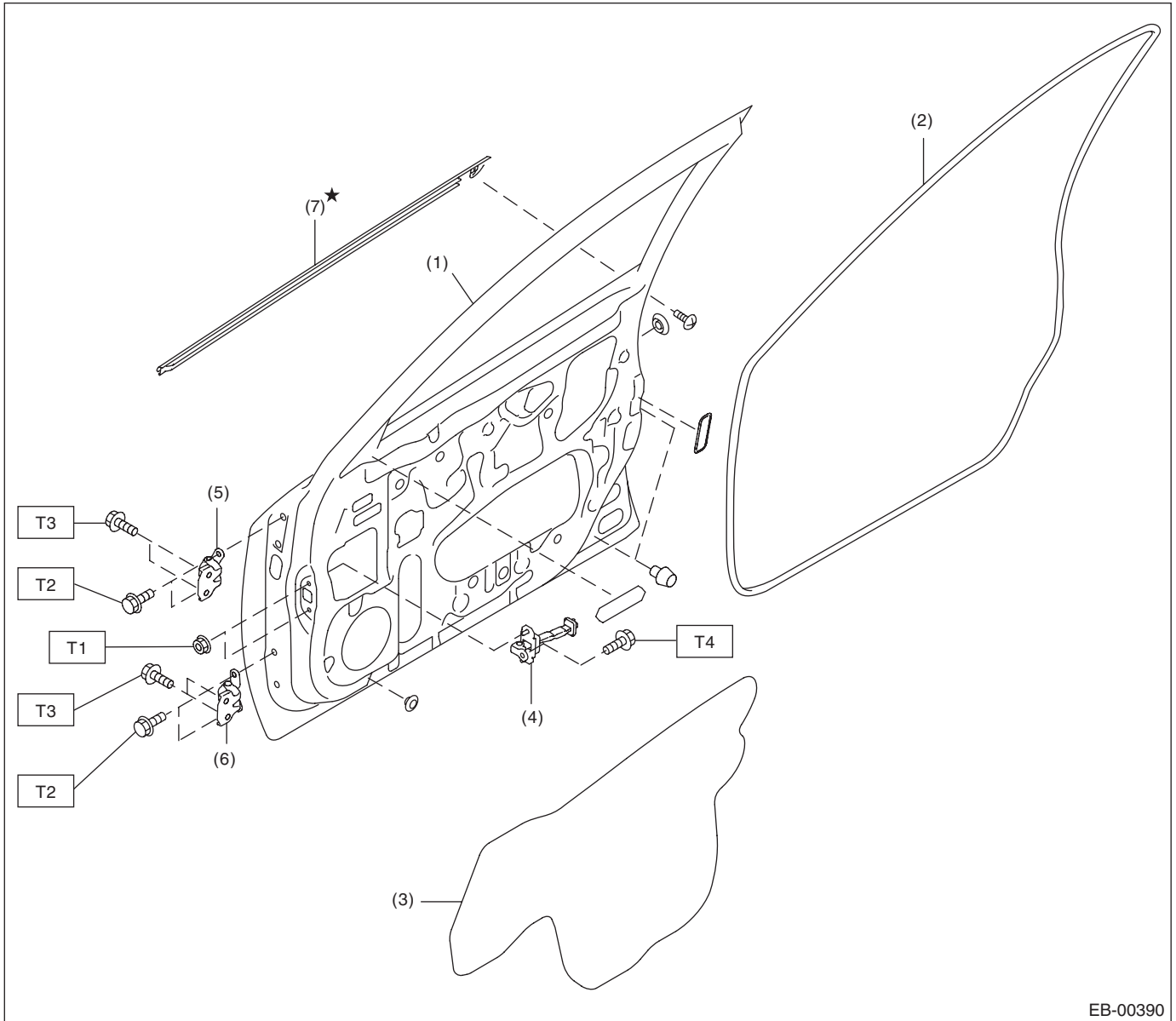

EB-00390

- |                                    |                                    |
|------------------------------------|------------------------------------|
| (1) Front door panel               | (5) Upper hinge                    |
| (2) Front door weather strip inner | (6) Lower hinge                    |
| (3) Sealing cover                  | (7) Front door weather strip outer |
| (4) Checker                        |                                    |

**Tightening torque: N·m (kgf·m, ft·lb)**

**T1: 7.5 (0.76, 5.5)**

**T2: 25 (2.55, 18.4)**

**T3: 30 (3.06, 22.1)**

**T4: 33 (3.36, 24.3)**

## 4. REAR DOOR

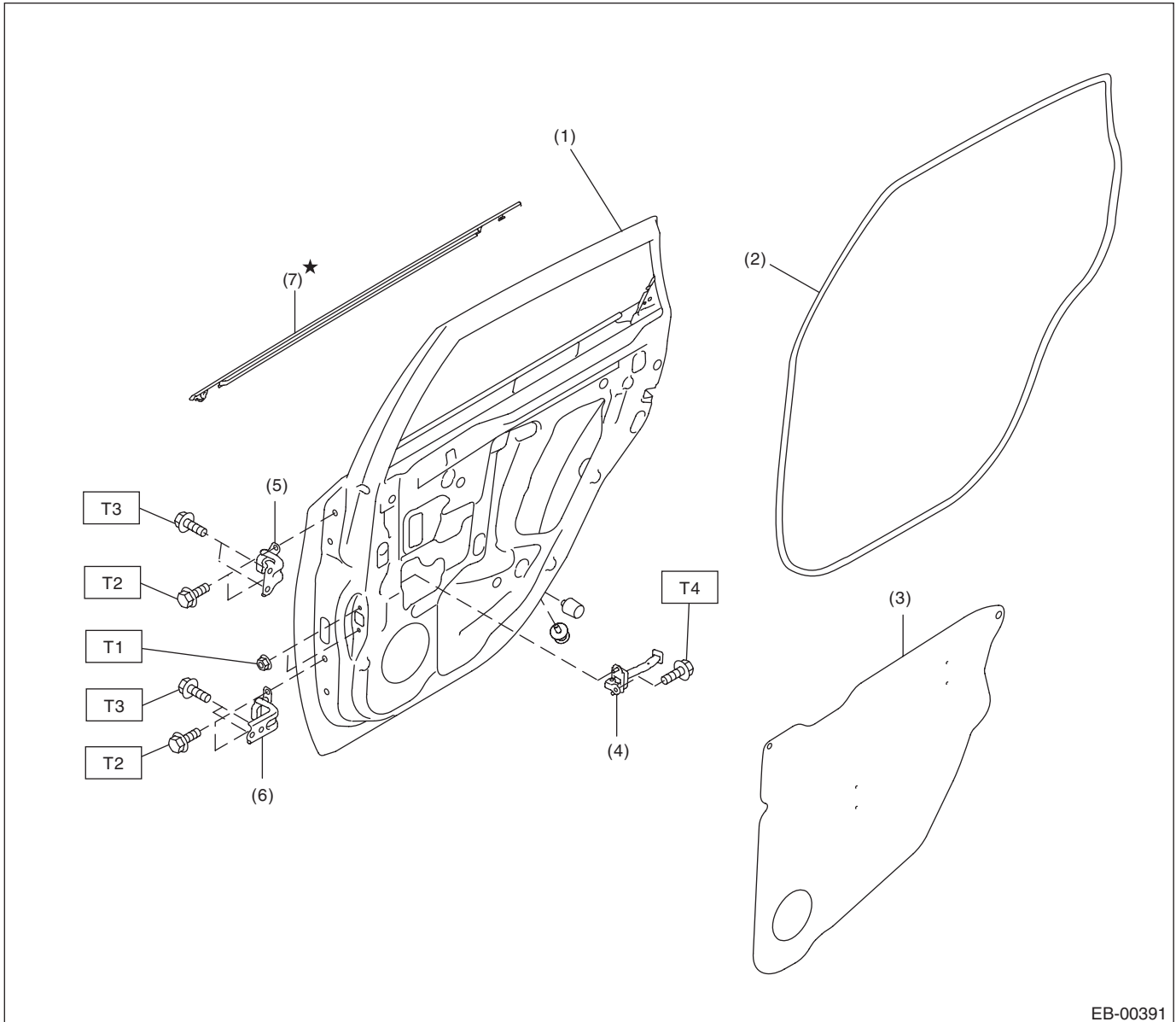

EB-00391

- |                                   |                                   |
|-----------------------------------|-----------------------------------|
| (1) Rear door panel               | (5) Upper hinge                   |
| (2) Rear door weather strip inner | (6) Lower hinge                   |
| (3) Sealing cover                 | (7) Rear door weather strip outer |
| (4) Checker                       |                                   |

**Tightening torque: N·m (kgf·m, ft·lb)**

**T1: 7.5 (0.76, 5.5)**

**T2: 25 (2.55, 18.4)**

**T3: 30 (3.06, 22.1)**

**T4: 33 (3.36, 24.3)**

# General Description

## EXTERIOR BODY PANELS

### 5. REAR GATE

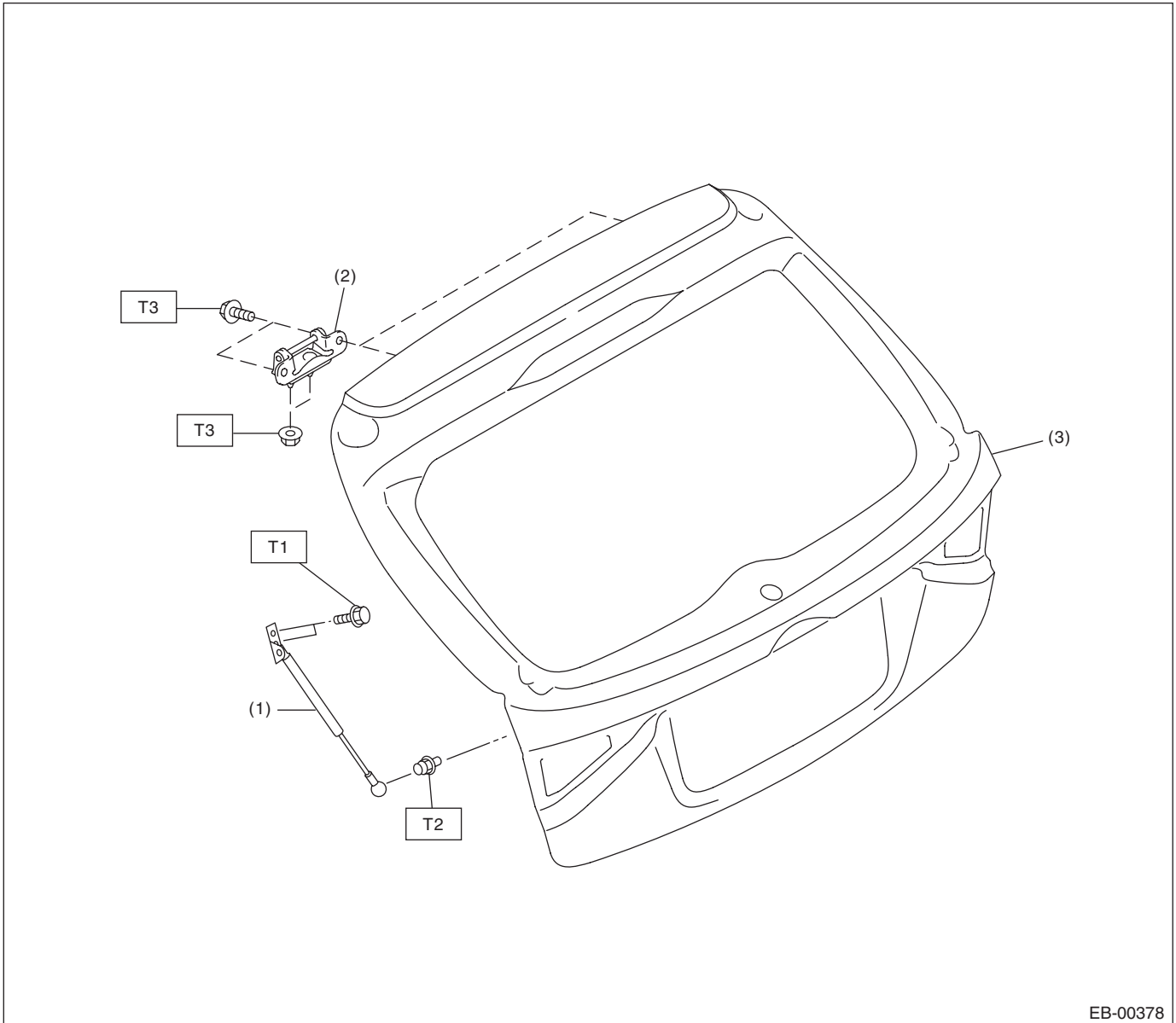

- (1) Rear gate damper stay
- (2) Hinge
- (3) Rear gate panel

**Tightening torque: N·m (kgf·m, ft·lb)**

**T1: 10 (1.02, 7.4)**

**T2: 20 (2.04, 14.8)**

**T3: 25 (2.55, 18.4)**

## 6. TRUNK LID PANEL

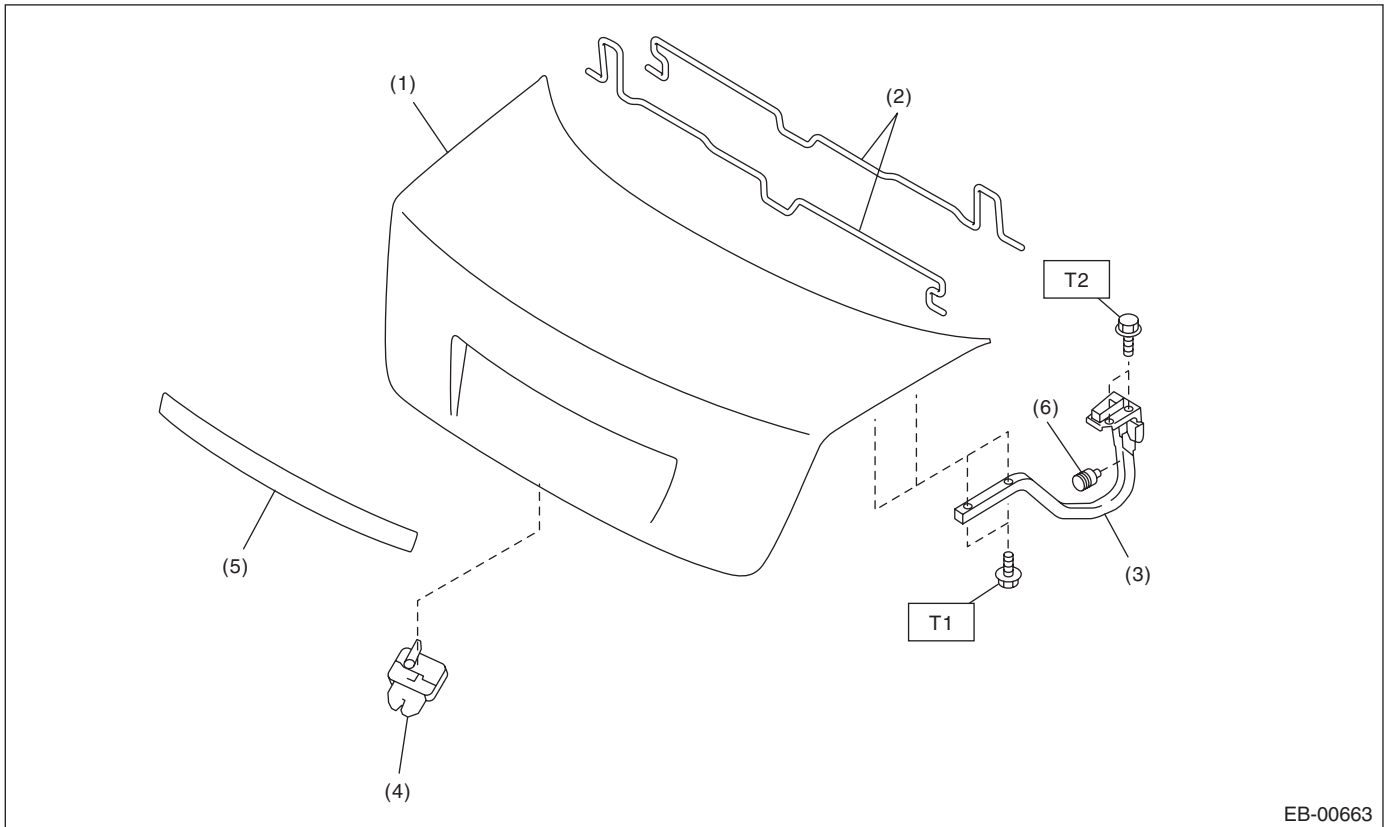

EB-00663

- |                        |                         |
|------------------------|-------------------------|
| (1) Trunk lid panel    | (4) Trunk lid lock ASSY |
| (2) Torsion bar        | (5) Trunk lid garnish   |
| (3) Trunk lid arm ASSY | (6) Stopper             |

**Tightening torque: N·m (kgf-m, ft-lb)**

**T1: 14 (1.43, 10.3)**

**T2: 18 (1.84, 13.3)**

### C: CAUTION

Exterior body panels are heavy. When removing or installing, do not drop and damage the panels. Do not damage the panel painting surface.

# General Description

## EXTERIOR BODY PANELS

### D: PREPARATION TOOL

#### 1. SPECIAL TOOL

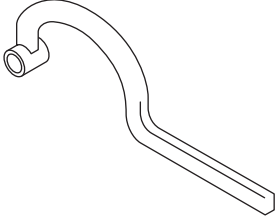
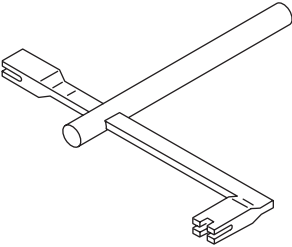
ILLUSTRATION	TOOL NUMBER	DESCRIPTION	REMARKS
 ST-925610000	925610000	WRENCH	Used for removing and installing door hinge.
 ST-927780000	927780000	REMOVER	Used for removing and installing the trunk torsion bar.

#### 2. GENERAL TOOL

TOOL NAME	REMARKS
Support jack	Used for supporting door panel.
Clip remover	Used for removing various types of clips

## 2. Front Hood

### A: REMOVAL

#### 1. FRONT HOOD INSULATOR

**CAUTION:**

Do not reuse any clips damaged during removal. Always replace with new clips.

Release the clips to remove the front hood insulator.

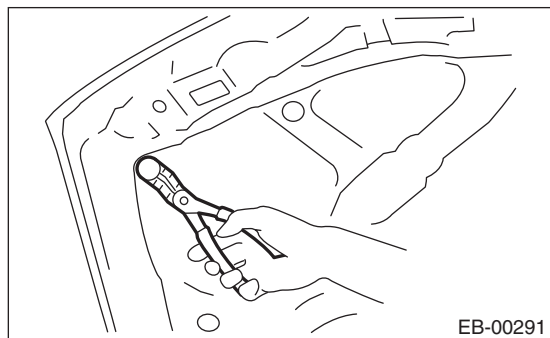

#### 2. FRONT HOOD SEAL

Remove the seal.

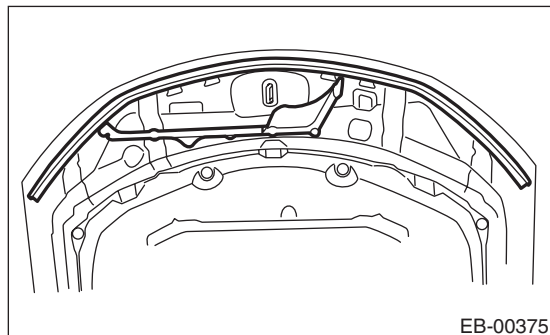

#### 3. FRONT HOOD DAMPER

**CAUTION:**

- Do not damage piston rods and oil seals.
- Never disassemble cylinders: They contain gas.
- The front hood panel is heavy. When removing or installing the damper stay and hood hinge, be sure to work in a group of two or more.

1) Remove mounting bolt, and remove the damper stay.

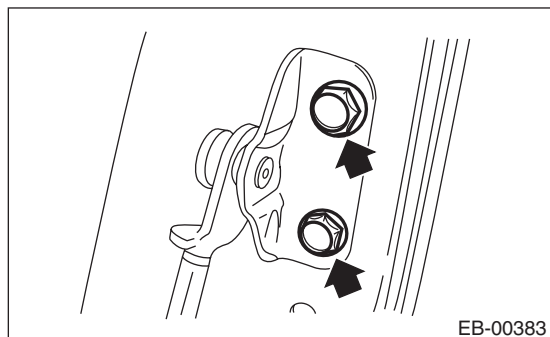

2) Remove the mounting bolt of front hood damper stay.

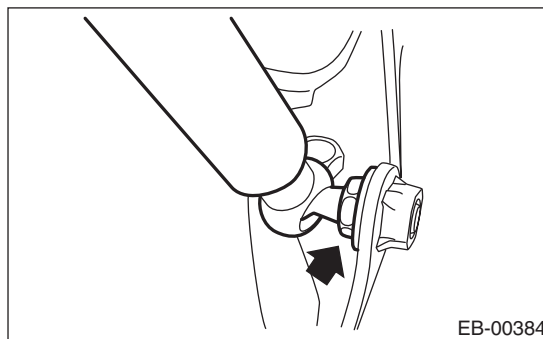

#### 4. FRONT HOOD HINGE

**CAUTION:**

The front hood panel is heavy. When removing or installing the damper stay and hood hinge, be sure to work in a group of two or more.

- 1) Remove the front hood damper.
- 2) Remove the bolt, and remove the front hood panel.

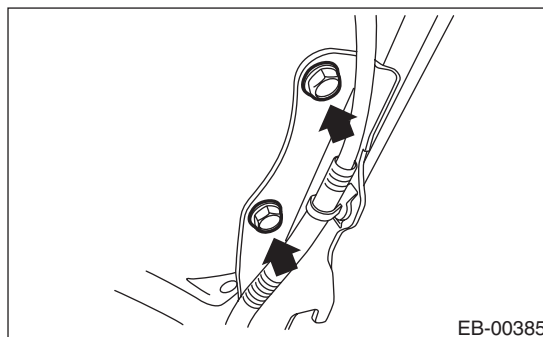

3) Detach the tabs and remove the cowl side panel.

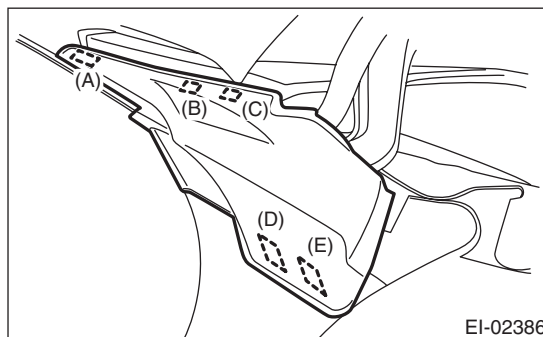

(1) Detach tabs (A), (B), and (C) from the vehicle exterior.

(2) Detach tabs (D) and (E).



# Front Hood

## EXTERIOR BODY PANELS

- 4) Remove the bolts of front hood hinge.

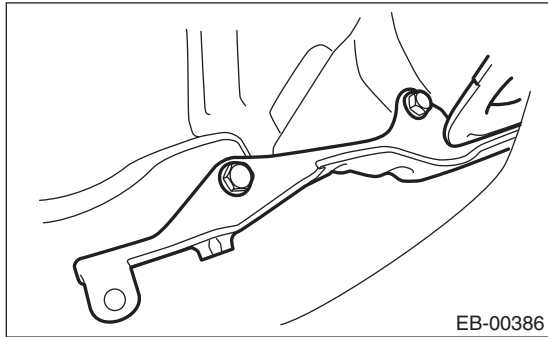

## 5. FRONT HOOD PANEL

### CAUTION:

The front hood panel is heavy. When removing or installing the damper stay and hood hinge, be sure to work in a group of two or more.

- 1) Remove the front hood insulator.
- 2) Remove the front hood seal.
- 3) Remove the window washer hose and nozzle. <Ref. to WW-18, REMOVAL, Front Washer Nozzle.>
- 4) Remove the front hood damper.
- 5) Remove the bolt, and remove the front hood panel from the front hood hinge.

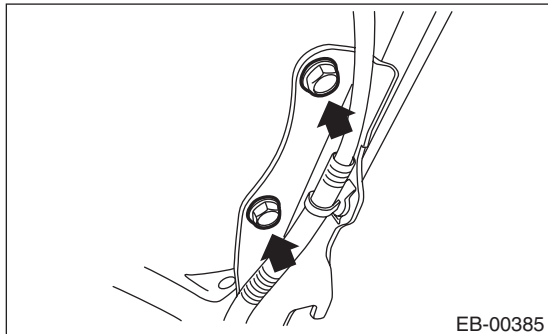

## B: INSTALLATION

Install each part in the reverse order of removal.

### NOTE:

- Be careful not to catch the window washer hose between insulators etc.
- Install while paying attention to make a uniform clearance around the front hood panel. For the dimension of clearance, refer to "SPECIFICATION" in "General Description". <Ref. to EB-2, SPECIFICATION, General Description.>

### Tightening torque:

Refer to "COMPONENT" of "General Description". <Ref. to EB-8, FRONT HOOD, COMPONENT, General Description.>

## C: ADJUSTMENT

- 1) Adjust the clearance between front hood panel and front fender panel. Clearance must be equal at both sides. For the clearance dimensions, refer to "SPECIFICATION" in "General Description". <Ref. to EB-2, SPECIFICATION, General Description.>
- 2) Use the hinge mounting bolts to align the front hood longitudinal and lateral position.

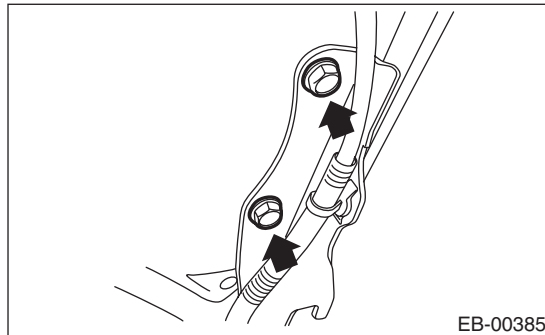

- 3) Adjust the height at the front end of hood. <Ref. to SL-39, ADJUSTMENT, Front Hood Lock Assembly.>
- 4) Rotate the hood buffer to adjust lateral height.

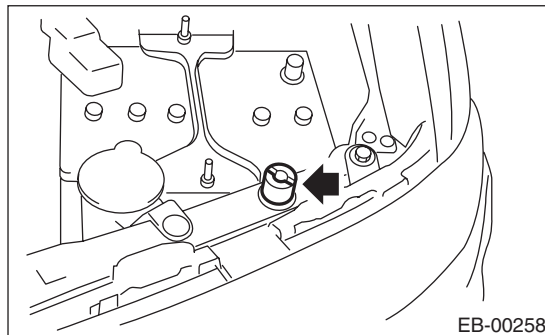

## D: DISPOSAL

For the disposal procedures of front hood damper stay, refer to Disposal Procedures of "Rear Gate Damper Stay". <Ref. to EB-32, REAR GATE DAMPER STAY, DISPOSAL, Rear Gate.>

## 3. Front Fender

### A: REMOVAL

#### 1. FENDER PANEL

- 1) Disconnect the ground cable from battery.
- 2) Remove the side sill spoilers. <Ref. to EI-43, REMOVAL, Side Sill Spoiler.>
- 3) Remove the front bumper face. <Ref. to EI-31, FRONT BUMPER FACE, REMOVAL, Front Bumper.>
- 4) Remove the headlight assembly. <Ref. to LI-15, REMOVAL, Headlight Assembly.>
- 5) Remove the mud guard. <Ref. to EI-30, REMOVAL, Mud Guard.>
- 6) Detach the tabs and remove the cowl panel side.

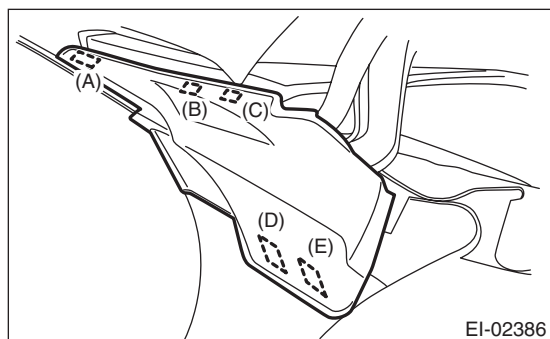

- (1) Detach tabs (A), (B), and (C) from the vehicle exterior.
  - (2) Detach tabs (D) and (E).
- 7) Remove the bolt, and remove the front fender panel.

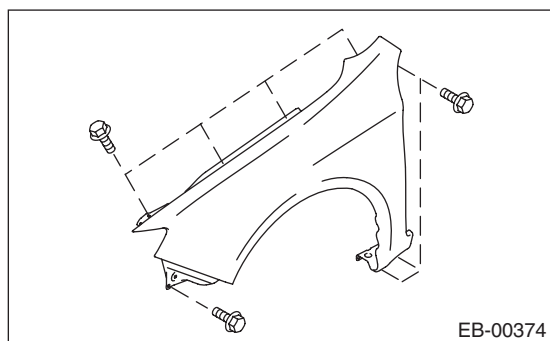

#### 2. COWL SIDE STAY

For operation procedures, refer to performance stay items. <Ref. to EB-18, REMOVAL, Front Performance Stay.>

### 3. FENDER GARNISH

- 1) Disconnect the ground cable from battery.
- 2) Remove the side sill spoilers. <Ref. to EI-43, REMOVAL, Side Sill Spoiler.>
- 3) Remove the clips and remove the front fender garnish.

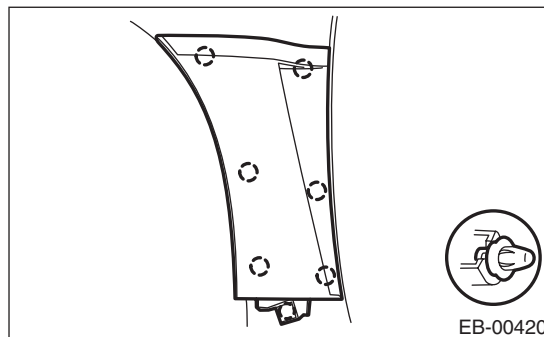

### B: INSTALLATION

#### CAUTION:

- Always use new double sided tape.
  - After the installation of front fender panel, be sure to perform headlight beam adjustment.
- 1) Install each part in the reverse order of removal.

#### Tightening torque:

**7.5 N·m (0.76 kgf·m, 5.5 ft·lb)**

#### NOTE:

- Install while paying attention to make a uniform clearance around the front fender panel. For the dimension of clearance, refer to "SPECIFICATION" in "General Description". <Ref. to EB-2, SPECIFICATION, General Description.>
- 2) Adjust the headlight beam and fog light beam.
    - Adjust the headlight beam. <Ref. to LI-16, HEADLIGHT BEAM ADJUSTMENT, ADJUSTMENT, Headlight Assembly.>
    - Adjust the fog light beam. (Model with fog light) <Ref. to LI-21, FOG LIGHT AIMING, ADJUSTMENT, Front Fog Light Assembly.>

### 4. Front Performance Stay

#### A: REMOVAL

- 1) Remove the front fender. <Ref. to EB-17, REMOVAL, Front Fender.>
- 2) Remove the bolts and harness clip, and remove the front performance stay.

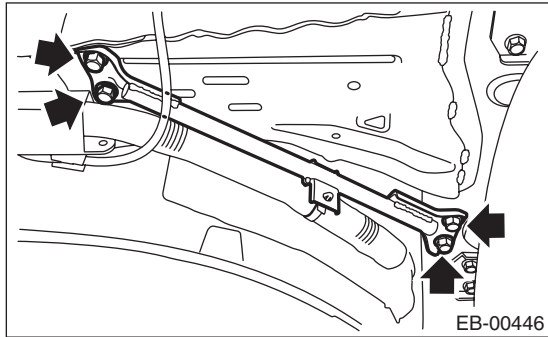

#### B: INSTALLATION

Install each part in the reverse order of removal.

***Tightening torque:***

***70 N·m (7.14 kgf·m, 51.6 ft·lb)***

## 5. Front Door

### A: REMOVAL

- 1) Disconnect the ground cable from battery.
- 2) Remove the front door trim. <Ref. to EI-45, REMOVAL, Door Trim.>
- 3) Remove the outer mirror assembly. <Ref. to GW-16, REMOVAL, Outer Mirror Assembly.>
- 4) Remove the front door speaker. <Ref. to ET-7, REMOVAL, Front Speaker.>
- 5) Remove the sealing cover. <Ref. to EB-21, REMOVAL, Front Sealing Cover.>
- 6) Remove the front door glass. <Ref. to GW-12, REMOVAL, Front Door Glass.>
- 7) Remove the front door regulator and motor. <Ref. to GW-13, REMOVAL, Front Regulator and Motor Assembly.>
- 8) Remove the front door latch assembly. <Ref. to SL-32, REMOVAL, Front Door Latch and Door Lock Actuator Assembly.>
- 9) Remove the front outer handle. <Ref. to SL-31, REMOVAL, Front Outer Handle.>
- 10) Remove the front door weather strip.

**NOTE:**

If the weather strip clip is removed with excessive force, the weather strip may be damaged. Be sure to use clip remover to remove.

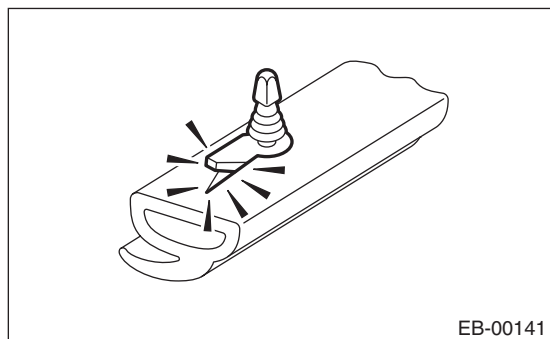

- 11) Remove the bolts and nuts to remove the door checker.

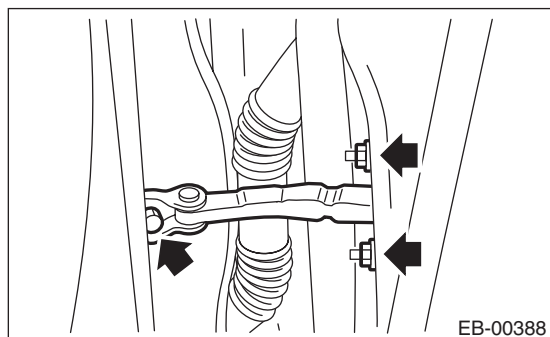

- 12) Remove the front pillar lower trim. <Ref. to EI-57, REMOVAL, Lower Inner Trim.>

- 13) Disconnect the connector of door harness from body harness.

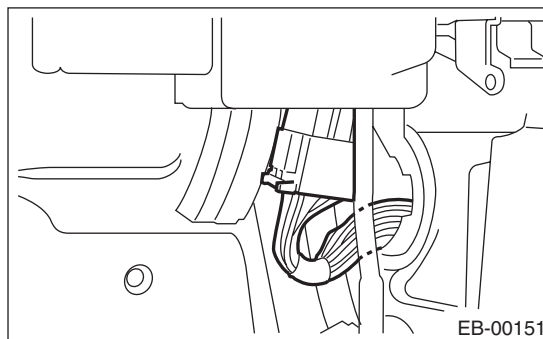

- 14) Put a wooden block on jack and place jack under the front door. Support the door with a jack to protect it from damage.

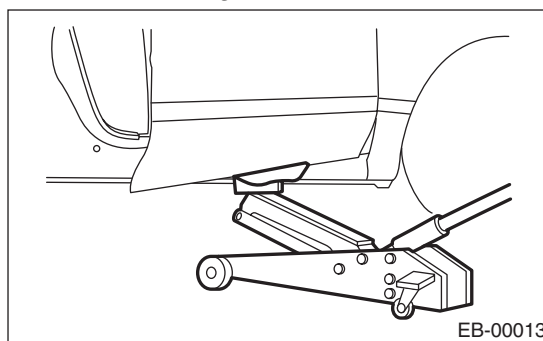

- 15) Remove the door-side bolts for upper and lower hinges to remove front door panel.

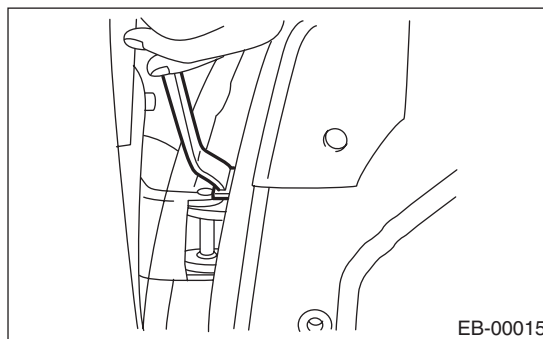

- 16) Remove the door hinge from vehicle.

# Front Door

## EXTERIOR BODY PANELS

### B: INSTALLATION

1) Put a wooden block on jack and place the front door on that.

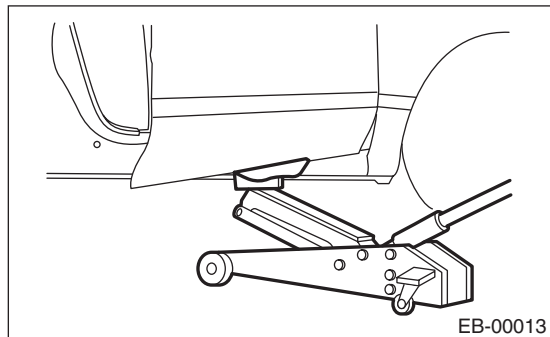

2) Apply grease to the sliding area of door hinges, and install the door hinge to vehicle.

3) Install the front door to upper hinge and lower hinge adjusting by jack.

4) Tighten bolt of door checker.

5) Connect door harness connector, and install the instrument panel lower cover.

6) Install the front pillar lower trim.

#### **Tightening torque:**

**Refer to "COMPONENT" of "General Description". <Ref. to EB-10, FRONT DOOR, COMPONENT, General Description.>**

7) Install while paying attention to make a uniform clearance around the front door panel. For the dimension of clearance, refer to "SPECIFICATION" in "General Description". <Ref. to EB-2, SPECIFICATION, General Description.>

### C: ADJUSTMENT

1) Using the ST, loosen the body-side bolts of the upper and lower hinges to align the position for vertical and horizontal direction of the front door panel.

**Preparation tool: WRENCH (925610000)**

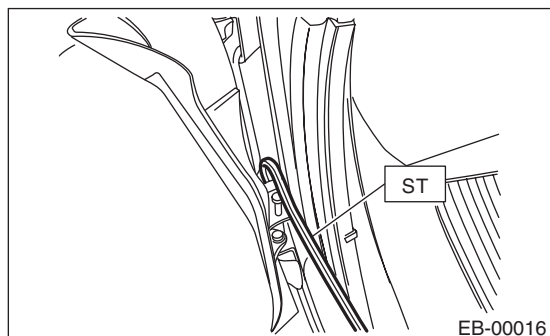

2) Loosen the screw (A), and tap the striker (B) using a plastic hammer to adjust the gap between rear end surface of front door panel and front end surface of rear door.

#### **CAUTION:**

**Do not use an impact wrench. Welding area on the striker nut plate is easily broken.**

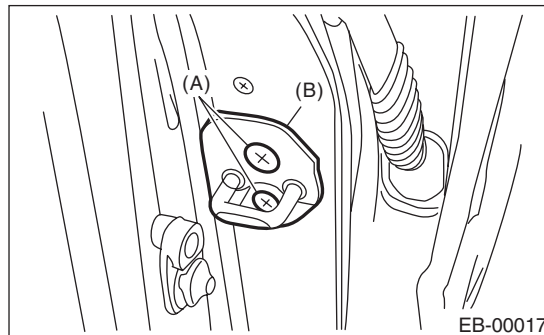

## 6. Front Sealing Cover

### A: REMOVAL

- 1) Disconnect the ground cable from battery.
- 2) Remove the front door trim. <Ref. to EI-45, REMOVAL, Door Trim.>
- 3) Remove the sealing cover.

#### CAUTION:

- Carefully remove the butyl tape. Excessive force will easily break the cover.
- If the sealing cover gets broken, replace it with a new part.

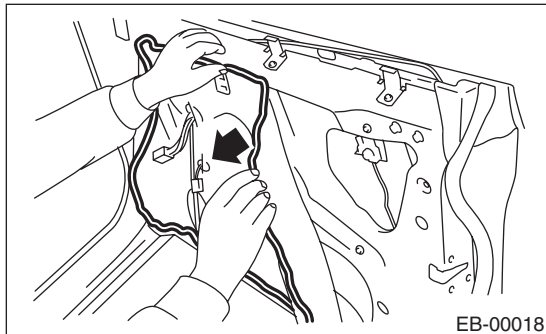

### B: INSTALLATION

#### CAUTION:

- If the sealing cover gets broken, replace it with a new part.
- Apply a uniform bead of butyl tape.
- Attach the sealing cover, keeping it from becoming wrinkled.
- Breaks in the bead will allow water leakage and contamination.

- 1) Install each part in the reverse order of removal.
- 2) When replacing the sealing cover, use the butyl tape.
- 3) Press the butyl tape-applied area firmly to prevent any floating on surface.

#### **Butyl tape:**

**3M8626 or the equivalent**

#### NOTE:

- Apply a uniform bead of butyl tape.
- Attach the sealing cover, keeping it from becoming wrinkled.
- Breaks in the bead will allow water leakage and contamination.

### C: INSPECTION

If the sealing cover gets damaged, replace it with a new part.

# Rear Door

## EXTERIOR BODY PANELS

### 7. Rear Door

#### A: REMOVAL

- 1) Disconnect the ground cable from battery.
- 2) Remove the rear door trim. <Ref. to EI-46, REAR DOOR, REMOVAL, Door Trim.>
- 3) Remove the rear speaker. <Ref. to ET-9, REMOVAL, Rear Speaker.>
- 4) Remove the sealing cover. <Ref. to EB-24, REMOVAL, Rear Sealing Cover.>
- 5) Remove the door sash and rear door glass. <Ref. to GW-19, REMOVAL, Rear Door Glass.>
- 6) Remove the rear door regulator and motor assembly. <Ref. to GW-20, REMOVAL, Rear Regulator and Motor Assembly.>
- 7) Remove the rear door latch. <Ref. to SL-35, REMOVAL, Rear Door Latch and Door Lock Actuator Assembly.>
- 8) Remove the rear outer handle. <Ref. to SL-34, REMOVAL, Rear Outer Handle.>
- 9) Remove the rear door weather strip.

#### NOTE:

If the weather strip clip is removed with excessive force, the weather strip may be damaged. Be sure to use clip remover to remove.

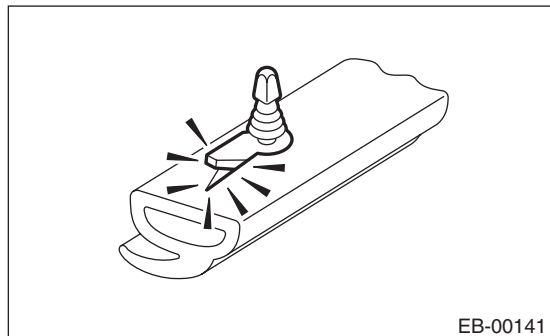

- 10) Remove the bolts and nuts to remove the door checker.

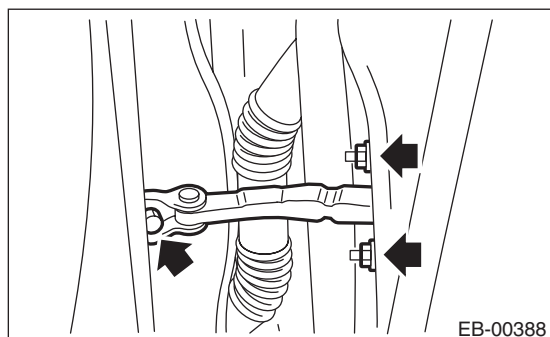

- 11) Pull the door harness connector inside the center pillar, then disconnect the connector.

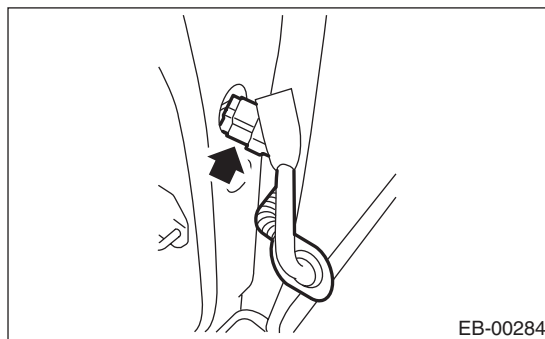

- 12) Put a wooden block on jack and place jack under the rear door. Support the rear door with a jack to protect it from damage.

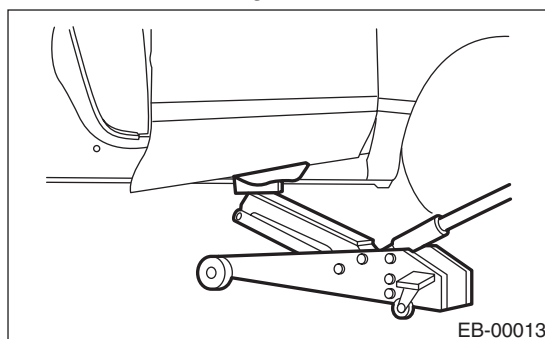

- 13) Remove the door-side bolts for upper and lower hinges to remove the rear door panel.

#### CAUTION:

Door panels are heavy. When removing and installing them, always work in a team of two or more persons.

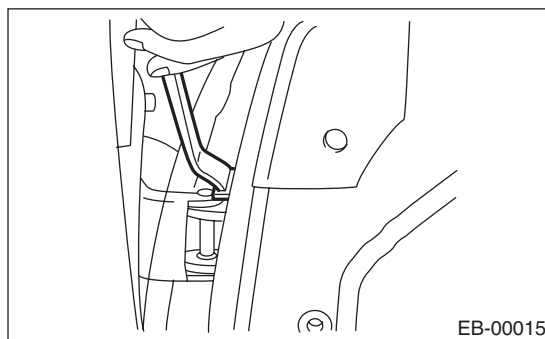

- 14) Remove the door hinge from vehicle.



**B: INSTALLATION**

- 1) Put a wooden block on jack and place the rear door on that.

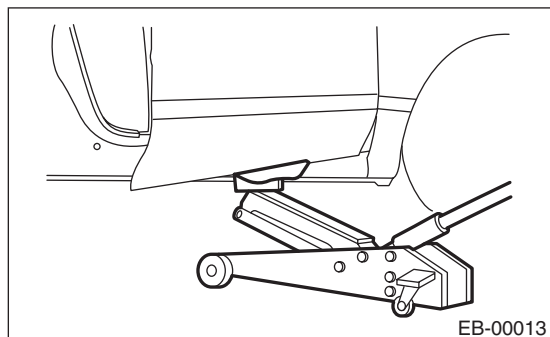

- 2) Apply grease to the moving part of door hinges.
- 3) Install the rear door to upper hinge and lower hinge adjusting by jack.
- 4) Tighten bolt of door checker.
- 5) Connect door harness connector.

**Tightening torque:**

**Refer to "COMPONENT" of "General Description". <Ref. to EB-11, REAR DOOR, COMPONENT, General Description.>**

- 6) Install while paying attention to make a uniform clearance around the rear door panel. For the dimension of clearance, refer to "SPECIFICATION" in "General Description". <Ref. to EB-2, SPECIFICATION, General Description.>

**C: ADJUSTMENT**

- 1) Open the rear door, loosen the door-side bolts of upper and lower hinges to align the position for vertical and horizontal direction of rear door panel.

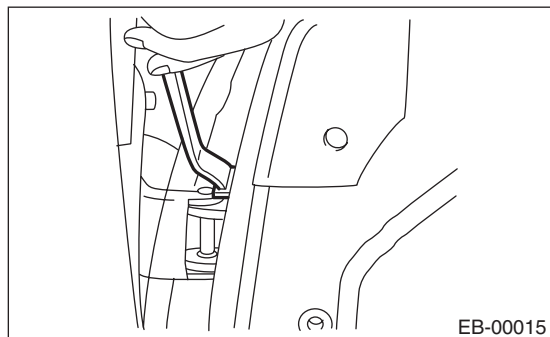

- 2) Loosen the screw (A) and tap striker (B) using plastic hammer to adjust the gap between rear end surface of rear door panel and body surface.

**CAUTION:**

**Do not use an impact wrench. Welding area on the striker nut plate is easily broken.**

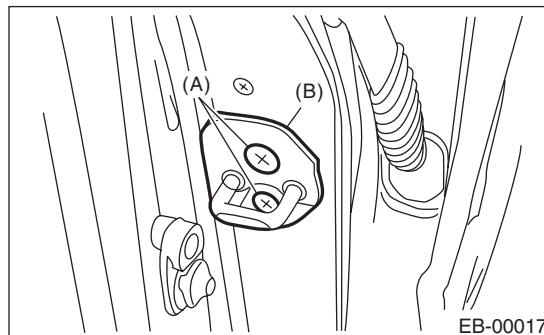



# Rear Sealing Cover

## EXTERIOR BODY PANELS

---

### 8. Rear Sealing Cover

#### A: REMOVAL

- 1) Disconnect the ground cable from battery.
- 2) Remove the rear door trim. <Ref. to EI-46, REAR DOOR, REMOVAL, Door Trim.>
- 3) Remove the rear speaker. <Ref. to ET-9, REMOVAL, Rear Speaker.>
- 4) Remove the sealing cover.

#### CAUTION:

- Carefully remove the butyl tape. Excessive force will easily break the cover.
- If the sealing cover gets broken, replace it with a new part.

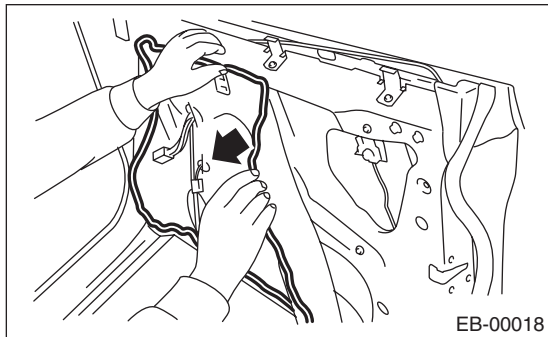

#### B: INSTALLATION

#### CAUTION:

- If the sealing cover gets broken, replace it with a new part.
- Apply a butyl tape evenly.
- Attach the sealing cover, keeping it from becoming wrinkled.
- If the butyl tape is applied unevenly, it will cause water leakage and soiling.

- 1) Install each part in the reverse order of removal.
- 2) When replacing the sealing cover, use the butyl tape.
- 3) Press the butyl tape-applied area firmly to prevent any floating on surface.

#### **Butyl tape:**

**3M8626 or the equivalent**

#### C: INSPECTION

If the sealing cover gets damaged, replace it with a new part.

## 9. Door Sash Tape

### A: REMOVAL

#### 1. FRONT DOOR

- 1) Disconnect the ground cable from battery.
- 2) Remove the front door trim. <Ref. to EI-45, FRONT DOOR, REMOVAL, Door Trim.>
- 3) Remove the outer mirror assembly. <Ref. to GW-16, REMOVAL, Outer Mirror Assembly.>
- 4) Remove the sealing cover. <Ref. to EB-21, REMOVAL, Front Sealing Cover.>
- 5) Remove the front door glass. <Ref. to GW-12, REMOVAL, Front Door Glass.>
- 6) Remove the glass run rubber.
- 7) Remove the B pillar upper clip, and remove the front door weather strip.

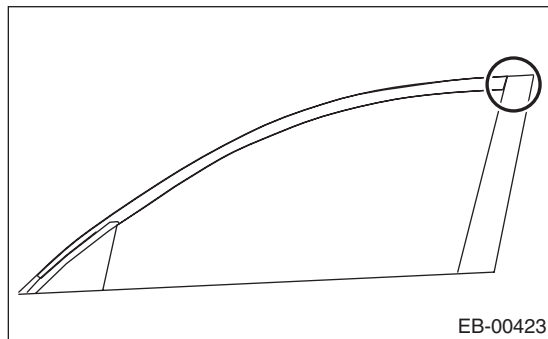

- 8) Remove the screws, and remove the front door weather strip outer.

#### CAUTION:

- When removing the weather strip outer, be careful not to damage the vehicle.
- If the weather strip outer is deformed, always replace with a new part.

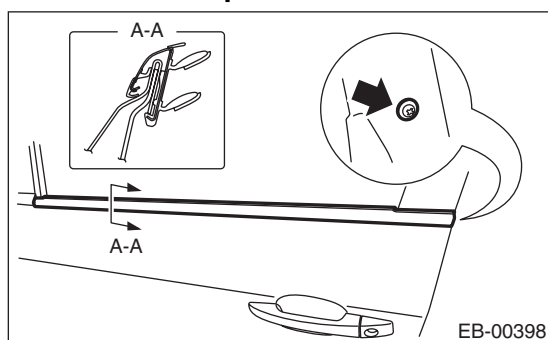

- 9) Peel the door sash tape from the door sash.

#### NOTE:

- If the tape is difficult to remove, warm the tape with a hairdryer, etc. to make the removal easier. Use a household hairdryer. Do not use industrial dryers.
- If tape residue is remaining on the door sash, wipe clean.

#### 2. REAR DOOR

- 1) Disconnect the ground cable from battery.
- 2) Remove the rear door trim. <Ref. to EI-46, REAR DOOR, REMOVAL, Door Trim.>
- 3) Remove the sealing cover. <Ref. to EB-24, REMOVAL, Rear Sealing Cover.>
- 4) Remove the rear door glass. <Ref. to GW-19, REMOVAL, Rear Door Glass.>
- 5) Remove the glass run rubber.
- 6) Remove the B pillar upper clip, and remove the front door weather strip.

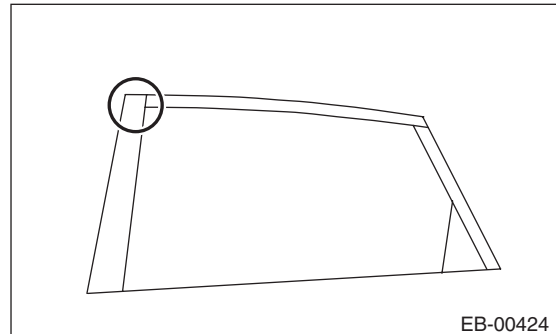

- 7) Loosen the screws and clips to remove the gusset cover outer.

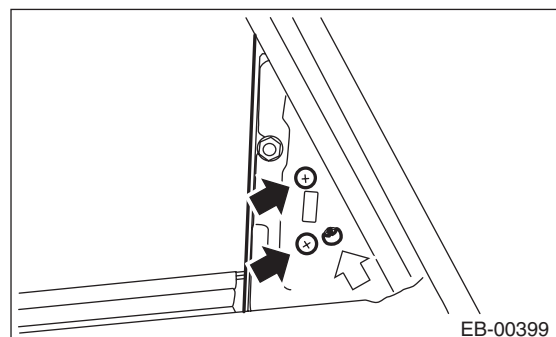

- 8) Remove the rear door weather strip outer.

#### CAUTION:

- When removing the weather strip outer, be careful not to damage the vehicle.
- If the weather strip outer is deformed, always replace with a new part.

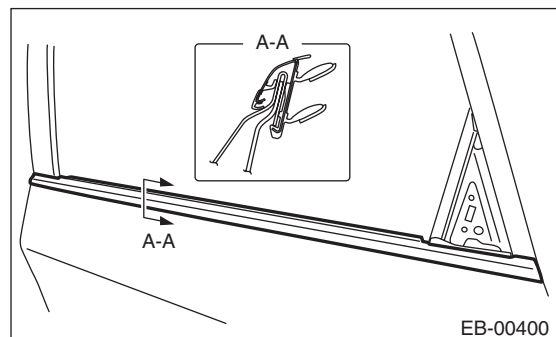

# Door Sash Tape

## EXTERIOR BODY PANELS

9) Peel the door sash tape from the door sash.

### NOTE:

- If the tape is difficult to remove, warm the tape with a hairdryer, etc. to make the removal easier. Use a household hairdryer. Do not use industrial dryers.
- If tape residue is remaining on the door sash, wipe clean.

## B: INSTALLATION

### CAUTION:

- When applying tape, use a spatula, etc. to apply evenly, pushing it against the sash to make sure that no air bubbles are formed. If air bubbles are formed, reapply the tape.
- If the tape is wrinkled, etc. during application, replace the tape.
- Turning points and ends of the tape will be a cause for peeling if the pressure is insufficient during application, so make sure to push down on the tape firmly when applying.
- There are locations where the tape ends will overlap each other. When applying the tape, be careful of the order of their application.

#### • Front

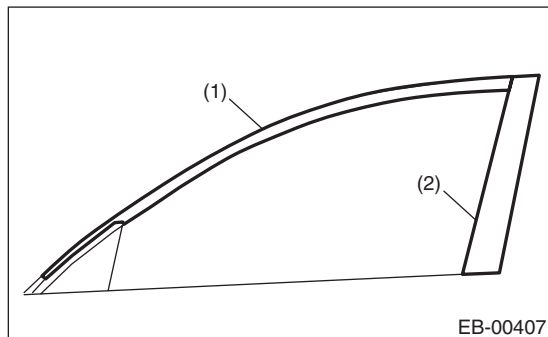

#### • Rear

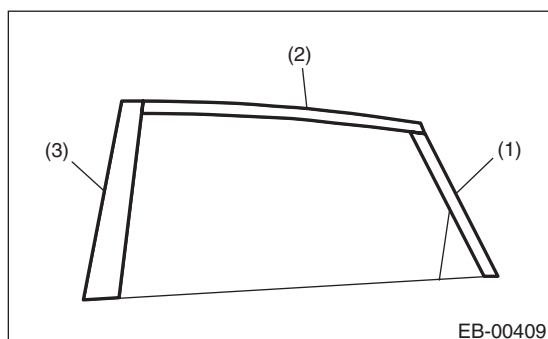

## 1. FRONT DOOR

1) Match the upper area of the gusset and the cut area of the tape as shown in the figure. (Position of the arrow)

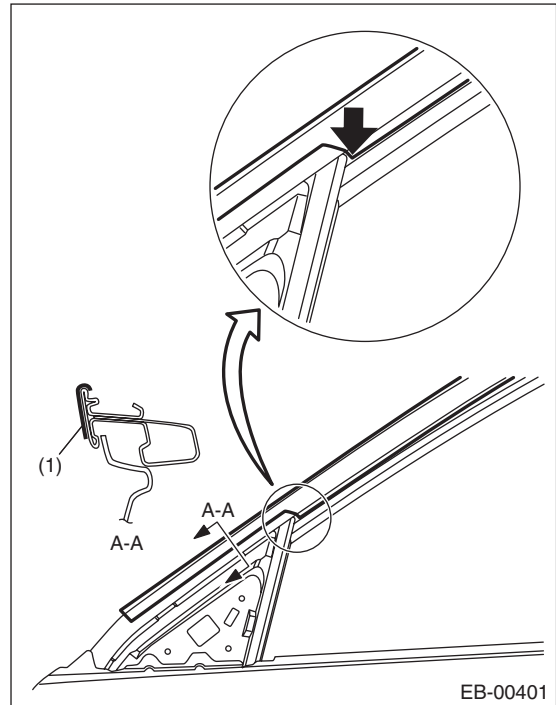

(1) Front door sash tape - front

2) Apply tape from the front of the vehicle towards the rear.

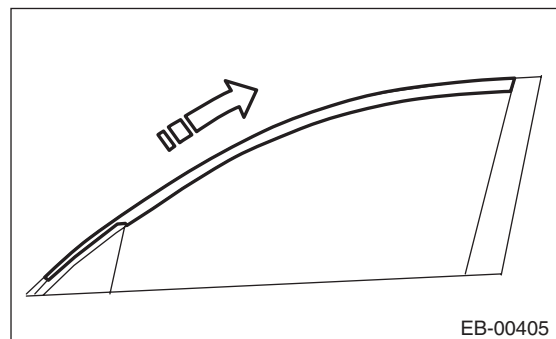

# Door Sash Tape

**NOTE:**

Apply the tape so that the end of the tape is within  $2.5 \pm 1.5$  mm ( $0.1 \pm 0.06$  in) from a line extending from the front door rear sash.

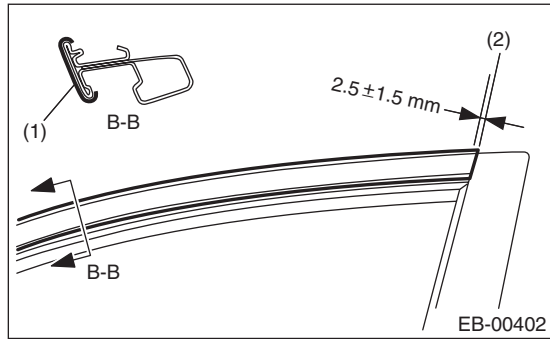

- (1) Front door sash tape - front
- (2) Line extending from the front door rear sash

3) Cut away both ends of the front door sash tape - rear.

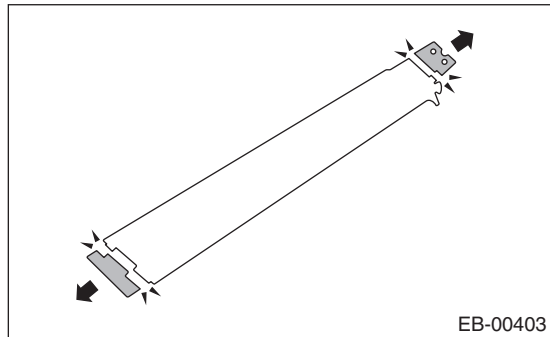

4) Match the sash corner and the cut area of the tape as shown in the figure. (Position of the arrow)

5) The lower end of the tape is to be aligned so that a space of approximately 3.7 mm (0.15 in) remains, so that the attachment holes of the weather strip outer are not blocked. (Position of the arrow)

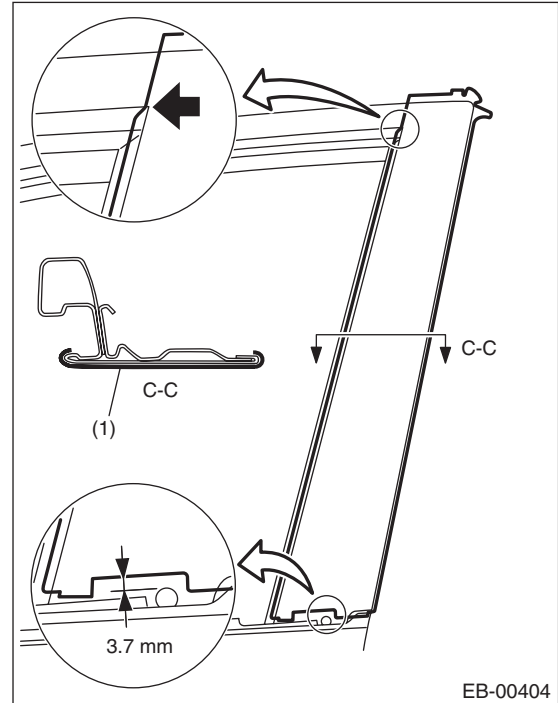

- (1) Front door sash tape - rear

6) Apply tape from the top of the vehicle towards the bottom.

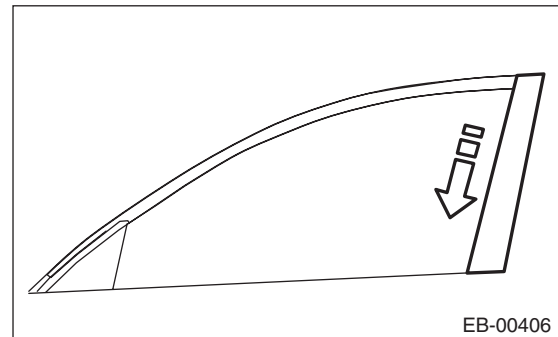

7) Fold the corners at the door upper end area in the order of (1) - (3).

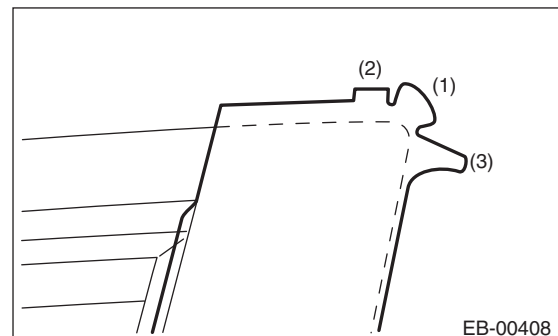

8) Thereafter, install door parts in the reverse order of disassembly.

# Door Sash Tape

## EXTERIOR BODY PANELS

9) Install while paying attention to make a uniform clearance around the front door panel. For the dimension of clearance, refer to "SPECIFICATION" in "General Description". <Ref. to EB-2, SPECIFICATION, General Description.>

### 2. REAR DOOR

1) Apply the tape so that the end of the tape is within  $2.5 \pm 1.5$  mm ( $0.1 \pm 0.06$  in) of a line extending from the rear door front sash.

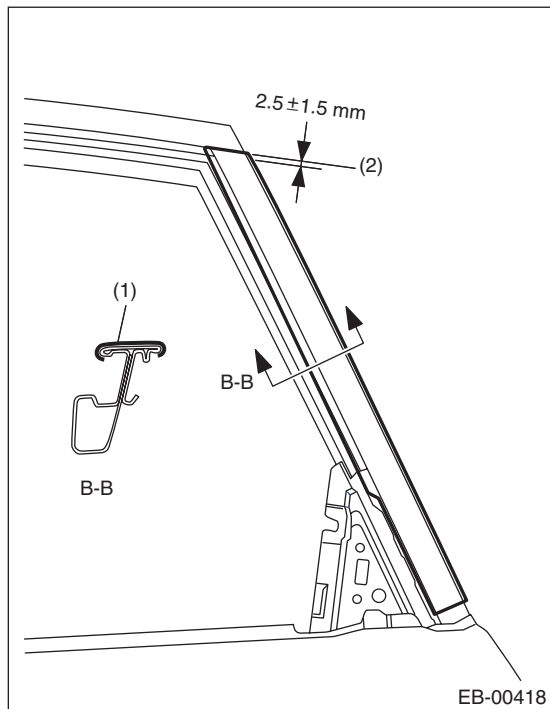

- (1) Rear door sash tape - rear
- (2) Line extending from the rear door upper sash

2) Apply tape from the top of the vehicle towards the bottom.

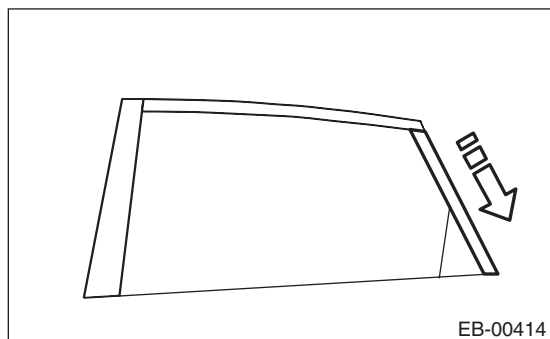

3) Match the rear door upper sash corner and the cut area of the tape as shown in the figure. (Position of the arrow)

#### NOTE:

Apply the tape so that the end of the tape is within  $2.5 \pm 1.5$  mm ( $0.1 \pm 0.06$  in) of a line extending from the rear door front sash.

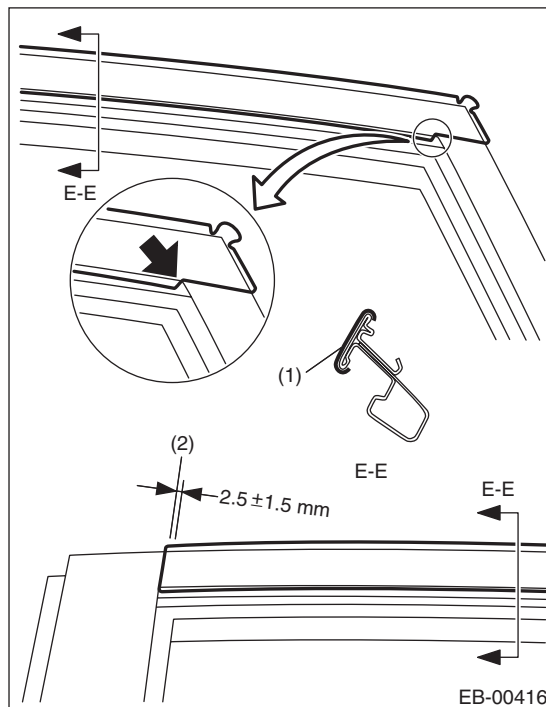

- (1) Rear door sash tape - medium
- (2) Line extending from the front sash of the rear door

4) Apply tape from the rear of the vehicle towards the front.

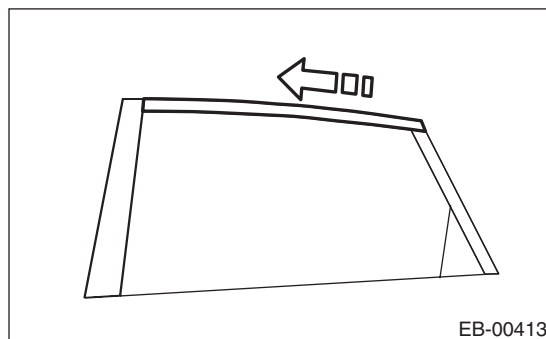

# Door Sash Tape

5) Fold the corners at the door upper end area in the order of (1) - (3).

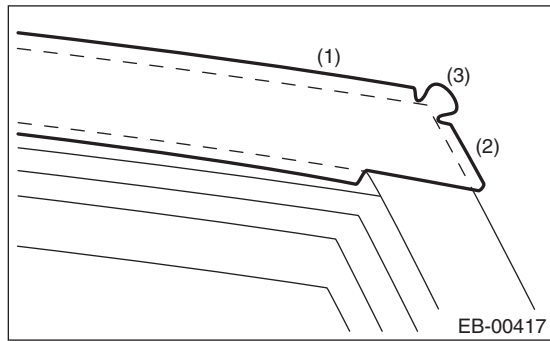

6) Cut away both ends of the rear door sash tape - front.

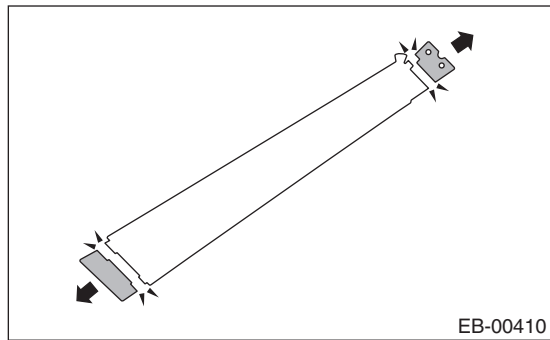

7) Match the sash corner and the cut area of the tape as shown in the figure. (Position of the arrow)

8) The lower end of the tape is to be aligned so that a space of approximately 3.7 mm (0.15 in) remains, so that the attachment holes of the weather strip outer are not blocked. (Position of the arrow)

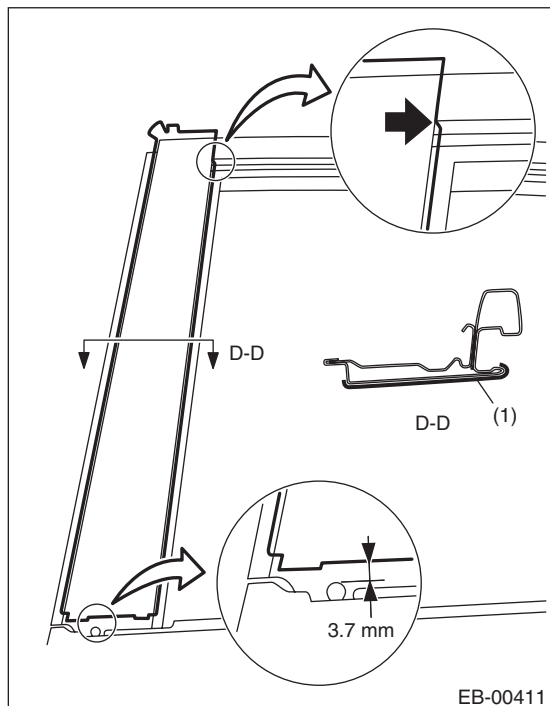

(1) Rear door sash tape - front

9) Apply tape from the top of the vehicle towards the bottom.

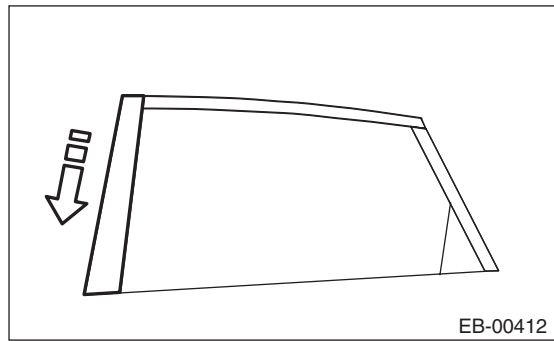

10) Fold the corners at the door upper end area in the order of (1) - (2).

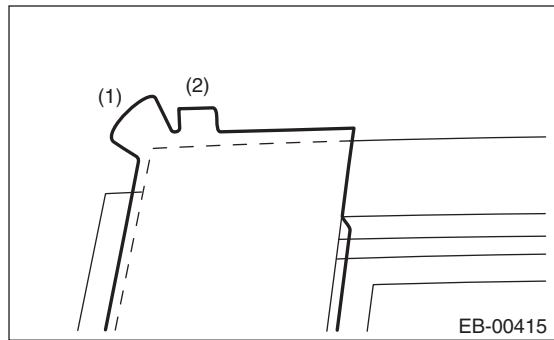

11) Thereafter, install door parts in the reverse order of disassembly.

12) Install while paying attention to make a uniform clearance around the rear door panel. For the dimension of clearance, refer to "SPECIFICATION" in "General Description". <Ref. to EB-2, SPECIFICATION, General Description.>

### 10.Rear Gate

#### A: REMOVAL

##### 1. REAR GATE PANEL

- 1) Disconnect the ground cable from battery.
- 2) Remove the rear gate trim. <Ref. to EI-69, REMOVAL, Rear Gate Trim.>
- 3) Remove the rear finisher light assembly. <Ref. to LI-29, REMOVAL, Rear Finisher Light Assembly.>
- 4) Remove the rear gate garnish. <Ref. to EI-72, REMOVAL, Rear Gate Garnish.>
- 5) Remove the rear wiper arm. <Ref. to WW-19, REMOVAL, Rear Wiper Arm.>
- 6) Remove the rear wiper motor. <Ref. to WW-20, REMOVAL, Rear Wiper Motor.>
- 7) Remove the rear gate latch and actuator assembly. <Ref. to SL-37, REMOVAL, Rear Gate Latch and Actuator Assembly.>
- 8) Remove the roof spoiler. <Ref. to EI-41, REMOVAL, Roof Spoiler.>
- 9) Remove the rubber duct (A) connection.

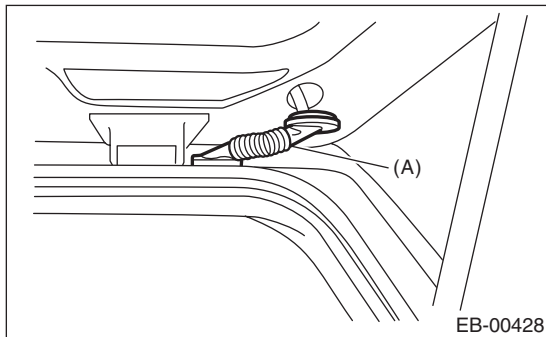

- 10) Remove harness clip of each connector from the rear gate panel.
- 11) Pull out the harness and washer hose from the rear gate.

- 12) Before removing the rear gate damper stay, prevent the rear gate from closing using prop or the like.

#### CAUTION:

**If the prop comes off, operators may get injured and vehicle may get damaged. Make sure to support the rear gate with secure material to prevent injury or damage.**

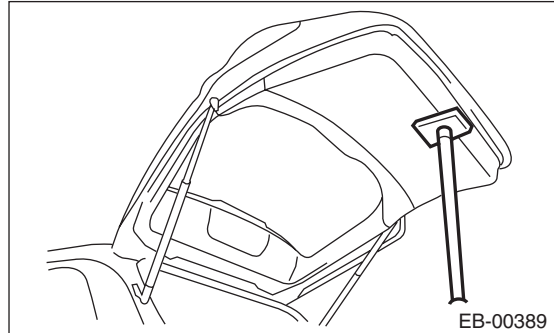

- 13) Remove the mounting bolt of rear gate damper stay.

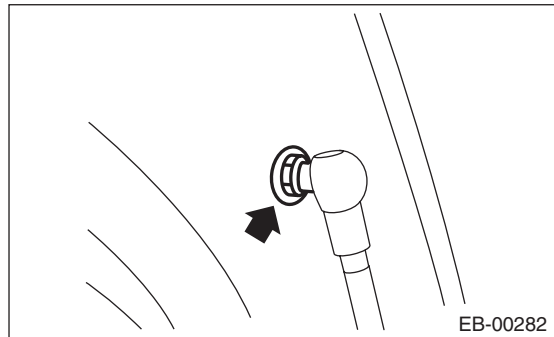

- 14) Remove the rear gate hinge bolt, and remove the rear gate panel.

#### CAUTION:

**Rear gate panels are heavy. When removing and installing them, always work in a team of two or more persons.**

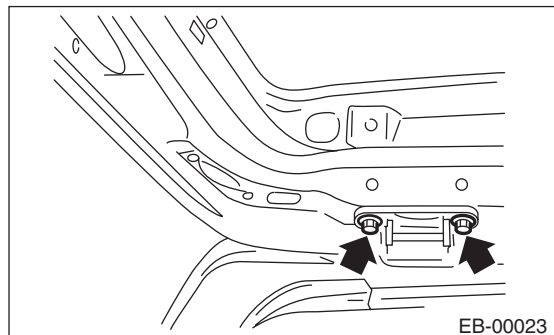

- 15) Remove the rear gate hinge from the vehicle.

## 2. REAR GATE DAMPER STAY

### CAUTION:

- Do not damage piston rods and oil seals.
- Never disassemble cylinders: They contain gas.
- Rear gate panels are heavy. When removing and installing them, always work in a team of two or more persons.

1) Before removing the rear gate damper stay, prevent the rear gate from closing using prop or the like.

### CAUTION:

If the prop comes off, operators may get injured and vehicle may get damaged. Make sure to support the rear gate with secure material to prevent injury or damage.

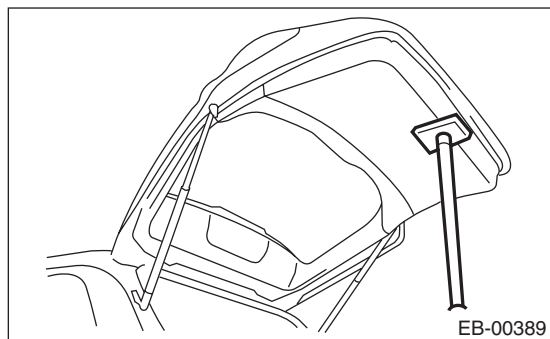

2) Remove the mounting bolt of rear gate damper stay.

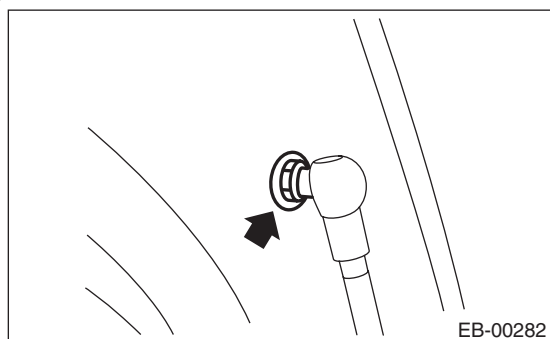

3) Remove mounting bolt, and remove the damper stay.

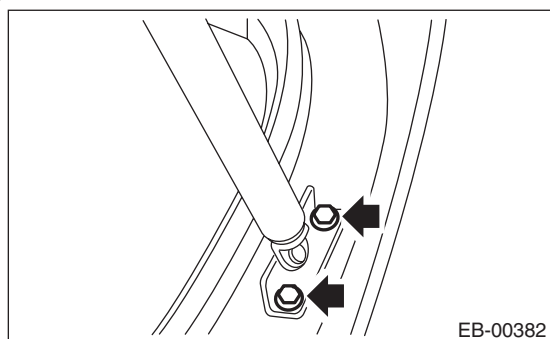

## B: INSTALLATION

### 1. REAR GATE PANEL

#### CAUTION:

Rear gate panels are heavy. When removing and installing them, always work in a team of two or more persons.

1) Install each part in the reverse order of removal.

#### Tightening torque:

**25 N·m (2.55 kgf-m, 18.4 ft-lb)**

2) Install while paying attention to make a uniform clearance around the rear gate panel. For the dimension of clearance, refer to "SPECIFICATION" in "General Description". <Ref. to EB-2, SPECIFICATION, General Description.>

### 2. REAR GATE DAMPER STAY

#### CAUTION:

Rear gate panels are heavy. When removing and installing them, always work in a team of two or more persons.

1) Prevent the rear gate from closing using prop or the like.

#### CAUTION:

If the prop comes off, operators may get injured and vehicle may get damaged. Make sure to support the rear gate with secure material to prevent injury or damage.

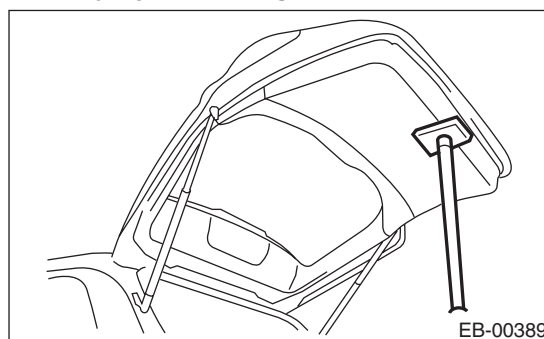

2) Install each part in the reverse order of removal.

#### Tightening torque:

Refer to "COMPONENT" of "General Description". <Ref. to EB-12, REAR GATE, COMPONENT, General Description.>



# Rear Gate

## EXTERIOR BODY PANELS

### C: ADJUSTMENT

For the dimension of panel around the rear gate panel, refer to "SPECIFICATION" in "General Description". <Ref. to EB-2, SPECIFICATION, General Description.>

- 1) Align the rear gate panel longitudinal and lateral position.

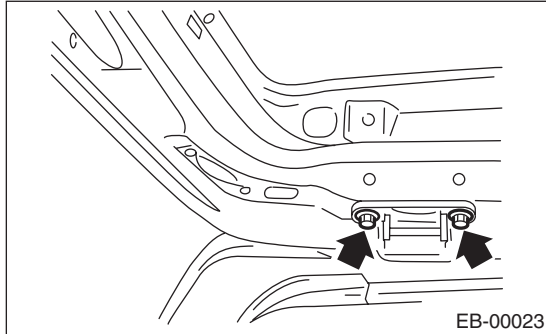

- (1) Loosen the hinge attaching bolts.
- (2) Align the rear gate panel longitudinal and lateral panel dimension.

- 2) Adjust the gap between rear gate panel and body surface.

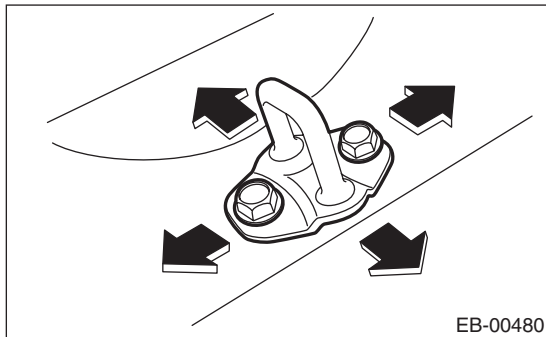

- (1) Loosen the bolt.
- (2) Tap striker using plastic hammer to adjust the gap between rear gate panel and body surface.

### D: DISPOSAL

#### 1. REAR GATE DAMPER STAY

##### CAUTION:

**Gas is colorless, odorless, and harmless. However, gas pressure may spray cutting powder or oil. Be sure to wear dust-resistant goggles.**

- 1) Cover with a vinyl sack as shown in the figure.

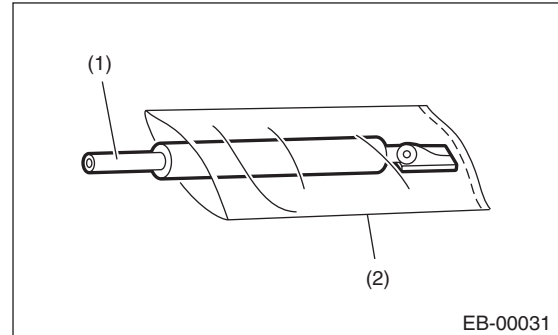

- (1) Rear gate damper stay
- (2) Vinyl sack

##### NOTE:

Prevent the vinyl sack from being caught by drill cutting edge.

- 2) Lift the body side slightly with piston rods fully extended, and secure the body side with vise.

Drill a hole of 2 to 3 mm (0.08 to 0.12 in) diameter at a point 10 to 200 mm (0.39 to 7.87 in) from the body side, and bleed the gas in the rear gate damper completely.

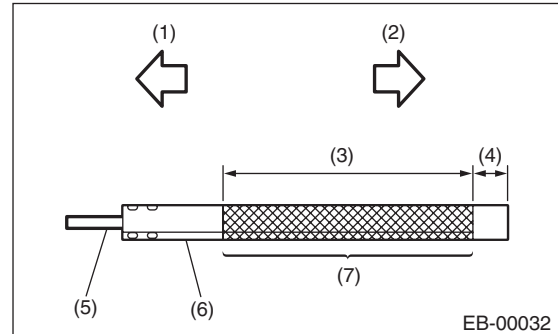

- (1) Door side
- (2) Body side
- (3) 190 mm (7.48 in)
- (4) 10 mm (0.39 in)
- (5) Piston rod
- (6) Cylinder
- (7) Portion to be drilled

## 11. Trunk Lid

### A: REMOVAL

#### 1. TORSION BAR

- 1) Open the trunk lid.
- 2) Using the ST, remove the torsion bar from the hinge link.

#### CAUTION:

During removal and installation, handle the torsion bar carefully, because it will generate reactive force.

Preparation tool: **REMOVER (927780000)**

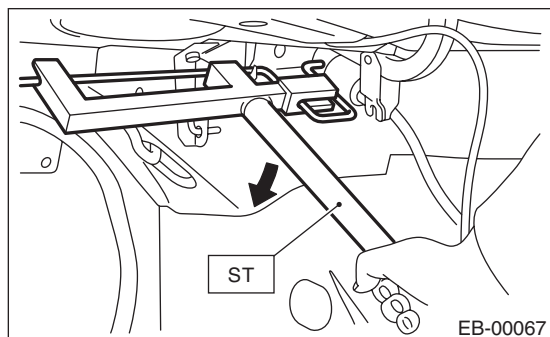

- 3) Remove the torsion bars RH/LH.

#### 2. TRUNK LID ARM

- 1) Disconnect the ground cable from battery.
- 2) Open the trunk lid to remove the trunk room trim. <Ref. to EI-63, REMOVAL, Trunk Room Trim.>
- 3) Disconnect the trunk lid release cable. <Ref. to SL-38, REMOVAL, Trunk Lid Latch and Actuator Assembly.>
- 4) Disconnect the connectors, and remove the harness clip, etc.
- 5) Remove the trunk lid mounting bolts, to remove the trunk lid panel from the trunk lid arm.

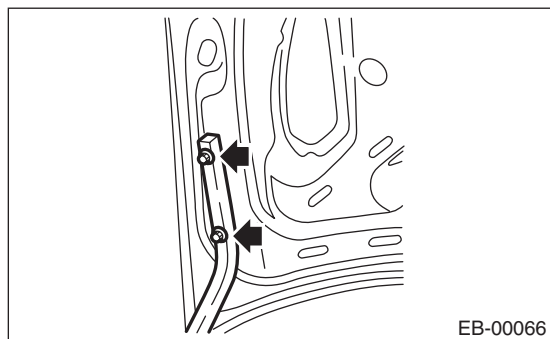

- 6) Remove the torsion bar from the trunk lid hinge link. <Ref. to EB-33, TORSION BAR, REMOVAL, Trunk Lid.>
- 7) Remove the rear shelf trim. <Ref. to EI-62, REMOVAL, Rear Shelf Trim.>

- 8) Remove the bolts, then remove the trunk lid arm.

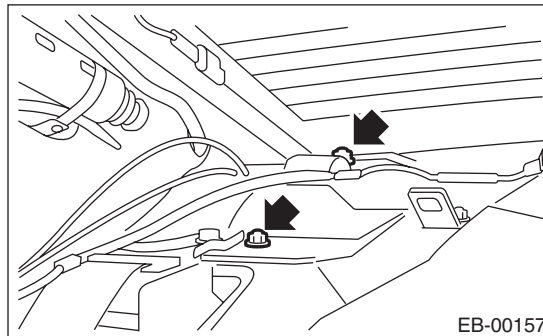

#### 3. TRUNK LID PANEL

- 1) Disconnect the ground cable from battery.
- 2) Disconnect the connector to remove the trunk lid harness.
- 3) Detach the rear spoiler. <Ref. to EI-42, REMOVAL, Rear Spoiler.>

#### CAUTION:

The trunk panel become lighter after removing the rear spoiler, so be careful when opening/closing the trunk lid.

- 4) Remove the trunk lid latch and actuator assembly. <Ref. to SL-38, REMOVAL, Trunk Lid Latch and Actuator Assembly.>
- 5) Remove the trunk lid garnish. <Ref. to EI-73, REMOVAL, Trunk Lid Garnish.>
- 6) Remove the bolts, then remove the trunk lid panel from the trunk lid arm.

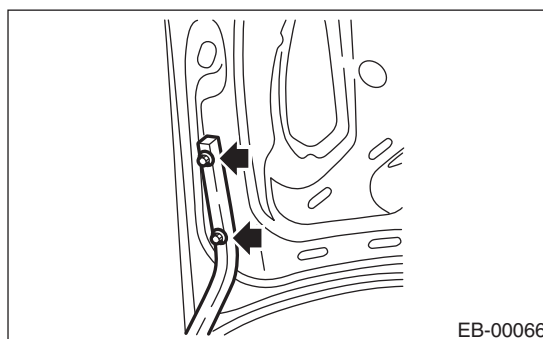

### B: INSTALLATION

- 1) Install each part in the reverse order of removal.
- 2) Apply grease to the rotating area of hinges and the torsion bar.
- 3) Install while paying attention to make a uniform clearance around the trunk lid panel. For the dimension of clearance, refer to "SPECIFICATION" in "General Description". <Ref. to EB-2, SPECIFICATION, General Description.>

#### Tightening torque:

Refer to "COMPONENT" of "General Description". <Ref. to EB-13, TRUNK LID PANEL, COMPONENT, General Description.>

# Trunk Lid

## EXTERIOR BODY PANELS

---

### C: ADJUSTMENT

For the dimension of panel around the trunk lid panel, refer to "SPECIFICATION" in "General Description". <Ref. to EB-2, SPECIFICATION, General Description.>

1) Adjust the trunk lid panel lateral position.

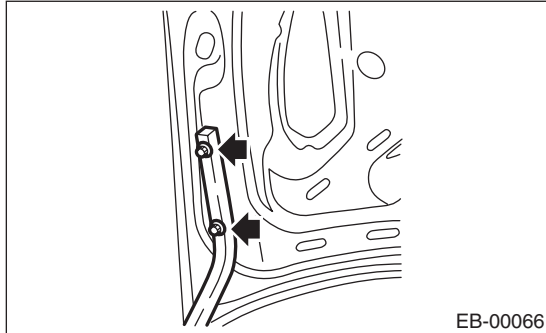

- (1) Loosen the mounting bolt.
- (2) Align the trunk lid panel lateral panel dimension.

2) Adjust the gap between trunk lid panel and body surface.

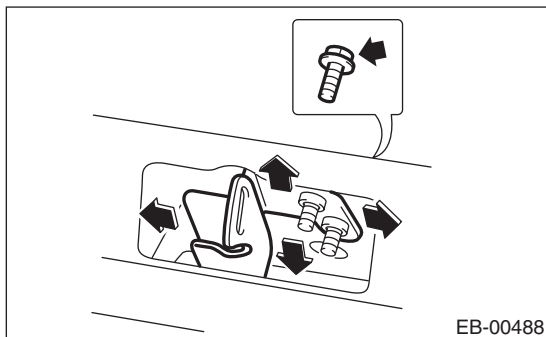

- (1) Loosen the bolt.
- (2) Tap striker using plastic hammer to adjust the gap between trunk lid panel and body surface.

## 12.Protector Tape

### A: INSTALLATION

Adhere the protector tape to position, follow the procedures below.

#### 1. REAR DOOR PROTECTOR

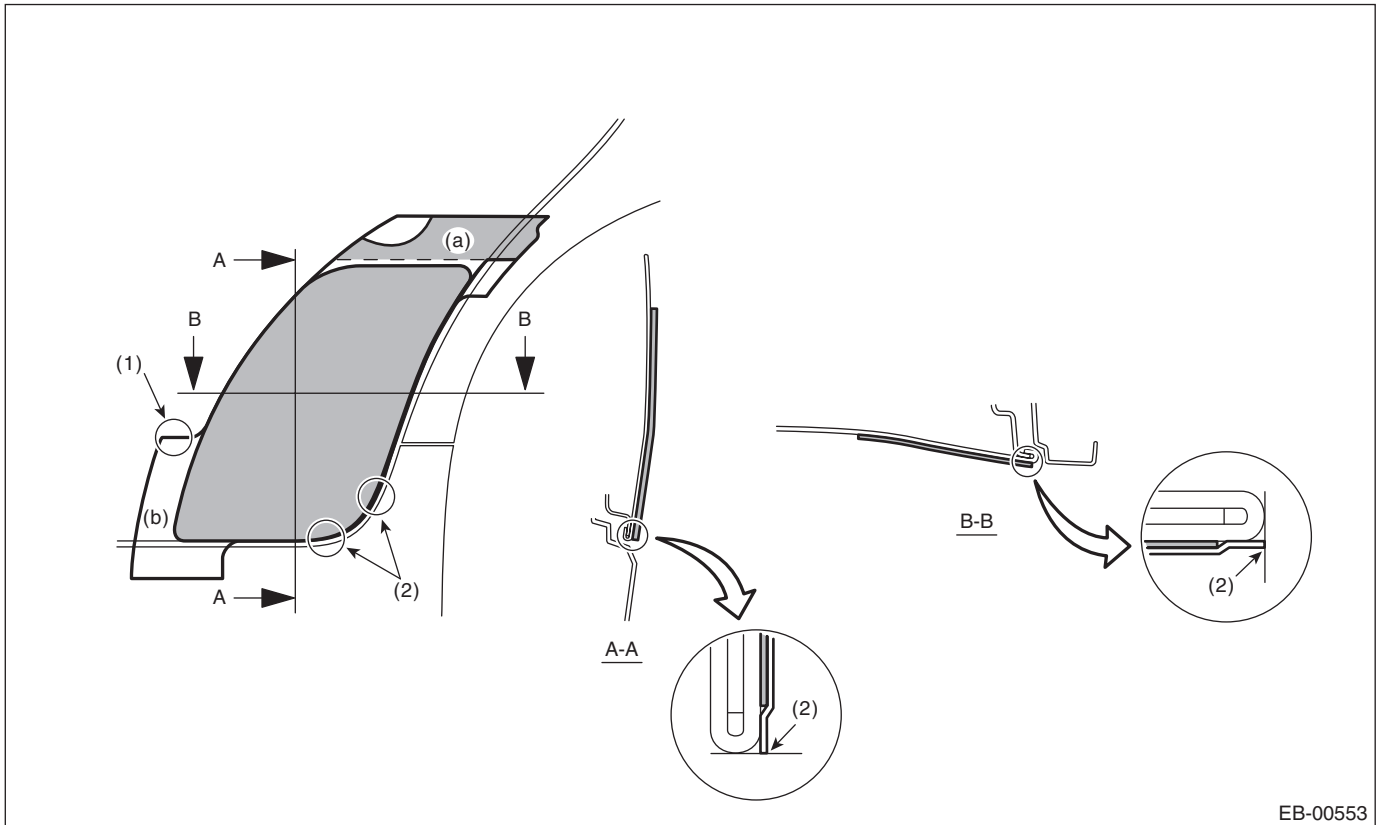

EB-00553

(1) Align the character line to the application tape.

(2) Align the application tape end to the door panel terminal.

1) Clean the area around applying position to remove any foreign objects on body.

2) Detach the backing paper from the temporary retention area (a) and apply the protector tape after positioning it correctly.

3) Detach the backing paper from area (b), and moisten the applying area and the backside of protector tape by spraying liquid (mild detergent solution at 3% concentration).

4) Apply the protector tape to the vehicle body.

#### CAUTION:

**Remove the water or air bubbles out of the protector tape by using the plastic or rubber spatula.**

5) Detach the application tape and temporary retention tape.

# Protector Tape

## EXTERIOR BODY PANELS

### 2. SIDE SILL PROTECTOR

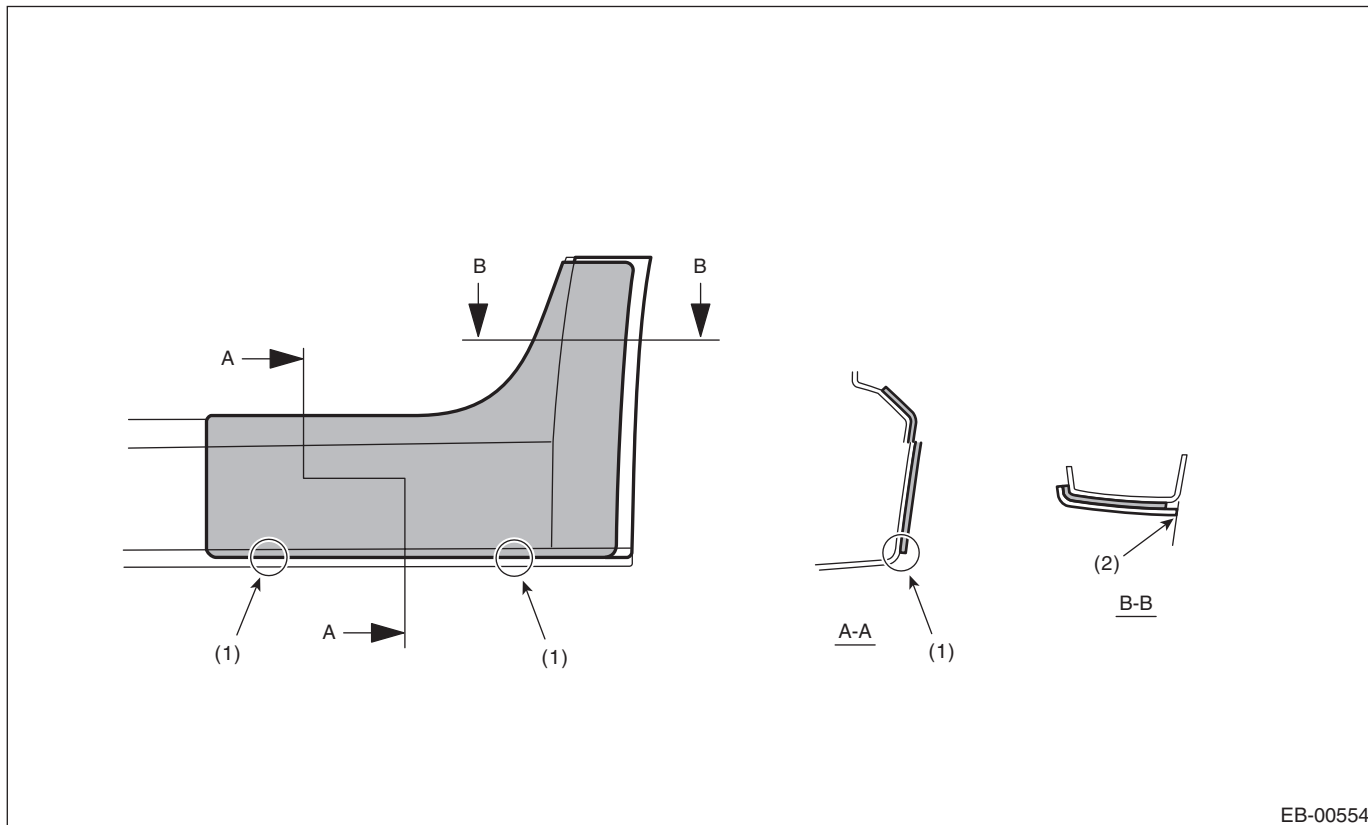

EB-00554

- (1) Align the R terminal of side sill spoiler to application tape.      (2) Align the terminal of side sill spoiler to application tape.

- 1) Clean the area around applying position to remove any foreign objects on body.
- 2) Open the rear door and moisten around the adhering position by using liquid such as mild detergent solution.
- 3) Detach the backing paper, and align the application tape to the position shown in the figure and apply the protector tape to the body.

#### **CAUTION:**

**Remove the water or air bubbles out of the protector tape by using the plastic or rubber spatula.**

## 3. REAR FENDER PROTECTOR

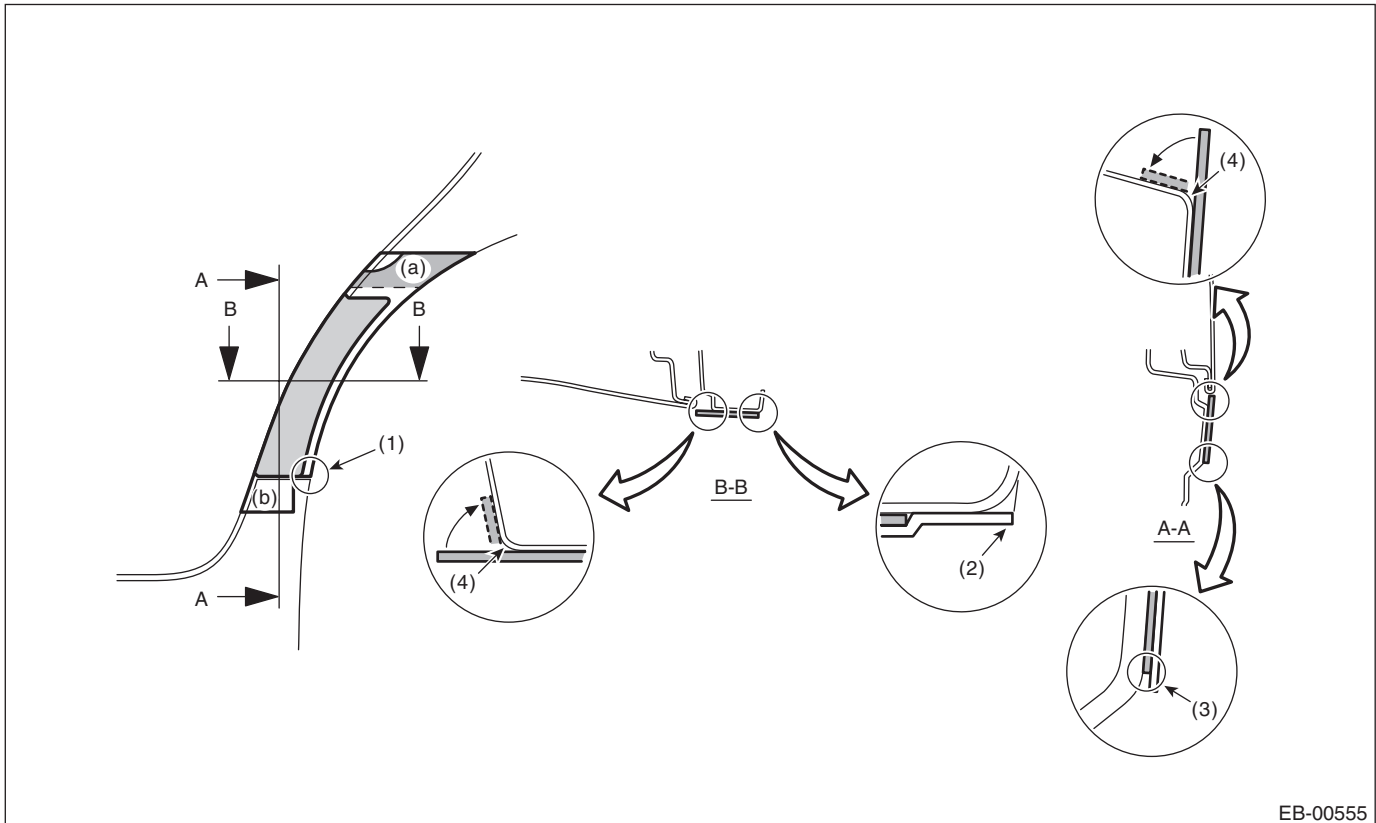

EB-00555

- (1) Align the application paper end to the rear quarter panel.
- (2) Align the panel terminal to the application paper.
- (3) Align the protector tape terminal to R terminal.
- (4) Apply the protector tape by aligning it to the rounded edge.

- 1) Clean the area around applying position to remove any foreign objects on body.
- 2) Detach the backing paper from the temporary retention area (a) and apply the protector tape after positioning it correctly.
- 3) Detach the backing paper from area (b), and moisten the applying area and the backside of protector tape by spraying liquid (mild detergent solution at 3% concentration).
- 4) Apply the protector tape to the vehicle body.

### CAUTION:

**Remove the water or air bubbles out of the protector tape by using the plastic or rubber spatula.**

- 5) Detach the application tape and temporary retention tape.
- 6) Bend the tack-in end and apply it as shown by (4) in the figure.

# Protector Tape

EXTERIOR BODY PANELS

---

**EB-38**

Brought to you by Ebay Seller "SubaruManuals"

# CRUISE CONTROL SYSTEM

# CC

---

	<b>Page</b>
1. General Description .....	2
2. Cruise Control System .....	4
3. Cruise Control Module .....	5
4. Cruise Control Command Switch .....	6
5. Combination Meter .....	8
6. Stop Light & Brake Switch .....	9
7. Clutch Switch .....	10
8. Neutral Position Switch .....	11



# General Description

## CRUISE CONTROL SYSTEM

### 1. General Description

#### A: COMPONENT

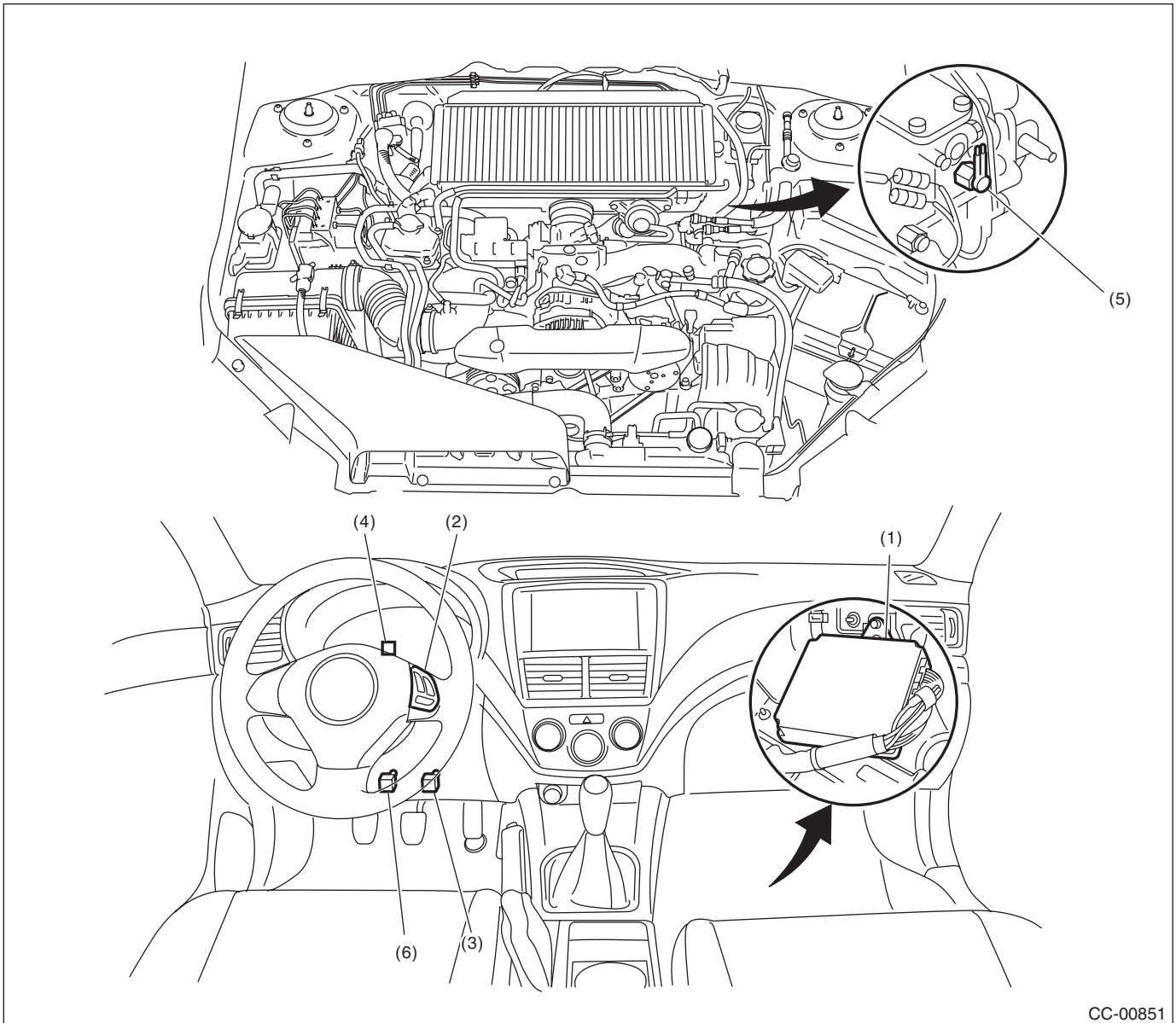

CC-00851

- |                                   |   |                             |
|-----------------------------------|---|-----------------------------|
| (1) Engine control module (ECM)   | (3) Stop light and brake switch                           | (5) Neutral position switch |
| (2) Cruise control command switch | (4) Cruise indicator light and cruise set indicator light | (6) Clutch switch           |

## B: CAUTION

- Before disassembling or reassembling parts, always disconnect the battery ground cable from battery. When replacing the audio, control module and other parts provided with memory functions, record the memory contents before disconnecting the battery ground cable. Otherwise, the memory is cleared.
- Reassemble the parts in the reverse order of disassembly procedure unless otherwise indicated.
- Adjust parts to the given specifications.
- Connect the connectors securely during reassembly.
- After reassembly, make sure that the functional parts operate normally.

## C: PREPARATION TOOL

TOOL NAME	REMARKS
Circuit tester	Used for measuring resistance and voltage.
TORX® bit T30	Used for removing/installing driver's airbag module.

# Cruise Control System

## CRUISE CONTROL SYSTEM

---

## 2. Cruise Control System

### A: WIRING DIAGRAM

Refer to "Cruise Control System" in the wiring diagram. <Ref. to WI-163, WIRING DIAGRAM, Cruise Control System.>

### B: INSPECTION

Refer to CRUISE CONTROL SYSTEM (DIAGNOSTICS) section. <Ref. to CC(diag)-2, Basic Diagnostic Procedure.>

### C: NOTE

For operation procedures of each component of the cruise control system, refer to the respective section.

- Cruise control unit: <Ref. to CC-5, Cruise Control Module.>
- Cruise control command switch: <Ref. to CC-6, Cruise Control Command Switch.>
- Combination meter: <Ref. to CC-8, Combination Meter.>
- Stop light and brake switch: <Ref. to CC-9, Stop Light & Brake Switch.>
- Clutch switch: <Ref. to CC-10, Clutch Switch.>
- Neutral position switch: <Ref. to CC-11, Neutral Position Switch.>

## 3. Cruise Control Module

### A: NOTE

The control of cruise control system is carried out in engine control module (ECM).

### B: REMOVAL

For removal procedures of the control module, refer to Engine section.

- Except for STI model: <Ref. to FU(w/o STI)-58, REMOVAL, Engine Control Module (ECM).>
- STI model: <Ref. to FU(STI)-59, REMOVAL, Engine Control Module (ECM).>

### C: INSTALLATION

For install procedures of the control module, refer to Engine section.

- Except for STI model: <Ref. to FU(w/o STI)-58, INSTALLATION, Engine Control Module (ECM).>
- STI model: <Ref. to FU(STI)-59, INSTALLATION, Engine Control Module (ECM).>

# Cruise Control Command Switch

## CRUISE CONTROL SYSTEM

### 4. Cruise Control Command Switch

#### A: REMOVAL

##### WARNING:

Before handling the airbag module, refer to "CAUTION" of "General Description" in the "AB" section. <Ref. to AB-5, CAUTION, General Description.>

- 1) Set the front wheels in straight ahead position.
- 2) Turn the ignition switch to OFF.
- 3) Disconnect the ground cable from battery and wait for at least 60 seconds before starting work.
- 4) Using TORX® bit T30 (1), loosen two TORX® bolts on the side of the steering wheel.

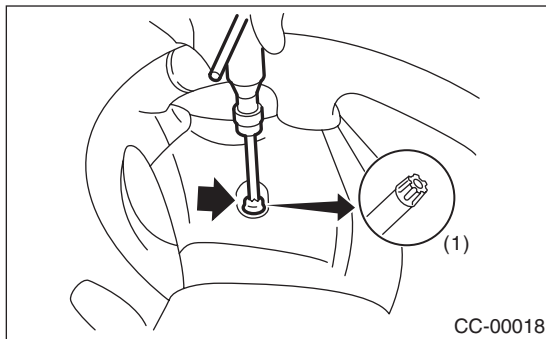

- 5) Disconnect the horn harness.
- 6) Disconnect the airbag module connector on the back of airbag module, and then remove the airbag module. <Ref. to AB-9, PROCEDURE, Airbag Connector.>

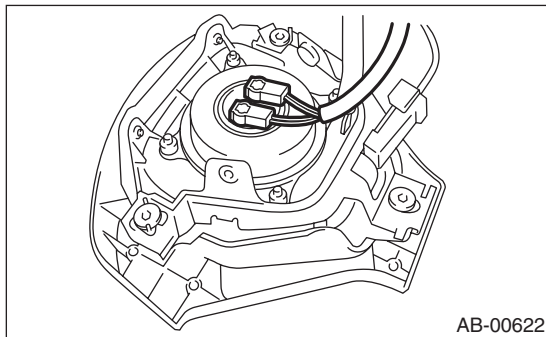

- 7) Remove the steering wheel. <Ref. to PS-12, REMOVAL, Steering Wheel.>

- 8) Remove the screws to remove the lower cover from steering wheel.

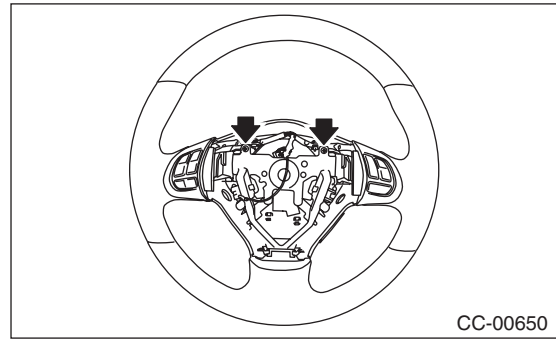

- 9) Remove the screws on the backside of the steering wheel to remove the cruise control command switch.

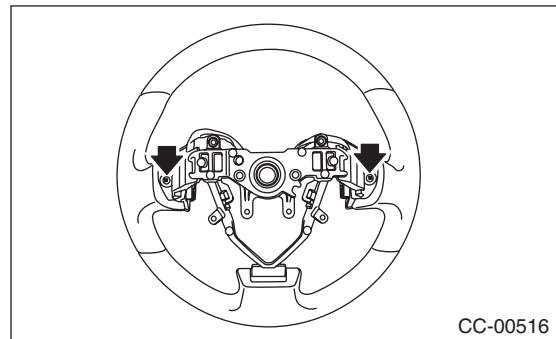

#### B: INSTALLATION

##### CAUTION:

- Before handling the airbag module, refer to "CAUTION" of "General Description" in the "AB" section. <Ref. to AB-5, CAUTION, General Description.>
  - Do not allow harness and connectors to interfere or get tangled up with other parts.
- Install each part in the reverse order of removal.

##### Tightening torque:

**Airbag module: 10 N·m (1.02 kgf·m, 7.4 ft·lb)**

#### C: INSPECTION

- 1) Disconnect the cruise control command switch connector.

# Cruise Control Command Switch

2) Check the resistance between cruise control command switch terminals.

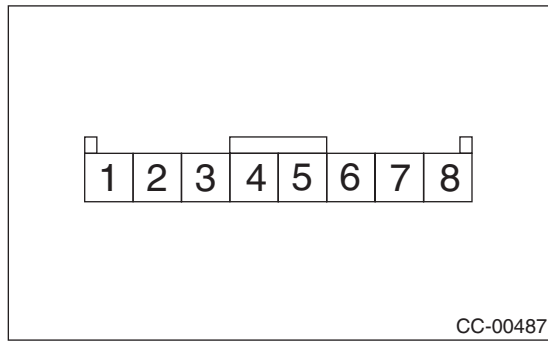

Switch	Position	Terminal No.	Standard
CANCEL SET/COAST RESUME/ ACCEL	All OFF	7 and 6	Approx. 4 k $\Omega$
CANCEL	ON	7 and 6	Less than 1 $\Omega$
SET/COAST	ON	7 and 6	Approx. 250 $\Omega$
RESUME/ ACCEL	ON	7 and 6	Approx. 1500 $\Omega$
MAIN (CRUISE)	OFF	8 and 6	1 M $\Omega$ or more
	ON	8 and 6	Less than 1 $\Omega$

3) Replace the cruise control command switch if the inspection result is not within the standard value.

### 5. Combination Meter

#### A: NOTE

For the combination meter, refer to the "IDI" section. <Ref. to IDI-16, Combination Meter.>

## 6. Stop Light & Brake Switch

### A: NOTE

For stop light & brake switch, refer to "BR". <Ref. to BR-46, Stop Light Switch.>



### 7. Clutch Switch

#### A: NOTE

For clutch switch, refer to "CL". <Ref. to CL-33, Clutch Switch.>

## 8. Neutral Position Switch

### A: NOTE

For neutral position switch, refer to following section.

- 5MT model: <Ref. to 5MT-33, Switches and Harness.>
- 6MT model: <Ref. to 6MT-42, Neutral Position Switch.>

# Neutral Position Switch

CRUISE CONTROL SYSTEM

---

# CRUISE CONTROL SYSTEM (DIAGNOSTICS)

## *CC(diag)*

---

	<b>Page</b>
1. Basic Diagnostic Procedure .....	2
2. General Description .....	4
3. Electrical Component Location .....	5
4. Engine Control Module (ECM) I/O Signal .....	6
5. Subaru Select Monitor .....	7
6. Diagnostics with Phenomenon .....	9
7. List of Cancel Code .....	12
8. Diagnostic Procedure with Cancel Code .....	15

# Basic Diagnostic Procedure

## CRUISE CONTROL SYSTEM (DIAGNOSTICS)

### 1. Basic Diagnostic Procedure

#### A: PROCEDURE

	Step	Check	Yes	No
1	<b>CHECK MALFUNCTION INDICATOR LIGHT.</b> Make sure the malfunction indicator light illuminates.	Does the malfunction indicator light illuminate?	Go to step 5.	Go to step 2.
2	<b>CHECK CRUISE INDICATOR LIGHT.</b> Make sure the cruise indicator light blinks.	Does the cruise indicator light blink?	Go to step 7.	Go to step 3.
3	<b>CHECK CRUISE CONTROL MAIN SWITCH OPERATION.</b> Check cruise control main switch operation. (Ensure the cruise indicator light illuminates.)	Is the cruise control main switch turned on? (Does the cruise indicator light illuminate?)	Go to step 4.	Go to phenomenon 1. <Ref. to CC(diag)-9, DIAGNOSTIC PROCEDURE WITH PHENOMENON, Diagnostics with Phenomenon.>
4	<b>CHECK CRUISE CONTROL SET OPERATION.</b> Check the cruise control setting operation.	Can the cruise control be set while driving at 40 km/h (25 MPH) or more?	Go to step 8.	Go to step 7.
5	<b>CHECK DTC.</b> Read all DTCs using the Subaru Select Monitor.	Is an engine or ABS/VDC related DTC displayed?	Record the DTC. Go to step 6.	Go to phenomenon 2. <Ref. to CC(diag)-9, DIAGNOSTIC PROCEDURE WITH PHENOMENON, Diagnostics with Phenomenon.>
6	<b>CHECK FREEZE FRAME DATA.</b> Using the Subaru Select Monitor, check the Freeze Frame Data or Information in Trouble State.	Was the Freeze Frame Data or Information in Trouble State recorded?	Record the data. Perform the diagnosis according to the engine or ABS/VDC related DTC.	Perform the diagnosis according to the engine or ABS/VDC related DTC.
7	<b>CHECK CANCEL CODE.</b> Using the Subaru Select Monitor, read the cancel codes.  NOTE: • Do not turn the ignition switch to OFF after the cruise control is deactivated. • Do not operate the cruise control command switch after the cruise control is deactivated. If the above is performed, the cancel code will be cleared.	Is it possible to read the cancel codes?	Perform the diagnosis according to the cancel code. <Ref. to CC(diag)-12, LIST, List of Cancel Code.>	Go to step 8.
8	<b>CHECK CRUISE SET INDICATOR LIGHT.</b> Make sure the cruise set indicator light illuminates.	Does the cruise set indicator light illuminate?	Go to step 9.	Go to phenomenon 3. <Ref. to CC(diag)-9, DIAGNOSTIC PROCEDURE WITH PHENOMENON, Diagnostics with Phenomenon.>
9	<b>CHECK VEHICLE SPEED IS HELD WITHIN SET SPEED.</b> Make sure the vehicle speed is held within set speed.	Is the vehicle speed kept within setting speed $\pm 3$ km/h ( $\pm 2$ MPH)? (Make sure that on a level road.)	Go to step 10.	Go to phenomenon 4. <Ref. to CC(diag)-9, DIAGNOSTIC PROCEDURE WITH PHENOMENON, Diagnostics with Phenomenon.>

# Basic Diagnostic Procedure

## CRUISE CONTROL SYSTEM (DIAGNOSTICS)

Step	Check	Yes	No
<b>10</b> <b>CHECK RESUME/ACCEL OPERATION.</b> Check the RESUME/ACCEL switch operation.	Does the vehicle speed increase or return to set speed after RESUME/ACCEL switch has been pressed?	Go to step 11.	Go to phenomenon 5. <Ref. to CC(diag)-9, DIAGNOSTIC PROCEDURE WITH PHENOMENON, Diagnostics with Phenomenon.>
<b>11</b> <b>CHECK SET/COAST OPERATION.</b> Check the SET/COAST switch operation.	Does the vehicle speed decrease after SET/COAST switch has been pressed?	Go to step 12.	Go to phenomenon 6. <Ref. to CC(diag)-9, DIAGNOSTIC PROCEDURE WITH PHENOMENON, Diagnostics with Phenomenon.>
<b>12</b> <b>CANCEL OPERATION CHECK.</b> Check the CANCEL switch operation.	Is the cruise control released after CANCEL switch has been pressed?	Go to step 13.	Go to phenomenon 7. <Ref. to CC(diag)-9, DIAGNOSTIC PROCEDURE WITH PHENOMENON, Diagnostics with Phenomenon.>
<b>13</b> <b>CHECK CRUISE CONTROL RELEASE OPERATION.</b> Check the cruise control release operation.	Is the cruise control released after brake pedal has been depressed?	Go to step 14.	Go to phenomenon 8. <Ref. to CC(diag)-9, DIAGNOSTIC PROCEDURE WITH PHENOMENON, Diagnostics with Phenomenon.>
<b>14</b> <b>CHECK CRUISE CONTROL RELEASE OPERATION.</b> Check the cruise control release operation.	Is the cruise control released after shifting to the neutral position?	Go to step 15.	Go to phenomenon 9. <Ref. to CC(diag)-9, DIAGNOSTIC PROCEDURE WITH PHENOMENON, Diagnostics with Phenomenon.>
<b>15</b> <b>CHECK CRUISE CONTROL RELEASE OPERATION.</b> Check the cruise control release operation.	Is the cruise control released after depressing the clutch pedal?	Finish the diagnosis.	Go to phenomenon 10. <Ref. to CC(diag)-9, DIAGNOSTIC PROCEDURE WITH PHENOMENON, Diagnostics with Phenomenon.>

# General Description

## CRUISE CONTROL SYSTEM (DIAGNOSTICS)

### 2. General Description

#### A: CAUTION

Airbag system wiring harness is routed near the cruise control command switch.

#### CAUTION:

- Do not use the electrical test equipment on the airbag system wiring harnesses and connector circuits.
- Be careful not to damage the airbag system wiring harness when servicing the cruise control command switch. Airbag system wiring harness is routed near the cruise control command switch.

#### B: PREPARATION TOOL

##### 1. SPECIAL TOOL

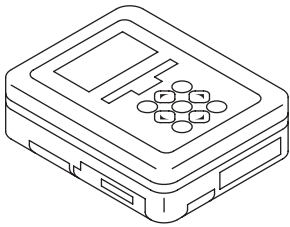
ILLUSTRATION	TOOL NUMBER	DESCRIPTION	REMARKS
 ST1B022XU0	1B022XU0	SUBARU SELECT MONITOR III KIT	Used for troubleshooting the electrical system.

##### 2. GENERAL TOOL

TOOL NAME	REMARKS
Circuit tester	Used for measuring resistance, voltage and current.

#### C: INSPECTION

Measure the battery voltage and specific gravity of electrolyte.

#### **Standard voltage:**

**12 V or more**

#### **Specific gravity:**

**1.260 or more**

# Electrical Component Location

CRUISE CONTROL SYSTEM (DIAGNOSTICS)

## 3. Electrical Component Location

### A: LOCATION

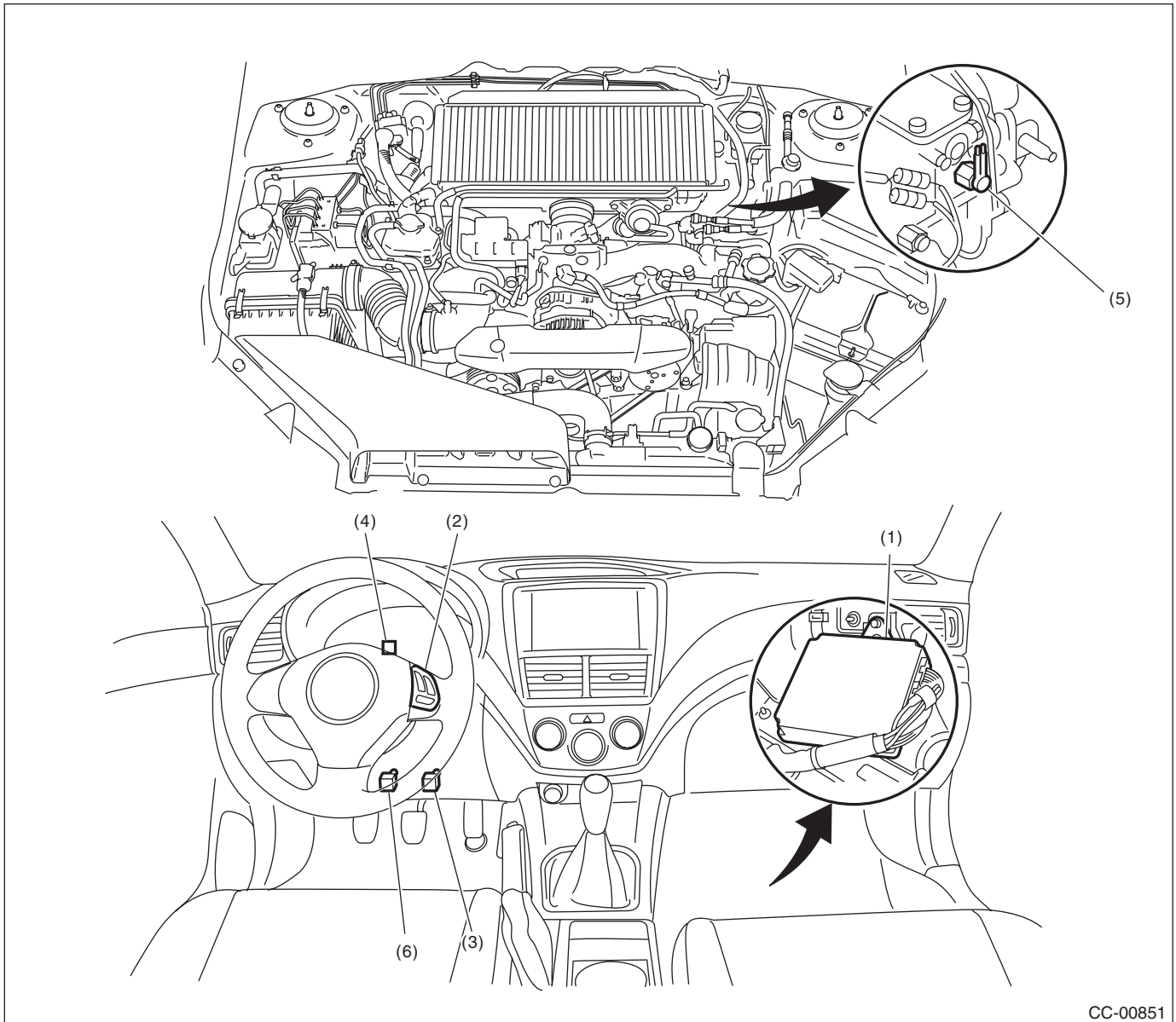

CC-00851

- |                                   |   |                             |
|-----------------------------------|---|-----------------------------|
| (1) Engine control module (ECM)   | (3) Stop light and brake switch                           | (5) Neutral position switch |
| (2) Cruise control command switch | (4) Cruise indicator light and cruise set indicator light | (6) Clutch switch           |

**CC(diag)-5**

Brought to you by Ebay Seller "SubaruManuals"



# Engine Control Module (ECM) I/O Signal

## CRUISE CONTROL SYSTEM (DIAGNOSTICS)

### 4. Engine Control Module (ECM) I/O Signal

#### A: ELECTRICAL SPECIFICATION

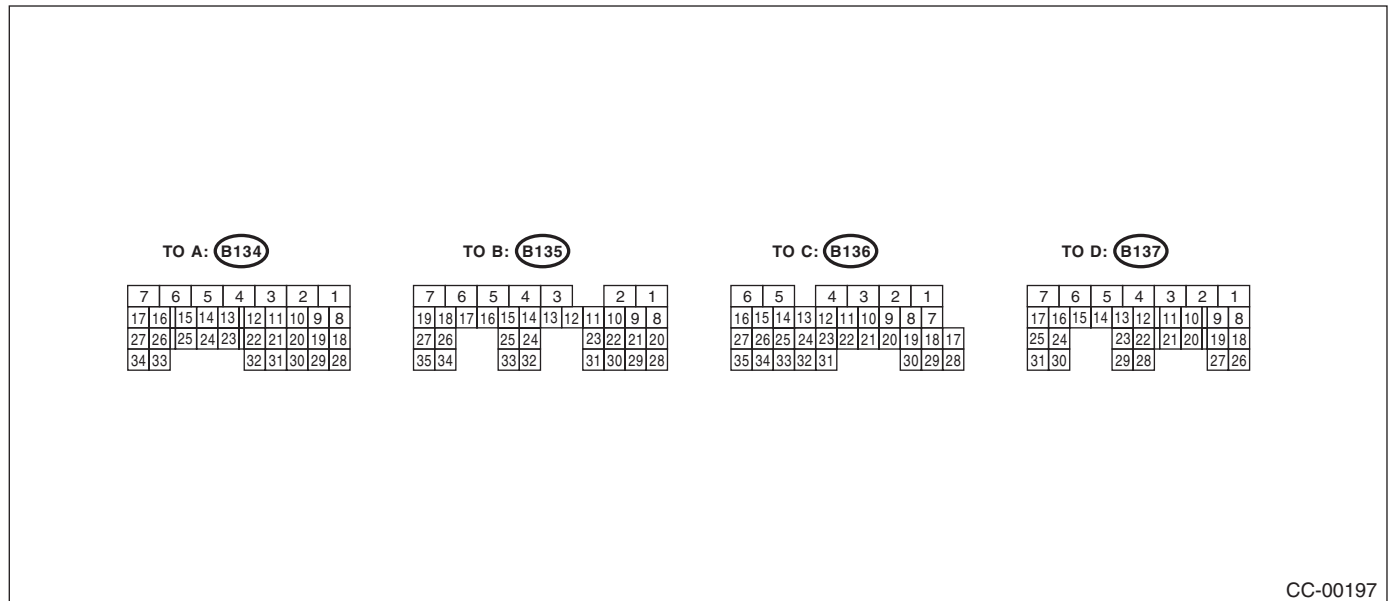

CC-00197

Content		Terminal No.	Measurement condition and I/O signal (Idling with ignition ON: except for cruise set light)
Main power supply	VB (CONTROL 1) VB (CONTROL 2)	C1 D7	<ul style="list-style-type: none"> <li>Battery voltage is detected when the main power is turned ON.</li> <li>"0 V" is detected when the main power is turned OFF.</li> </ul>
Command switch		C12	<ul style="list-style-type: none"> <li>"0 V" is detected when the command switch is in CANCEL position.</li> <li>"Approx. 1 V" is detected when the command switch is in SET/COAST position.</li> <li>"Approx. 3 V" is detected when the command switch is in RESUME/ACCEL position.</li> <li>"Approx. 4 V" is detected when the command switch is released.</li> </ul>
Brake switch 1 (brake switch)		C15	<ul style="list-style-type: none"> <li>Battery voltage is detected when the brake pedal is released.</li> <li>"0 V" is detected when brake pedal is depressed.</li> </ul>
Brake switch 2 (stop light switch)		C3	<ul style="list-style-type: none"> <li>Battery voltage is detected when brake pedal is depressed.</li> <li>"0 V" is detected when the brake pedal is released.</li> </ul>
Main switch		C13	<ul style="list-style-type: none"> <li>"0 V" is detected while the main switch is pressed or turned ON.</li> <li>Approx. "5 V" is detected when the main switch is OFF.</li> </ul>
Ground	GND (CONTROL)	A6	—
Ignition switch		C30	<ul style="list-style-type: none"> <li>Battery voltage is detected when the ignition switch is turned ON.</li> <li>"0 V" is detected when the ignition switch is turned OFF.</li> </ul>
Clutch switch		B9	<ul style="list-style-type: none"> <li>"0 V" is detected when clutch pedal is depressed.</li> <li>Battery voltage is detected when the clutch pedal is released.</li> </ul>
Neutral position switch		C35	<ul style="list-style-type: none"> <li>Battery voltage is detected when the shift lever is in any position except for neutral.</li> <li>"Approx. 0 V" is detected when the shift lever is in neutral position.</li> </ul>

#### B: WIRING DIAGRAM

<Ref. to WI-163, WIRING DIAGRAM, Cruise Control System.>

## 5. Subaru Select Monitor

### A: OPERATION

#### 1. GENERAL DESCRIPTION

The on-board diagnosis function of the cruise control system uses Subaru Select Monitor.

The on-board diagnosis function operates in two categories, which are used depending on the type of problems;

##### 1) Cruise Control Cancel Conditions Diagnosis:

(1) This category of diagnosis requires actual vehicle driving in order to determine the cause, as when cruise speed is cancelled during driving although cruise cancel condition is not entered.

(2) Cruise control memory in ECM stores the cancel code which occurred during driving. When there are multiple cancel code, they are shown on the Subaru Select Monitor.

#### CAUTION:

- **The cruise control memory stores not only the cruise “cancel” which occurred (although “cancel” operation is not entered by the driver), but also the “cancel” condition input by the driver.**

- **The latest memory content (latest code) is cleared when ignition switch is turned to OFF. However, memory contents set by the diagnosis of faulty switches related to the system and cruise control will remain as trouble history (memory code) after the ignition switch is turned to OFF.**

##### 2) Real-time Diagnosis:

Real-time diagnosis function is used to determine whether or not the input signal system is in good order, according to signal emitted from switches, sensors, etc.

(1) Vehicle cannot be driven at cruise speed when the problem occurs in the cruise control system or relevant circuits.

(2) Monitor the signal conditions from switches and sensors.

#### 2. CRUISE CONTROL CANCEL CONDITIONS DIAGNOSIS

1) Prepare the Subaru Select Monitor kit.

2) Connect the diagnosis cable to Subaru Select Monitor.

3) Connect the Subaru Select Monitor to data link connector.

(1) Data link connector is located in the lower portion of the instrument panel (on the driver's side).

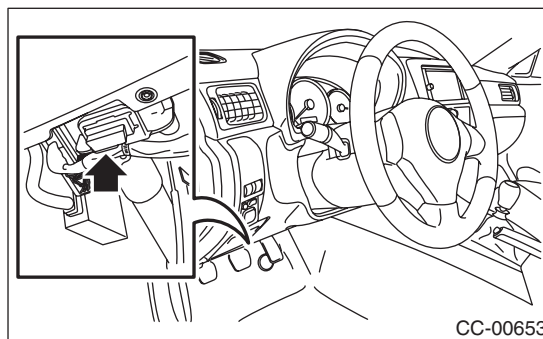

(2) Connect the diagnosis cable to data link connector.

4) Start the engine and turn the cruise control main switch to ON.

5) Run the Subaru Select Monitor.

6) On «Main Menu» display, select {Each System Check}.

On «System Selection Menu» display, select {Engine Control System} and select the [OK]. Select [OK] after the engine type information is displayed.

7) Drive vehicle at 40 km/h (25 MPH) or more and set the cruise control.

#### CAUTION:

- **When performing diagnosis, observe the legal speed limit on the road.**

- **The cancel code will be also appear when cruise control is cancelled by the driver's operation. Do not confuse them.**

- **Be sure to get an assistant to support the diagnosis while driving, and have him/her operate the select monitor.**

# Subaru Select Monitor

## CRUISE CONTROL SYSTEM (DIAGNOSTICS)

---

8) When the set speed is cancelled by itself (without any cancel operations such as applying brake) or when the cruise control could not be set by performing the setting operation, selecting the {Cancel Code(s) Display} on the engine malfunction diagnosis screen will display the cancel code on the select monitor display.

### NOTE:

The {Latest Diagnostic Code(s)} and {Memorized Diagnostic Code(s)} are contained in the cancel code. The latest code recognized during current test drive is displayed in {Latest Diagnostic Code(s)}. Cancel codes resulting from fault diagnosis of switches relating to the system and cruise control are also displayed in {Memorized Diagnostic Code(s)}.

9) Perform Engine DTC Clear Memory operation. <Ref. to EN(H4DOTC)(diag)-62, OPERATION, Clear Memory Mode.>

Cancel codes for switches relating to the system and cruise control are deleted by clearing memory on the engine side.

### NOTE:

The latest code will be cleared by turning ignition switch to OFF.

## 3. REAL-TIME DIAGNOSIS

- 1) Connect the Subaru Select Monitor.
- 2) Turn the ignition switch and cruise control main switch to ON.
- 3) Run the Subaru Select Monitor.
- 4) On «Main Menu» display, select {Each System Check}.
- 5) On «System Selection Menu» display, select {Engine Control System}.
- 6) Select [OK] after engine type information is displayed.
- 7) On «Cruise Control Diagnosis» display, select {Current Data Display & Save}.
- 8) Make sure that normal display is shown when operated as follows:
  - Depress and release the brake pedal. (Stop light switch and brake switch are turned ON.)
  - Turn the main switch to ON.
  - Turn the “CANCEL” switch to ON.
  - Turn the “SET/COAST” switch to ON.
  - Turn the “RESUME/ACCEL” switch to ON.
  - Depress or release the clutch pedal.
  - Place the shift lever in any position other than neutral.

### NOTE:

- For details concerning the operation procedure, refer to “PC application help for Subaru Select Monitor”.
- For detailed concerning cancel codes, refer to the “List of Cancel Codes”. <Ref. to CC(diag)-12, List of Cancel Code.>

# Diagnostics with Phenomenon

CRUISE CONTROL SYSTEM (DIAGNOSTICS)

## 6. Diagnostics with Phenomenon

### A: DIAGNOSTIC PROCEDURE WITH PHENOMENON

Phenomenon		Check item	Index
1	Cruise control main switch is not turned to ON. (Cruise indicator light does not illuminate.) Or cruise control is cancelled without operating the cruise control command switch.	(1) Perform cruise cancel conditions diagnosis.	Perform the diagnosis according to displayed cancel code.
		(2) Perform the real-time diagnosis.	Check the input signal of cruise control system.
		(3) Check the cruise control command switch.	<Ref. to CC(diag)-15, 11, Diagnostic Procedure with Cancel Code.>
		(4) Check the cruise indicator light.	<Ref. to CC(diag)-11, CHECK CRUISE INDICATOR LIGHT AND CRUISE SET INDICATOR LIGHT, Diagnostics with Phenomenon.>
2	Cruise control cannot be set. Or cruise control is cancelled without releasing operation.	(1) Perform cruise cancel conditions diagnosis.	Perform the diagnosis according to displayed cancel code.
		(2) Perform the real-time diagnosis.	Check the input signal of cruise control system.
		(3) Check the cruise control command switch.	<Ref. to CC(diag)-15, 11, Diagnostic Procedure with Cancel Code.>
		(4) Check stop light switch and brake switch.	<Ref. to BR-44, Brake Pedal.> <Ref. to CC(diag)-17, 12, Diagnostic Procedure with Cancel Code.>
		(5) Check clutch switch.	<Ref. to CL-33, Clutch Switch.> <Ref. to CC(diag)-19, 13, Diagnostic Procedure with Cancel Code.>
		(6) Check the neutral position switch.	<Ref. to CC(diag)-21, 14, Diagnostic Procedure with Cancel Code.> <Ref. to CC(diag)-25, 62, Diagnostic Procedure with Cancel Code.>
		(7) Check vehicle speed sensor.	<Ref. to CC(diag)-24, 22, Diagnostic Procedure with Cancel Code.>
3	Cruise set indicator light does not illuminate.	Check the cruise set indicator light.	<Ref. to CC(diag)-11, CHECK CRUISE INDICATOR LIGHT AND CRUISE SET INDICATOR LIGHT, Diagnostics with Phenomenon.>
4	Vehicle speed is not held within set speed $\pm 3$ km/h ( $\pm 2$ MPH).	Check the vehicle speed sensor.	<Ref. to CC(diag)-24, 22, Diagnostic Procedure with Cancel Code.>
5	Vehicle speed does not increase or does not return to set speed after RESUME/ACCEL switch has been pressed.	(1) Perform the real-time diagnosis.	Check the input signal of cruise control system.
		(2) Check the RESUME/ACCEL switch.	<Ref. to CC(diag)-15, 11, Diagnostic Procedure with Cancel Code.>
6	Vehicle speed does not decrease after SET/COAST switch has been pressed.	(1) Perform the real-time diagnosis.	Check the input signal of cruise control system.
		(2) Check the SET/COAST switch.	<Ref. to CC(diag)-15, 11, Diagnostic Procedure with Cancel Code.>
7	Cruise control is not released after CANCEL switch has been pressed.	(1) Perform the real-time diagnosis.	Check the input signal of cruise control system.
		(2) Check the CANCEL switch.	<Ref. to CC(diag)-15, 11, Diagnostic Procedure with Cancel Code.>
8	Cruise control is not released after brake pedal has been depressed.	(1) Perform the real-time diagnosis.	Check the input signal of cruise control system.
		(2) Check stop light switch and brake switch.	<Ref. to CC(diag)-17, 12, Diagnostic Procedure with Cancel Code.> <Ref. to BR-46, INSTALLATION, Stop Light Switch.>
9	Cruise control is not released after shifting to the neutral position.	(1) Perform the real-time diagnosis.	Check the input signal of cruise control system.
		(2) Check the neutral position switch.	<Ref. to CC(diag)-21, 14, Diagnostic Procedure with Cancel Code.>

**CC(diag)-9**

Brought to you by Ebay Seller "SubaruManuals"

## Diagnostics with Phenomenon

### CRUISE CONTROL SYSTEM (DIAGNOSTICS)

Phenomenon		Check item	Index
10	Cruise control is not released after clutch pedal has been depressed.	(1) Perform the real-time diagnosis.	Check the input signal of cruise control system.
		(2) Check clutch switch.	<Ref. to CC(diag)-19, 13, Diagnostic Procedure with Cancel Code.>

# Diagnostics with Phenomenon

CRUISE CONTROL SYSTEM (DIAGNOSTICS)

## B: CHECK CRUISE INDICATOR LIGHT AND CRUISE SET INDICATOR LIGHT

### TROUBLE SYMPTOM:

Cruise control can be set, but the cruise indicator light and cruise set indicator light do not illuminate.

Step	Check	Yes	No
<b>1</b> <b>CHECK CRUISE INDICATOR LIGHT AND CRUISE SET INDICATOR LIGHT.</b> 1) Perform the self-diagnosis of combination meter. <Ref. to IDI-5, SELF-DIAGNOSIS, INSPECTION, Combination Meter System.> 2) Check the cruise indicator light and cruise set indicator light if they illuminate.	Do the cruise indicator light and cruise set indicator light illuminate?	Go to step 2.	Replace the meter case assembly. <Ref. to IDI-16, Combination Meter.>
<b>2</b> <b>CHECK DTC OF LAN COMMUNICATION CIRCUIT.</b> 1) Complete self-diagnosis, and turn the ignition switch to ON again. 2) Read the DTC of body integrated unit using Subaru Select Monitor.	Is DTC of low-speed CAN displayed?	Check the LAN communication circuit. <Ref. to LAN(diag)-2, Basic Diagnostic Procedure.>	Replace the ECM. <Ref. to FU(STI)-59, Engine Control Module (ECM).> <Ref. to FU(w/o STI)-58, Engine Control Module (ECM).>

## List of Cancel Code

### CRUISE CONTROL SYSTEM (DIAGNOSTICS)

## 7. List of Cancel Code

### A: LIST

#### NOTE:

- The cancel code is registered even when cancel is performed intentionally by the driver.
- Cancel codes are cleared if the ignition switch is turned to OFF.
- If a different cancel code is input after a cancel code (latest code) has been input, the latest code is overwritten.
- If the cruise indicator light is flashing, a malfunction is occurring in the system or cruise control related switch. The cancel code at this time is saved even after ignition switch is OFF as a memory code of a past malfunction.
- To display a cancel code, use the Subaru Select Monitor to read the code after the cruise control is deactivated during a driving test.

Cancel code	Item	Contents of diagnosis	Note
11	Main Switch	Main switch of cruise control command switch is turned to OFF, and then the cruise control is released.	This code is displayed without operating the main switch. <Ref. to CC(diag)-15, 11, Diagnostic Procedure with Cancel Code.>
12	Stop Light & Brake Switch	Stop light switch or brake switch is turned to ON, and then the cruise control is released.	This code is displayed without depressing the brake pedal. <Ref. to CC(diag)-17, 12, Diagnostic Procedure with Cancel Code.>
13	Clutch Switch	Clutch switch is turned to ON, and then the cruise control is released.	This code is displayed without depressing the clutch pedal. <Ref. to CC(diag)-19, 13, Diagnostic Procedure with Cancel Code.>
14	Neutral Position Switch	Neutral position switch is turned to ON, and then the cruise control is released.	This code is displayed without shifting to neutral position. <Ref. to CC(diag)-21, 14, Diagnostic Procedure with Cancel Code.>
15	Cancel Switch	Cancel switch is turned to ON, and then the cruise control is released.	This code is displayed without operating the cancel switch. <Ref. to CC(diag)-22, 15, Diagnostic Procedure with Cancel Code.>
16	Ignition switch	Ignition switch is turned to OFF, and then the cruise control is released.	This code is displayed without operating the ignition switch. <Ref. to CC(diag)-23, 16, Diagnostic Procedure with Cancel Code.>
21	Cruise control switch malfunction when ignition switch is turned to ON	When the ignition switch is turned to ON, each switch of cruise control command switch is already turned to ON.	This code is displayed when the ignition switch is turned to ON without operating the cruise control command switch. <Ref. to CC(diag)-23, 21, Diagnostic Procedure with Cancel Code.>

# List of Cancel Code

## CRUISE CONTROL SYSTEM (DIAGNOSTICS)

Cancel code	Item	Contents of diagnosis	Note
22	Abnormality of change in vehicle speed	Malfunction of vehicle speed signal variation is detected.	<Ref. to CC(diag)-24, 22, Diagnostic Procedure with Cancel Code.>
24	Abnormality of switches related to cruise control	Open circuit of the cruise control switch is detected during cruise driving. (The system is judged as model without cruise control.)	This code is displayed with normal operation. <Ref. to CC(diag)-24, 24, Diagnostic Procedure with Cancel Code.>
31	Abnormal engine speed Signal	<ul style="list-style-type: none"> <li>Abnormal increase of engine speed is detected.</li> <li>Gear is placed in Neutral, 1st or Reverse position.</li> </ul>	Cruise in 2nd shift position or more. <Ref. to CC(diag)-24, 31, Diagnostic Procedure with Cancel Code.>
32	Cruse Control out of Range	<ul style="list-style-type: none"> <li>Controlled vehicle speed decreased under the limit during cruising.</li> <li>Set operation was performed at vehicle speed unavailable for setting.</li> <li>RESUME operation was performed without memorized vehicle speed.</li> </ul>	This code is displayed, though the vehicle speed is increased to the speed available for cruise set and set operation was performed again. <Ref. to CC(diag)-24, 32, Diagnostic Procedure with Cancel Code.>
34	Prohibition of cruise control at continuing big Accel. angle	The vehicle has been driven at higher speed than set vehicle speed for an abnormally long time (approximately 10 minutes) during cruise driving.	This code is displayed when driving for a long period of time at higher speed than appropriate cruise set vehicle speed by operating accelerator pedal. In this case, the cruise setting is deactivated. <Ref. to CC(diag)-24, 34, Diagnostic Procedure with Cancel Code.>
35	Prohibition of cruise control at vehicle speed F/B malfunction	Set vehicle speed cannot be kept because of some reasons (steep uphill, parking brake, abnormal decrease of engine output, etc.) during cruise driving.	This code is displayed when driving condition is not suitable for cruise control. Perform cruise set operation again after clearing the possible cause. <Ref. to CC(diag)-25, 35, Diagnostic Procedure with Cancel Code.>
41	VDC/TCS Operating	Vehicle dynamics control (VDC) or TCS is operated during cruise driving or cruise setting.	This code is displayed when driving condition is not suitable for cruise control. Perform cruise set operation again after clearing the possible cause. <Ref. to CC(diag)-25, 41, Diagnostic Procedure with Cancel Code.>
43	ABS/VDC Failure	ABS or Vehicle dynamics control (VDC) system malfunction is detected during cruise driving or cruise setting.	<Ref. to CC(diag)-25, 43, Diagnostic Procedure with Cancel Code.>
44	Body Integrated unit Failure	Body integrated unit system malfunction is detected during cruise driving or cruise setting.	<Ref. to CC(diag)-25, 44, Diagnostic Procedure with Cancel Code.>



## List of Cancel Code

### CRUISE CONTROL SYSTEM (DIAGNOSTICS)

Cancel code	Item	Contents of diagnosis	Note
45	Meter Failure	Combination meter malfunction is detected during cruise driving or cruise setting.	<Ref. to CC(diag)-25, 45, Diagnostic Procedure with Cancel Code.>
61	Brake switch abnormal	Malfunction in the stop light & brake switch is detected.	<Ref. to CC(diag)-25, 61, Diagnostic Procedure with Cancel Code.>
62	Neutral Switch Failure	Neutral position switch malfunction is detected.	<Ref. to CC(diag)-25, 62, Diagnostic Procedure with Cancel Code.>
63	Abnormality of change in vehicle speed	Malfunction of vehicle speed signal variation is detected.	<Ref. to CC(diag)-25, 63, Diagnostic Procedure with Cancel Code.>
64	Engine Sensor Failure 1	Malfunction related to engine is detected.	<Ref. to CC(diag)-25, 64, Diagnostic Procedure with Cancel Code.>
65	Abnormality 1 of switches related to cruise control	Cruise control command switch malfunction is detected. (When the switch is pressed ON for a long time (approximately two minutes), stuck ON condition is detected.)	<Ref. to CC(diag)-26, 65, Diagnostic Procedure with Cancel Code.>
66	Cruise Control Calculation Error	Cruise control calculation (microcomputer) malfunction is detected.	<Ref. to CC(diag)-26, 66, Diagnostic Procedure with Cancel Code.>

# Diagnostic Procedure with Cancel Code

CRUISE CONTROL SYSTEM (DIAGNOSTICS)

## 8. Diagnostic Procedure with Cancel Code

### A: 11

Detected when main switch is pressed or when main switch related malfunction occurs.

#### TROUBLE SYMPTOM:

- Cruise control cannot be set. (Cancelled immediately.)
- Cruise control cannot be released.

#### WIRING DIAGRAM:

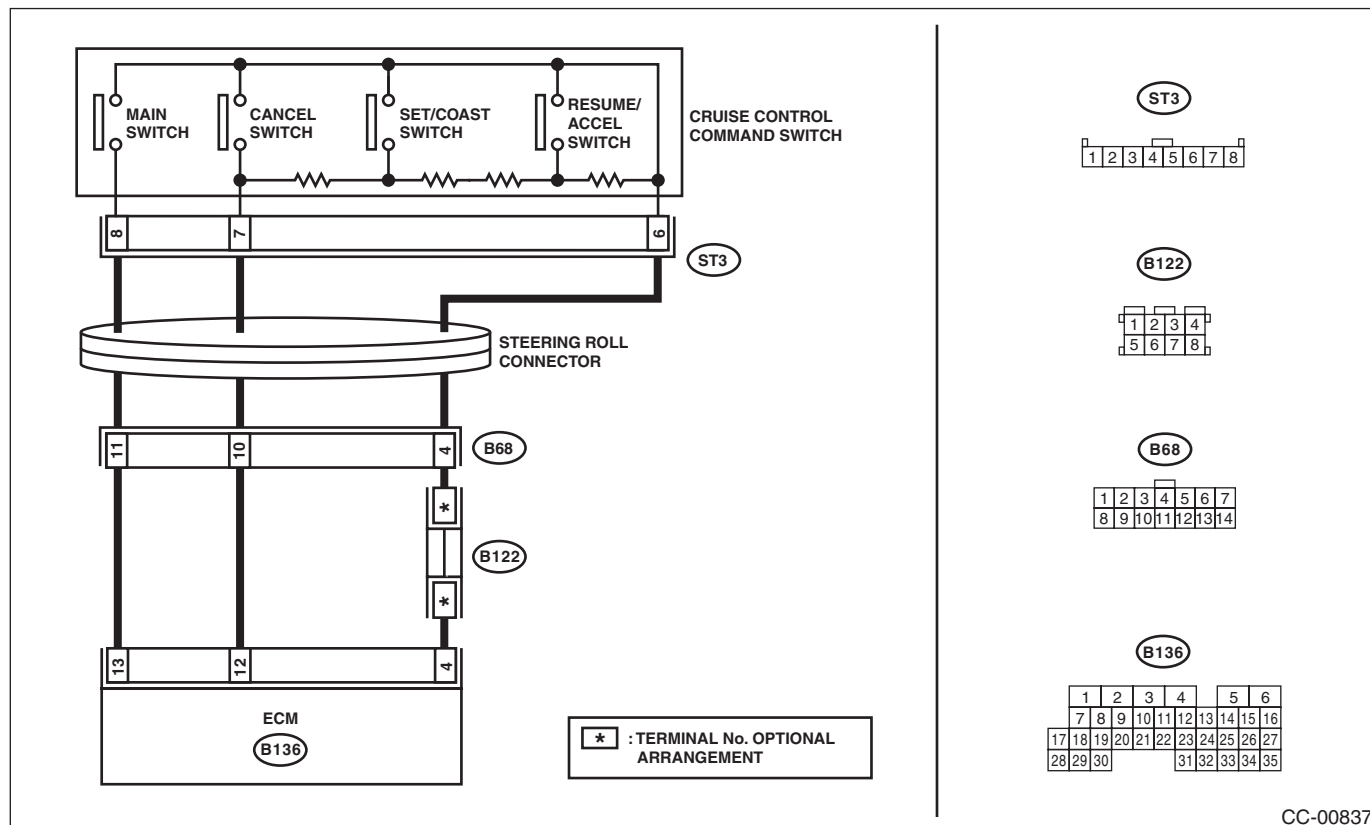

CC-00837

Step	Check	Yes	No
<b>1 CHECK CRUISE CONTROL COMMAND SWITCH CIRCUIT.</b> 1) Remove the driver's airbag module. <Ref. to AB-16, REMOVAL, Driver's Airbag Module.> 2) Disconnect the harness connector of cruise control command switch. 3) Turn the ignition switch to ON. 4) Measure the voltage between harness connector terminal and chassis ground. <b>Connector &amp; terminal</b> (ST3) No. 8 (+) — Chassis ground (-): (ST3) No. 7 (+) — Chassis ground (-):	Is the voltage 5 V or more?	Go to step 2.	Check the harness between cruise control command switch and ECM, and the steering roll connector for open or short circuit, or for poor contact.
<b>2 CHECK CRUISE CONTROL COMMAND SWITCH CIRCUIT.</b> 1) Turn the ignition switch to OFF. 2) Remove the cruise control command switch. <Ref. to CC-6, REMOVAL, Cruise Control Command Switch.> 3) Measure the resistance between harness connector terminal and chassis ground. <b>Connector &amp; terminal</b> (ST3) No. 6 — Chassis ground:	Is the resistance less than 10 Ω?	Go to step 3.	Check for open circuit between cruise control command switch, ECM, and chassis ground and check the ECM.

## Diagnostic Procedure with Cancel Code

### CRUISE CONTROL SYSTEM (DIAGNOSTICS)

Step	Check	Yes	No
<b>3 CHECK CRUISE CONTROL COMMAND SWITCH.</b> Measure the resistance between switch terminals when the cruise control command switch is not depressed. <i>Terminals</i> <b>No. 6 — No. 7:</b>	Is the resistance approx. 4 k $\Omega$ ?	Go to step 4.	Replace the cruise control command switch. <Ref. to CC-6, Cruise Control Command Switch.>
<b>4 CHECK CANCEL SWITCH.</b> 1) Turn the ignition switch to OFF. 2) Remove the cruise control command switch. <Ref. to CC-6, REMOVAL, Cruise Control Command Switch.> 3) Measure the resistance between switch terminals with the CANCEL switch pressed. <i>Terminals</i> <b>No. 6 — No. 7:</b>	Is the resistance approx. less than 1 $\Omega$ when the CANCEL switch is pressed?	Go to step 5.	Replace the cruise control command switch. <Ref. to CC-6, Cruise Control Command Switch.>
<b>5 CHECK SET/COAST SWITCH.</b> Measure the resistance between switch terminals with the SET/COAST switch pressed. <i>Terminals</i> <b>No. 6 — No. 7:</b>	Is the resistance approx. 250 $\Omega$ when SET/COAST switch is pressed?	Go to step 6.	Replace the cruise control command switch. <Ref. to CC-6, Cruise Control Command Switch.>
<b>6 CHECK RESUME/ACCEL SWITCH CIRCUIT.</b> Measure the resistance between switch terminals with the RESUME/ACCEL switch pressed. <i>Terminals</i> <b>No. 6 — No. 7:</b>	Is the resistance approx. 1,500 $\Omega$ when RESUME/ACCEL switch is pressed?	Replace the ECM. <Ref. to FU(STI)-59, Engine Control Module (ECM).> <Ref. to FU(w/o STI)-58, Engine Control Module (ECM).>	Replace the cruise control command switch. <Ref. to CC-6, Cruise Control Command Switch.>

# Diagnostic Procedure with Cancel Code

## CRUISE CONTROL SYSTEM (DIAGNOSTICS)

### B: 12

Detected when brake pedal is depressed or malfunction related to stop light & brake switch occurs.

#### TROUBLE SYMPTOM:

- Cruise control cannot be set.
- Cruise control cannot be released.

#### WIRING DIAGRAM:

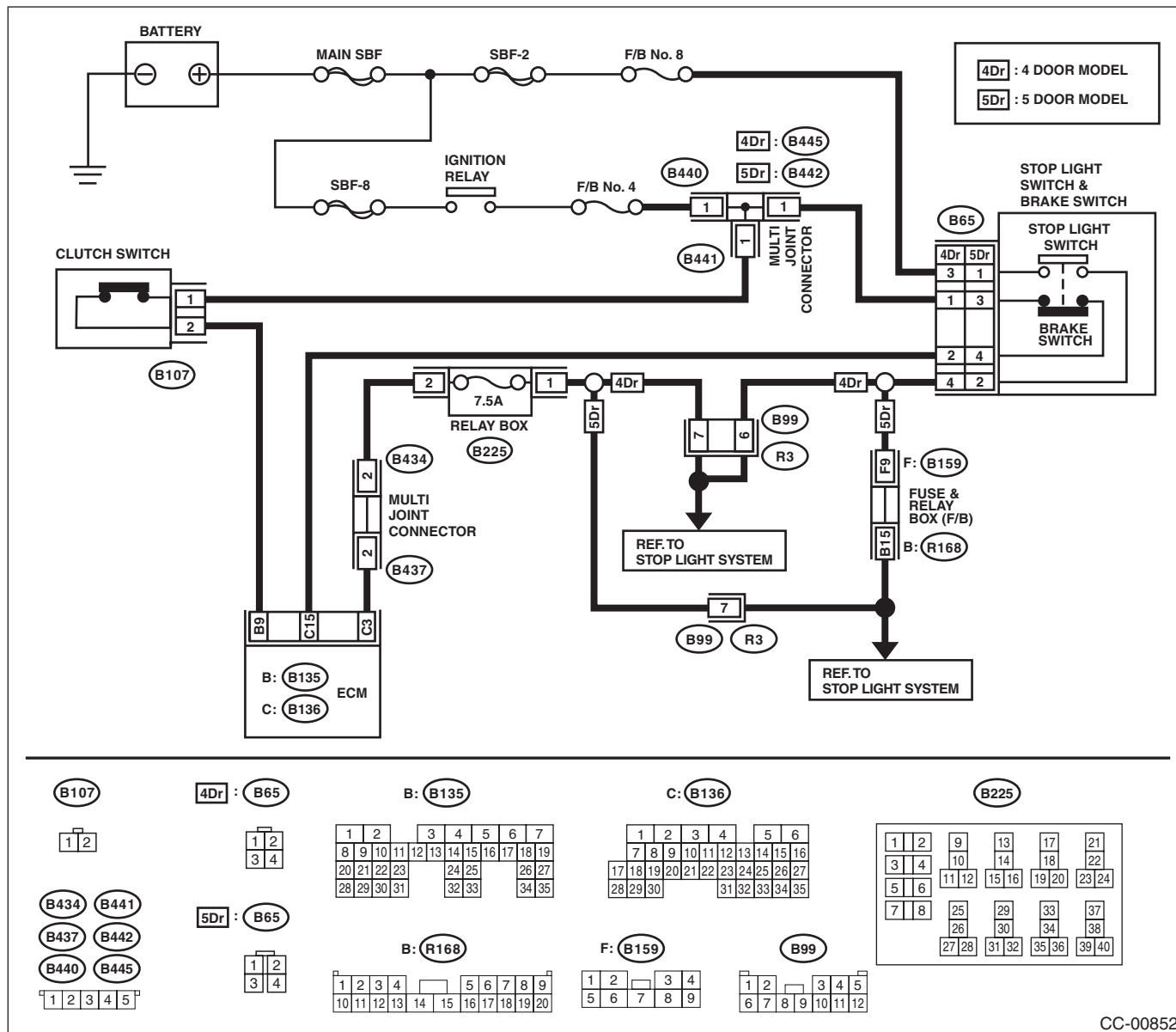

CC-00852

Step	Check	Yes	No
1	<b>CHECK STOP LIGHT &amp; BRAKE SWITCH.</b> Check the stop light & brake switch. <Ref. to CC-9, Stop Light & Brake Switch.>	Go to step 2.	Replace the stop light & brake switch. Or adjust the installation position.

## Diagnostic Procedure with Cancel Code

### CRUISE CONTROL SYSTEM (DIAGNOSTICS)

Step	Check	Yes	No
<p><b>2</b>      <b>CHECK STOP LIGHT &amp; BRAKE SWITCH CIRCUIT.</b>                      1) Turn the ignition switch to OFF.                      2) Disconnect the stop light &amp; brake switch harness connector.                      3) Turn the ignition switch to ON.                      4) Measure the voltage between harness connector terminal and chassis ground.</p> <p><b>Connector &amp; terminal</b>  <b>5 door model:</b>                      (B65) No. 1 (+) — Chassis ground (-):  <b>4 door model:</b>                      (B65) No. 3 (+) — Chassis ground (-):</p>	Is the voltage 10 V or more?	Go to step 3.	<ul style="list-style-type: none"> <li>• Check fuse No. 8 (in fuse &amp; relay box).</li> <li>• Check for open or short in the harness between stop light &amp; brake switch and fuse &amp; relay box.</li> </ul>
<p><b>3</b>      <b>CHECK STOP LIGHT &amp; BRAKE SWITCH CIRCUIT.</b>                      Measure the voltage between harness connector terminal and chassis ground.</p> <p><b>Connector &amp; terminal</b>  <b>5 door model:</b>                      (B65) No. 3 (+) — Chassis ground (-):  <b>4 door model:</b>                      (B65) No. 1 (+) — Chassis ground (-):</p>	Is the voltage 10 V or more?	Go to step 4.	<ul style="list-style-type: none"> <li>• Check fuse No. 4 (in fuse &amp; relay box).</li> <li>• Check for open or short in the harness between stop light &amp; brake switch and fuse &amp; relay box.</li> </ul>
<p><b>4</b>      <b>CHECK STOP LIGHT &amp; BRAKE SWITCH CIRCUIT.</b>                      1) Turn the ignition switch to OFF.                      2) Disconnect the harness connector of ECM.                      3) Measure the resistance between ECM harness connector terminal and stop light &amp; brake switch harness connector terminal.</p> <p><b>Connector &amp; terminal</b>  <b>5 door model:</b>                      (B136) No. 15 — (B65) No. 4:                      (B136) No. 3 — (B65) No. 2:  <b>4 door model:</b>                      (B136) No. 15 — (B65) No. 2:                      (B136) No. 3 — (B65) No. 4:</p>	Is the resistance less than 10 Ω?	Replace the ECM. <Ref. to FU(STI)-59, Engine Control Module (ECM).> <Ref. to FU(w/o STI)-58, Engine Control Module (ECM).>	Repair the harness.

# Diagnostic Procedure with Cancel Code

## CRUISE CONTROL SYSTEM (DIAGNOSTICS)

### C: 13

Detected when clutch pedal is depressed or malfunction related to clutch switch occurs.

#### TROUBLE SYMPTOM:

- Cruise control cannot be set.
- Cruise control cannot be released.

#### WIRING DIAGRAM:

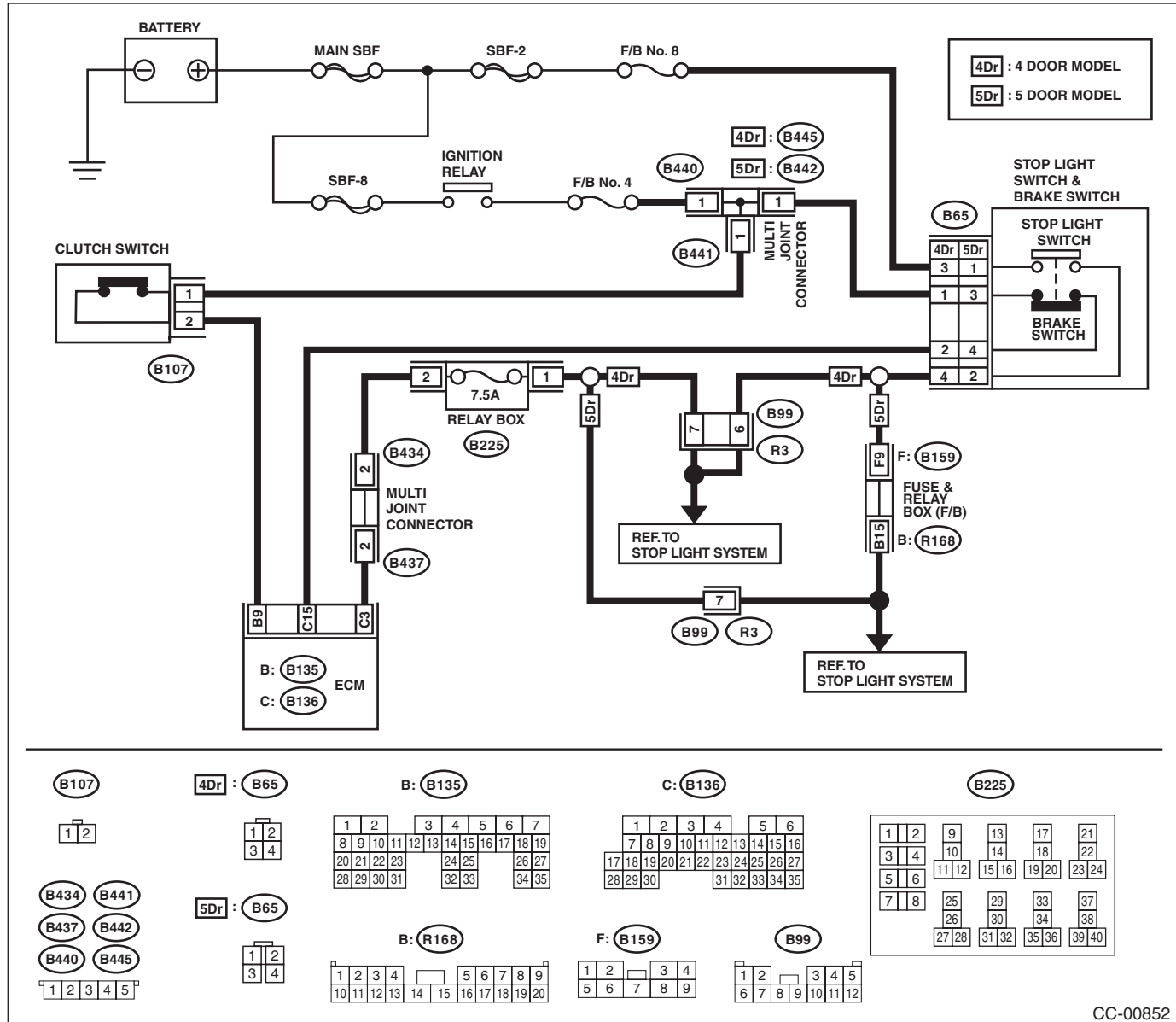

CC-00852

Step	Check	Yes	No
1	<b>CHECK CLUTCH SWITCH.</b> Check the clutch switch. <Ref. to CL-33, INSPECTION, Clutch Switch.>	Go to step 2.	Replace the clutch switch. Or adjust the installation position.

## Diagnostic Procedure with Cancel Code

### CRUISE CONTROL SYSTEM (DIAGNOSTICS)

Step	Check	Yes	No
<b>2</b> <b>CHECK CLUTCH SWITCH CIRCUIT.</b> 1) Turn the ignition switch to OFF. 2) Disconnect the clutch switch harness connector. 3) Turn the ignition switch to ON. 4) Measure the voltage between harness connector terminal and chassis ground. <b>Connector &amp; terminal</b> <b>(B107) No. 1 (+) — Chassis ground (-):</b>	Is the voltage 10 V or more?	Go to step 3.	<ul style="list-style-type: none"> <li>• Check fuse No. 4 (in fuse &amp; relay box).</li> <li>• Check open or shorted circuit of harness between clutch switch and fuse &amp; relay box.</li> </ul>
<b>3</b> <b>CHECK CLUTCH SWITCH CIRCUIT.</b> 1) Turn the ignition switch to OFF. 2) Disconnect the harness connector of ECM. 3) Measure the resistance between clutch switch harness connector terminal and ECM harness connector terminal. <b>Connector &amp; terminal</b> <b>(B107) No. 2 — (B135) No. 9:</b>	Is the resistance less than 10 $\Omega$ ?	Replace the ECM. <Ref. to FU(STI)-59, Engine Control Module (ECM).> <Ref. to FU(w/o STI)-58, Engine Control Module (ECM).>	Repair the harness.

# Diagnostic Procedure with Cancel Code

CRUISE CONTROL SYSTEM (DIAGNOSTICS)

## D: 14

Detected when select lever is set in the neutral position, or when malfunction related to neutral position switch occurs.

### TROUBLE SYMPTOM:

Cruise control cannot be set.

### WIRING DIAGRAM:

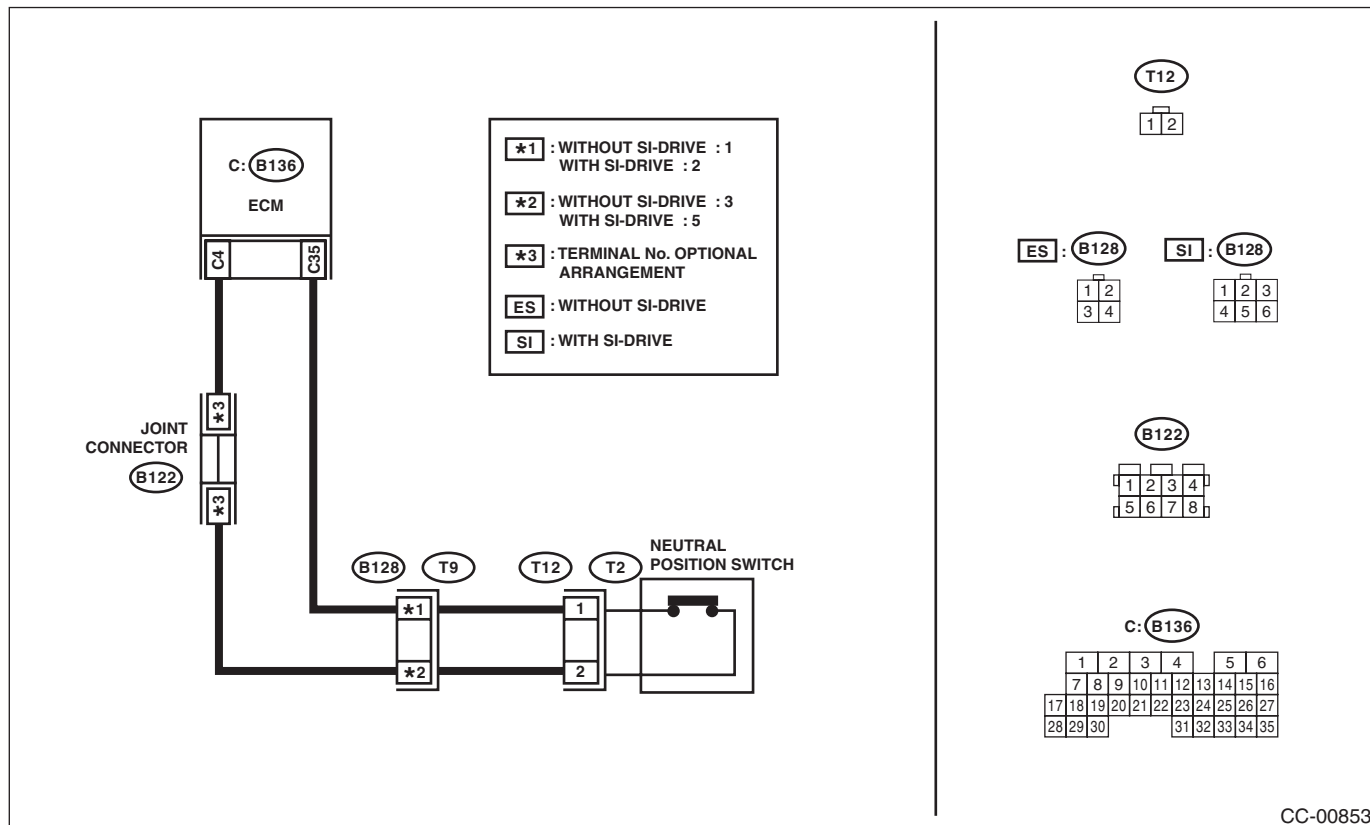

CC-00853

Step	Check	Yes	No
<b>1</b> <b>CHECK NEUTRAL POSITION SWITCH CIRCUIT.</b> 1) Turn the ignition switch to OFF. 2) Disconnect the neutral position switch harness connector. 3) Turn the ignition switch to ON. 4) Measure the voltage between harness connector terminal and chassis ground. <b>Connector &amp; terminal</b> <b>(T12) No. 1 (+) — Chassis ground (-):</b>	Is the voltage 10 V or more?	Go to step 2.	Check for open or short in the harness between neutral position switch and ECM.
<b>2</b> <b>CHECK NEUTRAL POSITION SWITCH CIRCUIT.</b> 1) Turn the ignition switch to OFF. 2) Measure resistance between harness connector terminal of neutral position switch and chassis ground. <b>Connector &amp; terminal</b> <b>(T12) No. 2 — Chassis ground:</b>	Is the resistance less than 10 Ω?	Go to step 3.	Repair the harness.



## Diagnostic Procedure with Cancel Code

### CRUISE CONTROL SYSTEM (DIAGNOSTICS)

Step	Check	Yes	No
<b>3</b> <b>CHECK NEUTRAL POSITION SWITCH.</b> Check the neutral position switch. <Ref. to 6MT-42, Neutral Position Switch.> <Ref. to 5MT-33, Switches and Harness.>	Is the neutral position switch OK?	Replace the ECM. <Ref. to FU(STI)-59, Engine Control Module (ECM).> <Ref. to FU(w/o STI)-58, Engine Control Module (ECM).>	Replace the neutral position switch.

### **E: 15**

Detected when CANCEL switch is pressed or malfunction related to main switch occurs.

#### **TROUBLE SYMPTOM:**

- Cruise control cannot be set. (Cancelled immediately.)
- Cruise control cannot be released.

Refer to DTC 11 for diagnostic procedure.

<Ref. to CC(diag)-15, 11, Diagnostic Procedure with Cancel Code.>

# Diagnostic Procedure with Cancel Code

CRUISE CONTROL SYSTEM (DIAGNOSTICS)

## F: 16

Detected when ignition switch is turned to OFF or malfunction related to the ignition switch occurs.

### TROUBLE SYMPTOM:

Cruise control cannot be set.

### WIRING DIAGRAM:

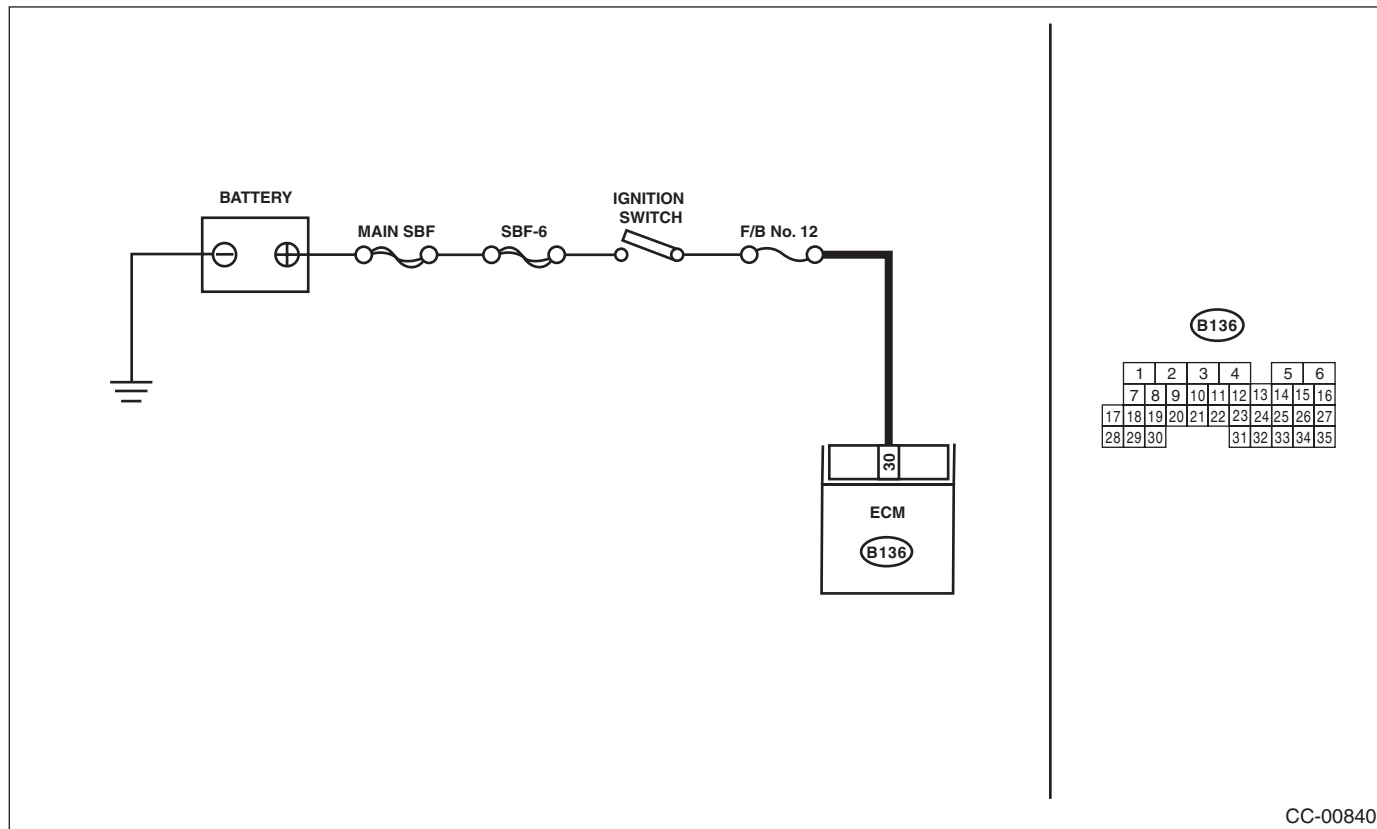

Step	Check	Yes	No
<b>1 CHECK IGNITION SWITCH CIRCUIT.</b> 1) Turn the ignition switch to OFF. 2) Disconnect the ECM harness connector. 3) Turn the ignition switch to ON. 4) Measure the voltage between harness connector terminal and chassis ground. <b>Connector &amp; terminal</b> <b>(B136) No. 30 (+) — Chassis ground (-):</b>	Is the voltage 10 V or more?	Check for poor contact of ECM connector.	<ul style="list-style-type: none"> <li>• Check fuse No. 12 (in fuse &amp; relay box).</li> <li>• Check the harness for open or short circuit between ignition switch and ECM.</li> </ul>

## G: 21

Cruise control command switch malfunction is detected.

### TROUBLE SYMPTOM:

- Cruise control cannot be set. (Cancelled immediately.)
- Cruise control cannot be released.

Refer to DTC 11 for diagnostic procedure. <Ref. to CC(diag)-15, 11, Diagnostic Procedure with Cancel Code.>

# Diagnostic Procedure with Cancel Code

## CRUISE CONTROL SYSTEM (DIAGNOSTICS)

### H: 22

Malfunction related to vehicle speed sensor is detected.

#### DIAGNOSIS:

Open or shorted circuit in vehicle speed sensor system.

#### TROUBLE SYMPTOM:

Cruise control cannot be set. (Cancelled immediately.)

	Step	Check	Yes	No
1	<b>CHECK ABS OR VDC WARNING LIGHT.</b> 1) Turn the ignition switch to ON. 2) After the initial operation of the combination meter is completed, check whether the VDC warning light continues to illuminate.	Does the warning light continue to illuminate?	Check the VDCCM. <Ref. to VDC(diag)-2, Basic Diagnostic Procedure.>	Go to step 2.
2	<b>CHECK DTC OF LAN COMMUNICATION CIRCUIT.</b> Read the DTC of body integrated unit using Subaru Select Monitor.	Is DTC of low-speed CAN displayed?	Check the LAN communication circuit.	Replace the ECM. <Ref. to FU(STI)-59, Engine Control Module (ECM).> <Ref. to FU(w/o STI)-58, Engine Control Module (ECM).>

### I: 24

Malfunction in cruise control-related switch is detected.

#### TROUBLE SYMPTOM:

- Cruise control cannot be set. (Cancelled immediately.)
- Cruise control cannot be released.

Refer to DTC 11 for diagnostic procedure.

<Ref. to CC(diag)-15, 11, Diagnostic Procedure with Cancel Code.>

### J: 31

Engine speed signal malfunction is detected.

Abnormal increase of engine speed is detected.

Gear is placed in 1st or Reverse position.

After driving at the 2nd gear position or higher, perform the cruise setting again. If a cancel code is not detected, it is normal.

### K: 32

Detected when the vehicle speed is out of the system controllable range.

Increase vehicle speed high enough to allow the cruise control to function, and then perform setting operation again.

If cancel code is still detected after setting cruise again, perform the diagnosis for DTC 22.

Refer to DTC 22 for diagnostic procedure.

<Ref. to CC(diag)-24, 22, Diagnostic Procedure with Cancel Code.>

### L: 34

The vehicle has been driven at a speed higher than set speed for a long time (approximately 10 minutes) during cruise driving.

This cancel code is detected when driving for a long period of time at a speed higher than appropriate for cruise control setting by operating the accelerator pedal.

Perform the cruise control setting operation again. If the cancel code is not detected, it is normal.

# Diagnostic Procedure with Cancel Code

CRUISE CONTROL SYSTEM (DIAGNOSTICS)

---

## **M: 35**

Detected when it is impossible to perform the vehicle speed feedback.

Set vehicle speed cannot be kept for some reasons (steep uphill, unreleased parking brake, etc.) during cruise driving.

Cancel code is detected when driving condition is not suitable for cruise control.

Perform cruise set operation again after clearing the possible cause.

## **N: 41**

VDC/TCS has operated.

Vehicle dynamics control (VDC) or TCS is operated during cruise driving or cruise setting.

<Ref. to VDC(diag)-2, PROCEDURE, Basic Diagnostic Procedure.>

## **O: 43**

ABS/VDC malfunction is detected.

VDC malfunction is detected during cruise driving or cruise setting.

<Ref. to VDC(diag)-2, PROCEDURE, Basic Diagnostic Procedure.>

## **P: 44**

Body integrated unit malfunction is detected.

Body integrated unit system malfunction is detected during cruise driving or cruise setting. <Ref. to LAN(diag)-2, PROCEDURE, Basic Diagnostic Procedure.>

## **Q: 45**

Combination meter malfunction is detected.

Combination meter malfunction is detected during cruise driving or cruise setting. <Ref. to LAN(diag)-2, PROCEDURE, Basic Diagnostic Procedure.>

## **R: 61**

Malfunction in the stop light & brake switch is detected.

### **TROUBLE SYMPTOM:**

- Cruise control cannot be set.
- Cruise control cannot be released.

Refer to DTC 12 for diagnostic procedure. <Ref. to CC(diag)-17, 12, Diagnostic Procedure with Cancel Code.>

## **S: 62**

Neutral position switch malfunction is detected.

### **TROUBLE SYMPTOM:**

Cruise control cannot be set.

Refer to DTC 14 for diagnostic procedure.

<Ref. to CC(diag)-21, 14, Diagnostic Procedure with Cancel Code.>

## **T: 63**

Malfunction of vehicle speed signal variation is detected.

### **TROUBLE SYMPTOM:**

Cruise control cannot be set. (Cancelled immediately.)

Refer to DTC 22 for diagnostic procedure.

<Ref. to CC(diag)-24, 22, Diagnostic Procedure with Cancel Code.>

## **U: 64**

Malfunction related to engine is detected.

Refer to the Engine Diagnostic Procedure for diagnostic procedure.

<Ref. to EN(H4DOTC)(diag)-2, PROCEDURE, Basic Diagnostic Procedure.>

## Diagnostic Procedure with Cancel Code

### CRUISE CONTROL SYSTEM (DIAGNOSTICS)

---

#### **V: 65**

Cruise control command switch malfunction is detected.

While the command switch is pressed ON for a long time (approximately two minutes), stuck ON condition is detected.

#### **TROUBLE SYMPTOM:**

- Cruise control cannot be set. (Cancelled immediately.)
- Cruise control cannot be released.

Refer to DTC 11 for diagnostic procedure. <Ref. to CC(diag)-15, 11, Diagnostic Procedure with Cancel Code.>

#### **W: 66**

Cruise control calculation malfunction is detected.

Refer to the Engine Diagnostic Procedure for diagnostic procedure.

<Ref. to EN(H4DOTC)(diag)-2, PROCEDURE, Basic Diagnostic Procedure.>

# IMMOBILIZER (DIAGNOSTICS)

# *IM(diag)*

---

	<b>Page</b>
1. Basic Diagnostic Procedure .....	2
2. General Description .....	4
3. Electrical Component Location .....	6
4. Immobilizer Control Module I/O Signal .....	7
5. Subaru Select Monitor .....	8
6. Read Diagnostic Trouble Code (DTC) .....	9
7. Clear Memory Mode .....	10
8. Diagnostics Chart for Security Indicator Light .....	11
9. List of Diagnostic Trouble Code (DTC) .....	14
10. Diagnostic Procedure with Diagnostic Trouble Code (DTC) .....	15

# Basic Diagnostic Procedure

## IMMOBILIZER (DIAGNOSTICS)

### 1. Basic Diagnostic Procedure

#### A: PROCEDURE

Step	Check	Yes	No
<b>1</b> <b>CHECK SECURITY INDICATOR LIGHT.</b> 1) Turn the ignition switch to "OFF" or "ACC". 2) Wait at least 60 seconds.	Does the security indicator light blink?	Go to step 2.	Check the security indicator light circuit. <Ref. to IM(diag)-11, CHECK SECURITY INDICATOR LIGHT CIRCUIT, INSPECTION, Diagnostics Chart for Security Indicator Light.>
<b>2</b> <b>CHECK KEY SWITCH.</b> Remove the key from ignition switch.	Does the security indicator light begin to blink within 1 second after the key is removed?	Go to step 3.	Check the key switch circuit. <Ref. to IM(diag)-13, CHECK KEY SWITCH CIRCUIT, INSPECTION, Diagnostics Chart for Security Indicator Light.>
<b>3</b> <b>CHECK SECURITY INDICATOR LIGHT.</b> Turn the ignition switch to ON.	Does the security indicator light go off?	Go to step 5.	Go to step 4.
<b>4</b> <b>CHECK ENGINE START.</b> Turn the ignition switch to START.	Does the starter operate?	Check the LAN communication system. <Ref. to LAN(diag)-2, Basic Diagnostic Procedure.>	Go to step 7.
<b>5</b> <b>CHECK ENGINE START.</b> Turn the ignition switch to START.	Does the starter operate?	Go to step 6.	Check the LAN communication system. <Ref. to LAN(diag)-2, Basic Diagnostic Procedure.>
<b>6</b> <b>CHECK ENGINE START.</b> Turn the ignition switch to START.	Does the engine start?	Immobilizer system is normal.	Go to step 8.
<b>7</b> <b>CHECK DTC.</b> 1) Turn the ignition switch to OFF. 2) Connect the Subaru Select Monitor to data link connector. <Ref. to IM(diag)-8, Subaru Select Monitor.> 3) Turn the ignition switch and Subaru Select Monitor switch to ON. 4) Read the DTC of the body integrated unit.	Is the DTC displayed on screen?	Go to step 10.	Replace the body integrated unit. <Ref. to SL-48, Body Integrated Unit.> Register all ignition keys (transponders). Refer to the "PC application help for Subaru Select Monitor".
<b>8</b> <b>CHECK DTC.</b> 1) Turn the ignition switch to OFF. 2) Connect the Subaru Select Monitor to data link connector. <Ref. to IM(diag)-8, Subaru Select Monitor.> 3) Turn the ignition switch and Subaru Select Monitor switch to ON. 4) Read the DTC of the ECM.	Is the DTC displayed on screen?	Go to step 9.	Perform the diagnosis for engine system. <Ref. to EN(H4DOTC)(diag)-73, PROCEDURE, Diagnostics for Engine Starting Failure.>

# Basic Diagnostic Procedure

IMMOBILIZER (DIAGNOSTICS)

Step	Check	Yes	No
<b>9</b> <b>CHECK FREEZE FRAME DATA.</b> Using the Subaru Select Monitor, check the Freeze Frame Data.	Was the Freeze Frame Data recorded?	Record the data. Go to step <b>10</b> .	Go to step <b>10</b> .
<b>10</b> <b>PERFORM DIAGNOSIS.</b> 1) Inspect using the "Diagnostic Procedure with Diagnostic Trouble Code (DTC)". <Ref. to IM(diag)-15, Diagnostic Procedure with Diagnostic Trouble Code (DTC).> 2) Repair the trouble cause. 3) Perform the Clear Memory Mode. 4) Read DTC's again.	Is the DTC displayed on screen?	Inspect using the "Diagnostic Procedure with Diagnostic Trouble Code (DTC)". <Ref. to IM(diag)-15, Diagnostic Procedure with Diagnostic Trouble Code (DTC).>	Finish the diagnosis.



# General Description

## IMMOBILIZER (DIAGNOSTICS)

### 2. General Description

#### A: CAUTION

##### CAUTION:

- Do not use the electrical test equipment on the airbag system wiring harnesses and connector circuits.
- Be careful not to damage the airbag system wiring harness.
- While diagnostic items are being checked, do not operate radios, portable telephones, etc. which emit electromagnetic waves near or inside the vehicle.

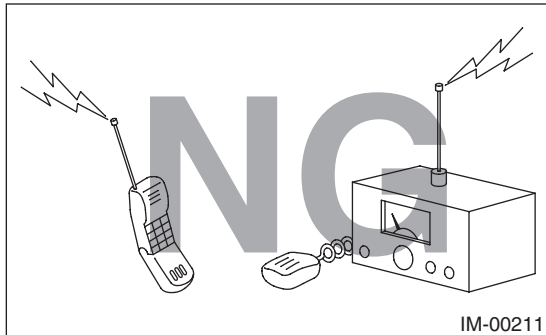

- When turning the ignition switch to ON or OFF while diagnostic items are being checked, do not allow keys with different ID codes close to the ignition switch. If the ignition key is on a key holder, remove it from the key holder before performing diagnoses.

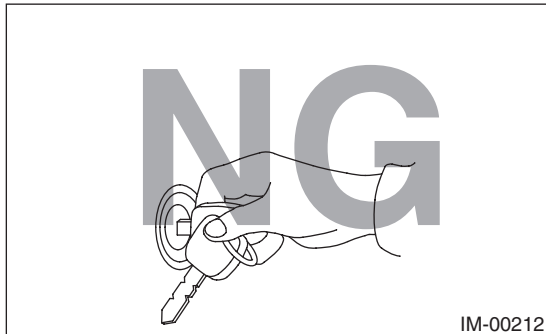

- When repeatedly turning the ignition switch to ON or OFF while diagnostic items are being checked, it should be switched in cycles of "ON" for at least 5 seconds → "OFF" for at least 8 seconds.

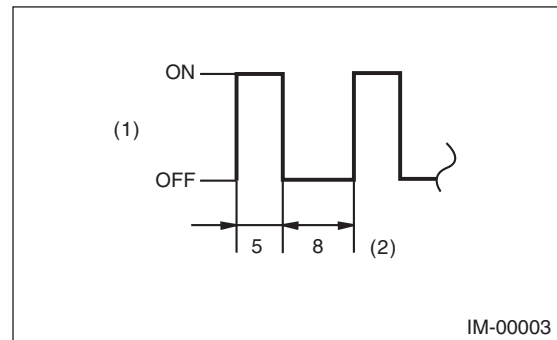

- (1) Ignition switch position
- (2) Sec.

- If the engine fails to start with a registered ignition key, detach the ignition key from ignition switch and wait for approx. 1 second until security indicator light begins to flash. And then start the engine again.
- Before performing the diagnostics, obtain all keys for the vehicle from the owner.
- Do not install or register a body integrated unit already registered to another vehicle to diagnose failures or inspect functions.

# General Description

IMMOBILIZER (DIAGNOSTICS)

## B: PREPARATION TOOL

### 1. SPECIAL TOOL

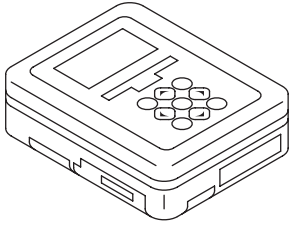
ILLUSTRATION	TOOL NUMBER	DESCRIPTION	REMARKS
 ST1B022XU0	1B022XU0	SUBARU SELECT MONITOR III KIT	Used for troubleshooting the electrical system.

### 2. GENERAL TOOL

TOOL NAME	REMARKS
Circuit tester	Used for measuring resistance, voltage and current.

# Electrical Component Location

## IMMOBILIZER (DIAGNOSTICS)

### 3. Electrical Component Location

#### A: LOCATION

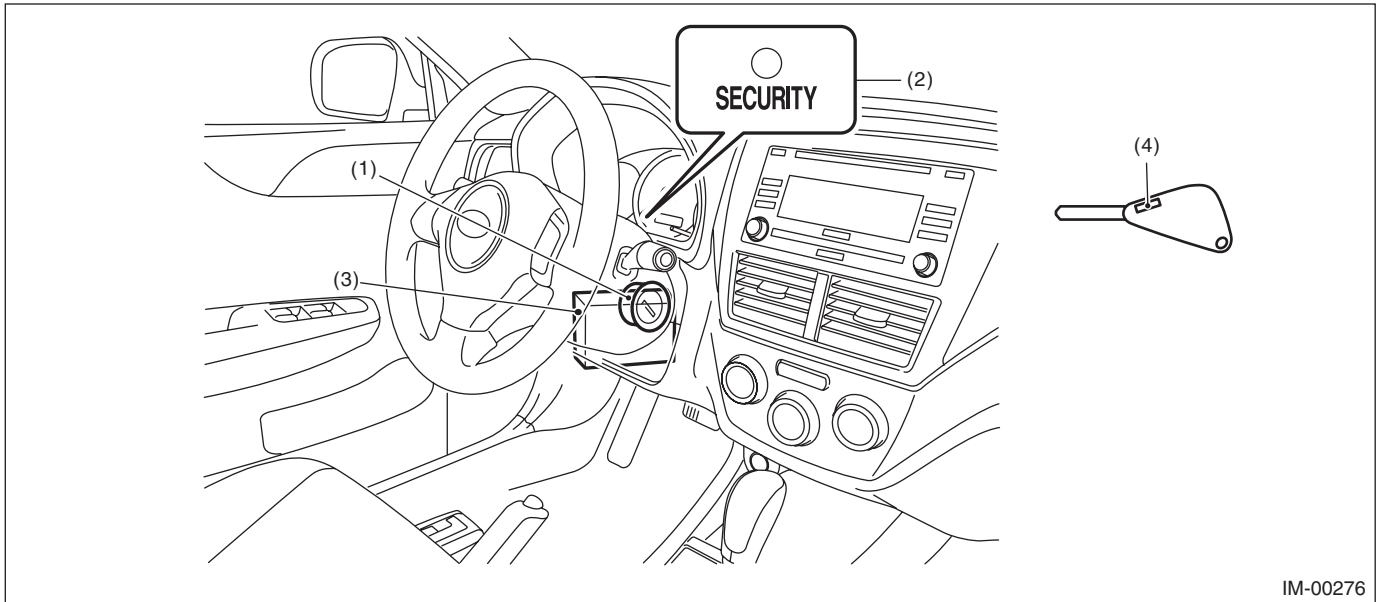

IM-00276

(1) Antenna

(3) Body integrated unit

(4) Transponder

(2) Security indicator light (LED bulb)

## 4. Immobilizer Control Module I/O Signal

### A: WIRING DIAGRAM

#### 1. IMMOBILIZER

<Ref. to WI-158, WIRING DIAGRAM, Immobilizer System.>

# Subaru Select Monitor

## IMMOBILIZER (DIAGNOSTICS)

### 5. Subaru Select Monitor

#### A: OPERATION

##### 1. HOW TO USE THE SUBARU SELECT MONITOR

- 1) Prepare the Subaru Select Monitor kit.
- 2) Connect the diagnosis cable to Subaru Select Monitor.
- 3) Connect the Subaru Select Monitor to data link connector.
  - (1) Data link connector is located in the lower portion of the instrument panel (on the driver's side).

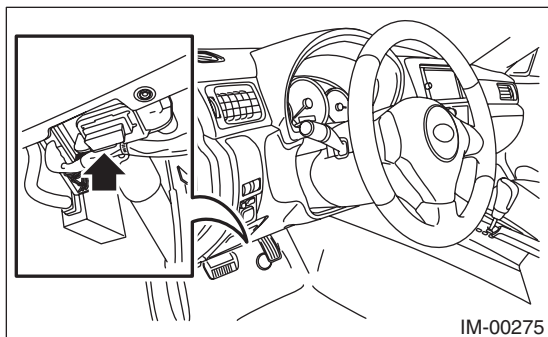

- (2) Connect the diagnosis cable to data link connector.

#### CAUTION:

**Do not connect scan tools other than the Subaru Select Monitor.**

- 4) Turn the ignition switch to ON and start the Subaru Select Monitor.
- 5) Using the Subaru Select Monitor, call up DTCs and various data, then record them.

##### 2. READ DIAGNOSTIC TROUBLE CODE (DTC) FOR ENGINE AND BODY INTEGRATED UNIT

Refer to "Read Diagnostic Trouble Code" for information about how to indicate DTC. <Ref. to IM(diag)-9, Read Diagnostic Trouble Code (DTC).>

##### 3. COMMUNICATION LINE CHECK

#### NOTE:

The communication line between ECM and body integrated unit can be checked in "System Operation Check Mode". This is referred to as "Communication line check".

- 1) Connect the Subaru Select Monitor.
- 2) On «Main Menu» display, select {Each System Check}.
- 3) On «System Selection Menu» display, select {Engine Control System}.
- 4) Select [OK] after the information of engine type is displayed.
- 5) On «Engine Diagnosis» display, select {System Operation Check Mode}.
- 6) On «System Operation Check Mode» display, select {Immobilizer System}.
- 7) Start the communication line check.
- 8) Is «OK» displayed on screen?  
If displayed, go to step 9).  
If not, go to step 10).
- 9) After diagnostic results, it is determined that the circuit is not shorted. Finish the communication line check.
- 10) If a problem is detected, repair the trouble cause. <Ref. to IM(diag)-19, DTC P1572 IMM CIRCUIT FAILURE (EXCEPT ANTENNA CIRCUIT), Diagnostic Procedure with Diagnostic Trouble Code (DTC).>

## 6. Read Diagnostic Trouble Code (DTC)

### A: OPERATION

#### 1. ECM

- 1) On «Main Menu» display, select {Each System Check}.
- 2) On «System Selection Menu» display, select {Engine Control System}.
- 3) Select [OK] after the information of engine type is displayed.
- 4) On «Engine Diagnosis» display, select {Diagnostic Code(s) Display}.
- 5) On «Diagnostic Code(s) Display» display, select {Current DTC} or {Past DTC}.

#### NOTE:

- For detailed operation procedures, refer to “PC application help for Subaru Select Monitor”.
- For detailed concerning DTC, refer to the List of Diagnostic Trouble Codes (DTC). <Ref. to IM(diag)-14, LIST, List of Diagnostic Trouble Code (DTC).>

#### 2. BODY INTEGRATED UNIT

- 1) On «Main Menu» display, select {Each System Check}.
- 2) On «System Selection Menu» display, select {Integ. Unit}.
- 3) After {Integ. unit} is displayed, select [OK].
- 4) On «Integ. unit mode failure diag» display, select {Diagnostic Code(s) Display}.

#### NOTE:

- For detailed operation procedures, refer to “PC application help for Subaru Select Monitor”.
- For detailed concerning DTC, refer to the List of Diagnostic Trouble Codes (DTC). <Ref. to IM(diag)-14, LIST, List of Diagnostic Trouble Code (DTC).>

## 7. Clear Memory Mode

### A: OPERATION

#### 1. ECM

- 1) On «Main Menu» display, select {Each System Check}.
- 2) On «System Selection Menu» display, select {Engine Control System}.
- 3) Select [OK] after the information of engine type is displayed.
- 4) On «Engine Diagnosis» display, select {Clear Memory}.
- 5) When “Done” is displayed on the display, end the Subaru Select Monitor and turn the ignition switch to OFF.

#### NOTE:

- After the memory is cleared, initial diagnosis of the electronic throttle control is performed. Wait for 10 seconds or more after turning the ignition switch to ON, and then start the engine.
- For detailed operation procedures, refer to “PC application help for Subaru Select Monitor”.

#### 2. BODY INTEGRATED UNIT

- 1) On «Main Menu» display, select {Each System Check}.
- 2) On «System Selection Menu» display, select {Integ. Unit}.
- 3) After {Integ. unit} is displayed, select [OK].
- 4) On «Integ. unit mode» display, select {Clear Memory}.
- 5) When “Done” is displayed on the display, end the Subaru Select Monitor and turn the ignition switch to OFF.

#### NOTE:

For detailed operation procedures, refer to “PC application help for Subaru Select Monitor”.

# Diagnostics Chart for Security Indicator Light

IMMOBILIZER (DIAGNOSTICS)

## 8. Diagnostics Chart for Security Indicator Light

### A: INSPECTION

#### 1. CHECK SECURITY INDICATOR LIGHT CIRCUIT

#### WIRING DIAGRAM:

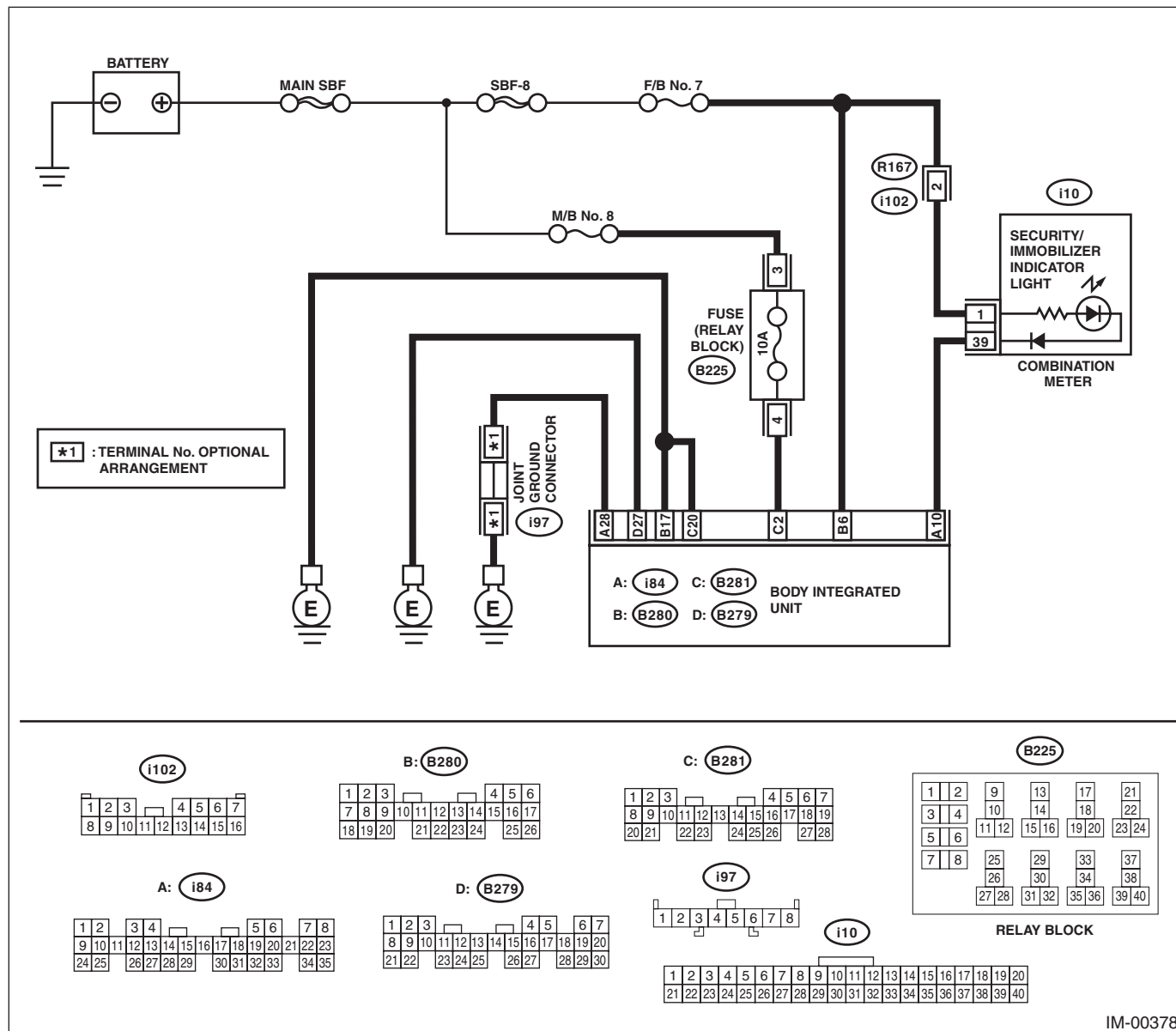

Step	Check	Yes	No
<b>1</b> <b>CHECK FUSE.</b> 1) Remove the ignition key from ignition switch. 2) Check the fuse (M/B No. 8).	Is the fuse OK?	Go to step 2.	Replace the fuse. If the replaced fuse blows out easily, repair the short circuit in the harness between the fuse and body integrated unit.



# Diagnostics Chart for Security Indicator Light

## IMMOBILIZER (DIAGNOSTICS)

Step	Check	Yes	No
<b>2 CHECK SECURITY INDICATOR LIGHT.</b> 1) Disconnect the connector from body integrated unit. 2) Connect the resistor (100 $\Omega$ ) between the body integrated unit connector terminal (i84) No. 10 and chassis ground.	Does the security indicator light illuminate?	Go to step 3.	Go to step 5.
<b>3 CHECK BODY INTEGRATED UNIT GROUND CIRCUIT.</b> Measure the resistance between the body integrated unit connector terminal and chassis ground. <i>Connector &amp; terminal</i> <i>(i84) No. 28 — Chassis ground:</i> <i>(B280) No. 17 — Chassis ground:</i> <i>(B281) No. 20 — Chassis ground:</i> <i>(B279) No. 27 — Chassis ground:</i>	Is the resistance less than 10 $\Omega$ ?	Go to step 4.	Repair the open circuit of the body integrated unit ground circuit.
<b>4 CHECK BODY INTEGRATED UNIT POWER SUPPLY CIRCUIT.</b> Measure the voltage between the body integrated unit connector terminal and chassis ground. <i>Connector &amp; terminal</i> <i>(B280) No. 6 (+) — Chassis ground (-):</i> <i>(B281) No. 2 (+) — Chassis ground (-):</i>	Is the voltage 10 V or more?	Replace the body integrated unit. <Ref. to SL-48, Body Integrated Unit.> Register all ignition keys (transponders). Refer to the "PC application help for Subaru Select Monitor".	Check the harness for open or short circuit between body integrated unit and fuse.
<b>5 CHECK COMBINATION METER CIRCUIT.</b> 1) Remove the combination meter. <Ref. to IDI-16, Combination Meter.> 2) Measure the voltage between combination meter connector terminal and chassis ground. <i>Connector &amp; terminal</i> <i>(i10) No. 1 (+) — Chassis ground (-):</i>	Is the voltage 10 V or more?	Go to step 6.	Check for an open or short circuit in the harness between the combination meter and fuse.
<b>6 CHECK COMBINATION METER CIRCUIT.</b> Measure the resistance between the body integrated unit connector terminal and combination meter connector terminal. <i>Connector &amp; terminal</i> <i>(i84) No. 10 — (i10) No. 39:</i>	Is the resistance less than 10 $\Omega$ ?	LED bulb is defective. Replace the combination meter case assembly. <Ref. to IDI-16, DISASSEMBLY, Combination Meter.>	Repair the harness or connector.

# Diagnostics Chart for Security Indicator Light

IMMOBILIZER (DIAGNOSTICS)

## 2. CHECK KEY SWITCH CIRCUIT

### WIRING DIAGRAM:

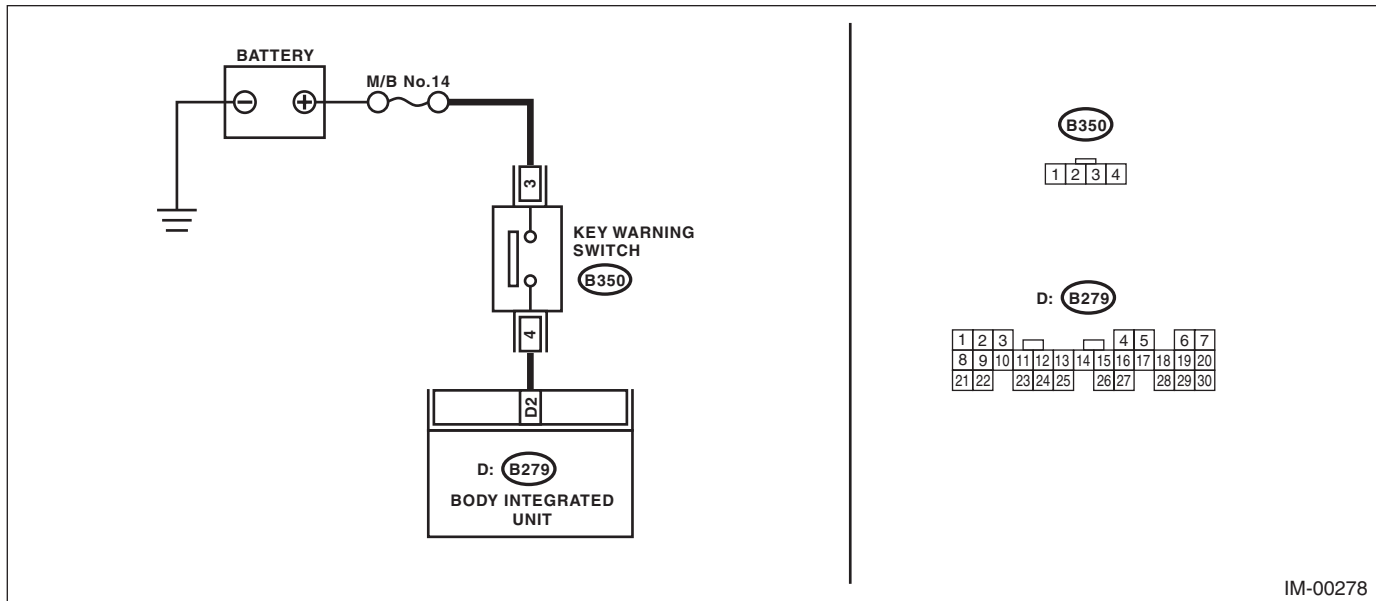

IM-00278

Step	Check	Yes	No
<b>1 CHECK POWER SUPPLY CIRCUIT.</b> 1) Disconnect the connector from key warning switch. 2) Measure the voltage between key warning switch connector terminal and chassis ground. <b>Connector &amp; terminal</b> <b>(B350) No. 3 (+) — Chassis ground (-):</b>	Is the voltage 10 V or more?	Go to step 2.	Check the harness for an open or short between the key warning switch and fuse.
<b>2 CHECK KEY WARNING SWITCH.</b> 1) Insert the ignition key in the ignition switch. (OFF or ACC) 2) Measure the resistance between key warning switch connector terminals. <b>Connector &amp; terminal</b> <b>No. 3 — No. 4:</b>	Is the resistance less than 1 $\Omega$ ?	Go to step 3.	Replace the key warning switch.
<b>3 CHECK KEY WARNING SWITCH.</b> 1) Remove the ignition key from ignition switch. 2) Measure the resistance between key warning switch connector terminals. <b>Connector &amp; terminal</b> <b>No. 3 — No. 4:</b>	Is the resistance 1 M $\Omega$ or more?	Go to step 4.	Replace the key warning switch.
<b>4 CHECK HARNESS BETWEEN KEY WARNING SWITCH AND BODY INTEGRATED UNIT.</b> 1) Disconnect the connector from body integrated unit. 2) Measure the resistance between key warning switch connector terminal and body integrated unit connector terminal. <b>Connector &amp; terminal</b> <b>(B350) No. 4 — (B279) No. 2:</b>	Is the resistance less than 10 $\Omega$ ?	Replace the body integrated unit. <Ref. to SL-48, Body Integrated Unit.> Register all ignition keys (transponders). Refer to the "PC application help for Subaru Select Monitor".	Repair the harness between key warning switch and body integrated unit.

# List of Diagnostic Trouble Code (DTC)

## IMMOBILIZER (DIAGNOSTICS)

### 9. List of Diagnostic Trouble Code (DTC)

#### A: LIST

##### 1. ECM

DTC	Item	Contents of diagnosis	Index No.
P0513	Incorrect Immobilizer Key	Incorrect immobilizer key (Use of unregistered key in body integrated unit)	<Ref. to IM(diag)-15, DTC P0513 INCORRECT IMMOBILIZER KEY, Diagnostic Procedure with Diagnostic Trouble Code (DTC).>
P1570	Antenna	Faulty antenna	<Ref. to IM(diag)-16, DTC P1570 ANTENNA, Diagnostic Procedure with Diagnostic Trouble Code (DTC).>
P1571	Reference Code Incompatibility	Reference code incompatibility between body integrated unit and ECM	<Ref. to IM(diag)-18, DTC P1571 REFERENCE CODE INCOMPATIBILITY, Diagnostic Procedure with Diagnostic Trouble Code (DTC).>
P1572	IMM Circuit Failure (Except Antenna Circuit)	Communication failure between body integrated unit and ECM	<Ref. to IM(diag)-19, DTC P1572 IMM CIRCUIT FAILURE (EXCEPT ANTENNA CIRCUIT), Diagnostic Procedure with Diagnostic Trouble Code (DTC).>
P1574	Key Communication Failure	Communication failure between key and body integrated unit	<Ref. to IM(diag)-22, DTC P1574 KEY COMMUNICATION FAILURE, Diagnostic Procedure with Diagnostic Trouble Code (DTC).>
P1576	EGI Control Module EEPROM	ECM malfunctioning	<Ref. to IM(diag)-22, DTC P1576 EGI CONTROL MODULE EEPROM, Diagnostic Procedure with Diagnostic Trouble Code (DTC).>
P1577	IMM Control Module EEPROM	Body integrated unit malfunctioning	<Ref. to IM(diag)-23, DTC P1577 IMM CONTROL MODULE EEPROM, Diagnostic Procedure with Diagnostic Trouble Code (DTC).>
P1578	Meter Failure	<ul style="list-style-type: none"> <li>Reference code incompatibility between combination meter and body integrated unit</li> <li>Communication failure between body integrated unit and ECM</li> </ul>	<Ref. to IM(diag)-24, DTC P1578 METER FAILURE, Diagnostic Procedure with Diagnostic Trouble Code (DTC).>

#### NOTE:

Perform diagnosis of engine DTC when a DTC other than an immobilizer DTC is detected. <Ref. to EN(H4DOTC)(diag)-88, List of Diagnostic Trouble Code (DTC).>

##### 2. BODY INTEGRATED UNIT

DTC	Item	Contents of diagnosis	Index No.	Relation between ECM and DTC
B1401	M Collation NG	Reference code incompatibility between combination meter and body integrated unit	<Ref. to IM(diag)-24, DTC B1401 M COLLATION NG, Diagnostic Procedure with Diagnostic Trouble Code (DTC).>	P1578
B1402	Immobilizer Key Collation NG	<ul style="list-style-type: none"> <li>Incorrect immobilizer key (Use of unregistered key in body integrated unit)</li> <li>Faulty antenna</li> </ul>	<Ref. to IM(diag)-24, DTC B1402 IMMOBILIZER KEY COLLATION NG, Diagnostic Procedure with Diagnostic Trouble Code (DTC).>	<ul style="list-style-type: none"> <li>P0513</li> <li>P1570</li> <li>P1574</li> </ul>
B1403	E/G request NG	Communication failure between body integrated unit and ECM	<Ref. to IM(diag)-24, DTC B1403 E/G REQUEST NG, Diagnostic Procedure with Diagnostic Trouble Code (DTC).>	P1572

#### NOTE:

The starter relay control is performed in immobilizer system. When the body integrated unit detects a non-conformity of reference code, it immediately outputs a starter relay cut signal to ECM, and then ECM stops the starter relay operation. In this case, engine does not start, and DTC is not recorded in ECM. Check that the engine does not start on the DTC of body integrated unit.

# Diagnostic Procedure with Diagnostic Trouble Code (DTC)

IMMOBILIZER (DIAGNOSTICS)

## 10. Diagnostic Procedure with Diagnostic Trouble Code (DTC)

### A: DTC P0513 INCORRECT IMMOBILIZER KEY

#### DTC DETECTING CONDITION:

Incorrect immobilizer key (Use of unregistered key in body integrated unit)

	Step	Check	Yes	No
1	<b>PERFORM IGNITION KEY REGISTRATION.</b> Perform registration to all keys used for the vehicle. Refer to the "PC application help for Subaru Select Monitor".	Is registration of all keys complete?	End.	Replace ignition keys (including transponder) which cannot be registered. Go to step 2.
2	<b>PERFORM IGNITION KEY REGISTRATION.</b> Perform registration to all keys used for the vehicle. Refer to the "PC application help for Subaru Select Monitor".	Is registration of all keys complete?	End.	Replace the body integrated unit. <Ref. to SL-48, Body Integrated Unit.> Register all ignition keys (transponders). Refer to the "PC application help for Subaru Select Monitor".

# Diagnostic Procedure with Diagnostic Trouble Code (DTC)

IMMOBILIZER (DIAGNOSTICS)

## B: DTC P1570 ANTENNA

### DTC DETECTING CONDITION:

Faulty antenna

### WIRING DIAGRAM:

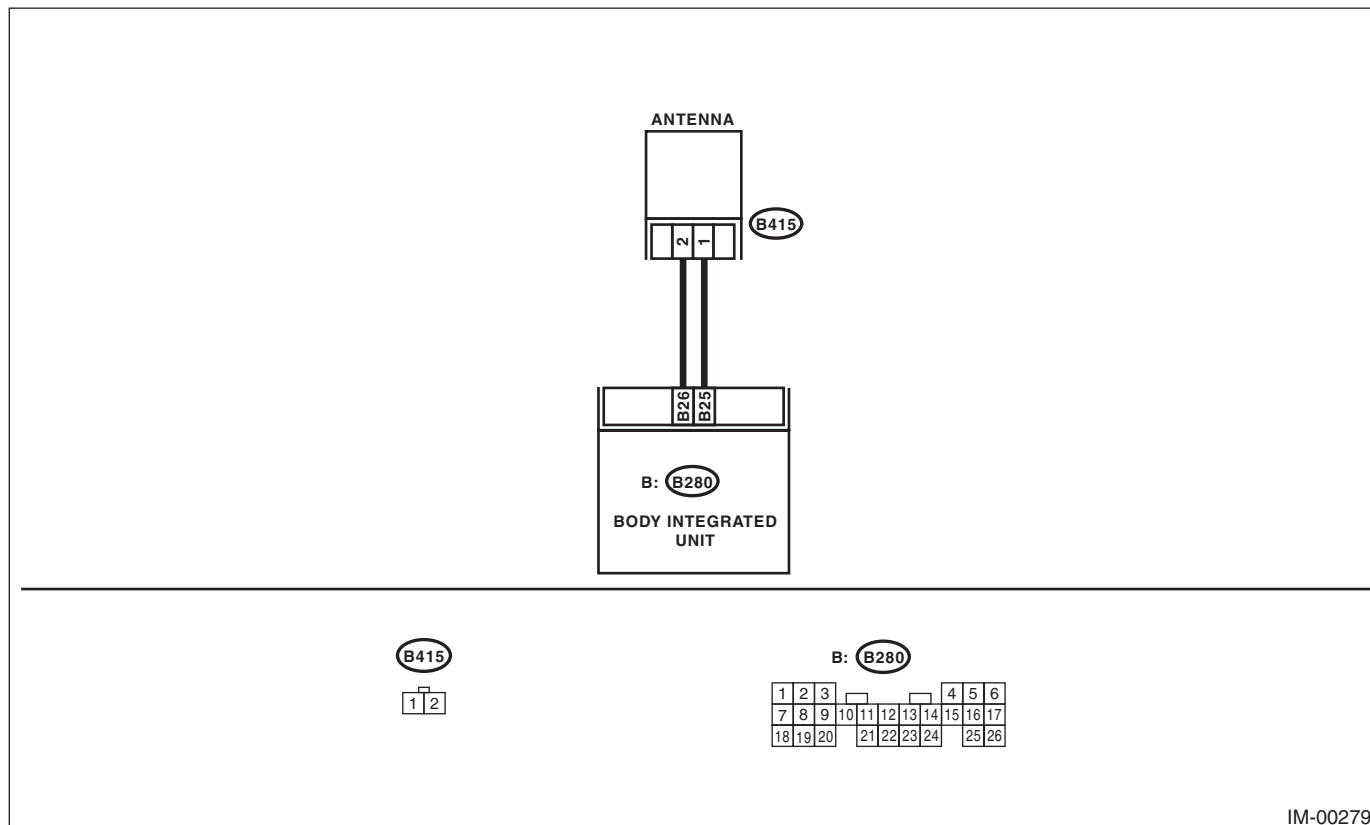

IM-00279

Step	Check	Yes	No
<b>1 CHECK ANTENNA CIRCUIT.</b> 1) Turn the ignition switch to OFF. 2) Disconnect the connector from the antenna. <Ref. to SL-52, Immobilizer Antenna.> 3) Measure the resistance of antenna circuit. <b>Connector &amp; terminal</b> <b>(B415) No. 1 — No. 2:</b>	Is the resistance less than 6 — 10 Ω?	Go to step 2.	Replace the antenna. <Ref. to SL-52, Immobilizer Antenna.>
<b>2 CHECK ANTENNA CIRCUIT.</b> 1) Disconnect the connector from body integrated unit. 2) Measure the resistance between body integrated unit connector and antenna connector. <b>Connector &amp; terminal</b> <b>(B280) No. 25 — (B415) No. 1:</b> <b>(B280) No. 26 — (B415) No. 2:</b>	Is the resistance less than 10 Ω?	Go to step 3.	Repair the harness.
<b>3 CHECK ANTENNA CIRCUIT.</b> Measure the resistance between body integrated unit connector and chassis ground. <b>Connector &amp; terminal</b> <b>(B280) No. 25 — Chassis ground:</b> <b>(B280) No. 26 — Chassis ground:</b>	Is the resistance 1 MΩ or more?	Go to step 4.	Repair the harness.

# Diagnostic Procedure with Diagnostic Trouble Code (DTC)

IMMOBILIZER (DIAGNOSTICS)

Step	Check	Yes	No
<p><b>4</b>      <b>CHECK BODY INTEGRATED UNIT FUNCTION.</b>                      1) Connect the connector to antenna.                      2) Connect the connector to body integrated unit.                      3) Insert the key into the ignition switch, then use an oscilloscope to measure changes in voltage between the antenna connector and the chassis ground.  <b>Connector &amp; terminal</b>  <b>(B280) No. 25 (+) — Chassis ground (-):</b></p>	<p>Is the maximum voltage more than 40 V? (Approx. 0.1 second after inserting the key) Is the voltage 0 V? (Approx. 1 second after inserting the key)</p>	<p>Go to step 5.</p>	<p>Replace the body integrated unit.                      &lt;Ref. to SL-48, Body Integrated Unit.&gt; Register all ignition keys (transponders). Refer to the "PC application help for Subaru Select Monitor".</p>
<p><b>5</b>      <b>CHECK IGNITION KEY (TRANSPONDER).</b>                      1) Remove the key from ignition switch.                      2) Start the engine using other key which is already registered.</p>	<p>Does the engine start?</p>	<p>Replace the ignition key (transponder). Execute the registration procedure next. Refer to the "PC application help for Subaru Select Monitor".</p>	<p>Replace the body integrated unit.                      &lt;Ref. to SL-48, Body Integrated Unit.&gt; Register all ignition keys (transponders). Refer to the "PC application help for Subaru Select Monitor".</p>

# Diagnostic Procedure with Diagnostic Trouble Code (DTC)

IMMOBILIZER (DIAGNOSTICS)

## C: DTC P1571 REFERENCE CODE INCOMPATIBILITY

### DTC DETECTING CONDITION:

Reference code incompatibility between body integrated unit and ECM

Step	Check	Yes	No
<b>1</b> <b>PERFORM IGNITION KEY REGISTRATION.</b> Perform registration to all keys used for the vehicle. Refer to the "PC application help for Subaru Select Monitor".	Is registration of all keys complete?	End.	Go to step 2.
<b>2</b> <b>CHECK FOR ANY OTHER DTC ON DISPLAY.</b>	Is any other immobilizer DTC displayed?	Check the appropriate DTC using the "List of Diagnostic Trouble Code (DTC)". <Ref. to IM(diag)-14, List of Diagnostic Trouble Code (DTC).> Execute the registration procedure next. Refer to the "PC application help for Subaru Select Monitor".	Replace the ECM. <Ref. to FU(STI)-59, Engine Control Module (ECM).> Replace the body integrated unit. <Ref. to FU(w/o STI)-58, Engine Control Module (ECM).> <Ref. to SL-48, Body Integrated Unit.> Register all ignition keys (transponders). Refer to the "PC application help for Subaru Select Monitor".

# Diagnostic Procedure with Diagnostic Trouble Code (DTC)

IMMOBILIZER (DIAGNOSTICS)

## D: DTC P1572 IMM CIRCUIT FAILURE (EXCEPT ANTENNA CIRCUIT)

### DTC DETECTING CONDITION:

Communication failure between body integrated unit and ECM

### WIRING DIAGRAM:

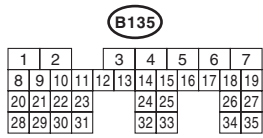
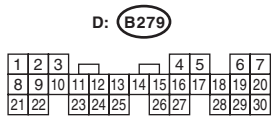
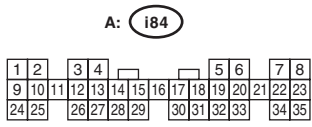
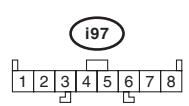
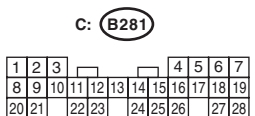
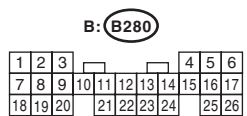
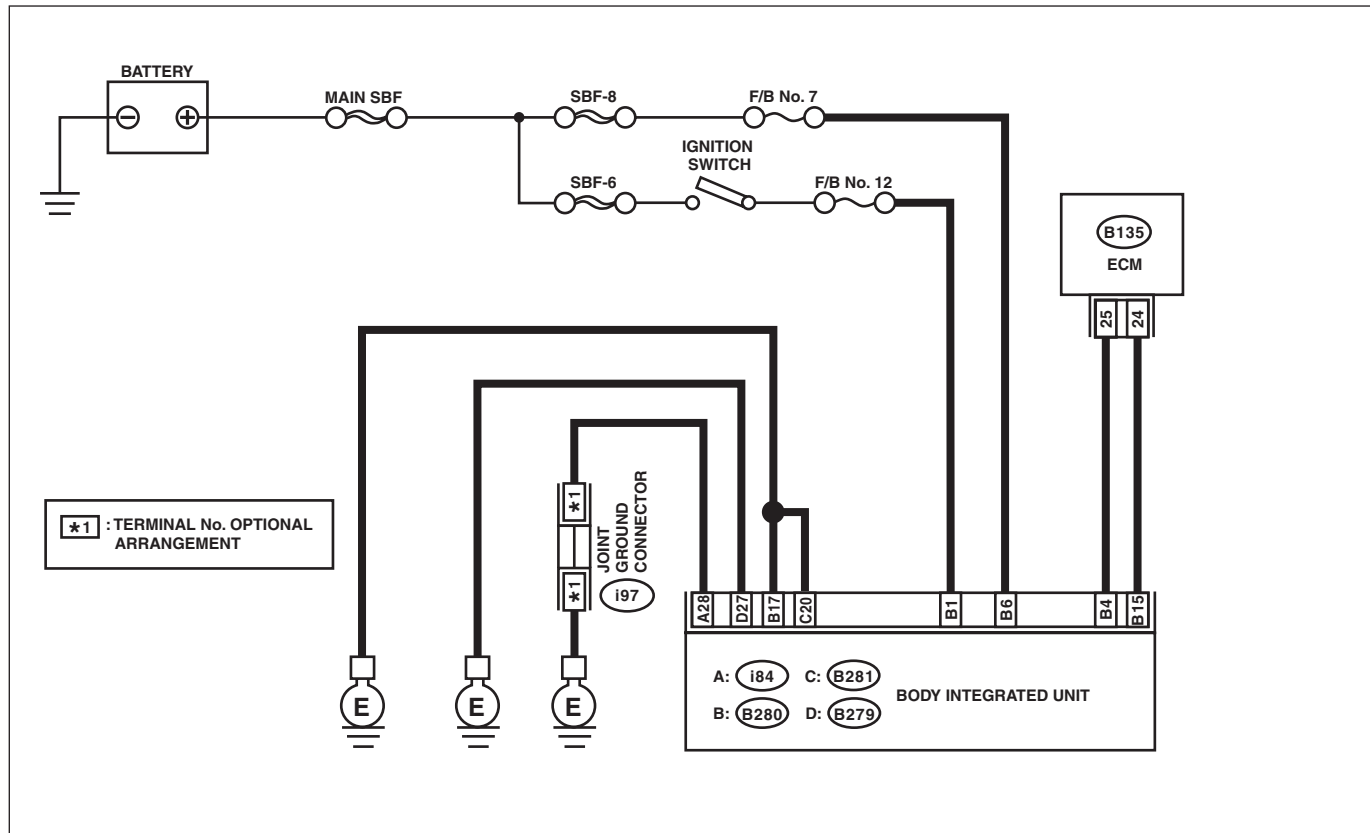

IM-00379



# Diagnostic Procedure with Diagnostic Trouble Code (DTC)

## IMMOBILIZER (DIAGNOSTICS)

Step	Check	Yes	No
<b>1 CHECK BODY INTEGRATED UNIT POWER SUPPLY CIRCUIT.</b> 1) Turn the ignition switch to OFF. 2) Disconnect the connector from body integrated unit. 3) Measure the voltage between the body integrated unit connector terminal and chassis ground. <b>Connector &amp; terminal</b> <b>(B280) No. 6 (+) — Chassis ground (-):</b>	Is the voltage 10 V or more?	Go to step 2.	Check the harness for open or short circuit between body integrated unit and fuse.
<b>2 CHECK BODY INTEGRATED UNIT POWER SUPPLY CIRCUIT.</b> 1) Turn the ignition switch to ON. 2) Measure the voltage between the body integrated unit connector terminal and chassis ground. <b>Connector &amp; terminal</b> <b>(B280) No. 1 (+) — Chassis ground (-):</b>	Is the voltage 10 V or more?	Go to step 3.	Check the harness for open or short circuit between the body integrated unit and ignition switch.
<b>3 CHECK BODY INTEGRATED UNIT GROUND CIRCUIT.</b> 1) Turn the ignition switch to OFF. 2) Measure the resistance between the body integrated unit connector terminal and chassis ground. <b>Connector &amp; terminal</b> <b>(i84) No. 28 — Chassis ground:</b> <b>(B280) No. 17 — Chassis ground:</b> <b>(B281) No. 20 — Chassis ground:</b> <b>(B279) No. 27 — Chassis ground:</b>	Is the resistance less than 10 $\Omega$ ?	Go to step 4.	Repair the open circuit of the body integrated unit ground circuit.
<b>4 CHECK GROUND CIRCUIT FOR ECM.</b> Measure the resistance between the ECM ground terminal and engine ground.	Is the resistance less than 10 $\Omega$ ?	Go to step 5.	Repair the ECM ground circuit.
<b>5 CHECK HARNESS BETWEEN BODY INTEGRATED UNIT AND ECM.</b> 1) Disconnect the connector from the ECM and body integrated unit. 2) Measure the resistance between body integrated unit connector terminal and ECM connector terminal. <b>Connector &amp; terminal</b> <b>(B280) No. 4 — (B135) No. 25:</b> <b>(B280) No. 15 — (B135) No. 24:</b>	Is the resistance less than 10 $\Omega$ ?	Go to step 6.	Repair the open circuit of the harness between the body integrated unit and ECM.
<b>6 CHECK COMMUNICATION CIRCUIT HARNESS.</b> 1) Turn the ignition switch to ON. 2) Measure the voltage between the body integrated unit connector terminal and chassis ground. <b>Connector &amp; terminal</b> <b>(B280) No. 4 (+) — Chassis ground (-):</b> <b>(B280) No. 15 (+) — Chassis ground (-):</b>	Is the voltage 6 V or more?	Repair the harness between body integrated unit and ECM.	Go to step 7.
<b>7 CHECK COMMUNICATION CIRCUIT HARNESS.</b> Measure the voltage between ECM connector terminal and engine ground. <b>Connector &amp; terminal</b> <b>(B135) No. 24 (+) — Engine ground (-):</b> <b>(B135) No. 25 (+) — Engine ground (-):</b>	Is the voltage 6 V or more?	Repair the harness between body integrated unit and ECM.	Go to step 8.

# Diagnostic Procedure with Diagnostic Trouble Code (DTC)

IMMOBILIZER (DIAGNOSTICS)

Step	Check	Yes	No
<b>8</b> <b>CHECK ECM BY COMMUNICATION SHORT CHECK.</b> 1) Connect the connector to ECM. 2) Disconnect the connector from body integrated unit. 3) Start the communication short check. <Ref. to IM(diag)-8, COMMUNICATION LINE CHECK, OPERATION, Subaru Select Monitor.>	Is the communication short check OK?	Replace the body integrated unit. <Ref. to SL-48, Body Integrated Unit.> Register all ignition keys (transponders). Refer to the "PC application help for Subaru Select Monitor".	Replace the ECM. <Ref. to FU(STI)-59, Engine Control Module (ECM).> Perform the registration procedure next. Refer to the "PC application help for Subaru Select Monitor".

**NOTE:**

Refer to the following inspection when DTC is detected after inspection above. <Ref. to IM(diag)-24, DTC P1578 METER FAILURE, Diagnostic Procedure with Diagnostic Trouble Code (DTC).>

# Diagnostic Procedure with Diagnostic Trouble Code (DTC)

IMMOBILIZER (DIAGNOSTICS)

## E: DTC P1574 KEY COMMUNICATION FAILURE

### DTC DETECTING CONDITION:

Communication failure between key and body integrated unit

Step	Check	Yes	No
<b>1</b> <b>CHECK BODY INTEGRATED UNIT FUNCTION.</b> Insert the key into the ignition switch (LOCK position), then measure changes in voltage between the antenna connector and the chassis ground. <i>Connector &amp; terminal</i> <i>(B415) No. 1 (+) — Chassis ground (-):</i>	Is the maximum voltage more than 40 V? (Approx. 0.1 second after inserting the key) Is the voltage 0 V? (Approx. 1 second after inserting the key)	Go to step 2.	Replace the body integrated unit. <Ref. to SL-48, Body Integrated Unit.> Register all ignition keys (transponders). Refer to the "PC application help for Subaru Select Monitor".
<b>2</b> <b>CHECK IGNITION KEY (TRANSPONDER).</b> 1) Remove the key from ignition switch. 2) Start the engine using other key which is already registered.	Does the engine start?	Register ignition keys (transponders). Refer to the "PC application help for Subaru Select Monitor".	Replace the body integrated unit. <Ref. to SL-48, Body Integrated Unit.> Register all ignition keys (transponders). Refer to the "PC application help for Subaru Select Monitor".

## F: DTC P1576 EGI CONTROL MODULE EEPROM

### DTC DETECTING CONDITION:

- ECM malfunctioning
- Inaccessible ROM in ECM during key registration.

Step	Check	Yes	No
<b>1</b> <b>PERFORM REGISTRATION ON IGNITION KEY.</b> Perform registration on all keys of the vehicle. Refer to the "PC application help for Subaru Select Monitor".	Is registration for all keys complete?	Make sure it is possible to start the engine with all keys that have been taught. This completes the work.	Go to step 2.
<b>2</b> <b>PERFORM REGISTRATION ON IGNITION KEY.</b> Perform registration on all keys of the vehicle. Refer to the "PC application help for Subaru Select Monitor".	Is registration for all keys complete?	Make sure it is possible to start the engine with all keys that have been taught. This completes the work.	Go to step 3.
<b>3</b> <b>PERFORM REGISTRATION ON IGNITION KEY.</b> Perform registration on all keys of the vehicle. Refer to the "PC application help for Subaru Select Monitor".	Is registration for all keys complete?	Make sure it is possible to start the engine with all keys that have been taught. This completes the work.	Replace the ECM. <Ref. to FU(STI)-59, Engine Control Module (ECM).> Execute the registration procedure next. Refer to the "PC application help for Subaru Select Monitor".

# Diagnostic Procedure with Diagnostic Trouble Code (DTC)

IMMOBILIZER (DIAGNOSTICS)

## G: DTC P1577 IMM CONTROL MODULE EEPROM

### DTC DETECTING CONDITION:

- Body integrated unit malfunctioning
- Failed to access the ROM inside the body integrated unit.

Step	Check	Yes	No
<b>1</b> <b>PERFORM IGNITION KEY REGISTRATION.</b> Perform registration to all keys used for the vehicle. Refer to the "PC application help for Subaru Select Monitor".	Is registration of all keys complete?	Using the all registered keys, make sure that the engine can start. This completes the work.	Go to step 2.
<b>2</b> <b>PERFORM IGNITION KEY REGISTRATION.</b> Perform registration to all keys used for the vehicle. Refer to the "PC application help for Subaru Select Monitor".	Is registration of all keys complete?	Using the all registered keys, make sure that the engine can start. This completes the work.	Go to step 3.
<b>3</b> <b>PERFORM IGNITION KEY REGISTRATION.</b> Perform registration to all keys used for the vehicle. Refer to the "PC application help for Subaru Select Monitor".	Is registration of all keys complete?	Using the all registered keys, make sure that the engine can start. This completes the work.	Replace the body integrated unit. <Ref. to SL-48, Body Integrated Unit.> Register all ignition keys (transponders). Refer to the "PC application help for Subaru Select Monitor".

# Diagnostic Procedure with Diagnostic Trouble Code (DTC)

## IMMOBILIZER (DIAGNOSTICS)

### H: DTC P1578 METER FAILURE

#### DTC DETECTING CONDITION:

- Reference code incompatibility between combination meter and body integrated unit
- Communication failure between body integrated unit and ECM

Step	Check	Yes	No
<b>1</b> <b>CHECK DTC.</b> Read the DTC of body integrated unit using Subaru Select Monitor.	Is DTC B1401 detected?	Go to step 2.	<Ref. to IM(diag)-19, DTC P1572 IMM CIRCUIT FAILURE (EXCEPT ANTENNA CIRCUIT), Diagnostic Procedure with Diagnostic Trouble Code (DTC).>
<b>2</b> <b>CHECK LAN COMMUNICATION SYSTEM.</b> Inspect LAN communication system. <Ref. to LAN(diag)-2, Basic Diagnostic Procedure.>	Is DTC U1300, U1301, U1302, B1100 or B1101 of the body integrated unit displayed?	Perform the diagnosis according to the DTC. <Ref. to LAN(diag)-33, List of Diagnostic Trouble Code (DTC).>	Go to step 3.
<b>3</b> <b>CHECK COMBINATION METER.</b> 1) Perform the registration of immobilizer. Refer to the "PC application help for Subaru Select Monitor". 2) Start the engine.	Does the engine start?	System is normal.	Replace the combination meter. <Ref. to IDI-16, REMOVAL, Combination Meter.>

#### NOTE:

- When the combination meter has been replaced, be sure to perform the registration procedure of immobilizer.
- When the combination meter and body integrated unit are replaced at a time, the registration can not be completed. In this case, it is necessary to rewrite the ID into the body integrated unit.

### I: DTC B1401 M COLLATION NG

#### NOTE:

Refer to DTC P1578 "METER FAILURE" for diagnostic procedure. <Ref. to IM(diag)-24, DTC P1578 METER FAILURE, Diagnostic Procedure with Diagnostic Trouble Code (DTC).>

### J: DTC B1402 IMMOBILIZER KEY COLLATION NG

#### NOTE:

For diagnostic procedures, refer to the following items.

- DTC P0513 "INCORRECT IMMOBILIZER KEY" <Ref. to IM(diag)-15, DTC P0513 INCORRECT IMMOBILIZER KEY, Diagnostic Procedure with Diagnostic Trouble Code (DTC).>
- DTC P1570 "ANTENNA" <Ref. to IM(diag)-16, DTC P1570 ANTENNA, Diagnostic Procedure with Diagnostic Trouble Code (DTC).>
- DTC P1574 "KEY COMMUNICATION FAILURE" <Ref. to IM(diag)-22, DTC P1574 KEY COMMUNICATION FAILURE, Diagnostic Procedure with Diagnostic Trouble Code (DTC).>

### K: DTC B1403 E/G REQUEST NG

#### NOTE:

For diagnostic procedures, refer to DTC P1572 "IMM CIRCUIT FAILURE (EXCEPT ANTENNA CIRCUIT)". <Ref. to IM(diag)-19, DTC P1572 IMM CIRCUIT FAILURE (EXCEPT ANTENNA CIRCUIT), Diagnostic Procedure with Diagnostic Trouble Code (DTC).>

# LAN SYSTEM (DIAGNOSTICS)

# *LAN(diag)*

---

	<b>Page</b>
1. Basic Diagnostic Procedure .....	2
2. Check List for Interview .....	3
3. General Description .....	6
4. Electrical Component Location .....	8
5. Control Module I/O Signal .....	10
6. Subaru Select Monitor .....	14
7. Read Diagnostic Trouble Code (DTC) .....	29
8. Clear Memory Mode .....	30
9. Read Current Data .....	31
10. User Customizing .....	32
11. List of Diagnostic Trouble Code (DTC) .....	33
12. Diagnostic Procedure with Diagnostic Trouble Code (DTC) .....	36
13. General Diagnostic Table .....	79

# Basic Diagnostic Procedure

LAN SYSTEM (DIAGNOSTICS)

## 1. Basic Diagnostic Procedure

### A: PROCEDURE

#### CAUTION:

- **Subaru Select Monitor is required for reading DTC, performing diagnosis and reading current data.**
- **Remove foreign matter (dust, water, oil, etc.) from the body integrated unit connector during removal and installation.**
- **For model with immobilizer, registration of immobilizer may be needed after the replacement of controller etc. For details, refer to the "PC application help for Subaru Select Monitor".**

#### NOTE:

- To check harness for open or short circuits, shake the suspected trouble spot or connector.
- Check List for Interview <Ref. to LAN(diag)-3, Check List for Interview.>

Step	Check	Yes	No
<b>1</b> <b>CHECK PRE-INSPECTION.</b> Ask the customer when and how the trouble occurred using the interview check list. <Ref. to LAN(diag)-3, Check List for Interview.>	Did you interview the customer?	Go to step 2.	Interview the customer.
<b>2</b> <b>BASIC INSPECTION.</b> Check components which might affect body control. <Ref. to LAN(diag)-6, INSPECTION, General Description.>	Is the component that might influence the body control problem normal?	Go to step 3.	Repair or replace each component.
<b>3</b> <b>CHECK DTC.</b> 1) Read the DTC. <Ref. to LAN(diag)-14, READ DIAGNOSTIC TROUBLE CODE (DTC), OPERATION, Subaru Select Monitor.> NOTE: If the communication function of the Subaru Select Monitor cannot be executed properly, check the communication circuit. <Ref. to LAN(diag)-26, COMMUNICATION FOR INITIALIZING IMPOSSIBLE, INSPECTION, Subaru Select Monitor.> 2) Record all DTCs and freeze frame data.	Is DTC displayed on Subaru Select Monitor?	Go to step 5.	Go to step 4.
<b>4</b> <b>PERFORM GENERAL DIAGNOSTICS.</b> Inspect using the "General Diagnostics Table". <Ref. to LAN(diag)-79, General Diagnostic Table.>	Is result of inspection OK?	LAN system is normal.	Go to step 5.
<b>5</b> <b>PERFORM DIAGNOSIS.</b> 1) Correct the cause of trouble. 2) Perform the Clear Memory Mode. <Ref. to LAN(diag)-23, CLEAR MEMORY MODE, OPERATION, Subaru Select Monitor.> 3) Read the DTC. <Ref. to LAN(diag)-14, READ DIAGNOSTIC TROUBLE CODE (DTC), OPERATION, Subaru Select Monitor.>	Is DTC displayed on Subaru Select Monitor?	Repeat step 5 until DTC is not shown.	Finish the diagnosis.

# Check List for Interview

LAN SYSTEM (DIAGNOSTICS)

## 2. Check List for Interview

### A: CHECK

Inspect the following item about the vehicle's state.

#### 1. DISPLAY STATUS IN THE COMBINATION METER

Display status in the combination meter	Engine coolant temperature gauge display	<input type="checkbox"/> OK / <input type="checkbox"/> NG
	Fuel gauge display	<input type="checkbox"/> OK / <input type="checkbox"/> NG
Display of other indicators	Malfunction indicator light	<input type="checkbox"/> ON / <input type="checkbox"/> OFF
	Engine coolant temperature warning light	<input type="checkbox"/> ON / <input type="checkbox"/> Blink / <input type="checkbox"/> OFF
	Fuel level warning light	<input type="checkbox"/> ON / <input type="checkbox"/> Blink / <input type="checkbox"/> OFF
	EBD warning light	<input type="checkbox"/> ON / <input type="checkbox"/> Blink / <input type="checkbox"/> OFF
	ABS warning light	<input type="checkbox"/> ON / <input type="checkbox"/> Blink / <input type="checkbox"/> OFF
	VDC warning light	<input type="checkbox"/> ON / <input type="checkbox"/> Blink / <input type="checkbox"/> OFF
	Hill start assist warning light	<input type="checkbox"/> ON / <input type="checkbox"/> Blink / <input type="checkbox"/> OFF
	Security/immobilizer indicator	<input type="checkbox"/> ON / <input type="checkbox"/> Blink / <input type="checkbox"/> OFF
	DCCD indicator	<input type="checkbox"/> ON / <input type="checkbox"/> Blink / <input type="checkbox"/> OFF



## Check List for Interview

LAN SYSTEM (DIAGNOSTICS)

### 2. SYMPTOMS

Vehicle condition	Clearance light does not illuminate.	<input type="checkbox"/> Yes / <input type="checkbox"/> No
	Clearance light indicator does not illuminate.	<input type="checkbox"/> Yes / <input type="checkbox"/> No
	Low beam does not illuminate.	<input type="checkbox"/> Yes / <input type="checkbox"/> No
	High beam does not illuminate.	<input type="checkbox"/> Yes / <input type="checkbox"/> No
	High beam indicator does not illuminate.	<input type="checkbox"/> Yes / <input type="checkbox"/> No
	Front fog light does not illuminate.	<input type="checkbox"/> Yes / <input type="checkbox"/> No
	Front fog light indicator does not illuminate.	<input type="checkbox"/> Yes / <input type="checkbox"/> No
	DRL does not illuminate.	<input type="checkbox"/> Yes / <input type="checkbox"/> No
	Warning buzzer for key left in ignition does not beep.	<input type="checkbox"/> Yes / <input type="checkbox"/> No
	Driver's seat belt warning light does not illuminate.	<input type="checkbox"/> Yes / <input type="checkbox"/> No
	Passenger's seat belt warning light does not illuminate.	<input type="checkbox"/> Yes / <input type="checkbox"/> No
	Seat belt warning alarm does not sound.	<input type="checkbox"/> Yes / <input type="checkbox"/> No
	Wiper deicer does not operate.	<input type="checkbox"/> Yes / <input type="checkbox"/> No
	Rear defogger does not operate.	<input type="checkbox"/> Yes / <input type="checkbox"/> No
	Illumination volume control is not available.	<input type="checkbox"/> Yes / <input type="checkbox"/> No
	Combination meter does not dim when headlights are ON.	<input type="checkbox"/> Yes / <input type="checkbox"/> No
	Rear wiper does not operate.	<input type="checkbox"/> Yes / <input type="checkbox"/> No
	Doors can not be locked/unlocked with central door lock switch.	<input type="checkbox"/> Yes / <input type="checkbox"/> No
	Doors can not be locked/unlocked with keyless entry system.	<input type="checkbox"/> Yes / <input type="checkbox"/> No
	Rear gate can not be opened when rear gate opener button is pressed.	<input type="checkbox"/> Yes / <input type="checkbox"/> No
	Trunk can not be opened with keyless entry system.	<input type="checkbox"/> Yes / <input type="checkbox"/> No
	Hazard answer-back does not operate.	<input type="checkbox"/> Yes / <input type="checkbox"/> No
	Answer-back buzzer does not sound	<input type="checkbox"/> Yes / <input type="checkbox"/> No
	Ignition key illumination does not light.	<input type="checkbox"/> Yes / <input type="checkbox"/> No
	Ignition key illumination blinks.	<input type="checkbox"/> Yes / <input type="checkbox"/> No
	Room light does not operate in accordance with door open/close operations.	<input type="checkbox"/> Yes / <input type="checkbox"/> No
	Room light blinks.	<input type="checkbox"/> Yes / <input type="checkbox"/> No
	Map light does not operate in accordance with door open/close operations. (model with sunroof)	<input type="checkbox"/> Yes / <input type="checkbox"/> No
	Map light blinks. (model with sunroof)	<input type="checkbox"/> Yes / <input type="checkbox"/> No
	Indicator does not illuminate when parking brake is operated.	<input type="checkbox"/> Yes / <input type="checkbox"/> No
	Security monitoring does not start	<input type="checkbox"/> Yes / <input type="checkbox"/> No
	Security cannot be cancelled	<input type="checkbox"/> Yes / <input type="checkbox"/> No
	Hazard answer-back does not blink during security monitoring	<input type="checkbox"/> Yes / <input type="checkbox"/> No
	Horn does not sound during security monitoring	<input type="checkbox"/> Yes / <input type="checkbox"/> No
Alarm operates as soon as security monitor condition occurs.	<input type="checkbox"/> Yes / <input type="checkbox"/> No	
Security alarm does not operate even when impact is applied (model with impact sensor).	<input type="checkbox"/> Yes / <input type="checkbox"/> No	
Engine does not start.	<input type="checkbox"/> Yes / <input type="checkbox"/> No	

# Check List for Interview

LAN SYSTEM (DIAGNOSTICS)

## 3. CONDITIONS UNDER WHICH TROUBLE OCCURS

Driving condition	<input type="checkbox"/> At standstill (While idling)
	<input type="checkbox"/> When the vehicle is running      Vehicle speed      km/h (MPH)
	<input type="checkbox"/> While accelerating      Acceleration      km/h (MPH) to      km/h (MPH)
	<input type="checkbox"/> Decelerating (With braking)      Deceleration      km/h (MPH) to      km/h (MPH)
	<input type="checkbox"/> Decelerating (Without braking)      Deceleration      km/h (MPH) to      km/h (MPH)
	<input type="checkbox"/> Flat road
	<input type="checkbox"/> Uphill
	<input type="checkbox"/> Downhill
	<input type="checkbox"/> Gravel road
	<input type="checkbox"/> Bumpy road
	<input type="checkbox"/> Snowy road
	Does it occur when operating any part? Operated part: <b>TRouble SYMPTOM:</b>
	Are there any other troubles occurred? From where: <b>TRouble SYMPTOM:</b>

# General Description

## LAN SYSTEM (DIAGNOSTICS)

### 3. General Description

#### A: CAUTION

##### 1. SUPPLEMENTAL RESTRAINT SYSTEM "AIRBAG"

Airbag system wiring harness is routed near the body integrated unit and twisted pair line.

##### CAUTION:

- Do not use the electrical test equipment on all airbag system wiring harnesses and connectors.
- Be careful not to damage the airbag system wiring harness when servicing the body integrated unit and LAN system.

##### 2. LAN SYSTEM

- Bus line of LAN system is twisted pair line. Be careful not to bypass or partly unbind the twisted pair line.
- Do not make clearance between bus lines (CAN High, CAN Low).
- Difference of bus line length should be within 10 cm (3.94 in).
- Fray near the connector should be within 8 cm (3.14 in).

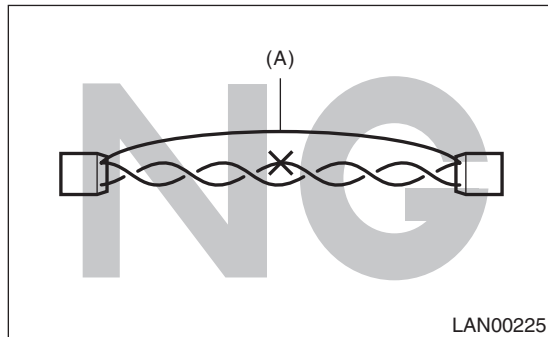

(A) Bypass wire connection

- If the characteristics of the twisted pair line are changed, it may extremely weaken against noise.
- When repairing the harness, connect the wires using soldering and protect it with insulating tape etc.

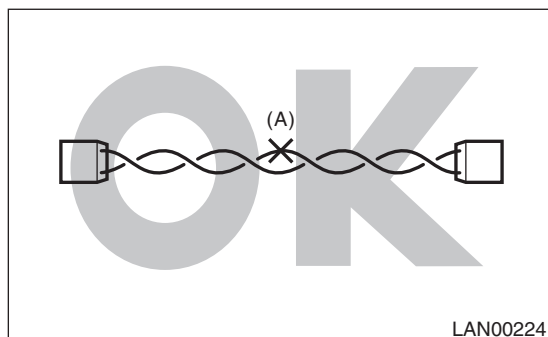

(A) Soldering and protection with insulating tape

#### B: INSPECTION

Before performing diagnostics, check the following item which might affect body integrated unit malfunctions.

1) Measure the battery voltage and check electrolyte.

**Standard voltage: 12 V or more**

**Specific gravity: 1.260 or more**

2) Check the fuse condition.

Make sure that ampere of the fuse is setting value, and it is not blown out.

(Be sure to check the back-up fuse also.)

3) Check the connecting condition of harness and harness connector.

4) Confirm settings of body integrated unit are corresponded to vehicle equipment. <Ref. to LAN(diag)-21, REGISTRATION BODY INTEGRATED UNIT (FUNCTION SETTING), OPERATION, Subaru Select Monitor.>

5) Make sure that the User Customizing of the body integrated unit matches the vehicle equipment. <Ref. to LAN(diag)-24, USER CUSTOMIZING, OPERATION, Subaru Select Monitor.>

6) Confirm "Factory or Market setting" of body integrated unit registrations is "Market".

7) Confirm key illumination does not blink with ignition switch turned to ON.

# General Description

LAN SYSTEM (DIAGNOSTICS)

## C: PREPARATION TOOL

### 1. SPECIAL TOOL

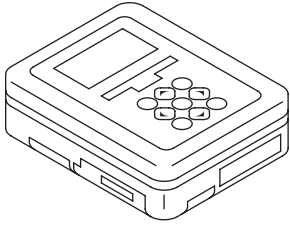
ILLUSTRATION	TOOL NUMBER	DESCRIPTION	REMARKS
 ST1B022XU0	1B022XU0	SUBARU SELECT MONITOR III KIT	Used for troubleshooting the electrical system.

### 2. GENERAL TOOL

TOOL NAME	REMARKS
Circuit tester	Used for measuring resistance, voltage and current.

# Electrical Component Location

LAN SYSTEM (DIAGNOSTICS)

## 4. Electrical Component Location

### A: LOCATION

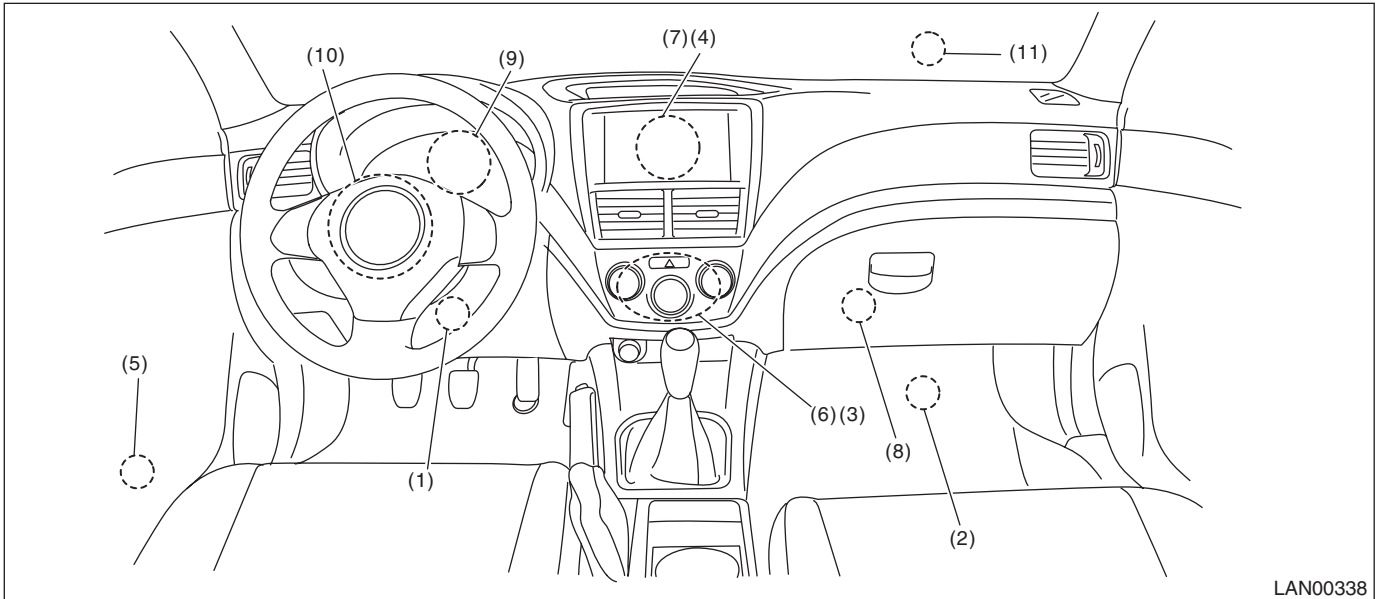

LAN00338

- |                                 |  |   |
|---------------------------------|--|---|
| (1) Body integrated unit        | (5) Keyless entry control module<br>(inside rear quarter trim) | (9) Combination meter                       |
| (2) Engine control module (ECM) | (6) A/C control panel  | (10) Steering angle sensor                  |
| (3) Auto A/C control module     | (7) Center display   | (11) VDCCM&H/U (in engine compart-<br>ment) |
| (4) Navigation unit             | (8) DCCD control module  |   |

# Electrical Component Location

LAN SYSTEM (DIAGNOSTICS)

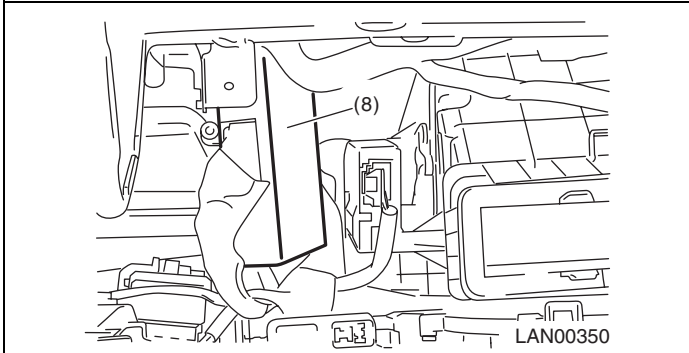
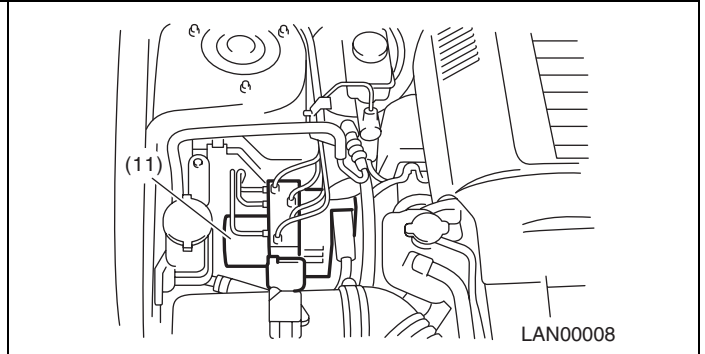
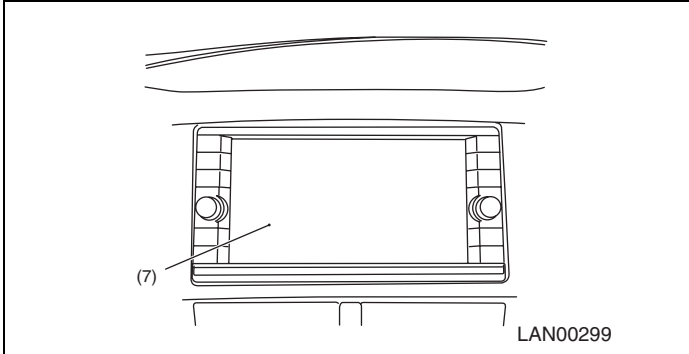
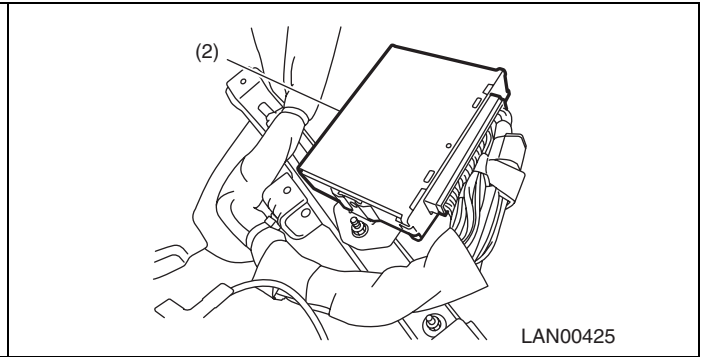
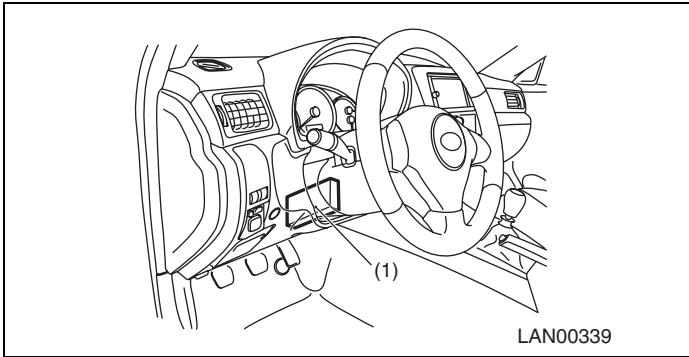

# Control Module I/O Signal

LAN SYSTEM (DIAGNOSTICS)

## 5. Control Module I/O Signal

### A: ELECTRICAL SPECIFICATION

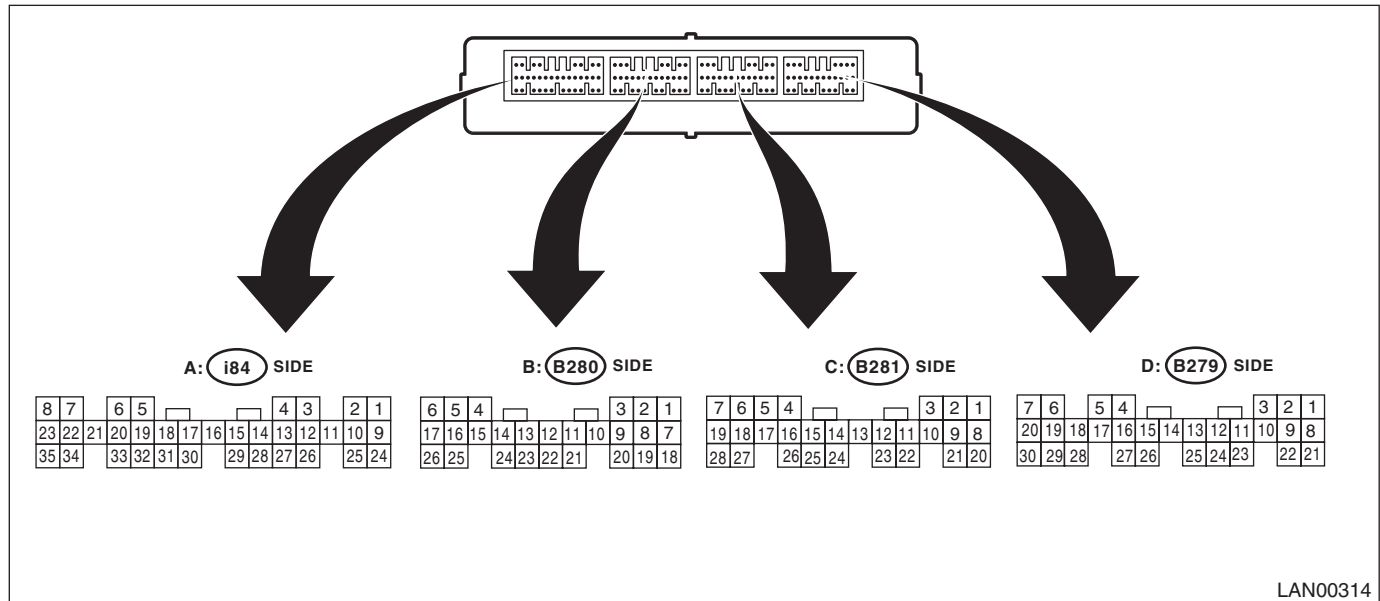

LAN00314

Contents	Terminal No.	Standard	Measuring condition
BAT (control)	B6 ↔ chassis ground	9 — 16 V	Always
BAT (backup)	C2 ↔ chassis ground	9 — 16 V	Always
BAT (door lock)	A34 ↔ chassis ground	9 — 16 V	Always
ACC (rear wiper)	D21 ↔ chassis ground	Less than 1.5 V → 9 — 16 V	ACC OFF → ACC ON
Ground	A28 ↔ chassis ground	Less than 1.5 V	Always
Ground	B17 ↔ chassis ground	Less than 1.5 V	Always
Ground	C20 ↔ chassis ground	Less than 1.5 V	Always
Ground	D27 ↔ chassis ground	Less than 1.5 V	Always
Key warning switch	D2 ↔ chassis ground	Less than 1.5 V → 9 — 16 V	With key removed → inserted
ACC	B7 ↔ chassis ground	Less than 1.5 V → 9 — 16 V	ACC OFF → ACC ON
IGN	B1 ↔ chassis ground	Less than 1.5 V → 9 — 16 V	IGN OFF → IGN ON
Stop light switch	B2 ↔ chassis ground	Less than 1.5 V → 8 V or more	With brake pedal released → depressed
Door switch, driver's seat	A19 ↔ chassis ground	8 V or more → less than 1.5 V	With driver's door closed → opened
Door switch, passenger's seat	A32 ↔ chassis ground	8 V or more → less than 1.5 V	With passenger's door closed → opened
Door switch, rear RH seat	A6 ↔ chassis ground	8 V or more → less than 1.5 V	With rear RH seat door closed → opened
Door switch, rear LH seat	A20 ↔ chassis ground	8 V or more → less than 1.5 V	With rear LH seat door closed → opened

LAN(diag)-10

Brought to you by Ebay Seller "SubaruManuals"

# Control Module I/O Signal

LAN SYSTEM (DIAGNOSTICS)

Contents	Terminal No.	Standard	Measuring condition
Door switch, trunk/rear gate	A33 ↔ chassis ground	8 V or more → less than 1.5 V	With trunk or rear gate closed → opened
Rear gate opener button	C24 ↔ chassis ground	8 V or more → less than 1.5 V	Switch OFF → ON
Manual switch (LOCK)	A15 ↔ chassis ground	8 V or more → less than 1.5 V	Switch OFF → ON
Manual switch (UNLOCK)	A29 ↔ chassis ground	8 V or more → less than 1.5 V	Switch OFF → ON
Delivery (test) mode connector	A17 ↔ chassis ground	8 V or more → less than 1.5 V	When delivery (test) mode connector is connected
Front wiper input RTN	C5 ↔ chassis ground	8 V or more → less than 1.5 V	When front wiper is reversed
Rear wiper switch ON	C18 ↔ chassis ground	8 V or more → less than 1.5 V	Switch OFF → ON
Rear wiper switch (INT)	C27 ↔ chassis ground	8 V or more → less than 1.5 V	Switch OFF → ON
Rear wiper switch, washer	C28 ↔ chassis ground	8 V or more → less than 1.5 V	Switch OFF → ON
Lighting I switch	B11 ↔ chassis ground	8 V or more → less than 1.5 V	Switch OFF → ON
Lighting II switch	C8 ↔ chassis ground	8 V or more → less than 1.5 V	Switch OFF → ON
	D6 ↔ chassis ground	8 V or more → less than 1.5 V	Key warning switch ON and lighting switch OFF → ON
Dimmer switch, Hi beam	B12 ↔ chassis ground	8 V or more → less than 1.5 V	Switch OFF → ON
Dimmer switch, passing	B22 ↔ chassis ground	8 V or more → less than 1.5 V	Switch OFF → ON
Front fog light switch	B24 ↔ chassis ground	8 V or more → less than 1.5 V	Switch OFF → ON
MT reverse switch	B18 ↔ chassis ground	Less than 1.5 V → 8 V or more	Other than reverse → reverse
Parking brake switch	C15 ↔ chassis ground	8 V or more → less than 1.5 V	With parking brake not operated → operated
Bright switch	A14 ↔ chassis ground	Less than 1.5 V → 8 V or more	Switch OFF → ON
Illumination (Vi1)	A12 ↔ chassis ground	Approx. 5 V	Always
Illumination (Vi2)	A3 ↔ chassis ground	0.5 V — 5.0 V	Always
Illumination (Vi3)	A26 ↔ chassis ground	Less than 1.5 V	Always
Fuel level sensor	C7 ↔ chassis ground	Approx. 2 — 96 Ω	Ignition ON
Wiper deicer & rear defogger switch	A16 ↔ chassis ground	8 V or more → less than 1.5 V	Switch OFF → ON
Seat belt switch (driver's seat)	C16 ↔ chassis ground	Less than 1.5 V → 8 V or more	With seat belt unbuckled → buckled
Seat belt switch (passenger's seat)	C26 ↔ chassis ground	Less than 1.5 V → 8 V or more	With seat belt unbuckled → buckled
Impact sensor	B8 ↔ chassis ground	Less than 1.5 V → 8 V or more	When a shock is applied
Rear wiper output ON	D9 ↔ chassis ground	Less than 1 V → 9 V or more	When rear wiper operates



## Control Module I/O Signal

### LAN SYSTEM (DIAGNOSTICS)

Contents	Terminal No.	Standard	Measuring condition
Rear wiper output RTN	D8 ↔ chassis ground	Less than 1 V → 9 V or more	When rear wiper reversed
Door lock output	A7 ↔ A8	Less than 1 V → 9 V or more	During lock output
Door unlock output	A8 ↔ A7	Less than 1 V → 9 V or more	While unlock output
Driver's side door unlock output	A23 ↔ A7	Less than 1 V → 9 V or more	While unlock output
Trunk/rear gate UNLOCK output	A22 ↔ chassis ground	Less than 1 V → 9 V or more	4 door: While trunk UNLOCK output 5 door: While rear gate UNLOCK output
Lighting power supply	C1 ↔ chassis ground	Less than 1 V → 9 V or more	"With back-up fuse inserted, ACC ON or IGN ON" or "When key warning switch is ON"
	D1 ↔ chassis ground		
Clearance light relay output	D19 ↔ chassis ground	9 V or more → less than 1 V	Small light ON
Lo beam relay output	C3 ↔ chassis ground	9 V or more → less than 1 V	Headlight switch ON
	D7 ↔ chassis ground	9 V or more → less than 1 V	Headlight switch ON
Hi beam relay output	D20 ↔ chassis ground	9 V or more → less than 1 V	"Headlight switch ON and Hi beam ON" or "Passing switch ON"
Front fog light relay output	D17 ↔ chassis ground	9 V or more → less than 1 V	Headlight switch ON, and front fog light switch ON
DRL cancel output	D18 ↔ chassis ground	9 V or more → less than 1 V	When Hi beam 100 % illuminates
Room light output	D5	Pulse control	Illumination is adjusted through PWM control
Key ring illumination output	C23	Pulse control	Illumination is adjusted through PWM control
Illumination output	A2	Pulse control	Illumination is adjusted through PWM control
Map light output (model with sunroof)	D4 ↔ chassis ground	Pulse control	Illumination is adjusted through PWM control
Rear defogger relay output	D16 ↔ chassis ground	9 V or more → less than 1 V	While rear defogger output
Wiper deicer relay output	D15 ↔ chassis ground	9 V or more → less than 1 V	While wiper deicer output
Seat belt warning light (passenger's seat)	A25 ← chassis ground	9 V or more → less than 1 V	Indicator go off → illuminate
Buzzer sound output	D24 ↔ chassis ground	Less than 1 V → 9 V or more	Door lock → unlock with keyless entry system
Turn & hazard output	C22 ↔ chassis ground	9 V or more → less than 1 V	Door lock or unlock with keyless entry system
Horn relay output	D29 ↔ chassis ground	9 V or more → less than 1 V	During security alarm operation
Security indicator output	A10 ↔ chassis ground	9 V or more → less than 3 V	While indicator in combination meter blinks
Immobilizer antenna 1	B26 ↔ B25	-30 — +30 V	While key secret code is verified
Immobilizer antenna 2	B25 ↔ B26		
Immobilizer communication_1	B4	Can not be measured because of digital communication	Serial communication line
Immobilizer communication_2	B15	Can not be measured because of digital communication	Serial communication line

# Control Module I/O Signal

LAN SYSTEM (DIAGNOSTICS)

Contents	Terminal No.	Standard	Measuring condition
Keyless entry module communication	A24	Can not be measured because of digital communication	Serial communication line
SSM communication (K line)	B20	Can not be measured because of digital communication	Serial communication line
Body system CAN_Hi	A1 ↔ chassis ground	Can not be measured because of digital communication	Serial communication line
Body system CAN_Lo	A9 ↔ chassis ground	Can not be measured because of digital communication	Serial communication line
Driving system CAN_Hi	B3 ↔ chassis ground	Can not be measured because of digital communication	Serial communication line
Driving system CAN_Lo	B9 ↔ chassis ground	Can not be measured because of digital communication	Serial communication line

## B: WIRING DIAGRAM

<Ref. to WI-171, WIRING DIAGRAM, CAN Communication System.>

# Subaru Select Monitor

LAN SYSTEM (DIAGNOSTICS)

## 6. Subaru Select Monitor

### A: OPERATION

#### 1. READ DIAGNOSTIC TROUBLE CODE (DTC)

1) Prepare the Subaru Select Monitor kit. <Ref. to LAN(diag)-7, PREPARATION TOOL, General Description.>

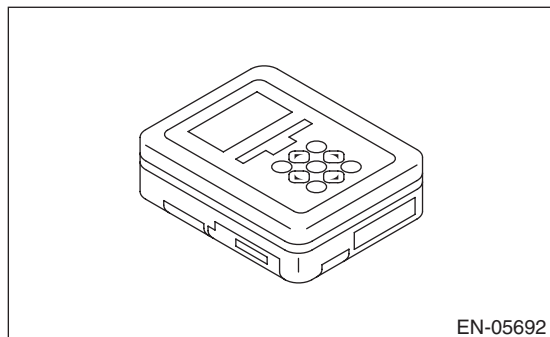

2) Prepare PC with Subaru Select Monitor installed.

3) Connect the USB cable between SDI (Subaru Diagnosis Interface) and USB port on the personal computer (dedicated port for the Subaru Select Monitor).

#### NOTE:

The dedicated port for the Subaru Select Monitor means the USB port which was used to install the Subaru Select Monitor.

4) Connect the diagnosis cable to SDI.

5) Connect SDI to data link connector located in the lower portion of the instrument panel (on the driver's side).

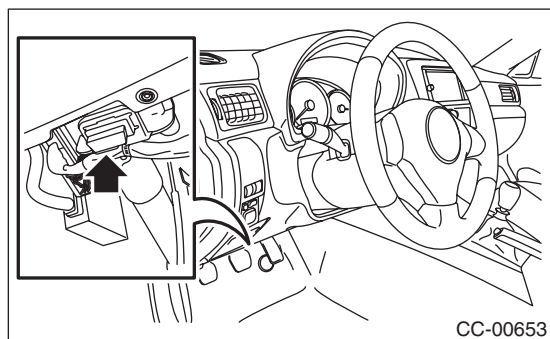

6) Start the PC.

7) Turn the ignition switch to ON and run the "PC application for Subaru Select Monitor".

8) Read the diagnostic trouble code and record it.

#### NOTE:

For detailed operation procedures, refer to "PC application help for Subaru Select Monitor".

#### 2. READ CURRENT DATA

1) On «Main Menu» display, select {Each System Check}.

2) On «System Selection Menu» display, select {Integ. unit mode}.

3) Select «Current Data Display & Save» screen.

4) Using the scroll key, scroll the display screen up or down until the desired data is shown.

## 3. DISPLAY OF DATA

Items to be displayed	Unit of measure	Remarks	Note
BATT voltage (control)	9 — 16 V	Body integrated unit input value	Always
BATT voltage (BACKUP)	9 — 16 V	Body integrated unit input value	Always
IG power supply voltage	9 — 16 V	Body integrated unit input value	Ignition switch ON
ACC voltage	9 — 16 V	Body integrated unit input value	Ignition switch ACC
Illumination VR Voltage	0 — 5 V	Body integrated unit input value	Input value from illumination volume
Illumi. output d-ratio	0 — 100%	Body integrated unit output value	Small light ON Illumination volume is other than bright.
Ambient Temperature	-40 — 87.5°C	CAN data input value	Ignition switch ON
Fuel level voltage	0 — 10 V	Body integrated unit input value	Ignition switch ON
Fuel level resistance	0 — 102.3 Ω	Body integrated unit input value	Ignition switch ON
key-lock solenoid V	6 — 15 V	Body integrated unit output value	Not applicable
number of regist.	0 — 4	Number of keyless key registered	Number of transmitter registered is displayed
Front Wheel Speed	km/h	CAN data input value	Reception from VDC module
VDC/ABS latest f-code	DTC display (Temporarily)	CAN data input value	It is normal when DTC is not been input even if this code is displayed. Received from VDC (Use after hexadecimal conversion)
Blower fan steps	0 — 2 levels	CAN data input value	0: OFF, 1: 1 level, 2: 2 levels or more Reception from air conditioner ECM
Fuel level resistance 2	0 — 102.3 Ω	CAN data output value	Reception from body integrated unit
Fuel consumption	cc/s	CAN data input value	Reception from ECM and transmission to center monitor
Coolant Temp.	-40 — 130°C	CAN data input value	Reception from ECM
Vehicle longitudinal G	m/s <sup>2</sup>	CAN data input value	Reception from VDC module
SPORT Shift Stages	0 — 7 levels	CAN data input value	Not applicable
Shift Position	0 — 7 levels	CAN data input value	Not applicable
VDC/ABS condition	0 — 4	CAN data input value	Reception from VDC module
Destination Code	0 — 16	CAN data input value	Reception from combination meter
Touch SW	0 — 64	CAN data input value	Reception from navigation module
key-lock warning SW	ON/OFF	Body integrated unit input value	ON when ignition key inserted
Stop light SW	ON/OFF	Body integrated unit input value	ON when brake pedal is depressed
Front fog lamp SW input	ON/OFF	Body integrated unit input value	When front fog light switch is ON
Driver's door SW input	ON/OFF	Body integrated unit input value	ON when driver's door is open
P-door SW input	ON/OFF	Body integrated unit input value	ON when passenger's door is open
Rear right door SW input	ON/OFF	Body integrated unit input value	ON when rear right door is open
Rear left door SW input	ON/OFF	Body integrated unit input value	ON when rear left door is open

# Subaru Select Monitor

## LAN SYSTEM (DIAGNOSTICS)

Items to be displayed	Unit of measure	Remarks	Note
R Gate SW input	ON/OFF	Body integrated unit input value	ON when rear gate/trunk open
Manual lock SW input	ON/OFF	Body integrated unit input value	Manual lock switch ON
Manual unlock SW input	ON/OFF	Body integrated unit input value	Manual unlock switch ON
Bright SW input	ON/OFF	Body integrated unit input value	ON when bright switch is ON
P SW	ON/OFF	Body integrated unit input value	Not applicable
MT Reverse Switch	ON/OFF	Body integrated unit input value	ON when shift lever is at reverse position
R wiper ON SW input	ON/OFF	Body integrated unit input value	Rear wiper switch ON
R wiper INT SW input	ON/OFF	Body integrated unit input value	Rear wiper switch (INT ON)
R washer SW input	ON/OFF	Body integrated unit input value	Rear washer switch ON
wiper deicer SW input	ON/OFF	Body integrated unit input value	Rear defogger switch ON
Rear Defogger SW Input	ON/OFF	Body integrated unit input value	
Driver's Seat SW input	ON/OFF	Body integrated unit input value	Driver's seat buckle switch ON
P seatbelt SW input	ON/OFF	Body integrated unit input value	Passenger's seat occupied and buckle switch ON
Fr wiper input	ON/OFF	Body integrated unit input value	ON when front wiper is operating
Parking Brake Switch Input	ON/OFF	Body integrated unit input value	ON when parking brake locked
R gate lock status SW input	ON/OFF	Body integrated unit inner memory value	Displays door lock/unlock state, ON when locked
R Gate Release SW input	ON/OFF	Body integrated unit input value	When rear gate opener button is ON
Rr Defogger output	ON/OFF	Body integrated unit output value	ON when rear defogger relay is operating
lock actuat. LOCK output	ON/OFF	Body integrated unit output value	ON when LOCK signal is output
All seat UNLOCK output	ON/OFF	Body integrated unit output value	ON when unlock signal is output
D-seat UNLOCK output	ON/OFF	Body integrated unit output value	ON when unlock signal is output
R gate/trunk UNLK output	ON/OFF	Body integrated unit output value	ON when rear gate/trunk unlock signal is output
R wiper output	ON/OFF	Body integrated unit output value	ON when rear wiper motor is operating
Shift Lock Solenoid	ON/OFF	Body integrated unit output value	Not applicable
Key locking output	ON/OFF	Body integrated unit output value	Not applicable
wiper deicer output	ON/OFF	Body integrated unit output value	ON when wiper deicer relay is operating
Hazard Output	ON/OFF	Body integrated unit output value	ON when answer-back signal is received or when emergency light (answer-back) is operating

# Subaru Select Monitor

## LAN SYSTEM (DIAGNOSTICS)

Items to be displayed	Unit of measure	Remarks	Note
Keyless Buzzer Output	ON/OFF	Body integrated unit output value	ON when lock/unlock signal is received
Horn Output	ON/OFF	Body integrated unit output value	ON when security warning is operating
D-belt warning light O/P	ON/OFF	CAN data output value	ON when ignition switch is turned to ON, and buckle switch is turned off
P-belt warning light O/P	ON/OFF	Body integrated unit output value	ON when ignition switch is turned to ON, occupant is seated, and buckle switch is turned off
Illumination lamp O/P	ON/OFF	Body integrated unit output value	ON when illumination is illuminated
Room lamp output	ON/OFF	Body integrated unit output value	ON when one of the doors is open
key illumi. lamp o/p	ON/OFF	Body integrated unit output value	ON when driver's door is open
Immobilizer lamp output	ON/OFF	Body integrated unit output value	ON when immobilizer pilot light blinks
Keyless operation 1	Regist./Normal	Body integrated unit input value	When keyless is registered
Keyless operation 2	Deletion/Normal	Body integrated unit input value	When keyless registration is deleted
CC Main Lamp	ON/OFF	CAN data input value	Cruise control switch ON Reception from ECM and transmission to combination meter
CC Set Lamp	ON/OFF	CAN data input value	ON when cruise control vehicle speed is set Reception from ECM and transmission to combination meter
SPORT Lamp	ON/OFF	CAN data input value	Not applicable
SPORT Blink	Blink/OFF	CAN data input value	Not applicable
ATF Temperature Lamp	ON/OFF	CAN data input value	Not applicable
ATF Blink	Blink/OFF	CAN data input value	Not applicable
ECO Lamp (AT)	ON/OFF	CAN data input value	Not applicable
ECO Lamp (MT)	ON/OFF	CAN data input value	Not applicable
Tire diameter abnormal 1	ON/OFF	CAN data input value	Not applicable
Tire diameter abnormal 2	Blink/OFF	CAN data input value	Not applicable
Shift Up Indication	UP/OFF	CAN data input value	Not applicable
Shift Down Indication	DOWN/OFF	CAN data input value	Not applicable
SPORT Shift (buzzer 1)	ON/OFF	CAN data input value	Not applicable
SPORT Shift (buzzer 2)	ON/OFF	CAN data input value	Not applicable
ABS/VDC Judging	ABS/VDC	CAN data input value	Transmission from vehicle dynamic control (VDC) to high speed control module
Small Light SW	ON/OFF	CAN data output value	ON when small light is illuminated
Headlamp	ON/OFF	CAN data output value	When headlight LO is ON
High Beam	ON/OFF	CAN data output value	When headlight HI is ON
km/mile display	mile/km	CAN data input value	Unit of distance received from meter
Large diameter tire	large Tire/Others	CAN data output value	Large tire when the standard tire is 18 in Reception from combination meter
Number of cylinders	4 Cylinder/6 Cylinder	CAN data input value	Display engine equipped
Cam shaft specification	SOHC/DOHC	CAN data input value	Display engine equipped
Turbo	TURBO/Without turbo	CAN data input value	Display engine equipped
E/G displacement (2.5L)	2.5 L/OFF	CAN data input value	Display engine equipped
E/G displacement (3.0L)	3.0 L/OFF	CAN data input value	Display engine equipped

# Subaru Select Monitor

## LAN SYSTEM (DIAGNOSTICS)

Items to be displayed	Unit of measure	Remarks	Note
AT Vehicle ID Signal	ON/OFF	CAN data input value	Display transmission equipped
Blower fan information	ON/OFF	CAN data input value	ON when blower fan is operating (always OFF for auto A/C equipped models)
Smart judging flag	Smart System/Other than Smart System	CAN data output value	Smart when integrated unit judges as a model with Smart
Diesel judging flag	Diesel/Other than Diesel	CAN data output value	Display diesel/other than diesel
Turbo judging flag	Without turbo/TURBO	CAN data output value	Display engine equipped
AT type judging flag	4AT/5AT	CAN data output value	Display transmission equipped
CVT judging flag	CVT/Other than CVT	CAN data output value	Display CVT judging
Center display failure	OK/NG	CAN data input value	NG when there is a center display failure Reception from center display (NAVI monitor)
NAVI Failure	OK/NG	CAN data input value	NG when there is a navigation system failure Reception from Center Display
IE Bus failure	Can not use	CAN data input value	Reception from Center Display
Auto A/C failure	OK/NG	CAN data input value	NG when there is a failure in auto air conditioning system Reception from auto A/C module
EBD Warning Light	ON/OFF	CAN data input value	OK when EBD warning light is illuminated Reception from VDC/ABS and transmission to combination meter
ABS Warning Light	ON/OFF	CAN data input value	OK when ABS warning light is illuminated Reception from VDC/ABS and transmission to combination meter
VDC OFF flag	ON/OFF	CAN data input value	Vehicle dynamics control OFF SW is ON Reception from VDC/ABS and transmission to combination meter
VDC/ABS OK B	OK/NG	CAN data input value	NG when there is an error in VDC/ABS system Reception from VDC/ABS
Lighting I Switch Input	ON/OFF	Body integrated unit input value	ON when lighting switch illumination is ON
Lighting II Switch Input	ON/OFF	Body integrated unit input value	ON when lighting switch headlight is ON
Dimmer Hi Switch Input	ON/OFF	Body integrated unit input value	ON when dimmer switch is Hi beam position
Dimmer Pass Switch Input	ON/OFF	Body integrated unit input value	ON when dimmer switch is passing position
Lighting I Lamp Output	ON/OFF	Body integrated unit output value	ON when small light is illuminated
Lighting II Lamp Output	ON/OFF	Body integrated unit output value	ON when headlight is illuminated
Lighting Hi Lamp Output	ON/OFF	Body integrated unit output value	ON when Hi beam is illuminated
Front Fog Lamp Output	ON/OFF	Body integrated unit output value	ON when front fog light is ON.
DRL Cancel Output	ON/OFF	Body integrated unit output value	ON when lighting switch is "Headlight ON" and dimmer switch is "Hi beam" or "Passing" position
Power Supply Tr	ON/OFF	Body integrated unit output value	ON when lighting switch is "Head" position without inserting key in key cylinder
Spot map lamp output	ON/OFF	Body integrated unit output value	ON when one of the doors is open (except for tail gate)

# Subaru Select Monitor

LAN SYSTEM (DIAGNOSTICS)

Items to be displayed	Unit of measure	Remarks	Note
Eco switch information	ON/OFF	CAN data output value	Not applicable
Off delay time	OFF, Short, Normal, Long	Body integrated unit setting items	Customize setting
Check engine warning lamp output	ON, OFF, Blink 1, Blink 2, Blink 3	Body integrated unit output value	Warning light is activated
Rear defogger operation mode	Continuous/Normal	Body integrated unit setting items	Customize setting
Security Alarm Setup	ON/OFF	Body integrated unit setting items	Customize setting
Impact Sensor Setup	ON/OFF	Body integrated unit setting items	Customize setting
Alarm delay setup	ON/OFF	Body integrated unit setting items	Customize setting
Lockout prevention	ON/OFF	Body integrated unit setting items	Customize setting
Impact sensor	ON/OFF	Body integrated unit setting items	Customize setting
Buzzer beeping setup	ON/OFF	Body integrated unit setting items	Customize setting
Hazard light setup	ON/OFF	Body integrated unit setting items	Customize setting
Buzzer setting	ON/OFF	Body integrated unit setting items	Inside condition of unit
Auto locking	ON/OFF	Body integrated unit setting items	Customize setting
Passive Alarm	ON/OFF	Body integrated unit setting items	Customize setting
Door open warning	ON/OFF	Body integrated unit setting items	Customize setting
Dome Light Alarm Setting	ON/OFF	Body integrated unit setting items	Customize setting
Map Light Setting	ON/OFF	Body integrated unit setting items	Customize setting
Belt Warning Switch	ON/OFF	Body integrated unit setting items	Customize setting
Map lamp 30 sec off record	ON/OFF	Body integrated unit setting items	Customize setting
A/C ECM setting	ON/OFF	Body integrated unit setting items	Equipment setting
wiperdeicer	ON/OFF	Body integrated unit setting items	Equipment setting
Sedan/Wagon Setting	Sedan/Wagon	Body integrated unit setting items	Equipment setting
MT/AT Setting	MT/AT	Body integrated unit setting items	Equipment setting
6MT Setting	6MT/Other than 6MT	Body integrated unit setting items	Equipment setting
Destination Setting	Each destination	Body integrated unit setting items	—
Factory initial setting	Factory/Market	Body integrated unit setting items	Equipment setting

**NOTE:**

For detailed operation procedures, refer to "PC application help for Subaru Select Monitor".



# Subaru Select Monitor

## LAN SYSTEM (DIAGNOSTICS)

### 4. CONFIRM CURRENT SETTING

- 1) On «Main Menu» display, select {Each System Check}.
- 2) On «System Selection Menu» display, select {Integ. unit mode}.
- 3) On «Integ. unit mode failure diag.» display, select {Current Data Display & Save}.
- 4) Using the scroll key, scroll the display screen up or down until the desired data is shown.
- 5) Display the following item and record the settings.

Required items for new registration (Except for system not equipped)

Item	Item to confirm				Remarks
	1	2	3	4	
number of regist.					Number of registered key
Off delay time	OFF	Long	Normal	Short	Setting for lighting off time
Rr Defogger op. mode	Normal		Continuous		
Security Alarm Setup	ON		OFF		
Impact Sensor Setup	ON		OFF		Option setting
Alarm delay setup	ON		OFF		
Lockout prevention	ON		OFF		
Impact sensor	support		no support		Option setting
Buzzer beeping setup	ON		OFF		
Emergency light setup	ON		OFF		
Buzzer setting	support		no support		
Passive Alarm	ON		OFF		
Door open warning	support		no support		
Dome Light Alarm Setting	ON		OFF		
Map Light Setting	ON		OFF		
Belt Warning Switch	ON		OFF		Switch the belt warning lighting and the buzzer sound.
Map lamp 30 sec off record	support		no support		
A/C ECM setting	support		no support		Model with auto A/C
wiperdeicer	support		no support		Option setting
Sedan/Wagon Setting	Sedan		Wagon		
MT/AT Setting	AT		MT		
6MT Setting	6MT		Other than 6MT		
Factory initial setting	Factory		Market		Do not change to factory mode.

## 5. REGISTRATION BODY INTEGRATED UNIT (FUNCTION SETTING)

### CAUTION:

Body integrated unit is core of LAN system, and also can select the function of all vehicle system control. It is possible to control the original functions of vehicle when registrations of body integrated unit, or User Customizing are corresponded to vehicle equipment.

If registrations and function setting are different from vehicle equipment, vehicle system does not operate normally and diagnosis cannot be performed correctly. Pay attention to following item.

- Be sure to correspond registrations, or User Customizing settings to vehicle equipment.
- Do not change the settings of vehicle improperly.
- Confirm key illumination does not blink when ignition key is turned ON, or "Factory initial setting" of body integrated unit registrations is set to "Market". If "Factory initial setting" is set to "Factory", key illumination blinks when ignition key is turned ON, to notify that the settings are unconfirmed.
- Key illumination does not blink with ignition switch turned to ON and go off with door closed.
- Be sure to register immobilizer if body integrated unit is replaced with a new part or if the parts related to immobilizer have been replaced. Refer to the "PC application help for Subaru Select Monitor".

1) Connect SDI to data link connector located in the lower portion of the instrument panel (on the driver's side).

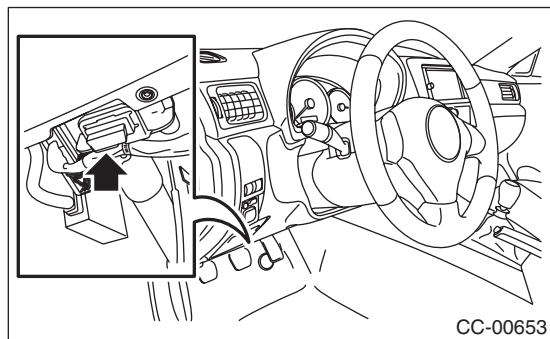

### CAUTION:

Do not connect scan tools other than the Subaru Select Monitor.

- 2) Start the PC.
- 3) Turn the ignition switch to ON and run the "PC application for Subaru Select Monitor".
- 4) On «Main Menu» display, select {Each System Check}.

5) On «System Selection Menu» display, select {Integ. unit mode}.

6) Click the [OK] button after the control module name (integrated unit) is displayed.

7) On «Integ. unit mode failure diag.» display, select {Unit customizing}.

8) Change the setting with UP/DOWN key.

# Subaru Select Monitor

## LAN SYSTEM (DIAGNOSTICS)

- List of body integrated unit registration item

### NOTE:

Setting is different depending on the grade of vehicle.

Data	Initial setting	Registration	Remarks
Map lamp 30 sec off record	OFF	ON	Set to "OFF" for models with door interlock switch in map light, "ON" for models without door interlock switch.
		OFF	
A/C ECM setting	OFF	ON	Set to "ON" in case of model with auto A/C. Set to "OFF" in case of model without auto A/C.
		OFF	
wiperdeicer (factory option)	OFF	ON	Be sure to set exactly according to vehicle equipment. ON signal does not output with switch operation when it is set to "OFF".
		OFF	
Sedan/Wagon Setting	Wagon	Sedan	Be sure to set exactly according to vehicle model. This relates to door lock control.
		Wagon	
MT/AT Setting	AT	MT	Be sure to set exactly according to vehicle model. This relates to key interlock control, shift lock control.
		AT	
6MT Setting	Other than 6MT	6MT	Set "6MT" for 6MT model, and set "Other than 6MT" for AT/5AT model.
		Other than 6MT	
Factory initial setting	Factory	Factory	Be sure to set to "Market". After setting change, turn the ignition switch to OFF and settle the changed settings.
		Market	

### CAUTION:

- To perform normal operation of vehicle and diagnosis, the above settings must match the actual vehicle equipment.
- When body integrated unit is a new part or "Factory" mode, key illumination blinks to show equipment settings have not been completed. Check the detailed procedures of User Customizing.
- Be sure not to change Factory initial setting except when installing a new body integrated unit.

### NOTE:

"Factory" mode:

- Body integrated unit has not been set yet. It can be recognized by key illumination blinking with ignition switch turned to ON.
- All replacement body integrated units are set to "Factory" mode. When replacing a body integrated unit, be sure to perform the registration operation.

"Market" mode:

- Each settings have been set. It can be recognized by key ring illumination coming on in concocting with room light and going off with ignition switch turned to ON.

9) Perform the Factory initial setting. On the «Unit customizing» display screen of Subaru Select Monitor, select the {Factory initial setting}.

10) Change the mode from Factory to Market and then turn the ignition switch to OFF.

11) Change the Subaru Select Monitor system selection to «Immobilizer» to register the immobilizer key. (model with immobilizer)

12) Perform the operation according to the “PC application help for Subaru Select Monitor”.

13) When key registration is completed, “Do you want to register remote engine start?” is displayed. Perform registration only for equipped models.

14) Perform the User Customizing.

<Ref. to LAN(diag)-24, USER CUSTOMIZING, OPERATION, Subaru Select Monitor.>

**NOTE:**

For detailed operation procedures, refer to “PC application help for Subaru Select Monitor”.

## 6. CLEAR MEMORY MODE

1) On «Main Menu» display, select {Each System Check}.

2) On «System Selection Menu» display, select {Integ. unit mode}.

3) Press the [OK] key after the information of body integrated unit type is displayed.

4) On «Integ. unit mode failure diag» display, select {Clear Memory} and press the [OK] key.

Display	Contents to be displayed
Clear Memory ?	Clear function of DTC and freeze frame data

5) When “Done” is shown on the display screen, turn the ignition switch to OFF.

**NOTE:**

For details concerning the operation procedure, refer to “PC application help for Subaru Select Monitor”.

## 7. FREEZE FRAME DATA

**NOTE:**

- Data stored at the time of trouble occurrence is shown on display.
- Freeze frame data will be memorized maximum to 20.
- If freeze frame data is not stored in memory correctly (caused by low power supply of body integrated unit), DTC will be displayed with “?” on the head of it in the Subaru Select Monitor display. This shows it may be an unreliable reading.

# Subaru Select Monitor

## LAN SYSTEM (DIAGNOSTICS)

### 8. USER CUSTOMIZING

- 1) On «Main Menu» display, select {Each System Check}.
- 2) On «System Selection Menu» display, select {Integ. unit mode}.
- 3) On «Integ. unit mode failure diag.» display, select {Integ. Unit customizing}.
- 4) Change the setting with UP/DOWN key and set with the [OK] key.

- List of User Customizing item

Data	Initial setting value	Customize setting	Remarks
Off delay time	Long		Delay time below can be selected by setting.
		OFF	0 seconds
		Short	10 seconds
		Normal	20 seconds
		Long	30 seconds
Rr Defogger op. mode	15 minutes	15 minutes	Automatically stops in 15 minutes after switch is turned to ON.
		Continuous	Repeats active condition for 15 minutes and inactive condition for 2 minutes until switch is turned to OFF.
Security Alarm Setup	ON	ON	Security alarm (hazard, horn or siren) in active condition
		OFF	Security alarm in inactive condition
Impact Sensor Setup	OFF	ON	Workable when Impact Sensor Setup is set to "ON" Impact sensor function becomes activated.
		OFF	Impact sensor in inactive condition (Set to "OFF" in models without sensors.)
Alarm delay setup	ON		After the keyless lock operation, the alarm monitor starts after the following delay time has passed.
		ON	Delay time is 30 seconds.
		OFF	Delay time is 0 seconds.
Lockout prevention	ON	ON	Lockout prevention in active condition. (The function does not operate if safety knob is locked by hand.)
		OFF	Lockout prevention in inactive condition
Impact sensor (OP)	OFF	ON	Workable when Impact Sensor Setup is set to "ON" Impact sensor function becomes activated.
		OFF	Impact sensor in inactive condition (Set to "OFF" in models without sensors.)
Buzzer beeping setup	ON	ON	Workable when Buzzer setting is "ON". When lock/unlock is selected by keyless entry system operation, buzzer operates.
		OFF	When lock/unlock is selected by keyless entry system operation, buzzer does not operate.
Emergency light setup	ON	ON	When lock/unlock is selected by keyless entry system operation, buzzer operates.
		OFF	When lock/unlock is selected by keyless entry system operation, buzzer does not operate.
Buzzer setting	ON	ON	Vehicle is controlled in answer-back buzzer equipped mode.
		OFF	Vehicle is controlled in answer-back buzzer non-equipped mode. (Make sure to set to "OFF" in models without answer back buzzers.)
Initial keyless setting	—	—	
		Execution	Settings of keyless entry system are initialized.
Initial button setting	—	—	
		Execution	Settings of each function are initialized.
Passive Alarm	OFF	ON	Setting only for North American models
		OFF	

# Subaru Select Monitor

LAN SYSTEM (DIAGNOSTICS)

Data	Initial setting value	Customize setting	Remarks
Door open warning	ON	ON	If detecting door open for 20 minutes, room light, map light, and key ring illumination that are related to doors are turned off to prevent battery run-out.
		OFF	Room light, map light, key illumination and door warning light are not turned off.
Dome Light Alarm Setting	OFF	ON	The room light lights by being interlocked with the activation of the alarm.
		OFF	
Map Light Setting	ON	ON	Illuminates in accordance with the door interlocked room light. (model with sunroof)
		OFF	
Belt Warning Switch	ON	ON	When using normally
		OFF	Stop the belt warning buzzer beep and warning light illumination.

5) After setting, make sure that the setting changed in the {Current Data Display & Save} is same as vehicle equipment.

## CAUTION:

- The above settings must match the actual vehicle equipment.
- Do not change settings except for above setting while performing the User Customizing.
- Be sure not to change Factory initial setting except when installing a new body integrated unit.

## NOTE:

For detailed operation procedures, refer to "PC application help for Subaru Select Monitor".

## 9. FUNCTION CHECK

In order to check the body integrated unit function, inspect the body integrated unit and actuator using Subaru Select Monitor without operating switches.

- 1) On «Main Menu» display, select {Each System Check}.
- 2) On «System Selection Menu» display, select {Integ. unit mode}.
- 3) On «Integ. unit mode failure diag.» display, select {Function check}.
- 4) Select the item to be operated on the «Function check» display screen with "UP/Down key" and press the [Next] button.
- 5) Pressing [Next] starts, [End] cancels the operation and [OK] returns to the System Operation Check Mode display screen.

## NOTE:

If not equipped (based on area or condition), process will not go on.

# Subaru Select Monitor

LAN SYSTEM (DIAGNOSTICS)

## B: INSPECTION

### 1. COMMUNICATION FOR INITIALIZING IMPOSSIBLE

#### DETECTING CONDITION:

Defective harness connector

#### TROUBLE SYMPTOM:

Not communicable with Subaru Select Monitor.

#### WIRING DIAGRAM:

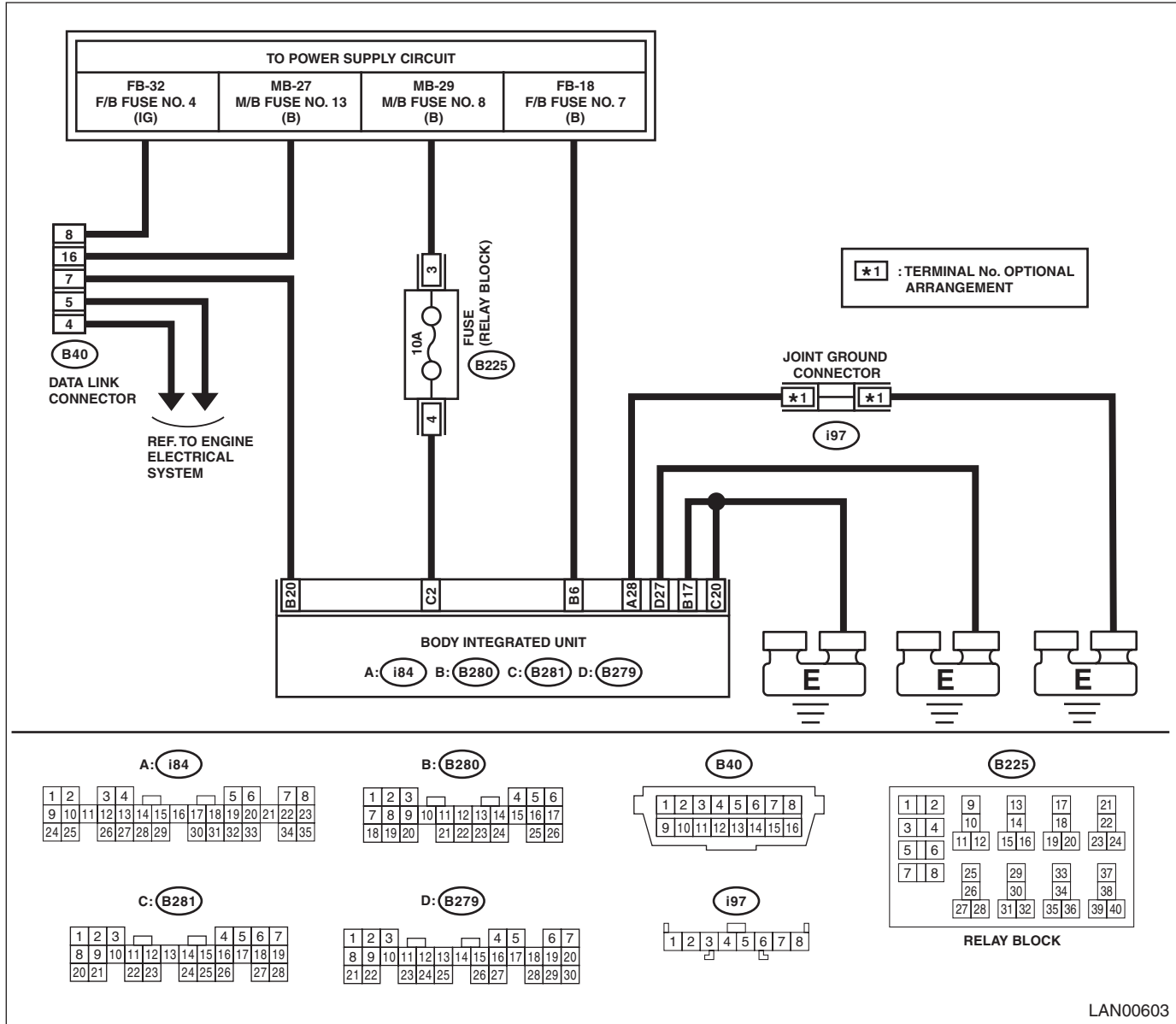

Step	Check	Yes	No
1 <b>CHECK IGNITION SWITCH.</b>	Is the ignition switch ON?	Go to step 2.	Turn the ignition switch to ON, and select Integ. unit mode using Subaru Select Monitor.
2 <b>CHECK BATTERY.</b> 1) Turn the ignition switch to OFF. 2) Measure the battery voltage.	Is the voltage 11 V or more?	Go to step 3.	Charge or replace the battery.

# Subaru Select Monitor

LAN SYSTEM (DIAGNOSTICS)

Step	Check	Yes	No
<b>3</b> <b>CHECK BATTERY TERMINAL.</b>	Is there poor contact at battery terminal?	Repair or tighten the battery terminal.	Go to step 4.
<b>4</b> <b>CHECK COMMUNICATION OF SUBARU SELECT MONITOR.</b> 1) Turn the ignition switch to ON. 2) Using the Subaru Select Monitor, check whether communication to other systems can be executed normally.	Is the system name displayed?	Go to step 7.	Go to step 5.
<b>5</b> <b>CHECK COMMUNICATION OF SUBARU SELECT MONITOR.</b> 1) Turn the ignition switch to OFF. 2) Disconnect the body integrated unit connector. 3) Turn the ignition switch to ON. 4) Check whether communication to other systems can be executed normally.	Is the system name displayed?	Go to step 7.	Go to step 6.
<b>6</b> <b>CHECK HARNESS CONNECTOR BETWEEN EACH CONTROL MODULE AND SUBARU SELECT MONITOR.</b> 1) Turn the ignition switch to OFF. 2) Measure the resistance between data link connector and chassis ground. <b>Connector &amp; terminal</b> <b>(B40) No. 7 — Chassis ground:</b>	Is the resistance 1 M $\Omega$ or more?	Go to step 7.	Repair the harness and connector between each control module and Subaru Select Monitor.
<b>7</b> <b>CHECK OUTPUT SIGNAL TO BODY INTEGRATED UNIT.</b> 1) Turn the ignition switch to ON. 2) Measure the voltage between data link connector and chassis ground. <b>Connector &amp; terminal</b> <b>(B40) No. 7 (+) — Chassis ground (-):</b>	Is the voltage less than 1 V?	Go to step 8.	Repair the harness and connector between each control module and Subaru Select Monitor.
<b>8</b> <b>CHECK HARNESS CONNECTOR BETWEEN BODY INTEGRATED UNIT AND DATA LINK CONNECTOR.</b> 1) Turn the ignition switch to OFF. 2) Measure the resistance between body integrated unit and data link connector. <b>Connector &amp; terminal</b> <b>(B40) No. 7 — (B280) No. 20:</b>	Is the resistance less than 1 $\Omega$ ?	Go to step 9.	Repair the harness and connector between body integrated unit and Subaru Select Monitor.
<b>9</b> <b>CHECK BACK-UP FUSE.</b> Check that back-up fuse is not blown out, or check that it is inserted.	Is back-up fuse OK?	Go to step 10.	Replace the back-up fuse, or insert it into the fuse holder.
<b>10</b> <b>CHECK POWER SUPPLY CIRCUIT.</b> 1) Connect the body integrated unit. 2) Measure the voltage between body integrated unit connector and chassis ground. <b>Connector &amp; terminal</b> <b>(B280) No. 6 (+) — Chassis ground (-):</b> <b>(B281) No. 2 (+) — Chassis ground (-):</b>	Is the voltage 10 V or more?	Go to step 11.	Repair the open circuit of harness between body integrated unit and battery.



# Subaru Select Monitor

## LAN SYSTEM (DIAGNOSTICS)

Step	Check	Yes	No
<b>11 CHECK HARNESS CONNECTOR BETWEEN BODY INTEGRATED UNIT AND CHASSIS GROUND.</b> 1) Turn the ignition switch to OFF. 2) Disconnect the connector from body integrated unit. 3) Measure the resistance of harness between the body integrated unit and chassis ground. <b>Connector &amp; terminal</b> <i>(i84) No. 28 — Chassis ground:</i> <i>(B279) No. 27 — Chassis ground:</i> <i>(B280) No. 17 — Chassis ground:</i> <i>(B281) No. 20 — Chassis ground:</i>	Is the resistance 1 MΩ or more?	Go to step 12.	Repair the poor contact of harness between body integrated unit and ground.
<b>12 CHECK POOR CONTACT OF CONNECTOR.</b>	Is there poor contact of the control unit ground and the Subaru Select Monitor?	Repair the poor contact of connector.	Replace the body integrated unit. <Ref. to SL-48, REMOVAL, Body Integrated Unit.>

**CAUTION:**

**For model with immobilizer, immobilizer registration work is necessary when the body integrated unit replaced. For details, refer to the “PC application help for Subaru Select Monitor”.**

### 7. Read Diagnostic Trouble Code (DTC)

#### A: OPERATION

For details concerning DTC reading procedure, refer to "Subaru Select Monitor". <Ref. to LAN(diag)-14, READ DIAGNOSTIC TROUBLE CODE (DTC), OPERATION, Subaru Select Monitor.>

# Clear Memory Mode

LAN SYSTEM (DIAGNOSTICS)

---

## 8. Clear Memory Mode

### A: OPERATION

For details concerning DTC clear operation, refer to "Subaru Select Monitor". <Ref. to LAN(diag)-23, CLEAR MEMORY MODE, OPERATION, Subaru Select Monitor.>

## 9. Read Current Data

### A: OPERATION

- 1) On «Main Menu» display, select {Each System Check}.
  - 2) On «System Selection Menu» display, select {Integ. unit mode}.
  - 3) On «Integ. unit mode failure diag» display, select {Current Data Display & Save}.
  - 4) Using the scroll key, scroll the display screen up or down until the desired data is shown.
- <Ref. to LAN(diag)-15, DISPLAY OF DATA, OPERATION, Subaru Select Monitor.>

### **10. User Customizing**

#### **A: OPERATION**

For detailed procedures of User Customizing, refer to "Subaru Select Monitor". <Ref. to LAN(diag)-24, USER CUSTOMIZING, OPERATION, Subaru Select Monitor.>

# List of Diagnostic Trouble Code (DTC)

LAN SYSTEM (DIAGNOSTICS)

## 11. List of Diagnostic Trouble Code (DTC)

### A: LIST

DTC	Item	Content of diagnosis	Note
B1100	Integ. Unit System Error	Memory read out error in body integrated unit	<Ref. to LAN(diag)-36, DTC B1100 INTEG. UNIT SYSTEM ERROR, Diagnostic Procedure with Diagnostic Trouble Code (DTC).>
B1101	BATT p/supply malfunction cont.	<ul style="list-style-type: none"> <li>• Open or short in battery power supply control circuit</li> <li>• Voltage malfunction caused by poor contact</li> </ul>	<Ref. to LAN(diag)-37, DTC B1101 BATT P/SUPPLY MALFUNCTION CONT, Diagnostic Procedure with Diagnostic Trouble Code (DTC).>
B1102	BATT p/supply malfunction backup	<ul style="list-style-type: none"> <li>• Battery power supply backup circuit is open or shorted.</li> <li>• Voltage malfunction caused by poor contact</li> </ul>	<Ref. to LAN(diag)-39, DTC B1102 BATT P/SUPPLY MALFUNCTION BACKUP, Diagnostic Procedure with Diagnostic Trouble Code (DTC).>
B1103	Ignition power failure	<ul style="list-style-type: none"> <li>• IGN power supply circuit is open or shorted.</li> <li>• Voltage malfunction caused by poor contact</li> </ul>	<Ref. to LAN(diag)-41, DTC B1103 IGNITION POWER FAILURE, Diagnostic Procedure with Diagnostic Trouble Code (DTC).>
B1104	ACC power failure	<ul style="list-style-type: none"> <li>• ACC power supply circuit is open or shorted.</li> <li>• Voltage malfunction caused by poor contact</li> </ul>	<Ref. to LAN(diag)-43, DTC B1104 ACC POWER FAILURE, Diagnostic Procedure with Diagnostic Trouble Code (DTC).>
U1201	CAN-HS counter abnormal	Communication is unstable because of high speed CAN communication error.	<Ref. to LAN(diag)-45, DTC U1201 CAN-HS COUNTER ABNORMAL, Diagnostic Procedure with Diagnostic Trouble Code (DTC).>
U1202	CAN-HS bus off	Integrated unit communication is shut down because of high speed CAN communication error.	<Ref. to LAN(diag)-49, DTC U1202 CAN-HS BUS OFF, Diagnostic Procedure with Diagnostic Trouble Code (DTC).>
U1211	CAN-HS ECM data abnormal	Received error data from ECM.	<Ref. to LAN(diag)-52, DTC U1211 CAN-HS ECM DATA ABNORMAL, Diagnostic Procedure with Diagnostic Trouble Code (DTC).>
U1213	CAN-HS VDC/ABS data abnormal	Received error data from VDC/ABS module.	<Ref. to LAN(diag)-54, DTC U1213 CAN-HS VDC/ABS DATA ABNORMAL, Diagnostic Procedure with Diagnostic Trouble Code (DTC).>
U1216	High-Speed CAN (DCCD) Data Error	Received error data from DCCD CM.	<Ref. to LAN(diag)-56, DTC U1216 HIGH-SPEED CAN (DCCD) DATA ERROR, Diagnostic Procedure with Diagnostic Trouble Code (DTC).>
U1221	CAN-HS ECM no-receive data	Not received data from ECM.	<Ref. to LAN(diag)-58, DTC U1221 CAN-HS ECM NO-RECEIVE DATA, Diagnostic Procedure with Diagnostic Trouble Code (DTC).>
U1223	CAN-HS VDC/ABS no-receive data	Not received data from VDC/ABS CM.	<Ref. to LAN(diag)-61, DTC U1223 CAN-HS VDC/ABS NO-RECEIVE DATA, Diagnostic Procedure with Diagnostic Trouble Code (DTC).>
U1226	High-Speed CAN (DCCD) Data is Not Received	Not received data from DCCD CM.	<Ref. to LAN(diag)-63, DTC U1226 HIGH-SPEED CAN (DCCD) DATA IS NOT RECEIVED, Diagnostic Procedure with Diagnostic Trouble Code (DTC).>
U1300	CAN-LS malfunction	CAN-LS circuit is open or shorted.	<Ref. to LAN(diag)-65, DTC U1300 CAN-LS MALFUNCTION, Diagnostic Procedure with Diagnostic Trouble Code (DTC).>
U1301	CAN-LS counter abnormal	Communication is unstable because of low speed CAN communication error.	<Ref. to LAN(diag)-68, DTC U1301 CAN-LS COUNTER ABNORMAL, Diagnostic Procedure with Diagnostic Trouble Code (DTC).>

**LAN(diag)-33**

Brought to you by Ebay Seller "SubaruManuals"

## List of Diagnostic Trouble Code (DTC)

### LAN SYSTEM (DIAGNOSTICS)

DTC	Item	Content of diagnosis	Note
U1302	CAN-LS bus off	Integrated unit communication is shut down because of low speed CAN communication error.	<Ref. to LAN(diag)-71, DTC U1302 CAN-LS BUS OFF, Diagnostic Procedure with Diagnostic Trouble Code (DTC).>
U1311	CAN-LS meter unit data abnormal	Received error data from meter.	<Ref. to LAN(diag)-74, DTC U1311 CAN-LS METER UNIT DATA ABNORMAL, Diagnostic Procedure with Diagnostic Trouble Code (DTC).>
U1321	CAN-LS meter no-receive data	Not received data from meter.	<Ref. to LAN(diag)-75, DTC U1321 CAN-LS METER NO-RECEIVE DATA, Diagnostic Procedure with Diagnostic Trouble Code (DTC).>
B1401	M Collation NG	Malfunction related immobilizer	<Ref. to IM(diag)-24, DTC B1401 M COLLATION NG, Diagnostic Procedure with Diagnostic Trouble Code (DTC).>
B1402	Immobilizer Key Collation NG	Malfunction related immobilizer	<Ref. to IM(diag)-24, DTC B1402 IMMOBILIZER KEY COLLATION NG, Diagnostic Procedure with Diagnostic Trouble Code (DTC).>
B1403	E/G request NG	Malfunction related immobilizer	<Ref. to IM(diag)-24, DTC B1403 E/G REQUEST NG, Diagnostic Procedure with Diagnostic Trouble Code (DTC).>
B1500	Keyless UART com. Malfunction	Open or short circuit in keyless UART circuit	<Ref. to LAN(diag)-77, DTC B1500 KEYLESS UART COM. MALFUNCTION, Diagnostic Procedure with Diagnostic Trouble Code (DTC).>

# List of Diagnostic Trouble Code (DTC)

LAN SYSTEM (DIAGNOSTICS)

## 1. DTC TABLE

### NOTE:

When more than two DTC codes are recorded, referring to their combination will make it easy to identify the possible cause. Refer to the list for typical examples.

DTC to Check	Diagnostic Code that was displayed.				Probable cause
	Body integrated unit	ECM	VDC/ABS CM	DCCD CM	
B1100 <Ref. to LAN(diag)-36, DTC B1100 INTEG. UNIT SYSTEM ERROR, Diagnostic Procedure with Diagnostic Trouble Code (DTC).>	B1100	—	—	—	There could be a problem in the body integrated unit.
U1221 <Ref. to LAN(diag)-58, DTC U1221 CAN-HS ECM NO-RECEIVE DATA, Diagnostic Procedure with Diagnostic Trouble Code (DTC).>	U1221	—	C0047	—	It is possible that the ECM is faulty.
U1223 <Ref. to LAN(diag)-61, DTC U1223 CAN-HS VDC/ABS NO-RECEIVE DATA, Diagnostic Procedure with Diagnostic Trouble Code (DTC).>	U1223	U0122	—	—	It is possible that the VDC/ABS CM is faulty.
U1226 <Ref. to LAN(diag)-63, DTC U1226 HIGH-SPEED CAN (DCCD) DATA IS NOT RECEIVED, Diagnostic Procedure with Diagnostic Trouble Code (DTC).>	U1226	—	—	—	It is possible that the DCCD CM is faulty.
U1321 <Ref. to LAN(diag)-75, DTC U1321 CAN-LS METER NO-RECEIVE DATA, Diagnostic Procedure with Diagnostic Trouble Code (DTC).>	U1321	—	—	—	It is possible that the combination meter is faulty.
B1500 <Ref. to LAN(diag)-77, DTC B1500 KEYLESS UART COM. MALFUNCTION, Diagnostic Procedure with Diagnostic Trouble Code (DTC).>	B1500	—	—	—	It's possible that there is an internal problem in the keyless entry control module, or a open circuit in the communication line.



## Diagnostic Procedure with Diagnostic Trouble Code (DTC)

LAN SYSTEM (DIAGNOSTICS)

### 12. Diagnostic Procedure with Diagnostic Trouble Code (DTC)

#### A: DTC B1100 INTEG. UNIT SYSTEM ERROR

##### DTC DETECTING CONDITION:

Memory read out error in body integrated unit

##### TROUBLE SYMPTOM:

LAN communication immobilizer function may not be executed normally.

	Step	Check	Yes	No
1	<b>CHECK DTC.</b> Check DTC indicated by body integrated unit. <Ref. to LAN(diag)-14, READ DIAGNOSTIC TROUBLE CODE (DTC), OPERATION, Subaru Select Monitor.>	Is B1100 a current malfunction?	Go to step 2.	Temporary EEPROM access error occurred.
2	<b>CHECK CONNECTOR.</b> 1) Turn the ignition switch to OFF. 2) Disconnect the body integrated unit connector. 3) Connect the disconnected connectors. 4) Turn the ignition switch to ON. 5) Read the DTC of body integrated unit using Subaru Select Monitor.	Is B1100 a current malfunction?	Replace the body integrated unit. <Ref. to SL-48, REMOVAL, Body Integrated Unit.>	Temporary EEPROM access error occurred.

# Diagnostic Procedure with Diagnostic Trouble Code (DTC)

LAN SYSTEM (DIAGNOSTICS)

## B: DTC B1101 BATT P/SUPPLY MALFUNCTION CONT

### DTC DETECTING CONDITION:

- Open or short in battery power supply control circuit
- Voltage malfunction caused by poor contact

### TROUBLE SYMPTOM:

Each function (such as door lock control) stops operation.

### NOTE:

- When B1102 BATT p/supply malfunction backup is output at the same time, all the function of body integrated unit may not operate.
- B1101 may input when the battery run-out occurs.

### WIRING DIAGRAM:

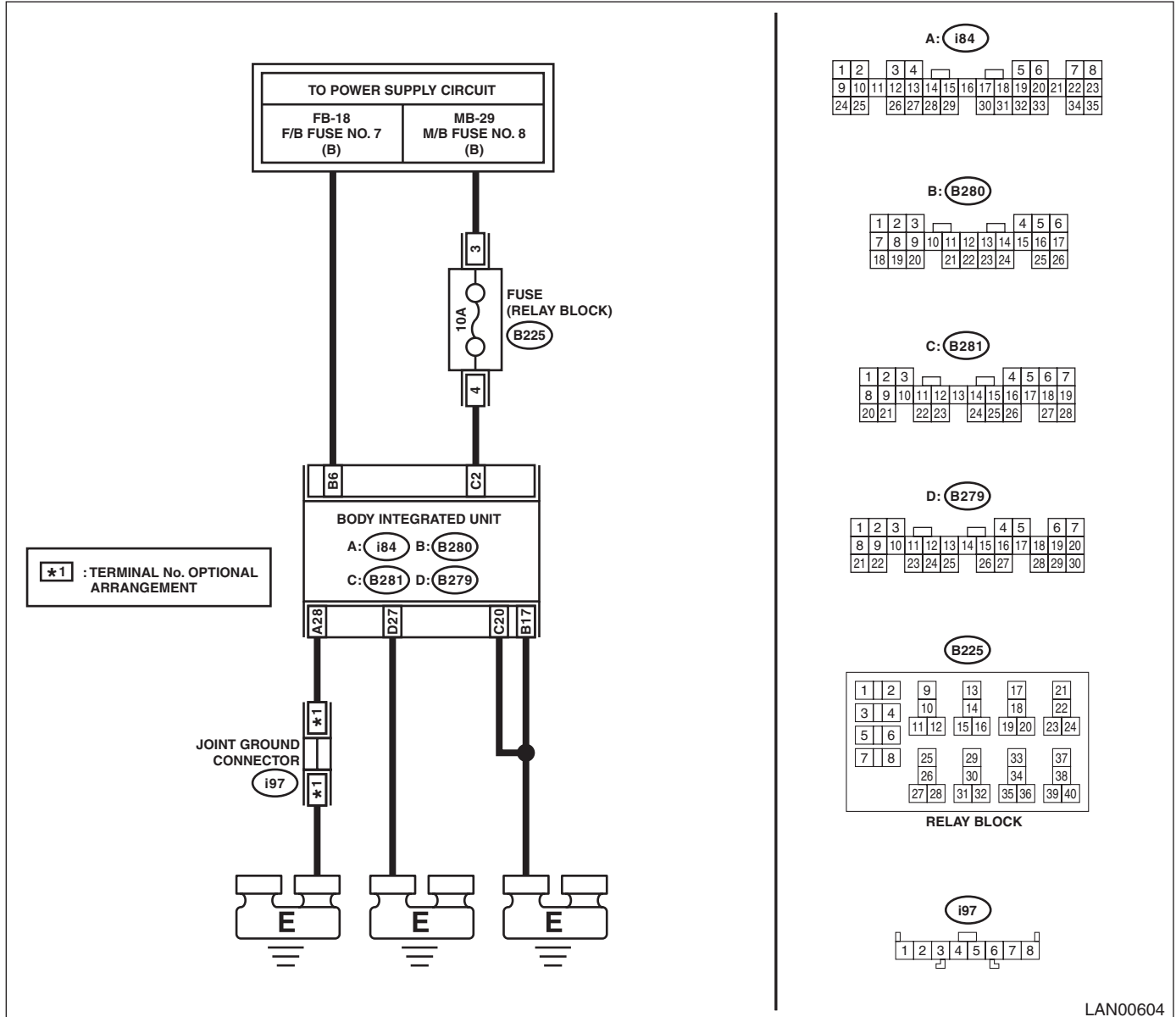

LAN00604

Step	Check	Yes	No	
1	<b>CHECK DTC.</b> Read the DTC of body integrated unit using Subaru Select Monitor. <Ref. to LAN(diag)-14, READ DIAGNOSTIC TROUBLE CODE (DTC), OPERATION, Subaru Select Monitor.>	Is B1101 current malfunction?	Go to step 2.	Go to step 5.

## Diagnostic Procedure with Diagnostic Trouble Code (DTC)

### LAN SYSTEM (DIAGNOSTICS)

Step	Check	Yes	No
<b>2 CHECK DTC.</b> 1) Turn the ignition switch to OFF. 2) Disconnect the connector from body integrated unit and reconnect. 3) Wait approx. 2 minutes. 4) Turn the ignition switch to ON. 5) Read the DTC of body integrated unit using Subaru Select Monitor.	Is B1101 current malfunction?	Go to step 3.	Go to step 5.
<b>3 CHECK FUSE.</b> 1) Turn the ignition switch to OFF. 2) Check the fuse.	Is the fuse OK?	Go to step 4.	Replace the defective fuse.
<b>4 CHECK HARNESS.</b> 1) Disconnect the body integrated unit connector (B280). 2) Measure the voltage between body integrated unit connector and chassis ground using tester.  <i>Connector &amp; terminal (B280) No. 6 (+) — Chassis ground (-):</i>	Is the voltage 8.5 — 16.5 V?	Replace the body integrated unit. <Ref. to SL-48, REMOVAL, Body Integrated Unit.>	Repair or replace the open or shorted circuit between body integrated unit and fuse.
<b>5 CHECK CONNECTOR.</b> 1) Turn the ignition switch to OFF. 2) Disconnect the body integrated unit connector (B280).	Is there poor contact of connector?	Repair or replace the poor contact of connector.	A temporary change of voltage occurred.

# Diagnostic Procedure with Diagnostic Trouble Code (DTC)

LAN SYSTEM (DIAGNOSTICS)

## C: DTC B1102 BATT P/SUPPLY MALFUNCTION BACKUP

### DTC DETECTING CONDITION:

- Open or short of battery power supply backup circuit
- Voltage malfunction caused by poor contact

### TROUBLE SYMPTOM:

No influence.

### NOTE:

- When B1101 BATT p/supply malfunction cont is output at the same time, all function of body integrated unit may not operate.
- B1101 may input when the battery run-out occurs.

### WIRING DIAGRAM:

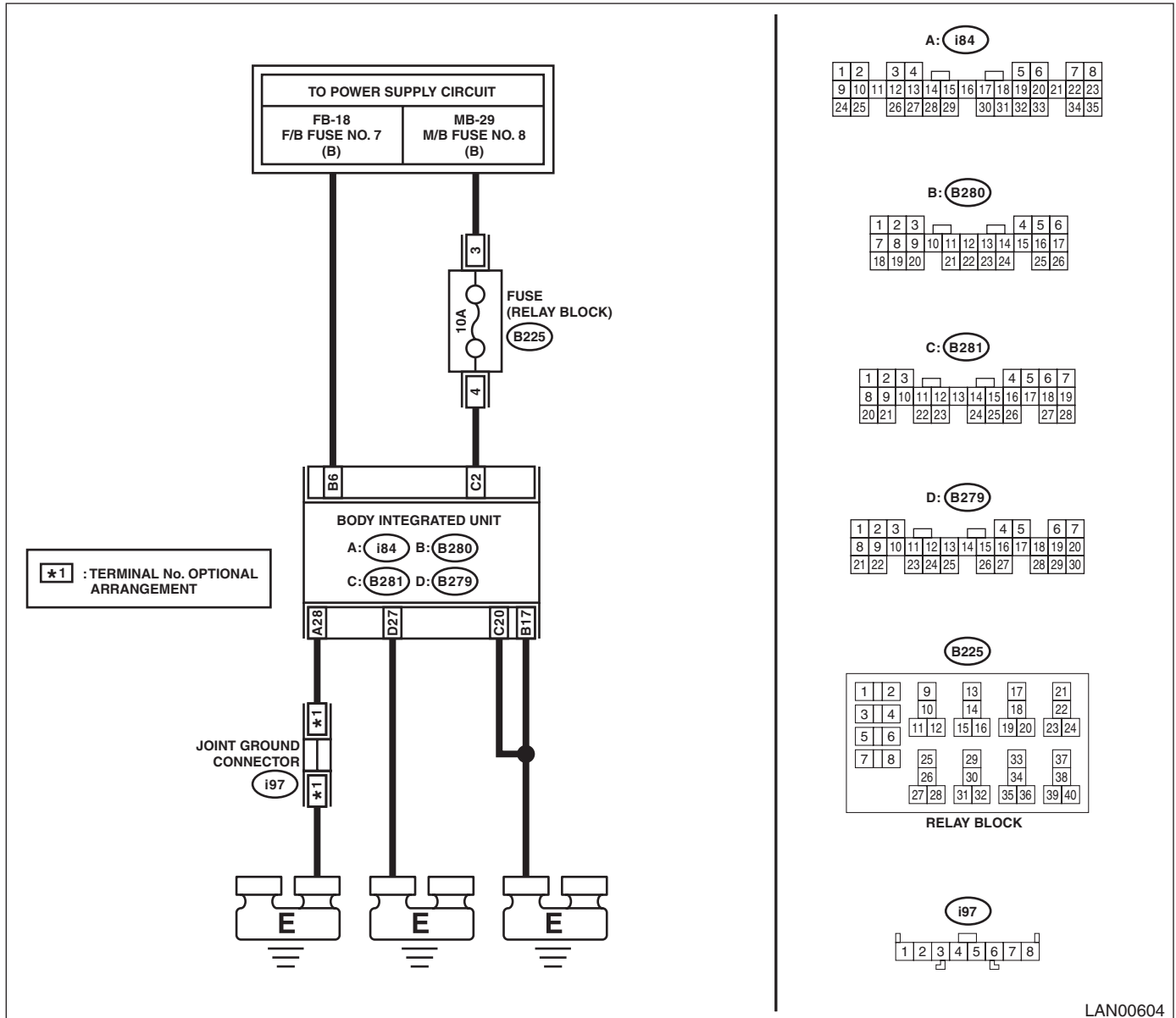

LAN00604

Step	Check	Yes	No
1	<b>CHECK DTC.</b> Read the DTC of body integrated unit using Subaru Select Monitor. <Ref. to LAN(diag)-14, READ DIAGNOSTIC TROUBLE CODE (DTC), OPERATION, Subaru Select Monitor.>	Go to step 2.	Go to step 5.

## Diagnostic Procedure with Diagnostic Trouble Code (DTC)

### LAN SYSTEM (DIAGNOSTICS)

Step	Check	Yes	No
<b>2 CHECK DTC.</b> 1) Turn the ignition switch to OFF. 2) Disconnect the connector from body integrated unit and reconnect. 3) Wait approx. 2 minutes. 4) Turn the ignition switch to ON. 5) Read the DTC of body integrated unit using Subaru Select Monitor.	Is B1102 current malfunction?	Go to step 3.	Go to step 5.
<b>3 CHECK FUSE.</b> 1) Turn the ignition switch to OFF. 2) Check the fuse.	Is the fuse OK?	Go to step 4.	Replace the defective fuse.
<b>4 CHECK HARNESS.</b> 1) Disconnect the body integrated unit connector (B281). 2) Measure the voltage between body integrated unit connector and chassis ground using tester.  <i>Connector &amp; terminal (B281) No. 2 (+) — Chassis ground (-):</i>	Is the voltage 8.5 — 16.5 V?	Replace the body integrated unit. <Ref. to SL-48, REMOVAL, Body Integrated Unit.>	Repair or replace the open or shorted circuit between body integrated unit and fuse.
<b>5 CHECK CONNECTOR.</b> 1) Turn the ignition switch to OFF. 2) Disconnect the body integrated unit connector (B281).	Is there poor contact of connector?	Repair or replace the poor contact of connector.	A temporary change of voltage occurred.

# Diagnostic Procedure with Diagnostic Trouble Code (DTC)

LAN SYSTEM (DIAGNOSTICS)

## D: DTC B1103 IGNITION POWER FAILURE

### DTC DETECTING CONDITION:

- Open or short in IGN power supply circuit
- Voltage malfunction caused by poor contact

### TROUBLE SYMPTOM:

Error related to LAN system will not be detected.

### NOTE:

B1103 may output when the ignition switch turns to ON with the weak battery condition.

### WIRING DIAGRAM:

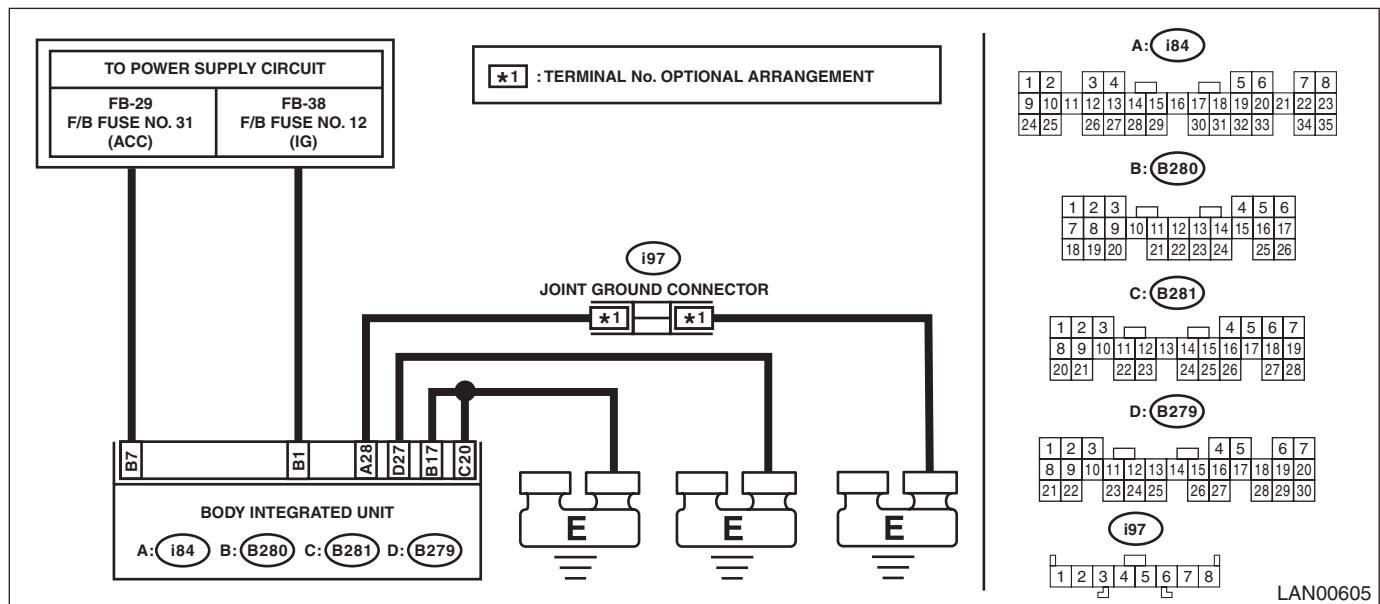

Step	Check	Yes	No
1	<b>CHECK DTC.</b> Read the DTC of body integrated unit using Subaru Select Monitor. <Ref. to LAN(diag)-14, READ DIAGNOSTIC TROUBLE CODE (DTC), OPERATION, Subaru Select Monitor.>	Go to step 2.	Go to step 5.
2	<b>CHECK DTC.</b> 1) Turn the ignition switch to OFF. 2) Disconnect the connector from body integrated unit and reconnect. 3) Turn the ignition switch to ON. 4) Wait approx. 2 minutes. 5) Read the DTC of body integrated unit using Subaru Select Monitor.	Go to step 3.	Go to step 5.
3	<b>CHECK FUSE.</b> 1) Turn the ignition switch to OFF. 2) Check the fuse.	Go to step 4.	Replace the defective fuse.
4	<b>CHECK HARNESS.</b> 1) Disconnect the body integrated unit connector (B280). 2) Turn the ignition switch to ON. 3) Measure the voltage between body integrated unit connector and chassis ground using tester. <b>Connector &amp; terminal</b> <b>(B280) No. 1 (+) — Chassis ground (-):</b>	Replace the body integrated unit. <Ref. to SL-48, REMOVAL, Body Integrated Unit.>	Repair or replace the open or shorted circuit between body integrated unit and fuse.

# Diagnostic Procedure with Diagnostic Trouble Code (DTC)

## LAN SYSTEM (DIAGNOSTICS)

	Step	Check	Yes	No
5	<b>CHECK CONNECTOR.</b> 1) Turn the ignition switch to OFF. 2) Disconnect the body integrated unit connector (B280).	Is there poor contact of connector?	Repair or replace the poor contact of connector.	A temporary change of voltage occurred.

# Diagnostic Procedure with Diagnostic Trouble Code (DTC)

LAN SYSTEM (DIAGNOSTICS)

## E: DTC B1104 ACC POWER FAILURE

### DTC DETECTING CONDITION:

- Open or short in ACC power supply circuit
- Voltage malfunction caused by poor contact

### TROUBLE SYMPTOM:

Does not exist.

### NOTE:

B1104 may output when the ignition switch turns to ACC with the weak battery condition.

### WIRING DIAGRAM:

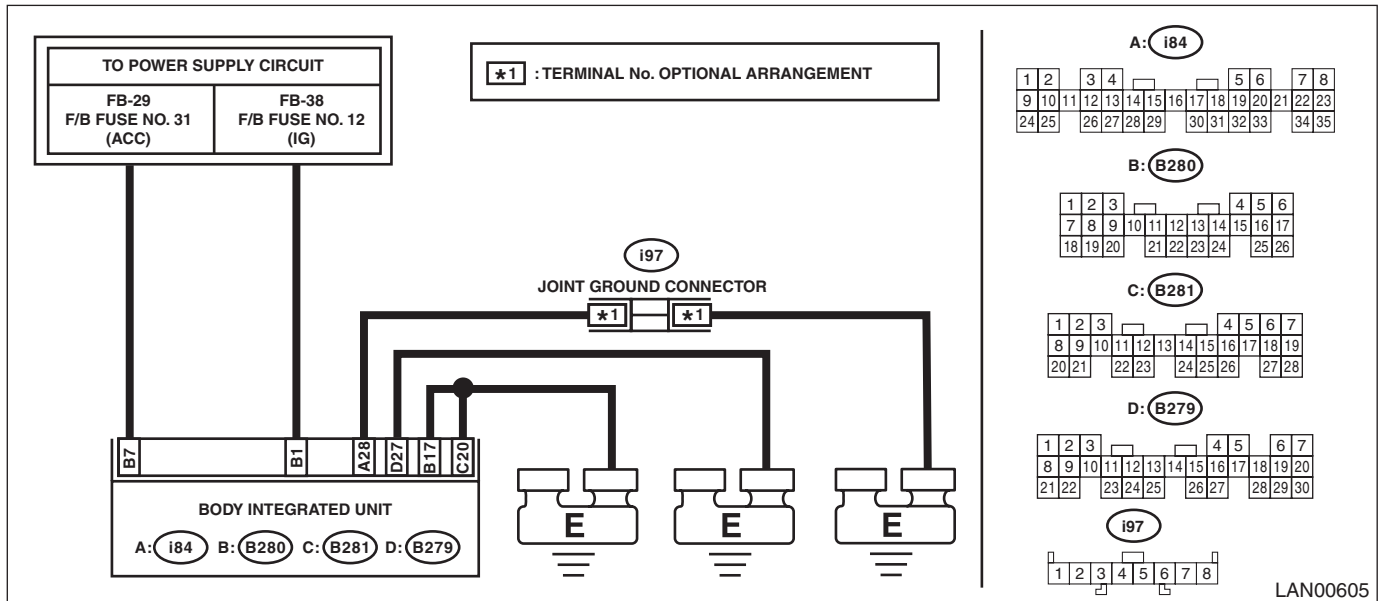

Step	Check	Yes	No
<b>1 CHECK DTC.</b> Read the DTC of body integrated unit using Subaru Select Monitor. <Ref. to LAN(diag)-14, READ DIAGNOSTIC TROUBLE CODE (DTC), OPERATION, Subaru Select Monitor.>	Is B1104 current malfunction?	Go to step 2.	Go to step 5.
<b>2 CHECK DTC.</b> 1) Turn the ignition switch to OFF. 2) Disconnect the connector from body integrated unit and reconnect. 3) Turn the ignition switch to ACC. 4) Wait approx. 2 minutes. 5) Turn the ignition switch to ON. 6) Read the DTC of body integrated unit using Subaru Select Monitor.	Is B1104 current malfunction?	Go to step 3.	Go to step 5.
<b>3 CHECK FUSE.</b> 1) Turn the ignition switch to OFF. 2) Check the fuse.	Is the fuse OK?	Go to step 4.	Replace the defective fuse.
<b>4 CHECK HARNESS.</b> 1) Disconnect the body integrated unit connector (B280). 2) Turn the ignition switch to ACC. 3) Measure the voltage between body integrated unit connector and chassis ground using tester.  <b>Connector &amp; terminal</b> <b>(B280) No. 7 (+) — Chassis ground (-):</b>	Is the voltage 8.5 — 16.5 V?	Replace the body integrated unit. <Ref. to SL-48, REMOVAL, Body Integrated Unit.>	Repair or replace the open or shorted circuit between body integrated unit and fuse.



# Diagnostic Procedure with Diagnostic Trouble Code (DTC)

## LAN SYSTEM (DIAGNOSTICS)

	Step	Check	Yes	No
5	<b>CHECK CONNECTOR.</b> 1) Turn the ignition switch to OFF. 2) Disconnect the body integrated unit connector (B280).	Is there poor contact of connector?	Repair or replace the poor contact of connector.	A temporary change of voltage occurred.

# Diagnostic Procedure with Diagnostic Trouble Code (DTC)

LAN SYSTEM (DIAGNOSTICS)

## F: DTC U1201 CAN-HS COUNTER ABNORMAL

### DTC DETECTING CONDITION:

Communication is unstable because of high speed CAN communication error.

### TROUBLE SYMPTOM:

Malfunction indicator light illuminates.

### WIRING DIAGRAM:

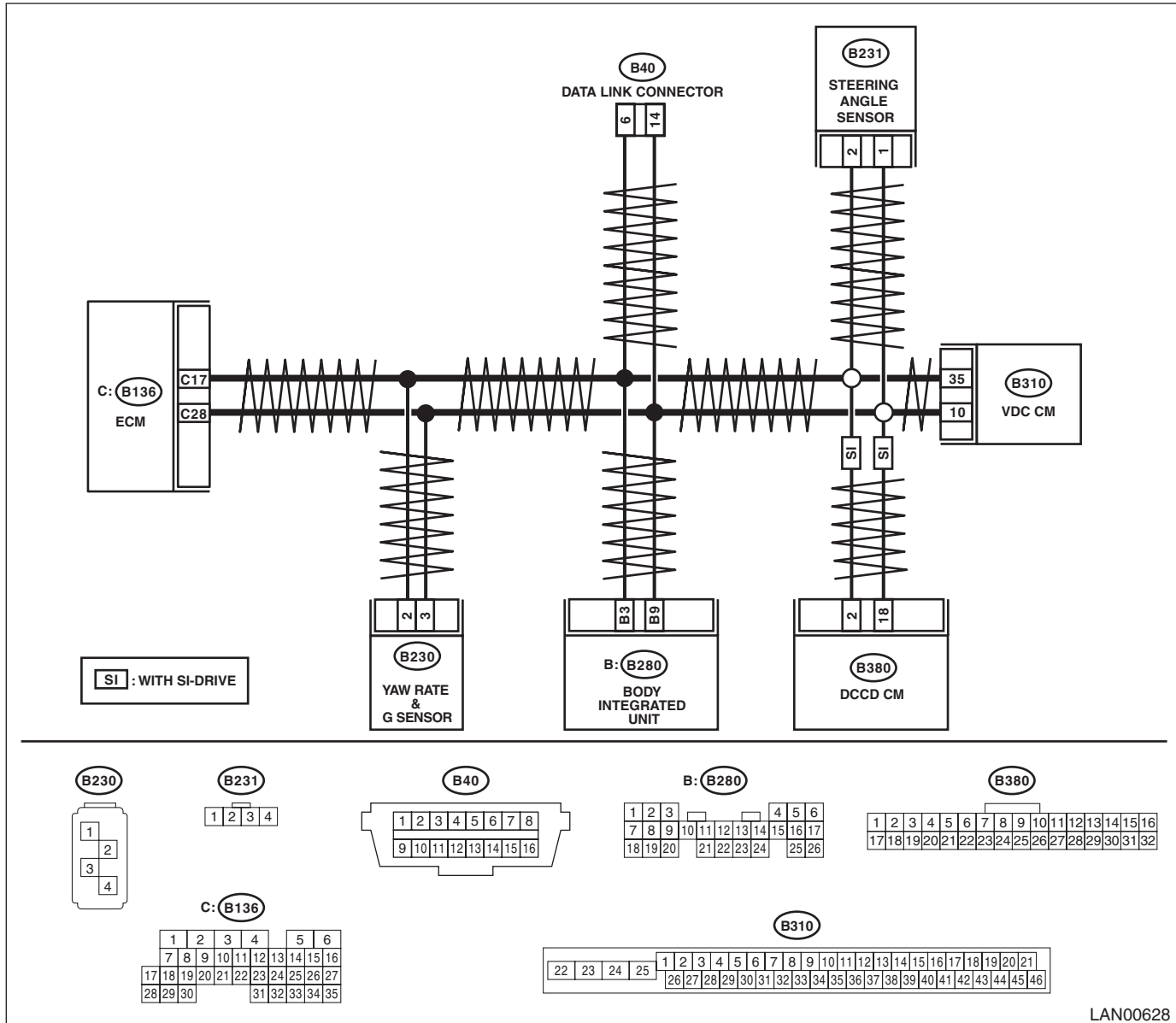

LAN00628

Step	Check	Yes	No	
1	<b>CHECK DTC.</b> Read all DTCs using the Subaru Select Monitor. <Ref. to LAN(diag)-14, READ DIAGNOSTIC TROUBLE CODE (DTC), OPERATION, Subaru Select Monitor.>	Are there U1202 or DTCs other than for the body integrated unit?	Perform the diagnosis according to DTC.	Go to step 2.
2	<b>CHECK DTC.</b> Check DTC indicated by body integrated unit.	Is U1201 a current malfunction?	Go to step 3.	Go to step 14.

# Diagnostic Procedure with Diagnostic Trouble Code (DTC)

## LAN SYSTEM (DIAGNOSTICS)

Step	Check	Yes	No
<b>3</b> <b>CHECK DTC.</b> 1) Turn the ignition switch to OFF. 2) Disconnect all connectors (B280, B310, B136, B230, B231, B380) that are connected to high speed CAN communication line. 3) Connect all the disconnected connectors. 4) Turn the ignition switch to ON. 5) Read the DTC of body integrated unit using Subaru Select Monitor.	Is U1201 a current malfunction?	For models without SI-DRIVE, Go to step 5. For models with SI-DRIVE, Go to step 4.	Go to step 14.
<b>4</b> <b>CHECK DCCD CM.</b> 1) Turn the ignition switch to OFF. 2) Disconnect the DCCD CM connector (B380). 3) Turn the ignition switch to ON. 4) Read the DTC of body integrated unit using Subaru Select Monitor.	Is U1201 a current malfunction?	Go to step 5.	Go to step 16.
<b>5</b> <b>CHECK STEERING ANGLE SENSOR.</b> 1) Turn the ignition switch to OFF. 2) Connect the DCCD CM connector. 3) Disconnect the steering angle sensor connector (B231). 4) Turn the ignition switch to ON. 5) Read the DTC of body integrated unit using Subaru Select Monitor.	Is U1201 a current malfunction?	Go to step 6.	Go to step 17.
<b>6</b> <b>CHECK YAW RATE SENSOR.</b> 1) Turn the ignition switch to OFF. 2) Connect the steering angle sensor connector. 3) Disconnect the yaw rate sensor connector (B230). 4) Turn the ignition switch to ON. 5) Read the DTC of body integrated unit using Subaru Select Monitor.	Is U1201 a current malfunction?	Go to step 7.	Go to step 18.
<b>7</b> <b>CHECK VDC/ABS CM.</b> 1) Turn the ignition switch to OFF. 2) Connect the yaw rate sensor connector. 3) Disconnect the VDC/ABS CM connector (B310). 4) Install the 120 $\Omega$ resistance to VDC/ABS CM connector terminals. <b>Terminals</b> <b>(B310) No. 10 — No. 35:</b> 5) Using the tester, measure the resistance between terminals of data link connector. <b>Terminals</b> <b>(B40) No. 6 — No. 14:</b>	Is the resistance 60 $\Omega$ ?	Go to step 8.	Go to step 10.
<b>8</b> <b>CHECK DTC.</b> 1) Turn the ignition switch to ON. 2) Read the DTC of body integrated unit using Subaru Select Monitor.	Is U1201 a current malfunction?	Go to step 9.	Go to step 10.
<b>9</b> <b>CHECK DTC.</b> Read the DTC of body integrated unit using Subaru Select Monitor.	Is U1202 a current malfunction?	Replace the VDC/ABS CM. <Ref. to VDC-8, REMOVAL, VDC Control Module and Hydraulic Control Unit (VDCCM&H/U).>	Go to step 10.

# Diagnostic Procedure with Diagnostic Trouble Code (DTC)

LAN SYSTEM (DIAGNOSTICS)

Step	Check	Yes	No
<b>10 CHECK ECM.</b> 1) Turn the ignition switch to OFF. 2) Connect the VDC/ABS CM. 3) Disconnect the ECM connector (B136). 4) Install the 120 Ω resistance to ECM connector. <b>Terminals</b> <b>(B136) No. 17 — No. 28:</b> 5) Using the tester, measure the resistance between terminals of data link connector. <b>Connector &amp; terminal</b> <b>(B40) No. 6 — No. 14:</b>	Is the resistance 60 Ω?	Go to step 11.	Repair or replace the open circuit of harness.
<b>11 CHECK DTC.</b> 1) Turn the ignition switch to ON. 2) Read the DTC of body integrated unit using Subaru Select Monitor.	Is U1201 a current malfunction?	Go to step 12.	Go to step 13.
<b>12 CHECK DTC.</b> Read the DTC of body integrated unit using Subaru Select Monitor.	Is U1202 a current malfunction?	Replace the ECM. <Ref. to FU(STI)-59, REMOVAL, Engine Control Module (ECM).> <Ref. to FU(w/o STI)-58, REMOVAL, Engine Control Module (ECM).>	Go to step 13.
<b>13 CHECK DTC.</b> 1) Turn the ignition switch to OFF. 2) Reconnect all the disconnected connectors. 3) Turn the ignition switch to ON. 4) Read the DTC of body integrated unit using Subaru Select Monitor.	Is U1201 a current malfunction?	Replace the body integrated unit. <Ref. to SL-48, REMOVAL, Body Integrated Unit.>	Go to step 14.
<b>14 CHECK HARNESS.</b> 1) Shake the instrument harness and bulkhead harness, rear harness. 2) Read the DTC of body integrated unit using Subaru Select Monitor.	Is U1201 a current malfunction?	Repair or replace the harness.	Go to step 15.
<b>15 CHECK CONNECTOR.</b> 1) Disconnect the connector used for CAN circuit. 2) Check the connector terminal.	Is there poor contact of connector terminal?	Repair the connector terminal where poor contact exists, or replace harness.	It is possible that temporary poor communication occurs.
<b>16 CHECK HARNESS.</b> Using the tester, check the open, short (power supply-output short, GND-output short) in the harness between data link connector and DCCD CM terminals. <b>Connector &amp; terminal</b> <b>(B40) No. 14 — (B380) No. 18:</b> <b>(B40) No. 6 — (B380) No. 2:</b>	Is harness normal?	Replace the DCCD CM. <Ref. to 6MT-119, REMOVAL, Driver's Control Center Differential Control Module.>	Repair or replace the harness.
<b>17 CHECK HARNESS.</b> Using the tester, check for open or short (power supply-output short, GND-output short) in the harness between terminals of data link connector and steering angle sensor. <b>Connector &amp; terminal</b> <b>(B40) No. 14 — (B231) No. 1:</b> <b>(B40) No. 6 — (B231) No. 2:</b>	Is harness normal?	Replace the steering angle sensor. <Ref. to VDC-22, REPLACEMENT, Steering Angle Sensor.>	Repair or replace the harness.

# Diagnostic Procedure with Diagnostic Trouble Code (DTC)

## LAN SYSTEM (DIAGNOSTICS)

Step	Check	Yes	No
<b>18</b> <b>CHECK HARNESS.</b> Using the tester, check for open or short (power supply-output short, GND-output short) in the harness between terminals of data link connector and yaw rate sensor. <b>Connector &amp; terminal</b> <b>(B40) No. 14 — (B230) No. 3:</b> <b>(B40) No. 6 — (B230) No. 2:</b>	Is harness normal?	Replace the yaw rate sensor. <Ref. to VDC-20, REMOVAL, Yaw Rate and G Sensor.>	Repair or replace the harness.

# Diagnostic Procedure with Diagnostic Trouble Code (DTC)

LAN SYSTEM (DIAGNOSTICS)

## G: DTC U1202 CAN-HS BUS OFF

### DTC DETECTING CONDITION:

Integrated unit communication is shut down because of high speed CAN error.

### TROUBLE SYMPTOM:

Each warning light illuminates because the CAN communication (sending and receiving) is not normal.

### WIRING DIAGRAM:

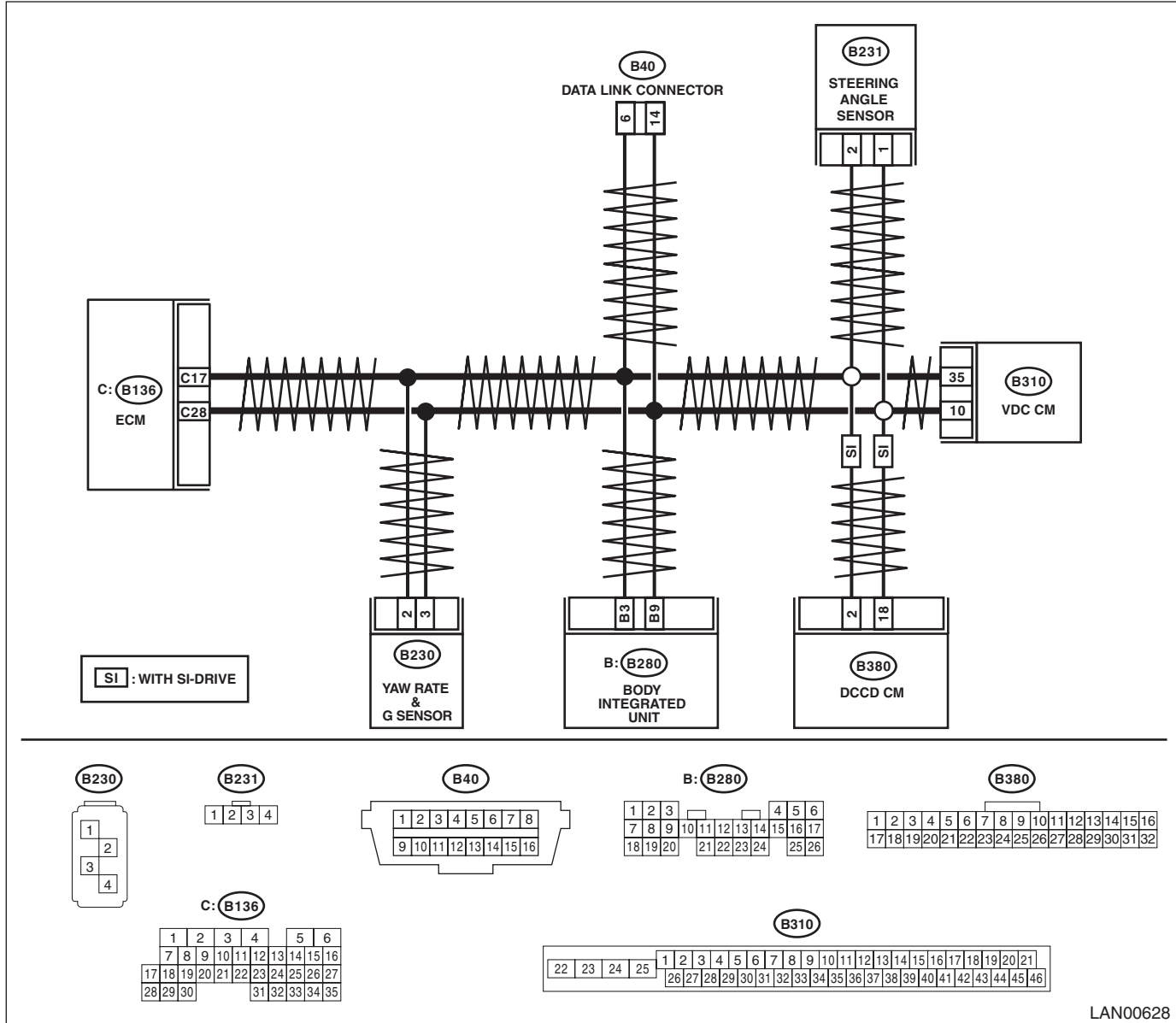

Step	Check	Yes	No
1	<b>CHECK DTC.</b> Using the Subaru Select Monitor, confirm all DTCs. <Ref. to LAN(diag)-14, READ DIAGNOSTIC TROUBLE CODE (DTC), OPERATION, Subaru Select Monitor.>	Perform the diagnosis according to displayed DTC.	Go to step 2.
2	<b>CHECK DTC.</b> 1) Turn the ignition switch to OFF → ON. 2) Read the DTC of body integrated unit using Subaru Select Monitor.	Go to step 3.	Go to step 10.

# Diagnostic Procedure with Diagnostic Trouble Code (DTC)

## LAN SYSTEM (DIAGNOSTICS)

Step	Check	Yes	No
<b>3</b> <b>CHECK DTC.</b> 1) Turn the ignition switch to OFF. 2) Disconnect all control module connectors (B280, B310, B136, B230, B231, B380) that are connected to high speed CAN communication line. 3) Connect the disconnected connectors. 4) Turn the ignition switch to ON. 5) Read the DTC of body integrated unit using Subaru Select Monitor.	Is U1202 a current malfunction?	Go to step 4.	Go to step 10.
<b>4</b> <b>CHECK HARNESS.</b> 1) Turn the ignition switch to OFF. 2) Disconnect all control module connectors (B280, B310, B136, B230, B231, B380) that are connected to high speed CAN communication line. 3) Using the tester, check for open, short (power supply-output short, GND-output short) in the harness.  <b>Connector &amp; terminal</b> (B40) No. 6 — (B136) No. 17: (B40) No. 6 — (B310) No. 35: (B40) No. 6 — (B230) No. 2: (B40) No. 6 — (B231) No. 2: (B40) No. 6 — (B380) No. 2 (with SI-DRIVE): (B40) No. 6 — (B280) No. 3:	Is harness normal?	Go to step 5.	Repair or replace the harness.
<b>5</b> <b>CHECK HARNESS.</b> Using the tester, check for open, short (power supply-output short, GND-output short) in the harness.  <b>Connector &amp; terminal</b> (B40) No. 14 — (B136) No. 28: (B40) No. 14 — (B310) No. 10: (B40) No. 14 — (B230) No. 3: (B40) No. 14 — (B231) No. 1: (B40) No. 14 — (B380) No. 18 (with SI-DRIVE): (B40) No. 14 — (B280) No. 9:	Is harness normal?	Go to step 6.	Repair or replace the harness.
<b>6</b> <b>CHECK ECM.</b> 1) Connect the ECM. 2) Using the tester, measure the resistance between terminals of data link connector.  <b>Connector &amp; terminal</b> (B40) No. 6 — No. 14:	Is the resistance $120 \pm 5 \Omega$ ?	Go to step 7.	Replace the ECM. <Ref. to FU(STI)-59, REMOVAL, Engine Control Module (ECM).> <Ref. to FU(w/o STI)-58, REMOVAL, Engine Control Module (ECM).>
<b>7</b> <b>CHECK VDC/ABS CM.</b> 1) Disconnect the ECM connector (B136). 2) Connect the VDC/ABS CM. 3) Using the tester, measure the resistance between terminals of data link connector.  <b>Connector &amp; terminal</b> (B40) No. 6 — No. 14:	Is the resistance $120 \pm 5 \Omega$ ?	Go to step 8.	Replace the VDC/ABS CM. <Ref. to VDC-8, REMOVAL, VDC Control Module and Hydraulic Control Unit (VDCCM&H/U).>

# Diagnostic Procedure with Diagnostic Trouble Code (DTC)

LAN SYSTEM (DIAGNOSTICS)

Step	Check	Yes	No
<b>8</b> <b>CHECK HARNESS.</b> 1) Connect the disconnected connectors. 2) Using the tester, measure the resistance between terminals of data link connector and chassis ground. <b>Connector &amp; terminal</b> <b>(B40) No. 6 — Chassis ground:</b> <b>(B40) No. 14 — Chassis ground:</b>	Is the resistance 1 M $\Omega$ or more?	Go to step 9.	Go to step 12.
<b>9</b> <b>CHECK HARNESS.</b> 1) Turn the ignition switch to ON. 2) Using the tester, measure the voltage between terminals of data link connector and chassis ground. <b>Connector &amp; terminal</b> <b>(B40) No. 6 (+) — Chassis ground (-):</b> <b>(B40) No. 14 (+) — Chassis ground (-):</b>	Is the voltage less than 6 V?	Replace the body integrated unit. <Ref. to SL-48, REMOVAL, Body Integrated Unit.>	Go to step 13.
<b>10</b> <b>CHECK HARNESS.</b> 1) Shake the harness. 2) Read the DTC of body integrated unit using Subaru Select Monitor.	Is U1202 a current malfunction?	Repair or replace the harness.	Go to step 11.
<b>11</b> <b>CHECK CONNECTOR.</b> Disconnect the connector used for high speed CAN circuit.	Is there poor contact of connector terminal?	Repair the connector terminal, or replace harness.	It is possible that temporary poor communication occurs.
<b>12</b> <b>CHECK CONTROL MODULE.</b> With the tester connected, disconnect each control module connector.	Is there any control module whose resistance has changed?	Replace the control module whose resistance has changed.	Repair or replace the open or short circuit of the harness.
<b>13</b> <b>CHECK CONTROL MODULE.</b> With the tester connected, disconnect each control module connector.	Is there any control module whose voltage has changed?	Replace the control module whose voltage has changed.	Repair or replace the short circuit of the harness.



# Diagnostic Procedure with Diagnostic Trouble Code (DTC)

LAN SYSTEM (DIAGNOSTICS)

## H: DTC U1211 CAN-HS ECM DATA ABNORMAL

### DTC DETECTING CONDITION:

Received error data from ECM.

### TROUBLE SYMPTOM:

It is possible that engine control error may occur.

### WIRING DIAGRAM:

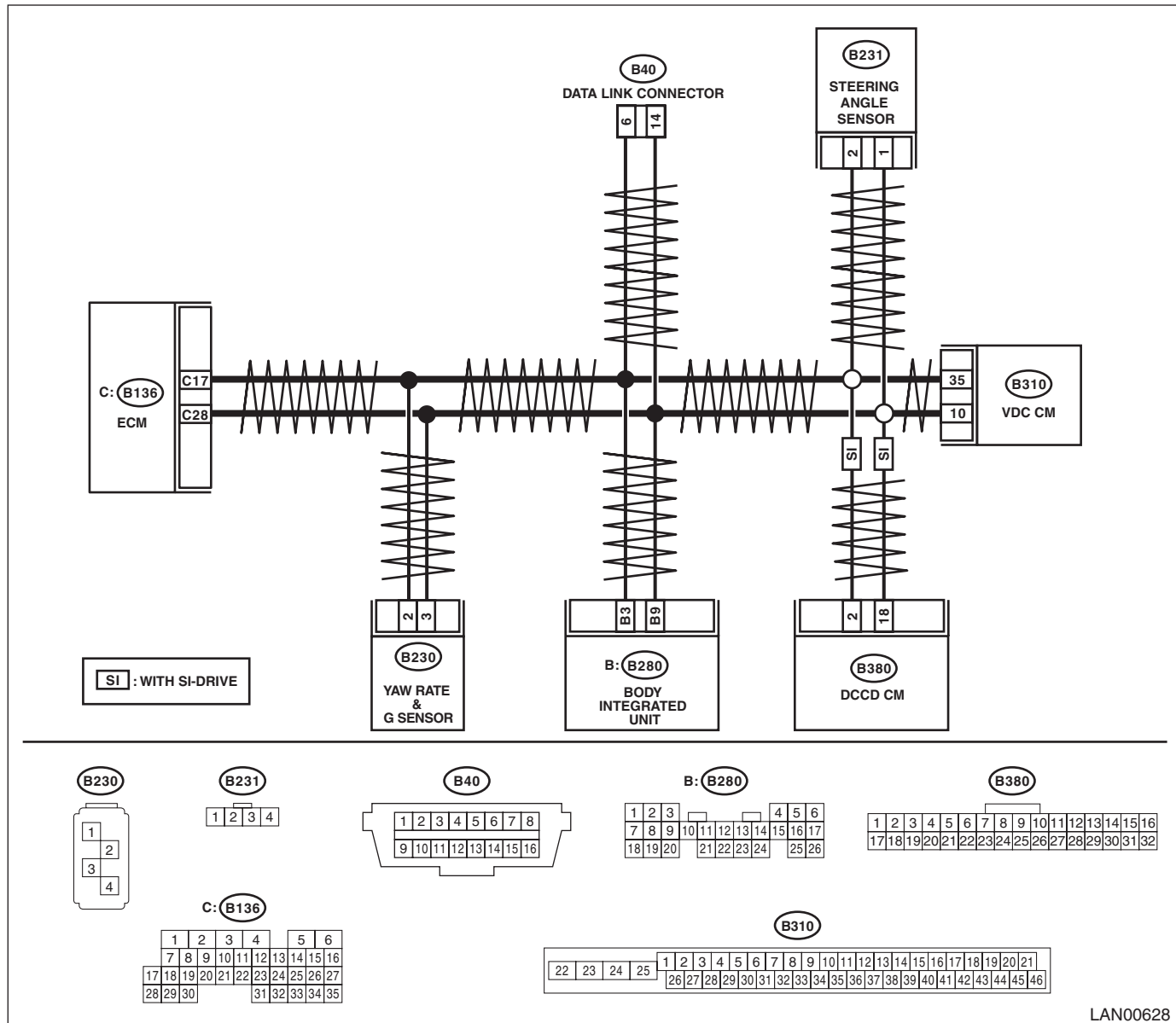

Step	Check	Yes	No	
1	<b>CHECK DTC.</b> Read all DTCs using the Subaru Select Monitor. <Ref. to LAN(diag)-14, READ DIAGNOSTIC TROUBLE CODE (DTC), OPERATION, Subaru Select Monitor.>	Is there DTC U1202?	Perform the diagnosis according to DTC.	Go to step 2.
2	<b>CHECK DTC.</b> Read the DTC of body integrated unit using Subaru Select Monitor.	Is U1211 a current malfunction?	Go to step 3.	Go to step 4.

# Diagnostic Procedure with Diagnostic Trouble Code (DTC)

LAN SYSTEM (DIAGNOSTICS)

Step	Check	Yes	No
<b>3</b> <b>CHECK ECM.</b> 1) Turn the ignition switch to OFF. 2) Disconnect the connector from ECM. 3) Connect the disconnected connectors. 4) Turn the ignition switch to ON. 5) Read the DTC of body integrated unit using Subaru Select Monitor.	Is U1211 a current malfunction?	Replace the ECM. <Ref. to FU(STI)-59, REMOVAL, Engine Control Module (ECM).> <Ref. to FU(w/o STI)-58, REMOVAL, Engine Control Module (ECM).>	Go to step 4.
<b>4</b> <b>CHECK HARNESS.</b> 1) Turn the ignition switch to OFF. 2) Shake the harness used for CAN communication circuit. 3) Turn the ignition switch to ON. 4) Read the DTC of body integrated unit using Subaru Select Monitor.	Is U1211 a current malfunction?	Repair the poor contact or temporary open circuit of harness.	Go to step 5.
<b>5</b> <b>CHECK CONNECTOR.</b> 1) Turn the ignition switch to OFF. 2) Disconnect the connector that is connected to high speed CAN circuit.	Is there poor contact of connector?	Repair the connector terminal where poor contact exists, or replace harness.	It is possible that temporary poor communication occurs.

# Diagnostic Procedure with Diagnostic Trouble Code (DTC)

LAN SYSTEM (DIAGNOSTICS)

## I: DTC U1213 CAN-HS VDC/ABS DATA ABNORMAL

### DTC DETECTING CONDITION:

Received error data from VDC/ABS CM.

### TROUBLE SYMPTOM:

It is possible that brake control error may occur.

### WIRING DIAGRAM:

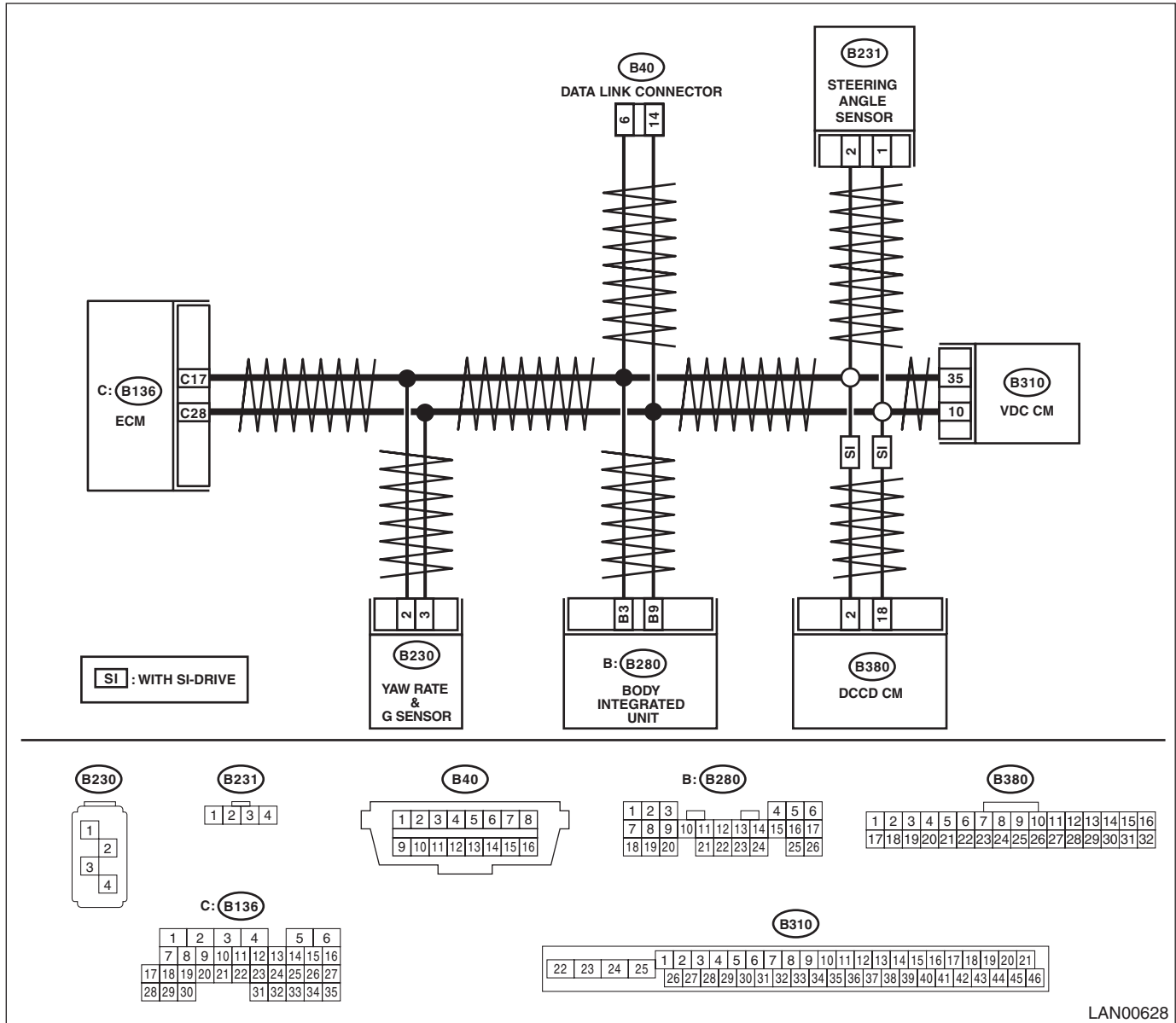

Step	Check	Yes	No	
1	<b>CHECK DTC.</b> Read all DTCs using the Subaru Select Monitor. <Ref. to LAN(diag)-14, READ DIAGNOSTIC TROUBLE CODE (DTC), OPERATION, Subaru Select Monitor.>	Is there DTC U1202?	Perform the diagnosis according to DTC.	Go to step 2.
2	<b>CHECK DTC.</b> Read the DTC of body integrated unit using Subaru Select Monitor.	Is U1213 a current malfunction?	Go to step 3.	Go to step 4.

# Diagnostic Procedure with Diagnostic Trouble Code (DTC)

LAN SYSTEM (DIAGNOSTICS)

Step	Check	Yes	No
<b>3</b> <b>CHECK DTC.</b> 1) Turn the ignition switch to OFF. 2) Disconnect the VDC/ABS CM connector. 3) Connect the disconnected connectors. 4) Turn the ignition switch to ON. 5) Read the DTC of body integrated unit using Subaru Select Monitor.	Is U1213 a current malfunction?	Replace the VDC/ABS CM. <Ref. to VDC-8, REMOVAL, VDC Control Module and Hydraulic Control Unit (VDCCM&H/U).>	Go to step 4.
<b>4</b> <b>CHECK HARNESS.</b> 1) Turn the ignition switch to OFF. 2) Shake the harness used for CAN communication circuit. 3) Turn the ignition switch to ON. 4) Read the DTC of body integrated unit using Subaru Select Monitor.	Is U1213 a current malfunction?	Repair or replace the harness.	Go to step 5.
<b>5</b> <b>CHECK CONNECTOR.</b> 1) Turn the ignition switch to OFF. 2) Disconnect the connector that is connected to high speed CAN circuit.	Is there poor contact of connector terminal?	Repair the connector terminal, or replace harness.	It is possible that temporary poor communication occurs.

# Diagnostic Procedure with Diagnostic Trouble Code (DTC)

LAN SYSTEM (DIAGNOSTICS)

## J: DTC U1216 HIGH-SPEED CAN (DCCD) DATA ERROR

### DTC DETECTING CONDITION:

Received error data from DCCD CM.

### TROUBLE SYMPTOM:

DCCD indicator blinks.

### WIRING DIAGRAM:

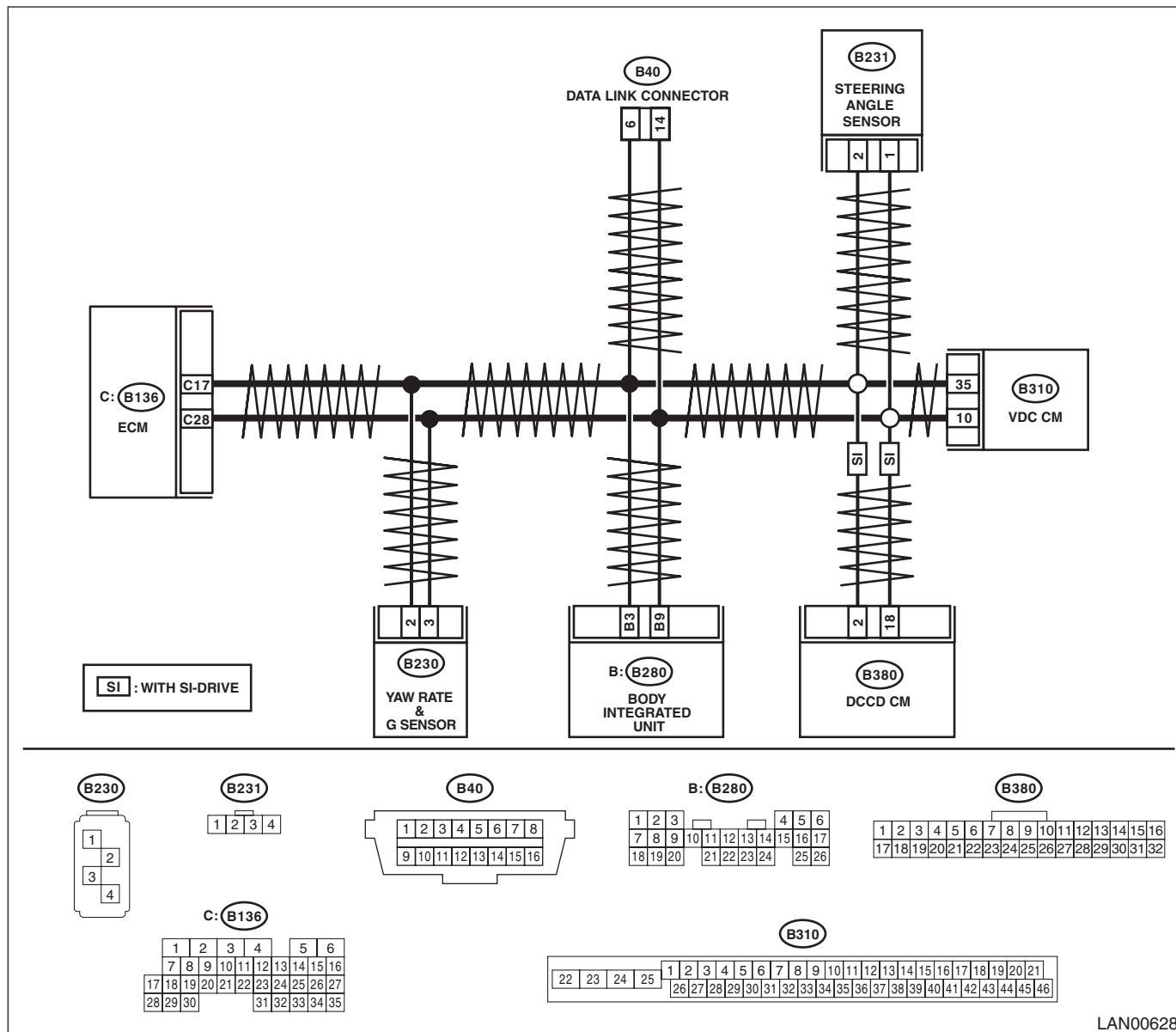

LAN00628

Step	Check	Yes	No
1	<b>CHECK DTC.</b> Read all DTCs using the Subaru Select Monitor. <Ref. to LAN(diag)-14, READ DIAGNOSTIC TROUBLE CODE (DTC), OPERATION, Subaru Select Monitor.>	Is there DTC U1202?	Perform the diagnosis according to DTC. Go to step 2.
2	<b>CHECK DTC.</b> Read the DTC of body integrated unit using Subaru Select Monitor.	Is U1216 a current malfunction?	Go to step 3. Go to step 4.

# Diagnostic Procedure with Diagnostic Trouble Code (DTC)

LAN SYSTEM (DIAGNOSTICS)

Step	Check	Yes	No
<b>3</b> <b>CHECK DTC.</b> 1) Turn the ignition switch to OFF. 2) Disconnect the DCCD CM connector. 3) Connect the disconnected connectors. 4) Turn the ignition switch to ON. 5) Read the DTC of body integrated unit using Subaru Select Monitor.	Is U1216 a current malfunction?	Replace the DCCD CM. <Ref. to 6MT-119, REMOVAL, Driver's Control Center Differential Control Module.>	Go to step 4.
<b>4</b> <b>CHECK HARNESS.</b> 1) Turn the ignition switch to OFF. 2) Shake the harness used for CAN communication circuit. 3) Turn the ignition switch to ON. 4) Read the DTC of body integrated unit using Subaru Select Monitor.	Is U1216 a current malfunction?	Repair or replace the harness.	Go to step 5.
<b>5</b> <b>CHECK CONNECTOR.</b> 1) Turn the ignition switch to OFF. 2) Disconnect the connector that is connected to high speed CAN circuit.	Is there poor contact of connector terminal?	Repair the connector terminal, or replace harness.	Temporary poor contact occurs.

# Diagnostic Procedure with Diagnostic Trouble Code (DTC)

LAN SYSTEM (DIAGNOSTICS)

## K: DTC U1221 CAN-HS ECM NO-RECEIVE DATA

### DTC DETECTING CONDITION:

Not received data from ECM.

### TROUBLE SYMPTOM:

Malfunction indicator light illuminates.

### WIRING DIAGRAM:

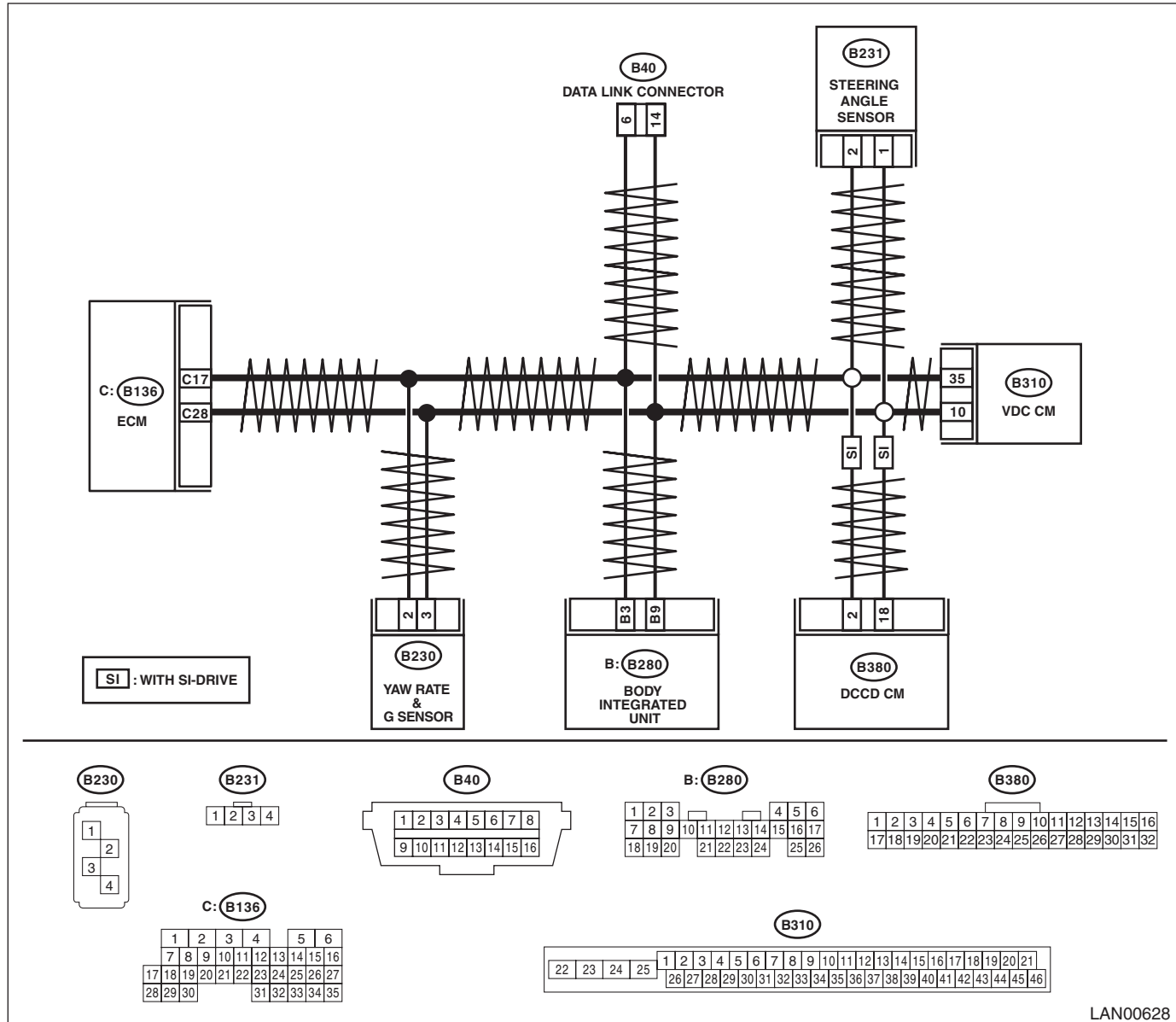

Step	Check	Yes	No	
1	<b>CHECK DTC.</b> Read all DTCs using the Subaru Select Monitor. <Ref. to LAN(diag)-14, READ DIAGNOSTIC TROUBLE CODE (DTC), OPERATION, Subaru Select Monitor.>	Is there DTC U1202?	Perform the diagnosis according to DTC.	Go to step 2.
2	<b>CHECK DTC.</b> Read the DTC of body integrated unit using Subaru Select Monitor.	Is U1221 a current malfunction?	Go to step 3.	Go to step 8.

# Diagnostic Procedure with Diagnostic Trouble Code (DTC)

LAN SYSTEM (DIAGNOSTICS)

Step	Check	Yes	No
<b>3</b> <b>CHECK DTC.</b> 1) Turn the ignition switch to OFF. 2) Disconnect all control module connectors (B280, B310, B136, B230, B231, B380) that are connected to high speed CAN communication line. 3) Connect the disconnected connectors. 4) Turn the ignition switch to ON. 5) Read the DTC of body integrated unit using Subaru Select Monitor.	Is U1221 a current malfunction?	Go to step 4.	Go to step 8.
<b>4</b> <b>CHECK HARNESS.</b> 1) Turn the ignition switch to OFF. 2) Disconnect all control module connectors (B280, B310, B136, B230, B231, B380) that are connected to high speed CAN communication line. 3) Using the tester, check for open, short (power supply-output short, GND-output short) in the harness. <b>Connector &amp; terminal</b> (B40) No. 6 — (B136) No. 17: (B40) No. 6 — (B310) No. 35: (B40) No. 6 — (B230) No. 2: (B40) No. 6 — (B231) No. 2: (B40) No. 6 — (B380) No. 2 (with SI-DRIVE): (B40) No. 6 — (B280) No. 3:	Is harness normal?	Go to step 5.	Repair or replace the harness.
<b>5</b> <b>CHECK HARNESS.</b> Using the tester, check for open, short (power supply-output short, GND-output short) in the harness. <b>Connector &amp; terminal</b> (B40) No. 14 — (B136) No. 28: (B40) No. 14 — (B310) No. 10: (B40) No. 14 — (B230) No. 3: (B40) No. 14 — (B231) No. 1: (B40) No. 14 — (B380) No. 18 (with SI-DRIVE): (B40) No. 14 — (B280) No. 9:	Is harness normal?	Go to step 6.	Repair or replace the harness.
<b>6</b> <b>CHECK DTC.</b> 1) Turn the ignition switch to OFF. 2) Connect the disconnected connectors. 3) Start the engine and stop. 4) Turn the ignition switch to ON. 5) Read the DTC of body integrated unit using Subaru Select Monitor.	Is U1221 a current malfunction?	Go to step 7.	Go to step 8.
<b>7</b> <b>CHECK DTC.</b> Read all DTCs using the Subaru Select Monitor.	Is DTC C0047 detected?	Replace the ECM. <Ref. to FU(STI)-59, REMOVAL, Engine Control Module (ECM).> <Ref. to FU(w/o STI)-58, REMOVAL, Engine Control Module (ECM).>	Replace the body integrated unit. <Ref. to SL-48, REMOVAL, Body Integrated Unit.>



# Diagnostic Procedure with Diagnostic Trouble Code (DTC)

## LAN SYSTEM (DIAGNOSTICS)

Step	Check	Yes	No
<b>8</b> <b>CHECK HARNESS.</b> 1) Turn the ignition switch to OFF. 2) Shake the harness used for CAN communication circuit. 3) Turn the ignition switch to ON. 4) Read the DTC of body integrated unit using Subaru Select Monitor.	Is U1221 a current malfunction?	Repair or replace the harness.	Go to step 9.
<b>9</b> <b>CHECK CONNECTOR.</b> 1) Turn the ignition switch to OFF. 2) Disconnect all the connector that is connected to high speed CAN circuit.	Is there poor contact of connector terminal?	Repair the connector terminal where poor contact exists, or replace harness.	Temporary communication failure occurs.

# Diagnostic Procedure with Diagnostic Trouble Code (DTC)

LAN SYSTEM (DIAGNOSTICS)

## L: DTC U1223 CAN-HS VDC/ABS NO-RECEIVE DATA

### DTC DETECTING CONDITION:

Not received data from VDC/ABS CM.

### TROUBLE SYMPTOM:

ABS warning light and VDC warning light illuminate.

### WIRING DIAGRAM:

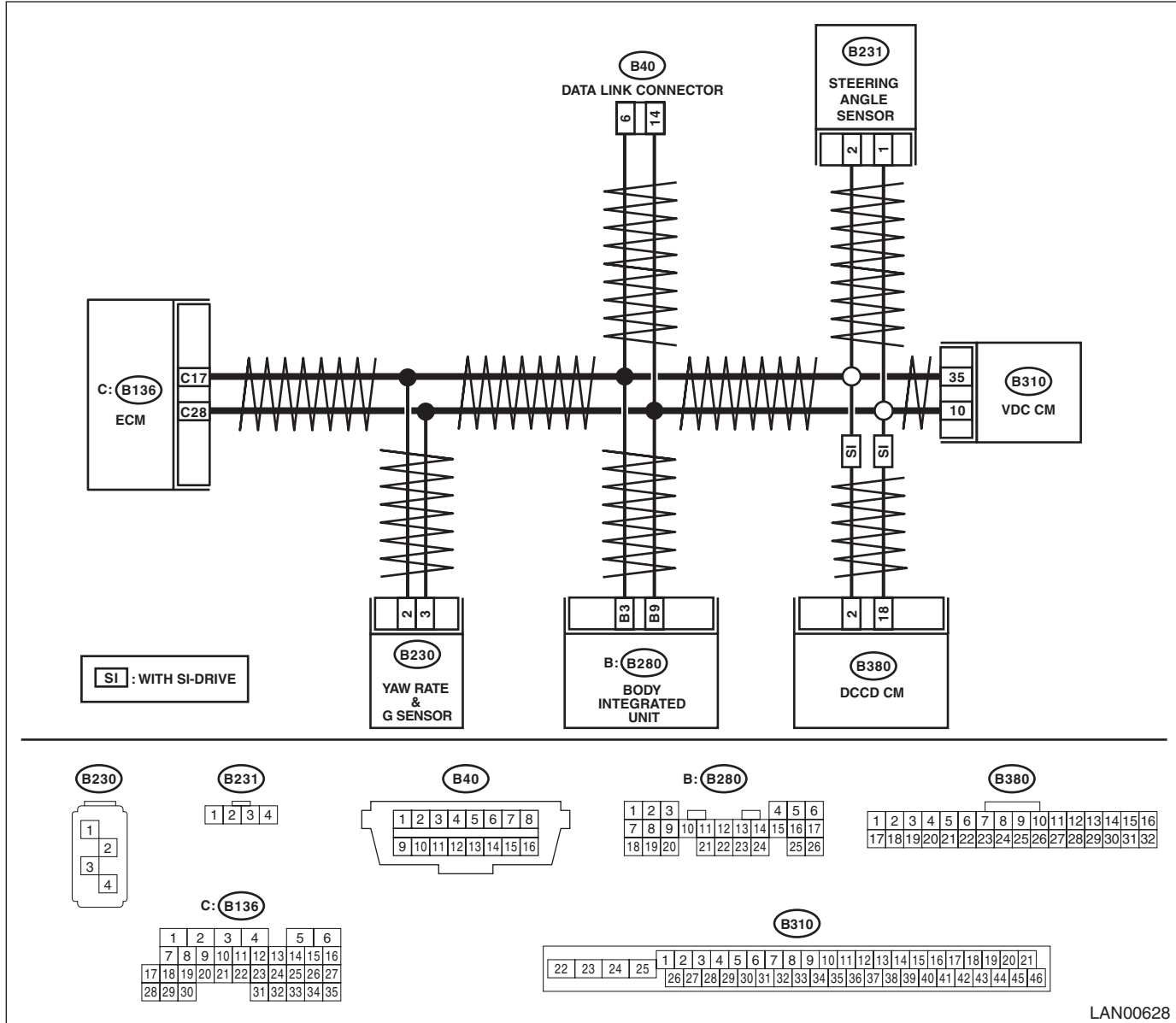

Step	Check	Yes	No
1	<b>CHECK DTC.</b> Read all DTCs using the Subaru Select Monitor. <Ref. to LAN(diag)-14, READ DIAGNOSTIC TROUBLE CODE (DTC), OPERATION, Subaru Select Monitor.>	Is there DTC U1202?	Perform the diagnosis according to DTC. Go to step 2.
2	<b>CHECK DTC.</b> Read the DTC of body integrated unit using Subaru Select Monitor.	Is U1223 a current malfunction?	Go to step 3. Go to step 7.

# Diagnostic Procedure with Diagnostic Trouble Code (DTC)

## LAN SYSTEM (DIAGNOSTICS)

Step	Check	Yes	No
<b>3</b> <b>CHECK DTC.</b> 1) Turn the ignition switch to OFF. 2) Disconnect all connectors (B280, B310, B136, B230, B231, B380) that are connected to high speed CAN communication line. 3) Connect the disconnected connectors. 4) Turn the ignition switch to ON. 5) Read the DTC of body integrated unit using Subaru Select Monitor.	Is U1223 a current malfunction?	Go to step 4.	Go to step 7.
<b>4</b> <b>CHECK HARNESS.</b> 1) Turn the ignition switch to OFF. 2) Disconnect all connectors (B280, B310, B136, B230, B231, B380) that are connected to high speed CAN communication line. 3) Using the tester, check for open, short (power supply-output short, GND-output short) in the harness. <b>Connector &amp; terminal</b> <b>(B40) No. 6 — (B310) No. 35:</b> <b>(B40) No. 14 — (B310) No. 10:</b>	Is harness normal?	Go to step 5.	Repair or replace the harness.
<b>5</b> <b>CHECK DTC.</b> 1) Connect the disconnected connectors. 2) Start the engine and stop. 3) Turn the ignition switch to ON. 4) Read the DTC of body integrated unit using Subaru Select Monitor.	Is U1223 a current malfunction?	Go to step 6.	Go to step 7.
<b>6</b> <b>CHECK DTC.</b> Read all DTCs using the Subaru Select Monitor.	Is U0122 displayed?	Replace the VDC/ABS CM. <Ref. to VDC-8, REMOVAL, VDC Control Module and Hydraulic Control Unit (VDCCM&H/U).>	Replace the body integrated unit. <Ref. to SL-48, REMOVAL, Body Integrated Unit.>
<b>7</b> <b>CHECK HARNESS.</b> 1) Shake the harness used for CAN communication circuit. 2) Read the DTC of body integrated unit using Subaru Select Monitor.	Is U1223 a current malfunction?	Repair or replace the harness.	Go to step 8.
<b>8</b> <b>CHECK CONNECTOR.</b> 1) Turn the ignition switch to OFF. 2) Disconnect all connectors (B280, B310, B136, B230, B231, B380) that are connected to high speed CAN communication line.	Is there connector terminal where poor contact exists?	Repair the connector terminal where poor contact exists, or replace harness.	Temporary poor contact occurs.

# Diagnostic Procedure with Diagnostic Trouble Code (DTC)

LAN SYSTEM (DIAGNOSTICS)

## M: DTC U1226 HIGH-SPEED CAN (DCCD) DATA IS NOT RECEIVED

### DTC DETECTING CONDITION:

Not received data from DCCD CM.

### TROUBLE SYMPTOM:

DCCD indicator blinks.

### WIRING DIAGRAM:

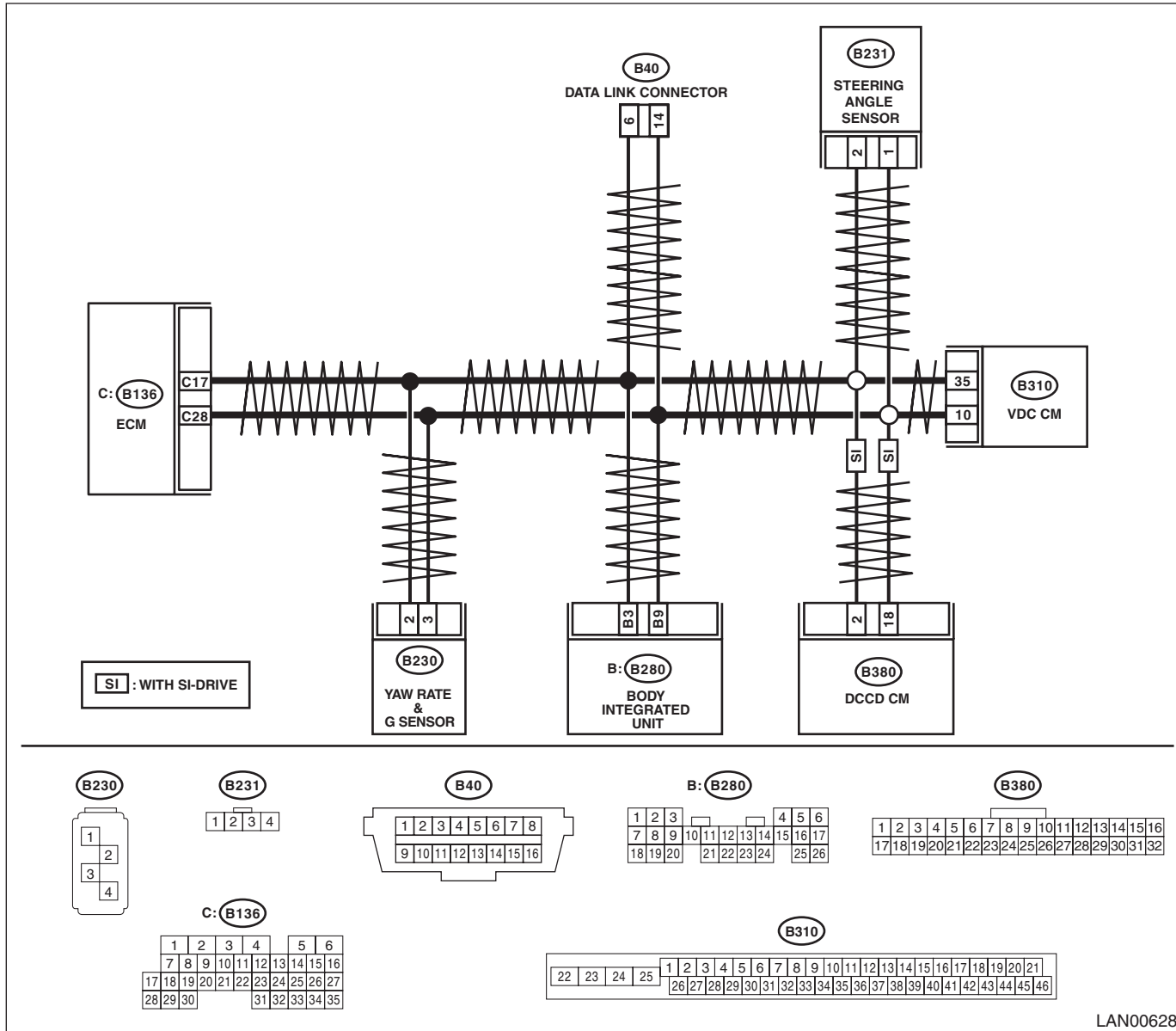

LAN00628

Step	Check	Yes	No	
1	<b>CHECK DTC.</b> Read all DTCs using the Subaru Select Monitor. <Ref. to LAN(diag)-14, READ DIAGNOSTIC TROUBLE CODE (DTC), OPERATION, Subaru Select Monitor.>	Is there DTC U1202?	Perform the diagnosis according to DTC.	Go to step 2.
2	<b>CHECK DTC.</b> Read the DTC of body integrated unit using Subaru Select Monitor.	Is U1226 a current malfunction?	Go to step 3.	Go to step 7.

# Diagnostic Procedure with Diagnostic Trouble Code (DTC)

## LAN SYSTEM (DIAGNOSTICS)

Step	Check	Yes	No
<b>3</b> <b>CHECK DTC.</b> 1) Turn the ignition switch to OFF. 2) Disconnect all connectors (B280, B310, B136, B230, B231, B380) that are connected to high speed CAN communication line. 3) Connect the disconnected connectors. 4) Turn the ignition switch to ON. 5) Read the DTC of body integrated unit using Subaru Select Monitor.	Is U1226 a current malfunction?	Go to step 4.	Go to step 7.
<b>4</b> <b>CHECK HARNESS.</b> 1) Turn the ignition switch to OFF. 2) Disconnect all connectors (B280, B310, B136, B230, B231, B380) that are connected to high speed CAN communication line. 3) Using the tester, check for open, short (power supply-output short, GND-output short) in the harness. <b>Connector &amp; terminal</b> <b>(B380) No. 18 — (B40) No. 14:</b> <b>(B380) No. 2 — (B40) No. 6:</b>	Is harness normal?	Go to step 5.	Repair or replace the harness.
<b>5</b> <b>CHECK DTC.</b> 1) Connect the disconnected connectors. 2) Start the engine and stop. 3) Turn the ignition switch to ON. 4) Read the DTC of body integrated unit using Subaru Select Monitor.	Is U1226 a current malfunction?	Go to step 6.	Go to step 7.
<b>6</b> <b>CHECK DCCD CM.</b> 1) Turn the ignition switch to OFF. 2) Replace with a DCCD CM that is operating normally. 3) Turn the ignition switch to ON. 4) Read the DTC of body integrated unit using Subaru Select Monitor.	Is U1226 a current malfunction?	Replace the body integrated unit. <Ref. to SL-48, REMOVAL, Body Integrated Unit.>	Replace the DCCD CM. <Ref. to 6MT-119, REMOVAL, Driver's Control Center Differential Control Module.>
<b>7</b> <b>CHECK HARNESS.</b> 1) Shake the harness used for CAN communication circuit. 2) Read the DTC of body integrated unit using Subaru Select Monitor.	Is U1226 a current malfunction?	Repair or replace the harness.	Go to step 8.
<b>8</b> <b>CHECK CONNECTOR.</b> 1) Turn the ignition switch to OFF. 2) Disconnect all the connector that is connected to high speed CAN circuit.	Is there poor contact of connector terminal?	Repair the connector terminal where poor contact exists, or replace harness.	Temporary poor contact occurs.

# Diagnostic Procedure with Diagnostic Trouble Code (DTC)

LAN SYSTEM (DIAGNOSTICS)

## N: DTC U1300 CAN-LS MALFUNCTION

### DTC DETECTING CONDITION:

Open or short in low speed CAN circuit

### TROUBLE SYMPTOM:

Low speed CAN communication can not be executed normally.

### WIRING DIAGRAM:

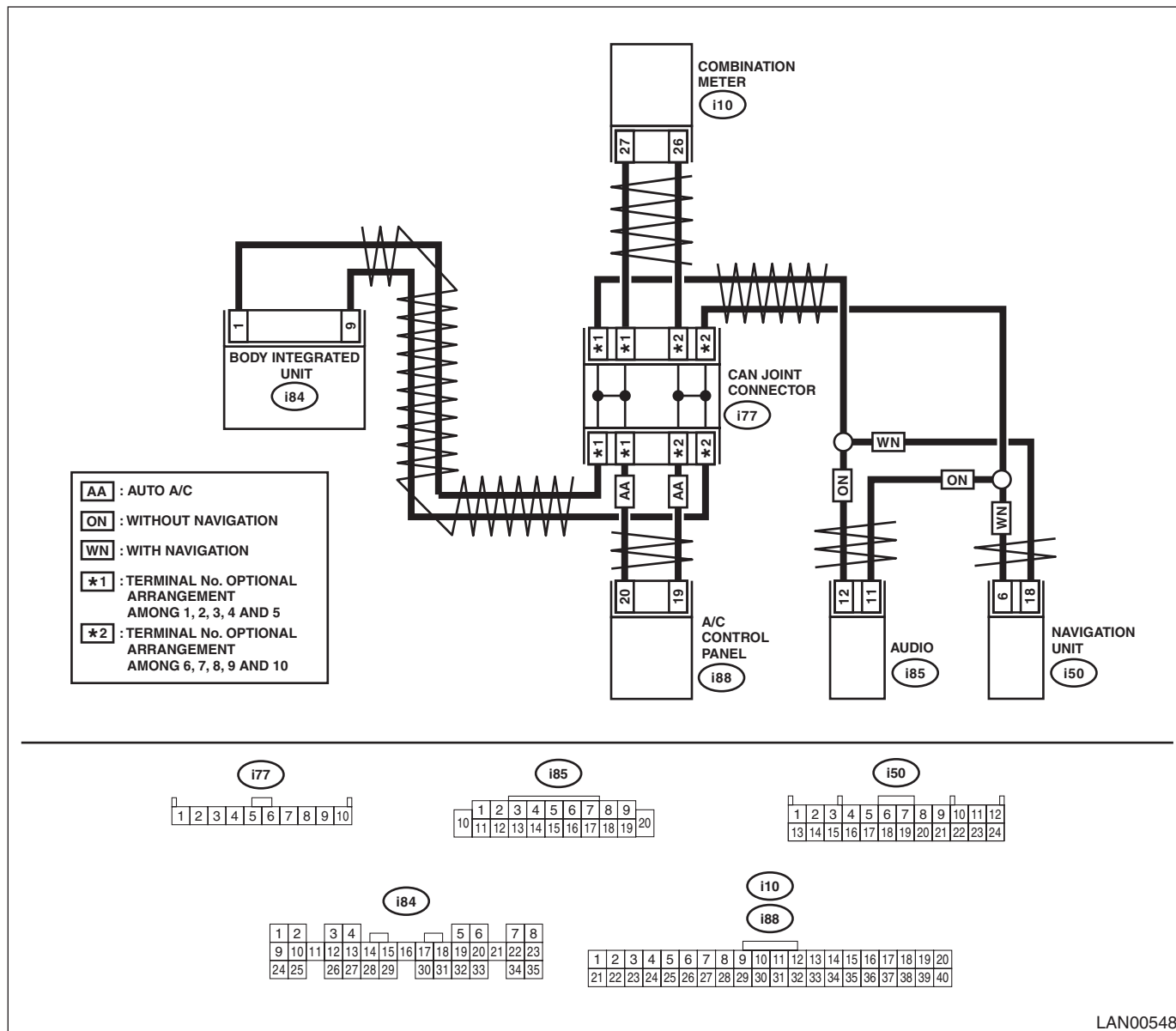

LAN00548

# Diagnostic Procedure with Diagnostic Trouble Code (DTC)

## LAN SYSTEM (DIAGNOSTICS)

Step	Check	Yes	No
<b>1 CHECK DTC.</b> Read the DTC of body integrated unit using Subaru Select Monitor. <Ref. to LAN(diag)-14, READ DIAGNOSTIC TROUBLE CODE (DTC), OPERATION, Subaru Select Monitor.>	Is U1300 a current malfunction?	Go to step 2.	Go to step 7.
<b>2 CHECK DTC.</b> 1) Disconnect all connectors (i84, i10, i88, i85 or i50) that are connected to low speed CAN communication line. 2) Connect the disconnected connectors. 3) Turn the ignition switch to ON. 4) Read the DTC of body integrated unit using Subaru Select Monitor.	Is U1300 a current malfunction?	Go to step 3.	Go to step 7.
<b>3 CHECK HARNESS.</b> 1) Turn the ignition switch to OFF. 2) Disconnect all connectors (i84, i10, i88, i85 or i50) that are connected to low speed CAN communication line. 3) Using the tester, check for open, short (power supply-output short, GND-output short) in the harness. <b>Connector &amp; terminal</b> <i>(i84) No. 1 — (i10) No. 27 (combination meter):</i> <i>(i84) No. 9 — (i10) No. 26 (combination meter):</i> <i>(i84) No. 1 — (i88) No. 20 (auto A/C):</i> <i>(i84) No. 9 — (i88) No. 19 (auto A/C):</i> <i>(i84) No. 1 — (i85) No. 12 (audio):</i> <i>(i84) No. 9 — (i85) No. 11 (audio):</i> <i>(i84) No. 1 — (i50) No. 18 (navigation):</i> <i>(i84) No. 9 — (i50) No. 6 (navigation):</i>	Is harness normal?	Go to step 4.	Repair or replace the harness.
<b>4 CHECK AUDIO OR NAVIGATION.</b> 1) Connect the disconnected connectors. 2) Disconnect the connector of navigation (i50) or audio (i85). 3) Turn the ignition switch to ON. 4) Read the DTC of body integrated unit using Subaru Select Monitor.	Is U1300 a current malfunction?	Go to step 5.	Replace the navigation or audio. <Ref. to ET-6, REMOVAL, Audio.>
<b>5 CHECK AUTO A/C CONTROL MODULE.</b> 1) Turn the ignition switch to OFF. 2) Connect the audio or navigation connectors. 3) Disconnect the auto A/C control module connector (i88). 4) Turn the ignition switch to ON. 5) Read the DTC of body integrated unit using Subaru Select Monitor.	Is U1300 a current malfunction?	Go to step 6.	Replace the auto A/C control module. <Ref. to AC-32, REMOVAL, Control Unit (Auto A/C Model).>
<b>6 CHECK BODY INTEGRATED UNIT.</b> 1) Turn the ignition switch to OFF. 2) Connect the auto A/C control module. 3) Replace the body integrated unit of your vehicle with the body integrated unit from other vehicle, which is working normally. 4) Turn the ignition switch to ON. 5) Read the DTC of body integrated unit using Subaru Select Monitor.	Is U1300 a current malfunction?	Replace the combination meter. <Ref. to IDI-16, REMOVAL, Combination Meter.>	Replace the body integrated unit. <Ref. to SL-48, REMOVAL, Body Integrated Unit.>

# Diagnostic Procedure with Diagnostic Trouble Code (DTC)

LAN SYSTEM (DIAGNOSTICS)

Step	Check	Yes	No
<b>7</b> <b>CHECK HARNESS.</b> 1) Turn the ignition switch to OFF. 2) Shake the harness used for CAN communication circuit. 3) Turn the ignition switch to ON. 4) Read the DTC of body integrated unit using Subaru Select Monitor.	Is U1300 a current malfunction?	Repair or replace the harness.	Go to step <b>8</b> .
<b>8</b> <b>CHECK CONNECTOR.</b> 1) Turn the ignition switch to OFF. 2) Disconnect the connector that is connected to low speed CAN circuit.	Is there poor contact at disconnected connector?	Repair the connector terminal, or replace harness.	Temporary poor contact occurs.



# Diagnostic Procedure with Diagnostic Trouble Code (DTC)

LAN SYSTEM (DIAGNOSTICS)

## O: DTC U1301 CAN-LS COUNTER ABNORMAL

### DTC DETECTING CONDITION:

Communication is unstable because of low speed CAN communication error.

### TROUBLE SYMPTOM:

Display error may occur in fuel gauge because the CAN communication is not transmitted (sending/receiving) normally.

### WIRING DIAGRAM:

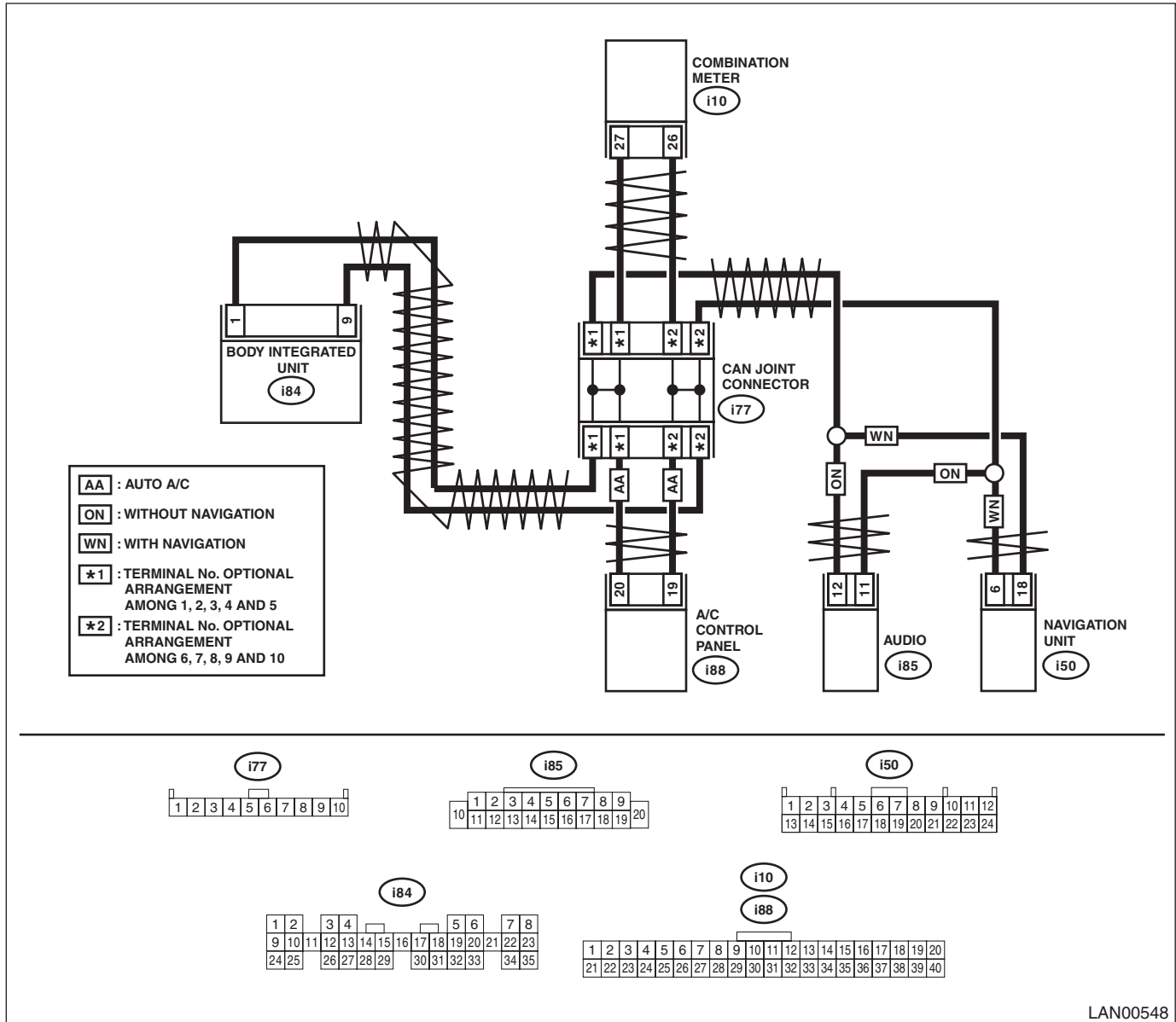

LAN00548

Step	Check	Yes	No
1	<b>CHECK DTC.</b> Read the DTC of body integrated unit using Subaru Select Monitor. <Ref. to LAN(diag)-14, READ DIAGNOSTIC TROUBLE CODE (DTC), OPERATION, Subaru Select Monitor.>	Perform the diagnosis according to DTC.	Go to step 2.
2	<b>CHECK DTC.</b> Read the DTC of body integrated unit using Subaru Select Monitor.	Go to step 3.	Go to step 9.

# Diagnostic Procedure with Diagnostic Trouble Code (DTC)

LAN SYSTEM (DIAGNOSTICS)

Step	Check	Yes	No
<b>3 CHECK DTC.</b> 1) Turn the ignition switch to OFF. 2) Disconnect all connectors (i84, i10, i88, i85 or i50) that are connected to low speed CAN communication line. 3) Connect the disconnected connectors. 4) Turn the ignition switch to ON. 5) Read the DTC of body integrated unit using Subaru Select Monitor.	Is U1301 a current malfunction?	Go to step 4.	Go to step 9.
<b>4 CHECK HARNESS.</b> 1) Turn the ignition switch to OFF. 2) Disconnect all connectors (i84, i10, i88, i85 or i50) that are connected to low speed CAN communication line. 3) Using the tester, check for open, short (power supply-output short, GND-output short) in the harness. <b>Connector &amp; terminal</b> <i>(i84) No. 1 — (i10) No. 27 (combination meter):</i> <i>(i84) No. 9 — (i10) No. 26 (combination meter):</i> <i>(i84) No. 1 — (i88) No. 20 (auto A/C):</i> <i>(i84) No. 9 — (i88) No. 19 (auto A/C):</i> <i>(i84) No. 1 — (i85) No. 12 (audio):</i> <i>(i84) No. 9 — (i85) No. 11 (audio):</i> <i>(i84) No. 1 — (i50) No. 18 (navigation):</i> <i>(i84) No. 9 — (i50) No. 6 (navigation):</i>	Is harness normal?	Go to step 5.	Repair or replace the harness.
<b>5 CHECK AUDIO OR NAVIGATION.</b> 1) Connect the disconnected connectors. 2) Disconnect the connector of navigation (i50) or audio (i85). 3) Turn the ignition switch to ON. 4) Read the DTC of body integrated unit using Subaru Select Monitor.	Is U1301 a current malfunction?	Go to step 6.	Replace the audio or navigation. <Ref. to ET-6, REMOVAL, Audio.>
<b>6 CHECK AUTO A/C CONTROL MODULE.</b> 1) Turn the ignition switch to OFF. 2) Connect the audio or navigation module. 3) Disconnect the auto A/C control module connector (i88). 4) Turn the ignition switch to ON. 5) Read the DTC of body integrated unit using Subaru Select Monitor.	Is U1301 a current malfunction?	Go to step 7.	Replace the auto A/C control module. <Ref. to AC-32, REMOVAL, Control Unit (Auto A/C Model).>
<b>7 CHECK COMBINATION METER.</b> 1) Turn the ignition switch to OFF. 2) Connect the disconnected connectors. 3) Perform the self-diagnosis of combination meter. <Ref. to IDI-5, SELF-DIAGNOSIS, INSPECTION, Combination Meter System.>	Is the self-diagnosis of combination meter OK?	Go to step 8.	Replace the combination meter. <Ref. to IDI-16, REMOVAL, Combination Meter.>
<b>8 CHECK BODY INTEGRATED UNIT.</b> 1) Turn the ignition switch to OFF. 2) Disconnect all connectors (i84, i10, i88, i85 or i50) that are connected to low speed CAN communication line. 3) Connect the disconnected connectors. 4) Turn the ignition switch to ON. 5) Read the DTC of body integrated unit using Subaru Select Monitor.	Is U1301 a current malfunction?	Replace the body integrated unit. <Ref. to SL-48, REMOVAL, Body Integrated Unit.>	Go to step 9.

## Diagnostic Procedure with Diagnostic Trouble Code (DTC)

### LAN SYSTEM (DIAGNOSTICS)

Step	Check	Yes	No
<b>9</b> <b>CHECK HARNESS.</b> 1) Turn the ignition switch to OFF. 2) Shake the harness used for low speed CAN communication circuit. 3) Turn the ignition switch to ON. 4) Read the DTC of body integrated unit using Subaru Select Monitor.	Is U1301 a current malfunction?	Repair or replace the harness.	Go to step 10.
<b>10</b> <b>CHECK CONNECTOR.</b> 1) Turn the ignition switch to OFF. 2) Disconnect all connectors (i84, i10, i88, i85 or i50) that are connected to low speed CAN communication line.	Is there poor contact of connector terminal?	Repair the connector terminal, or replace harness.	Temporary poor contact occurs.

# Diagnostic Procedure with Diagnostic Trouble Code (DTC)

LAN SYSTEM (DIAGNOSTICS)

## P: DTC U1302 CAN-LS BUS OFF

### DTC DETECTING CONDITION:

Integrated unit communication is shut down because of low speed CAN error.

### TROUBLE SYMPTOM:

Display error may occur in fuel gauge because the CAN communication is not transmitted (sending/receiving) normally.

### WIRING DIAGRAM:

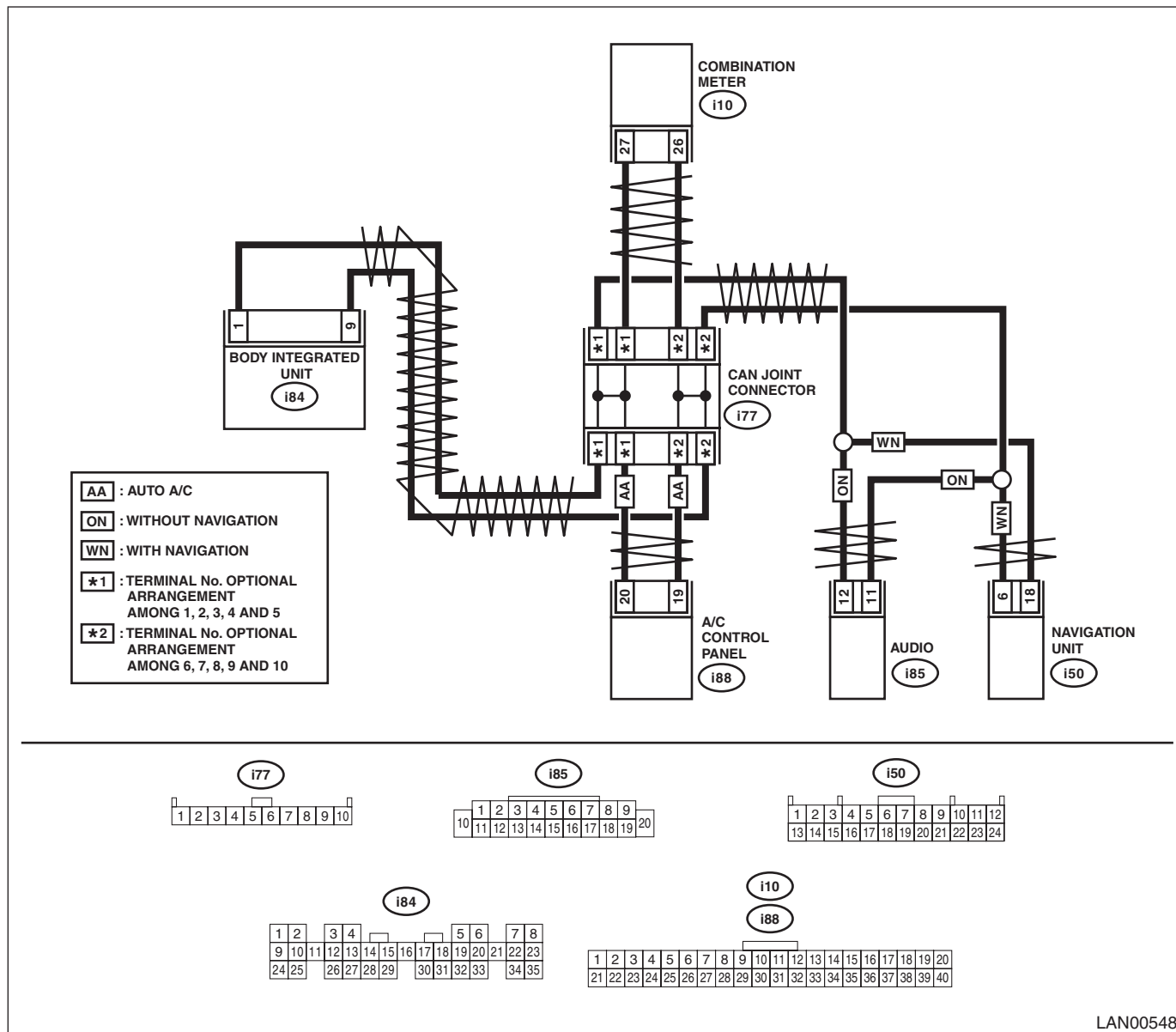

LAN00548

# Diagnostic Procedure with Diagnostic Trouble Code (DTC)

## LAN SYSTEM (DIAGNOSTICS)

Step	Check	Yes	No
<b>1 CHECK DTC.</b> Read the DTC of body integrated unit using Subaru Select Monitor. <Ref. to LAN(diag)-14, READ DIAGNOSTIC TROUBLE CODE (DTC), OPERATION, Subaru Select Monitor.>	Is U1302 a current malfunction?	Go to step 2.	Go to step 8.
<b>2 CHECK DTC.</b> 1) Turn the ignition switch to OFF. 2) Disconnect all connectors (i84, i10, i88, i85 or i50) that are connected to low speed CAN communication line. 3) Connect the disconnected connectors. 4) Turn the ignition switch to ON. 5) Read the DTC of body integrated unit using Subaru Select Monitor.	Is U1302 a current malfunction?	Go to step 3.	Go to step 8.
<b>3 CHECK HARNESS.</b> 1) Turn the ignition switch to OFF. 2) Disconnect all connectors (i84, i10, i88, i85 or i50) that are connected to low speed CAN communication line. 3) Using the tester, check for open, short (power supply-output short, GND-output short) in the harness. <b>Connector &amp; terminal</b> <i>(i84) No. 1 — (i10) No. 27 (combination meter):</i> <i>(i84) No. 9 — (i10) No. 26 (combination meter):</i> <i>(i84) No. 1 — (i88) No. 20 (auto A/C):</i> <i>(i84) No. 9 — (i88) No. 19 (auto A/C):</i> <i>(i84) No. 1 — (i85) No. 12 (audio):</i> <i>(i84) No. 9 — (i85) No. 11 (audio):</i> <i>(i84) No. 1 — (i50) No. 18 (navigation):</i> <i>(i84) No. 9 — (i50) No. 6 (navigation):</i>	Is harness normal?	Go to step 4.	Repair or replace the harness.
<b>4 CHECK HARNESS.</b> 1) Connect the disconnected connectors. 2) Using the tester, measure the resistance between harness connector and chassis ground. <b>Connector &amp; terminal</b> <i>(i84) No. 1 — Chassis ground:</i> <i>(i84) No. 9 — Chassis ground:</i>	Is the resistance 1 MΩ or more?	Go to step 5.	Go to step 7.
<b>5 CHECK HARNESS.</b> 1) Turn the ignition switch to ON. 2) Using the tester, measure the voltage between harness connector and chassis ground. <b>Connector &amp; terminal</b> <i>(i84) No. 1 (+) — Chassis ground (-):</i> <i>(i84) No. 9 (+) — Chassis ground (-):</i>	Is the voltage less than 6 V?	Replace the body integrated unit. <Ref. to SL-48, REMOVAL, Body Integrated Unit.>	Go to step 6.
<b>6 CHECK HARNESS.</b> With the tester connected, disconnect control module.	Is there any control module whose voltage has changed?	Replace the control module whose voltage has changed.	Repair or replace the short circuit of the harness.
<b>7 CHECK HARNESS.</b> With the tester connected, disconnect control module.	Is there any control module whose resistance has changed?	Replace the control module whose resistance has changed.	Repair or replace the short circuit of the harness.

# Diagnostic Procedure with Diagnostic Trouble Code (DTC)

LAN SYSTEM (DIAGNOSTICS)

	Step	Check	Yes	No
8	<b>CHECK HARNESS.</b> 1) Turn the ignition switch to OFF. 2) Shake the harness used for low speed CAN communication circuit. 3) Turn the ignition switch to ON. 4) Read the DTC of body integrated unit using Subaru Select Monitor.	Is U1302 a current malfunction?	Repair or replace the open, short circuit of the harness.	Go to step 9.
9	<b>CHECK CONNECTOR.</b> 1) Turn the ignition switch to OFF. 2) Disconnect all connectors (i84, i10, i88, i85 or i50) that are connected to low speed CAN communication line.	Is there poor contact of connector terminal?	Repair the connector terminal, or replace harness.	Temporary poor contact occurs.

# Diagnostic Procedure with Diagnostic Trouble Code (DTC)

LAN SYSTEM (DIAGNOSTICS)

## Q: DTC U1311 CAN-LS METER UNIT DATA ABNORMAL

### DTC DETECTING CONDITION:

Received error data from meter.

### TROUBLE SYMPTOM:

Defective data from combination meter occurs.

### WIRING DIAGRAM:

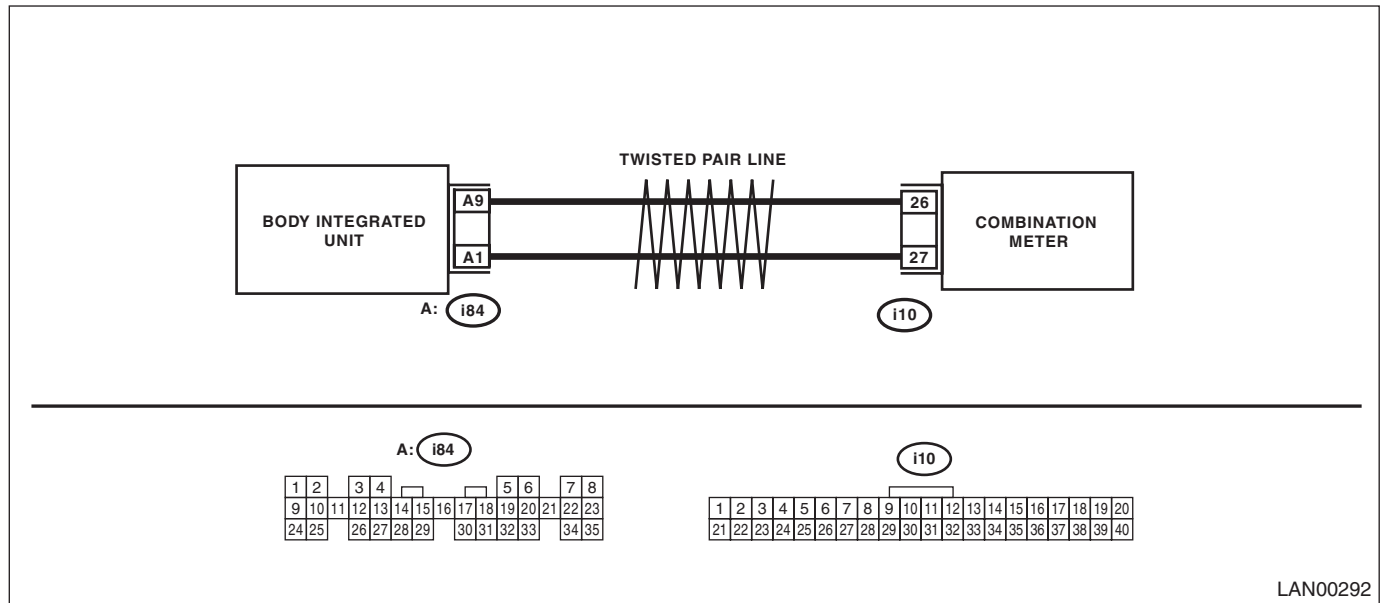

LAN00292

Step	Check	Yes	No	
1	<b>CHECK DTC.</b> Read the DTC of body integrated unit using Subaru Select Monitor. <Ref. to LAN(diag)-14, READ DIAGNOSTIC TROUBLE CODE (DTC), OPERATION, Subaru Select Monitor.>	Is DTC U1300 or U1302 displayed?	Perform the diagnosis according to DTC.	Go to step 2.
2	<b>CHECK DTC.</b> Read the DTC of body integrated unit using Subaru Select Monitor.	Is U1311 a current malfunction?	Go to step 3.	Go to step 4.
3	<b>CHECK DTC.</b> 1) Turn the ignition switch to OFF. 2) Disconnect the combination meter connector (i10). 3) Connect the disconnected connectors. 4) Turn the ignition switch to ON. 5) Read the DTC of body integrated unit using Subaru Select Monitor.	Is U1311 a current malfunction?	Replace the combination meter. <Ref. to IDI-16, REMOVAL, Combination Meter.>	Go to step 4.
4	<b>CHECK HARNESS.</b> 1) Turn the ignition switch to OFF. 2) Shake the harness used for low speed CAN communication circuit. 3) Turn the ignition switch to ON. 4) Read the DTC of body integrated unit using Subaru Select Monitor.	Is U1311 a current malfunction?	Repair or replace the harness.	Go to step 5.
5	<b>CHECK CONNECTOR.</b> 1) Turn the ignition switch to OFF. 2) Disconnect all connectors (i84, i10, i88, i85 or i50) that are connected to low speed CAN communication line.	Is there poor contact of connector terminal?	Repair the connector terminal, or replace harness.	Temporary poor contact occurs.

# Diagnostic Procedure with Diagnostic Trouble Code (DTC)

LAN SYSTEM (DIAGNOSTICS)

## R: DTC U1321 CAN-LS METER NO-RECEIVE DATA

### DTC DETECTING CONDITION:

Not received data from meter.

### TROUBLE SYMPTOM:

Engine may not be started.

### WIRING DIAGRAM:

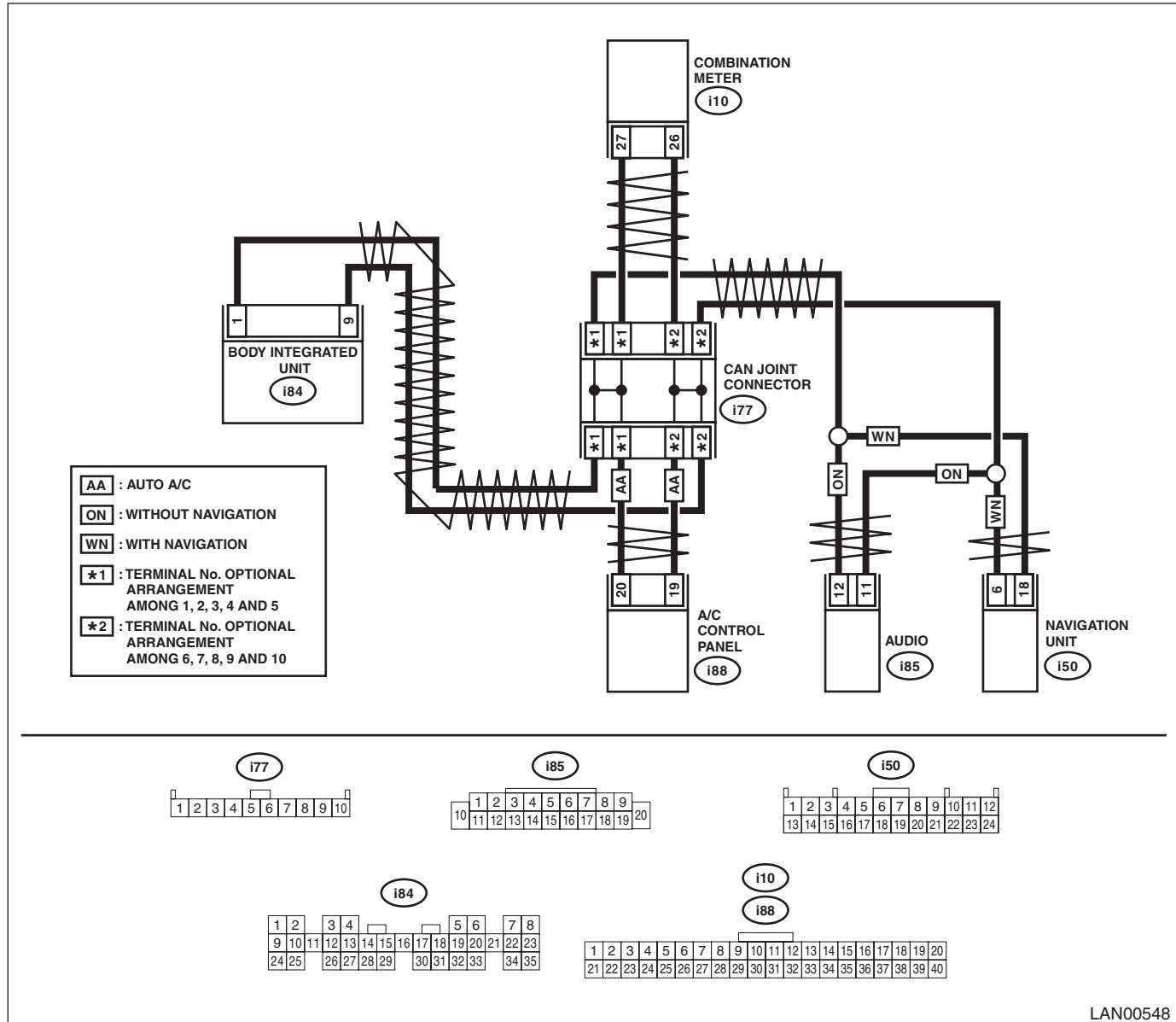

LAN00548

Step	Check	Yes	No	
1	<b>CHECK ALL DTCs.</b> Read all DTCs using the Subaru Select Monitor. <Ref. to LAN(diag)-14, READ DIAGNOSTIC TROUBLE CODE (DTC), OPERATION, Subaru Select Monitor.>	Is U1300 or U1302 displayed?	Perform the diagnosis according to DTC.	Go to step 2.
2	<b>CHECK DTC.</b> Read the DTC of body integrated unit using Subaru Select Monitor.	Is U1321 a current malfunction?	Go to step 3.	Go to step 7.



# Diagnostic Procedure with Diagnostic Trouble Code (DTC)

## LAN SYSTEM (DIAGNOSTICS)

Step	Check	Yes	No
<b>3 CHECK DTC.</b> 1) Turn the ignition switch to OFF. 2) Disconnect all connectors (i84, i10, i88, i85 or i50) that are connected to low speed CAN communication line. 3) Connect the disconnected connectors. 4) Turn the ignition switch to ON. 5) Read the DTC of body integrated unit using Subaru Select Monitor.	Is U1321 a current malfunction?	Go to step 4.	Go to step 7.
<b>4 CHECK HARNESS.</b> 1) Turn the ignition switch to OFF. 2) Disconnect all connectors (i84, i10, i88, i85 or i50) that are connected to low speed CAN communication line. 3) Using the tester, check for open, short (power supply-output short, GND-output short) in the harness. <b>Connector &amp; terminal</b> <i>(i84) No. 1 — (i10) No. 27 (combination meter):</i> <i>(i84) No. 9 — (i10) No. 26 (combination meter):</i> <i>(i84) No. 1 — (i88) No. 20 (auto A/C):</i> <i>(i84) No. 9 — (i88) No. 19 (auto A/C):</i> <i>(i84) No. 1 — (i85) No. 12 (audio):</i> <i>(i84) No. 9 — (i85) No. 11 (audio):</i> <i>(i84) No. 1 — (i50) No. 18 (navigation):</i> <i>(i84) No. 9 — (i50) No. 6 (navigation):</i>	Is harness normal?	Go to step 5.	Repair or replace the harness.
<b>5 CHECK COMBINATION METER.</b> 1) Connect the disconnected connectors. 2) Perform the self-diagnosis of combination meter. <Ref. to IDI-5, SELF-DIAGNOSIS, INSPECTION, Combination Meter System.>	Is the self diagnosis normal?	Go to step 6.	Replace the combination meter. <Ref. to IDI-16, REMOVAL, Combination Meter.>
<b>6 CHECK DTC.</b> 1) Turn the ignition switch to OFF. 2) Disconnect all connectors (i84, i10, i88, i85 or i50) that are connected to low speed CAN communication line. 3) Connect the disconnected connectors. 4) Turn the ignition switch to ON. 5) Read the DTC of body integrated unit using Subaru Select Monitor.	Is U1321 a current malfunction?	Replace the body integrated unit. <Ref. to SL-48, REMOVAL, Body Integrated Unit.>	Go to step 7.
<b>7 CHECK HARNESS.</b> 1) Turn the ignition switch to OFF. 2) Shake the harness used for low speed CAN communication circuit. 3) Turn the ignition switch to ON. 4) Read the DTC of body integrated unit using Subaru Select Monitor.	Is U1321 a current malfunction?	Repair the poor contact, open circuit of harness or replace harness.	Go to step 8.
<b>8 CHECK CONNECTOR.</b> 1) Turn the ignition switch to OFF. 2) Disconnect all connectors (i84, i10, i88, i85 or i50) that are connected to low speed CAN communication line.	Is there poor contact of connector terminal?	Repair the connector terminal, or replace harness.	It is possible that temporary poor communication occurs.

# Diagnostic Procedure with Diagnostic Trouble Code (DTC)

LAN SYSTEM (DIAGNOSTICS)

## S: DTC B1500 KEYLESS UART COM. MALFUNCTION

### DTC DETECTING CONDITION:

Open or short circuit in keyless UART circuit

### TROUBLE SYMPTOM:

Door lock does not operate with keyless.

### WIRING DIAGRAM:

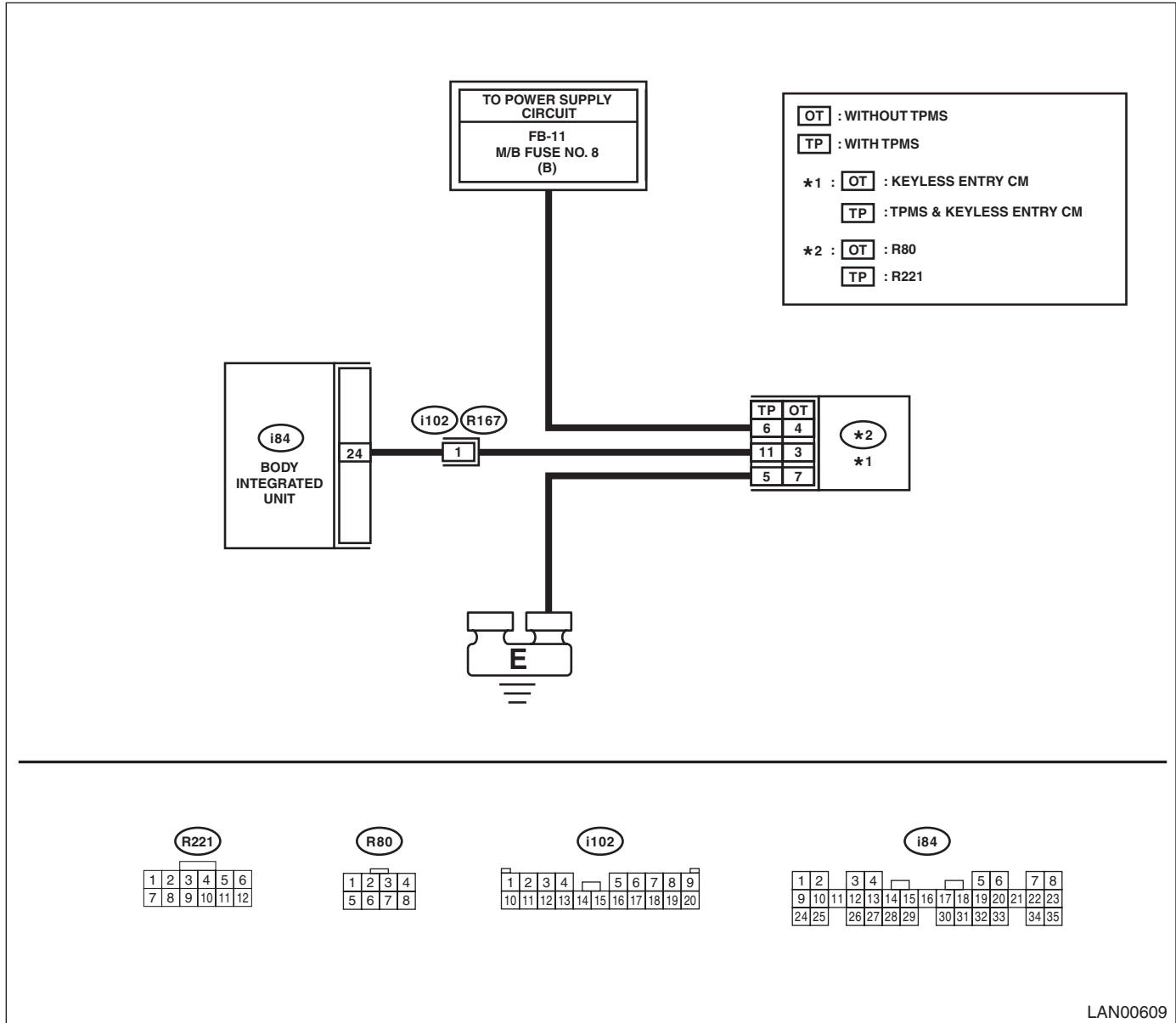

Step	Check	Yes	No	
1	<b>CHECK DTC.</b> Read the DTC of body integrated unit using Subaru Select Monitor. <Ref. to LAN(diag)-14, READ DIAGNOSTIC TROUBLE CODE (DTC), OPERATION, Subaru Select Monitor.>	Is B1500 current malfunction?	Go to step 2.	Go to step 7.

# Diagnostic Procedure with Diagnostic Trouble Code (DTC)

## LAN SYSTEM (DIAGNOSTICS)

Step	Check	Yes	No
<b>2 CHECK DTC.</b> 1) Turn the ignition switch to OFF. 2) Disconnect the connectors from body integrated unit and keyless entry control module. 3) Connect the disconnected connectors. 4) Turn the ignition switch to ON. 5) Read the DTC of body integrated unit using Subaru Select Monitor.	Is B1500 current malfunction?	Go to step 3.	Go to step 7.
<b>3 CHECK HARNESS.</b> 1) Turn the ignition switch to OFF. 2) Disconnect the connectors from body integrated unit and keyless entry control module. 3) Using the tester, check for open, short (power supply-output short, GND-output short) in the harness. <b>Connector &amp; terminal</b> <b>Keyless entry CM</b> <b>(i84) No. 24 — (R80) No. 3:</b> <b>TPMS &amp; keyless entry CM</b> <b>(i84) No. 24 — (R221) No. 11:</b>	Is harness normal?	Go to step 4.	Repair or replace the harness.
<b>4 CHECK HARNESS.</b> Using the tester, measure the voltage between keyless entry control module and chassis ground. <b>Connector &amp; terminal</b> <b>Keyless entry CM</b> <b>(R80) No. 4 (+) — Chassis ground (-):</b> <b>TPMS &amp; keyless entry CM</b> <b>(R221) No. 6 (+) — Chassis ground (-):</b>	Is the voltage battery voltage?	Go to step 5.	Check the power supply circuit for keyless entry control module.
<b>5 CHECK HARNESS.</b> Using the tester, measure the resistance between keyless entry control module and chassis ground. <b>Connector &amp; terminal</b> <b>Keyless entry CM</b> <b>(R80) No. 7 — Chassis ground:</b> <b>TPMS &amp; keyless entry CM</b> <b>(R221) No. 5 — Chassis ground:</b>	Is the resistance less than 10 $\Omega$ ?	Go to step 6.	Repair or replace the open circuit of harness.
<b>6 CHECK OPERATION.</b> 1) Install the keyless entry control module from other vehicle, which is working normally. 2) Register the keyless key which is working normally. 3) Operate the keyless key.	Is the door locking operate?	Replace the keyless entry control module. <Ref. to SL-46, REMOVAL, Keyless Entry Control Module.>	Replace the body integrated unit. <Ref. to SL-48, REMOVAL, Body Integrated Unit.>
<b>7 CHECK CONNECTOR.</b> Disconnect the connectors from body integrated unit and keyless entry control module.	Is there poor contact of connector?	Repair the connector, or replace harness.	Temporary poor contact occurs.

## 13. General Diagnostic Table

### A: INSPECTION

Item	Operation	Specifications		Note
		YES	NO	
Diagnostic code	DTC is not displayed when inspecting all DTCs.	System is normal.	Perform the diagnosis according to DTC.	—
Engine coolant temperature	Engine coolant temperature gauge displays correctly without engine coolant temperature warning light illuminating/blinking.	System is normal.	Refer to the following to check. <ul style="list-style-type: none"> <li>• Engine cooling system</li> <li>• LAN system</li> </ul>	If two data values are different when display the current data of ECM and body integrated unit, it is possible that driving system CAN is malfunction.
Remaining fuel level	Fuel gauge displays correctly. Fuel level warning light does not remain illuminated.	System is normal.	Refer to the following to check. <ul style="list-style-type: none"> <li>• Combination meter system</li> <li>• LAN system</li> </ul>	If the values of "Fuel level resistance" and "Fuel level resistance 2" are different when display the current data of body integrated unit, it is possible that body integrated unit is malfunction.
EBD warning light ABS warning light VDC warning light Hill start assist warning light	EBD warning light/ABS warning light/VDC warning light/Hill start assist warning light are free from ON/OFF all the time.	System is normal.	Refer to the following to check. <ul style="list-style-type: none"> <li>• VDC (diagnostics)</li> <li>• Parking brake</li> <li>• Combination meter system</li> <li>• LAN system</li> </ul>	—
Clearance light Low beam High beam	Clearance light/low beam/high beam illuminate correctly by switch operation. Indicator in the meter illuminates when clearance light/high beam are illuminating.	System is normal.	Refer to the following to check. <ul style="list-style-type: none"> <li>• Lighting system</li> <li>• Combination meter system</li> <li>• LAN system</li> </ul>	—
Fog light	Fog light illuminates correctly by switch operation. Indicator in the meter illuminates when each fog light is illuminating.	System is normal.	Refer to the following to check. <ul style="list-style-type: none"> <li>• Lighting system</li> <li>• Combination meter system</li> <li>• LAN system</li> </ul>	—
DRL	DRL operates correctly.	System is normal.	Refer to the following to check. <ul style="list-style-type: none"> <li>• Lighting system</li> <li>• LAN system</li> </ul>	—
Key warning switch alarm	Alarm sounds when drivers door is open with the key inserted.	System is normal.	Refer to the following to check. <ul style="list-style-type: none"> <li>• Combination meter system</li> <li>• LAN system</li> </ul>	—

# General Diagnostic Table

## LAN SYSTEM (DIAGNOSTICS)

Item	Operation	Specifications		Note
		YES	NO	
Seat belt warning alarm	Indicator in the meter illuminate and alarm sounds when driver's seat belt is not worn. Indicator in the clock illuminates. When passenger's seat is occupied without passenger's seat belt worn. Alarm sounds when vehicle speed is approx. 15 km/h without seat belt fastened.	System is normal.	Refer to the following to check. • Seat belt warning system • Combination meter system • LAN system	—
Rear window defogger	Rear window defogger operates by operating the switch. Indicator in the switch illuminates when rear window defogger is operating.	System is normal.	Refer to the following to check. • Rear window defogger • A/C control module	—
Wiper deicer	Wiper deicer operates by operating the switch. (When the outside temperature is 5°C or higher, press the switch for three seconds or more to operate forcibly, otherwise the wiper deicer operation will be canceled.)	System is normal.	Refer to the following to check. • Wiper deicer system • A/C control module	—
Rear wiper	Rear wiper operates by operating the switch.	System is normal.	Refer to the following to check. • Wiper and washer system	Vehicle speed response time varies depending on the condition of customization of the body integrated unit "Sedan/Wagon Setting".
Door lock	Lock/unlock operates by operating the central door lock switch. Rear gate opens by operating the rear gate opener button.	System is normal.	Refer to the following to check. • Security and locks • LAN system	Rear gate cannot open by operating the rear gate opener button when customization of the body integrated unit "Sedan/Wagon Setting" is set to "Sedan".
Keyless entry	Lock/unlock operates by operating the keyless transmitter.	System is normal.	Refer to the following to check. • Security and locks • LAN system	Rear gate swung to open by operating the trunk/rear gate unlock button when customization of the body integrated unit "Sedan/Wagon Setting" is set to "Sedan".
Hazard lights	Answer back operates by operating lock/unlock with the keyless entry.	System is normal.	Refer to the following to check. • Security and locks • LAN system	—
Room light	ON/OFF according to the door open/close operation, the lock/unlock operation with the keyless entry, and the ignition operation.	System is normal.	Refer to the following to check. • Room light system • Security and locks • LAN system	—

# General Diagnostic Table

LAN SYSTEM (DIAGNOSTICS)

Item	Operation	Specifications		Note
		YES	NO	
Map light (model with sun-roof)	ON/OFF according to the door open/close operation except rear gate, the lock/unlock operation with the keyless entry, and the ignition operation.	System is normal.	Refer to the following to check. <ul style="list-style-type: none"> <li>• Spot map light</li> <li>• Security and locks</li> <li>• LAN system</li> </ul>	—
Key illumination	ON/OFF according to the driver's door open/close operation, the lock/unlock operation with the keyless entry, and the ignition operation.	System is normal.	Refer to the following to check. <ul style="list-style-type: none"> <li>• Ignition switch illumination</li> <li>• Security and locks</li> <li>• LAN system</li> </ul>	Key illumination blinks when customization of the body integrated unit "Factory initial setting" is set to "Factory" for models with keyless entry.
Illumination control	Illumination volume control is available.	System is normal.	Refer to the following to check. <ul style="list-style-type: none"> <li>• Combination meter system</li> <li>• LAN system</li> </ul>	Lighting adjustment is not possible when customization of the body integrated unit "Illumination Control On/Off" is set to "OFF".
Engine start	Engine starts normally.	System is normal.	Refer to the following to check. <ul style="list-style-type: none"> <li>• Engine (diagnostics)</li> <li>• Immobilizer</li> <li>• LAN system</li> </ul>	—
Vehicle security	When locked by the keyless entry, security monitor condition starts. When unlocked by the keyless entry, security is released.	System is normal.	Refer to the following to check. <ul style="list-style-type: none"> <li>• Security and locks</li> <li>• LAN system</li> </ul>	When the "Impact sensor" setup is set to "ON" without connecting the impact sensor (dealer option), the alarm operates as soon as security monitor condition occurs.

# General Diagnostic Table

LAN SYSTEM (DIAGNOSTICS)

---

**WIRING SYSTEM SECTION**

**WIRING SYSTEM**

**WI**

This service manual has been prepared to provide SUBARU service personnel with the necessary information and data for the correct maintenance and repair of SUBARU vehicles.

This manual includes the procedures for maintenance, disassembling, reassembling, inspection and adjustment of components and diagnostics for guidance of experienced mechanics.

Please peruse and utilize this manual fully to ensure complete repair work for satisfying our customers by keeping their vehicle in optimum condition. When replacement of parts during repair work is needed, be sure to use SUBARU genuine parts.

All information, illustration and specifications contained in this manual are based on the latest product information available at the time of publication approval.



# WIRING SYSTEM

# WI

	<b>Page</b>
1. Basic Diagnostic Procedure .....	3
2. Working Precautions .....	14
3. Power Supply Circuit .....	15
4. Ground Circuit .....	23
5. Engine Electrical System .....	32
6. Radiator Fan System .....	64
7. Charging System .....	65
8. Starter System .....	66
9. Vehicle Dynamics Control System .....	67
10. Tire Pressure Monitoring System .....	71
11. Driver's Control Center Differential Control System .....	72
12. Air Conditioning System .....	74
13. Airbag System .....	82
14. Seat Belt Warning System .....	86
15. Occupant Detection System .....	87
16. Seat Heater System .....	88
17. Headlight System .....	90
18. Headlight Beam Leveler System .....	93
19. Front Fog Light System .....	94
20. Back-up Light System .....	95
21. Stop Light System .....	96
22. Clearance Light and Illumination Light System .....	98
23. Turn Signal Light and Hazard Light System .....	103
24. Interior Light System .....	106
25. Front Wiper and Washer System .....	109
26. Rear Wiper and Washer System .....	110
27. Wiper Deicer System .....	112
28. Audio System .....	113
29. Front Accessory Power Supply Socket System .....	121
30. Rear Accessory Power Supply Socket System .....	122
31. Navigation System .....	123
32. Horn System .....	129
33. Power Window System .....	130
34. Remote Control Mirror System .....	134
35. Rear Defogger System .....	135
36. Combination Meter System .....	136
37. Speedometer System .....	146
38. Clock System .....	147
39. Fuel Gauge System .....	148
40. Coolant Temperature System .....	149
41. Oil Pressure Warning Light System .....	150
42. Parking Brake / Brake Fluid Level Warning Light System .....	151
43. Rear Differential Oil Temperature Warning Light System .....	152
44. Sunroof Control System .....	153
45. Security System .....	154

46.	Immobilizer System .....	158
47.	Keyless Entry System .....	159
48.	Cruise Control System .....	163
49.	CAN Communication System .....	171
50.	Rearview Mirror System .....	173
51.	Harness Components Location .....	174
52.	Front Wiring Harness .....	176
53.	Bulkhead Wiring Harness (In Engine Compartment) .....	178
54.	Bulkhead Wiring Harness (In Compartment) .....	180
55.	Engine Wiring Harness and Transmission Cord .....	183
56.	Instrument Panel Wiring Harness .....	187
57.	Rear Wiring Harness .....	189
58.	Door Cord .....	192
59.	Rear Wiring Harness and Trunk Lid Cord .....	194
60.	Rear Wiring Harness and Rear Gate Cord .....	196

## 1. Basic Diagnostic Procedure

### A: BASIC PROCEDURES

#### 1. GENERAL DESCRIPTION

The most important purpose of diagnostics is to quickly determine which part is malfunctioning, to save time and labor.

#### 2. IDENTIFICATION OF TROUBLE SYMPTOM

Determine what the problem is based on the symptom.

#### 3. PROBABLE CAUSE OF TROUBLE

Look at the wiring diagram and check the system's circuit. Then check the switch, relay, fuse, ground, etc.

#### 4. LOCATION AND REPAIR OF TROUBLE

- 1) Using the diagnostics, narrow down the causes.
- 2) If necessary, use a voltmeter, ohmmeter, etc.
- 3) Before replacing certain component parts (switch, relay, etc.), check the power supply, ground, for open wiring harness, poor connectors, etc. If no problem is encountered, check the component parts.

#### 5. SYSTEM OPERATION CHECK

After repairing, ensure that the system operates properly.

### B: BASIC INSPECTION

#### 1. VOLTAGE MEASUREMENT

- 1) Using a voltmeter, connect the negative lead to a good ground point or negative battery terminal and the positive lead to the connector or component terminal.
- 2) Contact the positive lead of the voltmeter on connector (A). The voltmeter will indicate a voltage.
- 3) Touch connector (B) with the positive probe. The voltmeter will indicate no voltage.

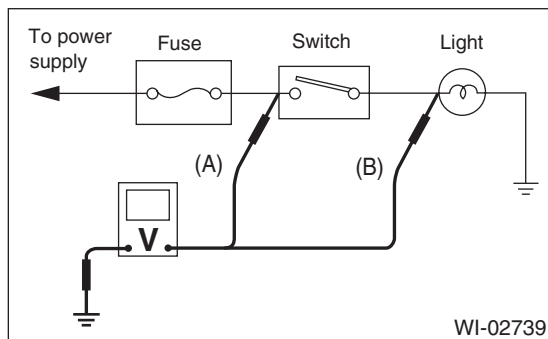

- 4) With the test set-up held as it is, turn the switch to ON. The voltmeter will indicate a voltage and, at the same time, the light will illuminate.

- 5) The circuit is in good order. If a problem such as a light failing to illuminate occurs, use the procedures outlined above to track down the malfunction.

#### 2. CIRCUIT CONTINUITY CHECKS

- 1) Disconnect the battery terminal or connector so there is no voltage between the check points. Contact the two leads of an ohmmeter to each of the check points.

If the circuit has diodes, reverse the two leads and check again.

- 2) Use an ohmmeter to check for diode continuity. When contacting the negative lead to the diode positive side and the positive lead to the negative side, there should be continuity.

When contacting the two leads in reverse, there should be no continuity.

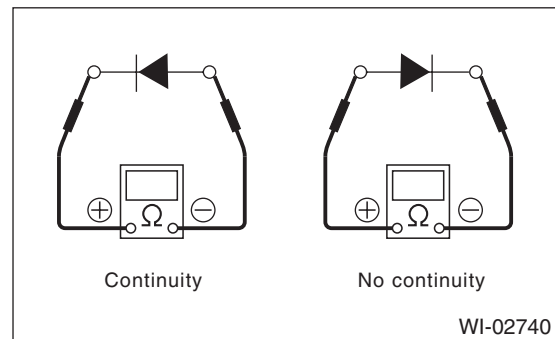

- 3) The symbol "○ — ○" indicates that continuity exists between two points or terminals. For example, when a switch position is at "3", continuity exists among terminals 1, 3 and 6, as shown in the table below.

Terminal	Switch Position					
	1	2	3	4	5	6
OFF						
1	○ — ○				○ — ○	
2	○ — ○			○ — ○		
3	○ — ○		○ — ○			○ — ○
4	○ — ○	○ — ○				○ — ○

WI-02741

# Basic Diagnostic Procedure

## WIRING SYSTEM

### 3. HOW TO DETERMINE AN OPEN CIRCUIT

#### 1) WITH VOLTMETER:

An open circuit is determined by measuring the voltage between respective connectors and ground using a voltmeter, starting with the connector closest to the power supply. The power supply must be turned ON so that current flows in the circuit. If voltage is not present between a particular connector and ground, the circuit between that connector and the previous connector is open.

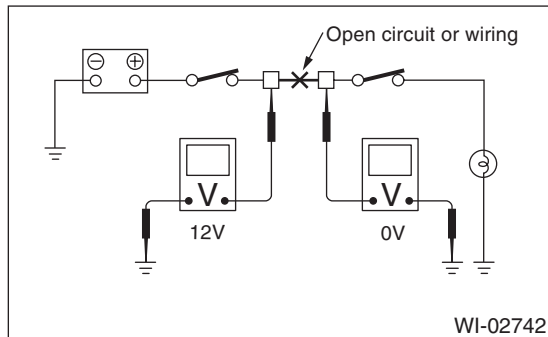

#### 2) WITH OHMMETER:

Disconnect all connectors affected, and check continuity in the wiring between adjacent connectors. When the ohmmeter indicates "infinite", the wiring is open.

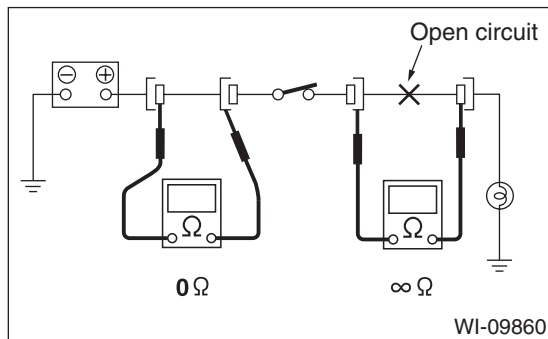

### 4. HOW TO DETERMINE A SHORT CIRCUIT

#### 1) WITH TEST LIGHT:

Connect a test light (rated at approx. 3 watts) in place of the blown fuse and allow current to flow through the circuit. Disconnect one connector at a time from the circuit. Starting with the one located farthest from the power supply. If the test light goes out when a connector is disconnected, the wiring between that connector and the next connector (farther from the power supply) is shorted.

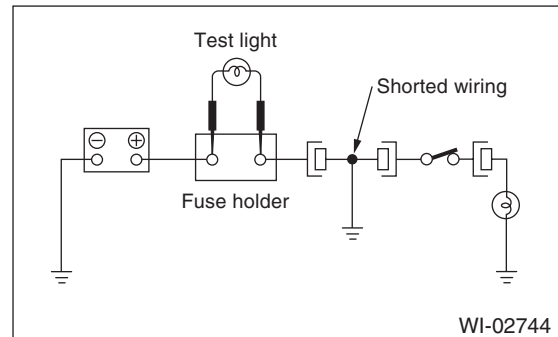

#### 2) WITH OHMMETER:

Disconnect all affected connectors, and check continuity between each connector and ground. When the ohmmeter indicates continuity between a particular connector and a ground, that connector is shorted.

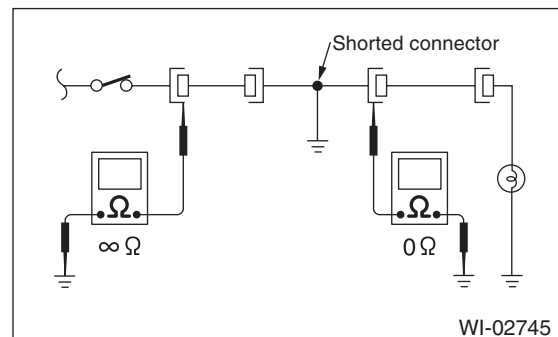

## C: HOW TO READ WIRING DIAGRAMS

### 1. WIRING DIAGRAM:

The wiring diagram of each system is illustrated so that you can understand the path through which the electric current flows from the battery.

Sketches and codes are used in the diagrams. They should read as follows:

- Each connector and its terminal position are indicated by a sketch of the connector in a disconnected state which is viewed from the front.

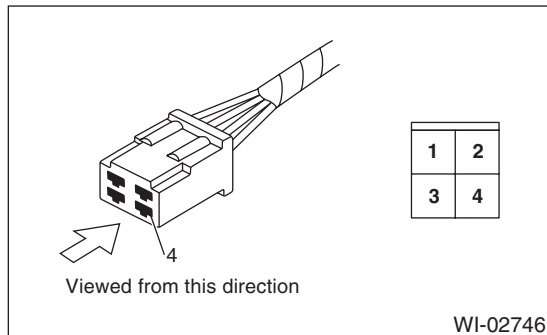

- The number of poles or pins, presence of a lock are indicated in the sketch of each connector. In the sketch, the highest pole number refers to the number of poles which the connector has. For example, the sketch of the connector shown in figure indicates the connector has 9 poles.

Connector used in vehicle	Connector shown in wiring diagram												
	Sketch	Symbol	Number of poles										
	<p>Double frames</p> <p>Indicates a lock is included.</p> <table border="1" style="margin: auto; text-align: center;"> <tr> <td>4</td><td>3</td><td>7</td><td>2</td><td>1</td> </tr> <tr> <td>9</td><td>8</td><td>7</td><td>6</td><td>5</td> </tr> </table> <p>Indicates the number of poles.</p>	4	3	7	2	1	9	8	7	6	5		<p>Numbered in order from upper right to lower left.</p>
4	3	7	2	1									
9	8	7	6	5									
	<p>Indicates a lock is included.</p> <table border="1" style="margin: auto; text-align: center;"> <tr> <td>1</td><td>2</td><td>7</td><td>3</td><td>4</td> </tr> <tr> <td>5</td><td>6</td><td>7</td><td>8</td><td>9</td> </tr> </table> <p>Single frame</p>	1	2	7	3	4	5	6	7	8	9		<p>Numbered in order from upper left to lower right.</p>
1	2	7	3	4									
5	6	7	8	9									

WI-02747

# Basic Diagnostic Procedure

## WIRING SYSTEM

- When one set of connectors is viewed from the front side, the pole numbers of one connector are symmetrical to those of the other. When these two connectors are connected as a unit, the poles which have the same number are joined.

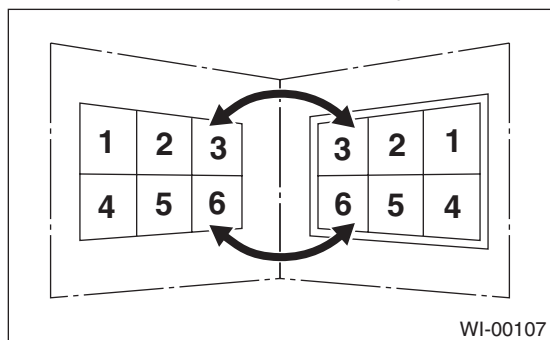

WI-00107

### • WIRING DIAGRAM:

The connectors are numbered along with the number of poles, external colors, and mating connections in the accompanying list.

- The sketch of each connector in the wiring diagram usually shows the (A) side of the connector. The relationship between the wire color, terminal number and connector is described in the figure.

### NOTE:

A wire which runs in one direction from a connector terminal sometimes may have a different color from that which runs in the other direction from that terminal.

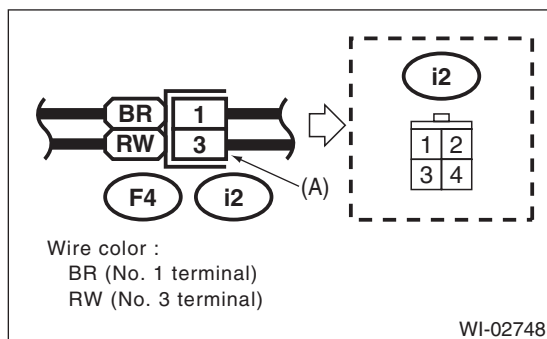

WI-02748

- In the wiring diagram, connectors which have no terminal number refer to one-pole types. Sketches of these connectors are omitted intentionally.

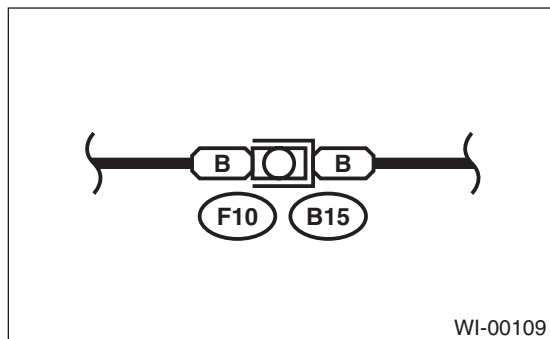

WI-00109

- The following color codes are used to indicate the colors of the wires.

Color code	Color
L	Blue
B	Black
Y	Yellow
G	Green
R	Red
W	White
Br	Brown
Lg	Light green
Gr	Gray
P	Pink
Or	Orange
Sb	Light blue
V	Violet
SA	Sealed (Inner)
SB	Sealed (Outer)

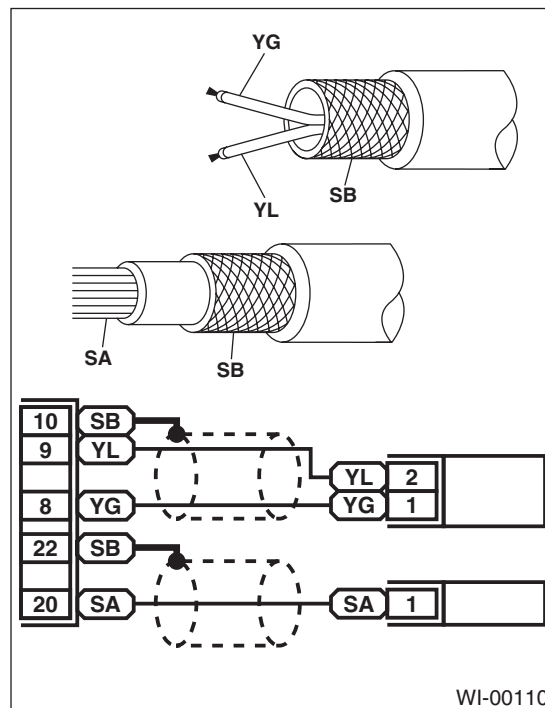

WI-00110

- The wire color code, which consists of two letters (or three letters including Br or Lg), indicates the standard color (base color of the wire covering) by its first letter and the stripe marking by its second letter.

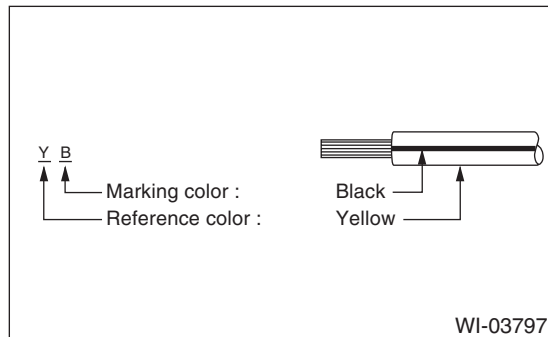

- The table lists the nominal sectional areas and allowable currents of the wires.

### CAUTION:

**When replacing or repairing a wire, be sure to use the same size and type of the wire which was originally used.**

### NOTE:

- The allowable current in the table indicates the tolerable amperage of each wire at an ambient temperature of 40°C (104°F).
- The allowable current changes with ambient temperature. Also, it changes if a bundle of more than two wires is used.

Nominal sectional area mm <sup>2</sup>	No. of strands/ strand diameter	Outside diameter of wiring mm	Allowable current Amps/ 40°C (104°F)
0.3	7/0.26	1.8	7
0.5	7/0.32	2.2 (or 2.0)	12
0.75	30/0.18	2.6 (or 2.4)	16
0.85	11/0.32	2.4 (or 2.2)	16
1.25	16/0.32	2.7 (or 2.5)	21
2	26/0.32	3.1 (or 2.9)	28
3	41/0.32	3.8 (or 3.6)	38
5	65/0.32	4.6 (or 4.4)	51
8	50/0.45	5.5	67

- Each unit is either directly grounded to the body or indirectly grounds through a harness ground terminal. Different symbols are used in the wiring diagram to identify the two grounding systems.

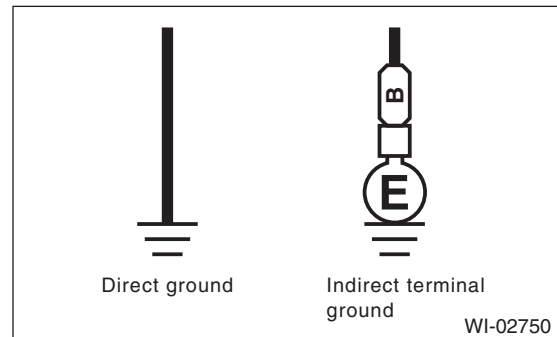

- The ground points shown in the wiring diagram refer to the following:

### NOTE:

All wiring harnesses are provided with a ground point which must be securely connected.

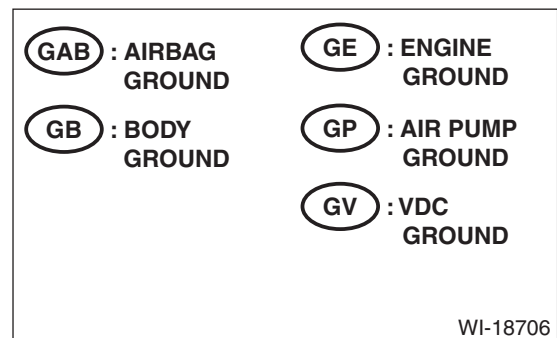

# Basic Diagnostic Procedure

## WIRING SYSTEM

- Relays are classified as normally-open or normally-closed.
- The normally-closed relay has one or more contacts. The wiring diagram shows the relay mode when the energizing circuit is OFF.

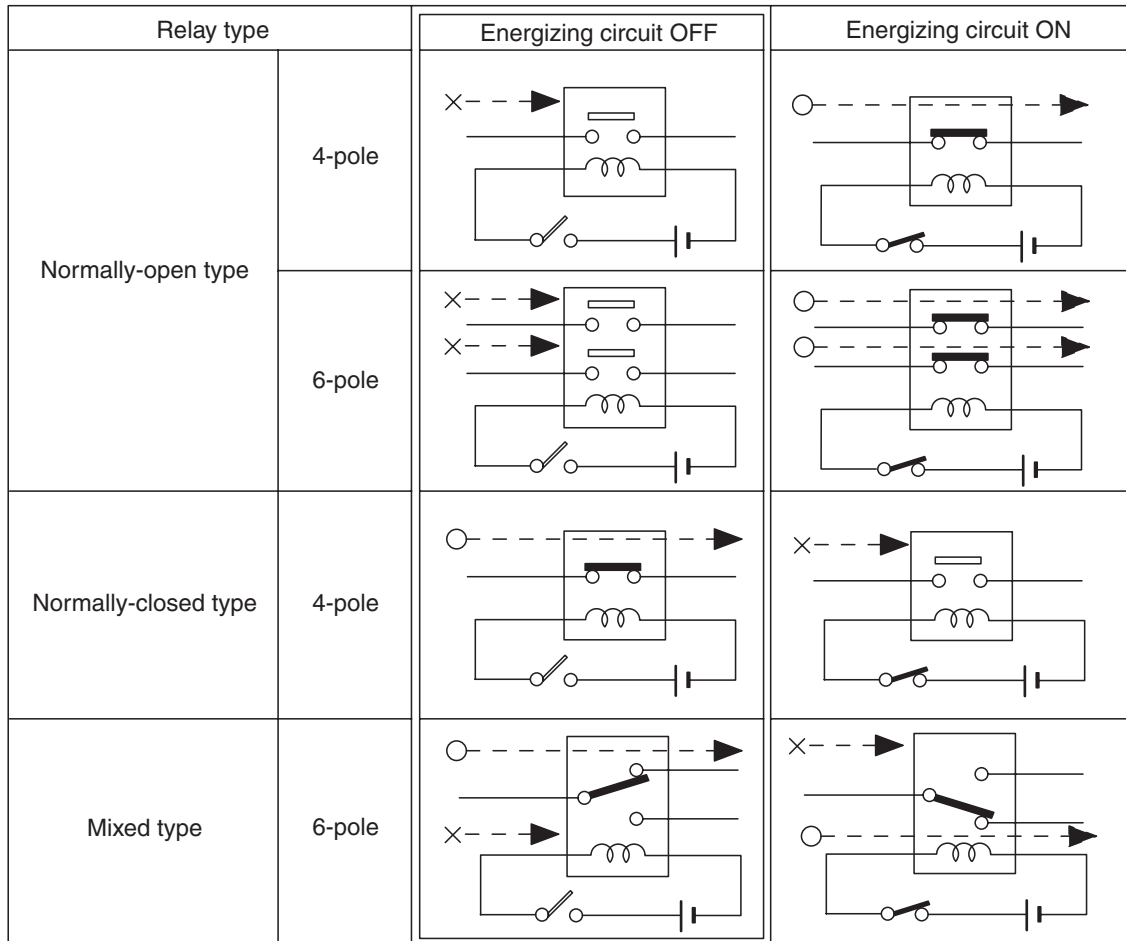

Key to symbols:

○ —▶ : Current flows.

× —▶ : Current does not flow.

WI-16724



- Each connector number shown in the wiring diagram corresponds to that in the wiring harness. The location of each connector in the actual vehicle is determined by reading the first character of the connector (for example, a "F" for F8, "i" for i16, etc.) and the type of wiring harness. The first character of each connector number corresponds to the area or system of the vehicle.

Symbol	Wiring harness and cord
F	Front wiring harness
B	Bulkhead wiring harness
E	Engine wiring harness
T	Transmission cord
D	Door cord LH & RH, Rear gate cord Rear door cord LH & RH, Rear defogger cord
i	Instrument panel wiring harness
R	Rear wiring harness, Fuel tank cord, Roof cord, Rear gate cord
AB	Airbag wiring harness

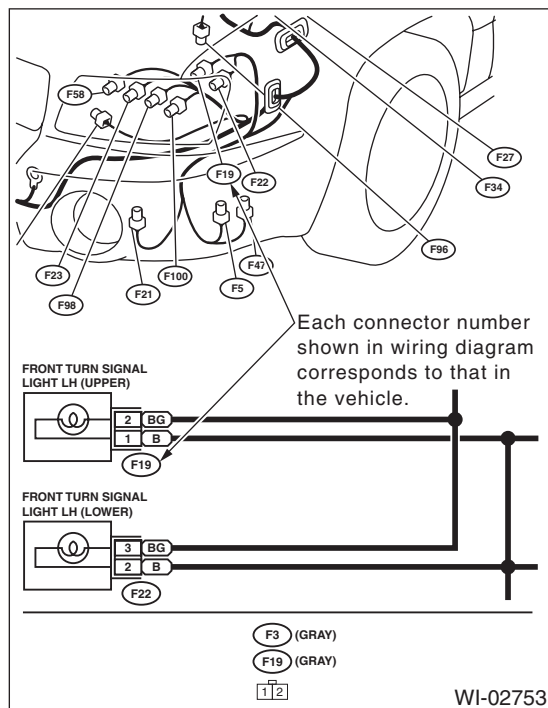

# Basic Diagnostic Procedure

## WIRING SYSTEM

### D: SYMBOLS IN WIRING DIAGRAMS

A number of symbols are used in each wiring diagram to easily identify parts or circuits.

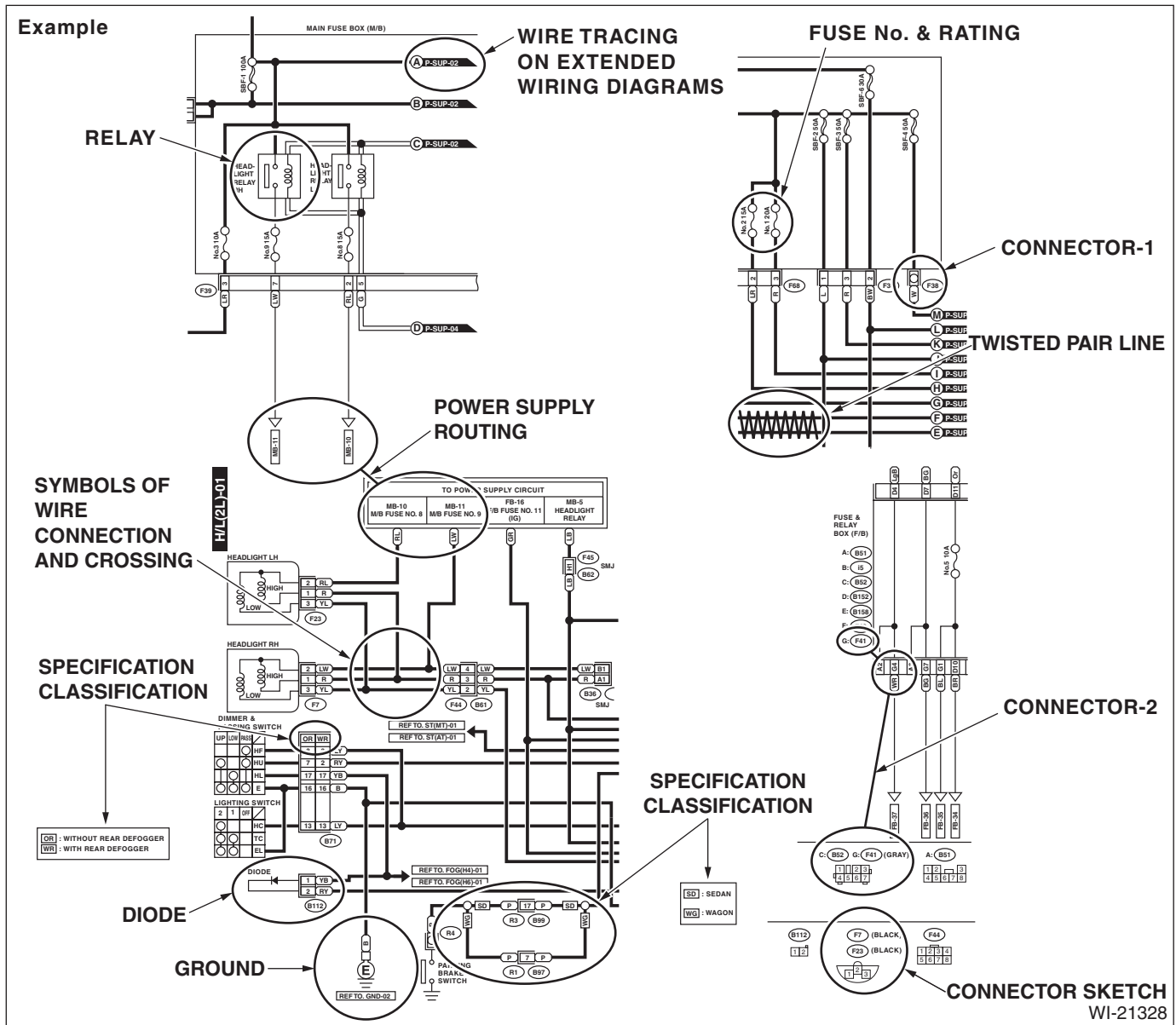

## 1. RELAY

A symbol used to indicate a relay.

## 2. CONNECTOR 1

The sketch of the connector indicates the one-pole types.

## 3. WIRING CONNECTION

Some wiring diagrams are indicated in foldouts for convenience. Wiring destinations are indicated where necessary by corresponding symbols. (When two pages are needed for clear indication)

## 4. FUSE NO. & RATING

The "FUSE No. & RATING" corresponds with that used in the fuse box (main fuse box, fuse and joint box).

## 5. CONNECTOR 2

- Each connector is indicated by a symbol.
- Each terminal number is indicated in the corresponding wiring diagram in an abbreviated form.
- For example, terminal number "G4" refers to No. 4 terminal of connector (G: F41) shown in the connector sketch.

## 6. CONNECTOR SKETCH

- Each connector sketch clearly identifies the shape and color of a connector as well as terminal locations. Non-colored connectors are indicated in natural color.
- When more than two types of connector number are indicated in a connector sketch, it means that the same type connectors are used.

## 7. GROUND

Each grounding point can be located easily by referring to the corresponding wiring harness.

## 8. DIODE

A symbol is used to indicate a diode.

## 9. WIRE TRACING ON EXTENDED WIRING DIAGRAMS

For a wiring diagram extending over at least two pages, a symbol (consisting of the same characters with arrows), facilitates wire tracing from one page to the next.

A ↔ A, B ↔ B

## 10. SYMBOLS OF WIRE CONNECTION AND CROSSING

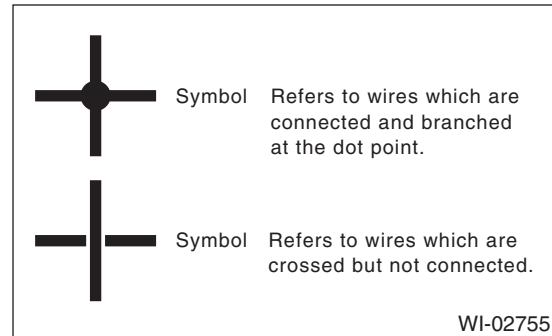

## 11. POWER SUPPLY CIRCUIT

A symbol is used to indicate the power supply in each wiring diagram.

"MB - 5", "MB - 6", etc., which are used as power-supply symbols throughout the text, correspond with those shown in the "DC POWER SUPPLY CIRCUIT" in the wiring diagram.

Accordingly, using the "DC POWER SUPPLY CIRCUIT" and wiring diagrams permits service personnel to understand the entire electrical arrangement of a system.

## 12. CLASSIFICATION BY SPECIFICATION

When the wiring diagram differ according to vehicle specifications, the specification difference is described by using abbreviations.

## 13. TWISTED PAIR LINE

The twisted pair line is indicated by a symbol in the wiring diagrams.

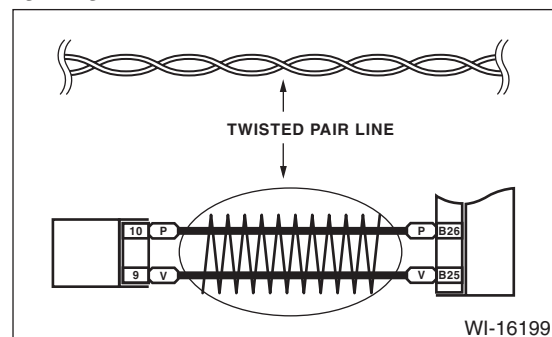







# Basic Diagnostic Procedure







## WIRING SYSTEM



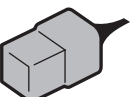



### E: CONNECTOR SYMBOL IN WIRING HARNESS

A number of connector symbols are used in each wiring diagram to easily identify the wiring harness connectors.

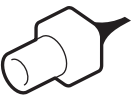





Standard type: Female		
Pole: From 1 to 8	Pole: From 9 to 20	Pole: More than 21
		
		

Standard type: Male		
		
		

Water proof type: Female		
Pole: From 1 to 8	Pole: From 9 to 20	Pole: More than 21
		
		

Water proof type: Male		
		
		

WI-02756

## F: ABBREVIATION IN WIRING DIAGRAMS

Abbr.	Full name
ABS	Anti-lock Brake System
ACC	Accessory
A/C	Air Conditioner
ASSY	Assembly
A/F	Air/Fuel (Air fuel ratio sensor)
AUX	Auxiliary Audio Input Terminal
B	Battery
CAN	Controller Area Network
CM	Control Module
DN	Down
DCCD	Driver's Control Center Differential
E	Ground
ECM	Engine Control Module
EEPROM	Electrically Erasable Programmable Read-Only Memory
ELCM	Evaporative Leak Check Module
F/B	Fuse & Relay Box
FL	Front Left
FR	Front Right
G	Gravity (G sensor)
H/L	Headlight
HI	High
I/F	Interface
IG	Ignition
INT	Intermittent
LCD	Liquid Crystal Display
LH	Left Hand
LO	Low
M	Motor
M/B	Main Fuse Box
PASS	Passing
RH	Right Hand
RL	Rear Left
RR	Rear Right
SBF	Slow Blow Fuse
SI-DRIVE	SUBARU Intelligent Drive
ST	Starter
SW	Switch
TPMS	Tire Pressure Monitor System
VDC	Vehicle Dynamics Control
VFD	Vacuum Fluorescent Display
WASH	Washer

# Working Precautions

## WIRING SYSTEM

### 2. Working Precautions

#### A: PRECAUTIONS WHEN WORKING WITH THE PARTS MOUNTED ON THE VEHICLE

- 1) When working under a vehicle which is jacked-up, always be sure to use rigid rack.
- 2) The parking brake must always be applied during working. Also, in automatic transmission vehicles, keep the select lever set to the P (Parking) range.
- 3) Be sure the workshop is properly ventilated when running the engine. Further, be careful not to touch the belt or fan while the engine is operating.
- 4) Be careful not to touch hot metal parts, especially the radiator and exhaust system immediately after the engine has been turned off.

#### B: PRECAUTIONS IN TROUBLE DIAGNOSIS AND REPAIR OF ELECTRIC PARTS

- 1) The battery cable must be disconnected from the battery's (-) terminal, and the ignition switch must be set to the OFF position, unless otherwise required by the diagnostics.
- 2) Securely fasten the wiring harness with clamps and clips so that the harness does not interfere with the body end parts, edges, bolts or screws.
- 3) When installing parts, be careful not to catch them on the wiring harness.
- 4) When disconnecting a connector, do not pull the wires, but pull while holding the connector body.

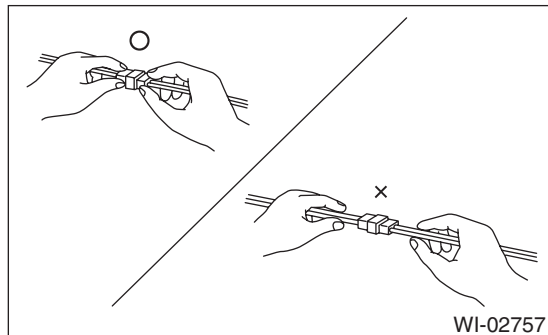

- 5) Some connectors are provided with a lock. One type of such a connector is disconnected by pushing the lock, and the other, by moving the lock up. In either type the lock shape must be identified before attempting to disconnect the connector. To connect, insert the connector until it snaps and confirm that it is connected securely.

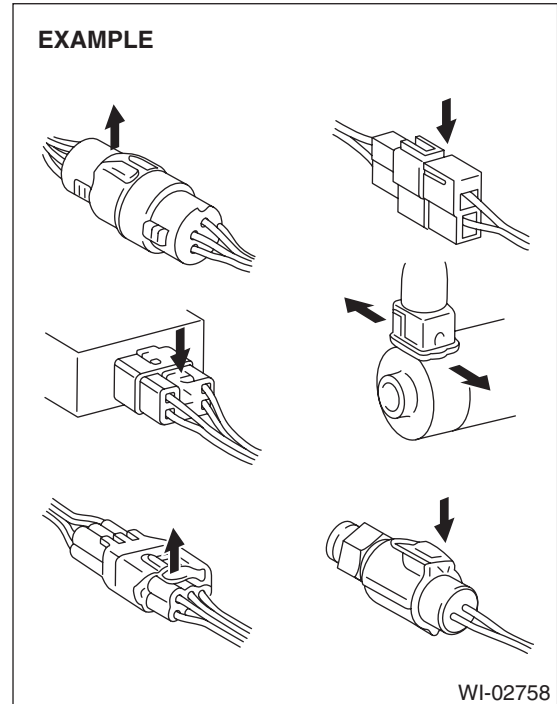

- 6) When checking continuity between connector terminals, or measuring voltage across the terminal and ground, always touch tester probe(s) to terminals from the wiring connection side. If the probe is too thick to gain access to the terminal, use "mini" test leads.

To check water-proof connectors (which are not measurable from the wiring side), touch test probes on the terminal side and be careful not to bend or damage the terminals.

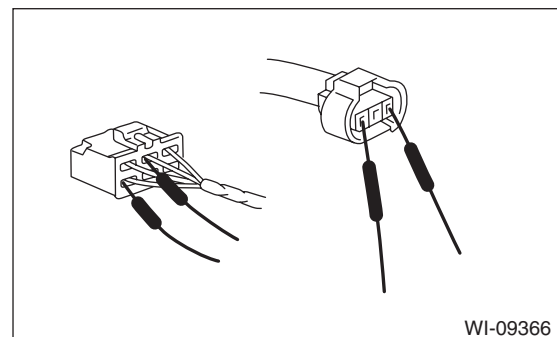

- 7) Sensors, relays, electrical unit, etc., are sensitive to strong impacts. Handle them with care so that they are not dropped or mishandled.

## 3. Power Supply Circuit

### A: WIRING DIAGRAM

- Engine room side

P-SUP-01

P-SUP-01

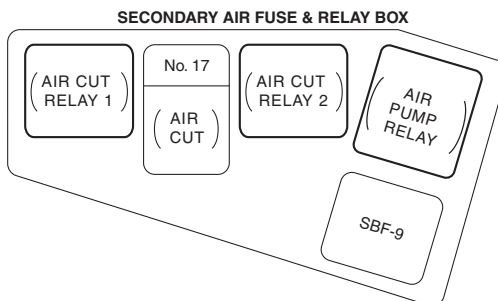
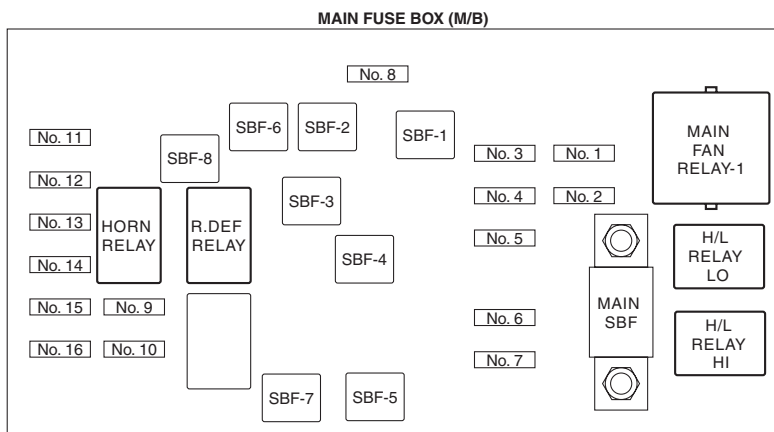

WI-30585

# Power Supply Circuit

## WIRING SYSTEM

### • Passenger room side

P-SUP-02

FUSE & RELAY BOX (F/B) FRONT SIDE

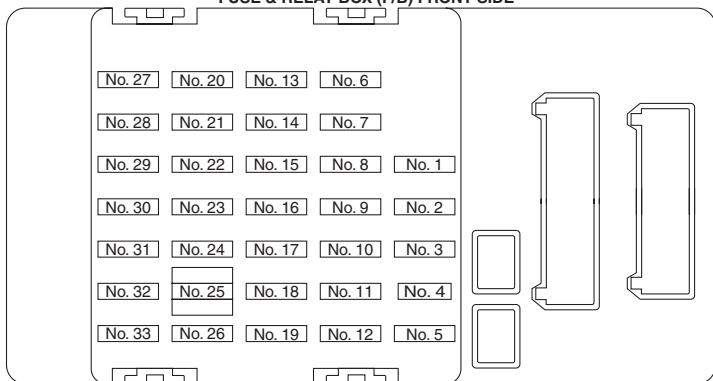

RELAY BLOCK

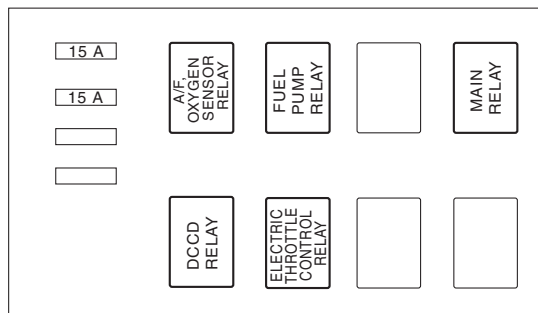

FUSE & RELAY BOX (F/B) BACK SIDE

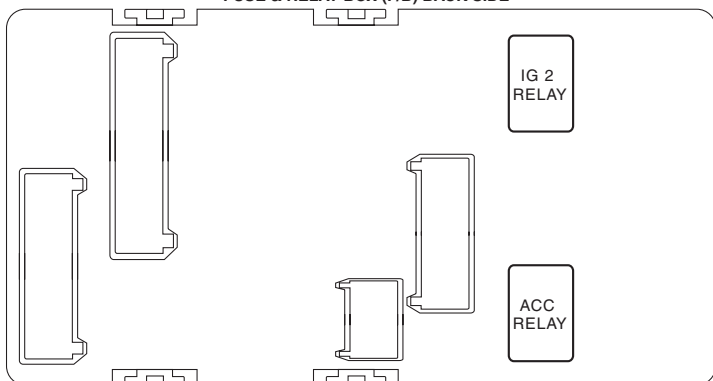

RELAY BLOCK

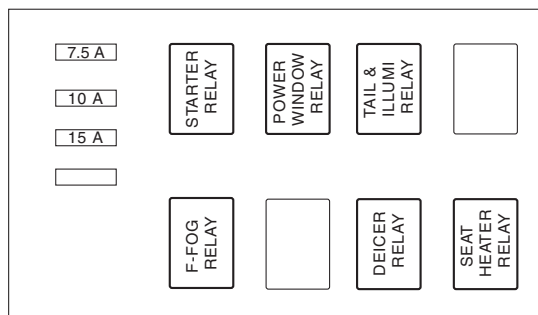

WI-30372



# Power Supply Circuit

WIRING SYSTEM

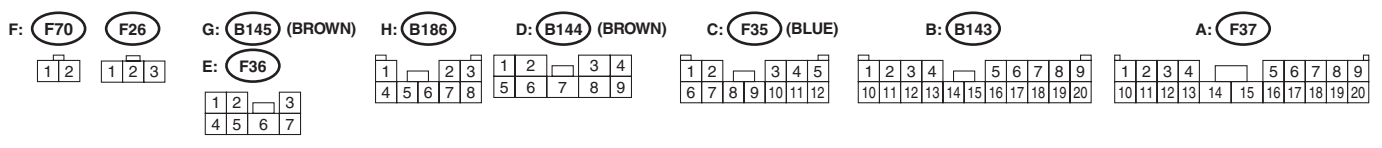
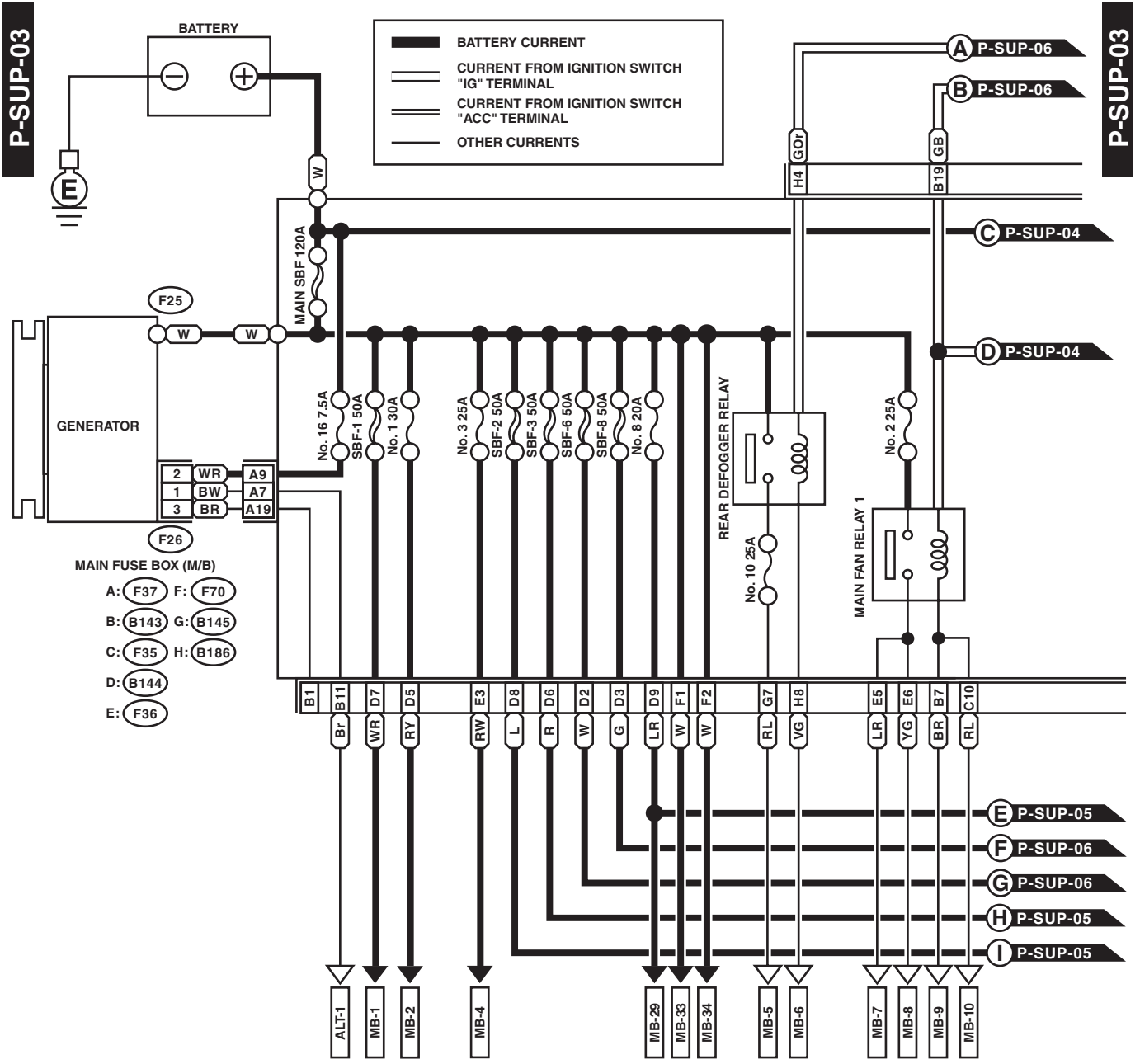

WI-30373

# Power Supply Circuit

WIRING SYSTEM

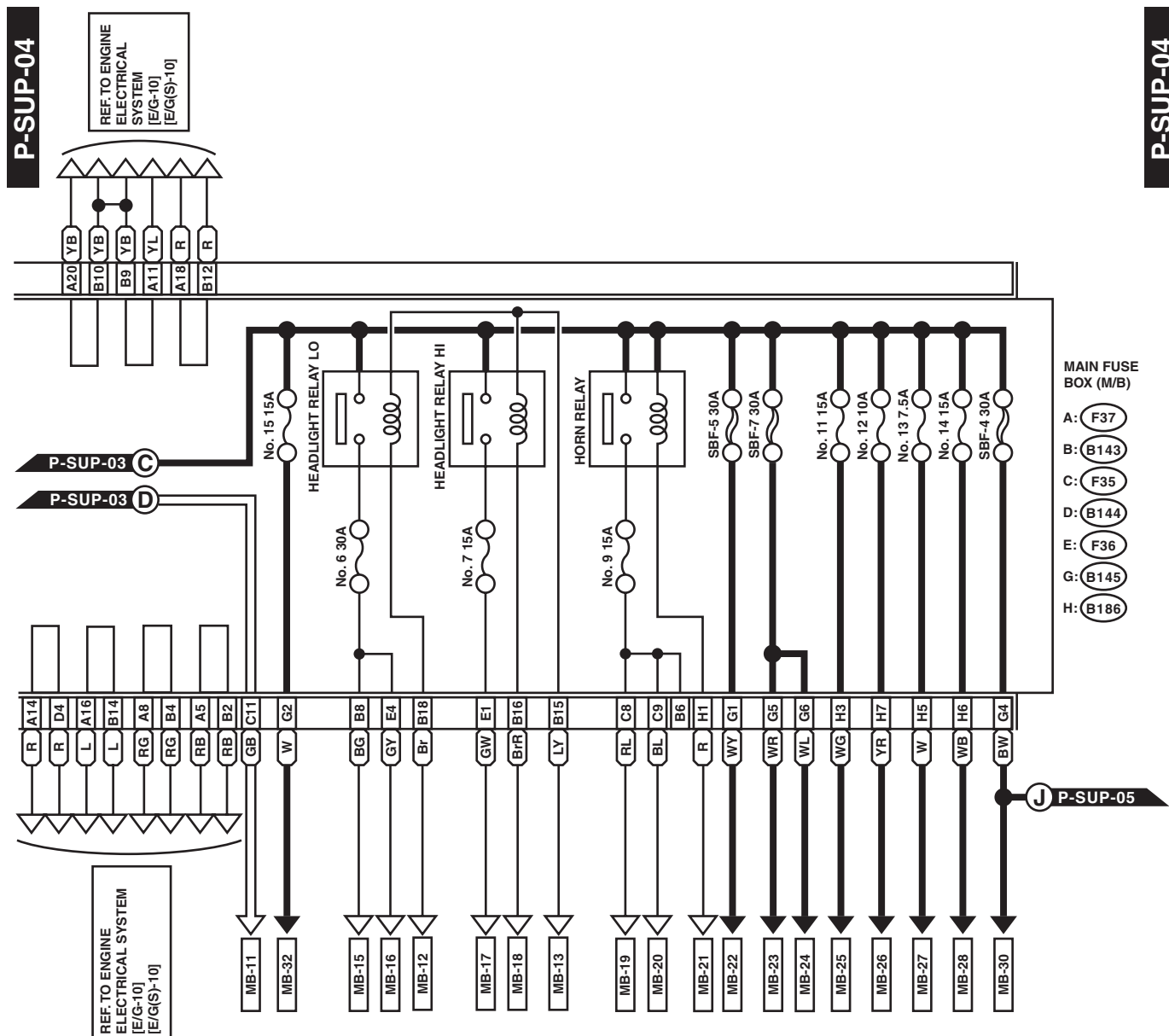

G: B145 (BROWN)

H: B186

D: B144 (BROWN)

C: F35 (BLUE)

B: B143

A: F37

E: F36

1	2	3
4	5	6
	7	

1	2	3	4
4	5	6	7
	8		9

1	2	3	4
5	6	7	8
	9		

1	2	3	4	5
6	7	8	9	10
	11		12	

1	2	3	4	5	6	7	8	9
10	11	12	13	14	15	16	17	18
	19		20					

1	2	3	4	5	6	7	8	9
10	11	12	13	14	15	16	17	18
	19		20					

WI-30374

# Power Supply Circuit

WIRING SYSTEM

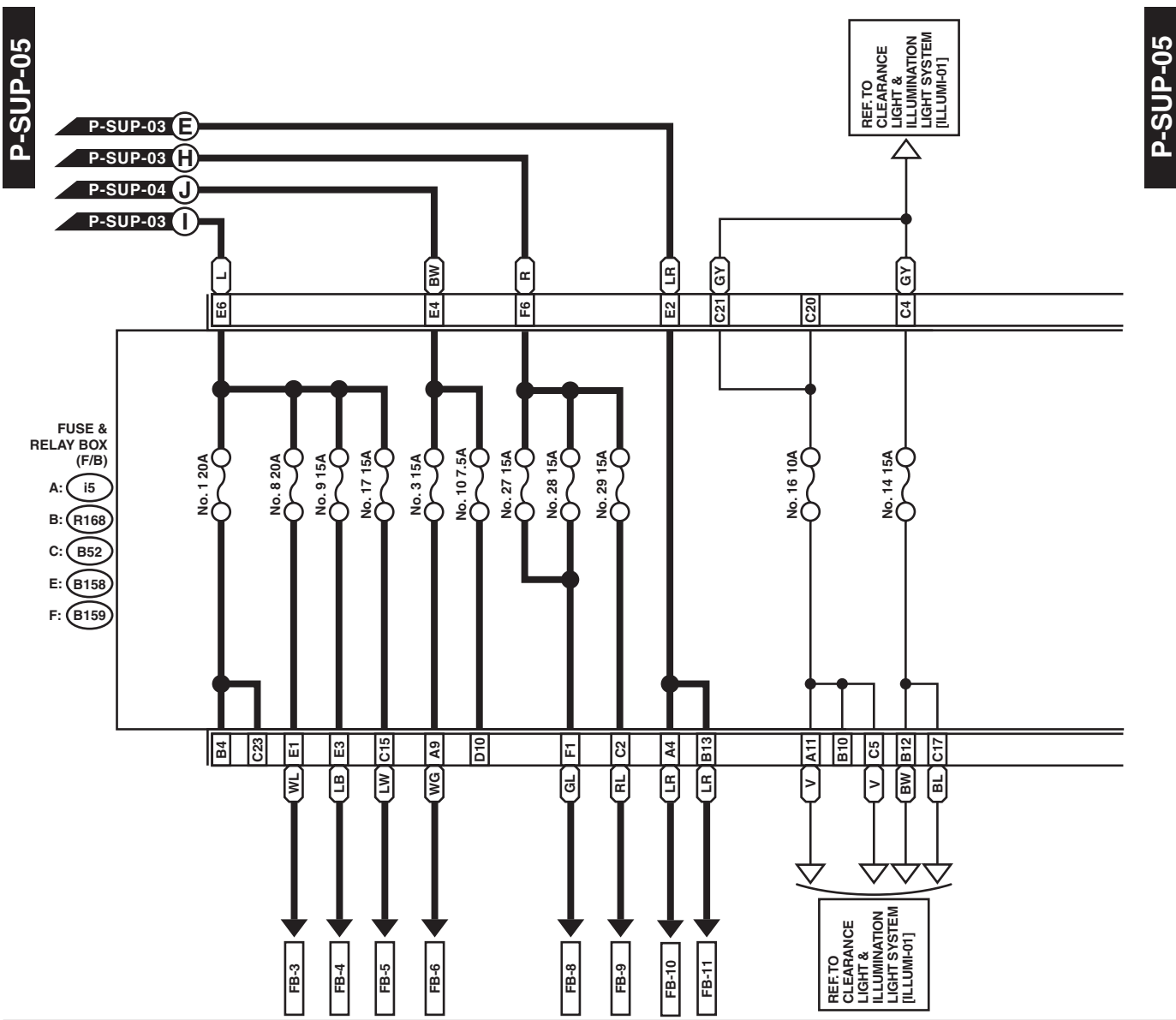

E: (B158)

1	2	3	4
5	6	7	8

F: (B159) (BROWN)

1	2	3	4
5	6	7	8

A: (i5)

1	2	3	4	5	6	7	8	9		
10	11	12	13	14	15	16	17	18	19	20

B: (R168)

1	2	3	4	5	6	7	8	9		
10	11	12	13	14	15	16	17	18	19	20

C: (B52)

1	2	3	4	5	6	7	8	9	10	11		
12	13	14	15	16	17	18	19	20	21	22	23	24

WI-30375

# Power Supply Circuit

WIRING SYSTEM

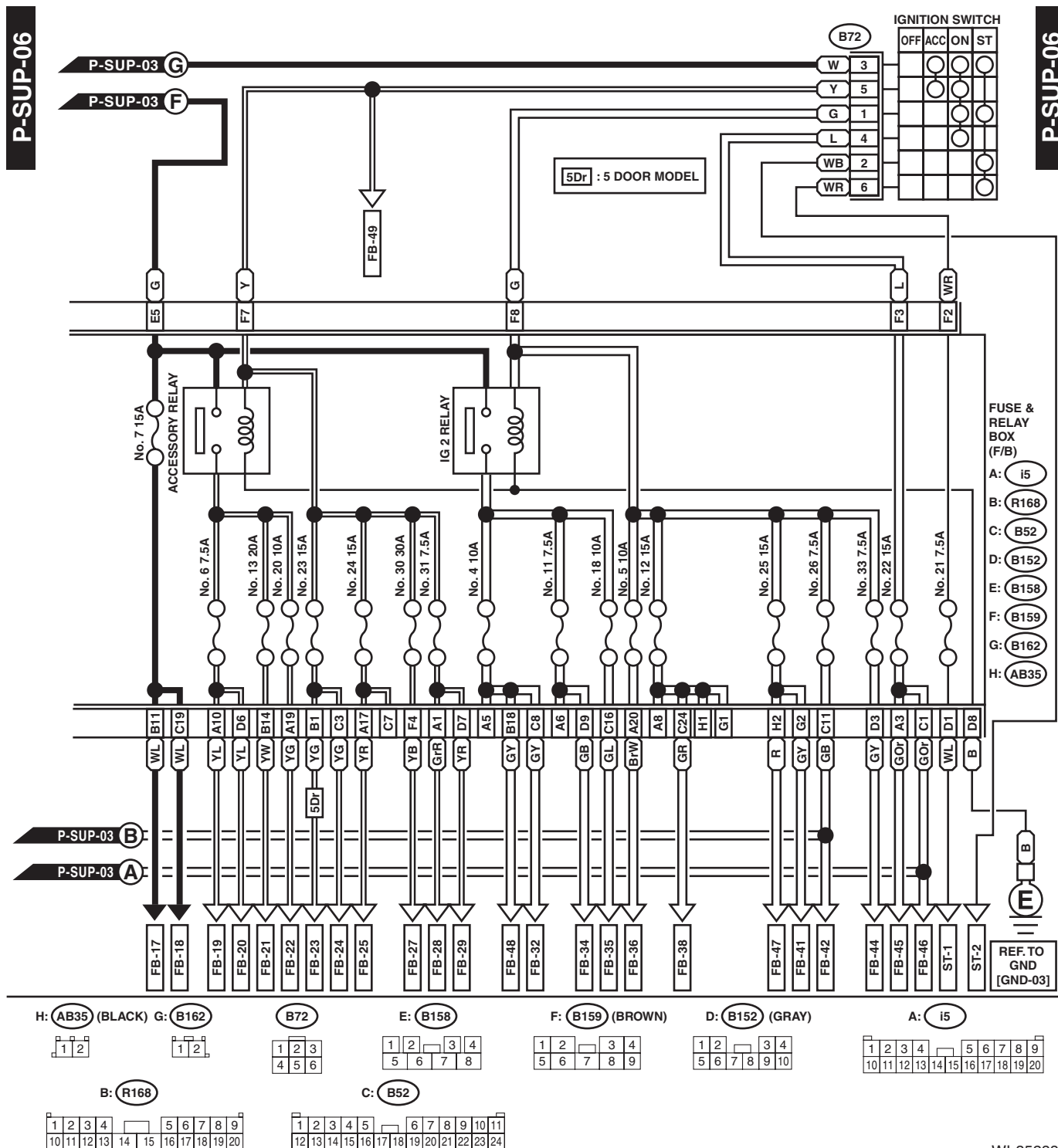

WI-35288

# Power Supply Circuit

WIRING SYSTEM

No.	Load
MB-1	VDC CM
MB-2	VDC CM
MB-4	Sub fan relay
MB-5	Mirror heater LH
	Mirror heater RH
	Rear defogger
	A/C control panel (manual A/C)
MB-6	Body integrated unit
MB-7	Main fan relay 2
MB-8	Main fan motor
MB-9	ECM
MB-10	Main fan relay 2
MB-11	Main fan relay 2
MB-12	Body integrated unit
MB-13	Body integrated unit
MB-15	Front fog light relay
MB-16	Headlight LH (LO)
	Headlight RH (LO)
MB-17	Daytime running light relay
MB-18	Body integrated unit
MB-19	Horn
MB-20	Horn
MB-21	Horn switch
	Body integrated unit
MB-22	A/F, oxygen sensor relay
MB-23	Main relay
	A/F, oxygen sensor relay
MB-24	Electronic throttle control relay
MB-25	Fuel pump relay
MB-26	DCCD CM
	DCCD relay
MB-27	ECM
	Data link connector
MB-28	Key illumination
	Key warning switch
	Turn signal and hazard unit
MB-29	Spot map light
	Room light
	Body integrated unit
	Foot light LH
MB-30	Power window circuit breaker
MB-32	Tail & Illumination relay
	Daytime running light relay
MB-33	Secondary air pump relay
MB-34	Secondary air combination valve relay 1
	Secondary air combination valve relay 2
ALT-1	Combination meter
ST-1	Clutch start switch
ST-2	Starter relay
FB-3	Stop light and brake switch

No.	Load
FB-4	Wiper deicer relay
FB-5	Seat heater relay
FB-6	Body integrated unit
FB-8	Blower motor relay
FB-9	Front fog light relay
FB-10	Audio
	Clock
	Foot light RH
	Navigation unit
FB-11	Keyless entry CM (without TPMS)
	TPMS & keyless entry CM (with TPMS)
	Trunk room light (4 door model)
	Luggage room light (5 door model)
FB-17	A/C control panel (auto A/C)
	Combination meter
FB-18	Body integrated unit
	Impact sensor
	Mode door actuator
	Air mix door actuator
FB-19	Remote control mirror switch
FB-20	Seat heater relay
	Rear view mirror
FB-21	Rear accessory power supply socket
FB-22	Front accessory power supply socket
FB-23	Rear wiper motor
FB-24	Body integrated unit
	Rear washer motor
FB-25	Audio
	Navigation unit
FB-27	Combination switch
	Front wiper motor
FB-28	A/C control panel (auto A/C)
FB-29	Body integrated unit
FB-32	Clutch switch
	Impact sensor
	Data link connector
	Stop light and brake switch
	Wiper deicer relay
	Sunroof motor assembly
	Sunroof switch
Sunroof switch (tilt)	
FB-34	Turn signal and hazard unit
FB-35	Back-up light switch
FB-36	Combination meter
	Clock

WI-21

Brought to you by Ebay Seller "SubaruManuals"

# Power Supply Circuit

## WIRING SYSTEM

---

No.	Load
FB-38	ECM
	Body integrated unit
	Fuel pump relay
	Ignition coil No. 1
	Ignition coil No. 2
	Ignition coil No. 3
	Ignition coil No. 4
	DCCD CM
DCCD relay	
FB-41	Airbag CM
FB-42	Power window relay
FB-44	VDC CM
	Steering angle sensor
	Yaw rate & G sensor
FB-45	A/C control panel
FB-46	A/C relay
	Intake door actuator
	Sub fan relay
	Pressure switch
	Blower motor relay
FB-47	Occupant detection control module
FB-48	TPMS & keyless entry CM
FB-49	Front washer motor

## 4. Ground Circuit

### A: WIRING DIAGRAM

#### 1. BODY GROUND

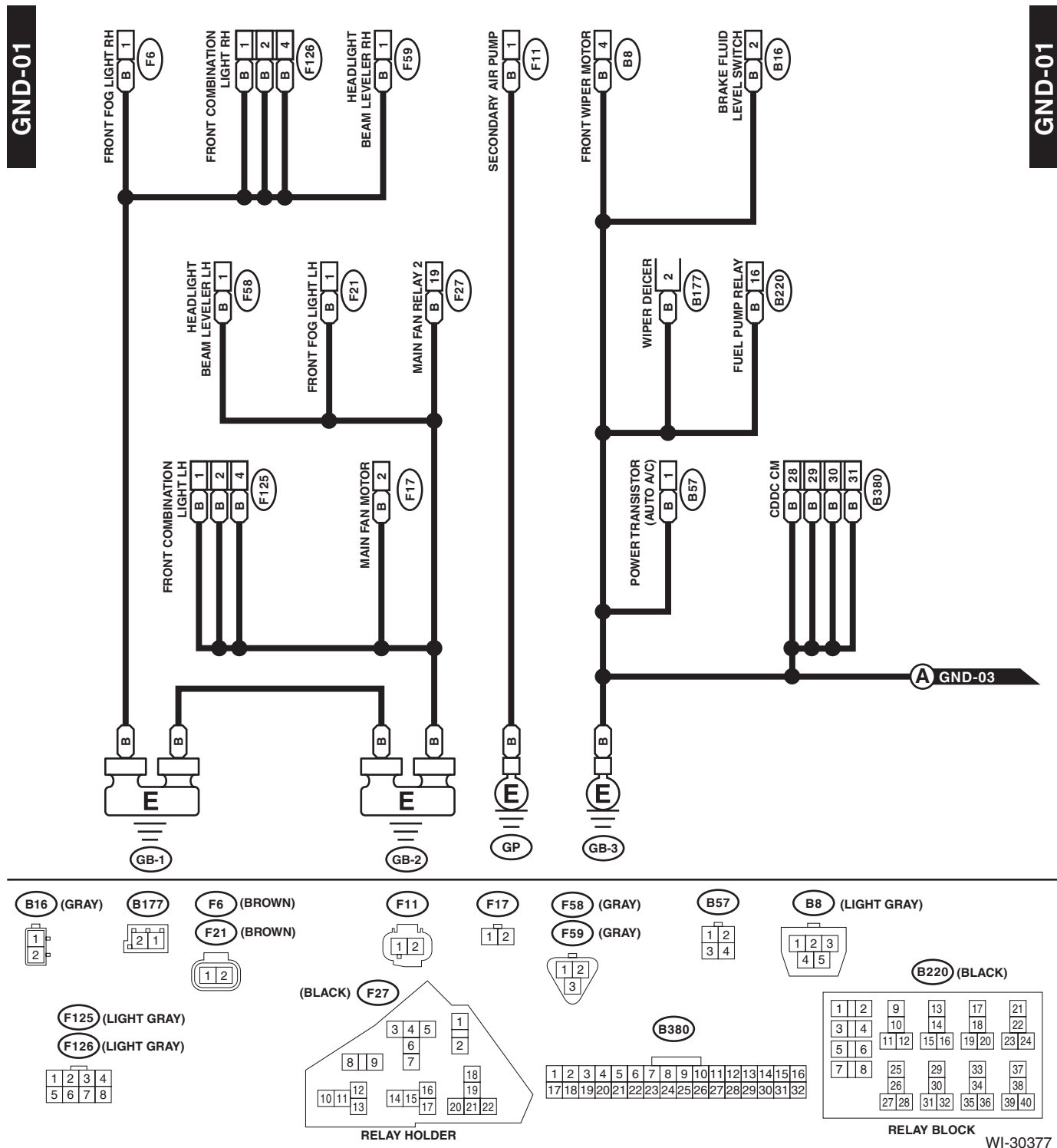

GND-01

GND-01

# Ground Circuit

WIRING SYSTEM

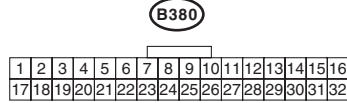
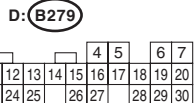
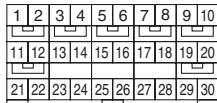
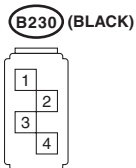
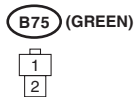
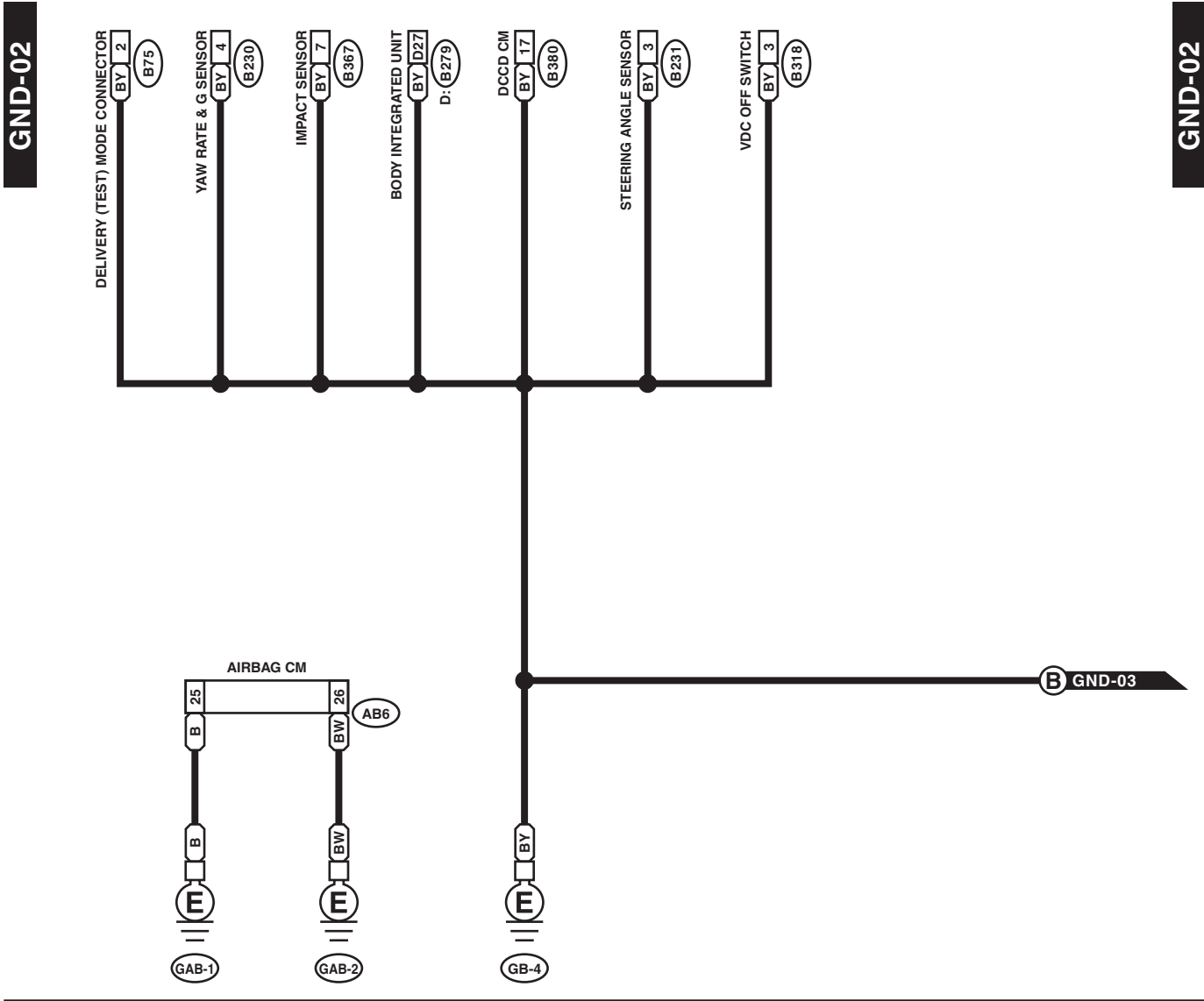

WI-35289



# Ground Circuit

WIRING SYSTEM

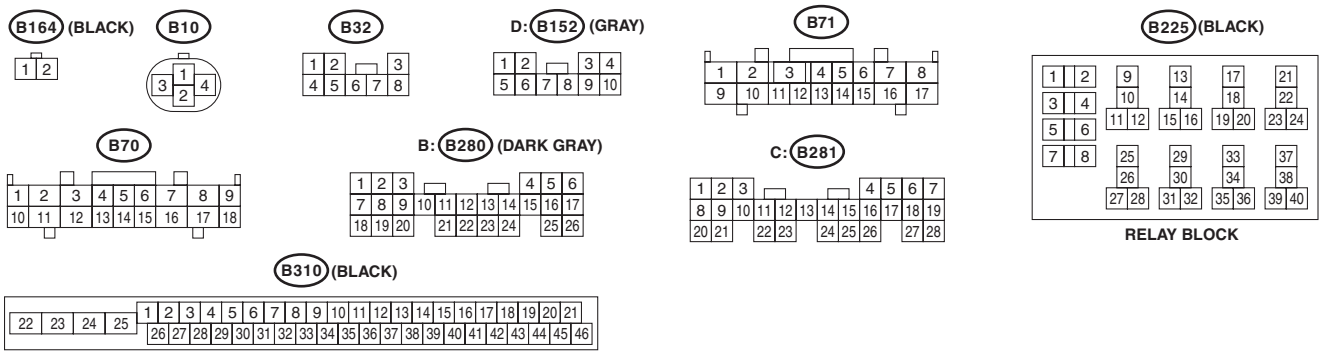
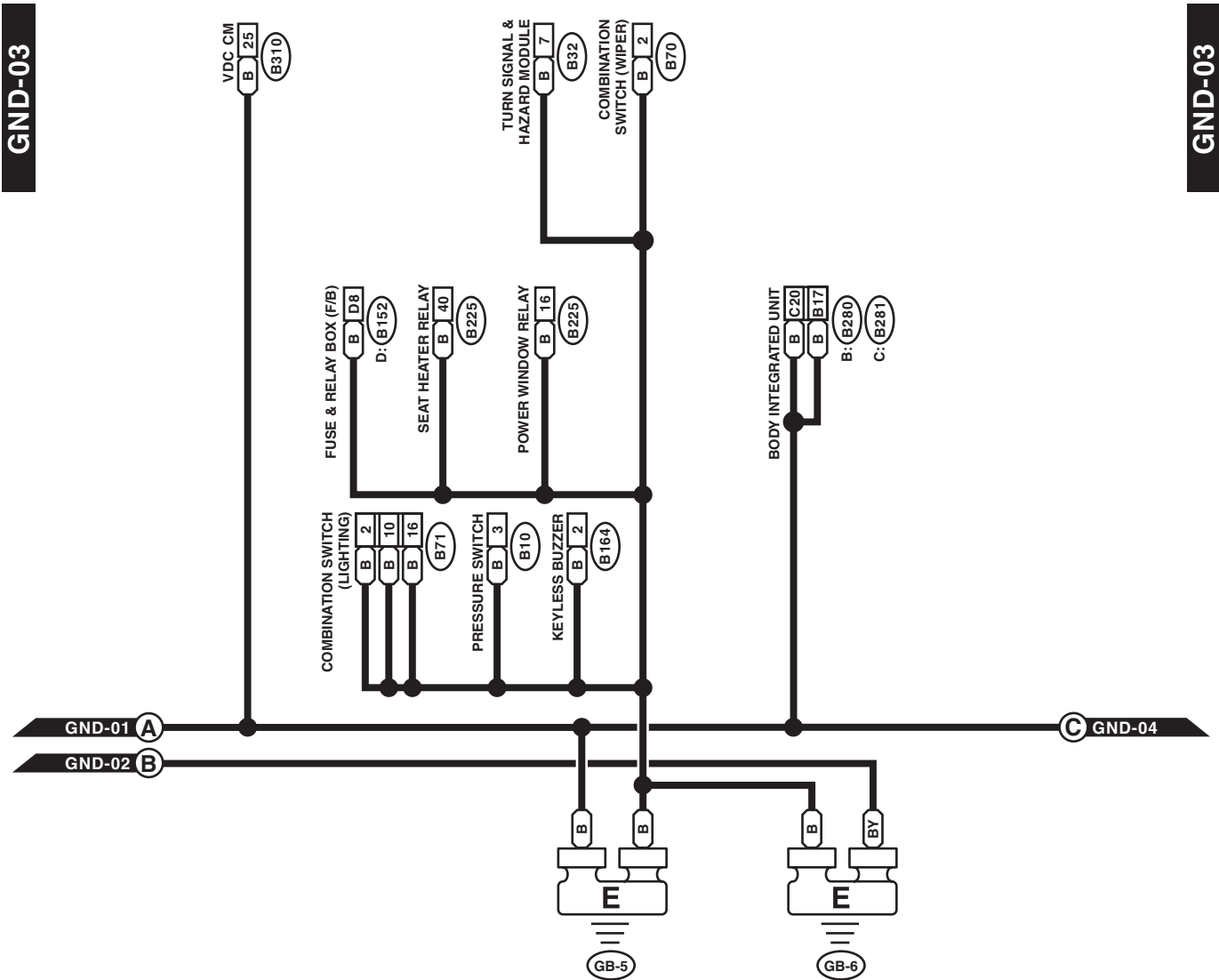

WI-30379

# Ground Circuit

WIRING SYSTEM

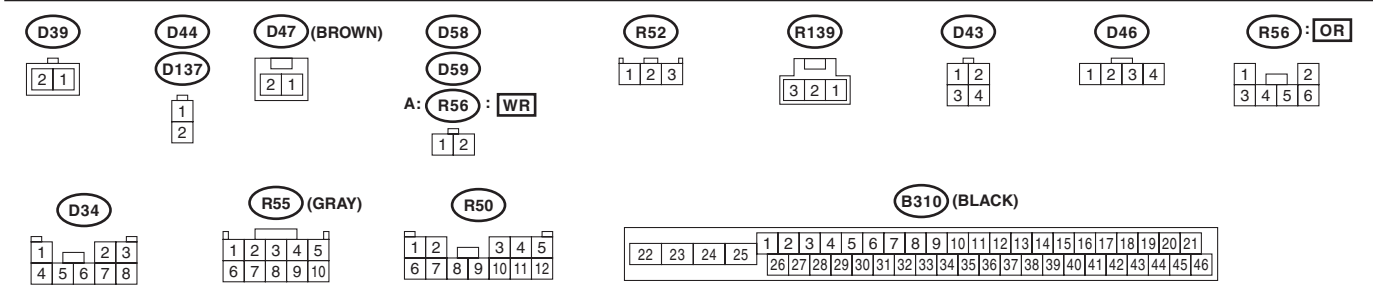
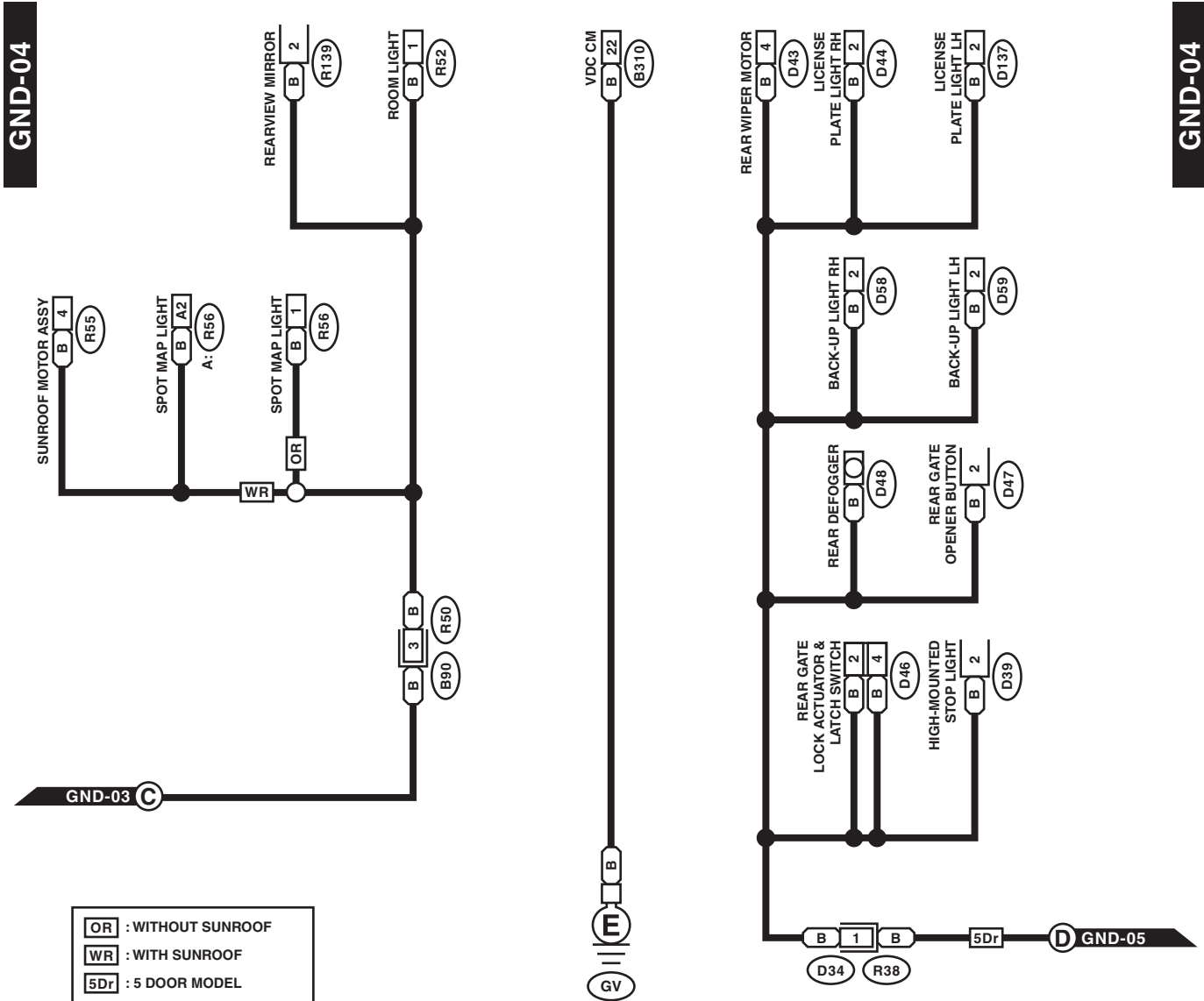

WI-30380

# Ground Circuit

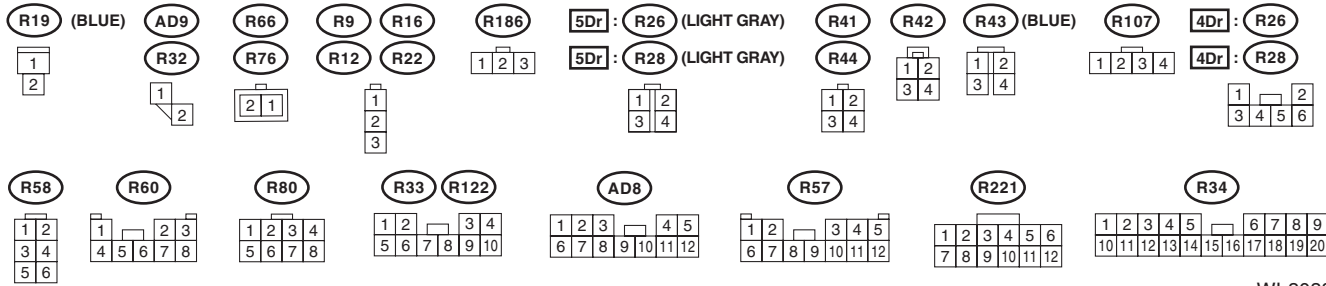
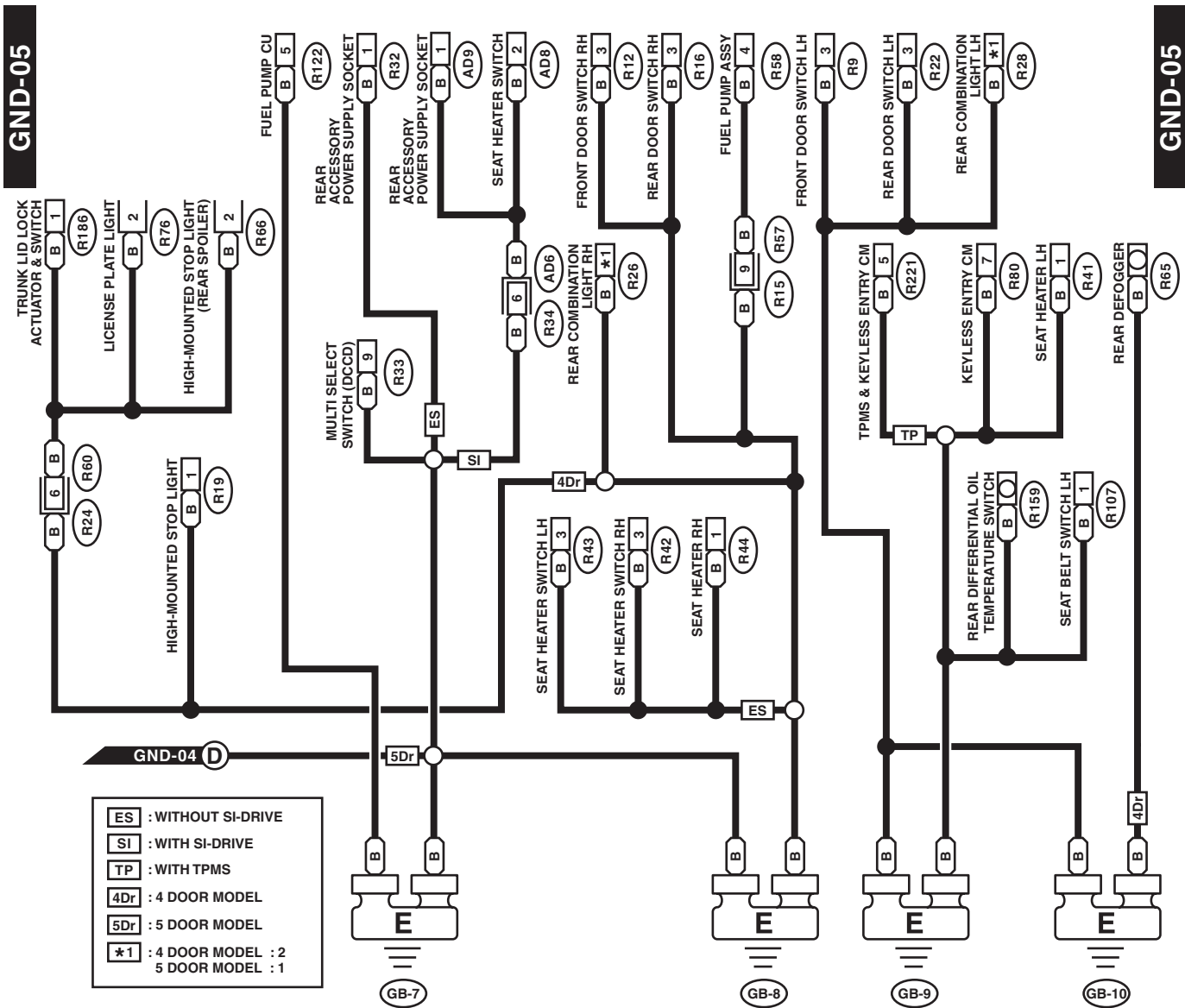

WI-30381

# Ground Circuit

## WIRING SYSTEM

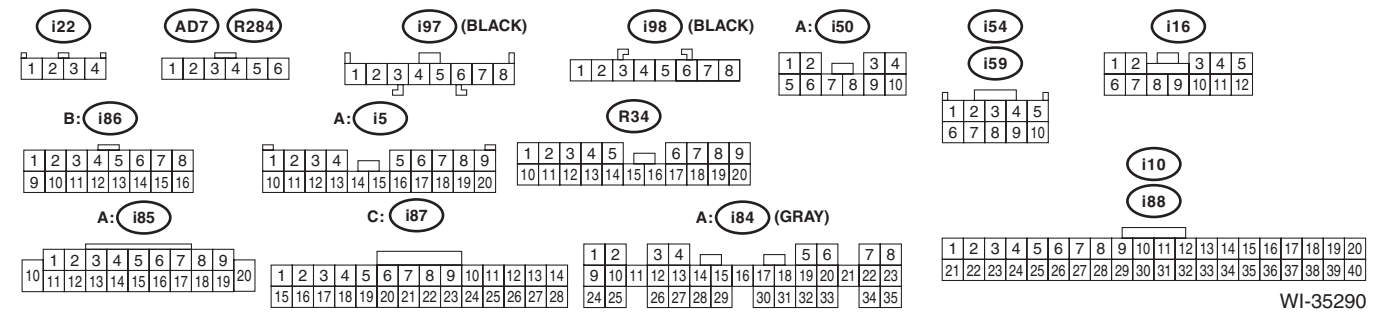
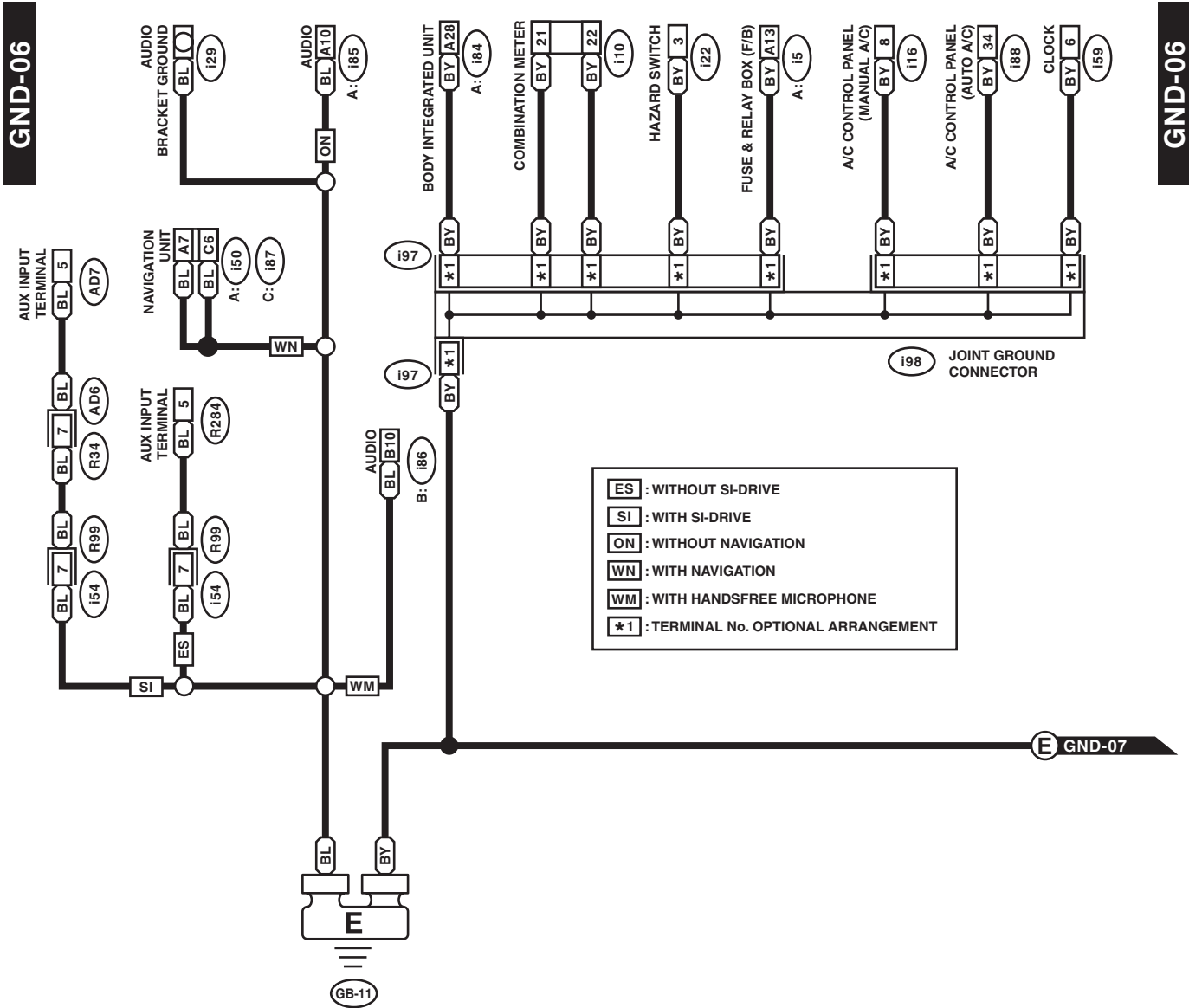

WI-35290

# Ground Circuit

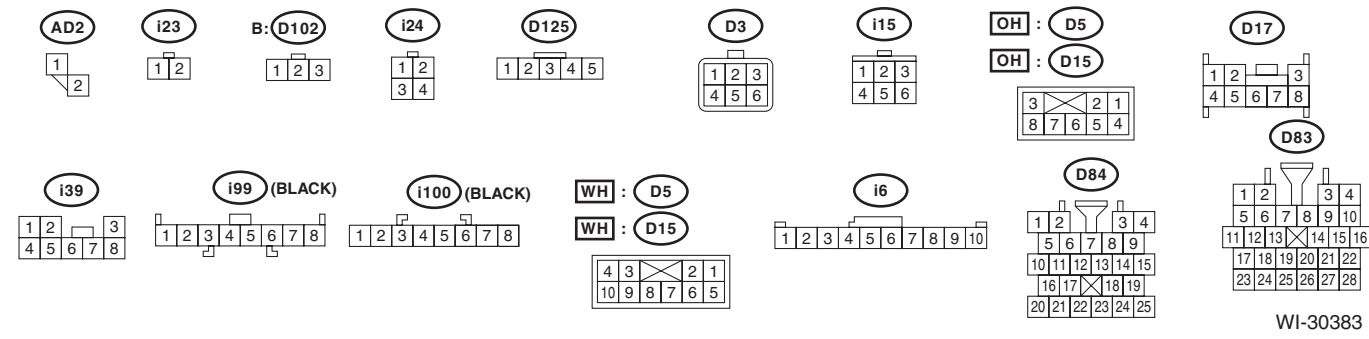
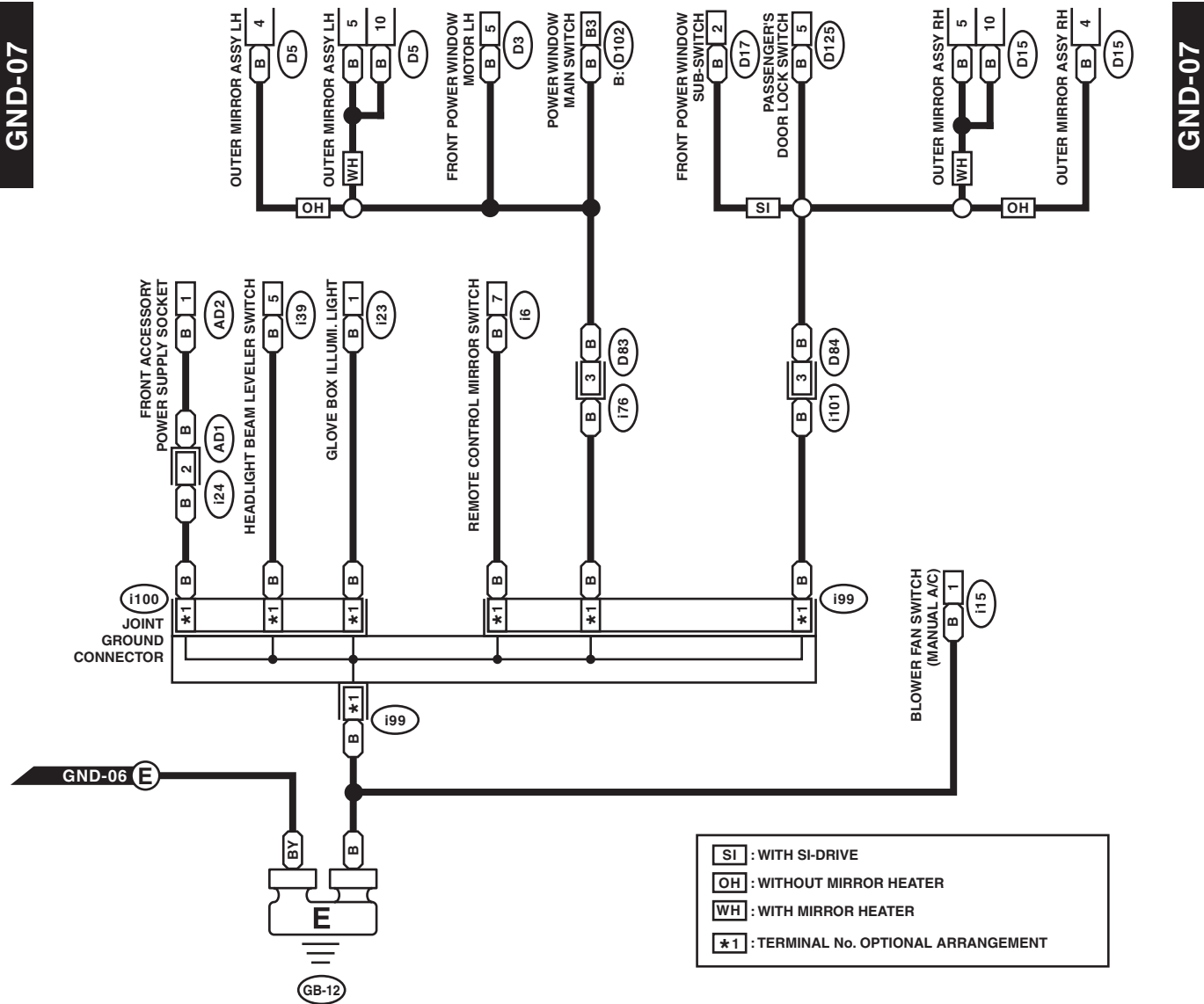

WI-30383

# Ground Circuit

## WIRING SYSTEM

### 2. ENGINE GROUND

- Without SI-DRIVE

GND-08

GND-08

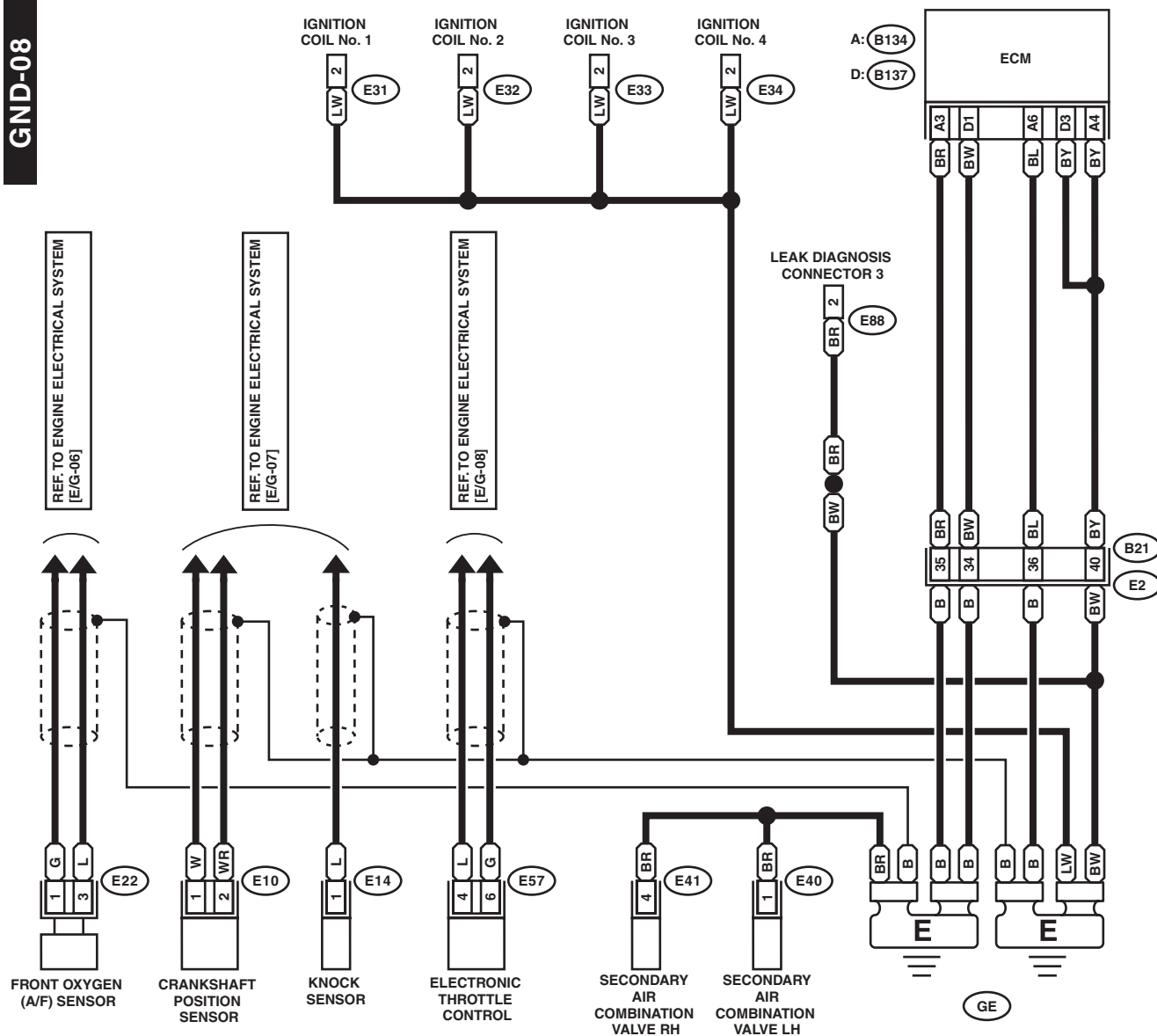

**E10** (LIGHT GRAY)    **E14** (LIGHT GRAY)    (GRAY) **E31** **E33** (GRAY)    **E22** (DARK GRAY)    **E41** (BLACK)    **B21** (BLACK)  
**E40** (BLACK)    1 2    (GRAY) **E32** **E34** (GRAY)    1 2    1 2 3    4 5 6  
**E88** (DARK GRAY)    1 2    **E57** (BLACK)    **D: B137**    **A: B134**    1 2 3    4 5 6  
1 2 3 4 5 6    1 2 3 4 5 6 7    1 2 3 4 5 6 7    1 2 3 4 5 6 7 8 9 10 11  
8 9 10 11 12 13 14 15 16 17    8 9 10 11 12 13 14 15 16 17    18 19 20 21 22 23 24 25 26 27    18 19 20 21 22 23 24 25 26 27  
18 19 20 21 22 23 24 25    26 27    28 29    30 31    28 29 30 31 32    33 34    34 35 36 37 38 39 40 41  
42 43 44 45 46 47    48 49 50 51 52 53 54

WI-33871

# Ground Circuit

WIRING SYSTEM

• With SI-DRIVE

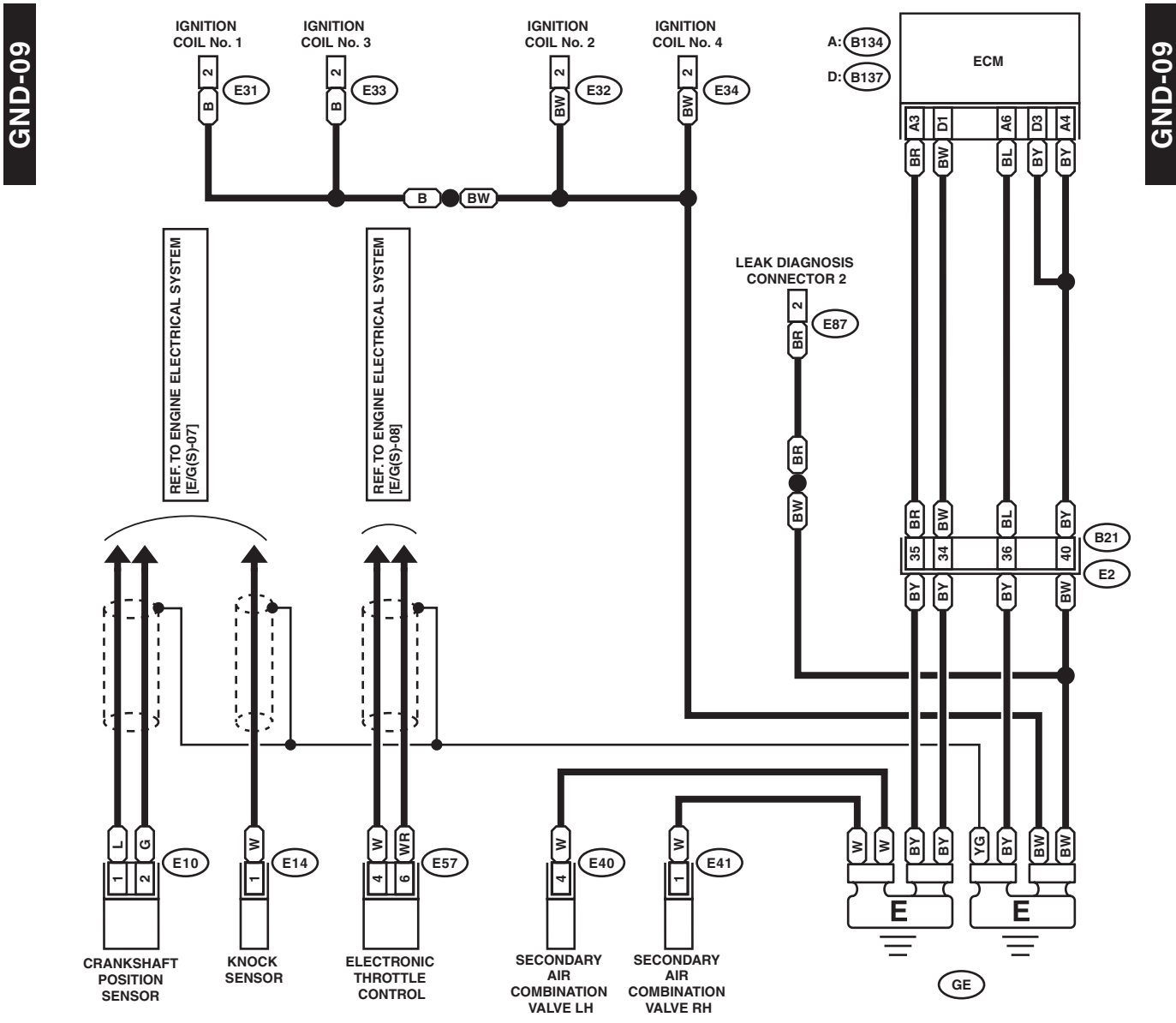

**E10** (LIGHT GRAY)    **E14** (LIGHT GRAY)    (GRAY) **E31** **E33** (GRAY)    **E40** (BLACK)    **E57**

**E41** (BLACK)    1 2    (GRAY) **E32** **E34** (GRAY)    1 2 3    1 2 3 4 5 6    **B21** (BLACK)

**E87** (DARK GRAY)    1 2    1 2 3    1 2 3 4 5 6    1 2 3 4 5 6 7 8 9 10 11 12 13 14 15 16 17 18 19 20 21 22 23 24 25 26 27 28 29 30 31 32 33

**D: B137**

1	2	3	4	5	6	7
8	9	10	11	12	13	14
15	16	17	18	19	20	21
22	23	24	25	26	27	28
29	30	31	32	33	34	35

**A: B134**

1	2	3	4	5	6	7
8	9	10	11	12	13	14
15	16	17	18	19	20	21
22	23	24	25	26	27	28
29	30	31	32	33	34	35

**B21** (BLACK)

1	2	3	4	5	6	7	8	9	10	11
12	13	14	15	16	17	18	19	20	21	22
23	24	25	26	27	28	29	30	31	32	33
34	35	36	37	38	39	40	41	42	43	44
45	46	47	48	49	50	51	52	53	54	55

WI-33872

# Engine Electrical System

WIRING SYSTEM

## 5. Engine Electrical System

### A: WIRING DIAGRAM

#### 1. WITHOUT SI-DRIVE

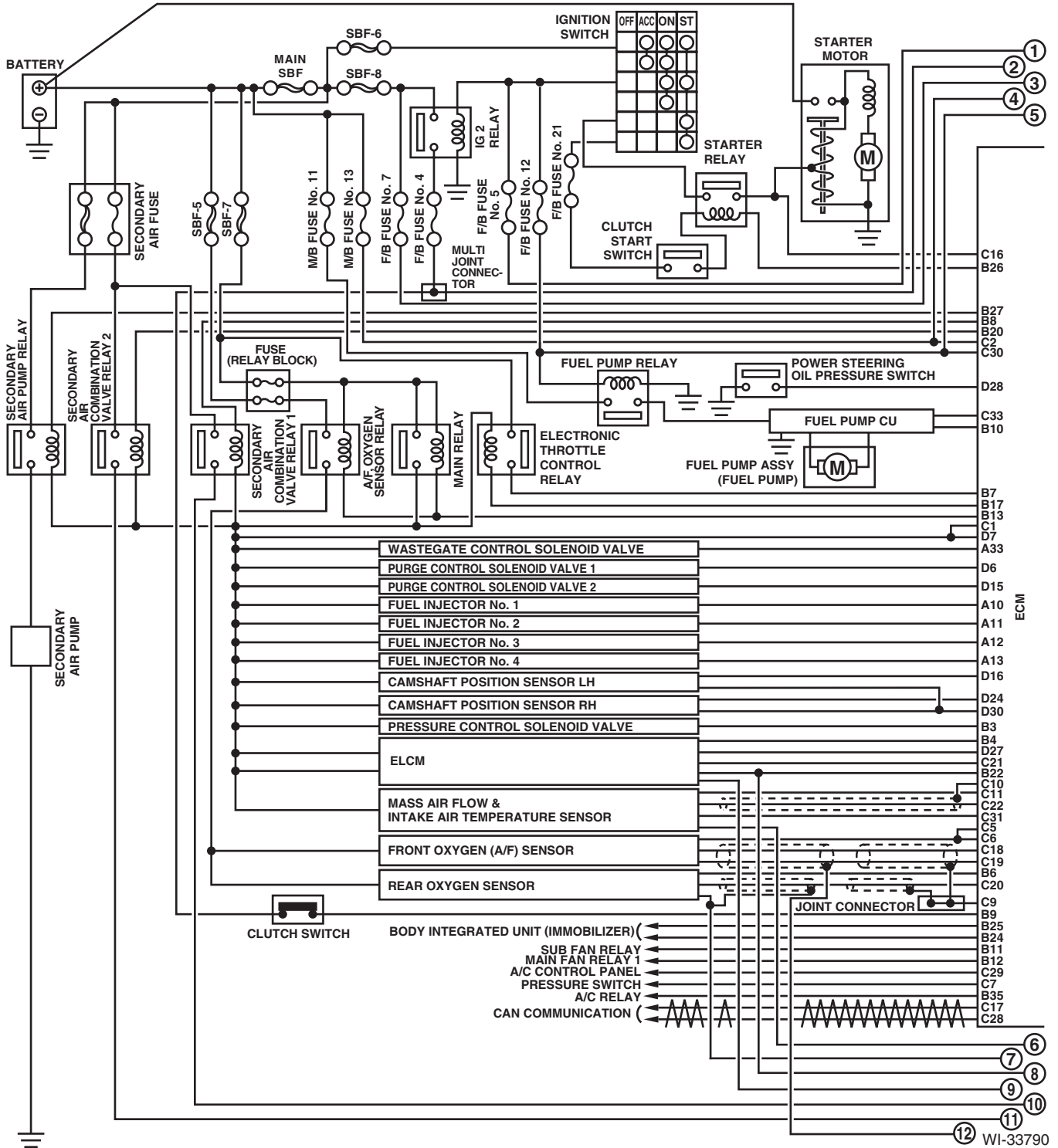

WI-32

Brought to you by Ebay Seller "SubaruManuals"



# Engine Electrical System

WIRING SYSTEM

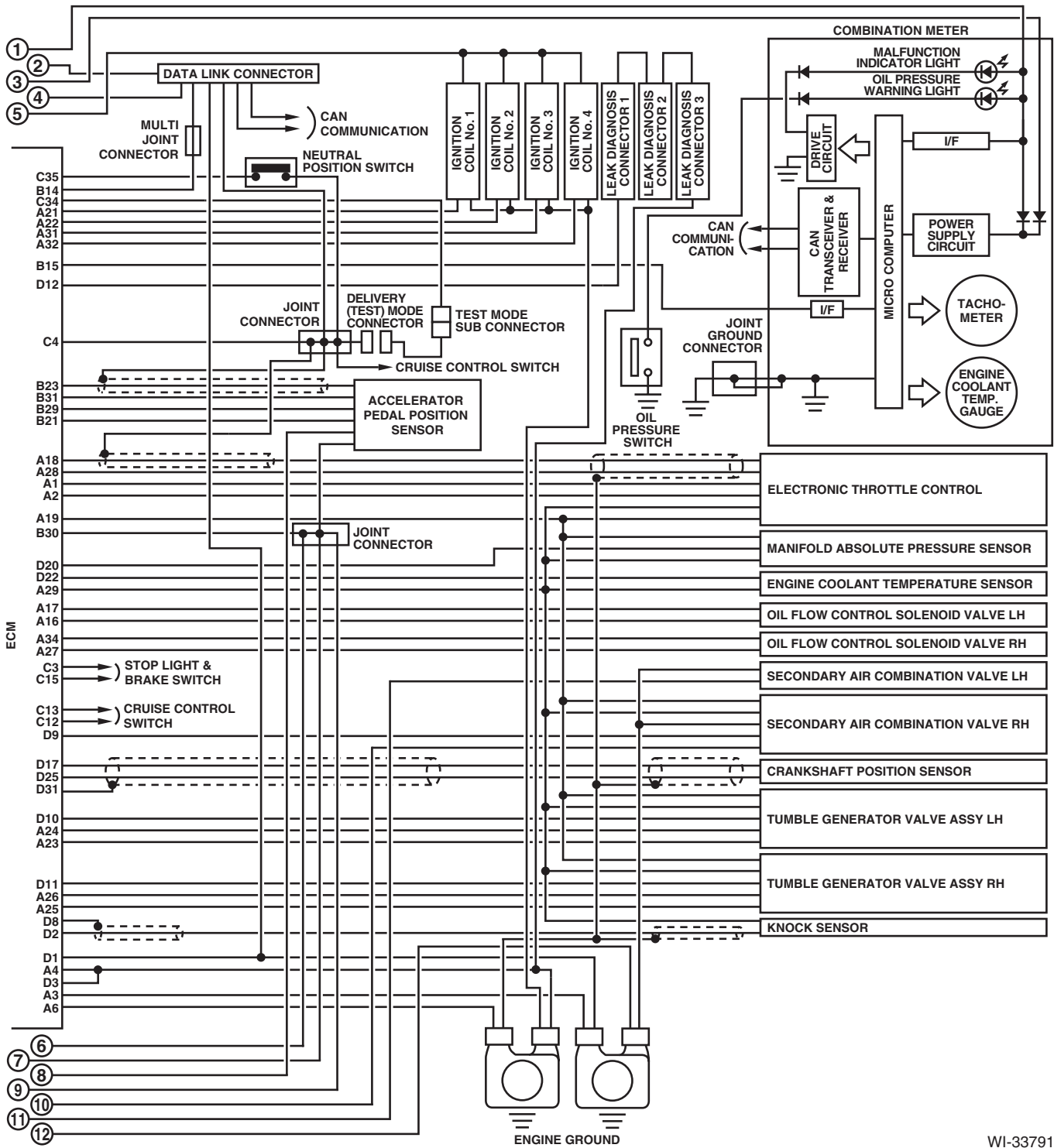

WI-33791

# Engine Electrical System

## WIRING SYSTEM

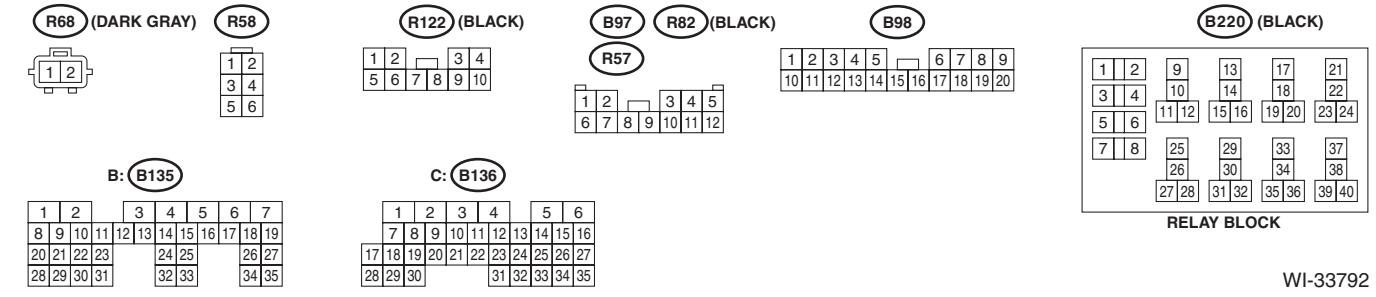
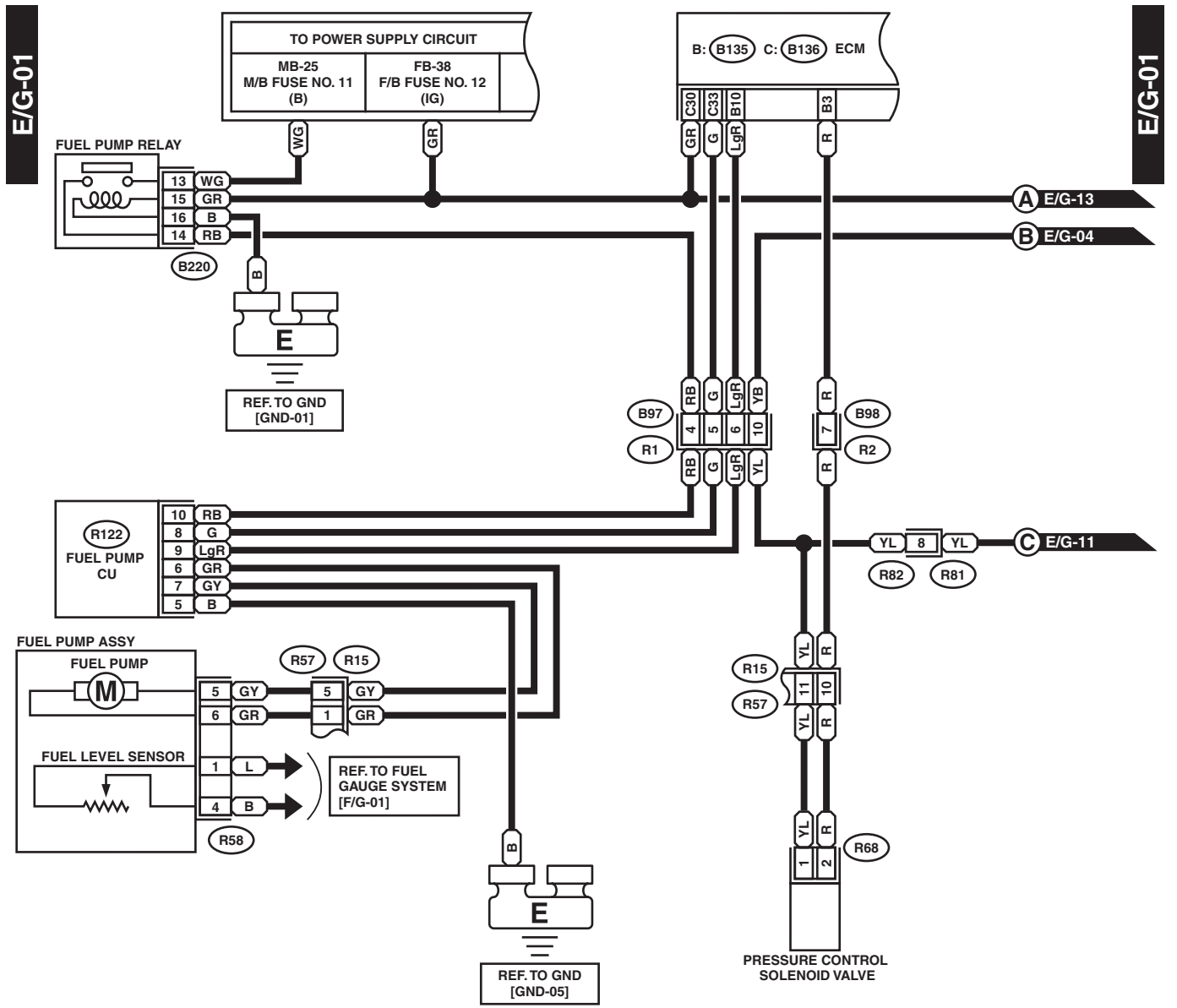

WI-33792

E/G-02

E/G-02

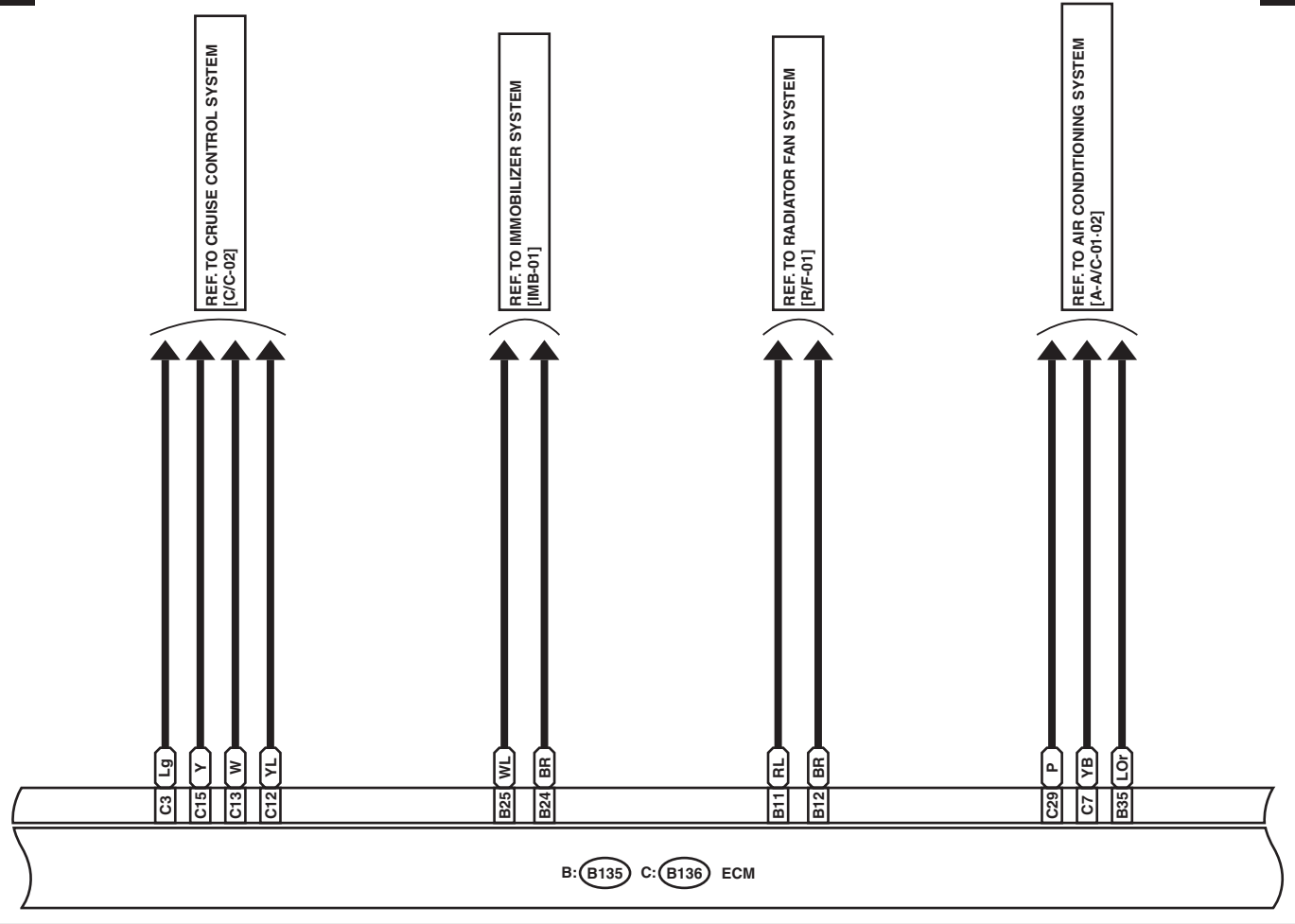

B: B135

1	2		3	4	5	6	7				
8	9	10	11	12	13	14	15	16	17	18	19
20	21	22	23		24	25		26	27		
28	29	30	31		32	33		34	35		

C: B136

	1	2	3	4		5	6			
	7	8	9	10	11	12	13	14	15	16
17	18	19	20	21	22	23	24	25	26	27
28	29	30			31	32	33	34	35	

WI-30389

# Engine Electrical System

## WIRING SYSTEM

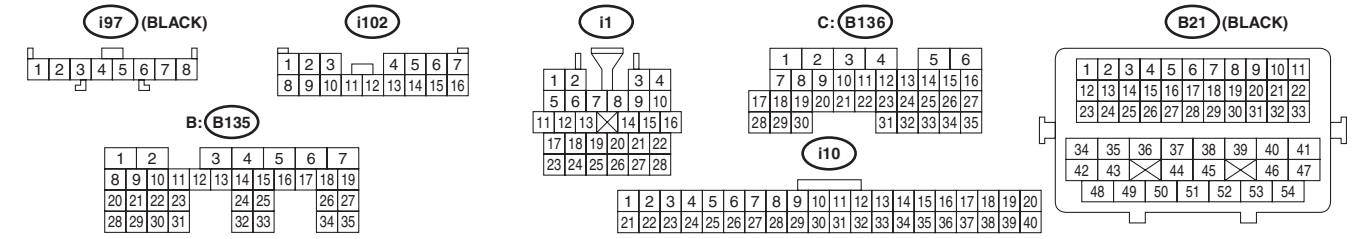
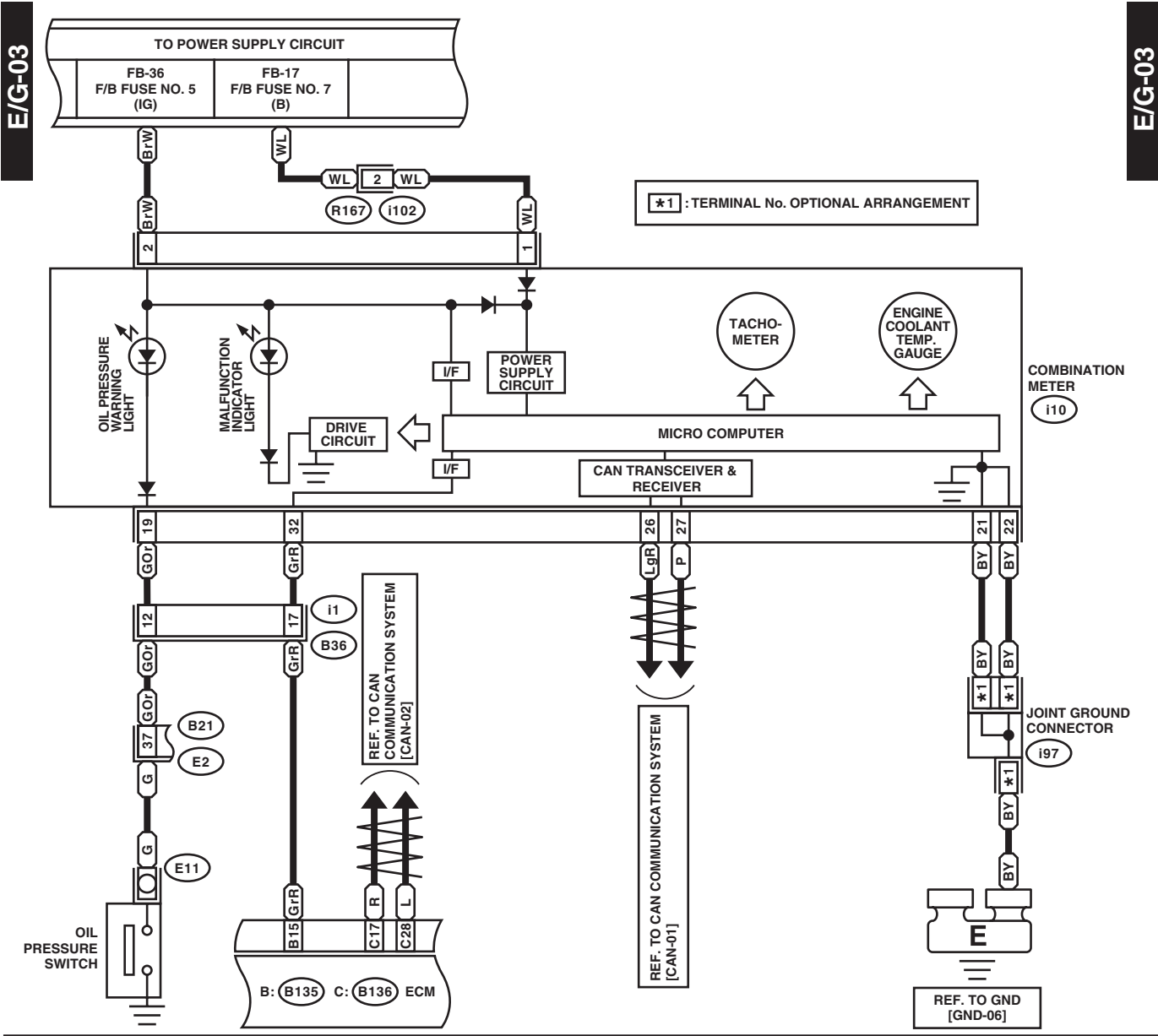

WI-33793

# Engine Electrical System

WIRING SYSTEM

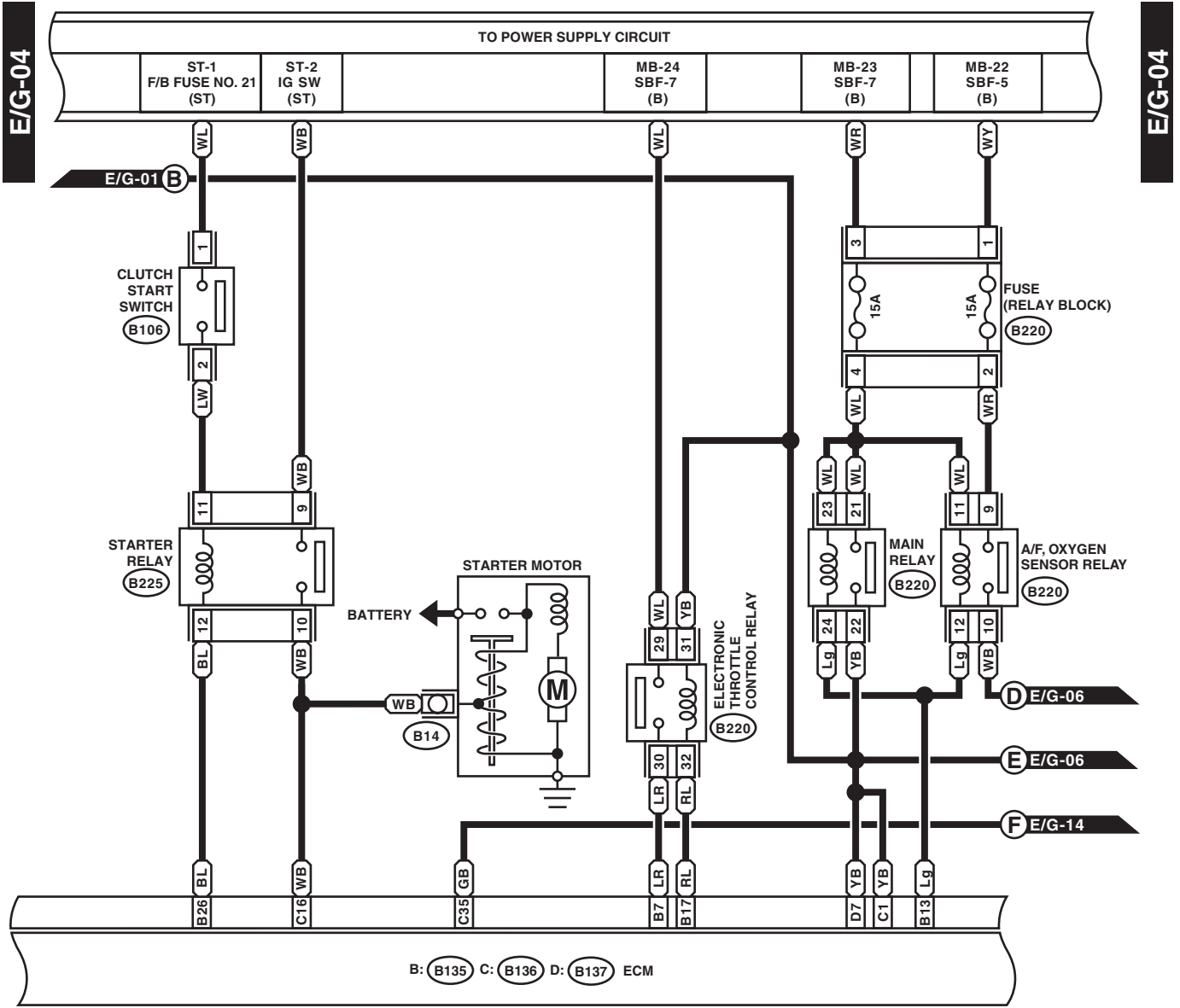

B106



D: B137



B: B135

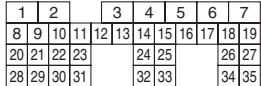

C: B136

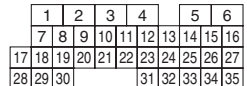

B220 (BLACK)

B225 (BLACK)

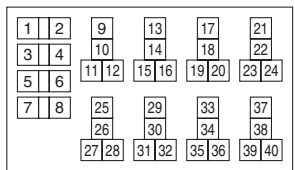

RELAY BLOCK

WI-33794

# Engine Electrical System

## WIRING SYSTEM

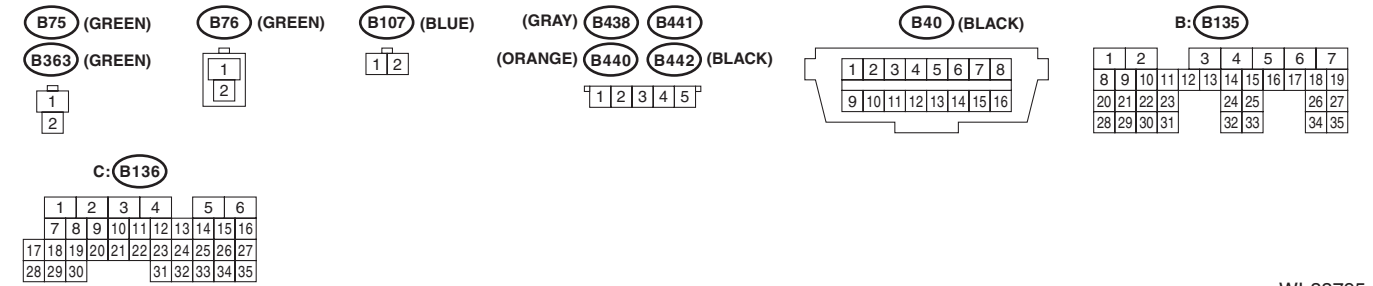
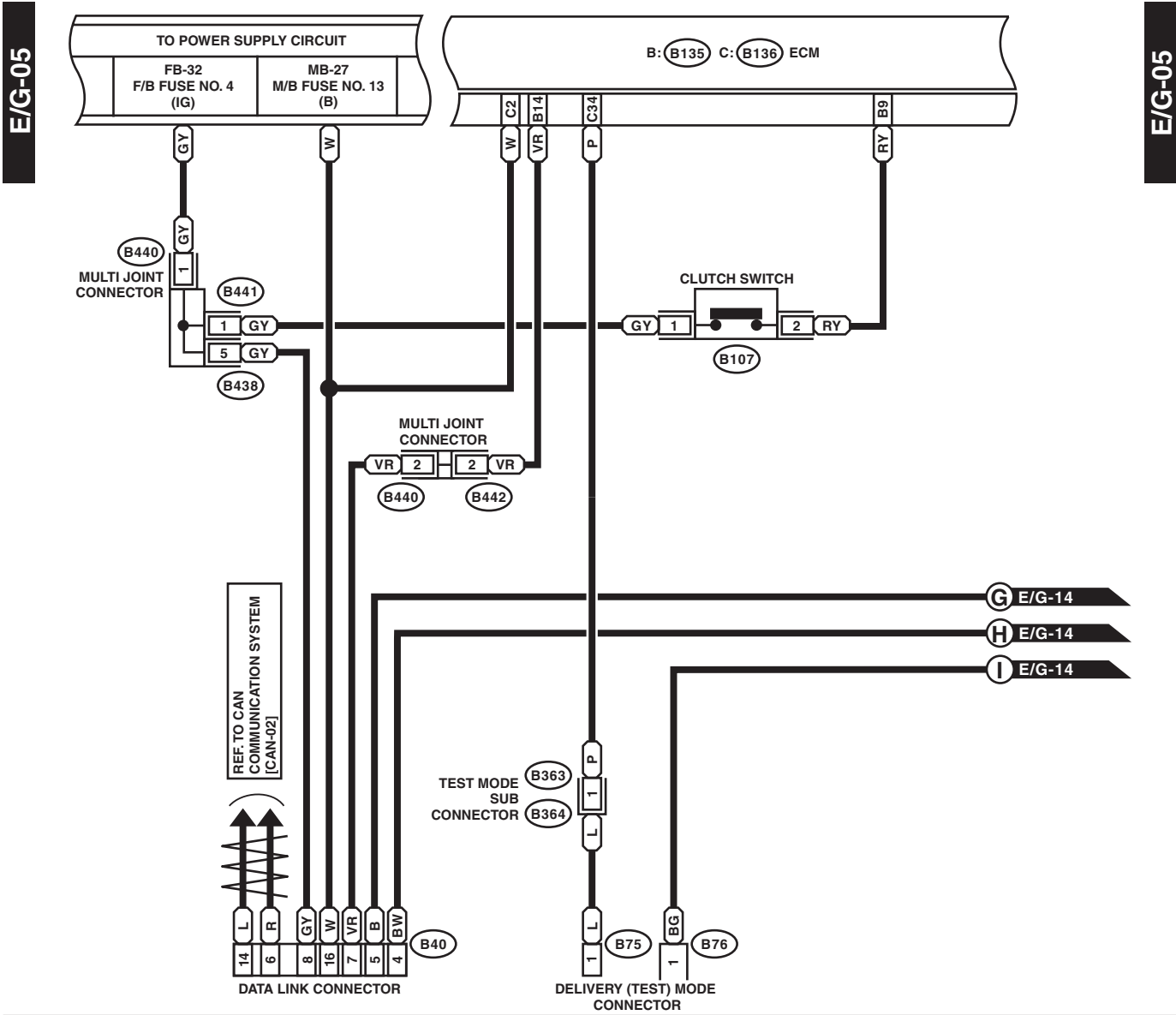

WI-33795

# Engine Electrical System

WIRING SYSTEM

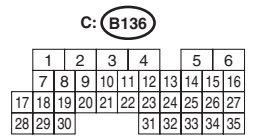
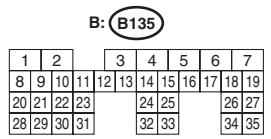
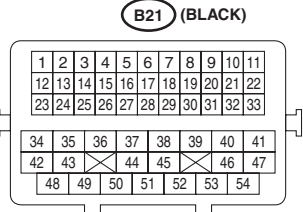
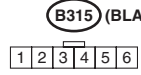
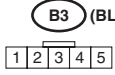
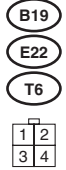
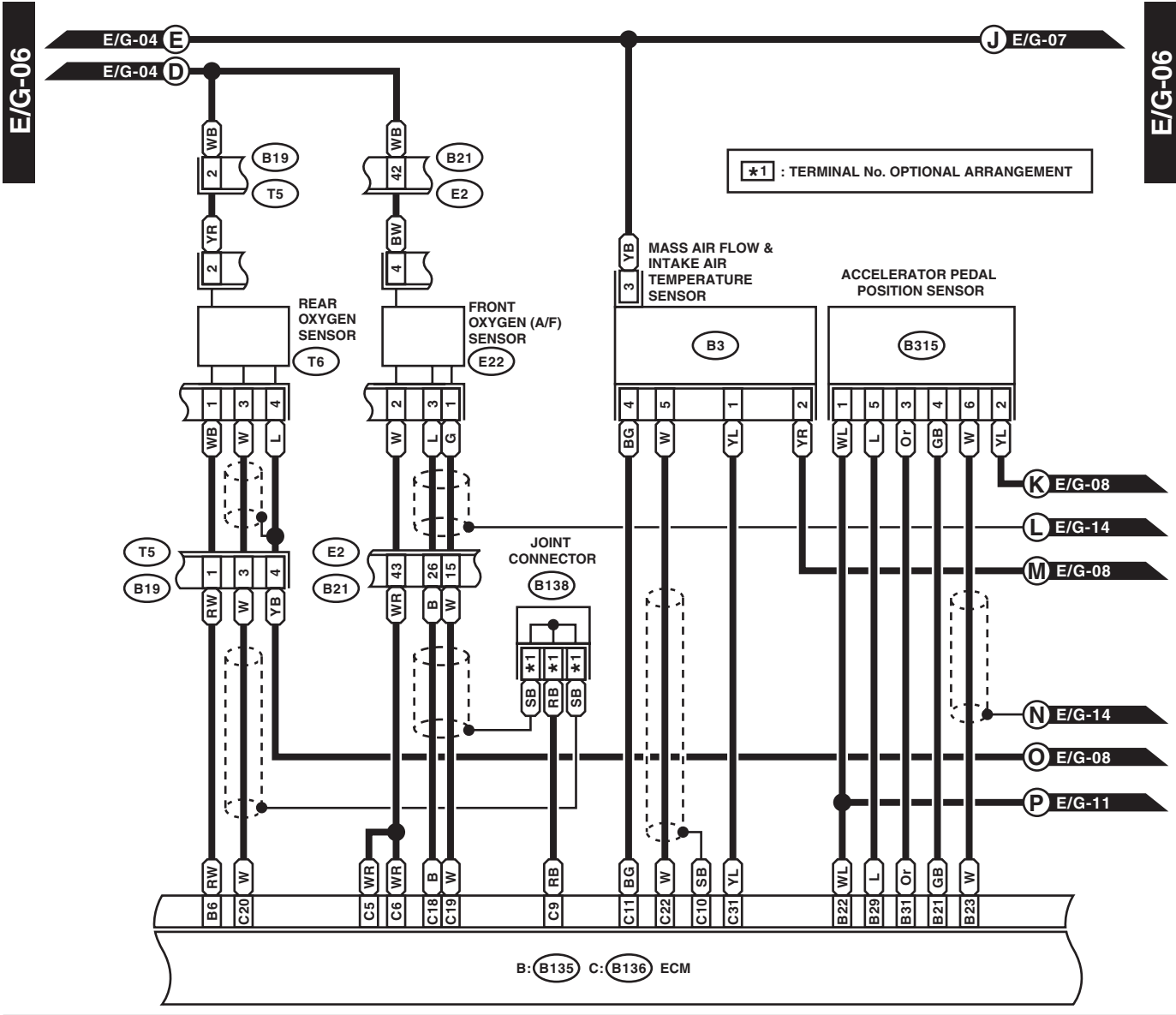

WI-33796

# Engine Electrical System

## WIRING SYSTEM

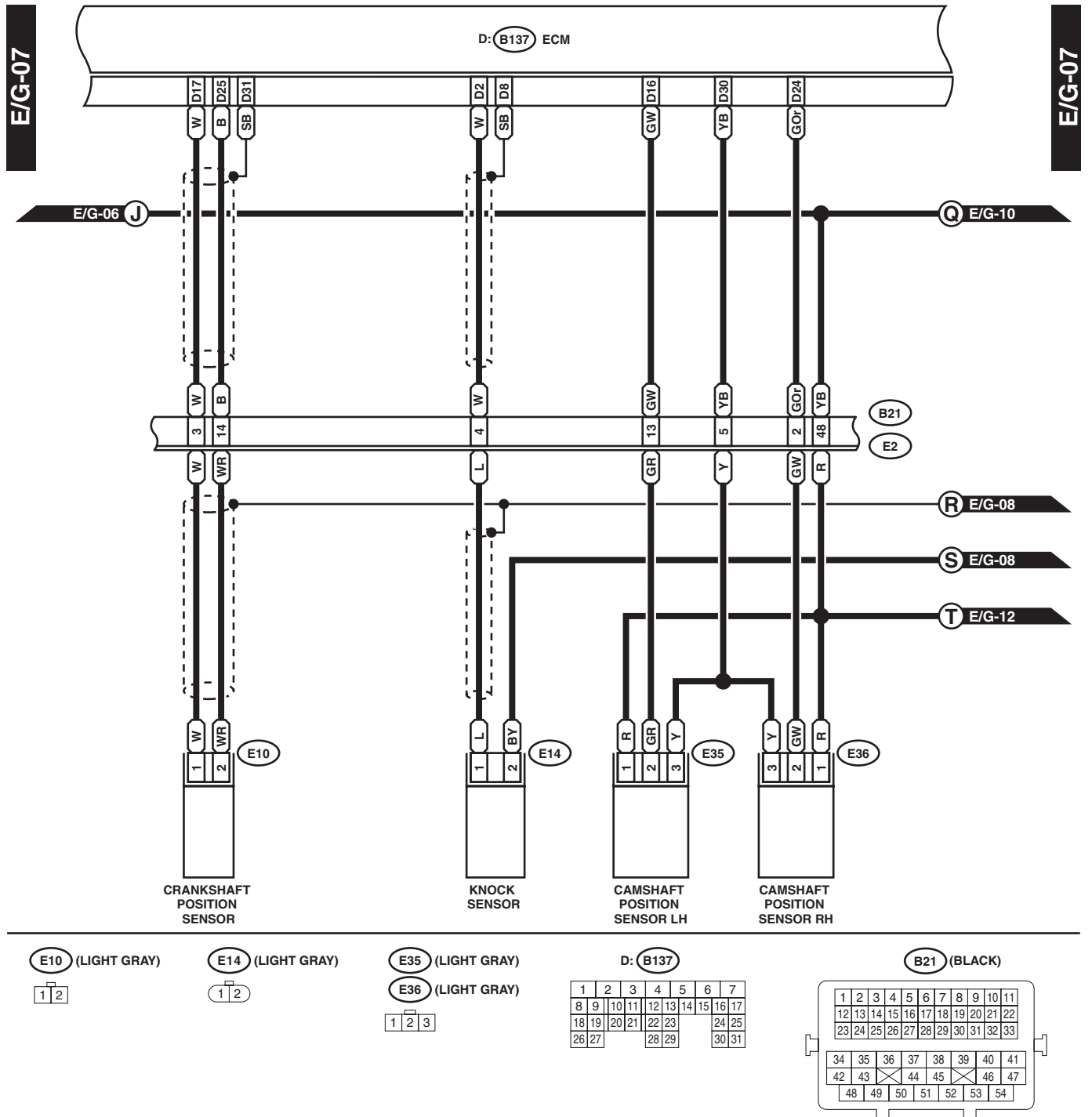

WI-33797



# Engine Electrical System

WIRING SYSTEM

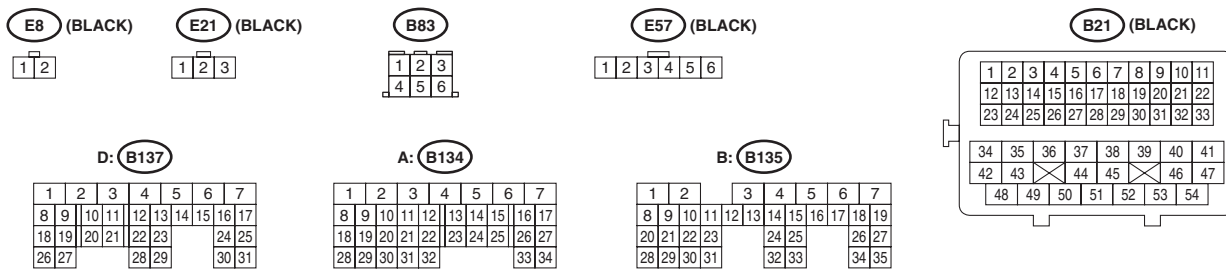
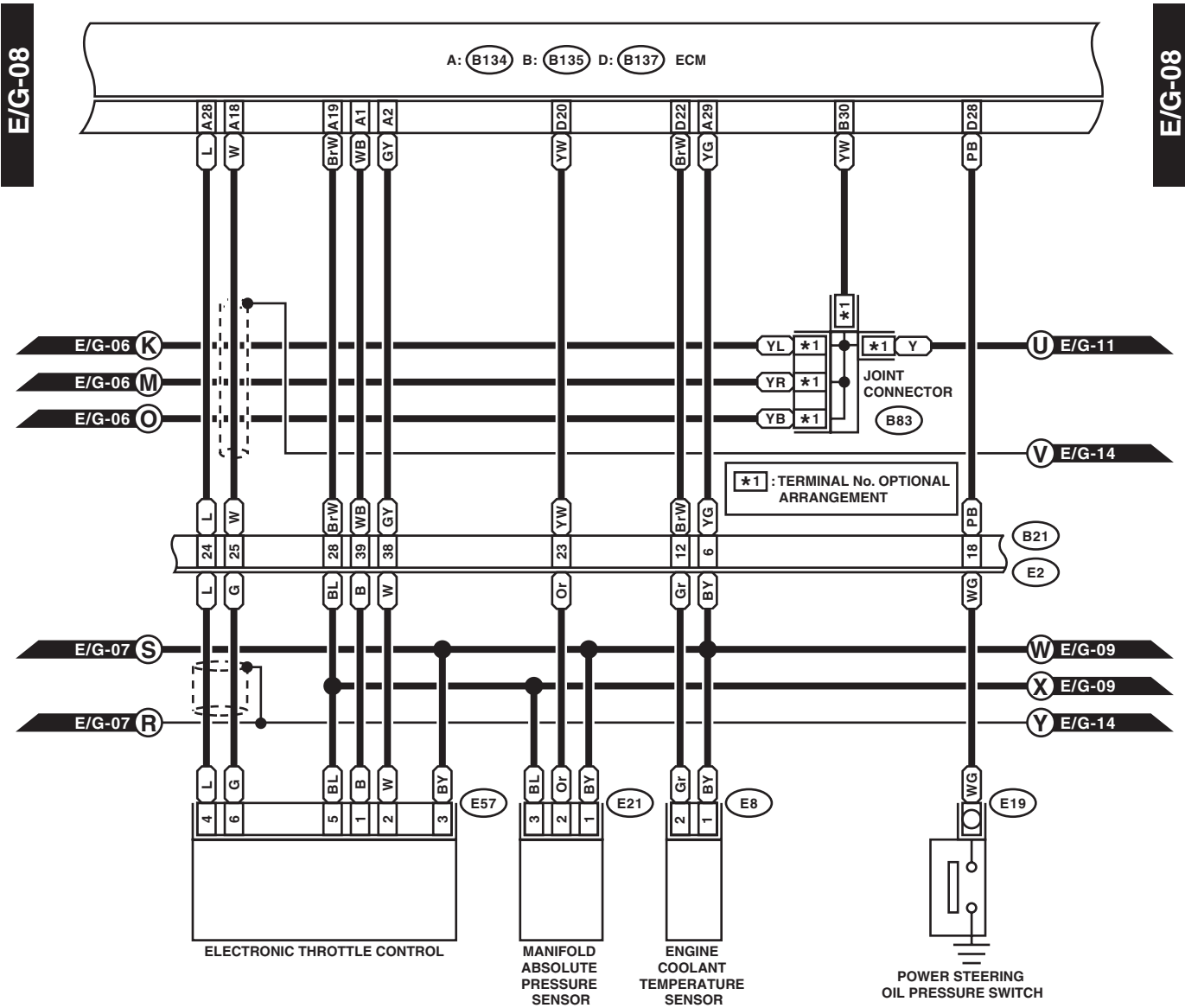

WI-33798

# Engine Electrical System

WIRING SYSTEM

E/G-09

E/G-09

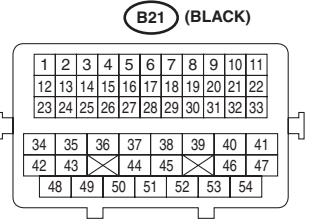
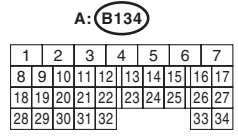
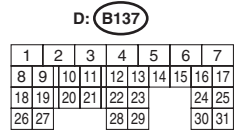
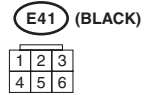
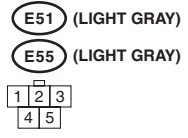
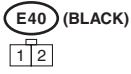
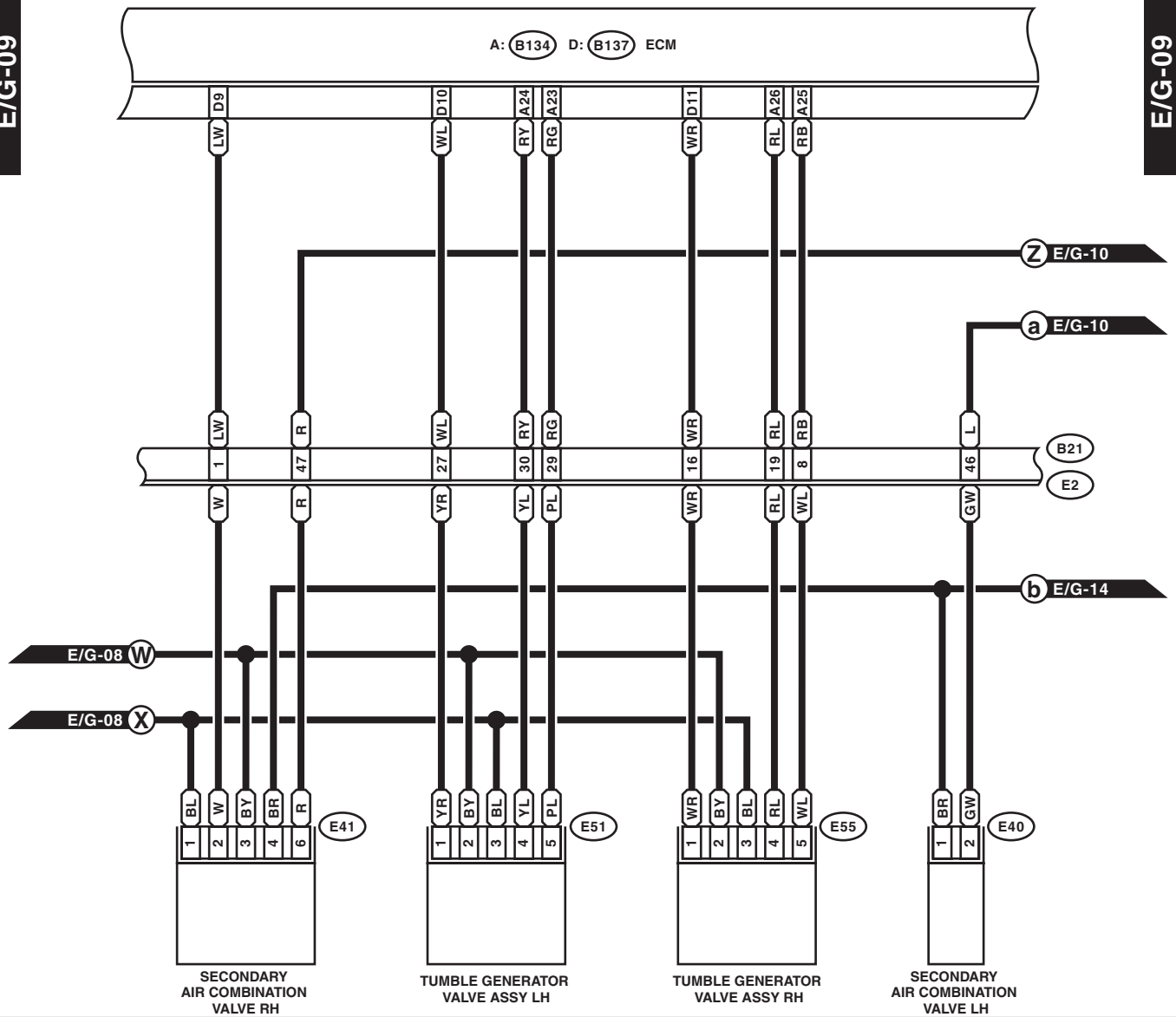

WI-30396

# Engine Electrical System

WIRING SYSTEM

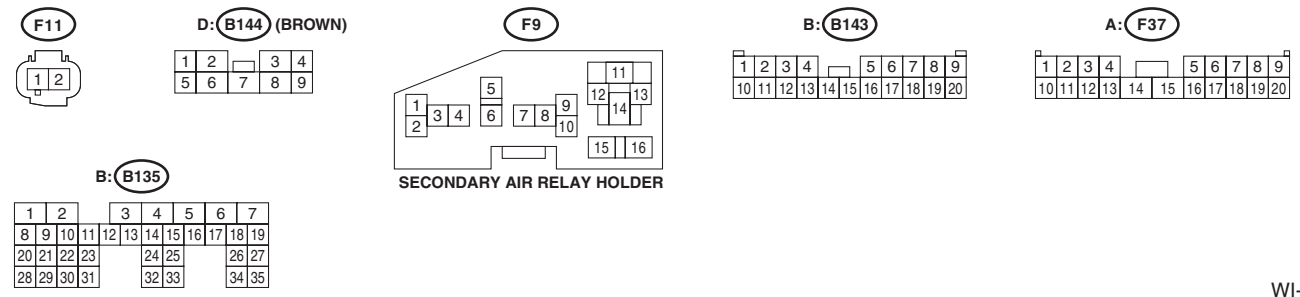
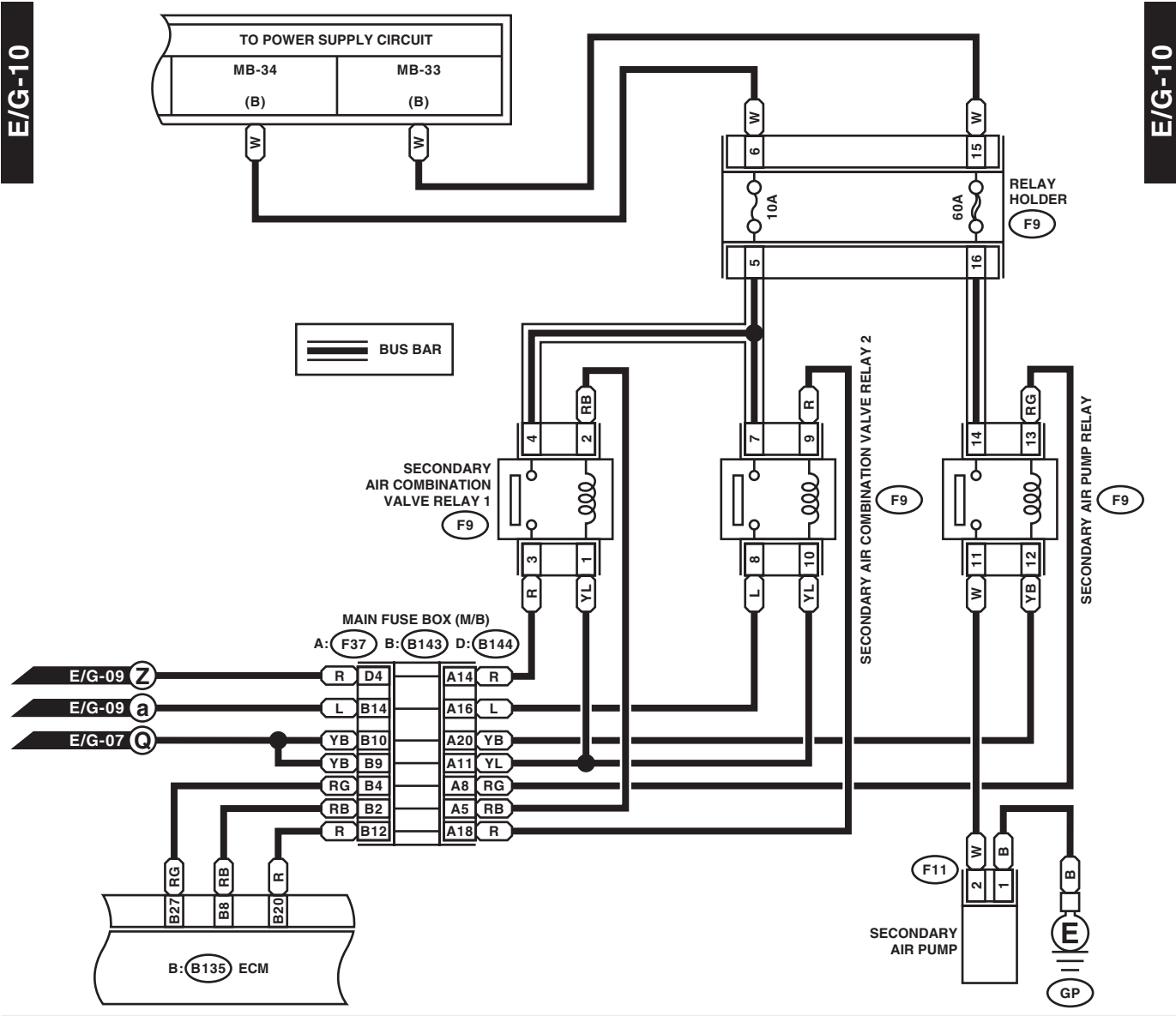

WI-33799

# Engine Electrical System

## WIRING SYSTEM

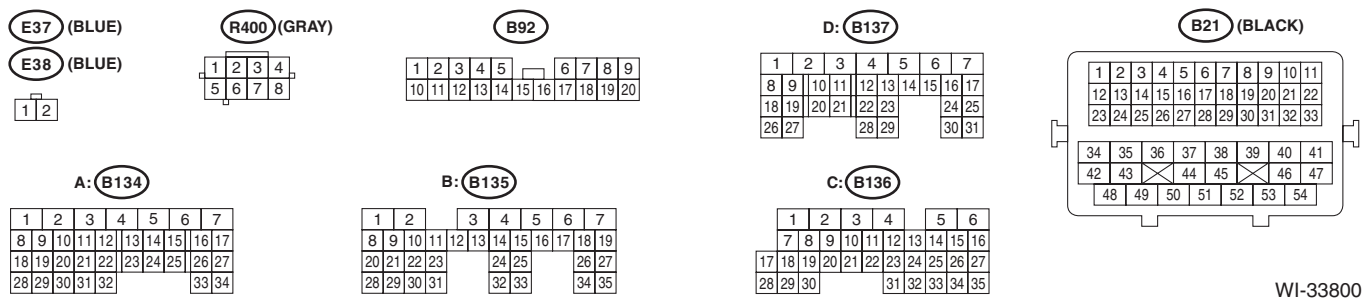
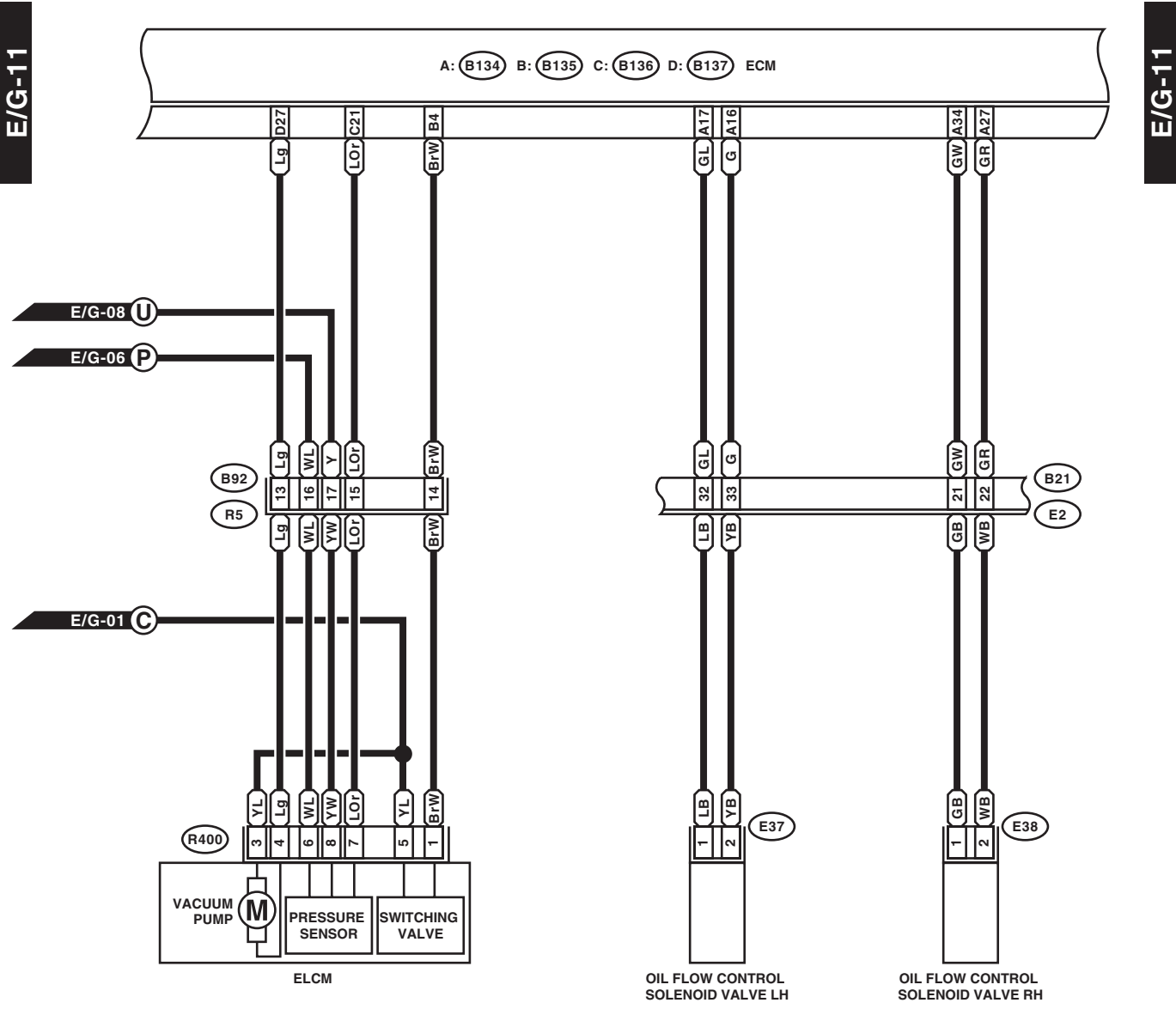

WI-33800

# Engine Electrical System

WIRING SYSTEM

E/G-12

E/G-12

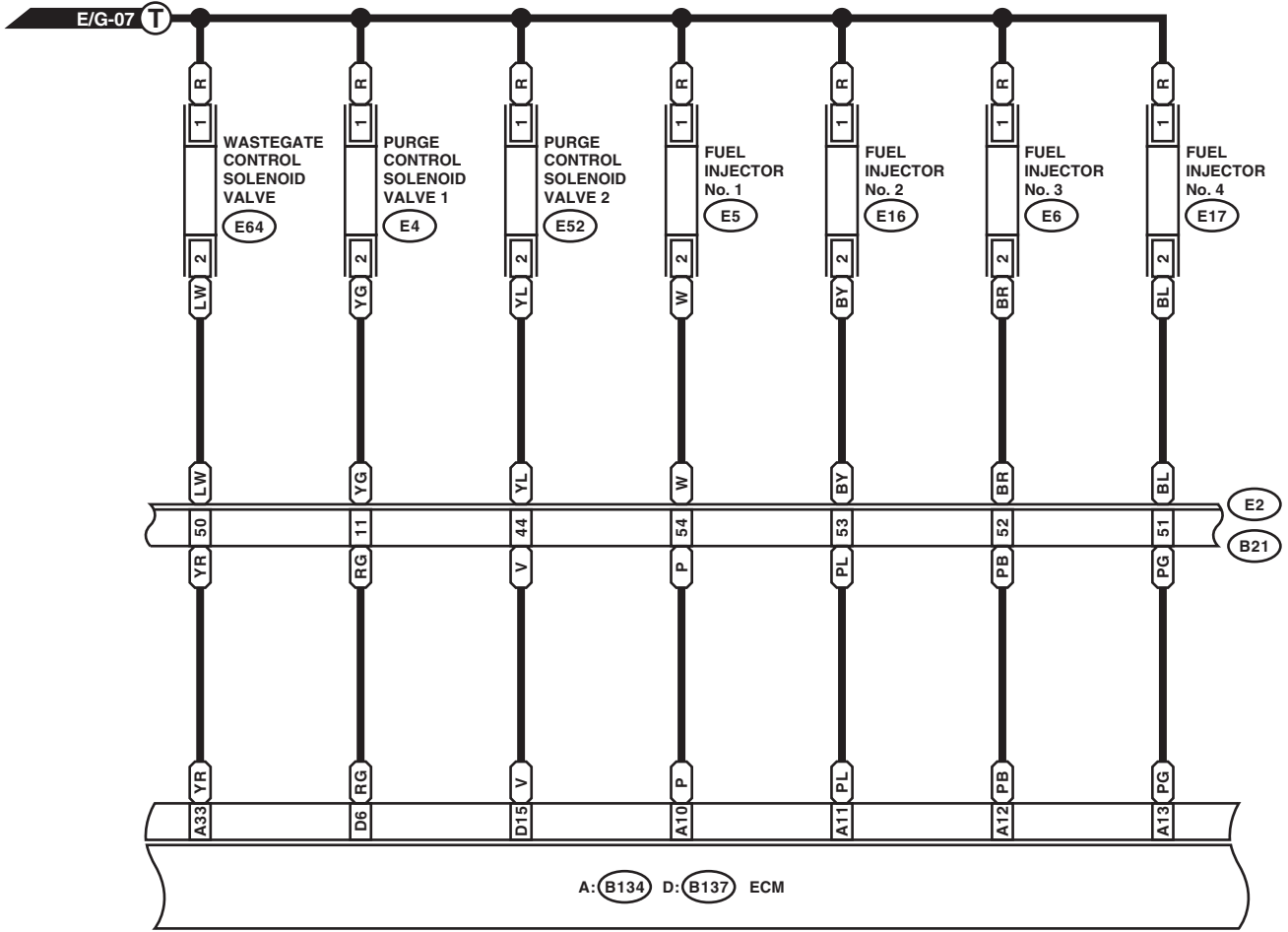

- E4 (BLACK)
- E52 (BLACK)
- E64 (BLUE)

- E5 (DARK GRAY)
- E6 (DARK GRAY)
- E16 (DARK GRAY)
- E17 (DARK GRAY)

D: B137

1	2	3	4	5	6	7
8	9	10	11	12	13	14
15	16	17	18	19	20	21
22	23	24	25	26	27	28
29	30	31	32	33	34	

A: B134

1	2	3	4	5	6	7
8	9	10	11	12	13	14
15	16	17	18	19	20	21
22	23	24	25	26	27	28
29	30	31	32	33	34	

B21 (BLACK)

1	2	3	4	5	6	7	8	9	10	11
12	13	14	15	16	17	18	19	20	21	22
23	24	25	26	27	28	29	30	31	32	33
34	35	36	37	38	39	40	41			
42	43	44	45	46	47					
48	49	50	51	52	53	54				

WI-33801

# Engine Electrical System

## WIRING SYSTEM

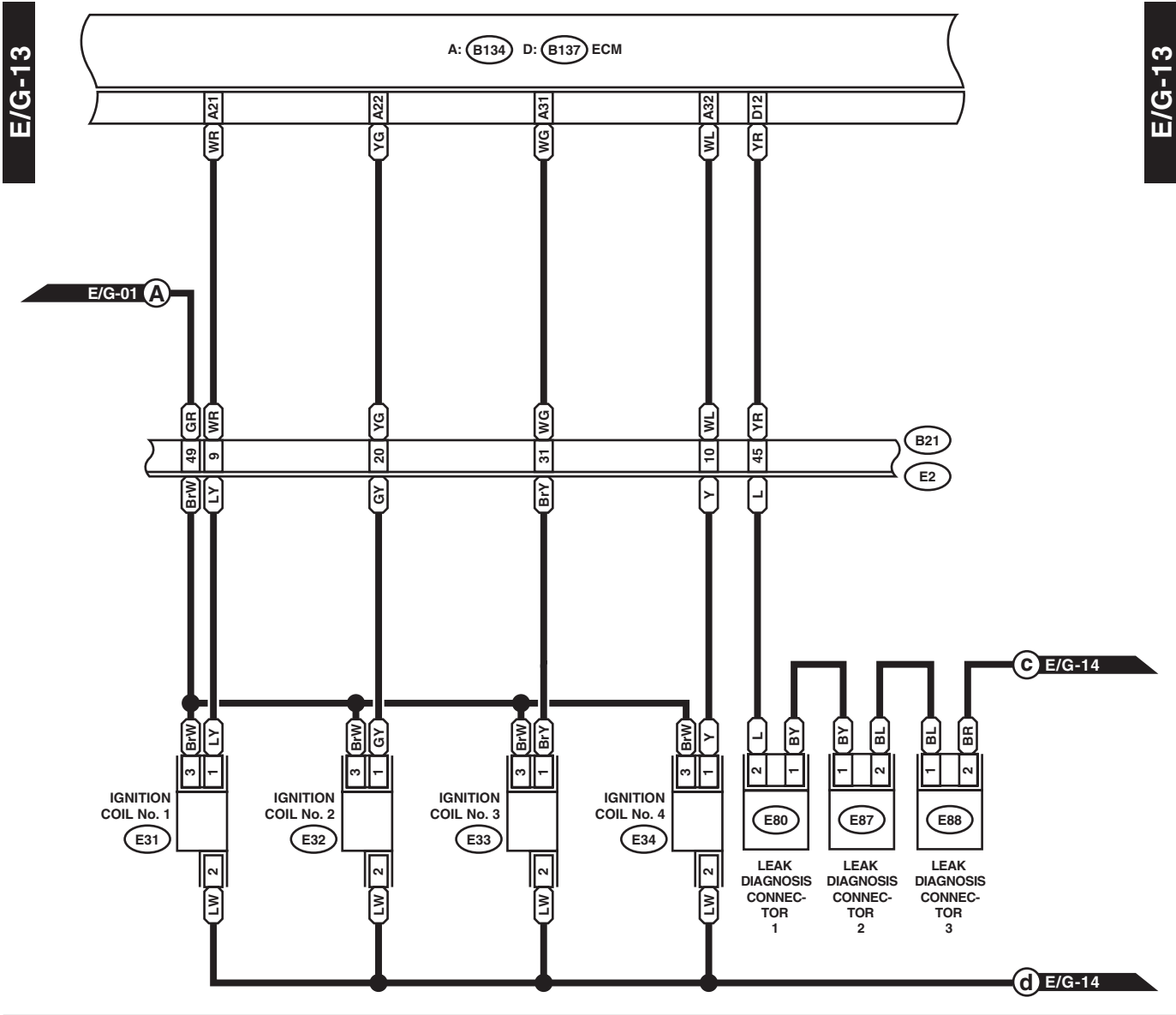

E80 (DARK GRAY)

(GRAY) E31 E33 (GRAY)

D: B137

A: B134

B21 (BLACK)

E87 (DARK GRAY)

(GRAY) E32 E34 (GRAY)

1	2	3	4	5	6	7
8	9	10	11	12	13	14
15	16	17	18	19	20	21
22	23	24	25	26	27	28
29	30	31	32	33	34	

1	2	3	4	5	6	7
8	9	10	11	12	13	14
15	16	17	18	19	20	21
22	23	24	25	26	27	28
29	30	31	32	33	34	

1	2	3	4	5	6	7	8	9	10	11
12	13	14	15	16	17	18	19	20	21	22
23	24	25	26	27	28	29	30	31	32	33
34	35	36	37	38	39	40	41			
42	43	44	45	46	47					
48	49	50	51	52	53	54				

1	2
---	---

1
2
3

WI-33873

# Engine Electrical System

WIRING SYSTEM

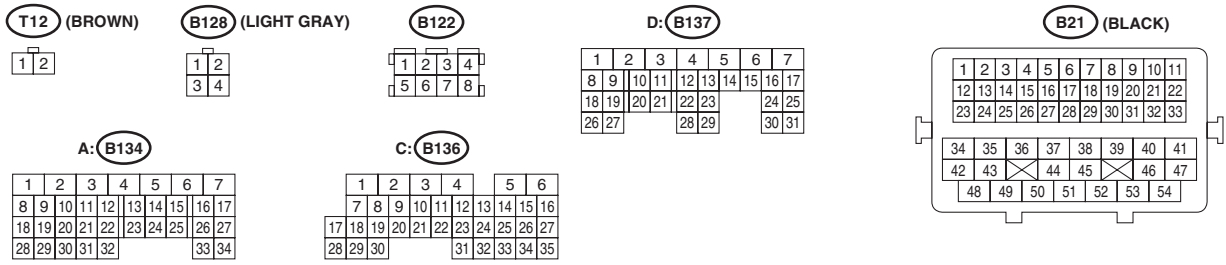
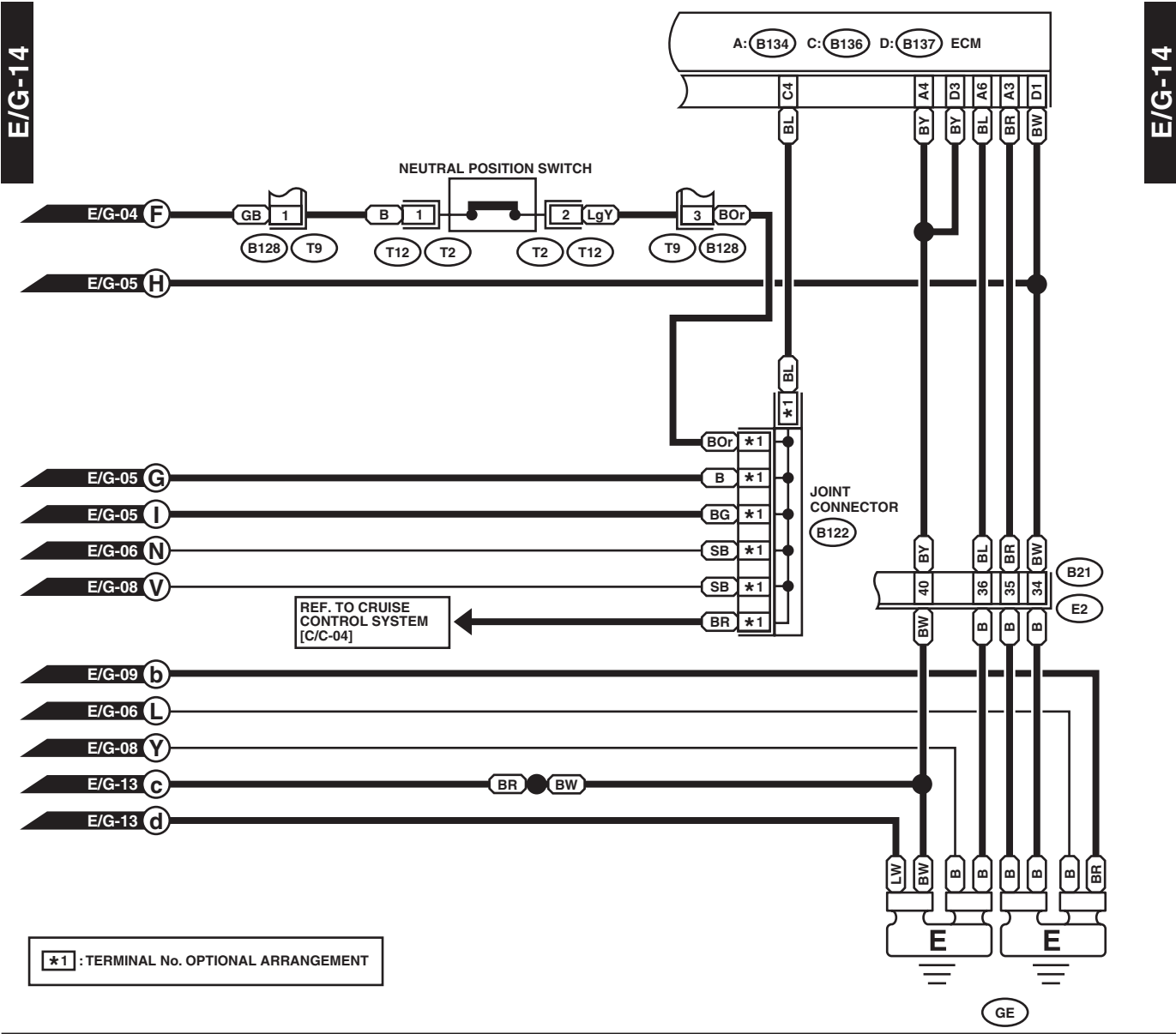

WI-33802

# Engine Electrical System

## WIRING SYSTEM

### 2. WITH SI-DRIVE

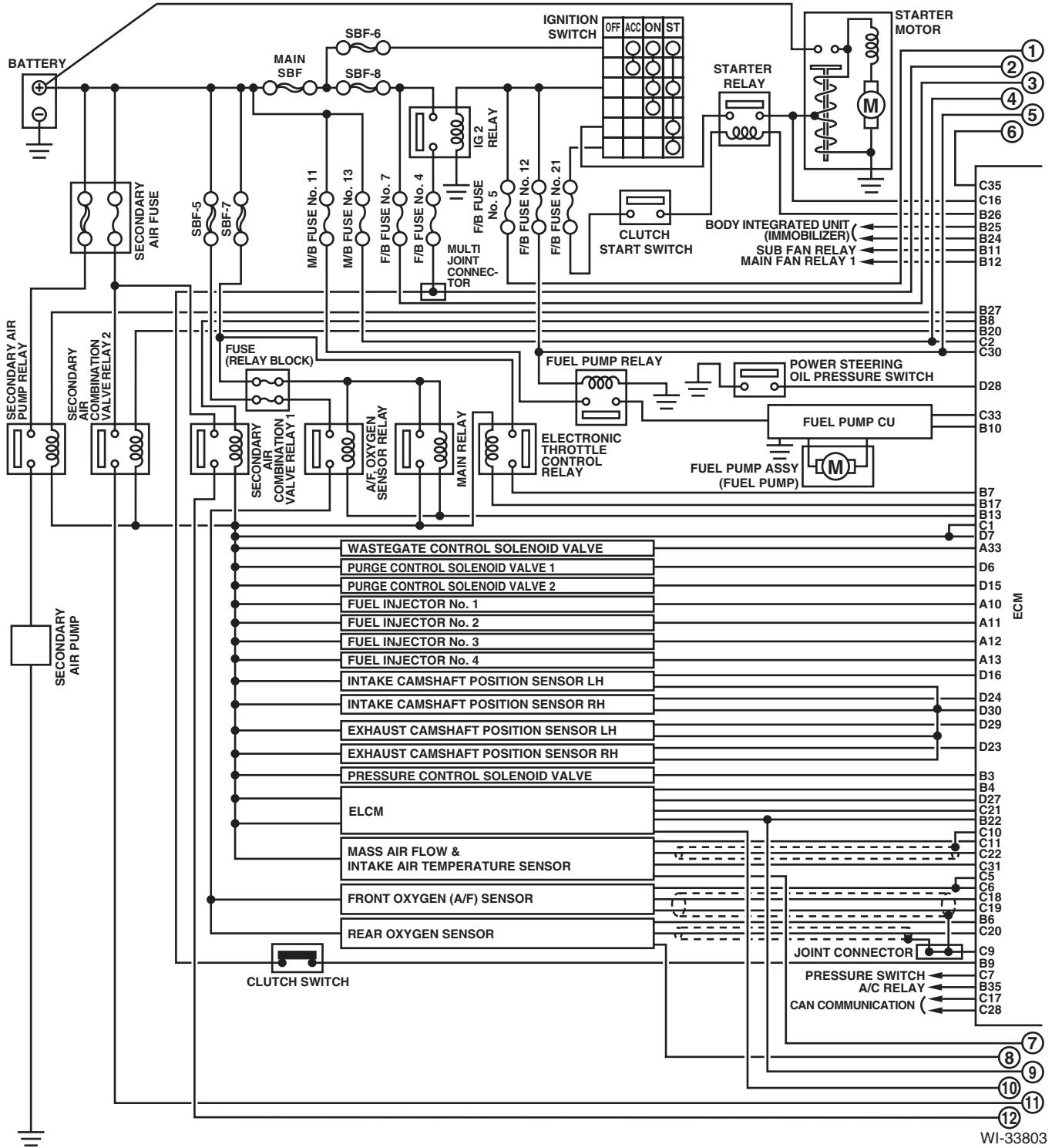

WI-33803



# Engine Electrical System

WIRING SYSTEM

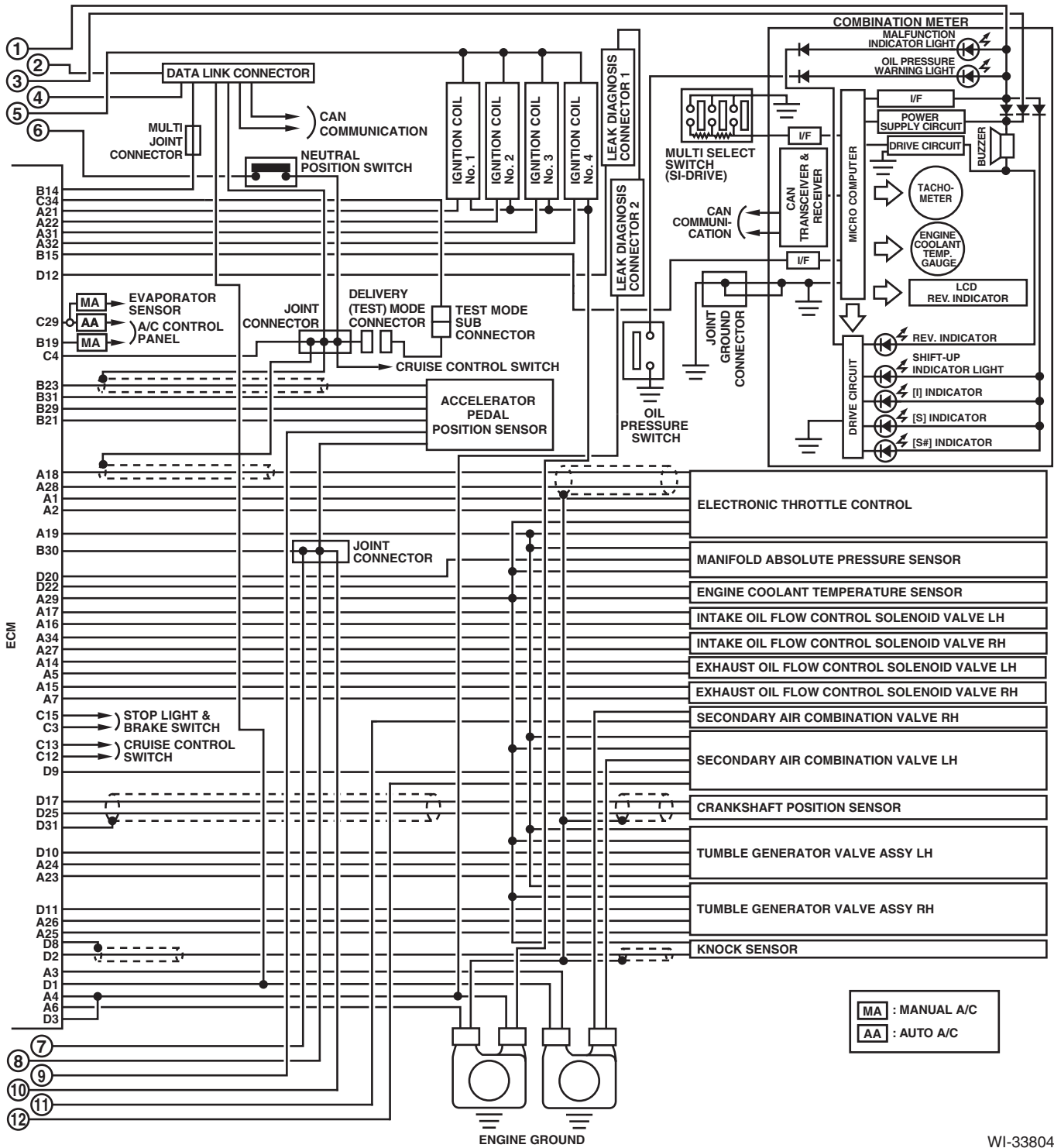

WI-33804

# Engine Electrical System

## WIRING SYSTEM

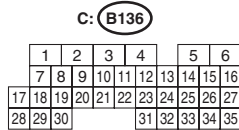
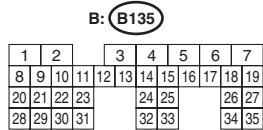
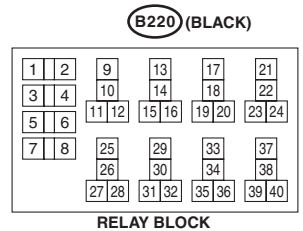
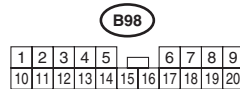
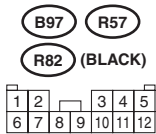
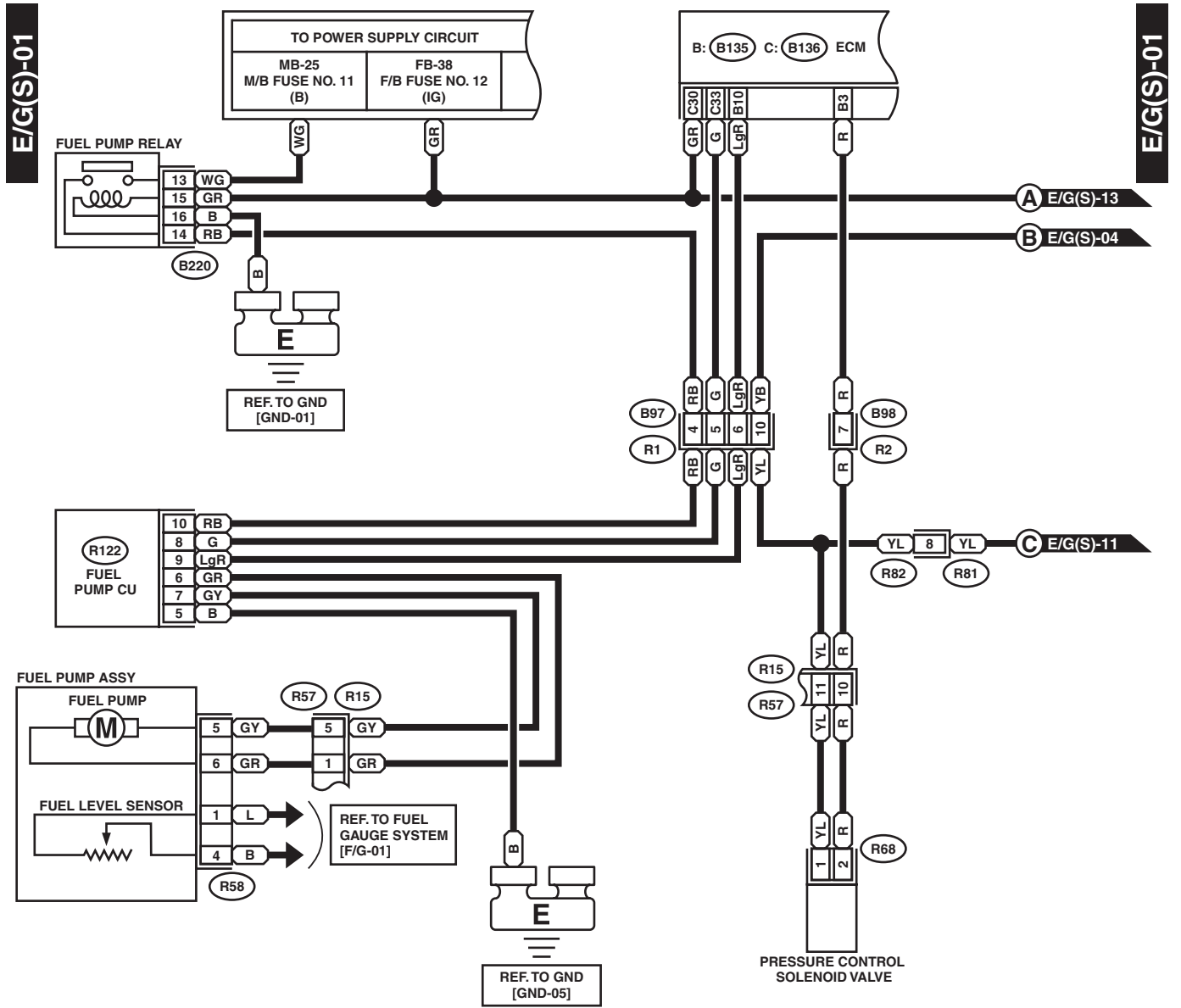

WI-33805

E/G(S)-02

E/G(S)-02

**MA** : MANUAL A/C

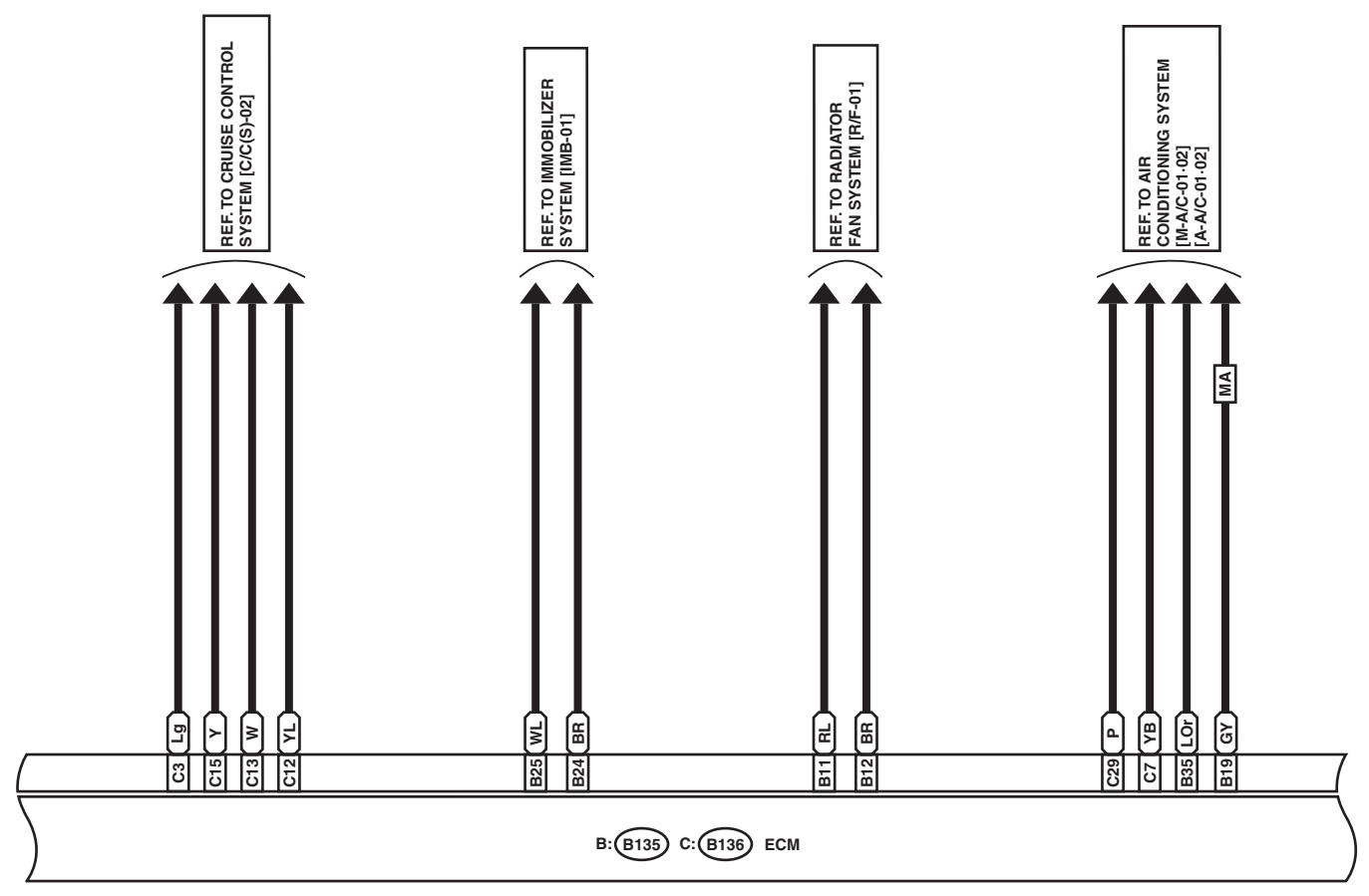

**B: B135**

1	2		3	4	5	6	7				
8	9	10	11	12	13	14	15	16	17	18	19
20	21	22	23		24	25		26	27		
28	29	30	31		32	33		34	35		

**C: B136**

	7	8	9	10	11	12	13	14	15	16	
17	18	19	20	21	22	23	24	25	26	27	
28	29	30			31	32	33	34	35		

WI-30405

# Engine Electrical System

## WIRING SYSTEM

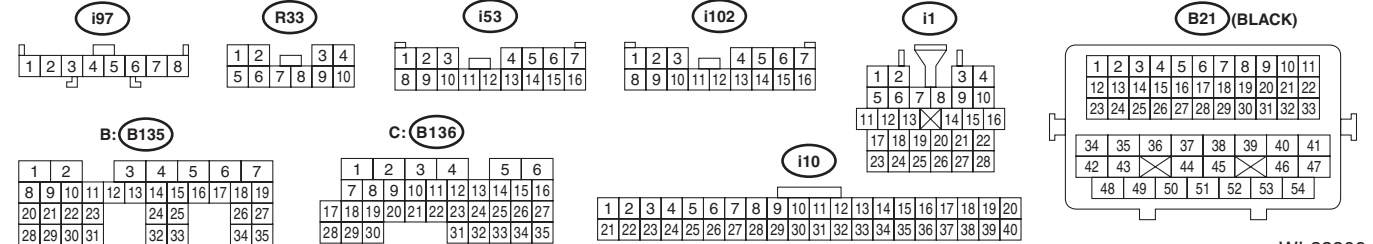
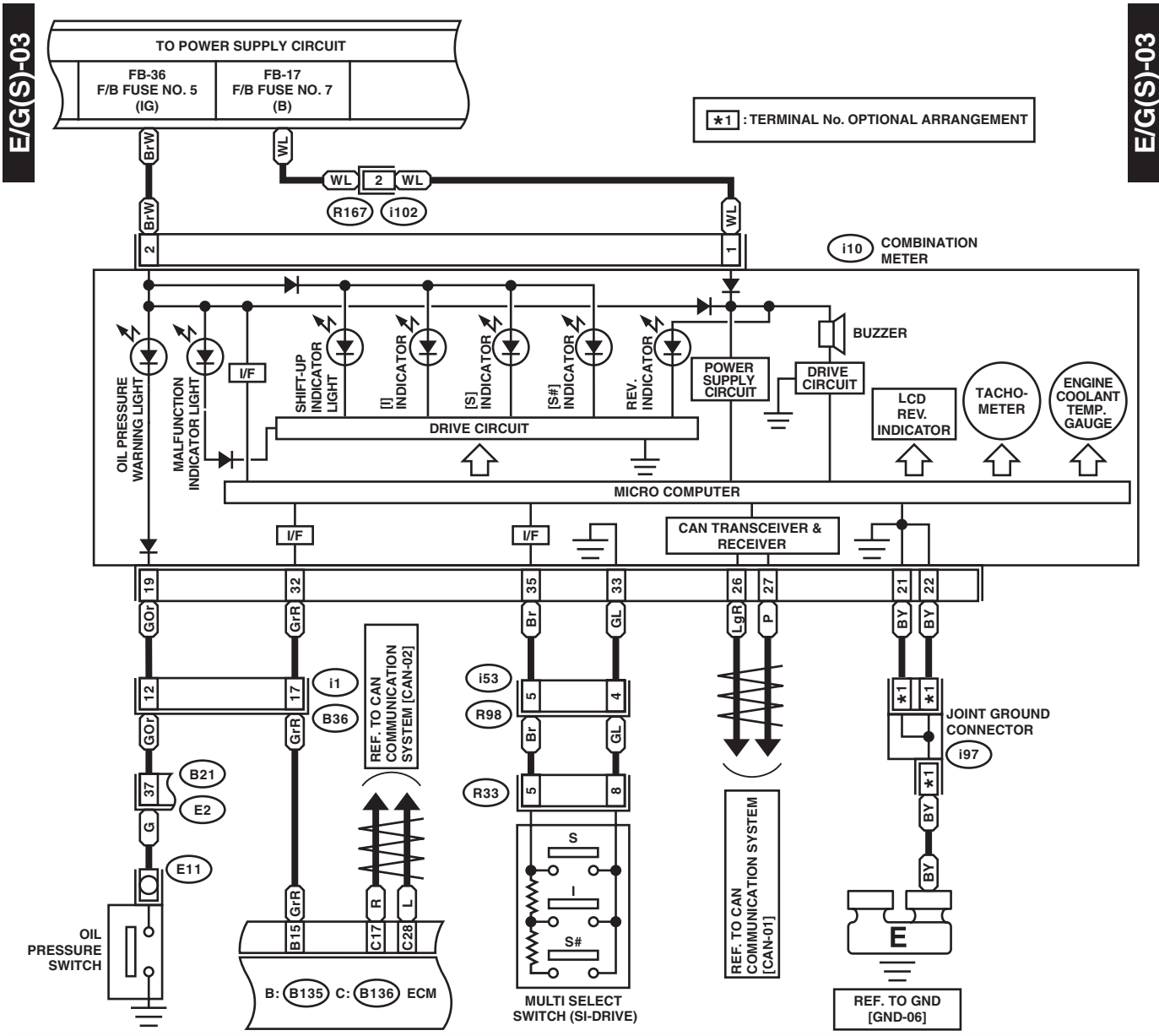

WI-33806

# Engine Electrical System

WIRING SYSTEM

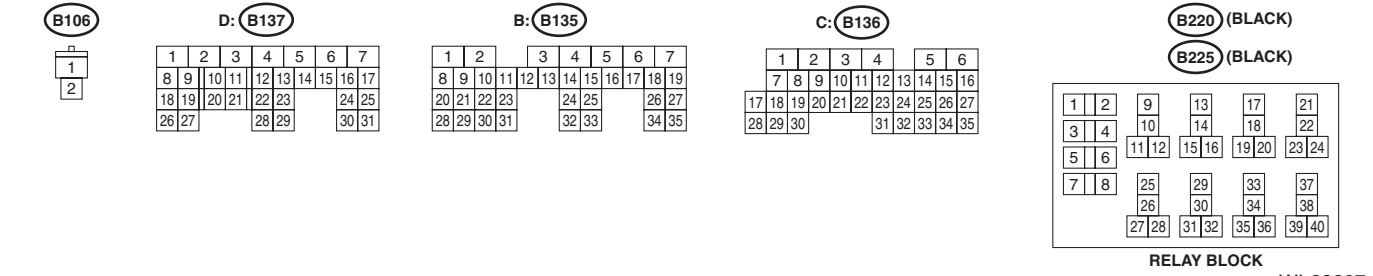
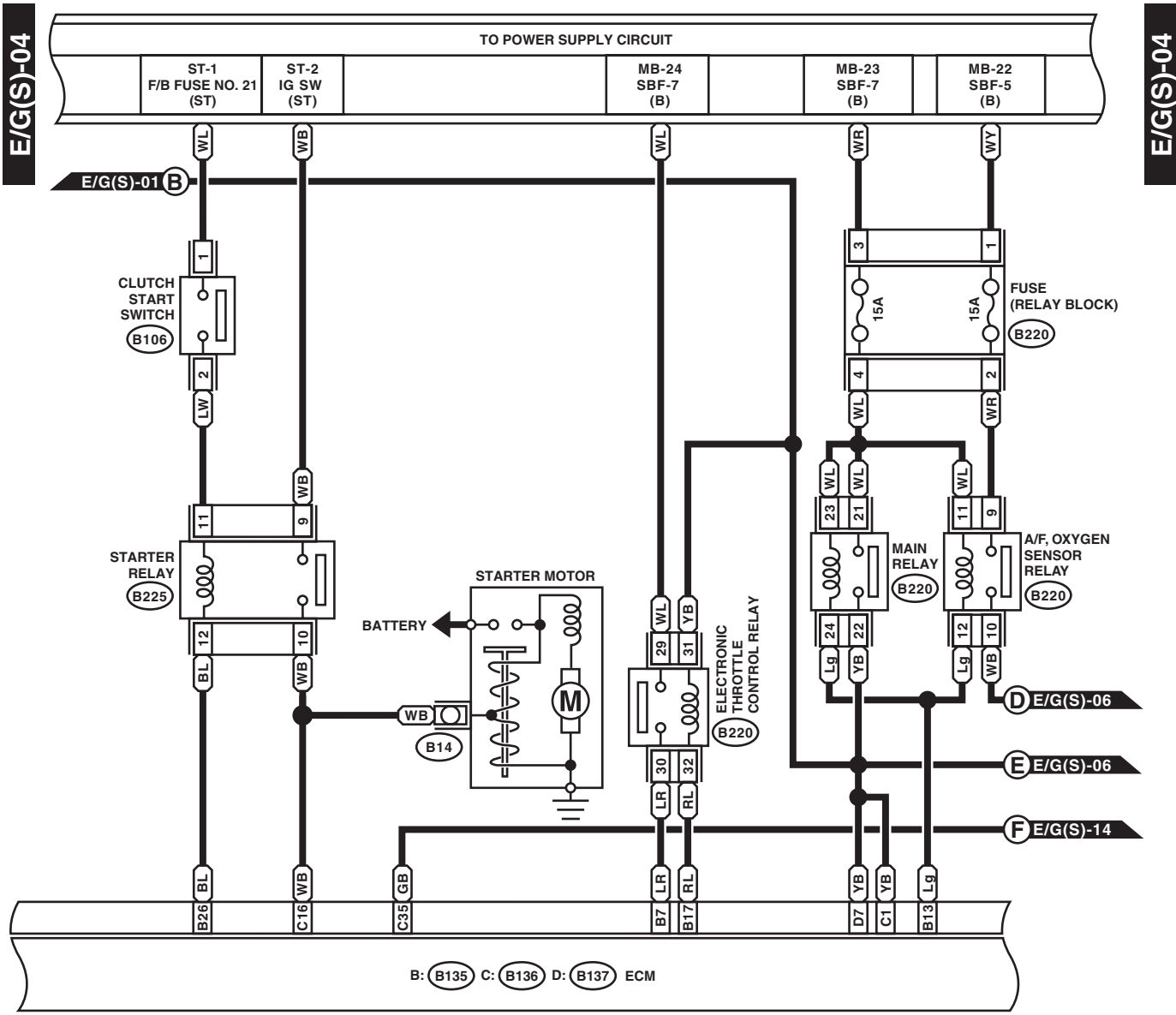

WI-33807

# Engine Electrical System

## WIRING SYSTEM

E/G(S)-05

E/G(S)-05

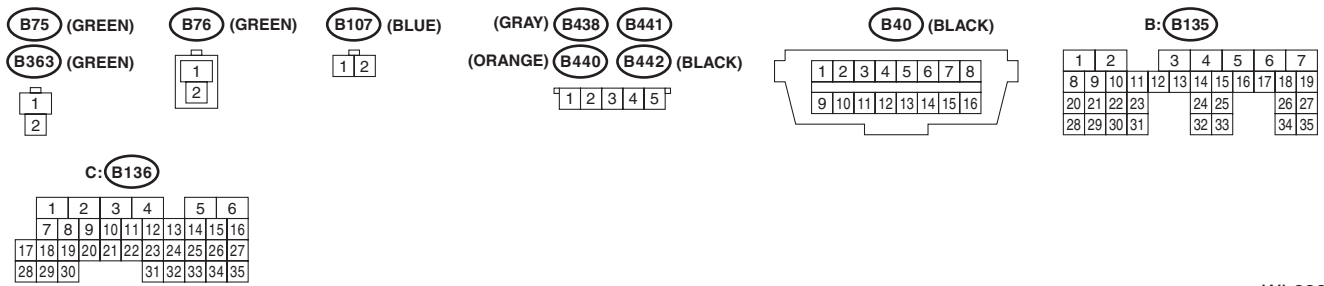
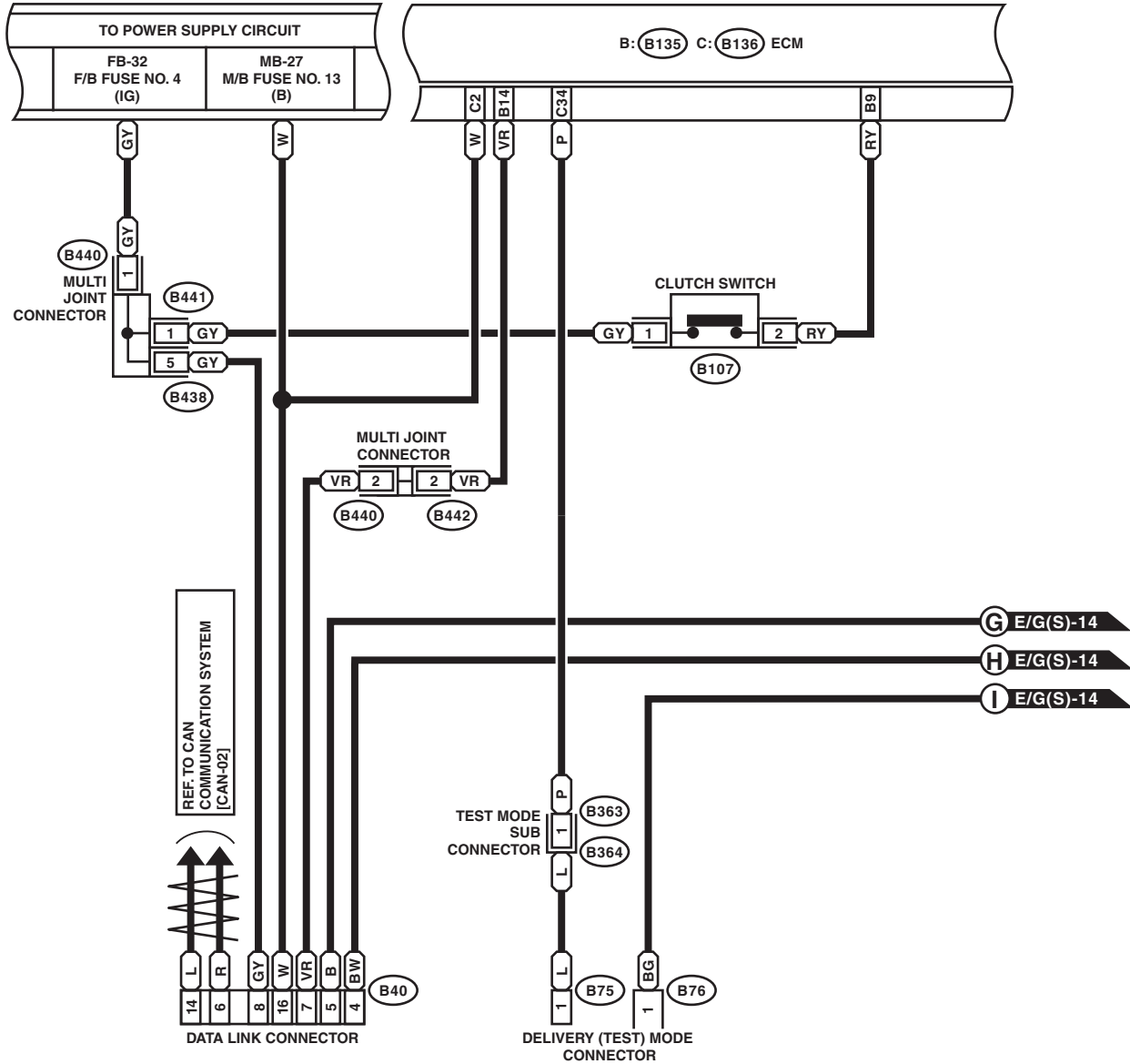

WI-33808

# Engine Electrical System

WIRING SYSTEM

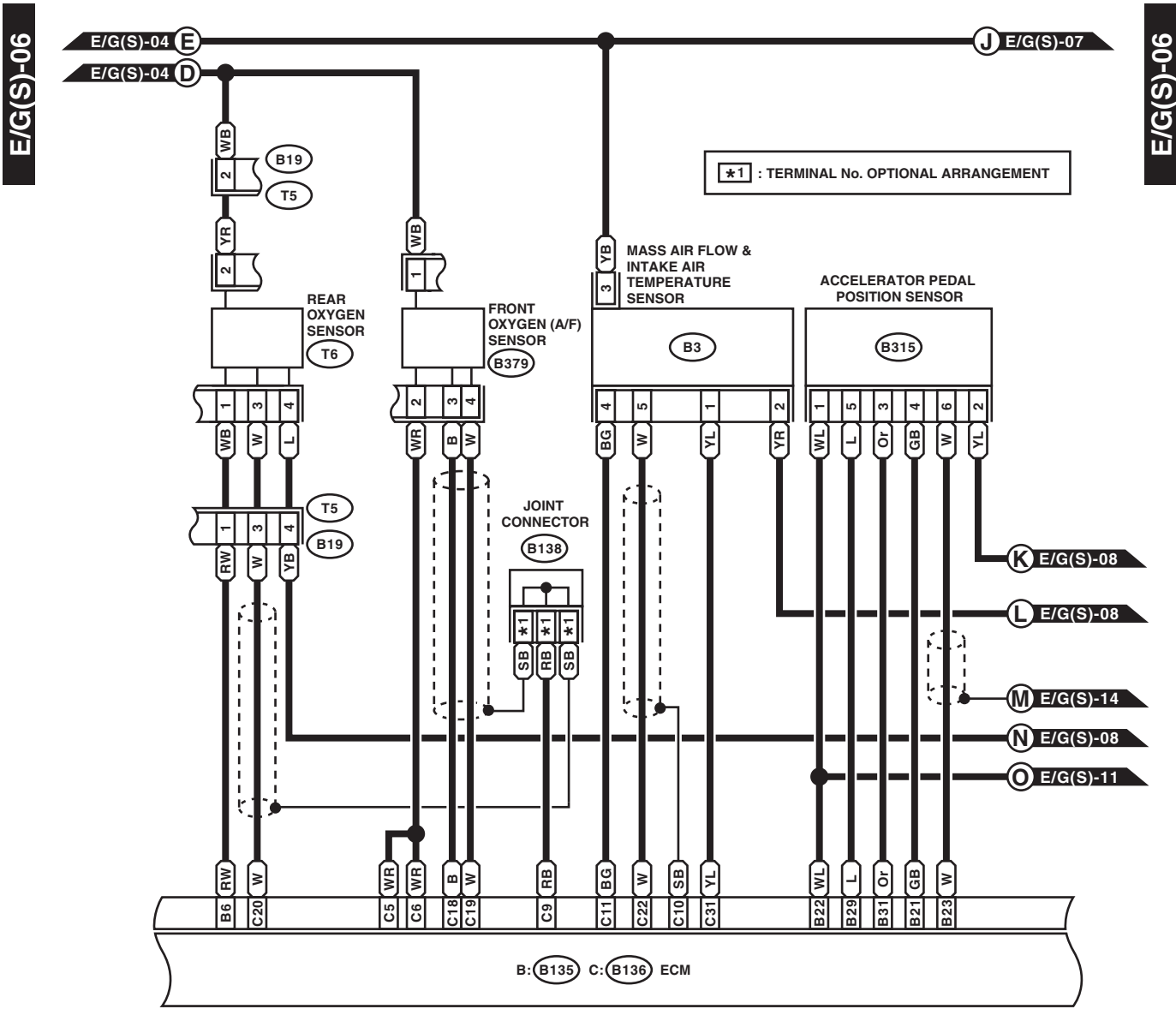

\*1 : TERMINAL No. OPTIONAL ARRANGEMENT

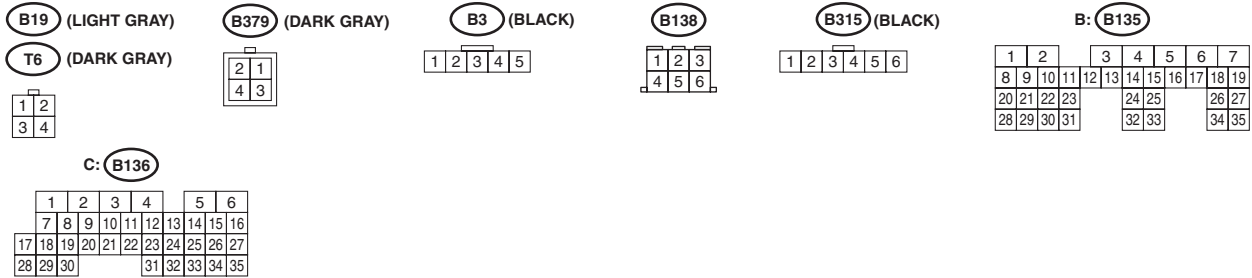

WI-33809

# Engine Electrical System

WIRING SYSTEM

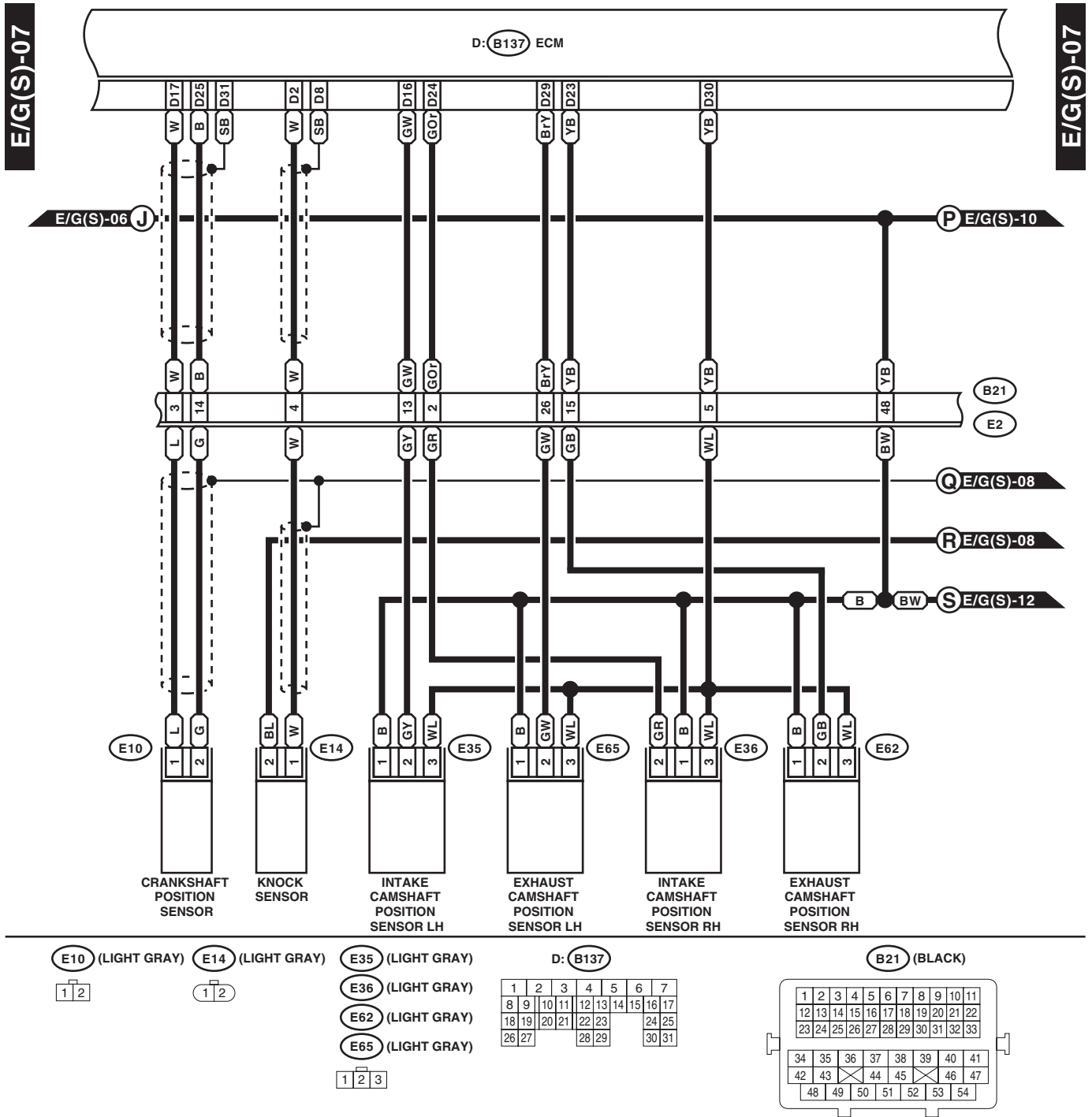

WI-33810



# Engine Electrical System

WIRING SYSTEM

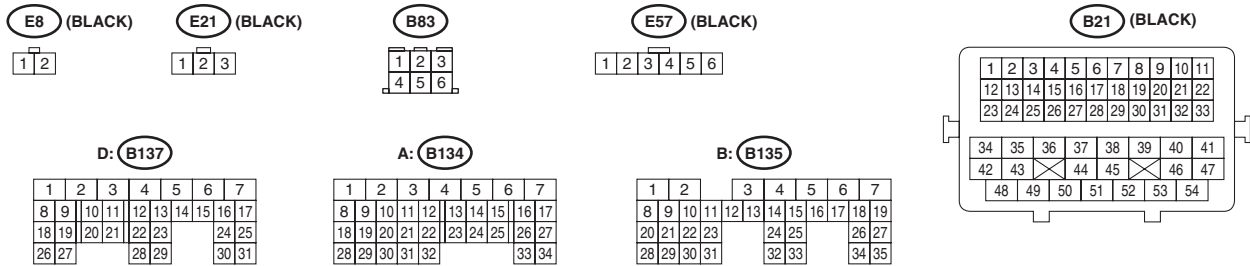
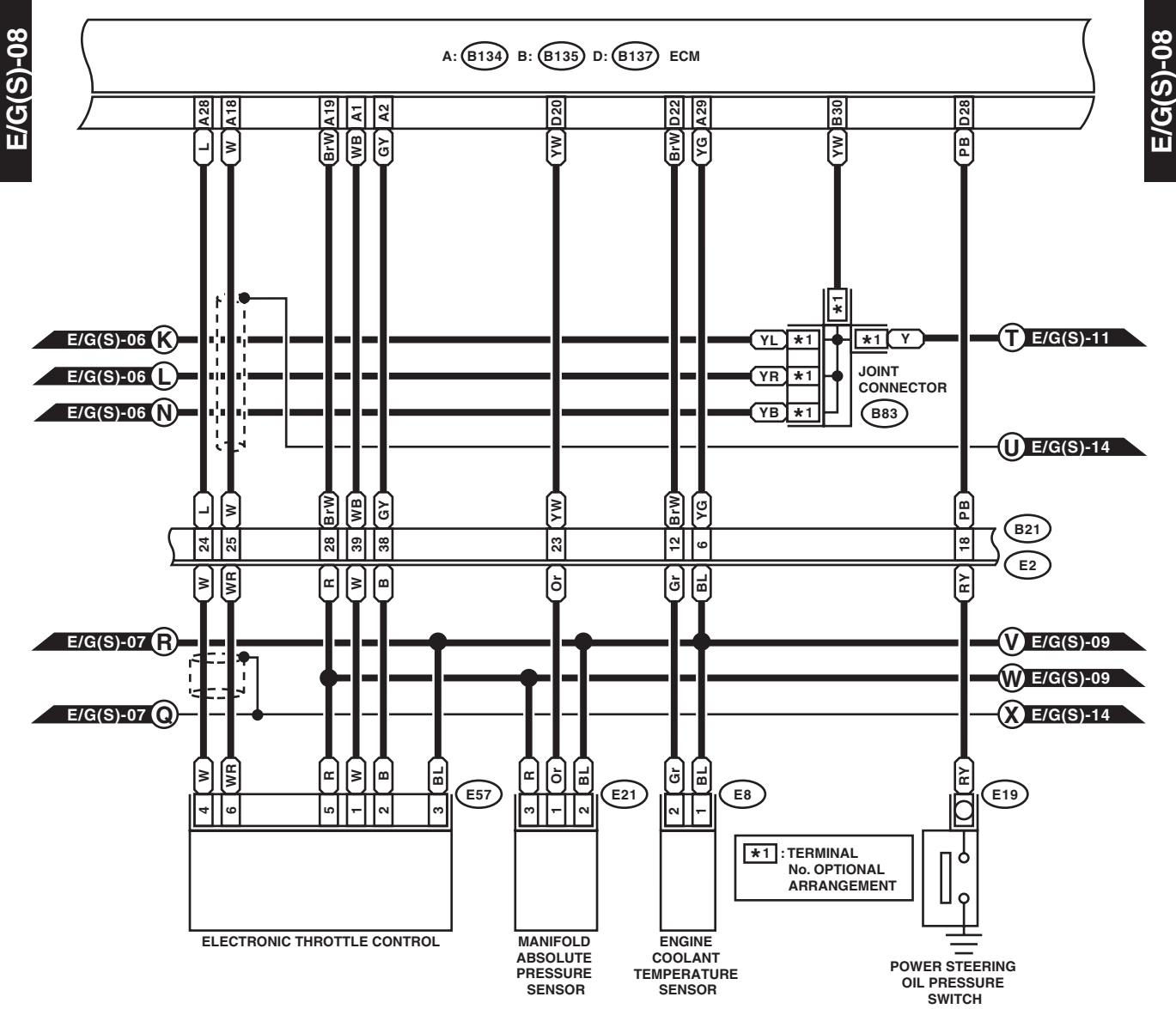

WI-33811

# Engine Electrical System

WIRING SYSTEM

E/G(S)-09

E/G(S)-09

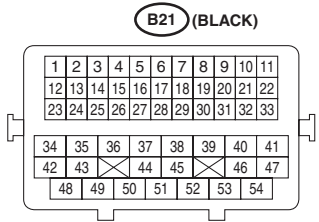
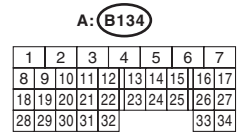
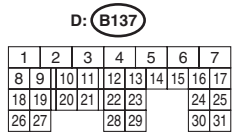
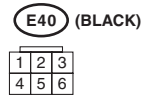
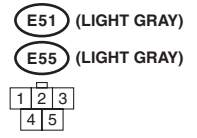
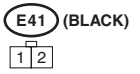
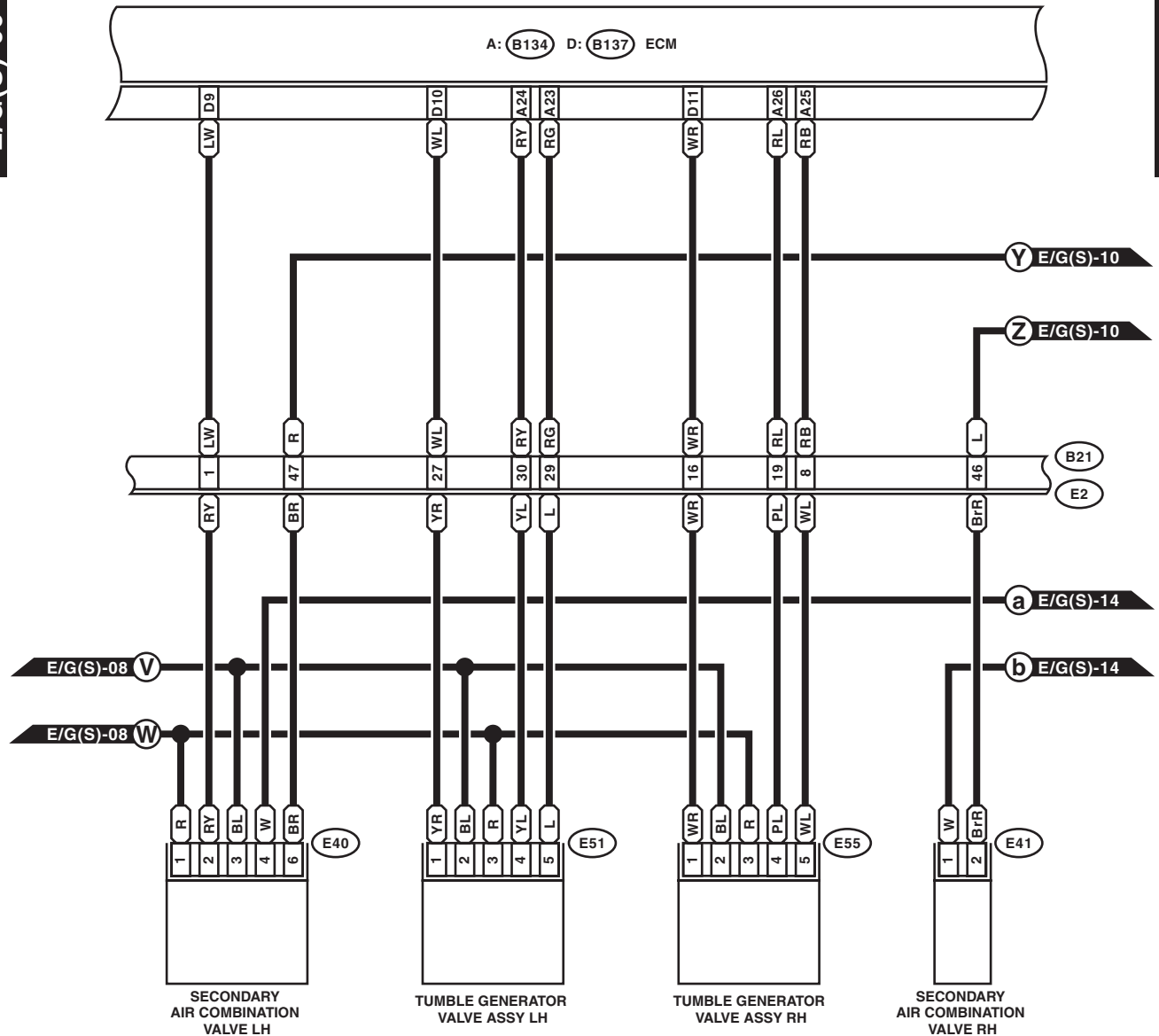

WI-30412

# Engine Electrical System

WIRING SYSTEM

E/G(S)-10

E/G(S)-10

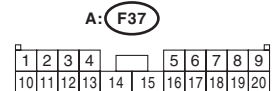
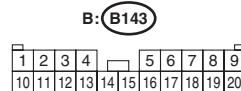
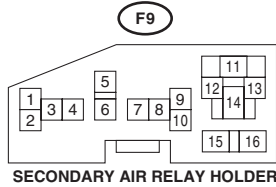
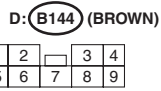
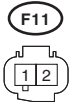
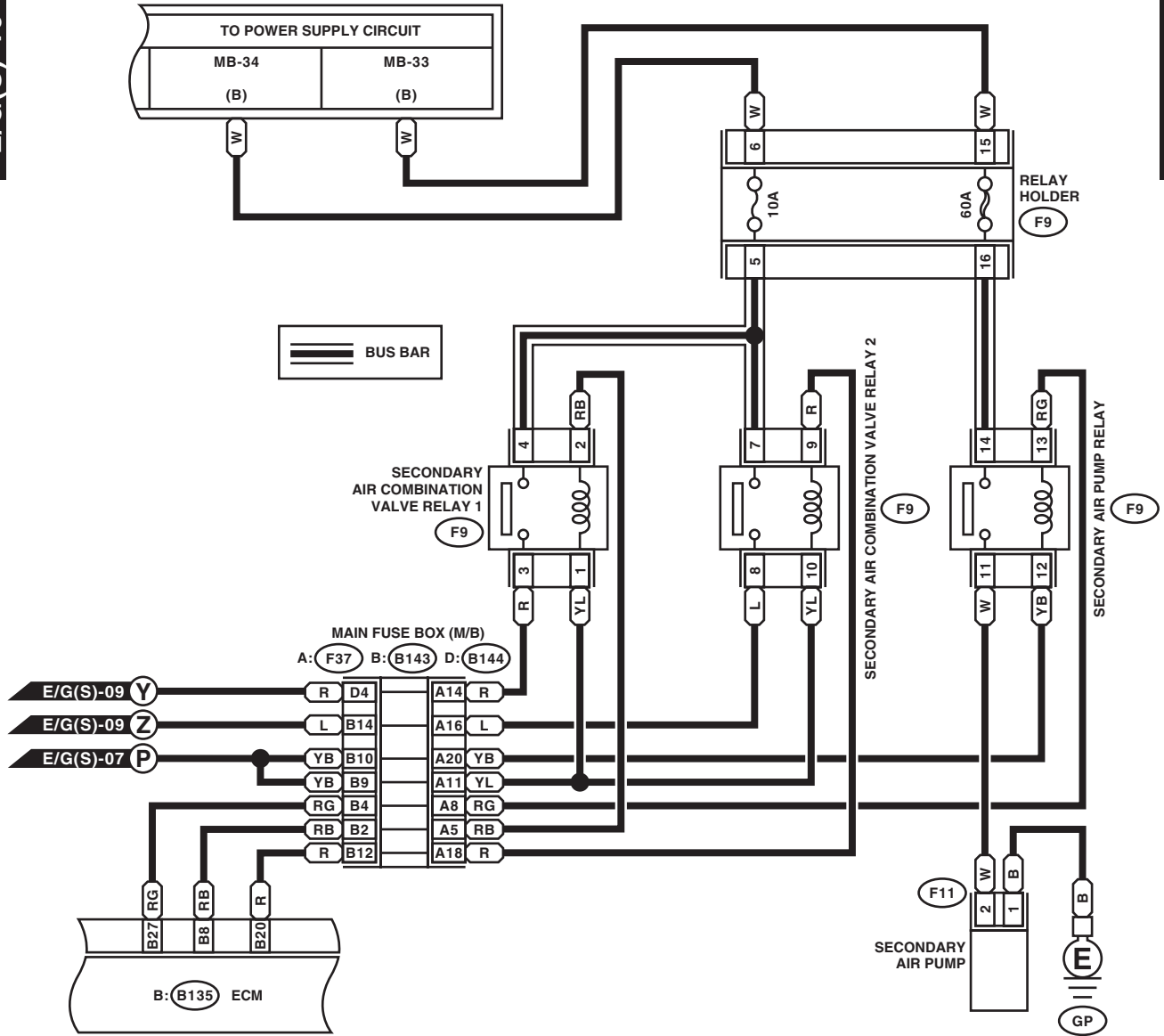

B: B135

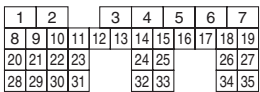

WI-33874

WI-59

Brought to you by Ebay Seller "SubaruManuals"

# Engine Electrical System

## WIRING SYSTEM

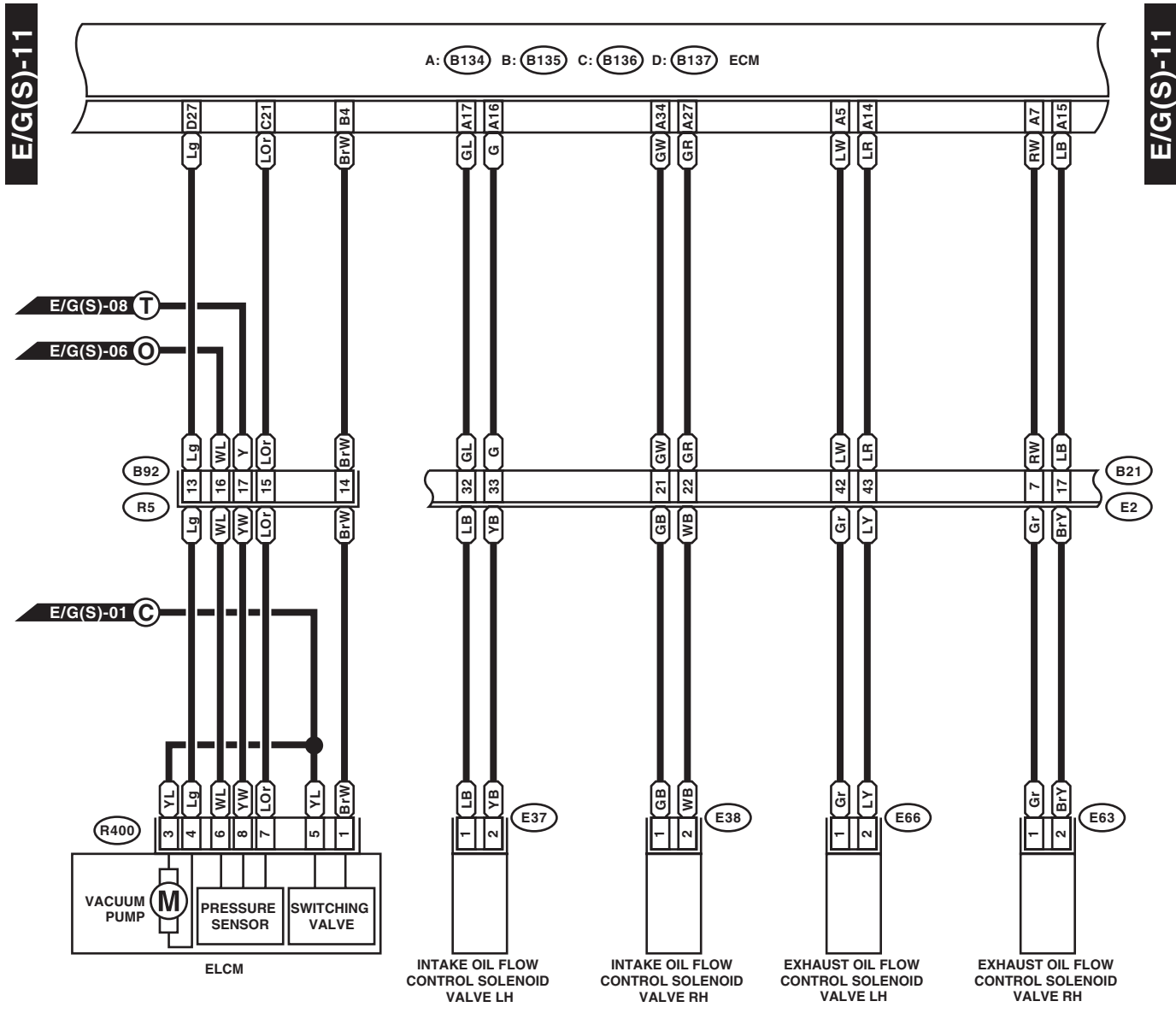

E37 (BLUE)

R400 (GRAY)

B92

D: B137

B21 (BLACK)

E38 (BLUE)

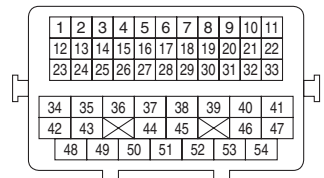
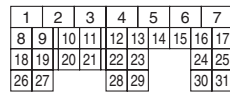
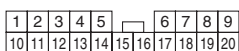

E63 (BLUE)

E66 (BLUE)



A: B134

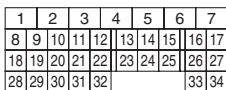

B: B135



C: B136



WI-33812

# Engine Electrical System

WIRING SYSTEM

E/G(S)-12

E/G(S)-12

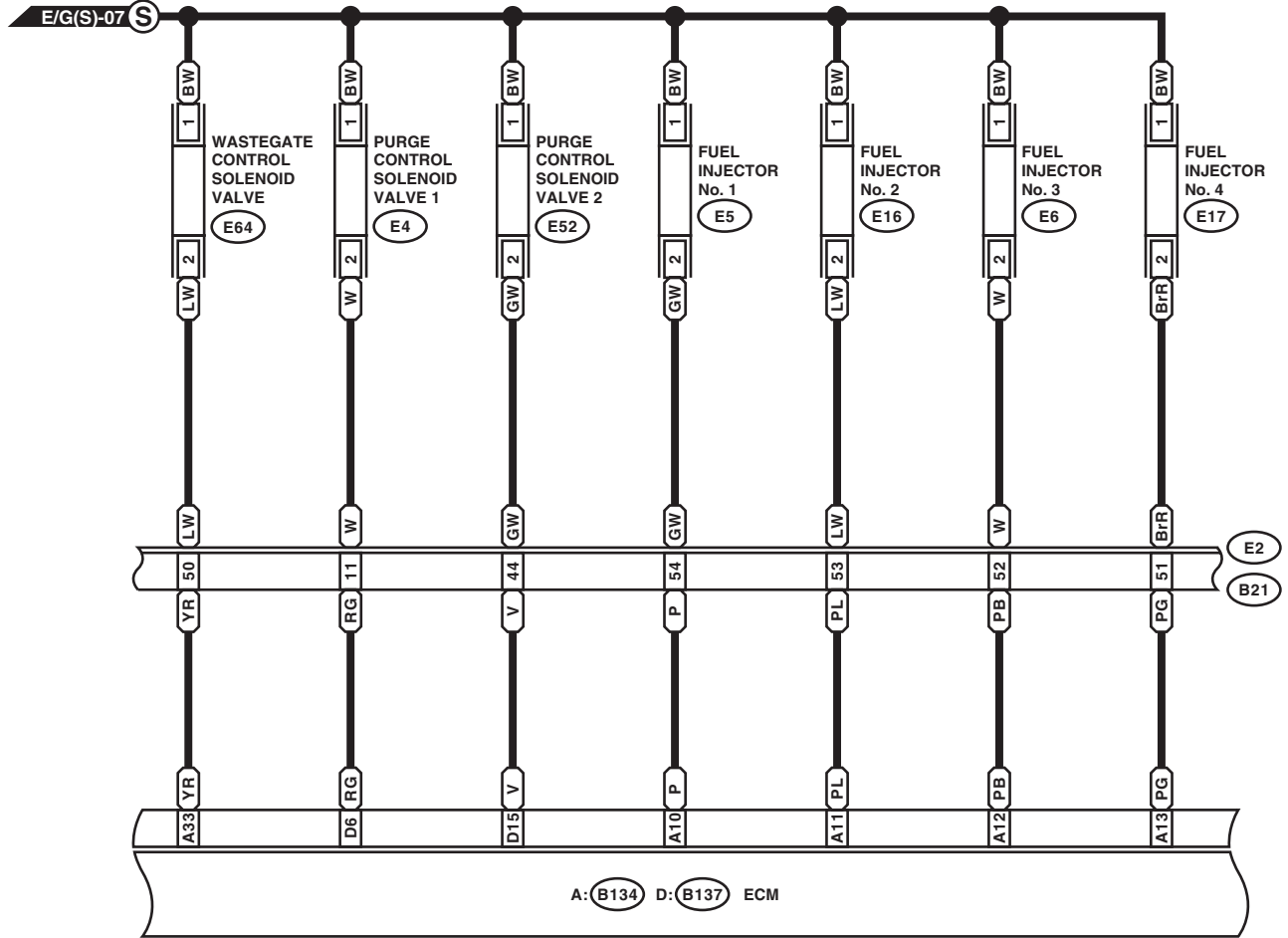

E4 (BLACK)

E52 (BLACK)

E64 (BLUE)

1 2

E5 (DARK GRAY)

E6 (DARK GRAY)

E16 (DARK GRAY)

E17 (DARK GRAY)

1 2

D: (B137)

1	2	3	4	5	6	7
8	9	10	11	12	13	14
15	16	17	18	19	20	21
22	23	24	25	26	27	28
29	30	31				

A: (B134)

1	2	3	4	5	6	7
8	9	10	11	12	13	14
15	16	17	18	19	20	21
22	23	24	25	26	27	28
29	30	31	32	33	34	

B21 (BLACK)

1	2	3	4	5	6	7	8	9	10	11
12	13	14	15	16	17	18	19	20	21	22
23	24	25	26	27	28	29	30	31	32	33
34	35	36	37	38	39	40	41			
42	43	44	45	46	47					
48	49	50	51	52	53	54				

WI-33813

WI-61

Brought to you by Ebay Seller "SubaruManuals"

# Engine Electrical System

WIRING SYSTEM

E/G(S)-13

E/G(S)-13

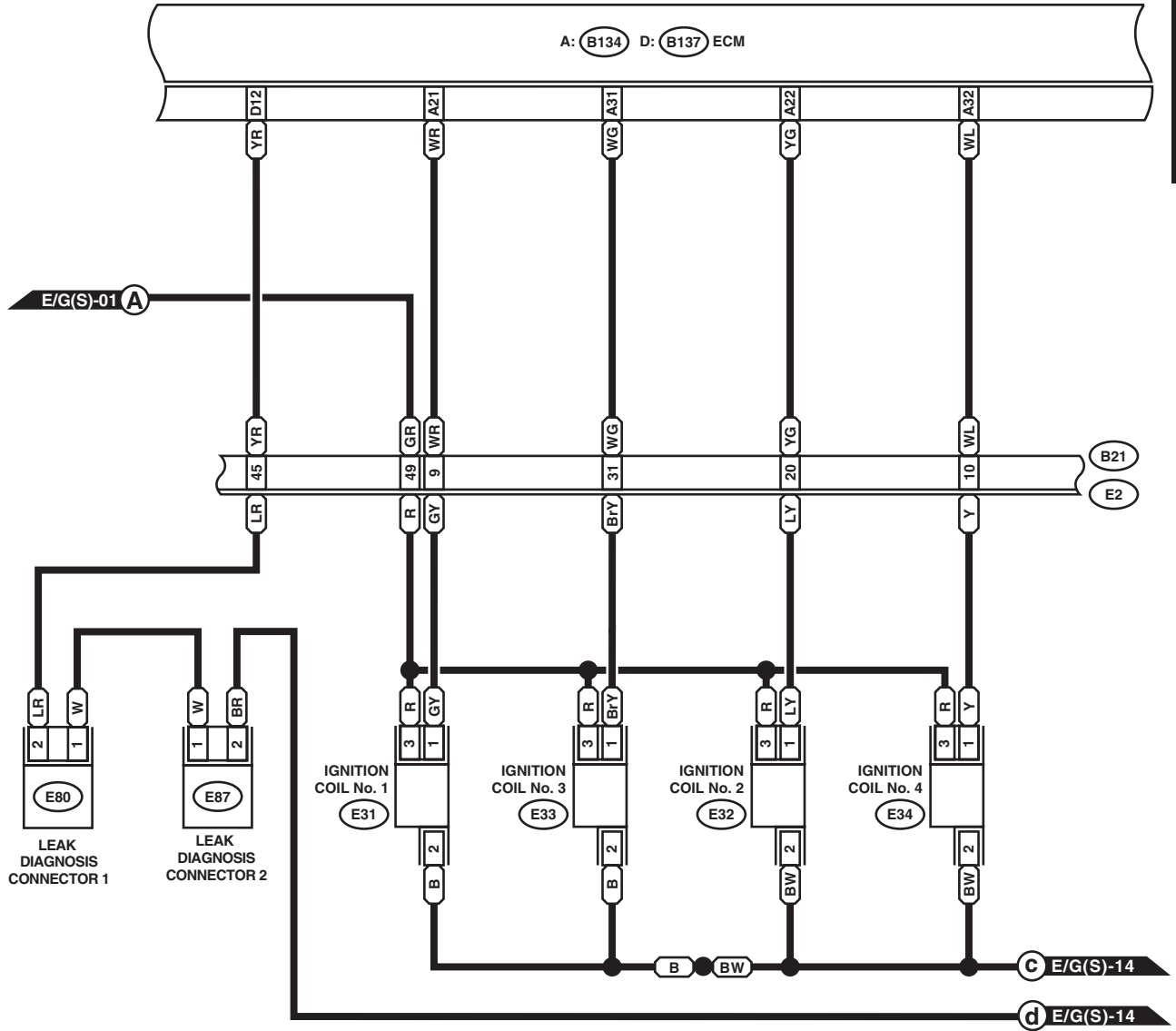

E80 (DARK GRAY)

(GRAY) E31 E33 (GRAY)

D: B137

A: B134

B21 (BLACK)

E87 (DARK GRAY)

(GRAY) E32 E34 (GRAY)

1	2	3	4	5	6	7
8	9	10	11	12	13	14
15	16	17	18	19	20	21
22	23	24	25	26	27	28
29	30	31				

1	2	3	4	5	6	7
8	9	10	11	12	13	14
15	16	17	18	19	20	21
22	23	24	25	26	27	28
29	30	31	32	33	34	

1	2	3	4	5	6	7	8	9	10	11
12	13	14	15	16	17	18	19	20	21	22
23	24	25	26	27	28	29	30	31	32	33
34	35	36	37	38	39	40	41			
42	43	44	45	46	47					
48	49	50	51	52	53	54				

WI-33875

WI-62

Brought to you by Ebay Seller "SubaruManuals"

# Engine Electrical System

WIRING SYSTEM

E/G(S)-14

E/G(S)-14

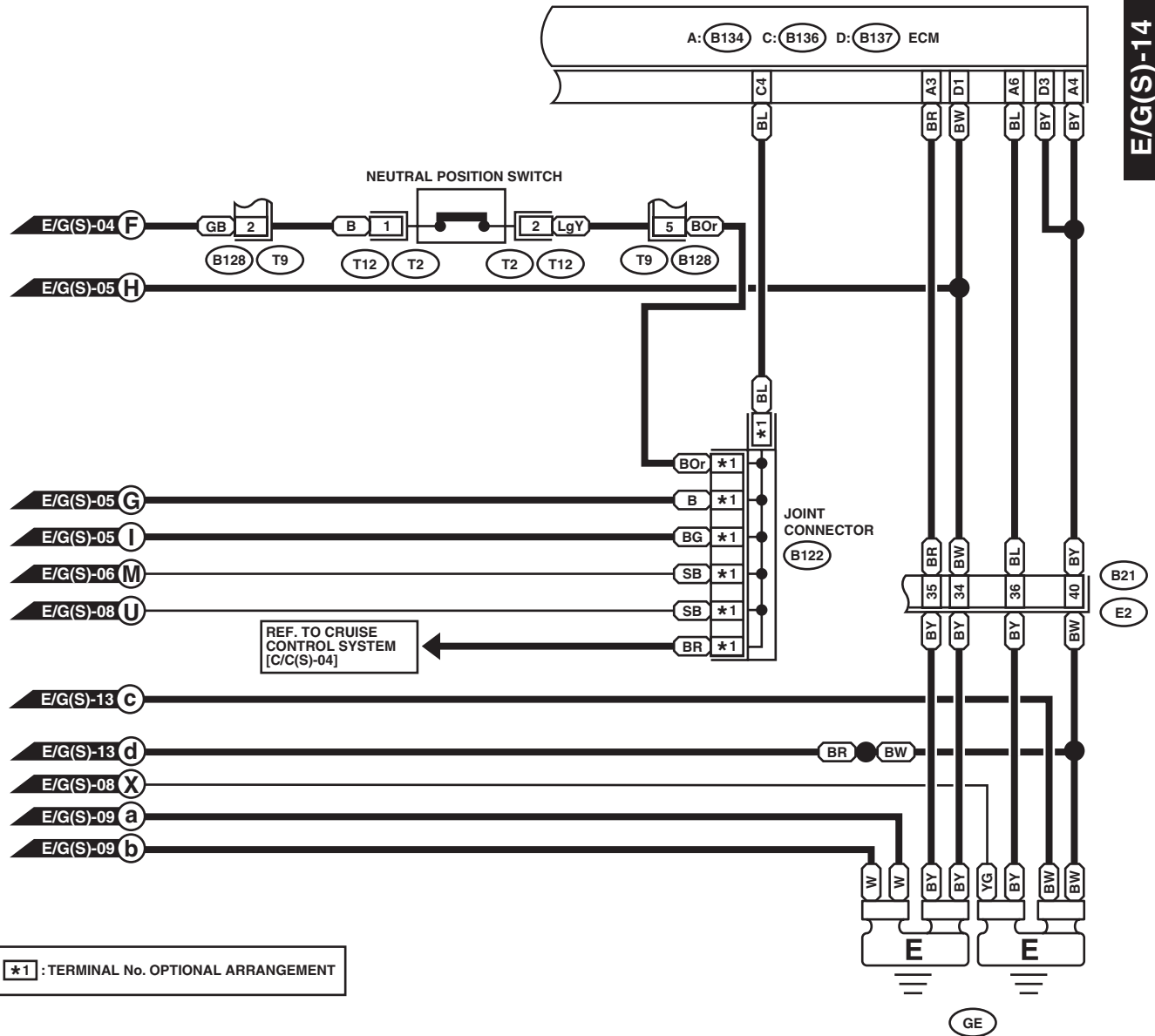

T12 (BROWN)



B128 (LIGHT GRAY)



B122

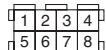

D: B137



B21 (BLACK)

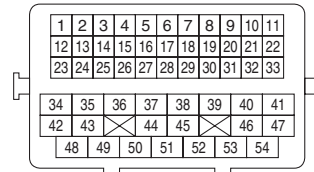

A: B134

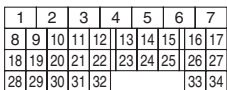

C: B136

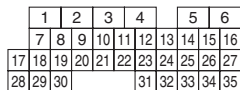

WI-33814

# Radiator Fan System

WIRING SYSTEM

## 6. Radiator Fan System

### A: WIRING DIAGRAM

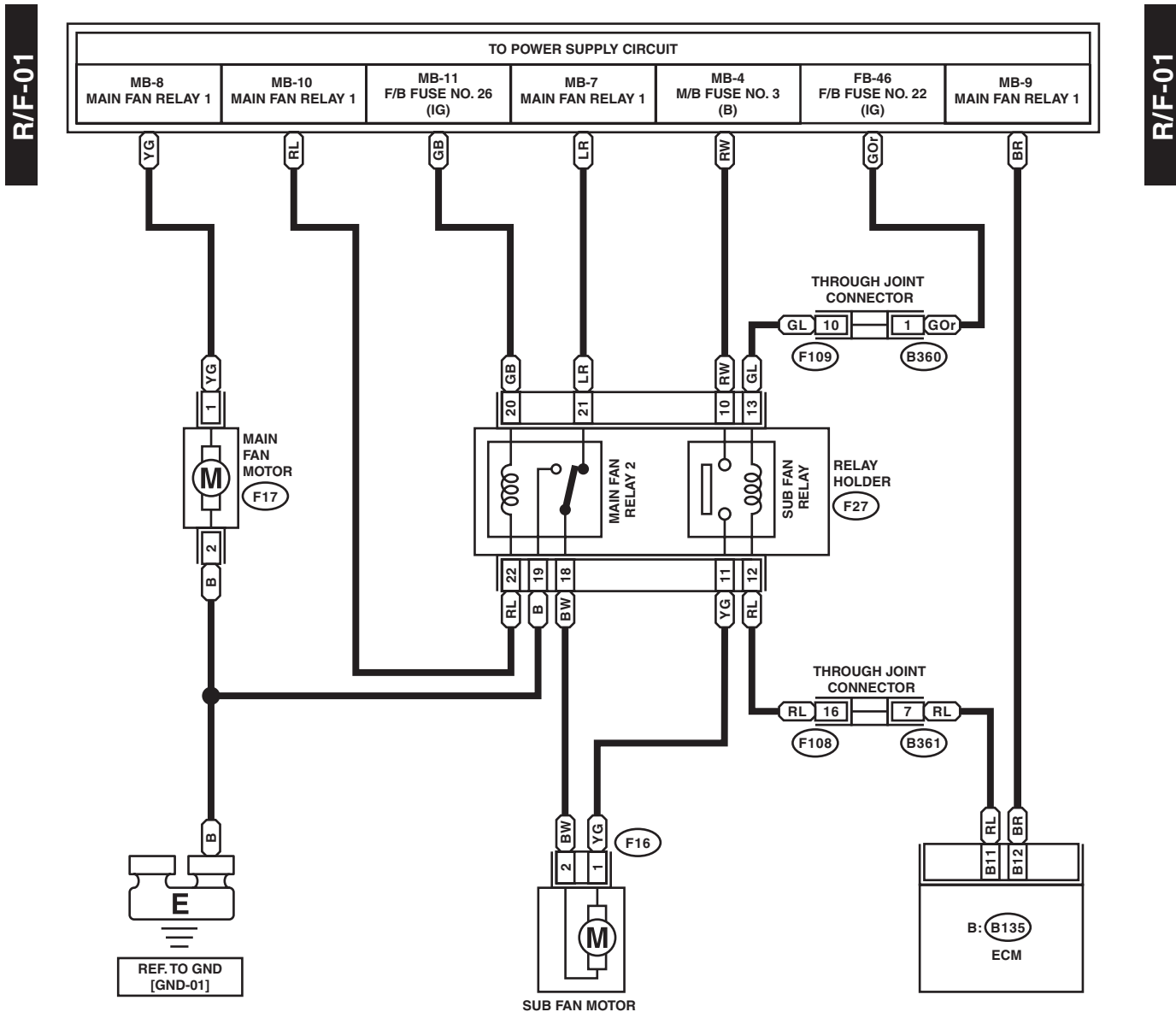

F16 (BLACK)

B361

B360 (GRAY)

F108 (GRAY)

F109

F27 (BLACK)

F17 (BLACK)

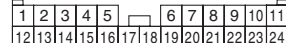
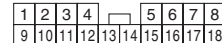

B: B135

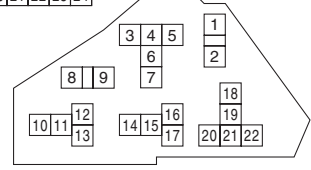
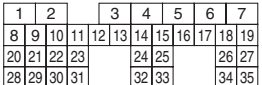

RELAY HOLDER

WI-30418



## 7. Charging System

### A: WIRING DIAGRAM

CHG-01

CHG-01

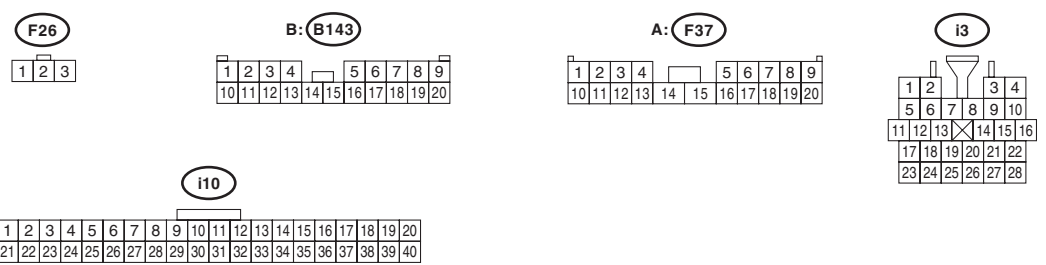
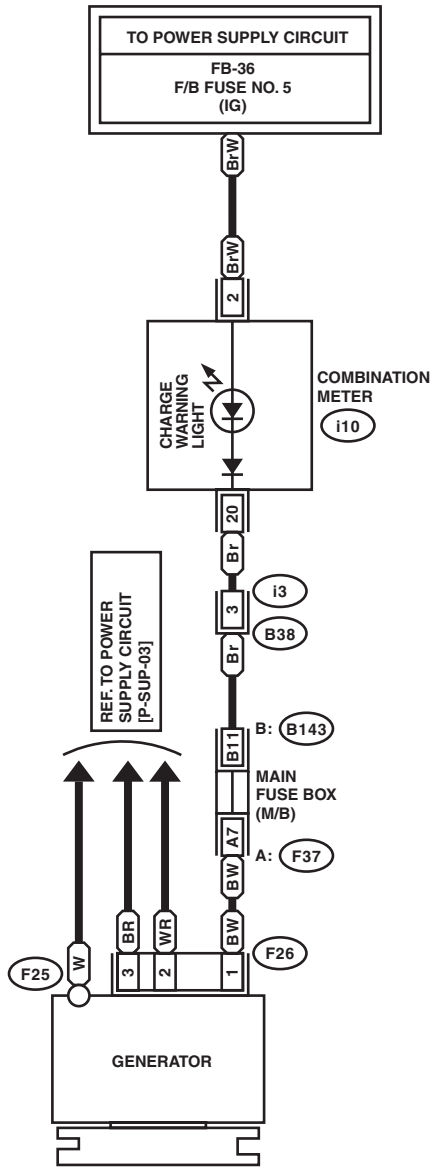

# Starter System

WIRING SYSTEM

## 8. Starter System

### A: WIRING DIAGRAM

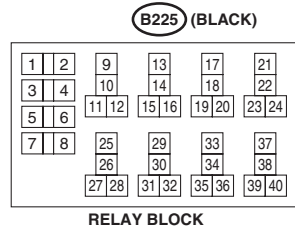
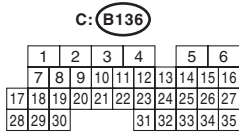
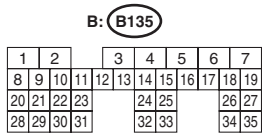
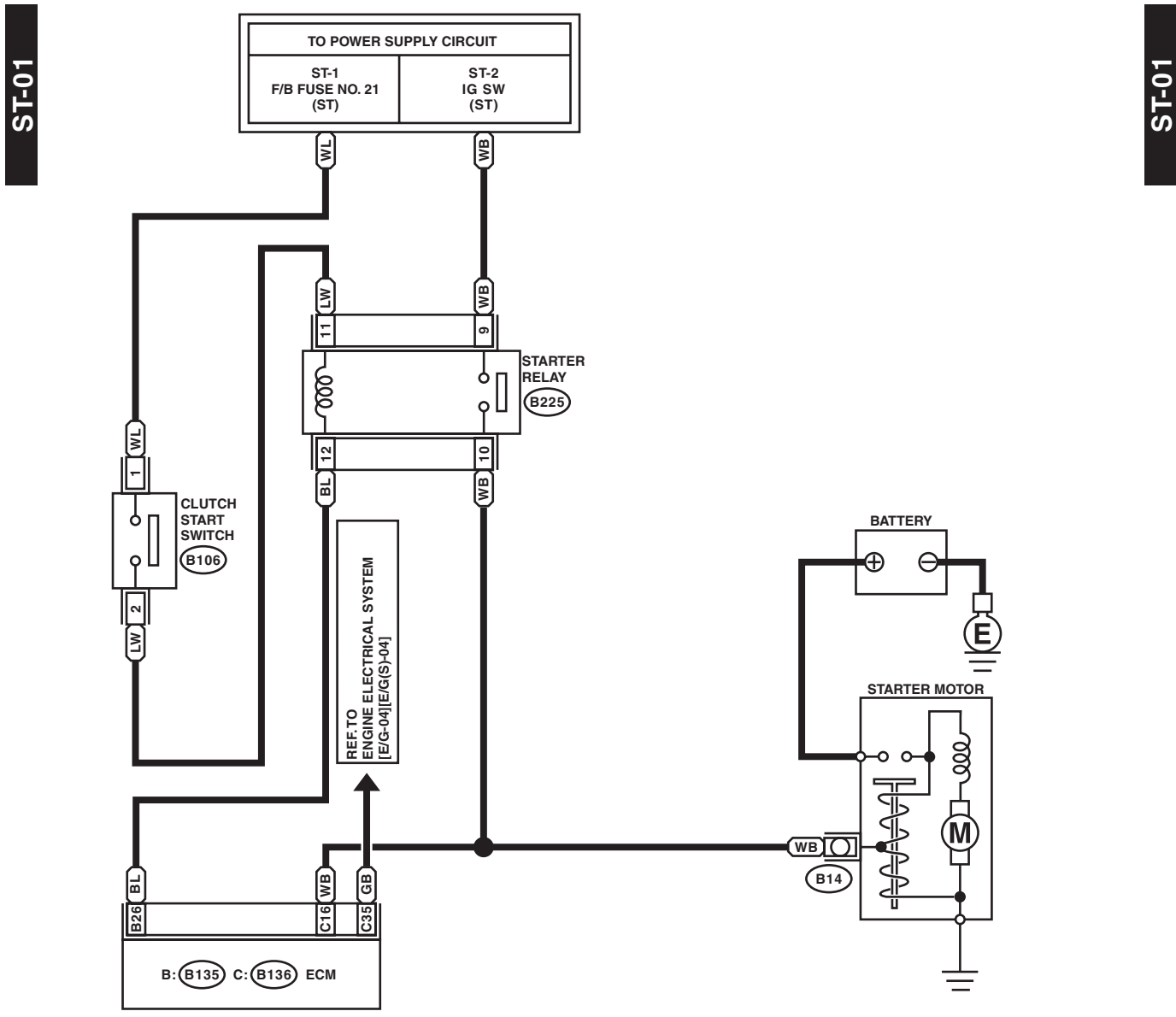

WI-33815

## 9. Vehicle Dynamics Control System

### A: WIRING DIAGRAM

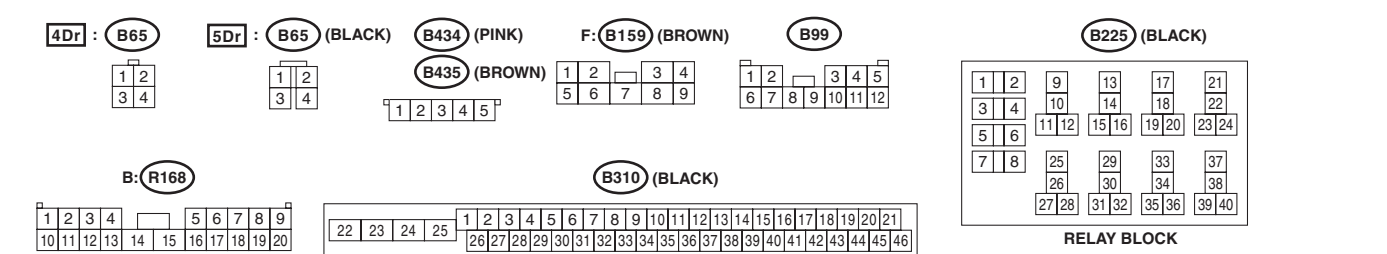
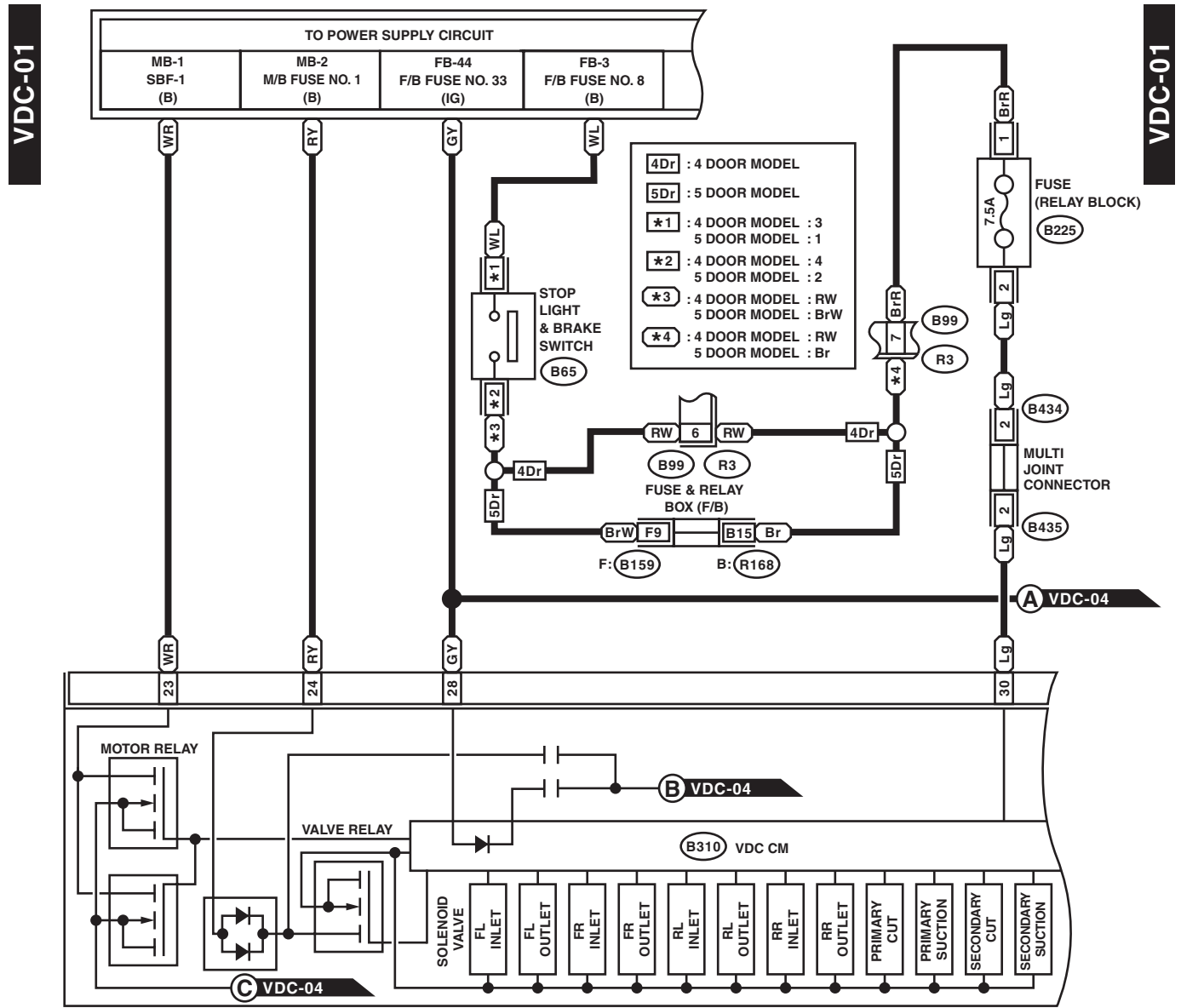

WI-27046

# Vehicle Dynamics Control System

WIRING SYSTEM

VDC-02

VDC-02

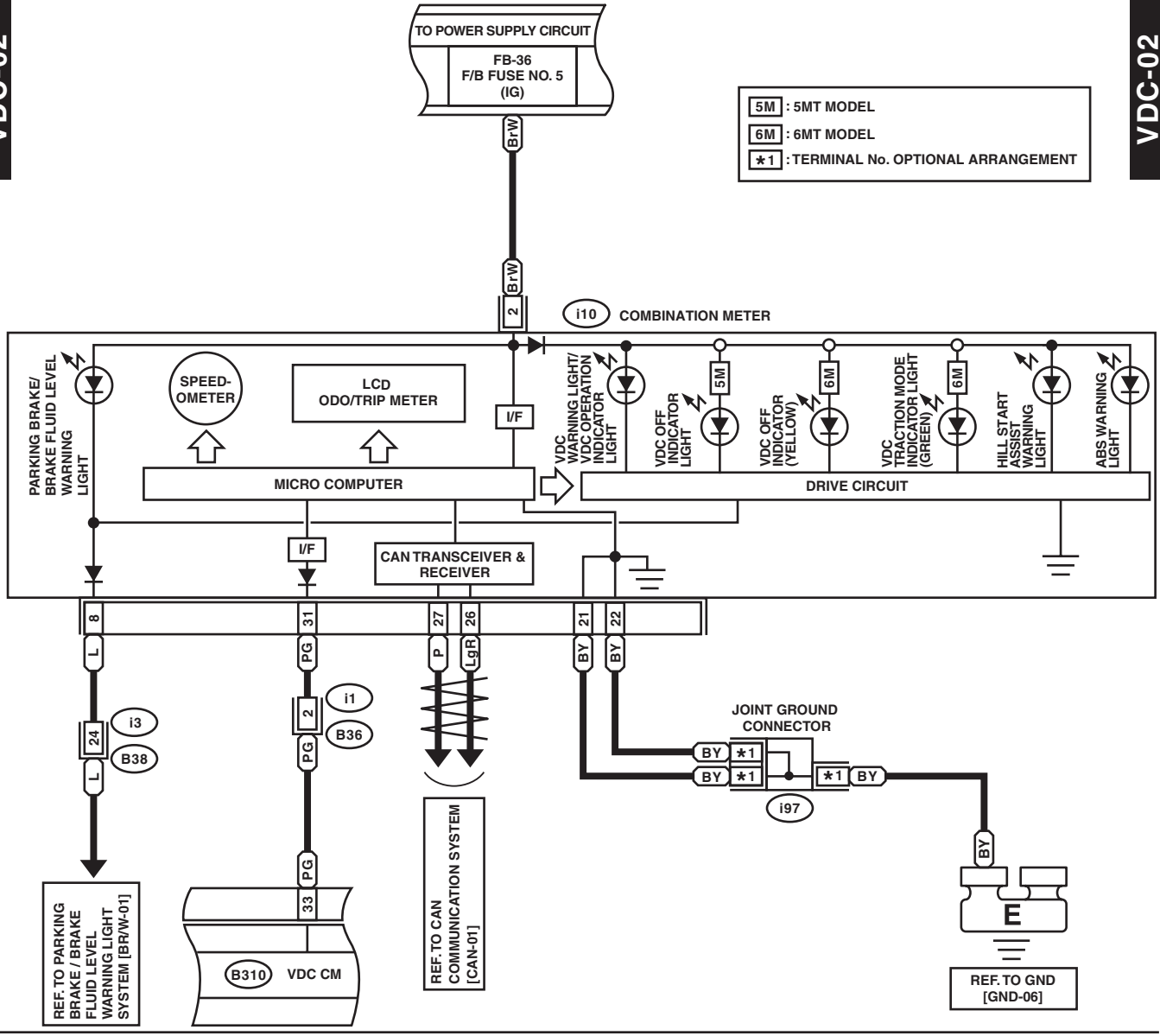

5M : 5MT MODEL  
 6M : 6MT MODEL  
 \*1 : TERMINAL No. OPTIONAL ARRANGEMENT

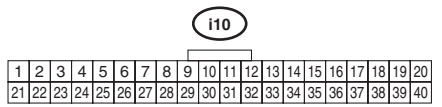
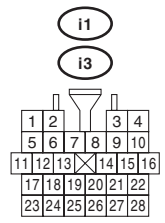
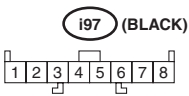

B310 (BLACK)

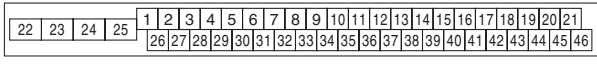

WI-33876

# Vehicle Dynamics Control System

WIRING SYSTEM

VDC-03

VDC-03

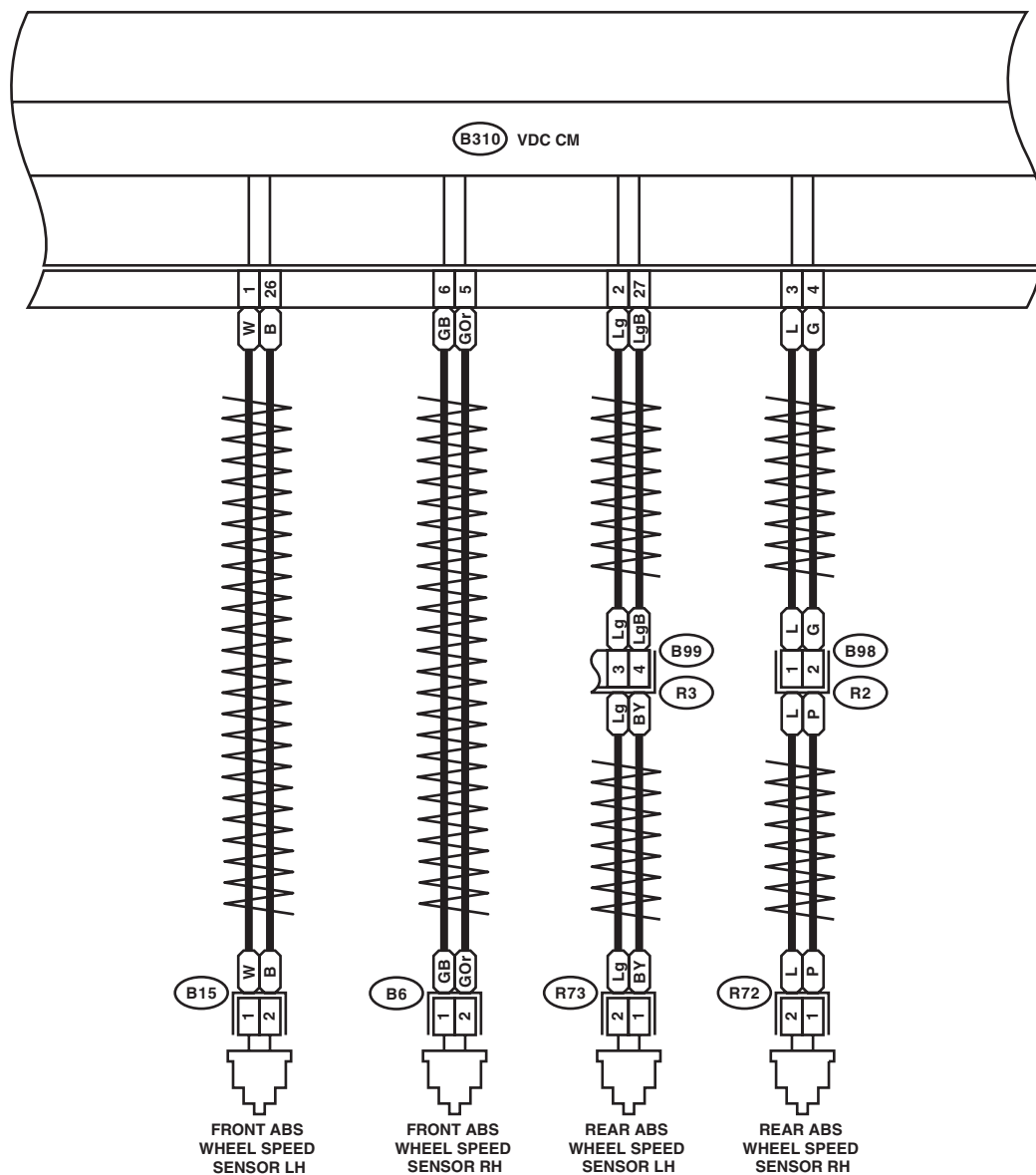

(LIGHT GRAY) (B6) (R72) (LIGHT GRAY)

(LIGHT GRAY) (B15) (R73) (LIGHT GRAY)

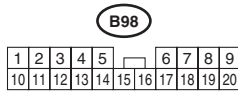
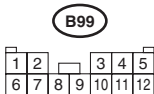

(B310) (BLACK)

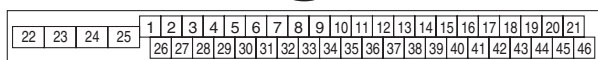

WI-31691

# Vehicle Dynamics Control System

## WIRING SYSTEM

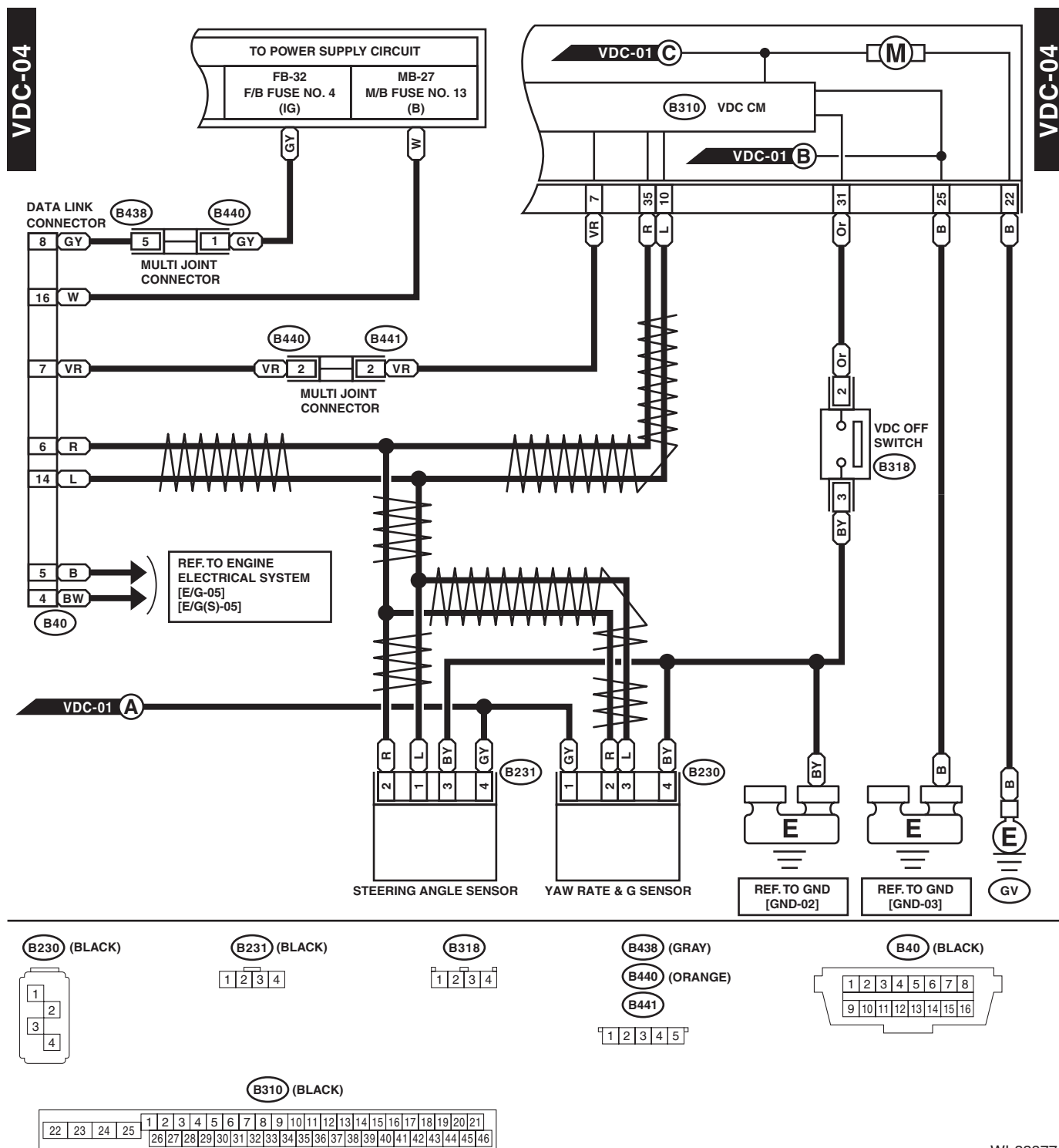

WI-33877

## 10. Tire Pressure Monitoring System

### A: WIRING DIAGRAM

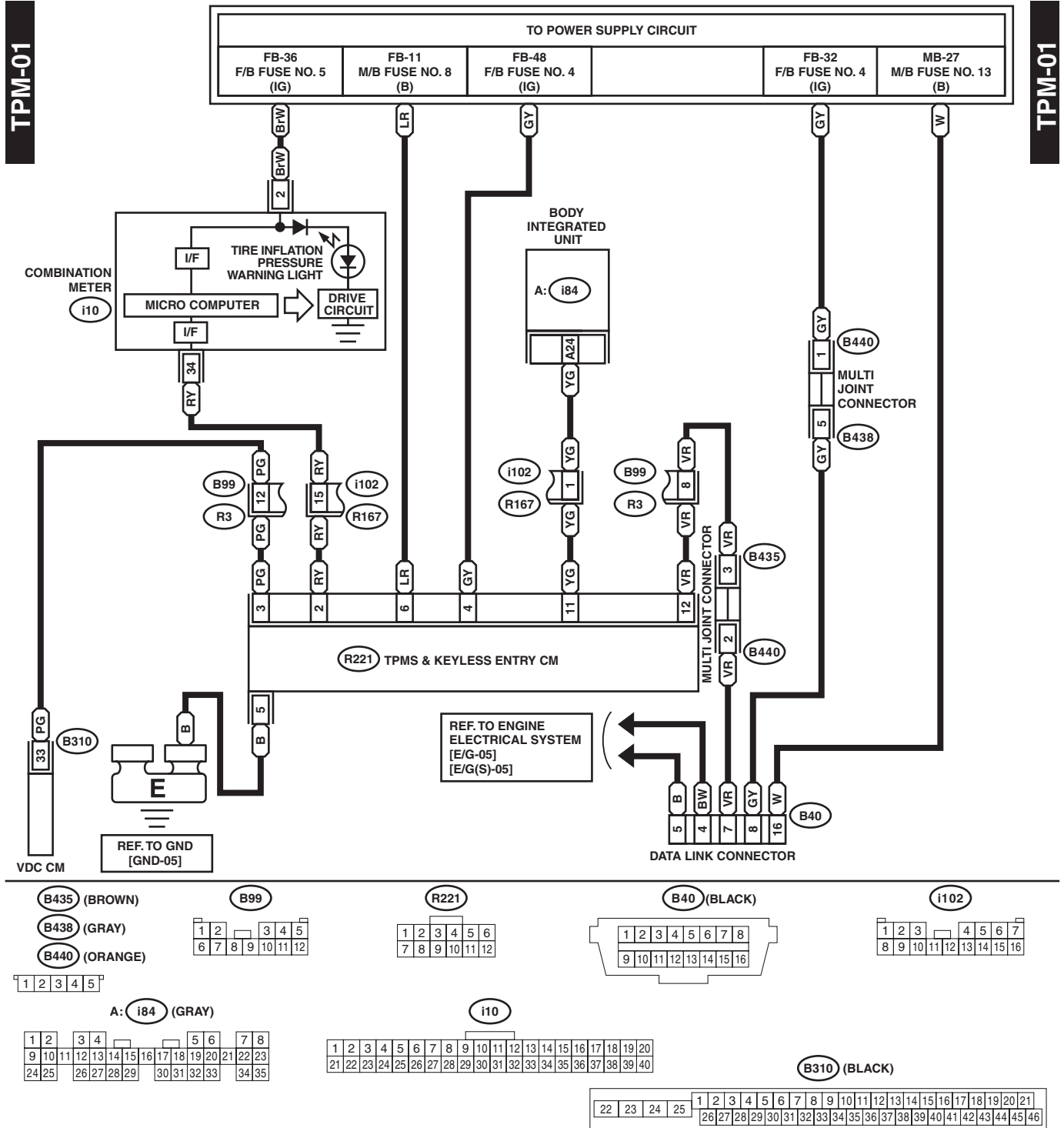

WI-30423

# Driver's Control Center Differential Control System

WIRING SYSTEM

## 11.Driver's Control Center Differential Control System

### A: WIRING DIAGRAM

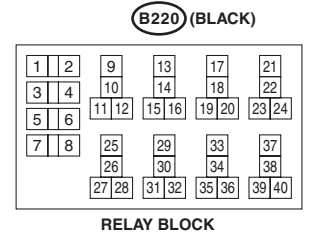
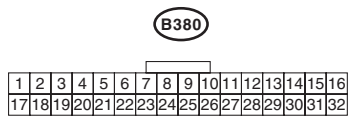
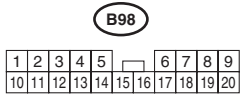
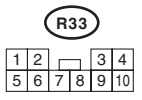
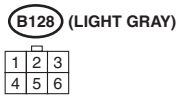
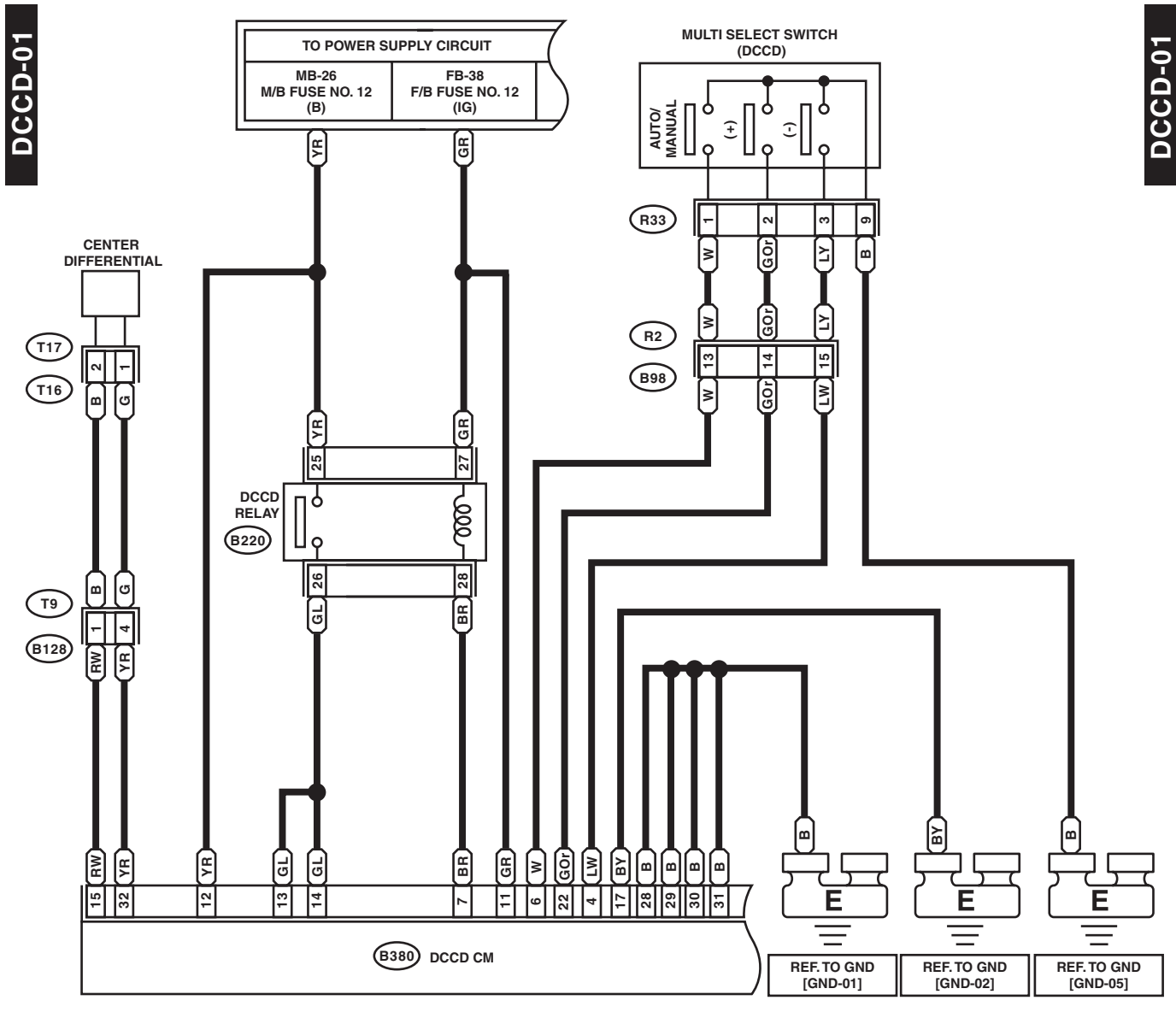

WI-30535



# Driver's Control Center Differential Control System

WIRING SYSTEM

DCCD-02

DCCD-02

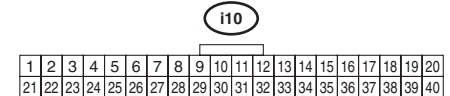
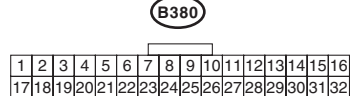
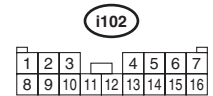
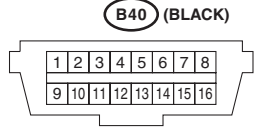
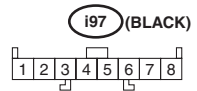
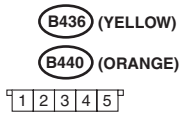
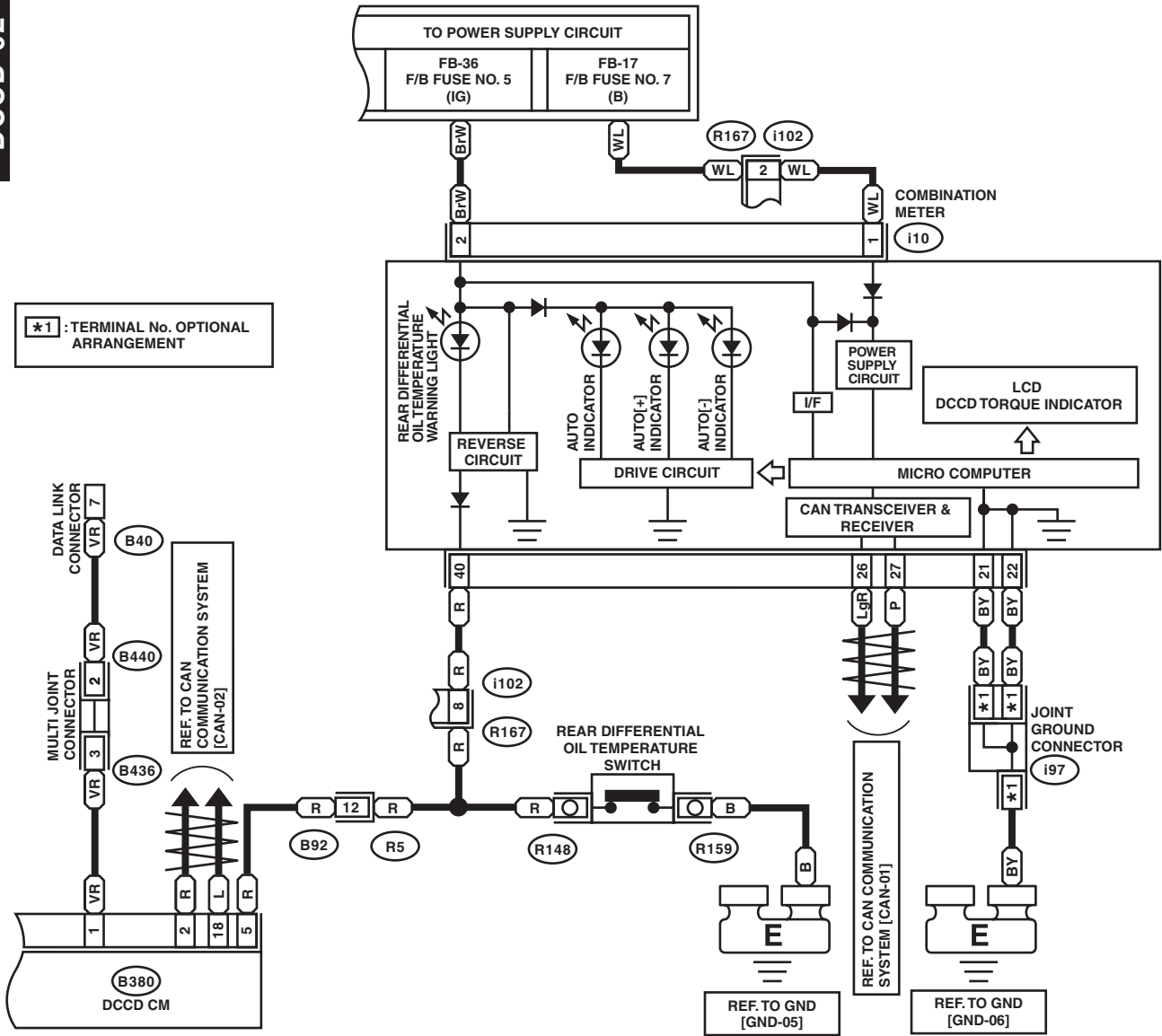

WI-30424

# Air Conditioning System

WIRING SYSTEM

## 12. Air Conditioning System

### A: WIRING DIAGRAM

#### 1. MANUAL A/C MODEL

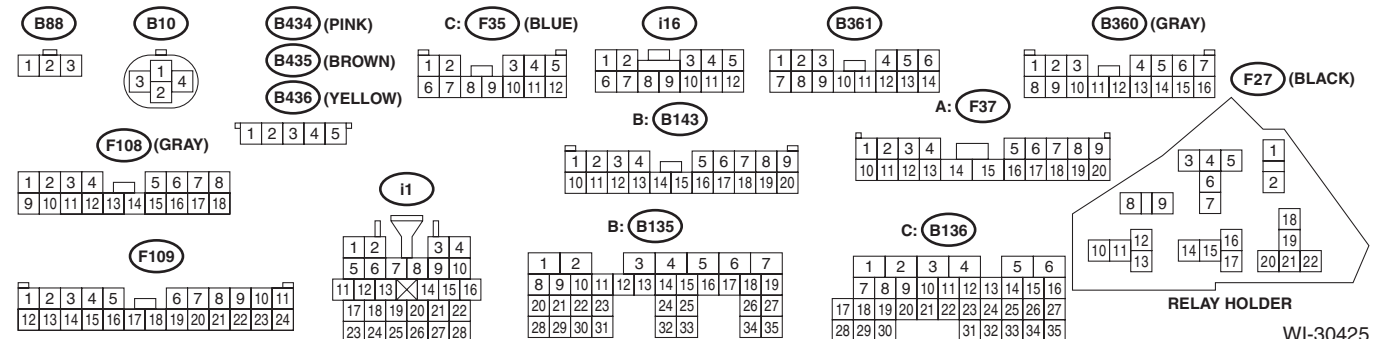
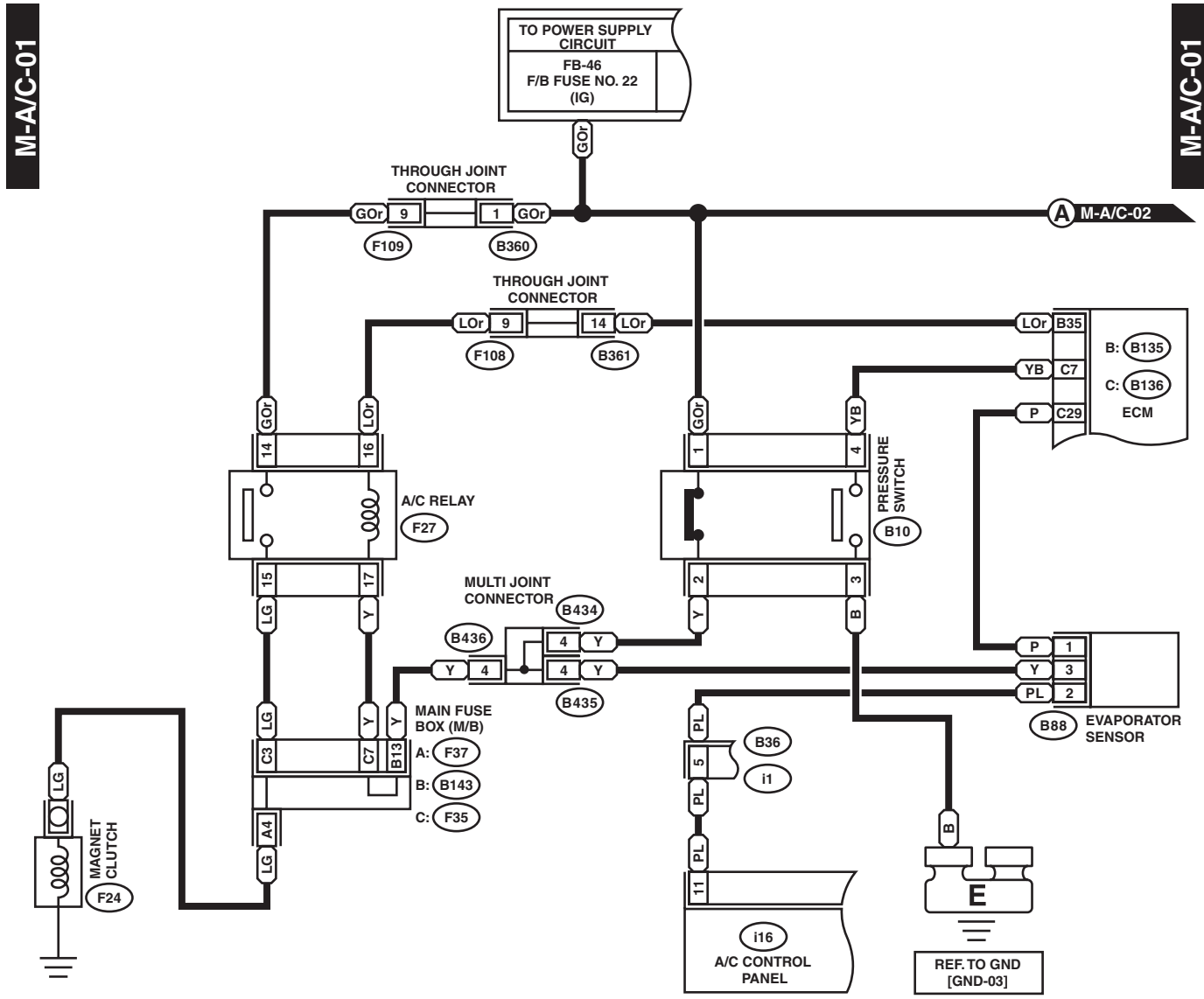

# Air Conditioning System

WIRING SYSTEM

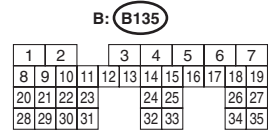
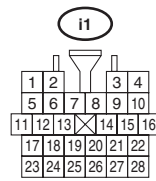
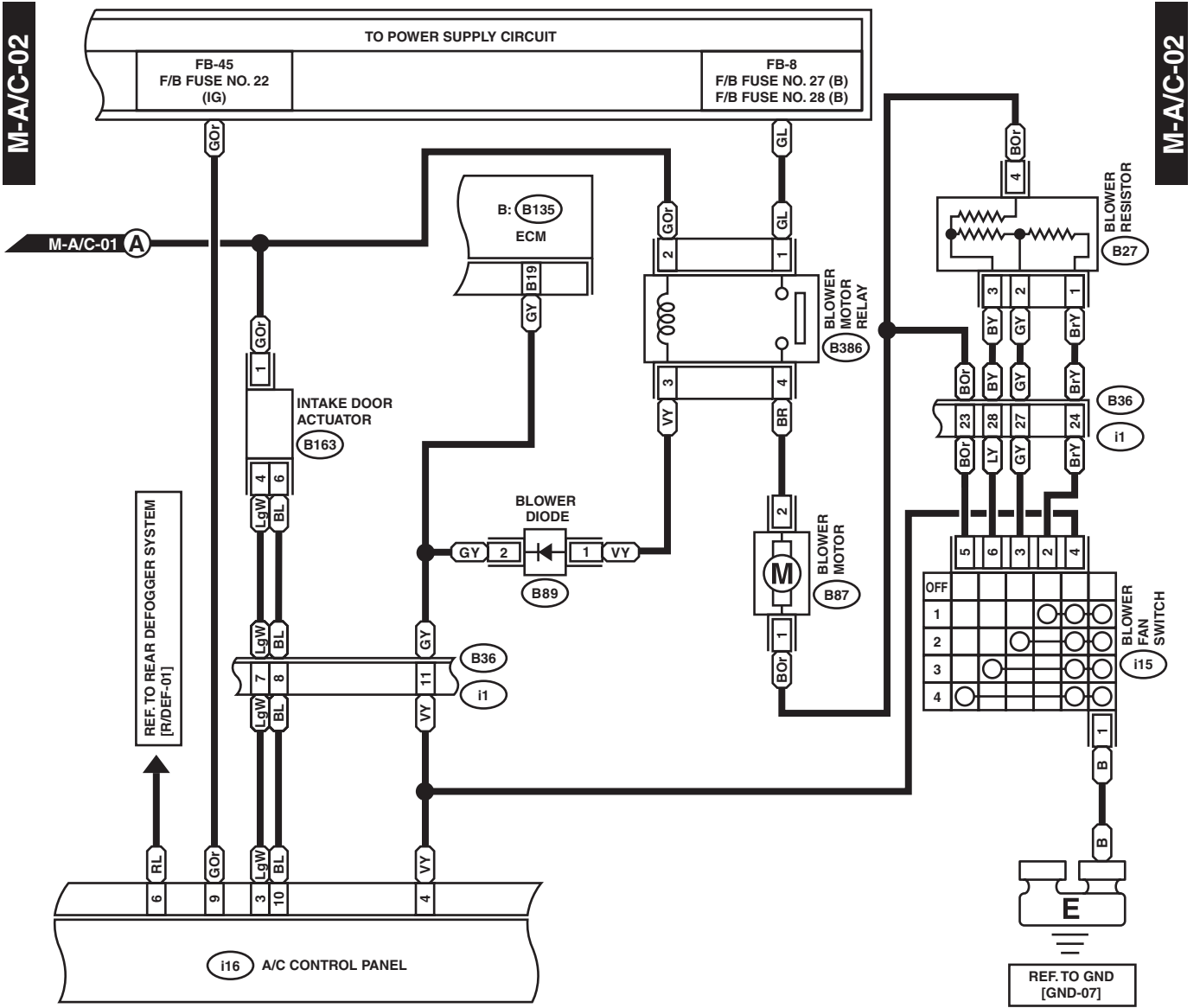

WI-33816

# Air Conditioning System

## WIRING SYSTEM

M-A/C-03

M-A/C-03

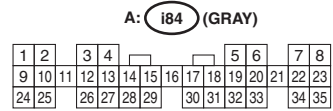
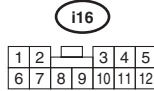
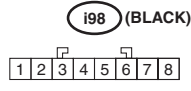
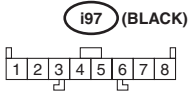
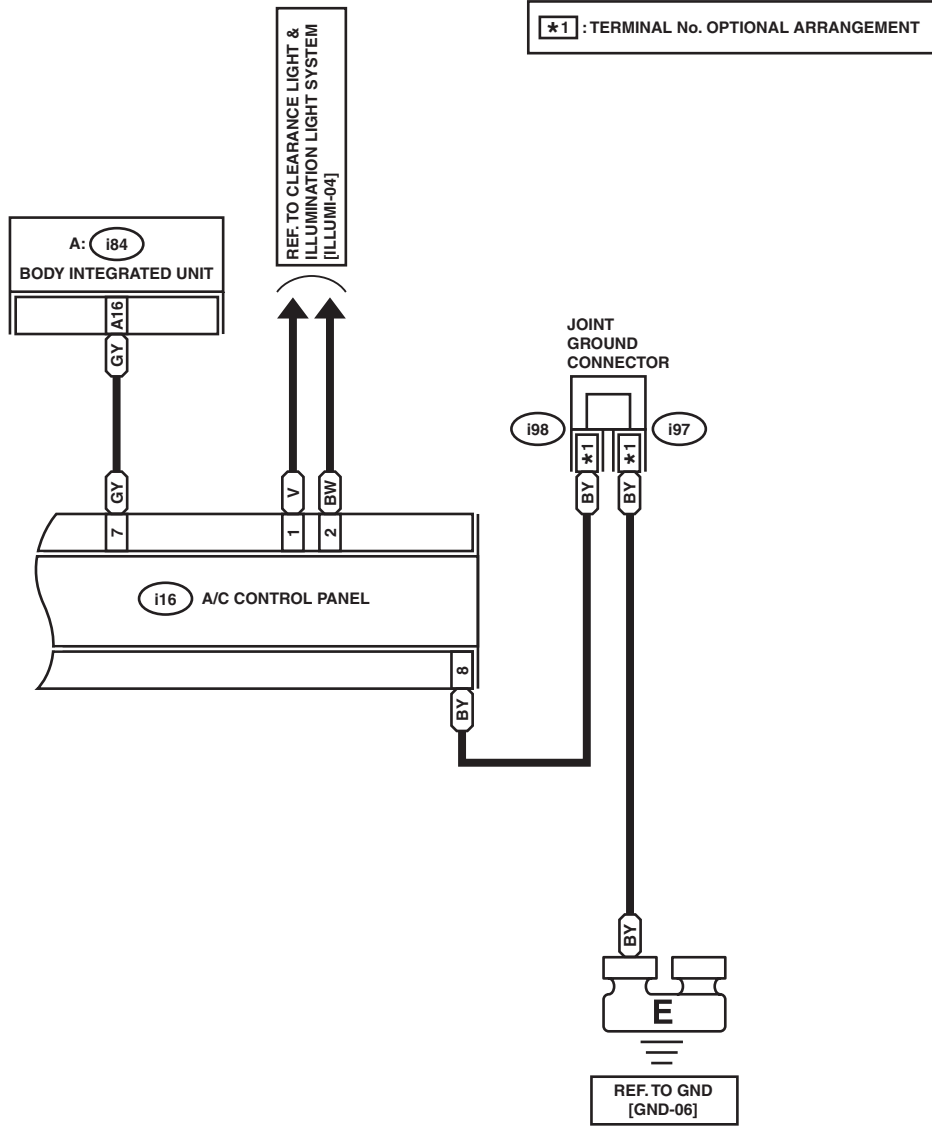

WI-21426

WI-76

Brought to you by Ebay Seller "SubaruManuals"

# Air Conditioning System

WIRING SYSTEM

## 2. AUTO A/C MODEL

A-A/C-01

A-A/C-01

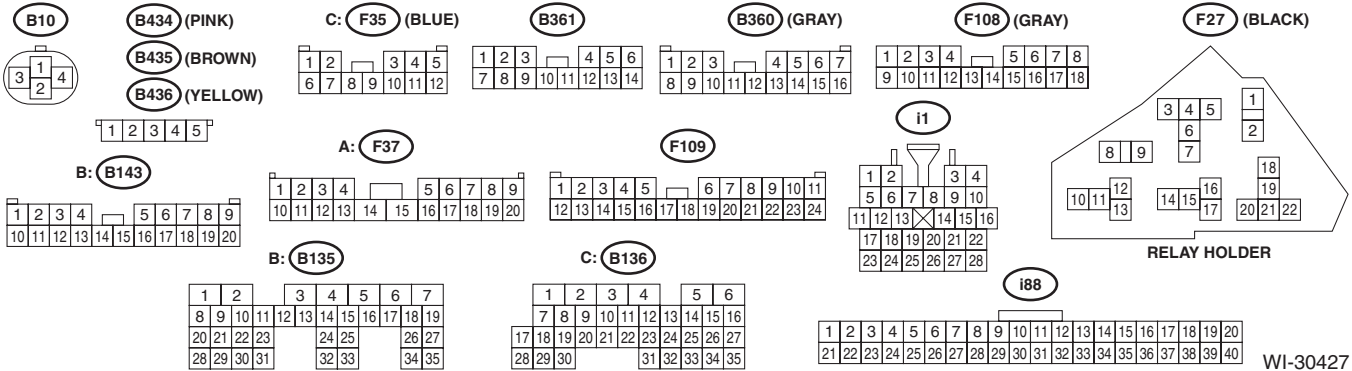
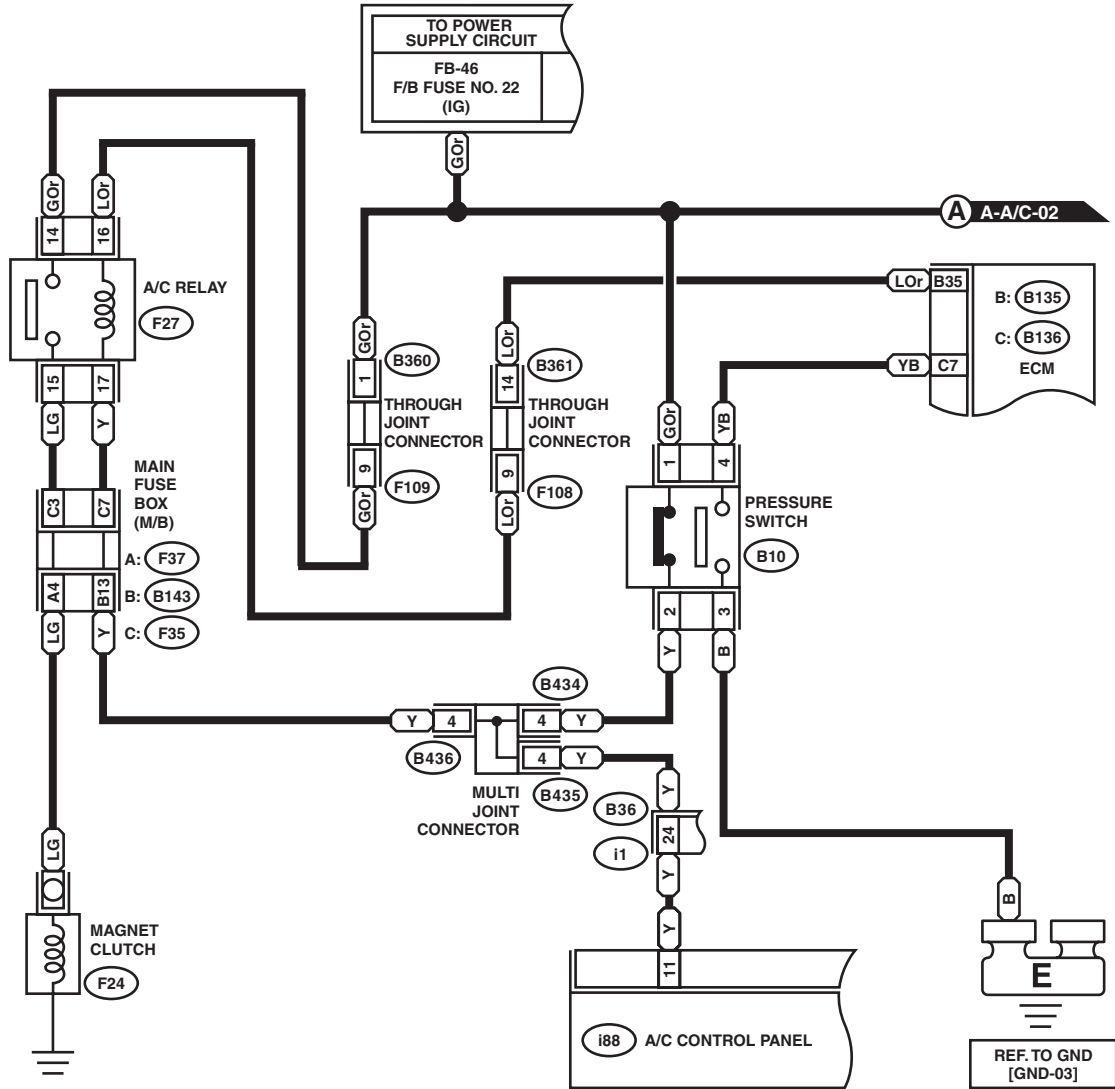

WI-30427

WI-77

Brought to you by Ebay Seller "SubaruManuals"

# Air Conditioning System

## WIRING SYSTEM

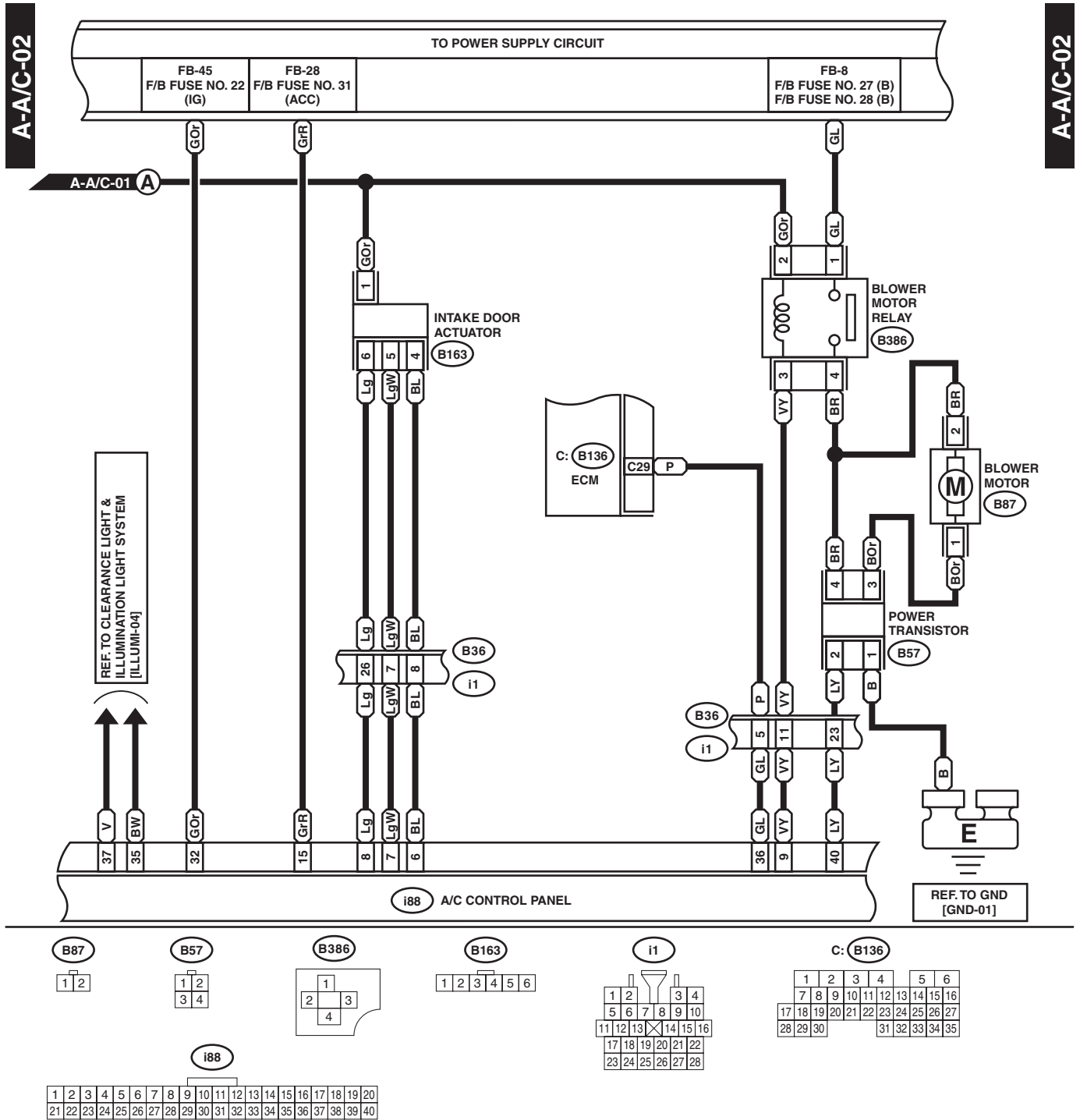

WI-33817

# Air Conditioning System

WIRING SYSTEM

A-A/C-03

A-A/C-03

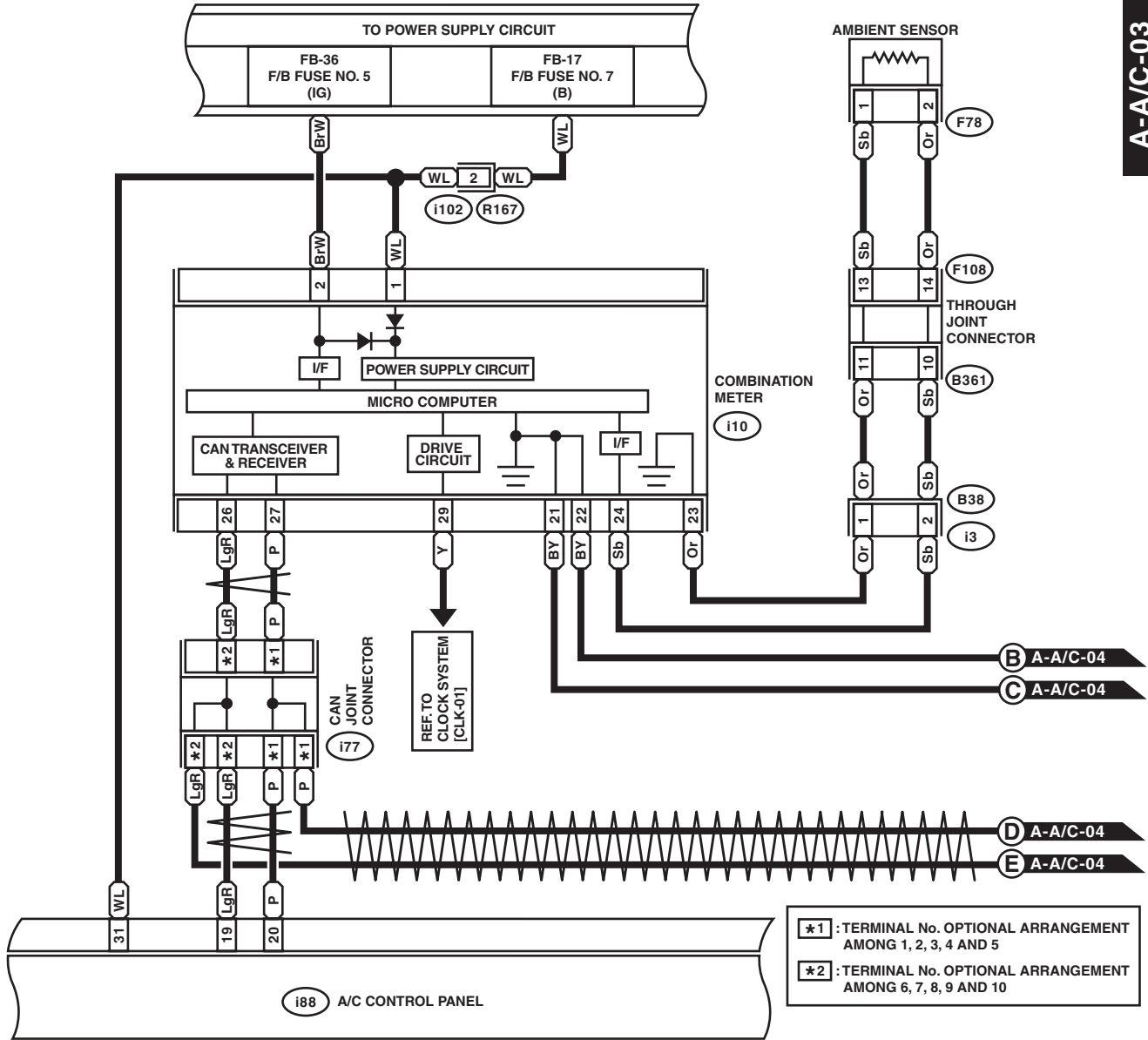

★1 : TERMINAL No. OPTIONAL ARRANGEMENT AMONG 1, 2, 3, 4 AND 5  
 ★2 : TERMINAL No. OPTIONAL ARRANGEMENT AMONG 6, 7, 8, 9 AND 10

F78 (BLACK)



i77 (GREEN)

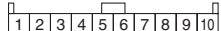

B361



i102



F108 (GRAY)



i3

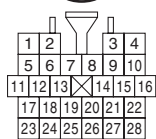

i10

i88

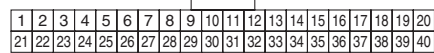

WI-30429

# Air Conditioning System

## WIRING SYSTEM

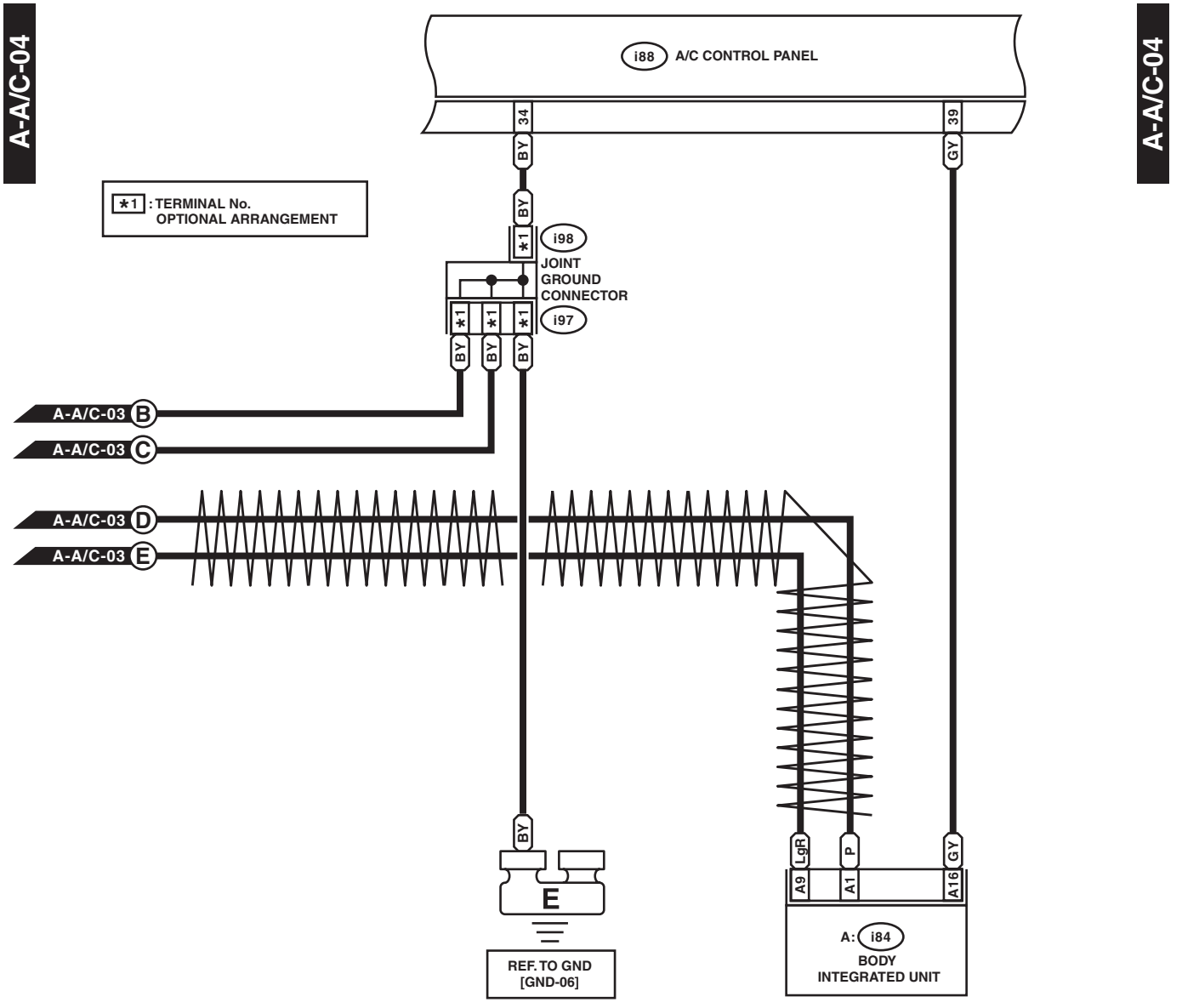

**i97 (BLACK)**

1	2	3	4	5	6	7	8
---	---	---	---	---	---	---	---

**i98 (BLACK)**

1	2	3	4	5	6	7	8
---	---	---	---	---	---	---	---

**A: i84 (GRAY)**

1	2	3	4	5	6	7	8
9	10	11	12	13	14	15	16
17	18	19	20	21	22	23	24
25	26	27	28	29	30	31	32
33	34	35					

**i88**

1	2	3	4	5	6	7	8	9	10	11	12	13	14	15	16	17	18	19	20
21	22	23	24	25	26	27	28	29	30	31	32	33	34	35	36	37	38	39	40

WI-30430



# Air Conditioning System

WIRING SYSTEM

A-A/C-05

A-A/C-05

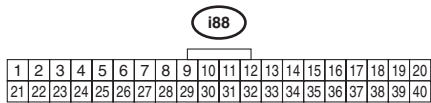
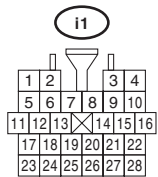
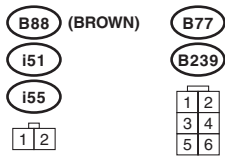
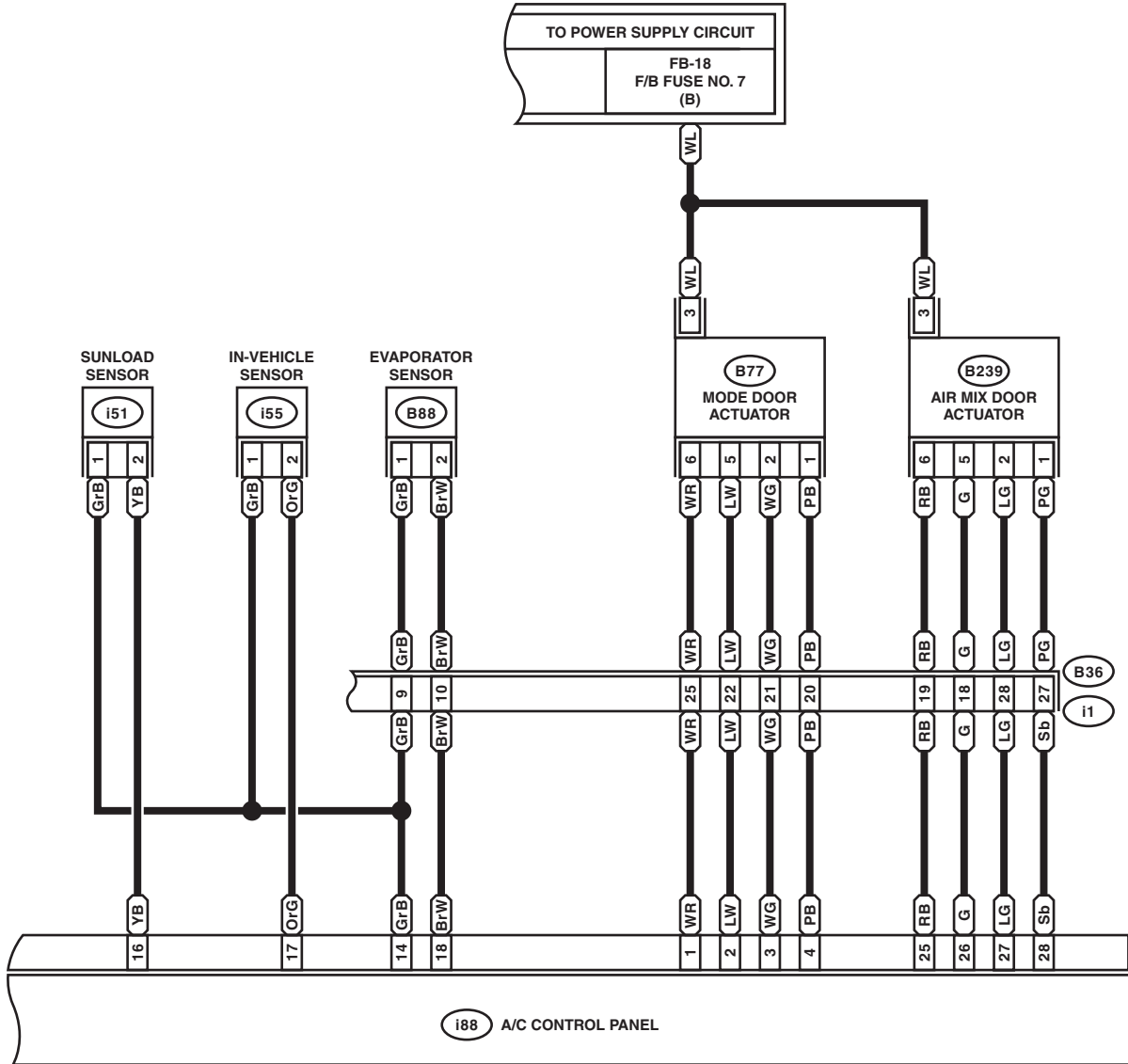

WI-17954

WI-81

Brought to you by Ebay Seller "SubaruManuals"

# Airbag System

WIRING SYSTEM

## 13. Airbag System

### A: WIRING DIAGRAM

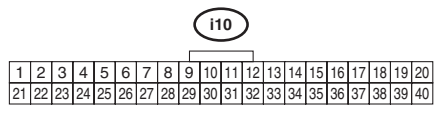
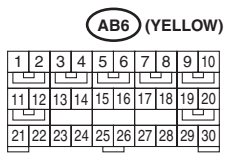
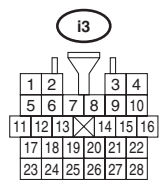
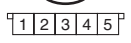
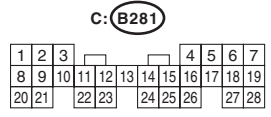
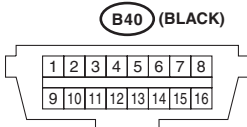
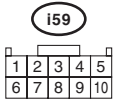
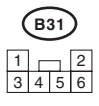
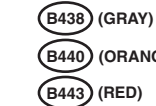
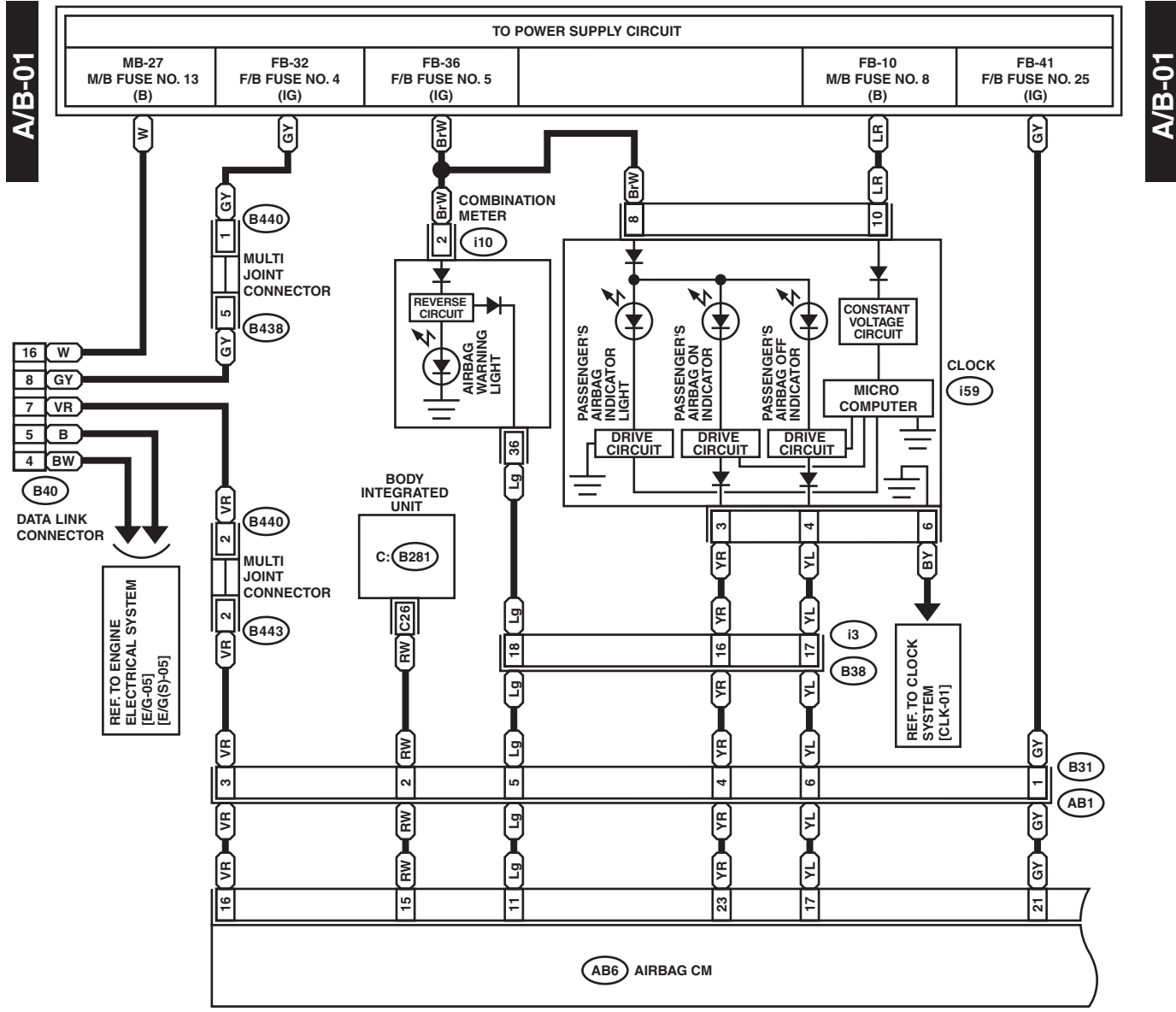

WI-30431

# Airbag System

WIRING SYSTEM

A/B-02

A/B-02

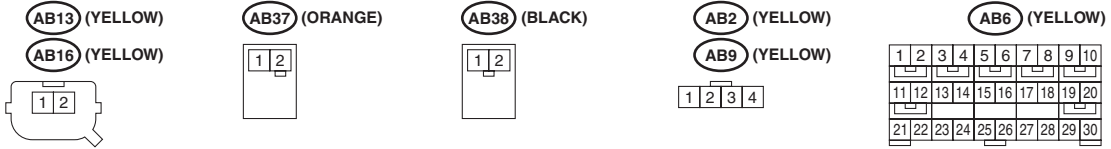
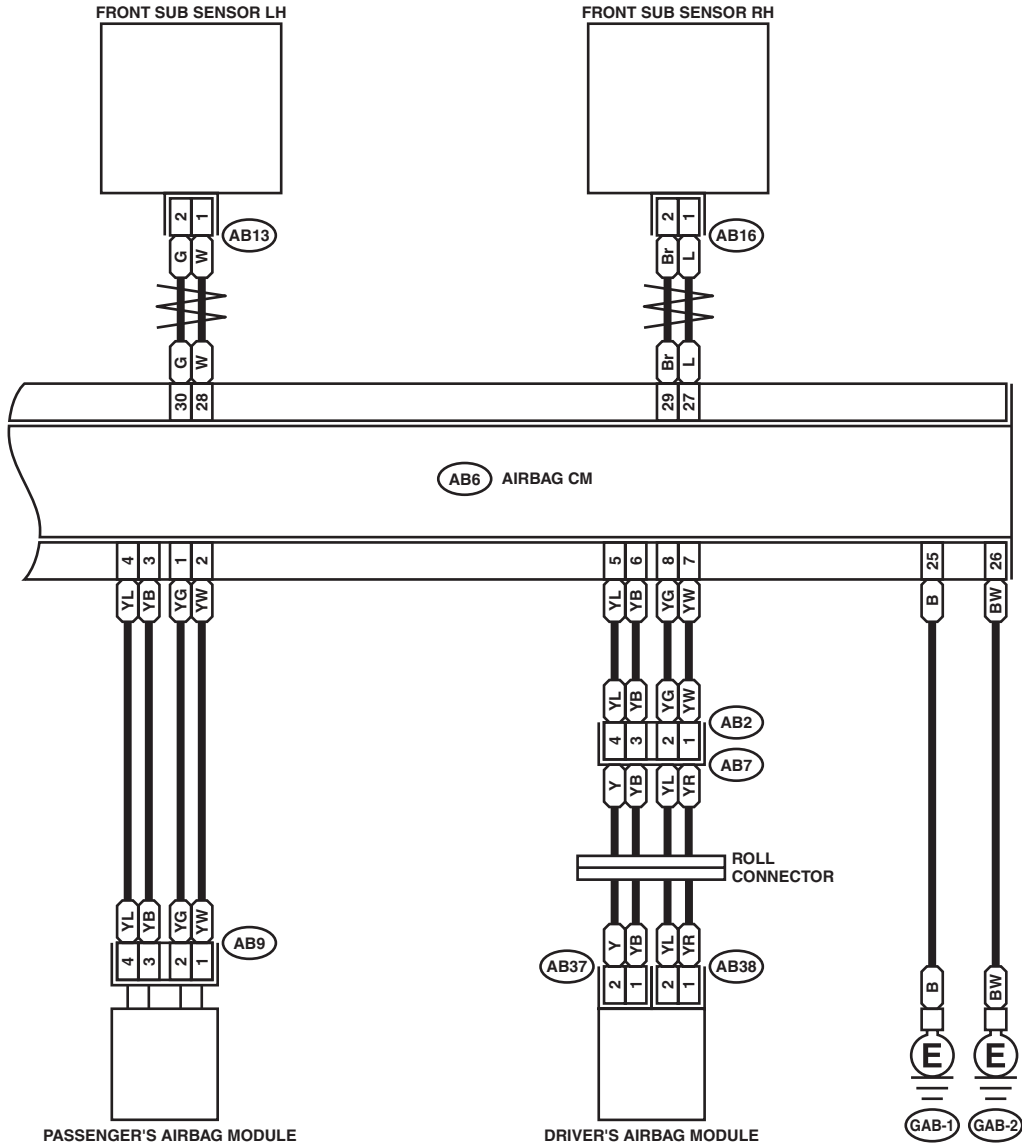

WI-26964

# Airbag System

## WIRING SYSTEM

A/B-03

A/B-03

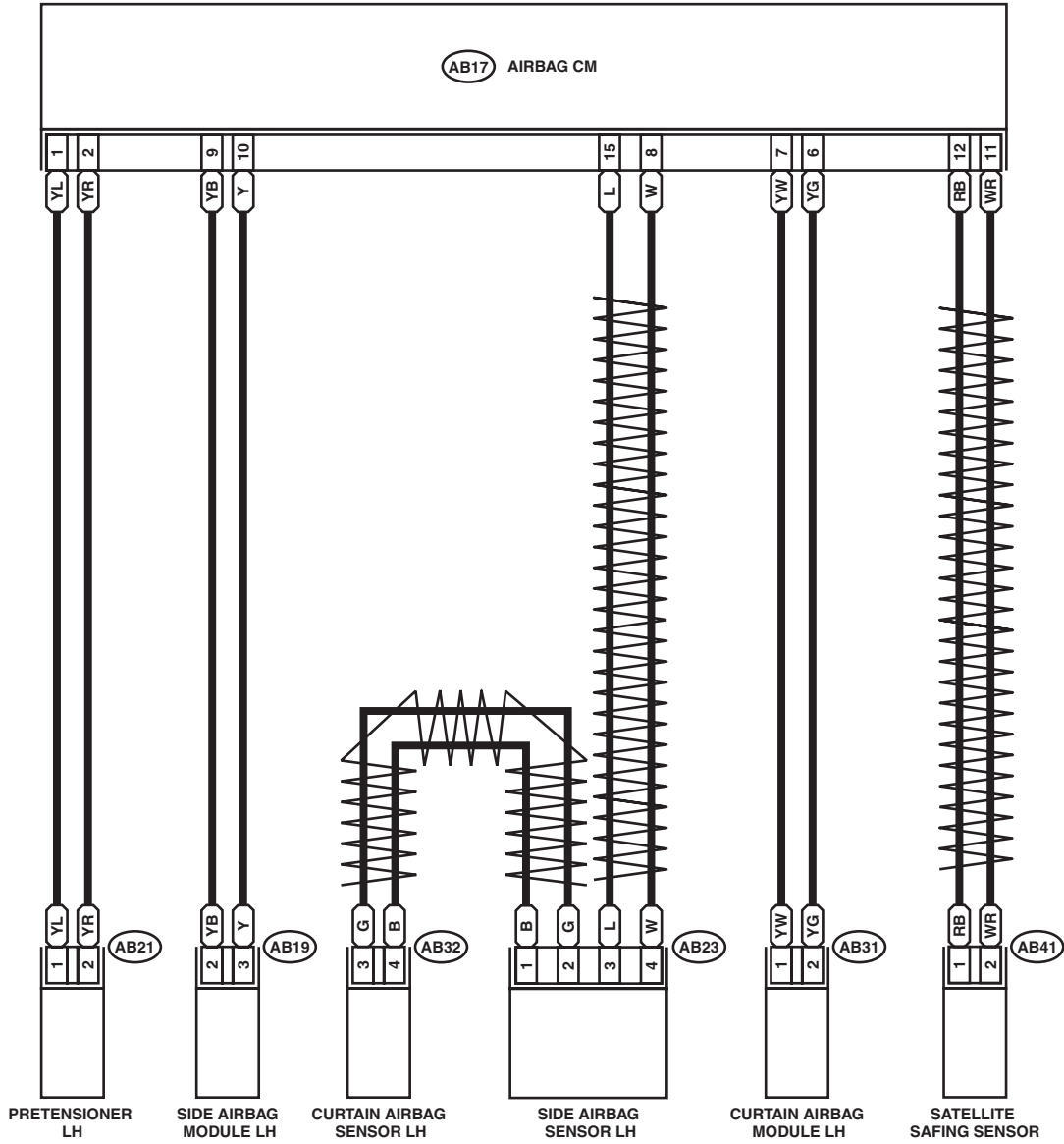

AB21 (BLACK)

AB41 (YELLOW)

AB19 (YELLOW)

AB23 (YELLOW)

AB17 (YELLOW)

AB31 (BLACK)

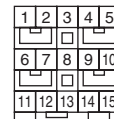
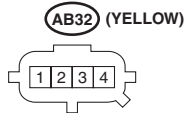
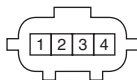
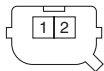

WI-29892

WI-84

Brought to you by Ebay Seller "SubaruManuals"

# Airbag System

WIRING SYSTEM

A/B-04

A/B-04

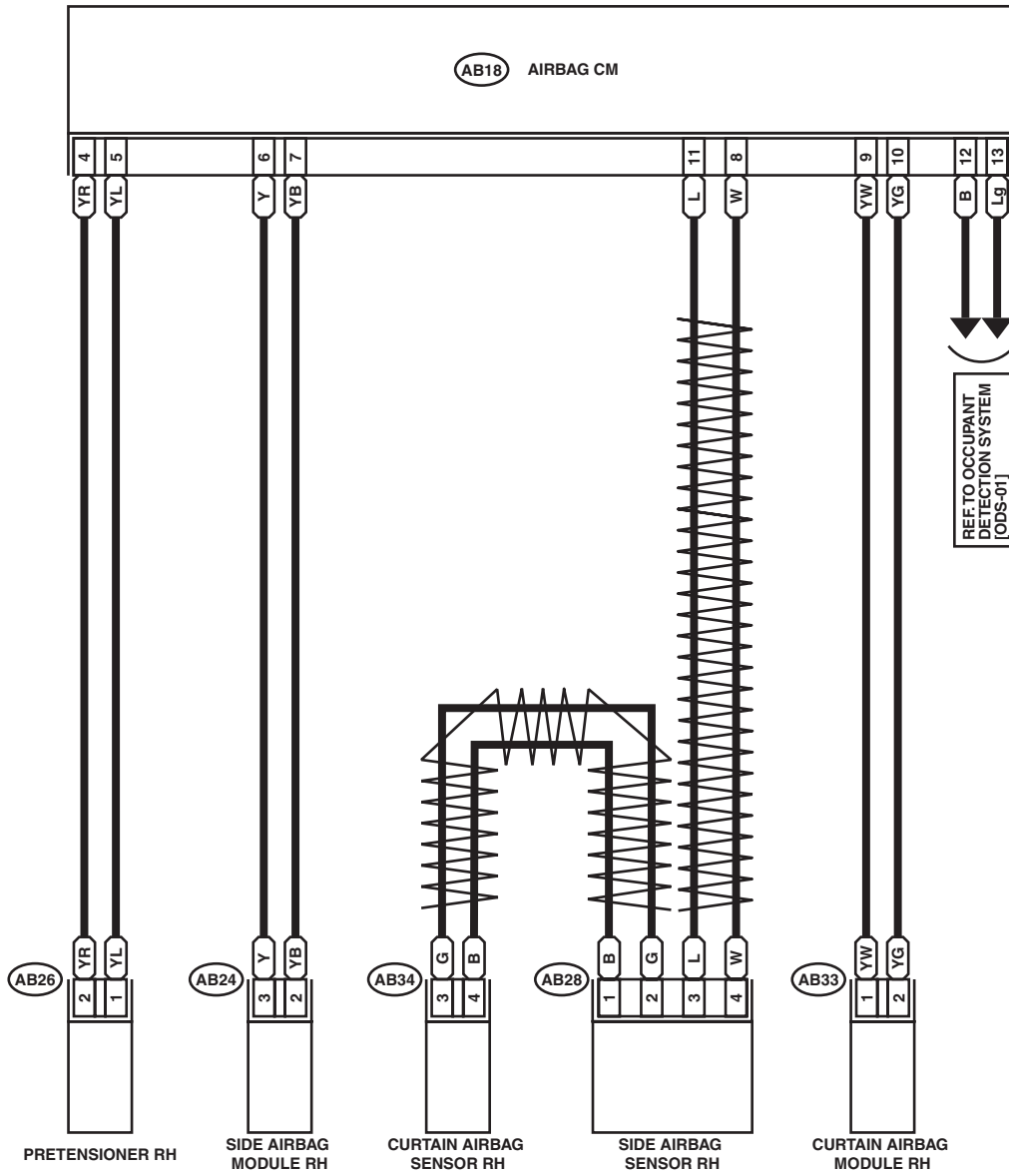

REF TO OCCUPANT  
DETECTION SYSTEM  
[ODS-01]

AB26 (BLACK)

AB24 (YELLOW)

AB28 (YELLOW)

AB18 (YELLOW)

AB33 (BLACK)

AB34 (YELLOW)

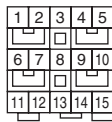
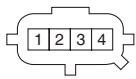
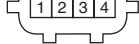

WI-29893

WI-85

Brought to you by Ebay Seller "SubaruManuals"

# Seat Belt Warning System

WIRING SYSTEM

## 14. Seat Belt Warning System

### A: WIRING DIAGRAM

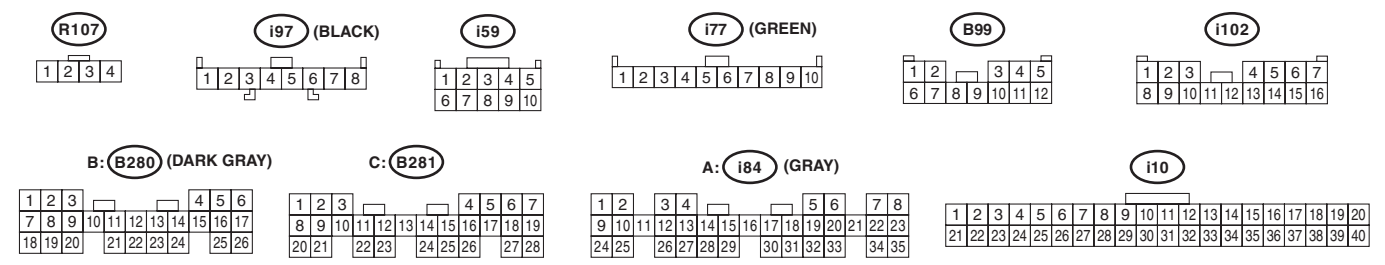
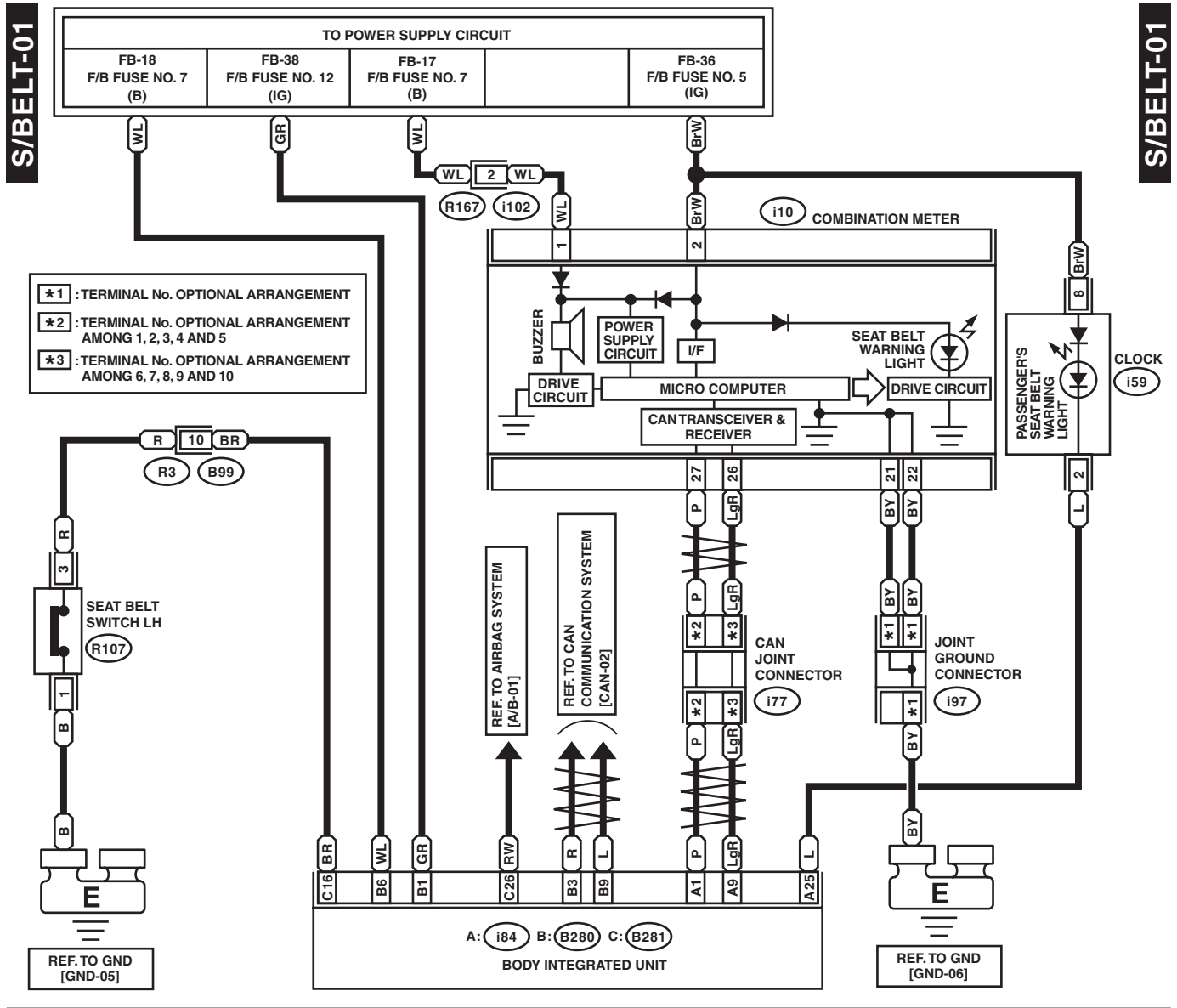

WI-30432

## 15. Occupant Detection System

### A: WIRING DIAGRAM

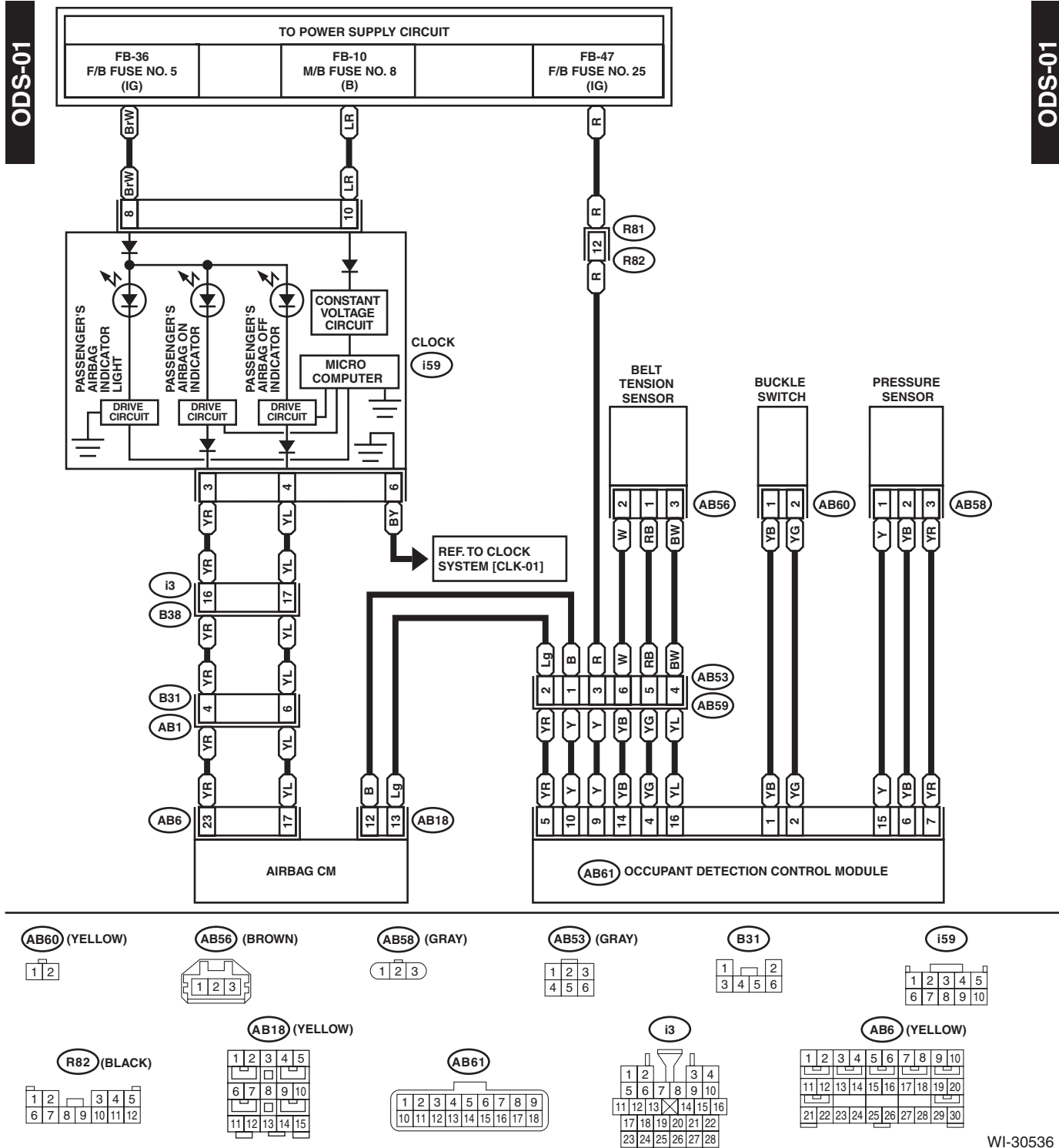

# Seat Heater System

WIRING SYSTEM

## 16. Seat Heater System

### A: WIRING DIAGRAM

#### 1. WITHOUT SI-DRIVE

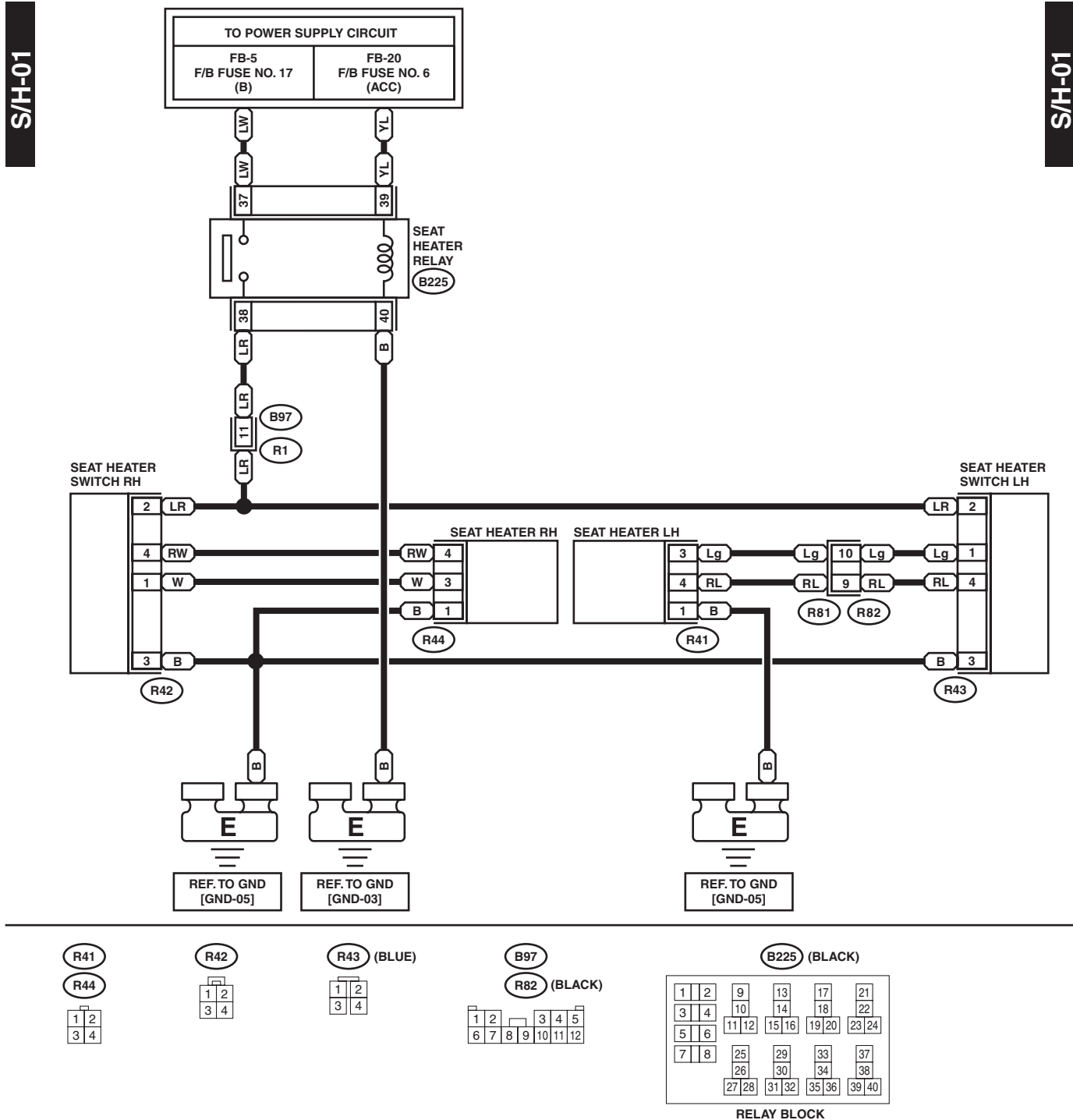

WI-30537



# Seat Heater System

WIRING SYSTEM

## 2. WITH SI-DRIVE

S/H(S)-01

S/H(S)-01

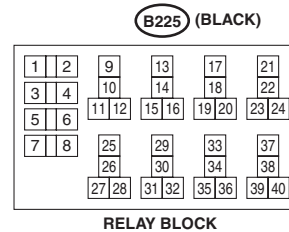
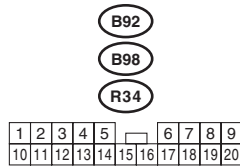
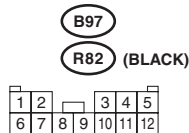
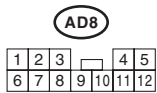
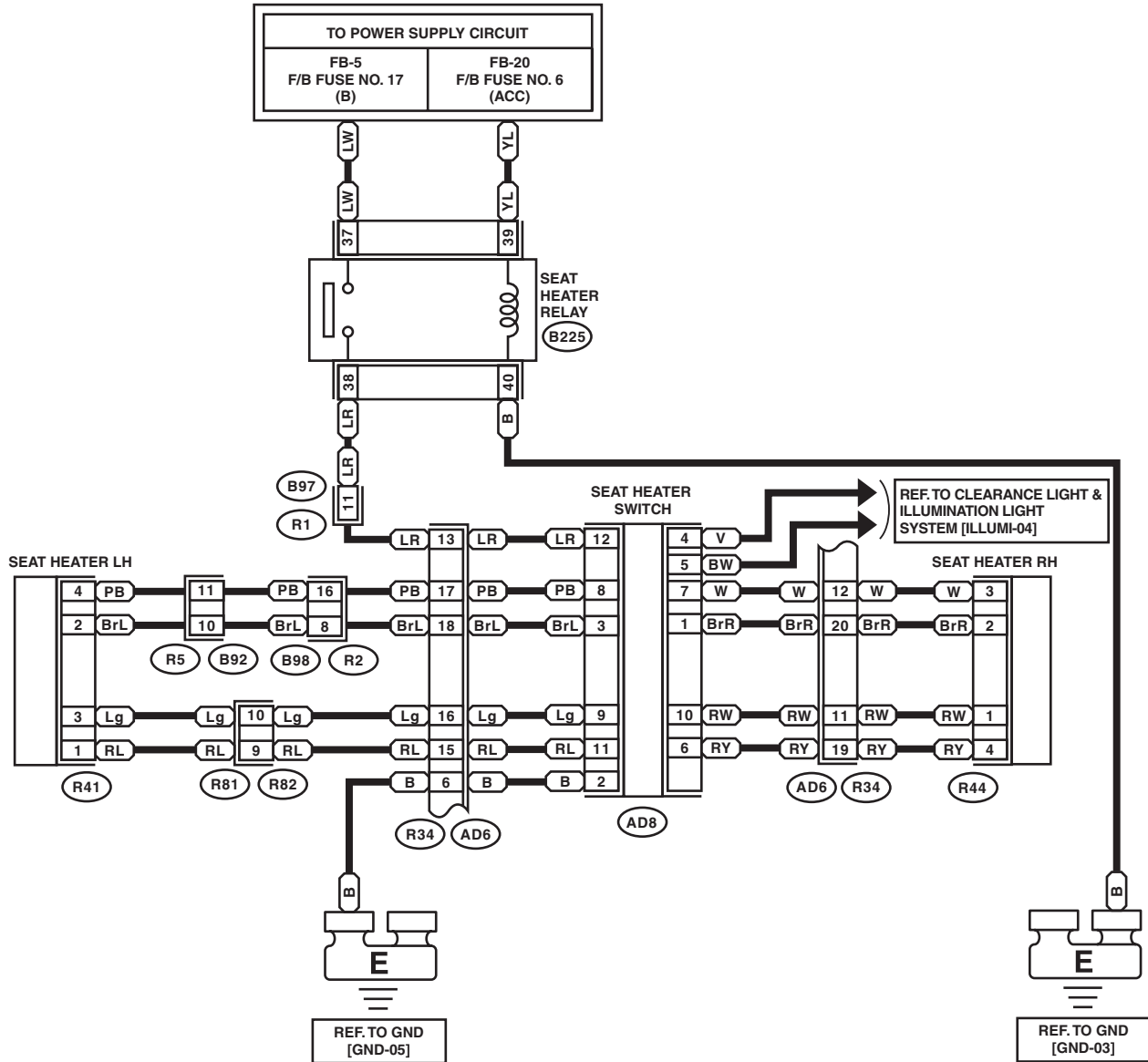

WI-30433

WI-89

Brought to you by Ebay Seller "SubaruManuals"

# Headlight System

WIRING SYSTEM

## 17. Headlight System

### A: WIRING DIAGRAM

H/L-01

H/L-01

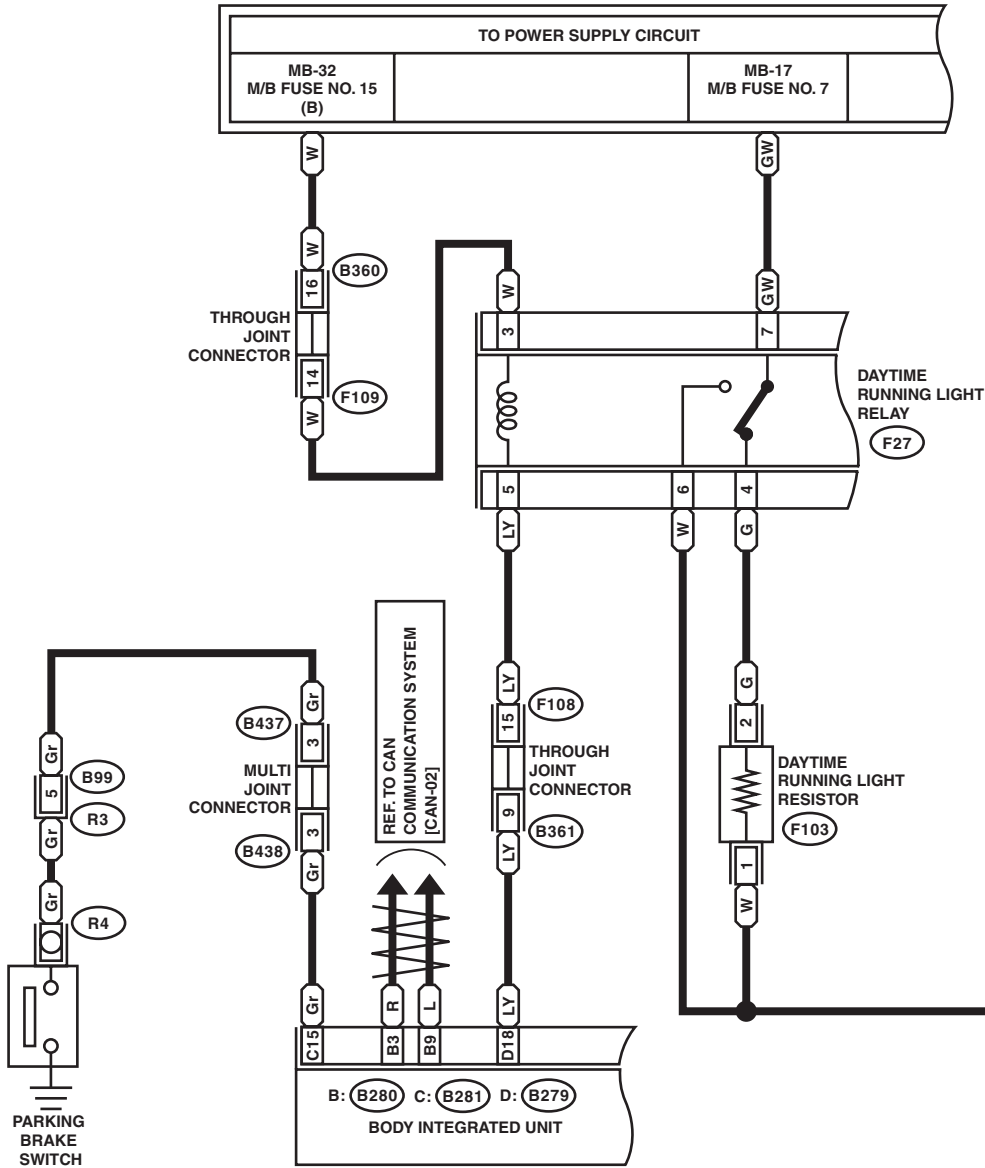

A H/L-02

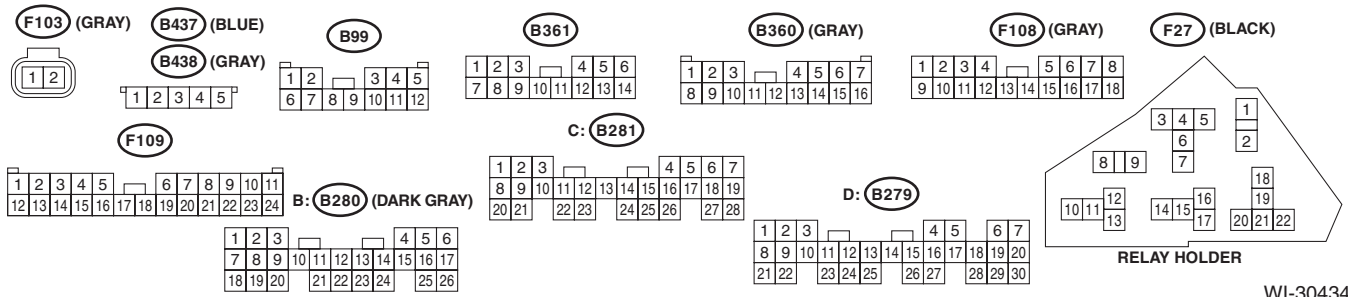

WI-30434

# Headlight System

WIRING SYSTEM

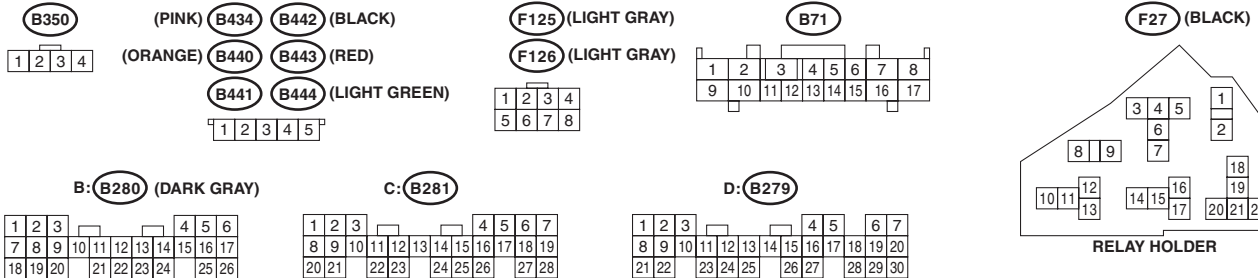
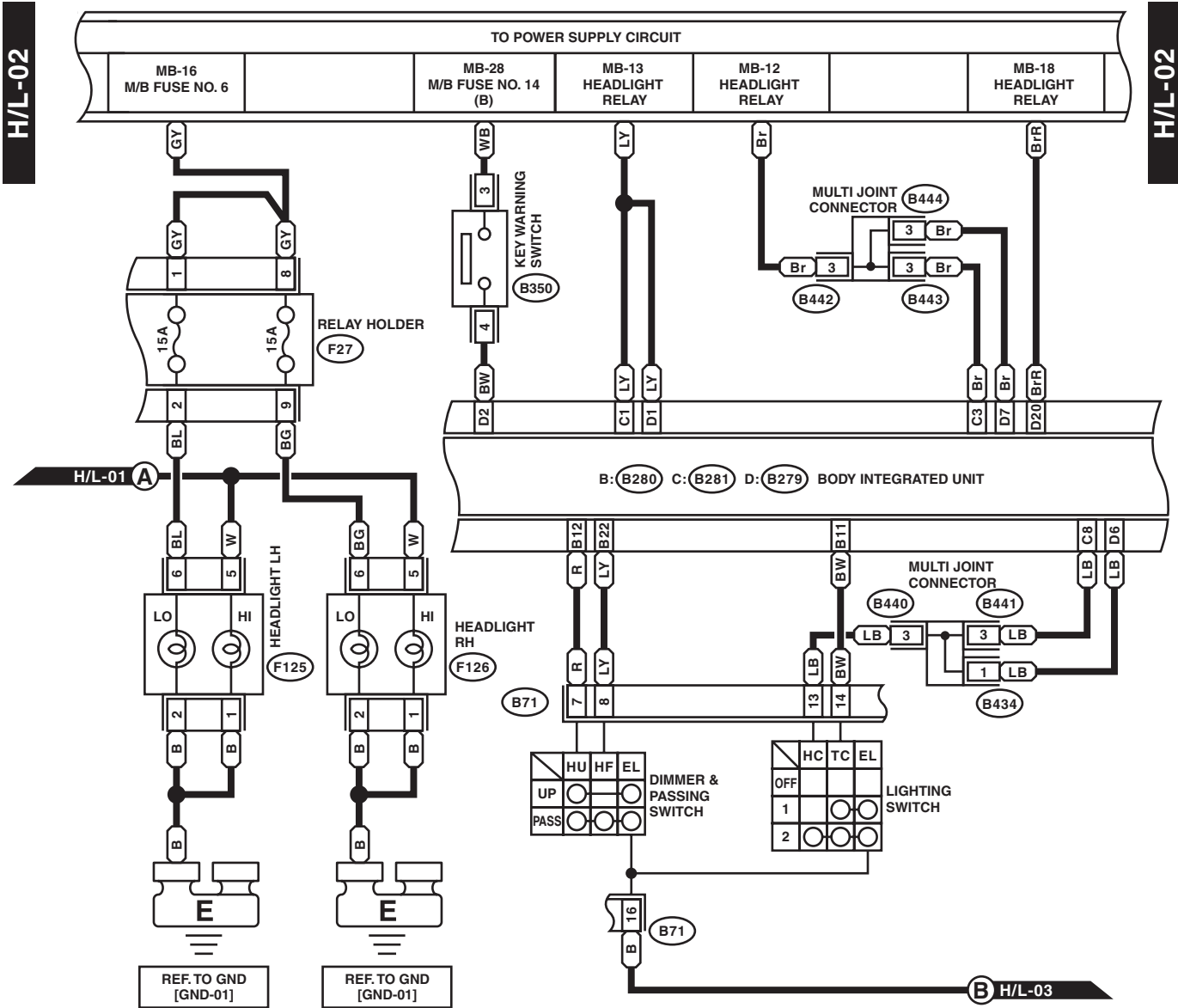

WI-30538

# Headlight System

## WIRING SYSTEM

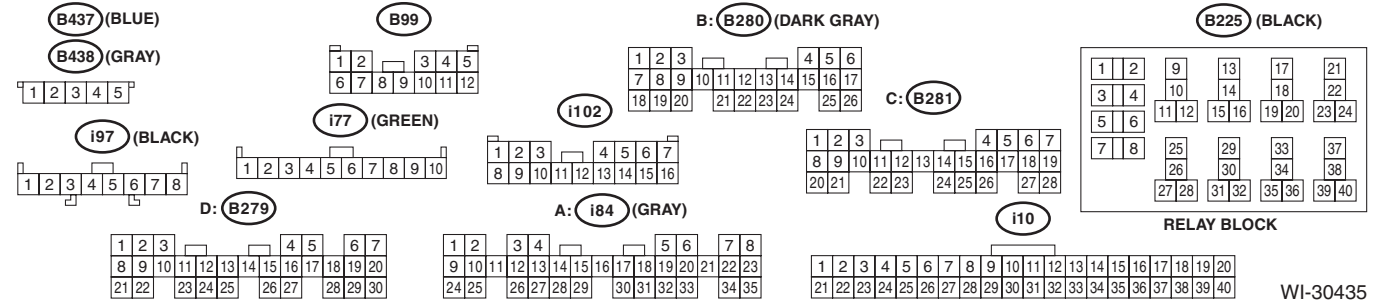
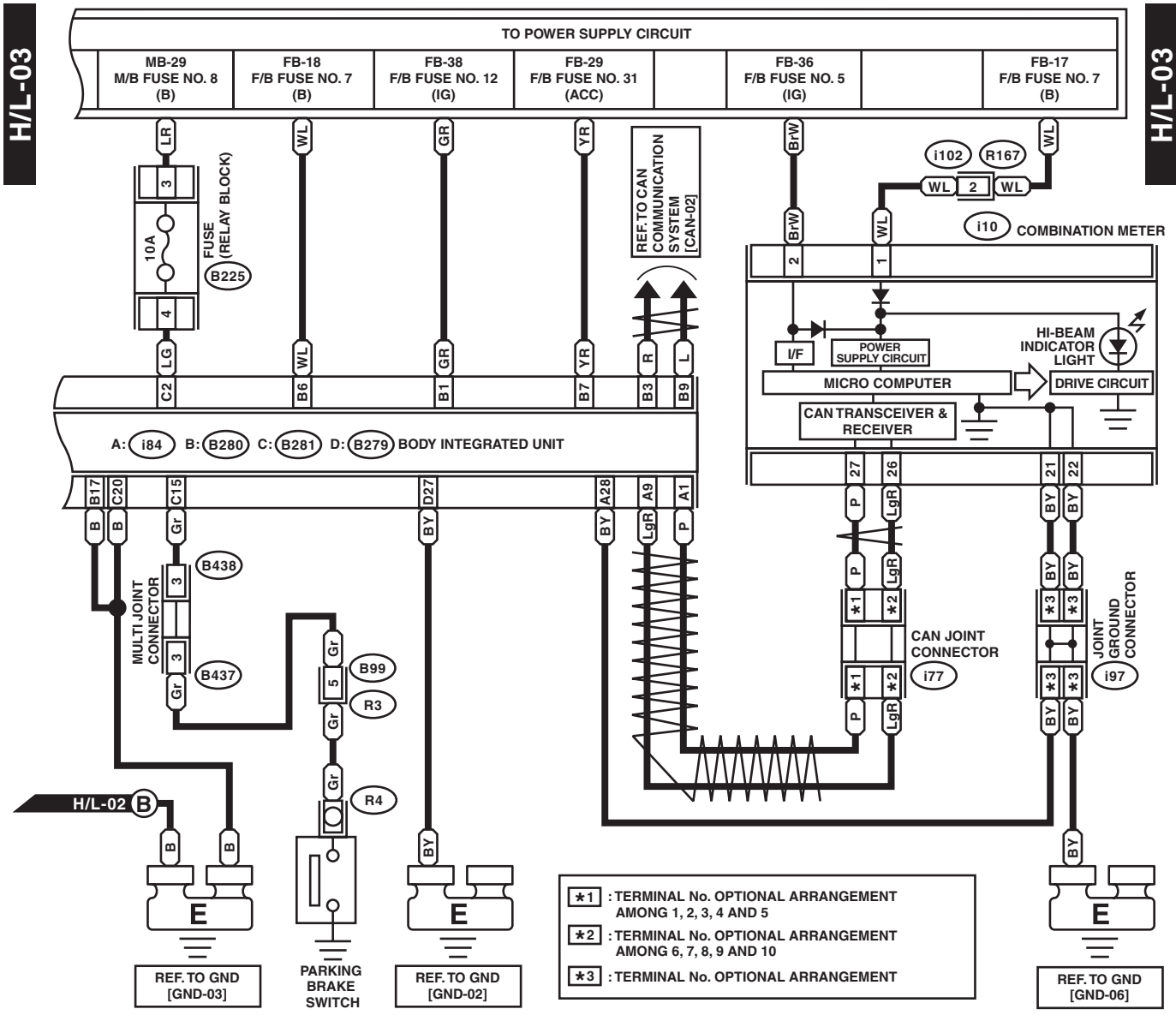

WI-30435

## 18. Headlight Beam Leveler System

### A: WIRING DIAGRAM

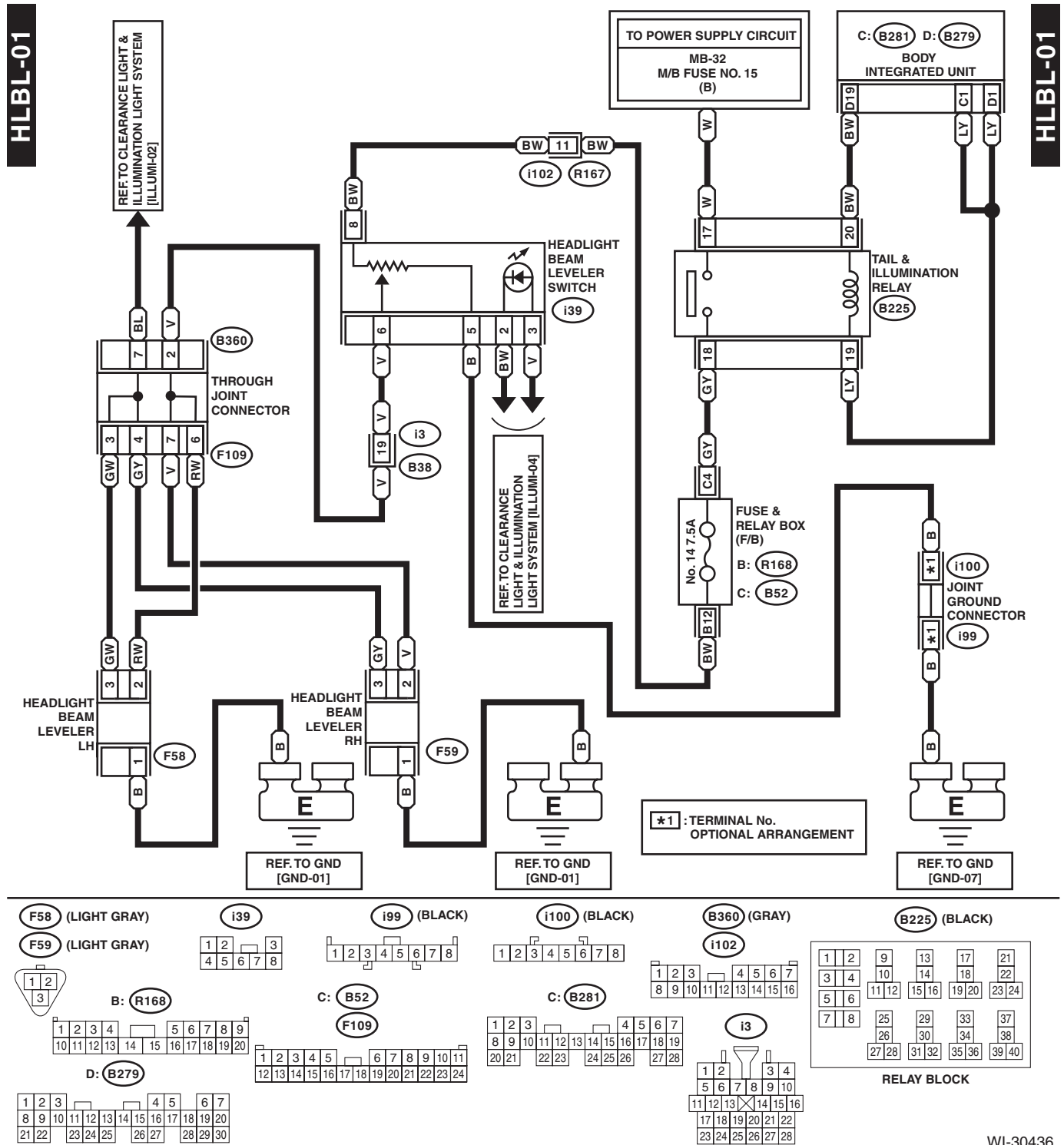

WI-30436

# Front Fog Light System

WIRING SYSTEM

## 19. Front Fog Light System

### A: WIRING DIAGRAM

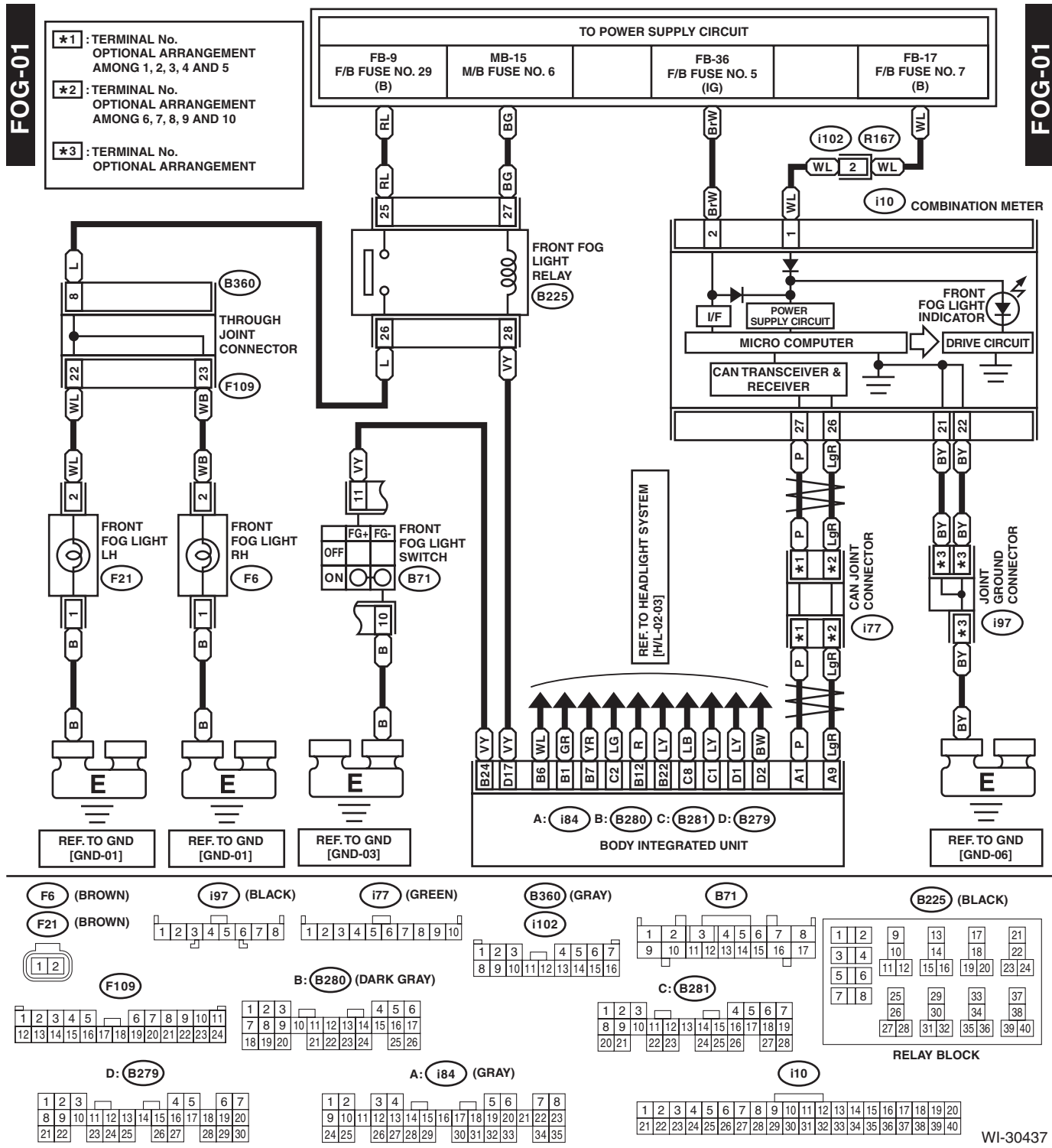

## 20.Back-up Light System

### A: WIRING DIAGRAM

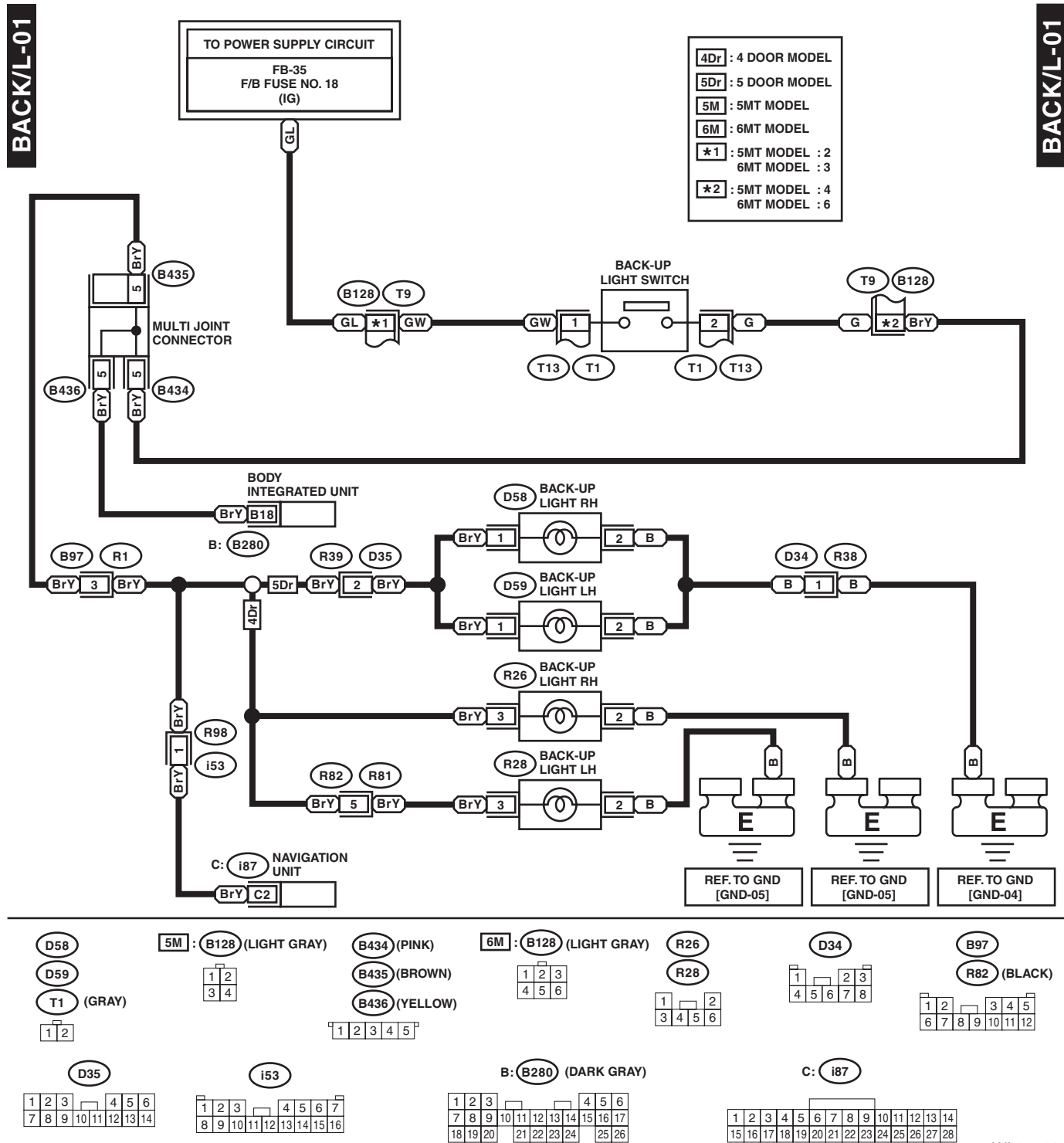

WI-35291

# Stop Light System

WIRING SYSTEM

## 21. Stop Light System

### A: WIRING DIAGRAM

#### 1. 4 DOOR MODEL

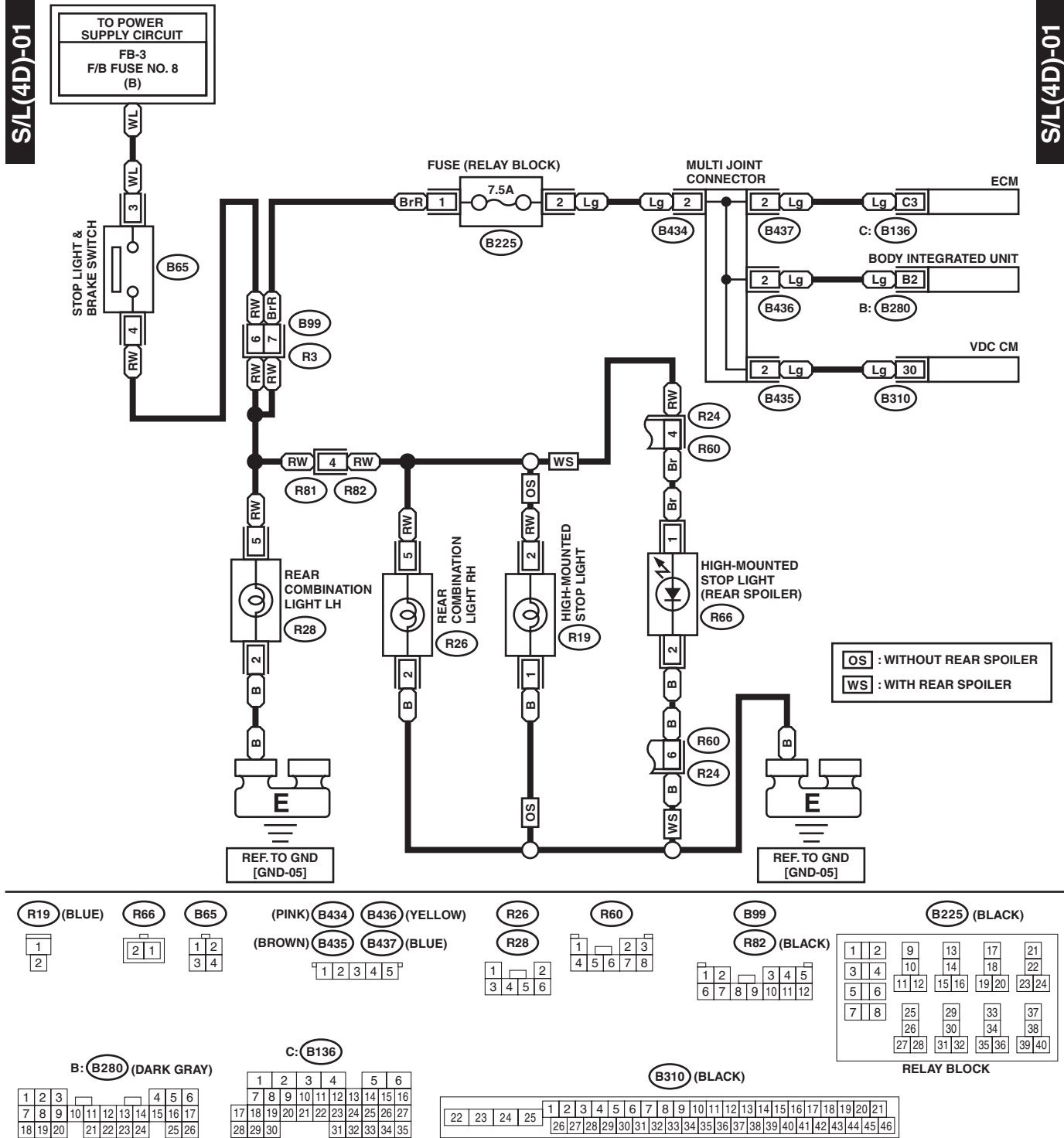

WI-30539



# Stop Light System

WIRING SYSTEM

## 2. 5 DOOR MODEL

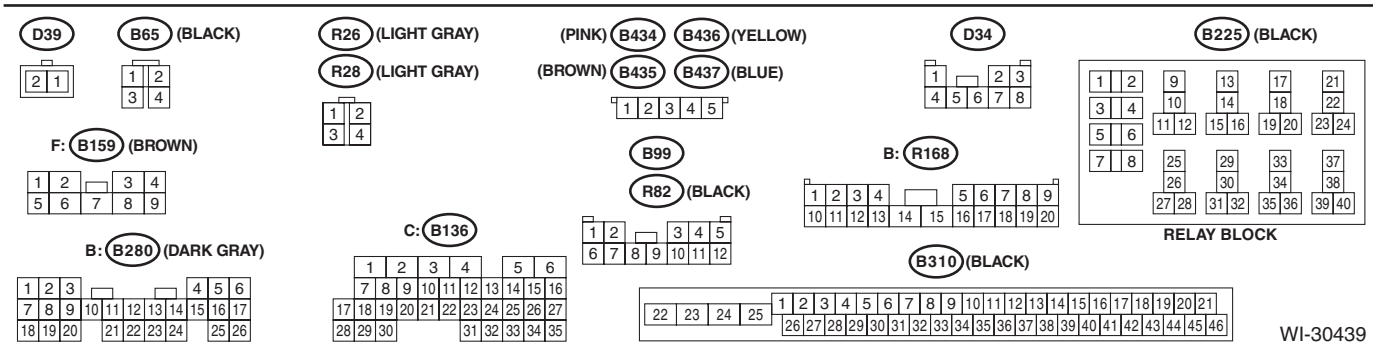
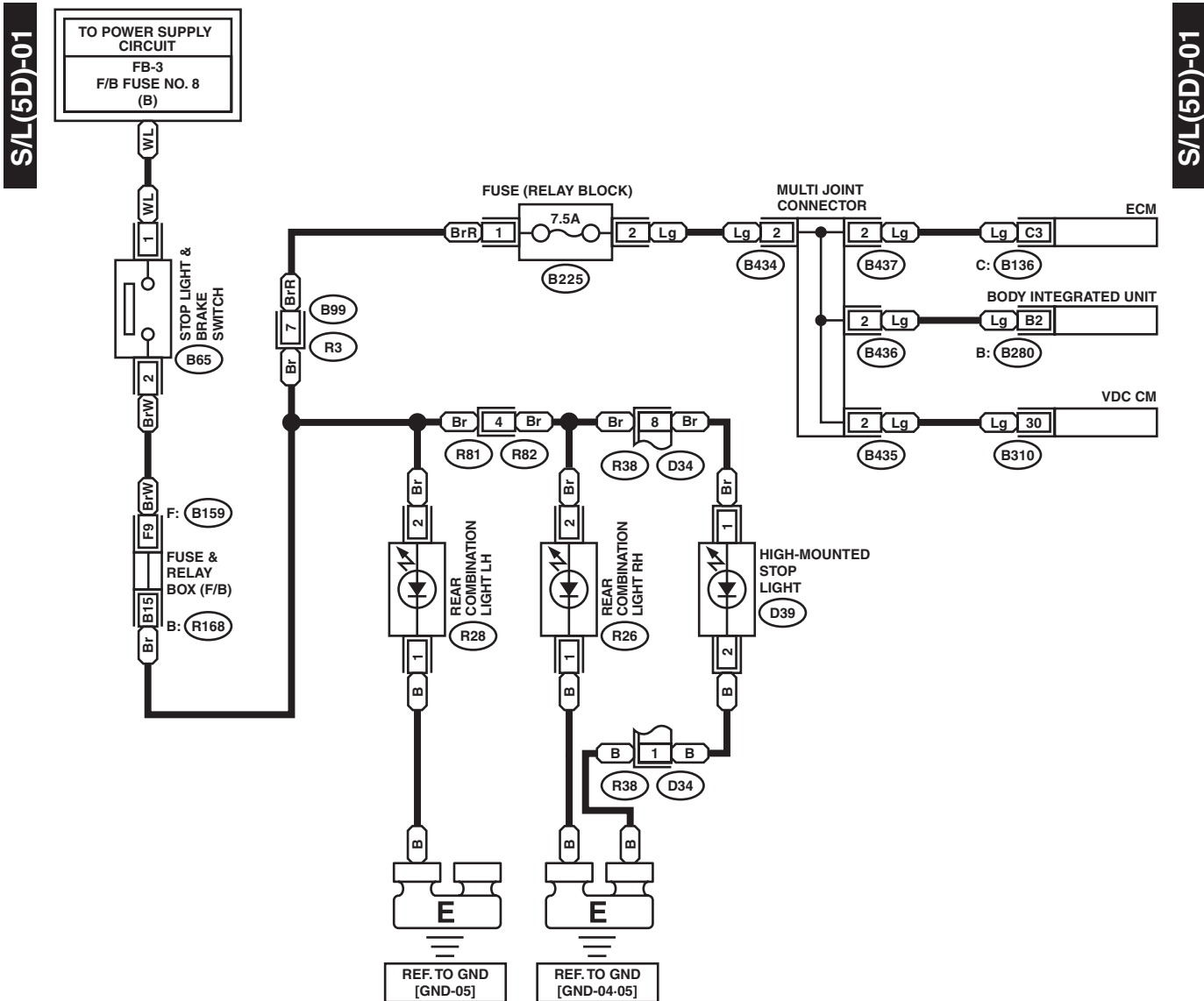

WI-30439

# Clearance Light and Illumination Light System

WIRING SYSTEM

## 22. Clearance Light and Illumination Light System

### A: WIRING DIAGRAM

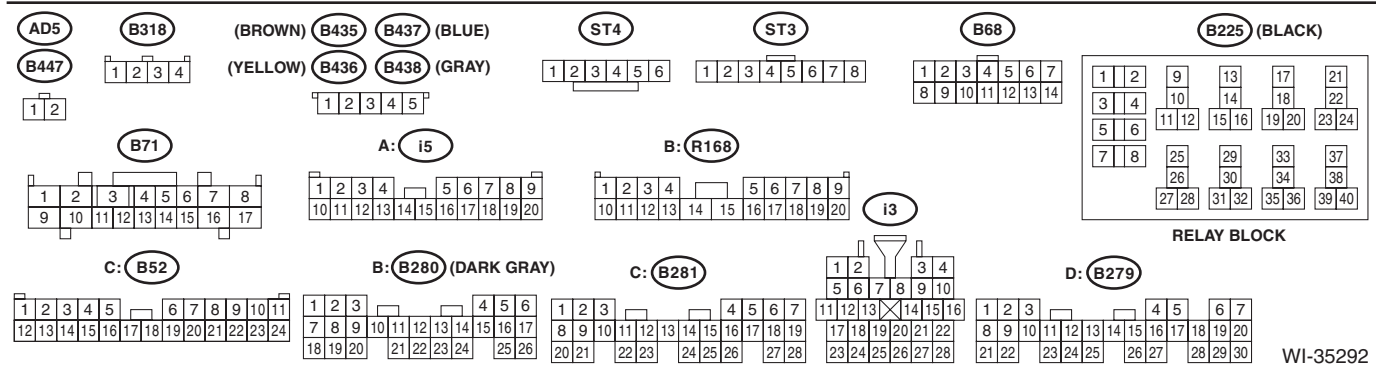
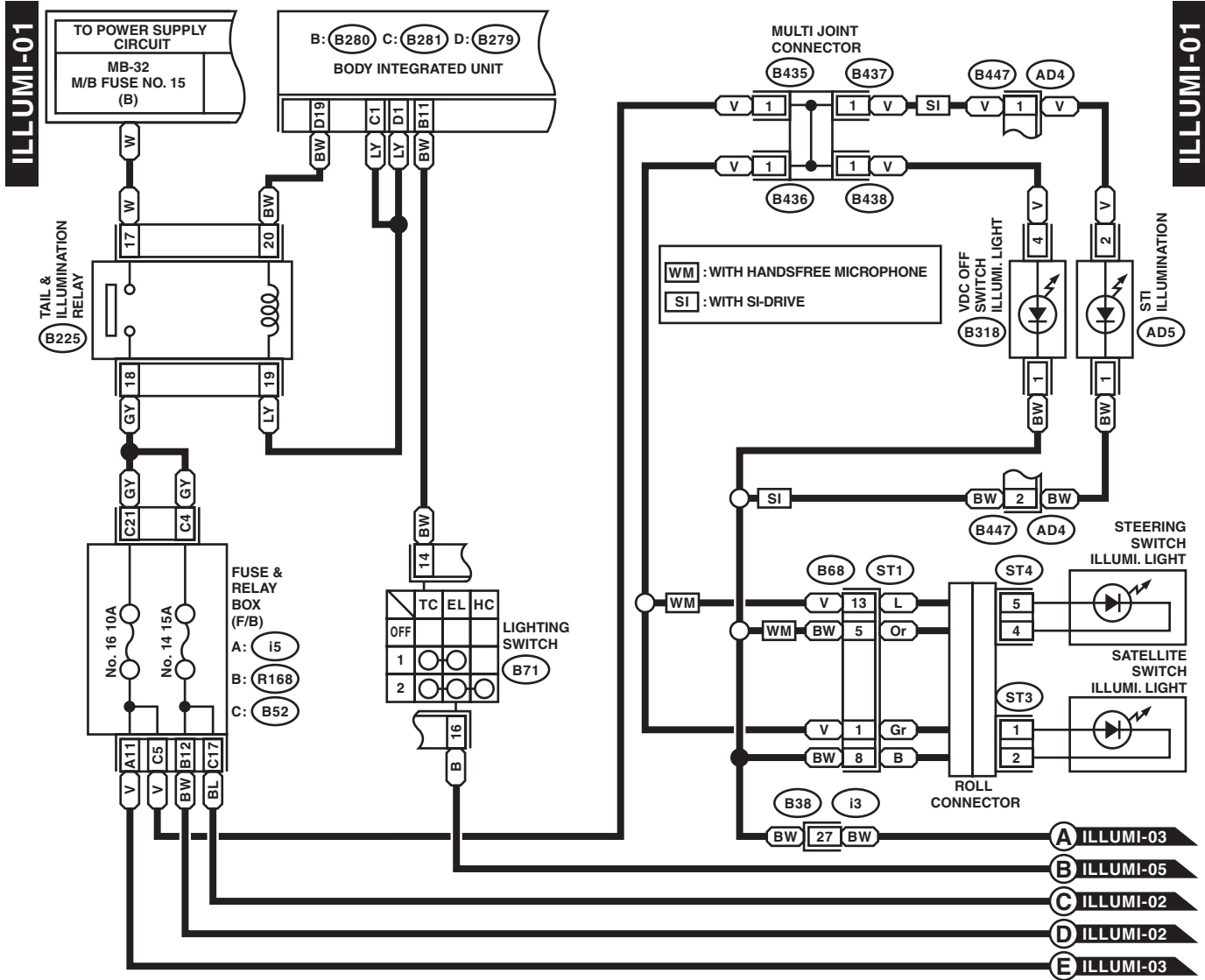

# Clearance Light and Illumination Light System

WIRING SYSTEM

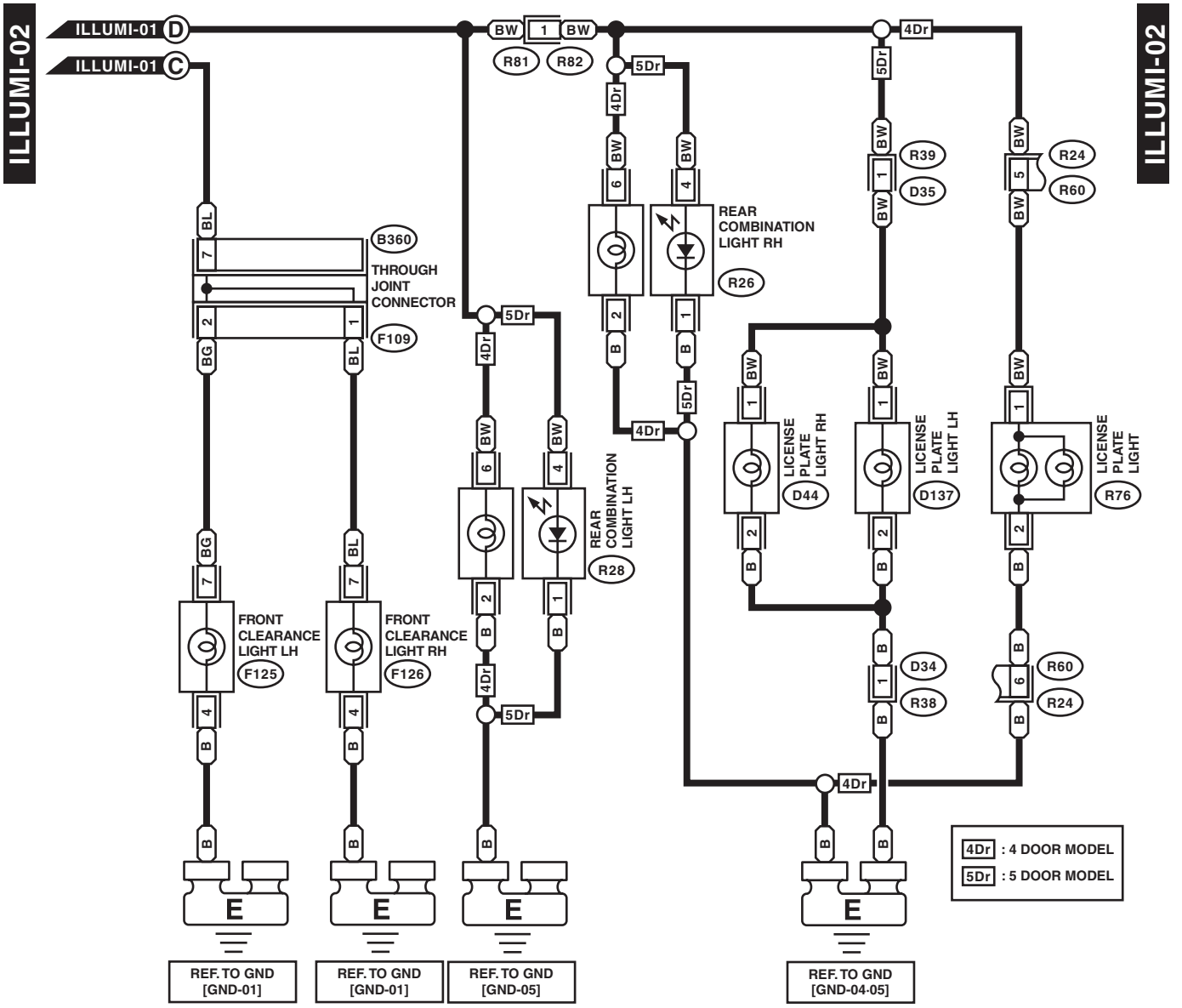

4Dr : 4 DOOR MODEL  
5Dr : 5 DOOR MODEL

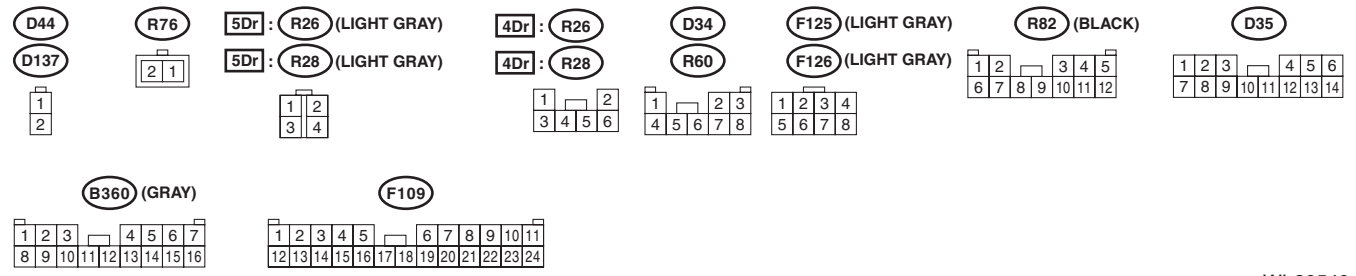

WI-30540

# Clearance Light and Illumination Light System

WIRING SYSTEM

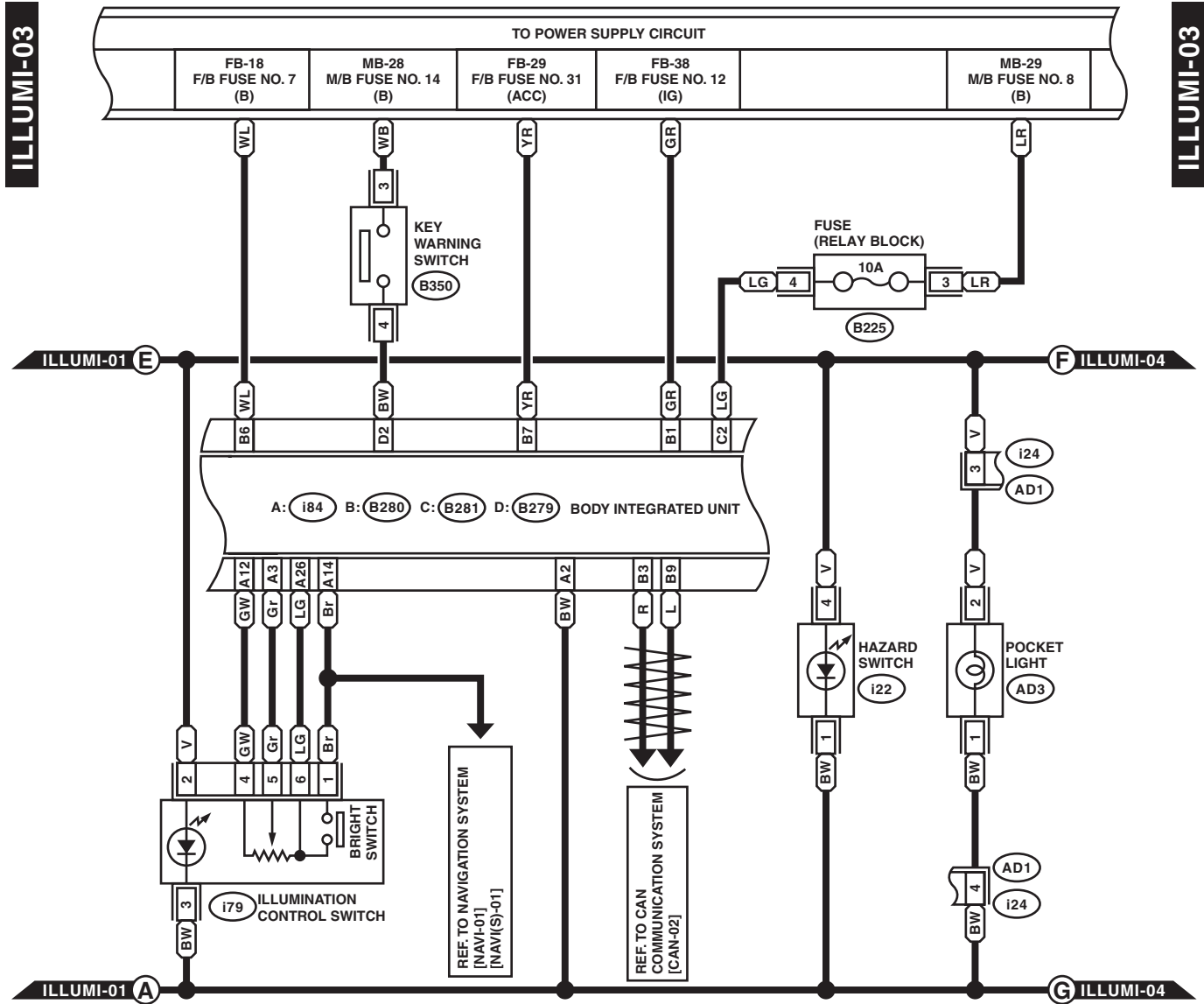

AD3

1	2
---	---

B350

1	2	3	4
---	---	---	---

i22

1	2	3	4
---	---	---	---

i24

1	2
3	4

i79 (GRAY)

1	2	3	4
5	6	7	8

B: B280 (DARK GRAY)

1	2	3	4	5	6
7	8	9	10	11	12
13	14	15	16	17	18
19	20	21	22	23	24
25	26	27	28	29	30

B225 (BLACK)

1	2	9	13	17	21
3	4	10	14	18	22
5	6	11	12	15	16
7	8	19	20	23	24
25	29	33	37		
26	30	34	38		
27	28	31	32	35	36
39	40				

RELAY BLOCK

C: B281

1	2	3	4	5	6	7
8	9	10	11	12	13	14
15	16	17	18	19	20	21
22	23	24	25	26	27	28

D: B279

1	2	3	4	5	6	7
8	9	10	11	12	13	14
15	16	17	18	19	20	21
22	23	24	25	26	27	28
29	30	31	32	33	34	35

A: i84 (GRAY)

1	2	3	4	5	6	7	8
9	10	11	12	13	14	15	16
17	18	19	20	21	22	23	24
25	26	27	28	29	30	31	32
33	34	35	36	37	38	39	40

WI-35293

WI-100

Brought to you by Ebay Seller "SubaruManuals"

# Clearance Light and Illumination Light System

WIRING SYSTEM

ILLUMI-04

ILLUMI-04

MA	: MANUAL A/C
AA	: AUTO A/C
ON	: WITHOUT NAVIGATION
WN	: WITH NAVIGATION
SI	: WITH SI-DRIVE
*1	: TERMINAL No. OPTIONAL ARRANGEMENT

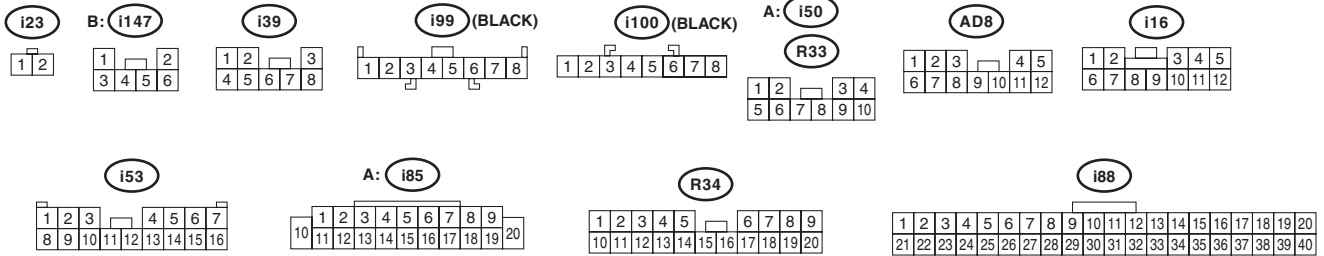
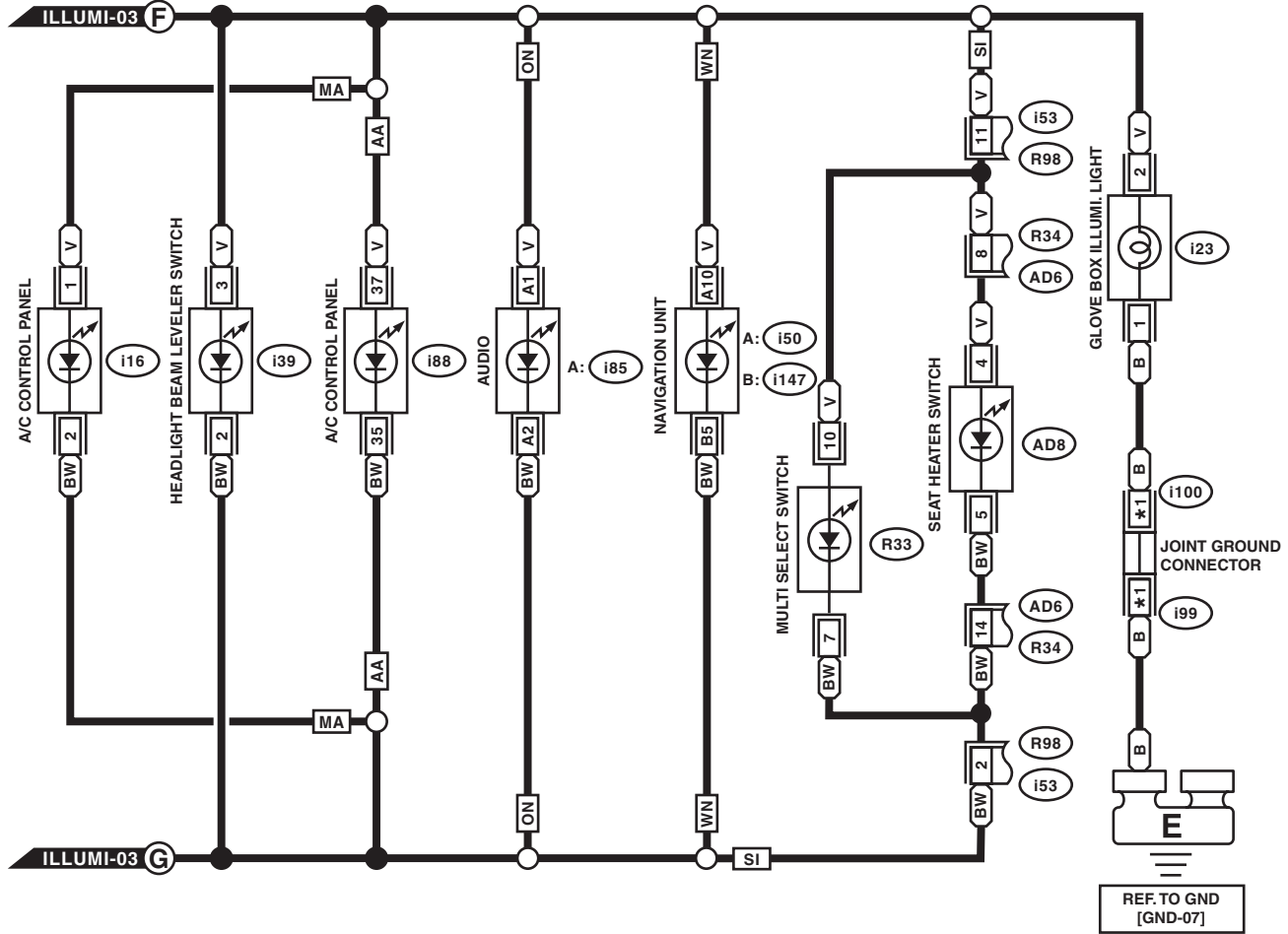

WI-35294

WI-101

Brought to you by Ebay Seller "SubaruManuals"

# Clearance Light and Illumination Light System

WIRING SYSTEM

ILLUMI-05

ILLUMI-05

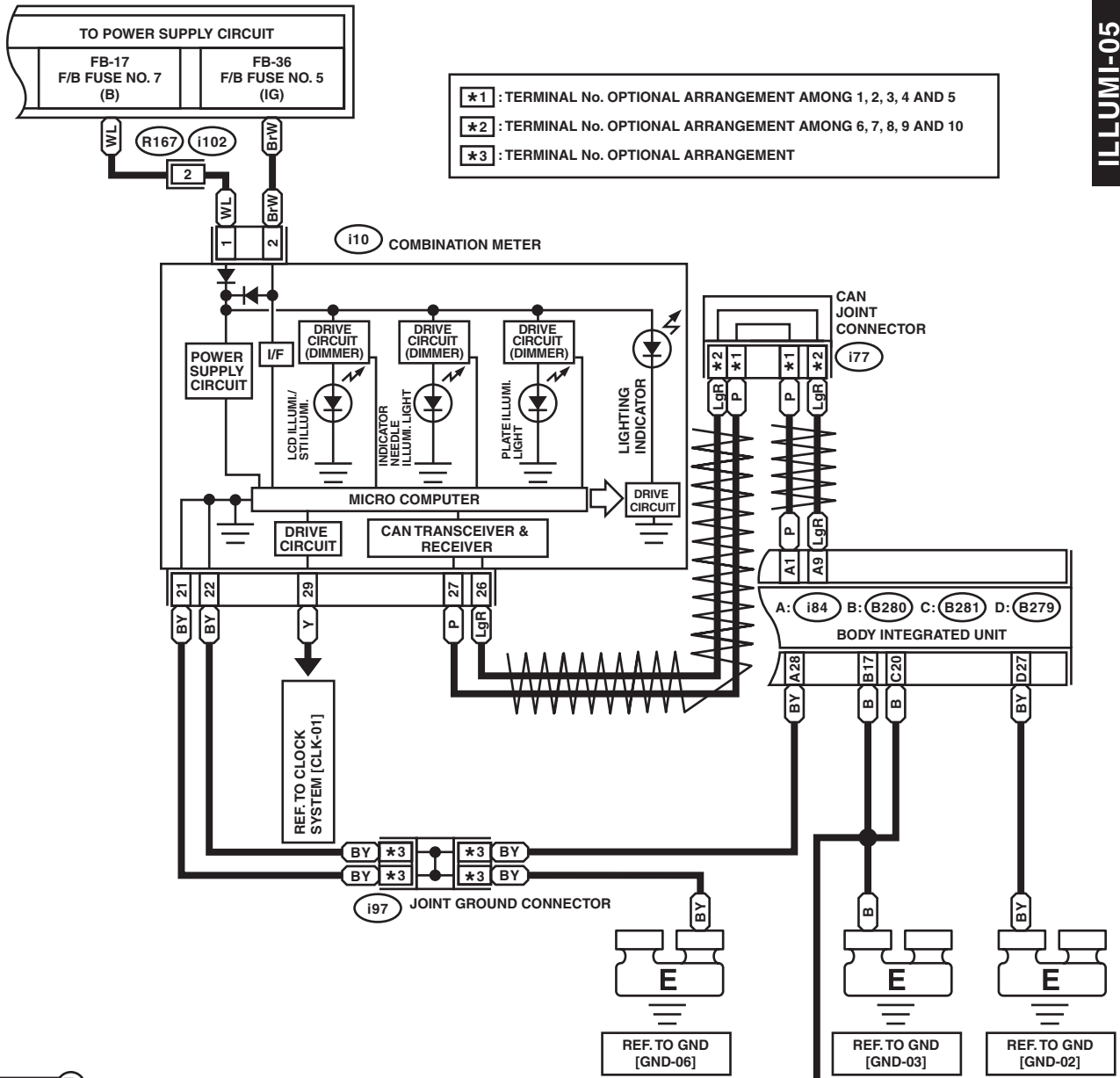

ILLUMI-01 B

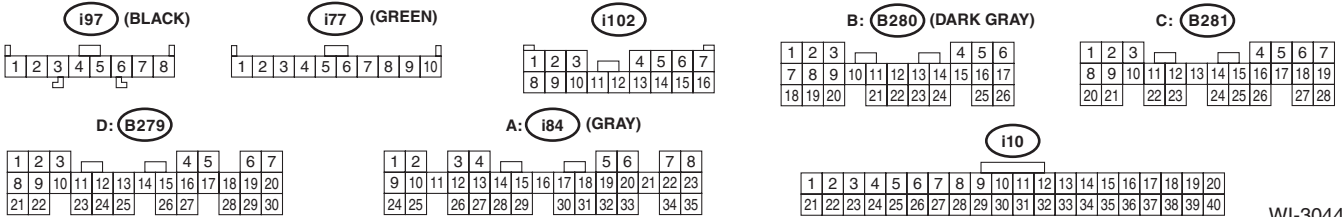

WI-30442

WI-102

Brought to you by Ebay Seller "SubaruManuals"

# Turn Signal Light and Hazard Light System

WIRING SYSTEM

## 23. Turn Signal Light and Hazard Light System

### A: WIRING DIAGRAM

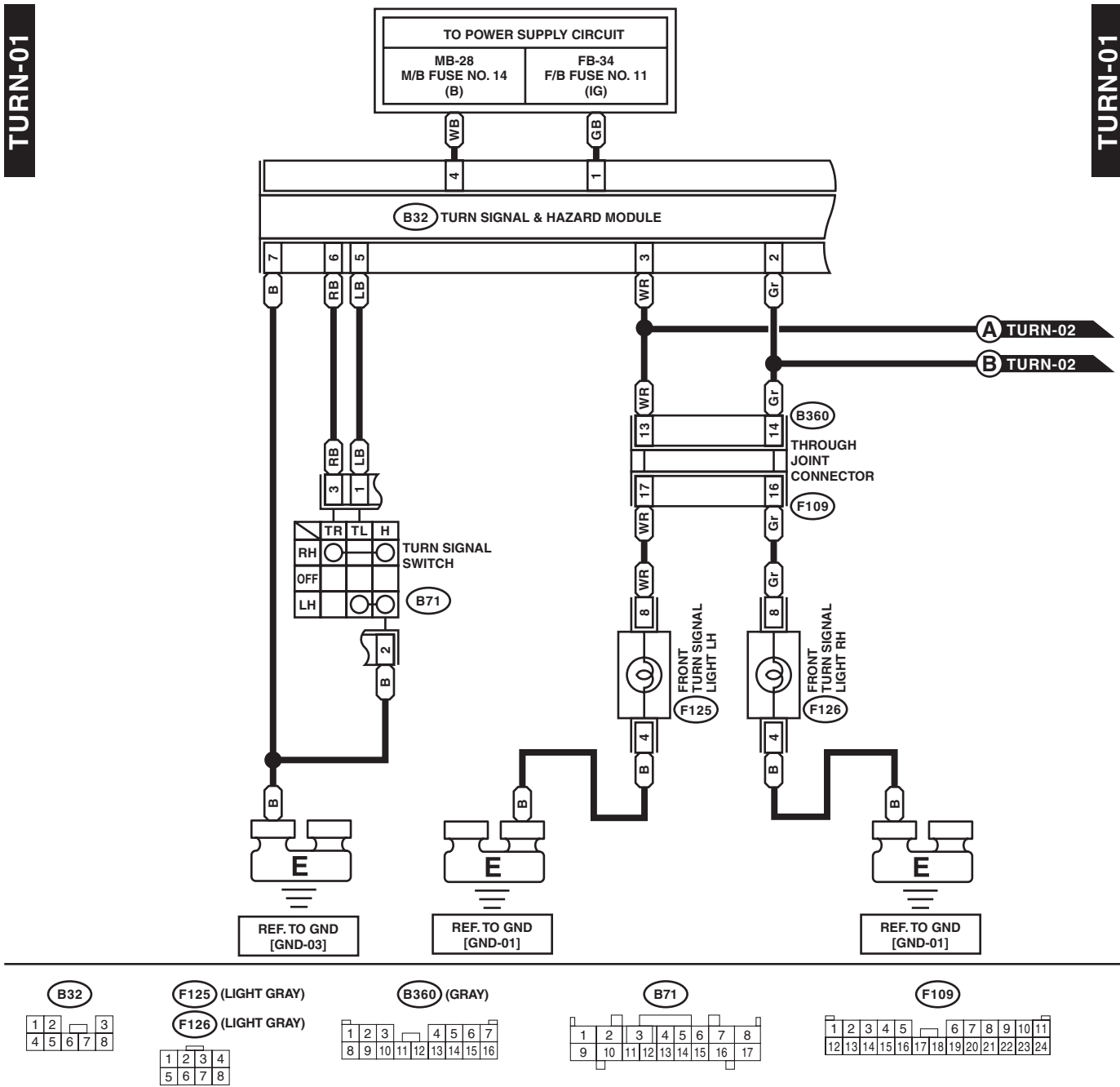

WI-30443

# Turn Signal Light and Hazard Light System

WIRING SYSTEM

TURN-02

TURN-02

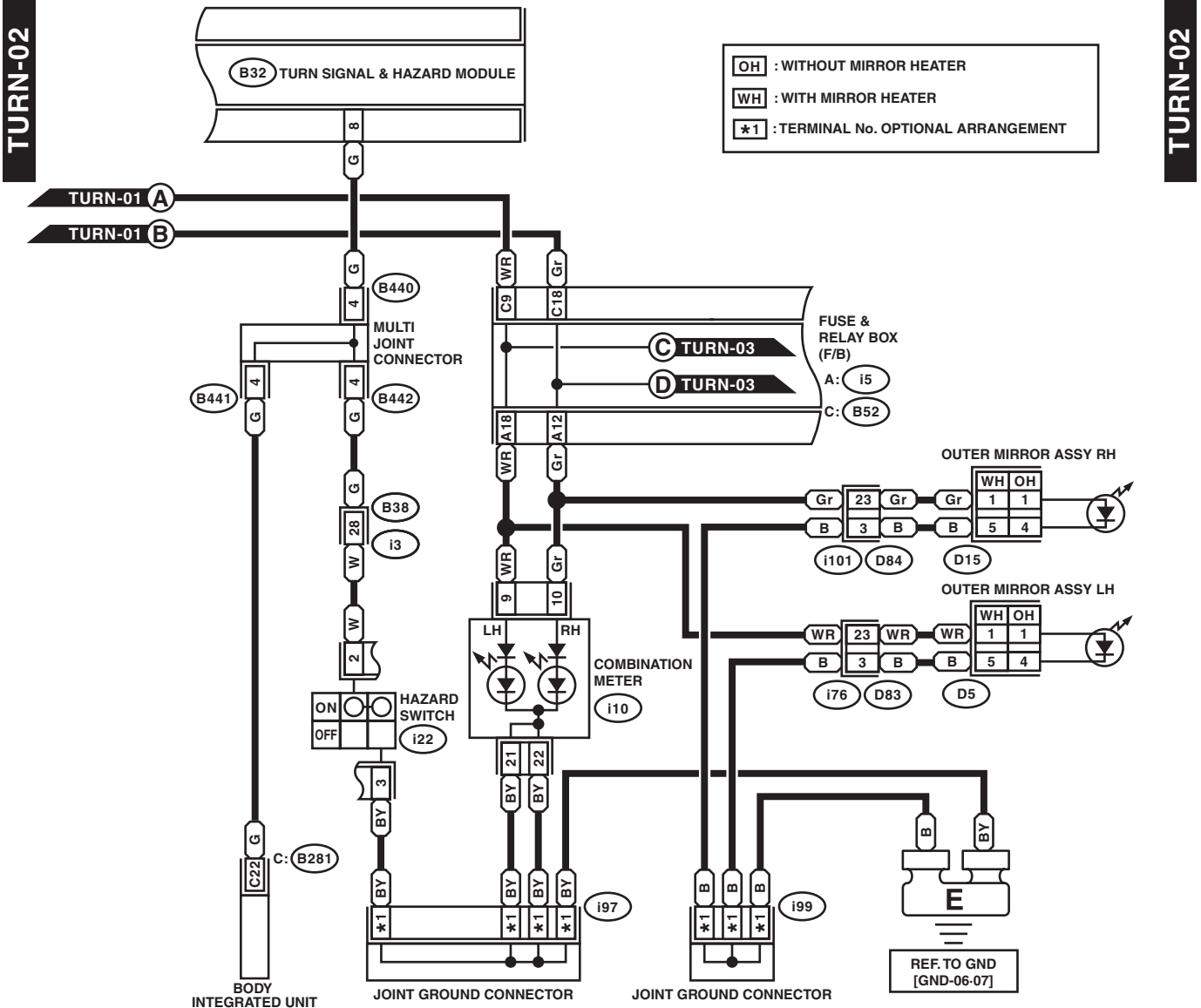

**OH** : WITHOUT MIRROR HEATER  
**WH** : WITH MIRROR HEATER  
**\*1** : TERMINAL No. OPTIONAL ARRANGEMENT

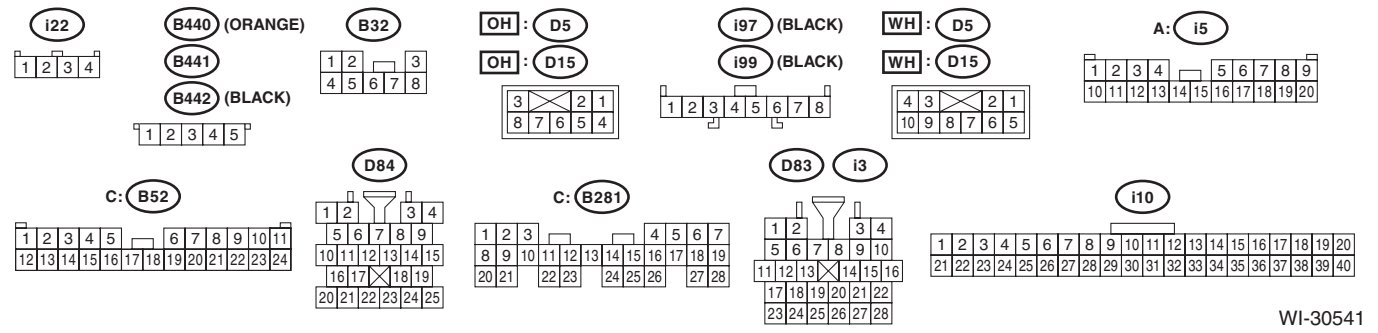

WI-30541

WI-104

Brought to you by Ebay Seller "SubaruManuals"



# Turn Signal Light and Hazard Light System

WIRING SYSTEM

TURN-03

TURN-03

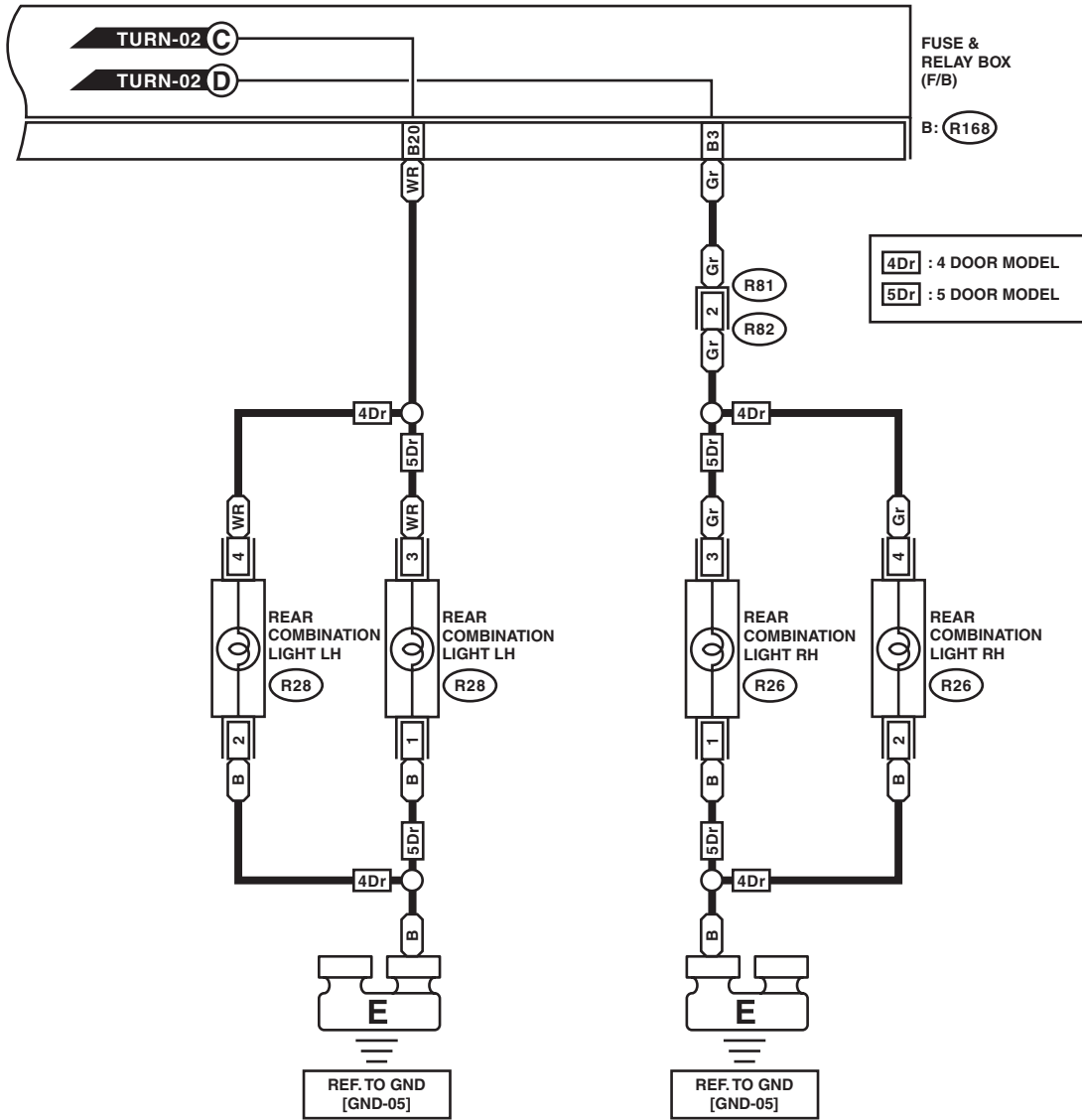

5Dr : (R26) (LIGHT GRAY)

5Dr : (R28) (LIGHT GRAY)



4Dr : (R26)

4Dr : (R28)



(R82) (BLACK)

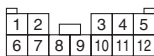

B: (R168)



WI-30542

WI-105

Brought to you by Ebay Seller "SubaruManuals"

# Interior Light System

WIRING SYSTEM

## 24. Interior Light System

### A: WIRING DIAGRAM

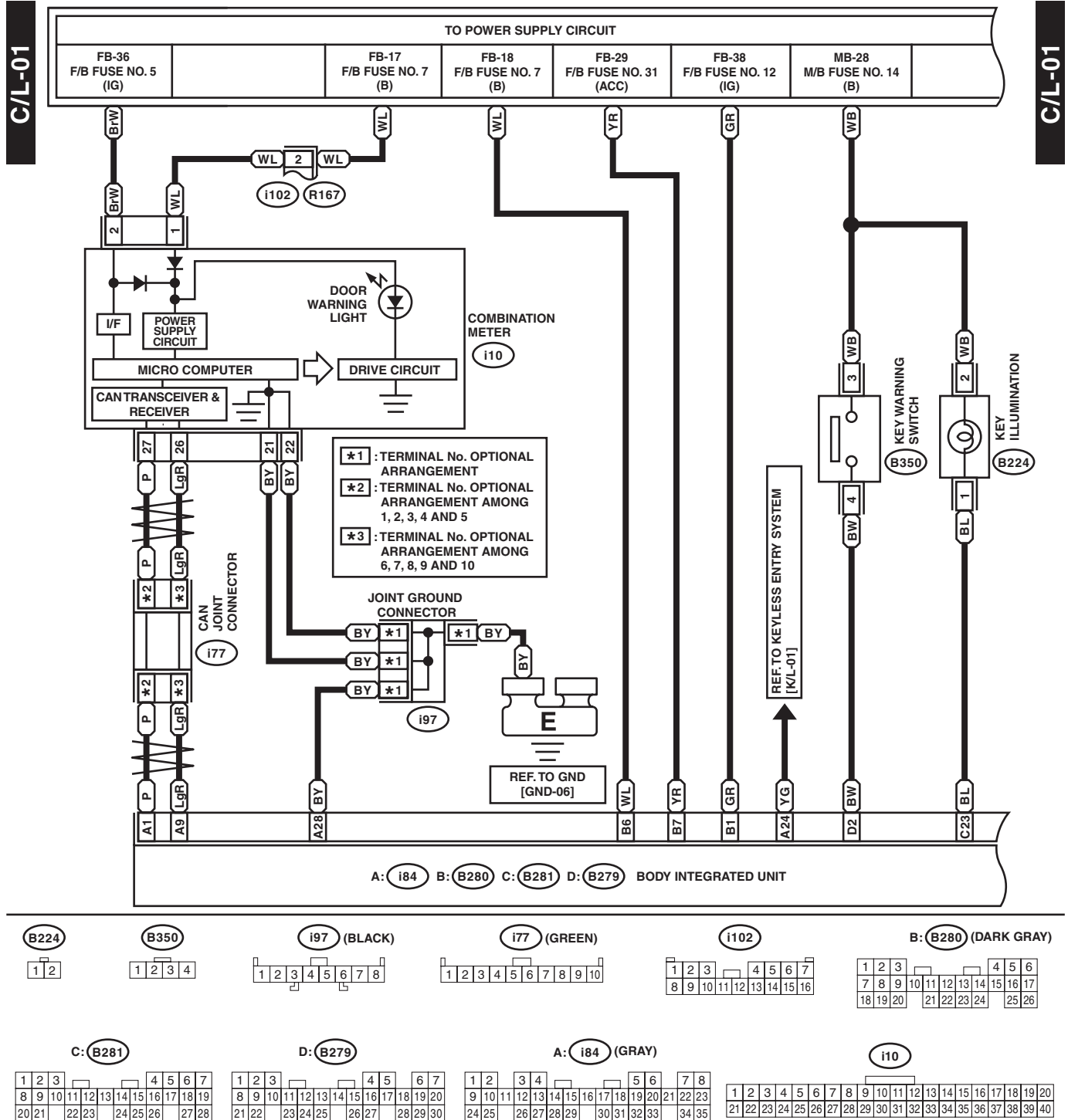

WI-30444

# Interior Light System

WIRING SYSTEM

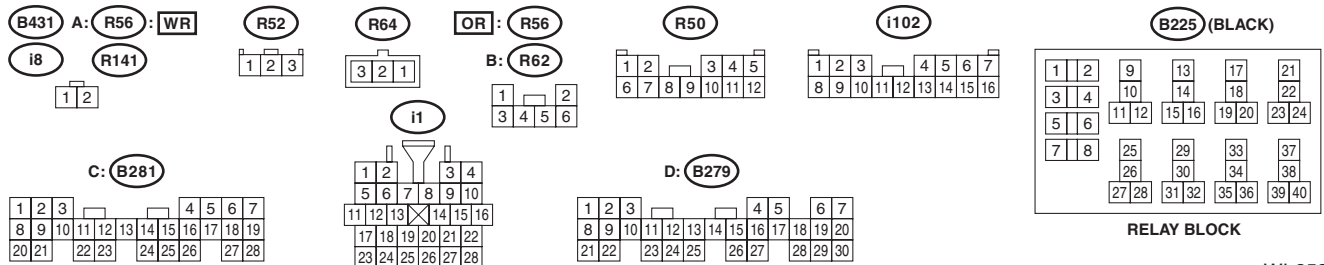
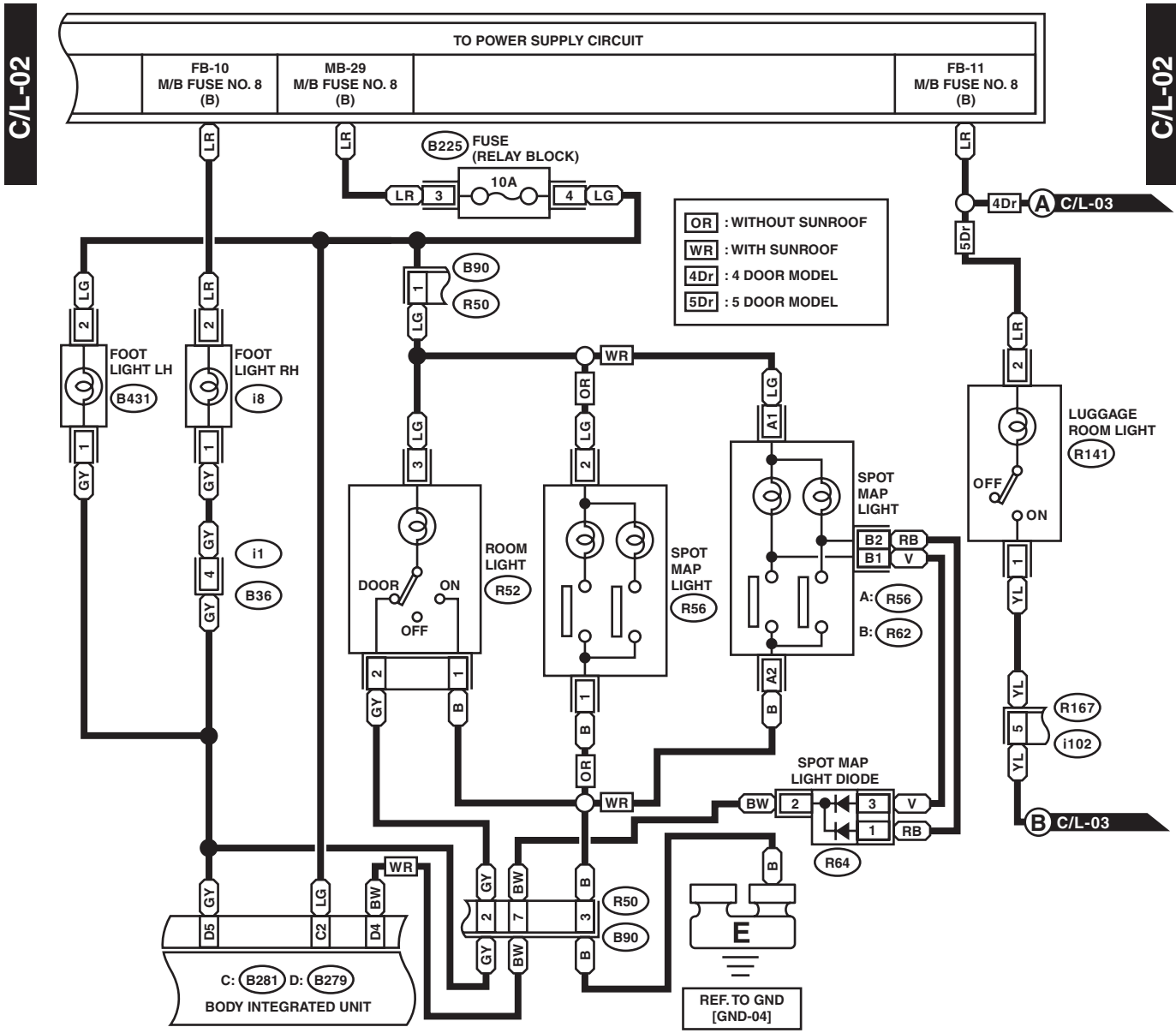

WI-35376

# Interior Light System

WIRING SYSTEM

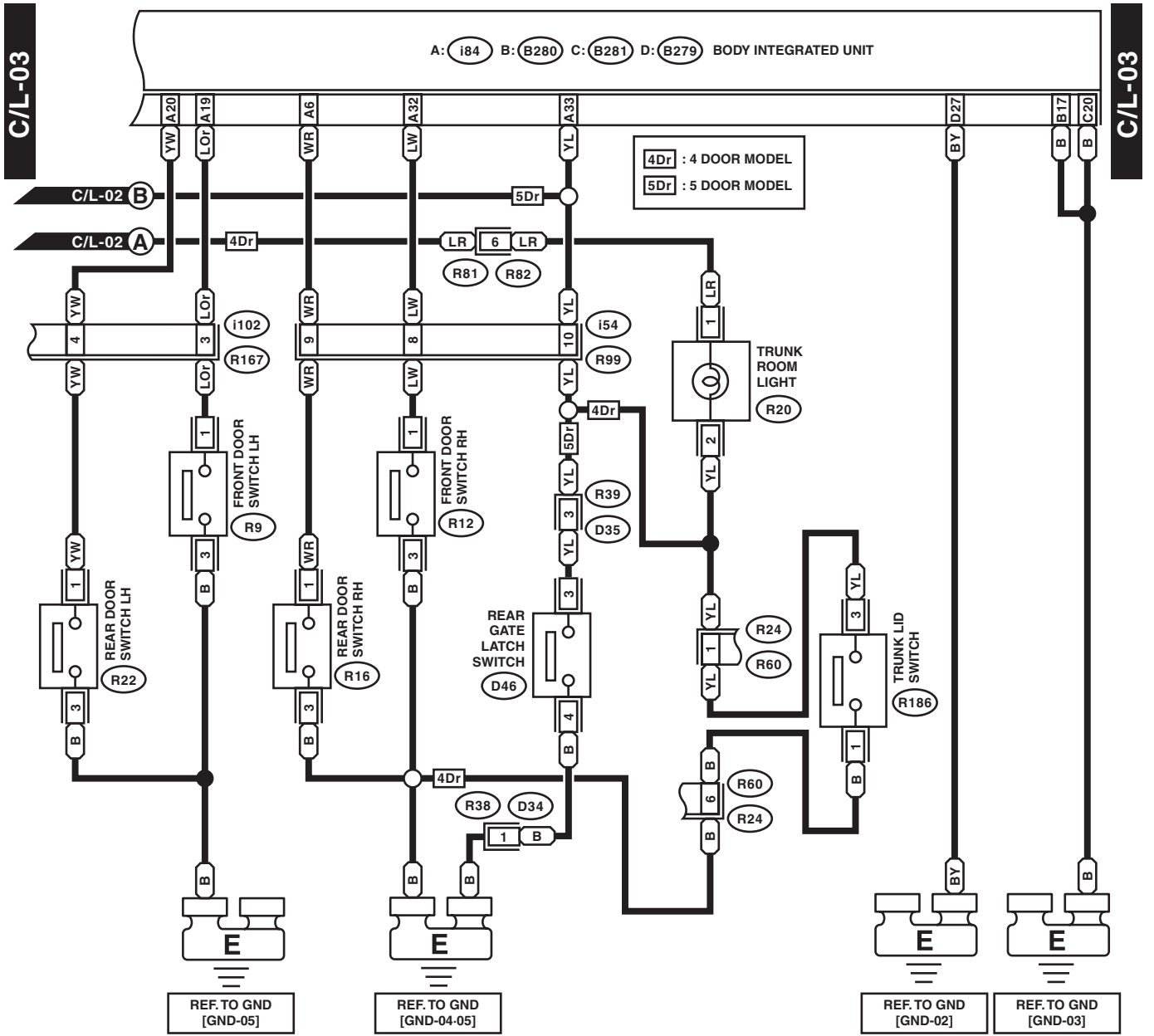

<b>R20 (BLACK)</b> 1 2	<b>R9</b> 1 2	<b>R16</b> 1 2	<b>R186</b> 1 2 3	<b>D46</b> 1 2 3 4	<b>D34</b> 1 2 3	<b>R60</b> 1 2 3 4 5 6 7 8 9 10	<b>i54</b> 1 2 3 4 5 6 7 8 9 10	<b>R82 (BLACK)</b> 1 2 3 4 5 6 7 8 9 10 11 12	<b>D35</b> 1 2 3 4 5 6 7 8 9 10 11 12 13 14	<b>i102</b> 1 2 3 4 5 6 7 8 9 10 11 12 13 14 15 16
<b>B: (B280) (DARK GRAY)</b> 1 2 3		<b>C: (B281)</b> 1 2 3 4 5 6 7 8 9 10 11 12 13 14 15 16 17 18 19 20 21 22 23 24 25 26 27 28		<b>D: (B279)</b> 1 2 3 4 5 6 7 8 9 10 11 12 13 14 15 16 17 18 19 20 21 22 23 24 25 26 27 28 29 30		<b>A: i84 (GRAY)</b> 1 2 3 4 5 6 7 8 9 10 11 12 13 14 15 16 17 18 19 20 21 22 23 24 25 26 27 28 29 30 31 32 33 34 35				

WI-35377

## 25. Front Wiper and Washer System

### A: WIRING DIAGRAM

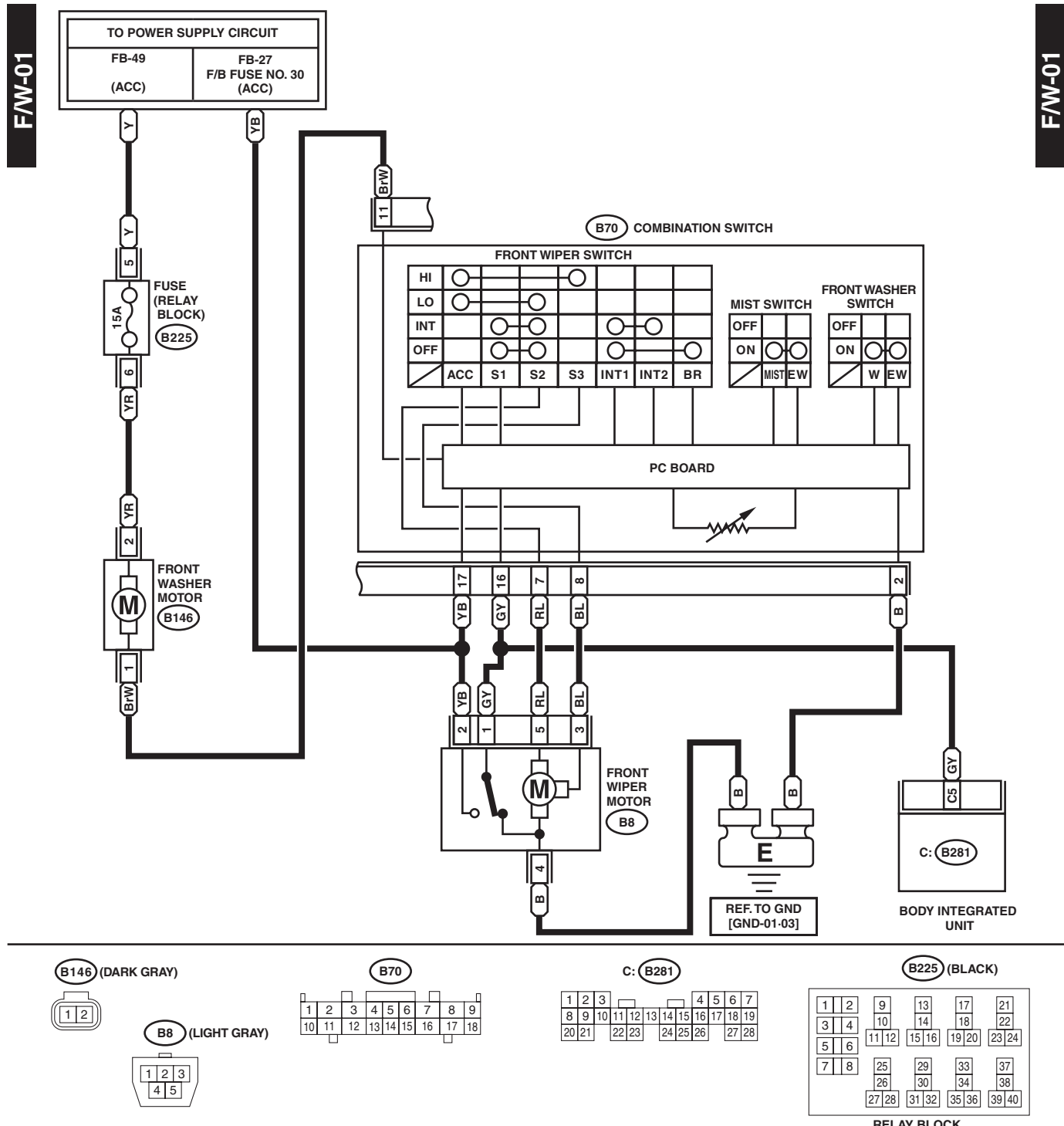

F/W-01

F/W-01

# Rear Wiper and Washer System

WIRING SYSTEM

## 26. Rear Wiper and Washer System

### A: WIRING DIAGRAM

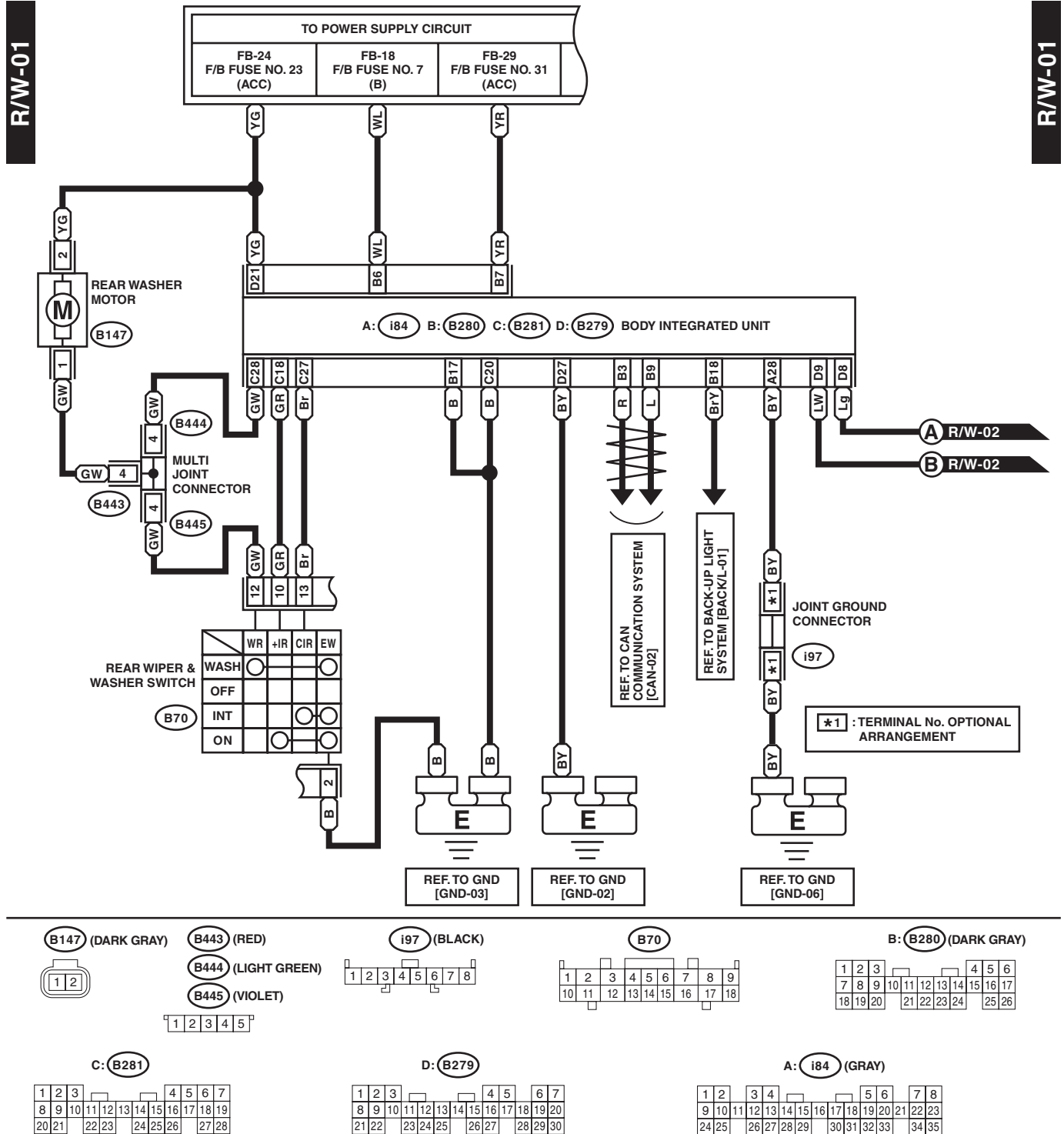

WI-30448

# Rear Wiper and Washer System

WIRING SYSTEM

R/W-02

R/W-02

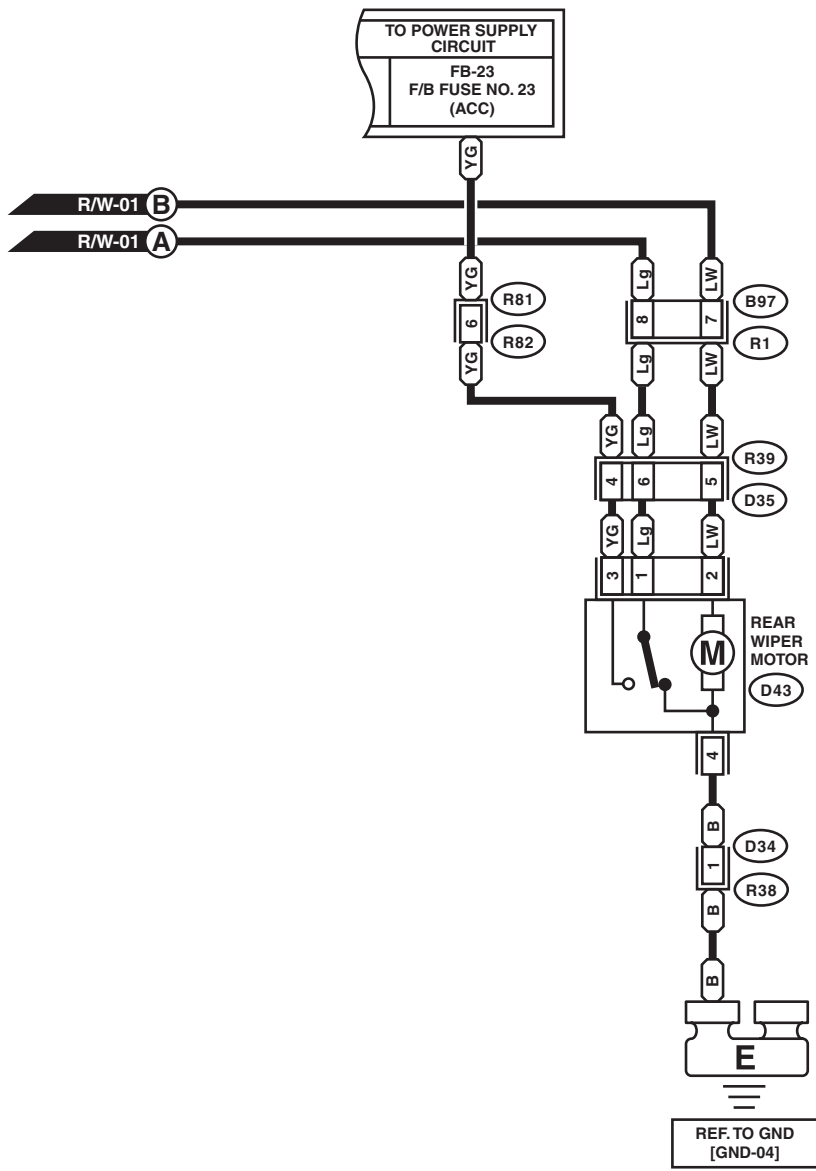

D43



D34

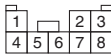

B97

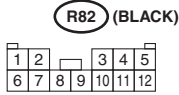

D35

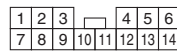

WI-19441

WI-111

Brought to you by Ebay Seller "SubaruManuals"

# Wiper Deicer System

WIRING SYSTEM

## 27. Wiper Deicer System

### A: WIRING DIAGRAM

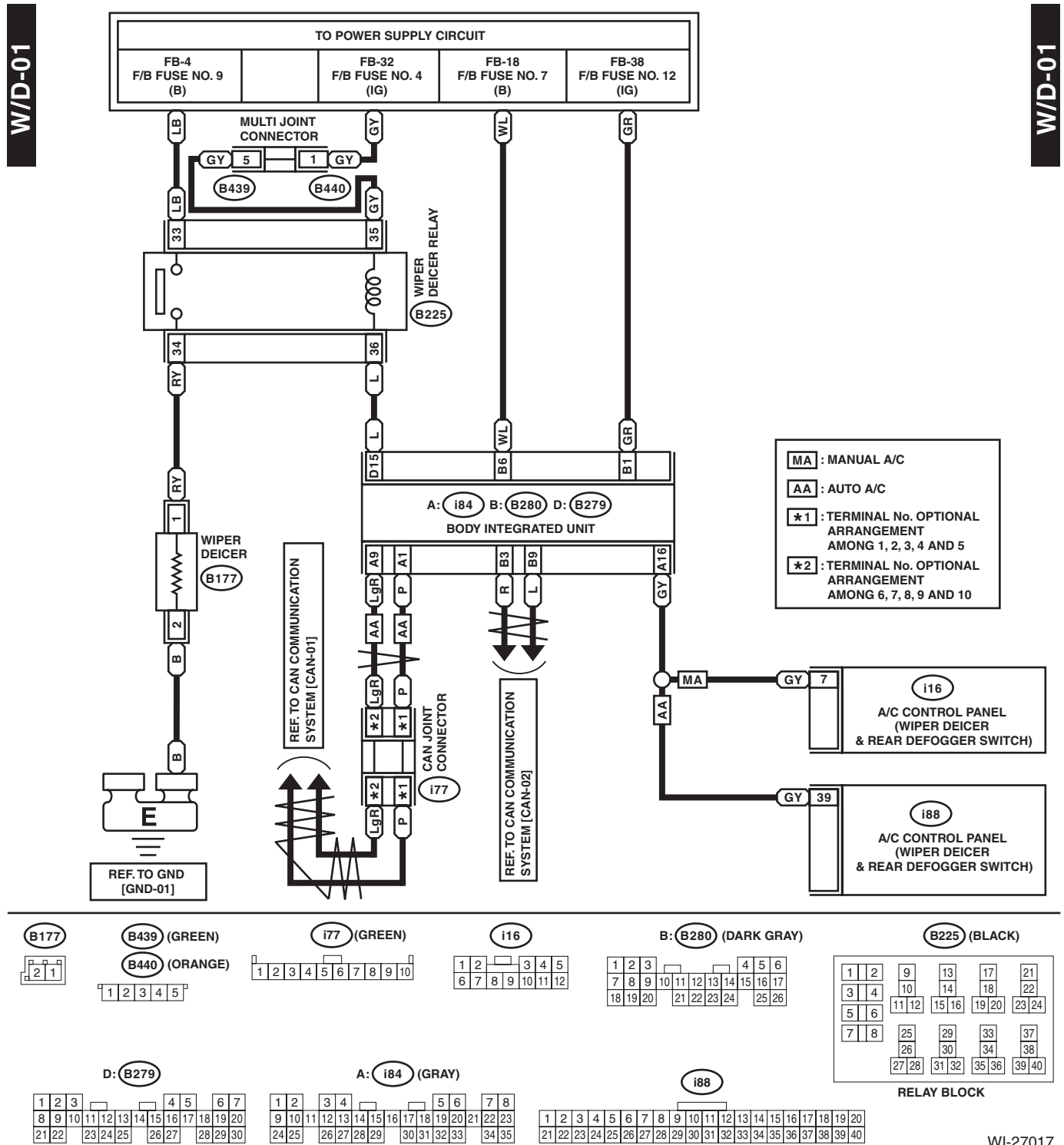



## 28. Audio System

### A: WIRING DIAGRAM

#### 1. WITHOUT HANDSFREE MICROPHONE

- Without SI-DRIVE

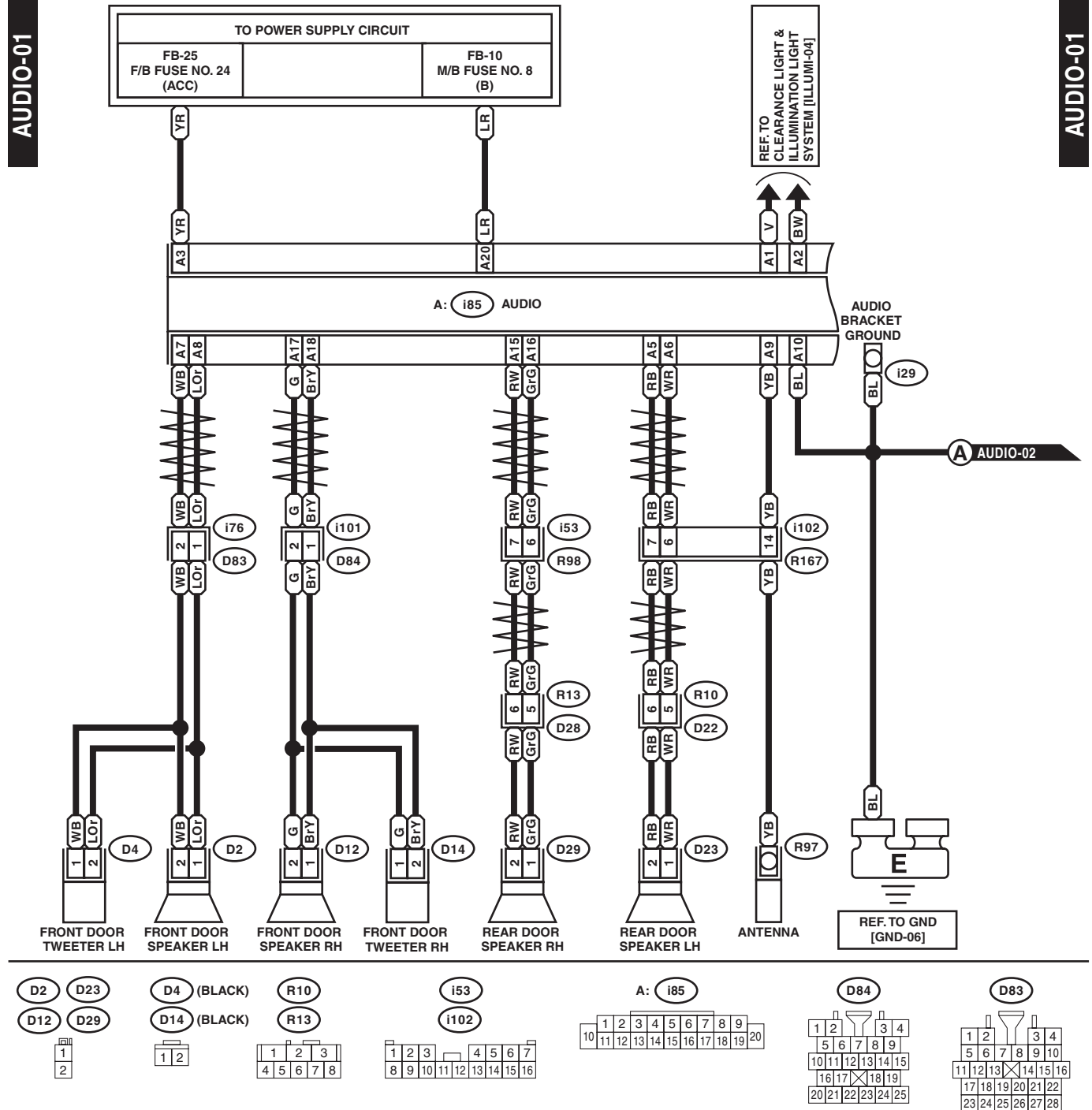

WI-35295



# Audio System

WIRING SYSTEM

• With SI-DRIVE

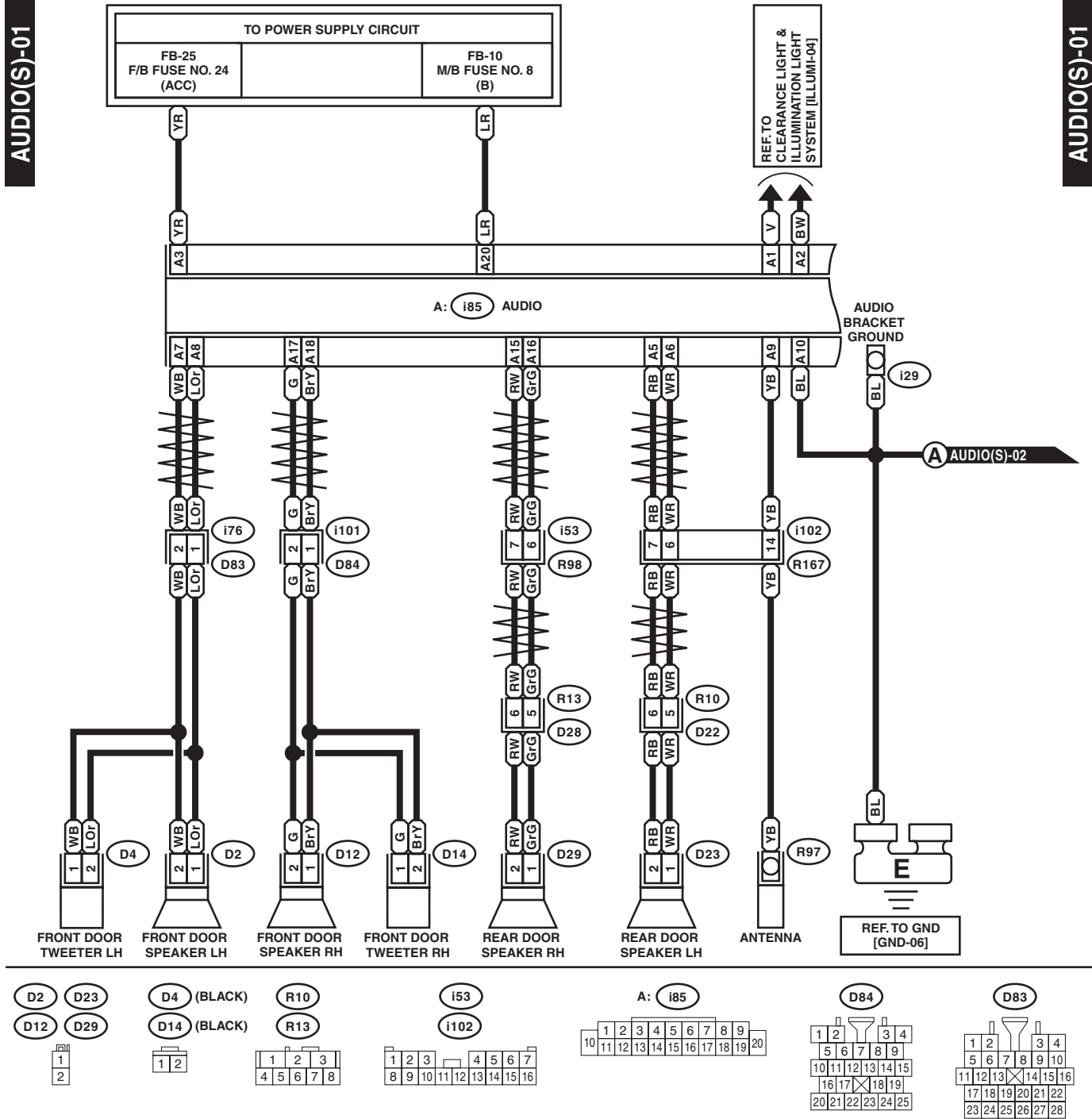

WI-35296

# Audio System

WIRING SYSTEM

AUDIO(S)-02

AUDIO(S)-02

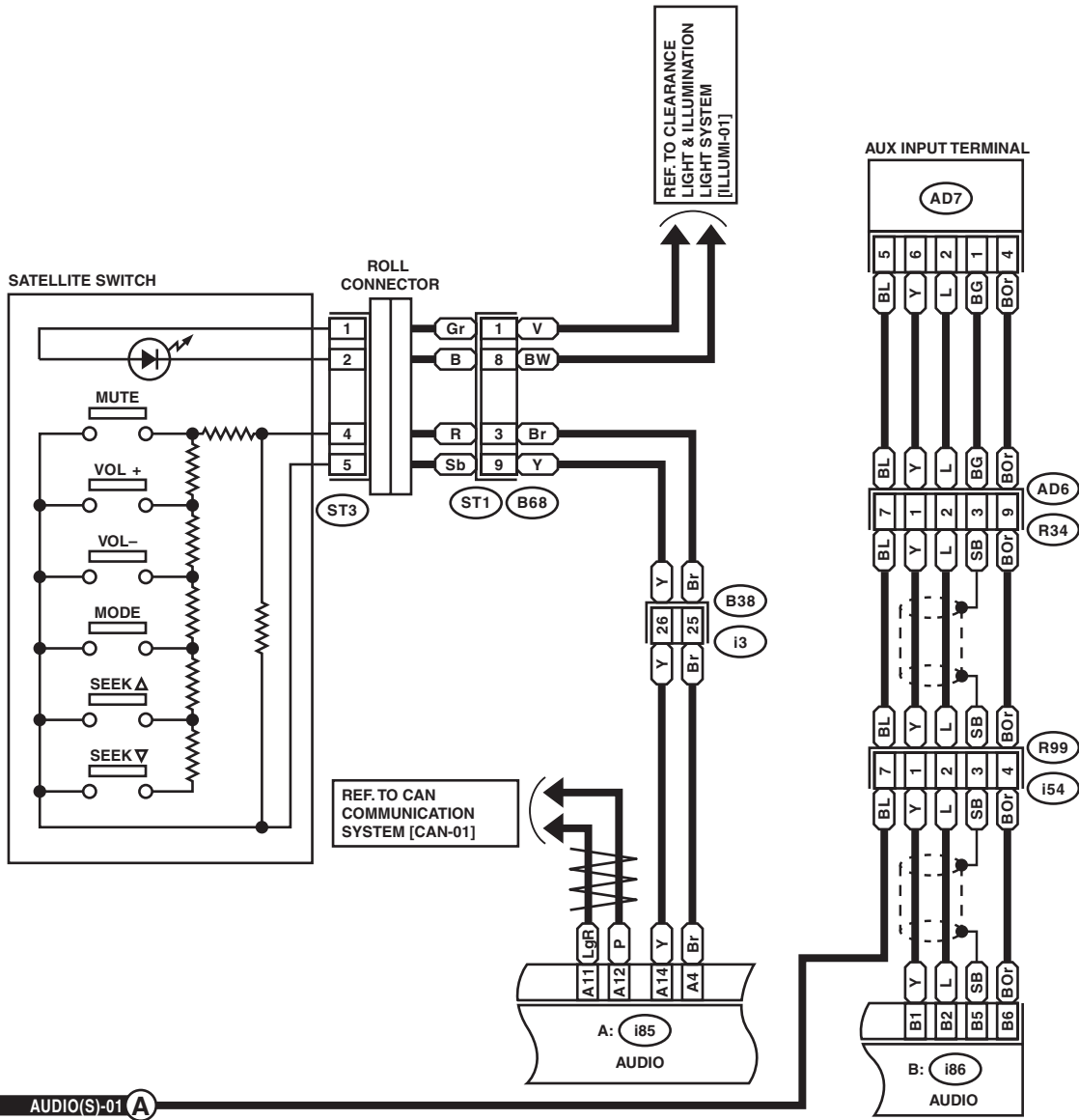

AUDIO(S)-01 A

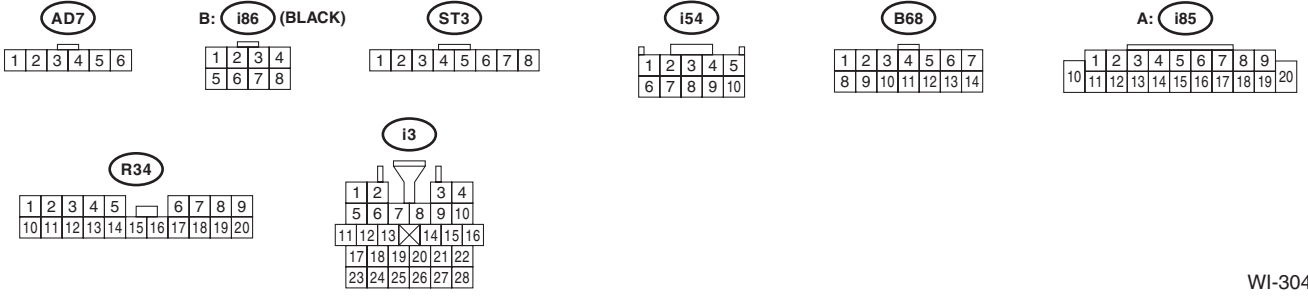

WI-30451

# Audio System

WIRING SYSTEM

## 2. WITH HANDSFREE MICROPHONE

- Without SI-DRIVE

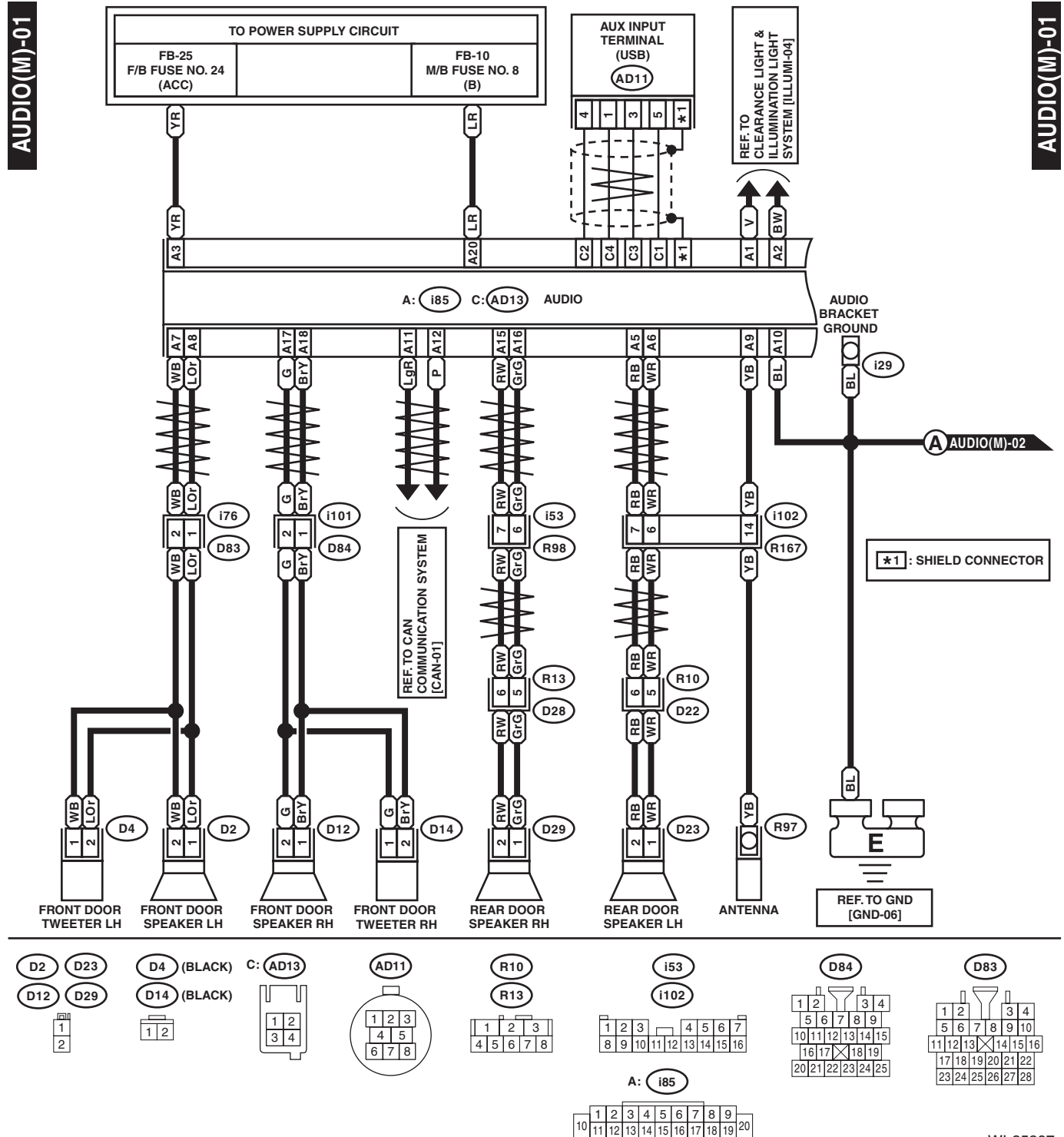

WI-35297

# Audio System

## WIRING SYSTEM

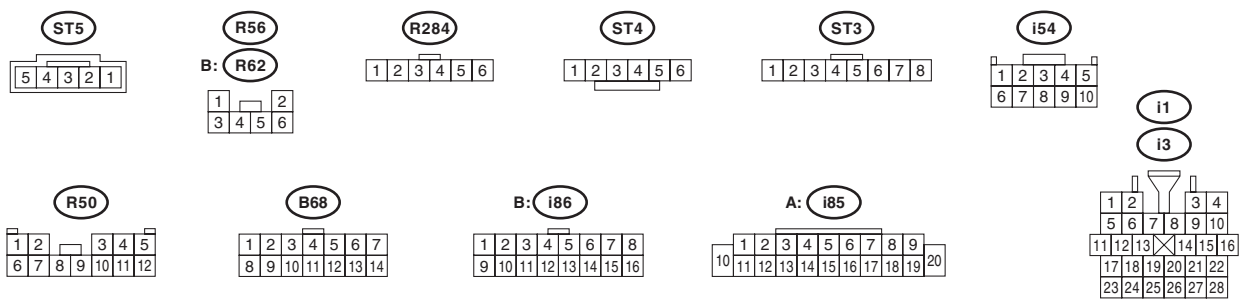
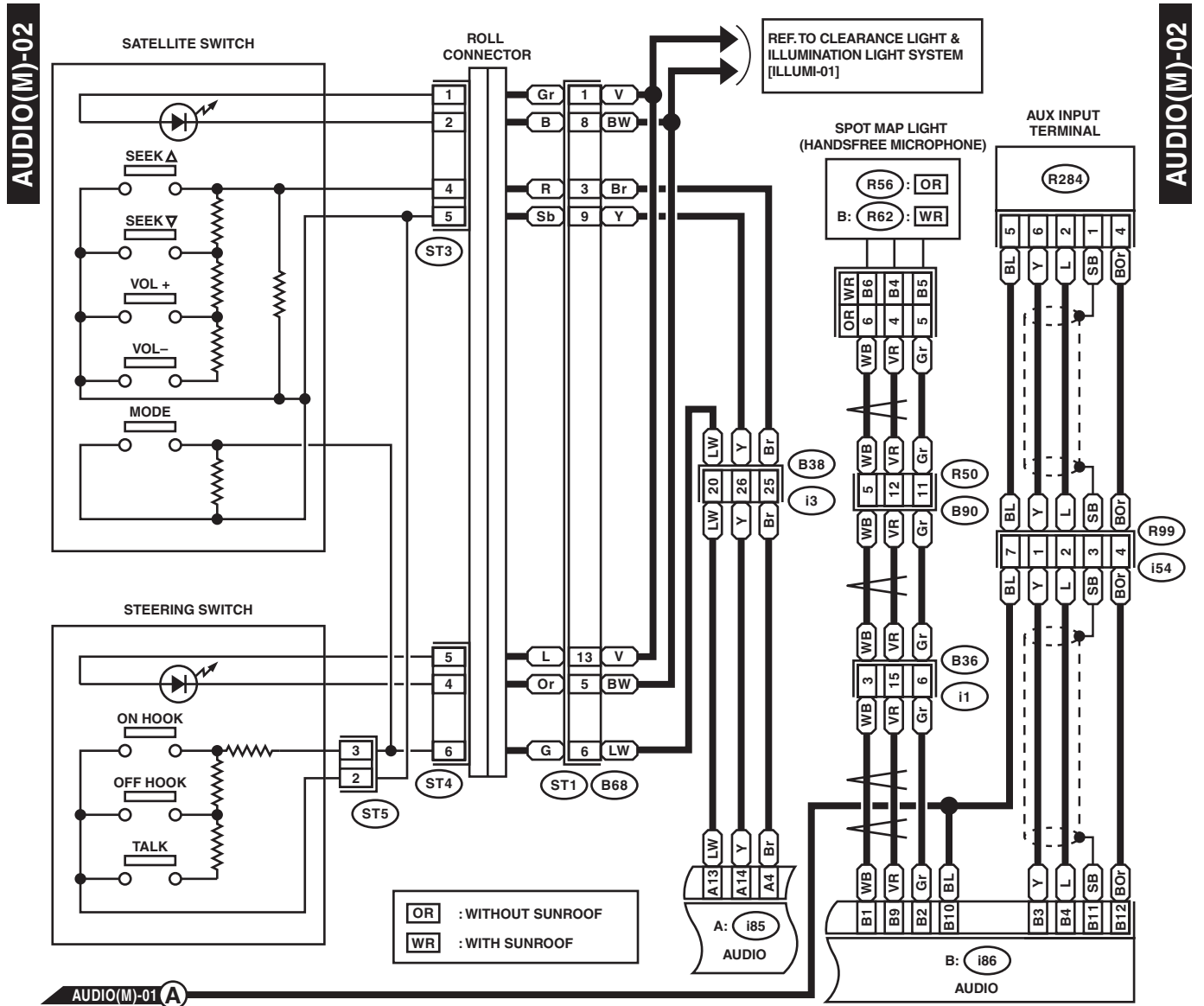

WI-29902

# Audio System

WIRING SYSTEM

• With SI-DRIVE

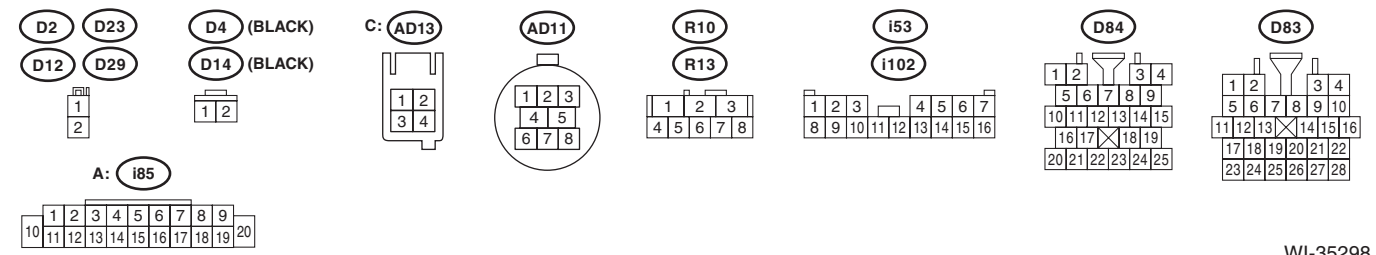
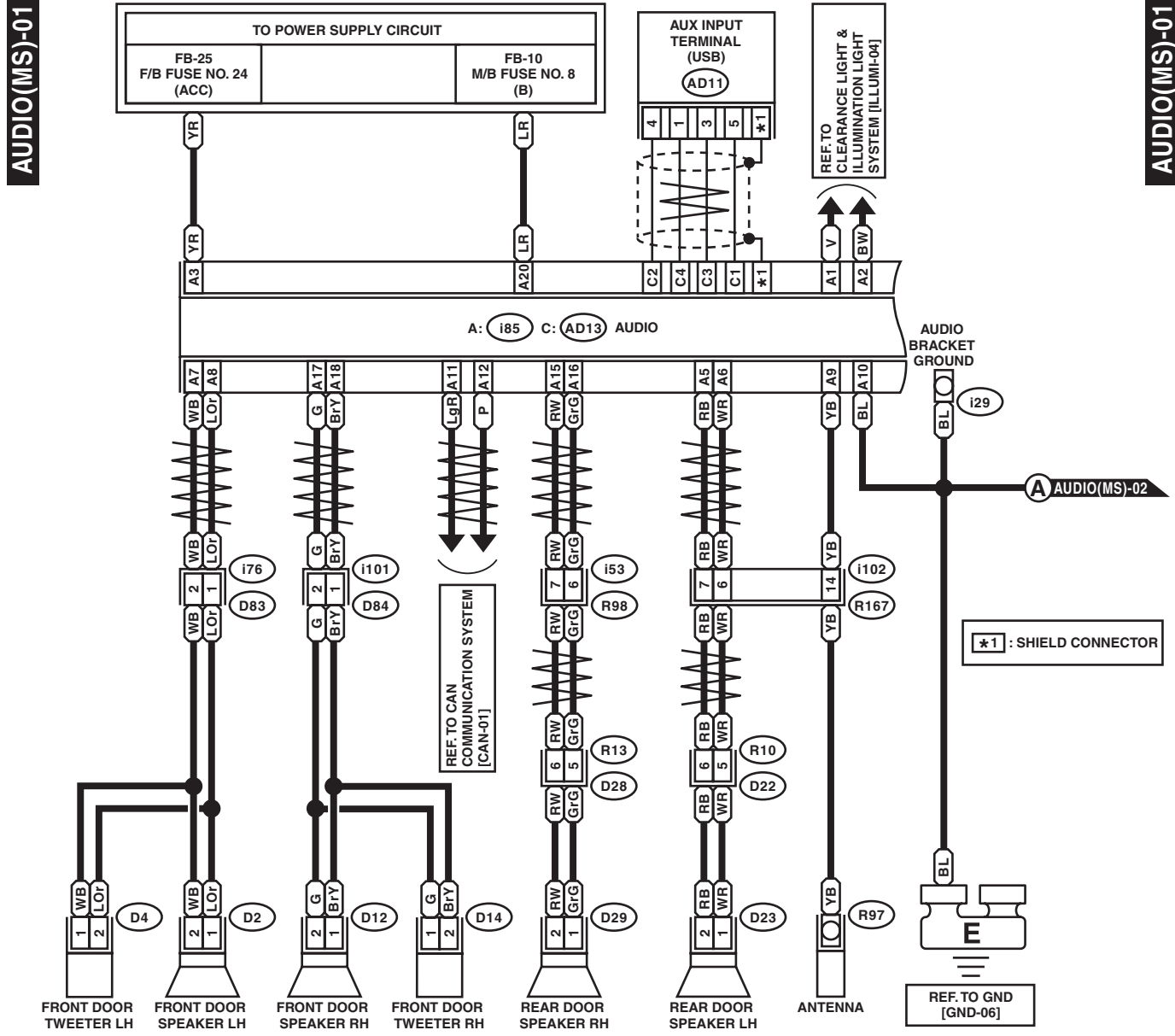

WI-35298

WI-119

Brought to you by Ebay Seller "SubaruManuals"

# Audio System

## WIRING SYSTEM

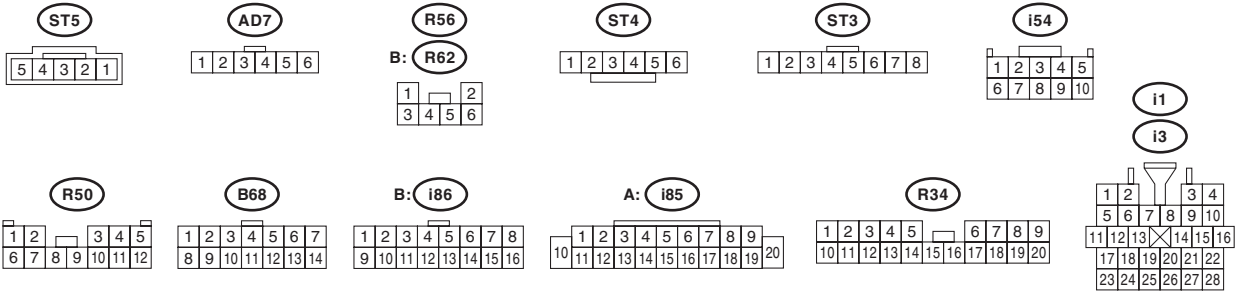
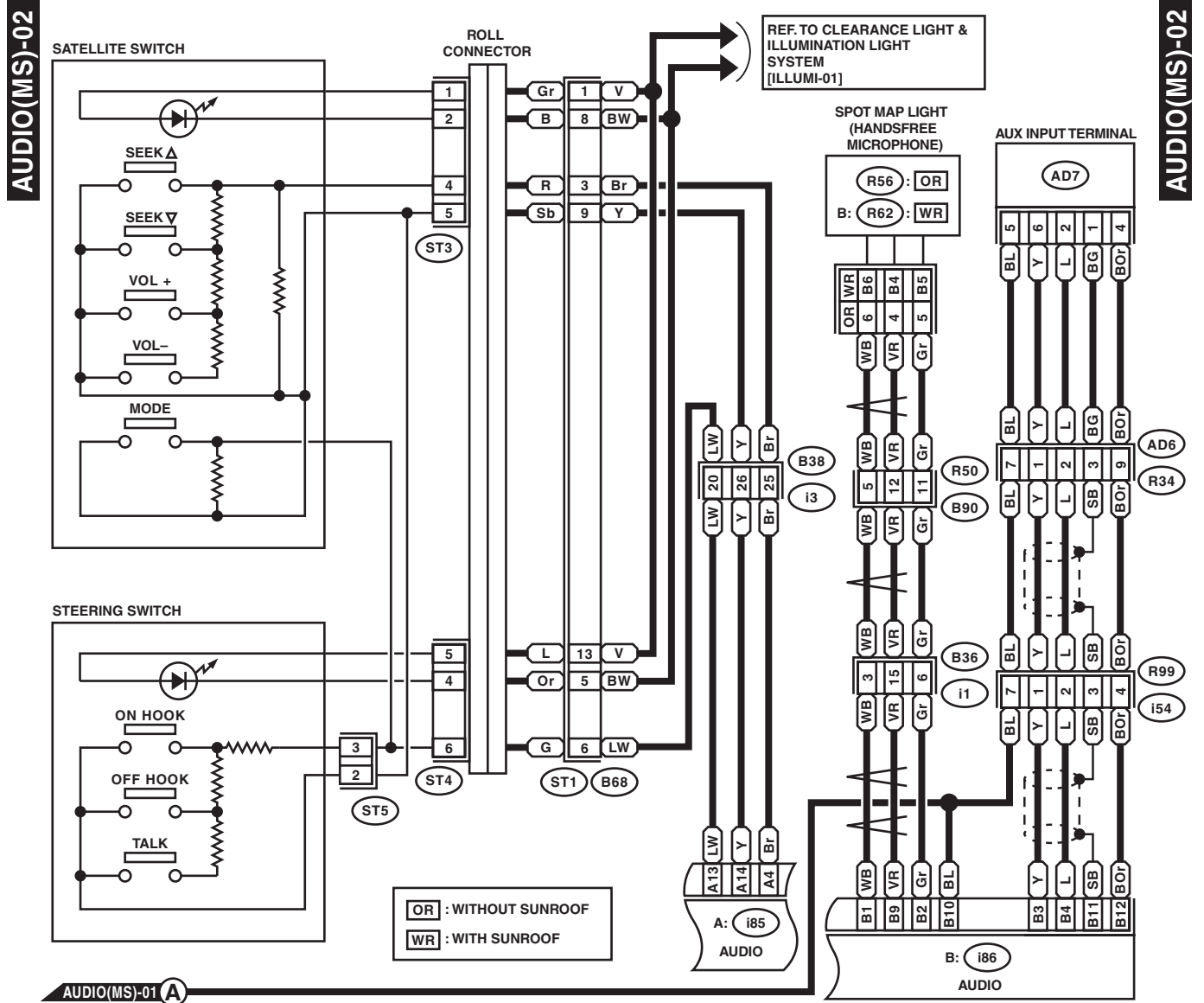

WI-30453



## 29. Front Accessory Power Supply Socket System

### A: WIRING DIAGRAM

FAPS-01

FAPS-01

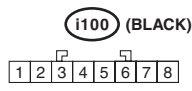
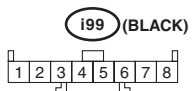
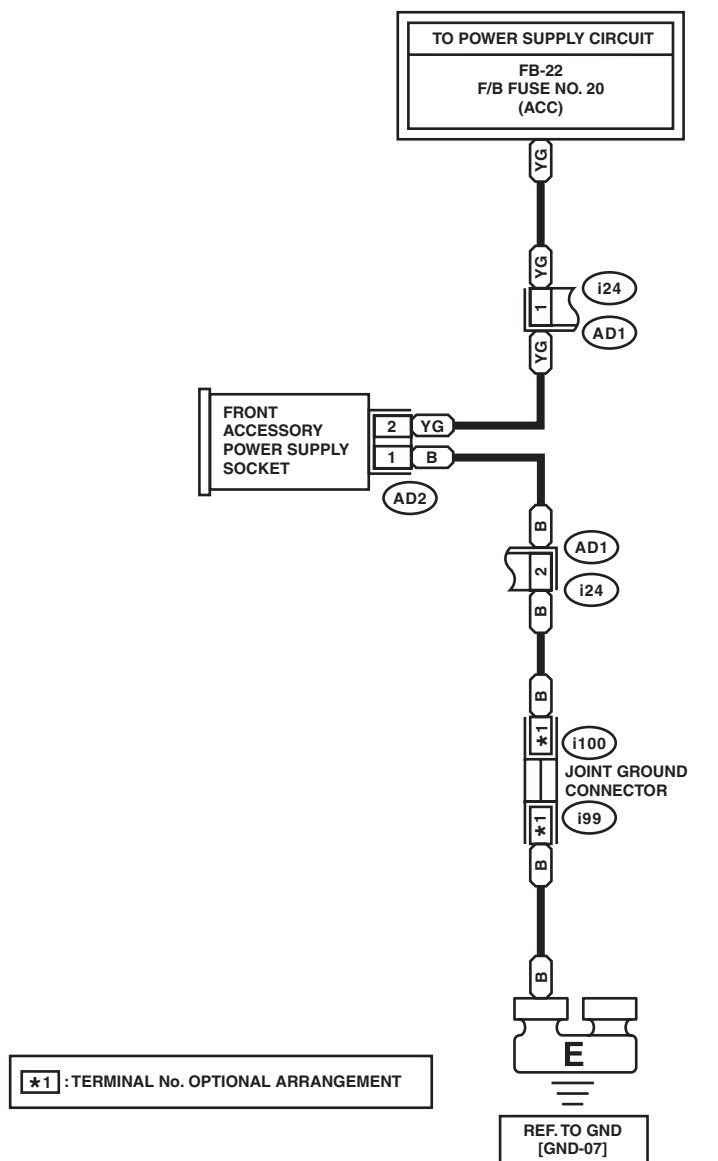

# Rear Accessory Power Supply Socket System

WIRING SYSTEM

## 30.Rear Accessory Power Supply Socket System

### A: WIRING DIAGRAM

RAPS-01

RAPS-01

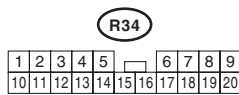
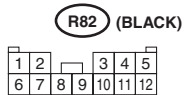
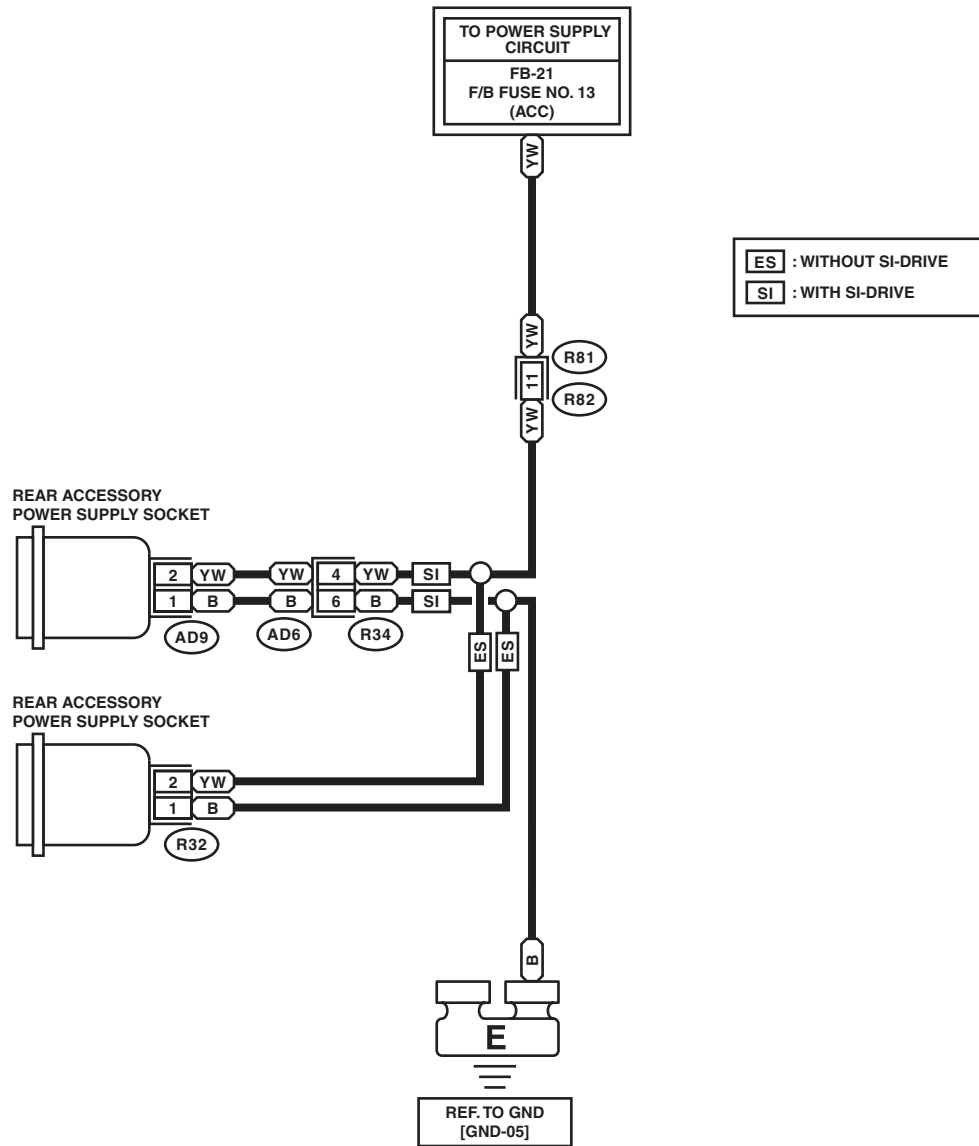

WI-30455

WI-122

Brought to you by Ebay Seller "SubaruManuals"

## 31. Navigation System

### A: WIRING DIAGRAM

#### 1. WITHOUT SI-DRIVE

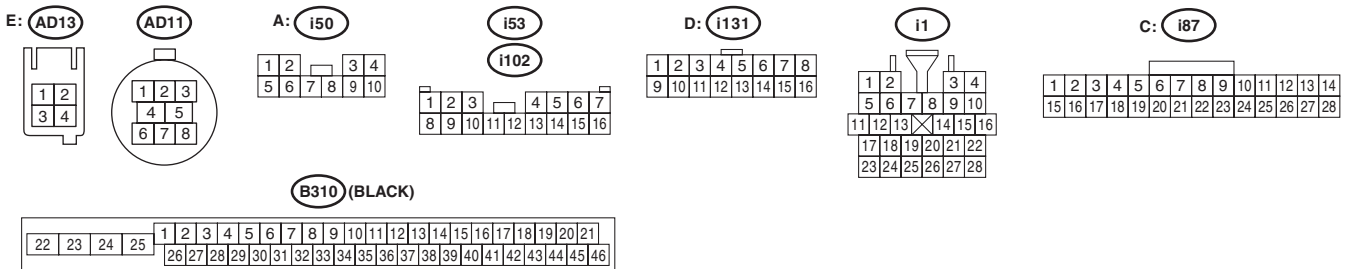
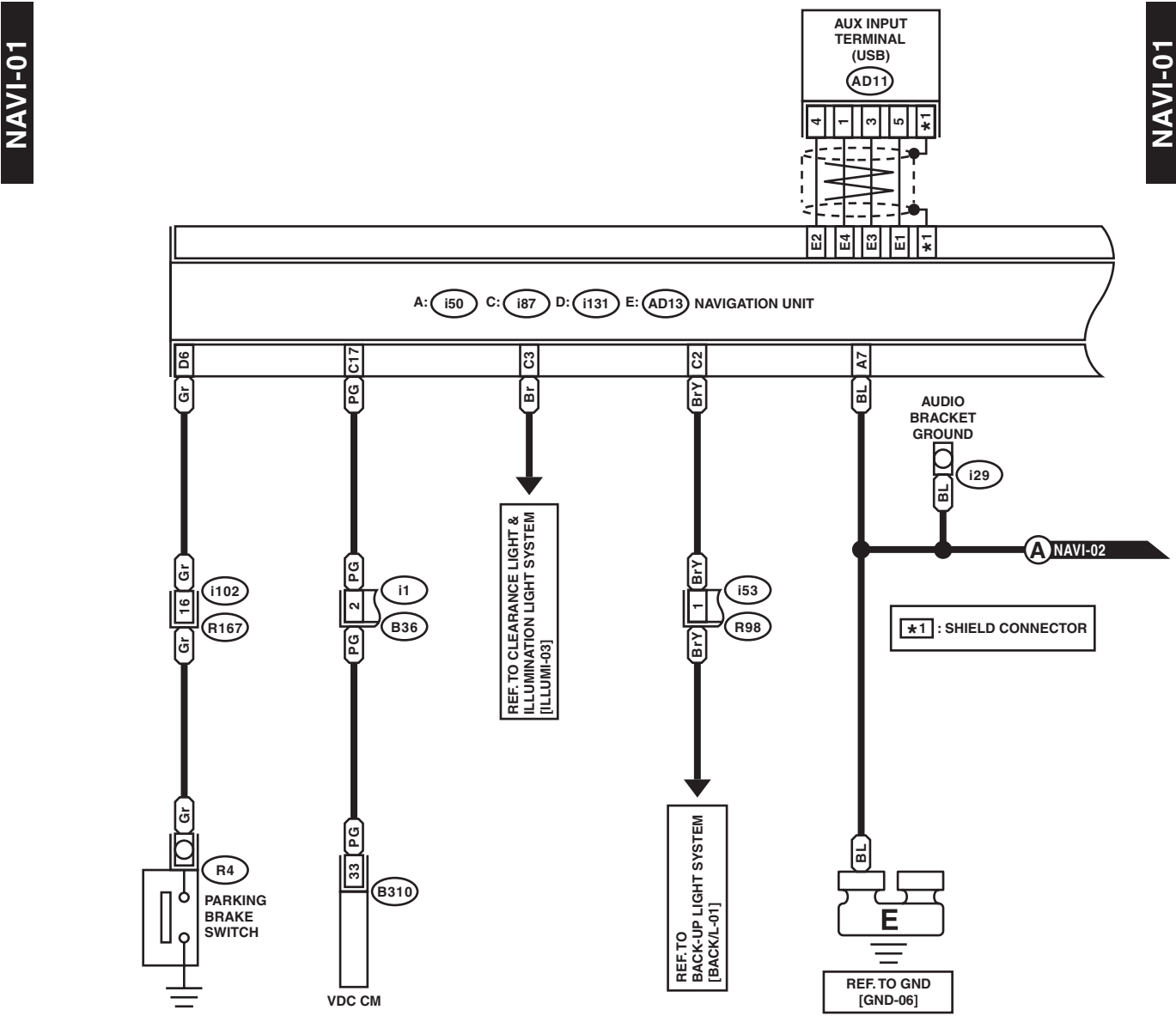

WI-35299

# Navigation System

## WIRING SYSTEM

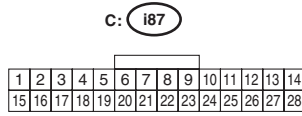
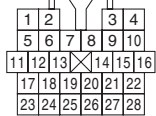
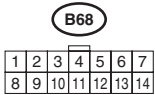
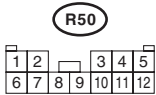
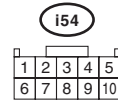
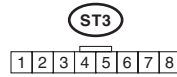
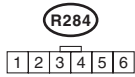
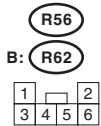
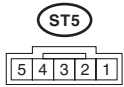
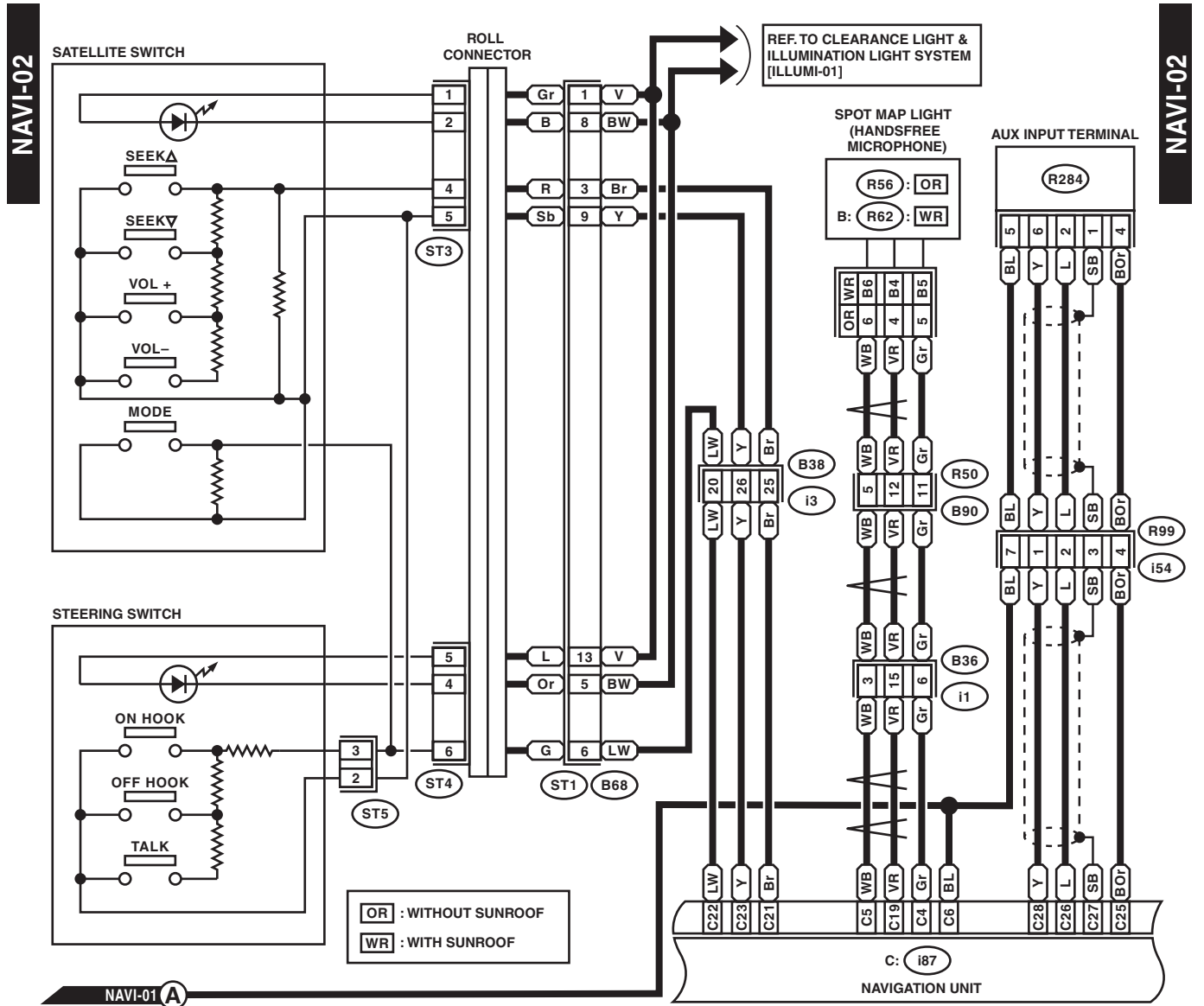

WI-35300

# Navigation System

WIRING SYSTEM

NAVI-03

NAVI-03

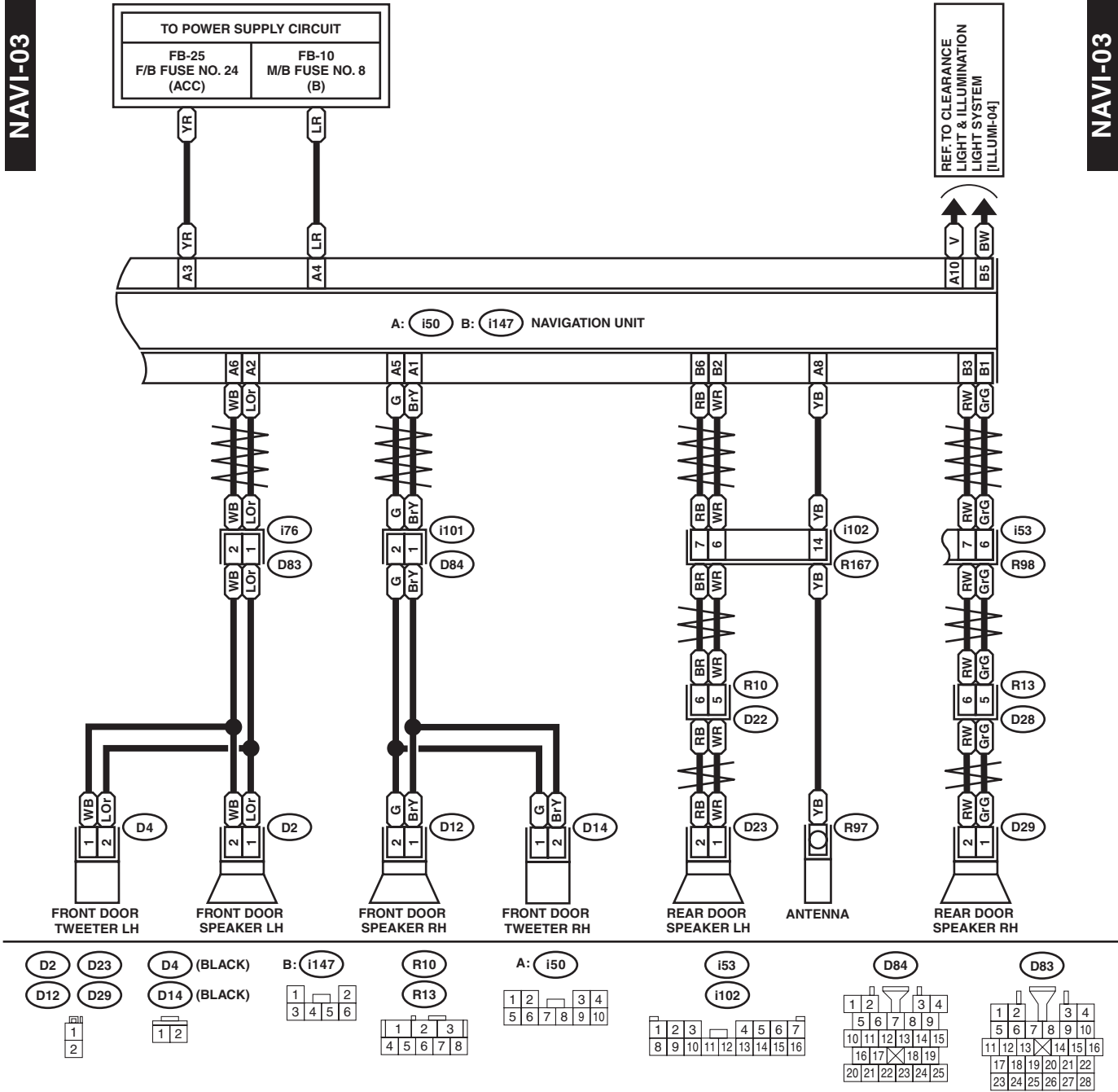

WI-35301

WI-125

Brought to you by Ebay Seller "SubaruManuals"

# Navigation System

## WIRING SYSTEM

### 2. WITH SI-DRIVE

NAVI(S)-01

NAVI(S)-01

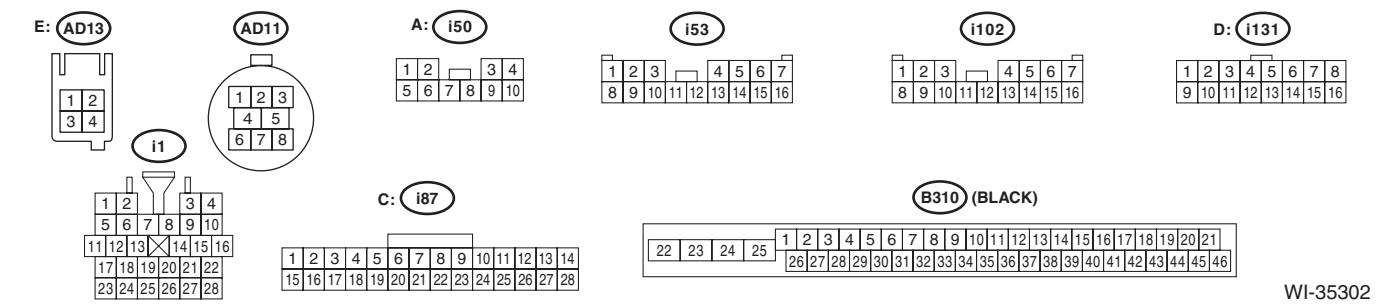
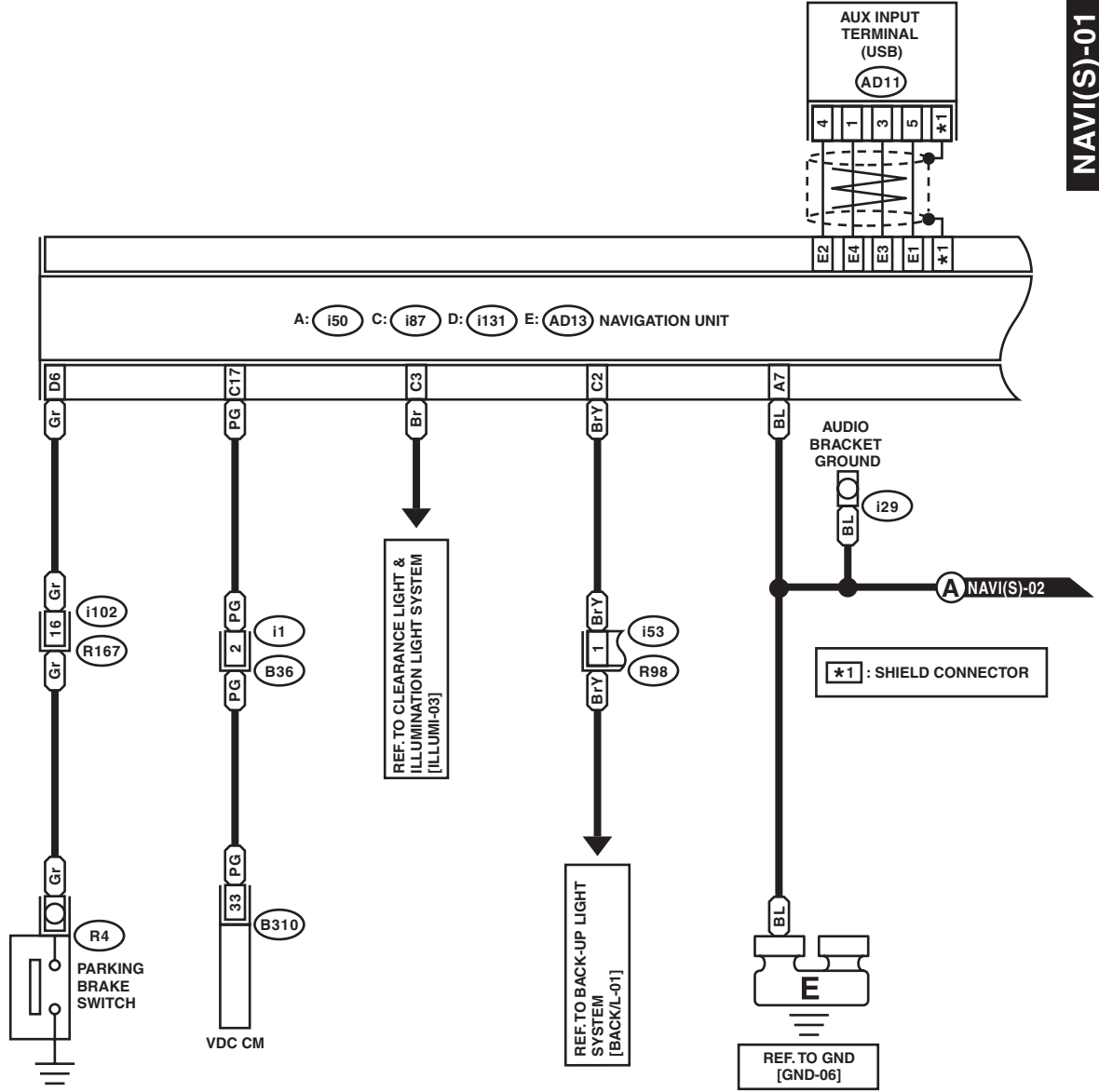

WI-35302

# Navigation System

WIRING SYSTEM

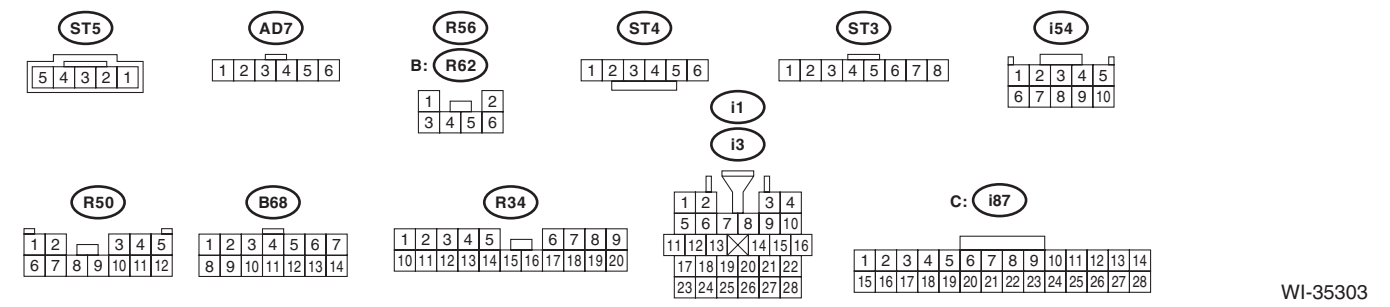
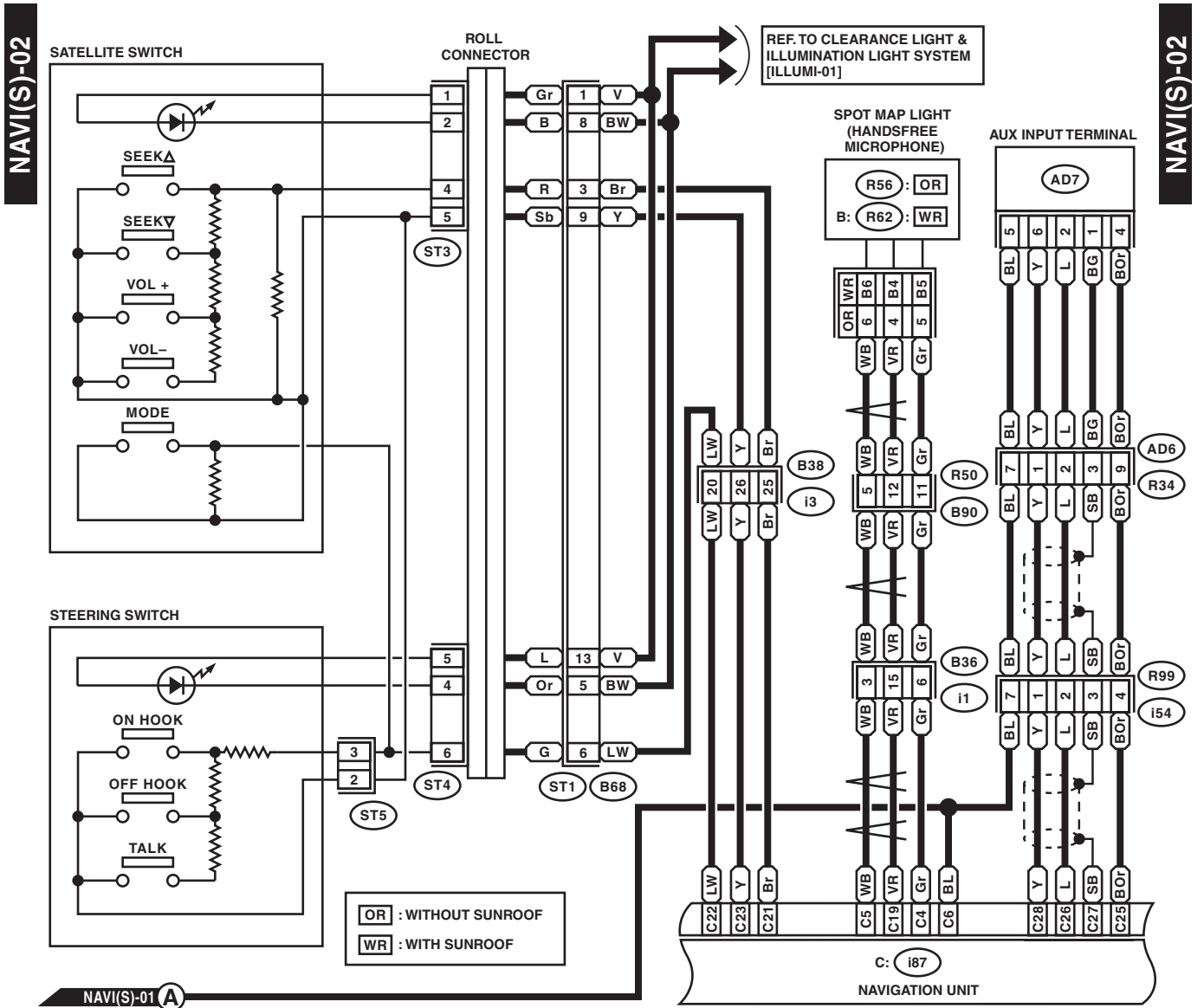

WI-35303

# Navigation System

## WIRING SYSTEM

NAVI(S)-03

NAVI(S)-03

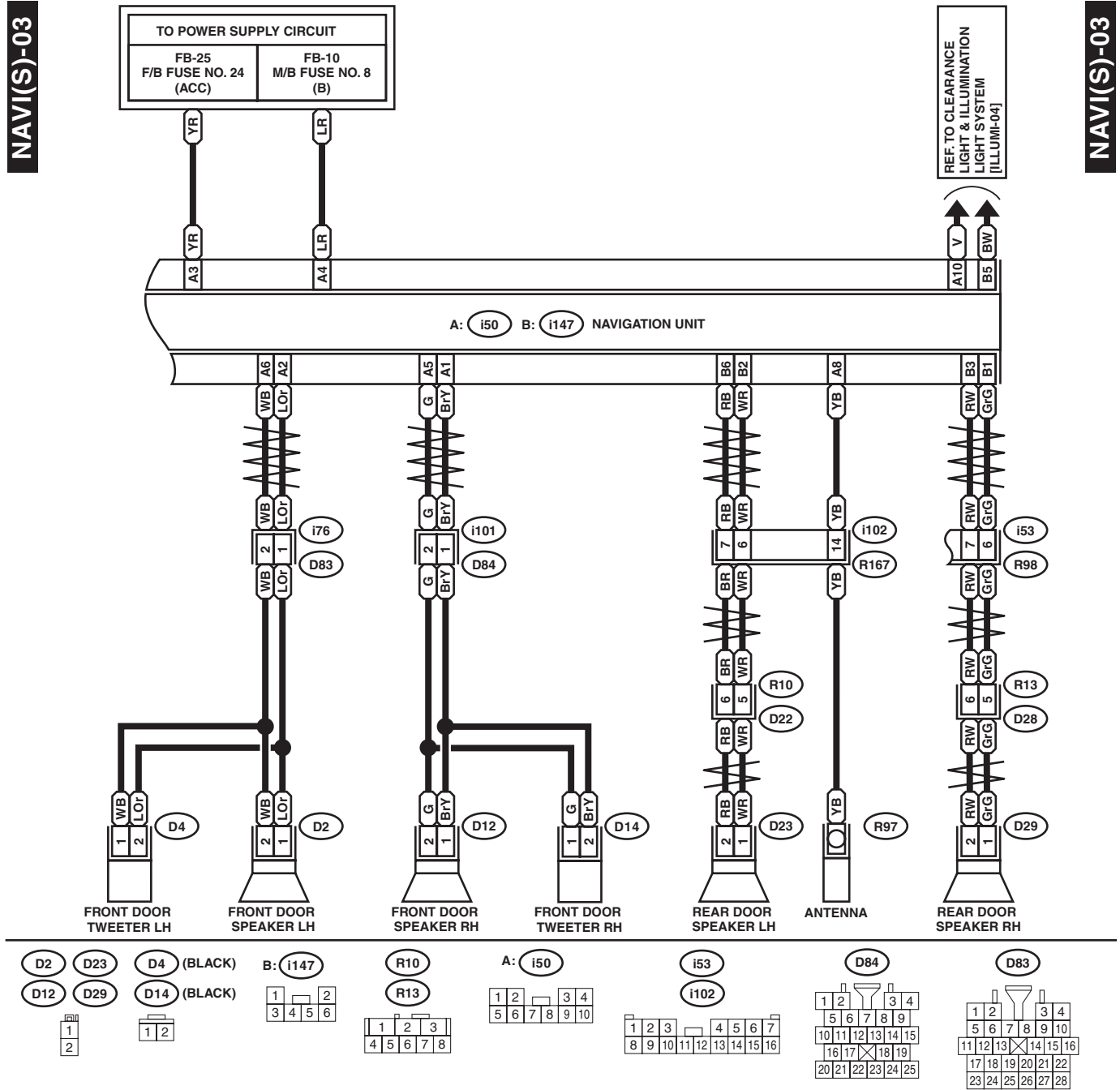

WI-35304

WI-128

Brought to you by Ebay Seller "SubaruManuals"



## 32.Horn System

### A: WIRING DIAGRAM

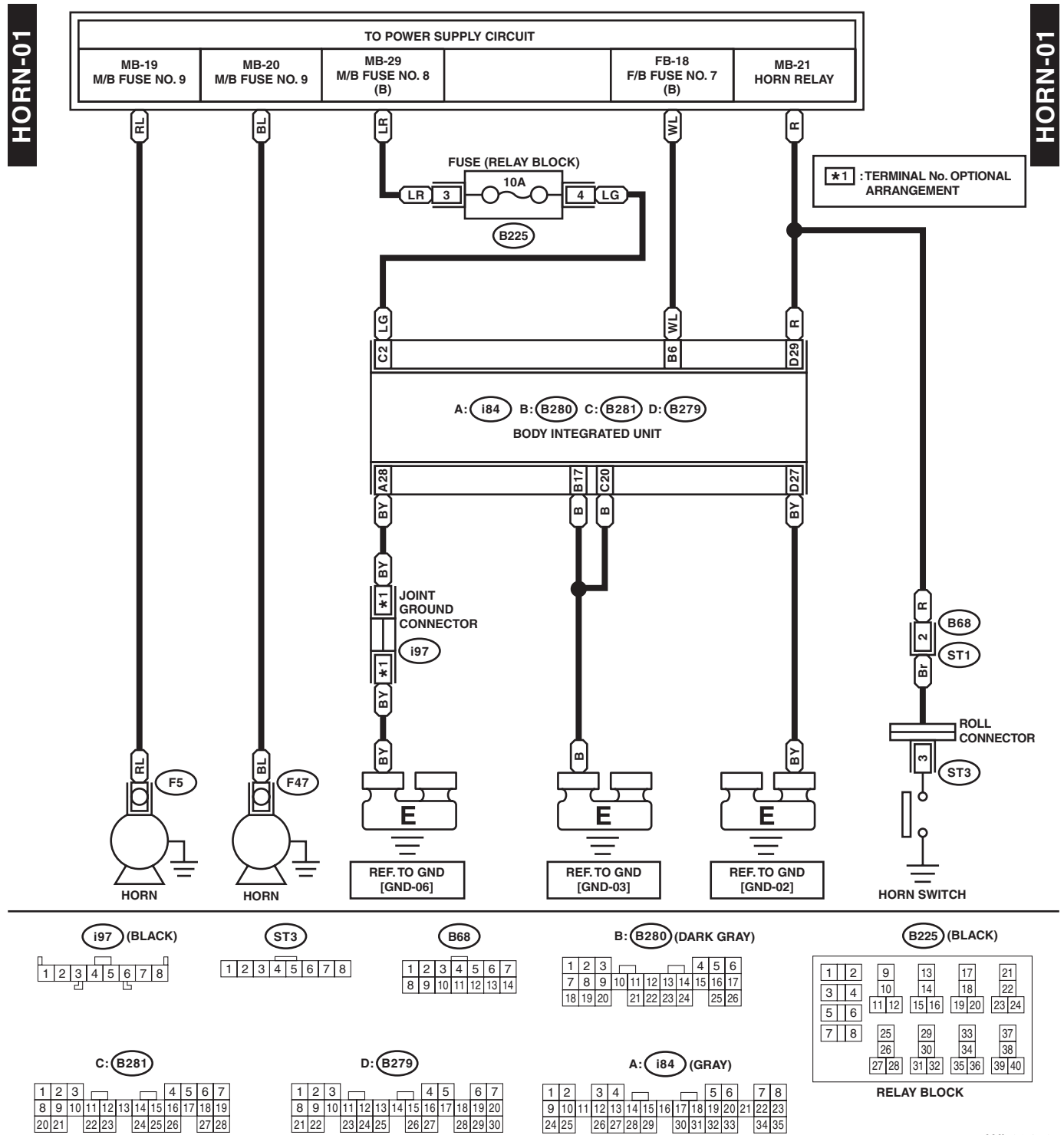

WI-30459

# Power Window System

WIRING SYSTEM

## 33. Power Window System

### A: WIRING DIAGRAM

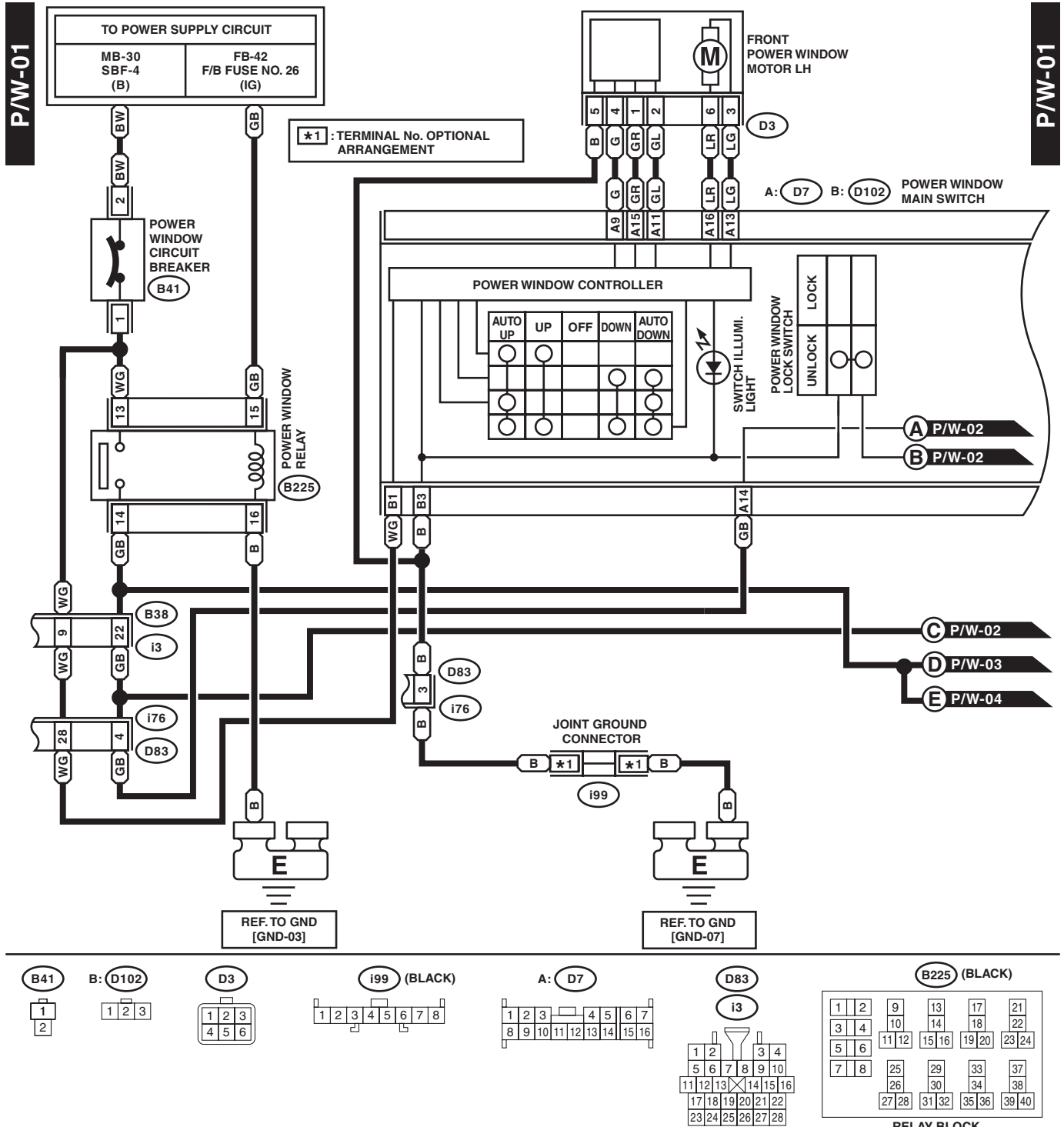

WI-30460

# Power Window System

WIRING SYSTEM

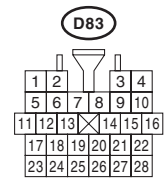
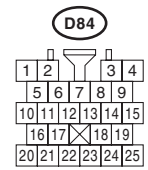
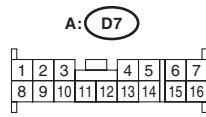
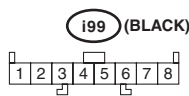
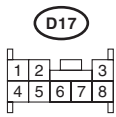
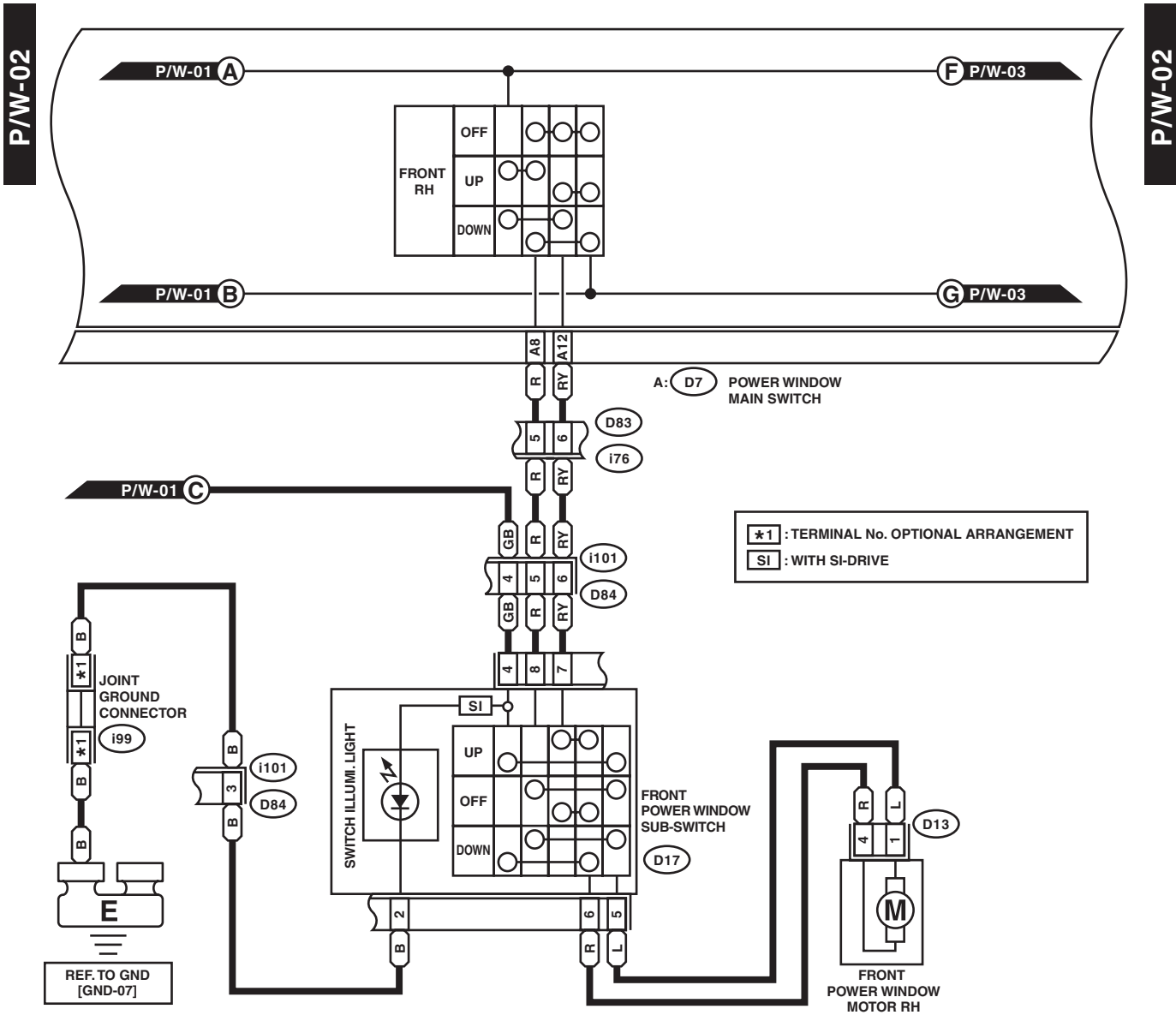

WI-30461

# Power Window System

## WIRING SYSTEM

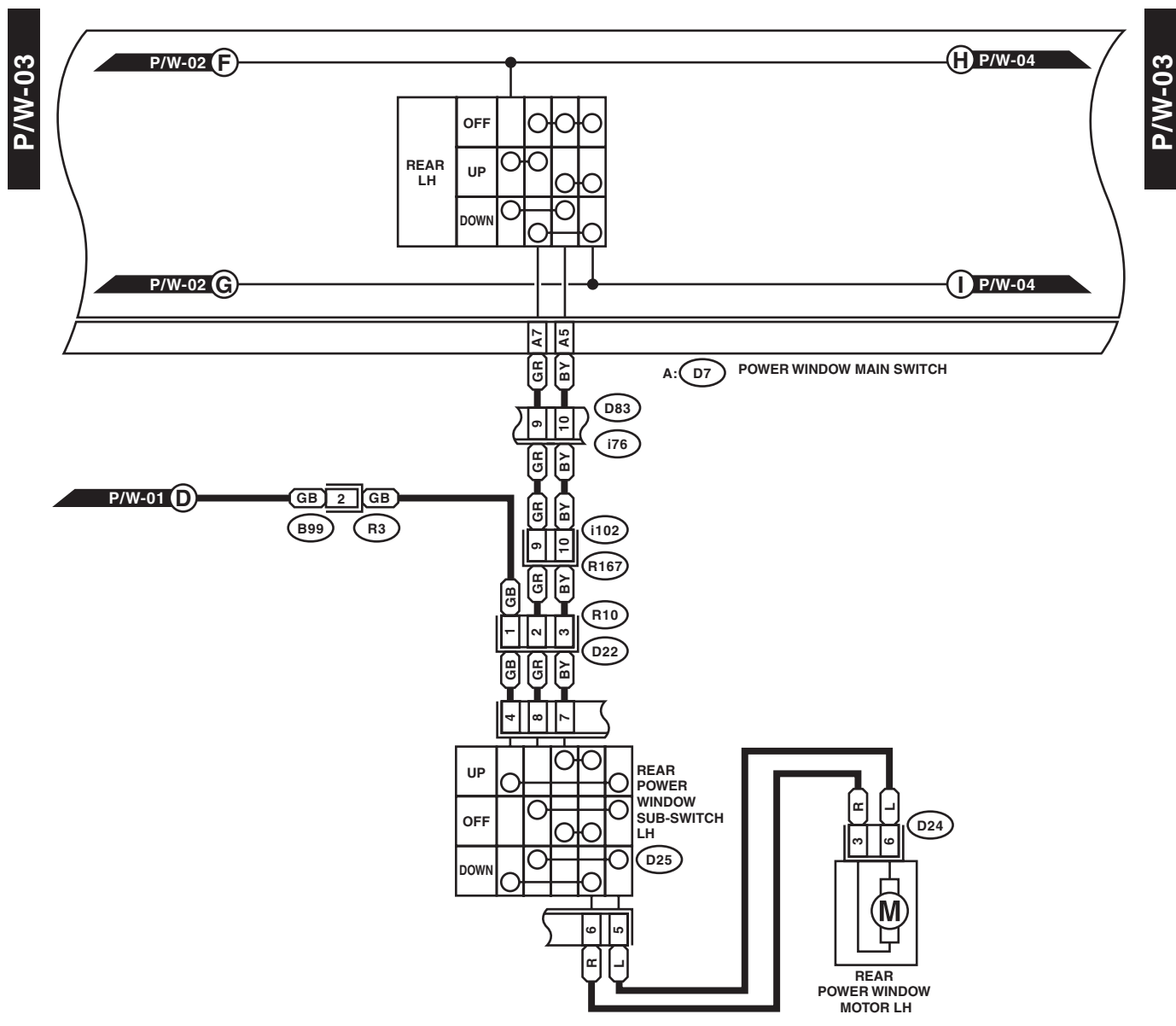

D24

1	2	3
4	5	6

D25

1	2	3
4	5	6
7	8	

R10

1	2	3
4	5	6
7	8	

B99

1	2	3	4	5
6	7	8	9	10
11	12			

A: D7

1	2	3	4	5	6	7
8	9	10	11	12	13	14
15	16					

i102

1	2	3	4	5	6	7
8	9	10	11	12	13	14
15	16					

D83

1	2	3	4
5	6	7	8
9	10	11	12
13	14	15	16
17	18	19	20
21	22	23	24
25	26	27	28

WI-30543

# Power Window System

WIRING SYSTEM

P/W-04

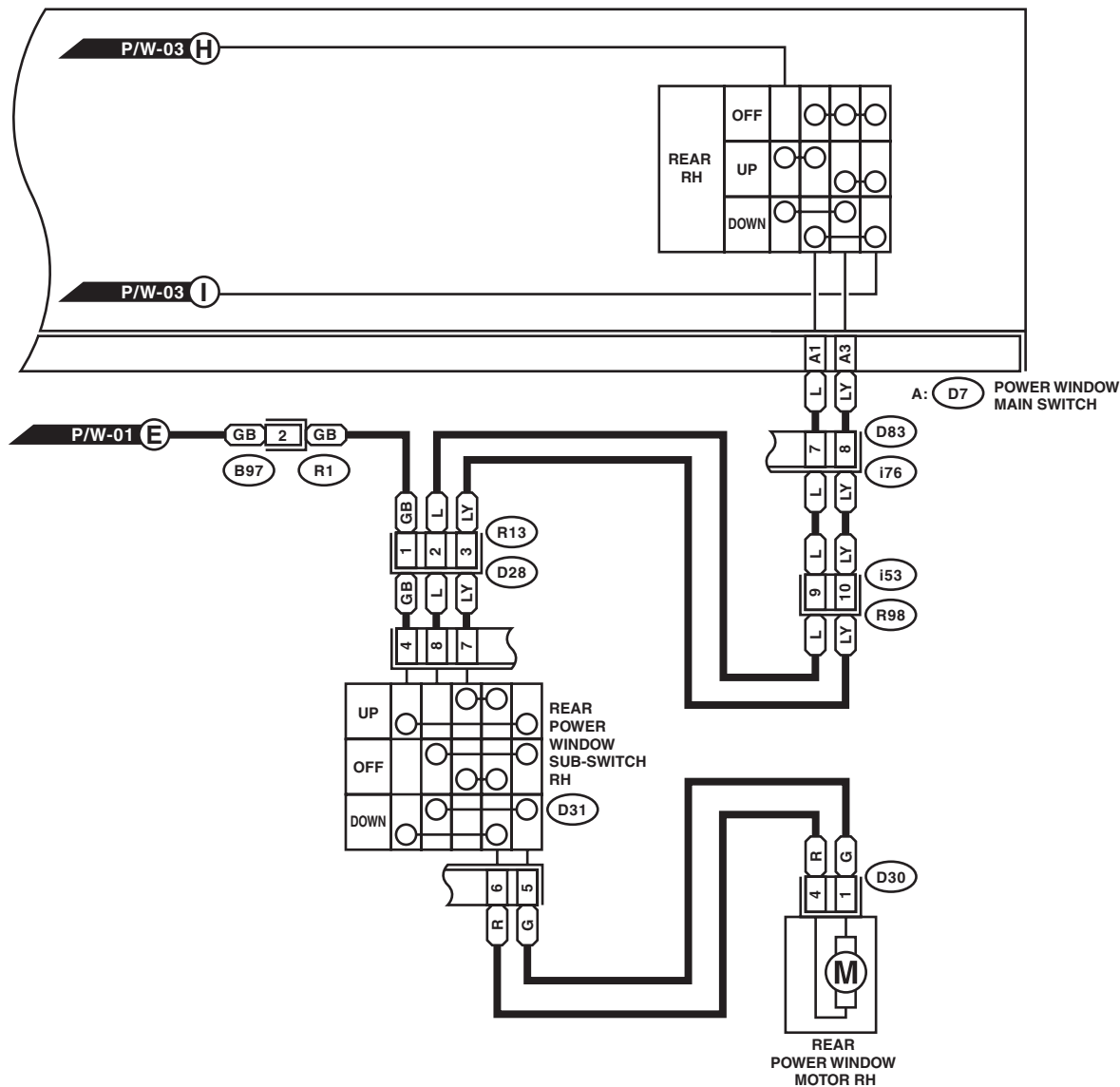

D30



D31

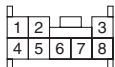

R13

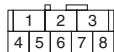

B97

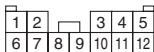

A: D7

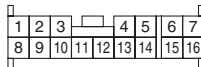

i53

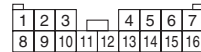

D83

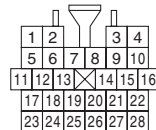

WI-30544

WI-133

Brought to you by Ebay Seller "SubaruManuals"

# Remote Control Mirror System

WIRING SYSTEM

## 34. Remote Control Mirror System

### A: WIRING DIAGRAM

R/M-01

R/M-01

OH : WITHOUT MIRROR HEATER  
 WH : WITH MIRROR HEATER  
 \*1 : TERMINAL No. OPTIONAL ARRANGEMENT

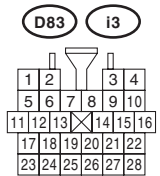
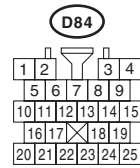
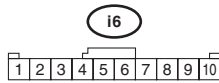
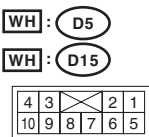
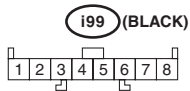
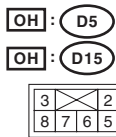
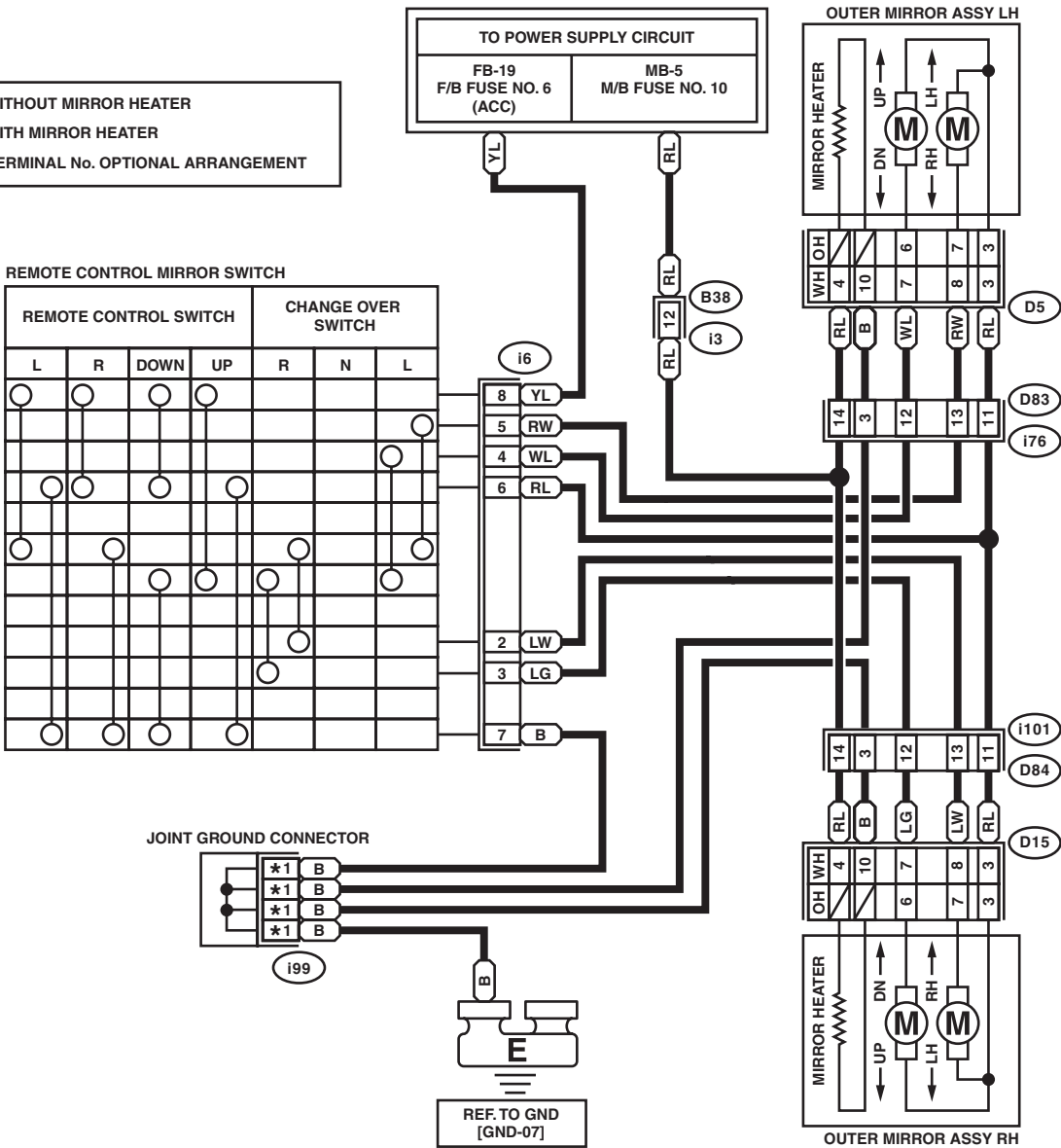

WI-30462

## 35.Rear Defogger System

### A: WIRING DIAGRAM

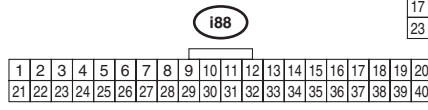
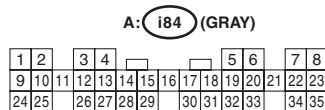
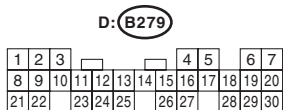
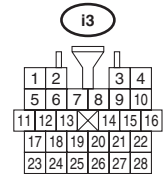
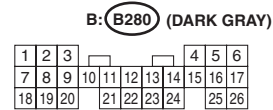
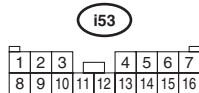
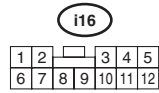
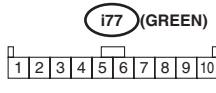
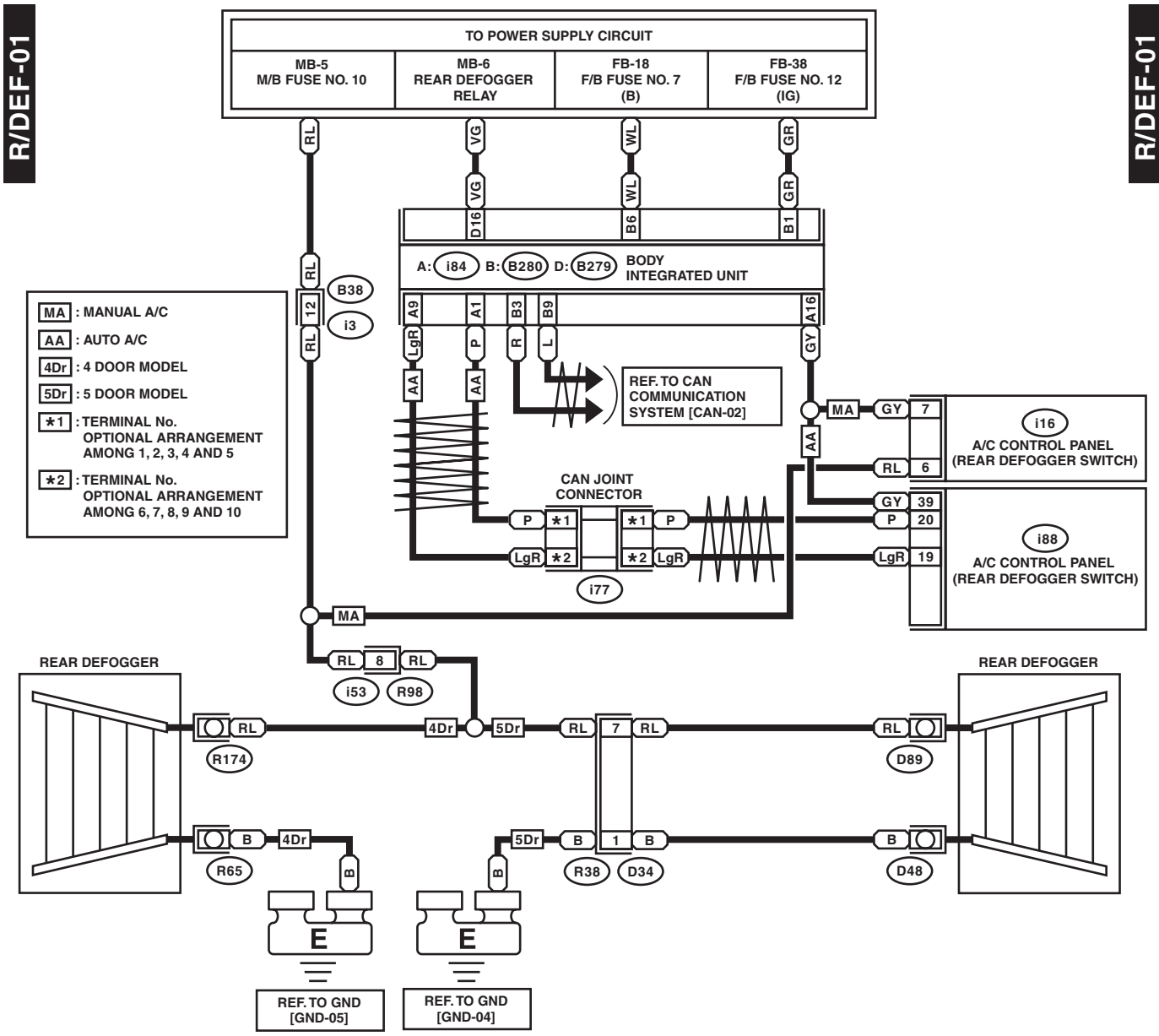

WI-30545

# Combination Meter System

WIRING SYSTEM

## 36. Combination Meter System

### A: WIRING DIAGRAM

#### 1. WITHOUT SI-DRIVE

C/M-01

C/M-01

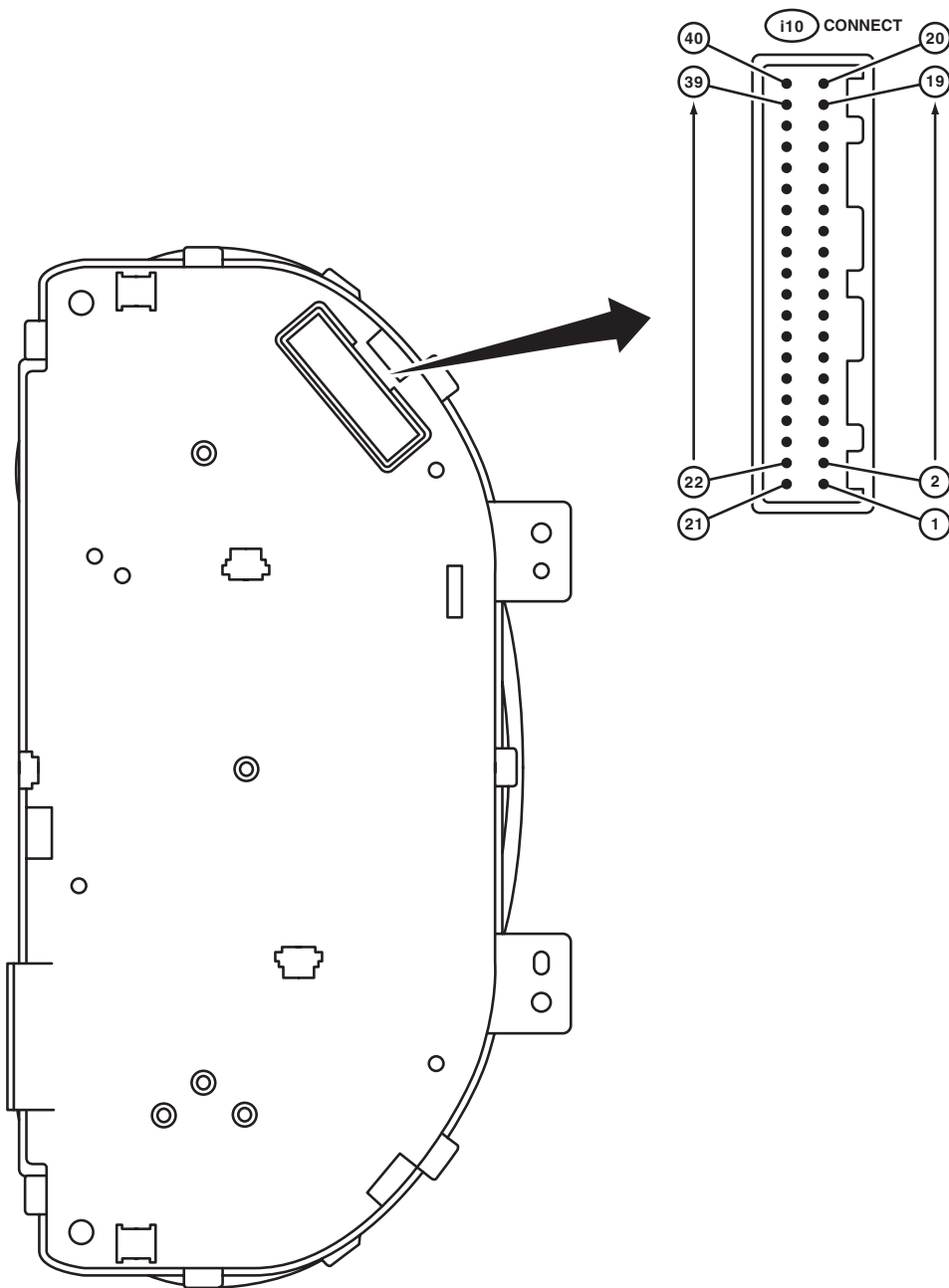

WI-30463

WI-136

Brought to you by Ebay Seller "SubaruManuals"



# Combination Meter System

WIRING SYSTEM

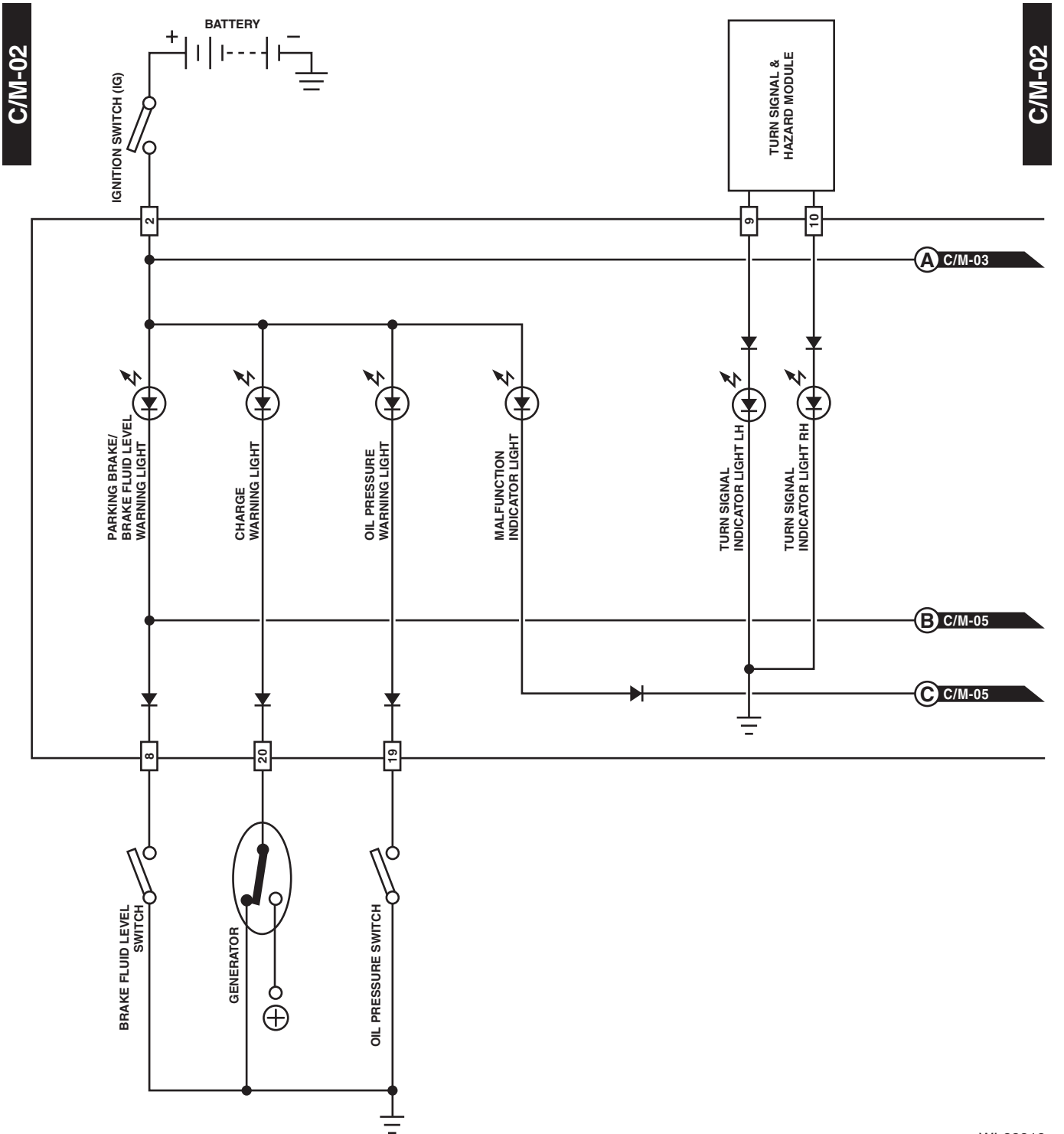

C/M-02

C/M-02

WI-33818

# Combination Meter System

WIRING SYSTEM

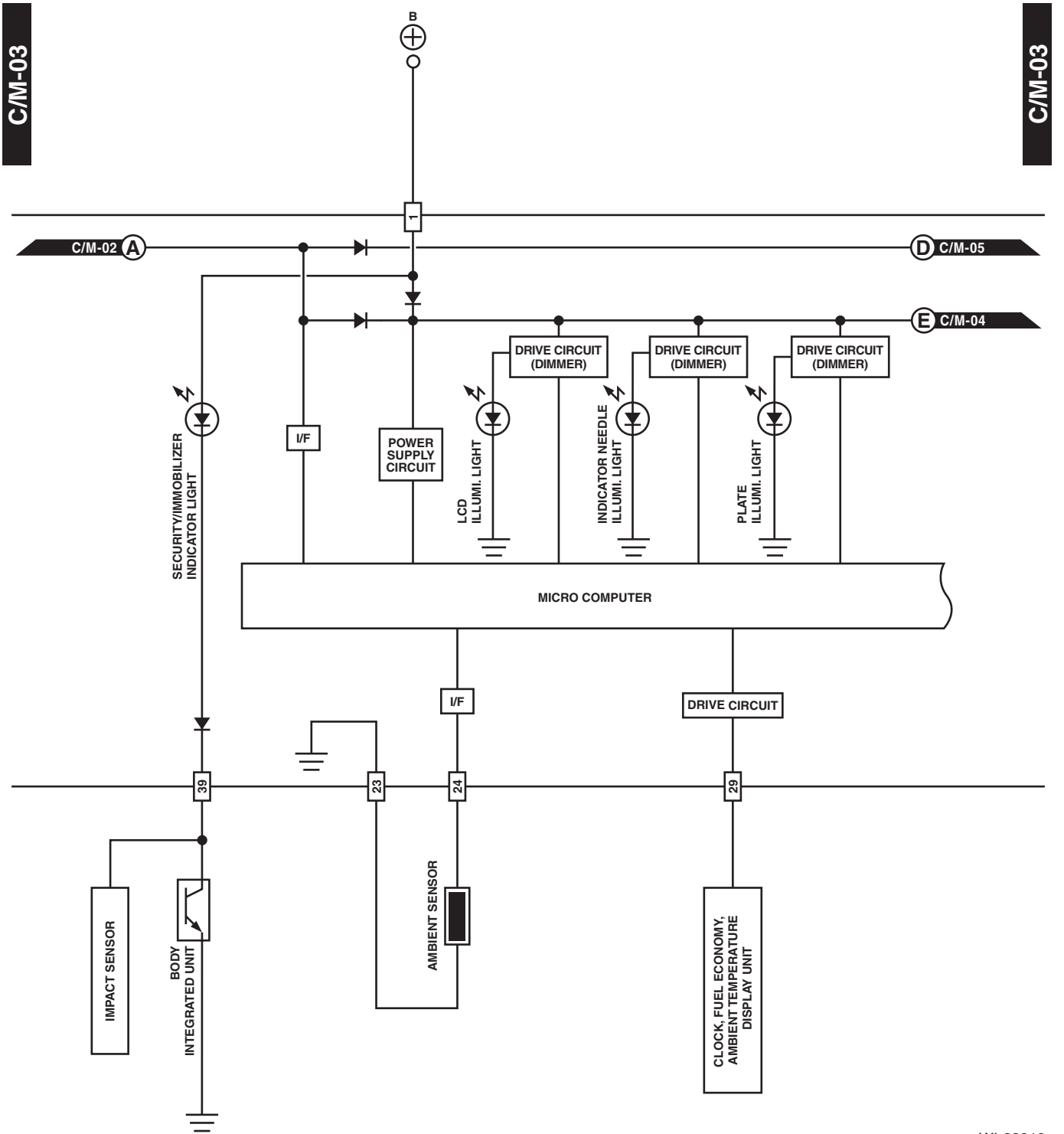

WI-33819

# Combination Meter System

WIRING SYSTEM

C/M-04

C/M-04

ON	: WITHOUT NAVIGATION
WN	: WITH NAVIGATION
*1 : SEAT BELT KEY WARNING HEADLIGHT ON WARNING CUSTOMIZED	

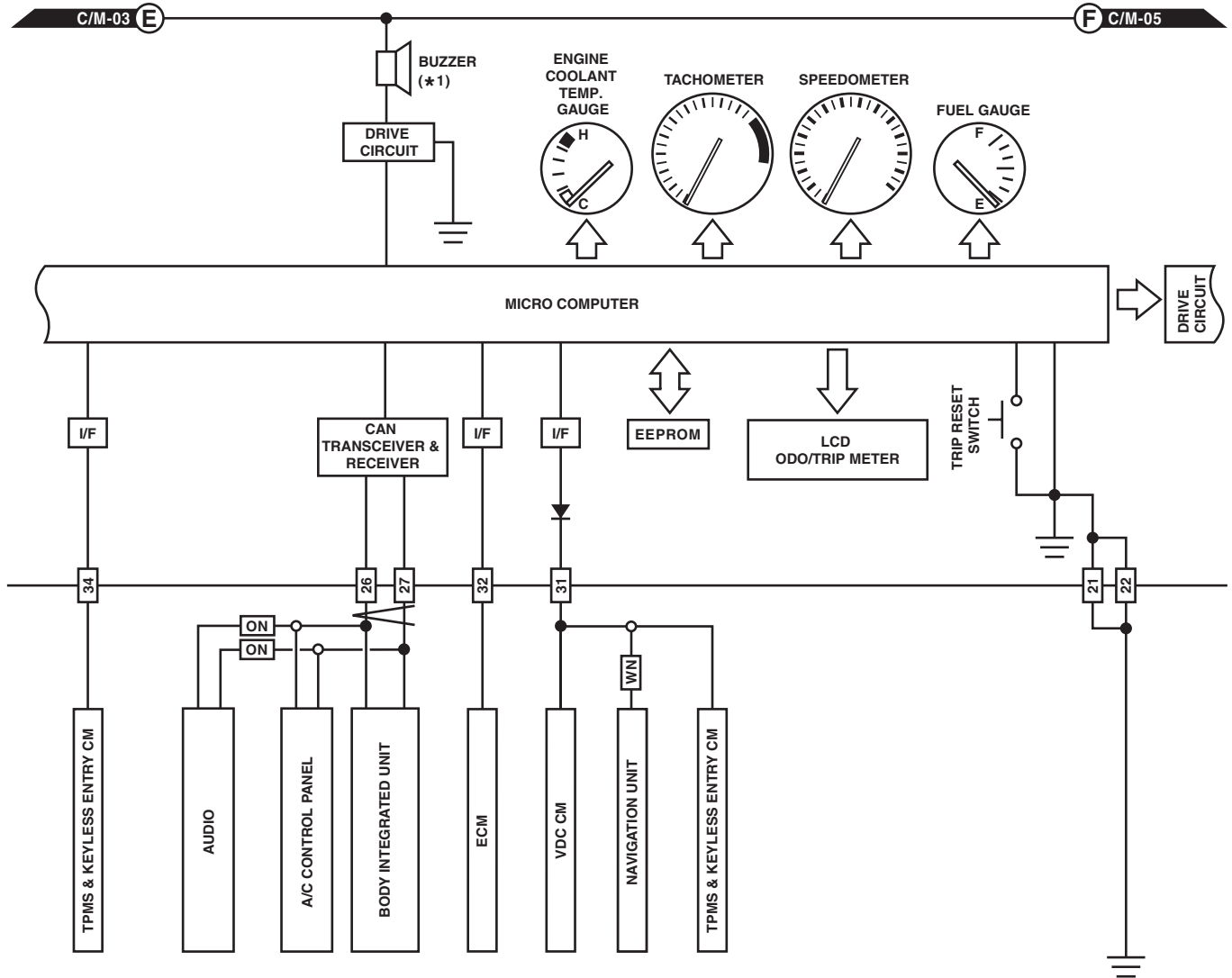

WI-33820

# Combination Meter System

## WIRING SYSTEM

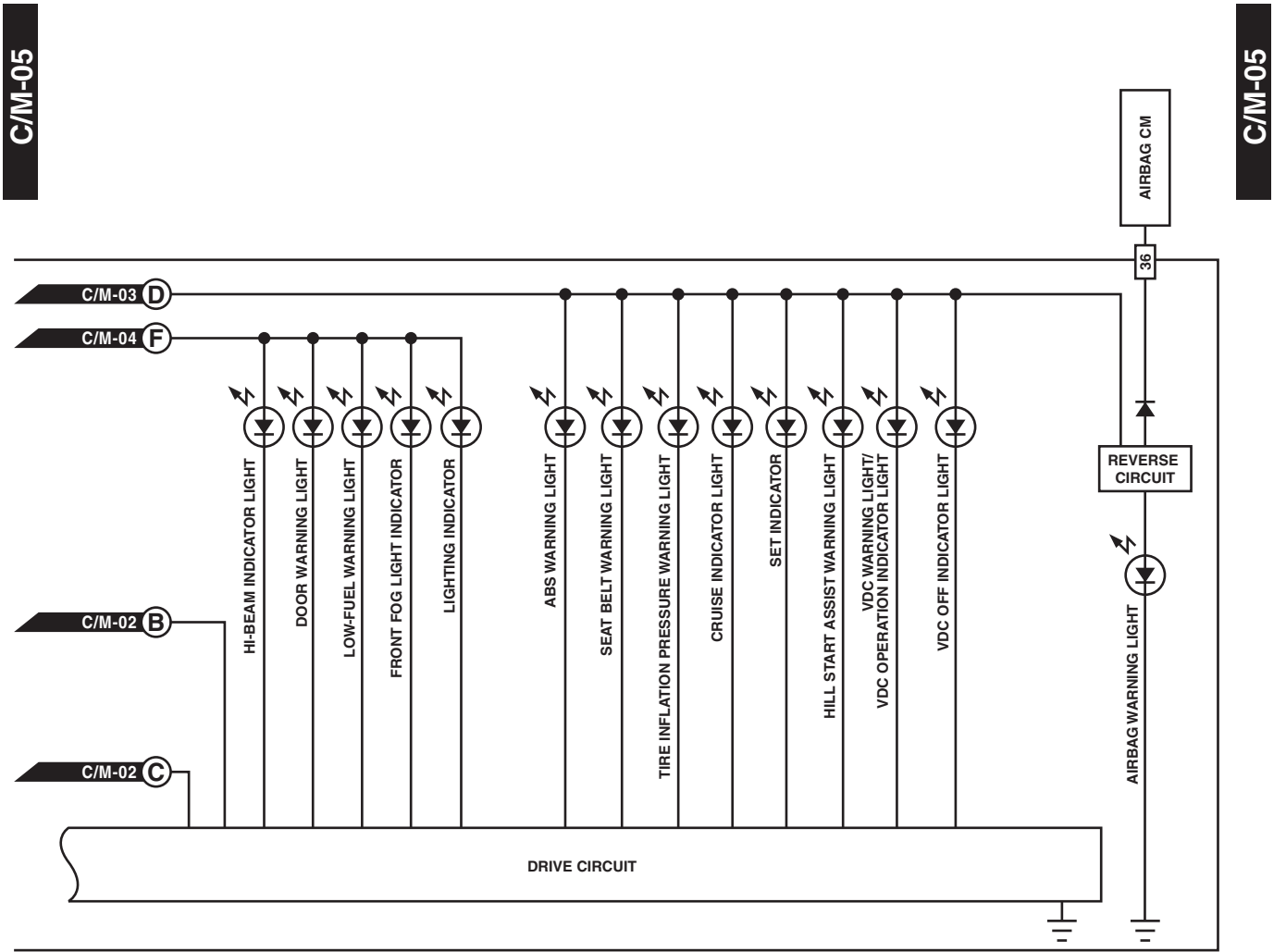

WI-33821

WI-140

Brought to you by Ebay Seller "SubaruManuals"

## 2. WITH SI-DRIVE

C/M(S)-01

C/M(S)-01

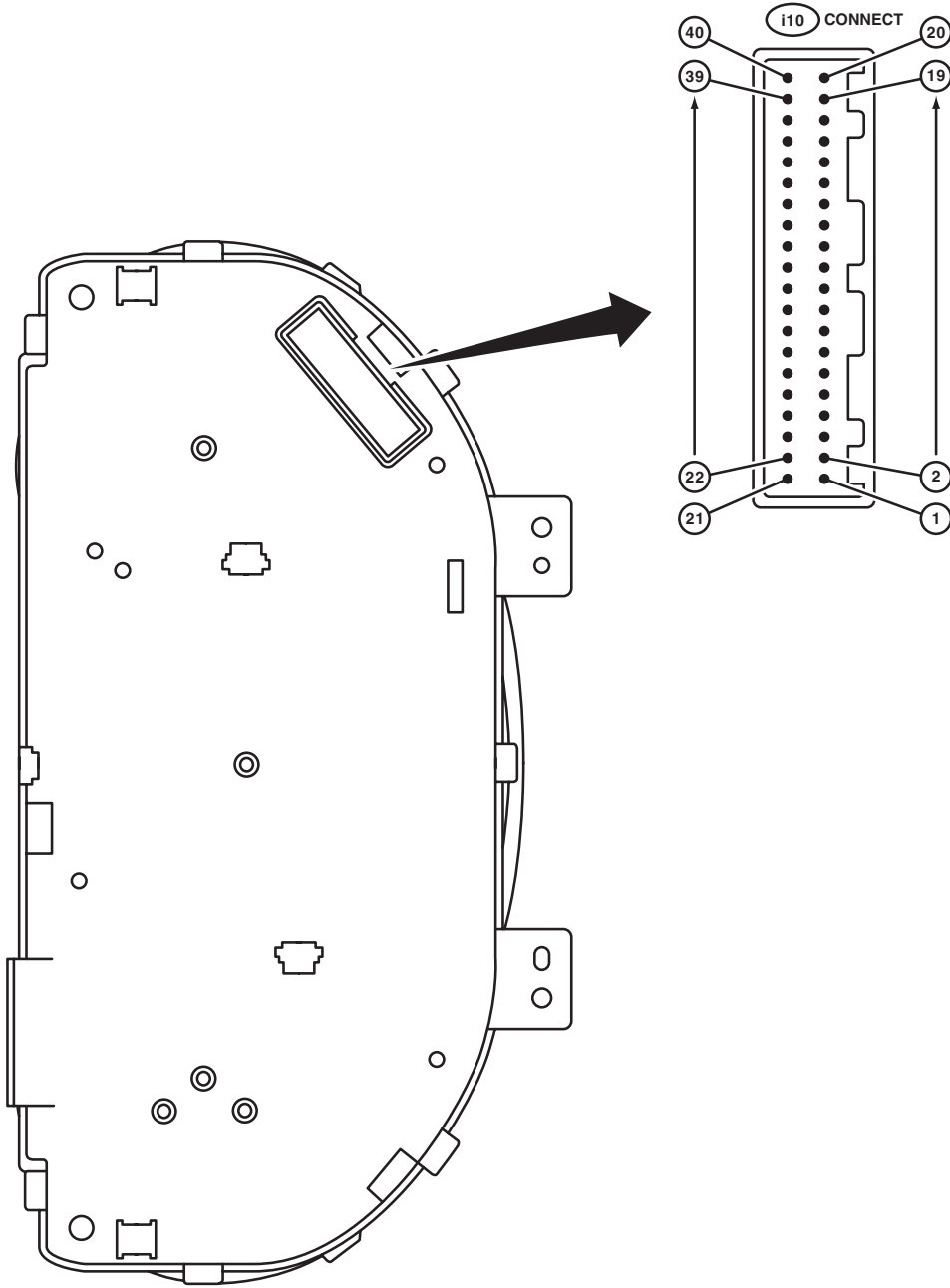

WI-30468

WI-141

Brought to you by Ebay Seller "SubaruManuals"

# Combination Meter System

WIRING SYSTEM

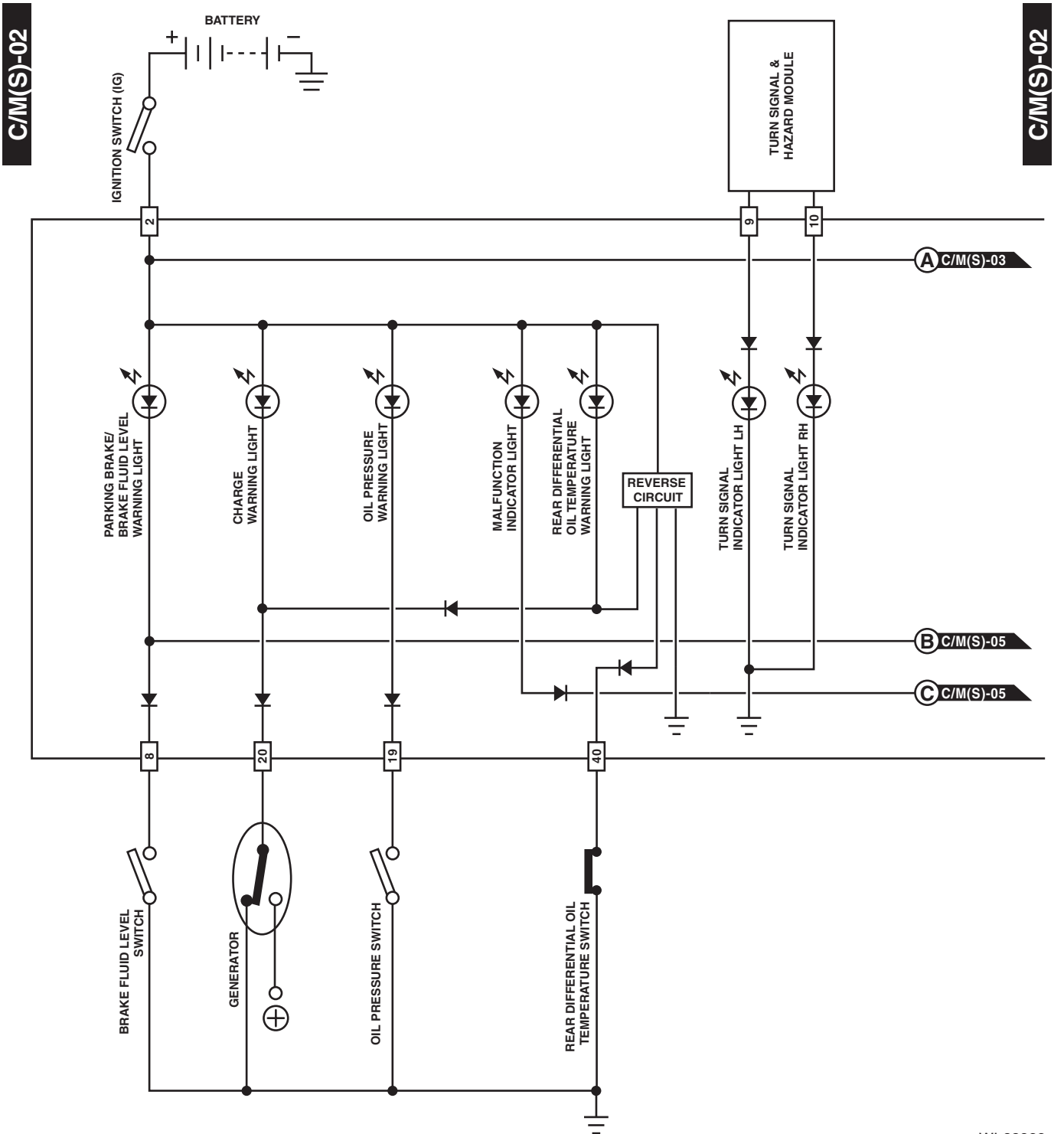

WI-33822

WI-142

Brought to you by Ebay Seller "SubaruManuals"

# Combination Meter System

WIRING SYSTEM

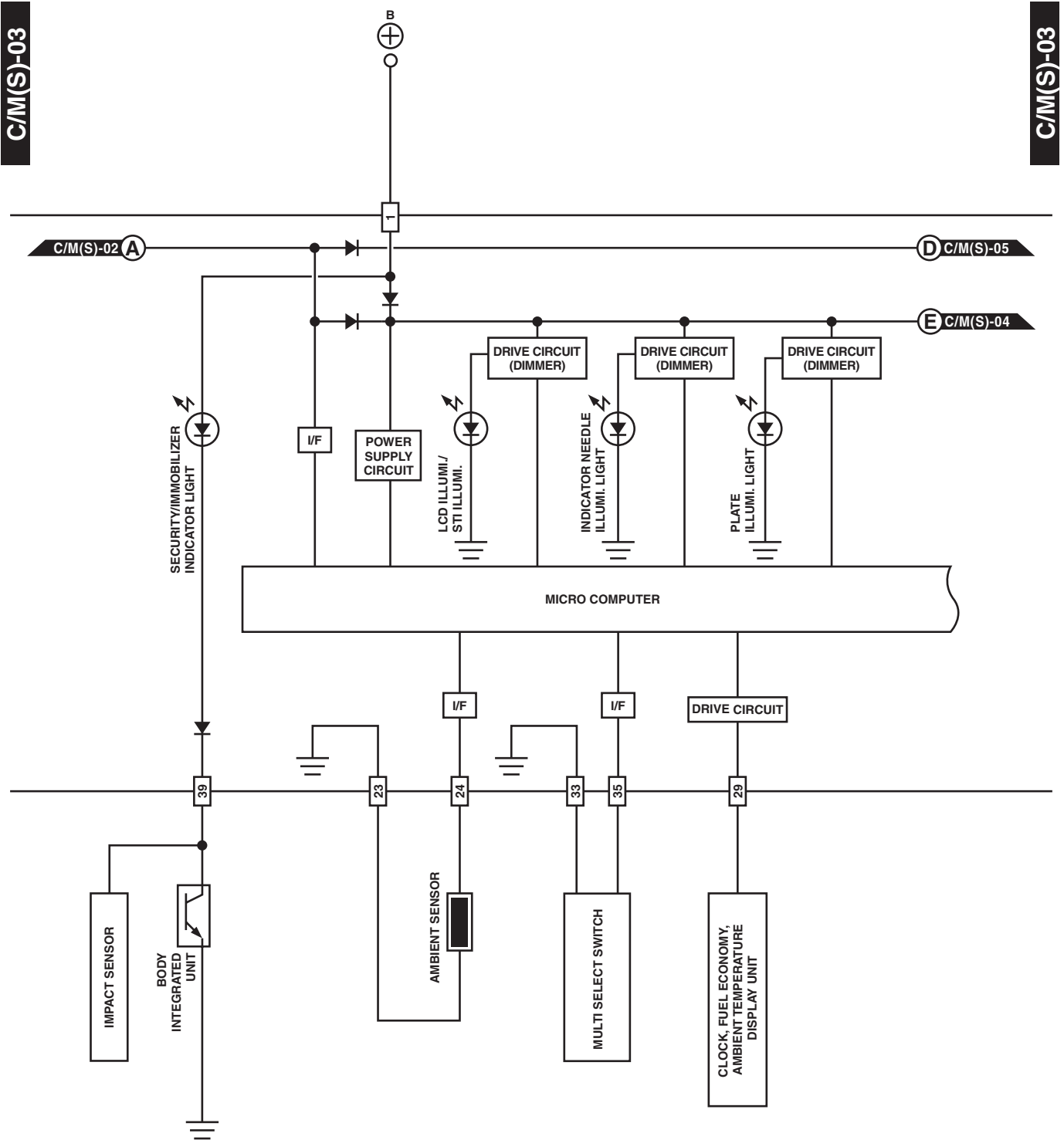

WI-33823

WI-143

Brought to you by Ebay Seller "SubaruManuals"

# Combination Meter System

WIRING SYSTEM

C/M(S)-04

C/M(S)-04

**ON** : WITHOUT NAVIGATION  
**WN** : WITH NAVIGATION  
 \*1 : SEAT BELT  
 KEY WARNING  
 HEADLIGHT ON WARNING  
 DCCD  
 REV.  
 CUSTOMIZED  
 SI-DRIVE

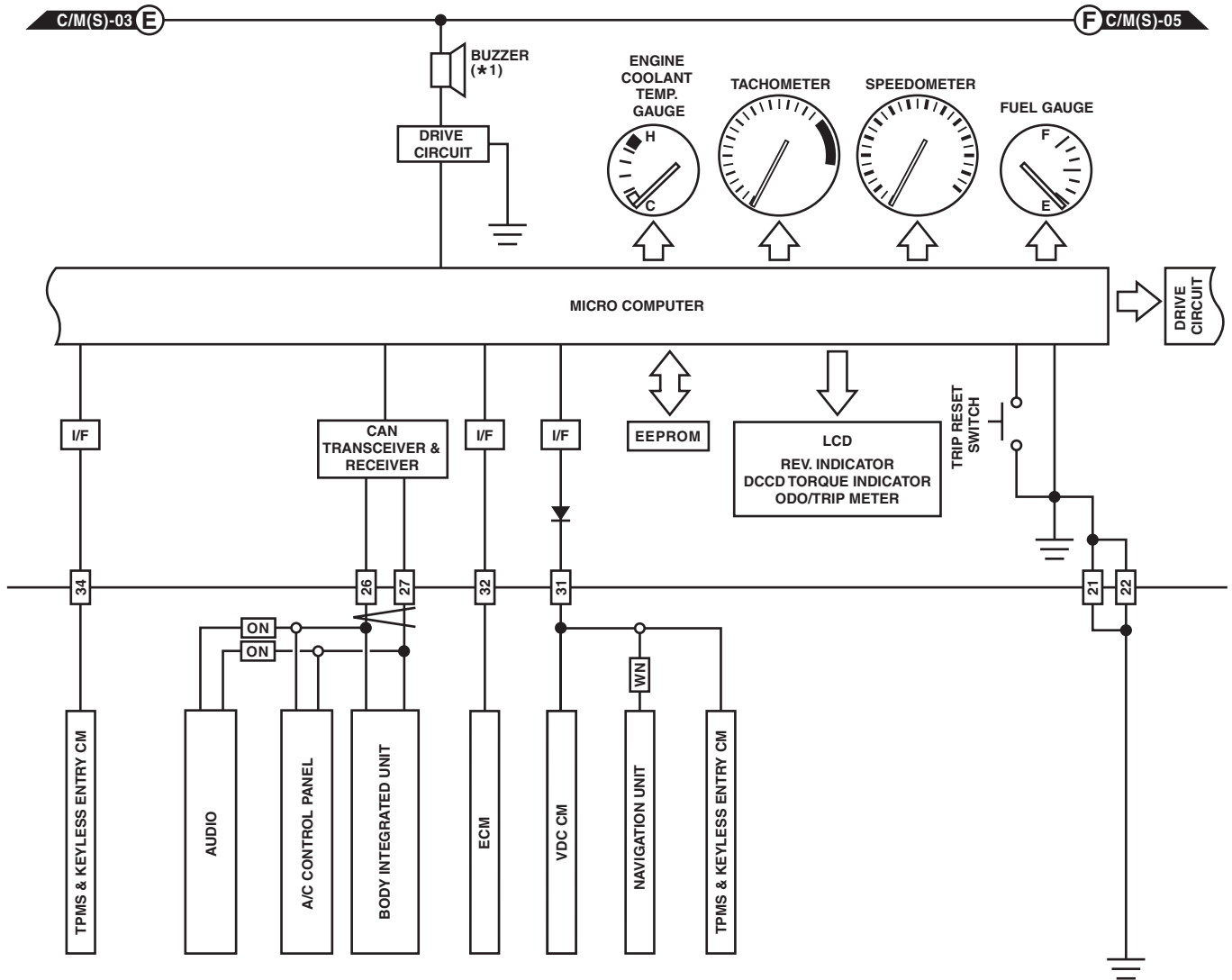

WI-33824



# Combination Meter System

WIRING SYSTEM

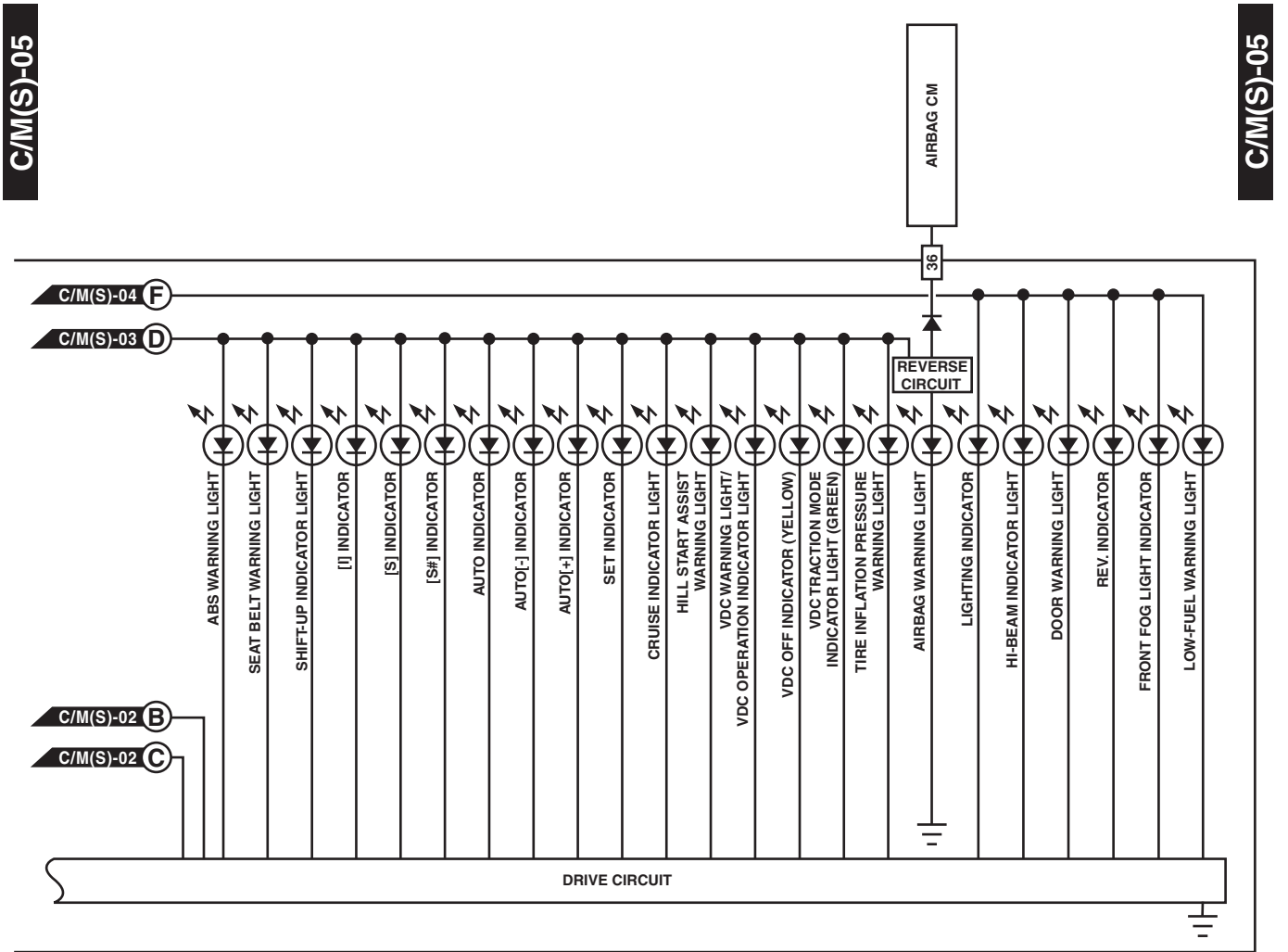

WI-33825

WI-145

Brought to you by Ebay Seller "SubaruManuals"

# Speedometer System

WIRING SYSTEM

## 37.Speedometer System

### A: WIRING DIAGRAM

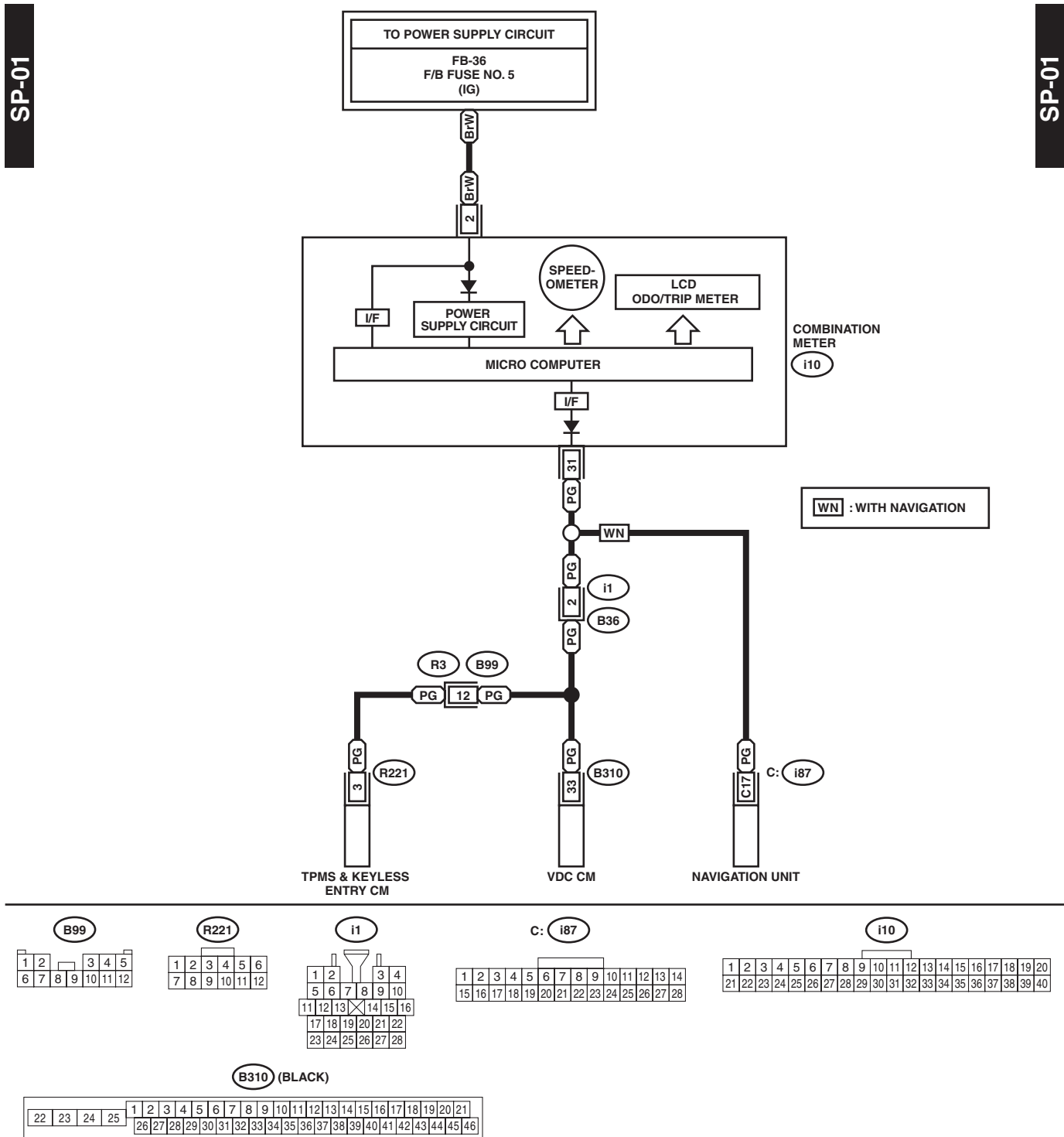

WI-33878

## 38.Clock System

### A: WIRING DIAGRAM

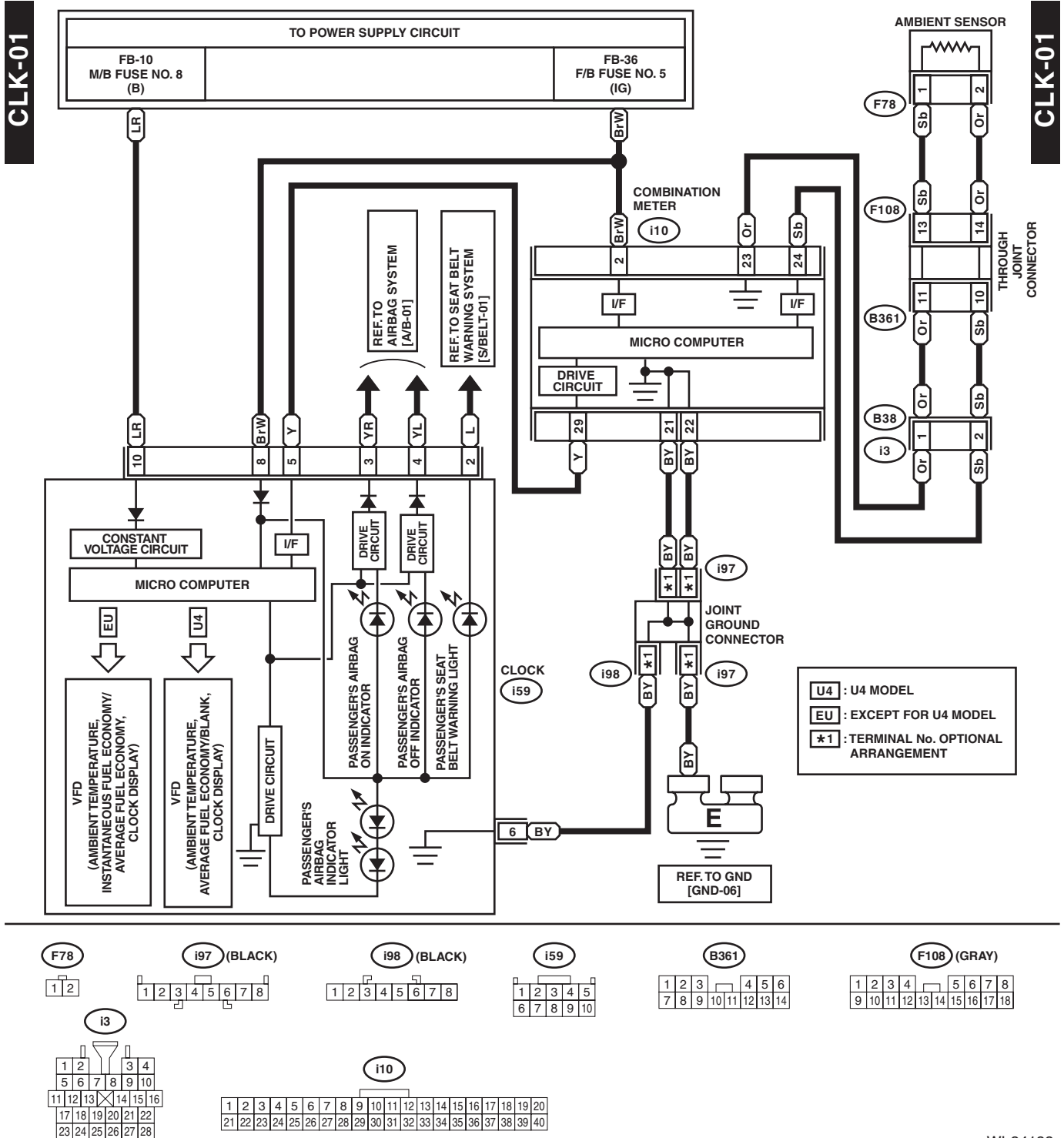

WI-34133

# Fuel Gauge System

WIRING SYSTEM

## 39. Fuel Gauge System

### A: WIRING DIAGRAM

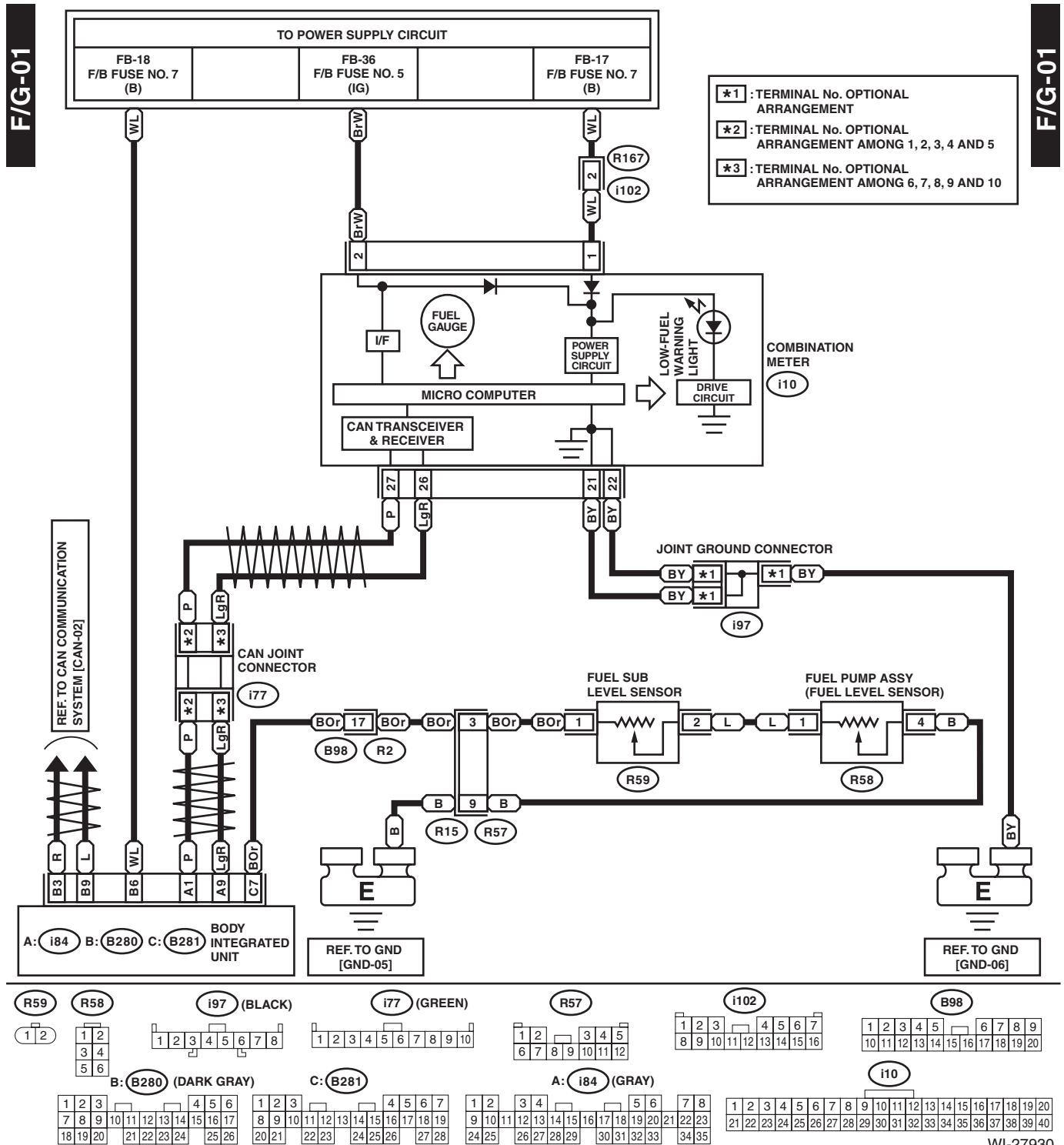

WI-27930

## 40. Coolant Temperature System

### A: WIRING DIAGRAM

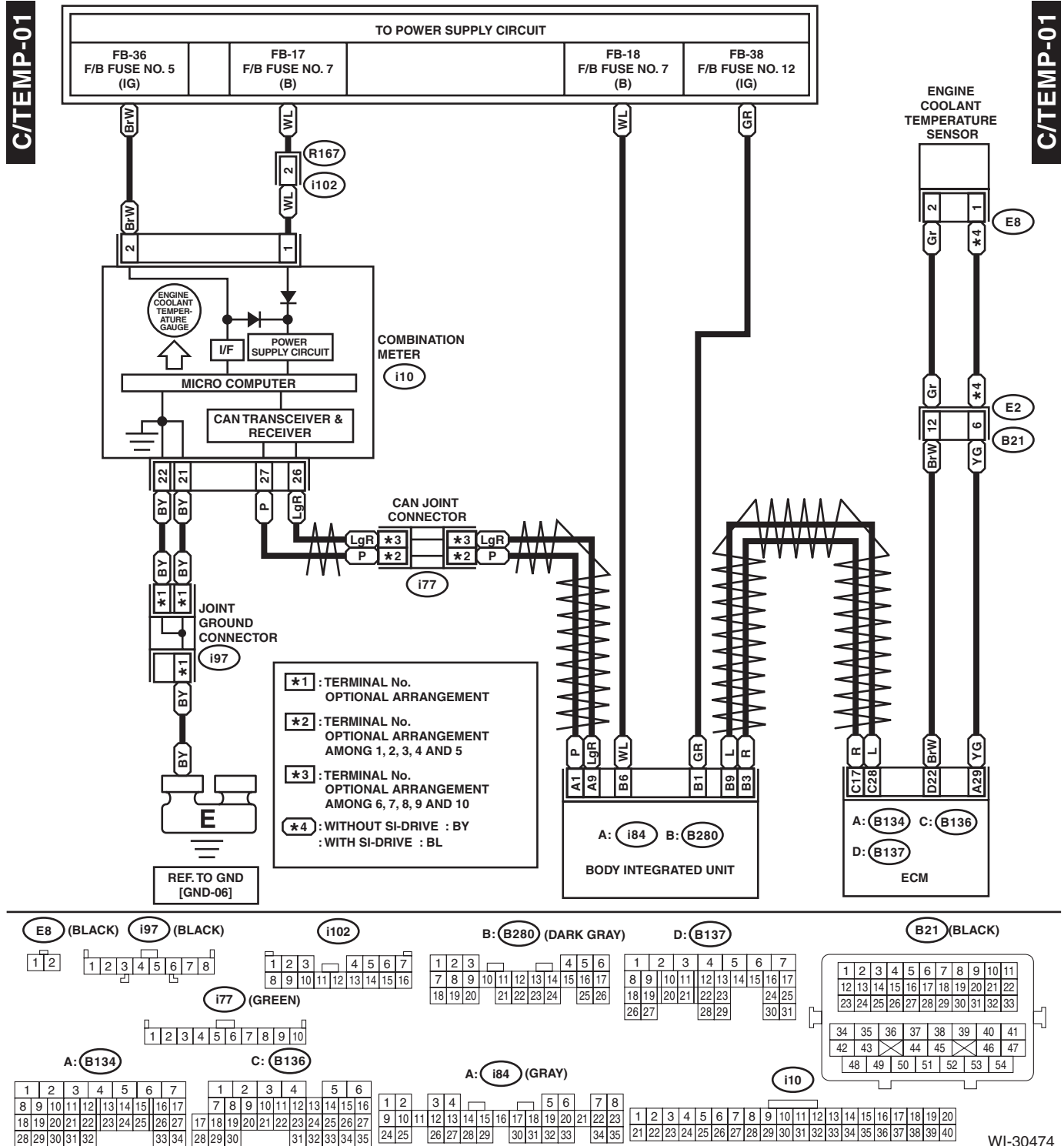

# Oil Pressure Warning Light System

WIRING SYSTEM

## 41.Oil Pressure Warning Light System

### A: WIRING DIAGRAM

OIL/P-01

OIL/P-01

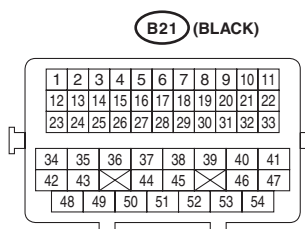
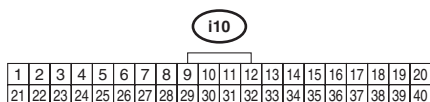
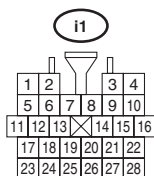
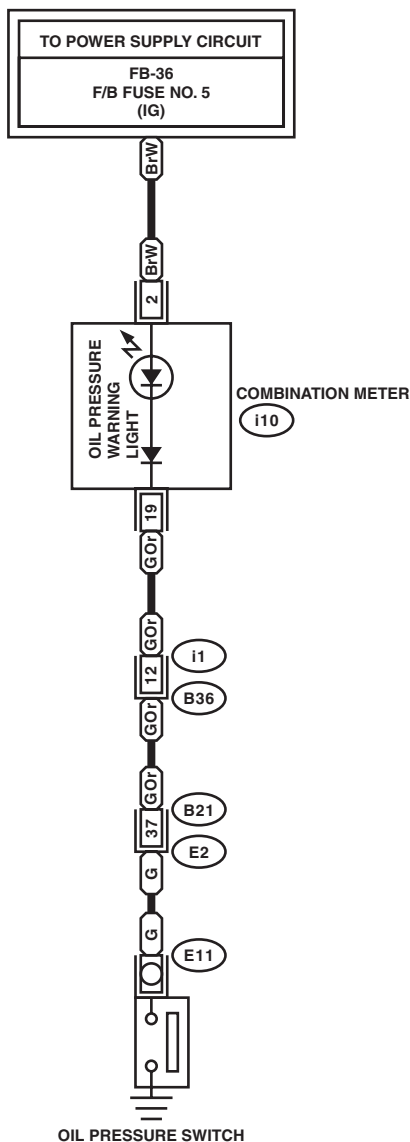

WI-30475

WI-150

Brought to you by Ebay Seller "SubaruManuals"

# Parking Brake / Brake Fluid Level Warning Light System

WIRING SYSTEM

## 42. Parking Brake / Brake Fluid Level Warning Light System

### A: WIRING DIAGRAM

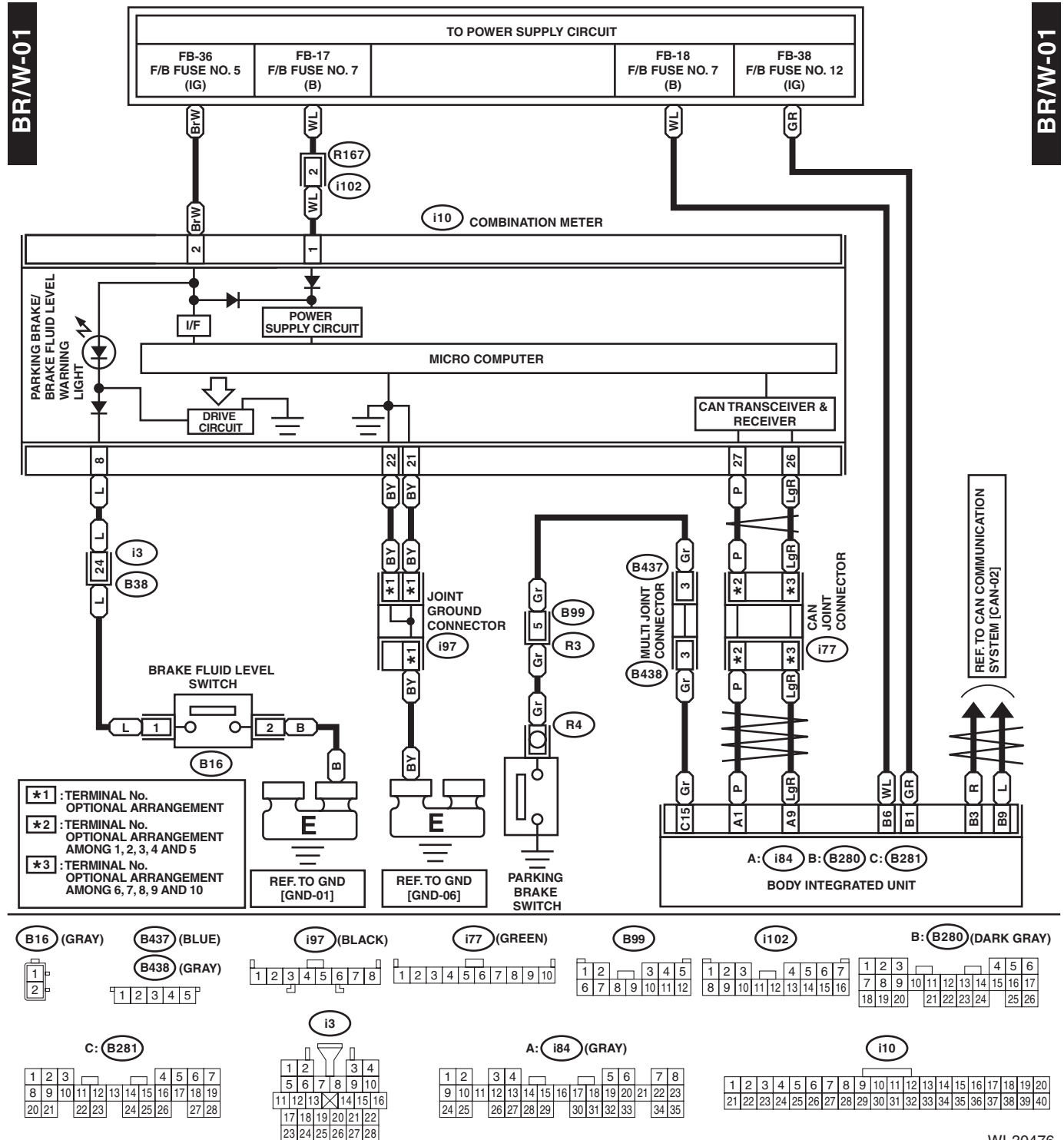

WI-30476

# Rear Differential Oil Temperature Warning Light System

WIRING SYSTEM

## 43.Rear Differential Oil Temperature Warning Light System

### A: WIRING DIAGRAM

D/TEMP-01

D/TEMP-01

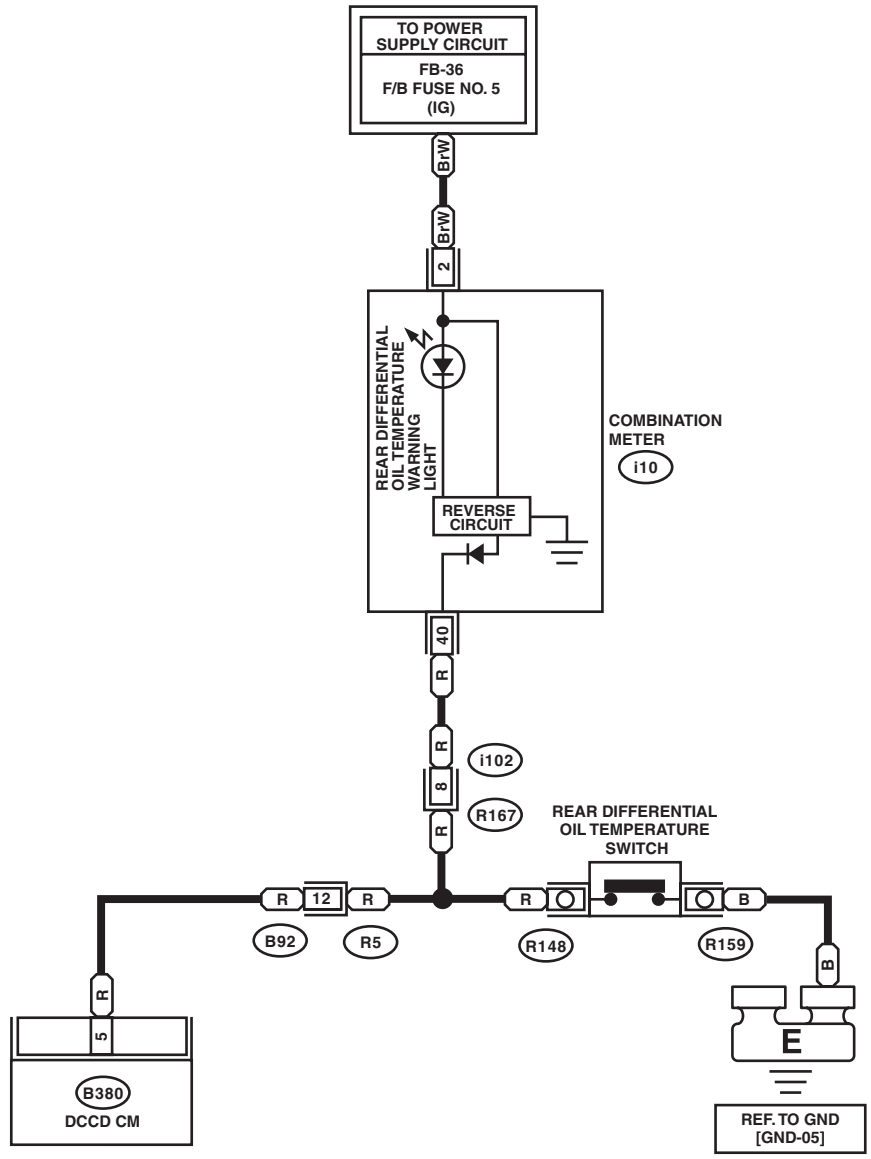

(i102)

1	2	3	4	5	6	7		
8	9	10	11	12	13	14	15	16

(B92)

1	2	3	4	5	6	7	8	9		
10	11	12	13	14	15	16	17	18	19	20

(B380)

1	2	3	4	5	6	7	8	9	10	11	12	13	14	15	16
17	18	19	20	21	22	23	24	25	26	27	28	29	30	31	32

(i10)

1	2	3	4	5	6	7	8	9	10	11	12	13	14	15	16	17	18	19	20
21	22	23	24	25	26	27	28	29	30	31	32	33	34	35	36	37	38	39	40

WI-31694



## 44.Sunroof Control System

### A: WIRING DIAGRAM

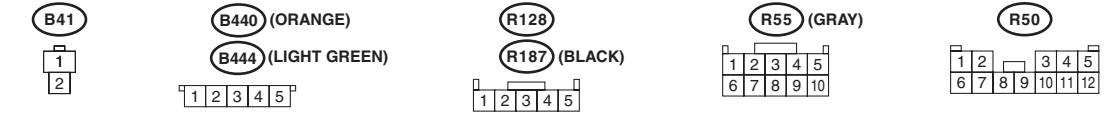
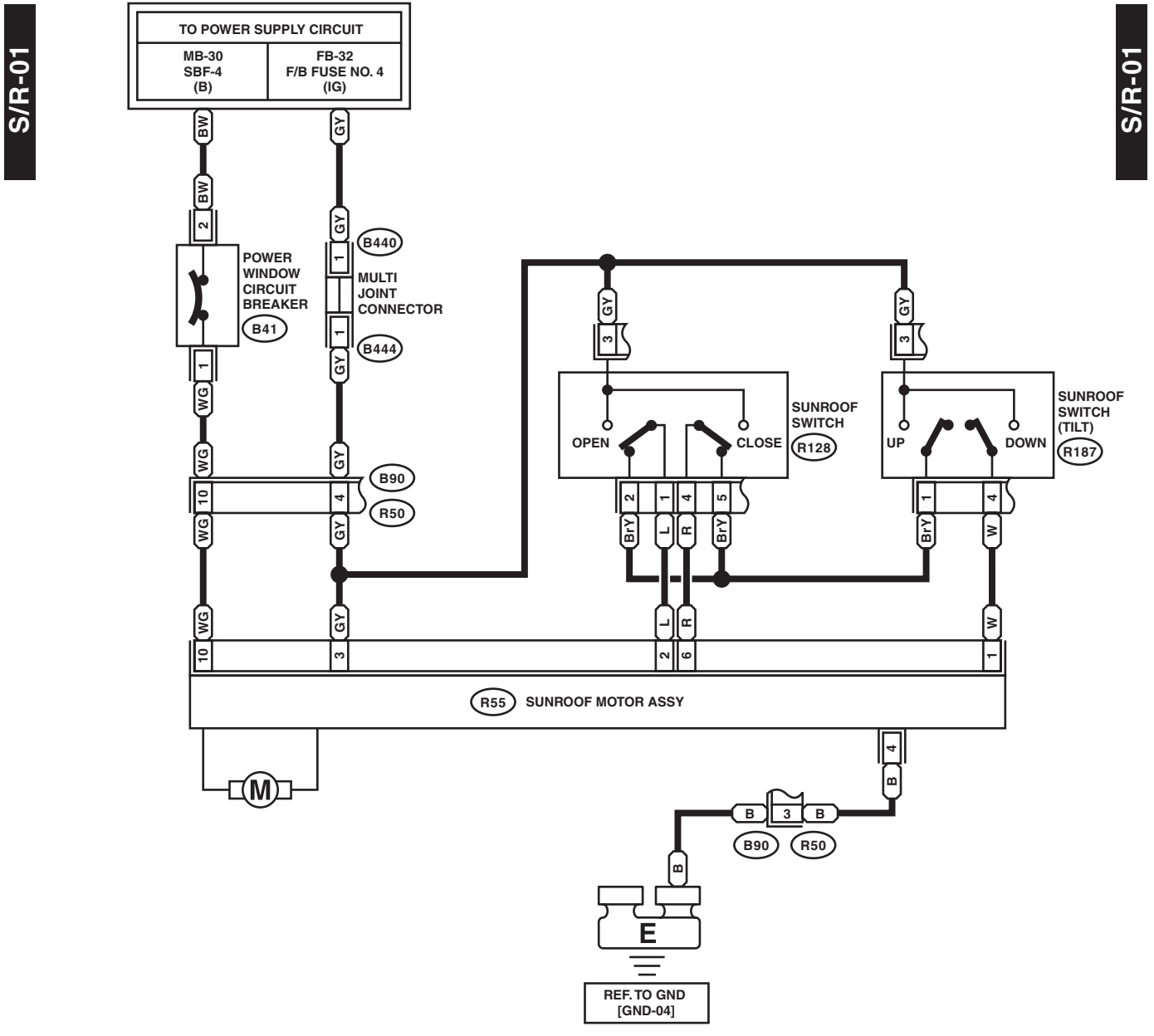

# Security System

WIRING SYSTEM

## 45. Security System

### A: WIRING DIAGRAM

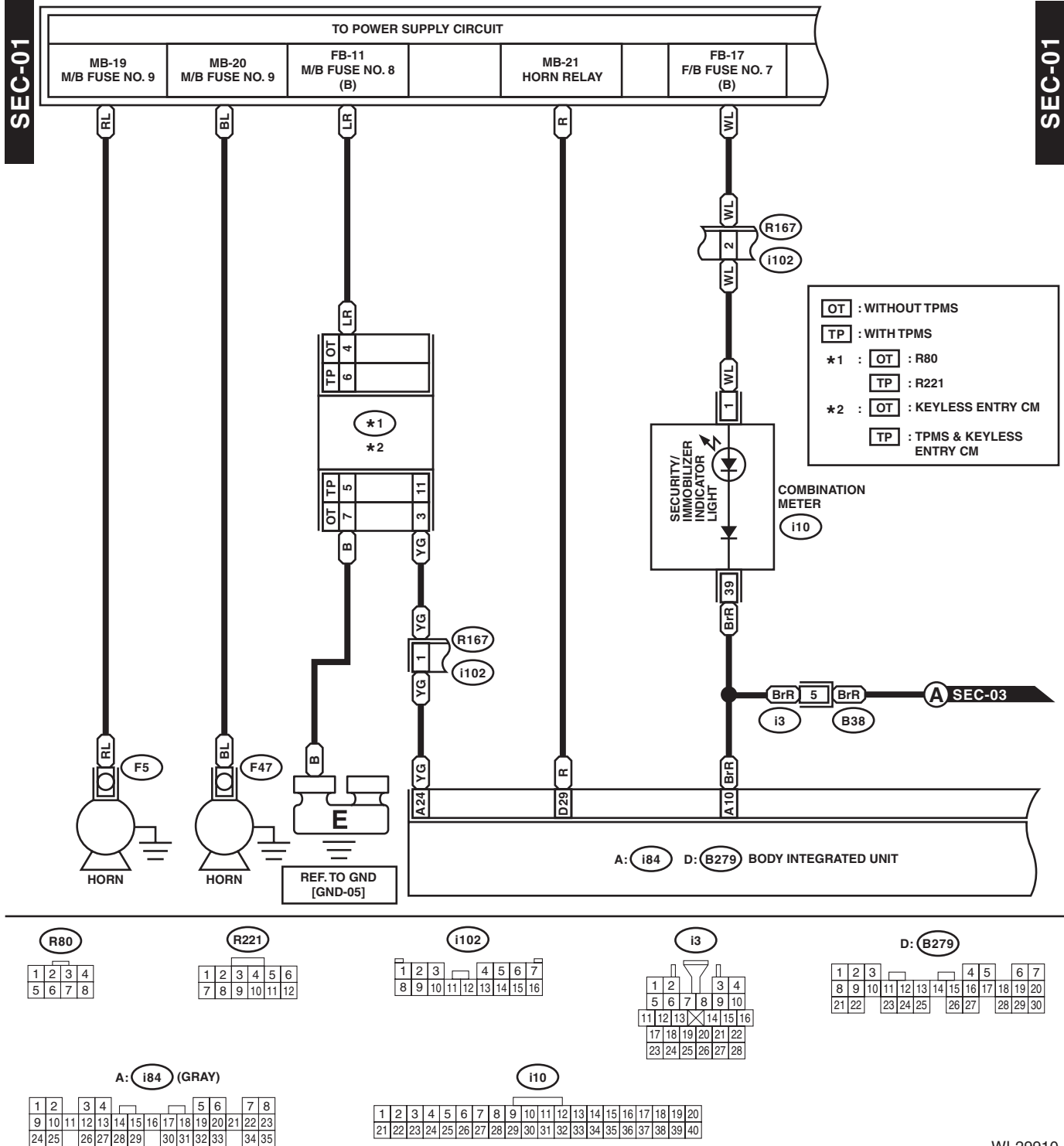

WI-29910

# Security System

## WIRING SYSTEM

SEC-02

SEC-02

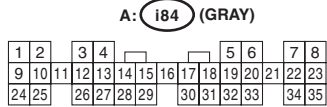
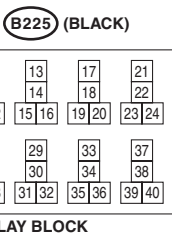
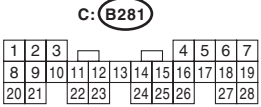
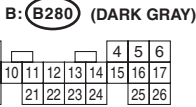
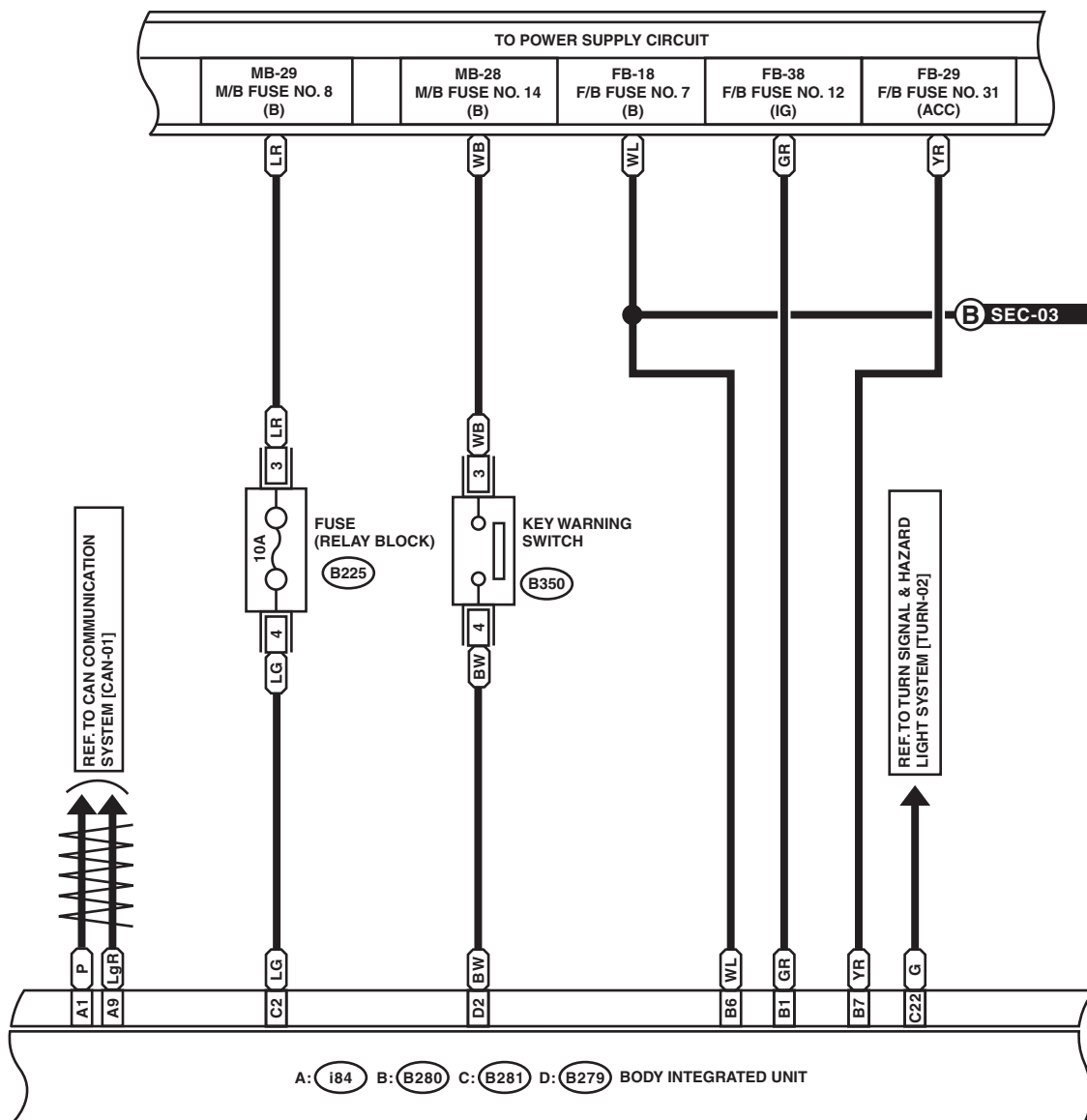

WI-27934

# Security System

## WIRING SYSTEM

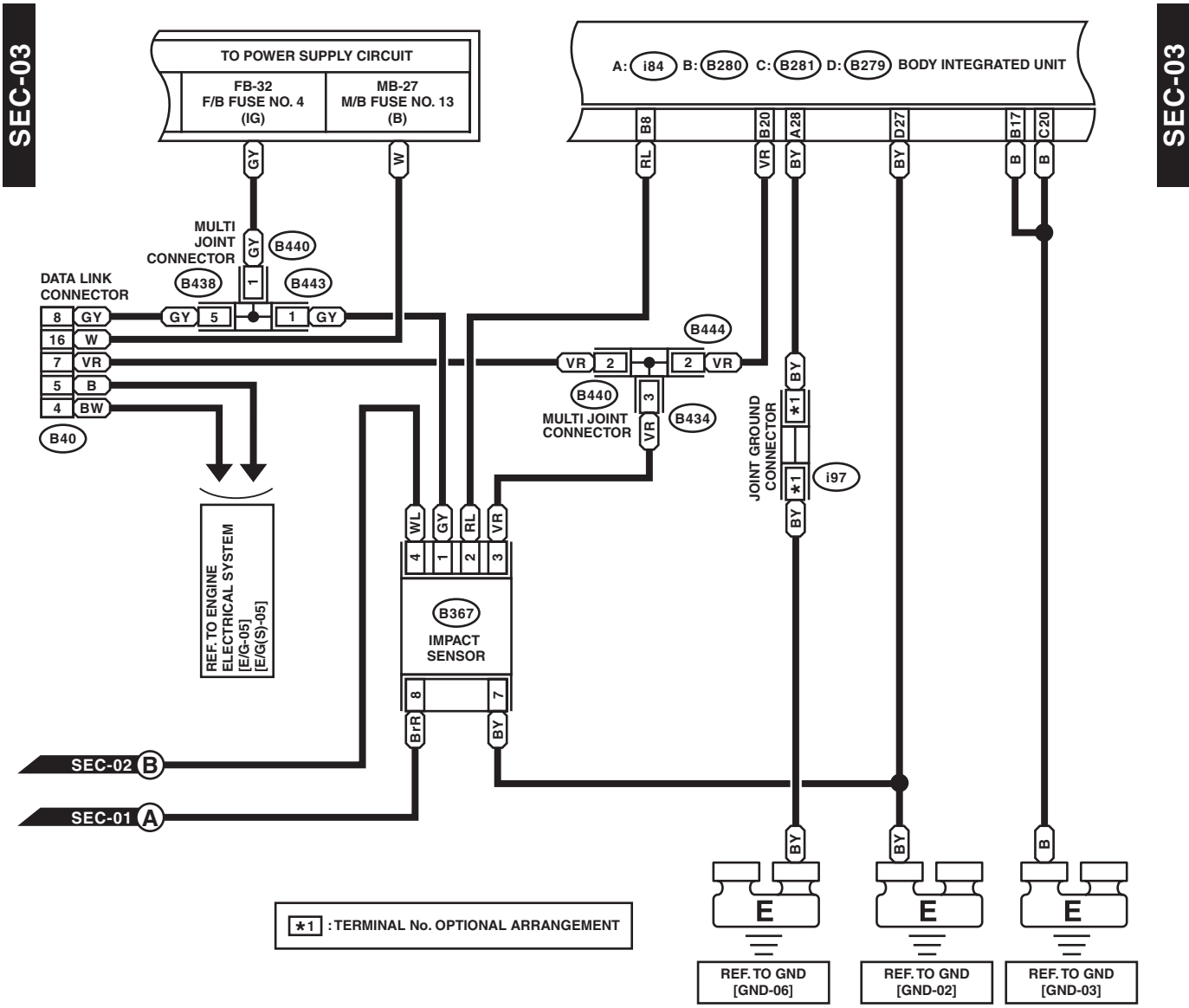

\*1 : TERMINAL No. OPTIONAL ARRANGEMENT

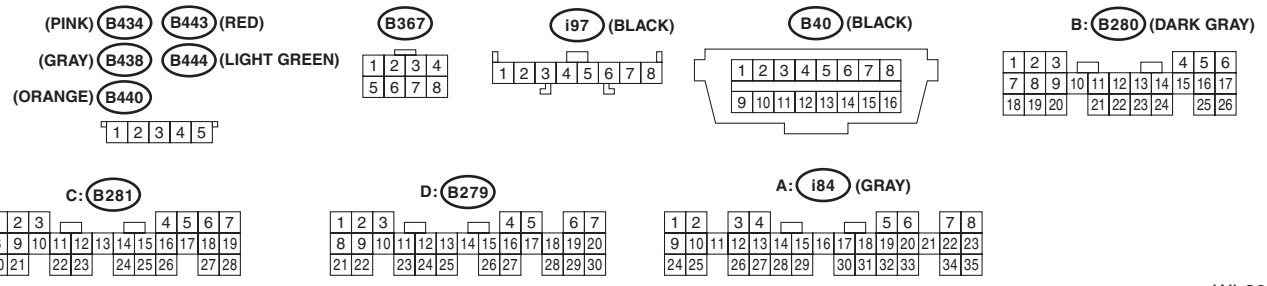

WI-30546

# Security System

WIRING SYSTEM

SEC-04

SEC-04

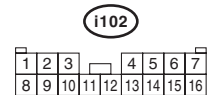
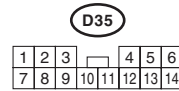
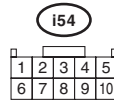
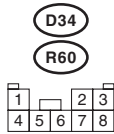
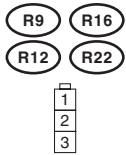
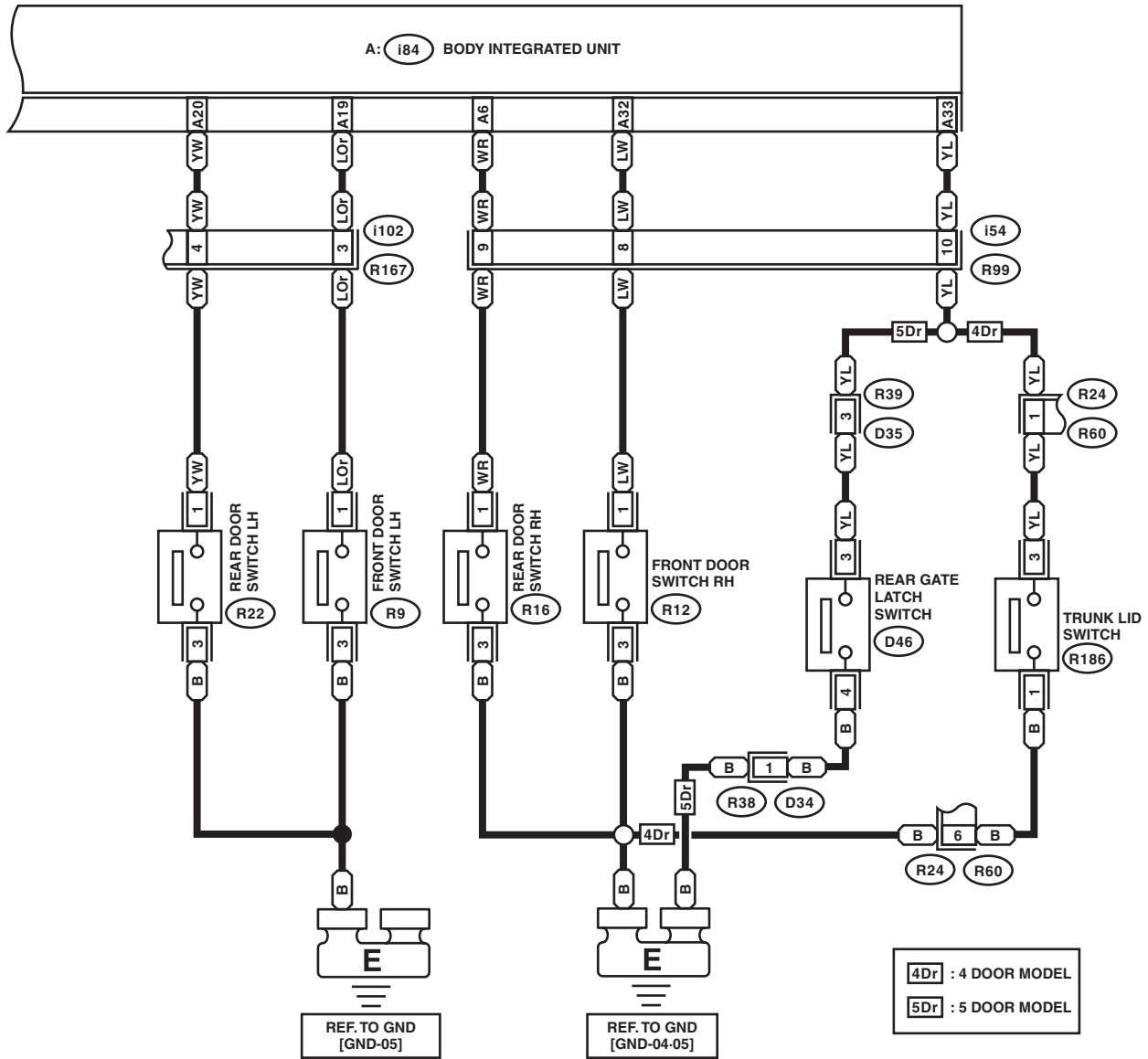

A: i84 (GRAY)

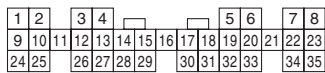

WI-30477

# Immobilizer System

WIRING SYSTEM

## 46. Immobilizer System

### A: WIRING DIAGRAM

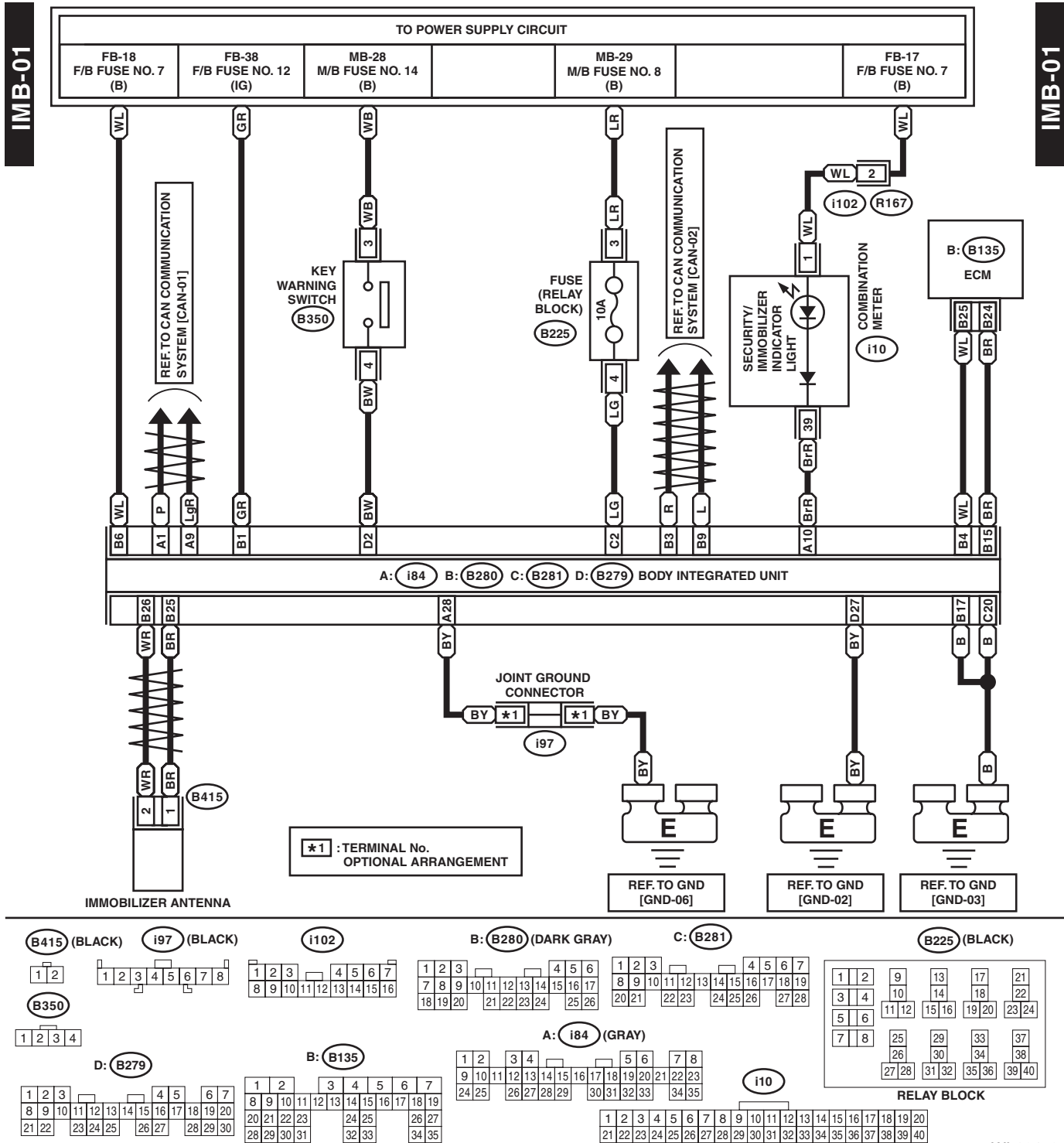

WI-30478

## 47. Keyless Entry System

### A: WIRING DIAGRAM

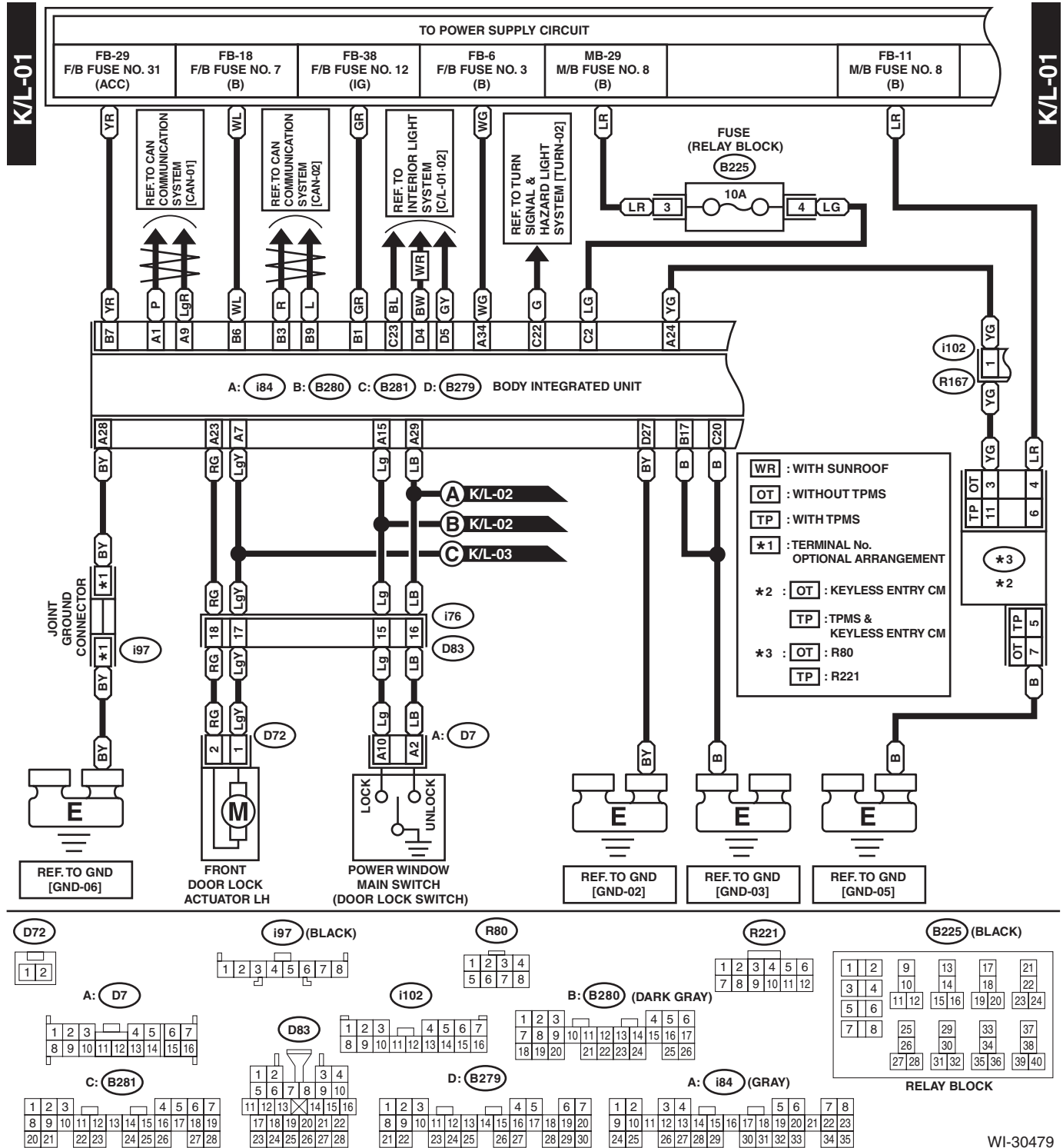

# Keyless Entry System

## WIRING SYSTEM

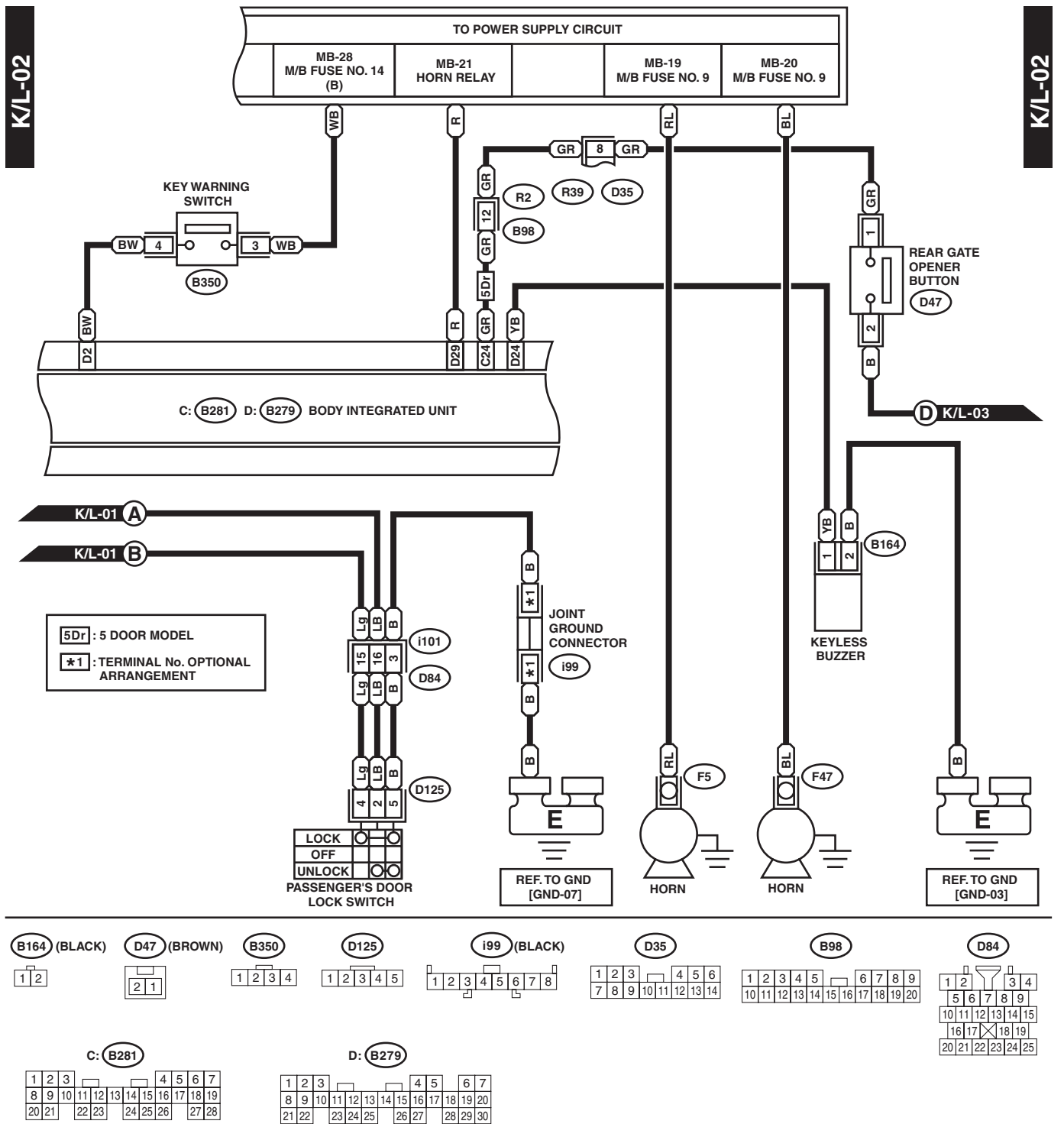

WI-27054



# Keyless Entry System

WIRING SYSTEM

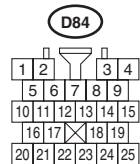
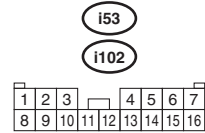
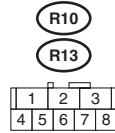
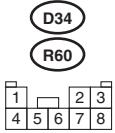
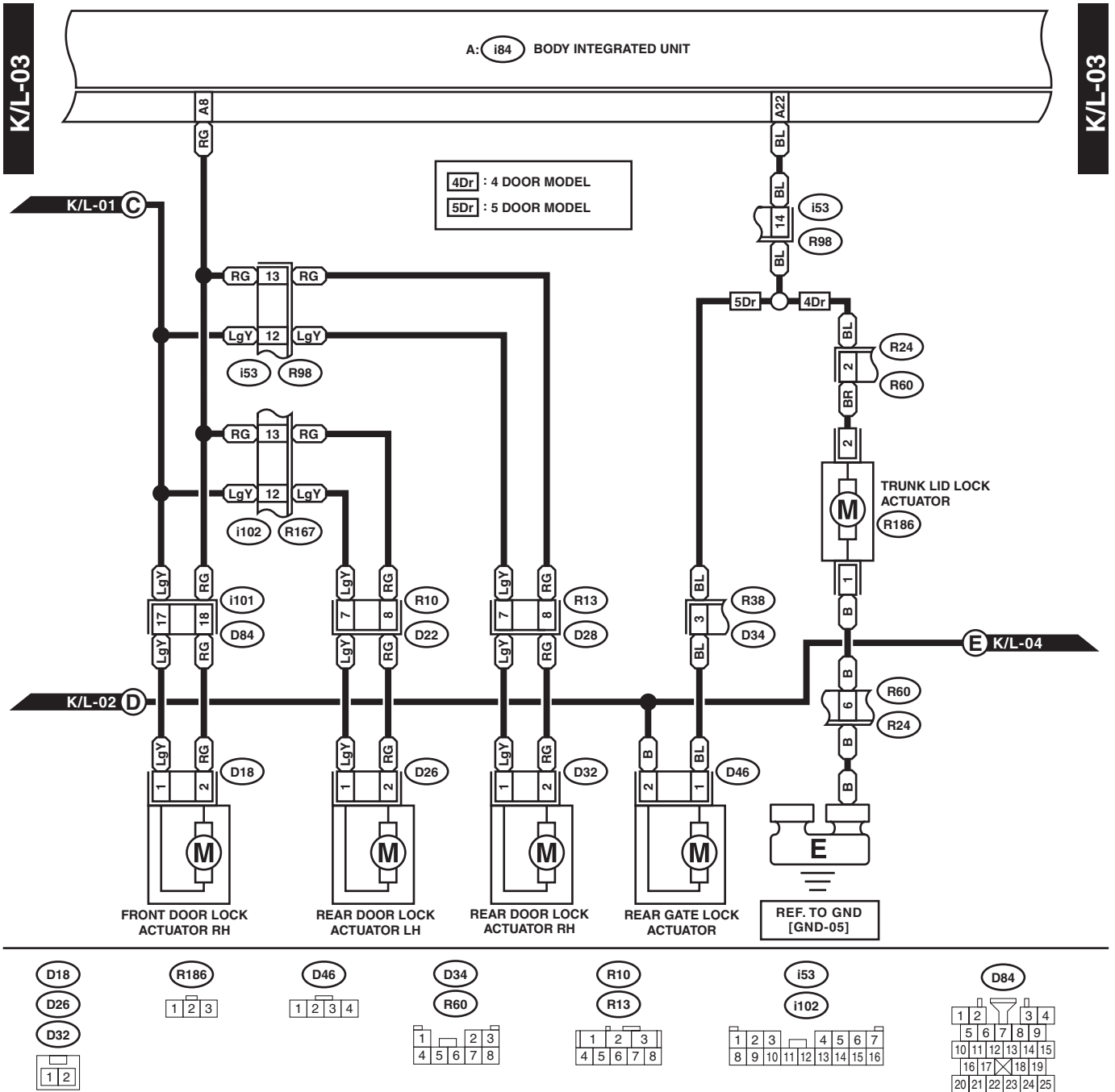

**A: i84 (GRAY)**

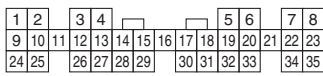

WI-21468

# Keyless Entry System

## WIRING SYSTEM

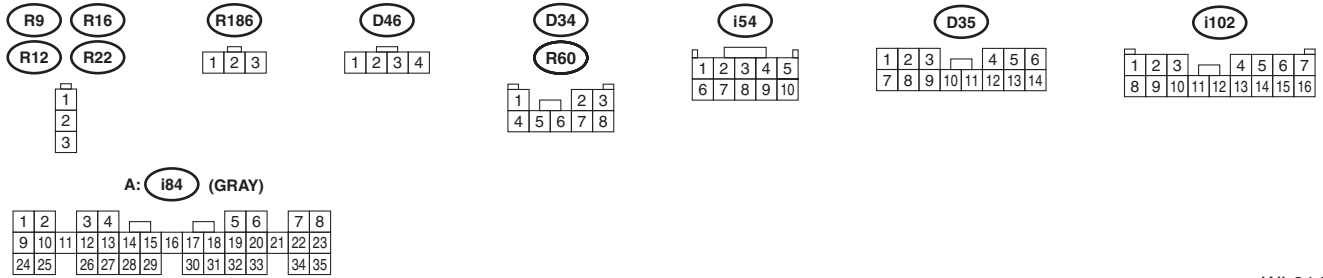
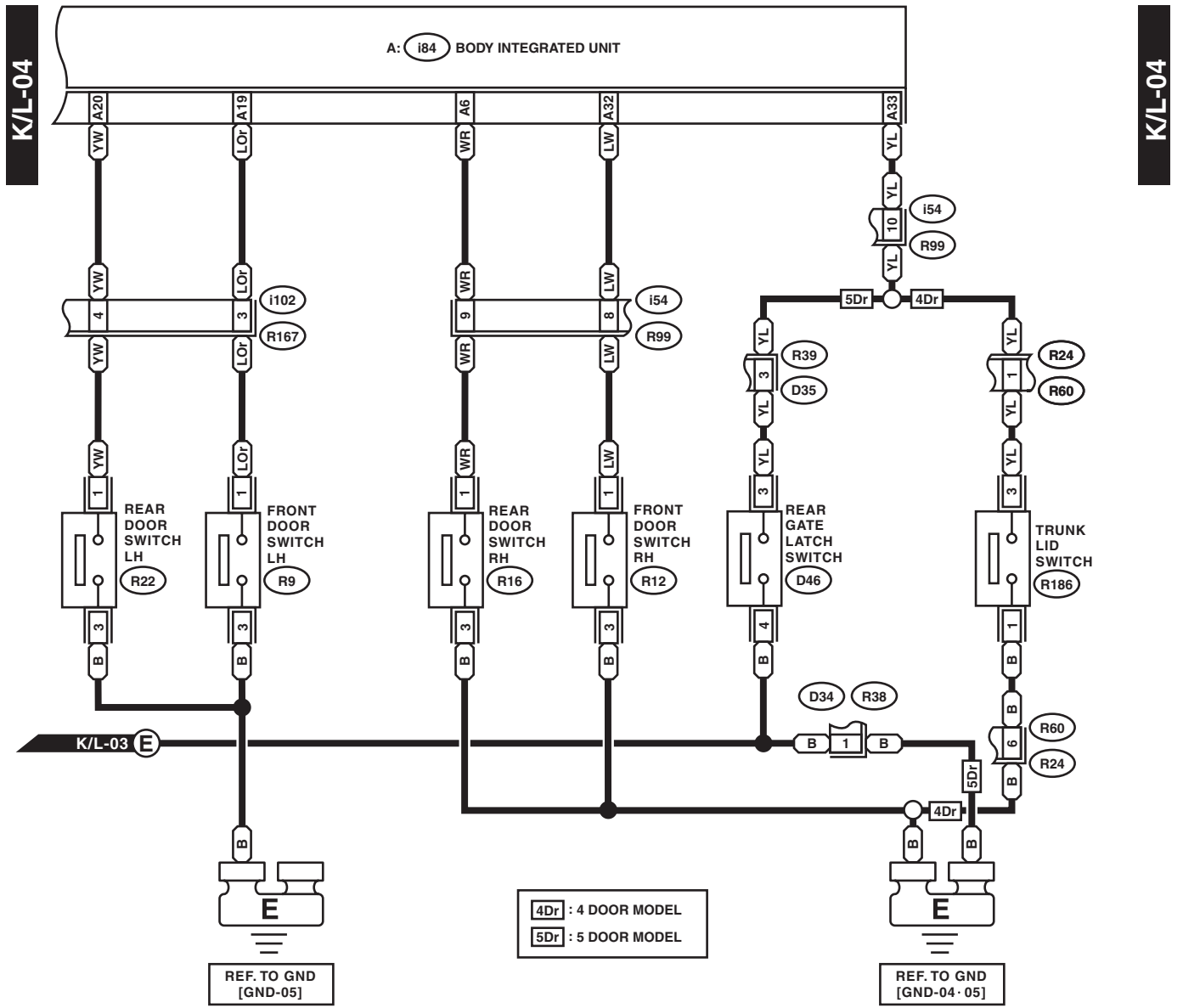

WI-21469

## 48. Cruise Control System

### A: WIRING DIAGRAM

#### 1. WITHOUT SI-DRIVE

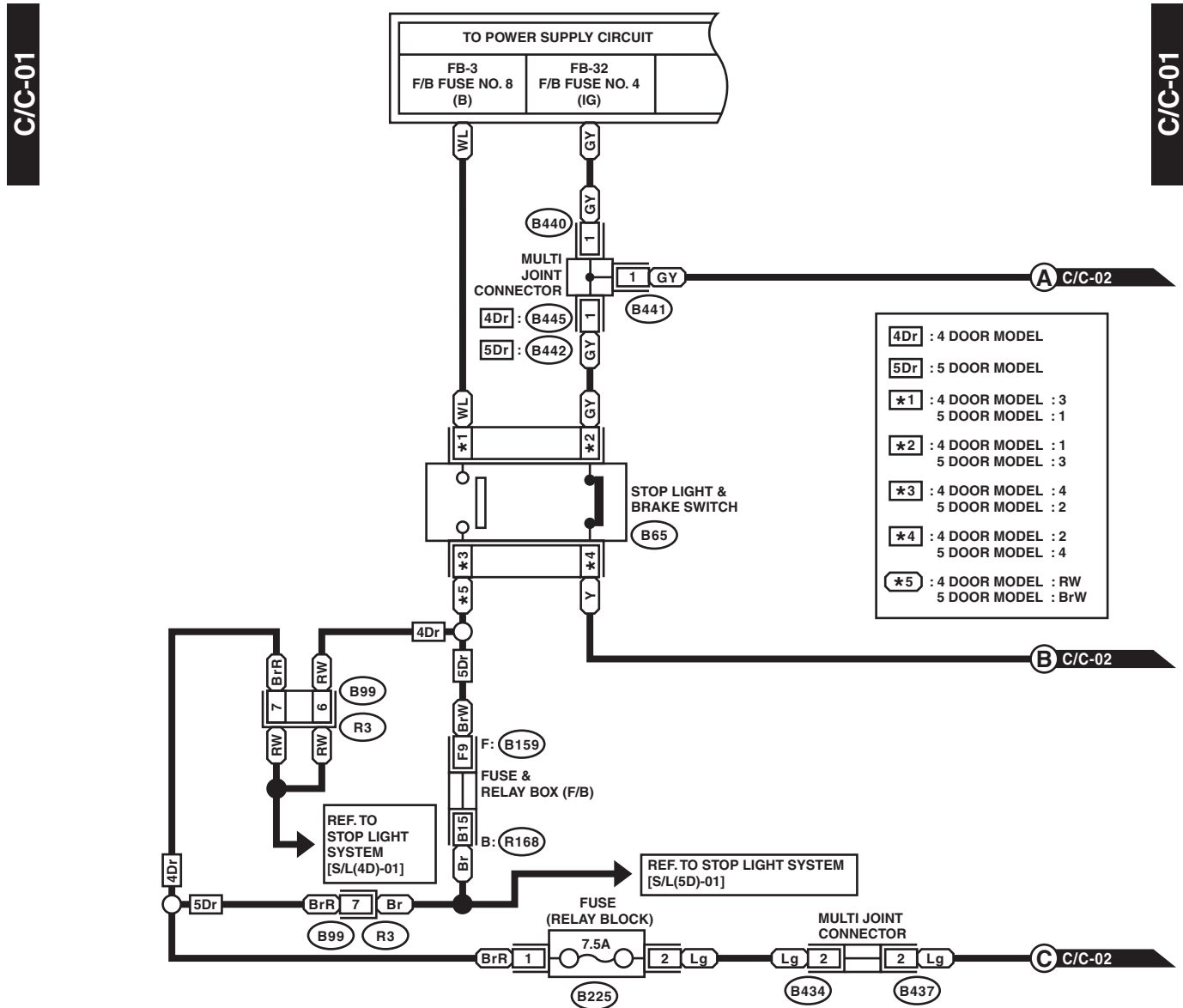

- 4Dr : 4 DOOR MODEL
- 5Dr : 5 DOOR MODEL
- \*1 : 4 DOOR MODEL : 3  
5 DOOR MODEL : 1
- \*2 : 4 DOOR MODEL : 1  
5 DOOR MODEL : 3
- \*3 : 4 DOOR MODEL : 4  
5 DOOR MODEL : 2
- \*4 : 4 DOOR MODEL : 2  
5 DOOR MODEL : 4
- \*5 : 4 DOOR MODEL : RW  
5 DOOR MODEL : BrW

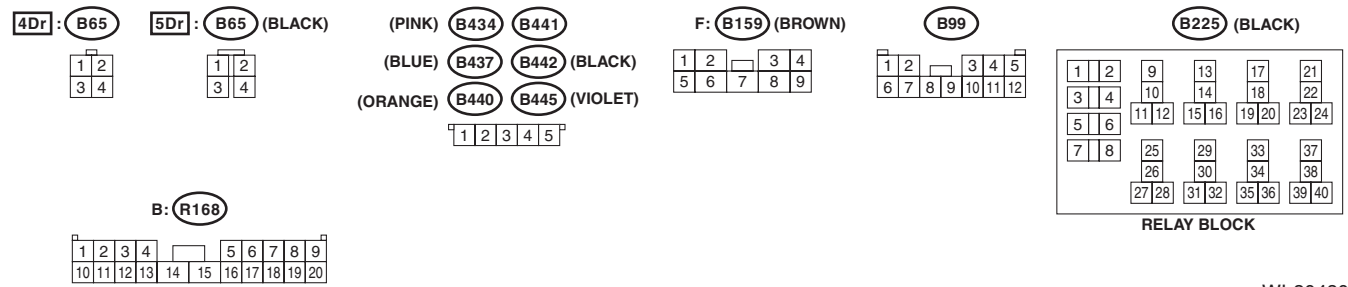

WI-30480

# Cruise Control System

WIRING SYSTEM

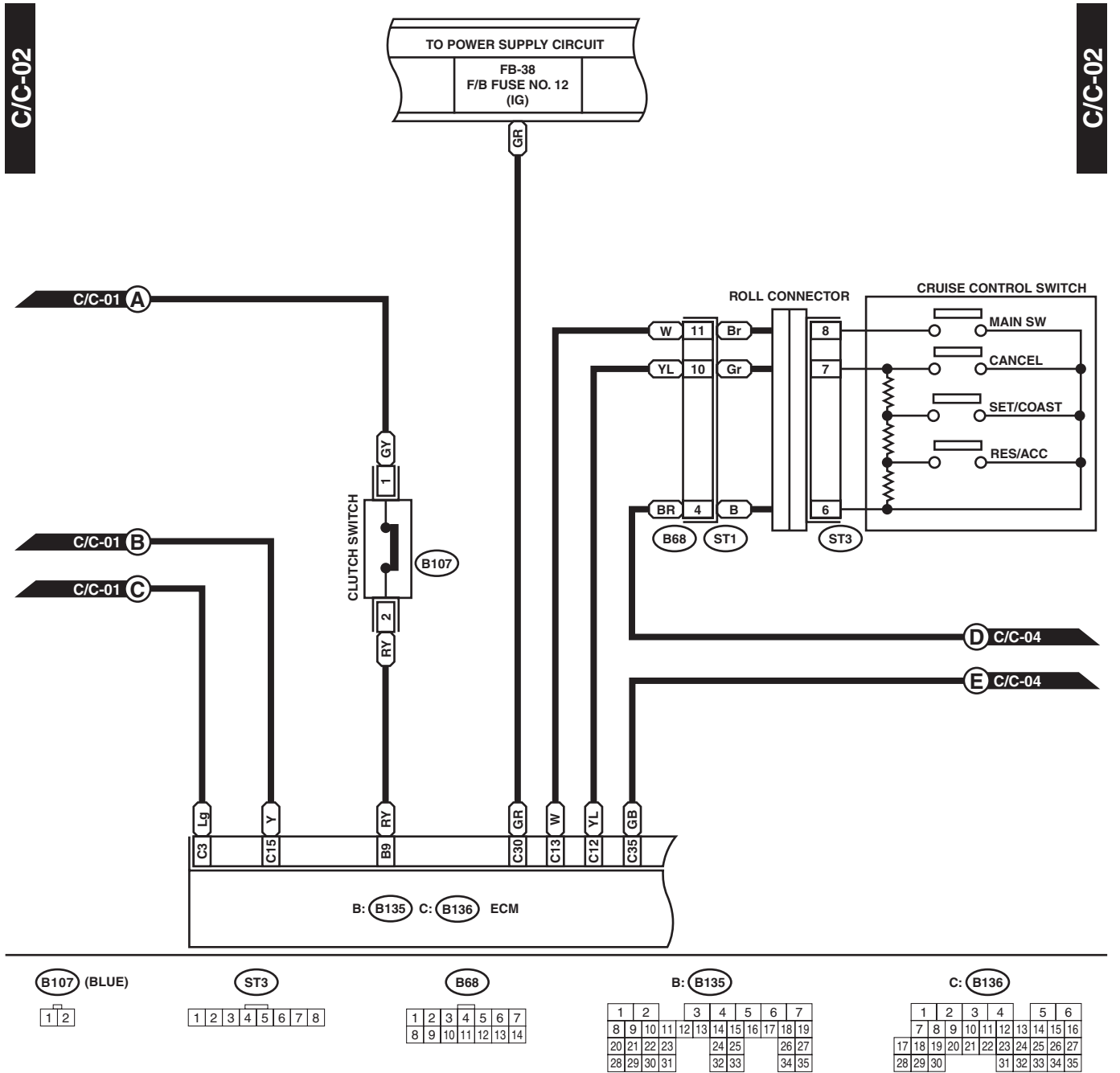

WI-30481

WI-164

Brought to you by Ebay Seller "SubaruManuals"

# Cruise Control System

WIRING SYSTEM

C/C-03

C/C-03

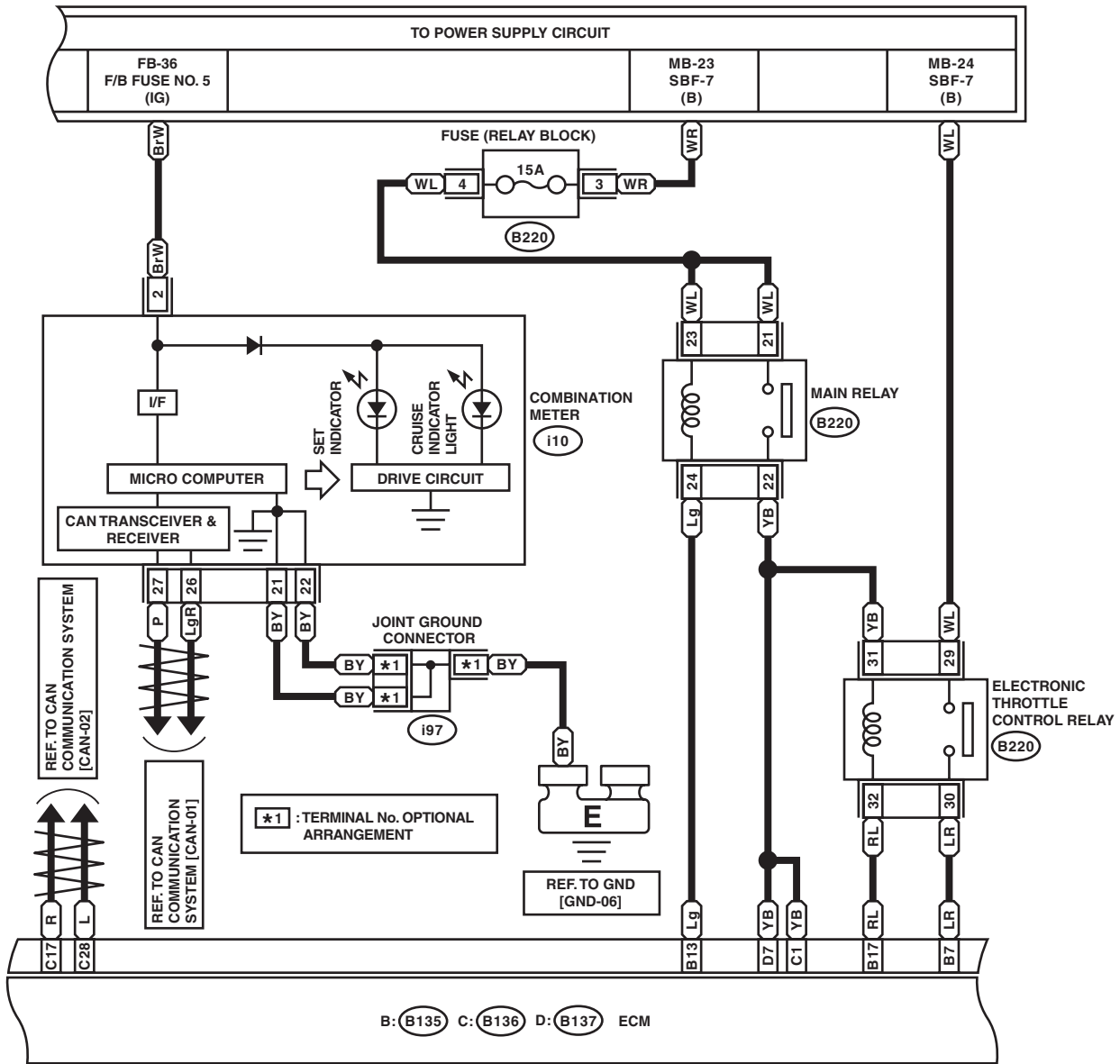

i97 (BLACK)

1	2	3	4	5	6	7	8
---	---	---	---	---	---	---	---

D: (B137)

1	2	3	4	5	6	7			
8	9	10	11	12	13	14	15	16	17
18	19	20	21	22	23	24	25		
26	27	28	29	30	31				

B: (B135)

1	2	3	4	5	6	7					
8	9	10	11	12	13	14	15	16	17	18	19
20	21	22	23	24	25	26	27				
28	29	30	31	32	33	34	35				

(B220) (BLACK)

1	2	9	13	17	21		
3	4	10	14	18	22		
5	6	11	15	19	23	24	
7	8	25	29	33	37		
26	30	34	38				
27	28	31	32	35	36	39	40

RELAY BLOCK

C: (B136)

1	2	3	4	5	6					
7	8	9	10	11	12	13	14	15	16	
17	18	19	20	21	22	23	24	25	26	27
28	29	30	31	32	33	34	35			

i10

1	2	3	4	5	6	7	8	9	10	11	12	13	14	15	16	17	18	19	20
21	22	23	24	25	26	27	28	29	30	31	32	33	34	35	36	37	38	39	40

WI-33879

# Cruise Control System

WIRING SYSTEM

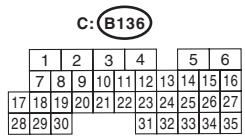
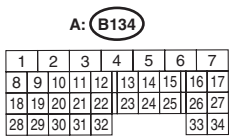
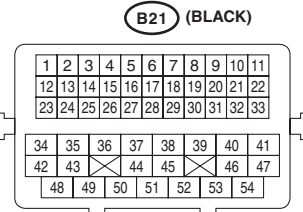
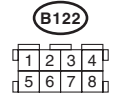
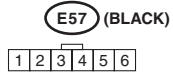
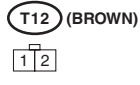
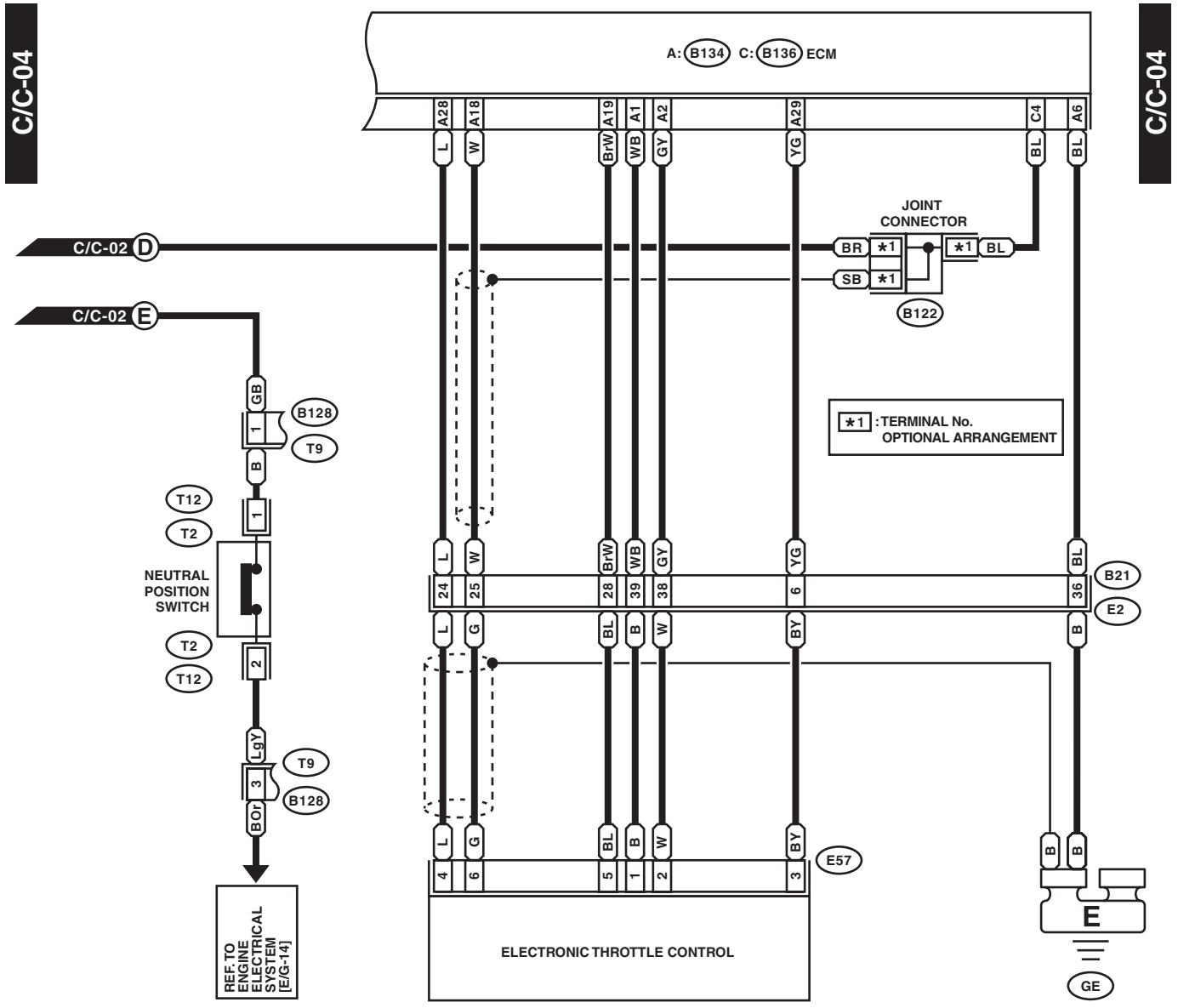

WI-30483

# Cruise Control System

WIRING SYSTEM

## 2. WITH SI-DRIVE

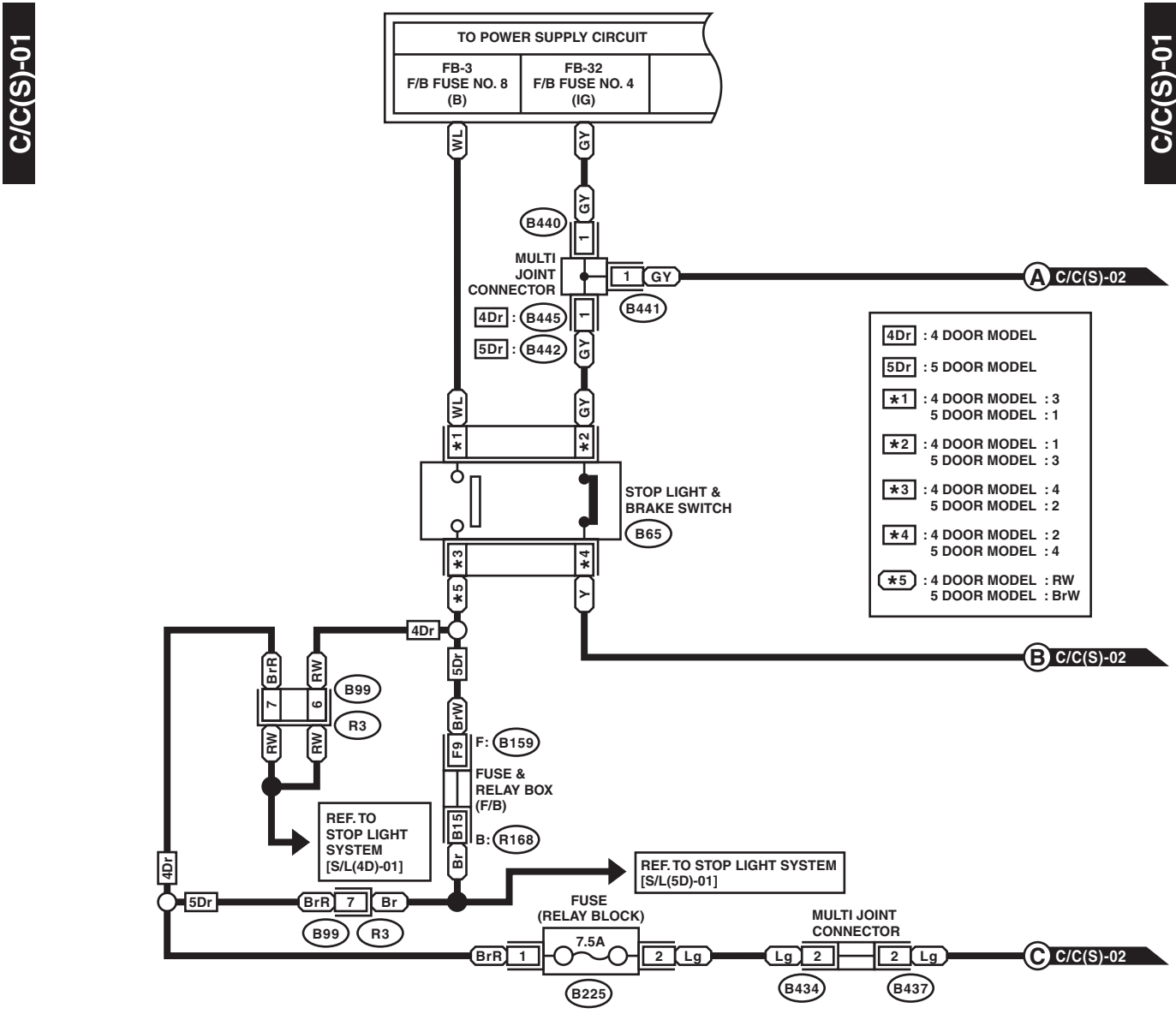

- 4Dr** : 4 DOOR MODEL
- 5Dr** : 5 DOOR MODEL
- \*1** : 4 DOOR MODEL : 3  
5 DOOR MODEL : 1
- \*2** : 4 DOOR MODEL : 1  
5 DOOR MODEL : 3
- \*3** : 4 DOOR MODEL : 4  
5 DOOR MODEL : 2
- \*4** : 4 DOOR MODEL : 2  
5 DOOR MODEL : 4
- \*5** : 4 DOOR MODEL : RW  
5 DOOR MODEL : BrW

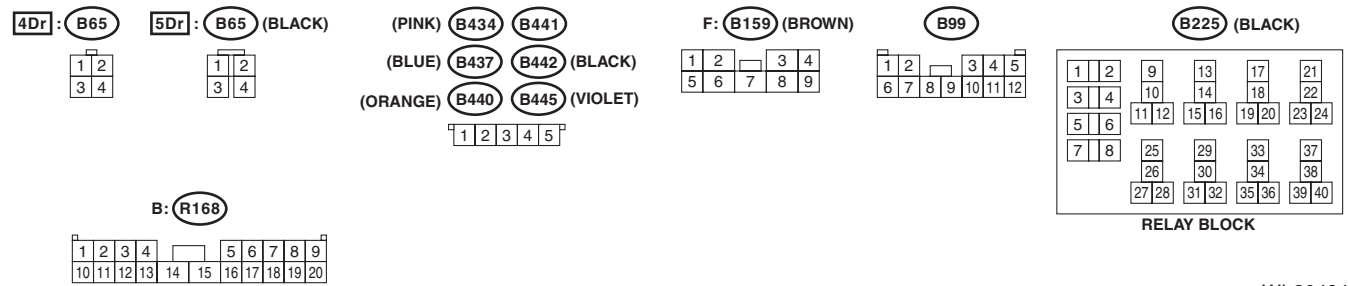

WI-30484

# Cruise Control System

WIRING SYSTEM

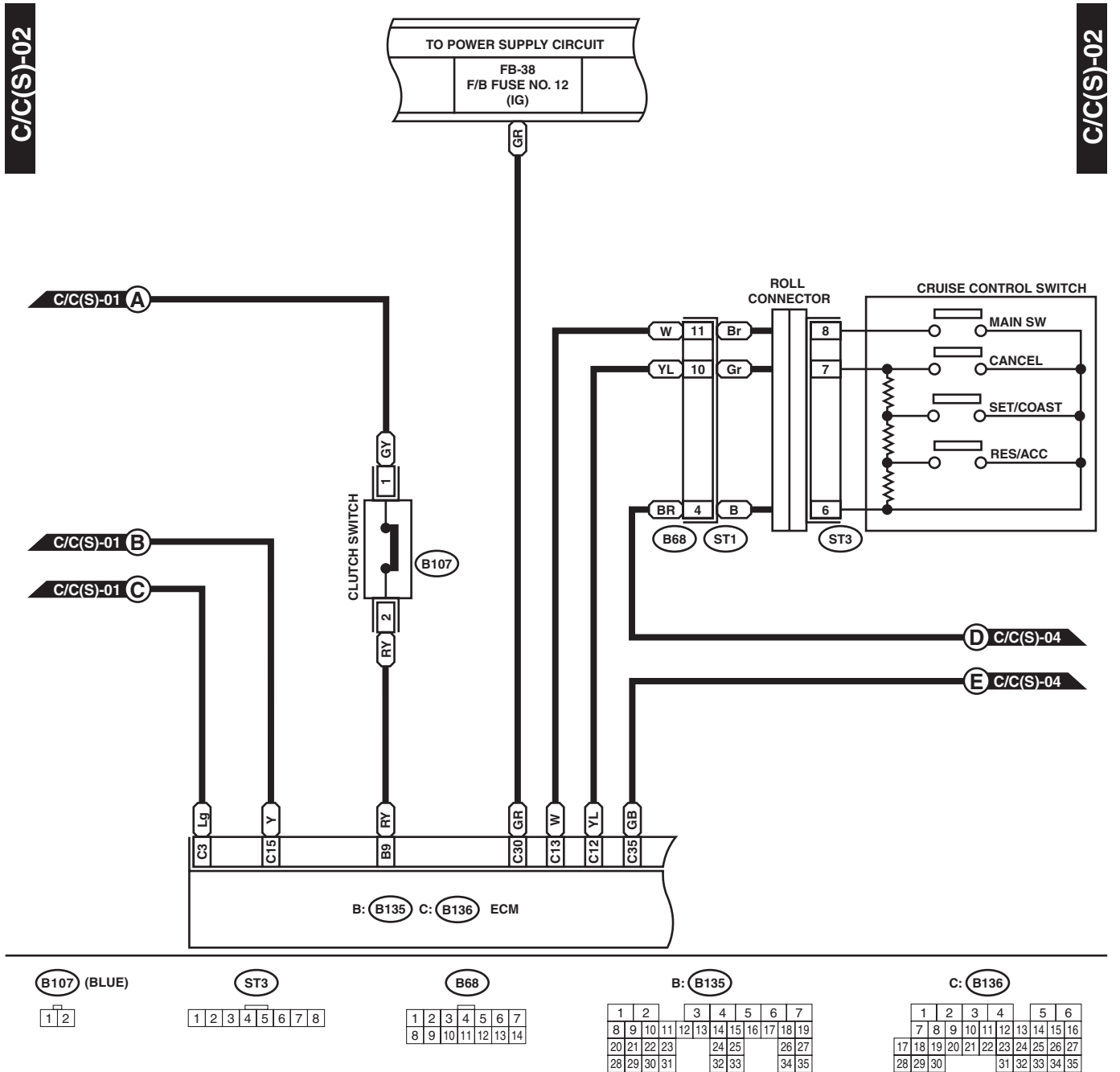

WI-30485



# Cruise Control System

WIRING SYSTEM

C/C(S)-03

C/C(S)-03

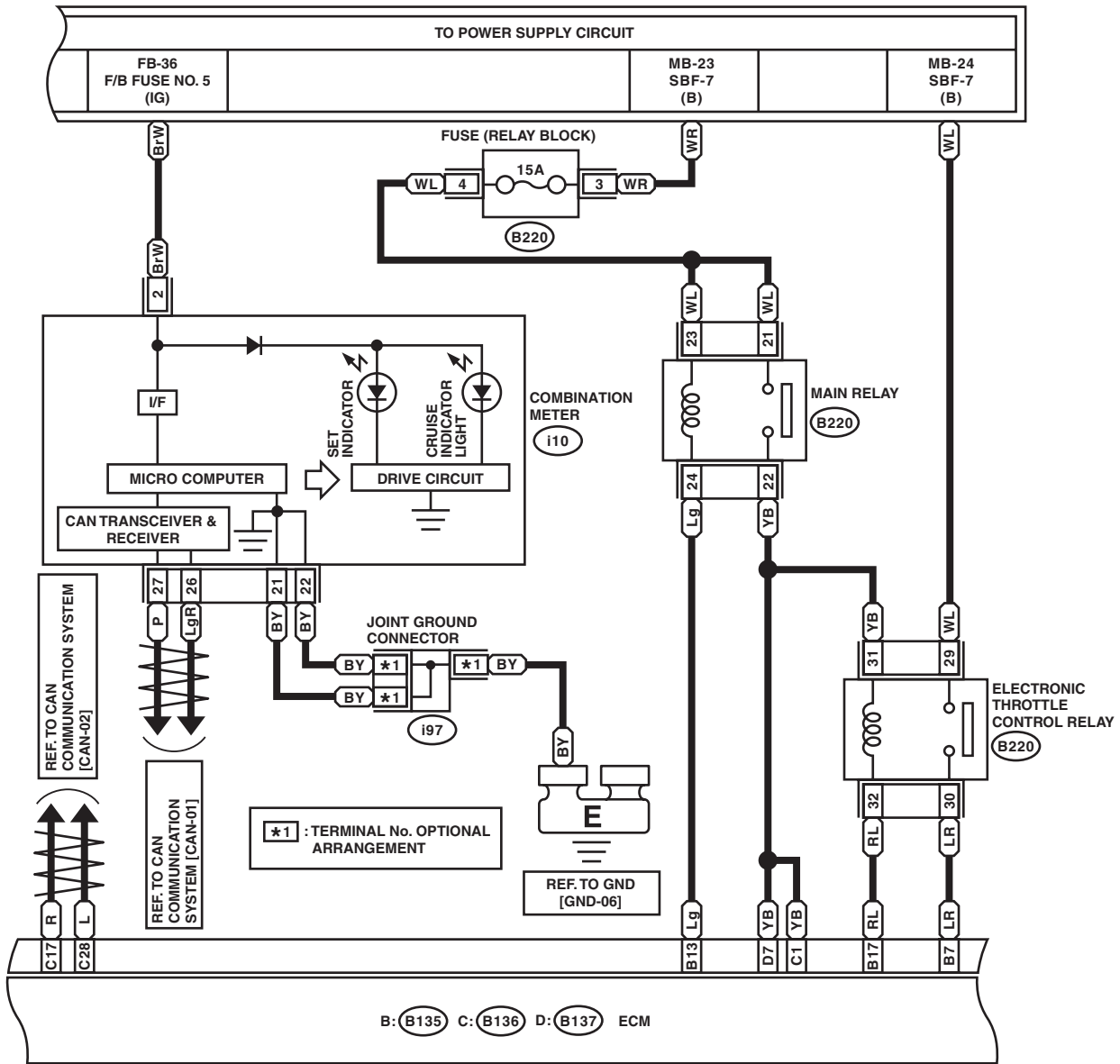

(i97) (BLACK)

1	2	3	4	5	6	7	8
---	---	---	---	---	---	---	---

D: (B137)

1	2	3	4	5	6	7			
8	9	10	11	12	13	14	15	16	17
18	19	20	21	22	23	24	25		
26	27	28	29	30	31				

B: (B135)

1	2	3	4	5	6	7					
8	9	10	11	12	13	14	15	16	17	18	19
20	21	22	23	24	25	26	27				
28	29	30	31	32	33	34	35				

(B220) (BLACK)

1	2	9	13	17	21		
3	4	10	14	18	22		
5	6	11	15	19	23	24	
7	8	25	29	33	37		
26	30	34	38				
27	28	31	32	35	36	39	40

RELAY BLOCK

C: (B136)

1	2	3	4	5	6					
7	8	9	10	11	12	13	14	15	16	
17	18	19	20	21	22	23	24	25	26	27
28	29	30	31	32	33	34	35			

(i10)

1	2	3	4	5	6	7	8	9	10	11	12	13	14	15	16	17	18	19	20
21	22	23	24	25	26	27	28	29	30	31	32	33	34	35	36	37	38	39	40

WI-33880

# Cruise Control System

WIRING SYSTEM

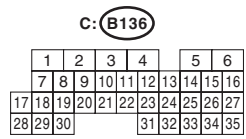
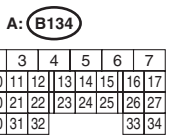
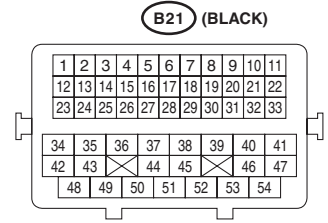
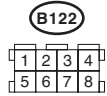
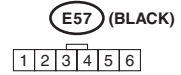
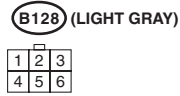
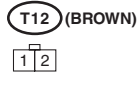
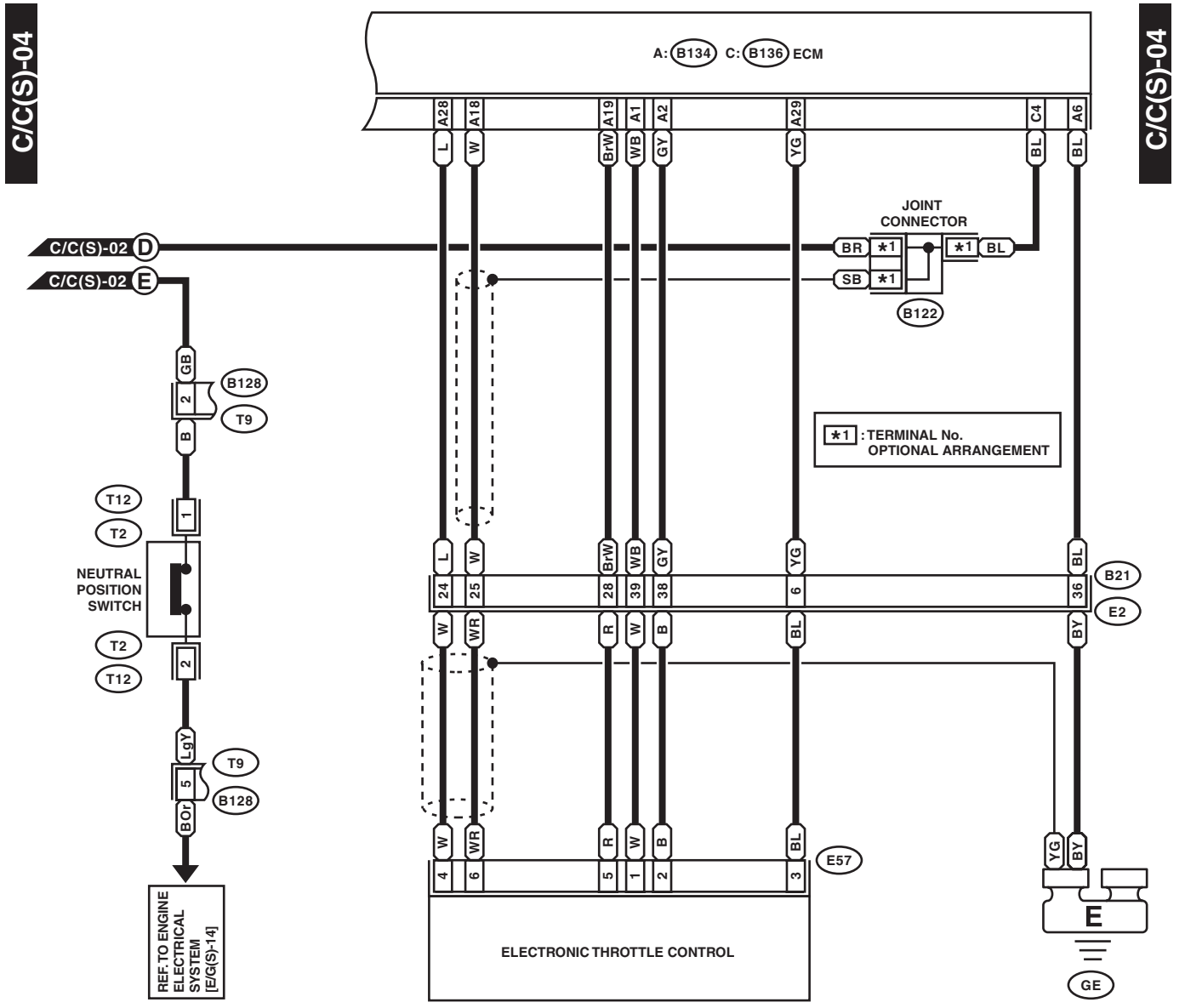

WI-30487

## 49. CAN Communication System

### A: WIRING DIAGRAM

#### 1. LOW-SPEED CAN

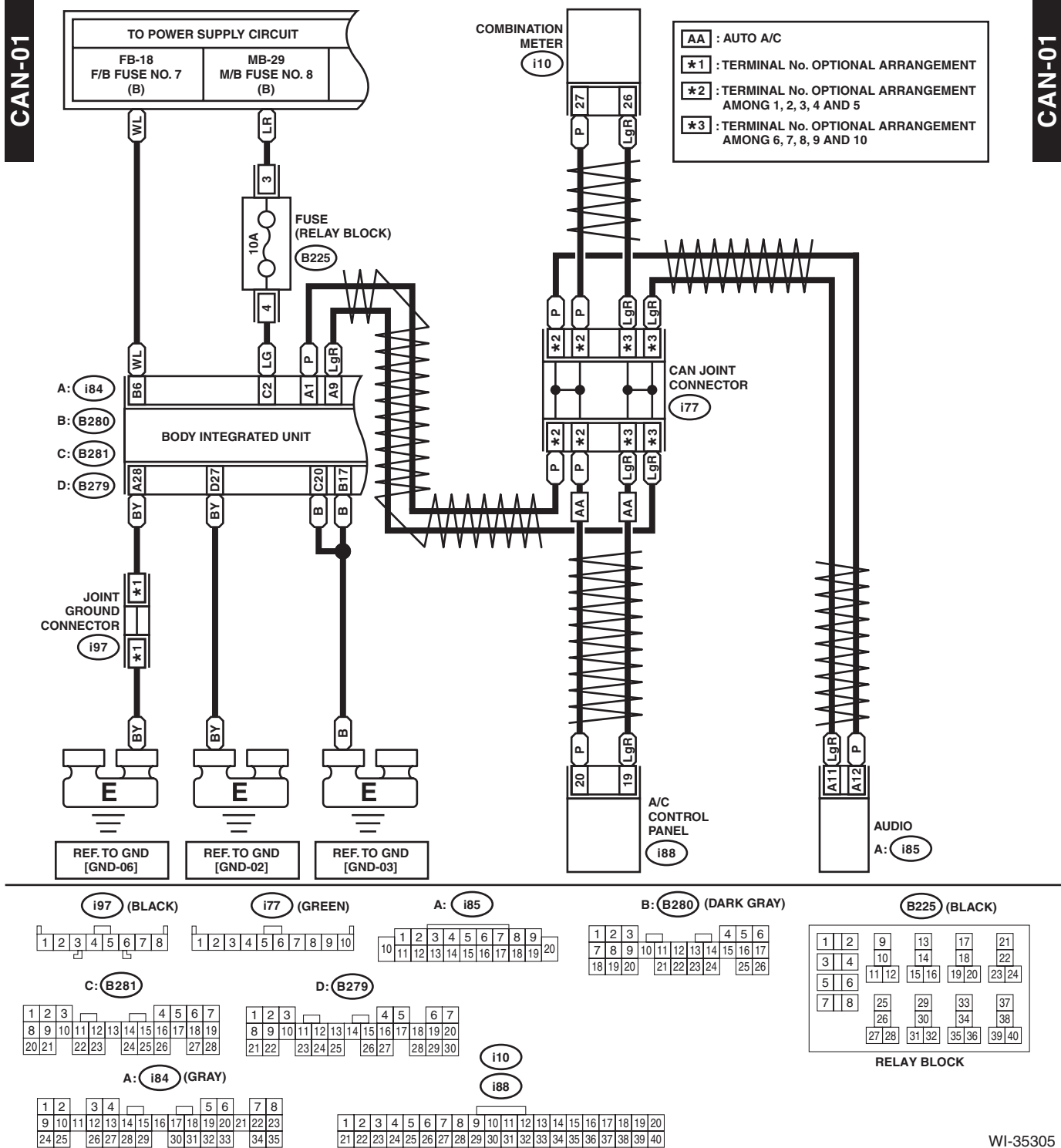

# CAN Communication System

## WIRING SYSTEM

### 2. HIGH-SPEED CAN

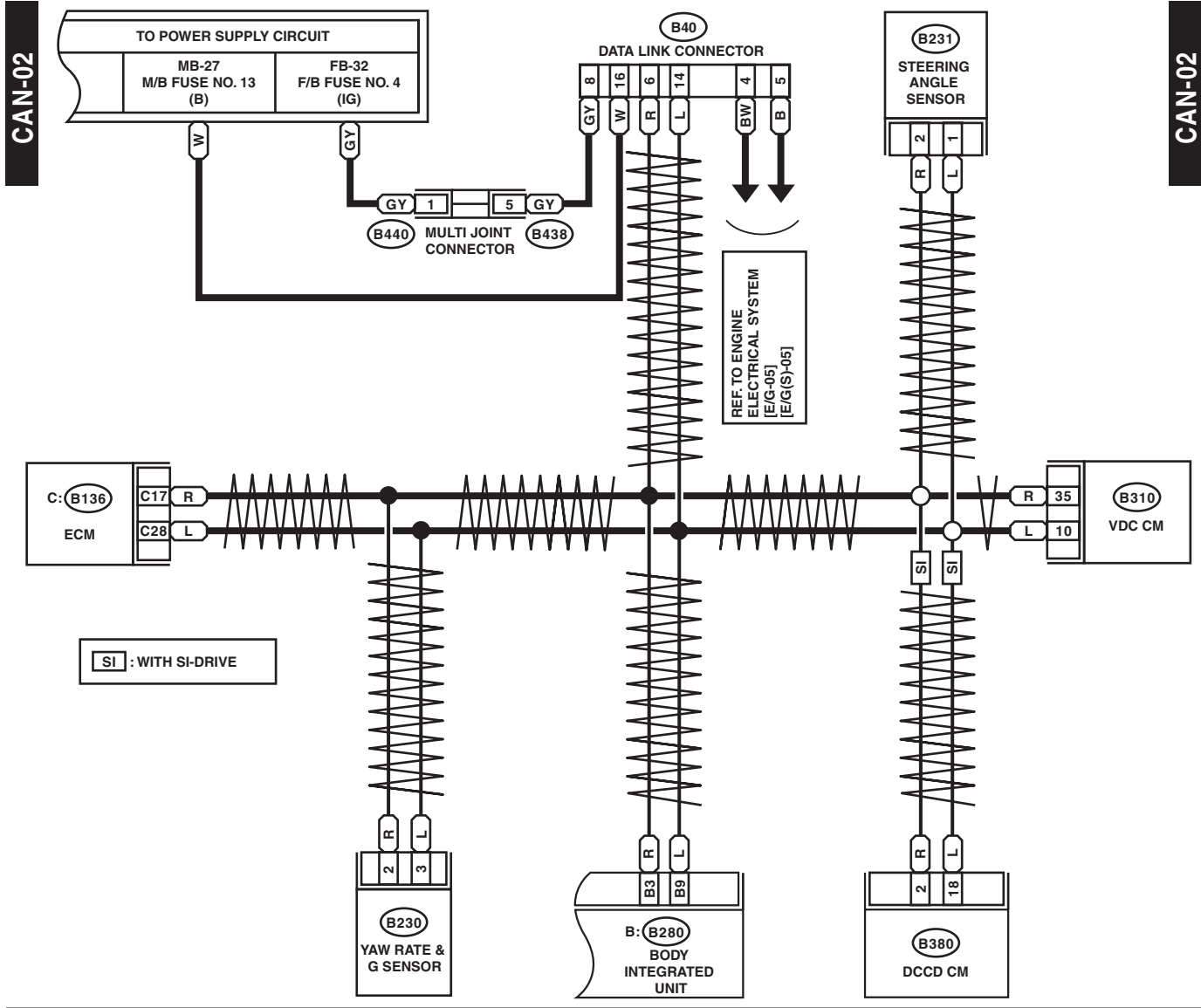

B230 (BLACK)

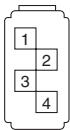

B231 (BLACK)



B438 (GRAY)



B40 (BLACK)

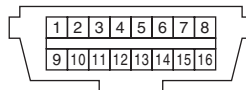

B: B280 (DARK GRAY)

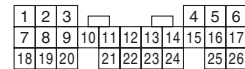

B380

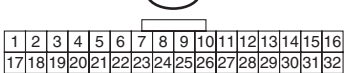

C: B136

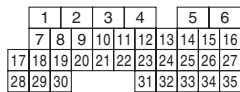

B310 (BLACK)

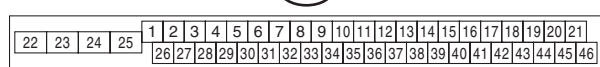

WI-30488

## 50.Rearview Mirror System

### A: WIRING DIAGRAM

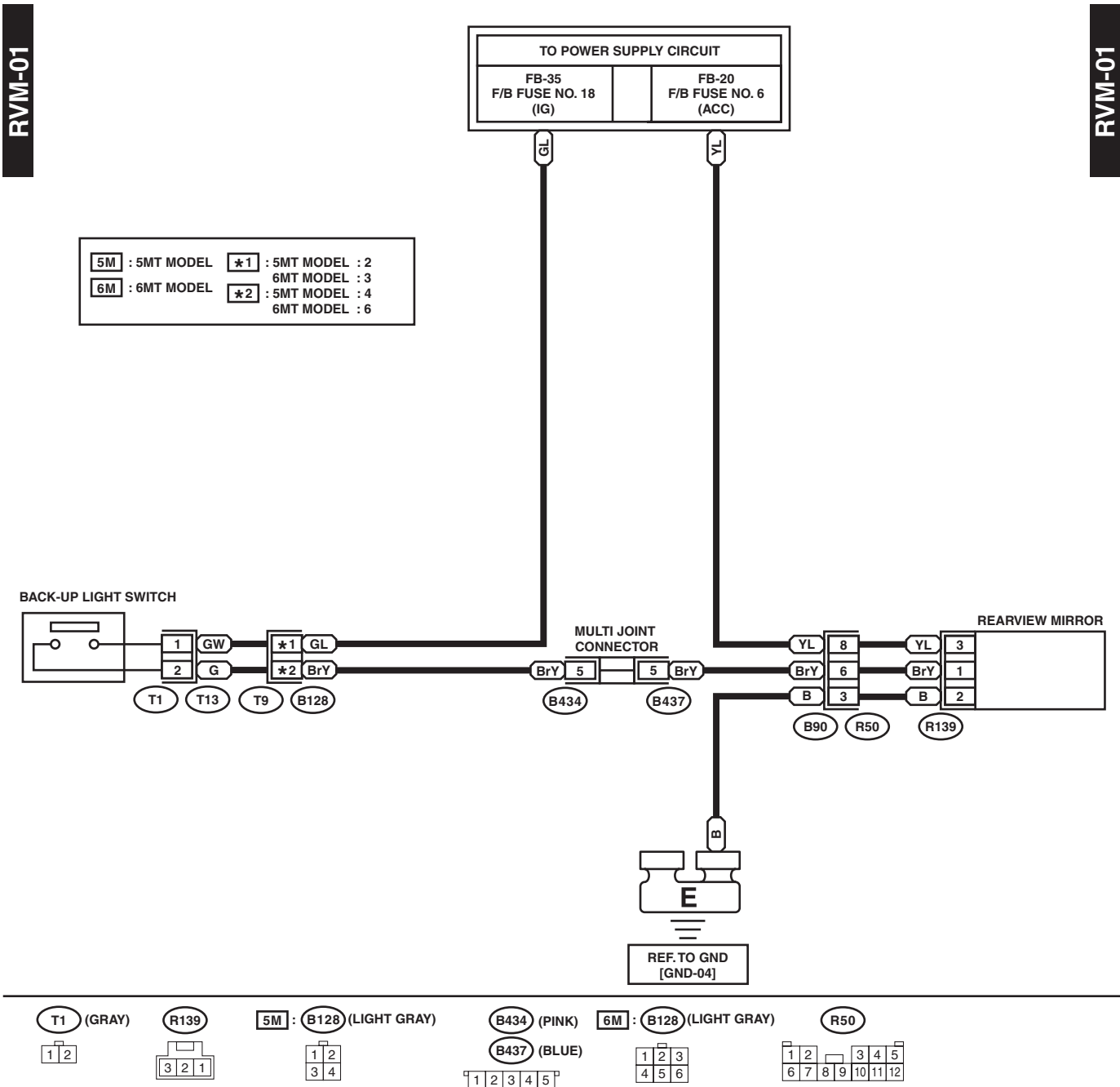

WI-30489

# Harness Components Location

WIRING SYSTEM

## 51. Harness Components Location

### A: LOCATION

#### 1. 4 DOOR MODEL

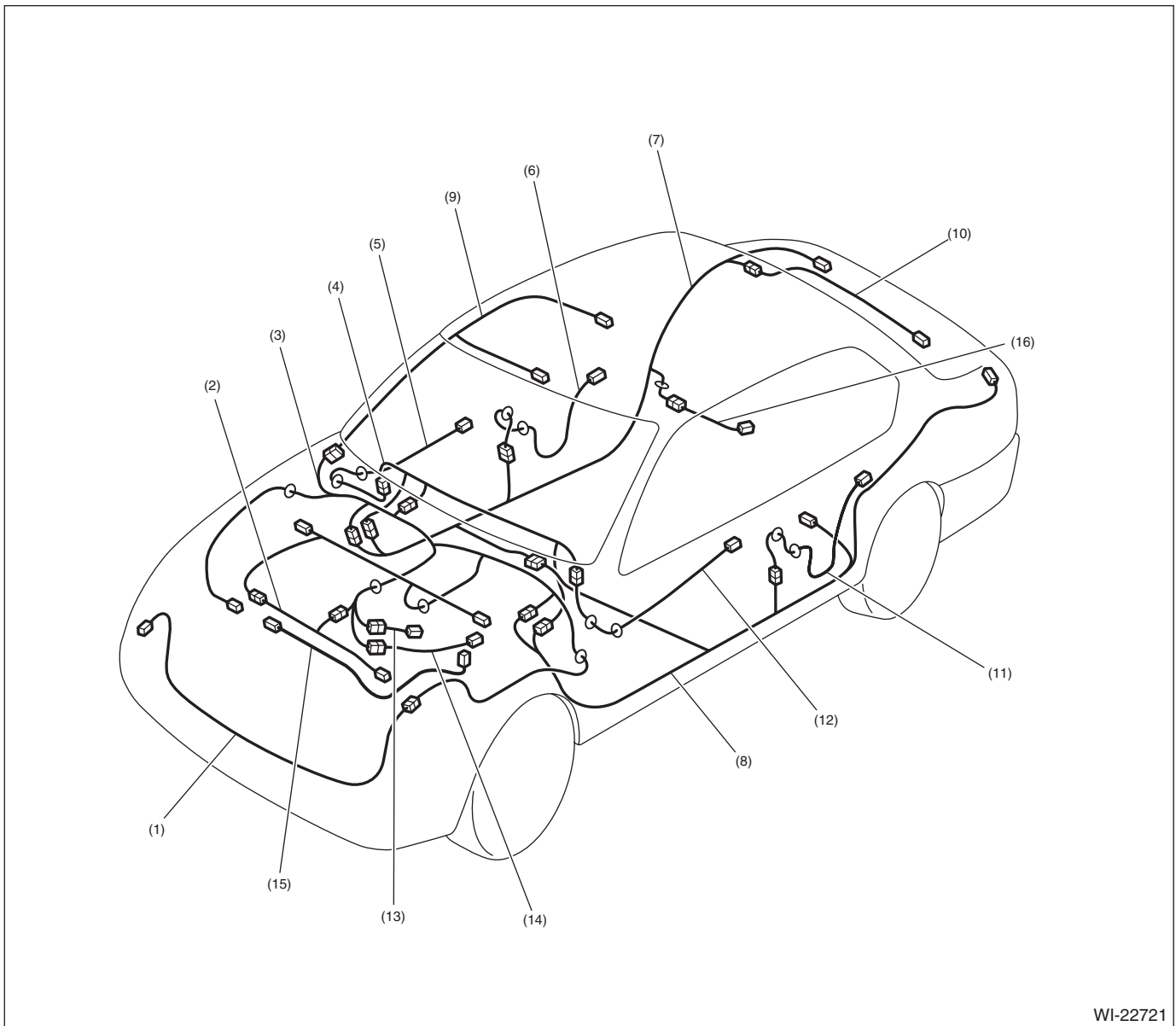

WI-22721

- |                                     |                            |                              |
|-------------------------------------|----------------------------|------------------------------|
| (1) Front wiring harness            | (7) Rear wiring harness RH | (12) Front door cord LH      |
| (2) Engine wiring harness           | (8) Rear wiring harness LH | (13) Transmission cord       |
| (3) Bulkhead wiring harness         | (9) Roof cord              | (14) Rear oxygen sensor cord |
| (4) Instrument panel wiring harness | (10) Trunk lid cord        | (15) Generator cord          |
| (5) Front door cord RH              | (11) Rear door cord LH     | (16) Fuel cord               |
| (6) Rear door cord RH               |                            |                              |

WI-174

Brought to you by Ebay Seller "SubaruManuals"

## 2. 5 DOOR MODEL

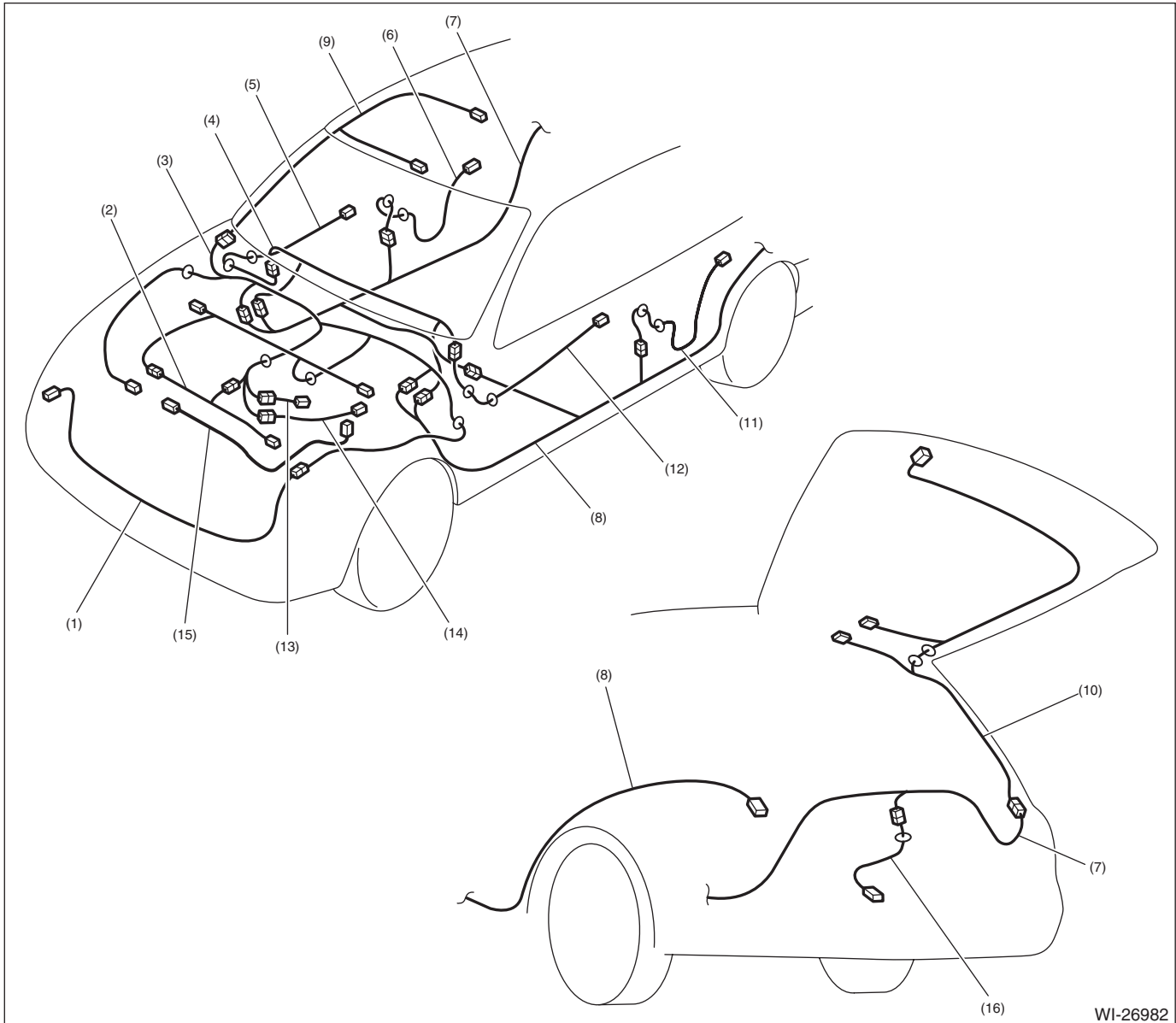

WI-26982

- |                                     |                            |                              |
|-------------------------------------|----------------------------|------------------------------|
| (1) Front wiring harness            | (7) Rear wiring harness RH | (12) Front door cord LH      |
| (2) Engine wiring harness           | (8) Rear wiring harness LH | (13) Transmission cord       |
| (3) Bulkhead wiring harness         | (9) Roof cord              | (14) Rear oxygen sensor cord |
| (4) Instrument panel wiring harness | (10) Rear gate cord        | (15) Generator cord          |
| (5) Front door cord RH              | (11) Rear door cord LH     | (16) Fuel cord               |
| (6) Rear door cord RH               |                            |                              |

# Front Wiring Harness

WIRING SYSTEM

## 52.Front Wiring Harness

### A: LOCATION

Connector				Connecting to	
No.	Pole	Color	Area	No.	Description
F5	1	Black	C-2		Horn
F6	2	Brown	C-1		Front fog light RH
F9	16	★	B-5		Secondary air relay holder
F11	2	★	C-3		Secondary air pump
F16	2	Black	C-1		Sub fan motor
F17	2	Black	C-2		Main fan motor
F21	2	Brown	D-3		Front fog light LH
F24	1	★	C-2		Magnet clutch
F25	1	★	C-2		Generator terminal B
F26	3	★	C-2		Generator
F27	22	Black	B-4		Relay holder
F35	12	Blue	B-4		Main fuse box (M/B)
F36	7	★	B-4		
F37	20	★	C-4		
F47	1	Black	C-2		Horn
F58	3	Light gray	C-3		Headlight beam leveler LH
F59	3	Light gray	C-1		Headlight beam leveler RH
F70	2	★	B-4		Main fuse box (M/B)
F78	2	Black	C-2		Ambient sensor
F103	2	Gray	B-1		Daytime running light resistor
F108	18	Gray	B-4	B361	Through joint connector
F109	24	★	B-3	B360	
F125	8	Light gray	C-3		Front combination light LH
F126	8	Light gray	C-1		Front combination light RH

★ : White or natural color



# Front Wiring Harness

WIRING SYSTEM

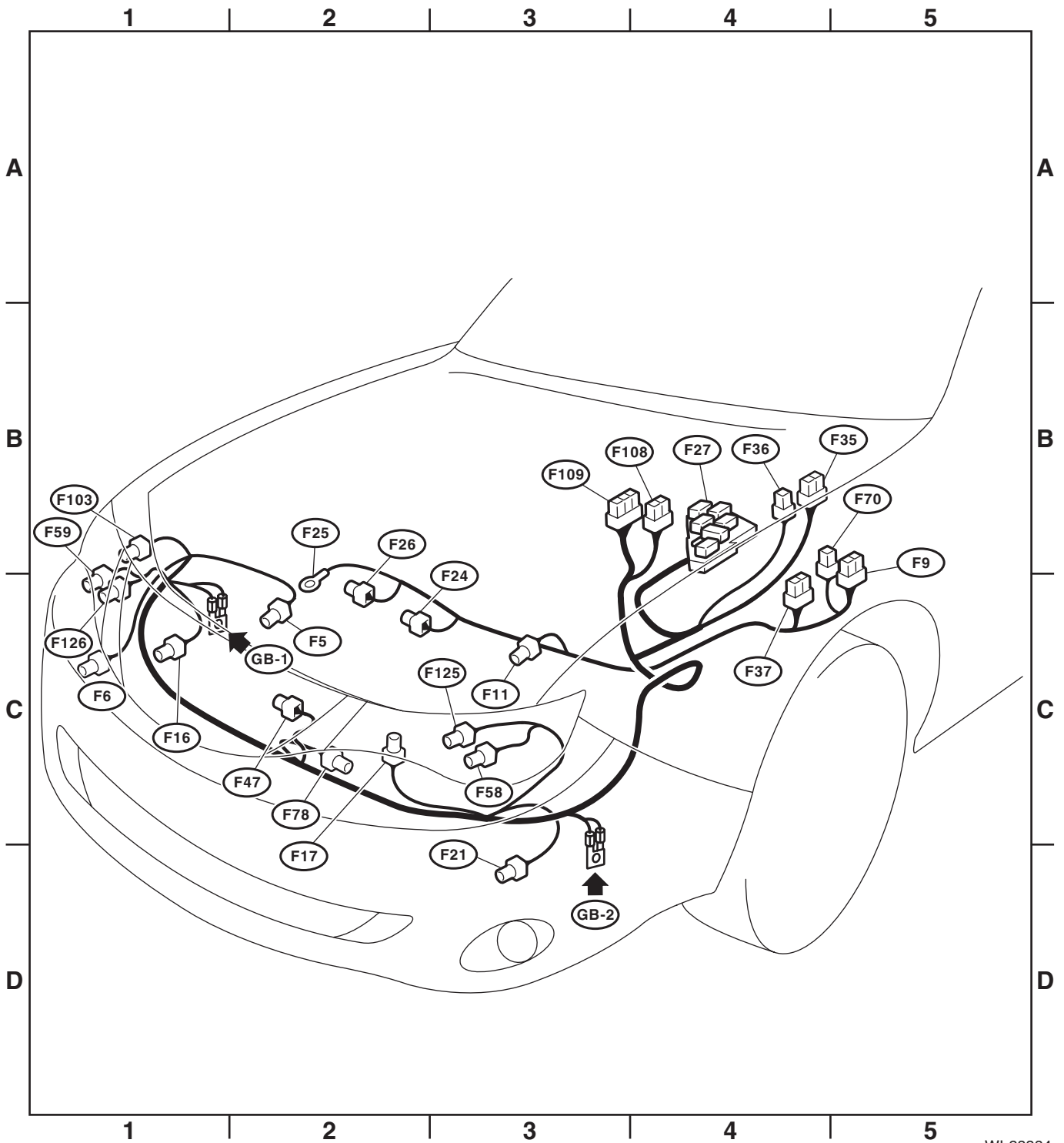

WI-28384

WI-177

Brought to you by Ebay Seller "SubaruManuals"

# Bulkhead Wiring Harness (In Engine Compartment)

## WIRING SYSTEM

### 53. Bulkhead Wiring Harness (In Engine Compartment)

#### A: LOCATION

Connector				Connecting to	
No.	Pole	Color	Area	No.	Description
B3	5	Black	B-2		Mass air flow and intake air temperature sensor
B6	2	Light gray	B-3		Front ABS wheel speed sensor RH
B8	5	Light gray	B-4		Front wiper motor
B10	4	★	B-4		Pressure switch
B14	1	Black	B-3		Starter motor
B15	2	Light gray	B-4		Front ABS wheel speed sensor LH
B16	2	Gray	B-4		Brake fluid level switch
B19	4	Light gray	B-3	T5	Rear oxygen sensor
B21	54	Black	B-2	E2	Engine wiring harness
B128	4	Light gray	B-3	T9	Transmission cord (5MT model)
	6	Light gray	B-3	T9	Transmission cord (6MT model)
B143	20	★	B-4		Main fuse box (M/B)
B144	9	Brown	B-4		
B145	7	Brown	B-4		
B146	2	Dark gray	C-4		Front washer motor
B147	2	Dark gray	C-4		Rear washer motor
B164	2	Black	C-3		Keyless buzzer
B186	8	★	B-4		Main fuse box (M/B)
B310	46	Black	B-2		VDC CM
B360	16	Gray	B-4	F109	Through joint connector
B361	14	★	B-4	F108	
B379	4	Dark gray	B-2		Front oxygen (A/F) sensor

★ : White or natural color

Connector				Connecting to	
No.	Pole	Color	Area	No.	Description
AB13	2	Yellow	C-3		Front sub sensor LH
AB16	2	Yellow	B-1		Front sub sensor RH

# Bulkhead Wiring Harness (In Engine Compartment)

WIRING SYSTEM

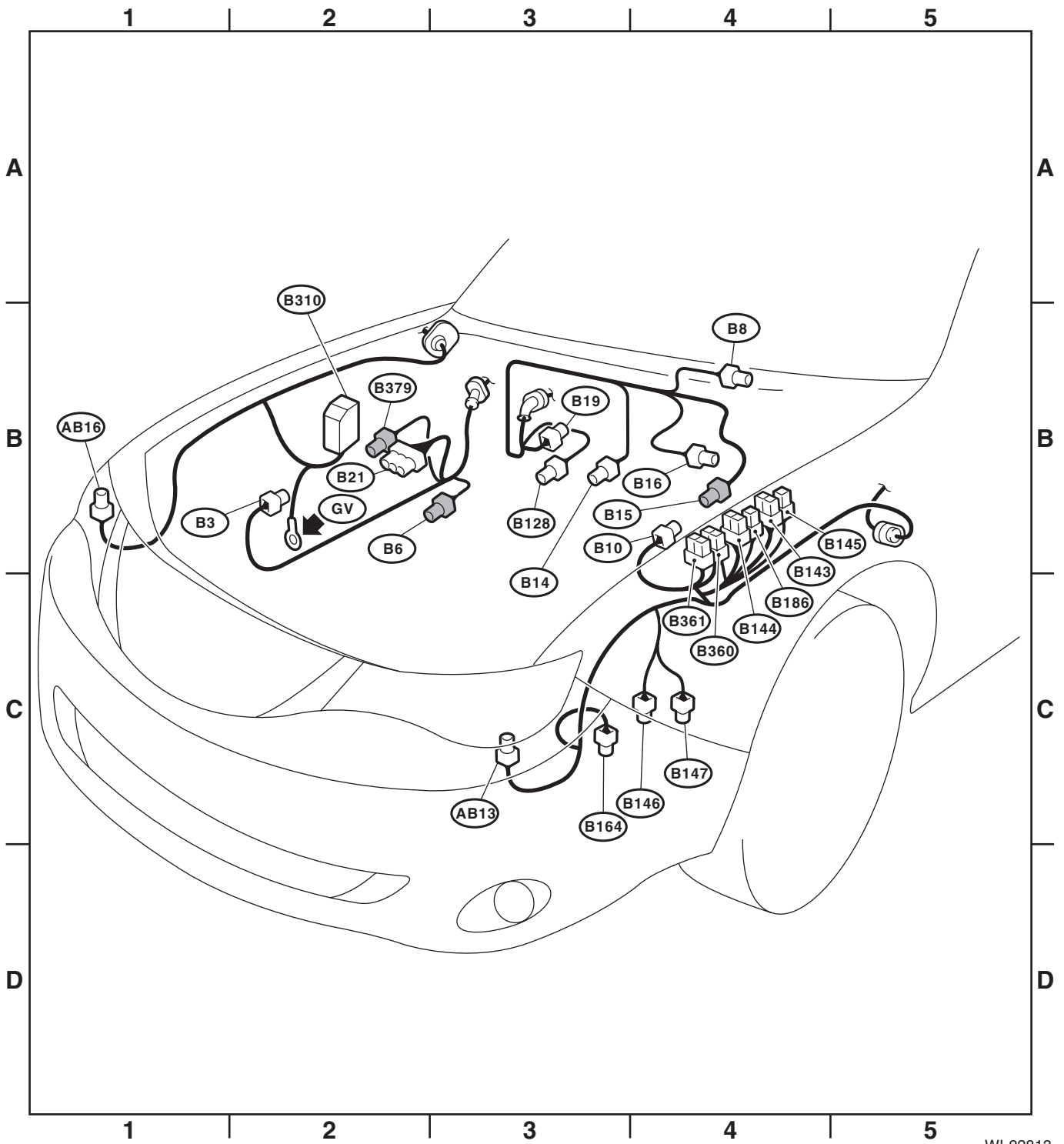

WI-22813

WI-179

Brought to you by Ebay Seller "SubaruManuals"

## Bulkhead Wiring Harness (In Compartment)

WIRING SYSTEM

### 54. Bulkhead Wiring Harness (In Compartment)

#### A: LOCATION

Connector				Connecting to	
No.	Pole	Color	Area	No.	Description
B27	4	★	B-3		Blower Resistor (manual A/C)
B31	6	★	C-1	AB1	Airbag wiring harness
B32	8	★	C-2		Turn signal and hazard unit
B36	28	★	B-4	i1	Instrument panel wiring harness
B38	28	★	B-2	i3	
B40	16	Black	C-2		Data link connector
B41	2	★	B-2		Power window circuit breaker
B52	24	★	B-2		Fuse & relay box (F/B)
B57	4	★	B-3		Power transistor (auto A/C)
B65	4	★	C-2		Stop light & brake switch (4 door model)
		Black	C-2		Stop light & brake switch (5 door model)
B68	14	★	C-2		Roll connector
B70	18	★	C-3		Combination switch
B71	17	★	C-2		
B72	6	★	C-2		Ignition switch
B75	2	Green	B-4	B76	Delivery (test) mode connector
B76	2	Green	B-4	B75	
B77	6	★	B-3		Mode door actuator (auto A/C)
B83	6	★	C-4		Joint connector
B87	2	★	B-4		Blower motor
B88	2	Brown	B-3		Evaporator sensor (auto A/C)
	3	★	B-3		Evaporator sensor (manual A/C)
B89	2	Black	B-5		Blower diode
B90	12	★	B-5	R50	Roof cord
B92	20	★	C-1	R5	Rear wiring harness
B97	12	★	C-5	R1	
B98	20	★	C-5	R2	
B99	12	★	C-1	R3	
B106	2	★	C-2		Clutch start switch
B107	2	Blue	C-2		Clutch switch
B122	8	★	C-4		Joint connector
B134	34	★	C-4		ECM
B135	35	★	C-4		
B136	35	★	C-4		
B137	31	★	C-4		
B138	6	★	C-4		Joint connector
B152	10	Gray	B-2		Fuse & relay box (F/B)
B158	8	★	B-2		
B159	9	Brown	B-2		
B162	2	★	B-2		
B163	6	★	C-4		Intake door actuator
B177	2	★	B-5		Wiper deicer

# Bulkhead Wiring Harness (In Compartment)

WIRING SYSTEM

Connector				Connecting to	
No.	Pole	Color	Area	No.	Description
B220	40	Black	B-4		Fuse (relay block)
					A/F, oxygen sensor relay
					Fuel pump relay
					DCCD relay
					IG relay
					Main relay
					Electronic throttle control relay
B224	2	★	C-2		Key illumination
B225	40	Black	C-2		Fuse (relay block)
					Starter relay
					Front fog light relay
					Power window relay
					Wiper deicer relay
					Tail & Illumination relay
					Seat heater relay
B230	4	Black	D-4		Yaw rate & G sensor
B231	4	Black	C-2		Steering angle sensor
B239	6	★	B-3		Air mix door actuator
B279	30	★	C-3		Body integrated unit
B280	26	Dark gray	C-3		
B281	28	★	C-3		
B315	6	Black	C-3		
B318	4	★	B-1		VDC OFF switch
B350	4	★	C-2		Key warning switch & key lock solenoid
B363	2	Green	C-1	B364	Test mode sub connector
B364	2	Green	C-1	B363	
B367	8	★	C-2		Impact sensor
B380	32	★	C-3		DCCD CM
B386	4	★	B-4		Blower motor relay
B415	2	Black	B-2		Immobilizer antenna
B431	2	★	C-2		Foot light LH
B434	5	Pink	D-1		Multi joint connector
B435	5	Brown	D-1		
B436	5	Yellow	D-1		
B437	5	Blue	D-1		
B438	5	Gray	D-1		
B439	5	Green	D-1		
B440	5	Orange	D-1		
B441	5	★	D-1		
B442	5	Black	D-2		
B443	5	Red	D-2		
B444	5	Light green	D-2		
B445	5	Violet	D-2		
B447	2	★	C-4	AD4	

★ : White or natural color

WI-181

Brought to you by Ebay Seller "SubaruManuals"

# Bulkhead Wiring Harness (In Compartment)

## WIRING SYSTEM

Connector				Connecting to	
No.	Pole	Color	Area	No.	Description
AB1	6	★	C-1	B31	Bulkhead wiring harness
AB2	4	Yellow	C-2	AB7	Driver's airbag module
AB6	30	Yellow	C-4		Airbag CM
AB9	4	Yellow	C-4		Passenger's airbag module

★ : White or natural color

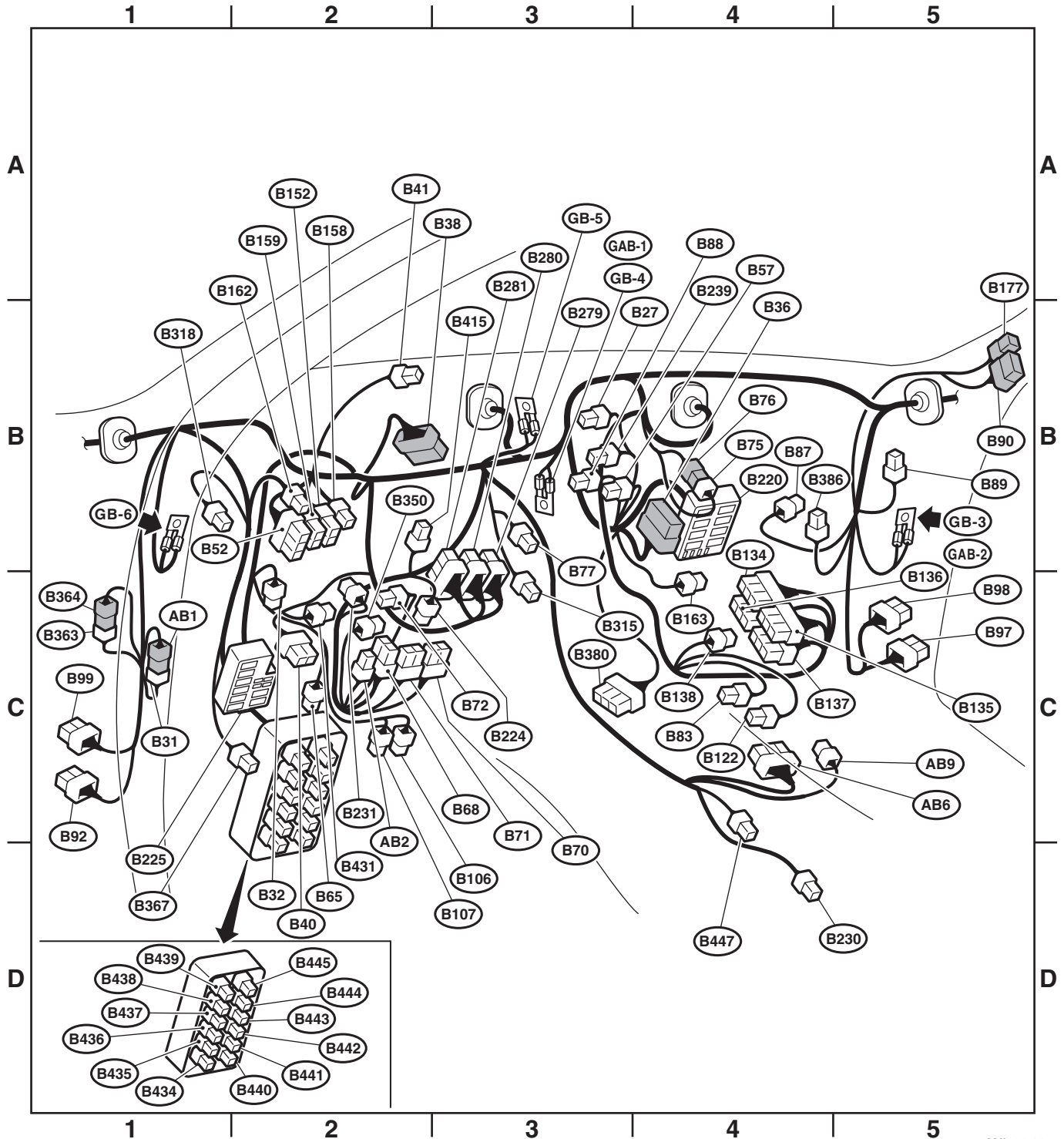

WI-30490

WI-182

Brought to you by Ebay Seller "SubaruManuals"

## 55.Engine Wiring Harness and Transmission Cord

### A: LOCATION

#### 1. WITHOUT SI-DRIVE

Connector				Connecting to	
No.	Pole	Color	Area	No.	Description
E2	54	Black	A-2	B21	Bulkhead wiring harness
E4	2	Black	B-3		Purge control solenoid valve 1
E5	2	Dark gray	B-2		Fuel injector No. 1
E6	2	Dark gray	A-2		Fuel injector No. 3
E8	2	Black	B-2		Engine coolant temperature sensor
E10	2	Light gray	B-2		Crankshaft position sensor
E11	1	—	B-2		Oil pressure switch
E14	2	Light gray	B-3		Knock sensor
E16	2	Dark gray	B-3		Fuel injector No. 2
E17	2	Dark gray	B-4		Fuel injector No. 4
E19	1	★	B-2		Power steering oil pressure switch
E21	3	Black	B-2		Manifold absolute pressure sensor
E22	4	Dark gray	B-1		Front oxygen (A/F) sensor
E31	3	Gray	B-1		Ignition coil No. 1
E32	3	Gray	C-4		Ignition coil No. 2
E33	3	Gray	B-2		Ignition coil No. 3
E34	3	Gray	C-4		Ignition coil No. 4
E35	3	Light gray	B-4		Camshaft position sensor LH
E36	3	Light gray	A-2		Camshaft position sensor RH
E37	2	Blue	B-4		Oil flow control solenoid valve LH
E38	2	Blue	B-2		Oil flow control solenoid valve RH
E40	2	Black	B-4		Secondary air combination valve LH
E41	6	Black	A-3		Secondary air combination valve RH
E51	5	Light gray	B-4		Tumble generator valve assembly LH
E52	2	Black	B-2		Purge control solenoid valve 2
E55	5	Light gray	B-1		Tumble generator valve assembly RH
E57	6	Black	B-3		Electronic throttle control
E64	2	Blue	B-2		Wastegate control solenoid valve
E80	2	Dark gray	B-3		Leak diagnosis connector 1
E87	2	Dark gray	A-2		Leak diagnosis connector 2
E88	2	Dark gray	B-5		Leak diagnosis connector 3

★ : White or natural color

Connector				Connecting to	
No.	Pole	Color	Area	No.	Description
T1	2	Gray	D-3	T13	Transmission cord
T2	2	Brown	D-3	T12	
T5	4	Dark gray	C-2	B19	Bulkhead wiring harness
T6	4	Dark gray	D-3		Rear oxygen sensor
T9	4	Gray	D-3	B128	Bulkhead wiring harness
T12	2	Brown	D-3	T2	Neutral position switch
T13	2	Gray	D-3	T1	Back-up light switch

# Engine Wiring Harness and Transmission Cord

WIRING SYSTEM

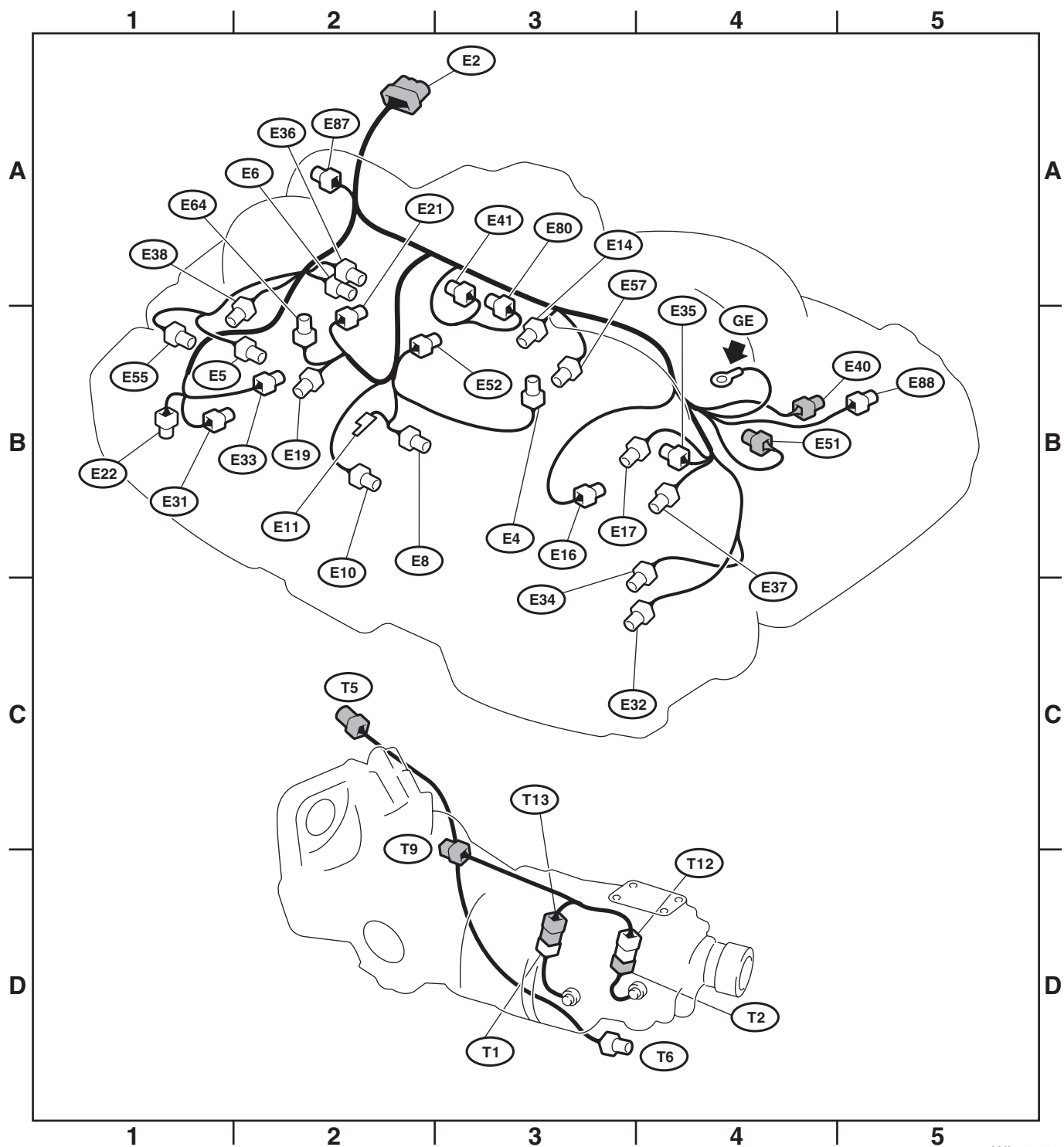

WI-33881

WI-184

Brought to you by Ebay Seller "SubaruManuals"



# Engine Wiring Harness and Transmission Cord

WIRING SYSTEM

## 2. WITH SI-DRIVE

Connector				Connecting to	
No.	Pole	Color	Area	No.	Description
E2	54	Black	A-2	B21	Bulkhead wiring harness
E4	2	Black	B-2		Purge control solenoid valve 1
E5	2	Dark gray	A-1		Fuel injector No. 1
E6	2	Dark gray	A-2		Fuel injector No. 3
E8	2	Black	B-2		Engine coolant temperature sensor
E10	2	Light gray	B-3		Crankshaft position sensor
E11	1	—	B-2		Oil pressure switch
E14	2	Light gray	A-3		Knock sensor
E16	2	Dark gray	B-4		Fuel injector No. 2
E17	2	Dark gray	B-4		Fuel injector No. 4
E19	1	★	B-2		Power steering oil pressure switch
E21	3	Black	A-3		Manifold absolute pressure sensor
E31	3	Gray	A-1		Ignition coil No. 1
E32	3	Gray	B-4		Ignition coil No. 2
E33	3	Gray	A-2		Ignition coil No. 3
E34	3	Gray	B-5		Ignition coil No. 4
E35	3	Light gray	A-4		Intake camshaft position sensor LH
E36	3	Light gray	A-2		Intake camshaft position sensor RH
E37	2	Blue	B-4		Intake oil flow control solenoid valve LH
E38	2	Blue	A-2		Intake oil flow control solenoid valve RH
E40	6	Black	A-4		Secondary air combination valve LH
E41	2	Black	A-3		Secondary air combination valve RH
E51	5	Light gray	B-5		Tumble generator valve assembly LH
E52	2	Black	B-2		Purge control solenoid valve 2
E55	5	Light gray	A-2		Tumble generator valve assembly RH
E57	6	Black	A-3		Electronic throttle control
E62	3	Light gray	B-1		Exhaust camshaft position sensor RH
E63	2	Blue	B-1		Exhaust oil flow control solenoid valve RH
E64	2	Blue	A-3		Wastegate control solenoid valve
E65	3	Light gray	B-4		Exhaust camshaft position sensor LH
E66	2	Blue	B-3		Exhaust oil flow control solenoid valve LH
E80	2	Dark gray	A-3		Leak diagnosis connector 1
E87	2	Dark gray	B-3		Leak diagnosis connector 2

★ : White or natural color

Connector				Connecting to	
No.	Pole	Color	Area	No.	Description
T1	2	Gray	D-3	T13	Transmission cord
T2	2	Brown	D-3	T12	
T5	4	Dark gray	C-2	B19	Bulkhead wiring harness
T6	4	Dark gray	D-3		Rear oxygen sensor
T9	6	Gray	C-2	B128	Bulkhead wiring harness
T12	2	Brown	D-3	T2	Neutral position switch
T13	2	Gray	D-3	T1	Back-up light switch
T16	2	★	D-3	T17	Center differential wiring harness
T17	2	★	D-3	T16	Transmission cord

★ : White or natural color

WI-185

Brought to you by Ebay Seller "SubaruManuals"

# Engine Wiring Harness and Transmission Cord

## WIRING SYSTEM

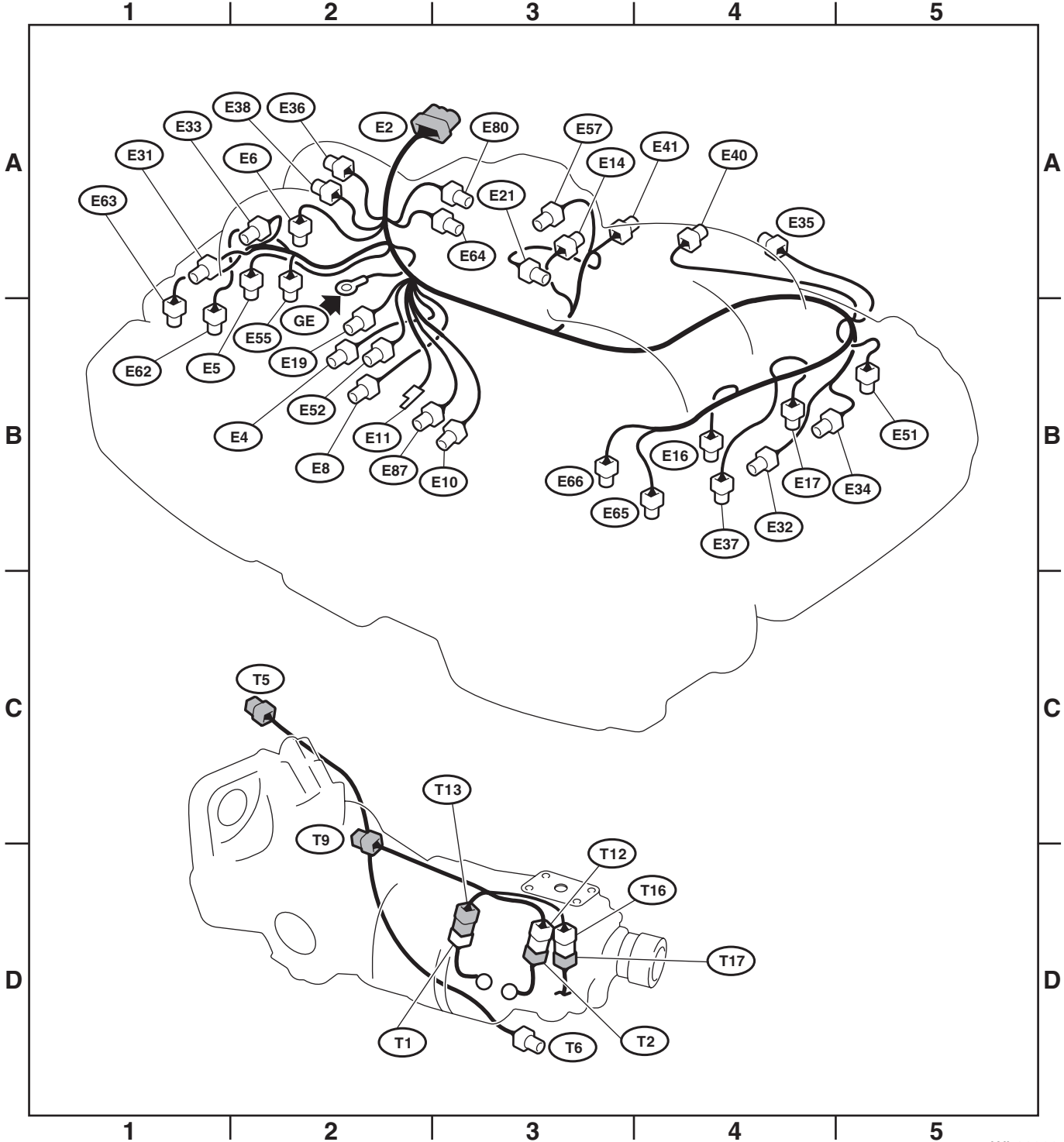

WI-33882

WI-186

Brought to you by Ebay Seller "SubaruManuals"

## 56. Instrument Panel Wiring Harness

### A: LOCATION

Connector				Connecting to	
No.	Pole	Color	Area	No.	Description
i1	28	★	B-4	B36	Bulkhead wiring harness
i3	28	★	B-1	B38	
i5	20	★	C-1		Fuse & relay box (F/B)
i6	10	★	C-2		Remote control mirror switch
i8	2	★	C-5		Foot light RH
i10	40	★	B-2		Combination meter
i15	6	★	B-4		Blower fan switch (manual A/C)
i16	12	★	B-4		A/C control panel (manual A/C)
i22	4	★	B-3		Hazard switch
i23	2	★	B-4		Glove box light
i24	4	★	C-4	AD1	Adapter cord (front accessory power supply socket, pocket light)
i29	1	Black	B-3		Audio bracket ground
i39	8	★	C-2		Headlight beam leveler switch
i50	10	★	B-4		Navigation unit
i51	2	★	B-3		Sunload sensor
i53	16	★	C-5	R98	Rear wiring harness RH
i54	10	★	C-5	R99	Rear wiring harness RH
i55	2	★	B-3		In-vehicle sensor
i59	10	★	B-3		Clock
i76	28	★	C-1	D83	Front door cord LH
i77	10	Green	B-3		CAN joint connector
i79	6	Gray	B-2		Illumination control switch
i84	35	Gray	B-2		Body integrated unit
i85	20	★	B-4		Audio
i86	8	Black	B-4		Audio (without handsfree microphone)
	16	★	B-4		Audio (with handsfree microphone)
i87	28	★	B-3		Navigation unit
i88	40	★	B-3		A/C control panel (auto A/C)
i97	8	Black	B-2		Joint ground connector
i98	8	Black	B-1		
i99	8	Black	B-5		
i100	8	Black	B-5		
i101	25	★	C-5	D84	Front door cord RH
i102	16	★	C-1	R167	Rear wiring harness LH
i131	16	★	B-4		Navigation unit
i147	6	★	B-3		

★ White or natural color

# Instrument Panel Wiring Harness

WIRING SYSTEM

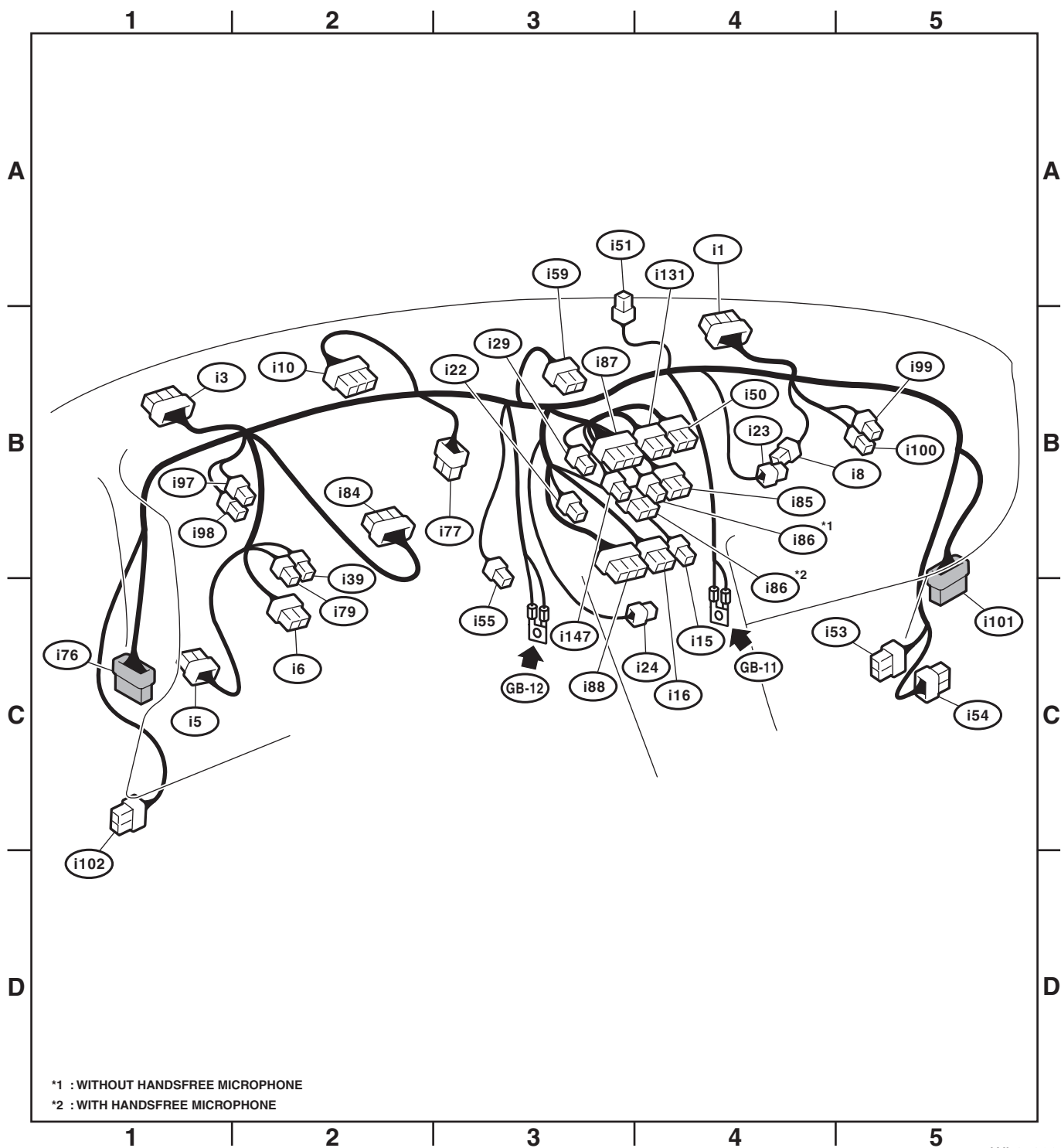

WI-35306

WI-188

Brought to you by Ebay Seller "SubaruManuals"

# Rear Wiring Harness

WIRING SYSTEM

## 57.Rear Wiring Harness

### A: LOCATION

Connector				Connecting to	
No.	Pole	Color	Area	No.	Description
R1	12	★	B-1	B97	Bulkhead wiring harness
R2	20	★	B-1	B98	
R3	12	★	C-3	B99	
R4	1	★	C-3		Parking brake switch
R5	20	★	C-3	B92	Bulkhead wiring harness
R9	3	★	C-4		Front door switch LH
R10	8	★	C-4	D22	Rear door cord LH
R12	3	★	B-2		Front door switch RH
R13	8	★	B-2	D28	Rear door cord RH
R15	12	★	B-4	R57	Fuel cord
R16	3	★	A-3		Rear door switch RH
R32	2	★	B-3		Rear accessory power supply socket (without SI-DRIVE)
R33	10	★	C-2		Multi select switch (with SI-DRIVE)
R34	20	★	C-3	AD6	Adapter cord
R41	4	★	C-3		Seat heater LH
R42	4	★	B-3		Seat heater switch RH (without SI-DRIVE)
R43	4	Blue	B-3		Seat heater switch LH (without SI-DRIVE)
R44	4	★	B-3		Seat heater RH
R50	12	★	B-1	B90	Bulkhead wiring harness
R52	3	★	A-3		Room light
R55	10	Gray	B-3		Sunroof motor assembly
R56	2	★	B-2		Spot map light (with sunroof)
	6	★	B-2		Spot map light (without sunroof)
R57	12	★	B-4	R15	Rear wiring harness RH
R58	6	★	B-4		Fuel pump assembly
R59	2	★	B-5		Fuel sub level sensor
R62	6	★	B-3		Spot map light (with sunroof)
R64	3	★	B-2		Spot map light diode (with sunroof)
R68	2	Dark gray	B-4		Pressure control solenoid valve
R72	2	Light gray	B-4		Rear ABS wheel speed sensor RH
R73	2	Light gray	B-4		Rear ABS wheel speed sensor LH
R81	12	Black	C-3	R82	Rear wiring harness RH
R82	12	Black	B-3	R81	Rear wiring harness LH
R98	16	★	B-1	i53	Instrument panel wiring harness
R99	10	★	B-1	i54	
R107	4	★	C-3		Seat belt switch LH
R128	5	★	B-3		Sunroof switch
R139	3	★	B-3		Rear view mirror
R167	16	★	C-3	i102	Instrument panel wiring harness
R168	20	★	C-3		Fuse & relay box (F/B)
R187	5	Black	B-3		Sunroof switch (tilt)
R284	6	★	B-3		AUX input terminal

★ : White or natural color

## Rear Wiring Harness

### WIRING SYSTEM

Connector				Connecting to	
No.	Pole	Color	Area	No.	Description
AB17	15	Yellow	C-2		Airbag CM
AB18	15	Yellow	C-2		
AB19	4	Yellow	C-3		Side airbag module LH
AB21	2	Black	C-4		Pretensioner LH
AB23	4	Yellow	C-4		Side airbag sensor LH
AB24	4	Yellow	B-2		Side airbag module RH
AB26	2	Black	B-2		Pretensioner RH
AB28	4	Yellow	B-2		Side airbag sensor RH
AB34	4	Yellow	B-3		Curtain airbag sensor RH
AB35	2	Black	C-3		Fuse & relay box (F/B)
AB41	2	Yellow	B-4		Satellite safing sensor
AB53	6	Gray	B-2		Occupant detection control module
AB56	3	Brown	B-3		Belt tension sensor

# Rear Wiring Harness

WIRING SYSTEM

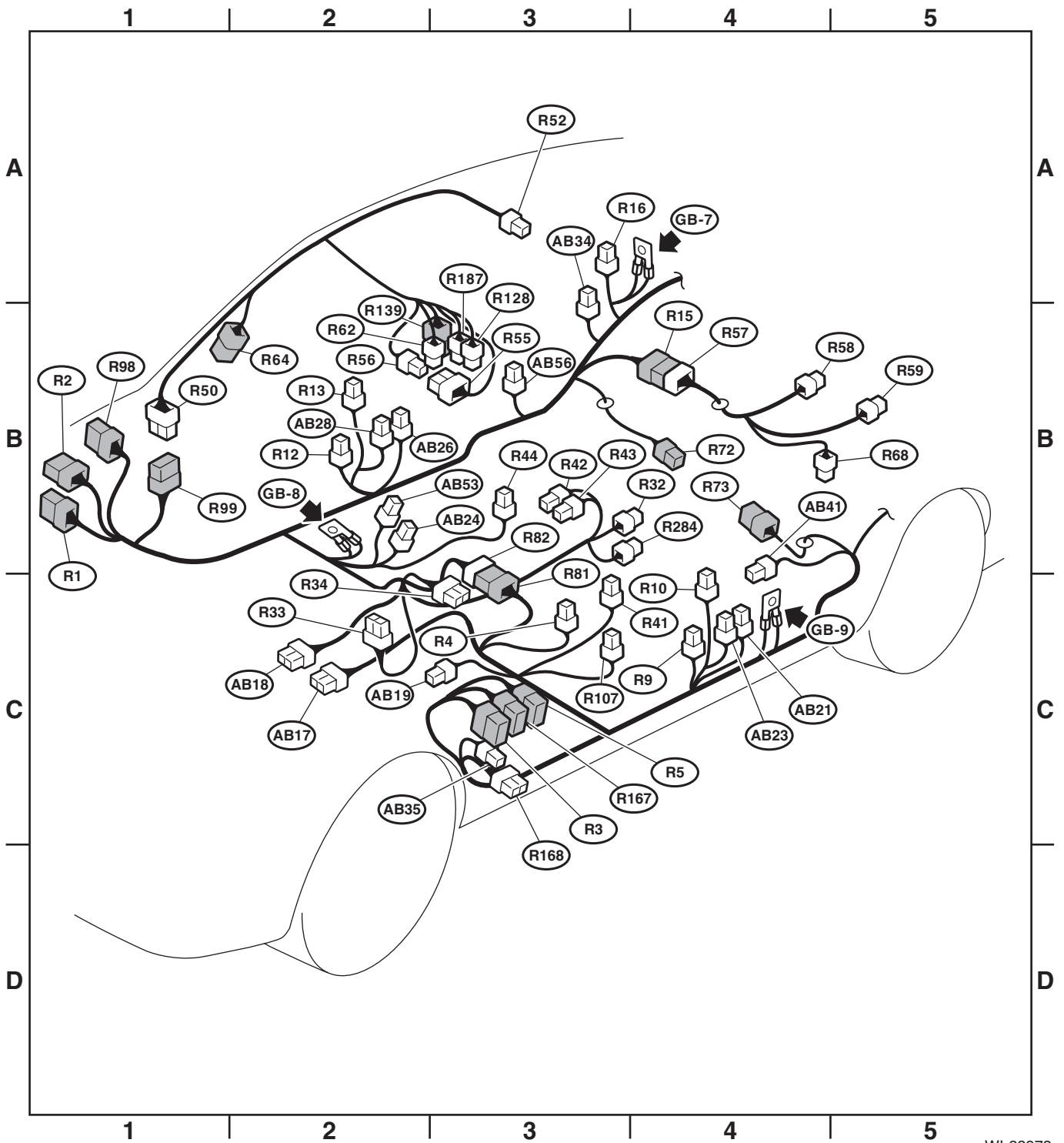

WI-33973

WI-191

Brought to you by Ebay Seller "SubaruManuals"

# Door Cord

WIRING SYSTEM

## 58. Door Cord

### A: LOCATION

Connector				Connecting to	
No.	Pole	Color	Area	No.	Description
D2	2	★	C-4		Front door speaker LH
D3	6	★	C-4		Front power window motor LH
D4	2	Black	C-3		Front door tweeter LH
D5	8	★	C-3		Outer mirror assembly LH (without mirror heater)
	10	★	C-4		Outer mirror assembly LH (with mirror heater)
D7	16	★	B-4		Power window main switch
D12	2	★	B-2		Front door speaker RH
D13	6	★	B-2		Front power window motor RH
D14	2	Black	B-2		Front door tweeter RH
D15	8	★	B-2		Outer mirror assembly RH (without mirror heater)
	10	★	B-2		Outer mirror assembly RH (with mirror heater)
D17	8	★	B-2		Front power window sub switch
D18	2	★	B-3		Front door lock actuator RH
D22	8	★	C-4	R10	Rear wiring harness LH
D23	2	★	C-4		Rear door speaker LH
D24	6	★	B-4		Rear power window motor LH
D25	8	★	B-4		Rear power window sub switch LH
D26	2	★	B-5		Rear door lock actuator LH
D28	8	★	B-3	R13	Rear wiring harness RH
D29	2	★	B-3		Rear door speaker RH
D30	6	★	B-3		Rear power window motor RH
D31	8	★	B-3		Rear power window sub switch RH
D32	2	★	B-3		Rear door lock actuator RH
D72	2	★	C-4		Front door lock actuator LH
D83	28	★	C-3	i76	Instrument panel wiring harness
D84	25	★	B-2	i101	
D102	3	★	C-4		Power window main switch
D125	5	★	B-2		Passenger's seat door lock switch

★ : White or natural color



# Door Cord

WIRING SYSTEM

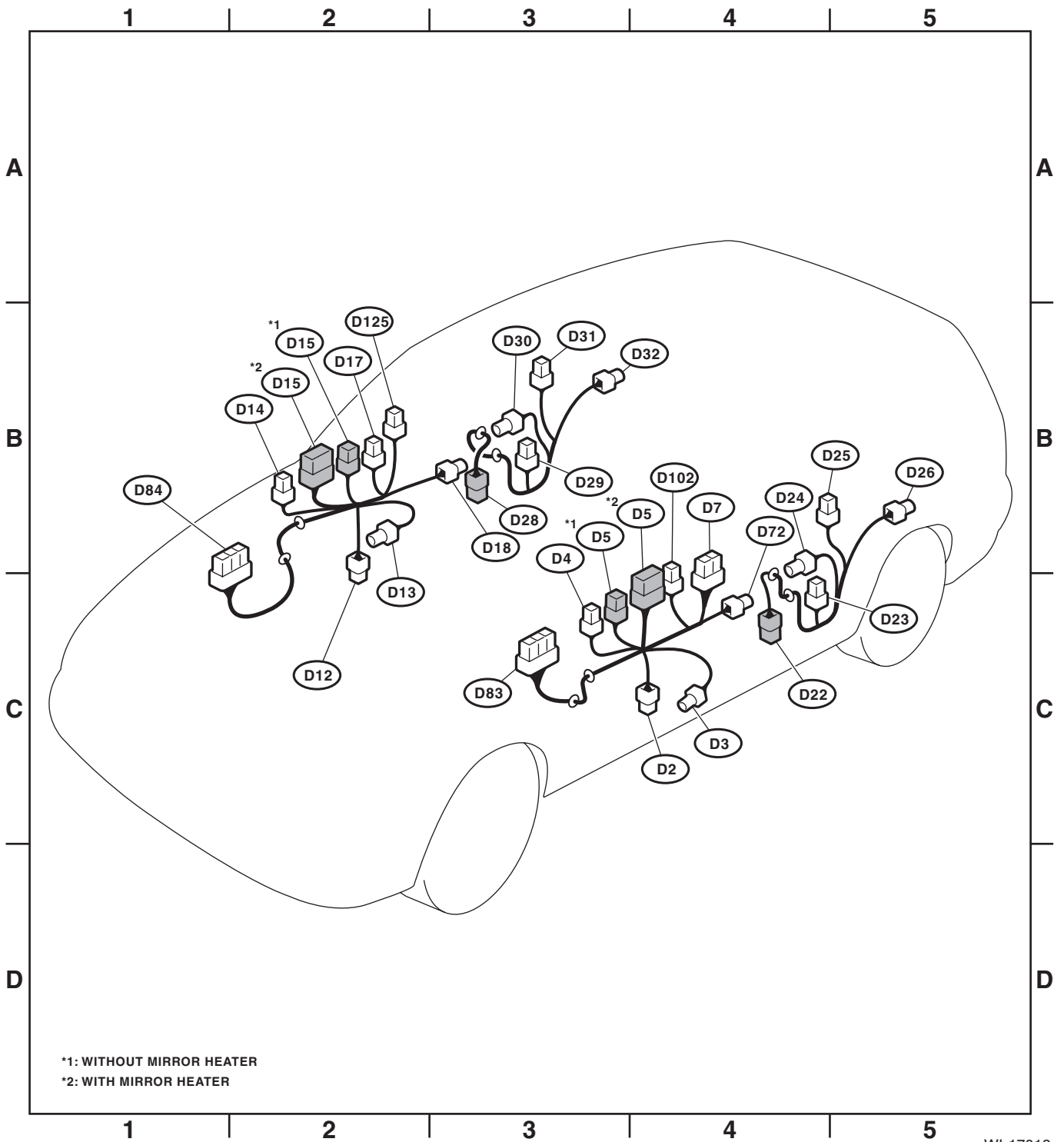

WI-17018

WI-193

Brought to you by Ebay Seller "SubaruManuals"

# Rear Wiring Harness and Trunk Lid Cord

## WIRING SYSTEM

### 59.Rear Wiring Harness and Trunk Lid Cord

#### A: LOCATION

Connector				Connecting to	
No.	Pole	Color	Area	No.	Description
R19	2	Blue	B-3		High-mounted stop light
R20	2	Black	B-4		Trunk room light
R22	3	★	B-1		Rear door switch LH
R24	8	★	B-4	R60	Trunk lid cord
R26	6	★	B-5		Rear combination light RH
R28	6	★	C-3		Rear combination light LH
R60	8	★	B-4	R24	Rear wiring harness RH
R65	1	★	B-2		Rear defogger (-)
R66	2	★	B-4		High-mounted stop light (rear spoiler)
R76	2	★	B-4		License plate light
R80	8	★	B-2		Keyless entry CM
R97	1	★	B-2		Antenna feeder cord
R122	10	★	B-5		Fuel pump CM
R148	1	★	C-3		Rear differential oil temperature switch
R159	1	★	C-3		
R174	1	★	B-4		Rear defogger (+)
R186	3	★	C-3		Trunk lid lock actuator & switch
R221	12	★	B-3		TPMS & keyless entry CM
R400	8	Gray	C-2		ELCM

★ : White or natural color

Connector				Connecting to	
No.	Pole	Color	Area	No.	Description
AB31	2	Black	B-2		Curtain airbag module LH
AB32	4	Yellow	B-1		Curtain airbag sensor LH
AB33	2	Black	B-4		Curtain airbag module RH

# Rear Wiring Harness and Trunk Lid Cord

WIRING SYSTEM

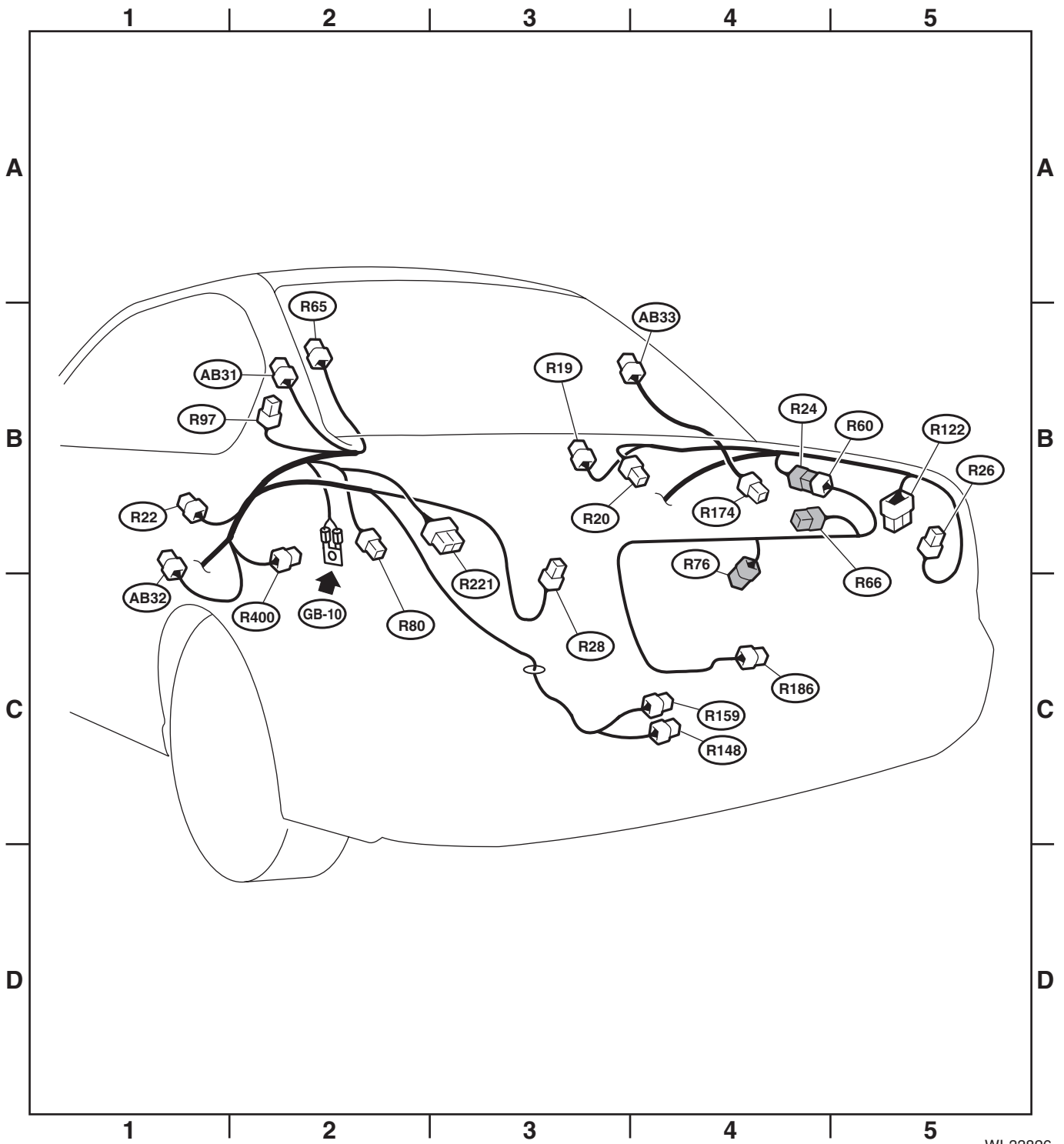

WI-33826

WI-195

Brought to you by Ebay Seller "SubaruManuals"

# Rear Wiring Harness and Rear Gate Cord

## WIRING SYSTEM

### 60. Rear Wiring Harness and Rear Gate Cord

#### A: LOCATION

Connector				Connecting to	
No.	Pole	Color	Area	No.	Description
R22	3	★	C-1		Rear door switch LH
R26	4	Light gray	C-5		Rear combination light RH
R28	4	Light gray	C-2		Rear combination light LH
R38	8	★	C-4	D34	Rear gate cord
R39	14	★	B-4	D35	
R80	8	★	C-1		Keyless entry CM
R97	1	★	C-2		Antenna feeder cord
R122	10	★	C-4		Fuel pump CM
R141	2	★	C-2		Luggage room light
R148	1	★	D-3		Rear differential oil temperature switch
R159	1	★	D-3		
R221	12	★	C-1		TPMS & keyless entry CM
R400	8	Gray	C-2		ELCM

★ : White or natural color

Connector				Connecting to	
No.	Pole	Color	Area	No.	Description
D34	8	★	B-4	R38	Rear wiring harness
D35	14	★	B-4	R39	
D39	2	★	B-3		High-mounted stop light
D43	4	★	B-4		Rear wiper motor
D44	2	★	B-4		License plate light RH
D46	4	★	A-4		Rear gate lock actuator & latch switch
D47	2	Brown	A-4		Rear gate opener button
D48	1	★	B-3		Rear defogger (-)
D58	2	★	B-5		Back-up light RH
D59	2	★	A-3		Back-up light LH
D89	1	★	B-4		Rear defogger (+)
D137	2	★	B-4		License plate light LH

★ : White or natural color

Connector				Connecting to	
No.	Pole	Color	Area	No.	Description
AB31	2	Black	C-2		Curtain airbag module LH
AB32	4	Yellow	C-1		Curtain airbag sensor LH
AB33	2	Black	C-4		Curtain airbag module RH

# Rear Wiring Harness and Rear Gate Cord

WIRING SYSTEM

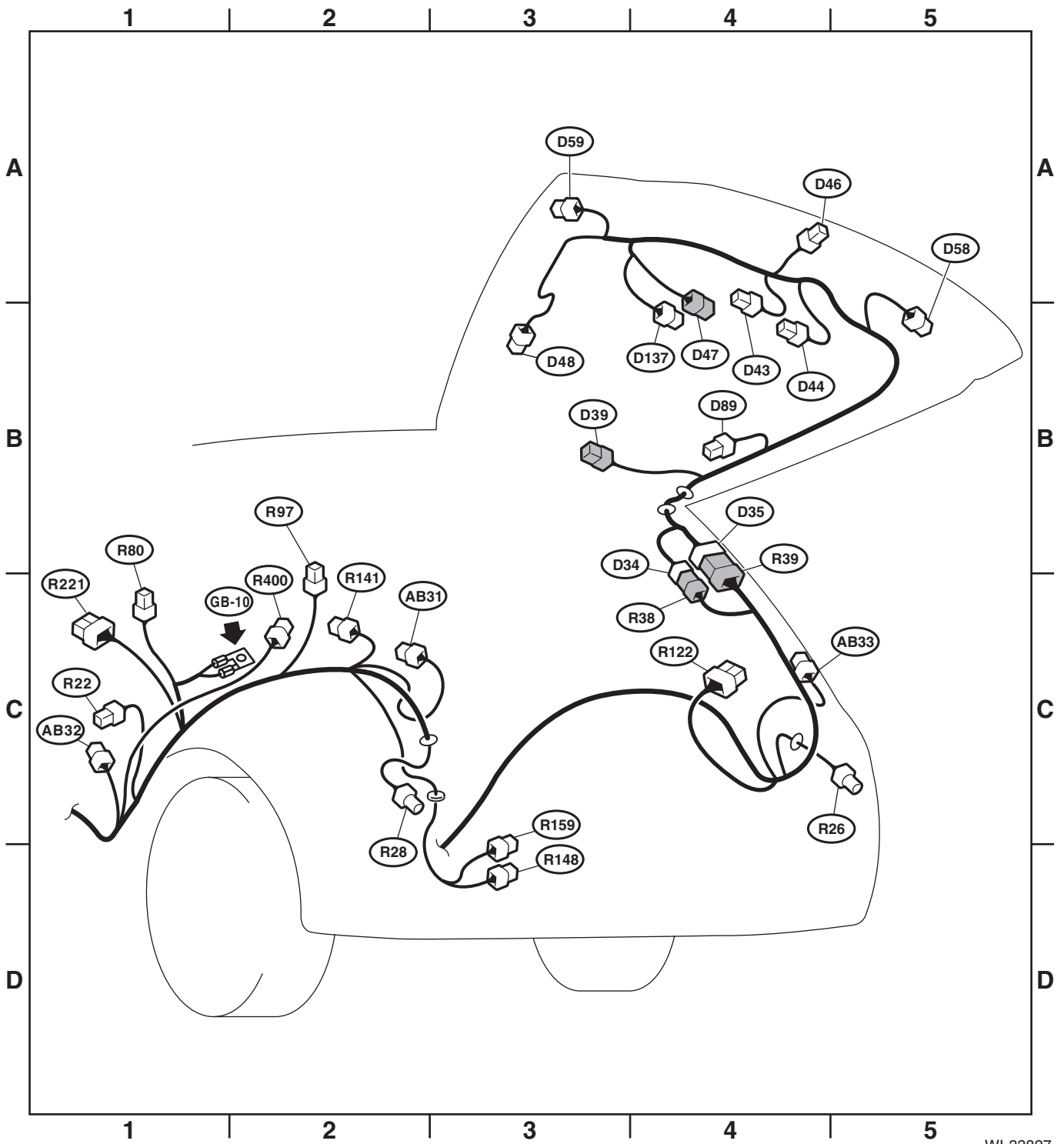

WI-33827

WI-197

Brought to you by Ebay Seller "SubaruManuals"

# Rear Wiring Harness and Rear Gate Cord

WIRING SYSTEM

---

**WI-198**

Brought to you by Ebay Seller "SubaruManuals"