

14. Timing Belt Cover

A: REMOVAL

NOTE:

Perform the work with the engine installed to body when replacing a single part.

- 1) Remove the V-belts. <Ref. to ME(H4DOTC)-40, REMOVAL, V-belt.>
- 2) Remove the crank pulley. <Ref. to ME(H4DOTC)-42, REMOVAL, Crank Pulley.>
- 3) Remove the timing belt cover (LH) (A).
- 4) Remove the timing belt cover (RH) (B).
- 5) Remove the front timing belt cover (C).

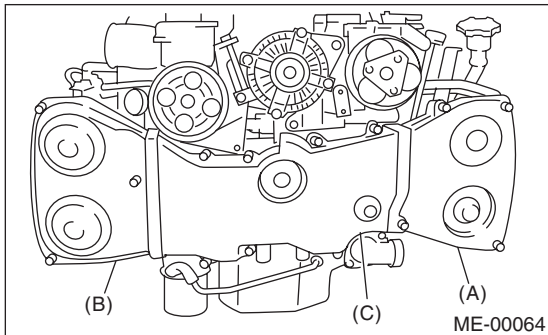

B: INSTALLATION

- 1) Install the front timing belt cover (C).

Tightening torque:

5 N·m (0.5 kgf-m, 3.6 ft-lb)

- 2) Install the timing belt cover (RH) (B).

Tightening torque:

5 N·m (0.5 kgf-m, 3.6 ft-lb)

- 3) Install the timing belt cover (LH) (A).

Tightening torque:

5 N·m (0.5 kgf-m, 3.6 ft-lb)

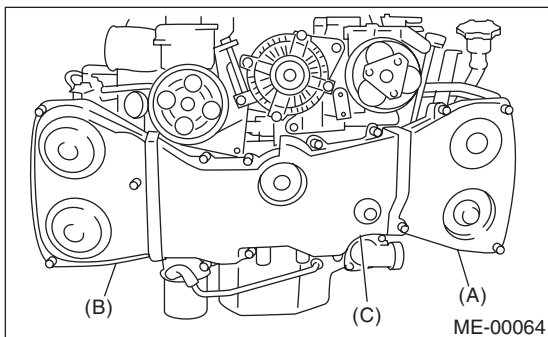

- 4) Install the crank pulley. <Ref. to ME(H4DOTC)-42, INSTALLATION, Crank Pulley.>
- 5) Install the V-belts. <Ref. to ME(H4DOTC)-40, INSTALLATION, V-belt.>

C: INSPECTION

Make sure the cover is not damaged.