

General Description

FUEL INJECTION (FUEL SYSTEMS)

1. General Description

A: SPECIFICATION

Fuel tank	Capacity	60 ℓ (15.9 US gal, 13.2 Imp gal)
	Locations	Under rear seat
Fuel pump	Type	Impeller
	Shutoff discharge pressure	450 — 677 kPa (4.59 — 6.9 kg/cm ² , 65.27 — 98.2 psi)
	Discharge rate	145 ℓ (38.3 US gal, 31.9 Imp gal)/h or more [300 kPa, 12 V (3.06 kg/cm ² , 43.5 psi)]
Fuel filter		Intank type

B: COMPONENT

1. INTAKE MANIFOLD

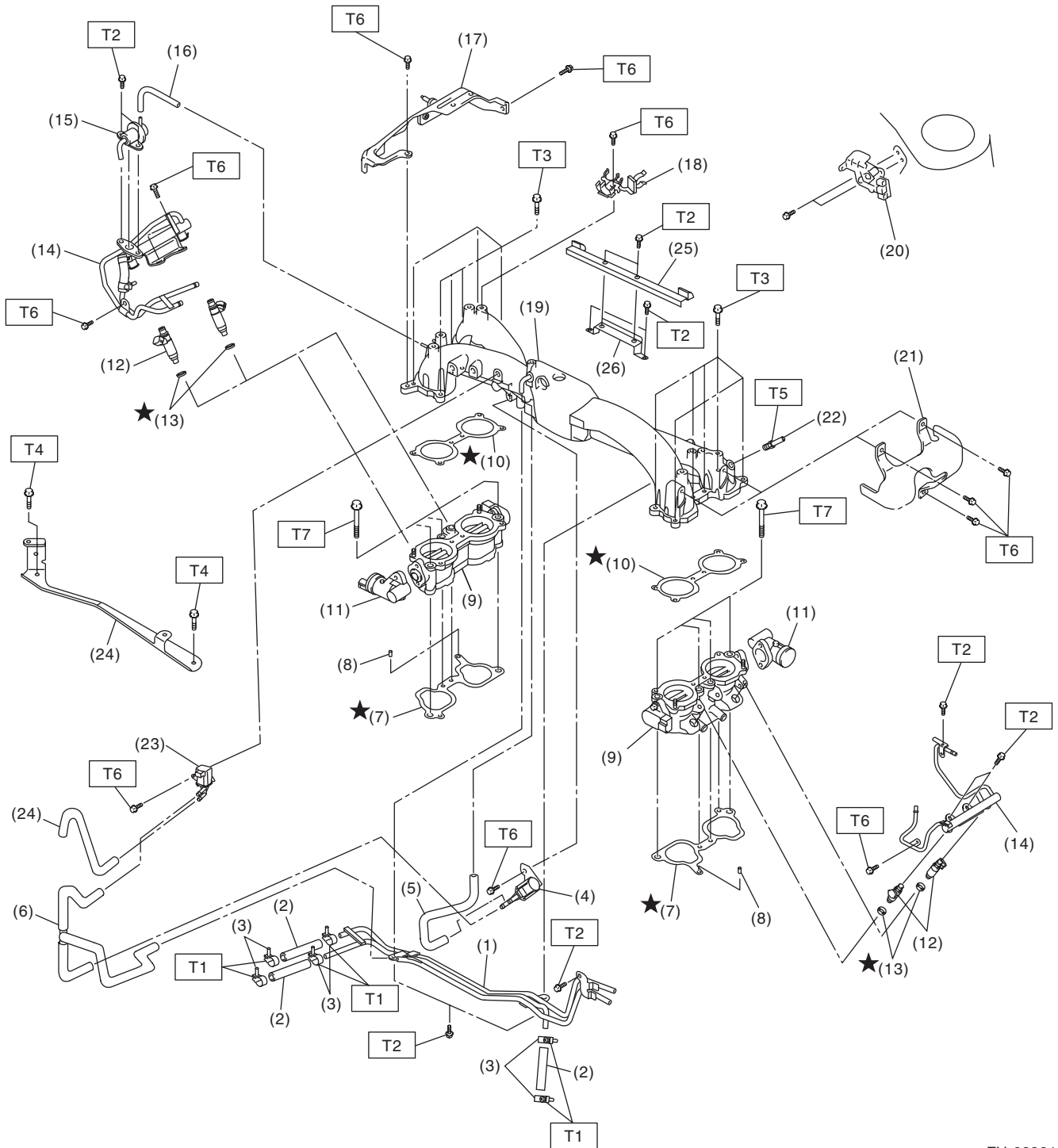

FU-02991

General Description

FUEL INJECTION (FUEL SYSTEMS)

(1) Fuel pipe ASSY	(14) Fuel injector pipe	(25) Collector cover bracket (Front)
(2) Fuel hose	(15) Pressure regulator	(26) Collector cover bracket (Rear)
(3) Clamp	(16) Pressure regulator hose	(27) Collector cover bracket (Rear)
(4) Purge control solenoid valve 1	(17) Fuel pipe protector RH	
(5) Vacuum hose A	(18) Blow-by hose stay	<hr/>
(6) Vacuum control hose	(19) Intake manifold	Tightening torque:N-m (kgf-m, ft-lb)
(7) Intake manifold gasket	(20) Wastegate control solenoid valve ASSY	T1: 1.25 (0.13, 0.94)
(8) Guide pin	(21) Fuel pipe protector LH	T2: 6.4 (0.65, 4.7)
(9) Tumble generator valve ASSY	(22) Nipple	T3: 8.25 (0.84, 6.1)
(10) Tumble generator valve gasket	(23) Purge control solenoid valve 2	T4: 8.5 (0.87, 6.3)
(11) Tumble generator valve actuator	(24) Vacuum hose B	T5: 17 (1.73, 12.5)
(12) Fuel injector		T6: 19 (1.9, 14.0)
(13) O-ring		T7: 25 (2.5, 18.1)

2. AIR INTAKE SYSTEM

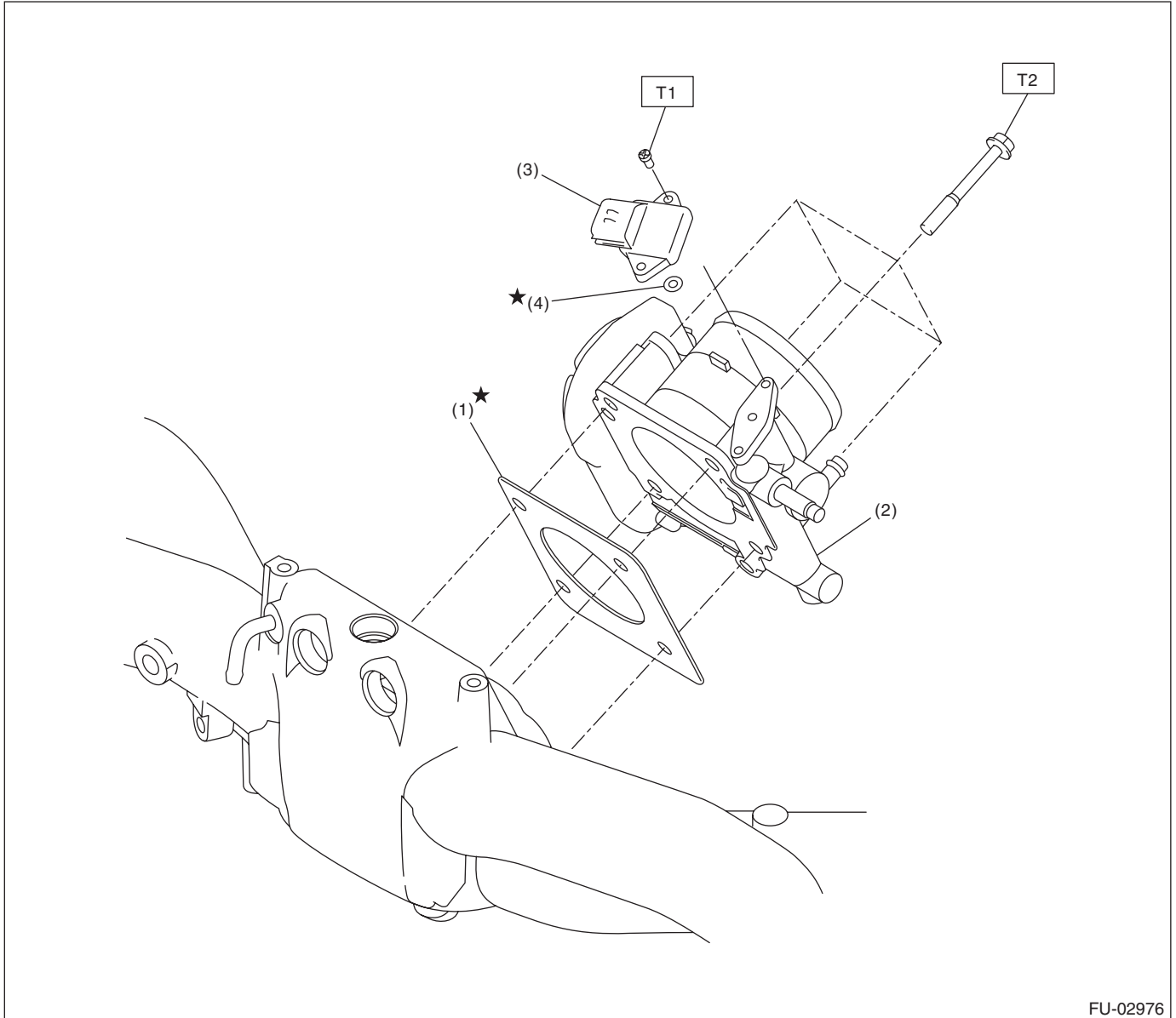

FU-02976

- (1) Gasket
- (2) Throttle body

- (3) Manifold absolute pressure sensor
- (4) O-ring

Tightening torque: N·m (kgf·m, ft·lb)

T1: 1.6 (0.16, 1.2)

T2: 8 (0.8, 5.8)

General Description

FUEL INJECTION (FUEL SYSTEMS)

3. CRANKSHAFT POSITION, CAMSHAFT POSITION AND KNOCK SENSORS

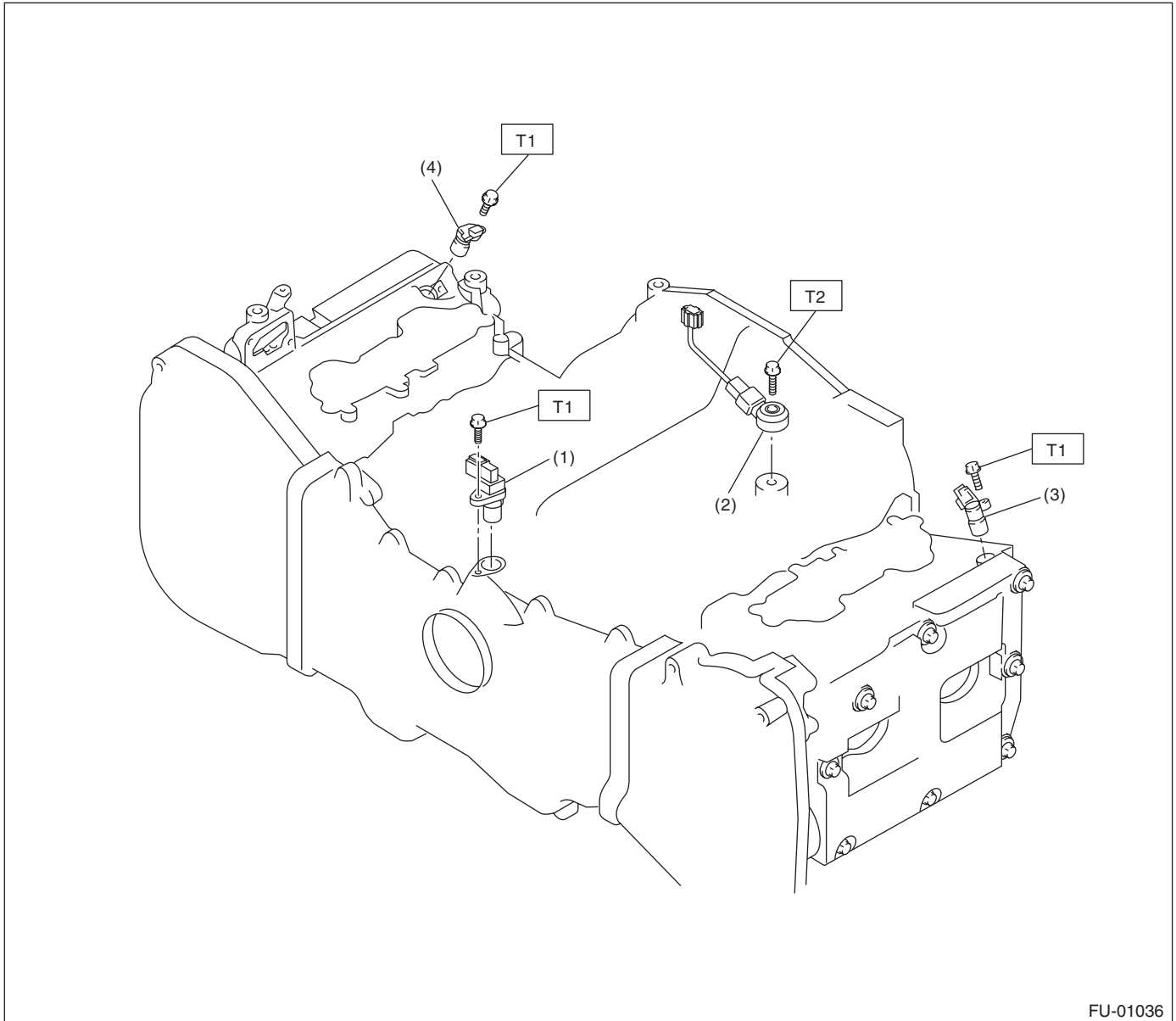

FU-01036

- (1) Crankshaft position sensor
- (2) Knock sensor

- (3) Camshaft position sensor LH
- (4) Camshaft position sensor RH

Tightening torque: N·m (kgf·m, ft·lb)

T1: 6.4 (0.65, 4.7)

T2: 24 (2.4, 17.4)

General Description

FUEL INJECTION (FUEL SYSTEMS)

4. FUEL TANK

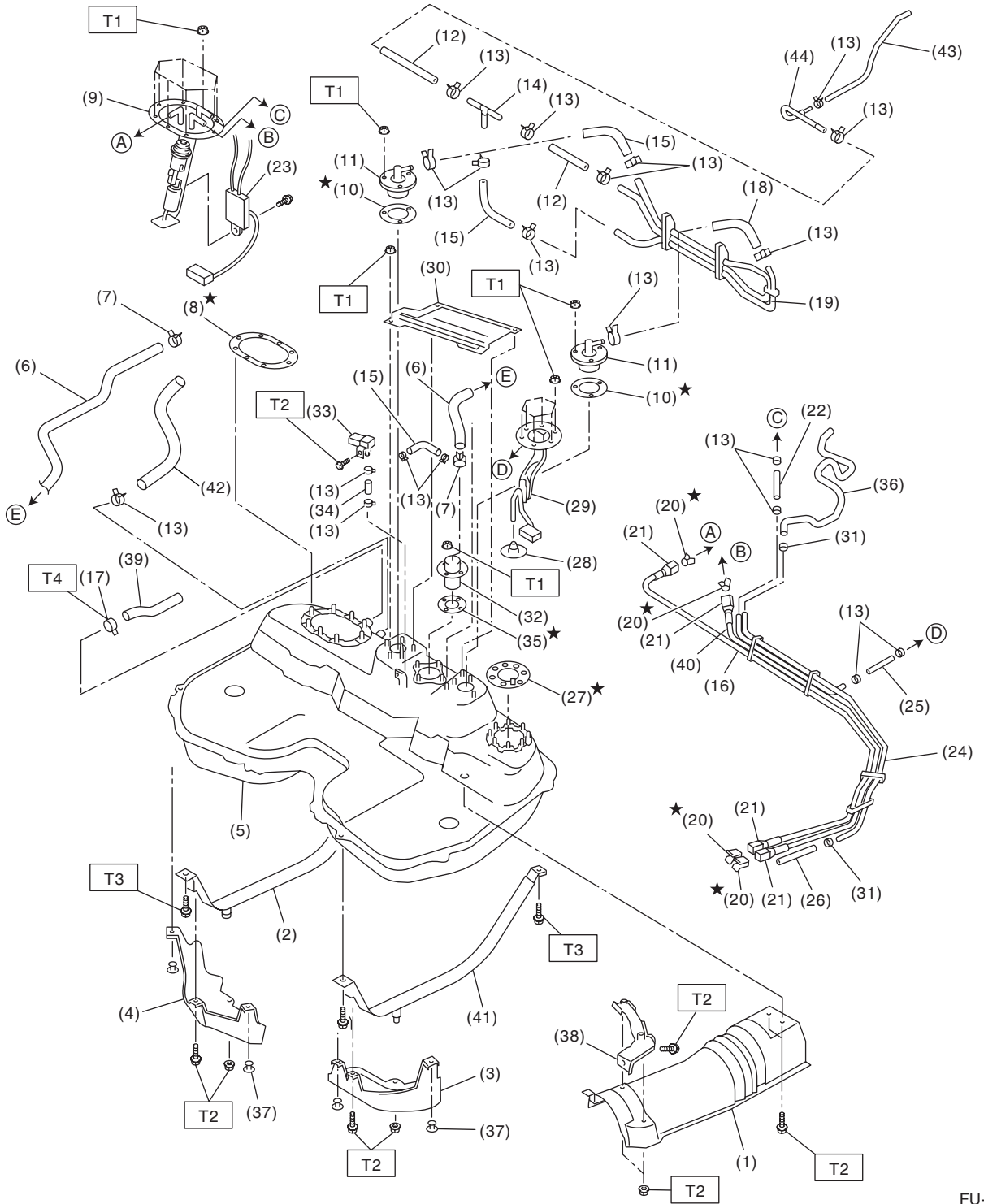

FU-02992

General Description

FUEL INJECTION (FUEL SYSTEMS)

(1) Heat shield cover	(18) Evaporation hose C	(35) Vent valve gasket
(2) Fuel tank band	(19) Evaporation pipe ASSY	(36) Purge hose
(3) Protector LH	(20) Retainer	(37) Clip
(4) Protector RH	(21) Quick connector	(38) Cover bracket
(5) Fuel tank	(22) Jet pump hose A	(39) Filler hose
(6) Canister hose A	(23) Fuel level sensor	(40) Fuel return tube
(7) Clamp	(24) Fuel pipe ASSY	(41) Fuel tank band LH
(8) Fuel pump gasket	(25) Jet pump hose B	(42) Evaporation hose E
(9) Fuel pump ASSY	(26) Evaporation hose D	(43) Evaporation hose F
(10) Fuel cut valve gasket	(27) Fuel sub level sensor gasket	(44) Evaporation pipe
(11) Fuel cut valve	(28) Jet pump filter	
(12) Evaporation hose A	(29) Fuel sub level sensor	
(13) Clip	(30) Protect cover	
(14) Joint pipe	(31) Clip	
(15) Evaporation hose B	(32) Vent valve	
(16) Fuel delivery tube	(33) Fuel tank pressure sensor	
(17) Clamp	(34) Fuel tank pressure sensor hose	

Tightening torque:N·m (kgf-m, ft-lb)**T1: 4.4 (0.45, 3.3)****T2: 7.4 (0.75, 5.4)****T3: 33 (3.4, 25)****T4: 1.96 (0.20, 1.45)**

General Description

FUEL INJECTION (FUEL SYSTEMS)

(1) Clamp	(16) Pressure control solenoid valve bracket	(29) Clip
(2) Fuel return hose A	(17) Drain hose C	(30) Clamp
(3) Fuel damper valve (Return)	(18) Canister upper bracket	(31) Pressure control solenoid valve hose
(4) Fuel return hose B	(19) Cushion rubber	(32) Clamp
(5) Evaporation hose A	(20) Canister lower bracket	(33) Retainer
(6) Clip	(21) Canister	(34) Clamp
(7) Fuel delivery hose A	(22) Drain valve	(35) Drain pipe
(8) Fuel delivery hose B	(23) Drain filter	(36) Canister bracket spacer
(9) Fuel damper valve bracket	(24) Pressure control solenoid valve tube	(37) Clamp
(10) Fuel damper valve (Delivery)		
(11) Fuel pipe ASSY		
(12) Evaporation hose B	(25) Drain hose A	<hr/> Tightening torque:N·m (kgf-m, ft-lb)
(13) Joint pipe	(26) Connector drain	T1: 25 (2.5, 18.1)
(14) Canister hose A	(27) Drain hose B	T2: 23 (2.3, 16.6)
(15) Pressure control solenoid valve	(28) Clip	T3: 1.25 (0.13, 0.9) <hr/>

General Description

FUEL INJECTION (FUEL SYSTEMS)

6. FUEL FILLER PIPE

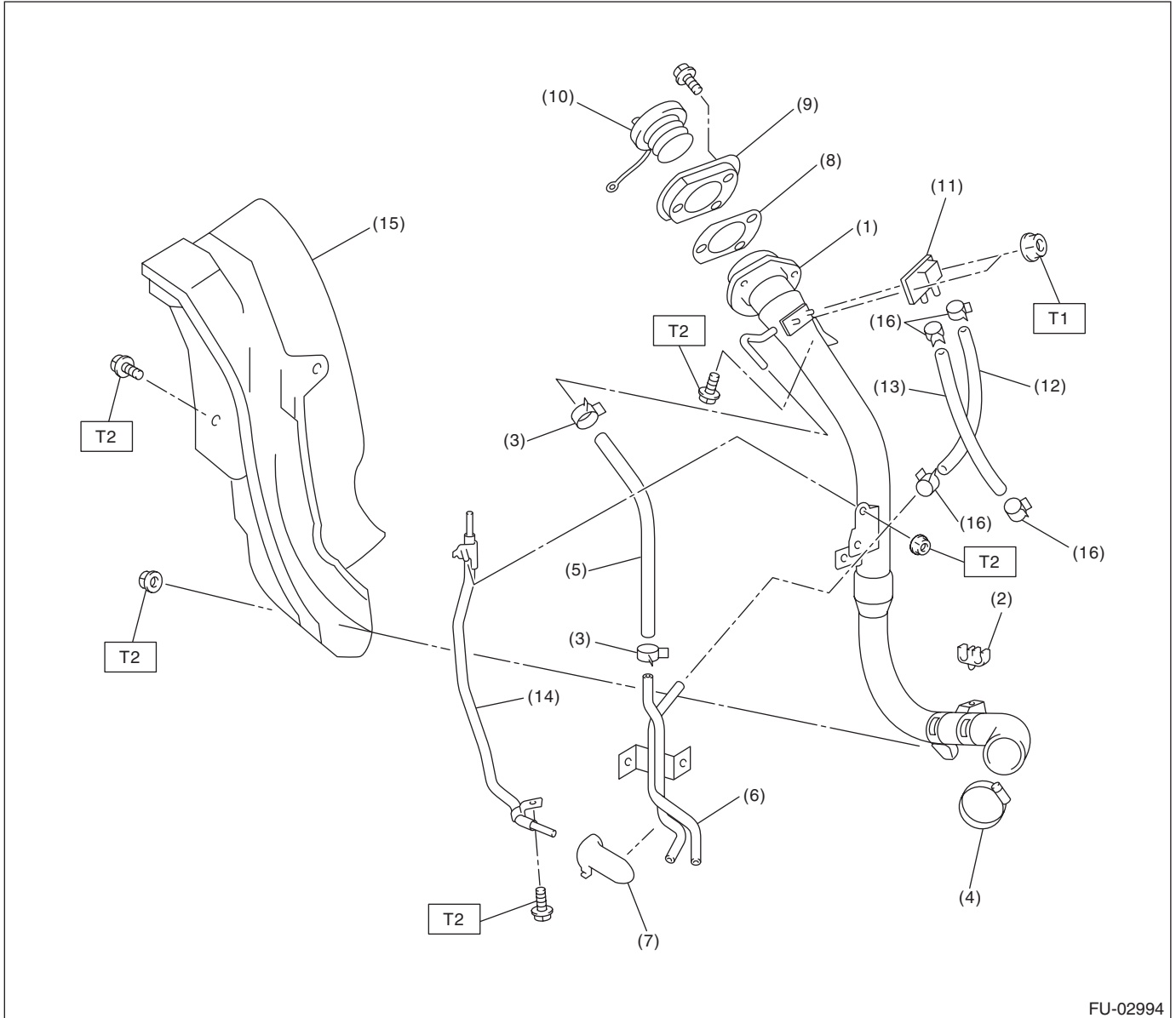

FU-02994

- | | | |
|-----------------------------|-------------------------|---------------------------------|
| (1) Fuel filler pipe ASSY | (8) Filler pipe packing | (15) Fuel filler pipe protector |
| (2) Evaporation hose holder | (9) Filler ring | (16) Clamp |
| (3) Clip | (10) Filler cap | |
| (4) Clamp | (11) Shut valve | |
| (5) Evaporation hose A | (12) Evaporation hose B | |
| (6) Evaporation pipe | (13) Evaporation hose C | |
| (7) Evaporation pipe holder | (14) Joint pipe | |

Tightening torque: N·m (kgf·m, ft·lb)

T1: 4.4 (0.45, 3.3)

T2: 7.5 (0.76, 5.5)

General Description

FUEL INJECTION (FUEL SYSTEMS)

C: CAUTION

- Wear appropriate work clothing, including a cap, protective goggles and protective shoes when performing any work.
- Remove contamination including dirt and corrosion before removal, installation or disassembly.
- Keep the disassembled parts in order and protect them from dust and dirt.
- Before removal, installation or disassembly, be sure to clarify the failure. Avoid unnecessary removal, installation, disassembly and replacement.
- Vehicle components are extremely hot after driving. Be wary of receiving burns from heated parts.

- Be sure to tighten fasteners including bolts and nuts to the specified torque.
- Place shop jacks or rigid racks at the specified points.
- Before disconnecting connectors of sensors or units, be sure to disconnect the ground cable from the battery.
- Place "NO FIRE" signs near the working area.
- Prepare a container and cloth to prevent scattering of fuels when performing work where fuels can be spilled. If the fuel spills, wipe it off immediately to prevent from penetrating into floor or flowing out for environmental protection.
- Follow all government and local regulations concerning disposal of refuse when disposing fuel.

D: PREPARATION TOOL

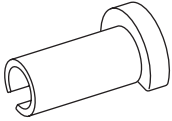
ILLUSTRATION	TOOL NUMBER	DESCRIPTION	REMARKS
 ST42099AE000	42099AE000	CONNECTOR REMOVER	Removal of quick connector