

# AUTOMATIC TRANSMISSION

## CONTENTS

<b>SERVICE SPECIFICATIONS</b> .....	2	Inhibitor Switch Control Cable Adjustment .....	46
<b>LUBRICANTS</b> .....	2	A/T Control Component Location .....	48
<b>SPECIAL TOOLS</b> .....	2	A/T Control Component Check .....	49
<b>TROUBLESHOOTING</b> .....	4	Torque Converter Stall Test .....	51
<b>ON-VEHICLE SERVICE</b> .....	44	Hydraulic Pressure Test .....	52
Automatic Transmission Fluid Check .....	44	Hydraulic Circuit .....	57
Oil Filter Replacement .....	44	Line Pressure Adjustment .....	58
Automatic Transmission Fluid Replacement ...	45	Selector Lever Operation Check .....	58
Throttle Position Sensor Adjustment .....	46	<b>TRANSMISSION CONTROL*</b> .....	59
Inhibitor Switch Continuity Check .....	46	<b>TRANSMISSION ASSEMBLY</b> .....	62

### WARNINGS REGARDING SERVICING OF SUPPLEMENTAL RESTRAINT SYSTEM (SRS) EQUIPPED VEHICLES

#### WARNING!

- (1) Improper service or maintenance of any component of the SRS, or any SRS-related component, can lead to personal injury or death to service personnel (from inadvertent firing of the air bag) or to the driver and passenger (from rendering the SRS inoperative).
- (2) If it is possible that the SRS components are subjected to heat over 93°C in baking or drying after painting, remove the SRS components (air bag module and SRS-ECU) beforehand.
- (3) Service or maintenance of any SRS component or SRS-related component must be performed only at an authorised MITSUBISHI dealer.
- (4) MITSUBISHI dealer personnel must thoroughly review this manual, and especially its GROUP 52B – Supplemental Restraint System (SRS) before beginning any service or maintenance of any component of the SRS or any SRS-related component.

#### NOTE

Section titles with the asterisk (\*) in the table of contents in each group indicate operations requiring warnings.



**SERVICE SPECIFICATIONS**

Items		Standard value
Oil temperature sensor k $\Omega$	at 0°C	16.7 – 20.5
	at 100°C	0.57 – 0.69
Resistance of damper clutch control solenoid coil [at 20°C] $\Omega$		2.7 – 3.4
Resistance of Low-Reverse solenoid valve coil [at 20°C] $\Omega$		2.7 – 3.4
Resistance of second solenoid valve coil [at 20°C] $\Omega$		2.7 – 3.4
Resistance of underdrive solenoid valve coil [at 20°C] $\Omega$		2.7 – 3.4
Resistance of overdrive solenoid valve coil [at 20°C] $\Omega$		2.7 – 3.4
Stall speed r/min.		2,100 – 2,600

**LUBRICANT**

Items	Specified lubricant	Quantity (litres)
Transmission fluid	DIAQUEEN ATF SPII or equivalent	8.5

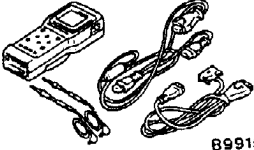
**SPECIAL TOOLS**

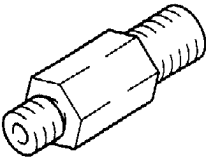
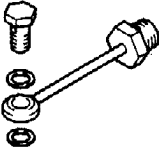
Tool	Number	Name	Application
 8991502	MB991502	MUT-II	Checking for diagnosis trouble codes
	MD998330	Oil pressure gauge 2,942 kPa	Measurement of oil pressure
	MD998332	Adaptor	
	MD998900	Adaptor	

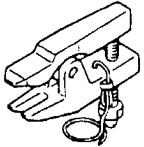
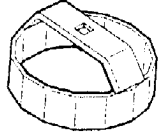
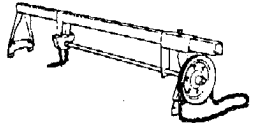
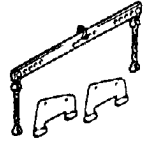
Tool	Number	Name	Application
 <p>B991113</p>	MB991113	Steering linkage puller	Removal of the tie rod end and the lower arm
	MB991610	Oil filter wrench	Removal and installation of automatic transmission oil filter
 <p>Z203827</p>	GENERAL SERVICE TOOL MZ203827	Engine lifter	Supporting the engine assembly during removal and installation of the transmission
 <p>B991453</p>	MB991453	Engine hanger assembly	Supporting the engine assembly during removal and installation of the transmission

**TROUBLESHOOTING**

**STANDARD FLOW OF DIAGNOSIS TROUBLESHOOTING**

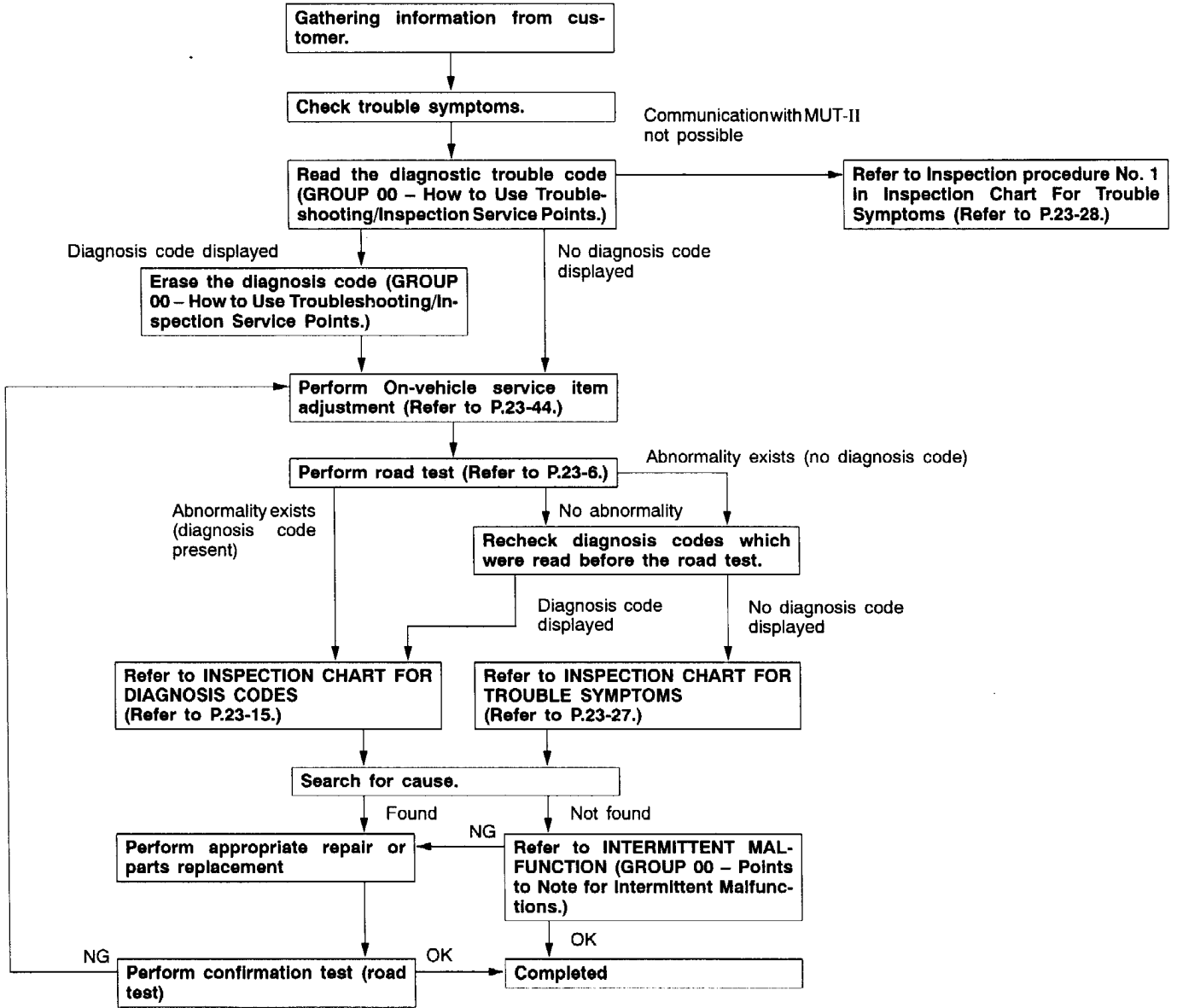

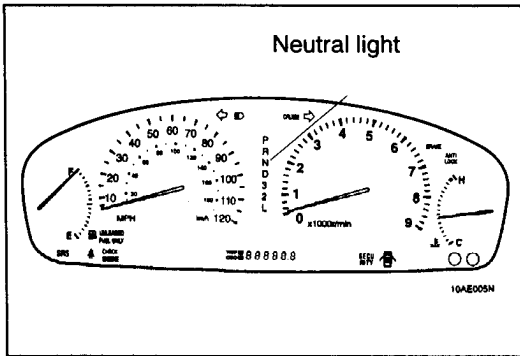

## DIAGNOSIS FUNCTION

### 1. N (Neutral) range light

The N range light flashes at a frequency of approximately 1 Hz (once per second) if there is an abnormality in any of the items in the table below which are related to the A/T system. Check for diagnostic trouble codes if the N range light is flashing at a frequency of approximately 1 Hz.

#### N range light flashing items

Input shaft speed sensor
Output shaft speed sensor
Each solenoid valve
Gear incorrect ratio

#### Caution

- If the N range light is flashing at a frequency of approximately 2 Hz (two flashes per second), it means that the automatic transmission fluid temperature is too high. Stop the vehicle in a safe place and wait until the N range light switches off.

### 2. Method of reading the diagnosis code

Use the MUT-II or the N range lamp to take a reading of the diagnosis codes. (Refer to GROUP 00 – How to Use Troubleshooting/Inspection Service Points.)

## ROAD TEST

Check by the following procedures

No.	Condition	Operation	Judgement value	Check item	Code No.	Inspection procedure page if there is an abnormality
1	Ignition switch: OFF	Ignition switch (1) ON	Data list No. 54 Control Relay Voltage	A/T Control relay	54	A/T Control relay system (23-26)
2	Ignition switch: ON Engine: Stopped Selector lever position: P	Selector lever position (1) P, (2) R, (3) N, (4) D, (5) 3, (6) 2, (7) L	Data list No. 61 (1) P, (2) R, (3)N, (4) D, (5) 3, (6) 2, (7) L	Inhibitor switch	27 28	Inhibitor switch system (23-19)
		Accelerator pedal (1) Fully closed (2) Depressed (3) Fully open	Data list No. 11 (1) 400 – 1,000 mV (2) Gradually rises from (1) (3) 4,500 – 5,000 mV	TPS	11 12 14	TPS system (23-16)
		Brake pedal (1) Depressed (2) Released	Data list No. 26 (1) ON (2) OFF	Stop light switch	26	Stop light switch system (23-19)
3	Ignition switch: ST Engine: Stopped	Starting test with lever P or N range	Starting should be possible	Starting	–	Starting impossible (23-28)
4	Warming up	Drive for 15 min- utes or more so that the automatic transmission fluid temperature be- comes 70 – 90°C.	Data list No. 15 Gradually rises to 70 – 90°C	Oil temperature sensor	15 16	Oil temperature sensor system (23-16)

No.	Condition	Operation	Judgement value	Check item	Code No.	Inspection procedure page if there is an abnormality
5	Engine: Idling Selector lever position: N	Brake pedal (Retest) (1) Depressed (2) Released	Data list No. 26 (1) ON (2) OFF	Stop light switch	26	Stop light switch system (23-19)
		A/C switch (1) ON (2) OFF	Data list No. 65 (1) ON (2) OFF	Dual pressure switch	–	Dual pressure switch system (23-36)
5	Engine: Idling Selector lever position: N	Accelerator pedal (1) Fully closed (2) Depressed	Data list No. 64 (1) ON (2) OFF	Idle position switch	–	Idle position switch system (23-36)
			Data list No. 21 (1) 600 – 900 r/min (2) Gradually rises from (1)	Crankshaft position sensor	21	Crankshaft position sensor system (23-16)
			Data list No. 57 (2) Data changes	Communication with Engine-ECU	51	Abnormal communication with Engine-ECU (23-26)
5	Engine: Idling Selector lever position: N	Selector lever position (1) N → D (2) N → R	Should be no abnormal shifting shocks Time lag when shifting should be within 2 seconds	Malfunction when starting	–	Engine stalling when shifting (23-30)
					--	Shocks when changing from N to D and large time lag (23-31)
					–	Shocks when changing from N to R and large time lag (23-32)
					–	Shocks when changing from N to D,N to R and long time lag (23-32)
				Driving impossible	–	Does not move forward (23-29)
					–	Does not reverse (23-29)
					–	Does not move (forward or reverse) (23-30)

No.	Condition	Operation	Judgement value	Check item	Code No.	Inspection procedure page if there is an abnormality
6	Selector lever position: N (on a flat and straight road.)	Selector lever position and vehicle speed (1) Idling in L range (Vehicle stopped) (2) Driving at constant speed of 10 km/h in L position (3) Driving at constant speed of 30 km/h in 2 position (4) Accelerate to 50 km/h in 3 position, then release accelerator pedal. (5) Driving at constant speed of 50 km/h in D position (Each condition should be maintained for 10 seconds or more.)	Data list No. 63 (2) 1st, (3) 2nd, (4) 3rd, (5) 4th	Shift condition	—	—
			Data list No. 31 (2) 0 %, (3) 100 %, (4) 100 %, (5) 100 %	Low and reverse solenoid valve	31	Low and reverse solenoid valve system (23-20)
			Data list No. 32 (2) 0 %, (3) 0 %, (4) 0 %, (5) 100 %	Underdrive solenoid valve	32	Underdrive solenoid valve system (23-20)
			Data list No. 33 (2) 100 %, (3) 0 %, (4) 100 %, (5) 0 %	Second solenoid valve	33	Second solenoid valve system (23-20)



No.	Condition	Operation	Judgement value	Check item	Code No.	Inspection procedure page if there is an abnormality
6	Selector lever position: N (on a flat and straight road.)	Selector lever position and vehicle speed (1) Idling in L range (Vehicle stopped) (2) Driving at constant speed of 10 km/h in L position (3) Driving at constant speed of 30 km/h in 2 position (4) Accelerate to 50 km/h mph in 3 position, then release accelerator pedal. (5) Driving at constant speed of 50 km/h in D position (Each condition should be maintained for 10 seconds or more.)	Data list No. 34 (2) 100 %, (3) 100 %, (4) 0 %, (5) 0 %	Overdrive solenoid valve	34	Overdrive solenoid valve system (23-20)
			Data list No. 29 (1) 0 km/h (4) 50 km/h	Vehicle speed sensor	–	Vehicle speed sensor system (23-37)
			Data list No. 22 (4) 1,800 – 2,100 r/min	Input shaft speed sensor	22	Input shaft speed sensor system (23-17)
			Data list No. 23 (4) 1,800 – 2,100 r/min	Output shaft speed sensor	23	Output shaft speed sensor system (23-18)
7	Selector lever position: 3 (on a flat and straight road.)	Selector lever position and vehicle speed (1) Accelerate to 50 km/h in 3 position, then release accelerator pedal. (2) Driving at constant speed of 50 km/h	Data list No. 36 (1) 0% (2) Approx.70 – 90% Data list No. 52 (1) Approx. 100 – 300 r/min (2) Approx. 0 – 10 r/min	Damper clutch solenoid	36 52 53	Damper clutch solenoid system (23-20)

No.	Condition	Operation	Judgement value	Check item	Code No.	Inspection procedure page if there is an abnormality
8	Use the MUT-II to stop the INVECS-II function. Selector lever position: D (on a flat and straight road.)	<p>Monitor data list No. 11, 23, and 63 with the MUT-II.</p> <p>(1) Accelerate to 4th gear at a throttle position sensor output of 1.5V (accelerator opening angle of 30 %).</p> <p>(2) Gently decelerate to a standstill.</p> <p>(3) Accelerate to 4th gear at a throttle position sensor output of 2.5 V (accelerator opening angle of 50%).</p> <p>(4) While driving at 60 km/h in 4th gear, shift down to 3 range.</p> <p>(5) While driving at 40 km/h in 3rd gear, shift down to 2 range.</p> <p>(6) While driving at 20 km/h in 2nd gear, shift down to L range.</p>	For (1), (2) and (3), the reading should be the same as the specified output shaft speed, and no abnormal shift shocks should occur.	Malfunction when shifting	–	Shift shocks and running up (23-33)
				Displaced shifting points	–	All points (23-33)
			Does not shift		–	No diagnosis code (23-34)
				22	Input shaft speed sensor system (23-17)	
				23	Output shaft speed sensor system (23-18)	
		For (4), (5) and (6), downshifting should occur immediately after shifting.				

No.	Condition	Operation	Judgement value	Check item	Code No.	Inspection procedure page if there is an abnormality
8	Use the MUT-II to stop the INVECS-II function. Selector lever position: D (on a flat and straight road.)	Monitor data list No. 11, 23, and 63 with the MUT-II. (1) Accelerate to 4th gear at a throttle position sensor output of 1.5V (accelerator opening angle of 30 %). (2) Gently decelerate to a standstill. (3) Accelerate to 4th gear at a throttle position sensor output of 2.5 V (accelerator opening angle of 50%). (4) While driving at 60 km/h in 4th gear, shift down to 3 range. (5) While driving at 40 km/h in 3rd gear, shift down to 2 range. (6) While driving at 20 km/h in 2nd gear, shift down to L range.	For (1), (2) and (3), the reading should be the same as the specified output shaft speed, and no abnormal shift shocks should occur. For (4), (5) and (6), downshifting should occur immediately after shifting.	Does not shift from 1 to 2 or 2 to 1	31	Low and reverse solenoid valve system (23-20)
					33	Second solenoid valve system (23-20)
					41	1st gear incorrect ratio (23-21)
					42	2nd gear incorrect ratio (23-22)

No.	Condition	Operation	Judgement value	Check item	Code No.	Inspection procedure page if there is an abnormality
8	Use the MUT-II to stop the INVECS-II function. Selector lever position: D (on a flat and straight road.)	Monitor data list No. 11, 23, and 63 with the MUT-II. (1) Accelerate to 4th gear at a throttle position sensor output of 1.5V (accelerator opening angle of 30 %). (2) Gently decelerate to a standstill. (3) Accelerate to 4th gear at a throttle position sensor output of 2.5 V (accelerator opening angle of 50%). (4) While driving at 60 km/h in 4th gear, shift down to 3 range. (5) While driving at 40 km/h in 3rd gear, shift down to 2 range. (6) While driving at 20 km/h in 2nd gear, shift down to L range.	For (1), (2) and (3), the reading should be the same as the specified output shaft speed, and no abnormal shift shocks should occur. For (4), (5) and (6), downshifting should occur immediately after shifting.	Does not shift from 2 to 3 or 3 to 2	33	Second solenoid valve system (23-20)
					34	Overdrive solenoid valve system (23-20)
					42	2nd gear incorrect ratio (23-22)
					43	3rd gear incorrect ratio (23-23)

No.	Condition	Operation	Judgement value	Check item	Code No.	Inspection procedure page if there is an abnormality
8	Use the MUT-II to stop the INVECS-II function. Selector lever position: D (on a flat and straight road.)	Monitor data list No. 11, 23, and 63 with the MUT-II. (1) Accelerate to 4th gear at a throttle position sensor output of 1.5V (accelerator opening angle of 30 %). (2) Gently decelerate to a standstill. (3) Accelerate to 4th gear at a throttle position sensor output of 2.5 V (accelerator opening angle of 50%). (4) While driving at 60 km/h in 4th gear, shift down to 3 range. (5) While driving at 40 km/h in 3rd gear, shift down to 2 range. (6) While driving at 20 km/h in 2nd gear, shift down to L range.	For (1), (2) and (3), the reading should be the same as the specified output shaft speed, and no abnormal shift shocks should occur. For (4), (5) and (6), downshifting should occur immediately after shifting.	Does not shift from 3 to 4 or 4 to 3	32	Underdrive solenoid valve system (23-20)
					33	Second solenoid valve system (23-20)
					43	3rd gear incorrect ratio (23-23)
					44	4th gear incorrect ratio (23-24)
9	Selector lever position: N (on a flat and straight road.)	Monitor data list No. 22 and No. 23 with the MUT-II. (1) Move selector lever to R range, drive at constant speed of 10 km/h.	The ratio between data list No. 22 and No. 23 should be the same as the gear ratio when reversing.	Does not shift	22	Input shaft speed sensor system (23-17)
					23	Output shaft speed sensor system (23-18)
					46	Reverse gear incorrect ratio (23-25)

SHIFT PATTERN

UPSHIFT PATTERN

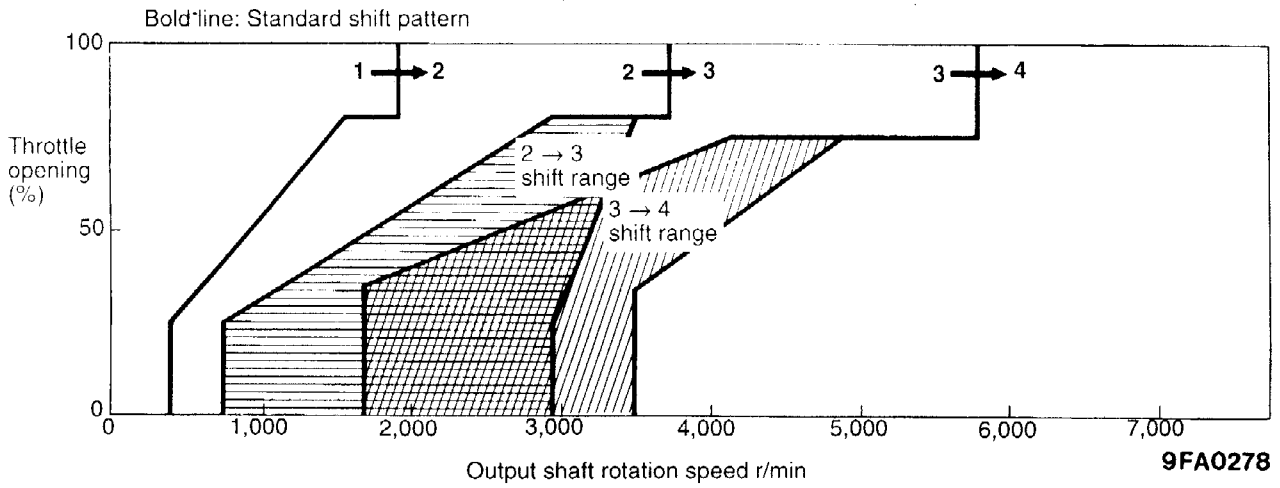

DOWNSHIFT PATTERN

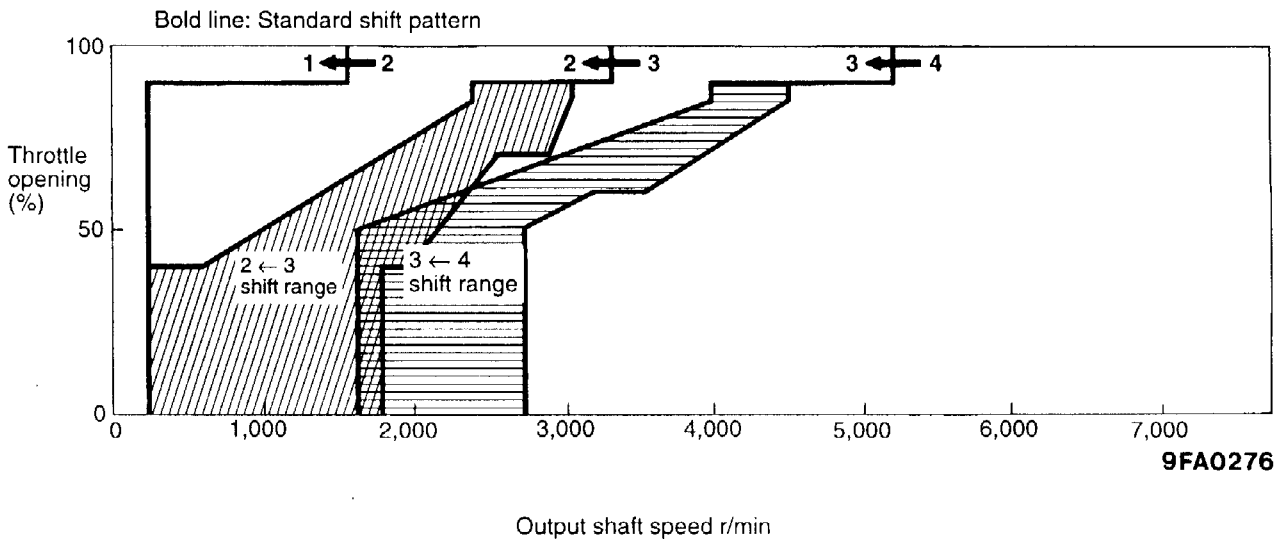

## INSPECTION CHART FOR DIAGNOSIS CODES

Code	Diagnosis item		Reference page
11	Throttle position sensor system	Short circuit	23-16
12		Open circuit	23-16
14		Sensor maladjustment	23-16
15	Oil temperature sensor system	Open circuit	23-16
16		Short circuit	23-16
21	Crankshaft position sensor system	Open circuit	23-16
22	Input shaft speed sensor system	Short circuit/open circuit	23-17
23	Output shaft speed sensor system	Short circuit/open circuit	23-18
26	Stop light switch system	Short circuit/open circuit	23-19
27	Inhibitor switch system	Open circuit	23-19
28		Short circuit	23-19
31	Low and reverse solenoid valve system	Short circuit/open circuit	23-20
32	Underdrive solenoid valve system	Short circuit/open circuit	23-20
33	Second solenoid valve system	Short circuit/open circuit	23-20
34	Overdrive solenoid valve system	Short circuit/open circuit	23-20
36	Damper clutch solenoid system	Short circuit/open circuit	23-20
41	1st gear incorrect ratio		23-21
42	2nd gear incorrect ratio		23-22
43	3rd gear incorrect ratio		23-23
44	4th gear incorrect ratio		23-24
46	Reverse gear incorrect ratio		23-25
51	Abnormal communication with Engine-ECU		23-26
52	Damper clutch solenoid system	Defective system	23-20
53		Lock-up stuck on	23-20
54	A/T Control relay system	Short circuit to ground/open circuit	23-26
56	N range light system	Short circuit to ground	23-26
71	Malfunction of A/T-ECU		23-26

**INSPECTION PROCEDURES FOR DIAGNOSIS CODES**

Code No. 11, 12, 14 Throttle position sensor system	Probable cause
<p>If the TPS output voltage is 4.8 V or higher when the engine is idling, the output is judged to be too high and diagnosis code No. 11 is output. If the TPS output voltage is 0.2 V or lower at times other than when the engine is idling, the output is judged to be too low and diagnosis code No. 12 is output. If the TPS output voltage is 0.2 V or lower or if it is 1.2 V or higher when the engine is idling, the TPS adjustment is judged to be incorrect and diagnosis code No. 14 is output.</p>	<ul style="list-style-type: none"> <li>● Malfunction of the throttle position sensor</li> <li>● Malfunction of connector</li> <li>● Malfunction of the A/T-ECU</li> </ul>

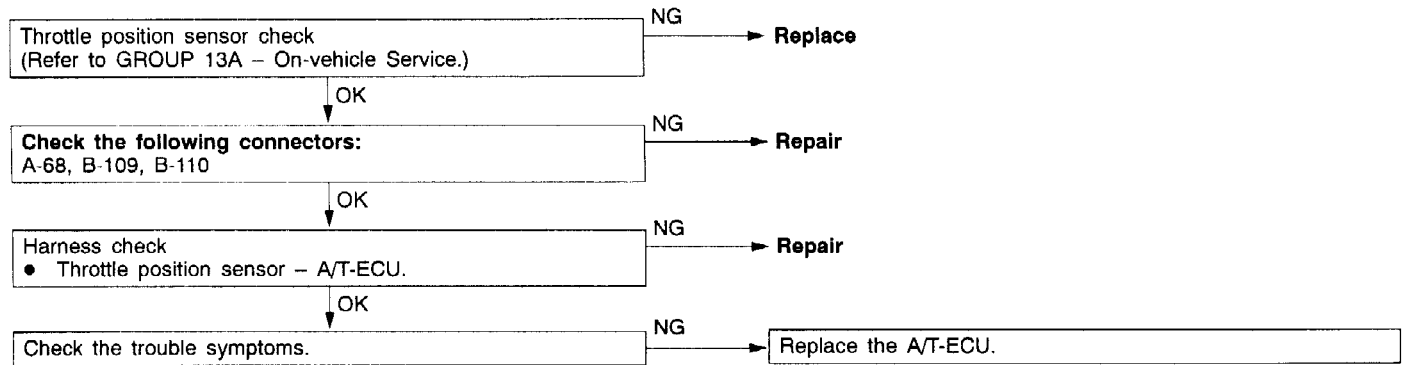

Code No. 15, 16 Oil temperature sensor system	Probable cause
<p>If the oil temperature sensor output voltage is 2.6 V or more even after driving for 10 minutes or more (if the oil temperature does not increase), it is judged that there is an open circuit in the oil temperature sensor and diagnosis code No. 15 is output. If the oil temperature sensor output detects the voltage which corresponds to 200°C or more for more than one second, it is judged that there is an open circuit in oil temperature sensor and diagnosis code No.16 is output.</p>	<ul style="list-style-type: none"> <li>● Malfunction of the oil temperature sensor</li> <li>● Malfunction of connector</li> <li>● Malfunction of the A/T-ECU</li> </ul>

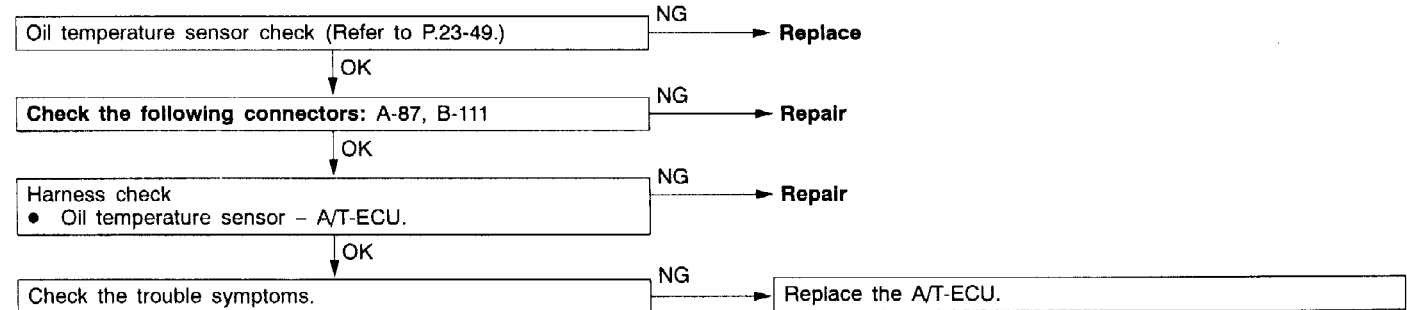

Code No. 21 Crankshaft position sensor system	Probable cause
<p>If no output pulse is detected from the crankshaft position sensor for 5 seconds or more while driving at 25 km/h or more, it is judged that there is an open circuit in the crankshaft position sensor and diagnosis code No. 21 is output.</p>	<ul style="list-style-type: none"> <li>● Malfunction of the crankshaft position sensor</li> <li>● Malfunction of connector</li> <li>● Malfunction of the A/T-ECU</li> </ul>

Refer to GROUP 13A – MPI



Code No. 22 Input shaft speed sensor system	Probable cause
<p>If no output pulse is detected from the input shaft speed sensor for 1 second or more while driving in 3rd or 4th gear at a speed of 30 km/h or more, it is judged to be an open circuit or short-circuit in the input shaft speed sensor and diagnosis code No. 22 is output. If diagnosis code No. 22 is output four times, the transmission is locked into 3rd gear or 2nd gear as a fail-safe measure, and the N range light flashes at a frequency of 1 Hz.</p>	<ul style="list-style-type: none"> <li>● Malfunction of the input shaft speed sensor</li> <li>● Malfunction of the underdrive clutch retainer</li> <li>● Malfunction of connector</li> <li>● Malfunction of the A/T-ECU</li> </ul>

★: Refer to the Transmission Workshop Manual.

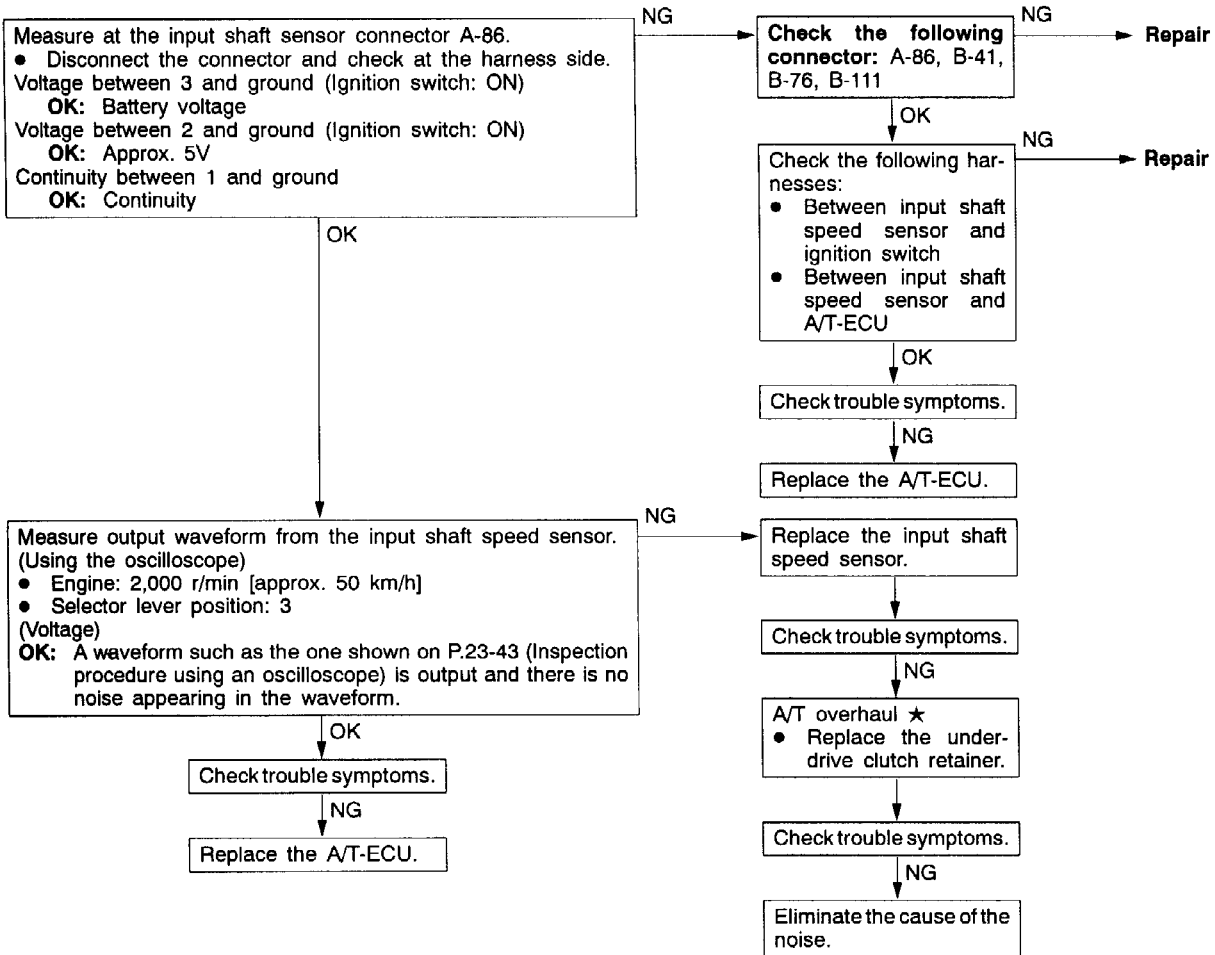

Code No. 23 Output shaft speed sensor system	Probable cause
If the output from the output shaft speed sensor is continuously 50% lower than the vehicle speed for 1 second or more while driving in 3rd or 4th gear at a speed of 30 km/h or more, it is judged to be an open circuit or short-circuit in the output shaft speed sensor and diagnosis code No. 23 is output. If diagnosis code No. 23 is output four times, the transmission is locked into 3rd gear or 2nd gear as a fail-safe measure, and the N range light flashes at a frequency of 1 Hz.	<ul style="list-style-type: none"> <li>● Malfunction of the output shaft speed sensor</li> <li>● Malfunction of the transfer drive gear or driven gear</li> <li>● Malfunction of connector</li> <li>● Malfunction of the A/T-ECU</li> </ul>

★: Refer to the Transmission Workshop Manual.

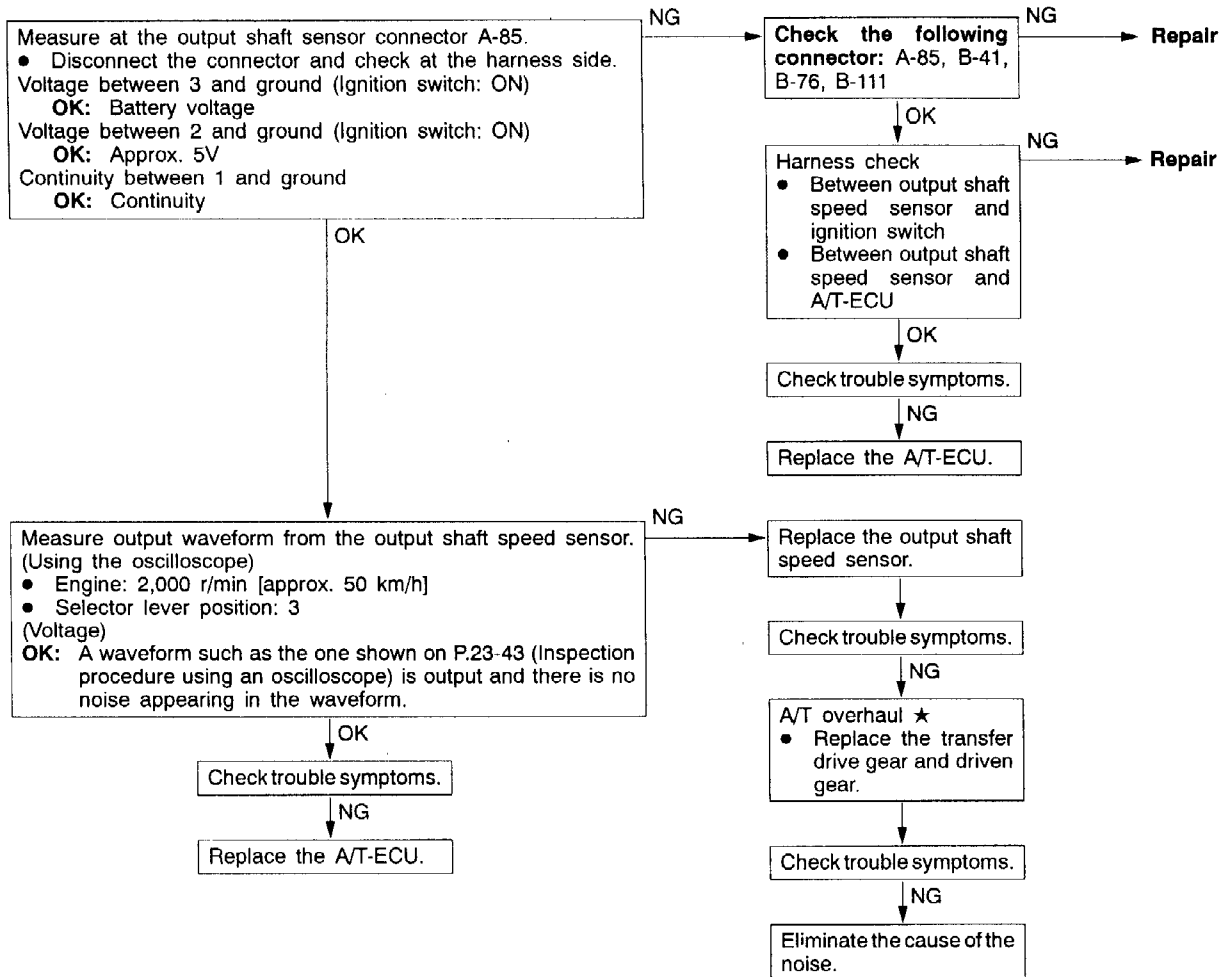

Code No. 26 Stop light switch system	Probable cause
If the stop light switch is on for 5 minutes or more while driving, it is judged that there is a short circuit in the stop light switch and diagnosis code No. 26 is output.	<ul style="list-style-type: none"> <li>● Malfunction of the stop light switch</li> <li>● Malfunction of connector</li> <li>● Malfunction of the A/T-ECU</li> </ul>

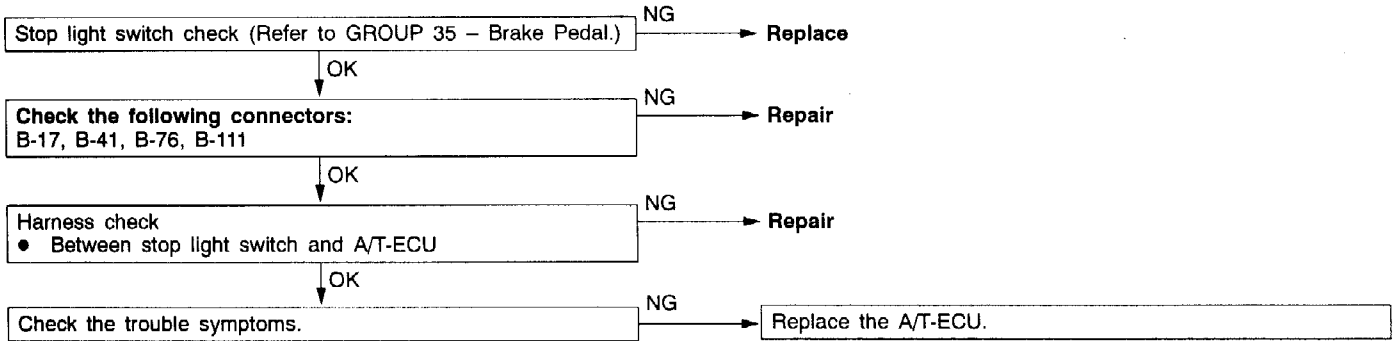

Code No.27, 28 Inhibitor switch system	Probable cause
If the A/T-ECU detects no inhibitor switch input signal for a continuous period of 30 seconds, it is judged that there is an open circuit in the inhibitor switch and diagnosis code No.27 is output. If the A/T-ECU detects more than two kinds of inhibitor switch input signals for a continuous period of 30 seconds, it is judged that there is an open circuit in the inhibitor switch and diagnosis code No.28 is output.	<ul style="list-style-type: none"> <li>● Malfunction of the inhibitor switch</li> <li>● Malfunction of the ignition switch</li> <li>● Malfunction of connector</li> <li>● Malfunction of the A/T-ECU</li> </ul>

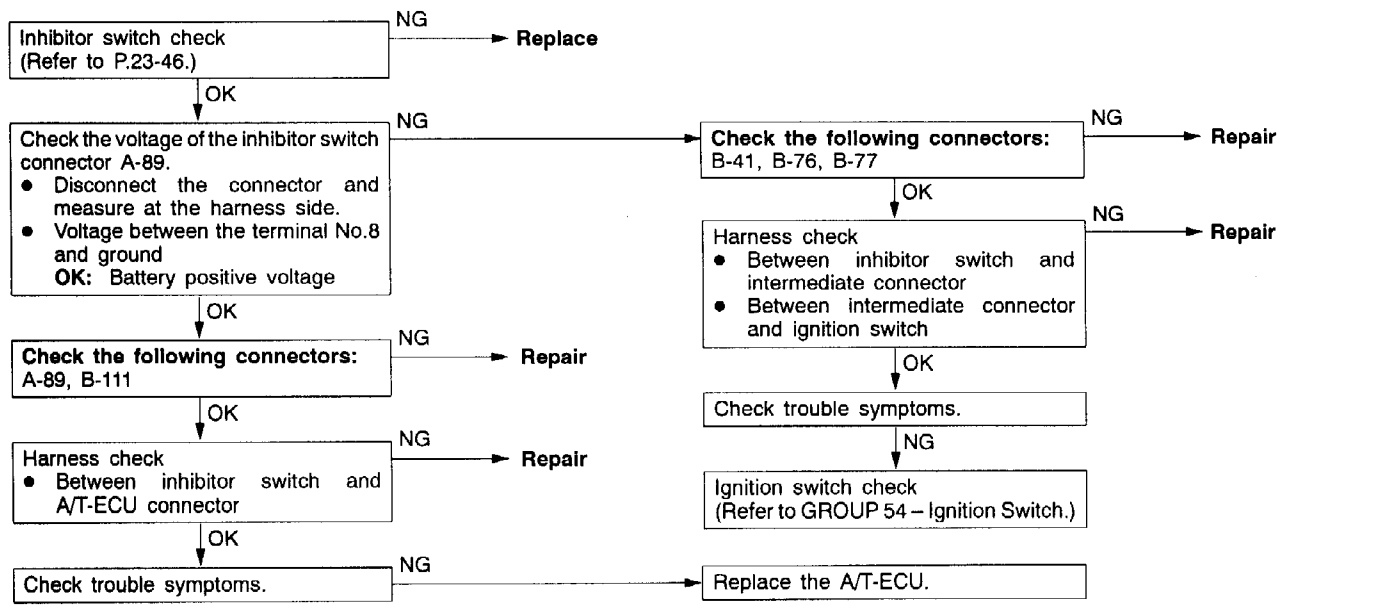

Code No. 31 Low and reverse solenoid valve system	Probable cause
Code No. 32 Underdrive solenoid valve system	
Code No. 33 Second solenoid valve system	
Code No. 34 Overdrive solenoid valve system	
If the resistance value for a solenoid valve is too large or too small, it is judged that there is a short-circuit or an open circuit in the solenoid valve and the respective diagnosis code is output. The transmission is locked into 3rd gear as a fail-safe measure, and the N range light flashes at a frequency of 1 Hz.	
<ul style="list-style-type: none"> <li>● Malfunction of solenoid valve</li> <li>● Malfunction of connector</li> <li>● Malfunction of the A/T-ECU</li> </ul>	

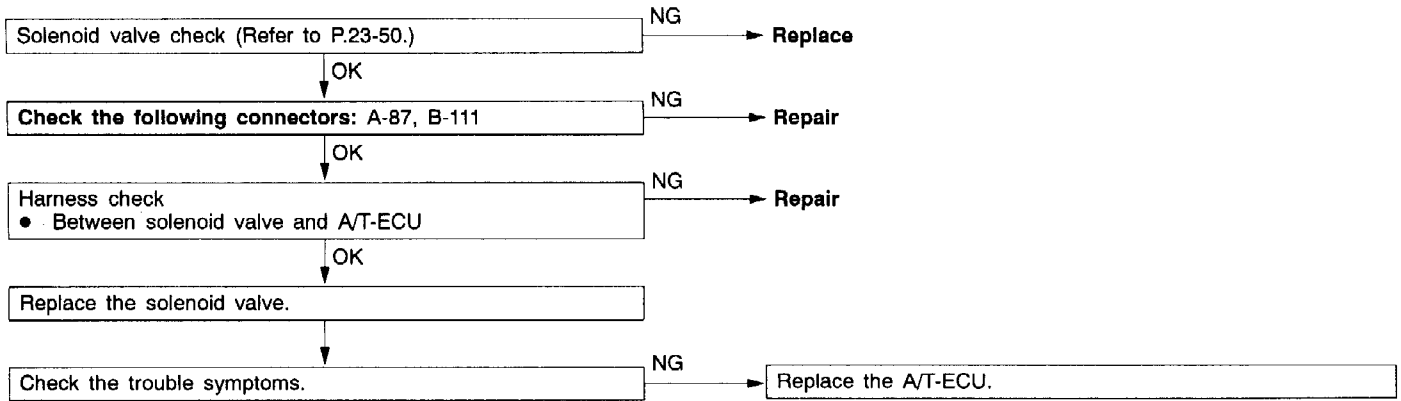

Code No. 36, 52, 53 Damper clutch solenoid system	Probable cause
If the resistance value for the damper clutch solenoid is too large or too small, it is judged that there is a short-circuit or an open circuit in the damper clutch solenoid and diagnosis code No. 36 is output. If the drive duty rate for the damper clutch solenoid is 100 % for a continuous period of 4 seconds or more, it is judged that there is an abnormality in the damper clutch system and diagnosis code No. 52 is output. When diagnosis code No. 36 is output, the transmission is locked into 3rd gear as a fail-safe measure, and the N range light flashes at a frequency of 1 Hz. If the lock-up clutch remains engaged for a continuous period of 10 seconds when the A/T-ECU is attempting to disengage the lock-up clutch, it is judged that the damper clutch is stuck on and diagnosis code No.53 is output.	
<ul style="list-style-type: none"> <li>● Malfunction of the damper clutch solenoid</li> <li>● Malfunction of connector</li> <li>● Malfunction of the A/T-ECU</li> </ul>	

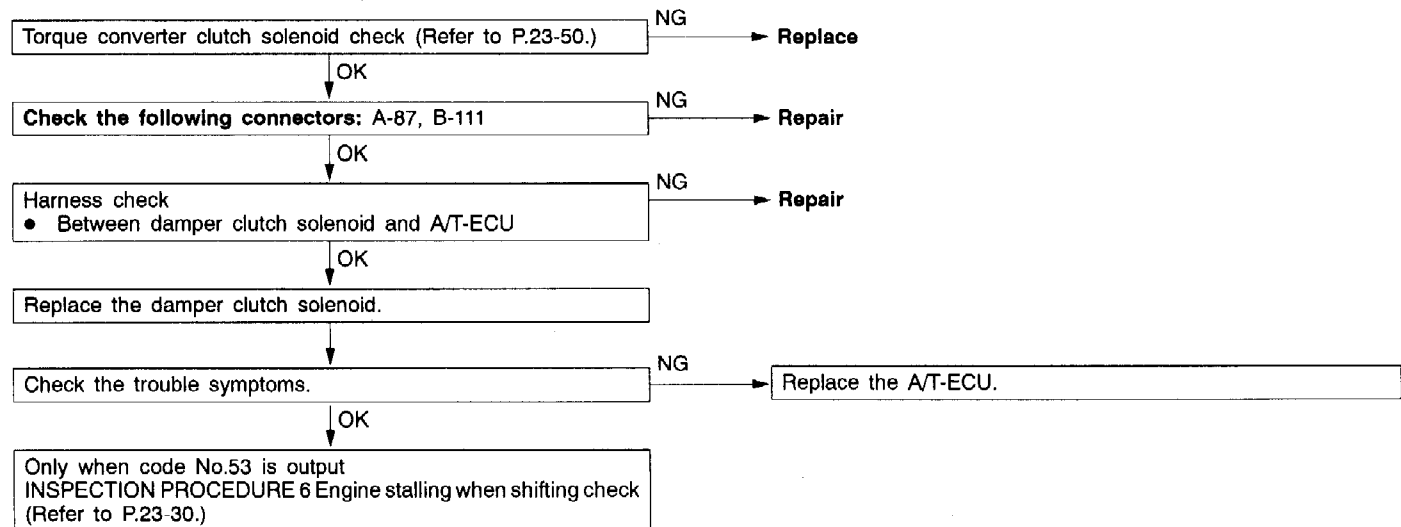

Code No. 41 1st gear incorrect ratio	Probable cause
<p>If the output from the output shaft speed sensor multiplied by the 1st gear ratio is not the same as the output from the input shaft speed sensor after shifting to 1st gear has been completed, diagnosis code No. 41 is output. If diagnosis code No. 41 is output four times, the transmission is locked into 3rd gear as a fail-safe measure, and the N range light flashes at a frequency of 1 Hz.</p>	<ul style="list-style-type: none"> <li>● Malfunction of the input shaft speed sensor</li> <li>● Malfunction of the output shaft speed sensor</li> <li>● Malfunction of the underdrive clutch retainer</li> <li>● Malfunction of the transfer drive gear or driven gear</li> <li>● Malfunction of the low and reverse brake system</li> <li>● Malfunction of the underdrive clutch system</li> <li>● Noise generated</li> </ul>

★: Refer to the Transmission Workshop Manual.

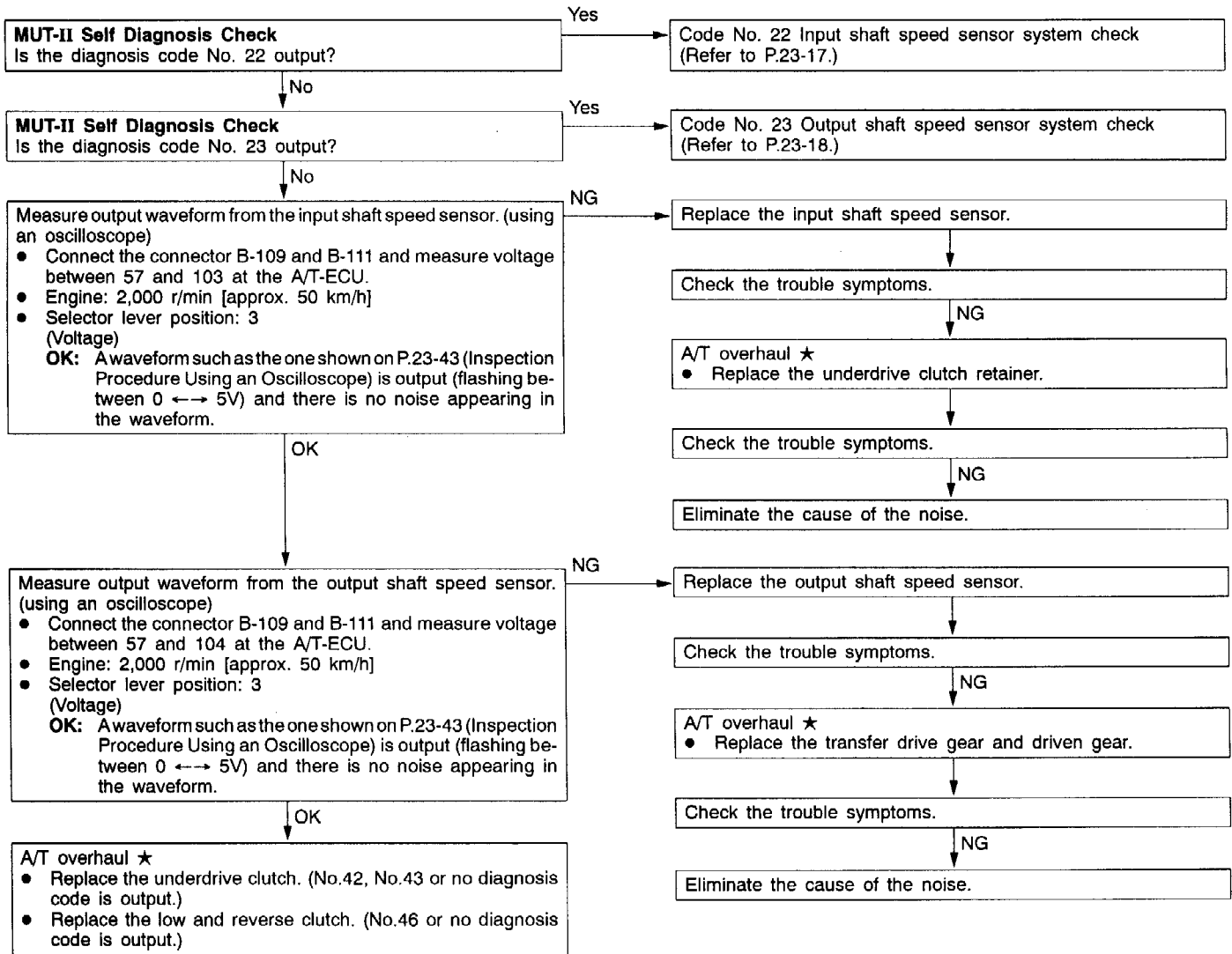

Code No. 42 2nd gear incorrect ratio	Probable cause
<p>If the output from the output shaft speed sensor multiplied by the 2nd gear ratio is not the same as the output from the input shaft speed sensor after shifting to 2nd gear has been completed, diagnosis code No. 42 is output. If diagnosis code No. 42 is output four times, the transmission is locked into 3rd gear as a fail-safe measure, and the N range light flashes at a frequency of 1 Hz.</p>	<ul style="list-style-type: none"> <li>● Malfunction of the input shaft speed sensor</li> <li>● Malfunction of the output shaft speed sensor</li> <li>● Malfunction of the underdrive clutch retainer</li> <li>● Malfunction of the transfer drive gear or driven gear</li> <li>● Malfunction of the second brake system</li> <li>● Malfunction of the underdrive clutch system</li> <li>● Noise generated</li> </ul>

★: Refer to the Transmission Workshop Manual.

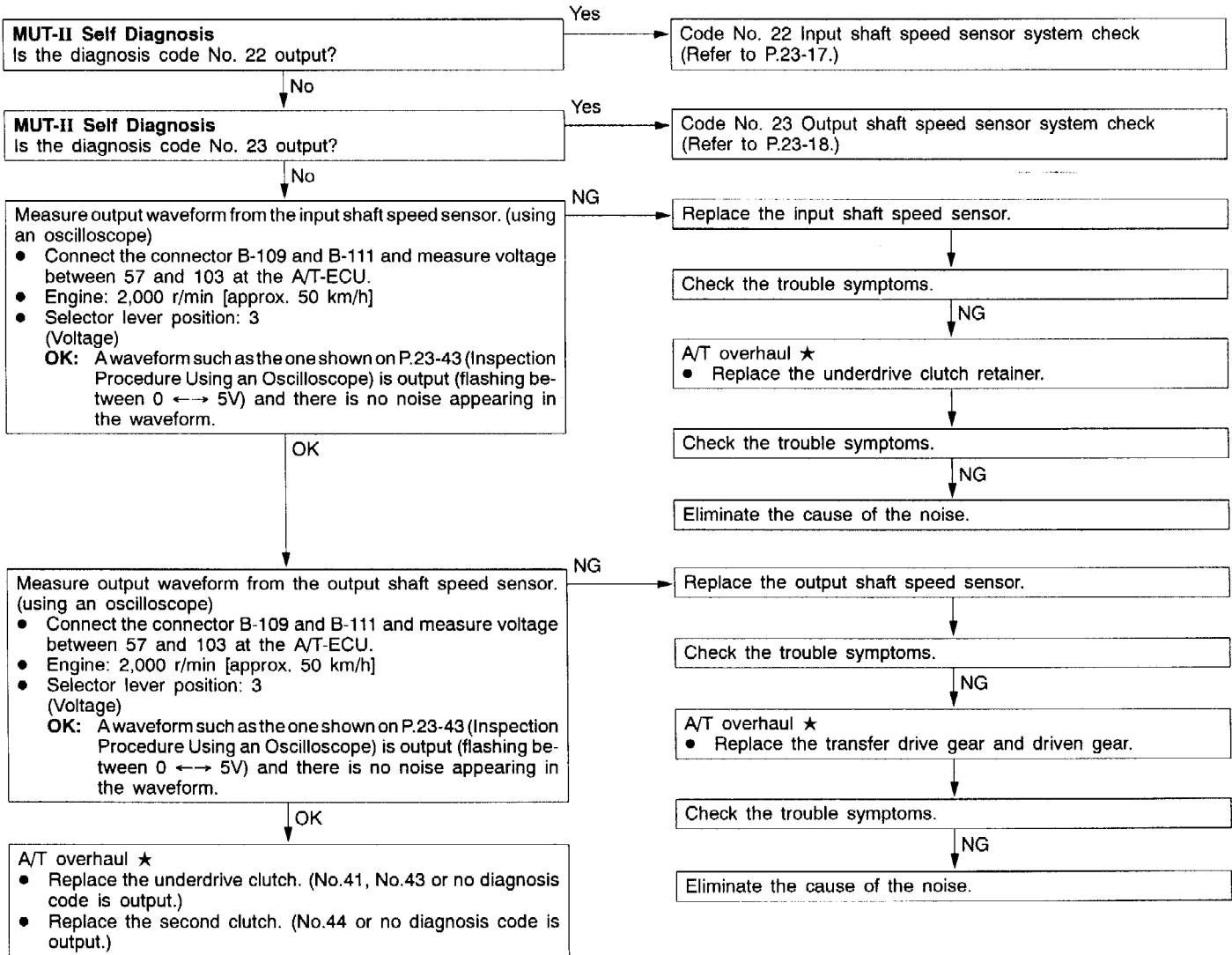

Code No. 43 3rd gear incorrect ratio	Probable cause
If the output from the output shaft speed sensor multiplied by the 3rd gear ratio is not the same as the output from the input shaft speed sensor after shifting to 3rd gear has been completed, diagnosis code No. 43 is output. If diagnosis code No. 43 is output four times, the transmission is locked into 3rd gear as a fail-safe measure, and the N range light flashes at a frequency of 1 Hz.	<ul style="list-style-type: none"> <li>● Malfunction of the input shaft speed sensor</li> <li>● Malfunction of the output shaft speed sensor</li> <li>● Malfunction of the underdrive clutch retainer</li> <li>● Malfunction of the transfer drive gear or driven gear</li> <li>● Malfunction of the underdrive clutch system</li> <li>● Malfunction of the overdrive clutch system</li> <li>● Noise generated</li> </ul>

★: Refer to the Transmission Workshop Manual.

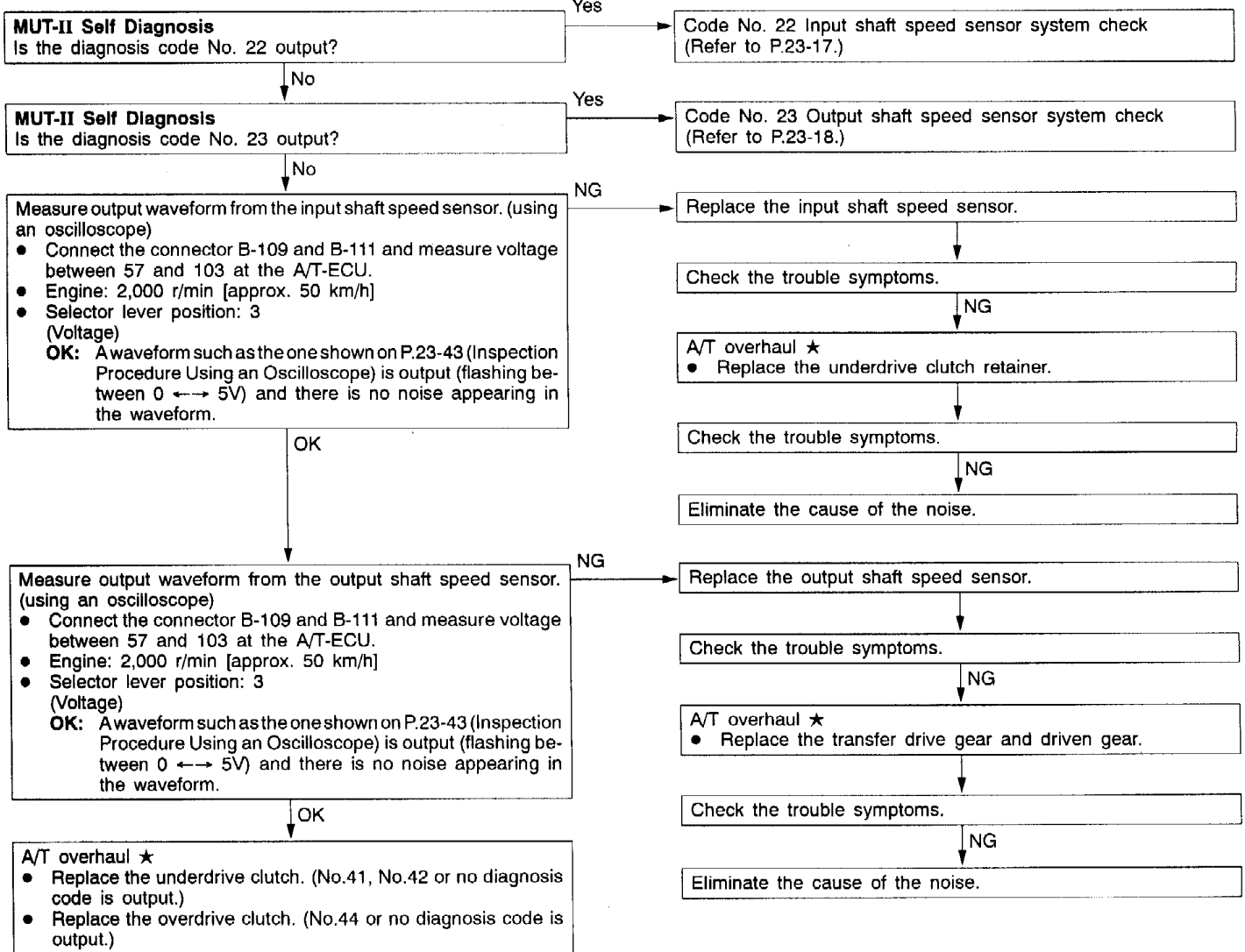

Code No. 44 4th gear incorrect ratio	Probable cause
<p>If the output from the output shaft speed sensor multiplied by the 4th gear ratio is not the same as the output from the input shaft speed sensor after shifting to 4th gear has been completed, diagnosis code No. 44 is output. If diagnosis code No. 44 is output four times, the transmission is locked into 3rd gear as a fail-safe measure, and the N range light flashes at a frequency of 1 Hz.</p>	<ul style="list-style-type: none"> <li>● Malfunction of the input shaft speed sensor</li> <li>● Malfunction of the output shaft speed sensor</li> <li>● Malfunction of the underdrive clutch retainer</li> <li>● Malfunction of the transfer drive gear or driven gear</li> <li>● Malfunction of the second brake system</li> <li>● Malfunction of the overdrive clutch system</li> <li>● Noise generated</li> </ul>

★: Refer to the Transmission Workshop Manual.

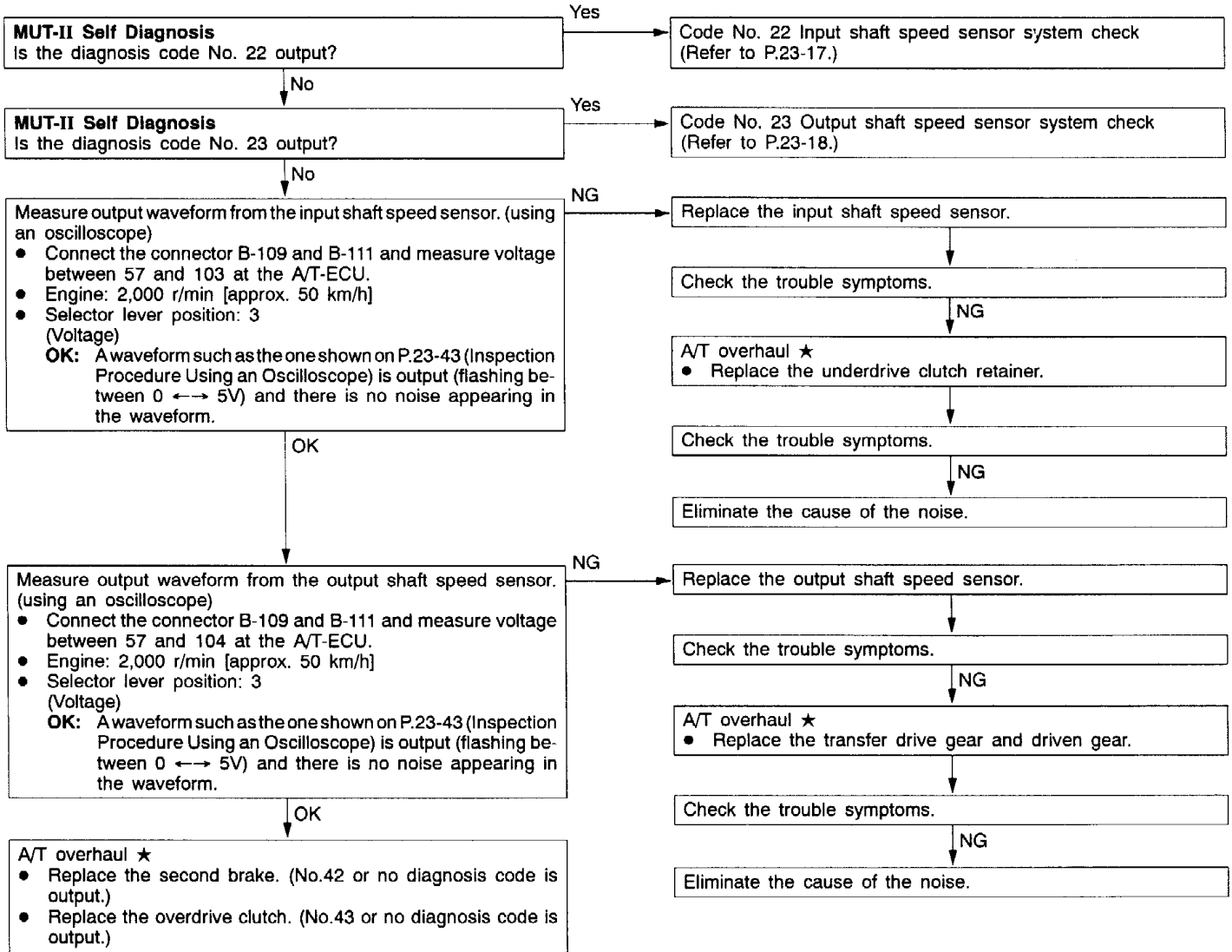



Code No. 46 Reverse gear incorrect ratio	Probable cause
If the output from the output shaft speed sensor multiplied by the reverse gear ratio is not the same as the output from the input shaft speed sensor after shifting to reverse gear has been completed, diagnosis code No. 46 is output. If diagnosis code No. 46 is output four times, the transmission is locked into 3rd gear as a fail-safe measure, and the N range light flashes at a frequency of 1 Hz.	<ul style="list-style-type: none"> <li>● Malfunction of the input shaft speed sensor</li> <li>● Malfunction of the output shaft speed sensor</li> <li>● Malfunction of the underdrive clutch retainer</li> <li>● Malfunction of the transfer drive gear or driven gear</li> <li>● Malfunction of the low and reverse brake system</li> <li>● Malfunction of the reverse clutch system</li> <li>● Noise generated</li> </ul>

★: Refer to the Transmission Workshop Manual.

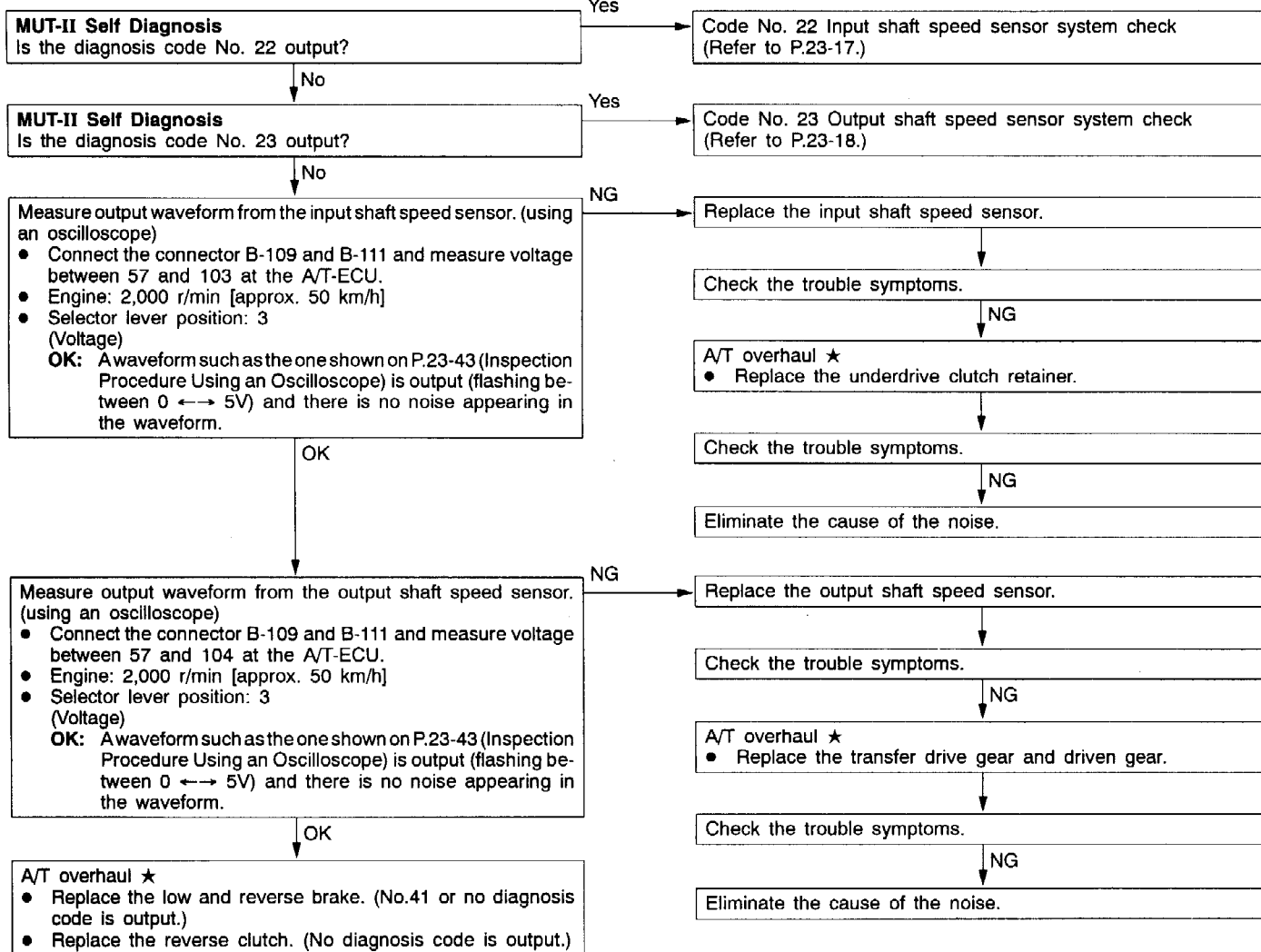

Code No. 51 Abnormal communication with Engine-ECU	Probable cause
<p>If normal communication is not possible for a continuous period of 1 second or more when the battery voltage is 10 V or more and the engine speed is 450 r/min or more, diagnosis code No. 51 is output. Diagnosis code No. 51 is also output if the data being received is abnormal for a continuous period of 4 seconds under the same conditions.</p>	<ul style="list-style-type: none"> <li>● Malfunction of the Engine-ECU</li> <li>● Malfunction of the A/T-ECU</li> </ul>

Replace the Engine-A/T-ECU.

Code No. 54 A/T Control relay system	Probable cause
<p>If the control relay voltage is less than 7 V after the ignition switch has been turned to ON, it is judged that there is an open circuit or a short-circuit in the A/T control relay earth and diagnosis code No. 54 is output. The transmission is locked into 3rd gear as a fail-safe measure, and the N range light flashes at a frequency of 1 Hz.</p>	<ul style="list-style-type: none"> <li>● Malfunction of the A/T control relay</li> <li>● Malfunction of connector</li> <li>● Malfunction of the A/T-ECU</li> </ul>

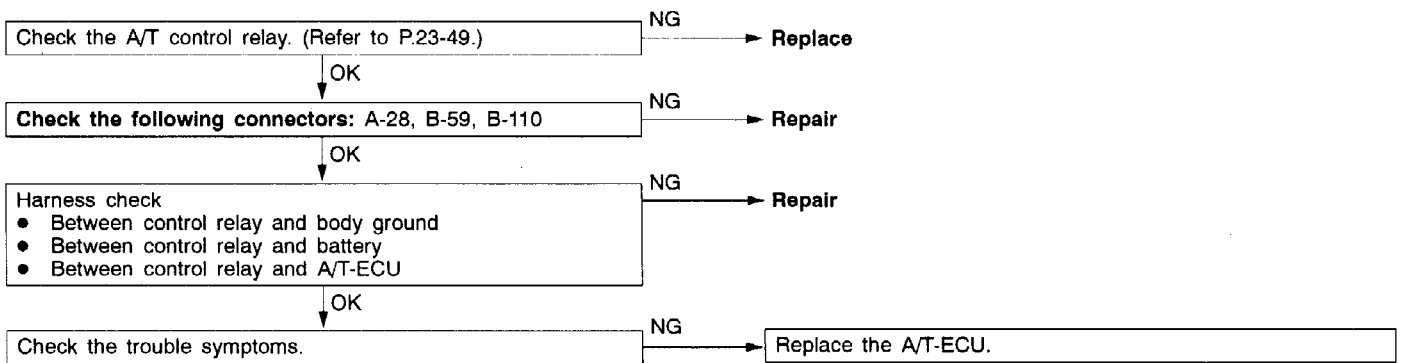

Code No. 56 N range light system	Probable cause
<p>If the N range signal is off after an N range light illumination instruction (ON instruction) has been given, it is judged that there is a short-circuit in the N range light earth and diagnosis code No. 56 is output.</p>	<ul style="list-style-type: none"> <li>● Malfunction of the Assist-ECU</li> <li>● Malfunction of connector</li> <li>● Malfunction of the A/T-ECU</li> </ul>

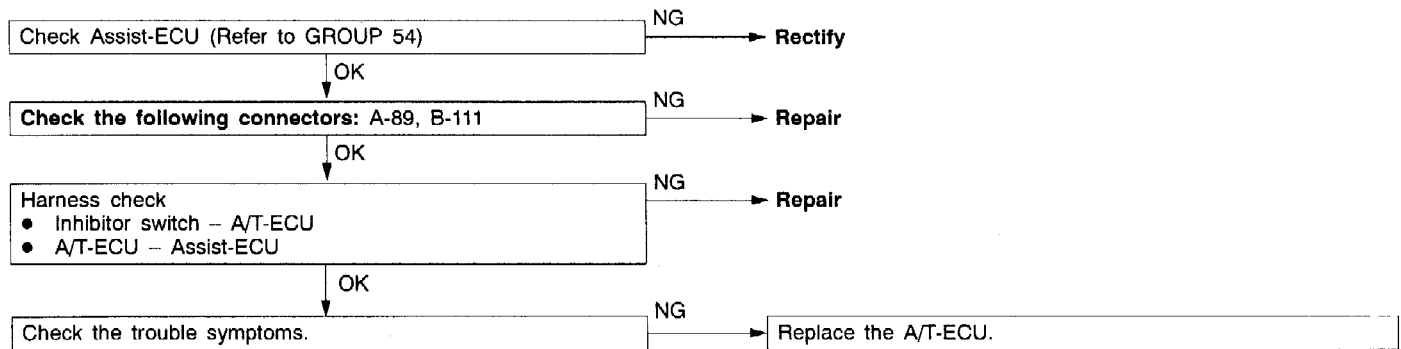

Code No. 71 Malfunction of A/T-ECU	Probable cause
<p>There is an abnormality in the A/T-ECU. The transmission is locked into 3rd gear as a fail-safe measure.</p>	<ul style="list-style-type: none"> <li>● Malfunction of the A/T-ECU</li> </ul>

Replace the Engine-A/T-ECU.

**INSPECTION CHART FOR TROUBLE SYMPTOMS**

Trouble symptom		Inspection procedure No.	Reference page
Communication with the MUT-II is not possible		1	23-28
Driving impossible	Starting impossible	2	23-28
	Does not move forward	3	23-29
	Does not reverse	4	23-29
	Does not move (forward or reverse)	5	23-30
Malfunction when starting	Engine stalling when shifting	6	23-30
	Shocks when changing from N to D and long time lag	7	23-31
	Shocks when changing from N to R and long time lag	8	23-32
	Shocks when changing from N to D, N to R and long time lag	9	23-32
Malfunction when shifting	Shocks and running up	10	23-33
Displaced shifting points	All points	11	23-33
	Some points	12	23-34
Does not shift	No diagnosis codes	13	23-34
Malfunction while driving	Poor acceleration	14	23-35
	Vibration	15	23-35
Idle position switch system		16	23-36
Dual pressure switch system		17	23-36
Vehicle speed sensor system		18	23-37
Auto-cruise-ECU signal system		19	23-37

INSPECTION PROCEDURE FOR TROUBLE SYMPTOMS

INSPECTION PROCEDURE 1

Communication with the MUT-II is not possible	Probable cause
If communication with the MUT-II is not possible, the cause is probably a defective diagnosis line or the A/T-ECU is not functioning.	<ul style="list-style-type: none"> <li>● Malfunction of diagnosis line</li> <li>● Malfunction of connector</li> <li>● Malfunction of the A/T-ECU</li> </ul>

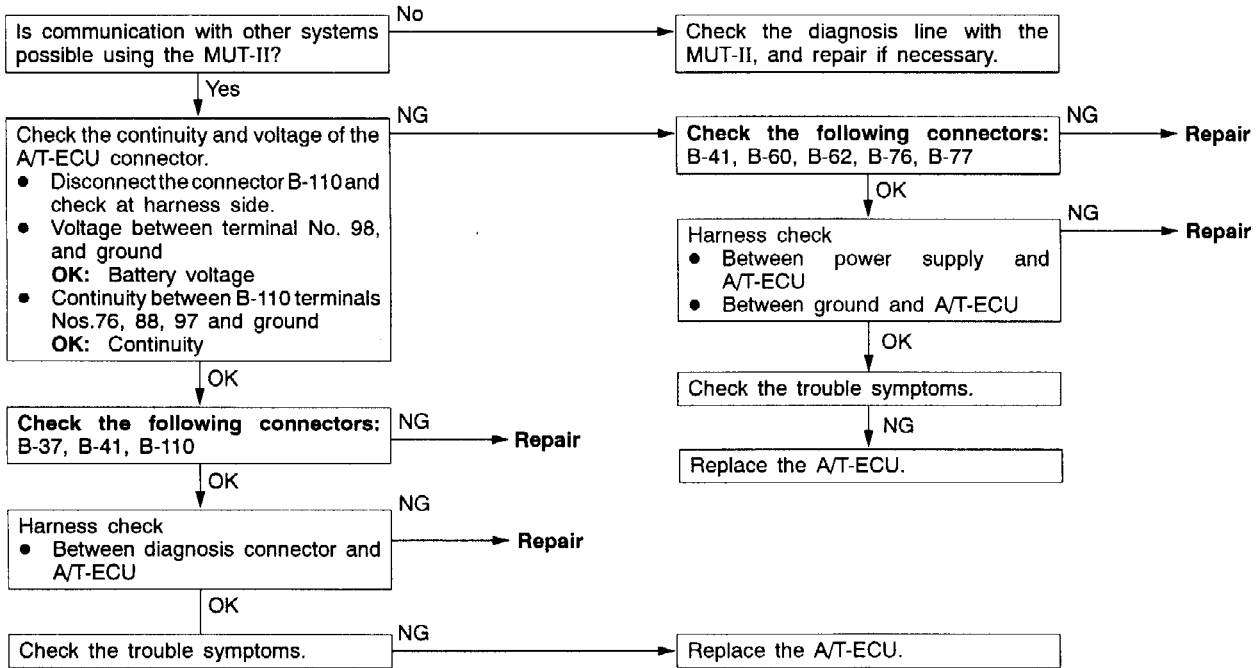

INSPECTION PROCEDURE 2

Starting impossible	Probable cause
Starting is not possible when the selector lever is in P or N range. In such cases, the cause is probably a defective engine system, torque converter or oil pump or seized oil pump.	<ul style="list-style-type: none"> <li>● Malfunction of the engine system</li> <li>● Malfunction of the torque converter</li> <li>● Malfunction of the oil pump</li> </ul>

★: Refer to the Transmission Workshop Manual.

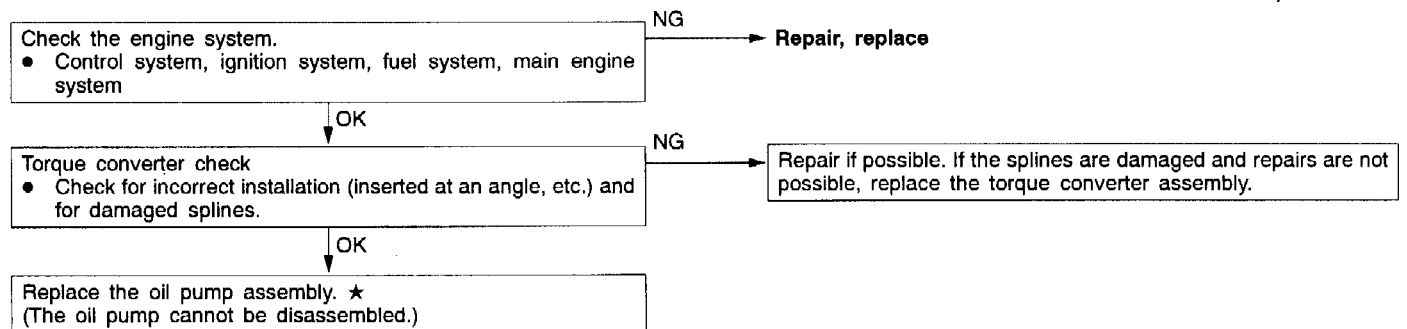

**INSPECTION PROCEDURE 3**

Does not move (forward)	Probable cause
If the vehicle does not move forward when the selector lever is shifted from N to D, 3, 2 or L range while the engine is idling, the cause is probably abnormal line pressure or a malfunction of the underdrive clutch or valve body.	<ul style="list-style-type: none"> <li>● Abnormal line pressure</li> <li>● Malfunction of the underdrive solenoid valve</li> <li>● Malfunction of the underdrive clutch</li> <li>● Malfunction of the valve body</li> </ul>

★: Refer to the Transmission Workshop Manual.

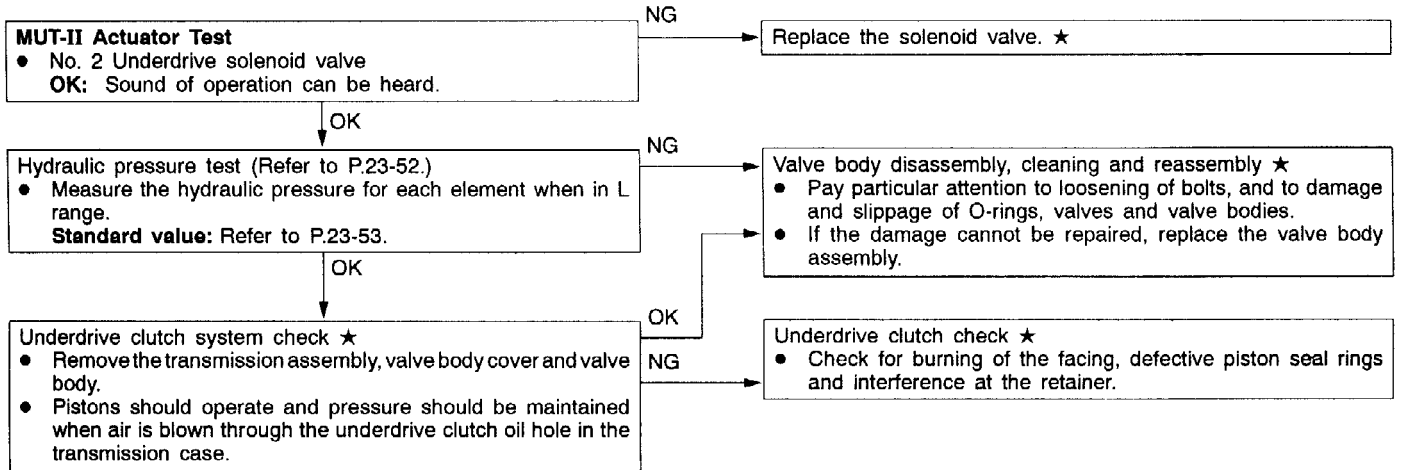

**INSPECTION PROCEDURE 4**

Does not reverse	Probable cause
If the vehicle does not reverse when the selector lever is shifted from N to R range while the engine is idling, the cause is probably abnormal pressure in the reverse clutch or low and reverse brake or a malfunction of the reverse clutch, low and reverse brake or valve body.	<ul style="list-style-type: none"> <li>● Abnormal reverse clutch pressure</li> <li>● Abnormal low and reverse brake pressure</li> <li>● Malfunction of the low and reverse solenoid valve</li> <li>● Malfunction of the reverse clutch</li> <li>● Malfunction of the low and reverse brake</li> <li>● Malfunction of the valve body</li> </ul>

★: Refer to the Transmission Workshop Manual.

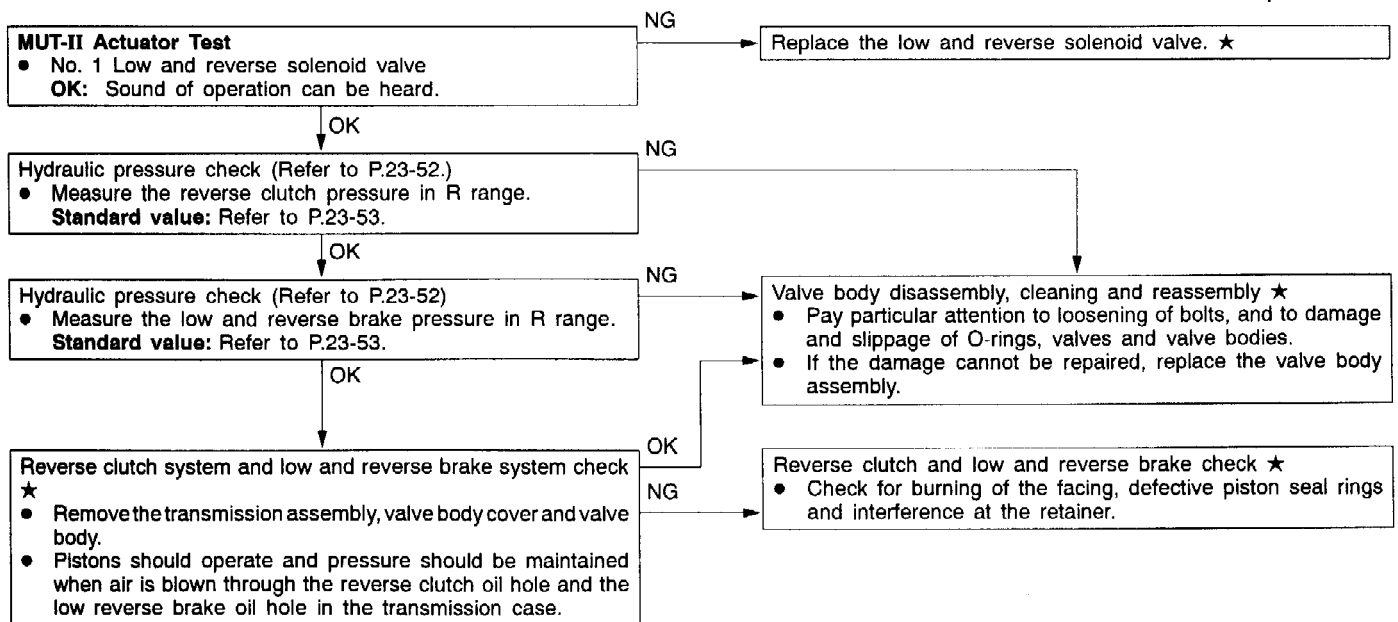

**INSPECTION PROCEDURE 5**

Does not move (forward or reverse)	Probable cause
If the vehicle does not move forward or reverse when the selector lever is shifted to any position while the engine is idling, the cause is probably abnormal line pressure, or a malfunction of the power train, oil pump or valve body.	<ul style="list-style-type: none"> <li>● Abnormal line pressure</li> <li>● Malfunction of power train</li> <li>● Malfunction of the oil pump</li> <li>● Malfunction of the valve body</li> </ul>

★: Refer to the Transmission Workshop Manual.

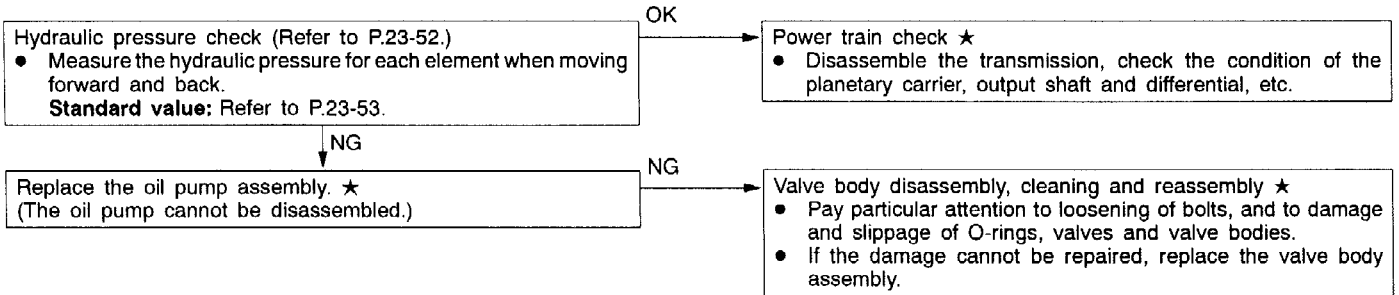

**INSPECTION PROCEDURE 6**

Engine stalling when shifting	Probable cause
If the engine stalls when the selector lever is shifted from N to D or R range while the engine is idling, the cause is probably a malfunction of the engine system, damper clutch control solenoid, valve body or torque converter (damper clutch malfunction).	<ul style="list-style-type: none"> <li>● Malfunction of the engine system</li> <li>● Malfunction of the damper clutch control solenoid</li> <li>● Malfunction of the valve body</li> <li>● Malfunction of the torque converter (Malfunction of the damper clutch)</li> </ul>

★: Refer to the Transmission Workshop Manual.

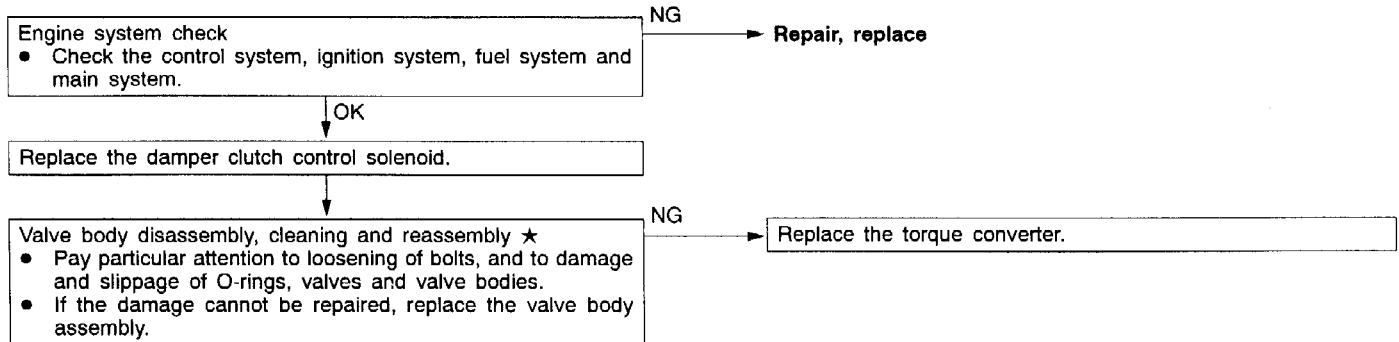

INSPECTION PROCEDURE 7

Shocks when changing from N to D and large time lag	Probable cause
If abnormal shocks or a time lag of 2 seconds or more occur when the selector lever is shifted from N to D range while the engine is idling, the cause is probably abnormal underdrive clutch pressure or a malfunction of the underdrive clutch, valve body or idle position switch.	<ul style="list-style-type: none"> <li>● Abnormal underdrive clutch pressure</li> <li>● Malfunction of the underdrive solenoid valve</li> <li>● Malfunction of the underdrive clutch</li> <li>● Malfunction of the valve body</li> <li>● Malfunction of the idle position switch</li> </ul>

★: Refer to the Transmission Workshop Manual.

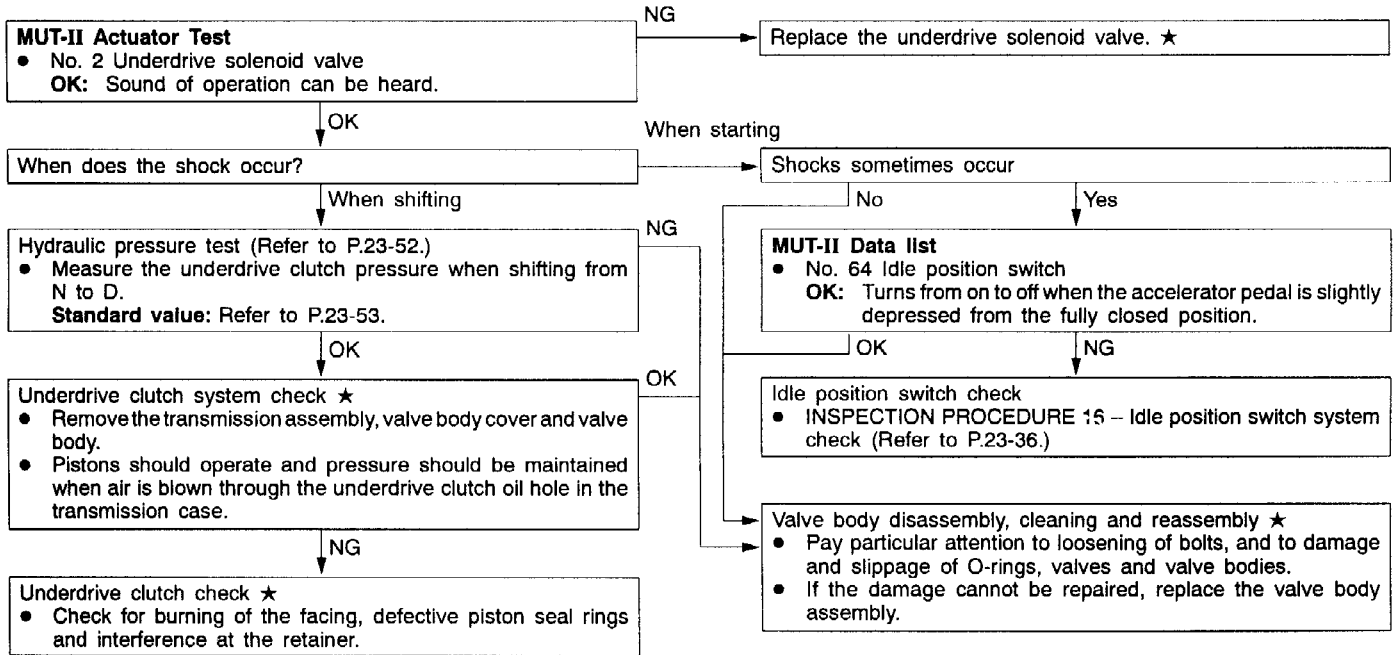

INSPECTION PROCEDURE 8

Shocks when changing from N to R and large time lag	Probable cause
<p>If abnormal shocks or a time lag of 2 seconds or more occurs when the selector lever is shifted from N to R range while the engine is idling, the cause is probably abnormal reverse clutch pressure or low and reverse brake pressure, or a malfunction of the reverse clutch, low and reverse brake, valve body or idle position switch.</p>	<ul style="list-style-type: none"> <li>Abnormal reverse clutch pressure</li> <li>Abnormal low and reverse brake pressure</li> <li>Malfunction of the low and reverse solenoid valve</li> <li>Malfunction of the reverse clutch</li> <li>Malfunction of the low and reverse brake</li> <li>Malfunction of the valve body</li> <li>Malfunction of the idle position switch</li> </ul>

★: Refer to the Transmission Workshop Manual.

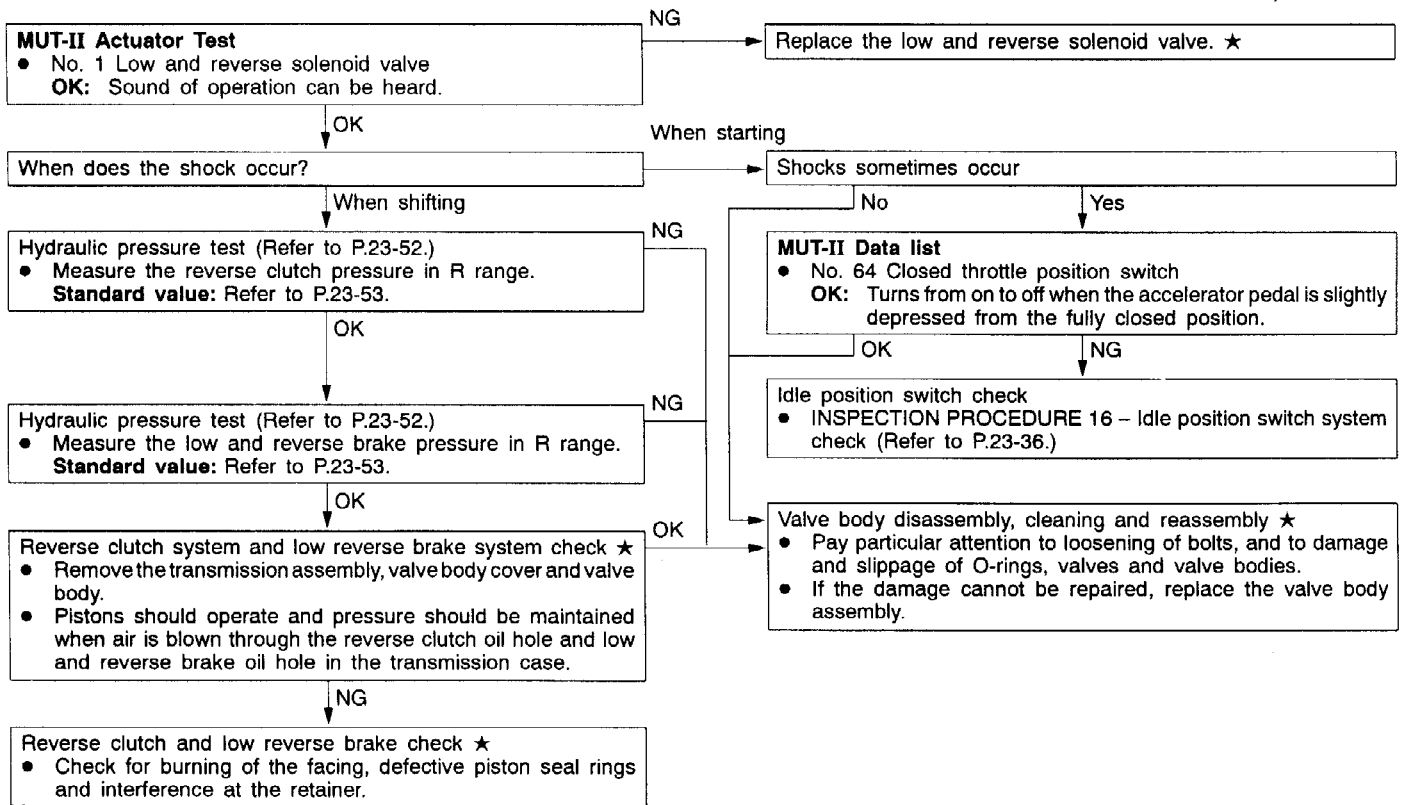

INSPECTION PROCEDURE 9

Shocks when changing from N to D, N to R and large time lag	Probable cause
<p>If abnormal shocks or a time lag of 2 seconds or more occur when the selector lever is shifted from N to D range and from N to R range while the engine is idling, the cause is probably abnormal line pressure or a malfunction of the oil pump or valve body.</p>	<ul style="list-style-type: none"> <li>Abnormal line pressure</li> <li>Malfunction of the oil pump</li> <li>Malfunction of the valve body</li> </ul>

★: Refer to the Transmission Workshop Manual.

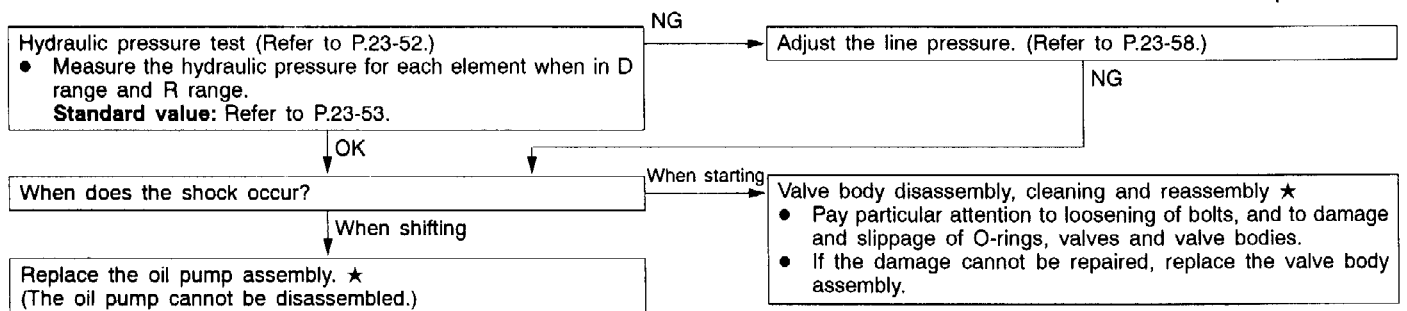



**INSPECTION PROCEDURE 10**

Shocks and running up	Probable cause
If shocks occur when driving due to upshifting or downshifting and the transmission speed becomes higher than the engine speed, the cause is probably abnormal line pressure or a malfunction of a solenoid valve, oil pump, valve body or of a brake or clutch.	<ul style="list-style-type: none"> <li>● Abnormal line pressure</li> <li>● Malfunction of each solenoid valve</li> <li>● Malfunction of the oil pump</li> <li>● Malfunction of the valve body</li> <li>● Malfunction of each brake or each clutch</li> </ul>

★: Refer to the Transmission Workshop Manual.

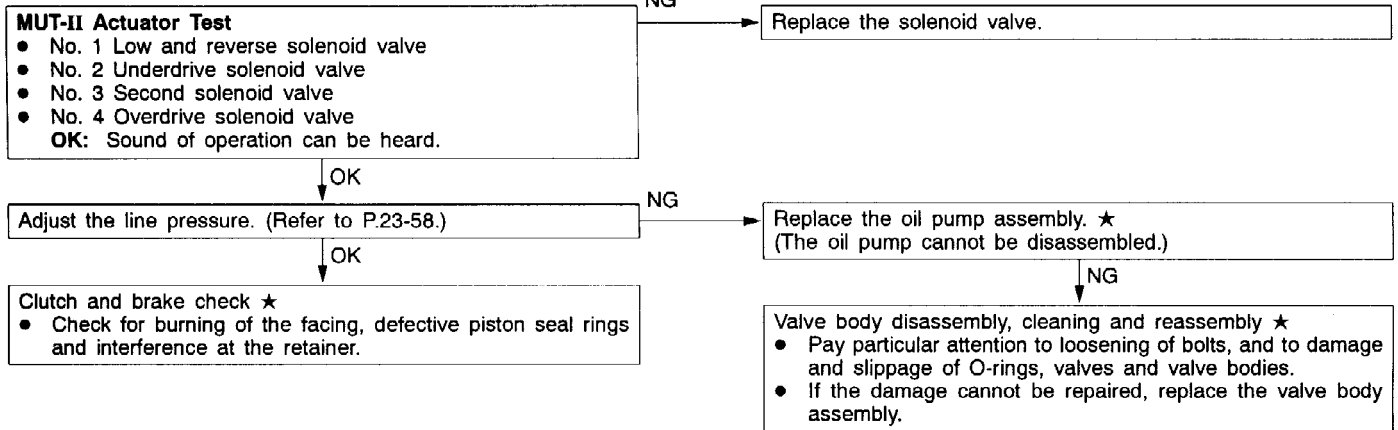

**INSPECTION PROCEDURE 11**

All points (Displaced shifting points)	Probable cause
If all shift points are displaced while driving, the cause is probably a malfunction of the output shaft speed sensor, TPS or of a solenoid valve.	<ul style="list-style-type: none"> <li>● Malfunction of the output shaft speed sensor</li> <li>● Malfunction of the throttle position sensor</li> <li>● Malfunction of each solenoid valve</li> <li>● Abnormal line pressure</li> <li>● Malfunction of the valve body</li> <li>● Malfunction of the A/T-ECU</li> </ul>

★: Refer to the Transmission Workshop Manual.

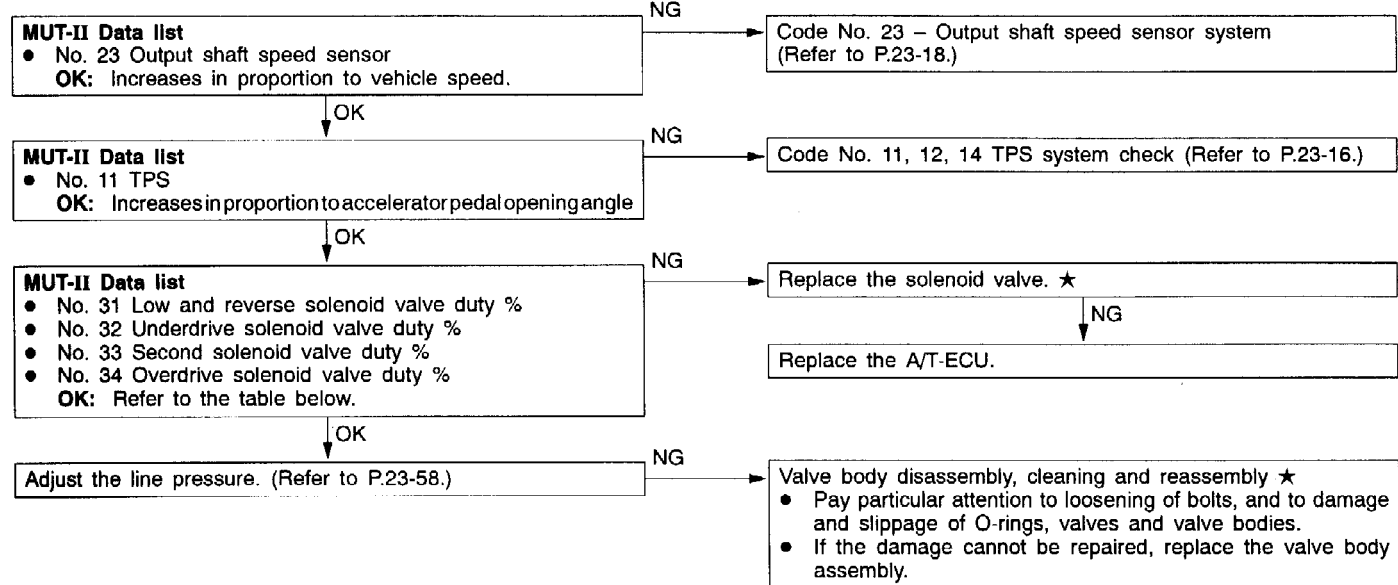

	No. 31	No. 32	No. 33	No. 34
Driving at constant speed in 1st gear	0 %	0 %	100 %	100 %
Driving at constant speed in 2nd gear	100 %	0 %	0 %	100 %
Driving at constant speed in 3rd gear	100 %	0 %	100 %	0 %
Driving at constant speed in 4th gear	100 %	100 %	0 %	0 %

**INSPECTION PROCEDURE 12**

Some points (Displaced shifting points)	Probable cause
If some of the shift points are displaced while driving, the cause is probably a malfunction of the valve body, or it is related to control and is not an abnormality.	<ul style="list-style-type: none"> <li>• Malfunction of the valve body</li> </ul>

★: Refer to the Transmission Workshop Manual.

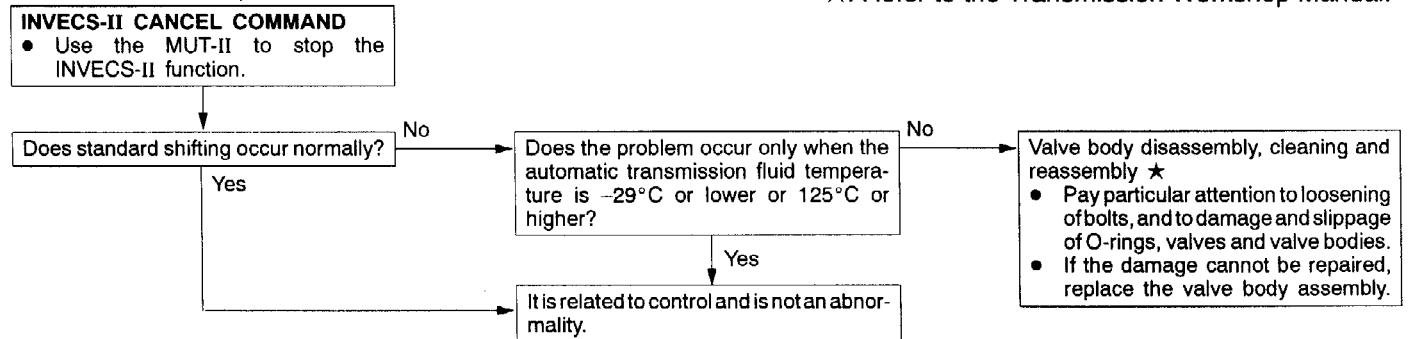

**INSPECTION PROCEDURE 13**

No diagnosis codes (Does not shift)	Probable cause
If shifting does not occur while driving and no diagnosis codes are output, the cause is probably a malfunction of the Inhibitor switch, or A/T-ECU.	<ul style="list-style-type: none"> <li>• Malfunction of the Inhibitor switch</li> <li>• Malfunction of the A/T-ECU</li> </ul>

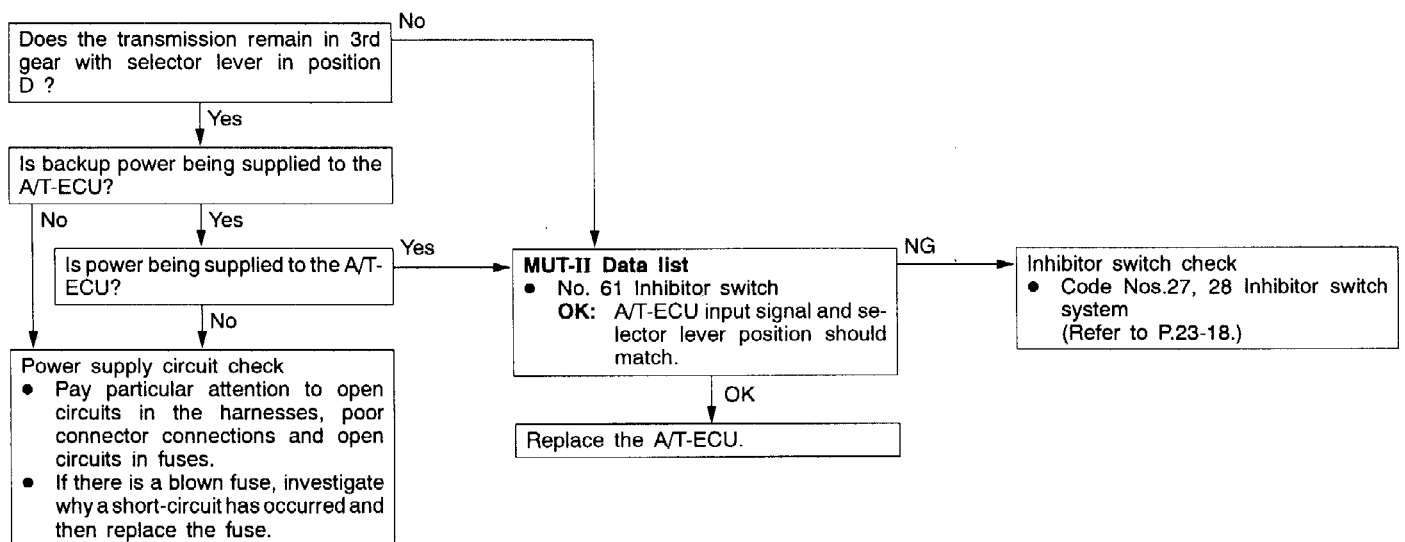

**INSPECTION PROCEDURE 14**

Poor acceleration	Probable cause
If acceleration is poor even if downshifting occurs while driving, the cause is probably a malfunction of the engine system or of a brake or clutch.	<ul style="list-style-type: none"> <li>● Malfunction of the engine system</li> <li>● Malfunction of the brake or clutch</li> </ul>

★: Refer to the Transmission Workshop Manual.

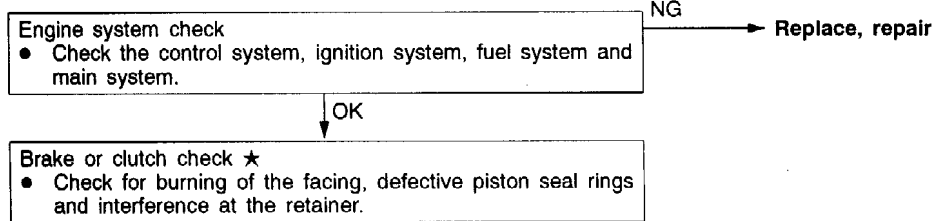

**INSPECTION PROCEDURE 15**

Vibration	Probable cause
If vibration occurs when driving at constant speed or when accelerating in top range, the cause is probably abnormal damper clutch pressure or a malfunction of the engine system, damper clutch solenoid, torque converter or valve body.	<ul style="list-style-type: none"> <li>● Abnormal damper clutch pressure</li> <li>● Malfunction of the engine system</li> <li>● Malfunction of the damper clutch solenoid</li> <li>● Malfunction of the torque converter</li> <li>● Malfunction of the valve body</li> </ul>

★: Refer to the Transmission Workshop Manual.

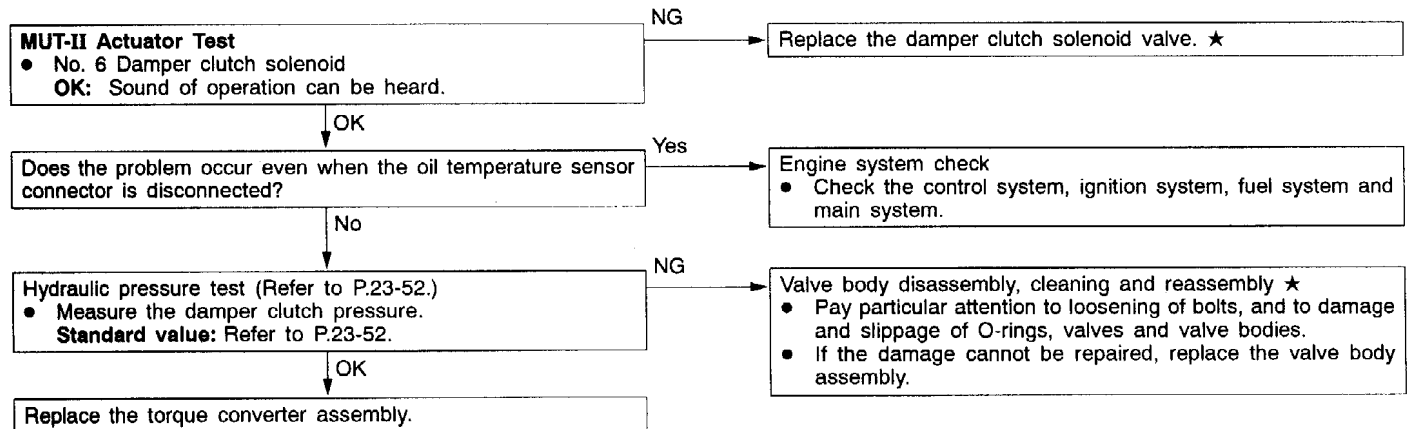

**INSPECTION PROCEDURE 16**

Idle position switch system	Probable cause
The cause is probably a defective idle position switch circuit or a defective A/T-ECU circuit.	<ul style="list-style-type: none"> <li>● Malfunction of the idle position switch</li> <li>● Malfunction of connector</li> <li>● Malfunction of the A/T-ECU</li> </ul>

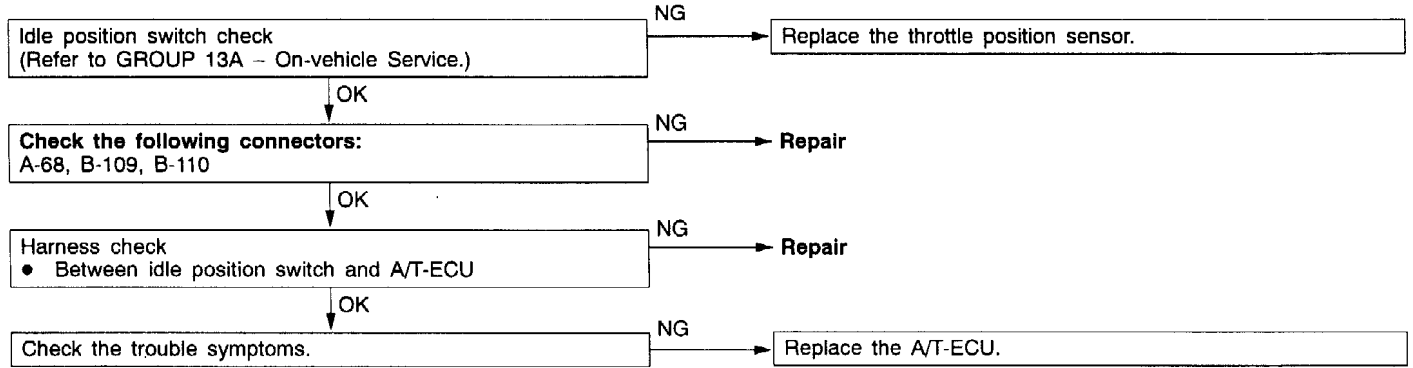

**INSPECTION PROCEDURE 17**

Dual pressure switch system	Probable cause
The cause is probably a defective dual pressure switch circuit or a defective A/T-ECU.	<ul style="list-style-type: none"> <li>● Malfunction of the dual pressure switch</li> <li>● Malfunction of connector</li> <li>● Malfunction of A/C system</li> <li>● Malfunction of the A/T-ECU</li> </ul>

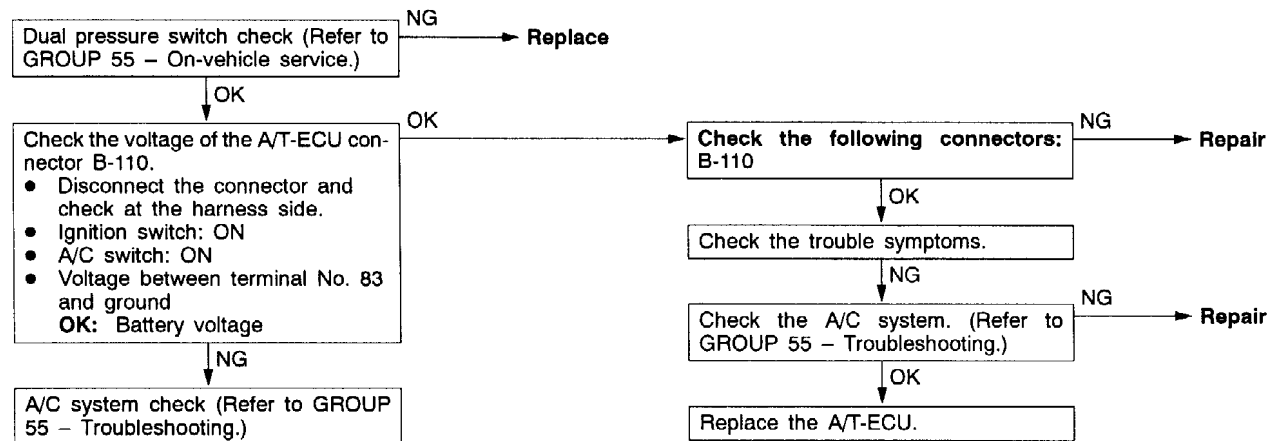

INSPECTION PROCEDURE 18

Vehicle speed sensor system	Probable cause
A malfunction may exist in the speed sensor circuit or the A/T-ECU.	<ul style="list-style-type: none"> <li>Malfunction of the vehicle speed sensor</li> <li>Malfunction of the connector</li> <li>Malfunction of the A/T-ECU</li> </ul>

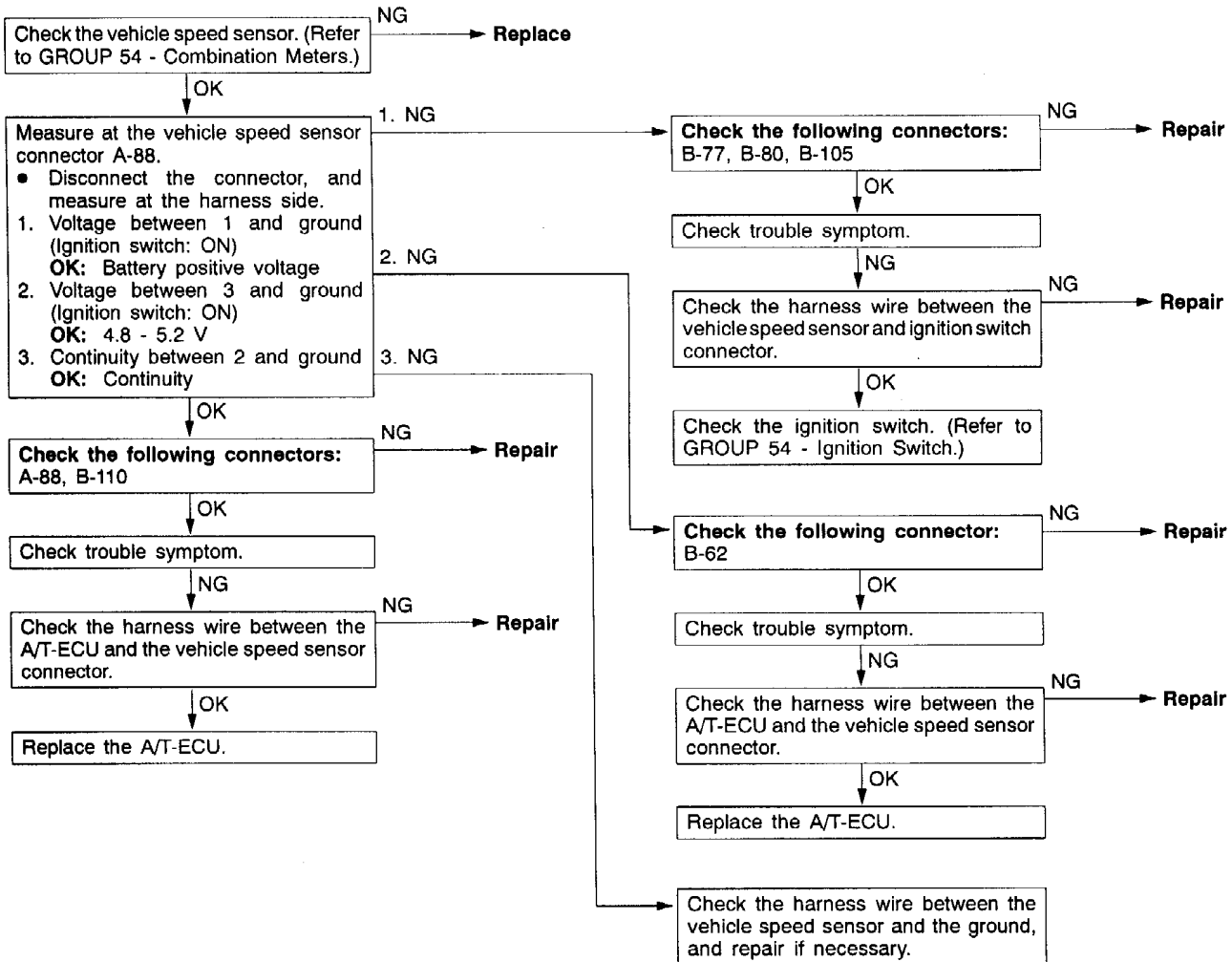

INSPECTION PROCEDURE 19

Auto-cruise-ECU signal system	Probable cause
A malfunction may exist in the auto-cruise signal line circuit or the A/T-ECU.	<ul style="list-style-type: none"> <li>Malfunction of connector</li> <li>Malfunction of the A/T-ECU</li> <li>Malfunction of the auto-cruise ECU</li> </ul>

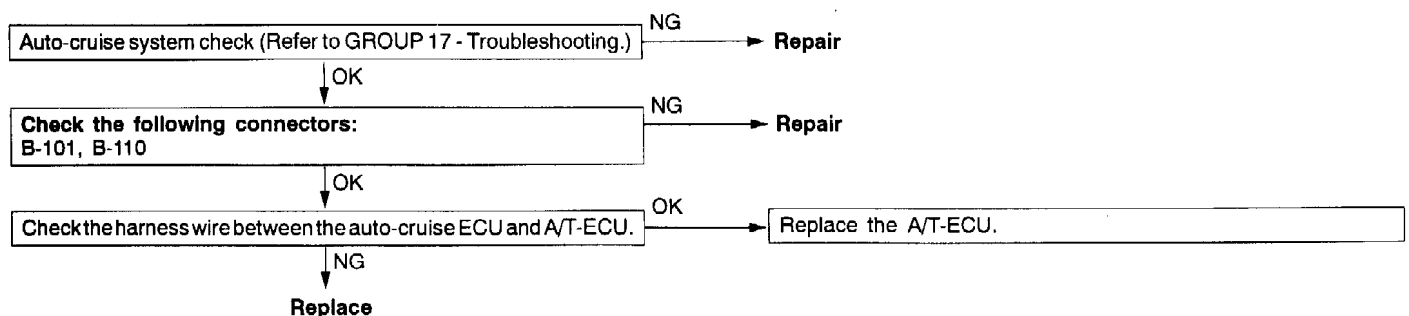

## SERVICE DATA REFERENCE TABLE

Item No.	Check item	Check requirement	Normal value	
11	Throttle position sensor	Engine: Stopped Selector lever position: P	Accelerator pedal: Fully closed	400 – 1,000 mV
			Accelerator pedal: Depressed	Gradually rises from the above value
			Accelerator pedal: Fully open	4,500 – 5,000 mV
15	Oil temperature sensor	Warming up	Drive for 15 minutes or more so that the automatic transmission fluid temperature becomes 70 – 90 °C.	Gradually rises to 70 – 90 °C
21	Crankshaft position sensor	Engine: Idling Selector lever position: P	Accelerator pedal: Fully closed	600 – 900 r/min
			Accelerator pedal: Depressed	Gradually rises from the above value
22	Input shaft speed sensor	Selector lever position: 3	Driving at constant speed of 50 km/h gear	1,800 – 2,100 r/min
23	Output shaft speed sensor	Selector lever position: 3	Driving at constant speed of 50 km/h in 3rd gear	1,800 – 2,100 r/min
26	Stop light switch	Ignition switch: ON Engine: Stopped	Brake pedal: Depressed	ON
			Brake pedal: Released	OFF
29	Vehicle speed sensor	Selector lever position: 3	Idling with 1st gear (Vehicle stopped)	0 km/h
			Driving at constant speed of 50 km/h in 3rd gear	50 km/h
31	Low and reverse solenoid valve duty %	Selector lever position: L, 2, 3, D	Driving at constant speed of 10 km/h in 1st gear	No. 31: 0 %, No. 32: 0 %, No. 33: 100 %, No. 34: 100%
32	Underdrive solenoid valve duty %		Driving at constant speed of 30 km/h in 2nd gear	No. 31: 100 %, No. 32: 0 %, No. 33: 0 %, No. 34: 100%
33	Second solenoid valve duty %		Driving at constant speed of 50 km/h in 3rd gear	No. 31: 100 %, No. 32: 0 %, No. 33: 100 %, No. 34: 0%
34	Overdrive solenoid valve duty %		Driving at constant speed of 50 km/h in 4th gear	No. 31: 100 %, No. 32: 100 %, No. 33: 0 %, No. 34: 0%
36	Damper clutch solenoid duty %	Selector lever position: 3	Accelerate to 50 km/h in 3 position, then release accelerator pedal*	0 %
			Driving at constant speed of 50 km/h in 3rd gear	Approx. 70 – 90 %

Item No.	Check item	Check requirement	Normal value	
52	Amount of damper clutch slippage	Selector lever position: 3	Accelerate to 50 km/h in 3 position, then release accelerator pedal*	Approx. 100 – 300 r/min*
			Driving at constant speed of 50 km/h in 3rd gear	Approx. 0 – 10 r/min
54	A/T control relay output voltage	Ignition switch: OFF → ON	0 mV → Battery voltage (mV)	
57	Engine volumetric efficiency	Selector lever position: N	Accelerator pedal fully closed → depressed	Data changes
61	Inhibitor switch	Ignition switch: ON Engine: Stopped	Selector lever position: P	P
			Selector lever position: R	R
			Selector lever position: N	N
			Selector lever position: D	D
			Selector lever position: 3	3
			Selector lever position: 2	2
63	Shift position	Selector lever position: L, 2, 3, D	Driving at constant speed of 10 km/h in 1st gear	1st
			Driving at constant speed of 30 km/h in 2nd gear	2nd
			Driving at constant speed of 50 km/h in 3rd gear	3rd
			Driving at constant speed of 50 km/h in 4th gear	4th
64	Idle position switch	Engine: Idling Selector lever position: N	Accelerator pedal: Fully closed	ON
			Accelerator pedal: Depressed	OFF
65	Dual pressure switch	Engine: Idling Selector lever position: N	A/C switch: ON	ON
			A/C switch: OFF	OFF
66	Auto-cruise ECU signal	While auto-cruise operating	Plain road	OFF
			Sloping road	ON

**NOTE**

\*: The damper clutch is released when the accelerator is fully closed (Idle position switch: ON).

**ACTUATOR TEST JUDGEMENT VALUE**

Item No.	Check item	Test content	Check requirement	Normal value
1	Low reverse solenoid valve	Drive the solenoid valve specified by the MUT-II at 50 % duty for 5 seconds. No other solenoid valve should be energised.	Ignition switch: ON Selector lever position: P Engine: 0 r/min Vehicle speed: 0 km/h (Vehicle stopped) Throttle opening voltage: Less than 1 V Idle position switch: ON While fail-safe function is not in operation.	The operation sound should be audible when the solenoid valve is driven.
2	Underdrive solenoid valve			
3	Second solenoid valve			
4	Overdrive solenoid valve			
6	Damper clutch solenoid			
12	A/T control relay	Control relay is OFF for 3 seconds.		Data list No. 54 (1) During test: 0 mV (2) Normal: Battery voltage [mV]

**INVECS-II CANCEL COMMAND**

Item No.	Item	Content	Remarks
14	INVECS-II	Stop the INVECS-II control and change gears according to the standard shift pattern.	Use this function when carrying out procedure 8 in the road tests. (Refer to P.23-10.)



CHECK AT A/T-ECU TERMINALS

1	2	3	4		5	6	7	8	41	42	43		44	45	46	71	72	73	74		75	76	77	101	102	103	104		105	106	107																			
9	10	11	12	13	14	15	16	17	18	19	20	21	22	23	47	48	49	50	51	52	53	54	55	56	57	78	79	80	81	82	83	84	85	86	87	88	89	108	109	110	111	112	113	114	115	116	117	118	119	120
24	25	26	27	28	29	30	31	32	33	34	35	58	59	60	61	62	63	64	65	66	90	91	92	93	94	95	96	97	98	121	122	123	124	125	126	127	128	129	130											

9FA0253

Terminal No.	Check item	Check requirement	Standard value
50	A/T control relay	Ignition switch: Off	0 V
		Ignition switch: On	Battery voltage
57	Sensor ground	Always	0 V
75	Cruise control unit	OD-OFF command not executed	Battery voltage
		OD-OFF command executed	0 V
76	Ground	Always	0 V
77	Power supply	Ignition switch: OFF	0 V
		Ignition switch: ON	Battery voltage
88	Ground	Always	0 V
89	Power supply	Ignition switch: OFF	0 V
		Ignition switch: ON	Battery voltage
97	Ground	Always	0 V
101	Inhibitor switch: P	Selector lever position: P	Battery voltage
		Selector lever position: Other than above	0 V
102	Inhibitor switch: D	Selector lever position: D	Battery voltage
		Selector lever position: Other than above	0 V
103	Input shaft speed sensor	Measure from terminal No. 104 to 57 with an oscilloscope. Engine: 2,000 r/min Selector lever position: D (3rd)	See procedures for checking with an oscilloscope (Page 23–40).
104	Output shaft speed sensor	Measure from terminal No. 104 to 57 with an oscilloscope. Engine: 2,000 r/min Selector lever position: D (3rd)	
106	2nd solenoid valve	Selector lever position: D (2nd)	Battery voltage
		Selector lever position: D (1st)	Approx. 7 – 9 V
107	DCC solenoid valve	Selector lever position: D (1st)	Battery voltage
		Selector lever position: D (3rd-60km/h)	Approx. 7 – 9 V
108	Inhibitor switch: R	Selector lever position: R	Battery voltage
		Selector lever position: Other than above	0 V

Terminal No.	Check item	Check requirement	Standard value
120	UD solenoid valve	Selector lever position: (1st)	Battery voltage
		Selector lever position: R	Approx. 7 – 9 V
121	Inhibitor switch: N	Selector lever position: N	Battery voltage
		Selector lever position: Other than above	0 V
123	Stop lamp switch	Brake pedal: Depressed	Battery voltage
		Brake pedal: Released	0 V
124	Oil temperature sensor	ATF temperature: 25°C	3.8 – 4.0 V
		ATF temperature: 80°C	2.3 – 2.5 V
129	LR solenoid valve	Selector lever position: D (1st)	Battery voltage
		Selector lever position: D (2nd)	Approx. 7 – 9 V
130	OD solenoid valve	Selector lever position: D (3rd)	Battery voltage
		Selector lever position: D (1st)	Approx. 7 – 9 V

**OSCILLOSCOPE INSPECTION PROCEDURE**

Check item	Check requirement		Normal condition (Waveform sample)
Crankshaft position sensor	Selector lever position: N	Idling (Vehicle stopped)	Waveform A
Input shaft speed sensor	Selector lever position: 3	Driving at constant speed of 50 km/h in 3rd gear (Engine: 1,800 – 2,100 r/min)	Waveform B
Output shaft speed sensor			
Vehicle speed sensor			
Low reverse solenoid valve	Ignition switch: ON Selector lever position: P Engine: 0 r/min Vehicle speed: 0 km/h (Vehicle stopped) Throttle (Accelerator) opening angle: Less than 1 V Closed throttle position switch: ON	Force drive each solenoid valve (Actuator test)	Waveform C
Underdrive solenoid valve			
Second solenoid valve			
Overdrive solenoid valve			
Damper clutch control solenoid			

**Waveform sample**

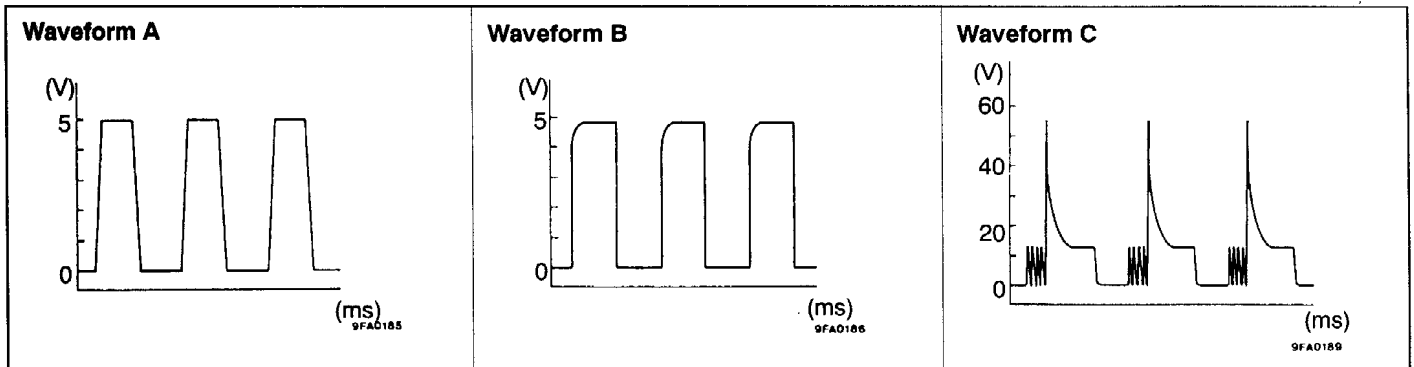

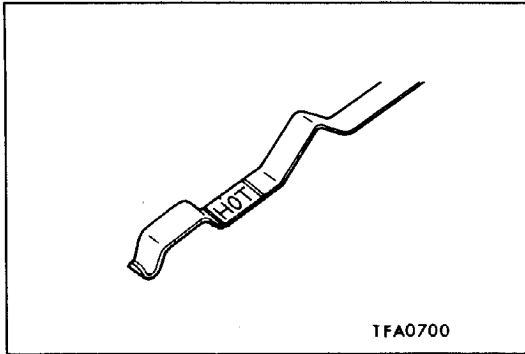

## ON-VEHICLE SERVICE

### AUTOMATIC TRANSMISSION FLUID CHECK

1. Drive until the fluid temperature reaches the operating temperature 70–80°C.
2. Place vehicle on level floor.
3. Move selector lever sequentially to every position to fill torque converter and hydraulic circuit with fluid, then place lever in “N” Neutral position. This operation is necessary to be sure that fluid level check is accurate.
4. Before removing the oil level gauge, wipe all dirt from area around the oil level gauge. Then take out the oil level gauge and check the condition of the fluid. Further investigation of the transmission is necessary if,
  - the fluid smells burnt.
  - the fluid colour is brown or black.
  - metal particles can be seen or felt on the dipstick.
5. Check to see if fluid level is in “HOT” range on oil level gauge. If fluid level is low, add ATF until level reaches “HOT” range.

#### NOTE

Low fluid level can cause a variety of conditions because it allows the pump to take in air along with fluid. Air trapped in the hydraulic circuit forms bubbles which make the fluid spongy.

Therefore, pressures will be erratic.

Improper filling can also raise fluid level too high. When the transmission has too much fluid, gears churn up foam and cause the same conditions which occur with low fluid level, resulting in accelerated deterioration of ATF. In either case, air bubbles can cause overheating, fluid oxidation, which can interfere with normal valve, clutch, and servo operation. Foaming can also result in fluid escaping from the transmission vent where it may be mistaken for a leak.

6. Be sure to examine the fluid on the oil level gauge closely.

### OIL FILTER REPLACEMENT

1. Use the special tool (MB991610) to remove the automatic transmission oil filter.
2. Clean the transmission case side mounting surface.
3. Apply a small amount of automatic transmission fluid to the O-ring of the new oil filter.
4. Use the special tool (MB991610) to install the automatic transmission oil filter.

#### NOTE

Tightening torque: 12 Nm.

5. Check the quantity of the automatic transmission fluid.

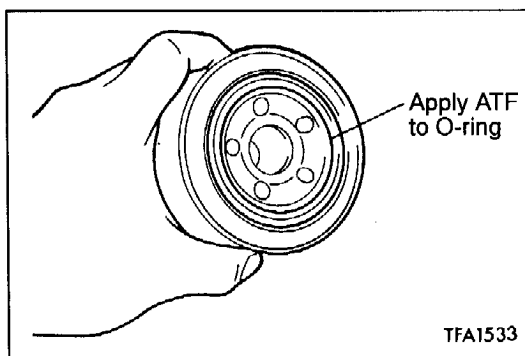

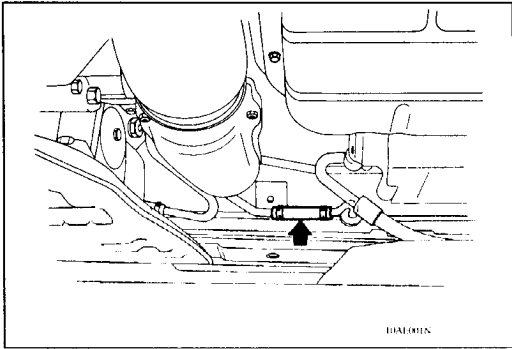

### AUTOMATIC TRANSMISSION FLUID REPLACEMENT

Drain the fluid and check if there is any evidence of contamination.

Replenish with new fluid after the cause of any contamination has been corrected.

1. Remove the right hand hose connecting the transmission oil cooler pipe to the oil cooler (built in to the bottom of the radiator).
2. Connect a suitable length of hose from the radiator cooler pipe to an oil drain receptacle, large enough to hold the quantity of discharged fluid.
3. Start the engine and discharge the ATF.  
Operating conditions: "N" Neutral gear and idling.

**Caution**

**Start the engine and then stop it within one minute. If the ATF is discharged before the one minute elapses, stop the engine at that time.**

**Amount of oil discharged: Approximately 6.5 litres**

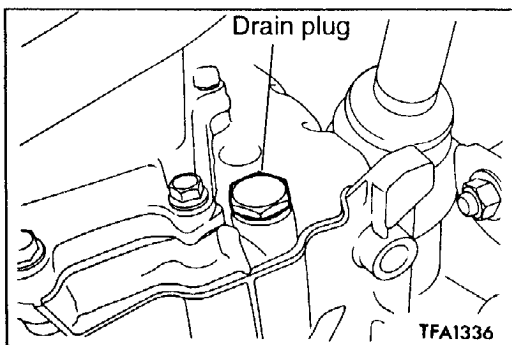

4. Remove the drain plug at the bottom of the transmission case and discharge the ATF.

**Amount of ATF discharged: Approximately 2.0 litres**

5. Check for deterioration of the oil filter. Change the oil filter if necessary.
6. Install the drain plug and gasket, applying the specified amount of torque.

**Tightening torque: 32 Nm**

7. Fill with new ATF through the oil filler tube.

**Amount of ATF added: Approximately 8.5 litres**

**NOTE**

If the entire amount of new ATF cannot be added, follow procedure (8) to add fluid.

8. Repeat step (3) to discharge ATF from the hose.
9. Add the new ATF through the oil filler tube.
10. Attach and secure the hose that was disconnected in step (1) and securely insert the oil level gauge.
11. Start the engine and let it idle for one or two minutes.
12. Move the selector lever through all gear positions, ending in Neutral position.

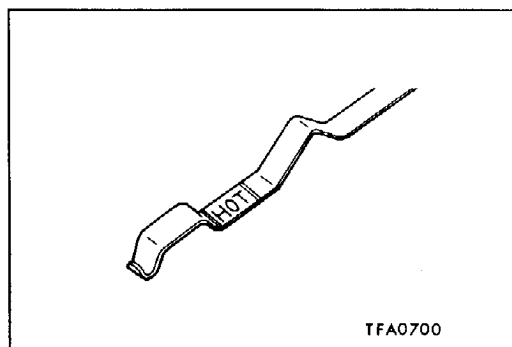

13. Make sure the ATF reaches the "COLD" mark on the oil level gauge. If there is not enough ATF, add more.
14. Drive the car until the ATF temperature reaches normal 70–80°C and recheck the ATF level. The ATF must be within the "HOT" range.

**NOTE**

The "COLD" level is for reference and the "HOT" level serves as the standard.

15. Securely insert the oil level gauge into the filler tube.

**THROTTLE POSITION SENSOR ADJUSTMENT**

Refer to GROUP 13A – On-vehicle Service.

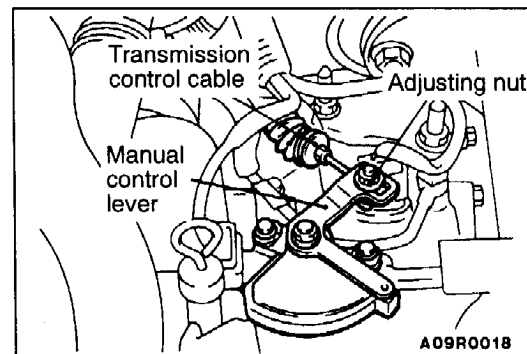
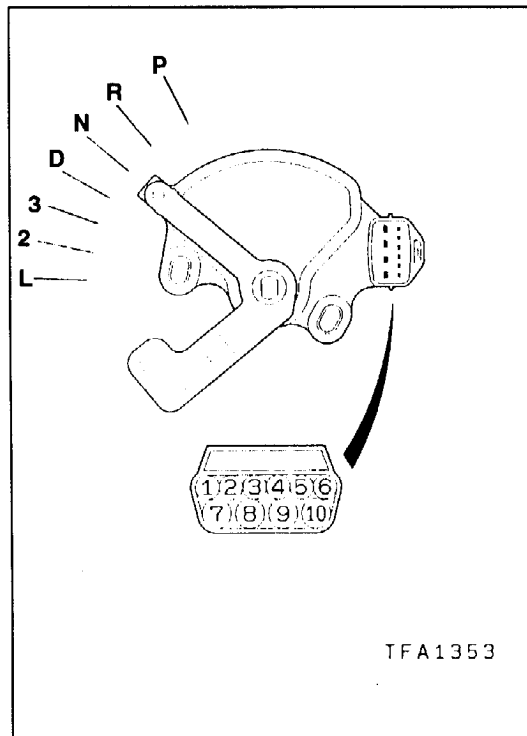
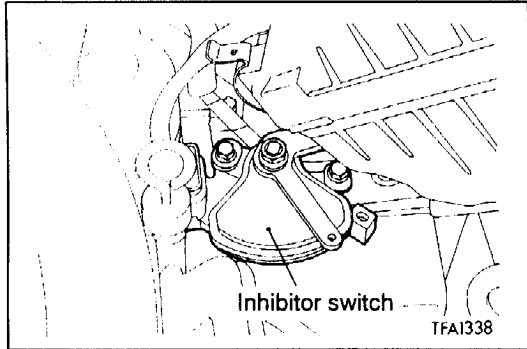

**INHIBITOR SWITCH CONTINUITY CHECK**

Items	Terminal No.									
	1	2	3	4	5	6	7	8	9	10
P			○	—				○	○	○
R							○	○		
N				○	—			○	○	○
D	○	—						○		
3					○	—		○		
2		○	—					○		
L							○	○		

**INHIBITOR SWITCH AND CONTROL CABLE ADJUSTMENT**

1. Set the selector lever to the "N" position.
2. Loosen the control cable to manual control lever coupling nut to free the cable and lever.
3. Set the manual control lever to the neutral position.

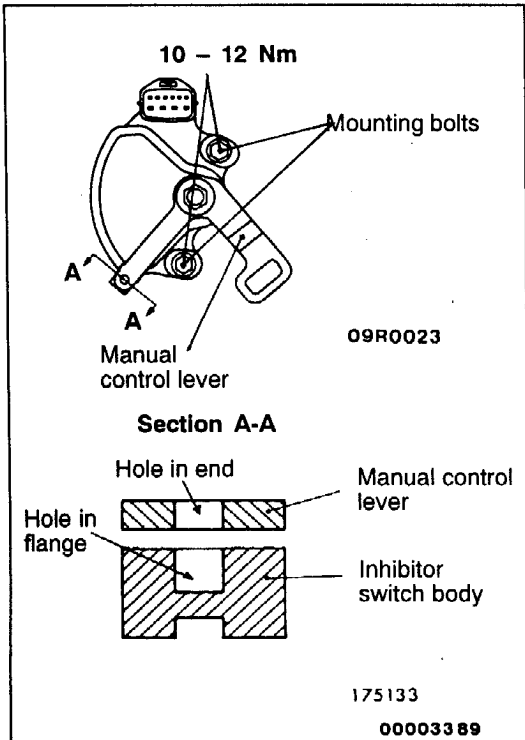

4. Loosen the inhibitor switch body mounting bolts and turn the inhibitor switch body so the hole in the end of the manual control lever and the hole (cross section A-A in the figure on the left) in the flange of the inhibitor switch body flange are aligned.
5. Tighten the inhibitor switch body mounting bolts to the specified torque. Be careful at this time that the position of the switch body is not changed.

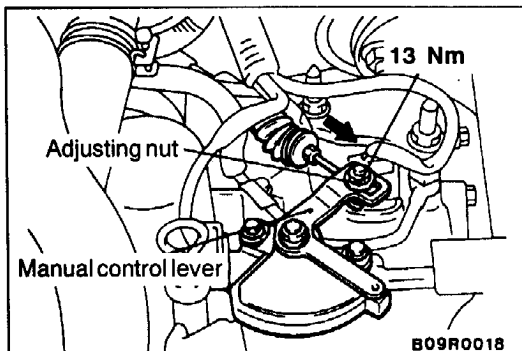

6. Gently pull the transmission control cable in the direction of the arrow, and then tighten the adjusting nut.
7. Check that the selector lever is in the "N" position.
8. Check that each range on the transmission side operates and functions correctly for each position of the selector lever.

**A/T CONTROL COMPONENT LOCATION**

Name	Symbol	Name	Symbol
A/T control relay	I	Oil temperature sensor	D
Crankshaft position sensor	F	Output shaft speed sensor	C
Diagnosis connector	J	Shift indicator light	G
Dual pressure switch	B	Solenoid valve	D
Engine-A/T-ECU	H	Stop light switch	K
Inhibitor switch	E	Throttle position sensor (with built-in idle position switch)	A
Input shaft speed sensor	C	Vehicle speed sensor	C

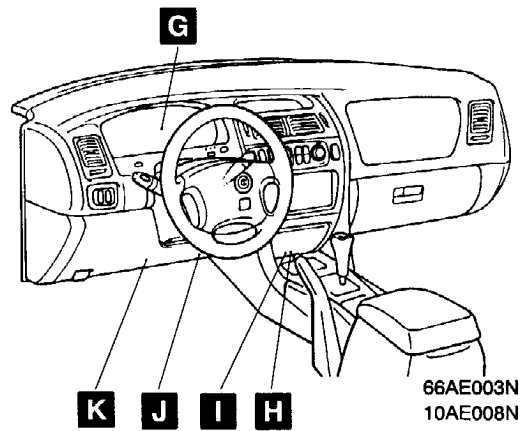
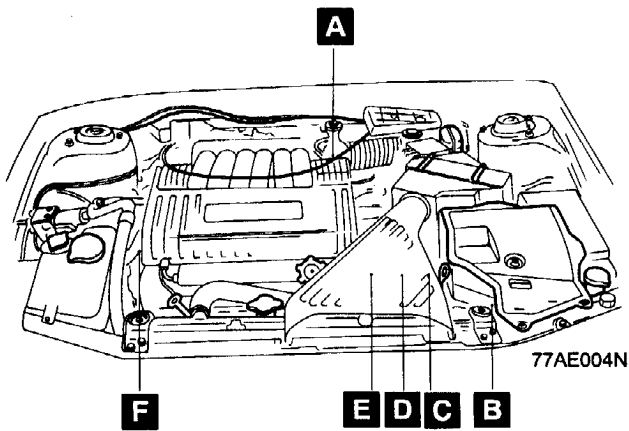



**A/T CONTROL COMPONENT CHECK**

**1. CRANKSHAFT POSITION SENSOR CHECK**

Refer to GROUP 13A – Troubleshooting.

**2. THROTTLE POSITION SENSOR CHECK**

Refer to GROUP 13A – On-vehicle Service.

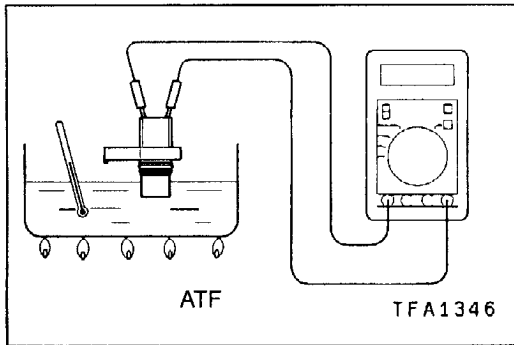

**3. OIL TEMPERATURE SENSOR CHECK**

1. Remove the oil temperature sensor.
2. Measure the resistance between terminals No.1 and No.2 of the oil temperature sensor connector.

**Standard value:**

Oil temperature [°C]	Resistance (kΩ)
0	1.67 – 20.5
100	0.57 – 0.69

3. Replace the sensor if not within the standard value.

**4. INHIBITOR SWITCH CHECK**

Refer to P.23-46.

**5. STOP LAMP SWITCH CHECK**

Refer to GROUP 35 – Brake Pedal.

**6. VEHICLE SPEED SENSOR CHECK**

Refer to GROUP 54 – On-vehicle Service.

**7. DUAL PRESSURE SWITCH CHECK**

Refer to GROUP 55 – On-vehicle Service.

**8. IDLE POSITION SWITCH CHECK**

Refer to GROUP 13A – On-vehicle Service.

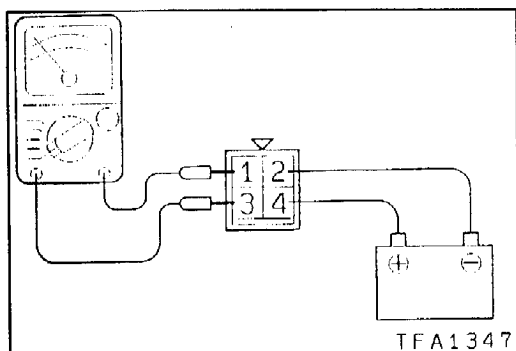

**9. A/T CONTROL RELAY CHECK**

1. Remove the A/T control relay.
2. Use jumper wires to connect the A/T control relay terminal (2) to the battery (-) terminal and terminal (4) to the battery (+) terminal.
3. Check the continuity between the terminal (1) and the terminal (3) of the A/T control relay when the jumper wires are connected to and disconnected from the battery.

Jumper wire	Continuity between terminals No.1 and No.3
Connected	Continuity
Disconnected	No continuity

- If there is a problem, replace the A/T control relay.

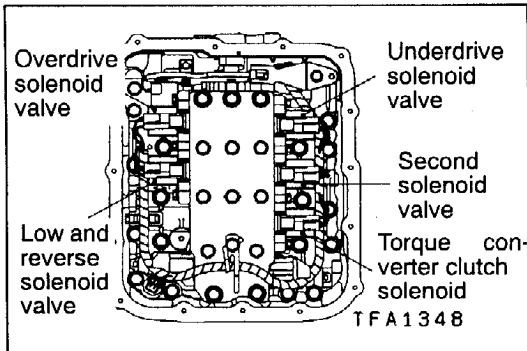

**10. SOLENOID VALVE CHECK**

- Remove the valve body cover.
- Disconnect the connectors of each solenoid valve.

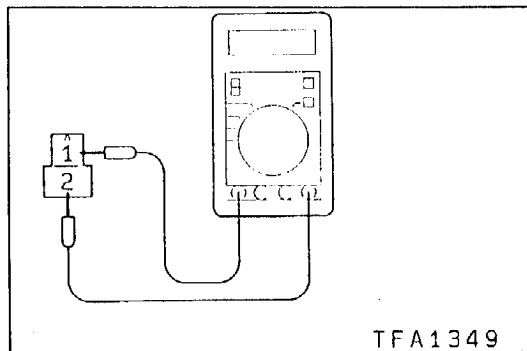

- Measure the resistance between terminals 1 and 2 of each solenoid valve.

**Standard value:**

Name	Resistance
Damper clutch solenoid	2.7 – 3.4 Ω (at 20°C)
Low and reverse solenoid valve	
Second solenoid valve	
Underdrive solenoid valve	
Overdrive solenoid valve	
Torque converter clutch solenoid	

- If the resistance is not within the standard value, replace the solenoid valve.

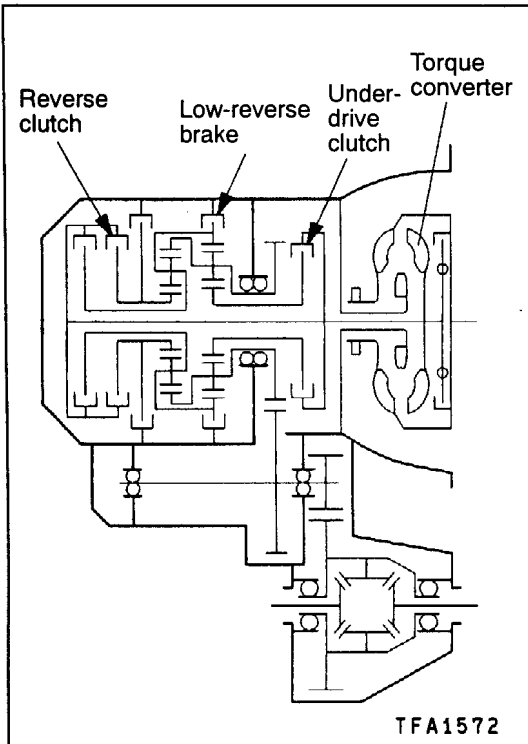

## TORQUE CONVERTER STALL TEST

This test measures the maximum engine speed when the selector lever is at the D or R position and the torque converter stalls to test the operation of the torque converter, starter motor and one-way clutch operation and the holding performance of the clutches and brakes in the transmission.

### Caution

**Do not let anybody stand in front of or behind the vehicle while this test is being carried out.**

1. Check the automatic transmission fluid level and temperature and the engine coolant temperature.
  - Fluid level: At the HOT mark on the oil level gauge
  - Fluid temperature: 80 – 100°C
  - Engine coolant temperature: 80 – 100°C
2. Chock both rear wheels.
3. Pull the parking brake lever on, with the brake pedal fully depressed.
4. Start the engine.
5. Move the selector lever to the D position, fully depress the accelerator pedal and take a reading of the maximum engine speed at this time.

### Caution

1. **The throttle should not be left fully open for any more than eight seconds.**
2. **If carrying out the stall test two or more times, move the selector lever to the N position and run the engine at 1,000 r/min to let the automatic transmission fluid cool down before carrying out subsequent tests.**

### Standard value:

**Stall speed: 2,100 – 2,600 r/min**

6. Move the selector lever to the R position and carry out the same test again.

### Standard value:

**Stall speed: 2,100 – 2,600 r/min**

## TORQUE CONVERTER STALL TEST JUDGEMENT RESULTS

- a. Stall speed is too high in both D and R ranges
  - Low line pressure
  - Low & reverse brake slippage
- b. Stall speed is too high in D range only
  - Underdrive clutch slippage
- c. Stall speed is too high in R range only
  - Reverse clutch slippage
- d. Stall speed too low in both D and R ranges
  - Malfunction of torque converter
  - Insufficient engine output

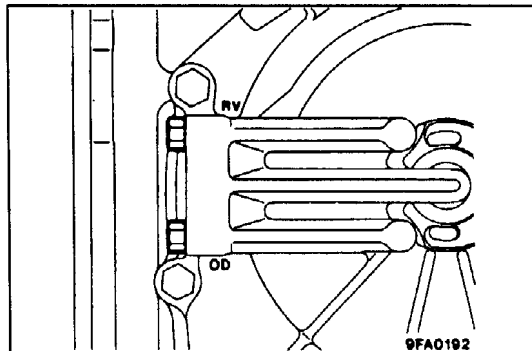
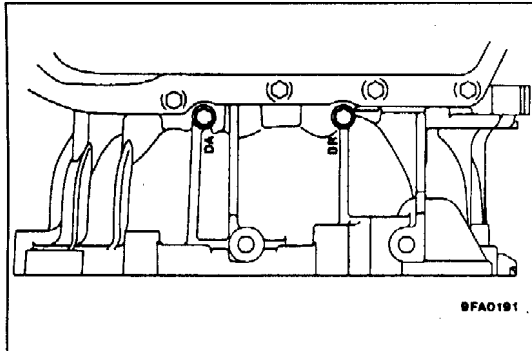
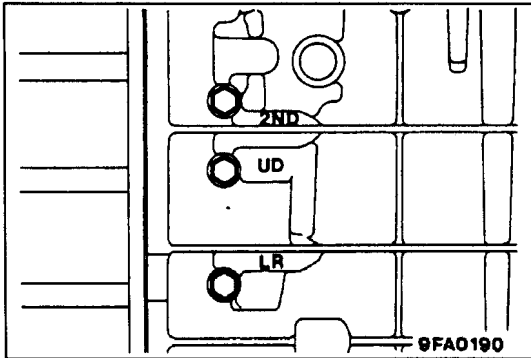

## HYDRAULIC PRESSURE TEST

1. Warm up the engine until the automatic transmission fluid temperature is 80–100°C.
2. Jack up the vehicle so that the wheels are free to turn.
3. Connect the special tools (2,942 kPa) oil pressure gauge [MD998330] and joints [MD998332, MD998900]) to each pressure discharge port.
4. Measure the hydraulic pressure at each port under the conditions given in the standard hydraulic pressure table, and check that the measured values are within the standard value ranges.
5. If a value is outside the standard range, correct the problem while referring to the hydraulic pressure test diagnosis table.

**STANDARD HYDRAULIC PRESSURE TEST**

Measurement condition			Standard hydraulic pressure kPa					
Selector lever position	Shift position	Engine speed (r/min)	Underdrive clutch pressure	Reverse clutch pressure	Overdrive clutch pressure	Low and reverse brake pressure	Second brake pressure	Torque converter pressure
P	–	2,500	–	–	–	260 – 340	–	260 – 340
R	Reverse	2,500	–	1,270 – 1,770	–	1,270 – 1,770	–	500 – 700
N	2,500	–	–	–	–	260 – 340	–	260 – 340
D	1st gear	2,500	1,010 – 1,050	–	–	1,010 – 1,050	–	500 – 700
	2nd gear	2,500	1,010 – 1,050	–	–	–	1,010 – 1,050	500 – 700
	3rd gear	2,500	780 – 880	–	780 – 880	–	–	450 – 650
	4th gear	2,500	–	–	780 – 880	–	780 – 880	450 – 650

**HYDRAULIC PRESSURE TEST DIAGNOSIS TABLE**

Trouble symptom	Probable cause
All hydraulic pressures are high.	Incorrectly adjusted line pressure
	Malfunction of the regulator valve
All hydraulic pressures are low.	Incorrectly adjusted line pressure
	Malfunction of the oil pump
	Clogged internal oil filter
	Clogged oil cooler
	Malfunction of the regulator valve
	Malfunction of the relief valve
	Incorrect valve body installation
Hydraulic pressure is abnormal in "R" range only.	Malfunction of the regulator valve
	Clogged orifice
	Incorrect valve body installation
Hydraulic pressure is abnormal in "3" or "4" range only.	Malfunction of the overdrive solenoid valve
	Malfunction of the overdrive pressure control valve
	Malfunction of the regulator valve
	Malfunction of the switch valve
	Clogged orifice
	Incorrect valve body installation

Trouble symptom	Probable cause
Only underdrive hydraulic pressure is abnormal.	Malfunction of the oil seal K
	Malfunction of the oil seal L
	Malfunction of the oil seal M
	Malfunction of the underdrive solenoid valve
	Malfunction of the underdrive pressure control valve
	Malfunction of check ball
	Clogged orifice
	Incorrect valve body installation
Only reverse clutch hydraulic pressure is abnormal.	Malfunction of the oil seal A
	Malfunction of the oil seal B
	Malfunction of the oil seal C
	Clogged orifice
	Incorrect valve body installation
Only overdrive hydraulic pressure is abnormal.	Malfunction of the oil seal D
	Malfunction of the oil seal E
	Malfunction of the oil seal F
	Malfunction of the overdrive solenoid valve
	Malfunction of the overdrive pressure control valve
	Malfunction of check ball
	Clogged orifice
	Incorrect valve body installation
Only low and reverse hydraulic pressure is abnormal.	Malfunction of the oil seal I
	Malfunction of the oil seal J
	Malfunction of the low and reverse solenoid valve
	Malfunction of the low and reverse pressure control valve
	Malfunction of the switch valve
	Malfunction of the fail safe valve A
	Malfunction of check ball
	Clogged orifice
Incorrect valve body installation	

Trouble symptom	Probable cause
Only second hydraulic pressure is abnormal.	Malfunction of the oil seal G
	Malfunction of the oil seal H
	Malfunction of the oil seal O
	Malfunction of the second solenoid valve
	Malfunction of the second pressure control valve
	Malfunction of the fail safe valve B
	Clogged orifice
	Incorrect valve body installation
Only torque converter pressure is abnormal.	Clogged oil cooler
	Malfunction of the oil seal N
	Malfunction of the damper clutch solenoid
	Malfunction of the damper clutch control valve
	Malfunction of the torque converter pressure control valve
	Clogged orifice
	Incorrect valve body installation
Pressure applied to element which should not receive pressure.	Incorrect transmission control cable adjustment
	Malfunction of the manual valve
	Malfunction of check ball
	Incorrect valve body installation

OIL SEAL LAYOUT

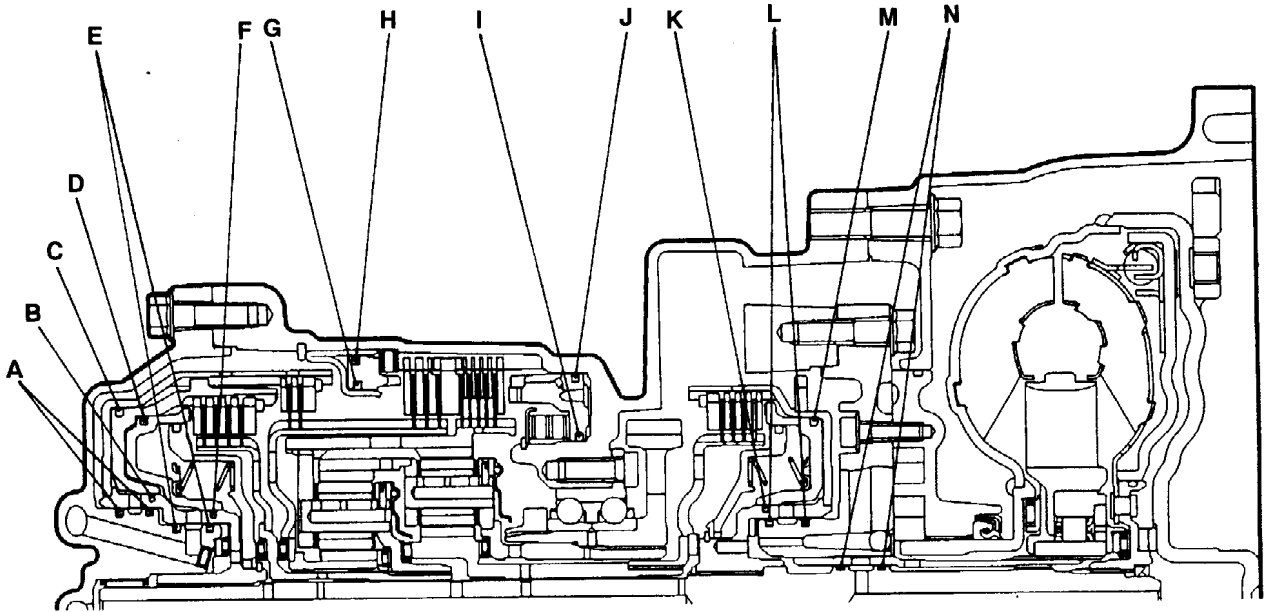

9FA0281

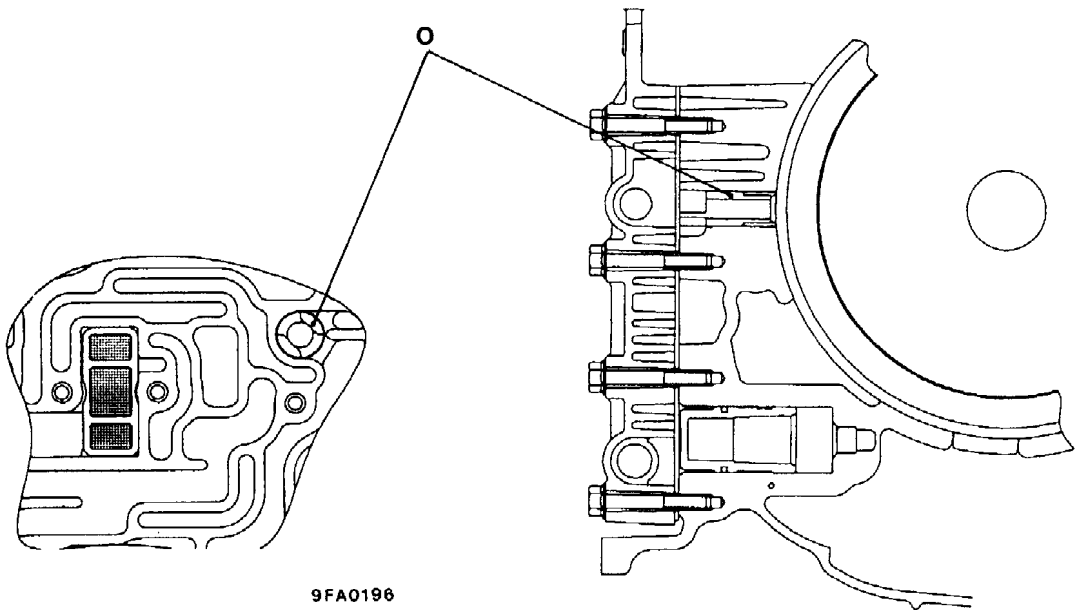

9FA0196

9FA0203  
00003693



**HYDRAULIC CIRCUIT  
PARKING AND NEUTRAL**

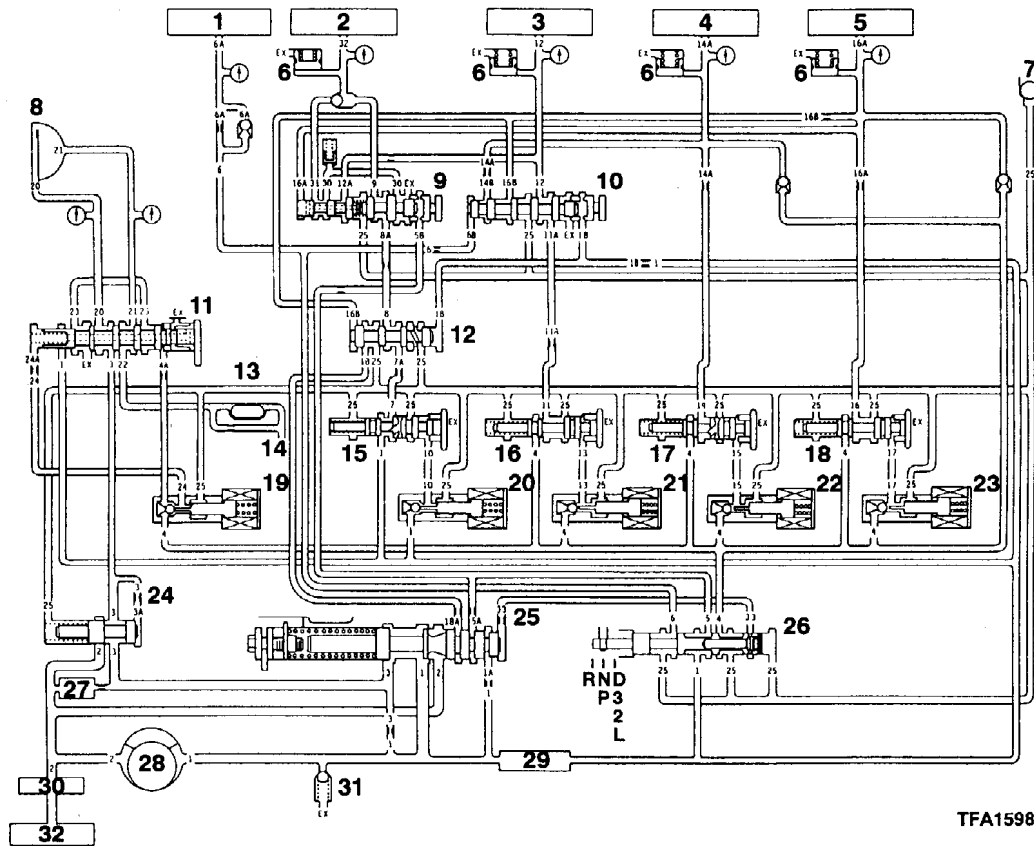

- |   |   |
|---|---|
| 1. Reverse clutch                         | 17. Underdrive pressure control valve       |
| 2. Low-reverse brake                      | 18. Overdrive pressure control valve        |
| 3. Second brake                           | 19. Torque converter clutch solenoid        |
| 4. Underdrive clutch                      | 20. Low-reverse solenoid valve              |
| 5. Overdrive clutch                       | 21. Second solenoid valve                   |
| 6. Accumulator                            | 22. Underdrive solenoid valve               |
| 7. Check ball                             | 23. Overdrive solenoid valve                |
| 8. Torque converter clutch                | 24. Torque converter pressure control valve |
| 9. Fail safe valve A                      | 25. Regulator valve                         |
| 10. Fail safe valve B                     | 26. Manual valve                            |
| 11. Torque converter clutch control valve | 27. Oil filter                              |
| 12. Switch valve                          | 28. Oil pump                                |
| 13. Automatic transmission fluid cooler   | 29. Oil strainer                            |
| 14. Lubrication                           | 30. Oil filter (Built-in type)              |
| 15. Low-reverse pressure control valve    | 31. Relief valve                            |
| 16. Second pressure control valve         | 32. Oil pan                                 |

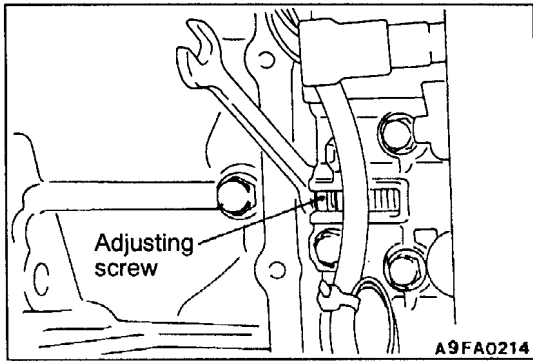

### LINE PRESSURE ADJUSTMENT

1. Discharge the automatic transmission fluid, and then remove the valve body cover.
2. Turn the adjusting screw shown in the illustration to adjust the underdrive pressure in "D" range 1st or 2nd gear to the standard value. The pressure increases when the screw is turned to the left.

#### NOTE

When adjusting the underdrive pressure, adjust to the middle of the standard value range.

**Standard value: 1,010 – 1,050 kPa**

Change in pressure for each turn of the adjusting screw:  
35 kPa

3. Install the valve body cover, and pour in the standard volume of automatic transmission fluid.
4. Carry out a hydraulic pressure test. (Refer to P.23-52.) Readjust the line pressure if necessary.

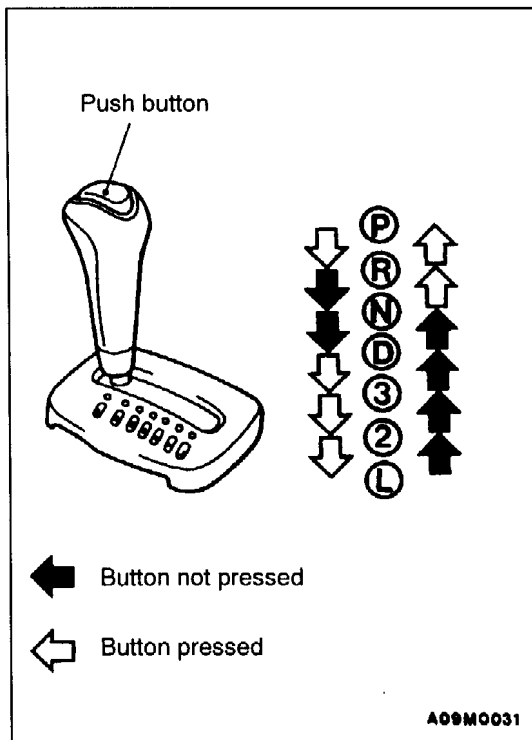

### SELECTOR LEVER OPERATION CHECK

1. Shift selector lever to each range and check that lever moves smoothly and clicks into position. Check that position indicator is correct.
2. Check to be sure the selector lever can be shifted to each position (by button operation as shown in the illustration).
3. Start the engine and check if the vehicle moves forward when the selector lever is shifted from N to D, and moves backward when shifted to R.
4. When the shift lever malfunctions, adjust control cable and selector lever sleeve. Check for worn shift lever assembly sliding parts.

# TRANSMISSION CONTROL REMOVAL AND INSTALLATION

**Pre-removal and Post-installation Operation**  
 (1) Air Cleaner Assembly Removal and Installation  
 (2) Front Floor Console Removal and Installation  
 (Refer to GROUP 52A)

**Caution: SRS**  
 Be careful not to subject the SRS-ECU to any shocks during removal and installation of the transmission control cable and selector lever assembly.

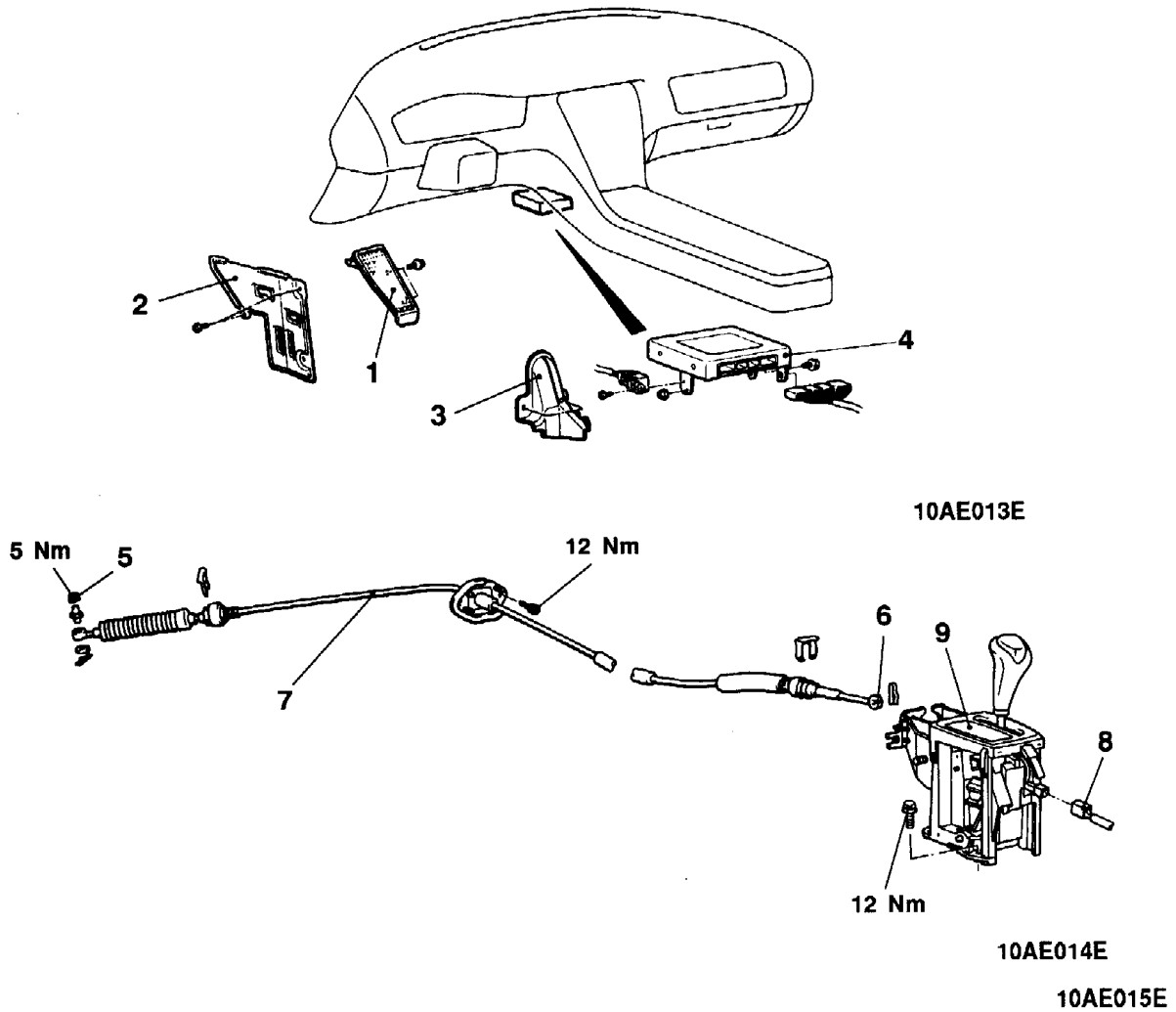

**Transmission control cable assembly removal steps**

1. Foot rest
2. Floor carpet front reinforcements (LH and RH)
3. Harness protector
4. Engine-A/T-ECU and A/T control relay
5. Nut
6. Connection of the transmission control cable



7. Transmission control cable assembly

**Selector lever assembly removal steps**

7. Transmission control cable assembly
8. Harness connector
9. Selector lever assembly

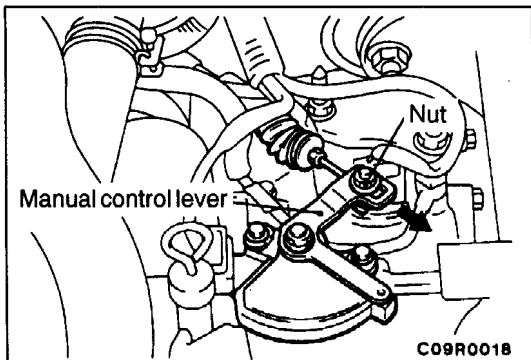

## INSTALLATION SERVICE POINT

### ▶A◀ NUT INSTALLATION

1. Put the selector lever in the "N" position.
2. Loosen the adjusting nut, gently pull the transmission control cable in the direction of the arrow and tighten the nut.

**SELECTOR LEVER ASSEMBLY  
DISASSEMBLY AND REASSEMBLY**

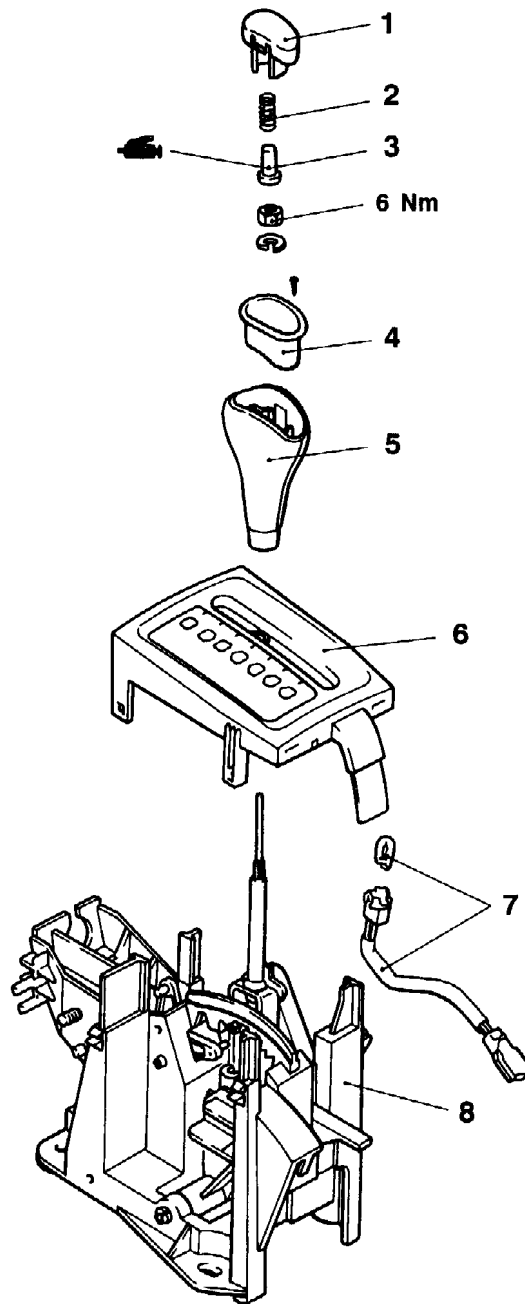

10AE012N

**Disassembly steps**

1. Push button
2. Spring
3. Adjuster
4. Bezel

5. Shift knob
6. Indicator panel assembly
7. Position indicator light assembly
8. Shift lever assembly

## TRANSMISSION ASSEMBLY

## REMOVAL AND INSTALLATION

**Pre-removal Operation**

- (1) Transmission Fluid Draining  
(Refer to P.23-45)
- (2) Under Cover Removal
- (3) Battery and Battery Tray Removal
- (4) Air Cleaner Assembly Removal  
(Refer to GROUP 15)

**Post-installation Operation**

- (1) Air Cleaner Assembly Installation  
(Refer to GROUP 15)
- (2) Battery and Battery Tray Installation
- (3) Under Cover Installation
- (4) Transmission Fluid Supplying  
(Refer to P.23-45)
- (5) Selector Lever Operation Check
- (6) Speedometer Operation Check

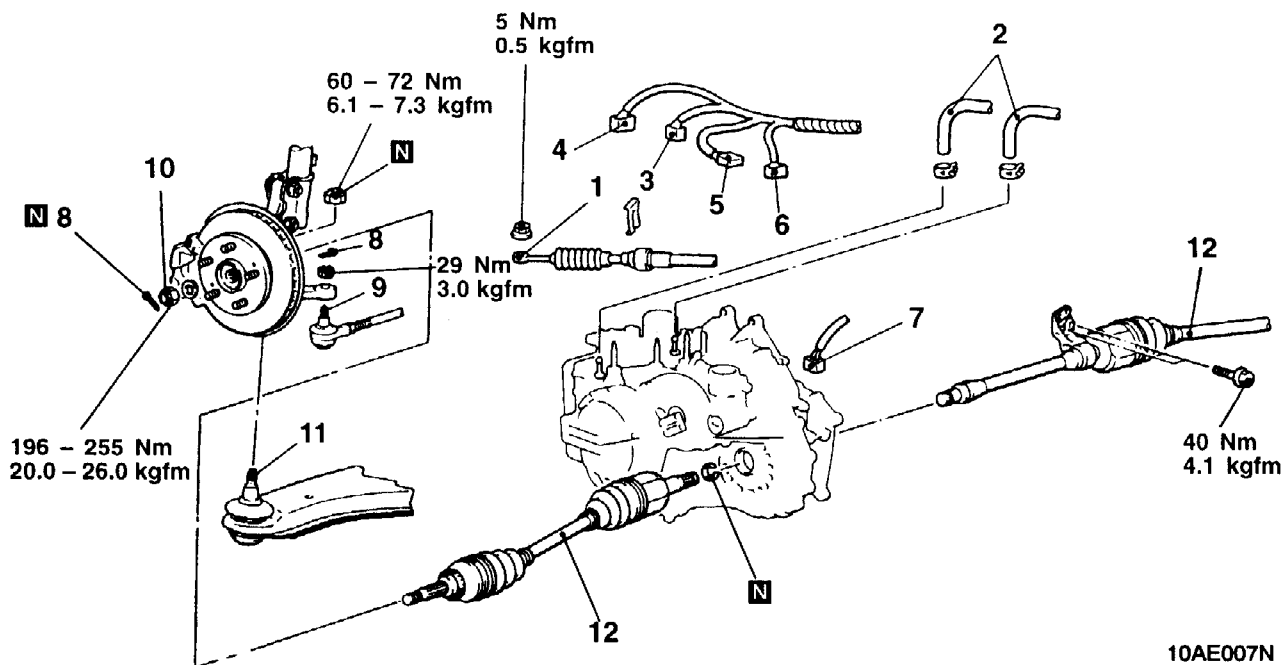
**Removal steps**

1. Transmission control cable connection
2. Transmission oil cooler hoses connection
3. Inhibitor switch connector
4. A/T control solenoid valve connector
5. Input shaft speed sensor connector
6. Output shaft speed sensor connector
7. Vehicle speed sensor connector
8. Split pin



9. Connection of the tie rod end
10. Drive shaft nut



11. Connection for the lower arm ball joint
12. Drive shaft and inner shaft assembly (RH) and the drive shaft (LH)

**Caution**

Mounting locations marked by \* should be provisionally tightened, and then fully tightened when the body is supporting the full weight of the engine.

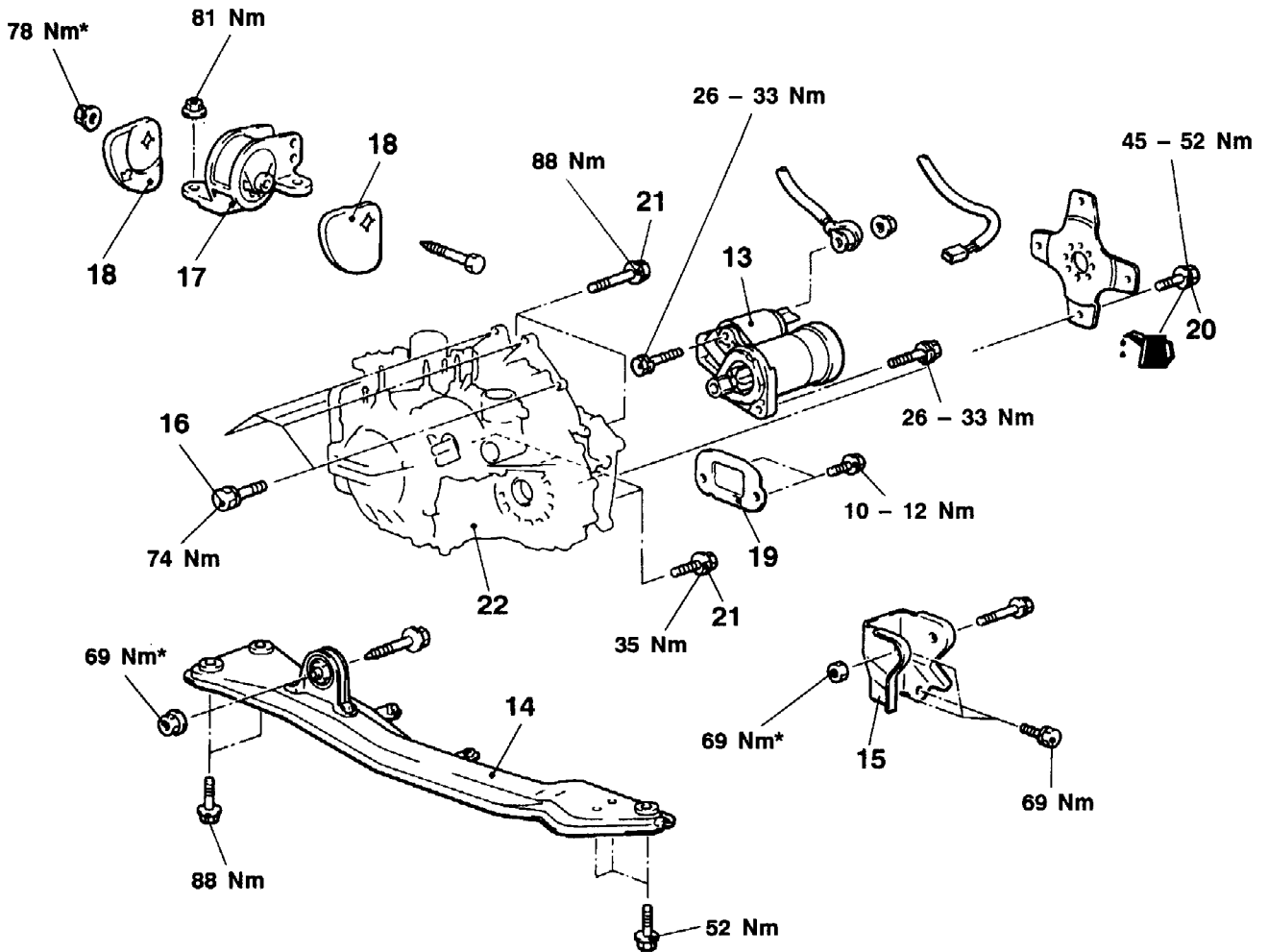

09P0034

**Lifting up of the vehicle**

- 13. Starter motor
- 14. Centre member assembly
- 15. Rear roll stopper bracket
- 16. Transmission upper portion fixing bolt
- 17. Transmission mounting bracket
- 18. Transmission mount stopper
  - Support the engine and transmission assembly
- 19. Bell housing cover

- ▶E▶ 20. Drive plate attaching bolt
- ▶E▶ 21. Transmission lower portion fixing bolt
- ▶E▶ ▶A▶ 22. Transmission assembly

**Caution**  
 Mounting locations marked by \* should be provisionally tightened, and then fully tightened when the body is supporting the full weight of the engine.

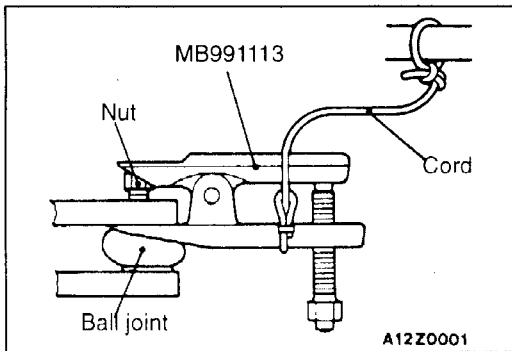

**REMOVAL SERVICE POINTS****◀A▶ TIE ROD END/LOWER ARM BALL JOINT DISCONNECTION****Caution**

1. Before using the special tool, loosen the tie-rod end mounting nut. Only loosen the nut; do not remove it from the ball joint.
2. Support the special tool with a cord, etc. to prevent it from coming off.

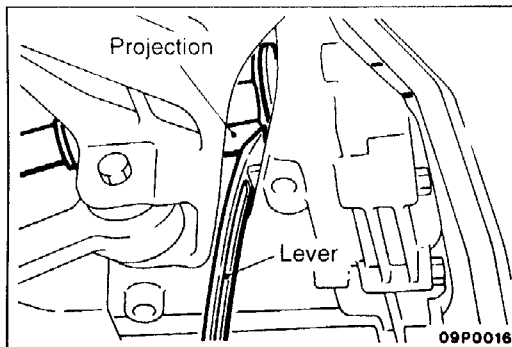
**◀B▶ DRIVE SHAFT <L.H.>/DRIVE SHAFT <R.H.> DISCONNECTION**

1. Insert a pry bar between the transmission case and the drive shaft as shown to remove the drive shaft.

**NOTE**

Do not remove the hub and knuckle from the drive shaft.

**Caution**

**Always use a pry bar, or the ball joint will be damaged.**

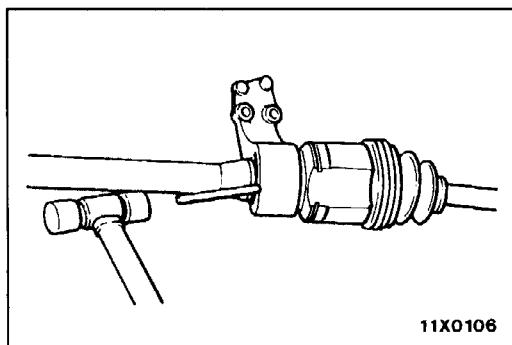

2. Lightly strike the centre bearing with a plastic hammer or similar object and pull out the inner shaft (RH) from the transmission.
3. Suspend the removed drive shaft with a wire so that there are no sharp bends in any of the joints.
4. Use a shop towel to cover the transmission case to prevent foreign material from entering it.

**◀C▶ TRANSMISSION MOUNT BRACKET REMOVAL**

Jack up the transmission assembly gently with a garage jack, and then remove the transmission mounting.

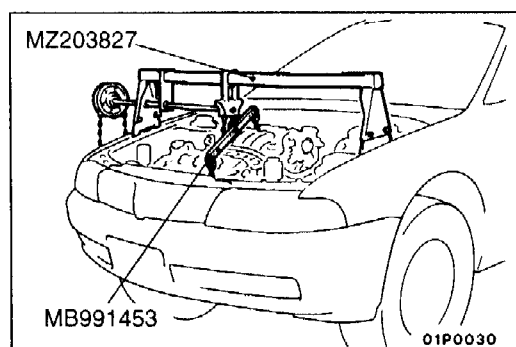
**◀D▶ ENGINE ASSEMBLY SUPPORTING**

Set the special tool to the vehicle to support the engine assembly.



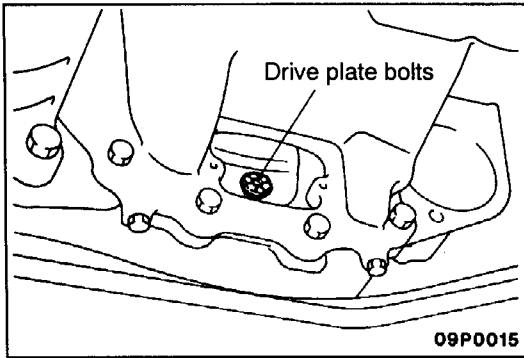

**◀E▶ DRIVE PLATE BOLTS/TRANSMISSION ASSEMBLY LOWER PART COUPLING BOLTS/TRANSMISSION ASSEMBLY REMOVAL**

1. Support the transmission assembly by using a transmission jack.
2. Remove the drive plate bolts while turning the crank shaft.
3. Press in the torque converter to the transmission side so that the torque converter does not remain on the engine side.
4. Remove the transmission assembly lower bolts and lower the transmission assembly.

**INSTALLATION SERVICE POINTS**

**▶A◀ TRANSMISSION ASSEMBLY INSTALLATION**

After securely inserting the torque converter into the transmission side so that the shown dimension is approx. 12.2 mm, install the transmission assembly to the engine.

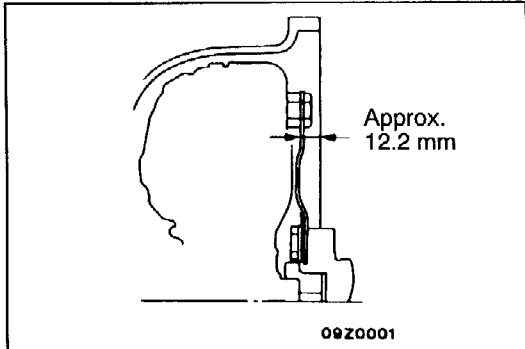

**▶B◀ TRANSMISSION MOUNT STOPPER INSTALLATION**

Install the transmission mount stopper so that the arrow mark points as shown in the illustration.

