CLUTCH

CONTENTS

GENERAL INFORMATION	2	CLUTCH PEDAL	5
SERVICE SPECIFICATIONS	2	CLUTCH CONTROL	6
LUBRICANTS	2	CLUTCH MASTER CYLINDER	8
ON-VEHICLE SERVICE	3	CLUTCH RELEASE CYLINDER	9
Clutch Pedal Check and Adjustment	3		
Bleeding	4		

GENERAL INFORMATION

A dry single-disc, diaphragm pull type clutch is used.
Hydraulic pressure is used for the clutch control.

Items	Specifications
Clutch operating method	Hydraulic type
Clutch disc type	Single dry disc type
Clutch disc facing diameter O.D. × I.D. mm	225 × 150
Clutch cover type	Diaphragm spring pull type
Clutch cover setting load N	6,300
Clutch release cylinder I.D. mm	20.5

SERVICE SPECIFICATIONS

Items	Standard value
Clutch pedal height mm	168–173
Clutch pedal clevis pin play mm	1–3
Clutch pedal free play mm	6–13
Distance between the clutch pedal and the firewall when the clutch is disengaged mm	60 or more

LUBRICANTS

Items	Specified lubricants	Quantity
Clutch fluid	Brake fluid DOT 3 or DOT 4	As required
Push rod assembly	Rubber grease	As required
Boot		
Release cylinder push rod	MITSUBISHI genuine grease Part No. 0101011	As required

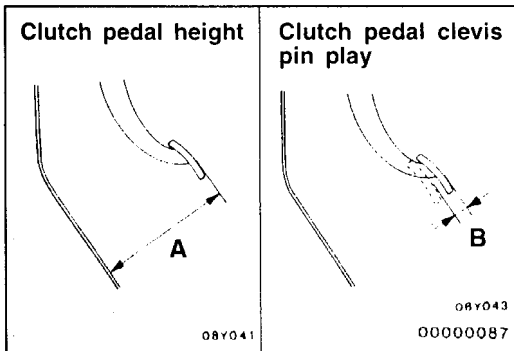

ON-VEHICLE SERVICE

CLUTCH PEDAL CHECK AND ADJUSTMENT

1. Turn up the carpet, etc. under the clutch pedal.
2. Measure the clutch pedal height and the clutch pedal clevis pin play.

Standard value (A): 168–173 mm

Standard value (B): 1–3 mm

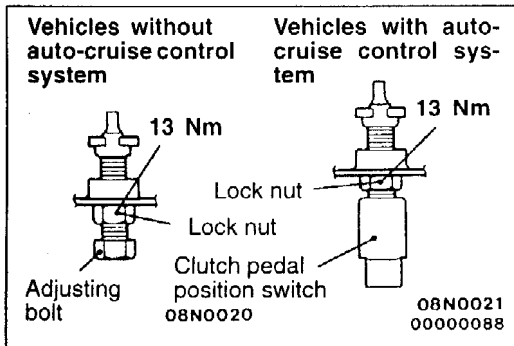

3. If the height of the clutch pedal is outside the standard value, loosen the lock nut and adjust the pedal height to the standard value using the adjusting bolt (Vehicles without auto-cruise control system) or clutch pedal position switch (Vehicles with auto-cruise control system).
4. If the clutch pedal play is outside the standard value, adjust with the push rod.

Caution

Do not push in the master cylinder push rod at this time.

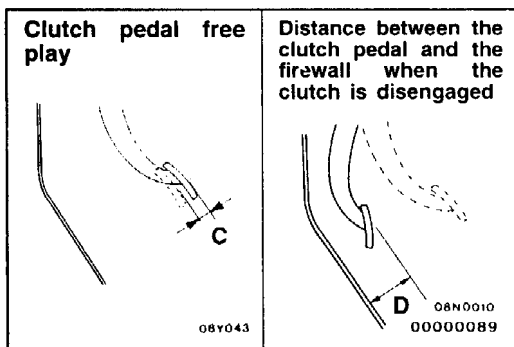

5. After completing the adjustments, confirm that the clutch pedal free play (measured at the face of the pedal pad) and the distance between the clutch pedal (the face of the pedal pad) and the firewall when the clutch is disengaged are within the standard value ranges.

Standard value (C): 6–13 mm

Standard value (D): 60 mm or more

6. If the clutch pedal free play and the distance between the clutch pedal and the firewall when the clutch is disengaged do not agree with the standard values, it is probably the result of either air in the hydraulic system or a faulty master cylinder or clutch. Bleed the air, or disassemble and inspect the master cylinder or clutch.
7. Turn back the carpet, etc.

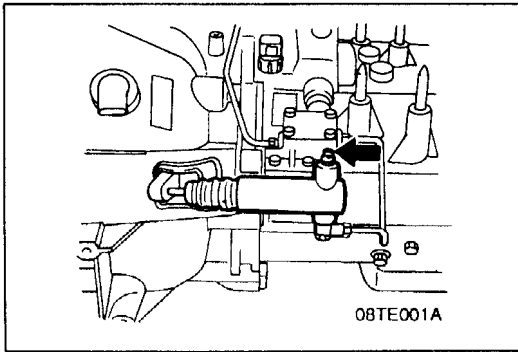

BLEEDING

1. Top up the fluid reservoir.

Specified brake fluid: DOT 3 or DOT 4

NOTE

Always use the specified fluid that is clean and uncontaminated and has been stored in a sealed container.

2. Attach a length of transparent tubing to the bleed valve and insert the other end into a jar, partially filled with hydraulic fluid.
3. With an assistant to operate the clutch, open the bleed valve approximately half a turn, and depress the pedal. Just before the pedal reaches the end of its travel, close the bleed valve and allow the pedal to return to the rest position.
4. Repeat step 4 until the fluid hose is free of air bubbles.

NOTE

Ensure the reservoir fluid is replenished throughout the bleeding procedure.

5. Fill the master cylinder to the correct level.

CLUTCH PEDAL

REMOVAL AND INSTALLATION

Post-Installation Operation
Clutch Pedal Adjustment (Refer to P.21-3.)

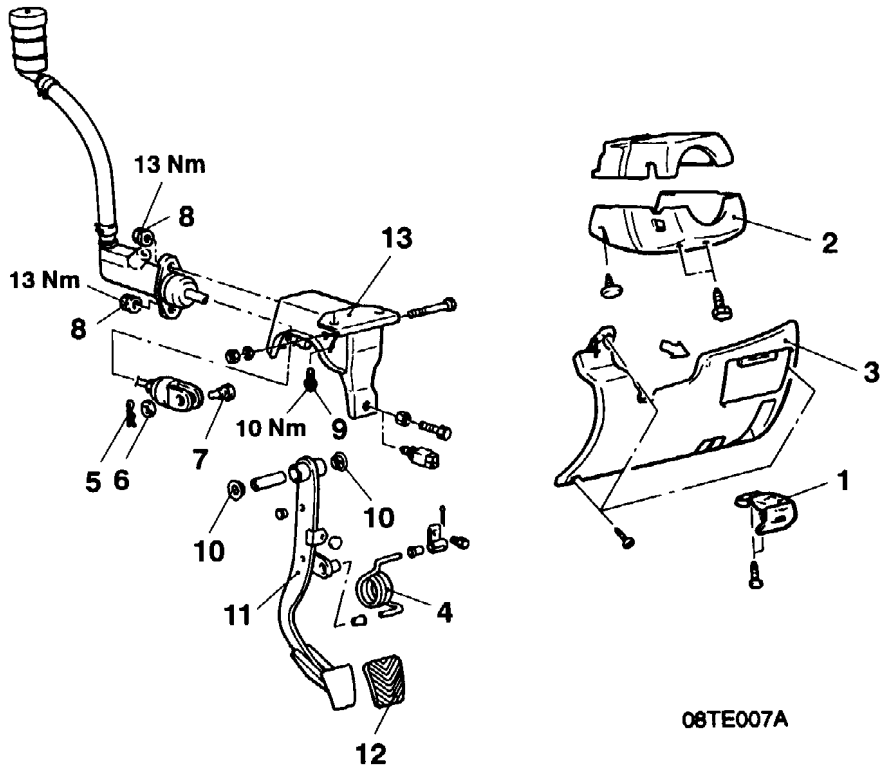

08TE007A

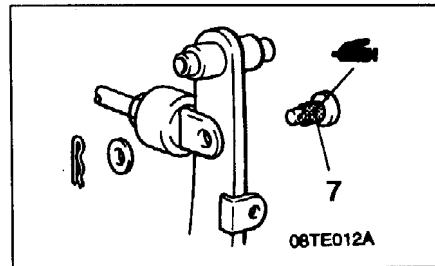

08AE015E

Removal steps

1. Hood release lever
2. Lower column cover
3. Instrument under cover
4. Return spring
5. R-clip
6. Washer
7. Clevis pin

8. Nut
9. Bolt
10. Bushing
11. Clutch pedal
12. Pedal pad
13. Pedal support member

INSPECTION

- Check the pedal shaft and bushing for wear.
- Check the clutch pedal for bend or torsion.
- Check the return spring for damage or deterioration.
- Check the pedal pad for damage or wear.

CLUTCH CONTROL

REMOVAL AND INSTALLATION

Pre-removal Operation
Clutch Fluid Draining

Post-installation Operation

- Clutch Fluid Supplying
- Clutch Line Bleeding (Refer to P.21-4.)
- Clutch Pedal Adjustment (Refer to P.21-3.)

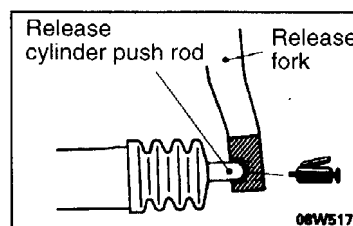
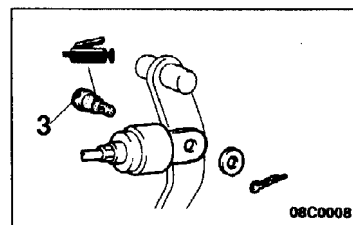
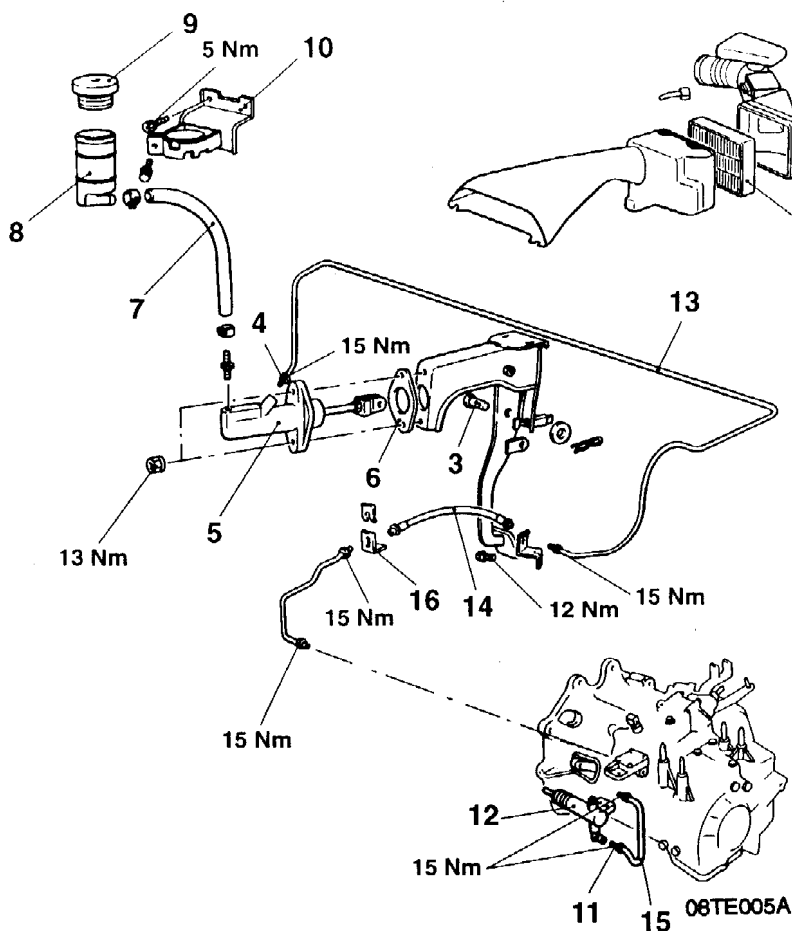

Specified grease:
MITSUBISHI genuine
grease Part No. 0101011

08AE017E

Clutch master cylinder removal steps

1. Air cleaner element
2. Air cleaner cover
3. Clevis pin
4. Clutch pipe connection
5. Clutch master cylinder
6. Sealer
7. Reservoir hose
8. Reservoir tank
9. Reservoir cap
10. Reservoir bracket

Clutch release cylinder removal steps

11. Clutch pipe connection
12. Clutch release cylinder

Clutch line removal steps

- | | | |
|-----|-----|-------------------------|
| ◀A▶ | ▶A◀ | 13. Clutch pipe |
| ◀A▶ | ▶A◀ | 14. Clutch hose |
| ◀A▶ | ▶A◀ | 15. Clutch pipe |
| | | 16. Clutch hose bracket |

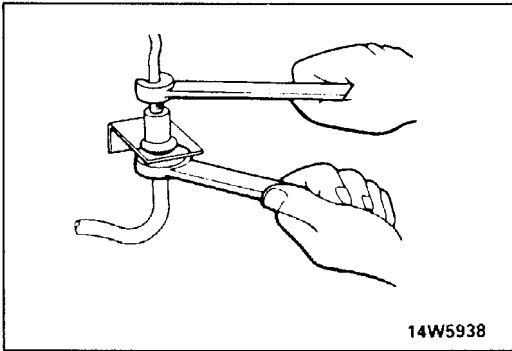
**REMOVAL SERVICE POINT****◀A▶ CLUTCH PIPE/CLUTCH HOSE REMOVAL**

Holding the nut at the clutch hose side, loosen the flare nut of the clutch pipe.

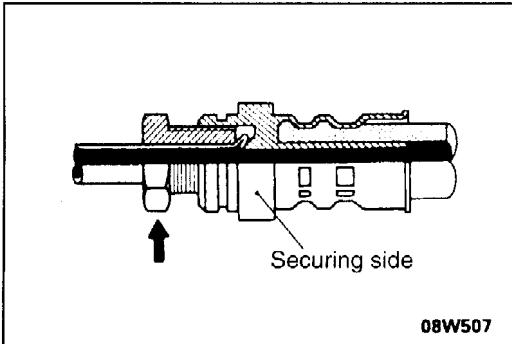
**INSTALLATION SERVICE POINT****▶A◀ CLUTCH HOSE/CLUTCH PIPE INSTALLATION**

1. Temporarily tighten the clutch pipe flare nut by hand, and then tighten it to the specified torque, being careful that the clutch hose does not become twisted.
2. After tightening the clutch pipe flare nut and eye bolt, check to be sure there is no clutch fluid leakage.

INSPECTION

- Check the pedal shaft bushing for wear.
- Check the pedal arm for bend or torsion.
- Check the fluid reservoir tank, master cylinder or clutch hose for fluid leakage.
- Check the clutch hose or pipe for cracks or clogging.

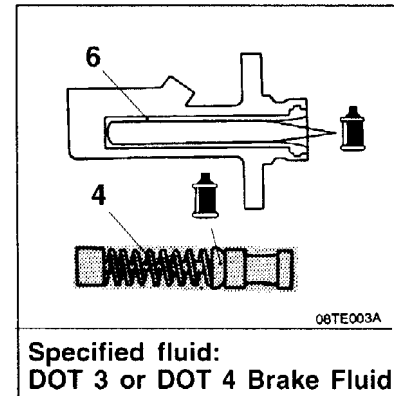
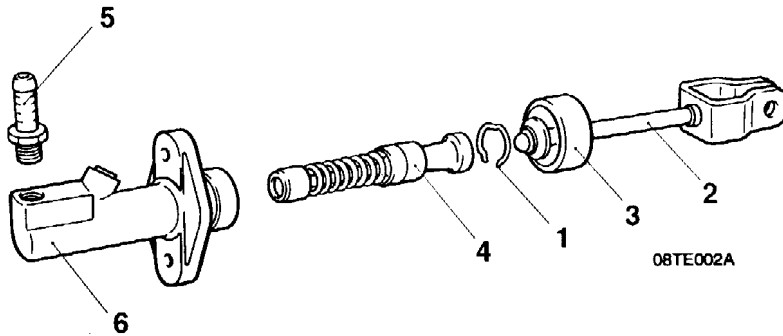
CLUTCH MASTER CYLINDER**DISASSEMBLY AND REASSEMBLY**

08AE016E

Disassembly steps

1. Piston stopper ring
2. Damper push rod
3. Boot
4. Piston assembly
5. Nipple
6. Clutch master cylinder

Caution

1. Do not damage the master cylinder bore or piston assembly.
2. Do not disassemble the piston assembly.

INSPECTION

- Check the inside cylinder body for rust or scars.
- Check the piston cup for wear or deformation.
- Check the piston for rust or scars.
- Check the clutch pipe connection for clogging.

**CLUTCH RELEASE CYLINDER
DISASSEMBLY AND REASSEMBLY**

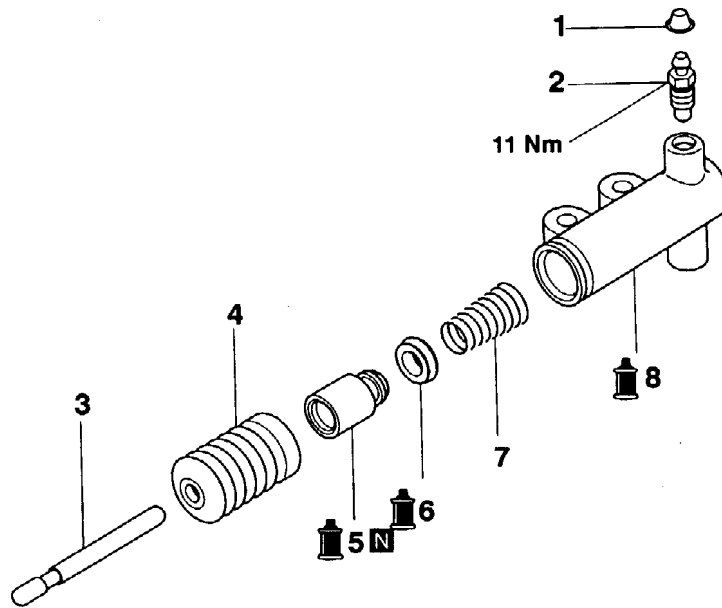

TFM0709

Disassembly steps

1. Cap
2. Air bleeder
3. Push rod
4. Boot

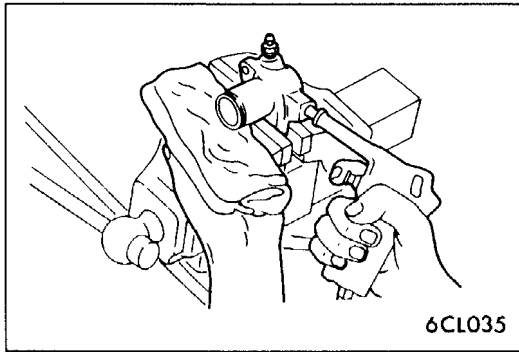

5. Piston cup
6. Piston
7. Conical spring
8. Release cylinder

**REMOVAL SERVICE POINT****◀▶ PISTON CUP / PISTON REMOVAL**

1. Remove the piston from the release cylinder using compressed air.

Caution

Cover with shop towel to prevent the piston from popping out.

Apply compressed air slowly to prevent brake fluid from splashing.

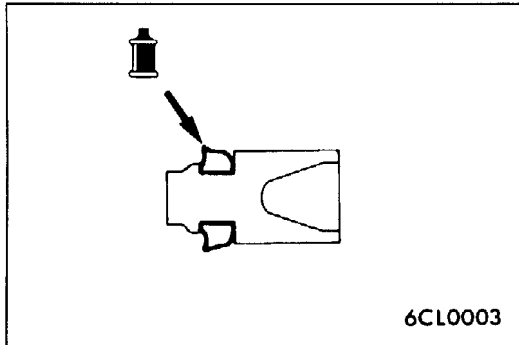
**INSTALLATION SERVICE POINT****▶◀ PISTON / PISTON CUP INSTALLATION**

1. After applying brake fluid to the inside wall surface of the release cylinder and all the circumferential surfaces of the piston and piston cup, insert the piston and piston cup into the cylinder.

Specified brake fluid:
DOT 3 or DOT 4

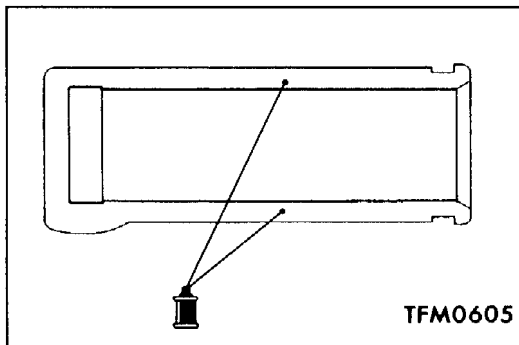
**INSPECTION****CLUTCH RELEASE CYLINDER**

1. Check the inner surface of the release cylinder for rust, scratches or irregular wear.
2. Using a cylinder gauge, measure the inside diameter of the release cylinder at about three positions (the deepest, middle and brim positions). If the clearance from the outside diameter of the piston exceeds the limit, replace the release cylinder assembly as an assembly.

Limit: 0.15mm