ENGINE ELECTRICAL

CONTENTS

CHARGING SYSTEM	2	GENERAL INFORMATION	26
GENERAL INFORMATION	2	SERVICE SPECIFICATIONS	27
SERVICE SPECIFICATIONS	3	SPECIAL TOOL	27
SPECIAL TOOL	3	ON-VEHICLE SERVICE	28
ON-VEHICLE SERVICE	4	Spark Plug Cable Test	28
Alternator Output Line Voltage Drop Test ...	4	Spark Plug Test	28
Output Current Test	5	Ignition Coil Check	28
Regulated Voltage Test	7	Power Transistor Check	29
Wave Pattern Check using an Analyser	9	Spark Plug Cable Resistance Check	29
Alternator Relay Continuity Check	11	Spark Plug Check and Cleaning	30
ALTERNATOR	12	Camshaft Position Sensor Check	30
STARTING SYSTEM	16	Ignition Secondary Voltage Wave Pattern Check	31
GENERAL INFORMATION	16	Ignition Primary Voltage Wave Pattern Check	34
SERVICE SPECIFICATIONS	17	IGNITION SYSTEM	38
STARTER MOTOR	18	DISTRIBUTOR	40
IGNITION SYSTEM	26	CRANKSHAFT POSITION SENSOR	41

CHARGING SYSTEM

GENERAL INFORMATION

The charging system is a system which charges the battery with the alternator output to keep the

battery charged at a constant level during varying electrical load.

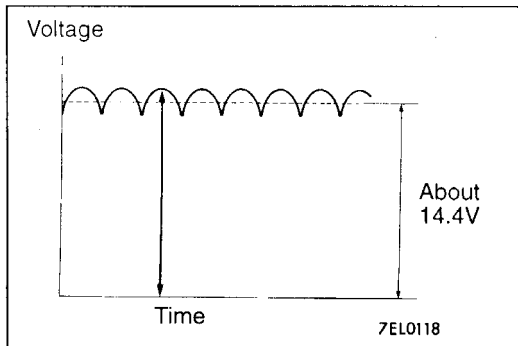

Operation

Rotation of the excited field coil generates AC voltage in the stator. This alternating current is rectified through diodes to DC voltage having a waveform shown in the illustration at left. The average output voltage fluctuates slightly with the alternator load condition.

When the ignition switch is turned on, current flows in the field coil and initial excitation of the field coil occurs.

When the stator coil begins to generate power after the engine is started, the field coil is excited by the output current of the stator coil.

The alternator output voltage rises as the field current increases and it falls as the field current decreases. When the battery voltage (alternator S

terminal voltage) reaches a regulated voltage of approx. 14.4V, the field current is cut off. When the battery voltage drops below the regulated voltage, the voltage regulator regulates the output voltage to a constant level by controlling the field current.

In addition, when the field current is constant, the alternator output voltage rises as the engine speed increases.

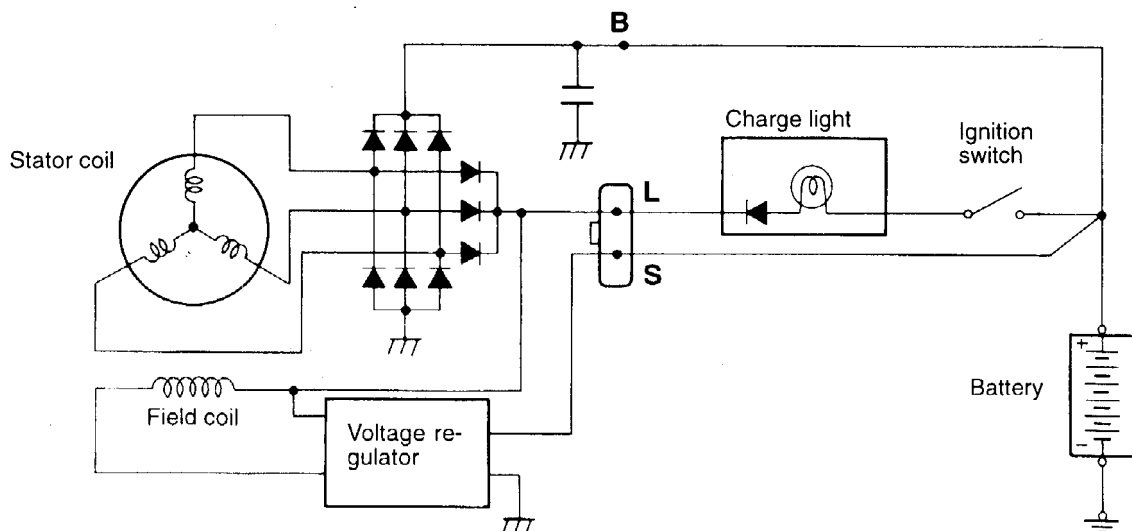

ALTERNATOR SPECIFICATIONS

Items	Specifications
Type	Battery voltage sensing
Rated output V/A	12/110
Voltage regulator	Electronic built-in type

SERVICE SPECIFICATIONS

Items	Standard value	Limit	
Regulated voltage V (Ambient temp. at voltage regulator)	-20°C	14.2–15.4	–
	20°C	13.9–14.9	–
	60°C	13.4–14.6	–
	80°C	13.1–14.5	–
Rotor coil resistance Ω	Approx. 3–5	–	
Output current	–	70% of nominal output current	

SPECIAL TOOL

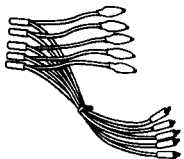
Tool	Number	Name	Application
	MB991348	Test harness set	Inspection of ignition primary voltage (power transistor connection)

ON-VEHICLE SERVICE

ALTERNATOR OUTPUT LINE VOLTAGE DROP TEST

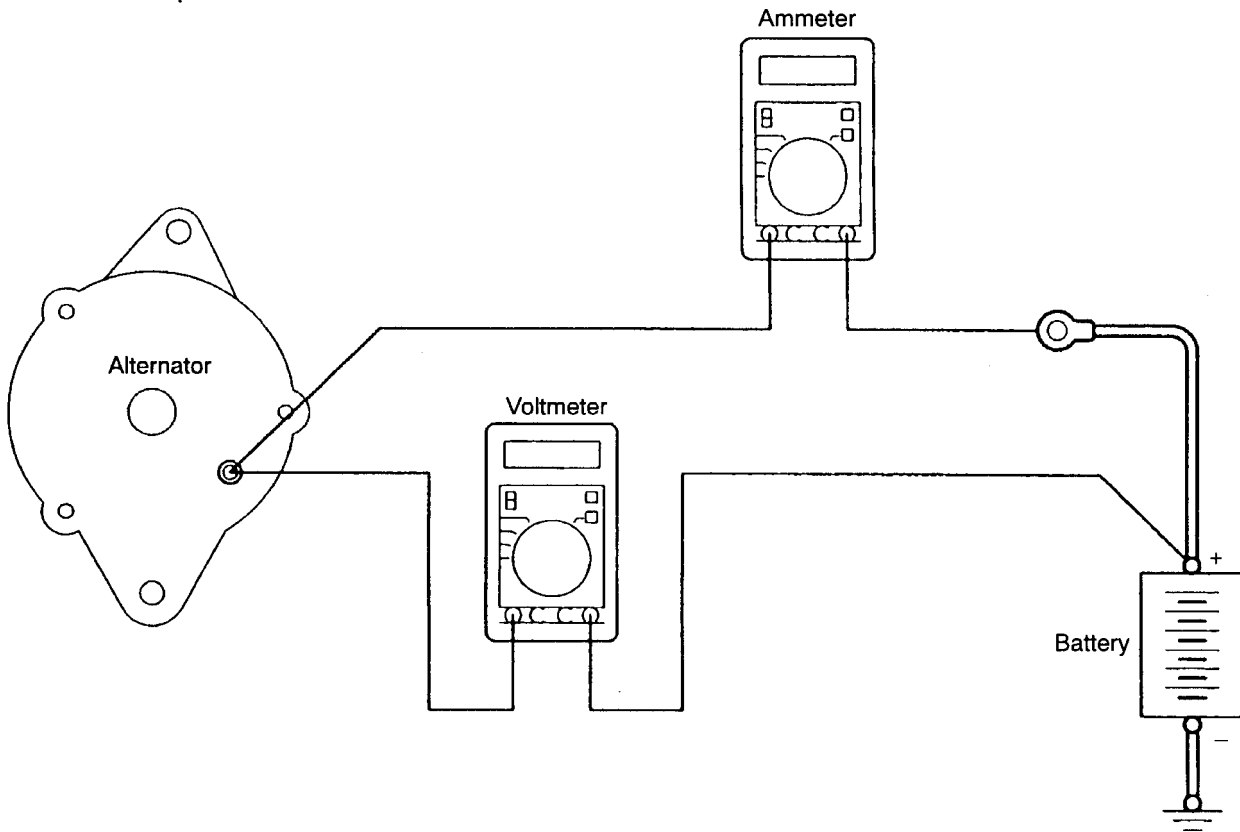

6EN0962

This test determines whether the wiring from the alternator "B" terminal to the battery (+) terminal (including the fusible link) is in a good condition or not.

1. Always be sure to check the following before the test.
 - Alternator installation
 - Alternator drive belt tension (Refer to GROUP 11 – On-vehicle Service.)
 - Fusible link
 - Abnormal noise from the alternator while the engine is running
2. Turn the ignition switch to the OFF position.
3. Disconnect the negative battery cable.
4. Disconnect the alternator output wire from the alternator "B" terminal and connect a DC test ammeter with a range of 0 – 130 A in series between the "B" terminal and the disconnected output wire. (Connect the (+) lead of the ammeter to the "B" terminal, and then connect

the (-) lead of the ammeter to the disconnected output wire.)

NOTE

An inductive-type ammeter which enables measurements to be taken without disconnecting the alternator output wire is recommended. The reason for this is if a vehicle in which the voltage may have dropped due to a poor connection at the alternator "B" terminal is being inspected, and the alternator "B" terminal is loosened when the test ammeter is connected, the connection will be completed at this time and the possibility of finding problems will be reduced.

5. Connect a digital-type voltmeter between the alternator "B" terminal and the battery (+) terminal. (Connect the (+) lead of the voltmeter to the "B" terminal, and then connect the (-) lead of the voltmeter to the battery (+) cable.)

6. Connect a tachometer.
(Refer to GROUP 11 – On-vehicle Service.)
7. Reconnect the negative battery cable.
8. Leave the hood open.
9. Start the engine.
10. With the engine running at 2500 rpm, turn the headlights and other lights on and off to adjust the alternator load so that the value displayed on the ammeter is slightly above 30 A.

Limit value: Max. 0.3 V

NOTE

When the alternator output is high and the value displayed on the ammeter does not decrease to 30A, set the value to 40A. Read the value displayed on the voltmeter at this time. In this case the limit value becomes max. 0.4V. Adjust the engine speed by gradually decreasing it until the value displayed on the ammeter

- is 30 A. Take a reading of the value displayed on the voltmeter at this time.
11. If the value displayed on the voltmeter is above the limit value, there is probably a malfunction in the alternator output wire, so check the wiring between the alternator "B" terminal and the battery (+) terminal (including fusible link). If a terminal is not sufficiently tight or if the harness has become discoloured due to overheating, repair and then test again.
12. After the test, run the engine at idle.
13. Turn off all lights and turn the ignition switch to the OFF position.
14. Disconnect the negative battery cable.
15. Disconnect the ammeter, voltmeter and tachometer.
16. Connect the alternator output wire to the alternator "B" terminal.
17. Connect the negative battery cable.

OUTPUT CURRENT TEST

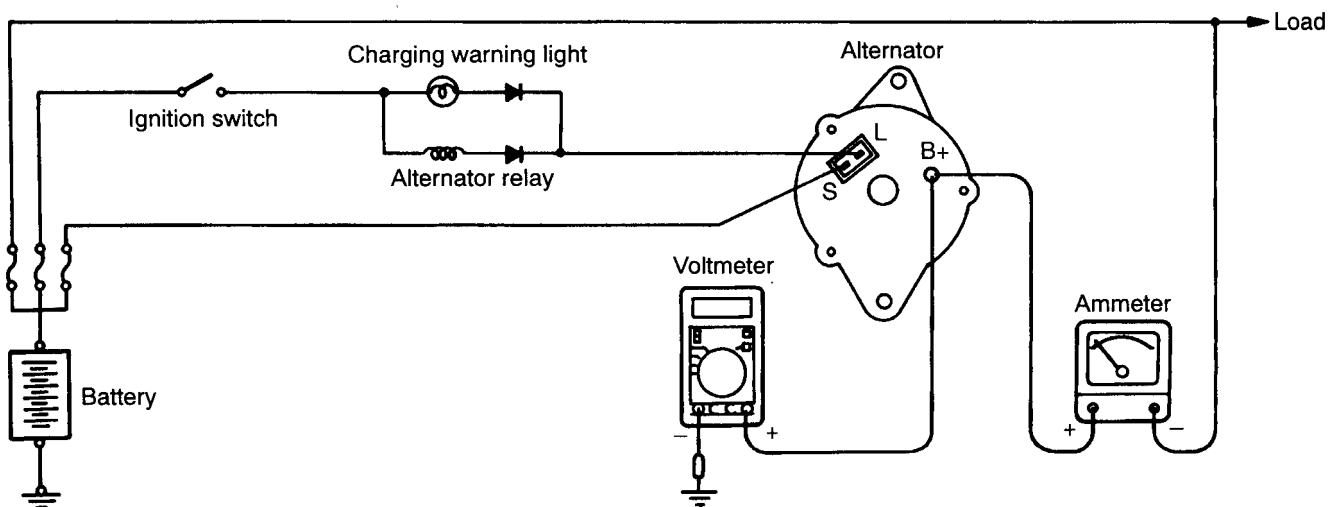

06AE014E

This test determines whether alternator output current is normal.

1. Before the test, always be sure to check the following.
 - Alternator installation
 - Battery (Refer to GROUP 54 – Battery.)

NOTE

The battery to be used should be slightly discharged. The load in a fully-charged battery will be insufficient and the test may not be able to be carried out correctly.

- Alternator drive belt tension (Refer to GROUP 11 – On-vehicle Service.)
 - Fusible link
 - Abnormal noise from the alternator while the engine is running
2. Turn the ignition switch to the OFF position.
 3. Disconnect the negative battery cable.
 4. Disconnect the alternator output wire from the alternator “B” terminal and connect a DC test ammeter with a range of 0–130 A in series between the “B” terminal and the disconnected output wire. (Connect the (+) lead of the ammeter to the “B” terminal, and then connect the (–) lead of the ammeter to the disconnected output wire.)

Caution

Never use clips but tighten bolts and nuts to connect the line. Otherwise loose connections (e.g. using clips) will lead to a serious accident because of high current.

NOTE

An inductive-type ammeter which enables measurements to be taken without disconnecting the alternator output wire is recommended.

5. Connect a voltmeter with a range of 0–20 V between the alternator “B” terminal and the ground. (Connect the (+) lead of the voltmeter to the “B” terminal, and then connect the (–) lead of the voltmeter to the ground.)
6. Connect a tachometer.
Refer to GROUP 11 – On-vehicle Service.)
7. Connect the negative battery cable.
8. Leave the hood open.
9. Check to be sure that the reading on the voltmeter is equal to the battery voltage.

NOTE

If the voltage is 0 V, the cause is probably

an open circuit in the wire or fusible link between the alternator “B” terminal and the battery (+) terminal.

10. After turning the light switch on and turning on the headlights, start the engine.
11. Immediately after setting the headlights to high beam and turning the heater blower switch to the high speed position, increase the engine speed to 2,500 rpm and read the maximum current output value displayed on the ammeter.

Limit value: 70% of nominal current output

NOTE

- For the nominal current output, refer to the Alternator Specifications.
 - Because the current from the battery will soon drop after the engine is started, the above step should be carried out as quickly as possible in order to obtain the maximum current output value.
 - The current output value will depend on the electrical load and the temperature of the alternator body.
 - If the electrical load is small while testing, the specified level of current may not be output even though the alternator is normal. In such cases, increase the electrical load by leaving the headlights turned on for some time to discharge the battery or by using the lighting system in another vehicle, and then test again.
 - The specified level of current also may not be output if the temperature of the alternator body or the ambient temperature is too high. In such cases, cool the alternator and then test again.
12. The reading on the ammeter should be above the limit value. If the reading is below the limit value and the alternator output wire is normal, remove the alternator from the engine and check the alternator.
 13. Run the engine at idle speed after the test.
 14. Turn the ignition switch to the OFF position.
 15. Disconnect the negative battery cable.
 16. Disconnect the ammeter, voltmeter and tachometer.
 17. Connect the alternator output wire to the alternator “B” terminal.
 18. Connect the negative battery cable.

REGULATED VOLTAGE TEST

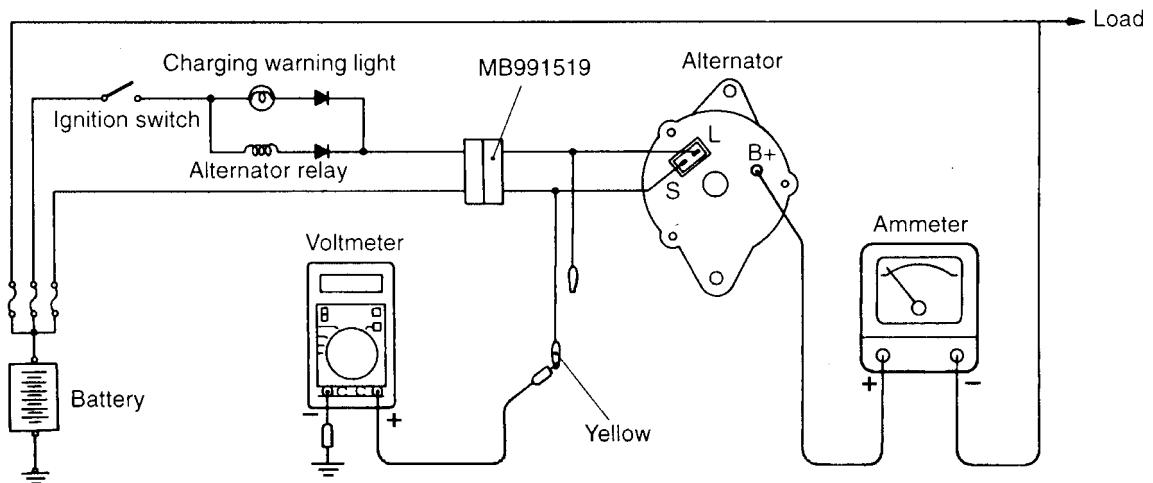

06AE015E

This test determines whether the voltage regulator is correctly controlling the alternator output voltage.

1. Always be sure to check the following before the test.
 - Alternator installation
 - Check to be sure that the battery installed in the vehicle is fully charged. (Refer to GROUP 54 – Battery.)
 - Alternator drive belt tension (Refer to GROUP 11 – On-vehicle Service.)
 - Fusible link
 - Abnormal noise from the alternator while the engine is running
2. Turn the ignition switch to the OFF position.
3. Disconnect the negative battery cable.
4. Connect a digital-type voltmeter between the alternator “S” terminal and the ground. (Connect the (+) lead of the voltmeter to the “S” terminal, and then connect the (–) lead of the voltmeter to a secure ground or to the battery (–) terminal.)
5. Disconnect the alternator output wire from the alternator “B” terminal.
6. Connect a DC test ammeter with a range of 0–130 A in series between the “B” terminal and the disconnected output wire. (Connect the (+) lead of the ammeter to the “B” terminal, and then connect the (–) lead of the ammeter to the disconnected output wire.)
7. Connect a tachometer or the MUT II. Refer to GROUP 11 – On-vehicle Service.)
8. Reconnect the negative battery cable.
9. Turn the ignition switch to the ON position and check that the reading on the voltmeter is equal to the battery voltage.

NOTE

If the voltage is 0 V, the cause is probably an open circuit in the wire or fusible link between the alternator “S” terminal and the battery (+) terminal.

10. Check to be sure that all lights and accessories are off.
11. Start the engine.
12. Increase the engine speed to 2,500 r/min
13. Read the value displayed on the voltmeter when the current output by the alternator becomes 10 A or less.
14. If the voltage reading conforms to the value in the voltage regulation table, then the voltage regulator is operating normally. If the voltage is outside the standard value, there is a malfunction of the voltage regulator or of the alternator.
15. After the test, lower the engine speed to the idle speed.
16. Turn the ignition switch to the “OFF” position.
17. Disconnect the negative battery cable.
18. Disconnect the ammeter, voltmeter and tachometer or the MUT II.
19. Connect the alternator output wire to the alternator “B” terminal.
20. Connect the negative battery cable.

VOLTAGE REGULATION TABLE

Inspection terminal	Voltage regulator ambient temperature (°C)	Standard value (V)
Terminal "S"	-20	14.2–15.4
	20	13.9–14.9
	60	13.4–14.6
	80	13.1–14.5

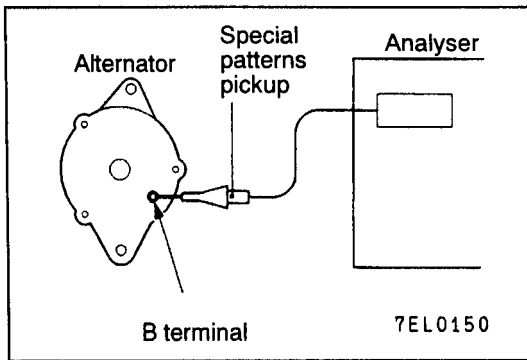

WAVE PATTERN CHECK USING AN ANALYSER

MEASUREMENT METHOD

Connect the analyser special patterns pick-up to the alternator B terminal.

STANDARD WAVEFORM
Observation Conditions

FUNCTION	SPECIAL PATTERNS
PATTERN HEIGHT	VARIABLE
VARIABLE knob	Adjust while viewing the wave pattern
PATTERN SELECTOR	RASTER
Engine speed	Curb idle speed

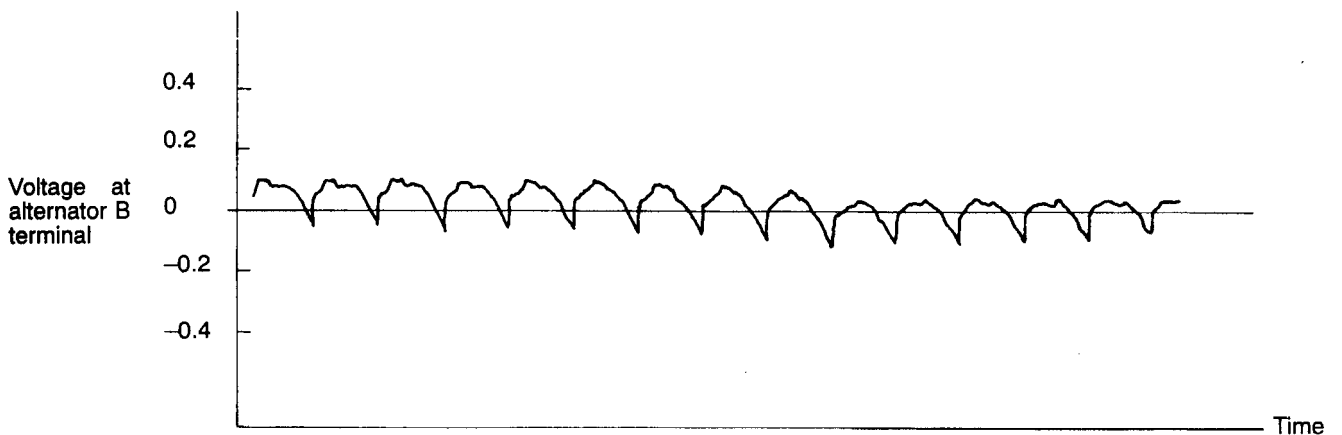

7EL0115

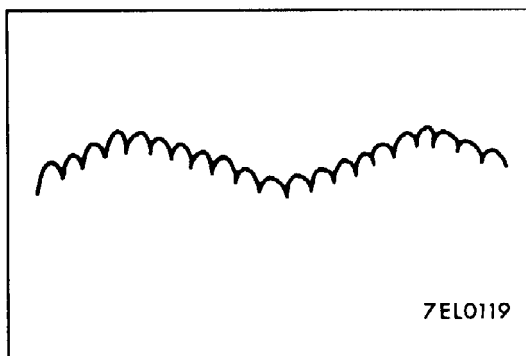





NOTE

The voltage waveform of the alternator B terminal can undulate as shown at left. This waveform is produced when the regulator operates according to fluctuations in the alternator load (current), and is normal for the alternator.

ABNORMAL WAVEFORM EXAMPLES

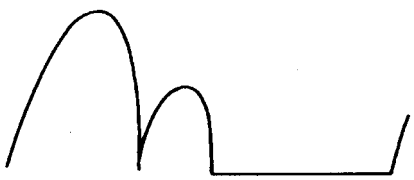
NOTE

1. The size of the waveform patterns differs largely depending on the adjustment of the variable knob on the analyser.
2. Identification of abnormal waveforms is easier when there is a large output current (regulator is not operating). (Waveforms can be observed when the headlamps are illuminated.)
3. Check the conditions of the charge light (illuminated/not illuminated). Also, carry out a total check of the charging system.

Abnormal waveforms	Problem cause
<p>Example 1</p>  <p style="text-align: right;">7EL0120</p>	<ul style="list-style-type: none"> ● Open diode
<p>Example 2</p>  <p style="text-align: right;">7EL0121</p>	<ul style="list-style-type: none"> ● Short in diode
<p>Example 3</p>  <p style="text-align: right;">7EL0122</p>	<ul style="list-style-type: none"> ● Broken wire in stator coil
<p>Example 4</p>  <p style="text-align: right;">7EL0123</p>	<ul style="list-style-type: none"> ● Short in stator coil
<p>Example 5</p>  <p>NOTE: At this time, the charge light is illuminated.</p> <p style="text-align: right;">7EL0124</p>	<ul style="list-style-type: none"> ● Open supplementary diode

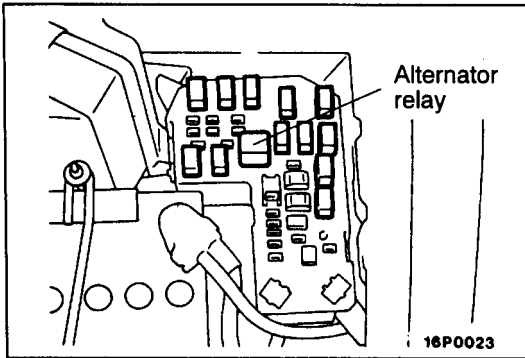

ALTERNATOR RELAY CONTINUITY CHECK

1. Remove the alternator from the relay box inside the engine compartment
2. Set the circuit tester to the Ω range and check that there is continuity when the (+) terminal of the tester is connected to terminal 4 of the alternator relay and the (-) terminal is connected to terminal 2.
3. Next, check that there is no continuity when the (+) terminal is connected to terminal 2 and the (-) terminal is connected to terminal 4.
4. If the continuity checks in steps 2 and 3 show a defect, replace the alternator relay.

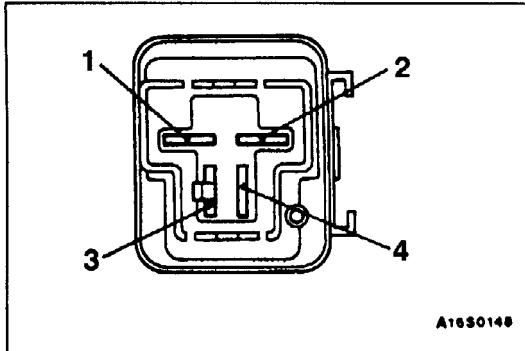

ALTERNATOR

REMOVAL AND INSTALLATION

Post-Installation Operation

- Drive belt tension adjustment (Refer to Group 11 – On-vehicle Service)

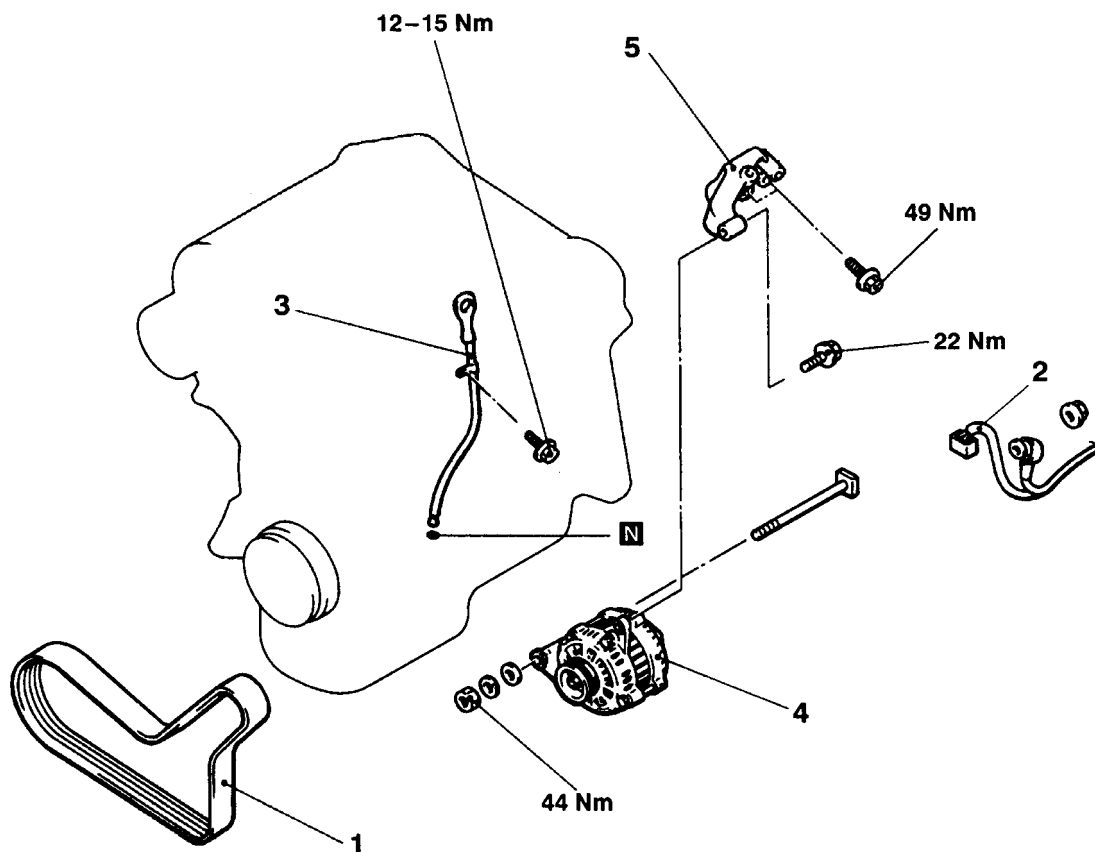

16 P0246

Removal steps

1. Drive belt (Alternator)
2. Alternator harness connector connection
3. Engine oil level dipstick
4. Alternator
5. Alternator bracket

ALTERNATOR

DISASSEMBLY AND REASSEMBLY

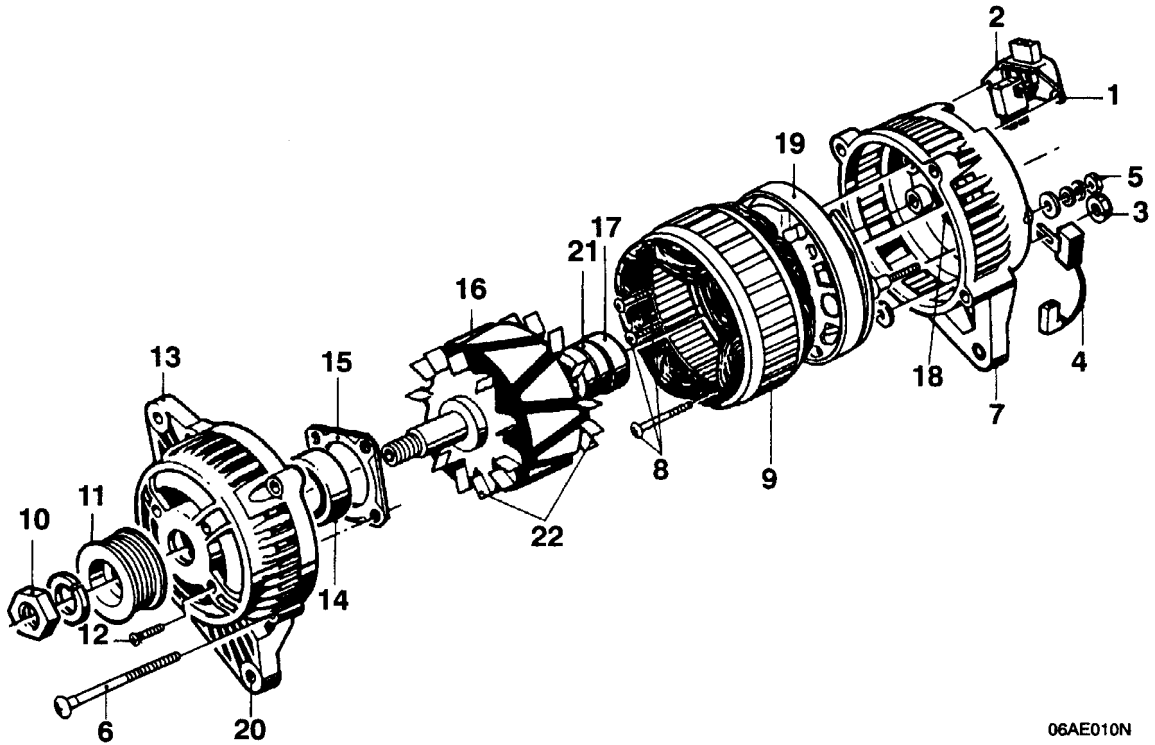

06AE010N

Disassembly steps

◀A▶

1. Voltage regulator retaining screws
2. Voltage regulator
3. Suppressor retaining nut
4. Suppressor
5. B+ terminal nut and washers
6. Through bolts
7. Slip ring end housing and stator assembly
8. Rectifier assembly retaining nuts
9. Stator assembly
10. Pulley retaining nut
11. Pulley

◀B▶

12. Drive end bearing retaining plate screws
13. Drive end plate
14. Drive end bearing
15. Bearing retaining plate
16. Rotor
17. Slip ring end housing bearing
18. Slip ring end housing bearing cap
19. Rectifier assembly
20. Bush
21. Slip ring assembly
22. Cooling fans

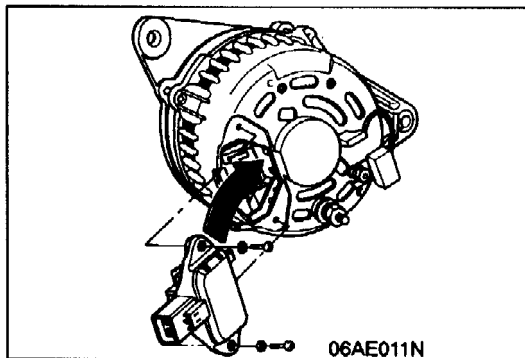

06AE011N

DISASSEMBLY SERVICE POINTS

◀A▶ VOLTAGE REGULATOR REMOVAL

Tilt the regulator slightly from the plug connection until the regulator clears the housing then lift clear.

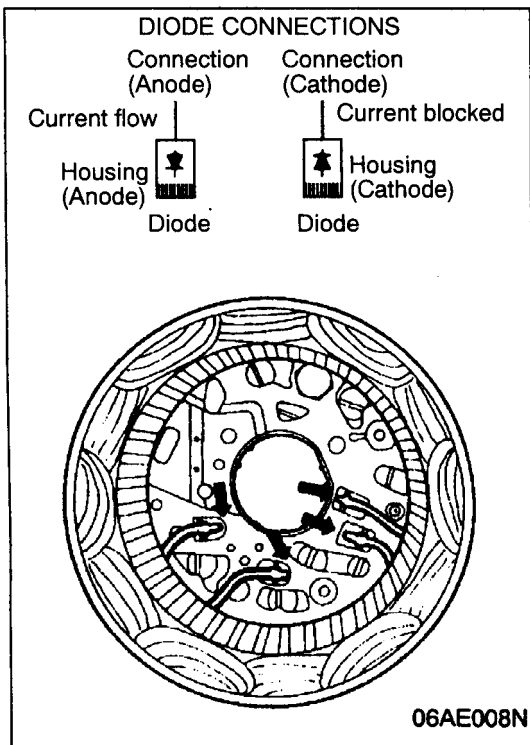

◀B▶ STATOR REMOVAL

When removing stator, unsolder the stator leads soldered to main diodes on rectifier.

Caution

1. When soldering or unsoldering, use care to make sure that heat of soldering iron is not transmitted to diodes for a long period. Finish soldering or unsoldering in as short a time as possible.
2. Use care that no undue force is exerted to leads of diodes.

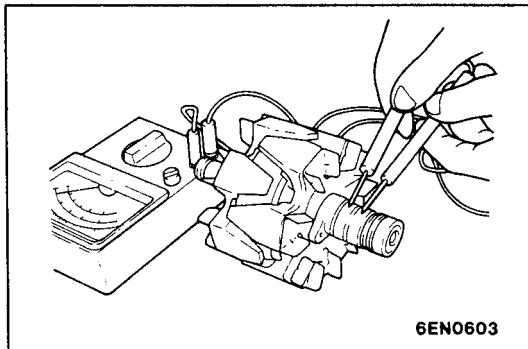

INSPECTION

ROTOR

1. Check rotor coil for continuity. Check to ensure that there is no continuity between slip rings. If resistance is too small, it means that there is a short circuit. If there is no continuity or if there is a short circuit, replace rotor assembly.

Resistance value: Approx. 3–5 Ω

2. Check rotor coil for grounding. Check to ensure that there is no continuity between slip ring and core. If there is continuity, replace rotor assembly.

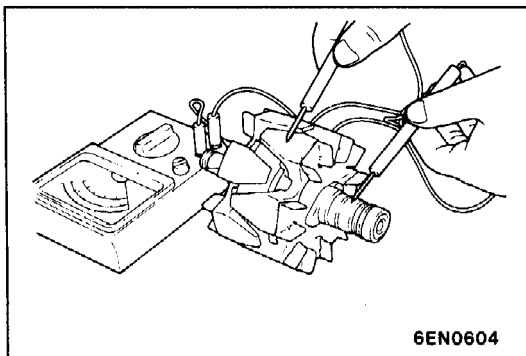

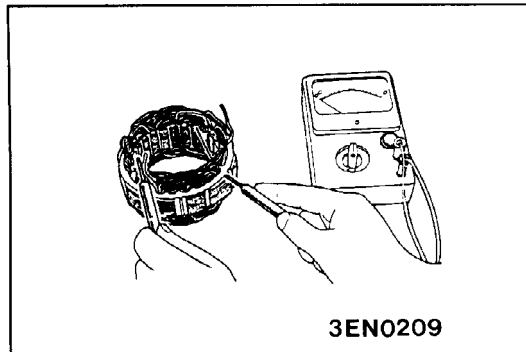
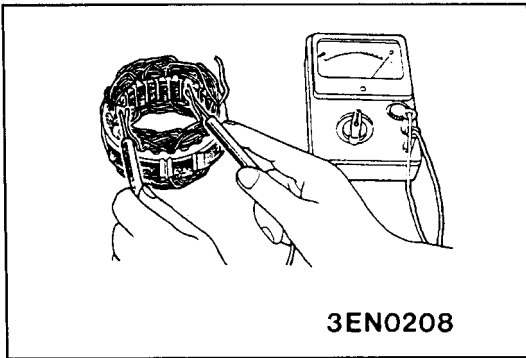

STATOR

1. Make continuity test on stator coil. Check to ensure that there is continuity between coil leads. If there is no continuity, replace stator assembly.
2. Check coil for grounding. Check to ensure that there is no continuity between coil and core. If there is continuity, replace stator assembly.

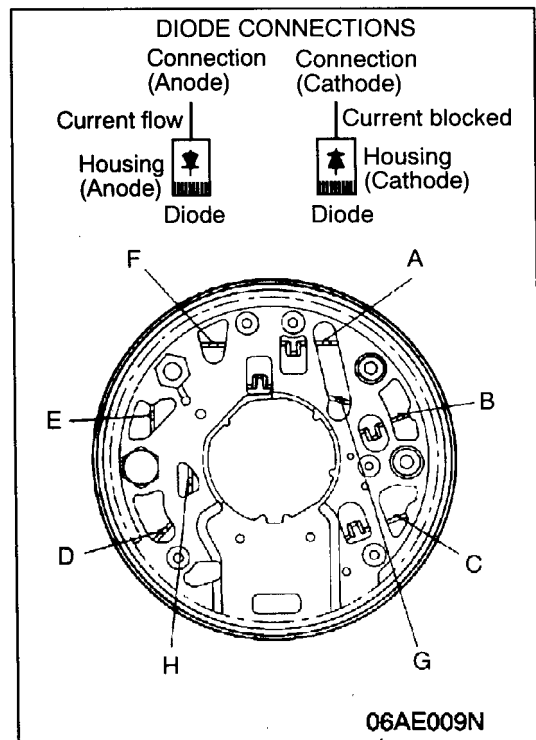

POWER DIODES

1. Apply the negative test probe of the diode tester or a multimeter with a diode test feature to the positive heatsink and the positive probe alternatively to A, B and C, a low resistance reading, or the forward voltage drop across the diode should be obtained. Reverse the test probes, a high resistance reading or a higher reverse voltage should be obtained.
2. Connect the positive test probe to the negative heatsink and the negative test probe alternatively to D, E and F, a low resistance of forward voltage drop across the diode should be obtained. Reverse the test probes, a high resistance reading or higher reverse voltage reading should be obtained.

BRUSHES

1. Ensure the brushes have not been worn to or beyond their wear limit,
Brush wear limit: 3.8mm
2. Check the brush springs for burning and loss of tension due to excessive heat.

SLIP RINGS

1. Check the slip rings for excessive wear and damage.
Minimum slip ring diameter: 26.7mm

STARTING SYSTEM

GENERAL INFORMATION

If the ignition switch is turned to the "START" position, current flows in the coil provided inside magnetic switch, attracting the plunger. When the plunger is attracted, the lever connected to the plunger is actuated to engage the starter clutch. Attracting the plunger will turn on the magnetic switch, allowing the B terminal and M terminal to conduct. Thus, current flows to engage the starter motor.

When the ignition switch is returned to the "ON" position after starting the engine, the starter clutch is disengaged from the ring gear.

An overrunning clutch is provided between the pinion and the armature shaft, to prevent damage to the starter.

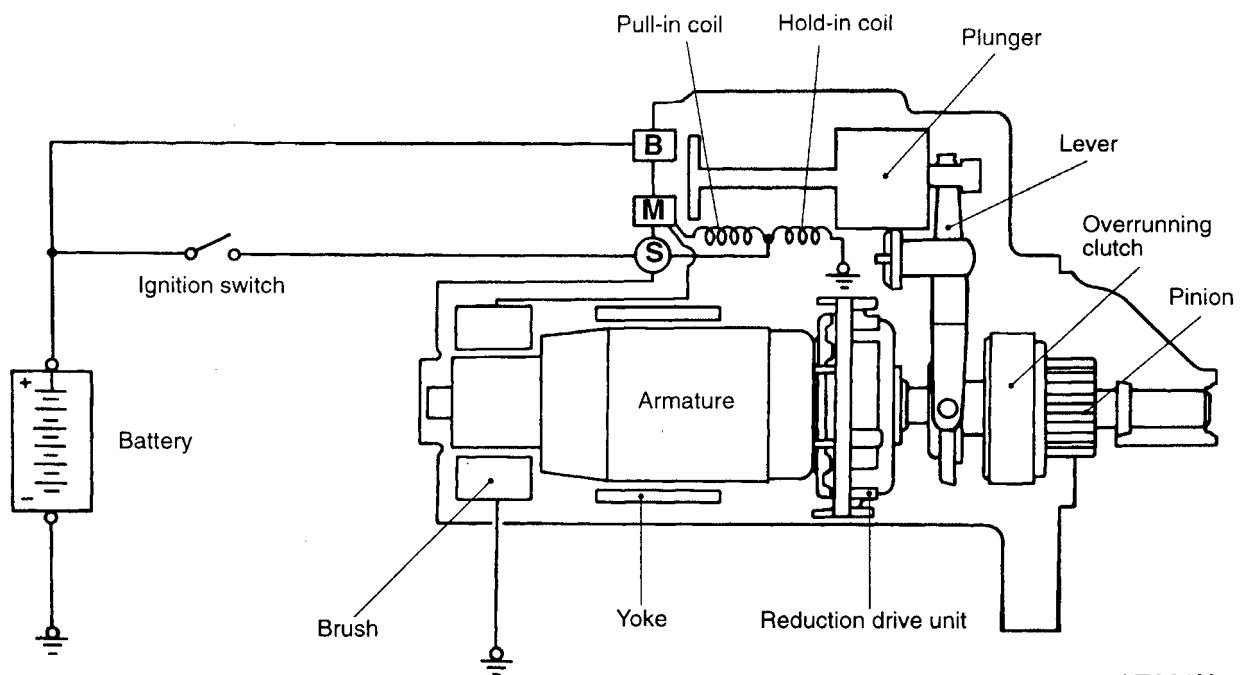

06AE001N

STARTER MOTOR SPECIFICATIONS

Items	Specifications
Type	Reduction drive with planetary gear
Rated output kW/V	1.2/12
No. of pinion teeth	8

SERVICE SPECIFICATIONS

Items		Standard value	Limit
Free running characteristics	Terminal voltage V	12	–
	Current A	110	–
	Speed r/min	5,000 or more	–
Pinion gap mm		0.5–2.0	–
Commutator run out mm		0.10	–
Commutator diameter mm		32.3	31.2
Undercut depth mm		0.5–0.8	–

STARTER MOTOR

REMOVAL AND INSTALLATION

Pre-removal and Post-installation Operation
Air Cleaner Removal and Installation

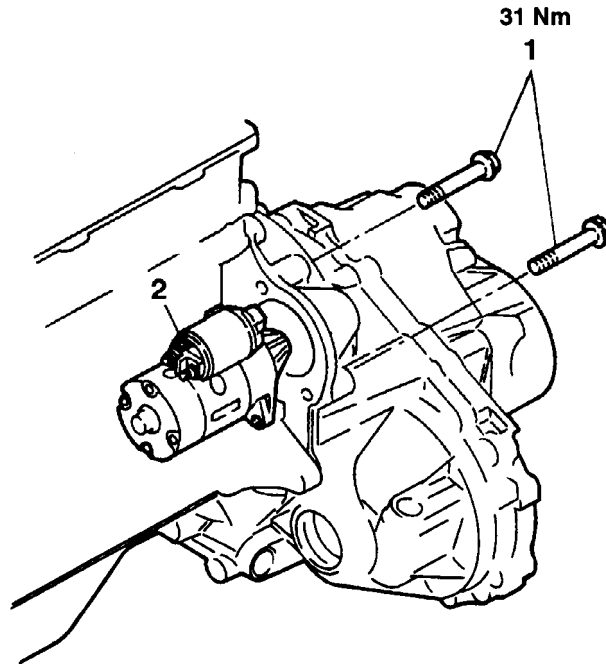

1EL097

Removal steps

1. Bolt
2. Starter motor

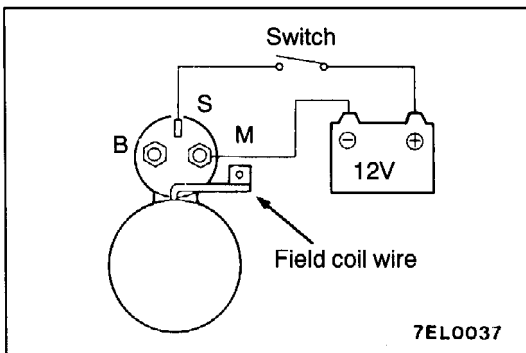

INSPECTION

PINION GAP ADJUSTMENT

1. Disconnect field coil wire from M-terminal of magnetic switch.
2. Connect a 12V battery between S-terminal and M-terminal.
3. Set the switch to "ON", and pinion will move out.

Caution

This test must be performed quickly (in less than 10 seconds) to prevent coil from burning.

4. Check pinion to stopper clearance (pinion gap) with a feeler gauge.

Pinion gap: 0.5–2.0 mm

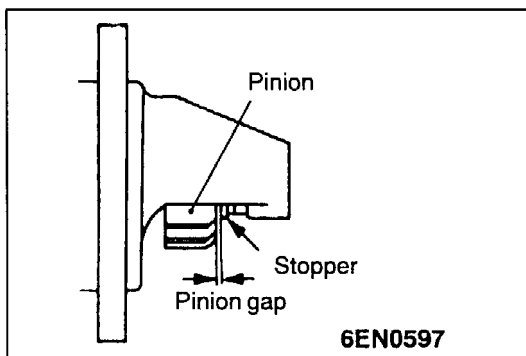

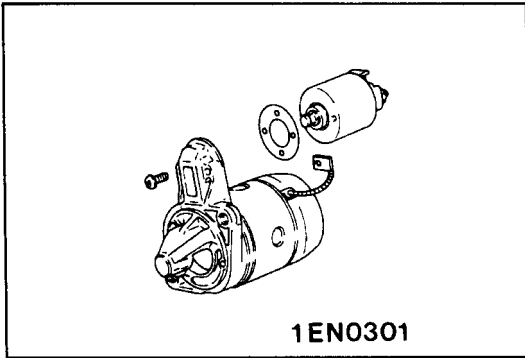

5. If pinion gap is out of specification, adjust by adding or removing gaskets between magnetic switch and front bracket.

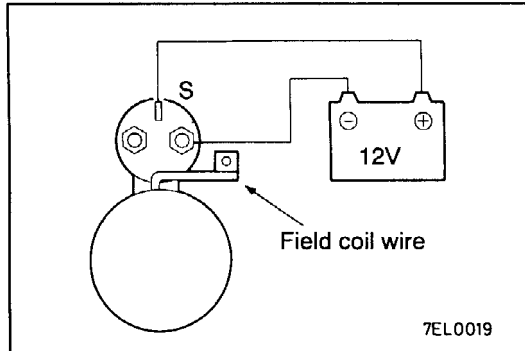

MAGNETIC SWITCH PULL-IN TEST

1. Disconnect field coil wire from M-terminal of magnetic switch.
2. Connect a 12V battery between S-terminal and M-terminal.

Caution

This test must be performed quickly (in less than 10 seconds) to prevent coil from burning.

3. If pinion moves out, then pull-in coil is good. If it doesn't, replace magnetic switch.

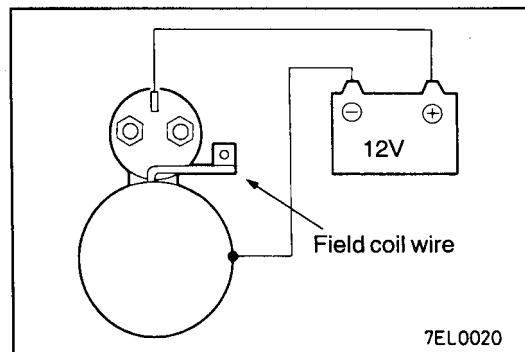

MAGNETIC SWITCH HOLD-IN TEST

1. Disconnect field coil wire from M-terminal of magnetic switch.
2. Connect a 12V battery between S-terminal and body.

Caution

This test must be performed quickly (in less than 10 seconds) to prevent coil from burning.

3. If pinion remains out, everything is in order. If pinion moves in, hold-in circuit is open. Replace magnetic switch.

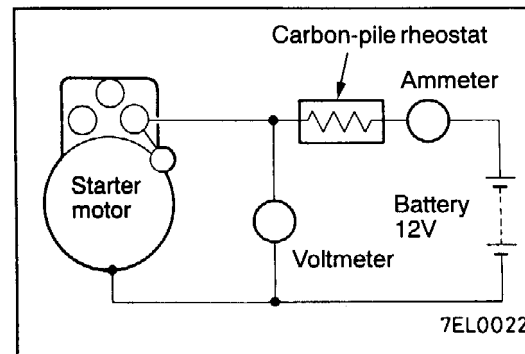

FREE RUNNING TEST

1. Place starter motor in a vice equipped with soft jaws and connect a fully-charged 12-volt battery to starter motor as follows:
2. Connect a test ammeter (130-ampere scale) and carbon pile rheostat in series between battery positive post and starter motor terminal.
3. Connect a voltmeter (15-volt scale) across starter motor.
4. Rotate carbon pile to full-resistance position.
5. Connect battery cable from battery negative post to starter motor body.
6. Adjust the rheostat until the battery voltage shown by the voltmeter is 11V.
7. Confirm that the maximum amperage is within the specifications and that the starter motor turns smoothly and freely.

Current: Max. 110 Amps

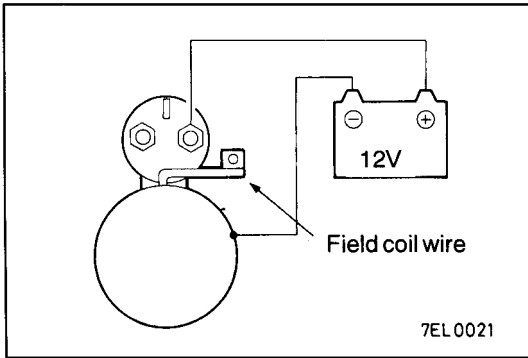

MAGNETIC SWITCH RETURN TEST

1. Disconnect field coil wire from M-terminal of magnetic switch.
2. Connect a 12V battery between M-terminal and body.

Caution

This test must be performed quickly (in less than 10 seconds) to prevent coil from burning.

3. Pull pinion out and release. If pinion quickly returns to its original position, everything is in order. If it doesn't, replace magnetic switch.

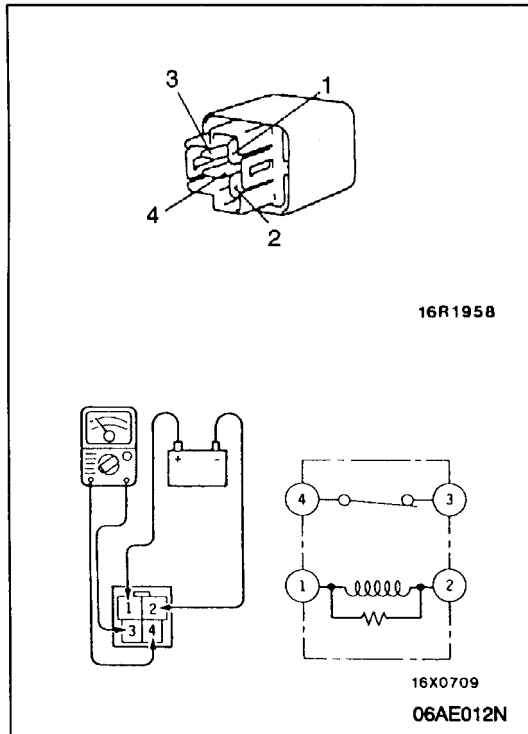

STARTER RELAY CONTINUITY CHECK

	Terminal No.			
Battery voltage	1	2	3	4
Not supplied	○	○		
Supplied	⊕	⊖	○	○

STARTER MOTOR

DISASSEMBLY AND REASSEMBLY

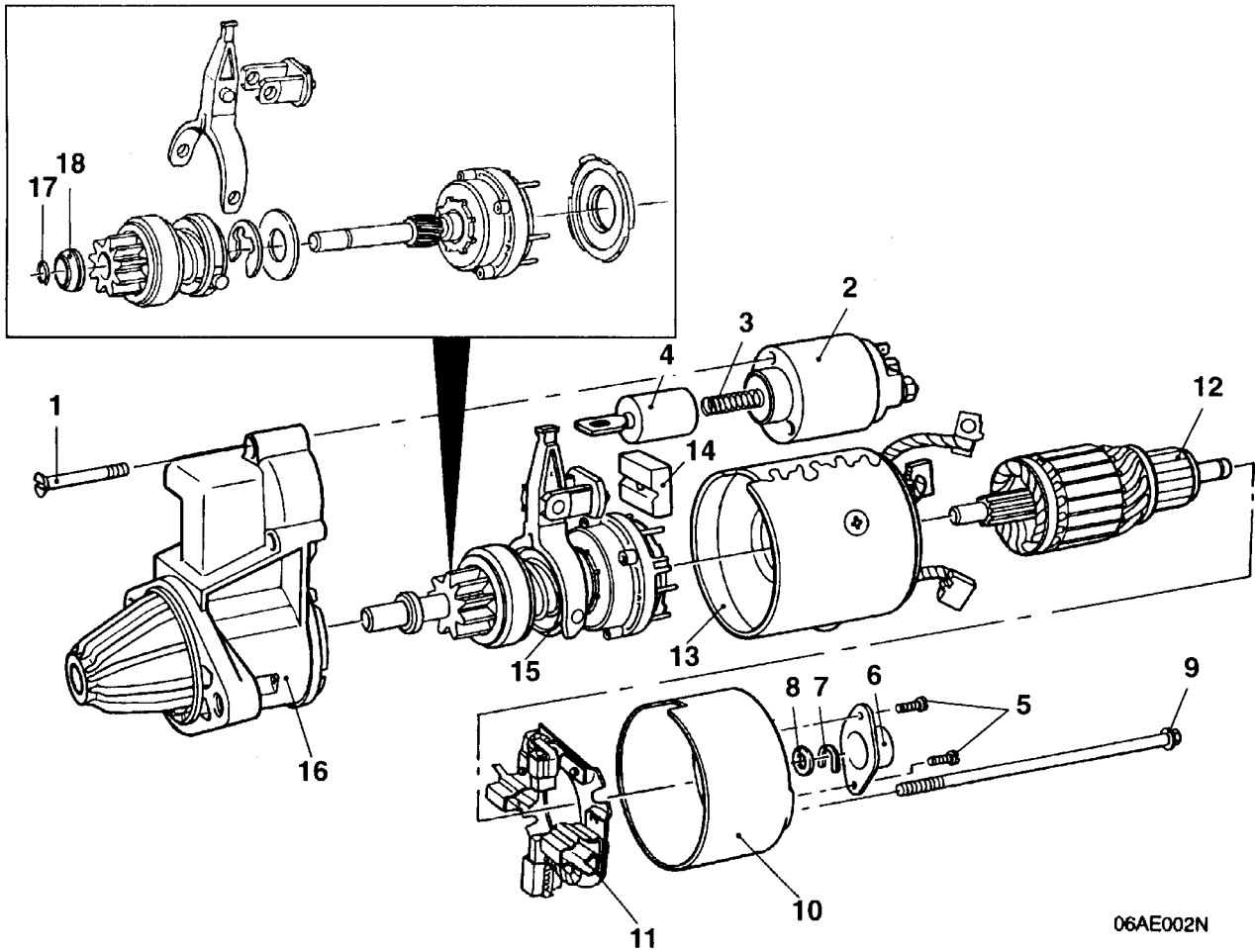

06AE002N

Disassembly steps

◀A▶

1. Screw
2. Magnetic switch
3. Spring
4. Solenoid barrel
5. End cover screws
6. End cover
7. C clip
8. Flat washer
9. Through bolts
10. Rear housing

◀B▶

11. Brush holder
12. Armature assembly
13. Yoke assembly
14. Rubber seal
15. Overrunning clutch, drive pinion assembly and gear set

◀C▶
◀C▶

- ▶B▶ 16. Front housing
- ▶A▶ 17. Snap ring
- ▶A▶ 18. Stop ring

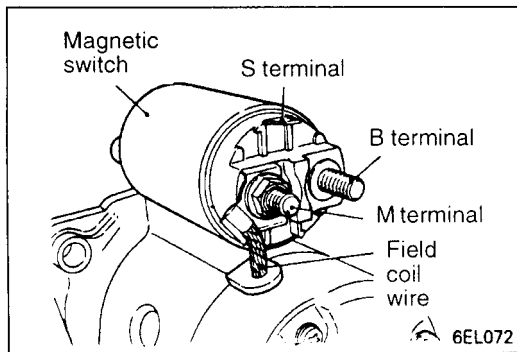
**DISASSEMBLY SERVICE POINTS****◀A▶ MAGNETIC SWITCH REMOVAL**

1. Disconnect the field coil wire from terminal M of the magnetic switch.

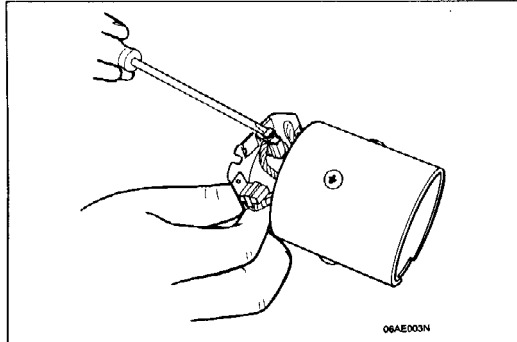
**◀B▶ BRUSH HOLDER REMOVAL**

1. Mark the position of the brush holder in relation to the yoke assembly.
2. Prise back the brush retaining lugs of the brushes which are connected to the yoke assembly and remove the brush plate.

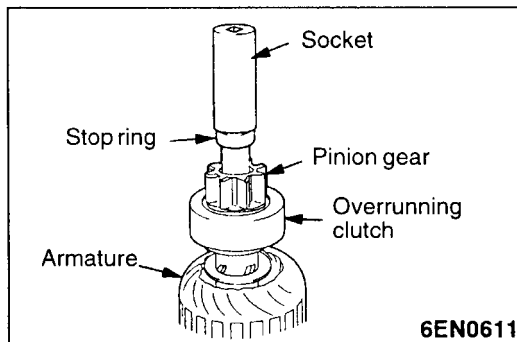
**◀C▶ SNAP RING/STOP RING REMOVAL**

1. Press the stop ring, by using an appropriate socket wrench.

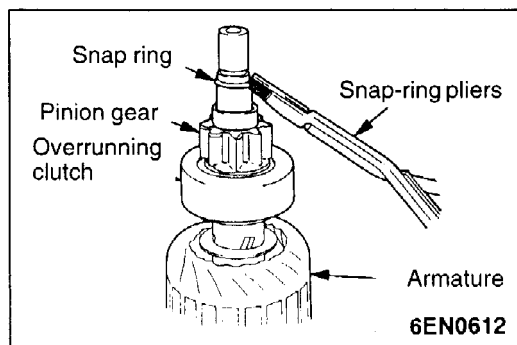

2. After removing the snap ring (by using snap-ring pliers), remove the stop ring and the overrunning clutch.

STARTER MOTOR PART CLEANING

1. Do not immerse parts in cleaning solvent. Immersing the yoke and field coil assembly and/or armature will damage insulation. Wipe these parts with a cloth only.
2. Do not immerse drive unit in cleaning solvent. Overrunning clutch is pre-lubricated at the factory and solvent will wash lubrication from clutch.
3. The drive unit may be cleaned with a brush moistened with cleaning solvent and wiped dry with a cloth.

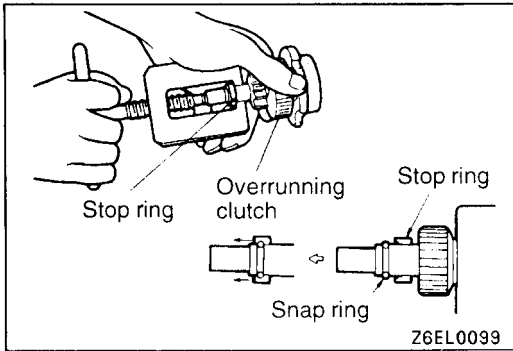
**REASSEMBLY SERVICE POINT****►A◄ STOP RING/SNAP RING INSTALLATION**

Using a suitable pulling tool, pull the overrunning clutch stop ring over the snap ring.

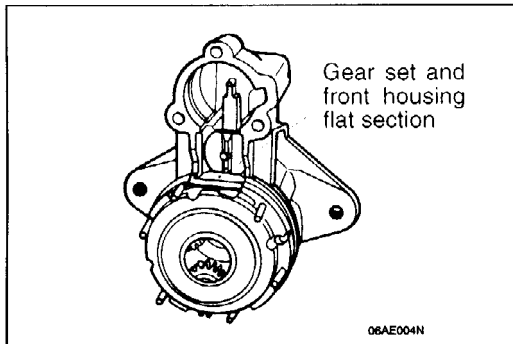
**►B◄ GEAR SET HOUSING INSTALLATION**

Ensure the flat of the gear set housing and the flat of the front housing are aligned together.

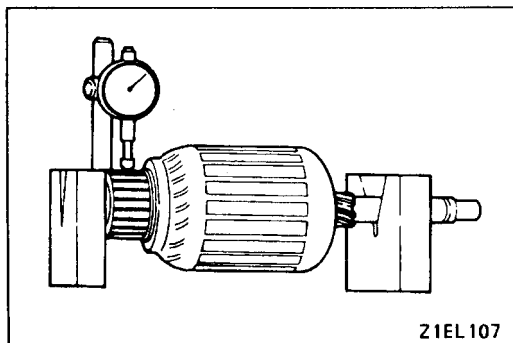
**INSPECTION****COMMUTATOR**

1. Place the armature on a pair of V-blocks, and check the deflection by using a dial gauge.

Standard value: 0.05 mm

Limit: 0.1 mm

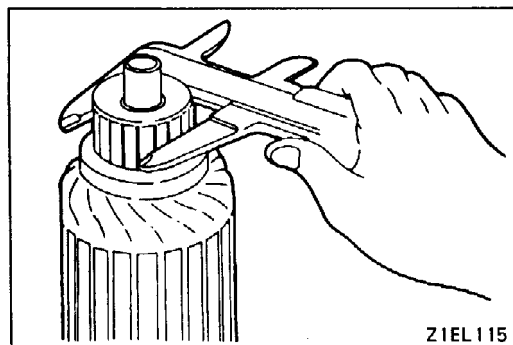

2. Check the outer diameter of the commutator.

Standard value: 32.3 mm

Limit: 31.2 mm

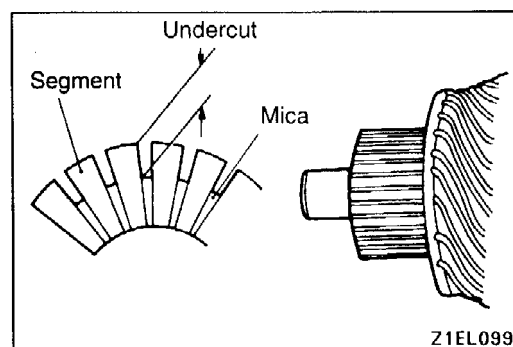

3. Check the depth of the undercut between segments.

Standard value: 0.5 mm

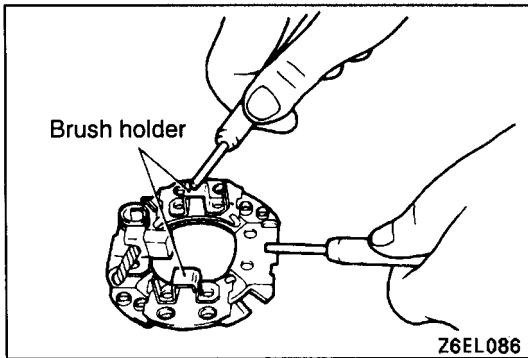
**BRUSH HOLDER**

Check for continuity between the brush holder plate and the brush holder.

The normal condition is non-continuity.

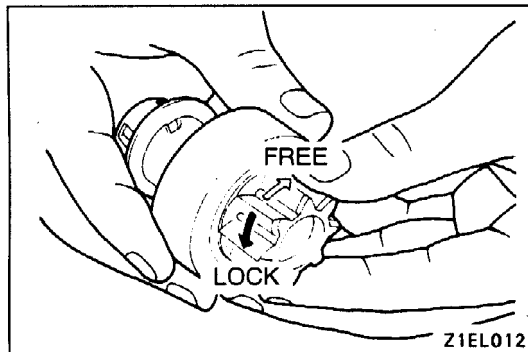
**OVERRUNNING CLUTCH**

1. While holding clutch housing, rotate the pinion. Drive pinion should rotate smoothly in one direction, but should not rotate in opposite direction. If clutch does not function properly, replace overrunning clutch assembly.
2. Inspect pinion for wear or burrs. If pinion is worn or burred, replace overrunning clutch assembly. If pinion is damaged, also inspect ring gear for wear or burrs.

FRONT AND REAR BRACKET BUSHING

Inspect bushing for wear or burrs. If bushing is worn or burred, replace front bracket assembly or rear bracket assembly.

BRUSH AND SPRING REPLACEMENT

1. Brushes that are worn beyond wear limit line, or oil-soaked, should be replaced.

Standard value: Brush minimum length 7mm

POSITIVE BRUSHES

1. Cut the old brush about 1mm away from the field coil connecting strap.
2. Tin the lead with solder, take the new brush and position it on the pre-tinned lead and solder the new brush to the lead.

NEGATIVE BRUSHES

1. Cut the old brush lead flush with the brush plate.
2. Pre-tin the remaining copper lead on the brush plate with solder.
3. Using a pair of pointed nose pliers position and solder new brushes to the brush plate.

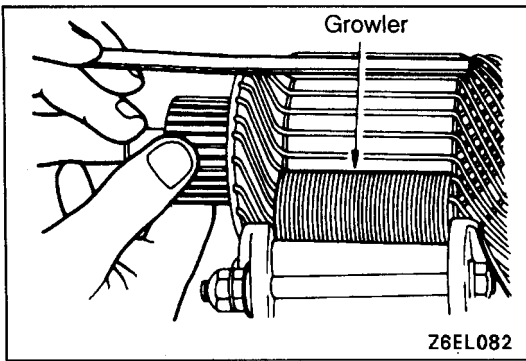
**ARMATURE TEST****ARMATURE SHORT-CIRCUIT TEST**

1. Place armature in a growler.
2. Hold a thin steel blade parallel and just above while rotating the armature slowly. A shorted armature will cause the blade to vibrate and be attracted to the core. Replace a shorted armature.

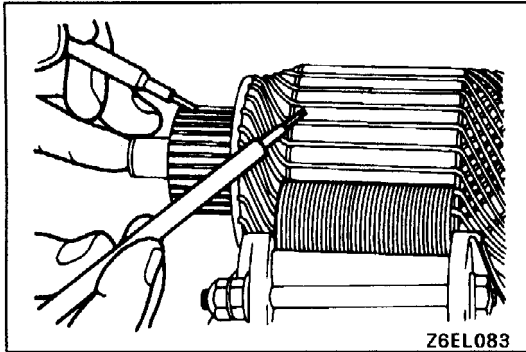
**ARMATURE COIL GROUND TEST**

Check the insulation between the armature coil cores and the commutator segments. They are normal if there is no continuity.

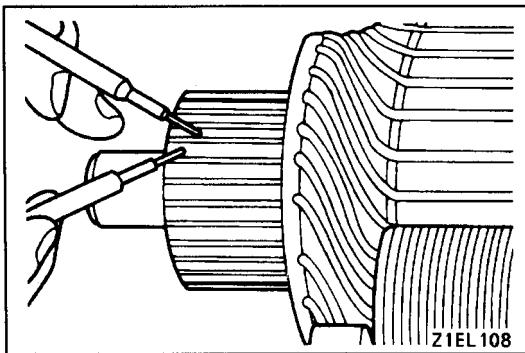
**ARMATURE COIL OPEN-CIRCUIT TEST**

Check for continuity between segments. The condition is normal if there is continuity.

IGNITION SYSTEM

GENERAL INFORMATION

Interruption of the primary current flowing in the primary side of the ignition coil generates high voltage in the secondary side of the ignition coil. The high voltage thus generated is directed by the distributor to the applicable spark plug. The engine firing order is 1-2-3-4-5-6 cylinders.

On application of high voltage, the spark plug generates a spark to ignite the compressed air fuel mixture in the combustion chamber.

The Engine-ECU makes and breaks the primary current of the ignition coil to regulate the ignition timing.

The Engine-ECU detects the crankshaft position by the crankshaft position sensor mounted on the engine to provide ignition at the most appropriate timing for the engine operating condition.

When the engine is cold or operated at a high altitude, the ignition timing is slightly advanced to provide optimum performance to the operating condition.

When the automatic transmission shifts gears, ignition timing is retarded to reduce output torque and alleviate shock during shifting.

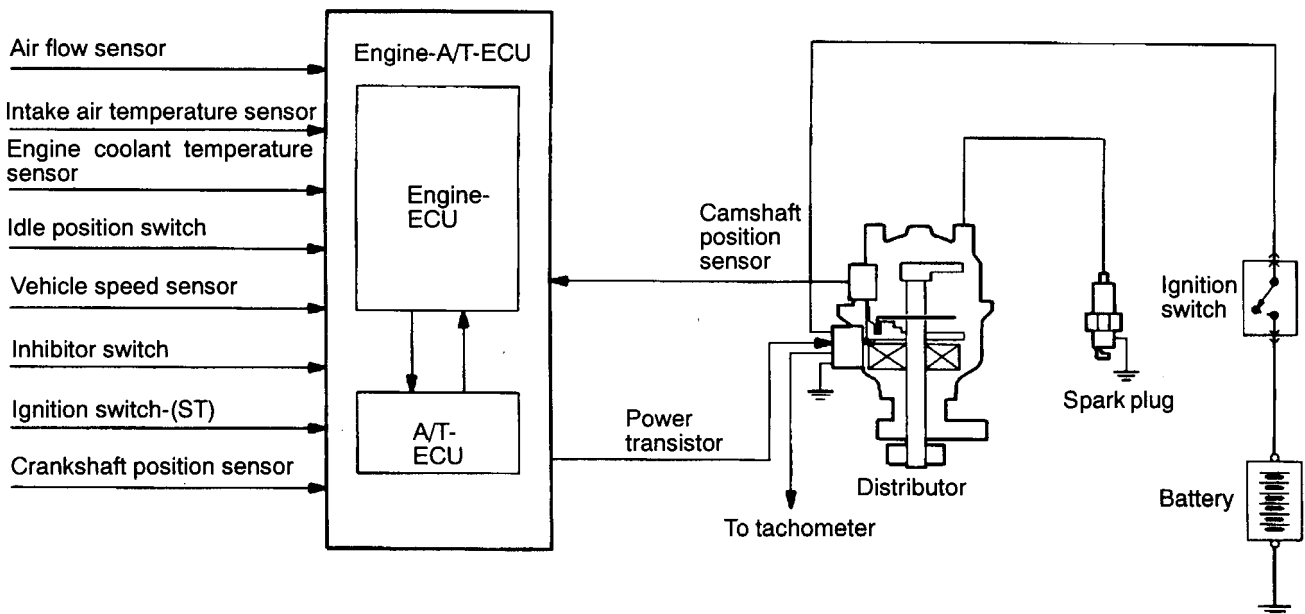

DISTRIBUTOR SPECIFICATIONS

Items	Specifications
Type	Contact pointless with built-in ignition coil and power transistor
Advance mechanism	Electronic
Firing order	1-2-3-4-5-6

IGNITION COIL SPECIFICATION

Items	Specification
Type	Moulded single-coil incorporated in distributor

SPARK PLUG SPECIFICATION

Items	Specifications
Champion	RC8YCC
NGK	BKR6E

SERVICE SPECIFICATIONS

Items	Standard value	Limit
Primary coil resistance Ω	0.5 – 0.7	–
Secondary coil resistance $k\Omega$	9 – 13	–
Spark plug cable resistance $k\Omega$	Max.22	–
Spark plug gap mm	1.0–1.1	–

SPECIAL TOOL

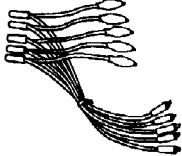
Tool	Number	Name	Use
	MB991348	Test harness set	Inspection of ignition primary voltage (power transistor connection)

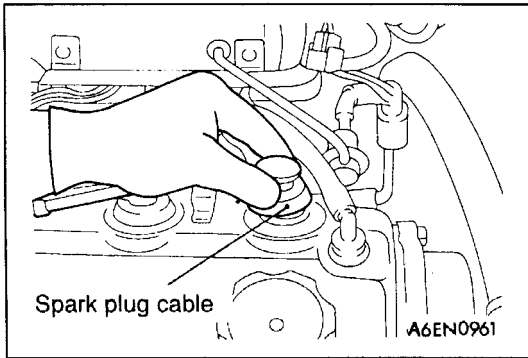

ON-VEHICLE SERVICE

SPARK PLUG CABLE TEST

1. Disconnect, one at a time, each of the spark plug cables while the engine is idling to check whether the engine's running performance changes or not.

Caution

Wear rubber gloves while doing so.

2. If the engine performance does not change, check the resistance of the spark plug cable, and check the spark plug itself.

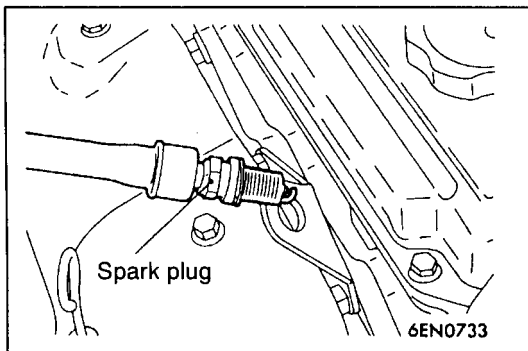

SPARK PLUG TEST

1. Remove the spark plug and connect to the spark plug cable.
2. Ground the spark plug outer electrode (body), and crank the engine. Check to be sure that there is an electrical discharge between the electrodes at this time.

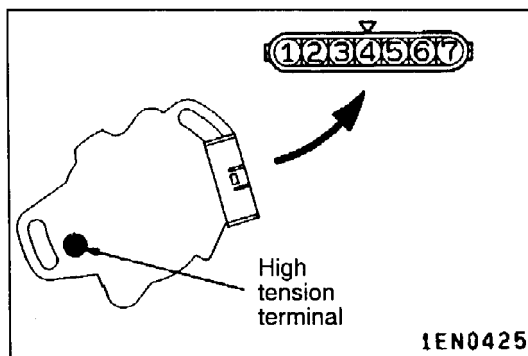
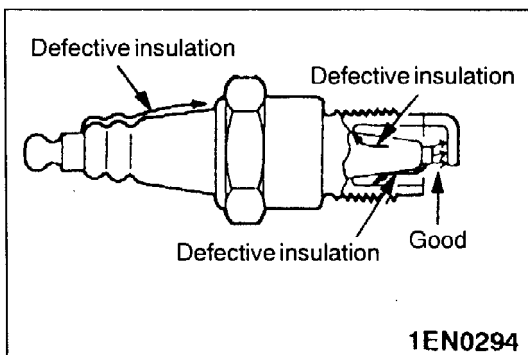

IGNITION COIL CHECK

1. Measurement of the primary coil resistance
Measure the resistance between connector terminal 1 and 2 of the distributor.

Standard value: 0.5–0.7Ω

2. Measurement of secondary coil resistance
Measure the resistance between the high-voltage terminals and connector terminals 1 or 2.

Standard value: 9–13 kΩ

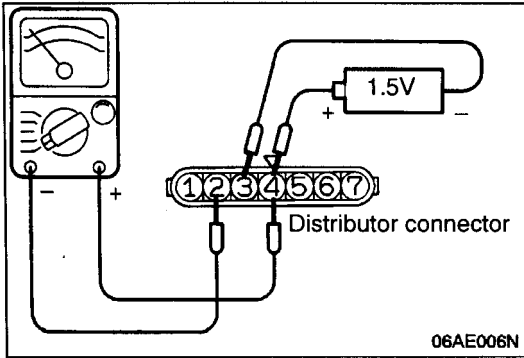

POWER TRANSISTOR CHECK

NOTE

An analog-type ohmmeter should be used.

1. Connect the negative (-) terminal of the 1.5V power supply to terminal 4 of the power transistor; then check whether there is continuity between terminal 4 and terminal 2 when terminal 3 and the positive (+) terminal are connected and disconnected.

NOTE

Connect the negative (-) probe of the circuit tester to terminal 12.

Terminal 6 and (+) terminal	Terminal 5 and terminal 12
Connected	Continuity
Unconnected	No continuity

2. Replace the power transistor if there is a malfunction.

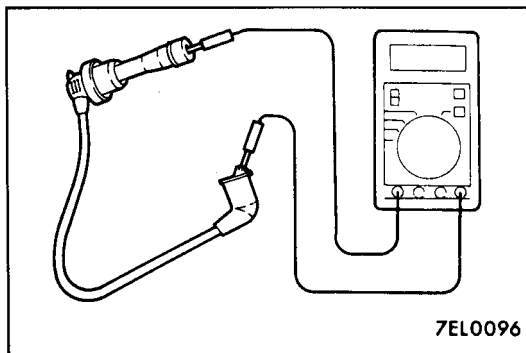

SPARK PLUG CABLE RESISTANCE CHECK

Measure the resistance of all spark plug leads.

1. Check cap and coating for cracks.
2. Measure resistance

Limit: Max. 22 kΩ

SPARK PLUG CHECK AND CLEANING

1. Remove the engine cover and intake manifold plenum, refer to GROUP 15.
2. Remove the spark plug cables.

Caution

When pulling off the spark plug cable from the plug always hold the cable cap, not the cable.

3. Remove the spark plugs.
4. Check for burned out electrode or damaged insulator. Check for even burning.
5. Remove carbon deposits with a plug cleaner. Remove sand from plug screw with compressed air.

Caution

When cleaning platinum tip spark plugs the tip may be damaged. If carbon deposits must be removed use a plug cleaner and complete cleaning within 20 seconds. Do not use a wire brush.

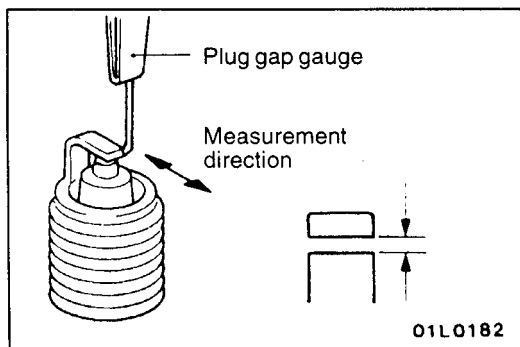

6. Use a plug gap gauge to check that the plug gap is within the standard value range. Replace the spark plug if the limit is exceeded.

Standard value: 1.0–1.1 mm

NOTE

On conventional type plugs, if plug is outside the specified value range, adjust by bending the earth electrode. If the plug gap is outside the specified value range on platinum tip plugs, the plug must be replaced.

7. Clean the engine plug holes.

Caution

Use care not to allow foreign matter in cylinders.

8. Install the spark plugs.

CAMSHAFT POSITION SENSOR CHECK

Refer to GROUP 13A – Troubleshooting.

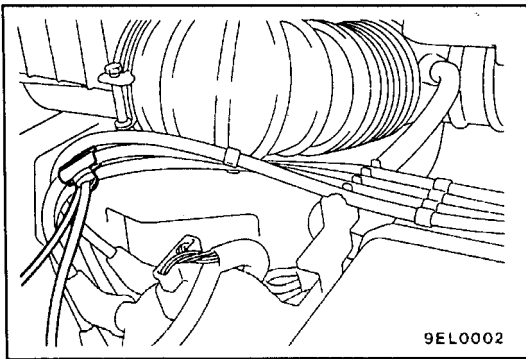

IGNITION SECONDARY VOLTAGE WAVE PATTERN CHECK

MEASUREMENT METHOD

1. Clamp the spark plug cable (No. 1, No. 2, No. 3, No.4, No. 5 or No. 6) with the secondary pickup.

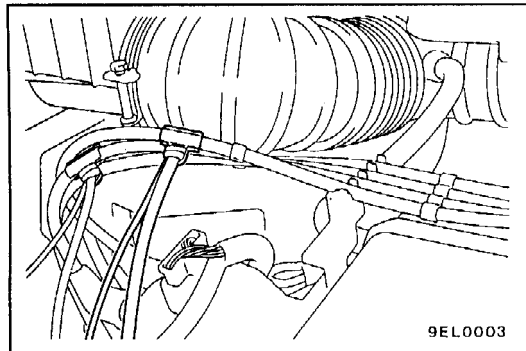

2. Clamp the No. 1 cylinder spark plug cable with the trigger pickup.

STANDARD WAVE PATTERN
Observation conditions

FUNCTION	SECONDARY
PATTERN HEIGHT	HIGH (or LOW)
PATTERN SELECTOR	RASTER
Engine Speed	Curb idle speed

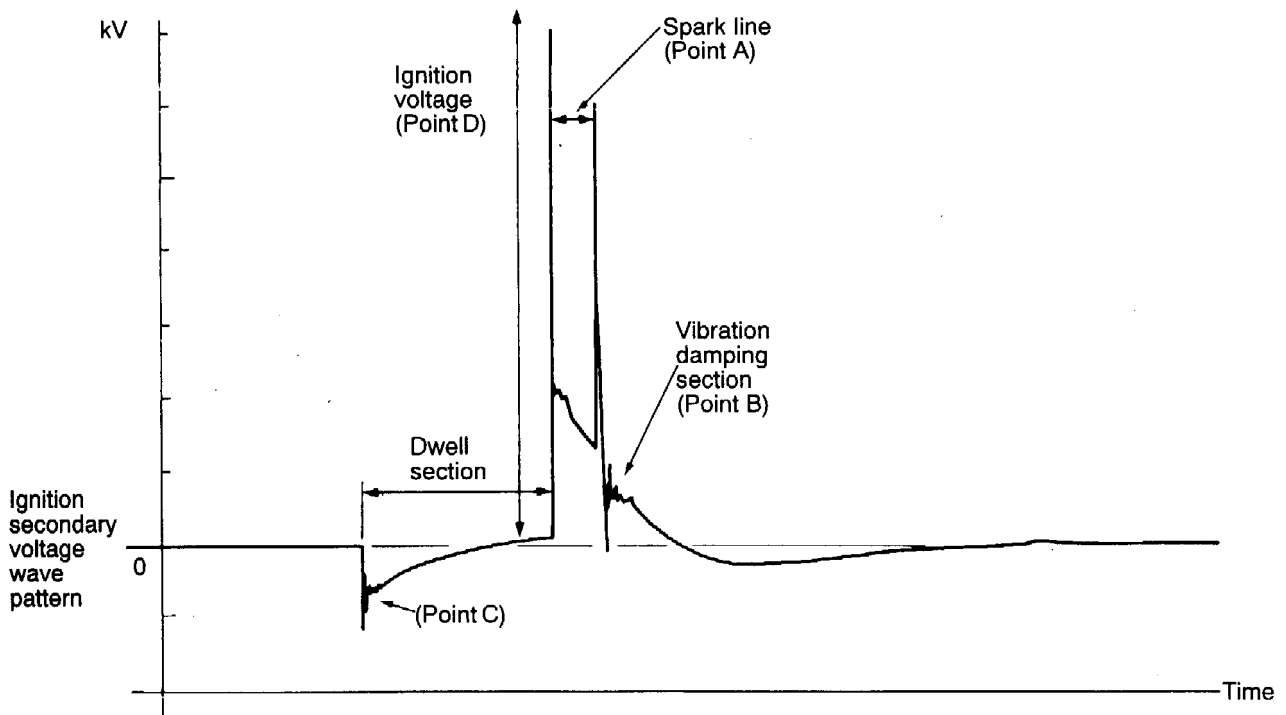

WAVEFORM OBSERVATION POINTS

Point A: The height, length and slope of the spark line (refer to abnormal waveform examples 1, 2, 3 and 4) show the following trends.

Spark line		Plug gap	Condition of electrode	Compression force	Concentration of air mixture	Ignition timing	Spark plug cable
Length	Long	Small	Normal	Low	Rich	Advanced	Leak
Length	Short	Large	Large wear	High	Lean	Retarded	High resistance
Height	High	Large	Large wear	High	Lean	Retarded	High Resistance
Height	Low	Small	Normal	Low	Rich	Advanced	Leak
Slope		Large	Plug is fouled	–	–	–	–

Point B: Number of vibration in reduction vibration section
(Refer to abnormal waveform example 5)

Number of vibrations	Coil and condenser
Three or more	Normal
Except above	Abnormal





Point C: Number of vibrations at beginning of dwell section
(Refer to abnormal waveform example 5)

Number of vibrations	Coil
5–6 or higher	Normal
Except above	Abnormal

Point D: Ignition voltage height (distribution per each cylinder) shows the following trends.

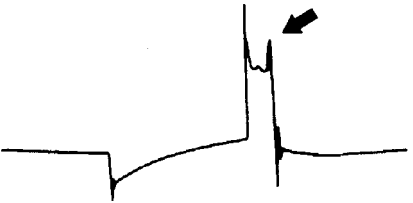
Ignition voltage	Plug gap	Condition of electrode	Compression force	Concentration of air mixture	Ignition timing	Spark plug cable
High	Large	Large wear	High	Lean	Retarded	High resistance
Low	Small	Normal	Low	Rich	Advanced	Leak

ABNORMAL WAVEFORMS EXAMPLES

Abnormal waveform	Wave characteristics	Cause of problem
<p>Example 1</p>  <p>01P021</p>	<p>Spark line is high and short.</p>	<p>Spark plug gap is too large.</p>
<p>Example 2</p>  <p>01P0216</p>	<p>Spark line is low and long, and is sloping. Also, the second half of the spark line is distorted. This could be a result of misfiring.</p>	<p>Spark plug gap is too small.</p>
<p>Example 3</p>  <p>01P0217</p>	<p>Spark line is low and long, and is sloping. However, there is almost no spark line distortion.</p>	<p>Spark plug gap is fouled.</p>
<p>Example 4</p>  <p>01P0218</p>	<p>Spark line is high and short. Difficult to distinguish between this and abnormal wave pattern example 1.</p>	<p>Spark plug cable is nearly falling off. (Causing a dual ignition)</p>
<p>Example 5</p>  <p>01P0219</p>	<p>No waves in wave damping section</p>	<p>Rare short in ignition coil.</p>

IGNITION PRIMARY VOLTAGE WAVE PATTERN CHECK**MEASUREMENT METHOD**

1. Disconnect the distributor connector and connect the special tool (test harness: MB991348) in between. (All of the terminals should be connected.)

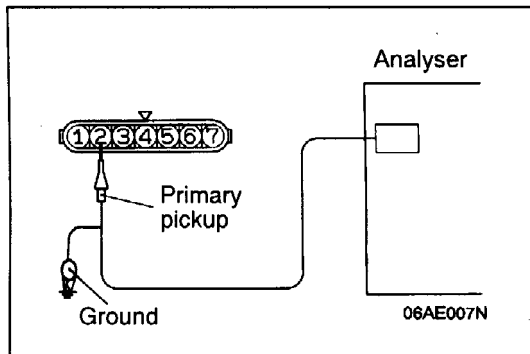

2. Connect the analyser primary pickup to the distributor connector terminal 2.
3. Connect the primary pickup earth terminal.
4. Clamp the spark plug cable with the trigger pickup.

NOTE

The wave pattern of the cylinder clamped to the trigger pickup will appear at the left edge of the screen.

STANDARD WAVE PATTERN

Observation conditions

FUNCTION	SECONDARY
PATTERN HEIGHT	HIGH (or LOW)
PATTERN SELECTOR	RASTER
Engine Speed	Curb idle speed

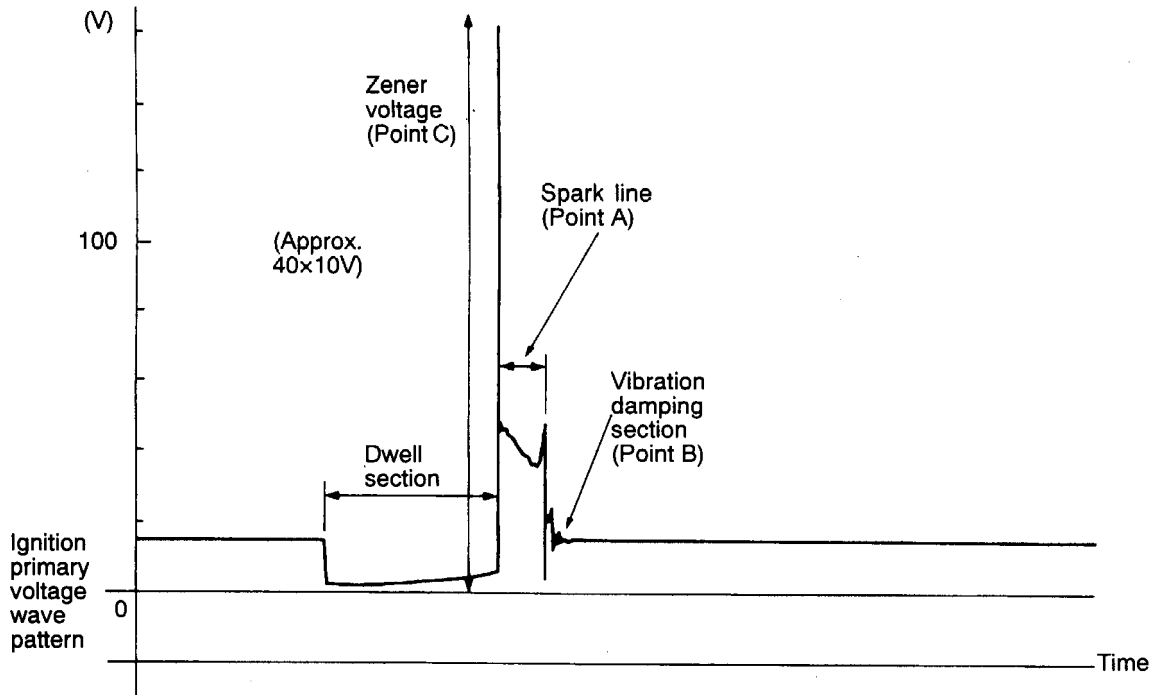

7EL0132

Observation conditions

(Only the pattern selector shown below changes from the previous conditions)

PATTERN SELECTOR	DISPLAY
------------------	---------

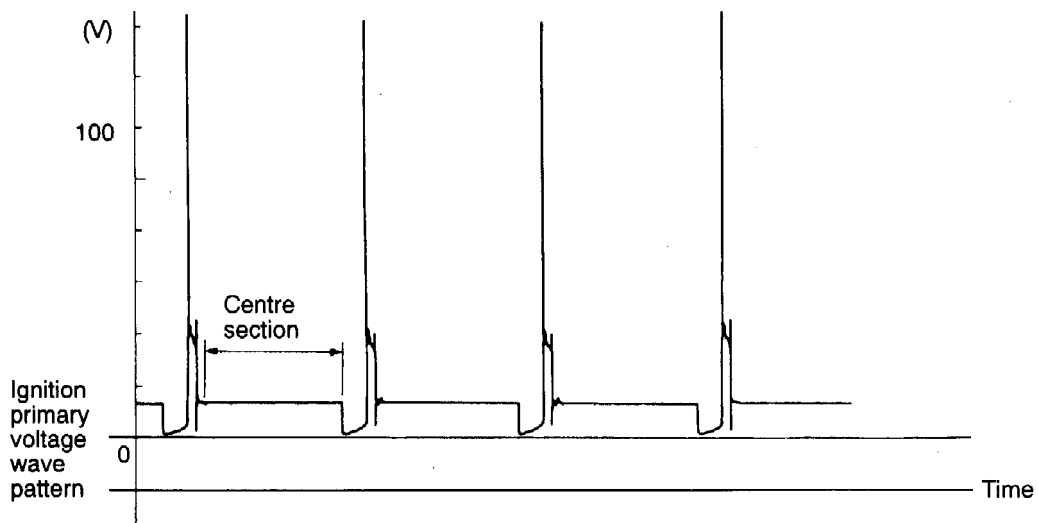

9EL0006

WAVEFORM OBSERVATION POINTS

Point A: The height, length and slope of the spark line (refer to abnormal waveform examples 1, 2, 3 and 4) show the following trends.

Spark line		Plug gap	Condition of electrode	Compression force	Concentration of air mixture	Ignition timing	Spark plug cable
Length	Long	Small	Normal	Low	Rich	Advanced	Leak
Length	Short	Large	Large wear	High	Lean	Retarded	High resistance
Height	High	Large	Large wear	High	Lean	Retarded	High Resistance
Height	Low	Small	Normal	Low	Rich	Advanced	Leak
Slope		Large	Plug is fouled	–	–	–	–





Point B: Number of vibration in reduction vibration section
(Refer to abnormal waveform example 5)

Number of vibrations	Coil, condenser
3 or higher	Normal
Except above	Abnormal

Point C: Height of Zener voltage

Height of Zener voltage	Probable cause
High	Problem in Zener diode
Low	Abnormal resistance in primary coil circuit

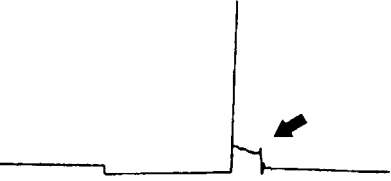
ABNORMAL WAVEFORMS EXAMPLES

Abnormal waveform	Wave characteristics	Cause of problem
<p>Example 1</p>  <p>01P0210</p>	<p>Spark line is high and short.</p>	<p>Spark plug gap is too large.</p>
<p>Example 2</p>  <p>01P0211</p>	<p>Spark line is low and long, and is sloping. Also, the second half of the spark line is distorted. This could be a result of misfiring.</p>	<p>Spark plug gap is too small.</p>
<p>Example 3</p>  <p>01P0212</p>	<p>Spark line is low and long, and is sloping. However, there is almost no spark line distortion.</p>	<p>Spark plug gap is fouled.</p>
<p>Example 4</p>  <p>01P0213</p>	<p>Spark line is high and short.</p>	<p>Spark plug cable is nearly falling off. (Causing a dual ignition)</p>
<p>Example 5</p>  <p>01P0214</p>	<p>No waves in wave damping section</p>	<p>Rare short in ignition coil.</p>

IGNITION SYSTEM

REMOVAL AND INSTALLATION

Pre-removal and Post-installation Operation
 Engine cover removal and installation (Refer to GROUP
 11 – Intake Manifold Plenum and Throttle Body.)

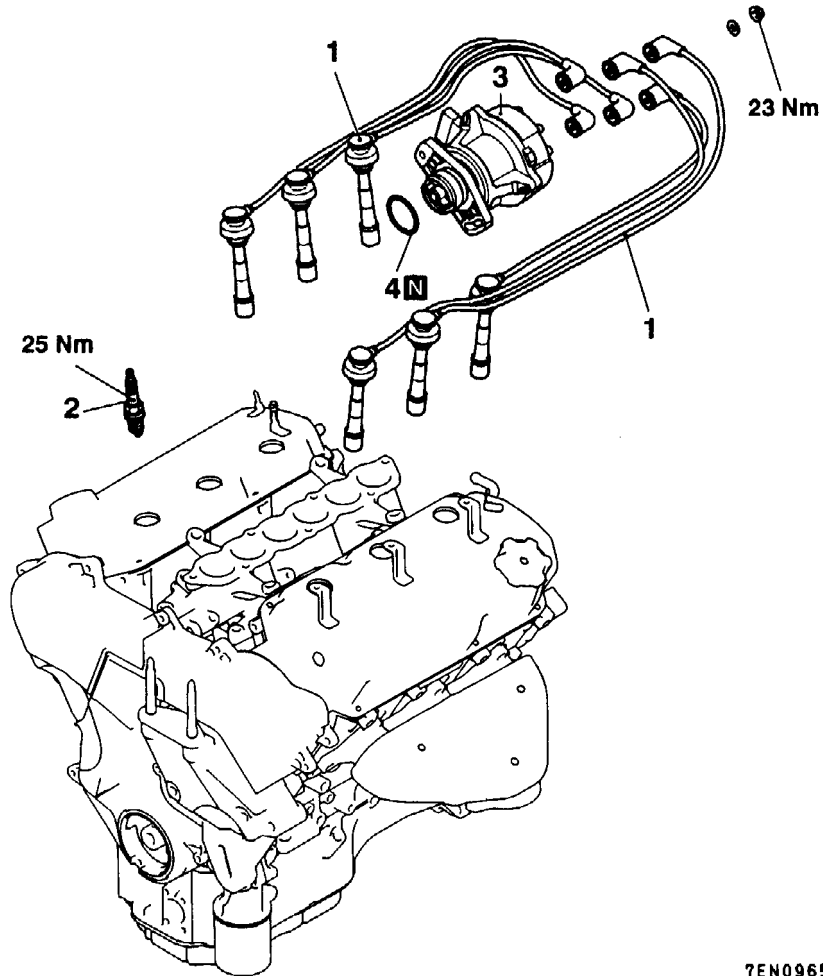

7EN0965

Removal steps

- ▶B◀ 1. Spark plug cable
- ▶A◀ 2. Spark plug
- ▶A◀ 3. Distributor
- ▶A◀ 4. O-ring

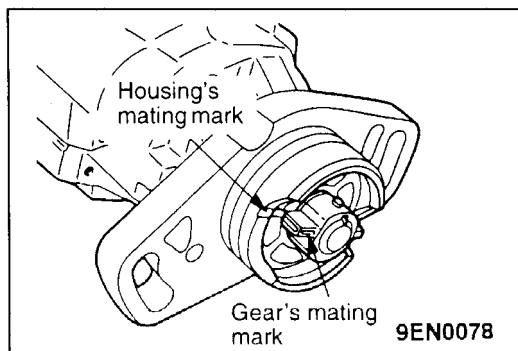

INSTALLATION SERVICE POINTS

▶A◀ DISTRIBUTOR INSTALLATION

1. Turn the crankshaft so that the No. 1 cylinder is at top dead centre.
2. Align the distributor housing and gear mating marks and install the distributor.

▶B◀ SPARK PLUG CABLE INSTALLATION

Improper arrangement of spark plug cables will induce voltage between the cables, causing misfiring and developing a surge at acceleration in high-speed operation.

Therefore, be careful to arrange the spark plug cables properly paying attention to the following items.

1. Install the cables securely to avoid possible contact with metal parts.
2. Install the cables neatly, ensuring they are not too tight, loose, twisted or kinked.

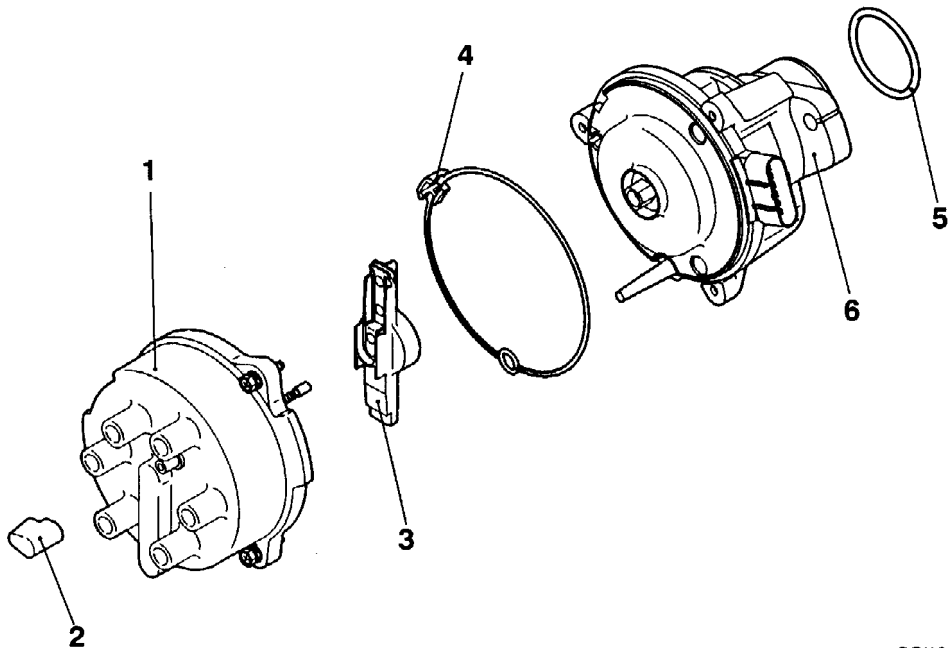
DISTRIBUTOR**DISASSEMBLY AND REASSEMBLY**

7EN0964

Disassembly steps

1. Distributor cap
2. Breather
3. Rotor
4. Seal
5. O-ring
6. Distributor housing

INSPECTION

Check the following points; repair or replace if a problem is found.

CAP ROTOR

1. There must be no cracking in the cap.
2. There must be no damage to the cap's electrode or the rotor's electrode.
3. Clean away any dirt from the cap and rotor.

CRANKSHAFT POSITION SENSOR

REMOVAL AND INSTALLATION

Pre-removal and Post-installation Operation
Timing Belt Cover Removal and Installation
(Refer to GROUP 11 – Timing Belt.)

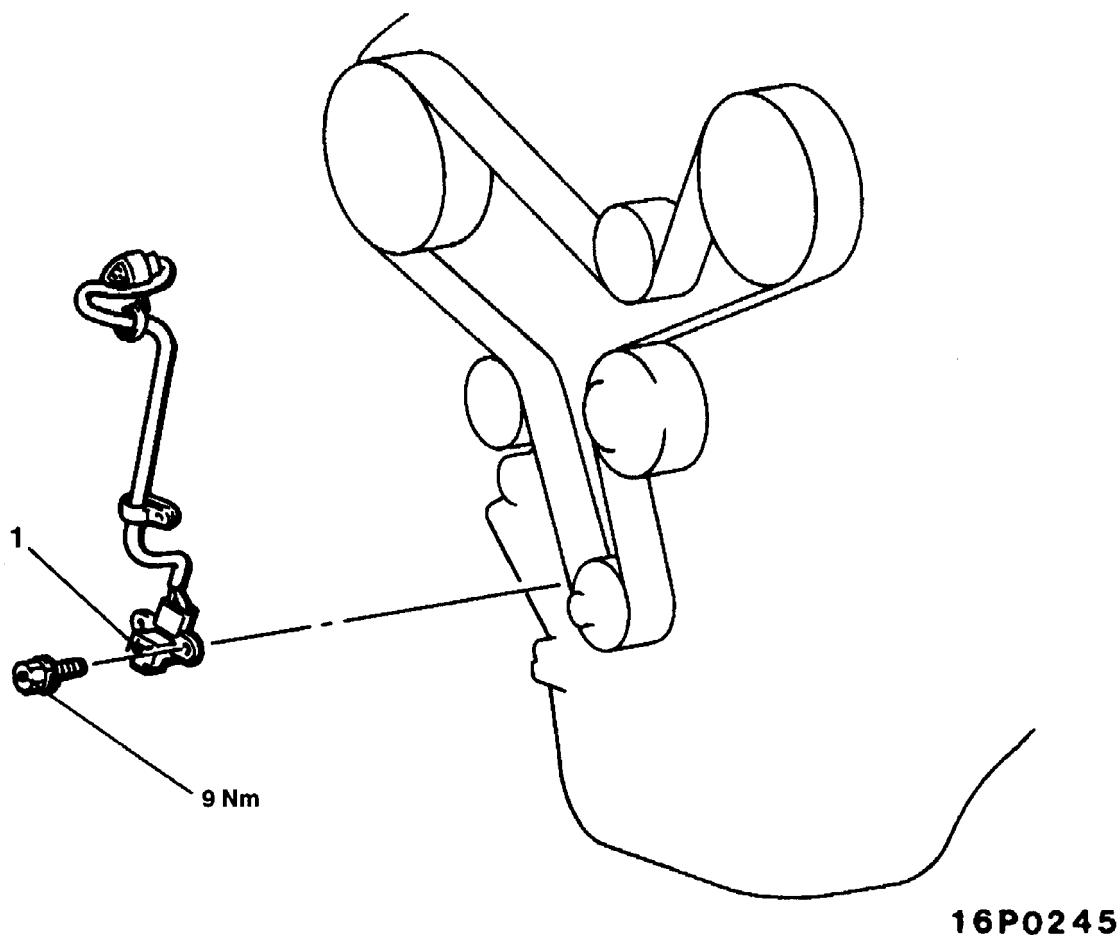

Removal steps

1. Crankshaft position sensor

INSPECTION

CRANKSHAFT POSITION SENSOR CHECK

Refer to GROUP 13A – Troubleshooting.