

---

# ENGINE COOLING

## CONTENTS

<b>GENERAL INFORMATION</b> .....	<b>2</b>	Engine Coolant Replacement .....	<b>3</b>
<b>SERVICE SPECIFICATIONS</b> .....	<b>2</b>	Concentration Measurement .....	<b>4</b>
<b>LUBRICANT</b> .....	<b>2</b>	<b>THERMOSTAT</b> .....	<b>5</b>
<b>SEALANT</b> .....	<b>2</b>	<b>WATER PUMP</b> .....	<b>8</b>
<b>ON-VEHICLE SERVICE</b> .....	<b>3</b>	<b>WATER HOSE AND WATER PIPE</b> .....	<b>9</b>
Engine Coolant Leak Check .....	3	<b>RADIATOR</b> .....	<b>11</b>
Radiator Cap Valve Opening Pressure Check .....	3		

---

## GENERAL INFORMATION

The cooling system is designed to keep every part of the engine at appropriate temperature in whatever condition the engine may be operated. The cooling method is of the water-cooled, pressure forced circulation type in which the water pump pressurises coolant and circulates it throughout the engine. If the coolant temperature exceeds the prescribed temperature, the thermostat opens to circu-

late the coolant through the radiator as well so that the heat absorbed by the coolant may be radiated into the air.

The water pump is of the centrifugal type and is driven by the camshaft drive belt.

The radiator is the corrugated fin, down flow type and is cooled by the electrical radiator fan.

## CONSTRUCTION DIAGRAM

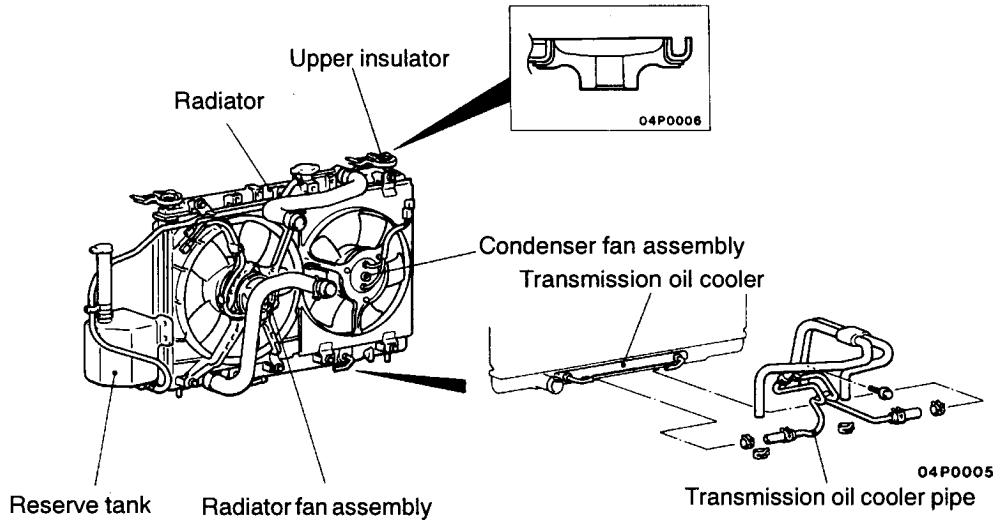

## SERVICE SPECIFICATIONS

Items		Standard value	Limit
Thermostat	Valve opening temperature of thermostat °C	82	—
	Full-opening temperature of thermostat °C	95	—
Radiator	Range of coolant antifreeze concentration %	30–60	—
Radiator cap	High pressure valve opening pressure kPa	75–105	65

## LUBRICANT

Items	Specified lubricant	Quantity (litres)
Engine coolant	High quality ethylene glycol antifreeze coolant	9.5

## SEALANT

Items	Specified sealant	Remarks
Cylinder block drain plug	3M Nut Locking Part No. 4171 or equivalent	Drying sealant

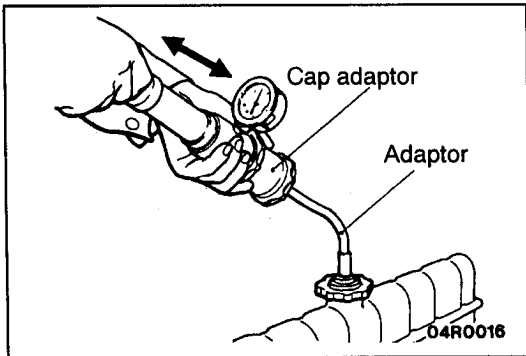

## ON-VEHICLE SERVICE

### ENGINE COOLANT LEAK CHECK

1. Confirm that the coolant level is up to the filler neck. Install a radiator cap tester and apply 160 kPa pressure, and then check for leakage from the radiator hose or connections.

#### Caution

1. Be sure to completely clean away any moisture from the places checked.
  2. When the tester is taken out, be careful not to spill any coolant from it.
  3. Be careful, when installing and removing the tester and when testing, not to deform the filler neck of the radiator.
2. If there is leakage, repair or replace the appropriate part.

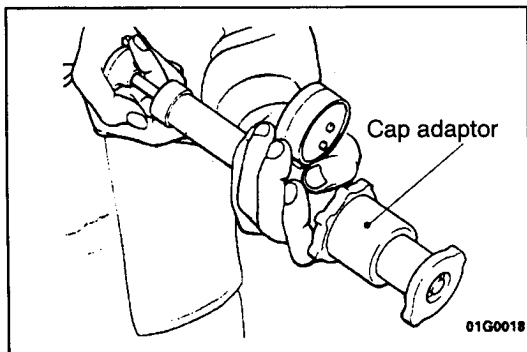

### RADIATOR CAP VALVE OPENING PRESSURE CHECK

1. Use a cap adaptor to attach the cap to the tester.
2. Increase the pressure until the indicator of the gauge stops moving.

**Limit: 65 kPa**

**Standard value: 75–105 kPa**

3. Replace the radiator cap if the reading does not remain at or above the limit.

#### NOTE

Be sure that the cap is clean before testing, since rust or other foreign material on the cap seal will cause an improper indication.

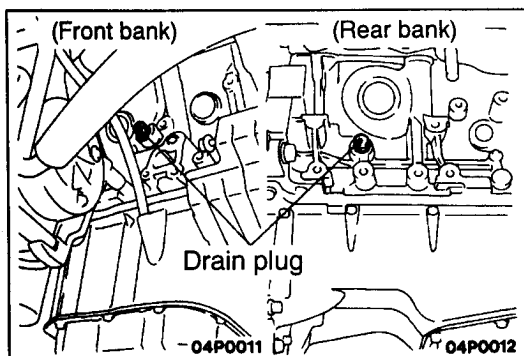

### ENGINE COOLANT REPLACEMENT

1. Remove the heat protectors (front and rear) from the exhaust manifold.
2. Loosen the radiator drain plug, remove two drain plugs from the engine block (one for each bank) and remove the radiator cap to discharge the coolant.
3. Remove the reserve tank and discharge the coolant.
4. When the coolant has been discharged, pour water through the filler port to flush the coolant passage.

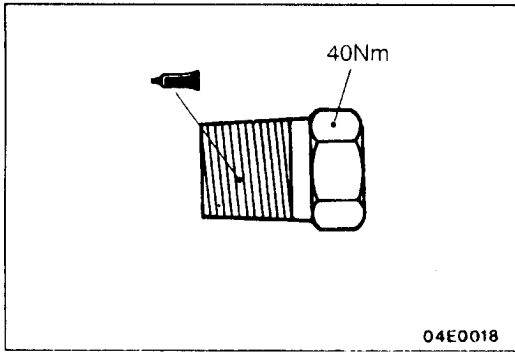

5. Coat the threads of the engine drain plugs with the specified sealant and tighten the plugs to specification.

**Specified Sealant: 3M Nut Locking Part No.4171 or equivalent.**

**Tightening torque: 40 Nm**

6. Fit the radiator drain plug securely.
7. Mount the reserve tank.
8. Slowly pour coolant into the radiator to the brim and also into the reserve tank to the full line.

**Recommended antifreeze:**

**DIA-QUEEN LONG-LIFE COOLANT (Part No.0103044) or High quality ethylene-glycol anti-freeze coolant.**

**Quantity: 9.5 ℓ**

9. Install the radiator cap securely.
10. Start the engine and warm up until the thermostat opens.
11. Race the engine up to around 3,000 r/min several times, then stop the engine.
12. When the engine has cooled down, remove the radiator cap and add coolant up to the brim. Add coolant to the reserve tank up to the FULL line.

**CONCENTRATION MEASUREMENT**

Measure the temperature and specific gravity of the engine coolant to check the antifreeze concentration.

**Standard value: 30–60% (allowable concentration range)**

**RECOMMENDED ANTIFREEZE**

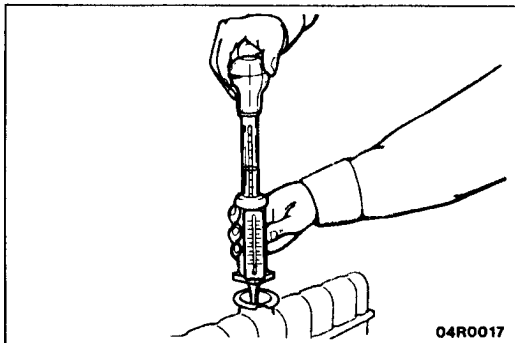

Antifreeze	Allowable concentration
HIGH QUALITY ETHYLENE GLYCOL ANTIFREEZE COOLANT	30–60%

**Caution**

If the concentration of the anti-freeze is below 30%, the anti-corrosion property will be adversely affected. In addition, if the concentration is above 60%, both the anti-freezing and the engine cooling properties will decrease, affecting the engine adversely. For these reasons, be sure to maintain the concentration level within the specified range.

**THERMOSTAT****REMOVAL AND INSTALLATION**

**Pre-removal and Post-installation Operation**  
Engine Coolant, Draining and Supplying (Refer to P.14-3)

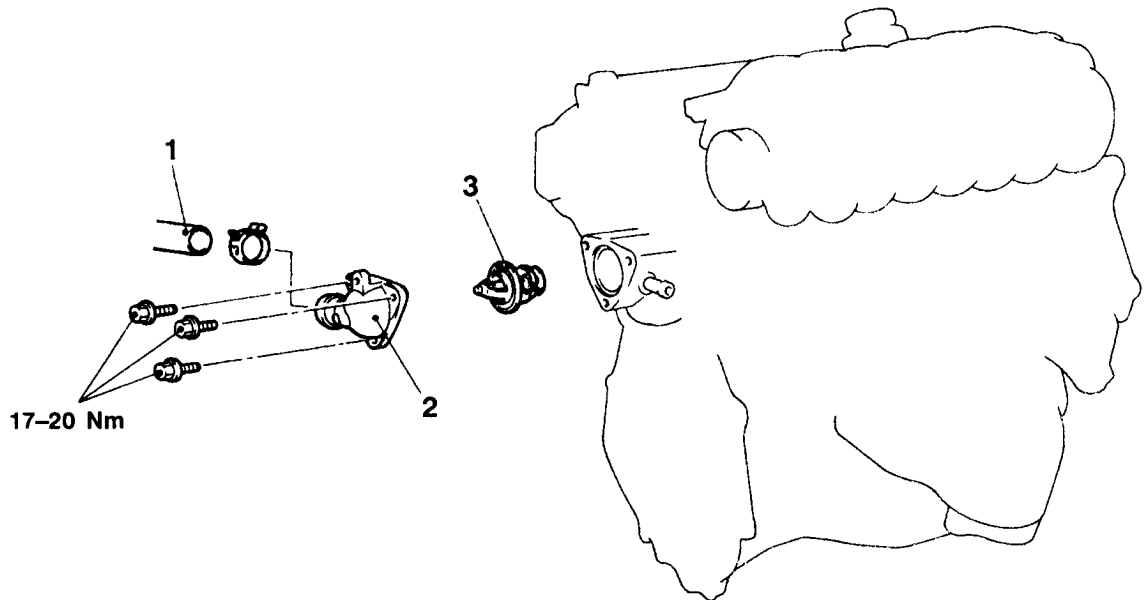

04P0013

**Removal steps**

- ◀A▶ ▶B▶ 1. Radiator lower hose connection  
▶A▶ 2. Water outlet fitting  
▶A▶ 3. Thermostat

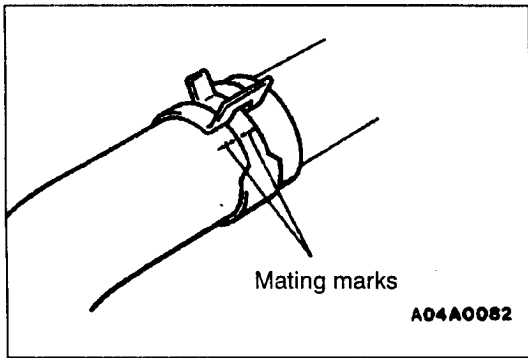

**REMOVAL SERVICE POINT**

**◀A▶ RADIATOR LOWER HOSE DISCONNECTION**

After making mating marks on the radiator hose and the hose clamp, disconnect the radiator hose.

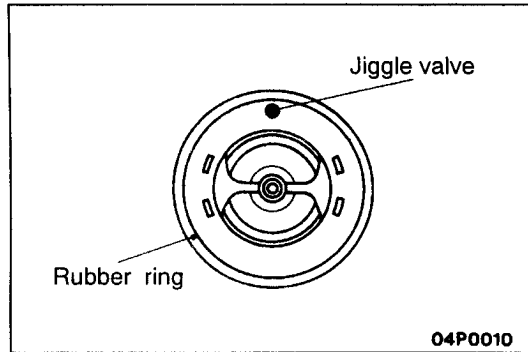

**INSTALLATION SERVICE POINTS**

**▶A◀ THERMOSTAT INSTALLATION**

Install the thermostat so that the jiggle valve is facing straight up and is aligned with the mark on the thermostat case as shown in the illustration.

**Caution**

**Make absolutely sure that no oil is adhering to the rubber ring of the thermostat. In addition, be careful not to fold over or scratch the rubber ring when inserting.**

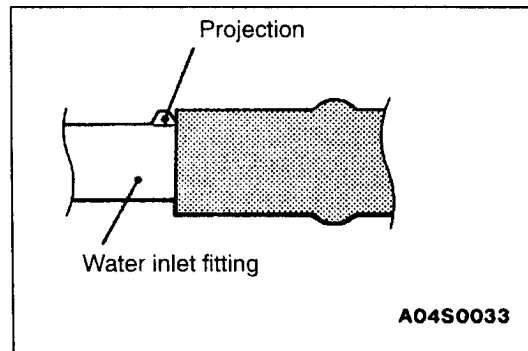

**▶B◀ RADIATOR LOWER HOSE CONNECTION**

1. Insert each hose as far as the projection of the water outlet fitting or water inlet fitting.

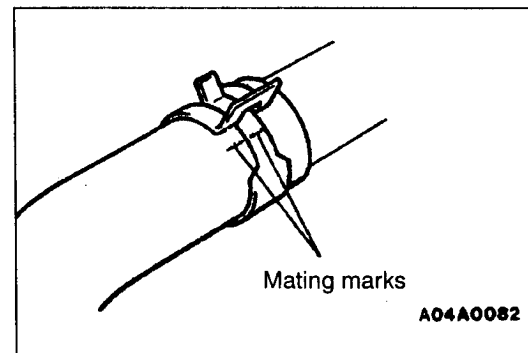

2. Align the mating marks on the radiator hose and hose clamp, and then connect the radiator hose.

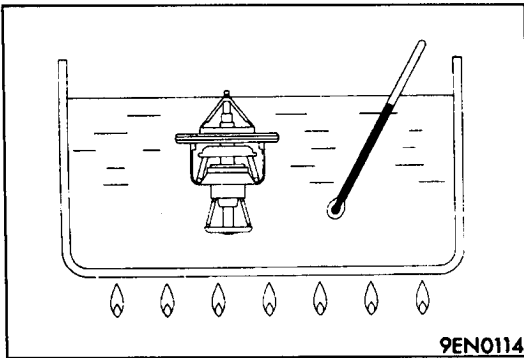
**INSPECTION****THERMOSTAT CHECK**

1. Immerse the thermostat in water, and heat the water while stirring. Check the thermostat valve opening temperature.

**Standard value:  $82 \pm 1.5^{\circ}\text{C}$**

2. Check that the amount of valve lift is at the standard value when the water is at the full-opening temperature.

**Standard value:**

**Full-opening temperature:  $95^{\circ}\text{C}$**

**Amount of valve lift: 8.5mm or more**

**NOTE**

Measure the valve height when the thermostat is fully closed, and use this measurement to calculate the valve height when the thermostat is fully open.

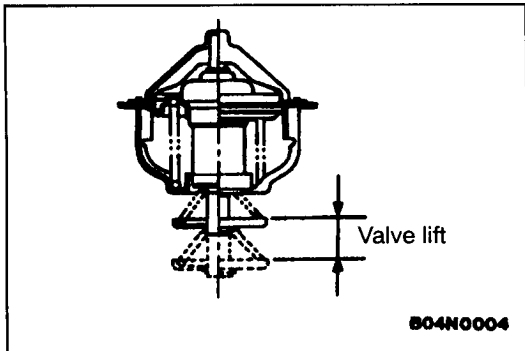

# WATER PUMP

## REMOVAL AND INSTALLATION

**Pre-removal and Post-installation Operation**

- Engine Coolant Draining and Supplying (Refer to P.14-3)
- Timing Belt Removal and Installation (Refer to GROUP 11.)

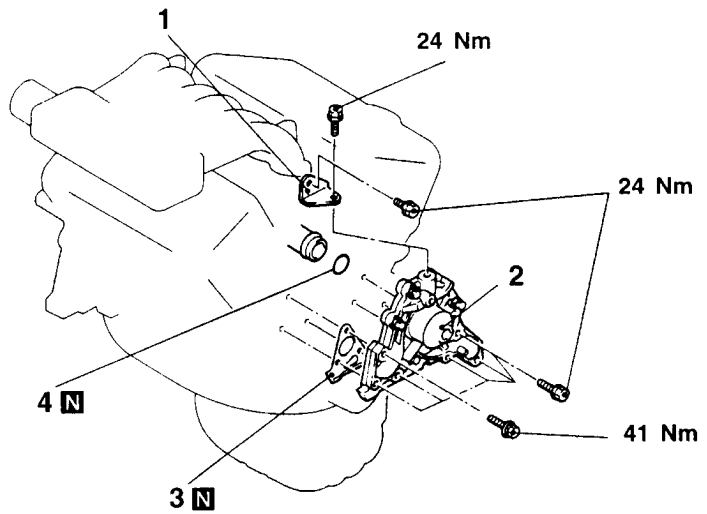
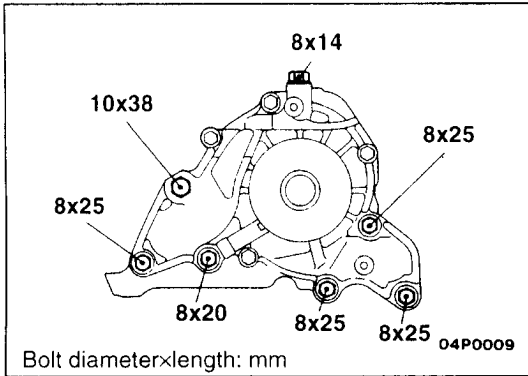

04TE003A

**Removal steps**

1. Alternator brace
2. Water pump
3. Water pump gasket
4. O-ring

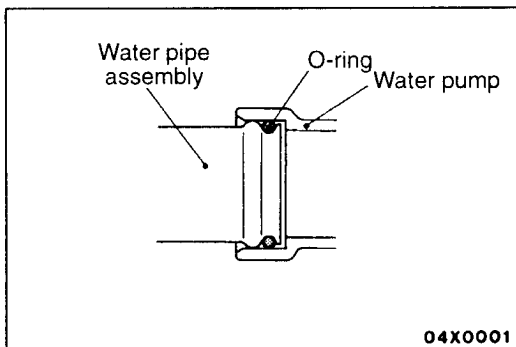

**INSTALLATION SERVICE POINT**

**▶A◀ O-RING INSTALLATION**

Insert the O-ring to the water inlet pipe, and coat the outlet circumference of the O-ring with water. By coating with water, the insertion to the water pump will become easier.

**Caution**

1. Care must be taken not to permit engine oil or other greases to adhere to the O-ring.
2. When inserting the pipe, check to be sure that there is no sand, dirt, etc. on its inner surface.



# WATER HOSE AND WATER PIPE

## REMOVAL AND INSTALLATION

**Pre-removal and Post-installation Operation**

- Engine Coolant Draining and Supplying (Refer to P.14-3)
- Air Cleaner Removal and Installation
- Distributor Removal and Installation (Refer to GROUP 16 – Engine Electrical.)

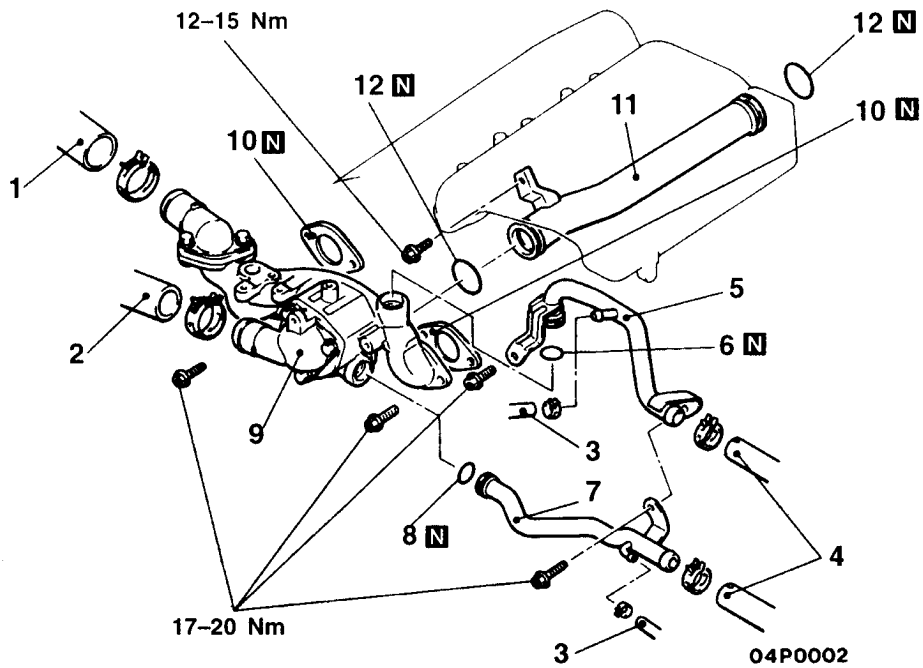

**Removal steps**

- ◀A▶ ▶B▶ 1. Radiator upper hose connection
- ◀A▶ ▶B▶ 2. Radiator lower hose connection
- 3. Water hose
- 4. Heater hose connection
- 5. Heater inlet pipe A
- ◀A▶ 6. O-ring

- 7. Heater inlet pipe B
- ▶A▶ 8. O-ring
- 9. Thermostat housing assembly
- 10. Gasket
- 11. Water inlet pipe assembly
- ▶A▶ 12. O-ring

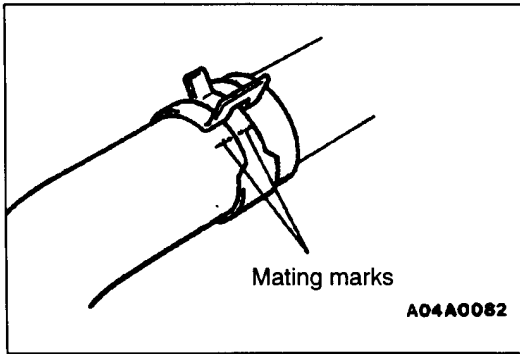
**REMOVAL SERVICE POINT****◀A▶ RADIATOR UPPER HOSE/RADIATOR LOWER HOSE DISCONNECTION**

After making mating marks on the radiator hose and the hose clamp, disconnect the radiator hose.

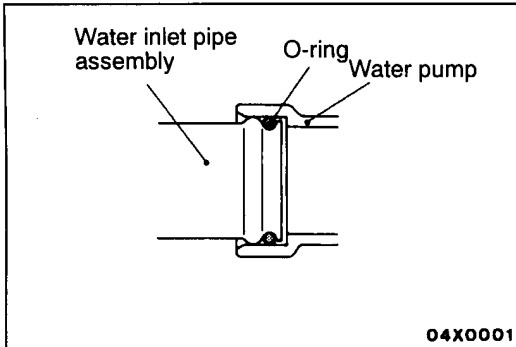
**INSTALLATION SERVICE POINTS****▶A◀ O-RING INSTALLATION**

Insert the O-ring to the water inlet pipe, and coat the outer circumference of the O-ring with water.

**Caution**

Care must be taken not to permit engine oil or other greases to adhere to the O-ring.

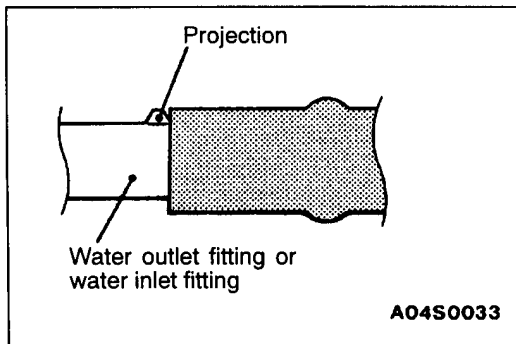
**▶B◀ RADIATOR LOWER HOSE/RADIATOR UPPER HOSE CONNECTION**

1. Insert each hose as far as the projection of the water outlet fitting or water inlet fitting.
2. Align the mating marks on the radiator hose and hose clamp, and then connect the radiator hose.

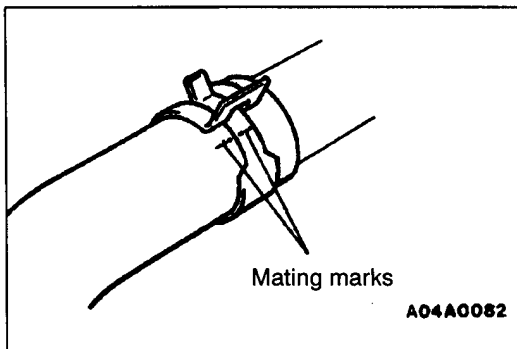
**INSPECTION****WATER PIPE AND HOSE CHECK**

Check the water pipe and hose for cracks, damage, blockage and replace them if necessary.

# RADIATOR

## REMOVAL AND INSTALLATION

**Pre-removal Operation**

Engine Coolant Draining (Refer to P.14-3)

**Post-installation Operation**

- Engine Coolant Supplying and Checking (Refer to P.14-3)
- A/T Fluid Checking and Refilling If Necessary (Refer to GROUP 23 – On-vehicle Service.)

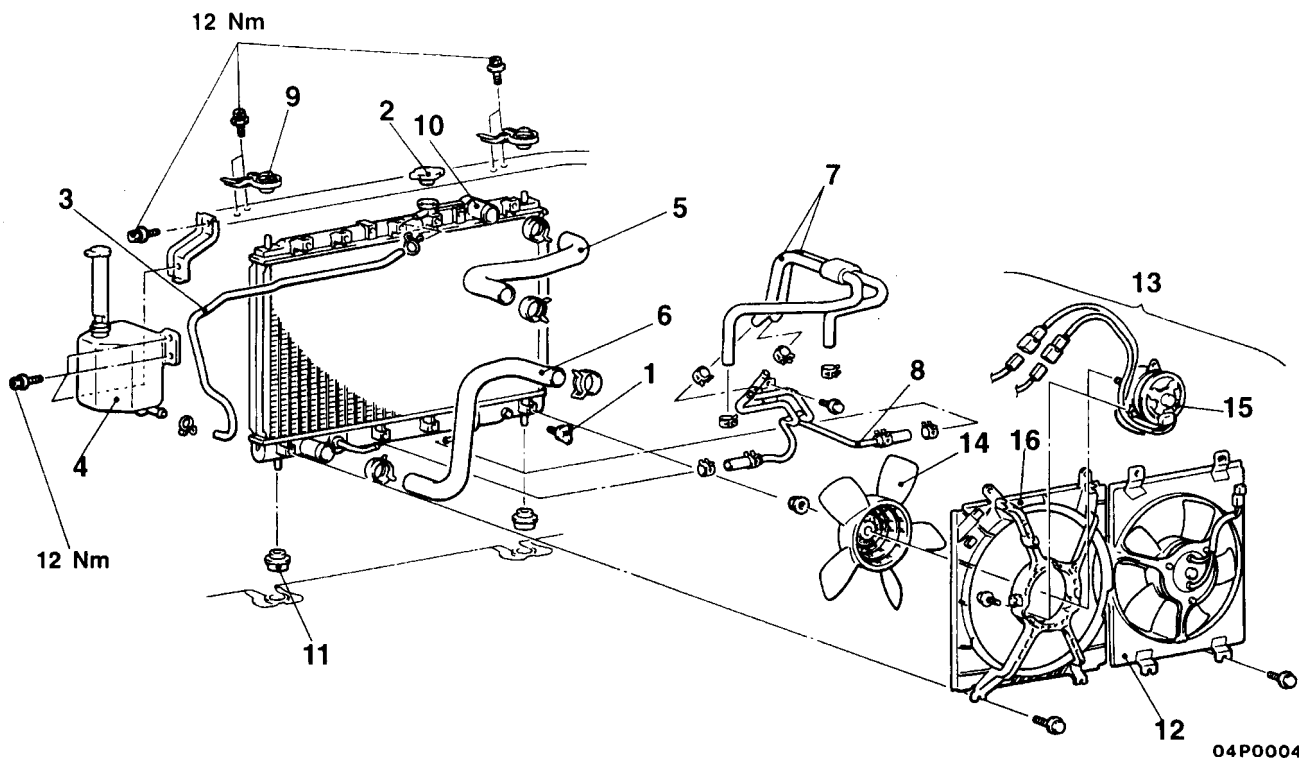

**Radiator removal steps**

1. Drain plug
2. Radiator cap
3. Overflow tube
4. Reserve tank
5. Radiator upper hose
6. Radiator lower hose
7. Transmission fluid cooler hose connection
8. Transmission fluid cooler hose connection
9. Upper insulator
10. Radiator assembly
11. Lower insulator
12. Condenser fan motor assembly
13. Radiator fan motor assembly
14. Fan
15. Radiator fan motor
16. Shroud

**Radiator fan motor removal steps**

1. Drain plug
2. Radiator cap
5. Radiator upper hose
12. Condenser fan motor assembly
13. Radiator fan motor assembly
14. Fan
15. Radiator fan motor
16. Shroud

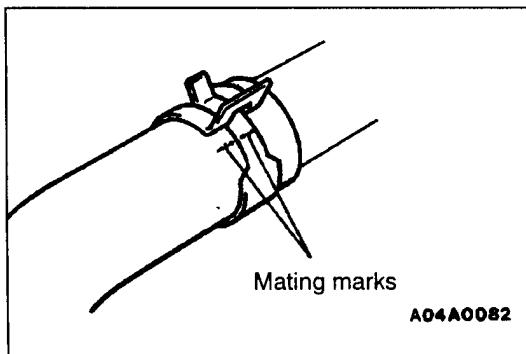

**REMOVAL SERVICE POINTS****◀A▶ RADIATOR UPPER HOSE/RADIATOR LOWER HOSE DISCONNECTION**

After making mating marks on the radiator hose and the hose clamp, disconnect the radiator hose.

**◀B▶ TRANSMISSION FLUID COOLER HOSE REMOVAL**

After removing the hose from the radiator, plug the hose and the radiator nipple to prevent dust or foreign particles from getting in.

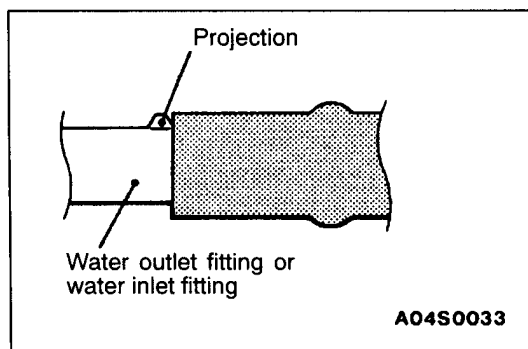
**INSTALLATION SERVICE POINT****▶A◀ RADIATOR LOWER HOSE/RADIATOR UPPER HOSE CONNECTION**

1. Insert each hose as far as the projection of the water outlet fitting or water inlet fitting.
2. Align the mating marks on the radiator hose and hose clamp, and then connect the radiator hose.

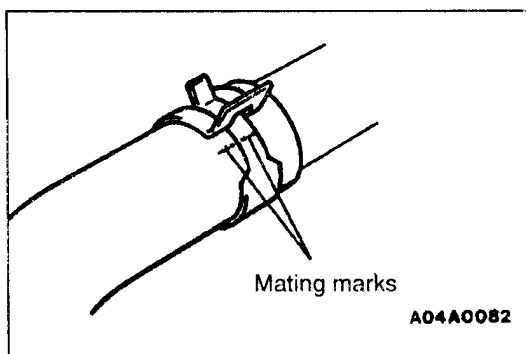

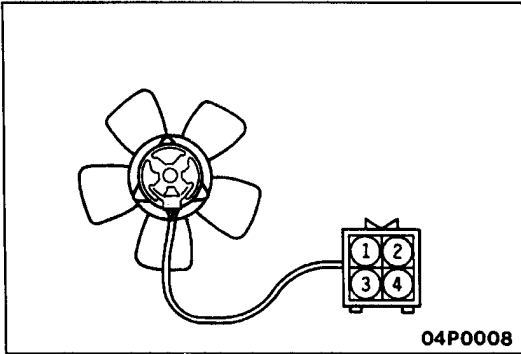

**INSPECTION**

**RADIATOR FAN MOTOR CHECK**

1. Check to be sure that the radiator fan rotates when battery voltage is applied between terminals.

Terminals connected to the battery				Radiator fan motor rotation
1	2	3	4	
		⊕ - - - - ⊖		Low
⊕ - - - - ⊖		⊕ - - - - ⊖		High

2. Check to see that abnormal noises are not produced, while motor is turning.

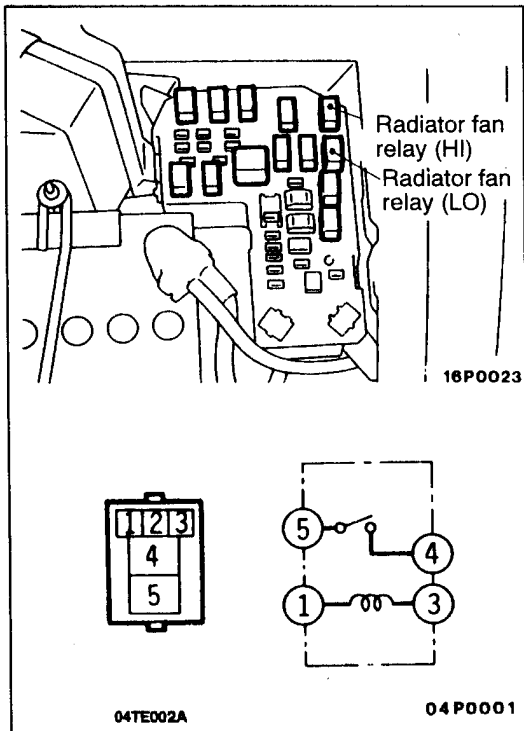

**RADIATOR RELAY CONTINUITY CHECK**

Battery voltage	Terminal No.			
	1	3	4	5
Not supplied	○ — ○			
Supplied	⊕ - - - - ⊖		○ — ○	