ENGINE LUBRICATION

CONTENTS

GENERAL INFORMATION	2	ON-VEHICLE SERVICE	3
LUBRICANTS	3	Engine Oil Inspection	3
SPECIAL TOOL	3	Engine Oil Replacement	3
		Oil Filter Replacement	4

GENERAL INFORMATION

The lubrication method is a fully force-fed, full flow filtration type. The oil pump is a trochoid type which is directly mounted to the crankshaft.

ENGINE OILS

Health Warning

Prolonged and repeated contact with mineral oil will result in the removal of natural fats from the skin, leading to dryness, irritation and dermatitis. In addition, used engine oil contains potentially

harmful contaminants which may cause skin cancer. Adequate means of skin protection and washing facilities must be provided.

Recommended Precautions

The most effective precaution is to adapt working practices which prevent, as far as practicable, the risk of skin contact with mineral oils, for example by using enclosed systems for handling used engine oil and by degreasing components, where practicable, before handling them.

Other precautions:

- Avoid prolonged and repeated contact with oils, particularly used engine oils.
 - Wear protective clothing, including impervious gloves where practicable.
 - Avoid contaminating clothes, particularly underpants, with oil.
 - Do not put oily rags in pockets, the use of overalls without pockets will avoid this.
 - Do not wear heavily soiled clothing and oil-impregnated foot-wear. Overalls must be cleaned regularly and kept separate from personal clothing.
- Where there is a risk of eye contact, eye protection should be worn, for example, chemical goggles or face shields; in addition an eye wash facility should be improved.
 - Obtain First Aid treatment immediately for open cuts and wounds.
 - Wash regularly with soap and water to ensure all oil is removed, especially before meals (skin cleansers and nail brushes will help). After cleaning, the application of preparations containing lanolin to replace the natural skin oils is advised.
 - Do not use petrol, kerosene, diesel fuel, gas oil, thinners or solvents for cleaning skin.
 - Use barrier creams, applying them before each work period, to help the removal of oil from the skin after work.
 - If skin disorders develop, obtain medical advice without delay.

LUBRICANTS

Items	Engine oil (API classification)	Quantity (litres)
Oil filter	Except China: SE or higher China: SC or higher	0.3
Total quantity		4.3

SPECIAL TOOLS

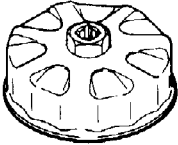
Tool	Number	Name	Use
	MB991396	Oil filter wrench	Removal and installation of engine oil filter

ON-VEHICLE SERVICE

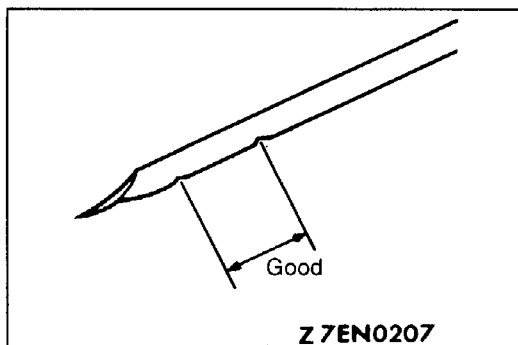

ENGINE OIL INSPECTION

1. Pull out the level gauge slowly and check that the oil level is in the illustrated range.
2. Check that the oil is not excessively dirty, that there is no coolant or gasoline mixed in, and that it has sufficient viscosity.

ENGINE OIL REPLACEMENT

1. Start the engine and allow it to warm up until the temperature of the coolant reaches 80°C to 90°C.
2. Remove the engine oil filler cap.
3. Remove the drain plug to drain oil.

Caution

Use care as oil could be hot.

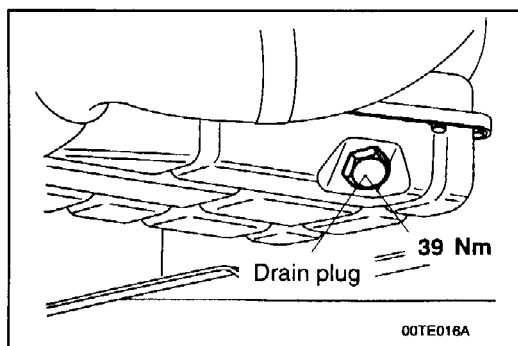

4. Install a new drain plug O-ring, and then tighten the drain plug to the specified torque.

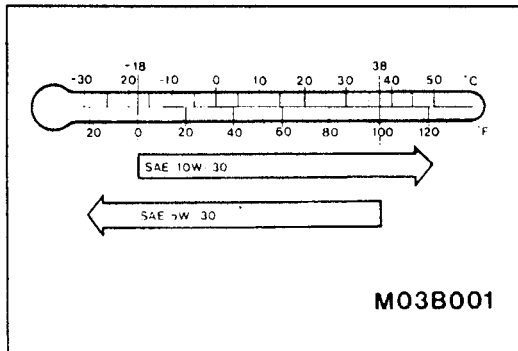

5. Refill with specified quantity of oil.

Specified Engine Oil (API classification):

Except China: SE or higher

China: SC or higher

Total quantity (Includes volume inside oil filter): 4.3ℓ

6. Install the engine oil filler cap.
7. Check oil level.

OIL FILTER REPLACEMENT

1. Start the engine and allow it to warm up until the engine temperature of the coolant reaches 80°C to 90°C.
2. Remove the engine oil filler cap.
3. Remove the drain plug to drain oil.

Caution

Use care as oil could be hot.

4. Use the Special Tool MB991396 (or equivalent) to remove the engine oil filter from the underside of the vehicle.
5. Clean the filter bracket side mounting surfaces.
6. Apply a small amount of engine oil to the O-ring of the new oil filter.
7. Install the engine oil filter.

NOTE

Tightening torque: 14Nm

8. Install the drain plug and refill engine oil. (Refer to Engine Oil Replacement P.12-3).
9. Race the engine 2-3 times, and check to be sure there are no engine oil leaks from the installation section of the filter.

